

REPAIR MANUAL

NEW HOLLAND

TD60D

TD70D

TD80D

TD90D

TD95D

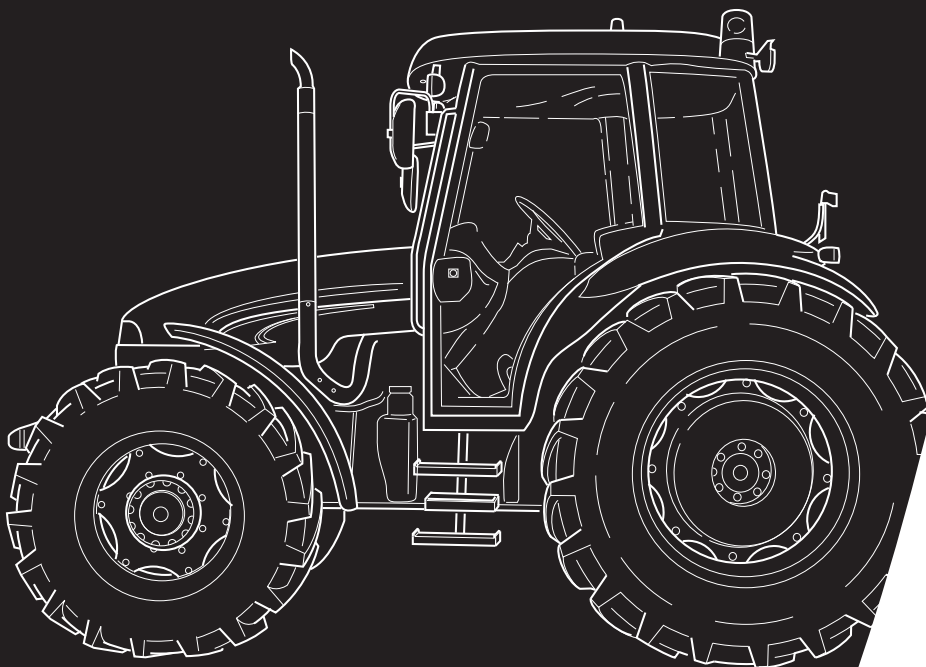

NEW HOLLAND



NEW HOLLAND



TD60D - TD70D - TD80D - TD90D - TD95D MODEL TRACTORS SERVICE MANUAL

SECTIONS	
GENERAL	00
ENGINE	10
CLUTCH	18
GEARBOX	21
TRANSMISSION OF MOTION	23
FRONT MECHANICAL TRANSMISSION	25
REAR MECHANICAL TRANSMISSION	27
POWER TAKE-OFF	31
BRAKES	33
HYDRAULIC SYSTEMS	35
STEERING	41
AXLE AND WHEELS	44
AIR CONDITIONING SYSTEM	50
ELECTRICAL SYSTEM	55
CAB	90

S E R V I C E

INTRODUCTION

- ◇ *This manual is divided into sections identified by two-figure numbers. Each section has independent page numbering.
For ease of reference, these sections have the same numbers and names as the Repairs Rate Book sections.*
- ◇ *The different sections can easily be found by consulting the table of contents on the following pages.*
- ◇ *The document number of the manual and the edition/update dates are given at the bottom of each page.*
- ◇ *Pages updated in the future will be identified by the same document number followed by a two-figure update number (for example: 1st update 603.54.471.01; 2nd update 603.54.471.02; etc.) and the corresponding issue date.
These pages will be supplemented by a reprint of the updated contents page.*
- ◇ *The information contained in this manual was current on the date printed on each section. As NEW HOLLAND constantly improves its product range, some information may be out of date subsequent to modifications implemented for technical or commercial reasons or to meet legal requirements in different countries.
In the event of conflicting information, consult the NEW HOLLAND Sales and Service Departments.*

IMPORTANT WARNINGS

- ◇ *All maintenance and repair work described in this manual must be performed exclusively by NEW HOLLAND service technicians in strict accordance with the instructions given and using any specific tools necessary.*
- ◇ *Anyone who performs the operations described herein without strictly following the instructions is personally responsible for resulting injury or damage to property.*
- ◇ *The Manufacturer and all organisations belonging to the Manufacturer's distribution network, including but not restricted to national, regional or local distributors, will accept no responsibility for personal injury or damage to property caused by abnormal function of parts and/or components not approved by the Manufacturer, including those used for maintenance and/or repair of the product manufactured or marketed by the Manufacturer.
In any case, the product manufactured or marketed by the Manufacturer is covered by no guarantee of any kind against personal injury or damage to property caused by abnormal function of parts and/or components not approved by the Manufacturer.*

TEXT AND ILLUSTRATIONS ARE THE PROPERTY
OF CNH ITALIA S.p.a.



No part of the text or illustrations
may be reproduced

PRINTED IN ITALY

CNH ITALIA S.p.a. - Viale delle Nazioni, 55 - 41100 MODENA - Italia
TECHNICAL SUPPORT - Technical Information
Print no. **603.54.471.00** - 11 - 2004

NEW HOLLAND

Repair Manual – TD Series Tractors

CONTENTS

GENERAL SECTION 00

General Instructions and Health and Safety Chapter 1

Section	Description	Page
00 000	General instructions	1
	Notes for spare parts	2
	Notes for equipment	2
	Safety rules	3
	Consumables	6

ENGINE SECTION 10

Engine System Chapter 1

Section	Description	Page
10 000	General specifications	2
	Injection pump calibration data	6
	General specifications	16
	Torque settings	24
	Tools	25
	Cross-sectional views	28
	Lubrication and cooling system diagrams	32
	Fault diagnosis	35
10 001 10	Engine <i>Removal-Installation</i>	39
10 001 54	Engine <i>Bench overhaul</i>	53
	Checks, measurements and repairs	78
10 406 10	Radiator <i>Removal-Installation</i>	103
10 102 70	Crankshaft front oil seal <i>removal installation</i>	106
10 402 10	Coolant pump <i>removal installation</i>	112
10 402 30	Cooling system thermostat	115
10 206 14	Bosch injection pump <i>removal installation</i>	118
	Bosch injection pump <i>timing</i>	121
	Bosch injection pump <i>air bleeding</i>	123
10 218 30	Injectors <i>removal installation</i>	124
10 106 12	Valve clearance adjustment	126
10 402 28	Coolant pump overhaul	129
10 001 30	Compression test	130

CLUTCH**SECTION 18****Clutches****Chapter 1**

Section	Description	Page
18 000	General specifications	1
	Tightening torques	2
	Tools	3
	Cross-sectional views	4
	Clutch Troubleshooting	5
18 110 10	Removal – Installation	6
	Overhaul	14
	Minimum permissible dimensions after refacing	18
18 100 40	Adjustments	19
	Adjustment of the main and PTO clutch control linkage	21

GEARBOX**SECTION 21****Mechanical Transmission (12x4)****Chapter 1**

Section	Description	Page
21 000	Main data	1
	Tightening torques	2
	Tools	3
	Section views	5
	Description and operation	8
	Fault diagnosis	8
21 110	Removal – Refitting	see sect 27

Reverser (12x12)**Chapter 2**

Section	Description	Page
21 000	Main data	1
	Tightening torques	2
	Tools	3
	Section views	3
	Description and operation	5
	Fault diagnosis	5
21 110	Removal–Refitting	6

Reverser and creeper unit (20x12)**Chapter 3**

Section	Description	Page
21 000	Main data	1
	Tightening torques	2
	Tools	3
	Section views	4
	Description and operation	6
	Fault diagnosis	6
21 110	Removal–Refitting	7

DRIVE LINES**SECTION 23****Drive Lines****Chapter 1**

Section	Description	Page
23 000	Main specification	1
	Torque settings and Tools	2
	Cross-Sectional views	3
23 101 26	Transmission shafts and guard (Disassembly – Assembly)	4
23 101 40	Drive gear housing (Removal – Installation)	5
23 101 42	Drive gear housing removed (Disassembly – Assembly)	7

FRONT AXLE MECHANICAL TRANSMISSION**SECTION 25****Front Axle Mechanical Transmission****Chapter 1**

Section	Description	Page
25 000	Main data	1
	Tightening torques	4
	Tools	6
	Cross-sectional views	7
	Description and operation	10
25 100 30	Complete front axle. Removal – Installation	10
25 100 38	Front axle. Removal – Installation	14
25 108 46–47	Steering knuckle bearing pins. Replacement	24
	Stub axle adjustment	25
	Wheel hub bearing adjustment	27
	Bevel drive adjustment	29
25 102 24	Front axle differential. Overhaul	36
25 100 27	Front axle differential with LIM–SLIP. Overhaul	37
	Front axle differential with NO SPIN. Overhaul	39
44 511 80	Leading drive wheels toe-in check	42

REAR AXLE AND TRANSMISSION**SECTION 27****Rear Axle And Transmission****Chapter 1**

Section	Description	Page
27 000	Main data	1
	Tightening torques	3
	Special tools	5
	Cross-sectional views	7
	Description and operation and troubleshooting	10
21.118.10 – 12	Transmission–gearbox casing Removal–Installation	11
21.118.85	Transmission–gearbox casing Disassembly–Overhaul	29
	Gearbox driven shaft end float adjustment	37
	Differential lock engagement sleeve adjustment	38
	Determining the bevel pinion positioning adjustment ring	39
	Adjusting the taper roller bearings for the bevel pinion shaft	41
	Adjusting the bearings and checking the backlash	42
	Differential pinion and side gear backlash adjustment	46

POWER TAKE-OFF**SECTION 31****Mechanical Power Take – Off****Chapter 1**

Section	Description	Page
31 000	Main specifications	1
	Tools	3
	Tightening torques	4
	Cross-sectional views	5
	Description and Operation	9
	Troubleshooting	10
31.112.20	540/750 Power take-off – Removal – Installation	11
31.112.45–48	540/750 Power take-off – Overhaul on bench	14
31.114	540/750 Power take-off – Overhaul on bench	17

BRAKES**SECTION 33****Braking System****Chapter 1**

Section	Description	Page
33 000	Main data	1
	Tightening torques	2
	Cross-sectional views	3
	Description & Operation	7
	Tools – Troubleshooting	8
33.206	Front brake assembly mod. TD60D and TD70D removal and refitting – overhauling on the bench	9
33.202.60	Service brake removal and refitting	12
33.202.50	Removal–Refitting of front brake pumps	17
33.202.40	Bleeding air from the front braking system	19
33.120.08	Adjusting service brake pedals travel	20
33.110.08	Parking brake travel adjustment	20

HYDRAULIC SYSTEM**SECTION 35****Rear Mechanical Hydraulic Lift****Chapter 1**

Section	Description	Page
35 000	Main specification	1
	Tightening torques	5
	Tools	6
	Cross-sectional views	7
	Description & Operation	9
	Hydraulic circuit	10
	Description and operation of lift phases	11
	Fault diagnosis	14
35 110.30	Hydraulic lift – disassembly reassembly	16
35.110.40–42–46	Hydraulic lift – bench overhaul	23
	Adjusting the lift	28
35.110.08	Linkage adjustment	34
35.110.30	Pressure relief valve – disassembly reassembly	36
35.110.32	Pressure relief valve – setting	36
35.110.14	Lift control valve – disassembly assembly and overhaul on bench	37
35.0101.10	Lift pump	41

Open Centre System Auxiliary Control Valves**Chapter 2**

Section	Description	Page
35 000	Main data – Tools	1
	Cross-sectional views	2
	Description & Operation	3
	Diagram of a convertible single/double-acting control valve with automatic release and detent in float	4
	Diagram of a convertible single/double-acting control valve	7
	Diagram of a convertible single/double-acting control valve with automatic release	9
35 204 46	Additional control valve – disassembly and reassembly	10
	Hydraulic Tests	11

Trailer Brake Auxiliary Control Valve**Chapter 3**

Section	Description	Page
35 000	Section views	1
	Hydraulic diagram	2
	Description and operation of valve phases	3
	Trailer brake auxiliary control valve linkage adjustment	5

STEERING**SECTION 41****Steering****Chapter 1**

Section	Description	Page
41 000	Principal data	1
	Tightening torques	3
	Hydraulic diagram	4
	Operation	5
	Section	8
	Fault diagnosis	9
	Tools	10
41 204.30	Removal-Installation – hydrostatic steering control valve	11
41.204.34	Hydrostatic steering control valve – Overhaul on bench	14
41.204.38	Hydrostatic steering control valve – Bench test	28
	Hydrostatic steering pump	30
41.216.20	Steering cylinder (two-wheel drive axle) – removal and installation	32
	Steering cylinder (four-wheel drive axle) – removal and installation	33

FRONT AXLE AND WHEELS**SECTION 44****Front Axle And Wheels****Chapter 1**

Section	Description	Page
44 000	Principal data	1
	Sectional views	3
	Torque settings	4
	Equipment – Fault diagnosis	5
	Removal-Refitting-Overhaul	6
44 101.30	Wheel hub disassembly-assembly	9
44 101.22	Stub axle overhaul	12
44 101.46	Stub axle overhaul	12
44 511.80	Checking wheel alignment	16

CAB AIR CONDITIONING SYSTEM**SECTION 50****Cab air conditioning system****Chapter 1**

Section	Description	Page
50 000	Safety instructions	2
	General characteristics	3
	Equipment	4
	Operating principles	5
	Fault diagnosis	7
	Cab controls	11
	Use	14
	Main components of the cab air conditioning system	15
	Refrigerant recovery–recycling and evacuation–charging stations	20
50.200.04	Drying recharging and checking cooling	22
50.200.03	Air–conditioning functional testing	27
	Summary of the cab air–conditioning system charging operations	28
	Checking for refrigerant leaks using an electronic leak detector	30
	Summary of fault diagnosis and maintenance	31
	Air conditioning and heating pipes – Replacement	33
50.200.04–74	Receiver–dryer – Replacement	36
50.200.04–72	Condenser – Replacement	38
50.200.04–26	Compressor – Removal–Refitting	39
50.200.10	Compressor drive belt tension adjustment	41

ELECTRICAL SYSTEM**SECTION 55****Instruments****Chapter 1**

Section	Description	Page
	Analogue instruments Introduction	1
	Transmitter and switch	4

Components**Chapter 2**

Section	Description	Page
55 500	Introduction	1
	Component description	1

Starting System**Chapter 3**

Section	Description	Page
55 000	Specifications	1
	Tightening torques	1
	Description and Operation	2
	System testing	4
55.201.50	Removal and re–installation of starter motor	7
	Section	8
55.201.54	Overhaul – disassembly and reassembly	8
	Bench tests	10

Charging System**Chapter 4**

Section	Description	Page
55 000	Technical information	1
	Tightening torques	1
	Description and operation	2
	System testing and trouble-shooting	4
55.301.10	Removal, re-installation and servicing	10

Battery**Chapter 5**

Section	Description	Page
55 000	Technical information	1
	Description and operation	1
55.301.040	Removal and re-installation	2
	Battery checking and maintenance	3
	Charging the battery	4
	Battery problems – Frequent causes	8

Electrical Circuits**Chapter 6**

Section	Description	Page
55 100	Content	1
	Fuses and Relays	2
	Electrical wire colour coding	4
	key to circuit symbols	5
	General diagram of tractor in non-cab version	6
	Starter switch system diagram	7
	Fuses and relays system diagram	8
	General diagram of tractor in cab/non-cab version	9
	Frame system diagram	9
	General diagram of tractor in cab version	10
	Starter switch system diagram	10
	Fuses and relays system diagram	12
	Cab system diagram	13
	Partial and connector diagrams	14
	Analog instrument circuit	14
	Starting circuit	16
	Direction indicator and hazard warning light circuit	21
	Windscreen and rear window wiper/washer circuit	28
	Brake warning light circuit	32
	Air conditioning and heating system circuit	37
	Work lights circuit (models without cab)	40
	Work lights circuit (models with cab)	42
	Sidelights, full beam, dipped beam and parking lights circuit	47

CAB**SECTION 90****Removing parts****Chapter 1**

Section	Description	Page
90 160 42 – 43		
90 120 10	Control levers, seat and electrical controls – disassembly and reassembly	2
90 156 52	Rear window, handle and lock – disassembly and reassembly	10
90 154 30	Left-hand door exterior handle and lock – disassembly and reassembly	11
90 154 10	Left-hand door – disassembly and reassembly	12
90 160 60		
55 518 52	Windscreen wiper motor – disassembly and reassembly	13
90154 24		
90 156 10 – 14		
90 156 28	Cab windows – replacement	15

GENERAL INSTRUCTIONS

IMPORTANT NOTICE

All maintenance and repair operations described in this manual should be carried out exclusively by the NEW HOLLAND authorised workshops. All instructions detailed should be carefully observed and special equipment indicated should be used if necessary.

Everyone who carries out service operations described without carefully observing these prescriptions will be directly responsible of deriving damages.

SHIMMING

At each adjustment, select adjusting shims, measure them individually using a micrometer and then sum up recorded values. Do not rely on measuring the whole shimming set, which may be incorrect, or on rated value indicated for each shim.

ROTATING SHAFT SEALS

To correctly install rotating shaft seals, observe the following instructions:

- Let the seal soak into the same oil as it will seal for at least half an hour before mounting;
- Thoroughly clean the shaft and ensure that the shaft working surface is not damaged;
- Place the sealing lip towards the fluid. In case of a hydrodynamic lip, consider the shaft rotation direction and orient grooves in order that they deviate the fluid towards the inner side of the seal;
- Coat the sealing lip with a thin layer of lubricant (oil rather than grease) and fill with grease the gap between the sealing lip and the dust lip of double lip seals;
- Insert the seal into its seat and press it down using a flat punch. Do not tap the seal with a hammer or a drift;
- Take care to insert the seal perpendicularly to its seat while you are pressing it. Once the seal is settled, ensure that it contacts the thrust element if required.;
- To prevent damaging the sealing lip against the shaft, place a suitable protection during installation.

O RINGS

Lubricate the O rings before inserting them into their seats. This will prevent the O rings from rolling over and twine during mounting which will jeopardise sealing.

SEALERS

Apply one of the following sealers: RTV SILMATE, RHODORSIL CAF 1, or LOCTITE PLASTIC GASKET over the mating surfaces marked with an X.

Before applying the sealer, prepare the surface as follows:

- remove possible scales using a metal brush;
- thoroughly degrease the surfaces using one of the following cleaning agent: trichlorethylene, petrol or a water and soda solution.

BEARINGS

It is advisable to heat the bearings to 80 to 90°C before mounting them on their shafts and cool them down before inserting them into their seats with external tapping.

ROLL PINS

When fitting straight roll pins, ensure that the pin notch is oriented in the direction of the effort to stress the pin. Coil roll pins can be installed in any position.

NOTES FOR SPARE PARTS

Use exclusively **genuine NEW HOLLAND spare parts**, the only ones that guarantee same quality, life, safety as original components as they are the same as mounted in production.

Only **genuine spare parts** can offer this guarantee.

All spare parts orders should be complete with the following data:

- tractor model (commercial name) and frame number;
- engine type and number;
- part number of the ordered part, which can be found on the “Microfiches” or the “Spare Parts Catalogue”, which is the base for order processing.

NOTES FOR EQUIPMENT

Equipment which NEW HOLLAND proposes and shows in this manual are as follows:

- studied and designed expressly for use on NEW HOLLAND tractors;
- necessary to make a reliable repair;
- accurately built and strictly tested to offer efficient and long-lasting working means.

We also remind the Repair Personnel that having these equipment means:

- work in optimal technical conditions;
- obtain best results;
- save time and effort;
- work more safely.

NOTICES

Wear limits indicated for some details should be intended as advised, but not binding values. The words “front”, “rear”, “right hand”, and “left hand” referred to the different parts should be intended as seen from the operator’s seat oriented to the normal sense of movement of the tractor.

HOW TO MOVE THE TRACTOR WITH THE BATTERY REMOVED

Cables from the external power supply should be connected exclusively to the respective terminals of the tractor positive and negative cables using pliers in good condition which allow proper and steady contact.

Disconnect all services (lights, wind-shield wipers, etc.) before starting the tractor.

If it is necessary to check the tractor electrical system, check it only with the power supply connected. At check end, disconnect all services and switch the power supply off before disconnecting the cables.

SAFETY RULES

PAY ATTENTION TO THIS SYMBOL



This warning symbol points out important messages involving personal safety. Carefully read the safety rules contained herein and follow advised precautions to avoid potential hazards and safeguard your safety and personal integrity.

In this manual you will find this symbol together with the following key-words:



WARNING – it gives warning about improper repair operations and deriving potential consequences affecting the service technician's personal safety.

DANGER – it gives specific warning about potential dangers for personal safety of the operator or other persons directly or indirectly involved.

TO PREVENT ACCIDENTS

Most accidents and personal injuries taking place in workshops are due from non-observance of some simple and essential prudential rule and safety precautions. For this reason, **IN MOST CASES THEY CAN BE AVOIDED**. It suffices to foresee possible causes and act consequently with necessary caution and care.

The possibility that an accident might occur with any type of machines should not be disregarded, no matter how well the machine in question was designed and built.

A wise and careful service technician is the best precautions against accidents.

Careful observance of this only basic precaution would be enough to avoid many severe accidents.

DANGER: Never carry out any cleaning, lubrication or maintenance operations when the engine is running.

SAFETY RULES

GENERALITIES

- ◇ Carefully follow specified repair and maintenance procedures.
- ◇ Do not wear rings, wristwatches, jewels, unbuttoned or flapping clothing such as ties, torn clothes, scarves, open jackets or shirts with open zips which could get hold into moving parts. We advise to use approved safety clothing such as anti-slipping footwear, gloves, safety goggles, helmets, etc.
- ◇ Never carry out any repair on the machine if someone is sitting on the operator's seat, except

if they are certified operators to assist in the operation to be carried out.

- ◇ Never operate the machine or use attachments from a place other than sitting at the operator's seat.
- ◇ Never carry out any operation on the machine when the engine is running, except when specifically indicated.
- ◇ Stop the engine and ensure that all pressure is relieved from hydraulic circuits before removing caps, covers, valves, etc.
- ◇ All repair and maintenance operations should be carried out with the greatest care and attention.
- ◇ Service stairs and platforms used in a workshop or in the field should be built in compliance with the safety rules in force.
- ◇ Disconnect the batteries and label all controls to warn that the tractor is being serviced. Block the machine and all equipment which should be raised.
- ◇ Never check or fill fuel tanks and accumulator batteries, nor use starting liquid if you are smoking or near open flames as such fluids are flammable.
- ◇ Brakes are inoperative when they are manually released for maintenance purposes. In such cases, the machine should be kept constantly under control using blocks or similar devices.
- ◇ The fuel filling gun should remain always in contact with the filler neck. Maintain this contact until the fuel stops flowing into the tank to avoid possible sparks due to static electricity buildup.

- ◇ Use exclusively specified towing points for towing the tractor. Connect parts carefully. Ensure that foreseen pins and/or locks are steadily fixed before applying traction. Do not stop near towing bars, cables or chains working under load.
- ◇ To transfer a failed tractor, use a trailer or a low loading platform trolley if available.
- ◇ To load and unload the machine from the transportation mean, select a flat area providing a firm support to the trailer or truck wheels. Firmly tie the machine to the truck or trailer platform and block wheels as required by the forwarder.
- ◇ For electrical heaters, battery–chargers and similar equipment use exclusive auxiliary power supplies with a efficient ground to avoid electrical shock hazard.
- ◇ Always use lifting equipment and similar of appropriate capacity to lift or move heavy components.
- ◇ Pay special attention to bystanders.
- ◇ Never pour gasoline or diesel oil into open, wide and low containers.
- ◇ Never use gasoline, diesel oil or other flammable liquids as cleaning agents. Use non–flammable non–toxic proprietary solvents.
- ◇ Wear protection goggles with side guards when cleaning parts using compressed air.
- ◇ Do not exceed a pressure of 2.1 bar, in accordance with local regulations.
- ◇ Do not run the engine in a closed building without proper ventilation.
- ◇ Do not smoke, use open flames, cause sparks in the nearby area when filling fuel or handling highly flammable liquids.
- ◇ Do not use flames as light sources when working on a machine or checking for leaks.
- ◇ Move with caution when working under a tractor, and also on or near a tractor. Wear proper safety accessories: helmets, goggles and special footwear.
- ◇ During checks which should be carried out with the engine running, ask an assistant to seat at the operator’s seat and keep the service technician under visual control at any moment.
- ◇ In case of operations outside the workshop, drive the tractor to a flat area and block it. If working on an incline cannot be avoided, first block the tractor carefully. Move it to a flat area as soon as possible with a certain extent of safety.
- ◇ Ruined or plied cables and chains are unreliable. Do not use them for lifting or trailing. Always handle them wearing gloves of proper thickness.
- ◇ Chains should always be safely fastened. Ensure that fastening device is strong enough to hold the load foreseen. No persons should stop near the fastening point, trailing chains or cables.
- ◇ The working area should be always kept CLEAN and DRY. Immediately clean any spillage of water or oil.
- ◇ Do not pile up grease or oil soaked rags, as they constitute a great fire hazard. Always place them into a metal container.
Before starting the tractor or its attachments, check, adjust and block the operator’s seat. Also ensure that there are no persons within the tractor or attachment operating range.
- ◇ Do not keep into your pockets any object which might fall unobserved into the tractor’s inner compartments.
- ◇ Whenever there is the possibility of being reached by ejected metal parts or similar, use protection eye mask or goggles with side guards, helmets, special footwear and heavy gloves.
- ◇ Wear suitable protection such as tinted eye protection, helmets, special clothing, gloves and footwear whenever it is necessary to carry out welding procedures. All persons standing in the vicinity of the welding process should wear tinted eye protection. NEVER LOOK AT THE WELDING ARC IF YOUR EYES ARE NOT SUITABLY PROTECTED.
- ◇ Metal cables with the use get frayed. Always wear adequate protections (heavy gloves, eye protection, etc.)
- ◇ Handle all parts with the greatest caution. Keep your hands and fingers far from gaps, moving gears and similar. Always use approved protective equipment, such as eye protection, heavy gloves and protective footwear.

START UP

- ◇ Never run the engine in confined spaces which are not equipped with adequate ventilation for exhaust gas extraction.
- ◇ Never bring your head, body, arms, legs, feet, hands, fingers near fans or rotating belts.

ENGINE

- ◇ Always loosen the radiator cap very slowly before removing it to allow pressure in the system to dissipate. Coolant should be topped up only when the engine is stopped or idle if hot.
- ◇ Do not fill up fuel tank when the engine is running, mainly if it is hot, to avoid ignition of fires in case of fuel spilling.
- ◇ Never check or adjust the fan belt tension when the engine is running.
Never adjust the fuel injection pump when the tractor is moving.
- ◇ Never lubricate the tractor when the engine is running.

ELECTRICAL SYSTEMS

- ◇ If it is necessary to use auxiliary batteries, cables must be connected at both sides as follows: (+) to (+) and (-) to (-). Avoid short-circuiting the terminals. **GAS RELEASED FROM BATTERIES IS HIGHLY FLAMMABLE.** During charging, leave the battery compartment uncovered to improve ventilation. Avoid checking the battery charge by means of “jumpers” made by placing metallic objects across the terminals. Avoid sparks or flames near the battery area. Do not smoke to prevent explosion hazards.
- ◇ Prior to any service, check for fuel or current leaks. Remove these leaks before going on with the work.
- ◇ Do not charge batteries in confined spaces. Ensure that ventilation is appropriate to prevent accidental explosion hazard due to build-up of gases released during charging.
- ◇ Always disconnect the batteries before performing any type of service on the electrical system.

HYDRAULIC SYSTEMS

- ◇ Some fluid slowly coming out from a very small port can be almost invisible and be strong enough to penetrate the skin. For this reason, **NEVER USE YOUR HANDS TO CHECK FOR LEAKS**, but use a piece of cardboard or a piece of wood to this purpose. If any fluid is injected into the skin, seek medical aid immediately. Lack of immediate medical attention, serious infections or dermatosis may result.
- ◇ Always take system pressure readings using the appropriate gauges.

WHEELS AND TYRES

- ◇ Check that the tyres are correctly inflated at the pressure specified by the manufacturer. Periodically check possible damages to the rims and tyres.
- ◇ Keep off and stay at the tyre side when correcting the inflation pressure.
- ◇ Check the pressure only when the tractor is unloaded and tyres are cold to avoid wrong readings due to over-pressure. Do not reuse parts of recovered wheels as improper welding, brazing or heating may weaken the wheel and make it fail.
- ◇ Never cut, nor weld a rim with the inflated tyre assembled.
- ◇ To remove the wheels, block both front and rear tractor wheels. Raise the tractor and install safe and stable supports under the tractor in accordance with regulations in force.
- ◇ Deflate the tyre before removing any object caught into the tyre tread.
- ◇ Never inflate tyres using flammable gases as they may originate explosions and cause injuries to bystanders.

REMOVAL AND INSTALLATION

- ◇ Lift and handle all heavy components using lifting equipment of adequate capacity. Ensure that parts are supported by appropriate slings and hooks. Use lifting eyes provided to this purpose. Take care of the persons near the loads to be lifted.
- ◇ Handle all parts with great care. Do not place your hands or fingers between two parts. Wear approved protective clothing such as safety goggles, gloves and footwear.
- ◇ Do not twine chains or metal cables. Always wear protection gloves to handle cables or chains.

CONSUMABLES

COMPONENT TO BE FILLED OR TOPPED UP	QTY dm³ (litres)	QUANTITY US gal	NEW HOLLAND RECOMMENDED PRODUCT	INTERNATIONAL SPECIFICATION
Cooling system : TD60D, TD70D models	12	3.2	Water & liquid AMBRA AGRIFLU 50% + 50% (NH 900 A)	–
TD80D, TD90D, TD95D models . with cab:	14	3.7		
TD60D, TD70D models	14	3.7		
TD80D, TD90D, TD95D models .	16	4.2		
Windscreen washer bottle	2	0.5	Water & cleaning liquid	–
Fuel tank	92	24.3	Decanted, filtered diesel fuel	–
Engine sump: without filter: TD60D, TD70D models	6.8	1.8	AMBRA Supergold SAE 15W – 40 (NH 330G) AMBRA Supergold SAE 10W – 30 (NH 324G)	API CF–4/SG CCMC D4 MIL–L–2104E
TD80D, TD90D, TD95D models . with filter	10.7	2.8		
TD60D, TD70D models	7.5	2.0		
TD80D, TD90D, TD95D models	11.4	3.0		
Brake control circuit	0.4	0.1	AMBRA BRAKE LHM Oil (NH 610 A)	ISO 7308
Hydrostatic steering circuit	2.0	0.5	Oil AMBRA MULTI F (NH 420 A)	API GL4 ISO 46/68 SAE 20W–30
Front axle : – axle housing : TD60D, TD70D models	4.5	1.2		
TD80D, TD90D, TD95D models .	7.0	1.8		
final drives (each) : TD60D, TD70D models	0.8	0.2		
TD80D, TD90D, TD95D models .	1.25	0.3		
Rear axle (bevel drive, final drives and brakes), transmission, hydraulic lift, power take–off and hydrostatic steering : TD60D, TD70D models	49	12.9		
TD80D, TD90D, TD95D models .	55	13.1		
– with synchro–reverser : All models	55	13.1		
Front wheel hubs	–		Grease AMBRA GR9 (NH 710 A)	NLGI 2
Grease fittings	–			

SECTION 10 – ENGINE

Chapter 1 – Engine

CONTENTS

Section	Description	Page
10 000	General specifications	2
	Injection pump calibration data	6
	General specifications	16
	Torque settings	24
	Tools	25
	Cross-sectional views	28
	Lubrication and cooling system diagrams	32
	Fault diagnosis	35
10 001 10	Engine <i>Removal-Installation</i>	39
10 001 54	Engine <i>Bench overhaul</i>	53
	Checks, measurements and repairs	78
10 406 10	Radiator <i>Removal-Installation</i>	103
10 102 70	Crankshaft front oil seal <i>removal installation</i>	106
10 402 10	Coolant pump <i>removal installation</i>	112
10 402 30	Cooling system thermostat	115
10 206 14	Bosch injection pump <i>removal installation</i>	118
	Bosch injection pump <i>timing</i>	121
	Bosch injection pump <i>air bleeding</i>	123
10 218 30	Injectors <i>removal installation</i>	124
10 106 12	Valve clearance adjustment	126
10 402 28	Coolant pump overhaul	129
10 001 30	Compression test	130

GENERAL SPECIFICATIONS	3 cylinders	4 cylinders
Engine type:		
– mod. TD60D normally aspirated – type 8035.05D.939 (BOSCH pump)	see data pages 6–7	–
– mod. TD70D turbocharged – type 8035.25C.939 (BOSCH pump)	see data pages 8–9	–
– mod. TD80D normally aspirated – type 8045.05R.939 (BOSCH pump)	–	see data pages 10–11
– mod. TD90D turbocharged – type 8045.25.939 (BOSCH pump)	–	see data pages 12–13
– mod. TD95D turbocharged – type 8045.25L.939 (BOSCH pump)	–	see data pages 14–15
Cycle	Diesel, 4–stroke	
Fuel injection	Direct	
Number of cylinders in line	3	4
Cylinder liners		dry force–fitted in cylinder block
Piston diameter		
– mod. TD60D	104 mm (4.0945 in.)	–
– mod. TD70D	104 mm (4.0945 in.)	–
– mod. TD80D	–	104 mm (4.0945 in.)
– mod. TD90D	–	104 mm (4.0945 in.)
– mod. TD95D	–	104 mm (4.0945 in.)
Piston stroke	115 mm (4.5276 in.)	
Total displacement:		
– mod. TD60D–TD70D	2931 cm ³ (178.8496 in. ³)	–
– mod. TD80D–TD90D–TD95D	–	3908 cm ³ (238.4662 in. ³)
Compression ratio	17 to 1 normally aspirated 16.5 to 1 turbocharged	
Maximum power 2000/25 EC at 2500 rpm:		
– mod. TD60D	43.4 kW (59 hp)	–
– mod. TD70D	50.7 kW (69 hp)	–
– mod. TD80D	–	58.8 kW (80 hp)
– mod. TD90D	–	65.5 kW (89 hp)
– mod. TD95D	–	69.1 kW (94 hp)
Maximum power ECE R 24 at 2500 rpm:		
– mod. TD60D	41.2 kW (56 hp)	–
– mod. TD70D	47.8 kW (65 hp)	–
– mod. TD80D	–	55.9 kW (76 hp)
– mod. TD90D	–	63.3 kW (86 hp)
– mod. TD95D	–	66.9 kW (91 hp)
Fast idling speed	2500 rpm.	
Maximum torque (daNm) at 1500 rpm: TD60D model	20.7 (152.6753 ft lb)	–
Maximum torque (daNm) at 1500 rpm: TD70D model	25.0 (184.3905 ft lb)	–
Maximum torque (daNm) at 1500 rpm: TD80D model	–	27.9 (205.9778 ft lb)
Maximum torque (daNm) at 1500 rpm: TD90D model	–	32.0 (236.0194 ft lb)
Maximum torque (daNm) at 1500 rpm: TD95D model	–	33.7 (248.5584 ft lb)
Number of main bearings	4	5
Sump	Structural, cast iron	

(Continued)

(continued)

GENERAL SPECIFICATIONS	3 cylinders	4 cylinders
Lubrication Pump drive Engine speed/oil pump speed ratio Oil cleaning Normal oil pressure, with engine hot and at fast idling speed: . Pressure relief valve Valve opening pressure For further lubrication data	forced, with gear pump camshaft 2:1 mesh filter on oil intake and cartridge filter on delivery line 2.9 to 3.9 bar (42.06 to 56.56 psi) built into pump housing 3.5 bar (50.76 psi) See page 23	
Cooling system Radiator on TD60D, TD70D, TD80D and TD90D models Radiator on TD95D models Fan, attached to coolant pump pulley Coolant pump Engine speed/coolant pump speed ratio Temperature control Coolant temperature gauge Temperature ranges corresponding to each section: – initial white section – middle green section – final red section For further cooling system data	coolant circulation three–row vertical pipes with copper fins four–row vertical pipes with copper fins four–blade steel exhauster fan 6–blade steel exhauster fan (TD95D) centrifugal vane–type 1:1,403 Thermostat coloured scale divided into three sections from 30° to 65° C (86° to 149° F) from 65° to 105° C (149° to 221° F) from 105° to 115° C (221° to 300.2° F) See page 23	
Rev counter Rev counter drive Hour counter calibrated for engine speed of	incorporated in control panel from gear on camshaft 1800 rpm.	

(Continued)

(continued)

GENERAL SPECIFICATIONS	3 cylinders	4 cylinders
Timing Intake: – start: before T.D.C – end: after B.D.C Exhaust: – start: before B.D.C – end: after T.D.C Valve clearance for timing check Valve clearance for normal running (engine cold): – intake – exhaust For further timing data	overhead valves operated by a camshaft located in the engine block through tappets, pushrods and rockers. Camshaft is driven by the crankshaft through helical gears. 12° 31° 50° 16° 0.45 mm (0.0177 in.) 0.30 ± 0.05 mm (0.0118 ± 0.0020 in.) 0.30 ± 0.05 mm (0.0118 ± 0.0020 in.) See page 20	
Fuel System Air cleaning Fuel pump Fuel filter Minimum fuel flow rate with pump shaft rotating at 1600 rev/min. Operated by eccentric cam BOSCH Injection pump All-speed governor, incorporated in pump: BOSCH Automatic advance regulator, incorporated in pump: BOSCH For further fuel system data: For fixed advance (pump setting for start of delivery before TDC) – Pressure setting – Injection order, and other information regarding the BOSCH pump	dual cartridge dry air filter, with clogged filter indicator with centrifugal pre-filter and automatic dust ejector. with double diaphragm mesh filter in fuel supply pump, and replaceable cartridge on delivery line to injection pump. 100 litres/hour on camshaft rotary distributor type centrifugal counterweights hydraulic see pages 5 to 15 refer to the data for the relevant engine type in the tables from page 6 to page 14.	

DATA

Turbocharger (Model TD95D): – GARRETT type		T25			
Fuel injection pump BOSCH pump: – TD60D model – TD70D model – TD80D model – TD90D model – TD95D model Direction of rotation Injection order		distributor type with incorporated speed governor and automatic advance regulator VE 3/12 F 1250 L 976 – 504054473 VE 3/12 F 1250 L 977 – 504054474 VE 4/12 F 1250 L 985 – 504041416 VE 4/12 F 1250 L 982 – 504042214 VE 4/12 F 1250 L 952 – 504042718 anticlockwise 1–2–3 (TD60D and TD70D) 1–3–4–2 (TD80D, TD90D and TD95D)			
Fuel injectors: BOSCH – Nozzle holder type – Nozzle type Number of nozzle holes Diameter of nozzle orifices Pressure setting	5 248–272 bar (3596.9176–3945.0064 psi)	6 248–272 bar (3596.9176–3945.0064 psi)			
	TD70D	TD95D	TD60D	TD80D	TD90D
Fuel delivery lines – BOSCH pump – Type – Dimensions mm	–	–	–	–	–

TD60D MODEL – CALIBRATION DATA FOR BOSCH INJECTION PUMP TYPE VE 3/12 F 1250 L 976 – 504054473

ASSEMBLY DATA

Pump timing on engine: delivery start $4^\circ \pm 0.5^\circ$ before TDC of cylinder 1 compression stroke.

Plunger pre-lift for timing on engine: 1 mm from B.D.C. (with tools **380000228 – 380001601**).

Cylinder no. 1 delivery line union on pump: marked with letter A.

ASSEMBLY DIMENSIONS

SYMBOL	K	KF	MS1	ya	yb
mm	3.6 to 3.8	3	0.85 to 1.15	36.9 to 40.9	41.5 to 46.5

Test bench conforming to ISO 4008/1.../2

Injectors conforming to ISO 7440–A61 – (1688901027 with pad \varnothing 0.5 mm)

Injector setting pressure: 250 bar (3625.925 psi).

Fuel supply pressure: 0.35 ± 0.05 bar (kg/cm²). (5.0763 \pm 0.7252 psi).

Delivery pipes (conforming to ISO 4093.2):

6 x 2 x 450 mm (0.2362 x 0.787 x 17.7165 in.).

Graduate drain time: 30 seconds

Test liquid: ISO 4113 at a temperature of $55^\circ \pm 1^\circ\text{C}$ ($131^\circ \pm 33.8^\circ\text{F}$).

CALIBRATION TEST CONDITIONS

1. START OF DELIVERY

Plunger pre-lift from BDC: mm –	Pump rotation (viewed from drive side): anticlockwise	Injection order: 1–2–3
---------------------------------	---	------------------------

2. ADVANCE REGULATOR STROKE

rpm: 1150	Advance stroke: mm 1.6 to 2.0
-----------	-------------------------------

3. FUEL SUPPLY PUMP PRESSURE

rpm: 1150	Internal pressure: bar 8.4 to 8.8
-----------	-----------------------------------

4. FULL LOAD DELIVERY

rpm: 800	Delivery per 1000 shots: cm ³ 77.3 to 77.7	Spread: cm ³ –
----------	---	---------------------------

5. SPREAD GOVERNOR AT IDLE SPEED

rpm: 325	Delivery per 1000 shots: cm ³ 9.5 to 10.5	Spread: cm ³ \leq 5.0
----------	--	------------------------------------

6. SPREAD GOVERNOR AT MAXIMUM SPEED

rpm: 1300	Delivery per 1000 shots: cm ³ 49.5 to 50.5	Spread: –
-----------	---	-----------

7. DELIVERY AT STARTING SPEED

rpm: 100	Delivery per 1000 shots: cm ³ 70 to 110
----------	--

8. INJECTION ADVANCE PROGRESSION

Rev/min		1250	1150	1050
Advance stroke	mm	1.9 to 2.9	1.6 to 2.0	0.8 to 1.6

9. TRANSFER PRESSURE PROGRESSION

Rev/min		500	1150	–
Internal pressure	bar	4.8 to 5.8	8.4 to 8.8	–

10. BACKFLOW

Rev/min		500	1250
Backflow	cm ³ /10 s	44.5 to 77.7	58.3 to 97.1

(continued)

Note: The values shown above in brackets must be used for checking purposes only.

(continued)

11. DELIVERY PROGRESSION

Rev/min	Delivery per 1000 shots: cm ³
1390	0 to 3
1300	49.5 to 50.5
1250	63.5 to 68.5
800	77.3 to 77.7
450	68,0

12. ZERO DELIVERY (STOP)

Rev/min	Voltage (volts)	Delivery per 1000 shots: cm ³
325	0	0 to 3

13. DELIVERY CHECK AT IDLE SPEED

Rev/min	250	325	390
Delivery per 1000 shots: cm ³	35	9.5 to 10.5	0 to 3.0

14. AUTOMATIC START SUPPLEMENT

Rev/min	Delivery per 1000 shots: cm ³
100	70 to 110
250	67 to 77

Note: The values shown above in brackets must be used for checking purposes only.

BENCH TEST PERFORMANCE DATA

Test Conditions		Relative humidity 70% ± 5. Ambient temperature 25 °C. Specific gravity of diesel fuel 830 ± 10 g/litre.			
TDC fixed advance with cylinder No. 1 in compression stroke: (see previous page).					
Engine without fan, air filter and exhaust silencer.					
Atmospheric pressure: 990 mbar					
Throttle lever position	Braking load applied	Engine rpm rpm	Power output with engine run-in for a total of:		Fuel consumption kg/h
			2 hours kW (HP)	50 hours kW	
Maximum	For maximum torque	2500	–	39,5 – 42,0	9,1 – 9,7
Maximum	For maximum torque	1500	–	31,5 – 33,5	6,8 – 7,2
Maximum	None (no-load)	2770 ± 25	–	–	–
Minimum	None (no-load)	650 ± 25	–	–	–

TD70D MODEL – CALIBRATION DATA FOR BOSCH INJECTION PUMP TYPE VE 3/12 F 1250 L 977 – 504054474

ASSEMBLY DATA

Pump timing on engine: delivery start $0^\circ \pm 0.5^\circ$ before TDC of cylinder 1 compression stroke.

Plunger pre-lift for pump timing on engine: 1 mm from B.D.C. with tools **380000228 – 380001601**).

Delivery line union on pump for cylinder no. 1: marked with letter A.

ASSEMBLY DIMENSIONS

SYMBOL	K	KF	MS	ya	yb
mm	3.6 to 3.8	3	0.5 to 0.9	35.5 to 39.5	39.8 to 44.8

Test bench conforming to ISO 4008/1.../2

Injectors conforming to ISO 7440–A61 – (1688901027 with pad \varnothing 0.5 mm (0.0197 in.))

Injector setting pressure: 250 bar (3625.925 psi).

Fuel supply pressure: 0.35 ± 0.05 bar (5.0763 \pm 0.7252 psi).

Delivery pipes (conforming to ISO 4093.2):

6 x 2 x 450 mm (0.2362 x 0.787 x 17.7165 in.)

Graduate drain time: 30 seconds

Test liquid: ISO 4113 at a temperature of $55^\circ \pm 1^\circ\text{C}$ ($131^\circ \pm 33.8^\circ\text{F}$).

CALIBRATION TEST CONDITIONS

1. START OF DELIVERY

Plunger pre-lift from B.D.C.: mm –	Pump rotation (viewed from drive side): anticlockwise	Injection order: 1–2–3
------------------------------------	---	------------------------

2. ADVANCE REGULATOR STROKE

1100 rpm	LDA pressure: kPa 100	Advance stroke: mm 1.8 to 2.2
----------	-----------------------	-------------------------------

3. FUEL SUPPLY PUMP PRESSURE

rpm: 800	LDA pressure: kPa 100	Internal pressure: bar 7.7 to 8.3
----------	-----------------------	-----------------------------------

4. FULL-LOAD DELIVERY WITH BOOSTER PRESSURE

rpm: 900	LDA pressure: kPa 100	Delivery per 1000 shots: cm^3 76.5 to 76.9	Spread: $\text{cm}^3 \leq 3.5$
----------	-----------------------	---	--------------------------------

5. FULL-LOAD DELIVERY WITHOUT BOOSTER PRESSURE

rpm: 600	LDA pressure: kPa 0	Delivery per 1000 shots: cm^3 73.8 to 74.2	Spread: cm^3 –
----------	---------------------	---	-------------------------

6. SPREAD GOVERNOR AT IDLE SPEED

rpm: 325	LDA pressure: kPa 0	Delivery per 1000 shots: cm^3 12 to 13	Spread: $\text{cm}^3 \leq 4.5$
----------	---------------------	---	--------------------------------

7. SPREAD GOVERNOR AT MAXIMUM SPEED

rpm: 1350	LDA pressure: kPa 100	Delivery per 1000 shots: cm^3 32.0 to 33.0	Spread: cm^3 –
-----------	-----------------------	---	-------------------------

8. DELIVERY AT STARTING SPEED

rpm: 100	Delivery per 1000 shots: cm^3 100 to 140
----------	---

9. INJECTION ADVANCE PROGRESSION

LDA pressure	kPa	100		
Rev/min		1250	1100	900
Advance stroke	mm	2.5 to 3.5	1.8 to 2.2	0.3 to 1.3

10. TRANSFER PRESSURE PROGRESSION

LDA pressure	kPa	100		
Rev/min		1250	1100	500
Internal pressure supply:	bar	8,7	7.7 to 8.3	4.5 to 5.5

11. BACKFLOW

Rev/min		1250	500
LDA pressure	kPa	100	100
Backflow for	$\text{cm}^3/10$ s	66.7 to 105.5	50.0 to 77.6

(continued)

Note: The values shown above in brackets must be used for checking purposes only.

(continued)

12. DELIVERY PROGRESSION

Rev/min	LDA pressure kPa	Delivery per 1000 shots: cm ³
1390	100	0 to 3.0
1350	100	32 to 33
1250	100	66 to 71
900	100	76.5 to 76.9
600	27,5	76.2 to 77.2
400	100	91
600	0	73.8 to 74.2

13. ZERO DELIVERY (STOP)

rpm: 325	Voltage (volts): 0	Delivery per 1000 shots: cm ³ : 0 to 3
----------	--------------------	---

14. DELIVERY CHECK AT IDLE SPEED

Rev/min	325	380	–
Delivery per 1000 shots: cm ³	12 to 13	0 to 3.0	–

15. AUTOMATIC START SUPPLEMENT

Rev/min	Delivery per 1000 shots: cm ³
100	100 to 140
300	77 to 87

Note: The values shown above in brackets must be used for checking purposes only.

BENCH TEST PERFORMANCE DATA

BENCH TEST PERFORMANCE DATA					
Test Conditions			Relative humidity 70% ± 5.		
TDC fixed advance with cylinder No. 1 in compression stroke: (see previous page)			Ambient temperature 25 °C.		
Engine without fan, air filter and exhaust silencer.			Specific gravity of diesel fuel 830 ± 10 g/litre.		
Atmospheric pressure: 990 mbar					
Throttle lever position	Braking load applied	Engine rpm rpm.	Power output with engine run-in for a total of:		Fuel consumption kg/h
			2 hours kW (HP)	50 hours kW	
Maximum	For maximum torque	2500	–	47.5 – 50.5	11.1 – 11.8
Maximum	For maximum torque	1500	–	37.0 – 39.5	8.2 – 8.7
Maximum	None (no-load)	2770 ± 25	–	–	–
Minimum	None (no-load)	650 ± 25	–	–	–

TD80D MODEL – CALIBRATION DATA FOR BOSCH INJECTION PUMP TYPE VE 4/12 F 1250 L 985 – 504041416

ASSEMBLY DATA

Pump timing on engine: delivery start $4^{\circ} \pm 0.5^{\circ}$ before T.D.C. of cylinder 1 on compression stroke.
Plunger pre-lift for timing on engine: 1 mm from B.D.C. (with tools **380000228** – **380001601**).
Delivery union of the pump corresponding to cylinder no. 1: marked with letter A.

ASSEMBLY DIMENSIONS

SYMBOL	K	A	MS	ya	yb
mm	3.64 to 3.76	1.4 to 1.5	0.5 to 0.9	38,9	43,0

Test bench conforming to ISO 4008/1 .../2
Injectors conforming to ISO 7440-A61 – (1.688.901.027 with calibrated pad \varnothing 0.5 mm (0.0197 in.)).
Injector pressure setting 250 to 253 bar (3625.925 to 3699.4361 psi)
Fuel supply pressure:
0.35 \pm 0.05 bar (5.0763 \pm 0.7252 psi).
Delivery pipes (conforming to ISO 4093.2):
6 x 2 x 450 mm (0.2362 x 0.787 x 17.7165 in.).
Graduate drain time : 30".
Test liquid: ISO 4113 at a temperature of $55^{\circ} \pm 1^{\circ}\text{C}$ ($131^{\circ} \pm 33.8^{\circ}\text{F}$).

CALIBRATION TEST CONDITIONS

1. START OF DELIVERY

Plunger pre-lift from BDC: mm –	Pump rotation (viewed from drive side): anticlockwise	Injection order: 1–3–4–2
------------------------------------	--	--------------------------

2. ADVANCE REGULATOR STROKE

rpm: 1250	Advance stroke: mm 2.0 to 3.2
-----------	-------------------------------

3. FUEL SUPPLY PUMP PRESSURE

rpm: 1000	Internal pressure: bar 6.7 to 8.1
-----------	-----------------------------------

4. FULL LOAD DELIVERY

rpm: 1000	Delivery per 1000 shots: cm^3 65.2 to 70.3	Spread: $\text{cm}^3 \leq 3.5$
-----------	---	--------------------------------

5. SPREAD GOVERNOR AT IDLE SPEED

rpm: 325	Delivery per 1000 shots: cm^3 4.0 to 18.0	Spread: $\text{cm}^3 \leq 4.5$
----------	--	--------------------------------

6. SPREAD GOVERNOR AT MAXIMUM SPEED

rpm: 1250	Delivery per 1000 shots: cm^3 60.0 to 66.0	Spread: –
-----------	---	-----------

7. DELIVERY AT STARTING SPEED

rpm: 100	Delivery per 1000 shots: cm^3 75 to 115
----------	--

8. INJECTION ADVANCE PROGRESSION

Rev/min		1000	1250
Advance stroke	mm	0.5 to 1.7	2.0 to 3.2

9. TRANSFER PRESSURE PROGRESSION

Rev/min		1000	400	
Internal pressure	bar	6.7 to 8.1	4.1 to 5.5	

10. BACKFLOW

Rev/min		400	1250
Backflow	l/h	16 to 30	21 to 39

(continued)

Note: The values shown above in brackets must be used for checking purposes only.

(continued)

11. DELIVERY PROGRESSION

Rev/min	Delivery per 1000 shots: cm ³
1400	0 to 3
1250	60.0 to 66.0
1000	65.2 to 70.3
450	63.5 to 70.3

12. ZERO DELIVERY (STOP)

Rev/min	Voltage (volts)	Delivery per 1000 shots: cm ³
325	0	0 to 3

13. DELIVERY CHECK AT IDLE SPEED

Rev/min	325	380	–
Delivery per 1000 shots: cm ³	4.0 to 18.0	0 to 3.0	–

14. AUTOMATIC START SUPPLEMENT

Rev/min	Delivery per 1000 shots: cm ³
100	75 to 115
250	60.5 to 74.5

Note: The values shown above in brackets must be used for checking purposes only.

BENCH TEST PERFORMANCE DATA

BENCH TEST PERFORMANCE DATA					
Test Conditions			Relative humidity 70% ± 5.		
TDC fixed advance with cylinder No. 1 in compression stroke: (see previous page)			Ambient temperature 25 °C.		
Engine without fan, air filter and exhaust silencer.			Specific gravity of diesel fuel 830 ± 10 g/litre.		
Atmospheric pressure: 990 mbar					
Throttle lever position	Braking load applied	Engine rpm rpm.	Power output with engine run-in for a total of:		Fuel consumption kg/h
			2 hours kW (HP)	50 hours kW (HP)	
Maximum	For maximum torque	2500	–	54.0 – 57.5	12.3 – 13.1
Maximum	For maximum torque	1500	–	39.5 – 42	8.5 – 9.0
Maximum	None (no-load)	2725 ± 25	–	–	–
Minimum	None (no-load)	650 ± 25	–	–	–

TD90D MODEL – CALIBRATION DATA FOR BOSCH INJECTION PUMP TYPE VE 4/12 F 1250 L 982 – 504042214

ASSEMBLY DATA

Pump timing on engine: delivery start $1^{\circ} \pm 0.5^{\circ}$ before T.D.C. of cylinder 1 on compression stroke.
Plunger pre-lift for timing on engine: 1 mm from B.D.C. (with tools **380000228** – **380001601**).
Delivery union of the pump corresponding to cylinder no. 1: marked with letter A.

ASSEMBLY DIMENSIONS

SYMBOL	K	A	MS	ya	yb
mm	3.64 to 3.76	1.4 to 1.5	0.7 to 0.9	37.9 to 39.9	39.3 to 44.7

Test bench conforming to ISO 4008/1 .../2
Injectors conforming to ISO 7440-A61 – (1.688.901.027 with calibrated pad \varnothing 0.5 mm (0.0197 in.)).
Injector pressure setting 250 to 253 bar (3625.925 to 3741.9546 psi).
Fuel supply pressure:
0.35 \pm 0.05 bar (5.0763 \pm 0.7252 psi).
Delivery pipes (conforming to ISO 4093.2):
6 x 2 x 450 mm (0.2362 x 0.787 x 17.7165 in.).
Graduate drain time : 30".
Test liquid: ISO 4113 at a temperature of $55^{\circ} \pm 1^{\circ}\text{C}$ ($131^{\circ} \pm 33.8^{\circ}\text{F}$).

CALIBRATION TEST CONDITIONS

1. START OF DELIVERY

Plunger pre-lift from BDC: mm –	Pump rotation (viewed from drive side): anticlockwise	Injection order: 1–3–4–2
------------------------------------	--	--------------------------

2. ADVANCE REGULATOR STROKE

rpm: 1250	Advance stroke: mm 2.4 to 3.6
-----------	-------------------------------

3. FUEL SUPPLY PUMP PRESSURE

rpm: 1250	Internal pressure: bar 8.7 to 10.1
-----------	------------------------------------

4. FULL LOAD DELIVERY

rpm: 900	Delivery per 1000 shots: cm^3 77.5 to 82.5	Spread: $\text{cm}^3 \leq 3.5$
----------	---	--------------------------------

5. SPREAD GOVERNOR AT IDLE SPEED

rpm: 375	Delivery per 1000 shots: cm^3 5.5 to 19.5	Spread: $\text{cm}^3 \leq 4.5$
----------	--	--------------------------------

6. SPREAD GOVERNOR AT MAXIMUM SPEED

rpm: 1250	Delivery per 1000 shots: cm^3 69.5 to 75.5	Spread: –
-----------	---	-----------

7. DELIVERY AT STARTING SPEED

rpm: 100	Delivery per 1000 shots: cm^3 80 to 120
----------	--

8. INJECTION ADVANCE PROGRESSION

Rev/min		1000	1250
Advance stroke	mm	0.2 to 1.0	2.4 to 3.6

9. TRANSFER PRESSURE PROGRESSION

Rev/min		1250	400	
Internal pressure	bar	8.7 to 10.1	3.6 to 5.0	

10. BACKFLOW

Rev/min		400	1250
Backflow	l/h	15 to 29	22 to 40

(continued)

Note: The values shown above in brackets must be used for checking purposes only.

(continued)

11. DELIVERY PROGRESSION

Rev/min	Delivery per 1000 shots: cm ³
1400	0 to 3
1250	69.5 to 75.5
900	77.5 to 82.5
400	76.5 to 83.5

12. ZERO DELIVERY (STOP)

Rev/min	Voltage (volts)	Delivery per 1000 shots: cm ³
375	0	0 to 3

13. DELIVERY CHECK AT IDLE SPEED

Rev/min	375	425	–
Delivery per 1000 shots: cm ³	5.5 to 19.5	0 to 3.0	–

14. AUTOMATIC START SUPPLEMENT

Rev/min	Delivery per 1000 shots: cm ³
100	80 to 120
275	68 to 92

Note: The values shown above in brackets must be used for checking purposes only.

BENCH TEST PERFORMANCE DATA

Test Conditions					
TDC fixed advance with cylinder No. 1 in compression stroke: (see previous page)			Relative humidity 70% ± 5.		
Engine without fan, air filter and exhaust silencer.			Ambient temperature 25 °C.		
Atmospheric pressure: 990 mbar			Specific gravity of diesel fuel 830 ± 10 g/litre.		
Throttle lever position	Braking load applied	Engine rpm rpm.	Power output with engine run-in for a total of:		Fuel consumption kg/h
			2 hours kW (HP)	50 hours kW (HP)	
Maximum	For maximum torque	2500	–	60.0 – 64.0	13.7 – 14.6
Maximum	For maximum torque	1500	–	46.0 – 48.8	9.8 – 10.4
Maximum	None (no-load)	2725 ± 25	–	–	–
Minimum	None (no-load)	650 ± 25	–	–	–

TD95D MODEL – CALIBRATION DATA FOR BOSCH INJECTION PUMP TYPE VE 4/12 F 1250 L 952 – 504042718

ASSEMBLY DATA

Pump timing on engine: delivery start $0^\circ \pm 0.5^\circ$ before T.D.C. of cylinder 1 on compression stroke.
Plunger pre-lift for timing on engine: 1 mm from B.D.C. (with tools **380000228** – **380001601**).
Delivery union of the pump corresponding to cylinder no. 1: marked with letter A.

ASSEMBLY DIMENSIONS

SYMBOL	K	A	MS	ya	yb
mm	3.64 to 3.76	0.98 to 1.02	0.6 to 1.0	36.5 to 38.5	41.3 to 46.7

Test bench conforming to ISO 4008/1 .../2
Injectors conforming to ISO 7440–A61 – (1.688.901.027 with calibrated pad \varnothing 0.5 mm) (0.0197 in.).
Injector pressure setting 250 to 253 bar (3625.925 to 3741.9546 psi).
Fuel supply pressure:
0.35 \pm 0.05 bar (5.0763 \pm 0.7252 psi).
Delivery pipes (conforming to ISO 4093.2):
6 x 2 x 450 mm (0.2362 x 0.787 x 17.7165 in.).
Graduate drain time : 30".
Test liquid: ISO 4113 at a temperature of $55^\circ \pm 1^\circ\text{C}$ ($131^\circ \pm 33.8^\circ\text{F}$).

CALIBRATION TEST CONDITIONS

1. START OF DELIVERY

Plunger pre-lift from B.D.C.: mm –	Pump rotation (viewed from drive side): anticlockwise	Injection order: 1–3–4–2
------------------------------------	---	--------------------------

2. ADVANCE REGULATOR STROKE

rpm: 1250	LDA pressure: kPa 100	Advance stroke: mm 2.2 to 3.4
-----------	-----------------------	-------------------------------

3. FUEL SUPPLY PUMP PRESSURE

1100 rpm	LDA pressure: kPa 100	Internal pressure: bar 6.5 to 7.9
----------	-----------------------	-----------------------------------

4. FULL-LOAD DELIVERY WITH BOOSTER PRESSURE

rpm: 900	LDA pressure: kPa 100	Delivery per 1000 shots: cm^3 75.5 to 80.5	Spread: $\text{cm}^3 \leq 3.5$
----------	-----------------------	---	--------------------------------

5. FULL-LOAD DELIVERY WITHOUT BOOSTER PRESSURE

rpm: 500	LDA pressure: kPa 0	Delivery per 1000 shots: cm^3 66.0 to 72.0	Spread: cm^3 –
----------	---------------------	---	-------------------------

6. SPREAD GOVERNOR AT IDLE SPEED

rpm: 350	LDA pressure: kPa 0	Delivery per 1000 shots: cm^3 8 to 23	Spread: $\text{cm}^3 \leq 5.5$
----------	---------------------	--	--------------------------------

7. SPREAD GOVERNOR AT MAXIMUM SPEED

rpm: 1250	LDA pressure: kPa 100	Delivery per 1000 shots: cm^3 66.0 to 72.0	Spread: cm^3 –
-----------	-----------------------	---	-------------------------

8. DELIVERY AT STARTING SPEED

rpm: 100	Delivery per 1000 shots: cm^3 75 to 115
----------	--

9. INJECTION ADVANCE PROGRESSION

LDA pressure	kPa	100	
Rev/min		1100	1250
Advance stroke	mm	1.4 to 2.6	2.2 to 3.4

10. TRANSFER PRESSURE PROGRESSION

LDA pressure	kPa	100	
Rev/min		500	1100
Internal pressure supply:	bar	4.1 to 5.5	6.5 to 7.9

11. BACKFLOW

Rev/min		500	1250
LDA pressure	kPa	100	100
Backflow for 10 sec.	l/h	18 to 32	21 to 39

(continued)

Note: The values shown above in brackets must be used for checking purposes only.

(continued)

12. DELIVERY PROGRESSION

Rev/min	LDA pressure kPa	Delivery per 1000 shots: cm ³
1405	100	0 to 3.0
1250	100	66 to 72
900	100	75.5 to 80.5
600	25	72 to 78
500	0	66 to 72

13. ZERO DELIVERY (STOP)

rpm: 300	Voltage (volts): 0	Delivery per 1000 shots: cm ³ : 0 to 3
----------	--------------------	---

14. DELIVERY CHECK AT IDLE SPEED

Rev/min	350	410	
Delivery per 1000 shots: cm ³	8 to 23	0 to 3.0	

15. AUTOMATIC START SUPPLEMENT

Rev/min	Delivery per 1000 shots: cm ³
100	75 to 115
250	63.5 to 77.5

Note: The values shown above in brackets must be used for checking purposes only.

BENCH TEST PERFORMANCE DATA

BENCH TEST PERFORMANCE DATA					
Test Conditions			Relative humidity 70% ± 5.		
TDC fixed advance with cylinder No. 1 in compression stroke: (see previous page)			Ambient temperature 25 °C.		
Engine without fan, air filter and exhaust silencer.			Specific gravity of diesel fuel 830 ± 10 g/litre.		
Atmospheric pressure: 990 mbar					
Throttle lever position	Braking load applied	Engine rpm	Power output with engine run-in for a total of:		Fuel consumption kg/h
		rpm.	2 hours kW	50 hours kW	
Maximum	For maximum torque	2500	–	66 – 70	15.5 – 15.9
Maximum	For maximum torque	1500	–	51 – 54	11 – 11.7
Maximum	None (no-load)	2700 ± 25	–	–	–
Minimum	None (no-load)	650 ± 25	–	–	–

FUEL SUPPLY PUMP DATA	mm (in.)
Eccentricity of drive shaft	3 (0.1181)
Diameter of drive shaft at bushings	31.975 to 32.000 (1.1049 to 1.1050)
Internal diameter of installed and reamed bushings	32.050 to 32.075 (1.2589 to 1.2628)
Interference between bushings and seats	0.063 to 0.140 (0.0025 to 0.0055)
Assembly clearance between shaft and bushings	0.050 to 0.100 (0.0020 to 0.0039)
Thickness of internal washer	1.45 to 1.50 (0.0571 to 0.0591)
Thickness of external washer	2.93 to 3.00 (0.1154 to 0.1181)

CRANKCASE/CYLINDER BLOCK DATA	mm (in.)
Cylinder block (4-cylinder engines)	cast-iron monobloc with replaceable dry-fitted cylinder liners, incorporating seatings for crankshaft bearings, camshaft and pushrod/tappet assemblies
Internal diameter of cylinder liners (4-cylinder engines)	104.000 to 104.024 (4.0945 to 4.0954) (¹)
External diameter of cylinder liners (4-cylinder engines)	107,020 to 107.050 (4.2134 to 4.2146)
Diameter of cylinder bores (4-cylinder engines)	106.850 to 106.900 (4.2067 to 4.2087)
Interference fit between cylinder liners and bores (4-cylinder engines)	0.120 to 0.200 (0.0047 to 0.0079)
Liner internal diameter oversizes (4-cylinder engines)	0.4 to 0.8 (0.0157 to 0.0315)
Liner external diameter oversizes (4-cylinder engines)	0.2 (0.0079)
Maximum permissible liner ovality or taper due to wear (²) (4-cylinder engines)	0.12 (0.0047)
Diameter of main shell bearing seats	84.200 to 84.230 (3.3150 to 3.3161)
Diameter of camshaft bearing seats:	
– front	54.780 to 54.805 (2.1567 to 2.1577)
– middle	54.280 to 54.305 (2.1370 to 2.1380)
– rear	53.780 to 53.805 (2.1173 to 2.1183)
Diameter of standard tappet bores in crankcase	15.000 to 15.018 (0.5906 to 0.5913)
Spare tappet oversizes	0.1–0.2–0.3 (0.0039–0.0079–0.0118)

(¹) Measured after press-fitting and reaming.

(²) Measure in the area swept by piston rings, both parallel and perpendicular to the crankshaft axis.

CRANKSHAFT AND BEARINGS DATA	mm (in.)
Crankshaft	balanced with integral counterweights
Standard journal diameter	79.791 to 79.810 (3.1414 to 3.1421) ⁽¹⁾
Journal undersizes	0.254 – 0.508 – 0.762 – 1.016 (0.01 – 0.02 – 0.03 – 0.04)
Standard main bearing shell thickness	2.168 to 2.178 (0.0854 to 0.0857)
Main bearing shell undersizes (internal diameter)	0.254 – 0.508 – 0.762 – 1.016 (0.01 – 0.02 – 0.03 – 0.04)
Bearing shell to journal clearance	0.034 to 0.103 (0.0013 to 0.0041)
Maximum permitted wear clearance	0.180 (0.0071)
Standard crankpin diameter	63.725 to 63.744 (2.5089 to 2.5096) ⁽¹⁾
Crankpin undersizes	0.254 – 0.508 – 0.762 – 1.016 (0.01 – 0.02 – 0.03 – 0.04)
Standard big–end bearing shell thickness	1.805 to 1.815 (0.0711 to 0.0715)
Big–end bearing shell undersizes (internal diameter)	0.254 – 0.508 – 0.762 – 1.016 (0.01 – 0.02 – 0.03 – 0.04)
Big–end bearing shell to crankpin clearance	0.033 to 0.087 (0.0013 to 0.0034)
Maximum permitted wear clearance	0.180 (0.0071)
Standard crankshaft thrust washer thickness	3.378 to 3.429 (0.133 to 0.135)
Thrust washer oversizes (thickness)	0.127 – 0.254 – 0.381 – 0.508 (0.005 – 0.010 – 0.015 – 0.020)
Width of main bearing including thrust washers	31.766 to 31.918 (1.2506 to 1.2566)
Width of corresponding crankshaft journal	32.000 to 32.100 (1.2598 to 1.2638)
Crankshaft assembly endfloat	0.082 to 0.334 (0.0032 to 0.0131)
Maximum permitted wear endfloat	0.40 (0.0157)
Maximum ovality or taper of journals and crankpin after regrinding	0.01 (0.0004)
Maximum ovality or taper of journals and crankpin	0.05 (0.002)
Maximum tolerance for alignment of crankshaft journals with crankshaft supported on the two outer journals	0.10 (0.0039)
Maximum tolerance for alignment, in both directions, of crankpins (3–cylinder engines) or each pair of crankpins (4–cylinder engines) relative to crankshaft journals	0.25 (0.0098)
Maximum tolerance for run–out between the outer surfaces of the crankshaft journals and the crankshaft centreline	± 0.10 (0.004)

(continued)

(1) Crankshafts with 0.1 mm (0.0039 in.) undersize journals and crankpins and consequently undersize bearing shells may be fitted in factory production.

(continued)

BENCH TEST PERFORMANCE DATA	mm (in.)
Maximum permitted tolerance on run–out of flywheel mounting flange surface relative to the crankshaft centreline, measured with 1/100 mm (0.0394/3.94 in.) scale dial gauge resting on front flange surface at a diameter of 108 mm (4.252 in.) (total gauge reading)	0.025 (0.001)
Maximum permitted tolerance on co–axial alignment of flywheel centering seat relative to the crankshaft journals (total gauge reading)	0.04 (0.0016)

CONNECTING ROD DATA	mm (in.)
Connecting Rods	cast–iron with oil way
Diameter of small end bushing seat	41.846 to 41.884 (1.6475 to 1.6490)
Outside diameter of small end bushing	41.979 to 42.017 (1.6527 to 1.6542)
Interference between small end bushing and seat	0.095 to 0.171 (0.0037 to 0.0067)
Inside diameter of small end bushing (measured after fitting) . . .	38.004 to 38.014 (1.4962 to 1.4966)
Diameter of big end shell bearing seats	67.407 to 67.422 (2.6538 to 2.6544)
Maximum tolerance for parallelism between the small end and big end axes measured at 25 mm (0.9843 in.)	± 0.07 (0.0028)
Maximum weight difference between con rods in same engine . .	25 grams (0.0551 lb)

PISTON DATA	mm (in.)	
	TD60D, TD80D	TD70D, TD90D, TD95D
Pistons	Light alloy with two compression and one oil control rings	
Standard piston diameter, measured at 57 mm (2.2441 in.) from base and perpendicularly to the gudgeon pin axis	103.852 to 103.870 (4.0886 to 4.0893)	
Piston clearance in cylinder liner	0.130 to 0.172 (0.0051 to 0.0067)	
Maximum permitted wear clearance	0.30 (0.0118)	
Piston oversizes	0.6 (0.0236)	
Piston protrusion at TDC from cylinder block face	0.355 to 0.761 (0.014 to 0.030)	
Gudgeon Pin Diameter	37.983 to 37.990 (1.4954 to 1.4957)	
Diameter of gudgeon pin seat in piston	37.994 to 38.000 (1.4958 to 1.4960)	
Gudgeon pin to seat clearance	0.004 to 0.017 (0.0001 to 0.0007)	
Gudgeon pin to small end bearing clearance	0.014 to 0.031 (0.0006 to 0.0012)	
Maximum permitted wear clearance	0.06 (0.0024)	
Maximum weight difference between pistons in same engine ...	20 grams (0.00441 lb)	
Piston ring groove clearance (measured vertically):		
– Top	0.090 to 0.122 (0.0035 to 0.0048)	0.105 to 0.155 (0.0041 to 0.0061)
– Second	0.060 to 0.092 (0.0024 to 0.0036)	
– Bottom	0.040 to 0.075 (0.0016 to 0.0030)	
Maximum permissible clearance (wear limit):		
– Top	0.50 (0.0197)	
– Second and bottom	0.20 (0.0079)	
Piston ring end gap (fitted):		
– Top	0.40 to 0.65 (0.0157 to 0.0256)	0.40 to 0.65 (0.0157 to 0.0256)
– Second	0.30 to 0.55 (0.0118 to 0.0217)	0.30 to 0.55 (0.0118 to 0.0217)
– Bottom	0.30 to 0.55 (0.0118 to 0.0217)	
Maximum permissible gap (wear limit)	1.20 (0.0472)	

VALVE TIMING GEAR DATA	mm (in.)
Timing gear tooth backlash	0.160 (0.0063)
Inside diameter of intermediate gear bushings (fitted and reamed)	37.050 to 37.075 (1.4578 to 1.4596)
Diameter of intermediate gear journal	36.975 to 37.000 (1.4557 to 1.4567)
Journal to bushing clearance	0.050 to 0.100 (0.0020 to 0.0039)
Maximum permissible clearance (wear limit)	0.15 (0.0059)
Bushing interference fit in seat in intermediate gear	0.063 to 0.140 (0.0025 to 0.0055)
Outside diameter of camshaft bearings:	
– front	54.875 to 54.930 (2.1604 to 2.1626)
– middle	54.375 to 54.430 (2.1407 to 2.1429)
– rear	53.875 to 53.930 (2.1175 to 2.1232)
Interference between bearings and seats in cylinder block	0.070 to 0.150 (0.0028 to 0.0059)
Inside diameter of camshaft bearings (fitted and reamed):	
– front	51.080 to 51.130 (2.0110 to 2.0130)
– middle	50.580 to 50.630 (1.9913 to 1.9933)
– rear	50.080 to 50.130 (1.9716 to 1.9736)
Diameter of camshaft journals:	
– front	50.970 to 51.000 (2.0067 to 2.0079)
– middle	50.470 to 50.500 (1.9870 to 1.9882)
– rear	49.970 to 50.000 (1.9913 to 1.9933)
Clearance between camshaft journals and bearings	0.080 to 0.160 (0.0031 to 0.0063)
Maximum permissible clearance (wear limit)	0.20 (0.0079)
Camshaft endfloat between thrust plate and seat on camshaft ..	0.070 to 0.220 (0.0028 to 0.0087)
For further valve timing gear data	See page 4

TAPPET DATA	mm (in.)
Tappet bore in crankcase	15.000 to 15.018 (0.5906 to 0.5913)
Outside diameter of standard tappet	14.950 to 14.970 (0.5886 to 0.5894)
Tappet running clearance	0.030 to 0.068 (0.0012 to 0.0027)
Maximum permissible clearance (wear limit)	0.15 (0.0059)
Spare tappet oversizes	0.1 – 0.2 – 0.3 (0.0039–0.0079–0.0118)

ROCKER ARM – VALVE DATA	mm (in.)
Diameter of shaft bores in rocker arms	18.016 to 18.034 (0.7093 to 0.71)
Rocker–arm shaft diameter	17.982 to 18.000 (0.708 to 0.7087)
Rocker shaft to rocker arm bore clearance	0.016 to 0.052 (0.0006 to 0.0020)
Maximum permissible clearance (wear limit)	0.15 (0.0059)
Rocker arm spacing springs:	
– free spring length	59.5 (2.3425)
– length under load of 46 to 52 N (10.4 to 11.7 lb)	44 (1.7323)
Valve clearance for timing check	0.45 (0.0177)
Cam lift:	
– inlet valve	5.97 (0.2350)
– exhaust valve	6.25 (0.2460)

BALANCER DATA (FIG. 108, page 67) (*)	(*) installed on 4–cylinder engines only
	mm (in.)
Interference fit between bushings (28) and seat in gear (26) . . .	0.063 to 0.140 (0.0025 to 0.0055)
Clearance between intermediate gear journal (27) and bushings (28)	0.050 to 0.100 (0.002 to 0.004)
Interference fit between bushings and carrier (20)	0.063 to 0.140 (0.0025 to 0.0055)
Clearance between gear shaft (22) and bushings	0.050 to 0.100 (0.002 to 0.004)
Tooth backlash between splined sleeve (17) connecting drive gear (22) and counterweight drive gear (13)	0.038 to 0.106 (0.0015 to 0.0041)
Interference fit between front bushing (16) and bore in housing (12)	0.063 to 0.140 (0.0025 to 0.0055)
Clearance between counterweight drive shaft (13) and front bushing (16)	0.050 to 0.100 (0.002 to 0.004)
Interference fit between rear bushing of counterweight drive gear (13) and seat in carrier (6)	0.037 to 0.101 (0.0015 to 0.004)
Clearance between counterweight drive shaft (13) and rear bushing	0.013 to 0.061 (0.0005 to 0.0024)
Interference fit between bushing and seat in counterweight (8) . .	0.040 to 0.100 (0.0016 to 0.004)
Clearance between counterweight rotation shaft (4) and bushing . .	0.020 to 0.073 (0.0008 to 0.0055)
Interference fit between intermediate gear bushing (9) and related seat in housing (12)	0.037 to 0.101 (0.0025 to 0.0029)
Clearance between intermediate gear shaft (9) and related bushing	0.013 to 0.061 (0.0005 to 0.0024)
Tooth backlash between meshed gears	0.080 (0.0031)

CYLINDER HEAD DATA	mm (in.)
Cylinder Head	with valve seats cut directly in the casting and press-fitted steel valve guides.
Original height of cylinder head	92 (3.622)
Maximum surface regrinding depth	0.5 (0.0197)
Diameter of standard valve guide bores in head	13.950 to 13.983 (0.5492 to 0.5505)
Outside diameter of standard valve guides	13.993 to 14.016 (0.5509 to 0.5518)
Guide interference fit in bores	0.010 to 0.066 (0.0004 to 0.0026)
Inside diameter of valve guide (fitted in head)	8.023 to 8.043 (0.3159 to 0.3167)
Valve stem diameter	7.985 to 8.000 (0.3144 to 0.3150)
Assembly clearance between valve stem and guide	0.023 to 0.058 (0.0009 to 0.0023)
Maximum permissible clearance (wear limit)	0.13 (0.0051)
Maximum run-out of valve guide on its stem measured through 360° with dial gauge contact point resting on valve head contact band	0.03 (0.0012)
Valve guide oversizes	0.2 (0.0079)
Valve seat angle in head:	
– inlet valve	60° ± 5'
– exhaust valve	45° ± 5'
Valve face angle:	
– inlet valve	60° 30' ± 7'
– exhaust valve	45° 30' ± 7'
Valve head diameter:	
– inlet valve	45.300 to 45.500 (1.7835 to 1.7913)
– exhaust valve	37.500 to 37.750 (1.4764 to 1.4862)
Valve stand-in relative to cylinder head face	0.7 to 1.0 (0.0276 to 0.0394)
Maximum permissible valve stand-in	1.3 (0.0512)
Inlet and exhaust valve springs:	
– free spring length	4.6 (1.7559)
– length with valve closed, under load of 256 to 284 N (57.54 to 63.71 lb)	34 (1.3386)
– length with valve open, under load of 502 to 544 N (112.87 to 124.78 lb)	23.8 (0.9370)
Injector protrusion relative to head face:	
● BOSCH injector	0.3 to 1.1 (0.0118 to 0.0433)

LUBRICATION SYSTEM DATA	mm (in.)	
	TD60D, TD80D	TD70D, TD90D and TD95D
Assembly clearance between oil pump drive shaft and bushing .	0.016 to 0.055 (0.0006 to 0.0022)	–
Clearance between shaft and driven gear	0.033 to 0.066 (0.0013 to 0.0026)	–
Tooth backlash between drive and driven gears	0.100 (0.004)	–
Radial clearance between drive and driven gears and housing .	0.060 to 0.170 (0.0024 to 0.0067)	–
Thickness of drive and driven gears	40.961 to 41.000 (1.6126 to 1.6142)	–
Height of gear seat in pump	41.025 to 41.087 (1.6152 to 1.6176)	–
Endfloat between gears and gear housing in pump	0.025 to 0.126 (0.0010 to 0.0050)	–
Pressure relief valve spring:		–
– free length	45 (1.7717)	35.9 (1.4134)
– length under load of 45 to 49 N (10.14 to 11.02 lb)	37.5 (1.4764)	–
– length under load of 88 to 94 N (19.84 to 21.16 lb)	30.5 (1.2008)	–
– length under load of 127.8 to 141.2 N (286.60 to 317.46 lb) (2, fig. 182)	–	29 (1.1417)
– length under load of 233.4 – 258 N (524.70 to 579.81 lb) (2, fig. 182)	–	3.2 (0.9134)
For further lubrication system data	See page 3	

COOLING SYSTEM DATA	mm (in.)
Interference fit between pump impeller and shaft	0.017 to 0.059 (0.0007 to 0.00231)
Interference fit between fan hub and shaft	0.024 to 0.058 (0.0009 to 0.0023)
Interference fit between front seal bushing and impeller	0.012 to 0.058 (0.0005 to 0.0023)
For further cooling system data	See page 3

ANGLE TIGHTENING TORQUE DATA

PART	Thread	Preliminary torque		Angle
		Nm	ft lb	
Cylinder head bolts (2) fig. 3 or 5	M 12 x 1.25	70	51.6293	90° + 90°
Main bearing cap bolts (4) fig. 3 or 5	M 14 x 1.5	80	59.0050	90°
Big-end cap bolts (5) fig. 3 or 5	M 11 x 1.5	40	29.5025	60°
Flywheel mounting bolts (3) fig. 3 or 5	M 12 x 1.25	40	29.5025	60°

TIGHTENING TORQUE DATA

PART	Thread	Tightening torque	
		Nm	ft lb
Rocker shaft pedestal bolts (1) fig. 3 or 5	M 8	25	18.4390
Crankshaft hub retaining nut (7) fig. 3 or 5	M 30 x 1.5	294	216.8432
Fan and alternator pulley bolts (6) fig. 3 or 5	M 10 x 1.25	55	40.5659
Additional counterweight retaining bolts (1) fig. 6 for TD80D, TD90D and TD95D models	M 12 x 1.25	110	81.1318
Inlet manifold retaining bolts (1) fig. 68	M 8	25	18.4390
Alternator and belt tension adjustment nut (1) fig. 54	M 10 x 1.25	55	40.5659
Coolant pump retaining bolts (1) fig. 59	M 10 x 1.25	55	40.5659
Nuts for injector mounting studs (1) fig. 138	M 8	25 (*)	18.4390 (*)
Rocker cover nuts (1) fig. 80	M 8	15	11.0634
Rocker shaft pedestal bolts (2) fig. 81	M 8	25	18.4390
Oil pump and pump cover retaining bolts (1) fig. 89	M 8	25	18.4390
Timing gear case and cover bolts (1) fig. 93	M 8	25	18.4390
Intermediate flanged journal bolts (1) fig. 96	M 10 x 1.25	55	40.5659
Camshaft thrust plate retaining bolts (4) fig. 97	M 8	35	25.8146
Rear crankcase cover bolts (2) fig. 117	M 8	25	18.4390
Tappet adjuster screw locknuts (1) fig. 137	M 8	22	16.2263
Exhaust manifold retaining bolts (1) fig. 64	M 8	25	18.4390
Injection pump mounting nuts (1) fig. 70	M 8	25	18.4390
Sump pan retaining bolts (4) fig. 86, to – inner rear timing cover and gear case	M 10 X 1.25	39 to 49	28.7692 to 36.1405
– cylinder block and flywheel case • TD60D, TD70D, TD80D and TD90D models	M 10 X 1.25	49 to 59	36.1405 to 43.5161
• TD95D models	M 10 X 1.25	49 to 69	36.1405 to 50.8918

(*) Tighten the nuts in two stages: see the operation in figure 138.

TOOLS

WARNING: The operations described in this section can only be carried out with the **ESSENTIAL** tools indicated by an **(X)**.

To work safely and efficiently and obtain the best results, it is also necessary to use the recommended specific tools listed below and certain other tools which are to be made according to the drawings included in this manual.

List of specific tools required for the various operations described in this section.

- | | |
|--|---|
| <p>X 380000236 Tractor dismantling stand.</p> <p>380000216 Engine lifting hook.</p> <p>380000301 Rotating engine service stand.</p> <p>380000313 Engine mounting brackets for rotating stand 380000301.</p> <p>X 380000303 Compression test kit (complete with dummy injector 380000617.</p> <p>291966 Digital rev counter.</p> <p>291979 Digital temperature gauge.</p> <p>380000240 Engine oil pressure test kit.</p> <p>293240 Check set, turbocharger (TD95D model).</p> <p>293679 Filter cartridge removal tool</p> <p>X 296118 Drive belt tension test tool.</p> <p>X 291160 Piston ring pliers.</p> <p>X 291048 Piston ring clamp.</p> <p>X 292248 Protractor for angular torque measurement.</p> <p>X 291504 Puller for crankshaft pulley hub.</p> <p>X 380000232 Wrench for valve clearance adjustment.</p> | <p>X 380000219 Punch for valve guide extraction / installation.</p> <p>X 380000276 Twist bit for enlarging valve guide bore.</p> <p>X 380000277 Tapered grinder for exhaust valve guides.</p> <p>X 380000242 Bush for valve guide installation (with 380000219).</p> <p>X 380000222 Valve guide reamer.</p> <p>X 380000302 Valve spring compressor.</p> <p>X 380000246 Set of grinding tools for regrinding injector seat.</p> <p>X 380000223 Puller for coolant pump impeller.</p> <p>X 380000247 Drift for installation of coolant pump impeller seal.</p> <p>380000311 Wrench for injection pump delivery line unions.</p> <p>380000254 Injector cleaning kit.</p> <p>380000308 Injector splitting support.</p> <p>X 380000309 Wrench set for injector dismantling.</p> <p>380000310 Injection check hand pump.</p> <p>380000215 Hand pump for injector calibration test.</p> <p>293830 Adaptor for injector removal (with 380000549).</p> <p>380000549 Slide hammer.</p> <p>Injection pump bench test</p> <p>380000228 Dial gauge (1/100 mm (0.0394/3.94 in.) scale, 5 mm (0.1968 in.) stroke, Ø 40 mm (1.5748 in.) with 380000229).</p> <p>380000229 Device for BOSCH injection pump timing on engine.</p> <p>X 380000322 Extractor for injection pump drive gear.</p> |
|--|---|

Splining tool to be manufactured for assembling the crankshaft front seal (print on the tool no. **50138** – values in mm).
Material UNI C40.

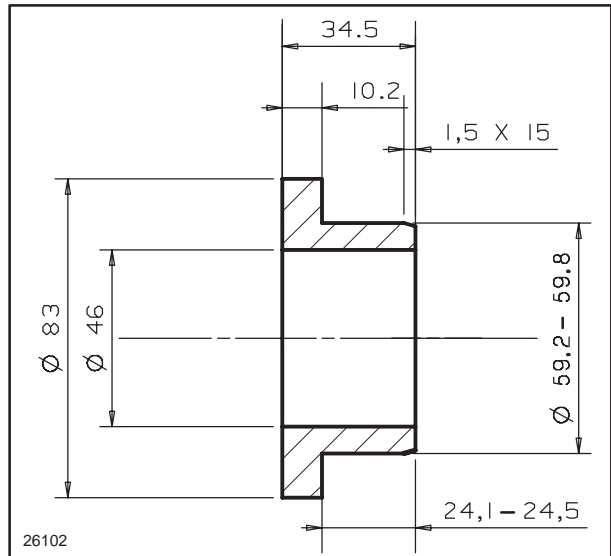

Splining tool to be manufactured for assembling the crankshaft rear seal (print on the tool no. **50139** – values in mm).
Material UNI C40.

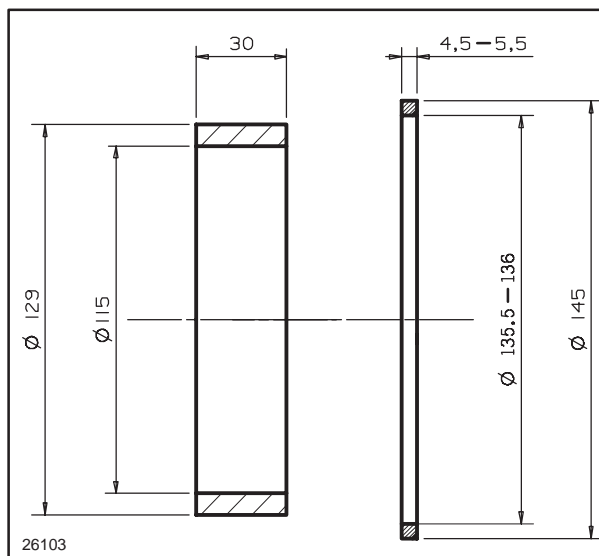

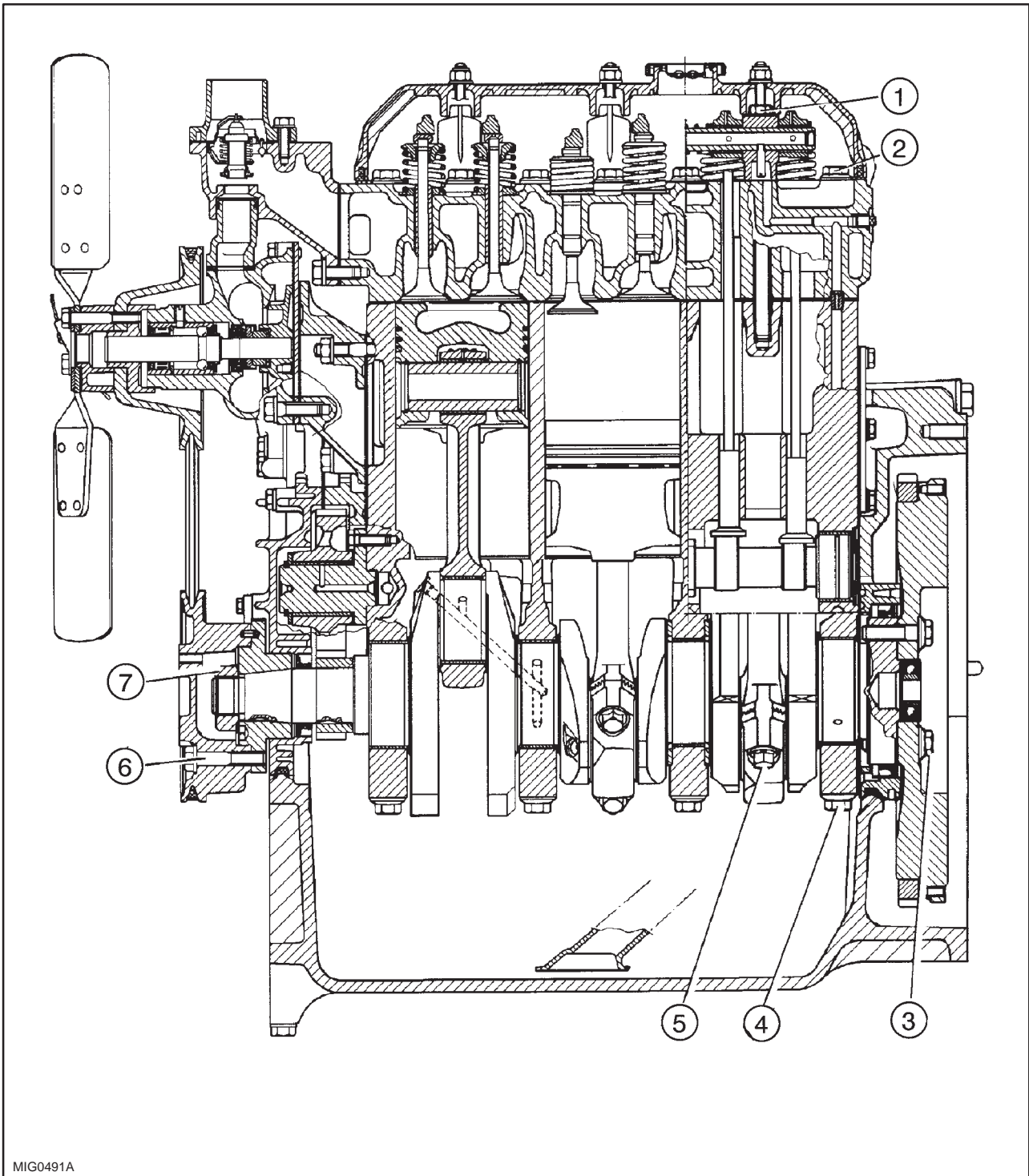

Longitudinal section of 3-cylinder TD60D and TD70D Models

3

- | | |
|--------------------------------|------------------------------------|
| 1. Rocker shaft pedestal bolts | 5. Big-end cap bolts |
| 2. Cylinder head bolts | 6. Fan and alternator pulley bolts |
| 3. Flywheel bolts | 7. Crankshaft hub bolts |
| 4. Main bearing cap bolts | |

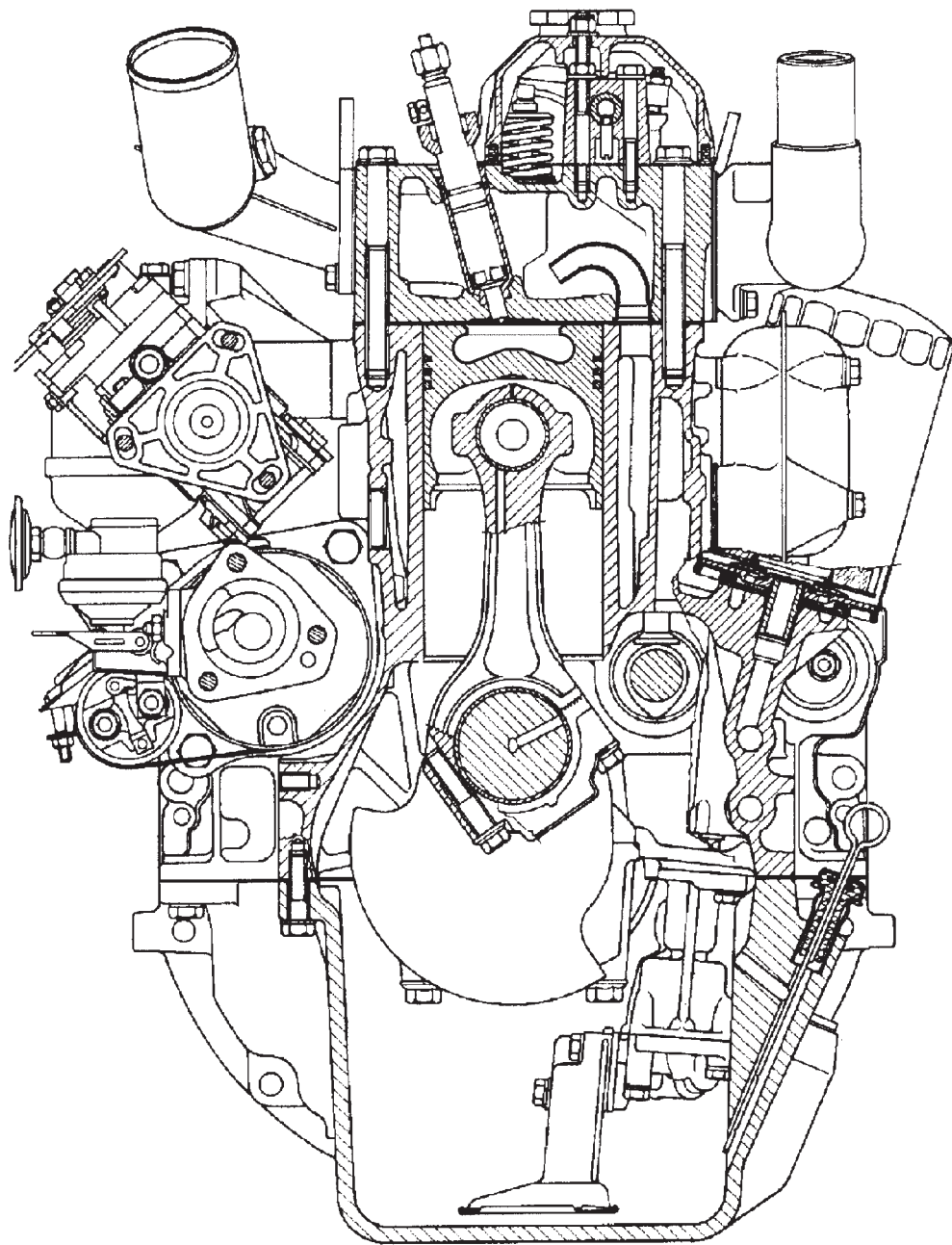

MIG0492A

4

Cross-section of 3-cylinder TD60D and TD70D Models

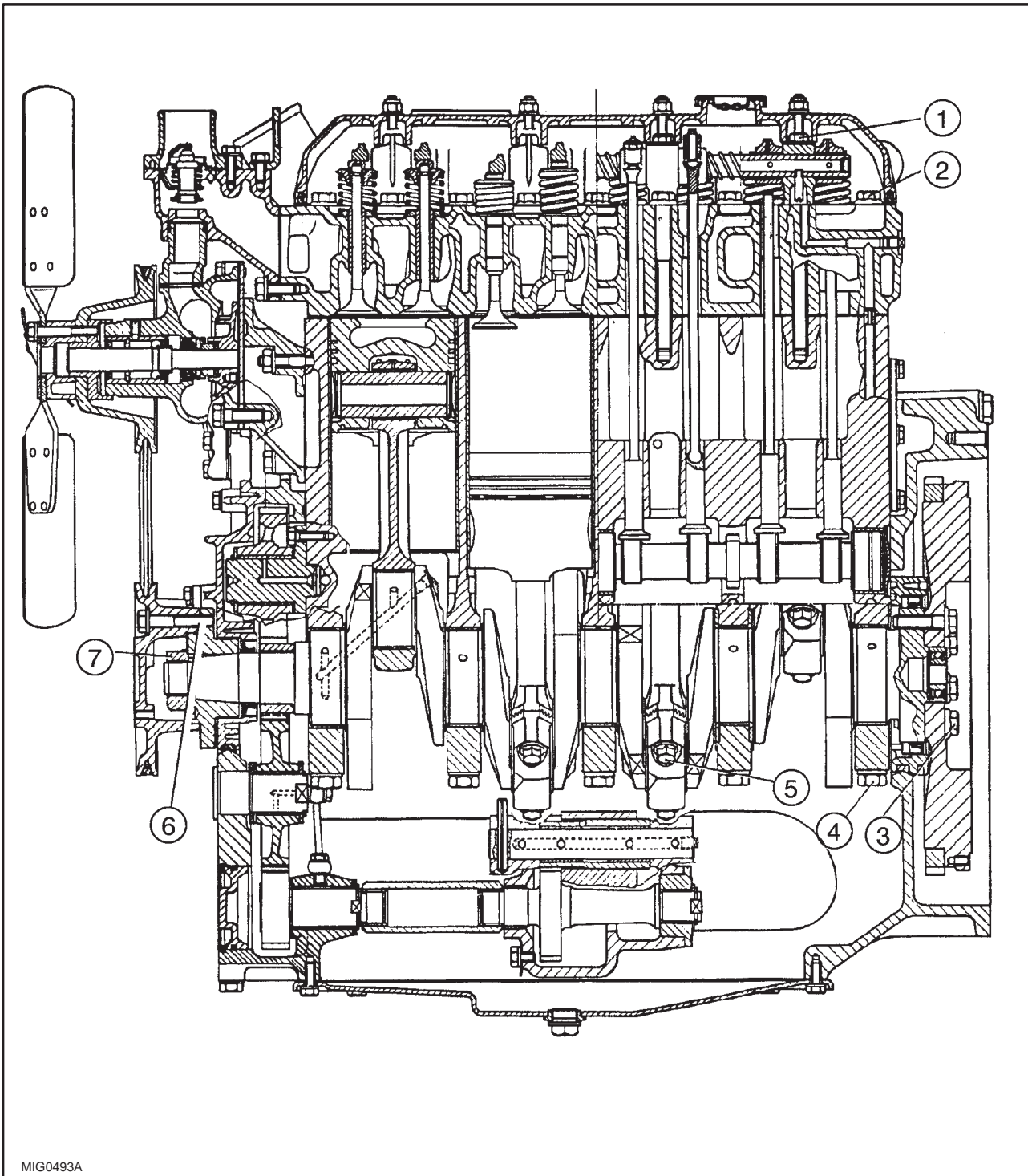

Longitudinal section of 4-cylinder model TD80D, TD90D and TD95D Models

5

- | | |
|--------------------------------|------------------------------------|
| 1. Rocker shaft pedestal bolts | 5. Big-end cap bolts |
| 2. Cylinder head bolts | 6. Fan and alternator pulley bolts |
| 3. Flywheel bolts | 7. Crankshaft hub bolts |
| 4. Main bearing cap bolts | |

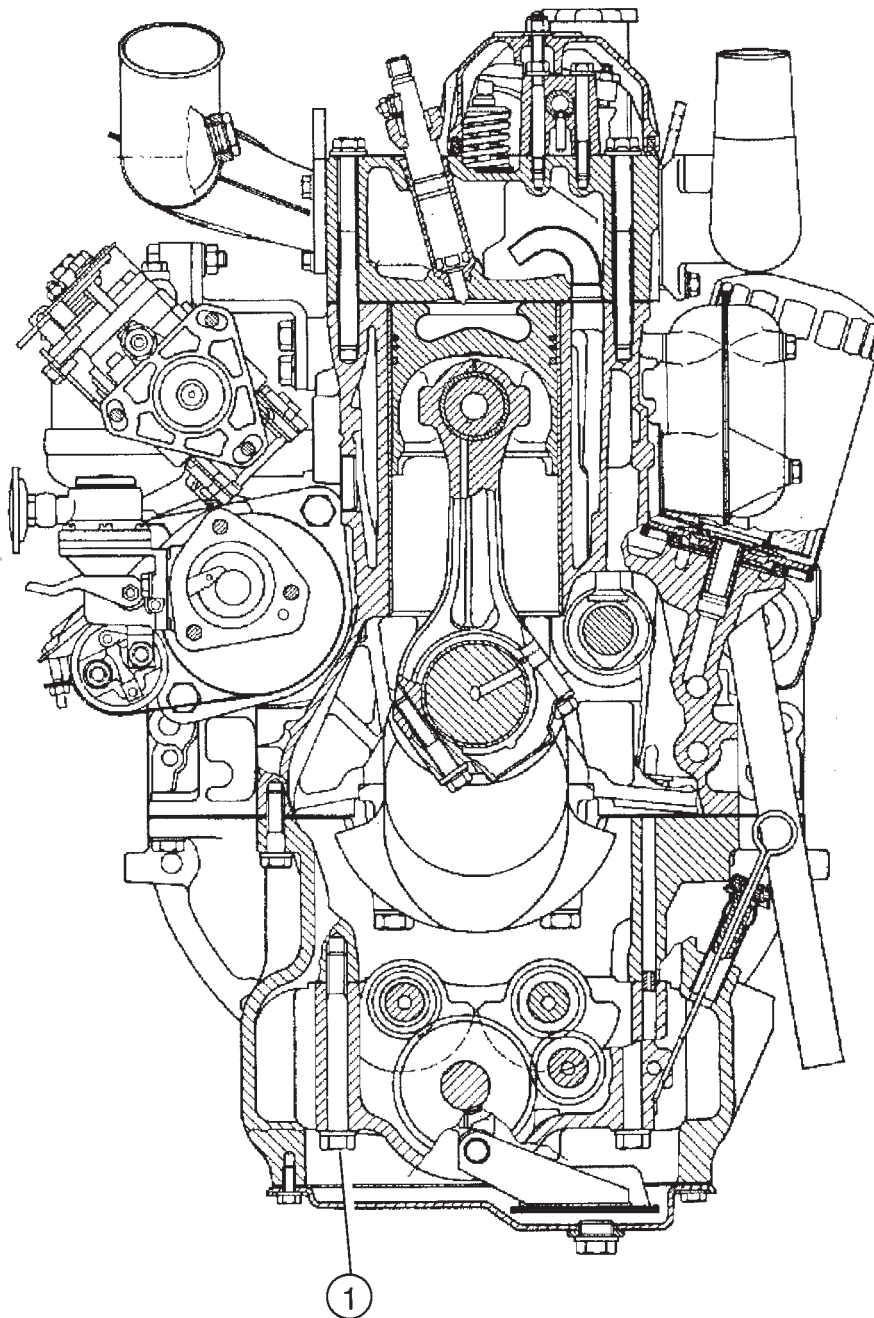

MIG0494A

Cross-section of 4-cylinder model TD80D, TD90D and TD95D

6

1. Counterweight retaining bolts

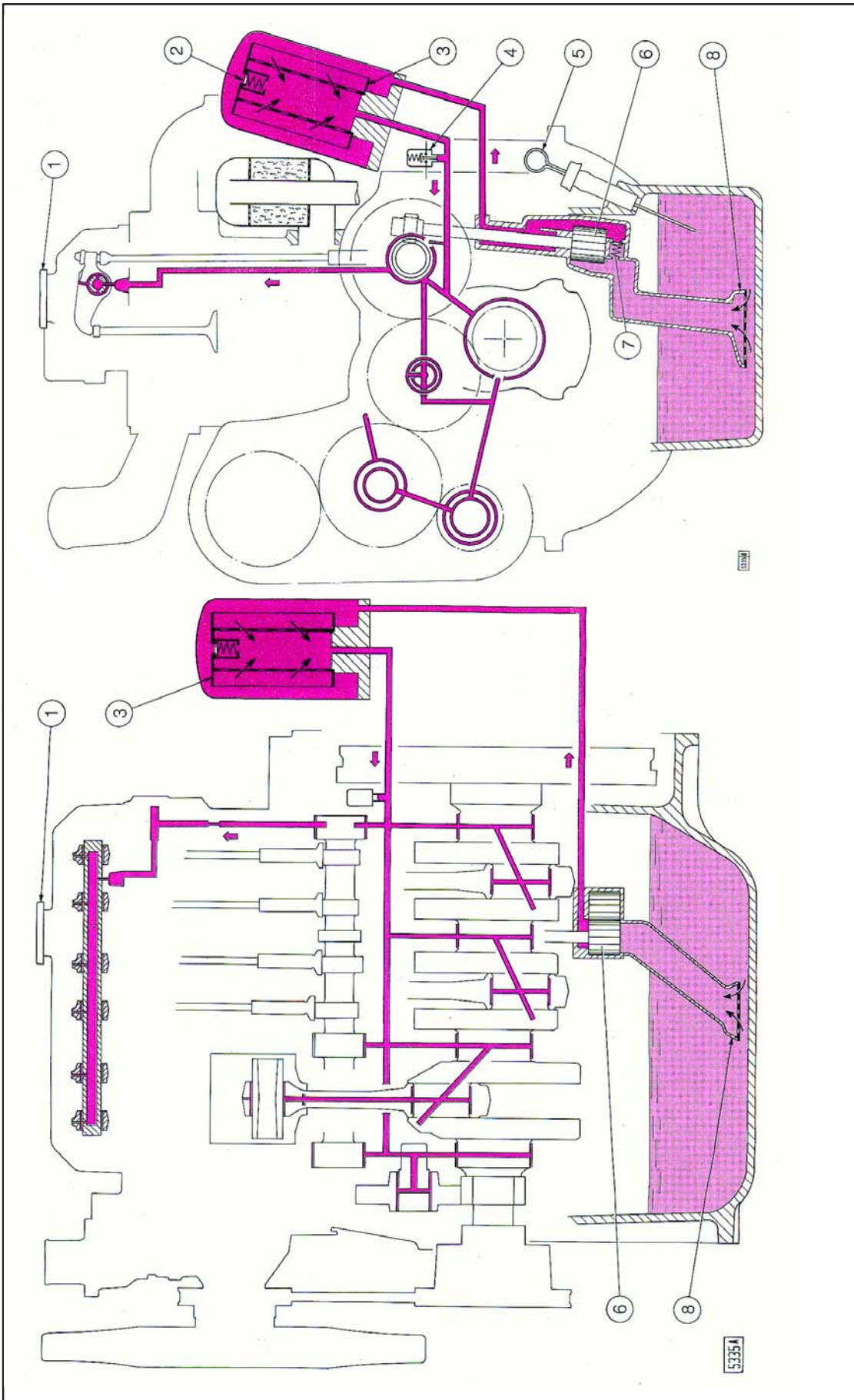

Lubrication system of normally aspirated 3-cylinder engines

- 1. Oil filler cap
- 2. Filter safety valve (opens when oil pressure at filter inlet exceeds the outlet pressure by 1.5–1.7 bar/cm² (140.355–159.068 psi/in²))
- 3. Filter
- 4. Switch for low engine oil pressure warning (on dashboard)
- 5. Dipstick
- 6. Pump
- 7. Oil pressure limiting valve
- 8. Screen filter on pick-up pipe

7

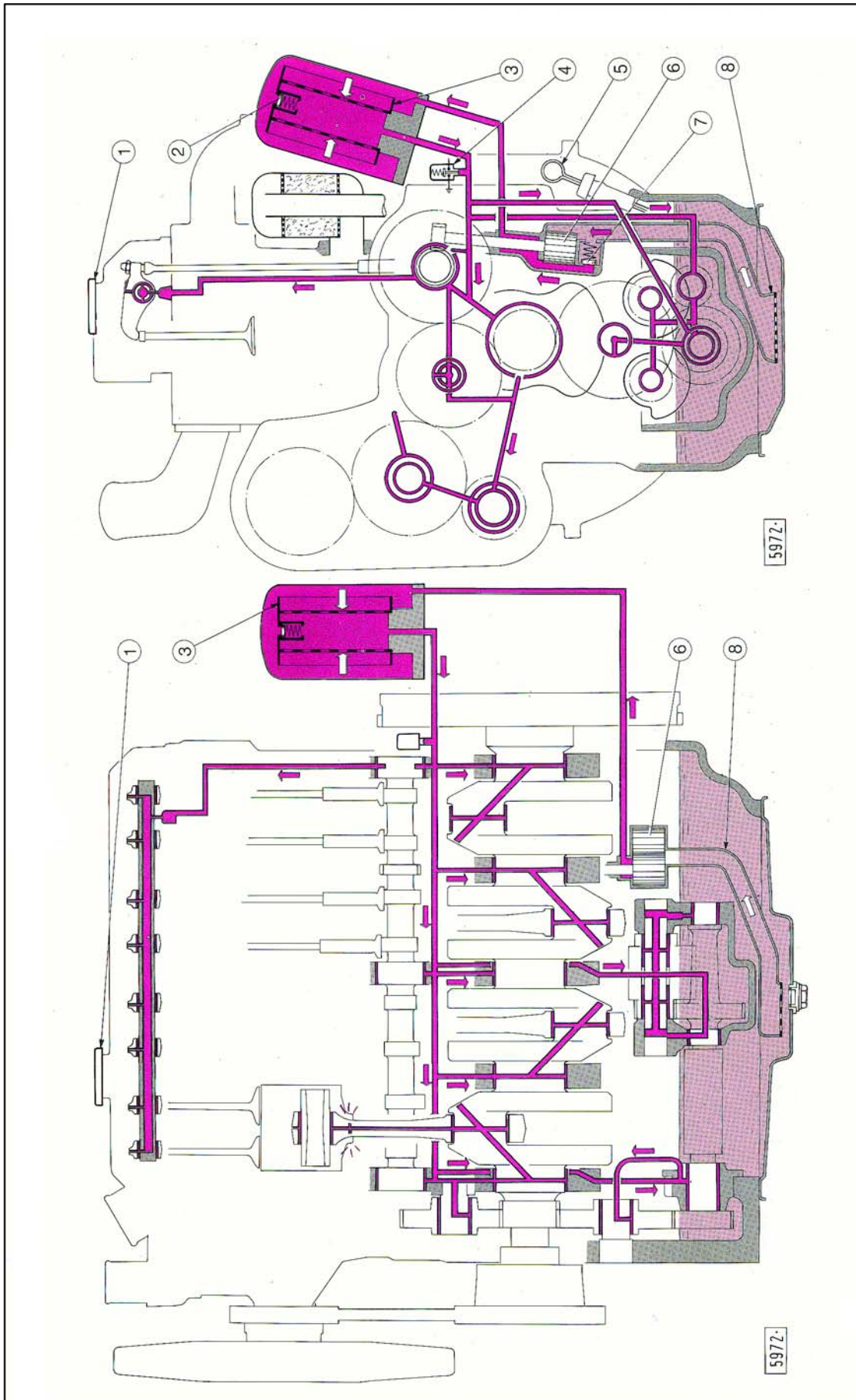

8

Lubrication system of normally aspirated 4-cylinder engines

1. Oil filler cap 2. Filter safety valve (opens when oil pressure at filter inlet exceeds the outlet pressure by 1.5–1.7 bar/cm² (140.355– 159.068 psi/in²))
3. Filter 4. Switch for low engine oil pressure warning (on dashboard) 5. Dipstick.
6. Pump 7. Oil pressure limiting valve 8. Screen filter on pick-up pipe

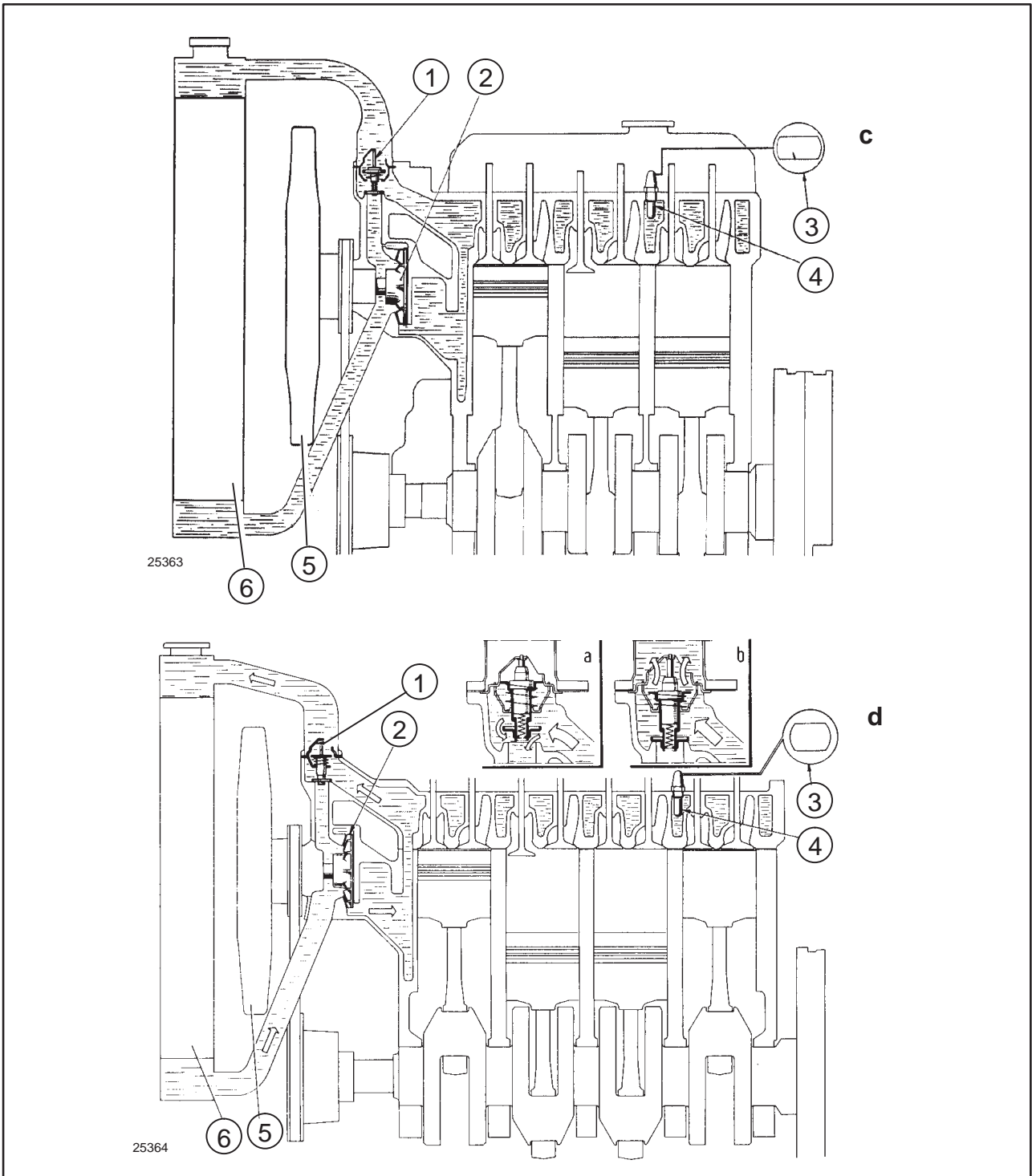

Engine cooling system.

9

- a. Coolant circulation with thermostat valve closed
- b. Coolant circulation with thermostat valve open
- c. 3-cylinder models
- d. 4-cylinder models
- 1. Thermostat

- 2. Coolant pump
- 3. Temperature gauge for engine coolant temperature
- 4. Temperature sender
- 5. Fan
- 6. Radiator

ENGINE TROUBLESHOOTING

Faults	Possible Cause	Correction
Engine does not start.	1. Batteries partially discharged.	Check and recharge battery. Replace if necessary.
	2. Battery terminal connections corroded or loose.	Clean, inspect and tighten terminal nuts. Replace terminals and nuts if excessively corroded.
	3. Incorrect injection pump timing.	Adjust injection pump timing.
	4. Impurities or water in fuel lines.	Disconnect fuel lines from injection pump and clean thoroughly. If necessary clean and dry the fuel tank.
	5. No fuel in tank.	Fill tank.
	6. Fuel supply pump malfunction.	Check and replace pump if necessary.
	7. Air in fuel system.	Check fuel lines, unions, supply pump, filters and injection pump for air, then bleed system.
	8. Starter motor faulty.	Repair or replace starter motor.
	9. Faulty thermostart.	Check and replace thermostart, if necessary.
Engine stalls.	1. Idle speed too low.	Adjust idle speed.
	2. Irregular delivery from injection pump.	Check injection pump delivery on test bench.
	3. Impurities or water in fuel lines.	Disconnect fuel lines from injection pump and clean thoroughly. If necessary clean and dry the fuel tank.
	4. Fuel filters clogged.	Renew filter cartridges.
	5. Incorrect valve clearances.	Adjust valve clearance.
	6. Burnt or cracked valves	Replace the valves.
	7. Air in fuel system.	Check fuel lines, unions, supply pump, filters and injection pump for air, then bleed system.
	8. Injection pump drive mechanism damaged.	Replace damaged parts.

(continued)

ENGINE TROUBLESHOOTING

(continued)

Faults	Possible Cause	Correction
Engine overheats.	<ol style="list-style-type: none"> 1. Coolant pump malfunction. 2. Faulty thermostat. 3. Radiator inefficient. 4. Deposits in cylinder head and crankcase coolant passages. 5. Coolant pump and fan drive belt slack. 6. Coolant level low. 7. Incorrect timing. 8. Injection pump calibration incorrect – delivering too much or too little fuel. 9. Air cleaner restricted. 	<p>Overhaul or replace pump.</p> <p>Replace the thermostat.</p> <p>Remove internal deposits by flushing. Check for leaks and rectify.</p> <p>Flush cooling system.</p> <p>Check and adjust belt tension.</p> <p>Top up expansion tank with specified coolant mixture.</p> <p>Check and adjust.</p> <p>Calibrate pump on test bench to values specified in calibration tables.</p> <p>Clean filter unit and replace filter element if necessary.</p>
Engine lacks power and runs unevenly.	<ol style="list-style-type: none"> 1. Incorrect injection pump timing. 2. Auto advance regulator in injection pump damaged. 3. Control valve journal worn. 4. Irregular delivery from injection pump. 5. All-speed governor damaged. 6. Injectors partially obstructed or damaged. 7. Impurities or water in fuel lines. 	<p>Adjust pump timing.</p> <p>Overhaul injection pump and adjust on test bench to the values specified in calibration table.</p> <p>Overhaul injection pump and adjust on test bench to the values specified in calibration table.</p> <p>Overhaul injection pump and adjust on test bench to the values specified in calibration table.</p> <p>Overhaul injection pump and adjust on test bench to the values specified in calibration table.</p> <p>Clean and overhaul injectors and adjust pressure setting.</p> <p>Disconnect fuel lines from injection pump and clean thoroughly. If necessary clean and dry the fuel tank.</p>

(continued)

ENGINE TROUBLESHOOTING

(continued)

Faults	Possible Cause	Correction
Engine produces abnormal knocking noises.	8. Fuel supply pump damaged.	Replace fuel supply pump.
	9. Incorrect valve clearances.	Adjust valve clearance.
	10. Cylinder compression low.	Test compression and overhaul engine if necessary.
	11. Air cleaner restricted.	Clear air filter unit and replace element if necessary.
	12. Tie-rod in linkage between accelerator and injection pump incorrectly adjusted.	Adjust to correct length.
	13. Maximum speed screw on injection pump incorrectly adjusted.	Adjust fast idling speed screw.
	1. Injectors partially obstructed or damaged.	Clean and overhaul injectors and adjust pressure setting.
	2. Impurities accumulating in fuel lines.	Clean fuel lines and replace severely dented pipes. Clean injection pump if necessary.
	3. Incorrect injection pump timing.	Adjust injection pump timing.
	4. Crankshaft knocking due to excessive play in one or more main or big-end bearings or excessive endfloat.	Re-grind crankshaft journals and crankpins. Fit oversize shell bearings and thrust washers.
5. Crankshaft out of balance.	Check crankshaft alignment and balance; if necessary, replace.	
6. Flywheel bolts loose.	Replace any bolts that have worked loose and tighten all bolts to the specified preliminary and angular torque values.	
7. Connecting rod axes not parallel.	Straighten connecting rods, check axes parallelism; replace con rods if necessary.	
8. Piston knock due to excessive wear.	Rebore cylinder liners and fit oversize pistons.	
9. Noise caused by excessive play of gudgeon pins in small-end and piston bushings, or loose fit of small-end bushing.	Fit oversize gudgeon pin, rebore piston seats and small-end bushings. Replace bushings.	
10. Excessive tappet/valve noise.	Check for broken springs or excessive play between valve stems and guides, cam followers and bores. Adjust valve clearance.	

(continued)

ENGINE TROUBLESHOOTING

(continued)

Faults	Possible Cause	Correction
Engine produces excessive black or dark grey smoke.	<ol style="list-style-type: none"> 1. Maximum delivery of injection pump too high. 2. Injection pump delivery excessively retarded or automatic advance regulator damaged. 3. Injection pump delivery excessively advanced. 4. Injectors partially or totally obstructed or incorrectly adjusted. 5. Air cleaner restricted. 6. Loss of engine compression due to: <ul style="list-style-type: none"> – piston rings sticking; – cylinder liner wear; – worn or incorrectly adjusted valves. 7. Damaged high–pressure fuel lines. 	<p>Adjust injection pump on test bench to the values specified in calibration chart.</p> <p>Adjust injection pump/engine timing or check automatic advance regulator.</p> <p>Adjust injection pump/engine timing.</p> <p>Clean and overhaul injectors and adjust pressure setting; replace if necessary.</p> <p>Clean air cleaner and replace filter element if necessary.</p> <p>Replace damaged parts or, if necessary, overhaul the engine.</p> <p>Inspect and replace if necessary.</p>
Blue, grey–blue or grey–white smoke.	<ol style="list-style-type: none"> 1. Injection pump delivery excessively retarded or automatic advance regulator damaged. 2. Injectors obstructed or damaged. 3. Oil leaking past piston rings due to sticking rings or cylinder liner wear. 4. Oil leaking through the inlet valve guides due to guide or valve stem wear. 5. Engine does not reach correct operating temperature (thermostat faulty). 	<p>Adjust injection pump/engine timing or check automatic advance regulator.</p> <p>Clean and overhaul injectors and adjust pressure setting; replace if necessary.</p> <p>Replace damaged parts or, if necessary, overhaul the engine.</p> <p>Recondition cylinder head.</p> <p>Replace the thermostat.</p>
Engine runs on after switching off.	<ol style="list-style-type: none"> 1. Engine stop solenoid damaged. 2. All–speed governor damaged. 	<p>Replace solenoid.</p> <p>Overhaul injection pump and adjust on test bench to the values specified in calibration table.</p>

ENGINE**Removal – Installation (Operation 10 001 10)****DANGER**

Lift and handle all heavy parts using suitable lifting equipment.

Make sure that assemblies or parts are supported by means of suitable slings and hooks.

Check that no one is in the vicinity of the load to be lifted.

**WARNING**

Always use suitable tools to align holes in parts.
NEVER USE FINGERS OR HANDS.

1. Disconnect the battery negative cable.
2. Drain oil from the transmission/gearbox and power steering unit.
3. Drain the cooling system.

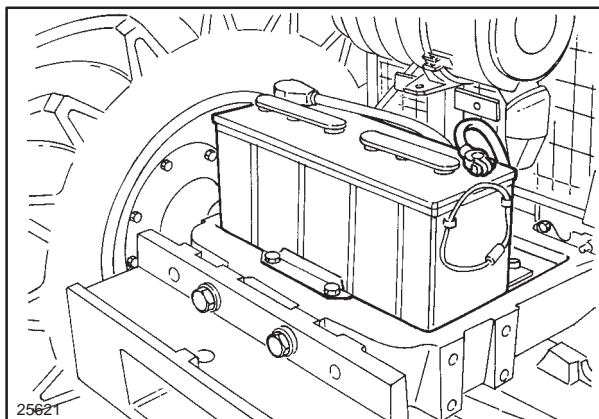

10

4. Unscrew the nut (1) from the weight retaining pin.

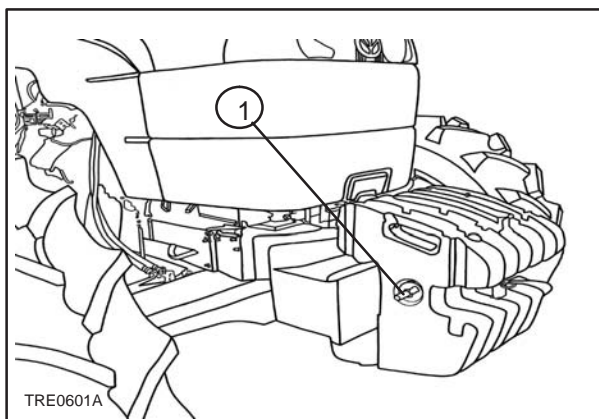

11

5. Remove the weights (1) from the front support.

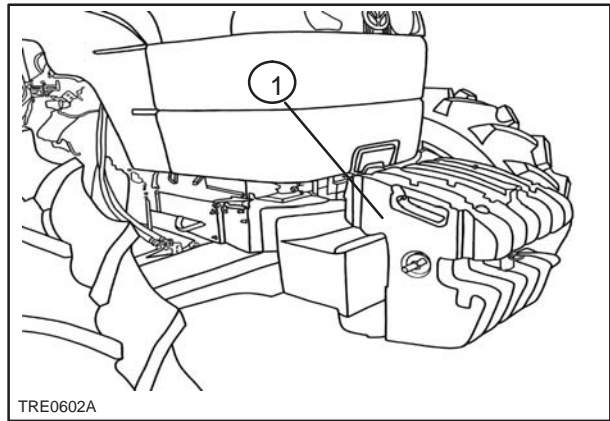

12

6. Remove the exhaust pipe, attach lifting chains to the bonnet (1) and attach the chain to the hoist.

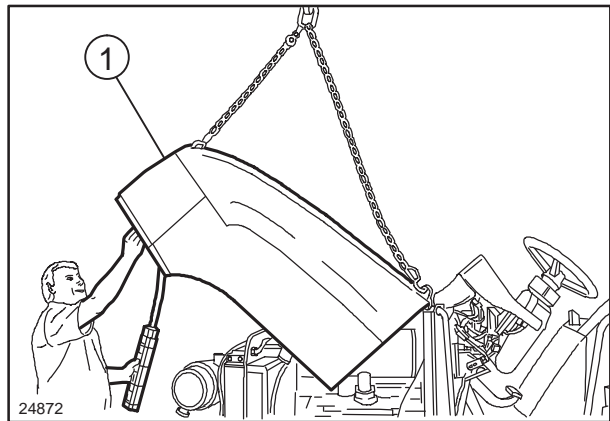

13

7. Disconnect the electrical leads (1) from headlamps (2).

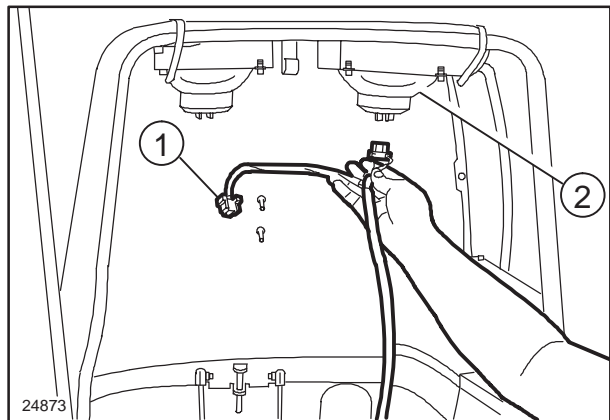

14

8. Detach the gas struts (1) from the bonnet.

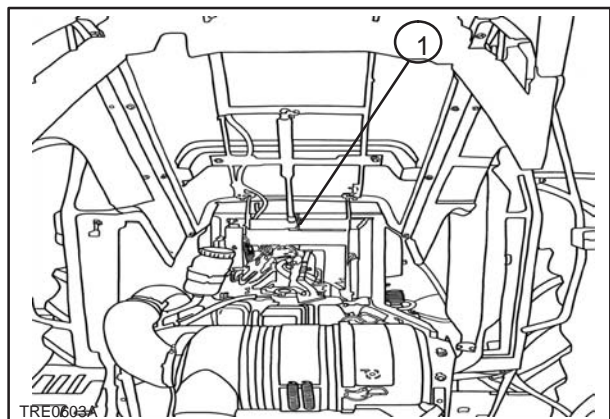

15

9. Remove the four bonnet hinge bolts (1) and lift the bonnet clear.

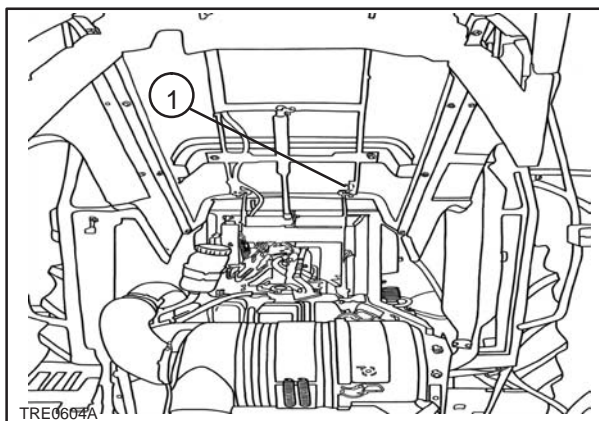

16

10. Remove the wire mesh guard (1) from right-hand side of the fan.

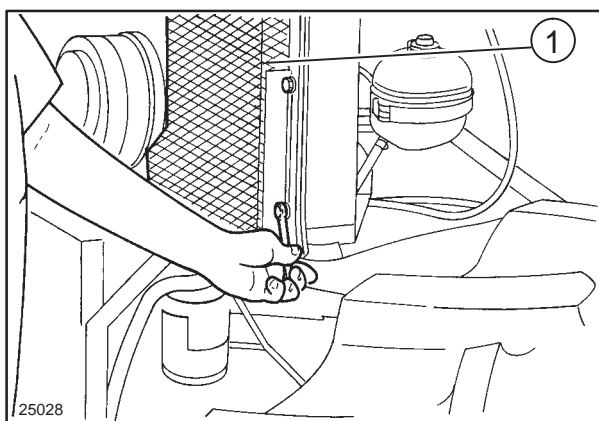

17

11. Disconnect the tachometer cable (1) and remove the retaining ring and sleeve.

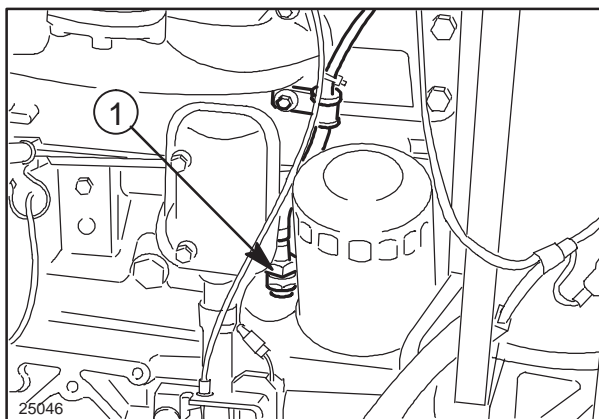

18

12. Detach the throttle control spring (1) and remove the throttle lever (2).

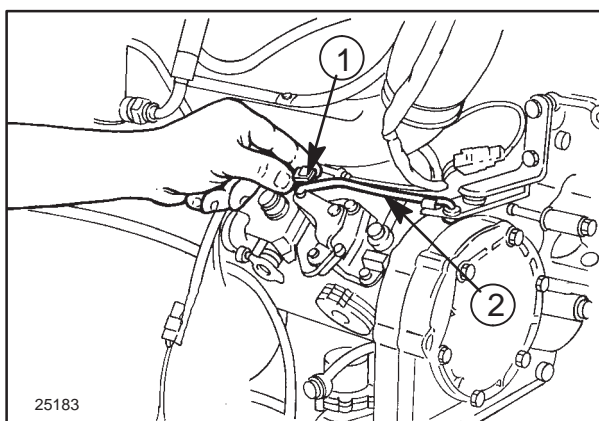

19

13. After recovering the air-conditioner gas (HRC 134a) with the **recovery and recycling station 294048**, disconnect the pipes of the cab air conditioner (1) and (2).

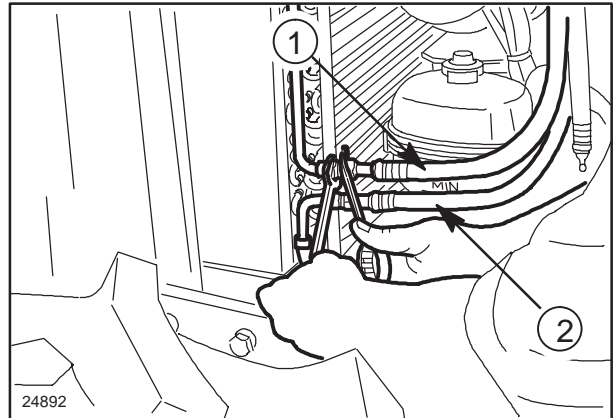

20

14. Detach the cab heating pipes (1) and (2).

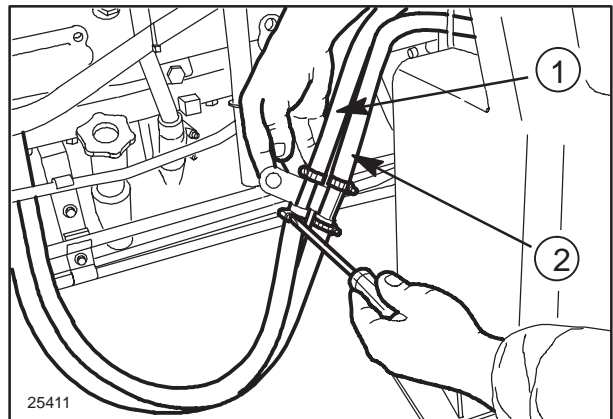

21

15. Disconnect the power steering hoses (1).

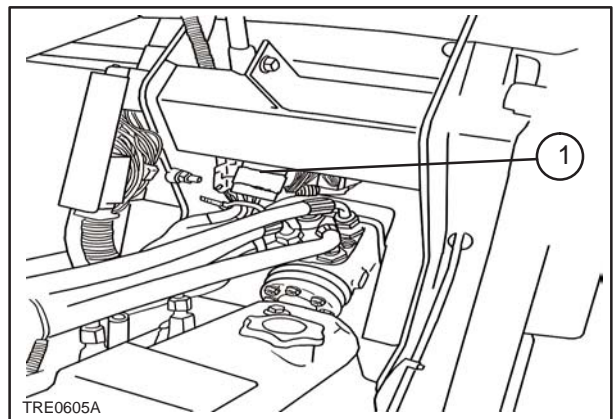

22

16. Disconnect the electrical connectors. Detach the fusebox by unscrewing the nut (1).

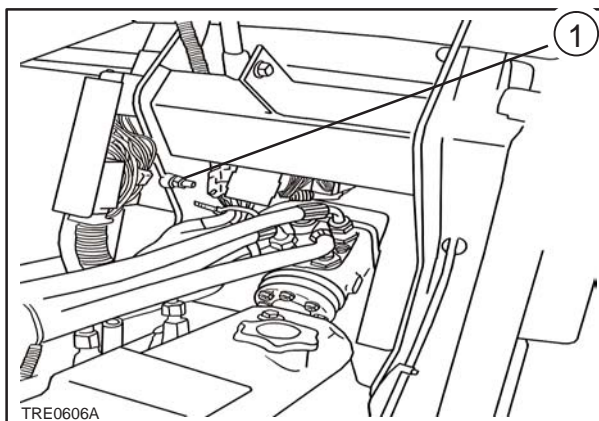

23

17. Disconnect the delivery and return lines (1) to the power steering cylinders.

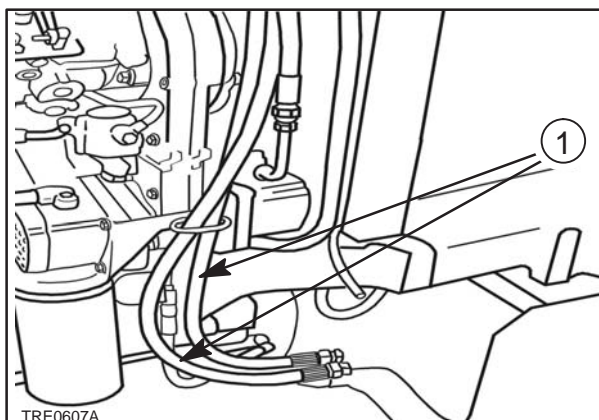

24

18. Remove the hose (1) from the lift pump suction pipe.

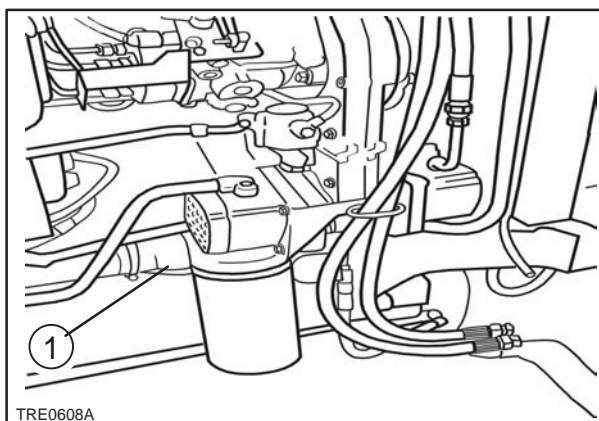

25

19. Detach the lift pump delivery pipe (1).

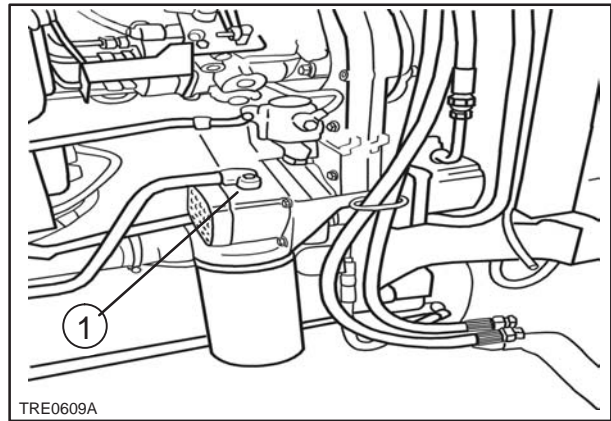

26

20. Detach the fuel pipes from the injection pump and fuel pump and the pipe connecting the tank to the sedimentation filter.

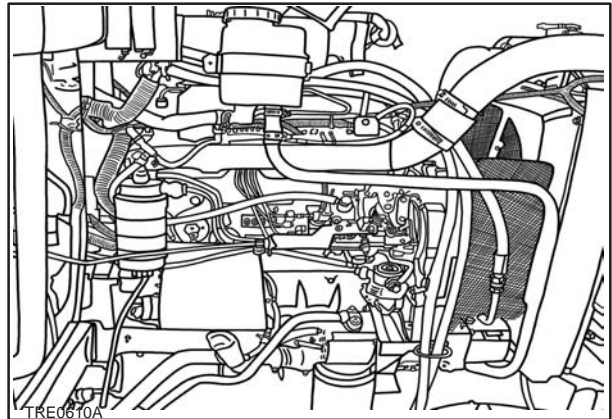

27

21. Remove the fuel filter (1) complete with its support.

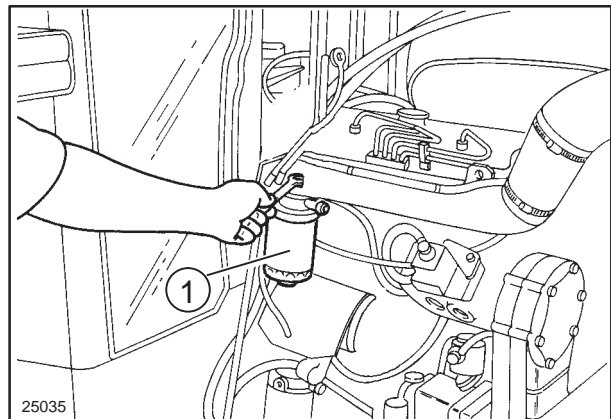

28

22. Remove the front, centre and rear retaining bolts from the front axle drive shaft guard and remove the guard.

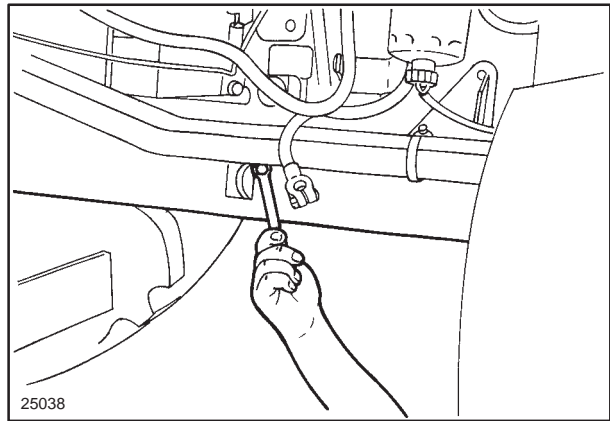

29

23. Remove the circlip (2) from the front of the prop shaft and slide the sleeve (1), in the direction shown by the arrow, until it is free of the splines on the front axle.

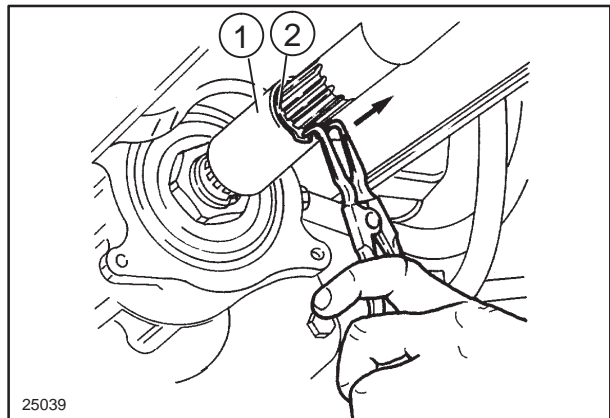

30

24. Remove the circlip (2) from the rear of the prop shaft and slide the sleeve (1), in the direction shown by the arrow, until it is free of the splines on the crankshaft.

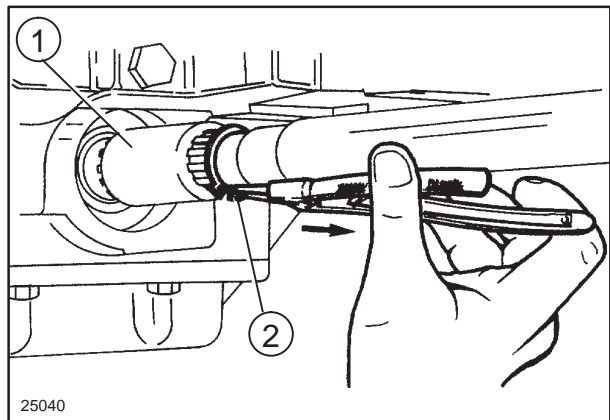

31

25. Remove the middle support bolts (1) from the propeller shaft and remove the shaft complete with support.

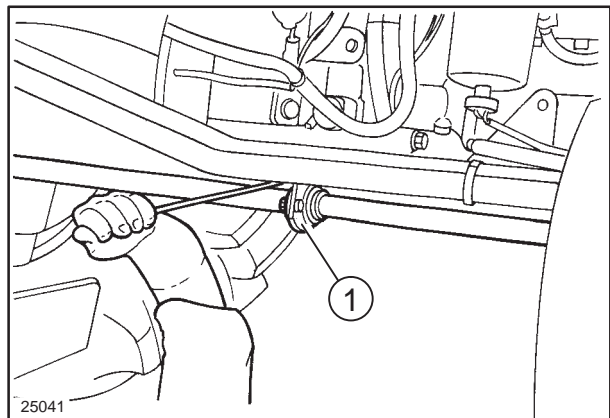

32

26. Withdraw the pin securing the differential lock knob, remove the knob and remove the mat from the floor.

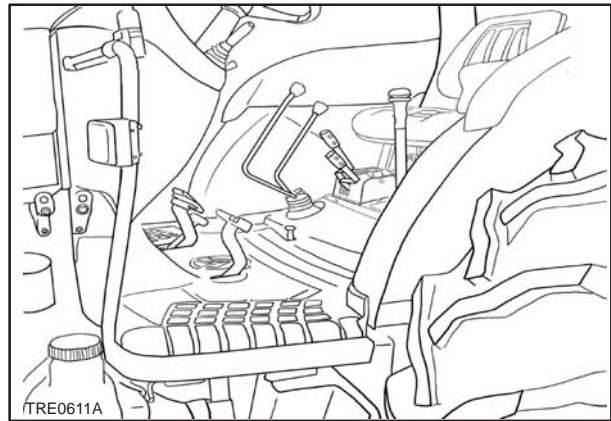

33

27. Unscrew the nuts (1) and the bolts securing the engine to the transmission. Access is through the two slots in the cab floor.

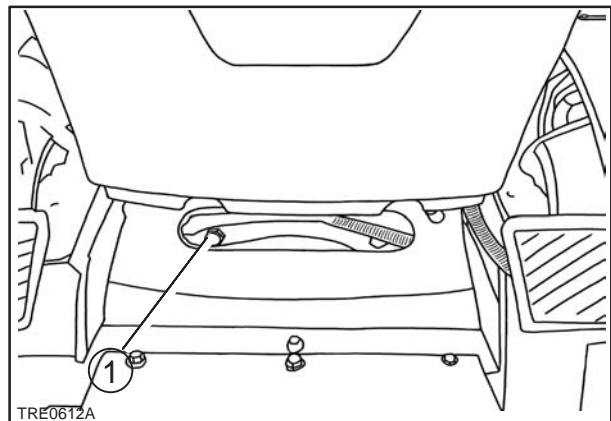

34

28. Unscrew the four lower bolts (1) securing the engine to the transmission.

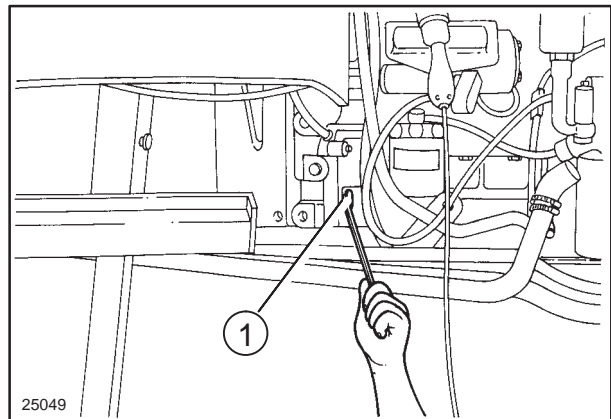

35

29. Position stand **380000236** underneath the tractor and insert a wedge (1), either side of the axle, to prevent the axle from pivoting.

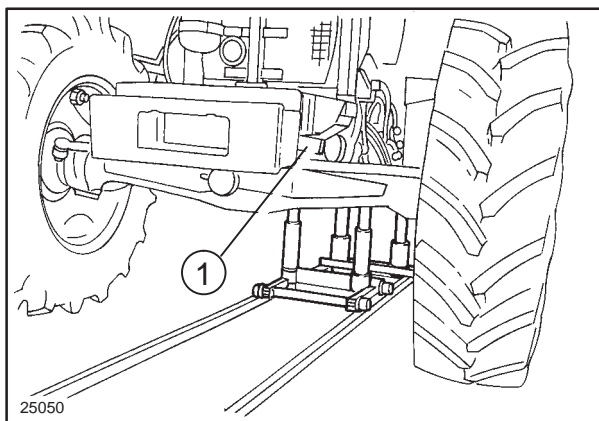

36

30. Insert a wooden block (1) between the stands and the tractor.

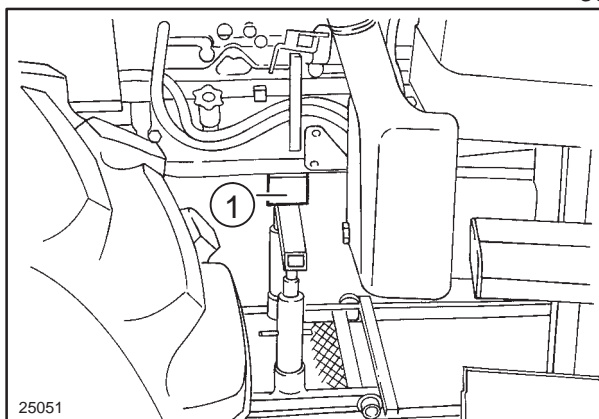

37

31. Place a fixed stand (1) underneath the drawbar support and apply the handbrake.

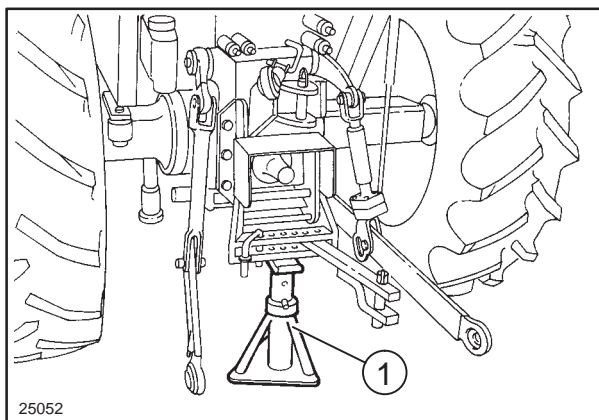

38

32. Unscrew the four remaining bolts securing the engine to the transmission.
 33. Separate the engine from the transmission.
 34. Remove the spacer collar (1) between the engine and the transmission on the TD95D model.

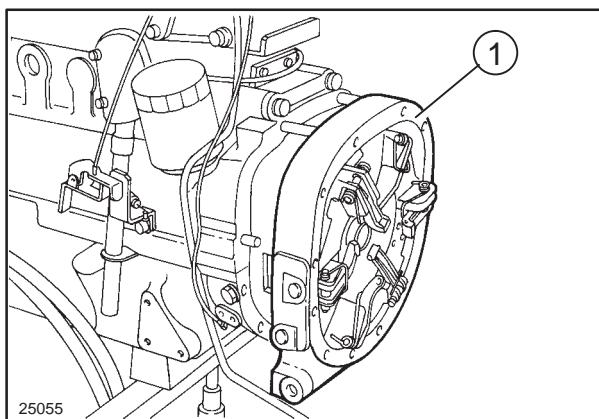

39

35. Place a fixed stand (1) underneath the front weight support and chock the wheels with wooden wedges (2).

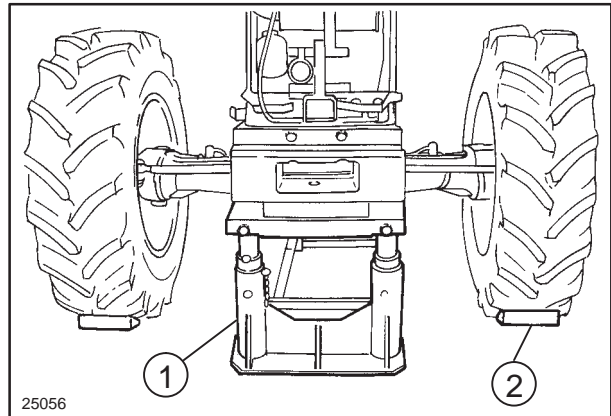

40

36. Insert the pin of kit **380000612** (11"/11" clutch) or the pin **380000292** (12"/12" clutch) (1) into the central hole of the clutch. Unscrew the six bolts (2) securing the clutch to the flywheel and remove complete clutch assembly.

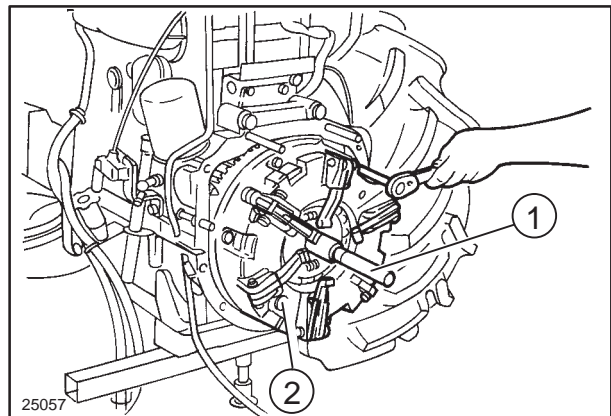

41

37. Remove the radiator mounting bolt (1).

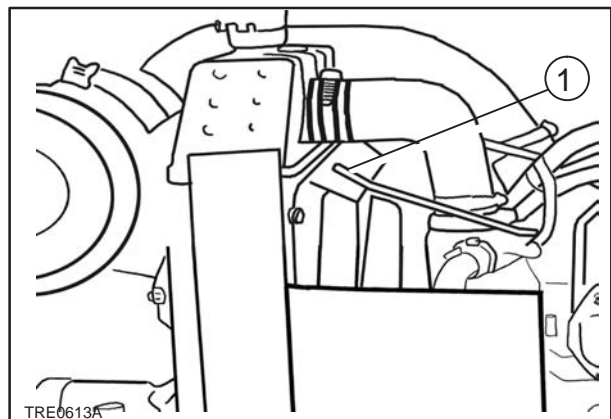

42

38. Attach the engine to the hoist using an adjustable chain (1) attached to the lifting points provided on the engine.

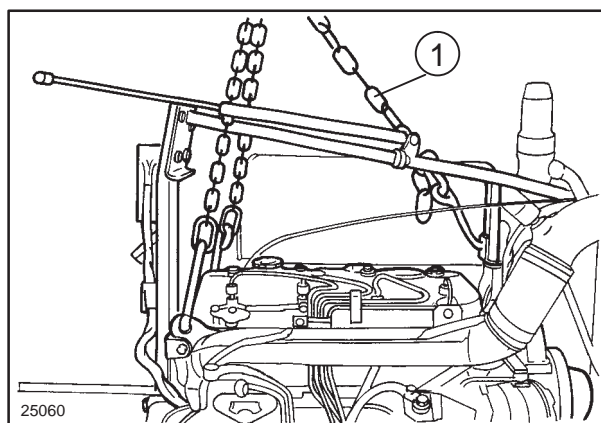

43

39. Remove the lift pump (1) complete with its filter by unscrewing the four retaining bolts.

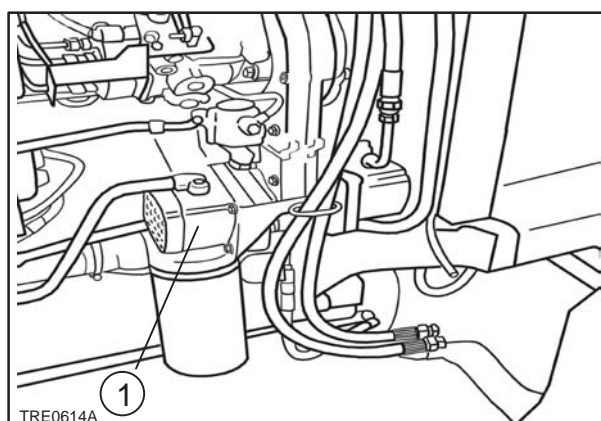

44

40. Disconnect all electrical connectors and remove the complete wiring harness (1).

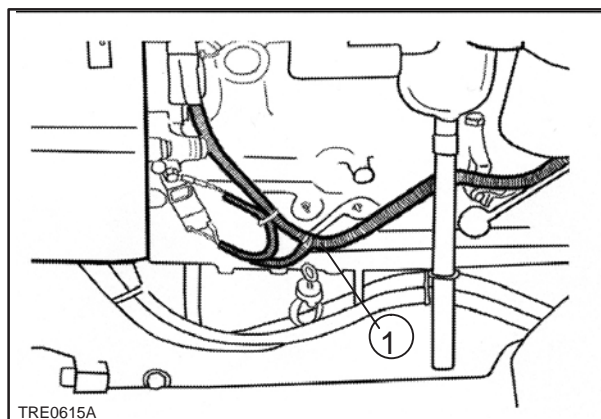

45

41. Slacken of the hose clamp and detach hose (1) from the inlet manifold.

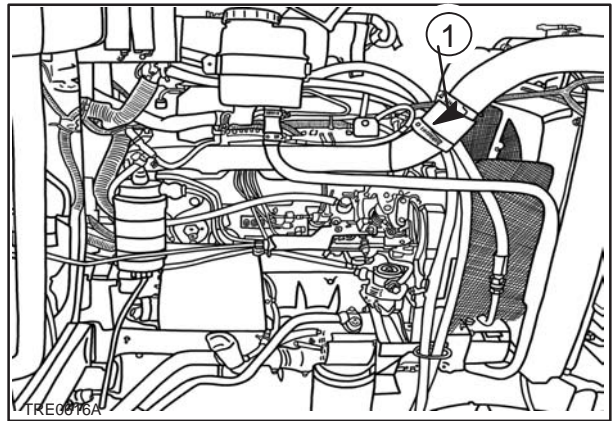

46

42. Remove the left-hand side fan guard (1).

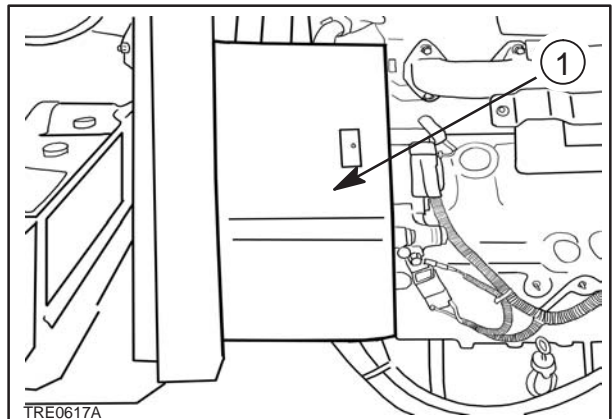

47

43. Unscrew the bolts (1) securing the silencer to its bracket.

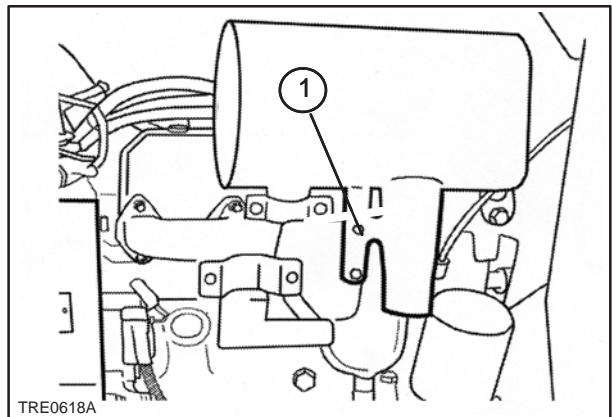

48

44. Undo the hose clamp and disconnect the top radiator hose (1).
45. Unscrew the three nuts securing the silencer to the manifold and lift off the entire silencer assembly.

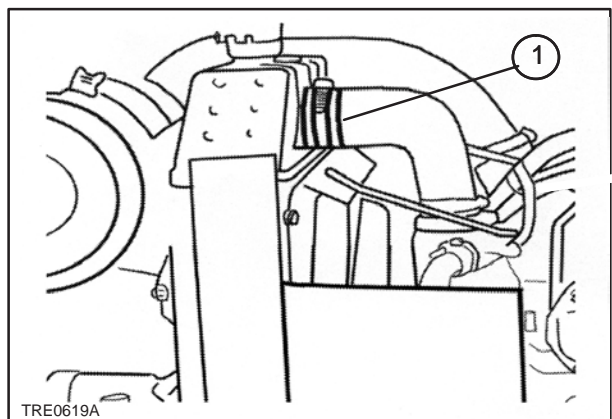

49

46. Using the hoist, raise the engine slightly and position the moveable stand (1) under the front axle.

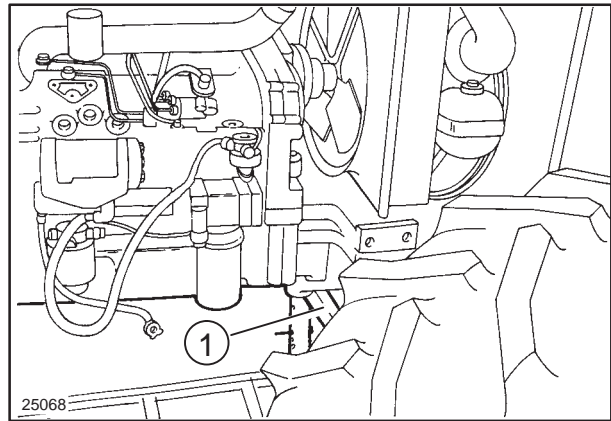

50

47. Undo the hose clamp and disconnect the bottom radiator hose (1).
48. Unscrew the four bolts (2) securing the engine to the front axle support, and lower the engine onto a wooden platform.

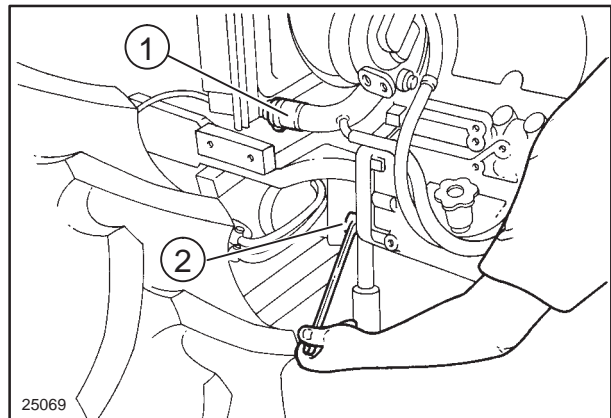

51

To re-install the engine, proceed as follows:

- Attach the three hooks of an adjustable lifting chain to the three eye bolts on the engine. Raise the engine from the platform and position it in front of the front axle support. Join the two units using the four securing bolts.
- Reposition the moveable stand from under the front axle differential housing to under the engine sump, inserting a suitably shaped block of wood between the stand and the sump pan.
- Attach the top radiator hose to the thermostat housing and secure with an adjustable hose clamp.
- Connect the bottom radiator hose to the coolant pump and secure at both ends with adjustable hose clamps.
- Refit the fuel pump.
- Detach the lifting chain from the engine.
- Connect the rigid pipe from the air cleaner to the inlet manifold and secure with the relative clamp.
- Reconnect all electrical leads: thermostart glow plug, coolant temperature sensor, 'air filter blocked' sensor, horn, front axle support earth, engine stop on injection pump, leads to the alternator and relay, oil pressure sensor, starter motor, fuel dryer filter. Secure all leads with plastic ties.
- Fit the clutch back on with the aid of kit **380000612** (11"/11" clutch) or pin **380000292** (12"/12" clutch). Fix clutch to the engine fly-wheel using the six retaining bolts.
- Reconnect the oil delivery pipe to the 4WD control valve. Tighten the pipe union on the anti-cavitation accumulator; fix the bracket on the left-hand side near the engine oil filter.
- Clean the distance collar and the mating surfaces of the overdrive clutch housing; scrape away all traces of old sealing compound.
- Apply LOCTITE sealing compound to the mating surfaces of engine and distance collar. Fit the distance ring on the engine studs.

- Apply LOCTITE sealing compound to the mating surfaces of the overdrive clutch housing.
- Remove the fixed stand from under the front weight support. Remove the wooden wedges from under the front wheels.
- Attach the adjustable lifting chain to the eyebolts on the engine.
- Place wooden wedges under the rear wheels, check that the handbrake is fully on and that the fixed and moveable stands are firmly in place.
- Detach the lifting chain from the engine. Connect the two wires still attached to the cab handrail to the hook of the hoist. Raise the front part of the cab about 6 cm.
- Replace and tighten all the bolts securing the engine to the overdrive clutch housing.
- Bolt the brake pipe support bracket to the right-hand side of the engine. Lower the hoist and detach the cables from the cab handrail.
- Lower the stands under the engine sump and the clutch housing. Remove tool **380000236** and the stand from under the drawbar support.
- Fix the cab in place with the two front securing bolts.
- Connect the injector leak-off pipe. Connect the pipes to the glowplug and to the fuel dryer filter.
- Refit the fuel filter mounting to the engine. Connect the two semi-rigid pipes to the mounting.
- Connect the oil suction pipes to the pumps; secure the rubber hoses with hose clamps.
- Connect the rigid lift control valve supply pipe to the relative pump, remembering to first fit the O-ring.
- Secure the three pipes with the adjustable hose clamp.
- Connect up all the electrical leads to the connectors on the vertical support bracket.
- Fit the cab heater pipe union on the engine/clutch distance collar. Connect the rubber heater hoses to the union and, if necessary, restore the gas in the air-conditioning system with tool **294030**.
- Connect the two flexible power steering pipes to the union on the left-hand side of the front axle. Secure the two pipes with the special clamp and screw the clamp to the tractor.
- Fit the tachometer cable and secure the sleeve with the retaining ring.
- Fit the silencer onto the exhaust manifold, remembering to replace the gas seal. Fix the front of the silencer to the vertical support bracket. Attach the flexible DONASPIN pipe.
- Attach the bonnet stay bracket to the radiator bracket.
- Refit the 4WD propeller shaft and the guard.
- Re-connect the throttle cable to the accelerator pedal. It may be necessary to adjust the cable at the injection pump lever end.
- Refit the clutch cable to the clutch pedal. Fix the sleeve to the travel stop.
- Replace the plastic plugs in the holes in the cab floor. Replace the mat.
- Refit the steering column cover panels.
- Replace the wire mesh fan guards.
- Attach slings to the bonnet in the manner described previously in the engine removal instructions. Screw the bonnet hinge to its bracket. Attach the gas strut, the electrical leads to the headlamps and then remove the slings.
- Refit the secondary bracket (battery support) to the overdrive clutch housing. Fit the rotating bracket with the battery to the fixed support.
- Refit the front weights and secure with the lock pin.
- Refit the tool box support bracket and then the tool box.
- Fill the transmission/gearbox and power steering unit with oil.
- Fill the radiator with coolant.
- Connect the battery positive and negative leads. Replace the plastic battery cover.

ENGINE**Removal – Installation (Operation 10 001 54)****WARNING**

Handle all parts carefully. Do not put your hands or fingers between parts.

Wear suitable safety clothing, safety goggles, gloves and footwear.

1. Remove the front and rear retaining screws from the bonnet stay bracket (1).

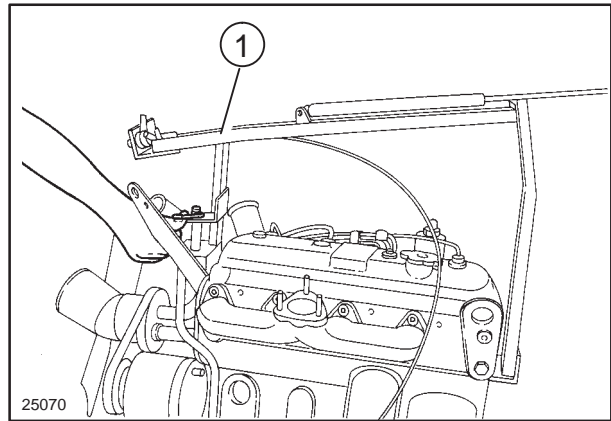

52

2. Remove the bonnet catch support side retaining bolts (1) and back retaining bolts (2) take off the bonnet catch and the bonnet stay bracket.

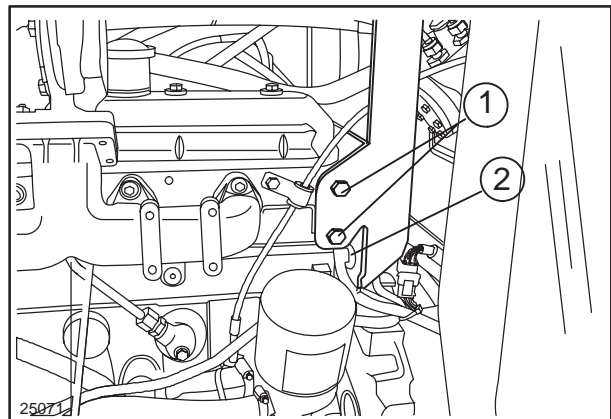

53

3. Loosen the alternator pivot bolt.
4. Loosen the belt tension adjustment bolt (1).
5. Release the belt tension adjustment arm by unscrewing the retaining nut.
6. Remove the alternator and coolant pump drive belt.

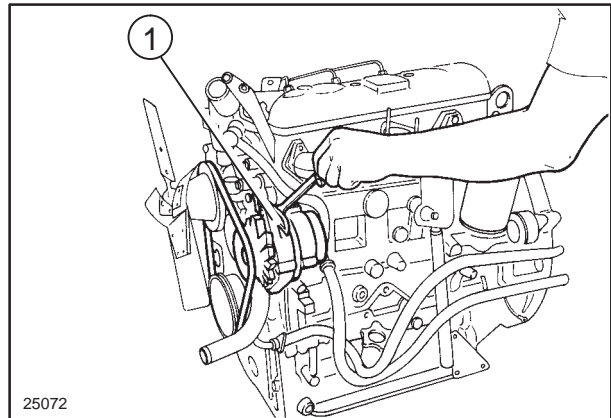

54

7. Unscrew the bolts securing the fan (1) and pulley to the coolant pump. Remove the fan and pulley.

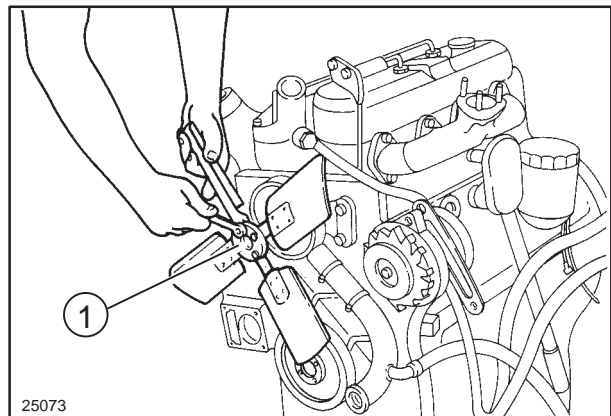

55

8. Unscrew the union (1) from the water supply pipe to the cab heater.

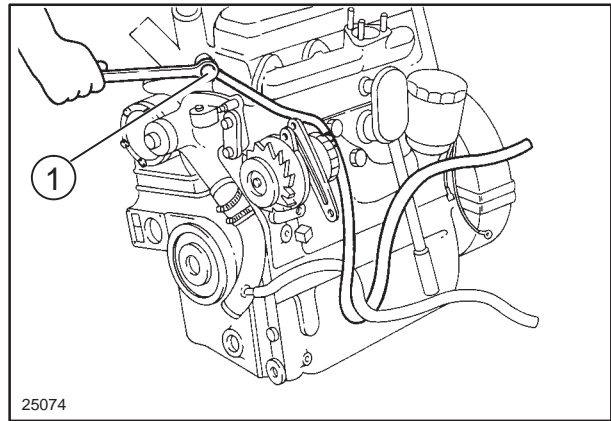

56

9. Loosen the hose clamp (1) and detach the hose from the coolant pump. Remove the curved hose and flexible cab heater hoses.

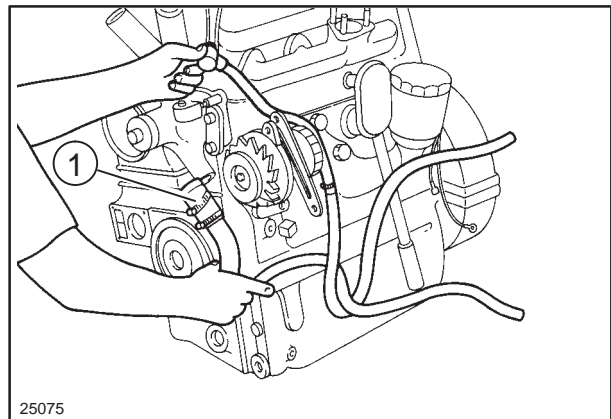

57

10. Remove the union (1) in order to gain access to the pump retaining bolt.

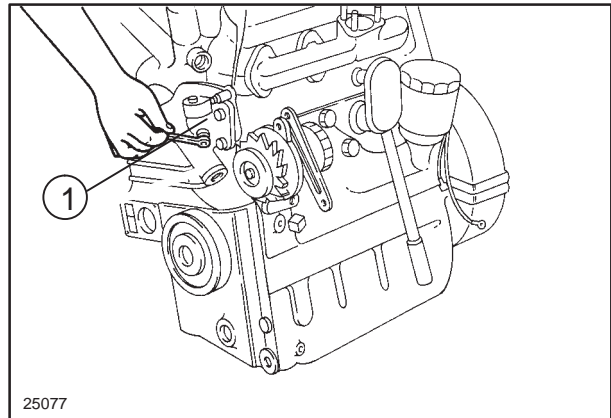

58

11. Unscrew the coolant pump retaining bolts (1) and remove the pump.

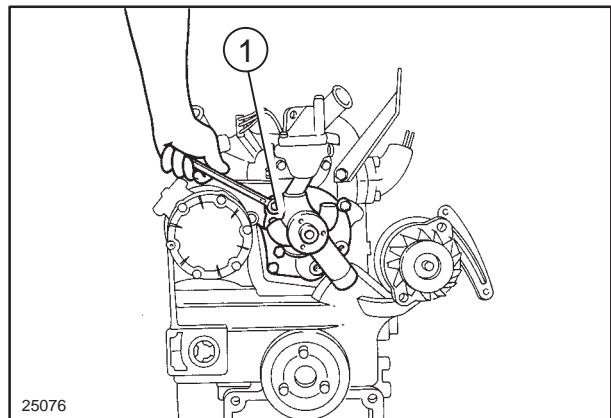

59

12. Unscrew the pump support bolts (1) and the silencer support bolt. Remove the two supports.

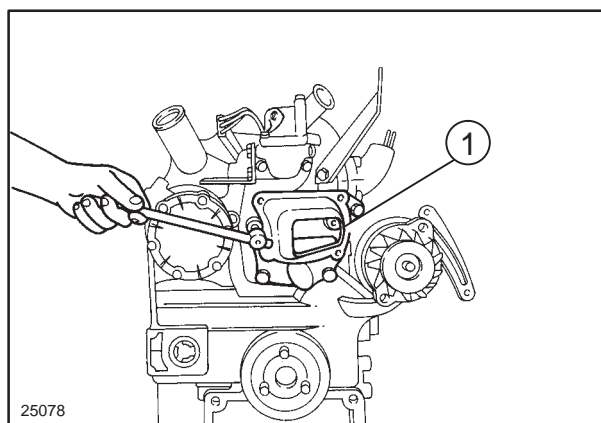

60

13. Fit mounting bracket (1) of the set **380000313** to permit attachment of the engine to the rotary stand **380000201**.

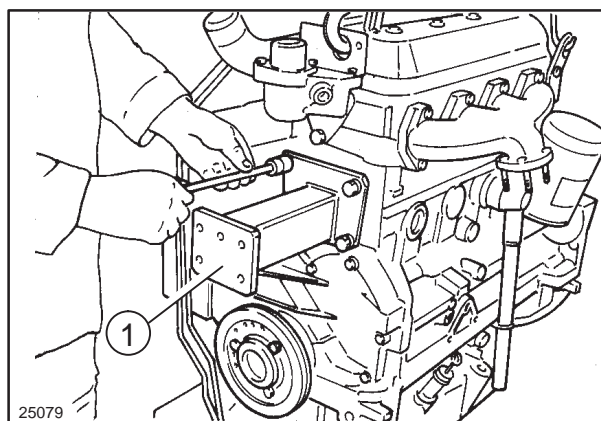

61

14. Fit an eyebolt (1) on the front of the engine in place of the silencer support.
15. Raise the engine from the wooden platform and move it to the rotary stand **380000301** (2). Secure it to the stand by means of the bracket (3) of the set **380000313**.

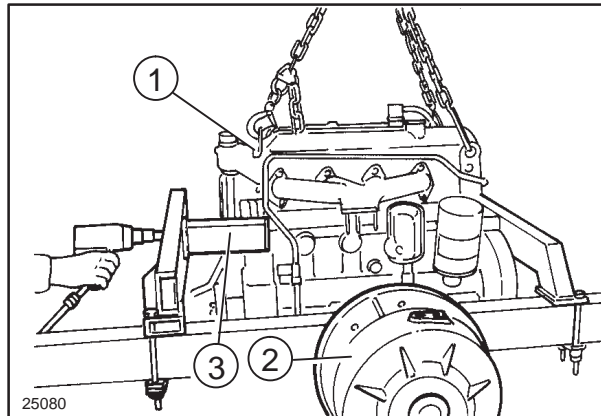

62

16. Undo the alternator support retaining bolts (1) and remove the complete alternator assembly.

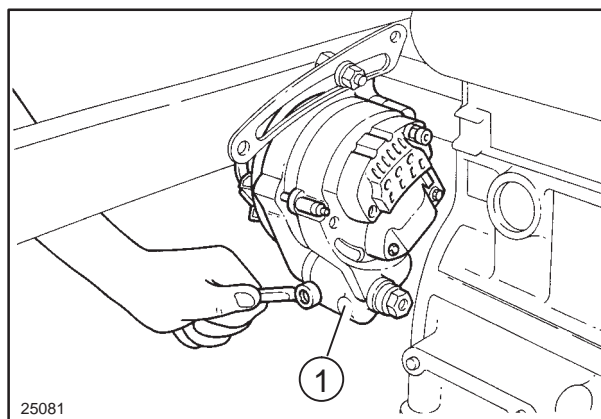

63

17. Unscrew the bolts (1) securing the exhaust manifold to the cylinder head and remove the manifold.

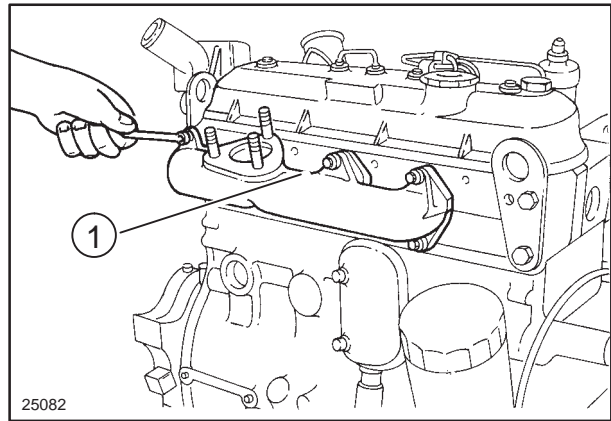

64

18. Detach the throttle control lever (1) from the injection pump.

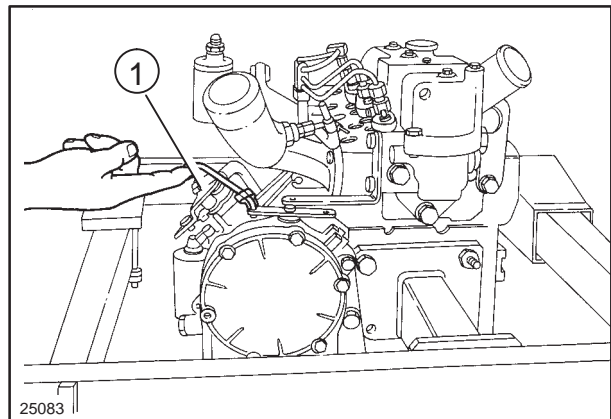

65

19. Remove the thermostat housing retaining bolts (1) and remove the thermostat housing.

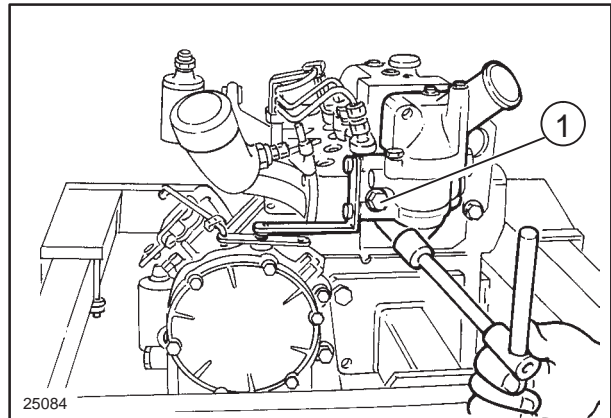

66

20. Unscrew the high pressure fuel line unions (1) on the injection pump and remove the fuel lines.

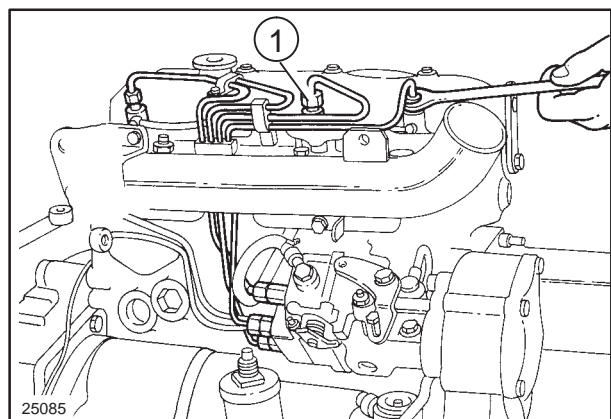

67

21. Unscrew the bolts (1) securing the inlet manifold to the cylinder head and remove the manifold.

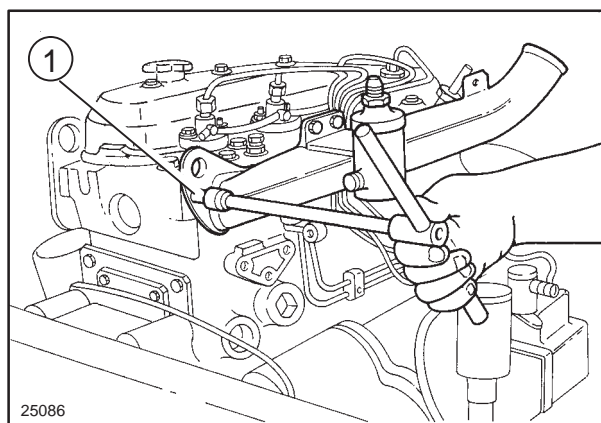

68

22. Unscrew the unions (1) on the fuel supply pump and detach the fuel lines.

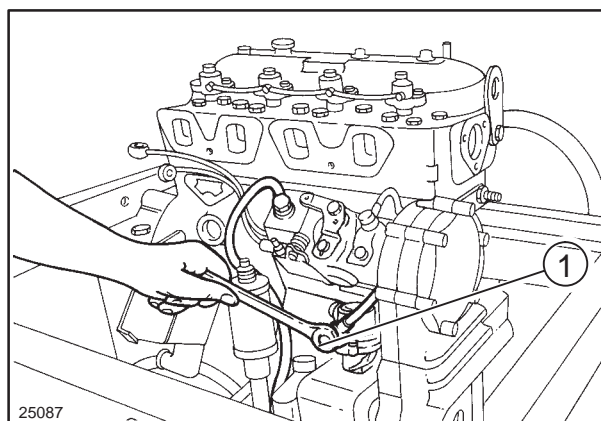

69

23. Unscrew the nuts (1) securing the injection pump to the timing gear case.

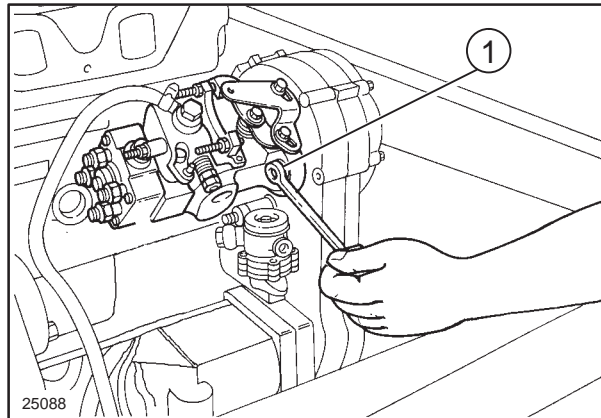

70

24. Undo screws (1) and remove the injection pump drive gear cover.

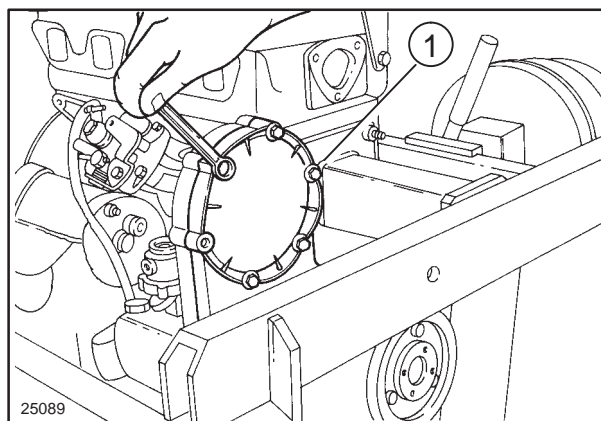

71

25. Unscrew the nut (1) securing the injection pump drive gear to the pump shaft.

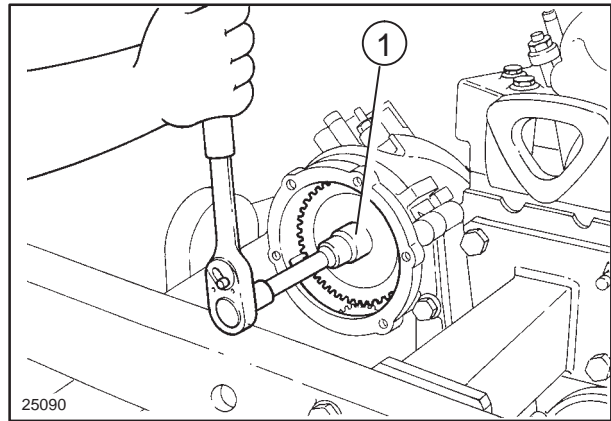

72

26. Extract the injection pump gearing using tool **380000835** (1) and remove the injection pump.

NOTE: If the injection pump does not require any specialist work it must be removed following the instructions given on page 118.

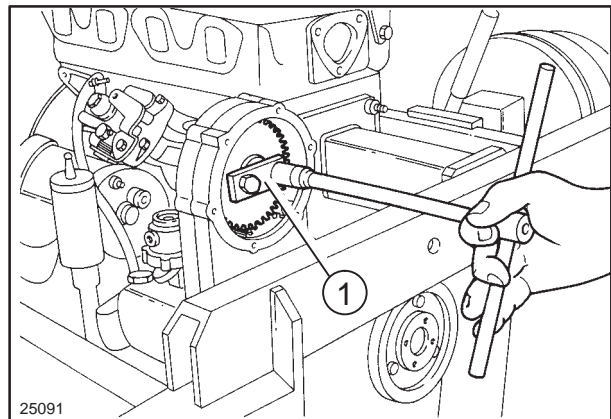

73

27. Undo the fuel line unions (1) on the fuel sedimentation filter.

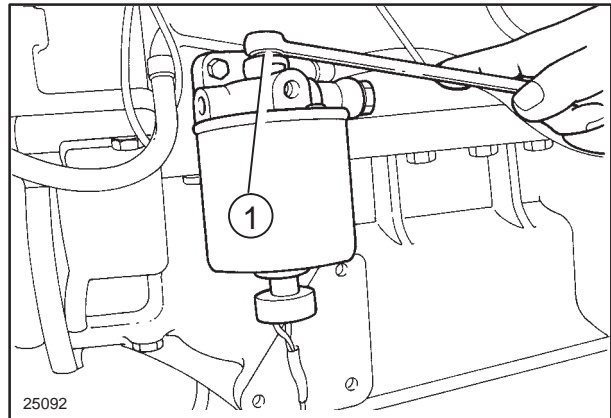

74

28. Unscrew the bolts securing the sedimentation filter support to the engine block and recover the complete filter assembly.

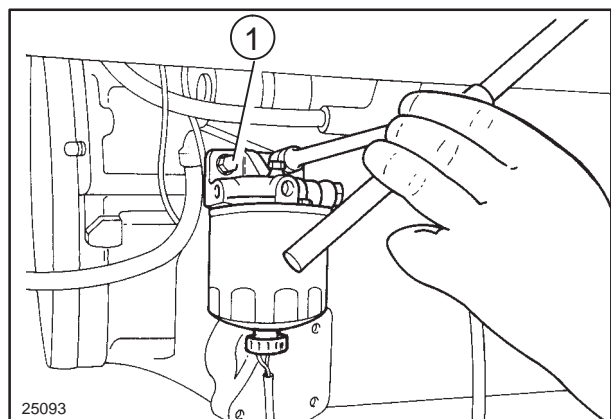

75

29. Unscrew the retaining nut (1) and remove the fuel pump support complete with the pump. Retain the gasket for re-use, if undamaged.

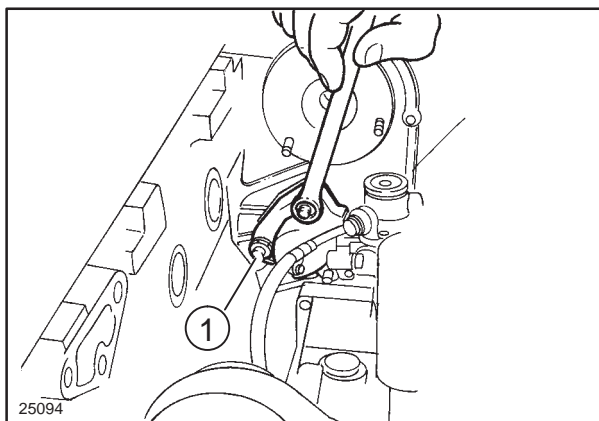

76

30. Unscrew the power steering pump retaining bolts (1) and remove the pump complete with filter and accumulator on the delivery line.

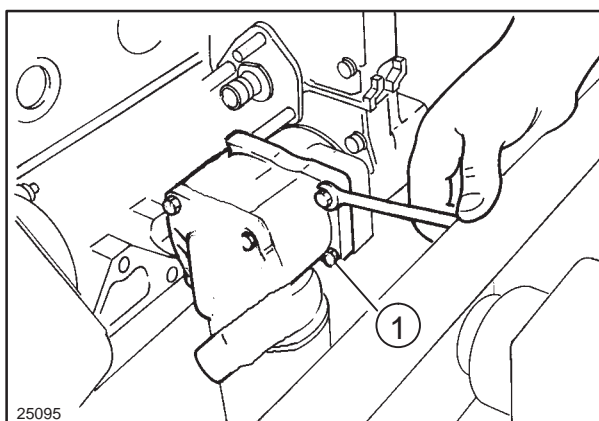

77

31. Remove spacer (3), gasket (2) and the pump drive connector (1).

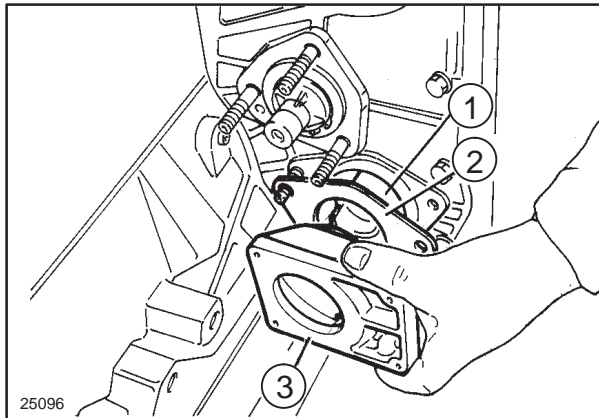

78

32. Unscrew the starter motor retaining bolts (1) and remove starter motor.

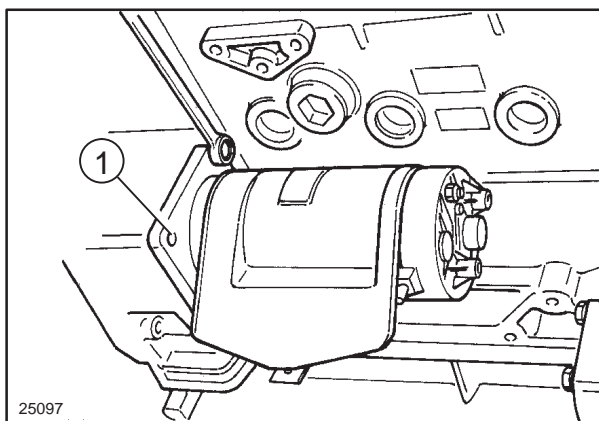

79

33. Remove the injector mounting nuts and the spherical washers beneath, then the supports and the injectors themselves.
34. Remove the rocker cover bolts (1), washers and seals and then the rocker cover and its gasket.

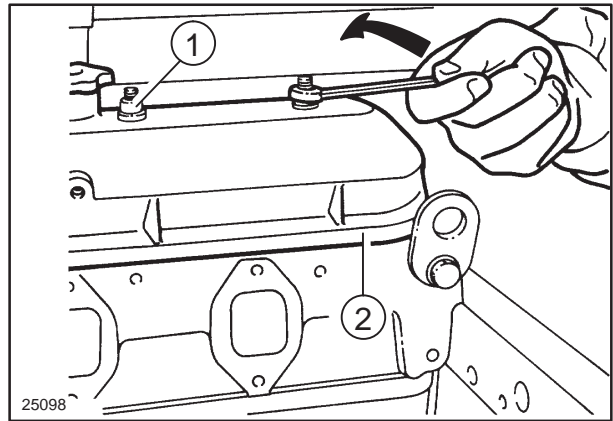

80

35. Remove the rocker shaft retaining bolts (2), then remove the entire rocker shaft assembly (1).

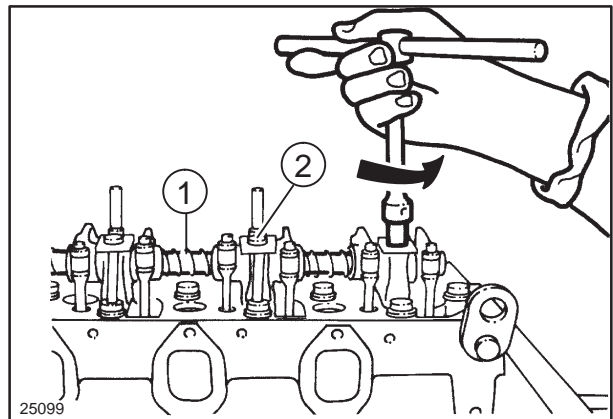

81

36. Remove the valve collets (1) and withdraw the pushrods (2). Retain the collets and pushrods for re-installation later.

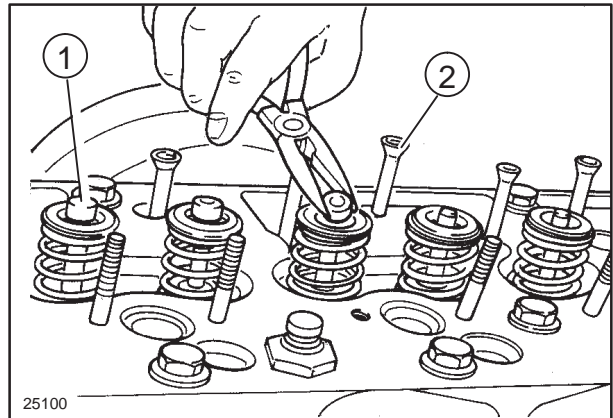

82

37. Unscrew the cylinder head bolts (1) and remove the head using a hoist and lifting hook **380000216**.

38. Remove the cylinder head gasket.

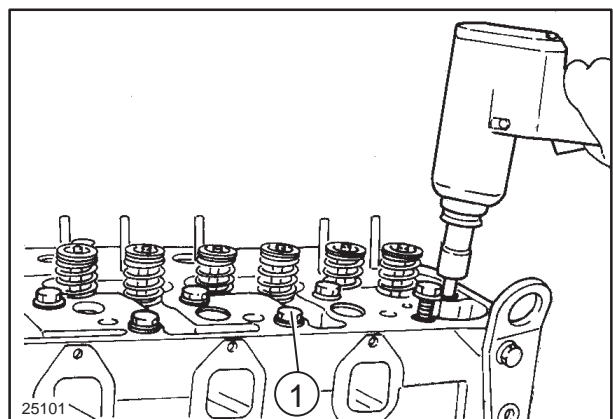

83

39. Turn the engine upside down on the rotary stand. Remove the sump pan bolts, the sump pan (1) and its gasket (2).

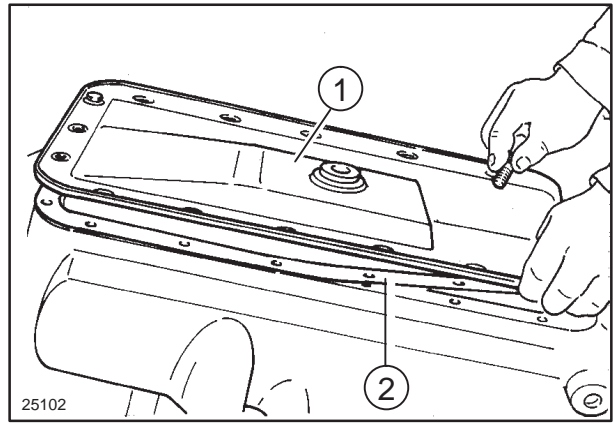

84

40. Unscrew the retaining bolts and remove the oil pick-up pipe (1) complete with the strainer and seal.
41. Unscrew the retaining bolts (2) and free the counterweight housing (3) by moving it outward. Remove the sleeve coupling (4) and housing.

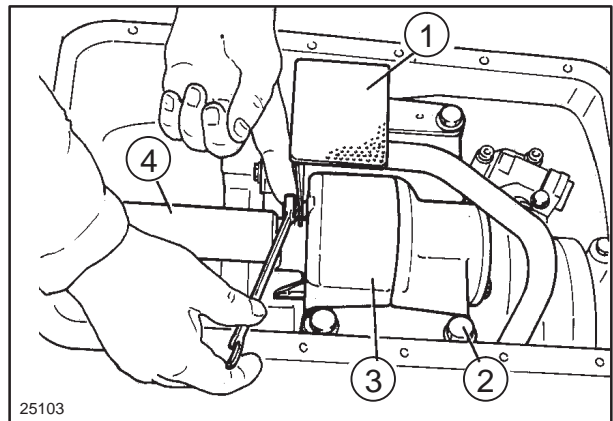

85

NOTE: Operations 39, 40 and 41 are to be carried out on 4-cylinder models only. To disassemble and reassemble the rotating counterweight dynamic balance, see pages 67 and 68.

42. Unscrew the sump pan retaining bolts (4) and remove the sump pan using a hoist, lifting hook **380000216** and lifting chain with eyeholes.
43. Remove the half-gaskets (1) and (3) between the crankcase and sump pan and the gasket (2) between the timing gear carrier and sump pan.

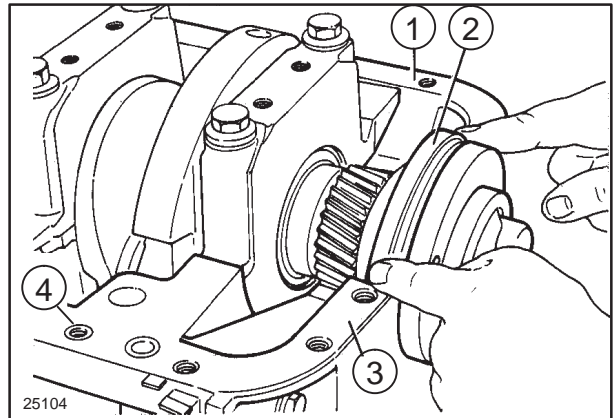

86

44. Remove the gasket (1) between the flywheel carrier and the sump pan.

NOTE: When fitting the gaskets (1) and (3) (fig. 86), apply **RHODORSIL CAF1** silicone sealing compound to the mating surfaces.

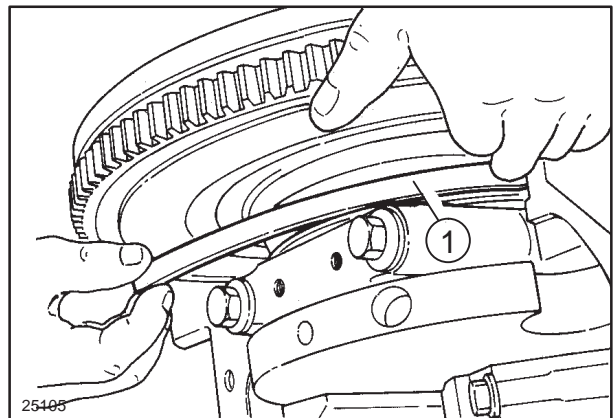

87

45. Remove the rotating counterweight oil seal O-ring (1) installed on the crankcase mating surface.

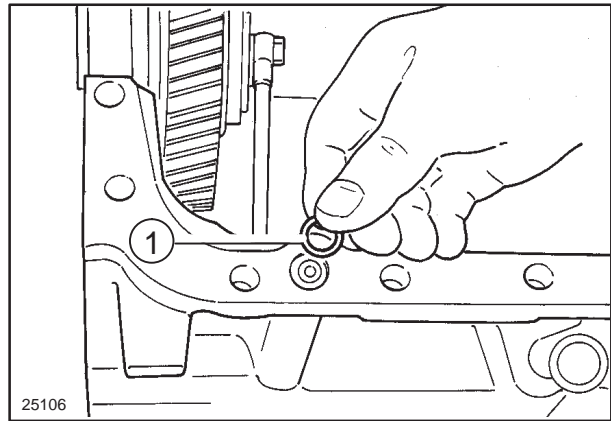

88

46. Undo the retaining bolts (1) and remove the complete oil pump assembly.

NOTE: For TD90D and TD95D models see fig. 106 on page 66.

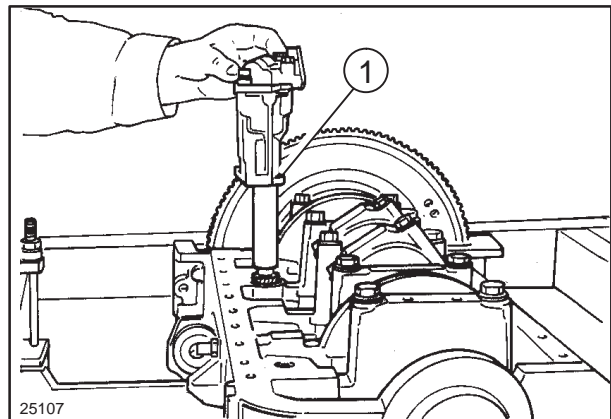

89

47. Unscrew the retaining bolts (2) and remove the crankshaft pulley (1).

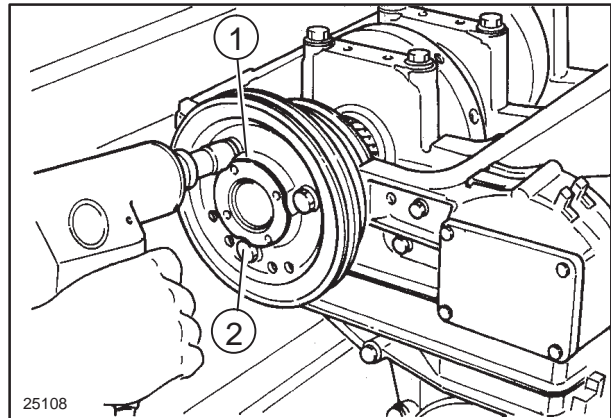

90

48. Straighten the lock tab, preventing rotation of the crankshaft and unscrew nut (1).

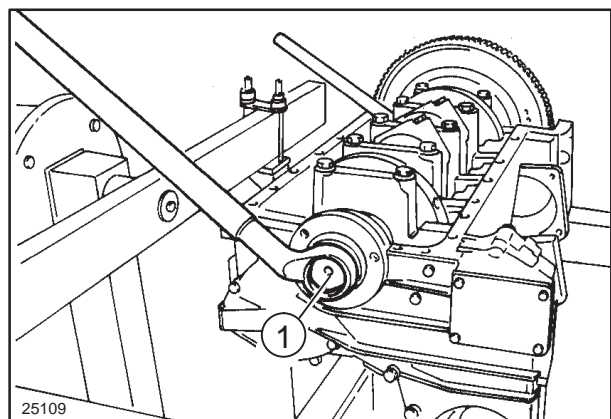

91

49. Pull the pulley hub off the crankshaft using tool **380000226** (1) and retain the woodruff key for re-use.

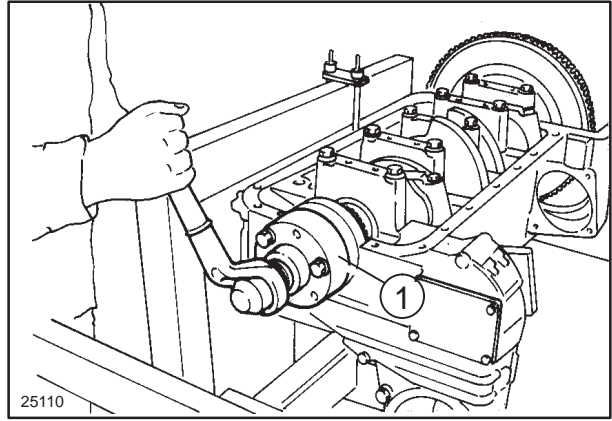

92

50. Unscrew the retaining bolt (1) and remove the timing cover and its gasket.

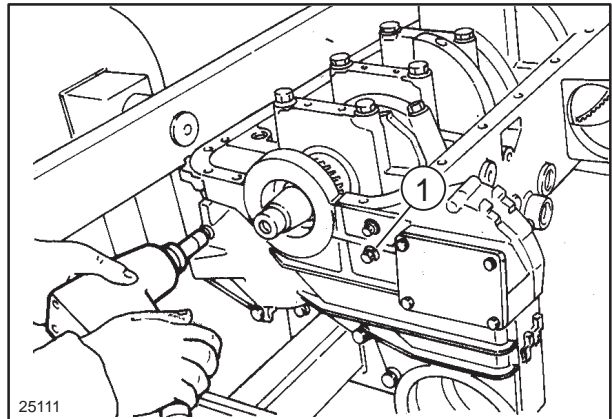

93

51. Unscrew the retaining bolts and remove the lift pump drive gear carrier (1).

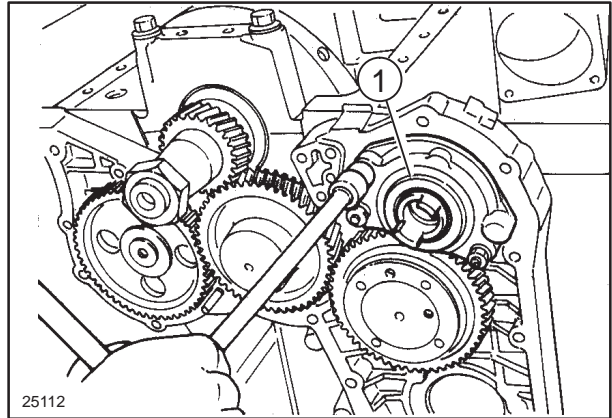

94

52. Remove the circlip (1) and remove the thrust washer and the intermediate gear (2).

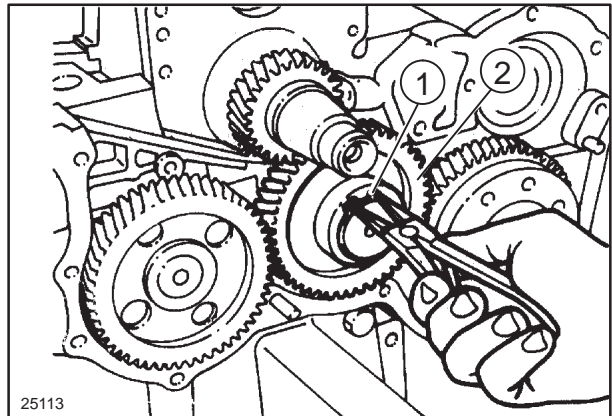

95

NOTE: When refitting the intermediate gear see engine timing instructions on page 73.

53. Unscrew the retaining bolts (1) and remove the intermediate gear journal.

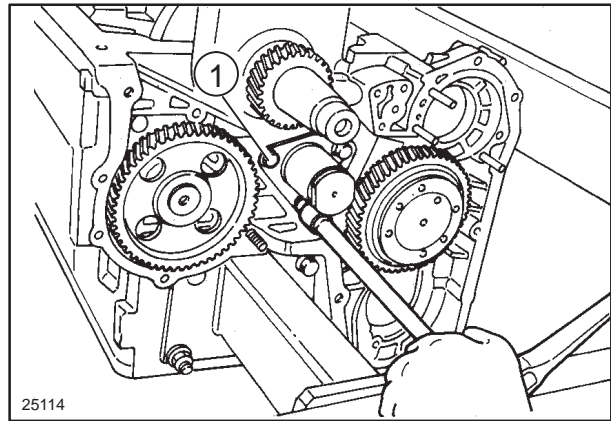

96

54. Unscrew the retaining bolts (4) and withdraw the camshaft (2) complete with the camshaft gear (1) and the end plate (3).

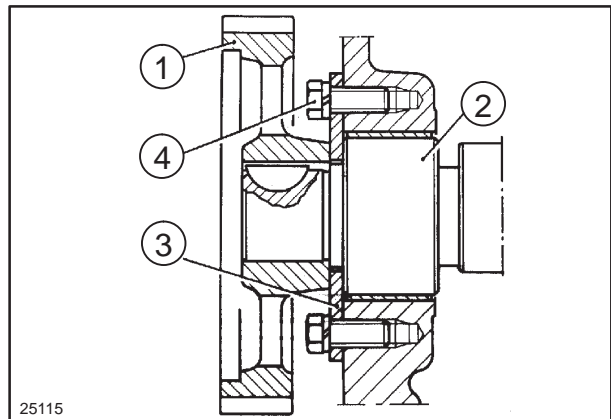

97

55. Remove the circlip (1) and the thrust washer. Withdraw the gear with fuel supply pump camshaft (2) from the opposite side.

NOTE: This gear transmits drive to the injection pump. On re-assembly see timing instructions on page 73.

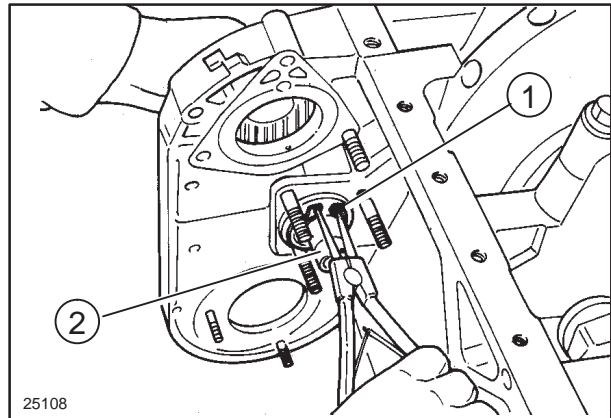

98

56. Unscrew the bolts (1) and remove the timing gear case.

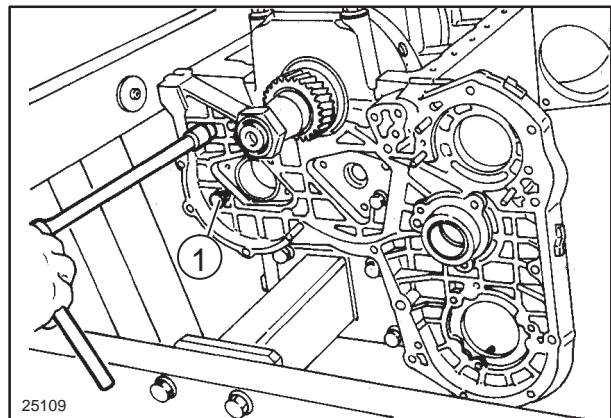

99

57. Renew the O-ring seal (1) installed in the lift pump drive shaft lubrication line.
58. Remove the crankcase – timing gear case gasket.

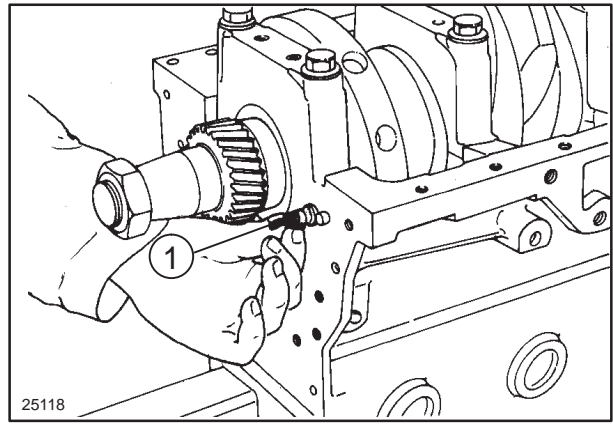

100

59. Rotate the engine on the stand through 90°. Unscrew the big-end cap bolts (2) and remove the big-end caps (1), complete with their half shell bearings.

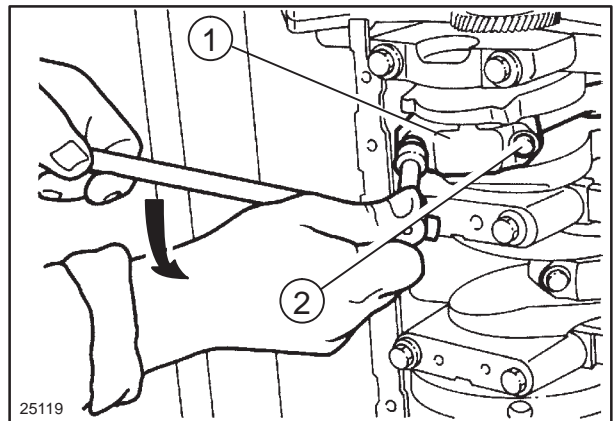

101

60. Slide the pistons (1), complete with rings, gudgeon pins and connecting rods, out of the cylinder liners.

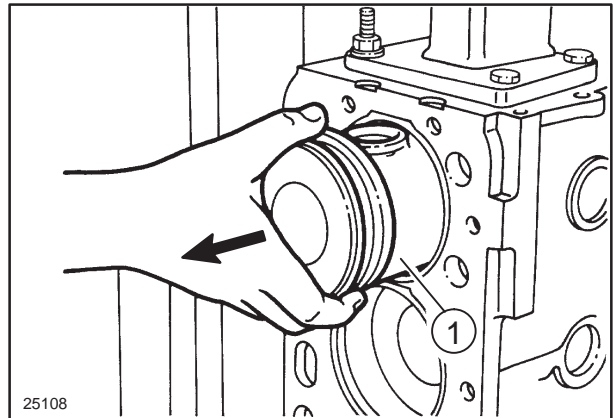

102

61. Rotate the engine on the stand through 90° back to the horizontal position. Unscrew the flywheel bolts and remove the flywheel with the aid of a hoist and hook **380000216**.
62. Unscrew retaining bolts and remove the rear oil seal carrier (1) complete with gasket.

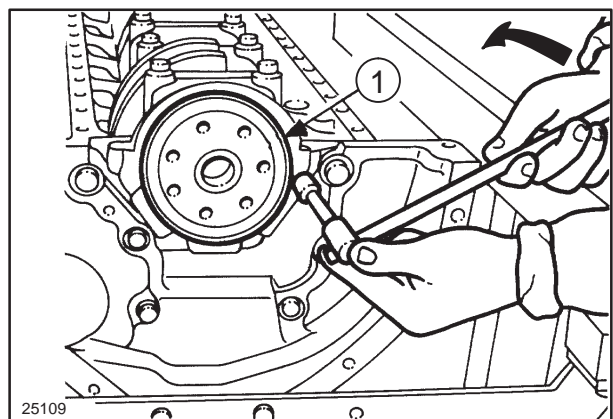

103

63. Unscrew the main bearing cap bolts (1) and remove the main bearing caps with related bearing shells. Remove the thrust washers located on the penultimate main bearing, as shown in the figure.
64. Lift the crankshaft clear of the crankcase using a hoist and nylon sling. Remove the bearing shells, thrust washers and tappets.

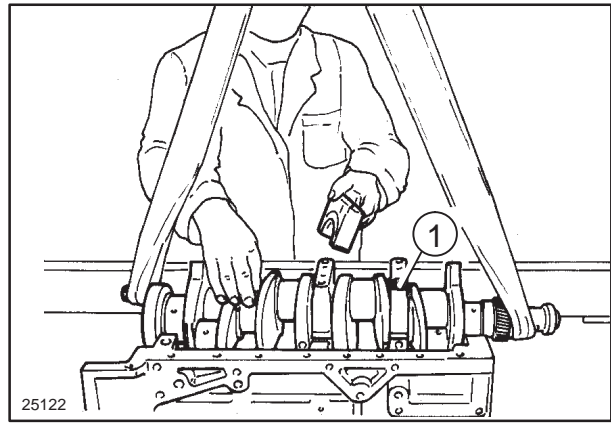

104

65. Turn the engine on the stand **380000301** (2) through 180°. Attach the lifting chain with eye holes to the crankcase as shown in the figure. Raise the hook **380000216** with the hoist so that the lifting chain is under slight tension. Unscrew the bolts securing the crankcase to the stand (2) and mounting bracket (3) (from set **380000313**).
66. Lift the engine clear of the stand.
67. Unscrew retaining bolts and remove the rear crankcase housing (1) and its gasket.

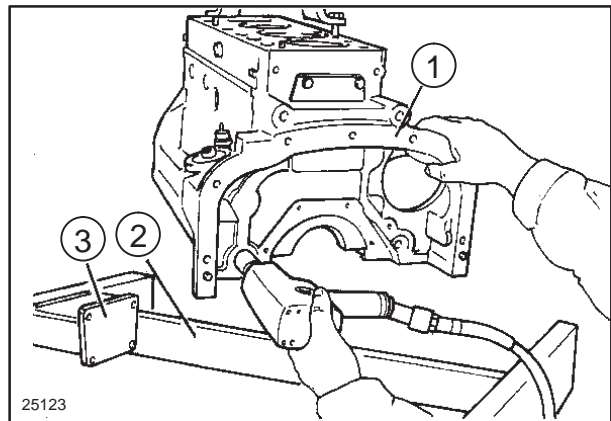

105

NOTE: The figure shows the oil pump for the TD90D and TD95D models

68. Remove the retaining screws (4), take off the washers (3) and the engine lubrication oil pump (2) complete with pressure relief valve (1).

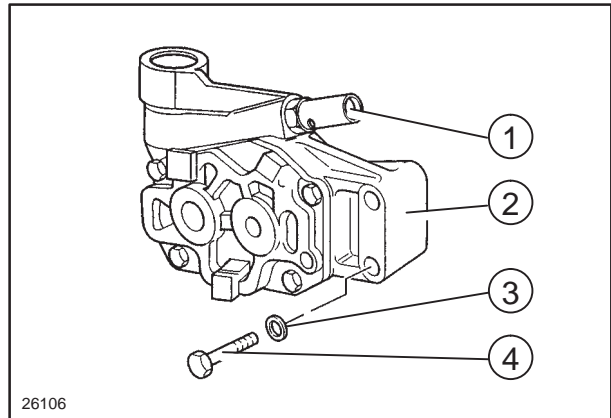

106

NOTE: Operations 1 to 9, relative to the dismantling of the rotating counterweight dynamic balancer, only apply to 4-cylinder models.

1. Remove the lubricating oil pipe (3) fig. 108.
2. Remove the circlip (18).
3. Remove the circlip (25) and cover (23) with relative O-ring seal (24).
4. Withdraw gear (22) from sump.
5. Remove the circlip (2), gear (26) and the two thrust washers (1).
6. Inspect shaft (27). If it shows signs of scoring or wear it must be replaced.
7. Extract the roll pins and remove the counterweight shafts (8) using a suitable drift.
8. Disassemble the counterweight gear unit (1) fig. 107 by removing the circlip (5) and the support retaining bolts (6).
9. Remove the circlip (3) and the intermediate gear (4) fig. 107.

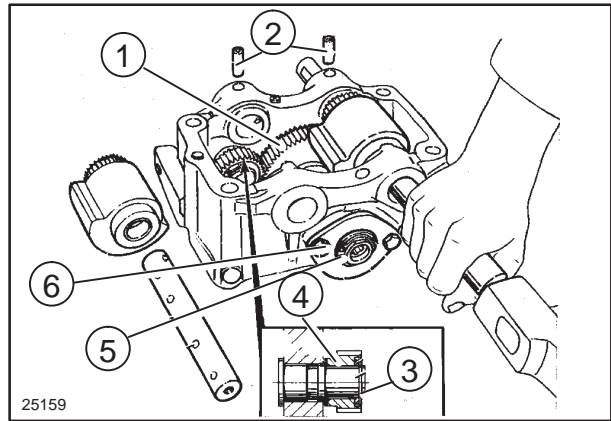

107

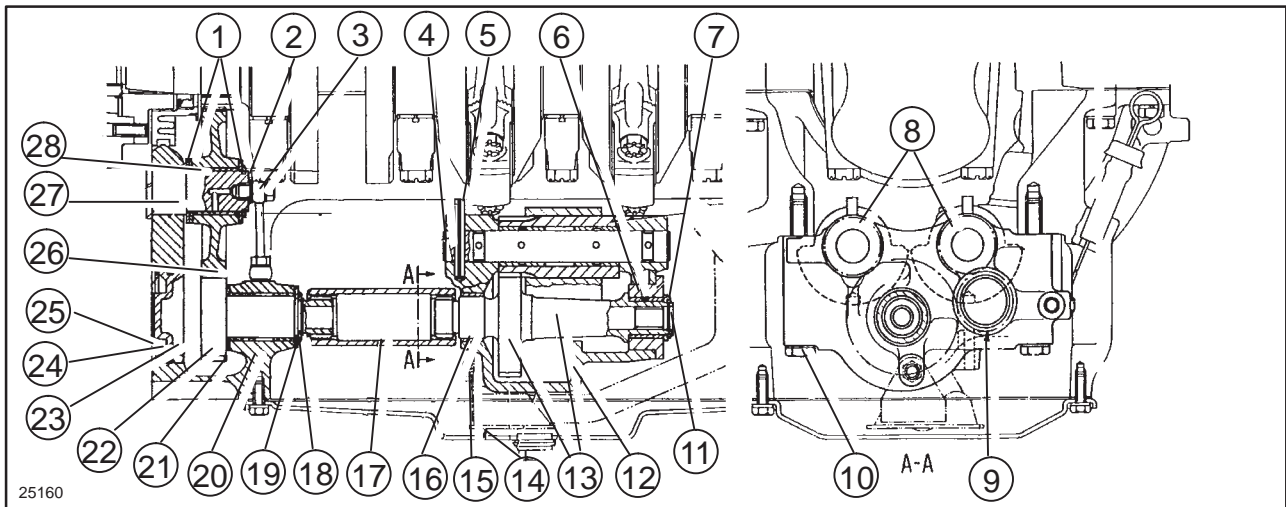

Sectional view of dynamic balancer

108

- | | |
|---|---------------------------------|
| 1. Thrust washers. | 15. Mesh filter retaining bolt. |
| 2. Circlip. | 16. Bushing. |
| 3. Lubricating oil pipe for bushing (28). | 17. Rigid coupling sleeve. |
| 4. Counterweight rotation shaft. | 18. Circlip. |
| 5. Shaft retaining spring pin. | 19. Thrust washer. |
| 6. Carrier for counterweight drive gear (13). | 20. Carrier for gear (22). |
| 7. Thrust washer. | 21. Thrust washer. |
| 8. Rotating counterweights. | 22. Counterweight drive gear. |
| 9. Counterweight intermediate gear. | 23. Cover. |
| 10. Bolts securing counterweight housing to sump. | 24. O-ring seal. |
| 11. Circlip. | 25. Circlip. |
| 12. Counterweight housing. | 26. Intermediate gear. |
| 13. Counterweight drive gear. | 27. Shaft for gear (26). |
| 14. Mesh filter. | 28. Bushing. |

GENERAL NOTES AND INFORMATION

- After dismantling the engine, clean all parts carefully.
- To reassemble the engine, carry out the dismantling operations described on pages 53 to 67 in reverse order.
- The following pages 68 to 77 concern those assembly operations requiring particular attention.
- Tightening torques are specified on page 24.

IN ADDITION, MAKE SURE TO:

- Replace all seals and gaskets at each complete or partial engine rebuild.
- Lubricate all rotating parts and oil seals with engine oil prior to installation.
- Lubricate the oil filter mounting seal prior to fitting the filter.

**WARNING**

Handle all parts carefully. Do not put your hands or fingers between parts.
Wear suitable safety clothing, safety goggles, gloves and footwear.

INSTALLING THE BALANCER GEARS WITH COUNTER-ROTATING WEIGHTS (Disassembly operations 1 – 9)

Proceed as follows:

- Assemble the counterweight components in the housing (2) carrying out dismantling operations 7 to 9 in reverse order. Align the positioning marks on the gear (4) and counterweights (1) (indicated by arrows in figure 127).
- The intermediate gear (3) fig. 109 must be installed with the longer side of its hub towards the casing side;
- The holes for the roll pins (1) in the counterweight shafts (2) must be aligned with corresponding holes in the casing.
- Install the counterweight assembly on the sump carrying out operations 1 to 9 (page 67) in reverse order.

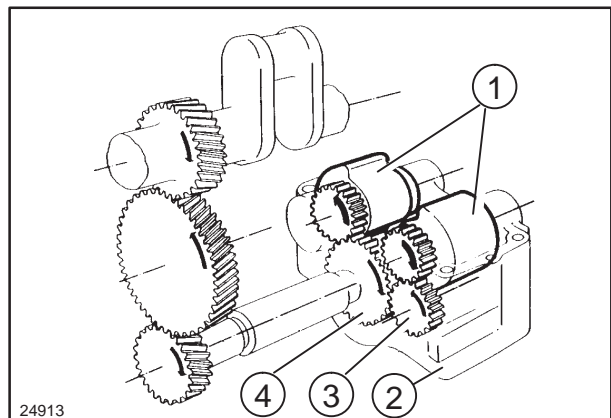

24913

109

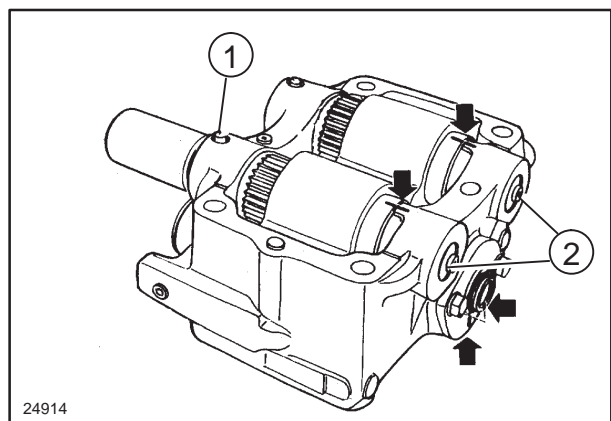

24914

110

INSTALLING THE TAPPETS AND CRANKSHAFT WITH MAIN BEARING CAPS, BEARINGS AND THRUST RINGS; CHECKING CRANKSHAFT END FLOAT (Disassembly operations 63 – 64)

Proceed as follows:

- Install the tappets in their crankcase bores.
- Lubricate the main bearing seats (2) with engine oil and install the half shell bearings (1).
- Stick the semi-circular thrust washers (3) to both sides of the penultimate main bearing with grease.

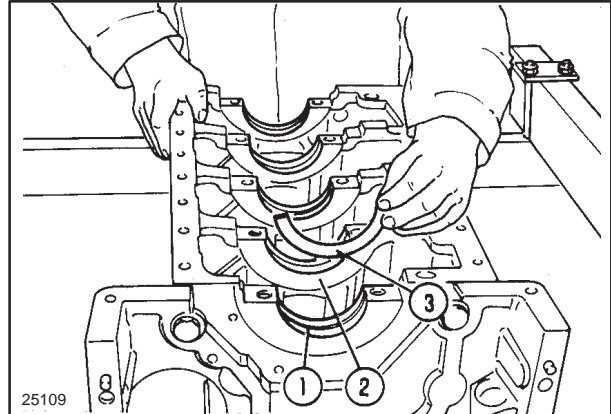

111

- Lubricate the upper surfaces of the main bearing shells with engine oil and lower the crankshaft (1) into position taking care not to dislodge the semi-circular thrust washers installed previously.

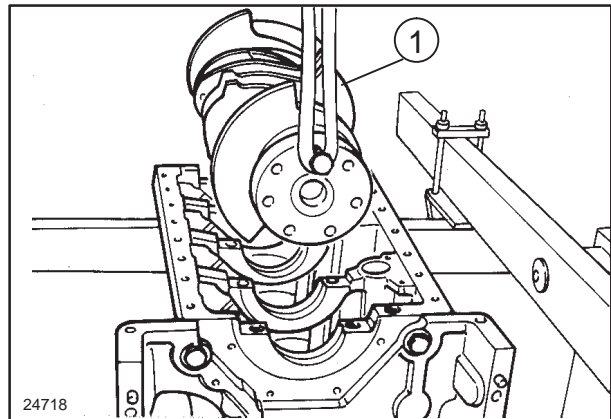

112

- Lubricate the crankshaft journals with engine oil and fit the main bearing caps (3) with the half-shells (4), fitting the top semi-circular thrust washers (2) to the penultimate bearing cap.
- Rotate the crankshaft (1) a few times to allow the parts to settle into position.
- Insert the main bearing cap bolts and screw in until the head of the bolt is up against the cap.

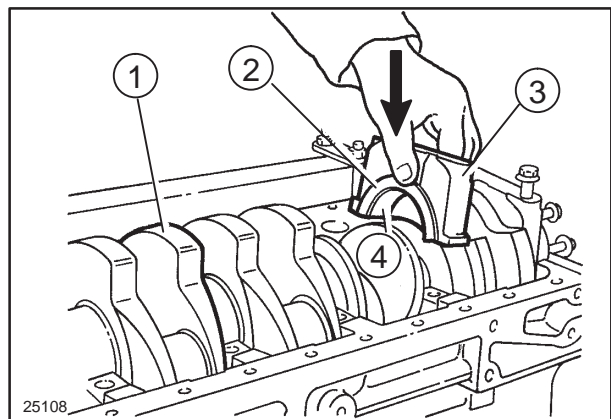

113

- Tighten all cap bolts (1) to a torque of 80 Nm (59.0050 ft lb).

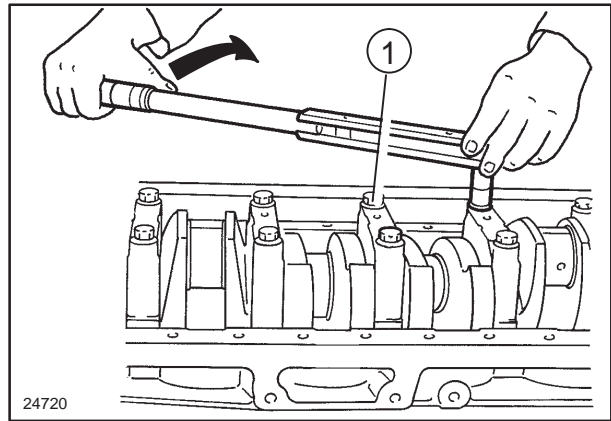

114

- Tighten each cap bolt (1) through a further 90° using tool **380000304** (2).

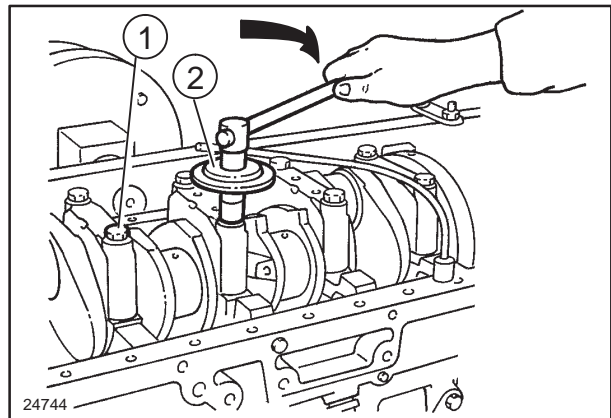

115

- Check that crankshaft endfloat does not exceed the value specified on page 17.

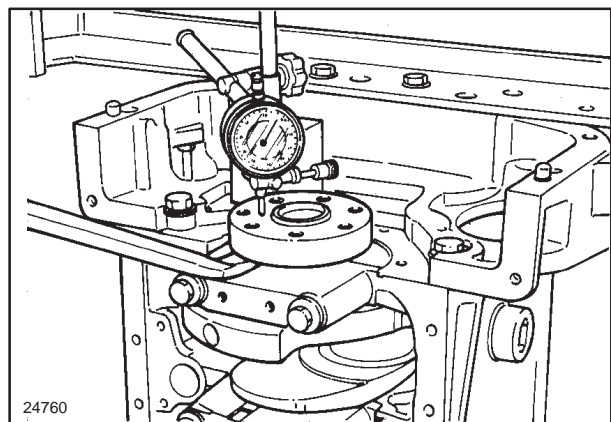

116

INSTALLING THE REAR COVER WITH SEAL, AND ENGINE FLYWHEEL (Disassembly operation 62)

Proceed as follows:

- Fit the rear oil seal carrier (3) with the outer seal. Tighten retaining bolts (2) to the torque specified on page 24. Using a feeler gauge (1), check that the crankshaft flange is coaxial with the carrier.

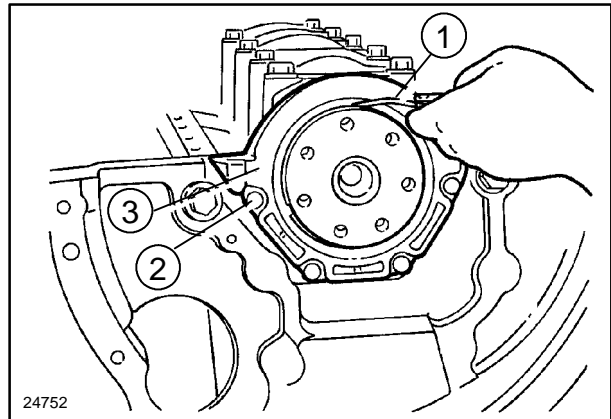

117

- Fit the inner rear oil seal using installer and hand grip 50139 (1).

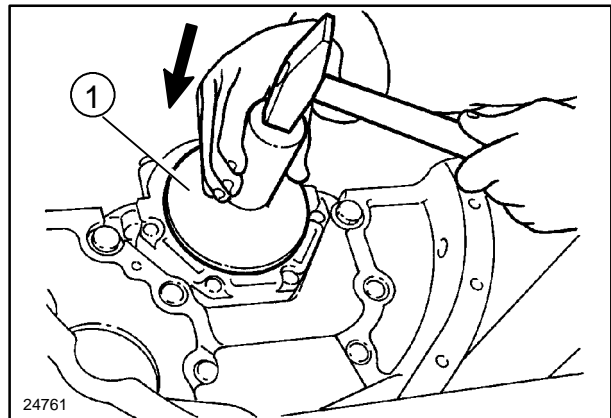

118

- Fit the flywheel and tighten the retaining bolts (1) to a torque of 40 Nm (29.5025 ft lb).

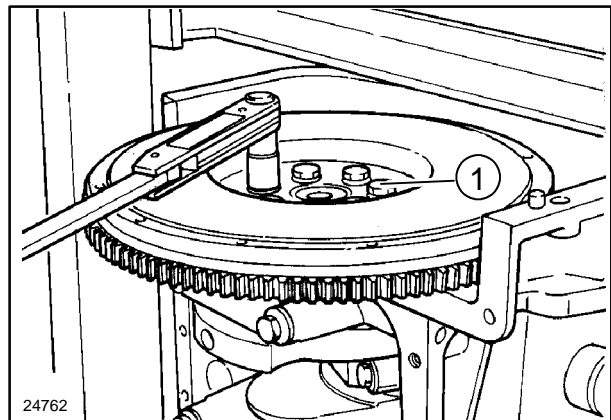

119

- Using tool 380000304 (1), tighten each flywheel bolt (2) through a further 60°.

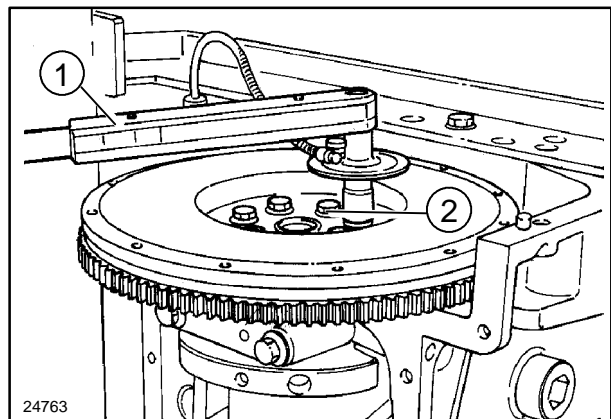

120

INSTALLING THE PISTONS COMPLETE WITH RINGS, PINS, CONNECTING RODS, BIG END CAPS AND BEARINGS – CHECKING PROTRUSION IN RELATION TO CYLINDER BLOCK FACE (Disassembly operations 59 and 60)

Proceed as follows:

- Lubricate pistons, rings and cylinder liners with engine oil prior to fitting.
- Fit the piston rings using piston ring pliers **380000221**. Make sure that the piston ring gaps are offset 180° apart.
- Fit piston ring clamp **380000220** (1) to compress the rings, making sure that the piston ring gaps remain 180° apart.
- Insert the piston/connecting rod into the cylinder liner. Ensure that the connecting rod number corresponds with the cylinder number and that the number stamped on the connecting rod is facing away from the camshaft.
- Fit the big-end caps (2) complete with shells to the crankpins and tighten the cap bolts (1) to a torque of 40 Nm (29.5025 ft lb).

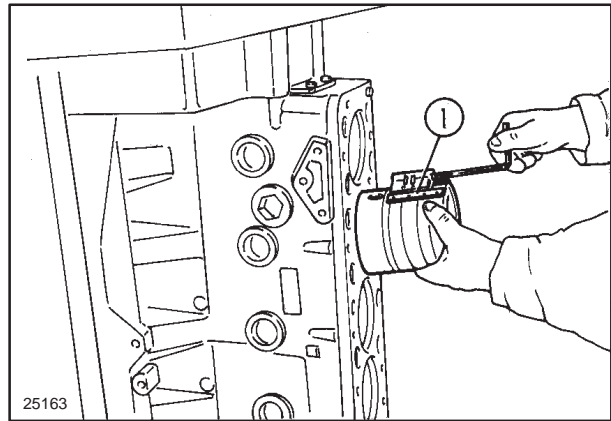

121

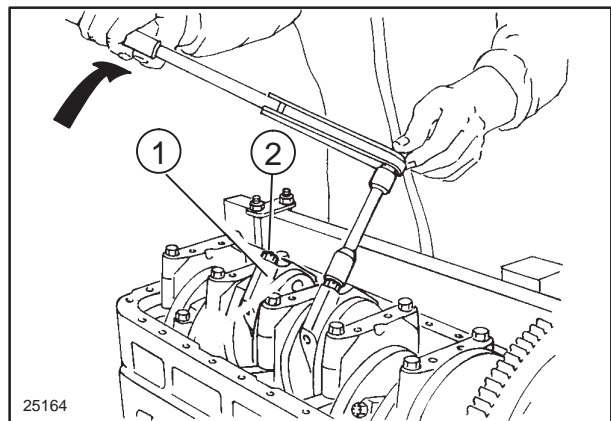

122

- Using tool **380000304** (1), tighten each big-end cap bolt (2) through a further 60°.

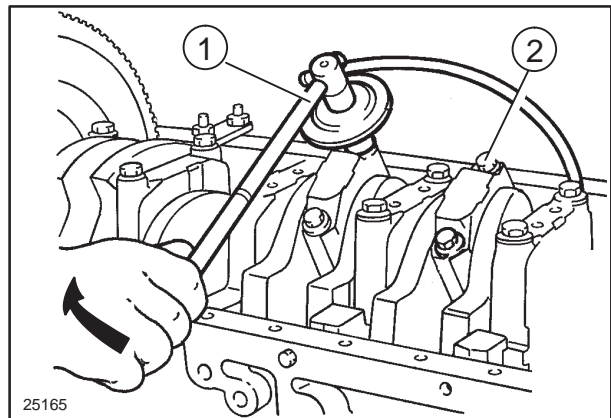

123

- Rotate the engine on the stand through 180° and clean the upper face of the cylinder block. Bring the pistons (2) up to TDC and, using a dial gauge with a magnetic base (1), check that the piston protrusion from the cylinder block face is within the tolerance limits specified on page 19.

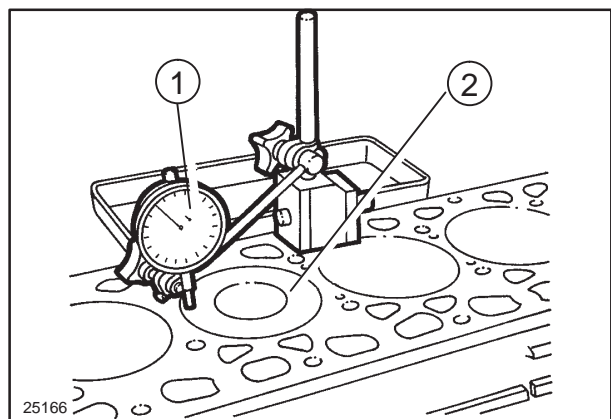

124

SYNCHRONIZING THE TIMING GEARS (Disassembly operations 51 – 55)

Proceed as follows:

- Remove the cover and gasket from the flywheel housing inspection window.

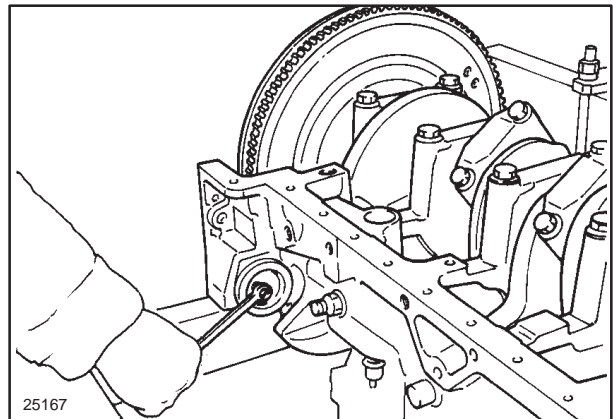

125

- The flywheel is marked in degrees BTDC. Rotate the crankshaft to bring cylinder no. 1 to TDC of the compression stroke. Look through the inspection window and check that the notch aligns with the appropriate index mark, according to the type of BOSCH pump installed on the tractor (see from page 6 to page 14).

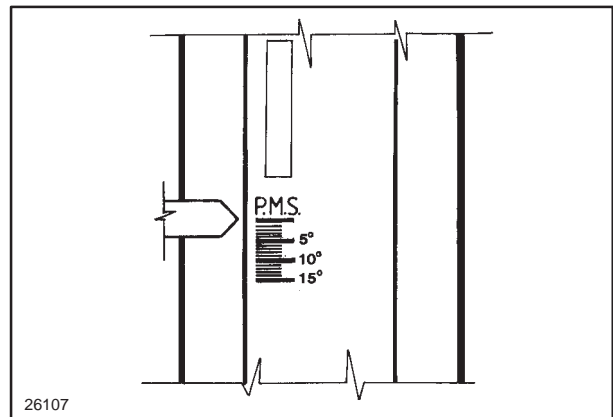

126

- Fit the timing gears making sure that the various reference marks on the mating gears (indicated by the arrows in the figure) are aligned.

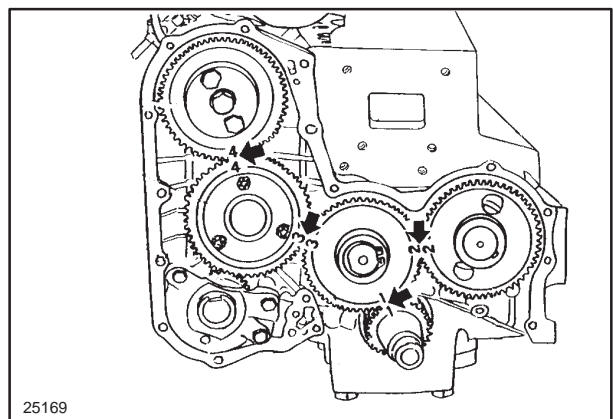

127

REFITTING THE COUNTER-ROTATING WEIGHT BOX TO THE OIL SUMP (Disassembly operation 41)

When refitting the counter-rotating weight box, synchronise as follows:

- Bring piston no. 1 to TDC.
- Position the rotating counterweights so that the timing reference marks are aligned as shown in the figure.

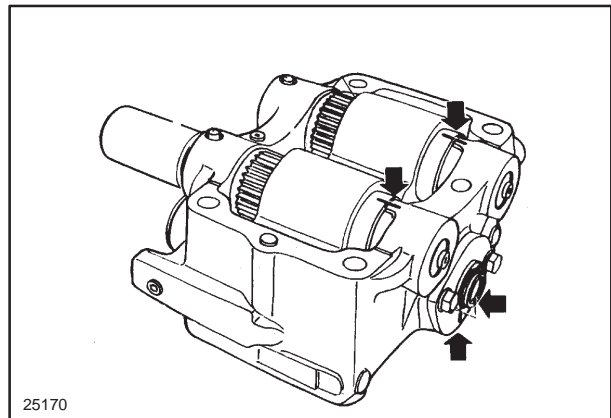

25170

128

- Turn the rotating counterweight unit over and insert the locating pin (2) in its hole. The pin serves to hold the counterweights in the correct timing position during installation of the unit.
- Using the hoist and a lifting chain, lower the counterweight unit onto its seating in the sump.

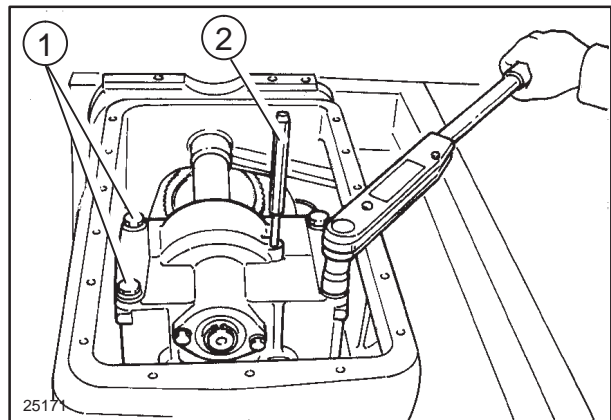

25171

129

- Slide the coupling sleeve (1) over the splines of the counterweight drive gear as shown in figure 85.
- Slide the other end of the coupling sleeve (1) over the splined shaft of the counterweight drive gear, so that the master spline in the sleeve coincides with the master spline (3) on the shaft (2).
- Tighten the dynamic balancer housing retaining bolts (1) fig. 129 to the torque specified on page 24.

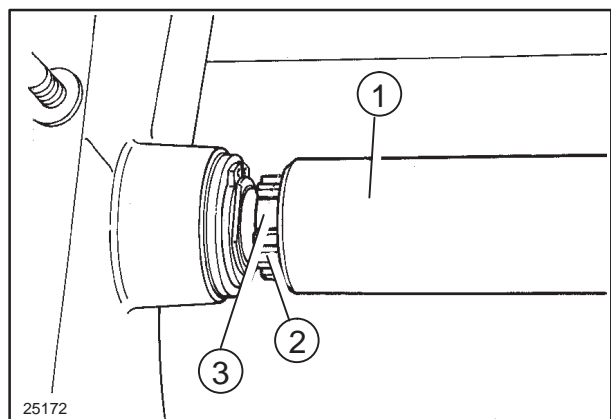

25172

130

REFITTING THE BOSCH INJECTION PUMP (Disassembly operations 23 – 26)

- Fit the BOSCH injection pump and proceed with the injection pump timing in the manner described on pages 121 to 124.

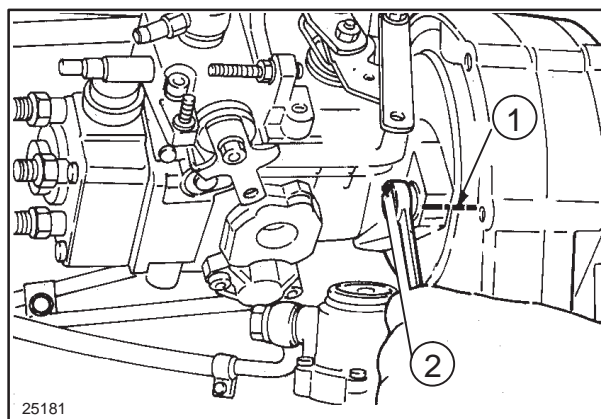

131

FITTING THE CYLINDER HEAD GASKET (Disassembly operation 38)

Proceed as follows:

- Before fitting the cylinder head, carefully clean and degrease the mating surface of the cylinder block. Locate a new cylinder head gasket (1) with the word **ALTO** uppermost.

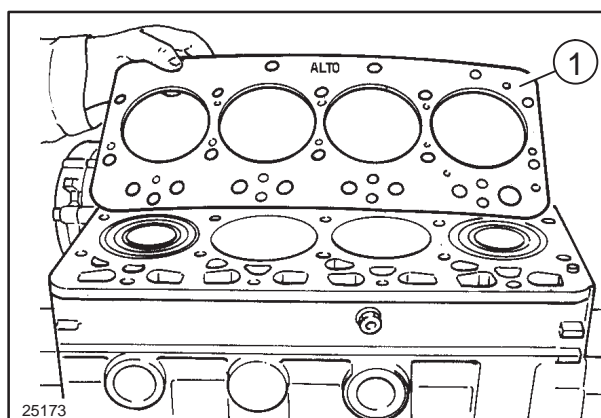

132

FITTING AND TIGHTENING THE CYLINDER HEAD (Disassembly operation 37)

Proceed as follows:

- Lower the cylinder head onto the block and screw in the cylinder head bolts (1) fig. 135, finger tight.
- fig. 133 – Tightening sequence for cylinder head bolts on 3–cylinder engines to be followed for each of the four tightening stages (A = fan end).

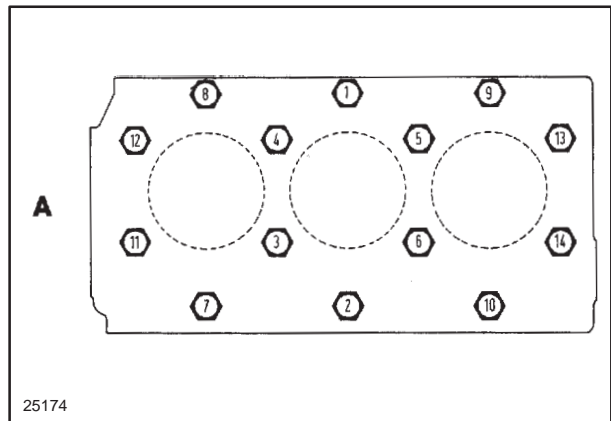

133

- Fig. 134 – Tightening sequence for cylinder head bolts on 4–cylinder engines to be followed for each of the four tightening stages (A = fan end).

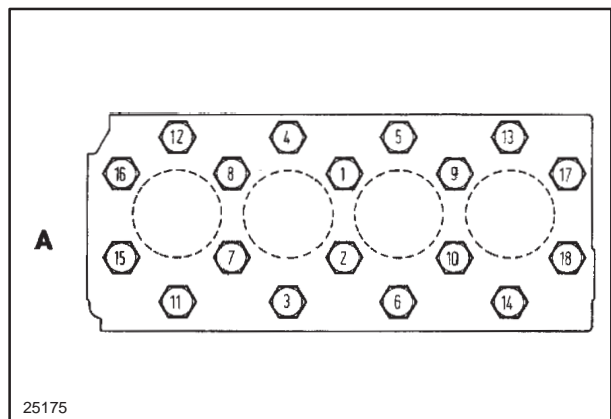

134

- First phase – Tighten the bolts (1) to a torque of 70 Nm (51.6293 ft lb) in the sequence shown in the above figures (fig. 133/134).
- Second phase – Recheck the torque of all the bolts in the sequence indicated above (fig. 133/134).

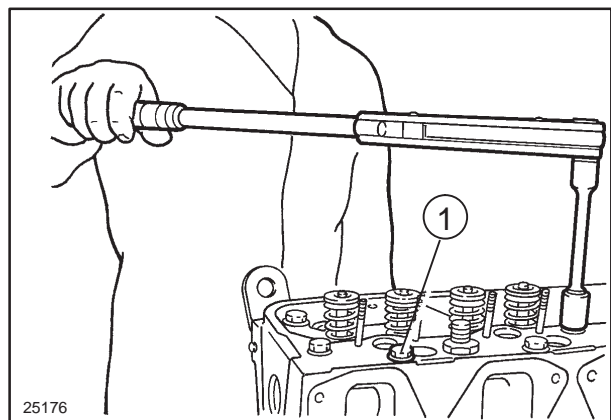

135

99. Using the angular tightening tool **380000304** (1), tighten each bolt (2) in sequence through 90° (third phase) and then through a further 90° (fourth phase) in the sequence indicated above (figures 133/134).

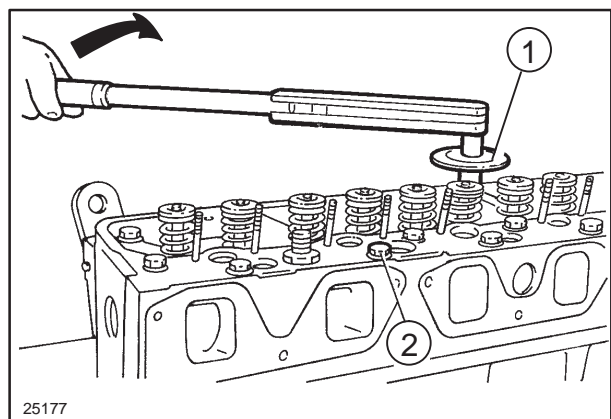

136

ADJUSTING VALVE/ROCKER ARM CLEARANCE (Disassembly operation 34)

- Before refitting the rocker cover, adjust the valve clearances as described on pages 128 – 130.
- Tighten the rocker arm adjuster screw locknuts (1) to the torque specified on page 24.

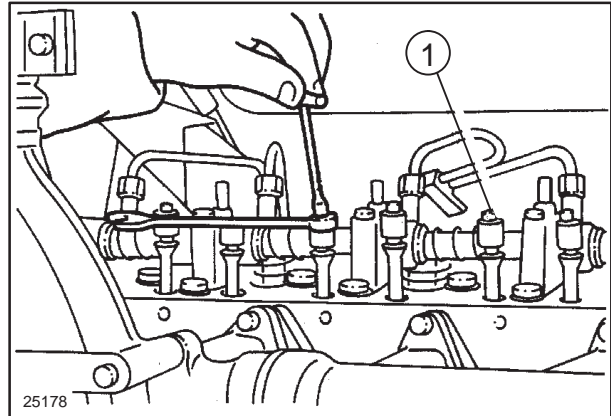

137

FITTING THE INJECTORS (Disassembly operation 33)

Proceed as follows:

- Insert the injectors (2) in their respective bores.
- Position the injector support brackets and fit the spherical washers.
- Screw the bracket retaining nuts (1) up to the spherical washers, then tighten to the torque specified on page 24, in two stages:
first stage – tighten nuts to 10 Nm (7.3756 ft lb);
second stage – tighten nuts to 25 Nm (18.4390 ft lb).
- Tighten the leak-off pipe unions.
- Tighten the high-pressure fuel line unions.

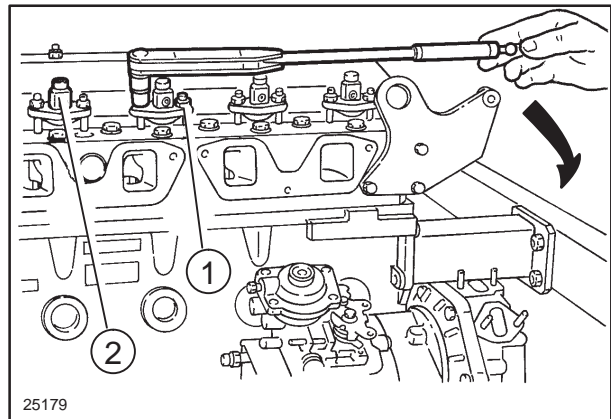

138

ADJUSTING COOLING SYSTEM BELT TENSION (Disassembly operations 3 – 6)

NOTE: Tension the belt correctly as described on page 102.

CHECKS, MEASUREMENTS AND REPAIRS – CYLINDER BLOCK and CYLINDER LINERS



WARNING



Handle all parts carefully. Do not put your hands or fingers between parts.

Wear suitable safety clothing, safety goggles, gloves and footwear.

Clean all parts carefully before proceeding with the operations described below.

NOTE: Cylinder liner dimensions must only be measured when the liner is installed in the cylinder bore as they are subject to deformation when not fitted.

Check liner wear as follows:

- measure the inside diameter in the area swept by the piston rings X (fig. 141);
- measure the inside diameter at the upper and lower ends of this area both parallel to the crankshaft centre line (a) and at right angles to the crankshaft centre line (b);
- compare measurements thus obtained to determine liner ovality and taper.

To check piston running clearance, measure the inside diameter of each liner in the area Z (fig. 141) along the axis at right angles to the crankshaft centre line.

If the bore is out of round or tapered by more than 0.12 mm (0.0047 in.) or the piston clearance exceeds 0.3 mm (0.0118 in.), it is necessary to re-bore and re-grind (or perhaps replace) the liners, taking them to one of the sizes specified in the chart on page 16.

Then pair up the cylinder liners with the pistons of the same dimensions (see page 19).

NOTE: If one of the liners requires reboring, **all** the liners in the engine must be rebored to the same oversize.

After reboring, the 0.5 mm (0.0197 in.) 30° chamfer must be restored on the liner (1).

In case of replacement, remove and install the liners in cylinder block cold using a press as follows:

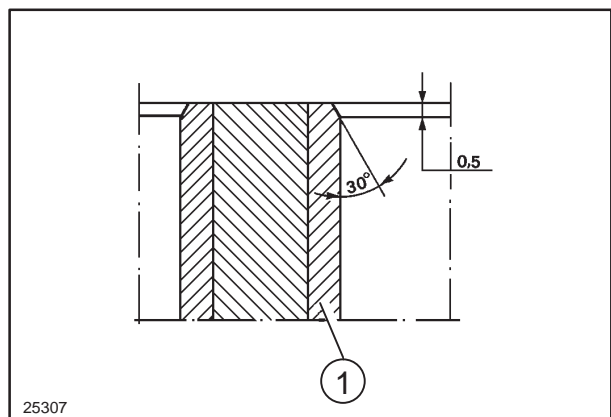

- Press the worn liner out of the block, operating from the bottom of the crankcase, using a stepped plate of appropriate diameter.
- Check the ovality of the bore in the block and rebores if necessary to 0.22 mm (0.0087 in.) oversize.
- Press-fit the new liner (0.22 mm (0.0087 in.) oversize if necessary) from the top of the block, using the stepped plate referred to above.
- Rebores and ream the liner to the specified inside diameter (see page 16).

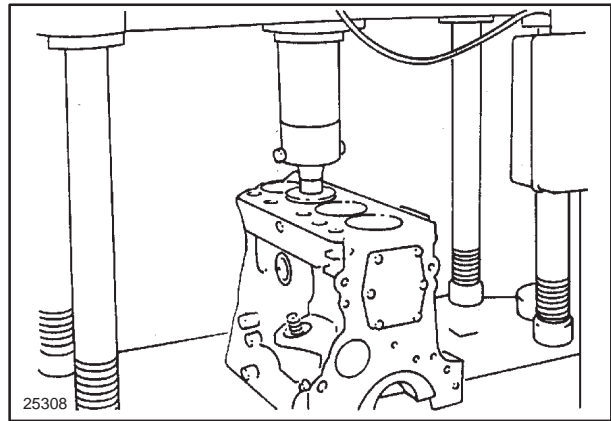

140

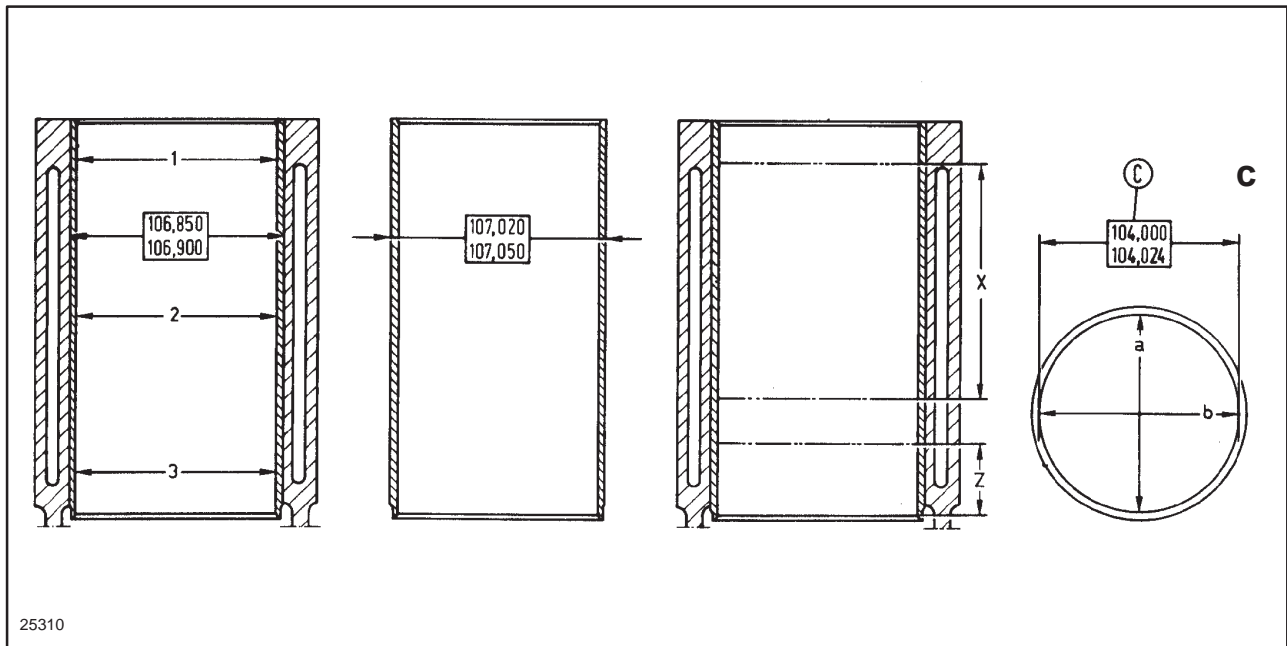

141

Standard dimensions (mm) of cylinder liners and bores in cylinder block and positions for checking liner wear.

- a,b. Position of dial gauge to measure liner inside diameter.
- c. TD70D, TD90D and TD95D Models.
- C. Dimension to achieve after press-fitting and reaming of liner.
- Z. Area for measurement of inside diameter of used liner to determine piston running clearance (measured along axis b at right angles to crankshaft).

- X. Area for measurement of inside diameter of worn liner (area swept by piston rings) to determine ovality and taper (measure along axes a and b, respectively parallel and at right angles to crankshaft).

- 1,2,3. Points at which to measure inside diameter of new or rebored liners along axes a and b.

**CHECKS, MEASUREMENTS AND REPAIRS –
CRANKSHAFT, MAIN BEARINGS AND FLYWHEEL**



WARNING:

Handle all parts carefully. Do not put your hands or fingers between parts. Wear suitable safety clothing, safety goggles, gloves and footwear.

Crankshaft

Clean parts carefully before proceeding with operations described below.

Carefully inspect the crankshaft. Any cracks, even minor ones, will necessitate replacement of the crankshaft.

Inspect the crankshaft journals and crankpins; slight scoring or seizure marks can be removed with very fine grade emery cloth.

If scoring, ovality or taper exceeds 0.05 mm (0.002 in.), the crankshaft will have to be reground. Measure journal diameter, fig. 142 to determine the nearest undersize (see page 17).

After regrinding, restore the journal and crankpin radii and fillets as shown in the details in fig. 143 and check that:

- main bearing journal and crankpin ovality does not exceed 0.008 mm (0.0003 in.);
- main bearing journal and crankpin taper does not exceed 0.01 mm (0.0004 in.);

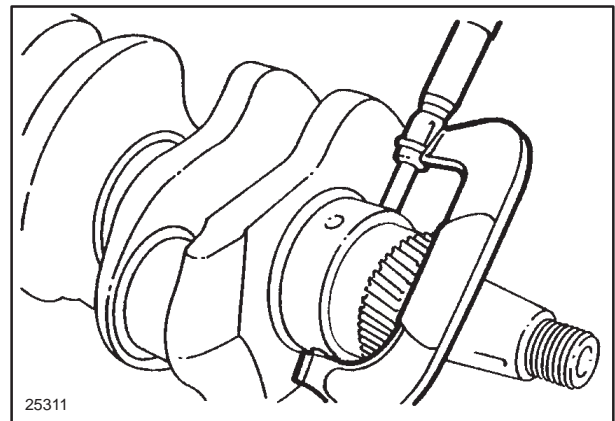

142

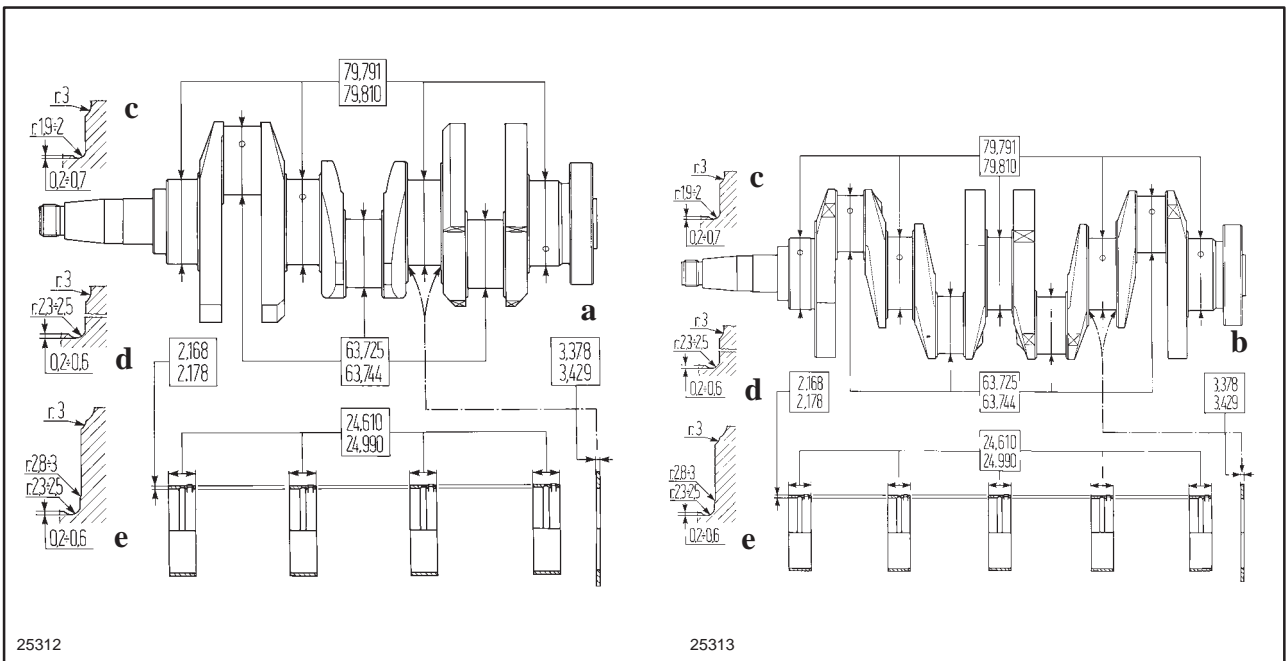

143

Standard dimensions (mm) of main bearing journals and crankpins, main bearings and semi-circular thrust washers.

- a. TD60D and TD70D models.
- b. TD80D, TD90D and TD95D models.
- c. Crankpin radii and fillets.
- d. Normal crankshaft journal radii and fillets.
- e. Radii and fillets of crankshaft journal with thrust washers.

- with the crankshaft resting on parallel gauge blocks, the maximum misalignment of the main bearing journals does not exceed 0.10 mm (0.004 in.) (D) fig. 161;
- the centrelines of the crankpins (mod. TD70D) or of each pair of crankpins (TD70D, TD80D, TD90D and TD95D models) lie in the same plane as the main journal centrelines, with a maximum deviation of ± 0.25 mm (0.0098 in.) as measured perpendicularly to the same plane (see fig. 143);
- the distances between the outer surfaces of the crankpins and the crankshaft centreline are equal with a tolerance of ± 0.10 mm (0.004 in.);
- the run-out measured with the dial gauge contact point resting on surface (A) or (B), fig. 144, does not exceed the measurement given in the chart on page 18;
- the oil plugs seal against an oil pressure of 14.7 bar (213.2 psi);
- if new plugs are fitted, punch-lock in position and re-check oil tightness with the system pressurised.

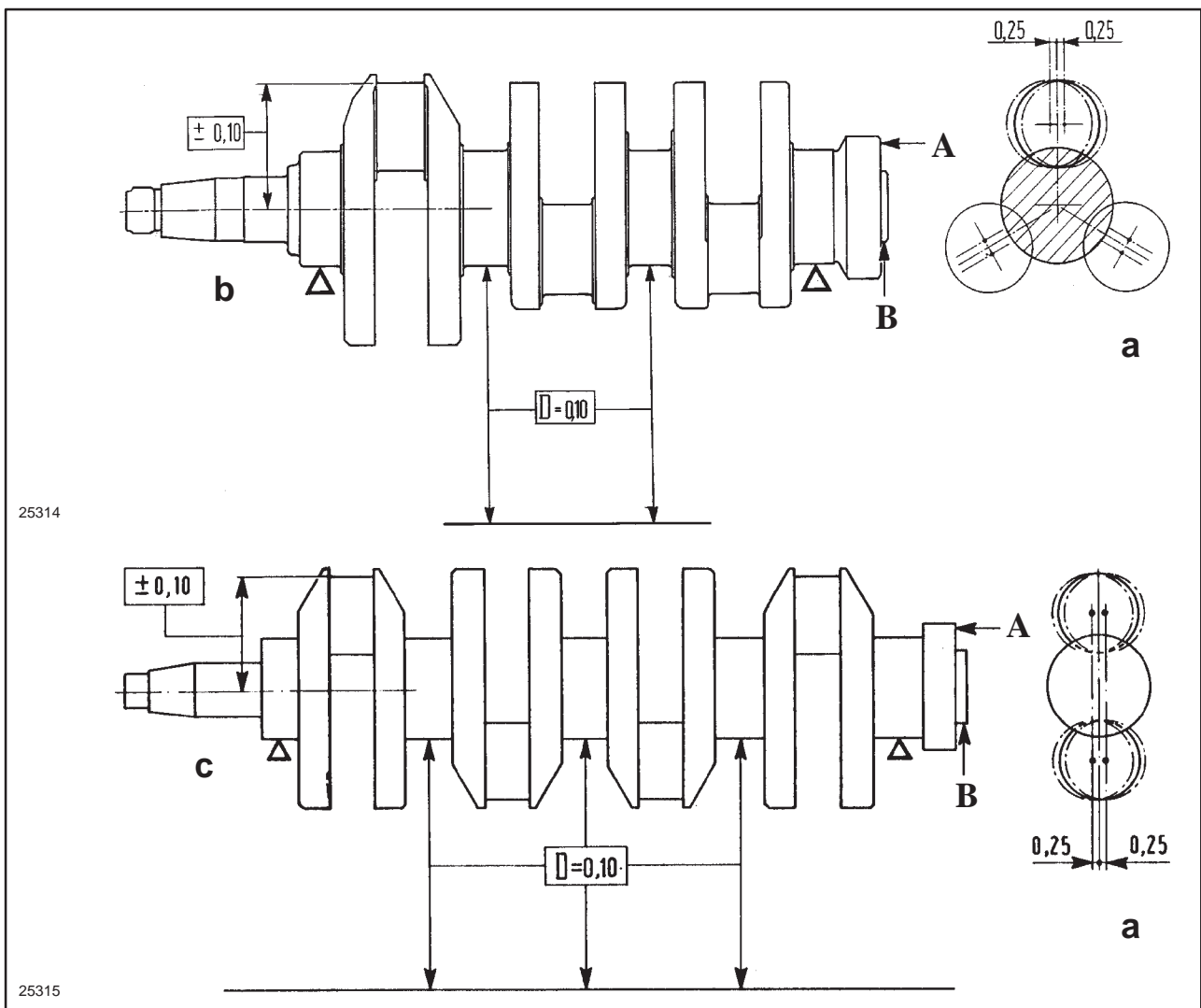

144

Maximum tolerances for alignment of main bearing journals and crankpin relative to crankshaft centreline and alignment of crankpins relative to main bearing journals (a)

- b. TD60D and TD70D models
- c. TD80D, TD90D and TD95D models
- A. and B. Dial gauge contact point positions for checking run-out of flywheel mounting flange.

- D. Maximum permissible main bearing journal alignment deviation

Bearings

Check the clearance between the crankshaft journals and bearing shells using a calibrated wire gauge as follows:

- make sure that all parts are perfectly clean and remove all traces of oil;
- locate the half-shells in their respective seats (5);
- install the crankshaft;
- position lengths of calibrating wire (6) on the crankshaft journals (4) corresponding with the crankshaft centreline.
- fit the caps (1) complete with half-shells (2) to the respective journals;

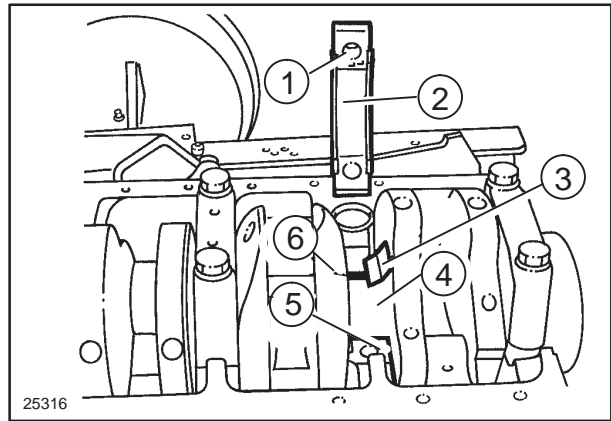

145

- lubricate the bolts (4, fig. 3 and 5) securing the main bearing caps with engine oil and tighten them to the prescribed torque using a torque wrench (see page 24);

Main bearing cap bolts (4, figs. 3 and 5)

If the bolts are to be re-used, check that diameter d (measured in area "a" shown in fig. 146) is greater than 13.5 mm (0.5315 in.). If not, replace the bolts.

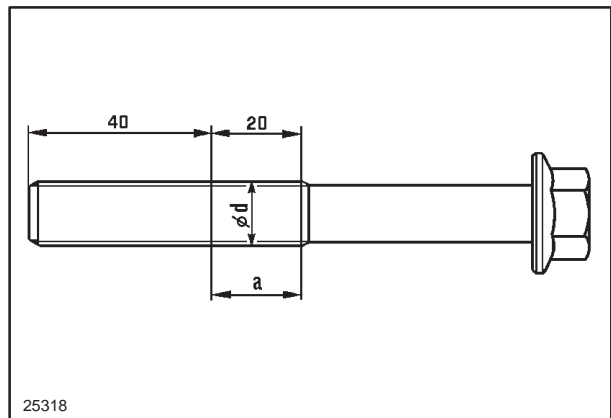

146

- remove the caps and determine the bearing clearance by comparing the width of the calibrating wire at the widest point against the scale printed on the packet (3) fig. 145, containing the wire;
- after refitting the crankshaft and the bearing caps and bolts, check crankshaft endfloat about the penultimate bearing with a dial gauge (1);
- if the endfloat exceeds the specified value (see page 17), replace the existing thrust washers with oversized ones.

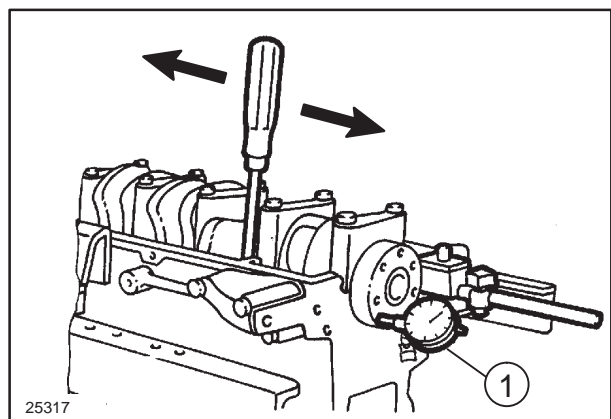

147

Flywheel

The flywheel is fixed to the crankshaft flange by means of self-locking bolts. The starter ring gear is shrunk-fit, after pre-heating, to the register on the engine side of the flywheel.

If the ring gear is to be replaced, heat in oil to 80° to 90° C (176° to 194° F) before fitting and position with the bevel on the teeth facing inward towards the starter motor.

The flywheel mounting holes are offset so that the flywheel can only be mounted in one position.

NOTE: To regrind the flywheel, see section 18, page 25.

- lubricate the screws securing the engine flywheel with engine oil, then tighten them to the prescribed torque (see page 24) using a torque wrench.

Flywheel bolts (3, figs. 3 and 5)

If the bolts are to be re-used, check that diameter d (measured in area "a" shown in figures 148 and 149) is greater than 13.5 mm (0.5315 in.). If not, replace the bolts.

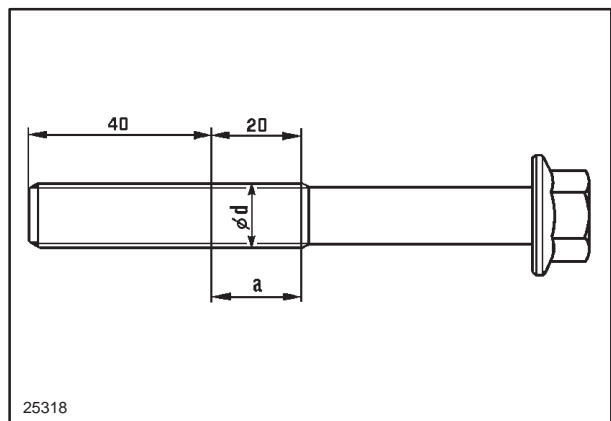

25318

148

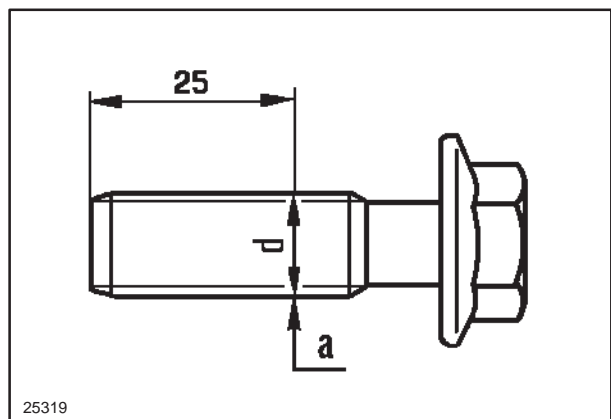

25319

149

CHECKS, MEASUREMENTS AND REPAIRS – CONNECTING RODS

CAUTION

Handle all parts carefully. Do not place hands or fingers between one part and another. Wear the recommended safety clothing such as goggles, gloves and safety boots.

Clean all parts carefully before carrying out the following operations.

Check that the bushings in the connecting rod small ends are tight in their bores and are flush with the sides of the rods.

If necessary, replace the bushings and ream after fitting to the specified diameter (A) shown in the drawing.

Dimensions (mm) of standard connecting rods, bearing shells, bushings and gudgeon pins.

A = Dimension required by reaming after fitting bushings – L, M = Oil ports.

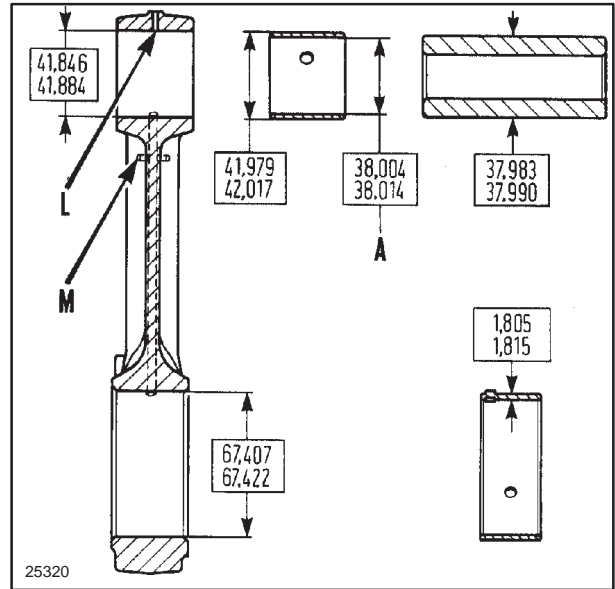

150

Check parallelism of small end and big end axes. Maximum permitted tolerance is ± 0.07 mm (0.0028 in.) measured at 125 mm (4.9213 in.) from longitudinal axis of the connecting rod.

Slightly twisted con rods can be straightened using a press. Severely deformed rods should be replaced.

New con rods must be marked with the number of the cylinder in which they are to be fitted. Check that the difference in weight of connecting rods in the same engine does not exceed 25 grams (0.0551 lb).

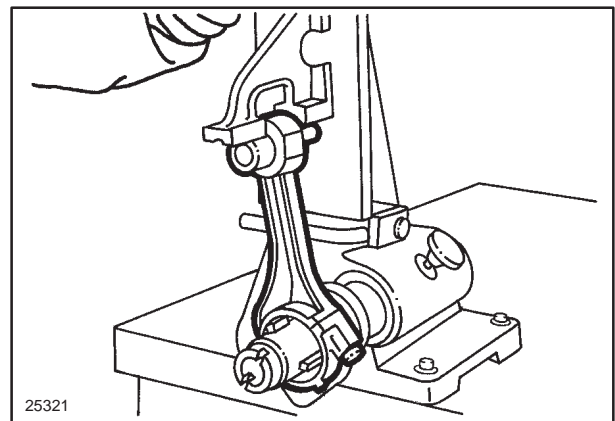

151

Also check that the oil ways (L and M) fig. 150 are not obstructed by scale or impurities.

CHECKS, MEASUREMENTS AND REPAIRS – PISTONS**⚠ WARNING ⚠**

Handle all parts carefully. Do not put your hands or fingers between parts. Wear suitable safety clothing, safety goggles, gloves and footwear.

Clean all parts carefully before carrying out the following operations.

Determine the degree of piston and liner wear in the manner described on pages 16 and 19 and the figures below.

If the piston running clearance exceeds 0.30 mm (0.0118 in.), rebore and ream the liners and fit oversize pistons and rings (see pages 16 and 19).

In case of piston replacement, check that the weight difference between pistons in the same engine does not exceed 20 grams (0.0441 lb).

Check that the piston ring groove clearance (b, fig. 152) and the end gap (c, fig. 152) are within the tolerances specified on page 19. If the end gap is less than that specified, correct by grinding the ends of the piston ring.

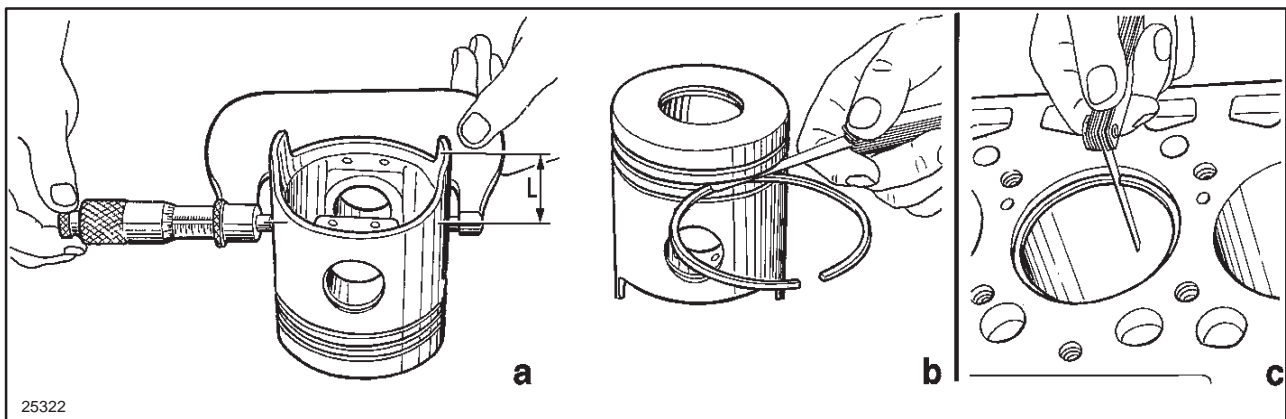
**Checking pistons and rings**

152

- a. Checking piston diameter at a distance (L) from the base of the skirt.
- b. Checking piston ring groove clearance.

- c. Checking the end gap with ring in cylinder bore.
- L. Distance from base of piston skirt: 12 mm (0.4724 in.).

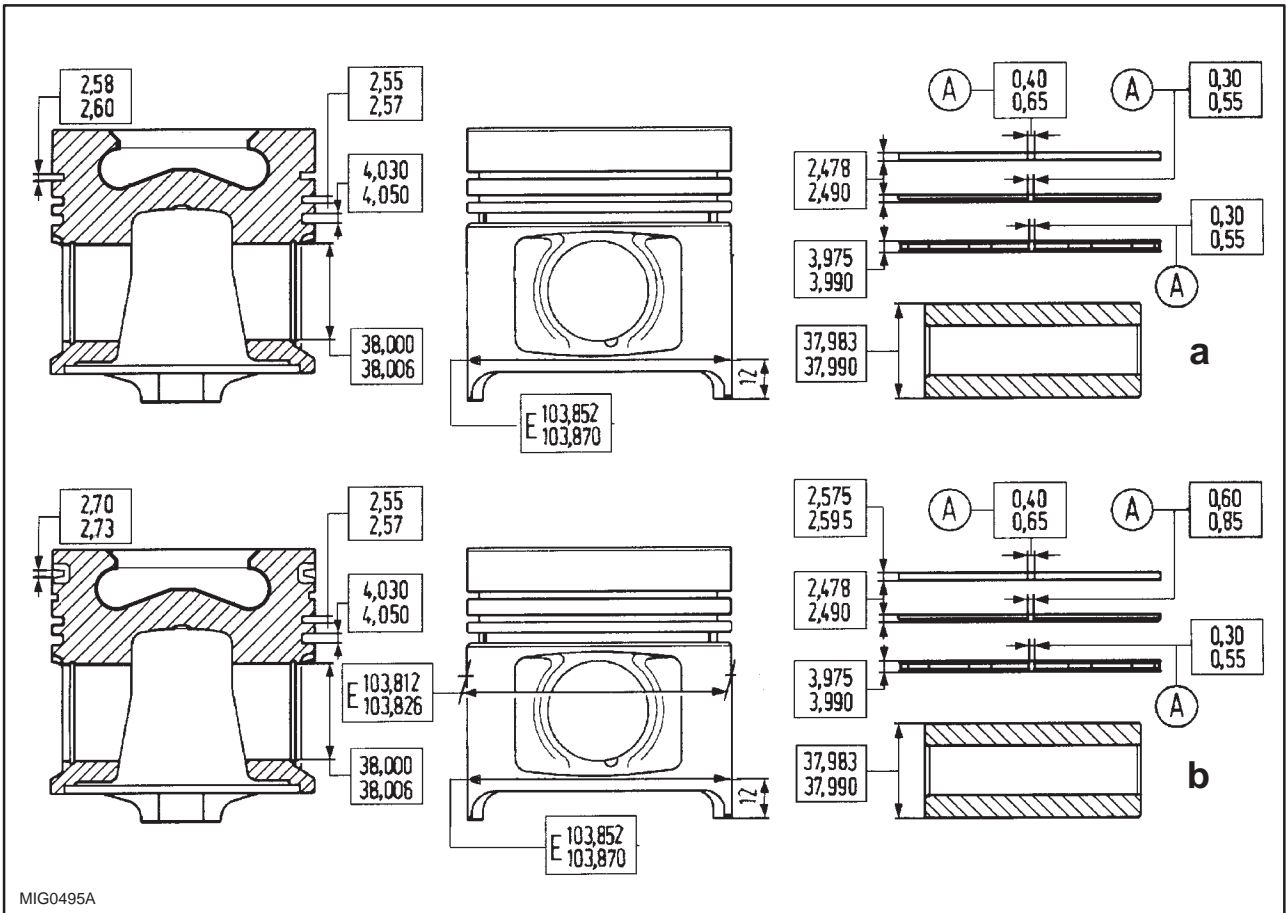

Dimensions (mm) of standard pistons, gudgeon pins and rings.

- a. TD60D and TD80D models.
- b. TD70D, TD90D and TD95D models.
- A. Measurement to be obtained with rings inserted in cylinder liners.

E Piston diameter measured at 12 mm (0.4724 in.) from the base of the skirt.

To remove or fit piston rings (1), use pliers **380000221** (2).

Fit rings in grooves in the order indicated in fig. 153.

When fitting pistons on connecting rods, check that the clearance between the gudgeon pin and its bore in the piston is within the tolerance specified on page 19.

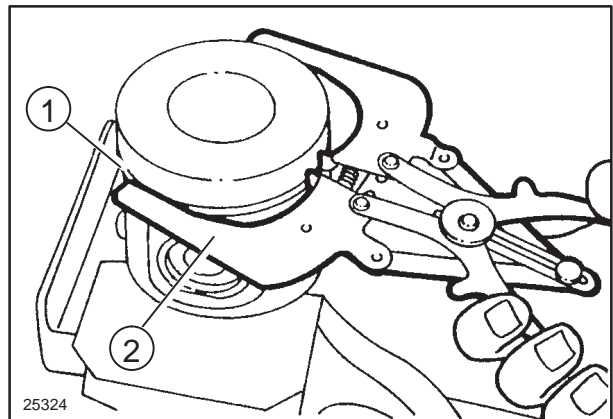

Check that the piston/connecting rod assembly is perfectly square.

If not, replace parts causing the problem.

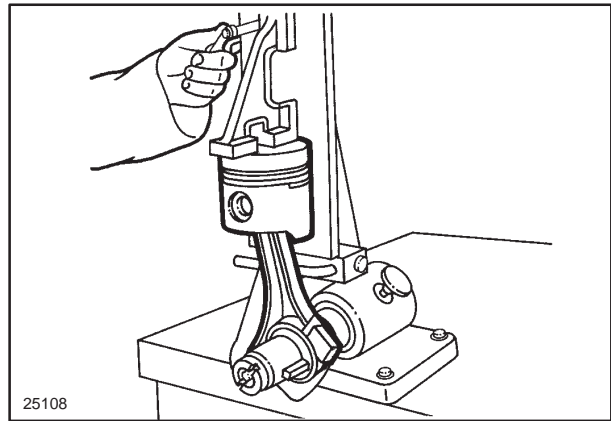

155

NOTES:

- Oil the pistons, rings and liners before inserting the pistons in their bores.
- Before fitting the ring clamp **380000220** (1) to compress the rings for insertion in the liner, check that the ring end gaps are offset by an angle of 180° i.e., opposite one another.

This will ensure better compression and better oil sealing.

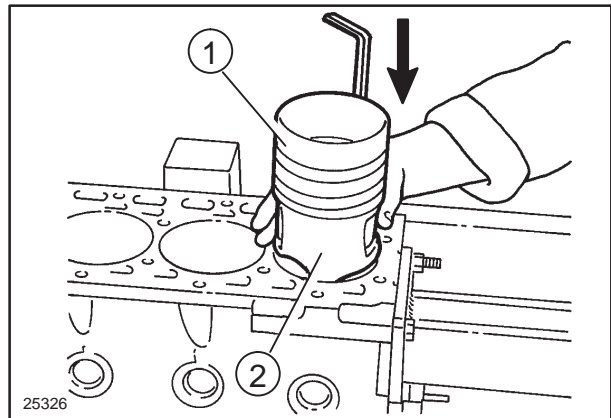

156

Big end cap bolts (5, fig. 3 and 5)

If the bolts are to be re-used, check that diameter **d** (measured as shown in the figure alongside, area a 157) is greater than 10.5 mm (0.4134 in.). If not, replace the bolts.

NOTE: It is advisable to replace the big end cap bolts each time the connecting rods are dismantled.

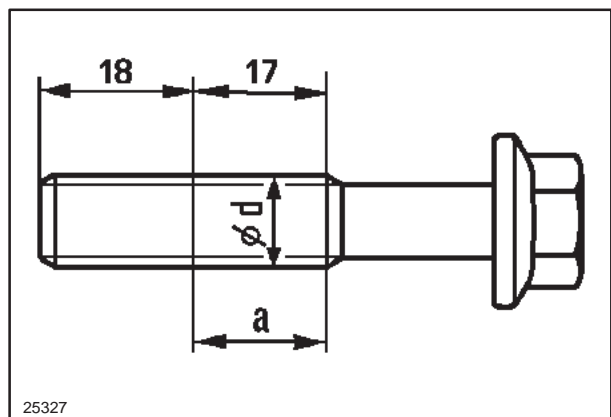

157

CHECKS, MEASUREMENTS AND REPAIRS – CAMSHAFT, TAPPETS AND VALVES

WARNING

Handle all parts carefully. Do not put your hands or fingers between parts. Wear suitable safety clothing, safety goggles, gloves and footwear.

Clean all parts carefully before carrying out the following operations.

Valves

Use tool **380000302** for valve removal and installation.

In the case of minor sealing faults, the valves and their seats in the cylinder head may be re-faced using a pneumatic grinder or universal grinder. In case of more serious defects, re-face the seats and grind the valves as shown in the relative chapter.

After grinding, check that the step below the valve contact band is no less than 0.5 mm (0.02 in.).

Dimensions (mm) of valves and valve guides

- A. Intake.
- B. Distance to be obtained by reaming fitted valve guide.
- S. Exhaust.

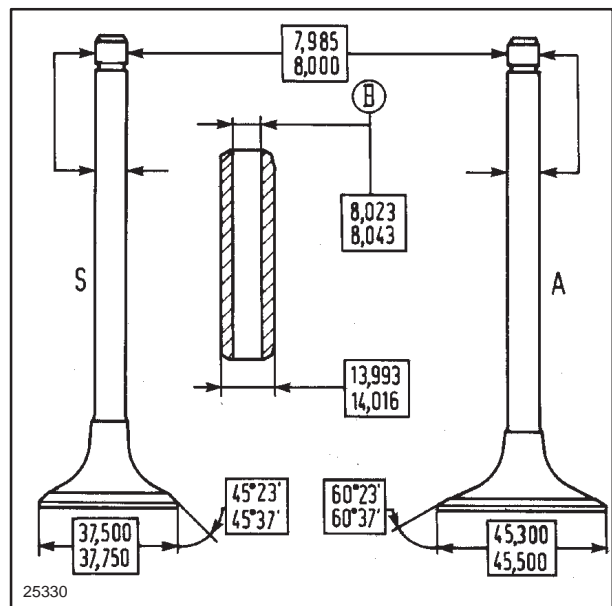

158

Tappets

Check that the tappets slide freely in their bores without excessive play.

In the case of excessive tappet-to-bore clearance, rebore the seats and fit oversize tappets (see page 20).

Pushrods must be perfectly straight, and the concave contact surface with the rocker arm adjuster screw must not show signs of seizure or excessive wear, otherwise the rod must be replaced.

In case of refacing of the contact surfaces, remove as little material as possible.

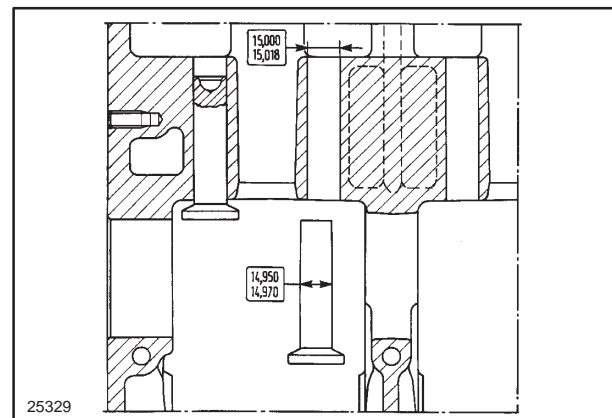

159

Camshaft

Place the camshaft on two parallel V blocks, as shown. Using a dial gauge with 1/100 mm (0.0394/3.94 in.) scale, check that journal run-out relative to the axis of rotation does not exceed 0.02 mm (0.0008 in.).

If run-out does not exceed 0.2 mm (0.0008 in.), the camshaft may be straightened using a press; otherwise replace the camshaft.

Check cam lift using a dial gauge, which should be as follows:

- inlet valves = 5.97 mm (0.235 in.);
- exhaust valves = 6.25 mm (0.2461 in.).

Replace worn bushings using suitable extractors and drifts. Ream to obtain the inside diameter indicated in figure 161.

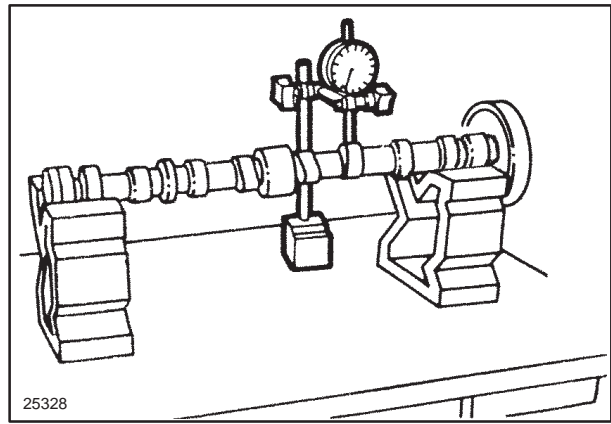

160

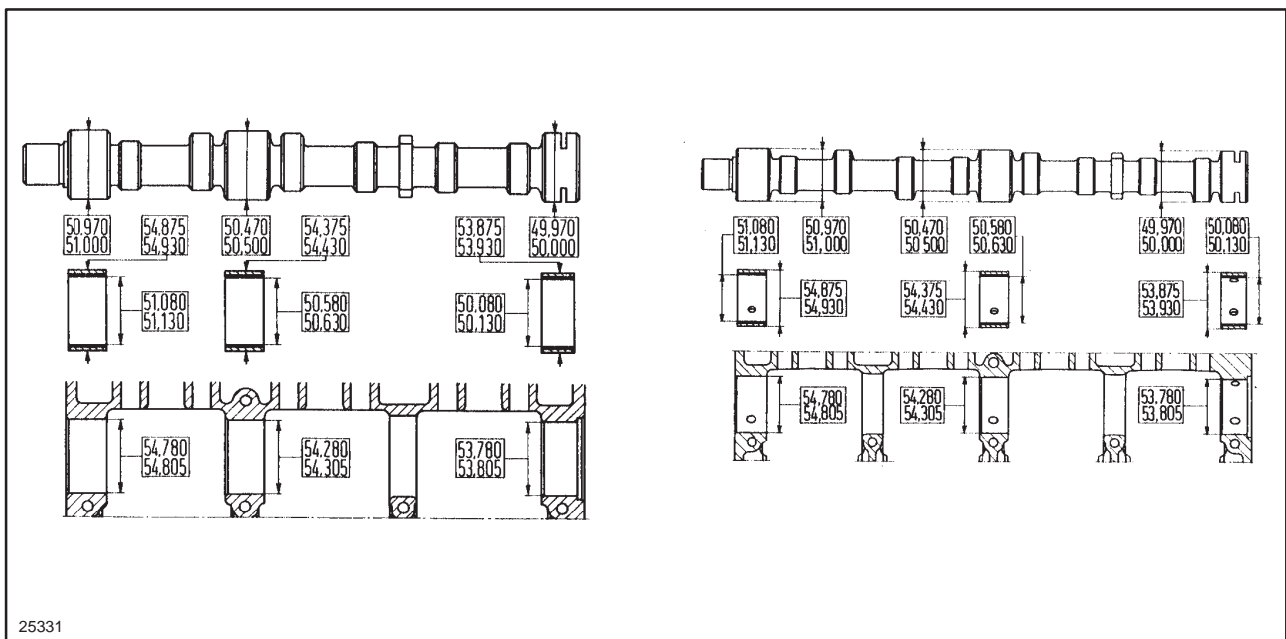

Dimensions (mm) of camshaft journals and relative seats in cylinder block.

161

a. TD60D and TD70D models.

b. TD80D, TD90D and TD95D models.

NOTE: The value indicated for the bushing inside diameter is for an installed bush.

Valve timing check

To check the valve timing after dismantling/assembly or overhaul of the valve timing gear, proceed as follows:

Check that the timing reference marks on the timing gears are aligned as indicated on page 73.

Provisionally set valve clearances to 0.45 mm (0.0177 in.).

Turn the crankshaft and, using a graduated timing disc, check that valves open and close at the angles indicated in the timing diagram.

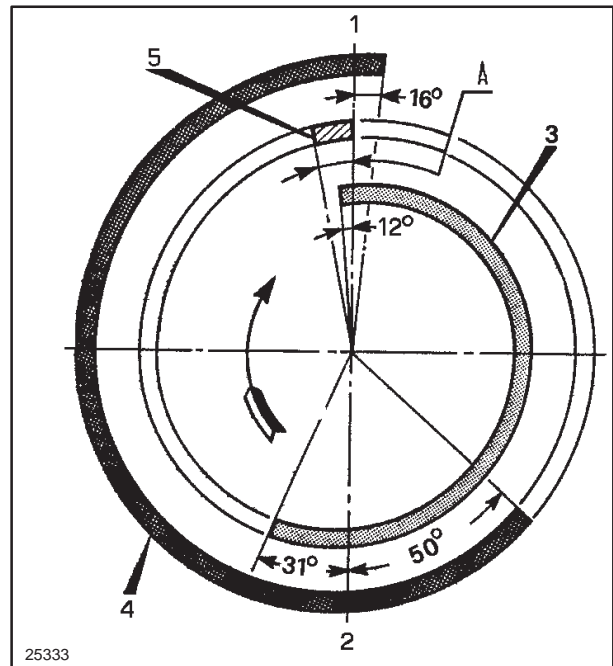

162

On completion of timing check, set the valve clearances for normal running as detailed on pages 127 to 129.

Valve timing diagram.

- A. Fixed advance (*).
- 1. TDC.
- 2. BDC.
- 3. Inlet.
- 4. Exhaust.
- 5. Injection.

(* According to pump type and engine model (see page 2).

CHECKS, MEASUREMENTS AND REPAIRS – CYLINDER HEAD

⚠ WARNING ⚠

Handle all parts carefully. Do not put your hands or fingers between parts. Wear suitable safety clothing, safety goggles, gloves and footwear.

Use valve spring compressor **380000302** to remove and refit valve springs.

Clean all parts carefully before proceeding with the operations described below.

Check that the cylinder head mating surface is flat using a straight edge (2) and feeler gauge (1).

If deviations of more than 0.15 mm (0.059 in.) are found, the head must be refaced.

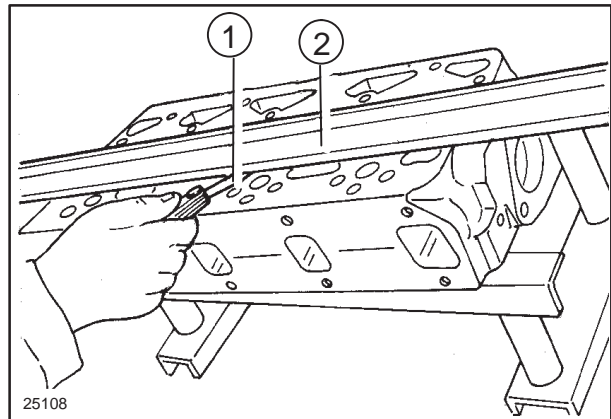

163

NOTE: Remove as little material as possible: the maximum depth of material that can be ground from the cylinder head is 0.5 mm (0.02 in.).

Using a dial gauge with magnetic base (1), check the run-out of the valve head (2) in the guide and the clearance between the valve stem and guide.

If the clearance exceeds the specified value (see page 22), replace the valve and, if necessary, the valve guide.

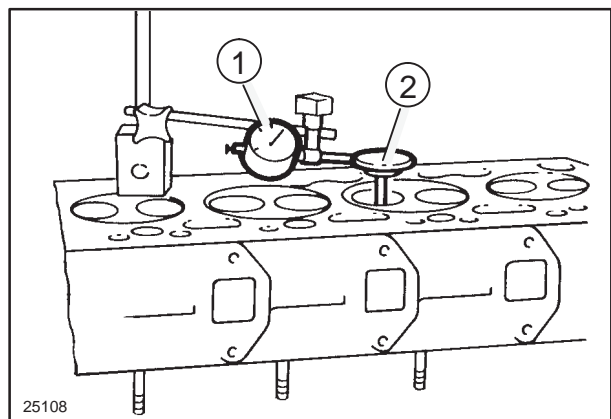

164

VALVE GUIDES**Replacement (Operation 10 101 53)****⚠ WARNING ⚠**

Lift and handle all heavy parts using suitable lifting equipment.

Make sure that assemblies or parts are supported by means of suitable slings and hooks.

Check that no one is in the vicinity of the load to be lifted.

⚠ WARNING ⚠

Always use suitable tools to align holes in parts.
NEVER USE FINGERS OR HANDS.

With the cylinder head on the test bench, proceed as follows:

1. Enlarge the bore of the valve guide to be fitted using twist drill **380000276**.
2. Place the cylinder head on a suitable support and remove the valve guide to be replaced, using drift **380000219** (1).

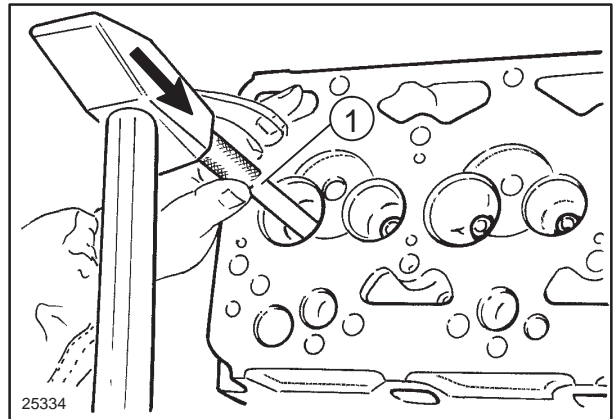

165

3. Turn the head upside down, and force fit the new valve guide with the enlarged bore using drift **380000219** (1) and bush **380000242** (2).

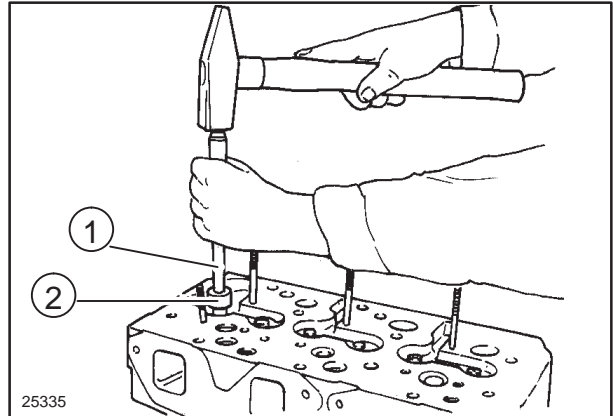

166

4. Ream out the valve guide bore (2) using reamer (1) **380000222**.

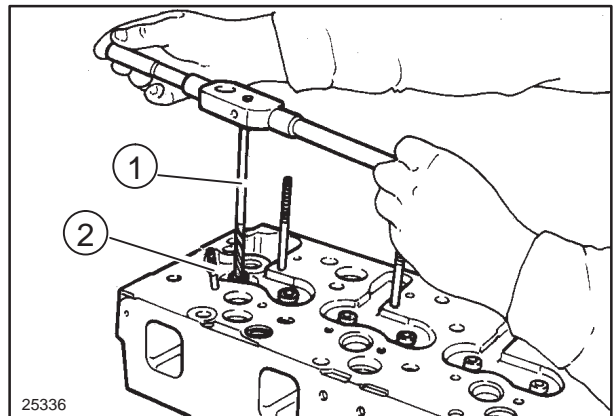

167

NOTE: When replacing exhaust valve guides you must also carry out the following further operations.

5. Measure the distance (L) between the cylinder head face and the base of the valve guide using a caliper gauge and the special plate of tool **380000277**.

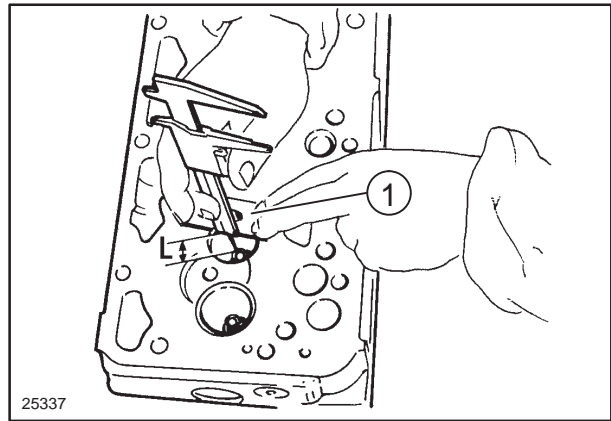

168

The depth of taper milling is given by:

$$B - L = C$$

where:

B = depth of taper relative to cylinder head face (see fig. 175).

L = distance measured between cylinder head face and valve guide base.

C = depth of taper milling.

Example (4-cylinder engine)

B = 43.1 to 43.6 mm (1.6968 to 1.7165 in.)

L = 34 mm (1.3386 in.) (distance measured).

C = (43.1 to 43.6) – 34 = 9.1 to 9.6 mm.
 ((1.6968 to 1.7165) – 1.3386 = 0.3582 to 0.3779 in.)
 Depth of taper milling.

6. From the upper side of the cylinder head, fit guide bush (1) of tool **380000277** on the guide valve to be milled (2).

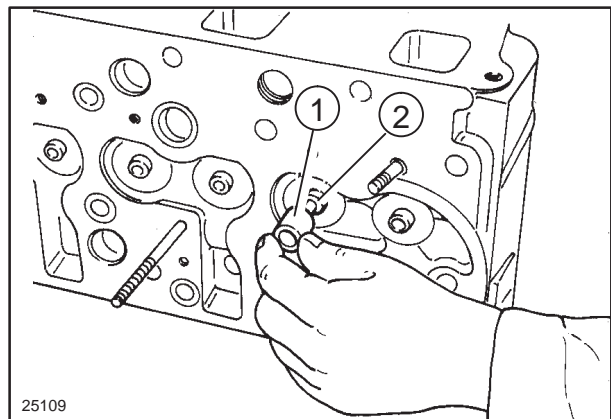

169

7. Slide the cutter (1) of tool **380000277**, complete with depth stop (2), into the previously located guide bush until the cutting head is in contact with the valve guide.

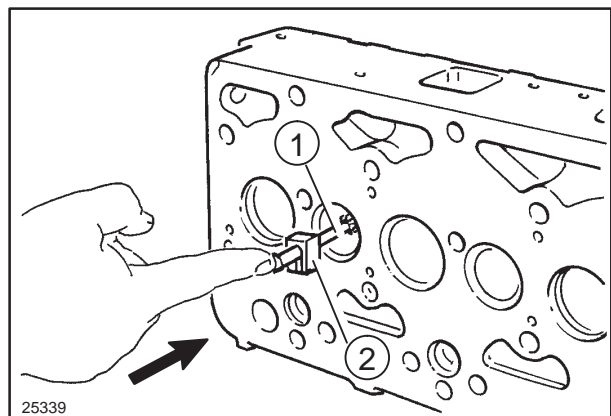

170

8. Position the plate (3) of tool **380000277** flush against the cylinder head face and slide the depth stop (2) up to the plate. Measure the distance (A) between the depth stop and the end of the cutter shank (1).

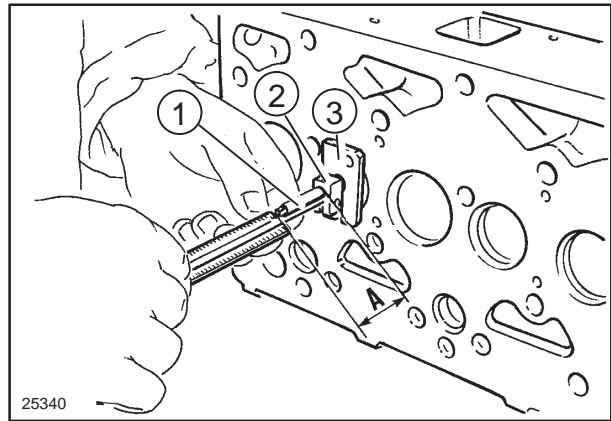

171

9. Position the depth stop (1) at a distance (D) = 35.9 to 336.4 mm (1.4134 to 13.2441 in.) from the end of the cutter shank and fix in place with its set screw.

Distance (D) is given by:

$$D = A - C$$

where:

D = the distance determining the end of the taper milling.

A = the distance between the end of the cutter shank and the depth stop, with the plate flush against the cylinder head.

C = the depth of taper milling.

Example

A = 45.5 mm (1.7913 in.)

C = 9.1 to 9.6 mm (0.3583 to 0.3780 in.)

D = 45.5 – (9.1 to 9.6) = 35.9 to 36.4 mm
(1.7913 – (0.3583 to 0.3780) = 1.433 to 1.4133 in.).

10. Turn the cutting tool (2) until the plate (3) is brought up to the cylinder head face by the depth stop (1).

NOTE: Before fitting the cylinder head, clean it thoroughly to remove all residue from the milling operation.

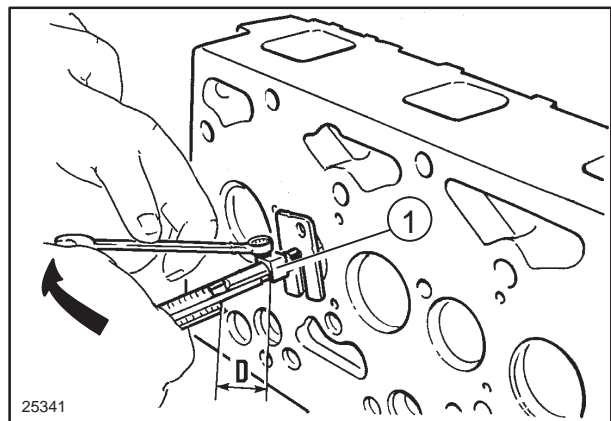

172

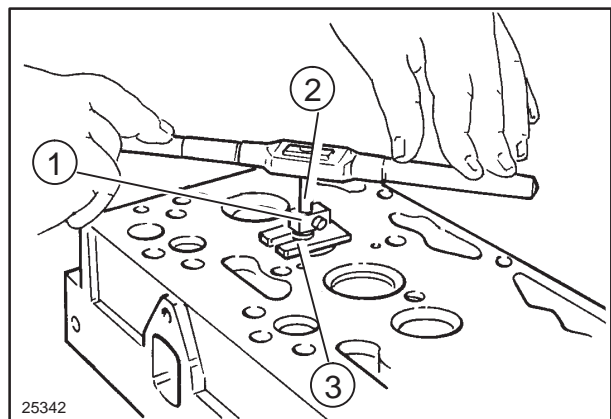

173

VALVE SEATS IN CYLINDER HEAD.**Reboring****CAUTION**

Handle all parts carefully. Do not put your hands or fingers between parts. Wear suitable safety clothing, safety goggles, gloves and footwear.

11. If the valve seats need refacing to improve valve sealing, use the universal valve grinder (1) and remove as little material as possible.

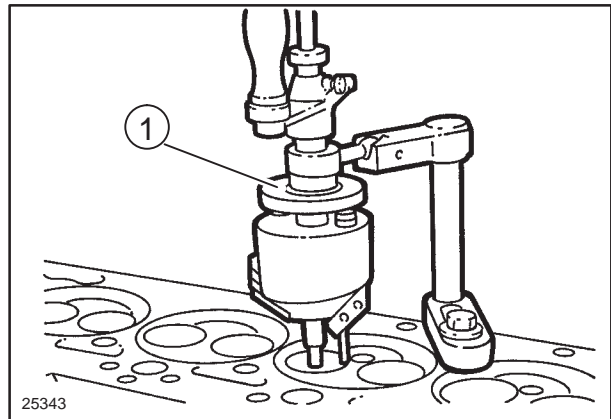

25343

174

Dimensions (mm) of valve seats and guide valves.

- A. Inlet.
 B. Depth of taper on 3 and 4-cylinder engines.
 S. Exhaust.
 C. Engines for TD60D and TD80D models.
 D. Engines for TD70D, TD90D and TD95D models

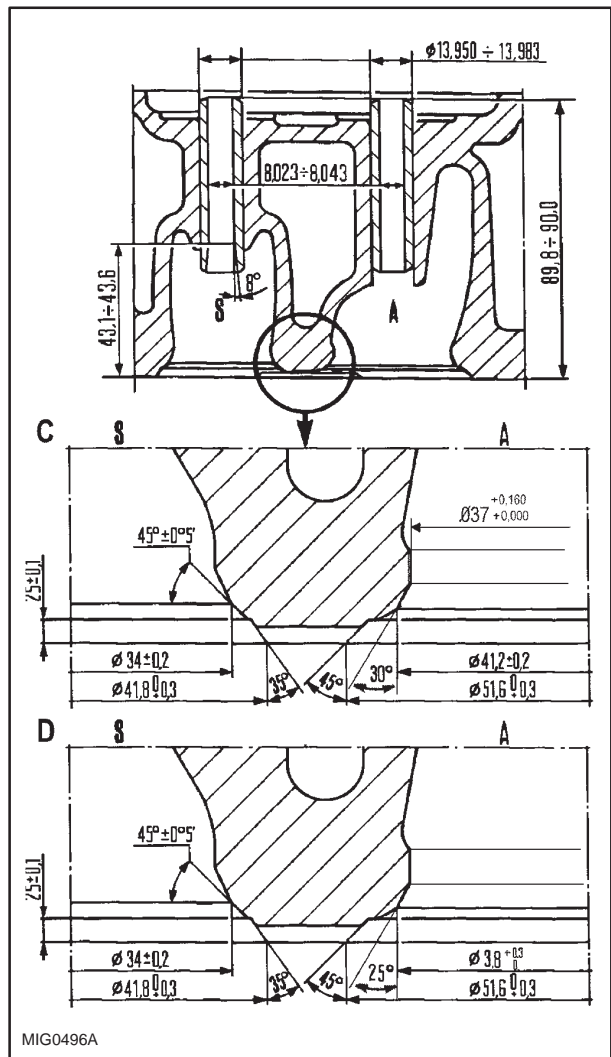

MIG0496A

175

INJECTOR SLEEVES – Replacement (Operation 10 101 60).

⚠ WARNING ⚠

Handle all parts carefully. Do not put your hands or fingers between parts. Wear suitable safety clothing, safety goggles, gloves and footwear.

1. If the cylinder head face has been reground, check that injector protrusion is within the tolerance limits specified on page 22.

Checking injector and valve height relative to the cylinder head face.

- a. Checking injector protrusion (see page 22)
- b. Checking valve stand-in: 0.7 to 1.0 mm (0.0276 to 0.0394 in.) (max. permissible stand-in = 1.3 mm (0.0512 in.)).

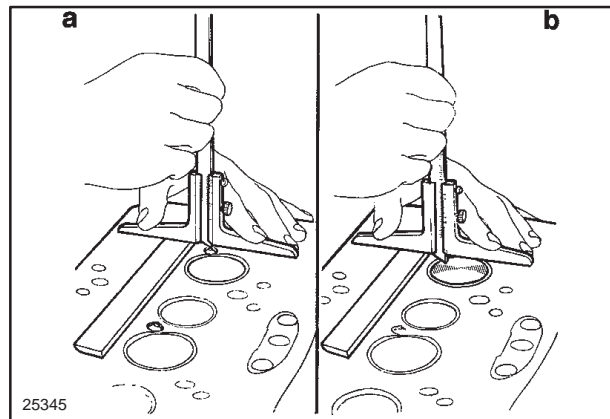

176

If injector protrusion exceeds the specified limit, replace the injector sleeve using tool kit **380000246** and proceed as follows:

2. Set distance (A) on tap (3) **380000829** to 9 mm (0.0295 in.) by means of the ring nut (5). Fix the ring nut in position by tightening the set screw (4).
3. Cut an internal thread (2) in the sleeve to be removed using tool **380000829** (M12 x 11.75) making sure that the thread is cut only in the sleeve.
4. Fit tool **380000832** (2) fig. 179 to the injector mounting studs on the cylinder head by means of the nuts (3) (M8 x 1,25).
5. Screw part (11) fig. 179) fully into the previously cut thread and turn nut (1) to withdraw the injector sleeve (12) from the head.
6. Remove any copper residue from inside the head using tool **380000370**.
7. Fit seals (6, fig.179) onto the new injector sleeve and fit the sleeve into its bore, making sure that the sleeve butts up against the bottom of the seating in the cylinder head, and dress with dressing tool **380000834** (5).

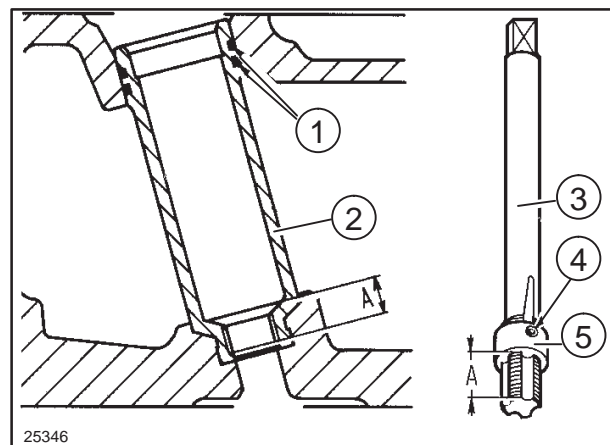

177

8. Fit guide bush **380000830** (10) fig.179 in the new sleeve (12), securing it in position by turning the ring nut (9) clockwise. Insert reamer (7) **380000831** in guide bush (10) and ream the lower part of the sleeve.
9. Remove the reamer (7) fig. 179 and back-off the ring nut (9) by about 10 mm (0.0328 in.).
10. Press by hand on the ring nut (or tap gently with a rubber mallet) to release the inside of the guide bush **380000830** (10) fig. 179.
11. Remove the guide bush, and fit the milling cutter **380000833** (8) fig. 179 in the bush. Install the bush in the sleeve (12) and fix in position by turning the ring nut (9) clockwise.
12. Work with the cutter to remove material until the seating is perfectly smooth and free from all marks.
13. This done, remove the cutter, fit the injector and check that stand-out is as specified on page 22.

Cylinder head bolts (2, fig. 3 and 5)

If the bolts are to be re-used, check that diameter **d** (measured in area **a**, as shown in fig. 178) is greater than 11.5 mm (0.0377 in.). If not, replace the bolts.

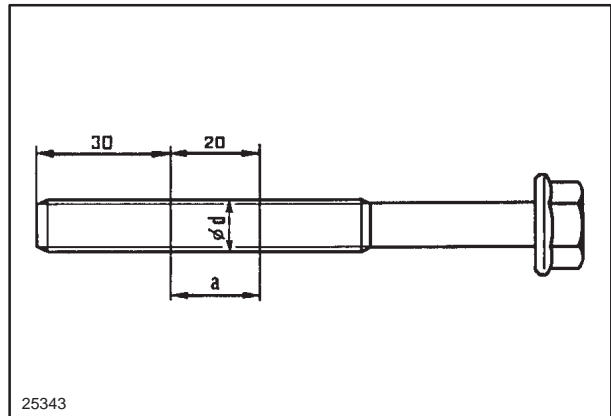

178

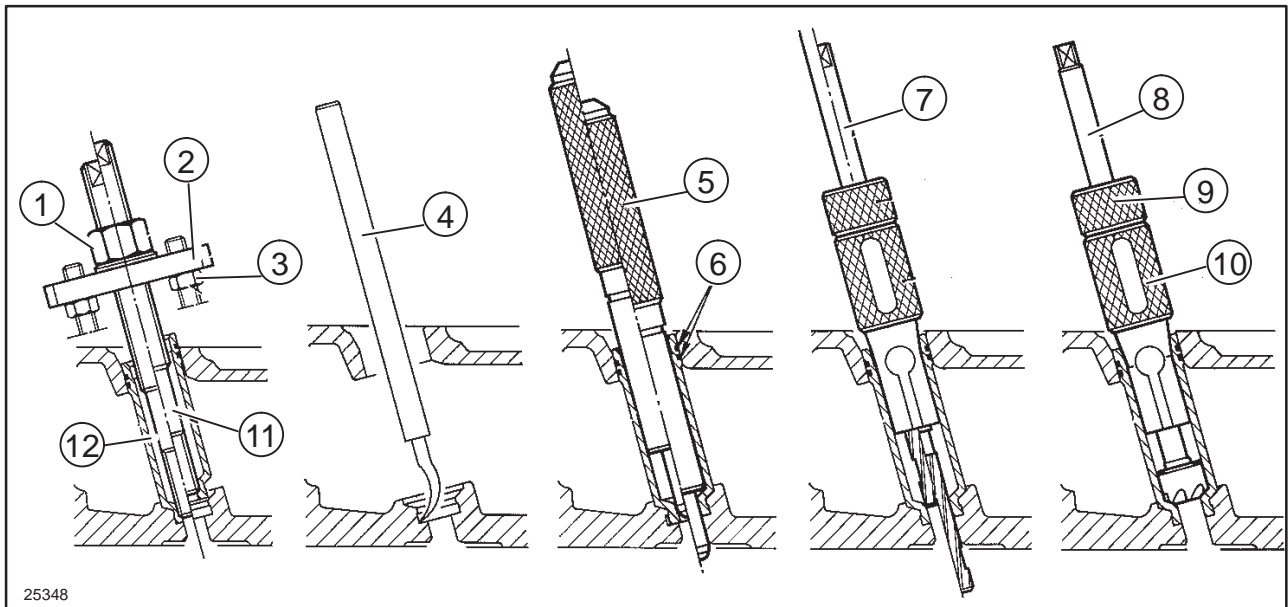

25348

Disassembly, removal of residue, installation and reaming of injector sleeve in cylinder head using tool kit 380000246.

179

- | | |
|--|-----------------------------------|
| 1, 2, and 11. Injector sleeve extractor 380000832 . | 6. O-ring seals. |
| 3. M8 x 1.25 retaining nuts. | 7. Reamer 380000831 . |
| 4. Waste removal tool 380000370 . | 8. Cutter 380000833 . |
| 5. Injector sleeve dressing tool 380000834 . | 9. Ring nut. |
| | 10. Guide bush 380000830 . |
| | 12. Injector sleeve. |

CHECKS, MEASUREMENTS AND REPAIRS – ROTATING COUNTERWEIGHT DYNAMIC BALANCER



WARNING



Handle all parts carefully. Do not put your hands or fingers between parts. Wear suitable safety clothing, safety goggles, gloves and footwear

Clean all parts carefully before proceeding with the operations described below.

Check component wear and replace any defective parts.

If the bushings of the counterweights are to be replaced, pre-heat the counterweights in oil to a temperature of 140° to 160° C (284° to 320° F) (or dip the bushings in nitrogen) before shrink-fitting in their bores.

Ream the new bushings after fitting using a reamer with expanding cutters to the inside diameter specified in the table on page 21.

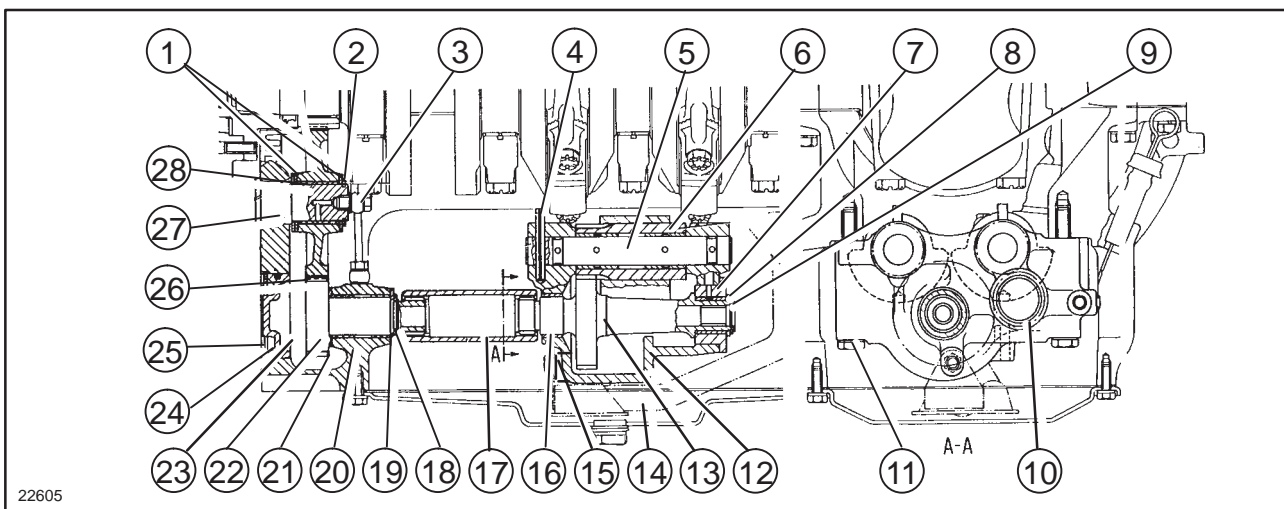

Cross-sectional view of rotating counterweight dynamic balancer.

180

- | | |
|---|--|
| 1. Thrust washers. | 15. Mesh filter retaining bolt. |
| 2. Circlip. | 16. Bushing. |
| 3. Bushing lubrication tube. | 17. Sleeve coupling. |
| 4. Rotation shaft for counterweight (8). | 18. Circlip. |
| 5. Retaining spring pin for shaft (4). | 19. Thrust washer. |
| 6. Carrier for counterweight drive gear (13). | 20. Carrier for gear (22). |
| 7. Thrust washer. | 21. Thrust washer. |
| 8. Counterweights. | 22. Drive box gear for dynamic balancer. |
| 9. Counterweight intermediate gear. | 23. Cover. |
| 10. Circlip. | 24. O-ring seal. |
| 11. Bolts securing balancer housing to sump. | 25. Circlip. |
| 12. Dynamic balancer housing. | 26. Intermediate gear. |
| 13. Counterweight drive gear. | 27. Rotation shaft for intermediate gear (26). |
| 14. Mesh filter. | 28. Bushing. |

CHECKS, MEASUREMENTS AND REPAIRS – LUBRICATION SYSTEM



WARNING



Handle all parts carefully. Do not put your hands or fingers between parts. Wear suitable safety clothing, safety goggles, gloves and footwear.

Clean all parts carefully before proceeding with the operations described below.

OIL PUMP – Overhaul

To access the oil pump, remove the sump pan.

When servicing the pump, check component wear against dimensions specified in the table.

In case of replacement, note that the drive shaft (3) and drive gear are supplied ready assembled, with the gear hot shrink-fitted on the shaft.

Cross-sectional view of engine lubrication oil pump models TD60D and TD80D Models

1. External drive gear.
2. Bushing.
3. Drive shaft and gear.
4. Driven shaft and gear.
5. Pressure relief valve.

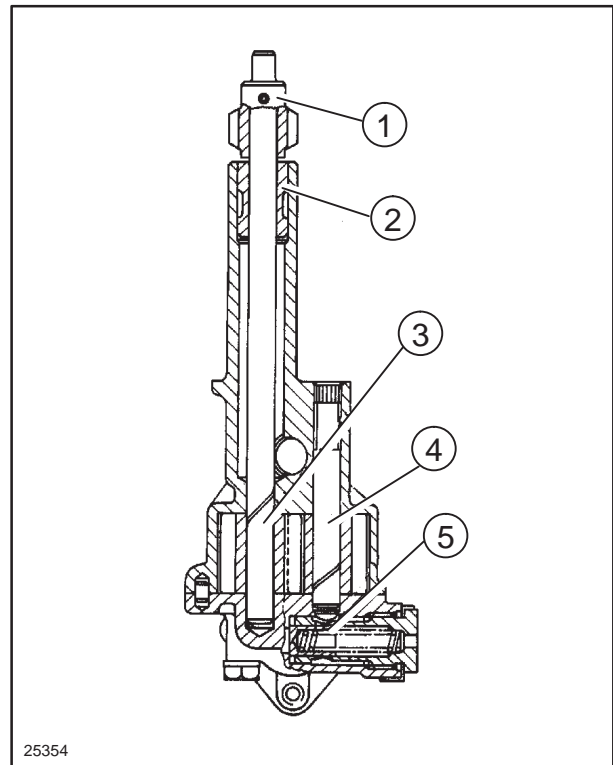

181

Cross-sectional view of engine lubrication oil pump models TD90D and TD95D Models

1. Pressure relief valve.
2. Spring.
3. Pump housing.
4. Internal gears.

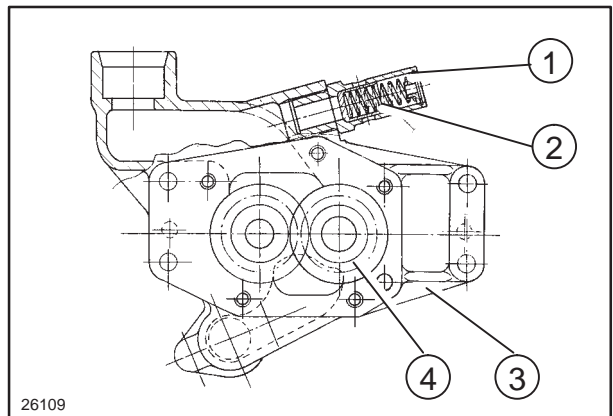

182

Cross-sectional view of engine lubrication oil pump models TD70D Model

1. Pump housing.
2. Internal gears.

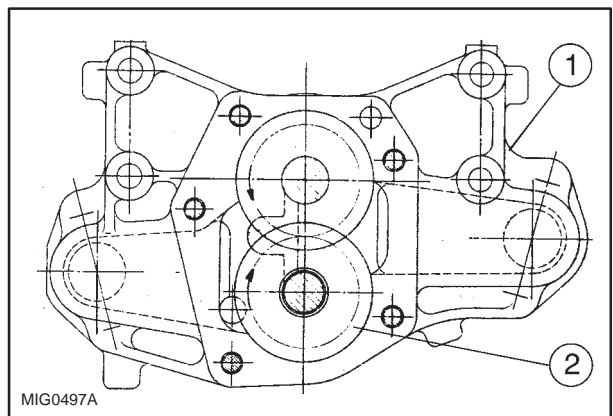

183

OIL FILTER – Replacement

The oil filter (3) figs. 7 and 8 is of the full-flow, integral paper cartridge type, and is installed in the pump delivery line.

Should the filter become clogged, the safety valve (2) will open to allow the oil to by-pass the filter, thus ensuring that the engine continues to be lubricated, although with unfiltered oil.

Replace the cartridge periodically (every 400 operating hours), remembering to:

- oil the outer part of the seal in contact with the mounting on the crankcase;
- screw on the new cartridge until the seal is up against the mounting;
- tighten the cartridge, **by hand only**, through a further 3/4 turn.

LOW OIL PRESSURE INDICATOR – Functional checks

The indicator consists of a control switch (4) figs. 7 and 8 and a red warning lamp in the instrument panel, which illuminates in the following conditions:

- low oil pressure (the warning lamp also illuminates in normal conditions, with no faults present, when the engine is hot and idling at low speed);
- control switch malfunction.

If the red lamp fails to illuminate when the engine is stopped and the ignition switch is turned to the power on position, the possible causes are:

- blown fuse;
- blown lamp;
- interruption in wire to the control switch.

CHECKS, MEASUREMENTS AND REPAIRS – COOLING SYSTEM

Clean all parts carefully before proceeding with the operations described below.

The cooling system is filled with a permanent coolant mixture consisting of water and “**AMBRA AGRIFLU**” antifreeze (up to 50% in volume). This mixture prevents freezing down to the following temperatures:

Degrees °C (°F)	-8 (17.6)	-15 (5)	-25 (-13)	-35 (-31)
% in volume of “ AMBRA AGRIFLU ”	20	30	40	50

This mixture also has anti-oxidant, anti-corrosion, anti-foaming and anti-scaling properties to ensure long-term protection of the cooling system.

The same mixture can be kept in the cooling system for a maximum of 2 years or 1600 operating hours, whichever comes sooner; after which it must be changed.

RADIATORS – Flushing and checks

Two valves are built into the radiator cap, one compression valve and one depression valve. Check periodically that they are working correctly.

When overhauling, remove deposits of lime scale in the radiator by means of a solution of water and de-scaling agent in the proportions shown on the container.

It is never advisable to limit flushing to the radiator only – always extend it to the entire cooling circuit and top up the engine with the solution referred to above.

Run the engine for about an hour. With the engine off, drain the solution through the drain plug aperture.

In the event of leakage, the radiator is checked by immersing it in a tank of water at a temperature of 20°–40° C (68°–104° F), introducing air into the radiator at a pressure of 0.98 bar (14.1 psi) for approximately two minutes (repeat the test at least three times).

COOLANT THERMOMETER – Testing

If malfunction is suspected, immerse the bulb of the thermometer in water and check the readings against a test thermometer (repeat the test a number of times with different water temperatures to be sure).

THERMOSTAT – Replacement

The thermostat (1), fig. 9 is fitted in the cylinder head coolant outlet union. The thermostat cannot be adjusted and therefore must be replaced if does not meet the temperature specifications in the table on page 4.

COOLANT PUMP AND ALTERNATOR DRIVE BELT – Tension adjustment (Operation 10 414 10).

The fan/coolant pump/alternator drive belt is tensioned correctly when it deflects 10 to 11 mm (0.3937 to 0.4331 in.) when a force of 78 to 98 N (17.64 to 22.05 lb) is applied at the mid-point of the run between the alternator and coolant pump pulleys.

1. Check the tension using the belt tension tester **296118**. Adjust tension if necessary as follows:
2. Slacken the nut (1) securing the alternator to the tensioner bracket;
3. Move the alternator to achieve the required belt tension and lock the nut (1).

NOTE: When fitting a new belt, check the tension again after one hour of running.

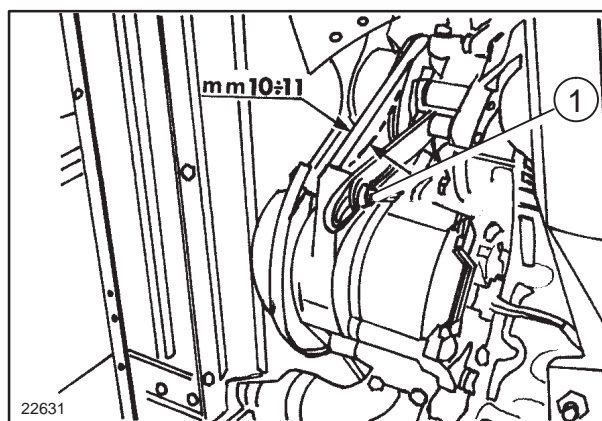

RADIATOR**Removal – Installation (Operation 10 406 10)****DANGER**

Lift and handle all heavy parts using suitable lifting equipment.

Make sure that assemblies or parts are supported by means of suitable slings and hooks.

Check that no one is in the vicinity of the load to be lifted.

1. Remove the exhaust pipe and open the bonnet.
2. Disconnect the battery negative cable.
3. Remove the left and right-hand safety guards (1) from around the fan.

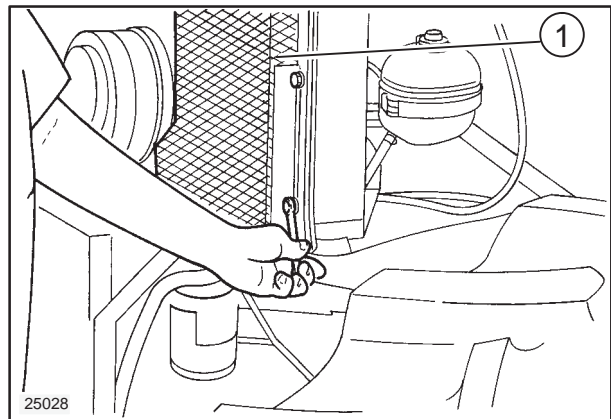

185

4. Remove the hose clamp, detach the bottom radiator hose (1) and drain off the coolant.

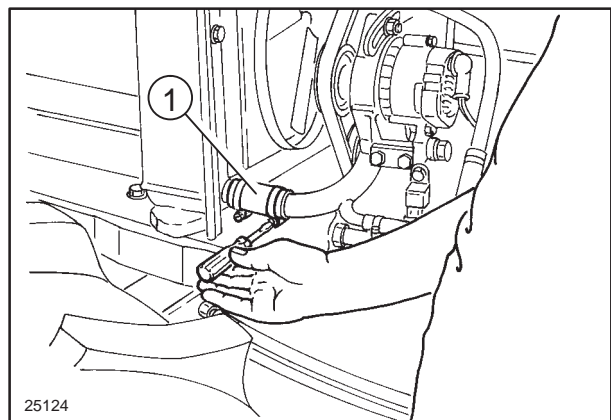

186

5. Unscrew the front axle earth cable fixing bolt (1).
6. Disconnect electrical leads from the horn.

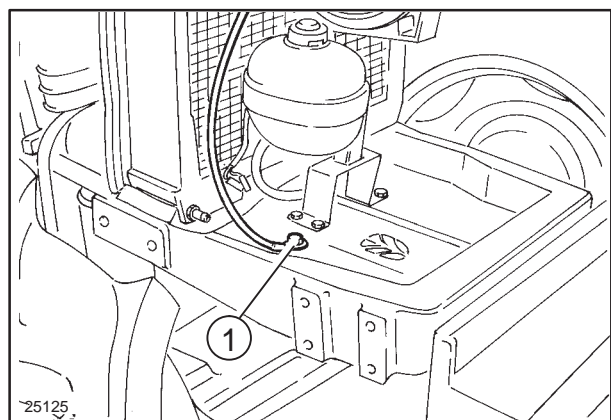

187

7. Disconnect electrical leads from air filter restriction sensor (1).

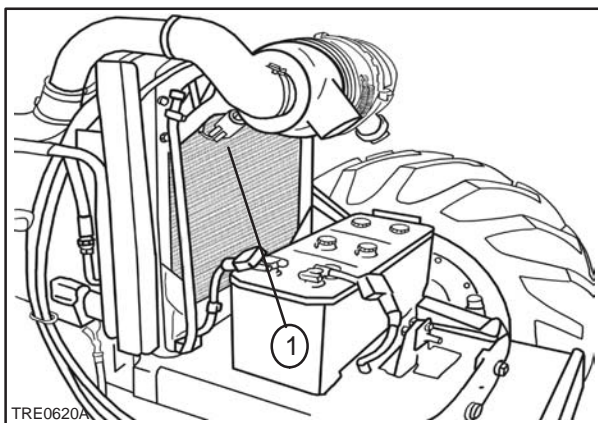

188

8. Remove the clamp (1) on the inlet manifold hose.

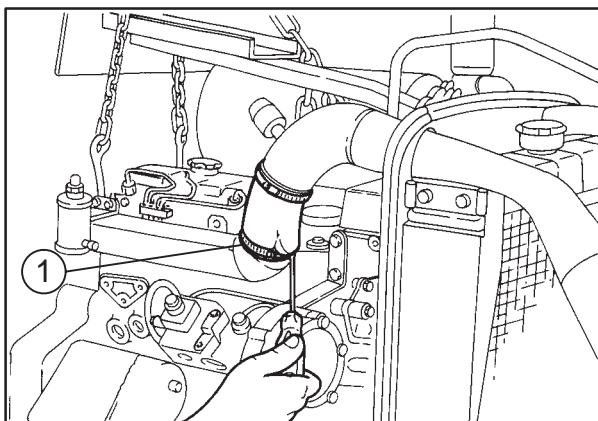

189

9. Remove the clamp (1) on the air filter hose.

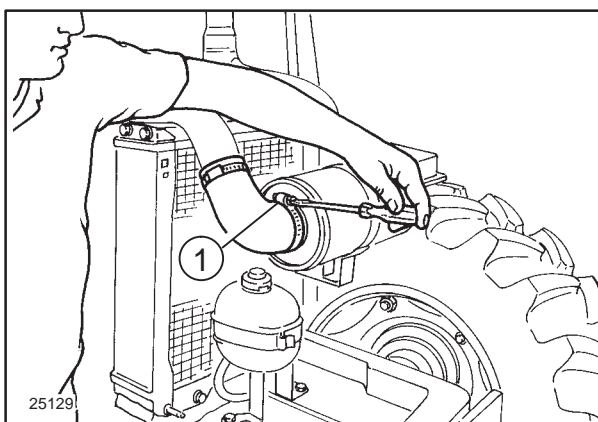

190

10. Remove the air filter restriction sensor (1) and re-cover the pipe.

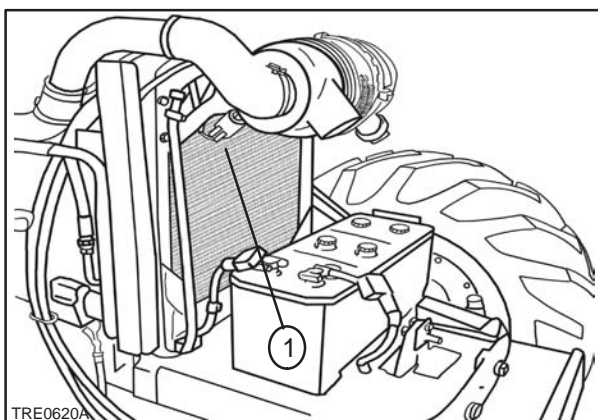

191

11. Unscrew the clamp and disconnect the pipe (1) connecting the air filter to the exhaust aspirator.

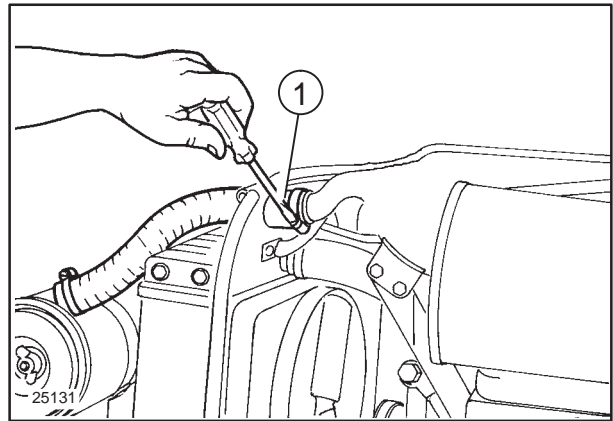

192

12. Unscrew the hose clamp (1) and remove the top radiator hose.

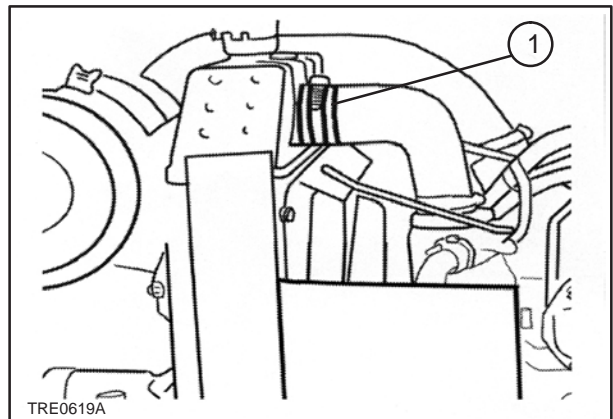

193

13. Unscrew the clamp and remove the pipe (1) from the radiator cap.

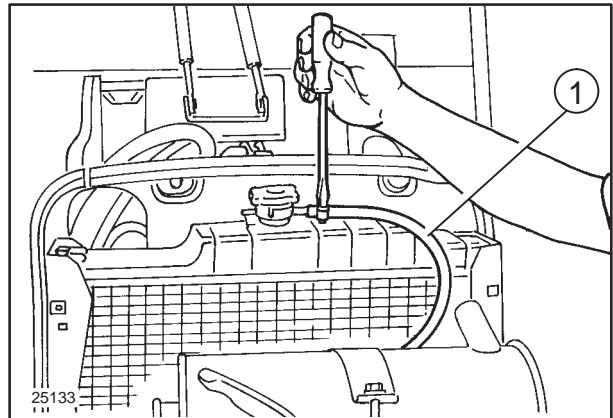

194

14. Unscrew the two bolts (1) securing the radiator to the front axle support and remove the bolts, rubber mountings and spacers.

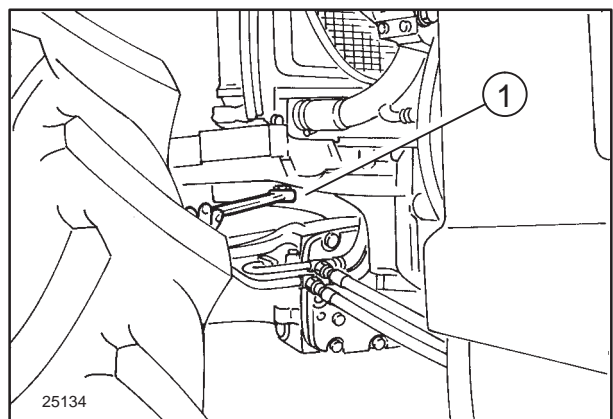

195

15. Remove the radiator (1) and the upper rubber mountings.

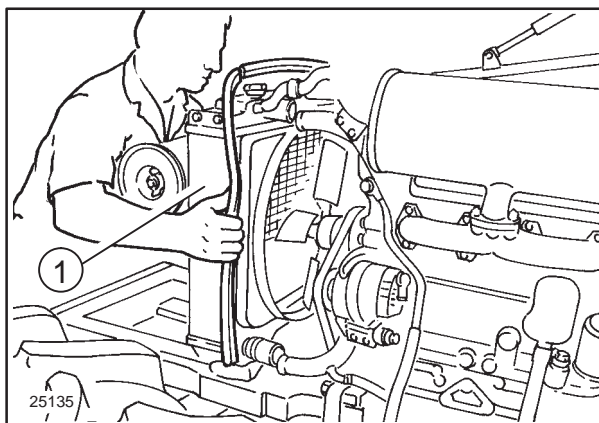

196

To refit the radiator proceed as follows:

- Replace the radiator and secure with the two bolts.
- Refit the two rubber hoses to the coolant pump and the thermostat housing. Reconnect the pipe to the radiator cap.
- Reconnect the bonnet stay bracket to the bracket mounted on the radiator and replace the retaining bolts.
- Refit the hose to the exhaust aspirator.
- Refit the hose connecting the air cleaner to the inlet manifold. Refit the air filter clogging sensor.
- Reconnect the electrical leads to the horn, air filter restriction sensor and the front axle earth lead.
- Refit the two wire mesh guards around the fan.
- Fill the radiator with coolant.
- Reconnect the battery negative lead; close the bonnet.

CRANKSHAFT FRONT OIL SEAL Removal/installation (Operation 10 102 70)



DANGER



Lift and handle all heavy parts using suitable lifting equipment. Make sure that assemblies or parts are supported by means of suitable slings and hooks. Check that no one is in the vicinity of the load to be lifted.

1. Remove the exhaust pipe and open the bonnet.
2. Disconnect the battery negative cable.
3. Remove the left and right-hand wire mesh guards (1) from around the fan.

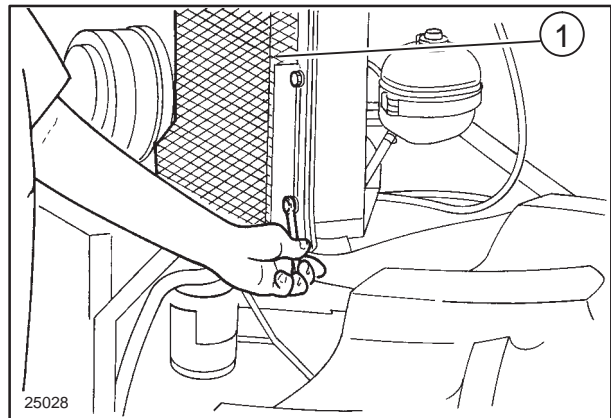

197

4. Remove the hose clamp, detach the bottom hose (1) and drain off the coolant.

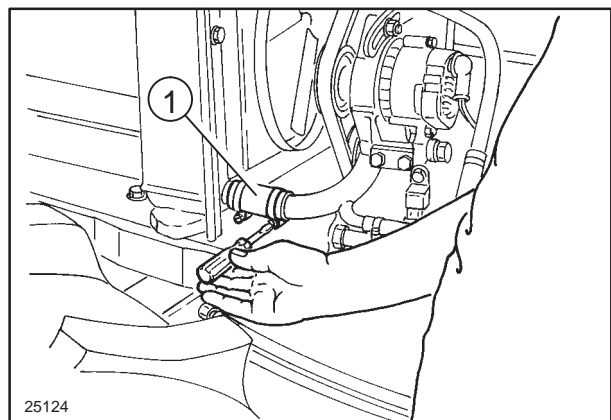

198

5. Unscrew the front axle earth cable fixing bolt (1).
6. Disconnect electrical leads from the horn.

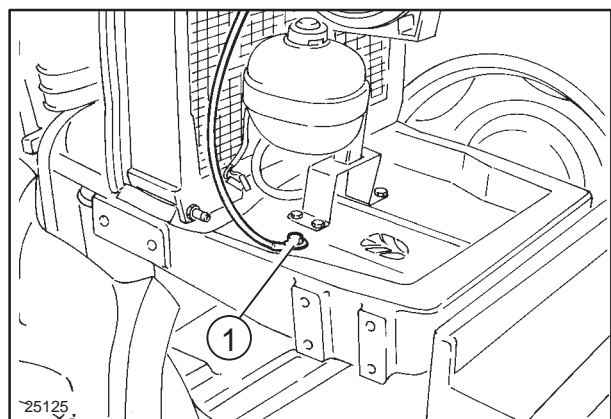

199

7. Disconnect electrical leads from air filter restriction sensor (1).

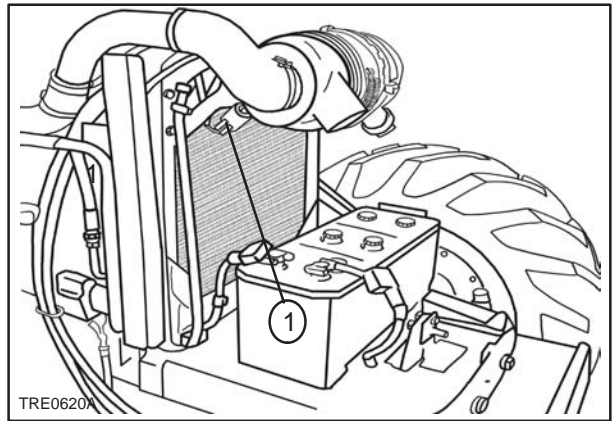

200

8. Remove the clamp (1) on the inlet manifold hose.

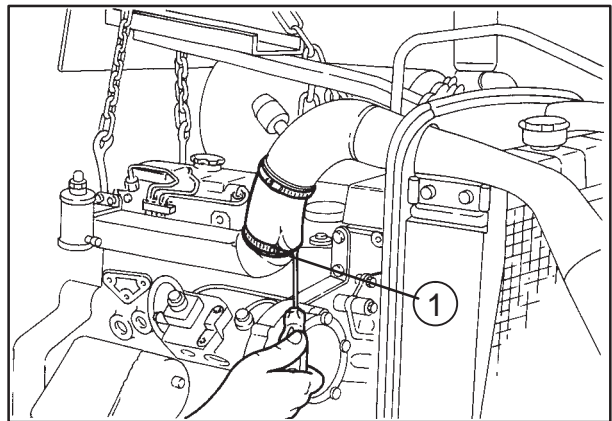

201

9. Remove the clamp (1) on the air filter hose.

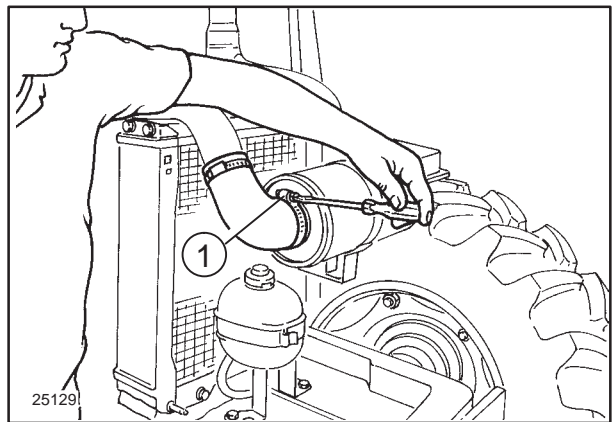

202

10. Remove the air filter restriction sensor (1) and pipe.

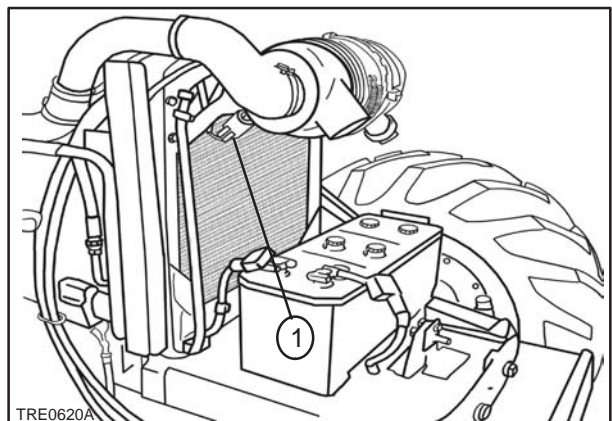

203

11. Unscrew the clamp and disconnect the pipe (1) connecting the air filter to the exhaust aspirator.

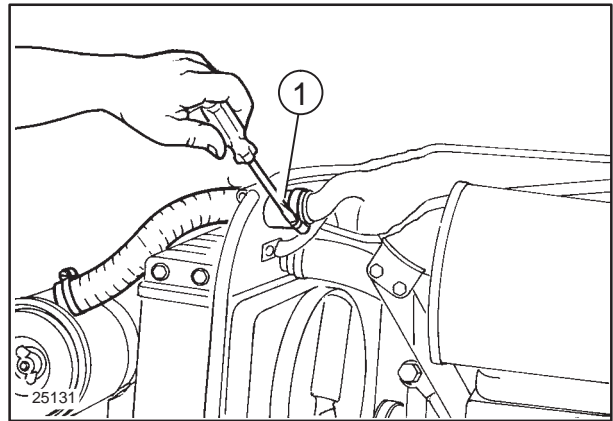

204

12. Unscrew the hose clamp remove the top radiator hose (1).

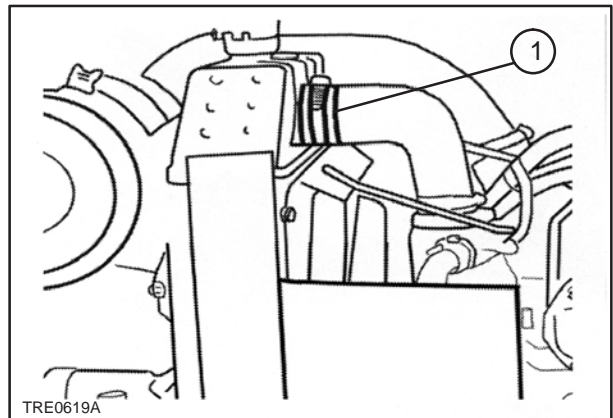

205

13. Unscrew the clamp and remove the pipe (1) from the radiator cap.

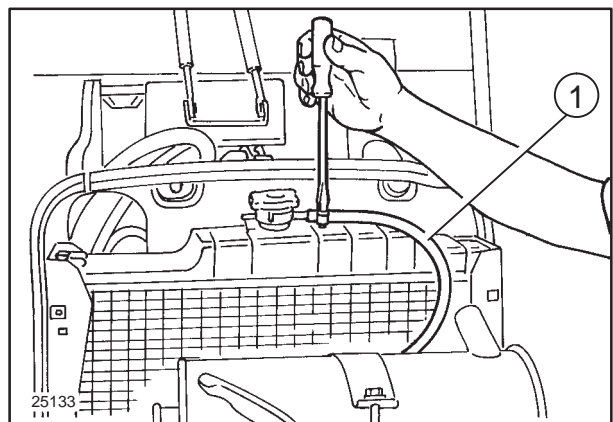

206

14. Unscrew the two bolts (1) securing the radiator to the front axle support and remove the bolts, rubber mountings and spacers.

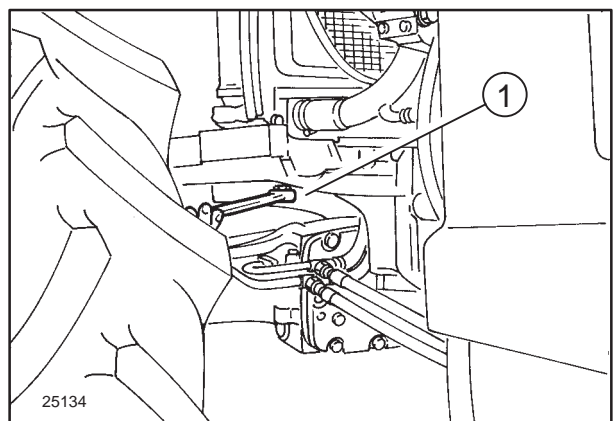

207

15. Remove the radiator (1) and the upper rubber mountings.

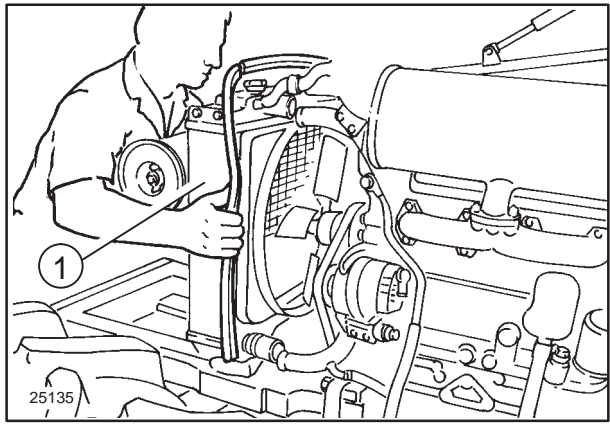

208

16. Loosen the alternator pivot bolt.

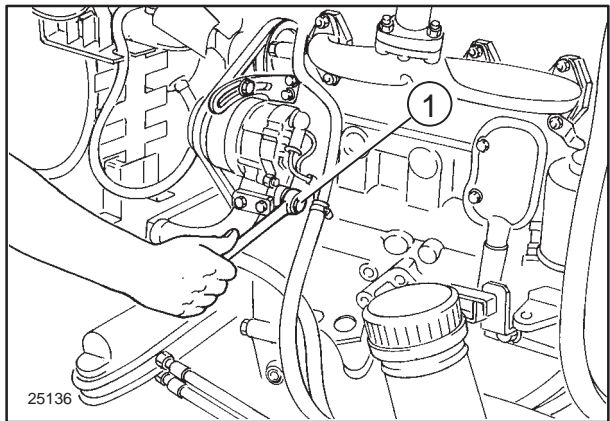

209

17. Loosen the belt tension adjuster bolt (1) and remove the belt.

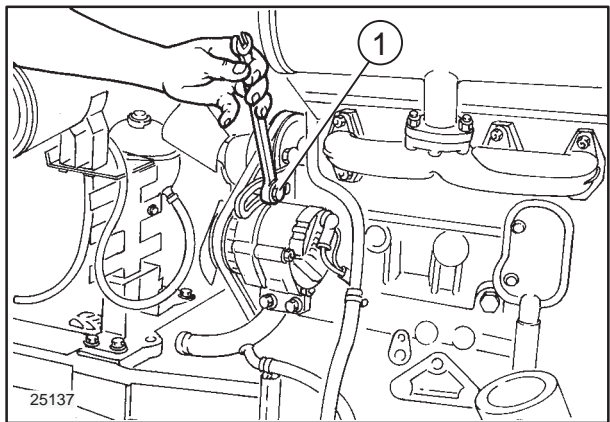

210

18. Remove the radiator fan (1).

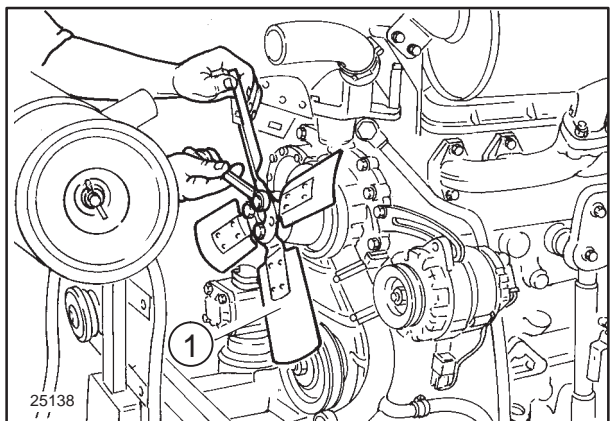

211

19. Unscrew the retaining bolts (1) and remove the crankshaft pulley.

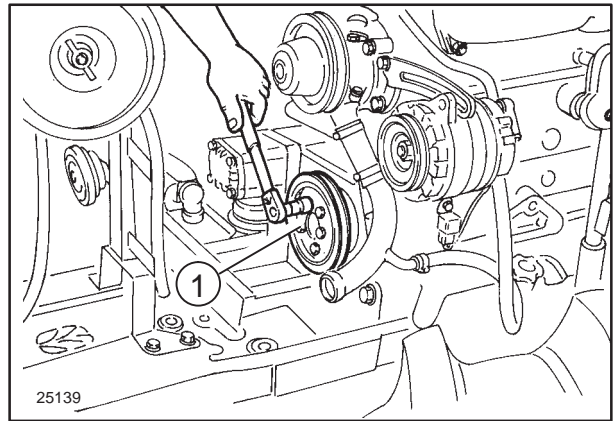

212

20. Straighten the tab on the lock washer, hold the crankshaft against rotation and unscrew nut (1).

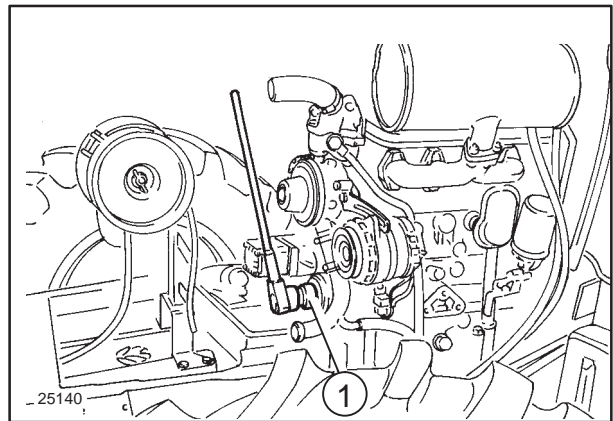

213

21. Remove the pulley hub from the crankshaft using tool 38000226 (1) and retrieve the woodruff key.

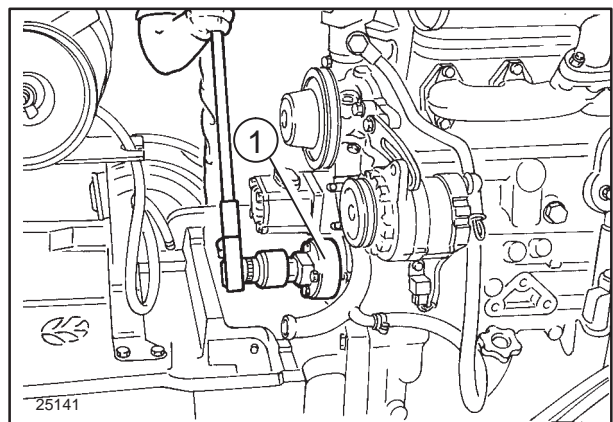

214

22. Remove the oil seal (1) from it seat.

To install the front oil seal, proceed as follows:

- Install the oil seal.
- Refit the crankshaft hub and retaining nut; bend tab over on lock washer.
- Refit fan.
- Refit the drive belt, adjust tension and tighten alternator bolts.
- Replace the radiator and secure with the two bolts.
- Refit the two rubber hoses to the coolant pump and the thermostat housing.
- Reconnect the pipe to the radiator cap.
- Reconnect the bonnet stay bracket to the bracket mounted on the radiator and replace the retaining bolts.
- Refit the hose to the exhaust aspirator.
- Refit the hose connecting the air cleaner to the inlet manifold. Refit the air filter restriction sensor.
- Refit the two wire mesh guards around the fan.
- Fill the radiator with coolant.
- Reconnect the battery negative lead; close the bonnet.

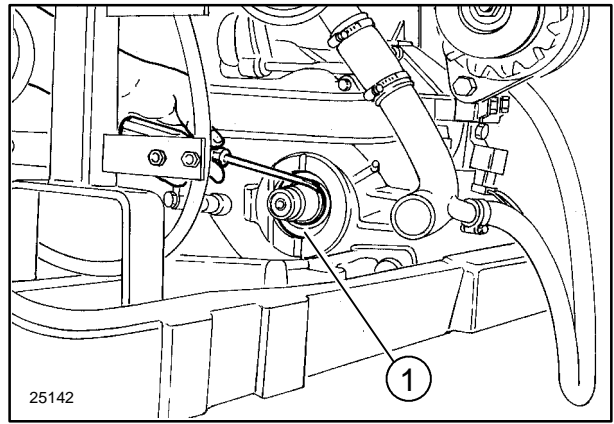

215

COOLANT PUMP**Removal–Installation (Operation 10 402 10)****WARNING**

Always use suitable tools to align holes in parts.
NEVER USE YOUR FINGERS OR HANDS.

1. Remove the exhaust pipe and open the bonnet.
2. Disconnect the battery negative cable.
3. Remove the wire mesh guards (1) from the left and right-hand sides of the fan.
4. Remove the hose clamp, detach the bottom radiator hose (1) and drain off the coolant.
5. Remove the fan shroud (1) retaining bolts.
6. Remove the two strips (1) from the sides of the radiator.

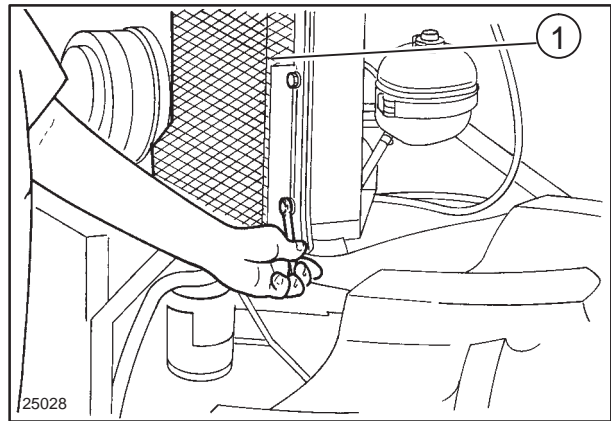

216

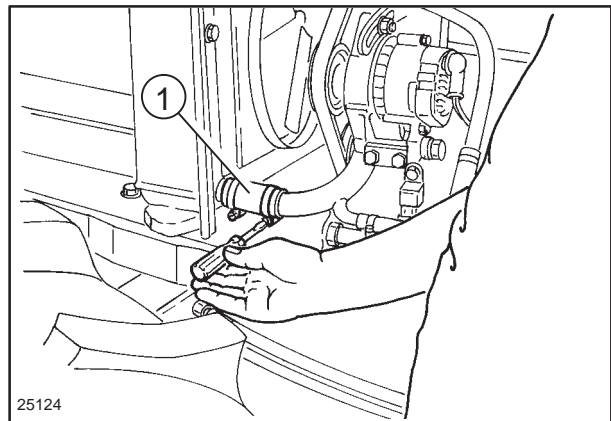

217

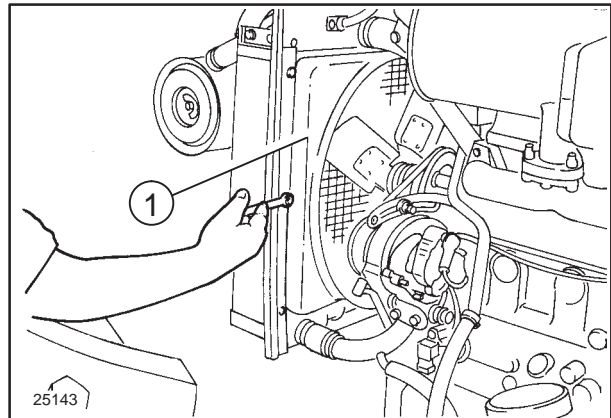

218

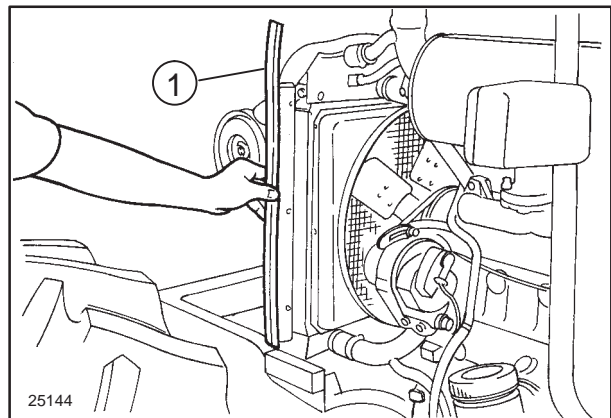

219

7. Move the fan shroud towards the engine.
8. Unscrew the three bolts securing the fan to the coolant pump shaft. Remove the fan and the fan cowling.

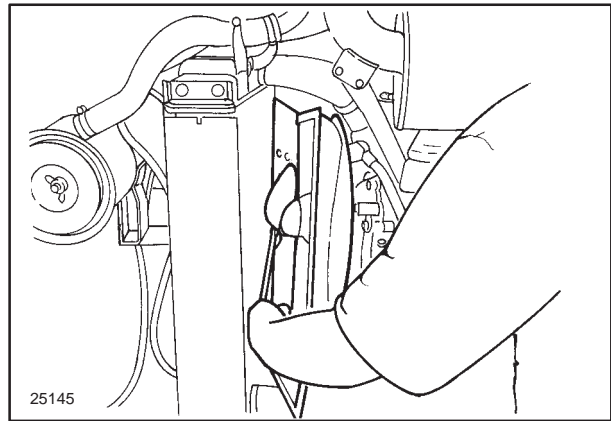

220

9. Loosen the alternator pivot bolt (2).
10. Loosen the belt tension adjustment bolt (1).

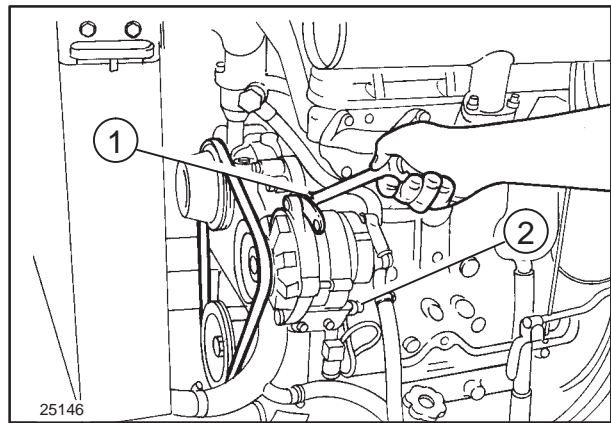

221

11. Remove the coolant pump pulley (1).

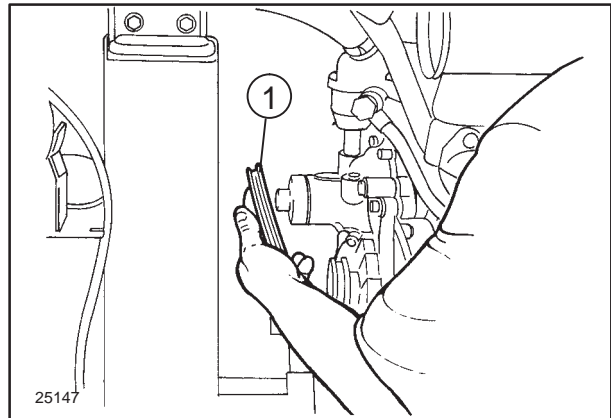

222

12. Loosen the hose clamp (1) and detach the hose from the coolant pump.

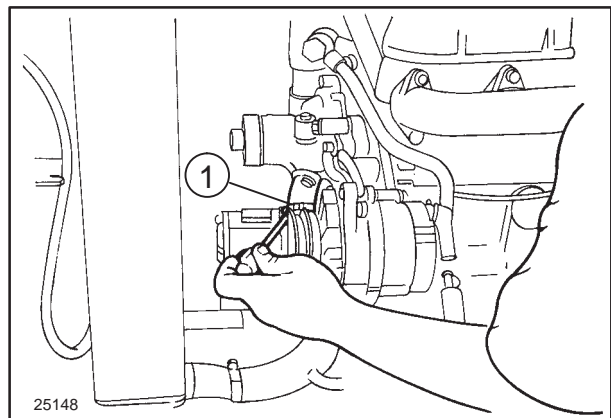

223

13. Unscrew the belt tension adjustment arm retaining nut (1) and move the alternator outward.

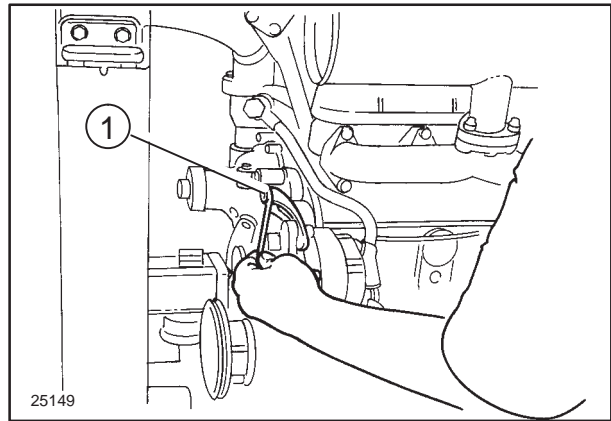

224

14. Remove pump connection pipe (1) to gain access to the coolant pump retaining bolt (2).

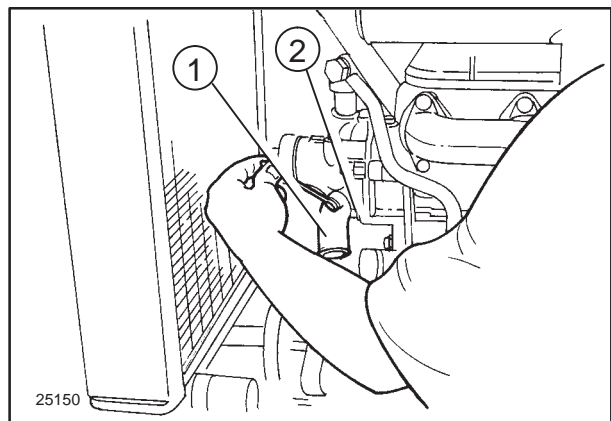

225

15. Unscrew the four bolts (1) fig. 226 securing the coolant pump to its mounting.

16. Disconnect the hose from the coolant pump to the thermostat housing, then remove the pump (1) fig. 227.

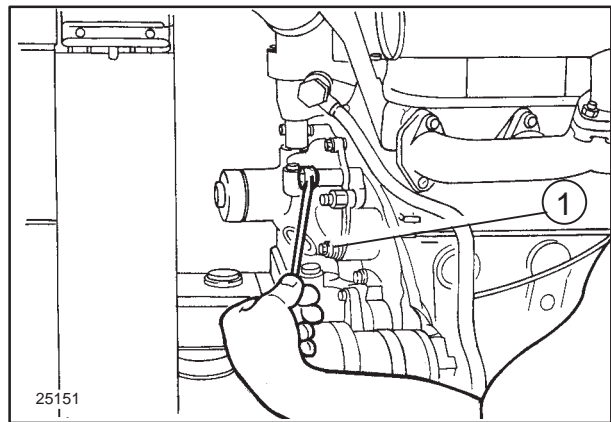

226

To refit the coolant pump proceed as follows:

- Refit the coolant pump. Take care not to lose the seals on the upright hose connecting the pump to the thermostat body.
- Refit the connection pipe to the pump, and replace the two retaining bolts.
- Refit the coolant pump pulley and the fan. Refit the fan shroud and the two vertical side strips to the radiator. Fix the belt tension adjustment arm. Tighten the alternator pivot bolt.
- Refit the bottom radiator hose to the connection pipe on the coolant pump and the radiator.
- Refit the right-hand wire mesh guard.
- Refit the left-hand wire mesh guard.
- Fill the cooling system from the radiator cap.
- Reconnect the negative battery lead and refit the exhaust pipe.

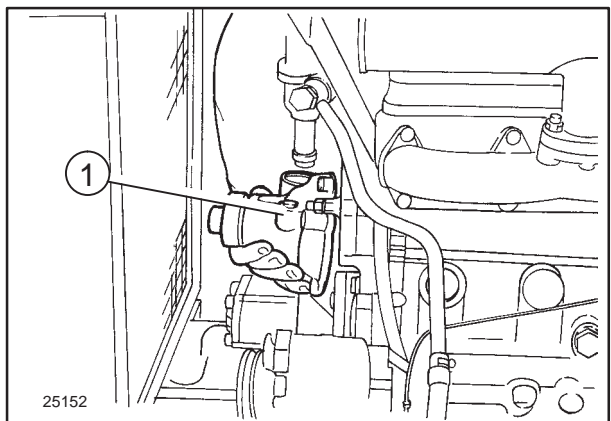

227

COOLING SYSTEM THERMOSTAT
Removal-Installation
(Operation 10 402 30)

⚠ WARNING ⚠

Always use suitable tools to align holes in parts.
 NEVER USE YOUR FINGERS OR HANDS.

1. Disconnect the battery negative cable.
2. Remove the exhaust pipe, attach lifting chains to the bonnet (1) and attach the chains to the hoist.
3. Disconnect the electrical leads (1) from headlamps (2).
4. Detach the gas struts (1) from the bonnet.
5. Remove the four bonnet hinge bolts (1) and lift the bonnet clear.

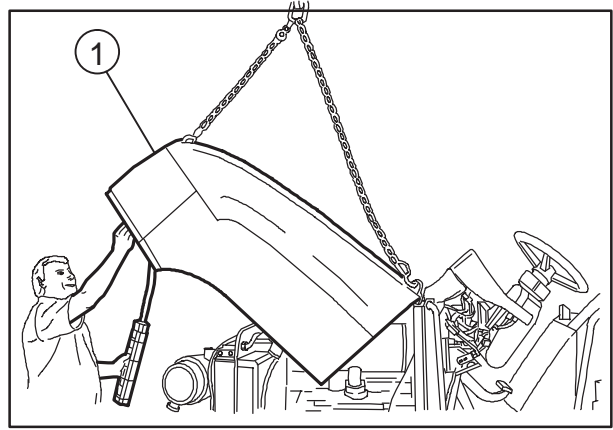

228

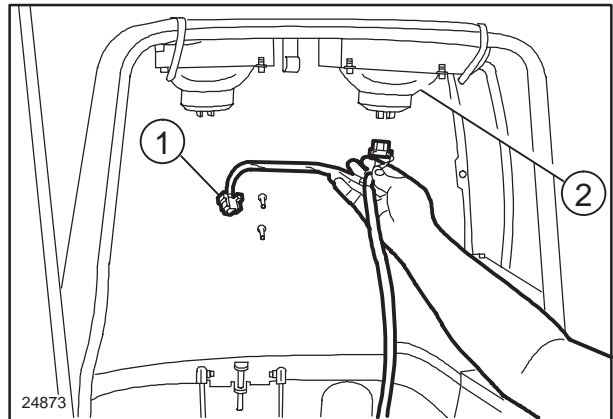

229

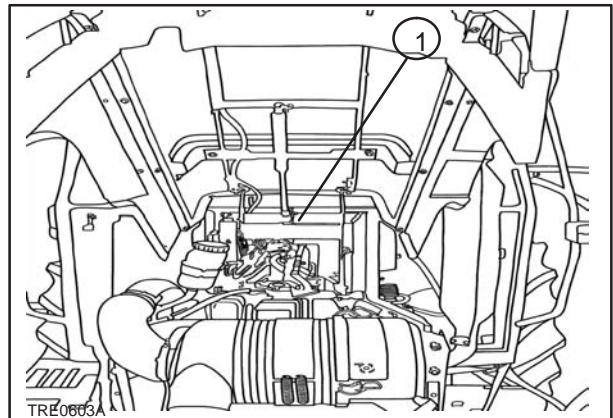

230

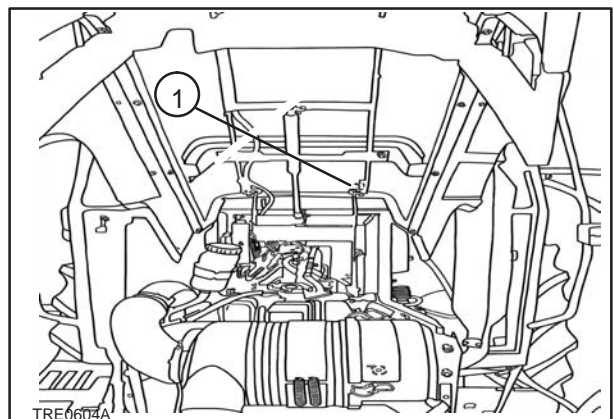

231

6. Drain the cooling system from the drain plug on the engine block.

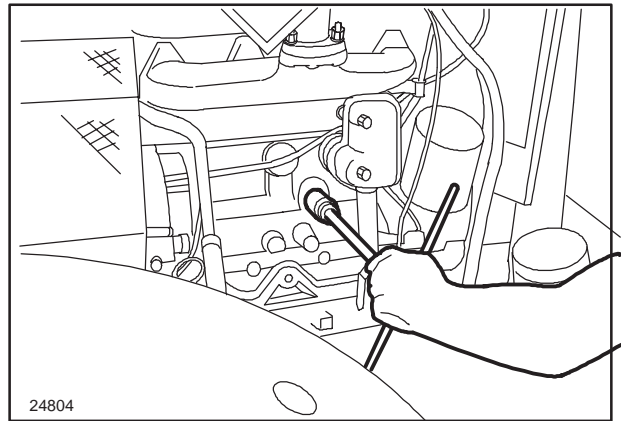

232

7. Remove the wire mesh guard (1) from the right-hand side of the radiator.

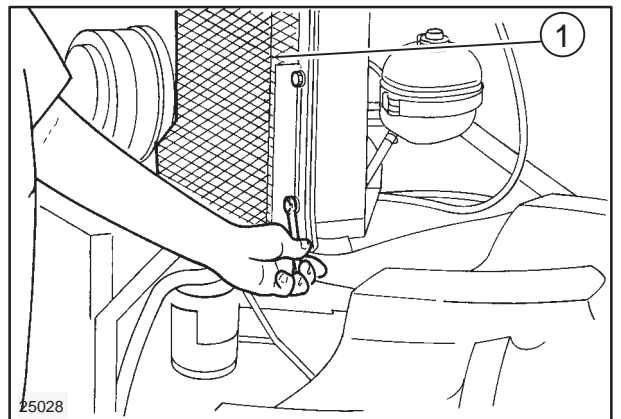

233

8. Unscrew the hose clamp and disconnect the hose (1) connecting the radiator to the thermostat housing.

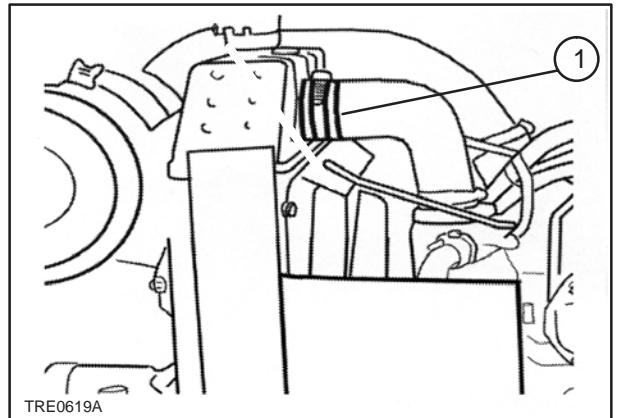

234

9. Remove the thermostat housing cover screws (1).

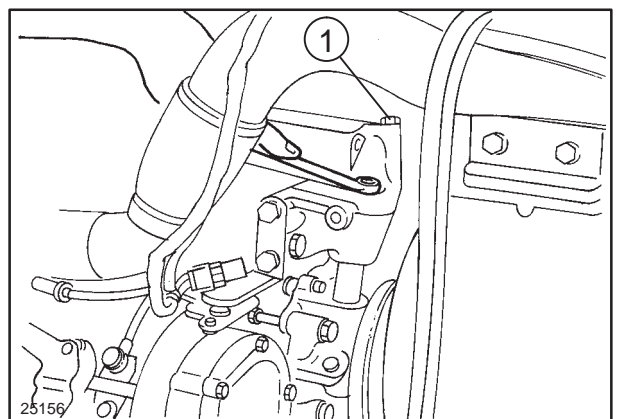

235

10. Lever the cover (1) off the housing using a screwdriver and remove the cover.

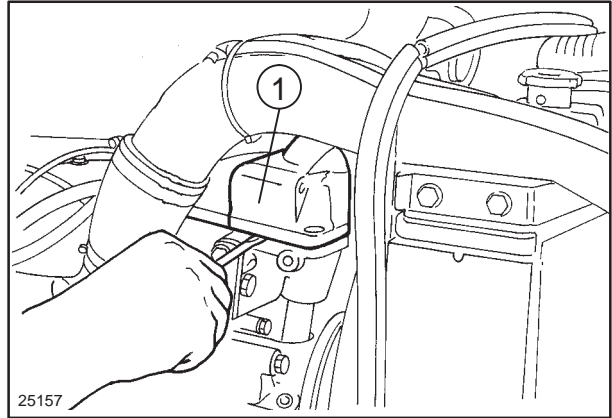

236

11. Remove the thermostat valve (1).

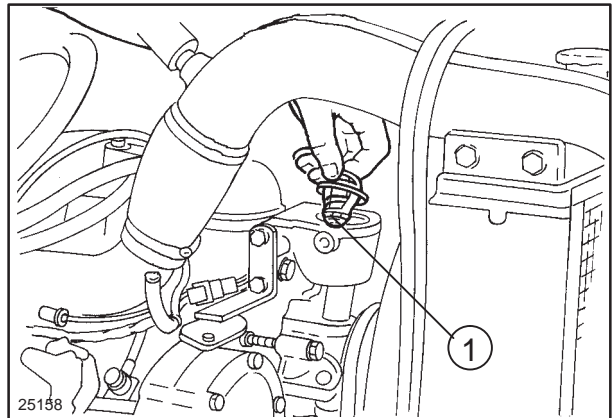

237

To refit the thermostat proceed as follows:

- Fit the thermostat in its housing and locate the gasket. Refit the cover to the housing.
- Connect the top radiator hose to the thermostat housing and secure with a hose clamp.
- Refit the bonnet stay.
- Refit the right-hand wire guard to the fan.
- Refit the bonnet.
- Fill the cooling system. Top up as necessary.
- Reconnect the battery negative lead. Close the bonnet and refit the exhaust pipe.

Op. 10 246 14
BOSCH INJECTION PUMP
Removal–Installation, timing and
air bleeding



Handle all parts carefully. Do not put your hands or fingers between parts. Wear the prescribed safety clothing, including goggles, gloves and safety footwear.



Always use appropriate tools to align fixing holes. NEVER USE FINGERS OR HANDS.

Proceed as follows:

1. Raise the bonnet.
2. Unscrew the retaining bolts and take off the injection pump gearbox cover (2); if there is an air-conditioning system compressor, remove the bracket (1) supporting the compressor.
3. Unscrew and remove the fuel filter.
4. Remove the flywheel inspection window cover (1) and the tappet cover.
5. Rotate the crankshaft to bring cylinder no. 1 to T.D.C. and make sure the valves are closed (compression stroke).
6. Disconnect the throttle control cable (1) from the lever on the injection pump, the engine cut-out electromagnet connection and the connection of the thermometric circuit breaker cutting out starting advance according to temperature (KSB).

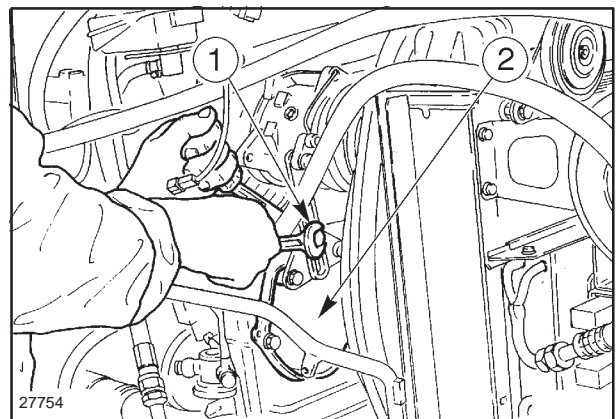

238

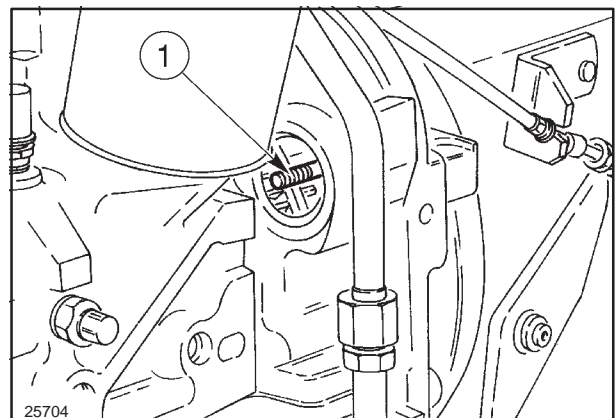

239

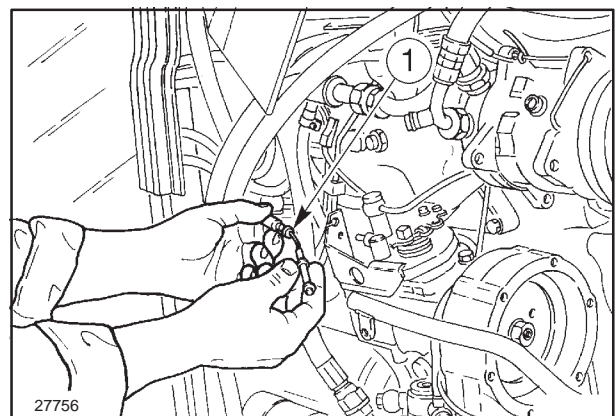

240

7. Unscrew the unions of the fuel supply lines (1) from the injection pump, from the fuel return pipe (2) and from the pump fuel supply line (3).
8. Disconnect the L.D.A. device connecting pipe to the inlet manifold (only TD70D and TD95D models).

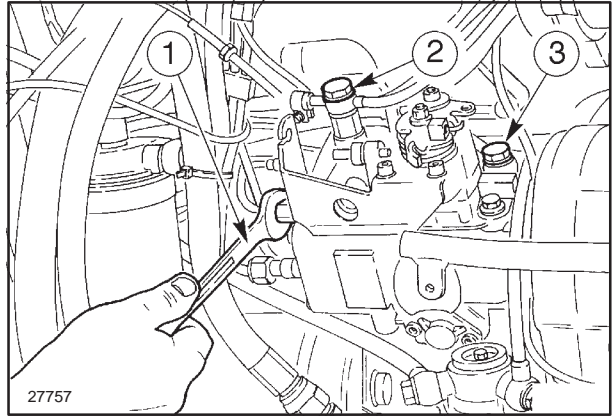

241

9. Unscrew the injection pump locknut on the relative gearing (1).

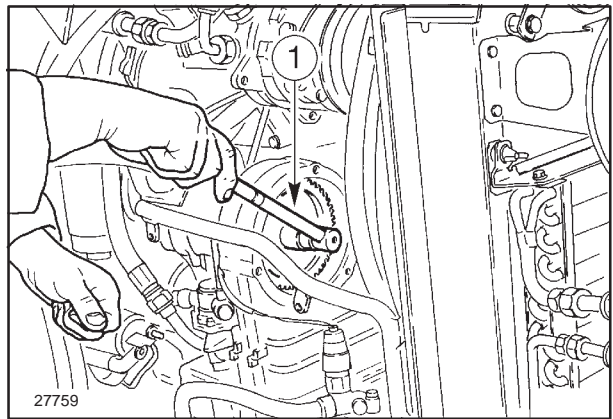

242

10. Using tool **380000322** (1) remove the injection pump from the gearing and recover the pump.

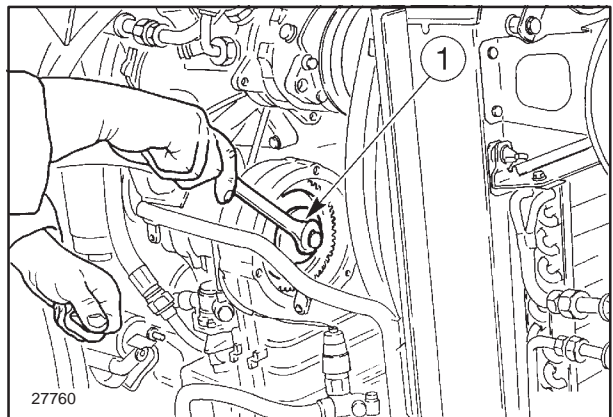

243

11. Unscrew the bolts (1) securing the injection pump.

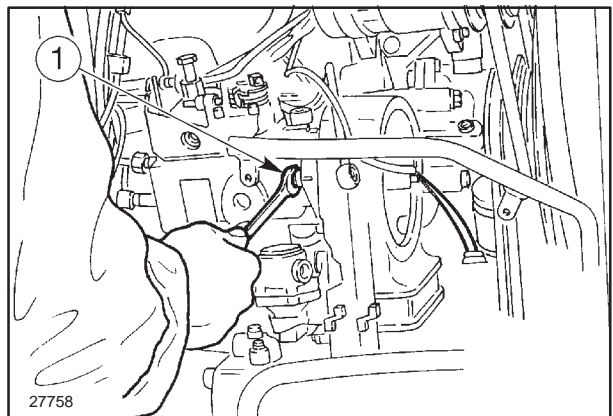

244

12. To refit the injection pump, proceed as follows.

**CAUTION**

Always use appropriate tools to align fixing holes.
NEVER USE FINGERS OR HANDS.

- Respect the tightening torques prescribed on page 24.
- Check that cylinder no. 1 is at T.D.C. and the valves are closed (compression stroke).
- Position the injection pump in its seat and secure it with the bolts, checking they are in the middle of the slot.
- Lock the injection pump drive gear with the nut tightened to a torque of 90 Nm, making sure the crankshaft does not turn.
- Loosen the screw stopping the injection pump from turning. Insert the relevant spacer and tighten the screw back. In these conditions, the pump spindle can turn freely.
- Refit the injection pump drive gear box access cover.
- Assemble the LDA device connection pipe to the inlet manifold (TD70D and TD95D models only).
- Connect the fuel supply and return lines to the injection pump.
- Connect the engine cut-out electromagnet cable and the cable of the thermometric circuit breaker cutting out starting advance according to temperature (KSB).
- Connect the delivery pipes to the injectors, to the injection pump.
- Connect the throttle lead to the injection pump.
- Fit the fuel filter.
- Close the bonnet.

BOSCH INJECTION PUMP**Timing**

1. Using an external cable, supply 12 V to the thermometric circuit breaker cutting out starting advance according to temperature (KSB) (1) attaching the positive terminal to the connection and earth to the pump housing.

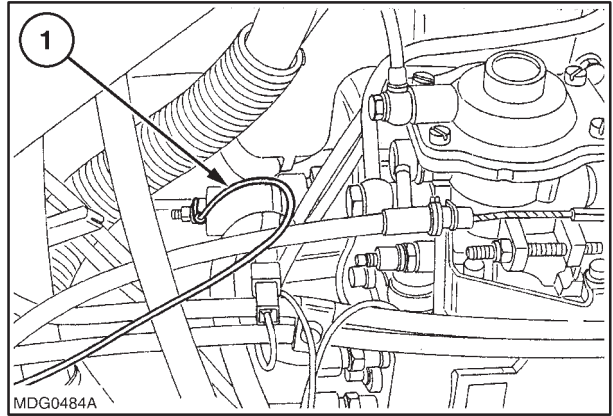

245

2. Make sure that the KSB fork (1) is free to move.

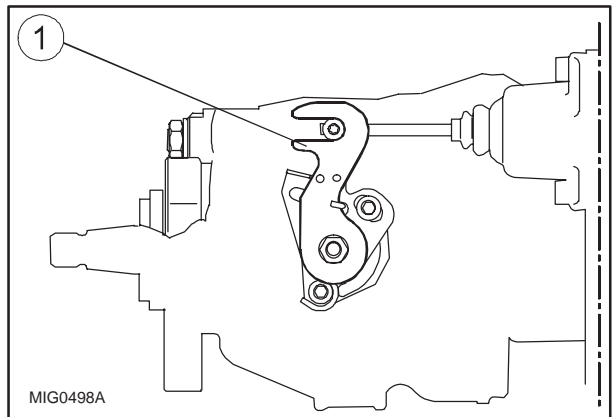

246

3. Unscrew the unions of the fuel supply lines (1), detaching them from the injection pump. If necessary, disconnect the injection pump supply and return lines (2 and 3) and the LDA/intake manifold connecting pipe.

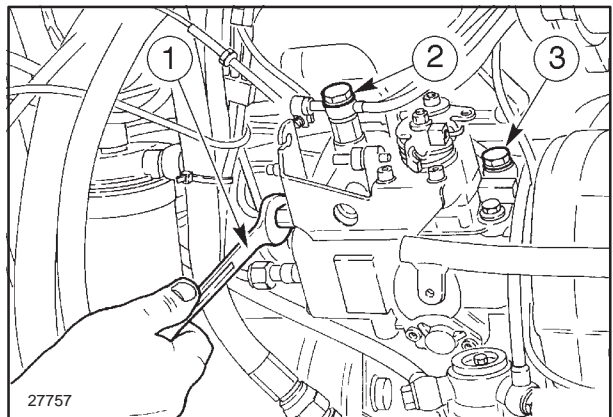

247

4. Remove the flywheel inspection window cover (1) and the tappet cover.
5. Rotate the crankshaft to bring cylinder no. 1 at T.D.C. and make sure the valves are closed (compression stroke).

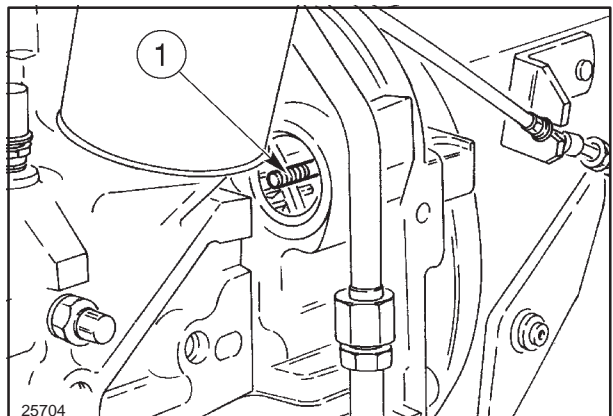

248

6. Check through the inspection window that the pointer is aligned with reference marks 4° for mod. **TD60D**, 0° for mod. **TD70D** and **TD95D**, or 1° for mod. **TD80D** and **TD90D**.

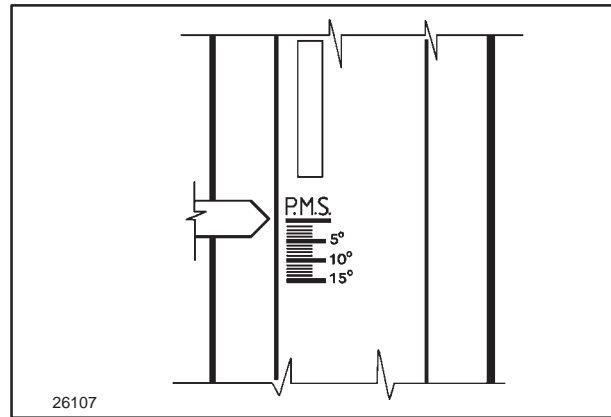

249

7. With the injection pump in its seat, remove the plug (1) on the pump cover.
8. Fit dial gauge **380000228** (1) fig. 251 and the associated tool **380000229** (2), pre-loading the shaft by approximately 2.5 mm (0.0984 in.).
9. Turn the flywheel slowly backwards, so as to bring the plunger to B.D.C. at the start of the delivery stroke (the point at which the dial gauge needle stops falling).

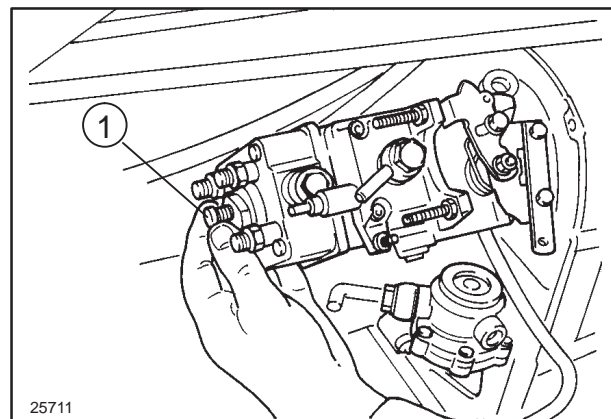

250

10. Zero-set the dial gauge and slowly turn the flywheel clockwise (as viewed from the fan end of the engine) until the pointer lines up with reference marks 4° for **TD60D** models, 0° for **TD70D** and **TD95D** models, or 1° for **TD80D** and **TD90D** models.
11. Check on the dial gauge that the plunger has completed a stroke of 1 mm (0.0394 in.) up to this point, if not, slacken off the pump mounting bolts. If the plunger stroke is checked with the pointer at the T.D.C. there must be a stroke of: **1.47 mm (0.0578 in.)** for mod. **TD60D** or **1.00 mm (0.0394 in.)** for mod. **TD70D** and **TD95D**, or **1.12 mm (0.0440 in.)** for mod. **TD80D** and **TD90D**.
12. Turn the pump anti-clockwise if the plunger has completed a shorter stroke and clockwise if the stroke is longer, repeating the test until the correct stroke is obtained.
13. Having obtained the correct plunger stroke, fix the pump in position by tightening the mounting nuts to the torque specified on page 24.
14. Remove the dial gauge **380000228** (1) and relative tool **380000229** (2) and replace the plug and tighten to a torque of 8 – 10 Nm (5.9005 – 7.3756 ft lb).
15. Disconnect the KSB external power supply unit.
16. Refit other parts in the reverse of the dismantling order.

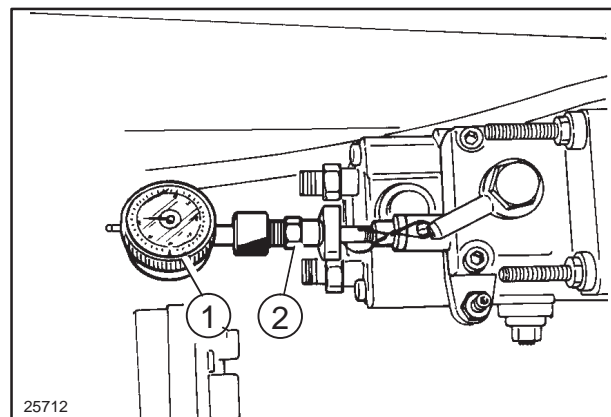

251

BOSCH INJECTION PUMP**Air bleeding**

1. Unscrew the plug (1) on the first filter.

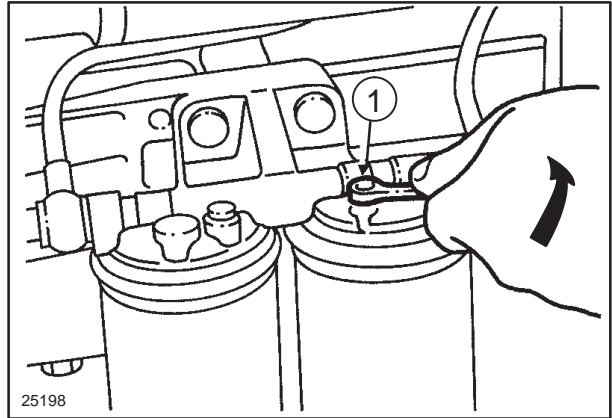

252

2. Operate the priming lever (1) fig. 253 on the fuel supply pump until the fuel coming out of the filter orifice is free of bubbles, then replace and tighten plug (1) fig. 252.

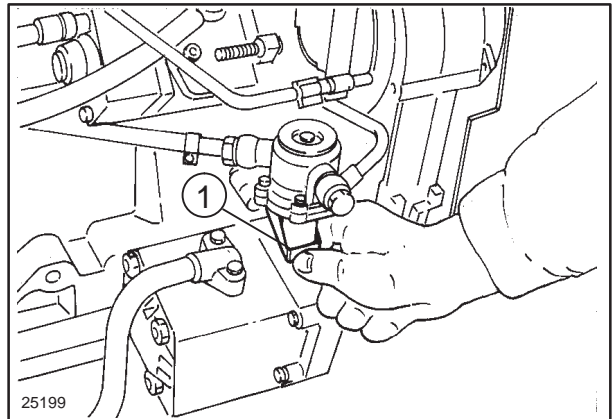

253

3. Slacken the fuel line unions (1) on the injectors, start the engine and then re-tighten the union (1) when the fuel flows out free of bubbles.

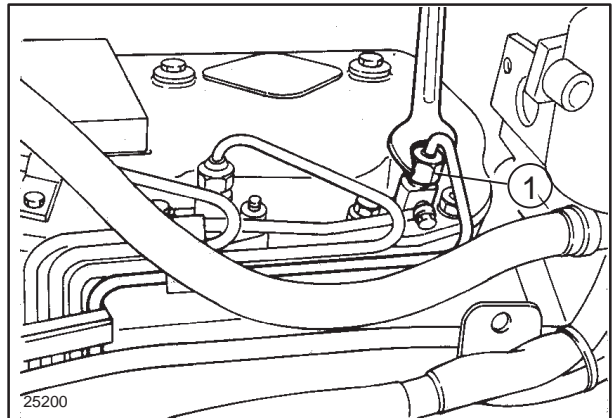

254

FUEL INJECTORS**Removal-Installation (Operation 10 218 30)****WARNING**

Always use suitable tools to align holes in parts.
NEVER USE YOUR FINGERS OR HANDS.

1. Disconnect the battery negative cable.
2. Attach lifting chains to the bonnet (1) and then attach the chains to the hoist.
3. Disconnect the electrical leads (1) from headlamps (2).
4. Detach the gas struts (1) from the bonnet.
5. Remove the four bonnet hinge bolts (1) and lift the bonnet clear.

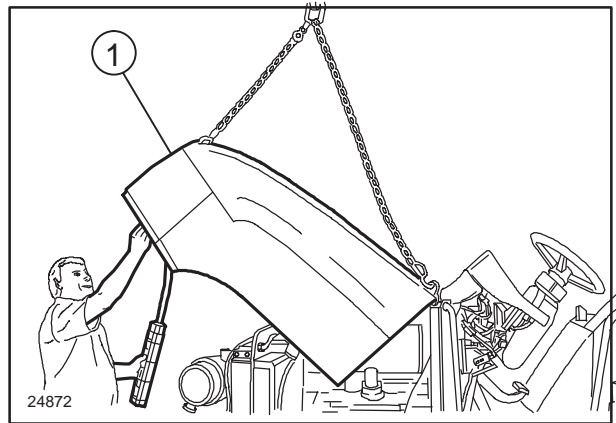

255

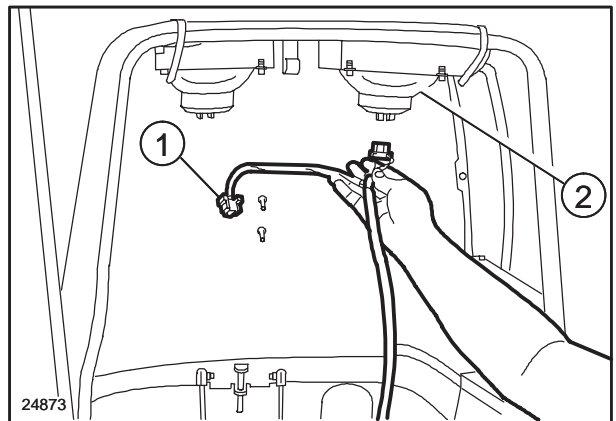

256

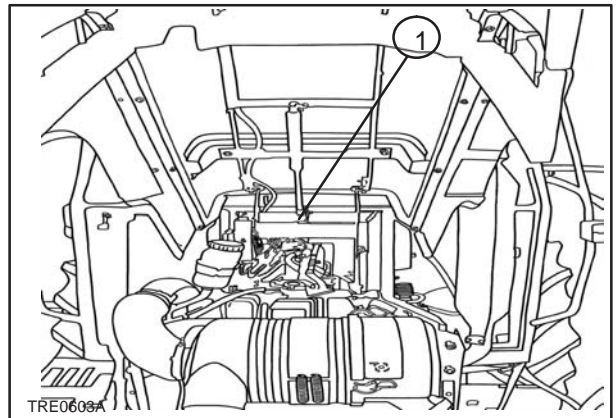

257

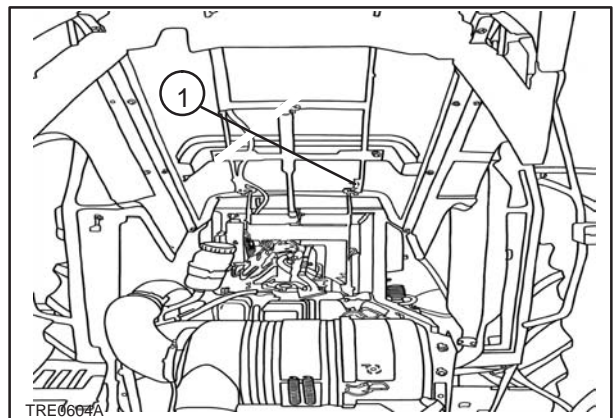

258

6. Unscrew the fuel leak-off pipe union (1) on the injector.

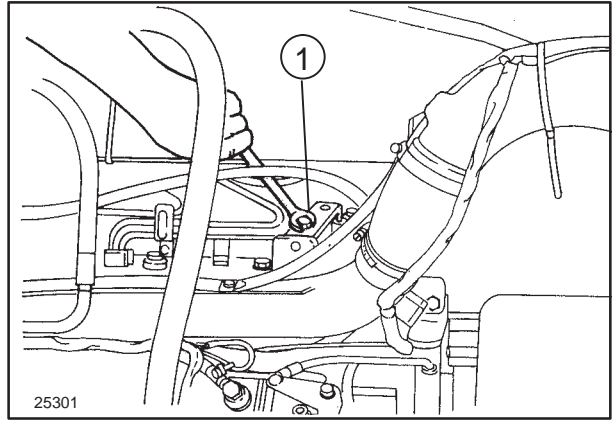

259

7. Unscrew the union (1) of the high-pressure fuel line on the injector.

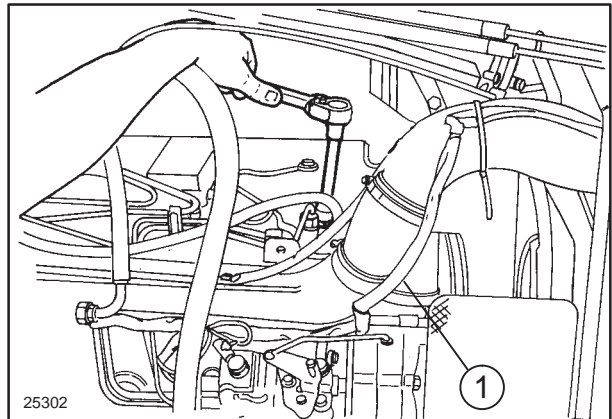

260

8. Unscrew the two retaining nuts (1) and withdraw the injector.

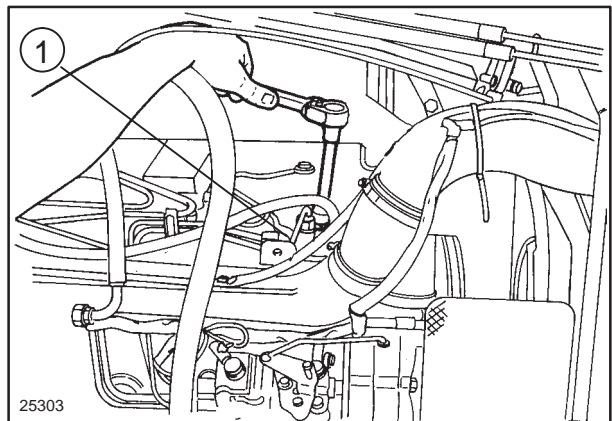

261

To refit the injector, proceed as follows:

- Insert the injector into its seat.
- Replace and tighten the two retaining nuts in two stages. 1st stage: tighten nuts to 10 Nm (7.3756 ft lb) 2nd stage: tighten nuts to 25 Nm (18.4390 ft lb).
- Reconnect the fuel leak-off pipe union.
- Reconnect the high-pressure fuel line union.
- Replace the bonnet.
- Reconnect the battery negative lead.

ADJUSTING VALVE CLEARANCE (Operation 10 106 12)



WARNING



Always use suitable tools to align holes in parts.
NEVER USE YOUR FINGERS OR HANDS.

1. Disconnect the battery negative cable.
2. Attach lifting chains to the bonnet (1) and then attach them to the hoist.

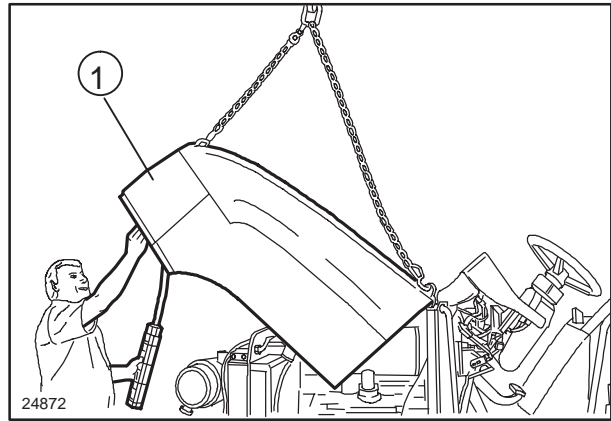

262

3. Disconnect the electrical leads (1) from headlamps (2).

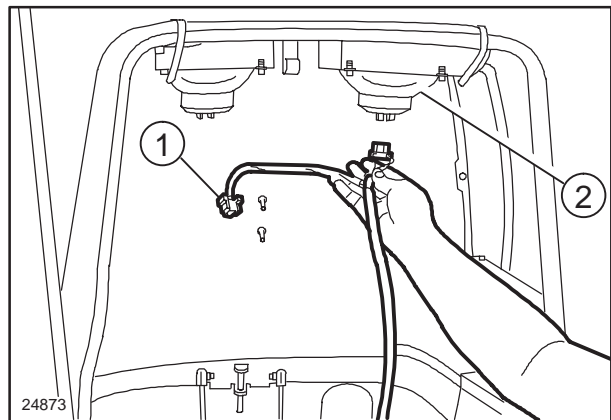

263

4. Detach the gas struts (1) from the bonnet.

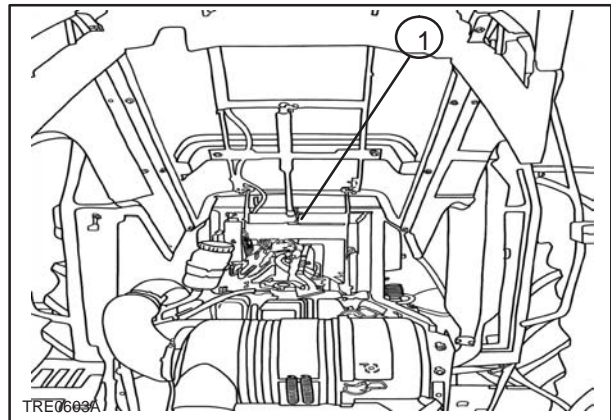

264

5. Remove the four bonnet hinge bolts (1) and lift the bonnet clear.

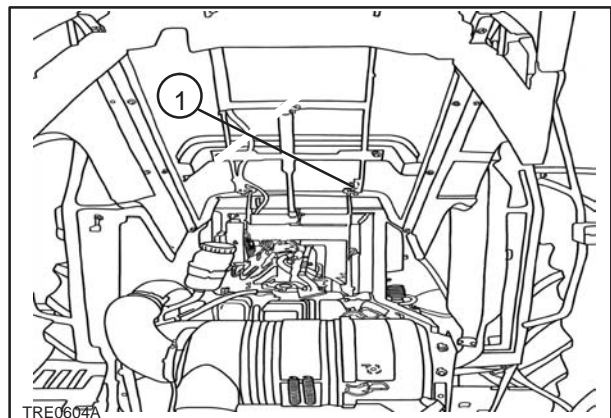

265

6. Undo the hose clamp and detach the hose from the silencer ejector.
7. Unscrew the two screws securing the silencer front support.
8. Unscrew the retaining nuts securing the silencer to the exhaust manifold and remove the silencer.

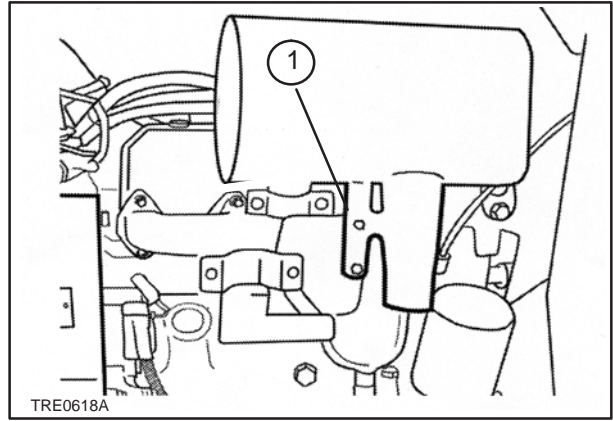

266

9. Unscrew the four rocker cover nuts (1) and remove cover.

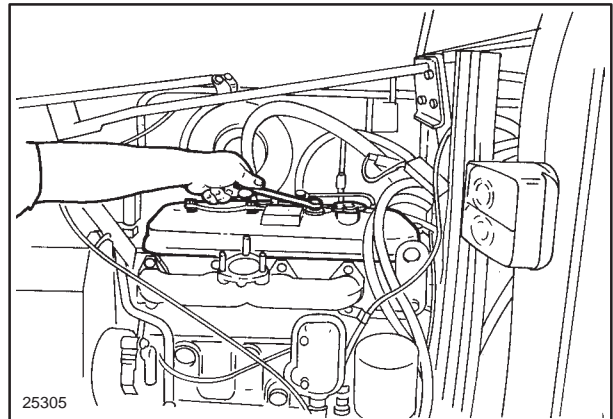

267

10. Remove the flywheel inspection window cover (1).

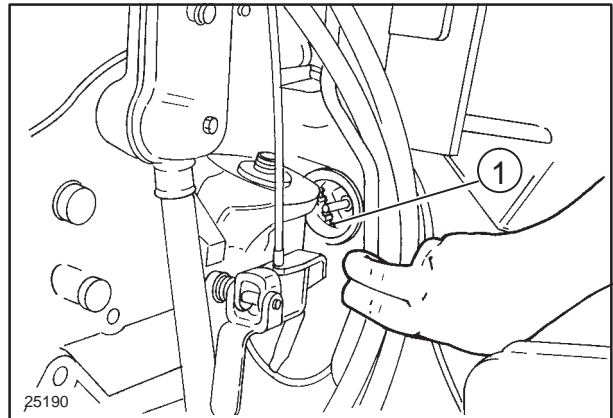

268

11. Adjust the clearance between the valves and the rocker arms using a feeler gauge, wrench (1) and the special tool 380000232 (2).

NOTE: Before proceeding with adjustment operations, position the valves as described on the following page.

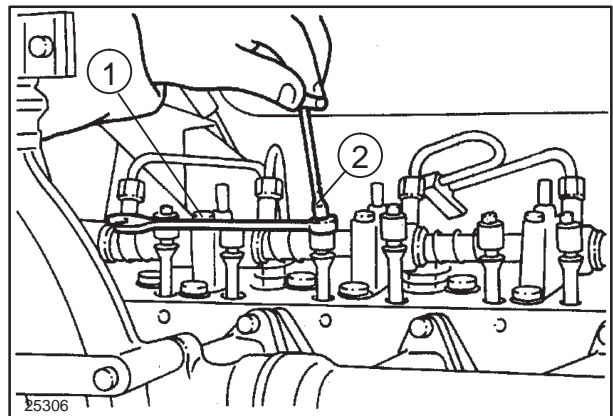

269

To adjust valve clearances on the 3-cylinder TD60D and TD70D engines, proceed as follows:

- Turn the crankshaft so that the inlet and exhaust valves of cylinder no. 1 are balanced (start of induction stroke). In this position the pointer will be aligned with the reference mark PMS 1 (TDC 1) on the flywheel.
- Rotate the crankshaft through a full revolution, returning to TDC 1, then check that the valve clearances correspond with the values specified in the table on page 4.
- Repeat this operation for the other valve pairs. Note that the TDC positions of cylinders 2 and 3 are not marked on the flywheel.

To check valve clearances on 4-cylinder TD80D, TD90D and TD95D models, proceed as follows:

- Turn the crankshaft so that the inlet and exhaust valves of cylinder no. 1 are balanced (start of induction stroke). In this position the pointer will be aligned with the reference mark PMS 1 (TDC 1) on the flywheel.
- Check that the clearance between valves and rocker arms on cylinder no. 4 corresponds with the values specified in the table on page 4. Rotate the crankshaft through 360° and check valve clearances on the opposing cylinder (No. 1).
- Repeat this operation for the other valve pairs. Note that the opposing cylinders are 1–4 and 2–3.

To reassemble proceed as follows:

- Refit the rocker cover.
- Refit the flywheel inspection window cover.
- Refit the exhaust silencer.
- Refit the bonnet.
- Reconnect the battery negative lead.

WATER PUMP – Overhaul (Operation 10 402 28)



WARNING

Use suitable tools for aligning holes. NEVER USE FINGERS OR HANDS.

NOTE: The bearing (9) forms a single piece with the control shaft (10). It is a sealed unit and requires no lubrication during running.

Overhaul the pump as follows:

- Remove the cover (4) fig. 270, and the shaft screw (2) retaining the shaft (10) and bearing (9).
- Gently tap the end of the shaft (10) fig. 270 on the rotor side (5) to break the film of oxide between the shaft and the rotor. Install the extractor **380000223** (1) fig. 271 and take out the rotor.
- Remove the front sealing bushing (7) fig. 270.
- Use a punch to extract from the pump housing (6) fig. 270 the shaft (10) complete with bearing (9) and the fan hub (1).

NOTE: Remove the seal (8) fig. 270 only when it needs to be changed.

Check components for wear, and change any that are in poor condition.

Refit the parts, proceeding as follows:

- Fit the shaft (10) fig. 270 complete with bearing (9) and hub (1) on the pump housing (6) and secure it with the retaining screw (2), having first coated it with LOCTITE 242.
- If changing the seal (8) fig. 270, fit the seal into the seat using tool **380000247** (1) fig. 272.
- Heat the rotor (1) fig. 270 in an air oven, until it reach a temperature of 130–150°C higher than the shaft (2).
- Place the rotor (1) on the shaft (2), easing it onto the end so as not to damage the bearing, until you obtain the operating clearance of $G = 0.5\text{--}0.7\text{ mm}$ (0.0197–0.0276 in.) (see fig. 270).
- Fit the seal (3) fig. 270 and the cover (4), securing it with the relevant screws.

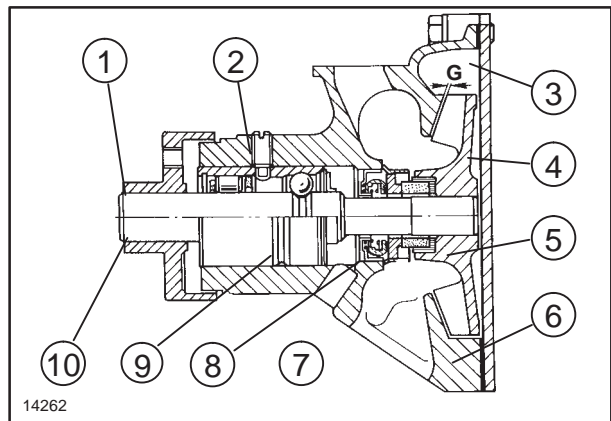

270

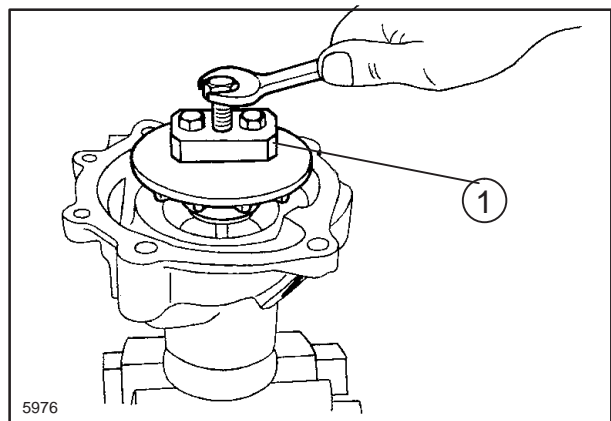

271

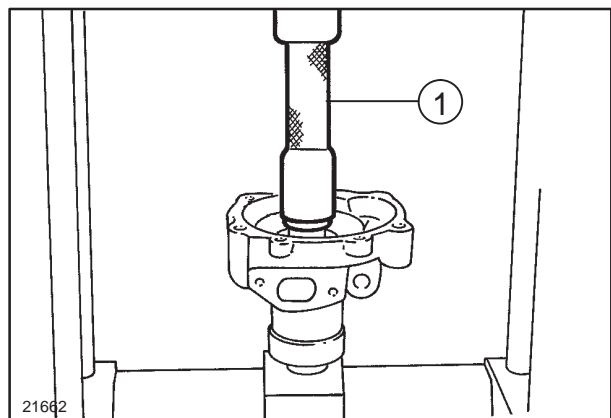

272

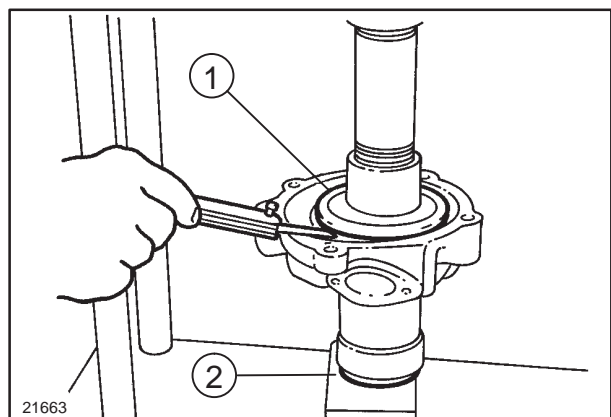

273

ENGINE**Compression test (Operation 10 001 30)**

In case of poor engine performance, in addition to checking the fuel injection system (injector nozzles and injection pump), also test the compression on each cylinder.

**DANGER**

Do not use matches, lighters, blow torches or any naked flame as a source of light when inspecting the engine due to the presence of inflammable fluids and vapour.

Compression ratio

The compression ratio is a measure of the quantity of air drawn into the cylinder and provides an indication of the efficiency of the sealing elements in the cylinder (piston rings and valves).

Uniform compression in all the cylinders ensures that they all perform an equal amount of work, provided of course that each cylinder is injected with the same quantity of fuel at the right time.

Low compression not only reduces engine performance, it also causes incomplete fuel combustion due to the lack of available combustion air.

The engine therefore gives poor performance with excessive fuel consumption, and consequently exhaust smoke and restriction of the exhaust passages.

As the compression ratio **also varies with the temperature of the engine** (cold engines produce lower compression values than hot engines) the compression should only be tested when the engine is at normal operating temperature.

Compression should be tested using the compression test kit **380000303** as follows:

- 1) Run the engine until it reaches normal operating temperature.
- 2) Switch off the engine.
- 3) Disconnect the lead from the engine stop solenoid on the injection pump in order to close the solenoid valve and block the flow of fuel to the injectors.
- 4) Remove the injector from the cylinder to be tested.

5) Turn the engine over a few times with the starter motor in order to expel any carbon residue.

6) Fit the dummy injector **380000617** in place of the injector removed previously, inserting the copper sealing washer.

7) Connect the compression tester **380000303** and take readings while turning the engine over with the starter motor.

On engines in perfect working order, with the sump oil at approx. 40°C, at sea level (760 mm (29.9212 in.) mercury) and at an engine speed of 200 – 280 rev/min, the compression should be 25.5 – 27.5 bar (369.84 to 406.1 psi).

8) Test the compression on the other cylinders, repeating steps 4, 5, 6 and 7, bearing in mind that:

The minimum permissible compression on a used engine is 21.6 bar (313.28 psi).

The maximum permissible compression difference between cylinders is 3 bar (43.51 psi).

Every 100 metres above sea level corresponds to a reduction in compression by about 1%.

CONSIDERATIONS:**Uniform compression**

Although high compression is important, it is more important as regards smooth running that the compression is the same in all cylinders.

Low compression readings

If very low compression readings are obtained on one cylinder it is advisable to repeat the test.

Before testing this time, pour about a spoonful of engine oil into the cylinder through the injector bore.

Turn the engine over a few times to distribute the oil evenly over the cylinder walls, and then repeat the test.

If the second test readings are significantly higher, suspect worn piston rings, out-of-round or damaged pistons or liners.

If the second test readings are not higher, the problem will be the valves.

On the other hand, if the second test reading shows only a slight improvement, the problem will be due to both the valves and the rings.

SECTION 18 – CLUTCH

Chapter 1 – Clutch

CONTENT

Section	Description	Page
18 000	General specifications	1
	Tightening torques	2
	Tools	3
	Cross-sectional views	4
	Clutch Troubleshooting	5
18 110 10	Removal – Installation	6
	Overhaul	14
	Minimum permissible dimensions after refacing	18
	Adjustments	19
18 100 40	Adjustment of the main and PTO clutch control linkage	21

GENERAL SPECIFICATIONS, CLUTCH 11”/11”

(Models TD60D, TD70D, TD80D and TD90D)

Type		Dual clutch consisting of two single dry plate clutches
Mechanical		control: pedal operation for main clutch and hand lever for power take-off clutch
Engagement and release mechanism		single Belleville spring
Driven plate lining material for main transmission clutch (11”)		Organic agglomerate
Models TD60D and TD70D		cerametallic
Models TD80D and TD90D		
Driven plate lining material for PTO clutch (11”)		Organic agglomerate
Models TD60D, TD70D, TD80D and TD90D		
Driven plate thickness:		
. main clutch (9, fig. 1)		
. VALEO	mm	10.2 to 10.8
. Organic agglomerate and cerametallic	(in.)	(0.4016 to 0.4252)
. PTO clutch (11, fig. 1)		
. VALEO	mm	7.3 to 7.9
. Organic agglomerate and cerametallic	(in.)	(0.2874 – 0.3110)
. wear limit	"	See pages 18
Clearance between main clutch release sleeve and related seat ..	mm	0.050 to 0.151
	(in.)	(0.0020 to 0.0059)
Clearance between PTO clutch release sleeve and related seat ..	mm	0.050 to 0.151
	(in.)	(0.0020 to 0.0059)
Release lever coplanarity adjustment		See page 19
Clutch control adjustment		See page 21

GENERAL SPECIFICATIONS, CLUTCH 11”/11”

(Model TD95D)

Type		Dual clutch consisting of two single dry plate clutches
Mechanical		control: pedal operation for main clutch and hand lever for power take-off clutch
Engagement and release mechanism		single Belleville spring
Driven plate lining material for main transmission clutch (12”) Model TD95D		Cerametallic
Driven plate lining material for PTO clutch (12”) Models TD95D		Organic agglomerate
Driven plate thickness: . main clutch (9, fig. 1) . VALEO . Organic agglomerate and cerametallic mm (in.)		10.2 to 10.8 (0.4016 to 0.4252)
. PTO clutch (11, fig. 1) . VALEO	mm (in.)	7.3 to 7.9 (0.2874 – 0.3110)
. wear limit	”	See pages 18
Clearance between main clutch release sleeve and related seat mm (in.)		0.050 to 0.151 (0.0020 to 0.0059)
Clearance between PTO clutch release sleeve and related seat mm (in.)		0.050 to 0.151 (0.0020 to 0.0059)
Release lever coplanarity adjustment		See page 19
Clutch control adjustment		See page 21

TIGHTENING TORQUES

PART	Thread	Tightening torque	
		Nm	ft lb
Clutch/flywheel retaining bolts – mod. TD60D, TD70D, TD80D and TD90D	M 8 x 1.25	25	18.439
– mod. TD95D	M 10 x 1.25	59	43.5162
Release command fork securing bolt (C ₃ , page 4)	M 16 x 1.5	157	115.7972
Retaining bolts securing clutch casing to engine (C ₂ , page 4) . . .	M 12 x 1.25	98	72.2811
Clutch casing/engine retaining nuts (3, fig. 1 page 4)	M 12 x 1.25	98	72.2811
Nut for sleeve cover fixing stud (C ₆ , page 4)	M 8 x 1.25	17	12.8355

TOOLS

List of specific tools required for the various operations described in this Section.

380000236 Tractor disassembly stand.

380000612 11"/11" clutch adjustment kit (pin and gauge).

380000292 Dowel for centring and adjustment of 12"/12" clutches.

380000293 12"/12 Clutch adjustment gauge.

293650 Clutch overhaul outfit.

380000458 Press for clutch lever release test.

LONGITUDINAL SECTION OF CLUTCH VALEO

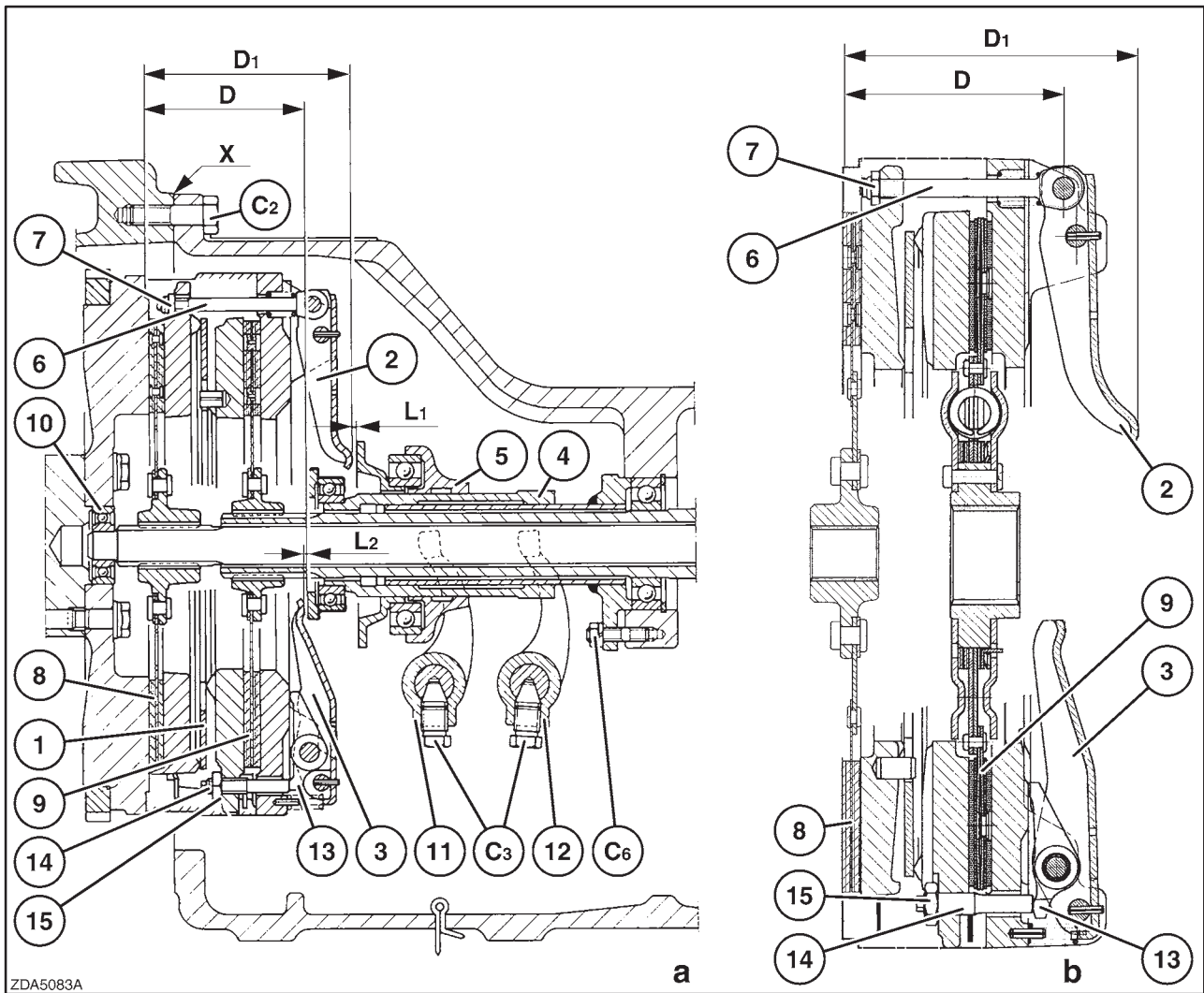

a . Main clutch with driven disc made of organic material.

b . Main clutch with driven disc made of cerametallic.

C₂ Bolts securing clutch casing to the engine.

C₃ Fork lever retaining bolts.

C₆ Nuts for sleeve studs.

D . Nominal distance of lever (3) from clutch contact surface on flywheel (mod. TD60D, TD70D, TD80D and TD90D, 11"/11" clutch **98 mm (3.8583 in.)** – mod. TD95D 12"/12" clutch **103 mm (4.0551 in.)**).

D₁ Nominal distance of lever (2) from clutch contact surface on flywheel (mod. TD60D, TD70D, TD80D and TD90D, 11"/11" clutch **123 mm (4.8425 in.)** – mod. TD95D 12"/12" clutch **137 mm (5.3937 in.)**).

L₁ Clearance between PTO release lever and related thrust bearing **2 mm (0.0787 in.)**.

L₂ Clearance between main clutch release lever and related thrust bearing **2.5 mm (0.0984 in.)**.

1. Belleville spring.

2. PTO clutch release lever.

3. Main clutch release lever.

4. Main clutch release sleeve, complete with thrust bearings.

5. PTO clutch release sleeve, complete with thrust bearings.

6. Power take-off clutch release lever adjustment tie rod.

7. Power take-off clutch release lever stop nut.

8. Power take-off clutch plate.

9. Main transmission clutch plate.

10. Bearing on flywheel.

11. PTO clutch release sleeve control fork.

12. Main clutch release sleeve control fork.

13. Main clutch release lever adjuster lever.

14. Main clutch release lever adjuster screw.

15. Main clutch release lever adjuster nut.

WARNING: When refitting the clutch, check that the clutch plates are positioned as in the drawing.

NOTE: When refitting, carefully clean and degrease the mating surfaces X and apply sealing compound.

CLUTCH TROUBLESHOOTING

Problems	Possible causes	Correction
Clutch slips	<ol style="list-style-type: none"> 1. Worn clutch plates (8 and 9, page 4) and/or worn pressure plate and flywheel. 2. Belleville spring (1, page 4) distorted or otherwise damaged. 3. Friction linings of discs (8 and 9, page 4) contaminated with oil and grease. 	<p>Check and compare the data given on the pages indicated; replace any parts which are worn up to or over the limit and adjust levers and clutch control linkage.</p> <p>Replace the Belleville spring.</p> <p>Replace discs; identify and eliminate the source of lubricant inside the clutch housing and thoroughly clean the friction surfaces.</p>
Fierce clutch	<ol style="list-style-type: none"> 1. Partial seizure of the external control linkage. 2. Friction disc (9, page 4) distorted. 3. Friction disc (9, page 4) with damaged hub springs or loose hub rivets. 4. Oil or grease contaminating the friction lining of discs (8 and 9, page 4). 	<p>Check linkage pivots and lubricate.</p> <p>Replace disc and adjust clutch control lever.</p> <p>Replace friction disc.</p> <p>Replace the discs, identify and eliminate the source of lubricant inside the clutch housing and thoroughly clean the friction surfaces.</p>
Clutch sticks and drags	<ol style="list-style-type: none"> 1. Disc friction linings (8 and 9, page 4) or discs deformed. 2. Seizure of the external control linkage. 3. Controls badly adjusted. 	<p>Replace and adjust the discs.</p> <p>Check, replace defective parts and lubricate.</p> <p>Adjust controls (see page 21).</p>
Clutch noisy when engaged and/or disengaged	<ol style="list-style-type: none"> 1. Thrust bearing worn. 2. Friction disc (9, page 4) with damaged hub springs or loose hub rivets. 	<p>Replace bearing.</p> <p>Replace friction disc.</p>
Clutch pedal too stiff	<ol style="list-style-type: none"> 1. Partial seizure of external control linkages. 2. Stiffening of pedal pivot. 	<p>Check linkage pivots and lubricate.</p> <p>Check pivot and lubricate.</p>

CLUTCH**Removal–Refitting (Operation 18 110 10)**

To access the clutch it is necessary to separate the engine complete with the front axle from the transmission.

**DANGER**

Lift and handle all heavy parts using suitable lifting equipment.

Make sure that assemblies or parts are supported by means of suitable slings and hooks. Check that no one is in the vicinity of the load to be lifted.

**ATTENTION**

Always use suitable tools to align holes. NEVER USE FINGERS OR HANDS.

Proceed as follows:

1. Disconnect the battery negative cable.
2. Drain off the oil from the gearbox/transmission casing.
3. Drain off the coolant from the engine cooling system.
4. Disconnect two flexible hoses from the power steering control cylinder and drain off the oil from the steering system.
5. Remove the front ballast (1).

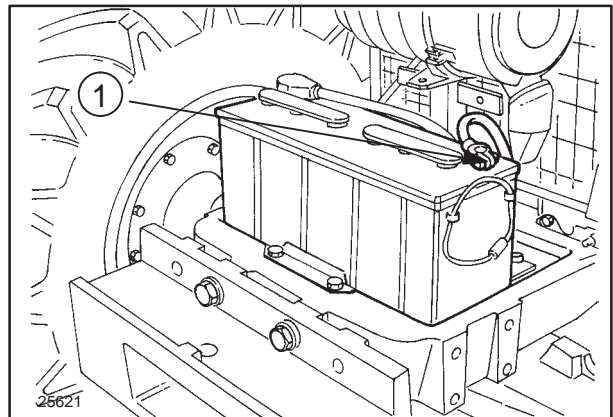

2

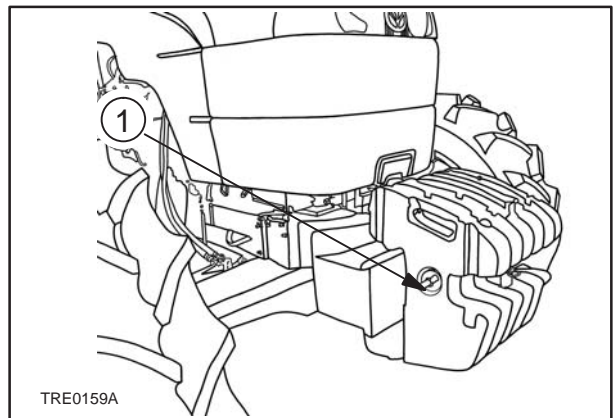

3

6. To access the engine, the bonnet must be opened.

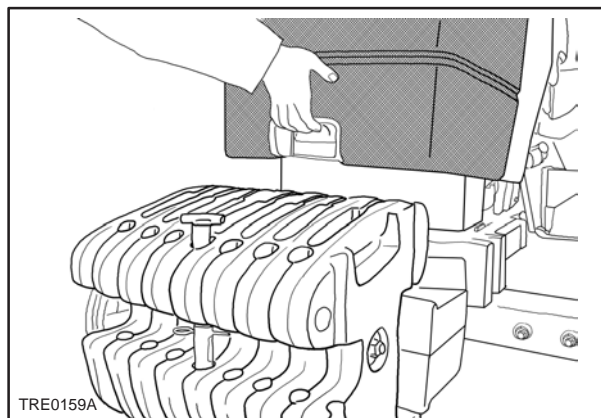

4

7. Remove the electrical connections (1).

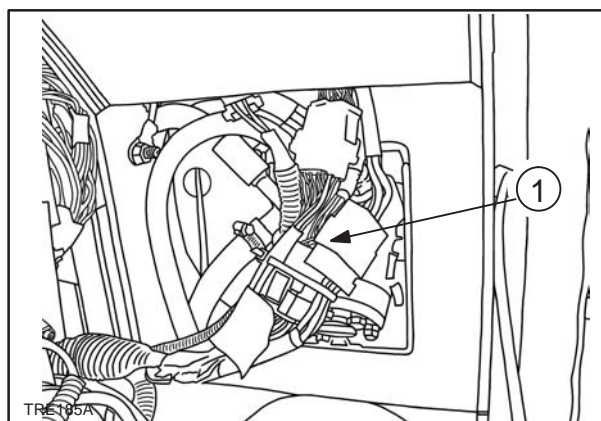

5

8. After draining off the oil from the power steering tank, disconnect the oil pipes (1) from the hydrostatic steering control valve unit.

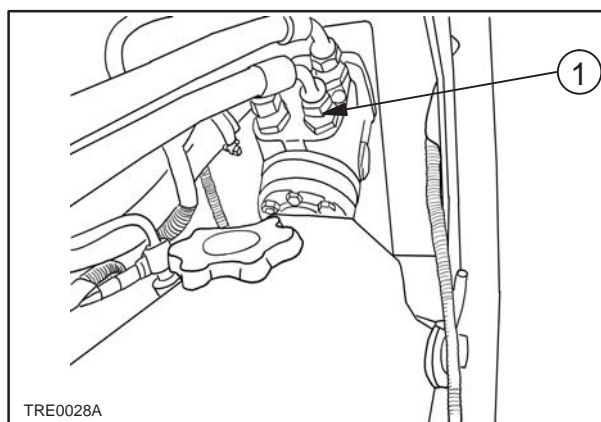

6

9. Disconnect the multimeter cable (1) from the engine and undo the mounting retaining bolt (2).

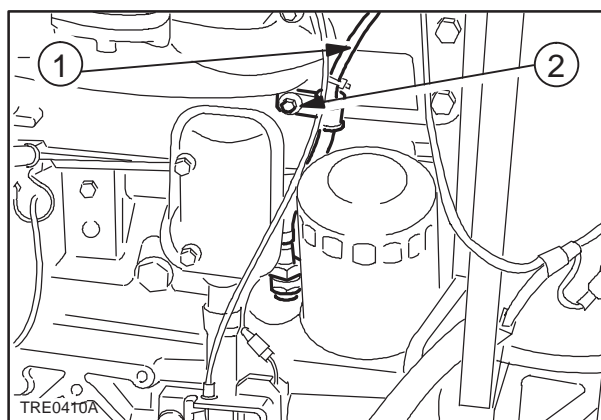

7

10. Detach the throttle control spring (1) and remove the throttle lever (2).

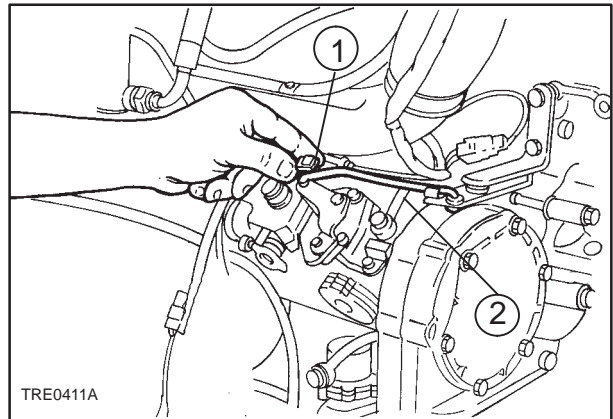

8

11. After recovering the air-conditioner gas (HRC _ 134a) with the **recovery and recycling station 294048**, disconnect the pipes of the cab air conditioner (1).

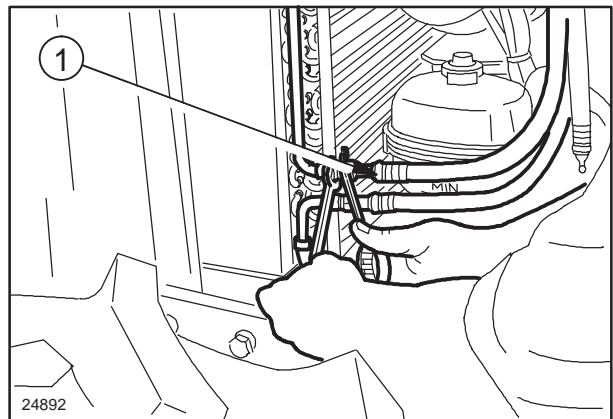

9

12. Slacken the clamps (1) and disconnect the cab heating pipes (2), being sure to mark them first.

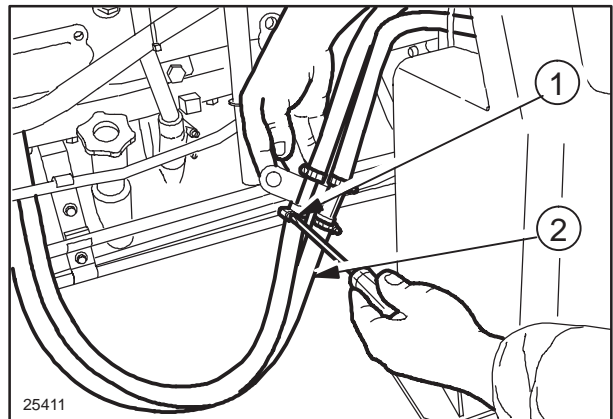

10

13. Remove the clamp (1) from around the pump and delivery pipes.

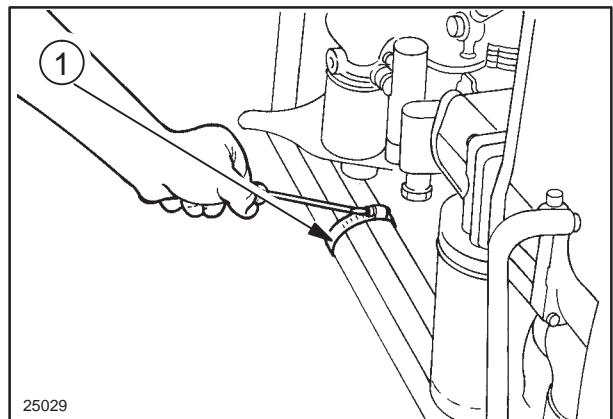

11

14. Disconnect the rubber connecting hose (1) of the hydraulic pump.

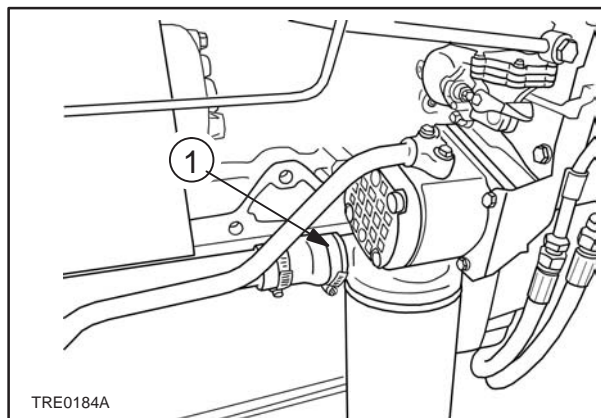

12

15. Disconnect the feed pump delivery line (1).

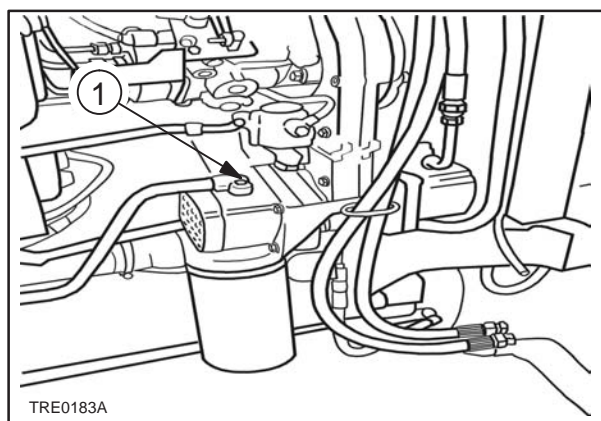

13

16. Disconnect the fuel line (1) from the glow plug.

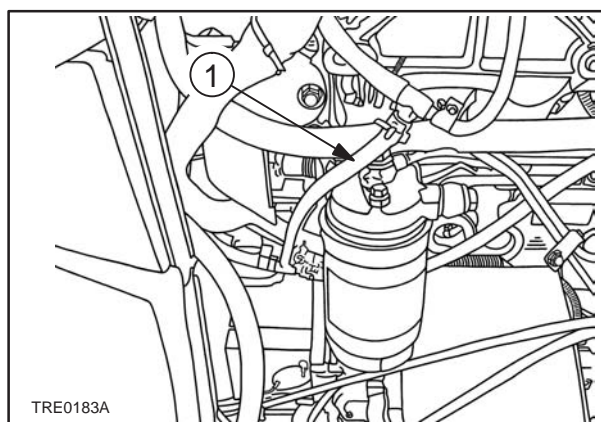

14

17. Remove the front, centre and rear screws securing the front axle prop shaft guard and remove the guard (1).

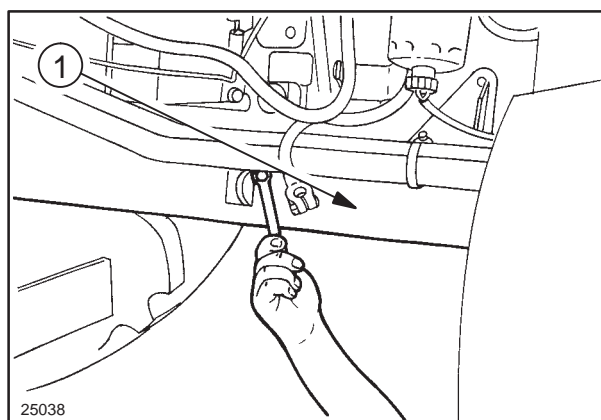

15

18. Remove circlip (2) and move sleeve (1) in the direction shown by the arrow to disengage it from the splined shaft of the front axle.

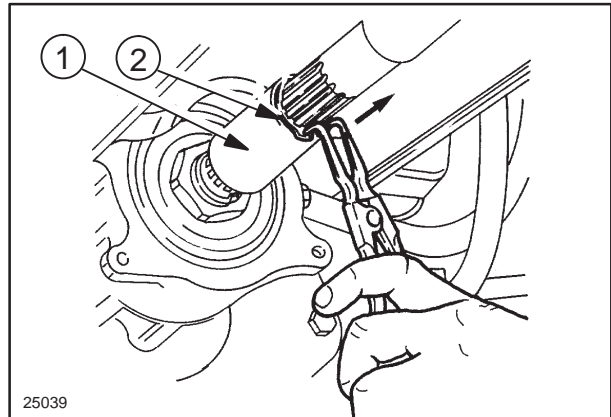

16

19. Remove circlip (2) and move sleeve (1) in the direction shown by the arrow to disengage it from the splined shaft of the drive.

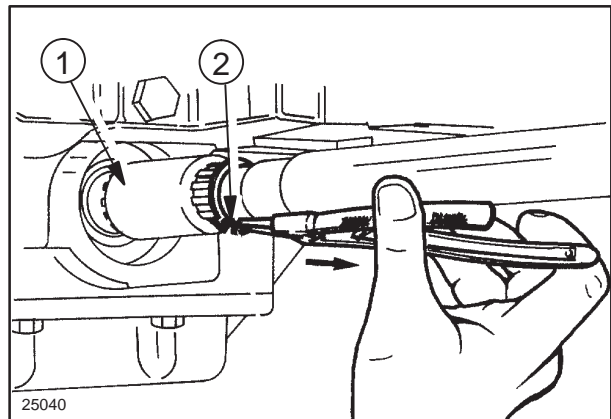

17

20. Remove the retaining bolts of the central support (1) of the prop shaft and recover the shaft complete with support.

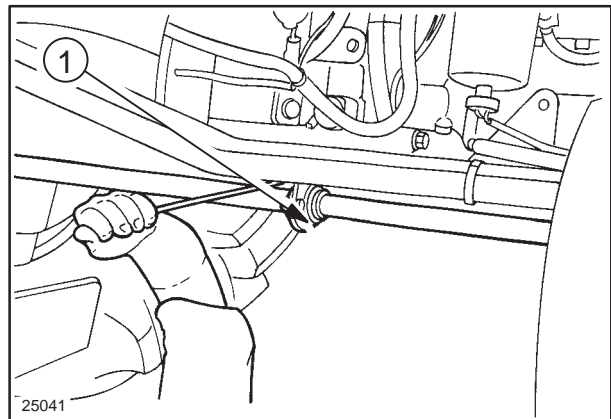

18

21. Withdraw the pin securing the differential lock knob, remove the knob and remove the mat from the cab floor (1).

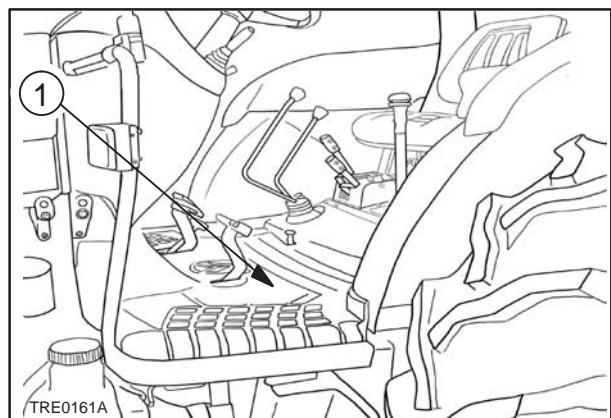

19

22. Unscrew the two nuts (1) and bolts securing the engine to the transmission, working through the two access slots.

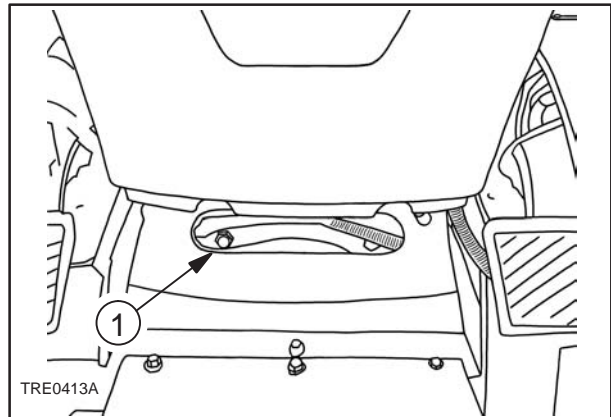

20

23. Unscrew the four lower bolts (1) securing the engine to the transmission.

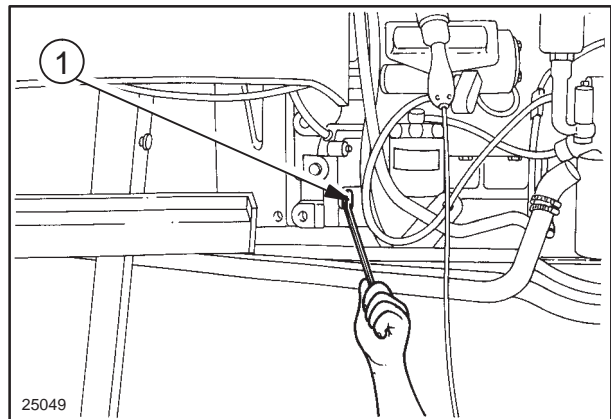

21

24. Position two wedges (3) on the front axle to prevent any movement of the engine about the axle pivot. Position the tractor dismantling stand **380000236**, so that the fixed support (1) is under the rear transmission housing in the area of the engine coupling flange and the mobile support (2) under the engine in the area of the flange attached to the transmission housing, as shown in fig. 23.

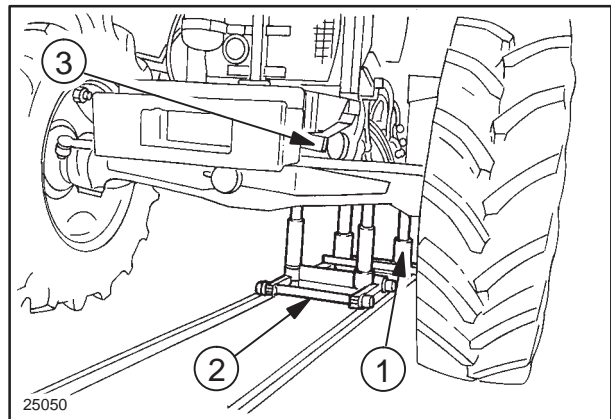

22

25. Place another mobile stand **380000236** under the front ballast carrier to prevent any possibility of the engine turning and tipping forwards when the gearbox case is removed.

26. Interpose wooden blocks (1) between the stands and the tractor, and turn the stand height adjustment screws to bring the blocks (1) into contact with the tractor.

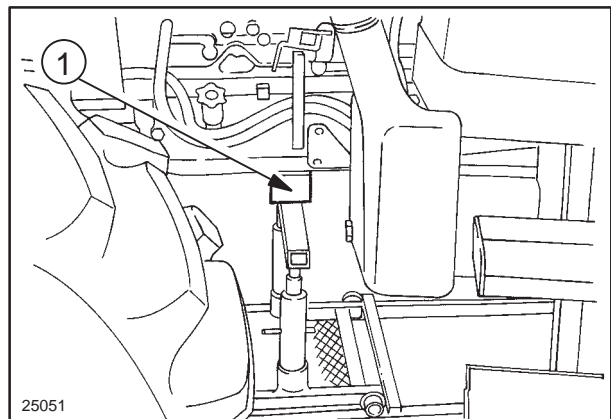

23

27. Position a fixed stand (1) under the draw bar support and pull on the hand brake.

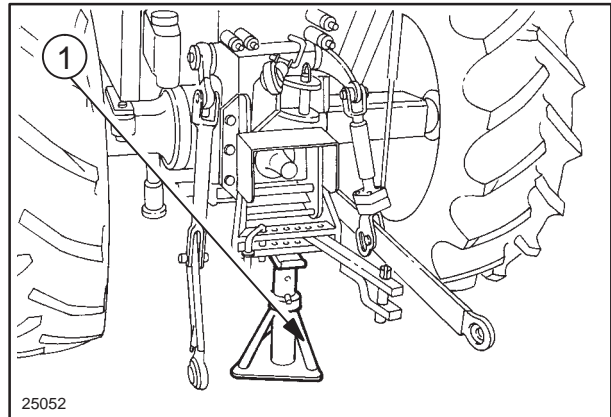

24

28. Remove the spacer collar (1) between the engine and the transmission (Model TD95D).

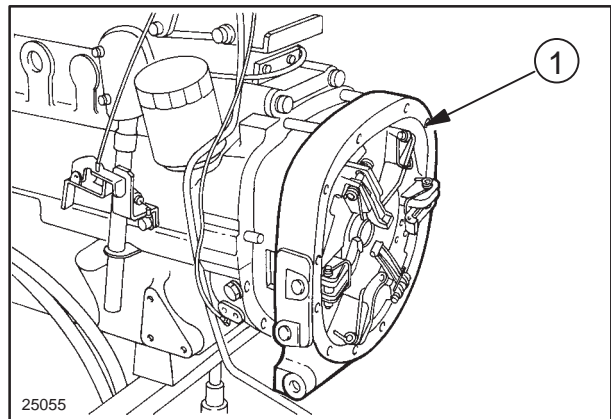

25

29. Using tool **380000612** (mod. TD60D, TD70D, TD80D and TD90D) or with tool **380000292** (mod. TD95D) (2), unscrew the retaining bolts (1) and remove the clutch.

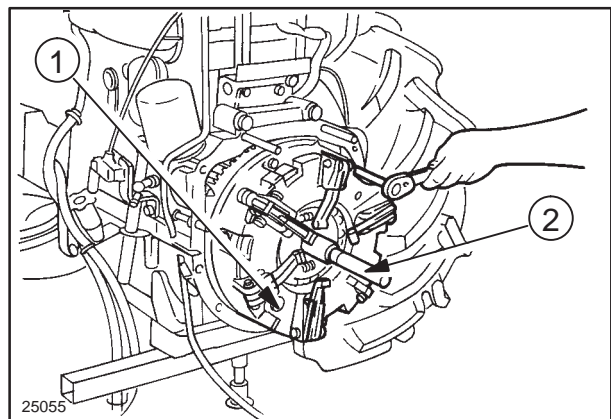

26

To re-install the engine, proceed as follows:

Check condition of ball bearings pressed in flywheel; replace in the event of excessive noise or binding. To install a new bearing pack, lubricate with grease.

Position the clutch using tool **380000612** (mod. TD60D, TD70D, TD80D and TD90D) or with tool **380000292** (mod. TD95D). Fix the clutch to the flywheel with the six bolts.

Adjust the coplanarity of the clutch release levers as described on page 20.

Clean the spacer collar and the mating surfaces of the clutch housing, and also scrape all residue of old sealing compound from the mating surface of the engine.

Spread LOCTITE compound on the mating surfaces of the engine and spacer collar. Install the spacer collar on the stud bolts screwed on the engine.

Before connecting the transmission casing to the engine – front axle assembly, grease the discs hubs.

Chock up the rear wheels with wooden wedges, check that the hand brake is fully on and that the fixed and mobile stands are well positioned.

Fit and tighten the bolts securing the clutch housing to the engine.

Make sure that no electrical leads or cables are trapped between the two units.

Next rotate the crankshaft by turning the cooling fan, so as to allow the sleeve to engage the splines on the power take-off shaft.

Remove the stands of tool **380000236** from under the engine and the gearbox/transmission and the stand under the draw bar.

Refit the cab heater pipe union on the clutch/engine spacer collar. Connect the flexible rubber hoses to the union.

Connect the flexible power steering pipes of the front axle and add oil to the system.

Connect the flexible pipe to the injector fuel leak-off pipe.

Refit the multimeter and secure the sleeve with the relative clamp.

Connect the compressor, condenser and filter/dryer inside the cab by connecting the pipes

Connect all the electrical connections.

Connect the throttle cable to the injection pump.

Refit the 4WD propeller shaft and the relative guard.

Refit the front ballast and secure with the vertical lock pin.

Fill the gearbox/transmission with oil.

Fill the engine cooling system with coolant.

Connect the battery negative lead.

OVERHAUL

The clutch is removed, refitted and adjusted with the universal outfit **293650**.

Parts of the universal outfit **293650** Necessary to adjust the VALEO clutch.

- A. Plate **293332**.
- B. Central spacer
293728. \varnothing 35mm (1.3779 in.) for 11"/11" clutch
293729. \varnothing 40mm (1.5748 in.) for 12"/12" clutch
- C. Gauge **293731**.
- D. Locknut **293730** for central spacer.
- E. Side spacers **293726**.
- F. Studs **293725**.
- I. Blocks.
- L. Handwheel **293739** securing the gauge.
- M. Handwheels **293740** securing the side spacers.
- N. Spacers for studs.

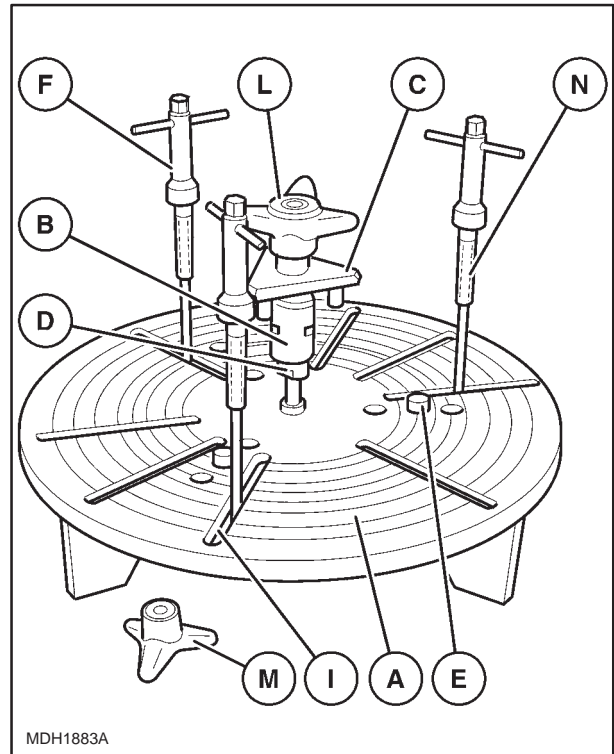

27

Note – Before fitting the clutch on the outfit **293650** it is advisable to remove the three bolts retaining the flexible tabs that drive the PTO clutch pressure plate ring from the supporting housing.

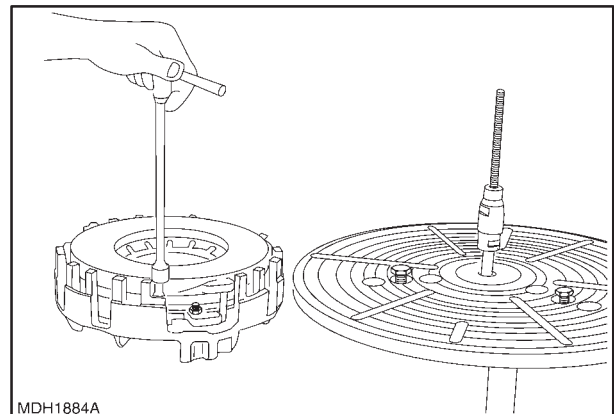

28

To fit the clutch on the universal outfit **293650** proceed as follows:

- place the central spacer (B) on the plate (A) and position it with the gauge bearing surface at a height of:

132 mm (5.1968 in.) (12”/12” clutches)

123 mm (4.8425 in.) (11”/11” clutch)

and lock it at this height with the locknut (D);

- measure the thickness (S) of the PTO driven disc of the relevant clutch and place the adjustable side spacers (E) on the circumference of 240 mm positioning them with the upper face at a height (h) given by:

$$h = R_v + S + B$$

where:

B additional distance to lower the PTO release levers by 9 mm so as to use the gauge **293731** (with a difference in height between the PTO release levers and the transmission release levers of 25 mm (0.9842 in.)) to check the coplanarity **2.2 mm (0.0886 in.)** for 12”/12” clutches (mod. TD95D)

no increase (already using gauge **293731**) for 11”/11” clutches (mod. TD60D, TD70D, TD80D and TD90D)

R_v flywheel external lowering distance

2 mm (0.0784 in.) for 11”/11” clutches (mod. TD60D, TD70D, TD80D and TD90D)

0.5 mm (0.0197 in.) for 12”/12” clutches (mod. TD95D)

S = measured thickness of the PTO driven disc;

- then lock the adjustable side spacers (E) with the relevant handwheels (M);
- rest the clutch assembly (of the PTO driven disc) with the PTO pressure plate on the plate and secure it with the three stud bolts (F, page 14), equipped with blocks (I) and spacers (N) of the necessary size.

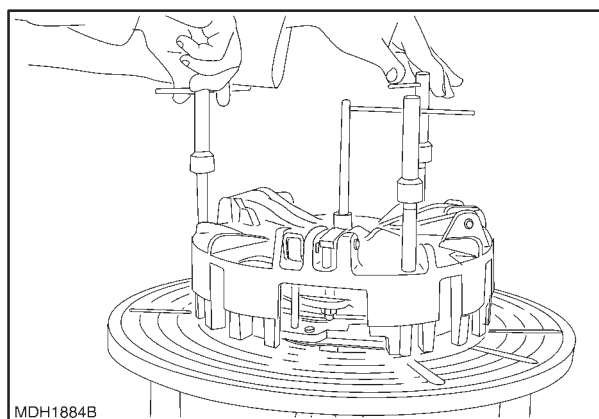

29

Remove the nuts (7; page 4) for the PTO clutch release lever adjuster tie rods and gradually unscrew the studs (F, page 14) thereby making it possible to extend the Belleville spring and break down the clutch into its parts.

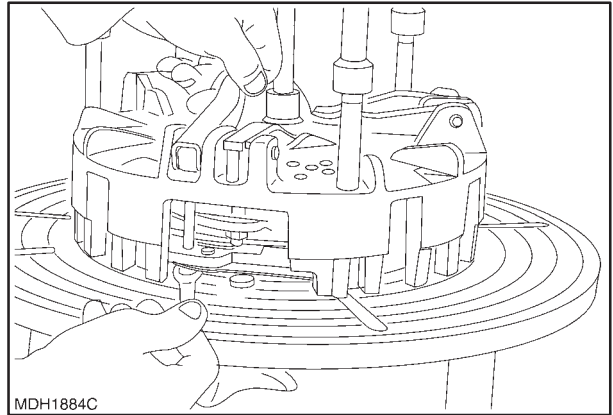

30

Remove the three bolts retaining the flexible tabs driving the main clutch pressure plate from the clutch carrier housing and retrieve the pressure plate.

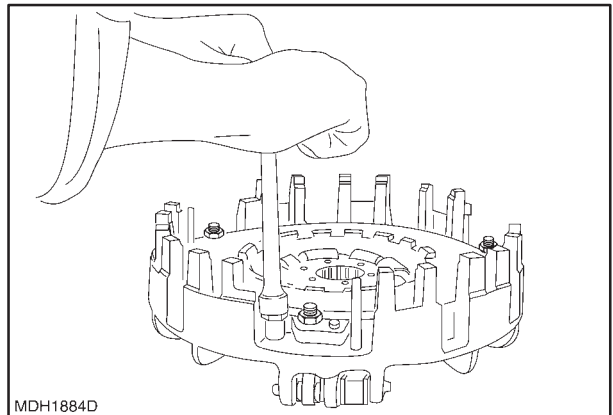

31



ATTENTION



When removing, overhauling and then refitting the clutch, pay special attention not to move the main clutch and PTO clutch pressure plate ring driving tables from their original assembly position on the pressure plate rings.

Check for wear on the clutch driven discs and replace them if the retaining rivets are worn down to or approaching the friction material. Replace the disc when the oil has soaked into the organic agglomerate surfaces.

Check the friction surface conditions of the pressure plates and the clutch casing.

If necessary, it is possible to reface them bearing in mind that the dimensions (A, B, C and D) of the refaced parts must not decrease beyond the limits shown in the figures below, in which case it would be necessary to replace the parts.

Proceed as follows:

- reface the surfaces of the pressure plates;
- replace damaged or worn discs;
- reface the surface of the clutch housing.

Calculate the distance (D), removing material from the bottom of the clutch housing, using the following formula.

$$D = A + B + S_1 + S_2 + P + L$$

where:

- A and B** = distances measured of the two pressure plates after refacing;
- S₁ and S₂** = measurements of the PTO and main clutch plates:
- L** = **2 mm (0.0784 in.)** for 11"/11" clutches mod. TD60D, TD70D, TD80D and TD90D
 = **0.5 mm (0.0197 in.)** for 12"/12" clutch mod. TD95D
 Lowering on the flywheel;
- P** = **4.20 ÷ 4.30 mm (0.1653 ÷ 0.1693 in.)** for 11"/11" clutch mod. TD60D, TD70D, TD80D and TD90D
 = **4.30 ÷ 4.40 mm (0.1693 ÷ 0.1732 in.)** for 12"/12" clutch mod. TD95D The dimension the spring must have to restore the original load.

- check that the value obtained (D) is greater than or equal to the measurement made on the clutch to overhaul and that, in order to be able to restore it, the distance (C, fig. 34 and 36) of the housing must not decrease under the stated value. If this is not so, replace one or both of the pressure plates.

For 11"/11" clutches, check that the distance (E) is greater than the value given on page 18 fig. 34 and restore it if necessary.

If required, pass the friction surface over the engine flywheel, remembering to restore the external lowering of the flywheel on completing this process.

Refit the parts of the clutch using the specific tools of outfit **293650** and taking care to:

- position the Belleville spring (1) correctly on the main clutch pressure plate (3), making the centring dowels (2) correspond with the notches (4);
- adjust the clutch as directed below.

Note – When reassembling, tighten the six bolts fastening the flexible tabs driving the main and PTO clutch pressure plates to the supporting housing to a torque of 1.5 Nm (2.0337 ft lb).

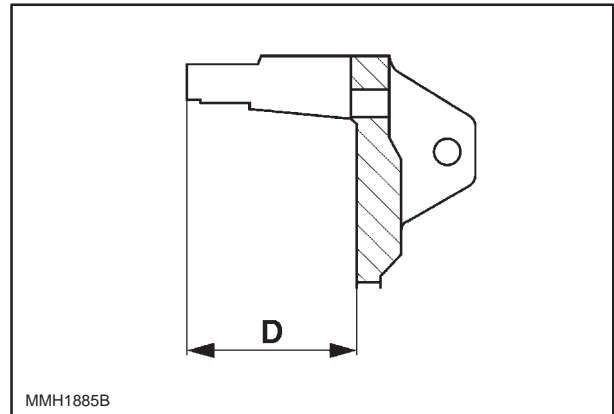

32

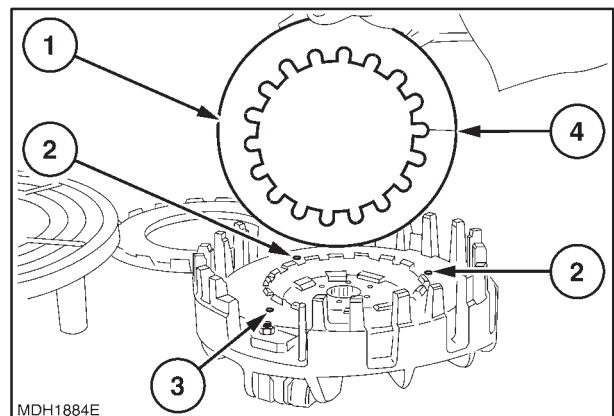

33

**MINIMUM PERMISSIBLE DIMENSIONS
AFTER REFACING PARTS SUBJECT TO
WEAR FOR VALEO CLUTCHES**

11”/11” dual clutches

If it is necessary to reface the friction surface on the flywheel, bear in mind that the maximum amount that can be removed in relation to the nominal thickness is 1 mm (0.0394 in.).

Once terminated, moreover, the external lowering will need to be restored to 2 mm (0.0784 in.) (see fig. 34).

- 11”/11” dual clutch
mod. TD60D, TD70D, TD80D, TD90D

- A. ≥12.50 mm (0.4921 in.)
- B. ≥20.00 mm (0.7874 in.)
- C. ≥18.00 mm (0.7087 in.)
- D. ≥12.50 mm (0.4921 in.)
- E. ≥2.50 mm (0.0984 in.)

- 1. Engine flywheel.
- 2. PTO clutch pressure plate.
- 3. Main transmission clutch pressure plate.
- 4. Supporting housing.

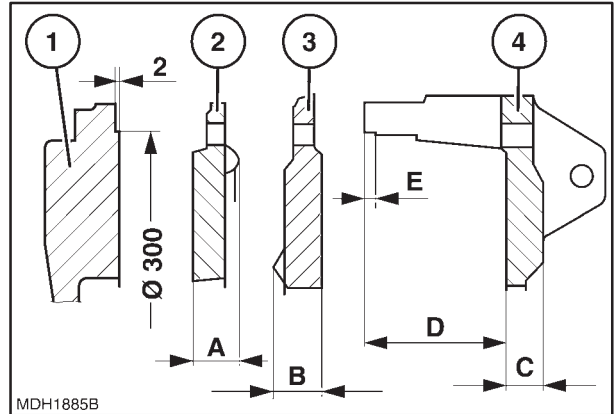

34

12”/12” dual clutches

If it is necessary to reface the friction surface on the flywheel, bear in mind that the maximum amount that can be removed in relation to the nominal thickness is 1 mm (0.0394 in.).

Once terminated, the external refacing will need to be re-set to 0.5 mm (0.0197 in.), as shown in figure 35 and 36.

- A. = 352 E8 mm (13.8582 in.)
- B. = 313 mm (12.3228 in.)
- C. = 73.5 mm (2.8937 in.)

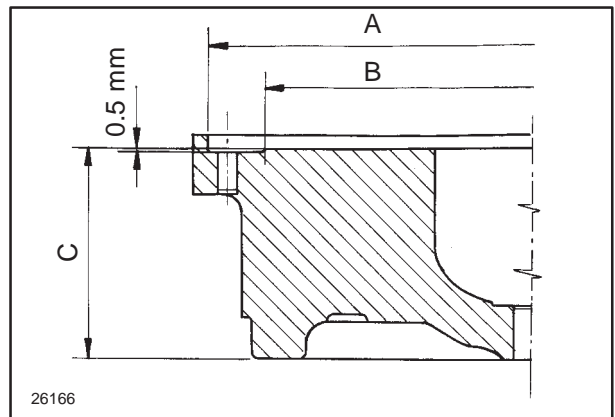

35

- 12”/12” dual clutch
mod. TD95D

- A. ≥15.50 mm (0.6102 in.)
- B. ≥21.50 mm (0.8464 in.)
- C. ≥20.50 mm (0.4921 in.)
- D. ≥12.50 mm (0.8071 in.)

- 1. Engine flywheel.
- 2. PTO clutch pressure plate.
- 3. Main transmission clutch pressure plate.
- 4. Supporting housing.

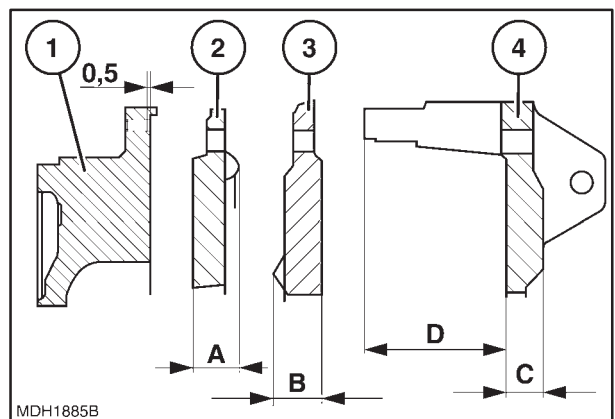

36

ADJUSTING THE VALEO CLUTCH

To adjust the clutch correctly it is necessary for the release levers to be coplanar and set at the distances (D and D_1 , page 4) in relation to the bearing surface on the engine flywheel.

NOTE: For the 12"/12" clutches the distance D_1 is reduced by **9 mm (0.3543 in.)** ($137 - 9 = 128$ mm ($5.3937 - 0.3543 = 5.0394$ in.), see page 15.), lowering distance of the point of contact with the thrust bearing of the PTO release levers so as to use the gauge **293731** where the difference between the release levers is 25 mm (0.9842 in.).

The adjustment can be made indistinctly with the clutch on the bench or fitted on the engine flywheel.

1. Adjustment with clutch on bench.

Set the clutch on the plate of the universal outfit **293650** and lock it using the parts as described above for disassembly.

Fit the gauge (C) and lock it with the handwheel (L) for the universal outfit **293650**.

Screw in or unscrew the adjuster screws (2) of the release levers for the main clutch (1) to obtain the clearance (V_1) between the ends of the gauge pins (C) and the main clutch release levers. Then lock the screws with the nuts (3).

C. Gauge.

L. Handwheel **293739**.

$V_1 = 0.1$ mm (0.0039 in.) Clearance to obtain between the ends of the gauge pins (C) and release levers (1) for 11"/11" clutch (mod. TD60D, TD70D, TD80D, TD90D) or:
= **0.1 mm (0.0039 in.)** for 12"/12" clutch (mod. TD95D).

1. Release levers.
2. Hex wrench.
3. Adjuster screw and locknut.

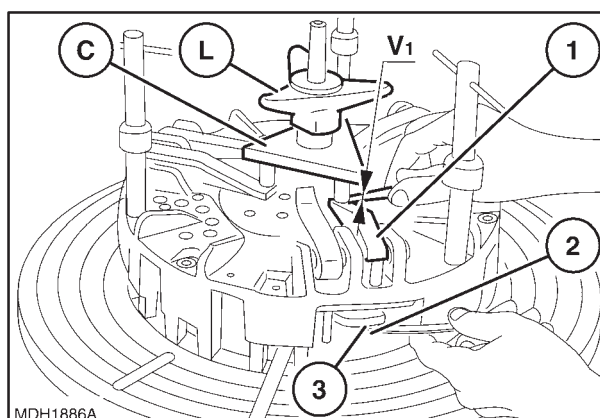

37

Screw in or unscrew the nuts (2) for the adjuster tie rods of the release levers for the PTO clutch (1) to obtain the clearance (V_2) between the end of each release lever and the face of the gauge (C).

C. Gauge.

L. Handwheel **293739**.

$V_2 = 0.1$ mm (0.0039 in.) Clearance to obtain between the gauge face (C) and release levers (1) for 11"/11" clutch (mod. TD60D, TD70D, TD80D, TD90D) or:
0.1 mm (0.0039 in.) for 12"/12" clutch (mod. TD95D).

1. Release levers.
2. Adjuster nut.

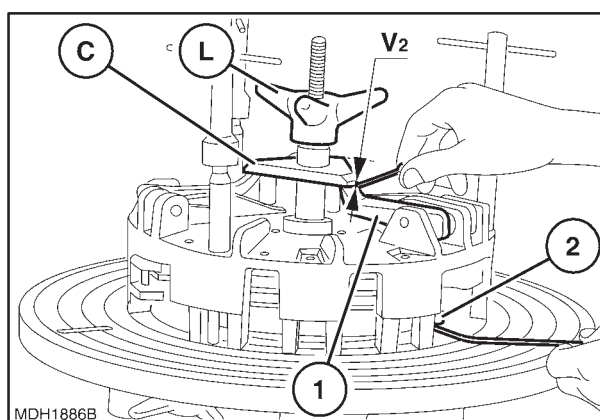

38

After adjusting the clutch lever, remove the hand-wheel (L, page 14) for the universal outfit **293650**. Fit the press **380000458** (P) on the plate of the outfit, adjust the length of the screws (1) so they are coplanar and rest on the release levers (3) of the PTO clutch and use the press lever (P), as shown in the figure, checking the PTO clutch gets released.

Then rest the screws (2) on the main clutch release levers (4) and check that this clutch gets released.

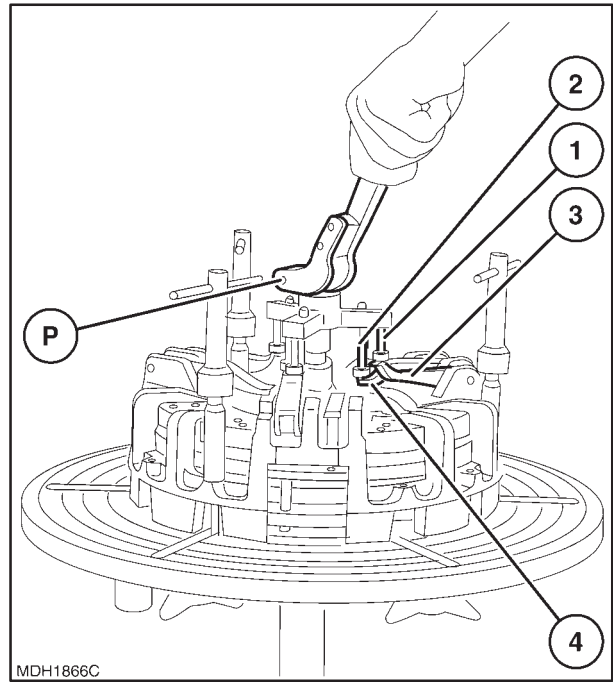

39

1. Adjustment with clutch fitted on engine fly-wheel

Insert the pin of the adjustment kit (pin T_1 with gauge T_2) **380000612** (11"/11", mod. TD60D, TD70D, TD80D and TD90D) or **380000292** (T_1 , for 12"/12" clutch, mod. TD95D) into the clutch driven disc shaft seats, making sure the end makes contact with the bearing (10, page 4) and press the relevant gauge against it **380000612** (T_2 , for 11"/11" clutch, mod. TD60D, TD70D, TD80D and TD90D) or **380000293** (T_2 , for 12"/12" clutch, mod. TD95D).

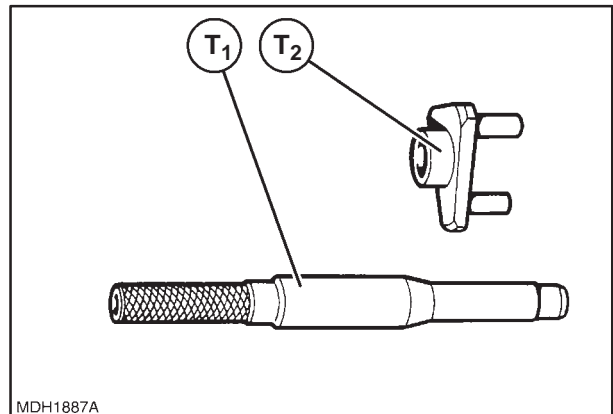

40

Then proceed as follows:

- screw in or unscrew the main clutch release lever adjuster screws so as to create a clearance between the end of the pins of the gauge (1) and the main clutch release levers of:

0.1 mm (0.0039 in.) for 11"/11" clutch
mod. TD60D, TD70D, TD80D, TD90D

8.1 mm (0.3189 in.) for 12"/12" clutch
mod. TD95D

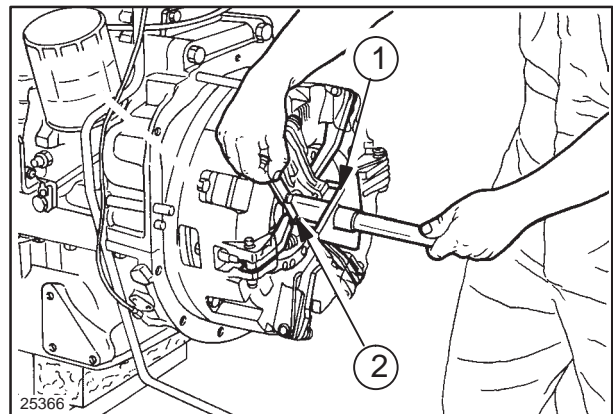

41

- screw in or unscrew the PTO clutch release lever adjuster screws so as to create a clearance between the end of the gauge face (1) and the PTO clutch release levers (2) of:

0.1 mm (0.0039 in.) for 11"/11" clutch

mod. TD60D, TD70D, TD80D, TD90D

8.1 mm (0.3189 in.) for 12"/12" clutch

mod. TD95D

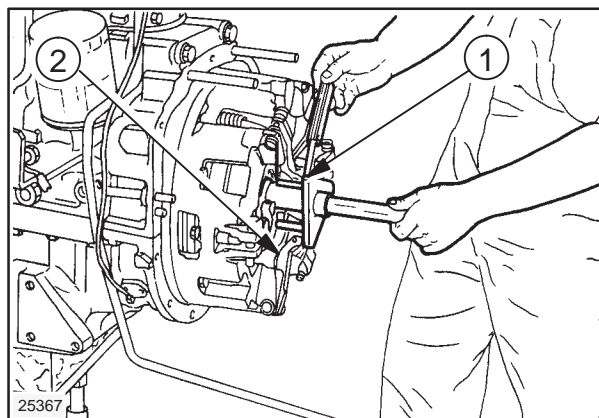

42

ADJUSTMENT OF THE MAIN CLUTCH CONTROL LINKAGE (Operation 18.100.40)

Check that pedal free travel before clutch release is approximately 25 mm. When free travel is down to 15 mm, adjust the clutch as follows:

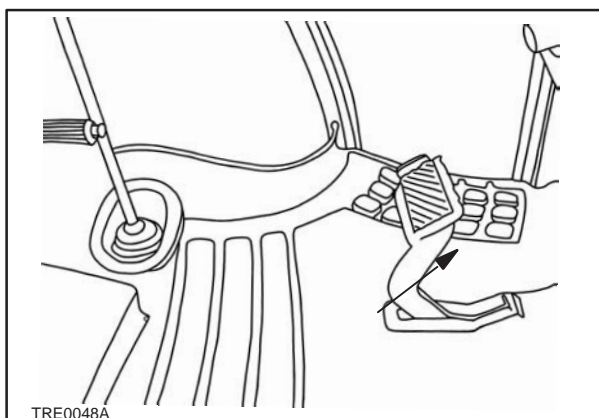

43

- Unscrew the locknut (1) and rotate sleeve (2) anticlockwise (each sleeve turn is equivalent to 12 mm in pedal displacement).
- Tighten locknut (1);
- Ensure that pedal free travel is 25 mm (0.9842 in.).

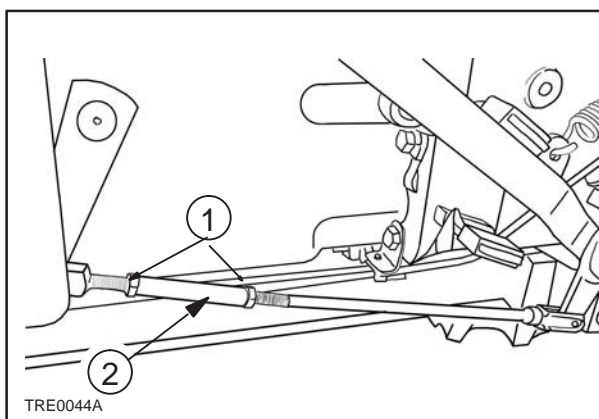

44

PTO CLUTCH LINKAGE ADJUSTMENT

The only clutch adjustment required is to check and, if necessary, adjust the clutch pedal free travel. This is the amount of pedal movement from fully released position (B) to the point where resistance is first encountered.

The clutch free travel (C, fig. 46) must be 4.5 mm (0.1772 in.). When this distance is down to 2.5 mm (0.0984 in.), adjust the clutch as follows:

- Move the PTO clutch lever (A) to position (B) (fully lowered).
- Loosen the locknut (1) and remove the split pin (2).
- Turn the sleeve (3) to lengthen or shorten the operating rod, as required.
- Lock the split pin (2) so as to restore the travel with no load to 4.5 mm (0.1772 in.) then tighten the locknut (1).

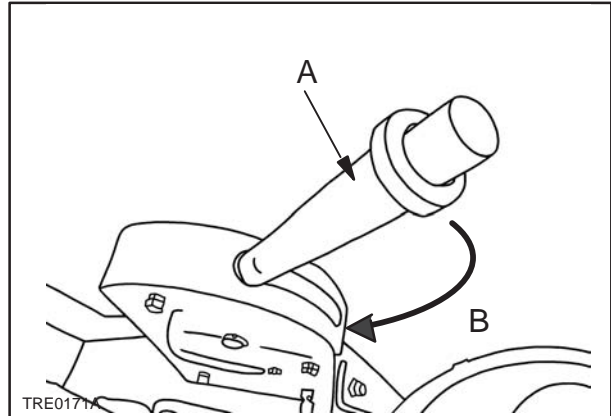

45

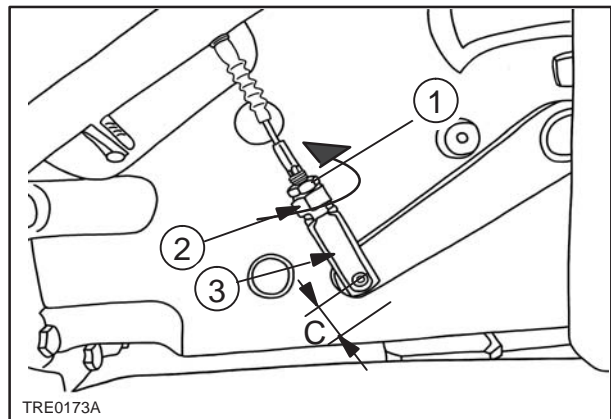

46

SECTION 21 - TRANSMISSIONS

Chapter 1 - Mechanical Transmission (12 x 4)

CONTENTS

Section	Description	Page
21 000	Main data	1
	Tightening torques	2
	Tools	3
	Section views	5
	Description and operation	8
	Fault diagnosis	8
21 110	Removal - Refitting	see sect 27

**21 000 - MAIN DATA - TIGHTENING TORQUES - SECTIONS - TOOL -
DESCRIPTION AND OPERATION - FAULT DIAGNOSIS**

MAIN DATA - GEARBOX AND RANGE GEAR

Gearbox		4-speed, constant-mesh with synchronisers on all gears
Gearing type		helical gears
Range gear		Ordinary gear train with 3 forward ranges and 1 reverse range those giving a total of 12 forward and 4 reverse speeds
- Gearing type		spur gears
- Reduction ratios :		
• Slow		$\frac{23 \times 17}{43 \times 50} = 1:(5.49)$
• Normal		$\frac{23 \times 27}{43 \times 34} = 1:(2.35)$
• Fast		1
Gearbox and range gear controls		Independent, hand operated levers located on right-hand side of operator
Thickness of gearbox driving shaft adjustment ring (5, page 5)	mm (in.)	3.00-3.25-3.50-3.75-4.00 (0.1181-0.128-0.1378-0.1476-0.1575)
Inside diameter of gearbox driven gears	mm (in.)	50.050 - 50.075 (1.9705 - 1.9715)
Outside diameter of bushings (17, page 5)	mm (in.)	49.925 - 49.950 (1.9655 - 1.9665)
Clearance between gears and bushings	mm (in.)	0.100 - 0.150 (0.0039 - 0.0059)
Diameter of gearbox driven shaft (19, page 5)	mm (in.)	39.175 - 39.191 (1.5423 - 1.5429)
Inside diameter of bushings (17, page 5)	mm (in.)	39.200 - 39.239 (1.5433 - 1.5448)
Clearance between shaft and bushings	mm (in.)	0.009 - 0.064 (0.0004 - 0.0025)

(continued overleaf)

TRANSMISSION AND RANGE GEAR MAIN DATA

(continued)

Diameter of power take off (PTO) clutch shaft (4, page 5)	mm (in.)	24.979 - 25.000 (0.9834 - 0.9843)
Inside diameter of fitted bushing (1, page 5)	mm (in.)	25.040 - 25.092 ⁽¹⁾ (0.9858 - 0.9879)
Clearance between PTO clutch shaft and relative bushing	mm (in.)	0.040 - 0.113 (0.0016 - 0.0044)
Interference fit between bushing on driving shaft	mm (in.)	0.037 - 0.091 (0.0015 - 0.0036)
Springs (16, page 7) for detent balls on gearbox and range gear control rods :		
- Spring free length	mm (in.)	30 (1.1811)
- Length of spring under load of 50-56 N (11.3148-12.5059 lb)	mm (in.)	25.5 (1.0039)
Gearbox and range gear control lever retaining springs:		
- Spring free length	mm (in.)	75 (2.9528)
- Length of spring under load of 94-104 N (21.1740-23.3796 lb)	mm (in.)	42 (1.6535)

(1) Measurement to obtain after fitting without reaming.

TORQUE VALUES

PARTS	Thread	Torque settings	
		Nm	ft lb
Retaining bolts for upper cover of rear transmission / gearbox (C ₁)	M 10 x 1.25	59	43.5162
Bolts for securing lift to rear transmission box (C ₂)	M 12 x 1.25	98	72.2811
Bolts for securing PTO box to transmission / gearbox (C ₃)	M 16 x 1.5	221	163.0012
Bolts for securing flexion bar to transmission / gearbox case (C ₄)	M 16 x 1.5	221	163.0012
Nuts for stud bolt securing final drive to transmission / gearbox (C ₅) .	M 12 x 1.25	98	72.2811
Nuts for securing steel plate disc to wheel drive hub (C ₆)	M 18 x 1.5	255	188.0783
Nuts for bolts securing steel plate disc to drive wheel rim (C ₇)	M 16 x 1.5	245	180.7027
Ring bevel gear retaining bolts (C ₈)	M 12 x 1.25	123	90.7201
Bevel gear pair support retaining bolts (C ₉)	M 10 x 1.25	59	43.5162

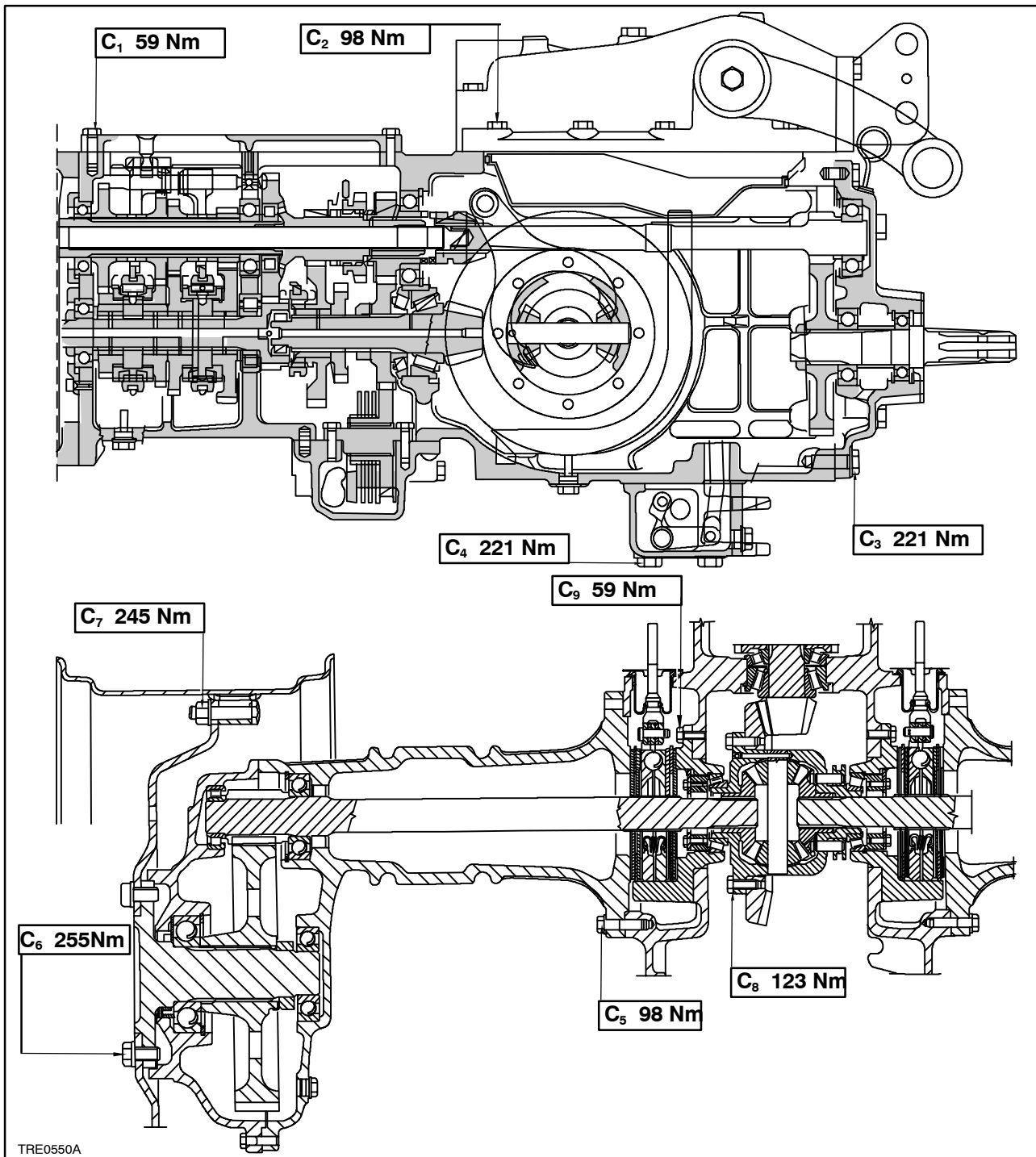

1

TOOLS

Warning - The operations described in this Section can only be carried out using the **ESSENTIAL** tools marked on the right side with an **(X)**.

However, for greater safety and to obtain the best results while saving time and effort, it is recommended that these essential tools are used together with the special tools listed here as well as certain tools which are to be made following the sectional drawings given in this manual.

List of special tools required for the various operations described in this Section:

- 380000236** Tractor dismantling trolley.
- 380000227** Clutch casing lifting hook.
- 380000301** Rotating overhaul stand.
- 380000271** Front bracket (with **380000301**).
- 380000272** Rear bracket (with **380000301**).
- X 380000838** Adaptor for removal of reverse gear pin (with **380000549**).

Drift to be made for removal of gearbox driving shaft (tool to be stamped no. **50006** - measurement in mm).
Make in material UNI C40.

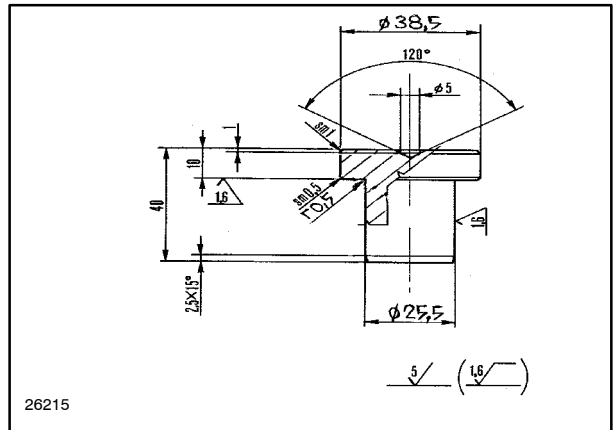

2

Tool to be made for adjustment of gearbox driving shaft bearings (tool be stamped no. **50007** - measurement in mm).
Make in material Aq 45.

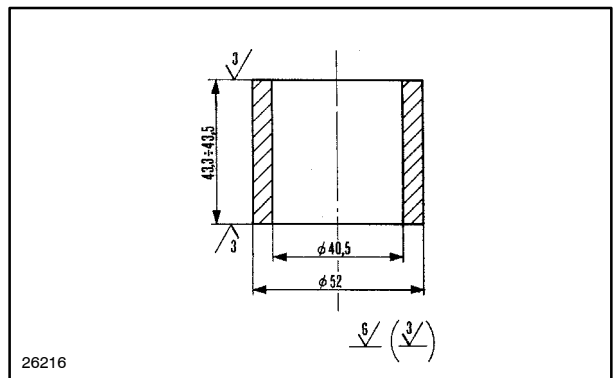

3

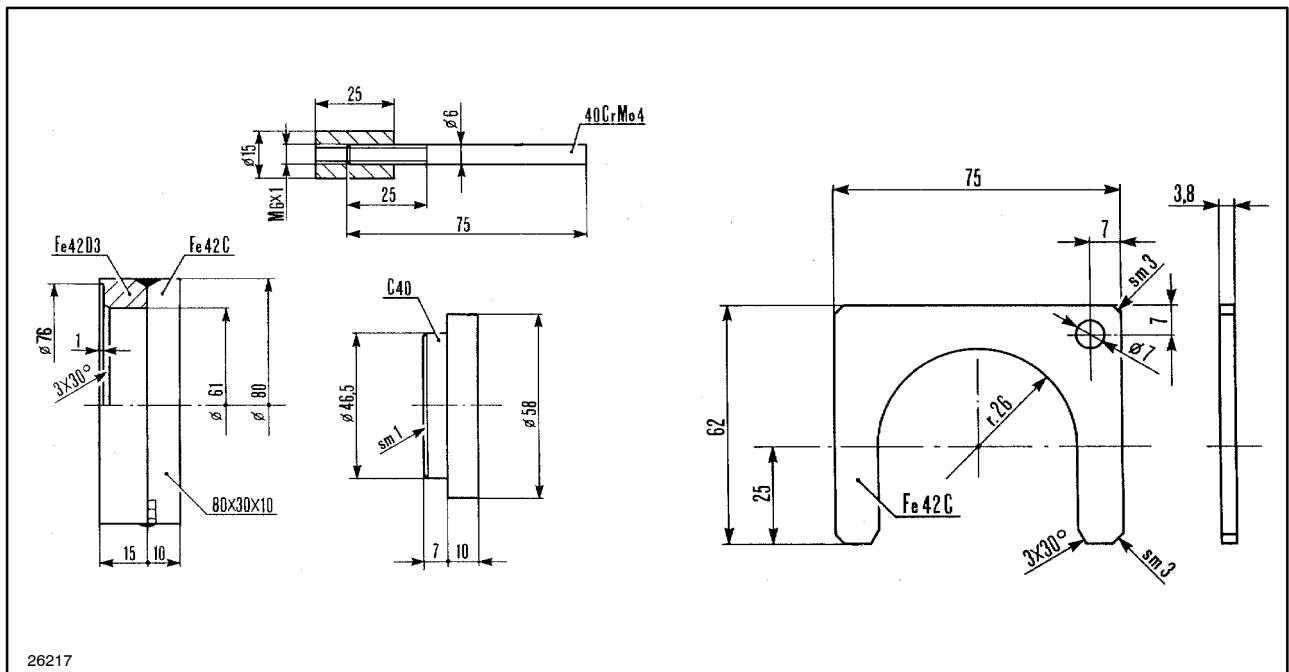

4

Tool to be made for removal of rear bearing of range gear driving shaft and the driving gear for the slow speeds (tool to be stamped no. **50028** - Measurements in mm).
Make in UNI C40.

Note - Make two parts from the tool shown at Figure 4, uppermost one .

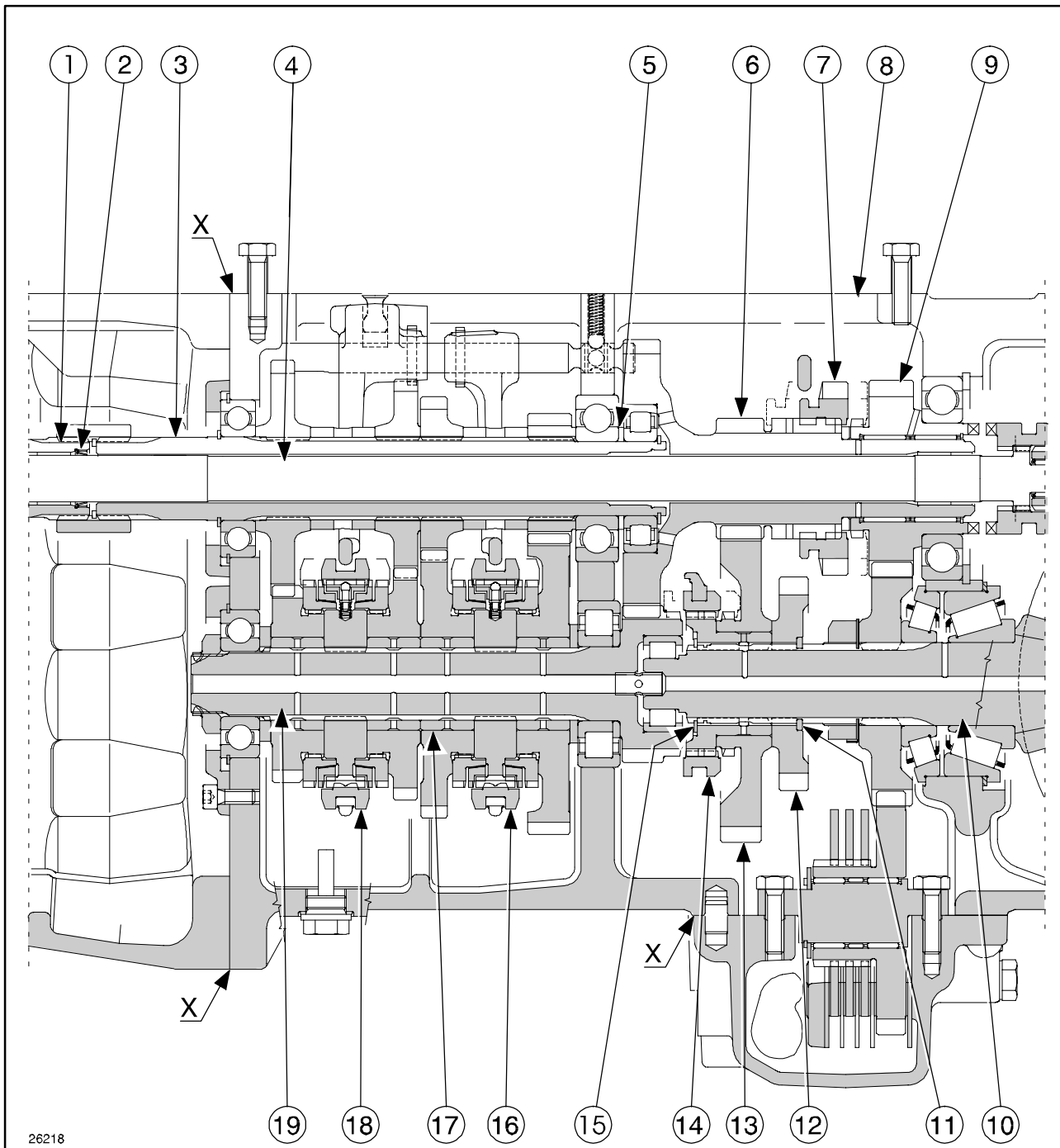

26218

5

Longitudinal cutaway section through gearbox and range gear.

- | | |
|--|--|
| 1. Power take-off (PTO) shaft support bushing. | 11. Retaining half-rings. |
| 2. Seal. | 12. Driven gear for reverse speeds. |
| 3. Gearbox driving shaft. | 13. Driven gear for low speeds. |
| 4. PTO shaft. | 14. Selector sleeve for high and low speeds. |
| 5. Driving shaft adjustment ring. | 15. Circlip. |
| 6. Range gear driving shaft. | 16. Synchroniser for 1 st and 2 nd speeds. |
| 7. Control gear for reverse and middle speeds. | 17. Support bushings for gearbox driven gears. |
| 8. Upper cover. | 18. Synchroniser for 3 rd and 4 th speeds. |
| 9. Driving gear for middle speeds. | 19. Gearbox driven shaft. |
| 10. Bevel pinion shaft. | |

NOTE - On assembly apply sealant to surfaces **X** following the indications given on page 6 in this Section.

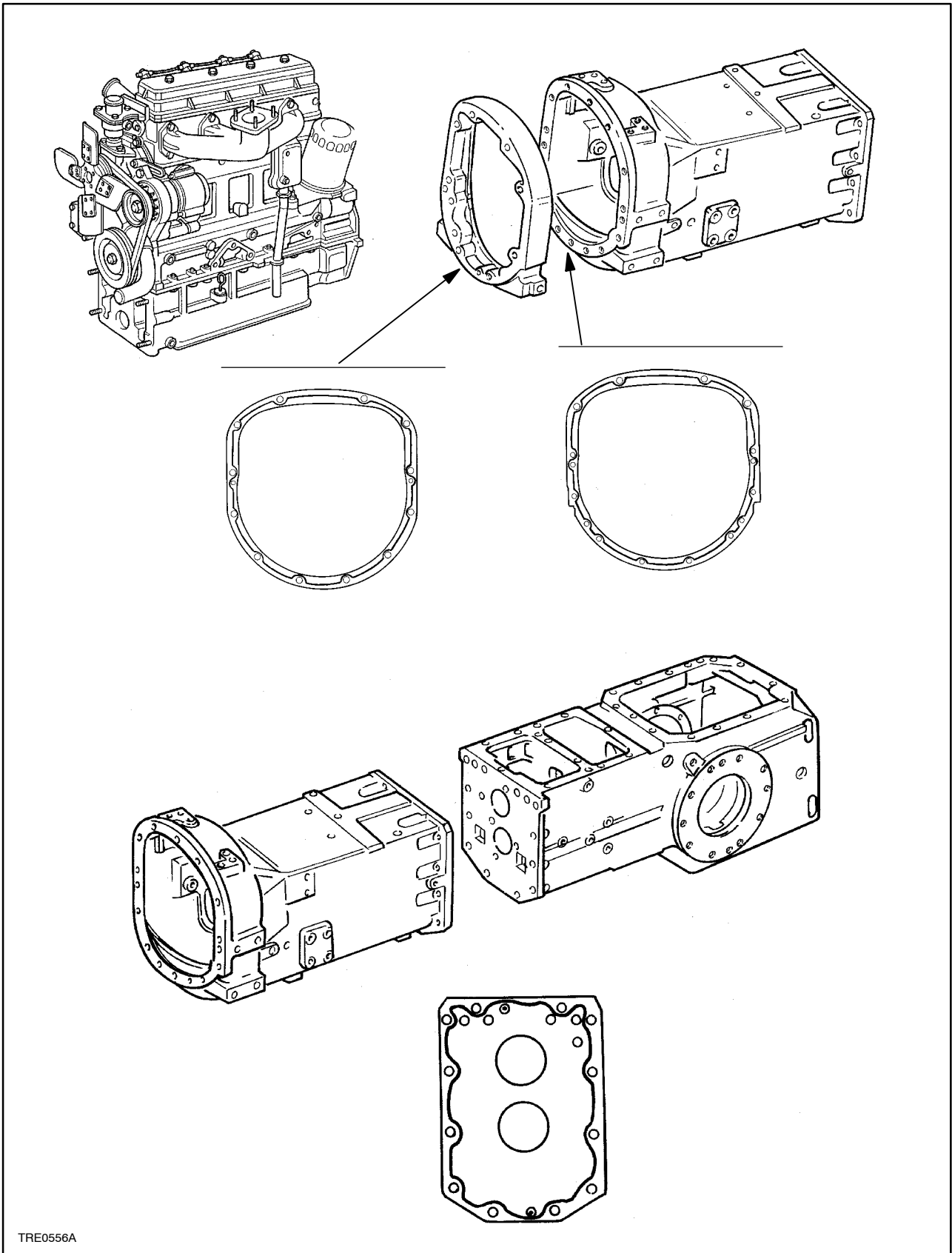

Sealing compound application diagram for mating surfaces between engine, clutch casing and rear transmission-gearbox.

The types of sealing compound to use are indicated on page 1, Sect. 00.

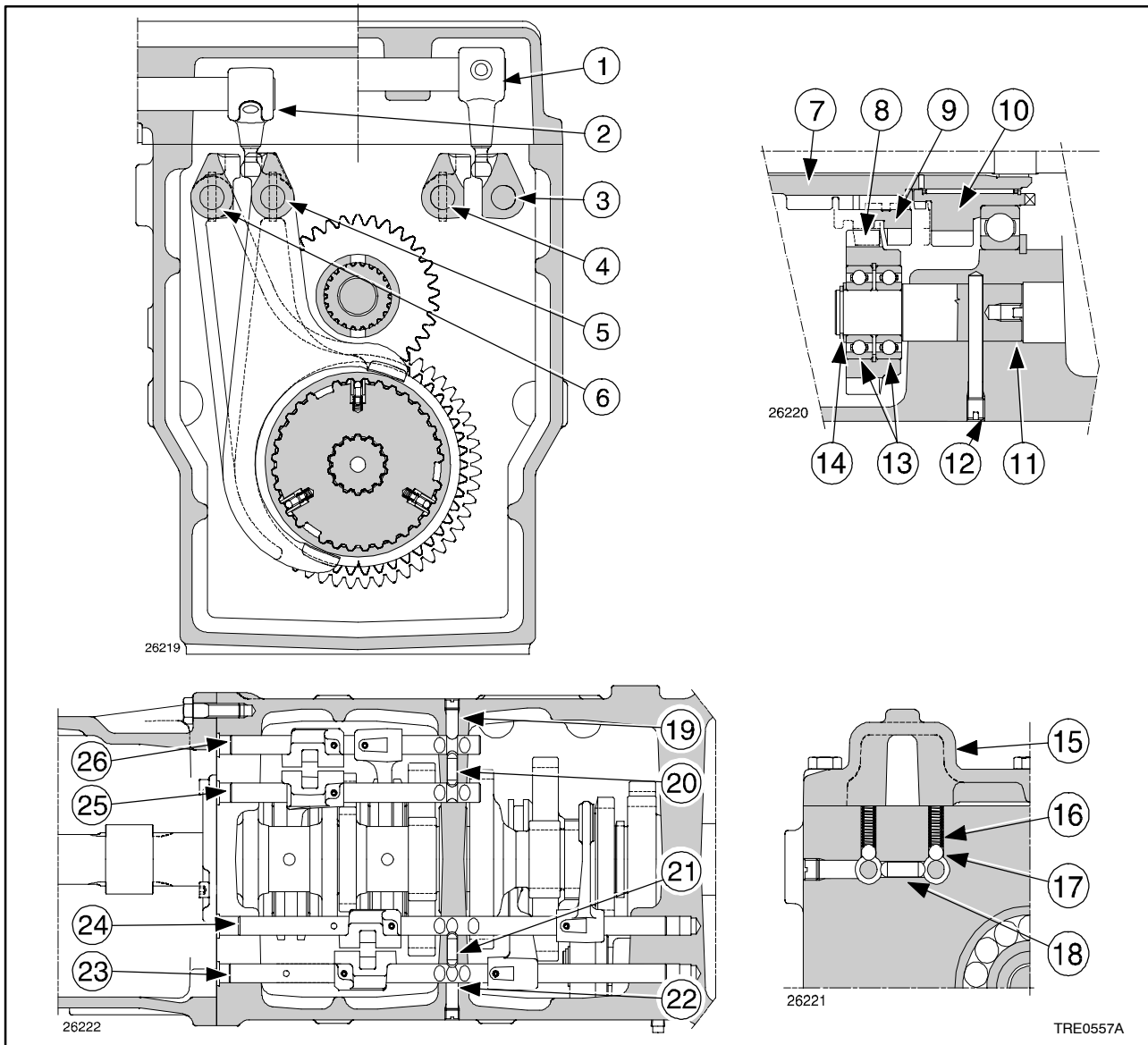

Cross-section through gearbox and range gear

- | | |
|--|---|
| 1. Range gear control relay rod. | 14. Circlip. |
| 2. Gearbox control relay rod. | 15. Upper cover of transmission / gearbox. |
| 3. Low and high speeds selector rod. | 16. Spring. |
| 4. Normal and reverse speeds selector rod. | 17. Detent ball. |
| 5. 3 rd and 4 th speed selector rod. | 18. Speed control safety pawl. |
| 6. 1 st and 2 nd speed selector rod. | 19. Plug. |
| 7. Range gear driving shaft. | 20. Speed control safety pawl. |
| 8. Intermediate gear for reverse speeds. | 21. Range control safety pawl. |
| 9. Control gear for normal and reverse speeds. | 22. Plug. |
| 10. Driving gear for normal speeds. | 23. Selector rod for low and high speeds. |
| 11. Journal of intermediate gear (8). | 24. Selector rod for middle and reverse speeds. |
| 12. Journal bolt (11). | 25. 3 rd and 4 th speed selector rod. |
| 13. Bearings. | 26. 1 st and 2 nd speed selector rod. |

Note – Before plugs (19 and 22) are bolted in, they must be covered with one of the sealants listed on page 1, Sect. 00.

DESCRIPTION AND OPERATION

4-speed gearbox with constant-mesh helical gears controlled by two synchronisers.

The range gear has cascade-type constant-mesh spur gears, excluding reverse.

The driven gears of the range gear are keyed directly onto the bevel pinion shaft.

The range gear provides 3 forward ranges and 1 reverse range.

The gearbox and the range gears are controlled by two independent levers located on the right-hand side of the operator.

GEARBOX AND RANGE GEAR TROUBLESHOOTING

Problems	Possible causes	Remedies
Spontaneous disengagement of gearbox and range gear.	<ol style="list-style-type: none"> 1. Levers and relay linkages incorrectly adjusted. 2. Selector rod retaining springs defective. 3. Defective teeth on synchroniser or engagement sleeve. 4. Incomplete engagement travel. 	<p>Adjust correctly.</p> <p>Replace the springs.</p> <p>Remove the transmission/gearbox and replace the synchronisers or the engagement sleeves.</p> <p>Eliminate the cause and restore full engagement travel.</p>
Difficulty in engaging the gearbox and range gear.	<ol style="list-style-type: none"> 1. Control levers and linkages incorrectly adjusted. 2. Stiffness and / or partial seizure of control levers and linkages. 3. Main clutch drag. 4. Synchronisers or engagement sleeves defective. 5. Internal controls do not slide freely: rods, forks and sleeves. 	<p>Adjust correctly.</p> <p>Check pivot points and lubricate.</p> <p>See page 5, Sect. 18.</p> <p>Remove the transmission / gearbox and replace the synchronisers or engagement sleeves.</p> <p>Perform the checks and overhaul for needed parts.</p>
Gearbox or range gear unduly noisy.	<ol style="list-style-type: none"> 1. Internal component/s worn or defective. 	<p>Remove the transmission / gearbox and replace the worn / defective parts.</p>

SECTION 21 - TRANSMISSIONS

Chapter 2 - Reverser

CONTENTS

Section	Description	Page
21 000	Main data	1
	Tightening torques	2
	Tools	3
	Section views	3
	Description and operation	5
	Fault diagnosis	5
21 110	Removal-Refitting	6

**21 000 - MAIN DATA - TIGHTENING TORQUES - SECTIONS - TOOLS -
DESCRIPTION AND OPERATION - FAULT DIAGNOSIS**

SYNCHRONISER REVERSER MAIN DATA

Type	Mechanical type spur gear unit, located between the main clutch and the gearbox. Comprises 1 driving gear, 1 intermediate gear and 1 idle gear.
Control	Hand lever located on left-hand side of the operator

GEARBOX MAIN DATA

Gearbox	4 speed, constant-mesh, with synchronisers on all gears
Gearing type	helical
Reduction unit	Ordinary gear train with 3 ranges providing a total of 12 gears
Gearing type	spur
Gearbox and reduction unit controls	Independent, with two hand levers located on right-hand side of the operator
For other main data see chapter 1.	

TORQUE VALUES

PARTS	Thread	Torque Settings	
		Nm	ft lb
Bolt or nut securing clutch / reverser casing to engine (C ₁)	M 12 x 1.25	98	72.2811
Sleeve cover retaining nuts (C ₂)	M 8 x 1.25	17	12.5386
Reverser driven shaft cover retaining bolts (C ₃)	M 8 x 1.25	28	20.6517
Reverser driven shaft plate retaining bolts (C ₄)	M 10 x 1.25	64	47.2040
Bolts securing clutch / reverser housing to gearbox / rear transmission (C ₅)	M 12 x 1.25	98	72.2811

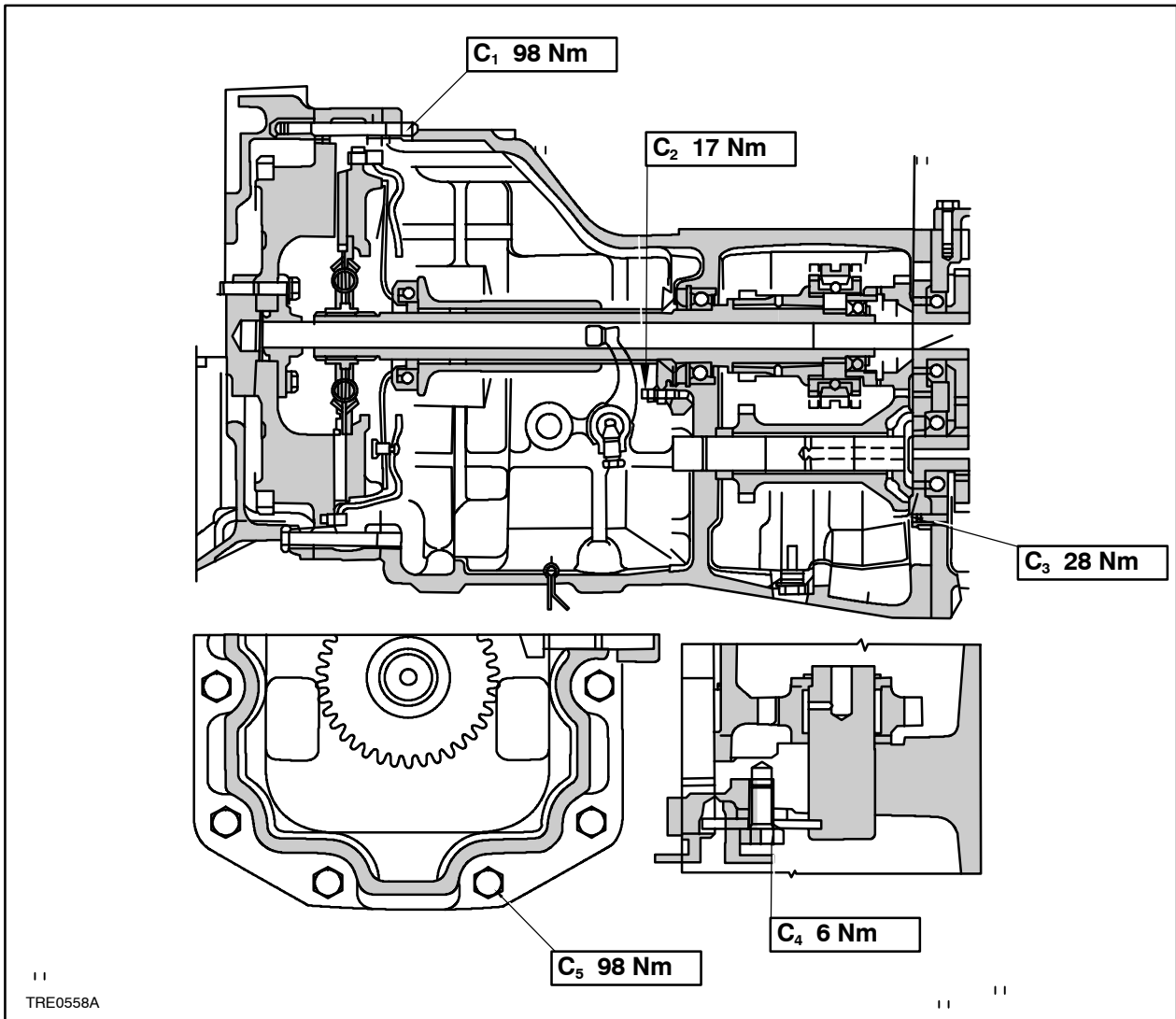

TOOLS

Warning - The operations described in this Section can only be carried out using the **ESSENTIAL** tools marked with an **(X)**. However, for greater safety and to obtain the best results while saving time and effort, it is recommended that these essential tools are used together with the special tools listed here as well as certain tools which are to be made following the sectional drawings given in this manual.

List of special tools required for the various operations described in this Section :

- 380000236** Tractor dismantling trolley.
- 380000227** Clutch casing lifting hook.
- 380000301** Rotating overhaul stand.
- 380000271** Front support bracket (with **380000301**).
- 380000272** Rear support bracket (with **380000301**).

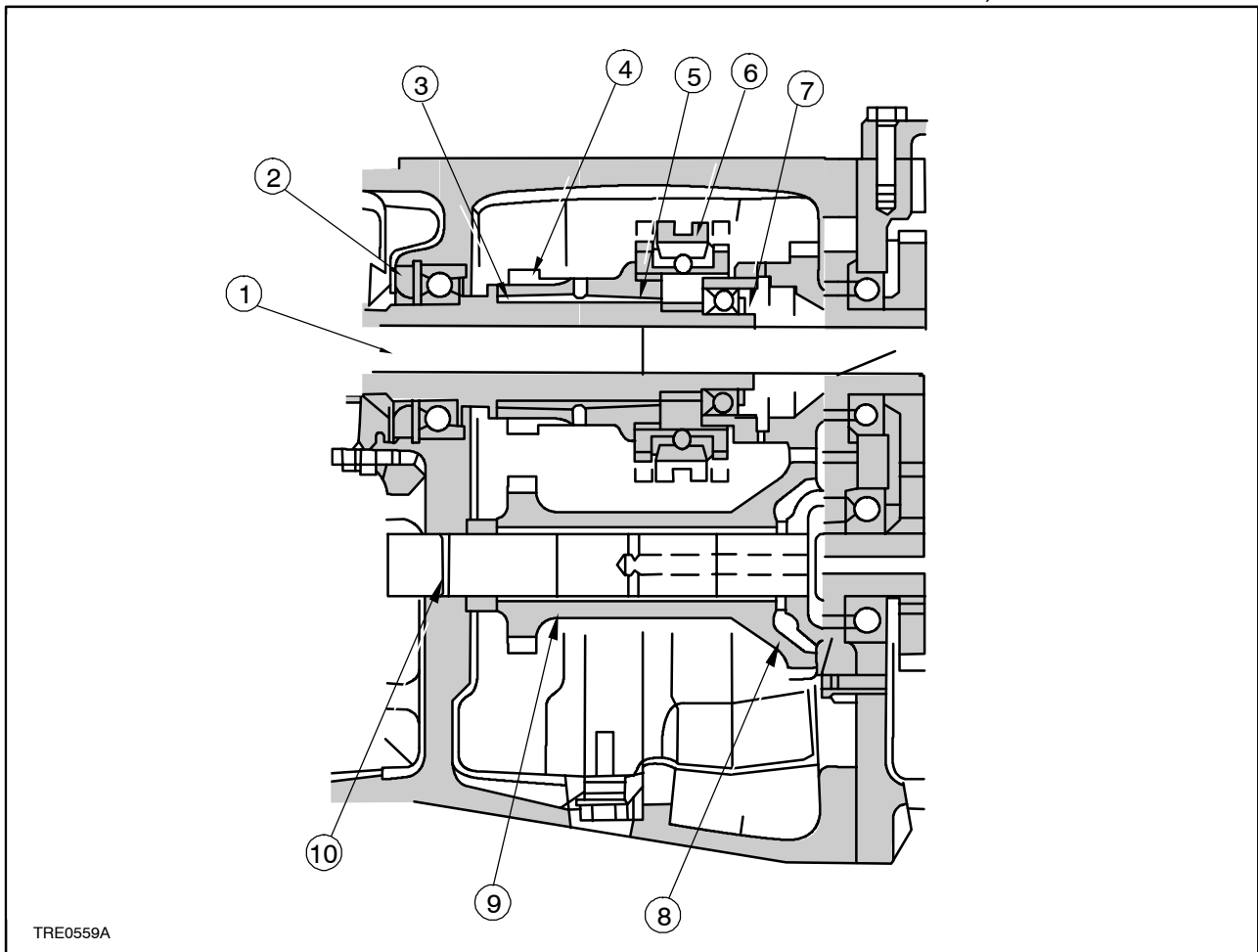

2

Longitudinal cutaway section of synchroniser reverser

- | | |
|---|---------------------------------------|
| 1. Synchroniser reverser control shaft. | 6. Reverser control synchroniser. |
| 2. Seal. | 7. Seal. |
| 3. Roller bearing. | 8. Synchroniser reverser driven gear. |
| 4. Synchroniser reverser driving gear. | 9. Journal for driven gear (8). |
| 5. Roller bearing. | 10. Seal. |

Note - On assembly apply jointing compound to surfaces **X** as indicated on page 6, chapter 1.

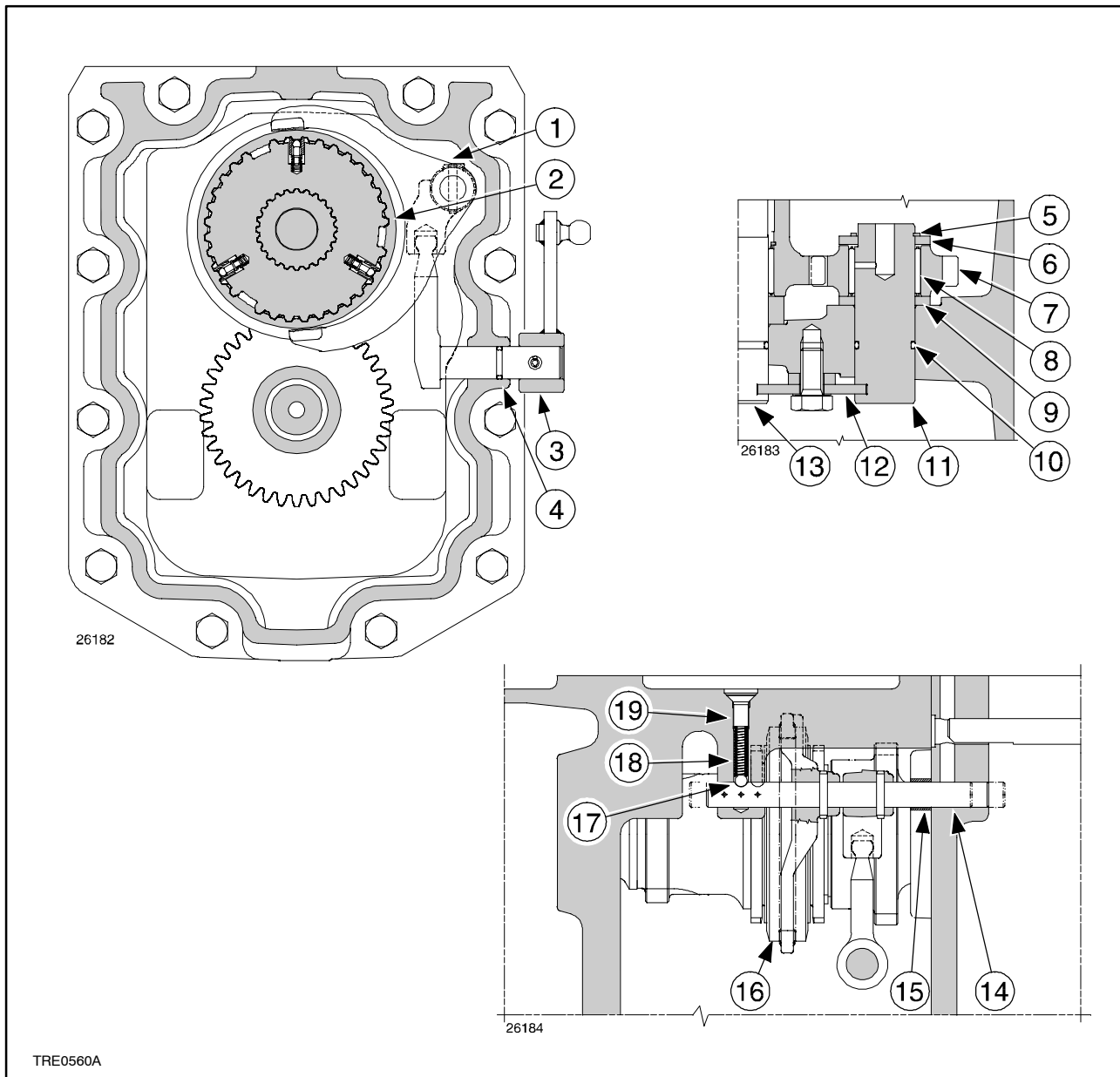

3

Synchroniser reverser sectional views

- | | |
|---|--|
| 1. Synchroniser reverser selector fork. | 12. Stop plate for journals (11 and 13). |
| 2. Reverser synchroniser. | 13. Synchroniser reverser driven gear. |
| 3. External reverser control lever. | 14. Synchroniser reverser control rod. |
| 4. Seal. | 15. Spacer. |
| 5. Circlip. | 16. Reverser synchroniser. |
| 6. Thrust washer. | 17. Detent ball. |
| 7. Synchroniser reverser idle gear. | 18. Spring for detent ball (17). |
| 8. Roller bearing. | 19. Detent ball retaining bolt (the bolt must be covered in one of the sealants listed on page 1, Sect. 00). |
| 9. Thrust washer. | |
| 10. Seal. | |
| 11. Journal of idle gear (7). | |

DESCRIPTION AND OPERATION

The synchroniser reverser is a mechanical device which makes it possible to obtain 12 forward and 12 reverse gears. It is controlled by a specific lever located on the platform to the left of the operator.

The synchroniser reverser is comprised of a group of three spur gears : driving reverser gear, intermediate gear and driven reverser gear. Selection is ef-

fectured by means of a synchroniser located in the group of gears.

The synchroniser reverser is installed inside the clutch casing between the clutch and the gearbox.

It is lubricated by the oil in the rear transmission / gearbox.

SYNCHRONISER REVERSER TROUBLESHOOTING

Problems	Possible causes	Remedies
Spontaneous disengagement of the synchroniser reverser.	<ol style="list-style-type: none"> 1. Incorrect adjustment of external levers and linkages. 2. Synchroniser engagement teeth damaged. 3. Engagement travel incomplete. 	<p>Adjust correctly.</p> <p>Remove the clutch casing and replace the synchroniser.</p> <p>Eliminate the cause and restore full engagement travel.</p>
Difficulty in engaging the reverser.	<ol style="list-style-type: none"> 1. Incorrect adjustment of external levers and linkages. 2. Stiffness and / or partial seizure of external levers and linkages. 3. Dragging of main clutch. 4. Synchroniser damaged. 5. Internal controls do not slide freely: rods, forks and sleeves. 	<p>Adjust correctly.</p> <p>Check pivot points and lubricate.</p> <p>See page 5, Sect. 18.</p> <p>Remove the clutch casing and replace the synchroniser.</p> <p>Perform the checks and overhaul for needed parts.</p>
Synchroniser reverser unduly noisy.	<ol style="list-style-type: none"> 1. Worn or damaged internal part/s. 	<p>Remove the clutch casing and replace damaged part/s.</p>

CLUTCH/REVERSER CASING Replacement (Op. 21 110 85)



WARNING



Handle all parts with great care.
Never insert fingers or hands between one piece and another. Wear suitable safety clothing, i.e., safety goggles, gloves and shoes.

1. Fix the clutch / reverser casing (1) to stand **380000301** (2) using the two brackets **380000271** and **380000272**.

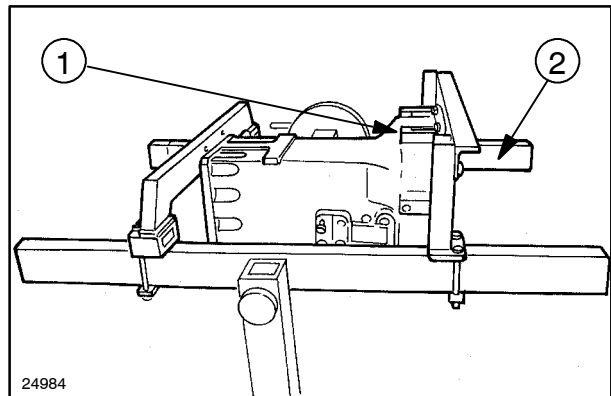

4

2. Withdraw the spring pin and recover the link lever (1) and the internal lever (2).

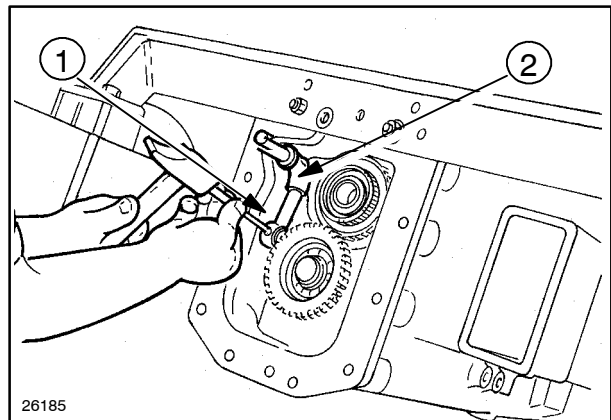

5

3. Unscrew the retaining bolt (1) and recover the detent ball and spring.

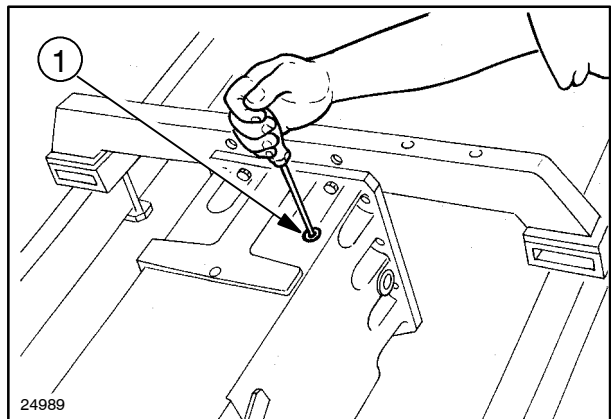

6

4. Remove the circlip (1) and take out : bearing, thrust washers, synchroniser assembly together with the selector fork and its rod, the reverser driven gear (2) complete with roller bearings and spacer.

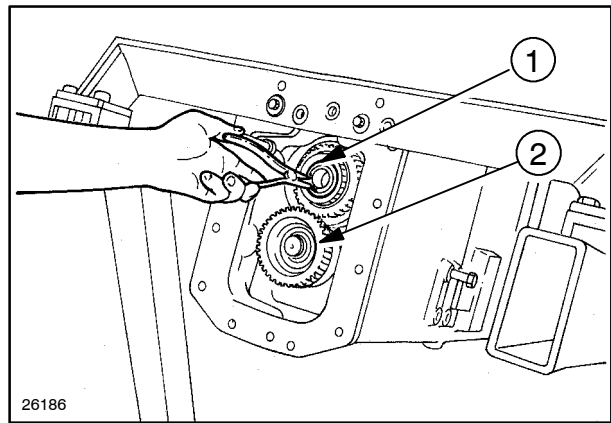

5. Remove the reverser driving gear (1) complete with roller bearings.

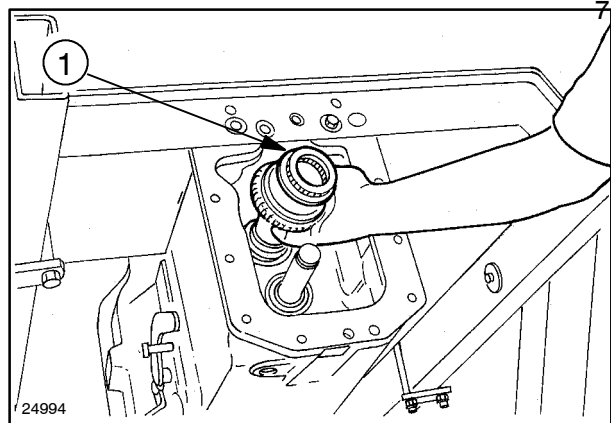

6. Remove the circlip (1) securing the reverser driving shaft.

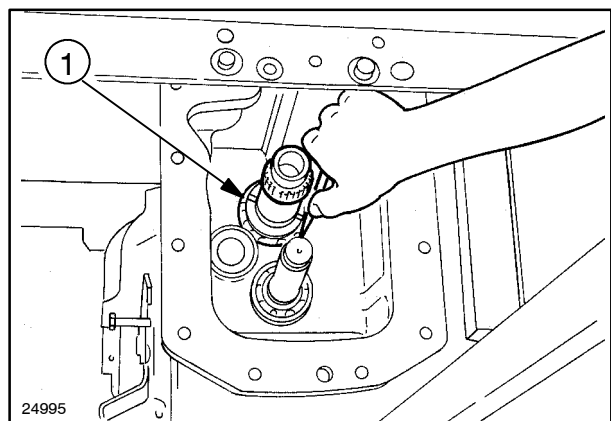

7. Working from the front of the clutch / reverser casing with an aluminium drift (2), drive out the reverser driving shaft (1) and remove it from the rear of the casing.

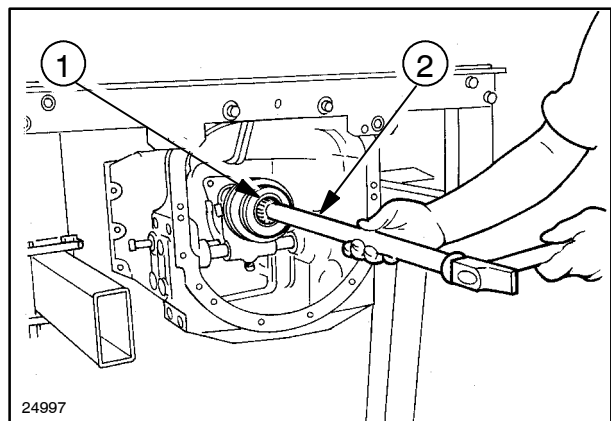

10

8. Detach the retaining springs and withdraw the sliding sleeves (1).

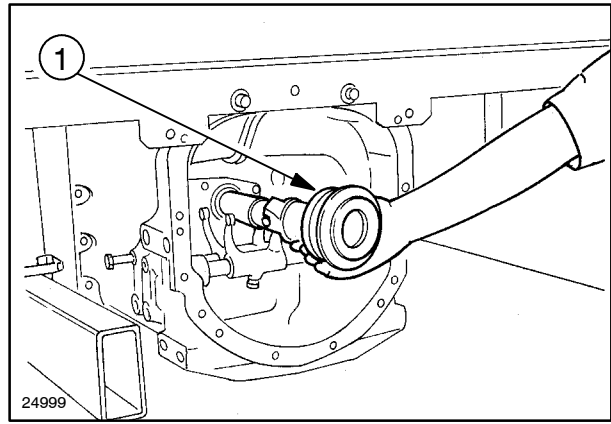

11

9. Unscrew the retaining bolts and remove the sleeve cover / support (1).

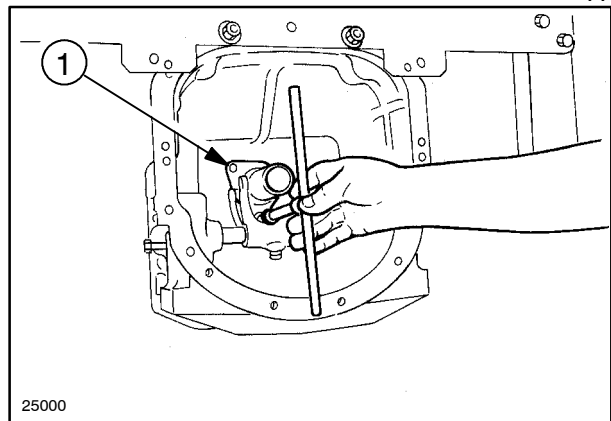

12

10. Unscrew the two securing bolts (1) of the sliding sleeve control forks (2).

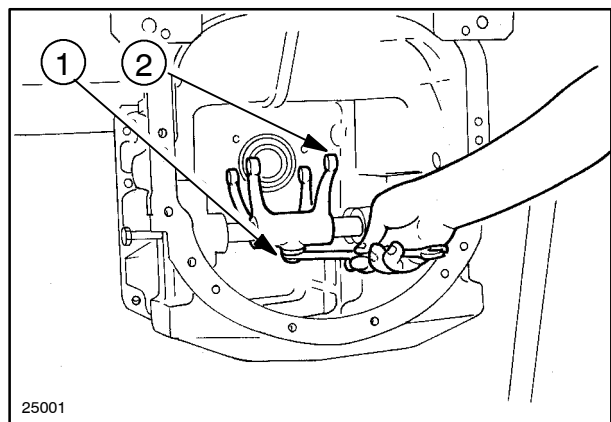

13

11. Withdraw the external clutch control levers (1) and remove the forks (2).

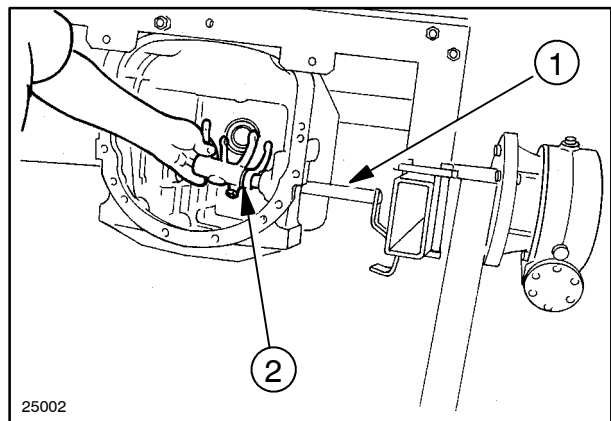

14

12. Relieve the staking and unscrew bolt (1) securing the stop plate for the journal of the reverser driven shaft (2) and the intermediate gear journal, removing the latter from the rear of the casing.

13. Refitting of the synchroniser reverser according to the following instructions:

- Refer to the illustrations on pages 3 and 4 to check the correct orientation of the various parts.
- Refer to the torque settings on page 2.
- Install the intermediate gear journal complete with the various associated parts, and the journal of the reverser driven gear and secure with the relative stop plate and bolt.
- Fit the sliding sleeve control forks on the relative clutch control levers and fix the previous to the latter.
- Fit the sliding sleeve cover and its support.
- Fit the sliding sleeve assembly to the relative support and secure with the springs.
- Insert the reverser driving shaft from the rear of the casing and fix it to the clutch / reverser casing with the circlip.
- Position the reverser driving gear complete with bearings on the driven shaft.
- Fit the reverser driving gear complete with the bearings and spacers.
- Fit the synchroniser assembly complete with control forks, rod, thrust washers and bearing, and fix in position with the relative circlip.
- Fit the detent ball, spring, and bolt in the locked position after covering the bolt using one of the sealants listed on page 1, Sect. 00.
- Position the internal lever and link lever and fix with the relative spring pin.
- Remove the clutch / reverser casing from the stand **380000301**.

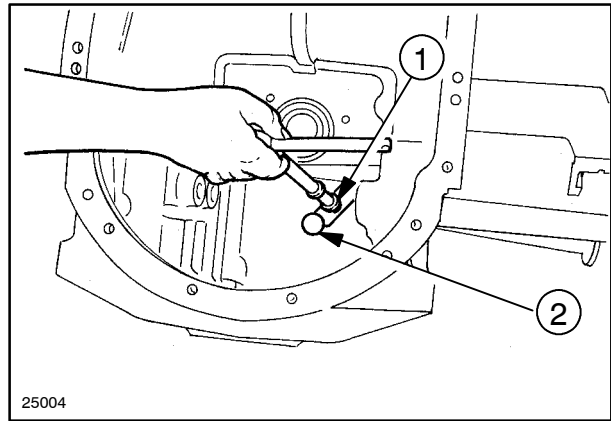

15

SECTION 21 - TRANSMISSIONS

Chapter 3 - Reverser and creeper unit (20x12)

CONTENTS

Section	Description	Page
21 000	Main data	1
	Tightening torques	2
	Tools	3
	Section views	4
	Description and operation	6
	Fault diagnosis	6
21 110	Removal-Refitting	7

21 000 - MAIN DATA - TIGHTENING TORQUES - SECTION VIEWS - TOOLS - DESCRIPTION AND OPERATION - FAULT DIAGNOSIS

SYNCHRONISER REVERSER-CREEPER UNIT MAIN DATA

Type	Mechanical, spur gears, located between engine and gearbox. Comprising 1 driving gear, 1 intermediate gear and 1 idle gear.
Control	by hand lever located on left-hand side of operator

CREEPER UNIT MAIN DATA

Type	Ordinary gear train with spur gears, located between main clutch and gearbox, in series with the reverser. Provides 20 forward speeds and 12 reverse speeds
Reduction ratio	$\frac{18 \times 26}{55 \times 47} = 1:5.524$
Control	by hand lever located on left-hand side of operator

GEARBOX MAIN DATA

Gearbox	4-speed constant mesh, synchronised on all gears
Gearing type	helical
Range gear	Ordinary gear train with three ranges for a total of 12 speeds
Gearing type	spur gears
Gearbox and range gear controls	Independent, by two hand levers
For further data see chapter 1.	

TORQUE VALUES

PARTS	Thread	Torque Settings	
		Nm	ft lb
Bolt or nut securing clutch casing - reverser and creeper unit to the engine (C ₁)	M 12 x 1.25	98	72.2811
Sleeve cover nuts (C ₂)	M 8 x 1.25	17	12.5385
Synchroniser reverser - creeper unit driven shaft cover nuts (C ₃)	M 8 x 1.25	17	12.5385
Gearbox driving and driven shaft bearings cover screws (C ₄) ..	M 8 x 1.25	28	20.6517
Bolt securing clutch casing - reverse and creeper unit to the rear transmission-gearbox	M 12 x 1.25	98	72.281117

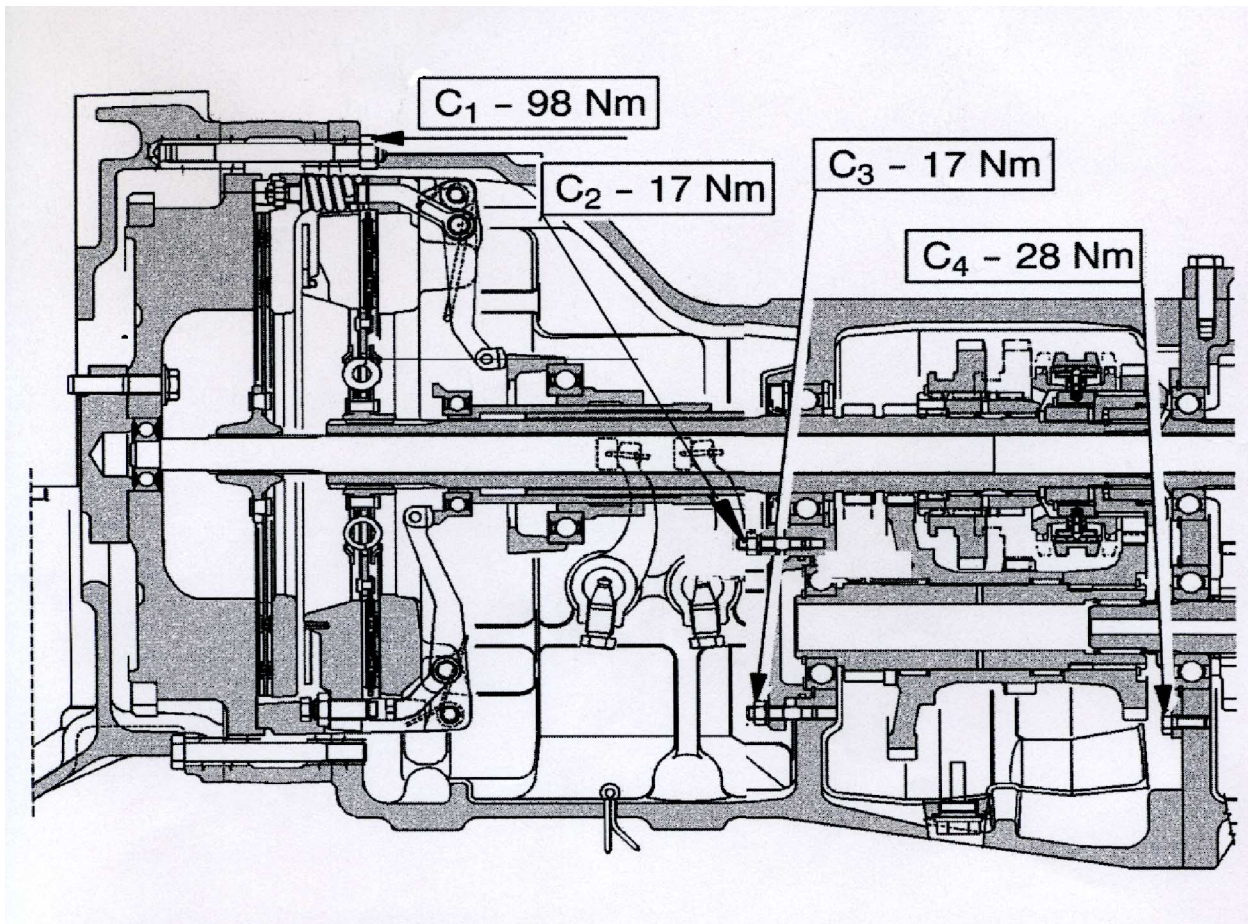

TRE0561A

TOOLS

Warning - The operations described in this Section can only be carried out using the **ESSENTIAL** tools marked with an (X).

However, for greater safety and to obtain the best results while saving time and effort, it is recommended that these essential tools are used together with the special tools listed here as well as certain tools which are to be made following sectional drawings given in this manual.

List of special tools required for the various operations in this Section :

- 380000236** Tractor dismantling stand.
- 380000227** Clutch casing lifting hook.
- 380000301** Rotating overhaul stand.
- 380000271** Front bracket (with **380000301**).
- 380000272** Rear bracket (with **380000301**).

Support bracket for installation of gearbox driving shaft seal (mark tool **50043**) (Dimensions in mm).

Part of kit **50043** - Make tool in UNI C40.

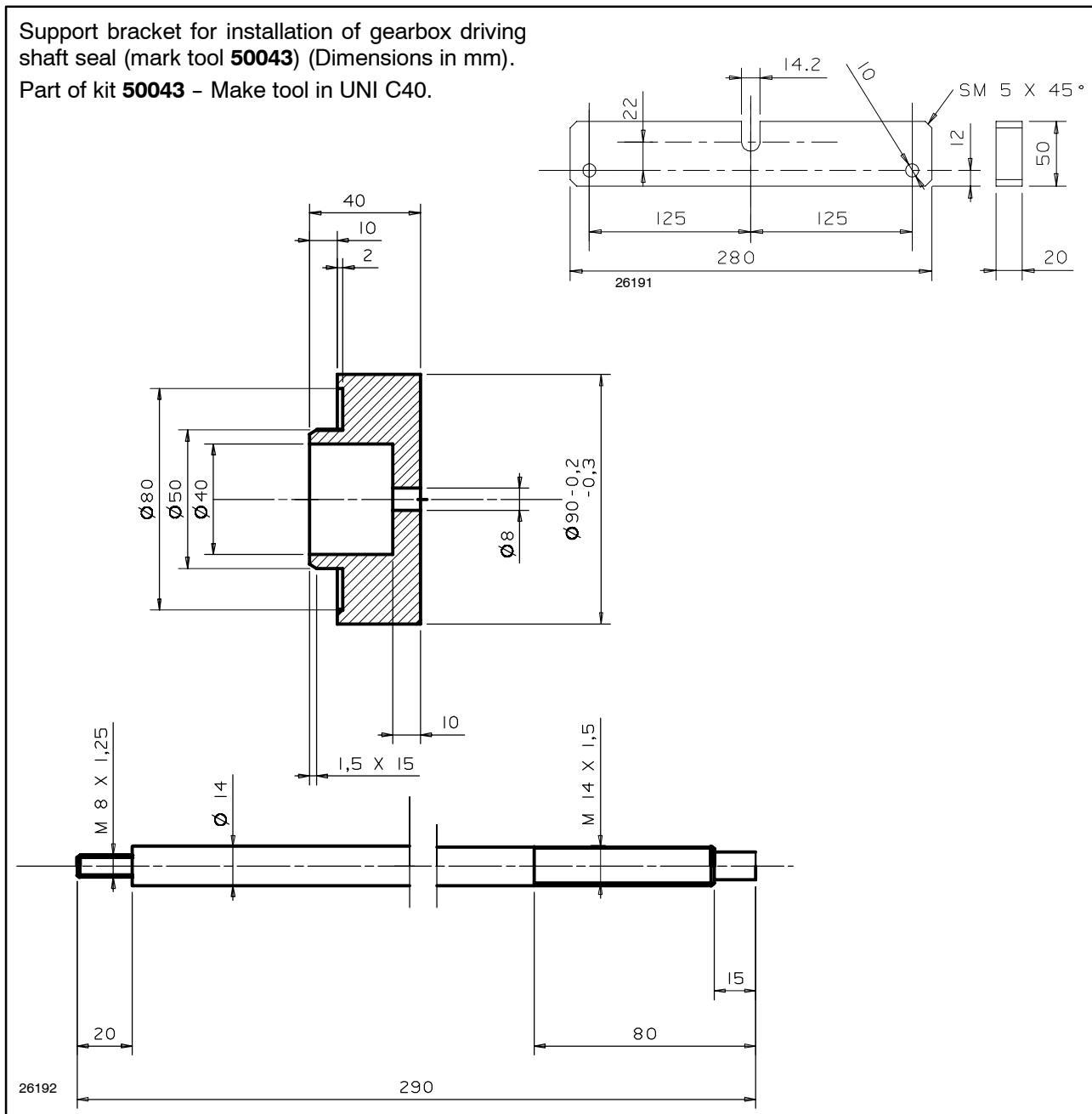

2

Tool for gearbox driving shaft seal (mark tool **50137**)
(Dimensions in mm)
make tool in UNI C40.

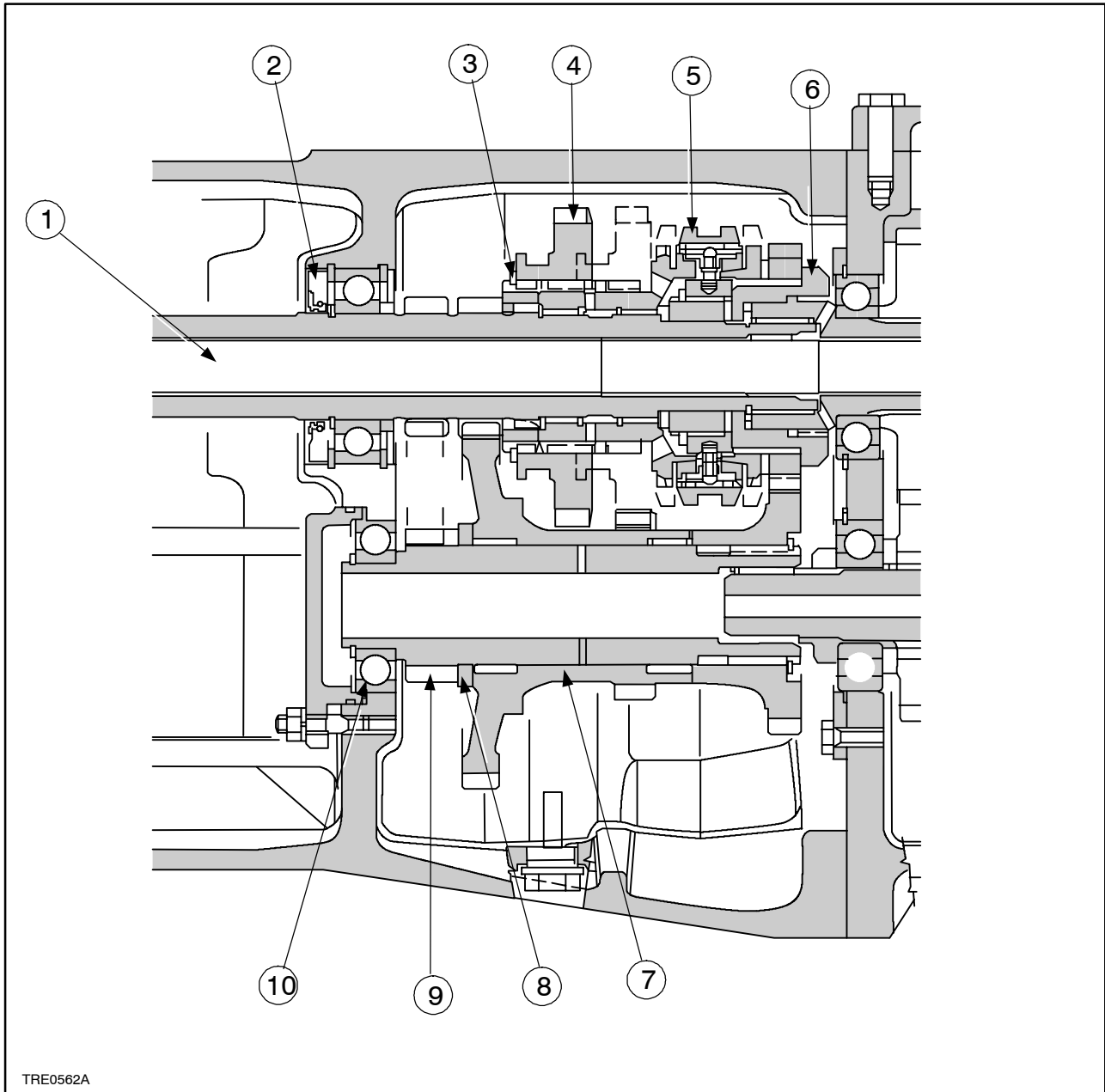

3

Longitudinal section through reverser-creeper unit

- | | |
|---|--|
| 1. Reverser and creeper unit control shaft. | 6. Gearbox driving shaft control gear. |
| 2. Seal. | 7. Creeper unit driven gear. |
| 3. Circlip. | 8. Thrust washer. |
| 4. Creeper unit control gear. | 9. Reverser driven shaft. |
| 5. Reverser-creeper unit synchroniser. | 10. Seal. |

Note – On assembly apply sealing compound to the surfaces **X** following the indications given on page 6 in chapter 1.

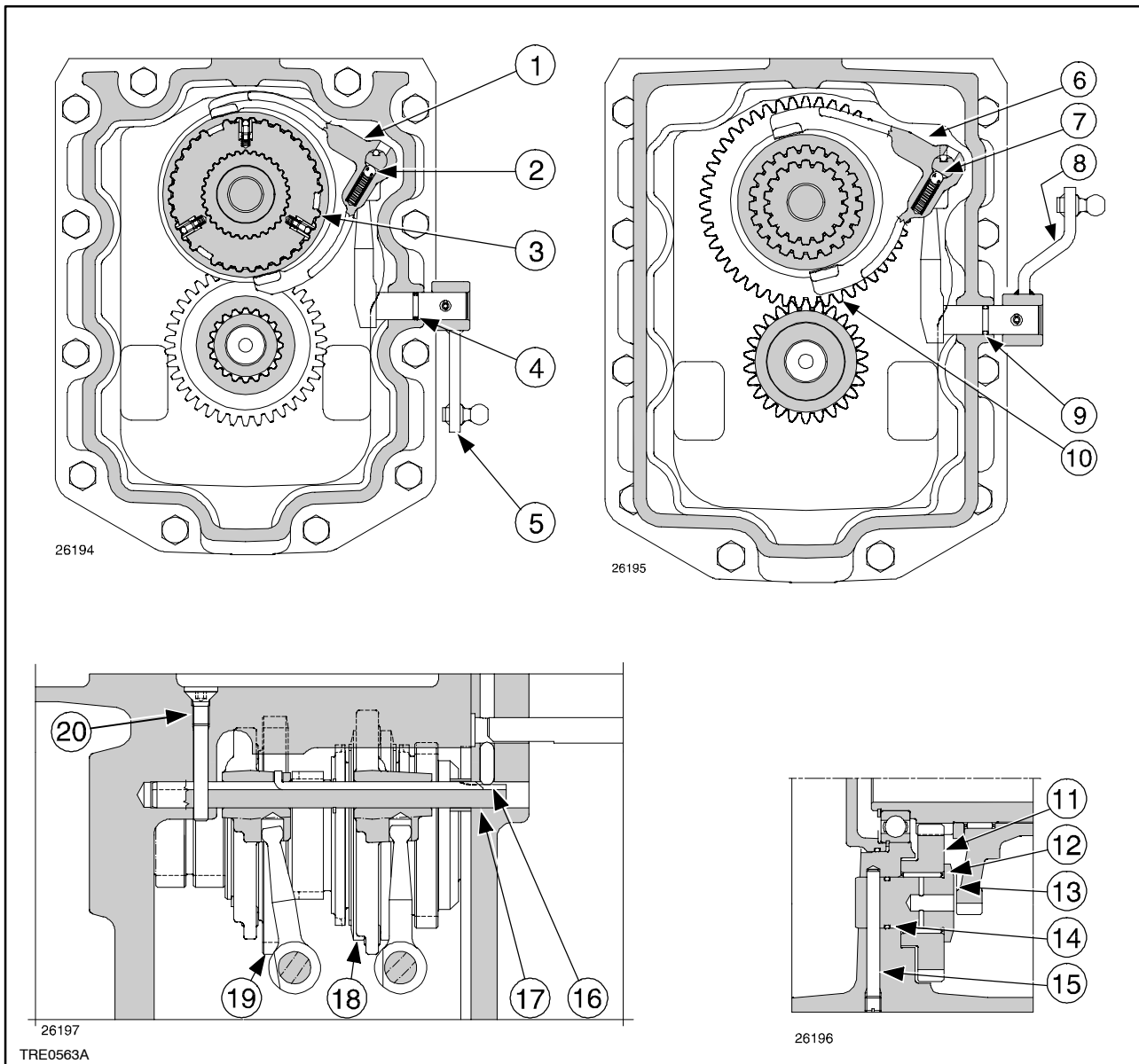

4

Cross sectional views of synchroniser reverser - creeper unit

- | | |
|-------------------------------------|--|
| 1. Reverser control fork. | 12. Roller bearing. |
| 2. Detent ball. | 13. Journal for gear (11). |
| 3. Reverser synchroniser. | 14. Seal. |
| 4. Seal. | 15. Reating screw for journal (13). |
| 5. External reverser control lever. | 16. Fast speeds lock pawl. |
| 6. Creeper unit control fork. | 17. Reverser and creeper unit control rod. |
| 7. Detent ball. | 18. Reverser synchroniser. |
| 8. External creeper control lever. | 19. Creeper unit control gear. |
| 9. Seal. | 20. Retaining screw for rod (17) (apply one of the sealing compounds listed on page 1, Sect. 00 to the screw). |
| 10. Creeper unit control gear. | |
| 11. Intermediate gear for reverser. | |

DESCRIPTION AND OPERATION

The reverser-creeper unit is a mechanical device providing the possibility to obtain 20 forward speeds and 12 reverse speeds.

The creeper unit engages only in slow and middle ranges, a mechanical interlock prevents creeper engagement in the fast ranges.

The creeper unit comprises a group of three spur gears : a sliding control gear, a synchroniser control gear and a driven gear; the unit utilises the same synchroniser as the reverser.

The creeper is installed in series with the reverser and is controlled by a hand lever located on the right-hand side of the operator.

The reverser comprises three spur gears : the reverser driving gear, an intermediate gear and the reverser driven gear; the reverser is engaged by means of a synchroniser located in the gear assembly.

The reverser-creeper unit is installed inside the clutch casing between the clutch and the gearbox.

Lubrication is provided by the oil contained in the rear transmission-gearbox.

SYNCHRONISER REVERSER-CREEPER UNIT TROUBLESHOOTING

Problems	Possible causes	Remedies
Spontaneous disengagement of the reverser-creeper unit.	<ol style="list-style-type: none"> 1. External levers and linkages incorrectly adjusted. 2. Synchroniser teeth damaged. 3. Engagement travel incomplete. 	<p>Adjust correctly.</p> <p>Remove the clutch casing and replace the synchroniser.</p> <p>Eliminate the cause and restore full travel.</p>
Difficulty in engaging the reverser-creeper unit.	<ol style="list-style-type: none"> 1. External levers and linkages incorrectly adjusted. 2. Stiffness and / or partial seizure of external levers and linkages. 3. Main clutch drag. 4. Synchroniser defective. 5. Internal control elements do not slide freely : rods, forks and sleeves. 	<p>Adjust correctly.</p> <p>Check pivot points and lubricate.</p> <p>See page 5, Sect. 18.</p> <p>Remove the clutch casing-gearbox and replace the synchroniser.</p> <p>Perform the checks and overhaul for needed parts.</p>
Reverser-creeper unit unduly noisy.	<ol style="list-style-type: none"> 1. Internal component/s worn or defective. 	<p>Remove clutch casing and replace defective parts.</p>

CLUTCH CASING - SYNCHRONISER REVERSER AND CREEPER UNIT

Replacement (Op. 21 110 87)



WARNING



Handle all parts with great care.
Never place your hands between one part and another. Wear suitable safety clothing, i.e. safety goggles, gloves and shoes.

To gain access to the synchroniser reverser-creeper unit, first remove the cab or platform following the instructions given in Sect. 27 and remove the clutch casing as described in Sect. 18, and then proceed as follows :

1. Fix the casing to the rotating stand **380000301** using the brackets **380000271** and **380000272**.

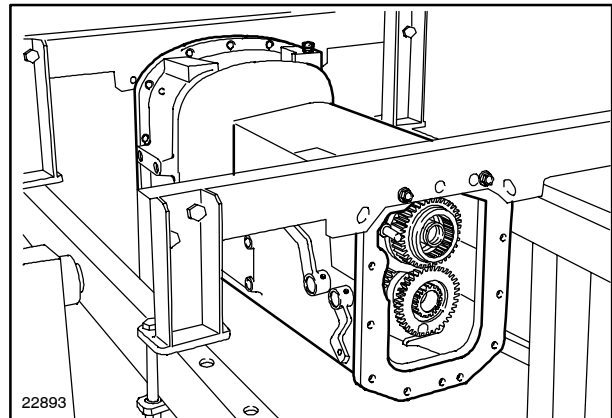

5

2. Remove circlip (1) and slide out constant mesh gear (2).

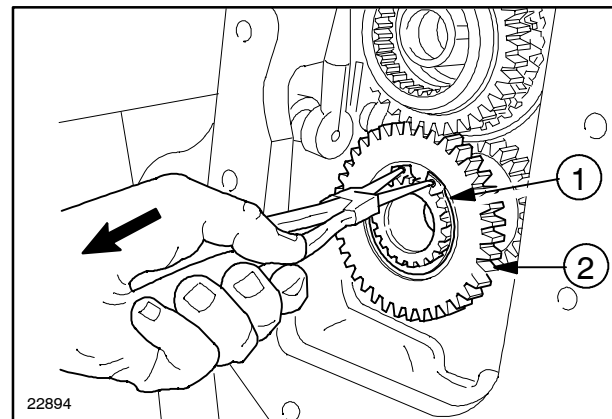

6

3. Remove circlip (1) of reverser transmission driving shaft.

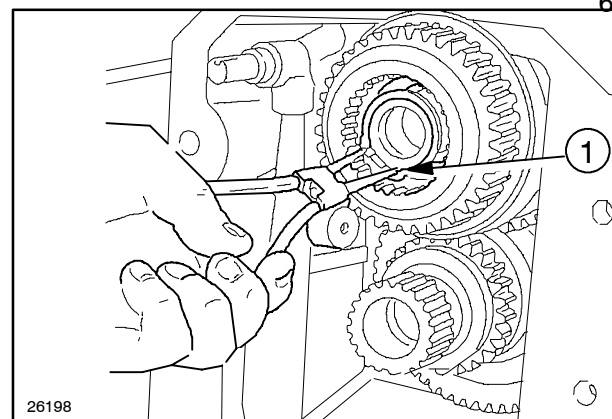

7

4. Remove plug and remove the control lever retaining pin (1).

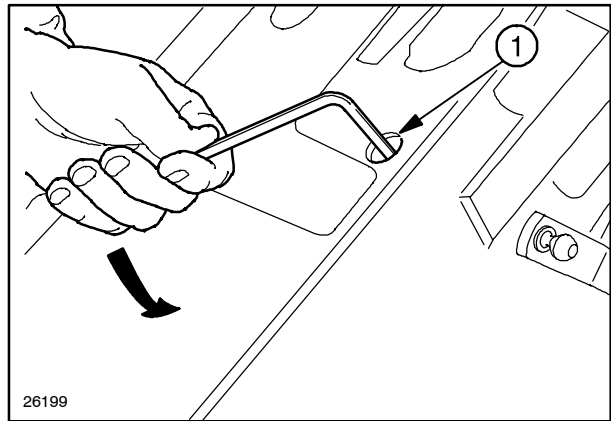

8

5. Remove the reverser synchroniser assembly (1) together with control forks and gears.

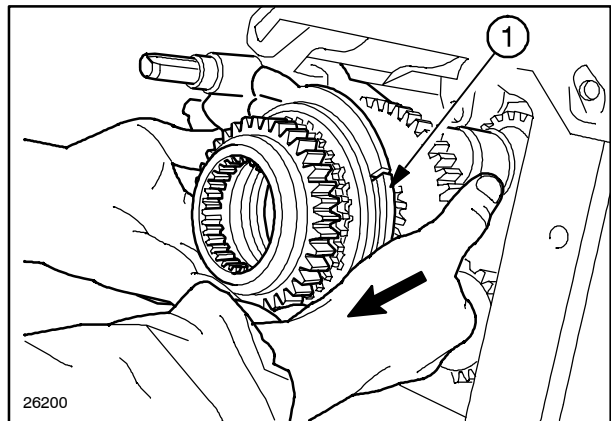

9

6. Withdraw the driven shaft gear (1) together with the roller bearings and remove the thrust washer.

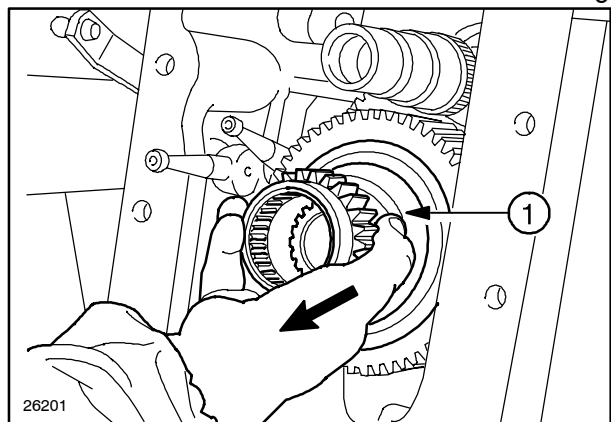

10

7. Remove the control fork retaining springs (2) and withdraw the clutch pressure plate bearing assembly (1).

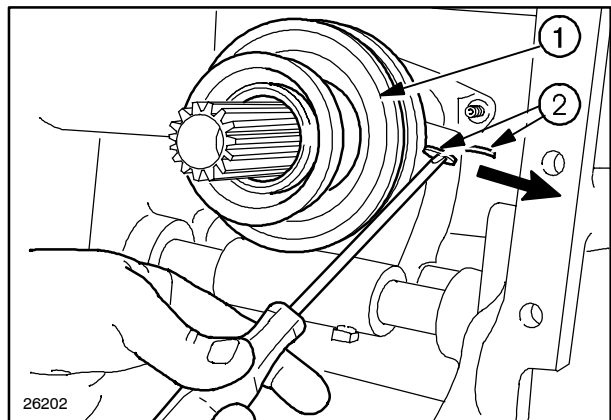

11

8. Unscrew the retaining screws (2) and remove the control forks (1).

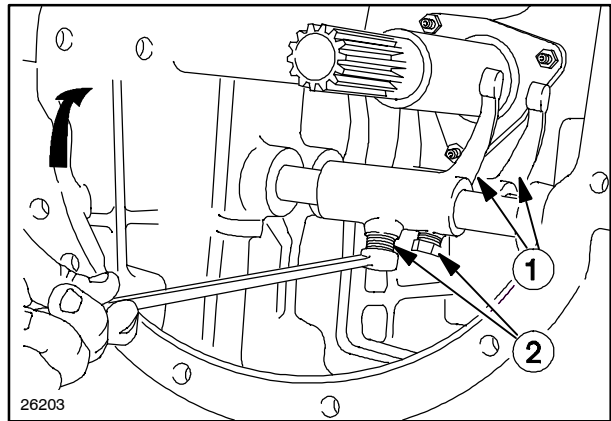

12

9. Unscrew the retaining screw (15, page 5) and withdraw the reverser intermediate gear assembly (1).

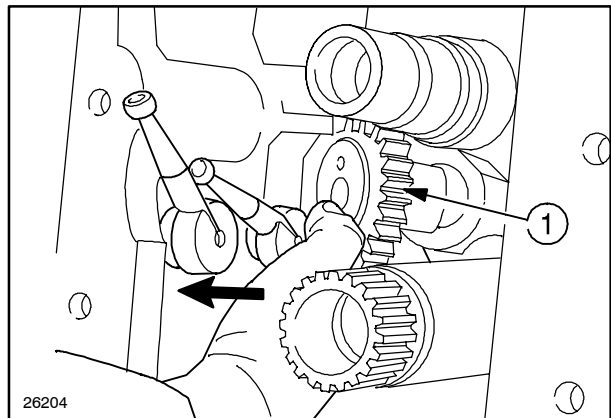

13

10. Unscrew the retaining bolts and remove the cover (1).

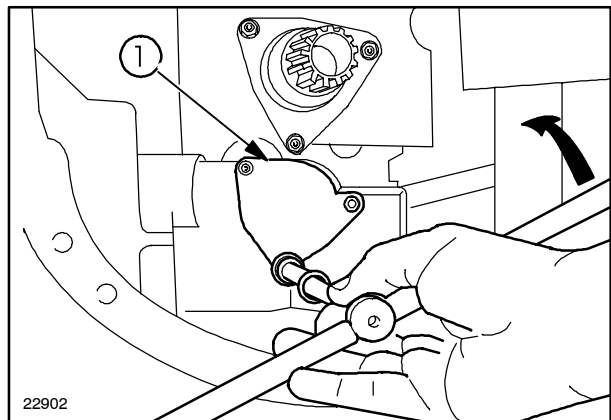

14

11. From the rear of the casing, withdraw the shaft (1) complete with the relative bearing.

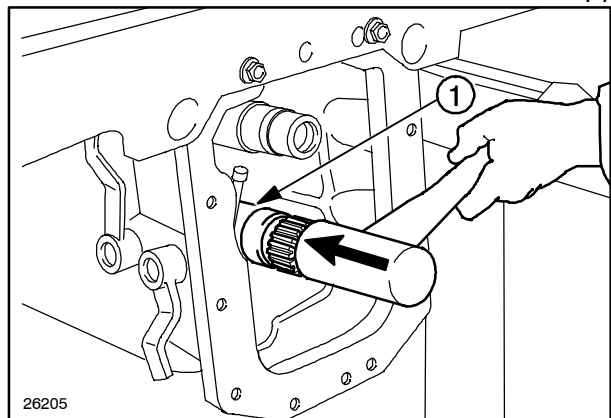

15

12. Unscrew the retaining bolts and remove the cover-support (1).

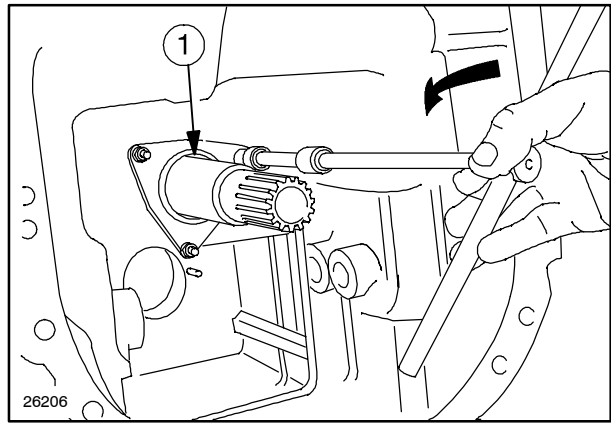

16

13. Remove the circlip (2) and withdraw the drive-shaft (1) complete with bearing.

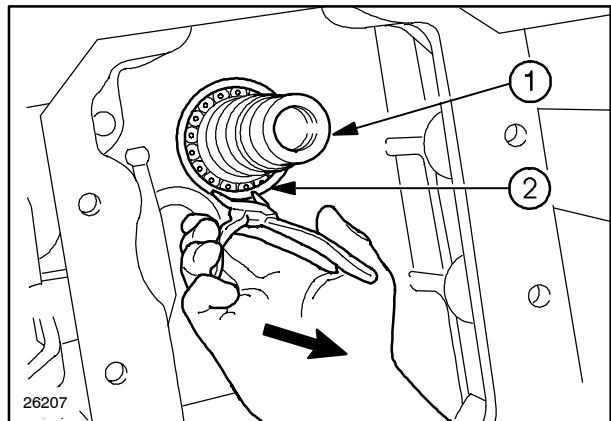

17

14. Remove the circlip (1).

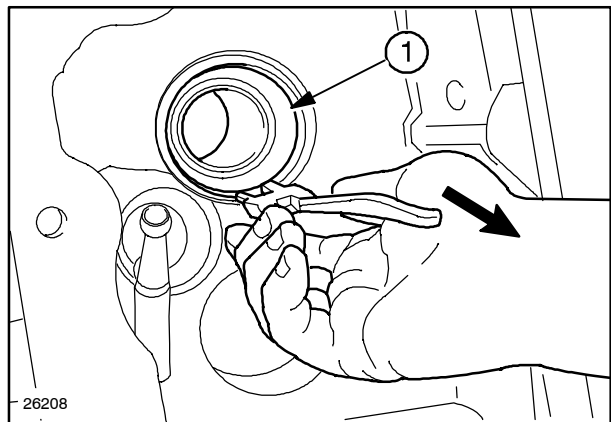

18

15. Remove the driveshaft seal (1) using a suitable implement.

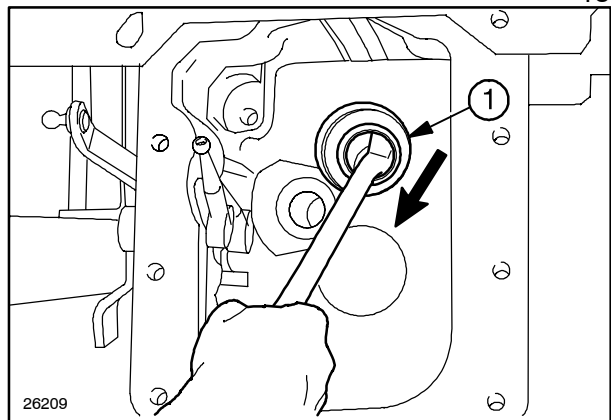

19

- 16.** To refit all the reverser and creeper components in the casing follow the instructions below :
- Refer to the illustrations on pages 4 and 5 for the orientation of the various components.
 - Adhere to the torque setting values prescribed on page 4.
 - To install the seal (1, fig. 19) follow the instructions in steps 17 - 24.
 - Install the driveshaft complete with bearing and circlips.
 - Fit the cover-support.
 - Install the reverser and creeper driven gear shaft.
 - Fit the cover for the driven gear shaft and secure with the relative screws.
 - Install the reverser intermediate gear assembly and secure with the relative screw.
 - Install and fix the clutch control forks to the relative levers.
 - Install the pressure plate bearings and hold in place with the relative springs.
 - Install the driven gear complete with bearing and thrust washer.
 - Install the complete synchroniser assembly and secure with the relative circlip.
 - Fit the rod retaining screw coated with one of the sealing compounds listed on page 1, Sect. 00.
 - Install the gear on the reverser driven shaft and secure with the relative circlip.
 - Remove the clutch casing -reverser and creeper unit from the stand **38000301**.

**WARNING**

Always use suitable tools to align holes. NEVER USE YOUR FINGERS OR HANDS.

- 17.** Fit the circlip (1, fig. 18) in its seat.
- 18.** Make the bracket of tool **50043** (4) and the tool **50137** (5) (see page 5).
- 19.** Fit the bracket (3) on the clutch casing, insert the installation drift (4) in the seal seat in contact with the circlip (1, fig. 18).
- 20.** Screw in nut (1) to obtain a distance (H) between the bracket and nut of 3.3 - 3.6 mm (0.1299 - 0.1417 in.) and secure the latter with the locknut (5).

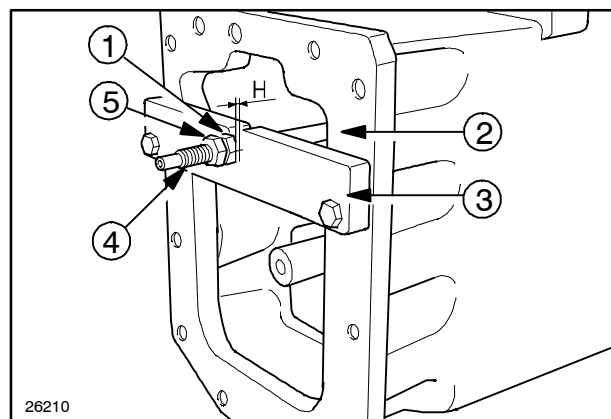

Note - Leave the drift (1) with the nut in the position reached on completion of the installation operation, and on future seal installation operations simply check that the distance (H, fig. 20) is as prescribed.

21. Remove the drift (1), the bracket (2) and the circlip (1, fig. 18).
22. Locate the new seal in its seat (see page 4 for correct orientation of seal), refit the bracket (2) on the clutch casing and insert the drift in the bracket.
23. Force the seal in until the nut (1, fig. 20) reaches up against the bracket (2).
24. Dismantle the bracket (2), remove the drift (1) and proceed with the installation of the other components.

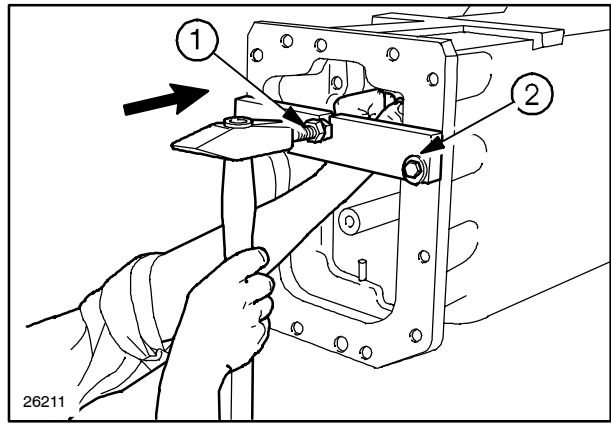

SECTION 23 - DRIVE LINES

Chapter 1 - Drive Lines

CONTENTS

Section	Description	Page
23 000	Main specification	1
	Torque settings and Tools	2
	Cross-Sectional views	3
23 101 26	Transmission shafts and guard (Disassembly - Assembly)	4
23 101 40	Drive gear housing (Removal - Installation)	5
23 101 42	Drive gear housing removed (Disassembly - Assembly)	7

MAIN SPECIFICATION

Reduction ratio		34/24x24/34= 1 to 1
Relay lever pad width	mm (in.)	7.978 - 8.000 (0.3141 - 0.3150)
Pad seat width in driven gear	mm (in.)	8.280 - 8.370 (0.3260 - 0.3295)
Pad clearance in seat	mm (in.)	0.280 - 0.460 (0.0110 - 0.315)
Relay lever pivot diameter	mm (in.)	15.973 - 16.000 (0.6289 - 0.6299)
Pivot housing bore in casing	mm (in.)	16.016 - 16.059 (0.6305 - 0.6322)
Pivot clearance in housing	mm (in.)	0.016 - 0.086 (0.0006 - 0.0124)
Relay lever detent spring length		
- Free	mm (in.)	130 (5.1181)
- Under 178.2 to 197.8 N (40 to 44 lb)	mm (in.)	142.5 (5.6102)

MAIN SPECIFICATION OF DRIVE SHAFT

Front drive sleeve adjustment		see page 4
Front drive sleeve shim thickness	mm (in.)	2.2.-2.5-2.8-3-3.3-3.7-4-4.3 (0.0866-0.0984-0.1102-0.1181- 0.1299-0.1457-0.1575-0.1693)

TORQUE SETTINGS

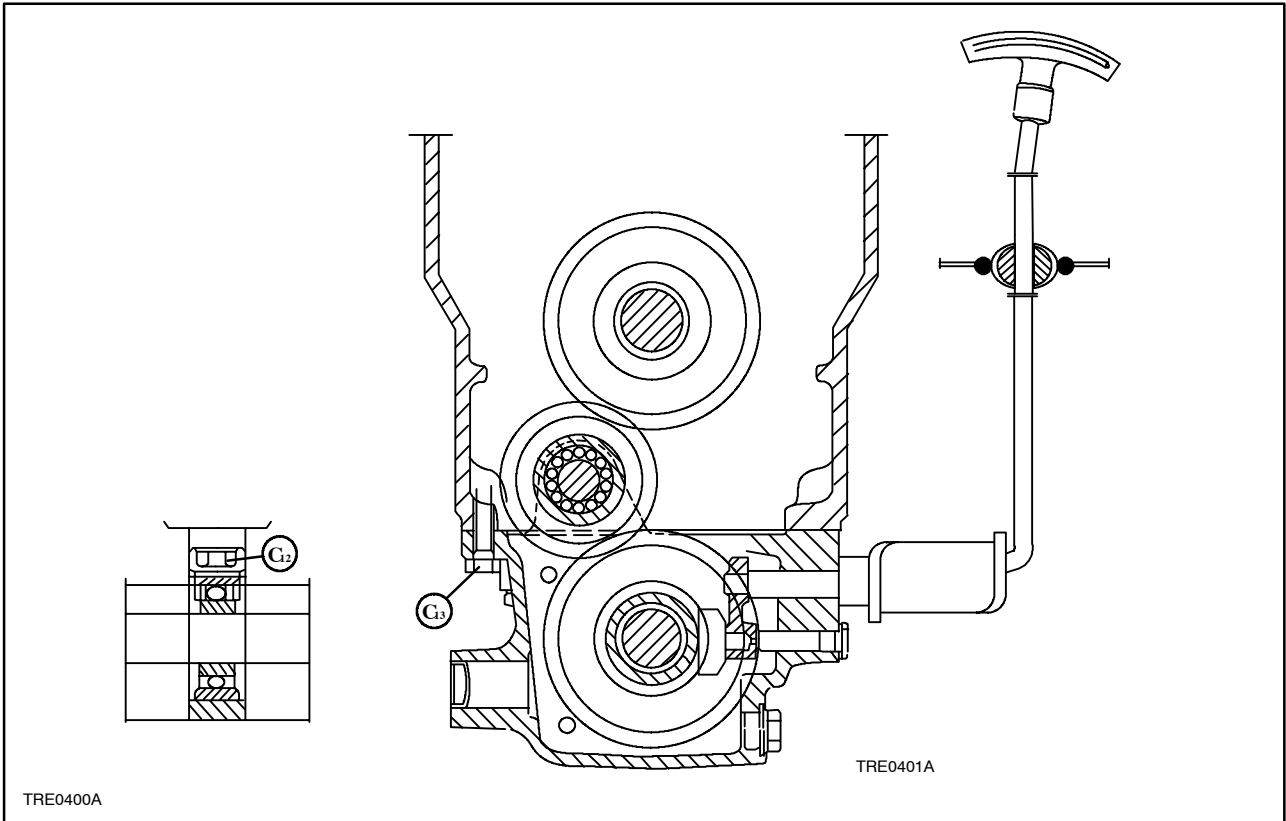

1

PART TO BE TORQUED	Thread	Torque setting	
		Nm	ft lb
Transmission shaft central support retaining bolt (C12)	M 12 x 1.5	98	72.2811
Drive gear housing retaining bolt (C13)	M 12 x 1.25	98	72.2811

TOOLS

380000821 Drive shaft seal key

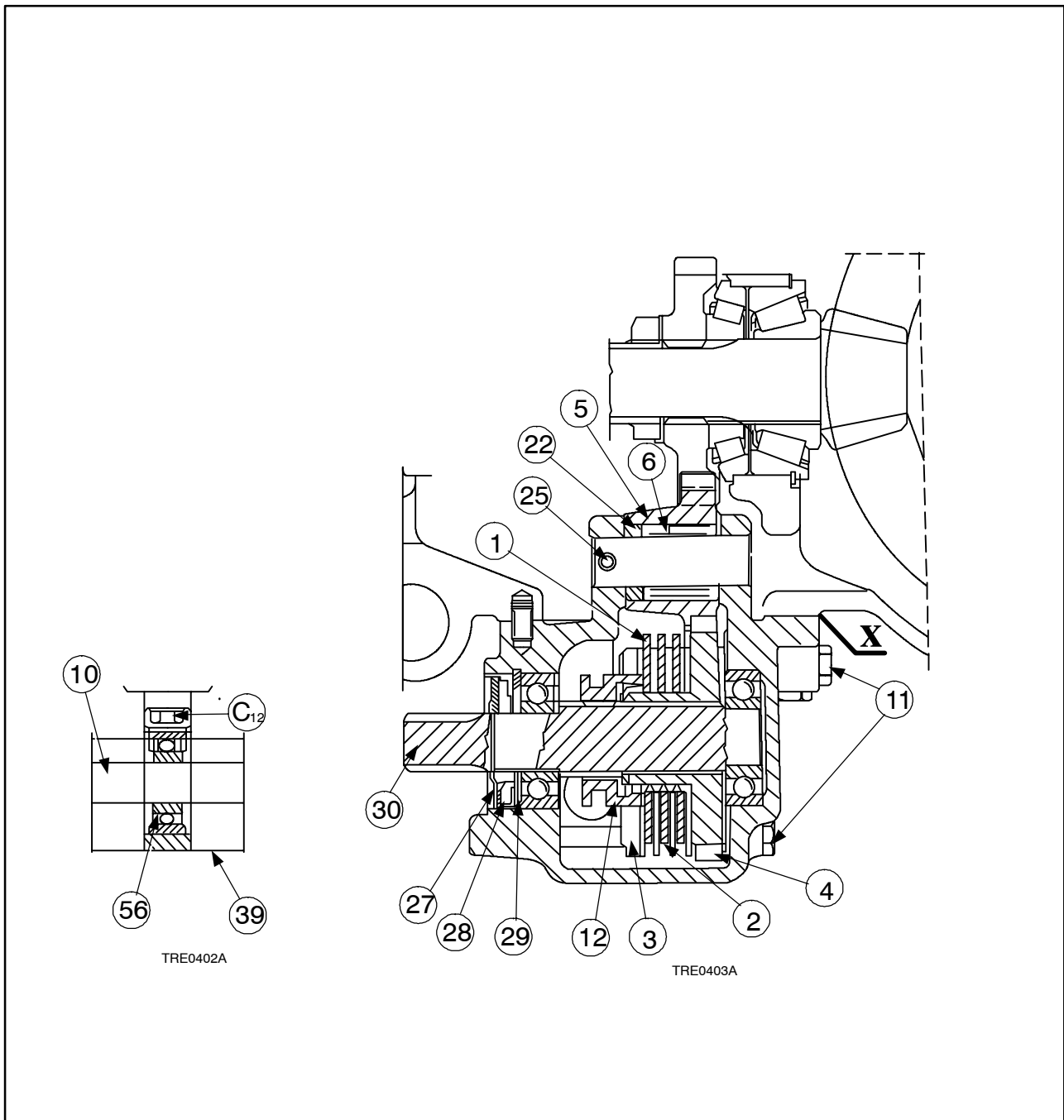

2

Cross-section of a drive transmission

C_{12} = Drive shaft centre bearing capscrew

C_{13} = Axle drive housing capscrew

X = On assembly, thoroughly clean and degrease mating surface X.

1. Brake driven discs

2. Brake linings

3. Brake shoe

4. Driven gear

5. Intermediate gear

6. Needle roller bearing

10. Driven shaft

11. Guide screws

22. Dentent plunger

25. Roll pin

26. Intermediate shaft

27. Dust excluder

28. Seal

29. Retaining ring

30. Splined driven shaft

39. Drive shaft guard

56. Centre bearing

Op. 23 101 26

TRANSMISSION SHAFTS AND GUARD

Disassembly - Assembly

**WARNING**

Handle all parts with great care.
Do not place hands or fingers between one part and another.
Always wear the prescribed safety clothing, including protective glasses, gloves and shoes.

To remove, proceed as follows:

1. Disconnect the negative battery lead.

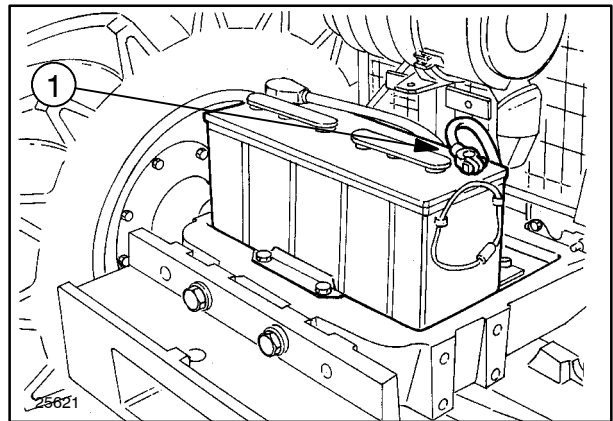

3

2. Remove the front, centre and rear screws securing the front axle prop shaft guard and remove the guard (1).
3. Remove circlip (2) fig. 5 and move sleeve (1) in the direction shown by the arrow to disengage it from the splined shaft of the front axle.
4. To re-fit the transmission shaft and guard, proceed as follows:

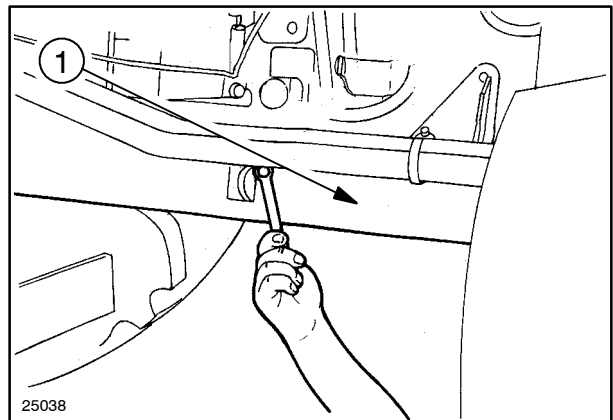

4

**WARNING**

Use suitable tools to align holes. NEVER USE FINGERS OR HANDS.

- Fit and secure the transmission shaft in position.

NOTE:

Move the front splined sleeve (27) against retaining ring (28). Using a feeler gauge, measure gap between the sleeve and the retaining ring (26) and install shim (S5) to obtain sleeve end play (L) of 1 to 1.5 mm (0.0394 to 0.0591 in.) (see Section 25 page 9).

- Fit and secure the guard.

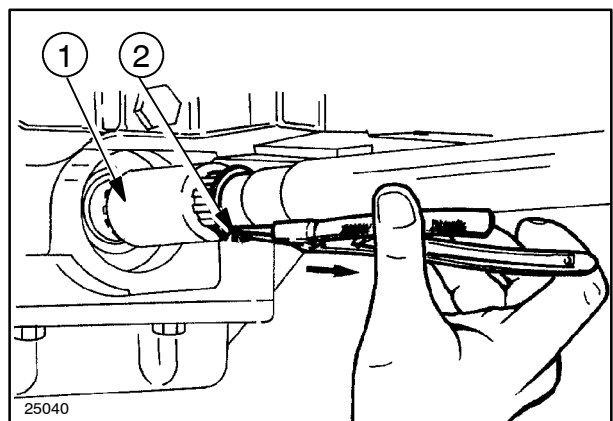

5

Op. 23 101 40

DRIVE GEAR HOUSING ASSEMBLY

Removal- Installation

**WARNING**

Handle all parts with great care.
Do not place hands or fingers between one part and another.
Always wear the prescribed safety clothing, including protective glasses, gloves and shoes.

To remove, proceed as follows:

1. Carry out operation **23 101 26** Transmission shafts and guard removal (see page 4)
2. Remove the plug (1) and drain the oil from the transmission box/gearbox.

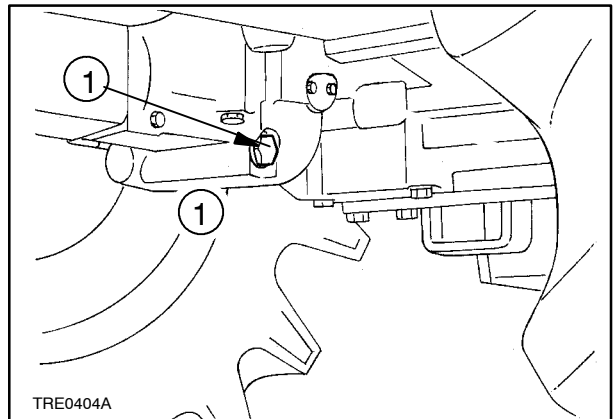

6

3. Detach the drive gear engagement control lever(1)

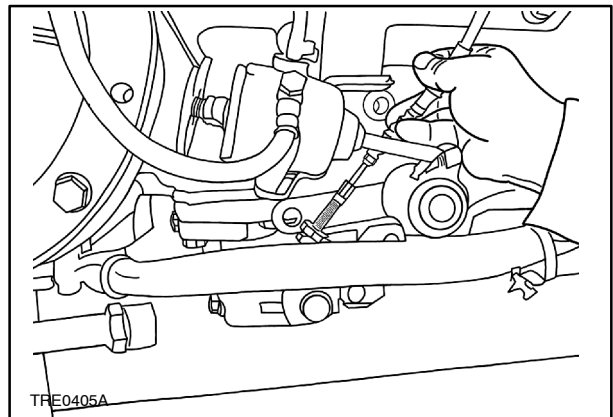

7

4. Remove the screws (1) that hold the drive gear housing (transfer box) to the transmission housing.
5. Remove the drive gear housing from the transmission housing.

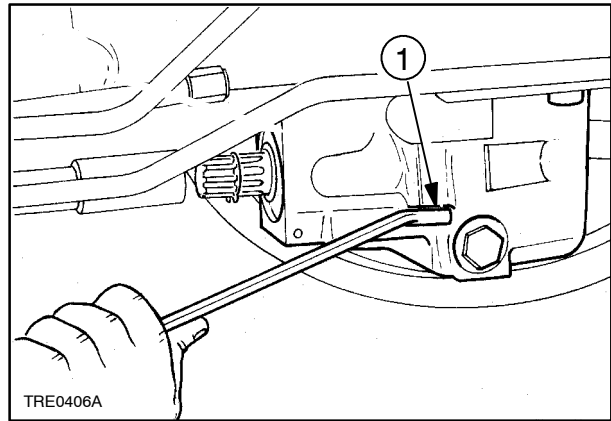

8

6. To re-fit the drive gear housing, proceed as follows:

⚠ WARNING ⚠

Use suitable tools for aligning holes. DO NOT USE YOUR HANDS OR FINGERS.

- Refer to the tightening torques shown on page 2.
- Carefully clean the contact surfaces.
- Apply sealing compound (approx. 2 mm (0.0787 in.) wide strip) to the contact surface of the drive gear housing.
- Fit the drive gear housing to the transmission housing.
- Connect the drive gear engagement control lever.
- Replace the transmission oil drain plug.
- Carry out operation **23 101 26** Transmission shafts and guard installation (see page 4).
- Fit the drive shaft guard.

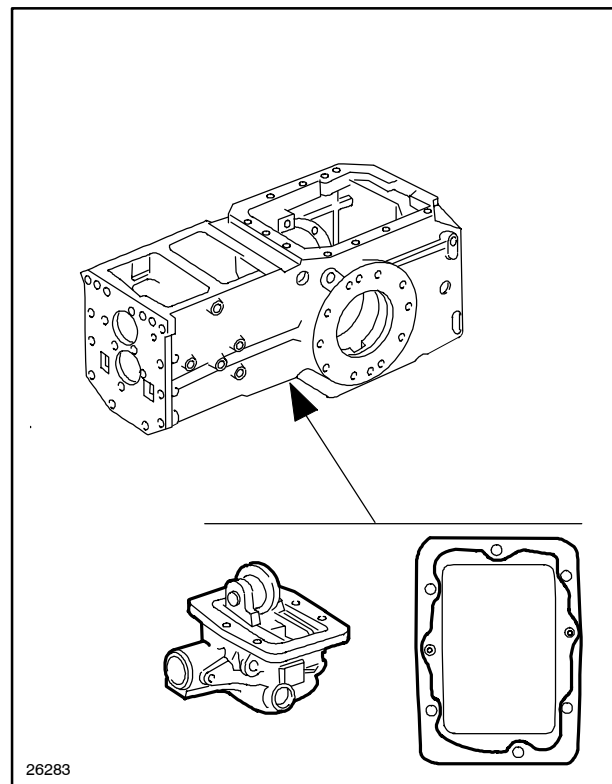

26283

9

Mastic application diagram for assembly of drive gear housing to transmission housing.

TRANSFER BOX, UNIT REMOVED**Disassembly - Assembly (Op. 23 101 42)**

Handle all parts with great care.
Do not place hands or fingers between one part and another.
Always wear the prescribed safety clothing, including protective glasses, gloves and shoes.

With the transfer box on the bench, proceed as follows:

1. Carry out operation **23 101 26** Transmission shafts and guard removal (see page 4).
2. Carry out operation **23 101 40** Drive gear housing removal (see page 5).

S

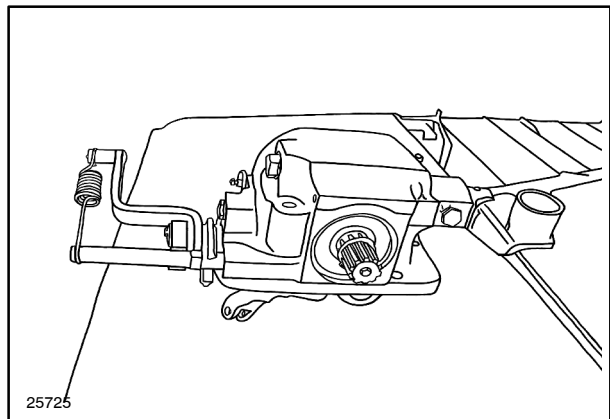

3. Use the special punch to withdraw the snap ring (1), then the pin (2). Remove the roller bearing, the spacer, the thrust washers and the intermediate gear (3).
4. Remove the parking brake control lever.

10

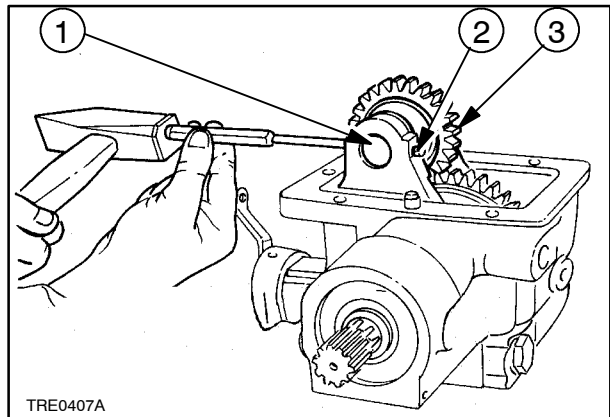

5. Use a screwdriver to remove the dust ring (1).
6. Remove the splined driven shaft, complete with parts, parking brake discs and the driven gear.

11

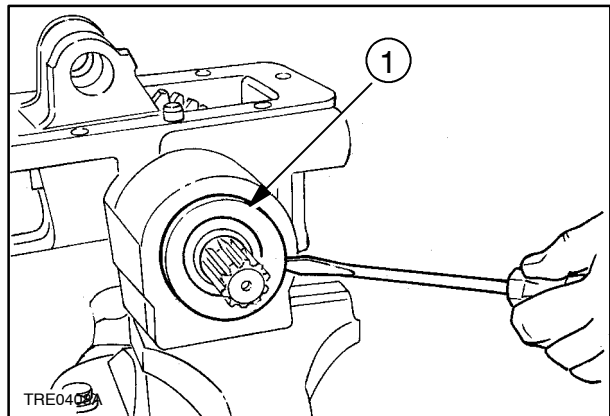

12

7. To refit the transfer box, proceed as follows:



WARNING



Use suitable tools to align holes. NEVER USE FINGERS OR HANDS.

Insert the shaft in the housing, then assemble the gear unit, washer and circlip.

Fit the internal lever, the external lever, the coupling pad and secure in position by means of the washer and relative circlip.

Fit the bearing and relative circlips

- Using tool **380000821**, fit the seal and dust ring (use the spacer to fit the dust ring).
- Carry out operation **23101 40** Drive gear housing installation (see page 5).

Carry out operation **23 101 26** Transmission shafts and guard installation (see page 4).

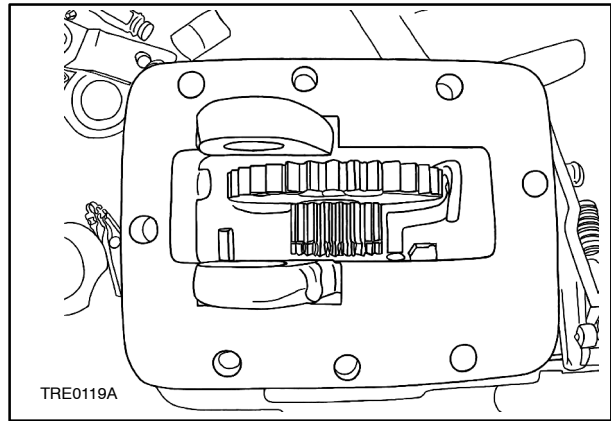

13

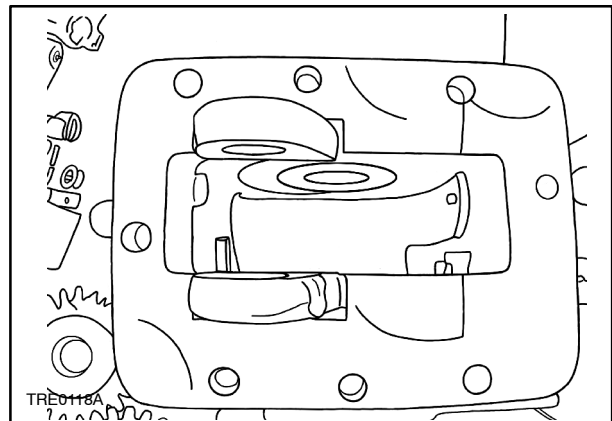

14

SECTION 25 – FRONT AXLE MECHANICAL TRANSMISSION

Chapter 1 – Front axle mechanical transmission

CONTENTS

Section	Description	Page
25 000	Main data	1
	Tightening torques	4
	Tools	6
	Cross-sectional views	7
	Description and operation	10
	Complete front axle. Removal – Installation	10
25 100 30	Complete front axle. Removal – Installation	10
25 100 38	Front axle. Removal – Installation	14
25 108 46–47	Steering knuckle bearing pins. Replacement	24
	Stub axle adjustment	25
	Wheel hub bearing adjustment	27
	Bevel drive adjustment	29
25 102 24	Front axle differential. Overhaul	36
25 100 27	Front axle differential with LIM–SLIP. Overhaul	37
	Front axle differential with NO SPIN. Overhaul	39
44 511 80	Leading drive wheels toe-in check	42

MAIN DATA

Type	steering, load bearing structure, pivoting at centre	
Bevel gear pair – differential		
Pinion–crown gear ratio: 30 km/h:		
– TD60D and TD70D Models		9/38 = 1:4.2
– TD80D, TD90D and TD95D Models		9/39 = 1:4.3
Pinion–crown gear ratio: 40 km/h:		
– TD60D and TD70D Models		11/38 = 1:3.45
– TD80D, TD90D and TD95D Models		11/39 = 1:3.54
Backlash between bevel gear pair:		
– TD60D and TD70D Models	mm (in.)	0.18 – 0.23 (0.0071 – 0.0091)
– TD80D, TD90D and TD95D Models	mm (in.)	0.15 – 0.20 (0.0059 – 0.0079)
Ratio between front wheel revs and rear wheel bevel drive revs		
– TD60D and TD70D Models	mm (in.)	1.386 (0.545)
– TD80D, TD90D and TD95D Models	mm (in.)	1.378 (0.542)
– TD95D Model		1.398 (0.550)

(continued overleaf)

MAIN DATA

Bevel Drive and Differential		
– Thickness of pinion bearing adjustment spacer		
TD60D and TD70D Models	mm	2.5–2.55–2.6–2.65–2.7–2.75–2.8–2.85–2.9–2.95–3.00–3.05–3.10–3.15–3.2–3.25–3.3–3.35–3.4–3.45–3.5–3.55–3.6–3.65–3.7
	(in.)	(0.0984–0.1004–0.1024–0.1043–0.1063–0.1083–0.1102–0.1122–0.1142–0.1161–0.1181–0.1201–0.1220–0.1240–0.1260–0.1280–0.1299–0.1319–0.1339–0.1358–0.1378–0.1398–0.1417–0.1437–0.1457)
TD80D, TD90D and TD95D Models	mm	2.2–2.25–2.30–2.35–2.40–2.45–2.5–2.55–2.6–2.65–2.7–2.75–2.8–2.85–2.9–2.95–3.00–3.05–3.1–3.15–3.2–3.25–3.3–3.35–3.4
	(in.)	(0.0866–0.0886–0.0906–0.0925–0.0945–0.0965–0.0984–0.1004–0.1024–0.1043–0.1063–0.1083–0.1102–0.1122–0.1142–0.1161–0.1181–0.1201–0.1220–0.1240–0.1260–0.1280–0.1299–0.1319–0.1339)
– Thickness of crown wheel position adjustment spacer		
TD60D and TD70D Models	mm	2.5–2.6–2.7–2.8–2.9–3.00–3.1–3.2–3.3–3.4–3.5–3.6–3.7
	(in.)	(0.0984–0.1024–0.1063–0.1102–0.1142–0.1181–0.1220–0.1260–0.1299–0.1339–0.1378–0.1417–0.1457)
TD80D, TD90D and TD95D Models	mm	2.2–2.3–2.4–2.5–2.6–2.7–2.8–2.9–3.0–3.1–3.2–3.3–3.4–3.5
	(in.)	(0.0984–0.1024–0.1063–0.1102–0.1142–0.1181–0.1220–0.1260–0.1299–0.1339–0.1378–0.1417–0.1457)
– Clearance between sides of planet and side pinion teeth	mm (in.)	0.15 (0.0059)
– Thickness of planet pinion thrust washers	mm (in.)	1.470 – 1.530 (0.0579 – 0.0602)
– Thickness of side gear thrust washers	mm (in.)	1.50 to 1.60 (0.0591 to 0.0630)
– Diameter of cross pin for planet pinions		
TD60D and TD70D Models	mm (in.)	21.939 – 21.960 (0.8637 – 0.8646)
TD80D, TD90D and TD95D Models	mm (in.)	23.939 – 23.960 (0.9425 – 0.9433)
– Side diameter cross pin bore diameter		
TD60D and TD70D Models	mm (in.)	22.040 – 22.961 (0.8677 – 0.9040)
TD80D, TD90D and TD95D Models	mm (in.)	23.940 – 23.961 (0.9425 – 0.9433)
– Clearance between cross pin and bores		0.080 – 0.122 (0.0031 – 0.0048)
– Diameter of outer axle shafts and corresponding bushes		
TD60D and TD70D Models	mm (in.)	37.961 – 38.000 (1.4945 – 1.4961)
TD80D, TD90D and TD95D Models	mm (in.)	43.961 – 44.000 (1.7307 – 1.7323)
– Inside diameter of installed bushes		
TD60D and TD70D Models	mm (in.)	0.77 – 0.83 (0.0303 – 0.0327)
TD80D, TD90D and TD95D Models	mm (in.)	38.080 – 38.199 (1.4992 – 1.5039)
TD80D, TD90D and TD95D Models	mm (in.)	44.080 – 44.119 (1.7354 – 1.7370)
– Clearance between axle shafts and bushes	mm (in.)	0.080 – 0.158 (0.0031 – 0.0062)

(continued overleaf)

MAIN DATA

Axle shafts and steering knuckles		
– Diameter of outer axle shafts and corresponding bushes		
TD60D and TD70D Models	mm (in.)	29.914 – 29.935 (1.1777 – 1.1785)
TD80D, TD90D and TD95D Models	mm (in.)	41.975 – 42.000 (1.6526 – 1.6535)
– Inside diameter of installed front bush		
TD60D and TD70D Models	mm (in.)	30.050 – 30.105 (1.1831 – 1.1852)
TD80D, TD90D and TD95D Models	mm (in.)	42.100 – 42.175 (1.6575 – 1.6604)
– Clearance between pin and bush		
TD60D and TD70D Models	mm (in.)	0.115 – 0.191 (0.0045 – 0.0075)
TD80D, TD90D and TD95D Models	mm (in.)	0.100 – 0.200 (0.0039 – 0.0079)
– Interference fit between bushes and respective bores		
	mm (in.)	0.064 – 0.129 (0.0025 – 0.0051)
– Thickness of steering knuckle bearing adjuster plates		
	mm (in.)	0.10–0.15–0.20–0.25–0.30 (0.0039–0.0059–0.0079–0.0098–0.0118)
Planetary Final Drives		
– Reduction ratio		
TD60D and TD70D Models	mm (in.)	$15:(15+54) = 1:4.6$ $0.5906:(0.5906+2.1260) = 1:4.6$
TD80D and TD90D Models	mm (in.)	$16:(16+62) = 1:4.88$ $0.6299:(0.6299+2.4409) = 1:4.88$
– Driven gear thrust washer thickness		
		0.77 – 0.83 (0.0303 – 0.0327)
Axle pivot		
Pivoting angle (on either side)		
		11°
Centre pivot and support end float		
	mm (in.)	0.3 – 1.1 (0.0118 – 0.0433)
Max. wear clearance		
	mm (in.)	2 (0.0787)
Centre pivot diameter		
	mm (in.)	52.652 – 52.671 (2.0729 – 2.0737)
Centre pivot front bushing fitted		
	mm (in.)	52.720 – 52.790 (2.0756 – 2.0783)
Centre pivot working clearance in bushing		
	mm (in.)	0.049 – 0.138 (0.0019 – 0.0054)
Rear bevel pinion carrier spigot		
	mm (in.)	99.040 – 99.72 (3.8992 – 3.9063)
Rear bushing fitted		
	mm (in.)	99.146 – 99.221 (3.9034 – 3.9063)
Spigot fitted clearance in bushing		
	mm (in.)	0.074 – 0.181 (0.0029 – 0.0071)
Axle front and rear thrust washer thickness		
	mm (in.)	4.95 – 5.00 (0.1949 – 0.1969)
Turning radius:		
– Live axle in Brakes on TD60D and TD70D Models		
	mm (in.)	3600 (141.732)
Brakes on TD80D, TD90D and TD95D Models		
	mm (in.)	4100 (161.417)
– Live axle in Brakes off TD60D and TD70D Models		
	mm (in.)	5300 (208.661)
Brakes off TD80D, TD90D and TD95D Models		
	mm (in.)	5600 (220.472)
– Live axle out Brakes on TD60D and TD70D Models		
	mm (in.)	4200 (141.732)
Brakes on TD80D, TD90D and TD95D Models		
	mm (in.)	4500 (165.354)
– Live axle out Brakes off TD60D and TD70D Models		
	mm (in.)	4900 (192.913)
Brakes off TD80D, TD90D and TD95D Models		
	mm (in.)	5100 (200.787)

(continued overleaf)

TIGHTENING TORQUES

PART	Thread	Tightening torque	
		Nm	ft lb
Front axle			
Lock ring, bevel pinion (C ₁)			
TD60D and TD70D Models	M 35 x 1.5	294	216.8432
TD80D TD90D and TD95D Models	M 40 x 1.5	294	216.8432
Capscrew, differential case to axle casing (C ₂)	M 12 x 1.25	113	83.3445
Capscrew, ring gear to differential case (C ₃)	M 12 x 1.25	113	83.3445
Steering knuckle capscrew (C ₅)			
– models TD60D and TD70D	M 12 x 1.25	113	83.3445
Wheel hub bearings lock nut (C ₆):			
– TD60D and TD70D models	M 45 x 1.5	118	87.0323
– TD80D, TD90D and TD95D models	M 75 x 2	392	289.11243
Capscrew, planetary final drive housing (C ₇)	M 10 x 1.25	64	47.2040
Front axle front and rear pivot support bolt (C ₉)	M 18 x 1.5	392	289.11243
Differential cage support cap bolt (C ₁₀)	M 12 x 1.25	113	83.3445
Front axle support to engine retaining bolt (C ₁₁)	M 18 x 1.5	314	231.5945

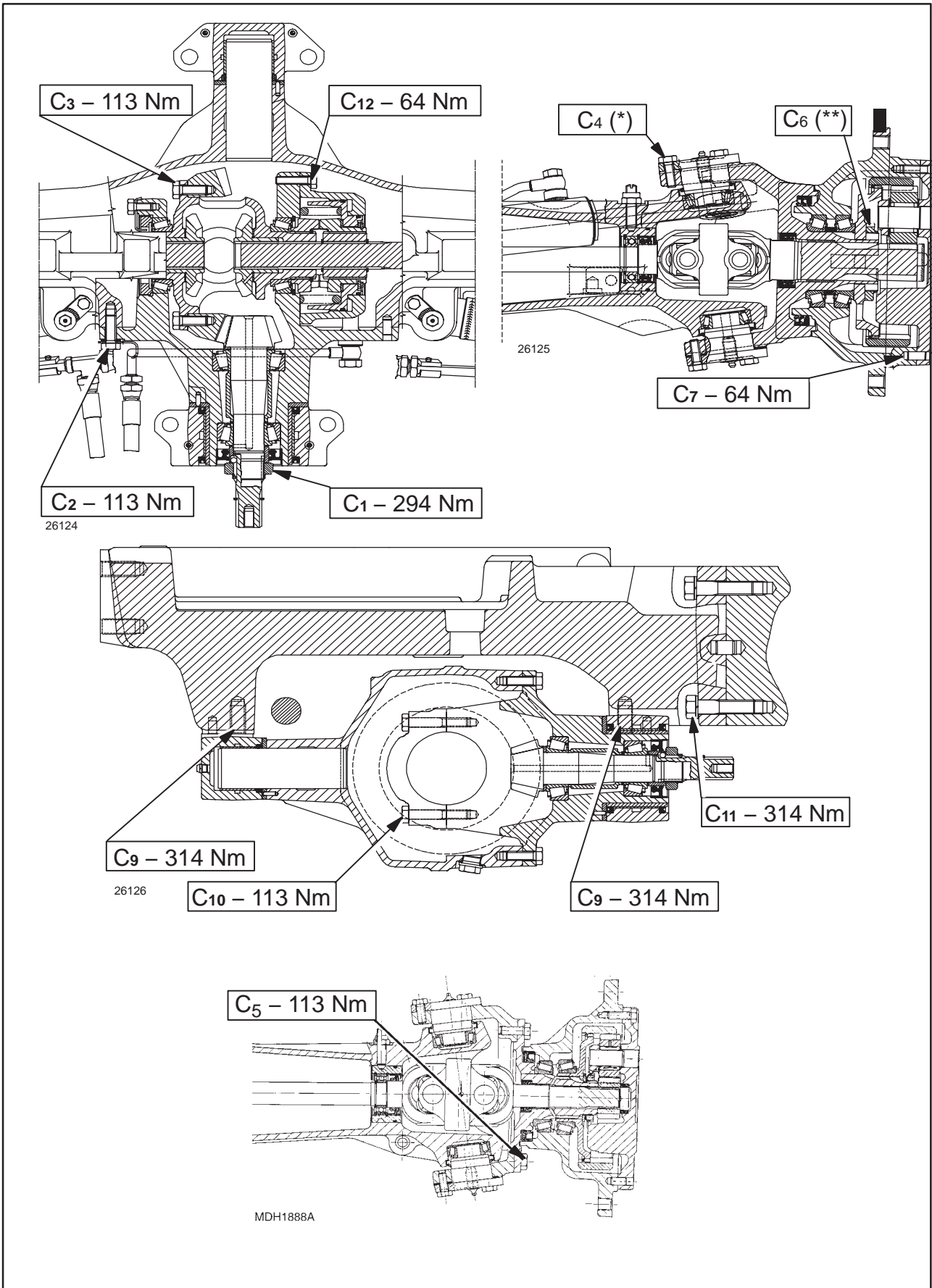

(*) See pages 25 and 26

(**) See page 27

TOOLS

WARNING: The tools marked below with an **(X)** are **ESSENTIAL** for the operations described in this section. To work in safety and obtain the best results whilst saving time and energy, these essential tools should be supplemented by the specific tools listed below and other tools which are to be made from the drawings provided in this manual.

List of specific tools required for the various operations described in this section.

- | | | | |
|------------------|---|--------------------|--|
| 380000251 | Front axle overhaul stand. | X 380000248 | Bevel pinion positioning adjustment tool |
| 380000227 | Hook for removal–installation of the front differential assembly. | X 380000532 | Pinion ring nut wrench mod. TD60D and TD70D |
| 380000255 | Overhaul support for front axle differential casing. | X 380000268 | Pinion ring nut wrench mod. TD80D, TD90D and TD95D |
| 380000249 | Universal gauge for positioning of front bevel drive pinion. | X 380000257 | Pinion grooved profile fastener wrench. |
| | | X 380000252 | Bevel drive bearing preloading ring nut wrench mod. TD60D and TD70D |
| | | X 380000253 | Bevel drive bearing preloading ring nut wrench mod. TD80D, TD90D and TD95D |
| | | X 380000234 | Front axle pivot bearing outer ring removal tool. |
| | | X 380000235 | Tool for measurement of rolling drag torque of front axle bearings. |
| | | X 380000616 | Wheel hub ring nut wrench. (TD60D, TD70D models) |
| | | X 380000269 | Wheel hub ring nut wrench. (TD80D, TD90D and TD95D models) |

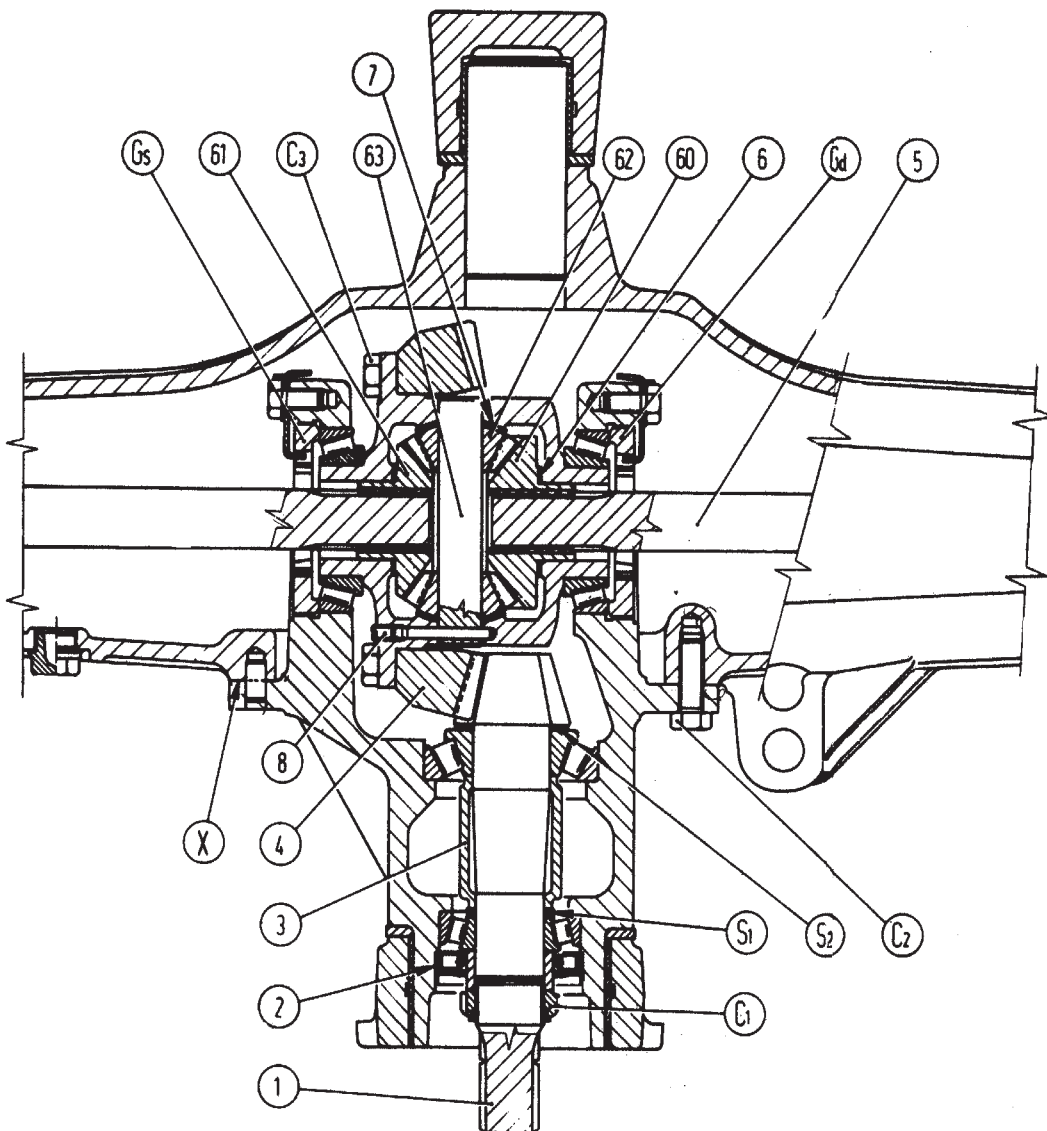

TRE0414A

2

Cross-sectional view of front axle differential

- | | |
|---|--|
| S₁ = Bevel pinion bearing shim | 1. Bevel pinion |
| S₂ = Bevel pinion position shim | 2. Seal |
| C₁ = Bevel pinion bearing locking. | 3. Bevel pinion bearing spacer |
| C₂ = Differential carrier capscrew. | 4. Ring gear |
| C₃ = Ring gear capscrew. | 5. Axle shaft with universal joint |
| Gd, Gs = R.H. and L.H. Differential bearing locking. | 6. Side gear washers |
| | 7. Differential pinion washers |
| | 8. Differential pinion journal capscrew |
| | 60. Side gear |
| | 61. Side gear |
| | 62. Differential pinion |
| | 63. Differential pinion journal |

NOTE: During installation, apply sealing compound to surfaces X as shown in Section 00, Chapter 1, page 1.

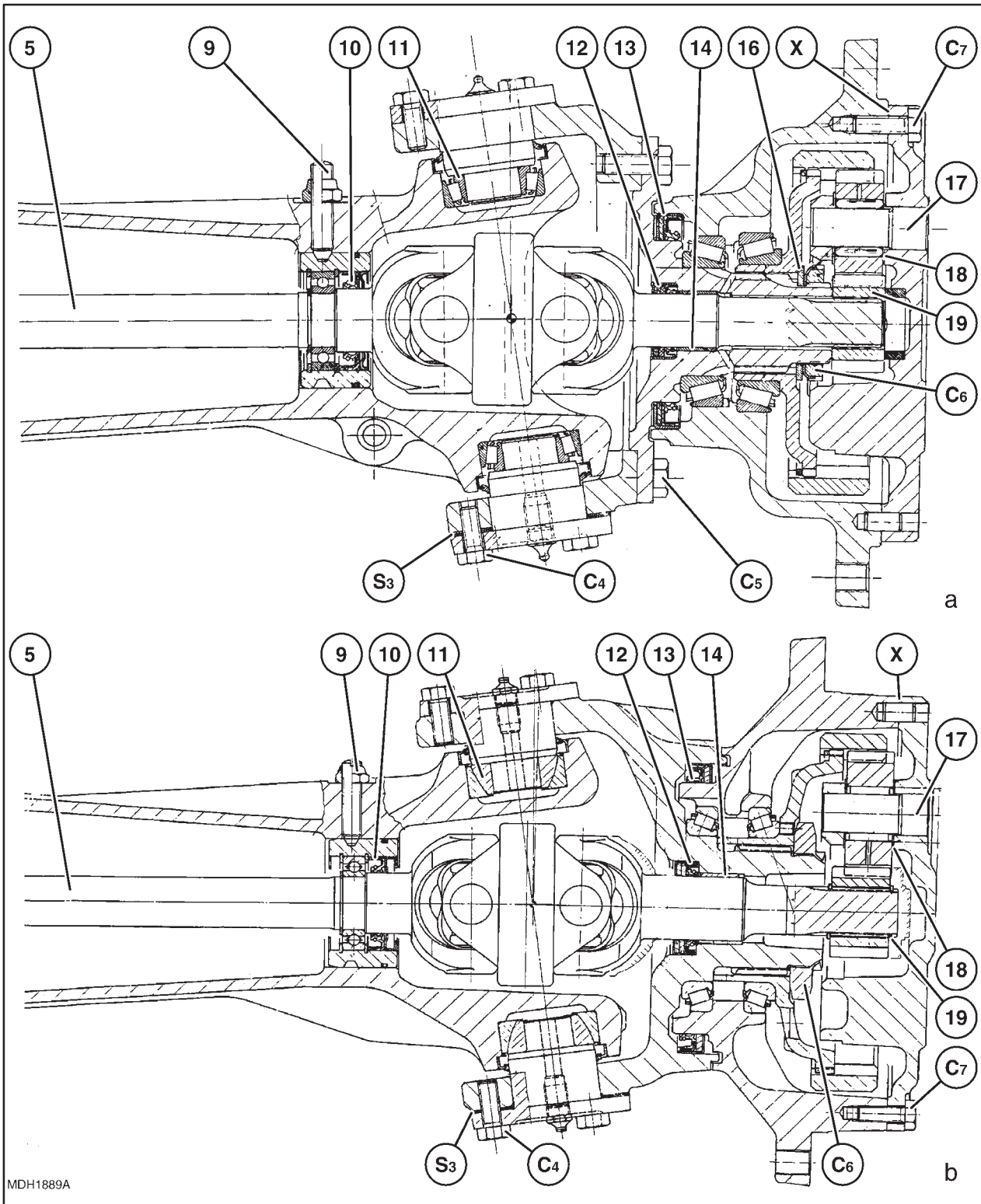

MDH1889A

Cross-sectional view of front axle steering knuckle and hub

- S₃** = King pin bearing shim
C₄ = King pin bearing capscrew.
C₅ = Steering knuckle capscrew.
C₆ = Wheel hub bearing locking
C₇ = Final drive housing capscrew.
5. Wheel shaft
9. Bearing carrier capscrew
10. Seal
11. King pin bearing
12. Seal
13. Seal
14. Axsule shaft bushing
15. Spacer
16. Thrust washers
17. Planet wheel journals
18. Planet wheel shims
19. Sun gear

NOTE: During installation, apply sealing compound to surfaces **X** as shown in Section 00, Chapter 1, page 1.

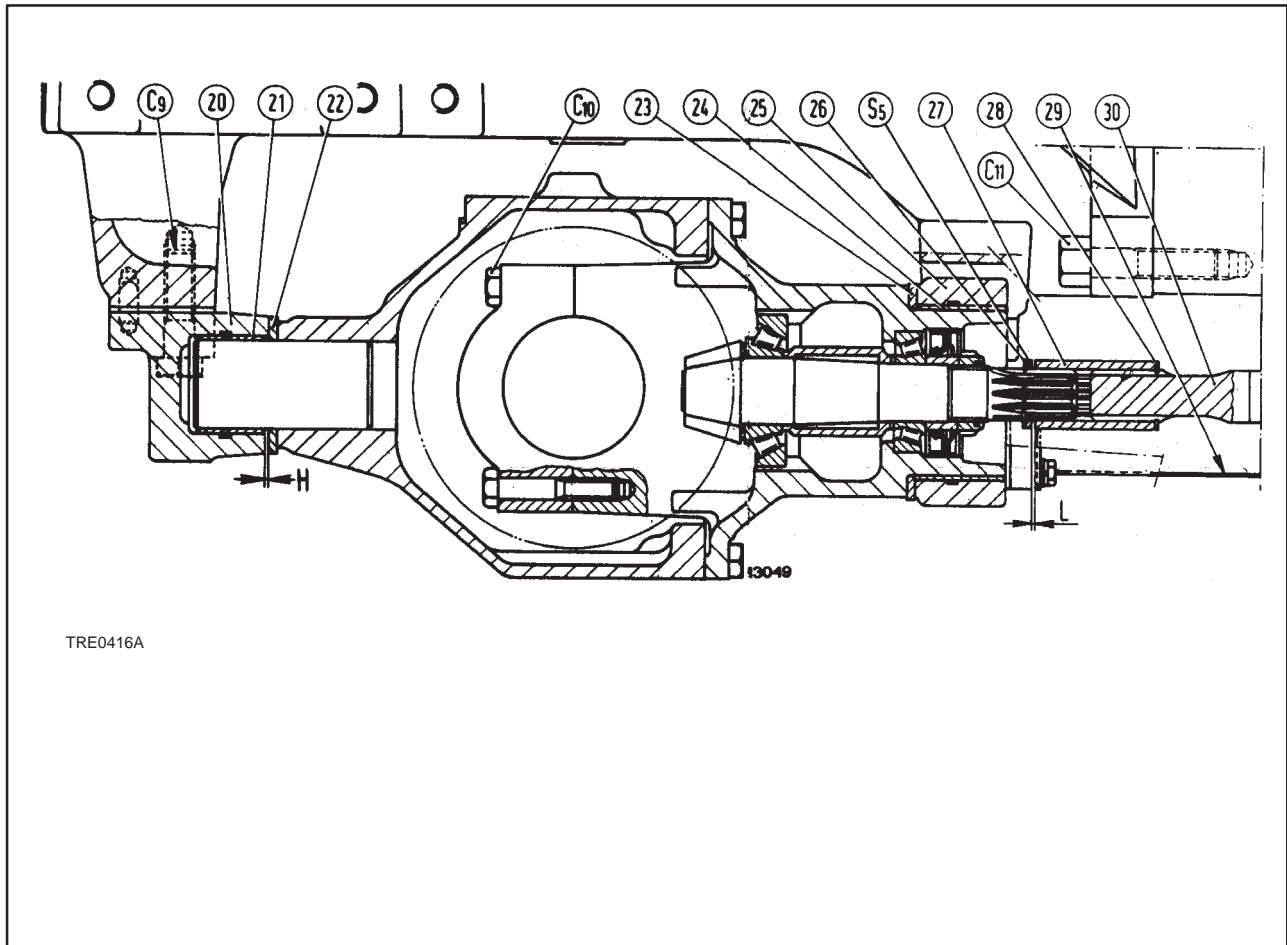

4

Cross-sectional view of front axle pivot

- H** = 1 mm (0.0394 in.)
L = 1 to 1.5 mm (0.0394 – 0.0590 in.)
S₅ = Sleeve position shim
C₉ = Axle pivot support capscrew
C₁₀ = Differential bearing cap capscrew.
C₁₁ = Capscrews securing front axle support to engine.
20. Front axle pivot support
21. Front bushing
22. Front thrust washer
23. Rear thrust washer
24. Rear bushing
25. Rear axle pivot support
26. Retaining rings
27. Front splined sleeve
28. Retaining rings
29. Drive shaft guard
30. Drive shaft

DESCRIPTION AND OPERATION

TD60D, TD70D, TD80D, TD90D and TD95D models have a centrally pivoting front axle with the pivot and the drive shaft coaxial with the longitudinal axis of the tractor. The drive shaft has no universal joints.

The differential has two planet pinions; drive is transmitted to lateral epicyclic final drive units (installed on the wheel hubs) through universal joints which require no maintenance.

COMPLETE FRONT AXLE

Removal– installation (Op. 25 100 30)



Lift and handle all heavy parts using suitable lifting equipment with a sufficient lifting capacity. Check that the assemblies or parts are held firmly and supported by suitable slings and hooks. Make sure nobody is standing near to the load.

Proceed as follows:

NOTE: The front axle assembly can be removed from the tractor either with or without previously removing the drive shaft. The description below refers to removal of the front axle with the drive shaft installed on the tractor. For removal of the drive shaft refer to section 23.

1. Disconnect the negative battery lead (1).

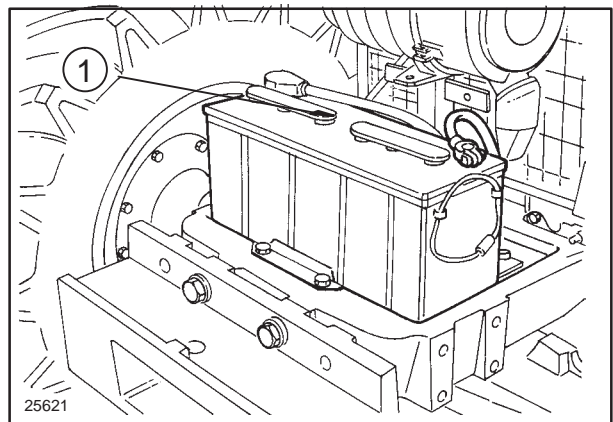

5

2. Unscrew bolts (1) and remove the front mud-guard supports (2).

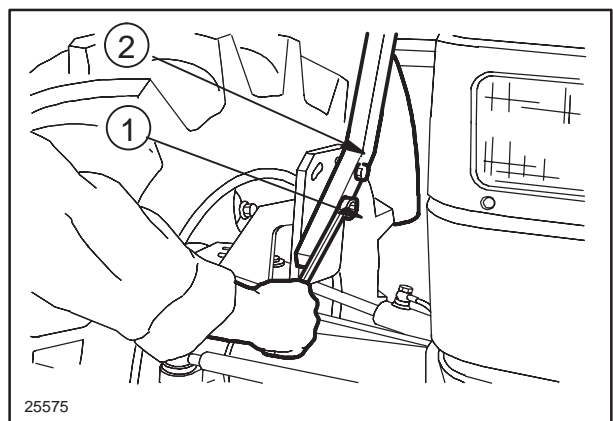

6

3. Attach nylon slings to the front weights (1). Loosen the locking screw from each weight, lift the weights clear of the tractor and place them in a safe position.

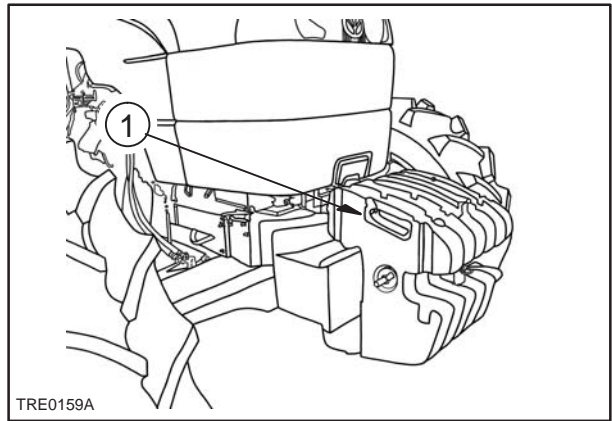

7

4. Unscrew bolts (1) and remove the drive shaft guard (2).

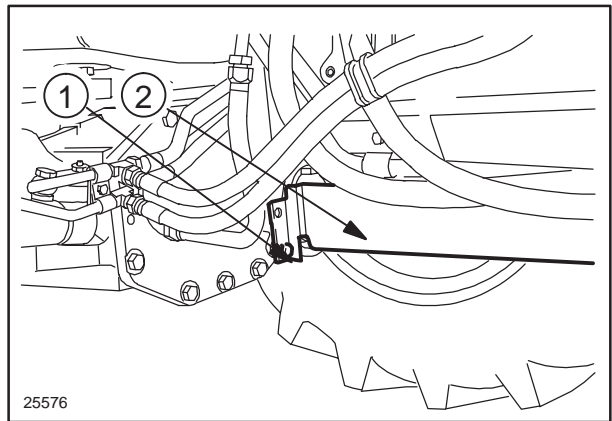

8

5. Remove the circlip (1) from the front of the drive shaft. Slide the sleeve rearwards and detach the drive shaft from the front axle.

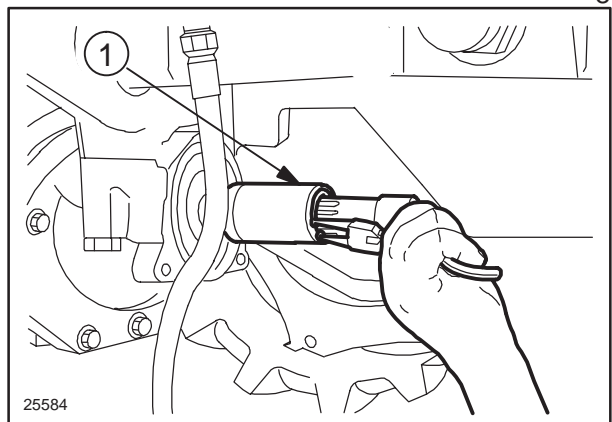

9

6. Pass two nylon slings around the front axle and attach them to a hoist.

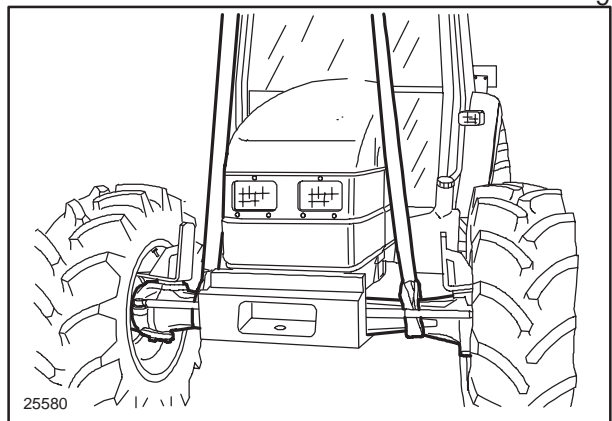

10

7. Lift the tractor with the hoist and place a stand under the sump pan.

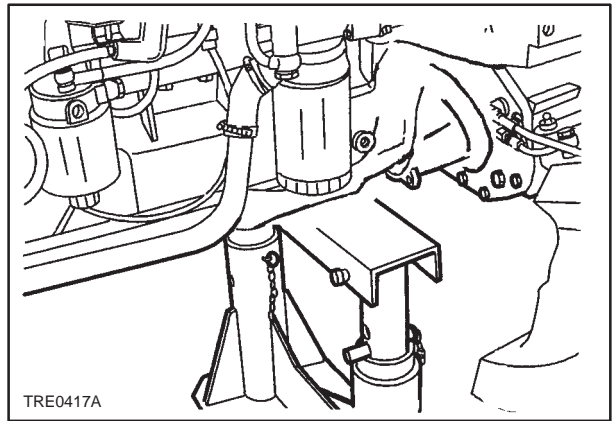

8. Unscrew unions (1) of the rigid pipes to the power steering cylinders and detach the two flexible hoses

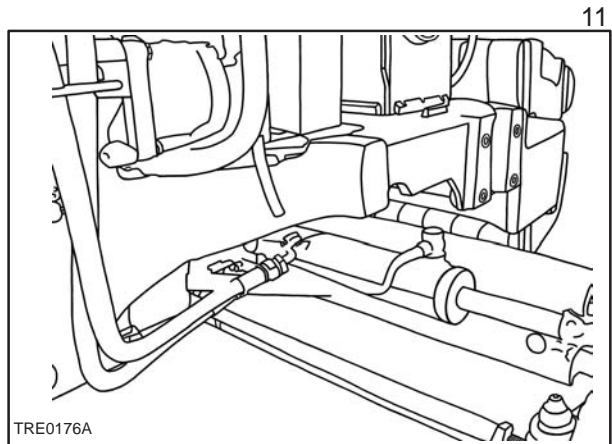

9. Unscrew the wheel bolts and remove the front wheels.

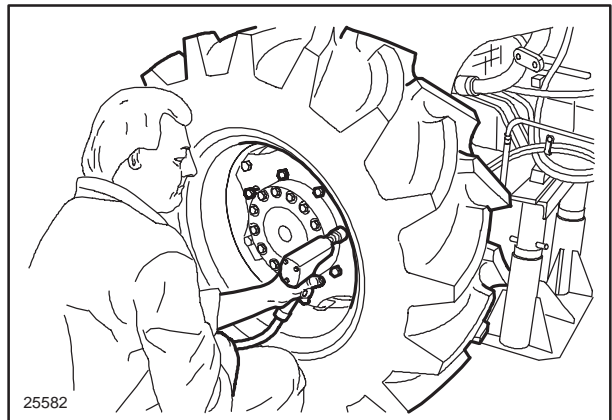

10. Unscrew the front axle rear support retaining bolts (1).

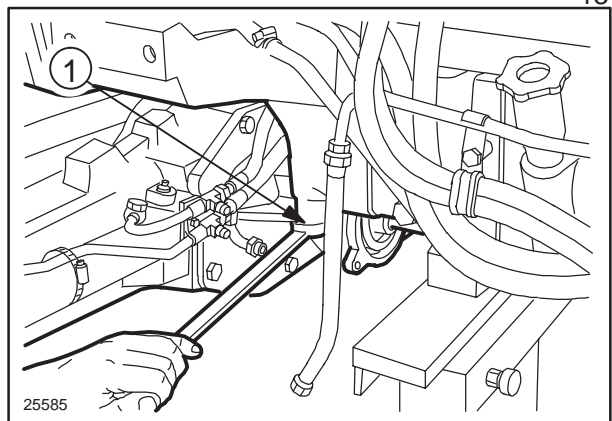

11. Unscrew the front axle front support retaining bolts (1).

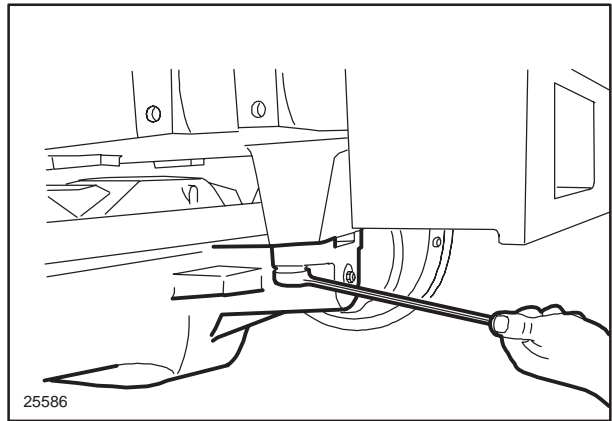

15

12. Using a hoist and two nylon cables (one for each side) detach the front axle from the tractor.

13. Refit the front axle following the instructions below.

**WARNING**

Always use appropriate tools to align fixing holes.
NEVER USE YOUR FINGERS OR HANDS.

- Refit the axle and bolt the front and rear supports in position.
- Reconnect the the power steering pipes.
- Fit the front wheels.
- Raise the front of the tractor using the hoist.
- Remove the fixed stand.
- Detach the nylon cables.
- Reconnect the drive shaft and refit the drive shaft guard.
- Refit the two front mudguards.
- Attach a nylon cable to the front weights, lift, refit to the tractor and secure with the locking screws.
- Reconnect the negative battery lead.
- Adhere to the tightening torques indicated on page 4.

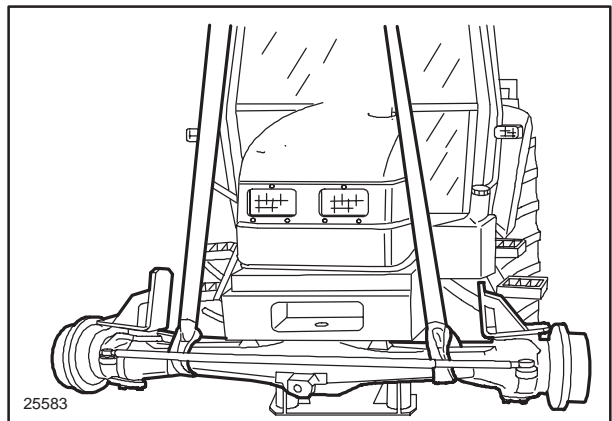

16

FRONT AXLE
Removal-Installation (Op 25 100 38)
TD60D and TD70D Models



WARNING

Handle all parts with care.
 Do not insert hands or fingers between one part and another. Wear suitable safety clothing, i.e. safety goggles, gloves and shoes.

1. Unscrew the drain plug and drain the oil from the axle casing.
2. Remove the planetary final drive housing (1) complete with planet wheels.
3. Remove sun gear (2).
4. Remove final drive ring gear – fixed gear unit, slacken ring nut using wrench **380000616** and remove assy from knuckle.
5. Remove wheel hub (6) with taper roller bearing cups (7) and associated seal. Be careful to prevent seal damage.
6. Remove steering knuckle (10) with wheel hub support.
7. Remove articulated axle shaft (9) with bearing housing. Back off the capscrew before withdrawing the axle shaft.
8. Replace worn bearings using suitable punches and universal pullers. Check seal efficiency.

Assembly axle parts referring to

– Before installing the final drive housing (1) thoroughly clean and degrease mating surfaces and apply 2 mm (0.0787 in.) of seaming compound.

- Insert articulated axle shaft (9) in axle case and install steering knuckle carrier (8)
- Adjust king pin bearing pre-load as directed in the appropriate section.
- Adjust wheel hub bearing pre-load as directed in the appropriate section.
- Fill wheel hubs and differential-bevel drive housing with the specified oil.

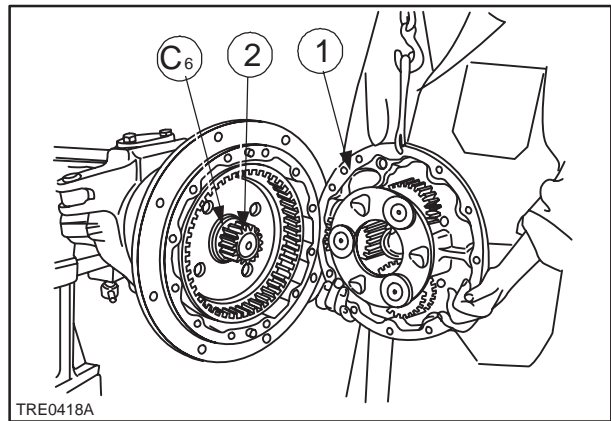

TRE0418A

17

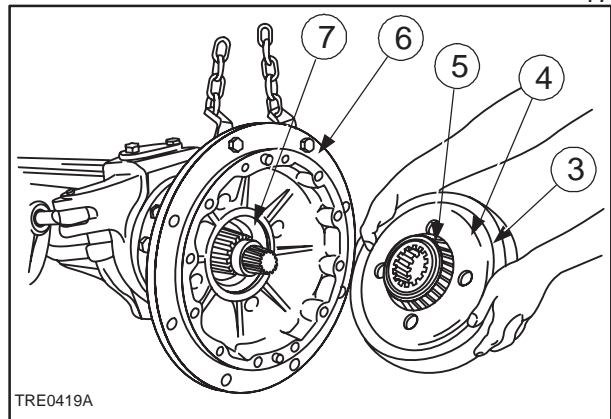

TRE0419A

18

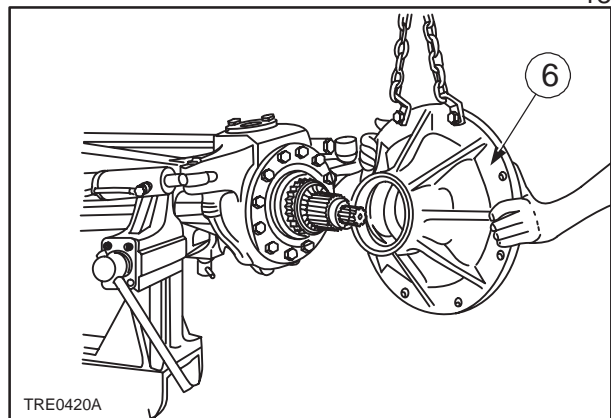

TRE0420A

19

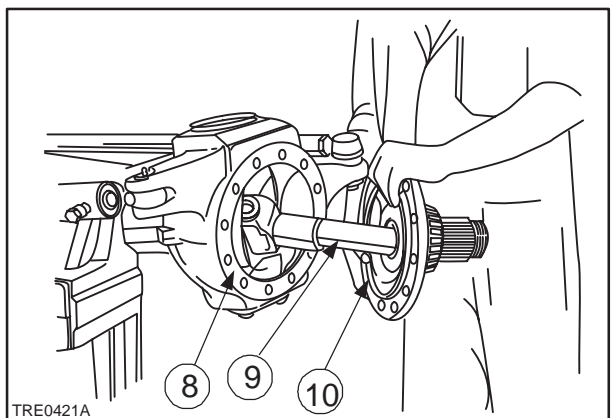

TRE0421A

20

TD80D, TD90D and TD95D Models

**WARNING**

Handle all parts with care.
Do not insert hands or fingers between one part and another. Wear suitable safety clothing, i.e. safety goggles, gloves and shoes.

NOTE: For overhaul, the front axle should be mounted on stand No. **380000251**.

1. Unscrew the plug (1) and drain the oil from the axle casing.

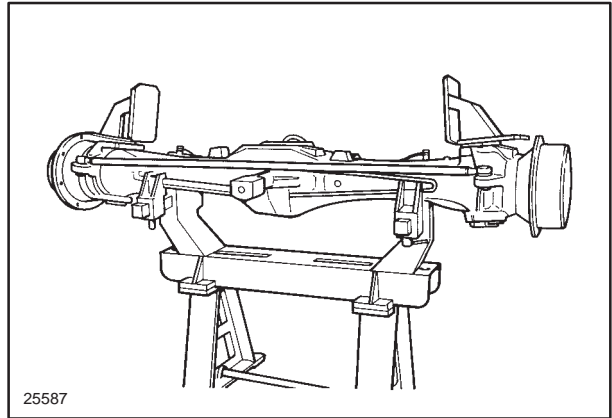

21

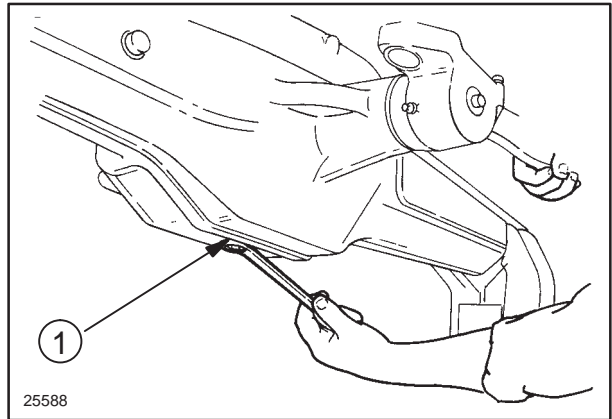

22

2. Unscrew plug (1) on the left-hand epicyclic final drive casing. Repeat this operation on the right-hand casing.

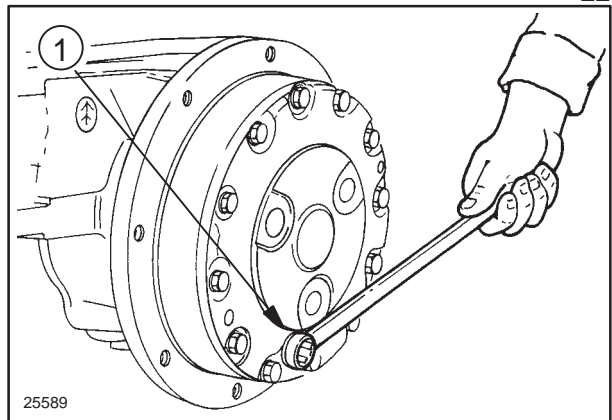

23

3. Remove the front axle rear support (1). Remove the front support and retrieve the washer.

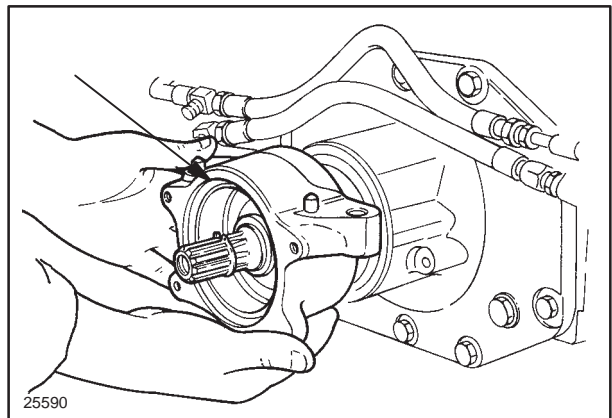

24

4. Unscrew the two track rod retaining bolts (1).

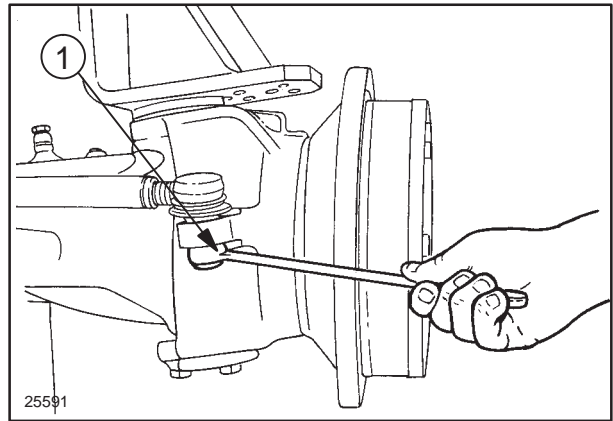

25

5. Using a suitable puller, withdraw the pins from their bores in the stub axle housing and remove the track rod.

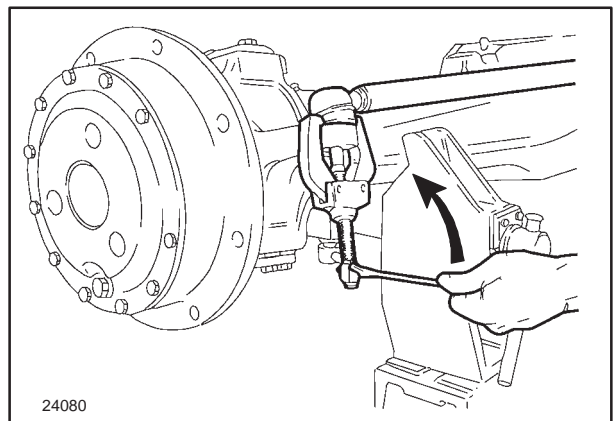

26

6. Remove the circlips (2) from the cylinder rod pivot pins, unscrew the pin retaining bolts of the cylinder (1), withdraw the pins and detach the two cylinders. Retrieve the four pins, washers, spacers and cylinders, complete with hoses.

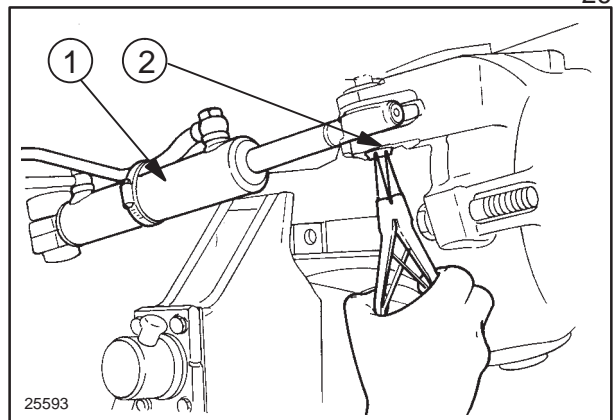

27

7. Unscrew the retaining bolts from the left-hand final drive casing cover (1). Screw in the two dowels (2), as shown. Using a slide hammer screwed into the oil drain plug hole, detach the cover (1) from the casing.

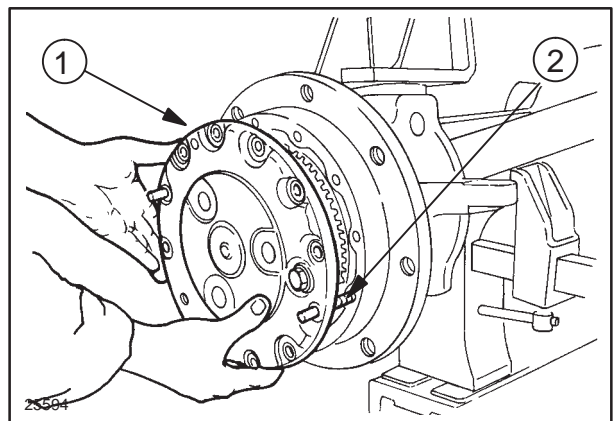

28

8. Remove the circlip (1) securing the sun gear (2) and remove the gear.

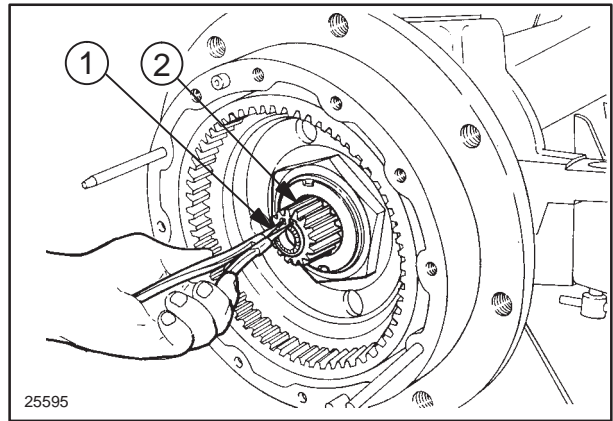

29

9. Remove the inner circlip (1) from the stub axle shaft.

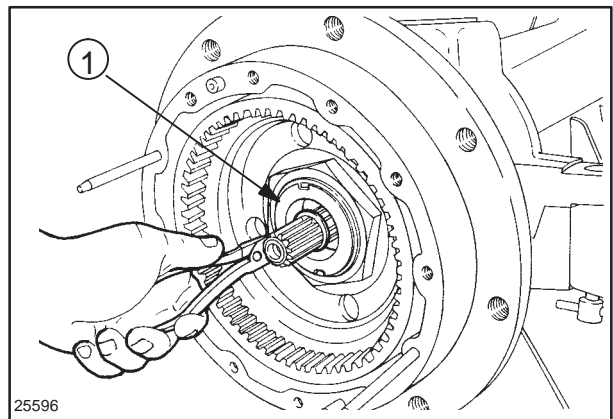

30

10. Remove the staking (1) on the wheel hub bearing lock ring (2).

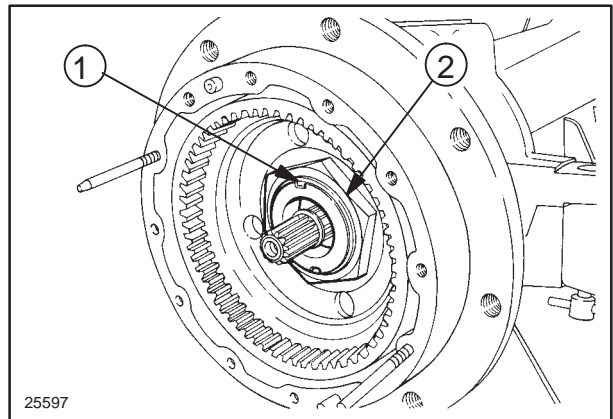

31

11. Remove the wheel hub bearing lock ring using wrench **380000269** (1) for models TD80D, TD90D and TD95D.

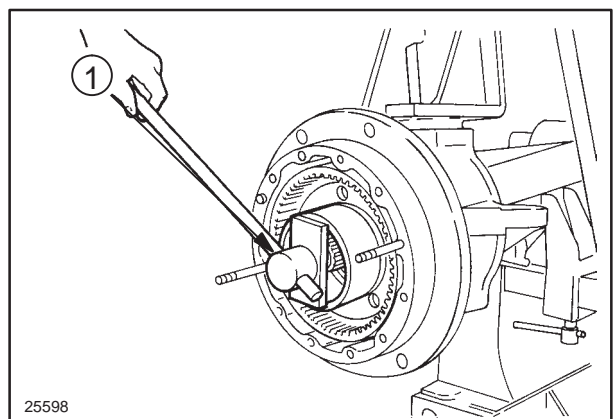

32

12. Remove the wheel hub (1) with the ring gear (2).
Retrieve all disassembled parts.

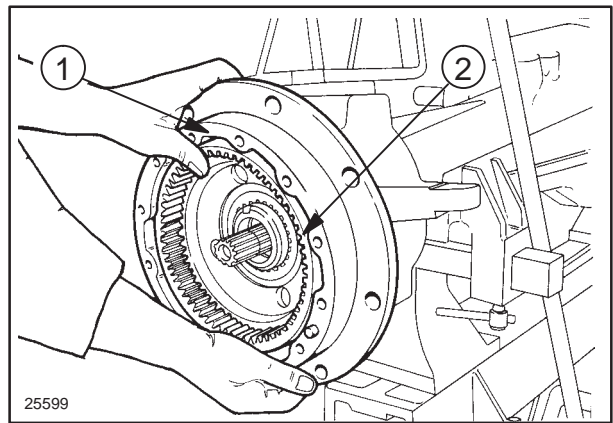

33

13. Unscrew the three retaining bolts (1) of the lower pivot pin of the stub axle housing. Recover the lower pivot pin and the related adjustment shims.

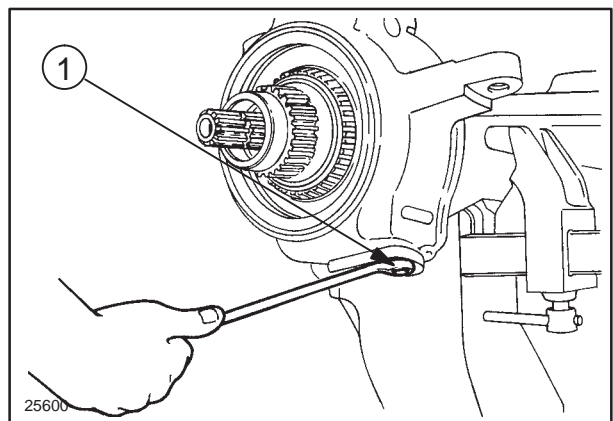

34

14. Unscrew the three retaining bolts (1) of the mudguard bracket (2).

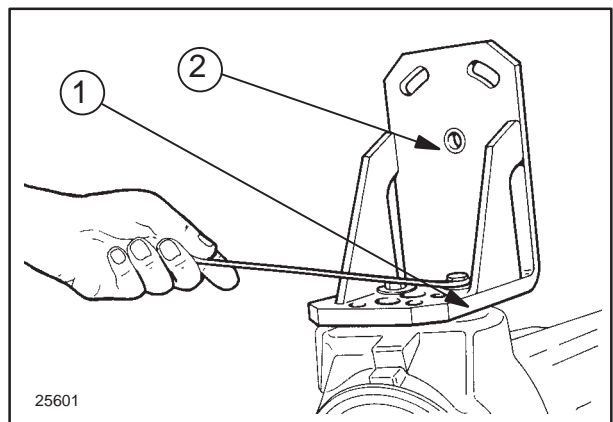

35

15. Withdraw the upper pivot pin (1) and detach the stub axle housing (2). Retrieve the disassembled parts.

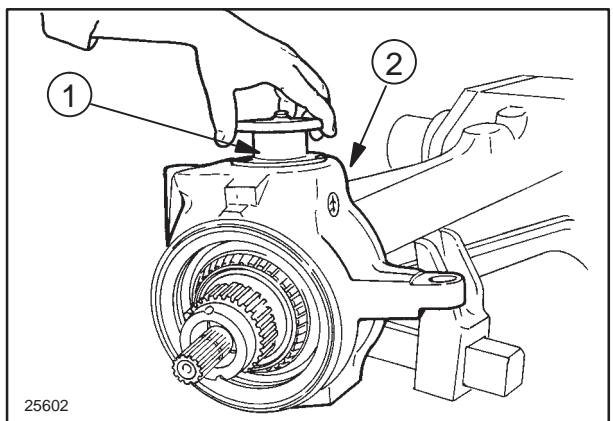

36

16. Unscrew the axle shaft retaining bolt and remove the axle shaft.

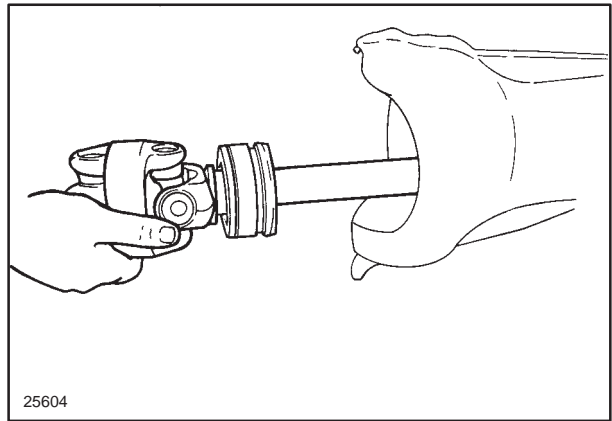

37

17. Remove bracket (1), unscrew the union (3) and detach the front brake pipe (2).

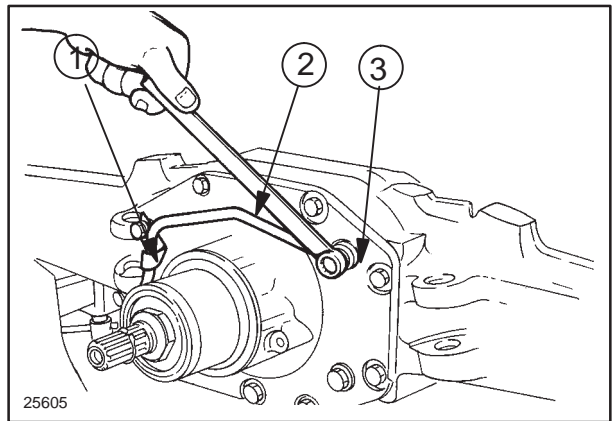

38

18. Unscrew two of the bolts fixing the bevel drive-differential support to the axle casing. Screw in the two dowels (1). Remove the remaining bolts and separate the bevel drive-differential support from the axle casing. Attach a cable (2) to the support and take up the strain with the hoist. Remove the bevel drive-differential support (3) from the axle casing.

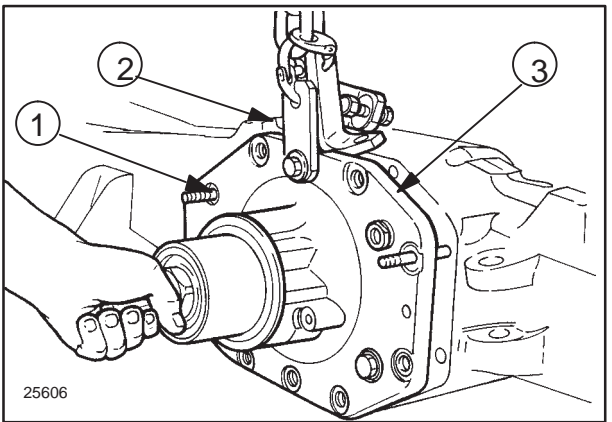

39

19. Install tool **380000255** (1) in the vice on the work bench. Bolt the bevel drive-differential support on to the tool. Detach the lifting cable.

20. Unscrew the bolt (2) and remove the ring nut lock tab (3).

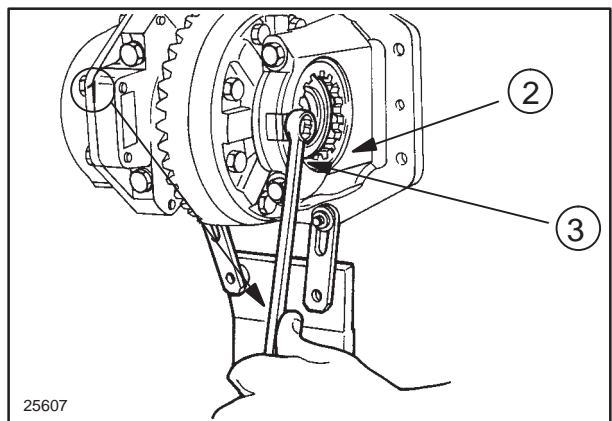

40

21. Remove the front brake bolts (1).

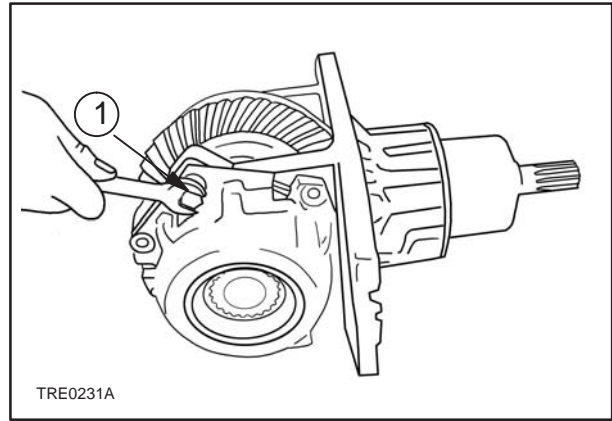

22. Remove the front brake housing (1).

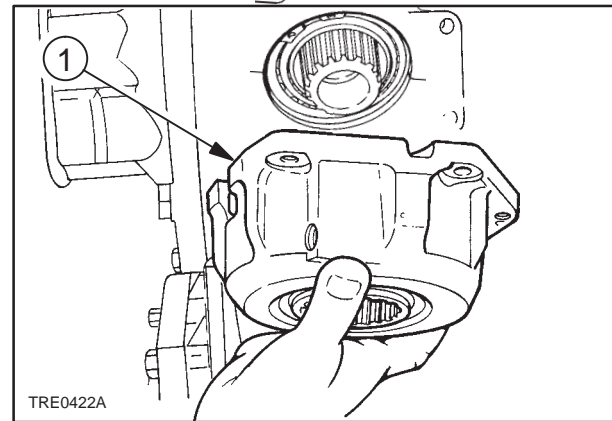

23. Remove the front brake hub gear (1).

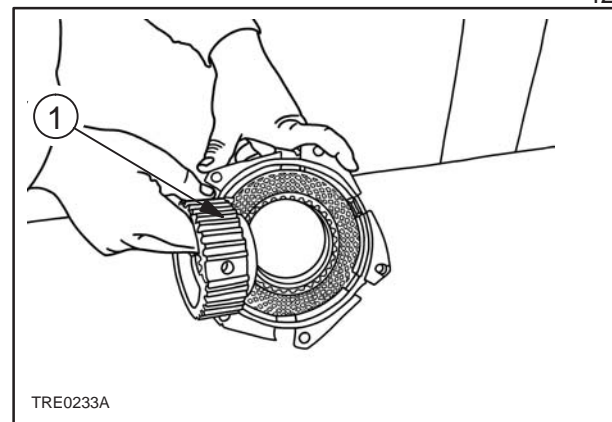

24. Remove the friction discs (1) and metal discs (2).

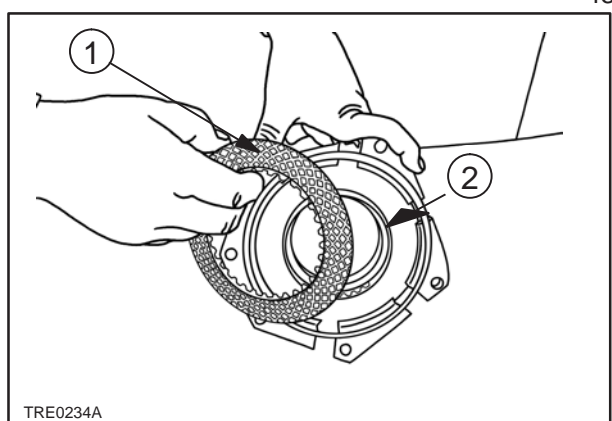

25. Remove front brake piston (1) and O-rings.

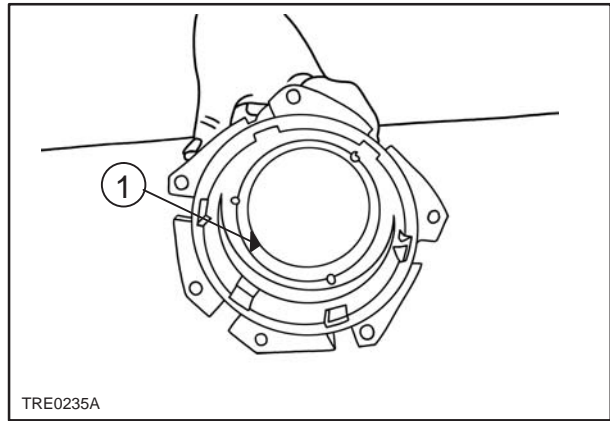

26. Unscrew the two bolts (2) of the crown wheel–differential support caps (1).

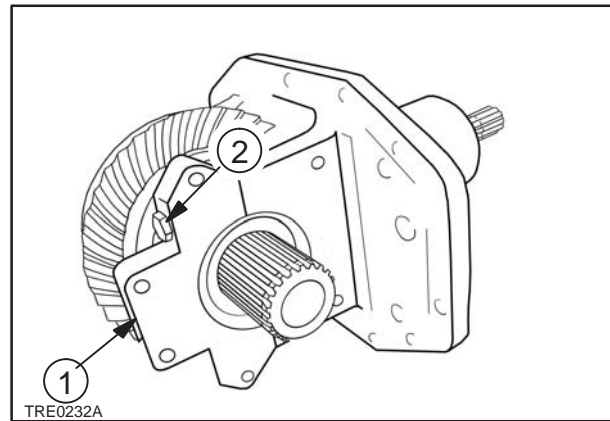

27. Remove the crown wheel–differential assembly (2) from the housing (1).

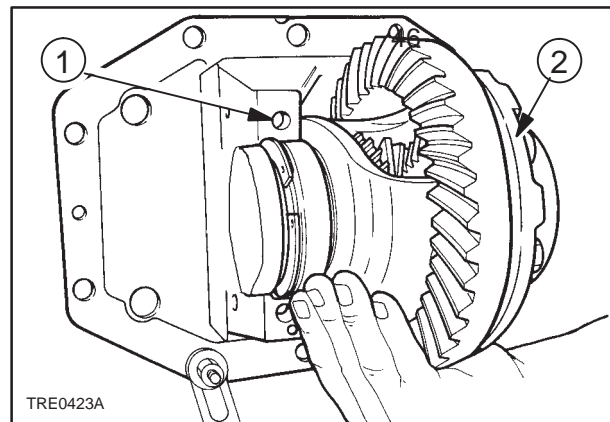

28. Remove the circlip (1) from the splined shaft (2).

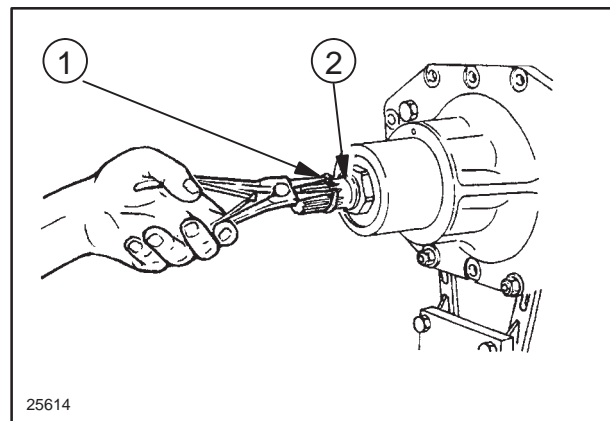

29. Straighten the locking tab on the splined shaft-lock nut (1).

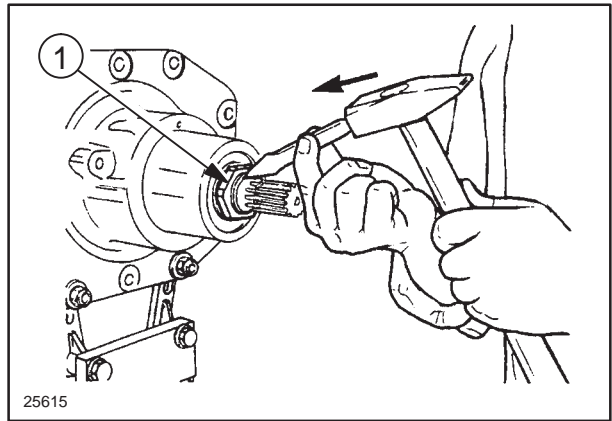

49

30. Unscrew the nut using wrench **380000268** (1) while preventing rotation of the bevel drive pinion shaft using wrench **380000257**.

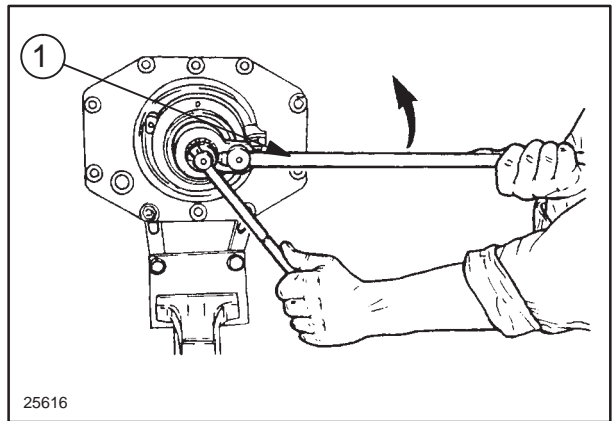

50

31. Recover the splined shaft detent ball (1).

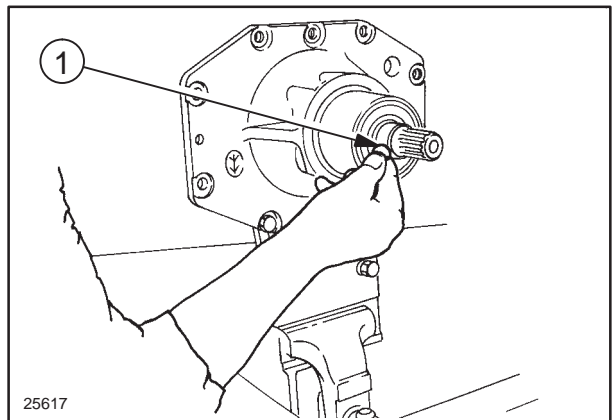

51

32. Withdraw the bevel drive pinion shaft (1) from the rear of the casing and recover the spacer, the adjustment shims and the bearing.

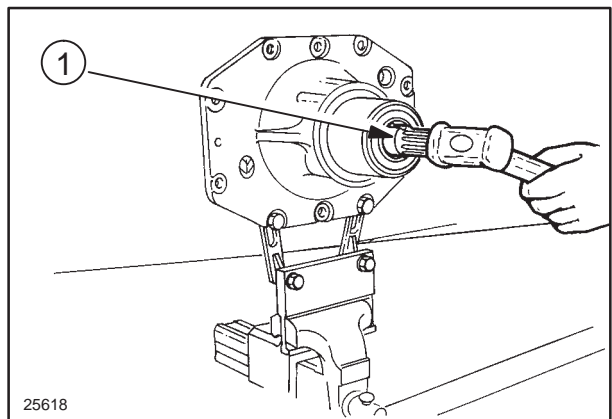

52

33. Using a screwdriver, detach and recover the dust seal, the oil seal (1) and the rear bearing.

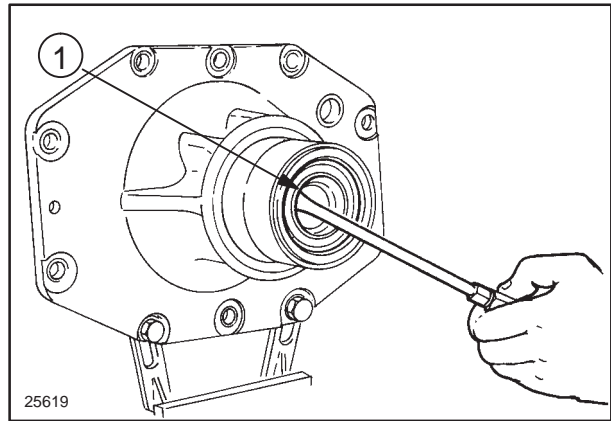

53

Reassemble the front axle adhering to the following instructions:

- Refer to the illustrations on pages 7, 8 and 9 to check the orientation of the various components.
- Respect the tightening torques prescribed on page 4.
- Carry out the adjustments described on pages 29 to 36.
- Install the rear bearing, the seal, the dust seal, the adjustment shims, the spacer and the bevel drive pinion shaft complete with front bearing.
- Position the detent ball, screw in the bevel drive pinion lock nut and secure in position by staking. Finally, replace the circlip.
- Install the crown wheel–differential assembly, the support caps and tighten the relative bolts.
- Install the front brake friction disc, metal disc hub gear, piston and front brake housing. Tighten the respective bolts.
- Install the bevel drive–differential housing on the front axle casing and fit the external front brake pipe.
- Install the axle shaft and relative bolt.
- Fit the stub axle, the adjustment shims, the upper and lower pivot pins, the mudguard bracket and related bolts.
- Fit the wheel hub, the ring gear of the final drive unit and the lock ring. Tighten to the prescribed torque value, while simultaneously turning the wheel hub, to ensure that the bearings are correctly seated.
- Fit the securing and stop circlips, the sun gear and the cover of the final drive unit.
- Fit the pins, washers, spacers and steering cylinders.
- Install the track rod, the front and rear supports and the oil drain plugs.

STEERING KNUCKLE PINS AND BEARINGS
Replacement (Op. 25 108 46 or 25 108 47)



Handle all parts with great care.
 Do not put your fingers or hands between one piece and another. Wear suitable safety clothing, i.e. safety goggles, gloves and footwear.

In the event that the steering knuckle pins prove difficult to remove, proceed as follows.

1. Remove the grease nipples and the steering knuckle pin retaining bolts.
2. Fit the bolts (1) of tool **380000265**.
3. Fit the plate (2) of the tool and fix it to the three bolts with nuts (5).
4. Fit the central tie bolt (4) screwing it fully into the grease nipple bore on the pin (6).
5. Screw in the nut (3) to drive the pin out of its bore.

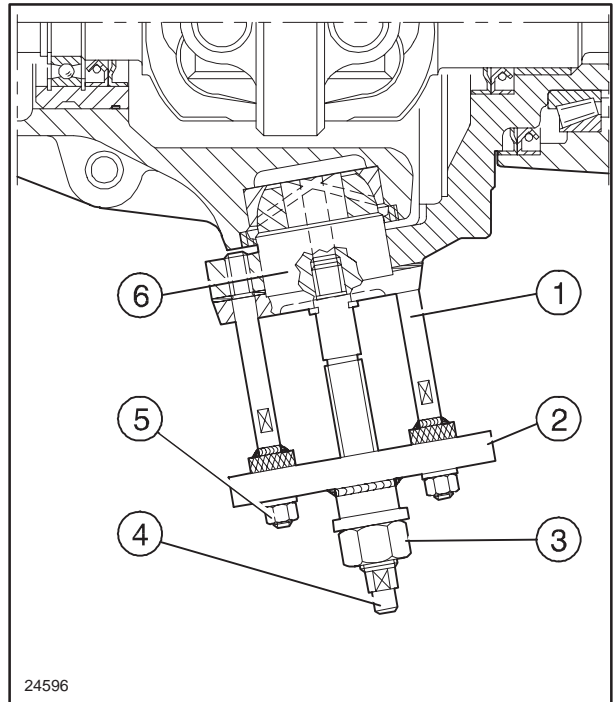

54

6. Using extractor tool **380000234** (1) remove the steering knuckle bearings.
7. Re-install the steering knuckle bearings using a suitable drift.

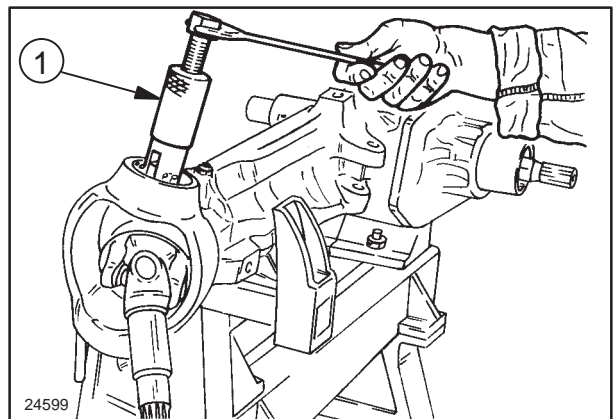

55

STUB AXLE ADJUSTMENT

**WARNING**

Handle all parts with great care.
Do not put your fingers or hands between one piece and another. Wear suitable safety clothing, i.e. safety goggles, gloves and footwear.

Install the front axle on stand **293460** and proceed as follows.

1. Smear grease **AMBRA GR 75MD** on the outer races of the bearings and fit the upper cover, without the adjustment plate, but with tool **380000235** (2). Tighten the retaining bolts (C₅, page 5) to the following torque values:

TD60D and TD70D	64 Nm (47.2040 ft lb)
TD80D, TD90D and TD95D	113 Nm (83.3445 ft lb)

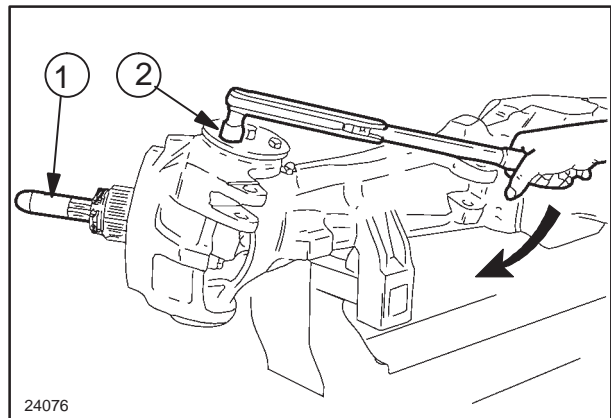

56

2. Fit the lower cover without the adjustment plate and lubricate the three retaining bolts with engine oil.
3. Gradually tighten the lower cover bolts in sequence, while simultaneously rotating the casing to allow excess grease to escape.

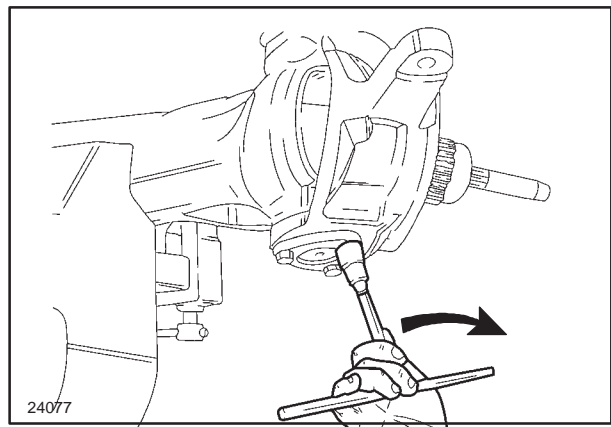

57

4. Using a torque wrench and tool **380000235** (1), check that the torque required to rotate the casing (ignoring the initial torque) is as follows:

models TD60D and TD70D	2.9 Nm (2.1389 ft lb)
(with torque increment of 0.98 Nm – 0.7228 ft lb)	
TD80D, TD90D and TD95D	15 – 25 Nm (11,0634 – 18.4390 ft lb)

If the recorded torque is not as specified, adjust by way of the lower cover bolts.

5. Measure the gap (H) created between the lower cover and the casing adjacent to each of the three bolts.

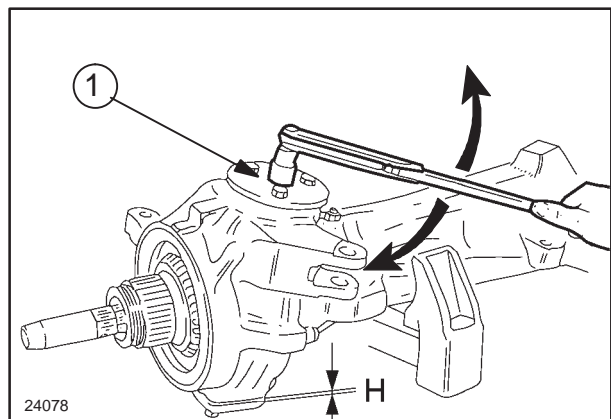

58

WHEEL HUB BEARING ADJUSTMENT:**First class axle mod. TD60D and TD70D**

Proceed as follows:

- Install wheel hub and fixed gear unit onto the steering knuckle;
- Using a torque wrench and lock ring wrench **380000616** (for TD60D and TD70D models), progressively tighten the ring nut (C6, page 8) to 147 – 196 Nm (15 – 20 kgm). While tightening the ring nut, rotate the hub to settle the bearings.
- Fully slacken the lock ring and retighten to 59 Nm (43.5162 ft lb) while rotating hub.
- Secure the lock ring by bending over a lock-washer tab (if necessary, further tighten the lock ring to align a slot with the tab)
- Turn the hub by hand to check for excessive play or binding.
- Carefully secure the ring nut.

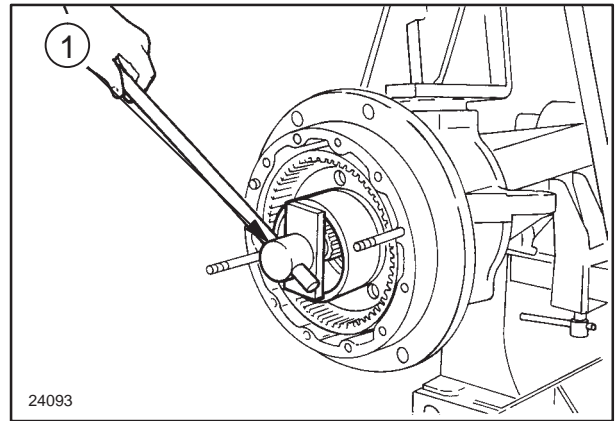

60

Second class axle mod. TD80D, TD90D and TD95D

Proceed as follows:

- Progressively tighten the ring nut, using the torque wrench and wrench **380000269** (1) to obtain a torque value of 392 Nm (289.12432 ft lb); at the same time, rotate the wheel hub to ensure that the bearings are correctly seated.
- Measure the rolling resistance (Rt) of the wheel hub using the relative torque wrench, or a torque meter and cord positioned on the base of the wheel disk flange.

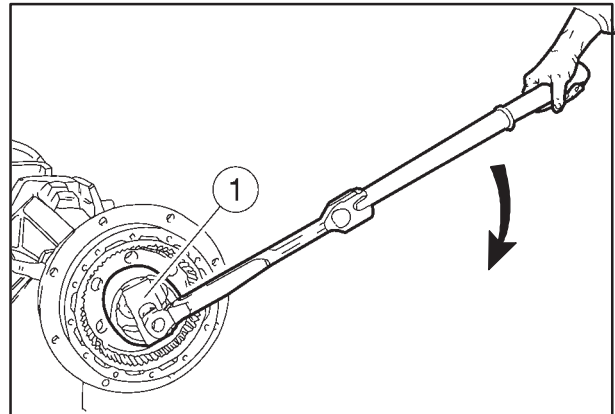

61

- Loosen the ring nut by **half a turn** and measure the rolling resistance (R) as described previously. The difference between the two measurements is the rolling torque value of the wheel hub bearings (Rc):
- $R_c = R_t - R = 5.9 \div 14.7 \text{ Nm}$ (4.3516 ÷ 10.8416 ft lb) or if measured with a torque meter.
- $R_c = R_t - R = 7.5 \div 18.75 \text{ kg}$ (41.3554 lb).
- If the measurement is less than 5.9 Nm (4.3516 ft lb) or with the torque meter on 4.8 kg (10.5870 lb) it is necessary to replace the affected parts and repeat the check.
- Progressively tighten the ring nut, using the torque wrench and wrench **380000269** (1) to obtain a torque value of 392 Nm (289.12432 ft lb); at the same time, rotate the wheel hub to ensure that the bearings are correctly seated.
- Carefully secure the ring nut.

BEVEL DRIVE ADJUSTMENTS

Adjustment of the preload of the pinion shaft bearings



WARNING

Handle all parts with care. Do not insert hands or fingers between one part and another. Wear suitable safety clothing, i.e. safety goggles, gloves and footwear.

Proceed as follows.

1. Install the bevel pinion bearing cones (7) and (9) with spacer (8) on tool 293438 (E).

NOTE: For TD60D and TD70D models, place the spacer M outside the bearings.

2. Fully tighten tool nut (M).
3. Measure the distance (H1) between the end of the pin on the bottom of the tool and the top surface of the tool.

4. Remove the bearing cones and spacer from the tool. Lubricate bearings with engine oil and re-install onto the tool, inserting differential carrier (10) with bearing cups.
5. Fully tighten tool nut (M) while rotating the differential carrier through ten revolutions to settle the bearings.
6. Measure dimension (H3) of the tool in this condition.

7. Thickness of shims (S1) will be given by:

$$S1 = H_3 - H1 + 0.10 \text{ mm (0.00039 in.)}$$

If necessary, round off (S1) to the nearest 0.05 mm (0.0020 in.)

NOTE On completing the adjustment, do not remove the adjustment tool from the bevel drive-differential housing. Leave in place for adjustment of the drive pinion position. See following subject matter.

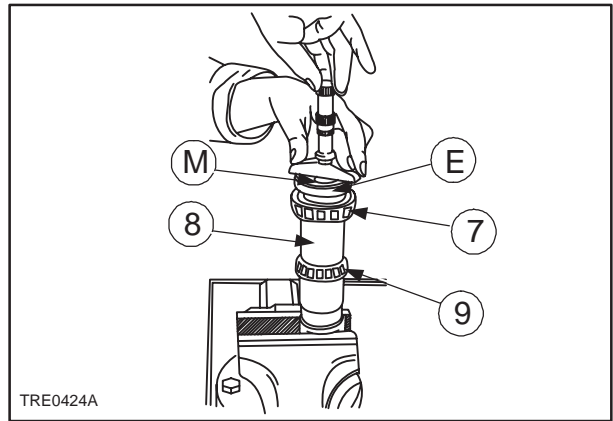

61

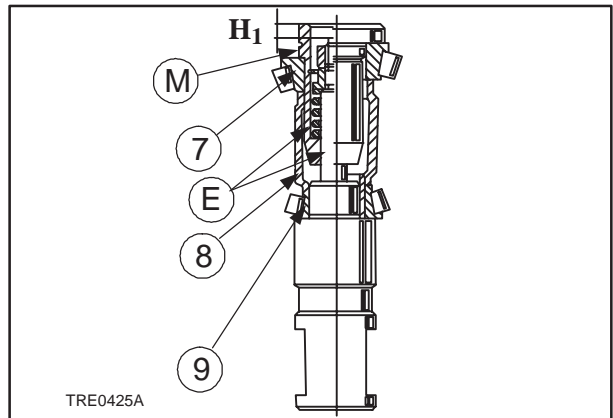

62

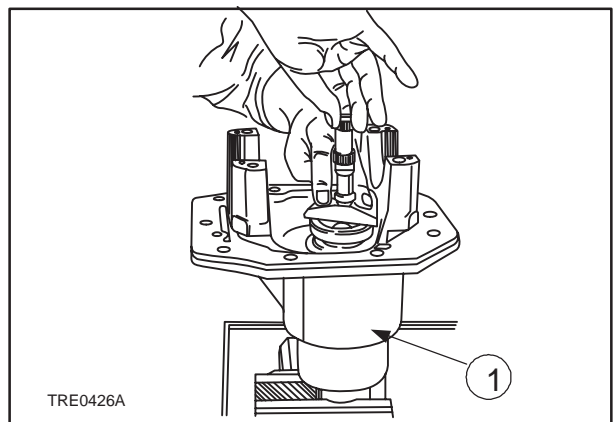

63

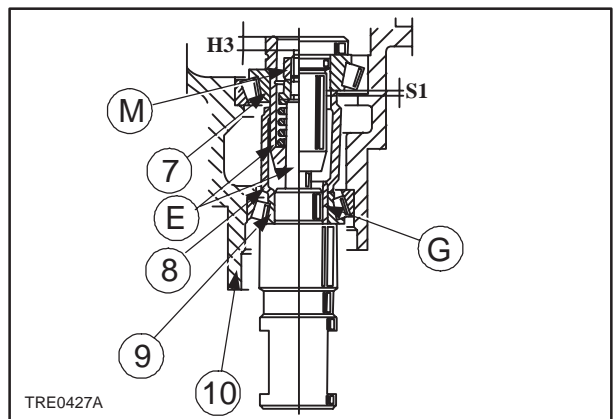

64

BEVEL DRIVE ADJUSTMENTS

Determining the thickness of the drive pinion position adjustment shim

Proceed as follows.

1. Fit tool **380000249** (1) in the bevel drive–differential housing (2), complete with outer bearing rings, crown wheel bearings adjustment ring, crown wheel bearings adjustment shim, circlip and differential housing caps, taking care to tighten the bolts (C₁₀) to a torque of 113 Nm (84.3445 ft lb).
2. Screw the cones (3) of tool **380000249** (1) in or out in order to position the micrometer shaft (4) in the direction of the inner bearing ring (5) and eliminate end float between the cones and the outer rings of the bevel crown wheel bearings.
3. Adjust the micrometer so that the shaft (4) is in contact with the inner bearing ring (5) and measure the distance (H₃).
4. Determine the correct distance (H₅) between the crown wheel axis and the large diameter base of the pinion:

$$H_5 = H_4 \pm C$$

where:

H₄ = Nominal distance between crown wheel centreline and pinion big end

- 100 mm for TD60D, TD70D models.
- 15 mm for TD80D, TD90D, TD95D models.

C = a correction value stamped on the pinion preceded by a + or – sign (if other than 0). This value to be added to or subtracted from the nominal distance (H₄) according to the sign.

5. The thickness of the adjustment shim (S₂) will be given by:

$$S_2 = H_3 - H_5$$

where:

H₃ = the distance measured using the micrometer;

H₅ = corrected nominal distance between the crown wheel axis and the large diameter base of the pinion.

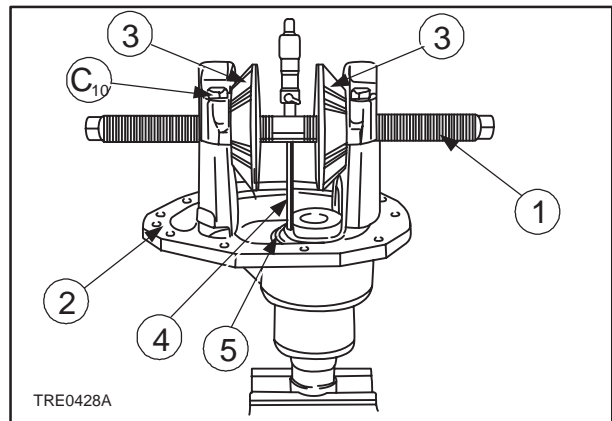

66

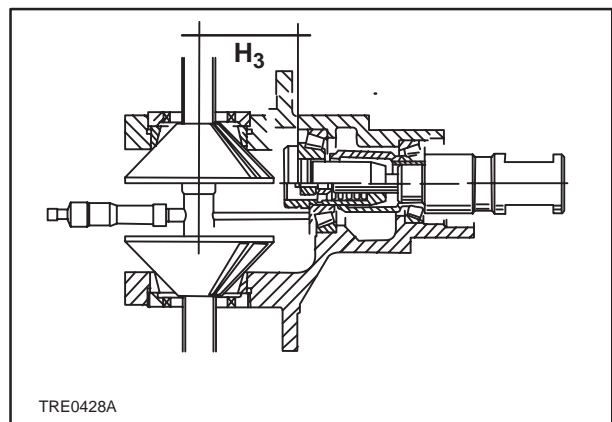

67

Examples (models TD60D and TD70D)**Example 1:**

- Distance measured using micrometer $H_5 = 103.3$ mm (4.0669 in.).
- Nominal distance between crown wheel axis and large diameter base of pinion $H_4 = 100$ mm (3.9370 in.).
- Correction value $C = + 0,2$ mm (0.0079 in.).
- Corrected nominal distance $H_5 = 100 + 0.2 = 100.2$ mm (3.9370 + 0.0079 = 3.9449 in.).
- Thickness of adjustment shim
 $S_2 = 103.3 - 100.2 = 3.1$ mm (4.0669 – 3.9449 = 0.1220 in.).

Example 2:

- Distance measured using micrometer $H_3 = 103.3$ mm (4.0669 in.).
- Nominal distance between crown wheel axis and large diameter base of pinion $H_6 = 100$ mm (3.9370 in.).
- Correction value $C = - 0.2$ mm (0.0079 in.).
- Corrected nominal distance $H_7 = 100 - 0.2 = 99.8$ mm (3.9370 – 0.0079 = 3.9291 in.).
- Thickness of adjustment shim
 $S_2 = 103.3 - 99.8 = 3.5$ mm (4.0669 – 3.9291 = 0.1378 in.).

Example 3:

- Distance measured using micrometer $H_3 = 103.3$ mm (4.0669 in.).
- Nominal distance between crown wheel axis and large diameter base of pinion $H_4 = 100$ mm (3.9370 in.).
- Correction value $C = 0$ mm (0 in.).
- Corrected nominal distance $H_5 = H_6 = 100$ mm (3.9370 in.).
- Thickness of adjustment shim
 $S_2 = 103.3 - 100 = 3.3$ mm (4.0669 – 3.9370 = 0.1299 in.).

BEVEL DRIVE ADJUSTMENTS

Adjustment of the crown wheel bearings and checking the backlash between the pinion and crown wheel.

Proceed as follows.

1. Install the bevel pinion with all parts (less the seal but including shims (S1 and S2, page 7) in the differential carrier. Shim sizes to be as determined in the procedure described on pages 29 and 30.
2. Fit pinion retaining tool **380000257**.
3. Insert wrench **380000532** on the adjuster ring nut mod. TD60D and TD70D **380000268** mod. TD80D, TD90D and TD95D.
4. Using the torque wrench on the pinion retaining wrench, hold the bevel pinion in position and, using a torque wrench positioned exactly as in fig. 68 on the ring nut wrench, tighten the ring nut (C1) to a torque value of 294 Nm (216.84352 ft lb) while simultaneously rotating the pinion shaft to ensure that the bearings are seated correctly.

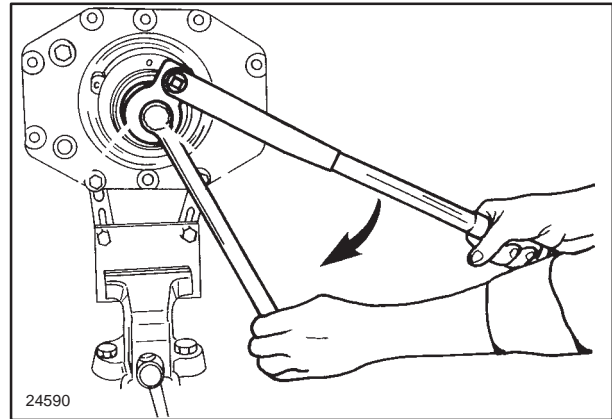

68

5. With torque wrench **380001633** (1) fitted on pinion retaining wrench **380000257** (2), check that the pinion rolling torque, without oil seal and relative dust seal, is $0.5 \div 1$ Nm ($0.3688 \div 0.7376$ ft lb).
If the rolling torque is less than the prescribed value, fit a thinner adjustment shim (S1, page 7); on the contrary, if the torque is greater than the prescribed value, fit a thicker adjustment shim.

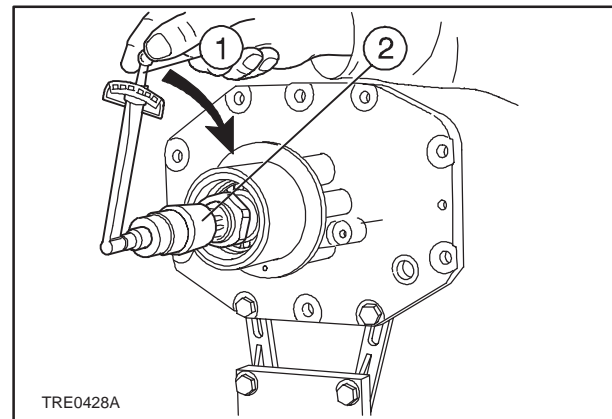

69

6. Unscrew the ring nut and fit the seal and the relative dust seal ring. Tighten the nut to a torque value of 294 Nm (216.84352 ft lb) while simultaneously rotating the pinion shaft to ensure that the bearings are seated correctly.

7. With torque wrench **380001633** (1) fitted on pinion retaining wrench **380000257** (2) check that the pinion rolling torque, with the oil seal and relative dust seal, is $- 0.50$ Nm (0.3688 ft lb) for mod. TD60D and TD70D or $- 0.75$ Nm (0.5532 ft lb) for mod. TD80D, TD90D and TD95D.

Finally, secure the ring nut and fit the circlip on the bevel pinion shaft.

8. Install the differential unit in the carrier ensuring that ring gear is not forced onto the pinion. Tighten screws (C10) to 59 Nm (43.5162 ft lb) then slacken and retighten to 20 Nm (14.7512 ft lb).
9. Lubricate the ring gear bearings, fit the adjuster shim on the left-hand side (front brake side for four-cylinder models if this variant is included in the tractor version), rotate the bevel drive and tighten the differential bearing lock ring (G_S, page 7).

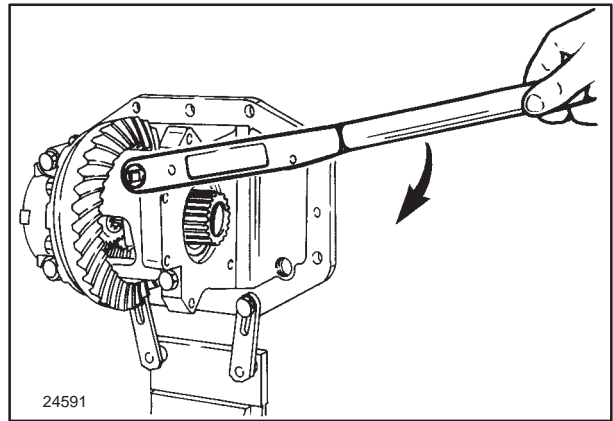

70

10. Using wrench (1) **380000252**, for TD60D or TD70D models, or wrench **380000253**, for TD80D, TD90D or TD95D models, check that the torque is 39 to 59 Nm (28.7649 to 43.5162 ft lb) to establish the specified axial pre-load.
11. Measure bevel drive backlash (1, fig. 72) using a dial gauge positioned at right angles to a bevel gear tooth.
12. Repeat the measurement at two other equidistant points, 120° apart. Compare the average of the three readings with the specified backlash of 0.15 – 0.20 mm (0.0059 – 0.0079 in.) (average 0.18 mm (0.0071 in.)).

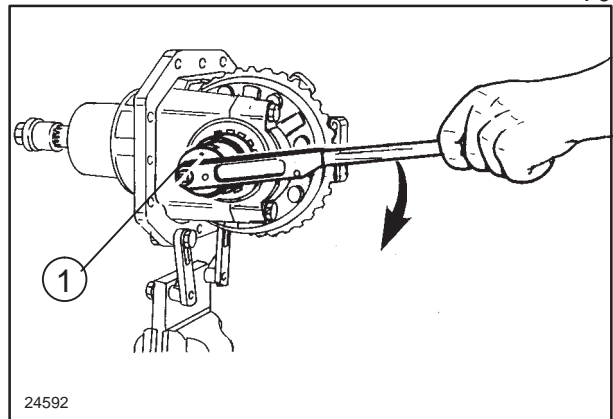

71

13. If the measured backlash exceeds the prescribed value, fit a thinner adjustment shim.

Note: On three-cylinder models or four-cylinder models without the front brake, if the clearance value is not within the prescribed field of tolerance, unscrew one of the ring nuts, whilst tightening the other to an equal amount, so as to reset the prescribed clearance.

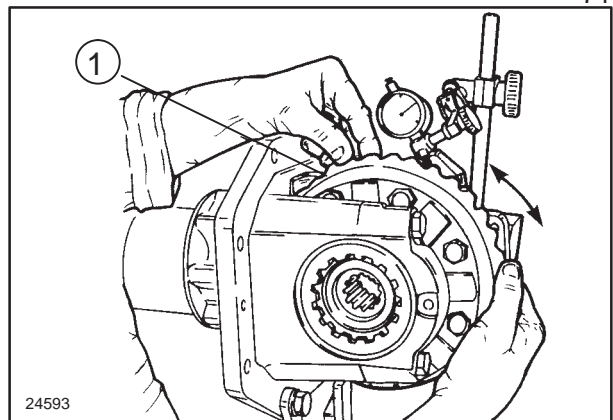

72

The definitive value to fit on the bevel drive-differential support will be given by:

$$S = S_p + \{(0.18 - G_m) \times 1.35\}$$

where:

S_p = thickness of test shim installed in the bevel drive-differential housing.

G_m = average backlash measured between the sides of the teeth of the bevel drive.

14. If the backlash measured is less than the prescribed value, it will be necessary to fit a thicker adjustment shim, the value being given by:

$$S = Sp + \{(0.18 - Gm) \times 1.35\}$$

where:

Sp = thickness of test shim installed in the bevel drive–differential housing.

Gm = average backlash measured between the sides of the teeth of the bevel drive.

15. Fit a shim of the calculated thickness and with a 1/100 scale dial gauge positioned perpendicular to the outside edge of one of the crown wheel teeth, check that the backlash between the pinion and the crown wheel is within the prescribed tolerance limits 0.15 ÷ 0.20 mm (0.0059 to 0.0079 in.).
16. Using wrench **380000252**, for TD60D or TD70D models, or wrench **380000253**, for TD80D, TD90D or TD95D models, turn the adjuster ring nut and, using torque wrench **380001633** fitted on wrench **380000257** (1, fig. 73), check that the rolling resistance torque of the crown wheel and pinion bearings, as measured in the same conditions used to check only the pinion, is:

$$A_2 = A_1 + 1 \div 1.5 \text{ Nm (0.7376.5 to 1.1063 ft lb)}$$

where:

A₂ = pinion–crown wheel rolling resistance torque;

A₁ = rolling torque of pinion only, 0.5 Nm (0.3688 lb) for TD60 or TD70 models and 0.75 Nm (0.5532 ft lb) with the pinion fitted with the seal, measured previously;

1 ÷ 1.5 Nm (0.7376.5 to 1.1063 ft lb) = rolling resistance torque of crown wheel only measured at the end of the pinion, using wrench **380000257** and torque wrench **380001633**.

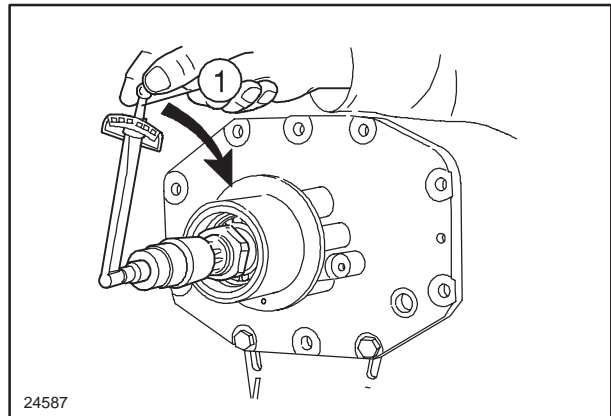

73

17. Tighten the cap bolts (C1, page 4) to a torque of 113 Nm (83.3445 ft lb).
18. Fit the safety plates, screwing the adjustment ring nut in or out, to reach the nearest notch.
19. Attach the differential bevel drive carrier to the axle casing after having carefully cleaned and degreased the mating surfaces and apply sealing compound (approx. 2 mm (0.0787) along the marked line shown in the drawing below.

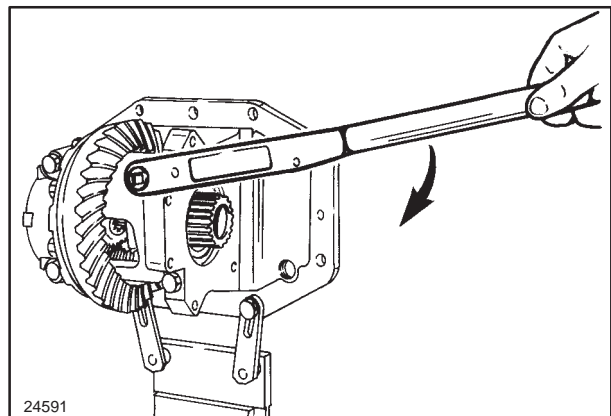

74

20. Attach the differential bevel drive carrier to the axle casing after having carefully cleaned and degreased the mating surfaces and apply sealing compound (approx. 2 mm) along the marked line shown in the drawing below.

Sealing compound application diagram for assembly of bevel drive unit and epicyclic final drive unit.

The types of mastic to use are listed on page 1 of section 00.

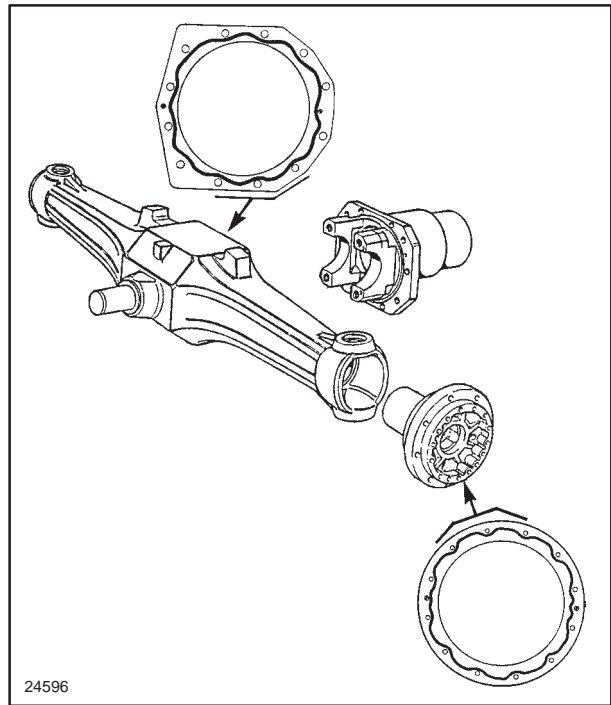

24596

75

FRONT AXLE DIFFERENTIAL

Overhaul (Op. 25 102 24)

When overhauling the differential assembly it is necessary to adjust the backlash between the teeth of the planet pinions and the side gears.

Proceed as follows:

1. Thoroughly clean the components of the differential to remove any traces of oil which would otherwise prevent accurate backlash measurement.
2. Install the two side gears without thrust washers.
3. Fit the planet pinions complete with thrust washers and pins and screw the pin retaining bolts in by a few turns sufficient to hold the pins in place.
4. Position a dial gauge on the differential housing, as shown.
5. Move the left-hand side gear to bring it into full contact with the planet pinion and then push it up against the differential housing, reading the endfloat (G_s) on the dial gauge.

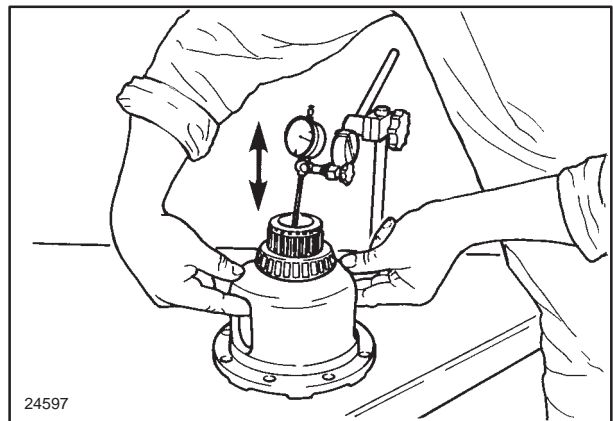

76

6. Repeat the above operations to measure the endfloat on the right-hand side gear (G_d).

The endfloat should be **0.25 mm (0.0098 in.)**. Therefore the shims to be inserted in the differential housing are given by:

$S_s = G_s - 0.25 \text{ mm (0.0098 in.)}$ for the left-hand side gear;

$S_d = G_d - 0.25 \text{ mm (0.0098 in.)}$ for the right-hand side gear.

7. Install shims as near as possible to the calculated value and, using a dial gauge and following the procedure described above, check that the endfloat of the left and right-hand side gears is approximately 0.25 mm (0.0098 in.).

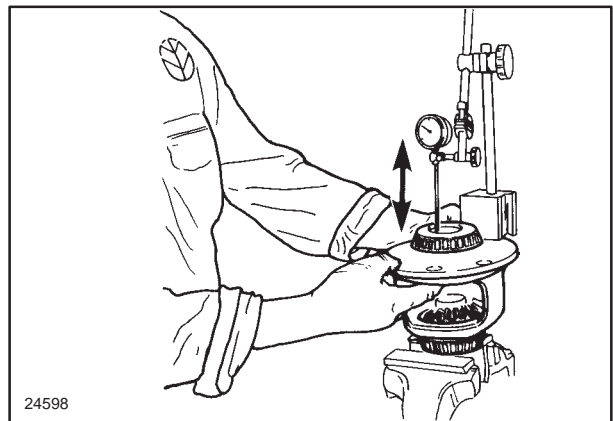

77

LIMITED-SLIP, SELF-LOCKING DIFFERENTIAL LOCK**Operation**

The differential with limited slip locking (LIM-SLIP) is of the two planet gear-type. It is provided with two multi-disc clutch assemblies fitted between the side gears and the differential casing.

This differential lock device is totally automatic. It requires no manual operation and significantly reduces (but does not completely eliminate) wheel slip.

The difference in speed between the side gears and the differential casing when a wheel loses grip and begins to slip, is prevented by the clutch assemblies that are compressed by axial thrust from the bevel drive torque transmitted to the side gears by means of the teeth on the two planet gears.

These torque values may be different, according to the nature of the ground and the route followed by the tractor. Torque may vary in intensity, thereby proportionally varying the axial thrust on the clutches. This causes the side gears to mesh with the differential casing which, in turn, permits the axle to overcome the unevenness of the ground.

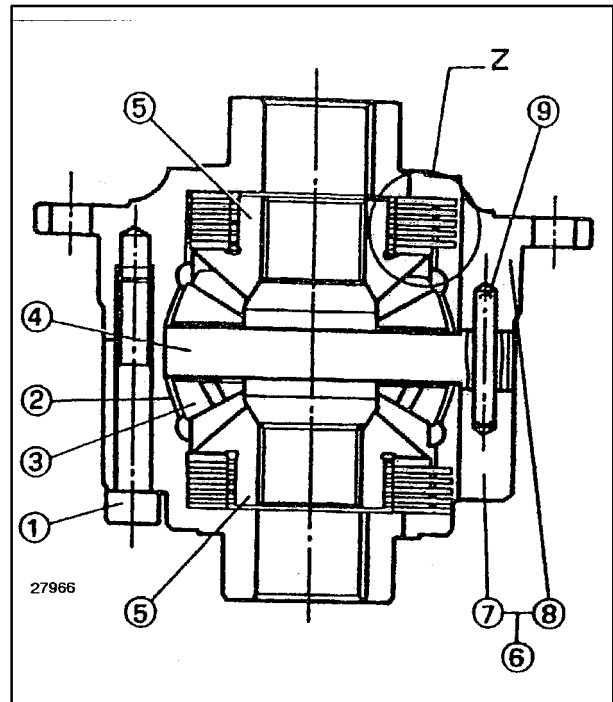

78

LIMITED-SLIP self-locking differential lock**FRONT AXLE DIFFERENTIAL WITH LIMITED-SLIP UNIT****Overhaul (Op. 25 102 27)****WARNING**

Handle all parts with care. Do not put your hands or fingers between parts. Wear suitable safety clothing, safety goggles, gloves and footwear.

1. Remove the bevel drive-differential casing assembly from the front axle and attach to the support **38000255** (4). Lock the support in a vice and proceed with disassembly, as follows.
2. Remove the bolts (2) and the left- and right-hand ring nut lock plates (3).
3. Check that the right and left-hand caps (1) are clearly marked, so as not to mix the parts during reassembly.
4. Remove the left- and right-hand bearing adjustment ring nuts (Gd) from the crown wheel.
5. Remove the bolts (C₉), securing the caps (1) and separate the crown wheel from the bevel pinion support.
6. If necessary, unscrew the retaining bolts (C₃, page 4) and remove the crown wheel.

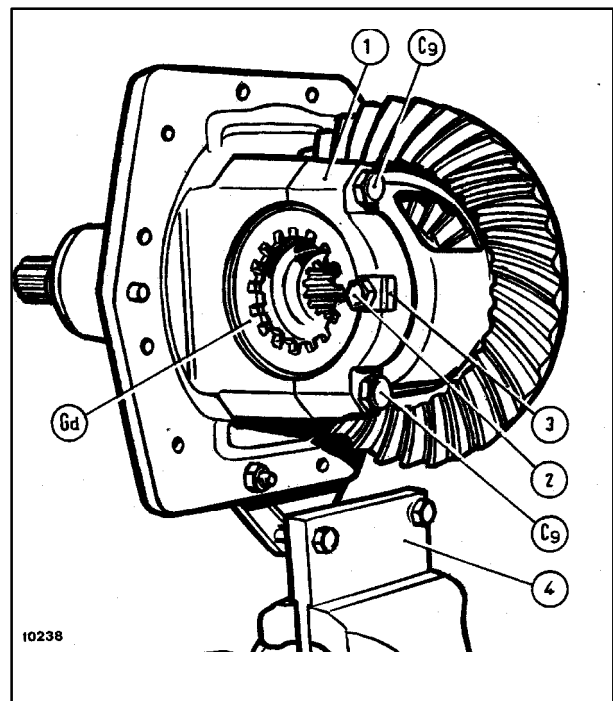

79

Disassemble the LIM–SLIP self–locking differential lock as follows:

7. Remove the retaining bolts (1) from the differential half–casing.
8. Open the differential casing (6).
9. Remove the half–casing (7) the differential pin (4), complete with the planet gears (3), the thrust washers (2) and the pins (9).
10. Remove the side gear (5) the friction disc (11), the metal discs (10) and the friction discs (12) from the half–casing (8).
11. Check the wear on the metal discs (10) and the friction discs (11) and (12) – see table below. Replace any parts that show signs of wear.
12. Proceed with the self–locking differential assembly operations, carrying out the previously described operations in reverse order. Apply LOCTITE 270 to the threads on the screws (1) and tighten to a torque value of 50 Nm (36.8781 ft lb).

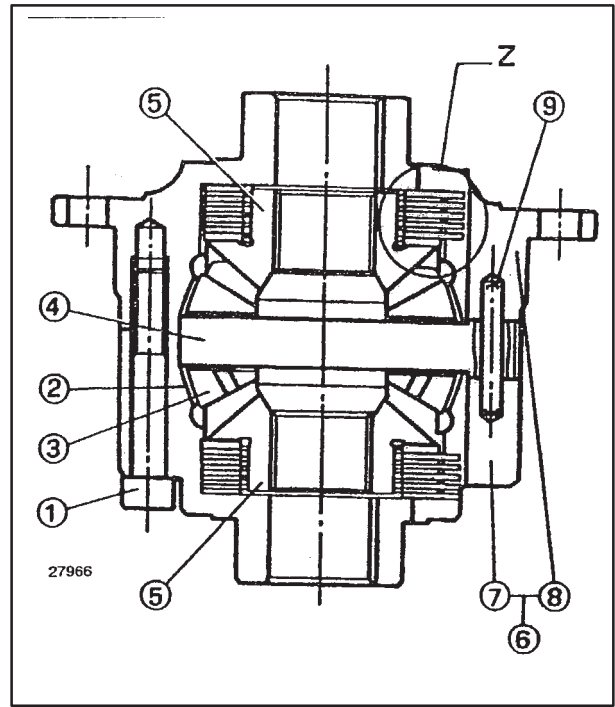

80

LIM–SLIP self–locking differential lock

13. Re–install the crown wheel (if previously disassembled) to the half–casing (8). Tighten the screws (C₃, page 4) to a torque of 113 Nm (11.5 kgm).
14. Check the rolling torque of the bevel pinion as indicated on page 32 and following.
15. Assemble the crown wheel, complete with LIM–SLIP self–locking differential lock, onto the bevel drive support. Do not forget to fit the previously marked crown wheel bearing support caps in the correct order. Assemble and then adjust the crown wheel bearings as indicated on page 32 and following.

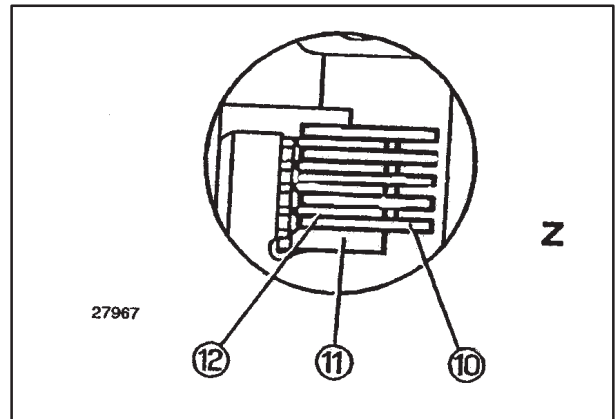

Friction parts detail

81

LIM–SLIP SELF – locking differential lock friction discs				
Part no.	Description	Quantity	Thickness mm (in.)	Maximum wear per disc mm (in.)
10	Metal discs	10	1.5 (0.0591)	–
11	Friction discs	2	2.8 (0.1102)	0.10 (0.0039)
12	Friction discs	8	1.6 (0.0630)	0.15 (0.0059)

NO SPIN DIFFERENTIAL (optional)

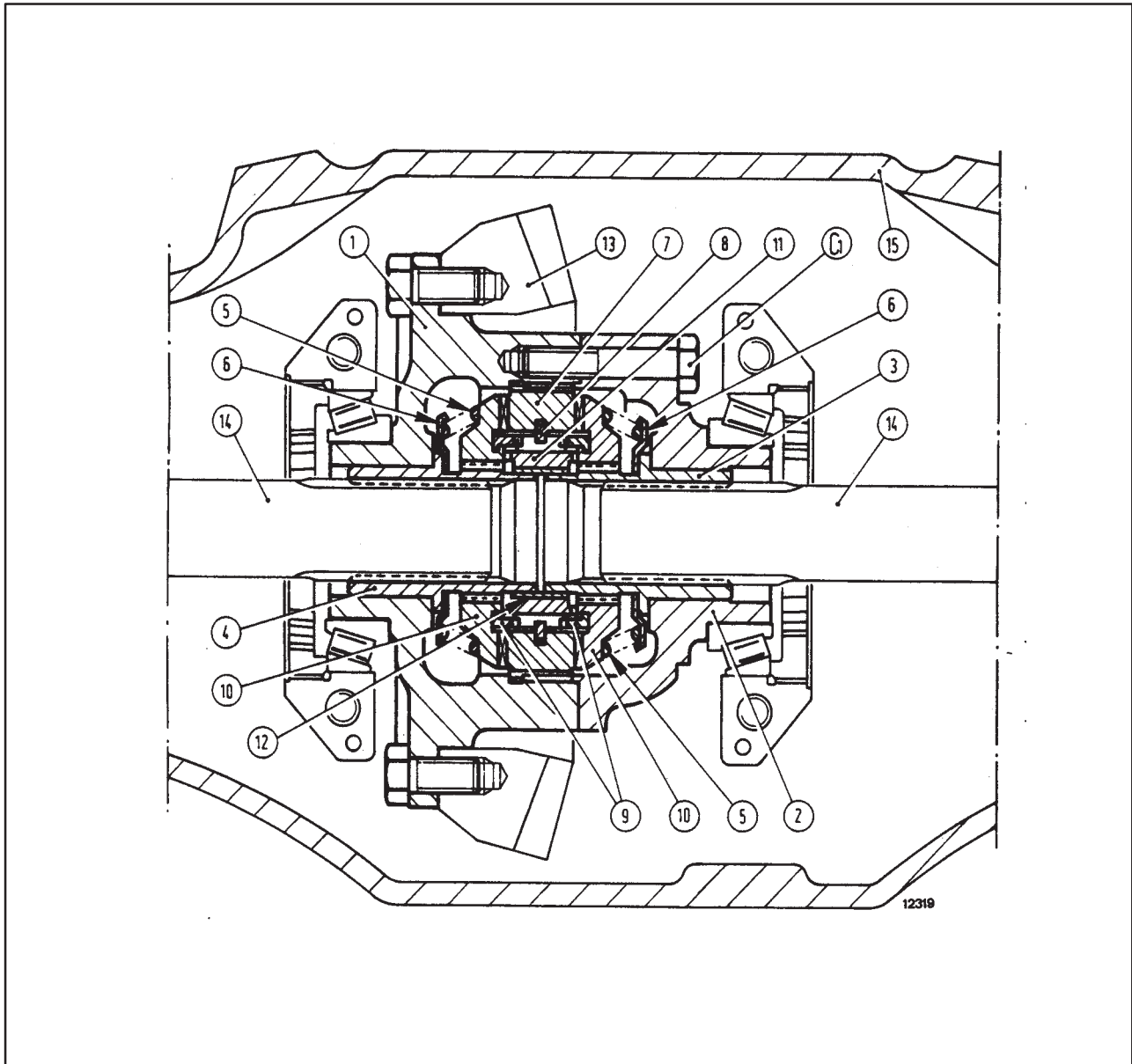

Section through differential with NO-SPIN unit

82

C1 = Case capscrew, tightening torque 56 to 62 Nm (41.3034 to 45.7288 ft lb)

- | | |
|-----------------------------|-------------------------|
| 1 – Case, flange half | 8 – Retaining ring |
| 2 – Case, cap half | 9 – Cam holdout rings |
| 3 – Side gear | 10 – Driven clutch |
| 4 – Side gear | 11 – Centre cam |
| 5 – Springs | 12 – Stop |
| 6 – Spring retainer | 13 – Ring gear |
| 7 – Central driven assembly | 14 – Axle shafts |
| | 15 – Front axle housing |

NOTE:

Check NO SPIN differential unit operation as follows:

- With the engine off, engage a gear and the front wheel drive, apply parking brake and raise front of tractor.
- Rotate the front wheels in a forward direction to eliminate play. Hold the L.H. wheel and rotate the R.H. wheel rearwards. The NO SPIN differential will disengage and the wheel will rotate with an indexing or metallic clicking sound.
- Stop the R.H. wheel, then turn forwards slightly. The NO SPIN differential will engage and stop the wheel. Rotate both wheels backwards to eliminate play, hold the L.H. wheel and rotate the R.H. wheel forwards. The NO SPIN differential will disengage and the wheel will rotate with an indexing or metallic clicking sound.
- Stop R.H. wheel, then turn backwards slightly. The NO SPIN differential will engage and stop the wheel.
- Repeat the above operations while holding the R.H. wheel.

OPERATION

The **NO SPIN** differential performs the following key functions:

- Permits full use of tractor pull.
- Prevents wheel-spin when one wheel loses traction.
- Compensates for differences in wheel travel which occur when turning or traveling over uneven ground.

When the tractor is in a straight forward or reverse mode of operation, the **NO SPIN** allows equal speed to be distributed to both wheels.

When the tractor makes a turn or a front wheel passes over an obstruction, the outer wheel or the wheel on the obstruction must travel faster and farther than the other. To do this it automatically disengages, passes over the obstruction or negotiates the curve and re-engages again automatically.

If one wheel should lose traction momentarily, the opposite wheel, which still has traction, continues to pull the vehicle until traction is regained by both wheels.

Turning: In a left turn, for instance, the right-hand wheel increases speed. The axle shaft (14) (page 39), transmits this speed increase to the left side gear (3) to the left driven clutch (10) and to the associated cam holdout ring (9). When the speed difference between the two wheels reaches a given value, ring (9) and clutch (10) overcome spring load and disengage from the centre cam (11), remaining in this position until the end of the curve.

NOTE: For correct **NO SPIN** differential operation, tyres must be equal (within a few millimetres) in rolling circumference. Small differences may be corrected by adjusting tyre inflation pressure. To check the rolling circumference of a tyre, proceed as follows:

With the tractor on a hard, level surface, mark the edge of the tyre, with chalk, at the lowest point (where it contacts the ground). Mark the ground at the same spot.

Move the tractor forward so that the tyre rotates exactly one revolution, i.e., when the chalk mark on the tyre contacts the ground again. Measure the distance travelled. This is the rolling circumference of the tyre.

Repeat on the opposite wheel to check that both tyres have the same rolling circumference.

FRONT AXLE DIFFERENTIAL WITH NO SPIN OP. 25 102 26

Overhaul



WARNING

Handle all parts with care. Do not put your hands or fingers between parts. Wear suitable safety clothing, safety goggles, gloves and footwear.

1. Remove the bevel drive-differential casing assembly from the front axle and attach to the support **380000255** (4). Lock the support in a vice and proceed with disassembly, as follows.
2. Remove the bolts (2) and the left- and right-hand ring nut lock plates (3).
3. Check that the right and left-hand caps (1) are clearly marked, so as not to mix the parts during reassembly.
4. Remove the left- and right-hand bearing adjustment ring nuts (Gd) from the crown wheel.
5. Remove the bolts (C₁₀), securing the caps (1) and separate the crown wheel from the bevel pinion support.
6. If necessary, unscrew the retaining bolts (C₃ page 4) and remove the crown wheel.

Disassemble the NO SPIN self-locking differential lock as follows.

7. Remove the retaining bolts (1) from the differential half-casing.
8. Open the differential casing
9. Remove the central driven (7), retaining the differential half-casing.
10. Proceed with self-locking the differential assembly operations, carrying out the previously described operations in reverse order. Tighten the bolts (C₁, fig. 84) torque value of 56–62 Nm (41.3034–45.7288 ft lb)
11. Refit the crown wheel bolts (C₃, page 4) and torque to a value of 113 Nm (83.3445 ft lb)
12. Assemble the crown wheel, complete with NO SPIN self-locking differential lock, onto the bevel drive support. Remember to fit the previously marked crown wheel bearing support caps in the correct order and assemble and then adjust the crown wheel bearings as indicated on page 32 and following.

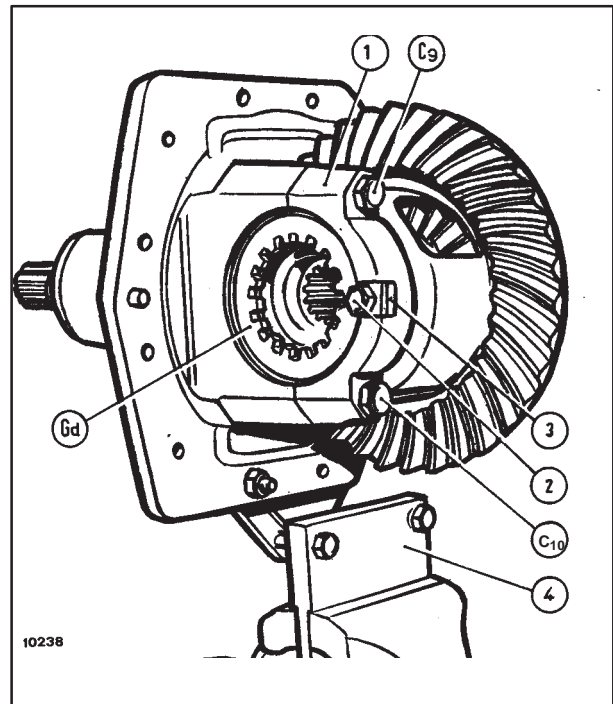

83

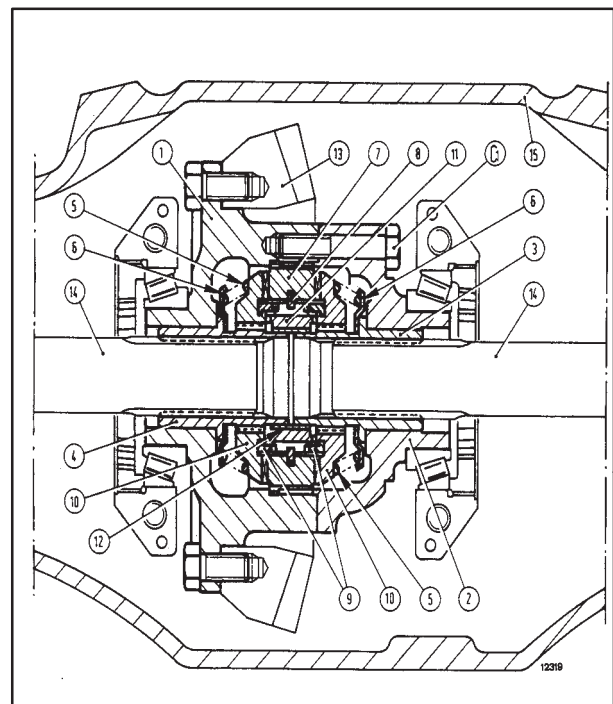

84

CHECKING THE ALIGNMENT OF STEERING DRIVE WHEELS (Op 44 511 80)

When travelling forward in a straight path, the wheels of four-wheel drive tractors must be parallel to the longitudinal axis of the tractor, alternatively a slight toe-in of the front wheels is permissible up to a maximum of 6 mm (0.2362 in.) as measured at the edges of the wheel rims.

To check the exact value of the toe-in setting of four-wheel drive tractors, proceed as follows.

1. Inflate the front tyres to the prescribed pressure.
2. Position the steering at the straight ahead position (along the longitudinal axis of the tractor).
3. Check that the wheels are parallel to the longitudinal axis of the tractor.
4. Make a chalk mark on the **front** inside edges of both wheel rims, at the height of the wheel hub centres. Measure the distance (1) between the chalk marks.
5. Move the tractor forward to turn both front wheels through 180°. The chalk marks will now be measure between the **rear** inside edges of the wheel rims at the height of the wheel hub centres. Now measure the distance (2) checking that this new measurement is equal to or greater than the distance (1) by a maximum of 6 mm.

The rotation of the wheels through 180° is necessary to eliminate the effect of wear, misalignment or distortion of the wheel rims on the measurements obtained.

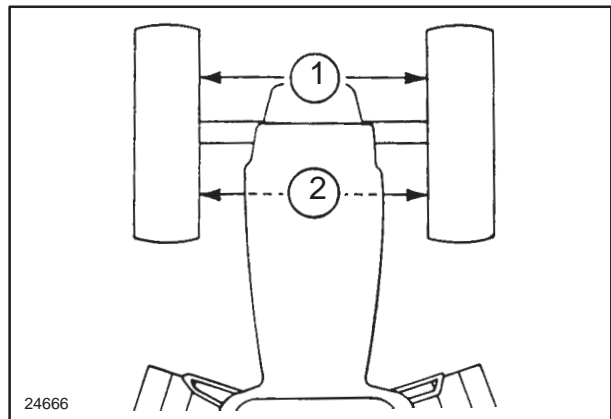

84

6. If it is necessary to correct the wheel alignment, remove nut (2) and pull the track rod end (1) out of its housing. Slacken off locknut (3) and screw the track rod end (1) in or out to increase or decrease the distance (2) fig. 84.

Reposition the track rod end (1) in its housing and re-check alignment as described in points 4 and 5 above.

After having adjusted the alignment to within the prescribed limits, tighten locknut (3) to a torque of 180 Nm (134.9738 ft lb) and nut (2) to 100 Nm (73.7562 ft lb).

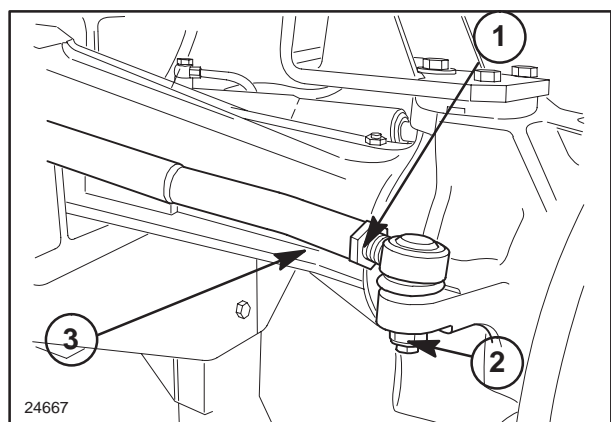

85

NOTE: The self-locking nut (2) must be renewed each time it is removed or partially unscrewed.

SECTION 27 - REAR AXLE AND TRANSMISSION**Chapter 1 - Rear axle and transmission****CONTENTS**

Section	Description	Page
27 000	Main data	1
	Tightening torques	3
	Special tools	5
	Cross-sectional views	7
	Description and operation and troubleshooting	10
21.118.10 - 12	Transmission-gearbox casing Removal-Installation	11
21.118.85	Transmission-gearbox casing Disassembly-Overhaul	29
	Gearbox driven shaft end float adjustment	37
	Differential lock engagement sleeve adjustment	38
	Determining the bevel pinion positioning adjustment ring	39
	Adjusting the taper roller bearings for the bevel pinion shaft	41
	Adjusting the bearings and checking the backlash	42
	Differential pinion and side gear backlash adjustment	46

**27 000 - MAIN SPECIFICATION - TORQUE SETTINGS - SPECIAL TOOLS - SECTIONAL VIEWS -
DESCRIPTION AND OPERATION - FAULT FINDING**

MAIN SPECIFICATION OF BEVEL GEAR PAIR AND DIFFERENTIAL

		TD60D - TD70D	TD80D - TD90D - TD95D
		Bevel gear pair gear ratio	9/43 = 1:4.8 (30 kph (18.6 mph)) 11/43 = 1:3.9 (40 kph (24.9 mph))
Bevel gear pair tooth clearance	mm (in.)	0.18 - 0.23 (0.0071 - 0.0091)	
Type of differential		with two planet gears	
Mechanical differential lock control		by means of pedal	
Release for mechanically controlled differential lock		controlled by foot brake pedals	
Differential pinion internal seat diameter	mm (in.)	24.040 - 24.061 (0.9465 - 0.9473)	25.040-25.061 (0.9858 - 0.9867) (for TD80D-TD90D)
Differential pinion pin diameter	mm (in.)	23.939 - 23.960 (0.9425 - 0.9433)	28.040-28.061 (1.1039 - 1.1048) (for TD95D) 24.939-24.960 (0.9818 - 0.9823) (for TD80D-TD90D)
Clearance between differential pinions and their pins ...	mm (in.)	27.939-27.960 (1.1000 - 1.1007) (for TD95D) 0.080 - 0.122 (0.0031 - 0.0048)	0.080 - 0.122 (0.0031 - 0.0048)
Diameter of side gear hub seats on differential box	mm (in.)	44.080 - 44.119 (1.7354 - 1.7370)	51.100 - 51.146 (2.0118 - 2.0136)
Diameter of side gear hubs	mm (in.)	43.961 - 44.000 (1.7307 - 1.7323)	50.954 - 51.000 (2.0061 - 2.0079)
Clearance between side gears and their seats	mm (in.)	0.080 - 0.158 (0.0031 - 0.0062)	0.100 - 0.192 (0.0039 - 0.0076)

(see over)

MAIN SPECIFICATION OF BEVEL GEAR PAIR AND DIFFERENTIAL

(cont.)

	TD60D - TD70D	TD80D - TD90D - TD95D
Bevel pinion positioning adjustment	see pages 39	
Adjuster shims for bevel pinion positioning mm (in.)	1.85 - 1.90 - 1.95 - 2.00 - 2.05 - 2.10 - 2.15 - 2.20 - 2.40 - 2.45 - 2.50 - 2.55 - 2.60 - 2.65 - 2.70 (0.0728 - 0.0748 - 0.0768 - 0.0787 - 0.0807 - 0.0827 - 0.0846 - 0.0866 - 0.0945 - 0.0965 - 0.0984 - 0.1004 - 0.1024 - 0.1043 - 0.1063)	
Adjusting ring bevel gear bearings and bevel gear pair coupling clearance	see page 42	
Differential pinion and side gear backlash mm (in.)	0.15 (0.0059)	0.18 (0.0071)
Thickness of differential side gear clearance adjustment shims mm (in.)	1.5-1.6 (0.0591-0.0630)	
Thickness of differential pinion thrust bearings mm (in.)	1.47-1.53 (0.0579-0.0602)	
Adjusting clearance between pinion and side gear teeth	see page 46	
Adjusting differential lock	see page 38	
Differential lock control fork adjuster shim mm (in.)	0.5 (0.0197)	
Spring for differential lock control fork:		
- free spring length mm (in.)	220 (8.6614)	
- length of spring under load of 177-195 N (3.9922-4.3892 lb) mm (in.)	157.5 (6.2008)	

MAIN SPECIFICATIONS OF FINAL DRIVES

	TD60D - TD70D	TD80D - TD90D - TD95D
Type	pinion type and spur gears	
Reduction ratio	11:62= 1:5.6	11:67=1:6.1 (for TD80D- TD90D) 11:68=1:6.2 (for TD95D)

TORQUE SETTINGS - Refer to fig. 1 on page 4

PART TO BE TIGHTENED	Thread	Torque settings	
		Nm	ft lb
Retaining bolts for rear transmission/gearbox upper cover (C ₁) . . .	M 10 x 1.25	59	43.5161
Bolts for securing lift to rear transmission box (C ₂)	M 12 x 1.25	98	72.2811
Bolts for securing PTO box to transmission / gearbox case (C ₃)	M 16 x 1.5	221	163.0012
Bolts for securing torsion bar to transmission / gearbox case (C ₄)	M 16 x 1.5	221	163.0012
Nuts for stud bolt securing final drive box to transmission / gearbox case (C ₅)	M 12 x 1.25	98	72.2811
Drive wheel hub to disc retaining nuts (C ₆)	M 18 x 1.5	255	188.0783
Drive wheel rim to disc retaining nuts (C ₇)	M 16 x 1.5	245	188.7027
Ring bevel gear retaining bolts (C ₈)	M 12 x 1.25	123	90.7201
Bevel drive - differential support retaining self-locking bolts (C ₉)	M 10 x 1.25	59	43.5161
Final drive casing cover retaining bolts (C ₁₀)	M 10 x 1.25	59	43.5161
Drive wheel axle retaining nut (C ₁₁)	M 55 x 1.5 M 60 x 2	882 882	650.5297 650.5297
Differential lock pedal support retaining bolts	M 10 x 1.25	49	36.1405
Nuts for drive wheel ballast ring retaining bolts	M 14 x 1.5	98	72.2811

SECTIONAL VIEWS

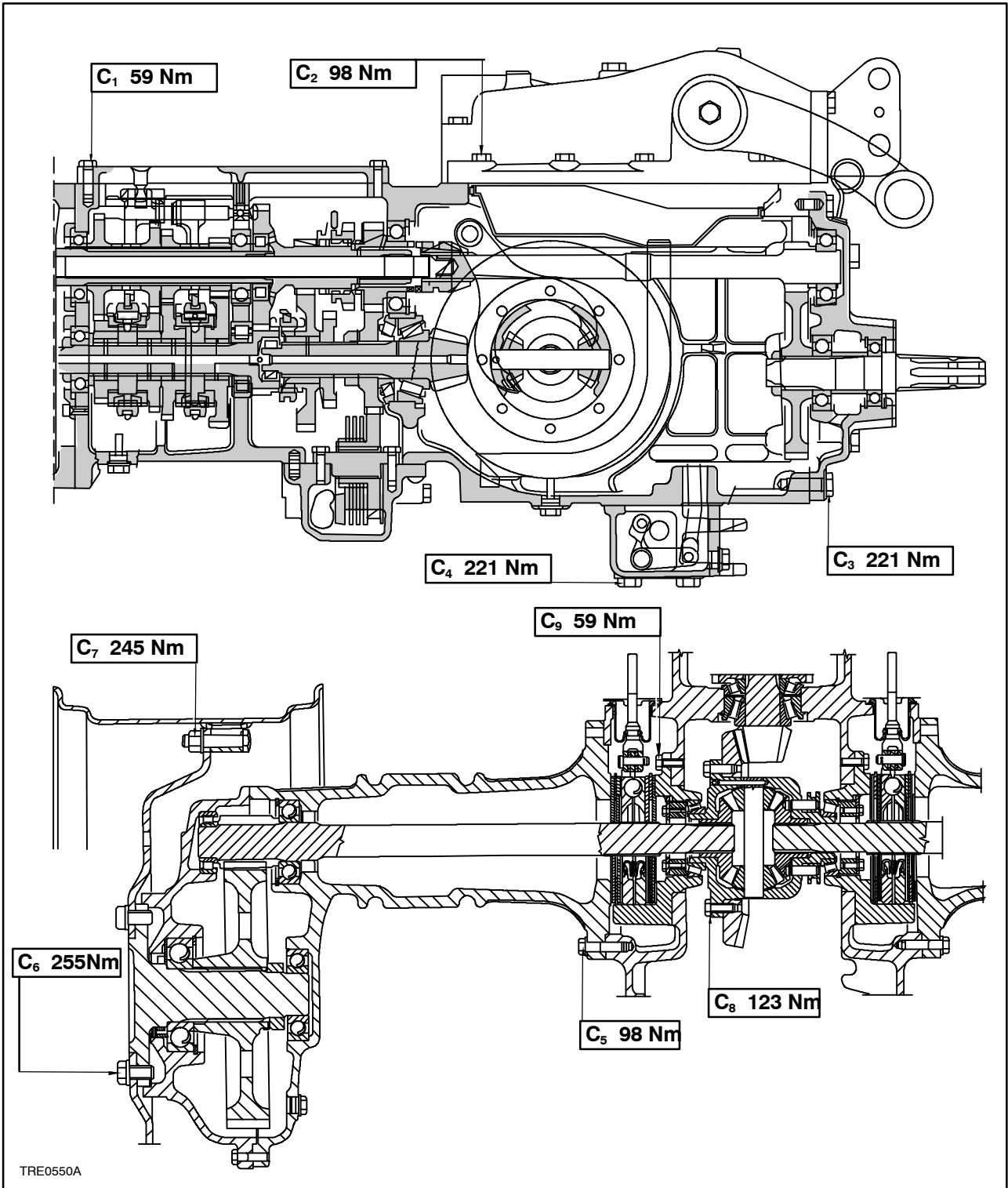

TRE0550A

SPECIAL TOOLS

IMPORTANT: The operations described in this Section must be performed only with the **ESSENTIAL** tools marked with **(X)**.

To work in complete safety and to ensure optimal technical results with a minimum of time and effort, they must be supplemented by the special tools recommended below and with those to be specially constructed by you and for which the construction diagrams are given in this manual.

List of special tools required for the various operations described in this Section :

380000236 Trolley for tractor disassembly.

- 380000277** Hook for lifting clutch box.
- 380000301** Rotating stand for overhaul.
- 380000271** Rear mounting (with **380000301**).
- 380000272** Front mounting (with **380000301**).
- X 380000838** Adapter for extracting bevel pinion (with **380000549**).
- 380000549** Slide hammer.
- 380000249** Bevel pinion positioning gauge.
- 50006** Punch for removing gearbox drive shaft (see page 4, Sect.21, Chap. 1).
- 50007** Tool for adjusting gearbox drive shaft (see page 4, Section 21, Chapter 1).

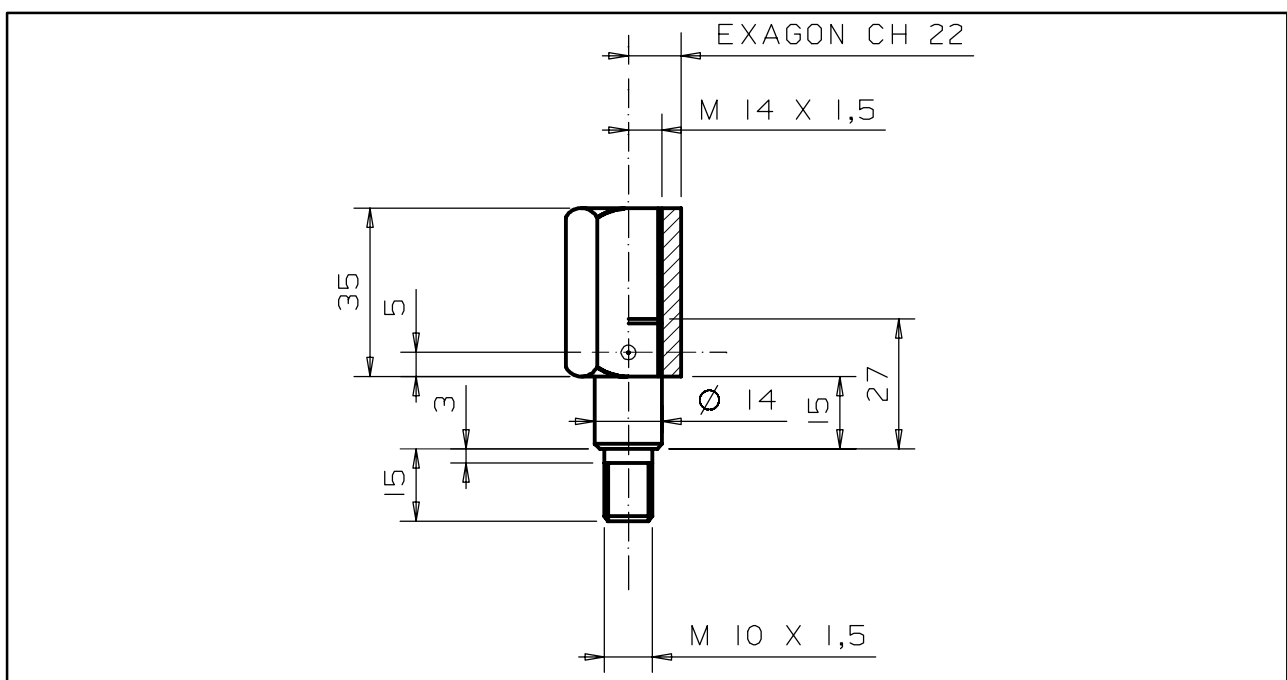

2

Tool to make for bevel pinion extraction
(Mark part with No. **50144** - Measurements in mm)
Make in UNI C40 material. Spring pin 3 x 20 mm.

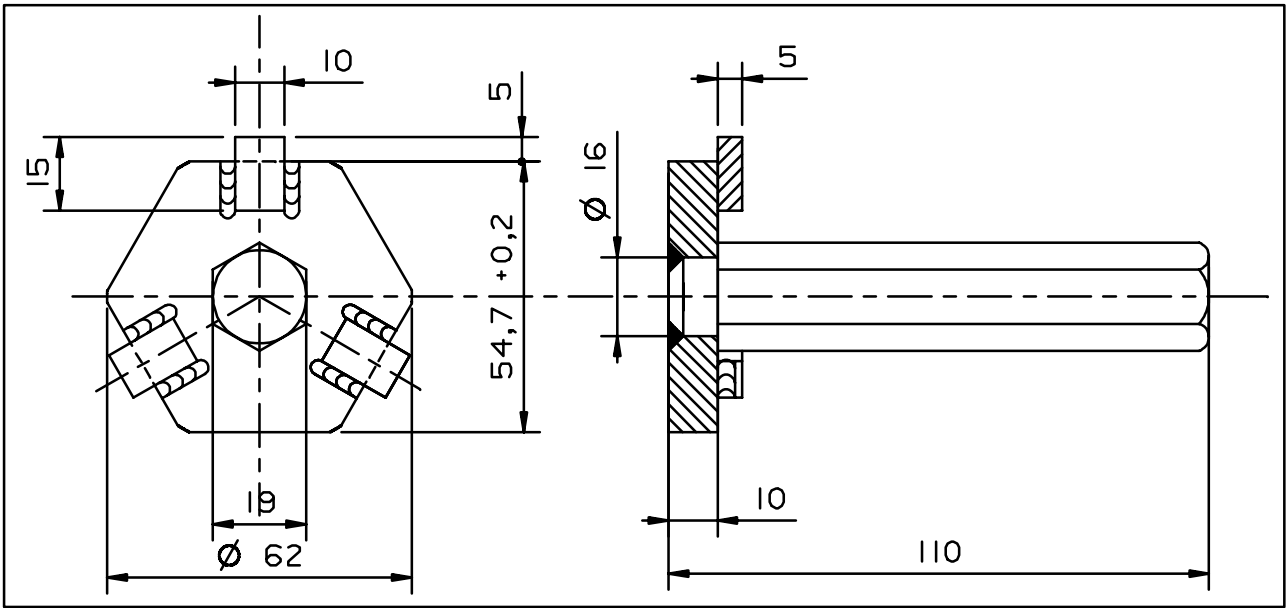

3

Tool to make for adjusting the bevel drive
 (engrave number **50027** on the tool - measurements in mm)
 Make in Fe 42 C material.

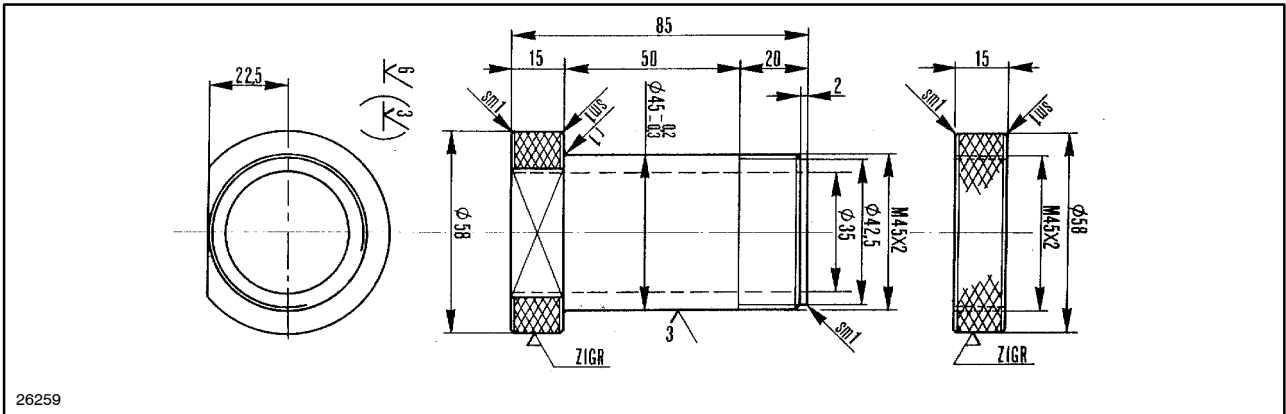

26259

4

Tool to make for adjusting the assembly position of the bevel pinion shaft
 (Mark tool with no. **50004** - Measurements in mm)
 Make using Aq 45 material.

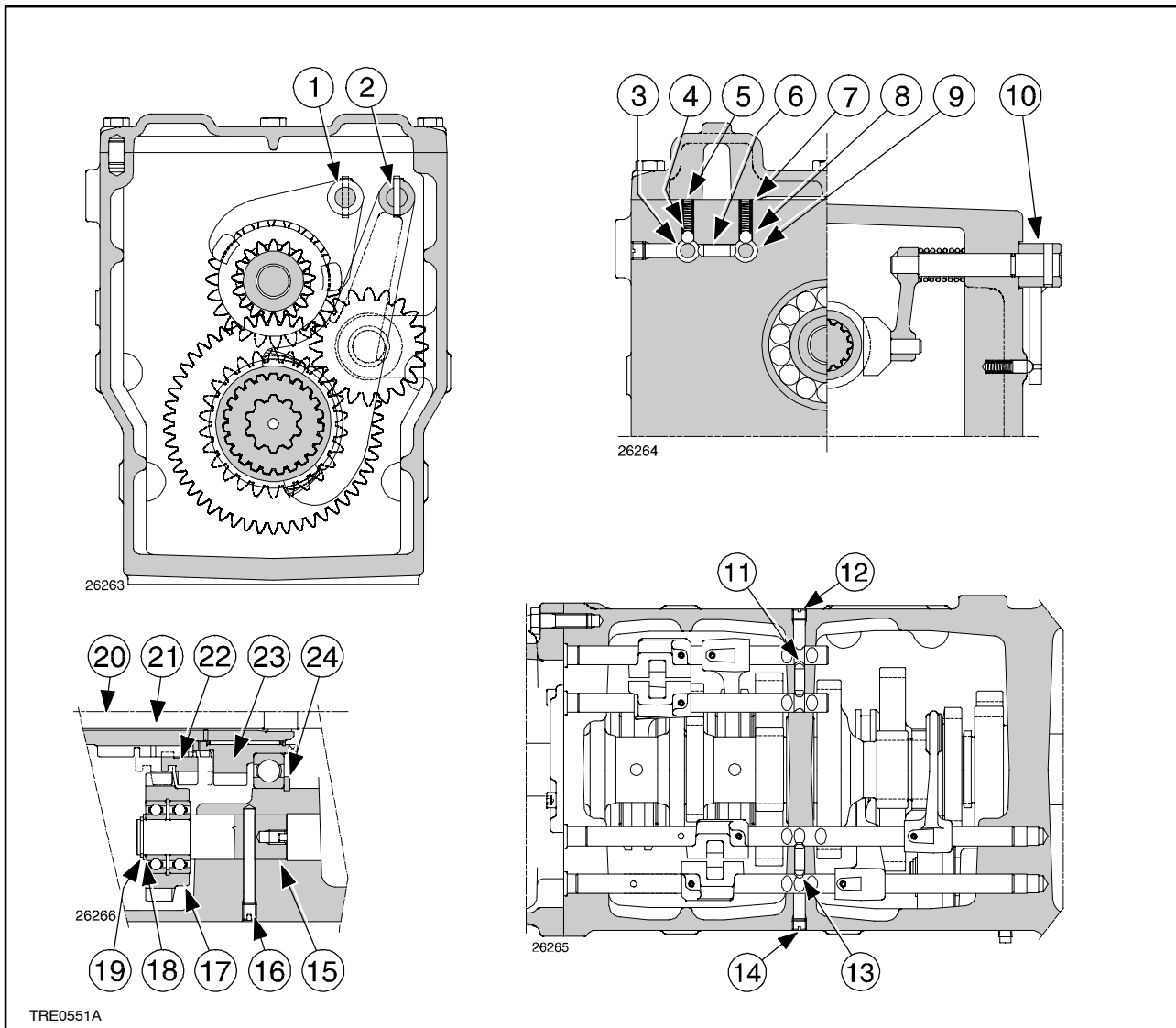

5

Sectional drawings of transmission-gearbox case

- | | |
|--|--|
| 1. Mid-range and reverse gear control rod. | 14. Plug. |
| 2. Slow and fast gear control rod. | 15. Reverse gear support pin. |
| 3. 1st and 2nd gear control rod. | 16. Retaining bolt. |
| 4. Detent balls. | 17. Reverse idler gear. |
| 5. Spring for ball (4). | 18. Thrust bearing. |
| 6. Gear engagement safety pawl. | 19. Snap ring. |
| 7. Spring for ball (8). | 20. PTO shaft. |
| 8. Detent ball. | 21. Reverser drive shaft. |
| 9. 3rd and 4th gear control rod. | 22. Engagement gear for mid-range and reverse gears. |
| 10. PTO external control lever. | 23. Driving gear for mid-range gears. |
| 11. Gear engagement safety pawl. | 24. Snap ring. |
| 12. Plug. | |
| 13. Range engagement safety pawl. | |

NOTE: Screw in plugs 12 and 14 using one of the sealing compounds listed on page 1, Section 00.

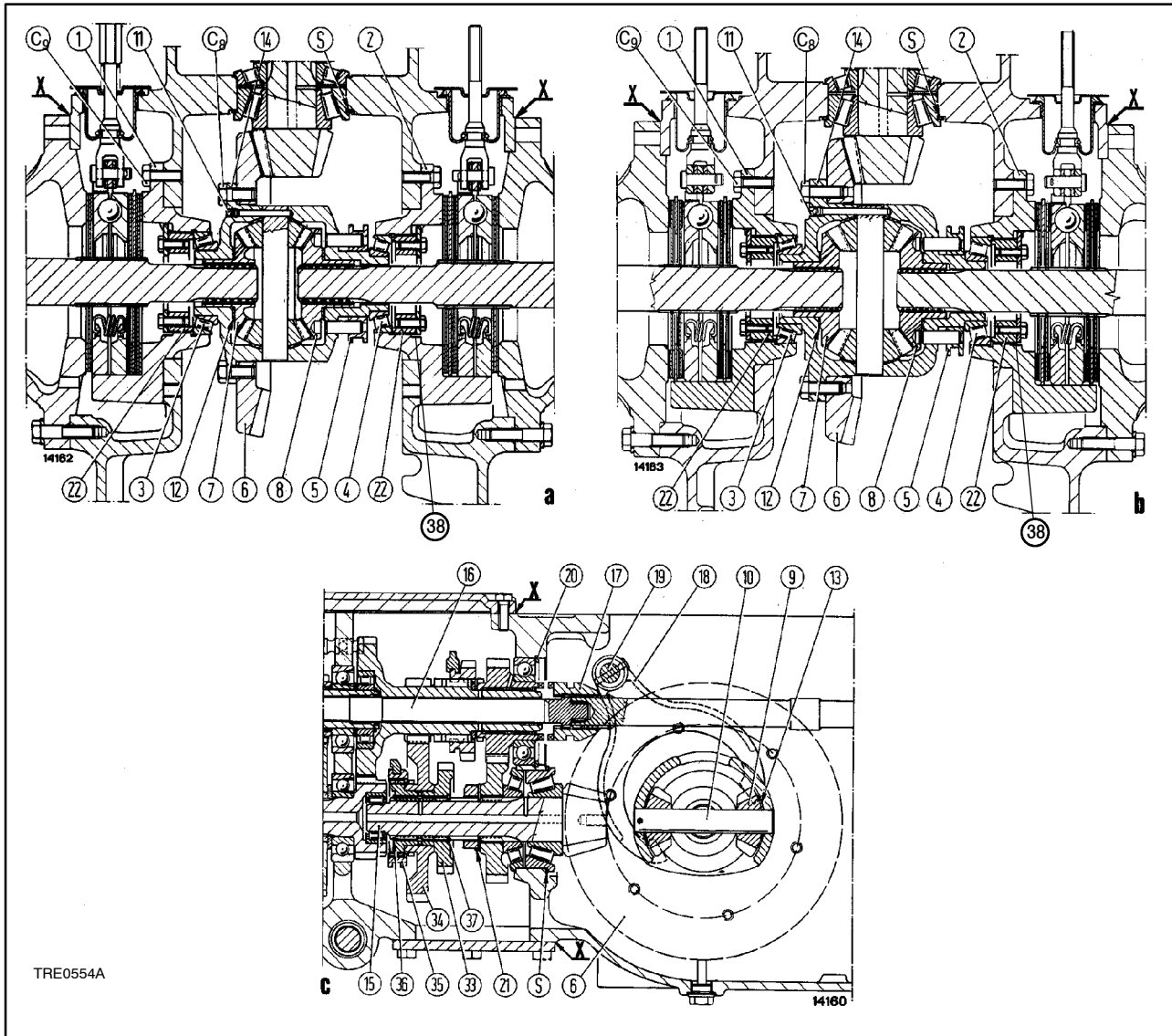

6

Longitudinal and cross sectional views of bevel drive and differential

- a. TD60D and TD70D models
 b. TD80D, TD90D and TD95D models
 c. Longitudinal section of range gear and bevel drive (all models).

- C_g. Bevel drive retaining bolts.
 C_s. Bevel drive support retaining bolts.
 S. Bevel pinion positioning shim.
 1. Differential support.
 2. Differential support.
 3. Taper roller bearing.
 4. Taper roller bearing.
 5. Differential lock sleeve.
 6. Bevel crown wheel.
 7. Side gear.
 8. Side gear.
 9. Side pinion.
 10. Pin.
 11. Side pinion pin retaining bolt.
 12. Shim ring.

13. Shim ring.
 14. Differential casing.
 15. Bevel pinion shaft.
 16. Power take-off shaft.
 17. PTO engagement sleeve.
 18. Fork.
 19. Differential lock control rod.
 20. Snap ring.
 21. Lock washer.
 22. Differential crown wheel bearing adjustment ring nut.
 23. Reverse gear.
 24. Slow speed driven gear.
 25. Gearbox direct engagement and slow speed engagement sleeve.
 26. Snap ring.
 27. Half rings.
 28. Ring nut retaining ring.

NOTE: During installation, apply sealing compound to surfaces X as shown in Section 00, Chapter 1, page 1.

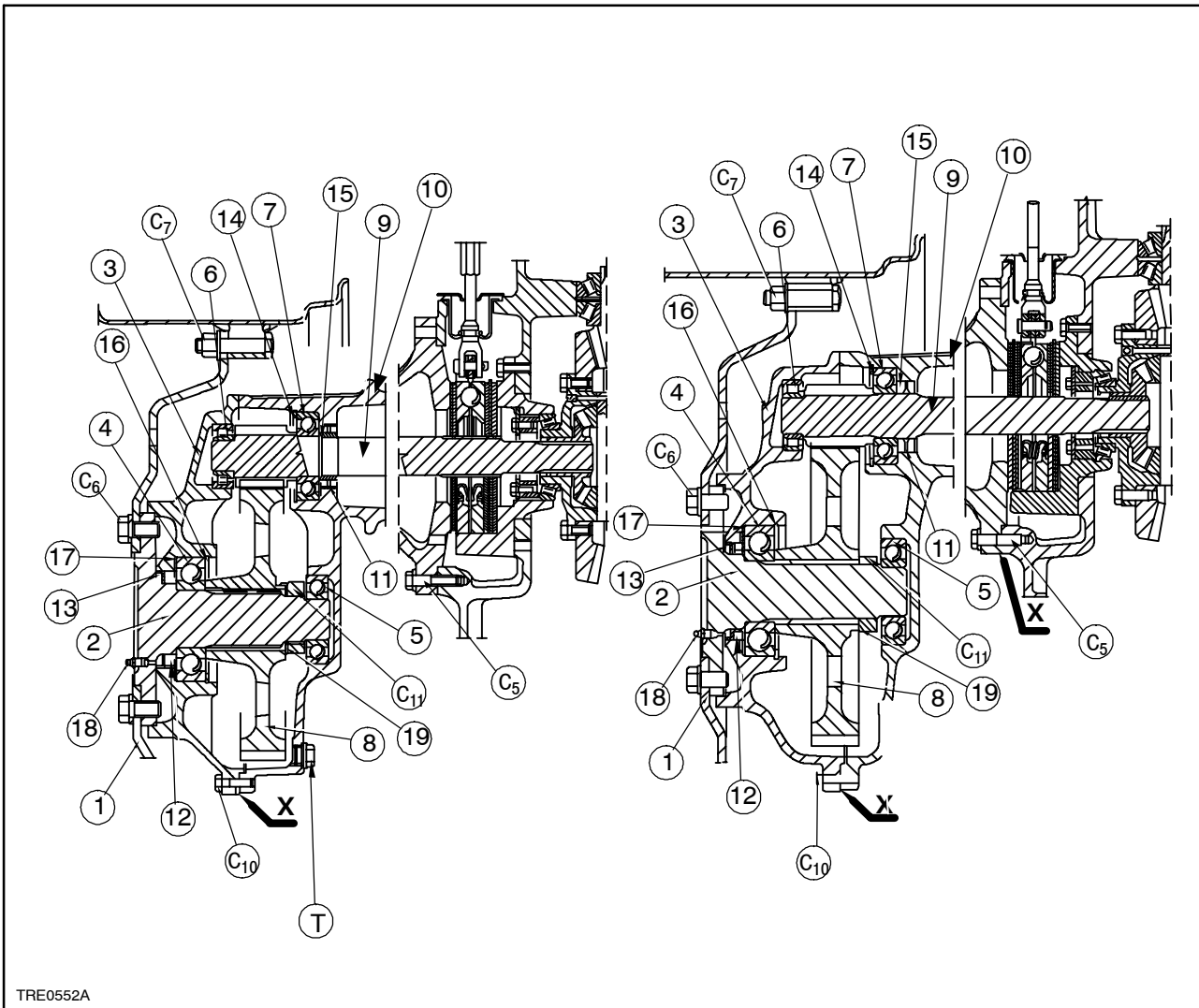

TRE0552A

7

- | | |
|---|----------------------------|
| a. TD60D and TD70D models | 6. Roller bearing |
| b. TD80D, TD90D and TD95D models | 7. Ball bearing |
| C ₅ . Gearbox to final drive box retaining bolts | 8. Final drive driven gear |
| C ₆ . Wheel hub to disc retaining nuts | 9. Axle shaft |
| C ₇ . Wheel rim to disc retaining nuts | 10. Final drive casing |
| C ₁₀ . Final drive housing - cover retaining bolts | 11,12. Seals |
| C ₁₁ . Drive wheel axle locknut | 13. Seal guard |
| T. Drain plug | 14,15,16. Retaining rings |
| 1. Wheel disc | 17. Seal thrust ring |
| 2. Drive wheel shaft | 18. Grease nipple |
| 3. Final drive housing cover | 19. Lockwasher |
| 4,5. Ball bearings | |

NOTE: During installation, apply sealing compound to surfaces X as shown in Section 00, Chapter 1, page 1.

DESCRIPTION AND OPERATION

The rear transmission transmits power from the gearbox to the lateral final drives by means of the bevel gear pair. The bevel gear pair is of the helical tooth type and is supported by taper-roller bearings.

The differential has two pinions and is equipped with a mechanically controlled differential lock.

FAULT FINDING FOR BEVEL GEAR PAIR AND DIFFERENTIAL

Problems	Possible causes	Remedies
Transmission noisy while the tractor is moving, even when the gearbox is in neutral (not arising from final drives).	1. Incorrect adjustment of bevel pinion and / or ring bevel gear bearings.	Remove the rear transmission box and adjust the pinion and ring bevel gear bearings correctly (page 39).
Transmission noisy when tractor is operated with or without load.	1. Excessive clearance between pinion and ring gear teeth.	Remove the rear transmission box and correctly adjust the pinion and ring gear bearings (page 39).
Differential repeats noise within short intervals.	1. An internal component is broken or defective.	Remove the rear transmission box, replace the worn parts and correctly adjust the differential gear clearance (page 42).
Transmission noisy and assembly overheats.	1. Pinion and / or ring gear bearing clearances insufficient. 2. Insufficient coupling clearance between the teeth of the pinion and the ring gear.	Remove the rear transmission box and correctly adjust the pinion and ring bevel gear bearings (page 39). Remove the rear transmission box and correctly adjust the ring bevel gear bearings (page 39).

FAULT FINDING FOR FINAL DRIVES

Problems	Possible causes	Remedies
Final drive noisy when tractor is moving, even with the gearbox in neutral.	1. An internal component is broken or defective.	Remove the final drive box and replace the damaged parts.

REAR TRANSMISSION - GEARBOX CASE**Removal-Refitting (Op. 21 118 10 - 21 118 12)**

Related service instructions up to item 44 - see pages from 11 to 21. Also describes removal operations of suspended cab/platform (**Op. 90 110 36**) with the exception of heating pipes and air conditioning components removal.



Lift and handle all heavy parts using proper equipment of adequate lifting capacity.

Make sure that the assemblies and parts are supported by appropriate tools and hooks. Keep personnel away from the vicinity of the load to be lifted.

To remove the gearbox-rear transmission, proceed as follows:

1. Disconnect the negative terminal from the battery. Remove the rear transmission drain plug (1) and the gearbox drain plug (2). Drain the oil into suitable containers.

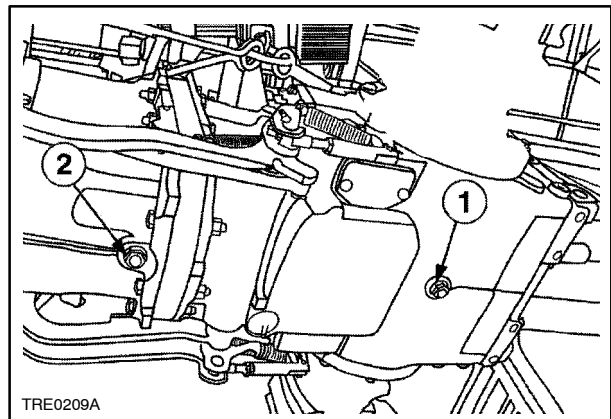

8

2. Remove the drain plug from the 4WD transfer box (1) and drain the oil into a suitable container.

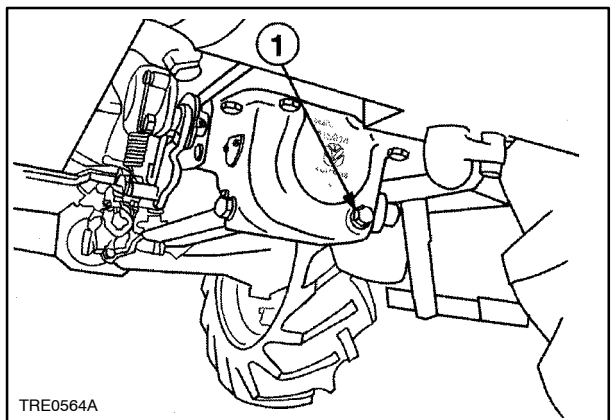

9

3. Place the tractor dismantling stand **380000236**, so that the fixed support (1) is beneath the rear transmission case in supporting the engine coupling flange and the moveable support (2) under the engine in supporting the flange attached to the gearbox case.

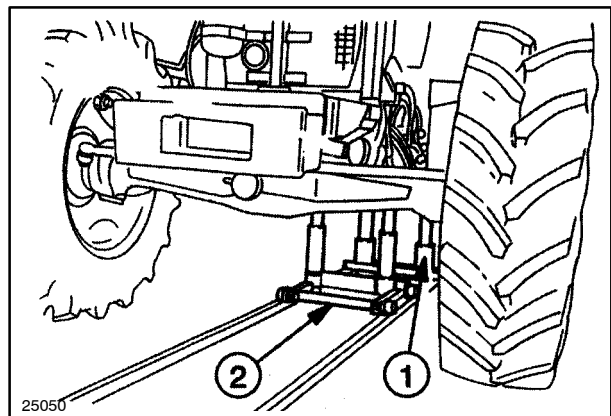

10

4. Place another moveable stand **380000236** under the front weight carrier to prevent any possibility of the engine tipping forwards when the gearbox is removed. Put wooden blocks (1) between the stands and the tractor body. Turn the stand height adjustment lever to bring the blocks (1) into contact with the tractor.

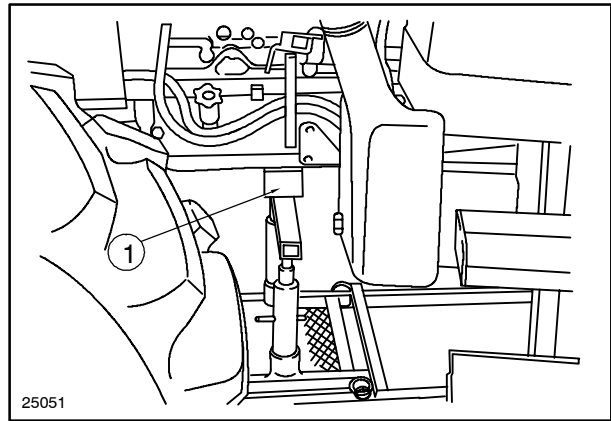

11

5. Remove electrical connections (1) going to the instrument panel.

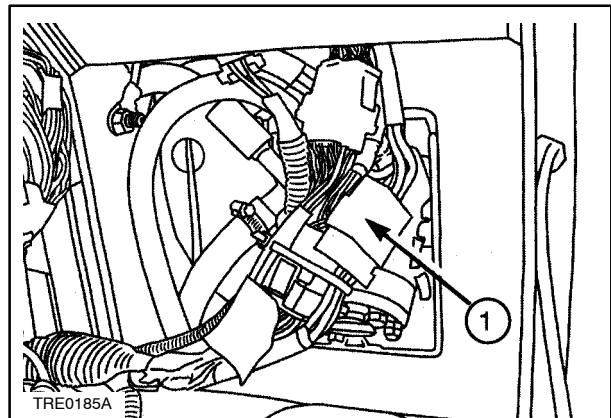

12

6. Remove the socket (1) with its cable that passes from the instrument panel and over the gearbox to the rear fender.

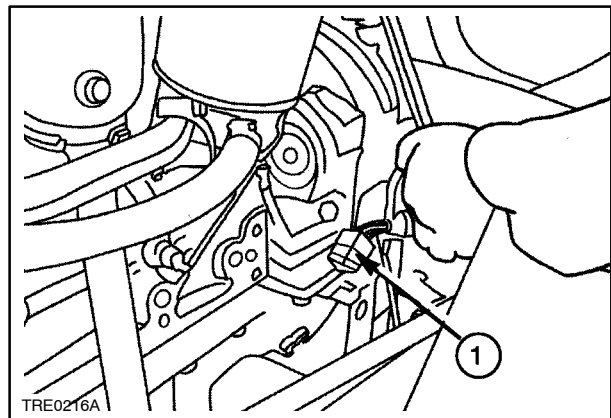

13

7. Remove the support bolt (1) from the injection pump and disconnect the hand and foot throttle cables.

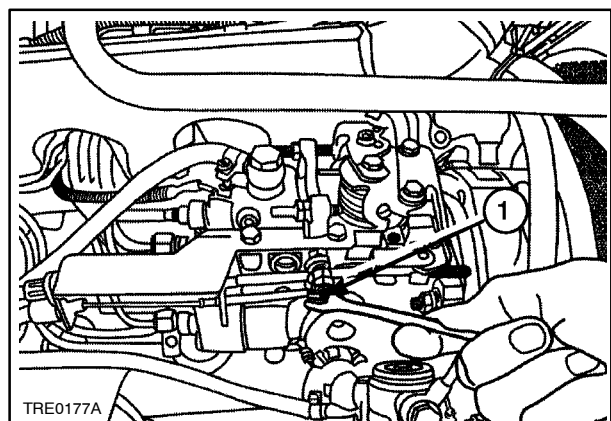

14

8. After retrieving the oil from the power steering tank, disconnect the hoses (1) from the power steering pump. (Mark the hoses, before removal, to facilitate refitting in the correct position).

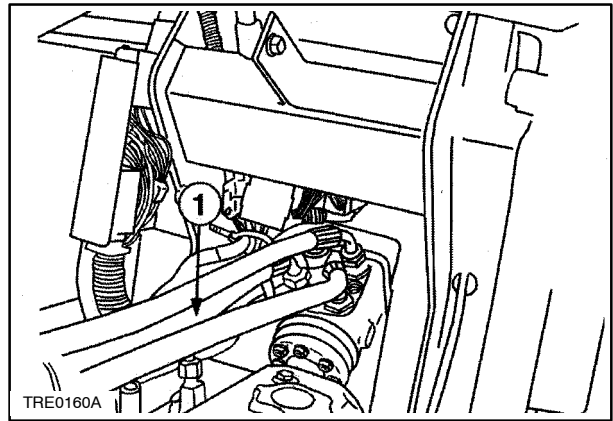

15

9. Disconnect the proofmeter drive cable from its adapter (1) and remove the retaining bolt (2).

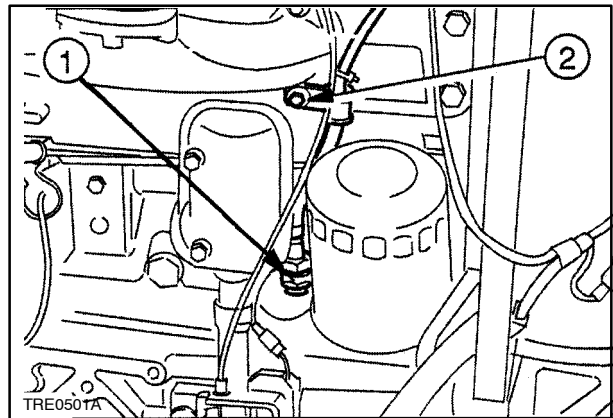

16

10. Remove the filter line (1) and pressure pipe (2) from hydraulic pump.

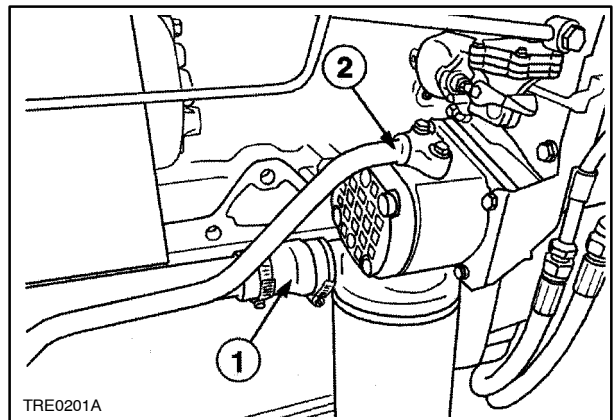

17

11. After draining off the coolant into suitable containers, unscrew the clamp (1) and remove the cab heating system intake pipe.

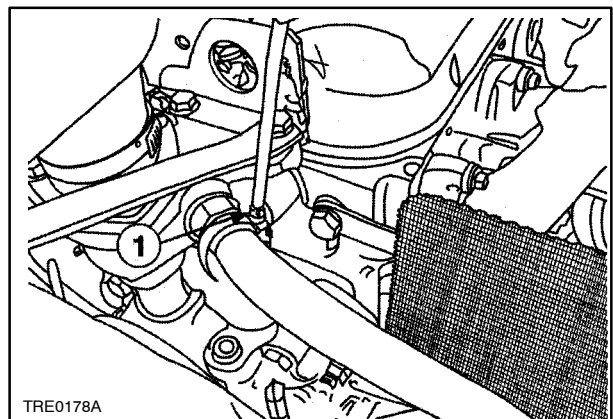

18

12. Loosen the clamps (1) and remove the cab heater outlet pipes (2). (Mark the hoses, before removal, to facilitate refitting in the correct position).

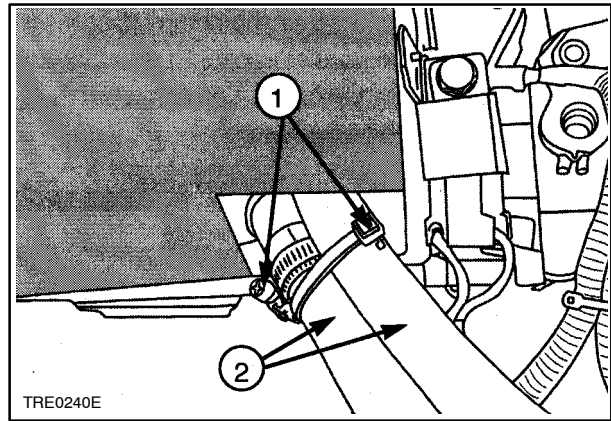

19

13. Remove the wing nut (1) securing the condenser (2).

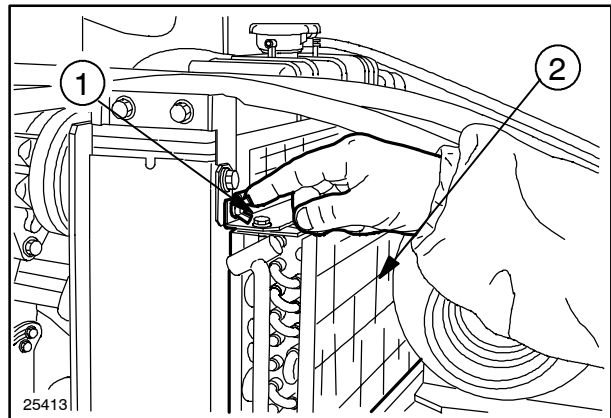

20

14. Remove the compressor retaining bolts (1) and take out the earth connection.

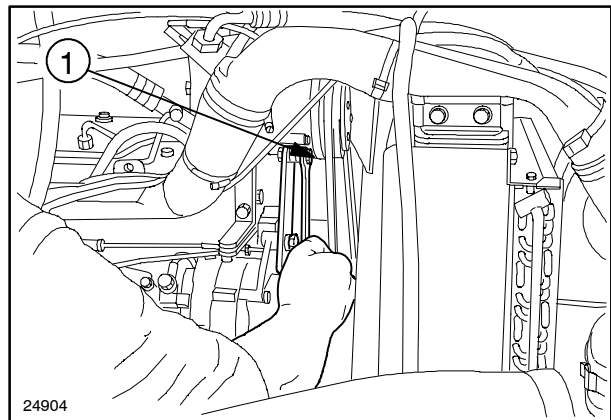

21

15. Move the disconnected compressor (1), condenser (2) and filter/dryer, together with flexible hoses and valves, onto the platform.

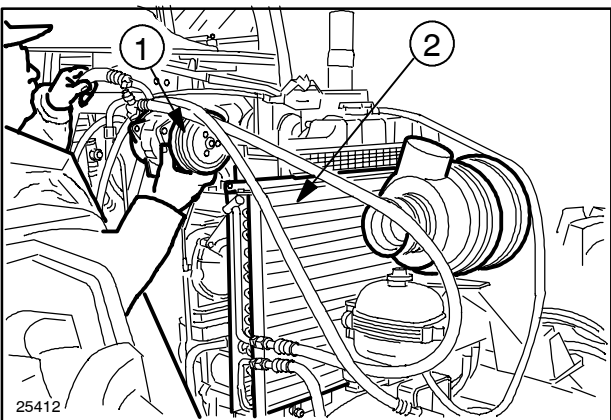

22

16. Remove the rubber floor mat from the cab/platform, then remove the surrounding bolts (1) securing engine-clutch assembly to the gear-box-rear transmission case.

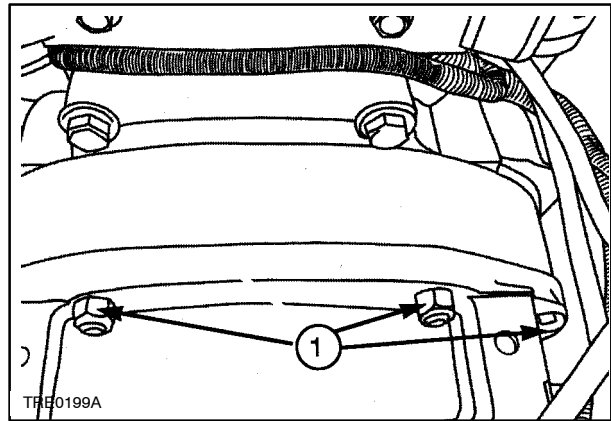

23

17. Place a hydraulic jack (1) underneath the centre of the fuel tank (2) and lift it, as necessary.

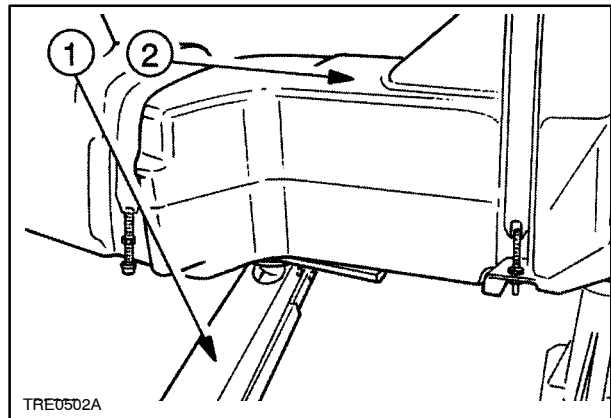

24

18. Using an Allen key, unscrew the plug (1) and drain the fuel tank using a suitable container (Choose a container taking into consideration the tank capacity of 90 litres (19.7879 gall. Imp.).)

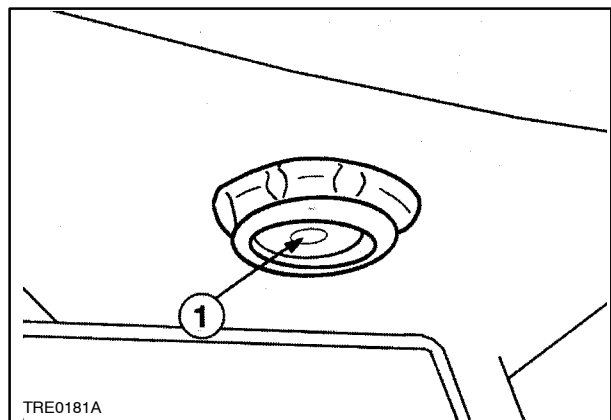

25

19. Remove the bolts (1) and (2) securing the fuel tank to the footstep.

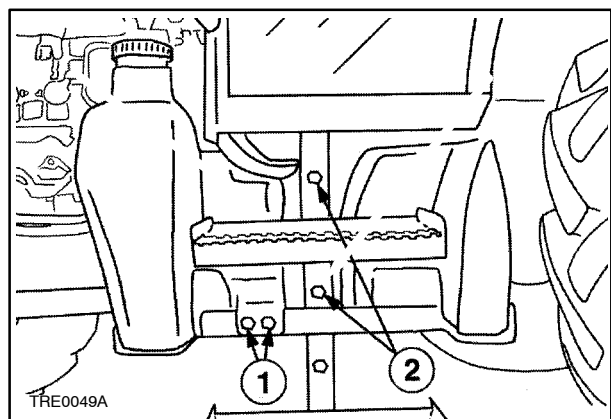

26

20. Remove the bolts (1) and (2) from steel support bracket beneath the fuel tank.

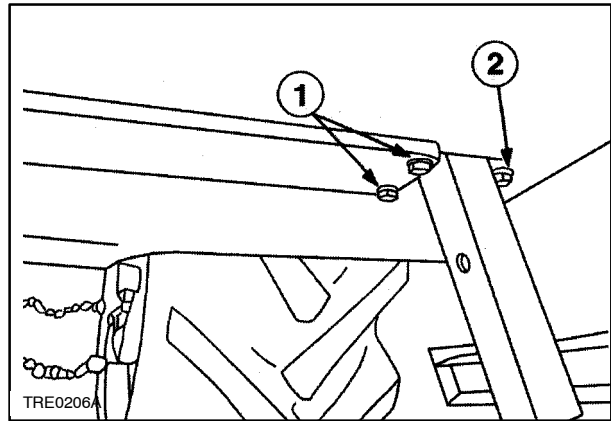

27

21. Remove the securing screws and remove the sheet metal protector (1) from beneath the fuel tank.

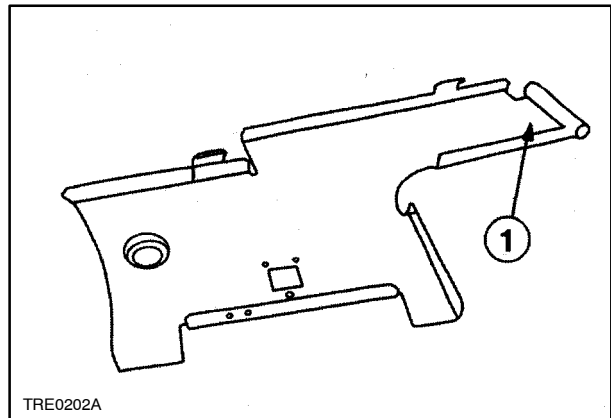

28

22. Rest the front edge of the fuel tank on the ground.

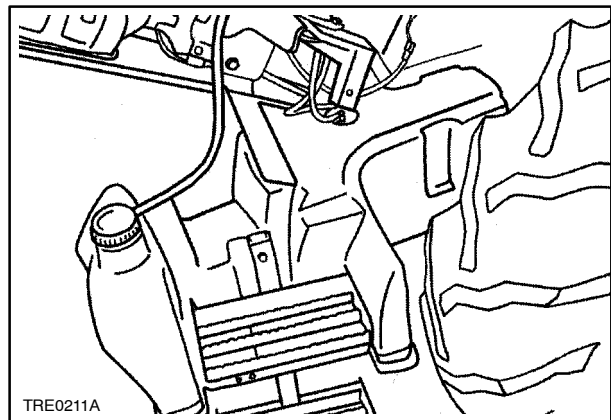

29

23. Loosen the clamps and remove the inlet (1) and return (2) pipes from the fuel tank. Remove the fuel tank completely.

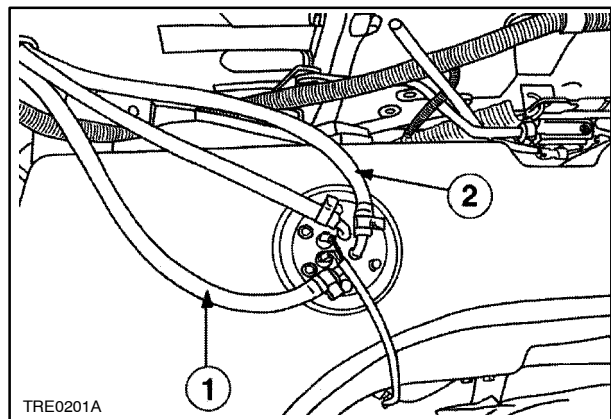

30

24. Remove the bolts (1) and remove the clutch pedal assembly from the upper surface of the cab/platform.

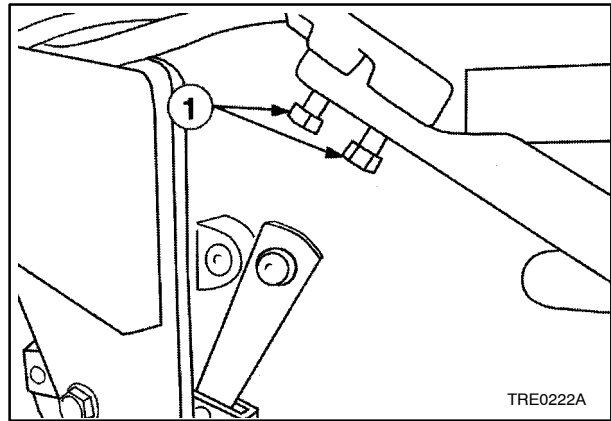

31

25. Remove the securing nuts (1) from the brake pedal retaining bolts. Remove the pedals from the upper surface of the cab/platform.

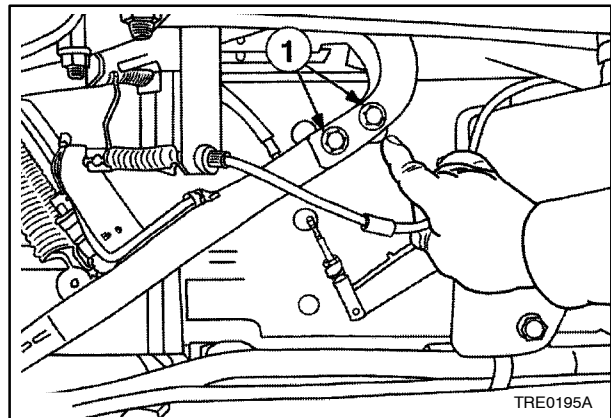

32

26. Remove the nut (1) from the parking brake control cable.

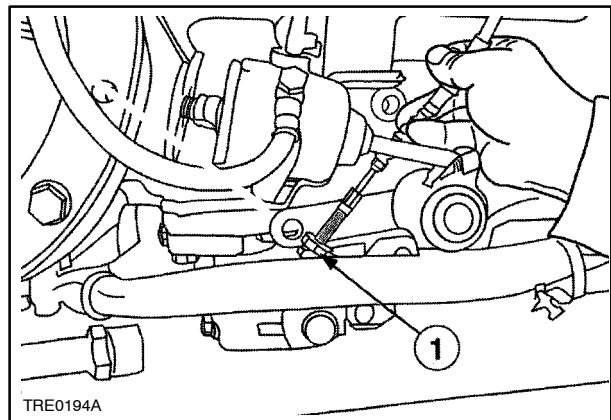

33

27. Remove the retaining pin (1) and disengage the PTO clutch cable.

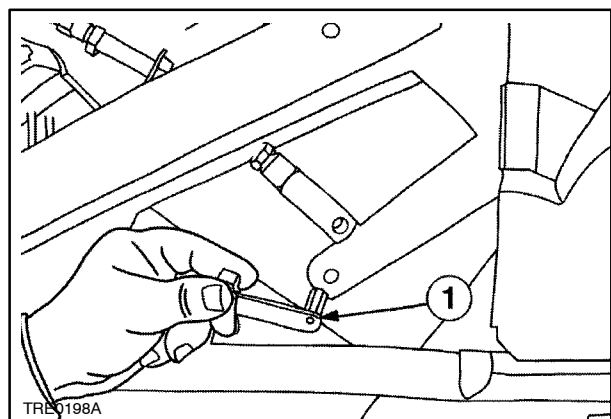

34

28. Remove the split pins (1) and disconnect the PTO engagement lever.

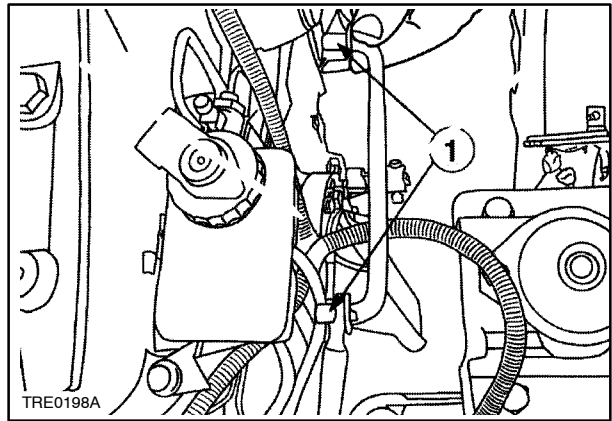

35

29. Remove the retaining pin (1) from the 4WD engagement lever and remove the lever.

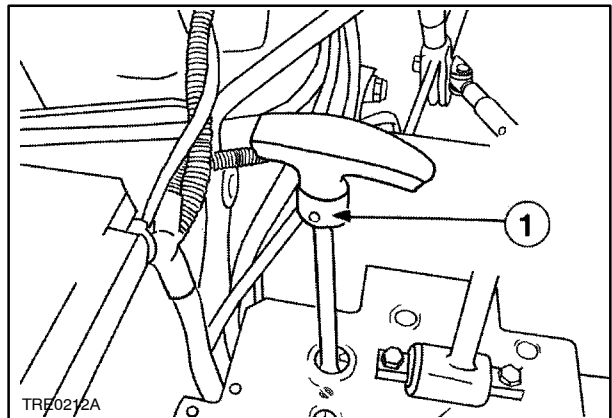

36

30. Remove the pin from the mechanical differential lock pedal and take off the pedal head (1).

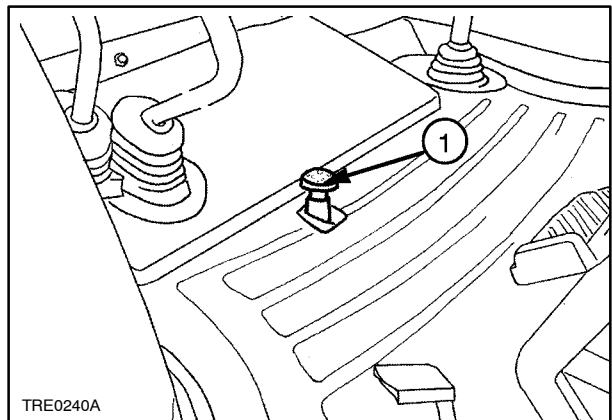

37

31. Pull up the plastic boot, remove the retaining bolt (1) and take out the reverser control lever.

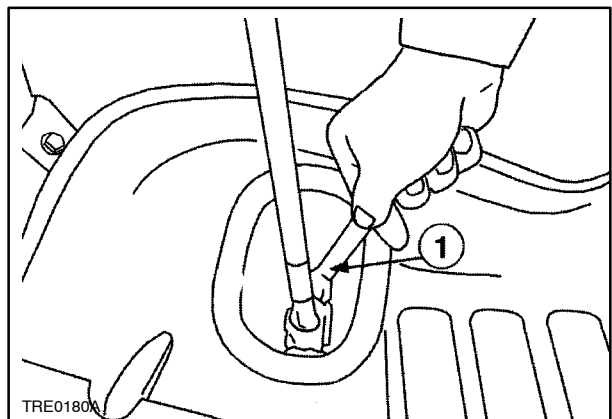

38

32. Unscrew the retaining bolts (1) and remove the main and range gear selector levers.

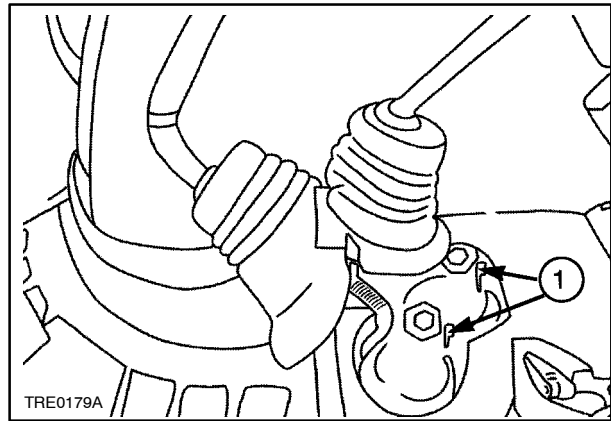

39

33. Remove the indicator and light connectors (1) from both sides of tractor.

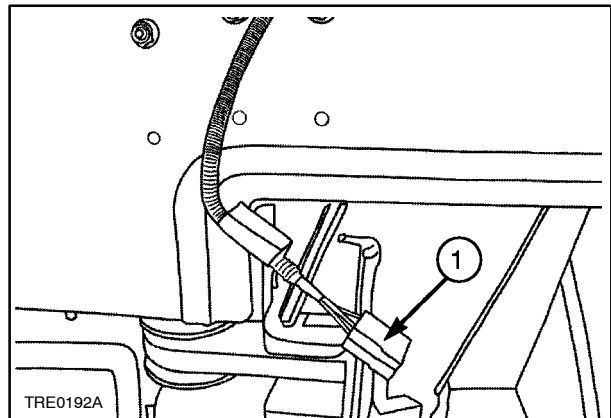

40

34. Disconnect the retaining bolts (1) from the electrical socket and remove the earth cable bolt (2).

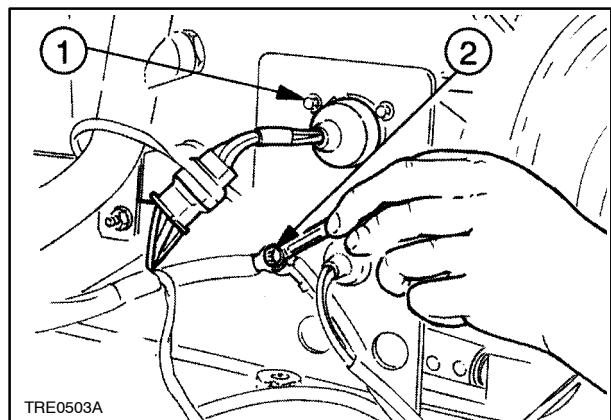

41

35. Remove the retaining pins (1) and take out the auxiliary hydraulic valve control rods.

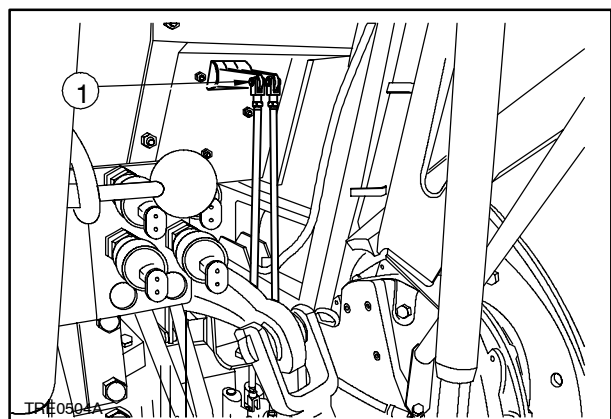

42

36. Disconnect the auxiliary valve nuts (1) from their pipes.

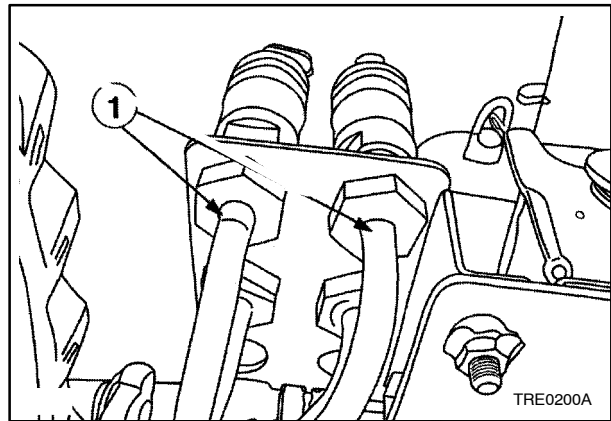

43

37. Remove the split pins (1) and respective draft and position control levers.

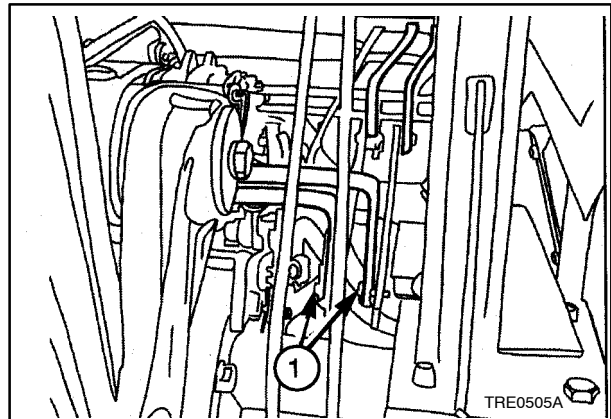

44

38. Remove the Lift-o-matic™ control cable (1) from the lever and from its mounting (2).

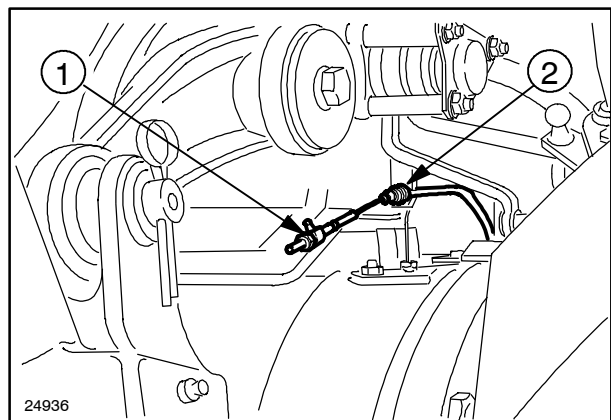

45

39. Remove the retaining pin (2) from the bottom and the support bracket bolts (1) from the top of the hydraulic lift control rod. Remove the left- and right-hand lift rods.

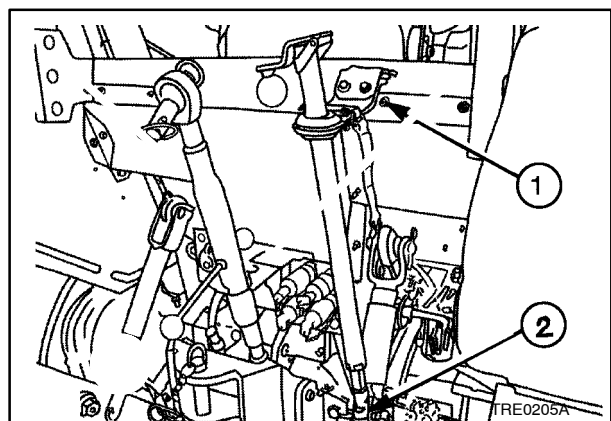

46

40. Remove the bolt (1) that secures the gearbox breather pipe clamp.

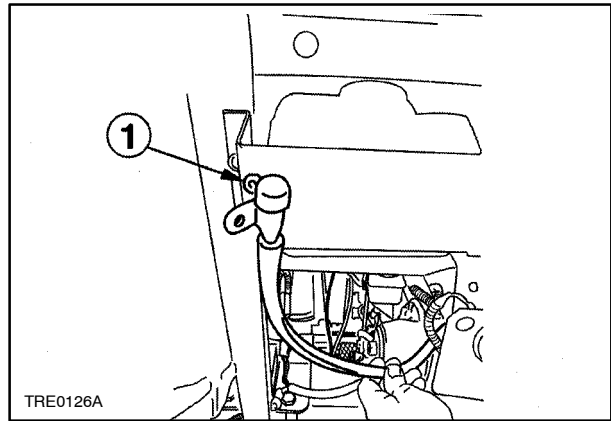

47

41. Remove the bolt (1) that secures each side of the front supports to the cab/platform.

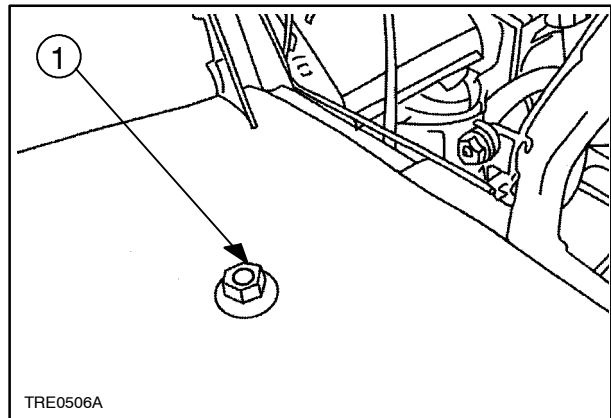

48

42. Remove four bolts (1) that secure the rear of the cab/platform to each end of the axle casing.

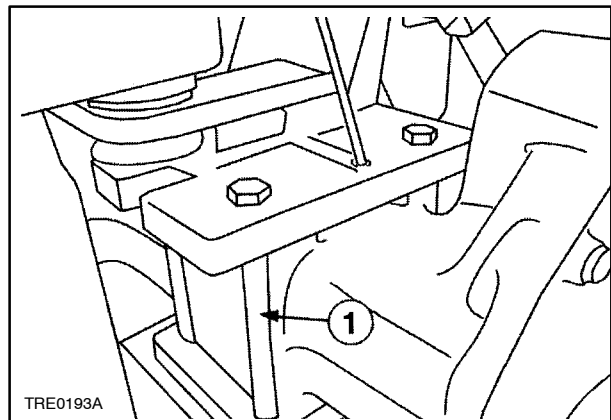

49

43. Attach the lifting bar to the lifting rings on the left and right side of the cab roof. Take all necessary precautions to prevent to prevent damaging the structure by using supports, where required. Raise the cab a little and check that there are no forgotten parts that will prevent the cab from being lifted further. If satisfactory, complete the lifting operation.

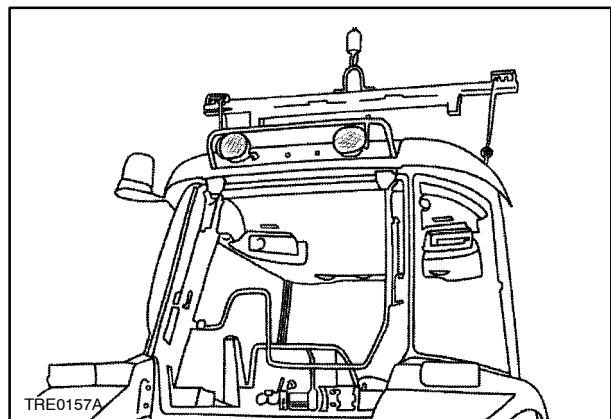

50

44. Attach two hooks to the signal support bar at the front and clamp the lifting tool to the roll-bar at the rear.

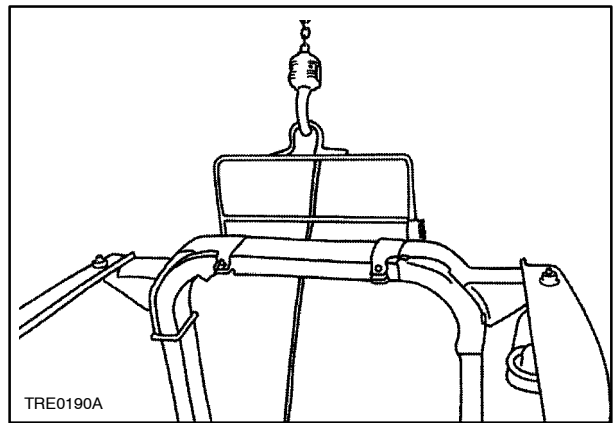

51

45. Remove the front retaining bolts (1), the centre bolts (2) and the rear retaining bolts from the 4WD drive shaft guard.

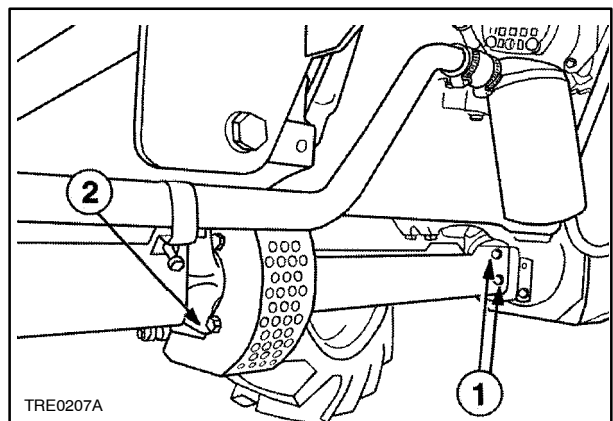

52

46. Remove the snap ring (2) and withdraw the sleeve (1) from 4WD transfer box, moving it in the direction of the arrow.

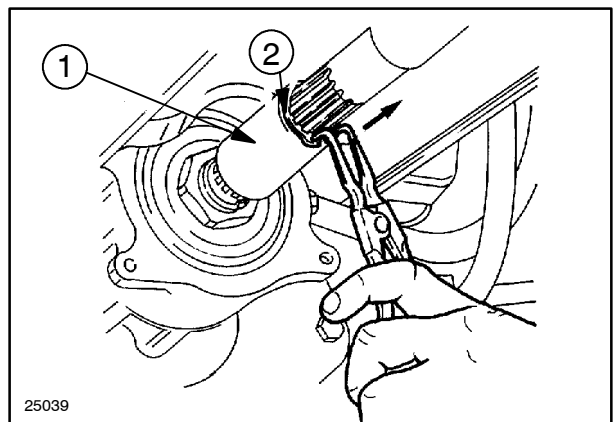

53

47. Remove the snap ring (2) and withdraw the sleeve (1) from the 4WD transfer box, moving it in the direction of the arrow.

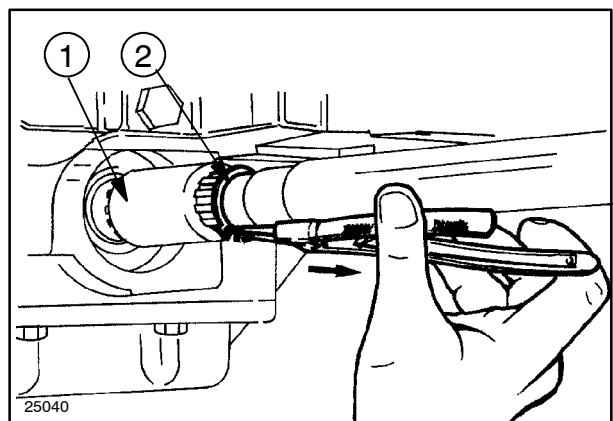

54

48. Unscrew the drive shaft centre support bolts (1) and remove the shaft complete with support.

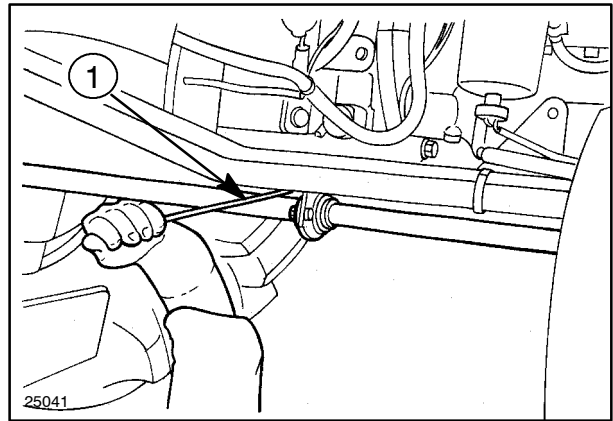

55

49. Disconnect the trailer brake pump inlet pipes (1) and (2) from the transmission-gearbox case. Remove the coupling from the trailer brake control valve supply pipe (3).

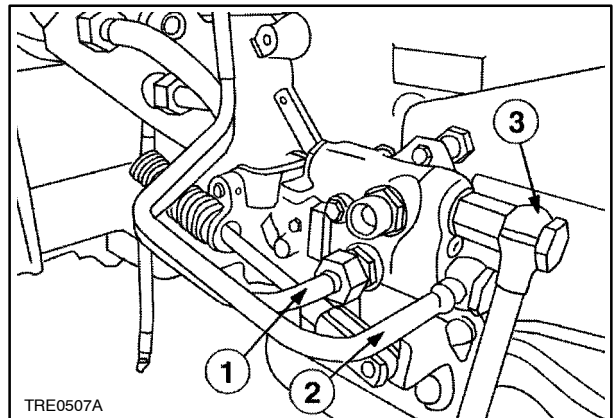

56

50. After removing the trailer brake control pipe, remove the retaining bolts (1) together with the complete trailer brake valve assembly.

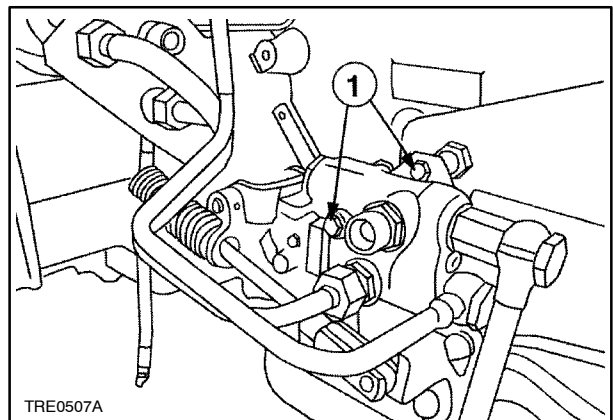

57

51. Disconnect the trailer brake control pipe (1) and the auxiliary valve pipes from the support plate (2).

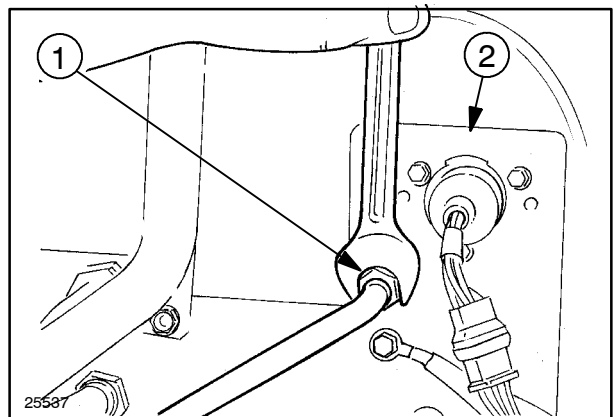

58

52. Remove the union (1) and drain the front brake fluid.

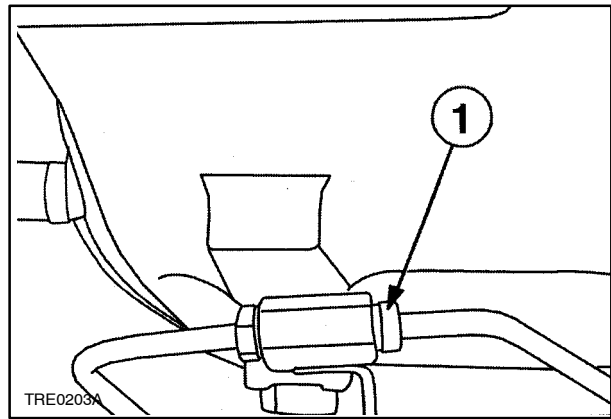

59

53. Remove the feed pipes (2) from the brake fluid reservoir (1).

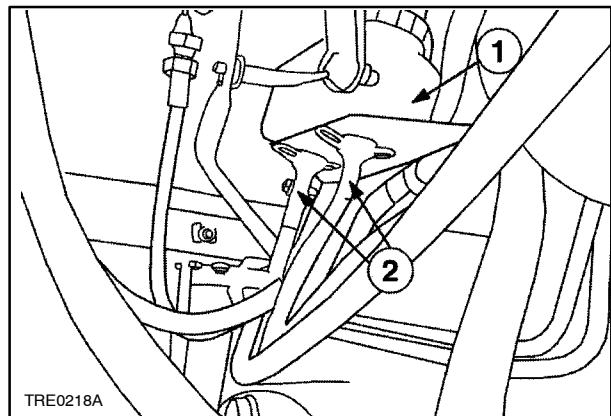

60

54. Connect a chain to one of the final drive assemblies and remove it from the transmission-gearbox case. Repeat on the other side.

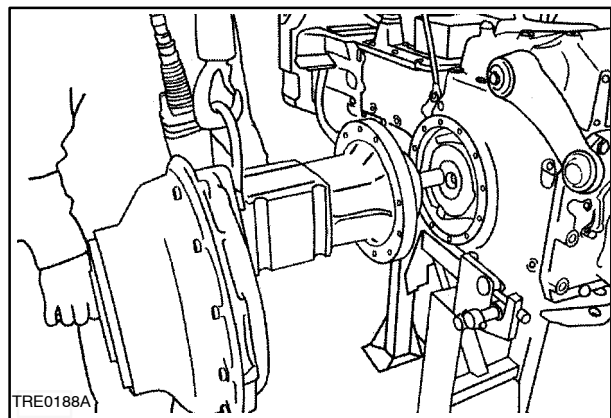

61

55. Remove the retaining bolts and lift the hydraulic housing using the hoist.

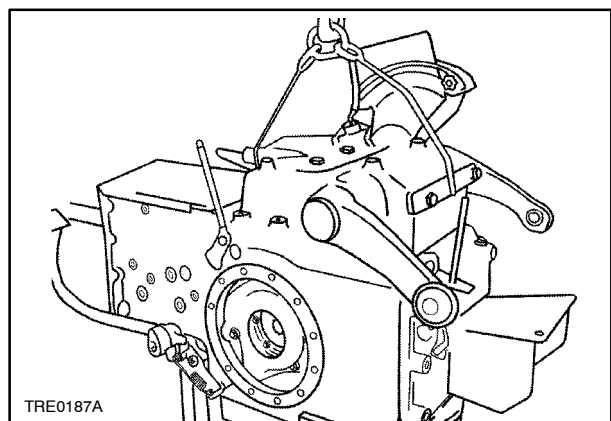

62

56. Use a chain to attach the tow hook and PTO to the hoist. Remove the three retaining bolts (1) from both sides and remove the unit from the rear transmission-gearbox case.

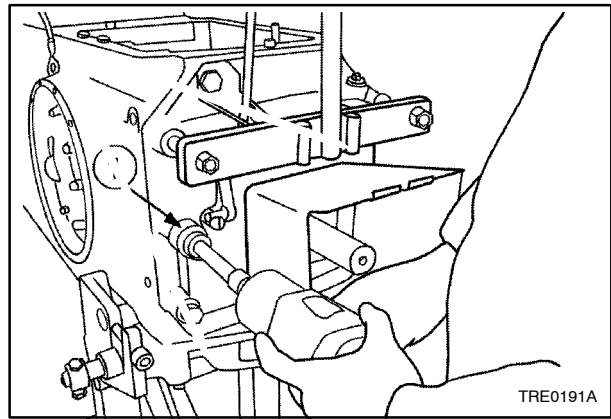

63

57. Unscrew the nut (1) and remove the bolt. Remove the left-hand lower link (3) and its spacer (2). Repeat on the right-hand lower link.

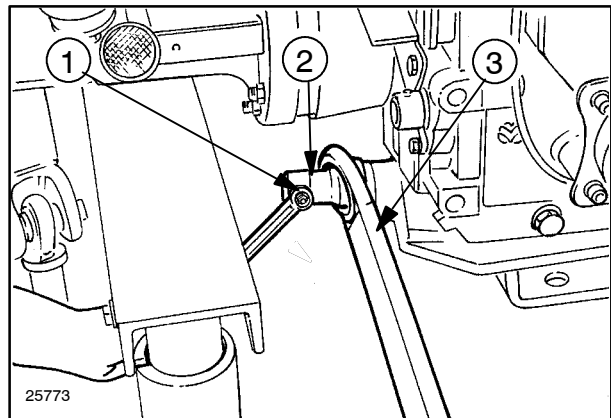

64

58. Attach a belt to both the ends of the torsion bar (1). Ensure that belt is strong enough to lift the assembly. Remove the retaining bolts (2) and take off the assembly.

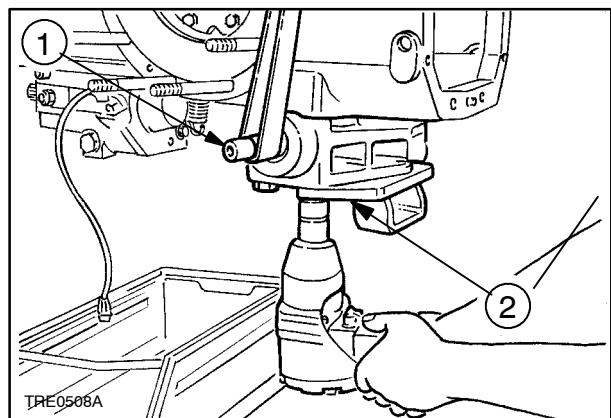

65

59. Remove the bolts securing the gearbox cover (1). Remove the cover.

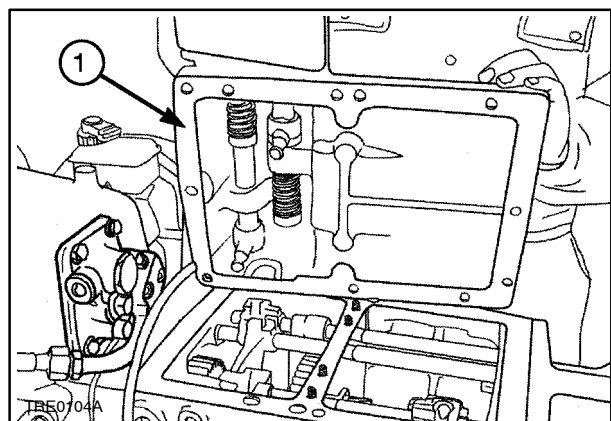

66

60. Unscrew the bolt (1) and remove the internal oil tank (2) from the rear transmission case.

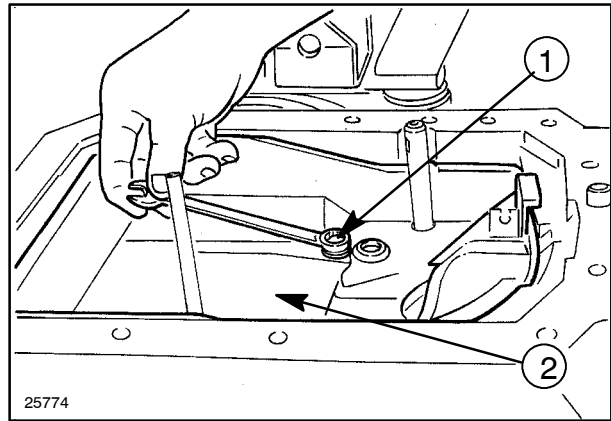

67

61. Connect the rear transmission-gearbox case to the hoist by chain. Remove the rear transmission-gearbox case using trolley stand **380000236**.

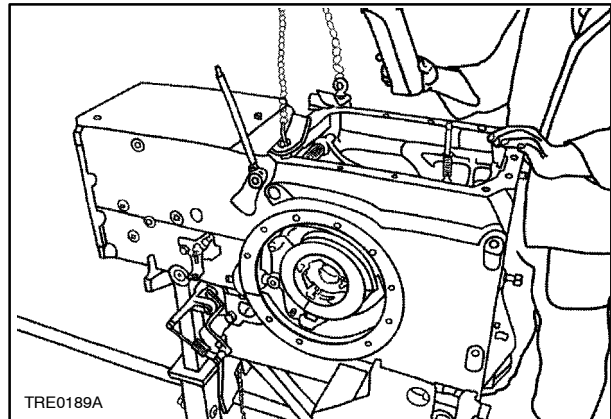

68

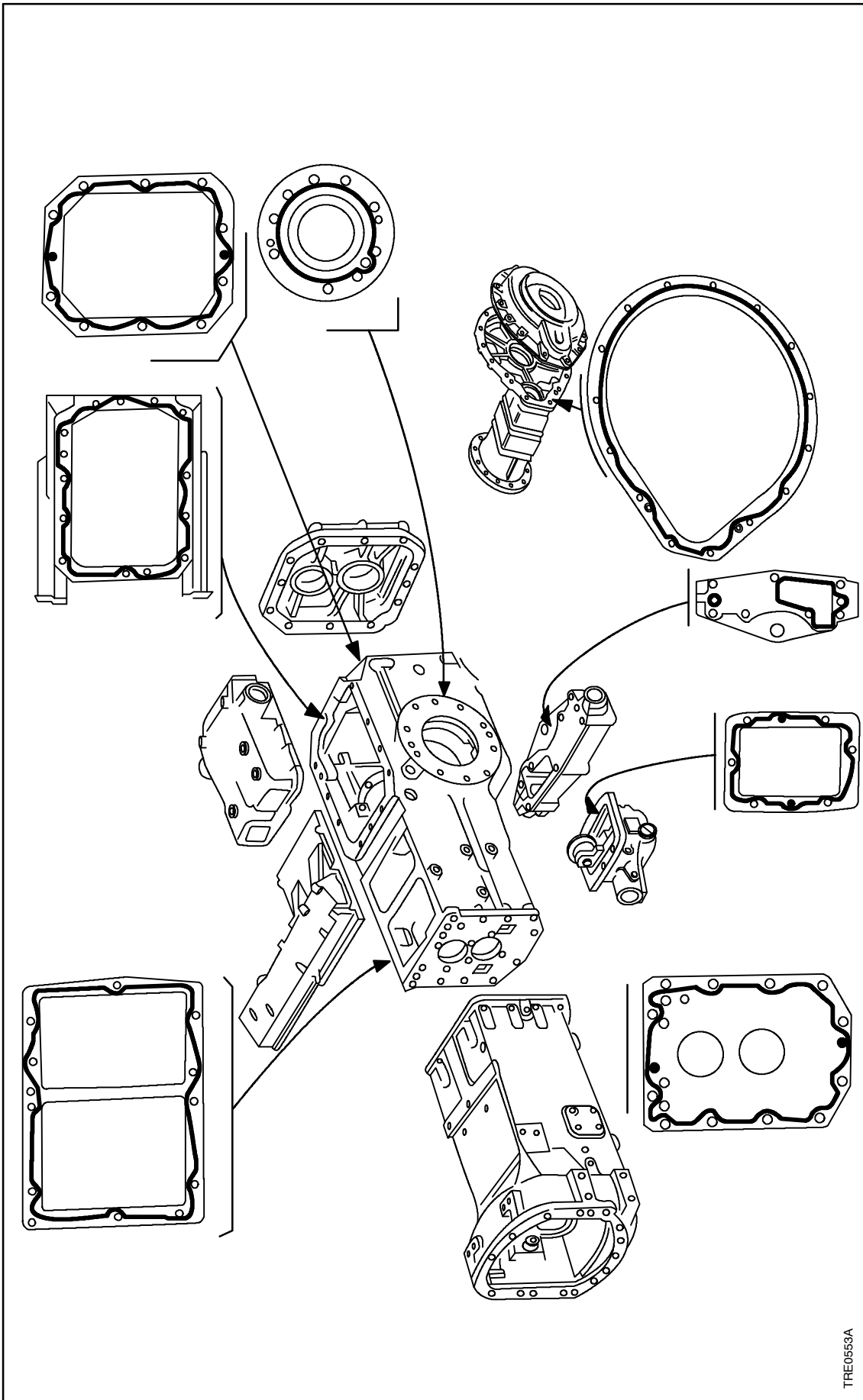

TRE0553A

Diagram for application of sealing compound to the rear transmission-gearbox casing
The types of sealing compound to be applied are listed on page 1 of Section 00.

62. Refit the rear transmission–gearbox case as follows:



WARNING



Use appropriate tools to align the holes. NEVER USE YOUR FINGERS OR HANDS.

- For the correct orientation of the various parts, refer to the illustrations on pages 11 to 26.
- Before refitting boxes, supports and covers, thoroughly clean and degrease the mating surfaces and apply a strip of sealing compound of about 2 mm (0.0787 in.) diameter as shown in the diagram on page 27.
- Apply the torque settings given on page 3.
- Using the stand **380000326**, refit the rear transmission–gearbox case onto the clutch box.
- Fit the torion bar support complete with internal connecting rod.
- Position the left and right brake friction discs. Fit the brake assembly, and the lateral final drive assembly.
- Refit the PTO cover to the transmission–gearbox case.
- Fit the internal tank complete with oil discharge pipe.
- Fit the lower links and spacers.
- Fit the tow hook assembly.
- Re–install the hydraulic lift complete.
- Insert the springs and poppet balls and fit the gearbox and final drive control rod support cover to the rear transmission–gearbox case.
- Fit and connect the lift control and oil filler pipes.
- Fit the three–point linkage support together with the quick–release fitting support plate and electrical power sockets with related connectors.
- Fit the trailer brake valve complete with hydraulic valves. Fit and connect the auxiliary hydraulic valve and trailer brake valve pipes.
- Fit and connect all the hydraulic pump inlet and outlet pipes and the connection pipes to the auxiliary hydraulic valves, hydraulic lift, 4WD transfer box, etc.
- Fit the rear wheels and remove stand **380000326**.
- Fit the 4WD drive shaft and secure it by means of the central support and, the front and rear sliding sleeves.
- Fix the guard onto the transfer box shaft.
- Screw in the rear transmission–gearbox case oil drain plugs and the fuel tank drain plug.
- Lower the cab onto the transmission casing and secure using the retaining bolts.
- Connect the Lift–o–matic™ control cable.
- Connect the differential lock control rod.
- Connect the parking brake control cable.
- Fit the gearbox and final drive control levers and connect the HI–LO control connection, if present.
- Fit the reverser control lever.
- Connect the PTO speed selection cable.
- Connect the synchronised PTO control lever.
- Connect the auxiliary hydraulic valve control levers.
- Fix the fuel tank together with fixing brackets, mountings and rear transmission–gearbox breather pipes.
- Connect the pipes and connections to the fuel tank.
- Refit and secure the compressor, the condenser and the filter/dryer.
- Connect and secure the heater control pipes.
- Connect the gearbox clutch control rod.
- Connect the front service brake feed and control pipes.
- Connect the throttle control cable.
- Make good all electrical socket connections between the cab and the tractor body.
- Connect up the front headlights.
- Screw in the engine cooling system drain plug.
- Fill up the fuel tank, the rear transmission–gearbox case and the cooling system. Recommended products and quantities are given on page 6 of Section 00.
- Connect the negative terminal to the battery.

TRANSMISSION-GEARBOX CASE**Removal-Refitting (Op. 21 118 85)****WARNING**

Handle all parts with great care.
Never place your hands or fingers between one part and another. Wear the prescribed safety clothing, including glasses, gloves and protective footwear.

1. Secure the transmission box-gearbox to the rotating stand **380000301** using the front **380000272** and rear **380000271** mountings.

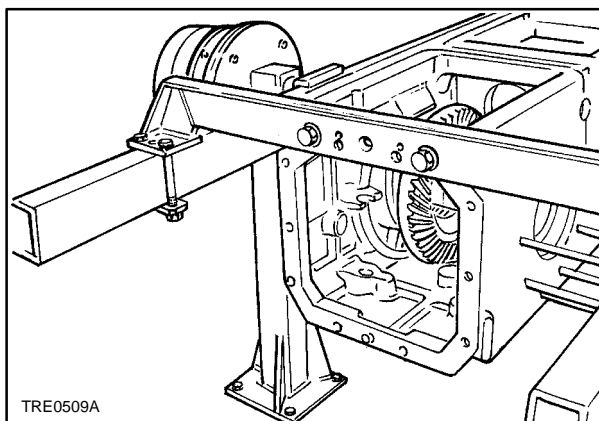

70

2. Turn the box by 180°, undo the bolts (1) and remove the transfer box (2).

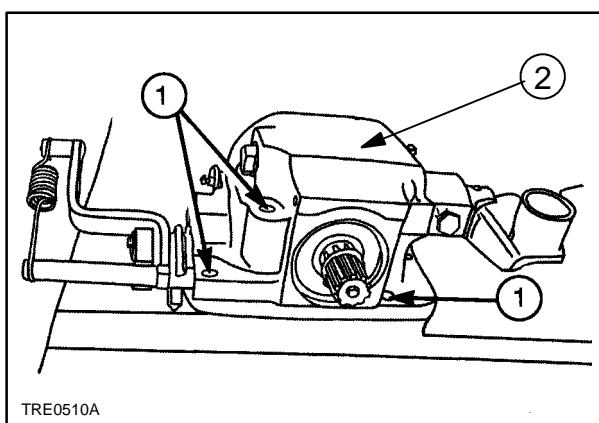

71

3. Turn the box back 180°, then use a punch to remove the roll pins (1) and take out the rods, the prongs, the gearbox and final drive control forks.

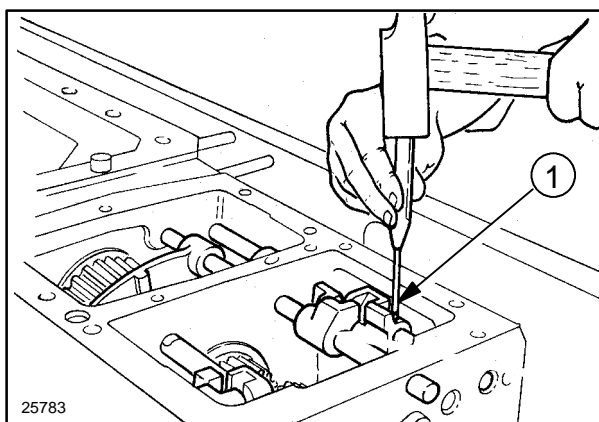

72

4. Use a punch to remove the roll pin (2) retaining the differential lock engagement fork (1). Withdraw the rod (4) and remove the helical spring (3) and the fork.

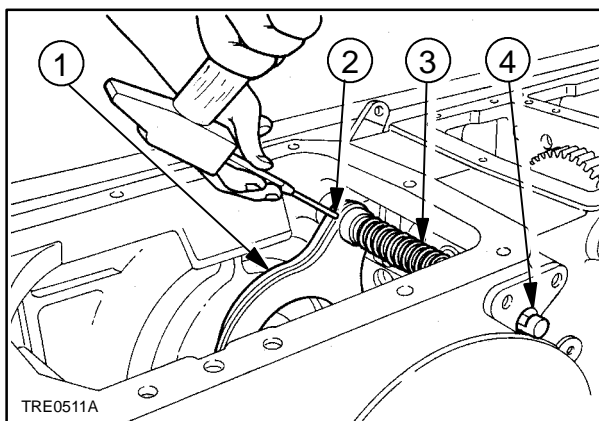

73

5. Unscrew the lock rings of the differential support bearing pre-load ring nuts (2) and slightly slacken the ring nuts.
6. Unscrew the differential support retaining bolts (1), retrieve the supports and then remove the entire differential bevel crown wheel assembly from the rear of the casing.

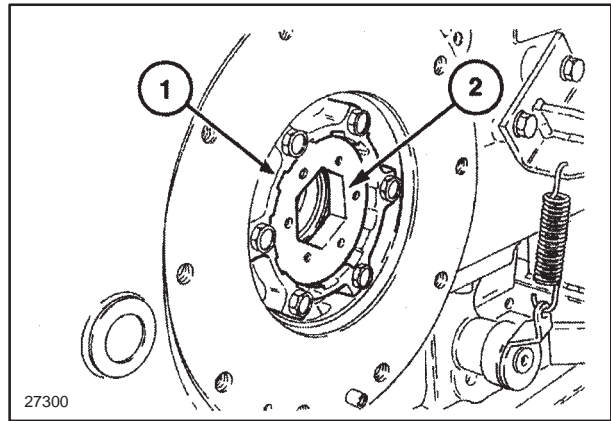

74

7. Remove the roll pin (2) and withdraw the external lever (1) that controls the PTO synchronised with the gearbox.

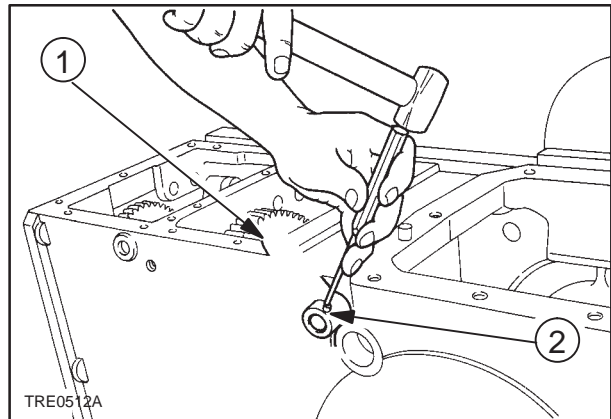

75

8. Extract the internal lever (2) complete with spring (1) and sliding block (3).

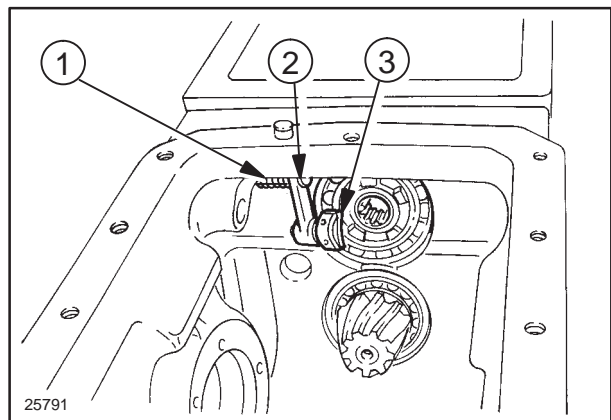

76

9. Straighten out the notches and undo the driven shaft locking nut (1).

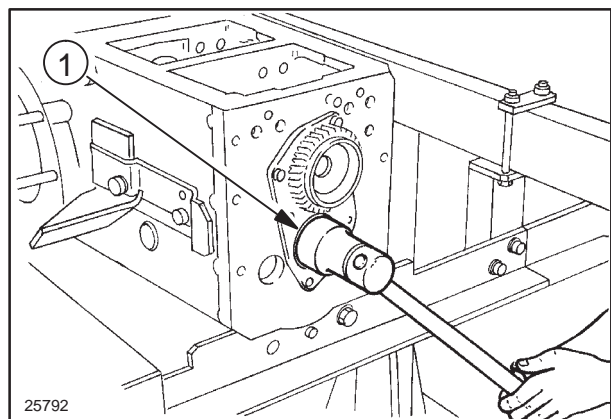

77

10. Remove from the rear the snap ring (1) that retains the final drive driving shaft bearing.

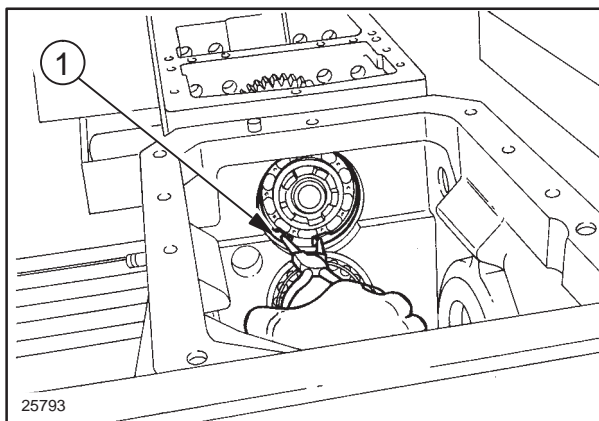

78

11. Using a hammer and a brass punch (1) withdraw the gear (2) for the mid-range speeds together with the related bearings and engagement sleeve (3).

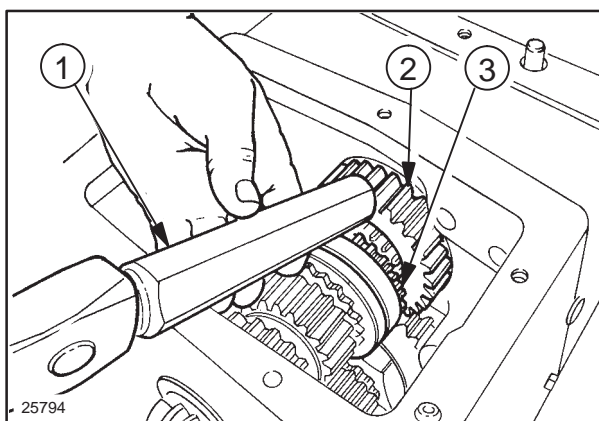

79

12. Extract the final drive driving shaft (1).

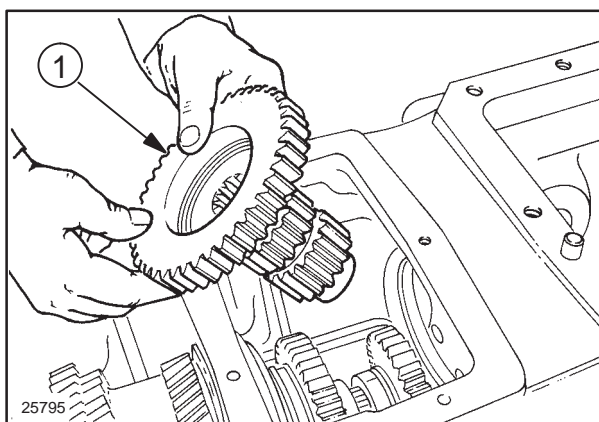

80

13. Remove the snap ring (1) that holds the bearing (2) onto the gearbox drive shaft.

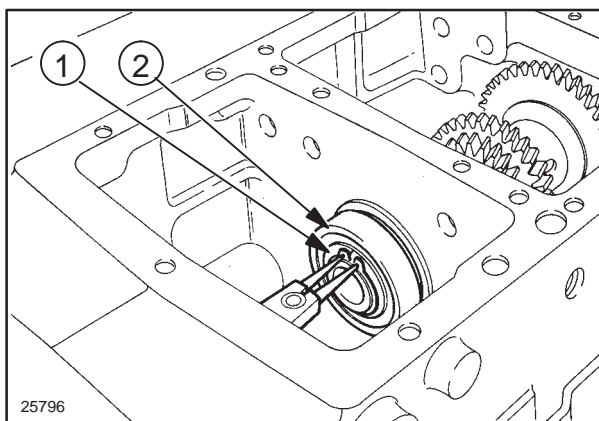

81

14. Fit the tool **50006** (2) (see page 4, Section 21, Chapter 1) onto the driving shaft and use the extractor (1) to withdraw the driving shaft. Remove the bearings, gears and respective bushings.

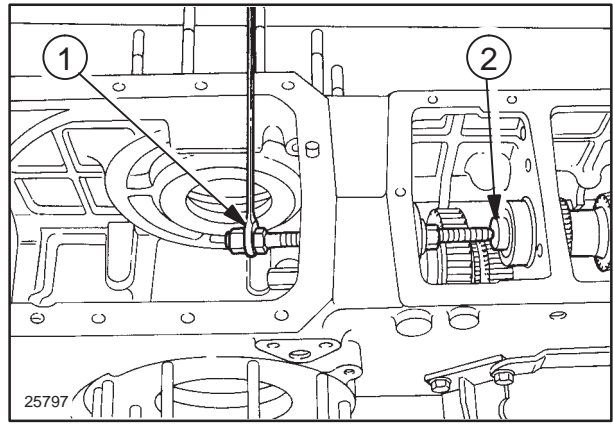

82

15. Straighten out the notches in the washer that retains the nut (1). Loosen the nut.

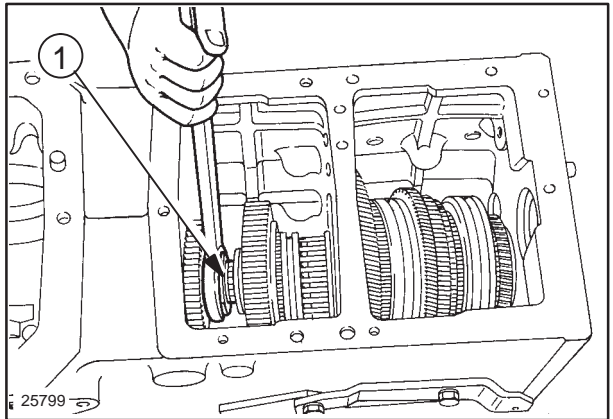

83

16. Screw the adapter **38000838** (2) onto the slide hammer **38000549** (1) to move the bevel pinion by a few millimetres in the direction shown by the arrow.

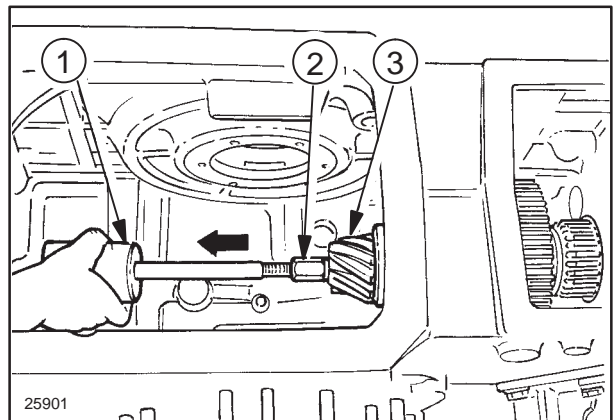

84

17. Move the engagement sleeve (1) until it is possible to gain access with pliers (2) to remove the retaining snap ring.

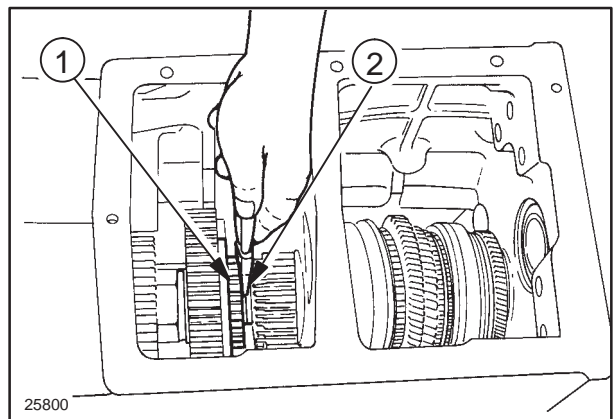

85

18. Move the gear (1) in the direction shown by the arrow and remove the two retaining half-rings (2). Undo the nut (3) completely and withdraw the bevel pinion, removing all parts.

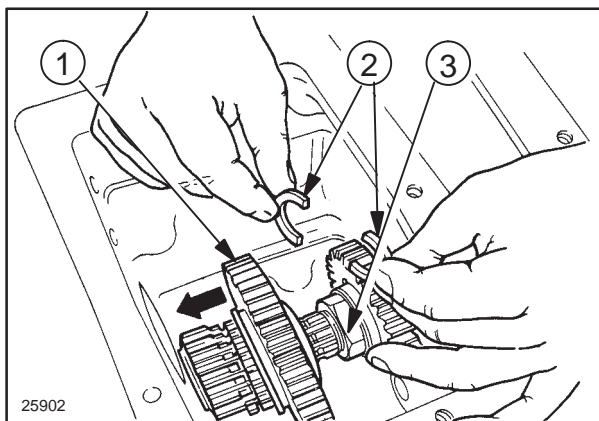

86

19. Undo the bolts (3), take out the support plate (1) and remove the bearing (2).

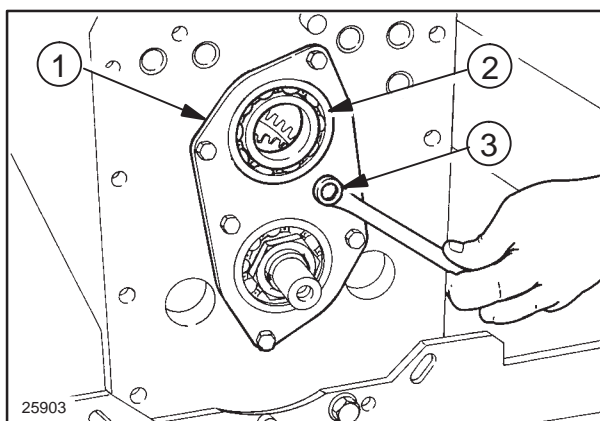

87

20. Use a brass punch (2) and a hammer to move the driven shaft (1), withdraw the shaft and remove all the parts.
21. Mount the rear transmission-gearbox case by following sectional views and instructions given.
22. Apply the torque settings listed on page 3.

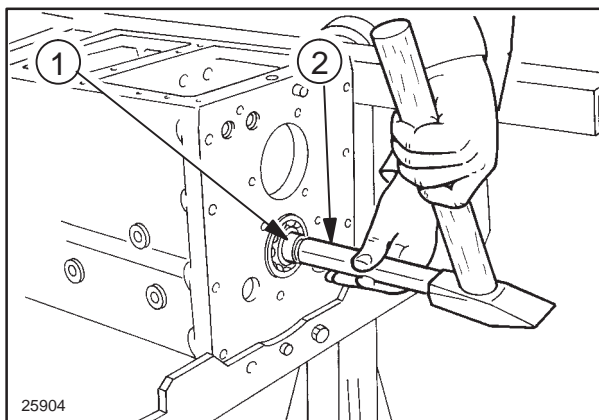

88

**WARNING**

Use appropriate tools to align the holes. NEVER USE YOUR FINGERS OR HANDS.

23. Position the box vertically, insert the gearbox driven shaft gear set (2) and insert the shaft (1).

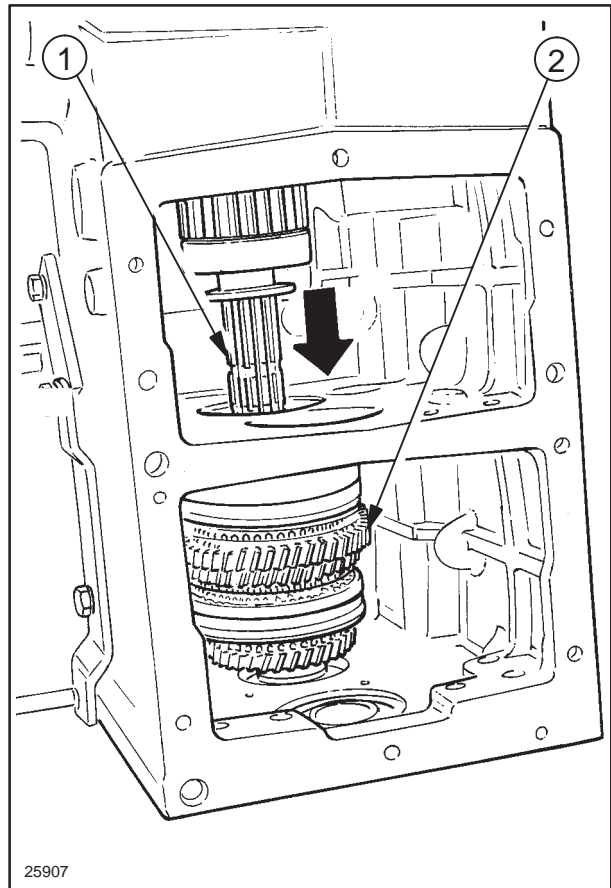

25907

89

24. Turn the box by 90°, fit the front bearing (1) and the nut (2) and tighten to the prescribed torque.

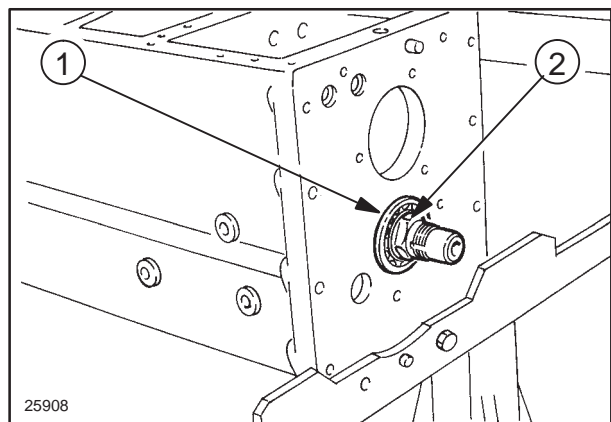

25908

90

25. Fit the bearing (2) in its housing on the box (front end) and lock it using the plate (1).

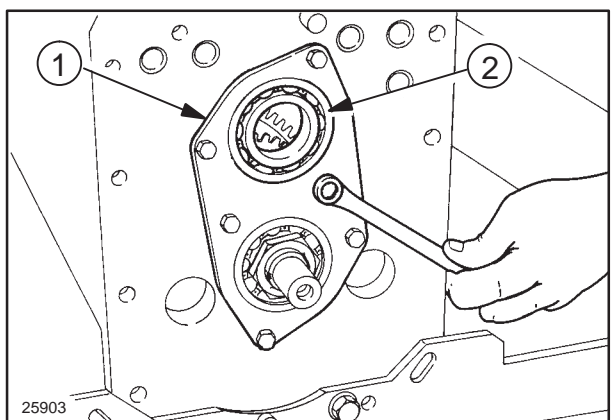

25903

91

26. Insert the gear shift forks (1) and (3) on the sliding rings (2) and (4) of the synchronisers.
27. Fit the bevel pinion complete with all the parts and carry out the adjustments given on pages 39 to 41.

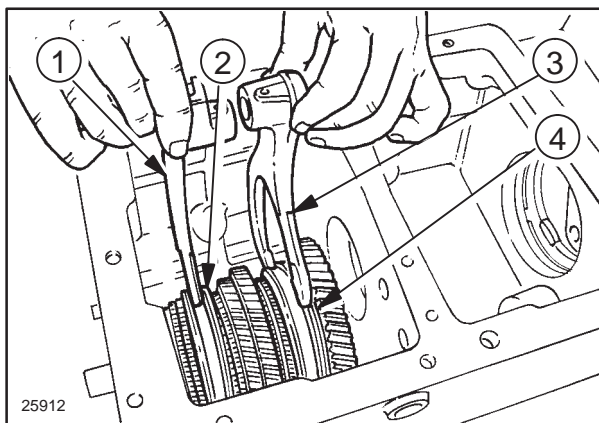

92

28. Fit the gearbox drive shaft complete with all parts and the adjuster shim (see page 37), then position the bearing (2) and secure it using the snap ring (1).

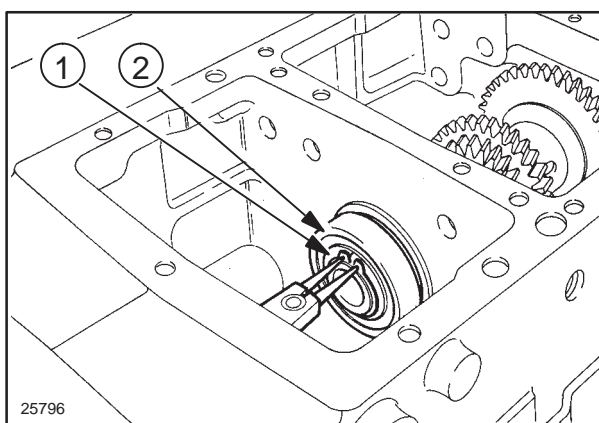

93

29. Insert the final drive driving shaft from the rear, fit the bearing (2) in its seat and secure it with the snap ring (1).

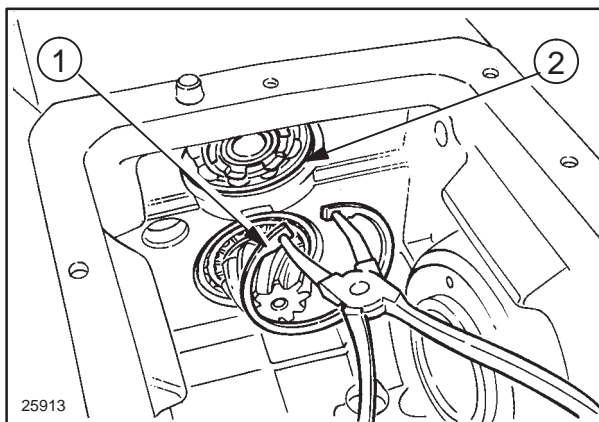

94

30. Fit the lever (1) that controls the PTO synchronised with the gearbox, complete with spring, pawl and external lever.
31. Fit the ring bevel gear complete with support and adjuster shims (see adjustments on pages 39 to 41).
32. Fit the differential lock engagement control fork complete with spring-rod unit, external plate and the corresponding adjuster shims (see page 38).
33. Fit the piston and the corresponding differential lock control union.
34. Fit all the rods, forks and gearbox and final drive control prongs.
35. Fit the transfer box assembly.

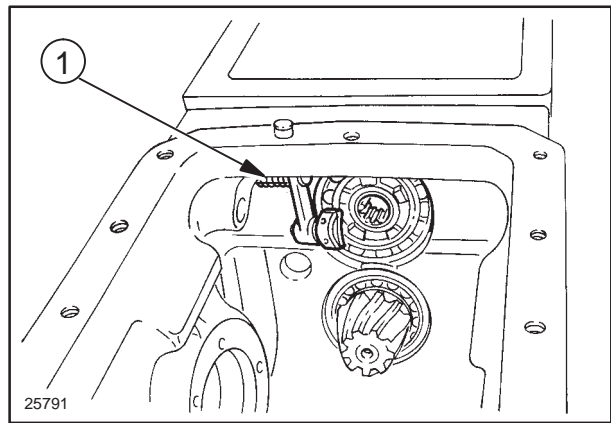

TRANSMISSION–GEARBOX CASE**Adjusting gearbox driving shaft axial clearance****WARNING**

Use appropriate tools to align the holes. NEVER USE YOUR FINGERS OR HANDS.

Proceed as follows :

NOTE: Once fitted, the driving shaft gears must have an axial clearance of 0–0.25 mm (0–0.0098 in.). The bearings must therefore be adjusted to prevent them from being mounted with an axial preload.

To perform this adjustment, it is recommended making a tool in the workshop according to the specifications given in the drawing on page 4, Section 21, Chapter 1.

1. On the bench mount all the various components on the driving shaft together with the snap ring (2), replacing the two rear bearings and the adjuster ring with the tool **50007** (1) (see page 4, Section 21, Chapter 1).

2. Insert a screwdriver between the gear and its bushing and use a feeler gauge to measure the clearance (H).

3. Measure the height (C) of the tool **50007** and the thickness of the inner rings of the two rear bearings (1 and 2).

4. The adjuster shims to be fitted is given by :

$$S = H + C - A - B$$

where:

H = measured clearance

A and **B** = **measured** thickness of the bearings

C = height of the tool.

Example :

– measured clearance **H** = 1.3 mm (0.0512 in.)

– height of tool = 43.5 mm (1.7126 in.)

– thickness of ball bearing (1) = 22.9 mm (0.9016 in.)

– thickness of roller bearing (2) = 18 mm (0.7087 in.)

Thickness of adjuster ring :

$$S = 1.3 + 43.5 - 22.9 - 18 = 3.9 \text{ mm}$$

$$(0.0512 + 1.7126 - 0.9016 - 0.7087 = 0.1535 \text{ in.})$$

NOTE: The gears should be mounted with an axial clearance of 0–0.25 mm. In this instance, it will be necessary to fit a shim (S) of 3.75 mm to provide an axial clearance of : 3.9–3.75 = 0.15 mm.

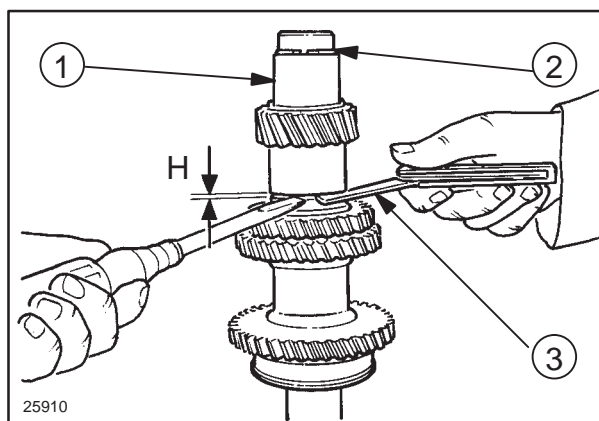

96

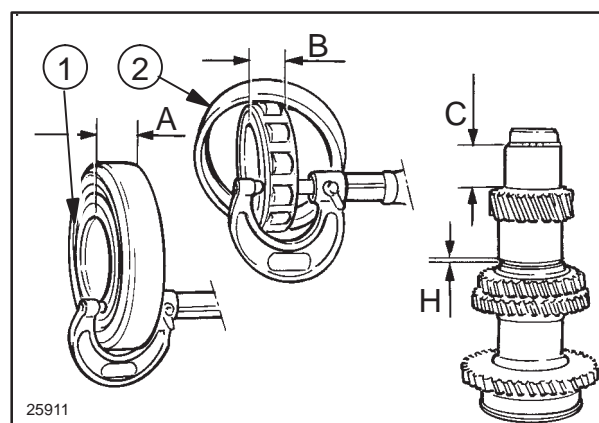

97

TRANSMISSION–GEARBOX**Adjusting the position of the differential lock engagement sleeve****WARNING**

Use appropriate tools to align the holes. NEVER USE YOUR FINGERS OR HANDS.

Proceed as follows:

1. Mount the differential release device without the adjuster shim (S).
2. Fit the differential bevel crown wheel assembly on its supports.
- G. Clearance between differential lock sleeve and the right-hand bevel crown wheel bearing support.

0.5 ± 1.25 mm (0.0197 ± 0.0492 in.) All models

- C₃. Lock pedal support retaining bolt.
 S. Differential lock sleeve travel adjuster shim.
 1. Differential lock pedal.
 2. Pedal support.
 3. Fork control rod.
 4. Fork.
 5. Return spring.
 6. Spring pin.
 7. Sliding Sleeve.
 8. Differential support right-hand bearing.

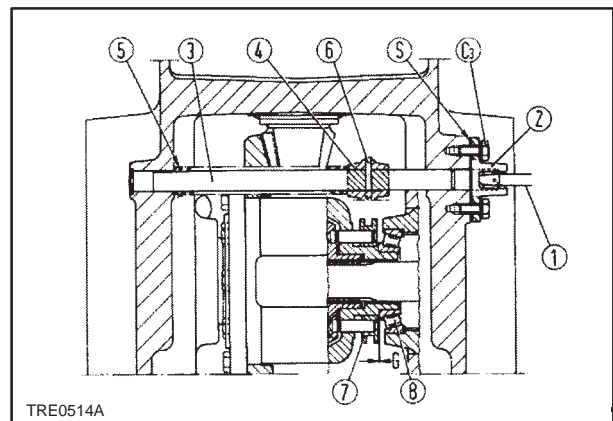

TRE0514A

98

3. Check there is a clearance (G) between the sliding sleeve (7) of the differential lock and the right-hand support bearing of the differential (8) of:

0.5 ± 1.25 mm (0.0197 ± 0.0492 in.)
 mod. TD60D and TD70D,
 TD80D, TD90D and TD95D

that can be measured with the feeler gauge (T).

4. Adjust this clearance by varying the shims (S) fitted between the support (2) and the transmission casing.

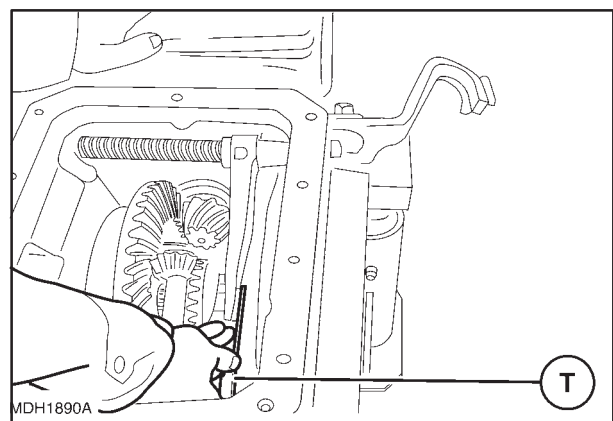

MDH1890A

T

99

ADJUSTING THE BEVEL GEAR PAIR

Determining the bevel pinion positioning adjustment ring

Proceed as follows:

1. On the transmission-gearbox case mount the outer ring of the bearing (1) fig. 100 with the test shim (2) and the outer bearing ring (3) fig. 101.

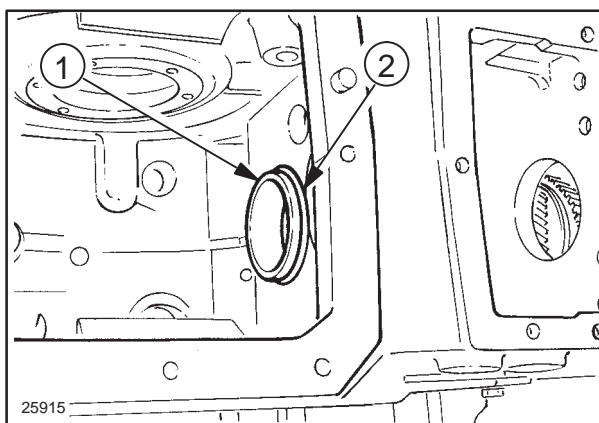

100

2. Position the bearing (2) on tool **50004** (1), insert the bearing (3) and lock the tool (1).

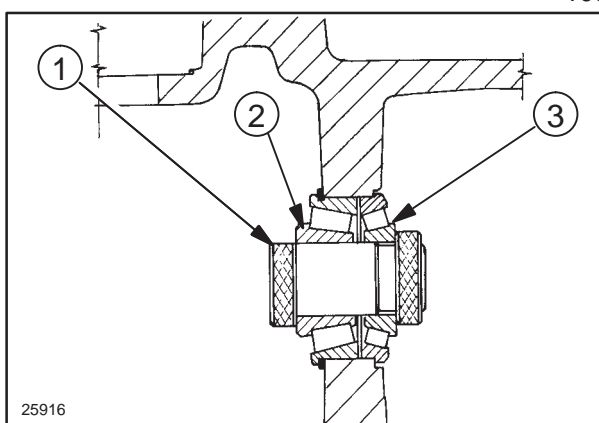

101

3. Position the tool **380000249** (2) with two conical parts in the ring gear supports and insert the micrometer (1) with depth rod into its seat and lock using the bolt.

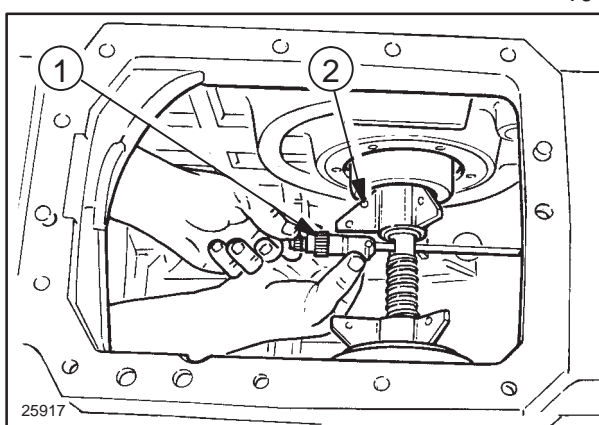

102

4. Screw down or unscrew the cones (1) and (2) so as to align the micrometer rod with the bearing. Adjust the cones (1) and (2) to lock the tool on the supports and eliminate any axial clearance.
5. Move the depth rod of the micrometer into contact with the bearing and measure the value (H_1).

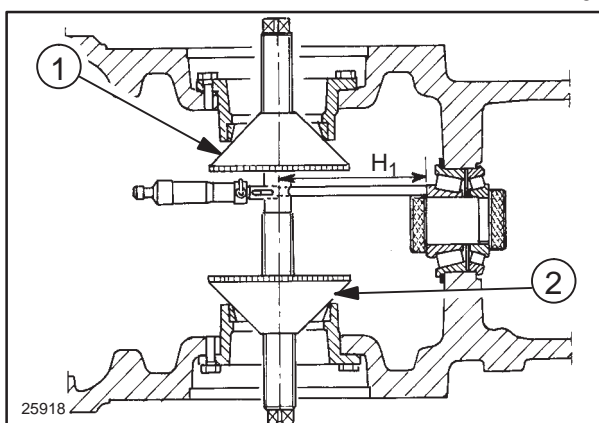

103

6. Calculate the corrected nominal distance (H_3) between the ring gear axis and the major base of the bevel pinion :

$$H_3 = H_2 + C$$

where :

$H_2 = 145.5 \text{ mm (5.7283 in.)}$. Nominal distance between the ring gear axis and major base of the bevel pinion.

C = Correction value stamped on the pinion, expressed in mm and preceded by a + or – sign (if other than 0) to be added to or subtracted from the nominal distance (H_2) respectively.

7. Thickness of the adjuster ring (S) is given by :

$$S = H_1 + Sp - H_3$$

where :

H_1 = Distance measured with the micrometer gauge.

H_3 = Corrected nominal distance between the ring gear axis and the major base of the bevel pinion.

Sp = Test ring.

Examples:

Distance measured with the micrometer gauge $H_1 = 145.9 \text{ mm (5.7441 in.)}$.

Thickness of test ring $Sp = 1.90 \text{ mm (0.0748 in.)}$.

Nominal distance between the ring gear axis and major base of the bevel pinion $H_2 = 145.5 \text{ mm (5.7283 in.)}$.

a) Correction value $C = + 0.2 \text{ mm (0.0079 in.)}$.
Corrected nominal distance $H_3 = 145.5 + 0.2 = 145.7 \text{ mm (5.7283 + 0.0079 = 5.7362 in.)}$.

Thickness of adjuster ring :

$S = 145.9 + 1.90 - 145.7 = 2.10 \text{ mm (5.7441 + 0.0748 = 5.7362 in.)}$.

b) Correction value $C = - 0.2 \text{ mm (0.0079 in.)}$.
Corrected nominal distance $H_3 = 145.5 - 0.2 = 145.3 \text{ mm (5.7283 - 0.0079 = 5.7204 in.)}$.

Thickness of adjuster ring :

$S = 145.9 + 1.90 - 145.3 = 2.50 \text{ mm (5.7441 + 0.0748 - 5.7204 = 0.0985 in.)}$.

c) Correction value $C = 0 \text{ mm}$.

Corrected nominal distance $H_3 = H_2 = 145.5 \text{ mm (5.7283 in.)}$.

Thickness of adjuster ring:

$S = 145.9 + 1.90 - 145.5 = 2.30 \text{ mm (5.7441 + 0.0748 - 5.7283 = 0.0906 in.)}$.

8. Remove the tools **380000249** and **50004**; take out the bearing external rings, the test shim and two differential supports.

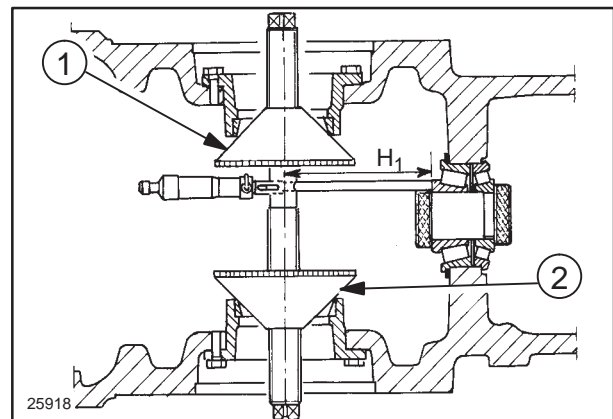

ADJUSTING THE BEVEL GEAR PAIR**Adjusting the taper-roller bearings for pinion shaft**

1. Mount the external track of the bearing together with the previously calculated adjuster shim (S) and the bevel pinion complete with its parts.
2. Tighten the bearing adjustment nut (1) while turning the pinion shaft to allow the bearings to bed in until rolling torque of 0.73–1.47 Nm (1.1063–1.4751 ft lb) is obtained.

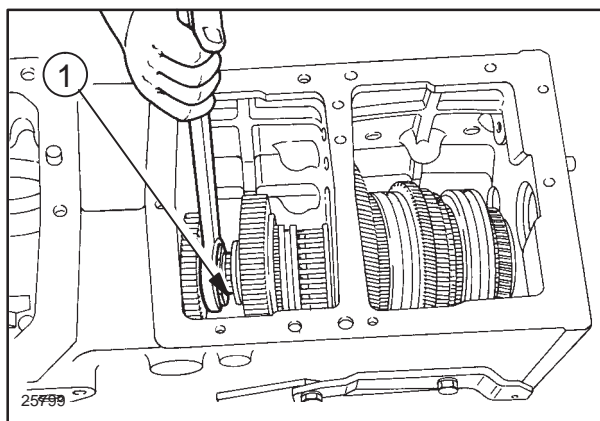

105

3. Mesh the range selecting sleeve with the slow range gear. Then measure the rolling torque with a torque meter and a cord wound around the slow range gear of the pinion; the prescribed torque corresponds to a force measured with the torque meter (1) of 8.63 – 17.2 N (1.9409 – 3.8598 lb)

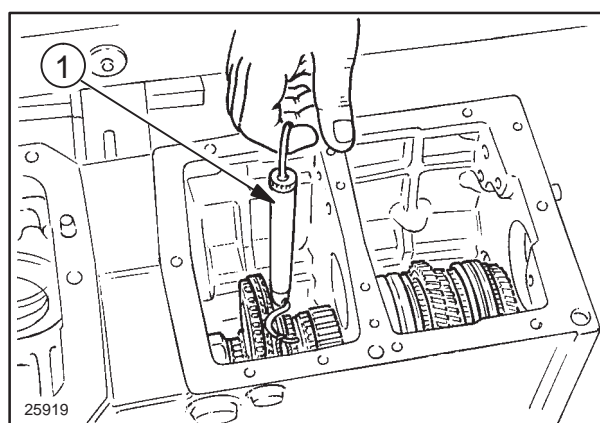

106

4. After obtaining the recommended torque, bend the securing thrust washer (1) onto the adjuster nut to prevent it unscrewing and decreasing the bearing pre-load.

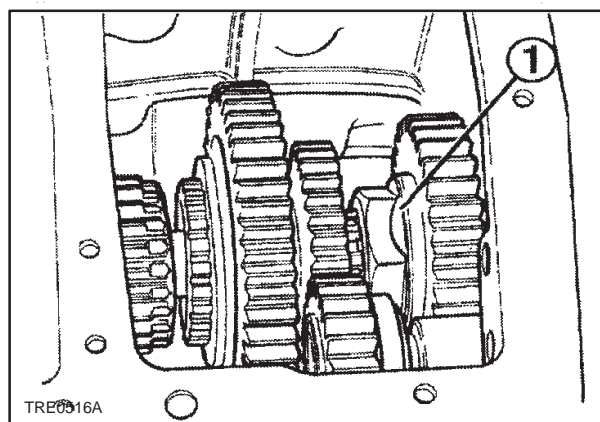

107

BEVEL DRIVE ADJUSTMENTS

Adjusting the ring bevel gear bearings and checking the clearance between the teeth of the bevel gear pair.

⚠ **WARNING** ⚠

Handle all parts with great care.
Never place your hands or fingers between one part and another. Wear the prescribed safety clothing, including glasses, gloves and protective footwear.

⚠ **WARNING** ⚠

Always use appropriate tools to align the holes.
NEVER USE YOUR FINGERS OR HANDS.

Proceed as follows :

1. With the bevel pinion fitted, insert the differential assembly complete with the bevel crown wheel. Secure the right- and left-hand supports on the gearbox transmission casing and bring the relevant ring nuts into contact with the races of the bearings.
2. Using wrench **50027** (see page 6) slightly screw the right-hand ring nut (2) onto the support (1), and then do the same for the left-hand ring nut. So as to obtain a slight pre-load on the bearings.
3. Using a 1/100 dial gauge (1) measure the radial clearance on the sides of the bevel drive teeth (three measurements at 120° and arithmetic mean of the three readings, the difference between the three measurements must not exceed 0.05 mm) and compare the result with the nominal clearance: 0.18 ÷ 0.23 mm (0.0071 ÷ 0.0090 in.).
We will initially be looking for a clearance of 0.18 mm (0.0071 in.).

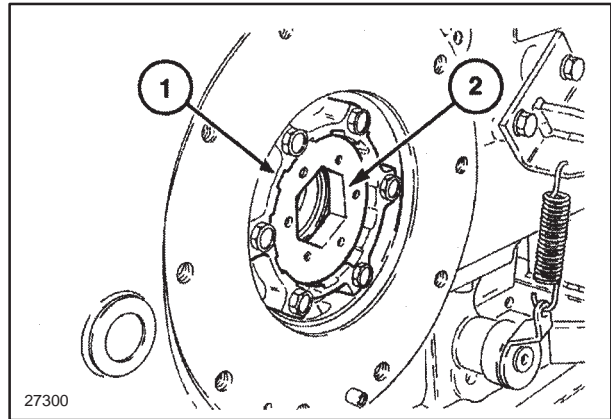

108

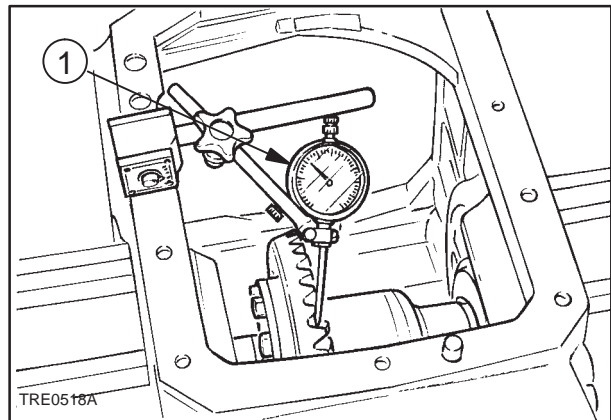

109

4. Setting high – low backlash depends on the ratio between the decrease – increase in clearance and the movement of the differential casing.
As a result, the end displacement (Z) of the differential unit is:

$$Z = (G - 0.18) \times 1.4$$

where:

1.4 = Ratio between decrease–increase in backlash and movement of the differential casing.

G = bevel drive backlash, as previously measured.

After calculating **Z**, proceed as follows:

if **Z < 0** move the crown wheel away from the pinion.

if **Z > 0** move the crown wheel nearer to the bevel pinion.

5. One complete turn of the ring nut corresponds to a 2 mm axial movement of the crown wheel. A 60° turn of the ring nut, equivalent to one side of the ring nut hexagon, corresponds to an axial movement of the ring nut of:

$$Z = (60 : 360) \times 2 = 0.33 \text{ mm (0.0130 in.)}$$

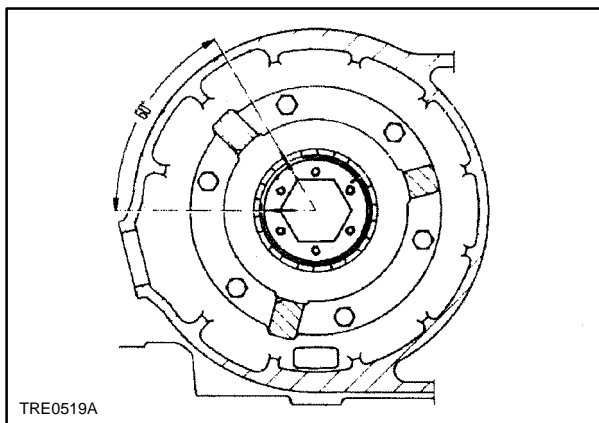

110

6. Making the differential turn, unscrew the right-hand ring nut with tool **50027** (2) and tighten the left-hand ring nut (1) by the same amount if $Z > 0$, otherwise unscrew the left-hand ring nut (1) and tighten the right-hand ring nut by the same amount if $Z < 0$ in order to obtain a backlash initially of 0.18 mm.

$$Z = (60 : 360) \times 2 = 0.33 \text{ mm (0.0130 in.)}$$

7. On obtaining a clearance of 0.18 mm, tighten the right-hand ring nut to obtain a rolling torque of:

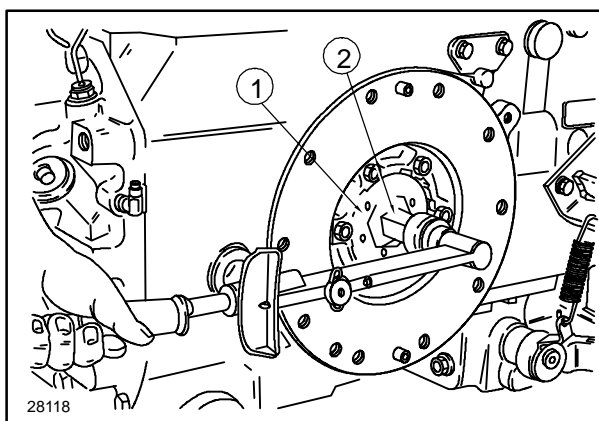

111

Pinion rolling torque		Pinion rolling torque on crown wheel (with bearings not pre-loaded)		Total rolling torque of pinion measured on crown wheel (with bearings not pre-loaded)	
ft lb	Nm	ft lb	Nm	ft lb	Nm
0.5421 to 1.0849	0.735 to 1.471	2.8934 to 5.0634	3.923 to 6.865	torque measured on pinion + (0.7235 to 1.4463)	torque measured on pinion + (0.981 to 1.961)

8. Making sure you do not drive the shafts of the gearbox, it is possible to check the rolling torque with a torque meter (1) and a cord wound around the outer diameter of the differential casing, keeping to the values stated in the table:

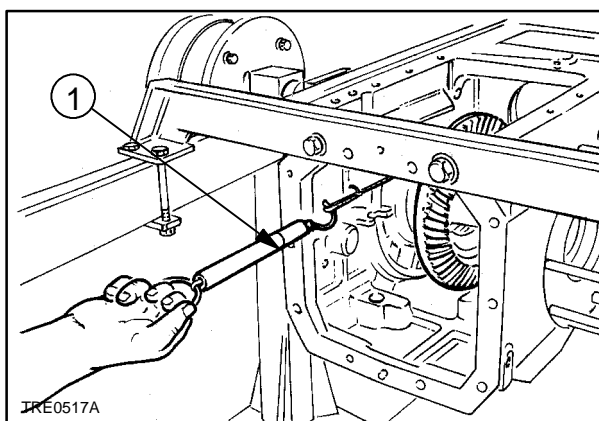

112

Differential casing \varnothing 187 mm (7.3622 in.)					
Pinion rolling torque		Force of the pinion at the torque meter measured on the crown wheel (with bearings not pre-loaded)		Force of the pinion at the torque meter measured on the crown wheel (with bearings pre-loaded)	
ft lb	Nm	lb	N	lb	N
0.5421 to 1.0849	0.735 to 1.471	9.4401 to 16.5201	41.97 to 73.45	Force on pinion + (2.36 to 4.72)	Force on pinion + (10.49 to 20.99)
Differential casing \varnothing 206 mm (8.1102 in.)					
Pinion rolling torque		Force of the pinion at the torque meter measured on the crown wheel (with bearings not pre-loaded)		Force of the pinion at the torque meter measured on the crown wheel (with bearings pre-loaded)	
ft lb	Nm	lb	N	lb	N
0.5421 to 1.0849	0.735 to 1.471	8.5578 to 14.9982	38.05 to 66.68	Force on pinion + (2.1394 to 4.2789)	Force on pinion + (9.51 to 19.02)

- Using a 1/100 dial gauge (1), check the clearance between the teeth of the bevel drive; if this backlash remains between 0.18 ÷ 0,23 mm (0.0071 ÷ 0.0090 in.) (0.21 mm (0.0083 in.) on average) fine, otherwise:

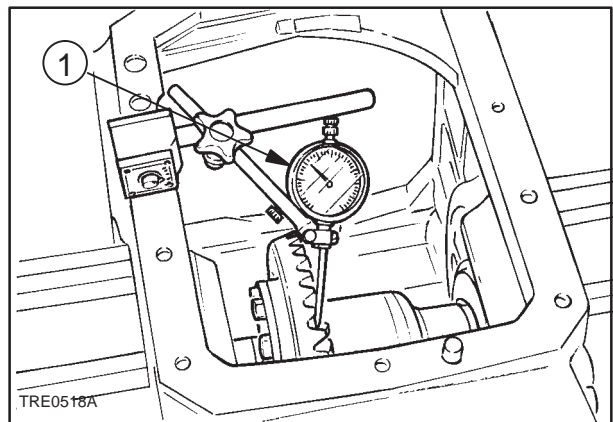

- if the backlash is any greater, use the wrench **50027** (1) to unscrew the right-hand ring nut and tighten the left-hand one by an equal amount.
- if the backlash is any lower, unscrew the left-hand ring nut and tighten the right-hand one by an equal amount.

NOTE: It is important to unscrew one ring nut and alternately tighten the opposite one by an equal amount so as not to change the bearing pre-load that has already been calculated.

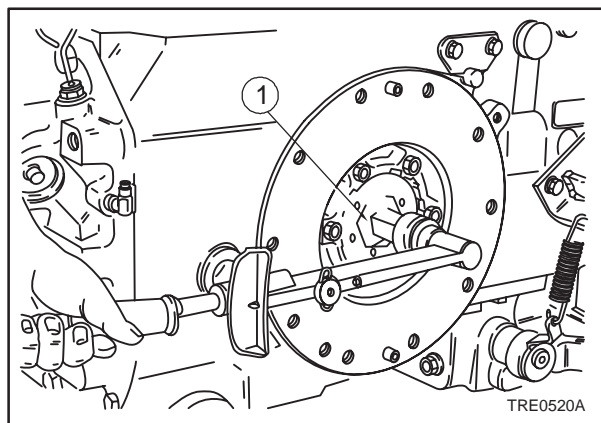

114

10. Lock the right and left-hand ring nuts in position with the lock ring (1).

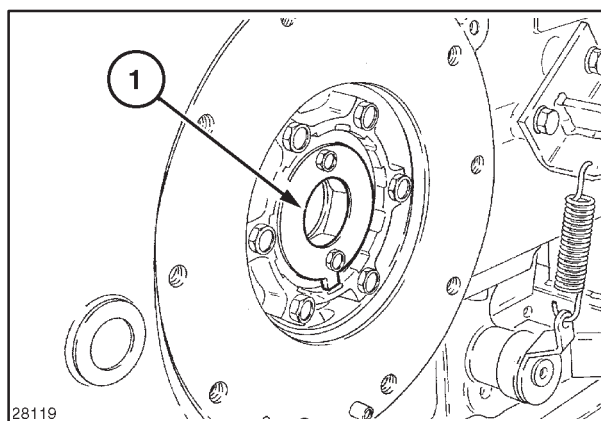

115

ADJUSTING THE BEVEL GEAR PAIR

Differential pinion and side gear backlash adjustment

With the dismantled differential on the bench, proceed as follows :

IMPORTANT

All parts of the differential must be cleaned so that oil residue does not effect the accuracy of the adjustment.

1. Mount the side gears (2) and (5) without rings (1) and (6) on the differential box. Insert the differential pinions (3) and (8) complete, with their related clearance rings and with the pin (7). Tighten the retaining bolt (4) by a few turns in order to prevent the pin from moving.

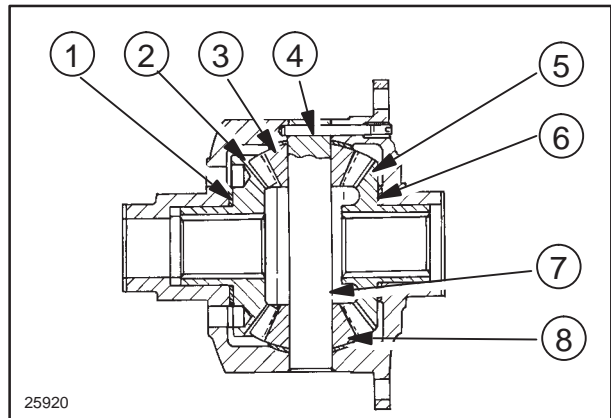

116

2. Manipulate the RH side gear so that it comes into contact with the side pinion and, using a depth micrometer, measure the distance (H_1), making two diametrically opposed measurements and taking the arithmetic mean of the two values measured.

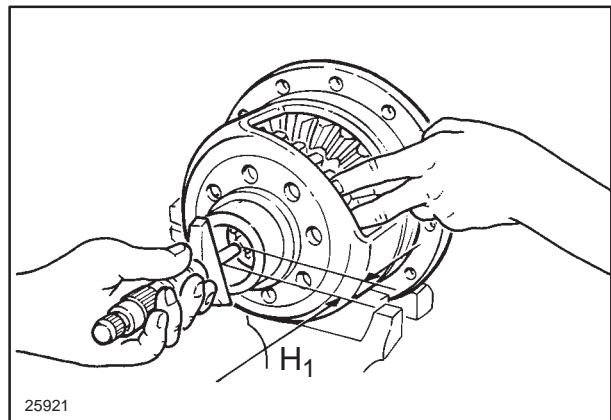

117

3. Push the side gear so that it touches the differential casing and measure the distance (H_2).
4. Repeat the same operations for the left-hand side gear.

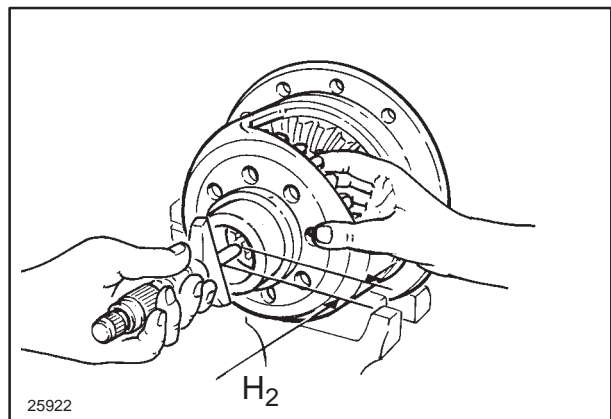

118

5. Axial movement of each side gear (2) and (5) without shims is given as :

$$\mathbf{G_s \text{ or } G_d = H_1 - H_2}$$

where :

G_s = axial movement of LH side gear;

G_d = axial movement of RH side gear;

H₁ and **H₂** = distances measured on LH or RH side gear (steps 2 and 3).

The normal clearance envisaged between the sides of the pinion and side gear teeth is 0.15 mm (0.0059 in.) for TD60D and TD70D models. It is 0.18 mm (0.0071 in.) for TD80D, TD90D and TD95D models.

Bear in mind that the average ratio between the normal clearance of differential pinion–side gear and the equivalent axial movement of the side gears is 1–1.7.

The axial movement of the side gears corresponding to the normal prescribed clearance between the teeth is :

0.15 x 1.7 = **0.25 mm (0.0098 in.)** for TD60D and TD70D models;

0.18 x 1.7 = **0.30 mm (0.0118 in.)** for TD80D, TD90D and TD95D models.

Thickness of the spacer rings (1) and (6) to be inserted on the differential box are :

S_s = G_s – 0.25 mm (0.0098 in.)
(for LH side gear of TD60D and TD70D models)

S_d = G_d – 0.25 mm (0.0098 in.)
(for RH side gear of TD60D and TD70D models)

S_s = G_s – 0.30 mm (0.0118 in.)
(for LH side gear of TD80D, TD90D and TD95D models)

S_d = G_d – 0.30 mm (0.0118 in.)
(for RH side gear of TD80D, TD90D and TD95D models)

Available shims are 1.5 and 1.6 mm to use for the side gear as shown on page 2. Fit shims of the closest thickness for the LH and RH side gears according to calculations).

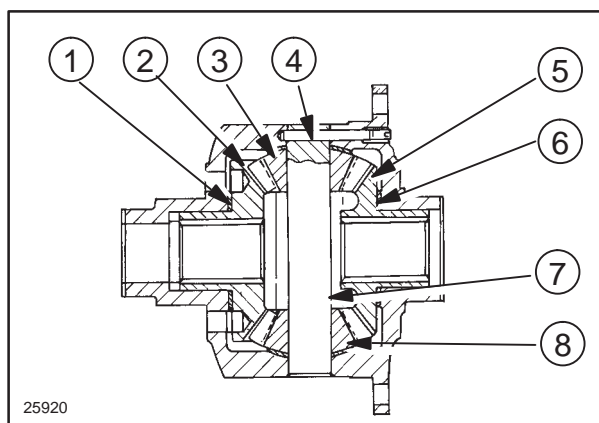

119

SECTION 31 - POWER TAKE-OFF

Chapter 1 - Mechanical Power take-off

CONTENTS

Section	Description	Page
31 000	Main specifications	1
	Tools	3
	Tightening torques	4
	Cross-sectional views	5
	Description and Operation	9
	Troubleshooting	10
31.112.20	540/750 Power take-off - Removal - Installation	11
31.112.45-48	540/750 Power take-off - Overhaul on bench	14
31.114	540/750 Power take-off - Overhaul on bench	17

**31 000 - MAIN SPECIFICATION - TORQUE SETTINGS - TOOLS - SECTIONAL DRAWINGS -
DESCRIPTION AND OPERATION - TROUBLESHOOTING**

MECHANICAL POWER TAKE-OFF

		TD60D and TD70D	TD80D, TD90D and TD95D	
540 rev/min PTO		{ 1) Independent of tractor travel speed or: 2) Synchronized with gearbox mechanical by means of hand levers located on RH and LH side of driver's seat (see page 9 and 10) clockwise		
Type (Independent and ground speed PTO)				
Engagement and control				
Direction of rotation (viewed from rear of tractor)				
Engine speed with PTO shaft rotating at 540 rev/min	rev/min	2200		
PTO speed with engine at maximum power (2500 rev/min)	rev/min	614		
Ground speed PTO. Rear wheel speed with PTO shaft rotating at 540 rev/min (30 km/h version)	wheel speed rev/min	8.2	8.9	
Ground speed PTO. Rear wheel speed with PTO shaft rotating at 540 rev/min (4WD 40 km/h version)	wheel speed rev/min	6.73	7.25	
Diameter of PTO shaft at position of bearings	mm (in.)	49.938 - 50.000 (1.9661 - 1.9685)		
Diameter of PTO shaft at splined end		1 ³ / ₈ in. (6-spline)		

(continued overleaf)

MECHANICAL POWER TAKE-OFF

(continued)

	TD60D and TD70D	TD80D, TD90D and TD95D
2-speed 540/750 rev/min PTO (option - all models)		
Type	as for single-speed PTO	
Engagement and control	as for single-speed PTO	
Direction of rotation (viewed from rear of tractor)	as for single-speed PTO	
Speed selection	by means of hand lever located to rear RH side of driver's seat	
Engine speed with PTO shaft rotating at 540 rev/min rev/min	2200	
Engine speed with PTO shaft rotating at 750 rev/min rev/min	2382	
PTO speed with engine at maximum power speed (2500 rev/min):		
- for 540 rev/min PTO rev/min	614	
- for 750 rev/min PTO rev/min	787	
Ground speed PTO. Rear wheel speed with PTO shaft rotating at 540 rev/min (30 and 40 km/h versions) wheel speed rev/min	see 540 rev/min PTO	
Ground speed PTO. Rear wheel speed with PTO shaft rotating at 750 rev/min (30 km/h version) wheel speed rev/min	10.51	11.4
Ground speed PTO. Rear wheel speed with PTO shaft rotating at 750 rev/min (40 km/h 4WD version) wheel speed rev/min	8.59	9.36
Diameter of driven shaft at grooved terminal	1 ³ / ₈ in. (6-spline)	
2-speed 540/1000 rev/min PTO (option - all models)		
Type	as for single-speed PTO	
Engagement and control	as for single-speed PTO	
Direction of rotation (viewed from rear of tractor)	as for single-speed PTO	
Speed selection	by means of hand lever located on rear RH side of driver's seat	
Engine speed with PTO shaft rotating at 540 rev/min rev/min	2200	
Engine speed with PTO shaft rotating at 1000 rev/min rev/min	2380	
PTO speed with engine at maximum power (2500 rev/min):		
- for 540 rev/min PTO rev/min	614	
- for 1000 rev/min PTO rev/min	1050	

(continued overleaf)

MECHANICAL POWER TAKE-OFF

(continued)

		TD60D and TD70D	TD80D, TD90D and TD95D
Ground speed PTO. Rear wheel speed with PTO shaft rotating at 540/750 rev/min (30 and 40 km/h versions)	wheel speed rev/min	as for single-speed PTO	
Ground speed PTO. Rear wheel speed with PTO shaft rotating at 1000 rev/min (30 km/h version)	wheel speed rev/min	14.1	15.2
Ground speed PTO. Rear wheel speed with PTO shaft rotating at 1000 rev/min (40 km/h 4WD version)	wheel speed rev/min	11.5	12.4
Diameter of PTO shaft at splined end:			
- 540 rev/min		1 ³ / ₈ in. (6-spline)	
- 750 rev/min		1 ³ / ₈ in. (6-spline)	
- 1000 rev/min		1 ³ / ₈ in. (21-spline)	
External diameter of driven gear support bushings	mm (in.)	49.925 - 49.950 (1.9655 - 1.9665)	
Internal diameter of driven gears	mm (in.)	50.050 - 50.089 (1.9705 - 1.9720)	
Clearance between driven gears	mm (in.)	0.100 - 0.164 (0.0039 - 0.0065)	
Diameter of driven shaft at front and centre bushings	mm (in.)	39.166 - 39.191 (1.5420 - 1.5429)	
Diameter of driven shaft at rear bushing	mm (in.)	34.984 - 35.000 (1.3773 - 1.3780)	
Internal diameter of front and centre bushing	mm (in.)	39.200 - 39.239 (1.5433 - 1.5448)	
Internal diameter of rear bushing	mm (in.)	35.009 - 35.048 (1.3783 - 1.3798)	
Clearance between shaft and front and centre bushings ..	mm (in.)	0.009 - 0.073 (0.0004 - 0.0029)	
Clearance between shaft and rear bushing	mm (in.)	0.009 - 0.064 (0.0004 - 0.0025)	

TOOLS

Important - The operations described in this section must be performed solely with the **ESSENTIAL** tools marked below with (X).

To work in complete safety and to ensure optimal technical results with a minimum of time and effort, they must however be supplemented with the specific tools recommended below and with those to be specially constructed by you and for which the construction diagrams are given in this manual.

380000227 Hook for lifting PTO

380001597 Guide pins for PTO unit

380000233 Installer for PTO driving shaft bearings

TORQUE SETTINGS

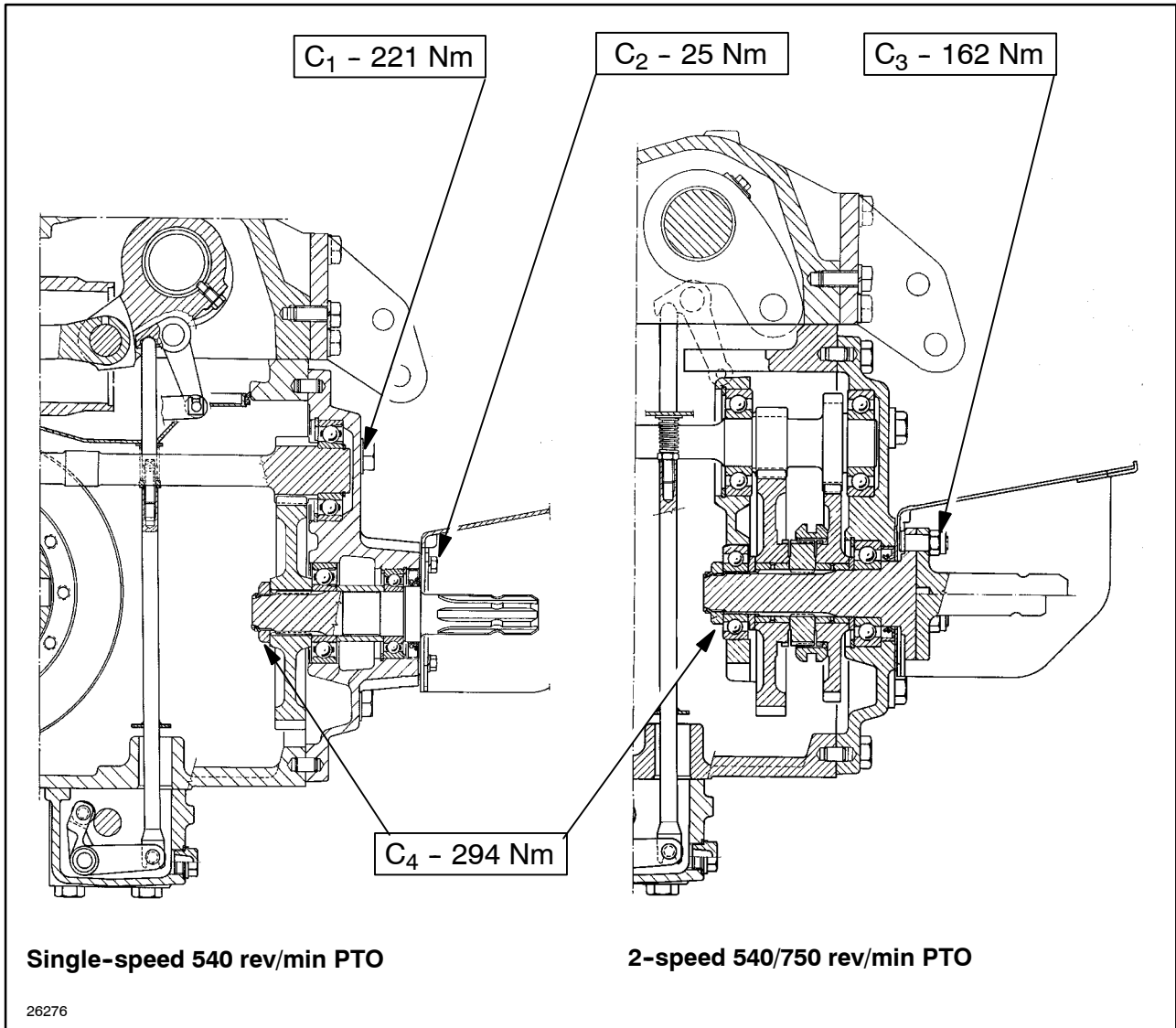

TORQUE SETTINGS

PART TO BE TORQUED	Thread	Torque setting	
		Nm	ft lb
PTO box fixing screws (C1, fig. 1)	M 16 x 1.5	221	163.0012
PTO guard fixing screws (C2, fig. 1)	M 8 x 1.25	25	18.439
Grooved endpiece self-locking nuts (2-speed PTO) (C3, fig. 1) .	M 12 x 1.25	162	119.485
Driven gear shaft locknut: (C4, fig. 1) for single- or 2-speed PTO	M 32 x 1.5	294	216.8432
Bearing support fixing screws (2- and 3-speed PTO) (C5, fig. 35)	M 12 x 1.25	98	72.281

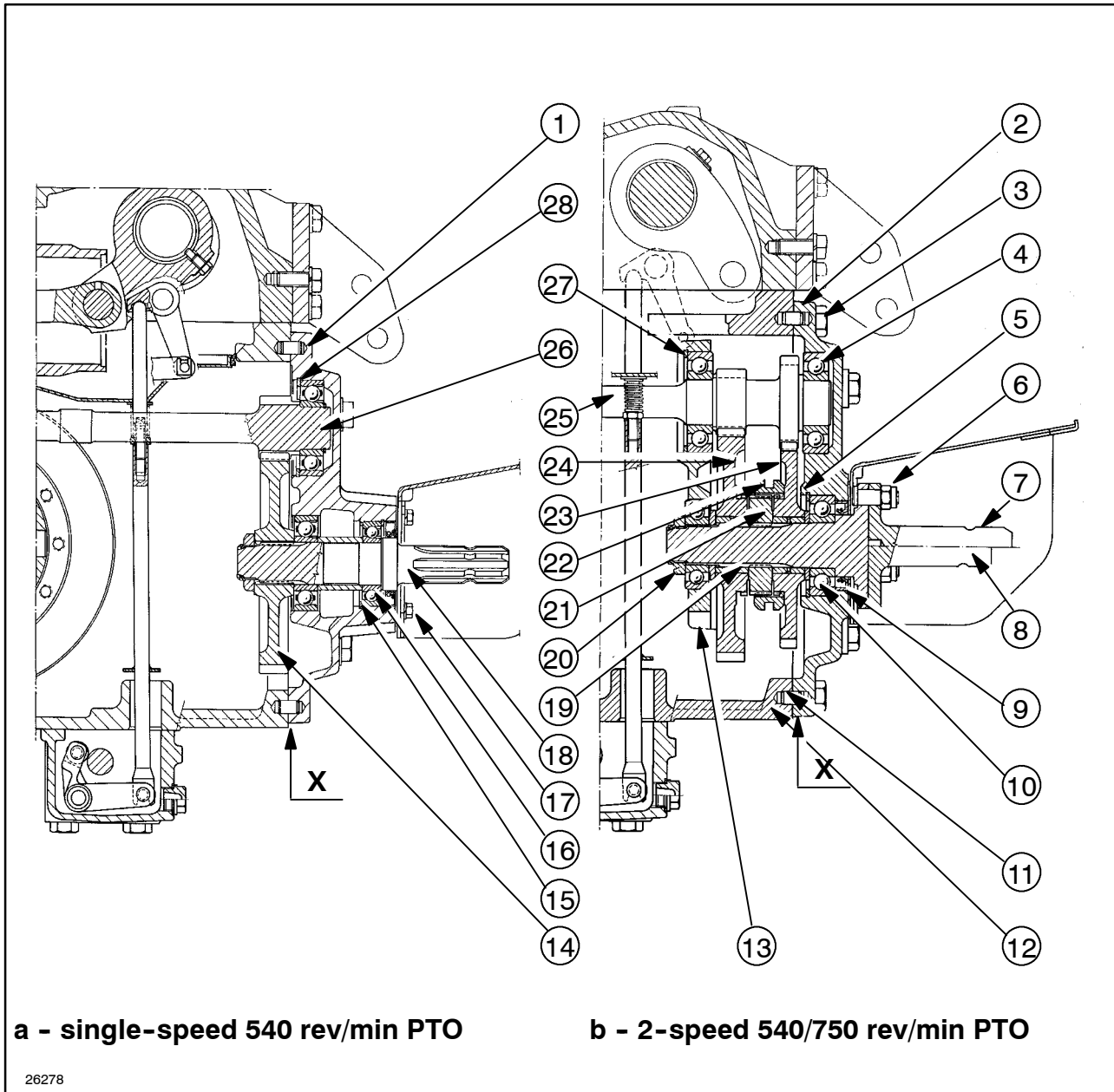

2

Sectional diagrams of single- and 2-speed PTO

- | | |
|---|---|
| a. Sectional diagram of single-speed PTO. | 13. Rear transmission support. |
| b. Sectional diagram of 2-speed PTO. | 14. Driven gear. |
| 1. 540 rev/min PTO cover. | 15, 27, 28, 16 and 5. Snap rings. |
| 2. 540/750 rev/min PTO cover. | 17. PTO guard retaining screws. |
| 3. PTO unit fixing screw. | 18. 540 rev/min PTO driven shaft |
| 4. Drive shaft bearings. | 19. Driven gear support bushings. |
| 6. Self-locking nut to secure splined shaft. | 20. Driven shaft lock nut. |
| 7. 540 rev/min splined shaft. | 21. Fixed gear. |
| 8. 750 rev/min splined shaft. | 22. Coupling sleeve. |
| 9. Seal. | 23. Driven gear for 750 rev/min speed. |
| 10. Driven shaft bearings. | 24. Driven gear for 540 rev/min speed. |
| 11. Cover locating pin. | 25. Double drive gear. |
| 12. Rear transmission casing. | 26. Drive gear. |

NOTE: When installing use sealing compound of the type shown on page 1 section 00 on surface X as shown above.

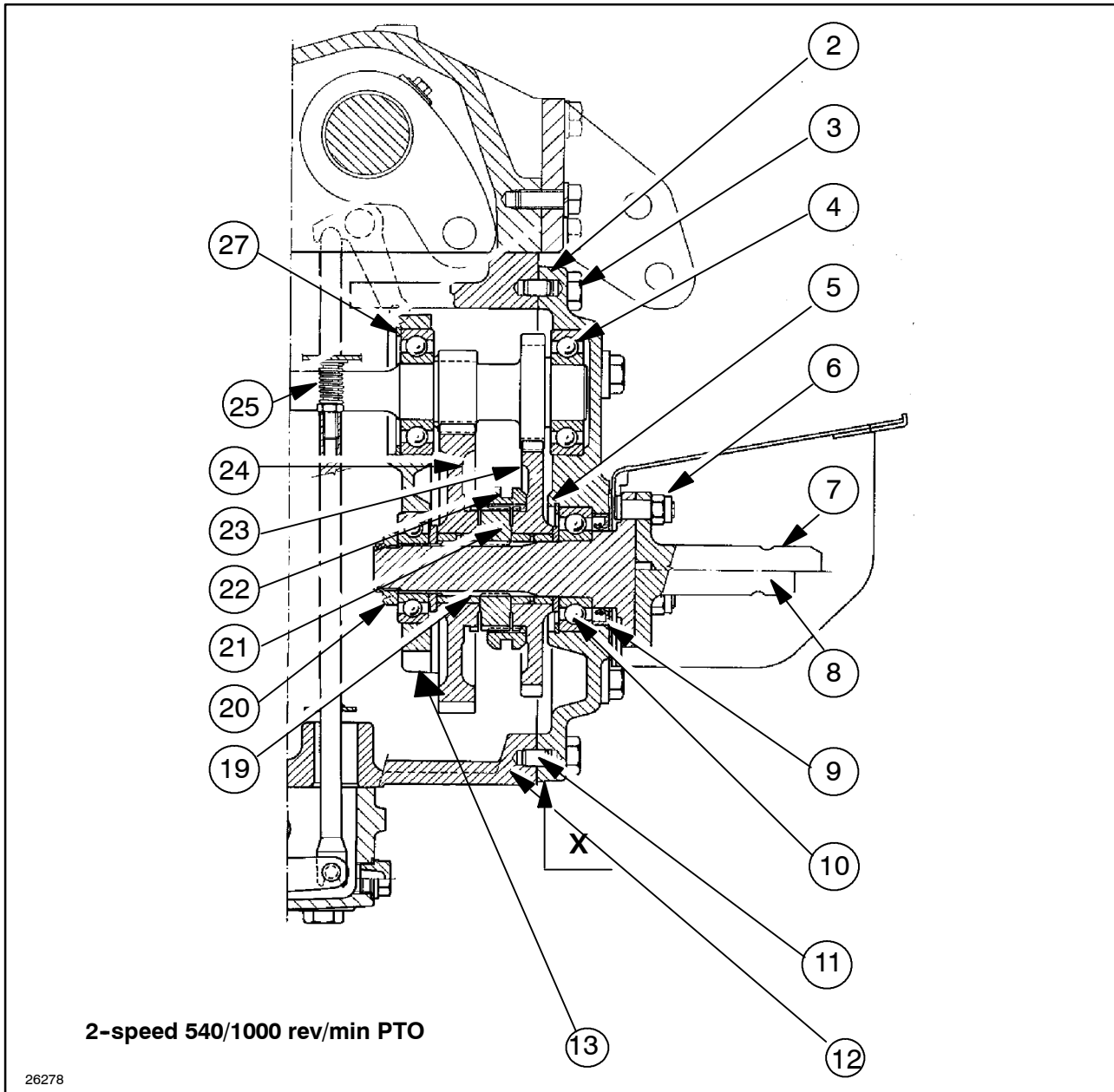

3

Sectional diagram of single- and 2-speed PTO

- | | |
|--|---|
| 2. 540/1000 rev/min PTO cover. | 12. Rear transmission casing. |
| 3. PTO unit retaining screw. | 13. Rear transmission support. |
| 4. Drive shaft bearings. | 19. Driven gear support bushings. |
| 5. Snap ring. | 20. Driven shaft lock nut. |
| 6. Self-locking nut to secure splined shaft. | 21. Fixed gear. |
| 7. 540 rev/min splined shaft. | 22. Coupling sleeve. |
| 8. 1000 rev/min splined shaft. | 23. Driven gear for 1000 rev/min speed. |
| 9. Seal. | 24. Driven gear for 540 rev/min speed. |
| 10. Driven shaft bearings. | 25. Double drive gear. |
| 11. Cover locating pin. | 27. Snap ring. |

NOTE: When installing use sealing compound of the type shown on page 1 section 00 on surface X as shown above.

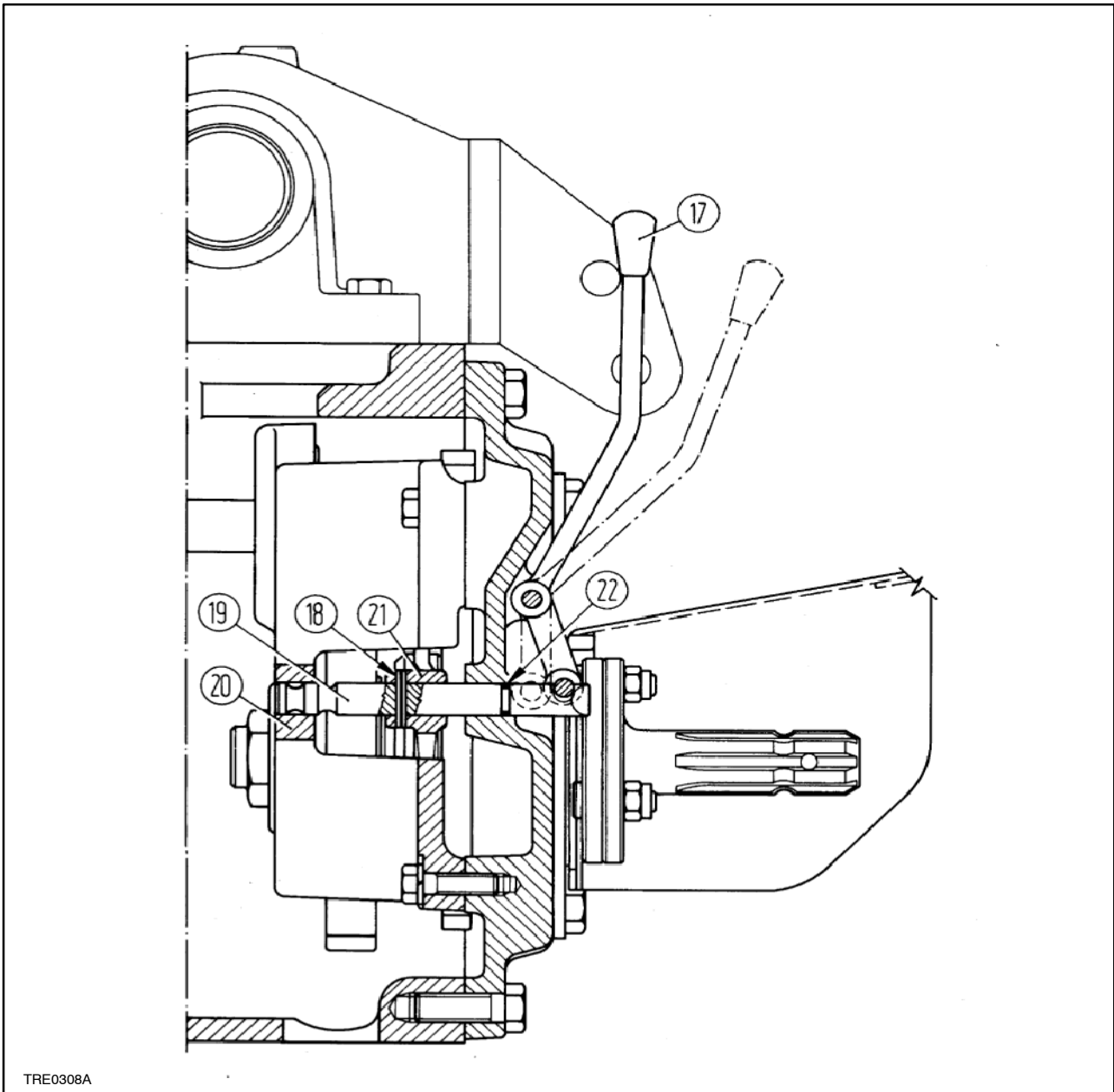

4

Sectional diagram of single- and 2-speed PTO

- 17. PTO speed selector lever.
- 18. Roll pin.
- 19. Shaft.

- 20. Rear cover.
- 21. Fork.
- 22. O-ring.

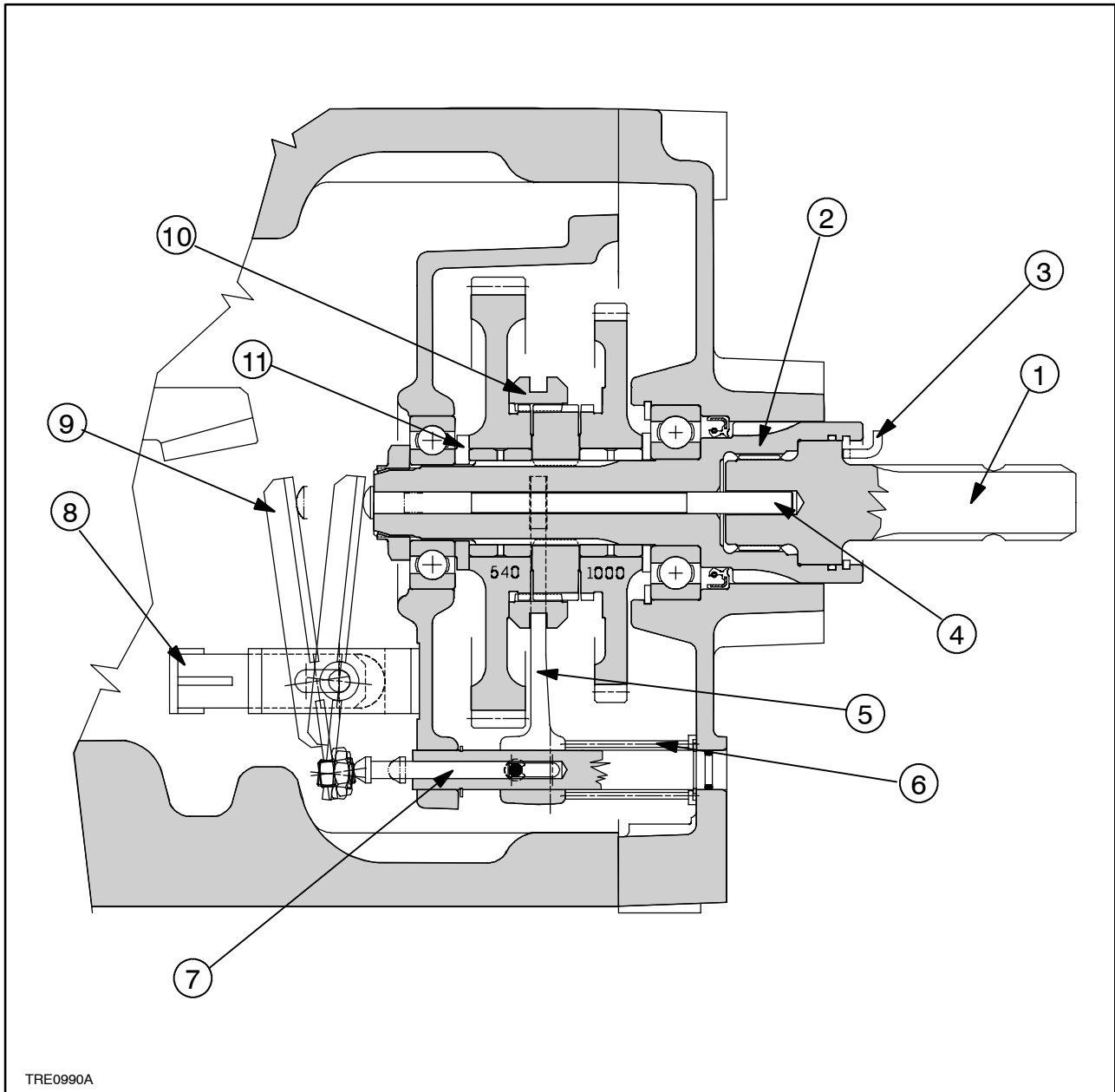

5

Section views - 540 - 1000 rev/min PTO North American version (available on request), not synchronised with gearbox, with speed selection by replacement of splined output shaft.

- | | |
|---|----------------------------------|
| 1. Splined $1 \frac{3}{8}$ " output shaft (6 splines) for 540 rpm PTO, or $1 \frac{3}{8}$ " output shaft (21 splines) for 1000 rpm PTO. | 6. Return spring. |
| 2. Driven shaft. | 7. Return rod. |
| 3. Snap ring securing part . | 8. Speed selector lever support. |
| 4. Speed selector rod. | 9. Speed selector lever. |
| 5. Speed selector sleeve control fork. | 10. Speed selector sleeve. |
| | 11. Thrust washer. |

DESCRIPTION AND OPERATION OF MECHANICAL PTO

The PTO, located at the rear of the tractor, transfers power to the implement being transported or towed. It can be controlled either directly from the engine clutch or from the gearbox clutch. The PTO is shown with the safety cap (1) and the guard (2) in position. The safety cap must be removed to couple up an implement to the PTO shaft.

The PTO with mechanical engagement/disengagement is available in three versions:

- single-speed PTO, 540 rev/min (standard)
- two-speed PTO, 540/750 rev/min (option)
- two-speed PTO, 540/1000 rev/min (option).

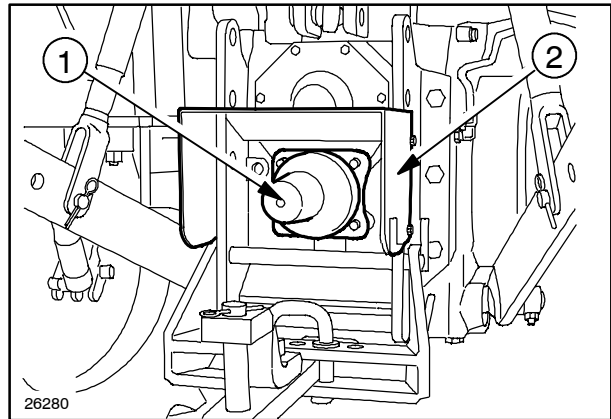

6

Independent PTO

Proceed as follows:

- with the PTO clutch disengaged, i.e. with the control lever (1) fig. 7, rearward at position A;
- move the PTO selector lever (1) fig. 8, to position B so as to engage the PTO sleeve (3) fig. 9, with the toothed coupling of the shaft (2) which is driven by the engine;
- engage the PTO by slowly moving the lever (1) fig. 7, forward to position D.

When engaged, the PTO shaft rotates and the PTO warning lamp on the instrument panel lights up.

In these conditions the operation of the PTO is completely independent of the travel of the tractor, so:

- the tractor can be stopped without stopping the PTO;
- the PTO can be stopped without stopping the tractor (by disengaging the PTO clutch).

To disengage the PTO move the PTO clutch control lever (1) fig. 7, rearward to position A then move the speed selector (1) fig. 8, to the central position E.

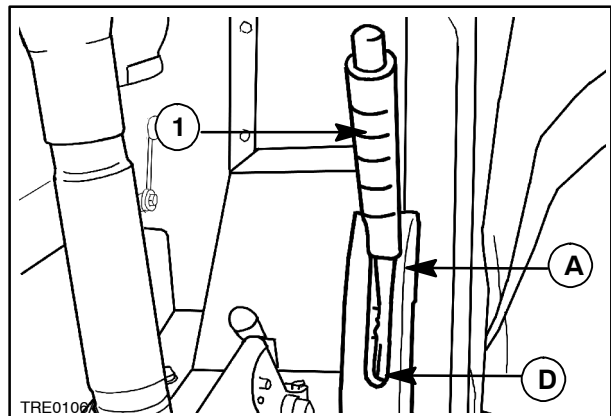

7

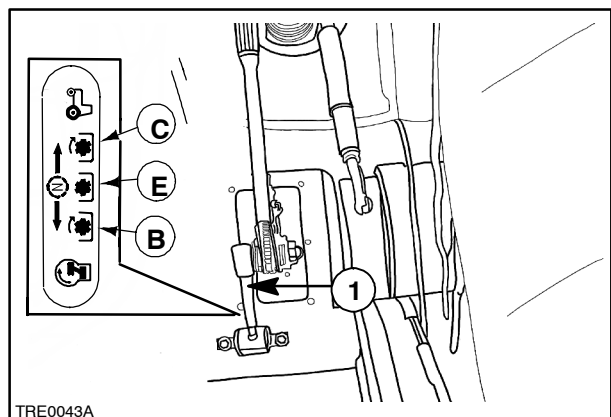

8

Ground speed PTO

Proceed as follows:

- keep the PTO clutch control lever (1) fig. 7 on position A with PTO disengaged;
- fully depress the gearbox/engine clutch pedal;
- wait briefly, then move the PTO operating mode selector (1) fig. 8 forward to position C and release the gearbox/engine clutch pedal;

In these conditions the PTO coupling sleeve (3) fig. 9, is turned directly by the toothed coupling of gear (1) in the gearbox.

When the tractor is stationary the PTO shaft does not turn. When changing from forward to reverse gear, the direction of rotation of the PTO shaft reverses.

NOTE: When the PTO is not being used, move the lever (1) fig. 8, to position E (the neutral position of the PTO engagement sleeve (3) fig. 9).

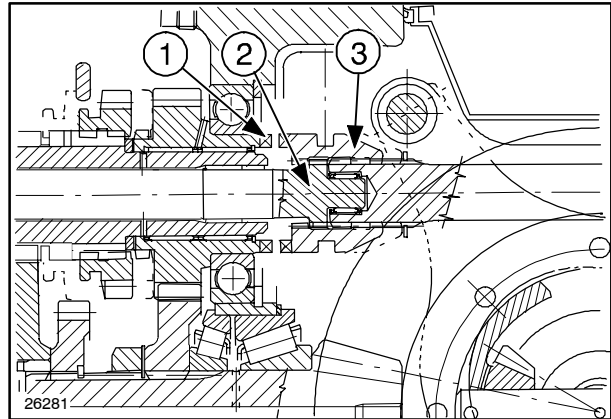

9

PTO speed selector lever (2) fig. 10

To change PTO speed, proceed as follows:

- lift the spring-loaded collar (1) upwards;
- move the lever (2) forward to position (3) to select 750 or 1000 rev/min PTO speed.

This activates the external control lever (17) fig. 4 by means of a tie-rod. The external control lever in turn rotates the internal fork device (21) and selects the PTO speed by means of the coupling sleeves.

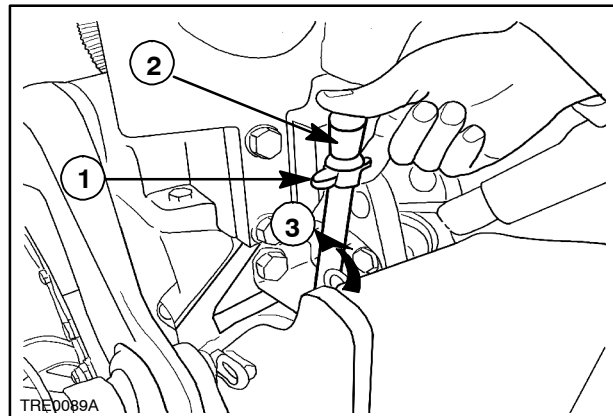

10

TROUBLESHOOTING FOR MECHANICAL PTO

Faults	Possible causes	Remedies
Slipping with loss of speed of PTO output shaft.	Wear of clutch disc or of engine flywheel pressure plate. Poor adjustment of PTO clutch control lever.	Check the data given in the appropriate pages of section 18, replace the worn parts and adjust the clutch control lever.
Difficulty in selecting PTO speed by means of lever (2) fig. 10.	External control stiff.	Check the control lever.

540/750 MECHANICAL PTO
Removal - Refitting (Op. 31 112 20)**⚠ WARNING ⚠**

Lift and handle all heavy parts using lifting tackle of sufficient capacity.
Make sure that the units or parts are supported by suitable harnesses and hooks. Check that no one is in the vicinity of the load to be lifted.

1. Disconnect the negative cable from the battery.
2. Remove the top link (1) of the three-point linkage.

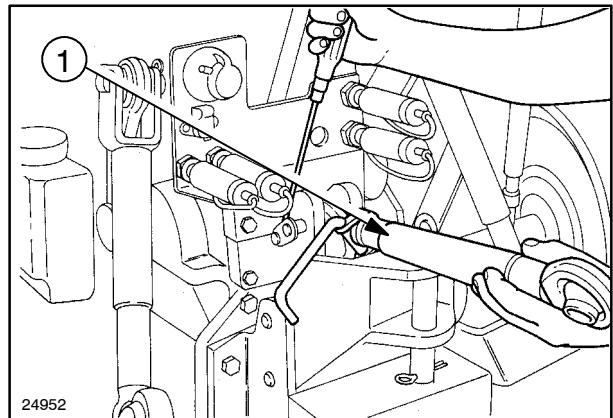

11

3. Remove the tow hook (1), if fitted.

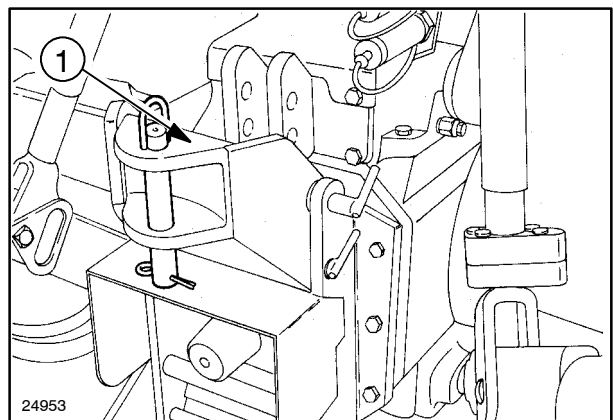

12

4. Remove the tow bar (1), if fitted.

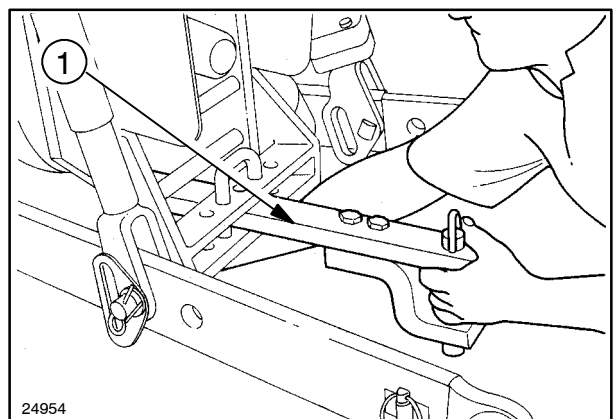

13

5. Remove the six tow hook support fixing screws (1).

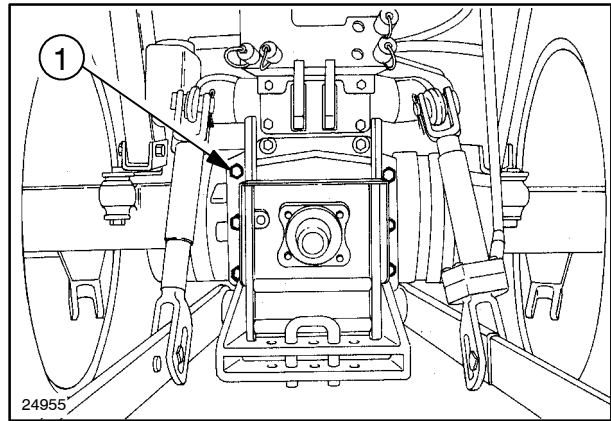

14

6. Drain out the transmission/gearbox oil and collect it in a suitable container.

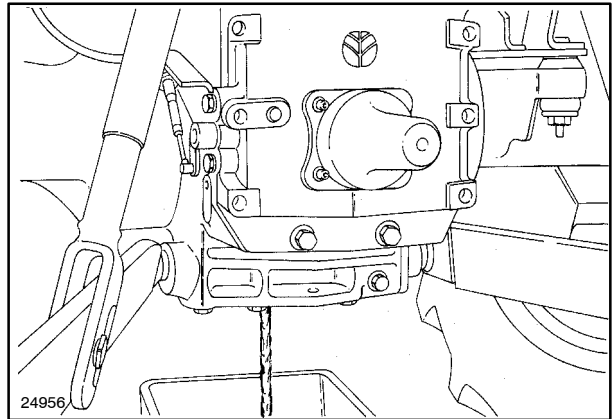

15

7. Remove the PTO speed selector control lever (1).

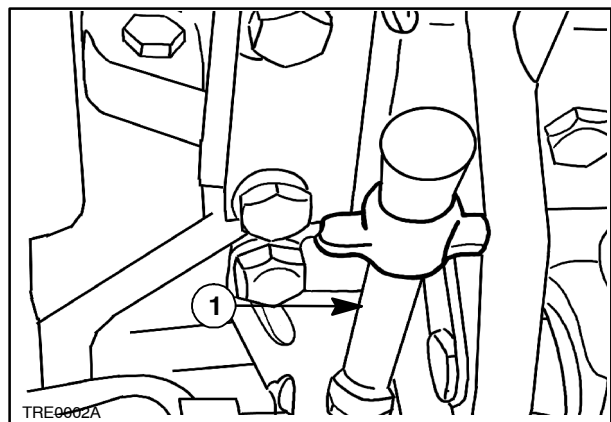

16

8. Remove the screws (2) that fasten the retaining bracket (1) for the PTO speed selector control.

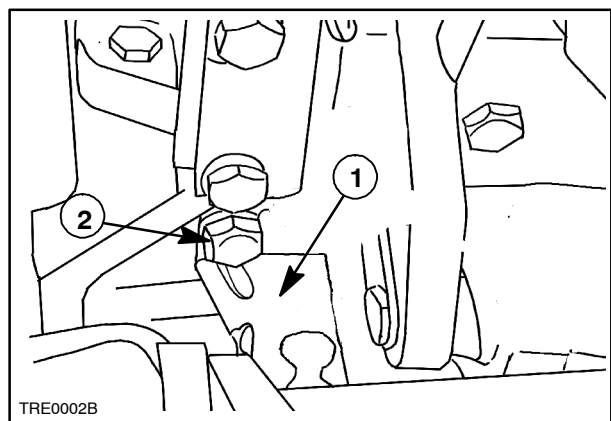

17

9. Remove the two upper screws (1) which fasten the PTO unit to the transmission.

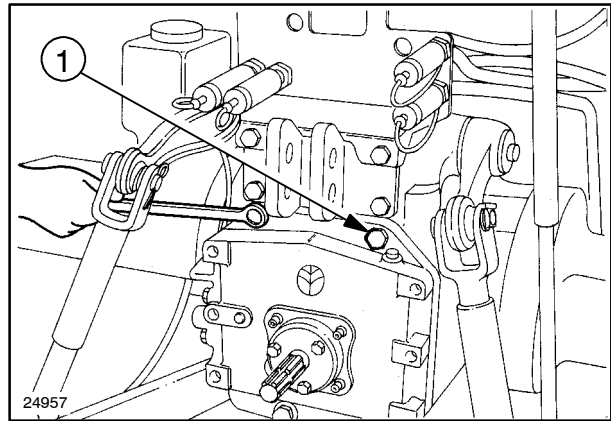

18

10. Insert the two guide pins **380001597** (1) and remove the two lower screws (2) which fasten the PTO unit to the transmission.

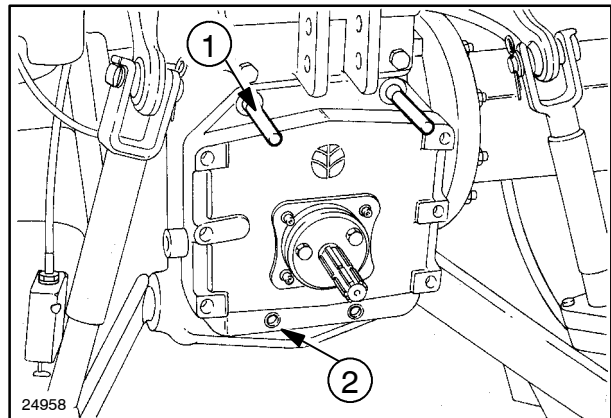

19

11. Engage the lever (1) fig. 8, in position (C), ground speed PTO, so that the sleeve (3) fig. 9, rests on the shaft (2) during the removal operation. Withdraw the PTO unit by a few centimetres and detach using the hook with lifting chain **380000227** (1).

To reinstall proceed as follows:

- Clean the mating surfaces between the transmission and PTO cover and apply sealing compound as shown in figure 21.
- Raise the PTO unit and position it directly behind the transmission casing. Slide the PTO cover onto the guide pins **380001597**, for ease of assembly.
- Remove the hook with chain (1) fig. 20, and fasten the PTO unit using the two lower screws.
- Remove the two guide pins **380001597** and install the two upper screws.
- Reinstall the bracket (1) fig. 17, that retains the PTO speed selector control lever.
- Refit the tow bar support.
- Refit the tow bar, the tow hook and the three-point linkage top link.
- Screw in and tighten the oil drain plug and fill the transmission/gearbox with oil.
- Reconnect the negative battery cable.

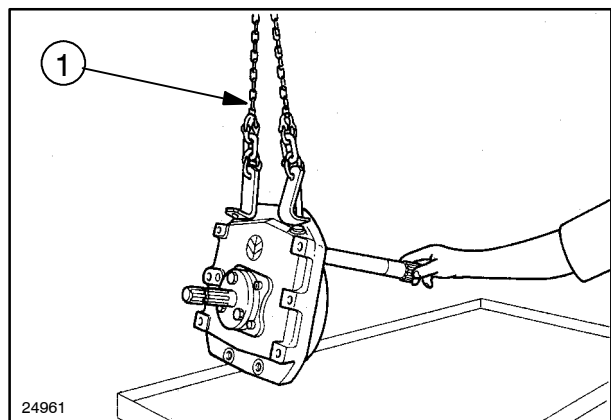

20

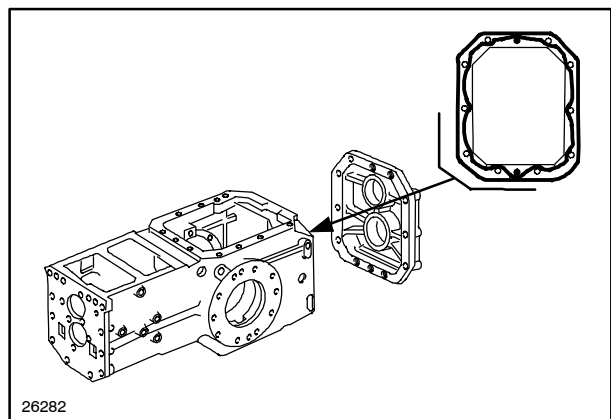

21

MECHANICAL PTO (540/750 rpm PTO)
Bench overhaul (Op. 31 112 45 - 31 112 48)

⚠ WARNING ⚠

Handle all parts with great care.
 Do not place hands or fingers between one part and another.
 Always wear the prescribed safety clothing, including protective glasses, gloves and shoes.

1. Place the PTO unit in the vice on the work bench (1).

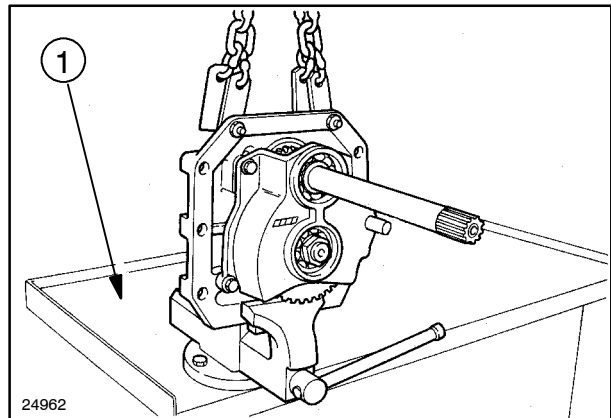

22

2. Use a punch to straighten the notching (1) on the ring nut that retains the driven shaft components.

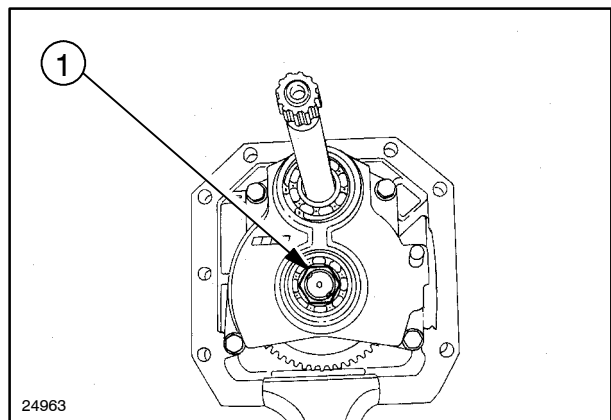

23

3. Remove the ring nut (1) from the driven shaft.

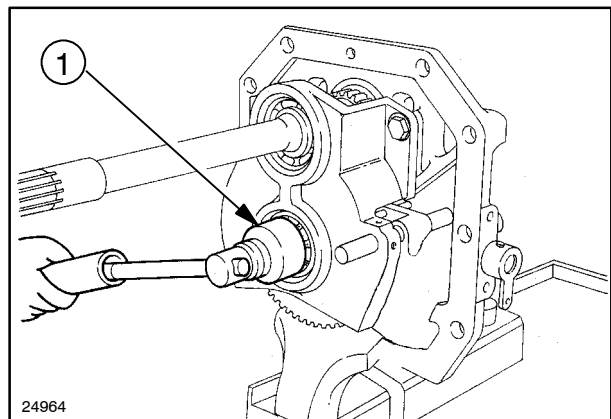

24

4. Remove the four PTO unit internal support fixing screws (1).

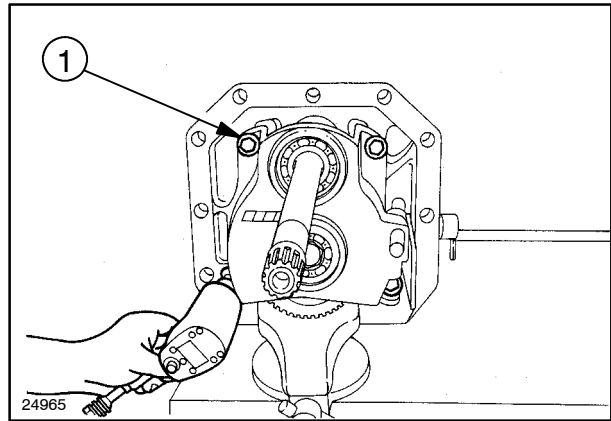

25

5. Remove the pin (1) securing the fork rod.

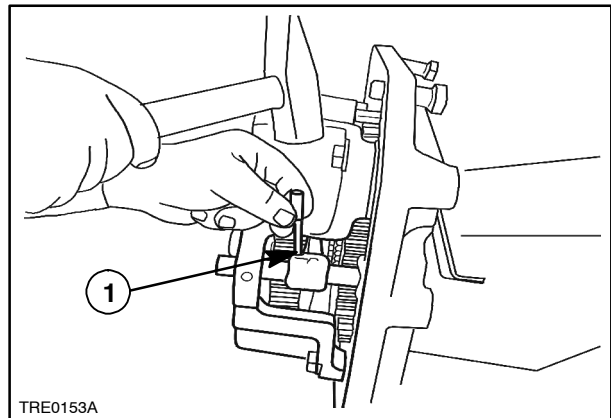

26

6. Withdraw the rod (1) from the rear cover.

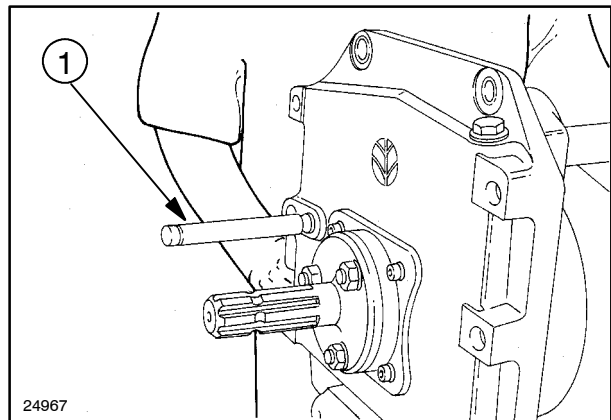

27

7. Partially withdraw the PTO output shaft (1) and remove the internal support (3) together with the drive shaft (2), the driven gears (4), the sleeve and the engagement/disengagement/neutral control fork of the 540/750 PTO. Also, retain the thrust washer from the gear (11) fig 5, for reuse during reassembly.

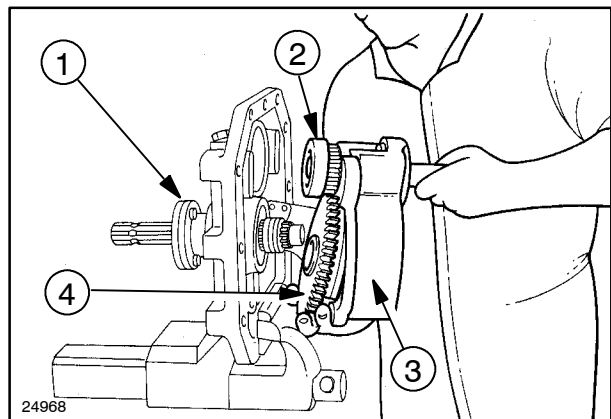

28

8. Remove the rear bearing thrust washer (1) and remove the secondary shaft (2) complete with PTO output shaft.

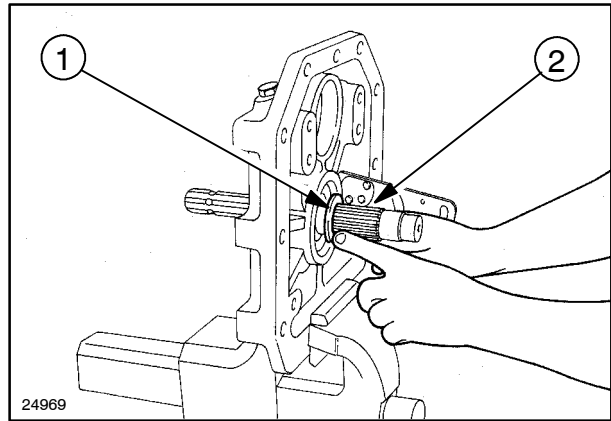

29

9. Remove the retaining snap ring, the bearing (1) and the seal (if it needs replacing) from the rear cover.

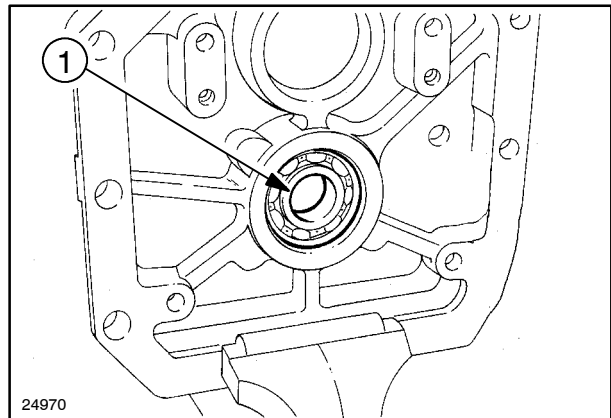

30

To reinstall, Refer to fig. 2b and proceed as follows:

- Mount the seal (9) (if removed in step 20), the rear bearing and the retaining snap ring (5) on the rear cover.
- Refit the thrust washer on the driven shaft.
- Refit the driven shaft gear (23), the fixed gear (21), the sleeve (22), the fork and the fork support rod.
- Insert the gear (24) onto the driven shaft, mount the internal support (13) complete with drive shaft (25). Fasten the support (13) using the four screws, tightening them to the torque setting specified on page 4.
- Mount the thrust washer on gear (11) fig 5, and install the bearing on the internal support (13) of the driven shaft.
- Fasten the rod that supports the PTO speed selector control fork pin as removed in step 5.
- Tighten the driven shaft locknut to the torque specified on page 4, then, using a suitable punch, notch the safety thrust washer in order to prevent it from loosening.

**MECHANICAL PTO (540/1000 rpm PTO)
(Interchangeable PTO Shaft) (NASO Version)
Bench overhaul (Op. 31-114)**

⚠ WARNING ⚠

Handle all parts with great care.
Do not place hands or fingers between one part and another.
Always wear the prescribed safety clothing, including protective glasses, gloves and shoes.

1. Place the PTO unit in the vice on the work bench (1).

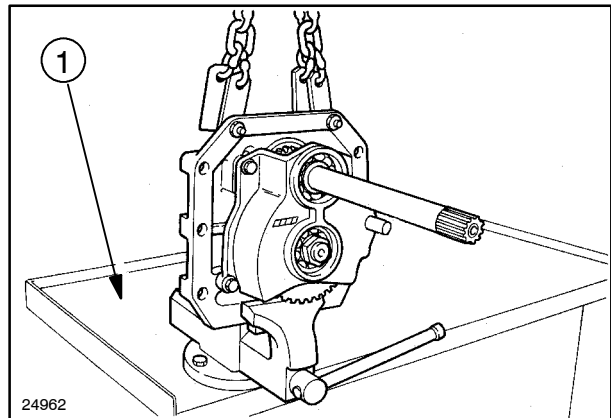

31

2. Remove the bolts (1) and take off the cover (2).

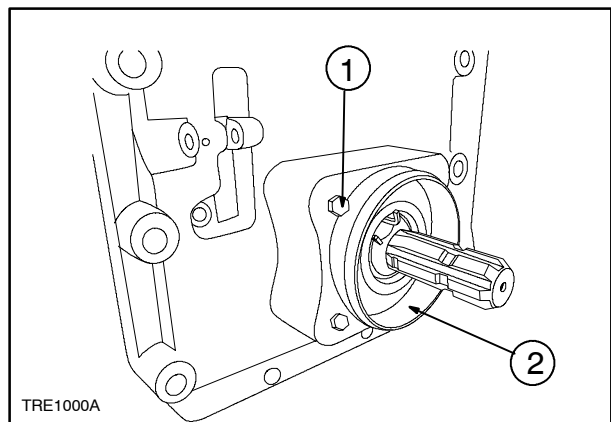

32

3. Remove the spacer (1).

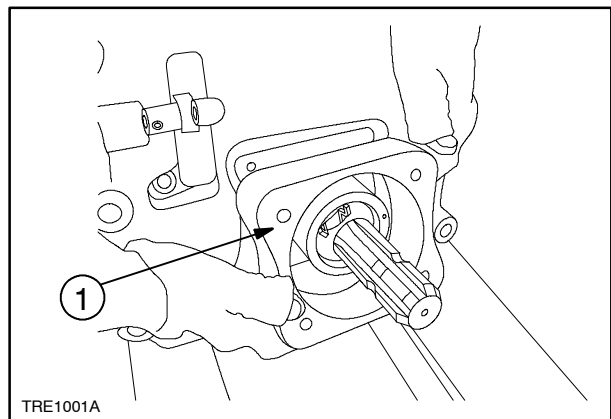

33

4. Remove the two socket head screws (1) and take off the PTO engagement mechanism (2) completely.

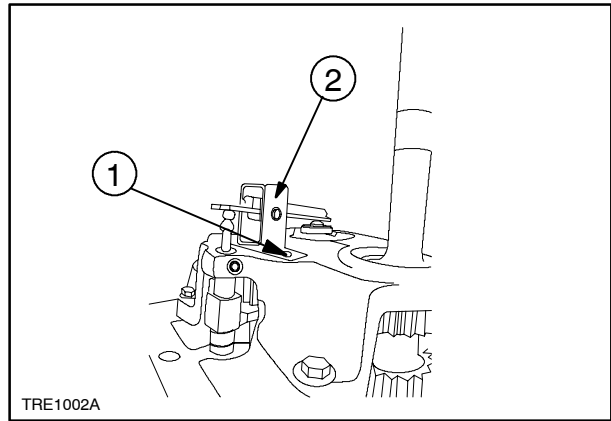

34

5. Withdraw two rods (1) from the cover.

C₄: Shaft securing nut tightening torque: 255Nm (188.0783 ft lb)

C₆: Cover retaining bolts tightening torque: 98 Nm (72.2811 ft lb)

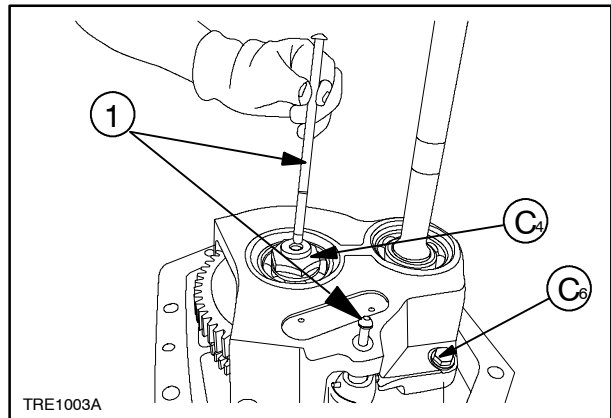

35

6. Remove the nut (1) securing the shaft and take off the 4 bolts (2).

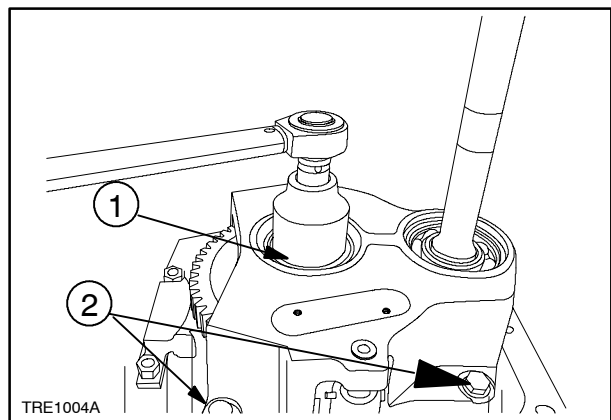

36

7. Remove the socket head screw bolt (1) on the side of the cover.

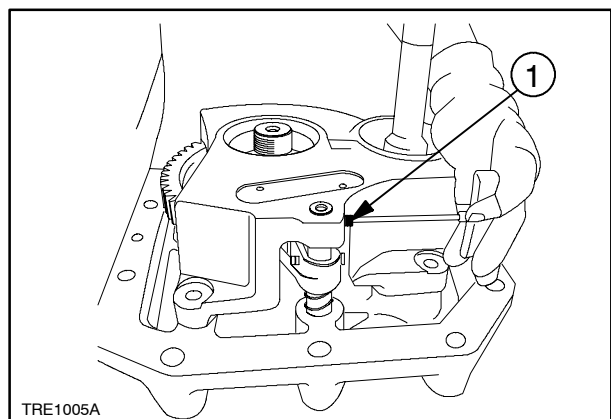

37

8. Remove the cover (1).

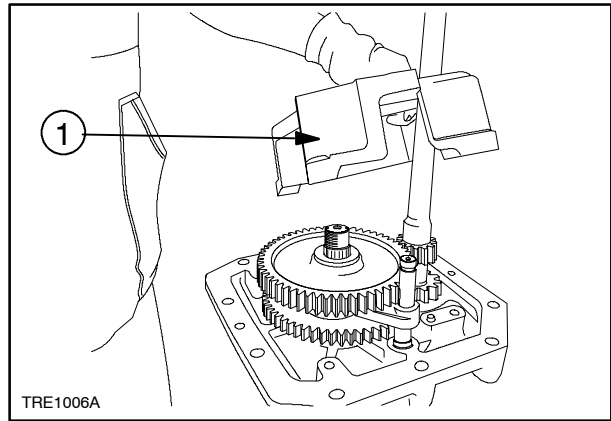

38

9. Remove the washer (1) and take off the gear (2).

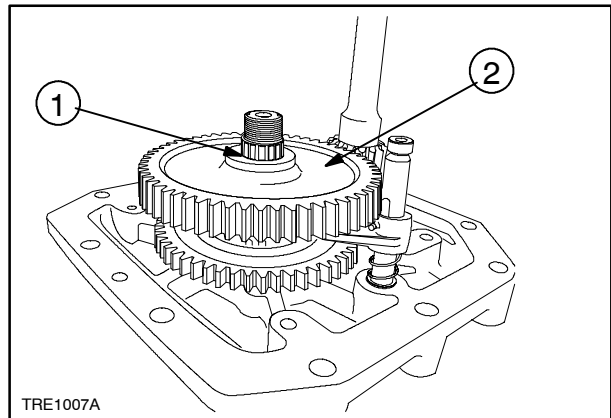

39

10. Remove the rod (1), spring (2), fork (3) and the synchroniser (4).

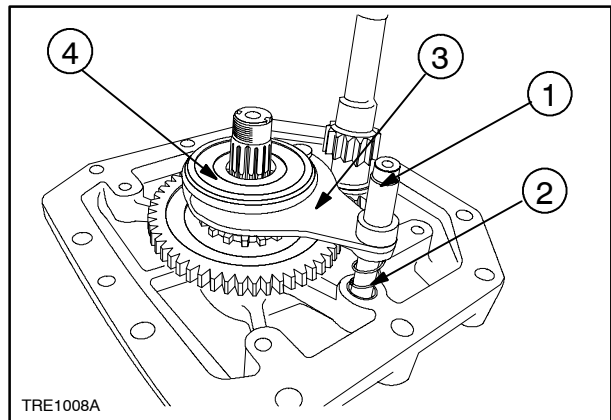

40

11. Remove the driven gear (1).

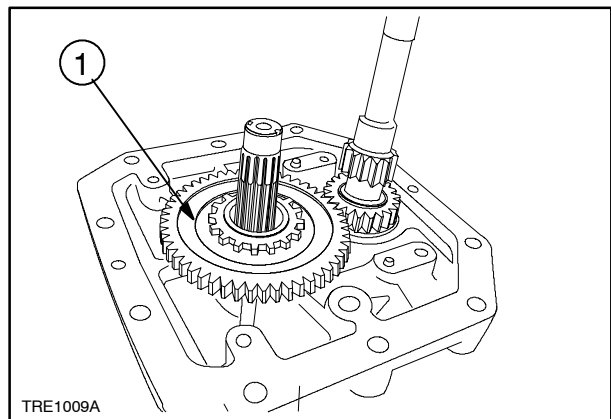

41

12. Remove the circlip (1).

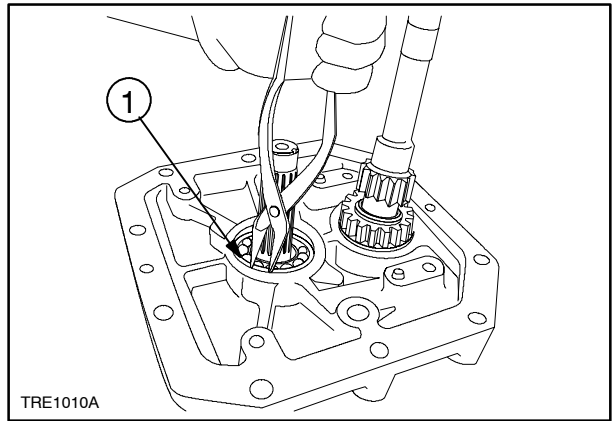

42

13. Remove the drive shaft(1).

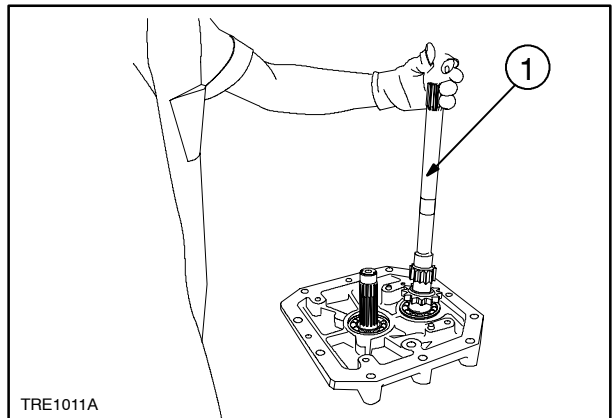

43

14. Remove both bearings (1) and (2) .

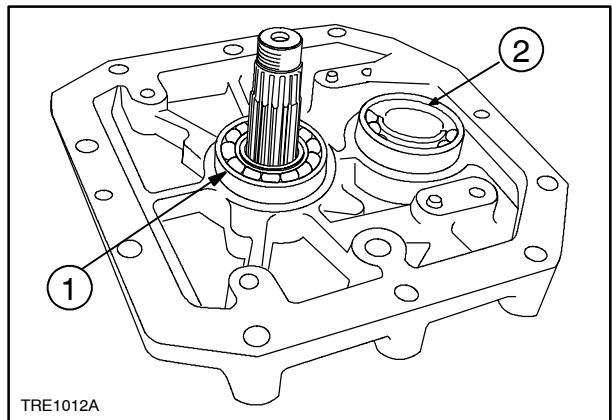

44

15. Remove the shaft (1) and the plate (2).

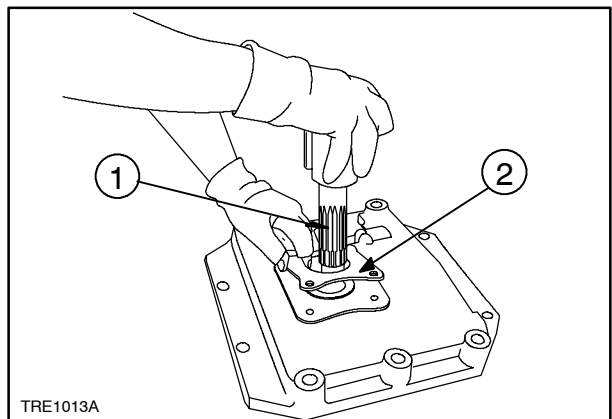

45

To reinstall, reverse the removal procedure and refer to fig. 5 and proceed as follows:

- Mount the shaft (1) and the plate (2) on the rear cover (fig. 45).
- Refit the two bearings (1 and 2) (fig. 44).
- Refit the drive shaft (1) (fig. 43)
- Install the circlip (1, fig. 42) securing the bearing
- Insert the gear (1, fig. 41).
- Install the rod (1), spring (2), fork (3) and the synchroniser (4, fig. 40).
- Install the washer (1) and the gear (2, fig. 39)
- Install the cover (1, fig. 38).
- Install the socket head screw (1, fig. 37) on the side of the cover.
- Install the nut (1) securing the shaft and refit the 4 bolts (2, fig. 36). Tighten the nut (1) to 255Nm (188.0783 ft lb) and bolts (2) to 98 Nm (72.2811 ft lb).
- Install the two rods (1) fig. 35.
- Refit the PTO engagement mechanism (1, fig. 34) and install the socket head screws securing the mechanism.
- Using a screwdriver (1) and a spanner (2) adjust the distance **X** to “**0 mm (0 in.)**” fig. 46.
- Install the spacer (1, fig. 33).
- Install the cover (2, fig. 32) and tighten the bolts (1).
- Use suitable hooks to assemble the unit to the tractor fig. 31.

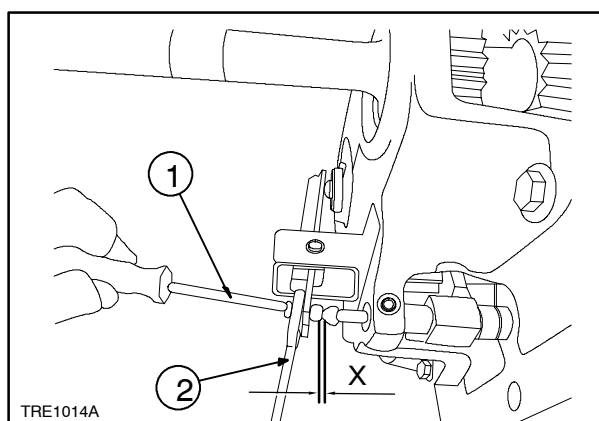

SECTION 33 - BRAKES

Chapter 1 - Brakes

CONTENT

Section	Description	Page
33 000	Main data	1
	Tightening torques	2
	Cross-sectional views	3
	Description & Operation	7
	Tools - Troubleshooting	8
33.206	Front brake assembly mod. TD60D and TD70D removal and refitting - overhauling on the bench	9
33.202.60	Service brake removal and refitting	12
33.202.50	Removal-Refitting of front brake pumps	17
33.202.40	Bleeding air from the front braking system	19
33.120.08	Adjusting service brake pedals travel	20
33.110.08	Parking brake travel adjustment	20

**33 000 - MAIN SPECIFICATIONS - TORQUE SETTINGS - TOOLS - SECTIONAL DRAWINGS -
DESCRIPTION AND OPERATION - TROUBLESHOOTING**

DATA

Type:		
- service brakes		with oil bath discs acting on differential half-shafts.
- parking brake		with oil bath discs acting on the differential half-shafts or, on request, independent with oil bath discs acting on a shaft integral with the bevel pinion by means of a gear.
Control:		
- service brakes		mechanical, with independent pedals (connectable by means of a pin).
- parking brake		mechanical, by means of a hand lever.
Disc material for service brake		organic agglomerate
Disc material for parking brake		steel
Mobile sector material for parking brake		sintered or organic agglomerate
Disc thickness:		
- service brakes	mm (in.)	4 (0.1575)
Discs for service brake:		
- TD60D and TD70D	n°	3
- TD80D, TD90D and TD95D	n°	4

(continued)

DATA

(continued)

Thickness of mobile sectors for independent parking brake:		
- lateral sectors	mm (in.)	3.1 - 3.4 (0.122 - 0.1339)
- intermediate sectors	mm (in.)	4.2 - 4.5 (0.1653 - 0.1772)
Front brakes (with 4WD models - on request) Hydrostatic control Hydraulic pump		with 2 control pumps operated independently by means of the brake pedals
Adjusting the control pedals		see page 20
Bleeding air from the front brake circuits (Optional)		see page 19

TIGHTENING TORQUES

PARTS TO BE TIGHTENED	Thread	Tightening torque	
		Nm	ft lb
Nuts securing final drive box to transmission box (C ₁)	M 12 x 1.25	98	72.281
Bolts for securing shaft for parking brake driven shaft (C ₂)	M 10 x 1.25	64	47.204
Guide dowels for parking brake mobile sector (C ₃)	M 12 x 1.25	24	17.7015
Bolts for securing parking brake support to transmission box (C ₄)	M 12 x 1.25	98	72.281
Brake box retaining bolt (C ₅ , page 6)	M 10 x 1.25	70	51.6293

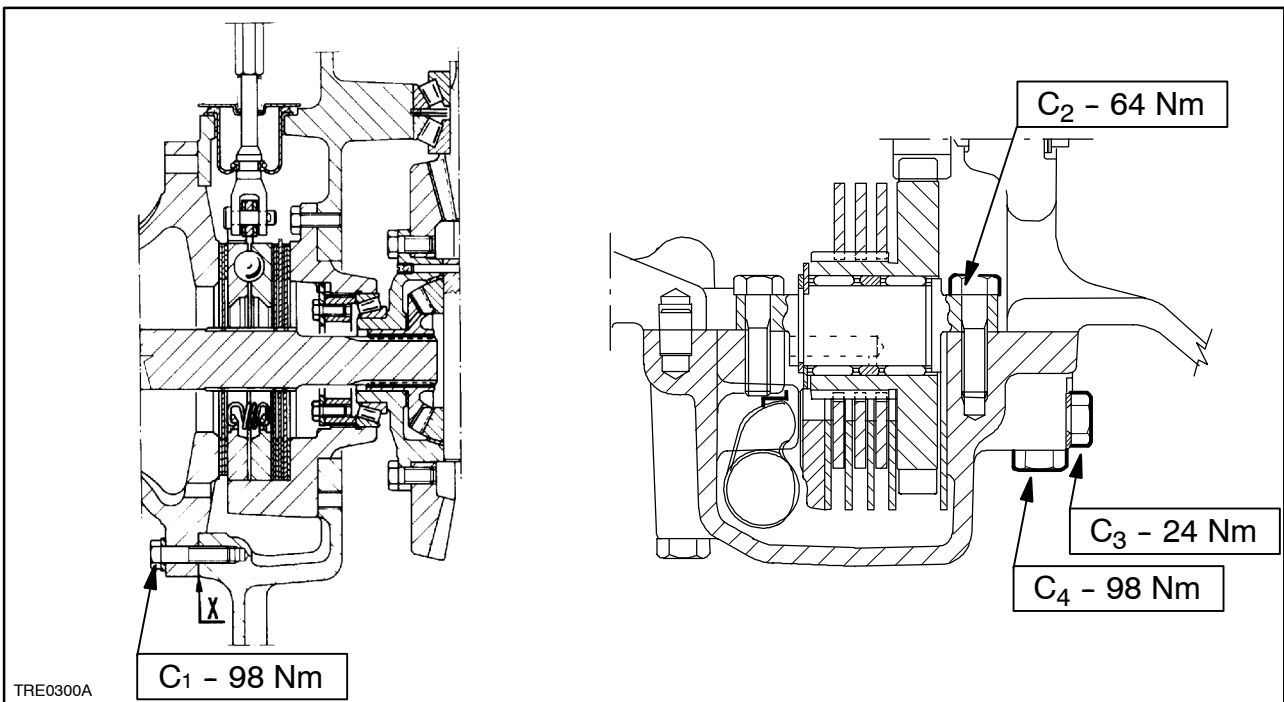

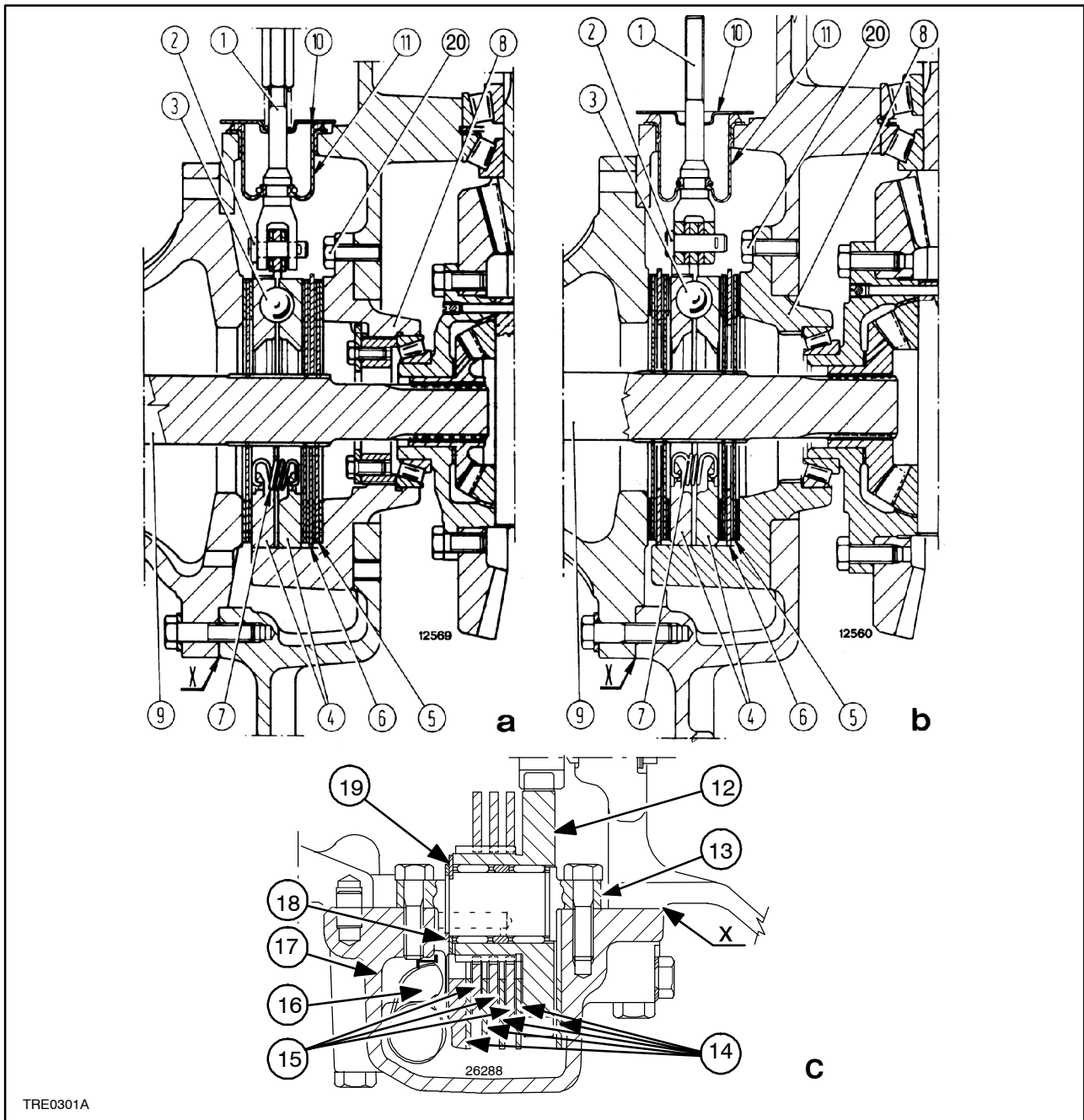

2

Sectional drawing of service and parking brakes

- | | |
|-----------------------------------|---|
| a. models TD60D and TD70D. | 10. Boot cover plate. |
| b. models TD80D, TD90D and TD95D. | 11. Boot. |
| c. Parking brake section. | 12. Driven gear. |
| 1. Brake link. | 13. Driven gear pin. |
| 2. Pin. | 14. Braking sectors. |
| 3. Ball. | 15. Parking brake discs. |
| 4. Brake actuator. | 16. Parking brake internal control lever. |
| 5. Brake discs. | 17. Parking brake support. |
| 6. Back-up discs | 18. Circlip. |
| 7. Actuator return spring. | 19. Thrust bearing. |
| 8. Differential support. | 20. Differential support retaining bolt. |
| 9. Axle shaft. | |

Note. - When mounting apply sealing compound to surfaces X as shown on page 16.

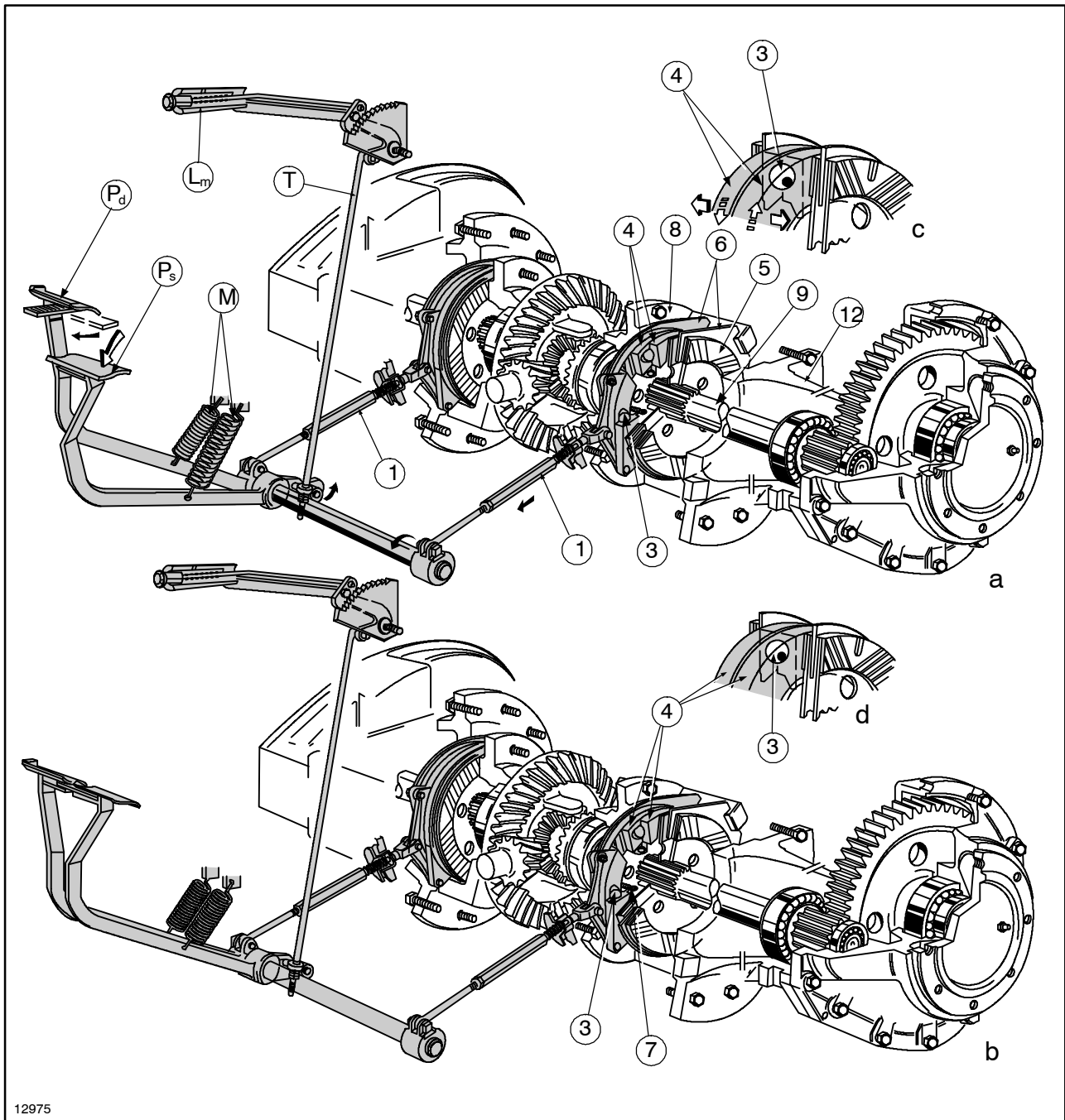

12975

3

Service brake and parking brake diagram.

- a. Right-hand brake pedal in rest position and left-hand pedal applied.
- b. Brakes in rest position.
- c. Brakes applied.
- d. Brakes in rest position.
- Lm. Parking brake hand lever.
- M. Brake pedal return springs.
- Pd. Right-hand brake pedal.
- Ps. Left-hand brake pedal.
- T. Parking brake link.

- 1. Brake links.
- 3. Actuator ball.
- 4. Brake actuator.
- 5. Brake discs.
- 6. Back-up discs.
- 7. Return spring.
- 8. Differential support.
- 9. Axle shaft.
- 12. Final drive housing.

FRONT BRAKE (MODELS TD60D and TD70D)

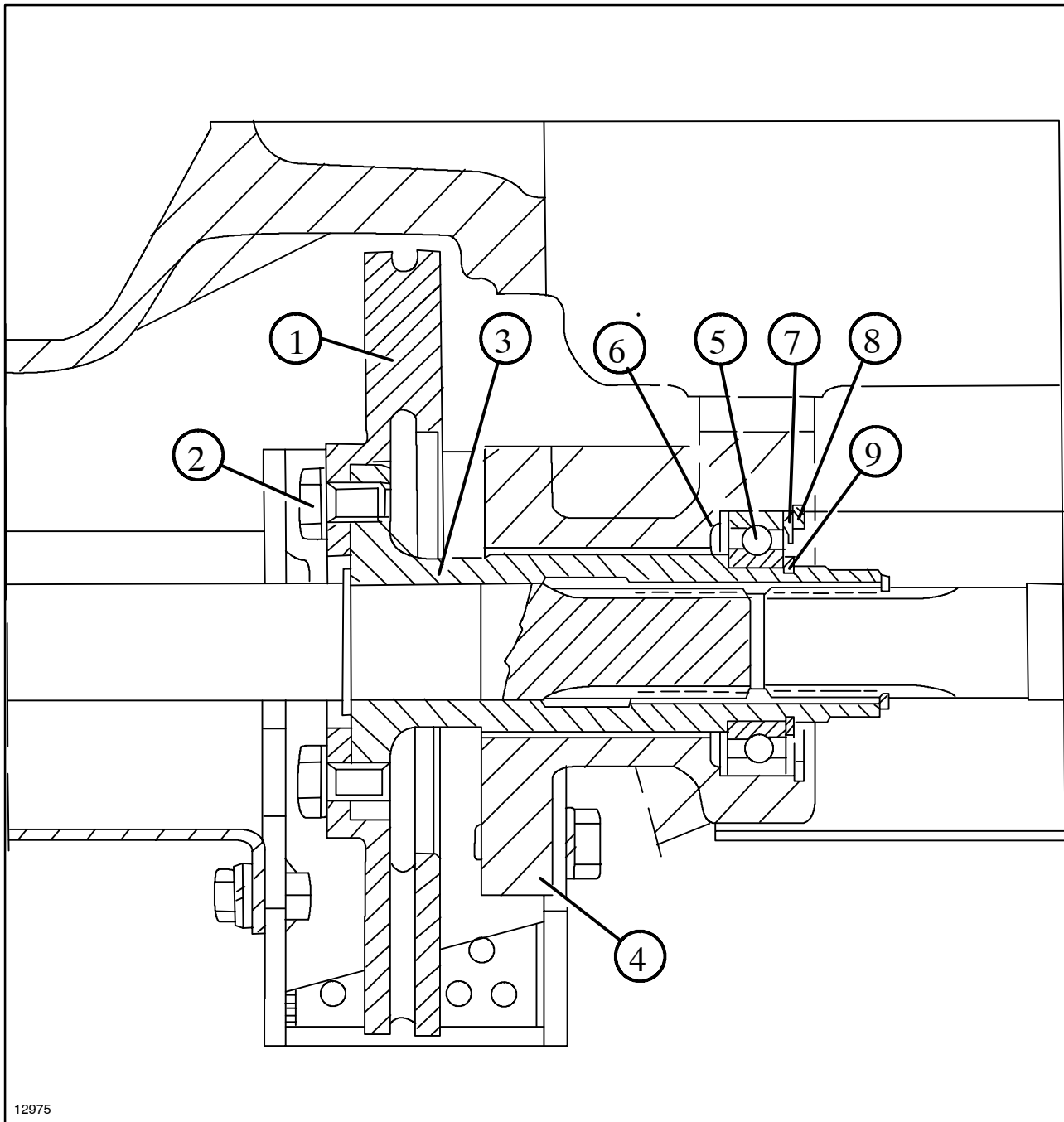

12975

4

Section through the brake fitted on the four-wheel drive shaft.

- | | |
|--------------------------|-------------------------|
| 1. Brake disc | 6. Front washer |
| 2. Disc retaining bolt | 7. Rear washer |
| 3. Shaft/sleeve assembly | 8. Outer retaining ring |
| 4. Support | 9. Inner retaining ring |
| 5. Bearing | |

FRONT BRAKE (MODELS TD80D, TD90D and TD95D)

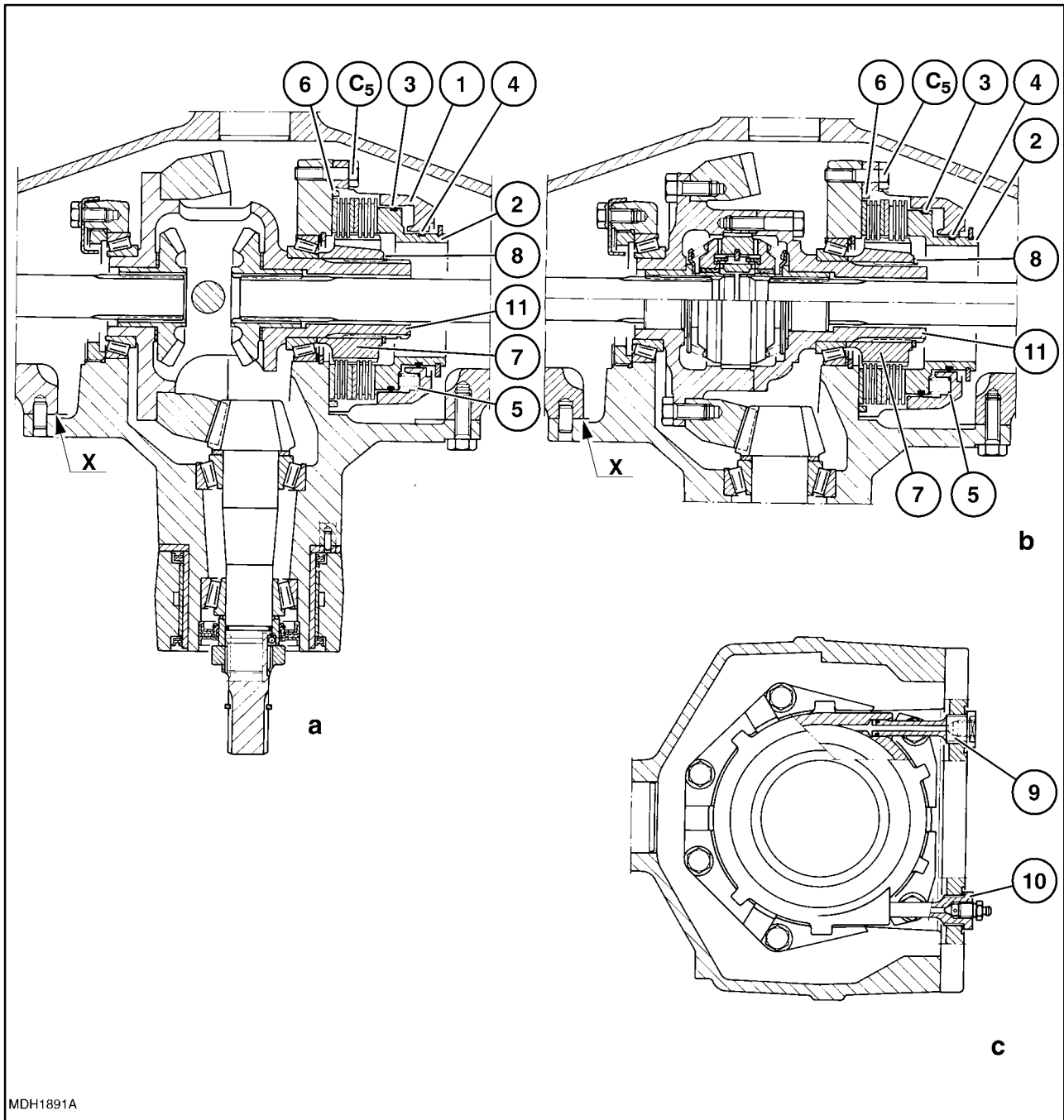

MDH1891A

5

View of brake mounted in front axle.

- | | |
|--|--------------------------------|
| a. Cross-sectional view of axle with differential. | 4. Seal. |
| b. Cross-sectional view of axle with NO-SPIN assembly. | 5. Piston contact spring. |
| c. View of oil delivery union and brake bleed. | 6. Centring ring. |
| C ₅ Brake box retaining bolt. | 7. Gear. |
| 1. Brake box. | 8. Circlip. |
| 2. Brake drive piston. | 9. Drive oil inlet pipe union. |
| 3. Seal. | 10. Plug pipe with breather. |
| | 11. Splined shaft. |

Note. - When mounting apply sealing compound to surfaces X.

DESCRIPTION & OPERATION

The mechanically operated service brake system acts on the rear wheels.

The parking brake basically acts on the service brakes. An entirely independent parking brake can be fitted that acts, via a mechanical clamp, on the discs splined onto a shaft integral with the bevel pinion.

The hydraulically controlled front brake circuit is shunted, via two hydraulic pumps fitted on the brake links (one on each side), to that of the rear brakes and

acts via clamps on the self-ventilated disc (for models with three-cylinder engine) or via a ring piston on the brake discs fitted inside the front axle (for models with a four-cylinder engine).

Application of the front brakes takes place at the same as the rear brakes when both brake pedals (latched for road travel) are depressed thanks to a hydraulic device (logic valve). this rear-mounted device excludes the front live axle drive shaft brakes when only one brake pedal is depressed.

SERVICE BRAKES

Refer to the illustrations on page 4. The service brakes are mechanic with oil bath discs. When the left-hand brake pedal (fig. a) is depressed, the links move as indicated by the arrows, this causing actuator discs to turn, ball (3) in the tapered seats to force the discs apart as shown in detail (c).

As a result, two simultaneous actions compress the brake discs against the differential support (8) and the back up discs, immediately upon releasing the pedal spring (7), pull the actuator (4) back into the rest position (figure b and detail d) and as a result the discs are released. The action is similar when the right-hand brake pedal is pressed (Rd).

PARKING BRAKE

Refer to the drawing on page 3 as shown in detail (c). The parking brake is controlled mechanically.

It operates on the rear bevel pinion shaft by means of an idler gear and is controlled by a lever located on the LH side of the operator.

When the parking brake control lever is applied, the flexible rod acts on the external support lever and

brings the braking sectors up against the three brake discs splined onto the idler gear, hence stopping the tractor.

TOOLS

WARNING - The operations described in this section must be performed only with the **ESSENTIAL** equipment marked with (X).

To operate safely and achieve best results however, while saving time and effort, essential equipment must be used in conjunction with the special tools recommended below, and tools which you must make yourself and for which you will find the design in this manual.

List of special tools necessary for the various operations described in this section.

X **380000822** Driver for boot installation.

380000227 Lifting hook.

BRAKE TROUBLESHOOTING

Problems	Possible causes	Correction
Braking ineffectual.	1. Friction material on brake discs worn.	Replace the brake discs.
Unbalanced braking.	1. Incorrect tyre pressure. 2. Friction material on one of the brake discs worn.	Inflate the tyres to the correct pressure. Replace discs.
Braking noisy.	1. Friction material on brake discs worn.	Replace discs.
Parking brake does not lock.	1. Braking sectors worn.	Replace the brake discs.
Brakes locked on when the parking brake is disengaged.	1. Brake discs seized.	Release and replace damaged parts.

FRONT BRAKE ASSEMBLY MOD: TD60D AND TD70D

Removal-Installation (Operation 33-206)



Lift and handle all heavy components using lifting equipment of adequate capacity.

Make sure that the units or parts are supported by appropriate harnesses and hooks. Check that no one is in the vicinity of the load to be lifted.

Proceed as follows to remove the unit:

1. Apply the handbrake.
2. Unscrew the retaining bolts and remove the guards from the propeller shaft.

Note. - Should the caliper (11) not need any servicing, back off its retaining screws (13) and disconnect taking care not to uncouple the hose (12): rest on suitable stand or suspend by wire.

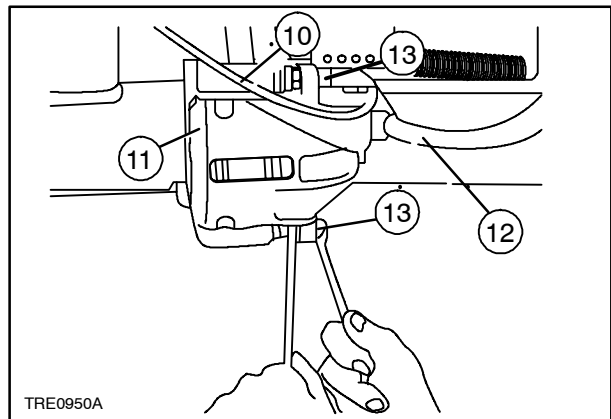

6

3. Disconnect wire (10) fig. 6 of the brake pad wear warning indicator and remove the pads (14 and 15) fig. 7.

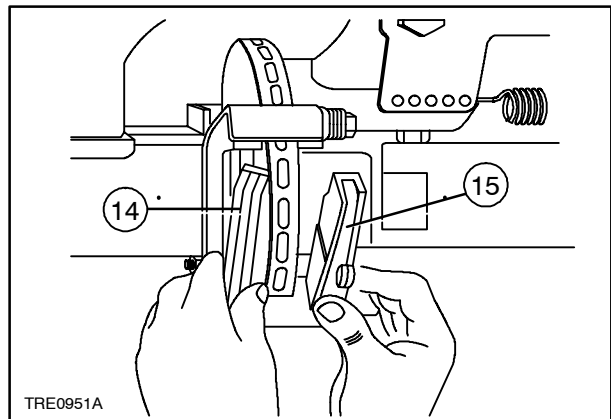

7

4. Remove the front sleeve rear retaining ring and back off the two screws (16) retaining the brake sleeve assembly carrier.
5. Slide the front sleeve along the drive shaft and remove the complete assembly (shaft and brake/bearing carrier).

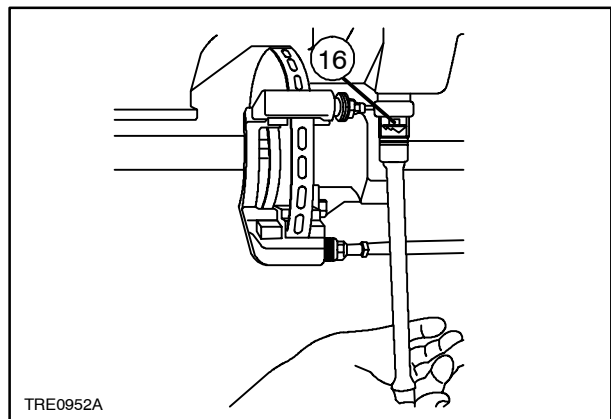

8

6. Take the two drive shafts out of the carrier and clamp the latter in a vice.

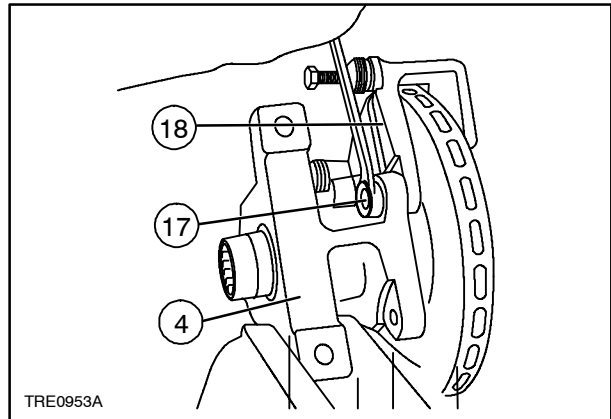

9

7. Unscrew the retaining bolts (17, fig. 9) of the calliper bracket and remove the bracket.
8. Unscrew the retaining bolts (2) of the brake disc and remove the disc (4).

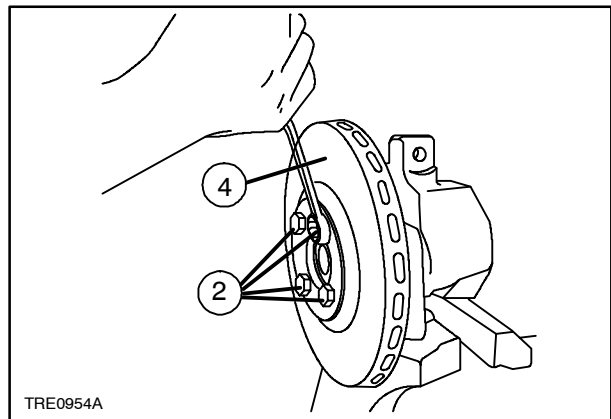

10

9. Take out retaining rings (8 and 9) from the support (4)

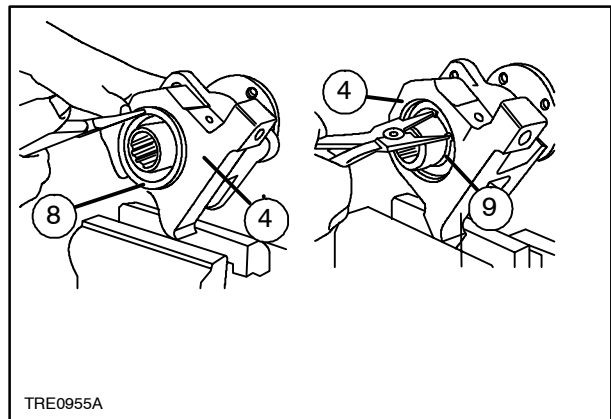

11

10. Using a suitable puller, remove the shaft/sleeve assembly (3) from the support (4).
11. Remove the bearing (5) using a suitable puller and take out the washer (6) Fig. 4.

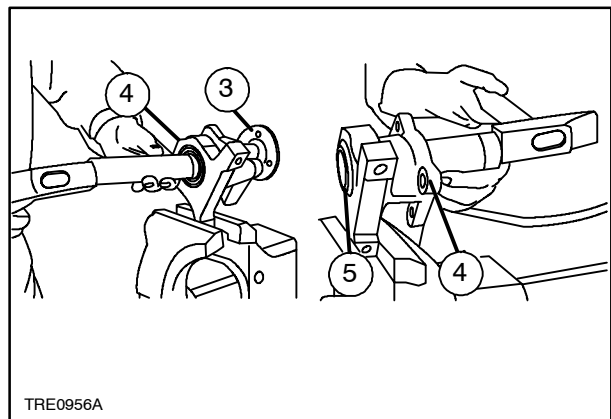

12

Bench overhaul (Operation 33-206)**DANGER**

Always use suitable tools to align holes. NEVER USE FINGERS OR HANDS.

Reverse the removal operation sequence minding the following points:

1. Position the shaft/sleeve assy (3) Fig. 4, upright, introduce the support (4) fig. 13, followed by the washer (6) Fig. 4 in the bearing seat with the chamfered side facing outwards.
2. Insert bearing (5) fig. 4 on assembly (3) fig. 14 and bring into contact with seat using a suitable drift or press tool; lock with the retaining ring (9) fig. 4.
3. Clamp the carrier in a vice then, using a suitable drift or press tool, locate properly against washer (6) Fig. 4. Position washer (7) Fig. 4 with the chamfered side facing the bearing (5) and lock the assembly with the retaining ring (8) fig. 4.

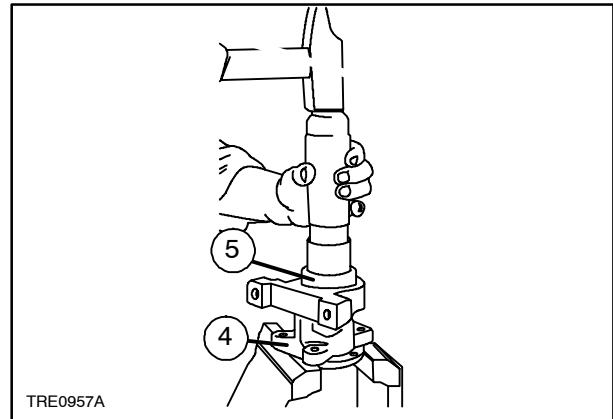

13

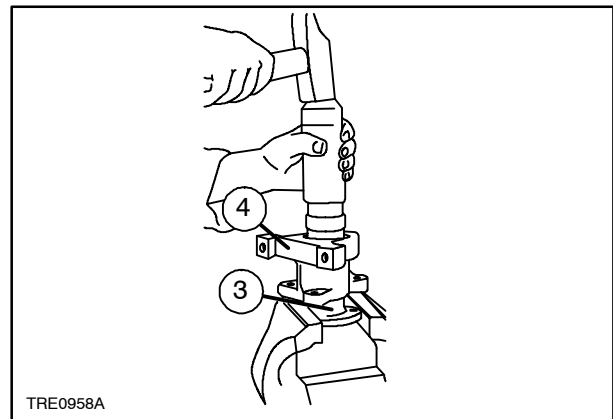

14

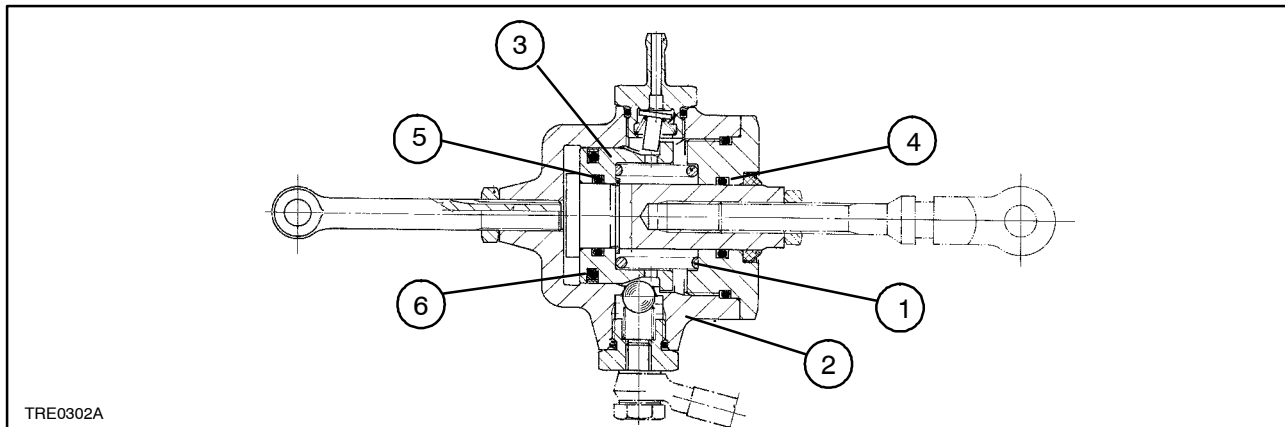

15

Sectional drawing of front service brake control pump (optional)

- | | |
|--------------------|------------------|
| 1. Spring. | 4. Rear seal. |
| 2. Pump body. | 5. Central seal. |
| 3. Control piston. | 6. Front seal. |

SERVICE BRAKE**Removal - Installation (Operation 33 202 60)****⚠ DANGER ⚠**

Lift and handle all heavy components using lifting equipment of adequate capacity.
 Make sure that the assemblies and parts are supported by appropriate tools and hooks. Check that no one is in the vicinity of the load to be lifted.

Proceed as follows to remove the final drive box.

1. Disconnect the negative battery cable (1).
2. Chock the front wheels using suitable wheel stops.

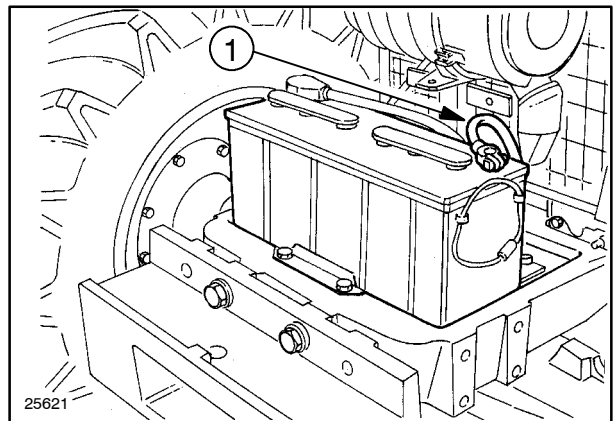

16

3. Remove the vertical rod (1) and the LH stabiliser strut (2).

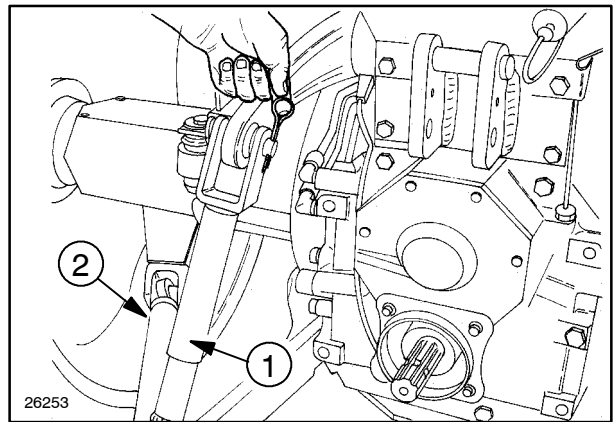

17

4. Raise the rear section of the tractor and place a fixed stand underneath the bending bar support.

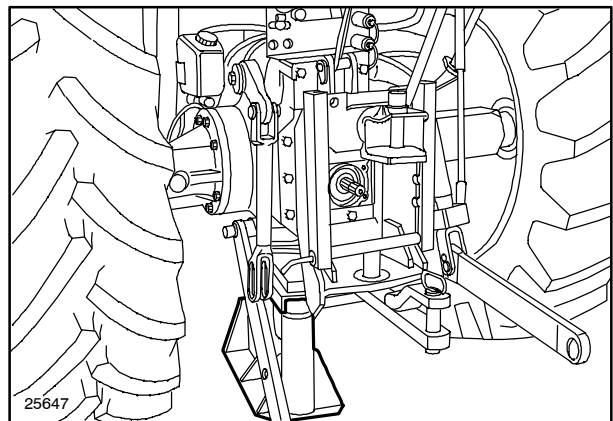

18

5. Undo the retaining bolts and remove the rear LH wheel.

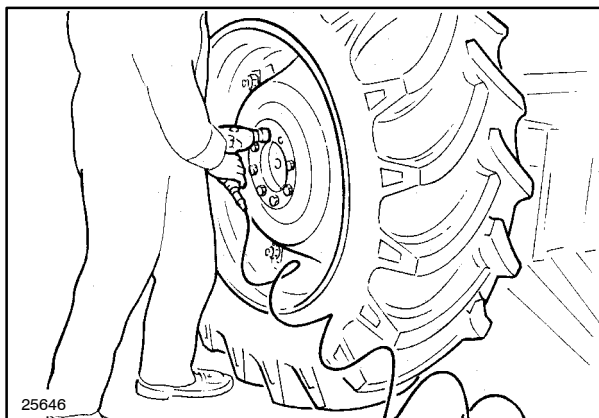

19

6. Undo the bolts (1) securing the cab to its mounting.
7. Raise the cab slightly and place a suitable piece of wood between the hydraulic lift and the cab, taking care to avoid contact with pipes.

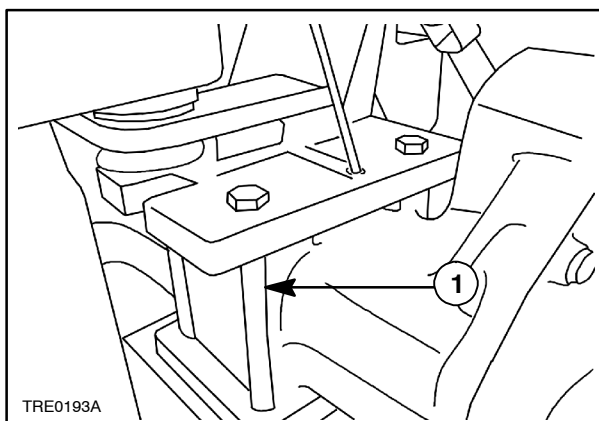

20

8. Remove the plug (1) and drain the oil from the rear transmission-gearbox casing.

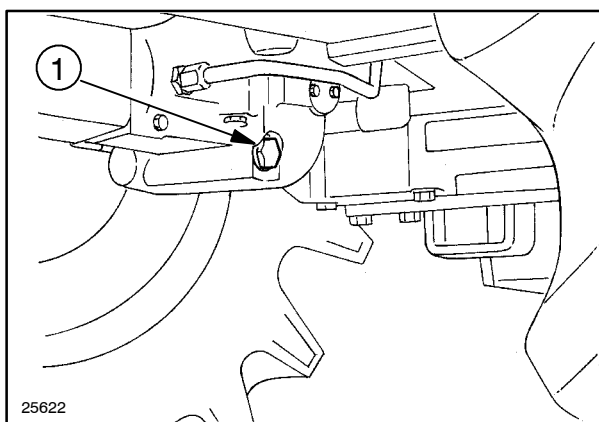

21

9. Undo the bolts securing the cab to its mounting (1).

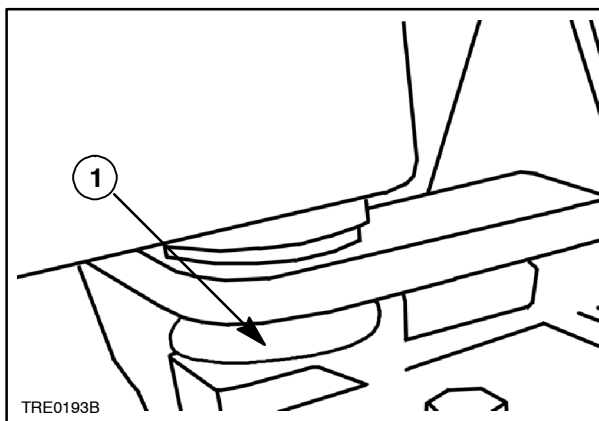

22

10. Position a stand (1) underneath the rear section of the fuel tank.

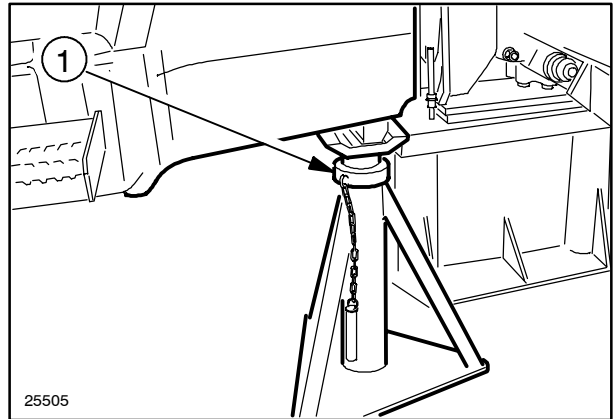

23

11. Fit lifting hooks (1) **380000227** onto the final drive box. Connect a hydraulic lift to the hooks, undo the retaining bolts and remove the LH final drive box from the transmission box.

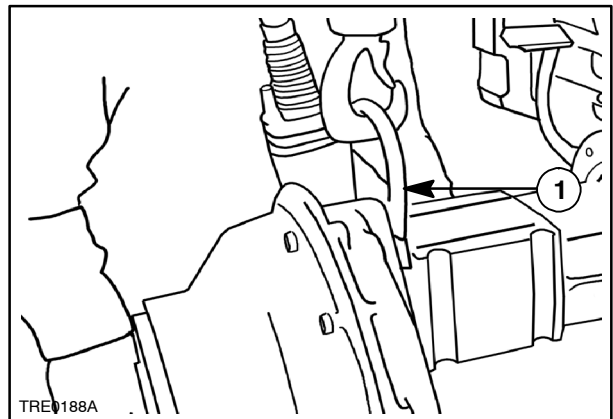

24

12. Remove the cotter pin (1).

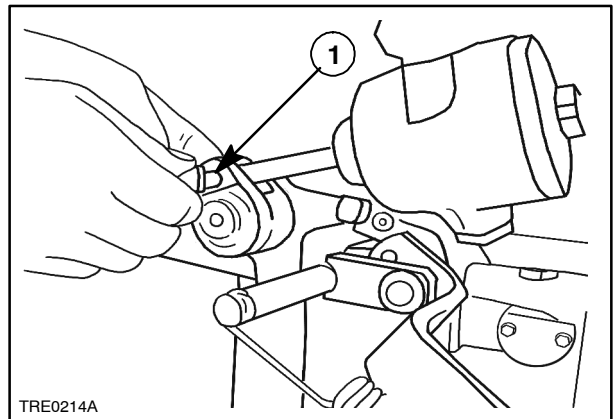

25

13. Unscrew the locknut and remove the control pump (1) from the link.

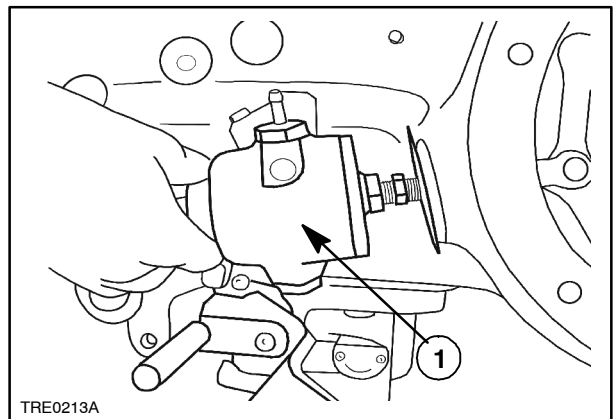

26

14. Back off the link (1) and remove the complete brake unit.

15. Check actuator and brake discs for wear.



Always use appropriate tools to align fixing holes.
NEVER USE FINGERS OR HANDS.

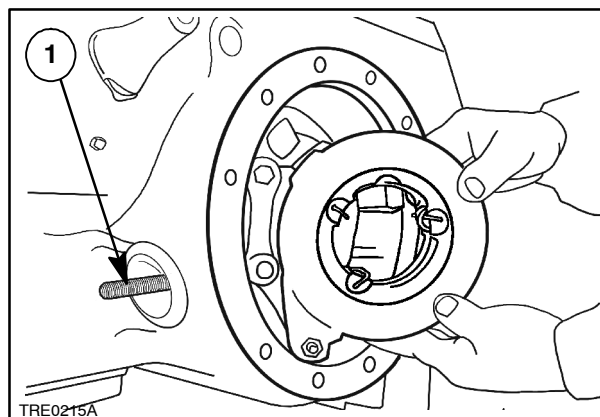

27

16. Refit the final drive box to the rear transmission box as follows:

- Refer to the illustrations on page 3 for the correct orientation of the various components.
- Before refitting the final drive box to the rear transmission box, thoroughly clean and degrease the mating surfaces and apply a strip of sealing compound of diameter about 2 mm as shown in the illustration on page 16.
- Apply the torque settings given on page 2.
- Using tool **380800022** (A) as shown, position boot (11) correctly on brake link (1). (see fig. 28)
- Fit the brake disc and spacers.
- Using tool **380000227** and a hydraulic lift, refit the final drive complete with axle shaft.
- Fit the rear cab mounting retaining bolts.
- Remove the piece of wood between the cab and the lift body.
- Tighten the bolt securing the cab to the rear LH support.
- Fit the LH wheel.
- Fit the stabiliser strut and the vertical rod.
- Remove the stands.
- Screw in the oil drain plug and refill.
- Connect the battery negative lead.

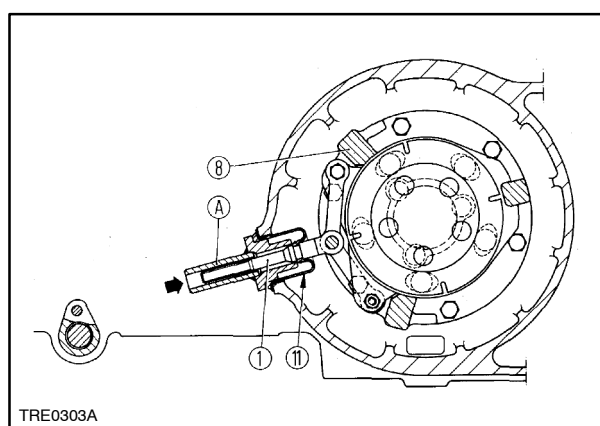

28

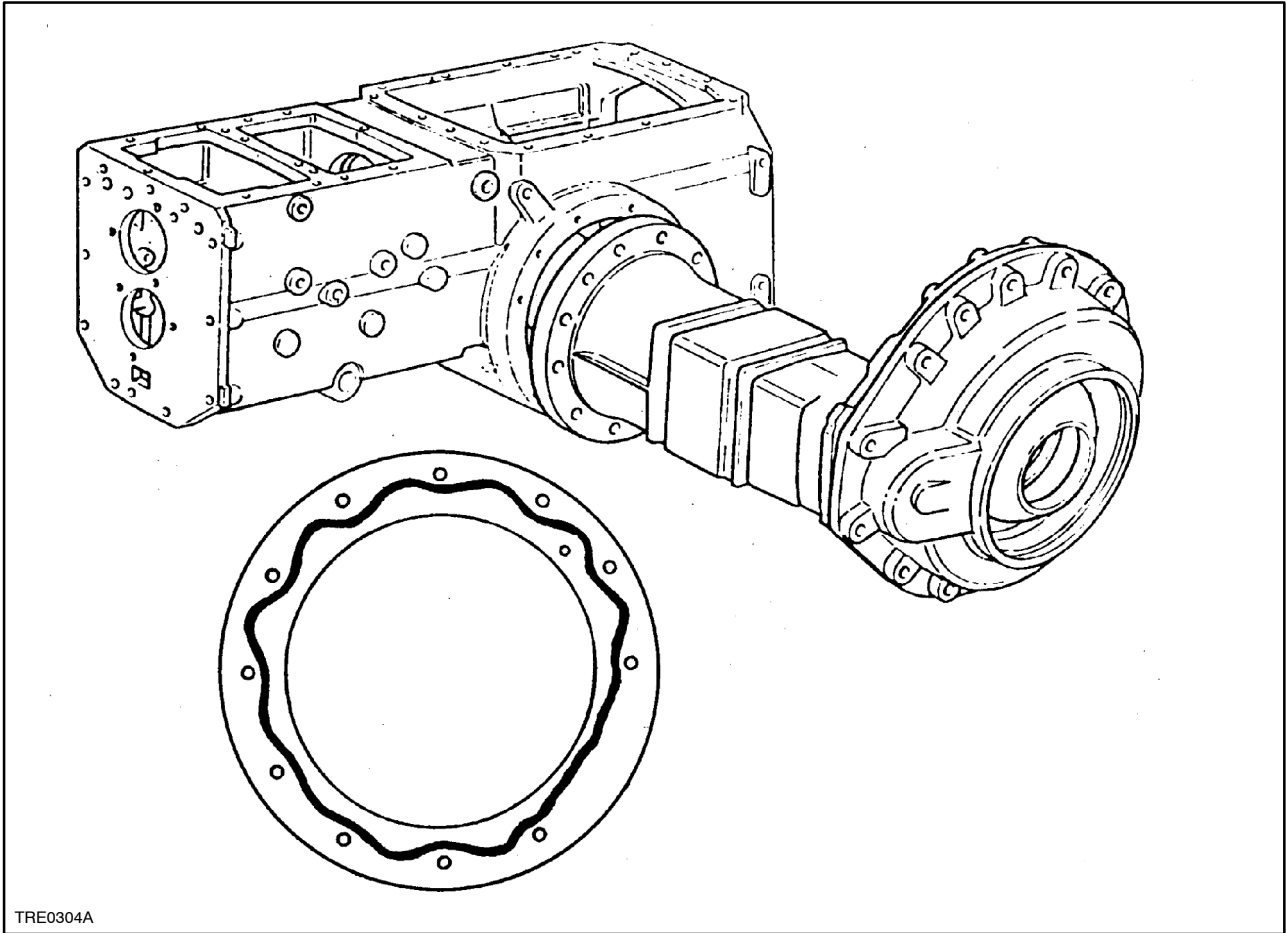

29

Diagram for application of sealing compound when fitting braking assembly between the final drive housing and the rear transmission box.

The types of sealing compound to be applied are listed on page 1 of Section 00.

HYDRAULIC FRONT BRAKE PUMP (OPTIONAL)

Removal - Installation (Operation. 33 202 50)

⚠ ATTENTION ⚠

Handle all parts carefully.
Do not insert fingers or hands between one part and another. Always wear the prescribed safety clothing, including protective glasses, gloves and shoes.

Proceed as follows to remove the hydraulic pump.

1. Disconnect the negative battery cable (1).
2. Chock the front wheels using suitable wheel stops.

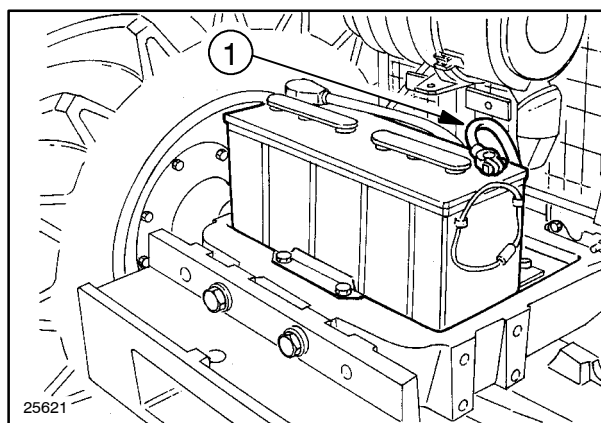

30

3. Disconnect the electrical connections from the plug (2) of the tank (1) and after retrieving the oil, remove the service brake control pipes (3).

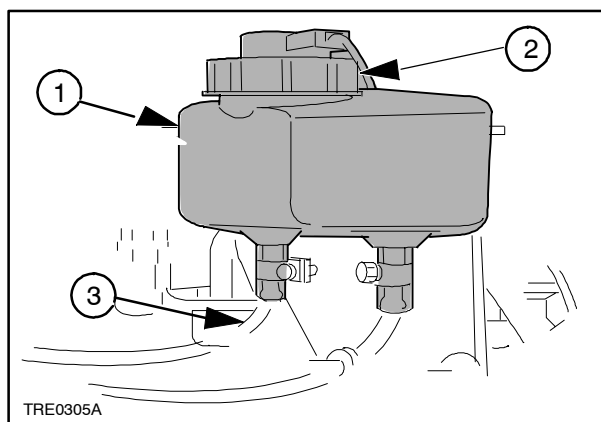

31

4. Remove the cotter pin (1).

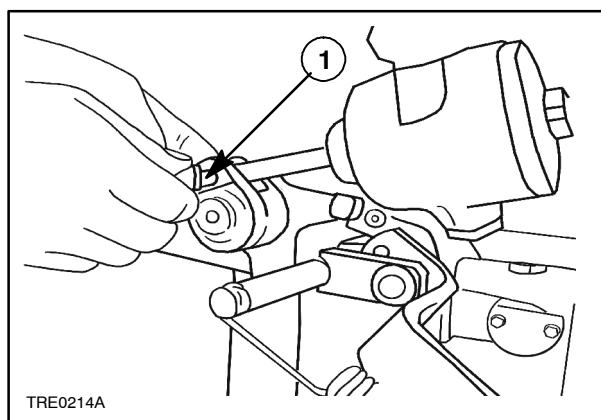

32

5. Unscrew the locknut and remove the control pump (1).

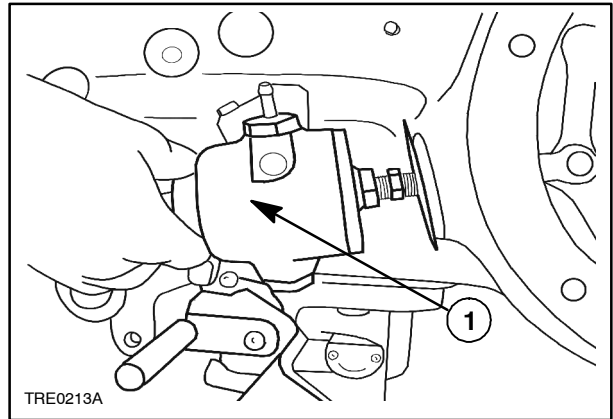

33

6. Remove the front hydraulic pump internal parts. Check the seals and piston.

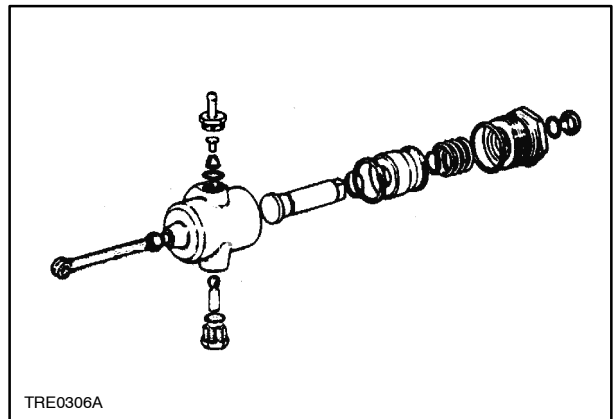

34

ATTENTION

Always use appropriate tools to align fixing holes.
NEVER USE FINGERS OR HANDS.

7. Refit the hydraulic brake control pump unit as follows.
- Fit the pumps, secure them, then connect them to the control pedals link.
 - Connect the control pipes and the tank and the connections to the oil level sensor, then fill.
 - Connect the battery negative lead.
 - Carry out the following adjustment and bleed the air from the circuit, observing the points described on page 19.

HYDRAULIC FRONT BRAKE SYSTEM (Optional)**Bleeding the air (Operation 33 202 04)**

Air must be bled whenever work has been carried out on the front brake hydraulic system.

Proceed as follows.

1. Thoroughly clean the external parts of the unit around the bleed screws (1 and 2, fig. 36), and the hydraulic oil tank lid (1, fig. 35).
2. Make sure that the hydraulic oil tank (1) is filled up above the minimum level before and during the bleeding operations.
3. Depress the LH brake pedal, slowly and to the end of its travel, so that the fluid is placed under pressure.

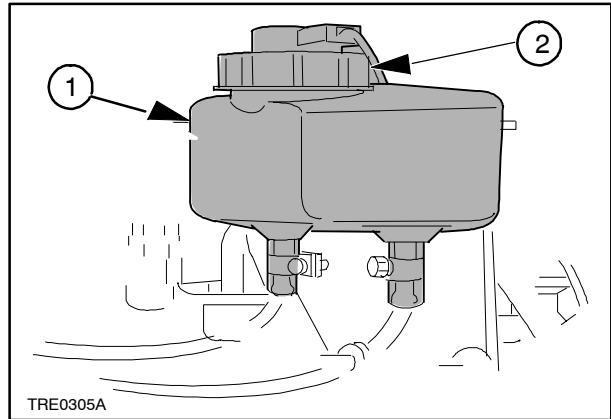

35

Note. - Filter all drained oil before reusing.

4. Keeping the pedal depressed, undo the bleed screw (1) by half a turn. Allow the fluid mixed with air bubbles to flow out.
5. Retighten the screw (1) and repeat the above operations until the oil that comes out is free of air bubbles.
6. Depress the LH brake pedal again to place the circuit under pressure. This occurs when the travel of the pedal returns to normal.
7. Repeat the above operations for the RH brake pedal from the bleed screw (2).

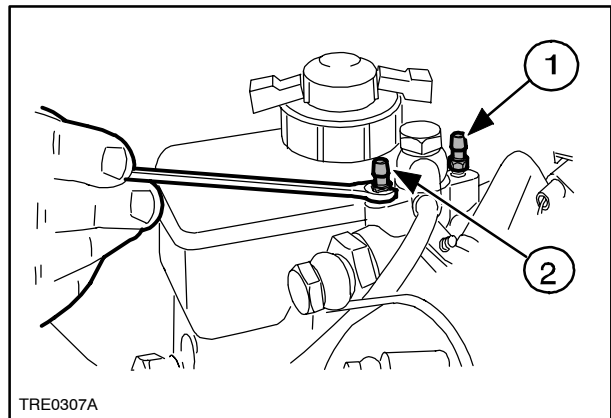

36

8. Depress the LH and RH brake pedal, slowly and to the end of its travel, so that the oil is placed under pressure.
9. Keeping the brake pedals depressed, undo the bleed screw (1) by half a turn. Allow the fluid mixed with air bubbles to flow out.
10. Retighten the screw (1) and repeat the above operations until the oil that comes out is free of air bubbles.
11. When the operation has been completed, replenish the fluid in the tank (1, fig. 35).

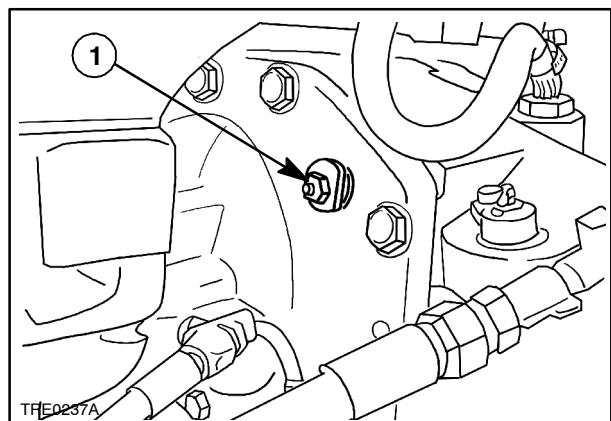

37

SERVICE BRAKE PEDALS

Adjusting height of service brake pedals

(Operation 33 120 08)

1. With the brake pedals connected to their respective forks and the pedal connecting pin removed, check that the pedal adjustment.
2. Check that pedal free travel is the same for both pedals and does not exceed 80 mm.

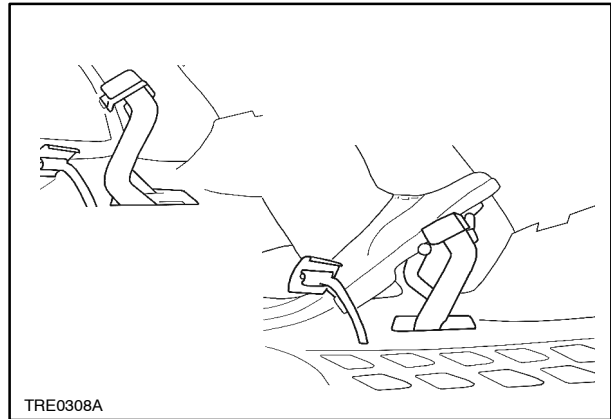

38

3. If adjustment is required, move brake hand lever downwards. Slacken the lock nuts (A) and tighten or slacken the sleeves (B) until the required free travel is 45 mm. Lastly tighten the lock nuts (A).

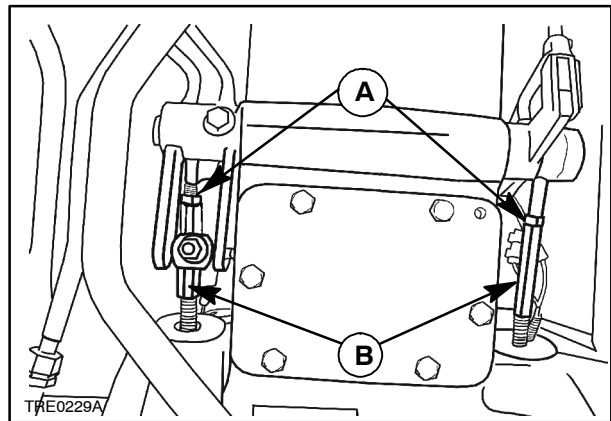

39

HAND BRAKE ADJUSTMENT

Adjusting travel (Operation 33 110 08)

The travel of the parking brake control lever must be adjusted whenever work is carried out on the unit and when the lever is not on the third notch of the sector gear when the brake is engaged.

Proceed as follows.

1. Slacken the lock nut (1).
2. Tighten or slacken the adjusting screw (2) until the control lever is locked on the third notch.
3. Tighten the lock nut (1).

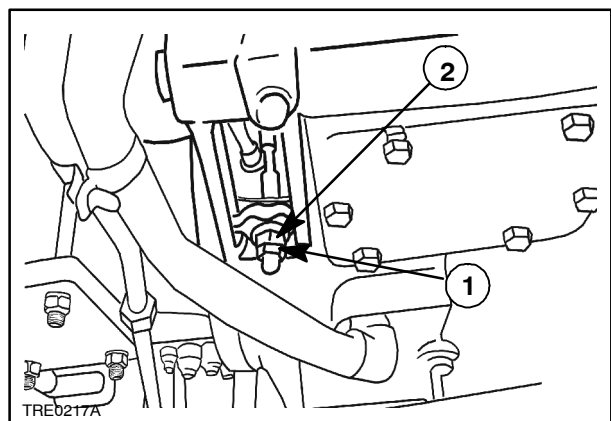

40

SECTION 35 – HYDRAULIC SYSTEM

Chapter 1 – Rear mechanical hydraulic lift

CONTENTS

Section	Description	Page
35 000	Main specification	1
	Tightening torques	5
	Tools	6
	Cross-sectional views	7
	Description & Operation	9
	Hydraulic circuit	10
	Description and operation of lift phases	11
	Fault diagnosis	14
35 110.30	Hydraulic lift – disassembly reassembly	16
35.110.40–42–46	Hydraulic lift – bench overhaul	23
	Adjusting the lift	28
35.110.08	Linkage adjustment	34
35.110.30	Pressure relief valve – disassembly reassembly	36
35.110.32	Pressure relief valve – setting	36
35.110.14	Lift control valve – disassembly assembly and overhaul on bench	37
35.0101.10	Lift pump	41

35 000 – MAIN SPECIFICATION – TORQUE SETTINGS – TOOLS – SECTIONAL DRAWINGS – DESCRIPTION AND OPERATION – TROUBLESHOOTING

MAIN SPECIFICATION OF REAR MECHANICAL HYDRAULIC LIFT

Type		position or draft control with a combination of the two
Operating system		two independent levers
LIFT-O-MATIC		provides fast lifting/lowering operations using pushbuttons, without using the position or draft control levers
Single-acting cylinder:		
– rated diameter and stroke:		
All models	mm (in.)	100x128 (3.9370x5.0394)
– capacity:		
All models	cm ³ (in. ³)	1005 (61.33)
Pressure relief valve setting	bar (psi)	186 – 191 (2697.69 – 2770.21)
Cylinder safety valve setting	bar (psi)	210 – 215 (3045.78 – 3118.30)

(continued overleaf)

MAIN SPECIFICATION OF REAR MECHANICAL HYDRAULIC LIFT

(continued)

Lift piston diameter:		
– All models	mm (in.)	99.980 – 100.000 (3.9362 – 3.9370)
Internal diameter of cylinder liner:		
– All models	mm (in.)	100.036 – 100.071 (3.9384 – 3.9398)
Clearance between piston and liner	mm (in.)	0.036 – 0.091 (0.0014 – 0.0036)
Diameter of lift arm shaft (11, fig. 3) at position of bushings:		
– right-hand side	mm (in.)	54.970 – 55.000 (2.1642 – 2.1654)
– left-hand side	mm (in.)	62.670 – 62.700 (2.1642 – 2.1654)
Internal diameter of bushings fitted on lift body:		
– right-hand side (8, fig. 3)	mm (in.)	55.100 – 55.184 ⁽¹⁾ (2.1693 – 2.1726)
– left-hand side (12)	mm (in.)	62.800 – 62.884 ⁽¹⁾ (2.4724 – 2.4757)
Clearance between lift arm shaft and bushings	mm (in.)	0.100 – 0.214 (0.0039 – 0.0084)
Interference between bushings and their seats	mm (in.)	0.065 – 0.185 (0.0026 – 0.0073)
Axial clearance of shaft complete with lift arms	mm (in.)	0.2 – 1.4 (0.0079 – 0.0551)
External diameter of draft control idler shaft	mm (in.)	21.967 – 22.000 (0.8648 – 0.8661)
Internal diameter of seats in support	mm (in.)	22.020 – 22.072 (0.8669 – 0.8690)
Clearance between idler shaft and its seat	mm (in.)	0.020 – 0.105 (0.0008 – 0.0041)
Diameter of position control idler shaft	mm (in.)	13.973 – 14.000 (0.5501 – 0.5512)
Internal diameter of position control idler shaft	mm (in.)	14.016 – 14.059 (0.5518 – 0.5535)
Clearance between draft control idler shaft and position control idler shaft	mm (in.)	0.016 – 0.086 (0.0006 – 0.0034)
Clearance between control valve block pin (8, fig. 4) and its seat on the control valve block body	mm (in.)	0.008 – 0.012 ⁽²⁾ (0.0003 – 0.0005)
Clearance between lift control valve (10) and its seat on the control valve block body	mm (in.)	0.008 – 0.012 ⁽²⁾ (0.0003 – 0.0005)
Control valve block pin return spring (5, fig. 4):		
– free spring length	mm (in.)	50.5 (1.9882)
– spring length under load of 31.7 – 35 N (7.1242 – 7.8741 lb)	mm (in.)	34 (1.3386)
Control valve return spring (9, fig. 4)		
– free spring length	mm (in.)	44 (1.7323)
– spring length under load of 103 – 114.7 N (23.1590 – 25.8058 lb)	mm (in.)	29 (1.1417)

MAIN SPECIFICATION OF IMPLEMENT HITCHING DEVICE

Type		three-point linkage
Category: – All Models		2
Draft control		by means of lower arms with flex bar
Maximum liftable load with centre of gravity 610 mm from the lower arm link ends: with arms horizontal (with top link connected to hole on upper support):		
– TD60D, TD70D Models	kg (lb)	2260 (4982.45)
– TD80D, TD90D and TD95D Models	kg (lb)	2700 (5952.48)
Maximum liftable load: with arms horizontal (with top link connected to upper support pin):		
– TD60D, TD70D Models	kg (lb)	3000 (6613.87)
– TD80D, TD90D and TD95D Models	kg (lb)	3565 (7859.48)
Flex bar diameter:		
– TD60D, TD70D, TD80D, TD90D Models	mm (in.)	24.867 – 24.900 (0.9790 – 0.9803)
Axial clearance of flex bar	mm (in.)	1.2 – 4.1 (0.0472 – 0.1614)

MAIN SPECIFICATION OF HYDRAULIC PUMP (All models)

Filter		
Type		paper cartridge
Location		fixed to the pump housing on suction side
Pump		
Type		gear type with oil suction from transmission casing
Location		Flanged on the rear left-hand side of the engine
Construction		BOSCH
Model		A31
Operation		by means of the engine gears
Direction of rotation (as seen from drive side)		left
Engine speed to pump speed ratio		1 : 1.080
Maximum speed of pump rotation (with engine at maximum power equivalent to 2500 rpm)	rpm	2700
Nominal flow rate	dm ³ /turn (inch ³ /turn)	0.01435 (0.8757)
Corresponding rated output for new pump	dm ³ /min (inch ³ /min)	38.7 (2361.6849)

(continued overleaf)

MAIN SPECIFICATION OF HYDRAULIC PUMP (All models)

(continued)

Driven and driving gear shaft diameter	mm (in.)	17.400 – 17.418 (0.6850 – 0.6857)
Internal diameter of seats in supports	mm (in.)	17.450 – 17.470 (0.6870 – 0.6878)
Clearance between gear shafts and their seats	mm (in.)	0.032 – 0.070 (0.0013 – 0.0025)
– maximum clearance due to wear	mm (in.)	0.1 (0.0039)
Radial clearance of gears in pump body	mm (in.)	0.020 – 0.064 (0.0008 – 0.0025)
Maximum wear on pump body, suction side, at position of gears	mm (in.)	0.1 (0.0039)
Width of gears (5, fig. 104)	mm (in.)	24.000 – 24.015 (0.9449 – 0.9455)
Width of supports (4 and 6)	mm (in.)	24.490 – 24.510 (0.9642 – 0.9650)
Width of pump body (3) for gear seats and supports	mm (in.)	73.135 – 73.160 (2.8793 – 2.8803)
Axial clearance of gears complete with supports in pump body (recondition if necessary)	mm (in.)	0.100 – 0.180 (2.8793 – 2.8803)

LIFT HYDRAULIC PUMP (OPTIONAL) DATA

Filter	
Type	paper cartridge
Location	fixed to the pump housing on suction side
Pump	
Type	gear type with oil suction from transmission casing
Location	Flanged on the rear left-hand side of the engine
Construction	BOSCH
Model	A42
Operation	by means of the engine gears
Direction of rotation (as seen from drive side)	left
Engine speed to pump speed ratio	1 : 1.080
Maximum speed of pump rotation (with engine at maximum power equivalent to 2500 rpm)	rpm 2700
Nominal flow rate	dm ³ /turn (inch ³ /turn) 0.01955 (1.1930)
Corresponding rated output for new pump	dm ³ /min (inch ³ /min) 52.7 (3216.0412)

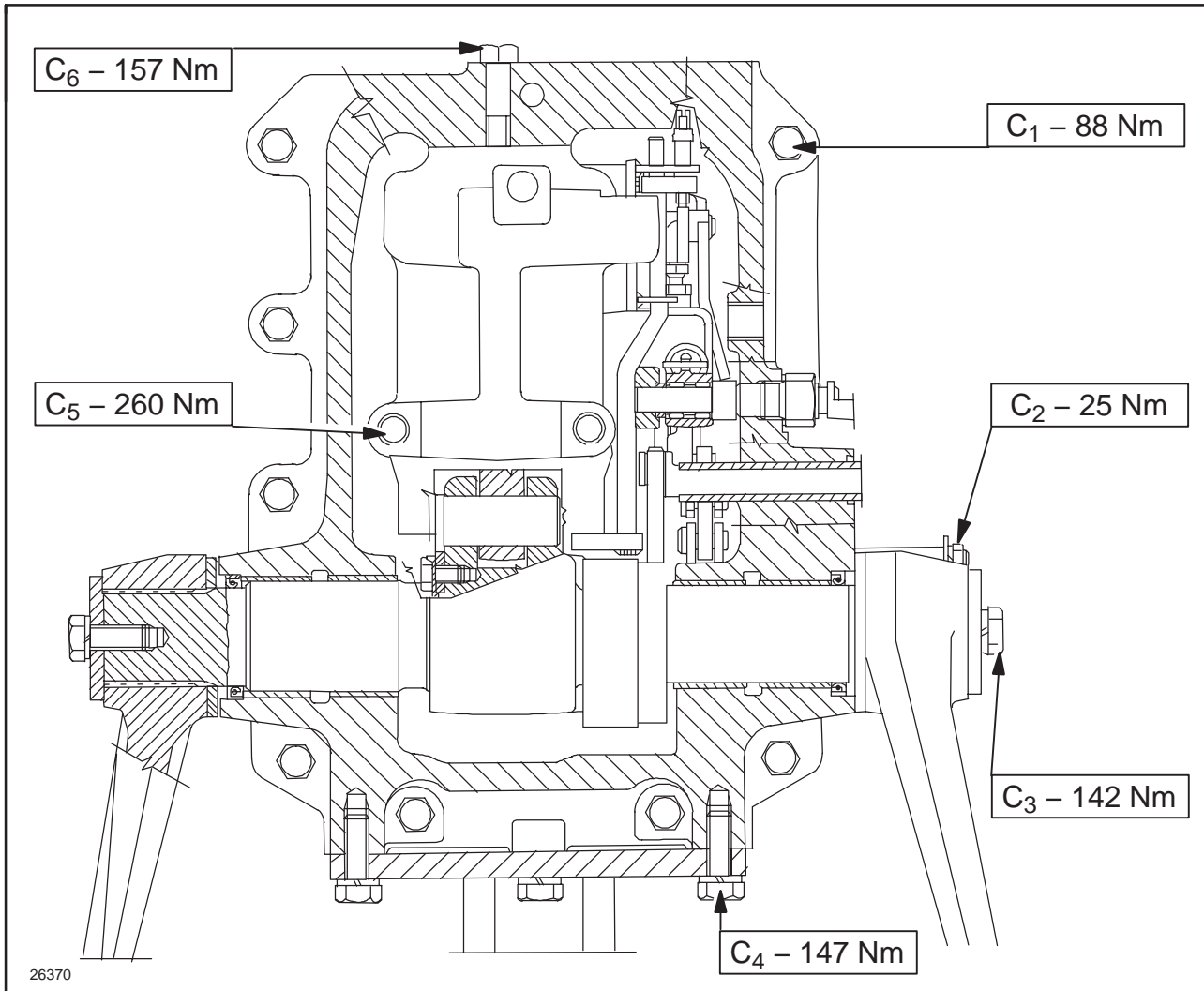

1

TORQUE SETTINGS

	Thread	Tightening torque	
		Nm	ft lb
Bolt securing lift to rear transmission casing (C ₁)	M 12 x 1.25	98	72.2811
Nuts for lift lever quadrant bracket stud bolts (C ₂)	M 8 x 1.25	25	18.4390
Lifting arm plate retaining bolts (C ₃)	M 14 x 1.5	142	104.7338
Three-point linkage support retaining bolts (C ₄)	M 14 x 1.5	103	75.9689
Lift cylinder retaining bolts:			
– upper (C ₅)	M 16 x 1.5	260	191.7661
– front (C ₆)	M 14 x 1.5	157	115.7972
Nuts for lever quadrant bracket securing stud bolts (2, Fig. 32)	M 8 x 1.25	25	18.4390
Cylinder safety valve (C ₇ , fig. 3)	M 20 x 1.5	83	61.2176
Check valve union (C ₈ , fig 3)	M 24 x 1.5	83	61.2176
Control valve cap (C ₉ , fig. 3)	M 20 x 1.5	54	39.8283
Bolts securing control valve block to lift (C ₁₀ , fig.3)	M 8 x 1.25	26	19.1766

TOOLS

HYDRAULIC LIFT EQUIPMENT

Warning – The operations described in this section cannot be carried out without the **ESSENTIAL** tools marked below with **(X)**.

However, to ensure greater safety and obtain the best results while saving time and effort, we recommend that these essential tools are used in conjunction with the specific tools listed below as well as certain tools which are to be made following the construction drawings given in this manual.

380000215 Hand pump for valve calibration.

380000224 Lifting hook.

380000238 Hook adapter **380000224**.

X 380000225 Ring for fitting piston with lift seals.

X 380000274 Union for checking control valve seal.

X 380000262 Punch for fitting lift arm shaft seals.

X 380000261 Punch for fitting needle bearings on control valve block control lever bushing.

X 380000260 Punch for fitting needle bearings to upper/lower draft control levers and to draft control link rod.

X 380000230 Wrench for cylinder safety valve setting ring nut.

X 380000218 Union for cylinder safety valve calibration.

X 380000267 Wrench for maximum lift screw locknut.

X 380000263 Draft control setting tool.

X 380000264 Position control setting tool.

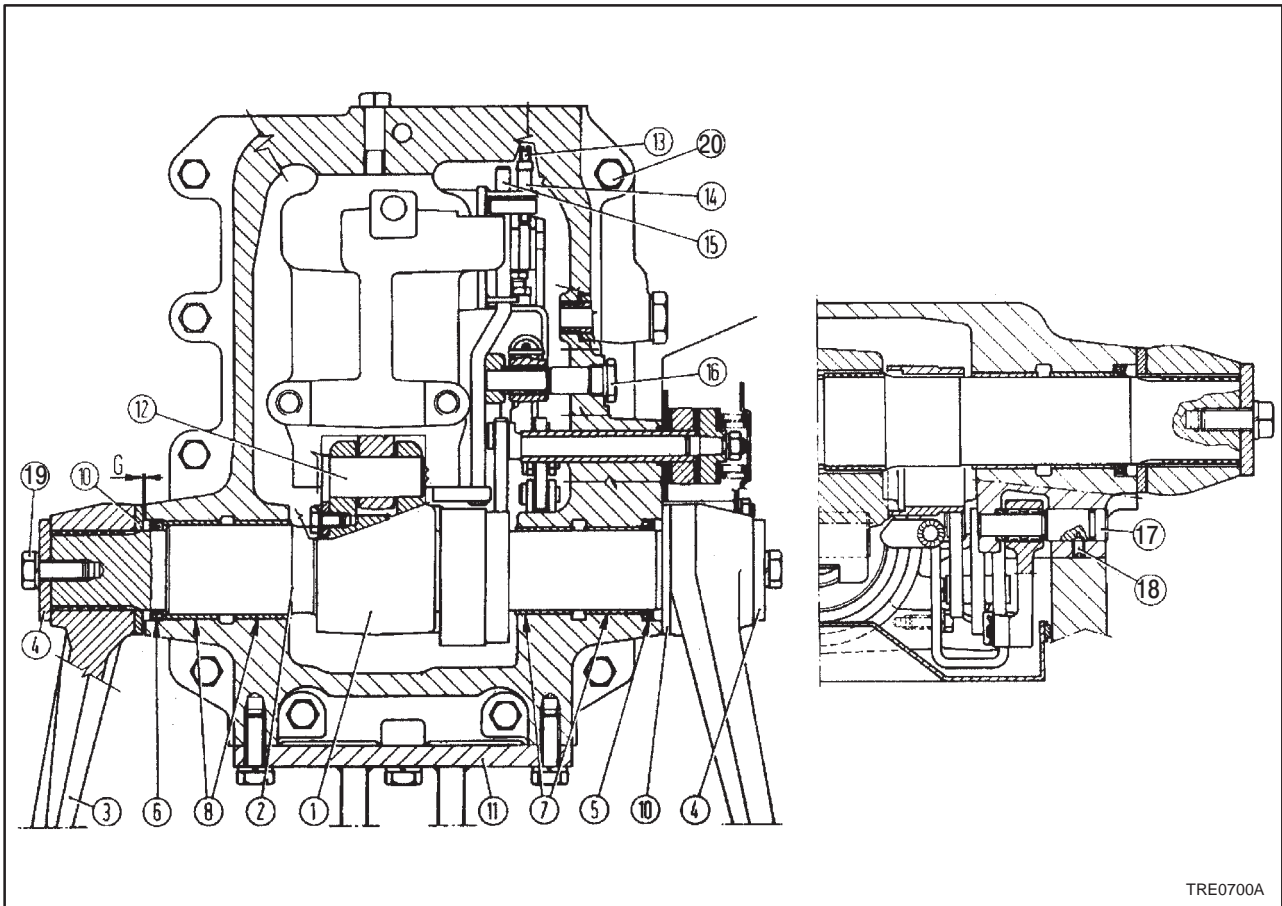

2

Sectional drawing of lift

G = 0.2 to 1.4 mm (0.0079 to 0.551 in.).
Shaft end float.

- | | |
|-----------------------|---|
| 1. Inner arm. | 11. Top link support. |
| 2. Cross shaft. | 12. Piston rod pin. |
| 3. Link arm. | 13. Travel limit adjusting screw. |
| 4. Arm thrust plates. | 14. Travel limit adjusting screw locknut. |
| 5. R.H.Seal. | 15. Travel limit control rod. |
| 6. L.H.Seal. | 16. Control valve link pin. |
| 7. R.H.Bushing. | 17. Draft control inner lever pivot. |
| 8. L.H.Bushing. | 18. Set screw |
| 10. Thrust washers. | 19. Lift capscrews |
| | 20. Thrust plate capscrews. |

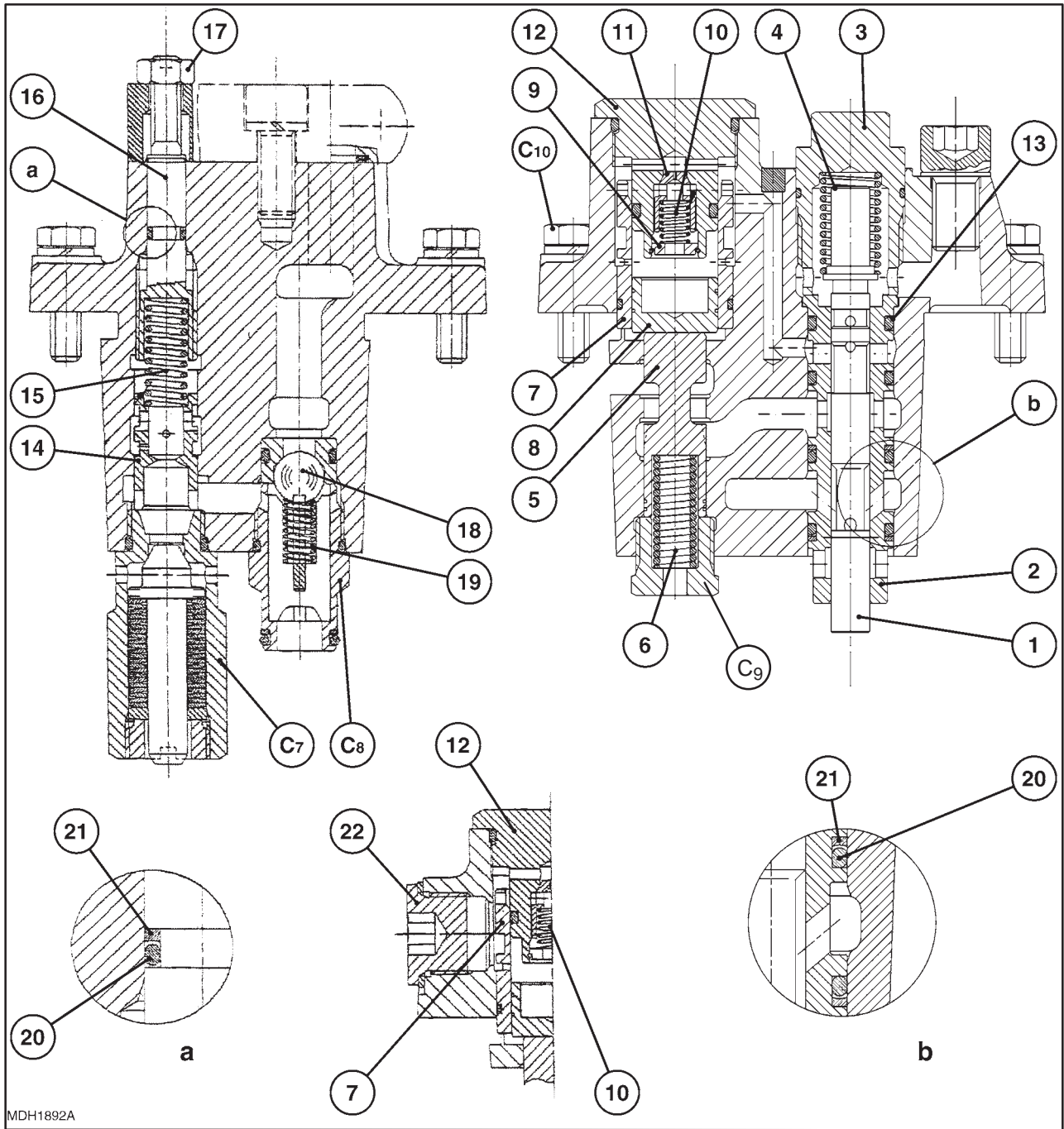

MDH1892A

Sectional drawing of hydraulic lift control valve block

Sectional drawing of hydraulic lift control valve block

- | | |
|---|---|
| <ul style="list-style-type: none"> a. Detail of O–ring and arm lowering adjuster valve anti–extrusion ring. b. Detail of O–ring and control valve pin seat anti–extrusion ring. C₇ Cylinder safety valve. C₈ Lift cylinder oil delivery union. C₉ Plug. C₁₀ Control valve to lift body retaining bolt. 1. Control valve block pin. 2. Control valve block pin seat. 3. Plug. 4. Spring positioning control valve pin in discharge phase. 5. Pilot valve pin. 6. Spring positioning pin when lifting. 7. Pilot valve piston seat. 8. Pilot valve piston. | <ul style="list-style-type: none"> 9. Spring cup. 10. Intervention speed adjustment valve spring. 11. Intervention speed adjustment valve oil inlet orifice. 12. Plug. 13. O–ring seal. 14. Lowering adjuster valve pin. 15. Arm descent speed control valve spring. 16. Arm descent adjustment valve spring loading pin. 17. Locknut for arm descent adjustment valve spring loading pin. 18. Check valve ball. 19. Check valve spring. 20. O–ring. 21. Anti–extrusion ring. 22. Plug. |
|---|---|

Note – Install the O–ring 20 and anti–extrusion ring 21 as illustrated in the drawing (a and b) using the protection device **380000266** and heating the ring 21 in oil at 50 °C. Take care to install ring 21 with the flat surface facing upwards and concave surface facing O–ring 20. Take necessary precautions not to damage them.

DESCRIPTION AND OPERATION

The mechanical lift can operate with controlled position or draft control and with a combination of the two. The lift is controlled by two levers located on the operator's right. It also features the Lift–O–Matic device which raises and lowers the implement without the need to use the position and draft control levers.

Draft control is actuated by the flex bar positioned in the special box mounted under the rear transmission.

The lower lift arms and corresponding control rods are connected to the flex bar.

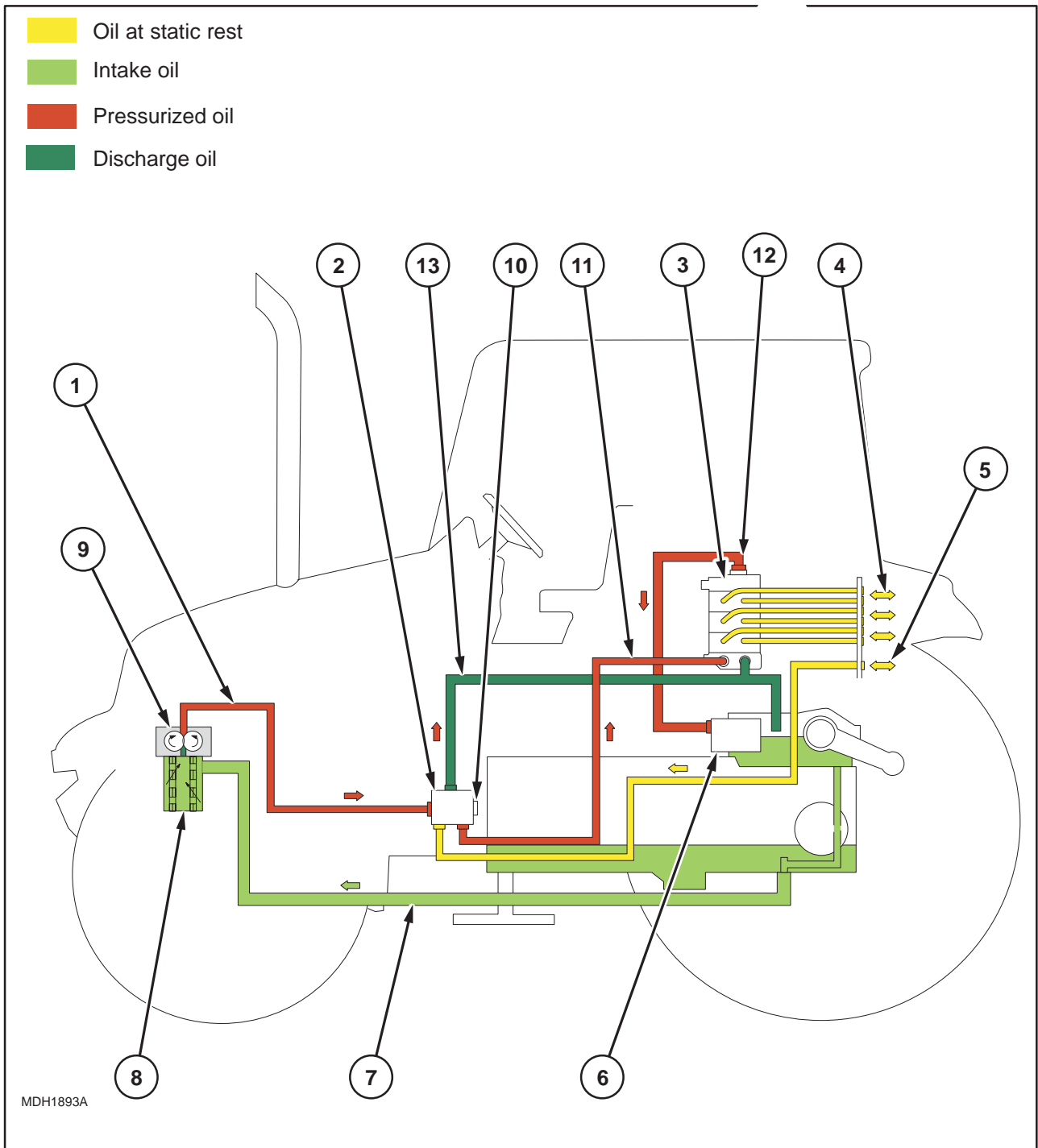

MDH1893A

HYDRAULIC LIFT CIRCUIT

- | | |
|---|--|
| <ul style="list-style-type: none"> 1. Trailer brake valve delivery line. 2. Trailer brake valve. 3. Auxiliary control valves. 4. Auxiliary control valve lines. 5. Trailer brake control valve line. 6. Lift control valve. 7. Suction line. | <ul style="list-style-type: none"> 8. Oil filter. 9. Hydraulic pump. 10. Trailer brake valve mechanical actuator. 11. Delivery line to additional control valves. 12. Delivery line to lift control valve. 13. Discharge line. |
|---|--|

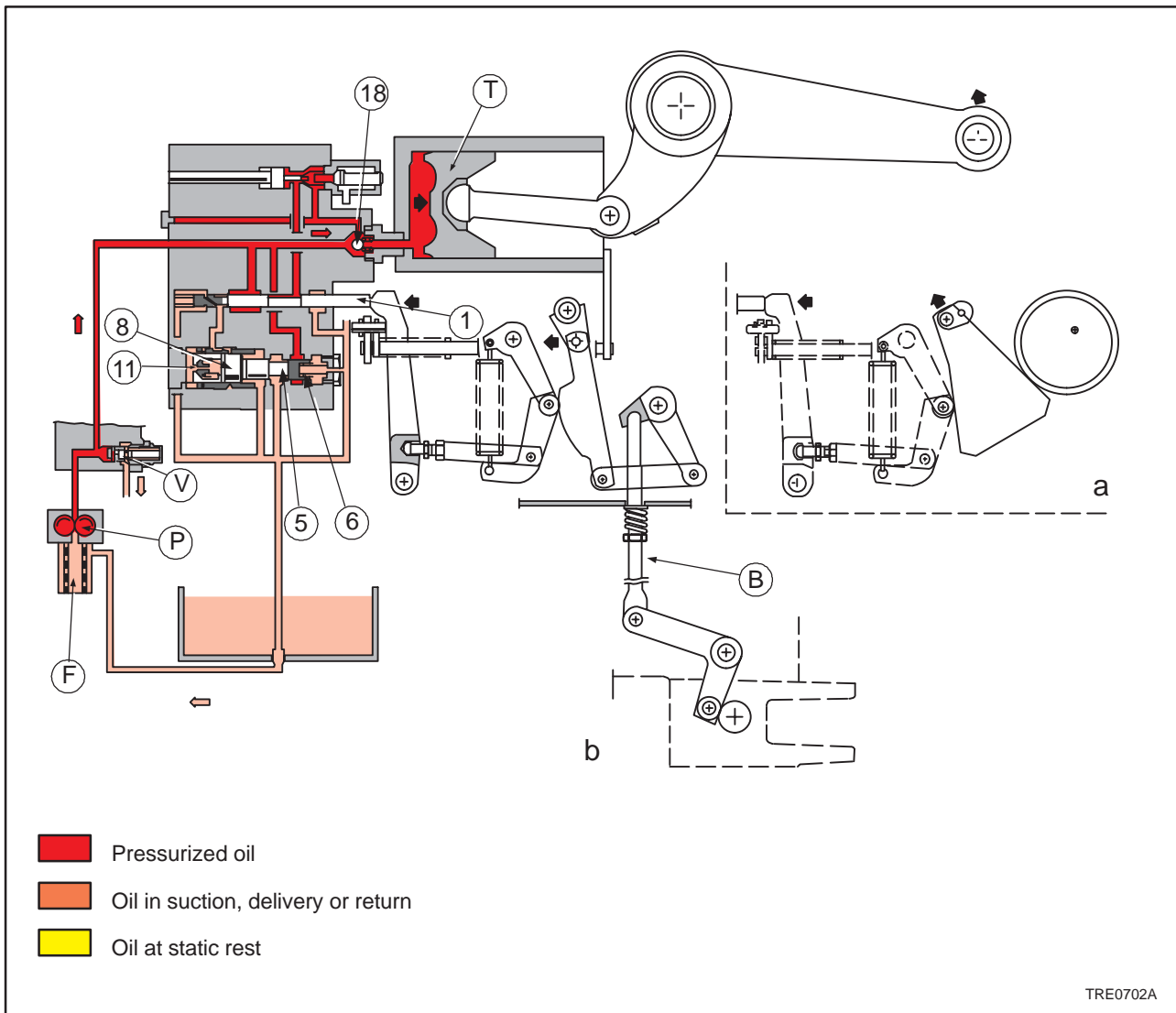

5

ARM LIFT PHASE

- a. Position control linkages.
- b. Draft control linkages.
- B. Draft control transmission.
- F. Filter.
- P. Hydraulic pump.
- T. Lift arm piston.
- V. Pressure relief valve fitted on additional control valves.

- 1. Control valve block pin.
- 5. Pilot valve pin.
- 6. Spring positioning pin when lifting.
- 8. Piston seat.
- 11. Pilot valve.
- 18. Check valve ball.

When the position control lever (located on the operator's right-hand side) is used to raise the arms, the movement shown by the arrows is transmitted by the internal lever mechanisms to the control valve block pin (1). This pin moves to cut off the flow of oil, passing through the intervention speed valve (11), to the pilot valve (8), which is pulled by its spring (6), and then the pin (5) stops the oil discharge.

The pressurized oil opens the check valve (16) and acts on the arm lifting piston.

In draft control operation (detail b), the lift control is sent to the flex bar that, via the transmission rod (B), transmits the movement, shown by the arrows, to the control valve pin (1).

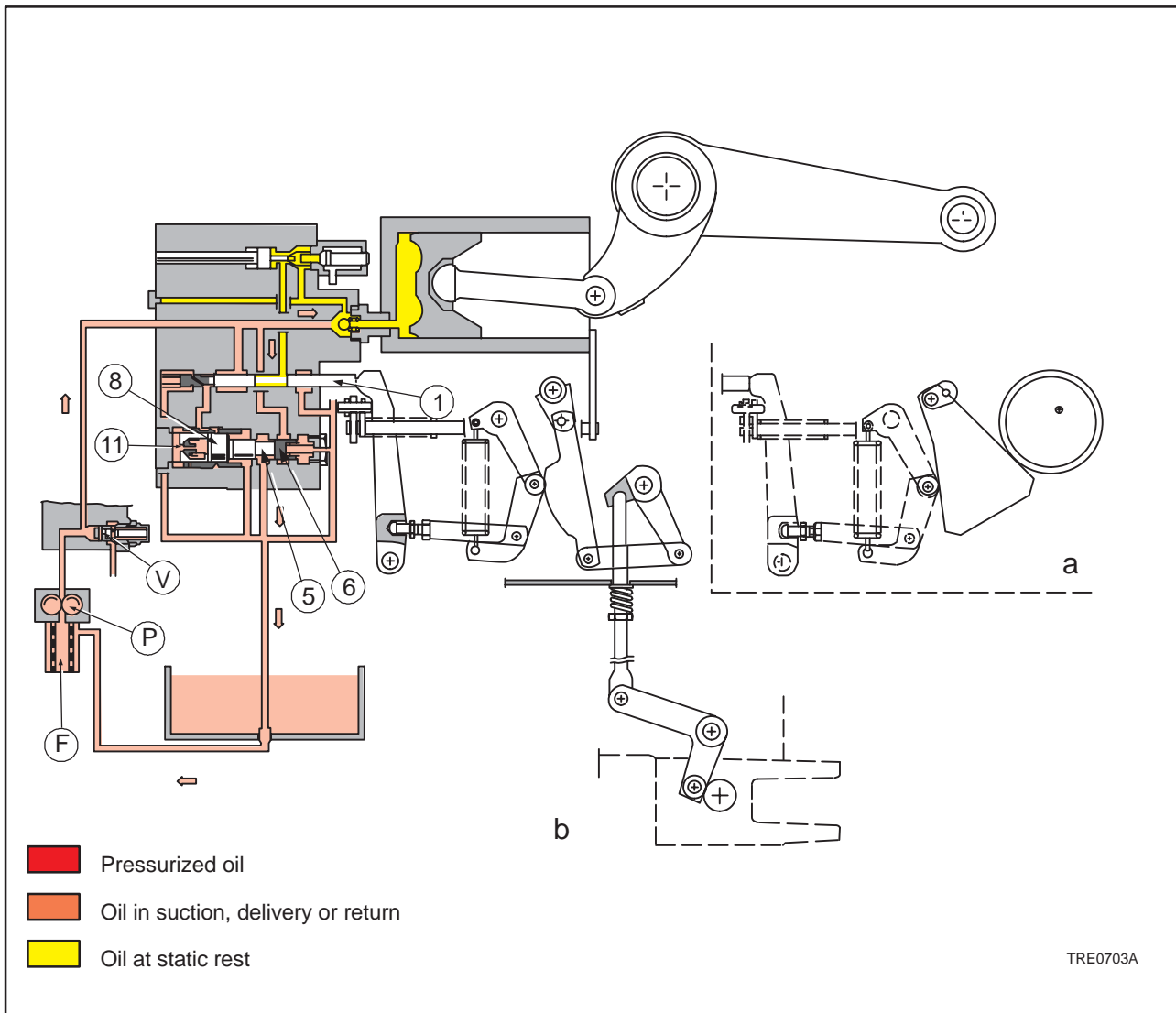

6

NEUTRAL PHASE

- a.** Position control linkages.
b. Draft control linkages.
F. Filter.
P. Hydraulic pump.
T. Lift arm piston.
V. Pressure relief valve fitted on additional control valves.

- 1.** Control valve block pin.
5. Pilot valve pin.
6. Spring positioning pin when lifting.
8. Piston seat.
11. Pilot valve.
18. Check valve ball.

When the lift arms have reached the predetermined height, the internal lever mechanisms stop. The position of the control valve block pin (1), allows the oil to be directed to the control valve piston (8), through the intervention speed adjustment valve (11).

When there is no oil pressure for the piston (8), the pin (5) pushed by the spring (6) opens a discharge gap, thereby allowing oil to flow out to the transmission casing instead of to the lifting cylinder.

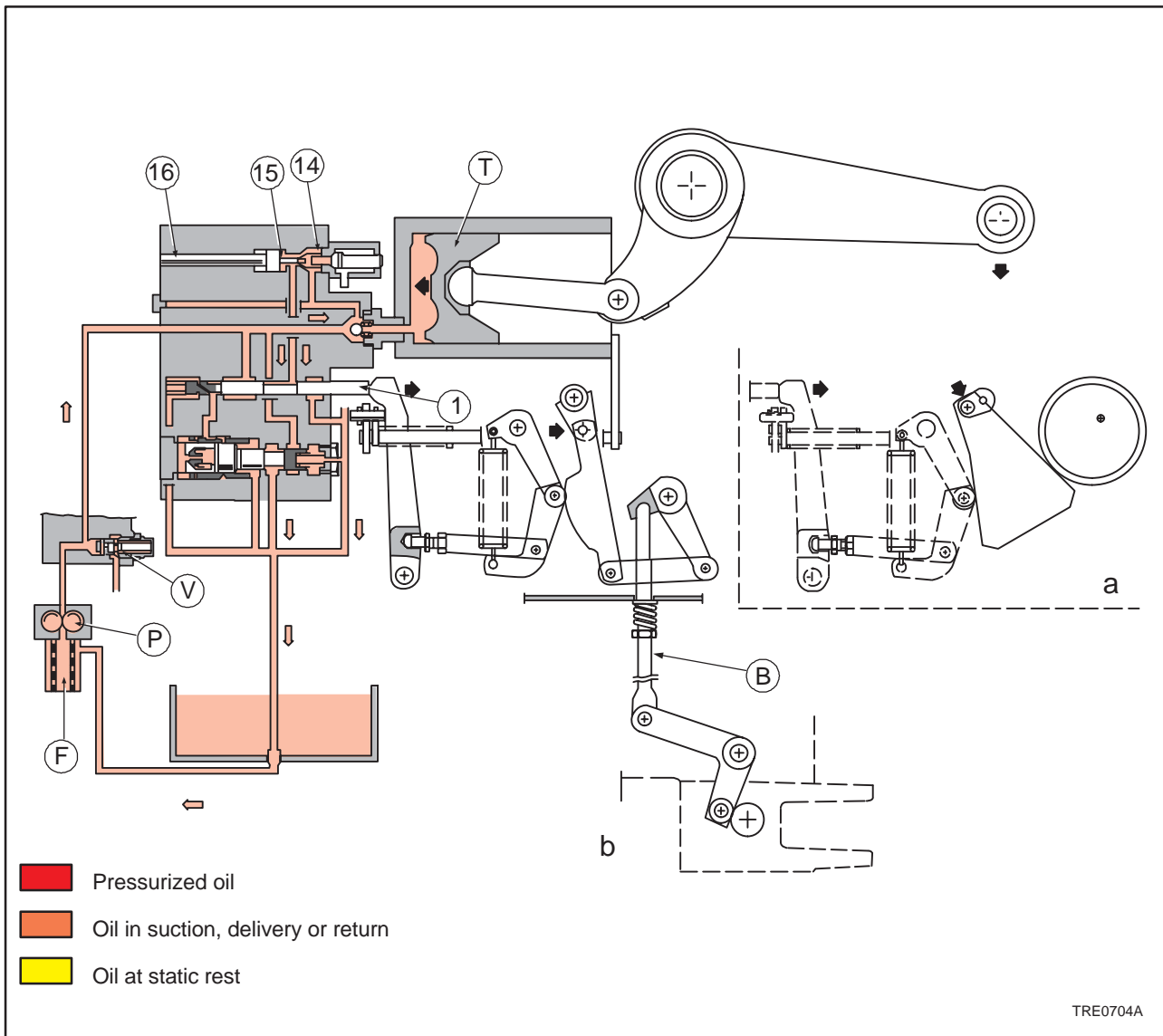

ARM LOWERING PHASE

7

- | | |
|--|--|
| <p>a. Position control linkages.</p> <p>b. Draft control linkages.</p> <p>B. Draft control transmission.</p> <p>F. Filter.</p> <p>P. Hydraulic pump.</p> <p>T. Lift arm piston.</p> <p>V. Pressure relief valve fitted on additional control valves.</p> | <p>1. Plunger.</p> <p>14. Plunger spring.</p> <p>18. Draft response control valve.</p> |
|--|--|

When the operator lowers the position control lever on the right-hand side, the arms are lowered.

The internal lever mechanisms transmit movement (shown by the arrows) to the control valve block pin (1). The control valve block pin (1) is pulled downward by the spring, allowing the cylinder oil, under the thrust of the piston, to discharge through the arm descent speed control valve (14).

With controlled draft operation (part b), the lowering command is sent to the flex bar, which in turn transmits the movement (shown by the arrows) to the control valve block pin (1) via the transmission rod (B).

The lowering speed of the implement connected to the lift arms is controlled by the load of the spring (15) that governs the vibration of the valve (14).

Unscrewing the screw (16) decreases the load on the spring (15), therefore the valve (14) can vibrate faster, slowing down the descent speed. **Tightening** the screw (16) slows down the vibration of the valve (14) that increases the descent speed of the arms since the valve (14) can remain in position in correspondence with the larger orifice where the oil flows out from the cylinder.

After adjusting the arm descent speed it will not depend on the weight bearing on the arms but will be virtually constant.

HYDRAULIC LIFT DIAGNOSTICS

Problems	Possible causes	Remedies
The lift does not raise.	<ol style="list-style-type: none"> 1. Oil filter clogged. 2. Control valve jammed in discharge position. 3. Hydraulic pump defective. 	<p>Replace filter.</p> <p>Release control valve.</p> <p>Overhaul or replace pump.</p>
The lift operates jerkily.	<ol style="list-style-type: none"> 1. Oil filter clogged. 2. Air has got into the pump suction line. 	<p>Replace filter.</p> <p>Check that the couplings are airtight and the seals are effective.</p>
The lift raises too slowly.	<ol style="list-style-type: none"> 1. Oil filter clogged. 2. Oil leaking past piston seals or seals on discharge fitting to cylinder, with consequent loss of pressure. 3. Hydraulic pump defective. 	<p>Replace filter.</p> <p>Replace all defective seals.</p> <p>Overhaul or replace pump.</p>
The lift operates too quickly.	<ol style="list-style-type: none"> 1. Foreign matter between the ball and its seat on the discharge control valve. 2. Discharge control valve ball seal defective. 3. Discharge control valve piston jammed. 	<p>Take off the valve, remove the foreign matter and inspect the oil filter.</p> <p>Replace discharge control valve.</p> <p>Take off the valve and free the piston.</p>
The lift operates too slowly.	<ol style="list-style-type: none"> 1. Discharge ports on the discharge control valve blocked. 2. Discharge control valve piston jammed. 	<p>Take off the valve, unblock the holes and inspect the oil filter.</p> <p>Take off the valve and free the piston.</p>

(continued overleaf)

HYDRAULIC LIFT DIAGNOSTICS

(continued)

Problems	Possible causes	Remedies
The lift is unable to keep the load raised (with the engine running, the load moves up and down rhythmically; with the engine turned off, the load lowers).	<ol style="list-style-type: none"> 1. Defective seal on check valve. 2. Oil leaking past the seals on the control valve block pin seat. 3. Control valve block pin seal defective. 4. Oil leaking past the lift piston seal or the seals on the cylinder oil discharge fitting. 5. Defective seal or cylinder safety valve set to very low value. 	<p>Take off, check, clean and if necessary replace the parts concerned.</p> <p>Replace seals.</p> <p>Take off and clean the seal and replace the control valve block pin and its seat if defective.</p> <p>Replace the seals.</p> <p>Replace the valve.</p>
The pressure relief valve cuts in when the lift arms reach their completely raised position.	<ol style="list-style-type: none"> 1. Lift arm travel set incorrectly. 	Set correctly.
Lift has poor lifting capacity.	<ol style="list-style-type: none"> 1. Pressure relief valve set incorrectly. 2. Cylinder safety valve set incorrectly. 3. Poor pump efficiency (generally accompanied by a considerable increase in lift time). 	<p>Replace the valve.</p> <p>Replace the valve.</p> <p>Overhaul or replace the pump.</p>

REMOVAL – REFITTING – OVERHAUL OF REAR MECHANICAL HYDRAULIC LIFT ASSEMBLY

REAR HYDRAULIC LIFT ASSEMBLY

Removal–Refitting (Op. 35 110 30)



Lift and handle all heavy parts using suitable lifting equipment with sufficient hoisting capacity. Check that the assemblies or parts are held firmly and supported by suitable slings and hooks. Make sure nobody is standing near to the load.

To remove the hydraulic lift assembly from the rear transmission casing, proceed as follows.

1. Disconnect the negative cable (1) from the battery.

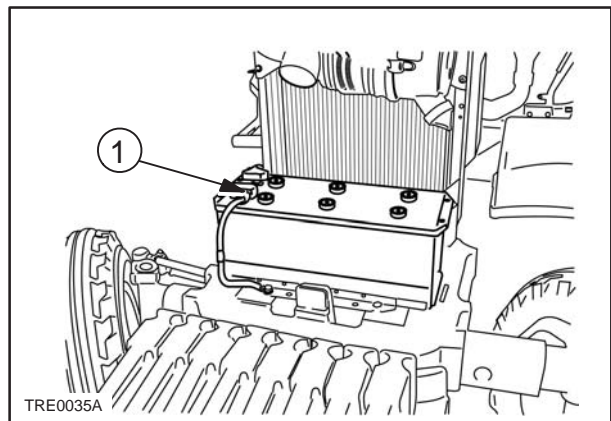

8

2. Remove the top link (1).

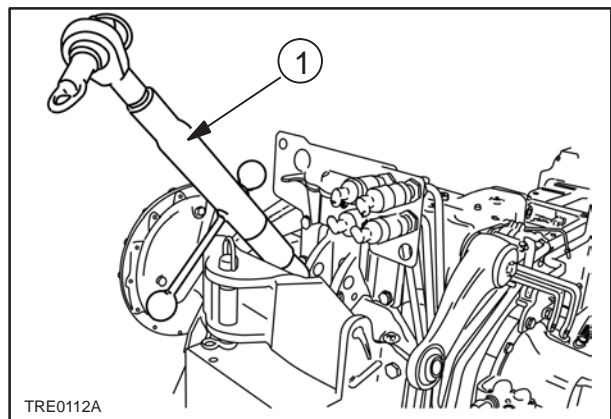

9

3. Undo the bolts (1) and use a chain and hoist to remove the pick-up hitch hook (2) from the PTO box.

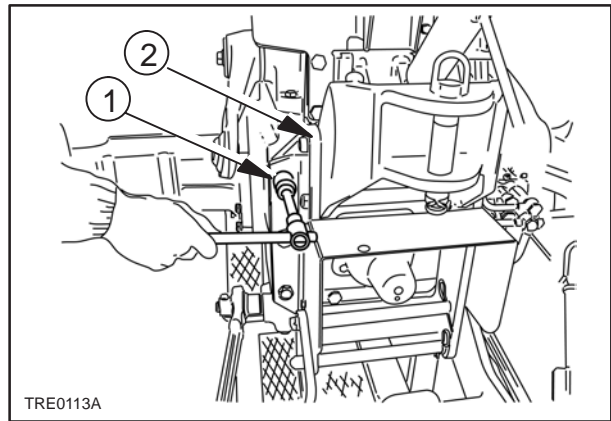

10

4. Remove the split pins and withdraw the shafts (1). Remove the lift rods (2) and the lateral stabiliser struts (3).

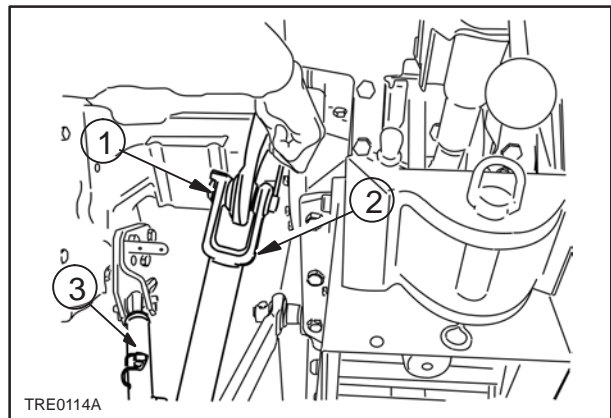

11

5. Undo the bolts (1) and remove the bracket (2) supporting the RH lift rod adjusting crank.

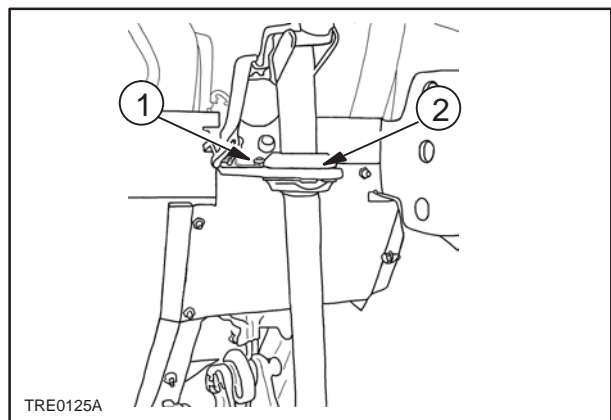

12

6. Unscrew: the trailer brake control pipe (1) and the auxiliary control valve pipes from the support plate (2).

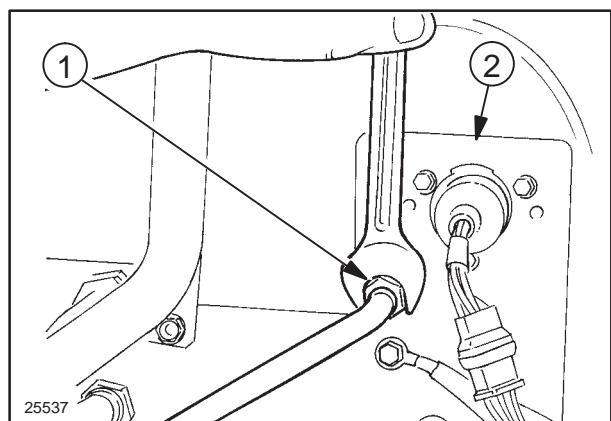

13

7. Remove auxiliary control valve pipes (2) from their support (1).

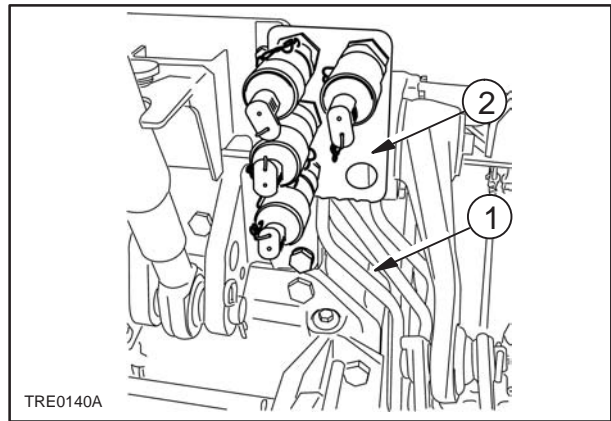

14

8. Undo the two bolts (1) that secure the seven-pole socket (2) and remove the socket.

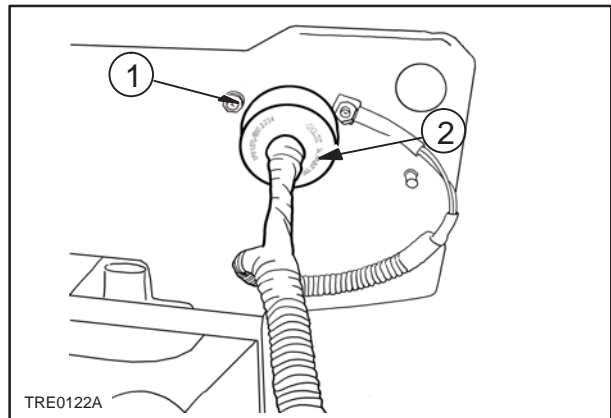

15

9. Undo the bolts (1) and remove the support (2).

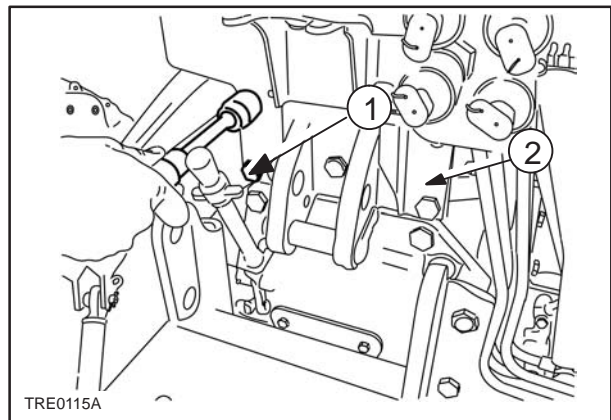

16

10. Undo the bolt (1) and disconnect the breather pipe connection.

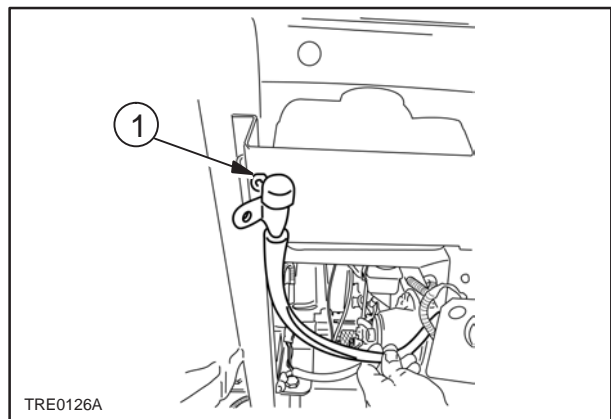

17

11. Remove the electric socket (1).

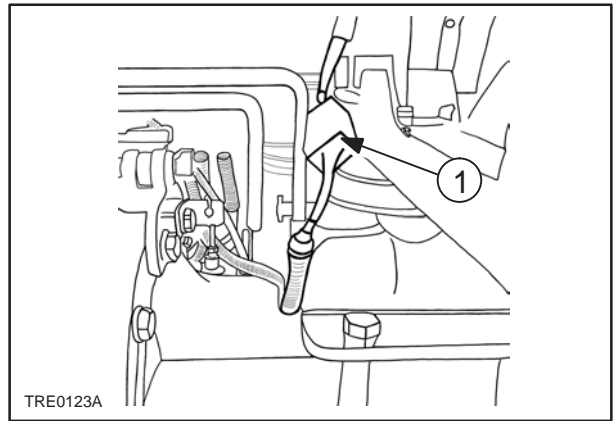

18

12. Remove the retaining clips (1) and detach the two control rods (2) from the lifting arms. Remove the additional control valve rods and the PTO operating mode rod.

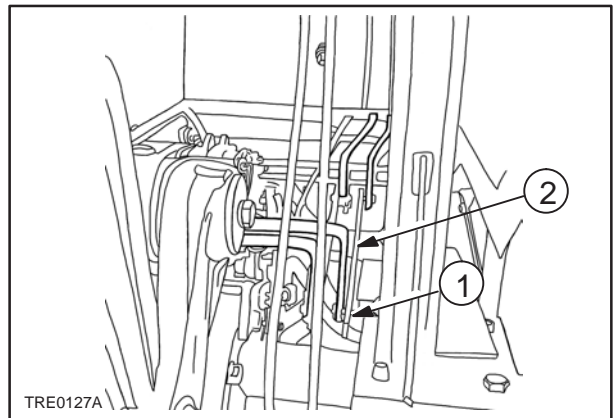

19

13. Remove the LIFT-O-MATIC control rod (1).

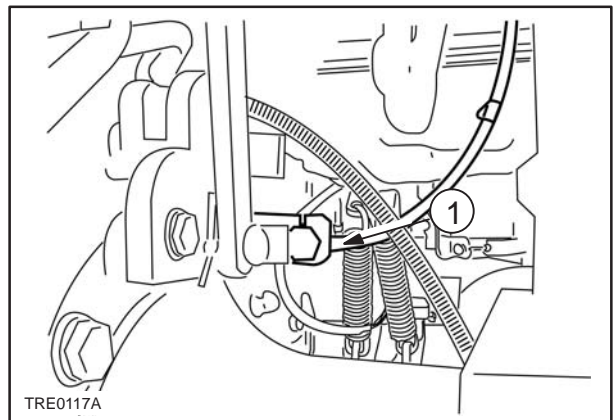

20

14. Connect a suitable hoist (2) to the cab lifting hooks (1) and tension the hoist.

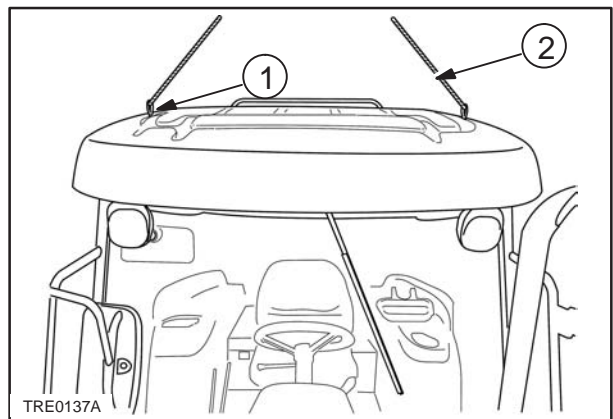

21

15. Unscrew the two cab front securing bolts (1).

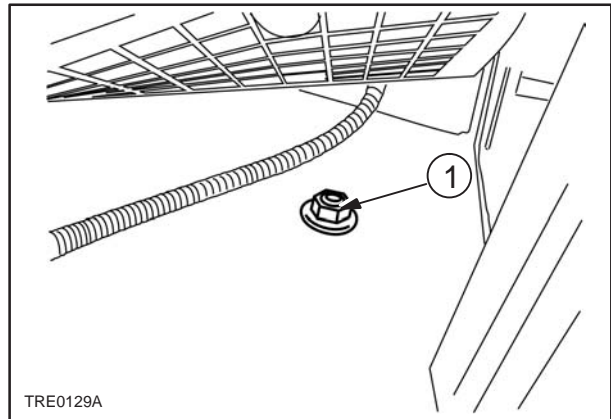

22

16. Unscrew the two cab rear securing bolts (1). Raise the cab approximately 5–6 cm (0.1969–0.2362 in.) and place wooden blocks (1) between the cab upright and the housing. Lower the hoist so that the cab rests securely on the wooden block.

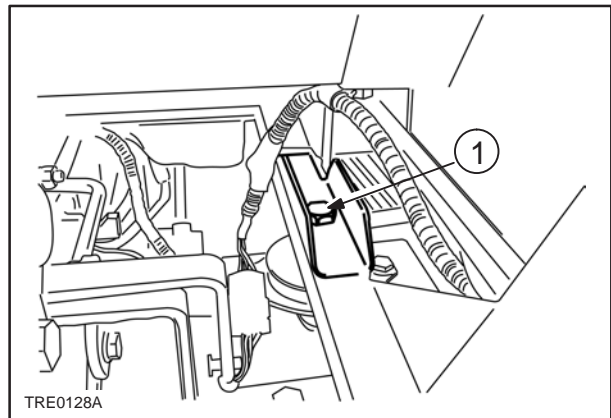

23

17. Remove the pipes on the lift (1) and from the control valve body (2).

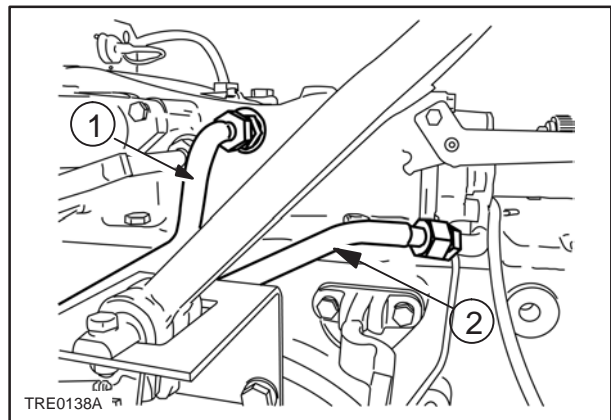

24

18. Unscrew the bolts (1) that secure the hydraulic lift assembly to the transmission casing.

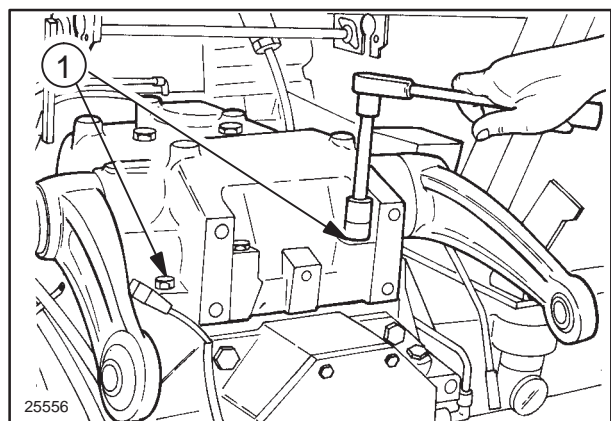

25

19. Fit tool **380000237** (1) on the lift and tighten the four bolts (2).

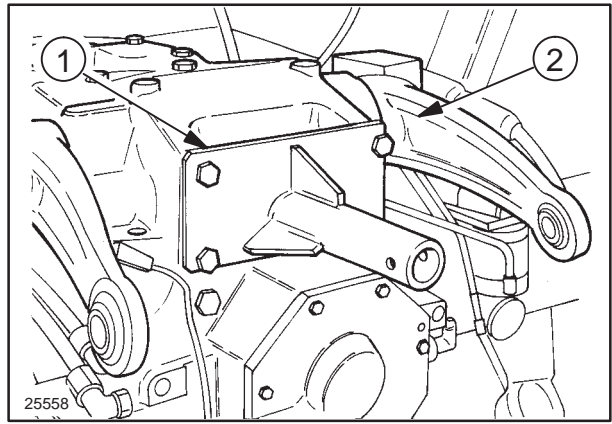

26

20. Fit tool **380000224** (1) onto tool **380000238** (2). Attach the hoist to tool **380000224**, raise the hydraulic lift by a few centimetres and pull it backwards, tilting it so that it clears the breather pipe (3) without damaging it.

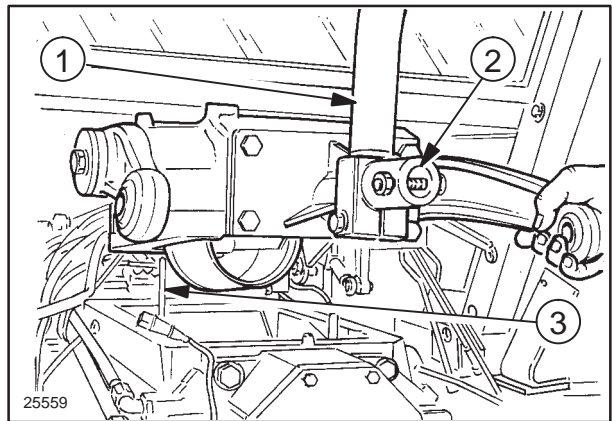

27

21. Refit the hydraulic lift assembly to the transmission casing as follows.



WARNING



Always use appropriate tools to align fixing holes.
NEVER USE YOUR FINGERS OR HANDS.

- Before refitting the hydraulic lift assembly to the rear transmission casing, clean and degrease the mating surfaces thoroughly and apply a strip of sealing compound of about 2 mm (0.0787 in.) diameter as shown in fig. 28.
- Apply the torque settings listed on page 5.
- Use tools **380000224** and **380000238** to fit the hydraulic lift assembly to the transmission casing and tighten the bolts securely.
- Insert the electric leads into their clips on the lift body.
- Fit the lift control pipe.
- Raise the cab by a few millimetres, remove the wooden blocks and tighten the bolts to secure the cab.
- Fit the trailer brake control pipe (if fitted) and the oil filler pipe.
- Connect the Lift-o-Matic control rod.
- Connect the lift control levers to their linkages.
- Fit the windscreen washer tank and transmission breather pipes onto the cab upright.
- Fit the top link attachment bracket and the quick-fitting support plate for auxiliary control valves.
- Fit the seven-pole socket, the earth leads, the quick-fittings and the trailer brake control pipe to their corresponding support brackets.
- Fit the additional control valve rods and the PTO operating mode rod.
- Fit the ground lift control lever.
- Fit the lift rods and the lateral stabiliser struts.
- Fit the pick-up hitch hook and the top link.
- Connect the negative cable to the battery.

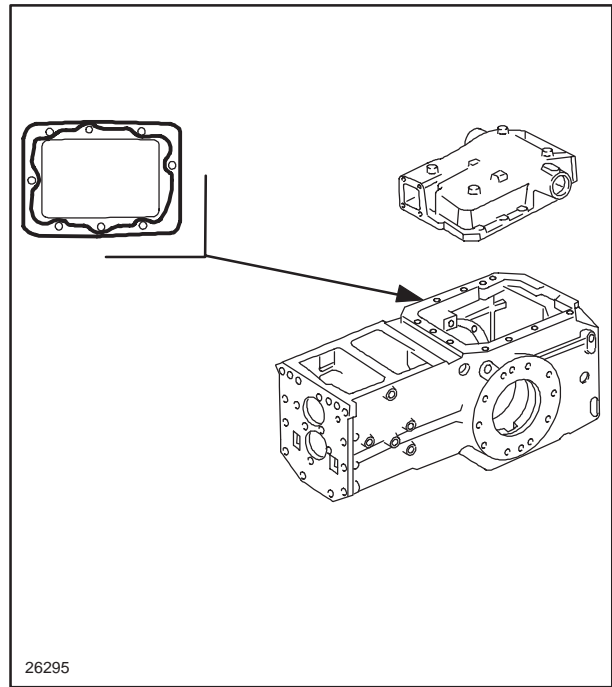

28

Diagram showing application of sealing compound when fitting the hydraulic lift assembly to transmission casing.

The types of sealing compounds to be applied are specified on page 1, section 00.

REAR HYDRAULIC LIFT ASSEMBLY**Disassembly–Assembly**

(Op. 35 110 17 – 35 110 40 – 35 110 42 – 35 110 46)

**DANGER**

Handle all parts with the utmost care.

Do not place your hands or fingers between one part and another. Wear the prescribed safety clothing, including glasses, gloves and protective footwear.

To disassemble the hydraulic lift, proceed as follows.

1. Position the hydraulic lift on a stand (1) fig. 29 , that will allow the assembly to be rotated.
2. Unscrew the securing bolts (1) and remove the control valve block (2) fig. 30.

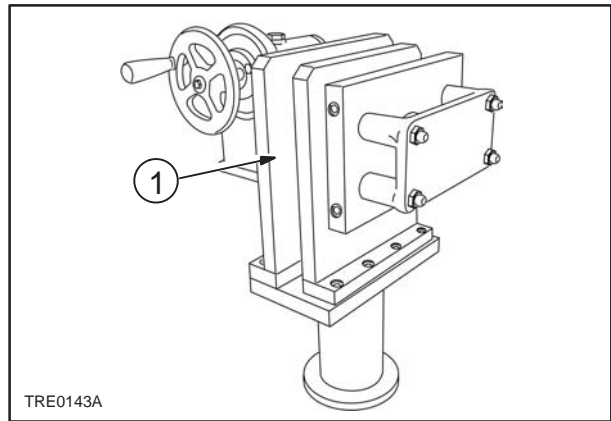

TRE0143A

29

3. Unscrew the two cylinder securing bolts positioned outside the cylinder body. Turn the lift assembly and unscrew the lateral bolt (3).
4. Undo the bolts (1) that secures the internal linkage (2) to the lift cylinder.

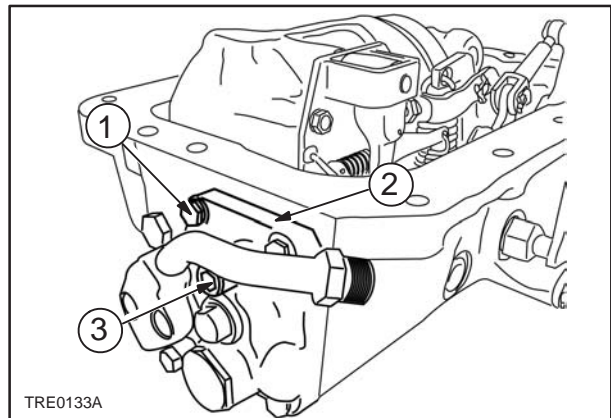

TRE0133A

30

5. Remove the cylinder (1) complete with piston.

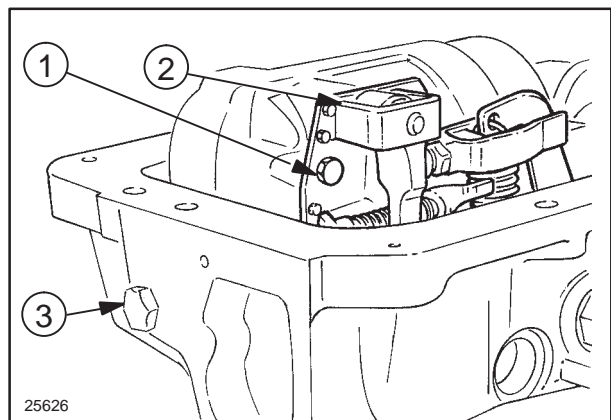

25626

31

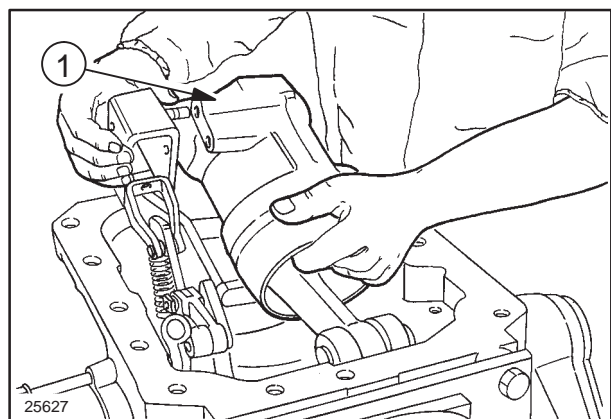

25627

32

6. Remove the retaining pin from the internal draft lever, unscrew the nut (1), then remove the unit complete with internal linkages and the LIFT-O-MATIC control lever.

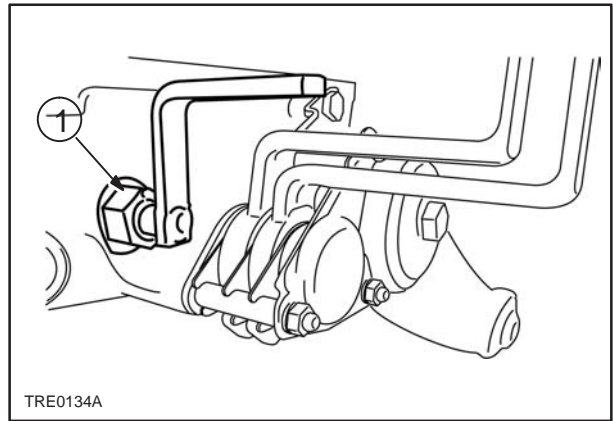

33

7. Take off the snap ring and remove the internal position control lever (1). Unscrew the nuts (2) and remove the spring and fixing bracket (4).
8. Take off the snap ring and remove lever (3), the friction discs, lever (5) and the stud bolts.

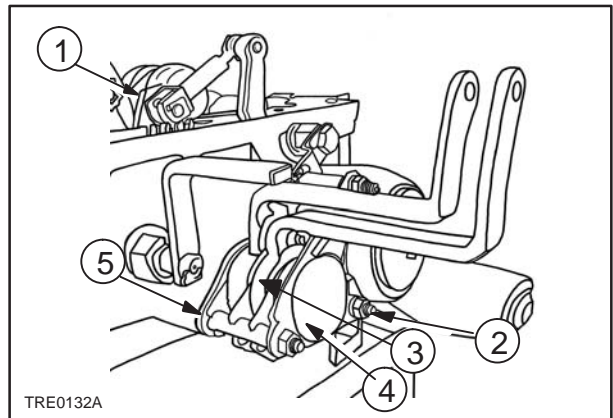

34

9. Slacken the eccentric pin (2) retaining bolt (1), withdraw the eccentric pin and remove the internal linkage.
10. Unscrew the bolt (3), remove the washer (4), withdraw the lift arm (5) and remove the thrust washer. Repeat on the other lift arm.

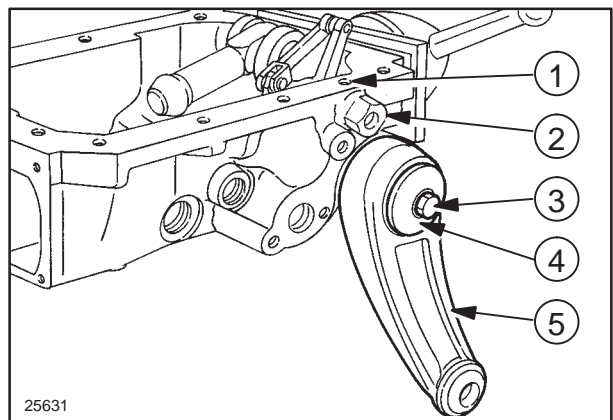

35

11. Remove the crimping on the internal arm locking bolt (1) and unscrew the bolt. Withdraw the shaft (2) and remove the seals (3).

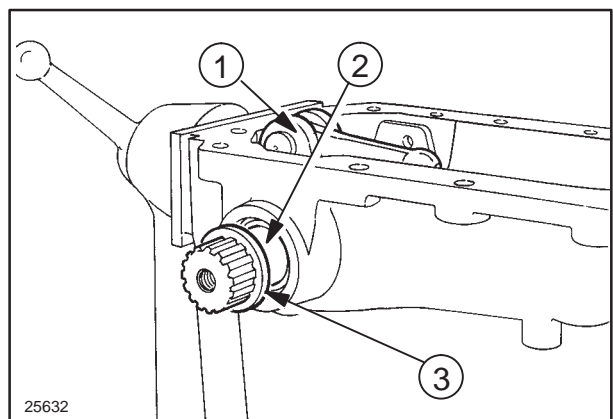

36

12. Use compressed air to remove the piston (2) from its cylinder (1).

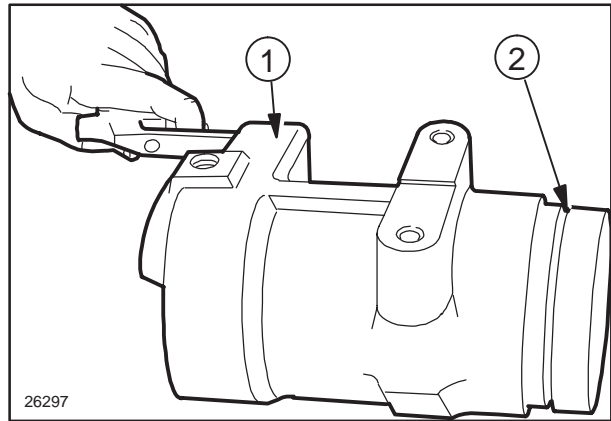

37

13. Use striker tool **380000260** (1) to replace the bearings in the internal draft control lever (2).
14. Use striker tool **380000261** to replace the control valve block control lever bearings.
15. Fit the hydraulic lift as follows.

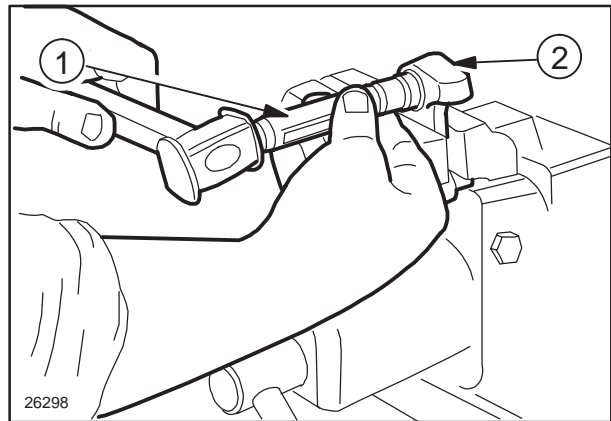

38

16. Insert the piston (1) into its cylinder (3), using tool **380000225** (2).

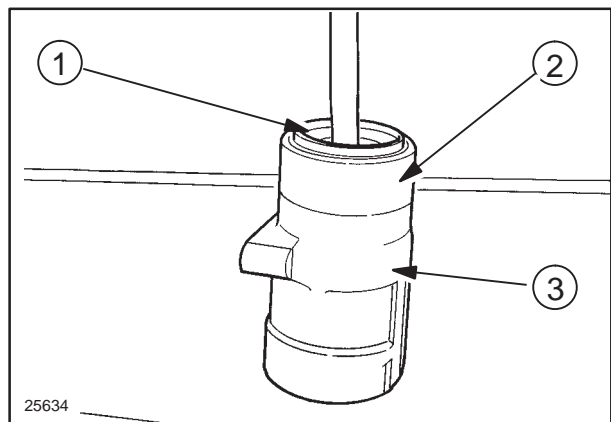

39

17. Fit the lift arm shaft (2) and the internal arm (1) inside the lift box, matching up the reference marks, as shown. Tighten the securing bolt.

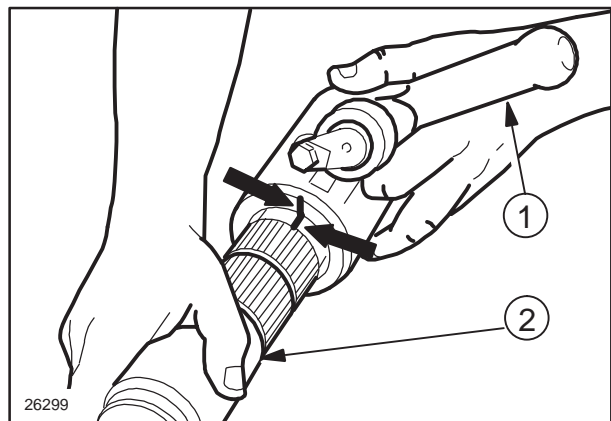

40

WARNING

Always use appropriate tools to align fixing holes.
NEVER USE YOUR FINGERS OR HANDS.

18. To avoid damaging the internal seal lips, use a flexible brass sheet (1) of size 200 x 90 mm (7.8740 x 3.5433 in.) and thickness 0.05 – 0.1 mm (0.0020 x 0.0039 in.). Roll the sheet up and insert the seal inside. Position the unit on the spline and push the seal manually into its seat. Then remove the sheet.

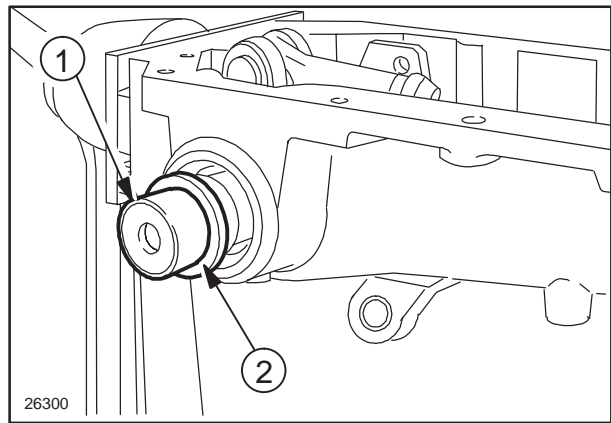

41

19. Use striker tool **380000262** (1) to complete the fitting of the seals into their seats on the lift arm shaft.

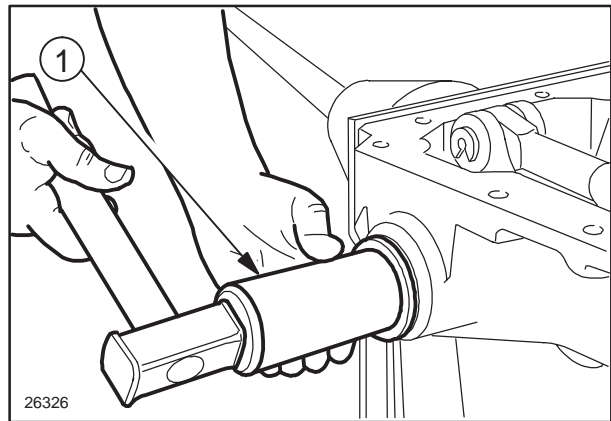

42

20. Fit the lift arms (1) on the shaft, matching up the reference marks, as shown. Secure them by tightening the bolts.

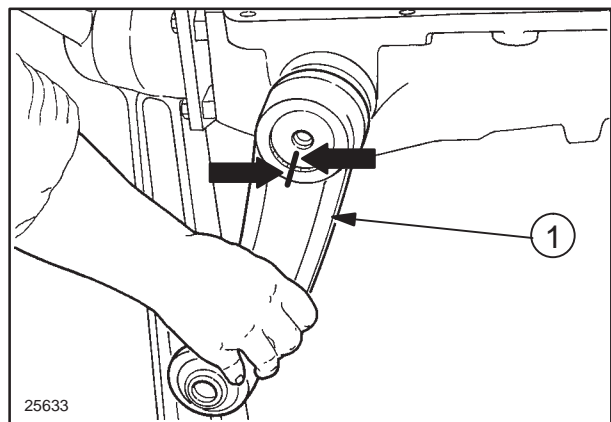

43

21. Fit the internal linkages and the corresponding eccentric pin. Fasten the eccentric pin by tightening the securing bolts.
22. Fit the control levers complete with friction discs, snap rings and stud bolts.
23. Fit the spring and use the bracket to secure the lever unit.
24. Fit the internal position control lever.
25. Fit the internal linkages and the Lift-o-Matic control lever.
26. Fit the cylinder complete with piston and secure it.
27. Fit the internal linkages and fasten them to the cylinder.
28. Clean the mating surfaces thoroughly and apply a 2 mm (0.0787 in.) diameter strip of sealing compound to the lift box, as shown in fig. 44. The types of sealing compound to be used are shown on page 1, section 00.
Fit the hydraulic control valve block on the lift box and secure it using the screws.
Make the following adjustments.

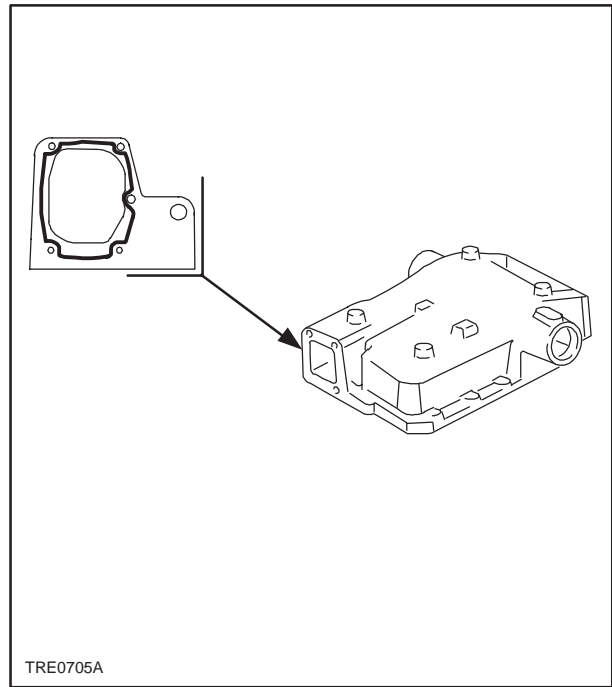

44

NOTE – The adjustments must be made in the order specified.

ADJUSTING THE LIFT

The following adjustments refer to a lift assembly without hydraulic control valve block and mounted on a rotary stand.

These adjustments must be made in the order specified.

The LIFT-O-MATIC device must be kept turned off (external control lever (1) locked in the vertical position) until otherwise specified.

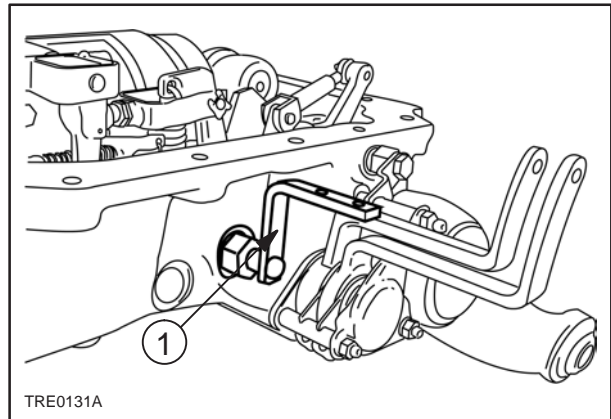

45

Adjusting position control

Proceed as follows:

1. Move the external position control lever (1) fully forward, against the spacer for the stud bolt securing the spring retaining bracket. Move the external draft control lever (2) fully rearward against the spacer.
2. Turn the lift arm control shaft until the internal arm is in contact with the lift body.
3. Use tool **380000267** (1) figure 47, to slacken the lock nut (4) figure 48. Loosen the end stop adjusting screw (5) until it is no longer in contact with the control valve block control lever (3).

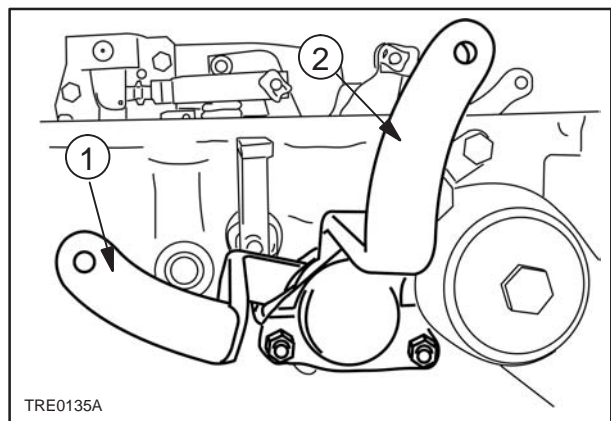

46

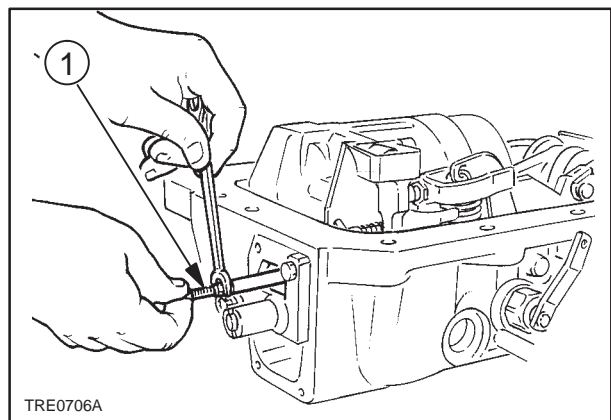

47

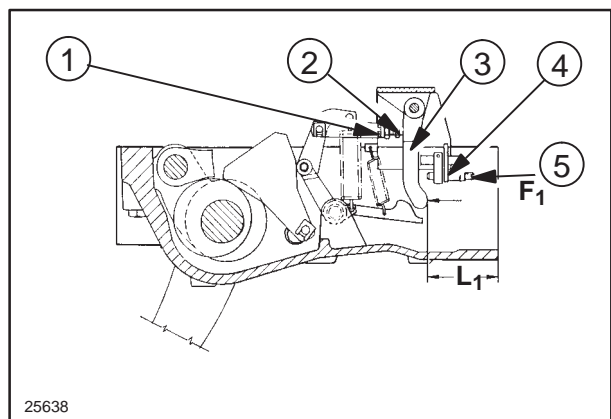

48

4. Fit tool **380000264** (4) fig 49, to the lift body. The tool has a plunger operating in a tube, the outer end of which has two reference surfaces (1) and (5).
5. Using two spanners (2) and (3), unscrew the lock nut (1) fig. 48 and tighten or loosen the adjustable push rod (2) fig. 48, so that the end of the plunger (5) fig 49, is flush with the outer register surface (6) of the tool.

NOTE – This corresponds to a distance (L_1 fig. 48) of 82.0 – 82.1 mm (3.2283 – 3.2323 in.) between the end of the lever (3) fig. 48 and the front surface of the lift body when a force (F_1 fig. 48) of 4 – 4.5 da N (25.40 – 39.82 inch lb) is applied to the end of the lever.

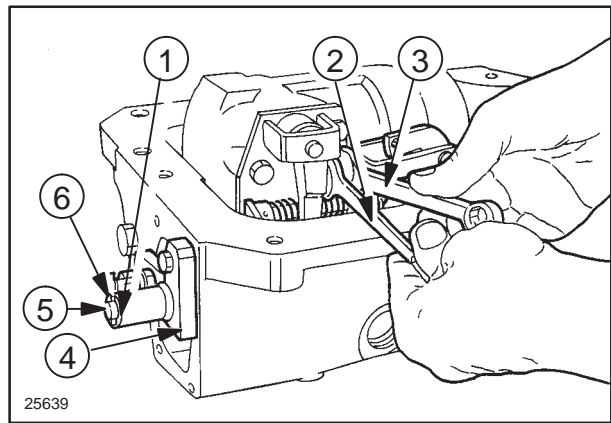

49

6. Tighten the lock nut (1) fig. 48.
7. Move the external position control lever (1) fully rearwards against the stud bolt spacer. Turn the lift arm control shaft so that the piston is fully forward and check that the plunger (5) fig. 49 is flush with or slightly inside the inner reference surface (1) of the tool (4).

NOTE – This corresponds to a distance (L_1) fig. 48, of greater than 86.5 mm (3.4055 in.) between the end of the lever (3) and the front surface of the lift body when a force (F_1) of 4 – 4.5 da N (25.40 – 39.82 inch lb) is applied to the end of the lever.

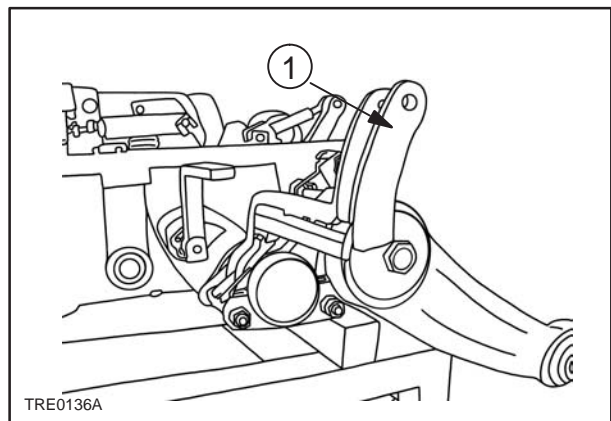

50

Adjusting the maximum height of the lift arms

Proceed as follows.

8. With tool **380000264** (4) fig. 49 fitted on the lift body, move the external draft control lever (2) fully rearward, against the spacer. Move the external position control lever (1) fully forward against the spacer.
9. Turn the lift arm control shaft until the internal arm touches the lift body.

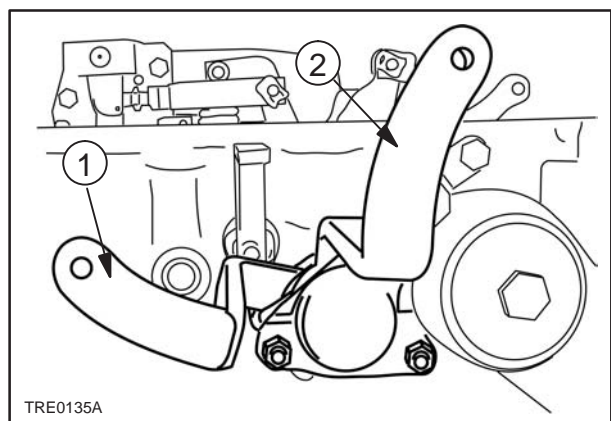

51

10. Connect the fitting (5) of tool (2) to the workshop compressed air system. Feed air into the cylinder barrel to make the piston perform its complete lifting stroke and use the air pressure to keep it in this position.
11. Using tool **380000267** (1), tighten the screw (5) fig. 48, until the end of the plunger (4) is flush with the inner reference surface (3) of the tool (2) or up to 0.5 mm (0.0197 in.) further in.

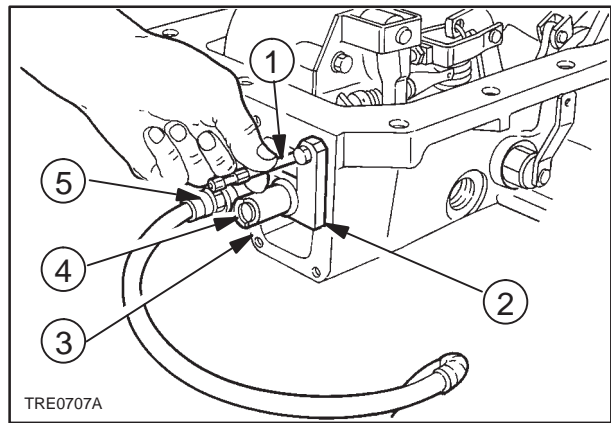

52

NOTE – This corresponds to a distance (L_1) of 86.3–86.7 mm (3.3976–3.4134 in.) between the end of the lever (3) and the front surface of the lift body.

12. Tighten the lock nut (4) to a torque of 15 Nm (11.0624 ft lb).

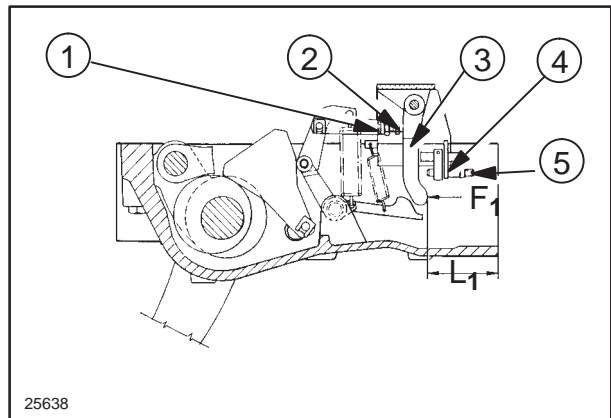

53

Adjusting draft control

Proceed as follows:

13. Remove the end section of the draft control rod (3) and mount it on the rod (5) of tool **380000263** (1). Fasten it using lock nut (4).
14. Place the tool **380000263** (1) complete with its rod (5) and the end section of the draft control rod (3) on a surface plate. Using a micrometer depth gauge (2), measure the distance (L_3) between the upper surface of the rod and the micrometer gauge bearing surface on the tool (be sure to tighten rod (3) onto rod (5) so that the surface of rod (5) is a few mm lower than the micrometer bearing surface on the tool).
15. With tool **380000264** (2) fig. 52 mounted on the lift body and disconnected from the compressed air system, move the position control lever (1) fig. 55 and the draft control lever (2) fully back against the spacer.
16. Move the eccentric pin (1) fig. 60, connected to the internal draft control lever, to the horizontal position with the eccentric cam pointed towards the rear of the lift assembly.

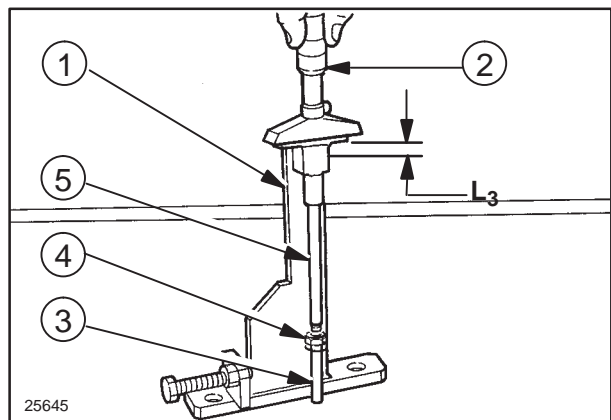

54

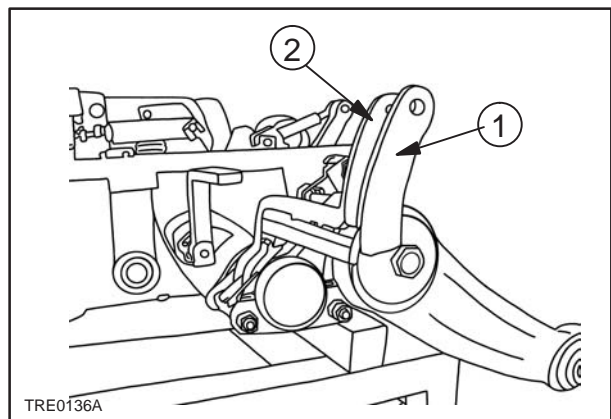

55

17. Fit tool **380000263** (1) to the lift body and fasten it to the two holes in the box as shown in figure 56.

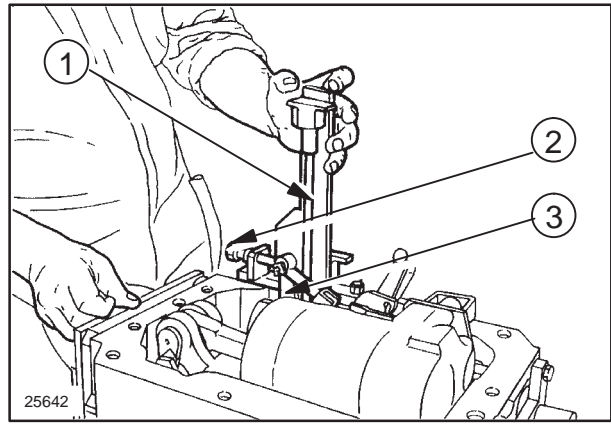

56

18. Turn the screw (2) fig. 56 on the internal draft control lever (3) fig. 56 until the end of the plunger (1) fig. 57 is flush with the inner reference surface (3) of tool **380000264** (2).

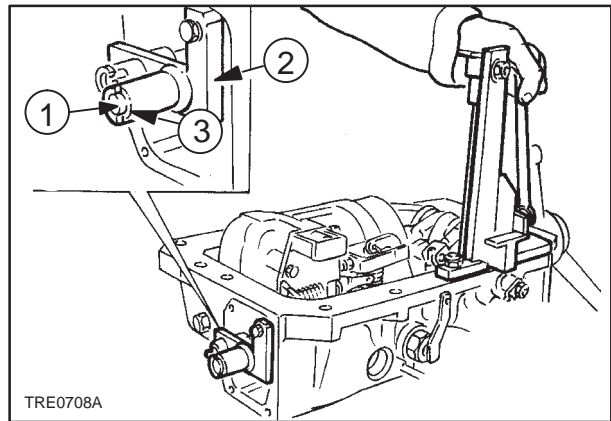

57

19. Turn the eccentric pin (1) slightly to withdraw the end of the plunger of tool **380000264** as far as possible.
20. Again turn the screw (2) fig. 56 to adjust the internal draft control lever (3) until the end of the plunger fig. 58 is flush with the inner reference surface (3) of the tool **380000264**.
21. Finally turn the eccentric pin (1) fig. 58 until the end of the plunger is flush with the outer register surface (2) of the tool **380000264**.

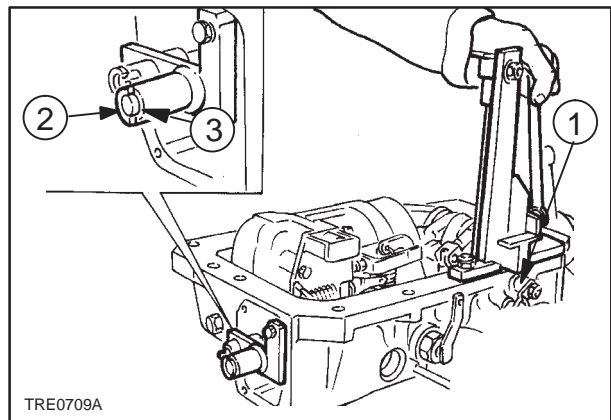

58

22. Insert rod of tool **380000263** (1) into the internal draft control lever seat (2).
23. With the end of the plunger of tool **380000264** flush with the outer reference surface (2) fig. 58, set the adjustable linkage (3) fig. 59 and use a micrometer depth gauge to measure the distance (L_2) between the upper surface of the rod and the micrometer gauge bearing surface on the tool **380000264** (1).

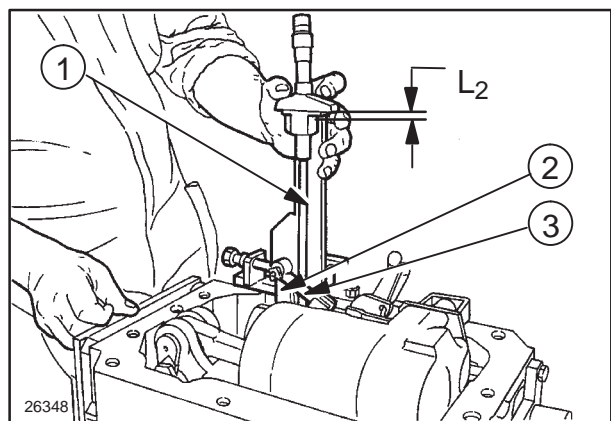

59

24. The distance (L_2 , page 32) must be:

$$L_2 = L_3 + L_4$$

where:

L_3 = distance measured with tool **380000263** mounted on a surface plate:

L_4 = 22.9 – 23.1 mm (0.9016 – 0.9094 in.). Operating distance between the lift box bearing surface on the transmission casing and the rod resting surface on the lever (3, fig. 59).

NOTE – This corresponds to a distance (L_1 , fig. 48) of 82.0 – 82.1 mm (3.2283 – 3.2323 in.) between the end of the lever and the front surface of the lift body, measured with a force (F_1) of 4 – 4.5 da N (25.40 – 39.82 inch lb) applied to the end of the lever.

WARNING – Always make sure that when the plunger of tool **380000264** is flush with the outer reference surface (2) the the distance (L_2 , fig.59) is:

$$L_2 = L_3 + L_4$$

where:

L_3 = distance measured with the tool **380000263** mounted on the reference surface;

L_4 = 22.9 – 23.1 mm (0.9016 – 0.9094 in.). Operating distance between the lift box bearing surface on the transmission casing and the rod bearing surface on the lever (3) fig. 59.

If these conditions are not met, adjust the eccentric pin (1) and the knurled screw (2) fig. 59 of tool **380000263** until they are.

25. Fit the threaded dowel (3) and tighten the screw (1) without bending over the safety washer (2).

26. Remove the tools **380000264** and **380000263** and fit the hydraulic control valve block on the lift body.

Proceed to mount the lift assembly onto the tractor as follows.

WARNING – First position tool **380000263** (1) on a surface plate and use a micrometer depth gauge (2) to measure the distance (L_5) between the surface plate and the point where the micrometer gauge rests on the tool.

Make a note of the measured distance (L_5).

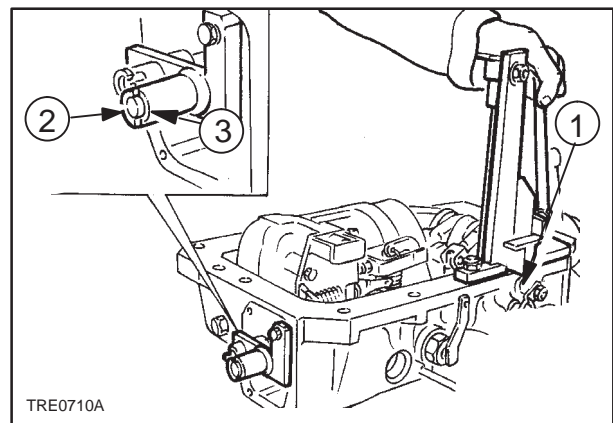

60

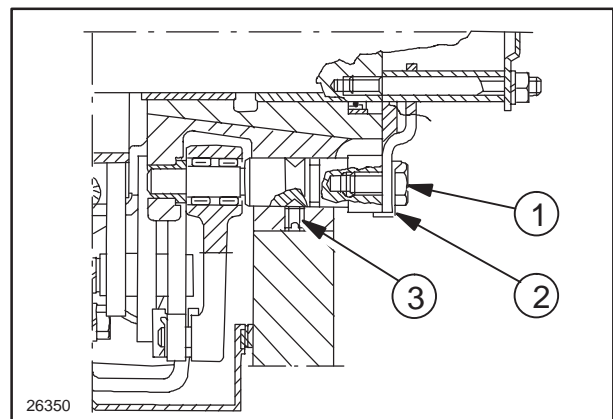

61

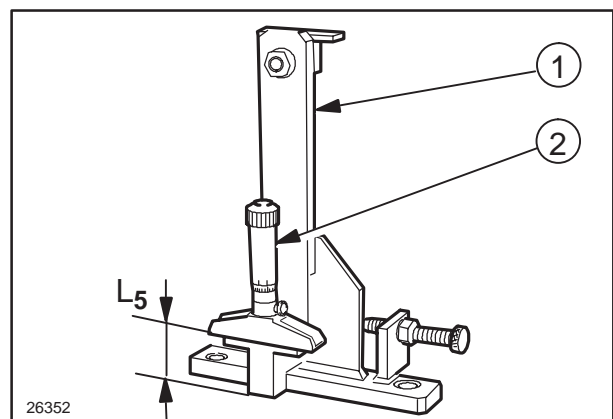

62

27. Fit the draft measuring device complete with transmission lever (3) and draft control lever (2), but without the flex bar, onto the rear transmission casing.
28. Rest the transmission lever (3) on the draft measuring device box and fit tool **380000263**. Fasten it to two holes on the box so that the draft control rod (2) fits exactly inside the tool hole as shown in figure 64
29. Using a micrometer depth gauge (2) fig.64, measure the distance (L_8) fig.64, between the top end of the rod (3) fig.64 and the micrometer gauge resting surface on the tool.

NOTE – The distance (L_6) the top end of rod (2) protrudes with respect to the transmission casing (with flex bar removed) is given by:

$$L_6 = L_5 - L_8$$

where:

L_5 and L_8 = distance measured with tool **380000263** fitted on the surface plate (L_5) fig. 62 or on the transmission casing (L_8) fig. 64.

30. Fit the flex bar and measure the new distance (L_9) between the top end of the rod (3) and the micrometer gauge resting surface on the tool.

NOTE – The distance (L_7) fig. 63, that the top end of the rod (2) fig. 63, protrudes with respect to the transmission casing (with flex bar fitted) is given by:

$$L_7 = L_5 - L_9$$

where:

L_5 and L_9 = distance measured with tool **380000263** mounted on surface plate (L_5) fig. 62 or on the transmission casing (L_9).

31. Check that the distance (L_7) is at least 5mm (0.1969 in.) greater than the distance (L_6).
32. Slacken the lock nut (1) fig. 63 and adjust the length of the draft control rod until it protrudes by a new distance ($L_7 = 18.3 - 18.5$ mm (0.7205 - 0.7283 in.)).
33. This distance (L_7) can be calculated by subtraction using tool **380000263**:

$$L_{10} = L_5 - L_7$$

where:

$L_7 = 18.3 - 18.5$ mm (0.7205 - 0.7283 in.). Distance the end of the rod (2) fig. 63, protrudes with respect to the transmission casing during operation.

L_5 = distance measured with tool **380000263** mounted on the surface plate.

L_{10} = distance to be measured with the micrometer gauge on tool **380000263**.

34. Tighten the lock nut (1) fig. 63, and mount the lift on the tractor.

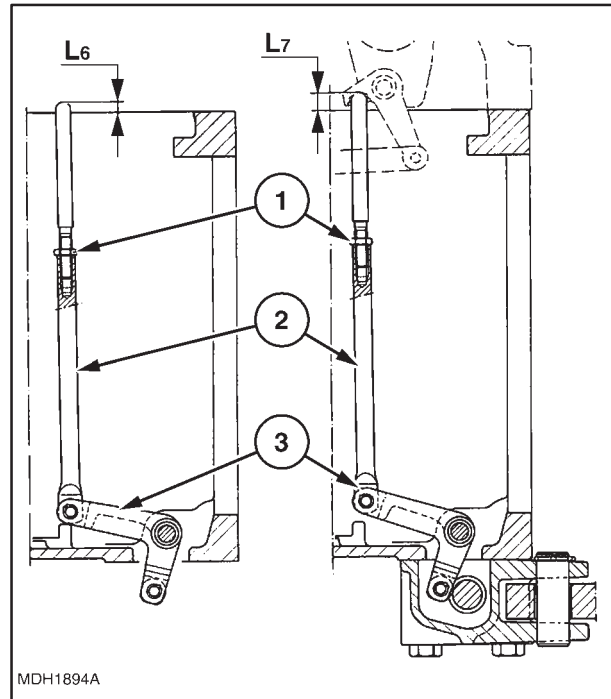

63

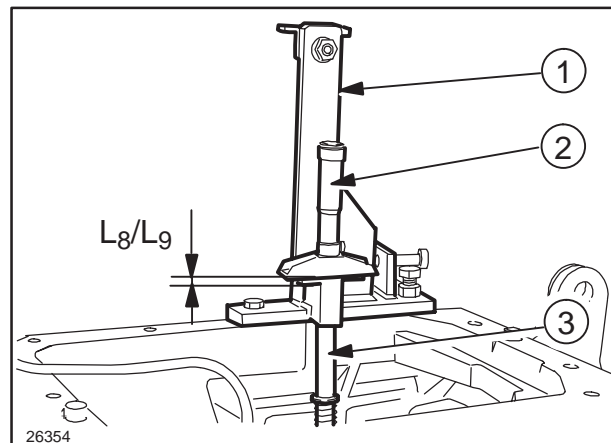

64

ADJUSTING LINKAGES (Op. 35 110 08)**Adjusting position control linkage**

Proceed as follows.

1. Move the position control lever (1) fully forward on the quadrant and check that the distance (L) is between 15 and 20 mm (0.5906 and 0.7874 in.).

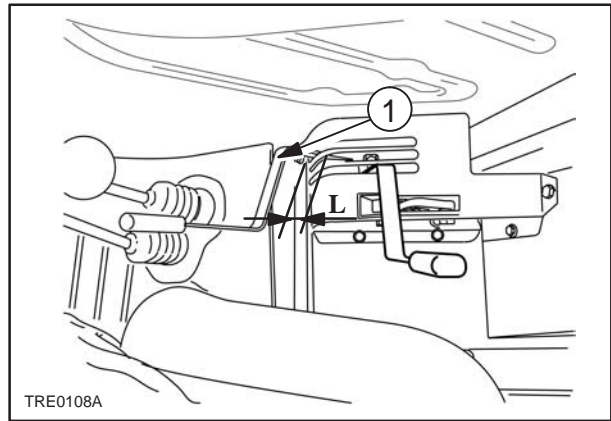

65

2. Move the external position control lever (1) fully rearward, against the spacer.
3. Connect the control linkage and adjust its length, if necessary.
4. Fasten the linkage using the lock nuts.

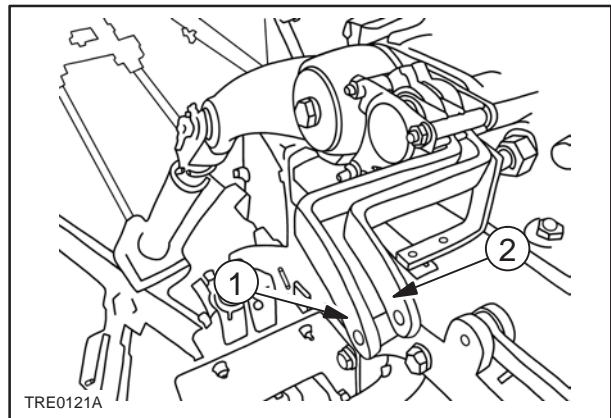

66

Adjusting draft control linkage

Test conditions:

- engine running at medium speed;
- allow the oil in the system to reach a temperature of 30 – 40 °C (86 – 104 °F).

Then proceed as follows:

5. Move the position control lever (1) fully forward on the quadrant and the draft control lever (2) to a distance (L_1) of 15 – 20 mm (0.5906 – 0.7874 in.) from the beginning of the slot.
6. Move the draft control lever (2) fully back against the spacer.
7. Connect the control linkage and adjust its length if necessary.

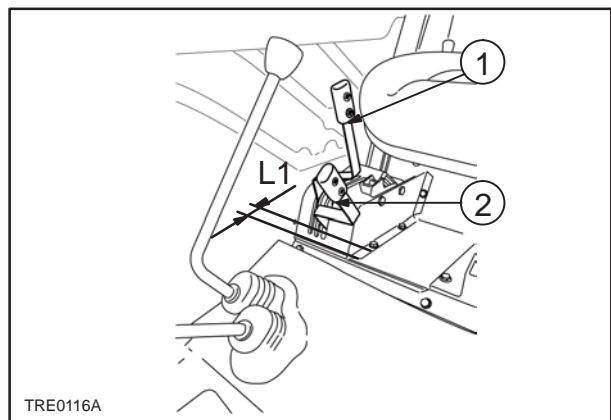

67

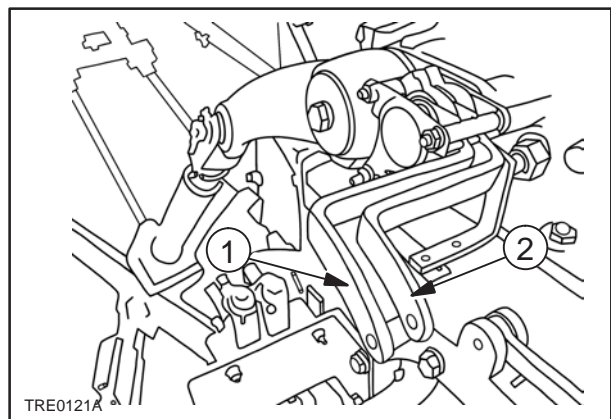

68

8. Move the draft control lever (2) to a distance (L_2) of 105 – 115 mm (4.1338 – 4.5275 in.) from the beginning of the slot and check that at this position the arms start to rise.
9. If they do not, adjust the eccentric pin (1) fig. 60, to restore this distance.
10. Fasten the eccentric pin using the securing bolt (1) fig. 61.

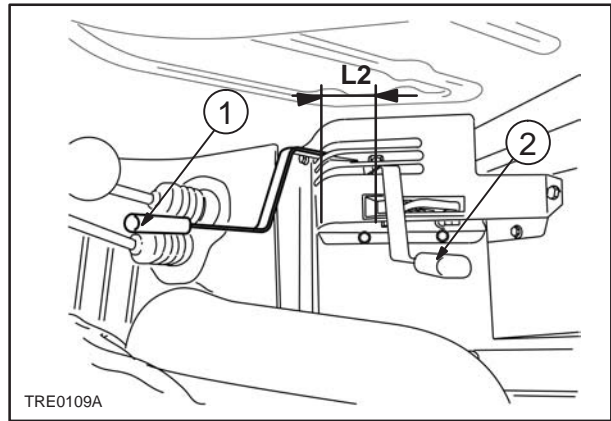

69

Adjusting LIFT-O-MATIC device

Proceed as follows:

11. Move the position control lever (1) and the draft control lever (2) fully forward in the sector.

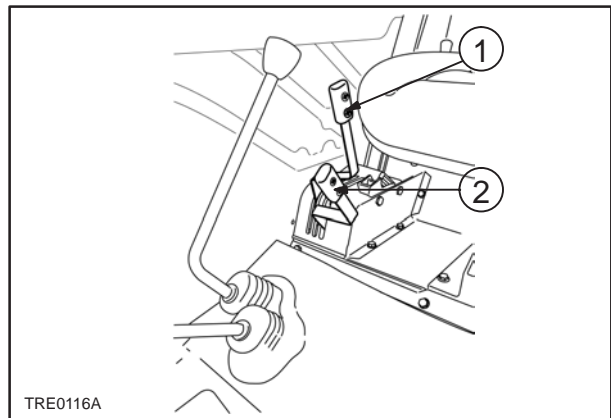

70

12. Raise the lift arms by means of the lever (1).

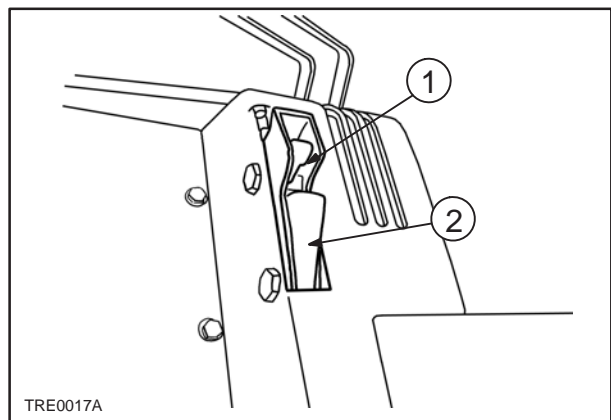

71

13. Tighten the nut (1) fig. 72, until the arms lower.
14. With the lever (1) fig. 71, still in the same position, unscrew the nut (1) fig. 72, until the arms begin to rise.
15. Unscrew the nut (1) by another 1.5 turns.
16. Using the levers (1) and (2) fig. 71, lower and raise the arms a few times to ensure that the system is operating correctly.

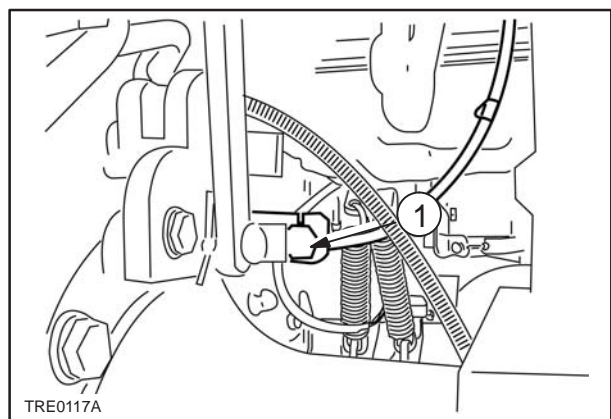

72

LIFT PRESSURE RELIEF VALVE**Removing–Refitting (Op. 35 114 30)**

Auxiliary control valve blocks. The lift pressure relief valve (1) is located as shown in fig. 73)

If defective, remove and change the valve.

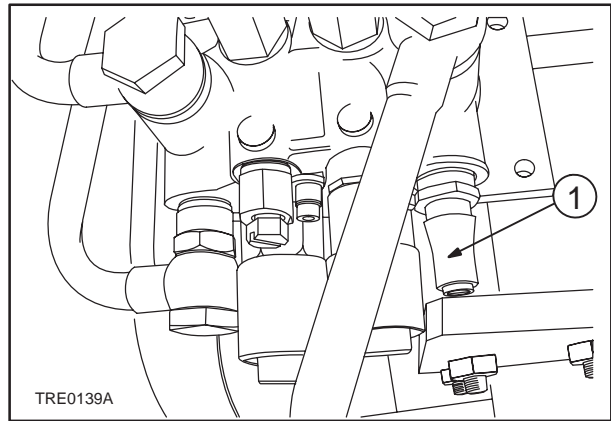

73

LIFT PRESSURE RELIEF VALVE**Calibration (Op. 35 114 32)**

Proceed as follows.

1. Run the engine until the oil reaches a temperature of about 50°C (122 °F).
2. Insert the fitting **380000554** (1) in a quick-fit female half-coupling and connect it to the 0 – 3555.84 psi scale pressure gauge supplied with kit **380000240**.
3. Activate the half-coupling control valve block lever until the pressure relief valve cuts in.
4. With the engine running at medium speed the pressure gauge must show a pressure of about 186 – 191 bar (2697.69 – 2828.22 psi). If the valve setting does not correspond to the prescribed value, it is best to change it immediately. If necessary it can be adjusted by turning the cap, after removing the plastic sealing and unscrewing the locknut, with a 4mm hex wrench. Tighten it to increase the valve setting, unscrew it to decrease the setting.

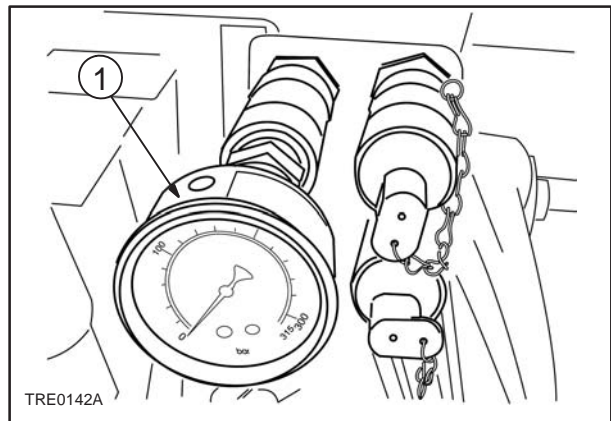

74

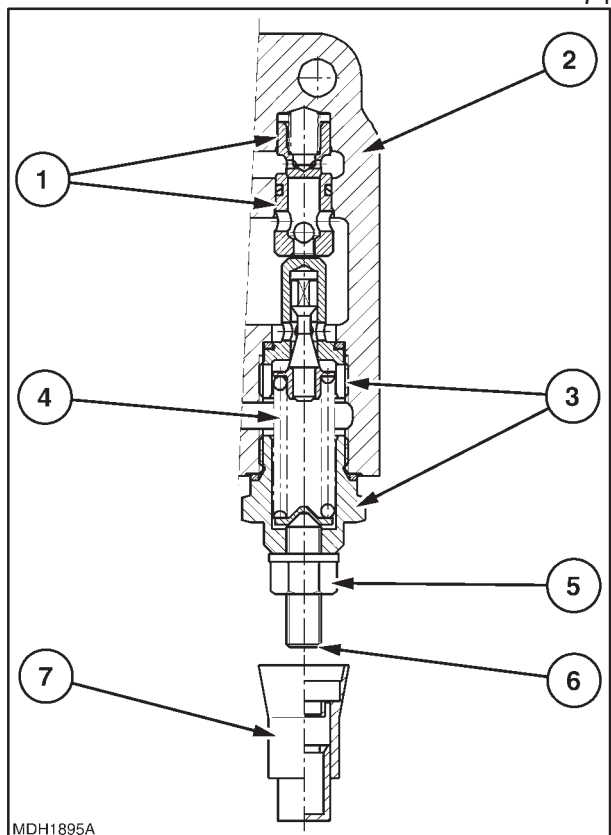

75

Pressure relief valve section.

1. One-way valve.
2. Additional control valve body.
3. Pressure relief valve body.
4. Valve spring.
5. Locknut.
6. Adjustable needle (4 mm wrench).
7. Plastic sealing.

LIFT CONTROL VALVE BLOCK, DETACHED**Disassembly–Assembly (Op. 35 114 14)**

Proceed as follows.

⚠
WARNING
⚠

Handle all parts with the utmost care.
Do not place your hands or fingers between one part and another. Wear the prescribed safety clothing, including glasses, gloves and protective footwear.

1. Before removing the control valve, first remove the transmission cover (1).

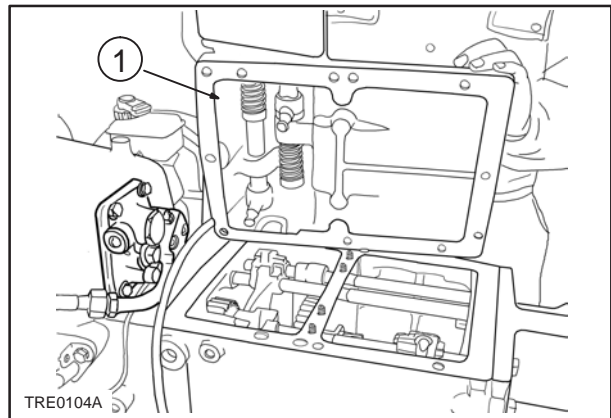

76

2. Before disassembly, thoroughly clean the surfaces of the control valve block. Lock the control valve block in a vice.

3. Unscrew the cap (1) and remove the spring (2) and the pilot valve (3).

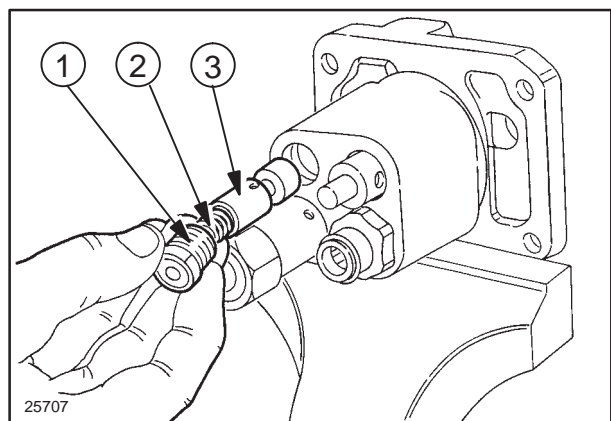

77

4. Take off the cylinder safety valve (4) and remove the arm lowering speed adjustment valve (3), the spring (2) and the pin (1).

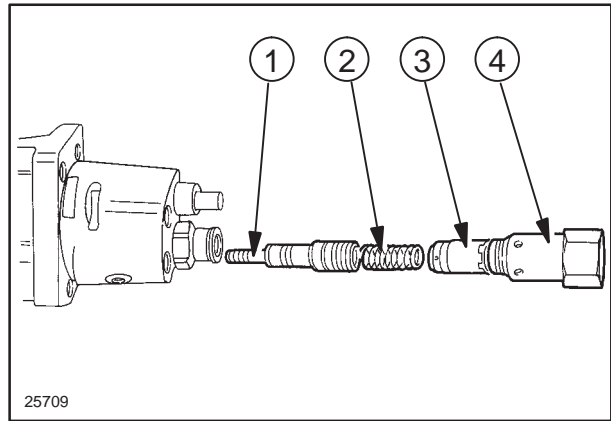

78

5. Remove the check valve union (1), spring (2) and ball (3).

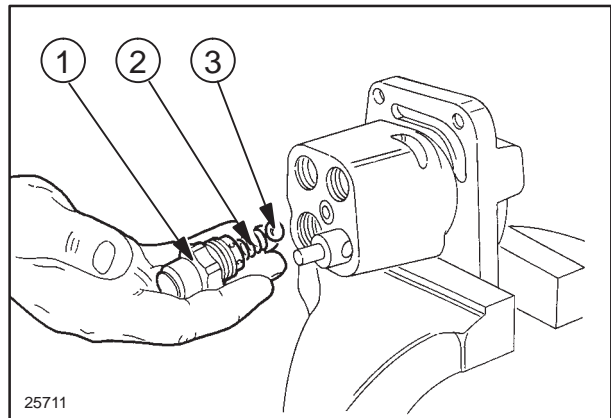

79

6. Remove the cap (1) and take out the spring (2) and the seat of the control valve pin with the pin inside it (3).

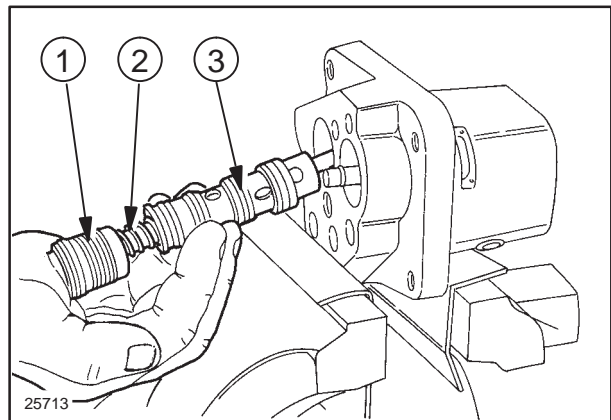

80

7. Check the wear of the seals on the control valve block pin seat. If damaged, replace them using protection device **380000275** (1), following the instructions given on page 9.
8. Check the efficiency of the control valve block pin as follows.

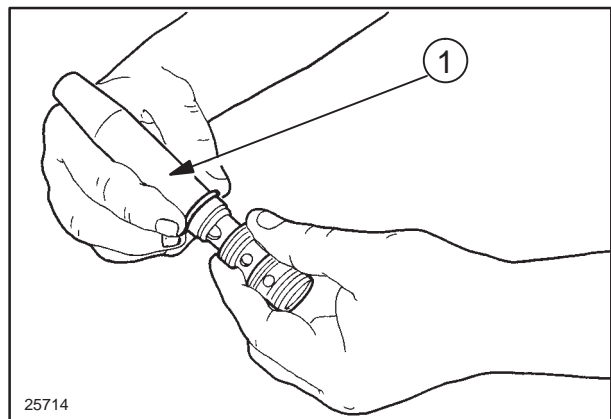

81

9. Fit the control valve block pin (2) complete with seat (3) on the tool **380000274** (1).

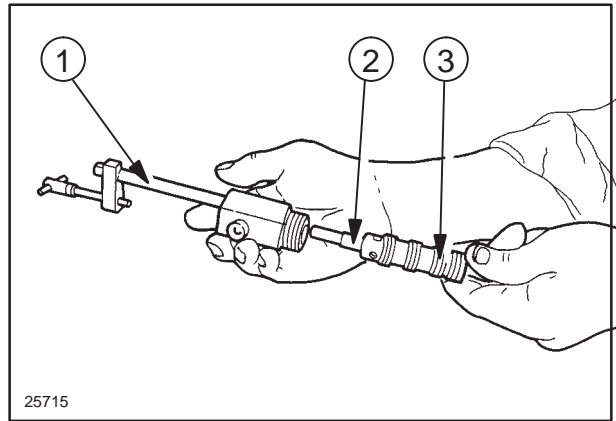

82

10. Fit the control valve block pin spring (1) and the cap (2) of tool **380000274**. Tighten the cap as far as it will go and check that the control valve block pin slides in its seat.

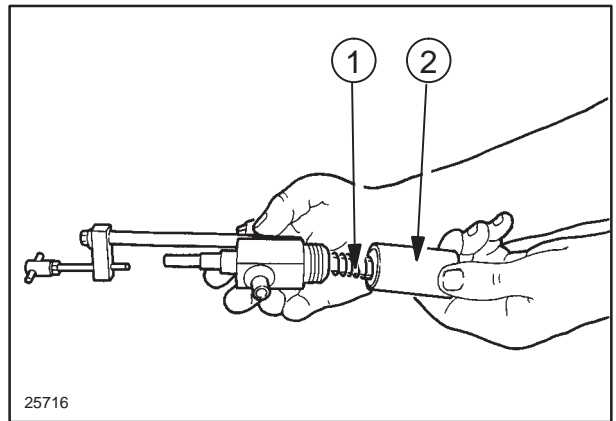

83

11. Fit tool **380000274** (2) on the hand pump **380000215** (3), supplied with **HYDROSYSTEM 68** oil. Connect a dial gauge (1) and secure it with its screw.

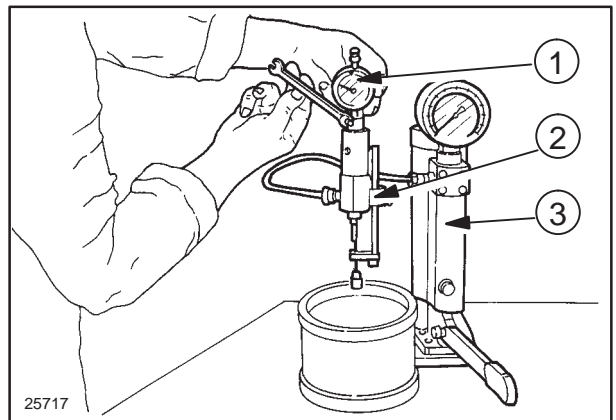

84

12. Operate the hand pump and at the same time tighten screw (1) on the tool until oil stops flowing out through the control valve block pin seat outlet.

13. Now zero the dial gauge.

14. Tighten the screw (1) on the tool further to move the control valve block pin by 1.8 – 2 mm (0.0709 – 0.0787 in.), using the dial gauge to read this distance.

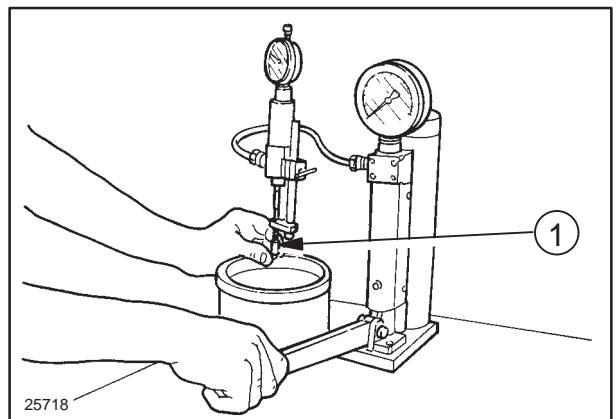

85

15. Operate the hand pump until the oil in the system is at an initial pressure of 245 bar – 3553.41 psi. Using the pressure gauge, check that it takes more than six seconds for the pressure to fall from 196 bar – 2842.73 psi to 98 bar – 1421.36 psi. If it takes less than this, replace the control valve block pin. Bear in mind that this part is supplied together with its seat.

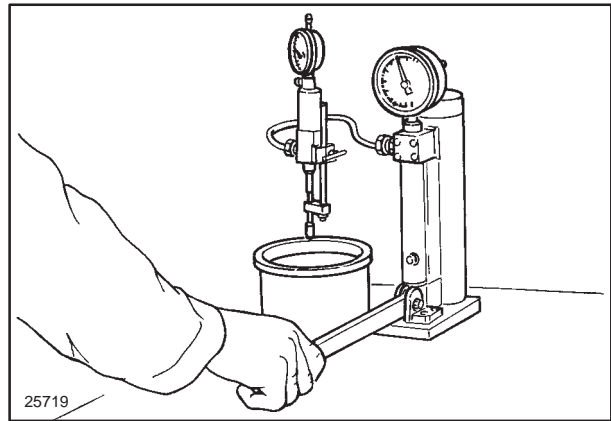

86

Cylinder safety valve setting

16. Fit the cylinder safety valve (1) on the valve union **380000218** (2) and connect it to the hand pump **380000215** (3).
17. Operate the hand pump (3) and check that the cylinder safety valve opens at a pressure of 210 – 215 bar (3045.78 – 3118.30 psi). If the valve setting does not correspond to the specified value, it is best to replace the valve straight away. If necessary, however, it can be adjusted by turning the threaded cap using spanner **380000230**. Tighten to increase the valve setting value, or slacken to decrease the value.
18. Fit the hydraulic control valve block as follows:



WARNING



Always use appropriate tools to align fixing holes.
NEVER USE YOUR FINGERS OR HANDS.

- Refer to the illustrations on page 8 for the orientation of the various components:
- Apply the torque settings listed on page 5.
- Fit the complete control valve block pin.
- Fit the check valve.
- Fit the cylinder safety valve.
- Fit the control valve.
- Fit the cover on the control valve block.

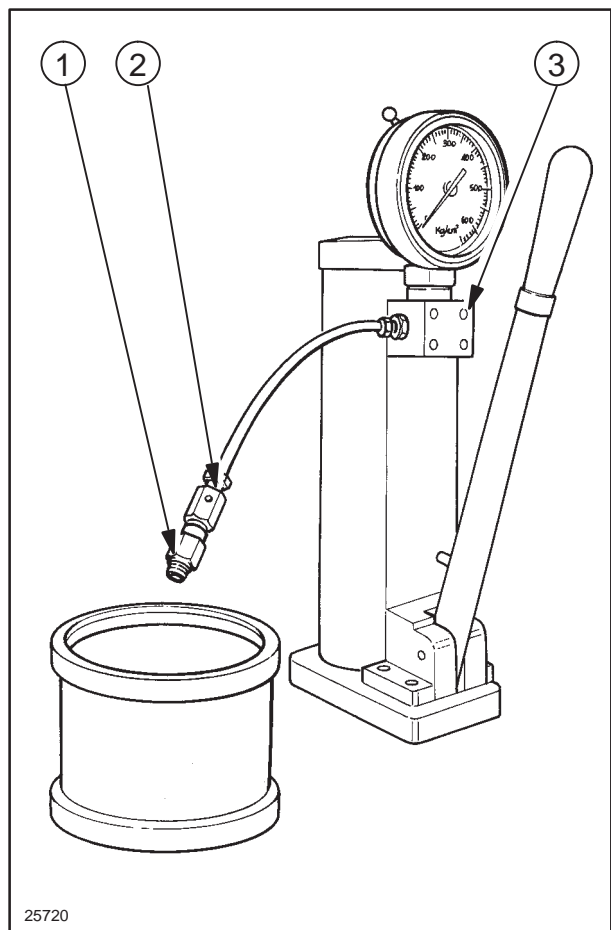

87

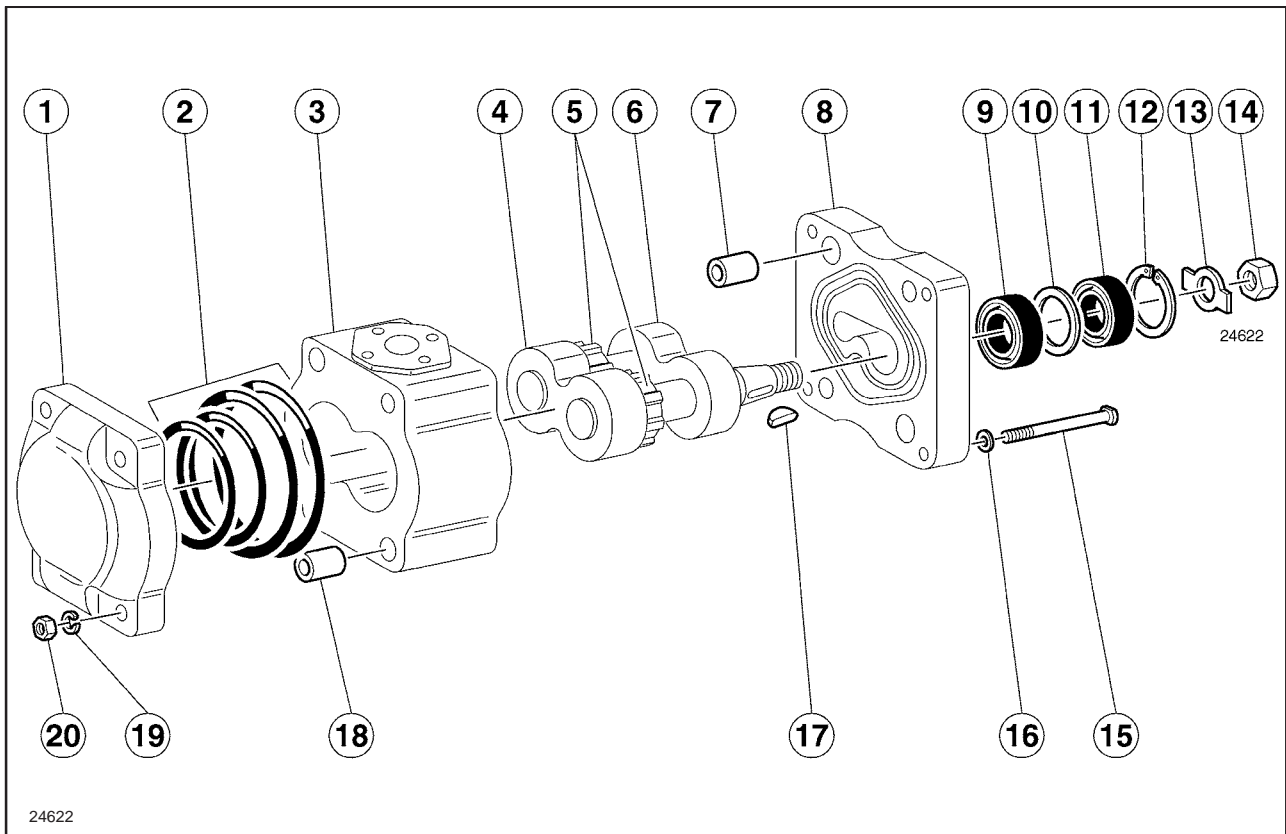

88

Hydraulic lift control pump components

- | | |
|------------------------------------|-------------------------|
| 1. Front cover. | 11. Driving shaft seal. |
| 2. Cover seals. | 12. Snap ring. |
| 3. Pump body. | 13. Safety washer. |
| 4. Gear support. | 14. Nut. |
| 5. Driven and driving gear shafts. | 15. Bolt. |
| 6. Gear support. | 16. Washer. |
| 7. Bushing. | 17. Key. |
| 8. Control side cover. | 18. Bushing. |
| 9. Driving shaft seal. | 19. Safety washer. |
| 10. Spacer. | 20. Nut. |

HYDRAULIC LIFT CONTROL OIL PUMP

Removal – refitting with pump removed (Op. 35 0101 10)

Proceed as follows:

1. Remove the cover fastening nuts (20), then the bolts (15) and the safety washers.
2. Remove the nut (14) that fastens the sleeve to the pump driving shaft and the safety washer.
3. Remove the front cover (8), the snap ring (12) and the seals (9 and 11).
4. Mark parts 3, 4, 5 and 6 to enable them to be remounted in the same position if they are in good condition.
5. Remove the supports (4 and 6) and the gears (5) from the rear cover (8) and the pump body (3).

6. Remove the seals (2) and the anti-extrusion rings.

Once the parts are removed, proceed as follows:

7. Check that the gear contact surfaces are flat and perpendicular to their supports. Insert a thin layer of carbon black. Small rough spots can be removed using extremely fine and well lubricated abrasive paper.
8. Check that the axial play of the gear-support unit in the pump body is 0.090 – 0.160 mm (0.0035 – 0.0063 in.). The distance (2) must be 0.090 – 0.160 mm (0.0035 – 0.0063 in.) smaller than the distance (1).

If necessary, true the flat surfaces involved using lubricated abrasive paper to remove extremely small quantities of material. Ensure that axial play is still within the limits of 0.090 – 0.160 mm (0.0035 – 0.0063 in.).

9. Clean all constituent parts thoroughly.

10. Replace the seals (2, 9 and 11).

11. Lubricate the parts with the same oil as the system. Refit the pump, referring to fig. 88 and proceed as follows:

12. refit, performing operations 6 to 1 in reverse order;

- always ensure maximum cleanliness to prevent foreign matter from entering, as this could damage the pump;
- fit together previously marked parts (3), (4), (5) and (6) fig.88; see procedure on page 42 to refit them in their original position;
- mount the gear supports (4) and (6) fig. 88, in the pump body. Mount them with the fittings on the external circumference matched up with the discharge pipes and the front faces with lubrication millings in contact with the gears;
- fit the plastic anti-extrusion rings on the seals (2) fig. 88:
- mount the seals (9) and (11) fig. 88, on the control side cover (8), complete with spacer (10). Mount them so that the cavity is between the seal lips on the opposite side from this spacer. Finally fill the cavity with **AMBRA GR 9** grease.

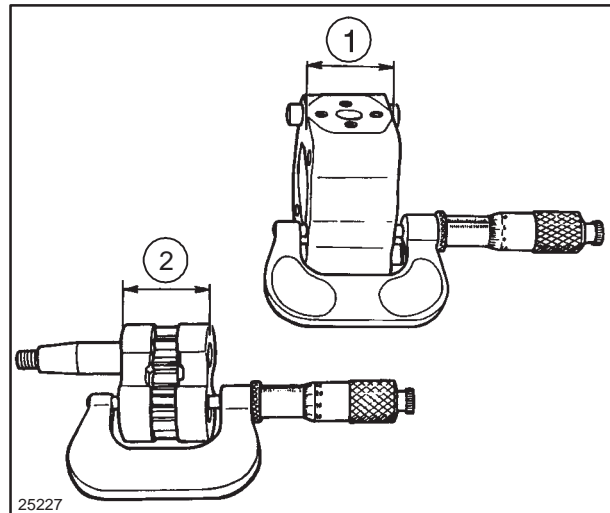

SECTION 35 - HYDRAULIC SYSTEM

Chapter 2 - Open centre system auxiliary control valves

CONTENT

Section	Description	Page
35 000	Main data - Tools	1
	Cross-sectional views	2
	Description & Operation	3
	Diagram of a convertible single/double-acting control valve with automatic release and detent in float	4
	Diagram of a convertible single/double-acting control valve	7
	Diagram of a convertible single/double-acting control valve with automatic release	9
35 204 46	Additional control valve - disassembly and reassembly	10
	Hydraulic Tests	11

**35 000 - MAIN DATA - TORQUE DATA - TOOLS - SECTIONAL VIEWS
- DESCRIPTION AND OPERATION**

DATA

Filter	
Pump	gear pump (common to the hydraulic lift circuit, see chapter 1)
Auxiliary control valves	
Location	valve stack (up to a maximum of 3 valves) attached to the rear of the centre housing
Operating	manually with lever
Pressure relief valve setting	190 (2755.703 psi)
Type	convertible single/double-acting, convertible single/double-acting with automatic release, convertible single/double-acting with automatic release and detent in float

TOOLS

WARNING: The operations described in this section can only be carried out with the **ESSENTIAL** tools indicated by an (X).

For greater safety and to obtain the best results while saving both time and effort, we recommend that these essential tools are used in conjunction with the specific tools listed below, and with certain tools which are to be made following the constructional drawings in this manual.

List of specific tools required for the various operations described in this Section.

380000240 Universal pressure testing kit.

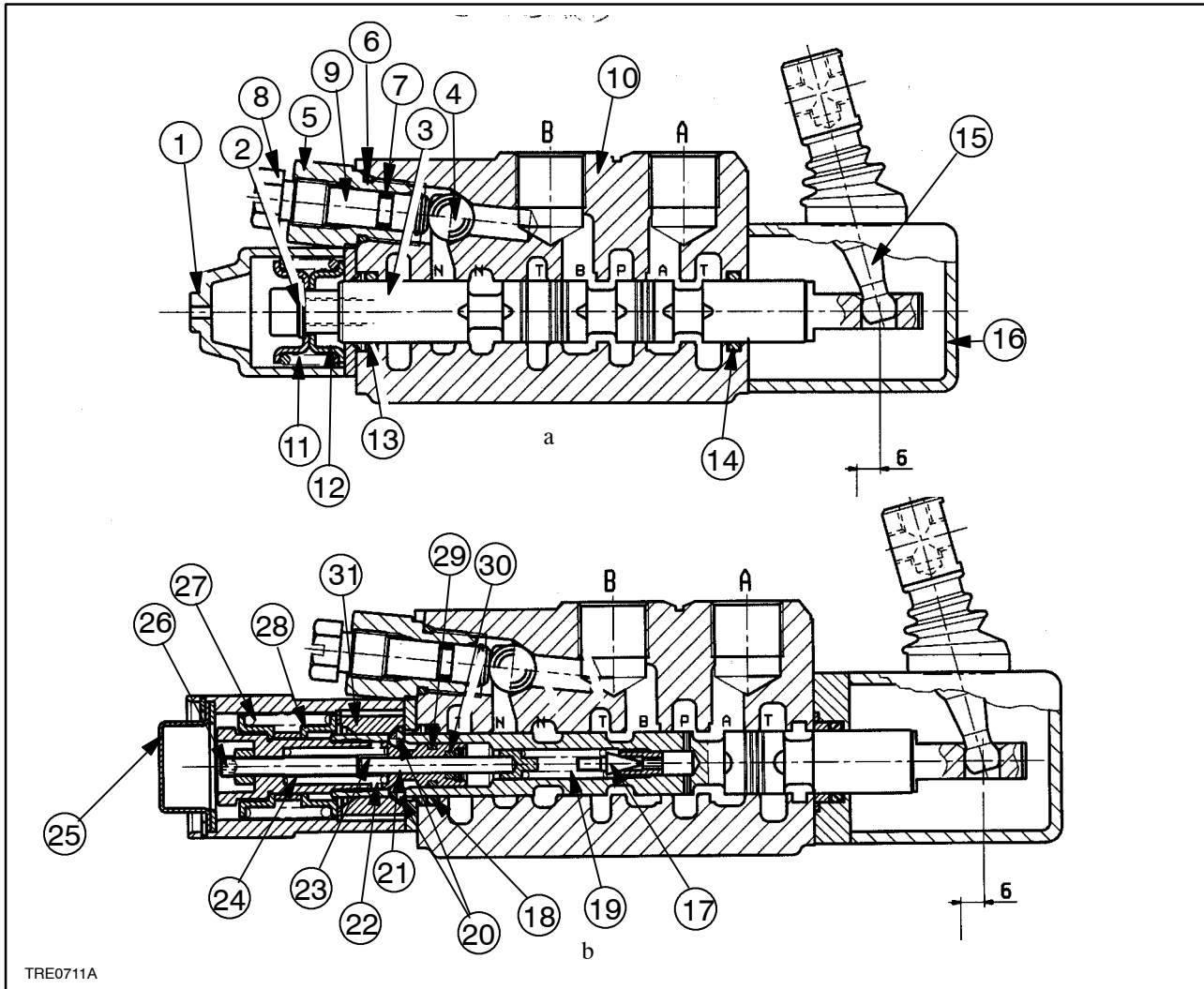

TRE0711A

1

Auxiliary control valves - Section views

- | | |
|--|---|
| <p>a. Auxiliary control valve for convertible single/double-acting cylinder.</p> <p>b. Auxiliary control valve for convertible single/double-acting cylinder with automatic hydraulic release.</p> | <p>14. Seal.</p> <p>15. Control lever.</p> <p>16. Control lever support.</p> <p>17. Tapered needle.</p> <p>18. Seal.</p> <p>19. Spring.</p> <p>20. Detent balls.</p> <p>21. Detent ball support.</p> <p>22. Seal.</p> <p>23. Internal plunger.</p> <p>24. Spring.</p> <p>25. Cover.</p> <p>26. Detent release pressure adjuster screw.</p> <p>27. Control valve pin return spring.</p> <p>28. Spring cup.</p> <p>29. Seal.</p> <p>30. Seal.</p> <p>31. Detent notch body.</p> |
| <p>1. Cover.</p> <p>2. Spacer.</p> <p>3. Control valve pin.</p> <p>4. Check valve.</p> <p>5. Single/double-acting conversion valve body.</p> <p>6. Seal.</p> <p>7. Seal.</p> <p>8. Single/double-acting switchover screw.</p> <p>9. Single/double-acting switchover pin</p> <p>10. Lift body.</p> <p>11. Pin return spring.</p> <p>12. Spring cup.</p> <p>13. Seal.</p> | |

DESCRIPTION & OPERATION

The auxiliary control valves serve for control of hydraulic loads external to the tractor.

Up to a maximum of **three** auxiliary control valves can be fitted, fixing them on the back of the transmission at the right-hand side.

- Convertible single/double-acting.
- Convertible single/double-acting + automatic release + float.
- Convertible single/double-acting + automatic release + detent in float.
- Single/double-acting.

The control valves are governed by levers (1, 2) located on the operator's right-hand side.

Each auxiliary control valve lever (1, 2 and 3, fig. 3) has three or four positions, depending on the type of control valve it operates.

- A** Lifting - Pull lever back to lift the implement.
- C** Lowering - Push the lever forward to lower the implement.
- B** Neutral - When the lever is released from the lifting and lowering positions it will automatically return to neutral position.
- D** Float - Push the lever forward beyond the "lowering" position to select "float position." In this position the only force exerted on the implement will be that created by its own weight, thus allowing the implement to follow the profile of the terrain.

Some control valves are fitted with a valve (1, fig. 4), acting on which it is possible to switch over the control valve from double-acting to single-acting.

The operation of the hydraulic control valves is described on the following pages.

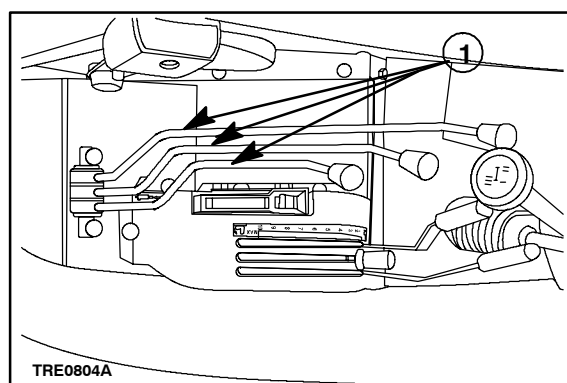

2

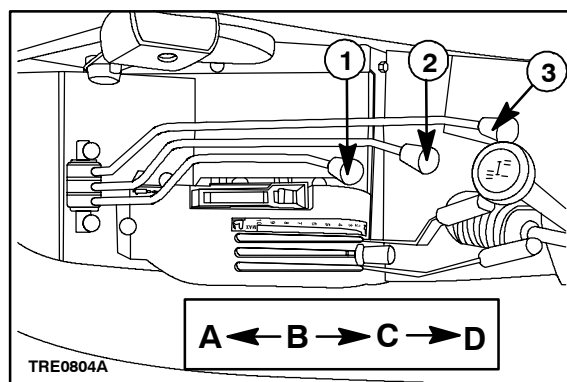

3

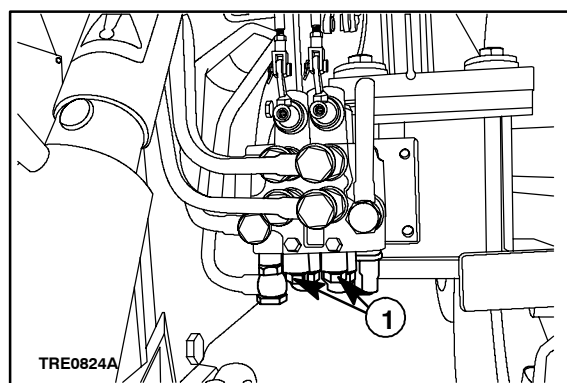

4

**OPERATING STAGES OF A CONVERTIBLE SINGLE/DOUBLE-ACTING AUXILIARY CONTROL VALVE
WITH AUTOMATIC RELEASE AND DETENT IN FLOAT
(Detail of automatic release and detent)**

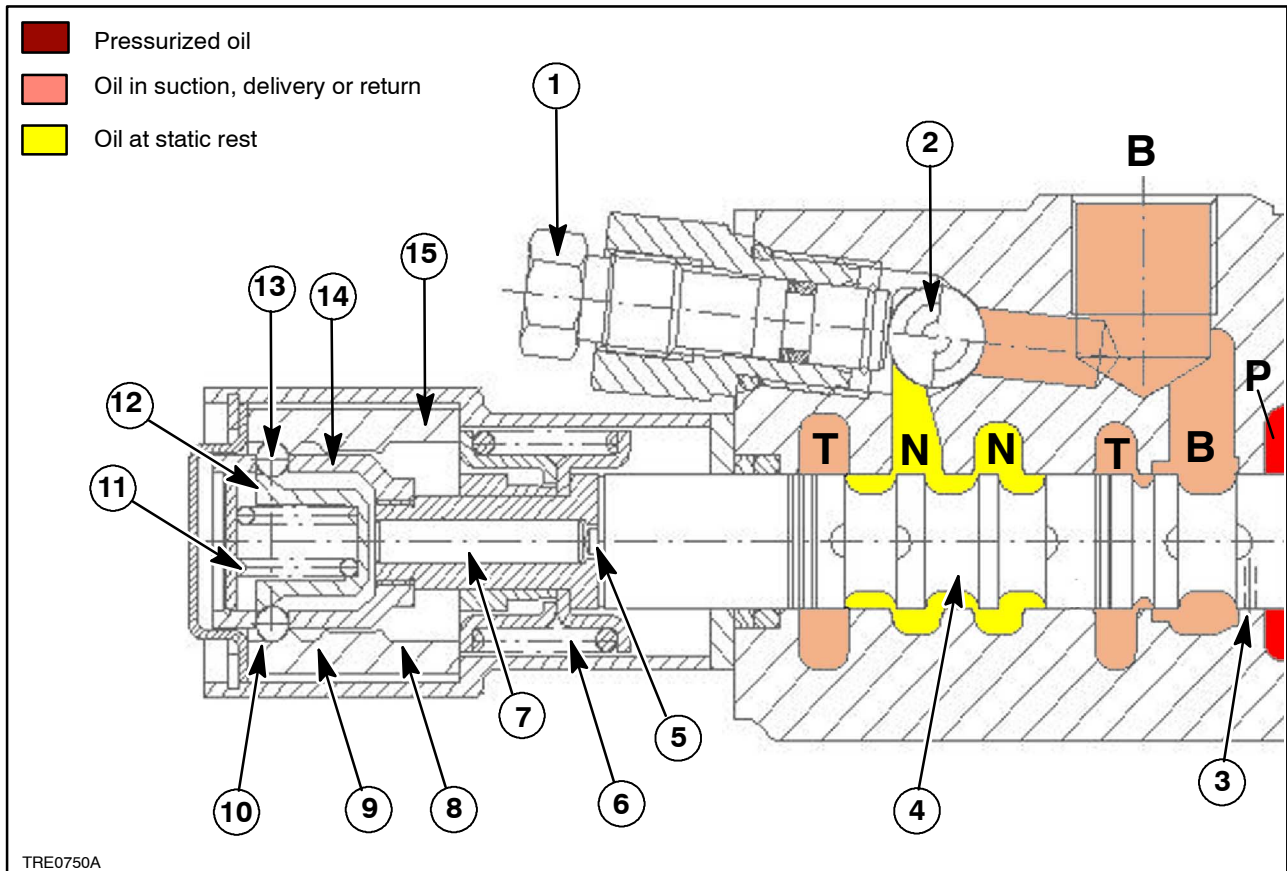

5

- | | |
|---|--|
| <ol style="list-style-type: none"> 1. Single/double-acting valve switchover screw. 2. Single/double-acting valve switchover ball. 3. HOle on the control valve pin to set the auto-matic release oil pressure. 4. Control valve pin. 5. Automatic release actuator pin. 6. Spring to return pin into neutral. 7. Automatic release pin. 8. Seat of ball with control valve on lifting. 9. Seat of ball with control valve on lowering. 10. Seat of ball with control valve in float position. | <ol style="list-style-type: none"> 11. Spring to position bracket 12. 12. Bracket to position balls in seat. 13. Ball. 14. Ball positioning ring. 15. Outer ring with ball seat. B Control valve pressure tap. N Pressure discharge lines line B with control valve switched over onto single-acting. P Oil delivery line from the pump. T Discharge lines. |
|---|--|

Automatic release operation

The control valve pin has a hole in it (3, fig. 5) through which the existing pressure on the control valve discharges onto a valve at the end of the pin.

When the pressure reaches the automatic release setting, the actuator pin (5, fig. 5) comes out of the control valve pin pushing the release pin (7, fig. 5) that by acting on the bracket (12, fig. 5) frees the balls and therefore the control valve pin, under the action

of the spring (6, fig. 5), returns to neutral; this holds for both lowering and lifting.

In the float phase, as there is no pressure in lines A and B of the control valve, the automatic release does not work automatically; therefore, in order to move the control valve lever into neutral, it must be done manually.

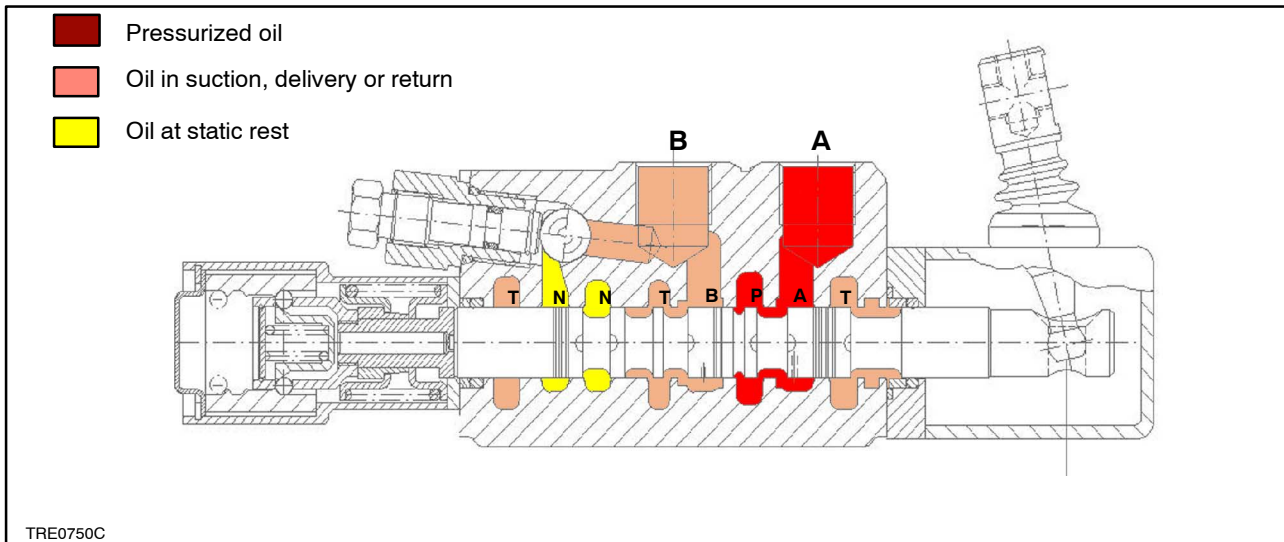

6

Operation in lifting phase.

When the pin (4, fig. 5)) moves to the right, the detent balls (10, fig. 5)) enter the slot (8, fig. 5), remaining blocked by the support (12, fig. 5) and the spring (11, fig. 5). In this condition the oil contained in the lower chamber of the cylinder can flow to the exhaust (T)

by way of line (B), while the upper chamber is connected with the pressure line (P) by way of line (A). On completion of the lifting operation, the detent will be automatically released as explained on page 4.

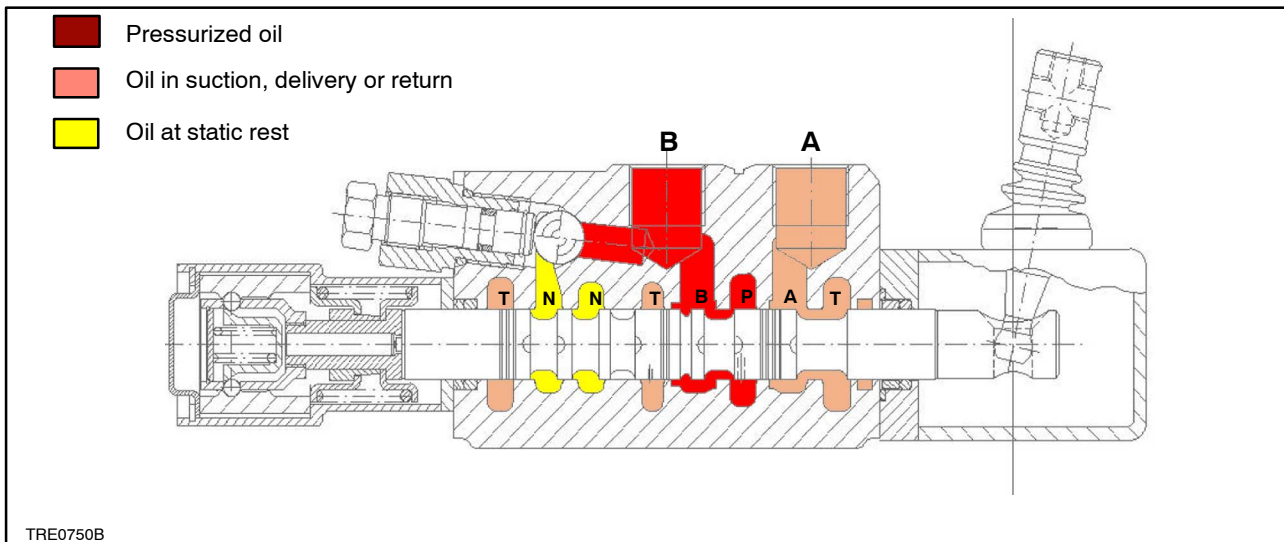

7

Operation in lowering phase.

When the pin (4, fig. 5)) moves to the left, the detent balls (10, fig. 5)) enter the slot (9, fig. 5), remaining blocked by the support (12, fig. 5) and the spring (11, fig. 5). The movement of the pin connects the delive-

ry line (P) with the lower line of cylinder (B) and moreover the upper chamber with the discharge line (T), via line (A). The working principle of the automatic release is explained on page 4.

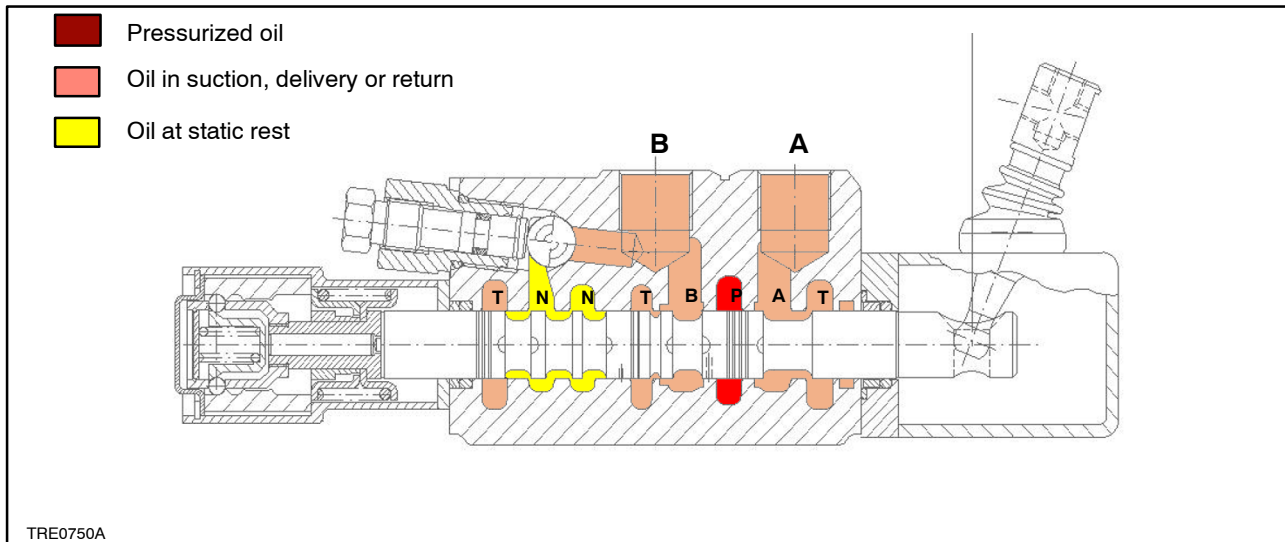

Float function

To select float mode operation, push the control lever in the cab fully forward. The pin of the control valve (4, fig. 5) moves and the detent balls (13, fig. 5) enter the slots (10, fig. 5), remaining blocked by the support (12, fig. 5) and by the spring (11, fig. 5). In this position the control valve pin directs the oil of ports A and B through the pipes to the discharge T. No pressure is applied to either port. In this condition, the only force

acting on the attached implement is that of gravity due to its own weight and the weight of the hydraulic lift, which keeps the implement in contact with the terrain, following its contours. Automatic detent release does not occur during float control as there is no pressure inside the auxiliary control valve so the return to neutral is manual.

OPERATING STAGES OF AUXILIARY CONTROL VALVE FOR OPERATION OF A DOUBLE-ACTING CYLINDER (FIGS. 9 and 10) AND A SINGLE-ACTING CYLINDER (FIGS.11 and 12)

1. LIFTING - Pushing the control lever in the cab forwards moves the pin (2), thereby connecting the delivery line (P) with the cylinder lower chamber via line (A) and moreover the discharge line (T), via line (B), with the upper chamber of the cylinder. Keep the lever pulled back, to extend the cylinder to its full stroke. On releasing the lever it will automatically return to neutral position, under the action of the return spring, and the entire flow from the pump will be conveyed to the lift control valve by way of line (P).

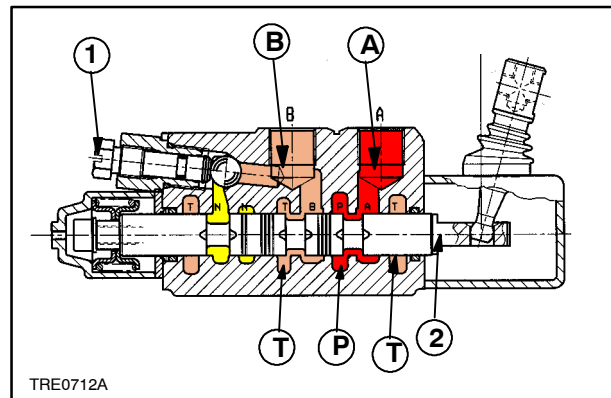

9

2. LOWERING - To lower the implement, pull the control lever (located in the cab) backward. The control valve pin (2) will move to the position indicated in fig. 10 and allows the oil contained in the lower chamber of the cylinder to flow to the exhaust (T) by way of line (A), while the upper chamber is connected with the pressure line (P) by way of line (B).

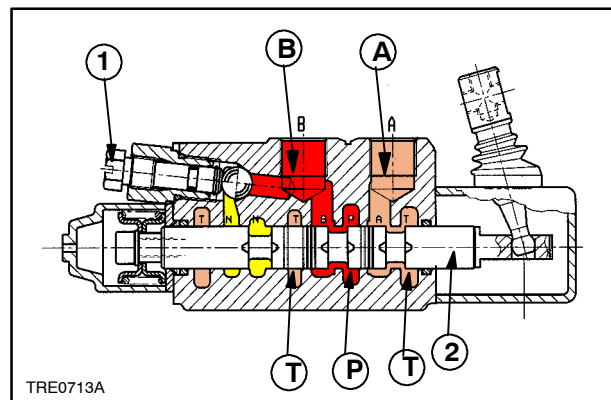

10

3. LIFTING - On pushing the control lever forwards, the pin (2) fig. 11 moves to connect the cylinder with the pressure line (P) by way of line (A). Line (C), for the control of single-acting cylinders, is not used as it is permanently connected to the exhaust (T) by the open position of the switching valve (1).

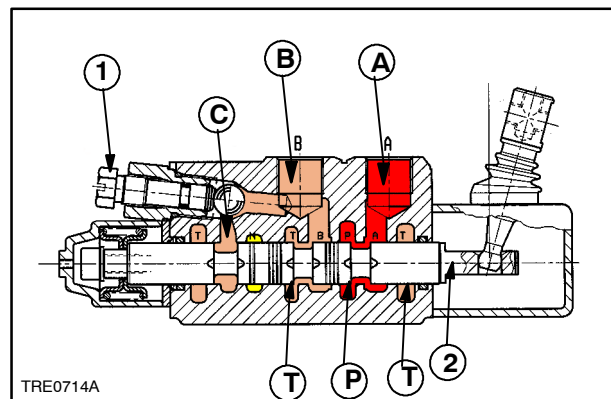

11

4. LOWERING - On pulling the control lever back, the control valve pin (2) moves as shown in fig. 12. The oil contained in the cylinder, pressurised by the weight of the lifted implement, will flow to the exhaust (T) by way of line (A), while the entire flow from the pump is also conveyed to the exhaust (T) through the line (B).

- Pressurized oil
- Oil in suction, delivery or return
- Oil at static rest

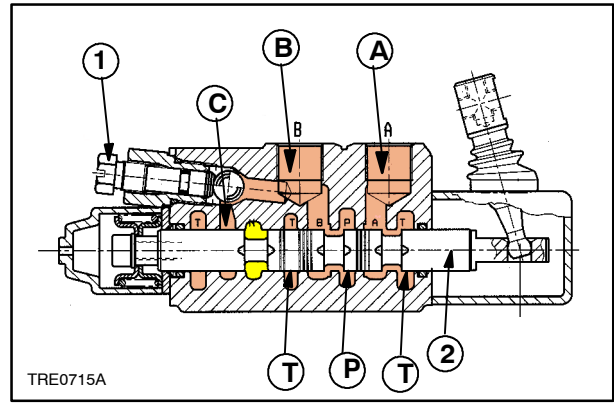

12

Note. - To operate a double-acting cylinder, tighten screw (1) fully home. To operate a single-acting cylinder, fully undo screw (1).

OPERATING STAGES OF AUXILIARY CONTROL VALVE OPERATING A DOUBLE-ACTING CYLINDER WITH AUTOMATIC DETENT RELEASE

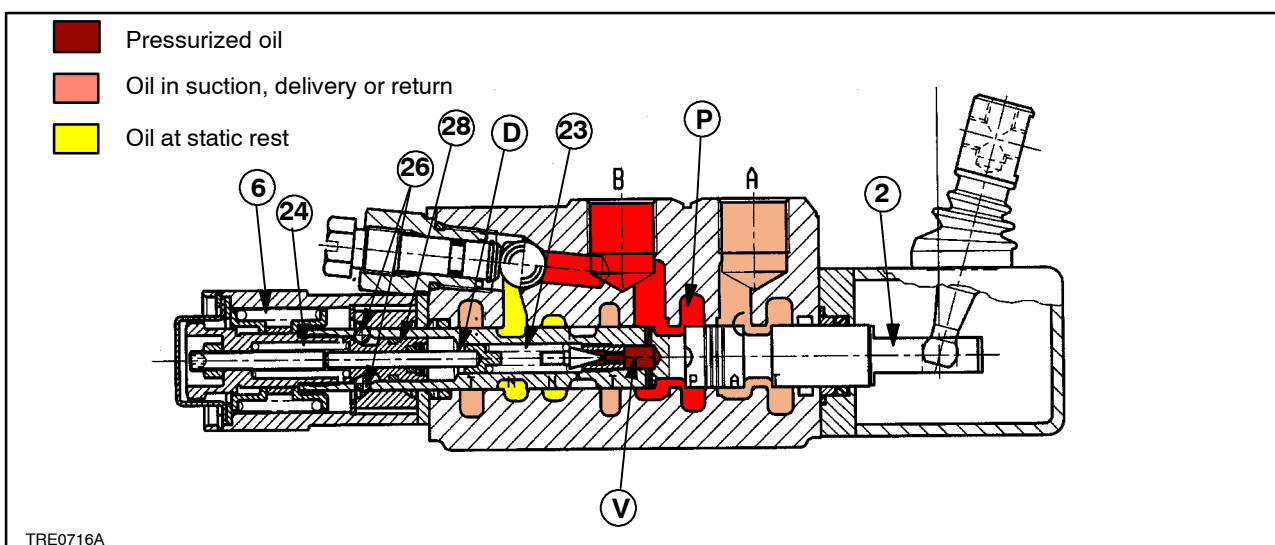

13

LOWERING

On pushing the control lever forwards, the (2) moves and the balls (26) enter their seat where they are held in position by the support (28) and the spring (24). The movement of the control valve pin (2) connects: the pressure line (P) with the line (B), and also the upper cylinder chamber with the exhaust line (T) by way of line (A).

On completion of the lifting movement, the oil pressure increases to 170-175 bar (173-178 kg/cm²). Acting through port (V), it overcomes the resistance

of the spring of the needle valve (23). The oil pressure increases inside the chamber (D) and, using the support (28), it overcomes the resistance of the spring and moves the support (28). In this condition the two detent balls (26) drop onto the support (28), releasing the control valve pin (2) which, under the action of spring (6) returns to neutral position. Consequently the entire flow from the pump is conveyed to the lift control valve through lines (P).

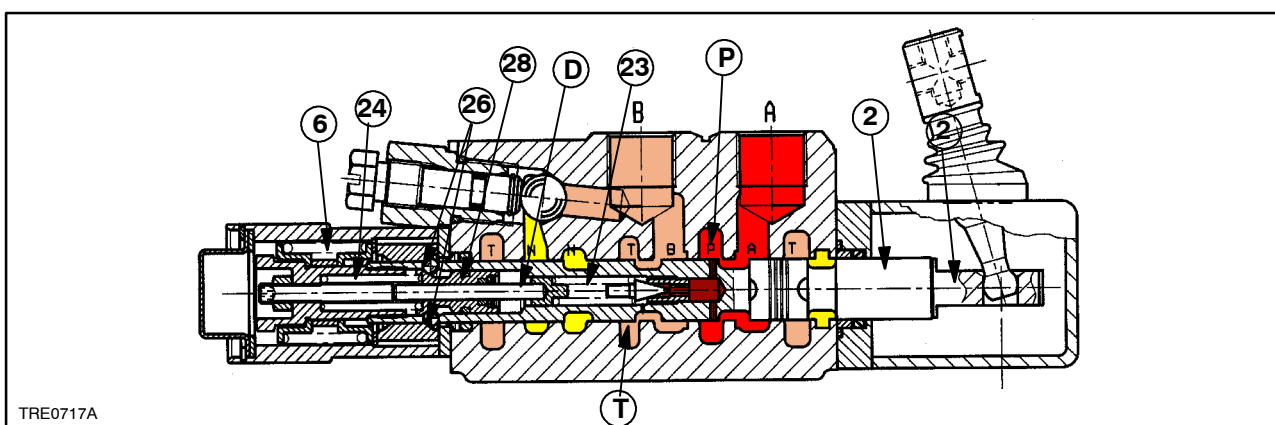

14

LIFTING

To lift the implement it is necessary to pull the control lever backward. The control valve pin (2) moves and the detent balls engage in the central groove where they are held in position by the support (28) and the spring (24). In this condition the oil contained in the lower chamber of the cylinder can flow to the exhaust

(T) by way of line (B), while the upper chamber is connected with the pressure line (P) by way of line (A). On completion of the lowering operation, the detent will be automatically released in the manner described previously.

AUXILIARY CONTROL VALVES (REMOVED FROM TRACTOR)

Disassembly - Assembly (Operation 35 204 46) of control valves removed from tractor



CAUTION



Handle all parts with care.
Do not insert fingers or hands between one part and another.
Wear suitable safety clothing - safety goggles, gloves and shoes.



CAUTION



Always use suitable tools to align holes. NEVER USE FINGERS OR HANDS.

Convertible single/double acting auxiliary control valve.

Disassemble the auxiliary control valve into its component parts referring to the sectional views (fig. 1) and the following instructions:

- Remove cover (9) and O-rings (7).
- Extract pin (8).
- Remove the control lever support (4) and take out the seal (7).
- Remove the plug (6) and recover the single/double action switching valve (5).
- Take out the pressure relief valve (1) and retrieve the one-way valve (2).
- Check the seat of the control valve (3) is sound
- Check the condition of the seals before assembly.

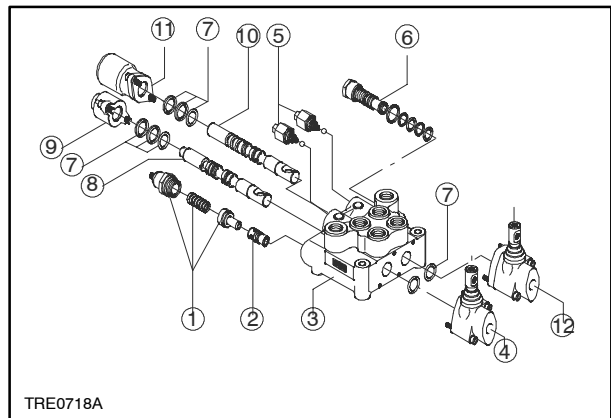

15

Single/double-acting auxiliary control valve with float control and automatic detent release.

Disassemble the auxiliary control valve into its component parts referring to the sectional views (fig. 1) and the following instructions:

- Unscrew the retaining bolts and remove the cover (11).
- Unscrew the retaining screws and remove the control lever support (12) and its seal (7).
- Extract the pin (10).
- Remove the control valve housing and extract the switchover valve (5).
- Check the condition of the seals before assembly.

CONTROL VALVE PIN BINDING TEST

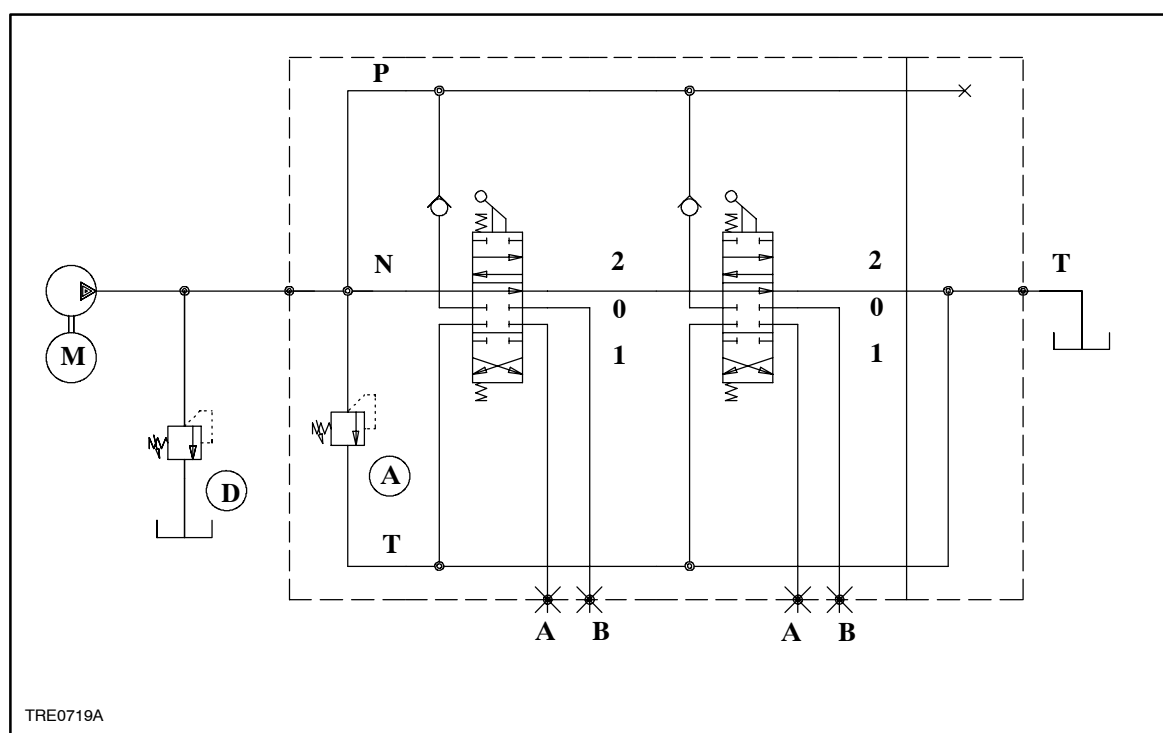

16

Control valve pin binding test (fig. 16).

Install the auxiliary control valve assembly and the test apparatus as indicated in the diagrams (fig. 16) and referring to the following instructions:

- The test is carried out with mineral oil in accordance with DIN 32 norm. Flow rate is the nominal for the valve (for VDM07 it is 50 l/min). Connect line P (pump line) to the inlet port of the valve and close the working ports A and B of each section (see schematic) with plugs. Start the test, increasing the flow coming from the pump until nominal flow plus 25% is reached (in the case of VDM07 it is 75 l/min). With the control lever in the neutral position (mid-posi-

tion) the flow goes through the valve from inlet to outlet (tank line) (P) to (T). Now regulate the maximum pressure of the VS (main relief valve) valve inside line A (in the schematic). This pressure is the maximum pressure that can be obtained with the type of valve and spring used. Now move each single control valve pin in each section. With the ports closed, the pressure will rise until the relief valve opens. In this situation check if spools move to the neutral (central) position without sticking, under the action of springs and flow forces only. The relief valve D, in line before the directional valve, has to substitute the VS in A in case of problems or in case of directional valve without VS.

CONTROL VALVE PIN LEAKAGE TEST

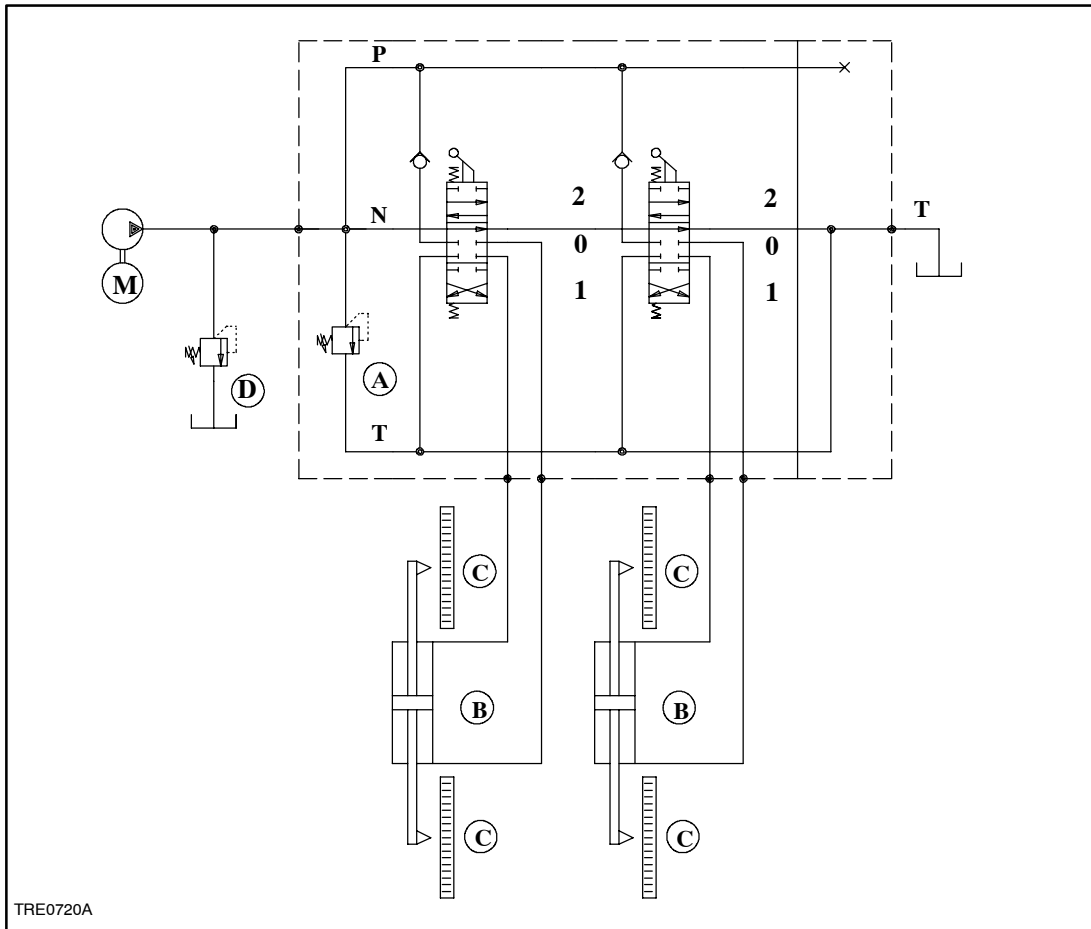

Valve leakage test

After the binding test (with hot oil and valve), measure the leakage rate for each section. It is important to do this with the system hot. Connect working ports A and B of each section to the cylinders (one for each section). Alongside each cylinder lay a ruler to measure the stroke.

Supply oil to the cylinder, moving the control valve pin to the working position (oil flowing from A or B) until it reaches the end of its stroke and the main relief valve opens. Now that the oil column is pressurised from the working section to the cylinder allow the lever to return to the neutral position (called 0). The control valve pin closes ports A and B. Now check the position of the cylinder observing the ruler beside it. As the cylinder moves, check the stroke in a fixed

time (say 60 seconds). From this stroke, calculate the volume of oil per minute through that section of the cylinder. This check has to be carried out for each section (each control valve pin).

After this check, with the pump disconnected, move the control valve pin to its working position: now test the check valve (VU: check valve) of the control valve. This valve closes the connection from P to T (N), also the connection P with A or B when B is open (control valve pin in working position). If the check valve is working correctly, the normal flow rate will be seen (the same value observed with the control valve pin in the neutral position). If it is seen that one or more sections operates more than in a previous check, it means that the check valve is not working properly (does not close completely).

SECTION 35 - HYDRAULIC SYSTEMS

Chapter 3 - Trailer brake auxiliary control valve

CONTENT

Section	Description	Page
35 000	Section views	1
	Hydraulic diagram	2
	Description and operation of valve phases	3
	Trailer brake auxiliary control valve linkage adjustment	5

Section view of auxiliary control valve for trailer braking

1. Flow control valve.
2. Slide piston.
3. Check valve.
4. Pressure limiter.

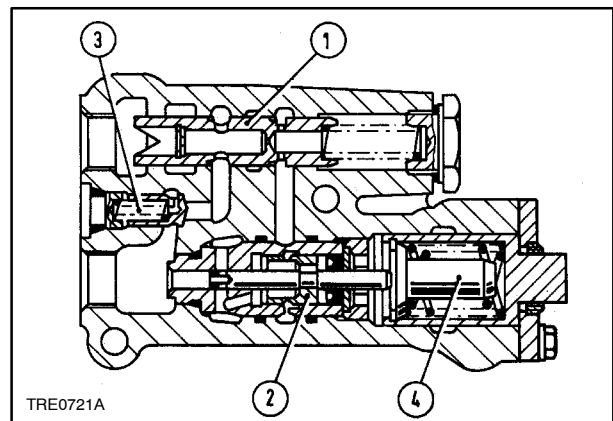

1

DESCRIPTION AND OPERATION

The trailer brake valve is mounted on the rear transmission casing forward of the hydraulic lift. It is supplied by the same pump as the lift circuit.

The trailer brake valve has priority over the auxiliary control valves and the hydraulic lift.

The hydraulic operation of these valves is described on pages 3 and 4.

HYDRAULIC DIAGRAM OF TRAILER BRAKE AUXILIARY CONTROL VALVE

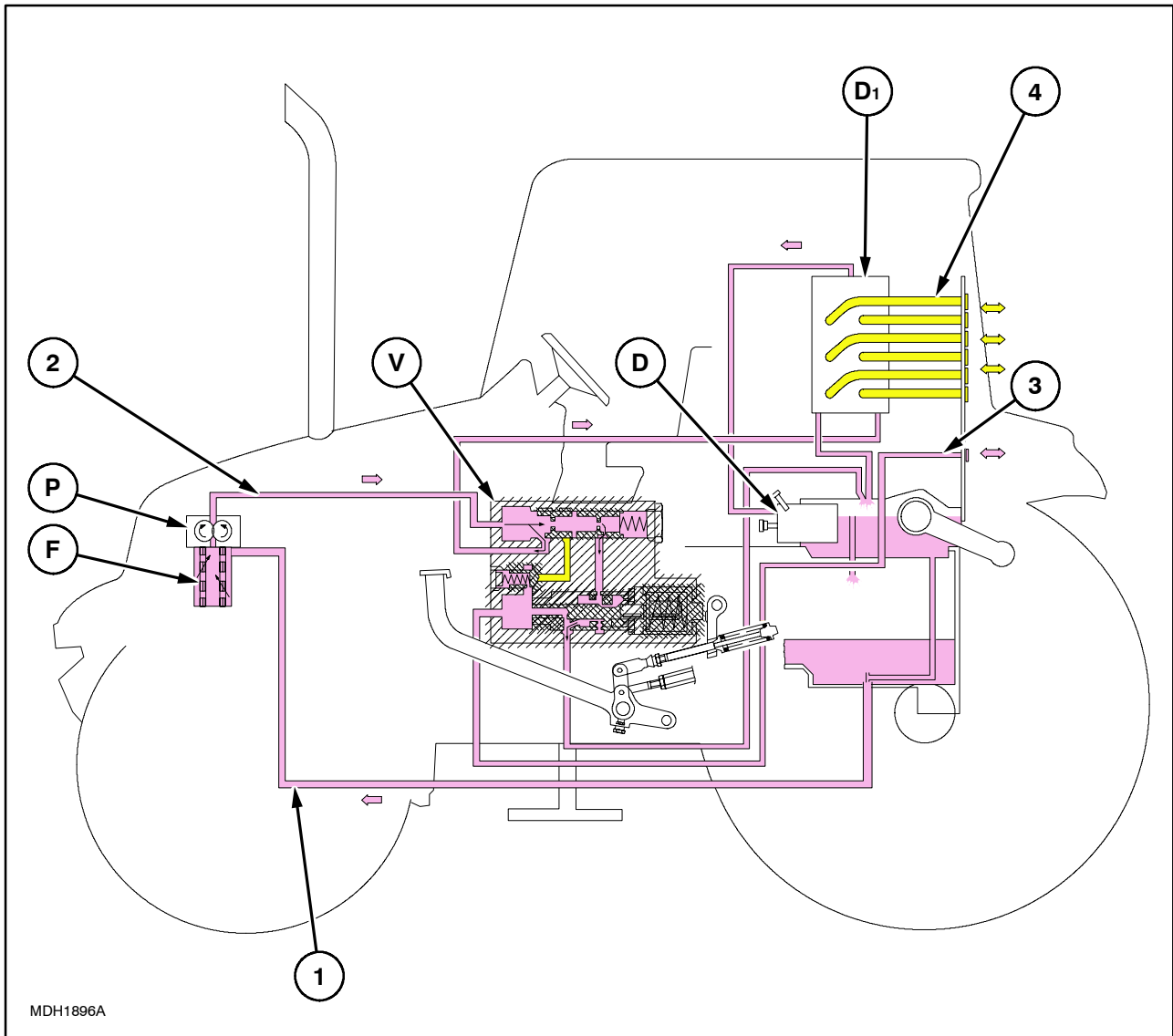

2

Diagram of the hydraulic trailer brake circuit

- | | |
|--|---|
| D Lift control valve. | 1. Suction line from rear transmission. |
| D₁ Additional control valve. | 2. Delivery line to the trailer brake control valve. |
| F Filter. | 3. Oil delivery line to the trailer brake. |
| P Hydraulic feed pump (common to the hydraulic lift). | 4. Oil delivery line to the services. |
| V Trailer brake auxiliary control valve. | |

TRAILER BRAKES OFF

When tractor brakes are inactive, pressure limiter (4) and slide piston (2) take up the positions shown in fig. 3.

Oil from hydraulic pump (P, fig 2) is directed to fitting (P₁) through diaphragm (11) and restriction (9) which causes a pressure drop to move flow control valve (1) to the right.

Most of the oil flows through connection (N) to the auxiliary control valves. The remaining output is drained into the hydraulic lift through port (10), slide piston (2) and union (R).

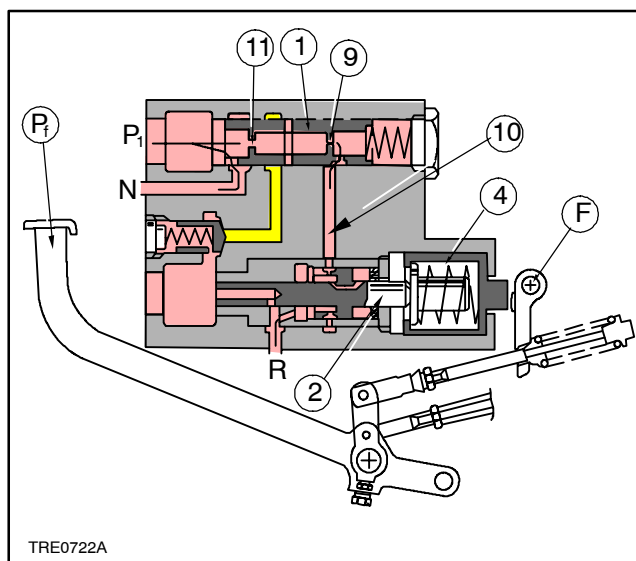

3

- Pressurized oil
- Oil in suction, delivery or return
- Oil at static rest

Trailer brakes off

- N.** To auxiliary control valves.
- P₁.** Oil from the hydraulic pump.
- R.** Discharge line.

START OF BRAKING - On operating the tractor brake pedal (Pf), the fork (F) shifts the pressure limiter (4) and the slide piston (2) to the left, which in turn closes the passage between the oil return port (R), trailer brake port (B) and the line (10).

The oil inside the flow control valve (1) is maintained at a uniform pressure and so the valve element, under the action of the spring, shifts to the left to assume the position indicated in fig. 4.

Part of the oil from the hydraulic pump in union (P₁) flows to the auxiliary control valves through union (N), while the remaining part arrives at the tractor braking element via the diaphragm (11), line (12), check valve (3) and port (B).

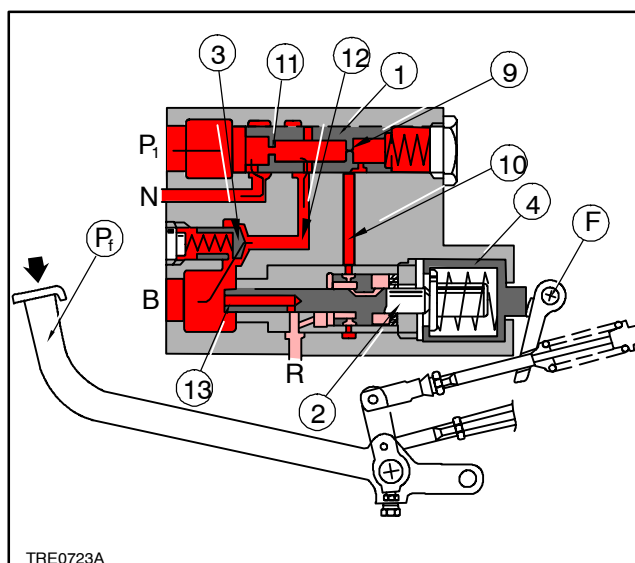

4

Start of braking

- B.** To trailer brakes
- N.** To auxiliary control valves.
- P₁.** Oil from the hydraulic pump.
- R.** Discharge line.

As the pressure of the oil in the trailer brake union (B) increases, it acts on the active surface (13) of the slide piston (2), opposing the pressure applied on the pressure limiter (4) by the control fork (F).

BRAKING – Continued brake pedal application (P_f) causes an increase in oil pressure at trailer brake connection (B) which, acting on the active surface (13) of slide piston (2), moves the latter to the right thereby overcoming the opposition of the check valve (8) of the pressure limiter (4).

When the trailer brake circuit oil pressure is equal to spring (8) pressure, slide piston (2) stabilises as shown in fig. 5 and establishes communication between oil from pump and lift drain through connection (P_1), diaphragm (11), restriction (9), port (10) and connection (R).

Diaphragm (11) and restriction (9) cause a pressure drop in flow control valve (1) which moves to the right to close line (12) and consequently, check valve (3).

Further pressure on the tractor brake pedals (P_f) shifts the pressure limiter (4) and the slide piston (2) to the left, thus causing an increase in the trailer brake circuit pressure, repeating the stages described in the paragraph **START OF BRAKING** on page 3.

Upon releasing the brake pedals, the system returns to the conditions shown in fig. 3 on page 3.

- Pressurized oil
- Oil in suction, delivery or return
- Oil at static rest

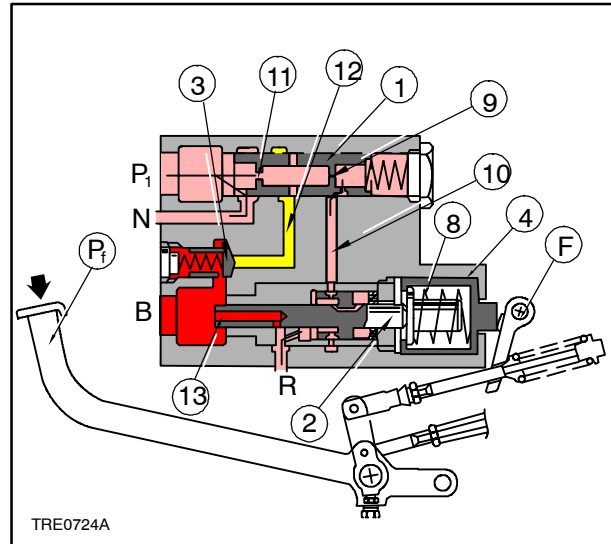

5

Braking

- B.** To trailer brakes
- N.** To auxiliary control valves.
- P₁.** Oil from the hydraulic pump.
- R.** Discharge line.

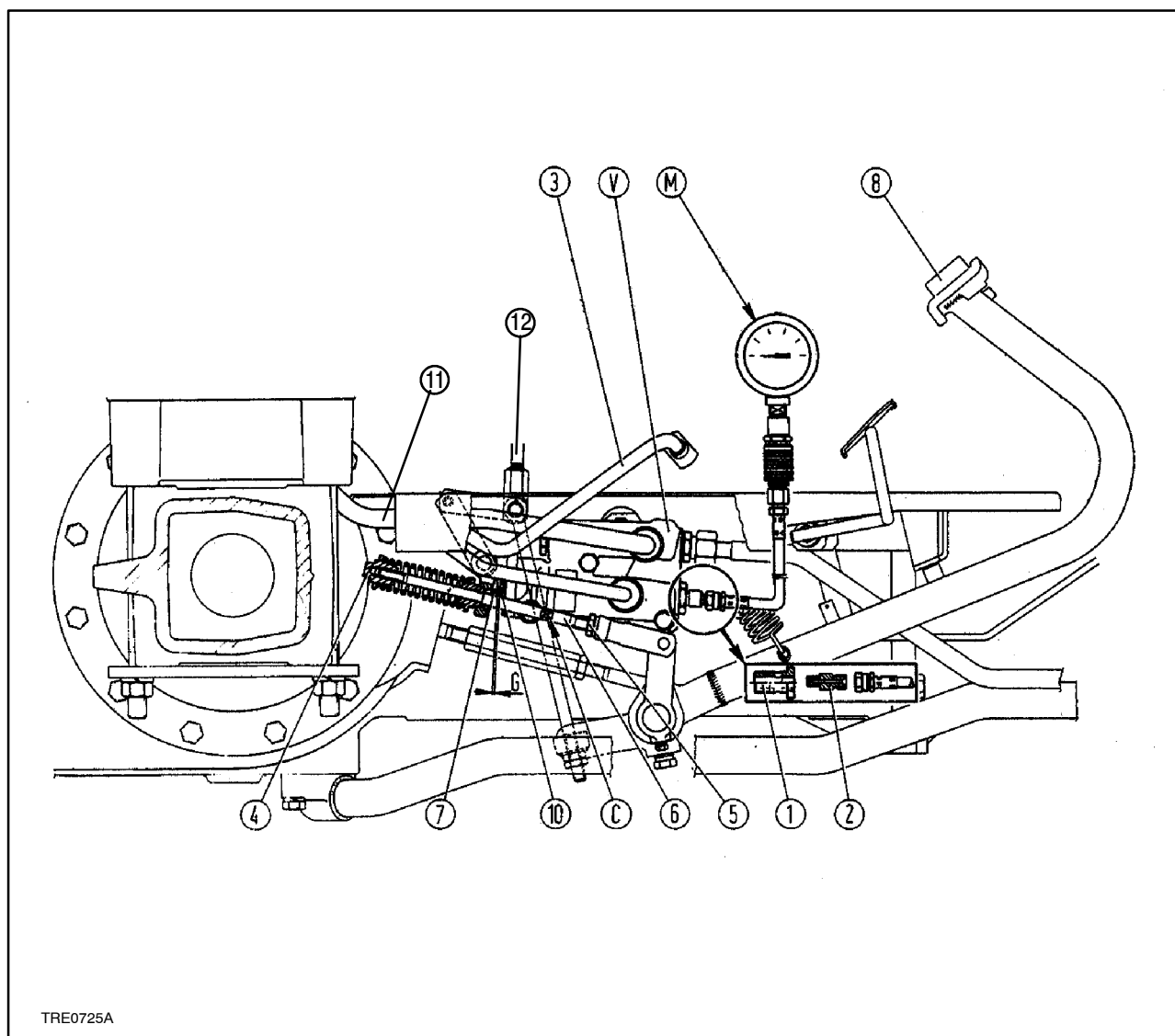

TRE0725A

Trailer brake remote control valve linkage adjustment

6

- C. Wrench flats on link (6).
- G Clearance between fork (7) and piston (10) $G = 0.3-0.5\text{mm}$.
- M. Pressure gauge with 0 to 250 kg/cm² scale of kit **380000240**.
- V. Trailer brake control valve.
- 1. Union **38000841** supplied in kit **380000240**.
- 2. Union **38000840** supplied in kit **380000240**.
- 3. Delivery line to the trailer brake.
- 4. Cup.
- 5. Locknut.
- 6. Link.
- 7. Fork.
- 8. Brake pedals.
- 10. Trailer brake control valve piston.
- 11. Oil delivery to the additional control valves.
- 12. Parking brake link.

**TRAILER BRAKE AUXILIARY CONTROL VALVE
LINKAGE ADJUSTMENT**

Proceed as follows:

1. Adjust the brake pedal travel (8) as indicated in section 33 chapter 1 page 20.
2. Adjust parking brake lever (9) as described in section 33 chapter 1 page 20.
3. Fully tighten cup (4), slacken locknut (5) and adjust length of link (6), using wrench flats (C) to obtain a clearance (G) of 0.3 to 0.5 mm (0.1118 to 0.01968 in.) between fork (7) and piston (10) of trailer brake control valve.
4. Tighten locknut (5).
5. Disconnect trailer brake oil delivery line (3) from brake control valve body (V).
6. Connect pressure gauge (M) with 0 to 250 kg/cm² scale of kit **380000240** to control valve body, using connections **380000841** (1) and **380000840** (2) (both connections belong to kit **380000240**)
7. Start the engine and take the oil up to a temperature of 50 - 60 °C (122 - 140 °F).
8. Run engine at around 2000 rpm.
9. Check that pressure gauge (M) reading is zero when brake pedals (8) are not applied.
10. Depress brake pedals until pedal free travel is taken up and check on pressure gauge (M) that pressure is 100 bar (1450.37 psi)
11. Repeat this operation at least three times, checking that system pressure reading drops to zero when pedals (8) are released.
12. Apply parking brake (9) a few times without depressing brake pedals and check that pressure reading on pressure gauge (M) remains at zero.

SECTION 41 – STEERING

Chapter 1

CONTENTS

Section	Description	Page
41 000	Principal data	1
	Tightening torques	3
	Hydraulic diagram	4
	Operation	5
	Section	8
	Fault diagnosis	9
	Tools	10
41 204.30	Removal–Installation – hydrostatic steering control valve	11
41.204.34	Hydrostatic steering control valve – Overhaul on bench	14
41.204.38	Hydrostatic steering control valve – Bench test	28
	Hydrostatic steering pump	30
41.216.20	Steering cylinder (two–wheel drive axle) – removal and installation	32
	Steering cylinder (four–wheel drive axle) – removal and installation	33

PRINCIPAL DATA

HYDROSTATIC STEERING	
Type	independent hydrostatic control, feed by hydraulic pump metal cartridge, built into oil reservoir
Hydraulic circuit	
Oil filter	
Control valve	
Make	DANFOSS rotary valve controlled directly from the steering column; the steering continues to function even if the pump is non–functional
Type	
Outfit code: – DANFOSS	OSPC 100
Pressure relief valve setting (18) fig. 5	
– 2WD models	100 bar (1450.37 psi)
– 4WD models	125 bar (1812.96 psi)
Shock valve setting (19) fig. 5	
– 2WD models	160 bar (163 kg/cm ²)
– 4WD models	185 bar (189 kg/cm ²)

MAIN SPECIFICATIONS OF HYDRAULIC PUMP

Pump	
Type	gear type, with oil suction from transmission casing
Location	behind the timing cover
Construction	BOSCH
Control	governed by the timing
Model	C25
Pump rotation (viewed from drive side)	clockwise
Engine speed to pump speed ratio	1:1,080
Maximum speed of pump rotation (with engine at power equivalent to 2500 rpm)	2700
Rated output	0.01126 (0.6871)
Corresponding rated output for new pump	30.4 (1855.1736)
Diameter of driven and driving gear shafts	17,400 – 17,418 (0.6850–0.6857)
Internal diameter of seats in supports	17,450 – 17,475 (0.6870–0.6880)
Clearance between gear shafts and their seats	0,032 – 0,075 (0.0013–0.0030)
– maximum permitted wear clearance	0,1 (0.0039)
Radial clearance of gears in pump body	0,020 – 0,064 (0.0008–0.0025)
Maximum wear on pump body, suction side, at position of gears	0,1 (0.0039)
Cylinder	
Type	Double acting, located behind front axle
Construction	OGNIBENE
Bore diameter:	
– two-wheel drive	48 (1.89 in)
– four-wheel drive	48 (1.89 in)
– four-wheel drive with 2 cylinders	42 (1.653 in)
Maximum piston stroke:	
– two-wheel drive	215 (8.464 in)
– four-wheel drive	202 (7.953 in)
– four-wheel drive with 2 cylinders	208 (8.189 in)
Pin diameter	22 (0.866 in)

TORQUE SETTINGS

PART	Thread	Torque setting	
		Nm	ft lb
Bolt fixing hydrostatic steering to tractor	3/8"–16 UNC	44	32.4527
Bolt fixing cover to hydrostatic steering housing (13, fig. 5)	M 8 x 1	34	25.0771
	M 8 x 1*	29	21.3893
Hydrostatic steering control pump fixing bolt	M 6 x 1	8	5.9005
Nut for bolt fixing cover to pump housing (20, fig. 71)	M 10 x 1,25	39	28.7649
Nut for securing thrust sleeve to pump drive shaft (14, fig. 71)	7/16 in –20UNF–2B	28	20.6517

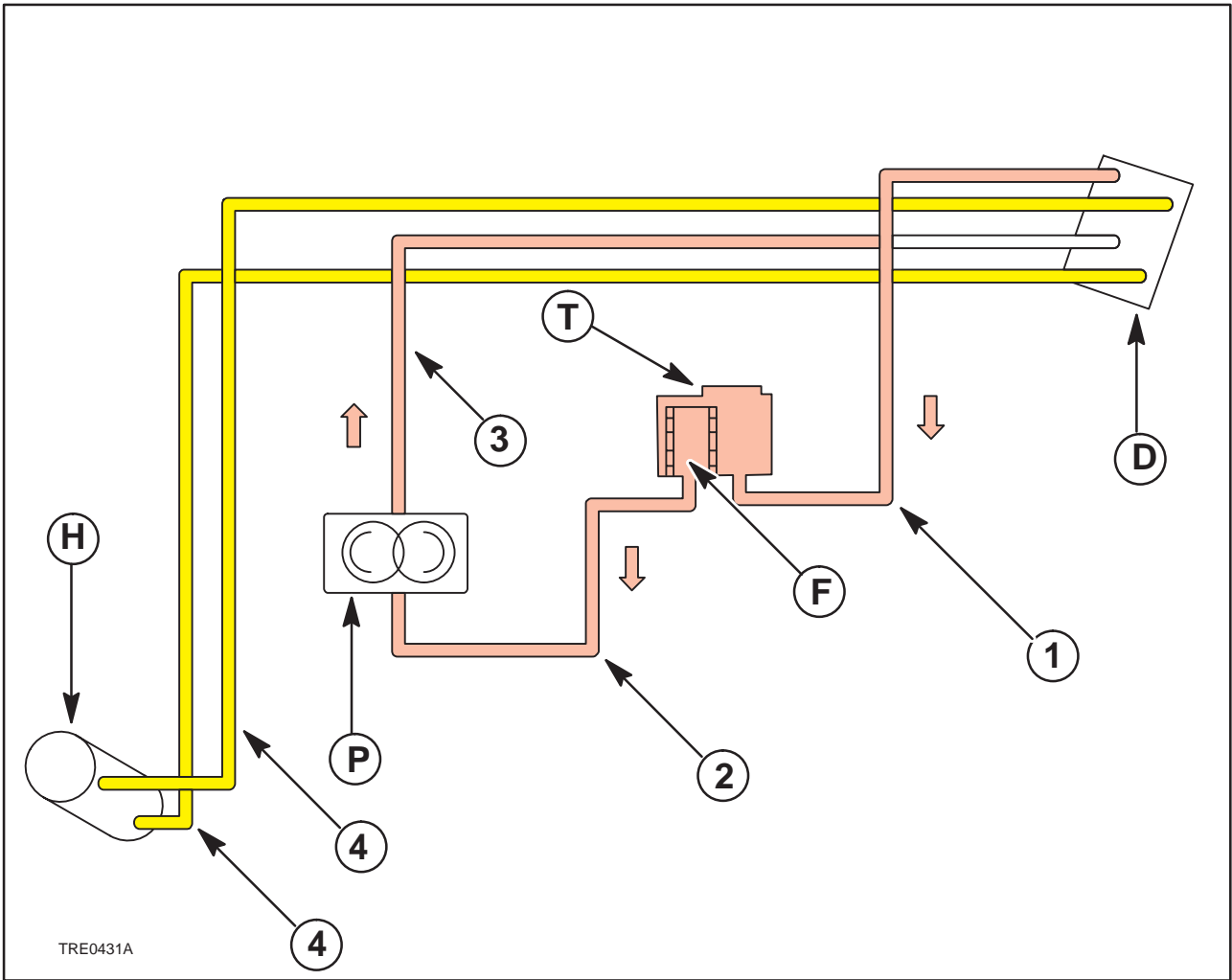

Hydraulic diagram

1

- H** Power steering cylinder.
- D** Hydrostatic steering control valve.
- F** Filter.
- T** Oil tank.
- P** Pump.

- 1** Control valve outlet.
- 2** Pump inlet.
- 3** Oil delivery to control valve.
- 4** Right – left steering.

OPERATION

Neutral position

When the steering wheel (V, fig. 3) is not moving, the rotating valve (5) is located in the neutral position in relation to the sleeve (6). In this position, retained by springs (2, sect. A–A), the following occurs:

- the pin (1, sect. B–B) will be in the central position in relation to the holes on the valve (5);
- the ducts (13 and 14) are aligned (sect. C–C) and the oil, from the pump (P), flows freely to and from the reservoir;

- the grooves (15, 17 and 19) on valve (sect. D–D, E–E) are not aligned with the ducts (16, 18 and 20) on the sleeve, therefore all connecting lines with the cylinder remain closed (See diagrams A and d, fig. 3 and 4).

Right-hand steering control

B, R–ht, e, f, (see fig. 3 and 4).

By turning the steering wheel (V) clockwise, the springs (2, sect. A–A) allowing the valve (5) to rotate in relation to the sleeve (6), until the clearance G1 is recovered (sect. B–B).

Under these conditions the following occurs:

- the ducts are not aligned (13 and 14, sect. C–C), therefore the oil discharge flow is interrupted;

- the six grooves are aligned (15, sect. D–D) with the same number of ducts (16), that are connected with the compartments on the rotor in the suction phase;

- the six delivery grooves are aligned (17, sect. E–E) with the ducts (18) connected to the cylinder and, at the same time, the grooves are aligned with the remaining ducts (16, sect. D–D), that are connected with the compartments on the rotor in the delivery phase;

- the six discharge grooves (19) are aligned with the ducts (20, sect. E–E) connecting to the cylinder.

Once the clearance (G1) has been recovered, the valve (5) rigidly transmits the steering wheel rotation to the sleeve (6) and rotor (9, fig. 3), through the pin (8, fig. 5) and shaft (11).

The details (e, f, fig. 4) illustrate how the mechanism operates at the start of a turn to the right and after a certain rotation of the steering wheel.

Note that there is an uninterrupted connection between the oil from the pump with the compartments on the rotor in the suction phase (and with oil when the compartments on the rotor are in the delivery phase) and the relative duct connected to the cylinder.

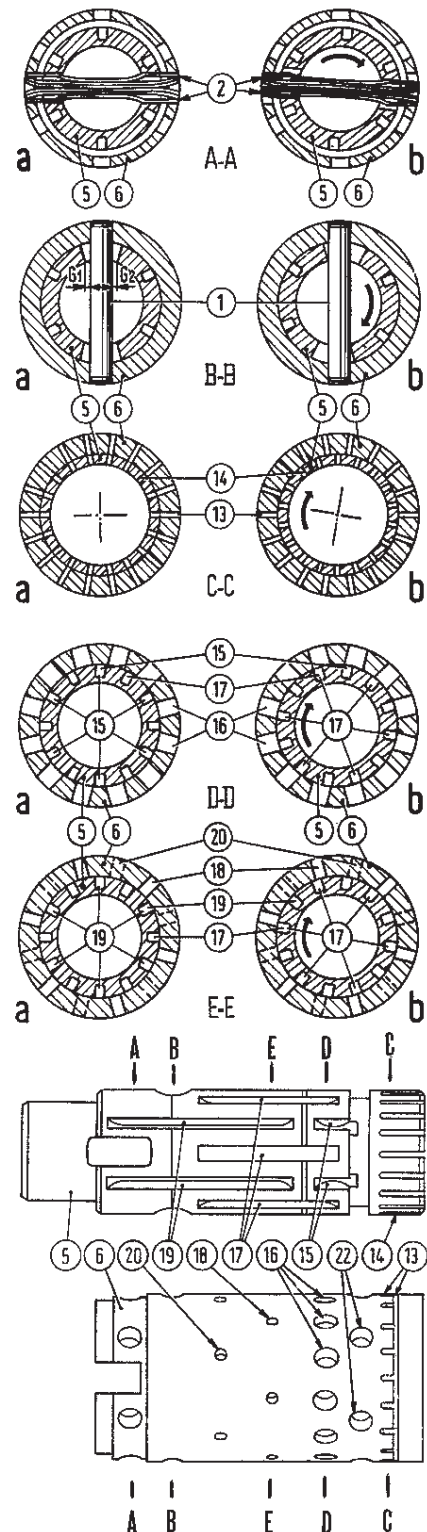

15714

2

Hydrostatic steering operation sectional view

a. Cross-sectional views with the valve (5) in the neutral position – b. Cross-sectional views with the valve (5) rotated for a right-hand turn (for a left-hand turn, the valve rotates symmetrically in the opposite direction) – G1 and G2. Clearances between pin (1) and hole on valve (5) – 1. Pin driving sleeve (6) and shaft (9, fig. 5) – 2. Sleeve return springs (6) – 5. Rotating valve – 6. Valve seat sleeve (5) – 13 and 14. Oil flow ducts in the neutral position – 15. Grooves (no.6) for delivery to rotor compartments under suction – 16. Ducts (no.12) connecting alternately with the grooves (15 and 17) – 17. Delivery grooves (n.6) to the cylinder connecting with the compartments on the rotor in the delivery phase and the ducts (18 and 20) – 18. Delivery or discharge ducts (no.6) for the cylinder right-hand chamber – 19. Discharge grooves (no.6) for cylinder connecting with the ducts (18 and 20) – 20. Delivery or discharge ducts (no.6) for the cylinder left-hand chamber – 22. Supply ducts for grooves (15).

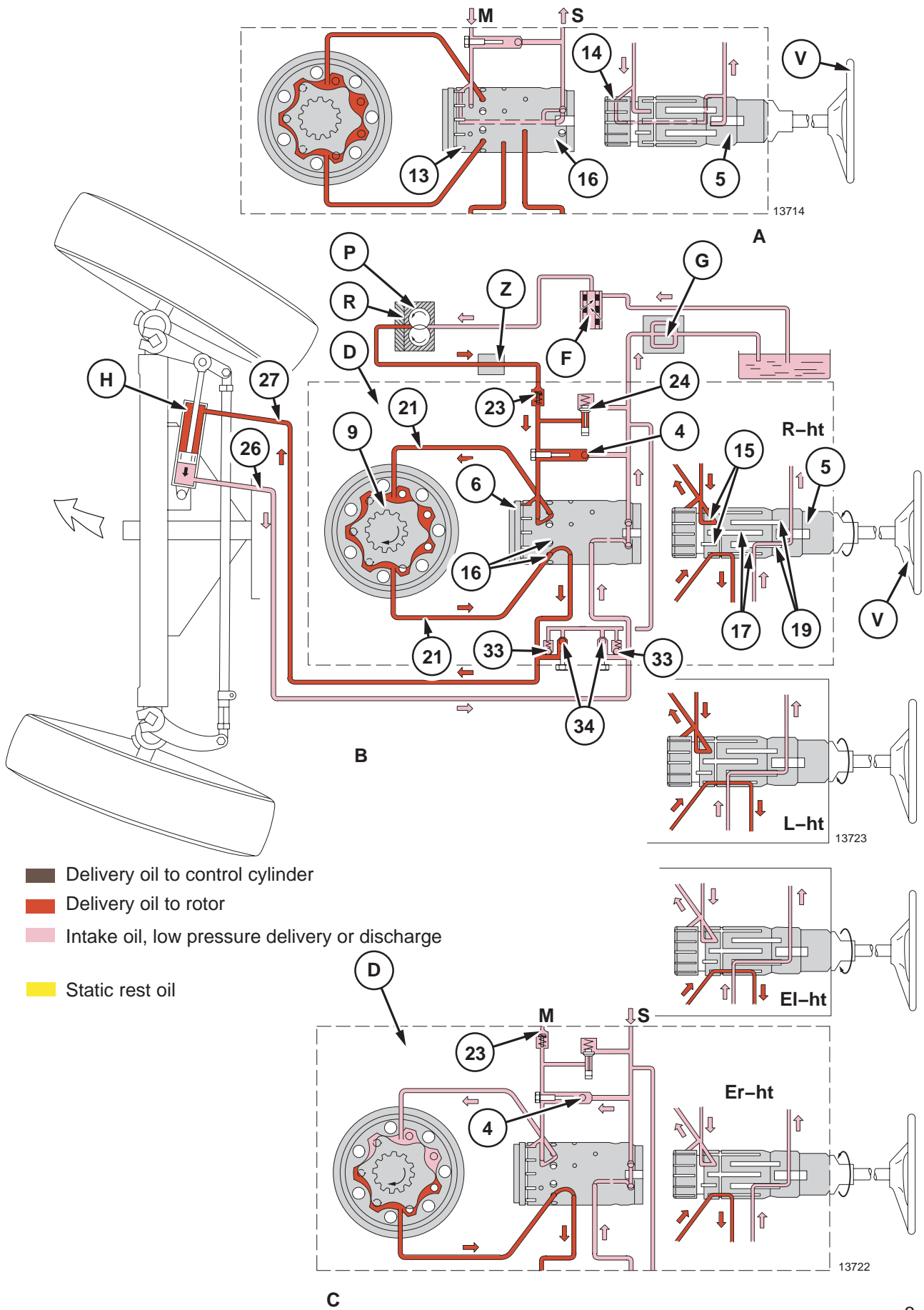

- Delivery oil to control cylinder
- Delivery oil to rotor
- Intake oil, low pressure delivery or discharge
- Static rest oil

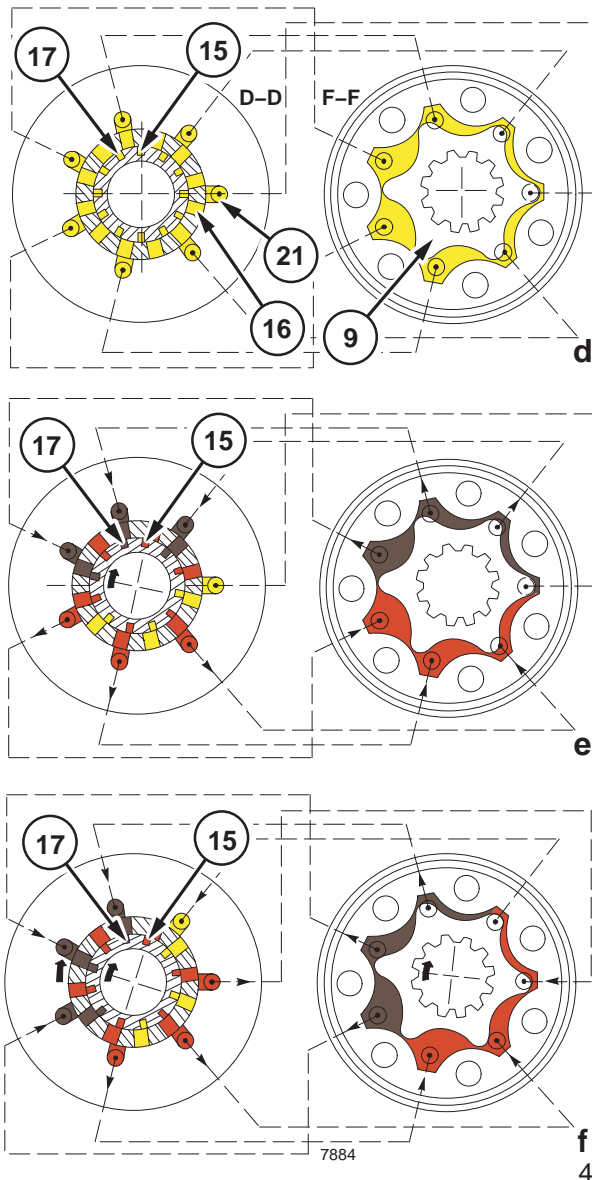

Hydrostatic steering operation circuit sectional view (*see fig. 2)

- | | |
|--|---|
| <p>A. Neutral position operation diagram.</p> <p>B. Right-hand turn (R-ht) and left-hand turn (L-ht) operation diagram.</p> <p>C. Emergency right-hand turn (Er-ht) and emergency left-hand turn (El-ht) operation diagram.</p> <p>d. Operation diagram for sections D-D and E-E in neutral conditions*.</p> <p>D. DANFOSS OSPC control valve.</p> <p>e,f. Operation diagrams for sections D-D and E-E in two successive right-hand turn phases*.</p> <p>F. Filter.</p> <p>H. Control cylinder.</p> <p>M. Pump delivery.</p> <p>N. Backflow valves (34) operation diagram with control valve (D) in neutral and cylinder (H) piston under external stress (indicated by the black arrow).</p> <p>P. Pump.</p> <p>R. Flow control.</p> <p>S. Discharge to gearbox.</p> <p>V. Steering wheel.</p> <p>Z. Resonance attenuator filter.</p> <p>4. Non-return valve.</p> | <p>5. Rotating valve.</p> <p>6. Valve seat sleeve (5).</p> <p>9. Rotor.</p> <p>13 and 14. Oil flow ducts in the neutral position.</p> <p>15. Delivery grooves (no. 6) to the compartments on the rotor in the suction phase.</p> <p>16. Ducts (n.12) alternately connecting with the grooves (15 and 17).</p> <p>17. Delivery grooves (n.6) to the cylinder connecting with the compartments on the rotor in the delivery phase and the ducts (18 and 20)*.</p> <p>19. Discharge grooves (n.6) to the cylinder connecting with the ducts (18 and 20)*.</p> <p>21. Ducts connecting the holes (16) with the compartments on the rotor in suction or delivery phases.</p> <p>23. Non-return valve.</p> <p>24. Pressure relief valve (setting: page 1).</p> <p>26. Left-hand cylinder chamber connecting duct.</p> <p>27. Right-hand cylinder chamber connecting duct.</p> <p>33. Cylinder safety valve (setting: page 1).</p> <p>34. Backflow valve.</p> |
|--|---|

Left-hand steering control

(B, L-ht, fig. 3)

By turning the steering wheel in an anticlockwise direction, the movement of the parts is inverted, the delivery grooves (17, sect. E-E, fig. 2) direct the oil to the ducts (20) and control the left-hand turning action.

Emergency hydraulic control

(C, Er-ht, El-ht, fig. 3)

In the event of feed faults, steering is still possible by turning the steering wheel. The valve (5) remains in the same position as with normal control and the rotor works in the same way as a hand pump, directing the oil to the control circuit. The non-return valve (4) opens and cuts off the feed pump, allowing the oil to flow directly from the reservoir to the rotor. The valve (23) remains closed in order to prevent oil leaks from faulty connecting pipes between the hydraulic pump and the hydrostatic steering unit.

Cylinder safety valve and backflow valve (see, fig. 3)

The safety valves (33), when open, discharge the pressure created by the piston (H) on one of the cylinder chambers as a result of the strong external stress on the wheels. At the same time, the lack of pressure in the opposite chamber is compensated by the flow of oil from the open backflow valve (34). Pressure on one of the cylinder chambers caused by weak external stress, insufficient to open the cylinder safety valve, is discharged by means of normal control valve seepage, whereas the lack of pressure in the opposite chamber is compensated by the backflow valve (34), as illustrated in fig. 3. These valves, as well as eliminating continuous steering corrections, prevent vibrations on front wheels (shimmy), hydraulic circuit failure and steering linkage distortion.

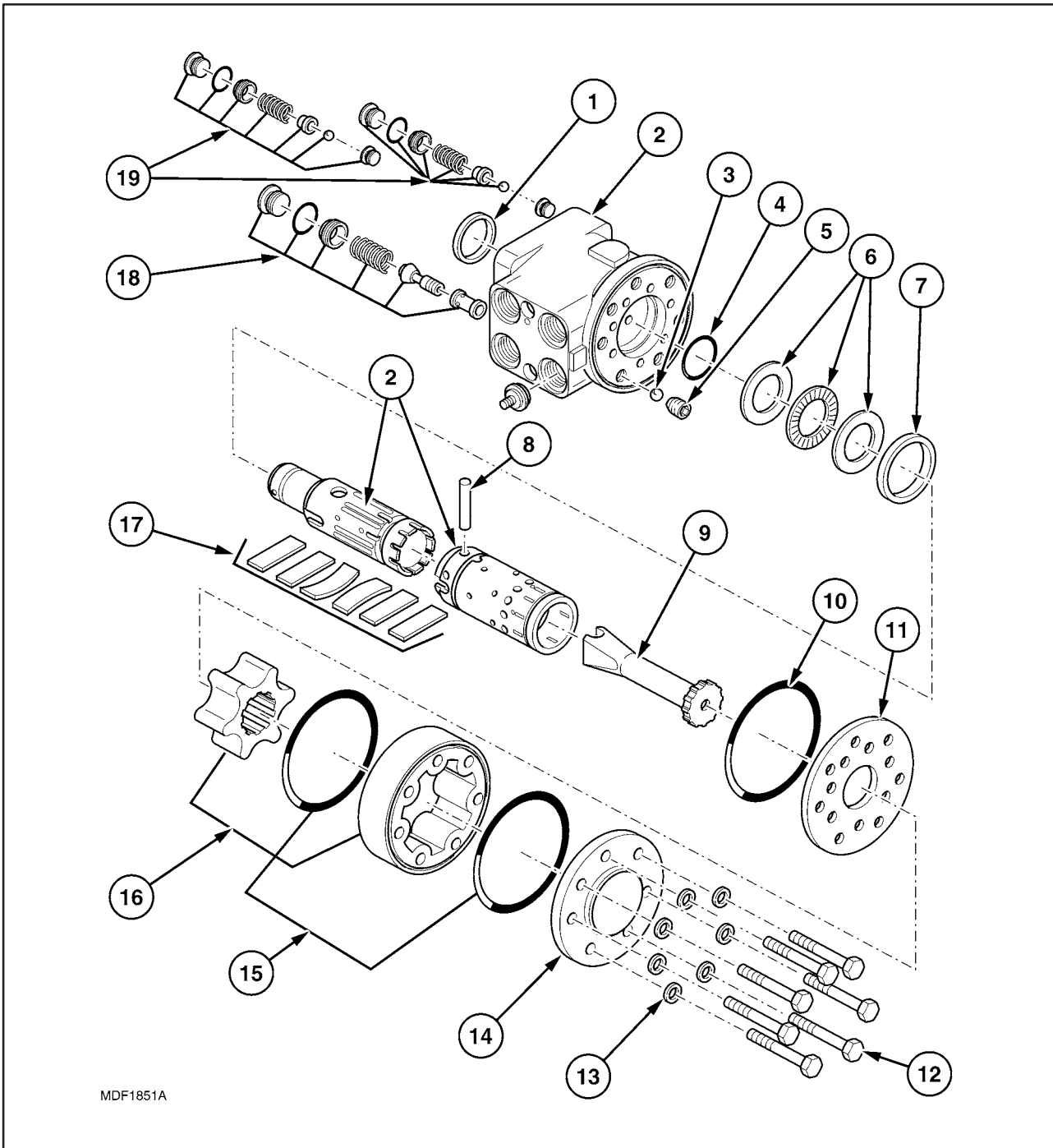

MDF1851A

5

Hydrostatic steering control valve components

- | | |
|---|---|
| 1. Dust seal ring. | 10. O-ring. |
| 2. Control valve body, rotating valve and rotating valve seat sleeve. | 11. Shim ring. |
| 3. Non-return valve ball. | 12. Cover retaining screws. |
| 2. Seal. | 13. Washers. |
| 3. Non-return valve threaded plug. | 14. Cover. |
| 6. Thrust bearing components. | 15. O-rings. |
| 7. Retaining ring for springs (17) (Danfoss only). | 16. Rotor and fixed ring for rotor. |
| 8. Rotor drive shaft – sleeve trim pin. | 17. Springs for returning sleeve to neutral position . |
| 9. Rotor drive shaft. | 18. Pressure relief valve. |
| | 19. Cylinder safety valve. |

HYDROSTATIC STEERING FAULT DIAGNOSIS

Refer to fig. 5 for component identification

Problem	Possible causes	Corrective action
Oil leaking from hydrostatic steering unit: a. Control side. b. Cover side.	<ol style="list-style-type: none"> 1. O–ring seal defective (4). 2. Screws (12) not sufficiently tight. 3. Sealing washers (13) or O–rings (15) defective. 	<p>Renew the seal and the stop ring using special tool 380000836.</p> <p>Tighten the screws to the prescribed torque (24–36 Nm, 17.7015–26.5522 ft lb).</p> <p>Renew the washers and seals.</p>
Steering wheel excessively stiff	<ol style="list-style-type: none"> 1. Hydraulic pump inefficient. 2. Check valve (3) held open by foreign bodies or open due to absence of ball. 3. Pressure relief valve (18) incorrectly set. 4. Pressure relief valve (18) jammed or held open by foreign bodies. 5. Steering column has become stiff on its bushing due to rusting, seizing, etc. 	<p>Repair the pump.</p> <p>Eliminate foreign bodies and clean the filter; put a new ball into the seat (if missing).</p> <p>Reset the valve.</p> <p>Eliminate foreign bodies and clean the filter.</p> <p>Eliminate the causes.</p>
Excessive play of steering wheel	<ol style="list-style-type: none"> 1. Excessive play between the steering column and the coupling with the rotary valve. 2. Excessive play in the coupling between shaft (9) and trim pin (8). 3. Excessive play in the splined coupling between the shaft (9) and the rotor (16). 4. Combination of excessive play as described above. 5. Leaf springs (17) broken or fatigued. 	<p>Renew the worn parts.</p> <p>Renew the worn parts.</p> <p>Renew the worn parts.</p> <p>Renew the most worn parts.</p> <p>Renew the springs.</p>
The steering wheel turns normally, but steering is: a. Slow. b. No steering.	<ol style="list-style-type: none"> 1. Inadequate seal of control cylinder. 2. Cylinder rod broken. 3. Rotor control shaft (9) or pin (8) broken. 	<p>Renew the seal.</p> <p>Renew the damaged part.</p> <p>Renew the damaged part.</p>
With the engine stopped, the steering wheel can be turned without turning the wheels.	<ol style="list-style-type: none"> 1. Excessive wear between rotor and fixed ring (16). 2. Check valve damaged. 	<p>Renew the worn parts.</p> <p>Renew the control valve.</p>

(continued)

HYDROSTATIC STEERING FAULT DIAGNOSIS

Refer to fig. 5 for component identification

(continuation)

Problem	Possible causes	Corrective action
Steering wheel jolts, steering uncontrollable, wheels steering in the opposite direction to the desired direction.	<ol style="list-style-type: none"> 1. Incorrect synchronization of hydrostatic steering. 2. Hoses to cylinder reversed. 	Synchronize correctly. Correct the connections.
The wheels do not maintain the desired alignment and continual correction with the steering wheel is necessary.	<ol style="list-style-type: none"> 1. Hydraulic cylinder piston seal worn. 2. Reflux valve damaged or held open by foreign bodies. 3. Mechanical wear of control valve. 	Renew the seal. Eliminate the foreign bodies and clean the filter or renew the control valve. Renew the control valve.
Neutral phase of hydrostatic steering unobtainable. During manual control, operation is normal. When stopping manual control, the steering wheel moves on its own or remains stationary, but steering continues slowly in the direction first turned (motoring), so the steering wheel must be continually corrected.	<ol style="list-style-type: none"> 1. Leaf springs (17) for returning sleeve (2) to neutral position broken or fatigued. 2. Sleeve and rotary valve blocked in delivery position by foreign bodies. 3. Crushing of sleeve (2) on rotary valve due to excessive pressure. 	Renew the pack of leaf springs. Eliminate the foreign bodies and clean the filter. Check the setting of the pressure relief valve (18).
Front wheel vibration (shimmy).	<ol style="list-style-type: none"> 1. Air pockets in the hydraulic cylinder. 2. Wear of mechanical joints of steering tie rods. 3. Reflux valve damaged or held open by foreign bodies. 	Bleed the air and eliminate the causes of possible infiltration. Renew the worn parts. Remove the foreign bodies and clean the filter or renew the control valve.
Difficulty in steering in general, or in one direction.	<ol style="list-style-type: none"> 1. Insufficient pressure. 2. Excessive leakage inside the control valve. 	Check the hydraulic pump and the setting of the pressure relief valve (18). Renew the control valve.

TOOLS

WARNING: The operations described in this section must be performed only with the **ESSENTIAL** equipment marked with **(X)**.

To operate safely and achieve best results, while saving time and effort, essential equipment must be used in conjunction with the special tools recommended below, and tools which you must make yourself and for which you will find the design in this manual.

List of special tools necessary for the various operations described in this section.

- X 380000307** Hyd. steering rotor retaining lever.
- X 380000223** Steering wheel extractor.
- X 380000240** Universal pressure checking kit.
- X 380000305** Tool for fitting hydrostatic steering toroidal seal.
- 380000306** Plug for fitting hydrostatic steering rotary valve return springs.

HYDROSTATIC STEERING CONTROL VALVE Removal–Refitting (Op. 41 204 30)

⚠ WARNING ⚠

Handle all parts with great care. Do not put your hands or fingers between one part and another. Wear the recommended safety clothing such as goggles, gloves and safety boots.

To remove the hydrostatic steering control valve, proceed as follows:

1. Disconnect the negative cable (1) from the battery.
2. Drain the oil from the steering system.
3. To access the engine the hood must be opened.

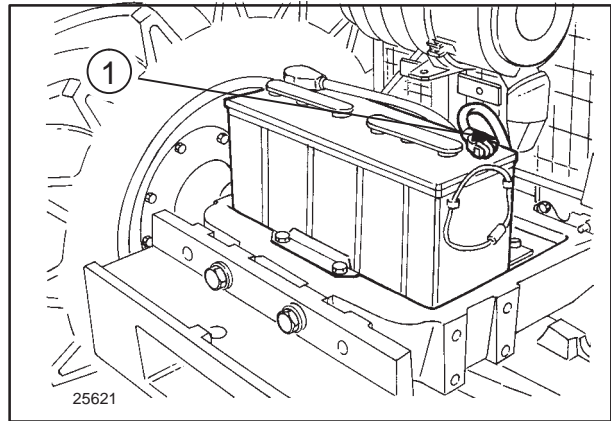

6

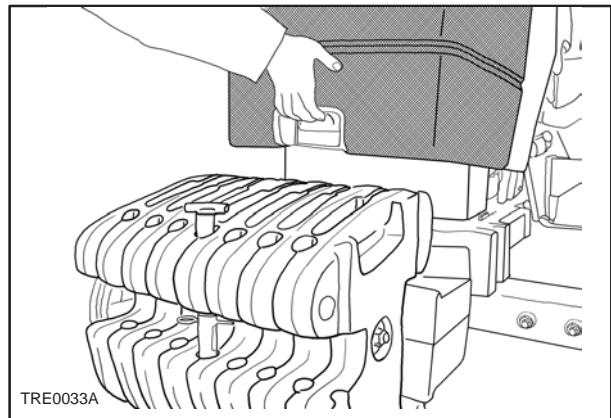

7

4. Disconnect the oil pipes from the hydrostatic steering control valve unit (1).

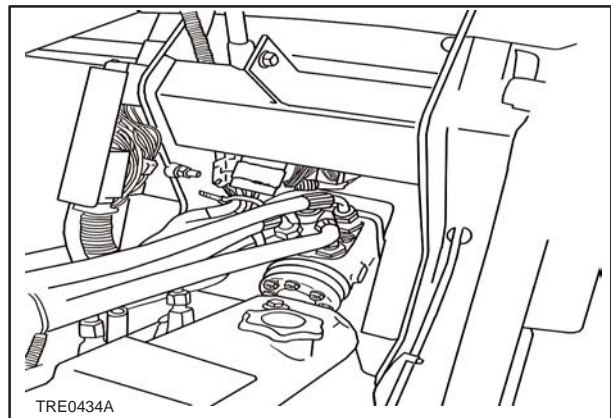

8

5. Remove the steering wheel (1) retaining nut and remove the steering wheel and hand throttle lever.

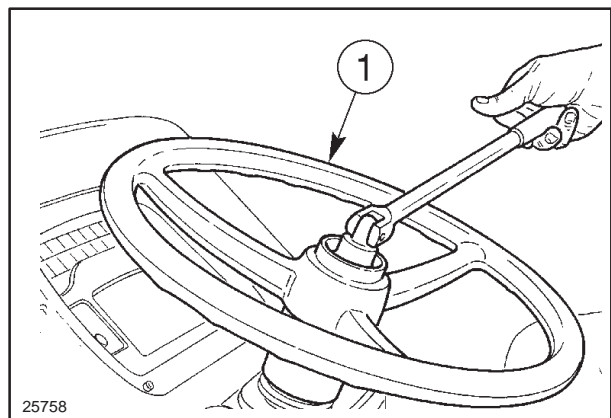

9

6. Remove the four securing screws (1) from the instrument panel (2).

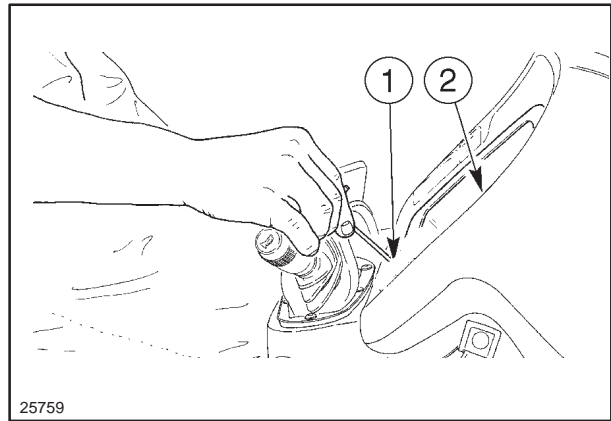

10

7. Disconnect the electrical leads (1) from the rear of the instrument panel. Unscrew the the tachometer cable (2). Remove the instrument panel and store in a safe place.

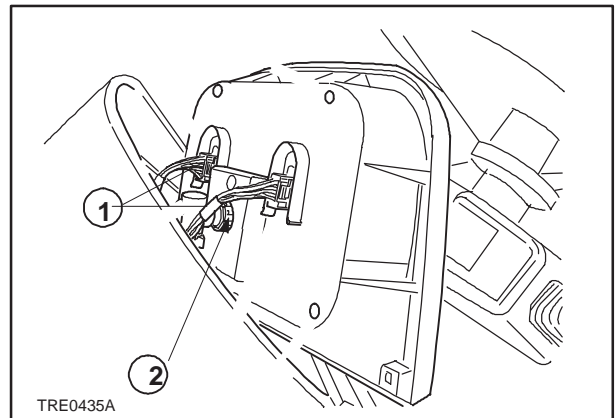

11

8. Unscrew the rear hood screws (1)

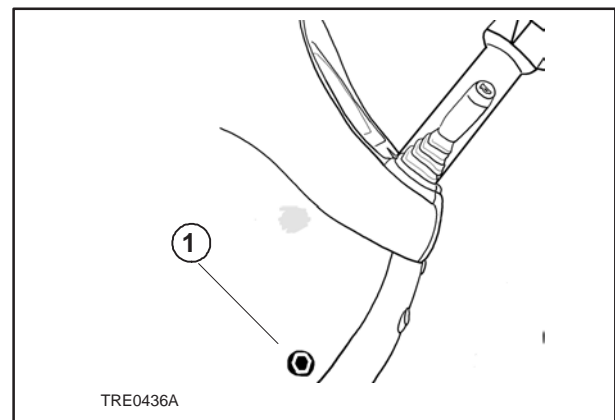

12

9. Take off the complete rear hood.

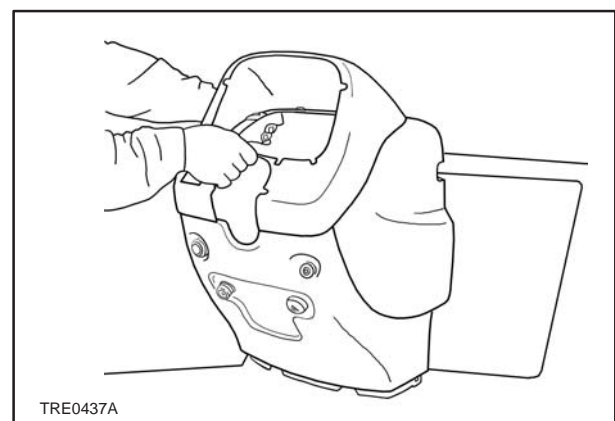

13

10. Remove the hydrostatic steering unit support bolts and take of the hydrostatic steering unit.

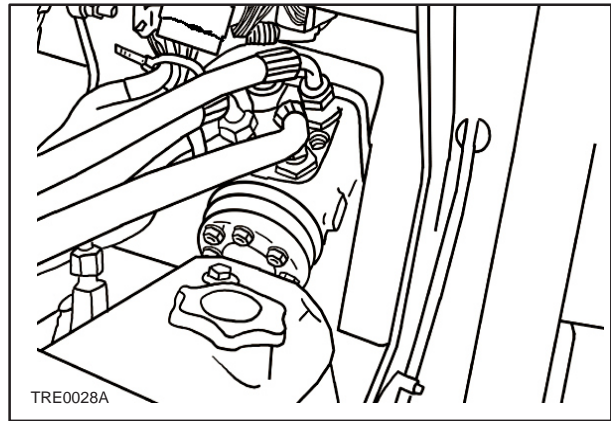

14

- To refit the control valve, proceed as follows:
- Refit the hydrostatic steering unit.
- Refit the complete rear hood.
- Secure the rear hood with the screws previously removed.
- Reconnect the electrical leads and reconnect the the tachometer cable.
- Re-install the four screws securing the instrument panel.
- Re-install the hand throttle and steering wheel. Secure the wheel with the central retaining nut.
- Reconnect the oil pipes to the hydrostatic steering control valve unit.
- Fill the the steering system with oil.
- Reconnect the negative cable to the battery and close the hood.

HYDROSTATIC STEERING CONTROL VALVE Overhaul on bench (Operation 41 204 34)

To disassemble the hydrostatic steering control valve, proceed as follows:

1. Remove the control valve cover retaining bolts.

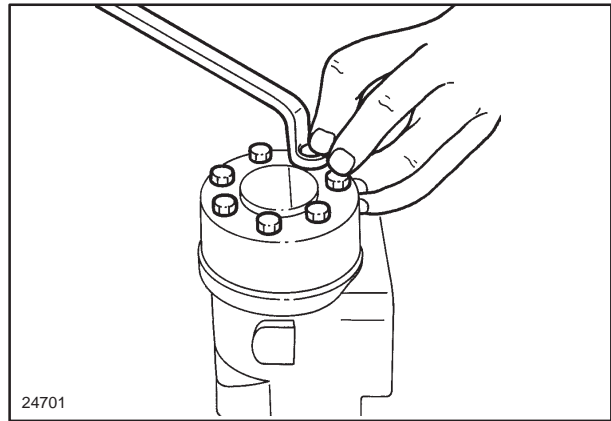

15

2. Remove the cover by sliding to one side.



16

3. Remove the rotor fixed ring, the rotor and the inner spacer.
4. Remove the two O-ring seals on the rotor fixed ring.

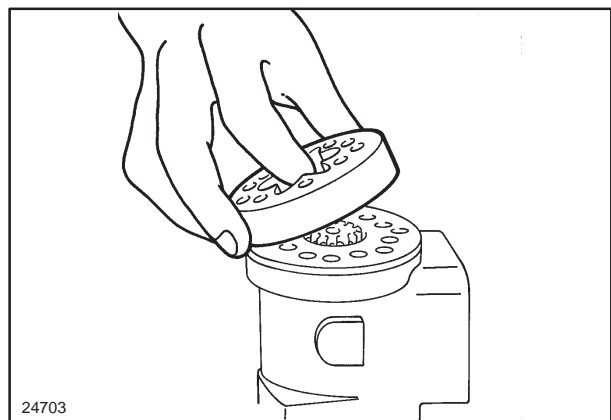

17

5. Extract the rotor drive shaft

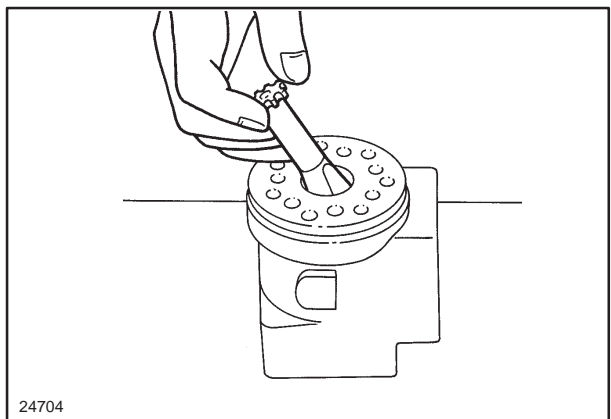

18

6. Extract the thrust washer.

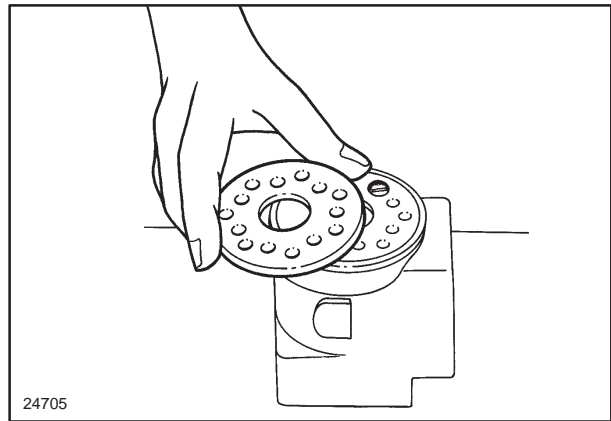

19

7. Remove the threaded plug on the non-return valve seat.

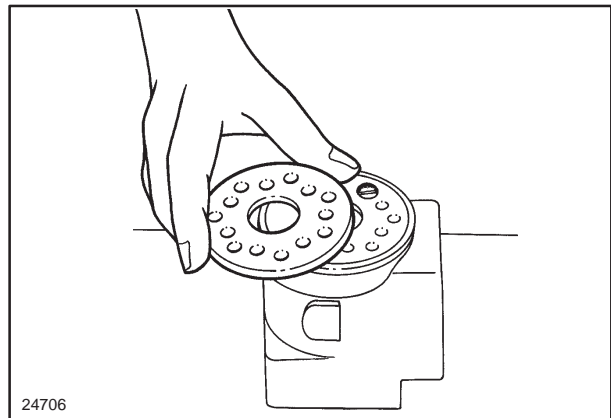

20

8. Extract the O-ring seal from the control valve body.

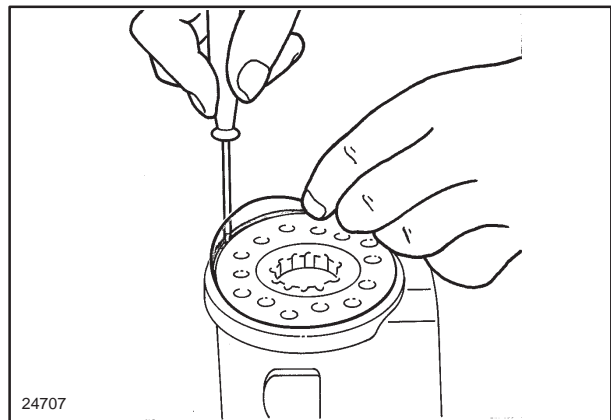

21

9. Position the control valve body and the rotor drive shaft so that the sleeve-control shaft trim pin is in a horizontal position.
10. Push the rotary valve inwards, so that the valve, the valve seat sleeve and the thrust bearing can be extracted from the control valve body.

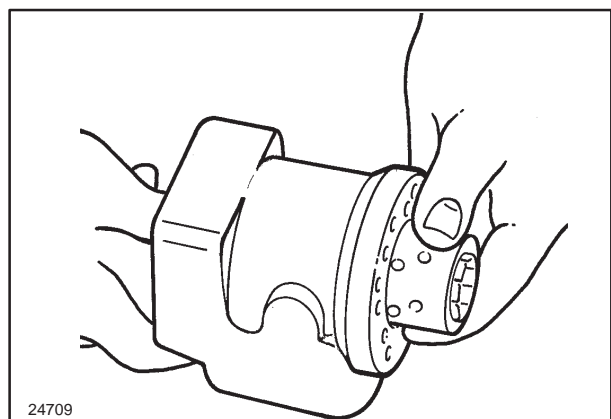

22

11. Extract the thrust bearing from the rotary valve, complete with the two external rings. Remove the spring retaining ring from the valve seat sleeve.

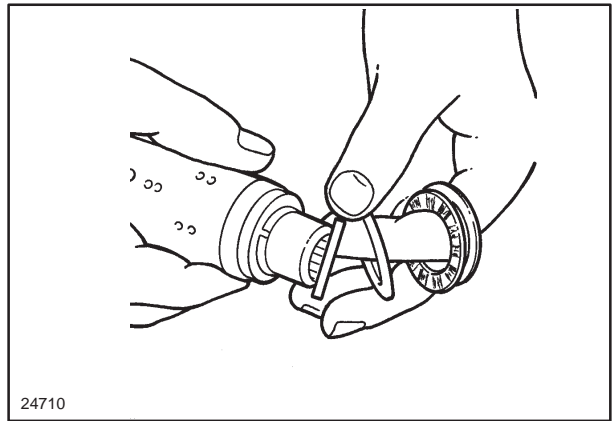

24710

23

12. Extract the valve-sleeve trim pin.

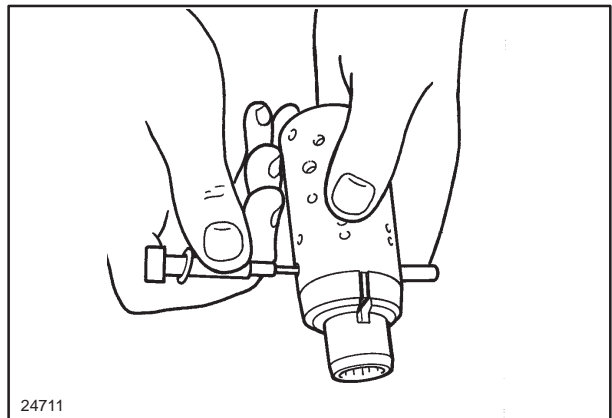

24711

24

WARNING: On assembly, two reference marks (arrowed) were made on the rotary valve and the sleeve, corresponding to the neutral position maintained by the springs. Before removing the springs, check that the marks are clearly visible. If not clear, make new reference marks.

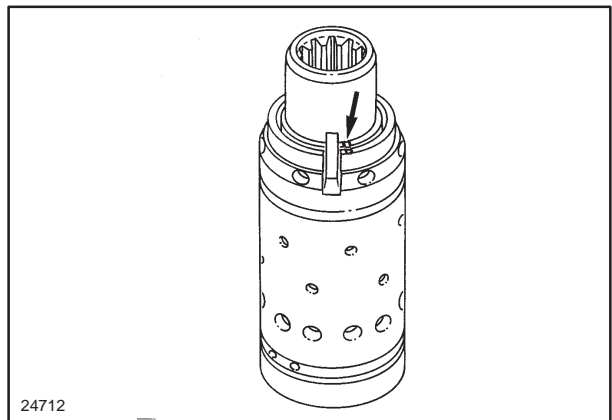

24712

25

13. Extract the rotary valve from the valve seat sleeve.

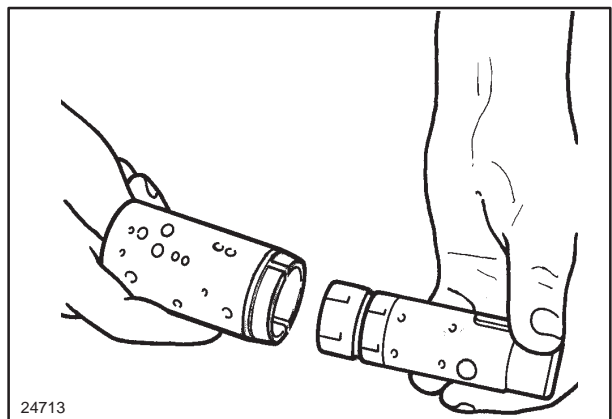

24713

26

14. Remove the **neutral** position springs, extracting them from their seats.

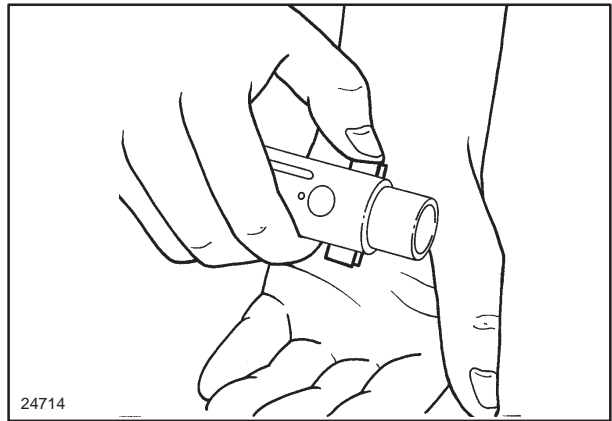

27

15. Remove the dust seal and the O-ring seal from their seats in the control valve body.

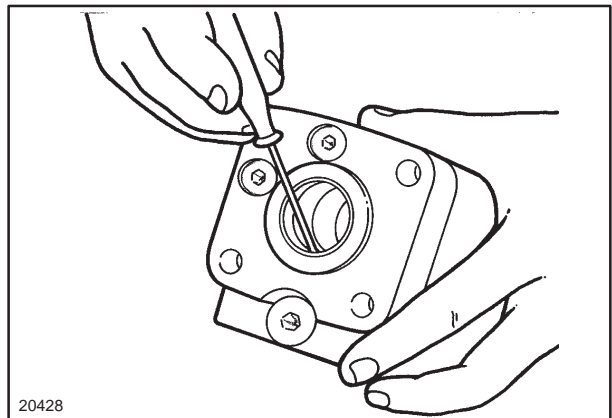

28

16. Using a 6 mm Allen wrench, remove the threaded plugs from the two cylinder safety valves and extract the seals.

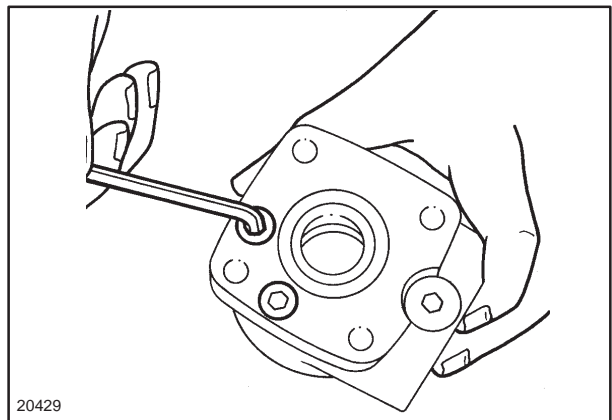

29

17. Using a 6 mm Allen wrench, remove the setting adjuster screws from the cylinder safety valves. See also fig. 31.

18. Turn the control valve body over and extract the balls, the springs and the spring guides from the two cylinder safety valves.

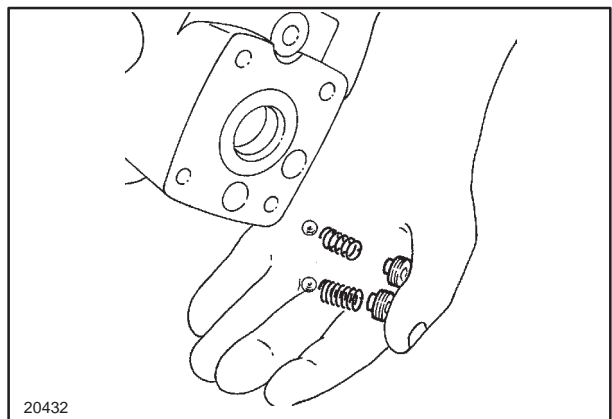

30

Cylinder safety valves components (order of disassembly-assembly).

1. Cylinder safety valve ball.
2. Pressure spring.
3. Setting adjuster screw.
4. Seal.
5. Plug.

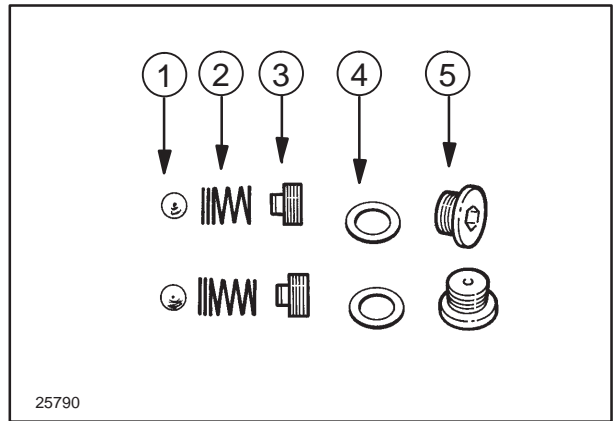

25790

31

19. Using a 6 mm Allen wrench, remove the threaded plug on the pressure relief valve and extract the seal.

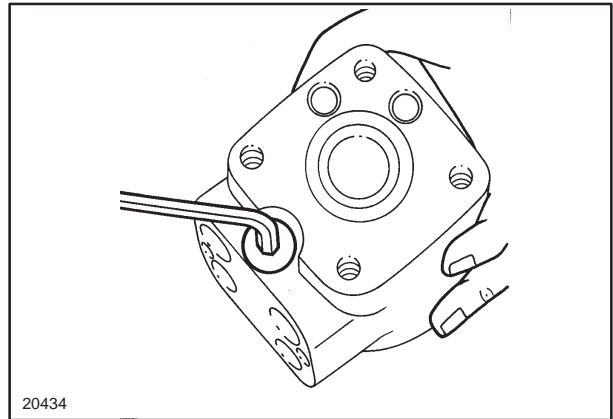

20434

32

20. Remove the pressure relief valve adjuster screw.
21. Turn the control valve body over and complete disassembly by extracting the spring and the pressure relief valve piston.

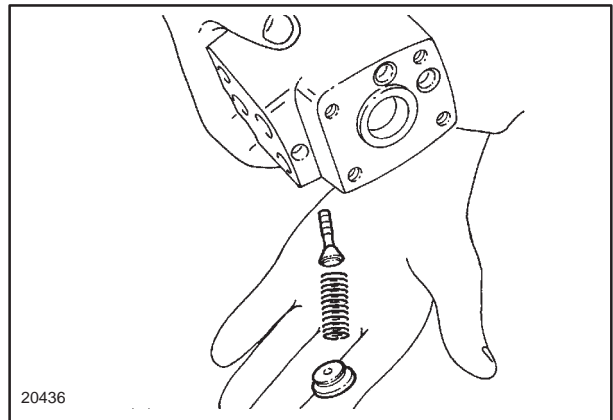

20436

33

Pressure relief valve components (order of assembly).

1. Pressure relief valve.
2. Pressure spring.
3. Setting adjuster screw.
4. Seal.
5. Plug.

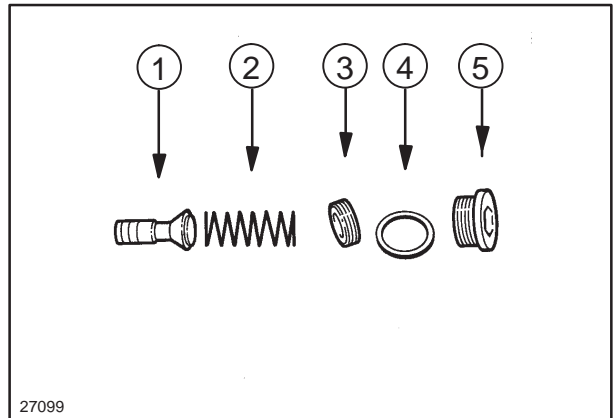

27099

34

22. Thoroughly clean all control valve component parts.
23. Replace the washers and seals.
24. Carefully check all mechanical parts, replacing components that show signs of wear.
25. Before re-fitting, lubricate the components with hydraulic oil.
26. Re-fit the rotary valve on the sleeve, checking that the reference marks indicated in the drawing coincide.

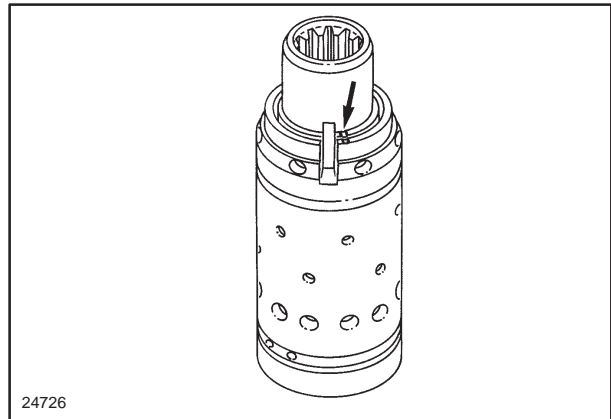

24726

35

27. Use tool **380000306** to insert the flat and curved springs (17) fig. 5.
Diagram for fitting springs (17) fig. 5 **neutral** position for OSPC 100 hydrostatic steering).

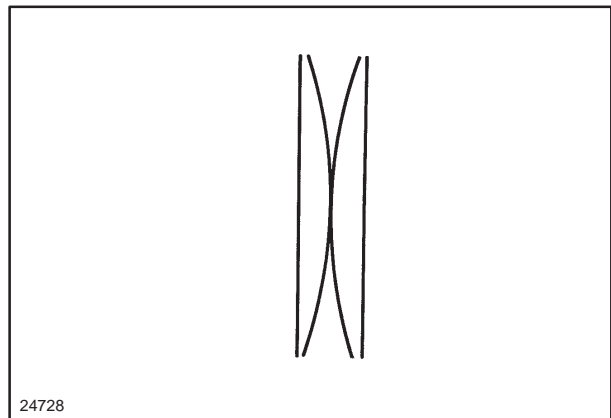

24728

36

28. After inserting the springs in the seat, align and centre (as shown in the drawing).

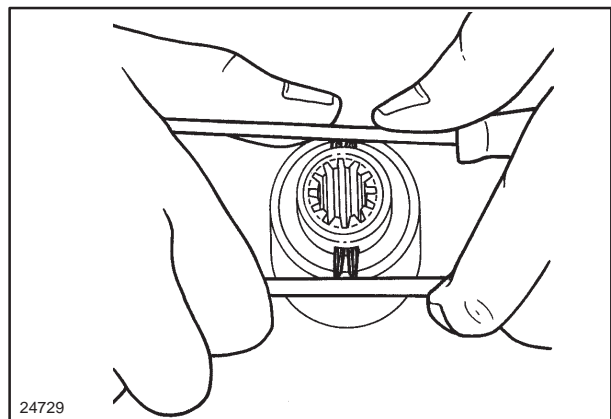

24729

37

29. Fit the **neutral** position spring retaining ring on the valve seat sleeve, remembering that the ring must rotate freely without being impeded by the springs.

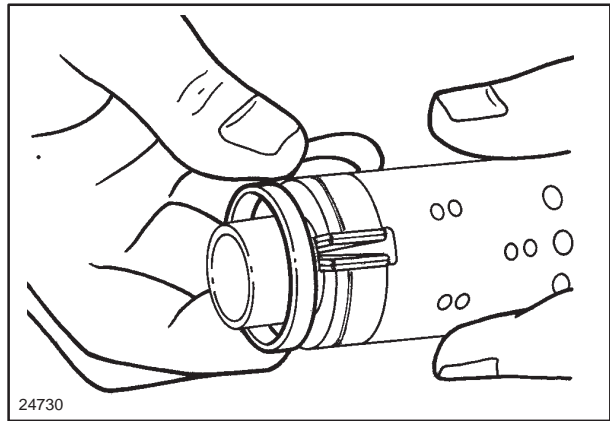

38

30. Insert the sleeve-rotor drive shaft trim pin.

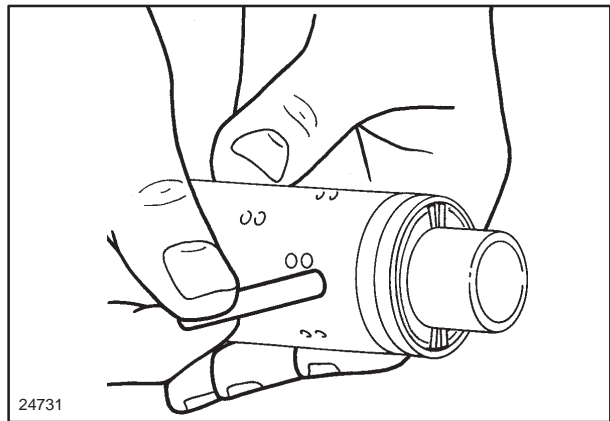

39

31. Fit the thrust bearing, following the order indicated in fig. 41.

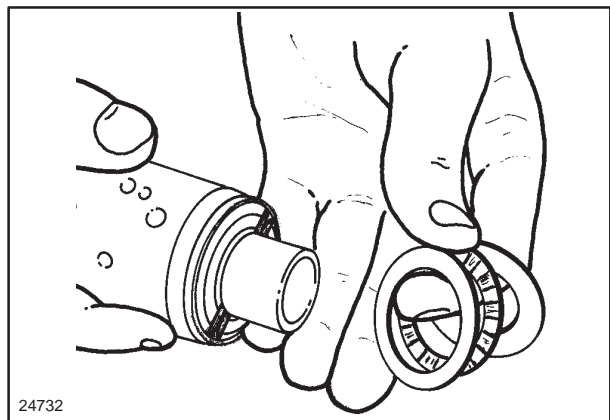

40

1. Bearing external ring.
2. Thrust bearing.
3. Bearing internal ring with bevel facing contact surface of part (5).
4. Rotary valve.
5. Rotary valve seat sleeve.

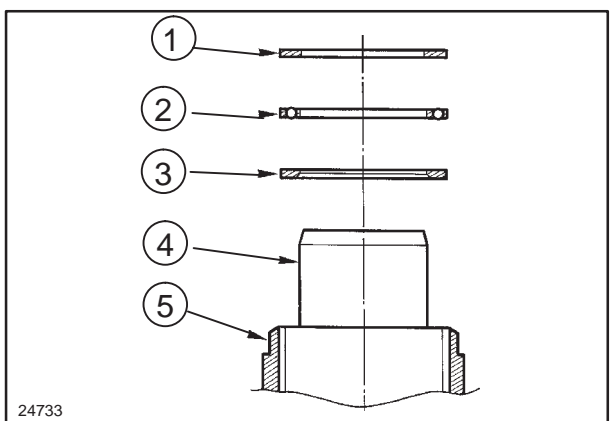

41

32. Position the control valve body so that the housing seat on the rotary valve sleeve is positioned horizontally, then insert the guide bushing (1) of tool **380000305**.

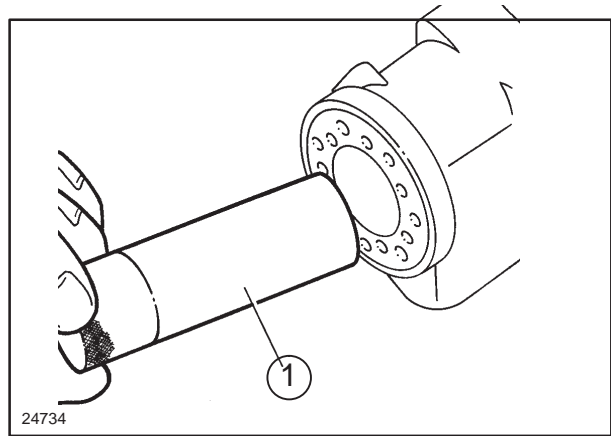

42

33. Lubricate the support ring (1) and O-ring seal (2) with hydraulic oil and fit them on the head (3) of the tool **380000305**, as shown in the drawing.

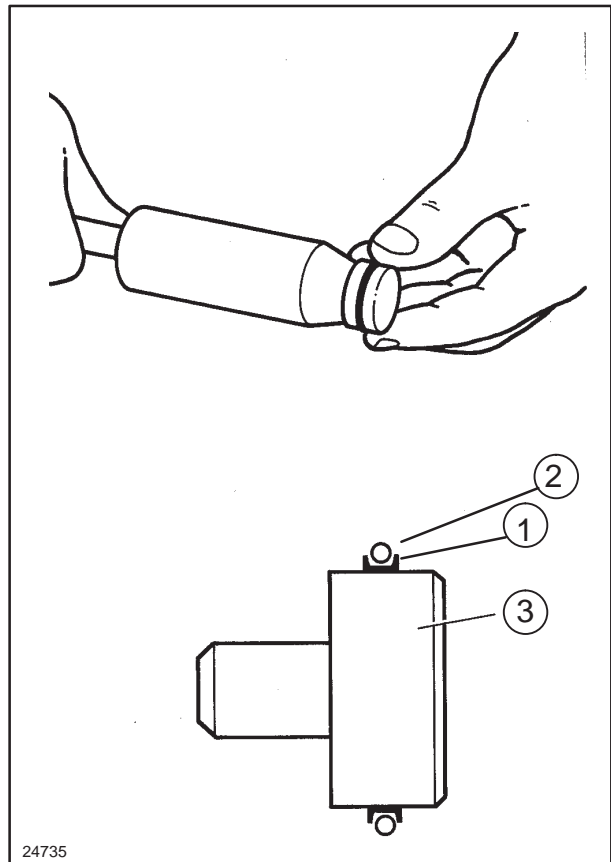

43

Support head for support and seal rings (part of tool 380000305)

34. Insert the complete drift in the guide bushing previously installed.

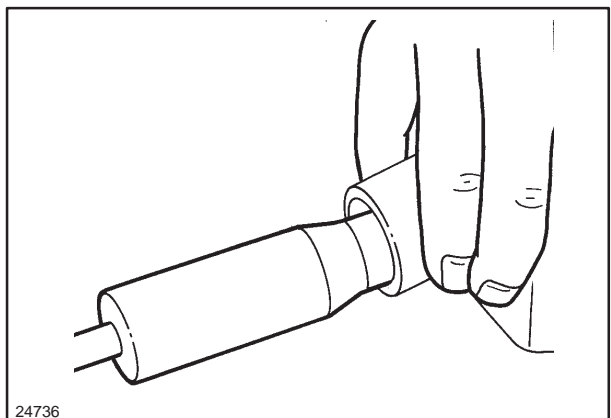

44

35. Holding the external bushing in position manually, press fully down, whilst simultaneously rotating the drift, in order to facilitate the entry of the O-ring seal in the control valve body seat.

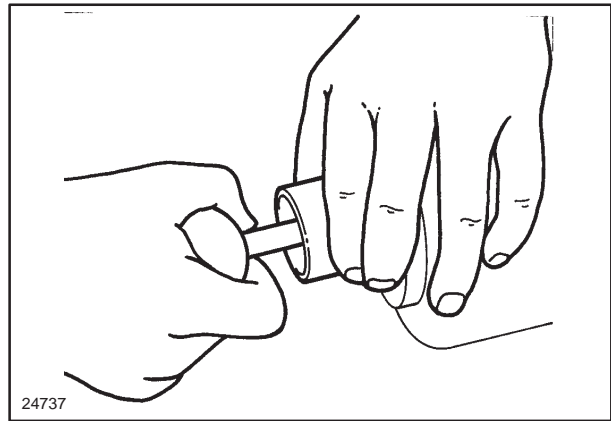

45

36. Extract the components of tool **380000305** (external bushing and drift).

NOTE: The support head of the support and seal rings remains on the control valve body (see fig. 43).

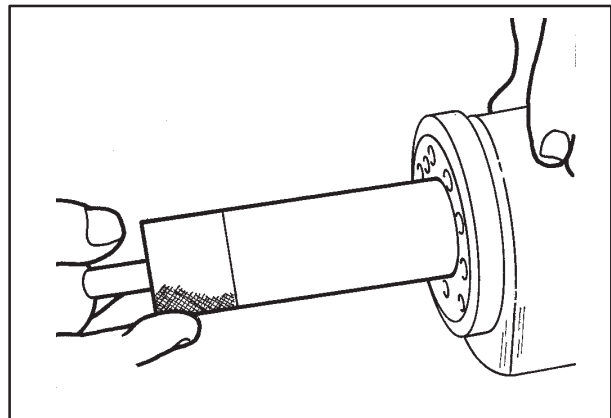

46

37. Insert the parts that were previously fitted in operations 26 – 31 on the control valve body. Hold the sleeve-to-rotor drive shaft trim pin in a horizontal position, to prevent it from slipping out and jamming in the slots inside the control valve body.

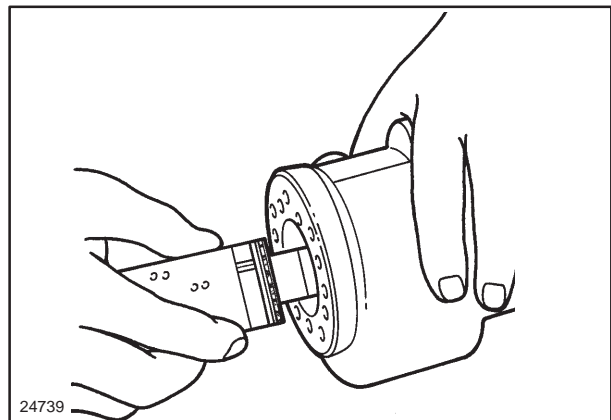

47

38. Press the rotary valve so as to bring the thrust bearing into contact with the control valve body. This operation simultaneously expels the head (1) of tool **380000305**, inserting the rings (1) and (2) fig 43 into the seat of the control valve body (see operation 33).

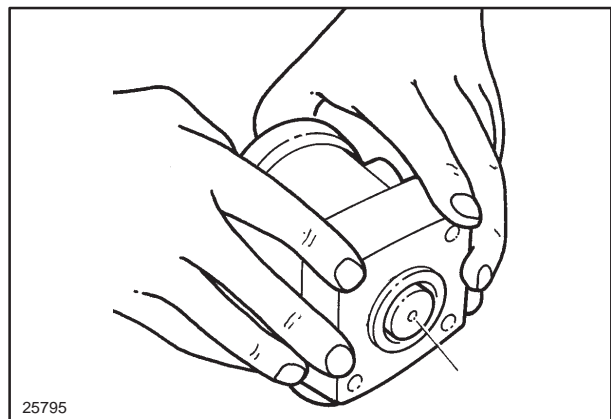

48

39. Rotate the control valve body and insert the non–return valve ball into the seat indicated by the arrow.

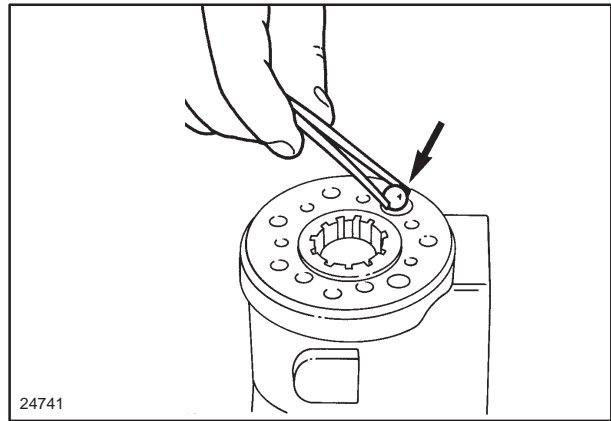

49

40. Screw the threaded plug into the non–return valve seat until the upper surface is below the coupling surface of the control valve body.

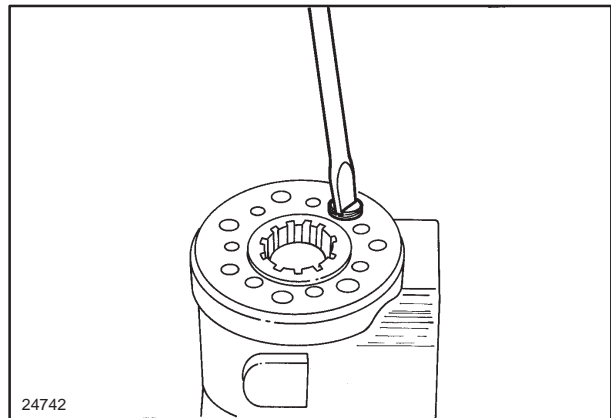

50

41. Lubricate the O–ring seal and insert into the seat on the control valve body.

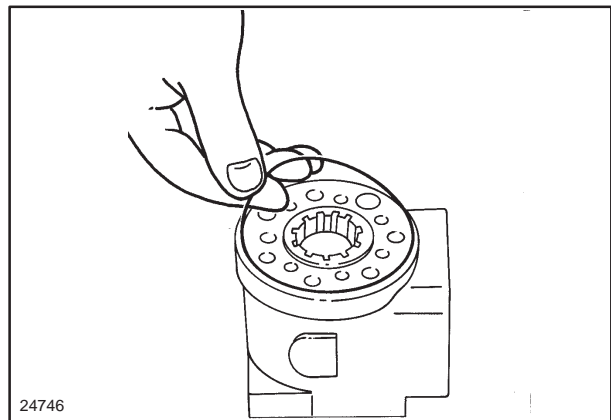

51

42. Fit the thrust washer, so that the holes coincide with the holes in the control valve body.

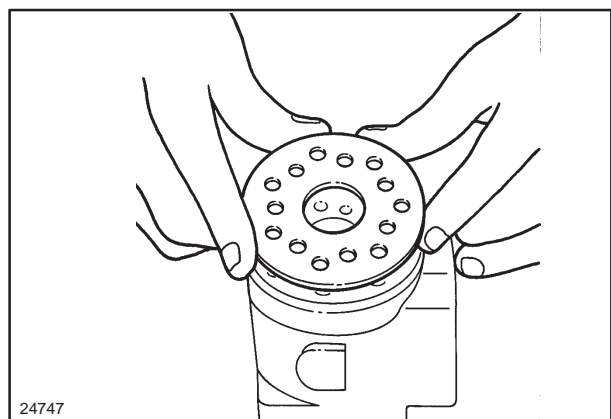

52

43. Make a reference mark on the upper part of the teeth (1), in line with the seat (2), to indicate the exact position of the valve-to-sleeve trim pin.

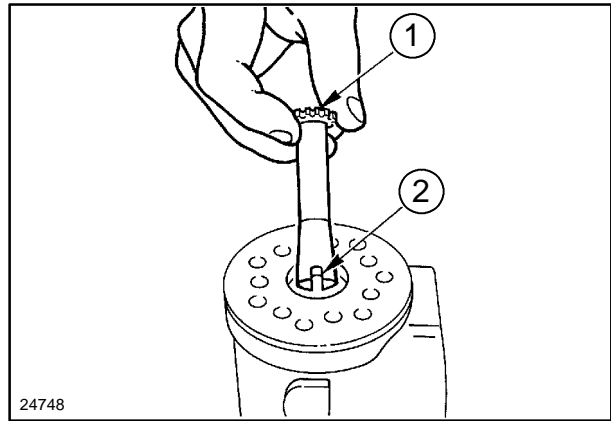

53

44. Fit the rotor drive shaft into the control valve body. Insert tool **380000307** for retaining and centring the rotor drive shaft, between the rotor drive shaft and the thrust washer. Rotate the shaft so as to facilitate coupling between the seat (2) fig. 53 and the trim pin installed in the sleeve.

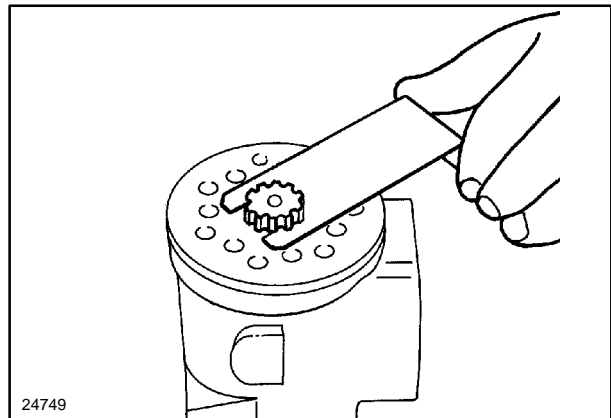

54

45. To refit the rotor, proceed as follows:

a) each time the hydrostatic steering is disassembled, turn the rotor over so as to limit wear to the splined coupling;

b) in the drawing below, the rotor shaft has been removed in order to show the phasing between the rotor, rotor drive shaft and the trim pin;

- c) fit the rotor on the drive shaft, remembering that phasing is obtained by aligning the teeth (1), on the trim pin axis plane (shown in fig. 53) with the centre line of one of the recesses between the lobes of the rotor.

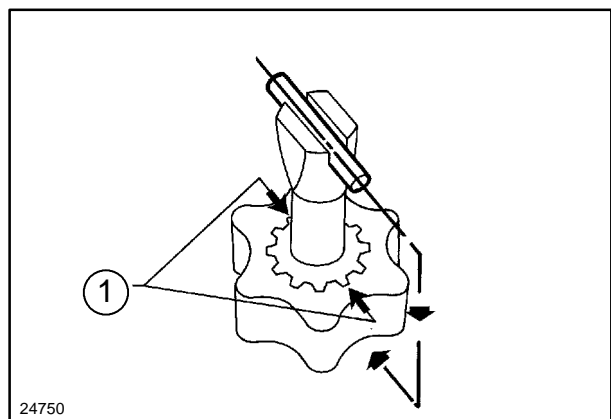

55

46. Lubricate the two O-ring seals (1) with hydraulic oil and insert them in the rotor fixed ring seat. Fix in position by aligning the retaining holes (2) with those on the thrust washer.

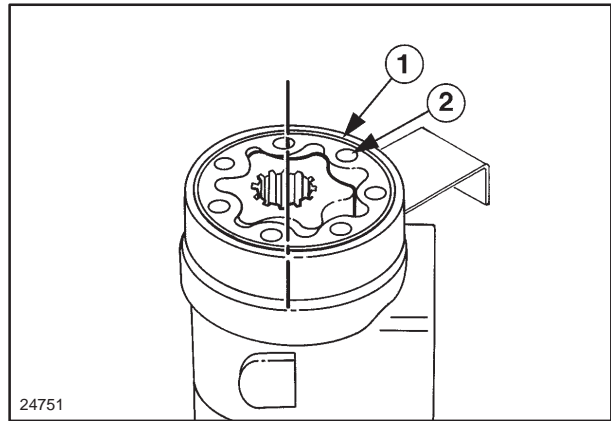

56

47. Fit the cover, aligning the retaining holes with those on the rotor fixed ring.

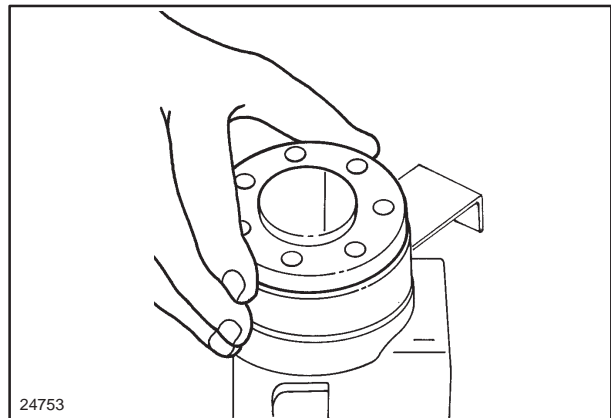

57

48. Remove retaining tool **380000307** and fit the special screw and washer in the non-return valve seat, shown in the drawing.

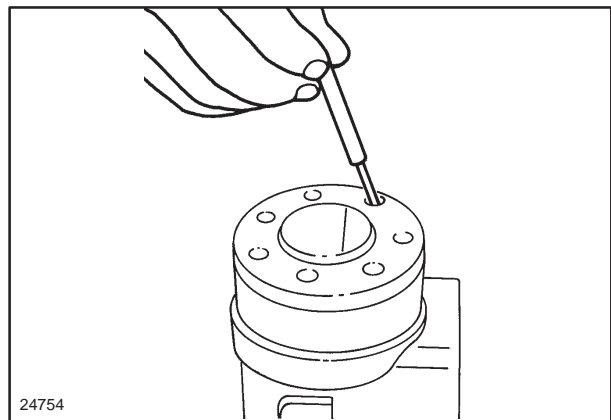

58

49. Fit the other six cover retaining bolts with the washers and tighten in diagonal sequence to the torque setting value shown in the table on page 3.

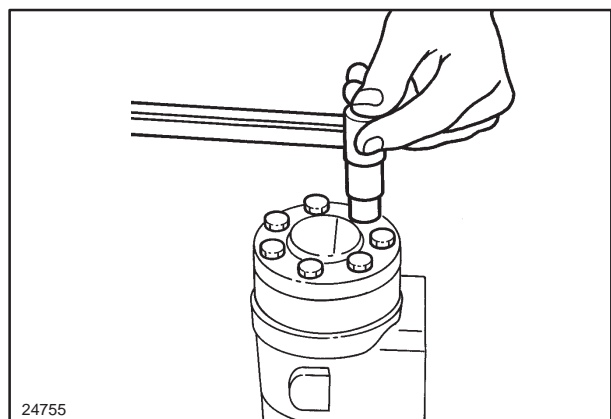

59

50. Turn over the control valve body and insert the pressure relief valve piston in the seat, as indicated in the drawing. See fig. 34 for component assembly order.

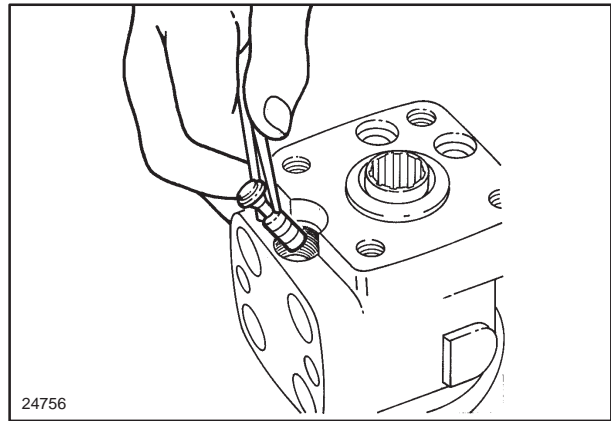

60

51. Insert the pressure relief valve spring.

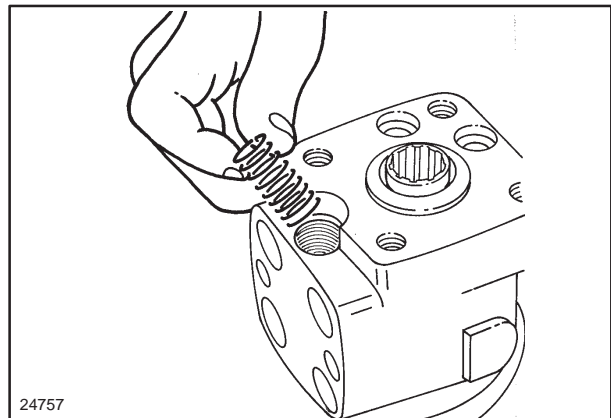

61

52. Using an 8 mm Allen wrench, insert the pressure relief valve setting screw.

NOTE: Setting should be carried out on the workbench or on the tractor to the values shown in the table on page 1.

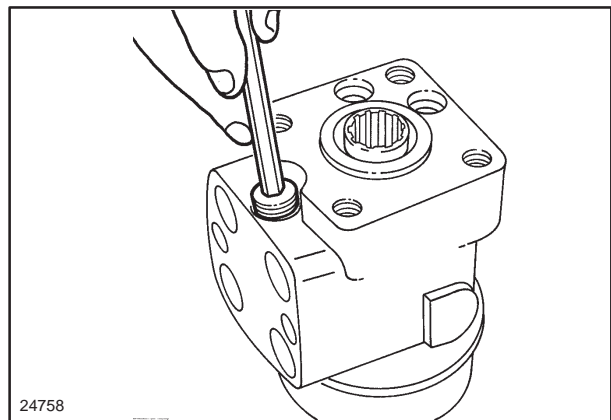

62

53. Tighten the plug (2), with the associated seal, using an 8 mm Allen wrench. Tighten to the prescribed torque value 40 – 60 Nm (29.5025 – 44.2537 ft lb), after having carried out the setting on the workbench or on the tractor.
54. Insert the balls (1) into the two cylinder safety valve seats, indicated by the arrows. See fig. 64 component assembly order.

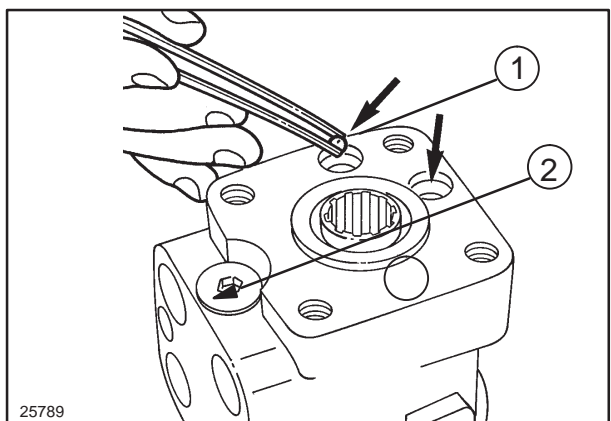

63

Cylinder safety valves components (order of assembly)

1. Cylinder safety valve ball.
2. Pressure spring.
3. Setting adjuster screw.
4. Seal.
5. Plug.

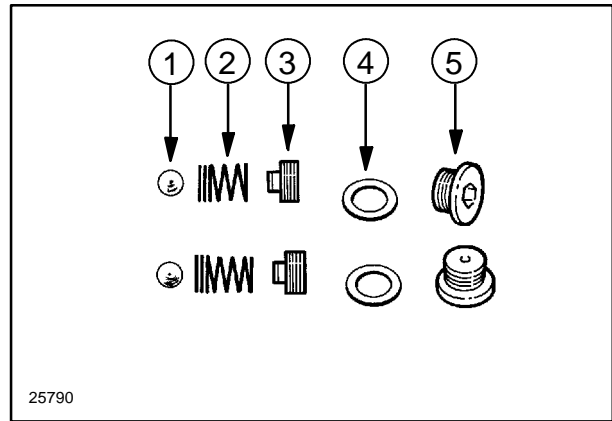

64

55. Insert the springs (2, fig. 64) in the cylinder safety valve seats.

56. Using a 6 mm Allen wrench, tighten the two cylinder safety valve setting adjuster bolts (3, fig. 64).

NOTE: Setting should be carried out on the workbench or on the tractor to the values shown in the table on page 1.

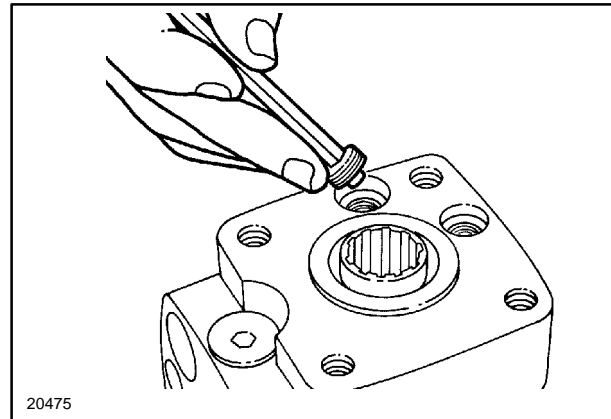

65

57. Tighten the two plugs (5, fig. 64) and the relative seals (4) using a 6 mm Allen wrench. Once setting is completed, tighten to the prescribed torque value of 30 Nm (22.1269 ft lb).

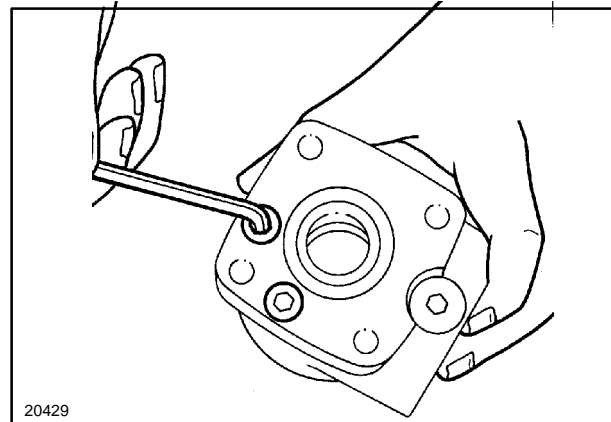

66

58. When the unit has been assembled, insert the dust seal in the seat in the control valve body.

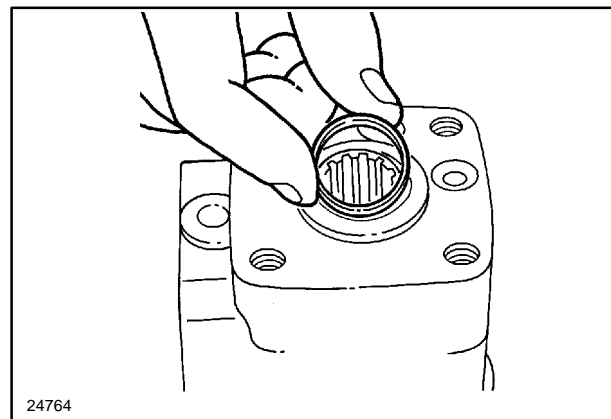

67

HYDROSTATIC STEERING CONTROL VALVE**Bench testing (Op. 41 204 38)****Test conditions**

Oil type ISO VG 68, DIN 51524/51525
 Oil viscosity SAE 20 W
 Oil temperature 60°C (140°F)
 Hydraulic pump capacity litres/min. 12
 (gall. imp/min 2.64)
 Speed of electric motor rpm 1450

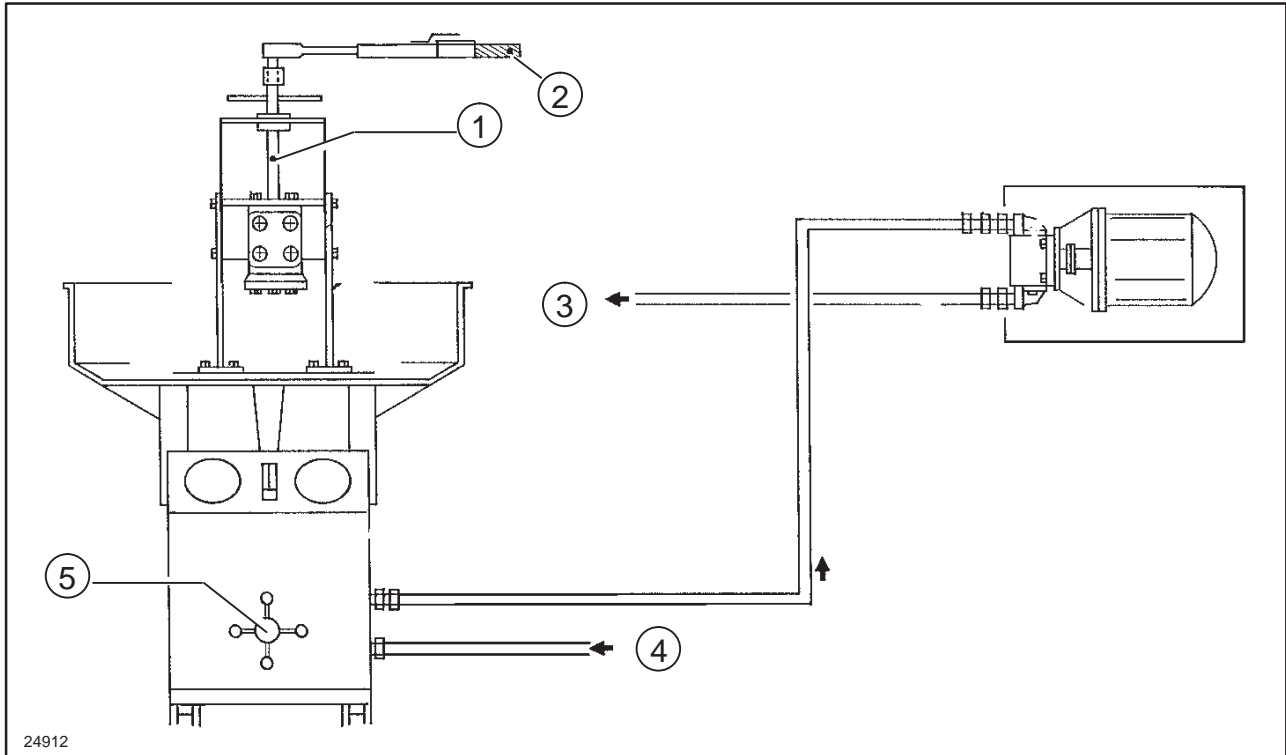

Installation diagram of equipment for testing the rotary valve, seals and for setting the pressure relief valve.

68

- | | |
|--------------------------|----------------------------------|
| 1. Splined control shaft | 4. Restriction |
| 2. Torque wrench | 5. Pressure adjustment handwheel |
| 3. Delivery line | |

A – CHECKING ROTARY VALVE WEAR

1. Make the connections shown in fig. 68 and complete the circuit as in fig. 69. Using the splined control shaft (1), hold the steering control valve in steering position (right or left).
2. Using the handwheel (5), increase the circuit pressure to as near as possible the pressure relief valve cracking pressure (page 1) without the valve actually opening.
3. Using a torque wrench (2), apply a torque of approx. 34 Nm (25.8147 ft lb) to the control shaft (1), and check that the rotary valve takes more than 10 seconds to complete one full rotation. If it takes less than 10 seconds, change the rotary valve and the sleeve .

B – CHECKING RETURN TO NEUTRAL POSITION

In the same test conditions as **A**, check that the valve automatically returns to neutral position when the control shaft (1) is released after each simulated steering movement.

C – CHECKING SEAL EFFICIENCY

In the same test conditions as **A**, hold the valve in steering position with the control shaft (1) for about three minutes and check the seals for leaks.

D – SETTING THE PRESSURE RELIEF VALVE

1. Make the connections as shown in figure (68) and complete the circuit as in figure (69).
2. Using the control shaft (1), simulate a steering cycle (to right or left) so as to interrupt the oil flow to the outlet.
3. Gradually increase the pressure in the circuit by turning the handwheel (5) fig. 68, and check on the pressure gauge that the pressure relief valve (18, fig. 5) cuts in at the pressure shown on page 1. If not, increase or reduce the pressure relief valve setting by tightening or slackening the adjuster screw.

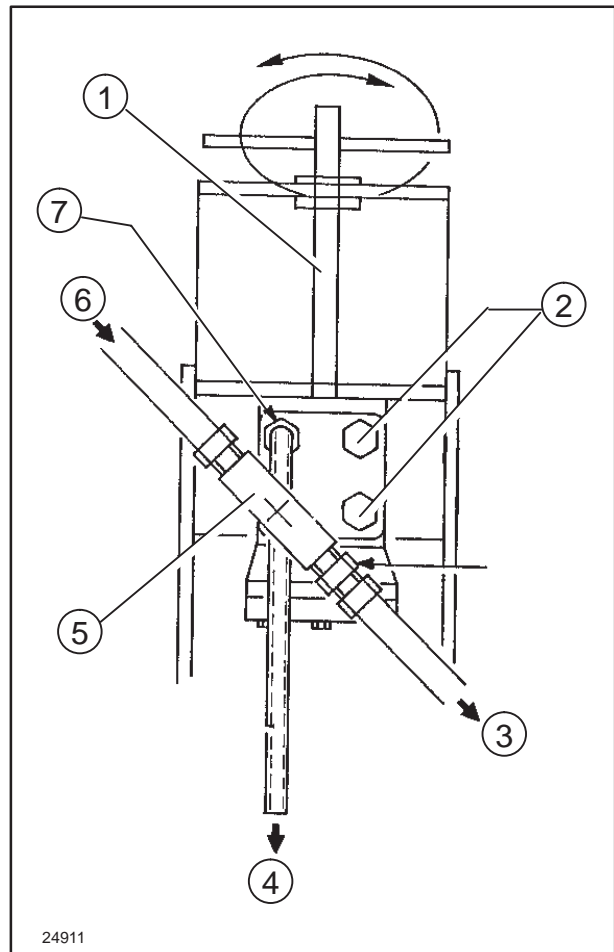

24911

69

1. Splined control shaft – 2. Plug G 1/2" – 3. To throttle – 4. Outlet – 5. Three-way coupling G 1/2" – 6. From delivery line – 7. Outlet coupling G 1/2"

CHECKING THE HYDROSTATIC STEERING PRESSURE RELIEF VALVE WITH STEERING CONTROL VALVE INSTALLED ON TRACTOR.

Proceed as follows:

1. Start the engine and run until the oil temperature reaches approx. 50°C (122°F).
2. Switch off the engine and unscrew the oil delivery pipe union (4) on the hydraulic cylinder (5).
3. Fit union (2) in place of union (4), and connect the pressure gauge (1) with a 0 – 21.3350 psi scale by way of union (3).
4. Start the engine again, bring the speed up to medium rpm, and apply full-steering lock to bring the hydraulic cylinder to the stroke-end position.

In this condition, the pressure relief valve (18, fig. 5) should open and the pressure gauge should indicate the value given on page 1.

5. If the pressure gauge reading deviates significantly from the prescribed value, adjust the valve opening pressure by way of the adjuster screw.

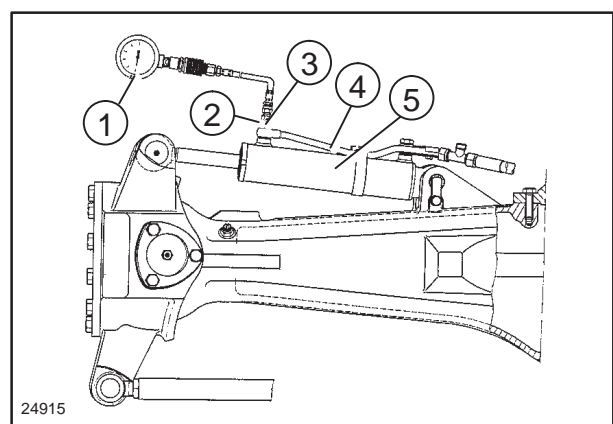

24915

70

1. Pressure gauge (supplied in kit **380000240**) – 2. Union **380000618** (supplied in kit **380000240**) to be fitted in place of original union – 3. Union **380000613** (supplied in kit **380000240**) – 4. Hydraulic cylinder oil feed pipe – 5. Hydraulic cylinder.

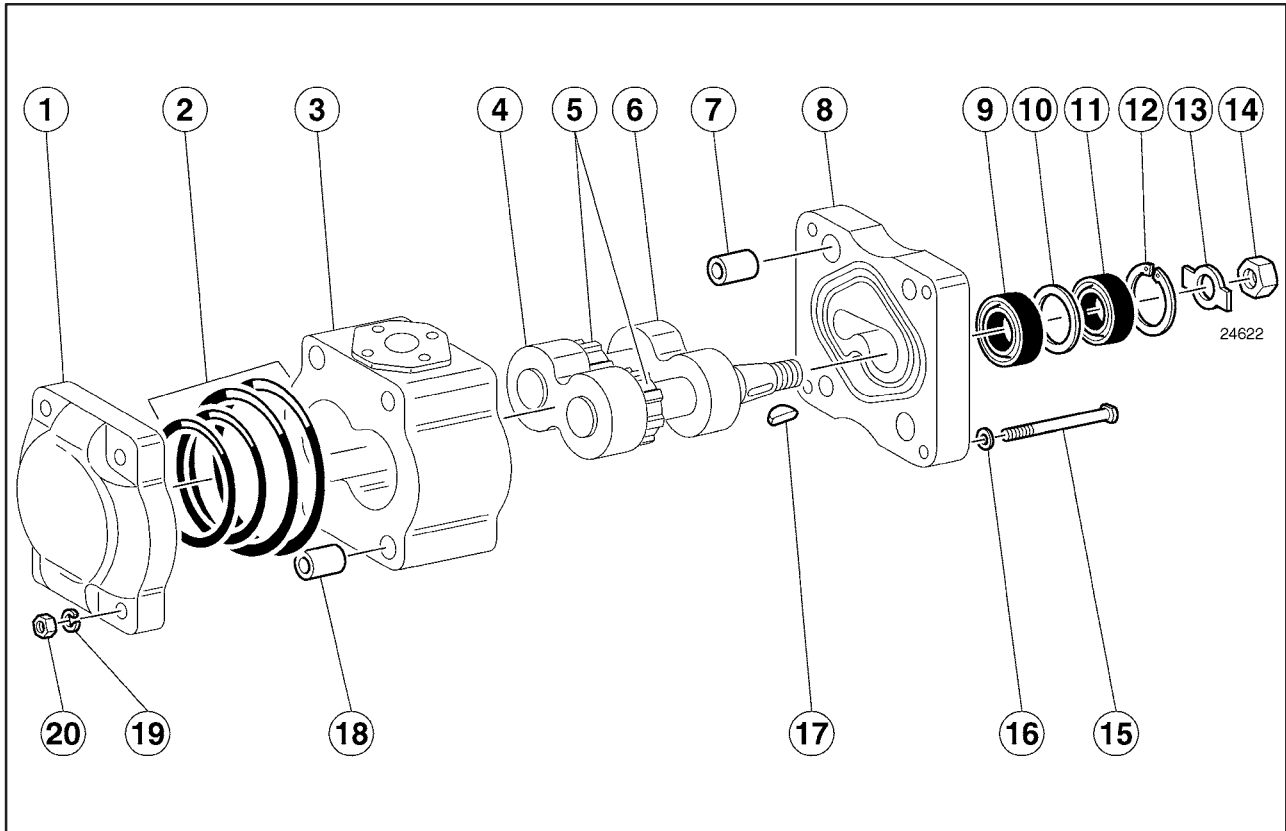

71

Hydrostatic steering – Oil pump components

- | | |
|-----------------------------------|------------------------|
| 1. Front cover | 11. Driving shaft seal |
| 2. Cover seals | 12. Snap ring |
| 3. Pump body | 13. Safety washer |
| 4. Gear support | 14. Nut |
| 5. Driven and driving gear shafts | 15. Bolt |
| 6. Gear support | 16. Washer |
| 7. Bushing | 17. Key |
| 8. Control side cover | 18. Bushing |
| 9. Driving shaft seal | 19. Safety washer |
| 10. Spacer | 20. Nut |

Proceed as follows:

1. Remove the cover fastening nuts (20), then the bolts (15) and the safety washers.
2. Remove the nut (14) that fastens the sleeve to the pump driving shaft and the safety washer.
3. Remove the front cover (8), the snap ring (12) and the seals (9 and 11).
4. Mark parts 3, 4, 5 and 6 to enable them to be remounted in the same position if they are in good condition.

5. Remove the supports (4 and 6) and the gears (5) from the rear cover (8) and the pump body (3).
6. Remove the seals (2) and the anti-extrusion rings. Once the parts are removed, proceed as follows:
7. Check that the gear contact surfaces are flat and perpendicular to their supports. Interpose a thin layer of carbon black. Small rough spots can be removed using extremely fine and adequately lubricated abrasive paper.
8. Check that the axial play of the gear-support unit in the pump body is 0.100 – 0.180 mm (0.0039 – 0.0189 in.). The distance (Fig 72, 2) must be 0.100 – 0.180 mm (0.0039 – 0.0189 in.) smaller than the distance (Fig 72, 1). If necessary, true the flat surfaces involved using lubricated abrasive paper to remove extremely small quantities of material
9. Clean all constituent parts thoroughly.
10. Replace the seals (2, 9 and 11).
11. Lubricate the parts with the same oil as the system. Refit the pump, referring to fig. 71 and proceeding as follows:
12. refit, performing operations 6 to 1 in reverse order;
 - always ensure the maximum cleanliness to prevent foreign matter from entering, as this could damage the pump;
 - fit together previously marked parts (3, 4, 5 and 6, fig. 71);
 - see op. page 45 to refit them in their original position;
 - mount the gear supports (4 and 6 fig. 71) in the pump body;
 - orient them with the fittings on the external circumference matched up with the discharge pipes and the front faces with lubrication millings in contact with the gears;
 - fit the plastic anti-extrusion rings on the seals (2, fig. 71);
 - mount the seals (9 and 11, fig. 71) on the control side cover (8) complete with spacer (10);
 - orient them so that the cavity is between the seal lips on the opposite side from this spacer;
 - lastly fill this cavity with **GR 75 MD** grease. Install the pump on the tractor. Fill the suction pipe and the pump housing with **AM-BRA MULTI F** oil in order to facilitate priming and prevent the risk of seizure during initial operation.

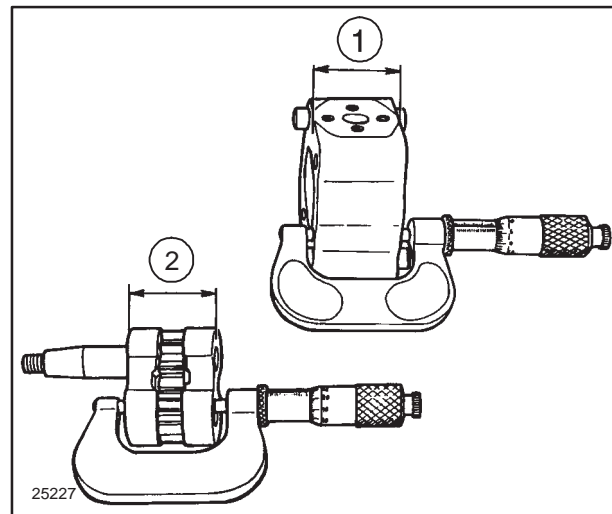

72

FRONT AXLE STEERING CYLINDER
(Two wheel drive axle) (Op. 41 216 20)
Removal–Refitting

⚠ WARNING ⚠

Handle all parts with great care. Do not put your hands or fingers between one part and another. Wear the recommended safety clothing such as goggles, gloves and safety boots.

To remove the front axle steering cylinder, proceed as follows:

1. Remove the exhaust pipe, lift the hood and disconnect the negative cable from the battery.
2. Unscrew the unions securing the oil delivery and return hoses (1) to the cylinder (2).
3. Remove the nut securing the cylinder rod ball end to the steering arm (1).

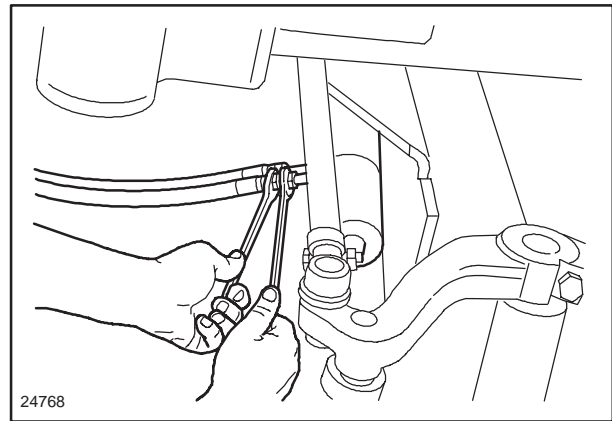

73

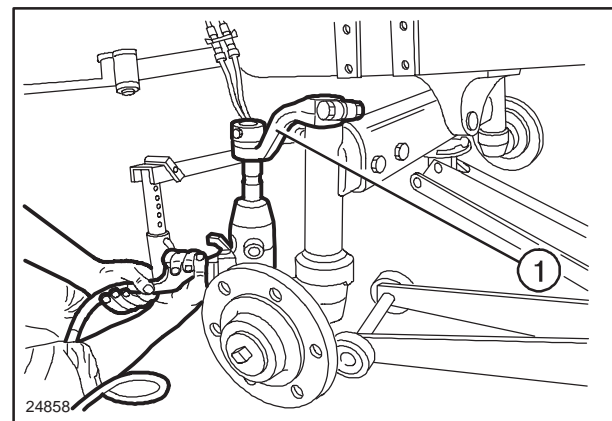

74

4. Using a suitable puller (1), separate the cylinder rod ball end from the steering arm.

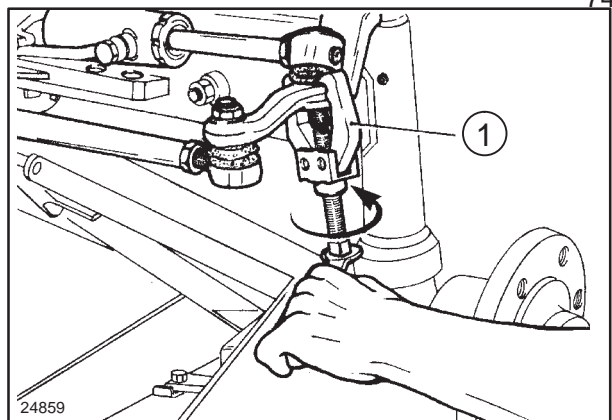

75

5. Remove the pin securing the steering cylinder (1) to the axle and remove the cylinder.
6. To refit the steering cylinder, follow the removal procedure in reverse order.

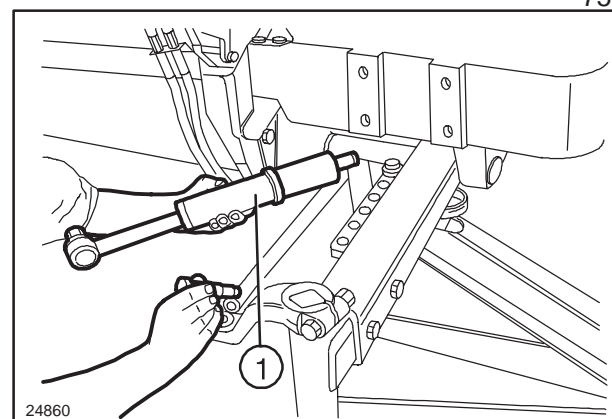

76

FRONT AXLE STEERING CYLINDER**(Four wheel drive axle)****Removal–Refitting****WARNING**

Handle all parts with great care. Do not put your hands or fingers between one part and another. Wear the recommended safety clothing such as goggles, gloves and safety boots.

To remove the front axle steering cylinder, proceed as follows:

1. Disconnect the negative cable from the battery.
2. Unscrew the unions securing the delivery and return hoses to the steering cylinder.
3. Remove the snap ring (1) and remove the cylinder rod articulation pin (2) connected to the stub axle housing.

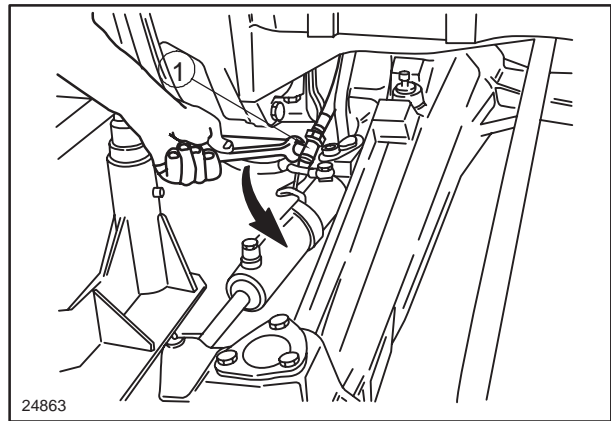

77

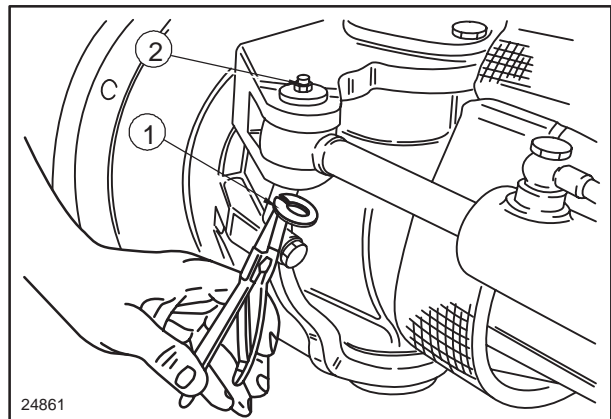

78

4. Remove the retaining screw and extract the pin (1) securing the steering cylinder to the axle. Remove the steering cylinder.

NOTE: Should you want to remove both steering cylinders complete with supply pipes, omit step 3 described above and carry out steps 2 and 4 for the other cylinder too.

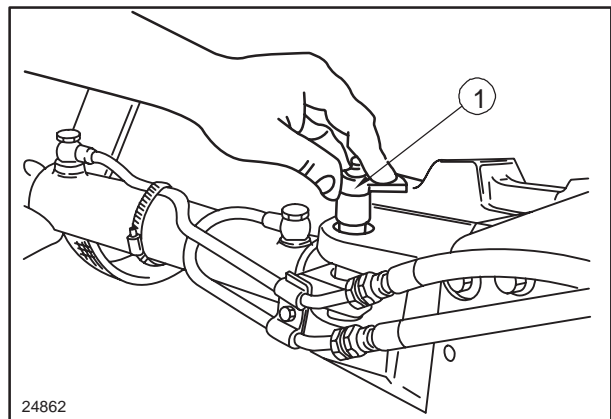

79

5. Remove the two actuator cylinders complete with supply pipes.

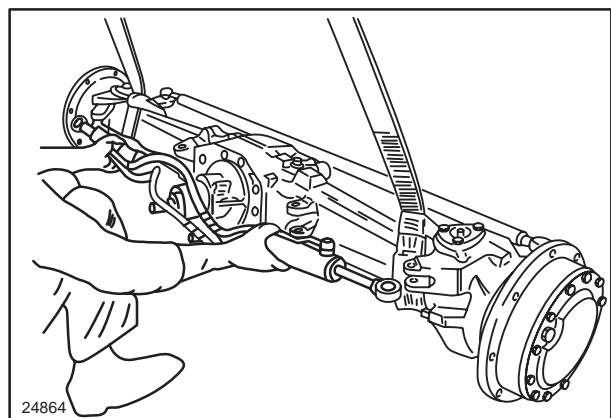

80

SECTION 44 - FRONT AXLE AND WHEELS

Chapter 1 - Front axle and wheels

CONTENTS

Section	Description	Page
44 000	Principal data	1
	Sectional views	3
	Torque settings	4
	Equipment - Fault diagnosis	5
44 101.30	Removal-Refitting-Overhaul	6
44 101.22	Wheel hub disassembly-assembly	9
44 101.46	Stub axle overhaul	12
44 511.80	Checking wheel alignment	16

PRINCIPAL DATA

Type		inverted U-section, telescopic and oscillating at centre
Wheel angle		2°, corresponding to 15 mm (0.5906 in.) for 16 in. wheels
Toe-in	mm (in.)	0 - 5 (0 - 0.1969)
Stub axle articulation		
Diameter of stub axle pin (7, page 3) at bushing	mm (in.)	37.961 - 38.000 (1.4945 - 1.4961)
Bore of installed bushings (6)	mm (in.)	38.050 - 38.140 (*) (1.4980 - 1.5016)
Clearance between stub axle pin and relative bushings	mm (in.)	0.050 - 0.179 (0.0020 - 0.0070)
Axle articulation		
Diameter of axle articulation pin (1, page 3)	mm (in.)	37.961 - 38.000 (1.4945 - 1.4961)
Bore of installed bushings (6)	mm (in.)	38.050 - 38.140 (*) (1.4980 - 1.5016)
Clearance between stub axle pin and bushing	mm (in.)	0.050 - 0.179 (0.0020 - 0.0070)

(*) Value to be obtained without refacing.

MAIN DATA

(cont.)

MODEL	Tyres	Standard wheel tracks mm (in.)	Alternative track settings mm (in.)					
			A	B	C	D	E	F
TD60D TD70D	7.50-16 in.	1500 (59.0550)	1400 (55.1180)	1500 (59.0550)	1600 (62.9920)	1700 (66.9290)	1800 (70.8660)	1900 (74.8030)
TD80D TD90D TD95D	7.50-18 in.	1510 (59.4487)	1410 (55.5117)	1510 (59.4487)	1610 (63.3857)	1710 (67.3227)	1810 (71.2597)	1910 (75.1967)

DIAGRAM OF 2WD FRONT WHEEL TRACKS

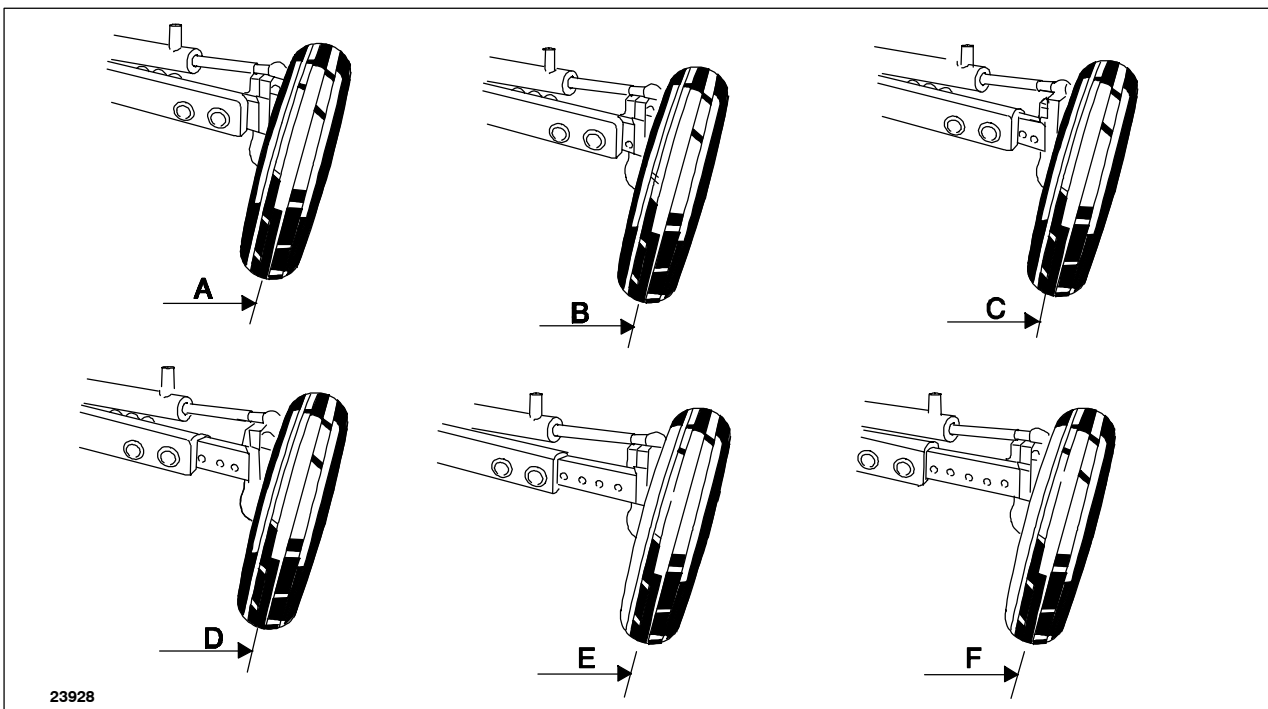

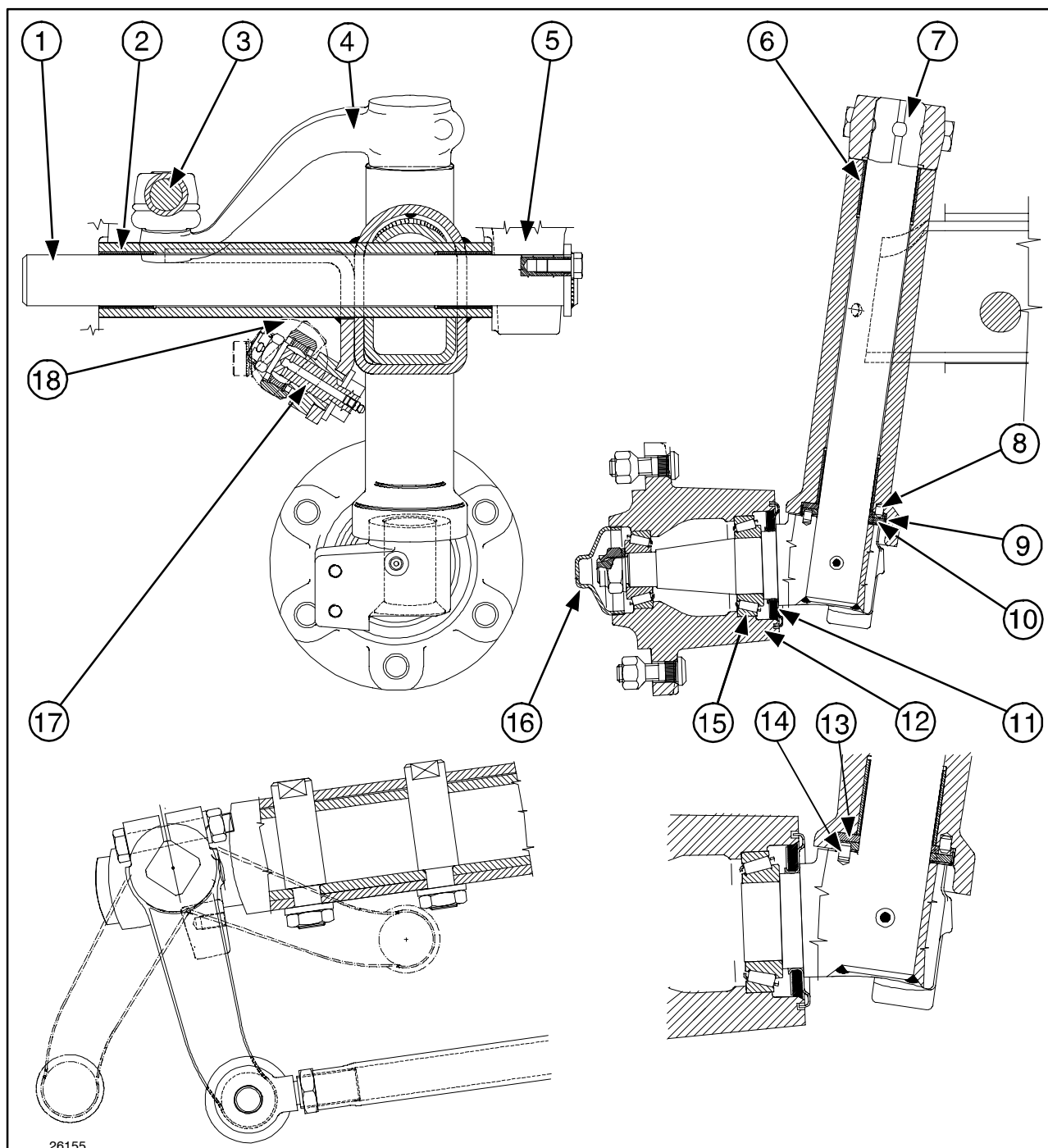

26155

2

Sections of stub axle, articulation pin and front axle

- | | |
|---------------------------------|--|
| 1. Axle articulation pin | 10. Bronze thrust ring |
| 2. Axle articulation bushing | 11. Seal |
| 3. Steering transverse tie rod | 12. Wheel hub |
| 4. Stub axle control lever | 13. Steel thrust washer |
| 5. Axle support | 14. Grub screw for cap (11) and thrust washer (12) |
| 6. Bushing | 15. Taper roller bearing for wheel |
| 7. Stub axle pin | 16. Bearing cover for greasing and adjustment |
| 8. Support ring grub screw (13) | 17. Cylinder fulcrum pin (18) |
| 9. Cap | 18. Power steering cylinder installation position |

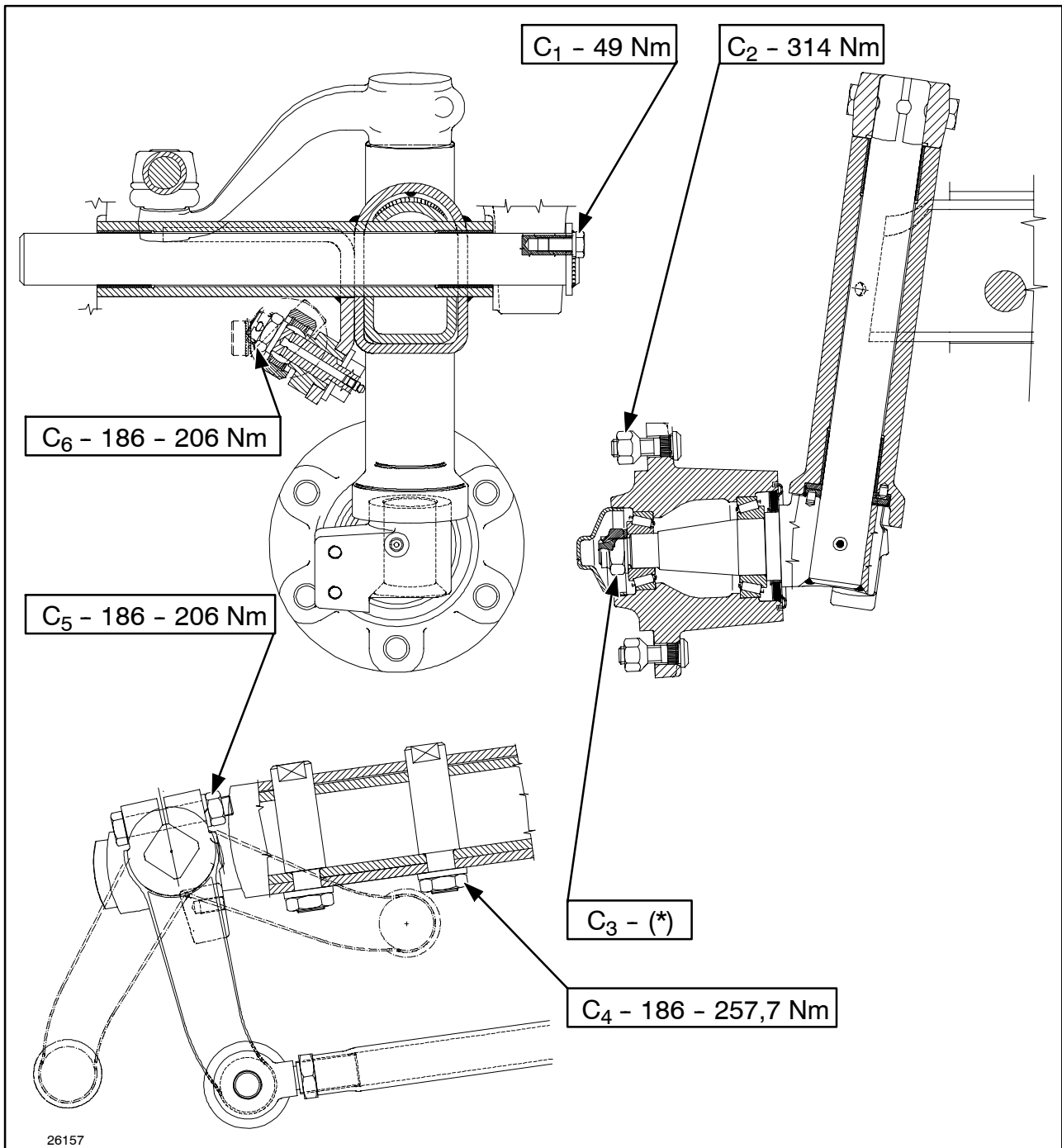

Front axle torque settings

C1 Axle articulation pin fixing screw
C2 Nut securing disc to wheel hub
C3 Bearing adjuster nut
C4 Axle end fixing nut

C5 Nut for stub axle pin control lever fixing screw
C6 Nut securing cylinder to fulcrum pin

TORQUE SETTINGS

PART	Thread	Torque setting	
		Nm	ft lb
Front axle			
Bolt securing axle to engine	M 18 x 1.5	353	478.6045
Axle articulation pin retaining bolt (C ₁ , fig. 3)	M 10 x 1.25	49	66.4352
Nut securing lading wheel to hub (C ₂ , fig. 3)	M 18 x 1.25	115	84.8196
Bearing adjuster nut (C ₃ , fig. 3)	M 20 x 1.5	(*)	(*)
Nut for pin securing end of axle (C ₄ , fig. 3)	M 20 x 1.5	186±257.7	137.1865± 190.0697
Nut for stub axles left and right-hand lever retaining pin (C ₅ , fig. 3)	M 14 x 1.5	186±206	137.1865± 151.9378
Nut securing cylinder to fulcrum pin (C ₆ , fig. 3)	M 18 x 1.5	186±206	137.1865± 151.9378

(*) See operations 12 and 13, page 11.

EQUIPMENT

WARNING: The operations described in this section must be performed only with the **ESSENTIAL** equipment marked with (X).

To operate safely and achieve best results, while saving time and effort, essential equipment must be used in conjunction with the special tools recommended below and tools which you must make yourself and for which you will find the design in this manual.

List of special tools necessary for the various operations described in this section.

X 380000541 Adaptor (M12x1.25) for axle articulation pin (use with slide hammer **380000549**)

380000237 Wheel lifting hook.

FAULT DIAGNOSIS

Problem	Possible cause	Corrective action
Abnormal wear of tyres.	1. Incorrect tyre pressure.	Inflate the tyres to the correct pressure, referring to the pressures recommended in the Use and Maintenance handbook, and more especially, to the pressures recommended by the manufacturer of the tyres fitted.
	2. Incorrect toe-in of front wheels.	Correct the toe-in.
Poor stability of tractor.	1. Incorrect tyre pressure.	Inflate the tyres correctly as detailed above.

FRONT AXLE**Removal-Refitting (Op. 44 101 30)****DANGER**

Lift and handle all heavy parts with lifting equipment of suitable capacity. Make certain that the units or parts are supported by appropriate slings and hooks. Ensure that there are no persons in the vicinity of the load to be lifted.

To remove the complete axle from the tractor, proceed as follows:

1. Disconnect the negative cable from the battery and isolate it; chock the rear wheels.

2. Lift the front of the tractor.

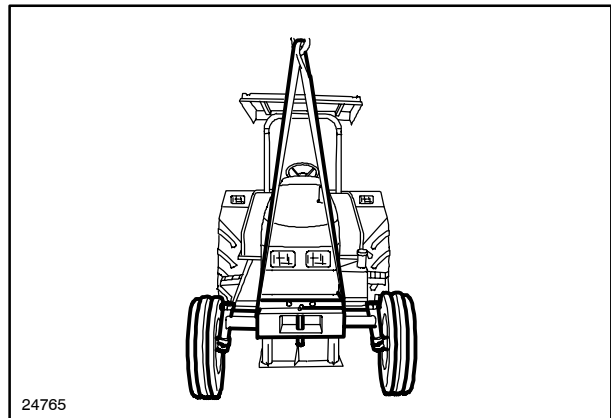

24765

4

3. Place a stand (1) beneath the engine sump, inserting a block of wood between the engine sump and stand.

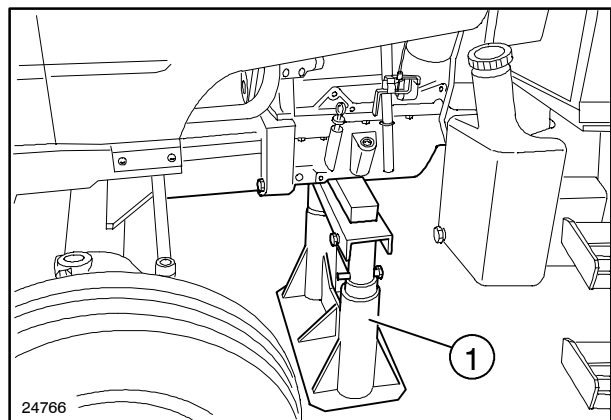

24766

5

4. Remove the front wheel fixing bolts (1).

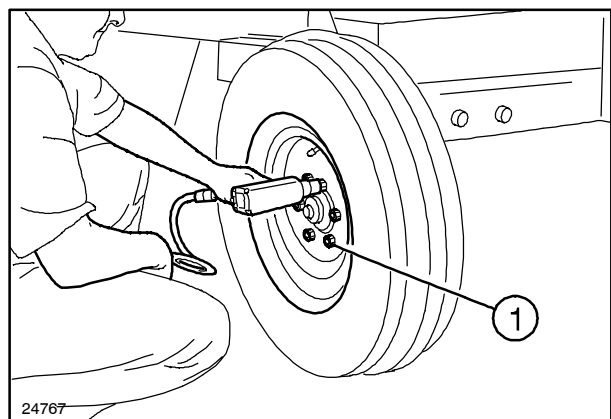

24767

6

5. Disconnect the hoses (1) of the power steering cylinder (2).

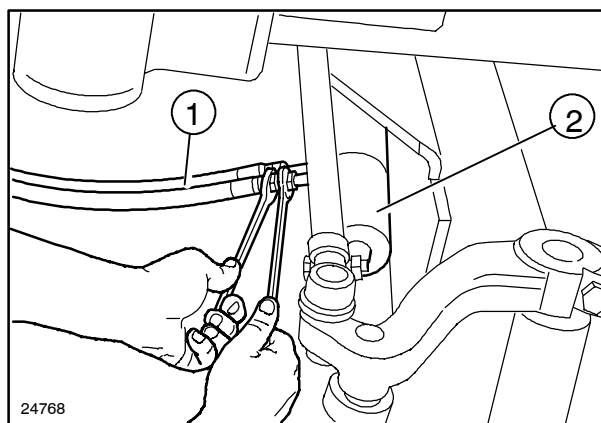

7

6. Remove the axle articulation pin securing bolt (1).

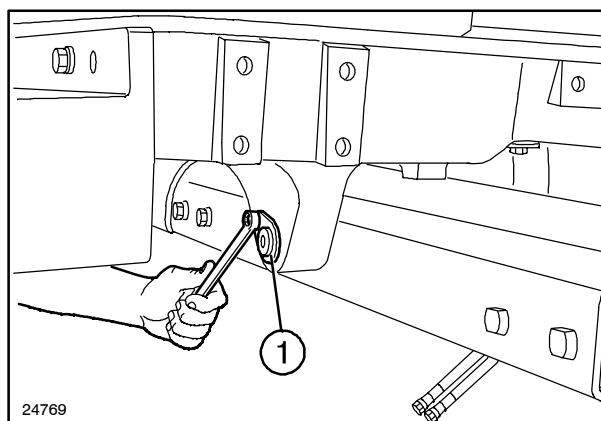

8

7. Secure the axle by means of a sling (1).

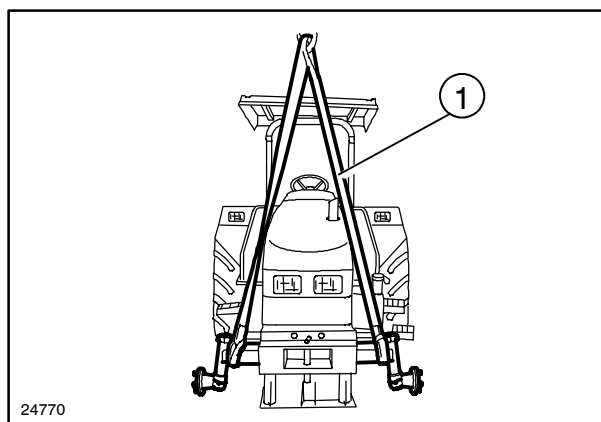

9

8. Take out the axle articulation pin (1) using slide hammer **380000549**, equipped with adaptor **380000541** and extension.

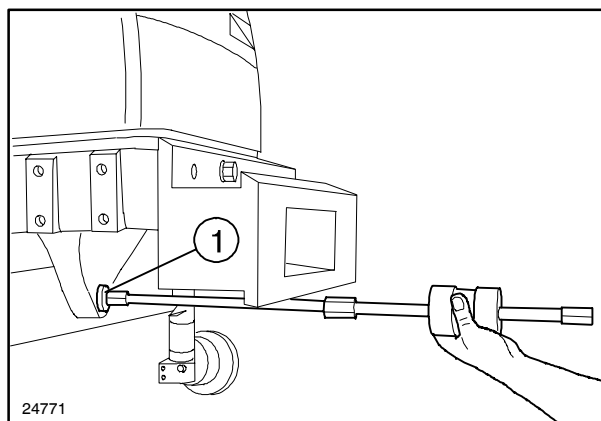

10

9. Remove the complete axle (1).

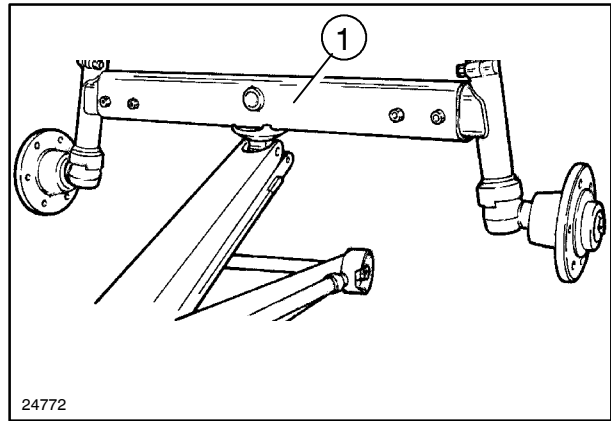

11

10. To refit the complete axle, follow the disassembly procedure in reverse order. Install the axle articulation pin (1) using a bronze punch.

11. Fit the screw fixing the axle articulation pin.

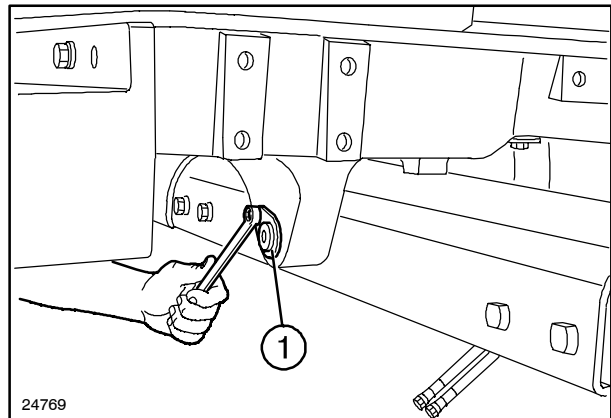

24769

12

12. Reconnect the hoses (1) of the power steering cylinder (2).

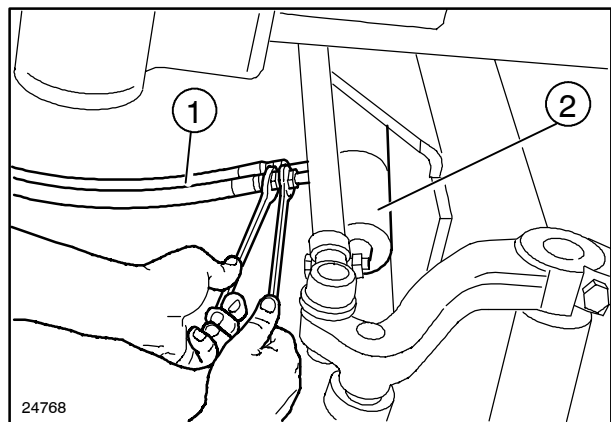

24768

13

AXLE WHEEL HUB**Removal-Refitting (Op. 44 101 22)****⚠ WARNING ⚠**

Handle all parts with great care. Do not put your hands or fingers between one part and another. Wear the recommended safety clothing such as goggles, gloves and safety boots.

The wheel hubs can be removed with the axle installed on the tractor. Proceed as follows for each wheel.

1. Disconnect the negative cable of the battery and isolate it; chock the rear wheels.
2. Lift the front of the tractor.

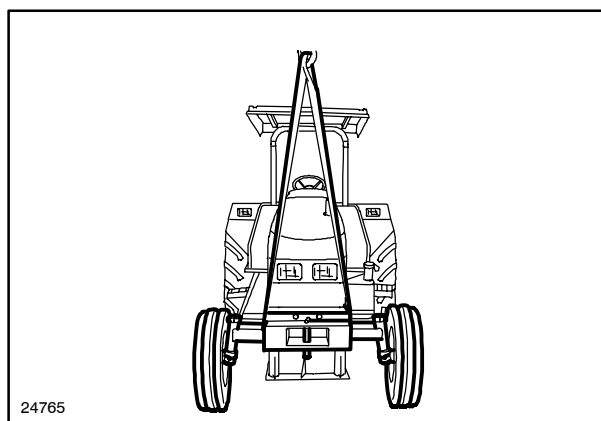

14

3. Place a stand (1) beneath the engine sump, inserting a block of wood between the engine sump and stand.

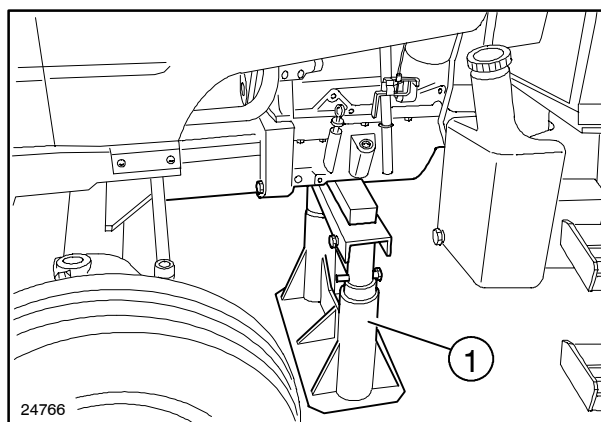

15

4. Remove the front wheel fixing bolts.

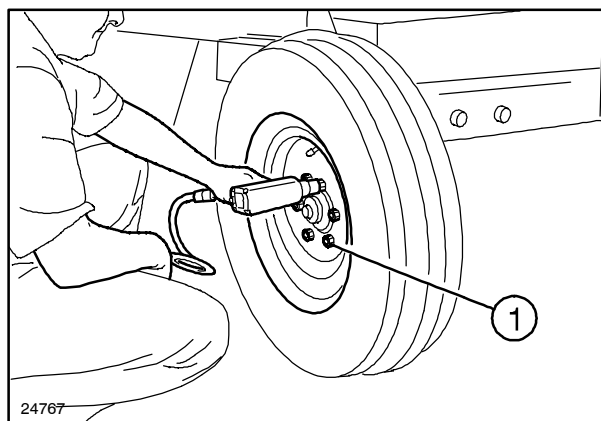

16

5. Remove the wheel hub bearing cover (1).

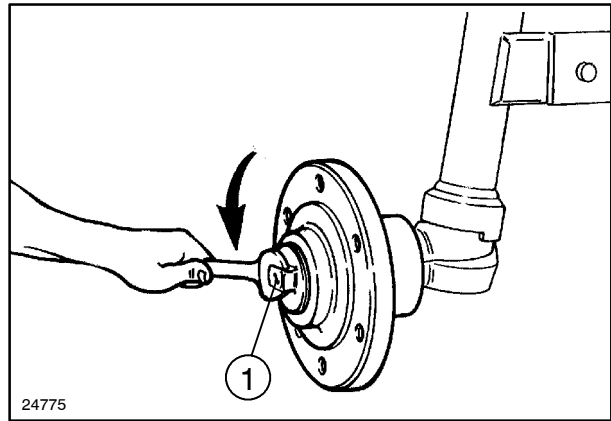

17

6. Remove the staking securing the wheel hub bearing adjuster nut (1).

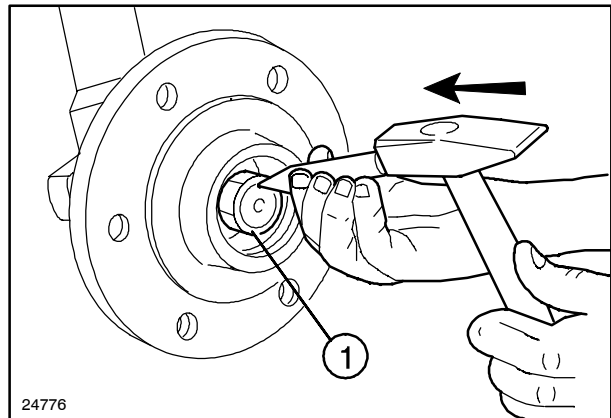

18

7. Using a socket wrench, unscrew the wheel hub bearing adjuster nut.

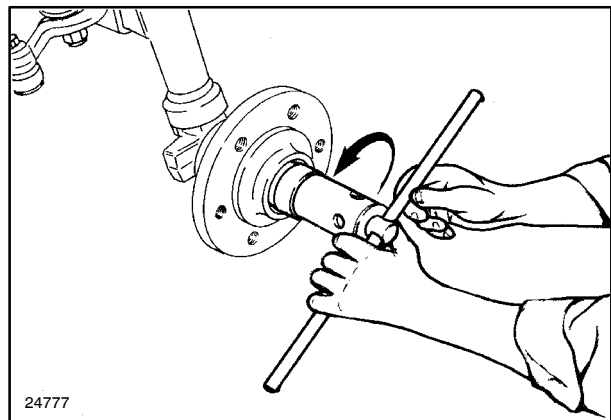

19

8. Remove the wheel hub (2) and take out the bearings (1 and 3).

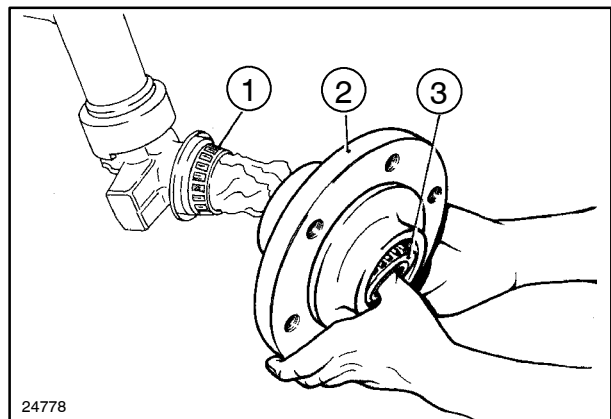

20

9. Renew worn bearings and seals, using suitable extractors and punches.

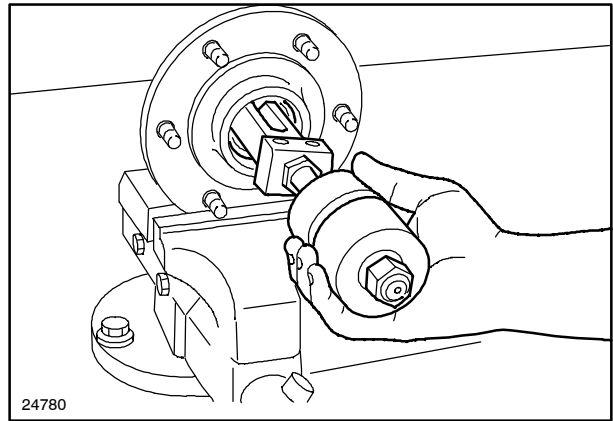

21

10. Pack the wheel hub with **AMBRA GR9 grease**.

11. Refit the wheel hub (2) complete with bearings (1 and 3).

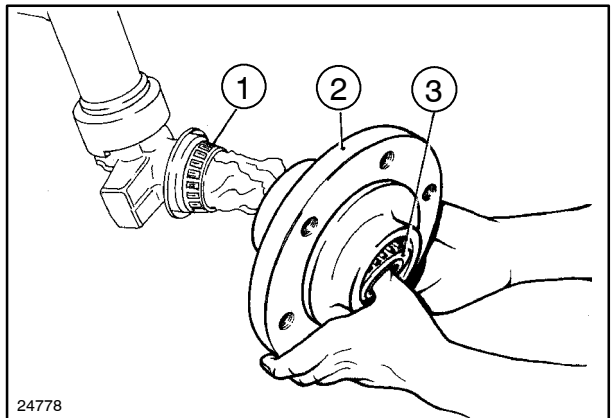

22

12. Install a new nut and, using a torque wrench, tighten the nut to a torque of 196 Nm (265.7407 ft lb), turning the wheel hub (1) simultaneously in order to settle the bearings.

13. Loosen the nut slightly and tighten it again to a torque of 24 - 29 Nm (32.5397 - 39.3188 fr lb) while continuing to turn the wheel hub.

Note - the nut must be changed each time the wheel hub is fitted.

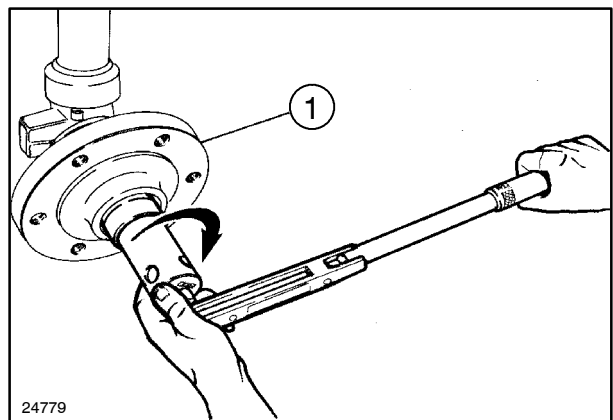

23

14. Check the rolling torque R, bearing in mind that:
 $R \leq 5.7864 \text{ ft lb}$

15. Secure the nut (1) by staking.

16. Refit the grease cover (1) Fig. 17.

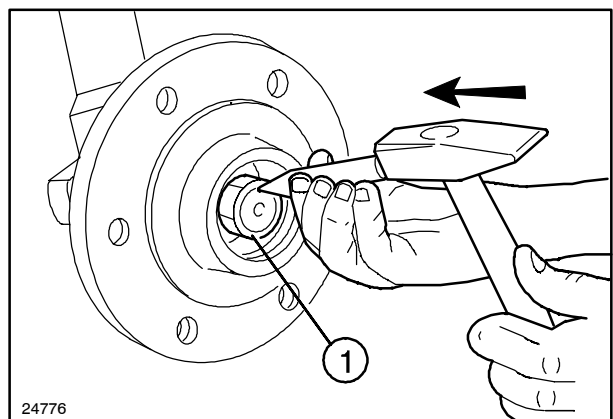

24

STUB AXLE**Overhaul (Op. 44 101 46)****WARNING**

Handle all parts with great care. Do not put your hands or fingers between one part and another. Wear the recommended safety clothing such as goggles, gloves and safety boots.

The stub axles can be removed with the axle installed on the tractor. Proceed as follows for each wheel.

1. Disconnect the negative cable of the battery and isolate it; chock the rear wheels.
2. Lift the front of the tractor.

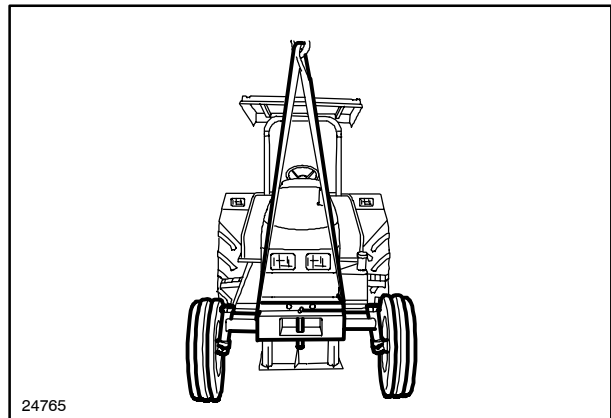

24765

25

3. Place a stand (1) beneath the engine sump, inserting a block of wood between the engine sump and stand.

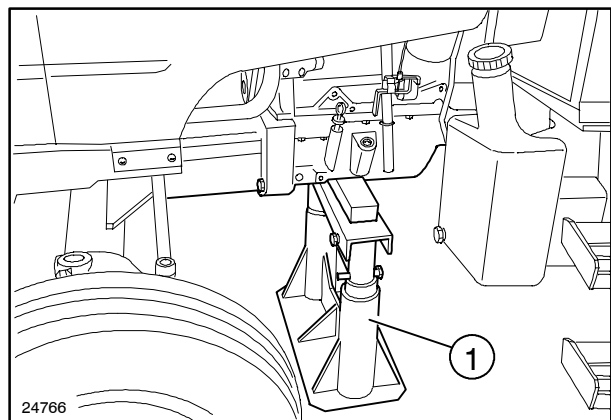

24766

26

4. Remove the front wheel fixing bolts (1).

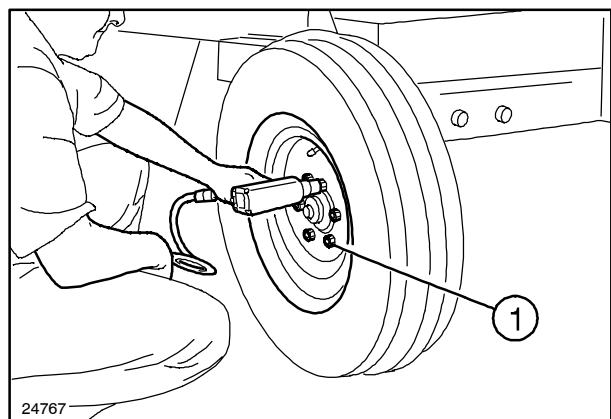

24767

27

5. Place a hydraulic jack beneath the stub axle and unscrew the bolt (1) fixing the control lever (2) to the stub axle pin.

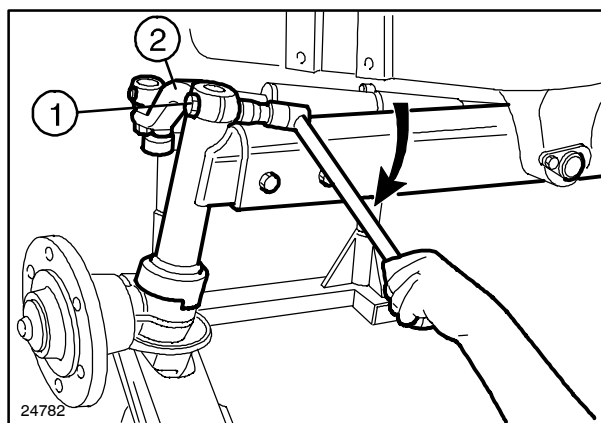

28

6. Withdraw the control lever (1) from the stub axle pin (2).

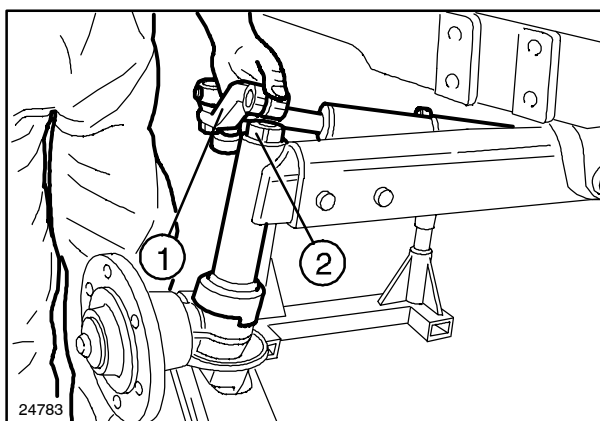

29

7. Lower the hydraulic jack and remove the stub axle (1).

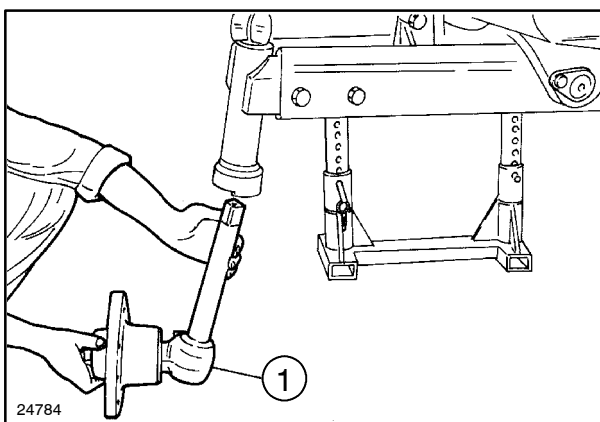

30

8. Unscrew the axle end securing bolts (1).

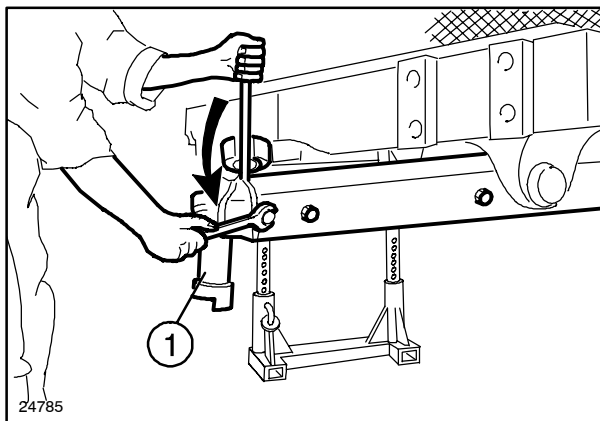

31

9. Remove the axle end (1).

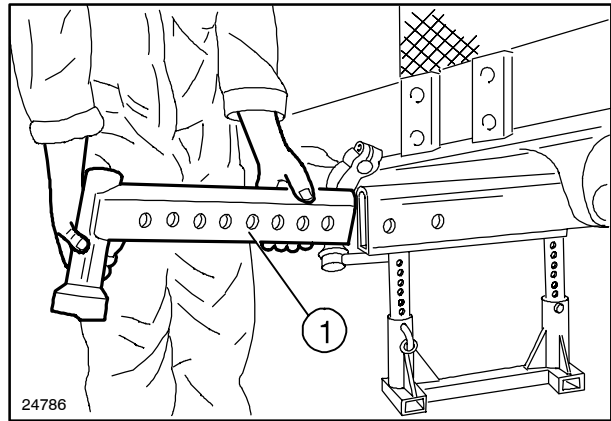

32

10. Clamp the end of the axle in a vice and using a slide hammer, take out the stub axle pin articulation bushing (1).

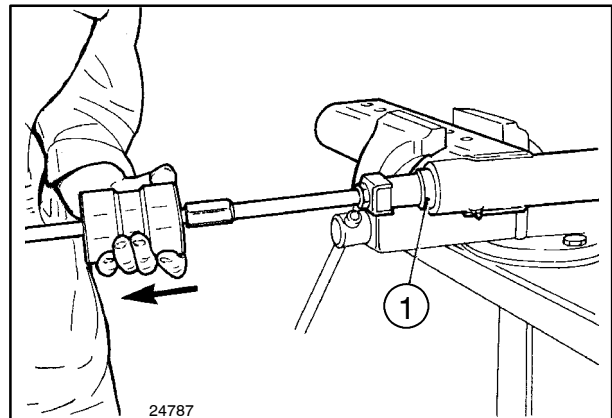

33

11. To refit the stub axle, follow the disassembly procedure in reverse order, using a suitable hammer to fit the new bushings on the axle ends.

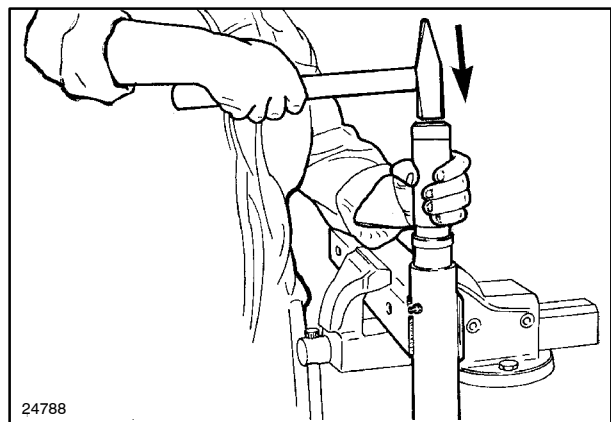

34

12. Fit the axle end (1).

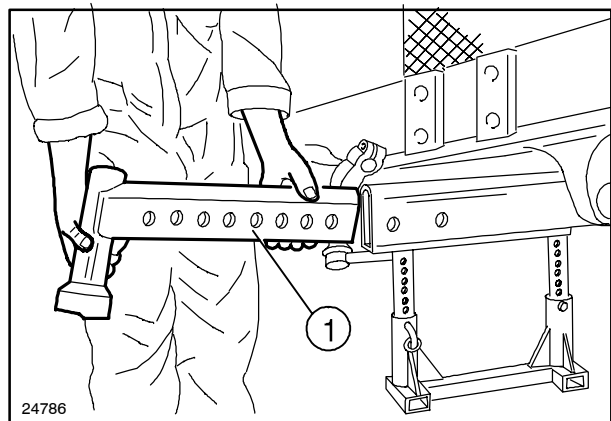

35

13. At the base of the stub axle refit the cap (9, fig. 2), then the levelling rings (1), inserting them on the stop grub screws (8 and 14, as shown in figure 2).

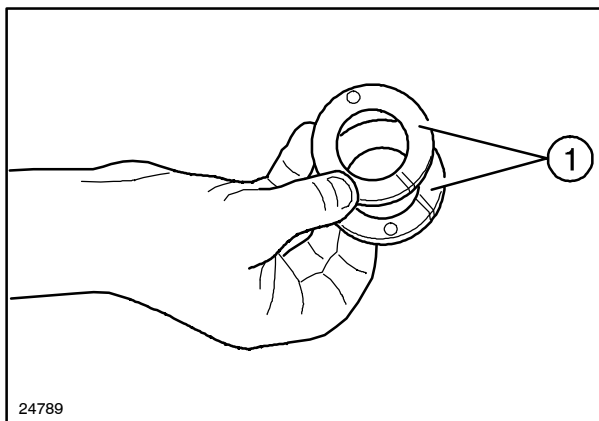

36

14. Fit the stub axle on the axle end.
15. Position the control lever (1) on the stub axle pin (2) and tighten the securing screw.

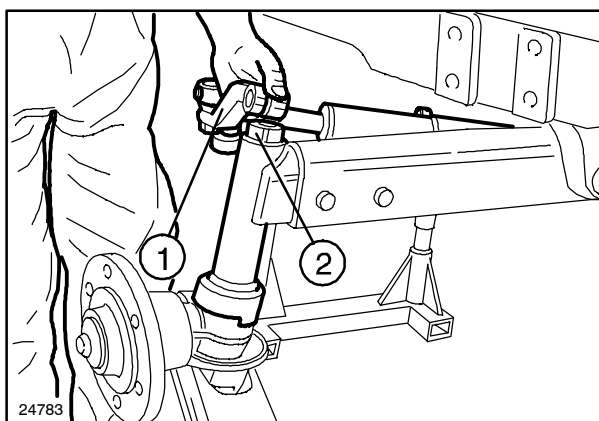

37

CHECKING THE ALIGNMENT OF THE FRONT WHEELS (Op. 44 511 80)

Check the alignment of the front wheels, bearing in mind that for driving in a straight line, the wheels must be at an angle of 2° to the vertical. This corresponds to a difference of approximately 15 mm (0.59056 in.) for 16 in. wheels, between the top edge of the rim (A) and bottom edge (A + X).

When driving in a straight line, the wheels must be parallel to the longitudinal axis of the tractor or have a maximum of 5 mm (0.1968 in.) toe-in at the front, measured between the wheel-rims.

To check the toe-in, proceed as follows:

1. Inflate the front tyres to a pressure of 2.5 bar (36.25 psi).
2. Position the steering wheel in the middle of its travel, with one spoke along the longitudinal axis of the tractor.
3. Check that the wheels are parallel with the longitudinal axis of the tractor.
4. With the tractor parked on a flat, level surface, measure the distance (B_1) between the **front** of the wheel rims, at hub height. Make a chalk mark on the rims where the measurement has taken place. Move the tractor forward to rotate both wheels exactly 180° and check the measurements again at the chalk marks B_2 (now positioned at the rear of the wheels). This will eliminate wheel rim run-out errors.
5. Correct the toe-in, if necessary, by adjustment of the end of the transverse steering tie-rod.

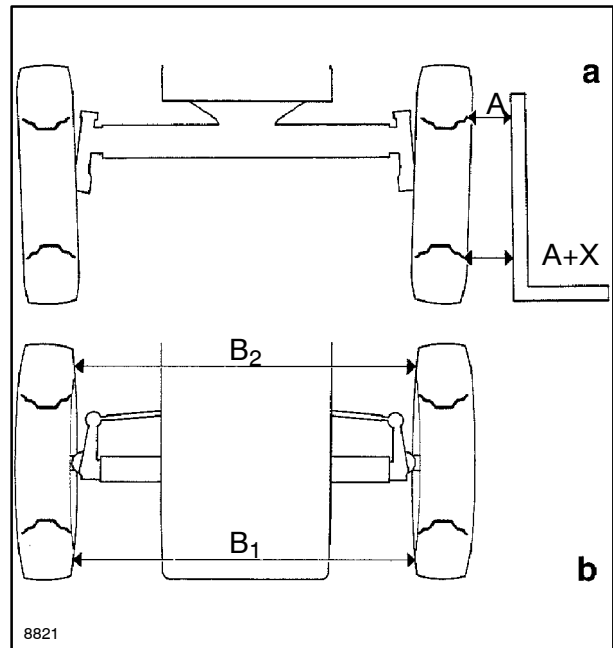

SECTION 50 - CAB AIR CONDITIONING SYSTEM**Chapter 1 - Cab air conditioning system****CONTENTS**

Section	Description	Page
50 000	Safety instructions	2
	General characteristics	3
	Equipment	4
	Operating principles	5
	Fault diagnosis	7
	Cab controls	11
	Use	14
	Main components of the cab air conditioning system	15
	Refrigerant recovery-recycling and evacuation-charging stations	20
50.200.04	Drying recharging and checking cooling	22
50.200.03	Air-conditioning functional testing	27
	Summary of the cab air-conditioning system charging operations	28
	Checking for refrigerant leaks using an electronic leak detector	30
	Summary of fault diagnosis and maintenance	31
	Air conditioning and heating pipes - Replacement	33
50.200.04-74	Receiver-dryer - Replacement	36
50.200.04-72	Condenser - Replacement	38
50.200.04-26	Compressor - Removal-Refitting	39
50.200.10	Compressor drive belt tension adjustment	41

CAB AIR CONDITIONING SYSTEM



SAFETY



Refrigerant must be handled with extreme care to avoid injury; always wear safety gloves and goggles.

Liquid refrigerant can cause freezing of the skin and serious damage to the eyes, even blindness in some cases.

Keep refrigerant containers away from heat sources, as the increase of internal pressure due to heating could cause the container to explode.

In contact with a naked flame or hot metal surfaces the refrigerant may give off a toxic gas. If inhaled this gas can cause serious harm.

To avoid the possibility of accidents take the simple precautions described below.

The operation of emptying the system must be carried out in a well-ventilated area, well away from any naked flames.

During the charging and emptying operations, take the necessary precautions to protect the face and above all the eyes from accidental contact with refrigerant.

In case of accident, proceed as follows:

- if has entered the eyes, wash immediately with a few drops of mineral oil, then wash them thoroughly with a solution of boric acid and water (one spoonful of acid in 1/4 cup of water) and seek medical assistance immediately.

- freezing of the skin caused by contact with liquid refrigerant can be treated by gradually warming the injured area with cold water followed by application of a greasy cream. Seek medical assistance.

- the air conditioning system contains a mixture of refrigerant and oil under high pressure; under no circumstances loosen pipe fittings/couplings or work on pipes without having first evacuated the system.

- for the same reason, never unscrew the compressor oil level plug when the system is charged.

- do not heat the refrigerant container. Above 50°C (122 °F) the pressure increases very rapidly.

- keep the air conditioning system away from heat sources to prevent possible explosion due to the increase of pressure in the system.

When transferring refrigerant from one container to another, only use homologated liquid refrigerant containers equipped with safety valves.

Never fill liquid refrigerant containers over 80% of their maximum capacity.

Do not modify the settings of safety valves and the control devices.

Never connect the recovery/recycling and evacuation/charging stations to electrical power outlets with voltages other than those specified; do not leave the stations powered on unless they are to be used immediately.

CAB AIR CONDITIONING SYSTEM CHARACTERISTICS

SANDEN SD 7H15 Compressor	
Number of cylinders	7
Total displacement cm ³ (inch ³)	155 (9.46)
Maximum speed rpm	6000
Weight kg (lb)	6.5 (14.33)
Quantity of lubricating oil cm ³ (inch ³)	185 (11.29)
Type of lubricating oil (code)	PAG SP 20

Air conditioning system	Gas HFC134a
Quantity of HFC-134a refrigerant gr (lb)	1400 (3.0879)
System delivery side pressure bar (psi)	16-24 (232.06-348.09)
System suction side pressure bar (psi)	0.5-3 (7.25-43.51)
Pressure switch setting (high pressure) bar (psi)	25 (362.59)
Pressure switch setting (high pressure) bar (psi)	2 (29.01)
Temperature of refrigerant fluid at outlet of compressor ... °C (°F)	60-120 (140-248)
Temperature of refrigerant fluid at outlet of condenser °C (°F)	40-60 (104-140)
Temperature of refrigerant fluid at outlet of evaporator °C (°F)	0-15 (32-59)
Maximum capacity of electric centrifugal fan I, II, III speed . m ³ /min (in. ³ /min)	3.5-8.5 (21.36-51.87)

Remember that altitude affects pressure, as shown in the table on the right.

To obtain the effective pressure in the system, subtract the corresponding correction value from the pressure gauge reading.

Altitude (m) s.l.m.	Absolute atmospheric pressure (psi)	Correction (psi)
0	14.63	0
300	14.13	- 0.50
600	13.64	- 1.00
900	13.14	- 1.49
1200	12.64	- 2.00
1500	12.14	- 2.50
1800	11.64	- 3.00
2100	11.25	- 3.39
2400	10.85	- 3.82

TOOLS REQUIRED FOR SERVICING THE AIR CONDITIONING SYSTEM

Warning - The operations described in this section cannot be carried out without the ESSENTIAL tools marked (X) in the following list.

To work in safety and to obtain the best possible results whilst saving both time and energy, we recommend that the other specific tools in the list are also used.

List of specific tools for the various operations in this section	
X 294030	Evacuation and charging station
X 294048	Recovery and recycling station
294044	Set of flexible hoses for 294030 and 294048
294043	Tool kit for 294030
294042	Receiver-drier for 294048
294036	Gas leak detector with audible leak indication
293826	Athermal tape for expansion valve
X 293831	Combs for cleaning and straightening the fins on the condenser and evaporator
293825	Oil for pumps of stations 294030 and 294048

OPERATING PRINCIPLES

The function of the air conditioning system is to create and maintain optimum working conditions inside the tractor cab.

These conditions regard four main factors:

- temperature;
- humidity;
- speed;
- purity of the air in the cab.

Obviously "ideal" conditions will vary from person to person, and so it is not possible to specify optimum values for the above factors; however, we can specify a range of values within which the majority of people will feel most comfortable.

As regards temperature and humidity, it is possible to define a zone, known as the "comfort zone", within which the temperature-humidity combination corresponds to pleasant environmental conditions.

From the diagram it can be seen that humidity should be within the range of 30% to 70% (below 30% there is excessive dehydration of the mucous tissues of the nose and throat, while above 70% the subject has an uncomfortable sensation of dampness in many areas of the body) whereas temperature can vary between 18 and 28°C (64.4 and 82.4°F).

The air flow speed must not be so high as to cause discomfort; speeds of 0.07 - 0.25 m/s (0.2296 - 0.82 ft/s) are normally acceptable

Simplified psychrometric diagram

1. Sensation of unbearable cold.
2. Sensation of cold.
3. Comfort zone.
4. Sensation of heat.
5. Sensation of unbearable heat.

As regards the purity of the air, there are no precise limits, but it is important to remember that the human metabolism alters the composition of the surrounding air, increasing the humidity and the quantity of carbon dioxide, while decreasing the percentage of oxygen, etc..

By drawing in small quantities of fresh air from outside the cab, it is possible to eliminate impurities in the air, particularly important in the case of agricultural tractors, where dust from earth, hay etc. can cause extreme discomfort, by installing dry filters on the external air inlets.

Air conditioning systems in tractors and agricultural vehicles in general thus serves to neutralise the heat and humidity generated in the cab by controlling the temperature and humidity of the air in - or drawn into - the cab to create comfortable working conditions for the operator.

The operating principle of an air conditioner is similar to that of a domestic refrigerator: to cool an environment, heat must be removed by means of a physical process (evaporation of a liquid) which absorbs heat from the surrounding air.

The liquid used in this process, known as the refrigerant, is product with a high refrigeration coefficient, low toxicity, which mixes well with lubricating oil.

The various components of the system are connected by suitable pipes which ensure that the pressure of the system is maintained.

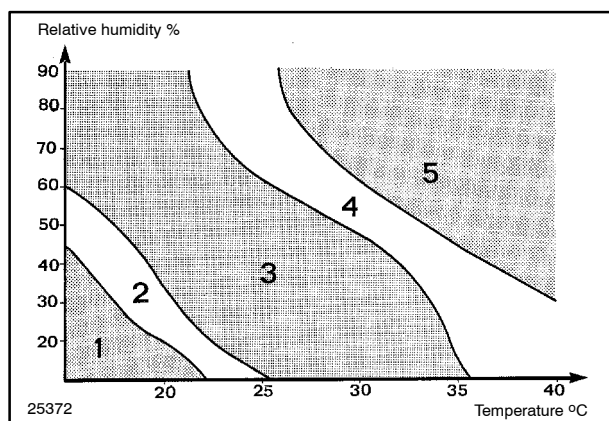

There are five main components of the air conditioning system:

1. **compressor;**
2. **condenser;**
3. **receiver-drier;**
4. **expansion valve;**
5. **evaporator.**

To understand the operating cycle of the system, follow the flow of the refrigerant starting from the compressor (1).

The compressor draws in refrigerant in vapour form at a pressure of 0.5 ÷ 3 bar (7.25 ÷ 43.51 psi) and it compresses it to a pressure of 16 ÷ 24 bar (232.06 ÷ 348.09 psi).

The refrigerant, heated by compression to hot vapour with a temperature of 60÷120 °C (140÷248 °F), enters the condenser coil (2) located forward of the engine radiator.

The air flow passing over the condenser fins and tubes produced by the forward movement of the tractor cools the refrigerant.

This action cools the refrigerant to the point of condensation between 40÷60 °C (104÷140 °F) (depend-

ing on the ambient temperature) which thus changes its state from a vapour to a liquid.

The refrigerant, in liquid state at high pressure, is purified by passing through the receiver-drier (3) from where it flows to the expansion valve (4), which restricts the flow of refrigerant and thus reduces its pressure.

As it passes through the expansion valve (4), part of the refrigerant is transformed into vapour and the low temperature mixture of vapour and liquid thus formed enters the evaporator (5).

Here the electric fan causes a continuous circulation of the cab air over the fins of the evaporator (5), helping the refrigerant to absorb heat from the air and thus change completely from a liquid to vapour.

The evaporation process removes heat from the air passing over the evaporator (5) and thus reduces the temperature inside the cab.

The flow of air over the cold surface of the evaporator (5) also condenses some of the moisture in the air and therefore reduces the humidity in the cab.

On leaving the evaporator (5) at 0÷15 °C (32÷59 °F), the low pressure mixture is aspirated by the compressor (1) to repeat the cycle.

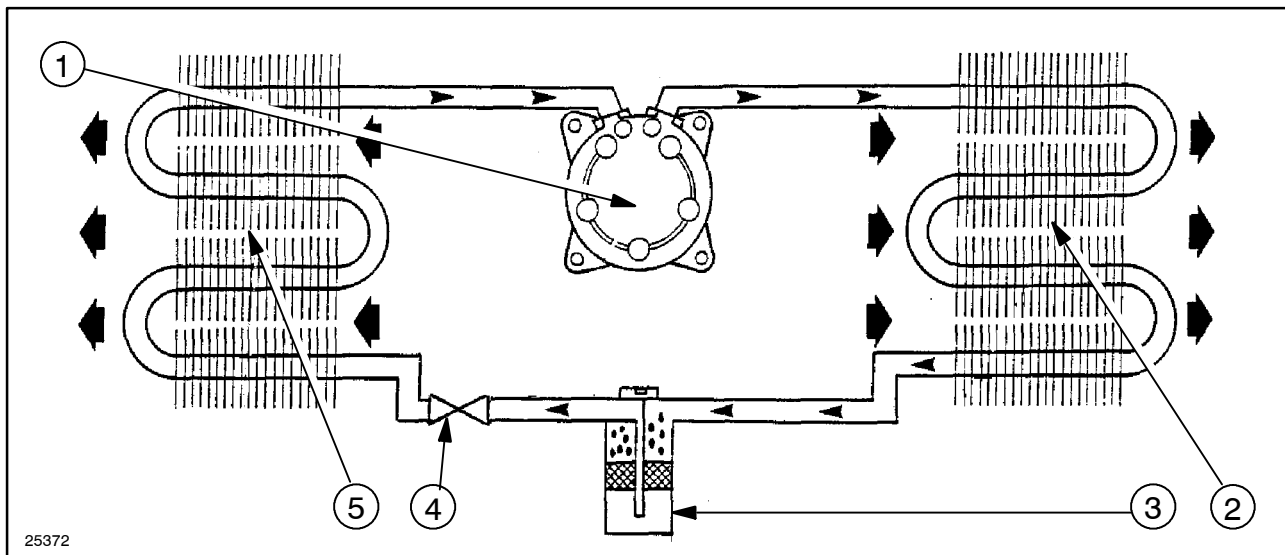

2

Simplified system diagram

- | | |
|--------------------|--|
| 1. Compressor. | 4. Expansion valve with thermostatic sensor. |
| 2. Condenser. | 5. Evaporator. |
| 3. Receiver-drier. | |

AIR CONDITIONING SYSTEM FAULT DIAGNOSIS

THE SYSTEM DOES NOT WORK

1. Check fuses.
2. Check compressor drive belt tension.
3. Check if the clutch coil is receiving power.
4. Check that the earth contact is efficient.

5. Check the system control devices - the relays, wiring, thermostat, etc.
6. Visually check the condition of all fittings, unions and pipes.
7. Check the clearance between the front disc and pulley of the electromagnetic clutch.

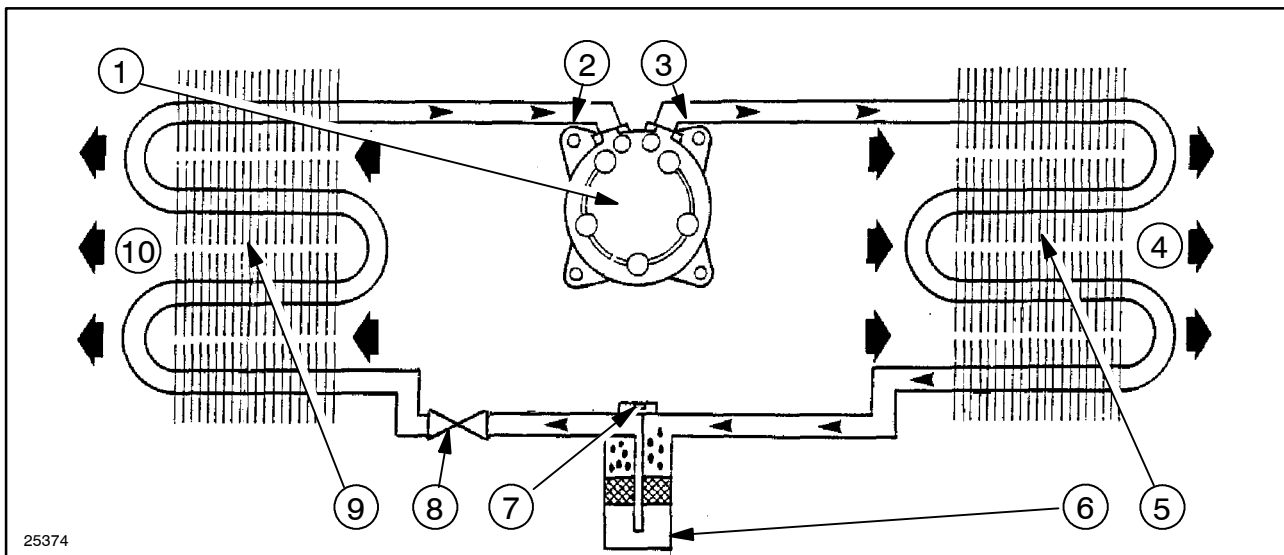

3

Schematic of air conditioning system.

- | | |
|--|--|
| 1. Compressor. | 6. Receiver-drier. |
| 2. Compressor inlet pipe (low pressure). | 7. Sight glass. |
| 3. Compressor outlet pipe (high pressure). | 8. Expansion valve with thermostatic sensor. |
| 4. Hot air. | 9. Evaporator. |
| 5. Condenser. | 10. Cool, dehumidified air. |

AIR CONDITIONING SYSTEM FAULT DIAGNOSIS (cont.)

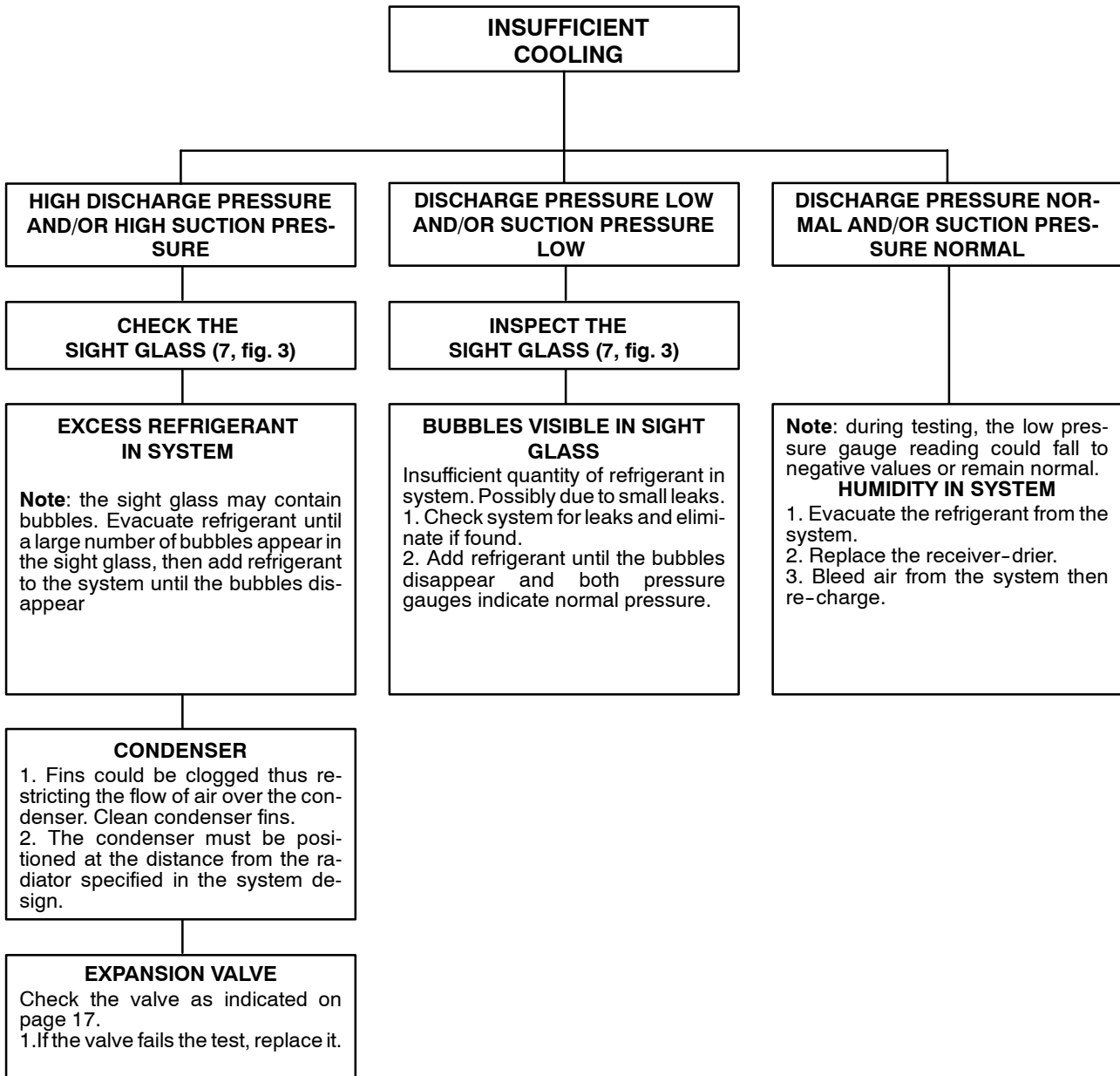

AIR CONDITIONING SYSTEM FAULT DIAGNOSIS (cont.)

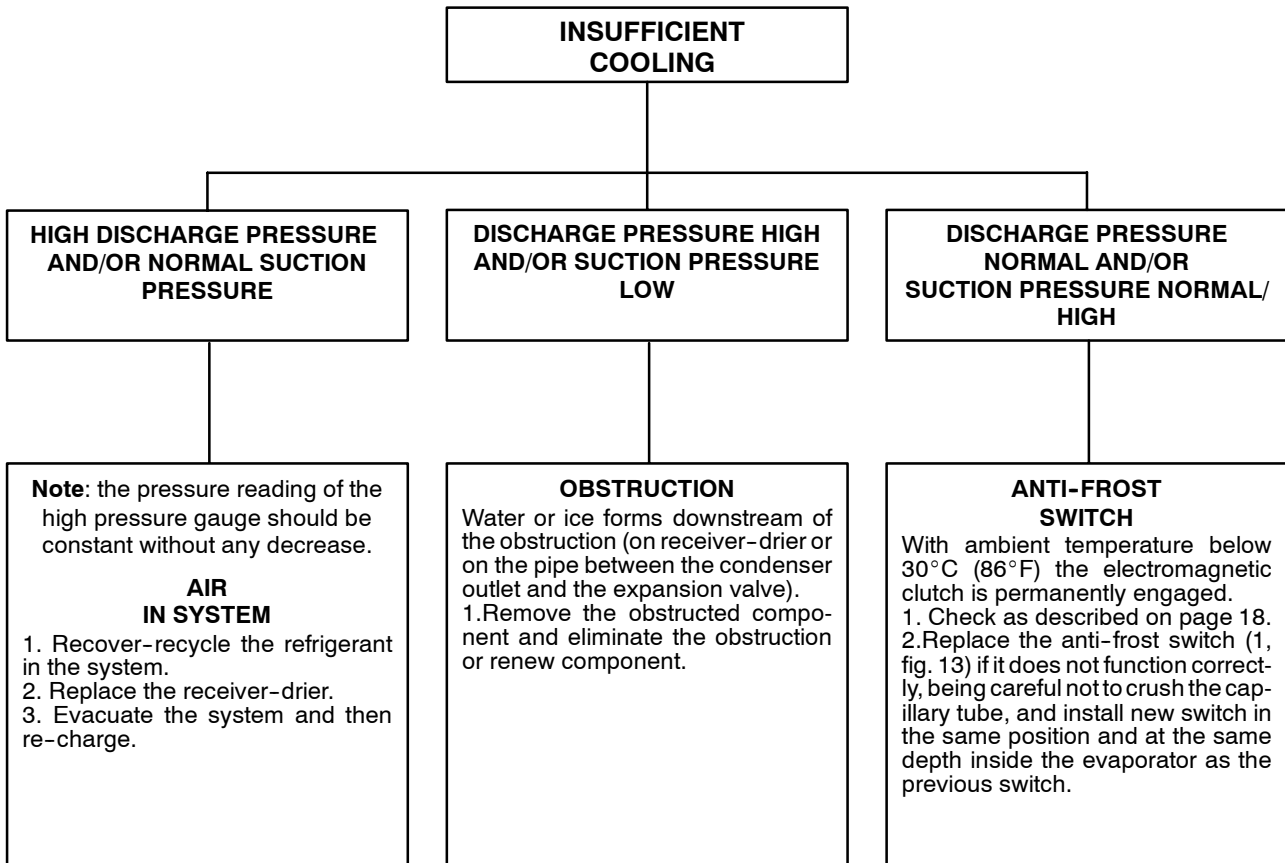

AIR CONDITIONING SYSTEM FAULT DIAGNOSIS (cont.)

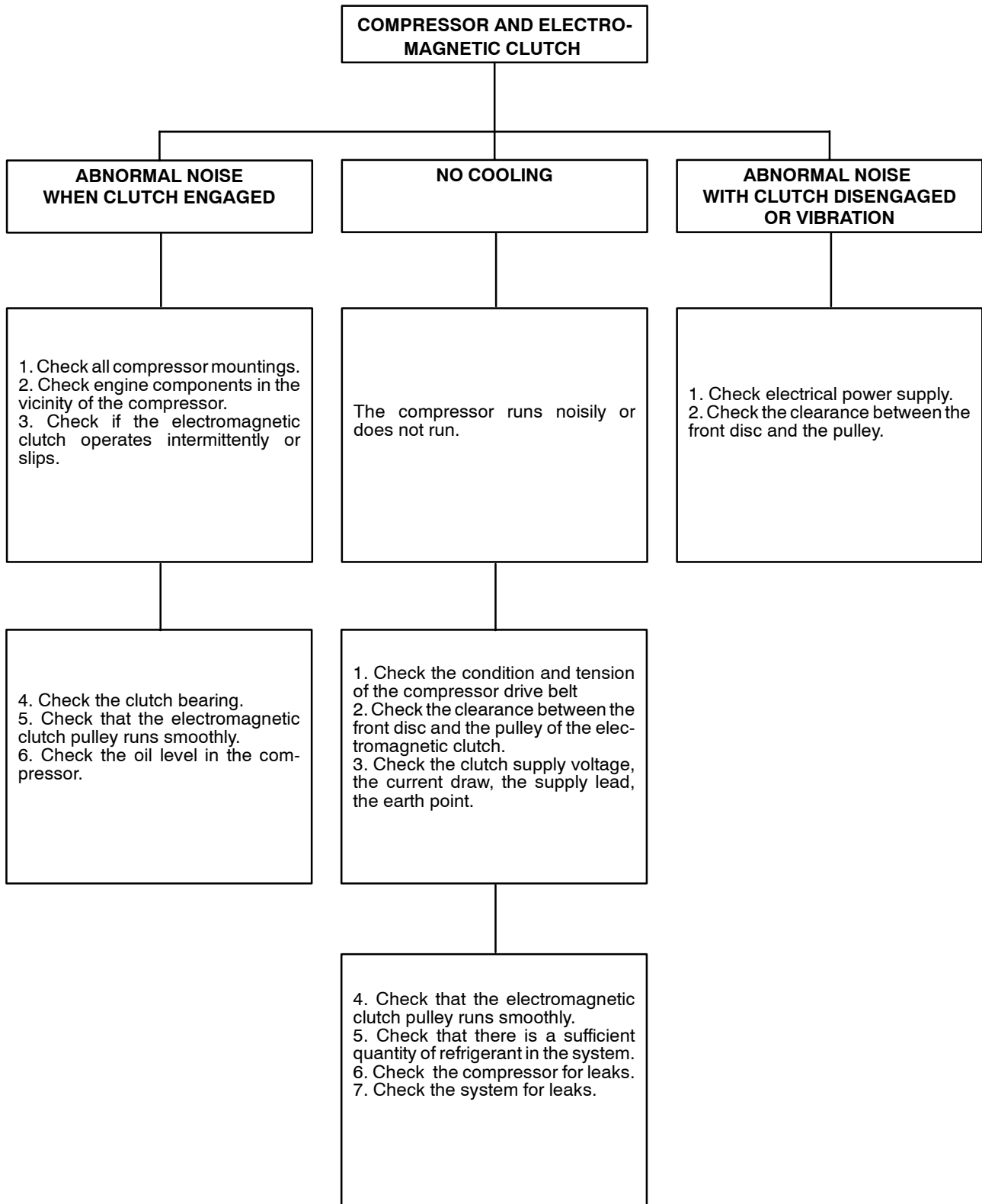

CAB HEATING AND VENTILATION CONTROLS

VENTILATION

Turn on cab ventilation by operating switch (2) fig. 4 and direct the air flow as required by positioning the front vents (3, fig. 5).

The operator may select outside air or inside air by adjusting the rear air recirculation vents (1, fig. 6) which can assume two positions.

- vents closed: air is drawn from outside the cab through the lateral filters.
- vents open: the greater part of the air is drawn from inside the air through the vents.

Fresh air drawn into the cab from outside is always filtered.

With the fan in operation, and the doors, windows and recirculation vents closed, the pressure inside the cab is greater than the external pressure and thus air can only enter the cab through the lateral filters after it has been suitably filtered.

Note - To increase the pressure inside the cab, select outside air only (air recirculation vents 1, fig. 6 closed).

Fan

The fan control switch (1, fig. 7) is powered when the ignition switch (fig. 8) is in position **B**.

- A.** Low speed.
- B.** Medium speed.
- C.** High speed.

Air filter

⚠ DANGER ⚠

Remember that the filters of the cab provide no protection against antiparasitic chemicals in general. Therefore complete protection against these products can only be achieved by the adoption of additional specific safety measures for the individual product. This applies to all types of filter, for which the prescriptions for use and maintenance must be followed scrupulously. Even the use of active carbon filters does not exempt the operator from adopting the personal safety precautions recommended for the product in question.

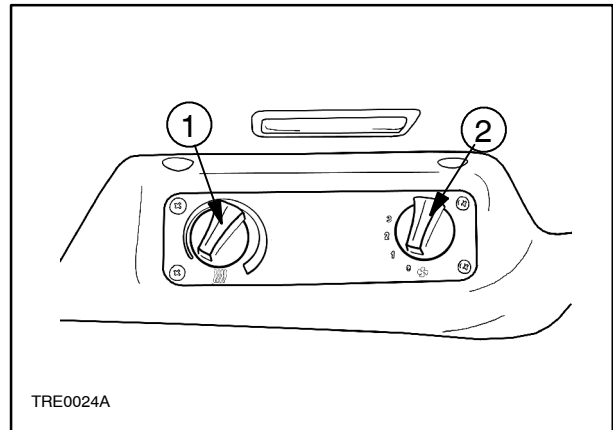

TRE0024A

4

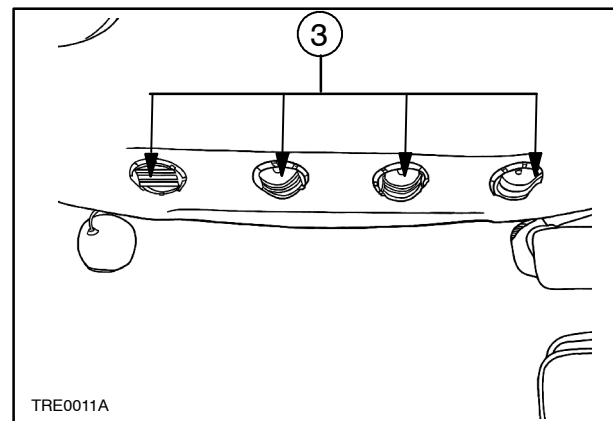

TRE0011A

5

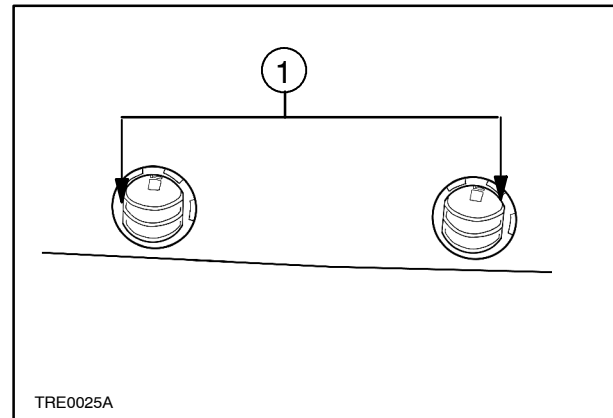

TRE0025A

6

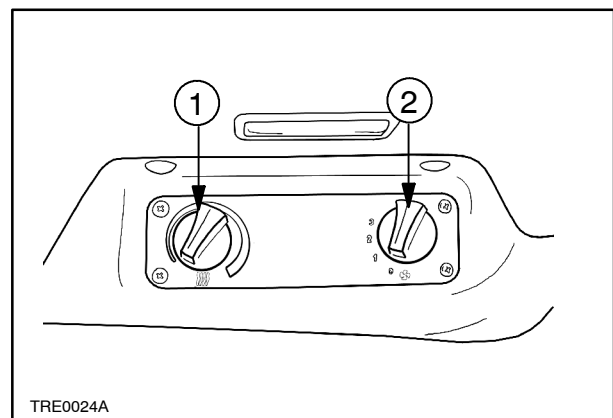

TRE0024A

7

HEATING

The heating control knob (1, fig. 4) allows the operator to regulate the temperature of the air by increasing or decreasing the circulation of coolant from the engine.

The fan control switch (1, fig 7) allows the operator to adjust the quantity of air blown into the cab through the vents (3, fig 5)

Temperature control knob (1)

- Turned fully counter-clockwise = minimum temperature (circulation of hot water shut off).
- Turned fully clockwise = maximum temperature (circulation of hot water fully open).

Note - The total capacity of the cooling system (*including the cab heating system) is 14 litres in the TD60D model or 16 litres in TD70D, TD80D, TD90D and TD95D models.

IGNITION SWITCH

The ignition switch (1) can assume four different positions:

- A.** No circuits powered (key can be removed). Engine stop:automatic operation of fuel injection shut-off device.
- B.** Predisposition for engine starting. Turn signals and instruments operational. Various devices powered.
- C.** Start engine: key returns automatically to position (B) when released.
- P.** Parking lights on, control panel illuminated, auxiliary lights switch powered (key can be removed).

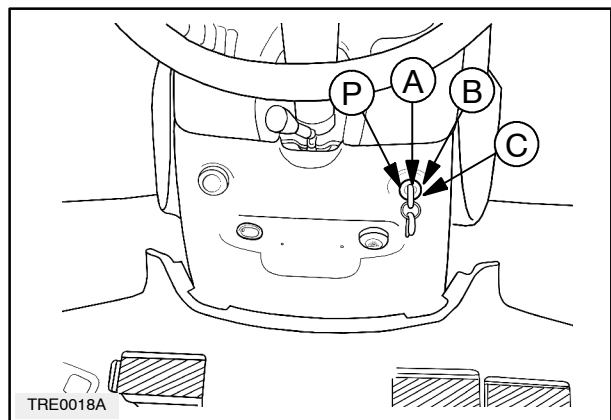

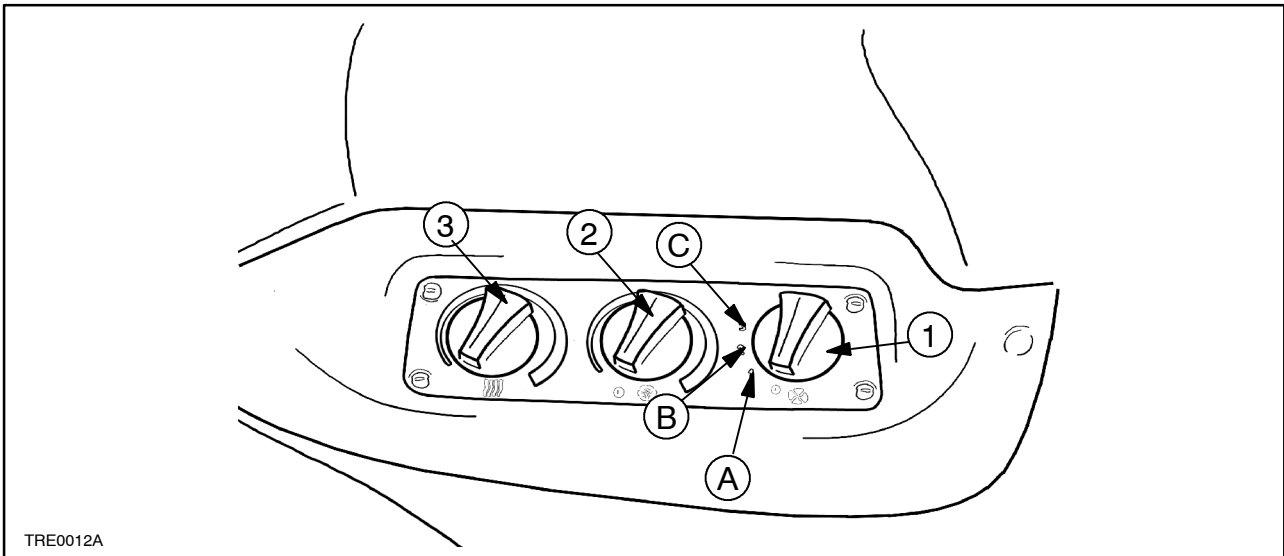

9

CAB AIR CONDITIONING CONTROLS

SWITCHING ON THE AIR CONDITIONING AND TEMPERATURE CONTROL

Air conditioning and temperature control button

Operational when ignition switch is in the starting position.

With fan control knob (1, fig 9) in positions A-B or C, turn knob (2, fig 9) to switch on the air conditioning.

Heating control knob (fig 4)

Turn the knob (1) fully clockwise for maximum heating.

Turn knob (1) fully counter-clockwise to shut off the flow of water to the heater and thus switch the heating off.

3-speed fan control knob

Operational when ignition switch is in starting position.

- A. Low speed.
- B. Medium speed.
- C. High speed.

Note - To pressurise the cab see the chapter **Ventilation** on page 11 of this section.

USE OF THE AIR CONDITIONING SYSTEM

The air conditioning system provides cool, dehumidified air or warm dehumidified air.

To operate the system proceed as follows.

Warning - The air conditioning system is not operational when the engine is not running as the compressor is driven by the engine.

SWITCHING ON THE AIR CONDITIONING

With the engine running, turn knob (2, fig. 9) to start the air conditioning.

Warning - Before switching on the conditioner, always switch on the fan.
When the fan control knob is in the "off" position, the air conditioning cannot function.

After a few minutes of operation, liquid visible in the sight glass (7, fig. 3) on top of the filter should be clear and free of bubbles. If not, consult the specialised personnel at your dealer.

ADJUSTMENT

To obtain correct cab air conditioning, when the system is in operation keep the recirculation vents open and keep the doors, hatch and rear window closed.

To lower the temperature and, at the same time, the humidity of the air inside the cab, turn knob (2, fig. 9) counter-clockwise until the desired temperature is obtained.

Warning - Before starting the engine, check that the air conditioning knob (2 fig. 9) is in the "off" position.

Note -When working in very dusty conditions, to increase the pressure inside the cab to prevent dust entering, it is advisable to close the recirculation vents.

If you wish to use the dehumidifying function without lowering the air temperature, turn knob (2, fig. 9) clockwise to obtain the desired temperature.

After prolonged operation in hot sunshine, to bring the air inside the cab back to the optimum temperature, without the tractor moving switch on the air conditioner and open the rear window or hatch to discharge the hot air.

SWITCHING OFF THE AIR CONDITIONING SYSTEM

Before stopping the engine, always switch off the air conditioner by turning knob (2, fig. 9), then turn the fan control knob (1, fig. 9) to the "off" position.

MAIN COMPONENTS OF THE AIR CONDITIONING SYSTEM

Axial flow reciprocating piston compressor SANDEN SD 7H15

1. Combined inlet and discharge valve.
2. Piston with seal ring.
3. Drive gear.
4. Swash-plate.
5. Cam rotor.

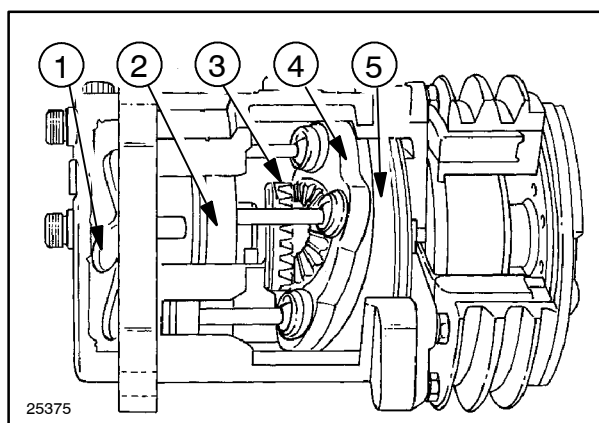

10

Compressor

The compressor serves to pressurise the refrigerant and force it through the system.

SANDEN SD 7H15

Axial reciprocating piston type, driven from the engine crankshaft via a vee belt.

The operating principle of the compressor is as follows:

The swashplate (4), on which pivot the ball ends of the connecting rods of the pistons (2), rests on the cam rotor (5).

As the cam rotor rotates it exerts a continuous thrust on the swashplate which cannot rotate as it is held by the fixed gear (3).

The angle of the swashplate relative to the axis of rotation causes the pistons to reciprocate in their bores.

A reed valve (1) in the cylinder head with seven lobes (one for each piston) controls the inlet and discharge stages of the cylinders.

The automatic opening and closing of these valves is obtained by preloading of the reeds.

The rotating parts of the compressor are lubricated by special oil, inserted during assembly, some of which circulates through the system mixed with the refrigerant.

Condenser

In the condenser the refrigerant is transformed from a vapour to a liquid state.

As this occurs by transfer of the heat from the refrigerant to the ambient air, the condenser functions in a similar way to the engine radiator.

The condenser consists of a series of tubes through which the refrigerant circulates and a finned block which is pressed onto the tubes to cover them completely in thin aluminium fins to help dissipate heat to the ambient air.

The condenser is installed in front of the engine cooling radiator so as to benefit from the air flow caused by forward motion of the tractor.

Receiver-drier

The receiver-drier, installed between the condenser and the expansion valve, performs two basic functions, acting as a filter to remove dirt and moisture from the refrigerant and as a temporary storage container during variable charge stages.

Water in the system can cause corrosion and damage to system components.

For this reason the filter contains substances to absorb humidity.

Solid contaminants, such as sand, metal particles resulting from wear of compressor components, oxides, particles from the pipes, etc., can cause damage to the system and therefore must be removed by suitable filters.

Receiver-drier

1. Sight glass.
2. Upper screen.
3. Disc.
4. Drying agent.
5. Lower screen.

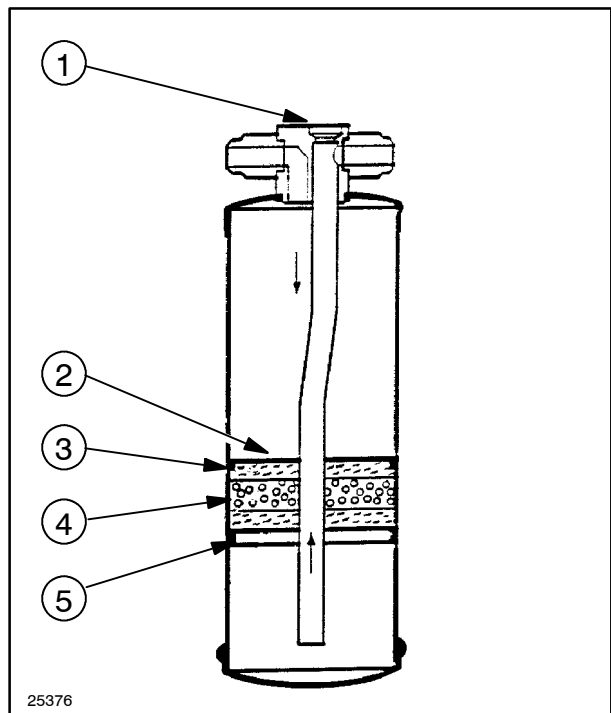

Thermostatic expansion valve

Serves to reduce the pressure of the refrigerant as it enters the evaporator so that it can change state and thus remove heat from the surrounding air.

The expansion valve performs two basic functions:

- metering: the calibrated orifice (6, fig. 12) in the valve body creates a difference in the pressure of the refrigerant at the inlet (4) (liquid state) and the outlet (7) (mixed liquid/vapour); the calibrated orifice (6) also serves to atomise the refrigerant to facilitate subsequent evaporation;
- modulation: inside the valve body a thermostatic sensor controls the valve aperture so that the right quantity of refrigerant enters the evaporator to ensure complete evaporation.

If the thermostatic sensor (2, fig. 12) detects an increase in the cab temperature, the flow of refrigerant is increased.

A drop in the temperature or an increase in the compressor capacity (due to an increase in the engine speed) will cause a reduction in the flow of refrigerant into the evaporator.

The expansion valve is installed on the evaporator inlet fitting (7), and as the internal refrigerant flow control system is completely automatic, it requires no special maintenance.

To perform functional testing, with the system is fully charged, check that the system operating pressures are those indicated on page 3.

Note - In case of malfunction, replace the valve.

Expansion valve block.

1. From evaporator outlet.
2. Thermostatic sensor.
3. To compressor suction inlet.
4. From receiver-drier.
5. Spring.
6. Calibrated orifice and ball.
7. To evaporator inlet.

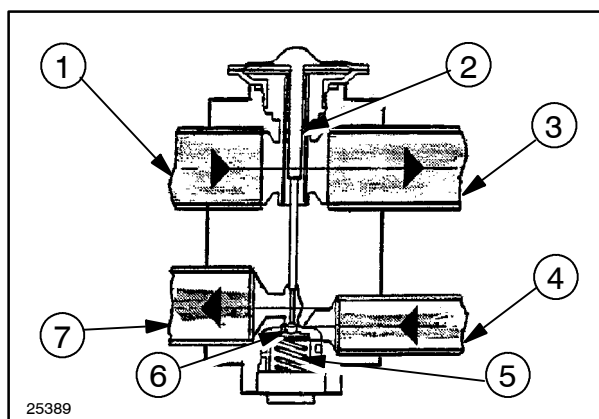

25389

Thermostatic switch (ANTIFROST)

The thermostatic switch is a safety device equipped with a sensor (1) which is inserted between the fins of the evaporator (2) where it constantly monitors the temperature.

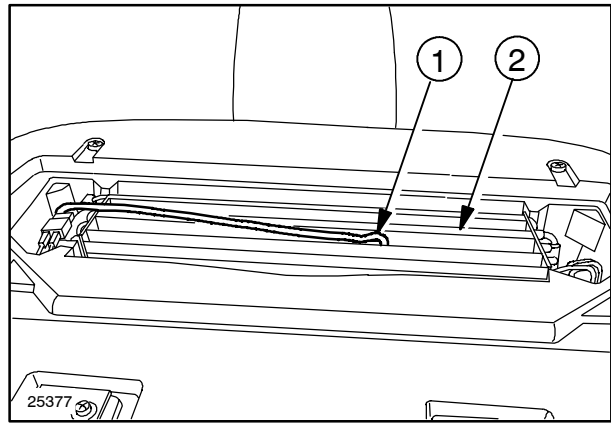

13

The bulb of the sensor (1) is filled with a special gas which expands or contracts according to the temperature and thus acts on a membrane connected to a complex mechanism which opens or closes a switch in the electrical circuit of the magnetic clutch to switch the compressor on or off as required.

The thermostatic sensor (1) thus prevents ice from forming on the evaporator and obstructing the flow of air into the cab.

For this reason it is very important to insert the sensor (1) between the fins of the evaporator (2) as shown in figure 13.

Note – In case of malfunction, replace the entire thermostatic switch.

Evaporator

The cycle is completed inside the evaporator.

The refrigerant leaving the expansion valve is a low temperature, low pressure mixture of vapour and liquid.

As it passes through the evaporator it absorbs heat from the ambient air, vaporises and, having performed its cooling function, is aspirated by the compressor as a vapour.

The operation of the evaporator is controlled by the expansion valve which delivers the exact quantity of refrigerant needed to produce the required air conditioning effect.

The evaporator performs the opposite function to the condenser, but its basic construction is the same, the only differences being its overall dimensions and the layout of the internal pipes.

The evaporator also performs another function: dehumidification of the cab.

The air passing over the evaporator contains a certain quantity of moisture, and this must be kept within certain limits for operator comfort.

Part of the moisture condenses on the fins evaporator and is thus removed from the air.

The centrifugal fan draws the ambient air through the fins of the evaporator (where it is cooled and dehumidified) and into the cab.

The housing around the evaporator is equipped with a condensate trap from which the condensate is carried outside the vehicle through discharge tubes.

WARNINGS REGARDING SERVICING AND REPAIR OF THE AIR CONDITIONING SYSTEM

Switching on the air conditioning system when the ambient temperature is low can damage the compressor. Only operate the air conditioner when the engine is hot and the temperature inside the cab is at least 20 °C (68 °F).

When disassembling pipes, plug the ends with plastic caps to prevent moisture and dust getting inside.

Handle the tube of the thermostatic sensor with great care to avoid damage which could prevent the entire system from operating correctly.

When unscrewing pipe fittings and unions, always use two spanners to avoid undue torsion.

Do not use engine oil of any type to lubricate the system or the compressor.

Do not leave the compressor oil container open. Make sure that the cap is replaced and fully tightened. The oil will absorb moisture, which is harmful to the system.

Do not transfer compressor oil from its original container to another.

Do not add any substances to the refrigerant or compressor oil. Any additives might contain elements incompatible with the refrigerant and thus alter its characteristics.

Check that the thermostatic sensor is correctly inserted between the fins of the evaporator.

REFRIGERANT RECOVERY-RECYCLING AND EVACUATION-CHARGING STATIONS



WARNING



Never under any circumstances use recovery/recycling or evacuation/charging stations designed for a different refrigerant than that used in the system, as the different chemical compositions of different types of refrigerant render them incompatible with each other.

When connecting the stations to the system service valves, always connect the low pressure blue pipes (11, fig. 15, or 17, fig. 16) to the service valve on the suction side of the compressor (S-Suction), and the high pressure red pipes (12, fig. 15, or 15, fig. 16) to the service valve on the discharge side of the compressor (D-Discharge).

Important: check the seals in the pipe connectors (11, 12, 16, fig. 15), or (15, 17, 24, fig. 16) and replace if faulty. (kit 294052)

Remember that the pipe fittings fitted with seals are to be hand-tightened only without forcing, otherwise the seal will be damaged.

RECOVERY AND RECYCLING STATION (294048)

Description (Refer to figure 15)

The station is designed for the recovery and recycling of refrigerants used in the cab air conditioning systems.

The recovered refrigerant is first separated from the system oil by means of a process of vaporisation which takes place in a suitable container.

In the filter section, the acidity is neutralised, moisture is absorbed and solid particles are screened out.

The decontaminated refrigerant is then stored in the metering cylinder.

TECHNICAL CHARACTERISTICS

Recovery compressor equipped with oil level indicator, discharge valve and service connection.

294042 anti-acid decontaminating filter (3), with a high moisture absorption capacity.

Refrigerant/oil distillation cylinder (4) with heating element, automatic device for return of oil to the recovery station compressor and automatic flow control valve for refrigerant entering the station.

Graduated cylinder (19) for recovered refrigerant, 2.2 kg (4.8524 lb) capacity, with heater and a safety valve.

2-way pressure gauge unit, with refrigerant flow indicator and pressure gauges (1 and 2) controlling the pressure in the cylinder and at the inlet.

294053, Humidity indicator (15) for checking the decontaminated refrigerant.

Low pressure switch for automatic cycling of the compressor.

Graduated container for the discharge of recovered contaminated oil.

Switch (5) 1-0-2 for recovery and cylinder heating.

Indicator lights.

294044 flexible service pipes (11, 12 and 16) with safety cocks.

Recovery capacity: 200 grams/minute
(0.4411 lb/minute).

Power supply: 220 V (50 Hz).

Maintenance

Replacement of refrigerant decontamination filter (3)

Refer to figure 15 and proceed as follows:

Warning - Every 12 months or earlier if the humidity indicator (15) turns yellow and stays yellow throughout the recovery/recirculation stage, renew the filter (3).

1. Close all the valves including the yellow service valve (9) installed below the distillation cylinder (4).
2. If refrigerant is present in the circuit set pushbutton (5) to position "1" and carry out the refrigerant recovery operation. The compressor will stop automatically when the pressure gauge (2) drops to -0.3 bar (-4.35 psi).
3. Remove and replace the contaminated filter (3).
4. Carry out a normal evacuation operation for about 30 minutes using the evacuation /charging system (**294030**) proceeding as follows: connect the pipe (17, fig. 16) to the service valve (14, fig. 15), open the cock installed on the pipe itself and cocks (4, 10 and 9, fig. 16). On completion of the evacuation operation, close cocks (4, 10 and 9), the cock on the pipe (17) and disconnect pipe (17).

Check filter connections for leaks (3)

Refer to figure 15 and proceed as follows:

5. To check for leaks at the connections of the previously replaced filter (3) open the yellow service cock (9) on the distillation cylinder (4).
6. Perform a brief recycling operation on the refrigerant contained in the cylinder (19), proceeding as described in the operations 18÷21, on page 23 and check with a leak detector for leaks at the connections of the new filter.
7. Record the operation on the appropriate service report card.

Changing the compressor oil in the recovery/recycling station

Refer to figure 15 and proceed as follows:

Warning - The oil in the compressor of the recovery/recycling station should be replaced with new oil (**code 293825**) every 12 months to maintain the station's refrigerant treatment capacity and to protect the compressor.

1. Open cock (13), and drain the oil into a container to be disposed of in accordance with local regulations for waste oil disposal.
2. Close cock (13).
3. Remove the caps from the service valves (14) on the side of the compressor and (13) on the sight glass.
4. Connect the service pipe of the evacuation station (**294030**) to valve (14) and connect a pick-up pipe from kit **294043** to valve (13) on the sight glass.
5. Perform the evacuation operation with the pump in operation. The new oil can be aspirated from an external container by means of the pick-up pipe.
6. Once the compressor has been filled with correct quantity of oil (half-way up the sight glass) close valve (13), disconnect the pick-up pipe, and replace the cap on service valve (13). Continue the evacuation for approx. 30 minutes.
7. On conclusion, close the cocks, switch off the pump, disconnect the service pipe and replace the cap on service valve (14).

8. Record the operation on the appropriate service report card.

EVACUATION/CHARGING STATION (294030)**Description** (Refer to figure 16)

The station is designed for the evacuation and subsequent charging of refrigerant in the cab air conditioning systems.

The system must first be evacuated to remove any moisture and impurities.

The new refrigerant from the external cylinder is transferred to the graduated cylinder before being pumped into the air conditioning system.

Technical characteristics

Double-acting, ballasted, rotary vacuum pump (21) in oil bath.

Charging cylinder (31) with maximum level indicator and graduated scale for measurement of quantity of refrigerant.

5-way pressure gauge manifold with 2 pressure gauges (5 and 6) and 1 vacuum meter.

294044 flexible service pipes (17, 15 and 24) with safety cocks:

Power supply: 220V (50 Hz).

Maintenance**Check level and change oil in pump of evacuation/charging station (periodic check)**

Refer to figure 16 and proceed as follows:

Periodically check the level and condition of the oil. Drain off the old oil, if necessary, through plug (18). Old oil must be disposed of in accordance with local regulations.)

Remove cap (13) and fill the vacuum pump (21) with new oil of the type indicated by the pump manufacturer up to the half-way line on the sight glass (14).

AIR CONDITIONING SYSTEM**Dehydration, recharging and refrigeration check
(Op. 50 200 04)****Recovery of refrigerant from the cab air conditioning system using the recovery/recycling station 294048**

Note - the recovery operation can be performed more quickly and completely if the system is previously heated, as heat will cause the refrigerant to evaporate and thus be more easily evacuated from the system.

Refer to figure 15 and proceed as follows:

1. If possible, operate the air conditioning system for a few minutes with the tractor engine running and the hood down, so that the heat produced is gradually transferred to the various components in the system, thus allowing any pockets of very cold fluid in the system to evaporate.

2. Stop the engine.

**DANGER**

The recovery operation must only be performed with the tractor engine stopped.

3. If the charging cylinder (19) already contains refrigerant, check that there is still sufficient free volume to contain all the refrigerant in the system (maximum cylinder capacity is 2 kg (4.4112 lb)); if not, transfer the excess refrigerant to an external cylinder in the manner described on page 24.
4. Connect the station's supply lead to a power outlet.
5. Make sure that all cocks are closed except the service cock (9).

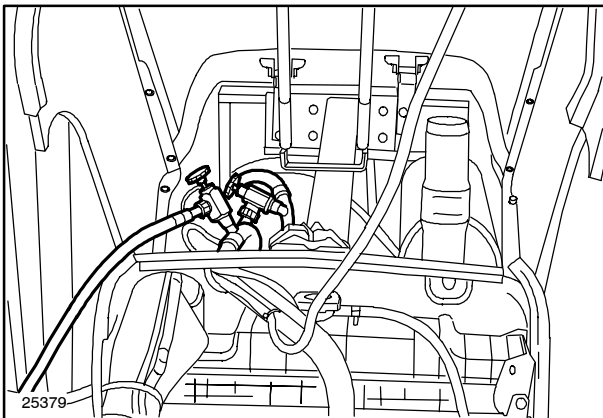

14

6. Remove the caps from the service valves installed on the suction and discharge lines of the compressor.

7. Connect the blue service pipe (11) to the valve on the suction (low pressure) side of the compressor (marked "S").
8. Connect the red service pipe (12) to the valve on the discharge (high pressure) side of the compressor (marked "D").
9. Switch on the cab ventilation fan at maximum speed to assist the transfer of heat between the ambient air and the evaporator coil.
10. Open cock (10) on pipe (12).
11. Slowly open cock (6-LOW) on the pressure gauge manifold. Pressure gauge (2) will indicate the presence and pressure of any refrigerant in the system; if the needle is near the "0", the system is empty.
12. Set switch (5) to position "1" (RECOVERY) - green indicator light will illuminate. The recovery compressor will now start.

During the recovery operation, the refrigerant will pass through the distillation cylinder (where it will be separated from the oil) and into the decontamination filter (where it will be partially cleaned of impurities) to arrive finally in the graduated cylinder.

The compressor will stop automatically when the pressure gauge (2) indicates a pressure of -0.3 bar (-4.35 psi).

13. Wait a few minutes to allow any pockets of liquid refrigerant left in the system to evaporate and be evacuated.
14. Check the pressure gauge (2): if the pressure has risen above the previous value of -0.3 bar (-4.35 psi), the station will automatically start a second recovery operation; if on the contrary the pressure has remained near the value obtained during the first recovery operation, this indicates that all the refrigerant has been removed from the system and therefore the operation is complete.

Note - If after 10 minutes of operation the station has not recovered more than 1 kg (2.2056 lb) of refrigerant, check pressure gauge (1). If the pressure reading is over 10 bar (145 psi) open cock (21) and discharge air, then check that pressure gauge (1) does not exceed a maximum of 10 bar (145 psi) throughout the entire recovery operation.

15. Close all the cocks except cock (9), disconnect the service pipes (11 and 12) from the air conditioning system compressor and switch off the station.

16. Switch off the cab ventilation fan.

Recycling recovered refrigerant

On completion of the recovery operation, the refrigerant, which has already been through an oil separation process, must now be completely decontaminated.



At this stage the recovered refrigerant has not yet been completely decontaminated and therefore must not be used in the air conditioning system in this condition.

Proceed as follows:

1. All cocks must be closed, with the exception of cock (9, fig. 15) and the station must be switched off - switch (5) in position "0" and green indicator light off.
2. Connect the end of the yellow service pipe (16) without the cock to the free connector (17) located on the left-hand side of the pressure gauge manifold.
3. Connect the 2 ends of the yellow (16) and blue (11) pipes with connector supplied.
4. Slowly open the cock (18-REF) and the blue cock (6-LOW) on the pressure gauge manifold, and the cocks on the two previously connected service pipes (16 and 11).
5. Set switch (5) to position "1" (RECOVERY) - green indicator light on.
The recovery compressor will start to operate and the refrigerant will pass from the graduated cylinder to the recovery circuit (distillation cylinder, filter and compressor) and then return to the graduated cylinder.
6. Continue the operation until the circular sector of the humidity indicator (15) turns green.
If after 15 minutes the circular sector of indicator (15) still has not turned green, replace the filter (3) as described on page 20.

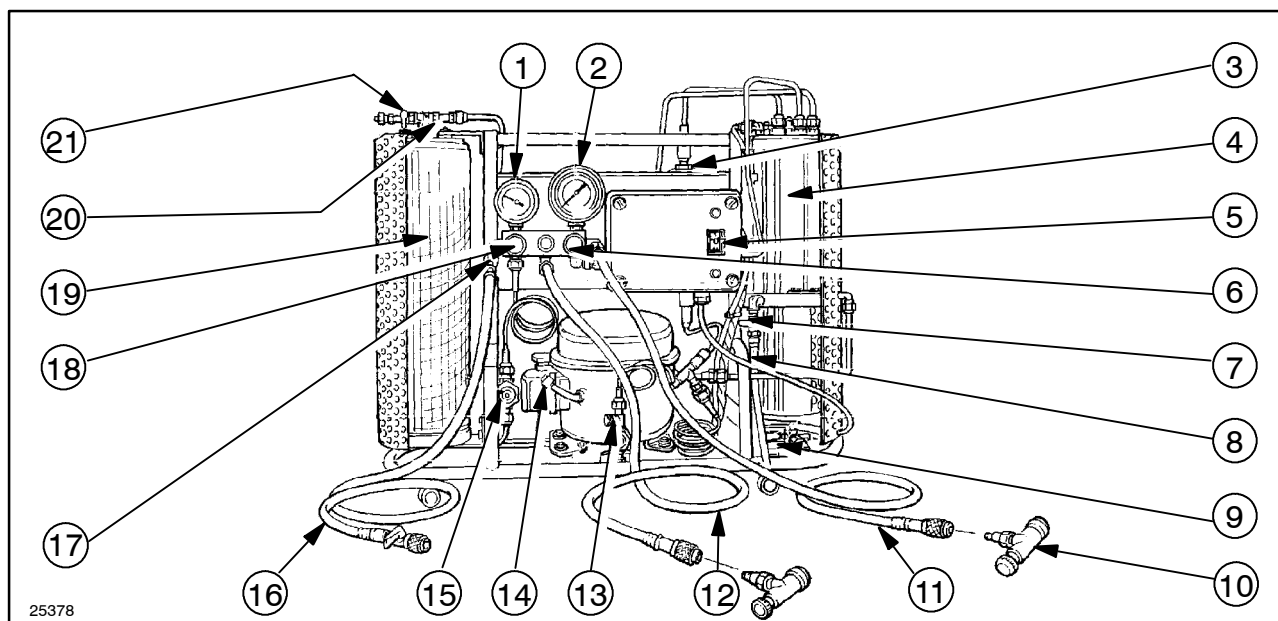

25378

15

Refrigerant recovery and recycling station

1. Cylinder pressure gauge.
2. Recovery control pressure gauge.
3. Anti-acid and decontamination filter.
4. Recovered refrigerant/oil distillation cylinder.
5. Switch.
6. Refrigerant inlet control cock (LOW).
7. Recovered oil discharge cock (yellow).
8. Recovered oil discharge pipe.
9. Oil return to compressor control cock (yellow).
10. Quick-fit connectors.
11. Blue service pipe for connection to suction side of compressor.
12. Red service pipe for connection to discharge side of compressor.
13. Recovered compressor oil discharge cock.
14. Recovery compressor service valve (suction).
15. Humidity indicator.
16. Yellow service pipe for refrigerant transfer.
17. Fitting for refrigerant transfer.
18. Cock (REF) for refrigerant transfer and recycling.
19. Refrigerant cylinder.
20. Safety valve.
21. Cylinder (gaseous stage) discharge cock (yellow).

Note - The circular sector of the humidity indicator (15, fig. 15) must remain green throughout the recycling operation.

If the colour of the sector tends to vary between yellow and green, or turns completely yellow, this means that the filter is saturated with moisture and therefore must be replaced.

7. On completion of the decontamination operation, close the yellow cock (18-REF) and continue to recover the refrigerant. The compressor will stop automatically when the pressure gauge (2) shows a reading of -0.3 bar (-4.35 psi).
8. Close the cock (6-LOW), the two cocks on the ends of the yellow (16) and blue (11) service pipes, disconnect pipes (16 and 11) and switch off the station, turning switch (5) to position "0".

Discharge of recovered oil

The presence of contaminated recovered oil can be seen in the distillation cylinder (4). The recovered oil must always be discharged and disposed of according to local regulations.

Proceed as follows:

9. Slowly open the yellow cock (7) and discharge the recovered oil in the graduated container.
10. If no refrigerant leaks, whether major or minor, have ever been detected in the system, on recharging, replace the contaminated oil with same quantity of new oil (see page 26).

Transfer of decontaminated refrigerant from cylinder (10) to an external cylinder

If for any reason the decontaminated refrigerant is not to be put back into the air conditioning system immediately, for reasons of safety it must be transferred from cylinder (19) to a homologated refillable gas container.

Proceed as follows:

11. Check that all the cocks are closed with the exception of cock (9) and that the station is switched off. Check that the container (cylinder) is large enough to contain all the refrigerant to be transferred without exceeding the permitted safety level.
12. Connect the end of the yellow service pipe (16) without the cock to the free connector on the left-hand side of the pressure gauge manifold, and

connect the other end (with the cock) to the red connector of the external cylinder.

13. Set switch (5) to position "2" HEATING CYLINDER to switch on the refrigerant heater fitted to the cylinder (19) so as to facilitate the transfer of the refrigerant from the cylinder to the external cylinder.
14. Open the yellow cock (18-REF), the yellow cock on the service pipe and red cock on the external cylinder.
15. On completion of the transfer, close all cocks and switch off the station by turning switch (5) to position 0.

Evacuation and charging the cab air conditioning system using the evacuation/charging station 294030.

Note - Operations 32 ÷ 34, must only be carried out if the graduated cylinder (31) is empty of refrigerant.

Evacuation of the graduated cylinder (31) of the evacuation/charging station

Refer to figure 16 and proceed as follows:

16. Close cocks (4, 22 and 27).
17. Open cocks (3, 9 and 10).
18. Start the pump by turning switch (19) to position "1" to evacuate the cylinder (31). After 5 minutes close cocks (3, 9 and 10) and switch off the pump.

Charging the graduated cylinder (31) of the evacuation/charging station

If the decontaminated refrigerant in the recovery/recycling station is to be put back into the tractor air conditioning system immediately, it must be transferred from cylinder (19, fig. 15) to cylinder (31, fig. 16) of the evacuation/charging station, proceeding as follows:

19. With reference to figure 16, connect the end (without cock) of the yellow service pipe (24) to the free connector (28) on the left-hand side of the pressure gauge manifold of the evacuation/charging station.
20. Connect the other end (with cock) of the service pipe to the free connector (17, fig. 15) on the left-hand side of the pressure gauge manifold of the recovery/recycling station.
21. With reference to figure 15, check that all the cocks of the recover/recycling station are closed

with the exception of cocks (9 and 18) and that on the pipe (16).

22. Check that all the cocks of the evacuation/charging station are closed, with the exception of cock (27).
23. Check that the stations are switched off with switches (5 and 19) in position "0".
24. With reference to figure 15, turn switch (5) to position "2" HEATING CYLINDER to switch on the refrigerant heater installed on cylinder (19), to facilitate the transfer of refrigerant to cylinder (31) of the evacuation/charging station.
25. On completion of the refrigerant transfer operation, close all the cocks with the exception of cock (9, fig. 15) and switch off the recovery/recycling station by turning the switch (5) to position "0".

26. Check the quantity of refrigerant in the graduated cylinder (31).
27. From the total quantity of refrigerant required in the air conditioning system indicated in the note on page 26, calculate the quantity of refrigerant that must be added to the cylinder (31) to make up the total amount required.
28. Transfer refrigerant from the external cylinder to the graduated cylinder (31) proceeding as follows.
29. Connect the yellow pipe (24) to connector (28) and to the external cylinder containing the refrigerant (upside down if not equipped outlet valve).
30. Open the cock on the external cylinder, the cock on the charging pipe (24) and cock (27).

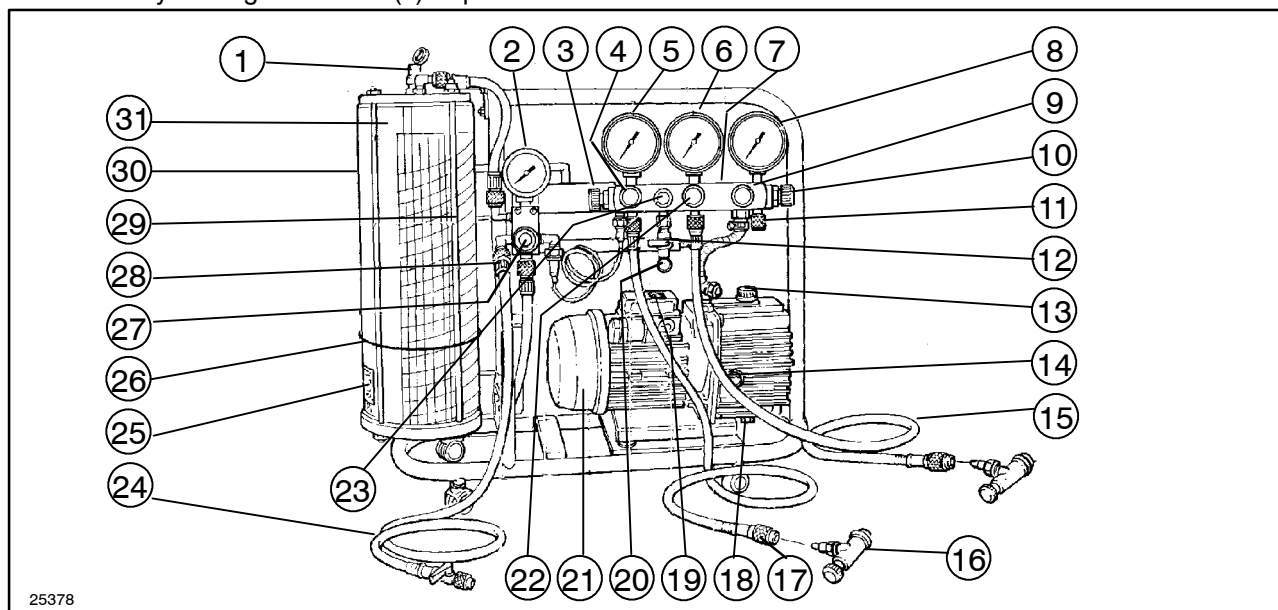

25378

16

Evacuation/charging station.

- | | |
|--|---|
| 1. Safety valve. | 17. Blue service pipe for connection to suction side of compressor. |
| 2. Cylinder pressure gauge. | 18. Oil drain plug. |
| 3. Refrigerant charging cock. | 19. On/Off switch (I), heater (II). |
| 4. Low pressure side cock (LOW). | 20. Oil meter connector. |
| 5. Low pressure gauge. | 21. Vacuum pump. |
| 6. High pressure gauge (red). | 22. High pressure side cock (HIGH). |
| 7. %-way pressure gauge manifold. | 23. Sight glass. |
| 8. Vacuum meter. | 24. Yellow service pipe. |
| 9. Vacuum test cock (VAC). | 25. Cylinder heater. |
| 10. Vacuum meter test cock. | 26. External ring. |
| 11. Vacuum meter safety valve. | 27. Refrigerant transfer cock (REF). |
| 12. Oil charging cock. | 28. Refrigerant transfer connector. |
| 13. Oil filler cap. | 29. Glass rod. |
| 14. Sight glass. | 30. Outer casing (Plexiglas). |
| 15. Red service pipe for connection to discharge side of compressor. | 31. Refrigerant charging cylinder. |
| 16. Quick-fit cocks. | |

31. Rotate the outer casing (30) so that pressure value indicated on the graduated scale corresponds with the value shown on pressure gauge (2).
32. When the refrigerant in the cylinder has reached the required level, as indicated on the glass rod (29), close the cock of the external cylinder, the cock on the charging pipe (24) and cock (27).

Note - If excessive time is required to transfer refrigerant from the external cylinder to cylinder (31), slightly open valve (1) and discharge air from the cylinder (31); the pressure reading on gauge (2) should not exceed 5 bar (72.5 psi).

Evacuation of the cab air conditioning system (previously discharged using the recovery/recycling station)

33. Remove the caps from the service valves on the suction and discharge lines of the compressor.

Refer to figure 16 and proceed as follows:

34. Connect the blue service pipe (17) to the valve on the low pressure side of the compressor marked " S ".
35. Connect the red service pipe (15) to the valve on the high pressure side of the compressor marked " D ".
36. Open the quick-fit cocks (16).
37. Open cocks (4 - 9 - 10 - 22).
38. Start the pump by turning switch (19) to position "1" and evacuate the system for at least thirty minutes; pressure gauges (5 - 6 - 8) should show a negative reading. If the evacuation procedure does not function correctly, check all connections.
39. Close cock (9), switch off the pump by turning switch (19) to position "0" and check the vacuum seal for at least five minutes using vacuum meter (8). This done, close all cocks.

Charging the cab air conditioning system (after evacuation) with new oil

If no refrigerant leaks, whether major or minor, have ever been found in the system, on recharging, replace the contaminated oil previously recovered in operations (25 and 26, page 24) with the same quantity of new oil. If, on the contrary, significant leaks have occurred in the past, proceed with the compressor oil level check procedure described on page 45.

Refer to figure 16 and proceed as follows:

40. Pour the oil into the graduated oil meter of kit **294043**.
41. Connect the oil meter to the oil meter (20).
42. Close cocks (4 and 10).
43. Set switch (19) to position "2" to switch on the refrigerant heater on cylinder (31).
44. Open cock (12) and the cock on the graduated oil meter.
45. Check the quantity of oil flowing from the oil meter, and once the required quantity has been reached, close cocks (12) and the cock on the oil meter, and remove the graduated meter.

Charging the cab air conditioning system with refrigerant (after evacuation)

Note - The quantity of refrigerant to be put into the system is 1400 grams (3.0879 lb) (refrigerant R134a).

Refer to figure 16 and proceed as follows:

46. Keep switch (19) in position 2, with the refrigerant heater in cylinder (31) on, and heat the refrigerant for approx. 10 ÷ 15 minutes to facilitate transfer from the cylinder to the air conditioning system on the tractor.
47. According to the refrigerant type, rotate the outer casing (30) so that the graduated scale and the pressure values correspond with the pressure reading on gauge (2).
48. Move the external ring (26) along the cylinder glass to mark the quantity of refrigerant to be charged.
49. Open cock (22) and charge from the high pressure side.
50. Open cock (3), charge approx. 300 grams (0.6617 lb) of refrigerant, close cock (3) and check for leaks.
51. If there are no leaks, continue charging up to the prescribed quantity.
52. On completion of charging, turn switch (19) back to position "0", close cocks (3 and 22), disconnect pipes (17 and 15), and replace the caps on the service valves.

Carry out functional tests with the system set to maximum performance levels, as described below.

FUNCTION TESTING OF CAB AIR CONDITIONING SYSTEM (Op. 50 200 03)

With the pressure gauges connected to the system in the manner described previously and the cocks closed, proceed as follows:

1. Start the engine and bring it up to a speed of 1500 rpm.
2. Set the cab ventilation fan (1, fig. 9) to the maximum speed.
3. Turn knob (2, fig. 9) to switch on the air conditioning.

After about 15 minutes of operation, take the following readings:

4. Pressure on suction side of compressor as indicated by low pressure gauge.
5. Pressure on discharge side of compressor, as indicated on high pressure gauge.
6. Ambient air temperature.
7. Ambient relative humidity.
8. Temperature of air leaving vents inside the cab.

The pressure values will depend on the external ambient conditions and the altitude.

The system is to be considered as functioning correctly if the pressure readings are within the value ranges indicated on page 3, and the temperature readings are within the value ranges indicated on page 29.

9. Check also the temperature of the low and high pressure sides of the system:
 - the high pressure side, from the compressor discharge to the expansion valve on the evaporator, should be uniformly hot to the touch;
 - the low pressure side, from the evaporator outlet to the suction side of the compressor, should be uniformly cold to the touch. There should not be excessive condensation on the suction pipe and the low pressure pipe connector on the compressor.

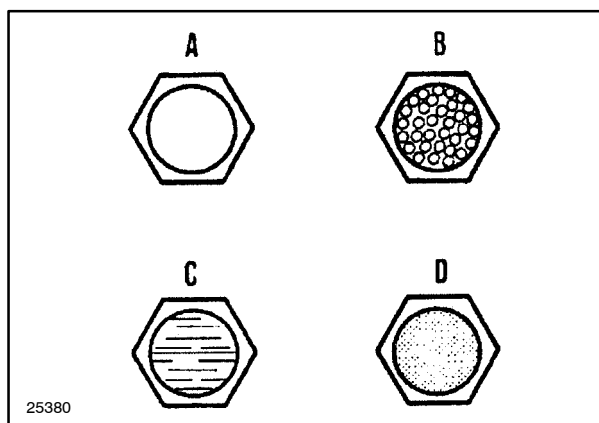

17

10. Check that the compressor does not make undue noise; there should be an audible click when the drive is engaged..

The sight glass on the receiver-drier can provide useful information about system operation.

The four main possible conditions of the sight glass are shown in figure 17.

A. Glass clear: indicates that the system is correctly charged, or that there is no refrigerant in the system (in the latter case the cooling action of the evaporator would be absent). In some cases, the glass may be clear when the system has been charged with an excessive quantity of refrigerant; in this case it would be necessary to check the pressure readings.

B. Bubbles: the formation of vapour or foam bubbles indicates that the system contains an insufficient quantity of refrigerant or the presence of air in the system; bubbles may also be seen on switching on the system and on disengagement of the electromagnetic clutch.

C. Threads of oil: indicates a lack of refrigerant and that the compressor oil is circulating the system.

D. Fluid appearance not uniform, streaky: indicates that the drying agent in the filter has escaped, as a result of the containment discs breaking, and is circulating in the system.

SUMMARY OF THE AIR CONDITIONING SYSTEM CHARGING OPERATIONS

Note - The pressure readings reported below are valid for an ambient temperature of 25 °C (77 °F).

- Pressure gauge readings on completion of refrigerant recovery and recycling operation.

- pressure gauge readings with cocks (4 - 10 - 22 and 9, fig. 16 page 25) open, cylinder (31) with 2000 gr (4.4112 lb) of refrigerant, red and blue service pipes connected to tractor system, cocks (16) closed and compressor off.

- Pressure gauge readings with cocks (4 - 10 - 22 and 9, fig. 16) open, cylinder (31) with 2000 gr (4.4112 lb) of refrigerant, red and blue service pipes connected to tractor system, cocks (16) open and compressor on (initial evacuation stage).

- Pressure gauge readings with cocks (4 - 10 - 22 and 9, fig. 16) open, cylinder (31) with 2000 gr (4.4112 lb) of refrigerant, red and blue service pipes connected to tractor system, cocks (16) open and compressor on (final stage of evacuation after 30 minutes).

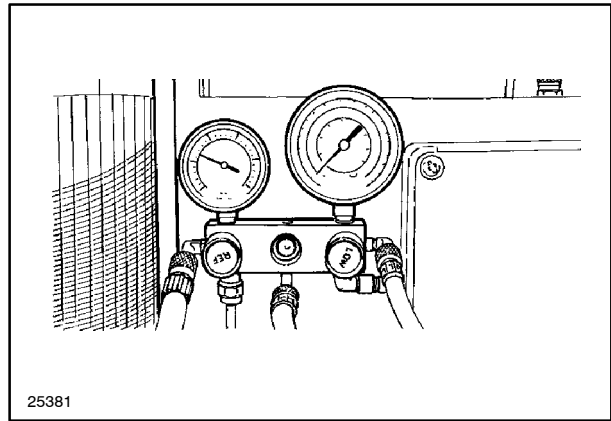

18

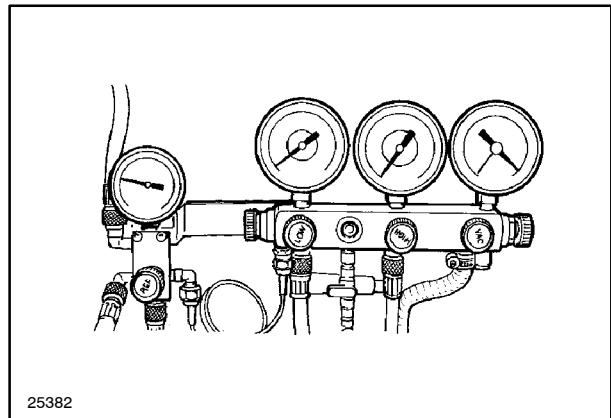

19

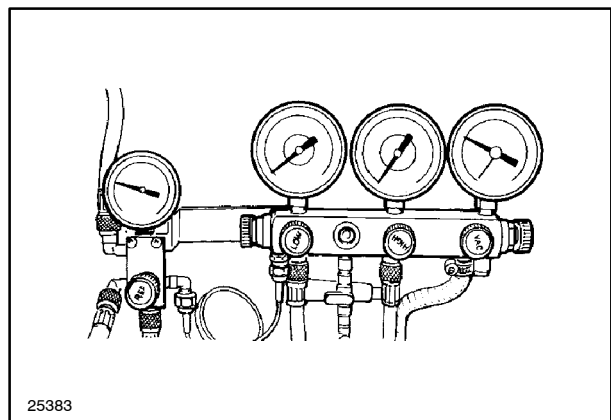

20

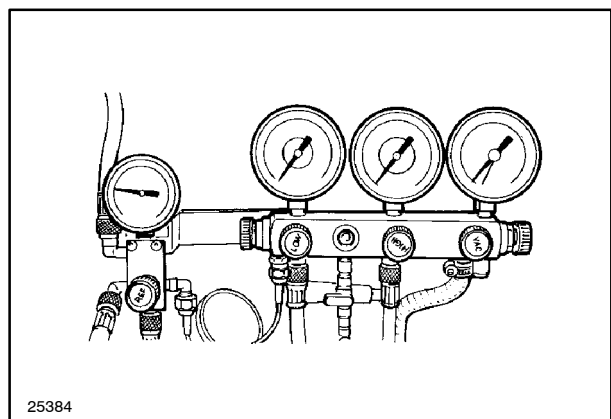

21

- Pressure gauge readings with cocks (4 - 10 - 22, fig. 16) open, cylinder (31) with 2000 gr of refrigerant, red and blue service pipes connected to tractor system, cocks (16) open, compressor off and cock (9) closed (check on vacuum meter that no pressure drops occur over a period of 5 minutes).

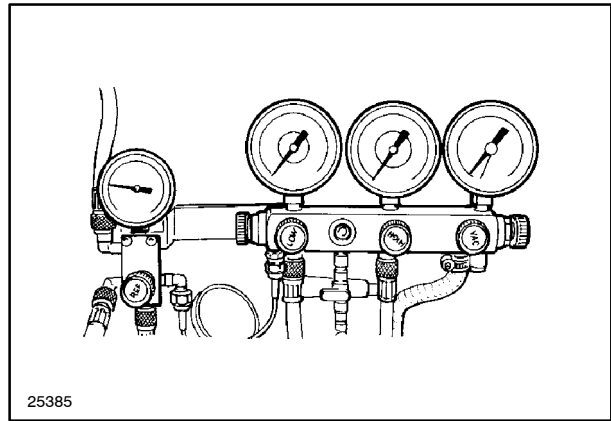

22

- Pressure gauge readings (start of charging - end of charging). All previously opened cocks are to be closed, with the exception of (4 and 3, fig. 16), compressor off. The level of refrigerant in the charging cylinder can be seen to drop; proceed until only 600 gr of refrigerant remain in the charging cylinder (1400 transferred). The reading of vacuum meter (8) remains the same from the beginning to the end of the charging operation.

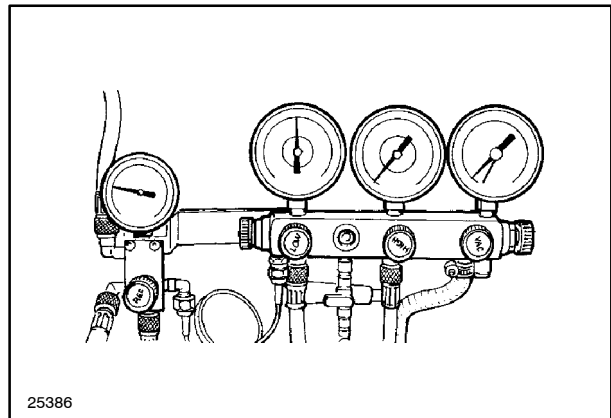

23

Checking the temperature of the air coming out of the vents inside the cab

If the temperature of the air measured at the vents is within the value range indicated in the table for the external ambient air temperatures specified, the system is functioning efficiently.

If the temperature of the air at the vents exceeds the maximum value indicated in the table, refer to the fault diagnosis guide in the following pages.

AIR CONDITIONING SYSTEM OPERATING TEMPERATURE VARIATIONS

External ambient temperature	20 °C (68 °F)	27 °C (80.6 °F)	28 °C (82.4 °F)	35 °C (95 °F)	36 °C (96.8 °F)	43 °C (109.4 °F)
Temperature of air at vent outlets (inside cab)	4 - 8 °C (39.2-46.4 °F)		6 - 12 °C (42.8-53.6 °F)		12 - 20 °C (53.6-68 °F)	

CHECKING FOR REFRIGERANT LEAKS USING AN ELECTRONIC LEAK DETECTOR

Leak detector (294036)

The leak detector **294036** is supplied in its own carrying case which also contains the two power supply batteries, the sensitivity test phial and an ear plug connection for audible leak indication.

The instrument consists of a hand-held unit with a flexible probe which houses the sensing tip.

To orient the flexible probe, first slacken off the locking ring on the lower left-hand corner of the case.

The front of case mounts the sliding on/off switch, the red indicator led, and the audible leak indicator.

The rear of the case mounts the ear plug connection socket. The battery compartment also houses a sensing tip and a number of spare felt pads.

Use

Switch the unit ON: start looking for leaks; the frequency and the amplitude of the audible signal will increase if gas is detected.

In areas affected by gas leaks, switch the instrument on and off; the detector will automatically select a new acoustic level. Perform this test each time the instrument is to be used.

Hold the sensing tip near the open phial to test sensitivity; when the instruments starts to emit a signal, switch it on and then off.

Refrigerant leak test

In this stage the instrument automatically regulates its sensitivity in accordance with the presence of gas in the environment around the sensing tip, and the test is performed solely by means of the on/off switch.

In ventilated areas, it can be extremely difficult to trace a large leak due to the rapid dispersion of gas from the source; in this case, place screens around the suspected source to enable more precise localisation of the leak.

In cases where large leaks obscure the presence of smaller leaks, locate and repair the large leaks first, and then locate the small leaks.

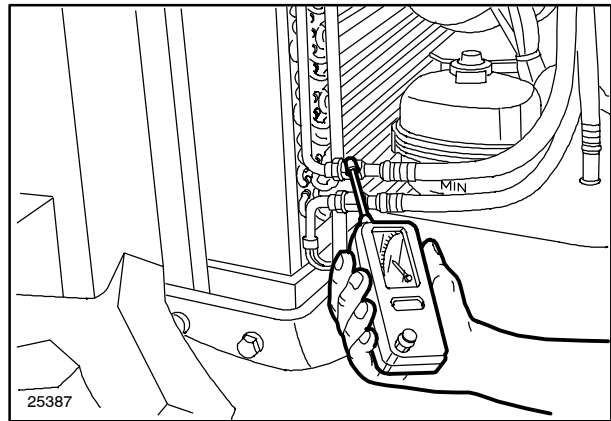

24

Maintenance

Always make sure that the instrument is switched off before replacing the sensing tip. To remove the tip, unscrew it in a counter-clockwise direction. Fit a new tip and a new felt pad, screwing them in a clockwise direction onto the flexible probe.

Do not switch on the instrument unless the sensing tip is firmly screwed on to the end of the flexible probe.

On fitting the tip, check that there is no grease or dirt in the connecting hole between the probe and the tip.

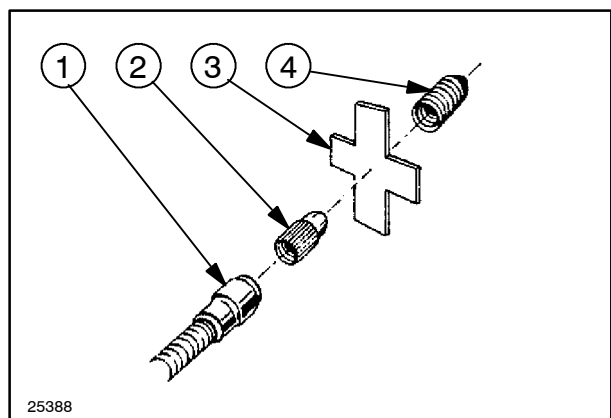

25

Leak detector probe

1. Flexible probe.
2. Sensing tip.
3. Felt pad.
4. Cover.

AIR CONDITIONING SYSTEM**Testing for leaks with leak detector 294036 and elimination of leaks (Op. 50 200 06)**

With the system charged and the pressure gauges connected, proceed as follows:

1. Start the engine.
2. Set the ventilation fan to maximum speed.
3. Turn knob (2, fig. 9) to switch on the air conditioner.
4. Bring the engine up to a speed of approx. 1500 rpm.
5. Switch on the electronic leak detector.
6. Move the probe around all pipe connections and all possible points of leakage:
 - The presence of refrigerant, and thus a leak, is signalled by an increase in the frequency of the audible signal.

Note - Refrigerant is heavier than air, and so it is easier to detect below the leak rather than above it.

7. If leaks are found in the pipe connections, tighten the fittings to eliminate them.

Warning - If any of the system components requires replacement, it is always necessary to perform the recovery, recycling and charging operations described on pages 22 to 27.

AIR CONDITIONING SYSTEM FAULT DIAGNOSIS SUMMARY

There are three main ways in which the system can malfunction:

- the system does not work at all;
- the system does not provide sufficient cooling;
- the compressor operates irregularly.

Bearing in mind that insufficient cooling may also result from causes external to the air conditioning system, generally a mechanical check and visual inspection will provide useful information about the efficiency of the system.

This information can then be completed by electrical testing.

If at this stage the problem has still not been identified, it will be necessary to carry out a more detailed search by analysing the pressure readings in the various parts of the system.

Visual inspection of components

These checks are to be carried out with the engine stopped and with the heating and air conditioning system switched off.

- Check the compressor mountings and the relative support, pulley alignment, belt tension..
- Look for visible signs of refrigerant leakage (presence of oil on fittings).
- Look for visible leaks of liquid refrigerant.
- Inspect the condition of the pipes, particularly those in contact with the engine, as well as pipe fittings/connectors and hose clamps.
- Check that the evaporator, the heater matrix, and the condenser are clean and remove any foreign bodies.
- Check the condition and position of the thermostatic sensor (fig. 13) in the evaporator.
- Check that external air intakes are not blocked.
- Check the condition of the condensate discharge pipes.

MAINTENANCE OF THE AIR CONDITIONING SYSTEM

At the start of the season in which the system will be used, check that the system is functioning correctly and efficiently.

If the system has been out of use and charged for a prolonged period, oil may have flowed out of the compressor to other parts of the system and consequently this oil must be returned to the compressor. To do this, start the engine and run it at approx. 1500 rpm for about 10 minutes.

Switch on the ventilation fan at maximum speed. Turn control knob (2, fig. 9) to switch on the air conditioning.

Check that the relative temperatures of the external ambient air and the air flowing out of the vents inside the cab correspond to the values indicated in the table on page 29.

If so, the system is operating efficiently, and a visual inspection of the main components will be sufficient:

1) COMPRESSOR: check the mountings, drive belt tension and oil level.

2) CONDENSER: check mounting, and that the fins are free from excessive deposits. Straighten any bent fins using the special comb **293831**.

Note - Carry out the same checks on the EVAPORATOR (9) and CONDENSER (5).

3) RECEIVER-DRIER: the sight glass on the receiver-drier can provide useful information regarding system operation; see page 27. Replace the receiver-drier after the system has been repaired on two occasions.

4) EXPANSION VALVE: does not require maintenance; in the case of malfunction, check the valve and thermostatic sensor as described on pages 17 and 18 or refer to specialised personnel of service network.

If the temperature of the air at the vent outlets does not conform to the indications given in the table on page 29, proceed with the system fault diagnosis procedure outlined on page 31.

Warning - Should one or more system components require replacement, in all cases it will be necessary to carry out the recovery, recycling and charging operations described on pages 22 to 27.

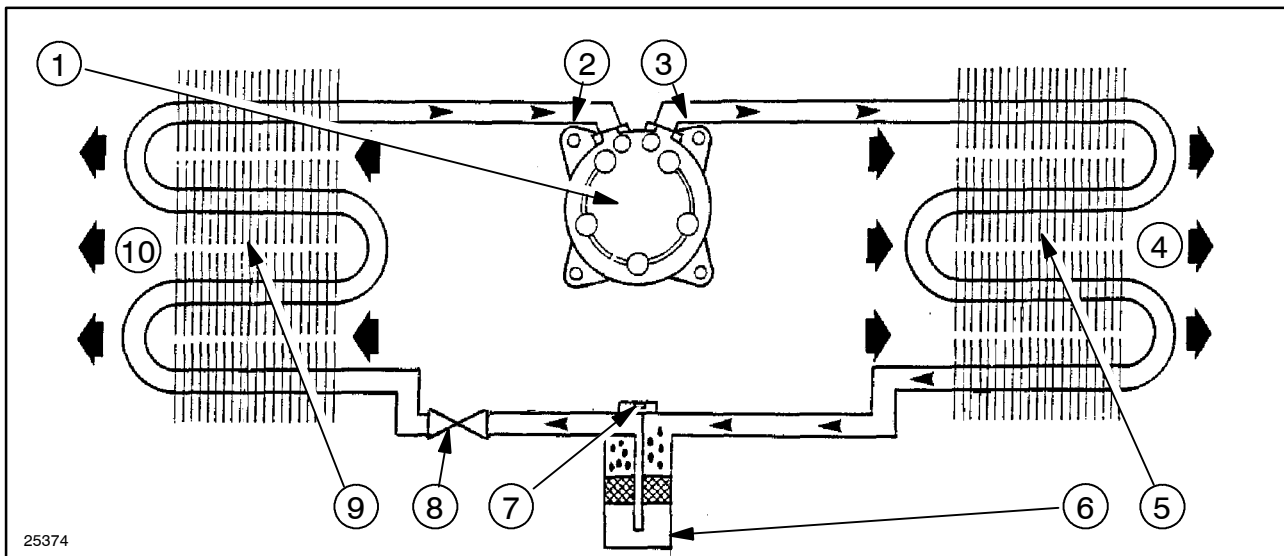

26

Schematic of the air conditioning system.

- | | |
|------------------------------------|--|
| 1. Compressor. | 6. Receiver-drier. |
| 2. Suction line (low pressure). | 7. Sight glass. |
| 3. Discharge line (high pressure). | 8. Expansion valve with thermostatic sensor. |
| 4. Hot air. | 9. Evaporator. |
| 5. Condenser. | 10. Cool, dehumidified air. |

AIR CONDITIONING AND HEATING PIPES
Replacement (Op. 50 200 04 - 50 206 56 -
50 206 51- 50 206 66 - 50 200 40 - 50 200 60)



DANGER



When recovering refrigerant from the system adhere to the safety rules on page 2.

1. Disconnect the negative battery lead.
2. Recover the refrigerant from the system using the recovery/recycling station **294048** as described on page 22.
3. Drain off approx. 3 litres (0.6599 gall. Imp.) of coolant from the drain plug (1) on the engine block.

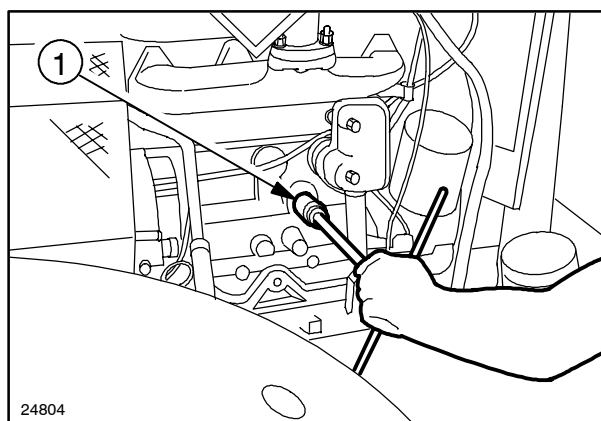

27

4. Remove the 4 cab roof retaining bolts (1).

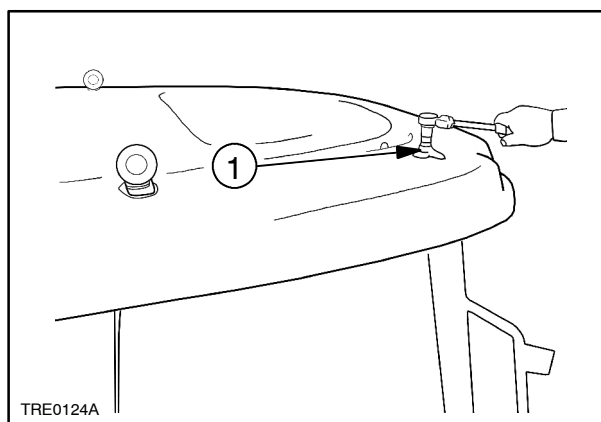

28

5. Remove the cab roof as shown in the figure 29.

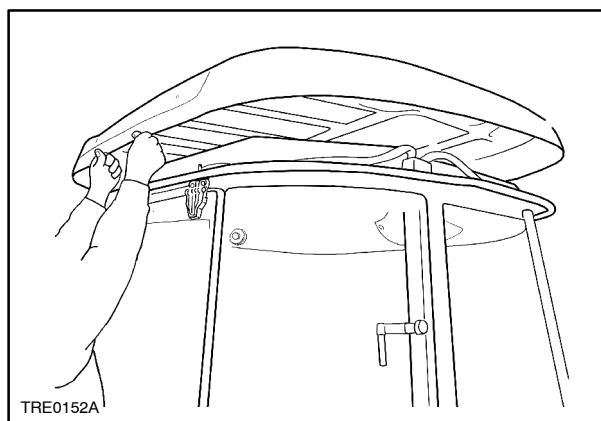

29

6. Remove plate fastening screws and take of the plate (1)

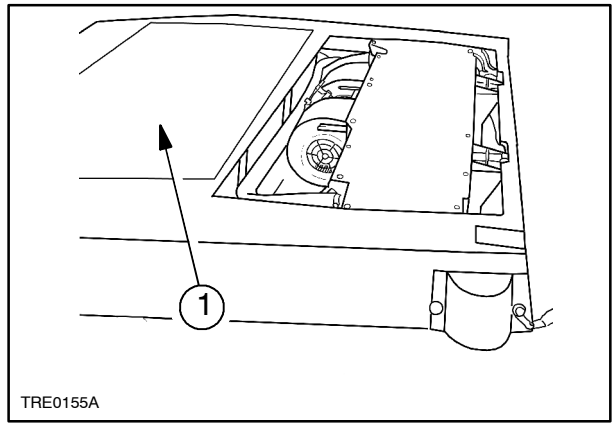

30

7. Remove A/C assembly fastening screws (1).

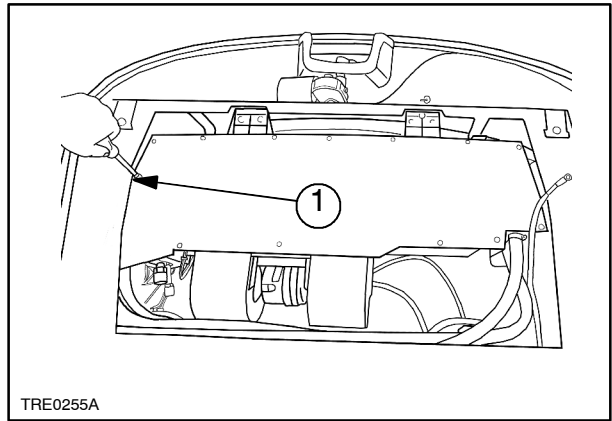

31

8. Remove A/C inlet and outlet pipes (1). Remove front retaining screws (2).

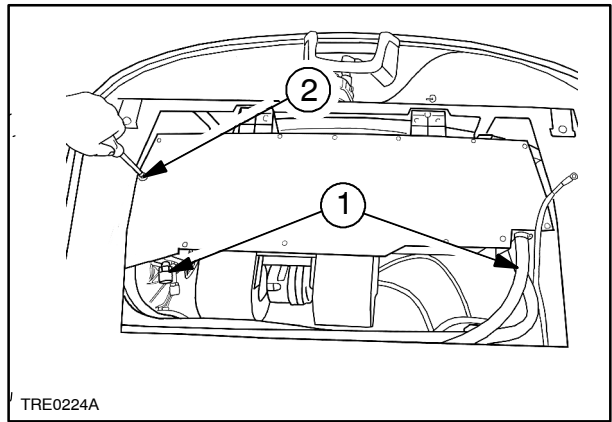

32

9. Remove heater pipe connections (1) and take off the pipes.

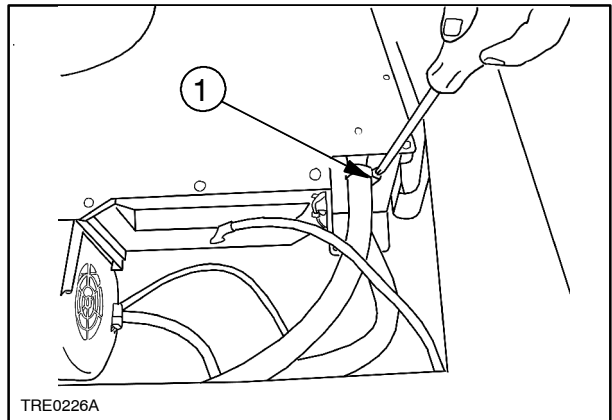

33

10. Remove the bracket (1) that secures the pipe.

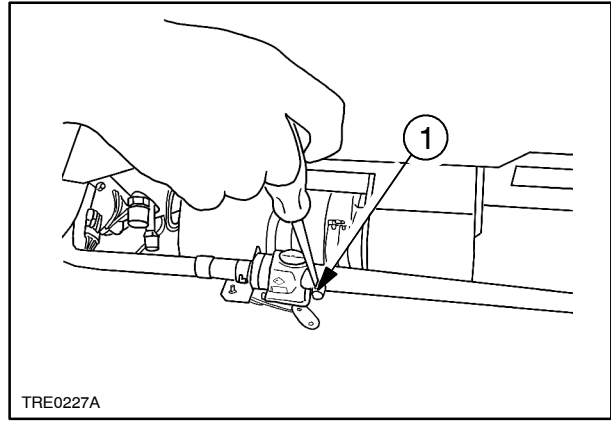

TRE0227A

34

11. Remove all electric connectors and take off the A/C assembly (1) completely.

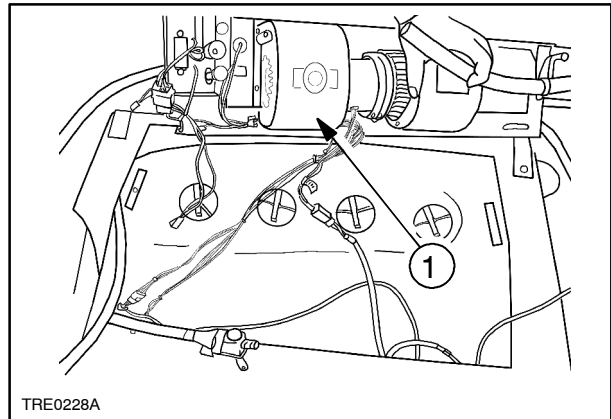

TRE0228A

35

12. A/C assembly is shown in fig 36.

13. To reassemble, clean all parts and proceed as follows:

- Refit A/C assembly completely and refit all electric connectors.
- Assembly the bracket that secures the heater pipe.
- Assembly the heater pipe connections refit the pipes.
- Refit A/C assembly inlet & outlet pipes.
- Refit A/C assembly fastening screws.
- Refit top cover plate.
- Assembly the cab roof.
- Refit the 4 cab roof retaining bolts.
- Pour the previously drained coolant back into the radiator.
- Reconnect the negative battery lead.
- Charge the air conditioning system with HFC 134 a refrigerant, using the evacuation/ charging station **294030** as described on page 24.

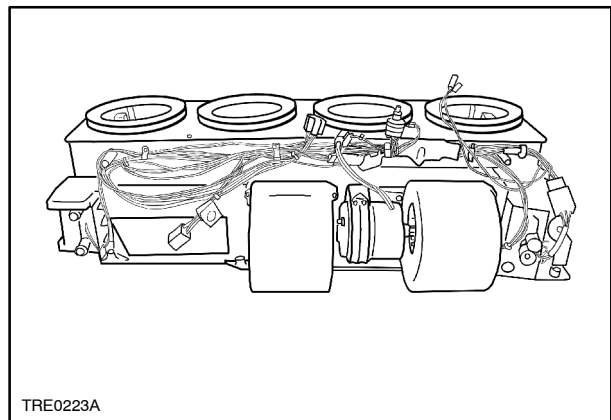

TRE0223A

36

RECEIVER-DRIER

Replacement (Op. 50 200 04 - 50 200 74)

**DANGER**

When recovering the refrigerant from the system adhere to the safety instructions on page 2.

1. Recover the refrigerant from the system using station **294048** as described on page 22.
2. Detach the exhaust pipe and raise the hood.
3. Disconnect the negative battery lead.
4. Disconnect the electrical connector (1) from the receiver-drier.

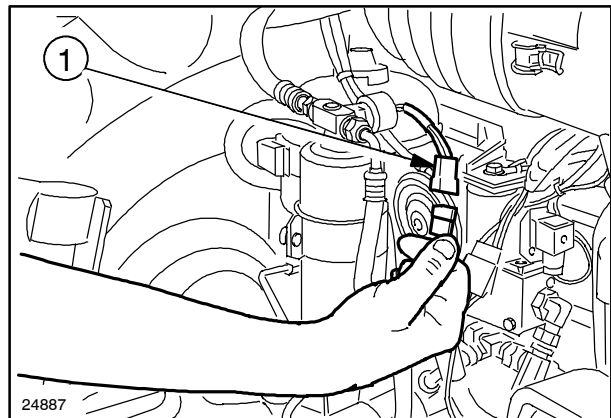

37

5. Detach the flexible pipe (1) connecting the condenser to the receiver-drier.

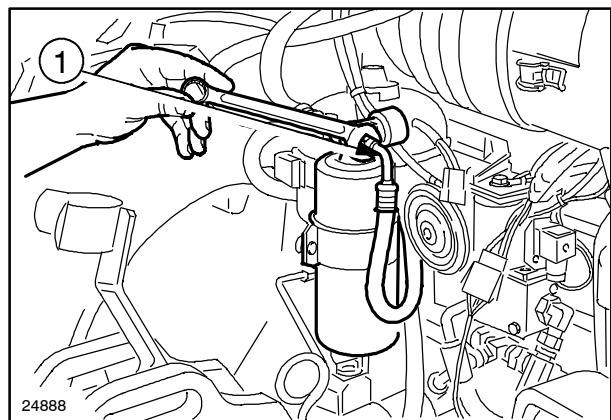

38

6. Detach the flexible pipe (1) connecting the receiver-drier to the evaporator.

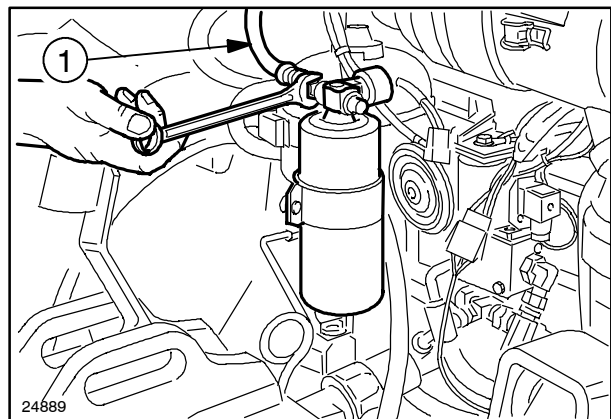

39

7. Remove the screw (1) securing the receiver-drier band clamp.

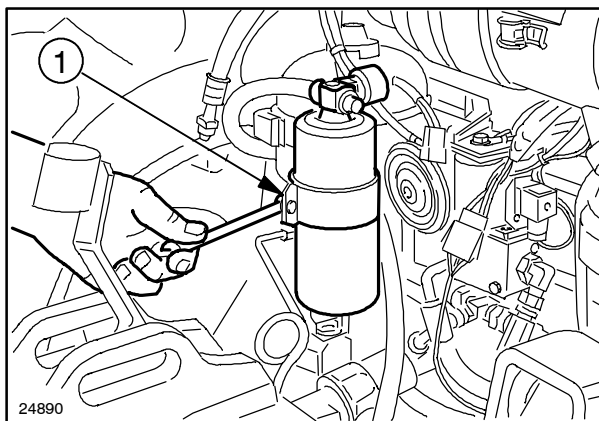

40

8. Recover the complete receiver-drier (1).

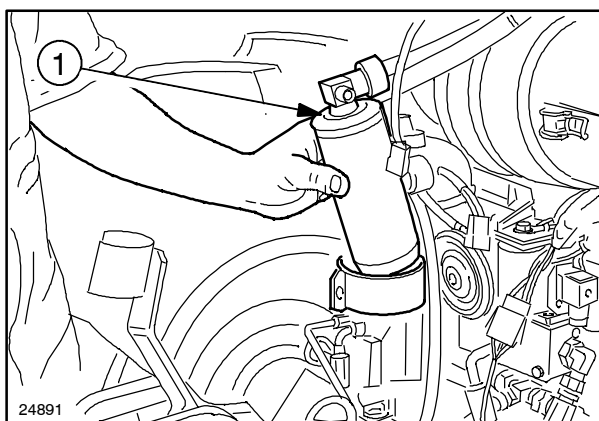

41

To refit proceed as follows:

- Replace the receiver-drier in the support clamp.
- Reconnect the two flexible return and delivery pipes. Connect the electrical connections on the filter.
- Connect the negative battery lead.
- Evacuate the system then charge with HFC 134a refrigerant, using the evacuation/charging station **294030**, as described on page 24.
- Close the hood.

CONDENSER**Replacement (Op. 50 200 04 - 50 200 72)****DANGER**

Recover the refrigerant from the system adhering to the safety instructions on page 2.

1. Disconnect the negative battery lead.
2. Recover the refrigerant from the system using the station **294048** as described on page 22.
3. Detach the flexible refrigerant delivery and return pipes (1) from the condenser.

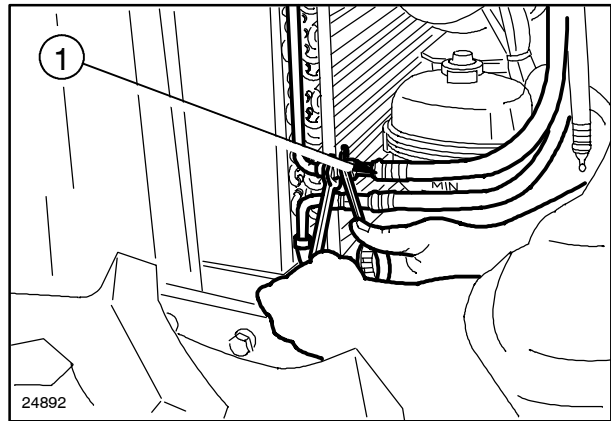

42

4. Unscrew the wingnut (1) securing the condenser.

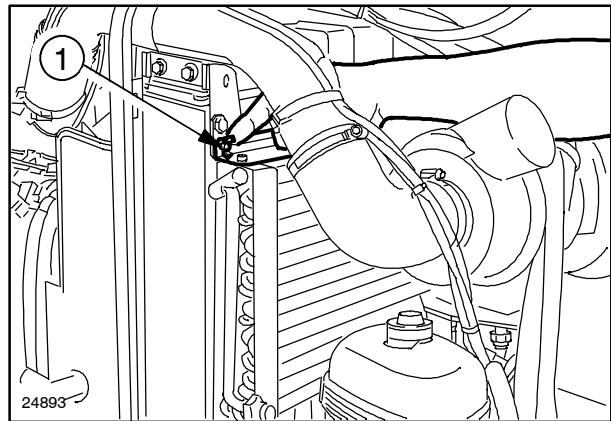

43

5. For tractors equipped with front mudguards, remove the two screws (1) securing the top bracket of the condenser (for tractors without front mudguards turn the steering wheel to full right-hand lock and withdraw the condenser from the right-hand side of the tractor).

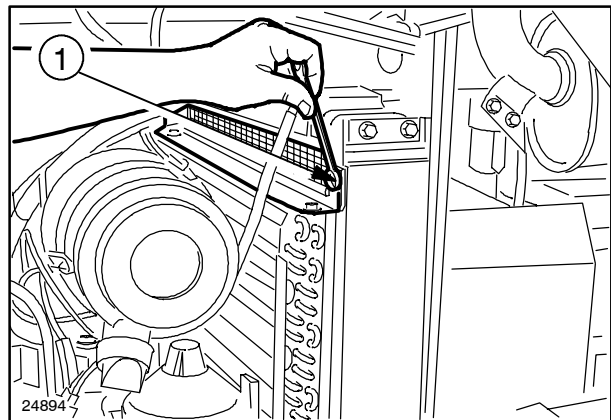

44

6. For tractors with front mudguards, remove the condenser group (1) with the top bracket.

To refit proceed as follows:

- Refit the condenser and the relative bracket, and secure the condenser with the wingnut and the bracket with the two retaining screws.
- Reconnect the two flexible pipes to the condenser.
- Connect the negative battery lead.
- Evacuate the air conditioning system and charge with HFC 134 a refrigerant, using the evacuation/charging station **294030** as described on page 24.
- Close the hood.

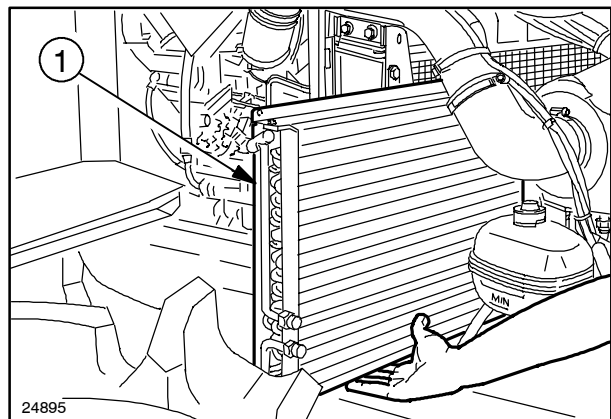

45

COMPRESSOR**Removal-Refitting (Op. 50 200 04 - 50 200 26)****DANGER**

Recover the refrigerant from the system adhering to the safety instructions reported on page 2.

1. Recover the refrigerant from the system using station **294048** as described on page 22.
2. Raise the hood.
3. Disconnect the negative battery lead.
4. Disconnect the flexible pipes (1) from the compressor.
5. Remove the right-hand guard retaining screws (1).

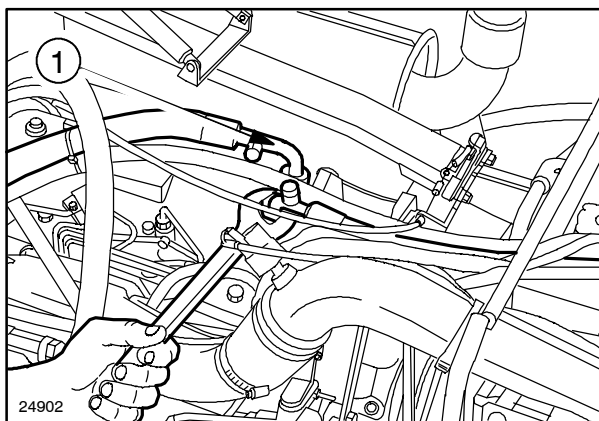

46

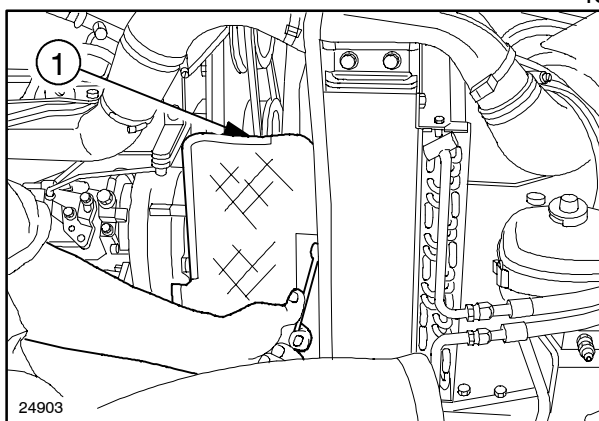

47

6. Remove the two securing nuts (1) of the compressor belt tensioner arm.

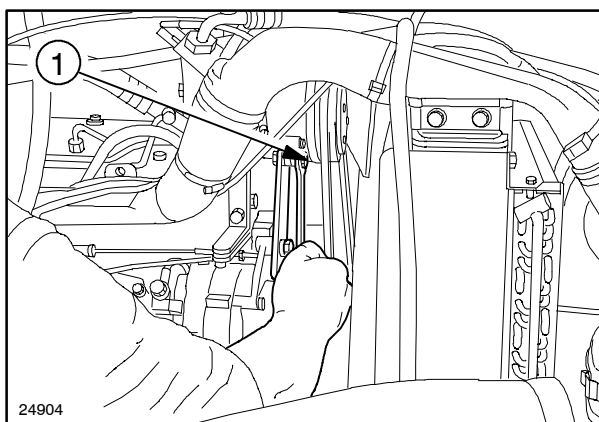

48

7. Disconnect the earth lead (1) from the compressor.

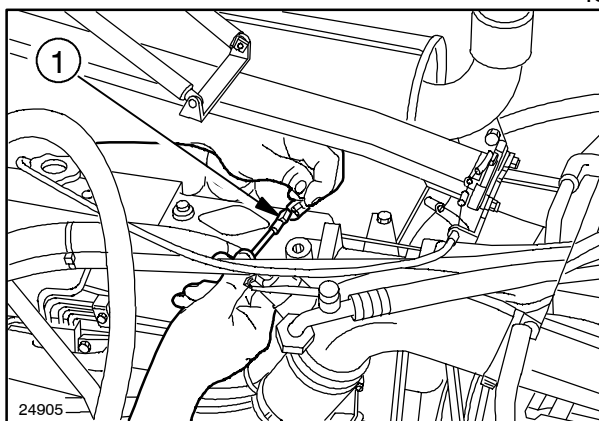

49

8. Loosen the bolt (1) securing the compressor to the engine and remove the drive belt from the pulleys.

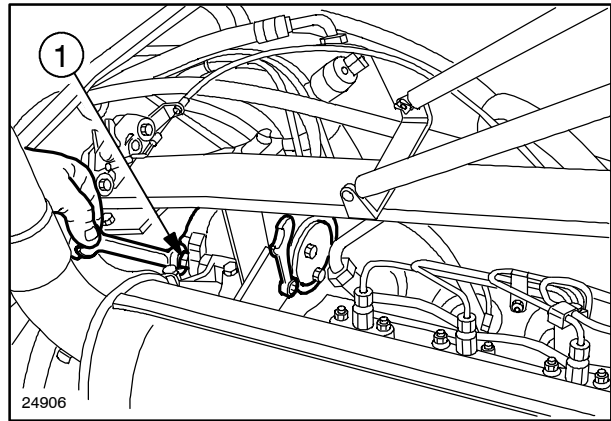

50

9. Remove the compressor bolt (1) and recover the compressor.

To refit proceed as follows:

- Refit the compressor, the support/belt tensioner arm. Reconnect the earth lead..
- Refit the right-hand guard.
- Reconnect the two flexible pipes to the compressor.
- Connect the negative battery lead.
- Evacuate the air conditioning system and charge with HFC 134 a refrigerant, using the evacuation/charging station **294030** as described on page 24.
- Close the hood.

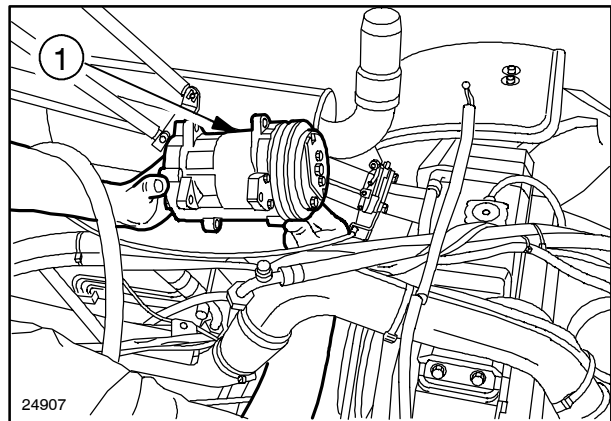

51

COMPRESSOR OIL - TYPE AND QUANTITY

The tractor is equipped with a SANDEN SD 7H15 compressor for refrigerant R134a.

The compressor is filled during assembly with 185cm³ (11.29 inch³) of PAG SP 20 lubricating oil.

In case of top up or oil change only use this type of oil.

It is not necessary to check the compressor oil level unless the system develops significant gas leaks.

Warning - If the system develops significant leaks of R134a refrigerant, there will also be a significant loss of compressor oil PAG SP20. It will therefore be necessary to check the compressor oil level, bearing in mind that, on average, only 130 ÷ 135 cm³ (7.93 ÷ 8.24 inch³), of the total quantity of lubricating oil (185 cm³ (11.29 inch³)) will be present in the compressor, as the remaining 50-55 cm³ (3.05-3.36 inch³) will be in circulation through the various system components. For problems of this type, we recommend that you seek assistance from an authorised service centre.

COMPRESSOR DRIVE BELT

Tension adjustment (Op. 50 200 10)

The tension and condition of the belt transmitting drive from the engine to the compressor is particularly important as regards the correct operation of the air conditioning system.

This drive belt therefore requires careful attention as follows:

- 1) Fit the belt correctly.
- 2) Check the tension.
- 3) Check the condition of the belt.

Fitting the compressor drive belt

When first fitted, the belt must not be forced, pulled with a screwdriver, or rolled over the edge of the pulley, as this would stretch the less deformable fabric in the belt thus causing subsequent breakage of the other fabrics.

When first fitted, the belt must more installed at a greater tension than normal to compensate for initial stretching during the running-in period. The belt must therefore be checked again after 50 hours of operation and adjusted to the normal tension.

This check is absolutely essential as if the belt is too taut, in addition to damaging the pulley bearings, it will cause premature fatigue of the reinforcement fabrics and thus early deterioration of the belt.

If on the contrary the belt is too slack, it will start to slip and overheat, and it will therefore wear out very quickly.

Checking compressor drive belt tension

Check the tension only when the belt is cool (at a temperature below a 40 °C (104 °F)).

Check the tension by applying a load of 78÷98 N (17.6450÷22.0562 lb) to the centre of the belt run indicated in the figure: the belt should deflect $\approx 12\div13$ mm (0.0394÷0.426 ft).

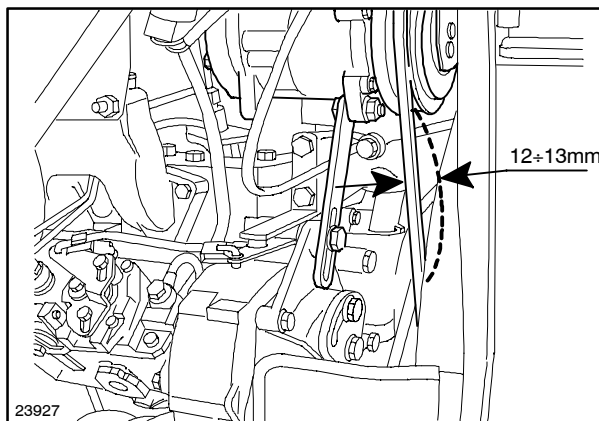

52

Periodic checking of drive belt

When checking the tension, also check the amount of drive belt wear.

The main problems are as follows:

- a) **Belt shiny** : smooth sides may slip on pulleys.
- b) **Belt cracked** : may break suddenly due to splits on the inner surface caused by excessive flexure.
- c) **Worn sides** : with the sides worn or the inner surface cracked, the belt can break at any moment.
- d) **Belt impregnated with grease** : the belt will wear more rapidly as the grease will cause softening of the internal part.

Take the following action:

- a) If the belt is too slack, tension it correctly; if the belt is very hot, renew it.
- b) If cracking is deep, extending to half the thickness of the belt, renew the belt.
- c) If the belt is excessively hot, replace the belt.

If the belt squeaks when running, check the tension and adjust if necessary. If the noise continues, renew the belt.

If the belt has been over-stretched and it is not possible to tension it sufficiently, renew it.

SECTION 55 – ELECTRICAL SYSTEM

Chapter 1 – INSTRUMENTS

CONTENTS

Description	Page
Analogue instruments Introduction	1
Transmitter and switch	4

ANALOGUE INSTRUMENTS

INTRODUCTION

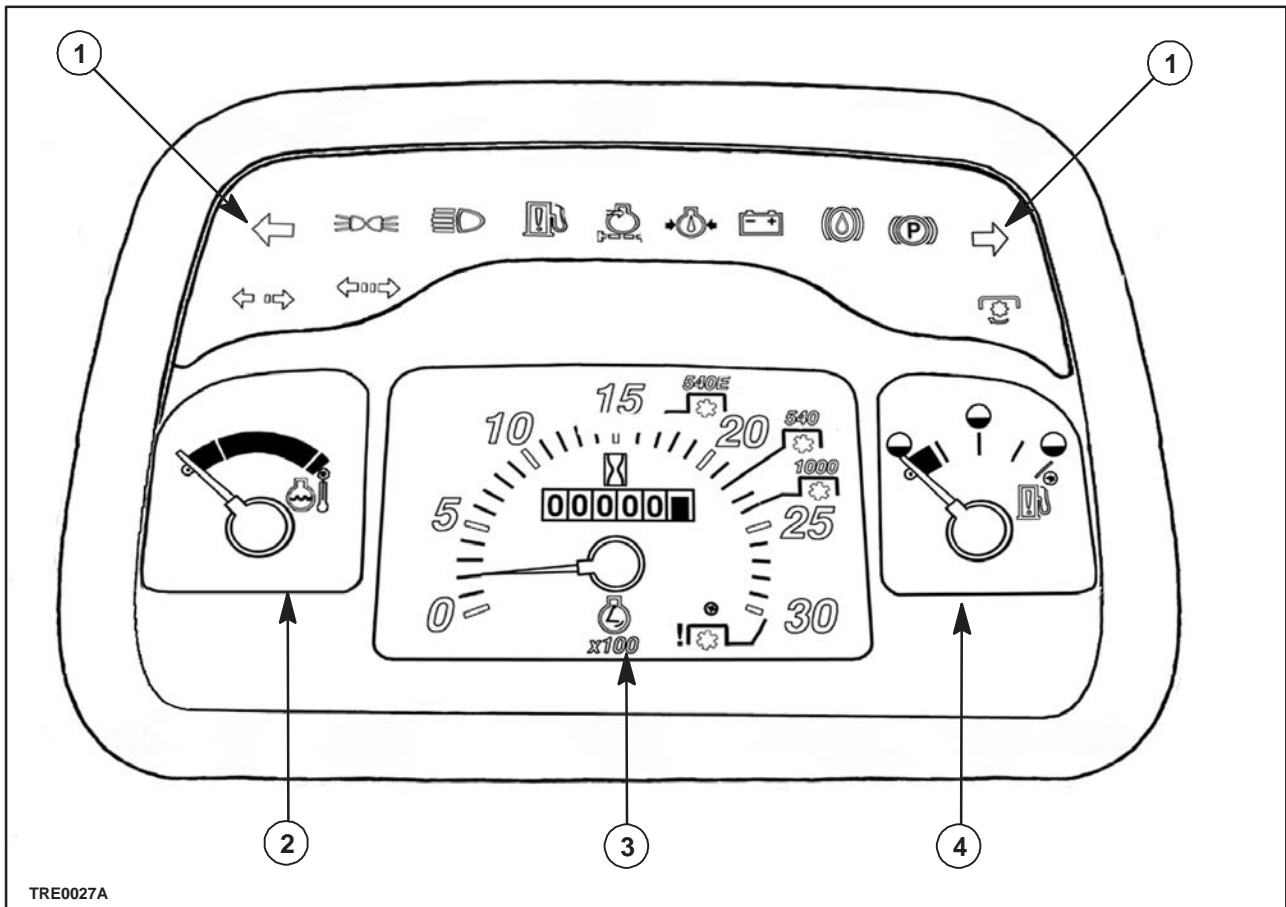

The analogue instrument panel consists of four display sections:

- 1) Warning and indicator lights;
- 2) Fuel level gauge;
- 3) Proofmeter;
- 4) Engine coolant temperature gauge.

Condition

- 1 – Left direction indicator
- 2 – Side lights
- 3 – Main beam headlights
- 4 – Water in fuel
- 5 – Air filter blocked
- 6 – First trailer direction indicator
- 7 – Second trailer direction indicator

Indicator

- Flashing (green)
- Fixed (green)
- Fixed (blue)
- Fixed (red)
- Fixed (amber)
- Flashing (green)
- Flashing (green)

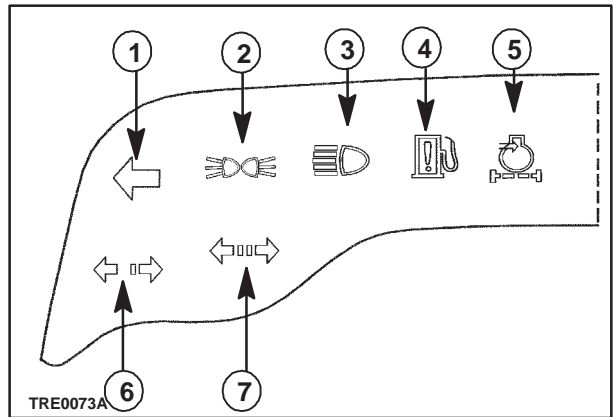

2

- 8 – Engine oil pressure low
- 9 – Battery charge low
- 10 – Brake fluid level low
- 11 – Hand brake on
- 12 – Right direction indicator
- 13 – Power take-off on

- Fixed (red)
- Fixed (red)
- Fixed (red)
- Fixed (red)
- Flashing (green)
- Fixed (amber)

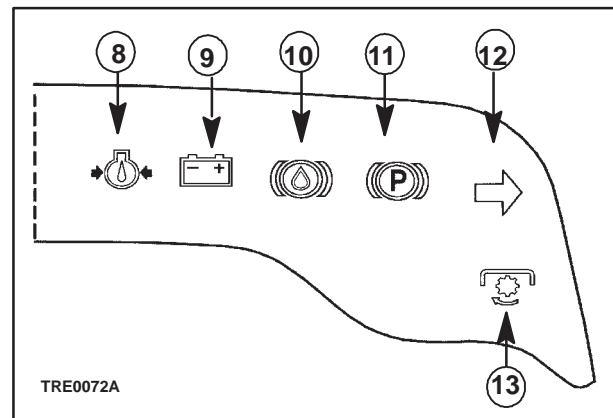

3

Fuel level gauge (Fig. 3)

This instrument shows the level of fuel in the tank.

When the tank is full, the hand moves completely to the right.

When the tank is less than 1/4 full, the hand moves into the yellow area.

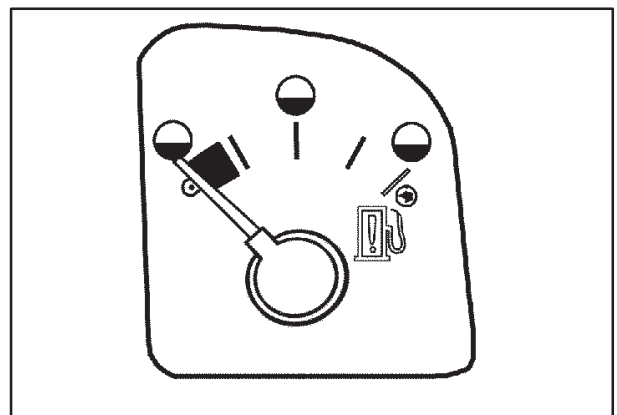

4

Proofmeter (Fig. 4).

Engine speed indicator and chronograph with a six figure hourmeter. The figures on black background count hours of work done and the figure on red background (far right) shows tenths of an hour.

The yellow and white sectors indicate the engine speed at which optimum PTO performance is obtained (respectively 540E, 540 and 1000 rpm).

- Yellow symbol = 540E rpm PTO
- White symbol = 540 and 1000 rpm PTO.

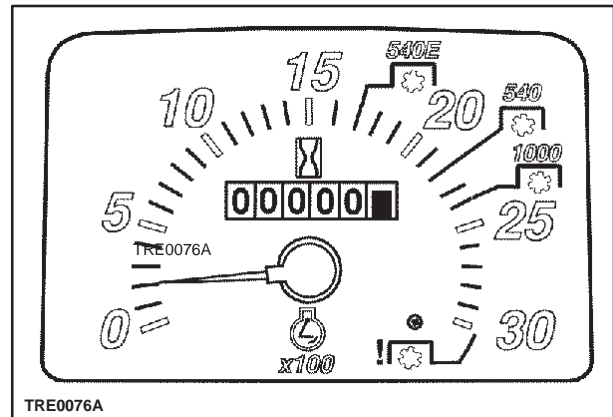

5

Engine coolant temperature gauge (Fig. 5)

- Green area = normal temperature.
- White area = temperature too low.
- Red area = engine overheating.

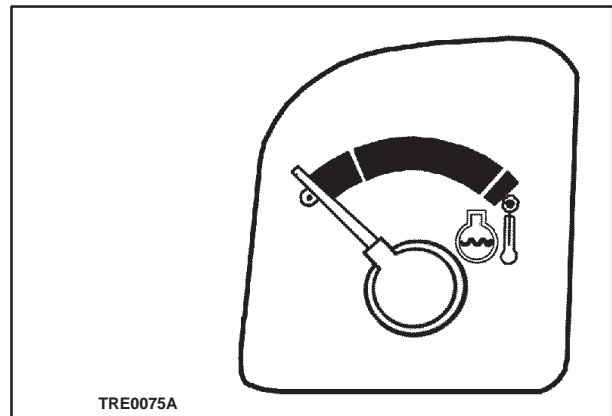

6

TRANSMITTERS, SENSORS AND SWITCHES**A. MAIN FUSE BOX**

The tractor's fuses and relays are housed under a plastic cover.

B. BATTERY

The tractor is fitted with maintenance-free batteries. Keep the top part clean and dry. Check that the level of electrolyte reaches the top mark and never falls below the lower mark.

C. ALTERNATOR

This provides a square wave signal and recharges the battery. It also provides power required by electric devices.

D. TRANSMISSION CLUTCH PEDAL SWITCH

This switch is activated when the clutch pedal is pressed and it prevents starting if the clutch pedal is not lowered.

E. AIR CLEANER CLOGGED SENSOR

This is activated when the vacuum in the air operating system exceeds a pre-set value. It lights up the warning light.

F. FUEL SEDIMENTER

Activated when water gets into the fuel filter and the relevant warning light comes on.

G. ENGINE OIL PRESSURE SWITCH

This is activated as soon as oil pressure in the engine drops less than 0.68 bar (9.86psi). It lights up the warning light. This switch is usually closed.

H. FUEL TANK LEVEL TRANSMITTER

A signal from the transmitter potentiometer defines the level of fuel in the tank. The level is shown by the gauge.

I. ENGINE COOLANT TEMPERATURE

The temperature transmitter resistance varies in proportion to the coolant temperature, generating a modulated voltage signal picked up by the gauge.

J. BRAKE LIGHT SWITCHES

These are activated when the brakes are on.

K. BRAKE OIL LEVEL SWITCH

This switch is activated when the fluid level drops below the minimum value and lights up the warning light.

L. PARKING BRAKE SWITCH

Activated when the parking brakes are applied, switching on the indicator light on the dashboard.

TRANSMITTERS AND SWITCHES

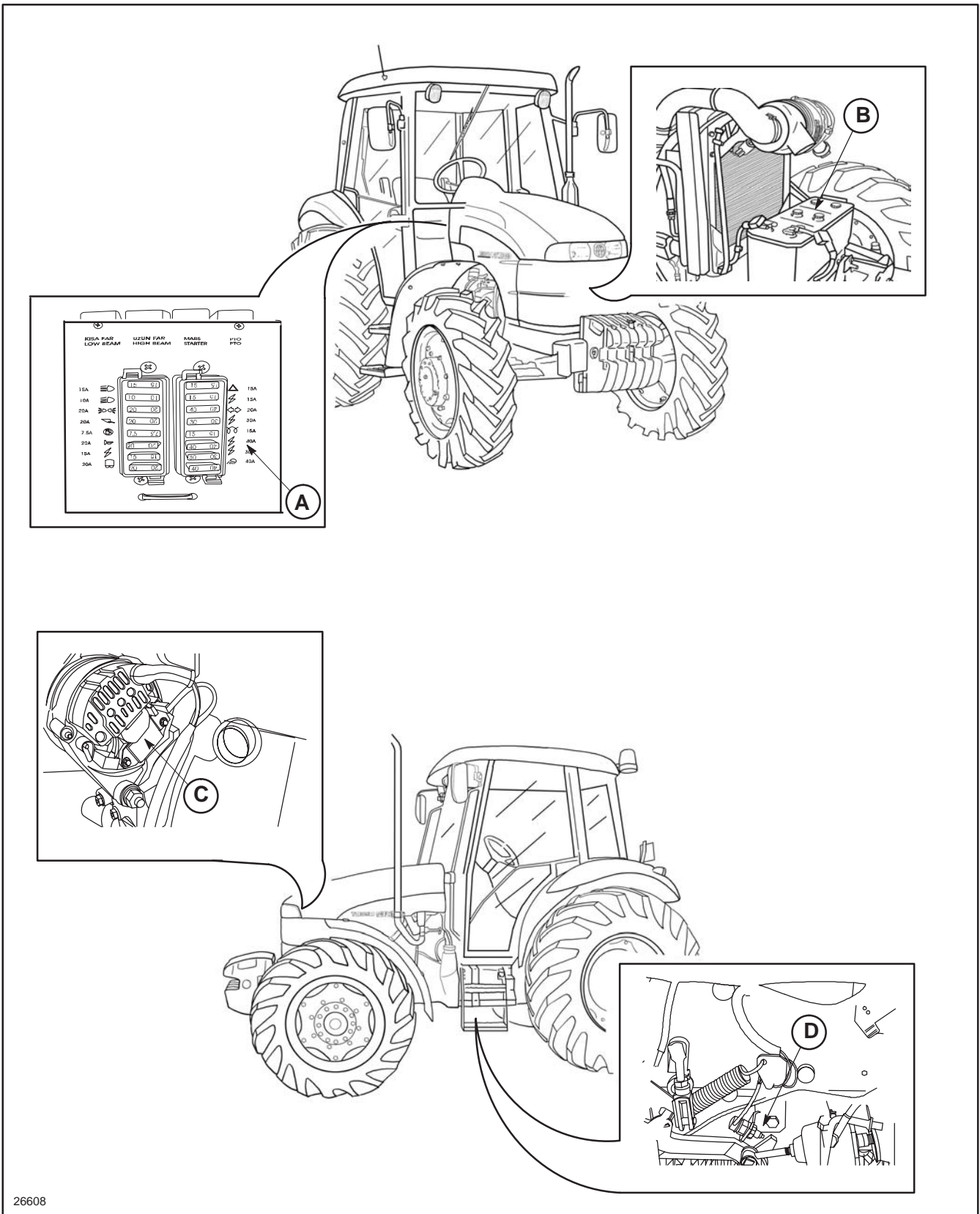

26608

TRANSMITTERS AND SWITCHES

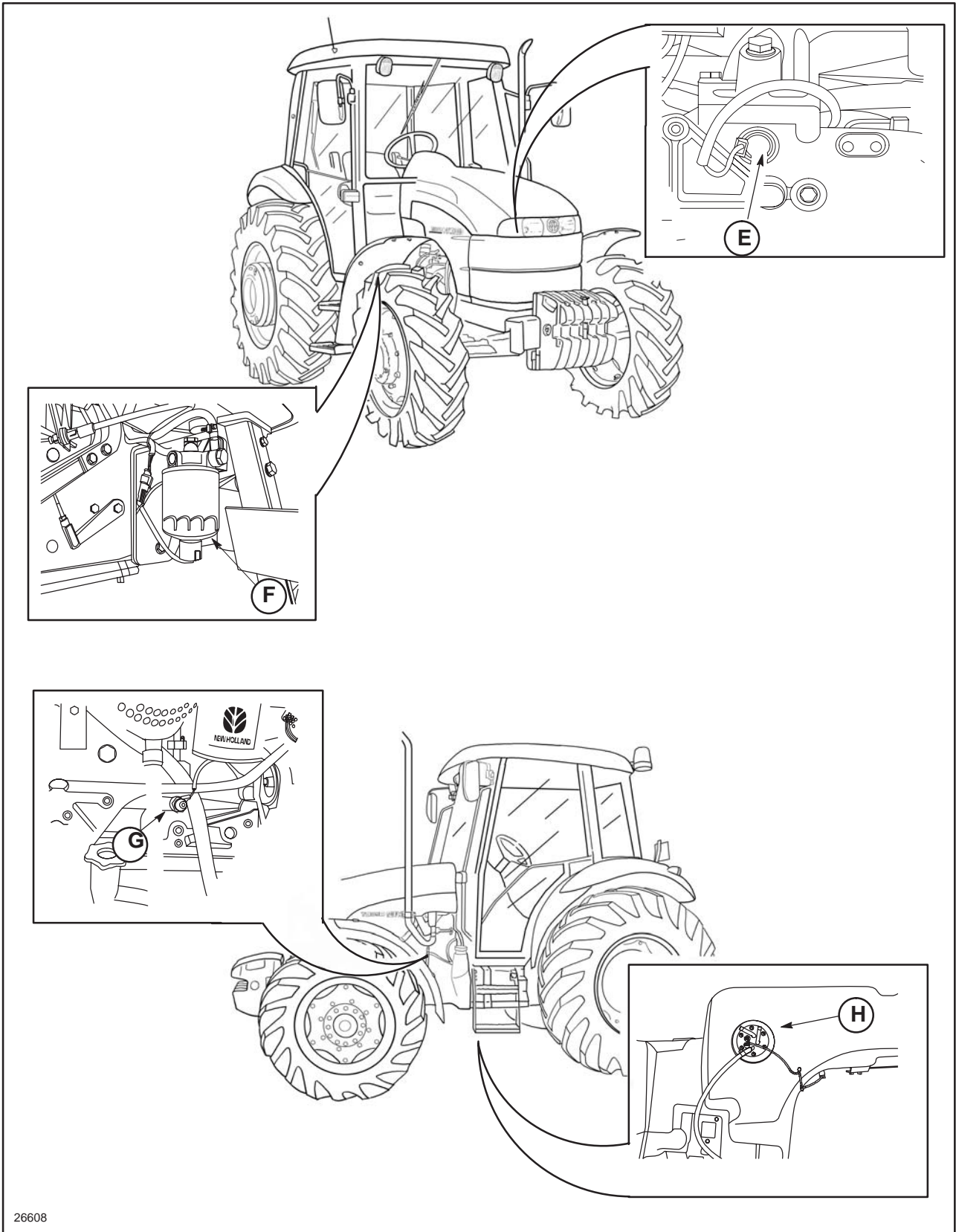

TRANSMITTERS AND SWITCHES

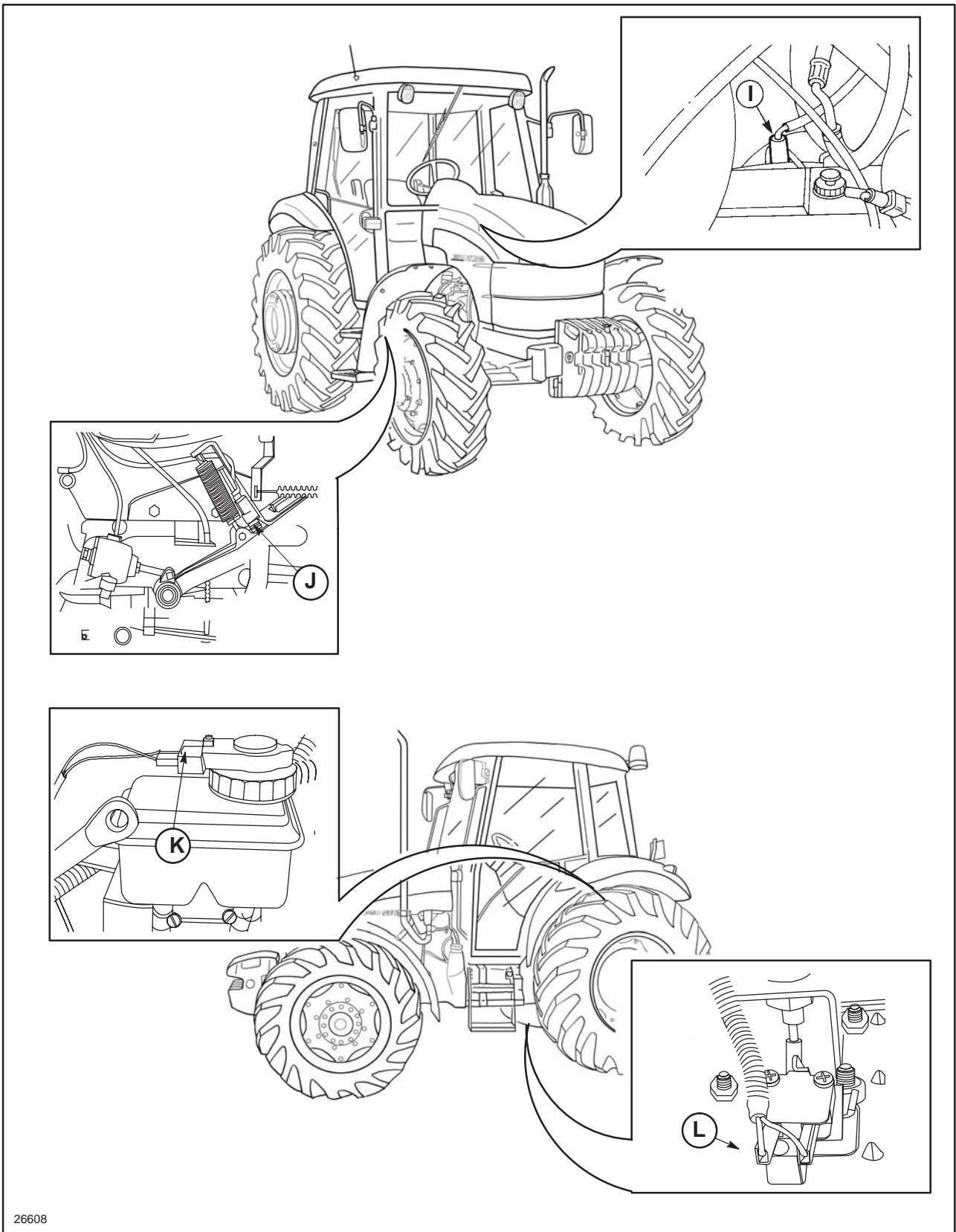

26608

SECTION 55 - ELECTRICAL SYSTEM

Chapter 2 - COMPONENTS

CONTENTS

Section	Description	Page
55 500	Introduction	1
	Component description	1

55 500 INTRODUCTION

The components described in this section are located on the instrument console (rear hood), in the cab roof and on the right-hand fender, inside the cab.

INSTRUMENT CONSOLE CONTROLS

Lights control lever.

The lever operates external lights, horn and the direction indicators.

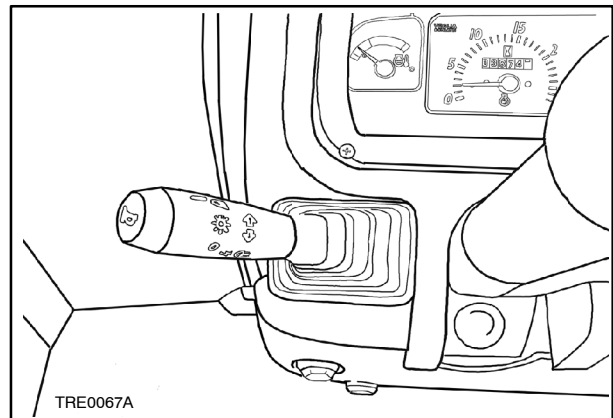

1

REAR HOOD CONTROLS

Starter switch

To operate the four switch functions, turn the key (1) through the following positions:

- A.** No power to circuits (key can be removed).
Engine stopped: automatic activation of fuel injection cut-off.
- B.** Control instrument and indicator power supply.
Power supplied to various circuits.
- C.** Starting the engine: when released, the key returns automatically to position (B).
- P.** Parking lights on, instrument panel lighted (key removable).

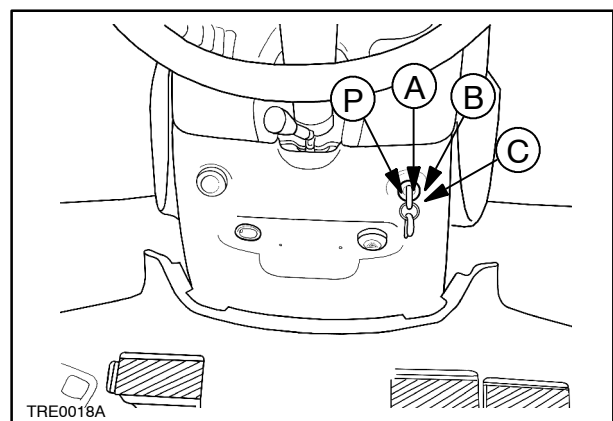

2

1. Starter switch.
2. Thermostarter.
3. Hazard warning lights switch.
4. Cigar lighter

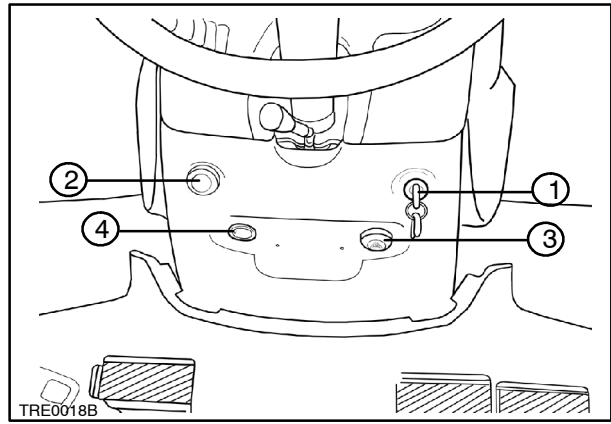

3

1. Rotating beacon switch (tractors without cab).

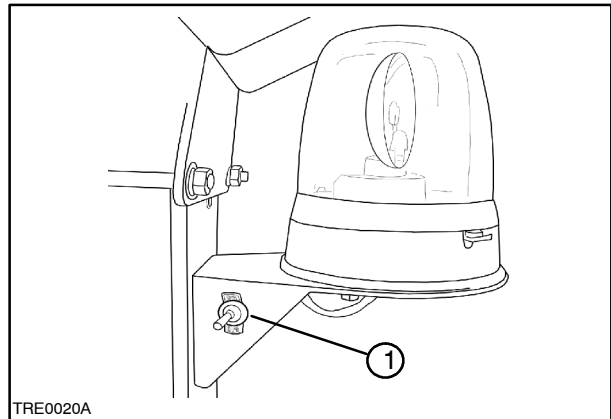

4

IN-CAB CONTROLS

Fender-mounted controls

1. Windscreen washer,
2. Windscreen wiper,
3. Front working lights,
4. Rear working lights and
5. Beacon controls (with cab)

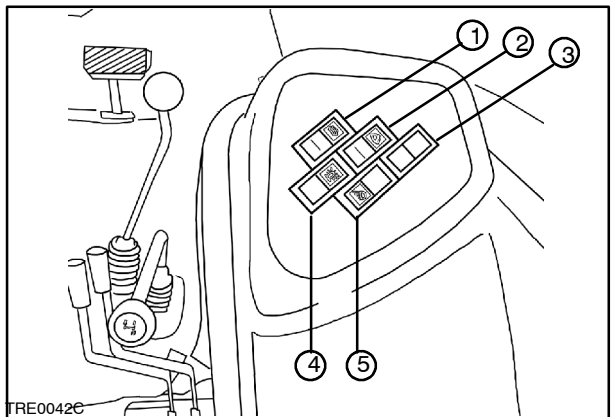

5

Heating and air-conditioning controls

1. Electric fan speed control
2. Heating control
3. Air-conditioning control

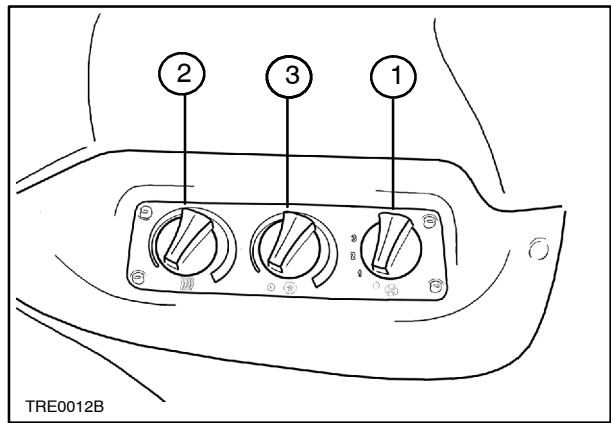

6

Radio

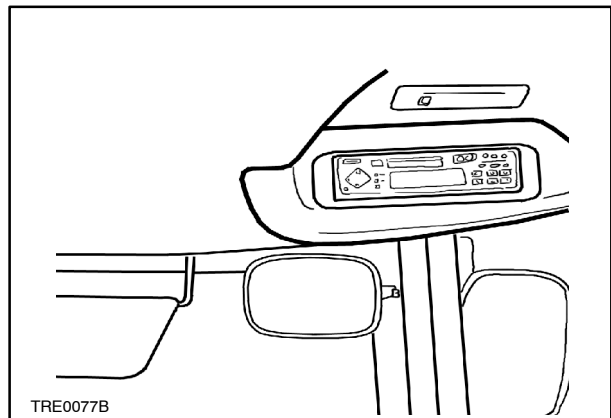

7

SECTION 55 - ELECTRICAL SYSTEM

Chapter 3 - STARTING SYSTEM

CONTENTS

Section	Description	Page
55 000	Specifications	1
	Tightening torques	1
	Description and Operation	2
	System testing	4
55.201.50	Removal and re-installation of starter motor	7
	Section	8
55.201.54	Overhaul - disassembly and reassembly	8
	Bench tests	10

55 000 TECHNICAL INFORMATION

CHARACTERISTICS	TD60D	TD70D	TD80D	TD90D	TD95D
Starter motor	BOSCH				
Power (kW)	2.5		3.5		
Maximum current drain without load (Amp)	60 A at 11,6 V and 8600 rev/min		160 at 11.5 V and 8000 rev/min		
Minimum brush length (mm) (in.)	-		7.0 (0.2756)		
Minimum switch diameter (mm) (in.)	42 (1.6535)		42.5 (1.6732)		
Maximum armature shaft end play (mm) (in.)	0.5 - 0.8 (0.0197 - 0.0315)		0.4		

TIGHTENING TORQUES

	Nm (ft lb)
Starter motor and engine block fastening bolts	34 (25.0771)
Box on starter motor/earth (ground) cable side	16 (11.8010)
Solenoid valve wire nuts	7 (5.1629)
Box nuts on starter motor side	10 (7.3756)
Solenoid valve fastening bolts	5 (3.6878)

DESCRIPTION AND OPERATION

The starting system installed depends on the type of gearbox fitted on the tractor. All systems consist of an ignition key switch, heavy-duty wiring, a starter motor with solenoid, a start-up relay and a clutch pedal switch. These are the basic circuit components used on versions with mechanical gearbox. More sophisticated systems include other components, which ensure the engine can be started only under the proper conditions.

There are four types of gearbox: with range reduction gear (synchro command), with range reduction gear and inverter (shuttle command). The starting circuit is illustrated in figure 1.

There are two available types of starter motors: 2.5 kW or 3.5 kW rating. They both have four poles, four brushes with integrated solenoid and positive mesh engagement control.

The solenoid consists of two coils connected in parallel. The low resistance pull-in coil is earthed (grounded) via the engine, while the high resistance hold-in coil is earthed (grounded) via the solenoid body.

When the ignition switch is closed, with the clutch pedal depressed and gear in neutral (except in the case of mechanical gearboxes), the coils are energised and the plunger is magnetically drawn inside the solenoid. This movement, transmitted by

means of a flexible joint mechanism, makes the driving pinion engage the flywheel ring gear. The moment the pinion touches the ring gear, the plunger closes a series of contacts and powers all four field windings directly from the battery, thus giving full power to the starter motor.

At this stage, one end of the pull-in coil is connected to the positive battery pole through the starter switch, while the other end in connected to the positive pole through the solenoid valve contacts. The pull-in coil is thus bypassed, without absorbing power, and the hold-in coil alone keeps the plunger in position.

The starter motor includes a series of contacts and a two-part solenoid plunger which completely closes the contacts even if the pinion teeth are not perfectly in line with the ring gear. When this happens, a clutch spring compresses the pinion, forcing it to connect completely as soon as the starter motor starts turning.

When the key ignition switch is released, power is taken from both the solenoid and the motor. The solenoid return spring, acting on the flexible joint mechanism, frees the driving pinion from the gear and opens the solenoid valve contacts again.

A roller type clutch is incorporated to the driving pinion group. This prevents the pinion from overspeeding if it stays engaged with the flywheel ring gear after the engine has been started.

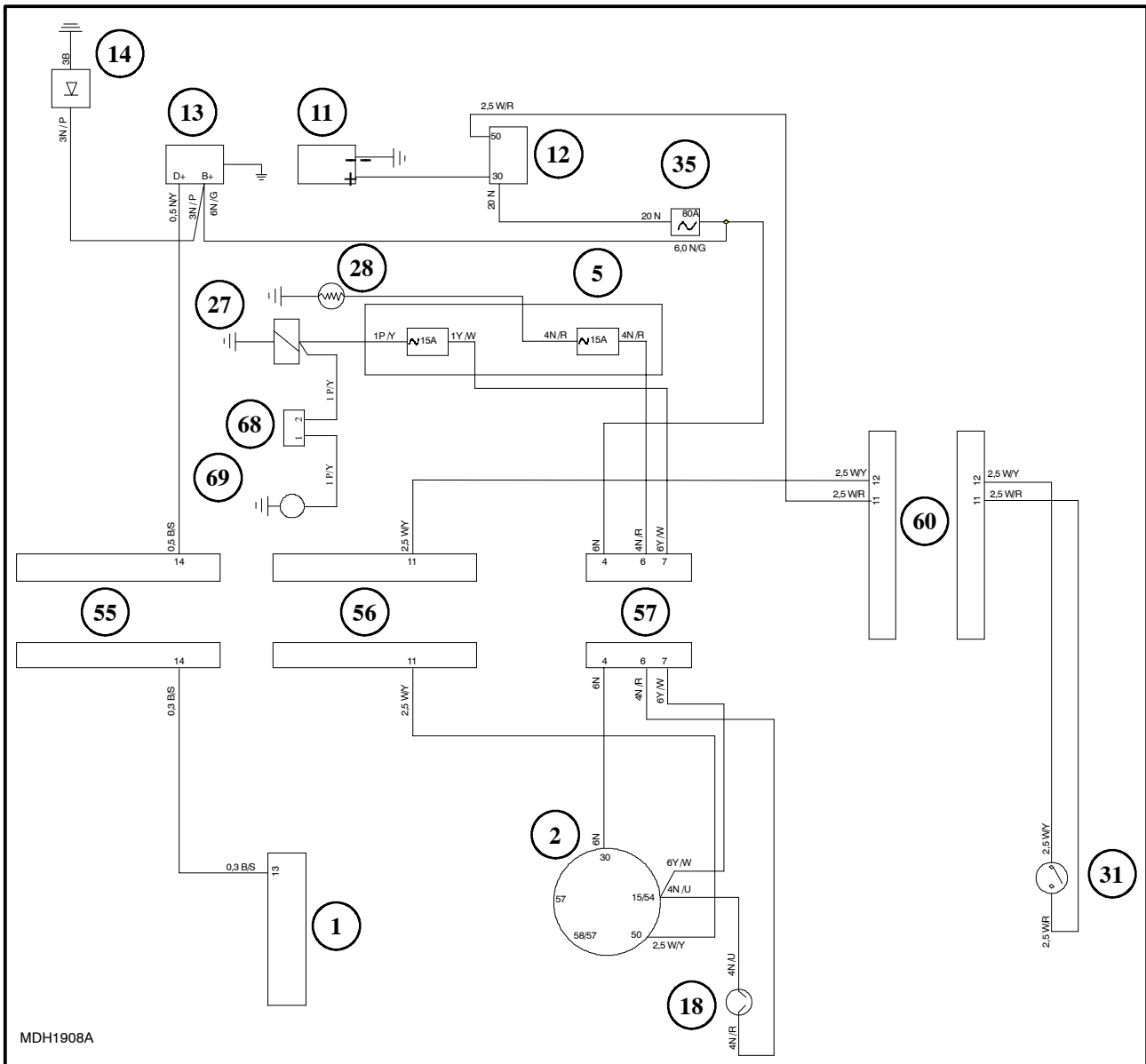

STARTING CIRCUIT

- | | |
|-------------------------------------|------------------------------------|
| 2. Starter switch | 31. Safety start unit |
| 5. Fusebox | 35. Main fuse |
| 11. Battery | 55. White (15 pin) connection |
| 12. Starter motor | 56. Black (15 pin) connection |
| 13. Alternator | 57. (8 pin) connection |
| 14. Circuit breaker | 60. (15 pin) connection |
| 18. Thermostarter pushbutton | 68. Thermostatic switch |
| 27. Engine shut-down solenoid valve | 69. Advance cut-out solenoid valve |
| 28. Thermostarter | |

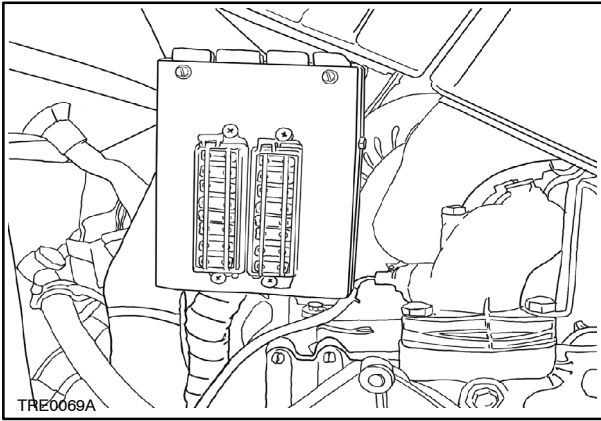

Fuse panel

2

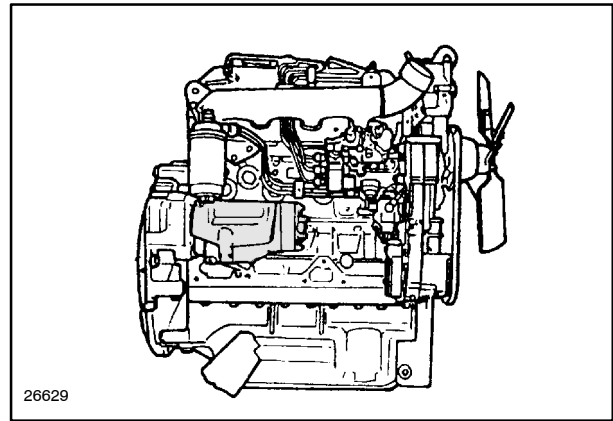

Starter motor

3

SYSTEM TESTS

STARTING SYSTEM ON TRACTOR TEST

To easily and quickly trouble-shoot the starting system problems and reach conclusive results, it is recommended that you use a battery/starting tester (high discharge multimeter) with incorporated 0-20V voltmeter and 0-500 A ammeter.

When using testing devices, follow test procedures recommended by the manufacturer. If you do not have access to testing devices, carry out the following test using a normal 0-20V voltmeter and a 0-500 Amp ammeter in order to check correct starter motor functioning without removing it from the engine.

Before carrying out the test:

- check the battery is fully charged;
- check that no wires in the starting system are broken or frayed and that there are no loose connections;
- check the engine is not seized.

POWER ABSORPTION IN STARTER MOTOR CIRCUIT (Fig. 4)

1. Disconnect earth (ground) (negative) battery cable (3).
 2. Disconnect positive battery cable from starter solenoid. Connect the positive ammeter point (1) to the positive battery terminal clamp and the negative point to the solenoid input terminal.
 3. Reconnect earth (ground) (negative) cable to negative battery terminal clamp (3).
 4. Connect the positive voltmeter point (2) to the positive battery terminal clamp and the negative to the negative battery terminal clamp.
5. Disconnect the wire from the injection pump shut-off solenoid.
 6. Run the engine and note voltmeter and ammeter readings. Voltage must be constantly about 12V and absorption in the range of 250-300 A.
 - If absorption corresponds to the readings above, then the starter motor (4) fig. 4, is working correctly. If voltage drops during the test, follow "Resistance in starting system circuit" procedure (see relative paragraph).
 - If absorption is higher than the readings above, check the circuit as follows. If the starting system circuits are in good condition, then the starter motor is malfunctioning and must be removed for further examination.
 - If absorption is lower than the readings above, the starter motor is malfunctioning and must be removed for further examination.

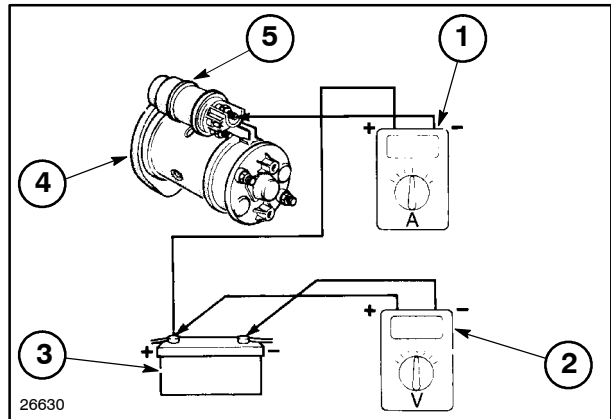

4

RESISTANCE IN IGNITION SYSTEM CIRCUIT (VOLTAGE DROP) (Fig. 5)

If there is a higher than necessary power absorption, check the circuit to find the cause of the voltage drop occurring within circuit components.

IMPORTANT: Disconnect the injection pump solenoid fuel closing wire.

POSITIVE BATTERY CABLE

1. Connect the positive voltmeter point (1) to the positive battery terminal clamp (2).
2. Connect the negative voltmeter point to starter motor solenoid terminal (3).
3. Run the engine and check the readings on the voltmeter. If voltage is higher than 0.2 V., check and tighten wire connections. Check voltage again and if it is still high install a new battery cable.

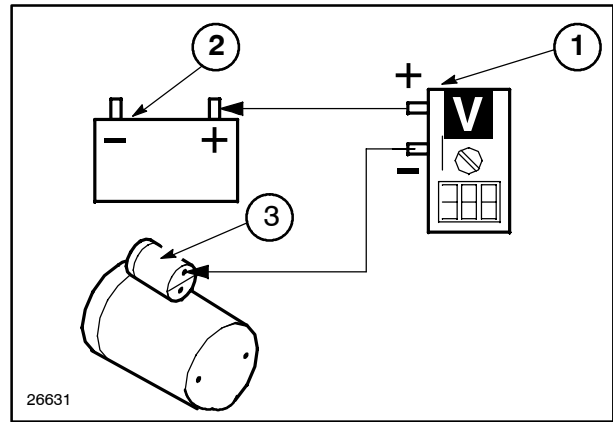

5

STARTER MOTOR EARTH (GROUND) (Fig. 6)

1. Connect the positive voltmeter point (1) to the starter motor casing (2).
2. Connect the negative voltmeter point to the engine block (3).
3. Run the engine and check the readings on the voltmeter. If voltage is higher than 0.2 V., check earth (ground) connections between the starter motor flange and the rear engine cover.

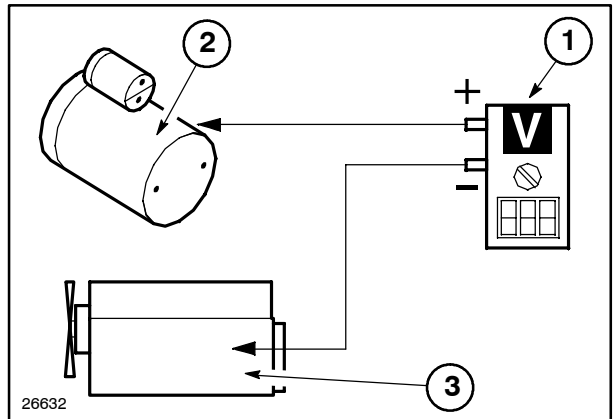

6

BATTERY EARTH (GROUND) CABLE (Fig. 7)

1. Connect the positive voltmeter point (1) to the engine block (2).
2. Connect the negative voltmeter point to the negative battery terminal clamp (3).
3. Run the engine and check the readings on the voltmeter. If voltage is higher than 0.2 V., check and tighten the earth (ground) cable connections. Check the voltage again and if it is still higher, then install a new earth (ground) cable.

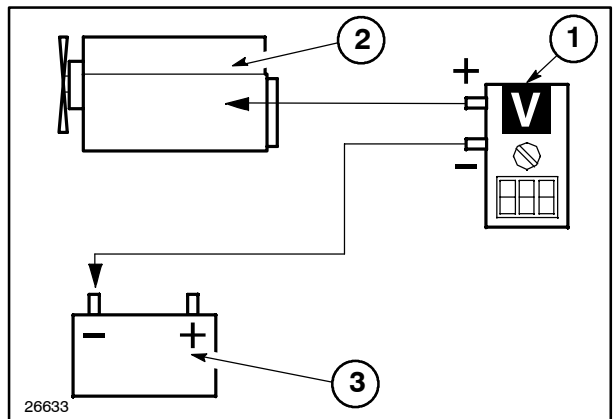

7

STARTER MOTOR REMOVAL AND RE-INSTALLATION (Fig. 8) (Op. 55 201 50)

1. Disconnect negative battery cable.
2. Unscrew the nut and bolt (1) and remove the protection cover (2) from starter motor (3).
3. Unscrew the nut and remove power clamp (5) and emergency switch clamp (4).
4. Remove the starter motor securing bolts (6) and remove the starter motor.
5. To re-install the starter motor, reverse the order of removal.

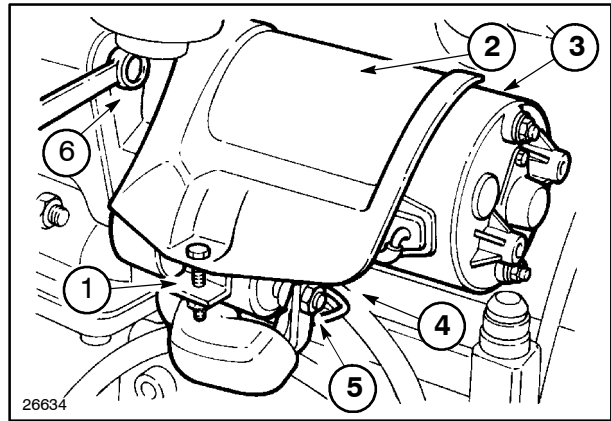

8

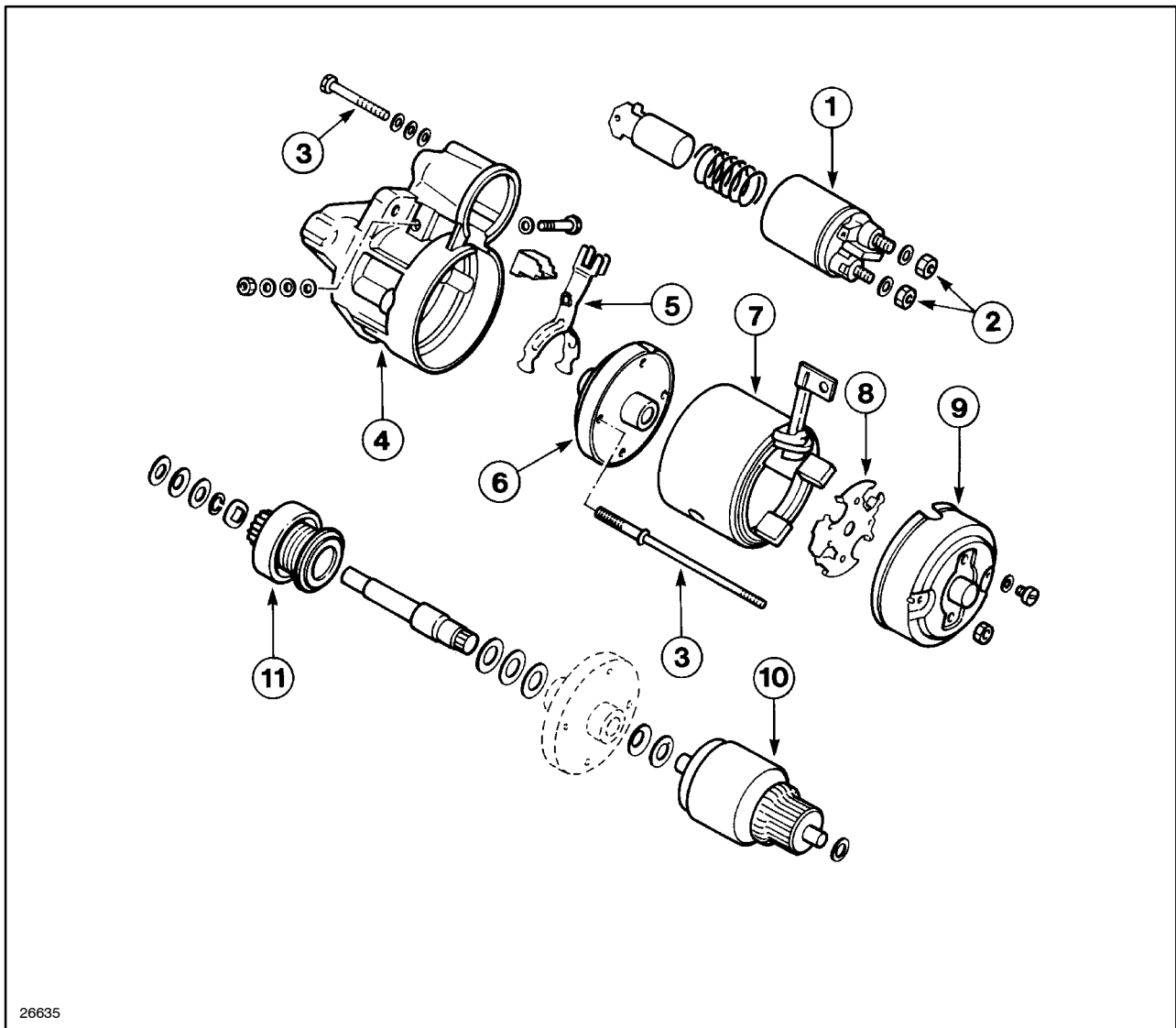

26635

9

Starter motor components

- | | |
|-------------------------|------------------------------|
| 1. Solenoid | 7. Field windings and casing |
| 2. Solenoid bolts | 8. Brush holder |
| 3. Bolt and stud group | 9. Brush plate |
| 4. Control side support | 10. Armature |
| 5. Lever | 11. Clutch |
| 6. Reducer | |

SERVICING**DISASSEMBLY (Op.55 201 54)**

Refer to figure 9.

1. Place the starter motor in a vice with protected jaws.
2. Disconnect the biggest braided wire which runs from the field winding casing to the solenoid.
3. Remove the three screws from the front casing and remove the solenoid. Note that the plunger will remain connected to the control lever.
4. Remove solenoid plunger from the control lever by holding and lifting it at the front in order to unclip it from the lever.
5. Remove the two nuts from the rear casing and the two screws which fasten the rear cover and brush plate to the casing. Remove clamp C and armature shaft end play spacers, leaving the brush gear on the commutator. Remove the thin metal washer on the commutator side of the armature.
6. At this stage of the procedure, check the brushes and commutator. Check that the brushes are not sticking and, if necessary, clean the brushes and their respective channels with a rag and solvent. Check the brushes are not worn. If they are worn and minimum length is less than that shown in the technical information table, it will be necessary to change the starter motor.

NOTE: *The brushes are not serviced separately. They are welded to their support and will not be changed for the whole operating life of the starter motor.*

7. Remove the motor casing from the armature and the control side bracket.
8. Remove the control lever knuckle pin from the control side of the casing.
9. Remove the retaining ring which holds the control group and the inner plate from the armature shaft, by first removing the pressure collar perpendicularly from the retaining ring support by means of an appropriately sized tube. Then lever the retaining ring from the groove.
10. Remove armature and control group.

REASSEMBLE

1. To reassemble the starter motor, reverse the removal procedure.

Before reconnecting, test the armature shaft end play and test the starter motor without load.

ARMATURE SHAFT END PLAY

1. Place the starter motor in a vice with protected jaws and connect a dial gauge to the flange on the control side of the casing. Position the dial gauge pointer on the end of the armature shaft.
2. Push the armature forward and reset the gauge to zero. Push the armature back as far as it will go and note the gauge reading.
3. Readings must fall within the limits specified in the technical information table. If the value is higher, check that armature and brush plate are not worn. Change the worn components, as necessary, and check end play again.

STARTER MOTOR TEST WITHOUT LOAD (Fig. 10)

NOTE: A fully charged battery and a battery/starting tester (high discharge multimeter) with carbon battery (variable load resistance) are needed to carry out this test.

1. Place the starter motor in a vice with protected jaws.
2. Connect negative battery cable (4) to the starter motor flange.
3. Bridge the solenoid contacts (6) with a short wire (7).
4. Connect the positive voltmeter point (3) to the positive battery terminal clamp and the negative voltmeter point to the negative battery terminal clamp. Connect the ammeter positive point (1) to the positive battery clamp (4) and the negative point to the battery or to the starter motor terminal clamp.
5. Place a manual tachometer (5) on the end of the armature shaft. Check maximum power absorption. This value is specific for each starter motor and must be included in the range of values in the TECHNICAL INFORMATION table. Regulate carbon battery voltage (2) and armature speed according to the information in the technical information table.
6. If the starter motor does not work according to the technical information specification, check if there are earthed (grounded) field windings, if the armature is scuffed or scraped or if the shaft is misshapen or otherwise damaged.

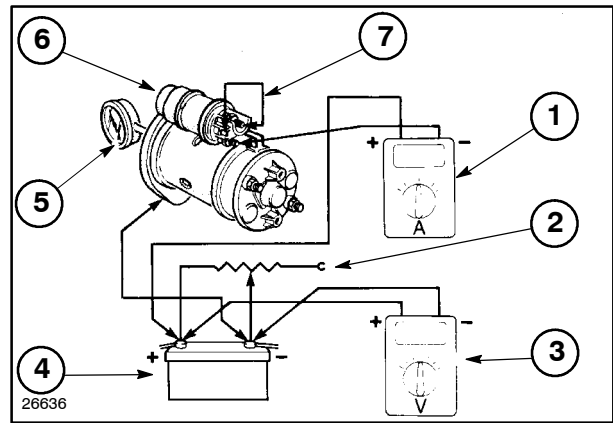

10

BENCH TESTS ARMATURE (Fig. 11)

1. The commutator surface must be clean and not burnt. If burning needs to be removed, use fine sandpaper and not abrasive fabric (emery cloth). Finally, clean the commutator with a rag and solvent.
2. If the commutator needs refacing, check it is not smaller than the minimum value specified in the TECHNICAL INFORMATION table. After refacing, the commutator must be polished with sandpaper and cleaned with a rag and solvent.

NOTE: Do not cut the armature metal when making insulation slots.

3. Armature insulation can be checked by connecting an ohmmeter (1) between commutator segments and armature shaft. This reading should show infinity, in other words there should be no continuity.
4. To test there are no short circuits, use an appropriate testing device. The only alternative is to try changing the armature.
5. If the armature circumference has obviously been in contact with pole pieces, the pole bearings are probably worn. First check the pole pieces are fixed and that the armature spins well in a lathe. If necessary, change the armature bearing.

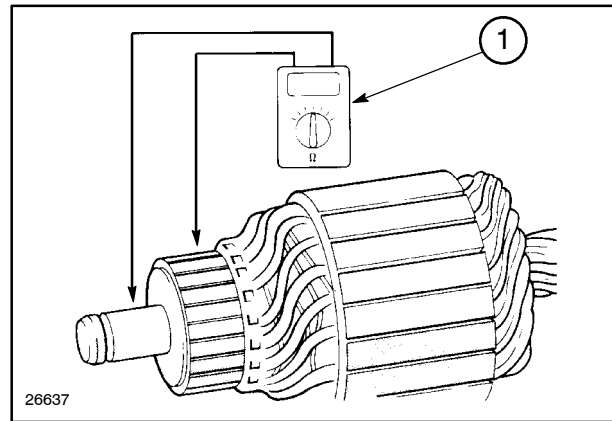

11

FIELD WINDINGS (Fig. 12)

1. To test field winding insulation, connect an ohmmeter to each of the coil brushes in turn and to a clean and unpainted area of the casing. There should be no readings, that is, there should be no continuity.
2. To test coil continuity, connect an ohmmeter to each of the coil brushes in turn and to the main power clamp (biggest braided wire). The reading should be 1 Ω .
3. If there is a failure in the field windings, then it will be necessary to change the whole box and field winding system.

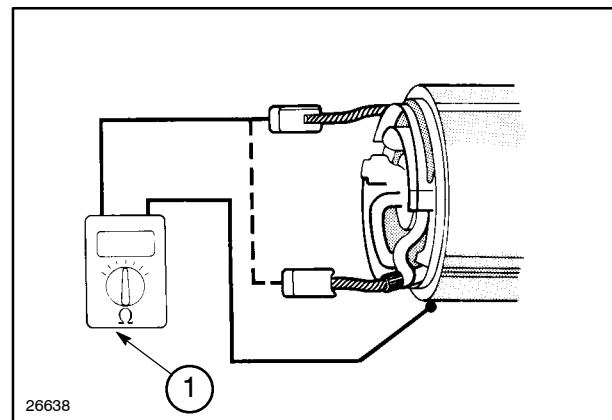

12

BEARING BUSHINGS

1. Check if the bushing on the brush plate and in the box on the pinion side are worn. Assemble the armature shaft and note play. Change the bushing if there is too much play. Check the field poles to see if there are any signs of scraping against the casing. This can also be caused by a worn bushing.

DRIVING PINION

1. Check the roller clutch operation. The pinion must spin clockwise only. If the pinion is either seized or spins in both directions, or if the pinion teeth are damaged, assemble a new control group.

If there is clear evidence of damage to the pinion teeth, check the flywheel ring gear, as described in section 10, Engines.

SECTION 55 - ELECTRICAL SYSTEM**Chapter 4 - CHARGING SYSTEM****CONTENTS**

Section	Description	Page
55 000	Technical information	1
	Tightening torques	1
	Description and operation	2
	System testing and trouble-shooting	4
55.301.10	Removal, re-installation and servicing	10

55 000 TECHNICAL INFORMATION

CHARACTERISTICS	TYPE OF ALTERNATOR		
	BOSCH 14V-45, 65 and 85A		
Polarity	Negative earth		
Nominal voltage (V)	14		
Max rotation speed (rpm)	15.000		
Maximum output (A)	45	65	85
Regulator controlled voltage (V)	13.6 - 14	13.6 - 14.4	
Rotor field winding resistance (Ω)	3.4- 3.8	2.9	
Stator field winding resistance (Ω)	-	0.2	
New brush length (mm) (in.)	-	20 (0.7874)	
Minimum brush length (mm) (in.)	-	5 (0.1969)	
Brush spring force (N) (lb)	-	1.3-2.7 (0.29-0.60)	

TIGHTENING TORQUE

	Nm (ft lb)
Alternator fastening bolts	5.5 (4.0566)
Pulley fastening nut	70 (51.6293)
Rectifier fastening screws	4.0 (2.9502)
Brush box and regulator screws	2.7 (1.9914)
Terminal nuts	2.7 (1.9914)

DESCRIPTION AND OPERATION

ALTERNATOR DESCRIPTION

Either a Magneti Marelli or a Bosch, 45 or 65 A, alternator, with external cooling fan, is fitted on all models. Stator winding is ventilated with an air conducting diaphragm in the support on the rectifier bridge side and peripheral openings in the support on the control side. The alternator, installed on the left side of the engine, is operated by a pulley and a V-type driving belt. Alternators are fitted with a built-in regulator.

45 or 65 A alternator

1. Battery connection (B+ terminal)
2. Terminal protection sheath
3. Alternator charge indicator connection (D+ terminal)

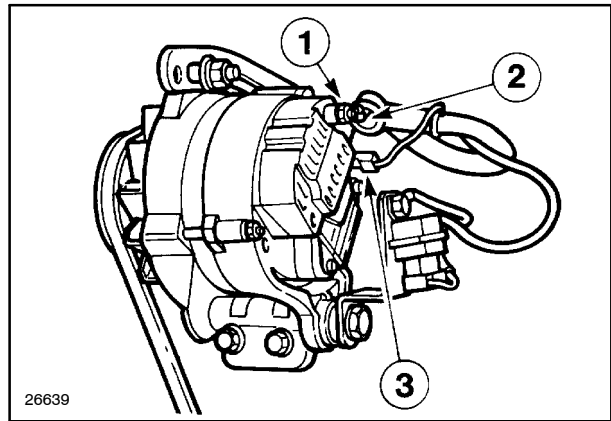

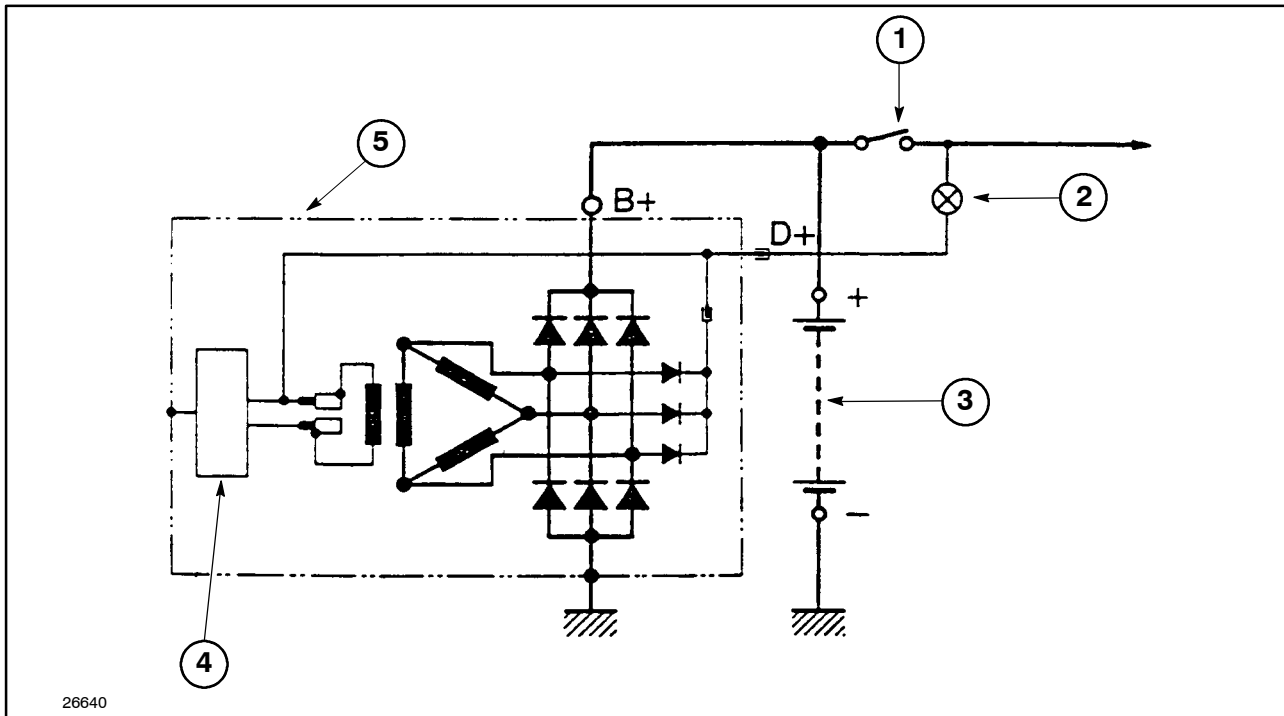

Alternator charging circuit

2

1. Ignition switch
2. Alternator charge warning light
3. Battery
4. Alternator
5. Alternator electronic voltage regulation circuit

B+ Battery connection
D+ Alternator charge indicator

ALTERNATOR FUNCTIONING

See figure 2.

When the ignition key is turned, a small current passes from the battery through the rotor field winding wiring. The circuit closes powering the charge warning light, the alternator D+ terminal, the rotor field winding, the alternator regulator and earth (ground).

At this stage, the warning light comes on and the rotor is partially magnetised.

When the engine starts and the rotor, partially magnetised, turns inside the stator windings and generates three-phase alternating current. A constant quantity of this current is transformed into direct current by three field diodes built into the rectifier.

The direct current is then reintroduced into the circuit to increase current flow through the rotor field winding.

This action causes a constant increase in the rotor magnetic field and a fast increase of current and voltage output.

As the generated voltage output (reflected by D+ terminal) increases, the warning light intensity decreases and when the voltage at the D+ terminal equals that on the battery side of the warning light, the light goes out.

Voltage increases until it reaches the pre-set regulated voltage level.

If the driving belt breaks, there will be no voltage accumulation in the alternator. The charge warning light will stay on, thus indicating a fault.

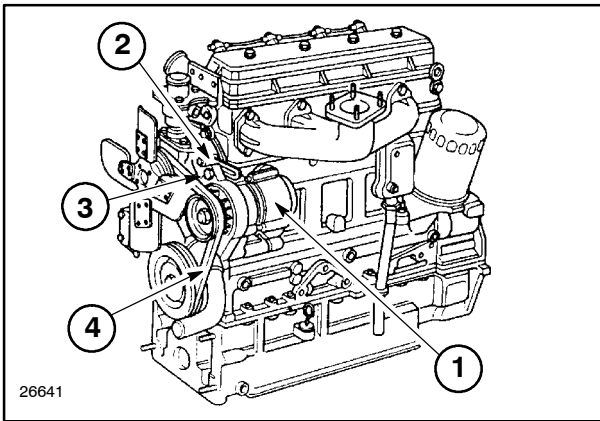

3

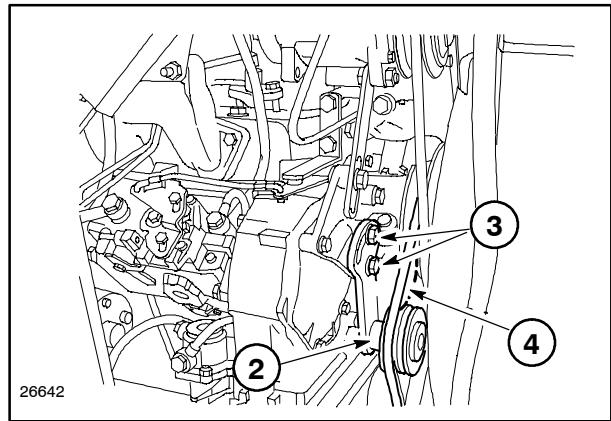

4

Fan belt tensioner

Fig. 3. Belt for versions without air conditioning

Fig. 4. Belt for versions with air conditioning

1. Alternator
2. Belt tensioner

3. Belt tensioner securing nut
4. Belt

SYSTEM TESTING AND TROUBLE-SHOOTING

PRECAUTIONS

To avoid damaging alternator charging system components, take the following precautions:

- **DO NOT MAKE OR INTERRUPT** any charging circuit connection, including the battery, while the engine is running.
- **NEVER SHORT-CIRCUIT** the alternator positive terminal to check if it is working.
- **ALWAYS DISCONNECT** battery cables when recharging the battery in the tractor with a battery charger.
- **ALWAYS CHECK** battery polarity when installing a battery or using a supplementary battery to start the engine.
- **DO NOT SHORT-CIRCUIT** regulator input/output terminals when the alternator is working.
- **CONNECT POSITIVE TO POSITIVE AND NEGATIVE TO NEGATIVE.**

PRELIMINARY CHECKS

Before carrying out these electrical tests, carefully inspect the charging system and the electrical system in general.

Check continuity in all conductors and connections. Check they are all clean and well fastened.

1. CHECKING THE BATTERY

Check all battery elements with a densimeter. The battery must be at least 70% charged and efficient.

2. CHECKING THE DRIVING BELT

Inspect the alternator driving belt and pulley, checking that they are both clean, with no traces of oil or lubricant and in good condition.

Check the alternator driving belt tension regularly. If you suspect the belt is not tight, check the tensioner as follows:

Belt for versions without air conditioning (Fig. 3)

- slacken the nut (3) which secures the alternator to the tensioner bracket (2).
- with a lever, move the alternator (1) on the tensioner bracket (2) to reach correct belt tension and tighten the securing nut (3) to 55 Nm (40.5659ft lb).

Belt for versions with air conditioning (Fig. 4)

- slacken the belt tensioner securing nuts (3)

- hold the belt tensioner arm (2) and move it on the bracket to reach the correct belt tension, then tighten the securing nuts (3) to 55 Nm (40.5659ft lb).

Correct deflection values, measured by applying the following loads to the middle of the belt:

	Version without cab or with cab without air conditioning	Version with cab and air conditioning
Load (N) (lb)	78 - 98 (17.20-21.61)	60 - 75 (13.28-16.53)
Deflection (mm) (in.)	10-11 0.3937-0.4331)	10 (0.3937)

3. CHECKING THE WARNING LIGHT

Turn the ignition key and check the light is completely lit.

If the warning light does not light completely, check the light bulb. If the light bulb has not blown, carry out the alternator wiring connection tests as described in the paragraph "PRELIMINARY TESTS" in this section.

If the light is on, start the engine and run it above minimum speed. The warning light should go out.

If the warning light does not go out, stop the engine and disconnect the D+ terminal wire. If the warning

light goes out now, one of the alternator components is malfunctioning. Carry out "ALTERNATOR COMPONENT TESTS" described in this section.

If the warning light stays on, check there is no short circuit between D+ wire ending and warning light.

PRELIMINARY TESTS

These preliminary tests can be carried out without removing any components from the tractor charging circuit. These tests check:

- the alternator wire connections
- alternator charging current and controlled voltage
- voltage drop in the alternator charging circuit
- maximum alternator output

The following testing devices are required:

- 0-30V moving coil voltmeter
- 0-1V millivoltmeter
- 0-110 A moving coil ammeter
- 1.5 ohm, 110 A varying load resistance

NOTE: Most testing devices on the market today combine several electrical test functions (multimeters). When using these devices, follow the manufacturer's instructions.

1. ALTERNATOR WIRE CONNECTIONS TEST

See figure 5.

1. Disconnect the battery.
2. Disconnect B+ (2) and D+ (3) alternator terminals.
3. Reconnect the battery and turn the ignition key into position ON but without starting the engine. Connect a voltmeter (4) between each terminal and earth (ground) (1). There must be voltage at the battery.

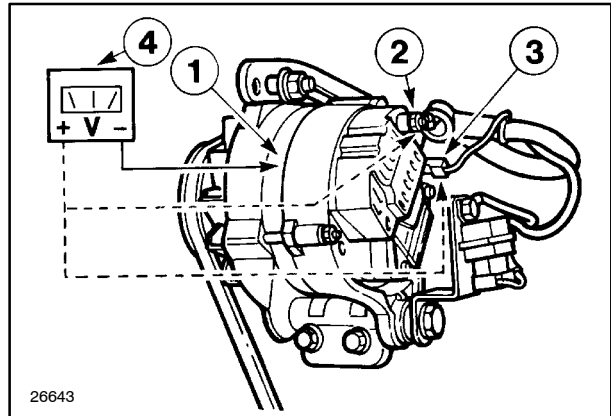

5

If there is no voltage at the battery, check for a continuity fault in the external wiring. See circuit diagram in figure 2.

4. Connect D+ terminal, warning light wire (red) and earth (ground). The warning light should illuminate.
5. Disconnect the battery and reconnect the cables to the alternator at (2) and (3) fig. 5.

NOTE: *If the warning light does not light up when the wire is connected to the alternator, this means that there is a fault either in the alternator regulator circuit or in the rotor circuit. Check D+ terminal is clean and then test the alternator components as described in this section.*

2. CHARGING CURRENT AND REGULATED VOLTAGE TESTS

See figure 6.

1. Check that all tractor electrical devices are switched off and the ignition key is in the OFF position.
2. Disconnect the negative battery terminal clamp and the B+ negative alternator terminal.
3. Connect an ammeter (1) between the disconnected wire (red) (4) and the B+ alternator terminal (3).
4. Connect a voltmeter (2) between the B+ alternator terminal (3) and earth (ground).
5. Reconnect the battery. Start the engine and run it at 2000 rev/min. Note the readings on the voltmeter and the ammeter.

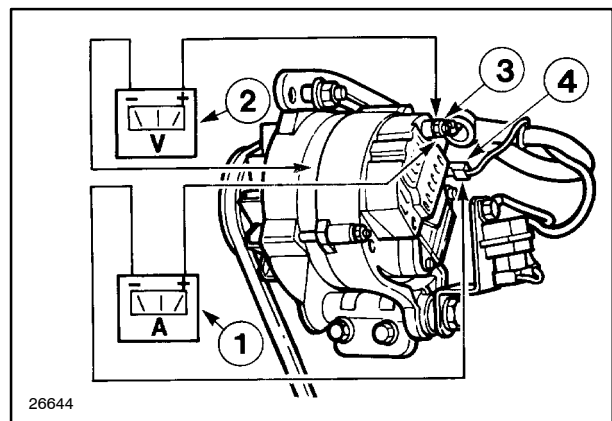

6

The voltmeter reading should be higher than the battery voltage and when the ammeter reading falls below 10 A, the voltmeter reading should stabilise at 13.6 - 14 V (Magneti Marelli alternator) or 13.6 - 14.4 V (Bosch alternator).

If the voltmeter reading is higher than 14 V or 14.4 V, for Magneti Marelli or Bosch alternators respectively, the alternator regulator must be changed, as described in this section. (After installing a new regulator, carry out tests 4 and 5).

If the voltmeter reading is less than 13.6 V, there is either a faulty component in the alternator or a failure due to excessive resistance in the external charging system connections.

If the ammeter reads zero amps, then one of the alternator components is malfunctioning. Turn the engine off and carry out the alternator component test, as described in this chapter.

3. CHARGING CIRCUIT VOLTAGE DROP TESTS

(a) Insulated side voltage drop test

See figure 7.

Check the ignition key is in OFF position.

1. Disconnect the negative battery cable and the B+ alternator wire (1).
2. Connect a millivoltmeter (5) between the positive battery terminal clamp and D+ wire (3) (positive side of the wire).
3. Connect an ammeter (2) between the B+ alternator terminal and the D+ wire (negative side of the wire).
4. Reconnect the negative battery cable and connect a varying load resistance (4) with cursor in minimum current absorption position (maximum resistance) through the battery terminal clamps.
5. Start the engine and increase speed to 2000 rev/min.
6. Decrease resistance charging load (decreasing resistance) slowly until the ammeter reads 45 or 65 A, according to the type of alternator.
7. Note the reading on the millivoltmeter. This must not be higher than 400 millivolts.

A reading higher than 400 millivolts indicates malfunctioning due to excessive resistance in the external circuits.

If the alternator does not output required power and the millivoltmeter reading is less than 400 millivolts, there is a malfunctioning component in the alternator. Carry out the alternator component tests, as described in this section.

8. Stop the engine.

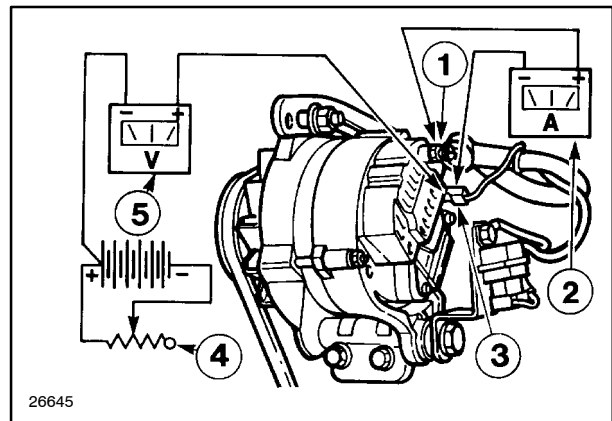

7

(b) Ground side voltage drop test

See figure 8.

1. Check the ignition key is in OFF position.
2. The circuit is the same as that described in the previous test, except that the millivoltmeter (4) is now connected between the negative battery terminal clamp and the alternator casing (negative side of casing).

NOTE: Check the varying load resistance (3) is in minimum current absorption position (maximum resistance).

3. Start the engine and increase speed to 2000 rev/min.
4. Increase resistance current load (decreasing resistance itself) slowly until the ammeter (2) reads 45 or 65 A. according to the type of alternator.
5. Note the reading on the voltmeter. This must not be higher than 200 millivolts.

A reading higher than 200 millivolts indicates malfunctioning due to excessive resistance in the external circuits.

If the alternator does not output required power and the millivoltmeter reading is less than 200 millivolts, there is a malfunctioning component in the alternator. Carry out the alternator component tests as described in this section.

6. Stop the engine.

4. MAXIMUM ALTERNATOR OUTPUT TEST

See figure 9.

1. Check the ignition key is in the OFF position.
2. Disconnect the negative battery cable and the B+ alternator wire (4).
3. Connect an ammeter (5) between B+ alternator terminal (4) and D+ wire (1) (negative side of the wire).
4. Connect a voltmeter (4) between the B+ alternator terminal (5) and earth (ground).
5. Reconnect the negative battery cable. Start the engine and increase speed to 2000 rev/min.

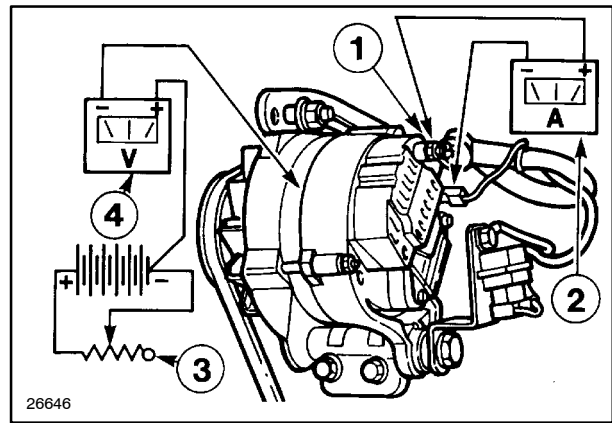

8

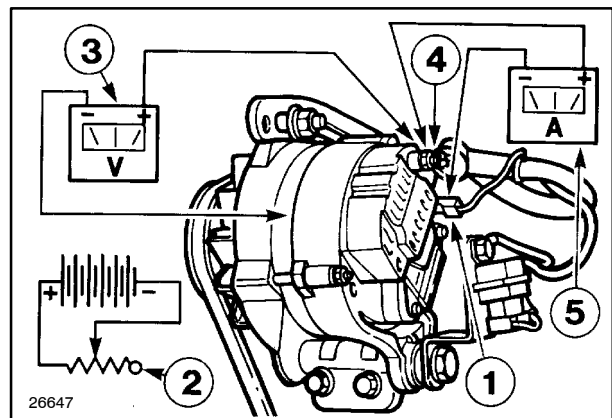

9

6. Increase resistance current load (2) (decreasing resistance) slowly until the ammeter reads 45 or 65 A., according to the type of alternator.
7. Note the reading on the voltmeter. This must not be less than 13.6 V.

A reading lower than 13.6 V. shows there is a malfunctioning component in the alternator. Carry out the alternator component tests, as described in this section.

ALTERNATOR COMPONENT TESTS

These alternator tests must be carried out only if the PRELIMINARY TESTS have shown a malfunctioning alternator component. These tests check:

- the regulator,
- rotor field winding continuity,
- rotor brushes, springs and contact rings.

NOTE: *The previously described component tests can be carried out with the alternator installed in the tractor. In order to carry out the other alternator tests, it will be necessary to remove the alternator from the tractor. Refer to the section "FUNCTIONAL TESTS" in this chapter.*

REMOVAL, REASSEMBLY AND SERVICING (Op. 55 301 10)

IMPORTANT NOTE: Before disconnecting the alternator wires, check that the ignition key is in the OFF position.

REMOVING THE ALTERNATOR

See figures 10 and 11.

1. Disconnect the negative battery cable.
2. Disconnect B+ (1) and D+ (2) wires from the alternator.

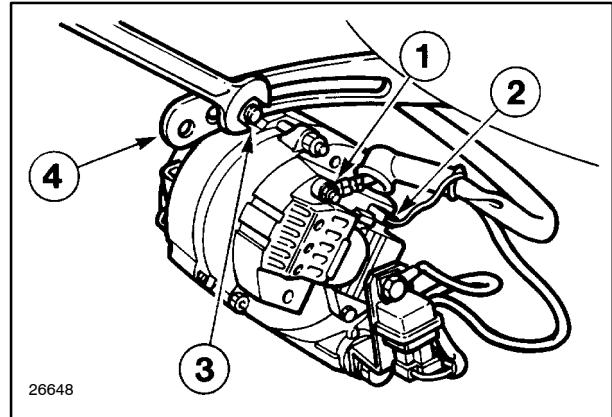

10

1. Slacken and remove the nut and bolt (3) securing the alternator to the belt tensioner (4).
2. Move the alternator to reduce belt tension (5) and remove it from the alternator pulley (6).
3. Unscrew and remove the nut and bolt (7). Remove the alternator.

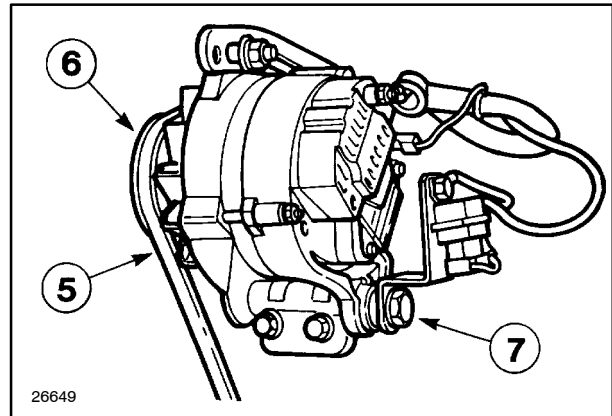

11

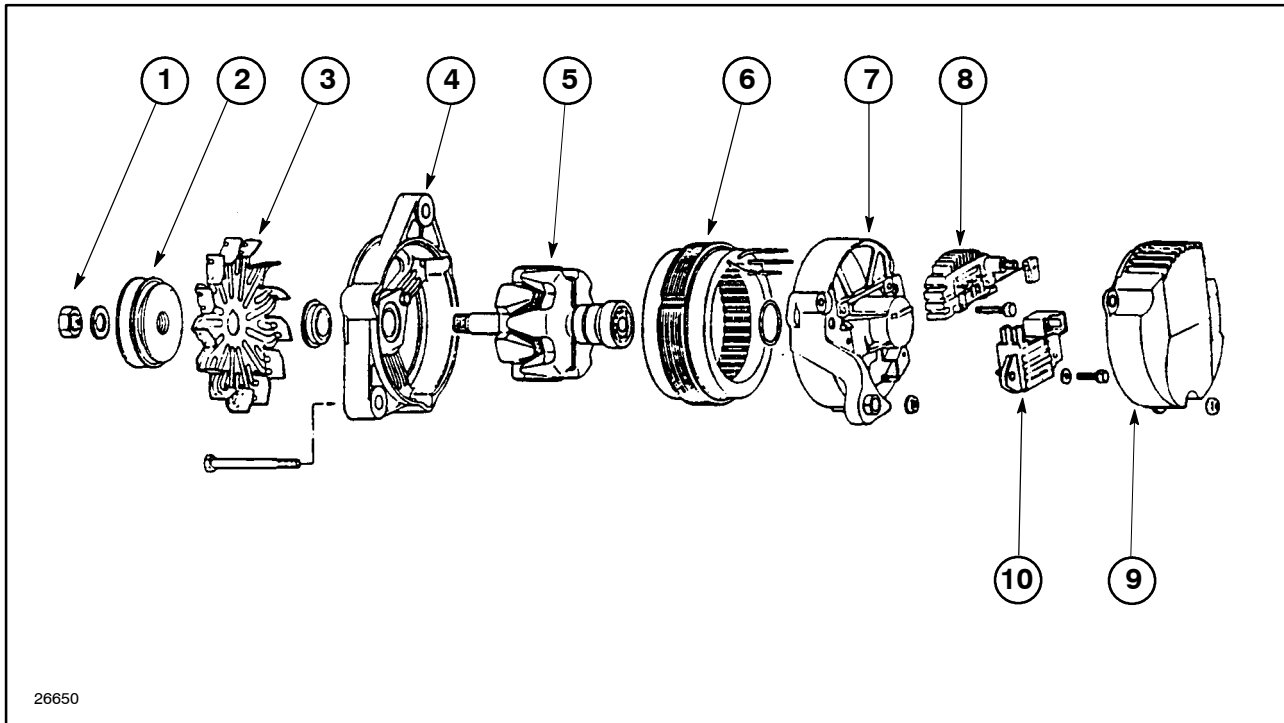

26650

Alternator components

12

- 1. Pulley retaining nut
- 2. Pulley
- 3. Cooling fan
- 4. Front support plate
- 5. Rotor

- 6. Stator
- 7. Rear support plate
- 8. Rectifier bridge
- 9. Protection guard

- 10. Electronic voltage regulator with built-in brushes

Firmly fix the alternator horizontally to an appropriate holder with internal surfaces protected with soft material.

Remove the guard (1) after unscrewing the nuts which fasten it to the alternator (Fig. 13)

Before dismantling the alternator completely, carry out the operations and tests described on the following pages.

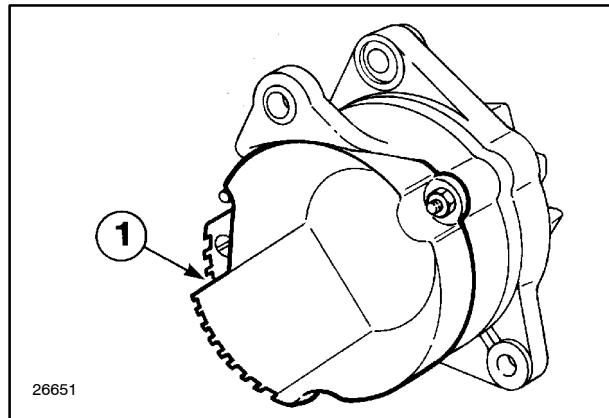

26651

13

ROTOR AND REGULATOR FIELD CIRCUIT TEST

The following testing devices are required:

- 12 volt battery
- multimeter
- 2 watt test lamp.

See figure 14.

1. Disconnect all alternator wires.
2. Connect a 12 V. battery and a 2.2 watt test lamp (2) in series to D+ (1) and alternator casing (negative side of the casing).
3. The test lamp should light up.

If the test lamp does not light up, then the rotor circuit is faulty. Check brushes, contact rings and rotor field winding continuity.

If the test shows these components are satisfactory, then the regulator may be faulty.

CHECKING THE CONTINUITY OF THREE STATOR WINDINGS

Position the points of an ohmmeter (regulated on Ω x1 scale) so that they touch the stator phase ends (a - b - c) in the three possible ways shown in figures 15, 16 and 17. Each reading should show a certain resistance value which should be the same for all three readings.

If resistance shows infinity or zero, the measured phase is either interrupted or short-circuited and the stator needs to be changed.

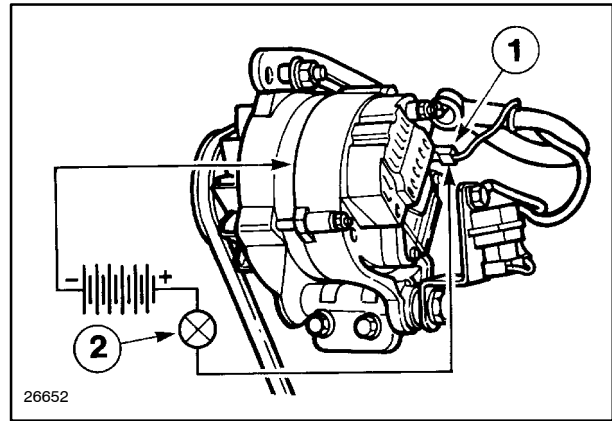

14

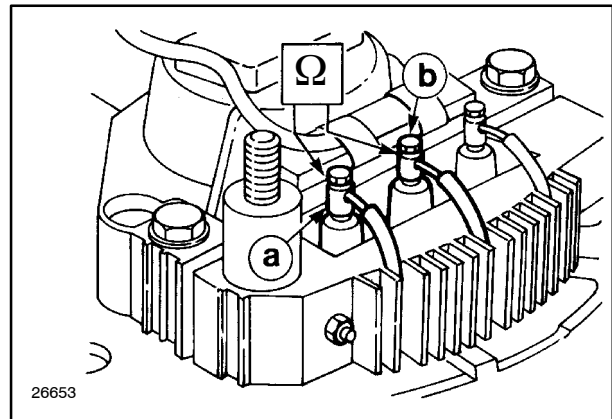

15

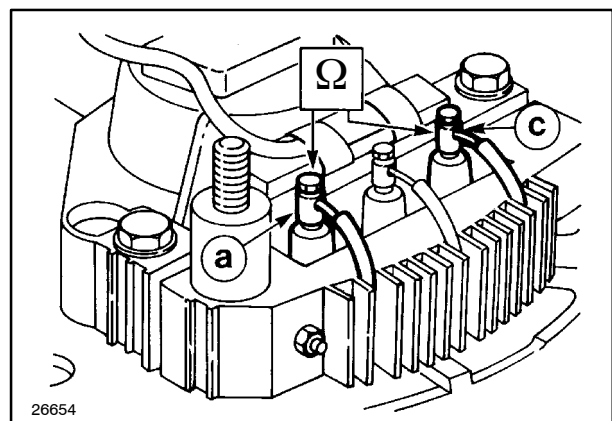

16

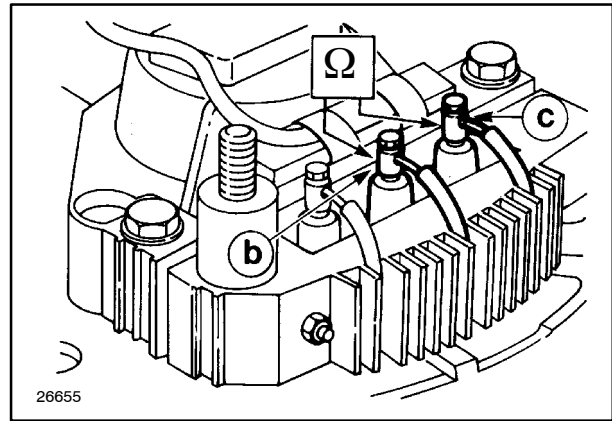

17

CHECKING THE DIODES

Disconnect the terminal wire connector (1) of the excitation diodes from the positive brush pin (Fig. 18).

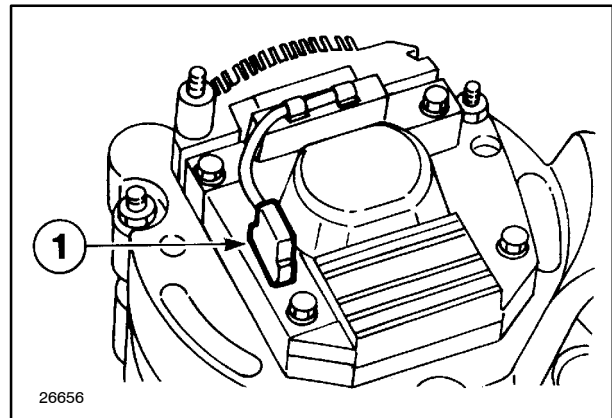

18

Unweld stator winding terminals (2) from the rectifier bridge (Fig. 19).

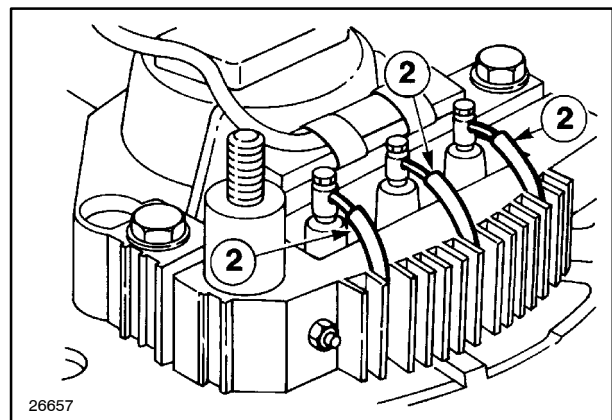

19

EXCITATION DIODES TEST

Insert an ohmmeter point in the connector mentioned above (1) (Fig. 18). The second point must be put in contact successively with each of the three terminals (A-B-C): Repeat the three measurements after reversing the instrument points (Fig. 20).

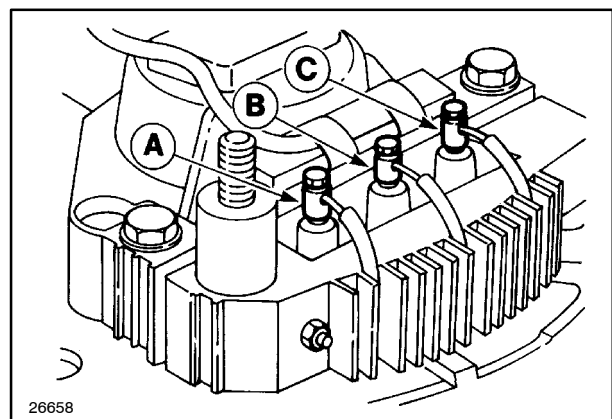

20

POSITIVE POWER DIODES TEST

Put an ohmmeter point in contact with the positive (X) alternator terminal and the other successively with each of the three terminals (A-B-C) (Fig. 21).

Repeat the three measurements after reversing the instrument point connections.

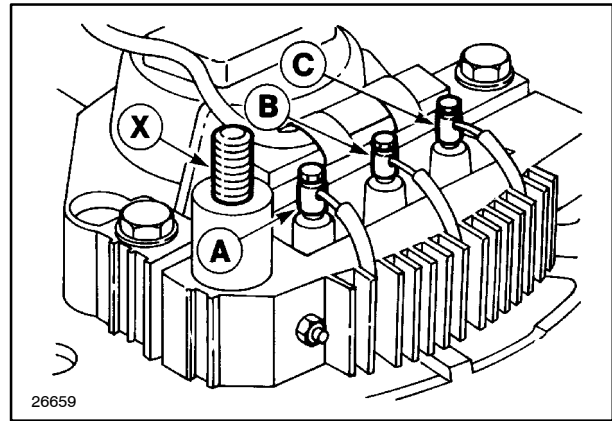

21

NEGATIVE POWER DIODES TEST

Put an ohmmeter point in contact with the negative (Y) diodes plate and the other successively with each of the three terminals (A-B-C) (Fig. 22).

Repeat the three measurements after reversing the instrument point connections.

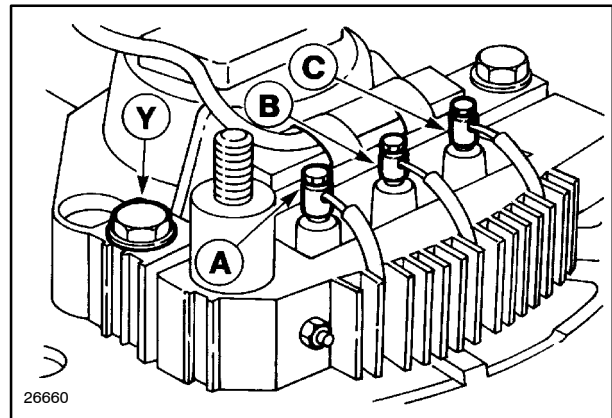

22

In the three tests described above, the instrument should show resistance at each terminal (A-B-C). Reversing the instrument point connection, there should be no resistance (Fig. 22). If there is resistance in both cases, this means short-circuited diodes. Otherwise, with a R=0 value (interrupted diode), change the whole rectifier bridge.

ROTOR

CHECK ON ROTOR WINDING RESISTANCE MEASURED BETWEEN PINS CONNECTED TO BRUSHES

Disconnect the excitation diode terminal wire connector (1) from the pin connected to the positive brush. Put both points of an ohmmeter (regulated on $\Omega \times 1$ scale) in contact with the two voltage regulator-brush holder pins. If resistance reading is different from the indicated value or if it shows infinity (interrupted circuit), check and, if necessary, change the rotor (Fig. 23).

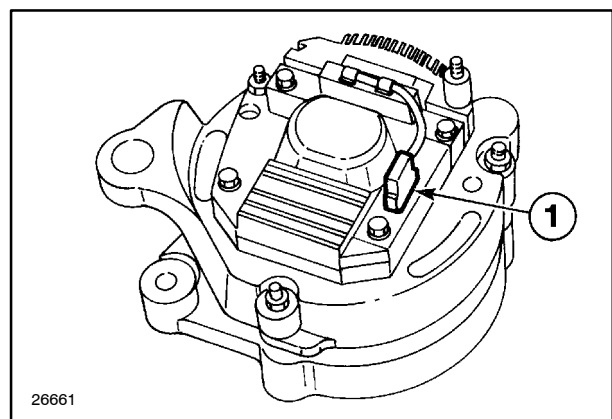

23

DISASSEMBLY (Op. 55 301 12)

Place a suitable Allen wrench in the hexagonal hole in the alternator shaft to prevent the alternator shaft from turning. With another wrench, unscrew the fan and rotor pulley fastening nut. Draw out the above mentioned parts, spacing collars and alternator washers (Fig. 24).

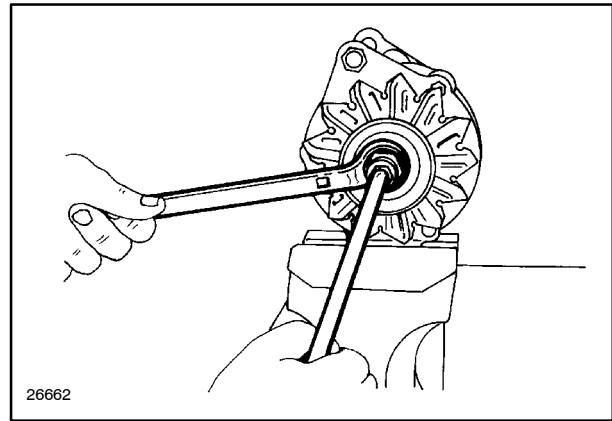

24

Disconnect the excitation diode terminal wire connector (2) from the pin connected to the positive brush. Unscrew and remove the screws (3) securing the electronic voltage regulator (4), complete with brushes, to the rear alternator support. Unscrew nuts (5) and remove the screws fastening the alternator main external parts (Fig. 25).

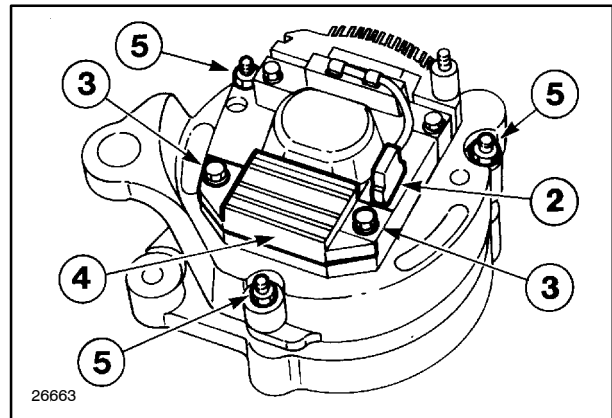

25

ELECTRONIC VOLTAGE REGULATOR (Fig. 26)

- a. Brushes
- b. Pins

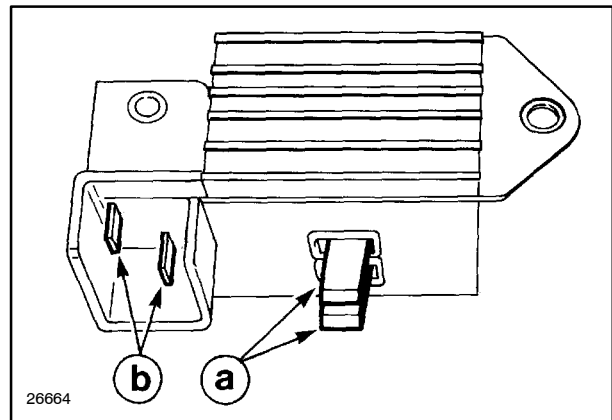

26

Separate the parts (as illustrated) bearing in mind that it is necessary to apply a considerable degree of pressure on the rotor shaft to free the front support plate (6) and the rotor (7) (Fig. 27).

If you do not have a press, use a brass drift, to avoid damaging the thread.

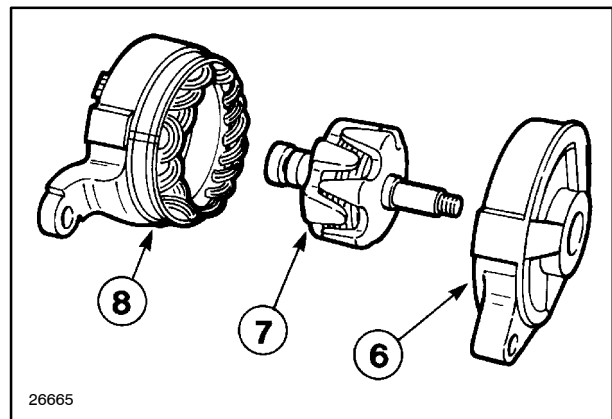

27

Unscrew the screws (9) which fasten the rectifier bridge (10) to the rear support plate (8) (Fig. 28).

The rectifier bridge must not be dismantled: the spare part is supplied as a complete unit.

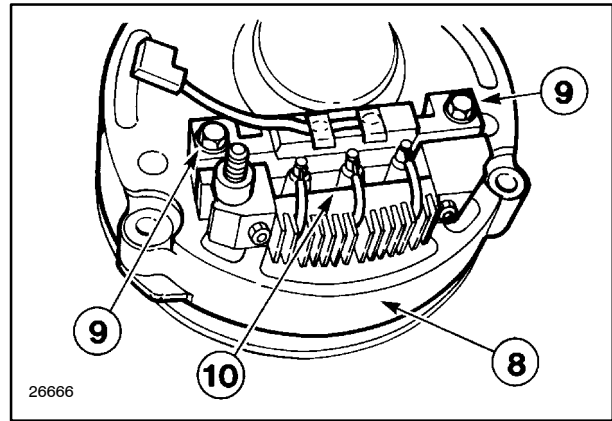

28

Separate the rectifier bridge (10) from the rear support plate. Unweld the stator winding terminals (11) (Fig. 29).

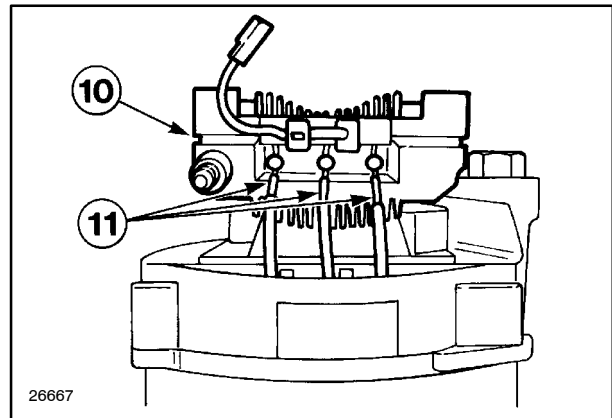

29

Separate the stator (12) and the terminals (11) from the rear support plate (8) (Fig. 30).

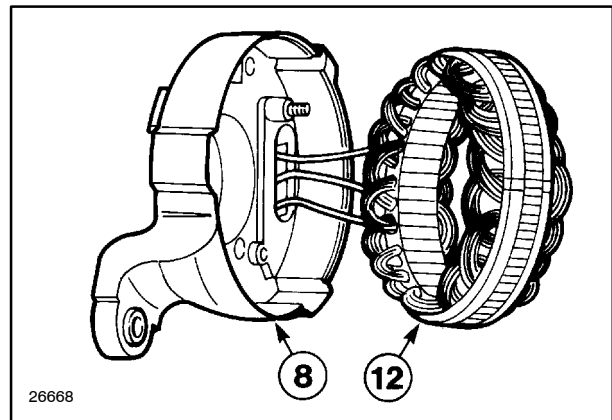

30

INDUCTOR COIL INSULATION TEST

Put both ohmmeter points (fixed at $\Omega \times 1$ scale) in contact respectively with a slip ring and the rotor casing (see arrows). The instrument should show infinity resistance. If this is not the case, change the rotor (Fig. 31).

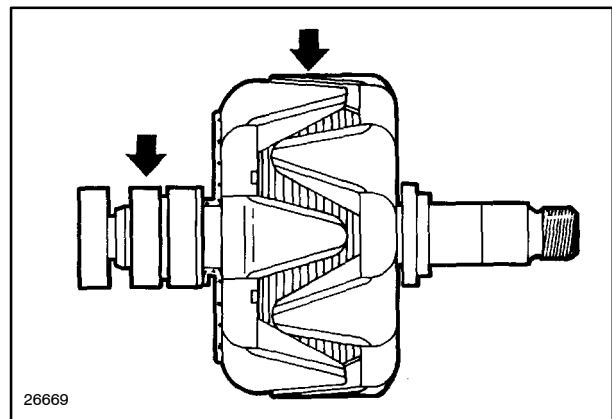

31

Check rotor inductor resistance on slip rings

Put both ohmmeter points (fixed at $\Omega \times 1$ scale) in contact respectively with the slip rings (see arrows). The instrument should show a certain degree of resistance (Fig. 32).

If the instrument reading is different from the prescribed value or shows infinity (interrupted circuit), change the rotor.

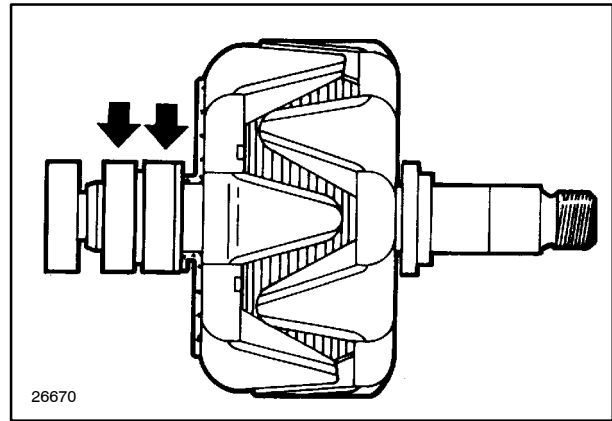

32

Check the ball bearing moves freely, without sticking or noise. Check the collectors have not been damaged by the brushes. If this is the case, change the whole rotor.

REASSEMBLY

To reassemble, reverse the order of the operations described.

SERVICING

1. Check the rotor and stator poles are not worn. If this is the case, it means the ball bearings are worn, the casings are not in line or the rotor shaft is misshapen.

NOTE: *alternator ball bearings cannot be serviced separately. When necessary, therefore, both must be changed.*

2. Unscrew the screws (1) securing plate (2) that locks bearing (3). Remove it from the front support plate (4) (Fig. 33). Check if it is worn or damaged; if so, change it. Before installing the ball bearing, check the front support plate holder and clean it carefully.
3. Installation of bearing (5) on support plate side is different from the one described above. A new rotor complete with bearing must be installed (Fig. 34).

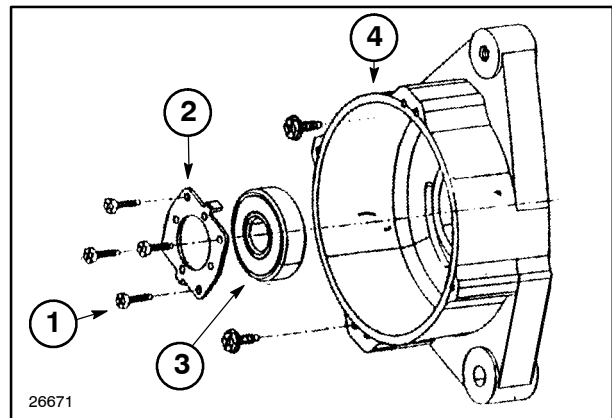

33

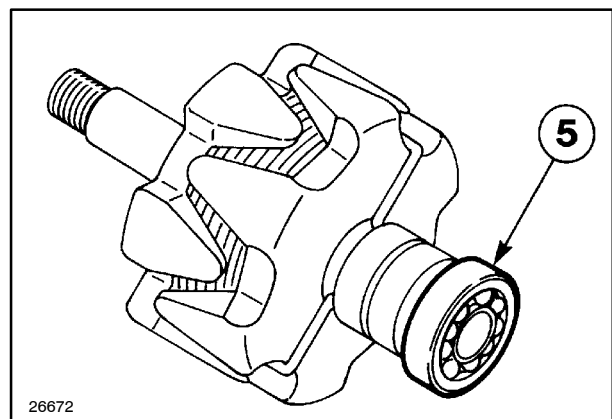

34

RE-INSTALLATION

1. Re-install the alternator by reversing the removal procedure.

During re-installation, remember to:

- Check the negative (ground) battery cable is disconnected from the battery while re-installing the alternator.
- Adjust the alternator drive belt, as described previously in this chapter.

SECTION 55 - ELECTRICAL SYSTEM

Chapter 5 - BATTERY

CONTENTS

Section	Description	Page
55 000	Technical information	1
	Description and operation	1
55.301.040	Removal and re-installation	2
	Battery checking and maintenance	3
	Charging the battery	4
	Battery problems - Frequent causes	8

55 000 TECHNICAL INFORMATION

CHARACTERISTICS	TYPE OF BATTERY	
	TD60D/TD70D/TD80D/ TD90D models	TD95D model (optional for other models)
Voltage (V)	12	
Cold start amperage (C.C.A)	1x760	1x800
Capacity (Ah)	105	120
Number of elements	6	
Number of plates per element	16	21
Energy reserve (SAE) (min.)	160	210
Weight (kg) (lb)	25 (55.12)	35 (77.16)
Earth (ground) terminal	Negative	

DESCRIPTION AND OPERATION

Both types of battery are of the "sealed, maintenance-free" type.

105 Ah batteries are fitted on TD60D, TD70D, TD80D and TD90D models. The battery is positioned in front of the radiator, in the front axle support compartment (Fig. 1).

120 Ah batteries are fitted on TD95D models with cab air conditioning and are optional for TD60D, TD70D, TD80D and TD90D models. The battery is installed above the front axle support (Fig. 2).

NOTE: "Maintenance-free" means that the battery electrolyte, in normal conditions of use, does not leak. It could leak if the battery is loaded over 14.4 V. This, in fact, causes the water to boil due to gas formed as the battery charges up completely. It can be caused by a faulty charging system, by quick charging or topping up.

The four main functions of a battery are:

- to supply a source of electricity for starting, ignition and instrument lighting and functioning.
- to control voltage in the electrical system.

- to supply electricity when the power required is higher than that produced by the alternator.
- to support inactive loads from radio and microprocessor memory.

Each element of the battery consists of positive and negative plates, positioned alternatively, one next to the other. Each positive plate is separated from the adjacent negative plate by means of a porous insulating spacer. If one of the positive plates touches a negative plate in the element, the element will short-circuit and be irreversibly damaged. The positive plates are welded to a collecting bar and form a positive terminal. The negative plates are welded to a similar collecting bar and form a negative terminal.

Each positive plate consists of a lead grid with lead peroxide pasted to the grid holes. The negative plates consist of a lead grid with lead sponge pasted to the grid holes.

The plates are covered by an electrolyte which consists of diluted sulphuric acid solution.

The battery casing is made of polypropylene.

REMOVAL AND RE-INSTALLATION (Op. 55 301 40)

REMOVAL

105 Ah and 120 Ah batteries fitted in front of the radiator (Figures 1 and 2)

1. Lift the engine hood.
2. Disconnect earth cable (ground) from tractor structure and position it safely, away from the structure itself.
3. Slacken the bolts on both terminal clamps and disconnect the positive and negative battery cables. Make sure they do not touch the battery itself.
4. Lift the battery from the tractor by the two handles at each end of the battery.

RE-INSTALLATION

Applicable to all types of battery

1. To re-install the battery, reverse the removal procedure, with the following precautions:
 - Check that the battery is clean, there are no signs of electrolyte leak and the breather covers are completely installed. Coat the terminals and clamps with a petroleum jelly (such as Vaseline). Do not use traditional lubricants as they can lead to electrolytic corrosion.
 - Check the battery compartment or support. The clamps should be clean and there should be no stones or other small objects, which could pierce the battery casing.
 - Check that terminal polarity is correct. Check terminal clamp connections are not too tight.
 - If a radio is installed, it will lose all saved data and will need to be reprogrammed. Electronic panels and microprocessors, for those models to which they are fitted, will not lose their memory function.

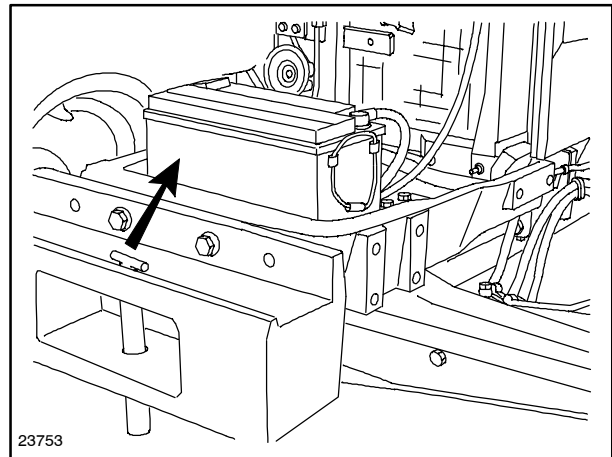

23753

1

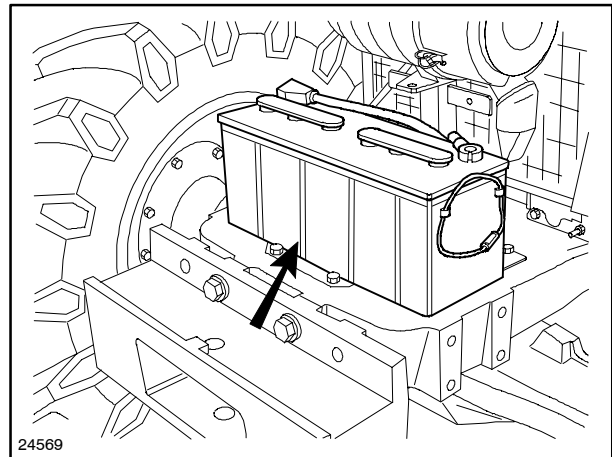

24569

2

BATTERY CHECKING AND MAINTENANCE

RELATIVE DENSITY

The relative density of the battery electrolyte shows the charge level of the battery. When the battery is fully charged, the relative density of the electrolyte, at 25°C (77°F), is at least 1.280.

Alternatively, approximate charge can be measured using a digital voltmeter (± 0.01 V) as follows:

less than	10.5 V unusable battery*
less than	11.8 V flat battery
less than	12.3 V half-charged battery
more than	12.6 V fully-charged battery

* See notes to paragraph "TESTS" for instructions on how to recuperate a slightly sulphurized battery.

Battery voltage must be registered on a flat battery considering the following:

- the battery must be flat for at least 4 hours
- if the vehicle has been used recently, or if the battery has been charged recently, switch the headlights on for 2 minutes.

When a battery is flat, the sulphuric acid in the electrolyte combines chemically with the plates and this decreases the relative density of the solution.

A battery densimeter will determine the relative density of the electrolyte in an element. A reduction in the amount of sulphuric acid in the solution will show the degree of charge of that element.

The lower the temperature at which the battery operates, the more necessary it is to keep the battery fully charged. For example, a battery with a relative density of 1.225 at 27°C (80°F) can start the engine at mild outside temperatures but might not do so at lower temperatures because of lower battery performance.

Table 1 shows the effect of temperature on battery performance.

Table 1

Temperature	Fully charged battery performance
25.0 °C (77.0 °F)	100%
-4.5 °C (23.9 °F)	82%
-24.0 °C (-11.2 °F)	64%
-27.5 °C (-17.5 °F)	58%
-31.0 °C (-23.8 °F)	50%
-34.5 °C (-30.1 °F)	40%
-37.5 °C (-35.5 °F)	33%

Maximum battery life can be obtained by paying the right attention and by carrying out regular checks. The energy capacity output must not be exceeded by constant overload and charging requirements must be respected.

BATTERY MAINTENANCE

WARNING: Batteries contain sulphuric acid and generate a highly explosive hydrogen and oxygen mix during charging.

- Do not use devices producing flames or sparks to inspect the electrolyte level.
- Do not remove battery caps without protecting your hands and your eyes.

During battery maintenance, follow the steps below:

- Keep the electrolyte level 17 mm (0.6993 in.) (over the plates. If this is not respected, the acid concentration will vary, which could damage spacers and cause a deterioration in plate performance.
- Use distilled or de-mineralized water only. Never use tap water or rain water or water from any other source.
- Keep the battery charged at least 75% to avoid plate sulphurization, performance loss and possible freezing at low temperatures.

4. Avoid overcharging the battery. Excessive charge will generate high internal heat which will cause grid deterioration and water loss.
5. During quick recharge, check the battery temperature does not exceed 50°C (122°F).
6. Do not add sulphuric acid to an element unless some electrolyte has been spilt. Before filling, check the solution has the correct relative density. Slow recharge is the only way to recharge the battery completely. You can use a high amperage battery charger to charge the battery with high current intensity for short periods of time. Use a slow charge to bring the battery to its full capacity.

DRY CHARGED BATTERIES

Dry charged batteries must be prepared as followed:

1. Remove the breather caps from each battery element.
2. Fill each element to the recommended level with electrolyte at a relative density of 1.260.

NOTE: *The electrolyte consists of diluted sulphuric acid, preferably at a temperature of 21° - 32°C (69.8 - 89.6°F).*

3. After filling, leave the battery to rest for 15 minutes. Check the electrolyte level and top up, if necessary.
4. Charge the battery for 4 hours at 5-8 A., checking that all the elements are producing gas freely.
5. Replace the breather caps.

CHARGING THE BATTERY

Before charging a battery:

1. Clean the battery casing and element covers carefully with ammonia diluted in warm water and clean the terminals;
2. Check the electrolyte level and, if it is below the plate level, top up with distilled water to cover the plates.

NORMAL CHARGING (TOP UP)

1. Charge the battery completely with a slow battery charger at 3 to 6 amperes for the required time. This can last 36 hours, or more, if the battery is very flat. A severely sulphated battery may not charge. When the battery is completely charged, the elements will produce gas freely and the relative density will remain constant. Disconnect the battery charger after three consecutive densimeter readings, recorded every hour, showing that relative density has stabilised.
2. When using a fast or high ampere charge, follow the manufacturer's instructions carefully. High charging amperage increases electrolyte temperature and, if the battery charger is not equipped with an automatic time or temperature switch, it can cause the electrolyte temperature to rise above 50°C (122°F). This can cause violent boiling in the battery and damage internal components.
3. Check electrolyte level in each element again and, if necessary, top up with distilled water.

WARNING: *Explosive gas is formed when a battery is charged. Do not smoke or use naked flames when checking electrolyte level. Check that the battery charger is switched off, before connection and disconnection, to avoid sparks which could ignite the gas.*

CHARGING VERY FLAT BATTERIES

To recharge a Pb-Ca maintenance-free battery we recommend using a constant voltage battery charger. For very flat batteries, charge for 48 hours, at 16 V., with current limitation (50 A. for 105 Ah and 66 A for 120 Ah).

This method is self-regulating. High current is provided at the beginning (when the battery voltage is very low). Current decreases progressively when the battery is fully charged (and its voltage is high).

If only constant voltage battery chargers are available, we recommend using voltage levels and times shown in table 2. These figures refer to very flat batteries. If the battery is only 50% discharged, use half the time shown (slow charging programme). For

other conditions, reduce charging time proportionally. When feasible, use the slowest charging programme for increased battery life.

If violent boiling occurs during charging, due to gas formation or electrolyte leakage, or if the battery box is hot (50°C (122°F) or higher), temporarily reduce or stop battery charging to avoid damaging the battery.

Table 2

	Type of battery	
	105Ah (760 cca)	120Ah (800 cca)
Slow charging programmes	25 hrs at 5A 12,5 hrs at 10A	30 hrs at 5A 15 hrs at 10A
Fast charging programmes (emergency use only)	7 hrs at 10A	10 hrs at 18A

TESTS

Before carrying out battery tests, check the breathers are not blocked, there is no rust, the breather caps are not open and the casing is not cracked.

Required testing equipment:

- Densimeter
- Battery starter tester (high amperage tester)
- Thermometer
- Battery charger

Relative density: This test shows the charge level of a battery.

1. With the float in a vertical position, note the reading.
2. Regulate the densimeter reading for battery electrolyte temperature variations subtracting 4 points (relative density 0.004) for every 5.5 °C (41.9 °F) below the temperature the densimeter is calibrated at and adding 4 points (relative density 0.004) for every 5.5 °C (41.9 °F) above this temperature.

The following examples have been calculated with a densimeter calibrated at 30 °C (86 °F).

Example 1:

$$\begin{array}{r}
 \text{Temperature below} \quad 30 \text{ }^{\circ}\text{C (86 }^{\circ}\text{F)} \\
 \text{Battery electrolyte temperature} \quad 19 \text{ }^{\circ}\text{C (66.2 }^{\circ}\text{F)} \\
 \text{Densimeter reading} \quad 1.270 \\
 \text{Subtract } 11.0 \times 0.004 \\
 \quad \quad \quad \underline{5.5} \\
 \text{Correct relative density} = \quad \underline{1.262}
 \end{array}$$

Example 2:

$$\begin{array}{r}
 \text{Temperature above} \quad 30 \text{ }^{\circ}\text{C (86 }^{\circ}\text{F)} \\
 \text{Battery electrolyte temperature} \quad 40 \text{ }^{\circ}\text{C (104 }^{\circ}\text{F)} \\
 \text{Densimeter reading} \quad 1.220 \\
 \text{Add } 10.0 \times 0.004 \quad 0.007 \\
 \quad \quad \quad \underline{5.5} \\
 \text{Correct relative density} = \quad \underline{1.227}
 \end{array}$$

2. Use the following table to determine the charge level.

Charge condition	Correct relative density at 15°C (86°F)	Correct relative density at 25°C (86°F)	Average battery voltage
100%	1.295	1.287	12.66
75%	1.253	1.246	12.45
50%	1.217	1.210	12.30
25%	1.177	1.170	12.00
Flat	1.137	1.130	11.84

NOTE: Relative density should not vary more than 0.025 points between cells.

4. If relative density is 1.280 or higher, the battery is fully charged and in good working condition.
5. If the correct relative density is less than 1.280, charge the battery and check the charging system, to find the cause of low battery load.

NOTE: If distilled water has recently been added, the battery must be charged for a short period of time to obtain precise densimeter readings.

If the battery has been loaded and kept still, the battery electrolyte will be thicker at the base of the elements. The battery must be shaken periodically to mix the electrolyte. This will improve charging amperage and allow more precise densimeter readings during tests.

Performance tests

Performance tests help to understand if a battery can adequately run the engine. Voltage readings show battery condition. Before carrying out the test, check the battery electrolyte level is correct and the open circuit voltage is 12.5V or more. The battery can be tested in the tractor or removed.

1. Switch the battery start tester current control to "off" (high amperage discharge tester). Calibrate the voltage selection switch to the nominal battery voltage or slightly higher. Connect the positive tester conductors to the positive battery terminal and the negative conductors to the negative battery terminal.
2. Turn the current control knob until the ammeter reading reaches half the cold start battery amperage and note the voltage reading.
 - If the reading shows 9.6 V. or higher after 15 seconds, the battery has adequate power output and can easily be charged following the normal procedure.
 - If the reading is lower than 9.6 V., battery is not satisfactory for use and the charge must be tested as follows.

WARNING: Do not leave a high discharge tester on the battery for more than 15 seconds.

Test charging: This test is only for those batteries which have not passed the performance test above.

1. Connect the positive battery charger tester conductors (high amperage discharge tester) to the positive battery terminal and the negative conductors to the negative battery terminal.
2. Connect the positive battery charger conductor to the positive battery terminal and the negative conductor to the negative battery terminal.
3. Turn the battery charger timer to more than a 3 minute charge and then back to a 3 minute charge.

4. Set the charging amperage as close as possible to 40 A.
5. After a 3 minute fast charge, read the voltmeter.
 - If the total voltage is higher than 15.5 V., the battery is not satisfactory. It is probably sulphated or worn and must be changed.

NOTE: A slightly sulphated battery can be renewed using a multiple type battery charger, with upper open circuit voltage limit of 50V. A sulphated battery has high resistance and for this reason it will be necessary to set a high voltage at the beginning to overcome resistance. At the beginning there may be no visible sign of charging. After some minutes of inactivity, a low charge will show. This is followed by a fast rise in amperage. Amperage must not exceed 14.0 A. and the battery electrolyte temperature must not exceed 50°C (122°F). When amperage stabilizes, set the voltage until amperage corresponds to 5 A. Continue this amperage until the relative density of the battery electrolyte stabilises (1.275 - 1.280 at 20°C (68°F)). This could take approximately 48 hours. Let the battery rest for 24 hours and then carry out the previously described performance test.

- If the total voltage is less than 15.5 V., check the relative density of each element and recharge the battery according to the following scale:

Relative density	Fast charge up to:
1.150 or less	60 minutes
from 1.151 to 1.175	45 minutes
from 1.176 to 1.200	30 minutes
from 1,200 to 1.225	15 minutes (slow charge only)

NOTE: When there are problems with a battery, check fan belt tension and the complete charging system.

BATTERY PROBLEMS - FREQUENT CAUSES

1. Internal open circuit.
2. Internal short-circuit.
3. Battery electrolyte leakage.
4. Grid active material separation.
5. Accumulation of sulphate crystals too big to be dispersed.

These problems are commonly caused by the following:

1. Component failure inside the elements.
2. Excessive crystal growth which can pierce the spacers and cause short circuits.
3. Excessive overload (bad charging system, high voltage fast charging, high operating temperatures).
4. Battery electrolyte freezing.
A fully charged battery freezes at -65°C (-85°F). A 50% charged battery freezes between -17°C and -27°C (16.6°F). A completely flat battery freezes between -3°C (26.6°F) and -11°C (12.2°F). Excessively fast charging and boiling caused by gas formation cause the separation of active material from the grids. Separation destroys the battery chemical function.

5. Crystals are formed when batteries are left flat. High temperature and long periods with the battery flat increase this condition. If a battery is left at room temperature for a week it can rarely be charged in the vehicle. Battery recharge requires higher constant voltage. After three weeks the battery will be permanently jeopardized and it will be necessary to follow the procedure described for "very flat batteries".

Fully charged batteries have longer a life. A lead-calcium battery discharges 3% a month. This means that in 16 months it will reach 50% charge. In the tractor, inactive load is approximately 50 mA. To forecast discharge on a vehicle not in use add approximately 8 Ah a week to this value.

It is worth noting that if a battery is weak during engine start-up, it is best to let the battery rest for two minutes. This rest time increases as the temperature decreases.

When two batteries are installed, do not use an old battery with a new one. One battery will always stop before the other one. If the battery has lasted as forecasted, charge both batteries. If one has stopped before the forecasted time due to a defect, then change only the defective battery.

SECTION 55 – ELECTRICAL SYSTEM**Chapter 6 – ELECTRICAL CIRCUITS****CONTENT**

55 100	Content	1
	Fuses and Relays	2
	Electrical wire colour coding	4
	key to circuit symbols	5
	General diagram of tractor in non-cab version	6
	Starter switch system diagram	7
	Fuses and relays system diagram	8
	General diagram of tractor in cab/non-cab version	9
	Frame system diagram	9
	General diagram of tractor in cab version	10
	Starter switch system diagram	10
	Fuses and relays system diagram	12
	Cab system diagram	13
	Partial and connector diagrams	14
	Analog instrument circuit	14
	Starting circuit	16
	Direction indicator and hazard warning light circuit	21
	Windscreen and rear window wiper/washer circuit	28
	Brake warning light circuit	32
	Air conditioning and heating system circuit	37
	Work lights circuit (models without cab)	40
	Work lights circuit (models with cab)	42
	Sidelights, full beam, dipped beam and parking lights circuit	47

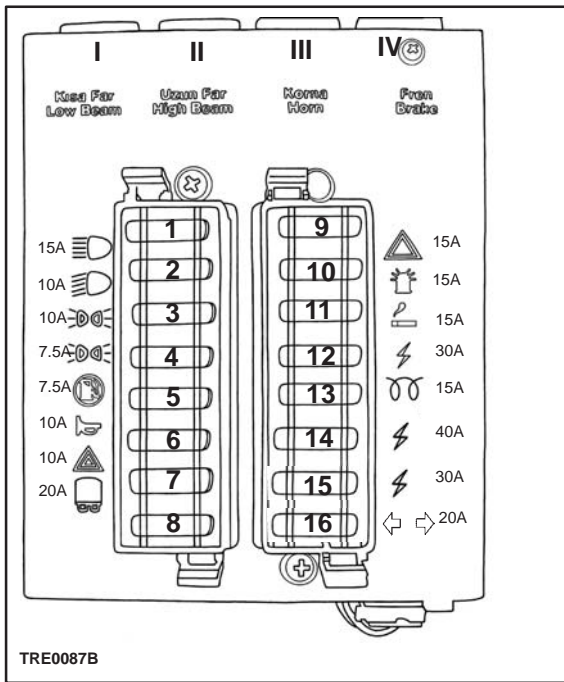

Fuses	PROTECTED CIRCUITS	Amps.
1	Main beam	15
2	Dipped beam	10
3	Front right and rear left side lights	10
4	Front left and rear right side lights	7,5
5	Engine shut down solenoid valve	7,5
6	Instruments, turn signal switch, horn	10
7	Hazard warning switch, fuel sedimentor	10
8	Relay	20
9	Hazard warning lights switch	15
10	Beacon lamp (radio, interior lamps – models with cab)	15
11	Cigar lighter	15
12	Power for cab (models with cab)	30
13	Cold starting aid (thermostarter)	15
14	Power socket (models with cab)	40
15	Power for cab (models with cab)	30
16	Turn indicator switch	20
I	Dipped beam relay	–
II	Main beam relay	–
III	Horn relay	–
IV	Brake relay	–

FUSES AND RELAY BOX (INSIDE CAB)

FIG. 2 – 3

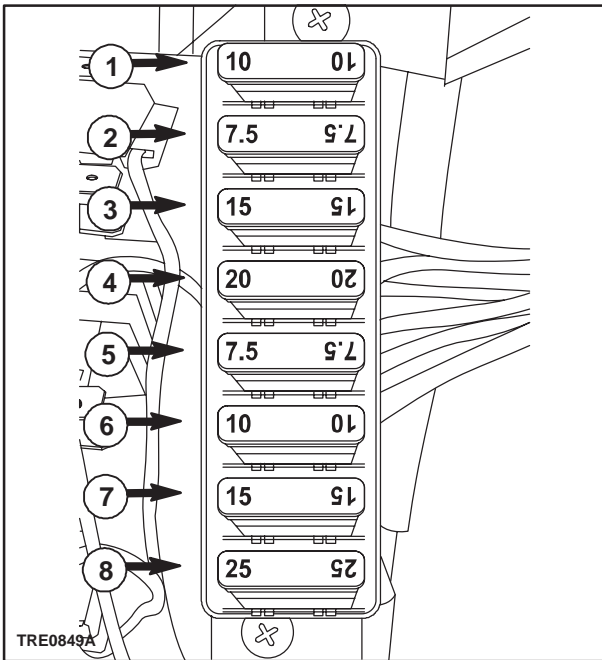

2

Fuses and protected circuits are listed below:

Fuses	PROTECTED CIRCUITS	Amps.
1.	Front windscreen wiper	10
2.	Windscreen washer	7,5
3.	Beacon lamp, interior lamps, radio	15
4.	Heater/Air Conditioning	20
5.	Rear wiper	7,5
6.	Working lamps switches	10
7.	Front worklamps	15
8.	Rear work lamps	25

Relays and related circuits are listed below:

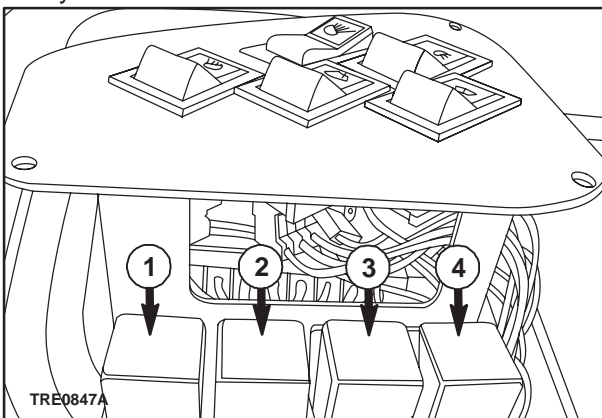

3

Relay	CIRCUITS
1.	Front worklamps
2.	Rear work lamps
3.	Supply
4.	Supply

ELECTRICAL WIRE COLOUR CODING

B	Black
G	Green
K	Pink
LG	Light Green
LN	Light Brown
N	Brown
O	Orange
P	Purple
R	Red
S	Grey
TQ	Turquoise
U	Blue
W	White
Y	Yellow

KEY TO CIRCUIT SYMBOLS

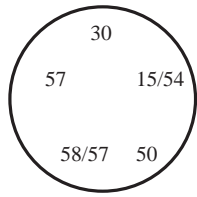

Starter switch

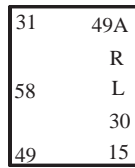

Electronic flasher



Hand brake switch



Battery



Relay



Circuit breaker



Starter motor



Safety start switch



Cold starting aid (thermostarter)



Fuse



Bulb



Ground connection



Solenoid valve



Speaker



Horn



Switch



Alternator



Oil pressure transmitter



Beacon – light



Fuel level transmitter



Water temperature transmitter



Air filter

GENERAL DIAGRAM OF TRACTOR IN NON-CAB VERSION

Starter switch system diagram

Component key

1. Instrument panel connection
2. Starter switch
3. Light control lever
4. Hazard lights flasher
18. Thermostarter button
20. Front RH light
33. Cigar lighter
52. Front LH light
55. White (15 pin) connection
56. Black (15 pin) connection
57. (8 pin) connection

ELECTRICAL WIRE COLOUR CODING			
B	Black	P	Purple
G	Green	R	Red
K	Pink	S	Grey
LG	Light Green	TQ	Turquoise
LN	Light Brown	U	Blue
N	Brown	W	White
O	Orange	Y	Yellow

GENERAL DIAGRAM OF TRACTOR IN NON-CAB VERSION - Starter switch system diagram

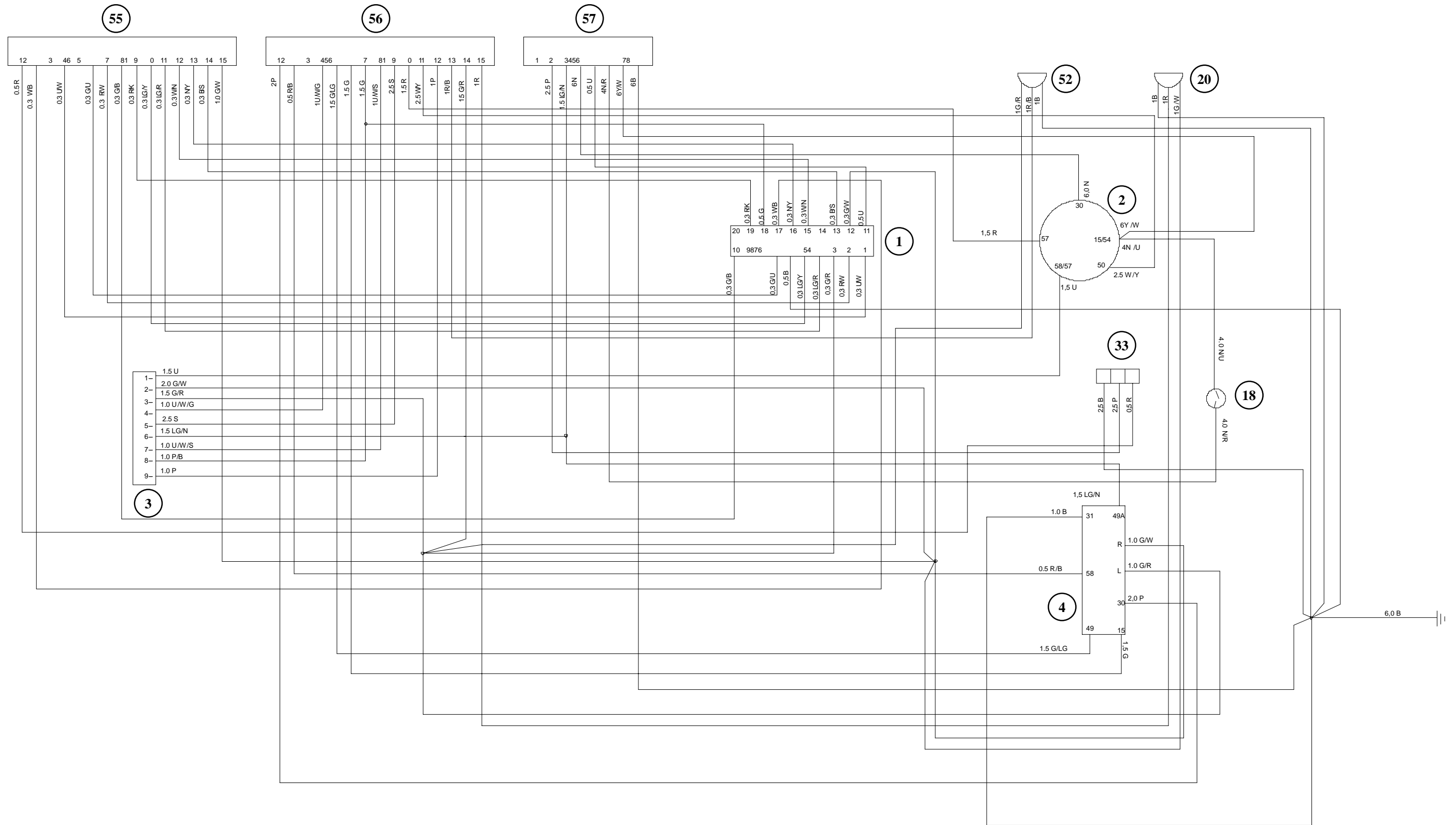

GENERAL DIAGRAM OF TRACTOR IN NON-CAB VERSION – Fuses and relays system diagram

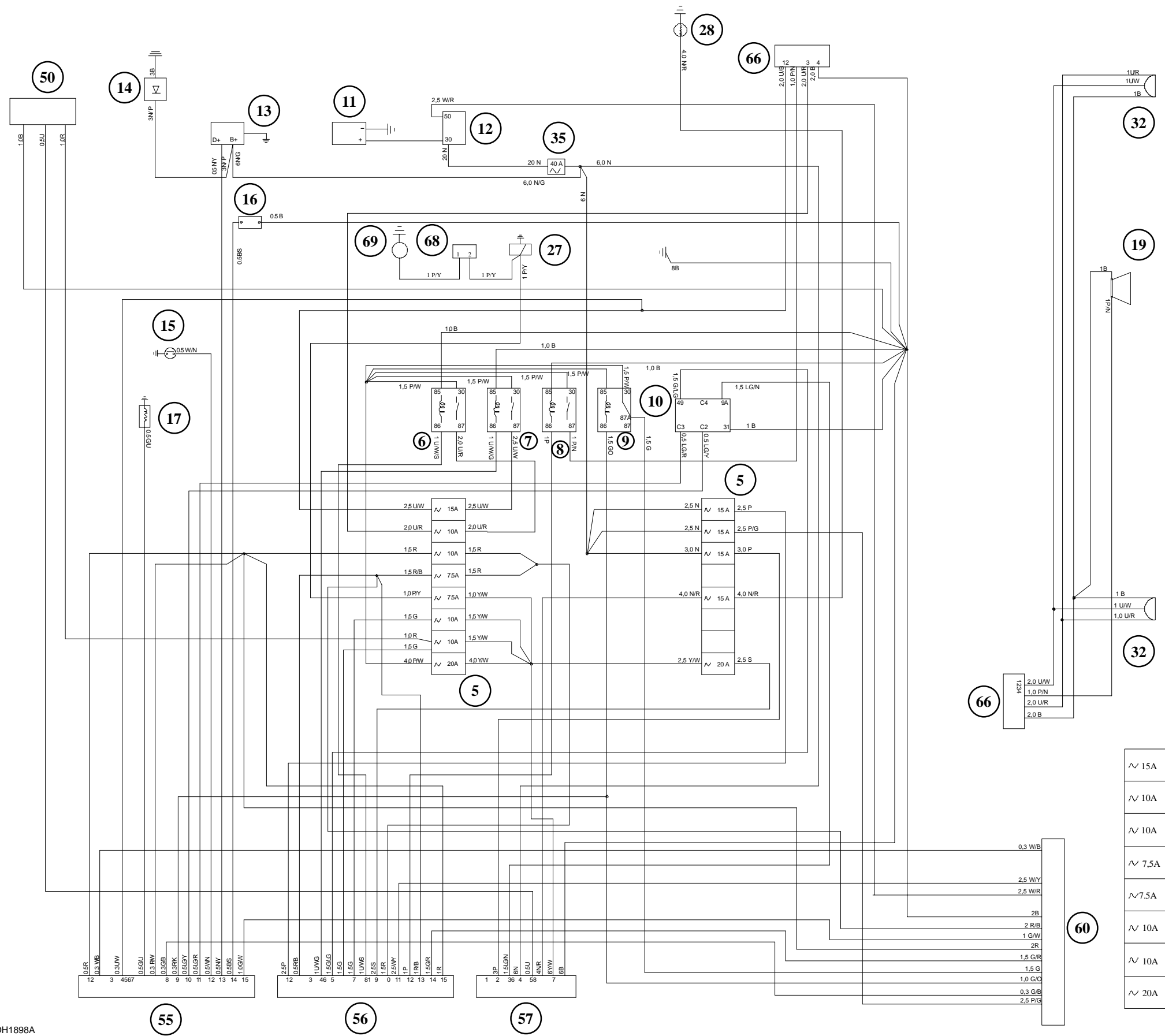

Component Key

- 5. Fusebox
- 6. Dipped beam relay
- 7. Main beam relay
- 8. Horn relay
- 9. Brakes system relay
- 10. Electronic flasher
- 11. Battery
- 12. Starter motor
- 13. Alternator
- 14. Overvoltage protection diode
- 15. Engine oil low pressure sensor
- 16. Air filter clogged sensor
- 17. Coolant temperature sensor
- 19. Horn
- 27. Engine shut-down solenoid valve
- 28. Thermostarter
- 32. Front lights
- 35. Main fuse
- 50. Fuel sedimentor element
- 55. White (15 pin) connection
- 56. Black (15 pin) connection
- 57. (8 pin) connection
- 60. (15 pin) connection
- 66. (4 pin) connection for lights cable
- 68. Thermometric switch
- 69. Advance cut-out solenoid valve

~ 15A	Main beam
~ 10A	Dipped beam
~ 10A	Side lamps
~ 7,5A	Side lamps
~ 7,5A	Engine shut-down solenoid valve
~ 10A	Instruments, turn signal switch, horn
~ 10A	Hazard warning switch and fuel sedimentor
~ 20A	Relay supply

~ 15A	Hazard warning lights switch
~ 15A	Rotating beacon
~ 15A	Cigar lighter
~ 15A	Cold starting aid (thermostarter)
~ 20A	Turn signal switches

GENERAL DIAGRAM OF TRACTOR IN CAB / NON-CAB VERSION – Frame system diagram

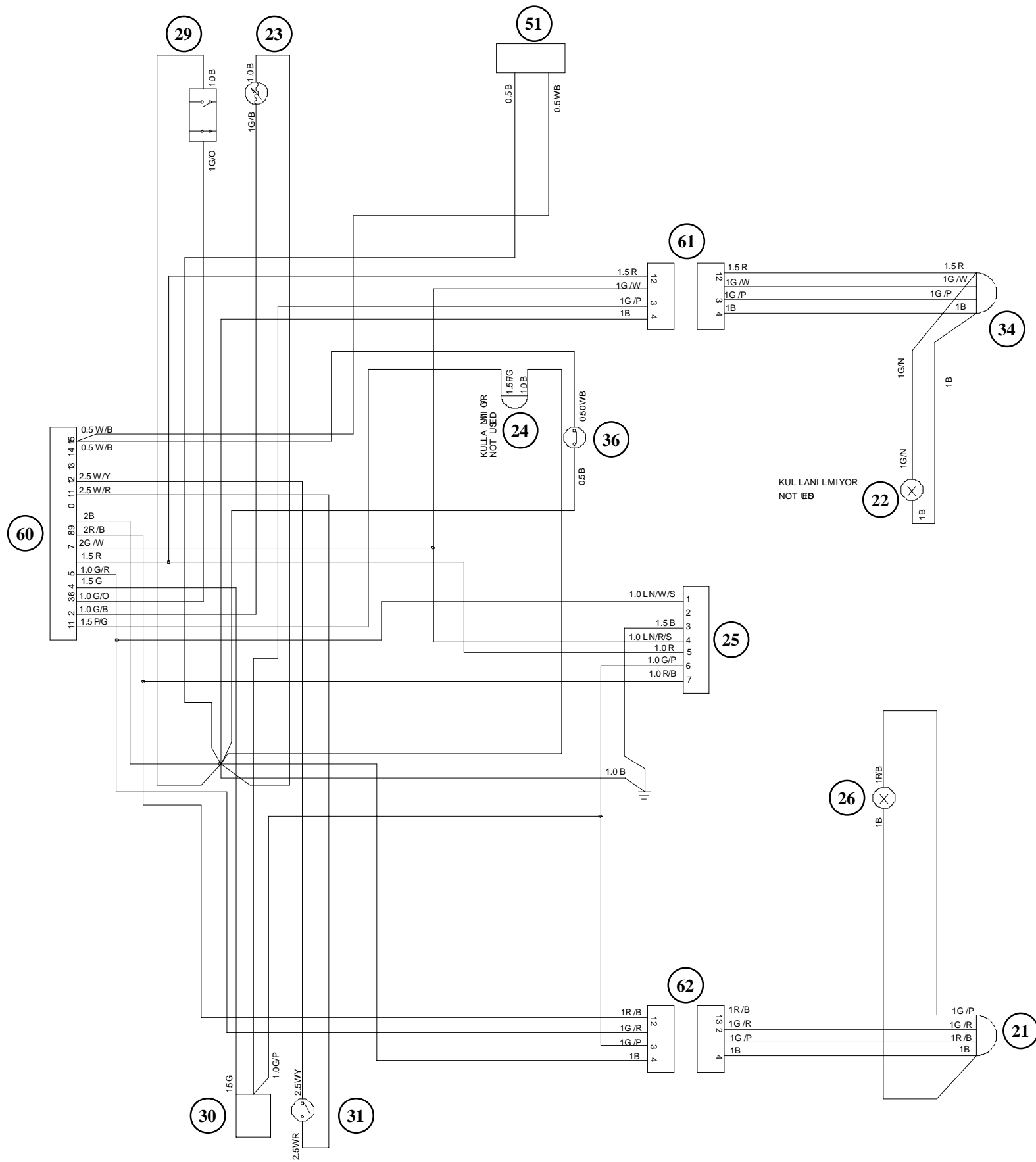

Component Key

- 21. LH tail light
- 22. RH rear work lamp
- 23. Fuel level gauge
- 24. Rotating beacon
- 25. Seven-pole connection
- 26. Number plate light
- 29. Handbrake switch
- 30. Brake lights switch
- 31. Safety start switch
- 34. RH tail light
- 36. Front brake fluid level gauge
- 51. Front brake wear gauge (for 3 cylinders)
- 60. (15 pin) connection
- 61. (4 pin) right-hand tail light connection
- 62. (4 pin) left-hand tail light connection

CABLE COLOUR CODE			
B	Black	P	Purple
G	Green	R	Red
K	Pink	S	Grey
LG	Light Green	TQ	Turquoise
LN	Light Brown	U	Blue
N	Brown	W	White
O	Orange	Y	Yellow

GENERAL DIAGRAM OF TRACTOR IN CAB VERSION

Starter switch system diagram

Component Key

1. Instrument panel connection
2. Starter switch
3. Light control lever
4. Hazard lights flasher
18. Thermostarter button
20. Front RH light
33. Cigar lighter
52. Front LH light
55. White (15 pin) connection
56. Black (15 pin) connection
57. (8 pin) connection
58. (4 pin) connection
59. (2 pin) connection
63. Cab connection (2 pin)
64. Cab connection (4 pin)
65. Cab connection (2 pin)

ELECTRICAL WIRE COLOUR CODING			
B	Black	P	Purple
G	Green	R	Red
K	Pink	S	Grey
LG	Light Green	TQ	Turquoise
LN	Light Brown	U	Blue
N	Brown	W	White
O	Orange	Y	Yellow

GENERAL DIAGRAM OF TRACTOR IN CAB VERSION - Starter switch system diagram

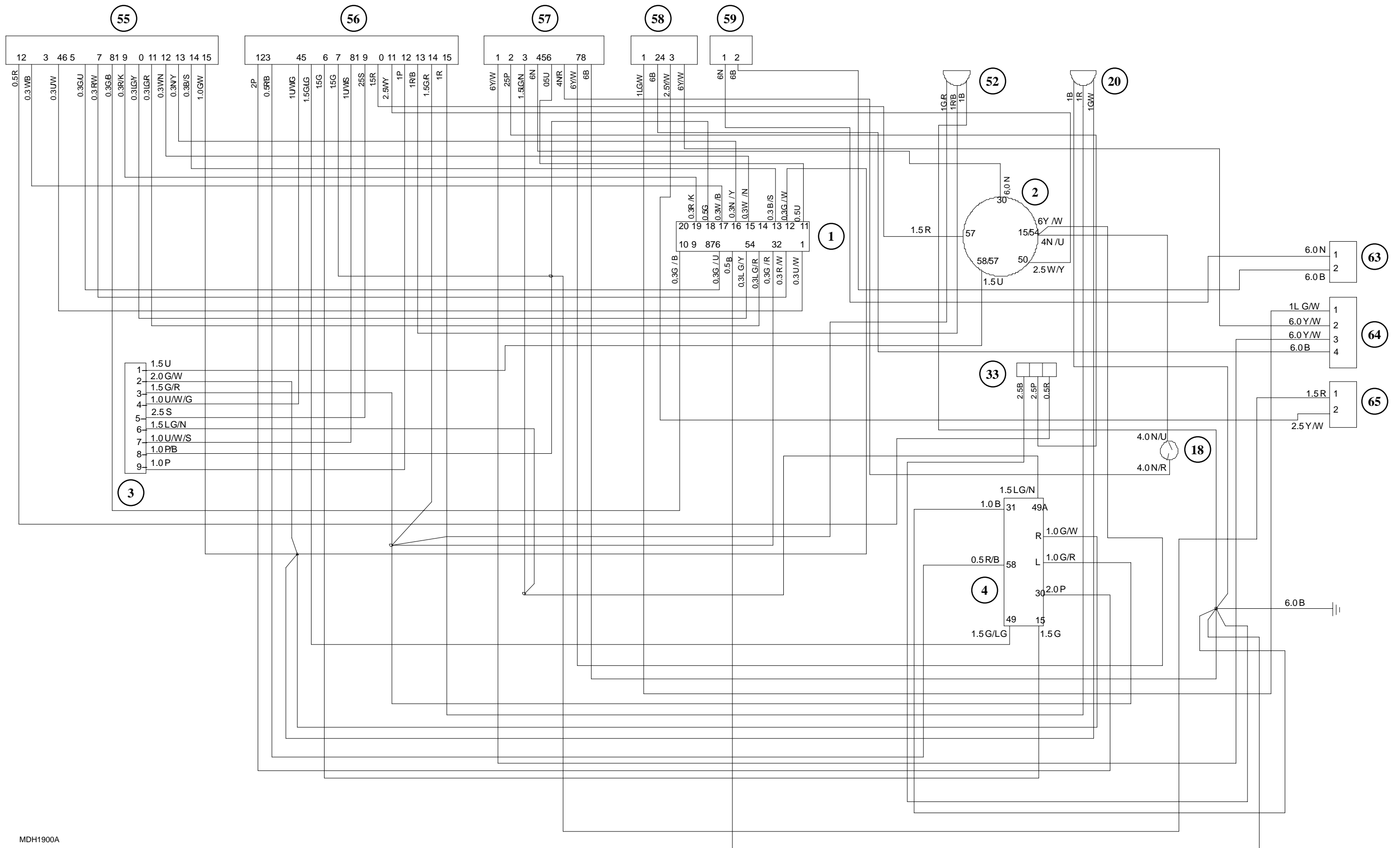

MDH1900A

GENERAL DIAGRAM OF TRACTOR IN CAB VERSION – Fuses and relays system diagram

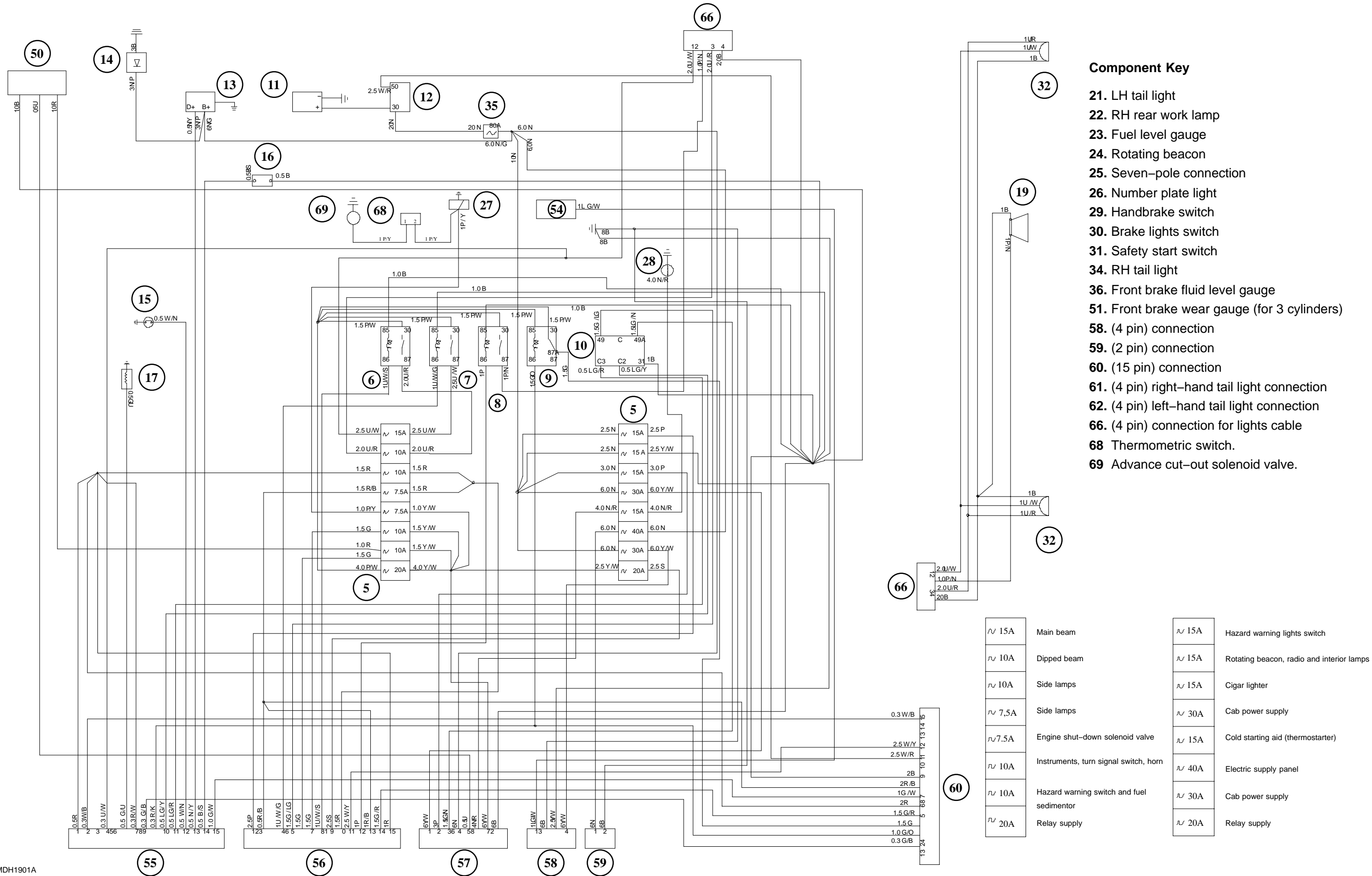

Component Key

- 21. LH tail light
- 22. RH rear work lamp
- 23. Fuel level gauge
- 24. Rotating beacon
- 25. Seven-pole connection
- 26. Number plate light
- 29. Handbrake switch
- 30. Brake lights switch
- 31. Safety start switch
- 34. RH tail light
- 36. Front brake fluid level gauge
- 51. Front brake wear gauge (for 3 cylinders)
- 58. (4 pin) connection
- 59. (2 pin) connection
- 60. (15 pin) connection
- 61. (4 pin) right-hand tail light connection
- 62. (4 pin) left-hand tail light connection
- 66. (4 pin) connection for lights cable
- 68. Thermometric switch.
- 69. Advance cut-out solenoid valve.

~ 15A	Main beam	~ 15A	Hazard warning lights switch
~ 10A	Dipped beam	~ 15A	Rotating beacon, radio and interior lamps
~ 10A	Side lamps	~ 15A	Cigar lighter
~ 7.5A	Side lamps	~ 30A	Cab power supply
~ 7.5A	Engine shut-down solenoid valve	~ 15A	Cold starting aid (thermostarter)
~ 10A	Instruments, turn signal switch, horn	~ 40A	Electric supply panel
~ 10A	Hazard warning switch and fuel sedimentor	~ 30A	Cab power supply
~ 20A	Relay supply	~ 20A	Relay supply

GENERAL DIAGRAM OF TRACTOR IN CAB VERSION – Cab system diagram

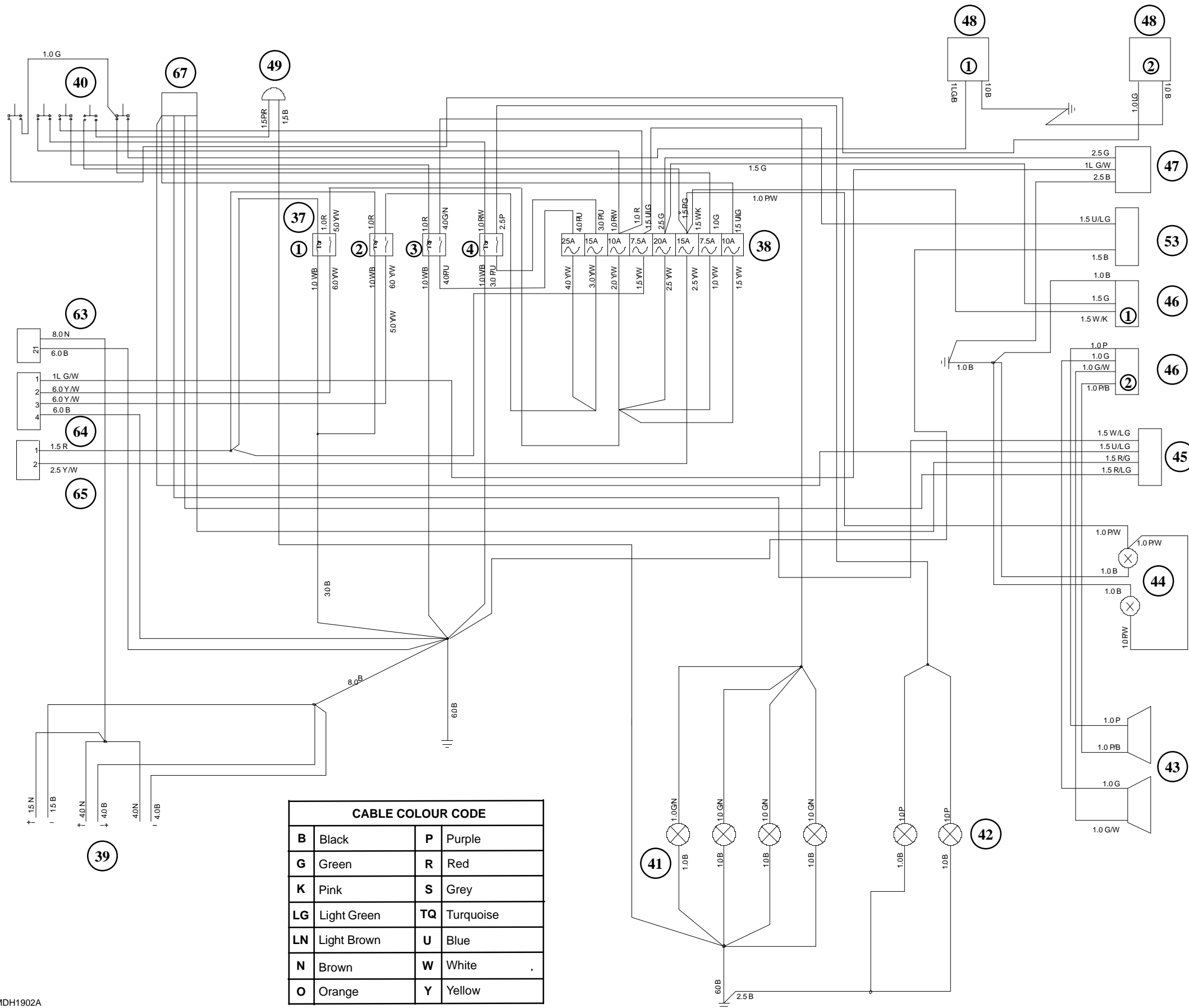

CABLE COLOUR CODE			
B	Black	P	Purple
G	Green	R	Red
K	Pink	S	Grey
LG	Light Green	TQ	Turquoise
LN	Light Brown	U	Blue
N	Brown	W	White
O	Orange	Y	Yellow

Component Key

- 37. Cab relay box
 - 1. Cab supply relay
 - 2. Cab supply relay
 - 3. Rear work lights relay
 - 4. Front work lights relay
- 38. Cab fuse box
- 39. Power sockets panel
- 40. Switches
- 41. Rear work lights
- 42. Front work lights
- 43. Speakers
- 44. Cab lighting lamps
 - 1. Windscreen wiper connector
 - 2. Rear window wiper connector
- 45. Windscreen washer connection
- 46. Radio connections
 - 1. Grey connector
 - 2. Brown connector
- 47. Fan connection
- 48. Windscreen wiper/washer pumps
 - 1. Windscreen wiper connector
 - 2. Rear window wiper connector
- 49. Rotating beacon
- 63. Cab connection (2 pin)
- 64. Cab connection (4 pin)
- 65. Cab connection (2 pin)
- 67. Windscreen washer switch

∩ 25A	Windscreen wiper
∩ 15A	Windscreen washer
∩ 10A	Beacon lamp, interior lamps, radio
∩ 7,5A	Heater – air conditioner
∩ 20A	Rear wiper
∩ 15A	Work lights switch
∩ 7,5	Front work lights
∩ 10A	Rear work lights

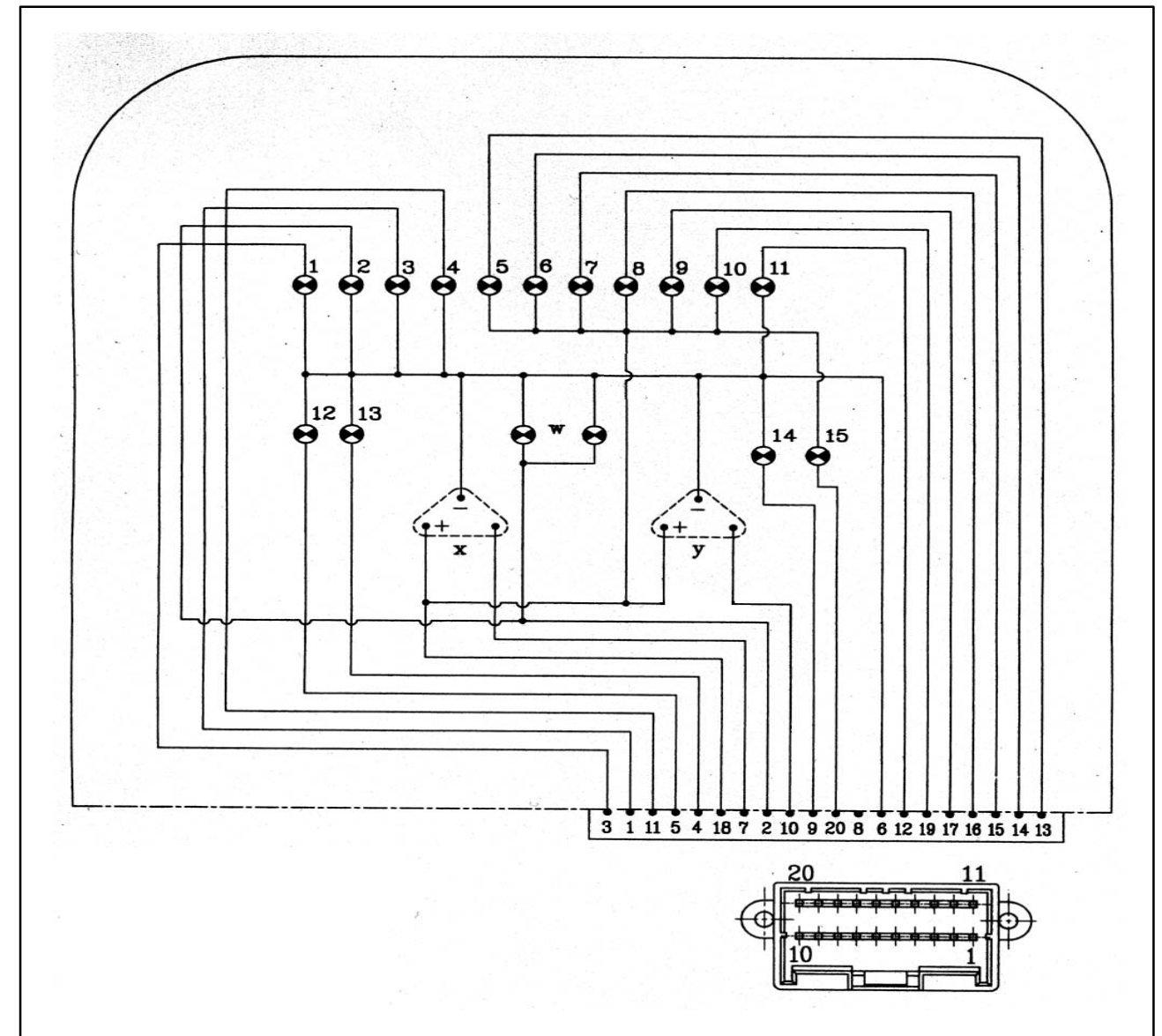

5

ANALOG INSTRUMENT CIRCUIT

- | | |
|---------------------------|------------------------------------|
| 1. LH direction indicator | 9. Brake fluid level low |
| 2. Side/tail lights | 10. Parking brake |
| 3. Dipped beam headlights | 11. Right hand turn signal |
| 4. Water in fuel | 12. First trailer turn indicators |
| 5. Air filter blocked | 13. Second trailer turn indicators |
| 6. Not used | 14. Not used |
| 7. Engine oil pressure | 15. Not used |
| 8. Battery charger | |

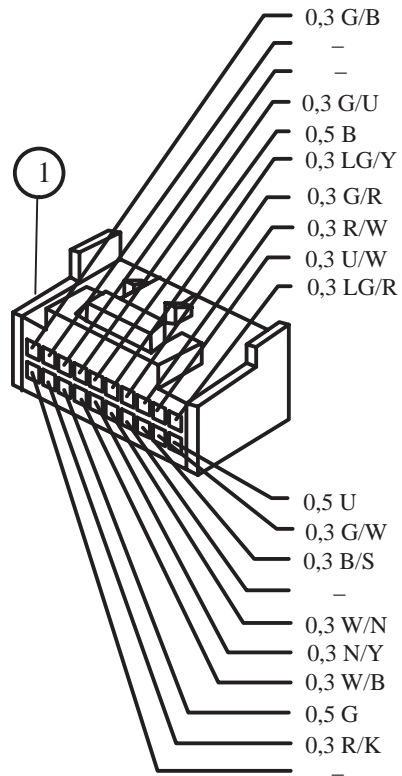

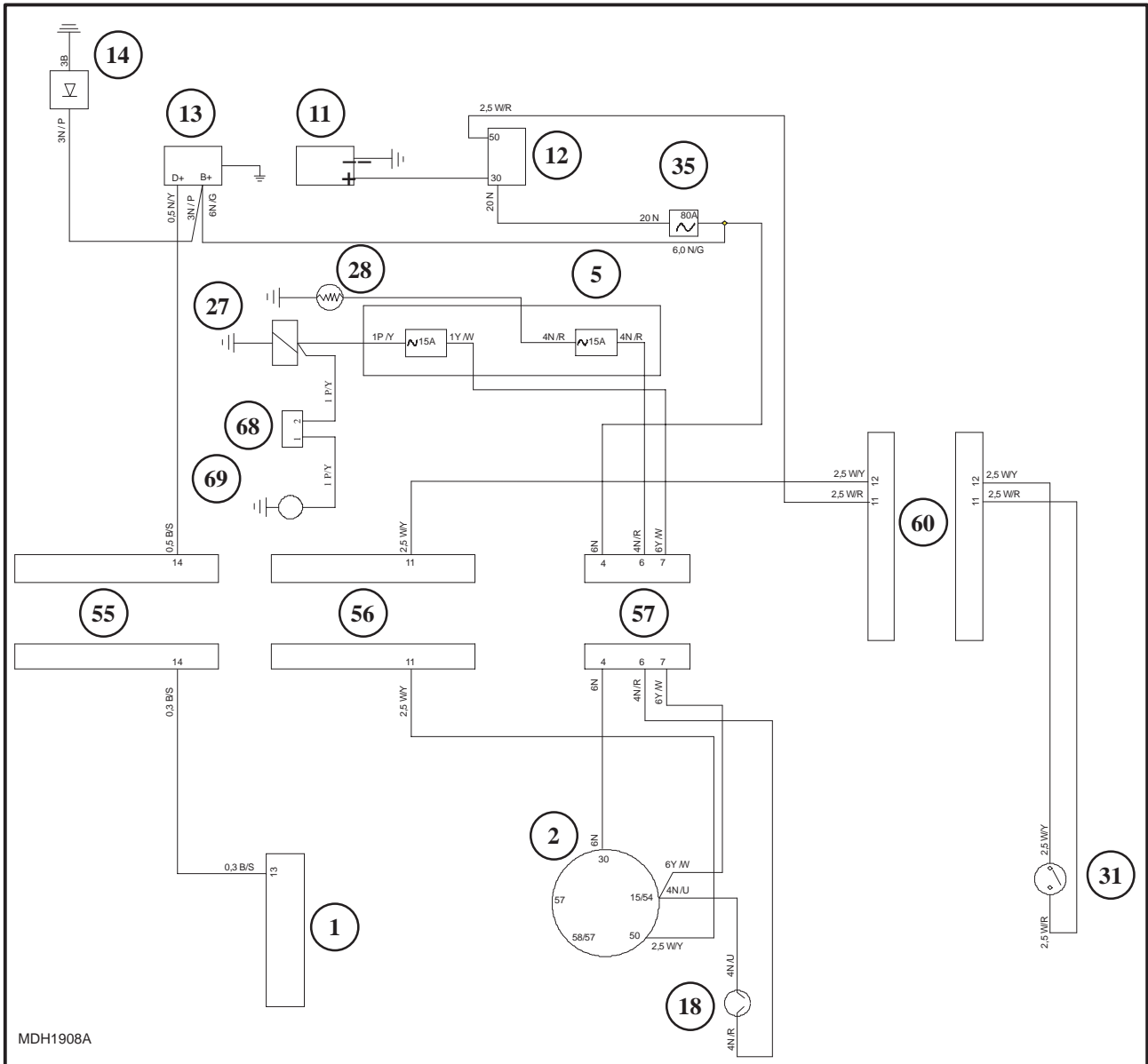

START-UP CIRCUIT

- 2. Starter switch
- 5. Fusebox
- 11. Battery
- 12. Starter motor
- 13. Alternator
- 14. Circuit breaker
- 18. Thermostarter pushbutton
- 27. Engine shut-down solenoid valve
- 28. Thermostarter
- 31. Safety start unit
- 35. Main fuse
- 55. White (15 pin) connection
- 56. Black (15 pin) connection
- 57. (8 pin) connection
- 60. (15 pin) connection, see page
- 68. Thermometric switch
- 69. Advance cut-out solenoid valve

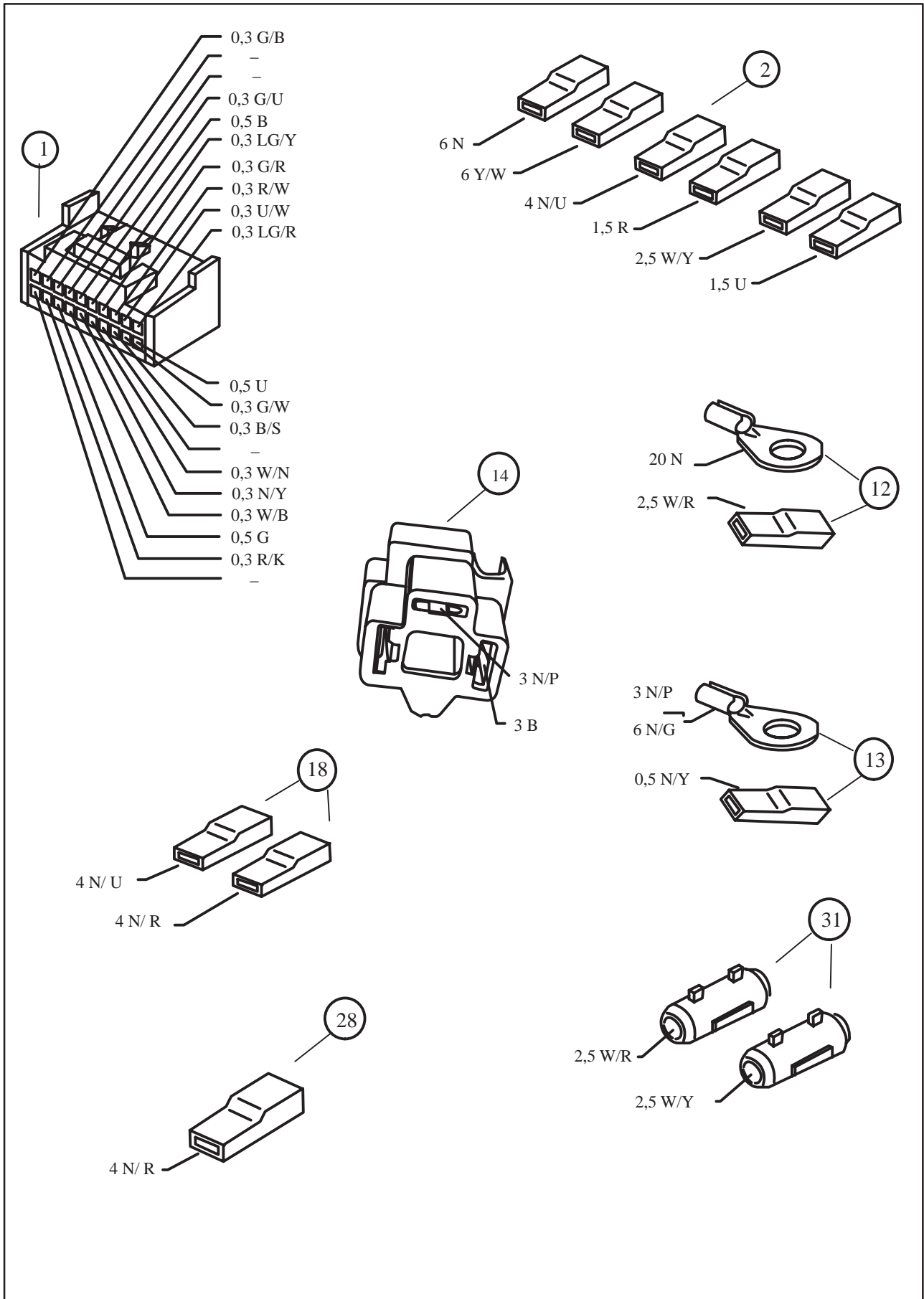

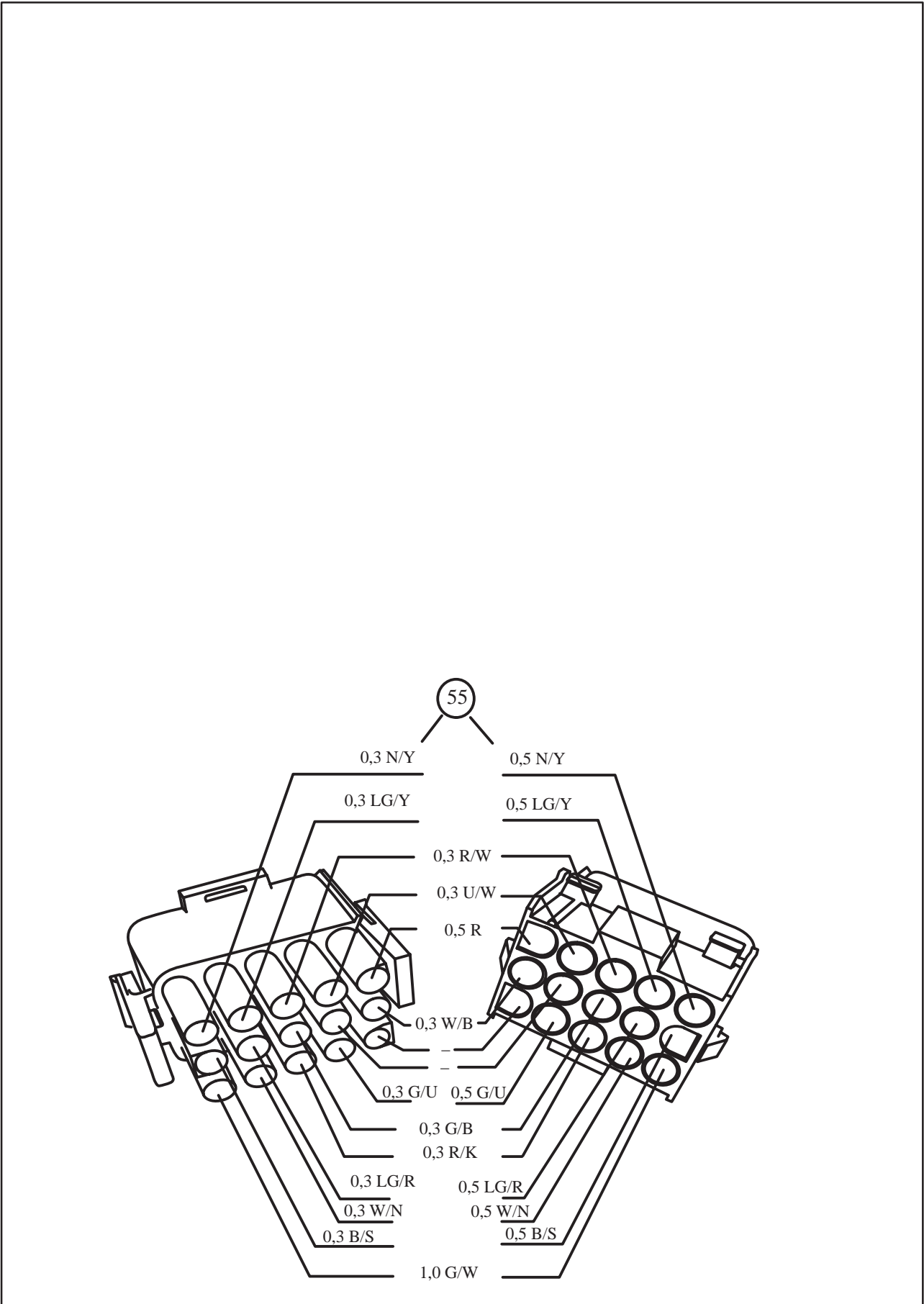

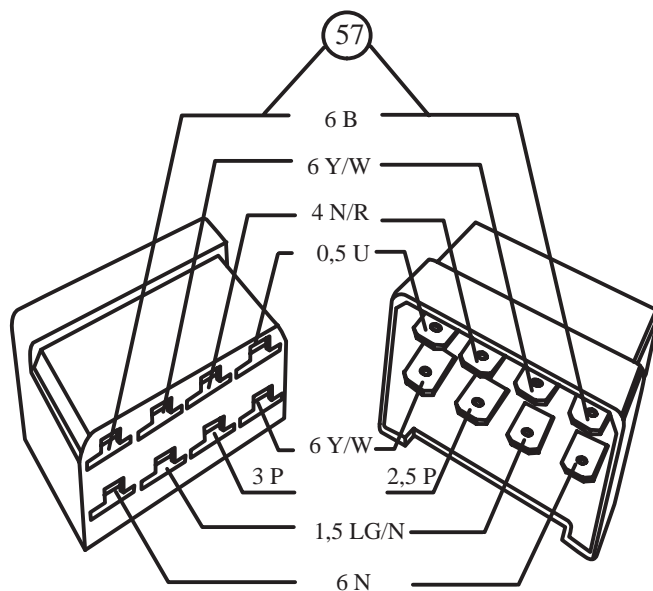
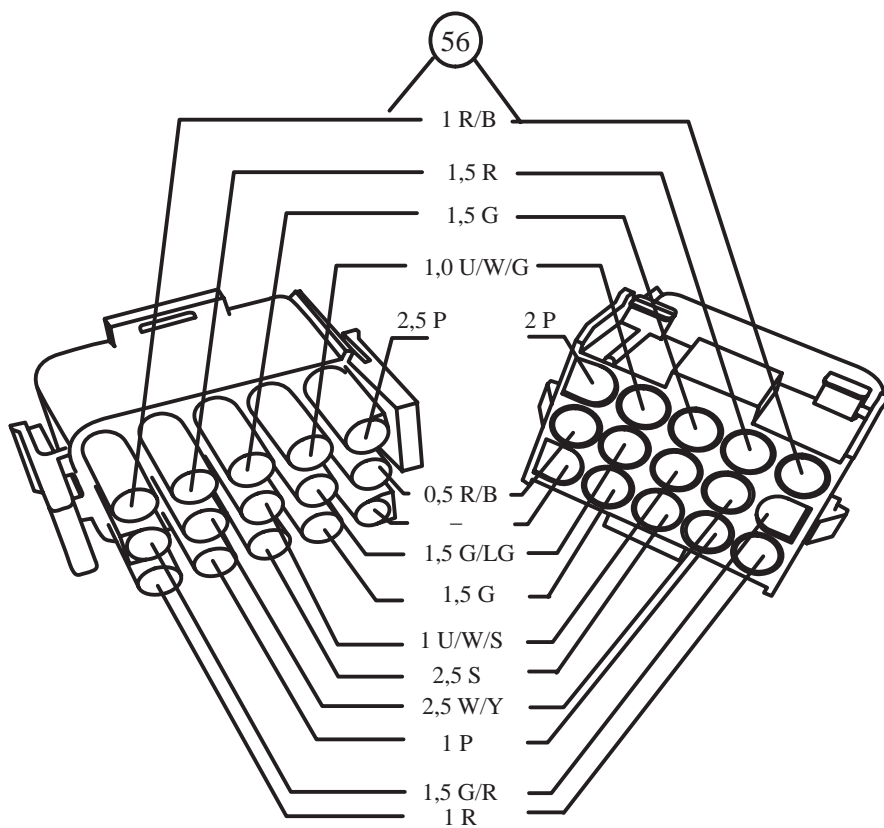

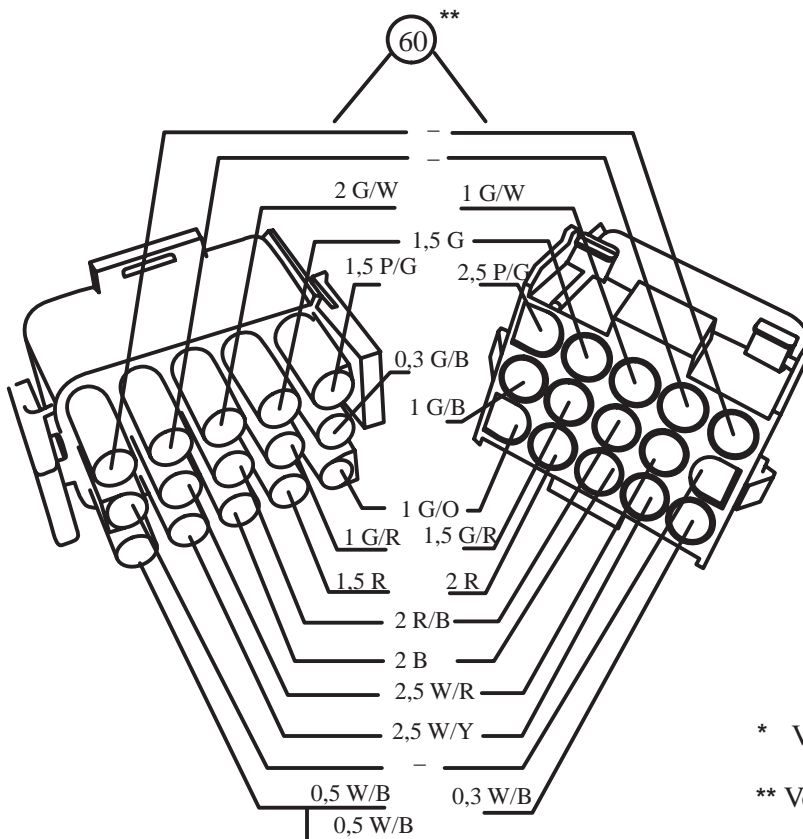
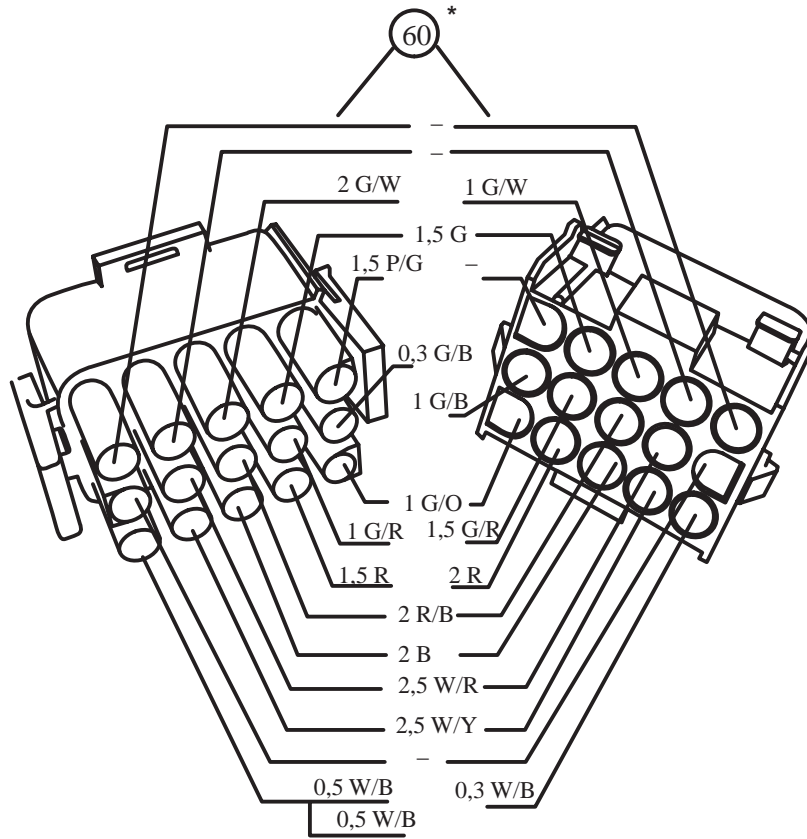

* Version with cab

** Version without cab

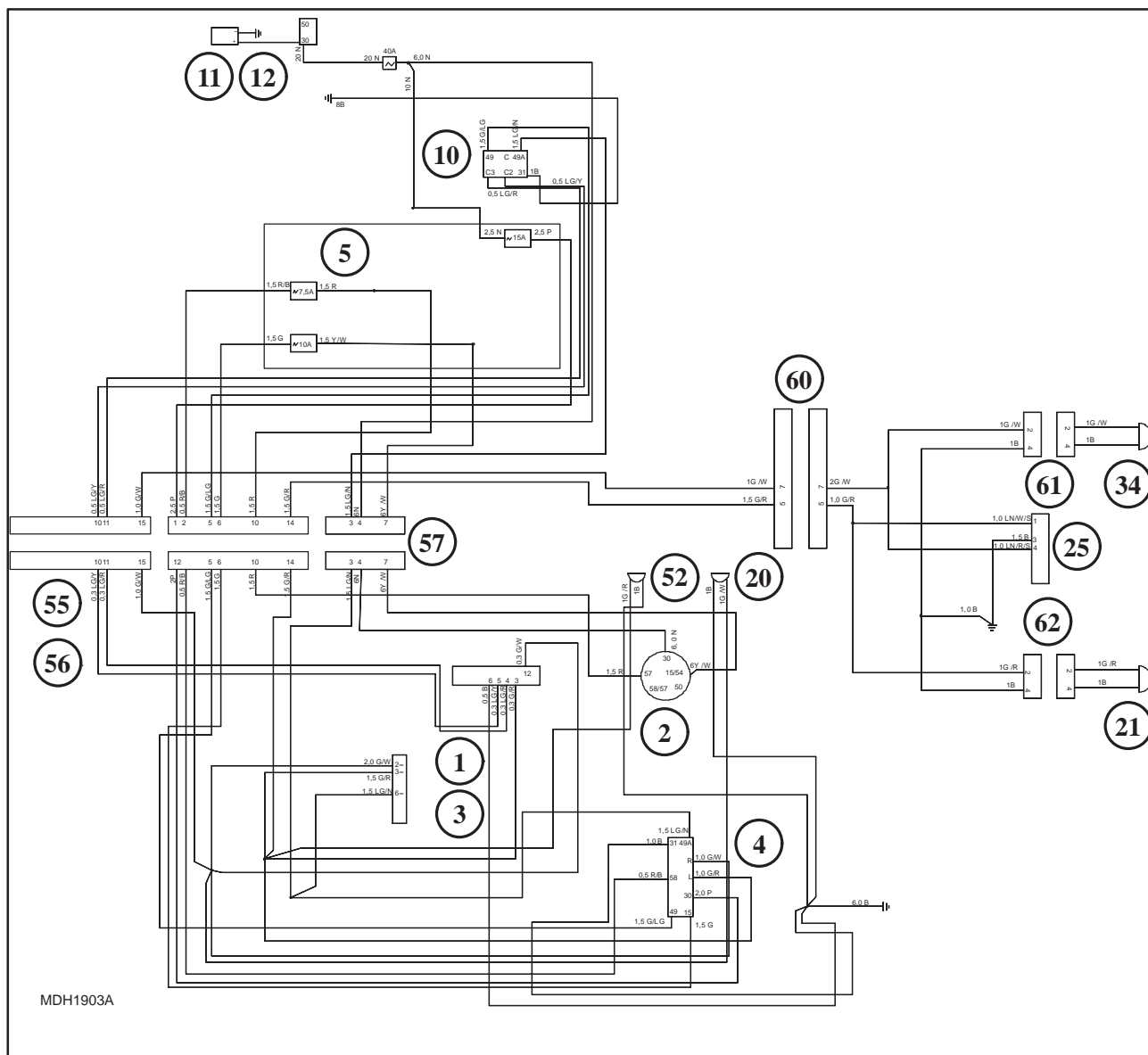

7

DIRECTION INDICATOR AND HAZARD WARNING LIGHT CIRCUIT

- | | |
|--|---|
| 1. Instruments cluster | 25. Trailer connector |
| 2. Starter switch | 34. Parking light, turn signal and brake light for rear right-hand side |
| 3. Turn signal switch | 52. Parking light and turn signal for front left-hand side |
| 4. Hazard warning lights indicator transmitter | 55. White (15 pin) connection |
| 5. Fusebox | 56. Black (15 pin) connection |
| 10. Electronic flasher | 57. (8 pin) connection |
| 11. Battery | 60. (15 pin) connection |
| 12. Starter motor | 61. (4 pin) right-hand tail light connection |
| 20. Parking light and turn signal for front right-hand side | 62. (4 pin) left-hand tail light connection |
| 21. Parking light, turn signal and brake light for rear left-hand side | |

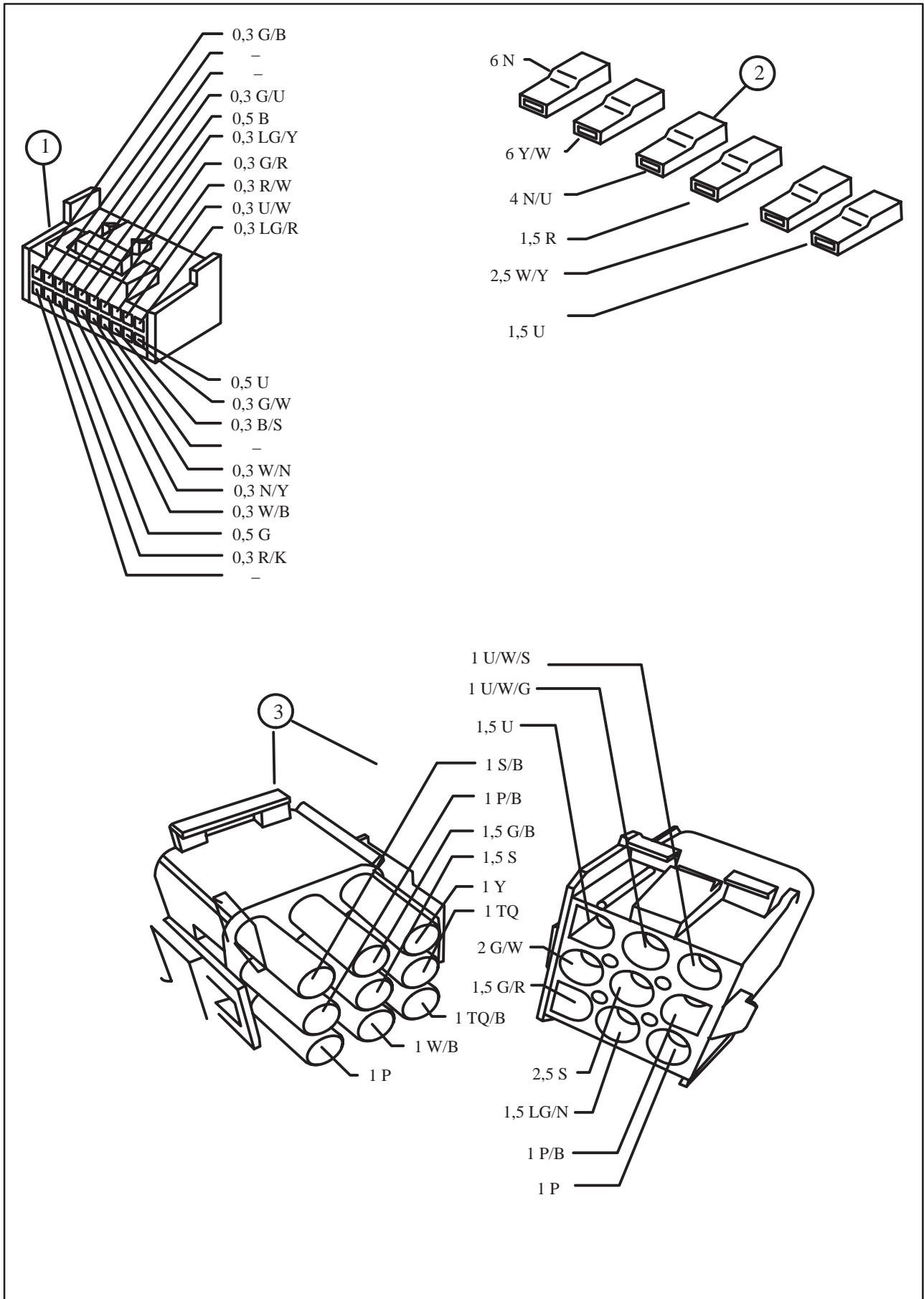

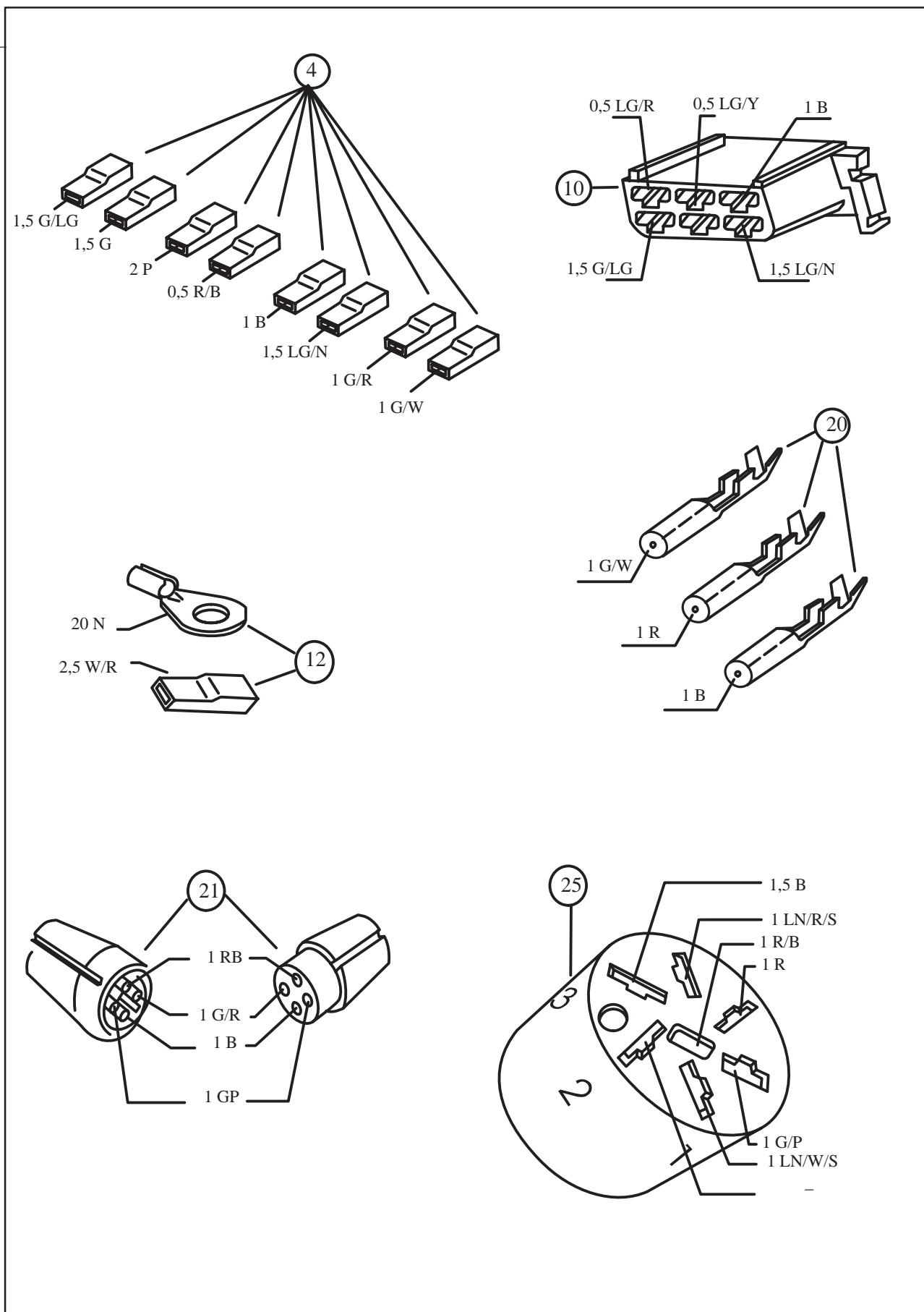

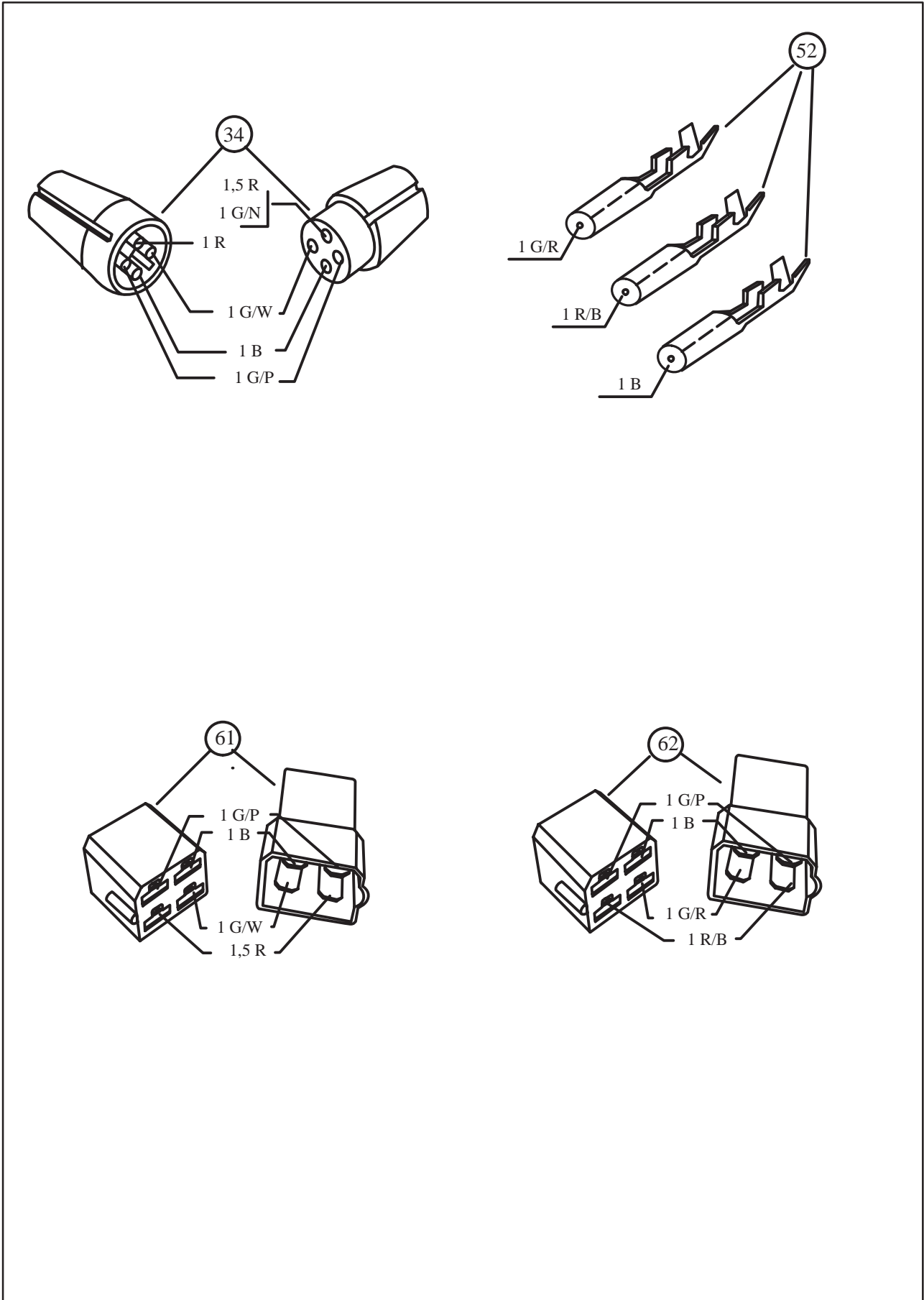

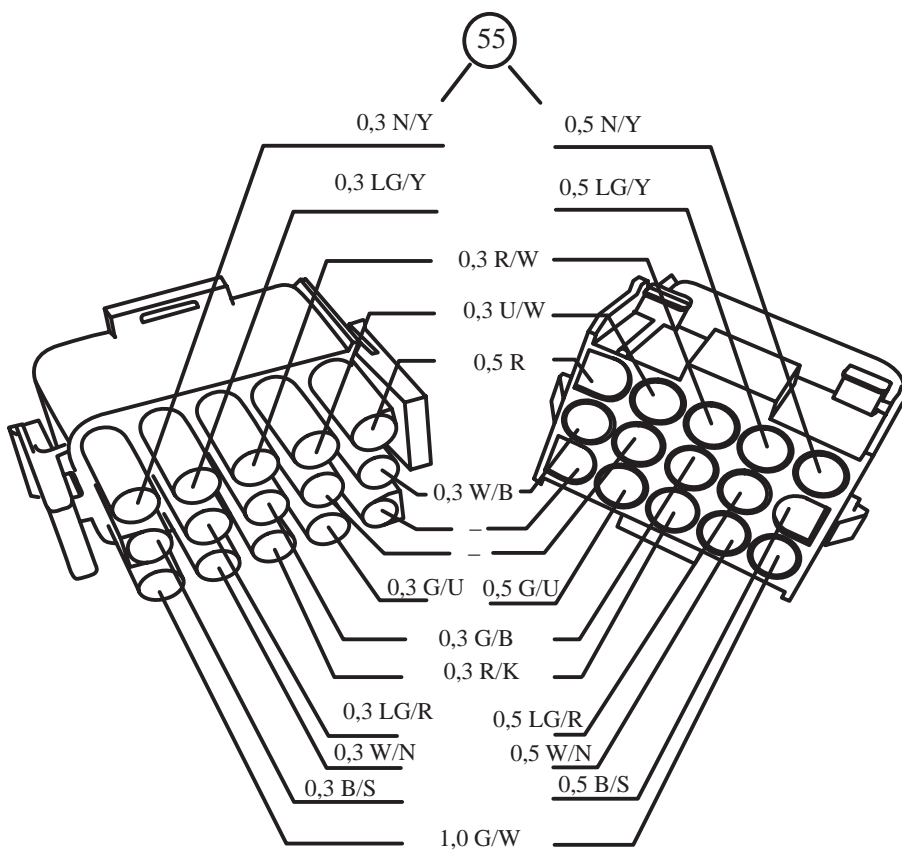

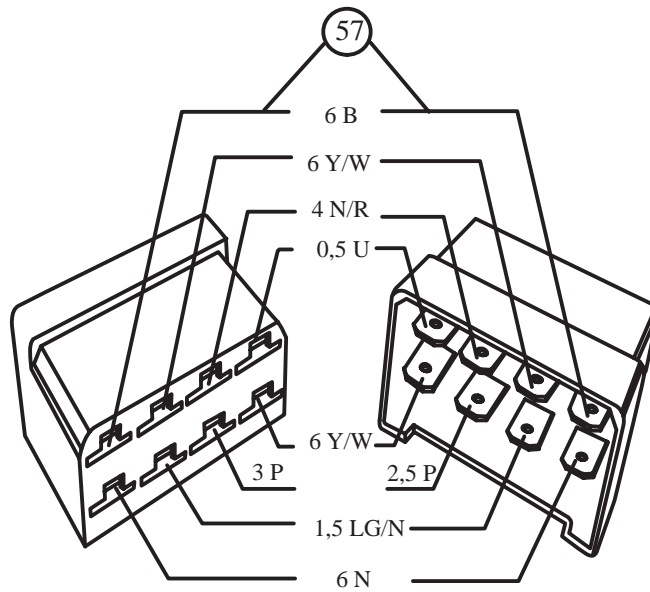
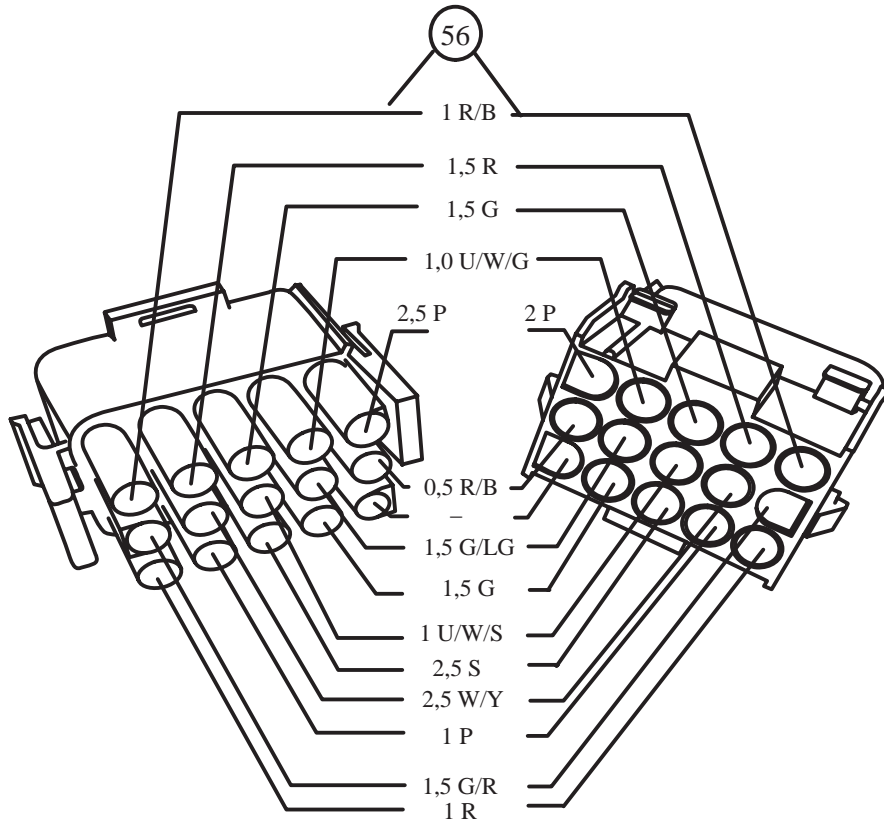

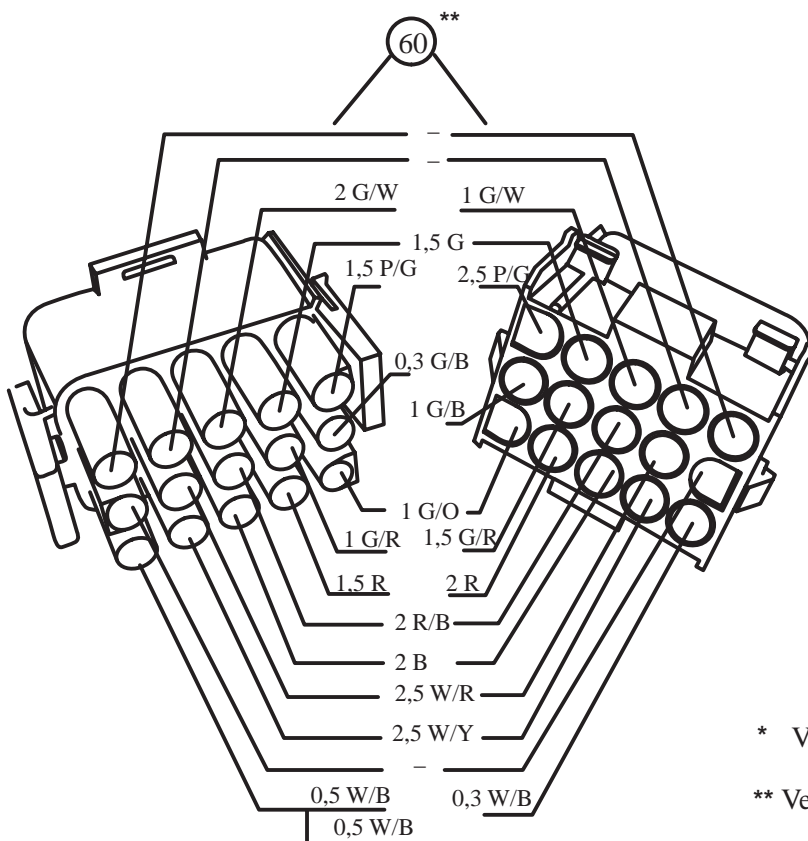
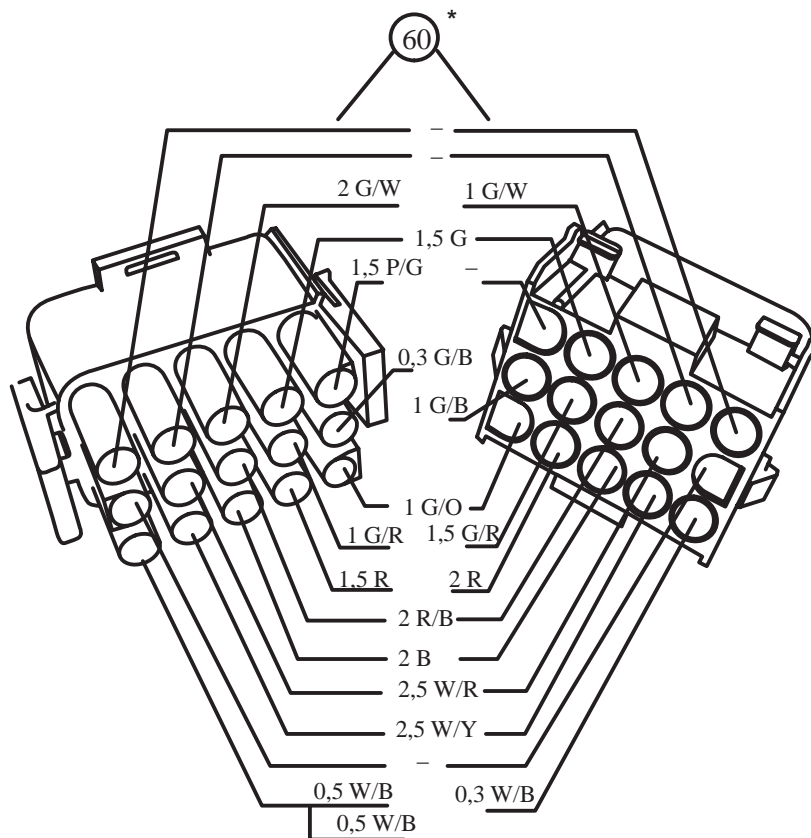

* Version with cab

** Version without cab

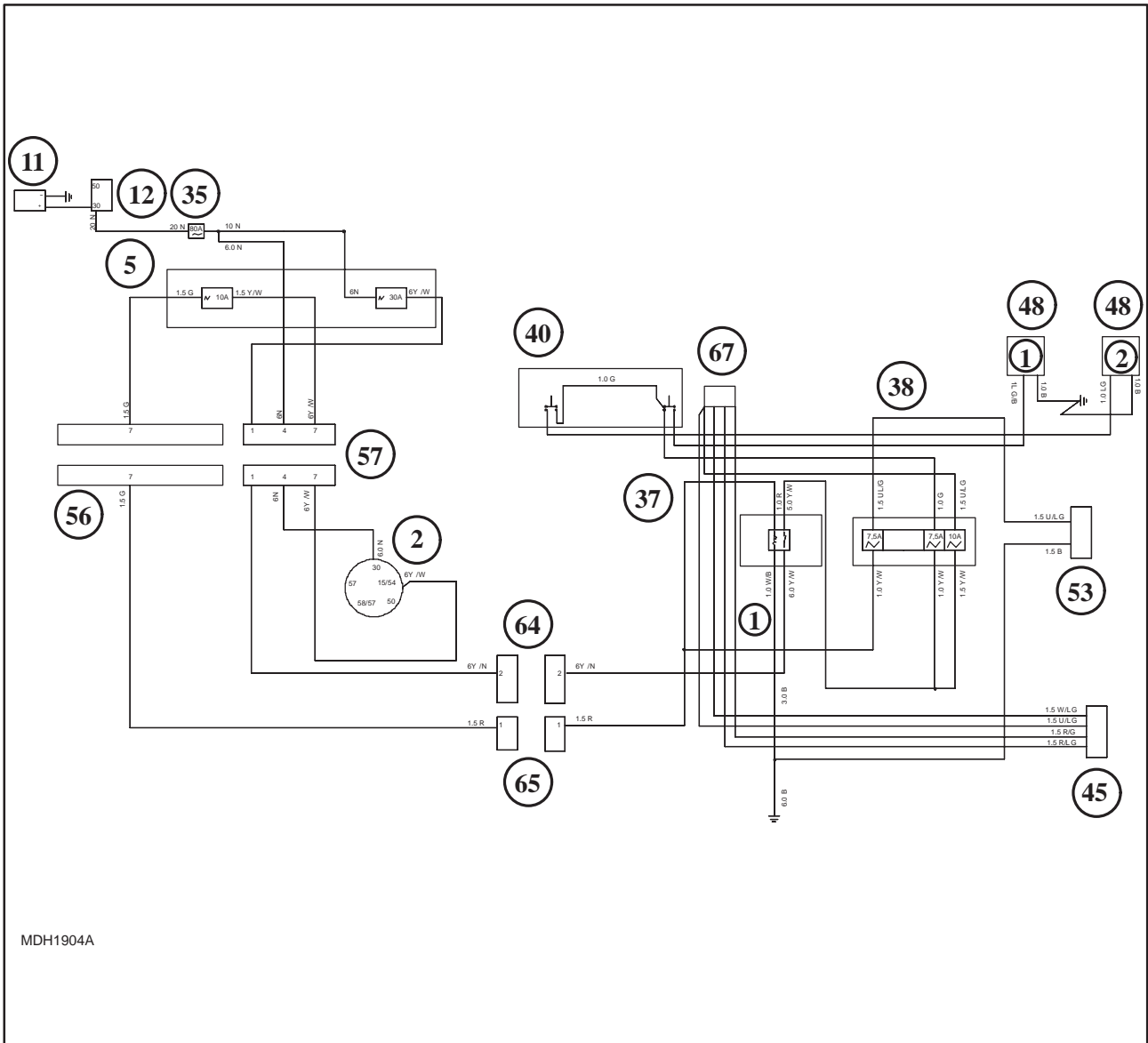

WINDSCREEN AND REAR WINDOW WIPER/WASHER CIRCUIT

- | | |
|--|--|
| <ul style="list-style-type: none"> 1. Instruments cluster 2. Starter switch 5. Fusebox 11. Battery 12. Starter motor 35. Main fuse 37. Relay box <ul style="list-style-type: none"> 1. Cab supply relay 38. Fuse box 40. Switch | <ul style="list-style-type: none"> 45. Windscreen washer 48. Windscreen wiper/washer pumps <ul style="list-style-type: none"> 1. Windscreen wiper connector 2. Rear window wiper connector 53. Rear window wiper 56. Black (15 pin) connection 57. (8 pin) connection 64. (4 pin) cab connection 65. (2 pin) cab connection 67. Windscreen wiper switch |
|--|--|

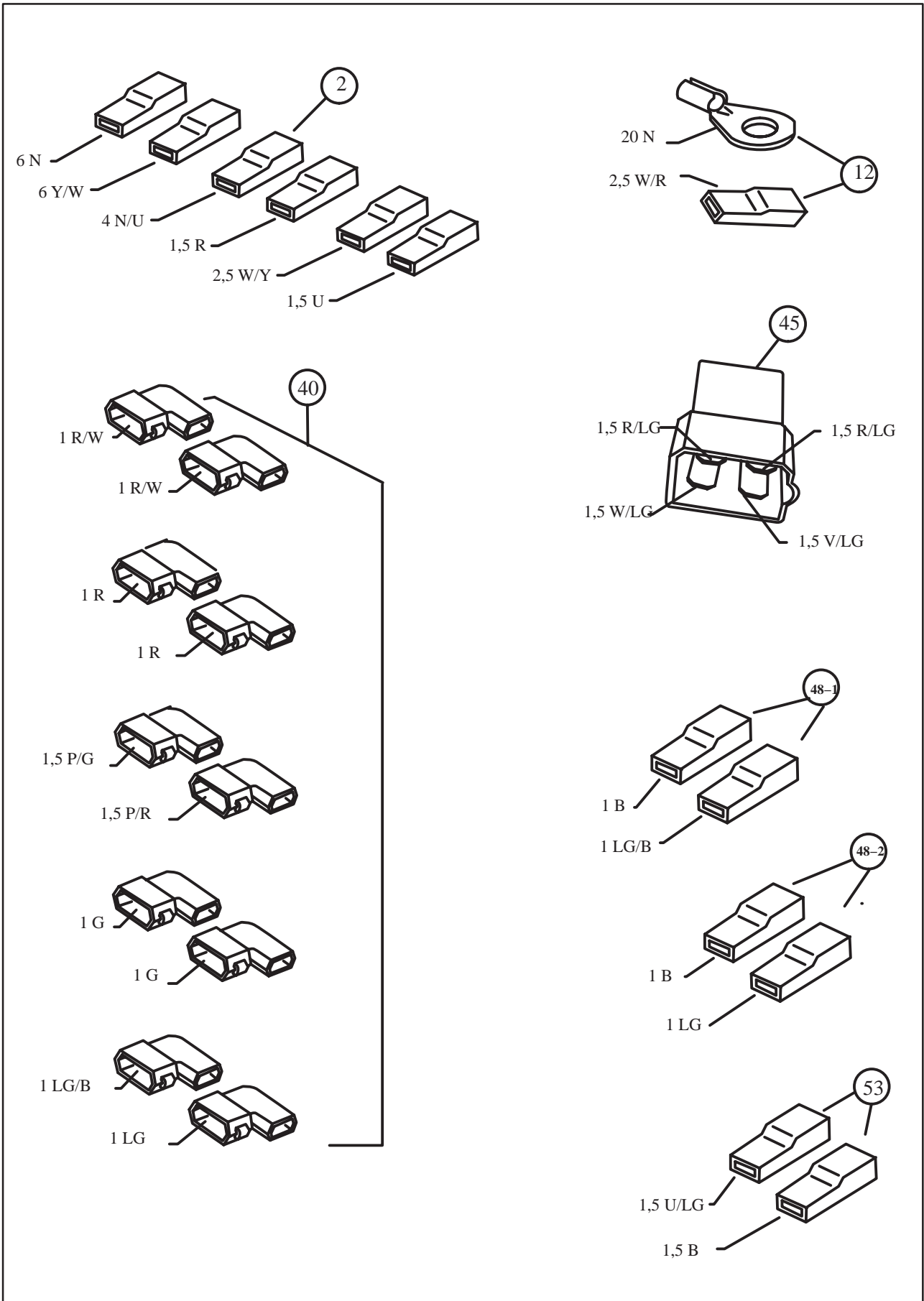

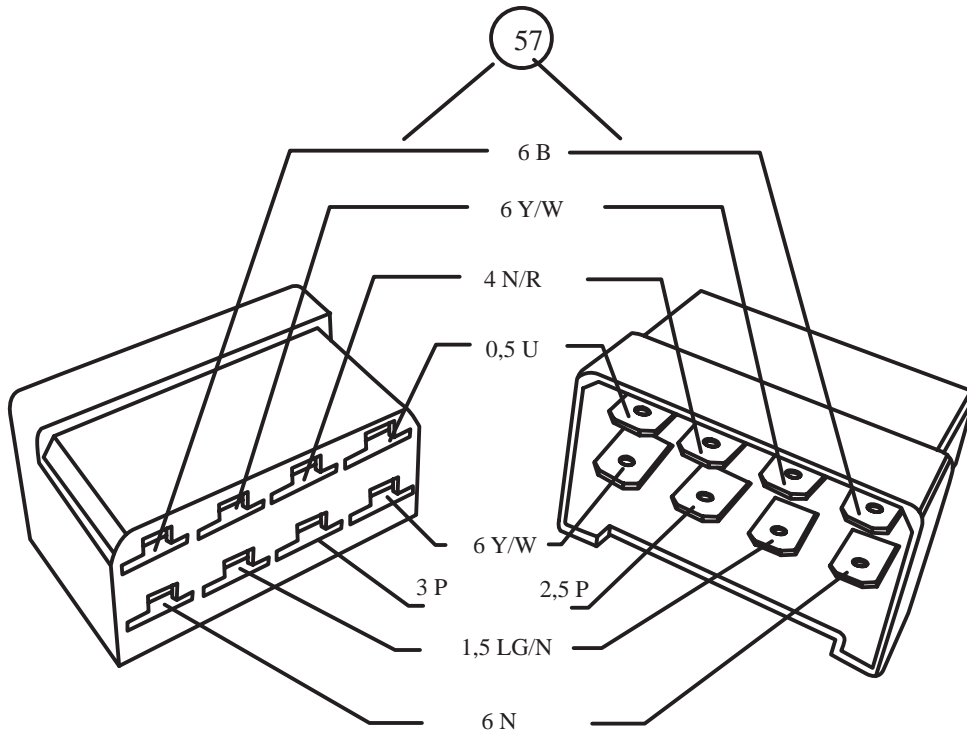
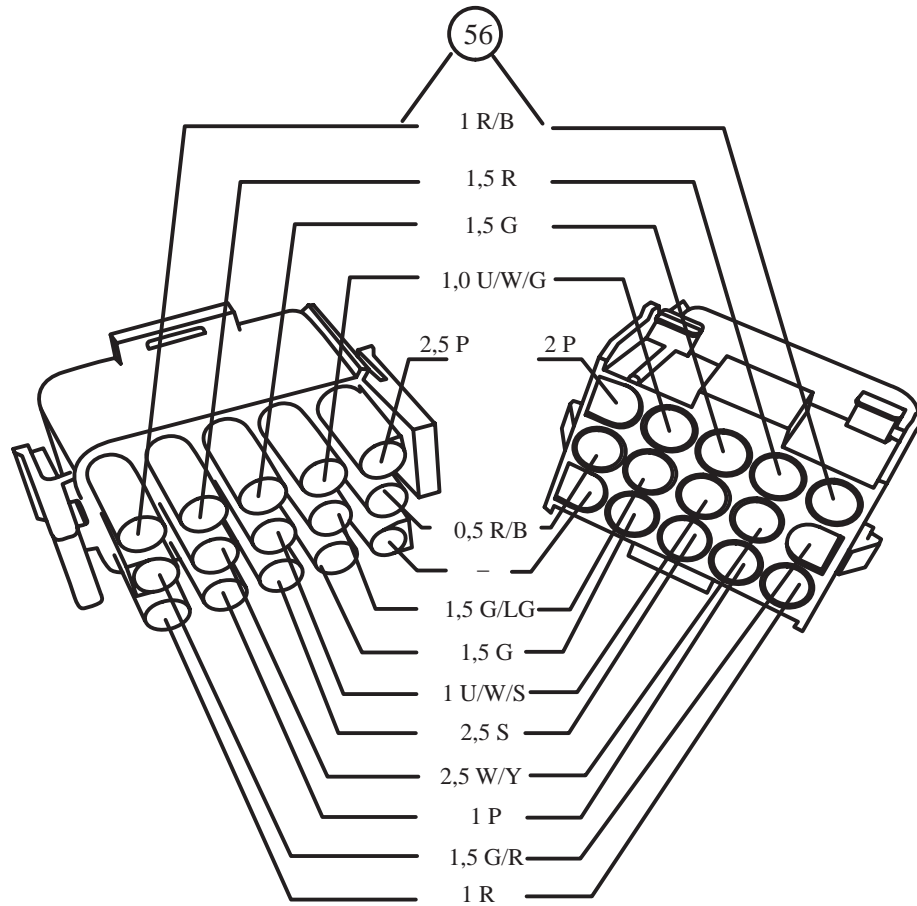

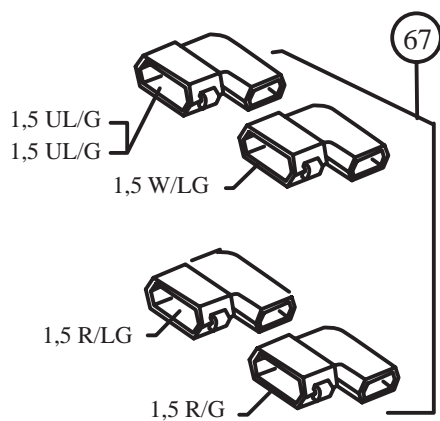
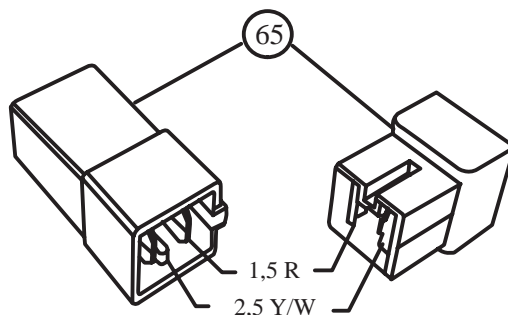
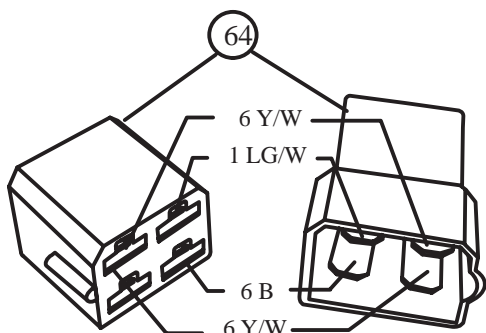

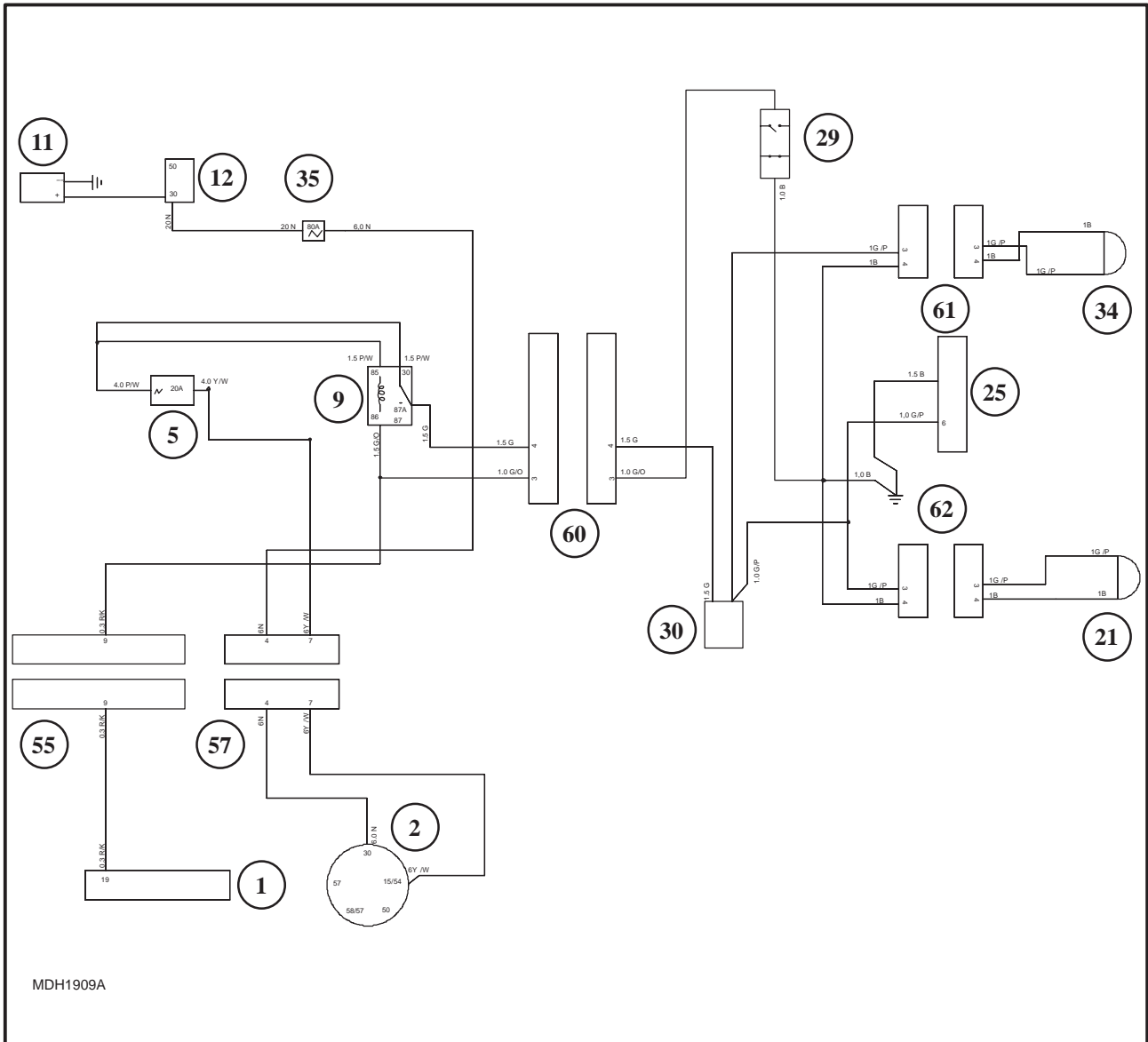

9

BRAKE LIGHT CIRCUIT

- | | |
|--|---|
| 1. Instruments cluster | 30. Brake lights switch |
| 2. Starter switch | 34. Parking light, turn signal and brake light for rear right-hand side |
| 5. Fusebox | 35. Main fuse |
| 9. Brakes system relay | 55. White (15 pin) connection |
| 11. Battery | 57. (8 pin) connection |
| 12. Starter motor | 60. (15 pin) connection |
| 21. Parking light, turn signal and brake light for rear left-hand side | 61. (4 pin) right-hand tail light connection |
| 25. Trailer connector | 62. (4 pin) left-hand tail light connection |
| 29. Handbrake switch | |

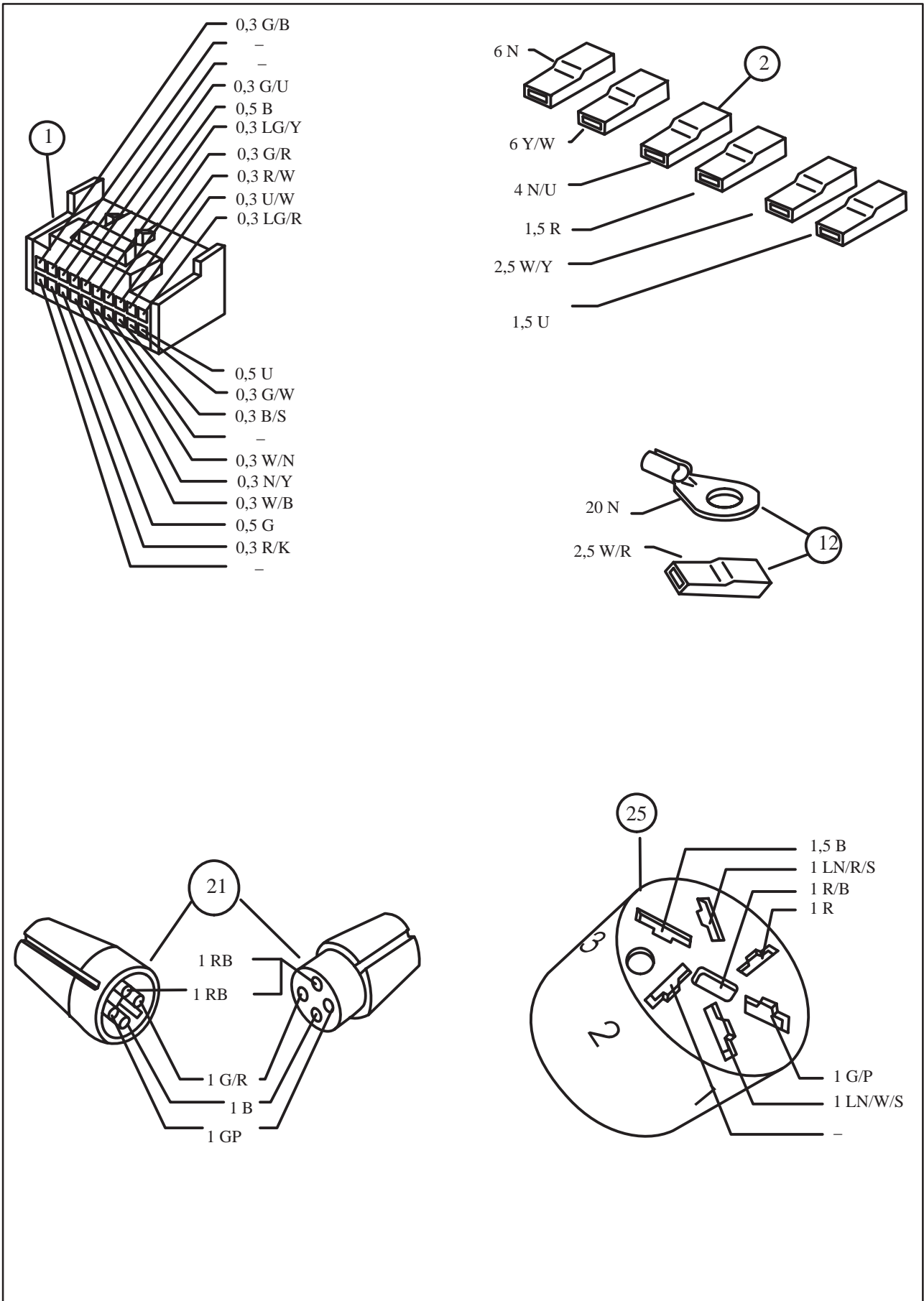

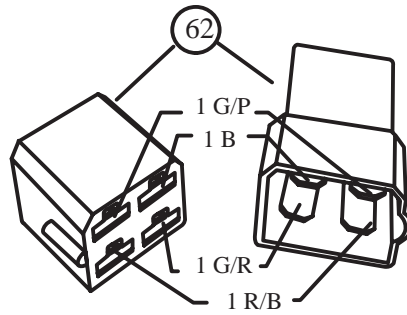
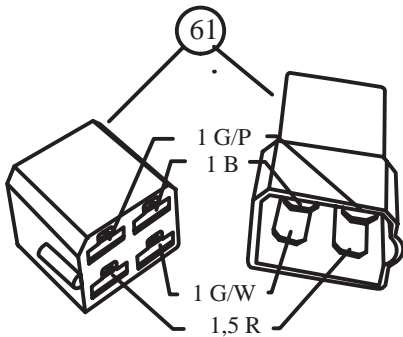
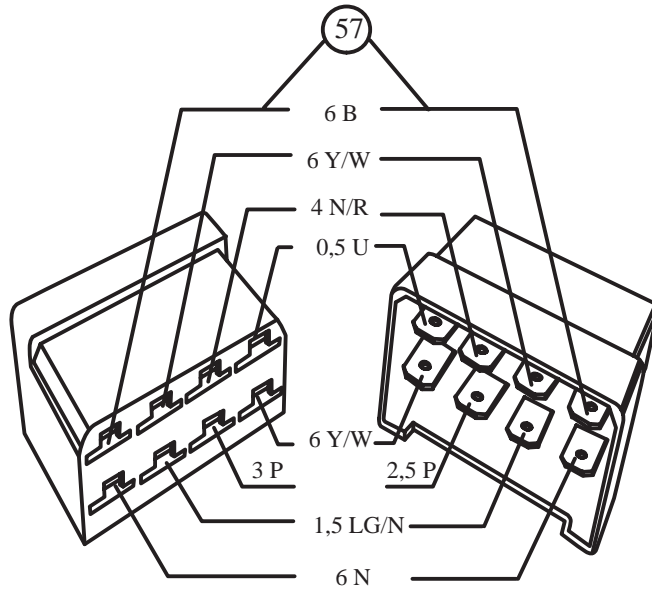
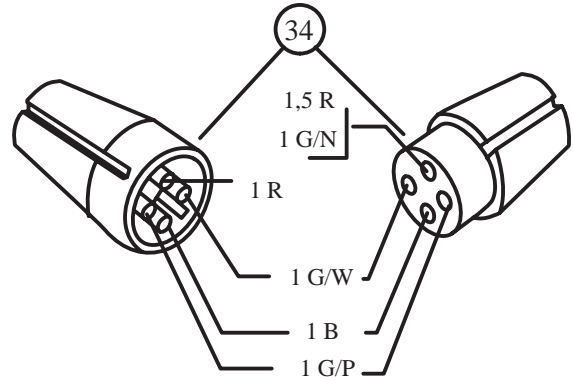
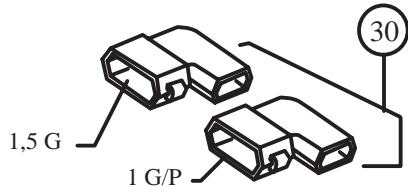

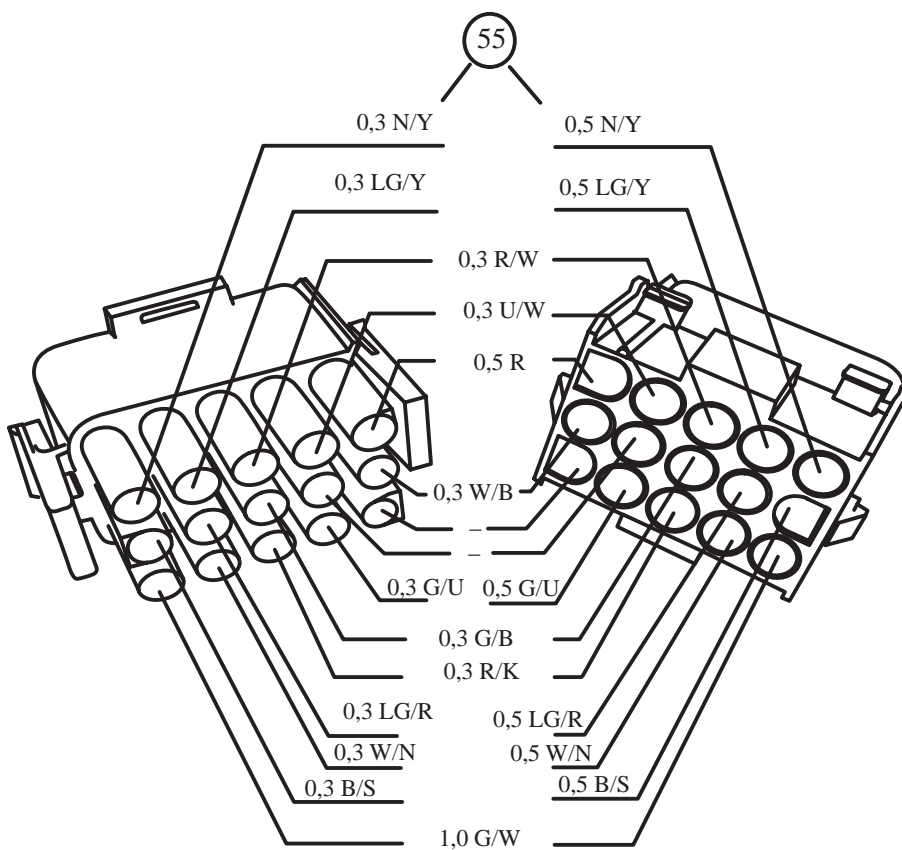

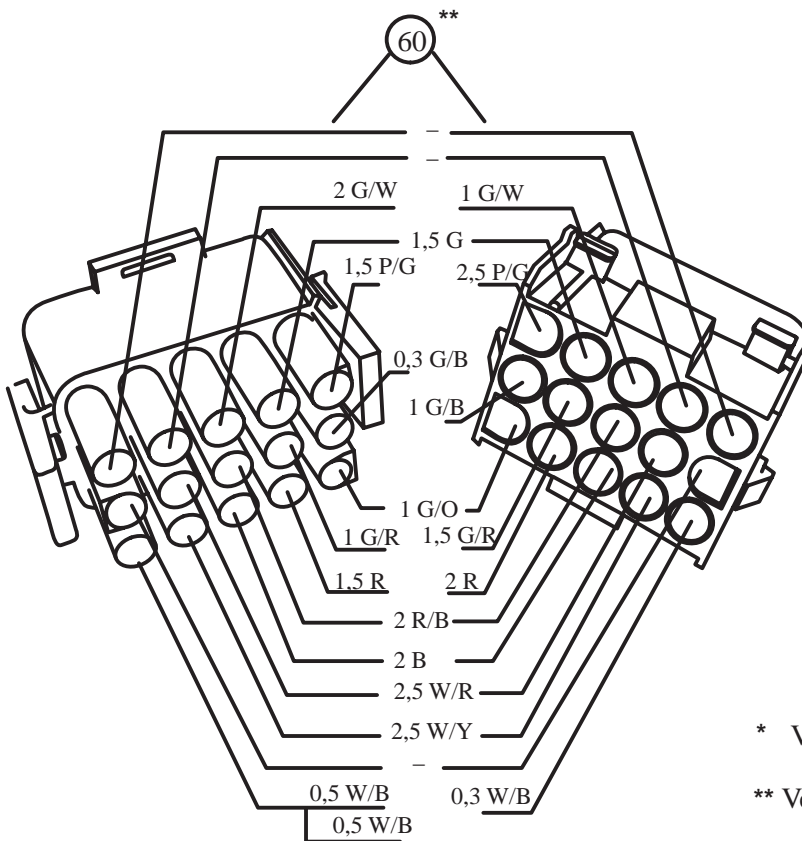
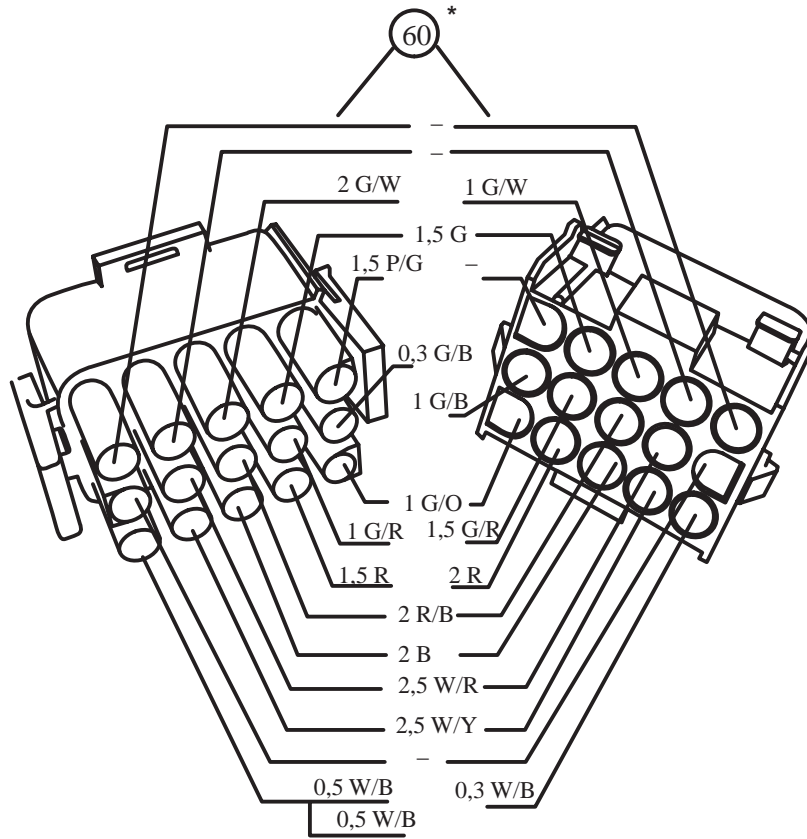

* Version with cab

** Version without cab

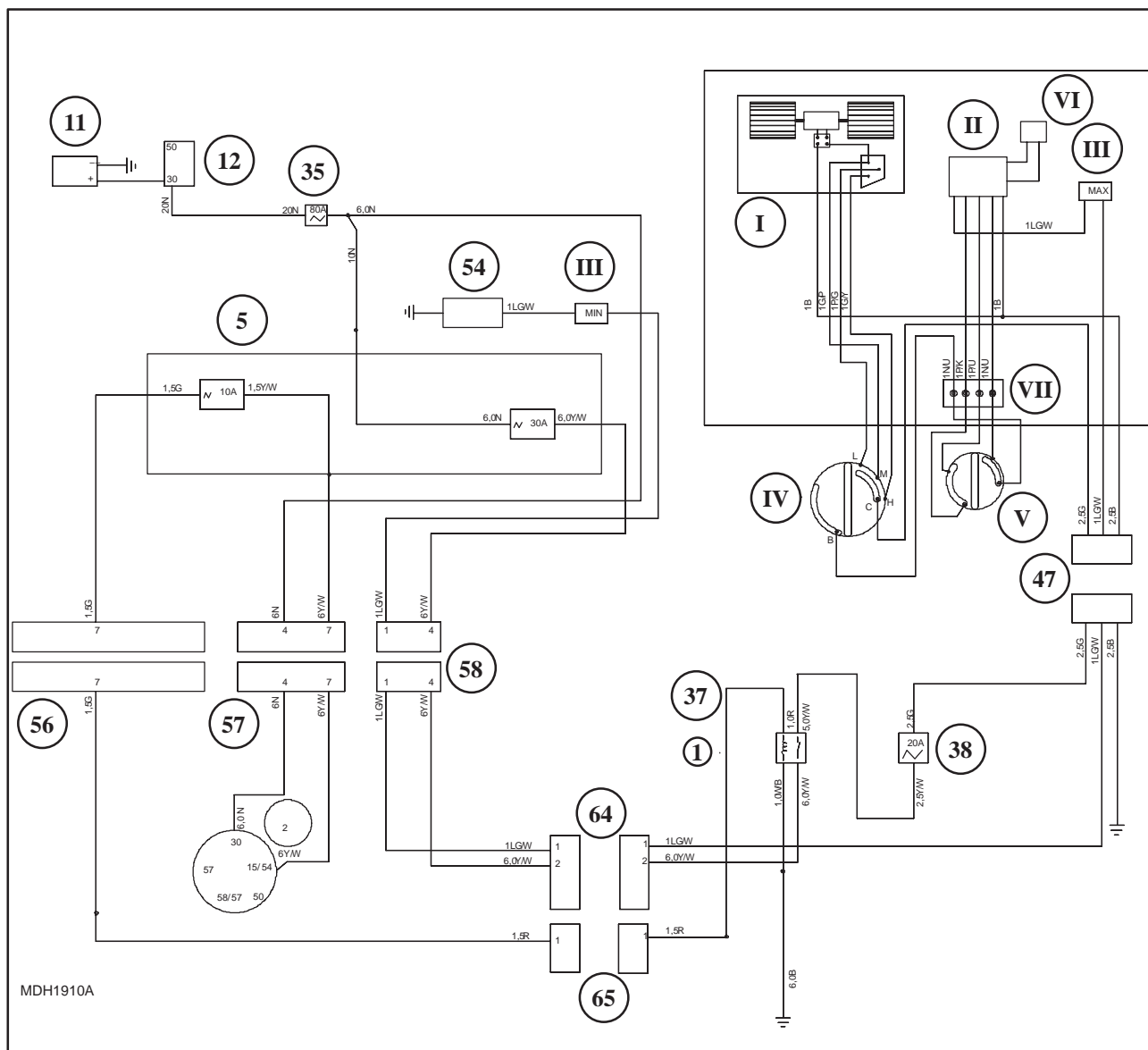

HEATING AND AIR-CONDITIONING SYSTEM CIRCUIT

- | | |
|-------------------------------|--|
| 2. Starter switch | 57. (8 pin) connection |
| 5. Fusebox | 58. (4 pin) connection |
| 11. Battery | 64. Cab connection (4 pin) |
| 12. Starter motor | 65. Cab connection (2 pin) |
| 35. Main fuse | I Electric fans |
| 37. Relay box | II Air conditioner thermostat |
| 1. Cab supply relay | III Air conditioner pressure switch |
| 38. Fuse box | IV Fan control switch |
| 47. Heater | V Air conditioning switch |
| 54. Compressor | VI Heating adjustment |
| 56. Black (15 pin) connection | VII Air conditioning switch connection |

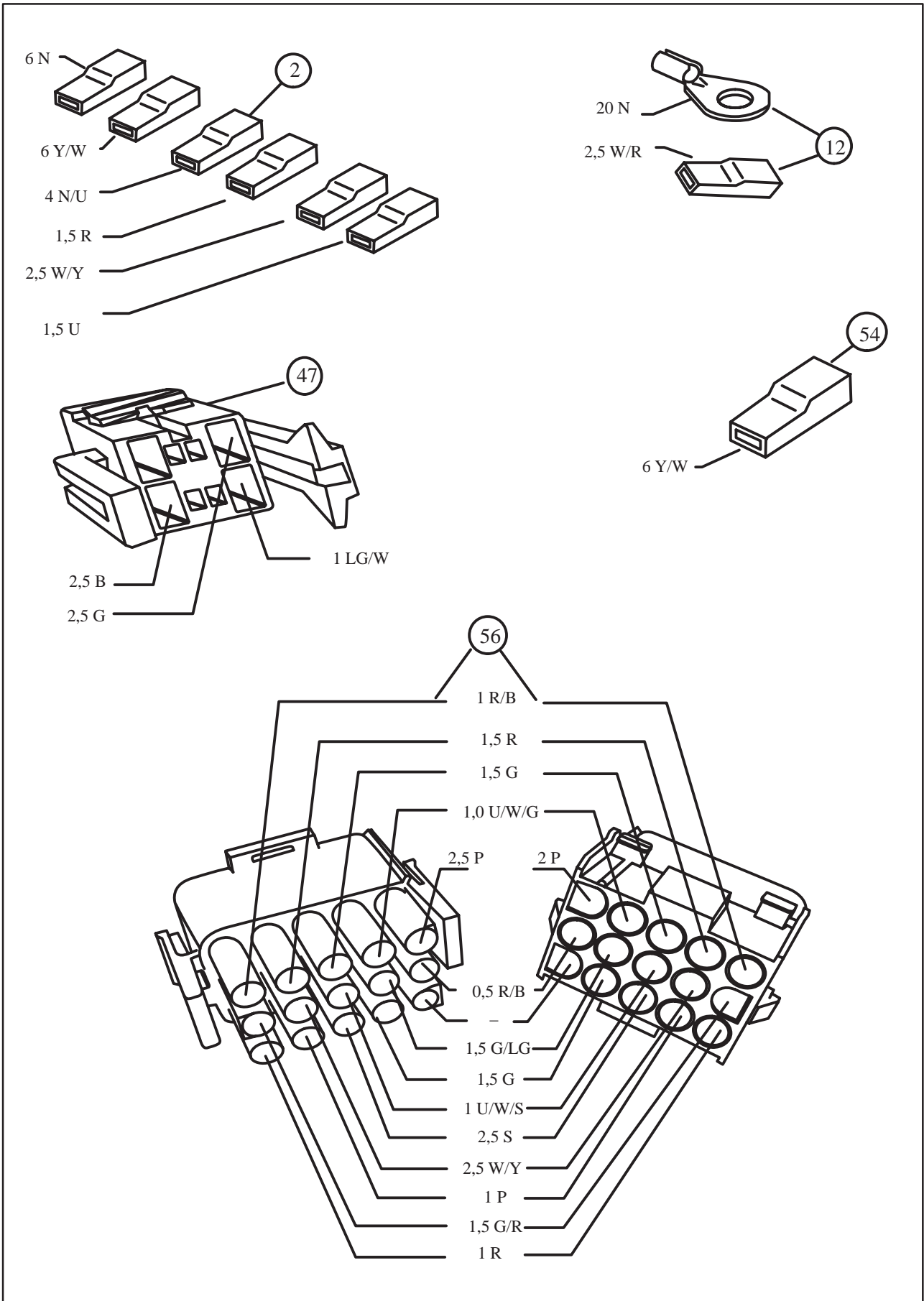

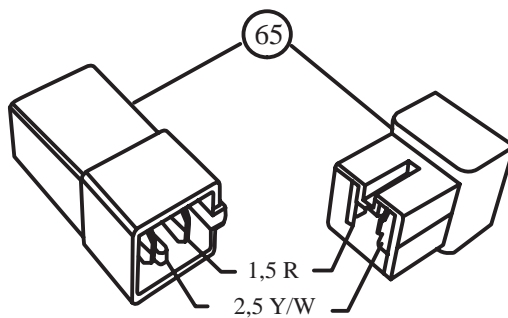
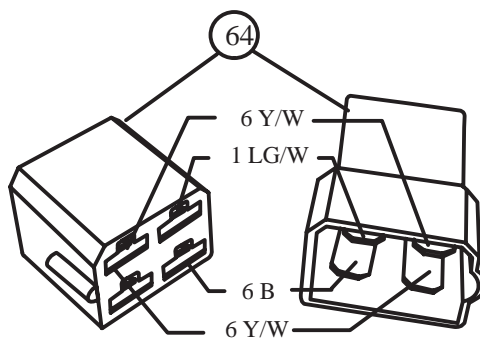
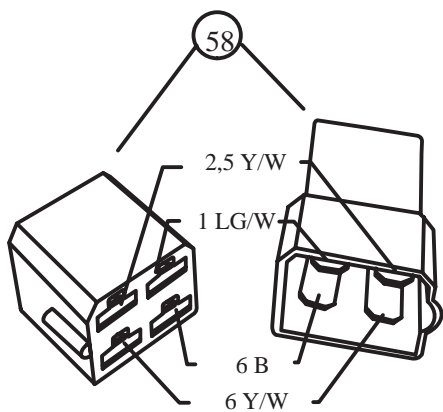
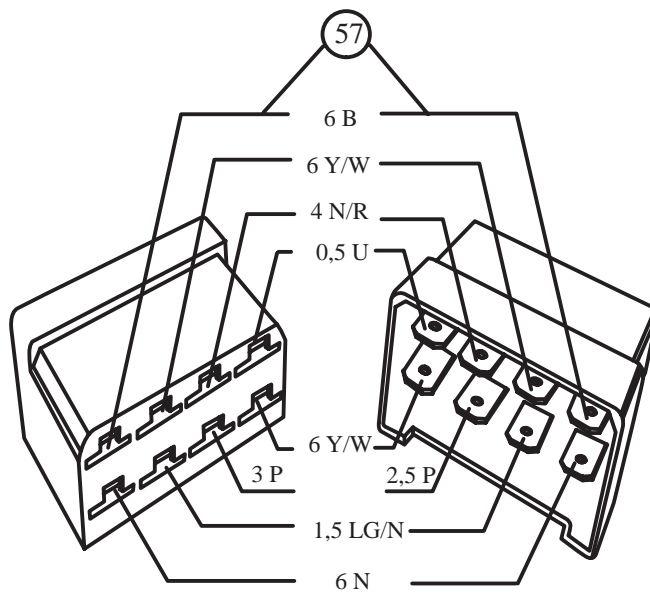

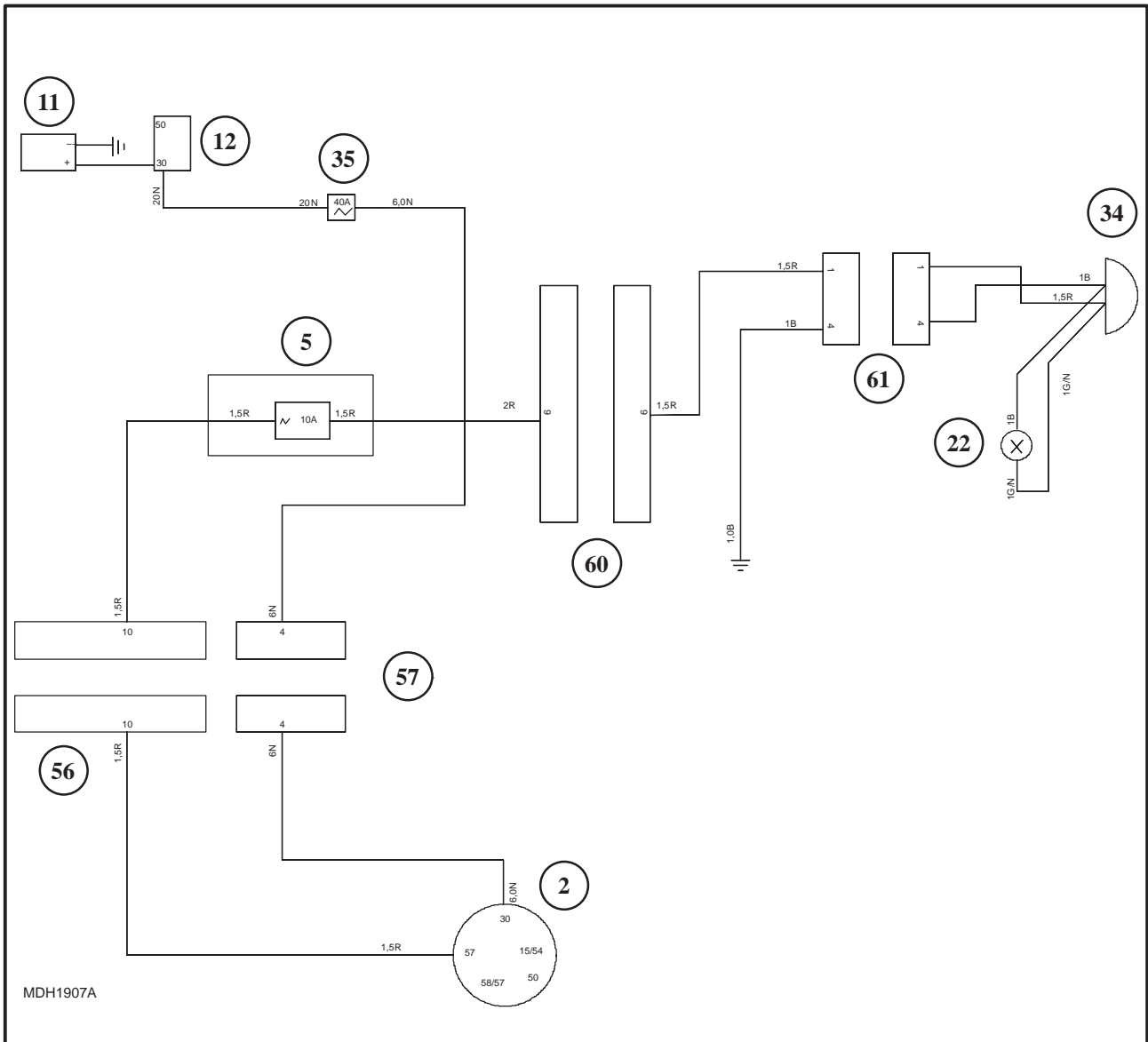

11

WORK LAMP (WITHOUT CAB) CIRCUIT

- | | |
|---|--|
| 2. Starter switch | 35. Main fuse |
| 5. Fusebox | 56. Black (15 pin) connection |
| 11. Battery | 57. (8 pin) connection |
| 12. Starter motor | 60. (15 pin) connection |
| 22. Work light | 61. (4 pin) right-hand tail light connection |
| 34. Parking light, turn signal and brake light for rear right-hand side | |

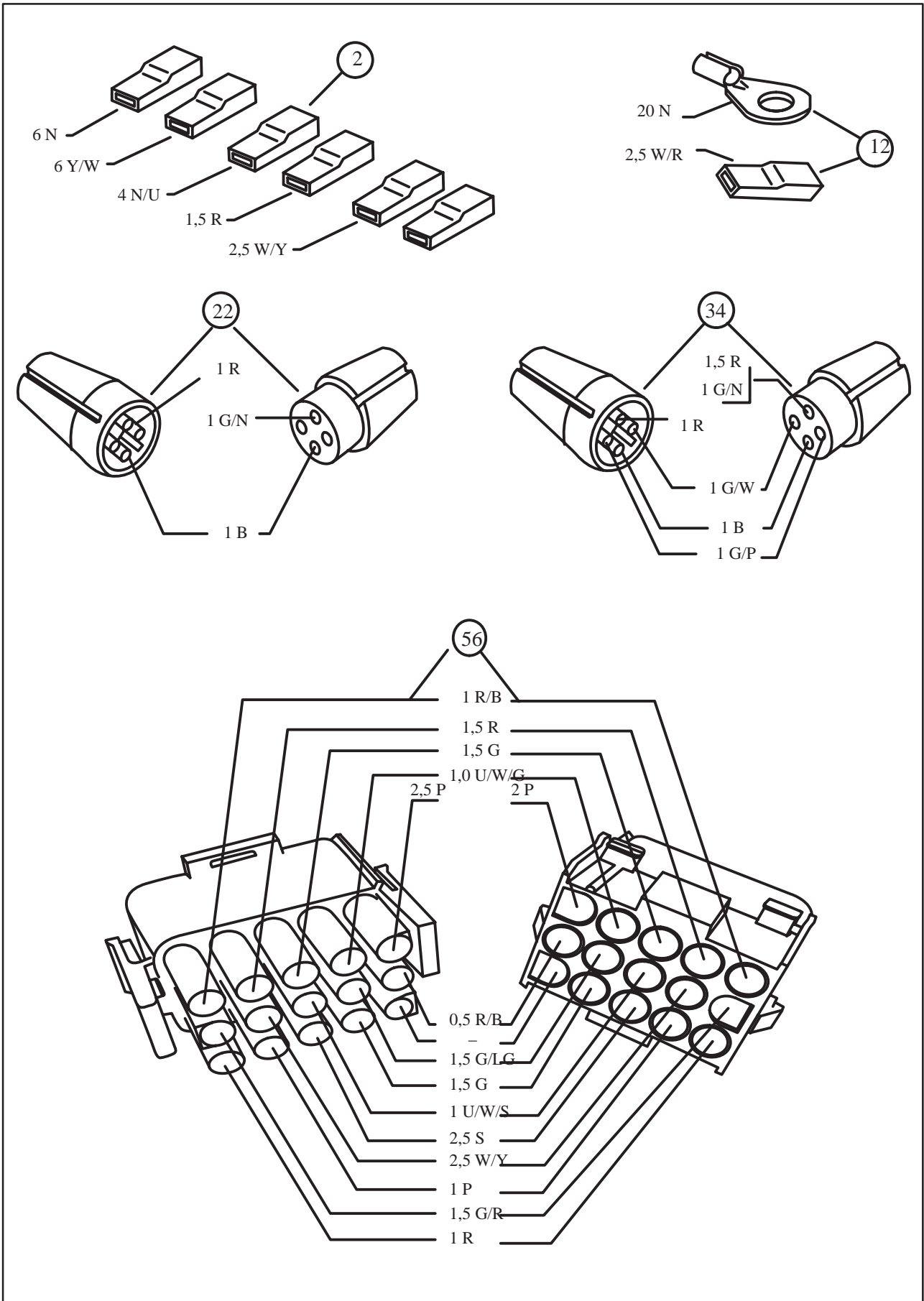

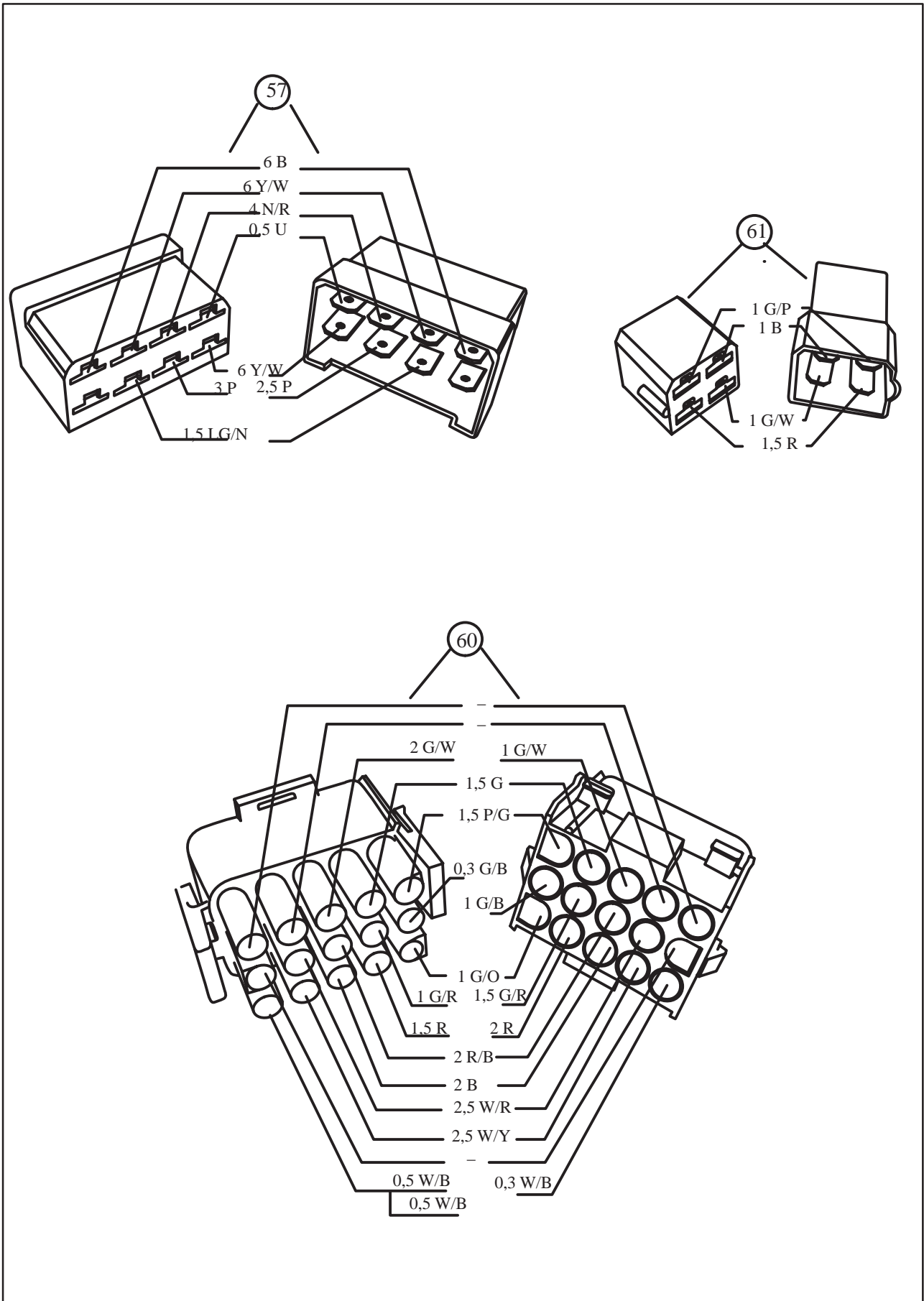

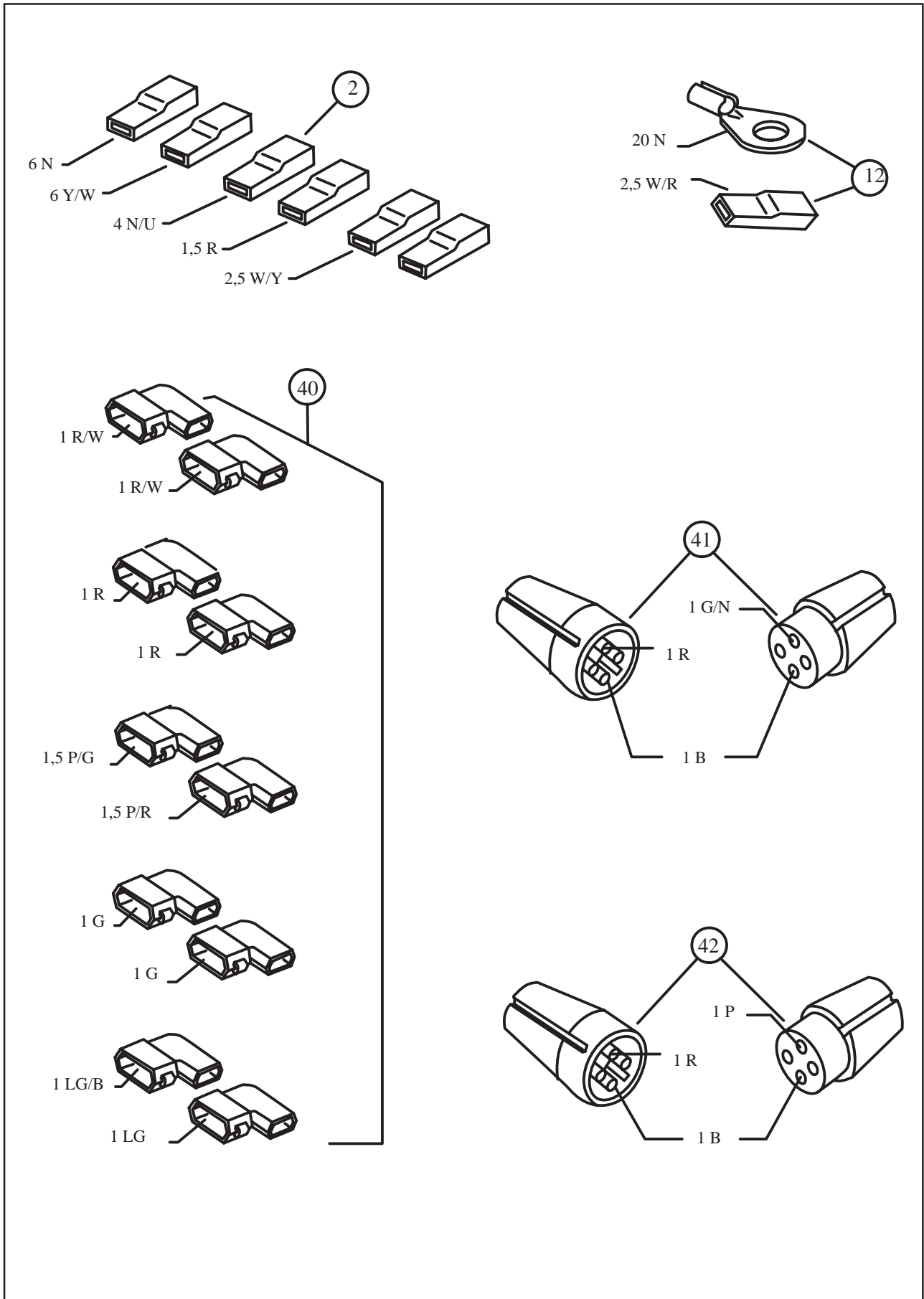

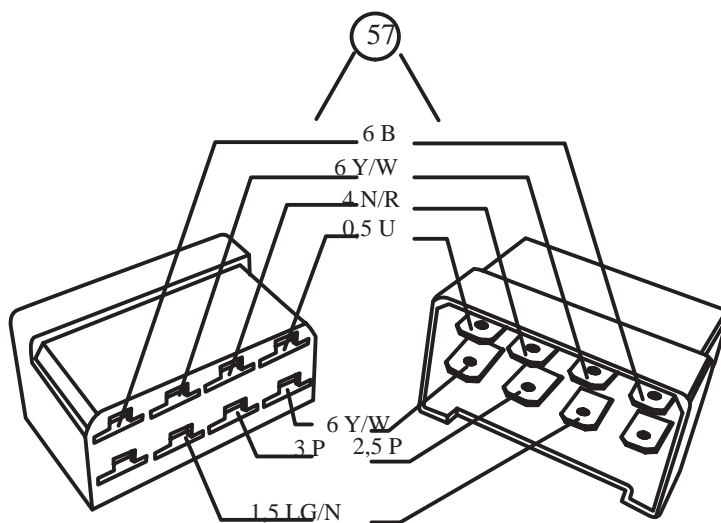
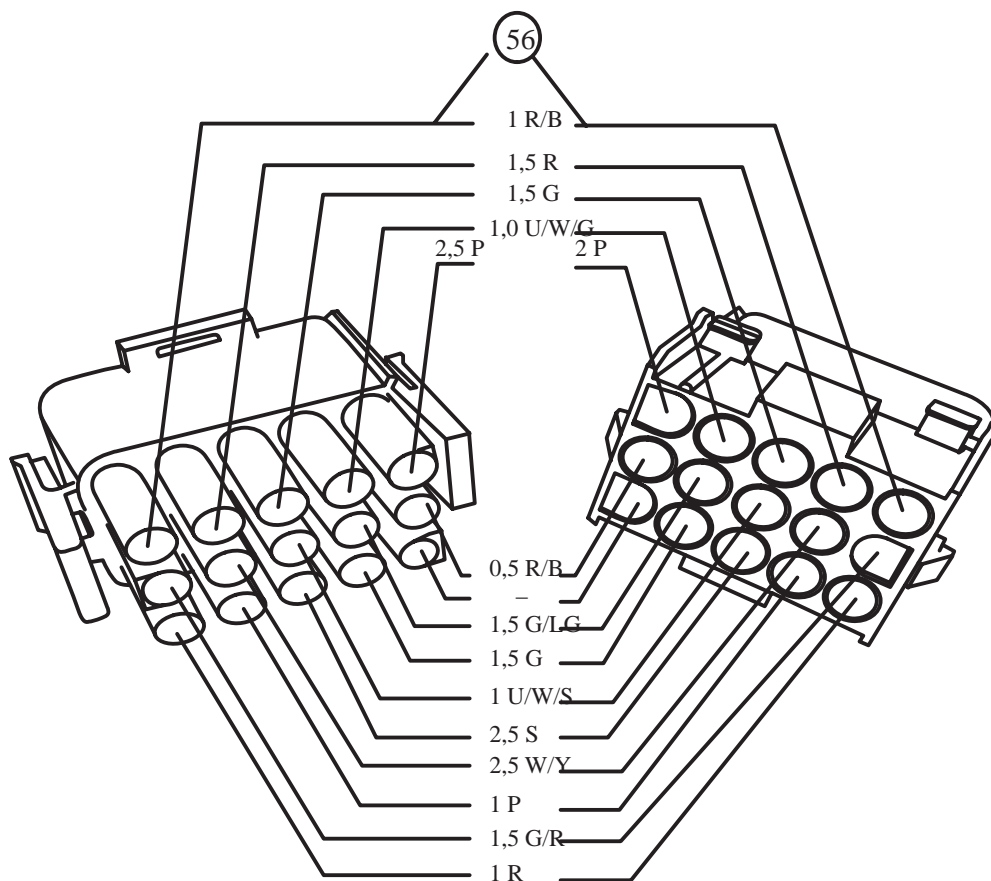

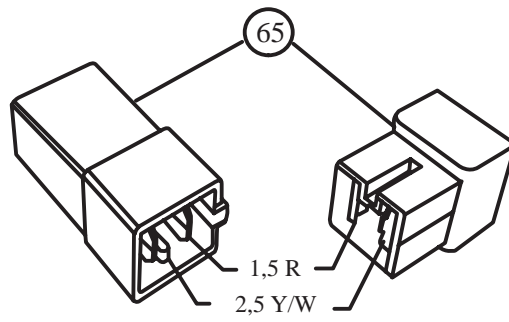
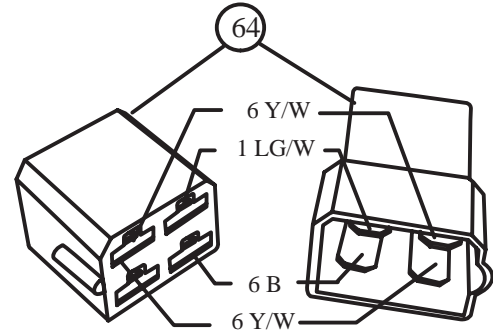
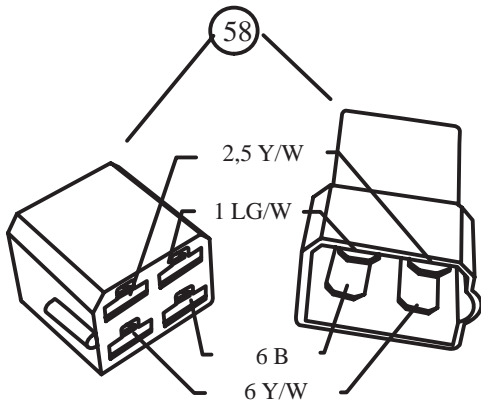

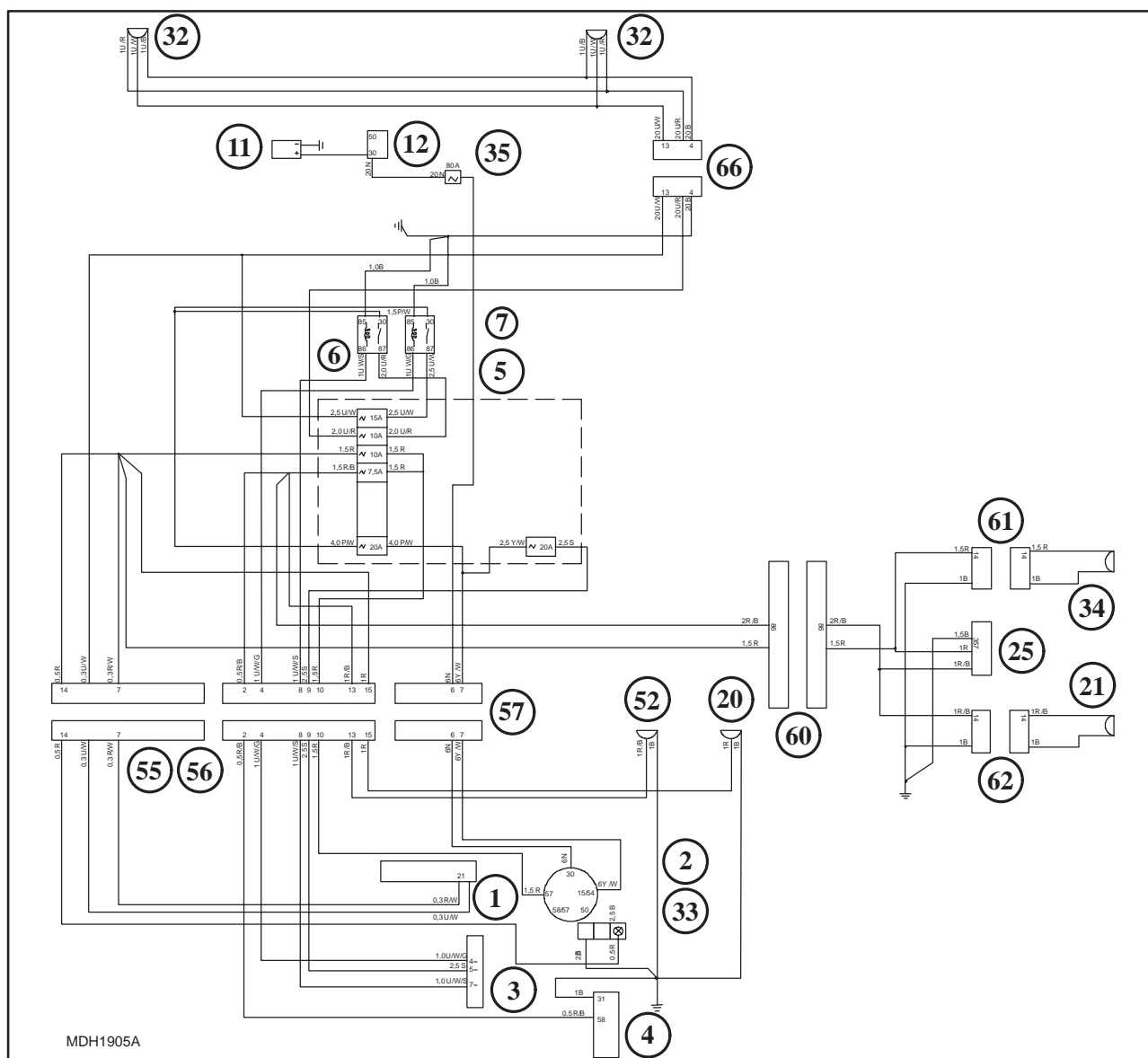

13

SIDE LIGHTS, MAIN AND DIPPED HEADLIGHTS, PARKING LIGHT CIRCUIT

- | | |
|--|--|
| 1. Instruments cluster | 32. Headlamps |
| 2. Starter switch | 33. Cigar lighter |
| 3. Turn signal switch | 34. RH tail light |
| 4. Hazard warning lights indicator transmitter | 35. Main fuse |
| 5. Fusebox | 52. Front LH light |
| 6. Dipped beam relay | 55. White (15 pin) connection |
| 7. Main beam relay | 56. Black (15 pin) connection |
| 11. Battery | 57. (8 pin) connection |
| 12. Starter motor | 60. (15 pin) connection |
| 20. Front RH light | 61. (4 pin) right-hand tail light connection |
| 21. LH tail light | 62. (4 pin) left-hand tail light connection |
| 25. Trailer connector | 66. (4 pin) connection for lights cable |

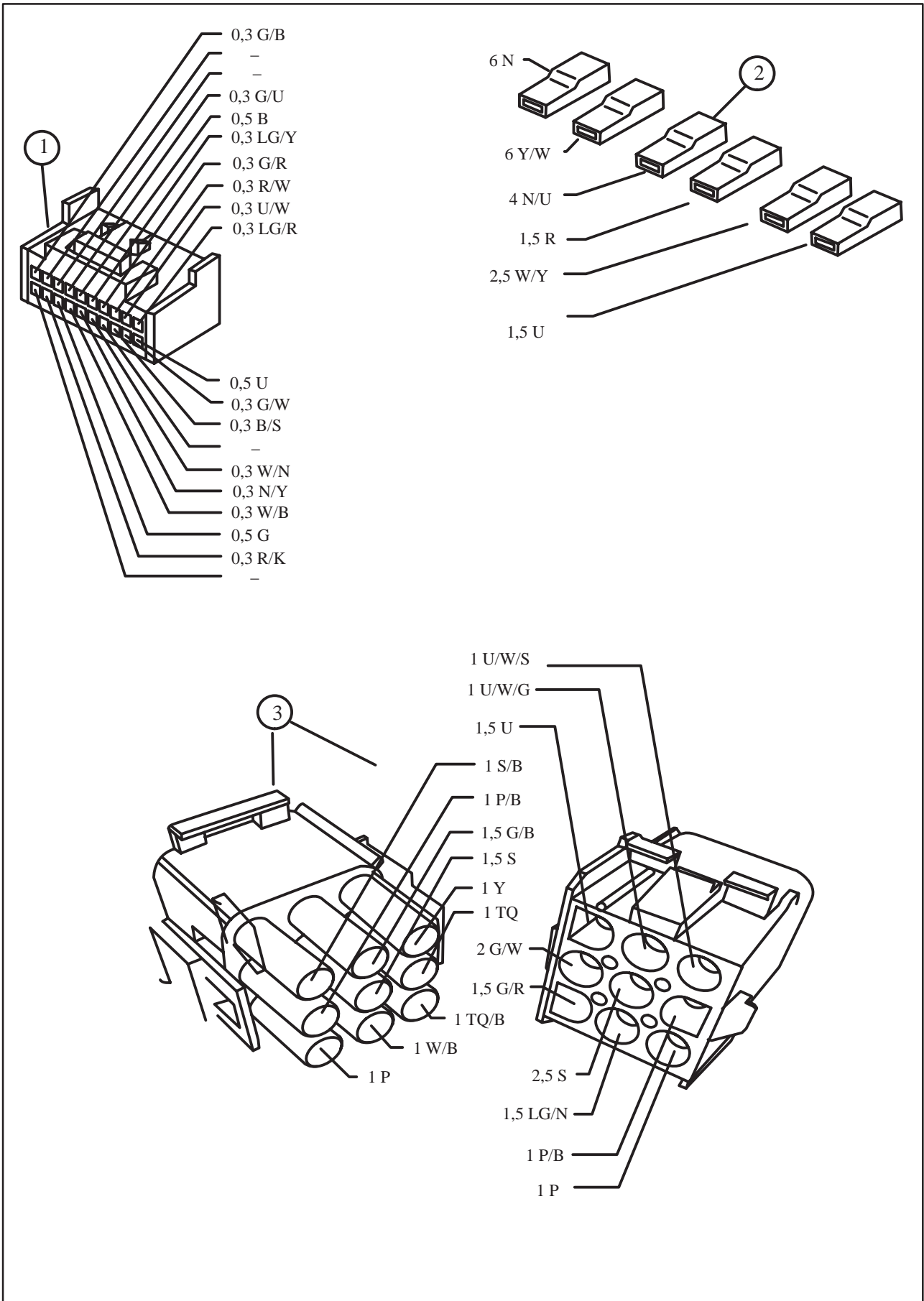

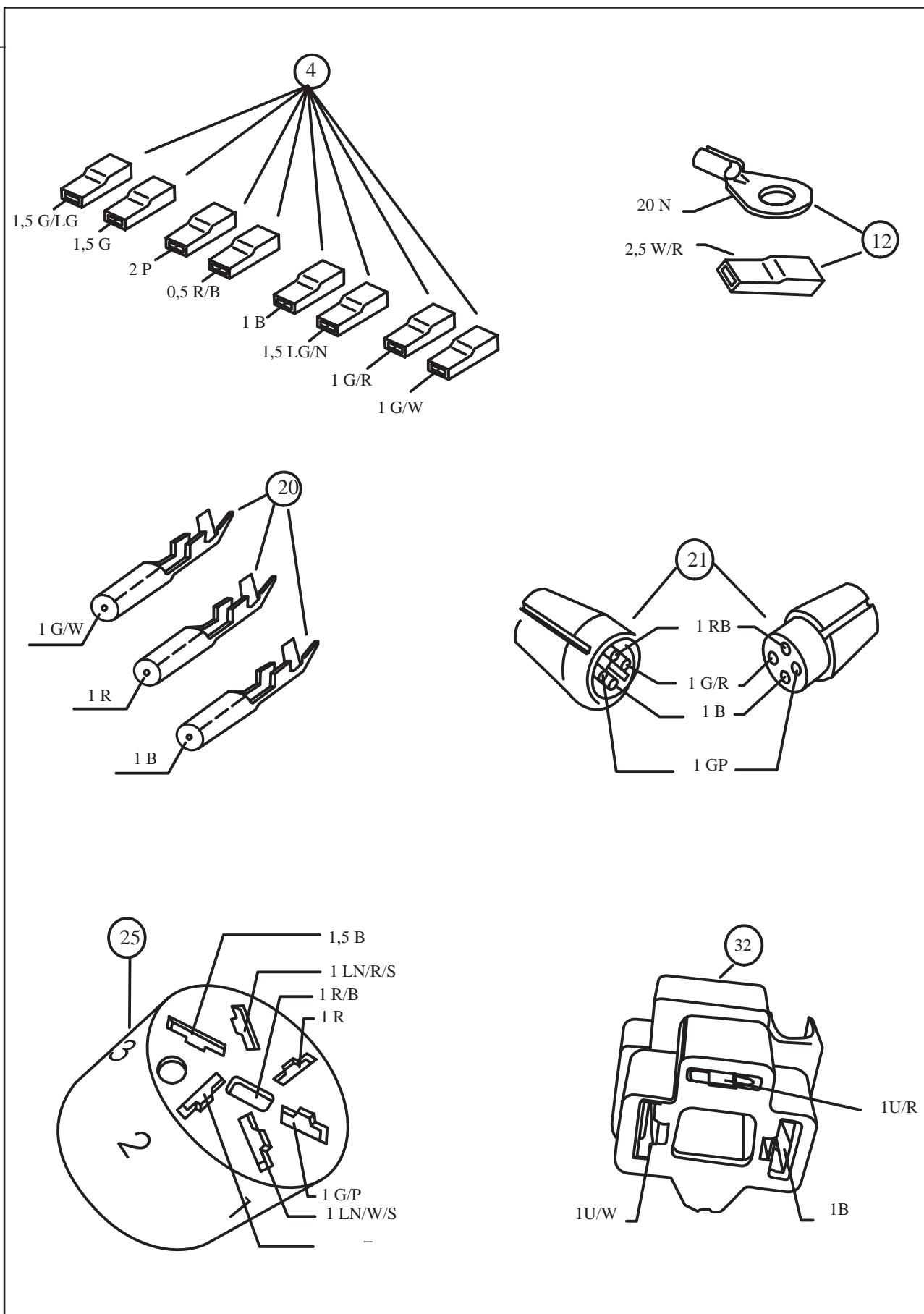

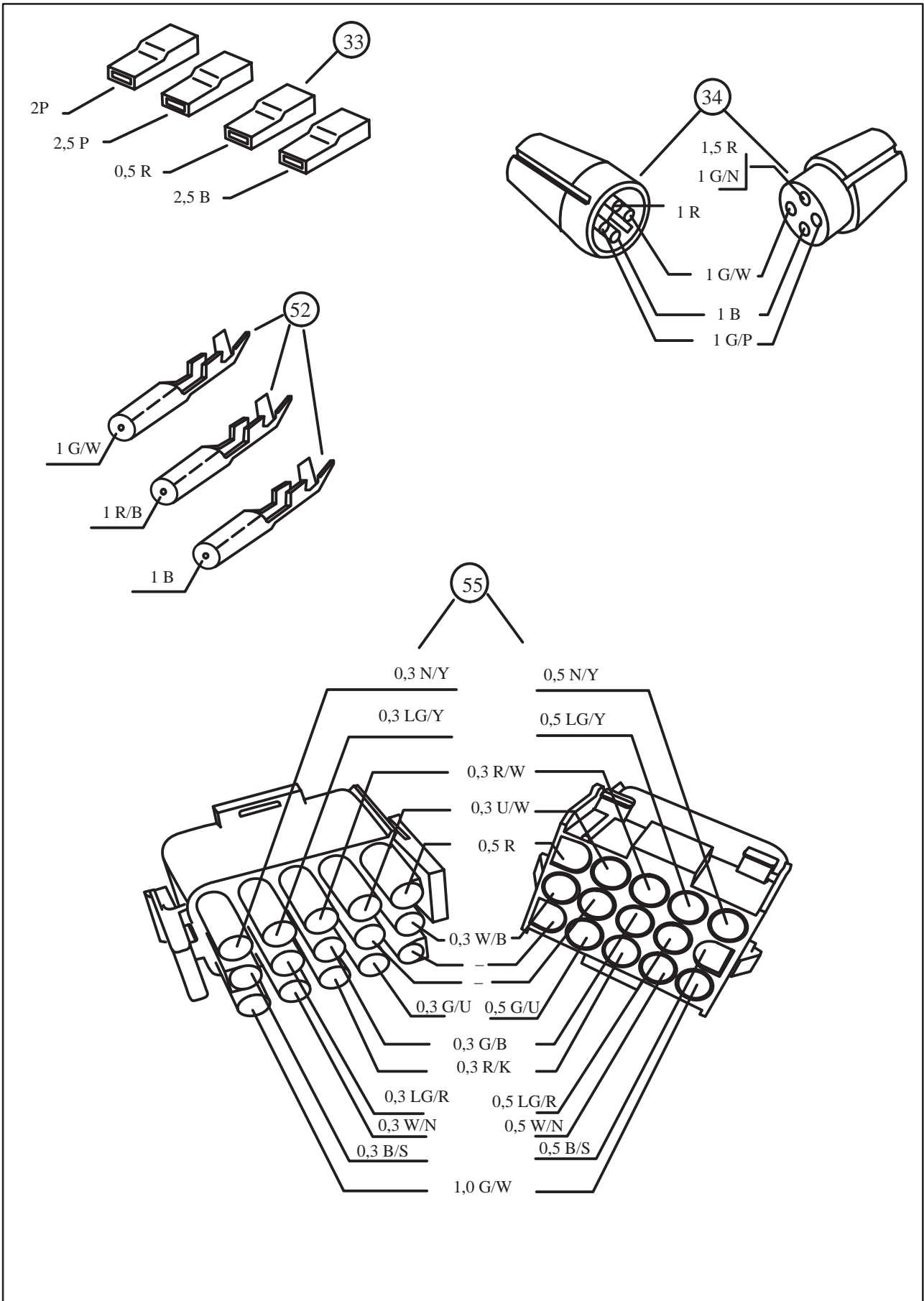

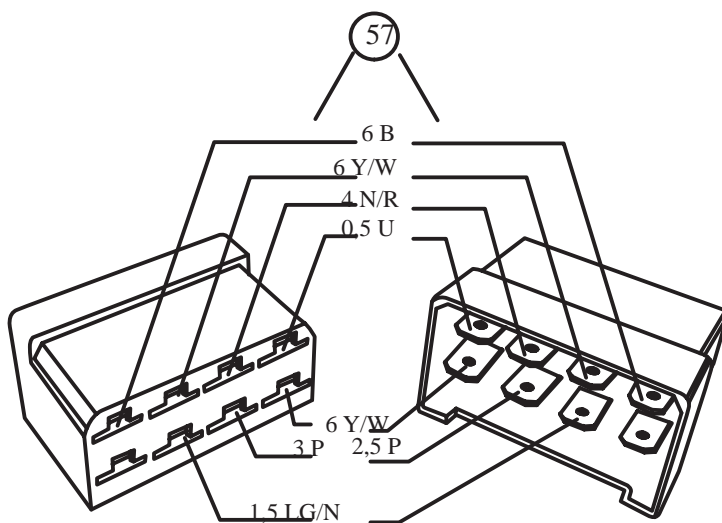
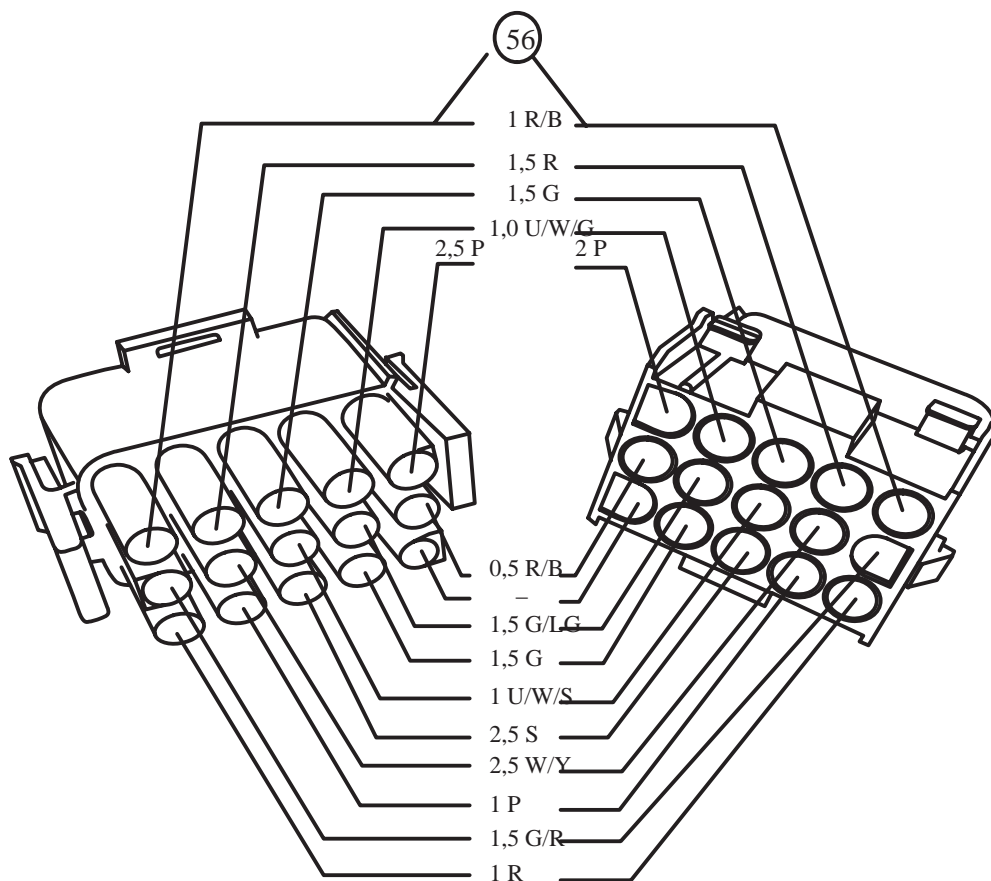

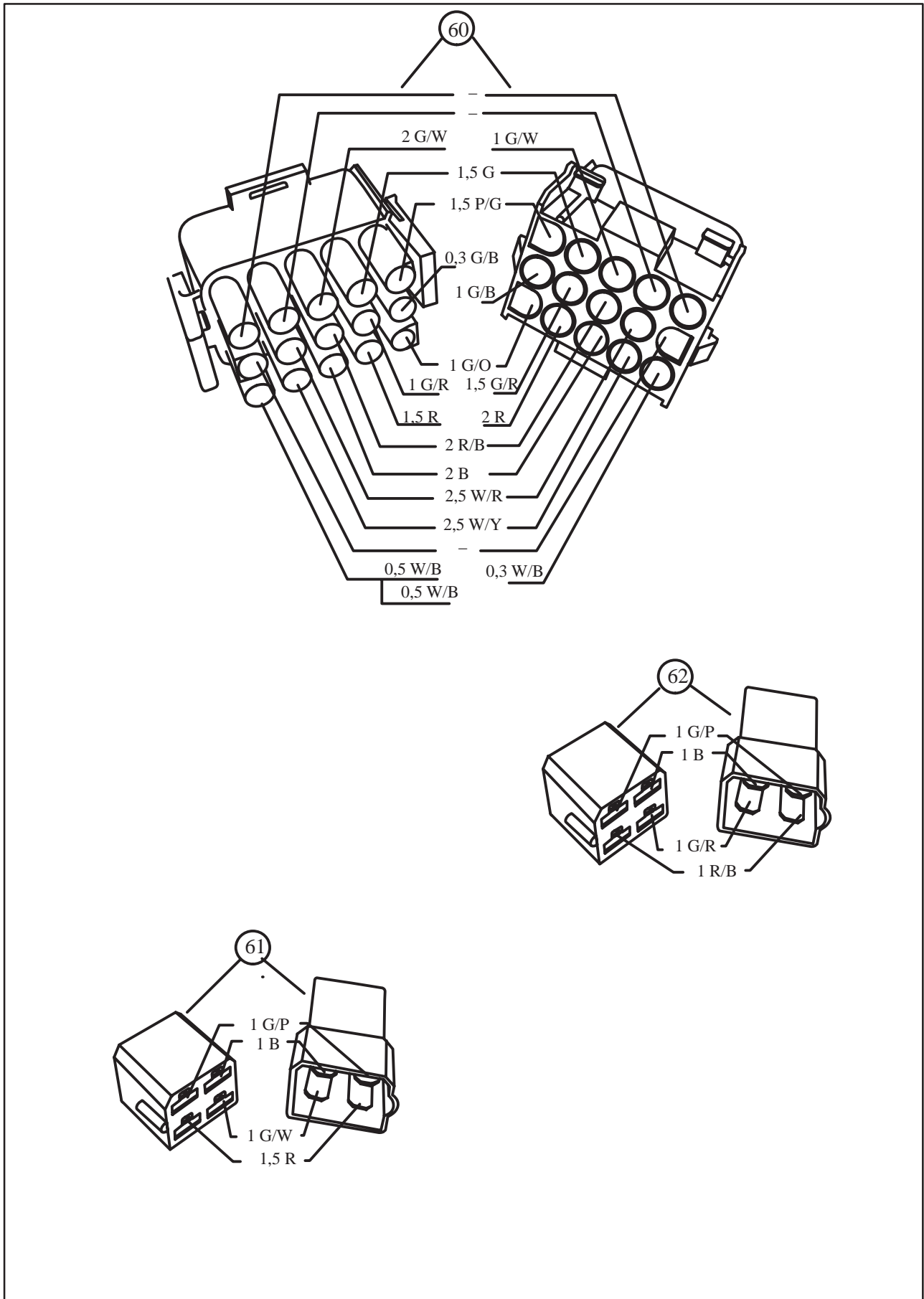

SECTION 90 - CAB

Chapter 1 - Removing parts

CONTENTS

Section	Description	Page
90 160 42 - 43		
90 120 10	Control levers, seat and electrical controls - disassembly and reassembly	2
90 156 52	Rear window, handle and lock - disassembly and reassembly	10
90 154 30	Left-hand door exterior handle and lock - disassembly and reassembly	11
90 154 10	Left-hand door - disassembly and reassembly	12
90 160 60		
55 518 52	Windscreen wiper motor - disassembly and reassembly	13
90154 24		
90 156 10 - 14		
90 156 28	Cab windows - replacement	15

**CONTROL LEVERS, SEAT,
ELECTRICAL CONTROLS**
Disassembly-Assembly
(Op. 90 160 43-90 160 42-90 120 10)

1. Disconnect the negative cable from the battery.

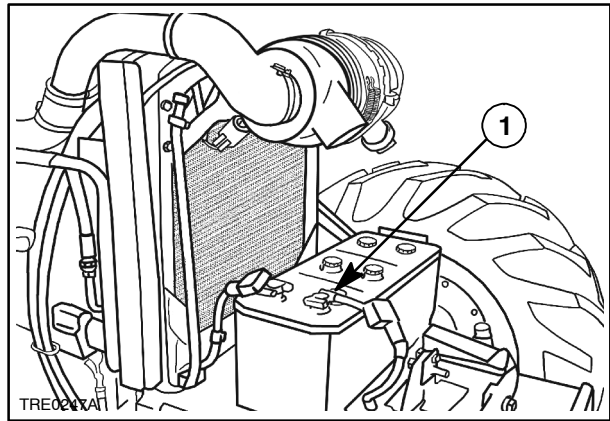

2. Take out the four securing screws (1) and remove the covering of the control panel.

3. Disconnect the electrical connector from the cab interior light switches (3) and remove the cover.

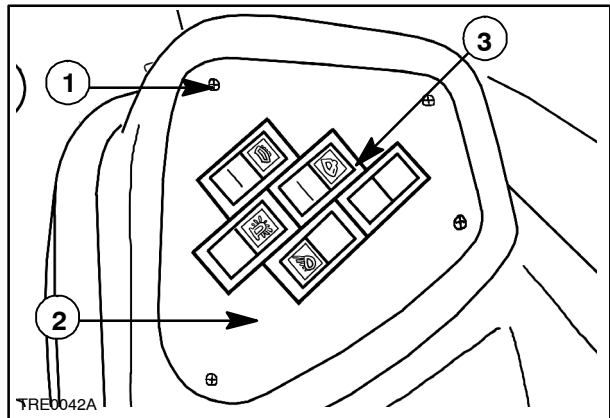

4. Remove the LH panel retaining screws (1).

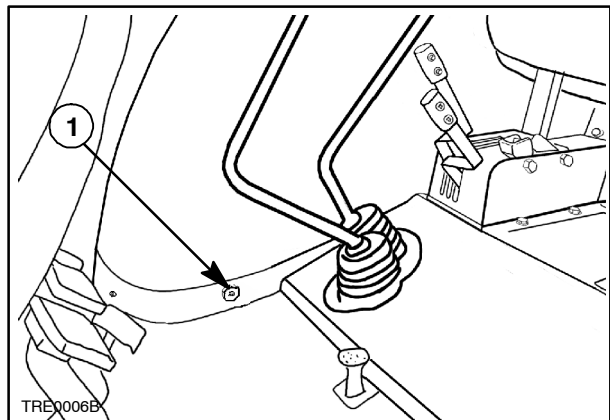

5. Remove the three LH panel retaining screws (1).

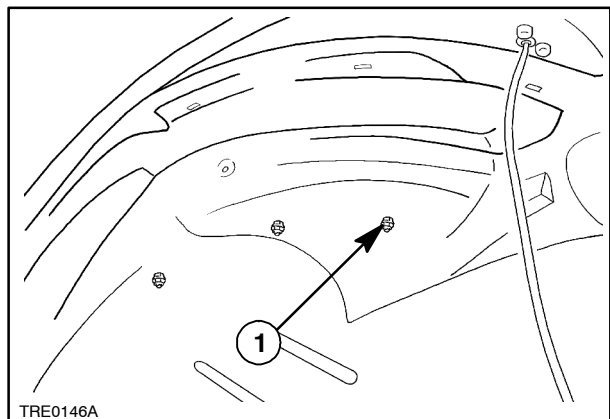

6. Remove the screws (1) on rear panel

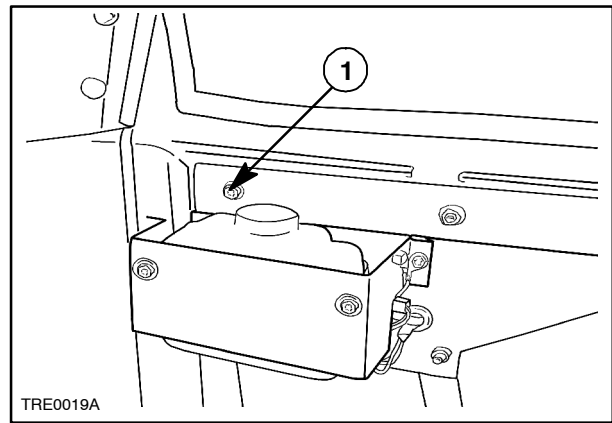

5

7. Remove the LH panel (1).

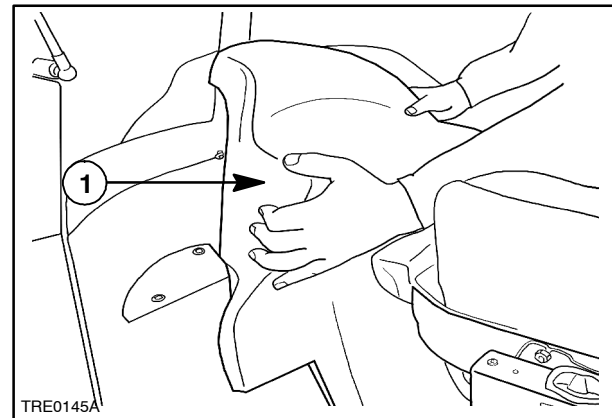

6

8. Remove the screws (1) of the RH panel retaining elements.

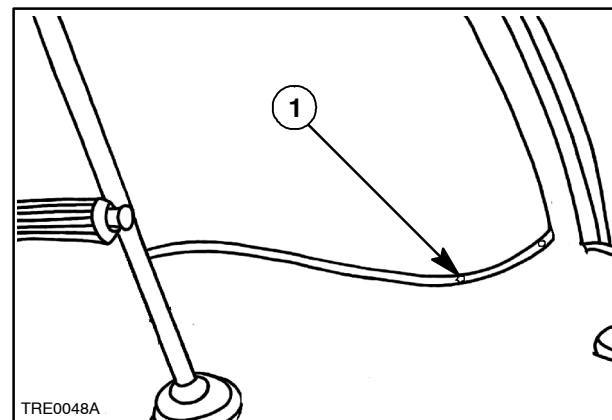

7

9. Remove the screws (1) from the RH fenders.

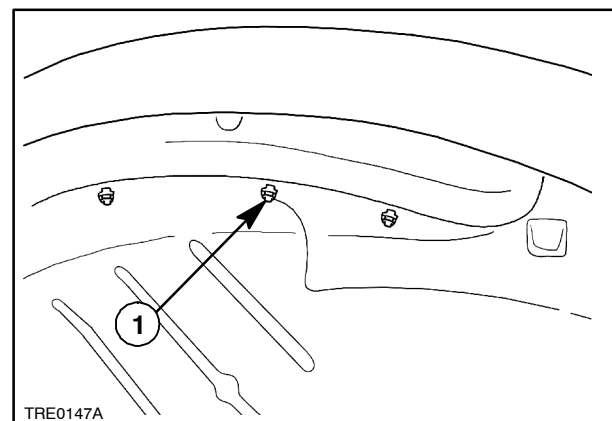

8

10. Remove the screws (1) from the rear panel

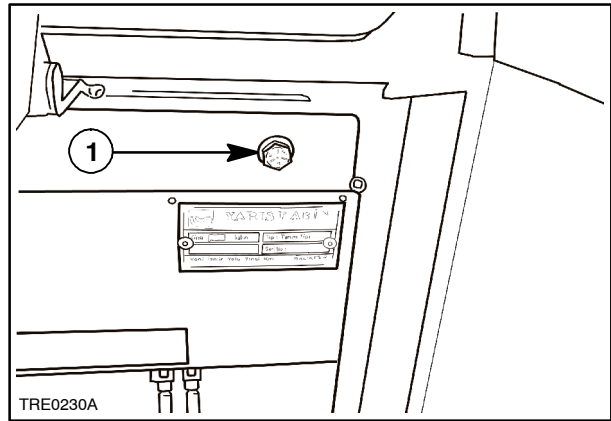

9

11. Remove the LH panel (1).

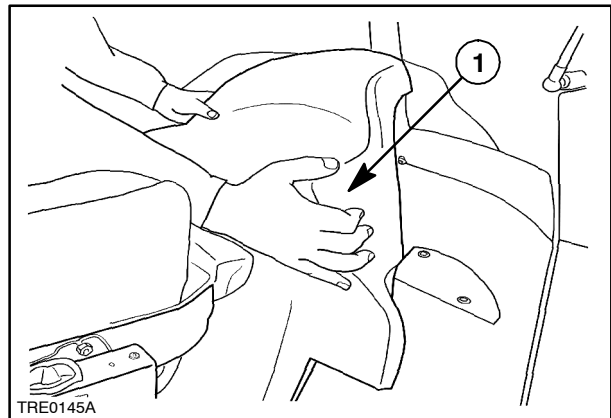

10

12. Remove the the hand throttle lever (1).

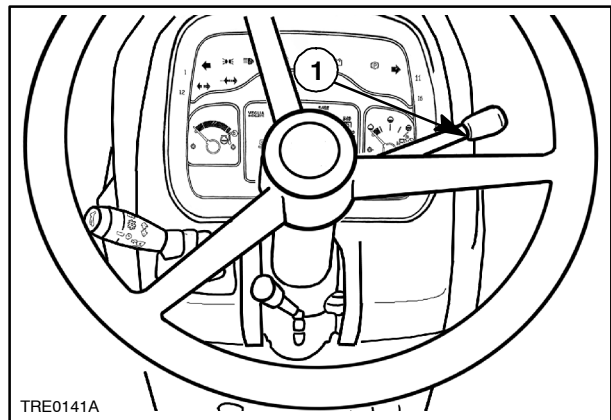

11

13. Remove the retaining nut (1) and take off the steering wheel.

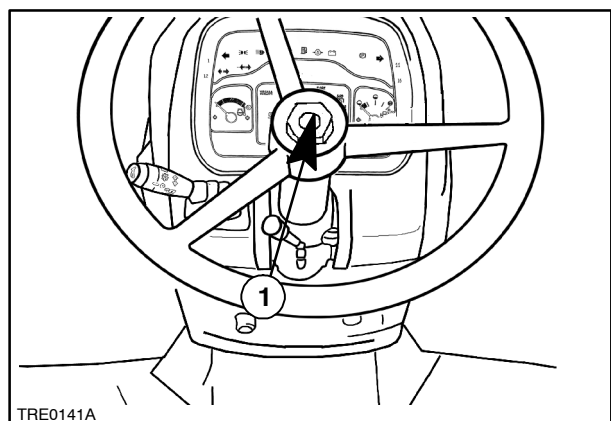

12

14. Remove the retaining bolts on the control panel and detach the electrical connector. Remove the rev counter and the control panel (1)

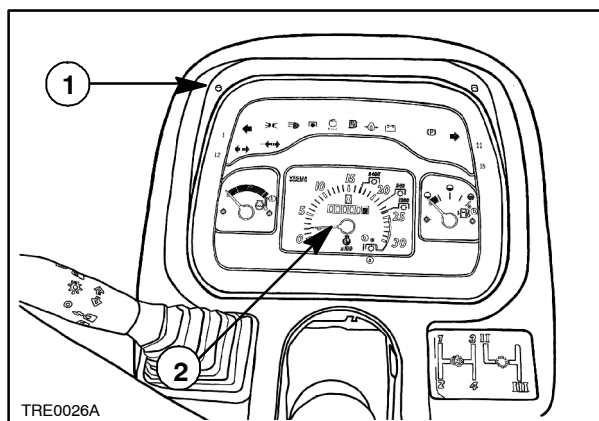

13

15. Unscrew the retaining screw (2) on the side of the instrument console (rear hood) (1).

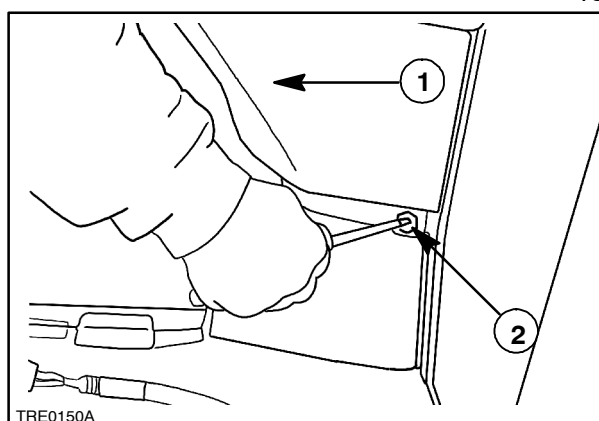

14

16. Remove the retaining screws (1) on top of instrument console (rear hood) (2).

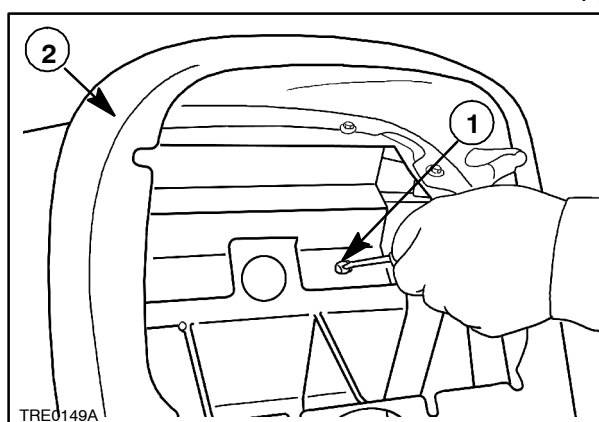

15

17. Remove the instrument console (rear hood) (1).

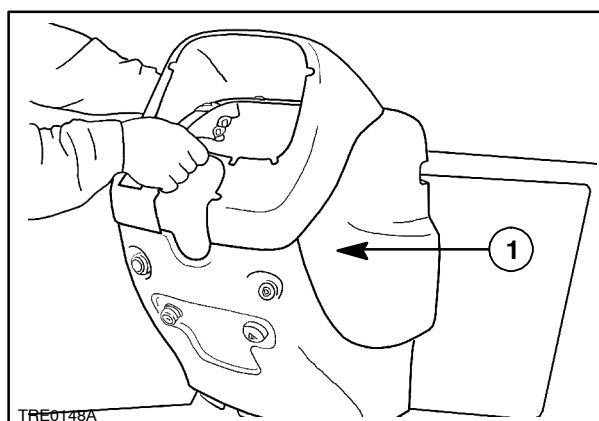

16

18. Remove the screws (1) securing the knobs to the control levers and remove the knobs.

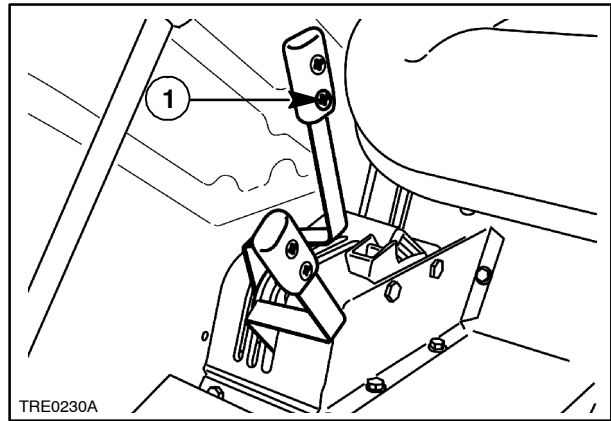

17

19. Unscrew the four screws (1) securing the lever panel.

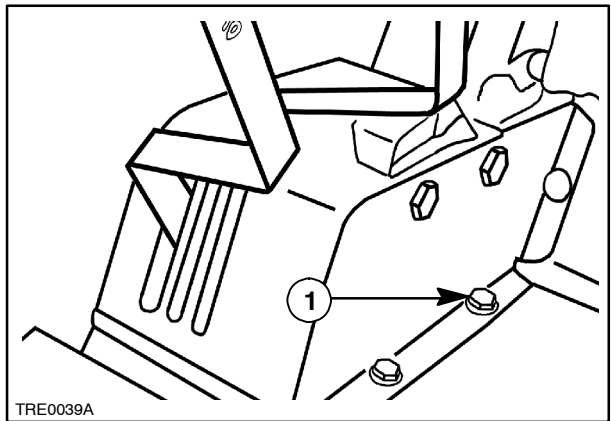

18

20. Unscrew the lift-o-matic switch retaining screws (1).

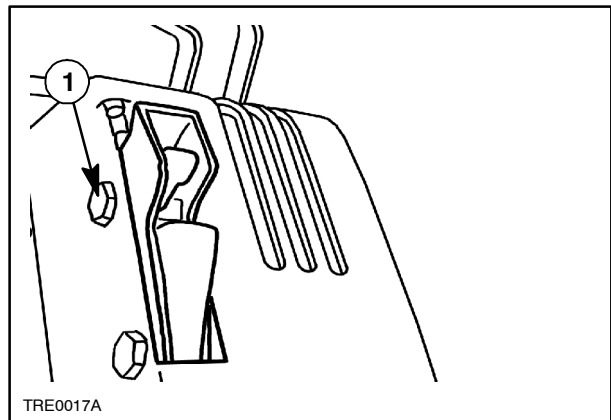

19

21. Remove the protective cover and the screws (1) securing the hydraulic control lever support (2) to the platform.

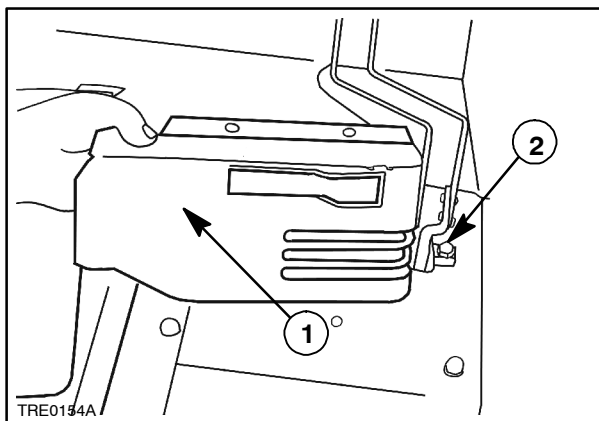

20

22. Remove the screws (1) holding the auxiliary control valves in place.

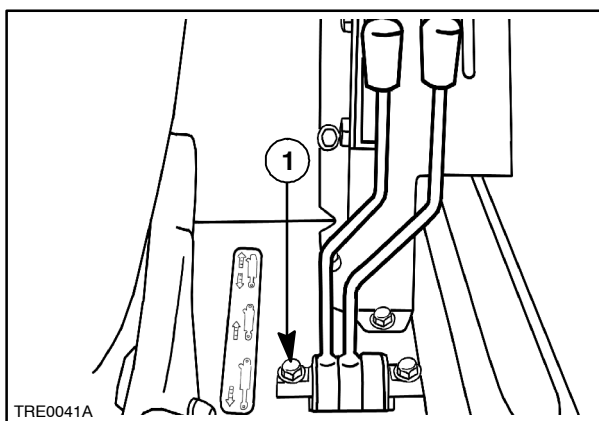

21

23. Remove the screws securing the parking brake support (1) to the platform. Disconnect the parking brake relay and the control lever from vertical rod.

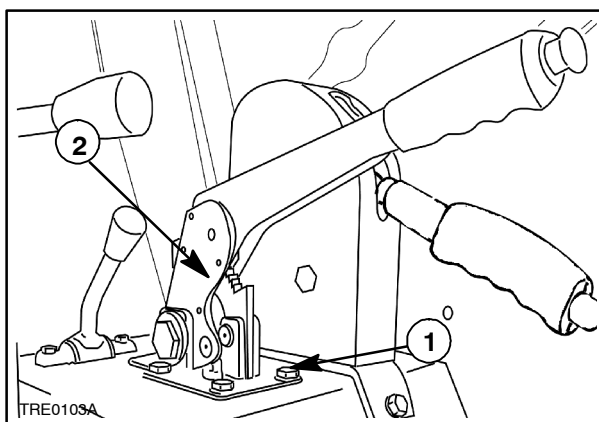

22

24. Unscrew the screws (1) securing the shuttle lever (2).

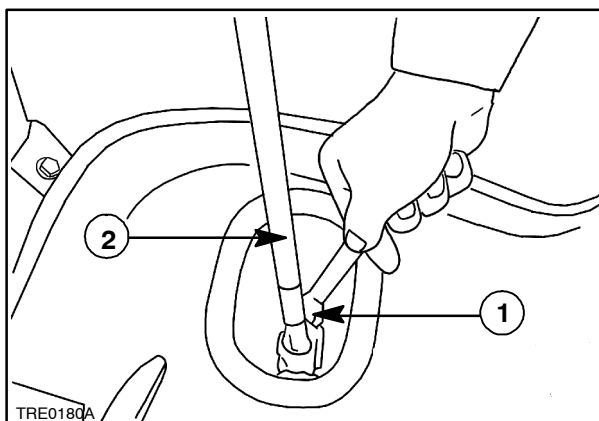

23

25. Unscrew the control lever retaining screws (1) and remove the control levers.

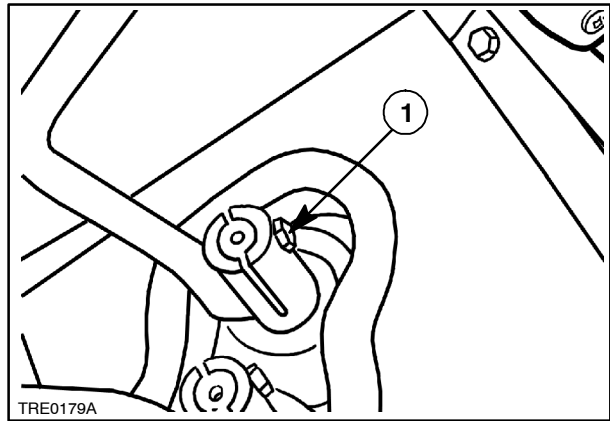

24

26. Remove the PTO clutch lever support securing screws (1). Disconnect the PTO control lever from the platform.

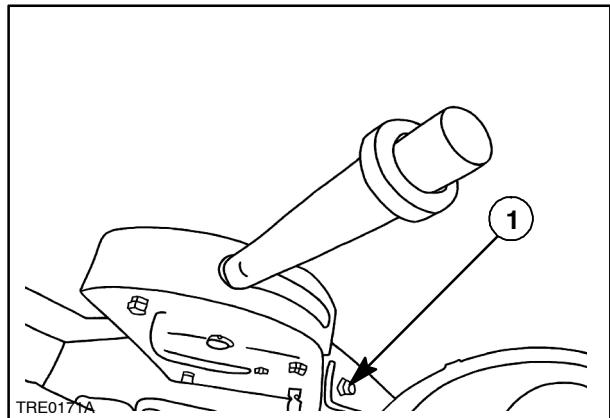

25

27. Unscrew the retaining screws (1) from the PTO synchronised control lever support (2).

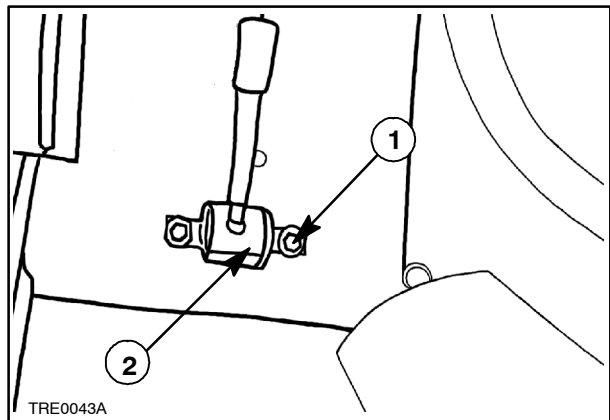

26

28. Remove the four seat securing screws (1). Remove the seat and the covering beneath it.

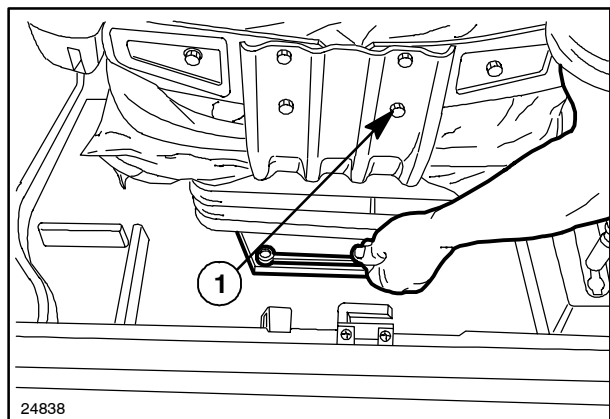

27

29. To refit, proceed as follows:

- Refit the PTO clutch lever and PTO synchronised control lever support.
- Refit the transmission control levers.
- Refit the LIFT-O-MATIC cover, securing it to the RH panel with the three screws.
- Refit the RH side panel, securing it to the cab body with the five screws.
- Refit the rectangular PTO cover, the yellow pushbutton and plastic plug. Secure the cover with the two screws.
- Refit the the LIFT-O-MATIC switch , the protective cover and the control levers.
- Refit the instrument panel and plug in the electrical connector.
- Secure the LH side panel with the screws previously removed.
- Fix the RH side panel and cab light control unit and with the securing screws. Reconnect the electrical connector to the plug on the control panel.
- Reinstall the driver's seat.
- Reconnect the negative cable to the battery.

REAR WINDOW, HANDLE AND LOCK

Disassembly-Assembly (Op. 90 156 52)

1. Disconnect the negative cable from the battery.

2. Remove the handle (2), the seals and the threaded pin (1).

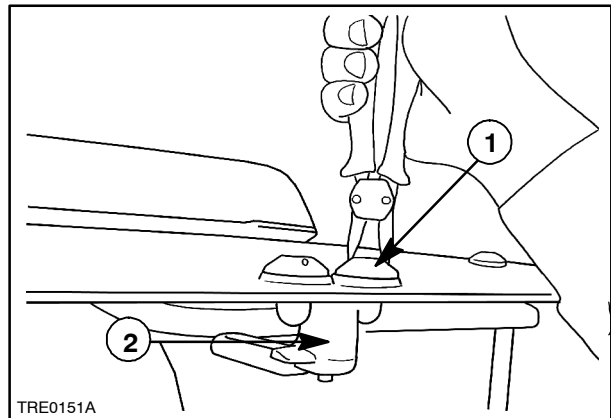

28

3. Disconnect the two gas struts at the ball and socket joints (1).

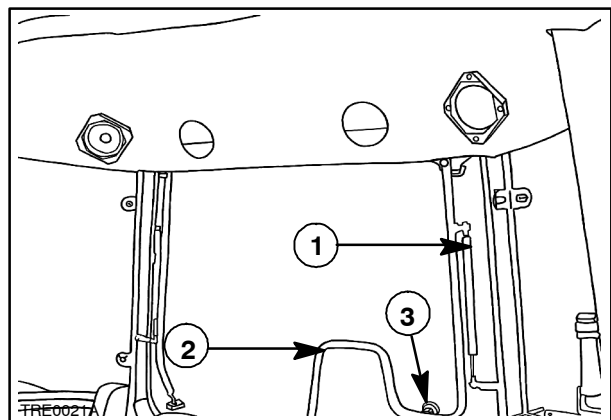

29

4. Remove the securing screws (1) fig. 30 from the hinges and take out the cab rear windscreen complete with frame (2) fig. 29.

5. With the cab rear windscreen removed, remove the securing screws and the frame (2) fig. 29.

6. To refit, proceed as follows:

- Refit the complete handle unit.
- Refit the locating pin.
- Renew the rear window rubber seal.
- Reconnect the negative cable to the battery.

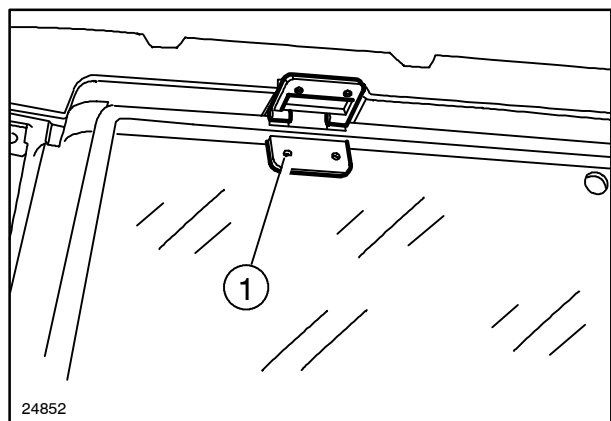

30

LOCK AND EXTERIOR HANDLE**LH DOOR****Disassembly-Assembly (Op. 90 154 30)**

1. Disconnect the negative cable from the battery.

2. Unscrew the three screws (1) securing the interior lock cover (2).

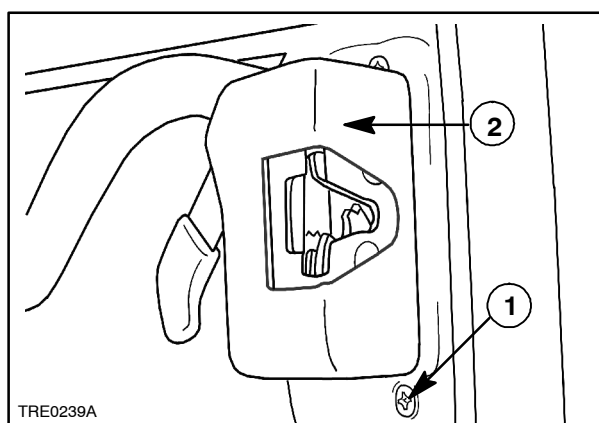

31

3. Remove two screws (1) securing the interior lock (2).

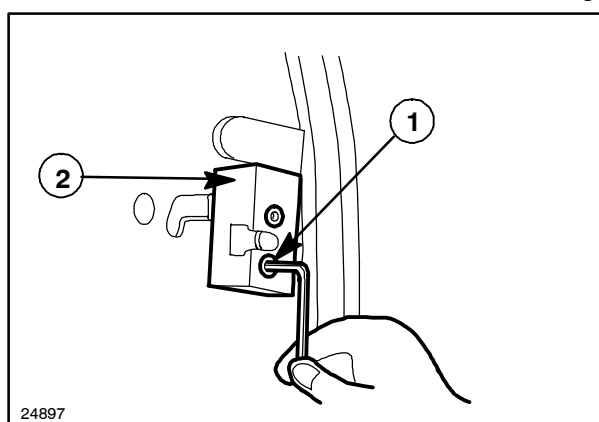

32

4. Remove the exterior handle by unscrewing the two retaining screws (1) from the inside.

To refit, proceed as follows:

- Refit the exterior handle.
- Fit the lock.
- Reconnect the negative cable to the battery.

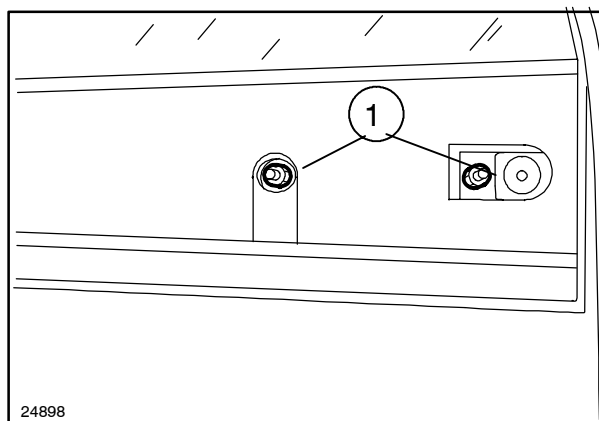

33

LH DOOR**Disassembly-Assembly (Op. 90 154 10)**

1. Disconnect the negative cable from the battery.

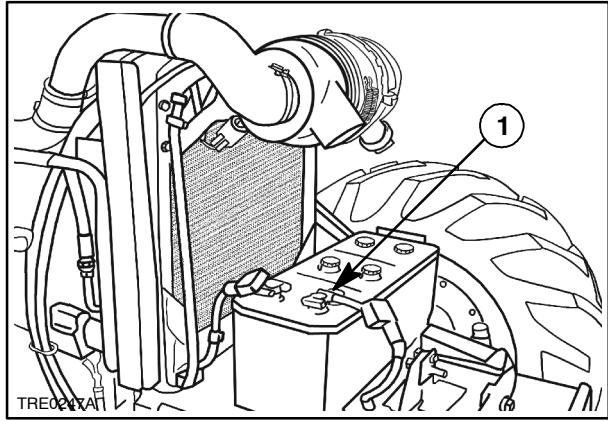

34

2. Remove the door closure (gas strut).

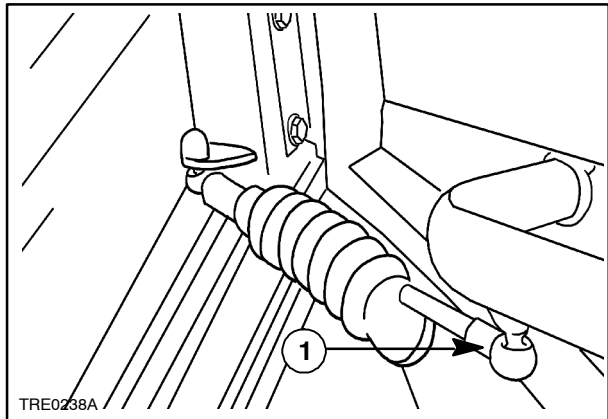

35

3. From inside the cab, unscrew the two top screws (1) securing the door hinge.

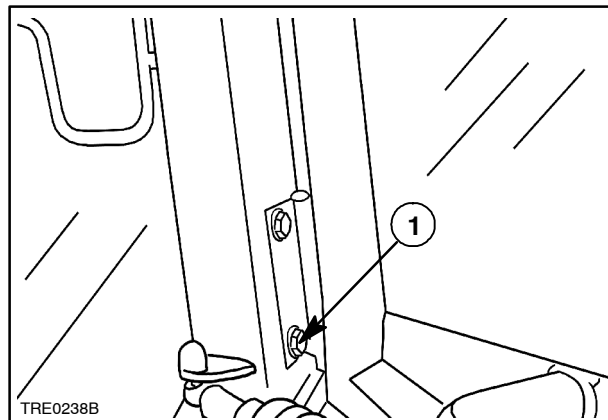

36

4. Remove the door.

To refit, proceed as follows:

- Refit the left hand door.
- Refit the left hand pillar seal.
- Reconnect the negative cable to the battery.

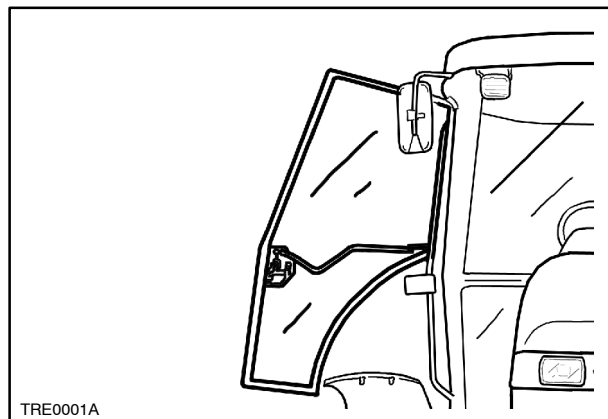

37

FRONT WIPER MOTOR
Disassembly-Assembly
(Op. 90 160 60 e 55 518 52)

1. Disconnect the negative cable from the battery.

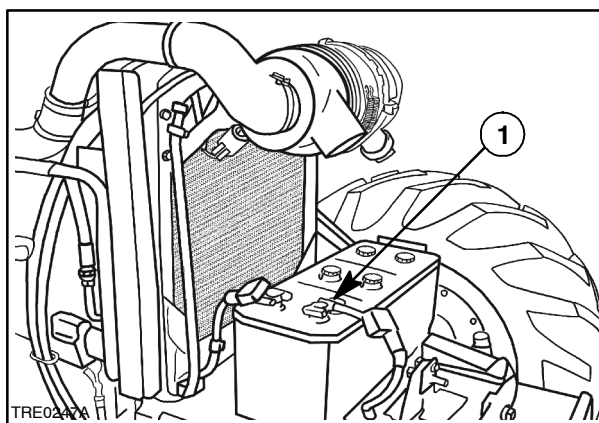

38

2. Remove the roof securing screws.

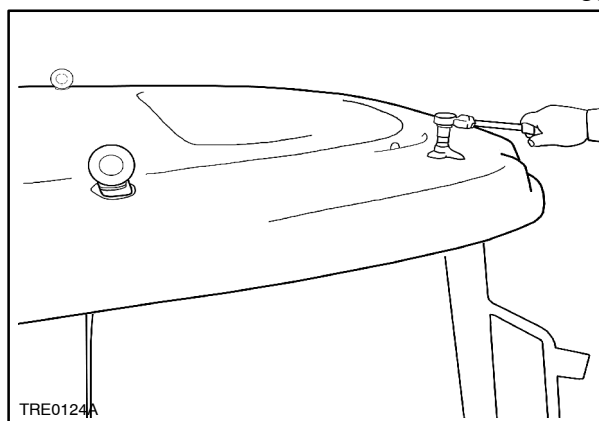

39

3. Remove the cap top cover (1) and disconnect the electrical connection from the front wiper motor.

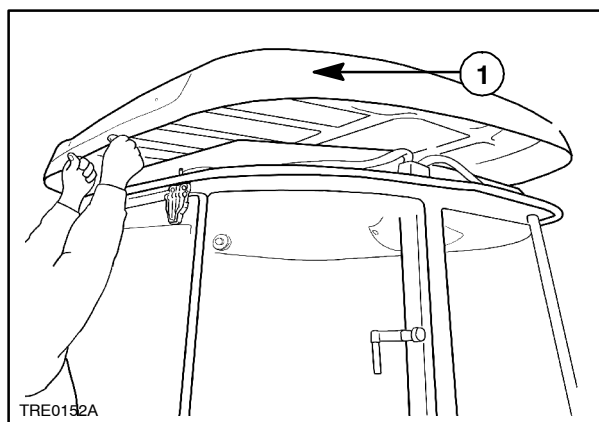

40

4. Unscrew the wiper blade retaining screw (1).

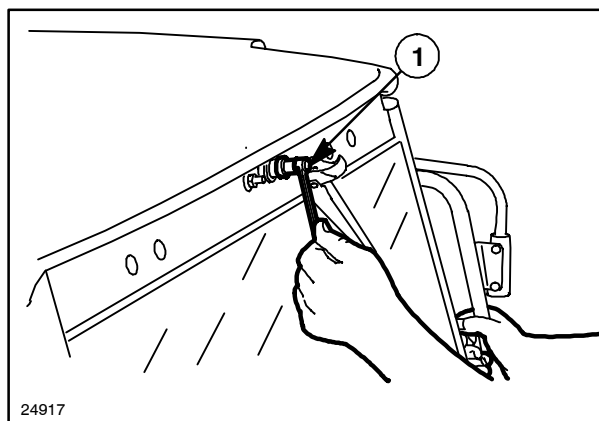

41

5. Unscrew the small nut (1) securing the wiper motor unit.

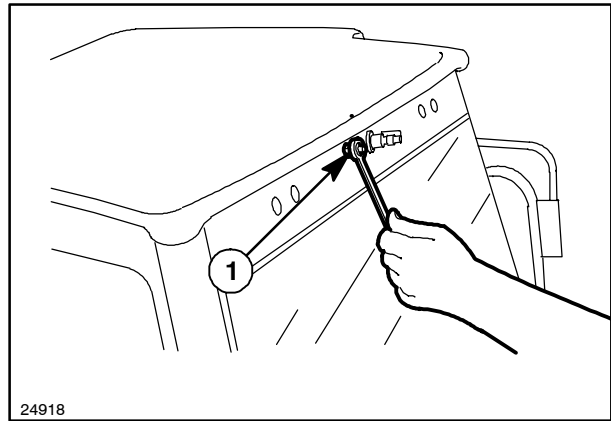

42

6. Unscrew the large nut and remove the wiper motor unit (1) from top the cab.

To reinstall, proceed as follows:

- Refit the motor unit and secure it with the two nuts.
- Refit the wiper blade.
- Reconnect the electrical connector to the motor
- Refit the cab roof lining and all the parts previously removed.
- Reconnect the negative cable to the battery.

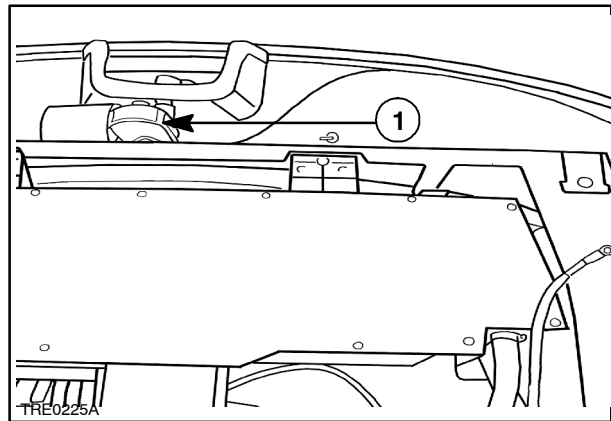

43

CAB WINDOWS**Replacing bonded cab windows (Op. 90 154 24 - 90 156 10 - 90 156 14 - 90 156 28)
Removing window**

Proceed as follows.



Handle all parts with great caution.
Do not insert your hands or fingers between one part and another.
Wear the prescribed safety clothing, including glasses, gloves and safety footwear.

1. If possible, remove any window support blocks present as they can restrict the action of the cutting wire.
2. From inside the cab use a pair of pliers to push the cutting wire (1) fig. 44 through the adhesive (2) between the glass and the frame.
3. Thread the cutting wire (1) fig. 45 into the handle and lock it with the screw (2).
4. Anchor the pointed end of the tool into the adhesive (see figure A). Keep the wire close to the glass and pull on the handgrip (2) fig. 46.
5. Pull the pointed tool from the adhesive and reposition it further along, as shown at (2). Again, pull on the wire, making long cuts on straight sections and short cuts around corners to avoid breaking the glass. Repeat this operation until the window is completely detached.
6. Use a tool with suction cups to remove the window and place it on a suitable surface to avoid damaging it.
7. Completely remove the adhesive from the window surround, taking care not to damage the surround.
8. Remove the adhesive from the glass using a suitable solvent.

NOTE: When replacing a broken window, remove the glass fragments still attached to the cab and use a knife blade to cut the adhesive (1) fig. 47, away from the frame. Take care not to damage the frame.

9. Clean the frame, as described in operation 7.

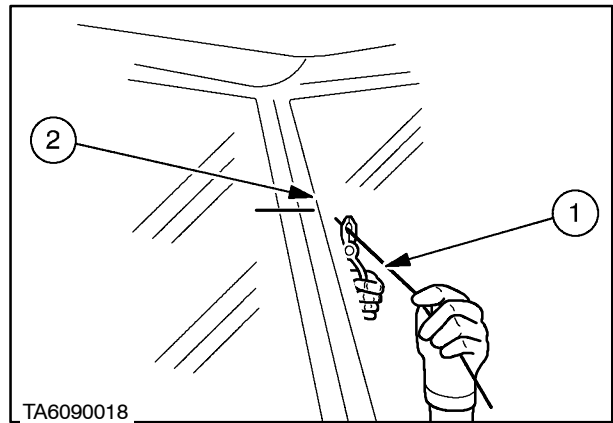

44

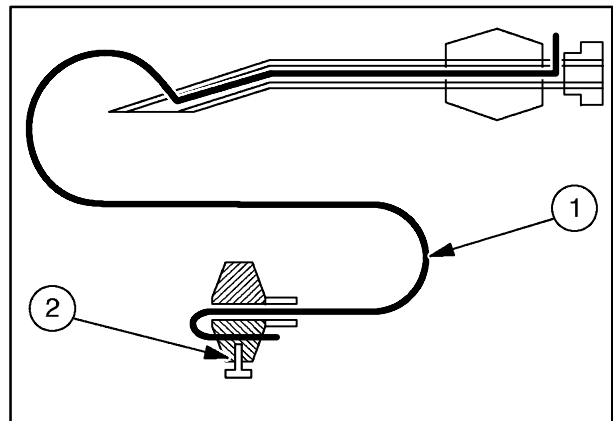

45

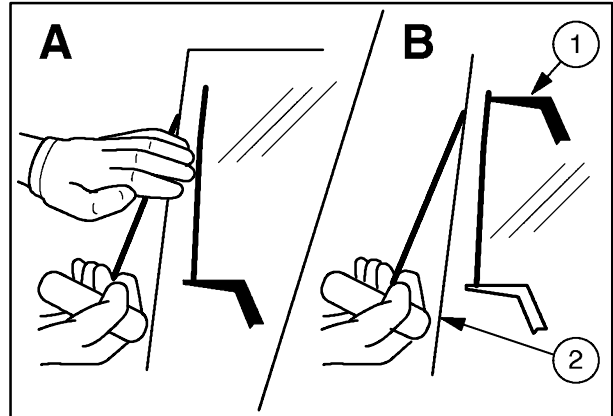

46

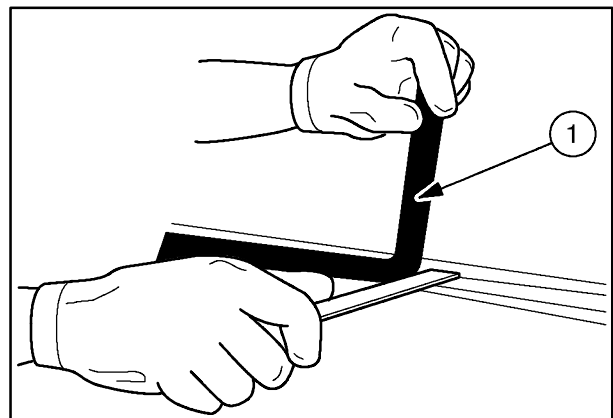

47

Refitting the window

Proceed as follows.

1. Make sure that the contact area between the glass and the metal frame in the cab is perfectly clean.
2. Using a clean tissue, apply the activator (VP 04604 GURIT ESSEX) around the edge of the glass, where contact will be made with the metal frame. Allow to dry.
3. Shake the bottle of glass primer (Betaprime 5100 GURIT ESSEX) for 60 seconds. Using the applicator provided (1) fig. 48, apply the primer (2) around the edge of the glass, over the top of the dried activator. Allow to dry thoroughly.
4. Shake the bottle of metal plate primer (Betaprime 5402 GURIT ESSEX) for 60 seconds. Using the applicator provided apply around the metal frame, where contact will be made with the glass. Allow to dry thoroughly.
5. Cut the spout of the adhesive dispenser as shown in fig. 49 to obtain a bead of triangular cross-section.
6. Apply a smooth, continuous bead of polyurethane adhesive (Betaseal 1703 GURIT ESSEX) around the edge of the glass over the previously primed area (the cross-section of this bead must be triangular, with a base width of 10 mm and a height of 10 mm).

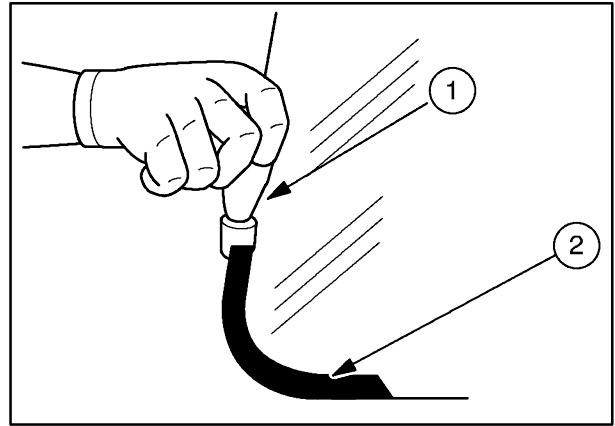

48

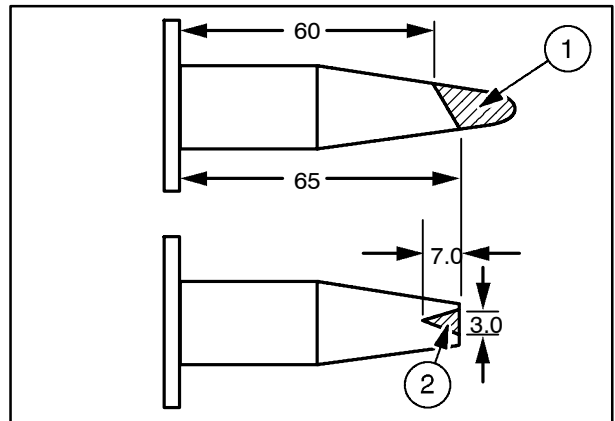

49

NOTE: Make sure that the adhesive bead is continuous, i.e., there are no areas where adhesive is missing, otherwise water may penetrate.

7. Insert the window support blocks, if present.
8. Using a tool with suction cups, position the window in its surround and use suitable clamps to apply a uniform pressure to obtain a 4 mm thickness of adhesive and ensure perfect adhesion.

NOTE: Leave the clamps in place for 4 hours until the adhesive has completely polymerised. To promote a good bond, do not move the cab or the tractor during this time.
