

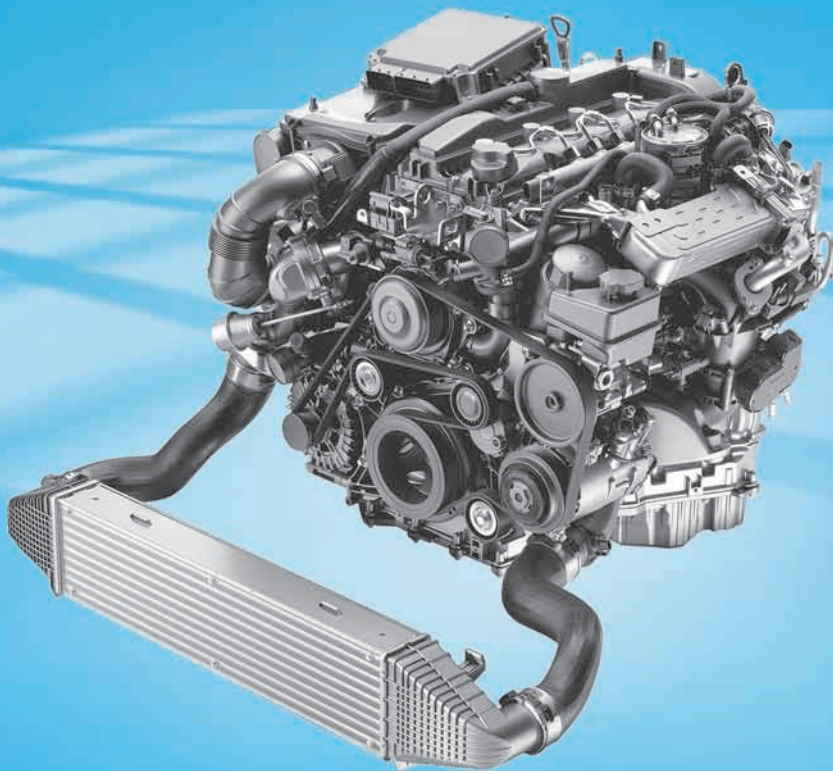

New Generation of 4-Cylinder Inline Engines, OM 651

Introduction into Service Manual

Mercedes-Benz



Introduction of New Generation of 4-Cylinder Inline Engines, OM 651

Ordering workshop information

All printed workshop information from GSP/OI, such as Introduction into Service Manuals, System Descriptions, Function Descriptions, Technology Guides, Technical Data Manuals and adhesive labels, can be ordered as follows:

Within Germany

Through our GSP/OI Shop on the Internet

Link: <http://gsp-ti-shop.de>

or alternatively

E-mail: customer.support@daimler.com

Phone: +49-(0)1805/010-7979

Fax: +49-(0)1805/010-7978

Outside Germany

Please get in touch with the contact person responsible for your market.

Product portfolio

You can also find comprehensive information on our complete product portfolio in our Internet portal.

Link: <http://open.aftersales.daimler.com>

Questions and suggestions

If you have any questions or suggestions concerning this product, please write to us.

E-mail: customer.support@daimler.com

Fax: +49-(0)18 05 / 0 10-79 78

or alternatively

Address: Daimler AG
GSP/OIS
HPC R822, W002
D-70546 Stuttgart

© 2008 by Daimler AG

This document, including all its parts, is protected by copyright.

Any further processing or use requires the previous written consent of Daimler AG, Department GSP/OIS, HPC R822, W002, D-70546 Stuttgart.

This applies in particular to reproduction, distribution, alteration, translation, microfilming and storage and/or processing in electronic systems, including databases and online services.

Image no. of title image: P01.00-3119-00

Order no. of this publication: 6516 1364 02

08/2008

Preface	5
----------------	---

Overview

Brief description	6
Engine data	7
Highlights	8
Engine views	9
System comparison	10
At a glance	11

Mechanical system

Crankcase	12
Cylinder head	13
Oil pan	14
Crankshaft assembly	15
Valve assembly	17
Gear drive	18
Belt drive	19

Combustion

Common rail injection	20
Charging	24
Air supply	29
Exhaust system	32
Exhaust system	34

Cooling and lubrication

Engine cooling	36
Engine lubrication and oil circuit	38
Oil pump	40
Coolant pump	41

Electrical and electronic systems

Engine control unit	42
Glow system	43

Pneumatic system

Vacuum control	44
----------------	----

Environmental protection

Emission reduction	46
--------------------	----

Service information

New features	48
--------------	----

Special tools

Engine	50
--------	----

Abbreviations	55
---------------	----

Index	56
-------	----

Dear Reader,

This Introduction into Service Manual presents the new 4-cylinder inline diesel engine 651 from Mercedes-Benz.

It allows you to familiarize yourself with the technical highlights of this new engine in advance of its market launch. This brochure primarily intended to provide information for people employed in service, maintenance and repair as well as for aftersales staff. It is assumed that the reader is already familiar with the Mercedes-Benz model series and major assemblies currently on the market.

In terms of the contents, the emphasis in this Introduction into Service Manual is on presenting new and modified components, systems, system components and their functions.

This Introduction into Service Manual aims to provide an overview of the technical innovations and an insight into their complicated designs.

However, this Introduction into Service Manual is not intended as a basis for repair work or technical diagnosis. For such needs, more extensive information is available in the Workshop Information System (WIS) and in the Diagnosis Assistance System (DAS).

WIS is updated monthly. Therefore, the information available there reflects the latest technical status of our vehicles.

The contents of this brochure are not updated and no provision is made for supplements. We will publicize modifications and new features in the relevant WIS documents. The information presented in this Introduction into Service manual may therefore differ from the more up-to-date information found in the WIS.

All information relating to technical data, equipment and options is valid as of the copy deadline in July 2008 and may therefore differ from the current production configuration.

Daimler AG

Technical Information and Workshop Equipment
(GSP/OI)

Brief description

Engine model series 651

The new generation of the 4-cylinder diesel engine 651 equipped with the second-generation Common Rail Direct Injection (CDI) system from Delphi will be launched on the market as of October 2008.

Engine 651 has a rated output of 150 kW with a displacement of 2,143 cm³ and a consumption of just 5.4 liters of diesel fuel per 100 kilometers. Despite this high output and an engine torque of 500 Nm, emissions of CO₂ have been further reduced. In addition, the engine meets the future Euro 5 standard.

A central feature of the new engine is its dual stage turbocharging system. The system combines a small high-pressure turbocharger with a large low-pressure turbocharger. Engine 651 also features two Lanchester balance shafts to make the engine run more smoothly.

In order to meet the new legal requirements of the Euro NCAP crash tests with respect to improved pedestrian protection, the gear drive has been located on the output side together with the chain drive. The increased space between the engine and engine hood reduces the risk of injury for pedestrians.



Engine 138

2.6 l displacement and 33 kW output. Installed in the Mercedes-Benz 260 D, the world's first diesel passenger car, in 1936.



Engine 651

2.2 l displacement and 150 kW output. Installed in the C-Class as of October 2008.

i Note

A detailed description of the new CDI system can be found in the System Description for engine 651.

Order number: 6516 1363 02

Comparison		Engine 646.821 EVO	Engine 651.911	Difference
Displacement	cm ³	2,148	2,143	-0.2%
Rated output	kW at rpm	125 3,800	150 4,200	+20%
Rated torque	Nm at rpm	400 2,000	500 1,600...1,800	+25%
Maximum rpm	rpm	4,900	5,200	+6%

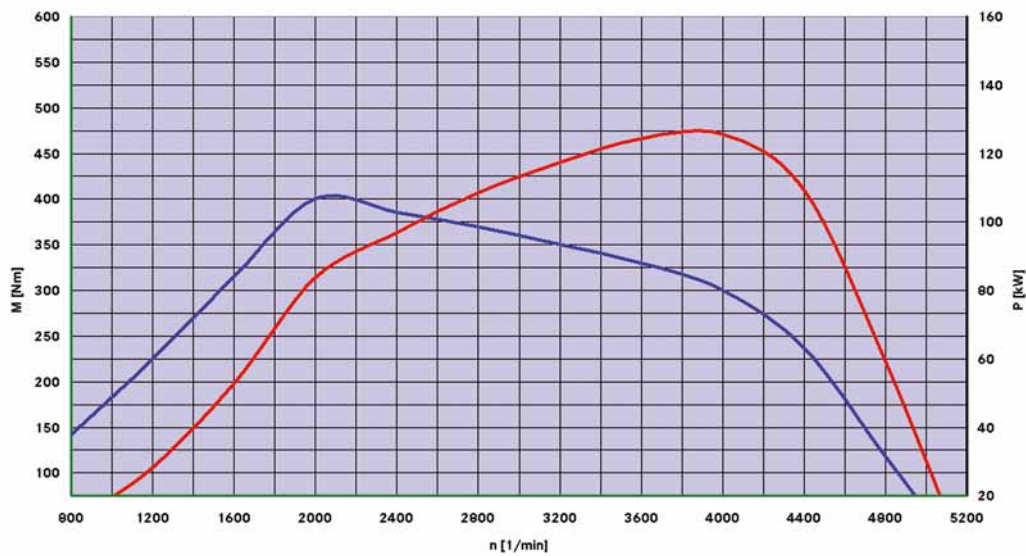

P00.01-3117-00

Engine 646.821 EVO

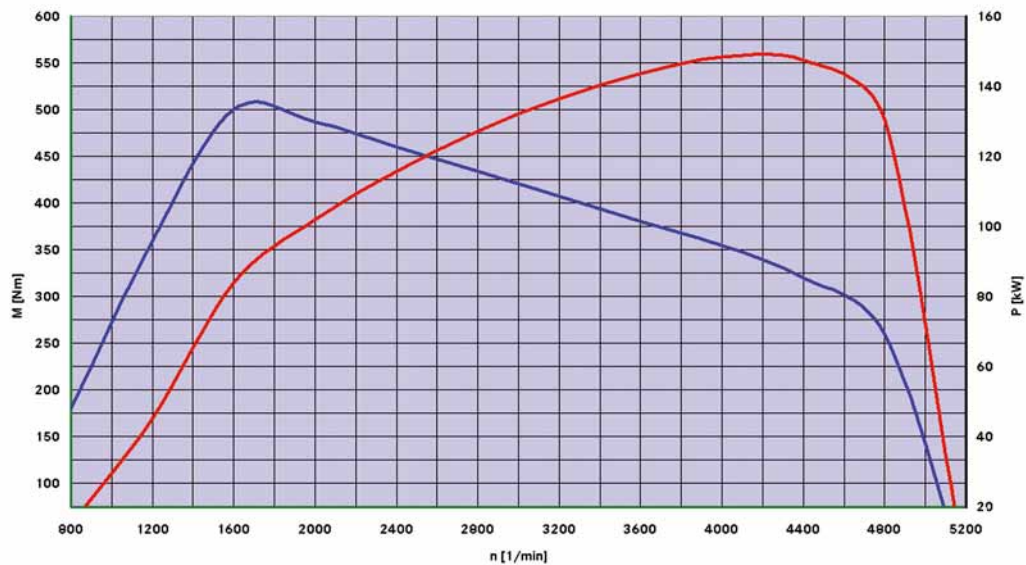

P00.01-3118-00

Engine 651.911

n Engine speed █ M Torque █ P Output

Highlights

New features

Based on the use of the latest innovative technologies, engine 651 sets a new standard in terms of output and torque characteristics, economy, exhaust emission levels and smooth running. The engine features a number of new developments which cannot be found in this combination in any other series-produced passenger car diesel engine.

Technology

The most important technical features of the new engine are:

- Dual stage turbocharging with fixed geometry
- Directly actuated piezo injectors
- Gear drive in combination with a chain drive on the output side
- Intake air-cooled engine control unit on air filter housing
- Main bearing bridge with integrated Lanchester housing
- Two Lanchester balance shafts
- Drive gear friction welded to crankshaft
- Vibration dampers (quadruple bolted)
- Universal timing case cover for adaptation to various transmission models
- Major assembly carrier with variable arrangement as per vehicle concept
- Two knock sensors
- Two-piece oil pan (noise optimized)
- Oil pan bottom section made of plastic

Thermal management

The new thermal management system consists of:

- Shutoff-capable coolant pump
- Cylinder head with two-piece water jacket
- Shutoff-capable oil spray nozzles combined with piston crown cooling
- Oil pump volume-controlled at clean oil side

Note

Friction-welded connections involve connecting two parts together by force. The application of friction and pressure produces a fixed connection without the use of welding consumable.

Note

Further information on repairing and maintaining engine 651 can be found in the Workshop Information System (WIS).

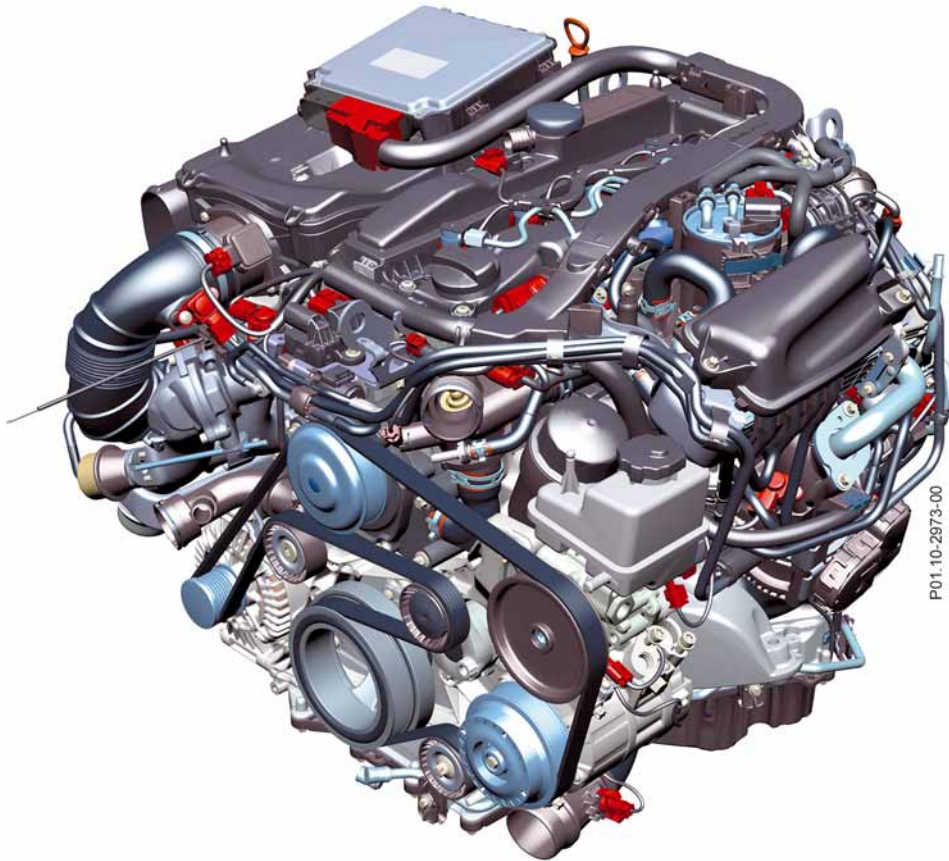

P01.10-2873-00

Engine 651: Side view from left

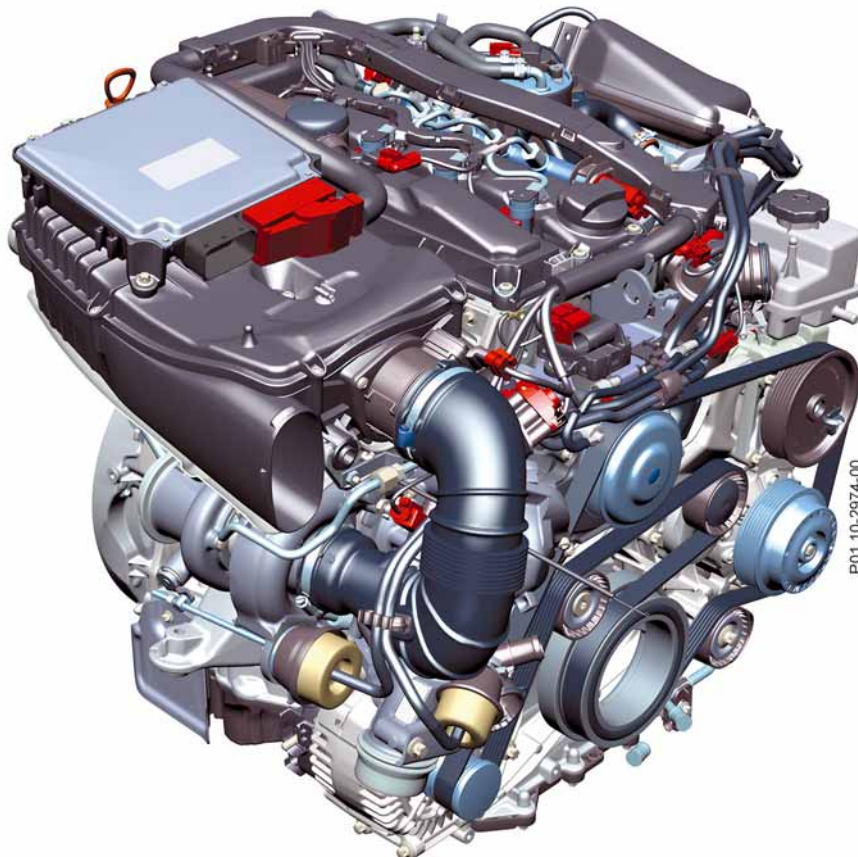

P01.10-2874-00

Engine 651: Side view from right

System comparison

Comparison		Engine 646.82 1EVO C 220 CDI	Engine 651.911 C 250 CDI
Market launch		06 / 2006	10 / 2008
Combustion system		Diesel direct injection	
No. of cylinders		4	
Engine configuration		Inline	
Bore	mm	88.3	83.0
Stroke	mm	88.3	99.0
Compression ratio	e	16.5:1	16.2:1
Camshafts – drive		Duplex chain	Simplex chain
Camshafts – number		2	2
Valve actuation		Cup tappet with hydraulic valve clearance compensation	Roller-type cam follower with hydraulic valve clearance compensation
Turbocharger type		1-stage turbocharging with variable turbine geometry	2-stage turbocharging with fixed geometry
Boost pressure control		Electric	Pneumatic
Measures for low-emission combustion		Intake port shutoff, exhaust gas recirculation (EGR) with separate EGR cooler	Intake port shutoff, EGR cooling and EGR bypass
Fuel injector – type		Solenoid injector	Directly controlled piezo injector
Fuel injector – diameter	mm	17	19
Firing order		1-3-4-2	
Oil pump – drive		Simplex chain	Gear drive
Alternator – current rating	A	200	180
Engine weight DIN (dry) approx.	kg	190	203



Objective	Measures on engine 651
Optimized comfort	Stiffer crankcase with full-length crankshaft bearing bridge
	Wide crankshaft main bearing; friction-optimized with center bearing
	Two low-positioned Lanchester balance shafts for smooth engine running
	Plastic cylinder head cover with integrated ventilation
	Maintenance-free, long-life simplex chain as camshaft drive
	Engine cover with adjusted acoustic damping
Improved fuel economy	Optimized flow conditions (air ducting, intake ports)
	Dual stage turbocharging
	Optimized charge air cooling and exhaust gas recirculation cooling
	Reduction in friction through gear drive and balance shafts mounted on roller bearings
Compliance with exhaust emissions standards (Euro 5 standard)	Optimized shape of combustion chamber
	7-hole injection nozzles
	More precise injection times
	Optimized air ducting
	Exhaust gas recirculation (EGR) with EGR pre-cooler and EGR cooler, EGR valve and switched EGR bypass
	Electric intake air throttling
	Shutoff-capable coolant pump and shutoff-capable oil spray nozzles
	Exhaust system with oxidation catalytic converter and diesel particulate filter

Crankcase

General

When engine 651 was developed, the design of the crankcase was based on an overall concept with optimized spatial features. Accordingly, the gear drive with the oil pump drive and the Lanchester balance shafts are positioned on the output side. The cast iron crankcase is manufactured by sand casting.

The new design concept provides the following advantages:

- 4 cm shorter crankcase compared to predecessor version
- Improved pedestrian protection through positioning of gear drive and camshaft drive on output side
- Universal timing case cover for adaptation to various transmission models

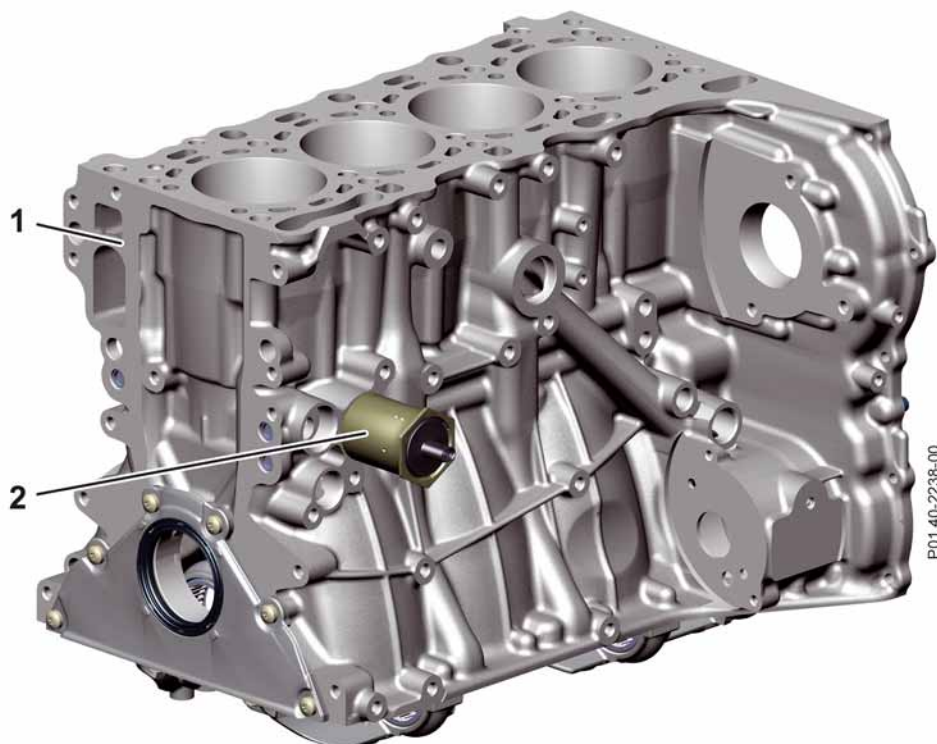

Crankcase

1 Crankcase

2 Oil spray nozzle shutoff valve

General

The cylinder head is made of high-strength aluminum. It is equipped with two camshafts and four valves per cylinder. The cylinder head cover is made of plastic with integrated ventilation. The cylinder head is characterized by the following new features:

- Maximum ignition pressure of 200 bar (previously 160 bar)
- Tangential and spiral intake ports
- Bore for piezo injector of 19 mm diameter

The upper duct of the two-piece water jacket supplies the cylinder head with coolant. The advantages of the two-piece water jacket include:

- Greater structural rigidity
- Better heat dissipation
- Improved thermal management

The improved thermal management system is particularly beneficial in those areas which are exposed to very high temperatures. The high ignition pressure of 200 bar is only made possible by targeted cooling of the individual components. The increased pressure potential and optimized injection quantity are responsible for the high engine torque of 500 Nm and the engine output of 150 kW.

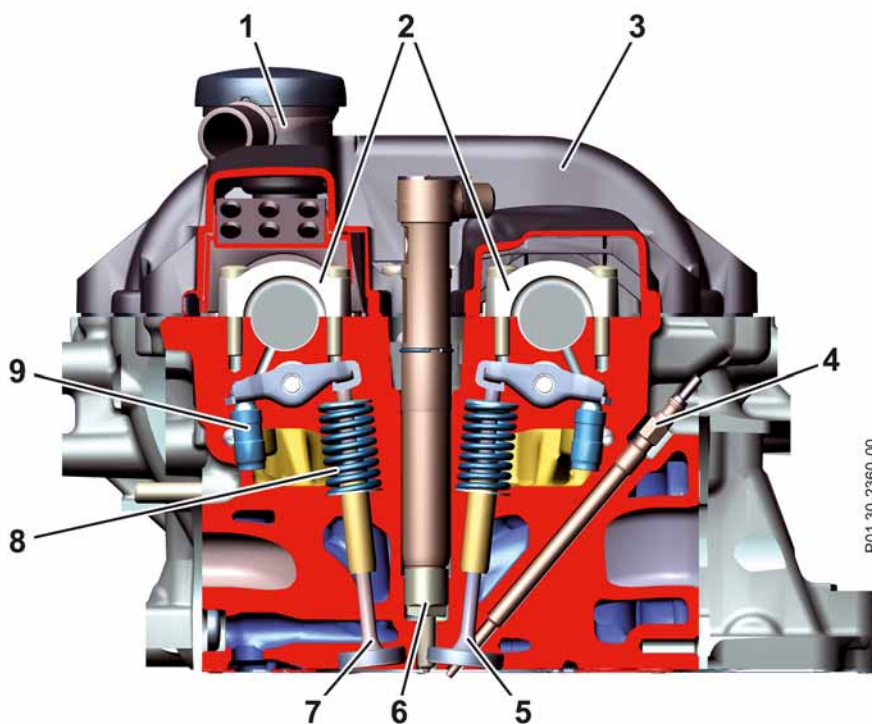

Cross-section of cylinder head

- | | | |
|-----------------------|------------------|--------------------------------|
| 1 Ventilation | 4 Glow plug | 7 Intake valve |
| 2 Main bearing bridge | 5 Exhaust valve | 8 Valve spring |
| 3 Cylinder head cover | 6 Piezo injector | 9 Valve clearance compensation |

Oil pan

Special design features

- Two-piece design
- Lower section of oil pan made of plastic
- Noise-optimized
- Service-optimized and cost-optimized replacement parts
- Bolts secured to prevent them being lost
- Installation can be checked via special pins on seal

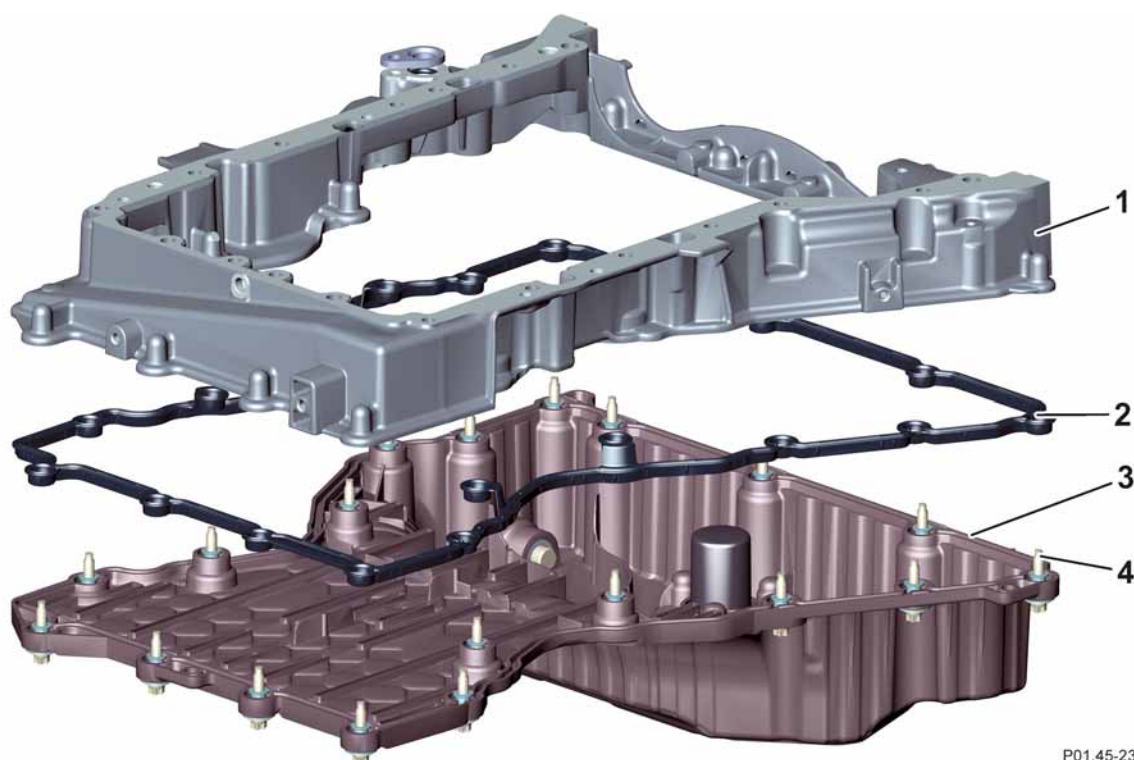

P01.45-2329-00

Oil pan

- 1 Upper section of oil pan
2 Seal with pins

- 3 Lower section of oil pan (plastic)
4 Bolts with retainer (anti-loss)

i Note

Temporary level fluctuations are balanced out by the volume of the housing and the size of the drain bores in the oil level check switch. This prevents unnecessary warning messages e.g. triggered by cornering.

Crankshaft

The forged crankshaft with eight counterweights is supported by five bearings for effective vibration damping. The radiuses of the crank pins are rolled to give them high strength. In addition, the connection between the drive gear and crankshaft is friction welded.

The vibration damper is fixed to the crankshaft with a fourfold threaded connection.

Connecting rods

The weight-optimized connecting rods are made of forged steel and are cracked at the level of the bearing shells.

Balance shafts

Two Lanchester balance shafts are integrated in the main bearing bridge and mounted on three roller bearings. They are driven in opposite directions by the gear drive to counteract the inertia forces of the second order which are generated. This ensures smooth engine running.

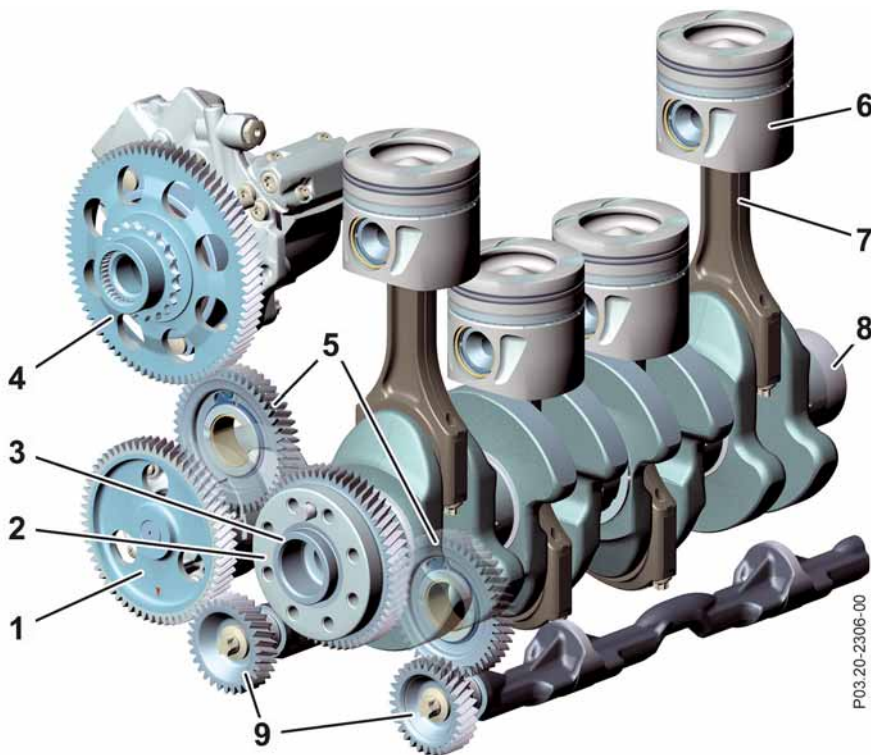

Crank assembly with gear drive

- | | | |
|----------------------------------|---|--------------------------|
| 1 Oil and vacuum pump drive gear | 5 Intermediate gears (tensioning gears) | 8 Vibration damper |
| 2 Crankshaft gear | 6 Piston | 9 Lanchester drive gears |
| 3 Crankshaft | 7 Connecting rod | |
| 4 High-pressure pump drive gear | | |

i Note

The aluminum pistons run in friction-optimized cast-iron cylinder barrels. On this engine, they are all manufactured uniformly. There is therefore no differentiation between A, B or X sizes on this engine.

Crankshaft assembly

Camshafts

The gear drive drives the camshaft sprockets and the connected camshafts via a timing chain. The maintenance free timing chain is tried and tested and has proven longevity. The cams are fixed to the camshaft by means of internal high-pressure forming (IHU).

Camshaft sprocket

The camshaft sprocket is connected to the camshaft by a center bolt. The center bolt of the camshaft has a left-hand thread.

Sensor wheel

The sensor wheel is fixed to the exhaust camshaft. In combination with the Hall sensor, the sensor wheel makes it possible to determine the camshaft position and rpm.

The Hall sensor generates a magnetic field through a built-in permanent magnet. The magnetic field is periodically interrupted by an orifice plate on the sensor wheel while the engine is running. The signal which this generates is used by the CDI control unit and serves as a substitute signal for emergency engine operation if the position sensor for the crankshaft fails.

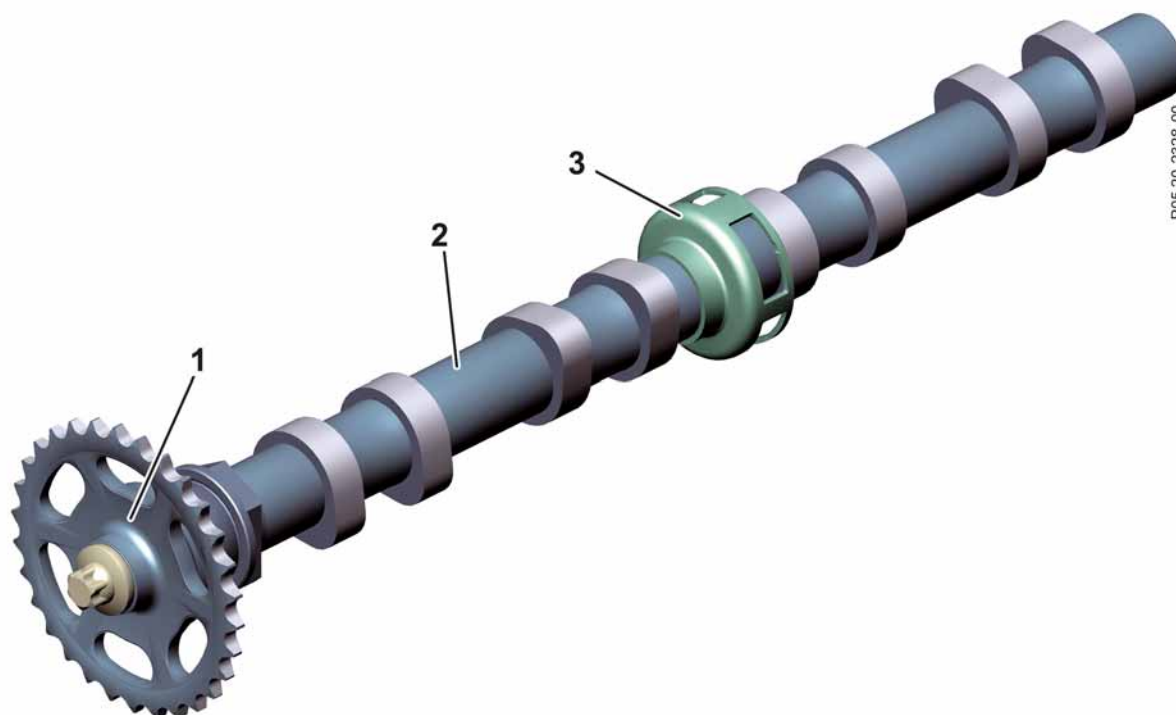

Exhaust camshaft with sensor wheel

1 Drive gear

2 Exhaust camshaft

3 Sensor wheel with orifice plate

Valve assembly with hydraulic valve clearance compensation

The valve assembly was modified with the aim of optimizing friction and reducing the moved masses.

The camshafts control two intake valves and two exhaust valves per cylinder. This valve timing system uses low-friction roller-type cam followers with hydraulic valve clearance compensation.

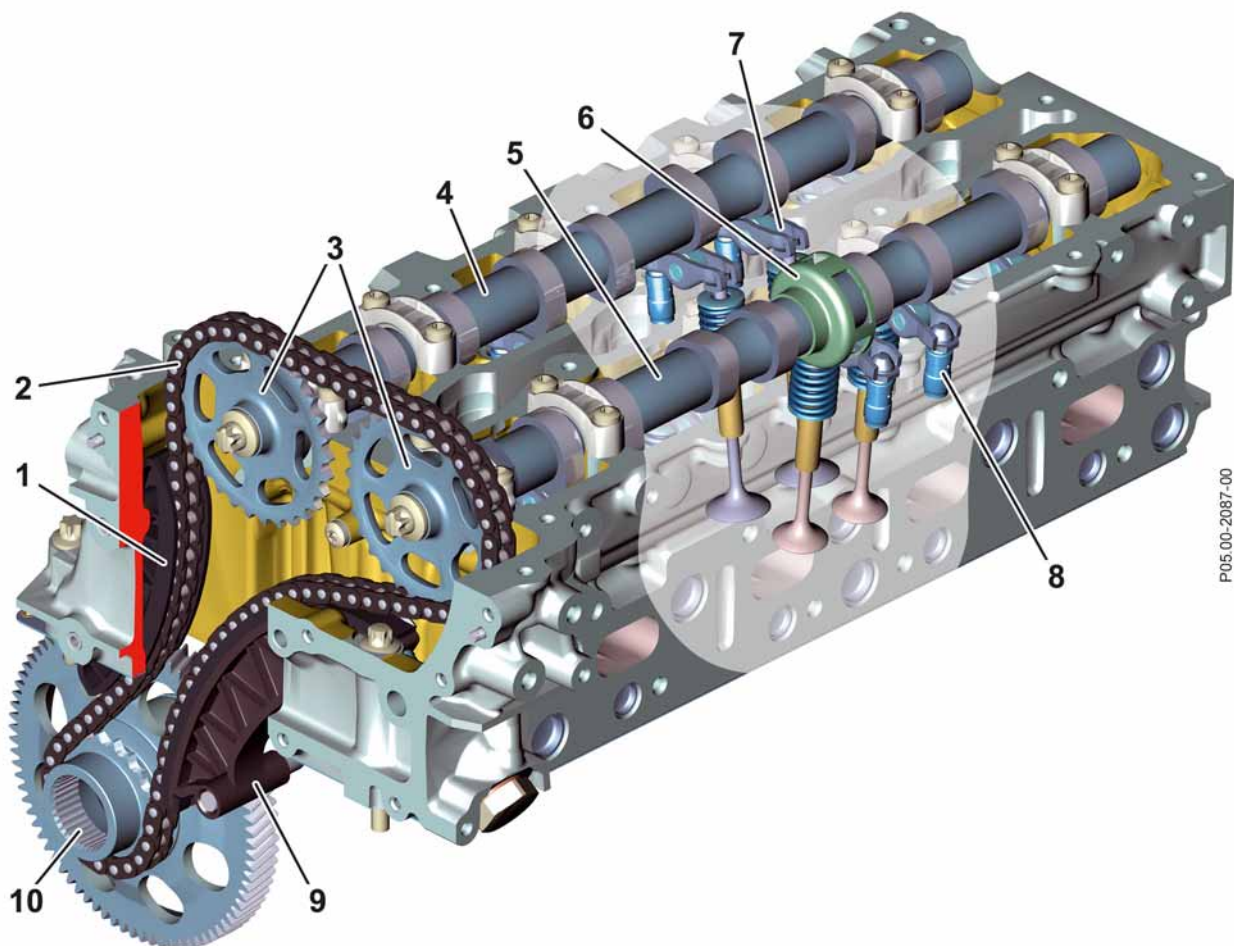

P05.00-2087-00

Valve assembly

- | | | | |
|---|----------------------|----|---------------------------------------|
| 1 | Slide rail | 6 | Sensor wheel with orifice plate |
| 2 | Timing chain | 7 | Roller-type cam followers |
| 3 | Camshaft drive gears | 8 | Hydraulic valve clearance compensator |
| 4 | Intake camshaft | 9 | Chain tensioner |
| 5 | Exhaust camshaft | 10 | Timing chain drive gear |

Gear drive

Gear drive

One of the most important innovations is the gear drive in combination with a chain drive on the output side. The reduction in the vibrations produced by the crankshaft results in a noticeably smoother running engine.

The following components are driven by the new gear drive system:

- Lanchester balance shafts
- Oil pump
- High pressure pump
- Vacuum pump via continuous central drive shaft of oil pump

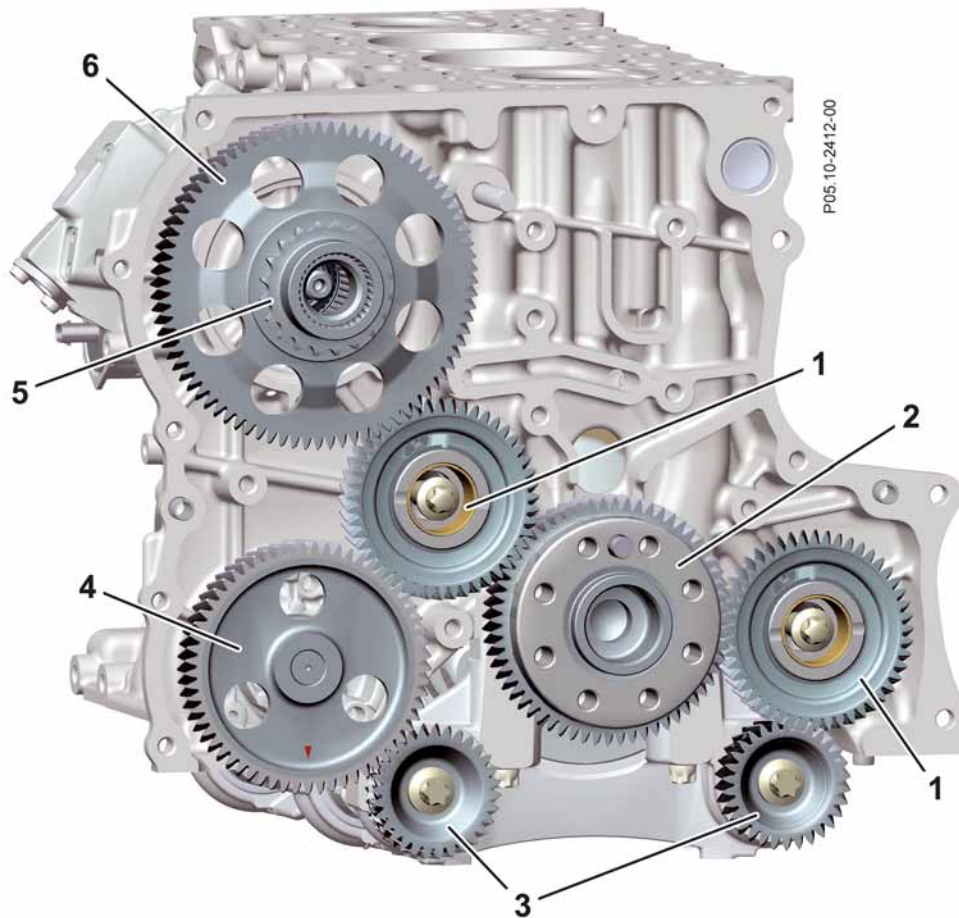

Gear drive

- | | | | |
|---|------------------------|---|--------------------------------|
| 1 | Intermediate gears | 4 | Oil and vacuum pump drive gear |
| 2 | Crankshaft gear | 5 | Drive sprocket |
| 3 | Lanchester drive gears | 6 | High-pressure pump drive gear |

Belt routing

The ancillary assemblies are driven by a single-piece, low-maintenance poly-V belt. The poly-V belt is tensioned by an automatic belt tensioner with tensioner pulley.

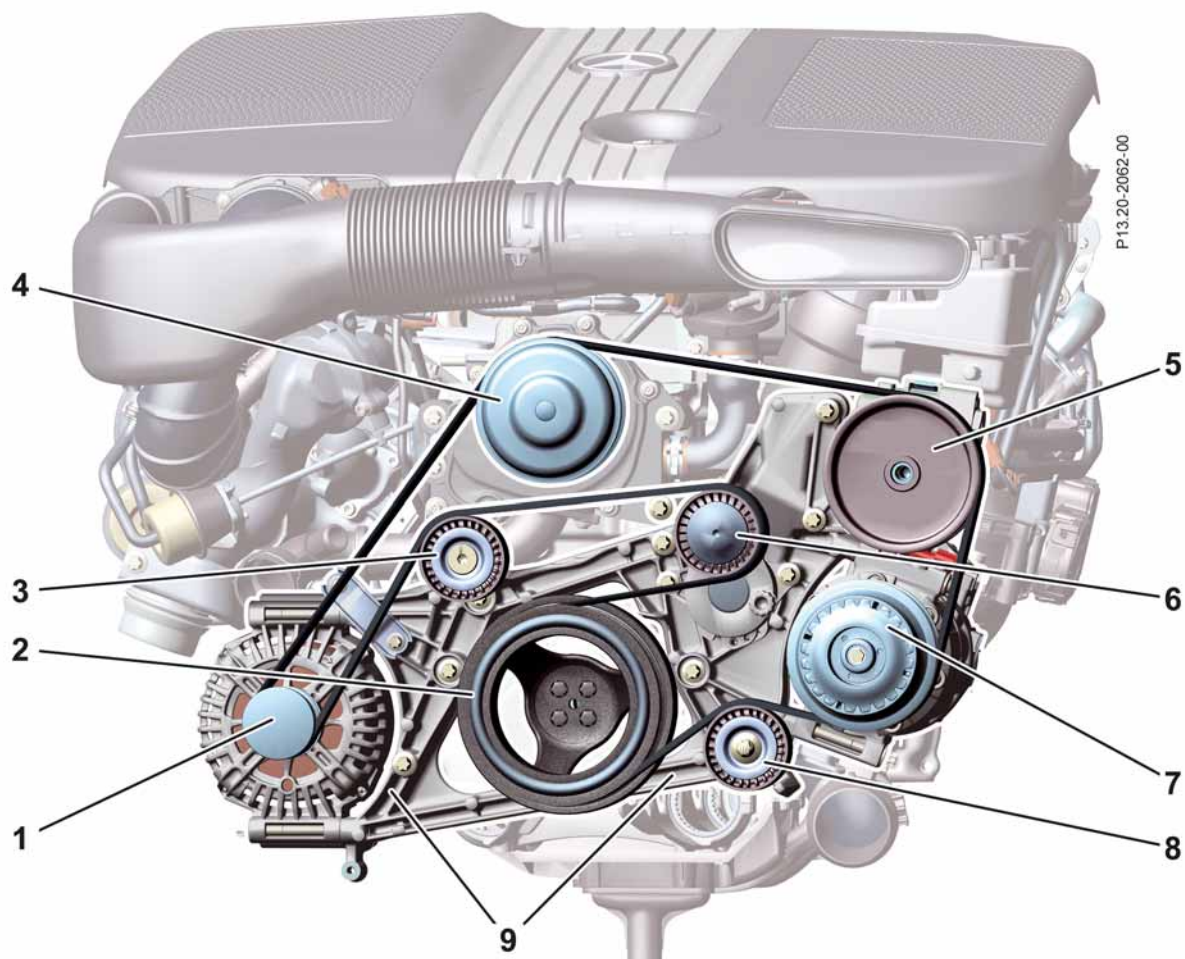

Belt routing

- | | | |
|----------------|--|--------------------------|
| 1 Alternator | 4 Coolant pump | 7 Refrigerant compressor |
| 2 Belt pulley | 5 Power steering pump | 8 Guide pulley |
| 3 Guide pulley | 6 Belt tensioner with tensioner pulley | 9 Major assembly carrier |

Common rail injection

Injection technology

Engine 651 uses the new Common Rail technology of the second generation from Delphi. The maximum injection pressure has been increased by 400 bar to 2,000 bar. A new feature is the piezo injector concept with direct nozzle needle control. Direct actuation allows the injection volume to be changed quickly and with the utmost precision.

The piezo injectors provide the following improvements:

- Greater flexibility for actuation of injection timing points
- Lower fuel consumption
- Higher engine output
- Minimized combustion noise
- Reduced emissions
- Smoother engine running

The most important new features of the injection system include:

- High-pressure pump with two pump elements (max. injection pressure 2,000 bar)
- Electronic engine control with more advanced actuation function for injection timing points
- Leak oil-free injection system with piezo injectors

The increase in engine output to 150 kW / 204 hp and the increase in engine torque to 500 Nm was only made possible by the increased pressure potential. At the same time, the level of raw emissions produced by the engine has been significantly improved.

Piezo injectors

An important component of the new Common Rail technology are the piezo injectors, which are an entirely new development. The injector needle is actuated directly by a piezo-ceramic actuator, instead of being moved by a hydraulic support system. Compared to a conventional fuel injector, the piezo injector injects fuel into the combustion chamber more rapidly, with better atomization and with greater precision.

A special feature of this system is that the piezo injectors open upon a voltage rise and not upon a voltage drop.



P07.03-2243-00

Piezo injector

Warning

Due to the **risk of engine damage**, no connections on the injection system may be disconnected while the engine is running.

The injector coupling may not be disconnected and switched to ground while the engine is running because this would trigger an injection.

Warning! Risk of death!

During engine operation, a **high voltage** of up to 250 V is applied to the piezo injectors.

Common rail injection

Advantages of the new injection technology

The advantages gained with the new technology include a larger available injection volume as well as particularly fine and rapid metering of injection quantities due to finely tuned switching times. In combination with direct actuation of the piezo injectors by the CDI control unit, the fuel injection process can be even more precisely adjusted to the respective load and rpm situation. This is achieved, for example, through precise multiple injections which enable fuel consumption, combustion noise and exhaust emissions to be reduced even further. The engine also runs significantly more smoothly at idle.

Injection quantity

The injection timing point and injection period are determined by the following factors:

- Direct actuation of piezoceramic element
- Opening/closing speed of the nozzle needle
- Needle lift
- Nozzle geometry with 7-hole nozzle module
- Engine load
- Torque request

Note

When working on the injection system (e.g. piezo injector, pressure lines, rail, high-pressure pump) particular care must be given to quality and cleanliness, as even the most minor contamination may very quickly lead to complaints about engine running characteristics and damage.

Common rail injection

Injection quantity correction

Injection quantity correction consists of two procedures:

- Main injection quantity correction
- Zero quantity calibration

Main injection quantity correction

With main injection quantity correction, the injected fuel quantity is corrected using the oxygen sensor upstream of the catalytic converter. The injection quantity is changed until the specified lambda value stored in the CDI control unit is reached.

Zero quantity calibration

The friction produced during opening and closing of the piezo injectors causes wear on the nozzle seat of the nozzle needle. This causes a change in the injection quantity over the service life of the injector.

This change in the injection quantity can be corrected by adjusting the actuation duration (zero quantity calibration). On engines with the Delphi injection system, correction is performed with the help of two knock sensors.

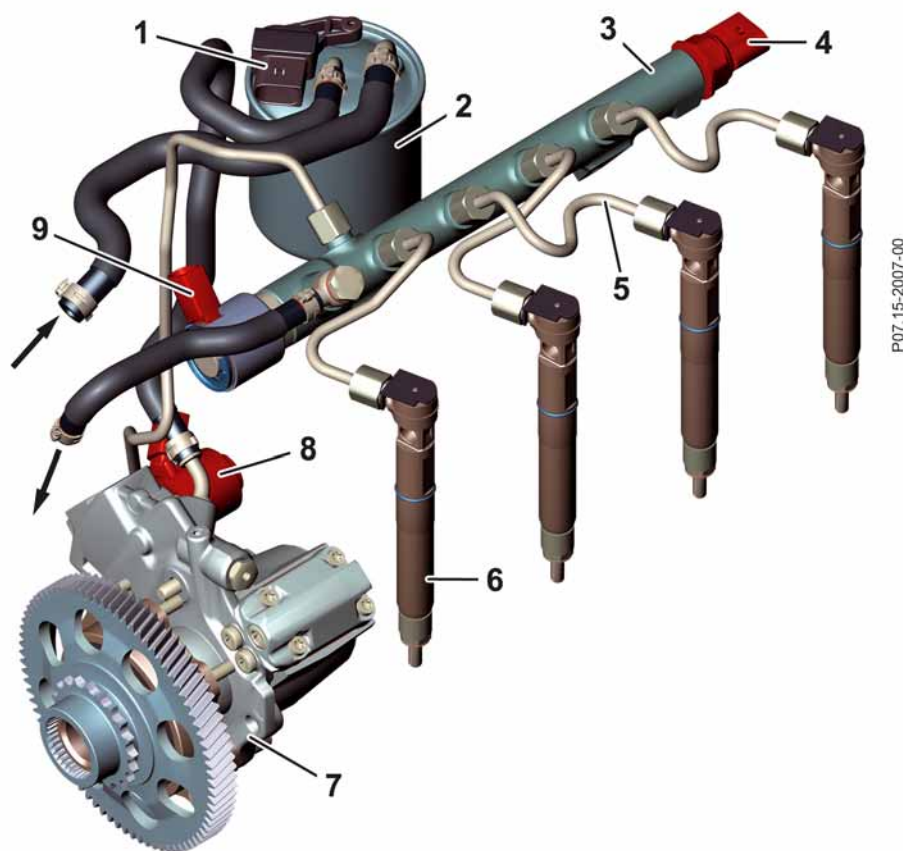

CDI injection system

- | | | |
|------------------------|------------------------|----------------------------|
| 1 Fuel heating element | 4 Rail pressure sensor | 7 High-pressure pump |
| 2 Fuel filter housing | 5 Pressure line | 8 Quantity control valve |
| 3 Rail | 6 Piezo injector | 9 Pressure regulator valve |

Charging

General

With engine 651, Mercedes-Benz has continued the development of dual stage turbocharging in its 4-cylinder inline diesel engines in a passenger car (the predecessor with dual stage turbocharging is engine 646 in the Mercedes-Benz Sprinter).

Design

The dual stage turbocharging system incorporates two turbochargers that differ in size and a bypass control system to achieve a high rated output and air mass throughput even at low rpm. The boost pressure is regulated via the boost pressure control flap (LRK), the wastegate and the charge air bypass flap. The control operations take into account the respective engine torque request based on performance maps.

Advantages of dual stage, controlled turbocharging

This complicated control system which uses two turbochargers to feed charge air to the engine in accordance with its requirements has the following advantages:

- Noticeably more dynamic start-off behavior
- No start-off sluggishness (turbo lag)
- Well-balanced driving characteristics
- Noticeably better driving performance throughout the entire rpm range
- Good acceleration (high torque at low rpm)
- High-pressure turbocharger is designed to build up boost pressure rapidly at low engine speeds
- Low-pressure turbocharger is designed to build up high boost pressure with high gas flow at medium and high engine speeds

The effects on the engine include:

- Better cylinder charging and thus higher output
- Well-balanced torque curve at extremely high level
- Improved rated output with a well-balanced torque curve
- Lower fuel consumption
- Long service life and high reliability
- Reduced nitrogen oxide (NO_x) emissions

Function sequence of boost pressure control

For a better overview of how dual stage turbocharging works, three different states of wide open throttle operation have been selected. These states will be used to explain and illustrate the exact process.

The following boost pressure control states are described:

- Wide open throttle operation up to 1,200 rpm
- Wide open throttle operation between 1,200 and 2,800 rpm
- Wide open throttle operation as of 2,800 rpm

P09.40-2351-00

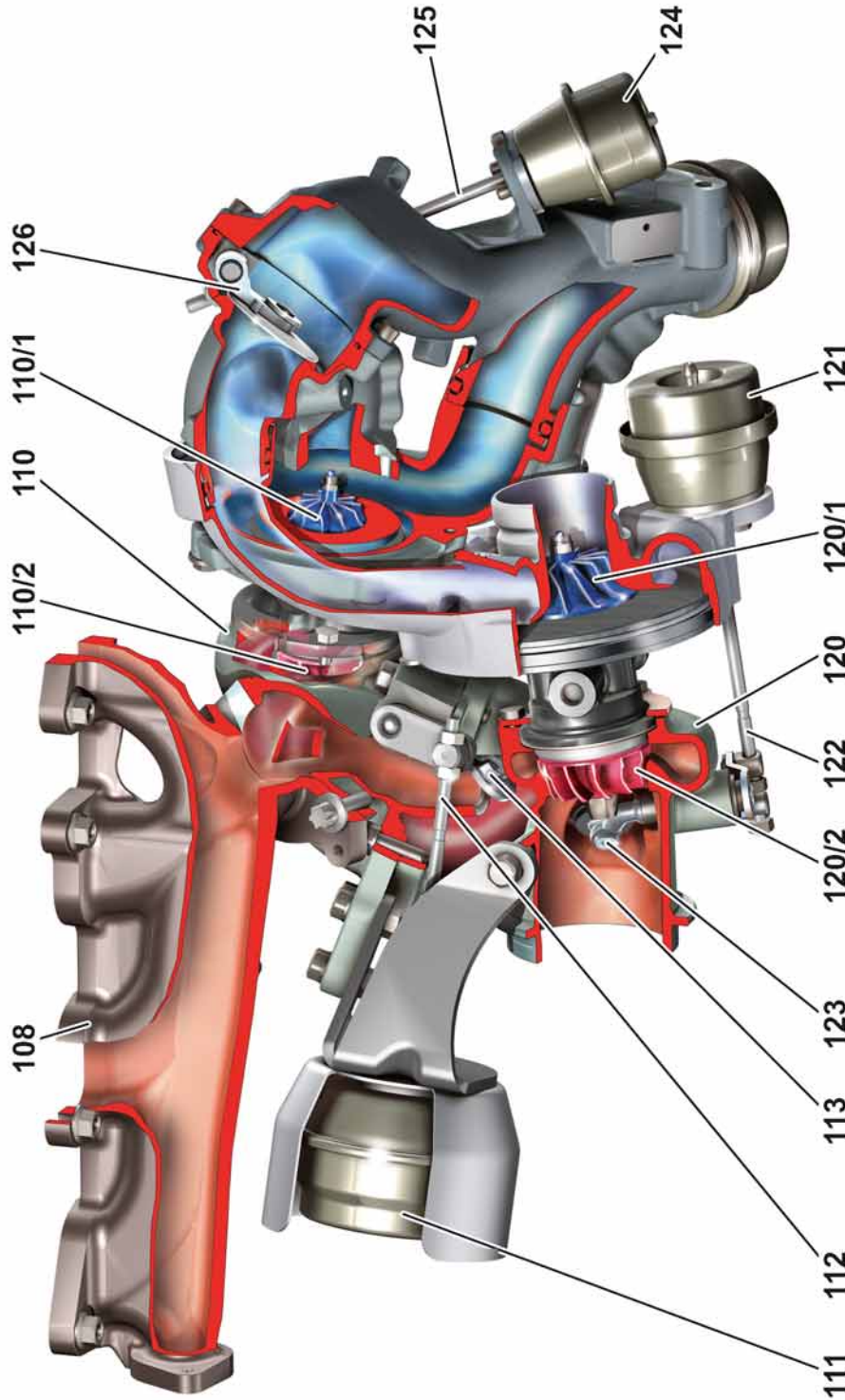

Dual stage turbocharging

108	Exhaust manifold	113	Boost pressure control flap	123	Wastegate
110	High-pressure turbocharger (HD-Lader)	120	Low-pressure turbocharger (ND-Lader)	124	Charge air bypass flap vacuum unit
110/1	HD-Lader compressor impeller	120/1	ND-Lader compressor impeller	125	Charge air bypass flap adjustment rod
110/2	HD-Lader turbine wheel	120/2	ND-Lader turbine wheel	126	Charge air bypass flap
111	Vacuum unit (boost pressure control flap)	121	Wastegate vacuum unit		
112	Adjustment rod (boost pressure control flap)	122	Wastegate adjustment rod		



Charging

Boost pressure control during wide open throttle operation up to 1,200 rpm

The boost pressure control flap (LRK) is almost closed up to an engine speed of 1,200 rpm during wide open throttle operation. In this state, the entire exhaust flow flows over the turbine wheel of the high-pressure turbocharger (HD-Lader) to the turbine wheel of the low-pressure turbocharger (ND-Lader) and then to the exhaust system.

The majority of the exhaust energy acts on the turbine wheel of the HD-Lader, which generates the main part of the required boost pressure. Despite the low exhaust flow, this produces a high boost pressure which builds up very quickly.

The remaining exhaust energy acts on the turbine wheel of the ND-Lader, which drives the compressor impeller via the supercharger shaft. The ND-Lader thus does not act as a hydrodynamic retarder. The wastegate and charge air bypass flap are closed in this operating condition.

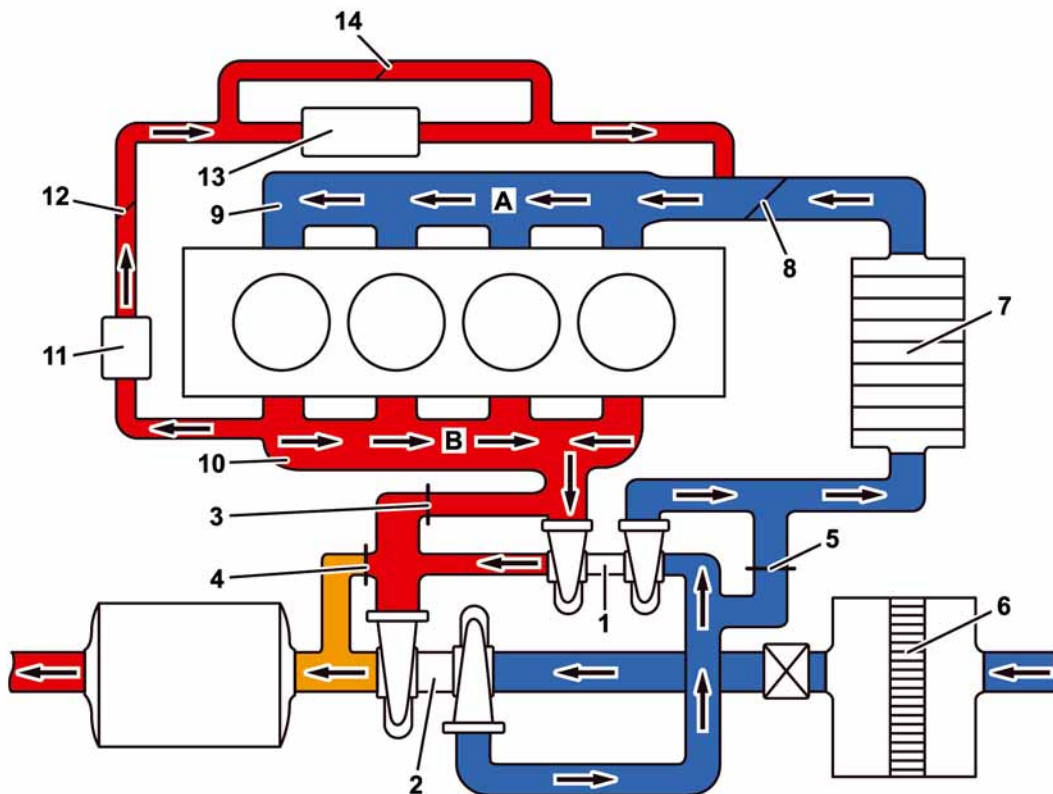

P09.40-2348-00

Schematic illustration of boost pressure control during wide open throttle operation up to 1,200 rpm

- | | | |
|-------------------------------------|---------------------------|---|
| A Intake air | 4 Wastegate | 10 Exhaust manifold |
| B Exhaust flow | 5 Charge air bypass flap | 11 Exhaust gas recirculation (EGR) pre-cooler |
| 1 High-pressure turbocharger | 6 Air filter | 12 EGR actuator |
| 2 Low-pressure turbocharger | 7 Charge air cooler | 13 EGR cooler |
| 3 Boost pressure control flap (LRK) | 8 Throttle valve actuator | 14 EGR bypass flap |
| | 9 Intake manifold | |

Boost pressure control during wide open throttle operation between 1,200 and 2,800 rpm

As of an engine speed of 1,200 rpm during wide open throttle operation, the boost pressure control flap (LRK) is opened in the working range (cross-section of opening) of 5% to 95% depending on the boost pressure required.

As the cross-section of the LRK opening increases, the ND-Lader is continuously engaged and a greater exhaust volume flows through it. The intake of clean air is further pre-compressed.

In this state, the two turbochargers work together and provide the required boost pressure jointly.

The wastegate and charge air bypass flap are closed in this operating condition.

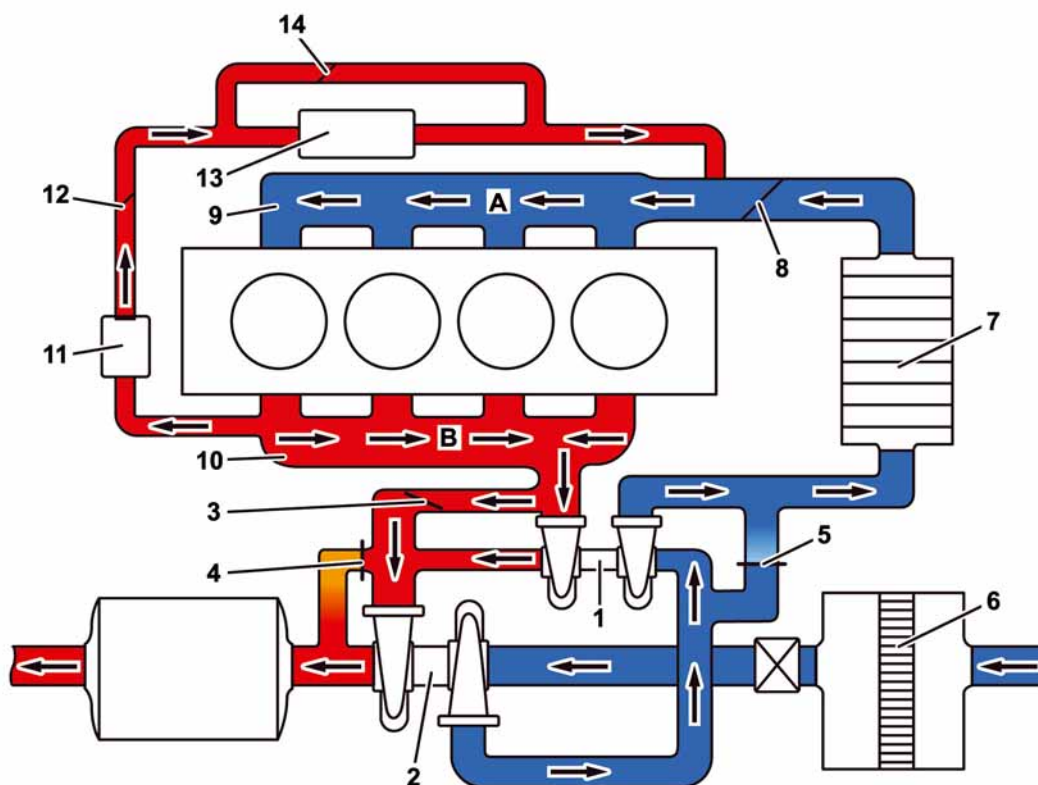

P09.40-2349-00

Schematic illustration of boost pressure control during wide open throttle operation between 1,200 and 2,800 rpm

- | | | |
|-------------------------------------|---------------------------|---|
| A Intake air | 4 Wastegate | 10 Exhaust manifold |
| B Exhaust flow | 5 Charge air bypass flap | 11 Exhaust gas recirculation (EGR) pre-cooler |
| 1 High-pressure turbocharger | 6 Air filter | 12 EGR actuator |
| 2 Low-pressure turbocharger | 7 Charge air cooler | 13 EGR cooler |
| 3 Boost pressure control flap (LRK) | 8 Throttle valve actuator | 14 EGR bypass flap |
| | 9 Intake manifold | |

Charging

Boost pressure control during wide open throttle operation as of 2,800 rpm

The LRK is fully open as of an engine speed of 2,800 rpm. This causes almost the entire flow of exhaust gas to be fed nearly without loss to the low-pressure turbine via the bypass duct and limits the level of exhaust back pressure.

This procedure means that the HD-Lader no longer makes any contribution to increasing the boost pressure. The HD-Lader has reached its choking limit. This means that it can no longer generate boost pressure and, in the event of further loading, the turbine speed would drop off significantly.

In order to prevent pressure loss and additional warming of the charge air as it flows through the high-pressure compressor, the charge air bypass flap is opened so that the main part of the air flow is guided to the charge air cooler along a direct, low-loss path.

The wastegate is used to regulate the turbine output of the low-pressure turbine in the engine performance map as required and depending on the load condition.

Depending on the load condition, the HD-Lader can build up a high level of boost pressure at low engine speeds and prevent overload of the ND-Lader at high engine speeds.

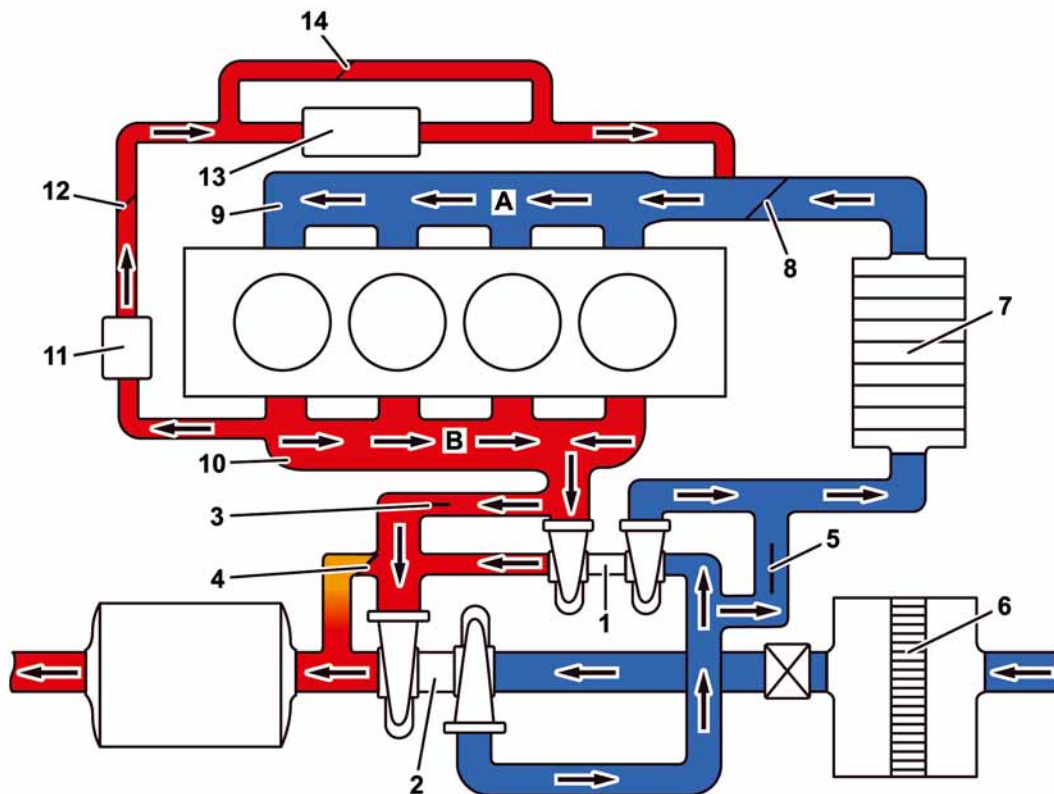

P09.40-2350-00

Schematic illustration of boost pressure control during wide open throttle operation as of 2,800 rpm

- | | | |
|-------------------------------------|---------------------------|---|
| A Intake air | 4 Wastegate | 10 Exhaust manifold |
| B Exhaust flow | 5 Charge air bypass flap | 11 Exhaust gas recirculation (EGR) pre-cooler |
| 1 High-pressure turbocharger | 6 Air filter | 12 EGR actuator |
| 2 Low-pressure turbocharger | 7 Charge air cooler | 13 EGR cooler |
| 3 Boost pressure control flap (LRK) | 8 Throttle valve actuator | 14 EGR bypass flap |
| | 9 Intake manifold | |

Air ducting

The hot film mass air flow sensor (HFM) is located in the clean air line downstream of the air filter housing. It determines the mass and temperature of the intake air and makes the measurement results available to the motor electronics as input factors.

The low-pressure turbocharger draws in clean air through the clean air line and air filter and compresses it. The air compressed by the turbochargers flows through the charge air cooler where it is cooled.

The throttle valve actuator influences the air volume fed to the engine and the mixing ratio of charge air and recirculated exhaust gas mixed in downstream of the throttle valve. The air mixture is then fed directly to the combustion chamber via the charge air manifold.

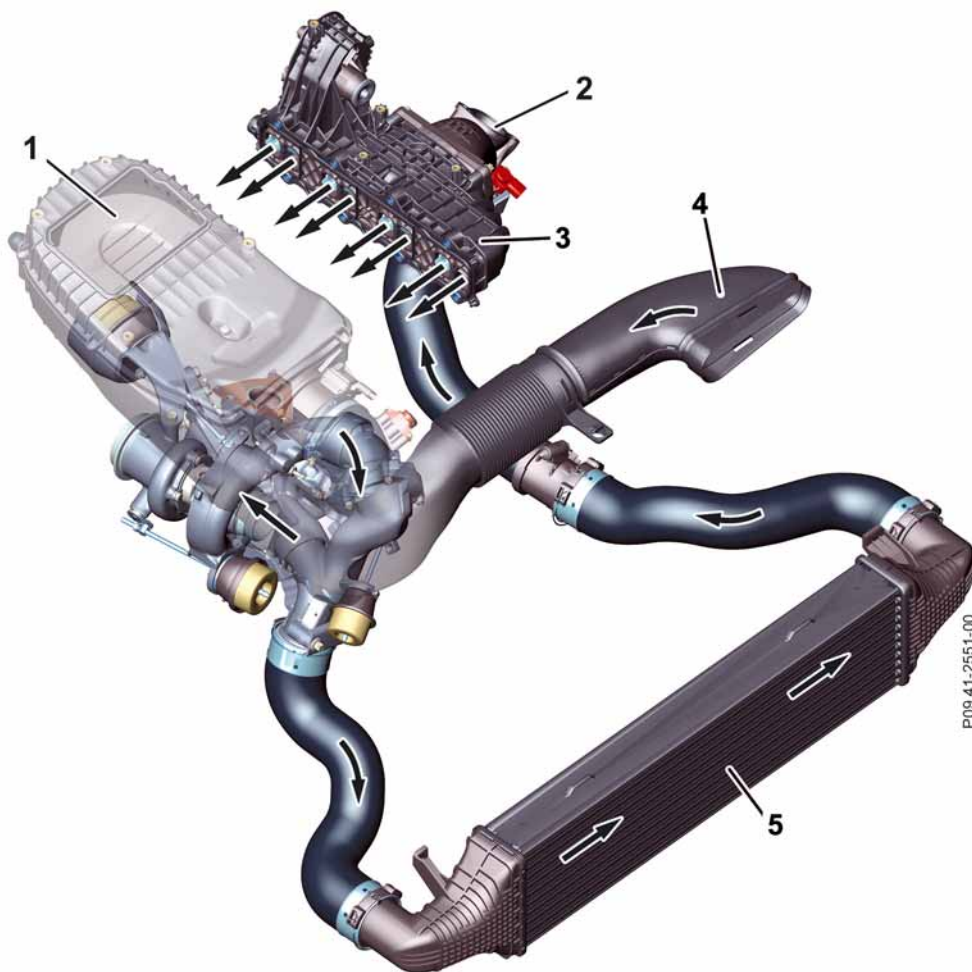

Air ducting

- | | |
|-----------------------|---------------------|
| 1 Air filter housing | 4 Clean air line |
| 2 Throttle valve | 5 Charge air cooler |
| 3 Charge air manifold | |

Air supply

Intake port shutoff

The intake port shutoff (EKAS) function ensures the best possible ratio between air mixing and air mass in all engine load conditions and thus an optimal fill level. This optimizes the exhaust characteristics and engine output. The charge air manifold is made of plastic and the flaps are made of metal.

In the charge air manifold, there is a permanently open tangential intake port and a flap-controlled spiral intake port for each cylinder. The flaps are connected to each other by a shaft. The CDI control unit controls the position of the flaps based on performance maps.

When the engine switches from the partial load range to the full load range, the flaps in the spiral intake ports are opened according to performance maps.

In the event of a fault or if the supply voltage is interrupted, the flaps in the spiral intake ports are mechanically opened by the return springs.

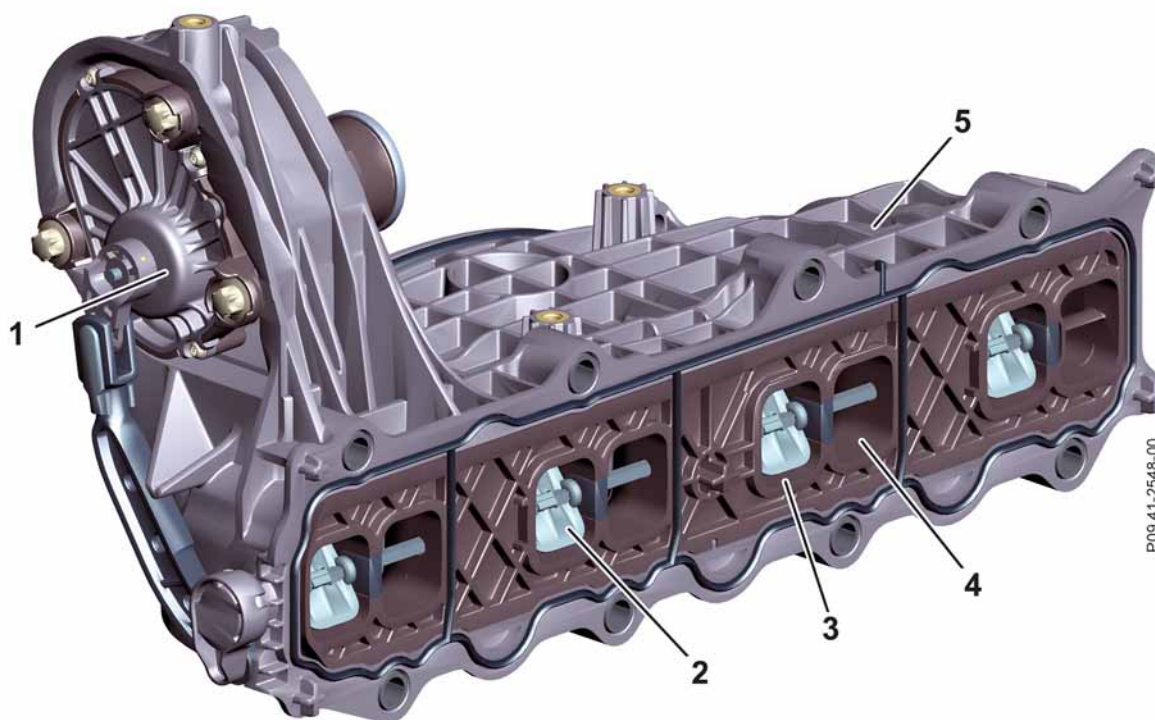

P09.41-2548-00

Charge air manifold

- 1 Actuator motor
- 2 Adjustment flap
- 3 Spiral intake port

- 4 Tangential intake port
- 5 Charge air manifold



Throttle valve

The throttle valve actuator uses the throttle valve to influence the air volume fed to the engine and the mixing ratio of charge air and recirculated exhaust gas mixed in downstream of the throttle valve.

When the engine is switched off, the throttle valve is closed. This keeps engine vibrations at a low level when the engine is switched off.

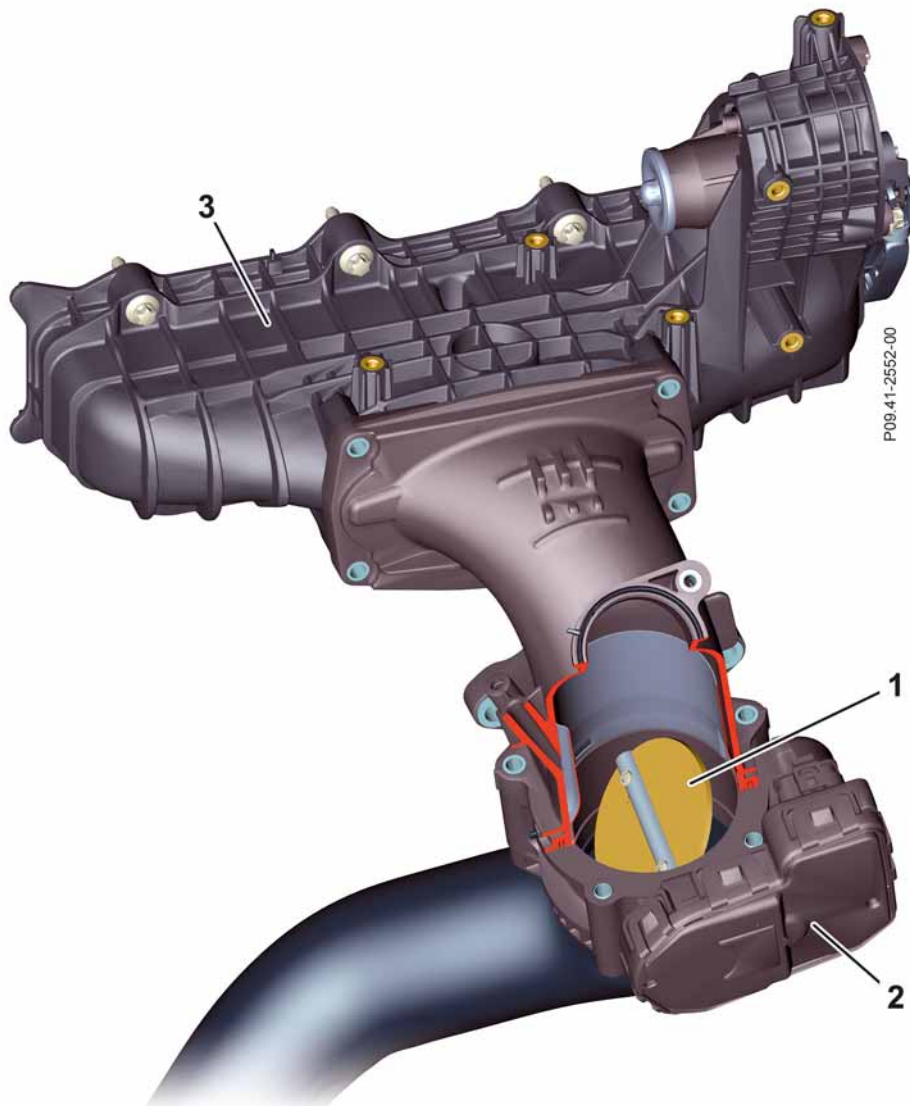

Throttle valve

1 Throttle valve

2 Throttle valve actuator

3 Charge air manifold

Exhaust system

Exhaust gas recirculation

The exhaust system of engine 651 combines two technologies for emission reduction. Exhaust gas recirculation (EGR) reduces emissions of nitrogen oxide (NO_x) and exhaust treatment reduces the emission of hydrocarbons (HC) and soot particles.

With exhaust gas recirculation, part of the exhaust flow is guided back through the EGR path to the charge air.

The recirculated exhaust gas enters the EGR path via a pre-cooler. There it is either cooled according to its temperature or fed directly to the charge air. The exhaust-air mixture enters the combustion chamber directly via the charge air manifold.

Exhaust gas recirculation reduces the oxygen (O₂) concentration and combustion temperature.

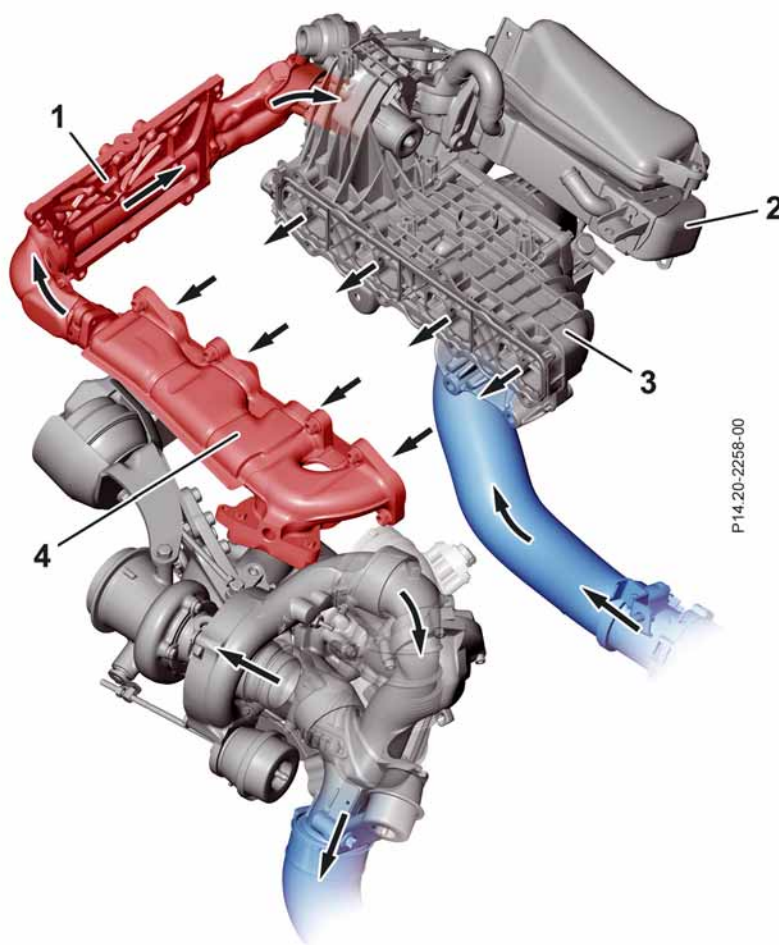

P14.20-2258-00

Exhaust gas recirculation

- 1 EGR pre-cooler
- 2 EGR cooler

- 3 Charge air manifold
- 4 Exhaust manifold



Exhaust gas recirculation path

Part of the exhaust gas enters the exhaust gas recirculation system via the exhaust manifold.

The EGR path is made up of the following components:

- EGR pre-cooler
- EGR actuator
- EGR bypass flap
- EGR cooler

The incoming quantity of exhaust gas is controlled by the EGR actuator.

The CDI control unit actuates the EGR actuator via a pulse width modulated signal, causing the EGR actuator to increase or reduce the size of the opening cross-section of the EGR valve. In order to further improve the efficiency, the exhaust gas can be directed via the EGR cooler and cooled further depending on the requirement.

However, if the temperature of the incoming exhaust gas is too low, the path to the EGR cooler is closed via a bypass flap and the exhaust gas is guided directly to the charge air manifold. The switchover valve for the bypass flap is controlled by a vacuum unit.

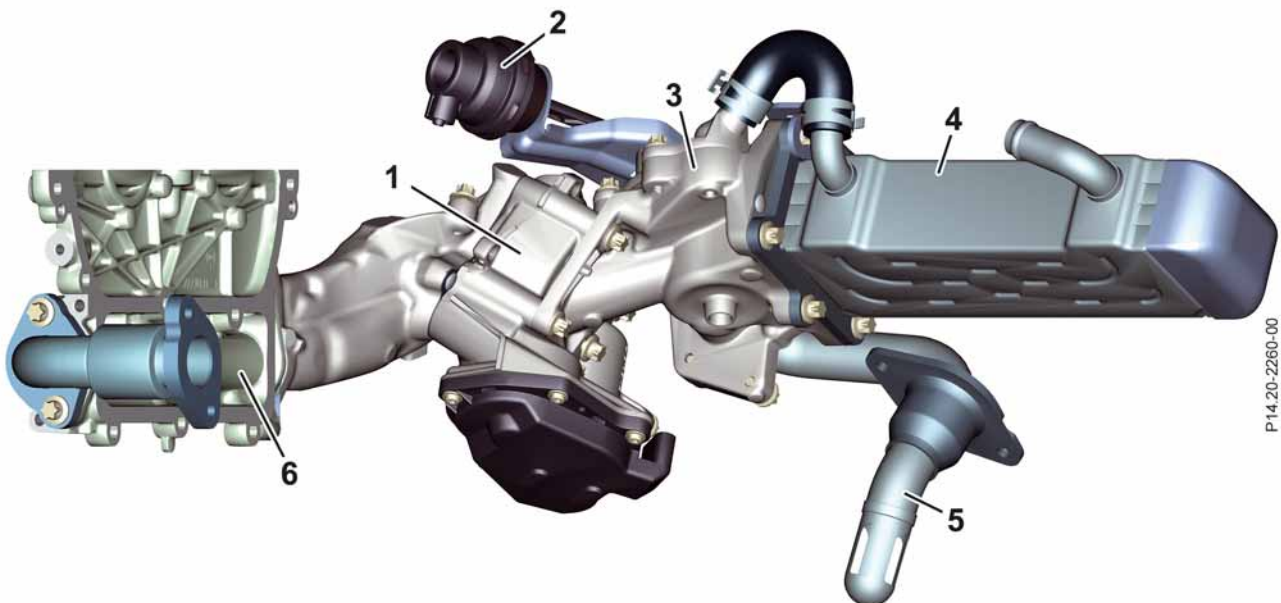

P14.20-2260-00

EGR path

- | | |
|----------------|------------------|
| 1 EGR actuator | 4 EGR cooler |
| 2 Vacuum unit | 5 EGR pipe |
| 3 EGR bypass | 6 EGR pre-cooler |

Exhaust system

Oxidation catalytic converter

The oxidation catalytic converter is part of the exhaust system and is located in the exhaust tract downstream of the turbocharger.

The ceramic body is made of highly temperature resistant magnesium-aluminum-alumosilicate and has several thousand small passages running all the way through it. The ceramic monolith reacts extremely sensitively to physical stress and is fixed in place inside a stainless steel housing.

The individual pollutant components are oxidized as follows:

Before oxidation	After oxidation
$2\text{CO} + \text{O}_2$	2CO_2
$4\text{HC} + 5\text{O}_2$	$2\text{H}_2\text{O} + 4\text{CO}_2$

Diesel particulate filter (DPF)

The diesel particulate filter (DPF) forms a unit with the oxidation catalytic converter.

The ceramic DPF is made of silicon carbide and coated with platinum. The individual channels open out alternately to the front or to the rear and are separated from each other by porous filter walls.

When the unfiltered exhaust gas flows through the porous ceramic honeycomb filter, the soot particles are held back by the porous filter walls. The CDI control unit measures the load condition of the DPF via the pressure differential sensor. The exhaust pressure upstream of and downstream of the DPF is measured for this purpose. Regeneration of the DPF is initiated once a defined value is reached. Temperatures of over 600 °C are necessary to burn off the soot. The CDI control unit initiates the following steps in order to reach these high temperatures:

- Post injection
- Exhaust gas recirculation with intake air throttling
- DPF glow function

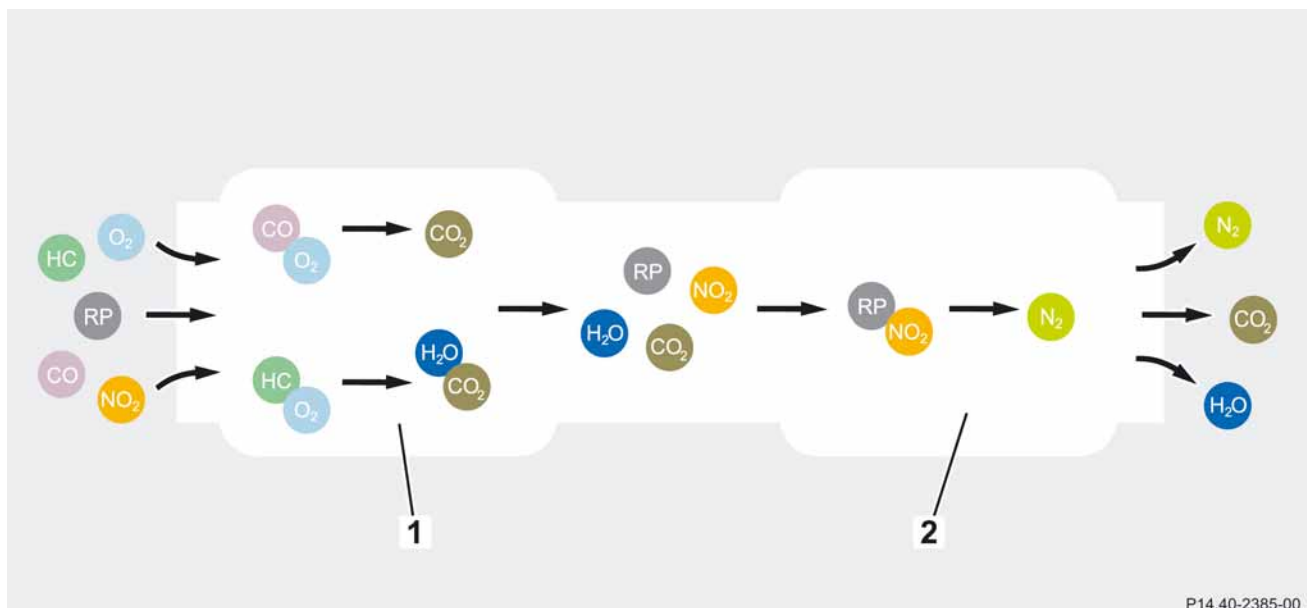

Schematic illustration of oxidation catalytic converter and DPF

- | | | |
|---------------------------------|--------------------------------|--------------------------------|
| 1 Oxidation catalytic converter | CO ₂ Carbon dioxide | N ₂ Nitrogen |
| 2 DPF | O ₂ Oxygen | NO ₂ Nitrogen oxide |
| CO Carbon monoxide | HC Hydrocarbon | PM Particulate matter |
| | H ₂ O Water | |

DPF regeneration

The exhaust back pressure increases as the soot load of the DPF increases. A sensor measures the pressure differential upstream of and downstream of the DPF and forwards this information to the engine control unit. Regeneration of the DPF is initiated when the threshold value stored there is reached.

Regeneration during driving operation is performed on average after 800 to 1,000 km, depending on soot emissions and filter size.

If the exhaust temperature required for regeneration is not reached during normal driving operation, selective post injection into the combustion chambers is performed to increase the exhaust temperature. The regeneration procedure only takes several minutes and depends on:

- Engine speed
- Vehicle speed
- Exhaust gas temperature

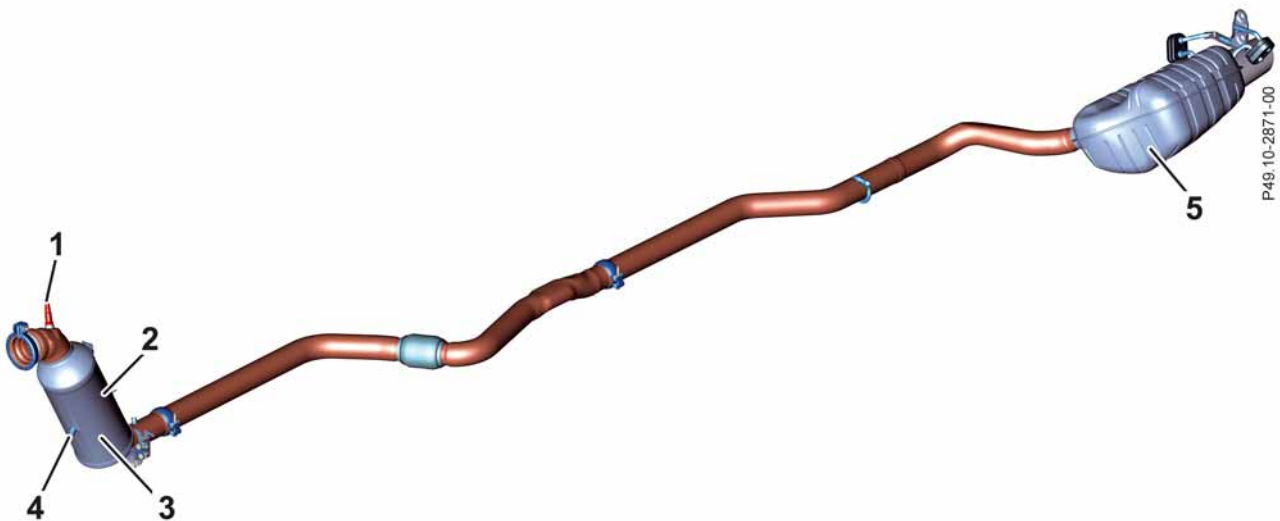

Exhaust system

- | | |
|---|--|
| 1 Oxygen sensor upstream of catalytic converter | 4 Temperature sensor upstream of diesel particulate filter |
| 2 Oxidation catalytic converter | 5 Rear muffler |
| 3 Diesel particulate filter | |

i Note

If DPF regeneration is not possible during normal operation, the engine diagnosis warning lamp lights up on the instrument cluster.

Engine cooling

Engine lubrication and cooling circuit

The coolant pump pumps coolant through two separate ducts. The lower duct supplies the crankcase and the oil-water heat exchanger with coolant and the upper duct supplies the cylinder head with coolant. The EGR path runs parallel to the upper duct. The following components of the EGR path are supplied with coolant:

- EGR valve
- EGR bypass housing
- EGR pre-cooler and EGR cooler

Thermal management

The coolant pump is switched off when the engine is cold-started so that the combustion chamber can heat up more rapidly.

The coolant pump is switched off during a cold start for max. 500 s if the following conditions are fulfilled:

- The limit values stored in the control unit for intake air and coolant temperature and for the total fuel injection quantity have not yet been reached.
- The engine speed or injection quantity has not exceeded the specified limit value.
- "Heat" has not been requested by the automatic air conditioning control and operating unit.

The position of the coolant thermostat is used to precisely adjust the quantity of coolant flowing to the radiator or direct to the coolant pump. This regulates the temperature of the coolant in the coolant circuit.

The coolant thermostat is controlled via the integrated heating element. The coolant pump and the heating element are controlled via the CDI control unit.

When the coolant thermostat is closed, the coolant flows back to the coolant pump and is fed back into the circuit.

Once the engine has reached operating temperature, the coolant thermostat is opened and the coolant circuit becomes active. The radiator is then incorporated into the coolant circuit.

A filling line between the coolant expansion reservoir and the radiator balances out the coolant level.

A vent line ventilates the coolant system between the coolant expansion reservoir and the housing of the coolant thermostat.

Note

The heating element of the coolant thermostat may not be removed / disassembled from the thermostat housing. The predetermined opening point shifts if the housing is damaged or if fluid enters the housing.

More detailed information on this can be found in the Workshop Information System (WIS).

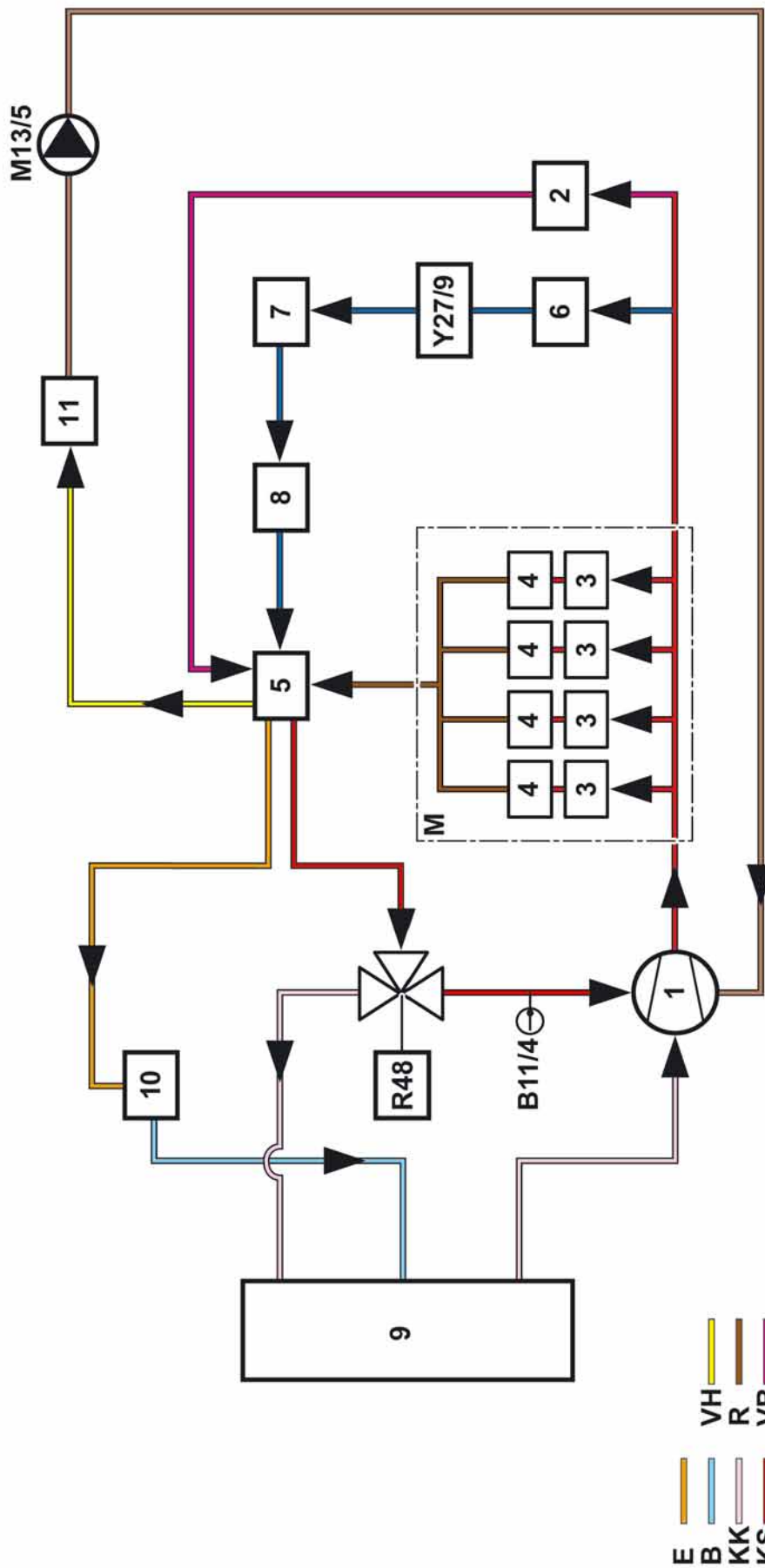

P20.00-2352-00

Cooling circuit

Component	Abbreviation	Description
1	KS	Short-circuited circuit
2	VH	Vehicle heater feed
3	M	Engine return flow
4	RH	Exhaust gas recirculation circuit (EGR)
5	VA	Oil-water heat exchanger circuit
6	VB	Oil-water heat exchanger circuit
7	B	Chain case housing
8	E	Bypass housing
9	KK	Radiator
10	B	Coolant expansion reservoir
11	RH	Heat exchanger for vehicle heater

Engine lubrication and oil circuit

Lubricating system

The engine lubrication system minimizes the mechanical friction and thus the wear on moving parts. In addition, the oil pads between the bearings and running surfaces reduce shocks and vibrations. A pressure differential valve is installed in parallel to the oil-water heat exchanger to ensure that the engine is lubricated at all times. This allows the oil to be routed around the oil-water heat exchanger.

Oil circuit

All of the moving components of the engine are lubricated and /or cooled with engine oil via the oil circuit of the engine.

The oil circuit of the engine is supplied with engine oil via the oil pump. In addition, the vacuum pump is driven and supplied with engine oil via the oil pump. The following components in the crankcase are supplied with engine oil via the main oil duct:

- Crankshaft bearings
- Connecting rod bearings
- Intermediate gears
- Oil spray nozzles

The two turbochargers are supplied with engine oil via a bypass of the main oil duct.

The oil supply for the cylinder head branches off from the main oil duct. The following lubrication points in the cylinder head are supplied with engine oil:

- Cam chain tensioner
- Intake camshaft
- Exhaust camshaft
- Hydraulic valve clearance compensator

The engine oil is returned to the oil pan via return ducts.



P18.10-2179-00

Oil pump

i Note

The CDI control unit reads in the oil level check switch to monitor the oil level and the oil temperature sensor to monitor the oil temperature.

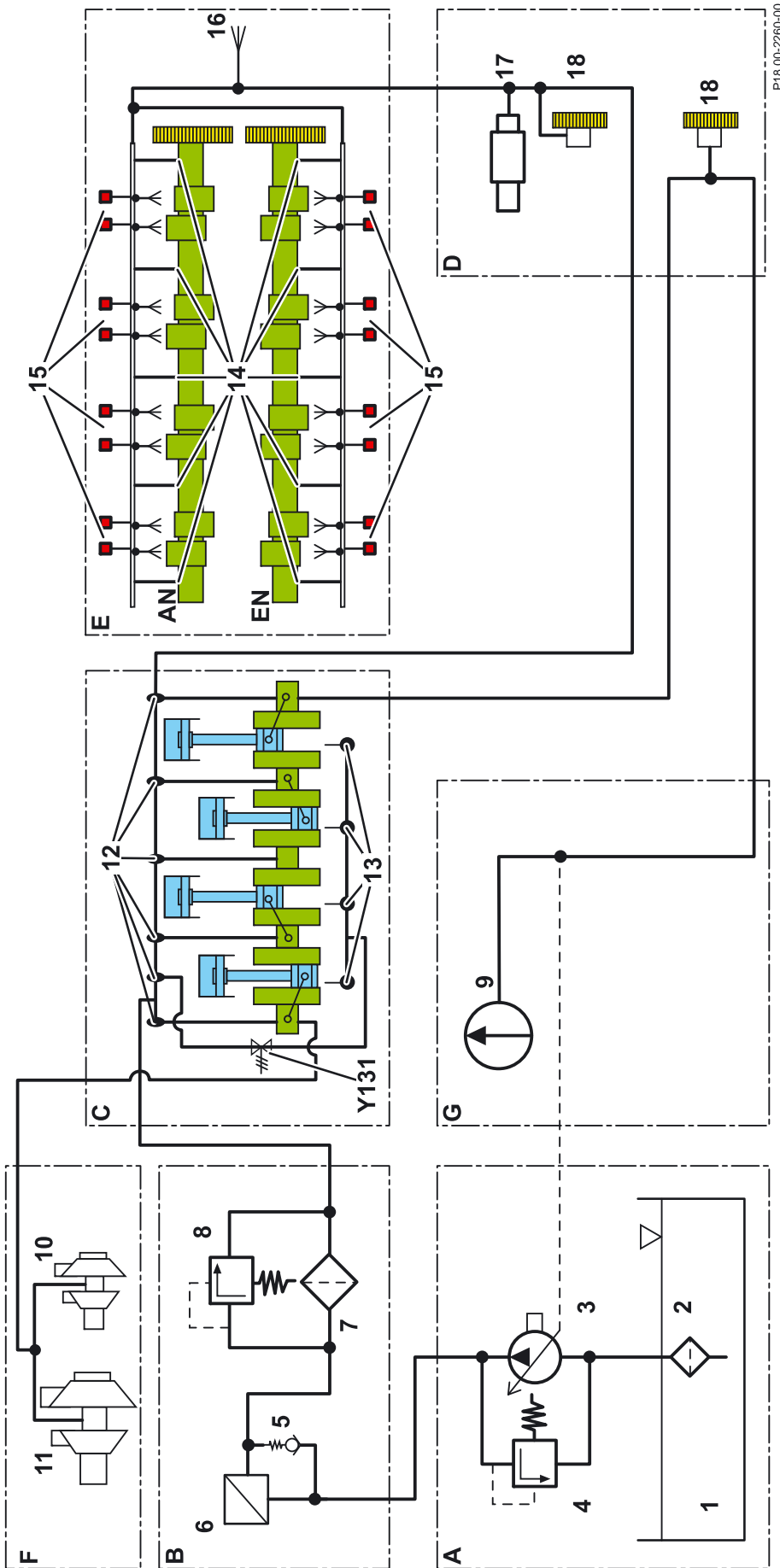

Oil circuit

1	Oil pan	EN	Intake camshaft
2	Prefilter	F	Charging
3	Oil pump (volume-controlled)	G	Vacuum pump
4	Pressure limiting valve	Y131	Oil spray nozzle shutoff valve
5	Pressure differential valve		
6	Oil-water heat exchanger		
7	Oil filter element		
8	Oil filter bypass valve		
9	Vacuum pump		
10	High-pressure turbocharger		
11	Low-pressure turbocharger		
12	Crankshaft main bearing and connecting rod bearing oil duct		
13	Oil spray nozzles		
14	Camshaft main bearing		
15	Hydraulic valve clearance compensator		
16	Timing chain oil spray nozzle		
17	Chain tensioner		
18	Intermediate gear of gear drive		
A	Oil pan with oil pump		
AN	Exhaust camshaft		
B	Oil filter module		
C	Crankcase		
D	Gear drive		
E	Cylinder head		

Oil pump

Oil pump

The oil pump is volume-controlled at the clean oil side and has a rotary vane design. The control pressure is 4.7 bar.

The oil pump is driven by the gear drive and is equipped with an integrated pressure limiting valve which limits the oil pressure to a maximum of 10 bar. As soon as the engine is started, the engine oil is drawn in via the intake line with integrated prefilter on the oil suction pipe and pumped to the oil filter module with integrated oil-water heat exchanger via the pressure line.

During the cold-start phase of engine operation, the oil-water heat exchanger ensures that the oil is heated up more quickly and in the warm-up phase it ensures that the engine oil is cooled adequately. If the oil flow is insufficient, the oil can be directed past the oil-water heat exchanger via the bypass valve installed in parallel. Only after this does the engine oil enter the oil filter unit. The oil then flows from outside to inside and is cleaned in the process. If the flow is insufficient, e.g. due to a high level of contamination, the oil filter bypass valve installed in parallel routes the oil flow around the oil filter.

Oil spray nozzles

The oil spray nozzles and the associated oil feed for piston crown cooling are actively shut off by the shutoff valve of the oil spray nozzles. The oil spray nozzles are shut off by the CDI control unit in the post-start phase under the following conditions:

- Engine oil temperature greater than $-10\text{ }^{\circ}\text{C}$
- And:
- The max. shutoff duration (depending on intake air and engine oil temperature) has not yet been reached
- Or:
- The engine speed or the injection quantity has not yet reached a specified limit value

If the oil spray nozzles are ever switched on, they are no longer shut off for as long as the engine is running.

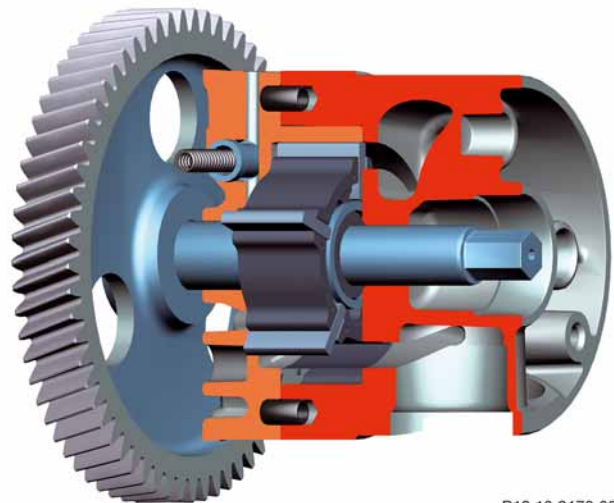

P18.10-2178-00

Cross-section of oil pump

Coolant pump

The coolant pump ensures that the coolant circulates in the coolant circuit. It is made of plastic, which makes a contribution to weight reduction.

Function

The coolant pump is driven via the belt pulley by means of a poly-V belt. The rotational movement of the belt pulley is transferred to the shaft via the hub. The impeller is driven by the shaft, which causes the coolant to circulate.

The coolant flow can be stopped by vacuum via the switchover valve of the coolant pump, which is located on the left on the throttle valve actuator. In this case, a regulating valve slides over the impeller, thus closing the coolant feed.

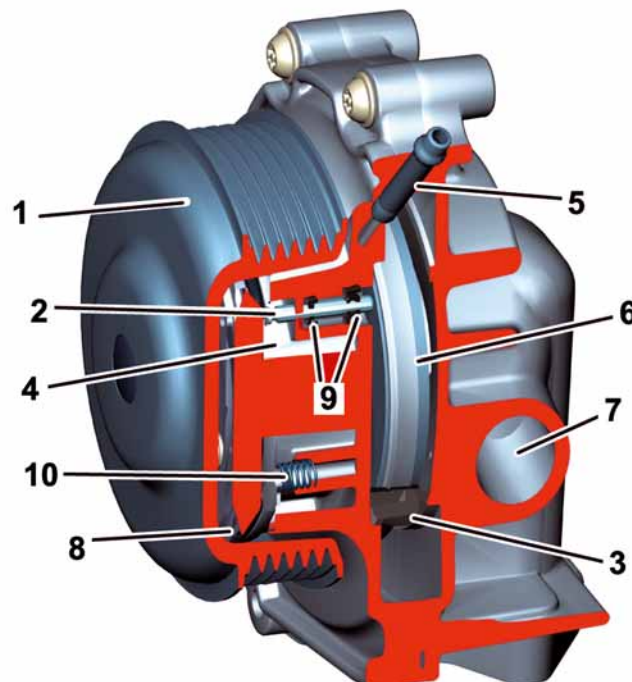

P20.10-2255-00

Cross-section of coolant pump

- | | |
|----------------------|-----------------------|
| 1 Belt pulley | 6 Impeller |
| 2 Control rod | 7 Coolant outlet |
| 3 Regulating valve | 8 Power diaphragm |
| 4 Evacuation chamber | 9 Rod seal |
| 5 Vacuum fitting | 10 Compression spring |

Engine control unit

CDI control unit

The CDI control unit is located on the air filter housing. The CDI control unit is equipped with cooling fins at the bottom which project inside the air filter housing and are cooled by the intake air.

The task of the CDI control unit is divided into the following subtasks:

- Engine torque control
- Injection control
- Charging
- Deceleration fuel shutoff
- Thermal management
- Exhaust gas recirculation (EGR)
- Exhaust treatment

The CDI control unit serves as an interface between the drive train CAN (CAN C) and the chassis CAN (CAN E).

The engine control system is equipped with a fault memory and powerful diagnostic functions for monitoring all system components and functions. This incorporates the following aspects:

- Fault memory checking
- Engine control diagnosis
- European On-Board Diagnosis (EOBD)
- Diagnosis via CAN bus
- Diagnosis via K-line



P15.00-2190-00

CDI control unit on air filter housing

- 1 CDI control unit
2 Cooling fins

- 3 Air filter housing
4 Air filter

Instant Start System

The electronically controlled Instant Start System consists of a glow output stage and four ceramic glow plugs. The Instant Start System allows the engine to be started immediately without preglowing at high coolant temperatures. In order to improve the cold start and warm-up characteristics of the engine, afterglowing is performed in steps via the controllable glow temperature. The CDI control unit regulates the voltage at the glow plugs via the glow output stage depending on time and temperature.

This has the following advantages:

- Short preglow time
- Stable idling
- Low exhaust gas emissions
- Good response behavior
- Controllable glow temperature

A distinction is drawn between the following glowing types:

- Preglowing
- Start-ready glowing
- Afterglowing
- Diagnostic glowing
- DPF glow function
- Emergency glowing

Risk of engine damage

Safety information for handling ceramic glow plugs:

- Only use glow plugs from unopened original packaging.
- If a glow plug is dropped on the floor, it must not be used.
- Important: Engine damage can occur because glow plugs are very sensitive to shock! Hairline cracks may develop in the ceramic element. As a consequence, parts may become detached and drop into the combustion chamber while the engine is running. Always handle glow plugs with the utmost care!
- The glow plugs must be removed before removing the cylinder head, and must not be reinstalled until the cylinder head has been installed.



P15.20-2181-00

Ceramic glow plug

Note

If a fault occurs in the preglow system, glow plugs or lines, this is indicated by the preglow indicator lamp and the fault is also stored in the CDI control unit.

Vacuum control

Vacuum control

The vacuum pump is driven indirectly via the oil pump drive. It generates vacuum pressure and is connected to the vacuum system via its central line to the brake booster. The system incorporates:

- Vacuum reservoir
- Wastegate control pressure transducer
- Boost pressure control flap pressure transducer
- EGR cooler bypass switchover valve
- Charge air bypass flap switchover valve
- Coolant pump switchover valve

The following components are actuated by a pulse width modulated signal:

- Boost pressure control flap pressure transducer
 - The boost pressure control flap opens steplessly and controls the exhaust flow between the high-pressure turbocharger and low-pressure turbocharger.
- Wastegate control pressure transducer
 - The wastegate opens steplessly. Part of the exhaust flow is directed past the low-pressure turbocharger to the exhaust system.
- Charge air bypass flap switchover valve
 - The bypass flap opens and relieves the load on the high-pressure turbocharger.
- EGR cooler bypass switchover valve
 - The bypass upstream of the EGR cooler opens and the exhaust flow is directed through the EGR cooler.
- Coolant pump switchover valve
 - The coolant flow to the coolant pump is closed off by the mechanical control components integrated in the coolant pump.



P07.09-2039-00

Vacuum pump

i Note

Ventilation of the pressure transducers for wastegate control and for the boost pressure control flap takes place via the same vent filter.

! Risk of engine damage

When vacuum lines are installed, attention must be paid to the respective color coding of the vacuum line and of the vacuum unit otherwise there is a risk of engine damage.

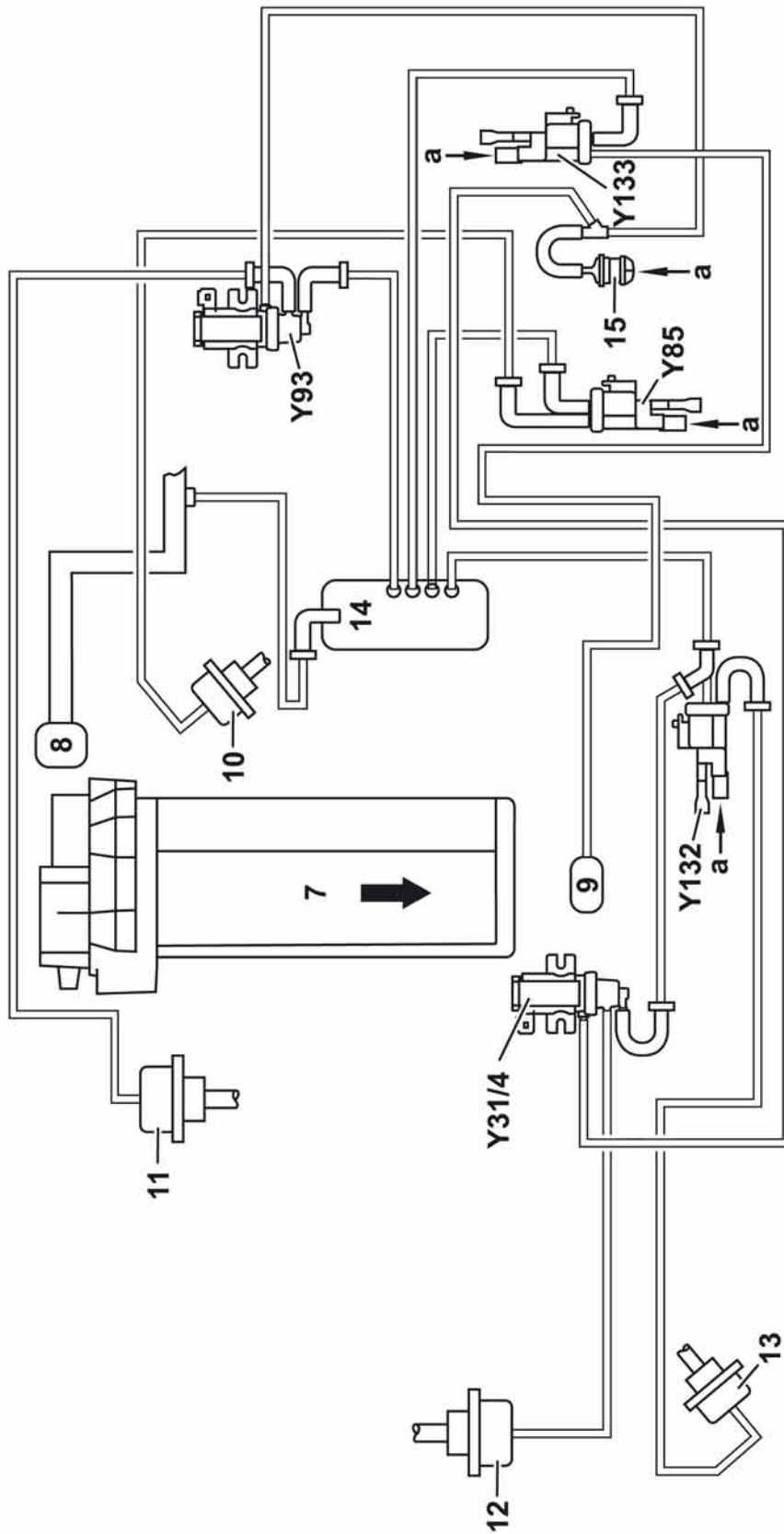

P07.09-2038-00

Vacuum system shown on engine 651.911

- ➔ Travel direction arrow
- a Ambient pressure
- 7 Wastegate control pressure transducer
- 8 EGR cooler bypass switchover valve
- 9 EGR cooler bypass switchover valve
- 10 Boost pressure control flap pressure transducer
- 11 Boost pressure control flap vacuum unit
- 12 Wastegate vacuum unit
- 13 Charge air bypass flap vacuum unit
- 14 Vacuum reservoir
- 15 Vent filter for Y31 / 4 and Y93
- Y31 / 4 Wastegate control pressure transducer
- Y85 EGR cooler bypass switchover valve
- Y93 Boost pressure control flap pressure transducer
- Y132 Charge air bypass flap switchover valve
- Y133 Coolant pump switchover valve

Emission reduction

Emission reduction measures

The wide range of new technical features used in the development of engine 651 have made it possible to reduce the level of raw emissions even further. The engine complies with the Euro 5 standard even without BlueTEC technology. The new engine has the potential to fulfill the limit values for the Euro 6 standard and the US BIN5 standard.

Mechanical measures

- Oil pump volume-controlled at the clean oil side with regulated pressure level (performance map)
- Friction-optimized vacuum pump
- Piston pins with PVD coating

Technical implementation

Raw emissions have been further reduced by optimizing the following components involved in the oil circuit:

- The spray nozzle for the timing chain has been omitted
- The control pressure has been lowered to 2.5 bar
- Shutoff-capable piston crown cooling
- Lanchester balance shafts supported by roller bearings
- Intermediate gears
- Reduced pressure resistance

Reduction of CO₂ emissions

The new Common Rail technology provides the basis for greater injection timing flexibility, which produces a smoother running engine with lower fuel consumption and reduced emissions. This has allowed the level of CO₂ emissions to be reduced by up to 13%. The new features responsible for this improvement include the increase in rail pressure by 400 bar to a maximum of 2,000 bar and the new piezo injector concept with direct nozzle needle control.

Reduction of nitrogen oxides

The combustion process has been optimized to sustainably reduce raw emissions by lowering the compression ratio from 16.5:1 to 16.2:1.

Significant improvements have been achieved, especially with respect to nitrogen oxides.

The proportion of nitrogen oxides in the exhaust gas is lowered through exhaust gas recirculation.

Note

The abbreviation "PVD" stands for "Physical Vapor Deposition". This is a coating procedure / thin-film technology whereby a coating is formed directly on a material surface through condensation of a material-containing vapor.

Thermal management

Along with optimization of the warm-up and cooling processes, the newly designed thermal management system incorporates the following function sequences:

- Maximum heating combustion
- Overheating protection
- Post-start phase

Exhaust emissions are reduced by the extended thermal management system. The table below shows the new measures and the associated results.

Exhaust treatment

Many pollutants can be converted before they leave the vehicle through exhaust treatment in the exhaust system. The use of an oxidation catalytic converter and a diesel particulate filter (DPF) enables the following pollutants in the exhaust gas to be reduced:

- Nitrogen oxides (NO_x)
- Hydrocarbons (HC)
- Carbon monoxide (CO)
- Soot particles

Measure	Result
Switchable oil spray nozzles and coolant pump	This speeds up the warm-up phase after a cold start.
Two-piece water jacket	This improves control capabilities and heat dissipation.
Optimized EGR cooling output	The temperature and oxygen concentration in the combustion chamber are lowered, which produces a cooler fuel / air mixture and reduces soot formation. The exhaust flow produced by the engine is reduced.
Oil pump volume-controlled at clean oil side	This reduces the drive resistance.

New features

Dual stage turbocharging

The vacuum units of the turbocharger can be replaced individually with the turbocharger installed.

Attention must be paid to the following important points:

- The color coding on the control lines
- The nuts secured with temperature-resistant paint

Oil spray nozzles

The oil spray nozzles can be replaced individually. The exact seating is defined by a positioning screw.

Crankshaft

The vibration damper (TSD) has a fourfold threaded connection. This means that the forces acting on the damper are distributed across four bolts, which reduces the stress on each specific bolt. A special tool is available for easy installation.

The signal from the camshaft sensor is used by the CDI control unit as a substitute value for engine control. If the sensor for the crankshaft fails, the engine can be operated and started in emergency operation mode using the camshaft sensor.

Seals

The seals in the exhaust area are equipped with pins and polygonal curves. The seals are prefixed and the screws are conveniently secured against falling out, which simplifies installation. In addition, the seals are equipped with an installation checking pin. This makes it possible to check whether the seal is installed after assembly.

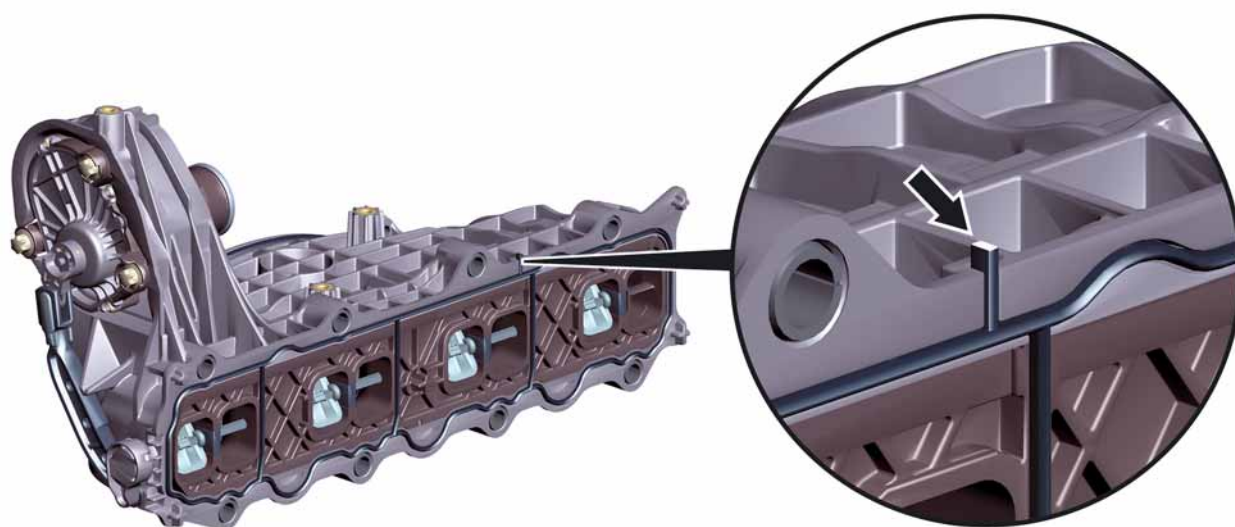

P09.41-2550-00

Seal with installation checking pin (arrow) on charge air manifold

Piezo injector

The piezo injectors are marked with a 24-digit I2C code.

The I2C coding permits even more accurate tuning (injection quantity and injection period) of the individual piezo injectors when new.

If a piezo injector is replaced, the CDI control unit must be supplied with this coding via Star Diagnosis.

Data matrix code

Some components feature a matrix code. The codes are predominantly applied using laser technology.

This code contains information which is useful for quality and assembly-related purposes only. The code has no use for service staff.

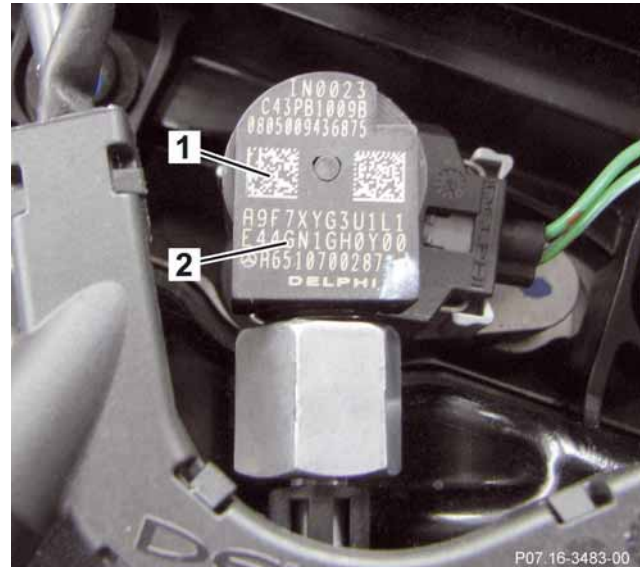

Piezo injector

- 1 Data matrix code
- 2 I2C code

i Note

The new features and notes shown here are not intended as repair instructions!

Further information on repairing and maintaining engine 651 can be found in the Workshop Information System (WIS).

Engine

Socket wrench

Use	For removing shift valve for controlling piston cooling.
Part number	W 651 589 00 09 00
FG	18
Set	B

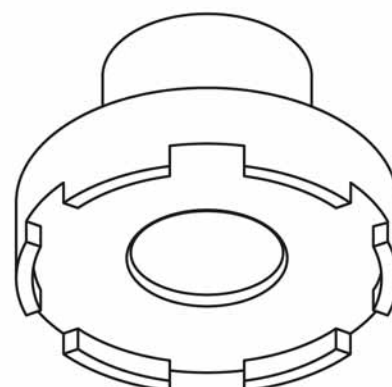

P58.20-2239-00

Hold-down device

Use	Fixing camshaft in place when tightening or loosening camshaft sprockets.
Part number	W 651 589 01 40 00
FG	05
Set	C

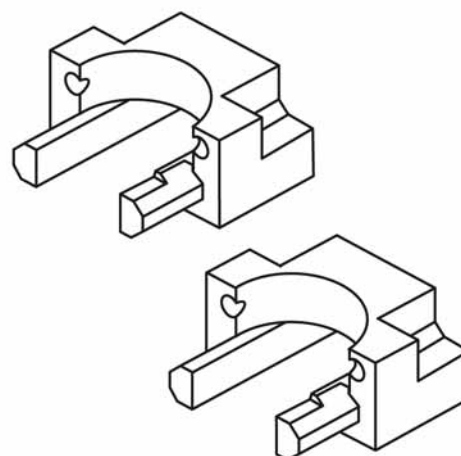

P58.20-2244-00

Assembly inserts

Use	For pressing on and riveting outer link plates of bush chain.
Part number	W 651 589 04 63 00
FG	05
Set	C

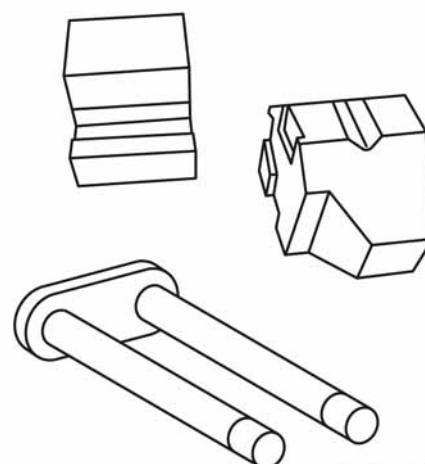

P58.20-2251-00

Leak test adapter

Use	For leak testing charge air system.
Part number	W 651 589 02 91 00
FG	09
Set	B

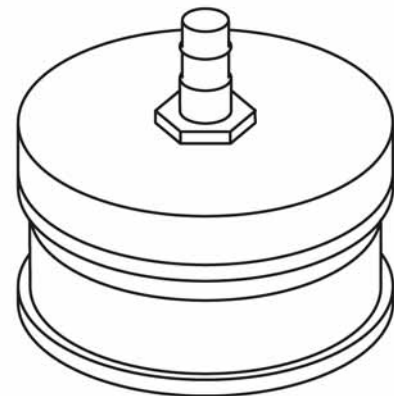

P58.20-2249-00

Counterholder

Use	For holding pinion of high-pressure pump during disassembly and assembly.
Part number	W 651 589 04 40 00
FG	07
Set	B

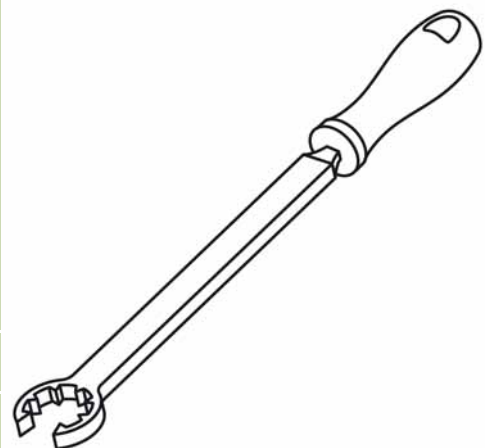

P58.20-2250-00

Valve test adapter

Use	For measuring return quantity at pressure regulating valve.
Part number	W 651 589 01 91 00
FG	07
Set	B



P58.20-2247-00

Engine

3-pin adapter cable

Use	For testing Hall sensor on camshaft.
Part number	W 651 589 01 63 00
FG	15
Set	B

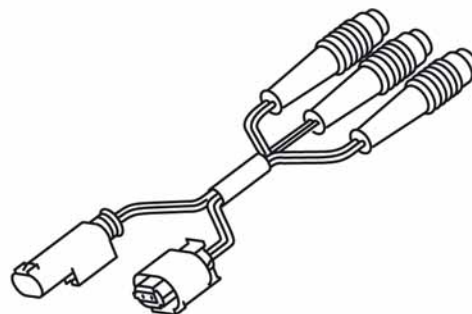

P58.20-2246-00

5-pin adapter cable

Use	For testing resistances and voltages e.g. on actuators for exhaust gas recirculation, throttle valve and intake port shutoff.
Part number	W 651 589 00 63 00
FG	15
Set	B

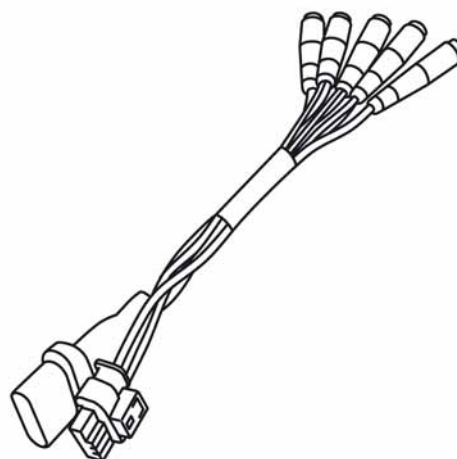

P58.20-2243-00

Extraction claw

Use	For knocking out fuel injectors.
Part number	W 651 589 00 33 00
FG	07
Set	B

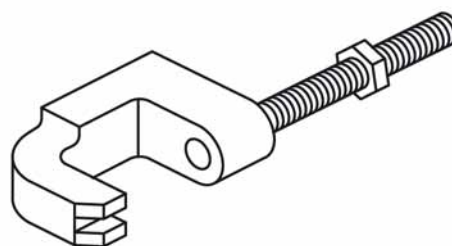

P58.20-2240-00



Rear radial shaft sealing ring insertion tool

Use	For inserting rear radial shaft sealing ring of crankshaft.
Part number	W 651 589 01 61 00
FG	03
Set	B

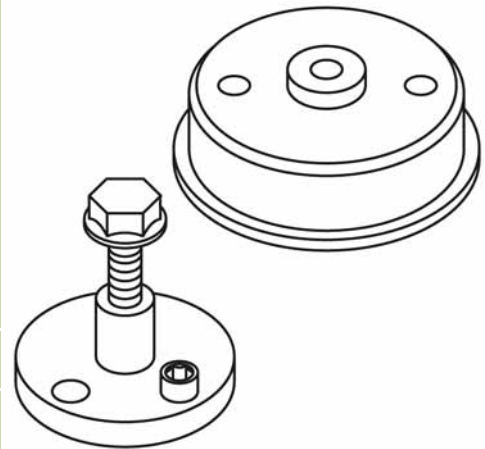

P58.20-2245-00

Assembly tool

Use	For fixing balance shafts in place when disassembling and assembling drive gears.
Part number	W 651 589 02 63 00
FG	03
Set	C

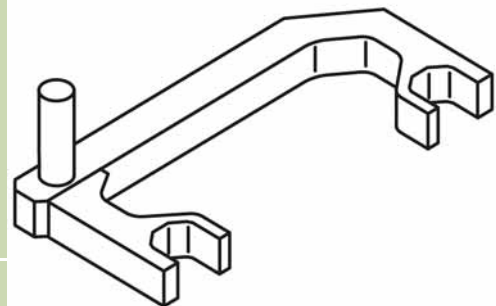

P58.20-2248-00

Front radial shaft sealing ring insertion tool

Use	For inserting front radial shaft sealing ring of crankshaft.
Part number	W 651 589 00 61 00
FG	03
Set	B

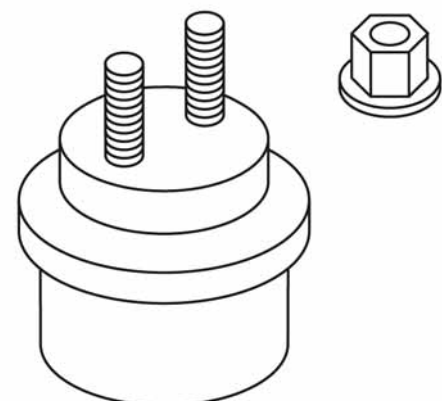

P58.20-2242-00

Engine

Counterholder

Use	For fixing crankshaft belt pulley in place when loosening mounting screws.
Part number	W 651 589 00 40 00
FG	03
Set	B

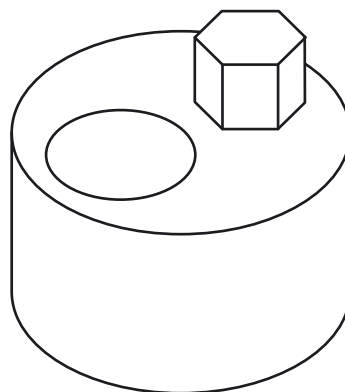

P58.20-2241-00

i Note

For more information on workshop equipment, commercially available tools and special tools, see the following website:

<http://gotis.aftersales.mercedes-benz.com>



AGR	HFM
Exhaust gas recirculation (EGR)	Hot film mass air flow sensor
CAN	H₂O
Controller Area Network	Water
CDI	IHU
Common rail Direct Injection	Internal high-pressure forming
CO	LIN
Carbon monoxide	Local Interconnect Network
CO₂	NEFZ
Carbon dioxide	New European Driving Cycle (NEDC) (system for determining consumption)
DAS	NO_x
Diagnosis Assistance System	Nitrogen oxides
DPF	O₂
Diesel Particulate Filter	Oxygen
EOBD	PVD
European On-Board-Diagnosis	Physical Vapor Deposition
Euro NCAP	TSD
European New Car Assessment Program	Vibration damper
HC	WIS
Hydrocarbon	Workshop Information System

A		D	
Air ducting	29	Data matrix code	49
Air supply	29	Diesel particulate filter	34
B		Displacement	7
Balance shaft	15	E	
Belt drive	19	Emission reduction	46
Belt routing	19	Engine configuration	10
Boost pressure control	26	Engine cooling	36
Bore	10	Engine weight	10
C		Exhaust gas recirculation	32
Camshafts	16	Exhaust gas recirculation path	33
CDI control unit	42	Exhaust treatment	47
Charging	24	G	
Choking limit	28	Gear drive	18
CO ₂ measures	46	Glow system	43
Combustion system	10	I	
Compression ratio	10	Injection quantity correction	23
Connecting rods	15	Injection technology	20
Coolant pump	41	Instant Start System	43
Cooling	36	Intake port shutoff	30
Cooling circuit	37		
Crankcase	12		
Crankshaft	15		
Crankshaft assembly	15		
Cylinder head	13		



L			
Lubricating system		38	
M			
Main injection quantity correction		23	
N			
Number of cylinders		10	
O			
Oil circuit		38	
Oil pan		14	
Oil pump		40	
Oil spray nozzles		40	
Oxidation catalytic converter		34	
P			
Performance graph		7	
Piezo injector		21, 49	
Pressure transducer			
Boost pressure control flap		44	
Wastegate control		44	
R			
Rated output		7	
Rated torque		7	
Roller-type cam followers		17	
S			
Seals		48	
Sensor wheel		16	
Special tools			
3-pin adapter cable		52	
5-pin adapter cable		52	
Assembly inserts		50	
Assembly tool		53	
Counterholder		51, 54	
Extraction claw		52	
Front radial shaft sealing ring insertion tool		53	
Hold-down device		50	
Leak test adapter		51	
Rear radial shaft sealing ring insertion tool		53	
Socket wrench		50	
Valve test adapter		51	
Stroke		10	
Switchover valve			
Charge air bypass flap		44	
Coolant pump		44	
EGR cooler bypass		44	
T			
Thermal management		8, 36, 47	
Throttle valve		31	
V			
Vacuum control		44	
Vacuum pump		44	
Valve assembly		17	
Valve clearance compensation		17	
Z			
Zero quantity calibration		23	