

SERVICE MANUAL

CX Forklift Truck

Federal Environmental Protection Agency (EPA) Emission-Control Compliant
S/N 130001A~

Gasoline & LP FG35/45ST-8
FG40/45T(2)-8
FG35/45BCS-8
FG50AT2-8
FG40ZT(2)-8

CX20

Diesel FD40/45T(2)-8
FD50AT2-8
FD40ZT(2)-8

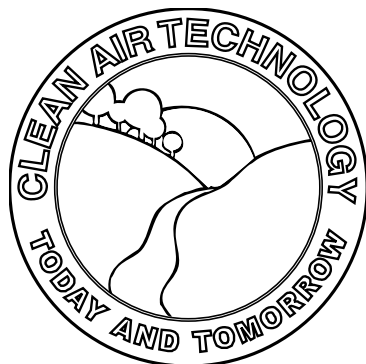

WARNING

Read and observe all warnings on this unit before operating it.

DO NOT operate this equipment unless all factory-installed guards and shields are properly secured in place.

ISSUED: APRIL 2008

KOMATSU
Komatsu Forklift USA, Inc.

The information and specifications contained herein were accurate at the time of publication, but may change without notice as required for product improvements. Neither Komatsu Forklift USA, Inc., nor its parent company nor any of its subsidiaries will be held responsible for damages due to misuse or inappropriate use of its products.

Requests for information, comments and other inquiries should be sent to:

Komatsu Forklift USA, Inc.
14481 Lochridge Blvd., Bldg. #2
Covington, Georgia 30014-4908

Voice phone: (770) 385-4815
Fax phone: (770) 385-4838

© Copyright 2008, Komatsu Forklift USA, Inc. All rights reserved. No part of this document may be photocopied or reproduced in any way without prior written consent of Komatsu Forklift USA, Inc.

INTRODUCTION

This Service Manual has been developed as an information resource to help the reader learn about, understand, repair and maintain the CX20 Series forklift trucks, and the various equipment, systems, inspections, sensors, diagnostic procedures and diagnostic equipment utilized to maintain, adjust and troubleshoot these systems. Although reference is made to maintenance procedures necessary to perform servicing of this vehicle, you should refer to the applicable *Operation and Maintenance Manual* for these lift trucks for more complete maintenance information.

Komatsu is involved in a concentrated and highly technical program of designing and developing cleaner burning, more efficient and more powerful engines for use in the industrial truck market. As a result, new computerized sensors, systems and diagnostic monitors have been created to make the job of maintaining and repairing these systems simple and easy.

Read this manual carefully, refer to it often and learn the repair, testing and adjustment procedures to the best of your ability. Please note that some illustrations are generic and may not look exactly like your unit in every detail.

Ensure that, when you are working on or around industrial trucks, **Safety is priority Number One**. Read, understand and obey all **WARNINGS** and **CAUTIONS**.

Follow the instructions and procedures presented in this manual when working on these lift trucks and their systems. Damage to the equipment, and possible injury to yourself or others, may result if these procedures are not adhered to carefully.

Keep this manual nearby and accessible for use when necessary. If this book becomes dirty, worn or illegible, contact Komatsu for a replacement. The procedures outlined in this manual will be updated periodically. Be sure that you have the latest revision in order to learn the newest information available. Revision dates will be clearly displayed on the lower left hand corner of the cover page.

This will aid in maintaining your equipment in excellent condition and in ensuring that these lift trucks will operate safely at maximum efficiency.

ENGINE SERIAL NUMBER LOCATION

The TB45E series engine serial number is stamped on a flat machined, painted pad on the right side of the engine block just behind the distributor. The right side is determined by the operator's right side when seated on the lift truck.

The serial number faces upwards for ease of identification.

The S6D102E series engine serial number is stamped on the left side of the engine to the left of the oil filter.

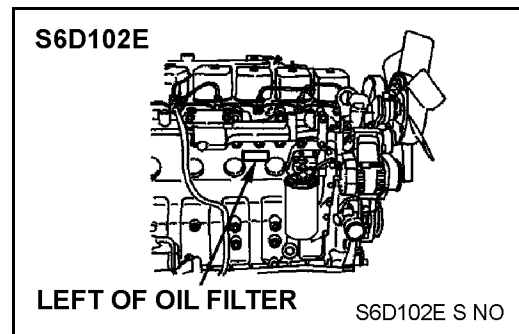
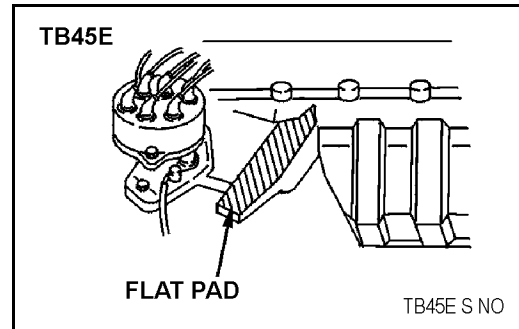

NOTICE

For EPA TB45E(D)(G)(L) engine-related troubleshooting, refer to the following manual:

- TM100 - "EPA Engine Training Manual"

NOTICE

For EPA S6D102E engine-related troubleshooting, refer to the following manual:

- SM140 - "S6D102E Service Manual"

CONTENTS

	Page No.
INTRODUCTION	3
ENGINE SERIAL NUMBER LOCATION	4
FORKLIFT TRUCKS COVERED IN THIS PUBLICATION	9
FEDERAL EPA EMISSION CONTROL STATEMENT	11
1. SAFETY	
1.1. SAFETY MANAGEMENT	1-2
1.2. SAFE TRAVEL	1-6
1.3. LOADING OPERATIONS	1-14
1.4. SAFETY IN PERIODIC MAINTENANCE	1-19
1.5. TOWING	1-25
1.6. STRUCTURE AND STABILITY OF THE LIFT TRUCK	1-26
1.7. SAFETY LABELS	1-29
1.8. OPTIONAL EQUIPMENT	1-35
1.8.1 REAR LAMP	1-35
1.8.2 HIGH LOAD BACKREST	1-35
1.8.3 WIDE FORK CARRIAGE	1-35
1.8.4 AUDIBLE SPEED ALARM	1-35
1.8.5 WARNING LAMPS	1-35
2. GENERAL INFORMATION & SPECIFICATIONS	
2.1 SPECIFICATIONS - MAST DATA & FEATURES - INDOOR (CUSHION) TRUCK	2-2
2.2 SPECIFICATIONS - MAST DATA & FEATURES - OUTDOOR (PNEUMATIC) TRUCKS	2-5
2.3 TRUCK DATA - CUSHION TIRE LIFT TRUCKS (INDOOR)	2-8
2.4 TRUCK DATA - PNEUMATIC TIRE LIFT TRUCKS	2-13
3. SERVICE DATA	
3.1 SERVICE DATA - GASOLINE ENGINE TRUCKS	3-2
3.2 SERVICE DATA - DIESEL ENGINE TRUCKS	3-5
4. TESTING, ADJUSTING AND MEASURING	
4.1 CHECK ENGINE OIL (TB45E)	4-2
4.2 ADJUST ENGINE OIL LEVEL	4-2
4.3 ADJUST IGNITION TIMING (TB45E)	4-2
4.4 ADJUST SPARK PLUG GAP (TB45E)	4-3
4.5 ADJUST VALVE CLEARANCE (TB45E)	4-4
4.6 ADJUST VALVE CLEARANCE (S6D102E)	4-6
4.7 ADJUSTMENT OF ENGINE DRIVE BELTS (TB45E)	4-7
4.7.1 BELTS IN SERVICE ON ENGINE - GENERAL	4-7
4.7.2 INSTALL NEW BELT(S) - GENERAL	4-8
4.8 MEASURE ENGINE CYLINDER COMPRESSION (TB45E)	4-8
4.9 MEASURE HYDRAULIC DRIFT ON LIFT & TILT CYLINDERS	4-10

4.10	ADJUST - TYPICAL MAST	4-11
4.10.1	OUTER MAIN ROLLER	4-11
4.10.2	INNER MAIN ROLLER	4-11
4.10.3	FORK CARRIAGE - TYPICAL	4-12
4.10.4	ADJUST CLEARANCE - THRUST PAD AND RAIL	4-13
4.10.5	CHANGE PAD	4-13
4.10.6	ADJUST CLEARANCE BETWEEN INNER MAST AND FORK CARRIAGE	4-13
4.10.7	ADJUST CLEARANCE BETWEEN INNER MAST AND INTERMEDIATE MAST	4-14
4.11	ADJUST PARKING BRAKE LEVER	4-15
4.12	ADJUST ACCELERATOR PEDAL (TB45E ENGINE)	4-15
4.13	ACCELERATOR PEDAL POSITION SENSOR - TB45 ENGINE	4-17
4.14	ADJUST ACCELERATOR PEDAL (S6D102E ENGINE)	4-18
4.15	MEASURE BRAKE STOPPING DISTANCE (BRAKING EFFECT)	4-19
4.16	ADJUST INCHING/BRAKE PEDAL (TORQFLOW TRUCKS)	4-19
4.16.1	BRAKE PEDAL	4-19
4.16.2	INCHING PEDAL	4-19
4.16.3	INCHING PEDAL/BRAKE PEDAL INTERCONNECTED TRAVEL	4-20
4.17	ADJUST STOP LAMP SWITCH	4-21
4.18	ADJUST WHEEL BRAKE	4-22
4.19	CHECK OPERATION OF THE AUTOMATIC ADJUSTMENT DEVICE	4-23
4.20	CHECK TORQFLOW CLUTCH ACTUATION PRESSURE - PNEUMATIC TIRE	4-24
4.21	CHECK TORQUE CONVERTER STALL SPEED	4-24
4.22	CHECK TORQFLOW CLUTCH ACTUATION PRESSURE - CUSHION TIRE	4-25
4.23	CHECK TORQUE CONVERTER STALL SPEED	4-25
4.24	ADJUST INCHING VALVE/SPOOL	4-26
4.25	TEST SPECIFIC GRAVITY OF BATTERY ELECTROLYTE	4-26
4.26	CHECK TIRES AND ADJUSTING PNEUMATIC TIRE PRESSURE	4-27
4.27	MEASURE MINIMUM LEFT AND RIGHT TURNING RADIUS	4-28
4.28	ADJUST TURNING RADIUS	4-28
4.29	ADJUST REAR AXLE - THRUST CLEARANCE	4-31

5. INSPECTION

5.1	INSPECT ENGINE STARTING OPERATION	5-2
5.2	INSPECT ENGINE RUNNING CONDITION	5-2
5.3	INSPECT AIR CLEANER ASSEMBLY	5-2
5.4	INSPECT THE FILTER ELEMENT	5-2
5.5	INSPECT/RE-TORQUE CYLINDER HEAD MOUNTING BOLTS (TB45E)	5-3
5.6	INSPECT / RE-TORQUE CYLINDER HEAD BOLTS (S6D102E)	5-4
5.7	INSPECT ENGINE MOUNTS	5-5
5.8	INSPECT THE ENGINE LUBRICATING SYSTEM	5-5
5.9	INSPECT ENGINE FUEL SYSTEM	5-5
5.10	INSPECT DIESEL FUEL INJECTION NOZZLES	5-6
5.11	INSPECT LPG VAPORIZER FOR TAR BUILDUP (TB45E)	5-6
5.12	INSPECT BLOW-BY GAS RECIRCULATION SYSTEM (TB45E)	5-7
5.13	INSPECT COOLING SYSTEM AND RADIATOR	5-7
5.14	INSPECT COOLANT SUB-TANK LEVEL	5-8

5.15	INSPECT FAN ASSEMBLY	5-8
5.16	INSPECT CHARGING SYSTEM WIRING	5-8
5.17	INSPECT FRONT AXLE AND RE-TORQUE MOUNTING BOLTS	5-9
5.18	INSPECT REAR AXLE AND RE-TORQUE MOUNTING BOLTS	5-9
5.19	INSPECT WHEELS	5-9
5.20	INSPECT RIM SIDE RING	5-10
5.21	INSPECT WHEEL BEARINGS	5-10
5.22	INSPECT STEERING AXLE	5-10
5.23	INSPECT STEERING WHEEL	5-10
5.24	INSPECT LIGHTING/TURN SIGNAL SWITCH - W/O DIMMER SWITCH	5-10
5.25	INSPECT LIGHTING/TURN SIGNAL SWITCH - WITH DIMMER SWITCH	5-11
5.26	INSPECT LIGHTING/TURN SIGNAL SWITCH.	5-12
5.27	INSPECT F/R SWITCH	5-13
5.28	INSPECT POWER STEERING SYSTEM	5-14
5.29	INSPECT BRAKE SYSTEM RODS, CABLES AND LINKS	5-14
5.30	INSPECT BRAKE PIPING AND CONNECTIONS.	5-14
5.31	INSPECT BRAKE MASTER AND WHEEL CYLINDERS	5-15
5.32	INSPECT BRAKE SHOES AND ASSOCIATED PARTS.	5-15
5.33	INSPECT BRAKE DRUMS	5-16
5.34	INSPECT BRAKE BACKING PLATES	5-16
5.35	INSPECT LOAD FORKS	5-16
5.36	INSPECT MAST.	5-17
5.37	INSPECT FORK CARRIAGE.	5-17
5.38	INSPECT LIFT CHAINS.	5-18
5.39	INSPECT CHAIN WHEELS	5-18
5.40	INSPECT ATTACHMENTS	5-18
5.41	INSPECT HYDRAULIC TANK	5-18
5.42	INSPECT CHASSIS AND ATTACHMENT PIPING	5-19
5.43	INSPECT HYDRAULIC PUMP	5-19
5.44	INSPECT LIFT CYLINDER	5-19
5.45	INSPECT TILT CYLINDERS	5-19
5.46	INSPECT ATTACHMENT CYLINDERS (IF EQUIPPED)	5-19
5.47	INSPECT LIFT TRUCK CHASSIS AND FRAME.	5-19
5.48	INSPECT CAB (IF EQUIPPED).	5-20
5.49	INSPECT OPERATOR'S SEAT	5-20
	5.49.1 VEHICLE CONTROLLER.	5-20
	5.49.2 TUSK OPERATOR PRESENT SYSTEM (TOPS)	5-20
	5.49.3 CONTROLLER TROUBLESHOOTING	5-22
5.50	INSPECT EQUIPMENT USED FOR ACCESSING THE LIFT TRUCK	5-24
5.51	INSPECT DISPLAY PANEL.	5-24
5.52	INSPECT OVERHEAD GUARD	5-24
5.53	INSPECT LIGHTS, GAUGES AND WARNING DEVICES	5-24
5.54	INSPECT REAR VIEW MIRROR AND REFLECTORS.	5-25

6. MAINTENANCE OPERATIONS

6.1	LUBRICANT LIST - GASOLINE ENGINE LIFT TRUCKS	6-2
6.2	LUBRICANT LIST - DIESEL ENGINE LIFT TRUCKS	6-3
6.3	OIL AND GREASING CHART	6-8
6.4	CHANGE OIL AND FILTER IN GASOLINE ENGINES	6-9
6.5	CHANGE OIL AND FILTER IN DIESEL ENGINES	6-11
6.6	CHANGE GEAR OIL IN DIFFERENTIAL CASE	6-12
6.6.1	CHECK DIFFERENTIAL OIL LEVEL	6-12
6.6.2	CHANGE DIFFERENTIAL OIL	6-12
6.7	CHANGE TRANSMISSION FLUID IN TORQFLOW TRANSMISSION CASE	6-13
6.7.1	CHECK TORQFLOW TRANSMISSION FLUID LEVEL	6-13
6.7.2	CHANGE TORQFLOW TRANSMISSION FLUID AND CLEAN THE STRAINER	6-13
6.8	CHANGE OIL IN HYDRAULIC TANK	6-14
6.9	REPLACE FUEL FILTER - GASOLINE ENGINES	6-15
6.10	REPLACE FUEL FILTER - DIESEL ENGINES	6-15
6.11	REPLACE AIR CLEANER ELEMENT	6-16
6.12	CLEAN RADIATOR	6-17
6.13	CLEAN RADIATOR FINS	6-18
6.14	BLEED AIR FROM BRAKE SYSTEM	6-18

7. REMOVAL, DISASSEMBLY, ASSEMBLY, INSTALLATION

	UNIT INSTALLATION POSITIONS DIAGRAM	7-2
	OVERALL DISASSEMBLY/ASSEMBLY FLOW CHART	7-3
	WEIGHT TABLE - COMPONENT ASSEMBLIES AND PARTS	7-4
7.1	MAST	7-5
7.1.1	MAST REMOVAL - TYPICAL	7-5
7.1.2	MAST INSTALLATION - TYPICAL	7-6
7.2	ENGINE	7-7
7.2.1	ENGINE REMOVAL FROM CHASSIS	7-7
7.2.2	ENGINE DISASSEMBLY/ASSEMBLY	7-8
7.2.3	ENGINE INSTALLATION	7-9
7.3	TRANSMISSION AND DRIVE AXLE	7-11
7.3.1	REMOVE TORQUE CONVERTER, TRANSMISSION, AND DRIVE AXLE	7-11
7.3.2	TORQUE CONVERTER INSTALLATION	7-13
7.3.3	TRANSMISSION AND DRIVE AXLE INSTALLATION	7-13
7.3.4	DRIVE AXLE SUPPORT MOUNTING BOLTS AND NUTS	7-13
7.3.5	INSTALL COUNTERWEIGHT	7-13
7.4	TORQUE CONVERTER/TRANSMISSION CONTROL VALVE - PNEUMATIC TRUCKS	7-14
7.4.1	OVERVIEW	7-14
7.4.2	TRANSMISSION HYDRAULIC FLUID CIRCULATION PATH	7-17
	TORQUE CONVERTER ASSEMBLY - FLUID DIAGRAM	7-18
	TRANSMISSION CONTROL VALVE ASSEMBLY EXTERNAL VIEW	7-19
	TRANSMISSION CONTROL VALVE INTERNAL VIEW	7-19
	TRANSMISSION CONTROL VALVE - PARTS BREAKDOWN	7-21
	TRANSMISSION CONTROL VALVE - SPECIFICATIONS	7-23
	HYDRAULIC CHARACTERISTICS OF THE INCHING VALVE	7-25
7.4.3	REMOVE TRANSMISSION CONTROL VALVE	7-26
7.4.4	INSTALL TRANSMISSION CONTROL VALVE	7-27
7.4.5	TORQUE CONVERTER (PNEUMATIC)	7-28

	POSITION OF TORQUE CONVERTER HOUSING HYDRAULIC PORTS	7-28
	TORQUE CONVERTER - TORQUE SPECIFICATIONS	7-29
	TORQUE CONVERTER PARTS BREAKDOWN	7-30
	TORQUE CONVERTER - PART STANDARD	7-31
	GEAR PUMP ASSEMBLY - PARTS BREAKDOWN	7-32
7.4.6	DISASSEMBLE TORQUE CONVERTER (PNEUMATIC)	7-33
7.4.7	ASSEMBLE TORQUE CONVERTER (PNEUMATIC)	7-34
	ASSEMBLED TORQUE CONVERTER	7-35
7.4.8	TEST F1/R1 TRANSMISSION (SINGLE SPEED)	7-36
	F1/R1 TRANSMISSION - PART STANDARD	7-37
7.4.9	TEST F2/R1 TRANSMISSION (TWO SPEED)	7-39
	F2/R1 TRANSMISSION - PART STANDARD	7-40
7.4.10	DISASSEMBLE TORQFLOW TRANSMISSION (PNEUMATIC TRUCKS)	7-42
7.4.11	DISASSEMBLE INPUT SHAFT CLUTCH PACK	7-45
7.4.12	DISASSEMBLE INTERMEDIATE SHAFT CLUTCH PACK	7-47
7.4.13	ASSEMBLE F1/R1 AND F2/R1 TRANSMISSION - INPUT SHAFT	7-49
	ASSEMBLED F1/R1 AND F2/R1 TRANSMISSION - INPUT SHAFT	7-51
7.4.14	ASSEMBLE F2/R1 TRANSMISSION - INTERMEDIATE SHAFT (2ND SPEED)	7-52
	ASSEMBLED F2/R1 TRANSMISSION - INTERMEDIATE SHAFT (2ND SPEED)	7-54
7.4.15	ASSEMBLE OUTPUT SHAFT	7-55
7.4.16	ASSEMBLE F1/R1 TRANSMISSION	7-56
	ASSEMBLED F1/R1 TRANSMISSION - TORQFLOW TRANSMISSION	7-62
7.4.17	ASSEMBLE F2/R1 TRANSMISSION	7-63
7.5	TORQFLOW TRANSMISSION W/ TORQUE CONVERTER - CUSHION TRUCKS	7-67
	TRANSMISSION CONTROL VALVE - PARTS BREAKDOWN	7-67
	TRANSMISSION CONTROL VALVE - SPECIFICATIONS	7-68
7.5.1	DISASSEMBLE TRANSMISSION CONTROL VALVE (CUSHION TRUCKS) . .	7-69
	TORQUE CONVERTER PARTS BREAKDOWN	7-70
	TORQUE CONVERTER - PARTS SPECIFICATION	7-71
	HYDRAULIC CIRCUIT DIAGRAM	7-72
	TORQUE CONVERTER PRESSURE TESTING PORTS	7-73
7.5.2	SERVICE AND INSPECTION	7-74
7.5.3	DISASSEMBLE TORQFLOW TRANSMISSION (CUSHION TRUCKS)	7-75
7.5.4	DISASSEMBLE REVERSE MAIN SHAFT	7-79
7.5.5	DISASSEMBLE THE FORWARD MAIN SHAFT	7-80
7.5.6	ASSEMBLE REVERSE MAIN SHAFT	7-81
	ASSEMBLED MAIN SHAFT (REVERSE)	7-83
7.5.7	ASSEMBLE FORWARD MAIN SHAFT	7-83
	ASSEMBLED MAIN SHAFT (FORWARD)	7-85
7.5.8	ASSEMBLE THE OUTPUT SHAFT	7-86
7.5.9	ASSEMBLE TORQFLOW TRANSMISSION (CUSHION TRUCKS)	7-88
7.6	DRIVE AXLE	7-93
	DRIVE AXLE - PARTS BREAKDOWN (PNEUMATIC)	7-93
	DRIVE AXLE - TORQUE CHART (PNEUMATIC)	7-94
	DRIVE AXLE - PARTS BREAKDOWN (CUSHION)	7-95
	DRIVE AXLE - TORQUE CHART (CUSHION)	7-96
7.7	DIFFERENTIAL	7-97
	DIFFERENTIAL - TORQFLOW TRANSMISSION - PARTS BREAKDOWN . .	7-97
	DIFFERENTIAL - TORQFLOW TRANSMISSION - SPECIFICATIONS	7-98
7.7.1	ADJUST DIFFERENTIAL	7-101
7.8	BRAKE BOOSTER AND MASTER CYLINDER	7-104
	BRAKE MASTER CYLINDER - PARTS BREAKDOWN	7-104

	BRAKE MASTER CYLINDER/BRAKE BOOSTER DIAGRAM	7-106
7.8.1	BRAKE MASTER CYLINDER - DISASSEMBLY	7-107
7.8.2	DISASSEMBLE BRAKE BOOSTER UNIT	7-108
	BRAKE BOOSTER & MASTER CYLINDER - SPECIFICATIONS	7-109
	BRAKE BOOSTER & MASTER CYLINDER - INSPECTION & TESTING	7-110
7.8.3	ASSEMBLE BRAKE MASTER CYLINDER	7-112
7.8.4	BRAKE BOOSTER - ASSEMBLY	7-113
7.9	WHEEL BRAKE	7-115
7.9.1	WHEEL BRAKE REMOVAL	7-115
	WHEEL BRAKE - STRUCTURE	7-117
	WHEEL BRAKE - DISASSEMBLY/ASSEMBLY DRAWING - CUSHION	7-119
	WHEEL BRAKE - DISASSEMBLY/ASSEMBLY DRAWING - PNEUMATIC ..	7-120
7.9.2	INSTALL WHEEL BRAKE	7-121
7.9.3	INSTALL PEDAL ASSEMBLY - BRAKE PIPING	7-121
7.9.4	BRAKE SYSTEM - BLEEDING AIR FROM LINES	7-122
7.10	STEERING AXLE	7-123
7.10.1	REMOVE STEERING AXLE AND POWER STEERING CYLINDER	7-123
	POWER STEERING CYLINDER - STRUCTURE	7-124
	STEERING AXLE BREAKDOWN	7-125
	STEERING AXLE - LUBRICATION AND TORQUE VALUES	7-126
	STEERING AXLE SPECIFICATIONS	7-127
7.10.2	STEERING AXLE AND POWER STEERING CYLINDER INSTALLATION	7-128
7.11	POWER STEERING CYLINDER	7-129
	POWER STEERING CYLINDER - PARTS BREAKDOWN	7-129
7.12	POWER STEERING VALVE (ORBITAL)	7-130
	POWER STEERING VALVE - PARTS BREAKDOWN	7-130
7.12.1	REMOVE POWER STEERING VALVE	7-131
7.12.2	DISASSEMBLE POWER STEERING VALVE	7-131
7.12.3	CLEAN POWER STEERING VALVE	7-136
7.12.4	ASSEMBLE POWER STEERING VALVE	7-136
7.12.5	INSTALL POWER STEERING VALVE	7-145
7.13	HYDRAULIC PUMP - GASOLINE ENGINES	7-146
	HYDRAULIC PUMP - GASOLINE ENGINE (PNEUMATIC) PARTS BREAKDOWN	7-146
7.13.1	DISASSEMBLE HYDRAULIC PUMP - REAR PUMP SECTION - GASOLINE (PNEUMATIC)	7-147
7.13.2	DISASSEMBLE HYDRAULIC PUMP - FRONT PUMP SECTION - GASOLINE (PNEUMATIC)	7-147
7.13.3	ASSEMBLE HYDRAULIC PUMP - REAR PUMP SECTION - GASOLINE (PNEUMATIC)	7-147
7.13.4	ASSEMBLE HYDRAULIC PUMP - FRONT PUMP SECTION - GASOLINE (PNEUMATIC)	7-148
	HYDRAULIC PUMP - GASOLINE ENGINE (CUSHION) PARTS BREAKDOWN	7-150
7.13.5	DISASSEMBLE HYDRAULIC PUMP - REAR PUMP SECTION - GASOLINE (CUSHION)	7-151
7.13.6	DISASSEMBLE HYDRAULIC PUMP - FRONT PUMP SECTION - GASOLINE (CUSHION)	7-151
7.13.7	ASSEMBLE HYDRAULIC PUMP - REAR PUMP SECTION - GASOLINE (CUSHION)	7-151

7.13.8	ASSEMBLE HYDRAULIC PUMP - FRONT PUMP SECTION - GASOLINE (CUSHION)	7-152
7.13.9	INSPECTION AND REPAIR - HYDRAULIC PUMP - GASOLINE (CUSHION)	7-153
7.14	HYDRAULIC PUMP - DIESEL ENGINES	7-154
	HYDRAULIC PUMP - FRONT UNIT - DIESEL	7-154
7.14.1	DISASSEMBLE HYDRAULIC PUMP - FRONT PUMP UNIT - DIESEL	7-155
7.14.2	INSPECT AND REPAIR HYDRAULIC PUMP - DIESEL	7-156
7.14.3	REASSEMBLE HYDRAULIC PUMP FRONT PUMP UNIT - DIESEL	7-157
	HYDRAULIC PUMP - OIL SEAL INSTALLATION JIG DIAGRAM	7-160
	HYDRAULIC PUMP - REAR UNIT - DIESEL - PARTS BREAKDOWN	7-161
7.14.4	DISASSEMBLE HYDRAULIC PUMP REAR PUMP UNIT - DIESEL	7-162
7.14.5	INSPECT AND REPAIR HYDRAULIC PUMP - DIESEL	7-162
7.14.6	REASSEMBLE HYDRAULIC PUMP - REAR PUMP UNIT - DIESEL	7-164
7.15	TEST HYDRAULIC PUMP	7-167
7.16	HYDRAULIC CONTROL VALVE	7-169
7.16.1	ASSEMBLE CONTROL VALVE	7-169
7.16.2	SET PRESSURE ON WORK PORT RELIEF	7-170
7.16.3	SERVICING AND REPAIR INFORMATION	7-170
7.16.4	SHUT-OFF VALVE	7-171
7.16.5	SERVICE INFORMATION COMBINATION WORK PORT RELIEF/ANTI-VOID UNIT	7-172
7.17	TILT CYLINDER	7-173
	TILT CYLINDER - PARTS BREAKDOWN	7-173
7.17.1	DISASSEMBLE TILT CYLINDER	7-174
7.17.2	INSPECT TILT CYLINDER PARTS	7-174
7.17.3	ASSEMBLE TILT CYLINDER	7-175
7.18	SIDESHIFTER	7-176
7.19	COMBINATION SWITCH	7-177
	COMBINATION SWITCH PARTS BREAKDOWN	7-177
7.19.1	REPLACE COMBINATION SWITCH ASSEMBLY	7-178
7.19.2	REPLACE LIGHTING AND F/R SWITCH	7-179

8. TROUBLESHOOTING

8.1	ENGINE TROUBLESHOOTING CHART	8-2
8.2	TORQFLOW TROUBLESHOOTING CHART	8-3
8.3	TORQUE CONVERTER TROUBLESHOOTING CHART - CUSHION TRUCKS	8-9
8.4	TORQUE CONVERTER TROUBLESHOOTING CHART - PNEUMATIC TRUCKS	8-11
8.5	TORQFLOW CONTROL VALVE TROUBLESHOOTING CHART - CUSHION	8-13
8.6	TORQFLOW CONTROL VALVE TROUBLESHOOTING CHART - PNEUMATIC	8-14
8.7	ELECTRICAL SYSTEM TROUBLESHOOTING CHART	8-15
8.8	STEERING SYSTEM TROUBLESHOOTING CHART	8-16
8.9	POWER STEERING VALVE TROUBLESHOOTING CHART	8-18
8.10	BRAKE SYSTEM TROUBLESHOOTING CHART	8-21
8.11	HYDRAULIC SYSTEM TROUBLESHOOTING CHART	8-24
8.12	HYDRAULIC PUMP TROUBLESHOOTING CHART	8-25

9. 80D/100D/110D - MS 2-STAGE MAST

10. 80D/100D/110D - MT 3-STAGE MAST

11. CONVERSION TABLES

11.1	MILLIMETERS TO INCHES.....	11-53
11.2	INCHES TO MILLIMETERS.....	11-53
11.3	CUBIC METERS TO CUBIC YARDS.....	11-54
11.4	CUBIC YARDS TO CUBIC METERS.....	11-54
11.5	LITER TO U.S. GALLON.....	11-55
11.6	U.S. GALLON TO LITER.....	11-55
11.7	KILOGRAM TO POUND.....	11-56
11.8	POUND TO KILOGRAM.....	11-56
11.9	KILOGRAMS PER SQUARE CENTIMETER TO POUNDS PER SQUARE INCH....	11-57
11.10	KILOGRAM TO FOOT POUNDS OF FORCE.....	11-58
11.11	TEMPERATURE - FAHRENHEIT TO CENTIGRADE CONVERSION.....	11-59

A. SERVICE DIAGRAMS

WIRING DIAGRAMS.....	A-5
ELECTRICAL ASSEMBLY DRAWINGS.....	A-24
TRANSMISSION DRAWINGS.....	A-35
DRIVE AXLE DRAWINGS.....	A-43
STEERING AXLE DRAWINGS.....	A-53
FRAME DRAWINGS.....	A-57
PIPING DIAGRAMS.....	A-63
CONTROL VALVE DIAGRAM.....	A-75

B. E-SERIES SIDESHIFTER

C. D-SERIES SIDESHIFTER

FORKLIFT TRUCKS COVERED IN THIS PUBLICATION

S/N 130001A~

KOMATSU MODEL DESIGNATION	DESCRIPTION	ENGINE
Gasoline and LPG Trucks		
FG35ST-8	8,000 lb. capacity, cushion tire truck, 1-speed transmission	TB45
FG35BCS-8	8,000 lb. capacity, cushion tire truck, Box Car Special (BCS), 1-spd. trans.	TB45
FG40ZT-8	8,000 lb. capacity, pneumatic tire truck, compact wheelbase, 1-spd. trans.	TB45
FG40ZT2-8	8,000 lb. capacity, pneumatic tire truck, compact wheelbase, 2-spd. trans.	TB45
FG40T-8	9,000 lb. capacity, pneumatic tire truck, long wheelbase, 1-spd. trans.	TB45
FG40T2-8	9,000 lb. capacity, pneumatic tire truck, long wheelbase, 2-spd. trans.	TB45
FG45T-8	10,000 lb. capacity, pneumatic tire truck, long wheelbase, 1-spd. trans.	TB45
FG45T2-8	10,000 lb. capacity, pneumatic tire truck, long wheelbase, 2-spd. trans.	TB45
FG45ST-8	10,000 lb. capacity, cushion tire truck, long wheelbase, 1-spd. trans.	TB45
FG45BCS-8	10,000 lb. capacity, cushion tire truck, Box Car Special (BCS), 1-spd. trans.	TB45
FG50AT2-8	11,000 lb. capacity, pneumatic tire truck, long wheelbase, 2-spd. trans.	TB45
Diesel Trucks		
FD40ZT-8	8,000 lb. capacity, pneumatic tire truck, compact wheelbase, 1-spd. trans.	S6D102E
FD40ZT2-8	8,000 lb. capacity, pneumatic tire truck, compact wheelbase, 2-spd. trans.	S6D102E
FD40T-8	9,000 lb. capacity, pneumatic tire truck, long wheelbase, 1-spd. trans.	S6D102E
FD40T2-8	9,000 lb. capacity, pneumatic tire truck, long wheelbase, 2-spd. trans.	S6D102E
FD45T-8	10,000 lb. capacity, pneumatic tire truck, long wheelbase, 1-spd. trans.	S6D102E
FD45T2-8	10,000 lb. capacity, pneumatic tire truck, long wheelbase, 2-spd. trans.	S6D102E
FD50AT2-8	11,000 lb. capacity, pneumatic tire truck, long wheelbase, 2-spd. trans.	S6D102E

FEDERAL EPA EMISSION CONTROL STATEMENT

FOR OFF-ROAD LSI (NON-DIESEL) ENGINES (TB45E ENGINES)

This section presents information concerning the correct labeling, warranty, parts and maintenance of TB45E engines in order to comply with the EPA off-road, large-spark-ignition (LSI) engine regulations.

1. LABELS REQUIRED AND LABEL LOCATIONS

All engines will display the required identification label as follows. Note that decal content will vary between gasoline, LP and Dual-Fuel engines.

Location on TB45E Series engines: (Includes TB45D, TB45G and TB45L Series)

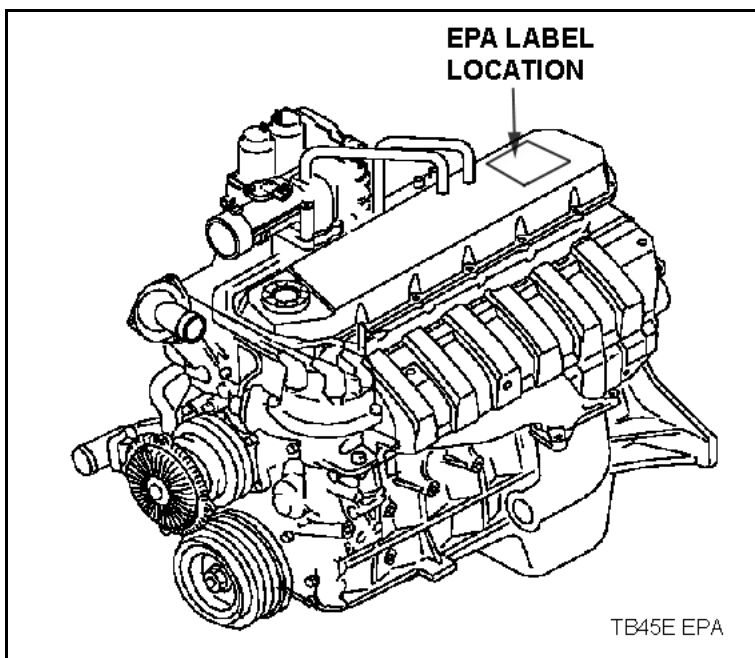

Emission compliance label (DUAL-FUEL (D) SAMPLE shown below)

EMISSION CONTROL INFORMATION		2003	NOV								
<p>ENGINE FAMILY: 4NSXB04.546C, ENGINE DISPLACEMENT: 4.5 LITER ENGINE MAXIMUM POWER: 106.1 HP THIS ENGINE IS CERTIFIED TO OPERATE ON GASOLINE AND LPG. ENGINE'S USEFUL LIFE IS 5000 HOURS OF OPERATION OR SEVEN YEARS. EXHAUST EMISSION CONTROL TYPE: MPI, TBI, TWC, HO2S TEST MODE: VARIABLE-SPEED ONLY</p> <table border="1" style="width: 100%; border-collapse: collapse;"> <tr> <td style="width: 30%;">IDLE SPEED</td> <td>NO OTHER ADJUSTMENTS NEEDED</td> </tr> <tr> <td>VALVE LASH</td> <td>0.35 mm (HOT)</td> </tr> <tr> <td>IGNITION TIMING</td> <td>10° B.T.D.C.</td> </tr> <tr> <td>SPARK PLUG GAP</td> <td>0.9 mm</td> </tr> </table> <p>NO OTHER ADJUSTMENTS NEEDED. THE ENGINE MEETS CALIFORNIA AND U.S. EPA REGULATIONS FOR 2004 LARGE NONROAD SI ENGINES.</p>			IDLE SPEED	NO OTHER ADJUSTMENTS NEEDED	VALVE LASH	0.35 mm (HOT)	IGNITION TIMING	10° B.T.D.C.	SPARK PLUG GAP	0.9 mm	2004
		IDLE SPEED	NO OTHER ADJUSTMENTS NEEDED								
		VALVE LASH	0.35 mm (HOT)								
		IGNITION TIMING	10° B.T.D.C.								
		SPARK PLUG GAP	0.9 mm								
					JAN						
					FEB						
					MAR						
					APR						
					MAY						
					JUN						
					JUL						
			AUG								
			SEP								
			OCT								
			NOV								
			DEC								
NISSAN MOTOR CO., LTD. TB45 D											

TB45E EPA LABEL

FEDERAL EPA EMISSION CONTROL STATEMENT

2. WARRANTY

The following statement is hereby provided as required by regulations of the United States Environmental Protection Agency (EPA).

YOUR WARRANTY RIGHTS AND OBLIGATIONS

All off-road large spark-ignition (LSI) engines must be designed, built and equipped to meet the Federal EPA's stringent anti-smog standards.

Komatsu Forklift USA, Inc. ("") must warrant the emission control system on your engine for the periods of time listed below provided there has been no abuse, damage, neglect or improper maintenance of your engine.

Your emission control system may include parts such as the carburetor, regulator or fuel-injection system, ignition system, engine computer unit (ECM), catalytic converter and air induction system.

Also included may be sensors, hoses, belts, connectors and other emission-related assemblies.

Where a warrantable condition exists, an Authorized Dealer will repair your LSI engine at no cost to you, including diagnosis, parts and labor.

MANUFACTURER'S WARRANTY COVERAGE

Beginning January 1, 2004 off-road large spark-ignition EPA engines are warranted for the time periods listed below. If any emission-related part on your engine is defective, the part will be repaired or replaced by an Authorized Komatsu Forklift Dealer.

OWNER'S WARRANTY RESPONSIBILITIES

As the off-road LSI engine owner, you are responsible for the performance of the required maintenance listed in your Operation and Maintenance Manual.

KFI recommends that you retain receipts covering maintenance on your off-road engine, but KFI cannot deny warranty solely for the lack of receipts or for your failure to ensure the performance of all scheduled maintenance.

As the off-road large spark-ignition engine owner, you should be aware, however, that KFI may deny you warranty coverage if your off-road large spark-ignition engine, or a part thereof, has failed due to abuse, damage, neglect, improper maintenance or unapproved modifications.

Your engine is designed to operate on gasoline and/or LPG fuel. Use of any other fuel may result in your engine no longer operating in compliance with the Federal EPA's emissions requirements.

You are responsible for initiating the warranty process. It is suggested that you present your off-road large spark-ignition engine to an Authorized Komatsu Dealer as soon as you become aware that a problem exists. The warranty repairs should be completed by the dealer as expeditiously as possible.

If you have any questions regarding your warranty rights and responsibilities, you should contact the Komatsu Product Support Dept. at 1-770-385-4815.

In addition to the standard warranty periods, the components listed below are covered by the following specific warranty periods.

FEDERAL EPA EMISSION CONTROL STATEMENT

EMISSION CONTROL WARRANTY – 36 MONTHS OR 2,500 HOURS FOR GENERAL PARTS

For the first 2,500 operating hours, or for a period of thirty-six months from the date of the first use by the original purchaser from an Authorized Komatsu Forklift Dealer, whichever occurs first, KFI warrants the following emission-related parts:

- Oxygen sensor
- Water temperature sensor
- LPG injector
- LPG solenoid
- Mass air flow sensor
- Ignition coil
- Camshaft position sensor
- Spark plugs
- PCV valve
- Gasoline injector
- LPG pressure sensor
- LPG switching module
- Throttle chamber
- Crankshaft position sensor
- Distributor

EMISSION CONTROL WARRANTY – 36 MONTHS OR 4,000 HOURS FOR POWER TRAIN PARTS

- Intake manifold
- Exhaust manifold

EMISSION CONTROL WARRANTY – 60 MONTHS OR 3,500 HOURS FOR GENERAL PARTS

- ECM
- Catalytic converter
- Vaporizer

NOTICE

Follow the instructions in the Operations Manual concerning any other maintenance programs not required for EPA compliance.

For questions and additional information concerning EPA Gasoline Engine Exhaust Regulations, contact:

Komatsu Forklift USA, Inc.
14481 Lochridge Blvd., Bldg. #2
Covington, GA 30014-4908

Voice phone: (770) 385-4815
Fax phone: (770) 385-4838

FEDERAL EPA EMISSION CONTROL STATEMENT

FEDERAL EPA EMISSION CONTROL STATEMENT FOR OFF-ROAD DIESEL ENGINES (S6D102E ENGINES)

Exhaust emissions produced by diesel engines are regulated by the United States Environmental Protection Agency (EPA). This section presents information concerning the correct labeling, warranty, parts and maintenance of S6D102E diesel engines in order to comply with current EPA regulations.

1. LABELS REQUIRED AND LABEL LOCATIONS

All certified S6D102E diesel engines will display the required identification labels (4) as follows:

- S6D102E diesel engines: Labels will be affixed to all appropriate engines on KFI production trucks.

Locations on S6D102E Series diesel engines:

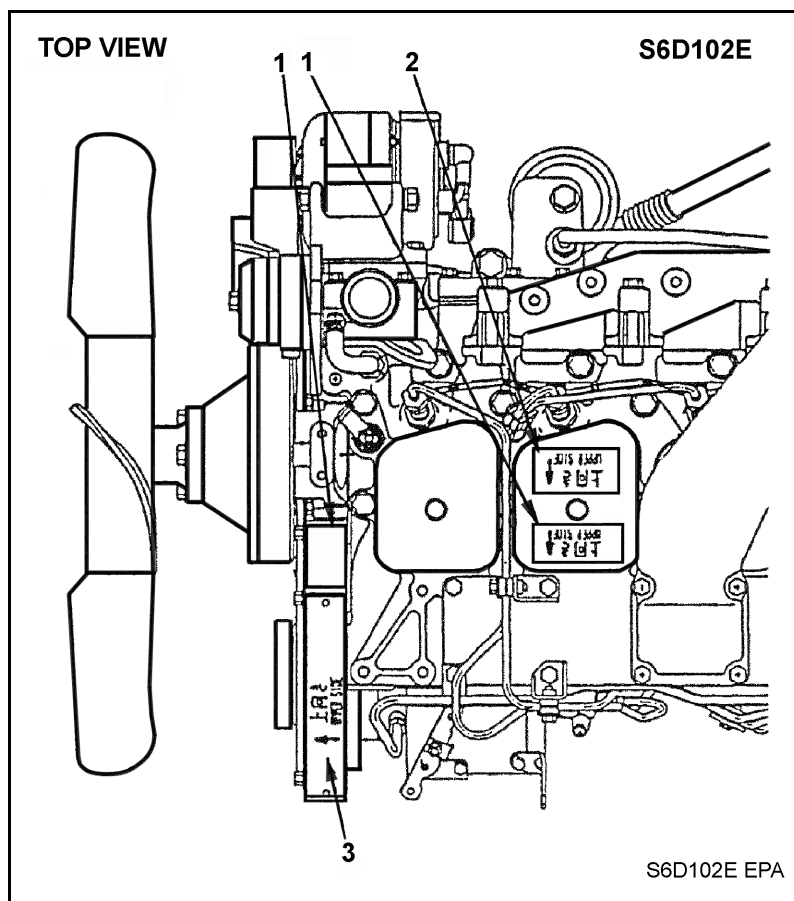

- 1.1 EPA/EC CERTIFICATION DECAL (2 LOCATIONS) (SEE ITEM #1 IN PRECEEDING ILLUSTRATION)**
- 1.2 EPA/EC CERTIFICATION ASSISTANCE PLATE (SEE ITEM #2 IN PRECEEDING ILLUSTRATION)**
- 1.3 EPA/EC CERTIFICATION DATA PLATE (SEE ITEM #3 IN PRECEEDING ILLUSTRATION)**

1. EPA/EU CERTIFICATION DECAL

<p>IMPORTANT ENGINE INFORMATION This engine conforms to 2004 U. S. EPA and California and EU Stage regulations for heavy duty non-road compression ignited diesel cycle engines as applicable THIS ENGINE IS CERTIFIED TO OPERATE ON DIESEL FUEL</p>

2. EPA/EU CERTIFICATION ASSISTANCE PLATE

KOMATSU		Komatsu Ltd.
Engine Model S6D102E-2	ESN	XXXXXXXX
EPA Cert. Family:	XXXXXXXXXXXX	
EU Approval NO.	XX+XX/XXX+XX/XX+XXX+XX	
Gross Rated HP/kW	XX/XX	at XXXXrpm
FRXXXX	Low Idle RPM	XXX rpm
CPL XXXX	CID/L.	XXXX/X.X
Timing BTDC XXdeg.	Firing Order	XXXXXX
Valve Lash Cold	In X.XXXmm	Ex X.XXXmm
Fuel Rate at Rated HP/kW	XXXXmm ³ /st	
Date of Manufacture	XXXXXXXX	6732-81-5870

3. EPA/EU CERTIFICATION DATA PLATE

<p align="center">KOMATSU Komatsu LTD.</p> <p>⊕ WARNING: Injury may result and warranty is voided if fuel rate, RPM or altitudes exceed published maximum values for this model and application.</p> <p>Date of Mfg. _____</p> <p>Made in JAPAN _____</p>	CID/L.	CPL	ENGINE SERIAL NO.		
	FAMILY			KOMATSU PN	
	e			KOMATSU MODEL	
	VALVE LASH	INCH	INT.	EXH.	TIMING - TDC 
	COLD	MM	INT.	EXH.	FUEL RATE AT RATED HP mm ³ /st
	FIRING ORDER			FR	LOW IDLE RPM
	GROSS RATED HP/KW		AT	RPM	

S6D102E EPA DECALS

2. WARRANTY

The following statement is hereby provided as required by regulations of the United States Environmental Protection Agency (EPA).

YOUR WARRANTY RIGHTS AND OBLIGATIONS

The Federal EPA and Komatsu Forklift USA, Inc. (hereinafter referred to as "KFI") are pleased to explain the emission control system warranty on your 2004 or later Diesel heavy duty off-road engine. All new, heavy-duty off-road engines must be designed, built and equipped to meet the EPA's stringent anti-smog standards. KFI must warrant the emission control system on your engine for the period of time listed below, provided there has been no abuse, damage, neglect or improper maintenance of your engine.

Your emission control system may include parts such as fuel injection pump. Also included may be hoses, belts, connectors and other emission-related assemblies.

Where a warrantable condition exists, an authorized Komatsu dealer will repair the heavy-duty off-road engine at no cost to the owner, including diagnosis, parts and labor.

Now, KFI hereby certifies that diesel engines for lift trucks produced in 2004 model year and after shall be regulated by Federal EPA exhaust gaseous regulations. The difference between current and EPA-certified engines is only the labels attached on the engine. See available drawing and/or illustration of emission label and its location.

FEDERAL EPA EMISSION CONTROL STATEMENT

MANUFACTURER'S WARRANTY COVERAGE

Beginning January 1, 2004 heavy-duty off-road EPA engines are warranted for a period of five (5) years, or three-thousand (3,000) hours of operation, whichever occurs first. If any emission-related part on your engine is defective, the part will be repaired or replaced by at an authorized Komatsu Forklift dealer.

EMISSION-RELATED PARTS

- Fuel injection pump
- Fuel injection nozzles
- Turbocharger

OWNER'S WARRANTY RESPONSIBILITIES

As the heavy-duty off-road engine owner, you are responsible for the performance of the required maintenance listed in owner's manual (Instruction Manual). KFI recommends that you retain all receipts and records covering the maintenance on your engine, but KFI cannot deny warranty solely for the lack of receipts and records or for your failure to ensure the performance of all scheduled maintenance. For your reference, the following is an emission control maintenance schedule for certified Diesel engines.

- Check oil level and coolant level – Every day
- Change of engine oil– Every 200 hours
- Change lubricating oil filter – Every 200 hours
- Initial adjustment of valve clearance – Every 200 hours
- Change fuel filter – Every 500 hours
- Check turbocharger, rebuild or replace if necessary – Every 3,000 hours
- Adjust valve clearance – Every 1,000 hours
- Check fuel injection nozzles, replace if necessary – Every 3,000 hours

Keep records to show proof of compliance with the required maintenance practices and intervals.

- As the heavy-duty off-road engine owner you should, however, be aware that KFI may deny your warranty coverage if your heavy-duty off-road engine or part has failed due to abuse, damage, neglect, improper maintenance or disapproved modifications.
- Your engine is designed to operate on commercial diesel fuel only. Use of any other fuel in our engine will result in the engine operating in non-compliance with the Federal EPA regulations. You are responsible for initiating the warranty process. It is suggested that you present your heavy duty off-road engine to an authorized Komatsu dealer as soon as you become aware that problem exists. The warranty repair should be completed by the dealer as expeditiously as possible.
- If you have any questions regarding your warranty rights and responsibilities, you should contact the authorized KFI dealer.

LIMITATIONS

KFI is not responsible for resultant damages to an emission-related part or component resulting from:

- Any application or installation KFI deems improper as explained in the Instruction Manual.
- Attachments, accessory items or parts not authorized for use by KFI.
- Improper off-road engine maintenance, repair or abuse.
- Owner's unreasonable delay in making the product available after being notified of a potential product problem.

This warranty is in addition to the KFI standard warranty applicable to the off-road engine product involved.

Remedies under this warranty are limited to the provision of material and services as specified herein. KFI is not responsible for incidental or consequential damages, such as downtime or lost use of the forklift truck.

FEDERAL EPA EMISSION CONTROL STATEMENT

CUSTOMER ASSISTANCE – EMISSION CONTROL SYSTEMS WARRANTY

Komatsu Forklift aims to ensure that the Emission Control Systems Warranty is properly administered. In the event that you do not receive the warranty service to which you believe you are entitled under the Emission Control Systems Warranty, call or write to your Komatsu Forklift Dealer.

Authorized dealers are recommended for major maintenance and repair work, as they are staffed with trained personnel, proper tools and are aware of the latest maintenance methods and procedures. Owners and others who desire to perform their own work should purchase a service manual and obtain current service information from their KFI engine dealer.

NOTICE

Follow the instructions in the Operations Manual concerning any other maintenance programs not required for EPA compliance.

For questions and additional information concerning EPA Diesel Engine Exhaust Regulations, contact:

Komatsu Forklift USA, Inc.
14481 Lochridge Blvd., Bldg. #2
Covington, GA 30014-4908

Voice phone: (770) 385-4815
Fax phone: (770) 385-4838

1. SAFETY

1.1. SAFETY MANAGEMENT

WARNING

FOLLOW THE INSTRUCTIONS IN THE OPERATION AND MAINTENANCE MANUAL AS WELL AS ON THE SAFETY LABELS

- Read the instructions in this manual and the safety labels attached to various parts of the lift truck, and make sure that you understand and follow them. If you do not understand or do not follow the instructions, this will lead to improper operation which may result in personal injury or damage.
- Be sure that you understand the proper method of using the lift truck and the procedure for carrying out an inspection, and ensure that they are carried out safely.
- Read this manual and safety labels again from time to time. If the Operation and Maintenance Manual or safety labels have been lost or have become dirty and cannot be read, obtain replacements from your Komatsu Forklift dealer and attach the safety labels in the specified positions.

WARNING

MAKE SAFETY PLANS BEFOREHAND

- Before operation, establish an operating plan and hold a meeting to discuss operating safety.
- In confined areas, position a signal person and carry out operations in accordance with his/her instructions.

WARNING

FOLLOW THE SAFETY RULES IN PLACE

- Do not operate the lift truck if you are fatigued, or when you have been drinking or have taken any medication which can make you sleepy.
- When carrying out operation, inspection, or maintenance of the lift truck, always follow all work shop rules, safety regulations and precautions.
- During operation, always pay attention to safety and be careful of pedestrians and other surrounding conditions.

WARNING

ENSURE SAFETY AT THE WORKING AREA

- Always work on level surfaces and wipe up all oil or grease from the ground.
- When working on quays, platforms, or docks, or other places where there is danger of falling, set up blocks to prevent the lift truck from going over the edge.
- Put warning signs up in dangerous places to warn the operator not to approach.
- Mark the travel areas clearly and maintain the road surface in good condition.
- Put up signs to prevent unauthorized lift trucks from entering areas where lift trucks are being operated.
- Ensure that there is adequate lighting to enable safe operations to be performed.

WARNING

WEAR SAFETY CLOTHES WHILE IN OPERATION

- Avoid loose clothing, jewelry, and loose long hair, which can catch on controls or in moving parts and cause serious injury or death.
- Always wear a hard hat and safety boots.
- Depending on the working conditions, wear other safety equipment in addition to the hard hat and safety boots.

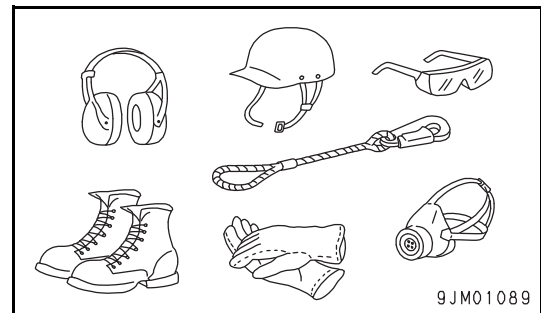

WARNING

KEEP THE OPERATOR'S COMPARTMENT CLEAN AND CLEAR

- Keep the operator's compartment clean and tidy. Be sure to clean up all oil or mud. If the operator's hand or foot slips it could lead to a serious accident.
- Do not leave tools or spare parts lying around in the operator's compartment; always keep them in the tool box when not being used. They may damage or obstruct the control levers or pedals.
- Do not drive the lift truck if your hands are wet or covered with oil. Your hands will slip on the work equipment control levers or directional lever and could cause a serious accident.

WARNING

REDUCE LOAD FOR LIFT TRUCKS WITH ATTACHMENT

- The permissible load for lift trucks equipped with any attachment is lower than the permissible load for the standard lift truck, the reasons being:
 1. The overall permissible load is lowered by as much as the weight of an attachment itself.
 2. The load center shifts toward the front due to the thickness of an attachment.
- Follow the load limit as indicated in the load capacity chart on the nameplate.
- On some detachable-type attachments and inserting-type attachments, there is an additional load capacity chart or attachment weight label provided at a certain place. Follow the instructions in the chart or the label when installing such an attachment.

WARNING

UNAUTHORIZED MODIFICATION

- Do not install any additional equipment, parts or the like on the lift truck, or modify the lift truck without prior written consent from Komatsu Forklifts. An additional counterweight or unauthorized modification of the lift truck can bring about a negative effect on the stability or strength of the lift truck, and can also impair its safety.
- Do not install any equipment or parts which obstruct or limit the operator's view.

WARNING

DON'T REMOVE THE OVERHEAD GUARD AND LOAD BACKREST

- The overhead guard is installed to protect the operator from falling objects. It is designed to withstand the force of light boxes or small packages. It is not designed to withstand every possible impact.
- Always be careful to prevent damage or injury from falling objects.
- Do not use a Komatsu lift truck when it is equipped with a non-genuine overhead guard or load backrest.
Note: Komatsu lift trucks are usually equipped with the optimum overhead guard and load backrest when they are shipped out of Komatsu Forklift plants.

WARNING

DON'T USE A DEFECTIVE LIFT TRUCK - USE LOCK-OUT TAG-OUT PROCEDURES

- Remove the key from the faulty lift truck and hang signs in the operator's compartment to prevent its use.
- If the lift truck has suffered a failure and the lift truck must be parked without lowering the forks, put markers on the tips of the forks and take steps to prevent pedestrians or other vehicles from hitting the forks.
- Select a parking place where people or vehicles do not pass, and stop the lift truck so that it is difficult for anyone to go under the forks. **The area under the forks is a danger zone.**

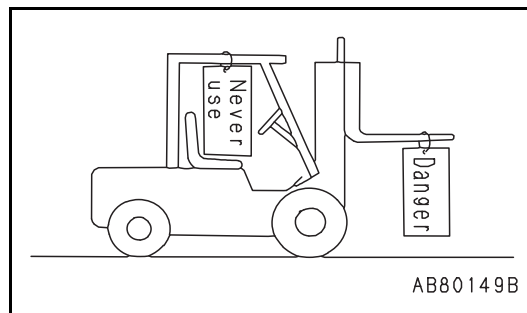

1.1. SAFETY MANAGEMENT

WARNING

PRECAUTIONS WHEN REFUELING LPG TRUCKS

- Only trained and authorized personnel may fill or change LPG tanks.
- When checking or filling tank, do not smoke, stop the engine and fill only at designated safe areas, preferably outdoors. Follow the filling and operating instructions in this manual.
- Before filling and reuse, check tanks for damage to valves, fittings and gauges or dirt in the openings.
- LPG is heavier than air and will sink to the lowest area possible. Avoid parking near areas near floor drains, lubrication pits, or other areas where escaped fuel may collect.
- Ensure that the tank is securely mounted.
- Do not completely fill the tank to prevent overflow and fire hazard when the LPG expands.
- If there is LPG odor or frost on the fuel tank, do not start the engine. Park and tag the truck and have qualified personnel inspect and repair the fuel system.

WARNING

ENGINE EXHAUST GAS IS POISONOUS

Do not leave the engine running where there is poor ventilation. The engine exhaust gas contains carbon monoxide, which can cause gas poisoning and result in serious injury or death.

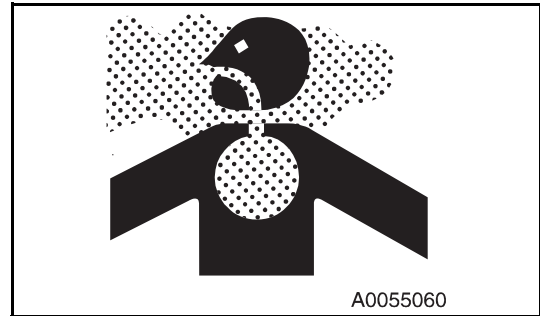

WARNING

FIRE IS STRICTLY PROHIBITED DURING REFUELING

Fuel is extremely flammable and can cause fires and explosions.

- Carry out refueling away from flames or sparks.
- Stop the engine when refueling.
- After refueling, tighten the gas cap securely and wipe up any spilled fuel.

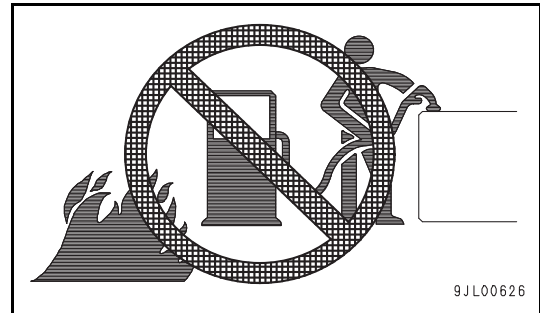

WARNING

FIRE, FIRST AID AND GENERAL SAFETY

- When you feel something unusual occurring with the lift truck, promptly stop working, move the lift truck to a safe place for parking, stop the engine for safety. Then report to the supervisor.
- Be sure that fire extinguishers have been provided and that you read the labels to ensure that you know how to use them.
- Know what to do in the event of a fire.
- Be sure that you know the phone numbers of persons you should contact in case of an emergency.
- Provide a first aid kit at the storage point.
- If a fuel leak is discovered, do not operate the lift truck. Be sure to make repairs, stopping the leak before starting the operation again, while reporting the trouble to the supervisor.

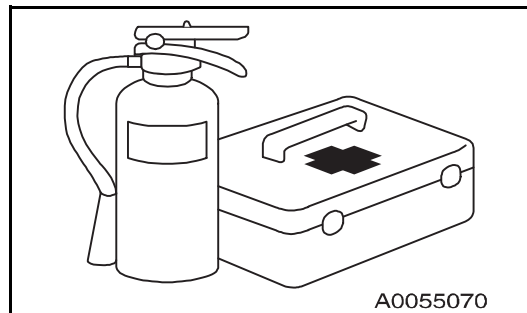

WARNING

LPG FUEL SYSTEM SAFETY

- Accidents involving fuel systems are always dangerous and can cause fire and explosion, serious injury, death and property damage. Keep the following points in mind when working with fuel systems.
 - LPG is heavier than air and will sink to the lowest area possible. Avoid parking truck in areas near floor drains or lubrication pits where escaped fuel may collect.
 - Store all LPG cylinders OUTDOORS in a secured area and safe from any vehicle traffic.
 - NEVER WELD ON AN LPG PRESSURE VESSEL, STORAGE TANK OR CYLINDER.
 - Ensure that the fuel tank is properly mounted. See “Maintenance” chapter.
 - Always use a UL-listed LPG tank.
- Before working on the LPG fuel system:
 - Read, understand and remember relevant information in standard 58 of the NATIONAL FIRE PROTECTION AGENCY (NFPA).
 - Ensure you are wearing proper personal protective equipment.
 - Ensure there are NO SOURCES OF IGNITION nearby.
 - Ensure your work area is adequately ventilated.
 - Keep in mind that LPG is stored under high pressure and ensure that the LPG fuel storage container valve is turned OFF (closed), and pressure is released from the lines.
 - Disconnect the battery.
 - Test for fuel leaks. DO NOT work on the system if the fuel storage container is filled with fuel past the 80% liquid level. Before testing, make sure the system gas pressure is greater than 90 psi (621 kPa). Test all connections, container, valves and fittings with soap and water or equivalent solution. If there are any leaks, have them repaired by qualified personnel.
- When replacing LPG fuel system components:
 - Do not use cast fittings.
 - Use only UL- or Factory Mutual-listed LPG hose assemblies in the pressure fuel line.
 - Use only UL- or Factory Mutual-listed LPG parts.

1.2. SAFE TRAVEL

WARNING

JUMPING ON AND OFF THE LIFT TRUCK IS STRICTLY PROHIBITED

- When getting in or out of the lift truck, be sure to first stop the truck and use the handrails (assist grip) as well as the step to hold yourself securely.
- Do not hold on to or pull yourself up with the control levers or steering wheel when getting on or off the lift truck.
- Keep the handrails (assist grip) clean all the time, and repair any damage.

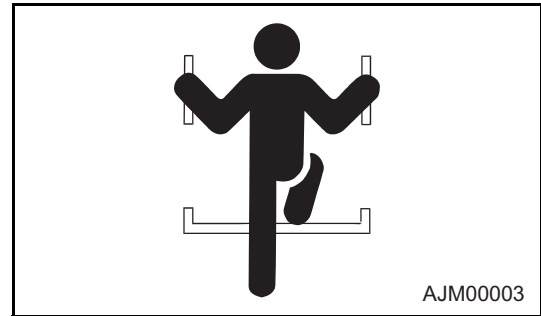

WARNING

DON'T TRY TO OPERATE THE LIFT TRUCK FROM OUTSIDE

- Always keep your body under the overhead guard.
- Do not put your hand or foot out of the overhead guard.
- You must be properly seated in the operator's seat when operating any function of the lift truck.



WARNING

MAINTAIN PROPER POSTURE WHILE OPERATING

Travel Interlock (power transmission cutoff) and Lift/Tilt Interlock (Option)

- If you operate the lift truck when you are not seated properly or off the seat, an accident may happen unexpectedly. To forestall such a possible accident, the truck is provided with Travel Interlock and Lift/Tilt Interlock that make travel and truck operation impossible if you are not seated properly (Operator Presence System).
- If you operate the lift truck in such a posture that your weight is not properly applied to the seat, like standing up or leaning forward or sideways, the Travel Interlock begins to alarm in approximately three seconds and cuts off the transmission of engine power. Then the truck will not move, even if you depress the accelerator pedal or operate the forward-reverse lever.
- Additionally, Lift/Tilt Interlock locks lifting/lowering and tilting operations. Even if you operate the lift lever or tilt lever, these functions will not work. (The lever for an attachment is not equipped with this function.)



WARNING

A SUDDEN SHIFT OF THE F-R LEVER IS DANGEROUS

To change the travel direction, stop the lift truck completely and then operate the F-R lever.

WARNING

DON'T ALLOW A PASSENGER ON THE TRUCK

- Never allow any other person to ride with you on the lift truck.
- Do not use anyone for a makeshift human counterweight.

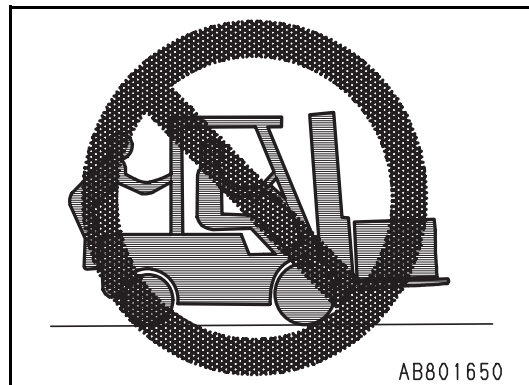

WARNING

BE SURE TO WEAR THE SAFETY SEAT BELT

- Always fit your seat belt correctly when operating. If your seat belt is fitted incorrectly, there is danger of serious personal injury if the lift truck should tip over.
- Always check the seat belt mounts and check for any damage to the seat belt. If any abnormality is found, repair or replace the seat belt immediately.

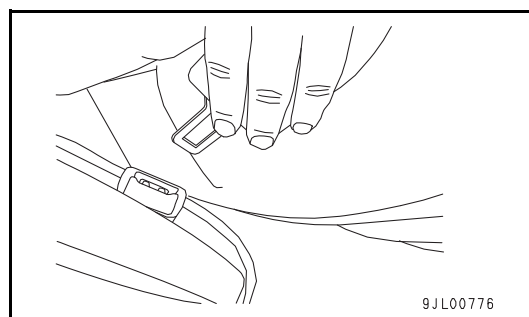

WARNING

CHECK THE SURROUNDINGS FOR SAFETY BEFORE STARTING UP THE ENGINE

- Before starting the engine, check that the parking brake is set, and that the directional and speed levers are in the neutral position.
- Adjust the operator's seat and the steering wheel before starting the engine. Always lock them in position after adjusting. Adjusting the seat or steering wheel during operation is dangerous as it may cause you to lose your balance or operate the lift truck in an unsafe manner.
- Before starting the engine, first check that the surrounding area is safe, and sit securely in the operator's seat.
- Sound the horn before starting the engine to warn people around you.
- Do not attempt to start the engine by intentionally short-circuiting the engine starting circuit.
- Do not attempt to jump start the lift truck.

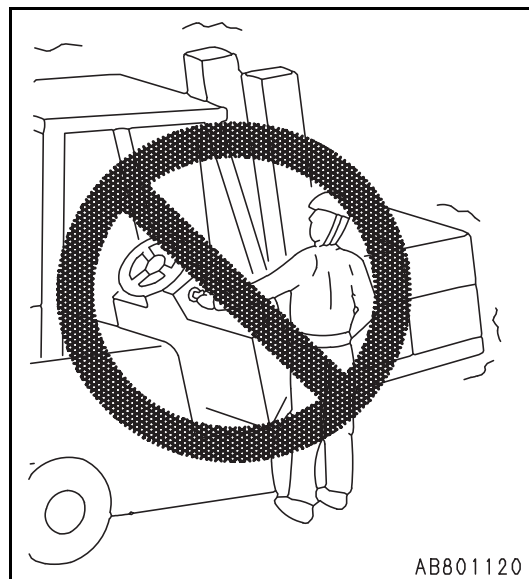

WARNING

CHECK AND ADJUST THE REAR VIEW MIRROR AND LAMPS

- When reversing, never depend on the rear view mirror. The operator must visually check behind him. Also, adjust the rear view mirror so that the operator can check from the operator's seat that the area behind the lift truck is safe. Always keep the surface of the mirror clean. If the mirror is broken, replace it with a new one.
- Check that all lamps light up correctly. Replace any broken bulbs (for lift trucks equipped with lamps).

1.2. SAFE TRAVEL

WARNING

PERFORM A SAFETY CHECK BEFORE STARTING THE LIFT TRUCK

- Before starting the lift truck, check that the surrounding area is safe.
- Before moving the lift truck, raise the forks [approximately 15 to 20 cm (6 - 8 in) from the ground surface], and tilt the mast back.
- When ready to move, release the parking brake.

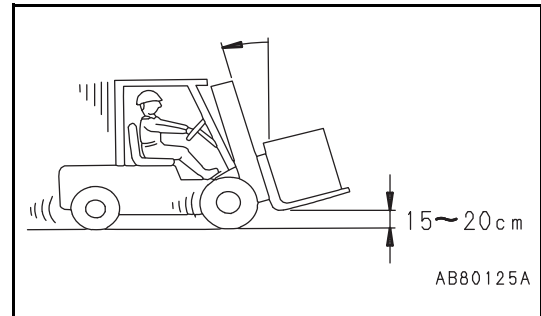

WARNING

BE SAFETY CONSCIOUS WHILE DRIVING

- Keep a clear view of the path of travel and watch for other traffic, personnel, and safe clearances.
- When passing oncoming vehicles, reduce speed and keep a safe distance from the other vehicle.
- In places where there are speed limits, observe the speed limit and maintain a safe distance from other vehicles.
- When traveling, always pay careful attention to the area around your lift truck, particularly in the direction of travel or when turning.
- Do not attempt to pass another lift truck or vehicle on a narrow path or on a spot of limited view like a crossing.
- When passing through an area of limited view, like a crossing or when running into a narrow path, sound the horn and check the surroundings for safety.
- Even if you sound the horn, not everyone in the surrounding area will necessarily hear it. Always pay careful attention to the movements of people in the surrounding area.
- When crossing a passage or turning at a corner, stop the lift truck once to confirm the safety around.
- Always pay careful attention to the movements of people in the surrounding area, and take steps to prevent people from entering the working area.
- When traveling on a slope or through a crowded spot, always give way (yield) to a loaded lift truck.

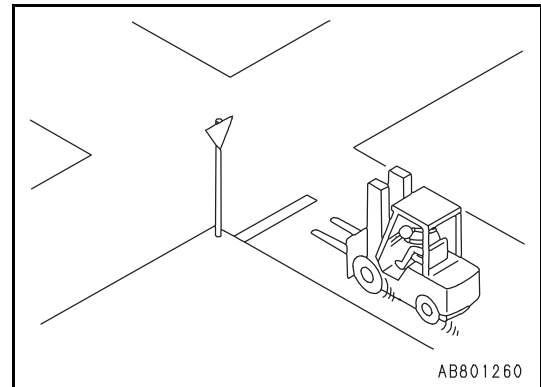

WARNING

DO NOT DRIVE ON ROUGH GROUND OR SURFACE

- Avoid traveling in places which are flooded or where there are holes.
- Do not try to drive the lift truck on soft ground.
- Avoid curbs, rails, ditches, or other obstacles, and do not travel directly over them.
- Do not travel on slippery road surfaces.
- When entering buildings, check the weight limit of the floor and be careful not to exceed the limit.

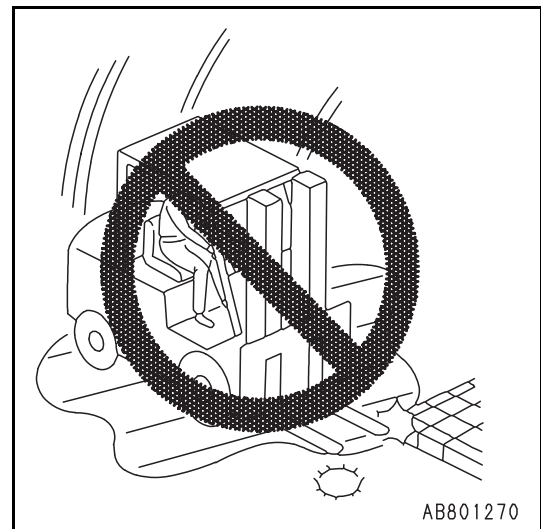

WARNING

DRIVING ON A ROAD SHOULDER IS STRICTLY PROHIBITED

- There is a danger that soft road shoulders may collapse, so do not go near them.
- Always maintain a safe distance from the edge of road shoulders and platforms.

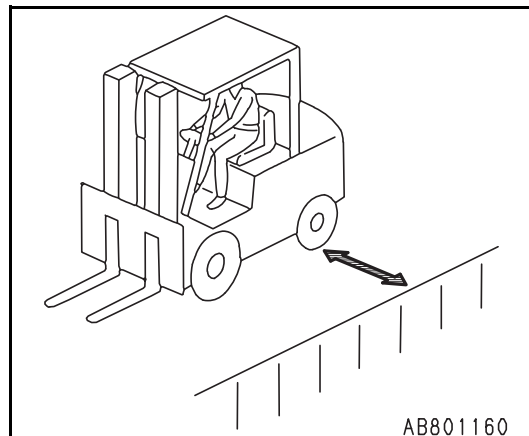

WARNING

WHEN DRIVING INTO A RAILWAY CAR, TRUCK OR CONTAINER, EXERCISE EXTRA CARE

- Do not travel on the edge of docks. There is a danger that the lift truck may fall, which may result in serious injury or death.
- Before starting operations, check the load limit for the gangplanks, and do not use them if they do not have ample strength to take the weight of the lift truck when loaded.
- Apply the brakes on the truck and block the wheels before driving the forklift into the truck.
- When driving into trailers, use jacks and take steps to prevent the trailer from sinking when the forklift truck travels on it.
- When driving the forklift inside trucks, reduce speed when backing out and be sure to check that the gangplanks are safe.
- Be careful of pedestrians.
- Tell the truck driver not to move the truck until the operation is completed.
- If there is some system to secure the truck to the dock, always use this system. Secure the gangplanks so that they do not slip and fall.

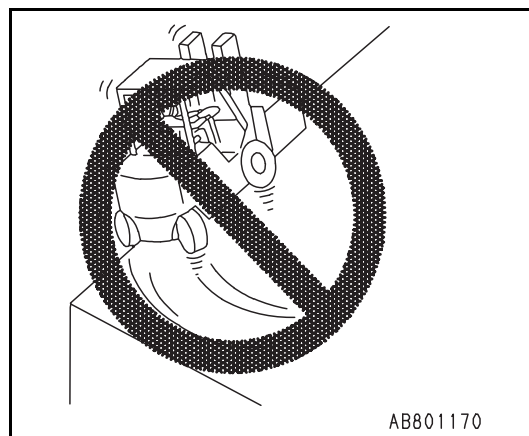
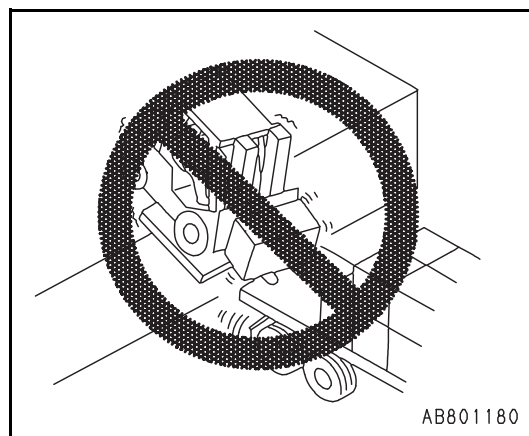

1.2. SAFE TRAVEL

WARNING

BE AWARE OF THE LIFT TRUCK'S MAXIMUM HEIGHT AND WIDTH

- Ensure that there is ample height and width for the lift truck to pass.
- Do not extend your hands or legs outside the operator's compartment or the area covered by the overhead guard (safe area).
- Check that the surrounding area is safe.
- Be careful of electric wires and other obstacles inside and outside the building.

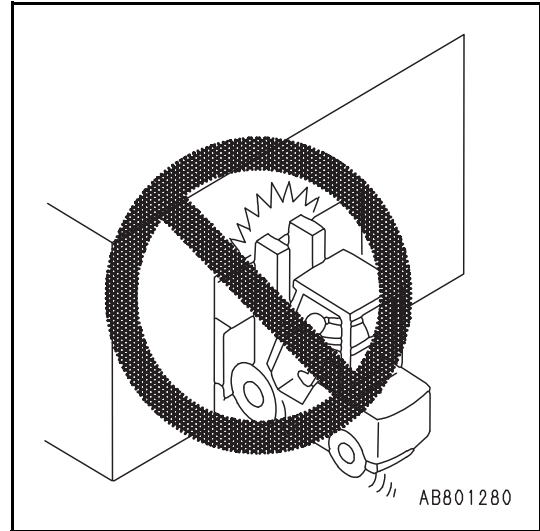

WARNING

WHEN DRIVING UP OR DOWN A SLOPE, EXERCISE EXTRA CARE

- Do not turn, or travel across or at an angle on slopes. There is danger that the lift truck will tip over.
- Before starting to drive up a slope, stop the lift truck and adjust the clearance between the ground surface and the bottom of the forks so that the bottom of the forks or pallet do not contact the ground surface or the tip of the fork does not stick into the ground when traveling.
- For safe travel on slopes:

When loaded: Travel forward up the slope, and in reverse down the slope with the load upgrade.

When unloaded: Travel in reverse up the slope and forward down the slope with the load-engaging means downgrade.

- On a downslope, drive down slowly and use the foot brake.
- When starting on slopes, the lift truck may start to move down the slope depending on the amount the pedals are depressed.
Always leave ample room in front of and behind the lift truck when starting on slopes.
- Be careful of the truck sliding downhill if Travel Interlock is engaged while traveling uphill or on a slope. Stay securely in the operator's seat!

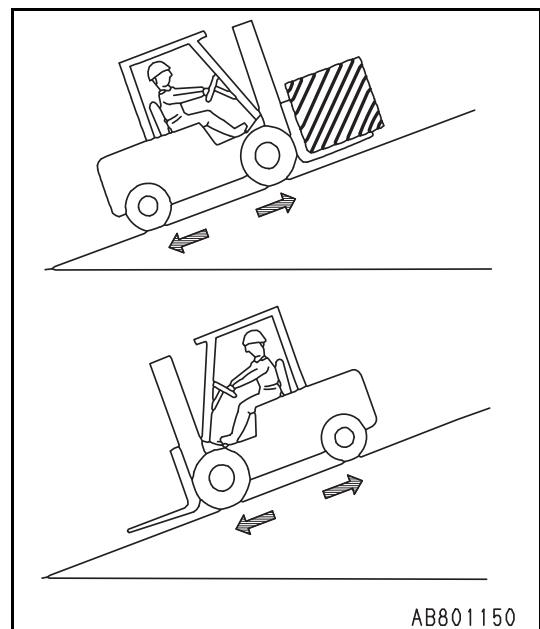
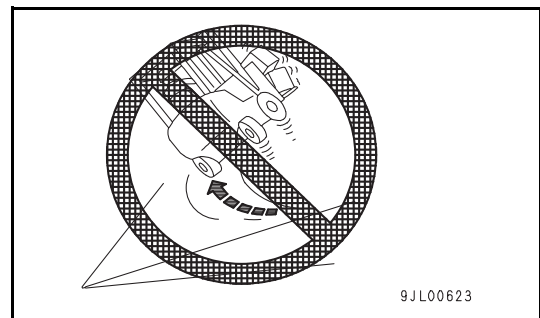

WARNING

WHEN MAKING A TURN, BE CAREFUL OF THE SWINGING COUNTERWEIGHT

- Remember that a fork lift truck steers with the rear wheels, not the front wheels. It will not drive like an automobile.
- When turning while traveling forward, the counterweight will swing far out. Keep an ample clearance from walls to ensure safety.
- When turning, travel slowly and be careful that the front or rear wheels do not come off the ground.
- When turning on soft road shoulders, there is danger that the rear wheels may come off the road shoulder and cause the lift truck to tip.

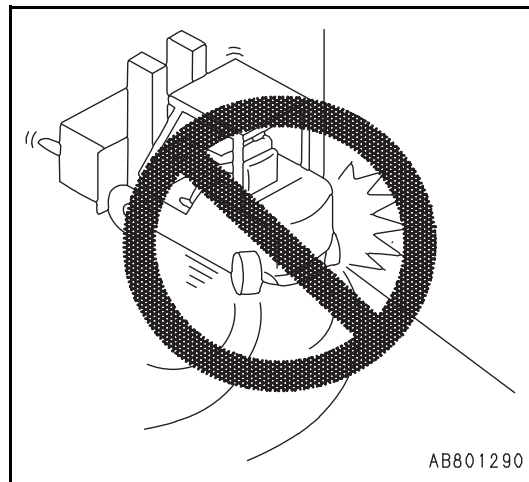

WARNING

ANY OPERATION THAT MIGHT OVERTURN THE LIFT TRUCK IS STRICTLY PROHIBITED

- If the load-engaging means or load is raised, the center of gravity of the lift truck will also rise and increase the danger of the lift truck tipping. Do not turn the lift truck when the forks are raised high.
- Do not suddenly raise the forks or tilt the mast to the front or rear when the forks are loaded. There is danger that the lift truck will tip.
- Reduce speed before turning the lift truck.
- In particular, when traveling unloaded, the rear of the lift truck is heavy. If the lift truck is turned at high speed, there is a greater chance of tipping than when traveling with the forks loaded.

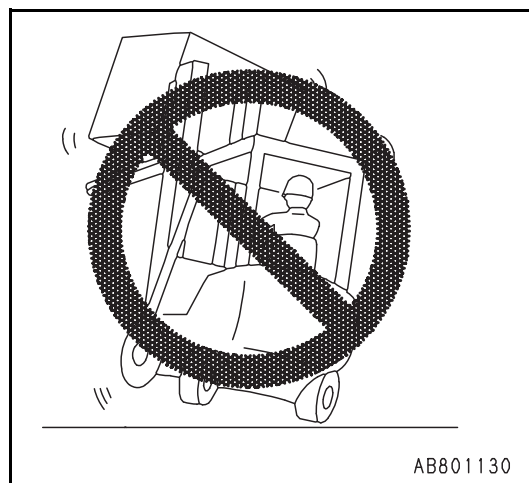

WARNING

WHEN BACKING UP THE LIFT TRUCK, VISUALLY CHECK BEHIND THE TRUCK

- Before backing the lift truck, make sure that there is no one behind the truck before starting to travel.
- The rear view mirror is simply an aid for checking the rear. When driving in reverse, do not use the rear view mirror. Turn to face the rear and check the area directly behind the lift truck for safe unobstructed travel.
- Even if you sound the backup buzzer, the people behind the truck may not necessarily hear it. Always check that there is no one behind the truck before driving the truck. (For lift trucks equipped with backup buzzer.)

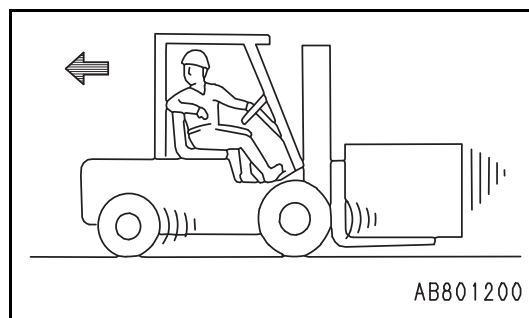

WARNING

DON'T USE A LIFT TRUCK TO TOW ANOTHER BROKEN-DOWN LIFT TRUCK

If there is any problem with the brakes or steering system of your lift truck, do not use another lift truck to tow it as there is danger that the lift truck may run out of control.

1.2. SAFE TRAVEL

WARNING

WHEN CARRYING A HIGH LOAD, USE A SIGNAL PERSON OR DRIVE BACKWARDS

- If the view to the front is obstructed by the load, turn to the rear and drive the lift truck in reverse.
- When driving in reverse with a high load, use a signal person to ensure the safety of the load and the safety in the surrounding area.

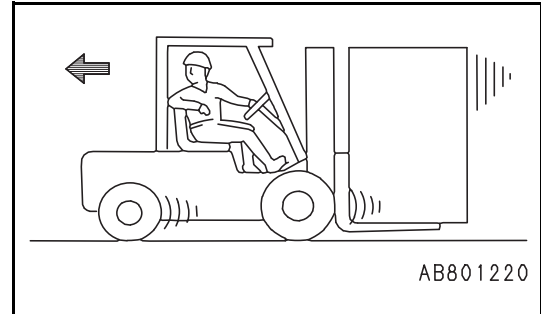

WARNING

APPLY THE BRAKES CORRECTLY WHILE RUNNING

- Do not stop the engine while the truck is in motion. When the engine is not running, the operating efforts for power steering and power brakes (if present) increase. Thus it is dangerous to stop the engine while running.
- If the inching pedal is depressed, the braking effect of the engine will be lost.
- Do not use the brakes unnecessarily or too frequently. If your lift truck is a TORQFLOW transmission type and you rest your foot on the inching pedal during operations, the multiple clutch plates of the transmission will overheat, deforming the clutch plates and causing them to malfunction, in the worst case.

WARNING

PAY SPECIAL ATTENTION TO THE REAR VIEW WITH AN LPG CYLINDER-INSTALLED (GASOLINE ENGINE) LIFT TRUCK

- The installed LP gas cylinder partially blocks the rear view and poses a danger of hitting people, piled commodities, or contact with nearby objects. Therefore, install backup warning devices (backup alarm buzzer, rotating warning lamp, etc.) or backup safety checking devices such as a rear view mirror in order to warn people nearby and check for safe conditions in the area of the truck.
- When installing optional warning devices, call your Komatsu Forklift dealer for details.

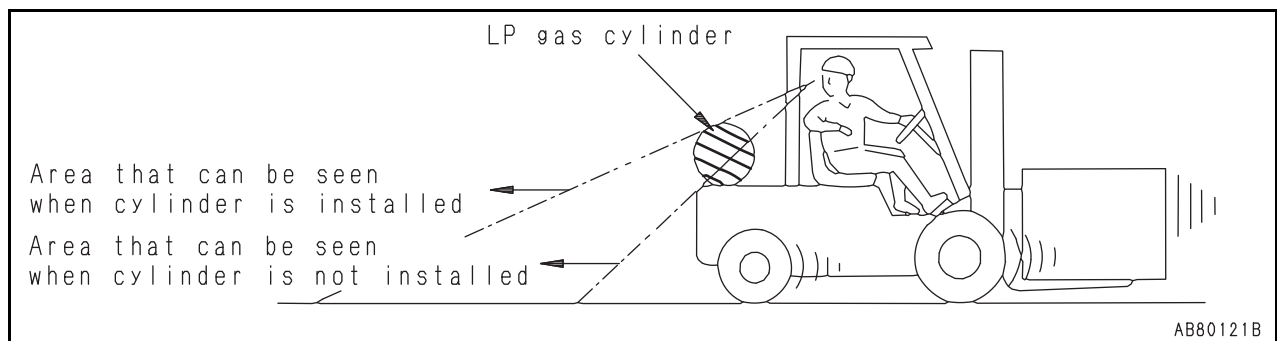

WARNING

REQUIRED BRAKING DISTANCE DIFFERS DEPENDING ON THE ROAD CONDITIONS

- When traveling downhill, it requires a longer distance for the lift truck to stop than when traveling on level ground.
- When traveling downhill, reduce the speed and make sure that you have ample room at the bottom of the slope to stop.
- Traveling on wet surfaces requires a longer distance to stop than when traveling on normal road surfaces. Always leave ample room to stop.

WARNING

FOLLOW THESE STEPS FOR PARKING

1. Stop the lift truck on level ground.
2. Apply the parking brake securely to make sure that the lift truck cannot move.
3. Set the directional lever and speed lever to neutral.
4. Tilt the mast forward and lower the fork to the floor.
5. Turn the starting switch to the OFF position.
6. Pull out the starting switch key and leave the lift truck.
7. LPG trucks: close fuel valve on fuel tank after parking the lift truck.

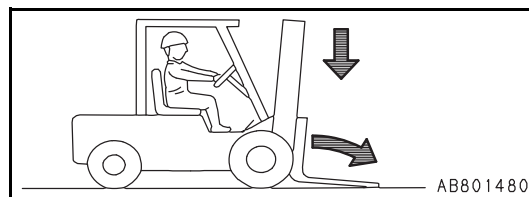
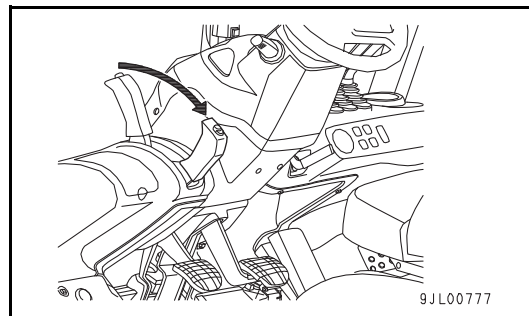

WARNING

PARK THE LIFT TRUCK IN A SAFE PLACE

- Park the lift truck in the specified place.
- Park the lift truck on a firm surface.
- Do not park near any emergency exit, stairway, fire extinguisher, or other safety equipment. Park the lift truck in a place where it will not obstruct pedestrians or other vehicles.
- Never park the lift truck near heat, ignition sources, or any flammable object.
- If there is no way to avoid parking on a slope, immobilize the lift truck by putting blocks under the tires in addition to normal parking procedures.
- LPG trucks: LPG is heavier than air and will sink to the lowest area possible. Avoid parking near areas near floor drains or lubrication pits where escaped fuel may collect.

WARNING

SHOULD THE LIFT TRUCK BECOME INOPERATIVE IN A DANGEROUS PLACE LIKE A RAILROAD CROSSING, LET ALL PEOPLE AROUND KNOW IMMEDIATELY

- If engine trouble occurs on a railroad crossing and the lift truck does not move, it is impossible to use the starting motor as can be done on a standard-shift automobile. (This is because a neutral safety switch is installed.)
- In such an emergency, light a flare or smoke candle to warn approaching trains and people in the area that there is a broken-down truck on the tracks.

WARNING

DON'T USE THE DRAWBAR PIN FOR OTHER THAN IT'S INTENDED PURPOSE

- Do not use the drawbar pin for any other towing purpose than to bail out a stuck lift truck, or to be towed by another lift truck or to be hoisted.
- The towing pin at the back of the counterweight is provided to pull out the lift truck when it has gotten stuck in dirt or a ditch as well as when it is being loaded on a truck.

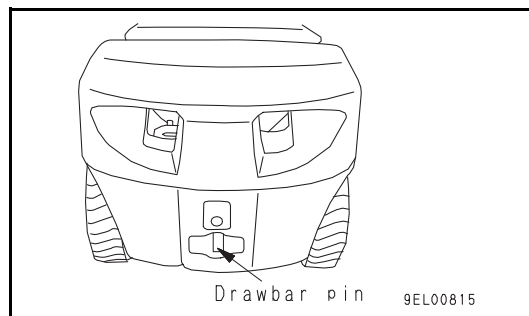

1.3. LOADING OPERATIONS

WARNING

PRECAUTIONS FOR LOADING AND UNLOADING

- If you operate the lift truck in such a posture that your weight is not properly applied to the seat, like standing up or leaning forward or sideways, Travel Interlock begins to alarm in approximately three seconds and cuts off the transmission of engine power. Then the truck does not move even if you depress the accelerator pedal or operate the forward-reverse lever.
The truck will slide downhill if Travel Interlock activates on an uphill grade or a slope.
- Select flat and solid ground for loading and unloading. Avoid a road shoulder or a place near a cliff.
- Use ramps of sufficient length, width and strength. Moreover, set them securely so that they will not shift or be displaced.
- Always operate the mast and forks from the operator's compartment. Be careful not to operate the lever by mistake. There is danger that the forks or work equipment may cause serious injury.

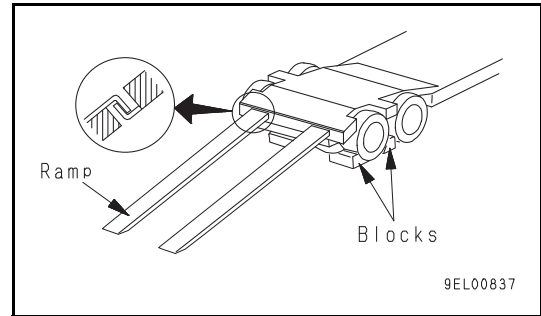

WARNING

KEEP UNAUTHORIZED PEOPLE OUT OF WORKING AREA AND ENSURE A SIGNAL PERSON IS ON DUTY

- Do not allow anyone in the working area except the signal person.
- Do not let any person or other lift truck come close during operation.
- When working with a signal person, always follow their instructions.

WARNING

NEVER GO BENEATH RAISED FORKS

The space under a lifted fork is an area of danger, so never allow anyone to go under the fork. There is a danger of personal injury to any person who could be crushed under the forks when they come down.

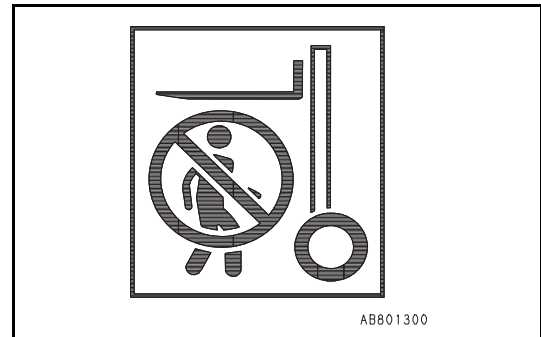

WARNING

STANDING ON THE FORK(S) IS STRICTLY PROHIBITED

- Do not let anyone place a load on the forks.
- Do not let anyone directly remove the load from the forks.
- Standing on the forks is dangerous because the forks are slippery and the load may move.
- Do not use anyone to keep the load stable. The lift truck may move unexpectedly, causing the load to fall and crush the person.

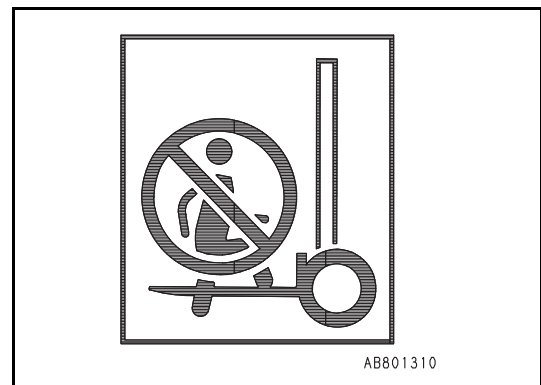

WARNING

BE CAREFUL NOT TO GET CAUGHT IN THE MAST STRUCTURE

Never put your hands or feet into the mast structure. There is danger that you will get caught in moving parts and be seriously injured.

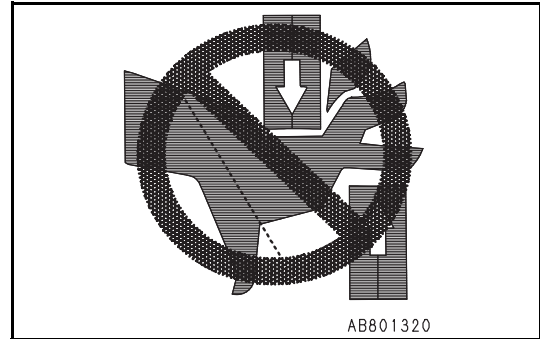

WARNING

DON'T CLIMB ON THE MAST OR LOAD BACKREST

If you climb on the mast or load backrest, there is a danger that you could get caught up in the moving parts or fall off.

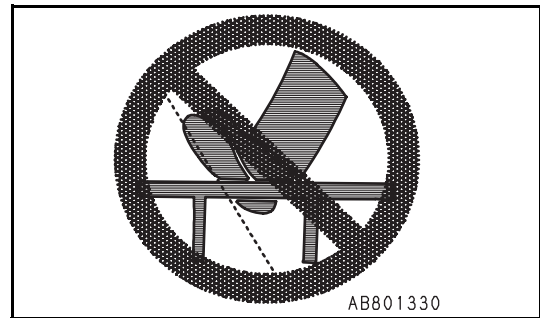

WARNING

USE A PALLET OR SKID OF SUFFICIENT STRENGTH

- Always be sure that the pallets and skids have ample strength. If broken or damaged pallets or skids are used, there is a risk that the load may fall.
- Always check that the load is positioned securely and safely on the pallet before moving the truck.

WARNING

HANDLE A LONG OR WIDE LOAD WITH EXTRA CARE

- Be extremely careful when carrying long or wide loads. Raise the load slowly and be careful not to touch anything in the surrounding area.
- Keep the load as low as possible and be sure to maintain the balance.
- When turning, operate slowly and be careful not to let the load shift or move.

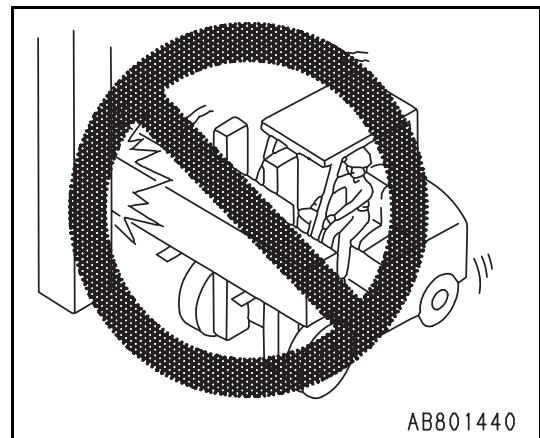

1.3. LOADING OPERATIONS

WARNING

WATCH OUT OVERHEAD

- As the fork goes up, the mast height increases. Be mindful of this fact during the operation.
- Take care so that the mast or the overhead guard will not hit electric wiring, piping, sprinklers, beams in the ceiling, and so on. If such contact occurs, there is the danger that the load on the fork may fall off or the lift truck may tip over.

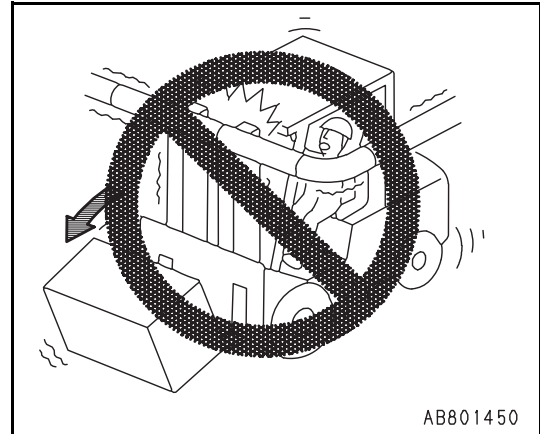

WARNING

OVERLOADING IS STRICTLY PROHIBITED

- Do not load the lift truck over the maximum capacity shown in the load capacity chart, otherwise there is the danger that the rear wheels may come off the ground, the operator may lose control of the lift truck; and the truck may tip over. Moreover the load on the forks can collapse.
- Never exceed the max. load shown in the load capacity chart on the nameplate.

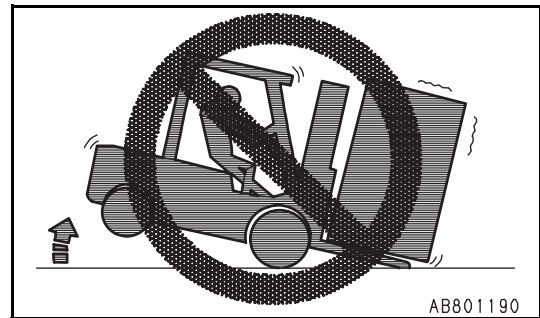

WARNING

DON'T HANDLE A LOAD IN AN INSECURE MANNER

- Make sure that the center of gravity of the load is in line with the center of the lift truck. Do not carry loads off-center. There is danger that unbalanced loads may cause the lift truck to tip.
- Place the load so that it contacts the load backrest.
- Do not handle unstable loads. If there is danger that the load may fall off, secure it in position and take steps to prevent the load from collapsing or falling.

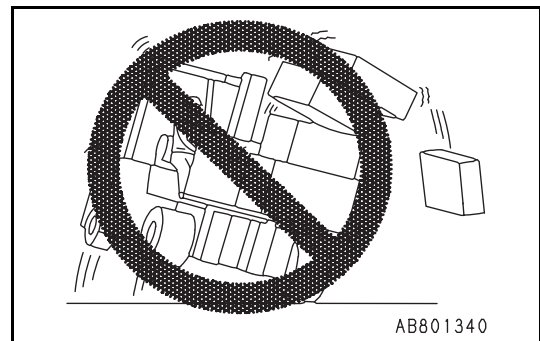

WARNING

DON'T HANDLE A LOAD EXCEEDING THE LOAD BACKREST HEIGHT

Keep the height of the load within the height of the load backrest. Do not carry any load that is higher than the load backrest. ***If the load is higher than the load backrest, there is danger that it will fall back on top of the operator, resulting in serious injury or death.***



WARNING

BE CAREFUL OF THE FORK TIPS

- Do not allow the tips of the forks to get close to people. The tips of the forks are pointed, so there is a risk that they may cause injury.
- Do not attempt to hook something with the tips of the fork, otherwise the hooked object can suddenly come off the tip, and the reaction can cause danger to the lift truck as well as to the hooked object.

WARNING

DON'T USE THE FORK TO PUSH OR PULL A LOAD

There is a risk that the load will be damaged or fall.

WARNING

DON'T TILT THE MAST FORWARD WITH A LOAD ON THE FORK.

- Do not tilt the mast forward with the load raised. Do not raise the load when the mast is tilted forward. There is danger of the load falling or the truck tipping over.
- Do not travel with the mast tilted forward.
- Do not load and unload on slopes.

WARNING

BE CAREFUL OF SLACK IN THE HOIST CHAINS

- If there is any slack in the chain, the mast rail or forks may catch in the load or a shelf, and there is danger that the load may fall and the lift truck tip.
- Always be careful that there is no slack in the chain when pulling the forks out from pallet or shelf.

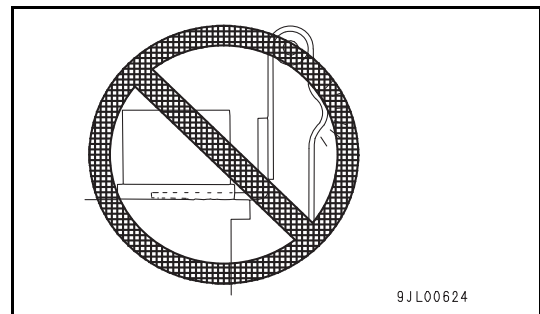
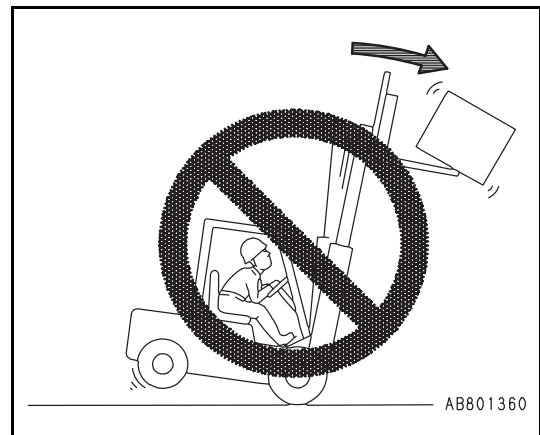
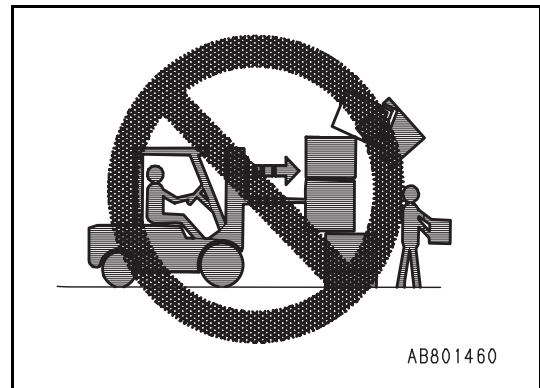
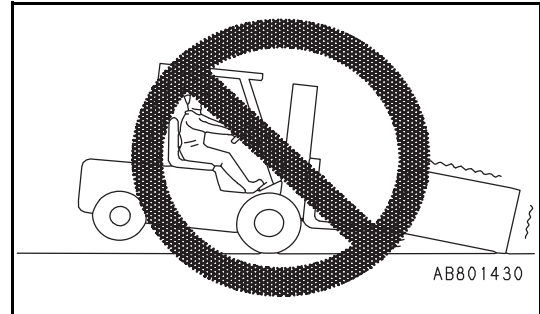

1.3. LOADING OPERATIONS

WARNING

DON'T USE THE LIFT TRUCK IMPROPERLY

- Do not use the lift truck for any other purpose than was originally intended (the loading work using the fork or attachments).
- Do not use the forks to open or close the doors of railroad cars or warehouses.
- Do not push any other vehicle.
- Do not hook ropes on the forks and use the forks to lift loads.
- Do not use the drawbar pin for towing operations.

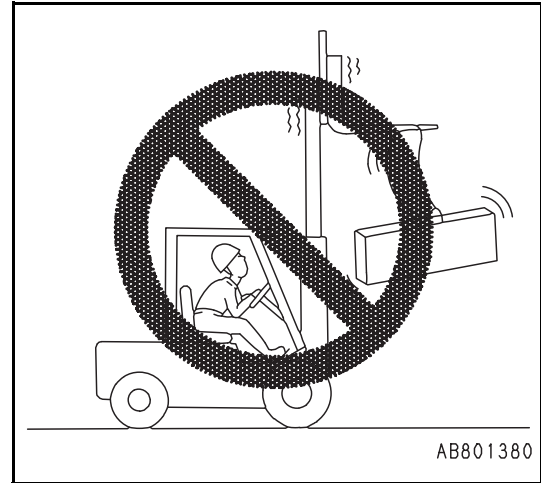

WARNING

PERIODIC MAINTENANCE WORK MUST BE CARRIED OUT BY QUALIFIED PERSONNEL

Only persons authorized by the owner or operator of the equipment and having proper certification (local or national) may carry out inspection, maintenance and repairs of the lift truck. If inspection, maintenance, or repair work is carried out incorrectly, it may create a hazardous condition.

WARNING

DESIGNATE A LOCATION FOR PERIODIC MAINTENANCE WORK

- When carrying out inspection and maintenance, use a level, dry, dust-free area.
- If the work is carried out inside a building, make sure that there is ample ventilation.

WARNING

PRECAUTIONS BEFORE PERIODIC MAINTENANCE WORK

- Read rules and regulations for safety control, safe driving, and loading and unloading operation carefully and understand them fully.
- To be prepared for a fire, have a fire extinguisher nearby and make sure that you know how to use it.
- Before carrying out inspection, lower the forks to the ground and stop the machine.
- Before starting the inspection and maintenance work, turn the engine starting switch to the OFF position and keep the engine at a standstill.
- Keep the engine starting switch in the OFF position except when otherwise required in order to keep the engine at a standstill.
- Set the MAINTENANCE IN PROGRESS sign in a place in the operator's compartment or near the control panel where it is easy to see.
- Set the forward-reverse lever, high/low speed lever, and work equipment lever each to the neutral position.
- Apply the parking brakes and put stoppers (chocks) both before and behind the tires.

WARNING

PRECAUTIONS DURING PERIODIC MAINTENANCE WORK

- Wipe off any oil or grease. Immediately wipe up any oil that has leaked. If the lift truck is dirty, it becomes difficult or impossible to find cracks or other problems.
- Always clean the lift truck before starting inspection.
- Do not smoke or allow any flame to exist under any circumstances.
- Do not use any cloth which is soaked in oil, or grease. There is danger that it may catch fire.
- Wear adequate working clothes and protective equipment (hard hat, safety shoes, goggles and gloves).
- When working on top of the lift truck, be careful not to fall.
- Do not put your feet under the forks.
- When opening or closing the floor plate or engine hood, be careful not to get your hands or body caught.
- When carrying out inspection with the forks raised, insert a stand under the inner mast to prevent the forks and mast from dropping.
- Before starting the inspection and maintenance work, disconnect the cable from the battery negative (-) terminal.
- When carrying out job with another worker, decide who is the leader and carry out the job in accordance with instructions from that person.
- After finishing repair work, perform a test drive of the lift truck.
- During the trial run, start/operate the lift truck carefully because it is possible that the trouble has not been fully corrected or that defective parts have not been removed.

1.4. SAFETY IN PERIODIC MAINTENANCE

WARNING

PERIODIC INSPECTION OF CRITICAL REPLACEMENT PARTS

Replace critical safety parts with a new one periodically even if no defect is found. Parts tend to deteriorate as time goes by, and can cause fire or failure in the work equipment system. However, if these parts show any abnormality before the replacement interval has passed, they should be repaired or replaced immediately.

WARNING

USE OF PROPER TOOLS AND EQUIPMENT

Always use tools that are suited for inspection and maintenance. It is extremely dangerous to use broken tools or tools designed for another purpose.

WARNING

SAFE HANDLING OF BRAKE OIL

It is dangerous if the brakes do not work because in this condition, the lift truck cannot be stopped. Always do the following.

- Check the level of the brake fluid periodically.
- Always use the specified brake fluid.
- Check that the breather of the brake fluid reserve tank is not clogged.
- Be careful not to let dirt or dust get into the brake fluid reserve tank.

WARNING

BE CAREFUL OF BOILING ENGINE COOLANT

- Immediately after using the lift truck, the engine coolant is at high temperature and high pressure. Do not remove the radiator cap under these conditions as hot water may spurt out and cause burns.
- When removing the radiator cap, turn it slowly to release the internal pressure.
- When checking the coolant level, stop the engine and wait for the engine and radiator to cool down before checking.

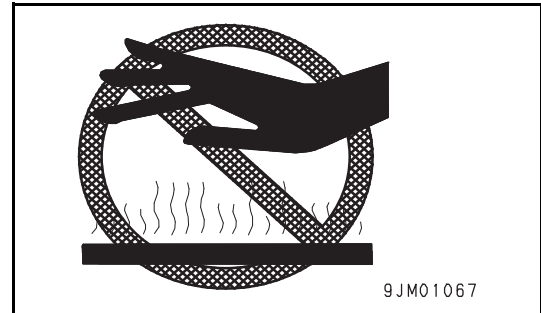

WARNING

BE CAREFUL OF HIGH PRESSURE AND HIGH TEMPERATURE HYDRAULIC OIL

- Immediately after using the lift truck, the oil is at high temperature. Do not drain the oil or replace the filter when the oil is hot as hot oil may spurt out and cause burns.
- Wait for the truck temperature to go down before carrying out the inspection and maintenance work.
- Do not forget that the work equipment circuits are always under pressure. Do not add oil, drain oil, or carry out maintenance or inspection before completely releasing the internal pressure.
- If oil is leaking under high pressure from small holes, it is dangerous if the jet of high-pressure oil hits your skin or eyes. Always wear safety glasses and thick gloves, and use a piece of cardboard or a sheet of plywood to check for oil leakage.
- If you are hit by a jet of high-pressure oil, consult a doctor immediately.

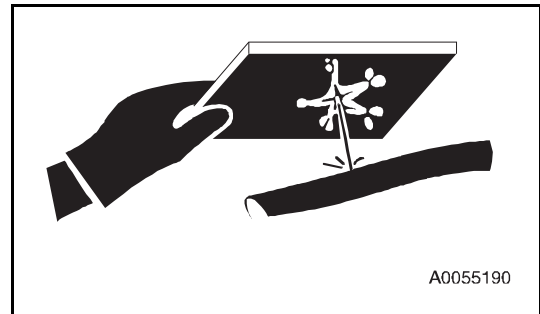
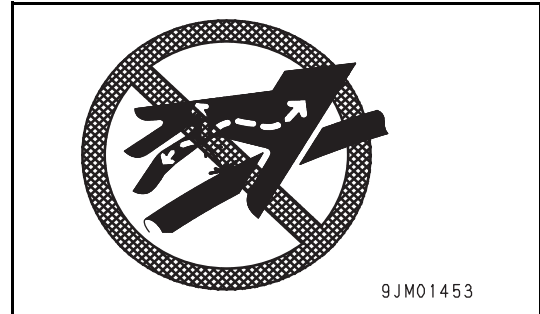

WARNING

BE CAREFUL OF THE ROTATING COOLING FAN AND BELT

- It is extremely dangerous if part of your body or a tool in your hand gets caught up in the rotating fan or fan belt. Never touch them when rotating.
- When inspecting rotating parts, do so only after the engine comes to a stop.
- When inspecting the areas around rotating parts, do not allow anything to come close which may get caught.

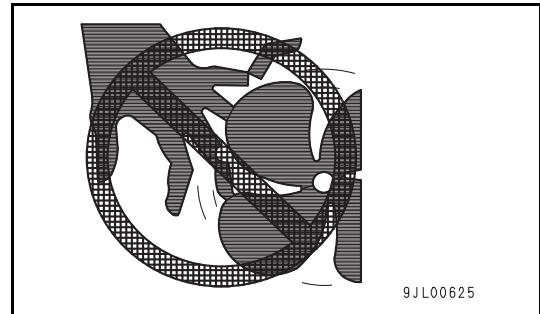

WARNING

JUMP STARTING THE ENGINE IS PROHIBITED

Do not push the lift truck to start the engine. There is danger that the lift truck may suddenly start and operate unexpectedly.

1.4. SAFETY IN PERIODIC MAINTENANCE

WARNING

AVOID THE DANGER OF GETTING CAUGHT UP OR FALLING OFF

- Never put your hands or feet into the mast structure. There is danger that you will get caught in moving parts and be seriously injured.
- Do not use the mast as a ladder. If you slip, there is danger that you will fall.

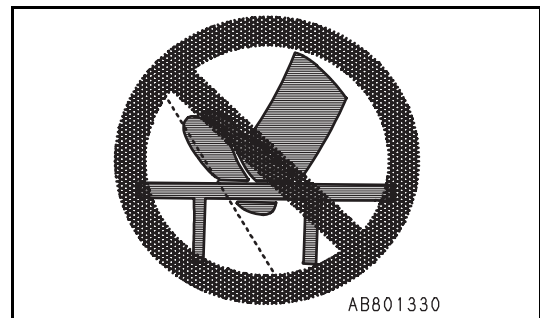
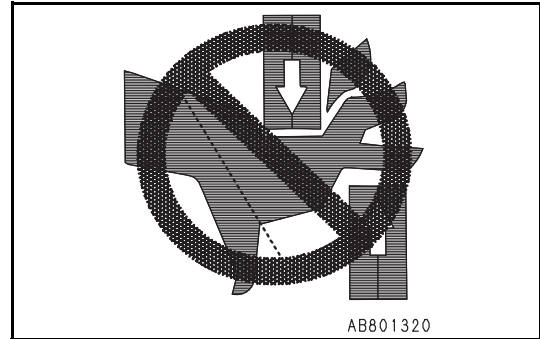

WARNING

INSPECTION AND INFLATION OF TIRES

- If the tire inflation pressure is low, it will affect truck stability. However, do not inflate the tires before checking the rims for damage. If a rim is damaged or cracked when a tire is inflated, there is danger that the rim will break under the high pressure of the tire, resulting in personal injury or death.
- For safety, when checking tire pressure, place your body in front of the tread face of the tire. Do not check from the side face of the tire.
- Always have tire inflation work carried out by properly qualified personnel.
- The tire inflation pressure on a forklift truck is several times higher than the pressure on an automobile, so exercise caution when handling tires.
- When the tires are being inflated, there is danger that dirt or dust may be thrown up by the compressed air and enter your eyes, so always wear safety glasses.

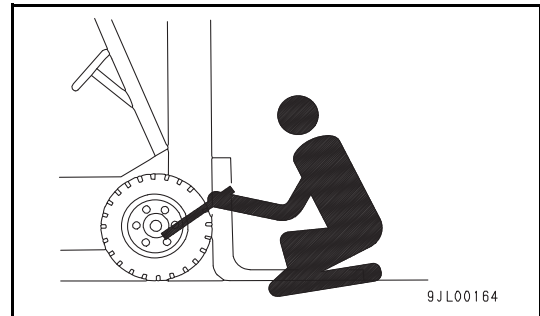

WARNING

HANDLING OF TIRES

- Disassembly and assembly of tires should be carried out by a qualified tire dealer.
- The tire inflation pressure is extremely high, so caution is needed when handling tires.
- When removing a tire, do so only after the internal air is released. Loosen hub nut (1) to remove the tire from the chassis. Never loosen rim nuts (2) if installed because it is very dangerous to do so.
- After replacing the tires, make a trial run to make sure that there are no loose hub nuts. If the tightening torque is not sufficient, further tighten the hub nuts to the specified torque.

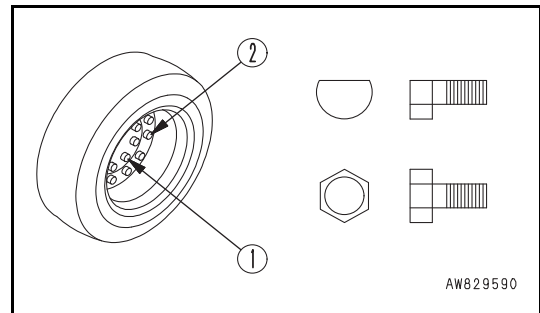

WARNING

JACKING-UP THE LIFT TRUCK FOR INSPECTION AND REPLACEMENT OF TIRES

- Do not go under the forklift truck when it is jacked up.
- Check the following before jacking up the lift truck.
- Check that there is no one on the lift truck.
 8. Check that there is no load on the forks.
- When jacking up, stop when the tires come off the ground surface. Put blocks under both sides of the frame to prevent the lift truck from coming down.
- Put a tire stopper behind the tires in contact with the floor so that the lift truck will not move freely.

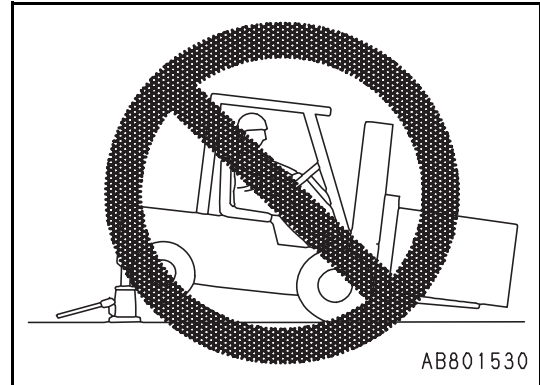

WARNING

PRECAUTIONS WHEN USING BOOSTER (JUMPER) CABLES

- ALWAYS wear safety glasses or goggles when starting the lift truck with booster cables.
- When starting using the battery of another lift truck, do not allow the two lift trucks to touch.
- Stop the engine before connecting the cables.
- Be extremely careful not to let the cables get caught in the fan or fan belt.
- Ensure that the cables are hooked up correctly - positive-to-positive and negative-to-negative. Never let the positive (+) and negative (-) terminals contact each other.

WARNING

SAFE HANDLING OF WASTES FROM LIFT TRUCK

Obey appropriate laws and regulations when disposing of harmful objects such as oil, filters, and batteries.

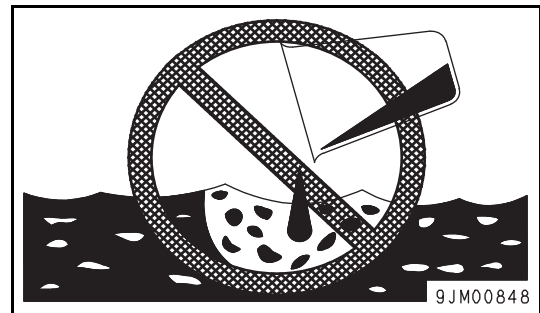

WARNING

PRECAUTIONS FOR WASHING LIFT TRUCK WITH WATER

- If water gets into the electrical system (controller, sensor, connectors, etc.), there is the hazard that it will cause malfunctions or operational failure. Do not wash the electrical system with water or high-pressure steam.
- For more details on the washing method, see "LIFT TRUCK WASHING PROCEDURE".

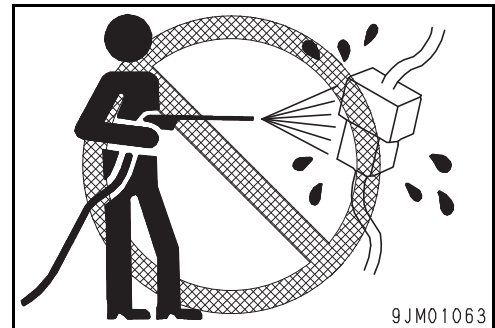

1.4. SAFETY IN PERIODIC MAINTENANCE

WARNING

SAFE HANDLING OF BATTERIES

- Battery electrolyte contains sulfuric acid, and can quickly burn the skin and eat holes in clothing. If you spill battery electrolyte on yourself, immediately shed the clothes, flush the part with a large quantity of tap water and then consult a doctor.
- Should battery electrolyte get into your eyes, flush them immediately with fresh tap water for 10 to 15 minutes and then consult a doctor at once.
- Should you drink battery electrolyte by accident, either drink a large quantity of water or milk mixed with beaten egg white or salad oil, and then consult a doctor at once.
- Be sure to wear goggles, safety gloves and rubber-soled shoes at the time of battery maintenance.
- Do not smoke or create any spark near the battery. Batteries generate hydrogen gas. Hydrogen gas is highly **EXPLOSIVE**, and is easily ignited with a small spark or flame.
- When inspecting or handling the battery, do so only after turning the engine starting switch key to the OFF position and stopping the engine.
- When disconnecting the battery cables, disconnect the cable of the negative (-) terminal first. Conversely, when connecting them again, connect the cable of the positive (+) terminal first.
- Avoid short-circuiting the battery terminals through accidental contact with tools or other metal objects across the terminals.
- Tighten the battery terminals securely. Loose terminals can generate sparks and lead to an explosion.
- When connecting the disconnected battery cables again, be sure which is the positive (+) terminal and which is the negative (-) terminal in order to avoid improper connection.
- Tighten the battery caps securely.
- When cleaning the battery, leave the battery caps tightened.
- Do not put a metallic tool or plate on the battery terminals by accident. There is danger that such a metallic object could cause short-circuiting leading to a fire.

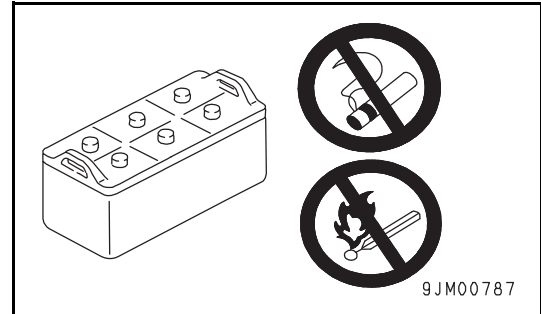

WARNING

PRECAUTIONS WHEN CHARGING BATTERIES

When the battery is charged, hydrogen gas is generated and the battery is heated by the chemical change. To prevent the danger of gas explosion, always do as follows.

- Before charging the battery, check that the battery electrolyte level stays within the specified range. If the electrolyte is found insufficient, add distilled or purified water without fail.
- Carry out the charging operation in a well-ventilated place.
- Do not smoke or allow any flame or ignition source.
- Start to charge the battery when the battery electrolyte temperature is below 35°C (95°F). If the electrolyte temperature is above 50°C (122°F), wait until it goes below 35°C (95°F).
- When using a battery charger to charge the battery, take the battery caps off.

WARNING

SAFE HANDLING OF ANTI-FREEZE

- Antifreeze can be a flammable. Keep away from flame when handling.
- Antifreeze is poisonous, so do not drink it. If you drink it by mistake, drink large amounts of water, vomit it out, and get medical attention immediately. Follow safety precautions on container.

WARNING

HOW TO MOVE A DISABLED LIFT TRUCK

Use extra care when towing a lift truck if there is a problem with any the following;

- a. Brakes do not operate correctly.
- b. Steering does not operate correctly.
- c. Tires are damaged.
- d. Traction conditions are poor.
- a. The lift truck must be moved on a steep grade.

If the steering pump motor does not operate, steering control of the lift truck can be slow. This can make the control of the lift truck difficult. If there is no power, there is no power steering.

DO NOT tow the lift truck if there is no power. Poor traction can cause the disabled lift truck or towing vehicle to slide. Steep grades will require additional brake force to stop the lift truck.

Never carry a disabled lift truck unless the lift truck MUST be moved and cannot be towed. The lift truck used to carry the disabled lift truck MUST have a rated capacity equal to or greater than the weight of the disabled lift truck. The capacity must be for a load center equal to half the width of the disabled lift truck. See the nameplate of the approximate total weight. The forks must extend the full width of the disabled lift truck. Center the weight of the disabled lift truck on the forks and be careful not to damage the under side of the lift truck.

WARNING

HOW TO TOW THE LIFT TRUCK

1. The towed lift truck must have an operator.
2. Tow the lift truck slowly.
3. Raise the carriage and mast channels and secure from moving.
4. If another lift truck is used to tow the disabled lift truck, that lift truck must have an equal or larger capacity than the disabled lift truck. Install an approximate half-capacity load on the forks of the lift truck that is being used to tow the disabled lift truck. This half-capacity load will increase the traction of the lift truck. Keep the load as low as possible.
5. Use a towing link made of steel that attaches to the tow pins in the counterweights of both lift trucks.

WARNING

HOISTING LIFT TRUCK

- Never lift the truck by the overhead guard. If the truck has to be lifted frequently, it is necessary to install special lifting equipment, so please contact your Komatsu Forklift dealer.
- Fit wire ropes to the specified lifting points.
- When lifting the lift truck, check that the wire ropes have ample strength and are not damaged.
- Never go under the lifted truck.
- If the specified lifting point is the counterweight, check that the counterweight mounting bolts are tightened to the specified torque before carrying out the lifting operation. Check also that there is no damage to the lifting portion on the counterweight.
- When using the hooks on the counterweight to hoist the lift truck, check beforehand that the counterweight mounting bolts are tightened to the specified torque and that there is no abnormality on the hooks.

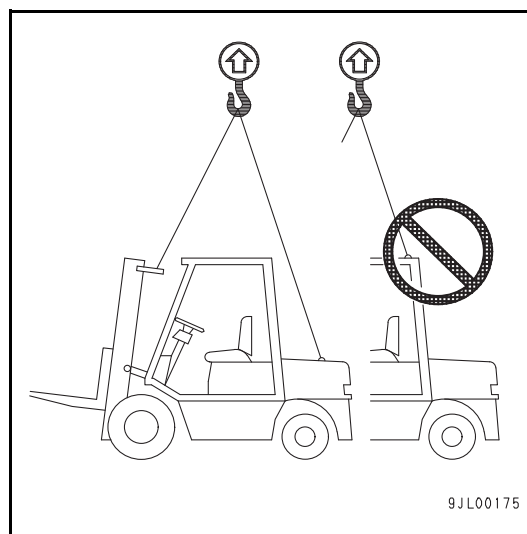

1.6. STRUCTURE AND STABILITY OF THE LIFT TRUCK

To operate the lift truck safely, it is important to understand the structure and stability of the lift truck. This section will educate the operator in methods to prevent tipping-over the lift truck.

STRUCTURE OF LIFT TRUCK

Forklift trucks basically consist of a lifting mechanism (fork and mast) and a main body (vehicle). The front wheels act as a fulcrum and the center of gravity of the lift truck and that of the load are kept in balance. The relationship between the positions of these two centers of gravity plays a very important role for the safety of the lift truck.

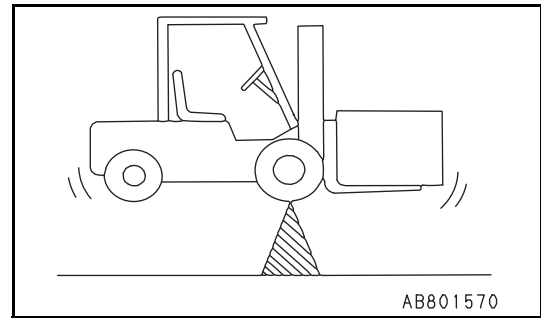

CENTER OF GRAVITY OF LOAD

The loads carried by forklift trucks come in various shapes from boxes to planks and long objects. To judge the stability of the lift truck, it is important to distinguish the position of the center of gravity for loads of various shapes.

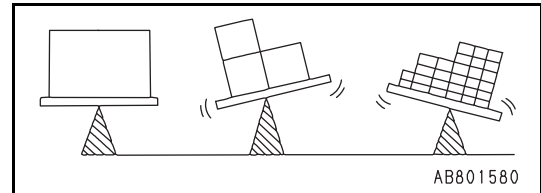

CENTER OF GRAVITY AND STABILITY

The stability of the lift truck is determined by the position of a combined center of gravity resulting from combining the centers of gravity of the lift truck and the load. When the lift truck is carrying no load, the center of gravity of the lift truck remains unchanged. On the other hand, when it is carrying a load, the center of gravity of the lift truck shifts to a combined center of gravity from the centers of gravity of both the lift truck and the load. The position of the center of gravity of a load changes as the mast is tilted back or forth, or it is raised or lowered. The position of the combined center of gravity also changes depending on the following factors.

- Size, weight, shape of load
- Lifting height
- Tilting angle of mast
- Inflation pressure of tires
- Acceleration, deceleration, turning radius
- Condition of road surface, angle of road
- Type of attachments

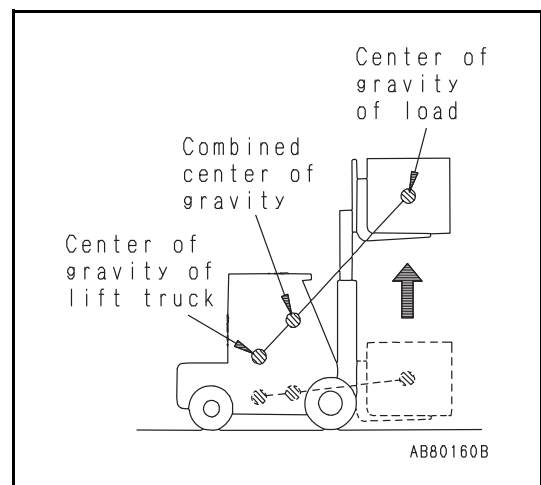
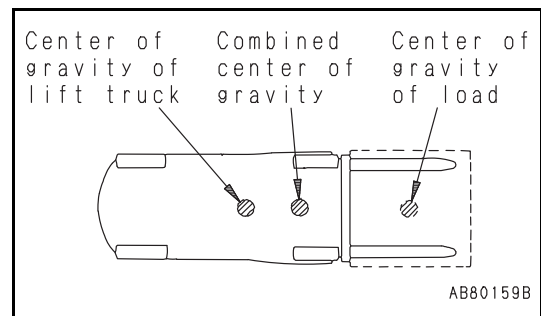

1.6. STRUCTURE AND STABILITY OF THE LIFT TRUCK

STABLE RANGE OF CENTER OF GRAVITY

For the lift truck to remain stable, the combined center of gravity of the lift truck must come within a stable range of the center of gravity, i.e. a triangle formed by three points of the right and left front wheels in contact with the floor and the center of the rear axle.

When a position of the combined center of gravity shifts beyond the front axle, the lift truck will tip over in the forward direction with the front wheels acting as a fulcrum. On the other hand, when a position of the combined center of gravity shifts outside of a stable range of the center of gravity, the lift truck will overturn in the direction of shifting.

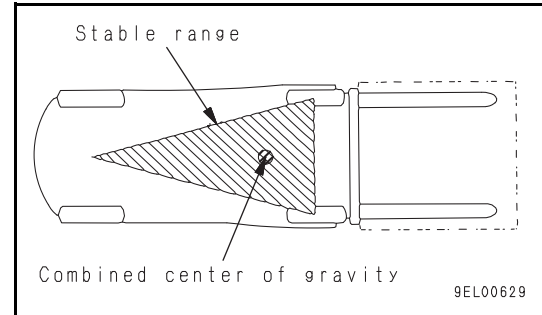

ACTUAL CAPACITY

The horizontal distance from the position of the center of gravity of a load on the fork to the upright load backrest of the fork is called a load center.

Actual capacity means the maximum weight of a load that can be loaded at a certain load center.

A load capacity chart is given in the name plate. The chart shows the relationship between the actual capacity and a load center.

As a load center shifts toward the fork tips, so does the position of the combined center of gravity, too. Therefore, the load has to be decreased accordingly in the actual operation.

When the lift truck is equipped with an attachment, or when the mast is raised high, the actual capacity is reduced. Take this fact into consideration in such a case.

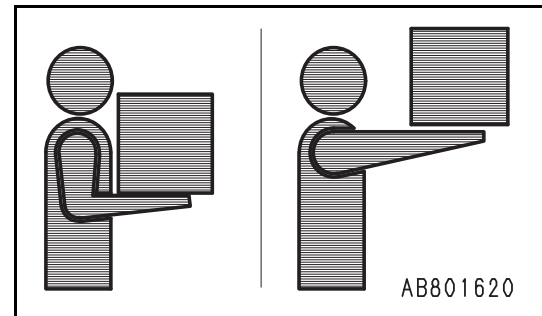

LOAD CAPACITY CHART

In the load capacity chart, capacity is shown in relation to load center. Capacity values are determined according to each model on the condition of the specifications shown on the plate.

Before proceeding to loading a load, make sure that the load center and the load are well within the confines of capacity.

When the load is in a complex shape, pull the load closer to the load backrest so that the heaviest portion of the load comes to the fork center.

Should a load be loaded beyond the confines of capacity, it would pose a serious danger to the lifting truck as the rear wheels (for steering) are likely to lift off the ground, causing the operator to lose control of steering.

To make the things still worse, the lift truck will likely tip over while in operation. Therefore, always make sure that the load is absolutely within the confines of capacity.

Komatsu Forklift USA, Inc. 14831 Lacey Road, Covington, Georgia 30014								
MODEL	TYPE	SERIAL #						
FRONT TIRE	TREAD	TILT						
REAR TIRE	YEAR OF MANUFACTURE							
ATTACHMENT								
A	B	C	D	CAPACITY	TRUCK WEIGHT	BATT. CAPACITY	TRUCK WEIGHT	BATT. CAPACITY
mm	mm	mm	mm	kg	kg	kg	kg	kg
10	10	10	10	10	10	10	10	10
TRUCK WEIGHT WITHOUT ATTACHMENT		CAPACITY LISTED ABOVE IS WITH MAST VERTICAL		THIS TRUCK MEETS ANSI/ASME B56.1				

LOAD CENTER AND ACTUAL CAPACITY

A nameplate shown at right is just an example. In the actual operation, follow the instructions on a nameplate of the actual lift truck.

An example here shows a nameplate for a lift truck which has a mast of max. fork height of 3.0 m and which is not equipped with any attachment.

- (1) When the load center is 500 mm (2) Capacity: 2,500 kg
- (1) When the load center is 600 mm (2) Capacity: 2,250 kg
- (1) When the load center is 1,000 mm (2) Capacity: 1,620 kg

MODEL	TYPE		SERIAL #					
FRONT TIRE	TREAD	TILT						
REAR TIRE	YEAR OF MANUFACTURE							
ATTACHMENT MODEL								
A	B	C	D	CAPACITY	TRUCK WEIGHT	BATT. CAPACITY	TRUCK WEIGHT	BATT. CAPACITY
mm	mm	mm	mm	kg	kg	kg	kg	kg
10	10	10	10	10	10	10	10	10
TRUCK WEIGHT WITHOUT BATT.		MAX		MIN	kg	BATT. CAPACITY WITHOUT ATTACHMENT		
THIS TRUCK MEETS ANSI/ASME B56.1								

AJL00123

Even when the load center is shorter than 500 mm, the actual capacity is 2,500 kg (2).

It is required to replace the present nameplate with a new one when the present nameplate is broken or has become difficult to read. In that case, call your Komatsu Forklift dealer asking for a new replacement nameplate.

1.6. STRUCTURE AND STABILITY OF THE LIFT TRUCK

SPEED AND ACCELERATION

If a stationary object is not subjected to external force, it will remain stationary. In the same way, if a moving object is not subjected to external force, it will continue to move at the same speed. This is called inertia.

Because of inertia, a force is applied towards the rear when the lift truck starts to move, and is applied towards the front when the lift truck stops. If the brakes are applied suddenly, there is danger of a large force being applied towards the front which may make the lift truck tip or the load to be expelled.

When the lift truck is turned, a centrifugal force is applied to the outside from the center of the turn.

This force pushes the lift truck to the outside and makes it tip. The range of stability to the left and right is particularly small, so it is necessary to reduce speed when turning, in order to prevent the lift truck from tipping. If the lift truck is traveling with a raised load, the position of the overall center of gravity is high, so the danger of tipping to the front, left, or right becomes greater.

1.7. SAFETY LABELS

Keep safety and other labels clean. If a label comes off, stick it on again or replace with a new one.

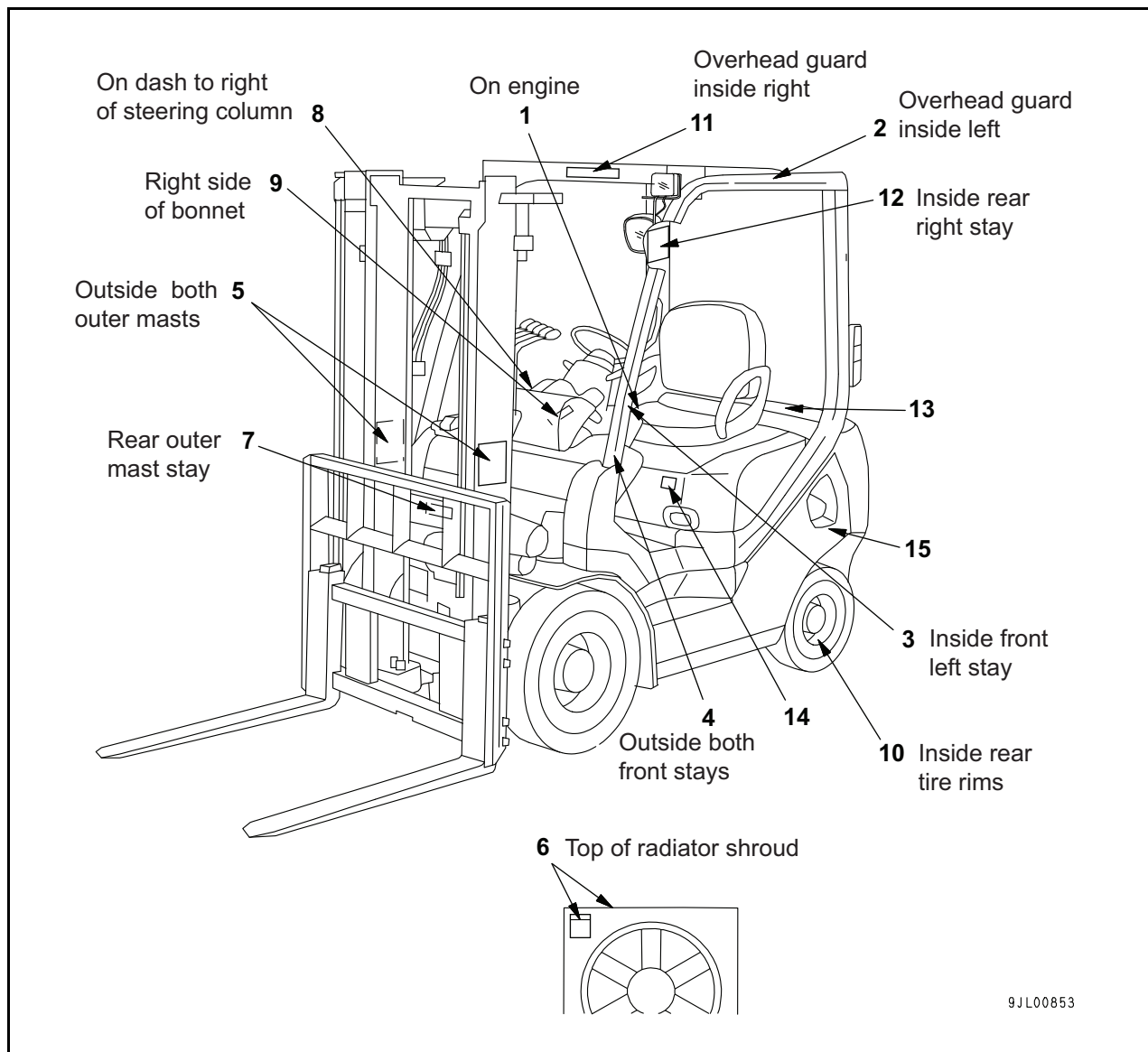

Details and ordering information for labels are given in the following sections.

1.7. SAFETY LABELS

1. Jump start prohibited. Start the engine only after sitting down in the operator's seat. Do not attempt to start the engine by short-circuiting the engine starting circuit. Such an act may cause serious bodily injury or fire.



2. Avoiding danger if lift truck overturns during operations.

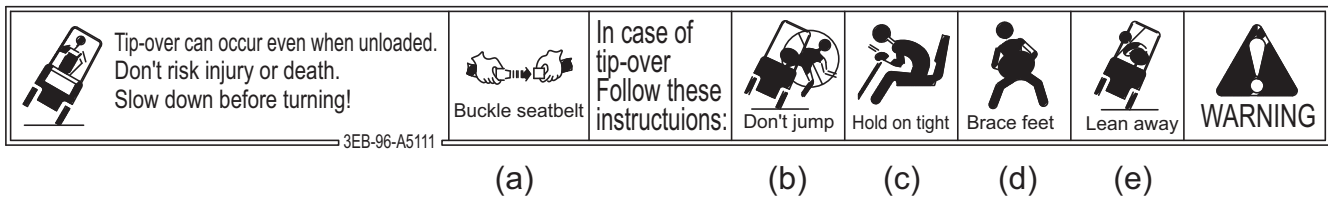

If the steering is operated suddenly during operations, there is danger that the lift truck may lose its balance and tip over. To avoid this danger, always observe the following precautions strictly.

- a. Always wear your seat belt during operations.
- b. Never jump off the lift truck.
- c. Hold on tight to avoid falling out and having the lift truck fall on top of you.
- d. Brace yourself with both feet to support your body.
- e. Lean in the opposite direction from the direction in which the lift truck is tipping.

Items (b) through (e) are instructions for when the lift truck tips over.

3. Using the parking brake.

 WARNING
<ul style="list-style-type: none"> • Pull parking brake to locked position and shut off power before leaving seat. • When parked with the power on, place high-low and forward-reverse lever in neutral. • If force required to engage brake is low (less than 44 lbs.), chock wheels when parking truck and contact forklift dealer for service. See manual for details.
<small>3EB-96-A5821</small>

1.7. SAFETY LABELS

4. Seating capacity – One No passengers allowed.



5. Prohibit the operator from standing on the forks.
Never enter the area under the forks.

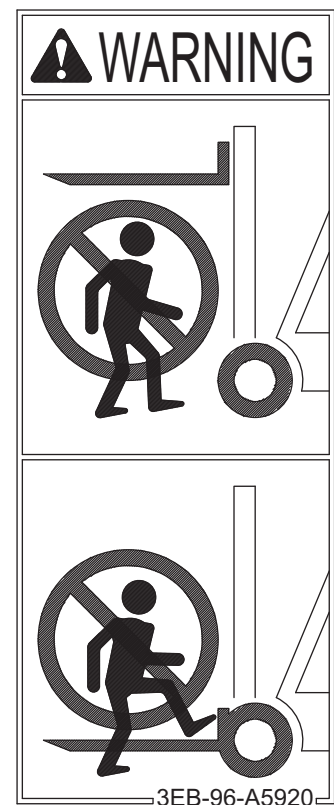

6. Use caution to avoid getting hand caught in fan (not shown).

7. Use caution to avoid getting hand caught.



1.7. SAFETY LABELS

8. Caution before operating machine.

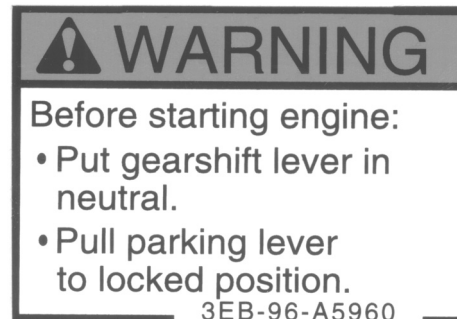

9. Warning for operation.



WARNING

SERIOUS INJURY OR DEATH MAY RESULT IF YOU FAIL TO FOLLOW THESE PRECAUTIONS!

Before Operating

- Do not operate or repair truck unless trained and authorized.
- Read and understand all warnings and instructions in manuals and on truck before operating.
- Dealers have replacement manuals.
- Check truck before use. If truck is in need of repair, do not operate until restored to safe condition.
- Do not start truck if fuel is leaking or has leaked.
- Use attachments for intended purpose only.

While Operating

- Operate truck only from operator's seat.
- Sit firmly in the seat with good posture while driving. Leaving the seat or sitting improperly for approximately 3 seconds may cause the drive system to disengage. Unintended truck movement like rolling on an incline may occur.
- Keep truck under control at all times.
- Do not overload truck. Check capacity plate for load weight and load center.
- Avoid any sudden starts, stops, turn or change of direction.
- Obey traffic safety rules. Yield right-of-way to pedestrians.
- Keep clear view of travel path. If load being carried blocks forward view, travel with load trailing.
- Slow down and sound horn when vision is blocked.
- Watch clearances, especially forks, mast, overhead guard and tailswing area.
- Slow down for turns and on uneven or slippery surfaces.
- Avoid running over loose objects.
- Never angle or turn on incline.
- Travel with load uphill when loaded.
- Travel with lifting mechanism downhill when empty.
- Secure dockboard or bridgeplate properly.
- Do not exceed rated capacity.
- Use special care when operating on dockboard or bridgeplate.

- Do not handle unstable loads or loosely stacked loads.
- Do not handle loads higher than load backrest.
- Space forks as far as load permits.
- Be sure load is centered and forks are completely under load.
- Never tilt load with mast tilted forward.
- Do not tilt forward when elevated except to pick up or deposit load.
- Travel load or lifting mechanism low and tilted back.
- Tipover can occur if operated improperly.
- Do not jump if truck begins to tipover. Hold on firmly and lean away from point of impact. Avoid being trapped between truck and ground.

General Precautions

- Allow no one to stand or pass under or near load or lifting mechanism.
- Never place any part of body into mast structure, between mast and truck or outside truck.
- Do not carry passengers on any part of truck.
- Lift no one under any circumstances.
- Do not operate without overhead guard and load backrest.
- Fill fuel or charge battery only in specified place.
- Stop engine when fueling and avoid open flame or sparks, and provide adequate ventilation.
- Keep vent caps clear when charging battery.
- Disconnect battery during servicing.

After Operating

- Before getting off truck, shift F-R lever and high-low lever (clutch type) to neutral position, fully lower lifting mechanism and pull parking lever securely.
- Shut off power when leaving truck unattended.
- Block wheels when parking on incline.

3EB-96-A6120

10. Warning for use of split rim (pneumatic tires only).



11. Replace overhead guard if damaged.



12. Method of hoisting the lift truck. Never use the overhead guard to lift the truck.

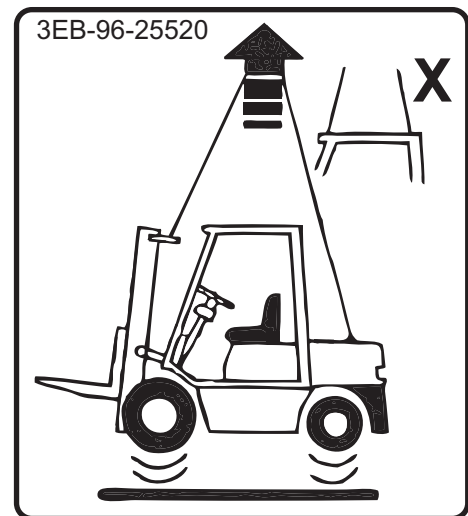

13. Warning for handling LPG/FLAMMABLE GAS (on LP tank bracket).

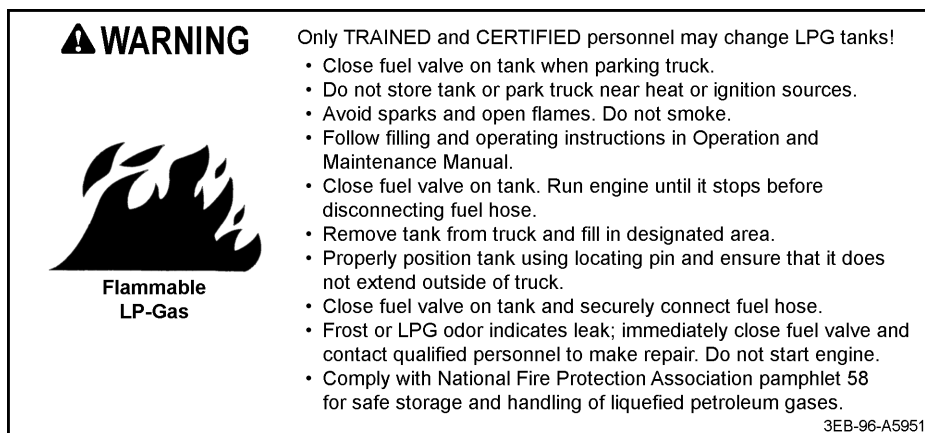

1.7. SAFETY LABELS

14. Slide seat forward prior to opening bonnet.

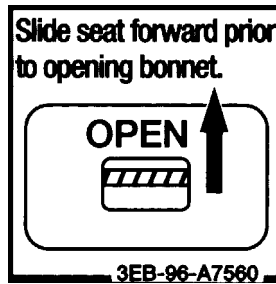

15. Fuel type.

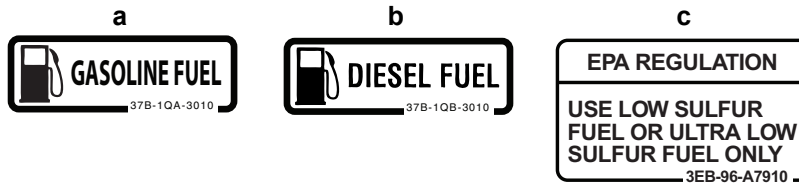

SAFETY LABEL ORDERING INFORMATION

Use the chart below to order the safety labels described above.

LABEL#	ORDER PART NO.
1	09842-A0481
2	3EB-96-A5111
3	3EB-96-A5821
4	3EB-96-A5910
5	3EB-96-A5920
6	3EB-96-A5931
7	3EB-96-A5940
8	3EB-96-A5960
9	3EB-96-A6120
10	3EB-96-A5970
11	37B-1QT-A030
12	3EB-96-25520
13	3EB-96-A5951
14	3EB-96-A7560
15	a: 37B-1QA-3010 b: 37B-1QB-3010 c: 3EB-96-A7910

Various safety devices are available as options. If operating conditions demand it, please install these devices. The devices listed below are only examples. Various other devices are also available. For details, please contact your Komatsu Forklift dealer.

1.8.1 REAR LAMP

Install this when carrying out operations at night which require the rear area to be lighted. (The law demands that sufficient lighting be provided to ensure safety.)

1.8.2 HIGH LOAD BACKREST

This improves the support for high loads and improves the stability of the load.

1.8.3 WIDE FORK CARRIAGE

This improves the support for wide load and improves the stability.

1.8.4 AUDIBLE SPEED ALARM

When the lift truck exceeds the preset speed, a buzzer sounds to warn the operator.

1.8.5 WARNING LAMPS

The following warning lamps may be added to the instrument panel.

- Battery electrolyte level warning lamp
- Air cleaner element clogging warning lamp
- Radiator cooling water level warning lamp