

**CALIFORNIA**  
**Proposition 65 Warning**

Diesel engine exhaust and some of its constituents are known to the State of California to cause cancer, birth defects, and other reproductive harm.



## To the Operator

This guide contains instructions on the safe operation and preventive maintenance of your Detroit Diesel Series 40™ engine used in motor coach, transit coach, construction/industrial, emergency vehicle and power generator set applications. Maintenance instructions cover routine engine services such as lube oil and filter changes in enough detail to permit self-servicing, if desired.

The operator should become familiar with the contents of this guide before operating the engine or carrying out maintenance procedures.

Power-driven equipment is only as safe as the person operating the controls. You are urged, as the operator of this diesel engine, to keep fingers and clothing away from the revolving belts, drive shafts, pulleys, etc. on the engine installation.

Throughout this guide **CAUTIONS** regarding personal safety and **NOTICES** regarding engine performance or service life will appear. To avoid personal injury and ensure long engine service life, always heed these instructions.

Whenever possible, it will benefit you to rely on an *authorized* Detroit Diesel service outlet for all your service needs from maintenance to

major parts replacement. Authorized service outlets worldwide stock factory-original parts and have the specialized equipment and experienced, trained personnel to provide prompt preventive maintenance and skilled engine repairs.

The information and specifications in this publication are based on the information in effect at the time of approval for printing. Contact an authorized Detroit Diesel service outlet for information on the latest revision. The right is reserved to make changes at any time without obligation.

## NOTICE:

**Failure to check and maintain SCA (supplemental coolant additive) levels at required concentrations will result in severe damage (corrosion) to the engine cooling system and related components.**

Coolant must be inhibited with the recommended SCAs listed in this guide. Refer to section G. How to Select Coolant. In addition, the engine can be equipped with a coolant filter/inhibitor system as an installed option or as an after-sale item.

## WARRANTY

The applicable engine warranty for Series 40 engines is contained in the Warranty Information section of this operator's guide. Individual engine warranty information booklets are available from authorized Detroit Diesel service outlets.

## Trademark Information

Detroit Diesel®, DDC®, DDEC®, reliabilt®, *POWER COOL*®, *POWER Trac*® and *POWER GUARD*® are registered trademarks of Detroit Diesel Corporation. Series 40™ is a trademark of Detroit Diesel Corporation. Delco Remy® is a registered trademark of Delco Remy America, Inc. Fuel Pro®, Sea Pro®, and Mega Filter® are registered trademarks of Davco Manufacturing, L.L.C.. PowerBand® is a registered trademark of Gates Rubber Company. Biobor® is a registered trademark of United States Borax and Chemical Corporation. All other trademarks used are the property of their respective owners.

**Keep this Operator's Guide with the engine installation at all times. It contains important operating, maintenance, and safety instructions.**

# TABLE OF CONTENTS

<b>INTRODUCTION</b> .....	1
NON-GENUINE AND REBUILT COMPONENT QUALITY ALERT ..	1
<b>CAUTION SUMMARY</b> .....	3
<b>GENERAL INFORMATION</b> .....	11
ENGINE FEATURES .....	11
COMPONENT LOCATION .....	11
<b>ENGINE MODEL AND SERIAL NUMBER LOCATIONS</b> .....	16
TURBOCHARGER IDENTIFICATION .....	17
<b>OPERATING INSTRUCTIONS</b> .....	18
PREPARATIONS FOR FIRST TIME ENGINE START .....	18
COOLING SYSTEM CHECKS .....	18
LUBRICATION SYSTEM CHECKS .....	19
FUEL SYSTEM CHECKS .....	20
OTHER CHECKS .....	21
STARTING THE ENGINE .....	22
ENGINE DIAGNOSTIC BUTTON .....	23
INITIAL ENGINE START .....	23
EMERGENCY JUMP STARTING .....	24
RUNNING THE ENGINE .....	26
OIL PRESSURE .....	26
WARM-UP .....	26
INSPECTION .....	26
AVOID UNNECESSARY IDLING .....	27
STOPPING THE ENGINE .....	27
NORMAL STOPPING .....	27
SHUTDOWN WARNING LIGHT AND BUZZER .....	27
ROAD OPERATION .....	28
COLD WEATHER OPERATION .....	28
HOT WEATHER OPERATION .....	29
EXTENDED IDLING PERIODS .....	29
<b>SERIES 40 ELECTRONIC CONTROL SYSTEM</b> .....	31

TABLE OF CONTENTS

---

<b>SERIES 40 ENGINE SYSTEMS</b> .....	36
FUEL SYSTEM .....	36
LUBRICATION SYSTEM .....	36
COOLING SYSTEM .....	36
ELECTRICAL SYSTEM .....	36
AIR INDUCTION SYSTEM .....	36
EXHAUST SYSTEM .....	36
<b>MAINTENANCE SCHEDULES</b> .....	37
MAINTENANCE INTERVALS .....	37
<b>LUBRICATION AND PREVENTIVE MAINTENANCE INTERVALS</b> ....	53
ITEM 1 – LUBRICATING OIL .....	53
ITEM 2 – FUEL AND FUEL TANK .....	55
ITEM 3 – FUEL LINES, FLEXIBLE HOSES .....	56
PRE-START INSPECTION .....	56
HOSE SERVICE LIFE .....	57
ITEM 4 – COOLING SYSTEM .....	58
COOLANT LEVEL .....	58
COOLANT INHIBITORS .....	58
COOLANT DRAIN INTERVAL .....	58
ITEM 5 – TURBOCHARGER, AIR-TO-AIR CHARGE COOLER .....	60
ITEM 6 – BATTERY .....	60
ITEM 7– DRIVE BELTS .....	61
ITEM 8 – AIR COMPRESSOR .....	62
ITEM 9 – AIR CLEANER .....	62
AIR CLEANER REPLACEMENT .....	63
ITEM 10 – LUBRICATING OIL FILTERS .....	63
ITEM 11 – FUEL FILTERS .....	64
FUEL FILTER AND STRAINER .....	64
FUEL PRO® 382 FILTERS .....	66
ITEM 12 – WATER PUMP, COOLANT INHIBITOR ELEMENT .....	66
WATER PUMP .....	66
COOLANT INHIBITOR ELEMENT .....	66
ITEM 13 – CRANKING MOTOR .....	66
ITEM 14 – AIR SYSTEM .....	67
ITEM 15 – EXHAUST SYSTEM .....	67
ITEM 16 – ENGINE (STEAM CLEAN) .....	67
ITEM 17 – RADIATOR .....	67

ITEM 18 – OIL PRESSURE .....	68
ITEM 19 – BATTERY-CHARGING ALTERNATOR .....	68
BOSCH & DELCO-REMY SERVICE REQUIREMENTS .....	68
ALTERNATOR PRECAUTIONS .....	68
ITEM 20 – ENGINE AND TRANSMISSION MOUNTS .....	69
ITEM 21 – CRANKCASE PRESSURE .....	69
ITEM 22 – FAN HUB .....	69
ITEM 23 – THERMOSTAT AND SEAL .....	70
ITEM 24 – CRANKCASE BREATHER .....	70
ITEM 25 – ENGINE TUNE-UP .....	70
ITEM 26 – IDLER PULLEY .....	71
ITEM 27 – VIBRATION DAMPER .....	71
WELDING PRECAUTION .....	72
<b>HOW-TO SECTION .....</b>	<b>73</b>
A. HOW TO SELECT LUBRICATING OIL .....	73
LUBRICANT SELECTION IN NORTH AMERICA .....	73
LUBRICANT REQUIREMENTS .....	73
THE USE OF SUPPLEMENTAL ADDITIVES .....	74
B. WHEN TO CHANGE OIL .....	75
OIL DRAIN INTERVALS .....	75
DISPOSING OF WASTE OIL .....	76
C. HOW TO REPLACE THE LUBE OIL FILTER .....	76
REPLACE SPIN-ON TYPE OIL FILTER .....	77
D. HOW TO SELECT FUEL OIL .....	78
QUALITY .....	78
FUEL CONTAMINATION .....	79
PROHIBITED ADDITIVES .....	79
USED LUBRICATING OIL .....	79
GASOLINE .....	79
E. HOW TO REPLACE THE FUEL FILTER .....	80
REPLACE FUEL FILTER AND STRAINER .....	80
PRIME THE FUEL SYSTEM .....	82
REPLACE FUEL/WATER SEPARATOR ELEMENT .....	84
REPLACE FUEL PRO FILTER ELEMENT .....	84
F. ENGINE OUT OF FUEL — HOW TO RESTART .....	87
G. HOW TO SELECT COOLANT .....	89
DEFINITIONS .....	89
APPROVED COOLANTS .....	89

TABLE OF CONTENTS

---

EG OR PG & WATER + SCA INHIBITOR .....	90
MIXING EG OR PG ANTIFREEZE AND WATER .....	90
RECYCLED ANTIFREEZE .....	92
EG OR PG & WATER + OAT INHIBITOR .....	93
WATER ONLY + SCA OR WATER ONLY + OAT INHIBITOR .....	93
WATER REQUIREMENTS .....	94
COOLANTS NOT RECOMMENDED .....	95
ADDITIVES NOT RECOMMENDED .....	95
MAINTENANCE .....	96
COOLANT INHIBITOR TEST INTERVALS .....	96
SUPPLEMENTAL ADDITIVES .....	96
MAINTENANCE INTERVALS .....	97
SCA TEST PROCEDURES .....	99
NEED-RELEASE FILTERS (NON-OAT SYSTEMS) .....	100
DROPOUT .....	101
EXTENDER ADDITIVE FOR OAT COOLANT .....	101
OAT COOLANT DRAIN INTERVAL .....	101
CHRONIC COOLANT SYSTEM PROBLEMS .....	102
MAINTENANCE PRODUCTS .....	102
POWER COOL SCAS .....	102
POWER COOL COOLANT FILTER ELEMENTS .....	102
POWER COOL CLEANERS .....	102
SUMMARY OF COOLANT RECOMMENDATIONS .....	103
H. HOW TO REPLACE THE COOLANT FILTER .....	105
I. HOW TO DRAIN AND FLUSH THE COOLING SYSTEM .....	106
J. WHEN TO SERVICE THE DRY TYPE AIR CLEANER .....	108
<b>BASIC TROUBLESHOOTING .....</b>	<b>109</b>
<b>ENGINE STORAGE .....</b>	<b>116</b>
PREPARING ENGINE FOR STORAGE .....	116
TEMPORARY STORAGE (30 DAYS OR LESS) .....	116
EXTENDED STORAGE (MORE THAN 30 DAYS) .....	117
RESTORING ENGINE TO SERVICE .....	120
<b>SERVICE PUBLICATIONS .....</b>	<b>122</b>
<b>DETROIT DIESEL CUSTOMER ASSISTANCE .....</b>	<b>123</b>



<b>MOTOR COACH, MOTOR HOME AND TRANSIT BUS ENGINE WARRANTY</b> .....	129
<b>FIRE TRUCK OR CRASH VEHICLE ENGINE WARRANTY</b> .....	132
<b>CONSTRUCTION/INDUSTRIAL ENGINE WARRANTY</b> .....	135
<b>PRIME AND STAND-BY POWER GENERATOR SET ENGINE WARRANTY</b> .....	139
<b>SPECIFICATIONS</b> .....	142
FUEL AND LUBRICATING OIL FILTER REQUIREMENTS .....	142
ENGINE OIL CAPACITY .....	142
POWER COOL ENGINE PRODUCTS .....	143
FULLY FORMULATED IEG COOLANT .....	143
LATIN AMERICAN COOLANT .....	143
2000 SUPPLEMENTAL COOLANT ADDITIVE .....	144
3000 SUPPLEMENTAL COOLANT ADDITIVE .....	144
3000 SUPPLEMENTAL ADDITIVE COOLANT FILTERS .....	145
SUPPLEMENTAL ADDITIVE NEED-RELEASE FILTERS .....	145
PLUS EXTENDED LIFE OAT COOLANT .....	146
PLUS EXTENDER FOR POWER COOL PLUS OAT COOLANT .....	146
PLUS OAT INHIBITOR FOR WATER-ONLY SYSTEMS .....	147
COOLING SYSTEM CLEANERS .....	147
COOLANT TESTING AND ANALYSIS PRODUCTS .....	148

*TABLE OF CONTENTS*

---

## INTRODUCTION

This guide is intended for use by the operator of a Detroit Diesel Series 40™ engine used in one of the following applications:

- Transit Coaches
- Construction/Industrial
- Generator Set

### Non-Genuine and Rebuilt Component Quality Alert

In recent years, electronic engine controls have been instrumental in aiding engine manufacturers in meeting the stringent emission requirements of the U.S. Environmental Protection Agency (U.S. EPA) and the California Air Resources Board (CARB) and also in meeting the ever-increasing performance demands of the customer.

Maintenance procedures are to be followed in order to continue satisfactory performance and durability and to ensure coverage of the engine under the manufacturer's warranty. Many of these maintenance procedures also ensure that the engine continues to comply with applicable emissions standards. The U.S. EPA specifically defines an engine's "useful emission life" — currently established as 290,000 miles (464,000 kilometers) for on-highway engines.

Proper maintenance procedures, using specific components engineered to comply with emissions regulations, may be performed by an authorized Detroit Diesel distributor or dealer, an independent outlet or the operator or owner. The owner is responsible for determining the suitability of components to maintain emissions compliance during the engine's useful emission life.

Electronic controls and components have significantly increased in sophistication, but the fundamental objective remains the same — precise timing and delivery of fuel. The very heart of the Detroit Diesel electronic controls is the electronic unit injector (EUI). The proper functioning of the EUI is absolutely paramount if the benefits of electronic controls are to be realized. Detroit Diesel Corporation has built over 650,000 engines with electronic unit injectors — more than anyone else in the business.

Detroit Diesel cautions that the indiscriminate rebuilding of precision components, without the benefit of specifications, specialized equipment, and knowledge of the electronic operating system, will jeopardize performance or lead to more serious problems, and can take the engine outside of compliance with U.S. EPA or CARB emissions standards.

## INTRODUCTION

---

There are other components in an engine, such as turbocharger, camshaft, piston, etc., which are specifically designed and manufactured to exacting standards for emissions compliance. It is important that these components, if replaced, modified or substituted, can be verified to ensure that the engine remains in compliance with emissions standards. The use of inadequately engineered, manufactured or tested components in repair or rebuild of the engine may be in violation of the federal Clean Air Act and applicable U.S. EPA (Environmental Protection Agency) or CARB (California Air Resources Board) regulations.

Furthermore, modern engines exhibit operating parameters which require the use of proper fluids, such as fuel, coolant and lubricating oil, to maintain long engine life. The use of fluids that do not meet Detroit Diesel Corporation specifications may result in early wear out or engine failure.

## CAUTION SUMMARY

The following cautions must be observed by the operator of the vehicle or equipment in which this engine is installed and/or by those performing basic engine preventive maintenance. Failure to read and heed these cautions and exercise reasonable care for personal safety and the safety of others when operating the vehicle/equipment or performing basic engine preventive maintenance may result in personal injury and engine and/or vehicle/equipment damage.

1. *Observe the following cautions when operating the engine:*

 <b>CAUTION:</b>
<p>To avoid injury from the loss of vehicle control, do not use cruise control under these conditions:</p> <ul style="list-style-type: none"> <li>□ When it is not possible to keep the vehicle at a constant speed (on winding roads, in heavy traffic, in traffic that varies in speed, etc.).</li> <li>□ On slippery roads (wet pavement, ice-or snow-covered roads, loose gravel, etc.).</li> </ul>

 <b>CAUTION:</b>
<p>To avoid injury from loss of vehicle control, do not activate the Engine Brake system under the following conditions:</p> <ul style="list-style-type: none"> <li>□ On wet or slippery pavement, unless the vehicle is equipped with ABS (anti-lock braking system) and you have had prior experience driving under these conditions.</li> <li>□ When driving without a trailer (bobtailing) or pulling and empty trailer.</li> <li>□ If the tractor drive wheels begin to lock or there is fishtail motion after the Engine Brake is activated. <i>Deactivate the brake system immediately, if this occurs.</i></li> </ul> <p>Failure to observe these precautions may result in loss of vehicle control and/or personal injury.</p>



**CAUTION:**

Diesel engine exhaust and some of its constituents are known to the State of California to cause cancer, birth defects, and other reproductive harm.

- Always start and operate an engine in a well ventilated area.
- If operating an engine in an enclosed area, vent the exhaust to the outside.
- Do not modify or tamper with the exhaust system or emission control system.



**CAUTION:**

To avoid injury when working on or near an operating engine, wear protective clothing, eye protection, and hearing protection.



**CAUTION:**

To avoid injury from hot oil, do not operate the engine with the rocker cover(s) removed.

2. *Observe the following cautions when performing basic preventive maintenance on the engine:*



**CAUTION:**

To avoid injury when working near or on an operating engine, remove loose items of clothing, jewelry, tie back or contain long hair that could be caught in any moving part causing injury.



**CAUTION:**

To avoid injury from fire, contain and eliminate leaks of flammable fluids as they occur. Failure to eliminate leaks could result in fire.



**CAUTION:**

To avoid injury from contact with the contaminants in used engine oil, wear protective gloves and apron.



**CAUTION:**

To avoid injury from hot surfaces, allow engine to cool before removing any component. Wear protective gloves.



**CAUTION:**

To avoid injury from slipping and falling, immediately clean up any spilled liquids.



**CAUTION:**

To avoid injury, use care when working around moving belts and rotating parts on the engine.



**CAUTION:**

To avoid injury from the expulsion of hot coolant, never remove the cooling system pressure cap while the engine is at operating temperature. Remove the cap slowly to relieve pressure. Wear adequate protective clothing (face shield or safety goggles, rubber gloves, apron, and boots).



**CAUTION:**

To avoid injury from contact with rotating parts when an engine is operating with the air inlet piping removed, install an air inlet screen shield over the turbocharger air inlet. The shield prevents contact with rotating parts.



**CAUTION:**

To avoid injury from fire caused by heated lubricating-oil vapors:

- Keep those people who are not directly involved in servicing away from the engine.
- Stop the engine immediately if an oil leak is detected.
- Do not allow open flames or smoke when working on an operating engine.
- Wear adequate protective clothing (face shield, insulated gloves, apron, etc.) to avoid burns.
- To prevent a buildup of potentially volatile vapors, keep the engine area well ventilated during operation.

Lubricating oil is relatively harmless at ambient temperatures.



**CAUTION:**

To avoid injury when using caustic cleaning agents, follow the chemical manufacturers usage, disposal, and safety instructions.

3. *Observe the following cautions when using compressed air:*



**CAUTION:**

To avoid injury from flying debris when using compressed air, wear adequate eye protection (face shield or safety goggles) and do not exceed 40 psi (276 kPa) air pressure.

4. *Observe the following cautions when using starting aids:*



**CAUTION:**

To avoid injury from rotating belts and fans, do not remove and discard safety guards.





**CAUTION:**

To avoid injury from flames, explosion, and toxicants when using ether, the following precautions must be taken:

- Always wear goggles when testing.
- If fluid enters the eyes or if fumes irritate the eyes, wash eyes with large quantities of clean water for 15 minutes. A physician, preferably an eye specialist, should be contacted.
- Contents of cylinder are under pressure. Store cylinders in a cool dry area. Do not incinerate, puncture or attempt to remove cores from cylinders.



**CAUTION:**

To avoid injury from flames, explosion, and toxicants when using ether, the following precautions must be taken:

- Do not smoke when servicing ether system.
- Work in well-ventilated area.
- Do not work near open flames, pilot flames (gas or oil heaters), or sparks.
- Do not weld or carry an open flame near the ether system if you smell ether or otherwise suspect a leak.

5. *Observe the following cautions when jump starting an engine, charging a battery, or working with the vehicle/application electrical system:*



**CAUTION:**

To avoid injury from accidental engine startup while servicing the engine, disconnect/disable the starting system.



**CAUTION:**

To avoid injury from battery explosion or contact with battery acid, work in a well-ventilated area, wear protective clothing, and avoid sparks or flames near the battery. Always establish correct polarity before connecting cables to the battery or battery circuit. If you come in contact with battery acid:

- Flush your skin with water.
- Apply baking soda or lime to help neutralize the acid.
- Flush your eyes with water.
- Get medical attention immediately.



**CAUTION:**

To avoid increased risk of a fuel fire, do not mix gasoline and diesel fuel.



**CAUTION:**

To avoid injury from fire, keep all potential ignition sources away from diesel fuel, open flames, sparks, and electrical resistance heating elements. Do not smoke when refueling.



**CAUTION:**

To avoid injury from electrical shock, do not touch battery terminals, alternator terminals, or wiring cables while the engine is operating.



**CAUTION:**

To avoid injury from fire, contain and eliminate leaks of flammable fluids as they occur. Failure to eliminate leaks could result in fire.

6. *Observe the following cautions when fueling the vehicle, replacing fuel filters or working with the engine fuel system.*



**CAUTION:**

To avoid injury from fire caused by heated diesel-fuel vapors:

- Keep those people who are not directly involved in servicing away from the engine.
- Stop the engine immediately if a fuel leak is detected.
- Do not allow open flames or smoke when working on an operating engine.
- Wear adequate protective clothing (face shield, insulated gloves and apron, etc.).
- To prevent a buildup of potentially volatile vapors, keep the engine area well ventilated during operation.

Diesel fuel is relatively harmless at ambient temperatures.

7. *Observe the following cautions when servicing the cooling system:*



**CAUTION:**

To avoid injury from the expulsion of hot coolant, never remove the cooling system pressure cap while the engine is at operating temperature. Remove the cap slowly to relieve pressure. Wear adequate protective clothing (face shield or safety goggles, rubber gloves, apron, and boots).



**CAUTION:**

To avoid injury from slipping and falling, immediately clean up any spilled liquids.

8. *Observe the following cautions when working on the engine air intake system:*



**CAUTION:**

To avoid injury from hot surfaces, allow engine to cool before removing any component. Wear protective gloves.



**CAUTION:**

To avoid injury from contact with rotating parts when an engine is operating with the air inlet piping removed, install an air inlet screen shield over the turbocharger air inlet. The shield prevents contact with rotating parts.

9. *Observe the following cautions when replacing the engine lubricating oil and filters:*



**CAUTION:**

To avoid injury from fire caused by heated lubricating-oil vapors:

- Keep those people who are not directly involved in servicing away from the engine.
- Stop the engine immediately if an oil leak is detected.
- Do not allow open flames or smoke when working on an operating engine.
- Wear adequate protective clothing (face shield, insulated gloves, apron, etc.) to avoid burns.
- To prevent a buildup of potentially volatile vapors, keep the engine area well ventilated during operation.

Lubricating oil is relatively harmless at ambient temperatures.



**CAUTION:**

To avoid injury from slipping and falling, immediately clean up any spilled liquids.

## GENERAL INFORMATION

### Engine Features

The Series 40 is a family of inline six-cylinder, 4-stroke cycle, water-cooled, turbocharged engines which may be equipped with a chassis-mounted, air-to-air charge cooler system.

Engines built prior to 1998 used a mechanical, high-pressure fuel pump and individual injector nozzles. Operators of these engines should refer to *Series 40 Engine Operators Guide* 6SE516 for preventive maintenance information.

Engines built from 1998 – present are direct fuel injected with hydraulically actuated, electronically controlled unit injectors. This operator's guide covers these current engines.

### Component Locations

The following figures show the locations of major engine components.

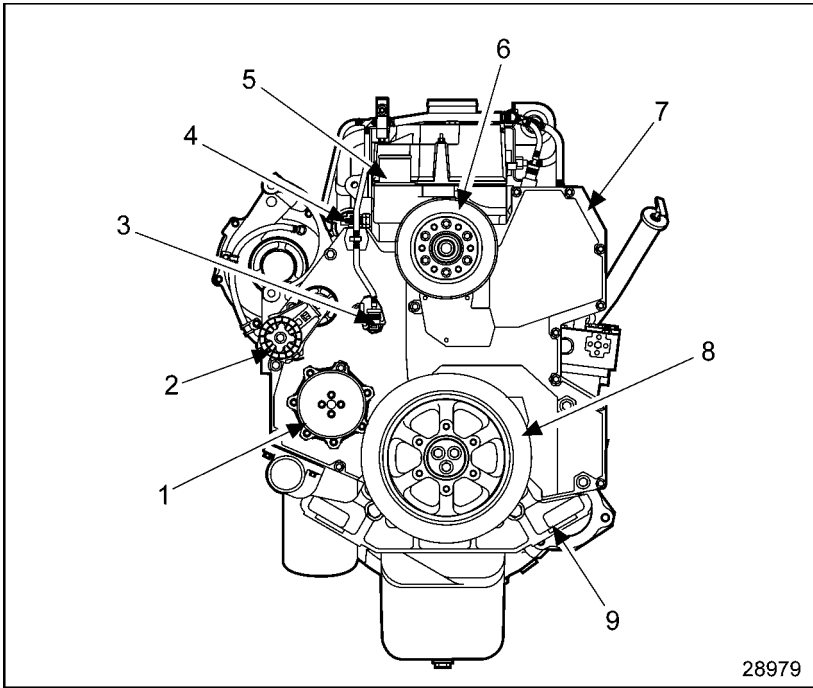

- |                               |                     |
|-------------------------------|---------------------|
| 1. Water Pump Pulley          | 6. Fan Pulley       |
| 2. Auto Belt Tensioner        | 7. Front Cover      |
| 3. Camshaft Position Sensor   | 8. Vibration Damper |
| 4. Coolant Temperature Sensor | 9. Mounting Bracket |
| 5. Thermostat                 |                     |

**Figure 1 Major Component Locations, Front View**

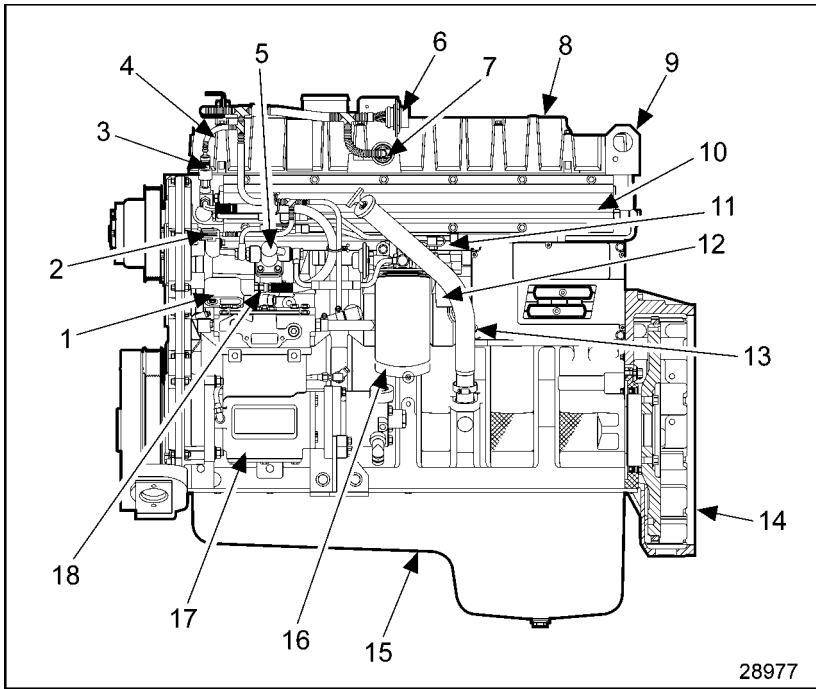

- |                                 |   |
|---------------------------------|---|
| 1. High Pressure Oil Pump       | 10. High-Pressure Oil/Fuel Manifold     |
| 2. Oil Temperature Sensor       | 11. Fuel Filter Header                  |
| 3. Injector Pressure Sensor     | 12. Fuel Strainer                       |
| 4. Wiring Harness               | 13. Oil Fill Tube                       |
| 5. Fuel Supply Pump             | 14. Flywheel Housing                    |
| 6. 31-Pin Connector             | 15. Oil Pan                             |
| 7. Wiring Harness Connector     | 16. Fuel Filter                         |
| 8. Valve Cover/ Intake Manifold | 17. Air Compressor (if equipped)        |
| 9. Lifting Eye (2)              | 18. Injection Pressure Regulating Valve |

**Figure 2 Major Component Locations, Left Side View**

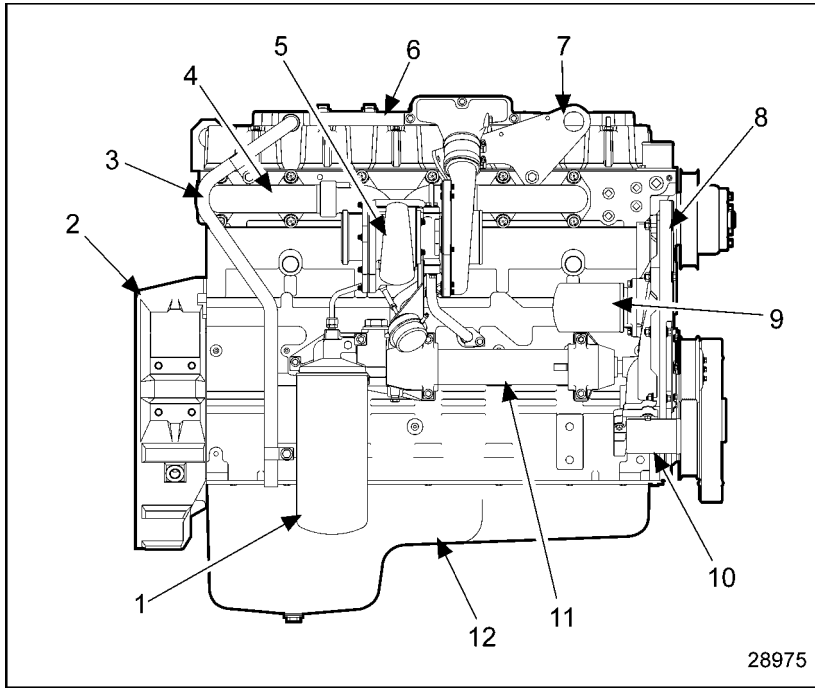

- |                                |                       |
|--------------------------------|-----------------------|
| 1. Oil Filter                  | 7. Lifting Eye (2)    |
| 2. Flywheel Housing            | 8. Alternator Bracket |
| 3. Road Draft Tube             | 9. Coolant Filter     |
| 4. Exhaust Manifold            | 10. Water Inlet       |
| 5. Turbocharger                | 11. Oil Cooler        |
| 6. Valve Cover/Intake Manifold | 12. Oil Pan           |

**Figure 3 Major Component Locations, Right Side View**



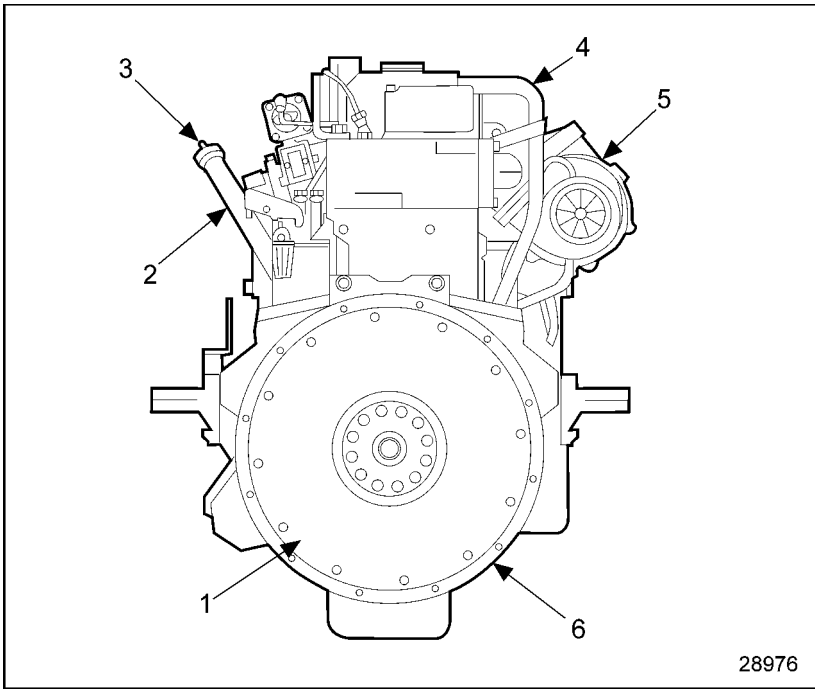

- |                   |                     |
|-------------------|---------------------|
| 1. Flywheel       | 4. Road Draft Tube  |
| 2. Oil Fill Tube  | 5. Turbocharger     |
| 3. Oil Level Gage | 6. Flywheel Housing |

**Figure 4 Major Component Locations, Rear View**

## ENGINE MODEL AND SERIAL NUMBER LOCATIONS

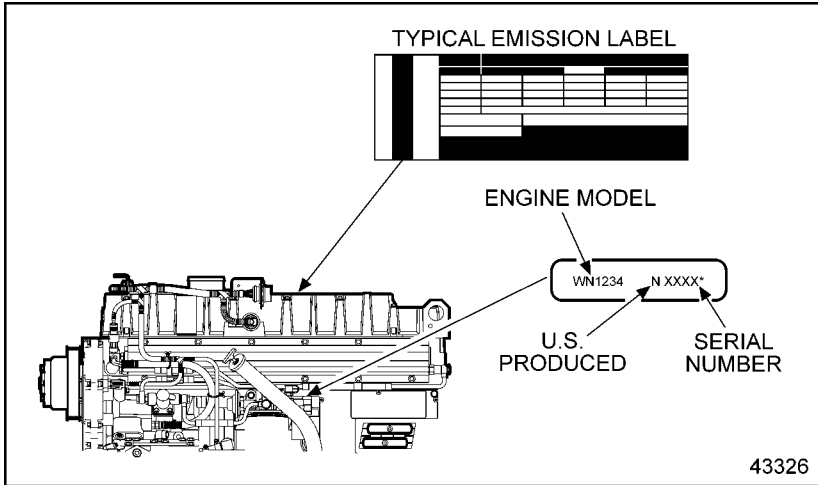

Figure 5 Model, Serial Number and Emission Label – Former Location

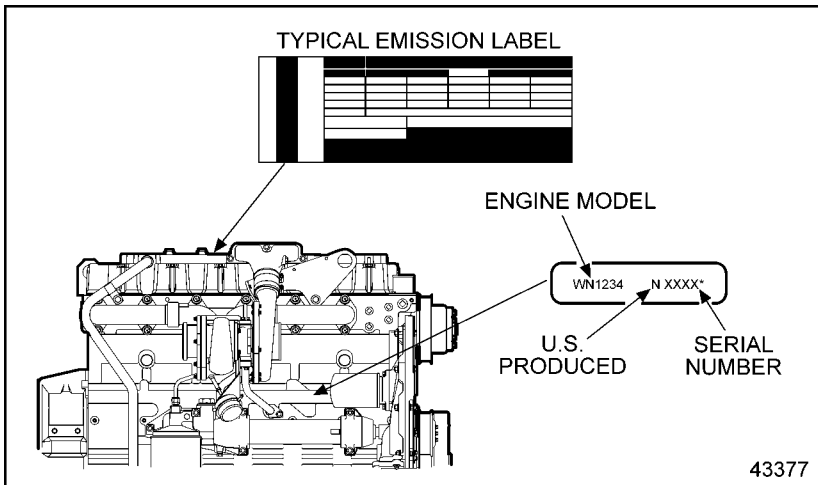

Figure 6 Model, Serial Number and Emission Label – Current Location

The engine model and serial numbers were previously laser etched on the left side, center of the cylinder block. See Figure 5. Beginning in late year 2000, these numbers were relocated to a machined pad on the right side of the block, and directly above the oil cooler. See Figure 6.

## Turbocharger Identification

The turbocharger identification plate is located on the flat, inboard face of the compressor housing. See Figure 7.

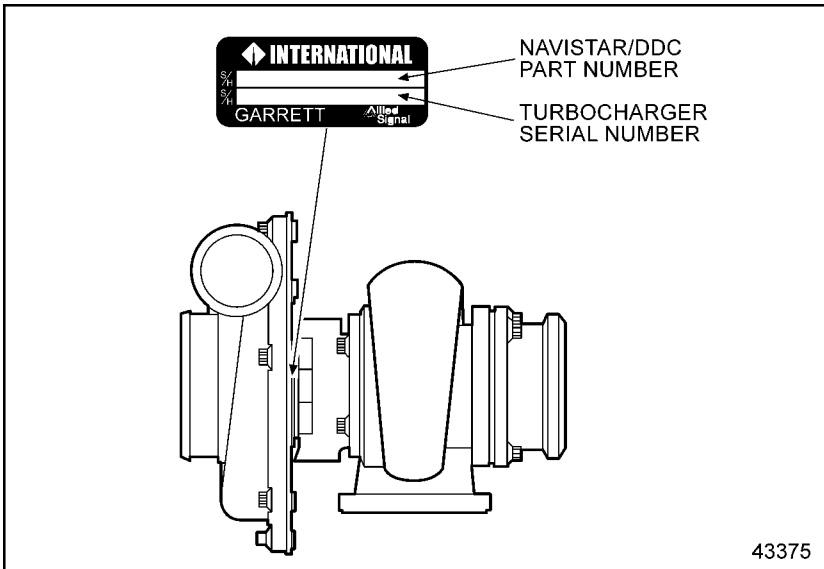

Figure 7 Turbocharger Identification (non-wastegate turbo shown)

## OPERATING INSTRUCTIONS

### Preparations for Starting the Engine the First Time

When preparing to start a new or newly overhauled engine which has been in storage, perform all of the operations listed below. Failure to follow these instructions may result in serious engine damage. Before a routine start, see the “Daily” checks for your engine. Refer to section MAINTENANCE SCHEDULES.



#### CAUTION:

**Diesel engine exhaust and some of its constituents are known to the State of California to cause cancer, birth defects, and other reproductive harm.**

- **Always start and operate an engine in a well ventilated area.**
- **If operating an engine in an enclosed area, vent the exhaust to the outside.**
- **Do not modify or tamper with the exhaust system or emission control system.**



#### CAUTION:

**To avoid injury when working near or on an operating engine, remove loose items of clothing, jewelry, tie back or contain long hair that could be caught in any moving part causing injury.**

### Cooling System Checks

1. Make sure all drain cocks in the cooling system are installed (drain cocks are often removed for shipping) and are closed tightly.
2. Remove the radiator pressure control cap and fill with genuine Detroit Diesel *Power Cool* antifreeze or an equivalent quality ethylene glycol or propylene glycol-base antifreeze solution in the required concentration. In extremely hot environments, **properly inhibited** water may be used in the summer. Keep the coolant level at the bottom of the filler neck to allow for expansion of the coolant. For more detailed recommendations,

refer to section G. How to Select Coolant in this guide.

**NOTE:**

Entrapped air must be purged after filling the cooling system. To do this, allow the engine to warm up with the pressure cap removed. With the transmission in neutral, increase engine speed above 1,000 rpm and add coolant to the radiator as required.

3. Check to make sure the front of the radiator and air-to-air charge cooler are unblocked and free of debris.

**Lubrication System Checks**

The lubricating oil film on the rotating parts and bearings of a new or newly overhauled engine, or one which has been in storage for six months or more, may be insufficient when the engine is started for the first time.

**NOTICE:**

Insufficient lubrication at startup can cause serious damage to engine components.

To insure an immediate flow of oil to all bearing surfaces at initial engine startup, the engine lubrication system should be charged with a commercially available pressure pre-lubricator. If this is impractical,

rocker cover should be removed and clean lubricating oil should be poured over the rocker arms. The oil should be the same weight and viscosity as that used in the crankcase. After pre-lubricating, replace rocker cover and add additional oil to bring the level to the proper mark on the dipstick. See Figure 8.

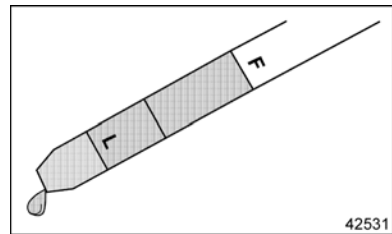

**Figure 8 Check Lube Oil Level Before Starting**

**NOTE:**

The current oil level gage is identified by the words "Operating Range" and "Add" separated by a cross-hatched area. When using this dipstick, keep the oil level within the cross-hatched area.

**NOTE:**

The former oil level gage has the word "Full" above the upper gage line and the word "Add" below the lower gage line. When using this dipstick, maintain the oil level between the "Full" and "Add" gage lines.

**NOTICE:**

To avoid engine damage, never operate the engine when the oil level is outside the cross-hatched area on the current dipstick or outside the area between the "Add" and "Full" gage lines on the former dipstick.

For lubricant recommendation, refer to section A. How to Select Lubricating Oil in the **How To** section of this guide.

**Extended Storage** – An engine in storage for an extended period of time (over winter, for example) may accumulate water in the oil pan through normal condensation of moisture (always present in the air) on the cold, internal surfaces of the engine. Lube oil diluted by water cannot provide adequate bearing protection at engine startup. For this reason, Detroit Diesel recommends replacing the engine lubricating oil and filters after extended storage.

**NOTICE:**

Failure to eliminate water-diluted lubricating oil may lead to serious engine damage at startup.

**Fuel System Checks**

Fill the tanks with the recommended fuel. Keeping tanks full reduces water

condensation and helps keep fuel cool, which is important to engine performance. Full tanks also reduce the chance for microbe (black slime) growth. For fuel recommendations, refer to section D. How to Select Fuel Oil in the **How To** section of this guide. Make sure the fuel shutoff valve (if used) is open.

**NOTICE:**

Do not use the engine starting system to prime the fuel system before initial engine start. This can result in damage to the starter, fuel pump and injectors tips and may cause erratic engine operation due to the amount of air in the lines and filters from the fuel supply tank to the cylinder head.

Engines equipped with starting devices dependent on compressed air or gas reservoirs should always be primed before initial startup. Otherwise, reserve pressure can be exhausted and injectors may be damaged from lack of lubrication and cooling.

**Under no circumstances should a starting aid such as ether be used to run the engine until the fuel system is primed. Injector tip damage will result if this method is used.**

**NOTICE:**

Starting an engine taken out of storage or one recently overhauled without first priming the fuel system will result in an overload condition that can damage the injector tips. To avoid injector tip damage, the fuel system must be primed before initial engine startup.

If the engine is equipped with a fuel/water separator, drain off any water that has accumulated. Water in fuel can seriously affect engine performance and may cause engine damage. Detroit Diesel recommends installation of a fuel/water separator wherever water contamination is a concern.

If previously disconnected, reconnect charge air cooler piping to valve cover/intake manifold.

To insure prompt starting, even running and avoid injector tip damage, the fuel system *must* be primed before initial engine start. Use this procedure:

**NOTE:**

Authorized Detroit Diesel service outlets are properly equipped and have the trained technicians to perform this service.

**NOTICE:**

Failure to disconnect the CMP (camshaft position sensor) before priming the engine may allow the engine to start during priming, which could result in severe engine damage.

1. Disconnect the CMP (camshaft position sensor) to prevent the engine from starting.
2. Using the manual priming pump on the fuel filter header, fill the system with clean fuel until the primer pump is hard to depress.
3. Crank the engine three times for 15 seconds each. Reapply the primer pump after each crank cycle.
4. Once the primer pump is hard to depress (usually three crank and hand prime cycles), reconnect the CMP.

**Other Checks**

Check the hydrometer “eye” of maintenance-free batteries for charge. See Figure 9.

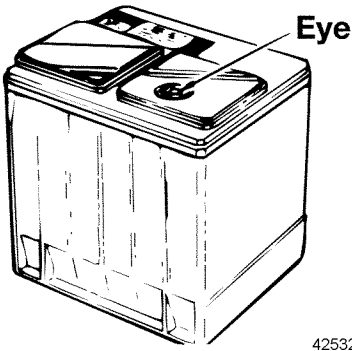

**Figure 9** Check "Eye" of Maintenance-Free Batteries

If lead-acid or low-maintenance batteries are used, make sure battery electrolyte level is normal.

Make sure cable connections to the storage batteries are clean and tight.

Check the turbocharger for signs of oil or exhaust leaks. Leaks should be corrected before starting the engine.

Check engine mounting bolts for tightness. Bolts should be retightened, if necessary.

Make sure the transmission is filled to the proper level with the fluid recommended by the gear manufacturer. Do not overfill.

Check drive belts to make sure they are in good condition (not cracked, torn, worn or glazed).

## Starting the Engine

Before starting the engine the first time, refer to section Preparations for Starting the Engine the First Time in the **Operating Instructions** section and perform the operations listed.



### CAUTION:

To avoid injury from flames, explosion, and toxicants when using ether, the following precautions must be taken:

- Do not smoke when servicing ether system.
- Work in well-ventilated area.
- Do not work near open flames, pilot flames (gas or oil heaters), or sparks.
- Do not weld or carry an open flame near the ether system if you smell ether or otherwise suspect a leak.

The engine may require the use of a cold weather starting aid if the ambient temperature is below 40 °F (4 °C).



## Engine Diagnostic Button

The engine diagnostic button, located on the vehicle dashboard, is used to read faults detected by the ECM (electronic control module). The ECM will flash the CEL (check engine light) to warn of problems with the engine, oil, or coolant and indicates which faults have been detected.

Depress and hold the engine diagnostic button. Turn the ignition switch to the ON position and then release the engine diagnostic button. **DO NOT START THE ENGINE.** The ECM will begin the self-test to check the sensor output circuits. If a fault is detected, the CEL will flash repeatedly, signaling the action fault code. Additional information on the engine diagnostic button is available in the *Series 40 Troubleshooting Manual*, 6SE241, available from authorized Detroit Diesel distributors.

## Initial Engine Start



### CAUTION:

**Diesel engine exhaust and some of its constituents are known to the State of California to cause cancer, birth defects, and other reproductive harm.**

- Always start and operate an engine in a well ventilated area.**
- If operating an engine in an enclosed area, vent the exhaust to the outside.**
- Do not modify or tamper with the exhaust system or emission control system.**

**Electric Starter** – Start an engine equipped with an electric starting motor as follows:

1. Set the parking brake and place the transmission in NEUTRAL. If an automatic transmission, place it in PARK or NEUTRAL.
2. Depress the clutch pedal, if equipped. *Do not depress the accelerator pedal.*

**NOTICE:**

To prevent serious starting motor damage, do not press the starter switch again after the engine has started.

3. With foot off of the accelerator pedal, turn the ignition key to the START position and crank the engine. If the vehicle has push button starting, PRESS and HOLD the starter button.
4. As soon as the engine starts, release the key or starter button, if applicable.

**NOTE:**

If the engine fails to start within 15 seconds, release the starter switch and allow the starter to cool for 15 seconds before trying again. If the engine fails to start after four attempts or if it starts and then stops immediately, an inspection should be made to determine the cause.

**Air Starter** – Because of the limited volume of most compressed air storage tanks and the relatively short duration of the cranking cycle, *it is important to make sure the engine is ready to start before activating the air starter.* Start an engine equipped with an air starter as follows:

1. Check the pressure in the air storage tank. If necessary, add air

to bring the pressure up to at least the recommended minimum for starting.

2. With foot OFF the foot pedal, turn the ignition key to the start position and press and hold the starter button until the engine starts.

**NOTE:**

If the engine fails to start after four attempts or if it starts and stops immediately, an inspection should be made to determine the cause.

**Emergency Jump Starting**



**CAUTION:**

**To avoid injury from battery explosion when jump starting the engine, do not attach the cable end to the negative terminal of the disabled battery.**

The Series 40 engine ECM (electronic control module) operates on either 12 or 24 volts. When jump starting an engine, do not exceed 18 volts for a 12-volt system or 32 volts for a 24-volt system.

**NOTICE:**

Jump starting with voltages greater than those indicated or reversing battery polarity may damage the ECM (electronic control module).

Perform the following operations for emergency jump starting:



**CAUTION:**

**To avoid injury from battery explosion or contact with battery acid, work in a well-ventilated area, wear protective clothing, and avoid sparks or flames near the battery. Always establish correct polarity before connecting cables to the battery or battery circuit. If you come in contact with battery acid:**

- **Flush your skin with water.**
- **Apply baking soda or lime to help neutralize the acid.**
- **Flush your eyes with water.**
- **Get medical attention immediately.**

1. To prevent possible shorting, remove metal rings and watches and do not allow metal tools to contact the positive terminal of the battery.

2. Place the transmission in NEUTRAL and set the parking brake.
3. Bring the assisting vehicle close to the disabled vehicle, but do not allow vehicles to touch. Stop the engine on the assisting vehicle.
4. Shut off all lights, heater, air conditioner and any other electrical loads in both vehicles.
5. Connect the first jumper cable to the positive (+) terminal of the dead battery and the positive (+) terminal of the booster battery. Connect the second jumper cable to the negative (-) terminal of the booster battery and an engine bolt head, metal support bracket or other good metallic contact on the disabled vehicle.
6. Start the engine on the assisting vehicle and allow it to charge the battery on the disabled vehicle for at least one minute.
7. With foot OFF the foot pedal, turn the ignition key to the start position and press and hold the starter button until the engine starts.

**NOTE:**

If the engine fails to start after four attempts or if it starts and stops immediately, an inspection should be made to determine the cause.

8. After the engine starts, remove jumper cables in reverse order of attachment.

## Running the Engine

### Oil Pressure

Observe the oil pressure gage immediately after starting the engine. A good indicator that all moving parts are getting lubrication is when the oil pressure gage exceeds 137 kPa (20 psi) after starting. If oil pressure is less than this or if no oil pressure is indicated, stop the engine, check for the cause and correct the condition.

After the engine has reached operating temperature, the oil pressure should be 276 kPa (40 psi) minimum. If oil pressure does not meet this minimum, stop the engine, check for the cause and correct the condition.



### CAUTION:

To avoid injury from hot oil, do not operate the engine with the rocker cover(s) removed.

### Warm-up

Run the engine at part throttle for about five minutes to allow it to warm up before applying a load.

## Inspection

**Transmission** – While the engine is idling, check the automatic transmission (if equipped) for proper oil level and add oil as required.

**Fluid Leaks** – Look for coolant, fuel or lubricating oil leaks. If any are found, shut down the engine immediately and have the leaks repaired after the engine has cooled.

**Crankcase** – If the engine oil was replaced, stop the engine after normal operating temperature has been reached. Allow the oil to drain back into the crankcase for about twenty minutes, then check the oil level. If necessary, add oil to bring the level to the proper mark on the dipstick. Use only the heavy-duty oils recommended. Refer to section A. How to Select Lubricating Oil in this guide.

**Turbocharger** – Make a visual inspection of the turbocharger for oil leaks, exhaust leaks, excessive noise or vibration. Stop the engine immediately if a leak or unusual noise or vibration is noted. *Do not restart the engine until the cause of the concern has been investigated and corrected.* Authorized Detroit Diesel service outlets are properly equipped to perform this service.

## Avoid Unnecessary Idling

Whenever possible, avoid unnecessary idling.

During long engine idling periods with the transmission in neutral, the engine coolant temperature may fall below the normal operating range. The incomplete combustion of fuel in a cold engine will cause crankcase oil dilution, formation of lacquer or gummy deposits on the valves, pistons, and rings, and rapid accumulation of sludge in the engine. When prolonged idling is necessary, maintain at least 850 rpm spring/summer and 1200 rpm fall/winter.

## Stopping the Engine

### Normal Stopping

Stop an engine under normal operating conditions as follows:

1. Reduce engine speed to idle and put all shift levers in the neutral position.

NOTICE:
Stopping a turbocharged engine immediately after high-speed operation without allowing a sufficient cool-down period may cause damage to the turbocharger, as it will continue to turn without an oil supply to the bearings.

2. Allow the engine to run between idle and 1000 rpm with no load for four or five minutes. This allows the engine to cool and permits the turbocharger to slow down. After four or five minutes, shut down the engine.

## Shutdown Warning Light and Buzzer

Vehicles may be equipped with an automatic engine shutdown system that will stop the engine in the event of high coolant temperature, low coolant level, or low engine oil pressure. The SEL (stop engine light) and alarm buzzer and light on the instrument panel alert the operator of high coolant temperature, low coolant level, or low oil pressure conditions. Should temperature or pressure continue to change beyond the warning point to a predetermined level, the engine will automatically shut down.

NOTICE:
To avoid engine damage when the override feature is selected, the engine should be run no longer than is absolutely necessary.

## Road Operation

To receive satisfactory engine performance with maximum fuel economy, the following general guidelines should be followed when operating the vehicle:

- Start the vehicle in motion by using the highest gear speed in the transmission that will move the load without slipping the clutch.
- Once in motion, accelerate smoothly and evenly to engine rated speed. Rapid acceleration will result in high fuel consumption with no increase in performance.
- To avoid “lugging,” do not allow engine speed to drop below peak torque when pulling at full throttle.
- When approaching a hill, depress the accelerator smoothly to start the climb at full power, then shift down as needed to maintain maximum permitted vehicle speed, depending on conditions.

<b>NOTICE:</b>
Do not allow the engine to overspeed when descending a grade with a load. Operating the engine beyond high idle speed can cause severe damage.

- Prevent overspeeding of the engine when descending a long and steep grade. The electronic governor has no control over engine speed when it is being pushed by the loaded vehicle. Operate in a gear that will permit an engine speed not in excess of high idle rpm.

## Cold Weather Operation

Observe the following instructions before operating the engine in temperatures of 32 °F (0 °C):

1. Ensure batteries are of sufficient size and are fully charged. Check that all other electrical equipment is in optimum condition.
2. Fill the cooling system with required coolant. Periodically check level and top off, if necessary. Refer to section G. How to Select Coolant in this guide.
3. At the end of each day's operation, allow the engine to cool and then drain the water from the fuel/water separator, if equipped. Fill the fuel tank with required fuel to prevent condensation. Refer to section D. How to Select Fuel Oil in this guide.
4. Use the proper lubricating oil for the ambient temperatures encountered. Refer to section A. How to Select Lubricating Oil

in this guide. Check the lube oil level at the start of each day and top off, if necessary.

5. At temperatures between 10 °F (–12 °C) and 20 °F (–7 °C), DDC recommends using an ether-start kit and block heater. An on/off fan is also recommended.
6. At temperatures below 20 °F (–7 °C), an ether-start kit, coolant heater and oil pan heater are required. Contact an authorized Detroit Diesel distributor about special cold weather equipment and precautions.

## Hot Weather Operation

Observe the following instructions before operating the engine in hot weather.

1. Ensure the battery has the proper amount of electrolyte in each cell, if not a maintenance-free battery. Top off cells with distilled water, or as per manufacturer's instructions.
2. Fill the cooling system with required coolant. Periodically check level and top off, if necessary. Refer to section G. How to Select Coolant in this guide.
3. At the end of each day's operation, allow the engine to cool and then drain the water from the

fuel/water separator, if equipped. Fill the fuel tank with required fuel to prevent condensation. Refer to section D. How to Select Fuel Oil in this guide.

4. Keep the external surfaces of the engine, radiator and accessories clean to avoid dirt buildup, which could lead to engine overheating.

## Extended Idling Periods

Avoid extended idling, especially at low engine speeds. The low idle speed for Series 40 vehicle engines is 700 rpm, while the low idle for construction/industrial engines is normally 800 rpm. If idling for long periods is necessary, *use the optional electronic fast idle feature*. Diesel engine efficiency is improved when cylinder temperatures remain high.

If cylinder temperatures are too low, the following may occur:

1. Unburned fuel, which has the dark-colored appearance of lubricating oil, may seep from the exhaust manifold gaskets and vehicle exhaust system connections. This seepage is commonly called exhaust "slobber."
2. Cylinder temperature will be too low to allow complete combustion and unburned fuel will wash lubricating oil from the

cylinder liners. The unburned fuel will be carried into the lubricating oil, causing fuel dilution.

3. Carbon deposits will form on fuel injector tips, causing nozzle plugging.
4. Carbon deposits will form on the turbine wheel of the turbocharger, reducing turbocharger efficiency.

A CAP (cold ambient protection) system has been added to the ECMs used on vehicles. This software aids in engine warm-up and helps maintain optimum engine heat during extended idling periods.

After five (5) minutes of idle time with the intake air temperature below 32 °F (0 °C), the CAP will slowly ramp up the engine idle speed to 900 rpm (engines with automatic transmissions) or 1400 rpm (engines with manual transmissions). Engine speed will increase or decrease to an rpm that will maintain a coolant temperature of 160 °F (71 °C).

**NOTE:**

The lower CAP rpm limit for engines with automatic transmissions minimizes the possibility of vehicle lurch, should the operator place the shift lever in gear without first applying the service brakes to lower the idle speed to 700 rpm.

The cycle described above will continue until one or a combination of any of the following occurs:

- Engine load is greater than 25%.
- Brake pedal is applied or brake switch fault is detected.
- Clutch pedal is depressed or clutch pedal switch fault is detected (manual transmission).
- Shift selector is moved from neutral to forward or reverse range (automatic transmission).
- PTO switch, also used for electronic hand throttle, is turned on.
- Accelerator pedal is depressed or accelerator pedal sensor fault is detected.
- Timed idle shutdown is enabled.
- CTO (coolant temperature sensor) fault is detected.
- AIT (ambient air intake temperature) sensor fault is detected.



## SERIES 40 ELECTRONIC CONTROL SYSTEM

Series 40 engines use a consolidated engine controller (CEC) and diagnosis system with its own ECM (electronic control module). See Figure 10.

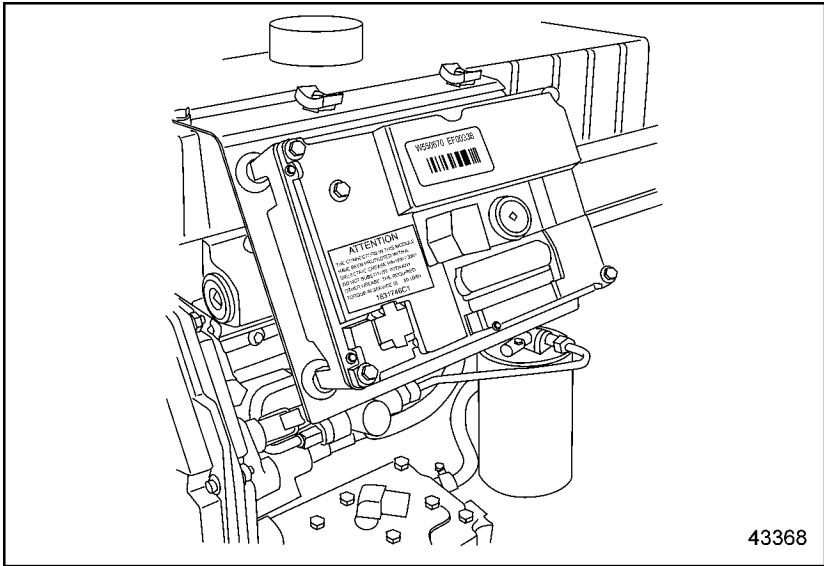

**Figure 10 Typical Series 40 Engine-Mounted ECM**

This system functions much like the DDEC system, but is configured differently and uses its own unique diagnostic codes. The diagnostic codes for Series 40 engines are listed in Table 1, Table 2, Table 3, and Table 4.

Flash Code	Circuit	Description
111	ECM	No Errors Detected
112	ECM_PWR	Elec. System Voltage B+ Out of Range HIGH
113	ECM_PWR	Elec. System Voltage B+ Out of Range LOW
114*	ECT	Eng. Coolant Temp Signal Out of Range LOW
115*	ECT	Eng. Coolant Temp Signal Out of Range HIGH
121*	MAP	Intake Manif. Abs. Press Signal Out of Range HIGH
122*	MAP	Intake Manif. Abs. Press. Signal Out of Range LOW
123*	MAP	Intake Manif. Abs. Press. In range Fault
124*	ICP	Injection Control Press. Signal Out of Range LOW
125	ICP	Injection Control Press. Signal Out of Range HIGH
131*	APS/IVS	Accelerator Position Signal Out of Range LOW
132*	APS/IVS	Accelerator Position Signal Out of Range HIGH
133*	APS/IVS	Accelerator Position Signal In range Fault
134*	APS/IVS	Accelerator Position and Idle Validation Disagree
135*	APS/IVS	Idle Validation Switch Circuit Fault
141	VSS	Vehicle Speed Signal Out of Range LOW
142	VSS	Vehicle Speed Signal Out of Range HIGH
143	CMP	Wrong Number of CMP Signal Transitions for Cam Rev
144	CMP	CMP Signal Noise Deleted

\* Indicates WARN Lamp on When Fault Set

**Table 1 Series 40 Diagnostic Flash Codes**

<b>Flash Code</b>	<b>Circuit</b>	<b>Description</b>
145	CMP	CMP Signal Inactive While ICP Has Increased
151	BARO	Barometric Press. Signal Out of Range HIGH
152	BARO	Barometric Press. Signal Out of Range LOW
154	IAT	Air Inlet Temp. Signal Out of Range LOW
155	IAT	Air Inlet Temp. Signal Out of Range HIGH
211*	EOP	Engine Oil Press. Signal Out of Range LOW
212*	EOP	Engine Oil Press. Signal Out of Range HIGH
213	SCCS	Remote Throttle Signal Out of Range LOW
214	SCCS	Remote Throttle Signal Out of Range HIGH
215	VSS	Vehicle Speed Signal Freq. Out of Range HIGH
216	HPS	Hydraulic Press. Signal Out of Range LOW
221	SCCS	Cruise-PTO Control Switch Circuit Fault
225	EOP	EOP Sensor Signal In-Range Fault
226	HPS	Hydraulic Press. Sensor Signal Out of Range HIGH
231	ATA	ATA Data Communication Link Error
236	ECLECL	Switch Circuit Fault
241	IPR	Injection Control Press. Regulator OCC Self Test Failed
244	EDL	Engine to Trans. Data Line OCC Self Test Failed
246	FAN	Engine Fan — OCC Self Test Fault
256	RSE	Radiator Shutter Enable OCC Fault
262	COL	Change Oil Lamp OCC Fault
263	OWL	Oil Water Lamp OCC Fault
265	VRE	Vehicle Retarder Relay OCC Fault
266	WEL	Engine Warning Light OCC Fault

\* Indicates WARN Lamp on When Fault Set

**Table 2 Series 40 Diagnostic Flash Codes (continued)**

Flash Code	Circuit	Description
311*	EOT	Engine Oil Temp. Signal Out of Range LOW
312*	EOT	Engine Oil Temp. Signal Out of Range HIGH
313	EOP**	Engine Oil Press. Below Warning Level
314	EOP**	Engine Oil Press. Below Critical Level
315*	—	Engine Speed Above Warning Level
316	—	Engine Coolant Temp. Unable to Reach Commanded Set Point
321	ECT**	Engine Coolant Temp. Above Warning Level
322	ECT**	Engine Coolant Temp. Above Critical Level
323	ECL	Engine Coolant Below Warning / Critical Level
324	ECT	Idle Shutdown Timer Enabled Engine Shutdown
325	ECT	“Power Reduced, Matched to Cooling System Performance”
331*	IPR	Injection Control Press. Above System Working Range
332*	ICP	Injection Control Press. Above Spec with Engine Off
333*	IPR	Injection Control Press. Above/Below Desired Level
334	IPR_SYS	ICP Unable to Achieve Setpoint in Time (Poor Performance)
335	IPR_SYS	ICP Unable to Build Pressure During Cranking
336	HGE	—
421 – 426	INJ	High Side to Low Side Open (Cyl. Number Indicated)
431 – 436	INJ	High Side Shorted to Low Side (Cyl. Number Indicated)
451 – 456	INJ	High Side Shorted to Ground or V Bat. (Cyl. Number Indicated)

\* Indicates WARN Lamp on When Fault Set

**Table 3 Series 40 Diagnostic Flash Codes (continued)**

Flash Code	Circuit	Description
461 – 466	Perf. Diag.	Cylinder Contrib. Test Failed (Cyl Number Indicated)
513*	INJ	Low Side to Bank 1 Open
514*	INJ	Low Side to Bank 2 Open
515*	INJ	Bank 1 Low Side Short to Ground or B+
521*	INJ	Bank 2 Low Side Short to Ground or B+
525	ECM	Injector Driver Circuit Fault
612*	CMP	Incorrect ECM Installed for CMP Timing Wheel
614*	ECM	EFRC/EECM Configuration Mismatch
621*	ECM	Engine Using Mfg. Default Rating Program Engine
622*	ECM	Engine Using Field Default Rating
623*	ECM	Invalid Engine Rating Code; ECM Programming
624	ECM	Field Default Active
626	ECM	Unexpected Reset Fault
631	ECM	ROM (Read-Only Memory) Self Test Fault
632	ECM	RAM Memory - CPU Self Test Fault
655	ECM	Programmable Parameter List Level Incomplete
661	ECM	RAM Programmable Parameter List Corrupt
664	ECM	Calibration Level Incompatible
665	ECM	Programmable Parameter Memory Content Corrupt

\* Indicates WARN Lamp on When Fault Set

**Table 4 Series 40 Diagnostic Flash Codes**

## SERIES 40 ENGINE SYSTEMS

### Fuel System

The fuel system consists of the fuel pump, hydraulically activated/electronically controlled unit injector assemblies, fuel pipes, fuel strainer and filter, and fuel lines.

### Lubrication System

The lubrication system consists of the oil pump, oil cooler, oil strainer and filter, bypass and pressure regulator valves, oil temperature control valve, and lubricating oil lines.

### Cooling System

The cooling system consists of a centrifugal-type fresh water pump, full-blocking thermostat, charge air cooler, radiator, and thermo-modulated fan. The fresh water pump circulates coolant within the engine and through the oil cooler, radiator and air-to-air charge cooler. The thermostat installed in a recess in the left-front corner of the cylinder head controls the flow of coolant, while the thermo-modulated fan controls the flow of air through the radiator and charge cooler.

### Electrical System

The electrical system consists of the starting motor, starting switch,

battery-charging alternator, storage batteries and necessary wiring.

### Air Induction System

The air induction system consists of the air cleaner, air-to-air charge cooler (some applications), compressor side of the turbocharger, valve cover/intake manifold and intake valves. Outside air is drawn through the air cleaner and into the turbocharger where it is compressed. It then flows through the air-to-air charge cooler, into the intake manifold and into the cylinders where it mixes with atomized fuel from the injector nozzles.

### Exhaust System

The exhaust system consists of the exhaust valves, exhaust manifold, turbine side of the turbocharger, exhaust piping and muffler. Hot exhaust gases flowing from the exhaust manifold into the exhaust riser drive the turbocharger. Exhaust gases then pass through the muffler and out to atmosphere.

## MAINTENANCE SCHEDULES

### Maintenance Intervals

Recommended maintenance intervals for Series 40 motor coach engines are listed in Table 5, Table 6 and Table 7. Recommended maintenance intervals for Series 40 transit coach engines are listed in Table 8, Table 9, and Table 10. Recommended maintenance intervals for Series 40 construction/industrial and stationary engines are listed in Table 11, Table 12, and Table 13. Recommended maintenance intervals for Series 40 fire fighting, crash/rescue, and emergency vehicle engines are listed in Table 14, Table 15, and Table 16. Recommended maintenance intervals for Series 40 generator drive engines are listed in Table 17, Table 18, and Table 19.

### NOTICE:

**Failure to check and maintain SCA (supplemental coolant additive) levels at required concentrations will result in severe damage (corrosion) to the engine cooling system and related components.**

Coolant must be inhibited with the recommended SCAs listed in this guide. Refer to section G. How to Select Coolant. In addition, the engine can be equipped with a coolant filter/inhibitor system as an installed option or as an after-sale item.

MAINTENANCE SCHEDULES

Item	Daily Checks	6,000 Miles (9,600 Km)	12,000 Miles (19,200 Km)	18,000 Miles ( 28,800 Km)	24,000 Miles ( 28,800 Km)
1 – Lubricating Oil*	I		R		R
2 – Fuel Tank*	I				
3 – Fuel Lines & Flex Hoses*	I				
4 – Cooling System*	I	I	I	I	I
5 – Turbocharger, A/A Charge Cooler*	I			I	
6 – Battery*		I			
7– Drive Belt*	I				
8 – Air Compressor*		I	I	I	I
9 – Air Cleaner*					
10 – Lube Oil Filters*			R		R
11 – Fuel Filters*					R
12 – Water Pump/ Inhibitor Level*				I	
14 – Air System*		I	I	I	I

\* – See item in text.

I – Inspect, service, correct or replace as necessary.

R – Replace.

**Table 5 Motor Coach Daily, 6,000 Mile, 12,000 Mile and 18,000 Mile Checks**



Item	Months	6	12	18	24	30	36	42	48	54	60
	Miles/Km ( X 1000)	12/ 19	24/ 38	36/ 58	48/ 77	60/ 96	72/ 115	84/ 134	96/ 154	108/ 173	124/ 198
1- Lubricating Oil*	Replace lubricating oil every 12,000 miles (19,200 km).										
2- Fuel Tank*		I		I		I		I		I	
4- Cooling System*					I				I		
5 - Turbocharger, A/A Charge Cooler*		I	I	I	I	I	I	I	I	I	I
6 - Battery*											
7- Drive Belt*	Inspect at each oil change. Replace every 100,000 miles (160,000 km).										
8- Air Compressor*		I	I	I	I	I	I	I	I	I	I
9 - Air Cleaner*		I	I	I	I	I	I	I	I	I	I
10 - Lube Oil Filter*	Replace when lubricating oil is changed.										
11 - Fuel Filters*					R				R		
12 - Water Pump/ Inhibitor Level*		I	I	I	I	I	I	I	I	I	I
13 - Cranking Motor*	Follow manufacturer's recommendations.										
14 - Air System*		I	I	I	I	I	I	I	I	I	I
15 - Exhaust System*		I	I	I	I	I	I	I	I	I	I

\* – See item in text.

I – Inspect, service, correct or replace as necessary.

R – Replace.

**Table 6 Motor Coach Regular Maintenance Intervals**

MAINTENANCE SCHEDULES

Item	Months	6	12	18	24	30	36	42	48	54	60
	Miles/Km ( X 1000)	12/ 19	24/ 38	36/ 58	48/ 77	60/ 96	72/ 115	84/ 134	96/ 154	108/ 173	124/ 198
16 - Engine (Steam Clean)*					I				I		
17 - Radiator*			I		I		I		I		I
18 - Oil Pressure*					I				I		
19 - Battery Charging Alternator*		I	I	I	I	I	I	I	I	I	I
20 - Engine & Transmission Mounts*					I				I		
21 - Crankcase Pressure*					I				I		
22 - Fan Hub*	Inspect every 15,000 miles or every oil change. Replace every 60,000 miles.										
23 - Thermostats & Seals*									I		
24 - Crankcase Breather*									I		
25 - Engine Tune-Up*					I						
26 - Idler Pulley*	Inspect every 45,000 miles (72,000 km). Replace every 60,000 miles (96,000 km).										
27 - Vibration Damper*	Inspect once a year. Replace at major engine overhaul or earlier if dented or damaged.										

\* – See item in text.

I – Inspect, service, correct or replace as necessary.

R – Replace.

**Table 7 Motor Coach Regular Maintenance Intervals (continued)**

Item	Daily Checks	6,000 Miles (9,600 Km)	12,000 Miles (19,200 Km)	18,000 Miles (28,800 Km)	24,000 Miles (38,400 Km)
1 - Lubricating Oil*	I	R	R	R	R
2 - Fuel Tank*	I				
3 - Fuel Lines & Flexible Hoses*	I				
4 - Cooling System*	I				
5 - Turbocharger, A/A Charge Cooler*			I		I
6 - Battery*			I		I
7 - Drive Belt*	I		I		I
8 - Air Compressor*			I		
9 - Air Cleaner*	I	I	I	I	I
10 - Lube Oil Filters*		R	R	R	R
11 - Fuel Filters*			R		R
12 - Water Pump/ Inhibitor Level*			I		I

\* – See item in text.

I – Inspect, service, correct or replace as necessary.

R – Replace.

**Table 8 Transit Coach Daily, 6,000 Mile, 12,000 Mile, and 18,000 Mile and 24,000 Mile Checks**

MAINTENANCE SCHEDULES

Item	Months	6	12	18	24	30	36	42	48	54	60
	Miles/Km ( X 1000)	15/ 24	30/ 48	45/ 72	60/ 96	75/ 120	90/ 144	105/ 168	120/ 192	135/ 216	150/ 240
1 - Lubricating Oil*	Replace lubricating oil every 12,000 miles (19,200 km).										
2 - Fuel Tank*		I		I		I		I		I	
4 - Cooling System*					I				I		
5 - Turbocharger, A/A Charge Cooler*		I	I	I	I	I	I	I	I	I	I
6 - Battery*											
7 - Drive Belt*	Inspect at each oil change. Replace every 100,000 miles (160,000 km).										
8 - Air Compressor*		I	I	I	I	I	I	I	I	I	I
9 - Air Cleaner*		I	I	I	I	I	I	I	I	I	I
10 - Lube Oil Filters*	Replace when lubricating oil is changed.										
11 - Fuel Filters*			R		R		R		R		R
12 - Water Pump/ Inhibitor Level*		I	I	I	I	I	I	I	I	I	I
13 - Cranking Motor*	Follow manufacturer's recommendations.										
14 - Air System*		I	I	I	I	I	I	I	I	I	I

\* – See item in text.

I – Inspect, service, correct or replace as necessary.

R – Replace.

**Table 9 Transit Coach Regular Maintenance Intervals**

Item	Months	6	12	18	24	30	36	42	48	54	60
	Miles/Km ( X 1000)	15/ 24	30/ 48	45/ 72	60/ 96	75/ 120	90/ 144	105/ 168	120/ 192	135/ 216	150/ 240
15 - Exhaust System*		I	I	I	I	I	I	I	I	I	I
16 - Engine (Steam Clean)*					I				I		
17 - Radiator*			I		I		I		I		I
18 - Oil Pressure*					I				I		
19 - Battery Charging Alternator*		I	I	I	I	I	I	I	I	I	I
20 - Engine & Transmission Mounts*					I				I		
21 - Crankcase Pressure*					I				I		
22 - Fan Hub*	Inspect every 6,000 miles or every oil change. Replace every 60,000 miles.										
23 - Thermostats & Seals*				I			I			I	
24 - Crankcase Breather*				I			I			I	
25 - Engine Tune-Up*				I			I			I	
26 - Idler Pulley*	Inspect every 45,000 miles (72,000 km). Replace every 60,000 miles (96,000 km).										
27 - Vibration Damper*	Inspect once a year. Replace at major engine overhaul or earlier if dented or damaged.										

\* – See item in text.

I – Inspect, service, correct or replace as necessary.

R – Replace.

**Table 10 Transit Coach Regular Maintenance Intervals (continued)**

*MAINTENANCE SCHEDULES*

Item	Daily Checks	100 Hours	150 Hours	200 Hours	300 Hours	450 Hours
1 - Lubricating Oil*	I					R
2 - Fuel Tank*	I				I	
3 - Fuel Lines & Flexible Hoses*	I					
4 - Cooling System*	I					
5 - Turbocharger, A/A Charge Cooler*	I					
6 - Battery*		I				
7 - Drive Belt*		I				
8 - Air Compressor*			I			
9 - Air Cleaner*			I			
10 - Lube Oil Filters*						R
11 - Fuel Filters*					R	
12 - Water Pump/ Inhibitor Level*				I		
17 - Radiator*					I	
19 - Battery Charging Alternator*					I	

\* – See item in text.

I – Inspect, service, correct or replace as necessary.

R – Replace.

**Table 11 Stationary or Construction/Industrial Engine Daily, 100 Hour, 150 Hour, 200 Hour, and 300 Hour Checks**

Item	Hours	150	300	450	600	750	900	1,050	1,200	1,350	1,500
1 - Lubricating Oil*		Change lubricating oil every 450 hours or 1 year, whichever comes first.									
2 - Fuel Tank*			I		I		I		I		I
4 - Cooling System*					I				I		
5 - Turbocharger, A/A Charge Cooler*		I	I	I	I	I	I	I	I	I	I
6 - Battery*		I	I	I	I	I	I	I	I	I	I
7 - Drive Belt*		Inspect at each oil change. Replace every 2,000 hours.									
8 - Air Compressor*		I	I	I	I	I	I	I	I	I	I
9 - Air Cleaner*		I	I	I	I	I	I	I	I	I	I
10 - Lube Oil Filters*		Replace when lubricating oil is changed.									
11 - Fuel Filters*			R		R		R		R		R
12 - Water Pump/ Inhibitor Level*		I	I	I	I	I	I	I	I	I	I
13 - Cranking Motor*		Follow manufacturer's recommendations.									
14 - Air System*		I	I	I	I	I	I	I	I	I	I

\* – See item in text.

I – Inspect, service, correct or replace as necessary.

R – Replace.

**Table 12 Stationary or Construction/Industrial Regular Maintenance Intervals**

MAINTENANCE SCHEDULES

Item	Hours	150	300	450	600	750	900	1,050	1,200	1,350	1,500
15 - Exhaust System*		I	I	I	I	I	I	I	I	I	I
16 - Engine (Steam Clean)*											
17 - Radiator*			I		I		I		I		I
18 - Oil Pressure*					I				I		
19 - Battery Charging Alternator*			I		I		I		I		I
20 - Engine & Transmission Mounts*					I				I		
21 - Crankcase Pressure*					I				I		
22 - Fan Hub*		Inspect every 150 hours. Replace every 1,000 hours.									
23 - Thermostats & Seals*											
24 - Crankcase Breather*											I
25 - Engine Tune-Up*											I
26 - Idler Pulley*		Inspect every 1,500 hours. Replace every 2,000 hours.									
27 - Vibration Damper*		Inspect once a year. Replace at major engine overhaul or earlier if dented or damaged.									

\* – See item in text.

I – Inspect, service, correct or replace as necessary.

R – Replace.

**Table 13 Stationary or Construction/Industrial Regular Maintenance Intervals (continued)**



Item	Daily Checks	100 Hours or 3,000 Miles ( 4,800 Km)	300 Hours or 6,000 Miles ( 9,600 Km)
1 - Lubricating Oil*	I		R
2 - Fuel Tank*	I		
3 - Fuel Lines & Flexible Hoses*	I		
4 - Cooling System*	I		
5 - Turbocharger, A/A Charge Cooler*	I		
6 - Battery*		I	
7 - Drive Belt*			I
8 - Air Compressor*	I		I
9 - Air Cleaner*	I		I
10 - Lube Oil Filter*			R
11 - Fuel Filters*			
12 - Water Pump/ Inhibitor Level*			I
17 - Radiator*			I
19 - Battery Charging Alternator*			I

\* – See item in text.

I – Inspect, service, correct or replace as necessary.

R – Replace.

**Table 14 Fire Fighting, Crash/Rescue and Emergency Vehicle Engine Daily, 100 Hour and 300 Hour Checks**

MAINTENANCE SCHEDULES

Item	Hours	300	600	900	1,200	1,500
	Miles/Km (X 1000)	6/ 1.6	12/ 9.6	18/ 28.8	24/ 38.4	30/ 48
1 - Lubricating Oil*	Change lubricating oil every 300 hours or 6,000 miles (9,600 km), whichever comes first.					
2 - Fuel Tank*						
4 - Cooling System*						
5 - Turbocharger, A/A Charge Cooler*						
6 - Battery*						
7 - Drive Belt*	Inspect at each oil change. Replace every 2,000 hours.					
8 - Air Compressor*						
9 - Air Cleaner*						
10 - Lube Oil Filters*	Replace when lubricating oil is changed.					
11 - Fuel Filters*		R			R	
12 - Water Pump/ Inhibitor Level*						
13 - Cranking Motor*	Follow manufacturer's recommendations.					
14 - Air System*						
15 - Exhaust System*						

\* – See item in text.

I – Inspect, service, correct or replace as necessary.

R – Replace.

**Table 15 Fire Fighting, Crash/Rescue and Emergency Vehicle Engine Regular Maintenance Intervals**

Item	Hours	300	600	900	1,200	1,500
	Miles/Km (X 1000)	6/ 1.6	12/ 9.6	18/ 28.8	24/ 38.4	30/ 48
16 - Engine (Steam Clean)*						
17 - Radiator*		I	I	I	I	I
18 - Oil Pressure*			I		I	
19 - Battery Charging Alternator*		I	I	I	I	I
20 - Engine & Transmission Mounts*			I		I	
21 - Crankcase Pressure*			I		I	
22 - Fan Hub*	Inspect every 6,000 miles or every oil change. Replace every 60,000 miles.					
23 - Thermostats & Seals*						
24 - Crankcase Breather*						I
25 - Engine Tune-Up*						I
26 - Idler Pulley*	Inspect every 45,000 miles (72,000 km) or 1,500 hours. Replace every 60,000 miles (96,000 km) or 2,000 hours.					
27 - Vibration Damper*	Inspect once a year. Replace at major engine overhaul or earlier if dented or damaged.					

\* – See item in text.

I – Inspect, service, correct or replace as necessary.

R – Replace.

**Table 16 Fire Fighting, Crash/Rescue and Emergency Vehicle Engine Regular Maintenance Intervals (continued)**

Item	Prime Daily	Standby Monthly
1 - Lubricating Oil*	I	I #
2 - Fuel Tank*	I	I
3 - Fuel Lines & Flexible Hoses*	I	
4 - Cooling System*	I	I #
5 - Turbocharger, A/A Charge Cooler*	I	
6 - Battery*		I
7 - Drive Belt*	I	I
9 - Cleaner*	I	I
11 - Fuel Filter, Water Separator*	I	I #
18 - Oil Pressure*	I	I #
Load Test		P

\* See item in text.

I – Inspect, service, correct or replace as necessary.

P – Perform

# Perform these items at time of load test. Load test should be at least 35% of the unit's full rated output. Refer to generator set manufacturer's instructions.

**Table 17 Generator Set Engine Prime Daily and Standby Monthly Maintenance Intervals**

Item	Hours							
	150	300	600	900	1,200	1,500	1,800	2,100
1 - Lubricating Oil*	<u>Prime:</u> Replace every 300 hours or 3 months, whichever comes first. <u>Standby:</u> Replace every 450 hours or 1 year, whichever comes first.							
2 - Fuel Tank*			I					
3 - Fuel Lines & Flexible Hoses*			I			R		
4 - Cooling System*								R
5 - Turbocharger, A/A Charge Cooler*	I							
6 - Battery*	I							
7 - Drive Belt*	Inspect at each oil change. Replace every 2,000 hours.							
9 - Air Cleaner*	I	I	I	I	I	I	I	I
10 - Lube Oil Filters*	Replace when lubricating oil is changed.							
11 - Fuel Filters*	<u>Prime:</u> Replace every 500 hours or 6 months, whichever comes first. <u>Standby:</u> Replace every 300 hours or 1 year, whichever comes first.							
12 - Water Pump/ Inhibitor Level*							I	
13 - Cranking Motor*	Follow manufacturer's recommendations.							

\* See item in text.

I – Inspect, service, correct or replace as necessary.

R – Replace

**Table 18 Generator Set Engine Regular Maintenance Intervals**

MAINTENANCE SCHEDULES

Item	Hours							
	150	300	600	900	1,200	1,500	1,800	2,100
14 - Air System*			I					
15 - Exhaust System*			I					
16 - Engine (Steam Clean)*								I
17 - Radiator*	I							
18 - Oil Pressure*			I					
19 - Battery Charging Alternator*		I						
20 - Engine & Generator Mounts*			I					
21 - Crankcase Pressure*			I					
22 - Fan Hub*	Inspect every 150 hours. Replace every 1,000 hours.							
23 - Thermostat & Seals*								R
24 - Crankcase Breather*						I		
25 - Engine Tune-Up*					I			
26 - Idler Pulley*	Inspect every 1,500 hours. Replace every 2,000 hours.							
27 - Vibration Damper*	Inspect once a year. Replace at major engine overhaul or earlier if dented or leaking.							

\* See item in text.

I – Inspect, service, correct or replace as necessary.

R – Replace

**Table 19 Generator Set Engine Regular Maintenance Intervals (continued)**

## LUBRICATION AND PREVENTIVE MAINTENANCE INTERVALS

The following is intended as a guide for establishing preventive maintenance intervals. The recommendations given should be followed as closely as possible to obtain long life and optimum performance from your engine. Maintenance intervals indicated are time (hours) of actual operation.

The intervals shown apply only to the maintenance functions described. These functions should be coordinated with other regularly scheduled maintenance.

The “Daily” instructions apply to routine or daily starting of the engine. They do not apply to a new engine or one that has been operated for a considerable period of time.

For new or stored engines, refer to Restoring an Engine to Service after Extended Storage in this guide.

Preventive maintenance other than the “Daily” checks should be performed by authorized Detroit Diesel service outlets. These outlets have the trained personnel and special tools to properly perform all services.

### Item 1 – Lubricating Oil

Check the oil level daily with the engine stopped. If the engine has

just been stopped and is warm, wait approximately 20 minutes to allow the oil to drain back into the oil pan before checking. Add the proper grade of oil to maintain the correct level on the dipstick.

See Figure 11 for the current oil level gage. When using this dipstick, keep the oil level within the cross-hatched area.

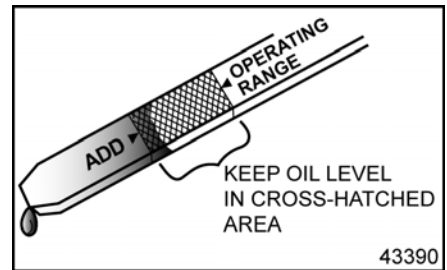

**Figure 11** Current Oil Level Gage

See Figure 12 for the former oil level gage. When using this dipstick, keep the oil level between the “Full” and “Add” lines.

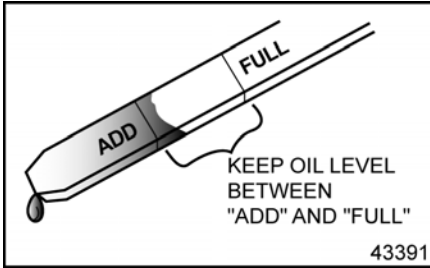

lubricating oil and filters at the intervals listed in Table 20 when using fuel with a sulfur content of less than 0.05 mass percent. When using fuel with a higher sulfur content, refer to section B. When to Change Oil.

**Figure 12 Former Oil Level Gage**

**NOTICE:**

When adding lubricating oil, do not overfill. Oil may be blown out through the crankcase breather if the crankcase is overfilled. For total engine oil capacity, refer to section Engine Oil Capacity.

All diesel engines are designed to use some oil, so the periodic addition of oil is normal.

**NOTICE:**

If the oil level is constantly above normal and excess oil has not been added to the crankcase, consult with an authorized Detroit Diesel service outlet for the cause. Fuel or coolant dilution of lubricating oil can result in serious engine damage.

Before adding lubricating oil, refer to section A. How to Select Lubricating Oil in this guide. Change



Service Application	Lube Oil and Filter Change Interval*
Motor Coach	12,000 Miles (19,200 Kilometers)
City Transit Coach	6,000 Miles (9,600 Kilometers)
Fire Fighting, Crash/Rescue, & Emergency Vehicles	6,000 Miles (9,600 Kilometers), 300 Hours or 1 Year, whichever comes first
Stationary or Construction/ Industrial & Agricultural	450 Hours or 1 Year, whichever comes first
Stationary Generator – Prime Power or Continuous	300 Hours or 3 Months, whichever comes first
Stationary Generator – Standby	450 Hours or 1 Year, whichever comes first

\* Change both full-flow filters when lube oil is changed.

**Table 20 Recommended Maximum Oil Drain/Filter Change Intervals (Diesel Fuel Sulfur Content Less Than 0.05 Mass %)**

The length of time an engine may operate before an oil change depends upon the lubricant and fuel used, engine oil consumption, and the operating cycle. The *maximum interval* at which the engine may operate before the oil and filters must be changed is listed in Table 20. Oil analysis may be used to determine whether this interval should be shortened, but it should not be used to lengthen the interval.

## Item 2 – Fuel and Fuel Tank

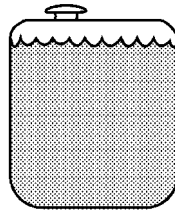

42538

**Figure 13 Keep Fuel Tank Filled to Reduce Condensation**

Keep the fuel tank filled to reduce condensation. Before adding fuel, refer to section D. How to Select Fuel Oil in this guide. See Figure 13.

Refill the tank at the end of each day's operation to prevent condensation from contaminating the fuel. Condensation formed in a partially filled tank promotes the growth of microorganisms that can clog fuel filters and restrict fuel flow.



### CAUTION:

**To avoid injury from improper use of chemicals, follow the chemical manufacturer's usage, handling, and disposal instructions. Observe all manufacturer's cautions.**

To prevent microbe growth, add a biocide to the fuel tank or primary fuel supply. Water accumulation can be controlled by using additives containing methyl carbitol or butyl cellulose. Follow manufacturer's usage, handling and safety precautions.

Open the drain at the bottom of the fuel tank every 30,000 miles (48,000 kilometers) or 300 hours for stationary and industrial engines to drain off any water and/or sediment.

Every 120,000 miles (192,000 kilometers), 12 months, or 600 hours for construction/industrial applications tighten all fuel tank mountings and brackets. At the same

time, check the seal in the fuel tank cap, the breather hole in the cap and the condition of the flexible fuel lines. Repair or replace the parts, as necessary.

### NOTICE:

Galvanized steel fuel tanks, fittings, pipes or supply lines should never be used, because the fuel reacts chemically with the zinc coating to form powdery flakes that can quickly clog the fuel filters and damage the fuel pump and injectors.

## Item 3 – Fuel Lines, Flexible Hoses

### Pre-Start Inspection

**Leaks** – Make a visual check for fuel leaks at all engine-mounted fuel lines and connections, and at the fuel tank suction and return lines. Since fuel tanks are susceptible to road hazards, leaks in this area may best be detected by checking for an accumulation of fuel under the tank.



**CAUTION:**

**To avoid injury from fire, contain and eliminate leaks of flammable fluids as they occur. Failure to eliminate leaks could result in fire.**

Leaks are not only detrimental to machine operation, but they can also result in added expense caused by the need to replace lost fluids.

**Hoses and Fittings**– Check hoses daily as part of the pre-start inspection. Examine hoses for leaks, and check all fittings, clamps and ties carefully. Make sure hoses are not resting on or touching shafts, couplings, heated surfaces including exhaust manifolds, any sharp edges, or other obviously hazardous areas. Since all machinery vibrates and moves to a certain extent, clamps and ties can fatigue with age. To ensure continued proper support, inspect fasteners frequently and tighten or replace them as necessary. If fittings have loosened or cracked or if hoses have ruptured or worn through, take corrective action immediately.

**Hose Service Life**

A hose has a finite service life. With this in mind, all hoses should be thoroughly inspected at least every

500 operating hours (1,000 hours for fire-resistant fuel and lubricating oil hoses) and/or annually. Look for cover damage and/or indications of twisted, worn, crimped, brittle, cracked or leaking lines. Hoses with their outer cover worn through or with damaged metal reinforcements should be considered unfit for further service.

All hoses in and out of machinery should be replaced during major overhaul and/or after a maximum of five (5) years of service.

**NOTE:**

Fire-resistant fuel and lube oil hose assemblies do not require automatic replacement after five years of service or at major overhaul, but should be inspected carefully before being put back into service.

## Item 4 – Cooling System



### CAUTION:

To avoid injury from the expulsion of hot coolant, never remove the cooling system pressure cap while the engine is at operating temperature. Remove the cap slowly to relieve pressure. Wear adequate protective clothing (face shield or safety goggles, rubber gloves, apron, and boots).

## Coolant Inhibitors

### NOTICE:

Coolant *must* be inhibited with the recommended SCA's (supplemental coolant additives) listed in this guide. In addition, the engine can be equipped with a coolant filter/inhibitor system as an installed option or as an after-sale item. **Failure to check and maintain SCA levels at required concentrations will result in severe damage (corrosion) to the engine cooling system and related components.**

### Coolant Level

The cooling system must be *full* for proper operation of the engine.

With the engine stopped, check the coolant level daily and maintain it near the bottom of the filler neck on the radiator. On some installations this is done by checking an overflow bottle or sight glass. Add coolant as required, but do not overfill. Before adding coolant, refer to section G. How to Select Coolant in this guide.

Make a daily visual check for cooling system leaks. Look for an accumulation of coolant when the engine is running and when it is stopped. Coolant leaks may be more apparent on a engine when it is cold.

Check the coolant SCA (supplemental coolant inhibitors) at the intervals listed in Table 28. The inhibitors in antifreeze solutions *must* be replenished with a non-chromate corrosion inhibitor supplement when indicated. Refer to section G. How to Select Coolant for required inhibitor levels.

### Coolant Drain Interval

**Detroit Diesel recommends replacing coolant at the intervals listed in Table 21.**

A coolant system properly maintained and protected with supplemental coolant inhibitors can be operated up to the intervals listed. At these intervals the coolant *must*

be drained and disposed of in an environmentally responsible manner according to state and/or federal (EPA) recommendations.

Coolant Type	Coolant Replacement Interval
A 50/50 mix of <i>Power Cool</i> ® fully formulated, inhibited ethylene glycol antifreeze and water or a 50/50 mix of fully formulated, inhibited propylene glycol antifreeze and water	With proper maintenance <sup>1</sup> coolant can be operated 2 years, 300,000 miles (480,000 km), or 4,000 hours, whichever comes first. At this time the cooling system must be completely drained and cleaned before refill.
A 50/50 mix of phosphate-free TMC RP-329 "Type A" (propylene glycol) antifreeze and water.	With proper maintenance <sup>1</sup> coolant can be operated for the life of the engine until overhaul. <sup>2</sup> For life to overhaul, pre-charged coolant in combination with a need-release filter <i>must</i> be used. At this time the cooling system must be completely drained and cleaned before refill.
A 50/50 mix of OAT (organic acid technology) coolant and water.	With proper maintenance coolant can be operated 4 years, 600,000 miles (960,000 km), or 10,000 operating hours, whichever comes first. <sup>3</sup> At this time the cooling system must be completely drained and cleaned before refill.

<sup>1</sup> Proper maintenance involves periodic evaluation using PowerTrac® 3-Way Coolant Test Strips and the addition of required SCA, as indicated by the test strip.

<sup>2</sup> To verify coolant acceptability, submit a sample to DDC for coolant analysis every 3 years, 300,000 miles (480,000 km) or 6,000 operating hours, whichever comes first. Submit sample using PowerTrac coolant analysis kit, part number 23516921 (IEG/IPG coolant) or 23523398 (organic coolant).

<sup>3</sup> OAT coolants require the addition of an extender every 2 years, 300,000 miles (480,000 km), or 5,000 hours, whichever comes first. Use 1 pint to 20 gallons of OAT coolant.

**Table 21 Coolant Drain Intervals**

## Item 5 – Turbocharger, Air-to-Air Charge Cooler



### CAUTION:

To avoid injury from hot surfaces, allow engine to cool before removing any component. Wear protective gloves.

Visually inspect the turbocharger mountings, intake and exhaust ducting and connections for leaks daily. Check the lube oil inlet and outlet lines for leaks or restrictions to oil flow. Check for unusual noise or vibration and, if excessive, stop the engine and do not operate until the cause is determined.

Periodically inspect the charge air cooler (if used) for buildup of dirt, mud, etc. and wash off. Check the charge cooler, ductwork, and flexible connections for leaks and have repaired or replaced, as required.

Check turbocharger heat-insulating exhaust system blankets (if used) for damage on a daily basis. Torn, matted, crushed, oil-soaked or otherwise damaged insulation blankets *must* be replaced immediately.

**Wastegated Turbochargers** – The turbocharger wastegate actuator is factory-calibrated and is not adjustable.

### NOTE:

If lack of engine performance is noted after high-mileage operation, the turbocharger wastegate should be checked for proper operation. Authorized Detroit Diesel distributors have the trained personnel and are properly equipped to perform this service.

## Item 6 – Battery



### CAUTION:

To avoid injury from accidental engine startup while servicing the engine, disconnect/disable the starting system.

Check the hydrometer “eye” of maintenance-free batteries for charge. See Figure 14. If lead-acid or low-maintenance batteries are used, check the specific gravity of each cell every 150 operating hours. Check more frequently in warm weather due to the more rapid loss of water through evaporation.

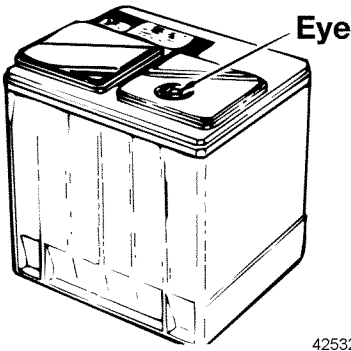

42532

**Figure 14 Check “Eye” of Maintenance-Free Batteries**

Maintain the electrolyte level according to the battery manufacturer's recommendations, but *do not overfill*. Overfilling can cause poor battery performance or early failure.

Keep the terminal side of the battery clean. When necessary, wash with a solution of baking soda and water. Rinse with fresh water. Do not allow the soda solution to enter the cells.

Inspect the cables, clamps and hold-down brackets regularly. Clean and reapply a light coating of petroleum jelly when needed. Have corroded or damaged parts replaced.

If the engine is to be out of service for more than 30 days, remove the batteries and store in a cool, dry place. Keep batteries fully charged,

if possible. Replace any battery that fails to hold a charge.

Periodically check battery connections for corrosion and tightness. If necessary, remove connections and wire brush any corrosion from terminals and cable ends. Replace damaged wiring.

## Item 7– Drive Belt

Inspect the serpentine drive belt after every oil change. Replace belt every 100,000 miles (160,000 km) on vehicle engines or every 2,000 hours on construction/industrial and stationary engines. Replace earlier if belt shows signs of excessive wear or damage.

Always replace the drive belt with the quality belt specified for your engine to ensure the belt will be neither too tight nor too loose. A belt that is too tight imposes extra loads on the crankshaft, water pump, alternator and fan hub bearings, shortening both belt and bearing life. A loose belt will slip and may cause damage to accessory components.

Before installing the drive belt, check the torque on the alternator and bracket mounting bolts. Retighten as required. The drive belt idler pulley should also be inspected whenever the belt is removed. Refer to Item 26 – Idler Pulley.



**CAUTION:**

To avoid injury from rotating belts and fans, do not remove and discard safety guards.

## Item 8 – Air Compressor

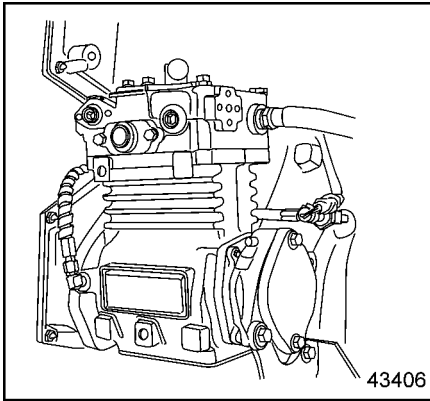

**Figure 15 Typical Air Compressor Assembly**

All air compressor intake parts should be removed and cleaned at the following intervals:

- Motor Coach, Transit Coach, Crash/Rescue, Pick-Up and Delivery Vehicle Engines – 6,000 miles (9,600 km)
- Construction/Industrial Engines/Stationary Engines–

150 Hours or 4,500 miles (7,200 km)

To clean either the hair type or the polyurethane type compressor air strainer element, saturate it and squeeze it in fuel oil or any other cleaning agent that is not detrimental to the element until it is dirt-free. Then saturate the element in lubricating oil and squeeze it dry before placing it back into the air strainer.

For air strainer replacement, contact the nearest servicing dealer. Replace hair type elements with the polyurethane type, if available.

The air compressor mounting bolts should be tightened every 12 months or 30,000 miles (48,000 km) for vehicle engines or every 300 hours for stationary and industrial engines.

## Item 9 – Air Cleaner

Check the air cleaner restriction indicator daily and service, if required. Inspect the air cleaner element every 12,000 miles (19,200 km) for vehicle engines, or 150 hours for stationary and industrial engines. Inspect more often if the engine is operated under severe dust conditions. Replace the element, if necessary. Check the gaskets for deterioration and replace, if necessary. If the dry type air cleaner is equipped with an aspirator, check for aspirator damage or clogging. Clean, repair or replace, as necessary.



**NOTICE:**

Do not allow the air inlet restriction to exceed 20 inches of water (5.0 kPa) under any engine operating conditions. A clogged air cleaner element will cause excessive intake restriction and a reduced air supply to the engine. This, in turn, can result in increased fuel consumption, inefficient engine operation and reduced engine life.

Inspect the entire air system for leaks daily. Look especially for torn air inlet piping or boots and loose or damaged clamps. Have worn or damaged parts repaired or replaced, as required. Retighten loose connections.

**Air Cleaner Replacement**

Dry type air cleaner elements should be replaced after one year of service or when the maximum allowable air intake restriction has been reached, whichever comes first. Refer to section J. When to Service the Dry Type Air Cleaner in this guide for additional information.

**Item 10 – Lubricating Oil Filter**



**CAUTION:**

To avoid injury from slipping and falling, immediately clean up any spilled liquids.

Install new spin-on oil filters whenever the engine oil is changed. Oil change intervals are listed in Table 20. Refer to section C. How to Replace the Lube Oil Filter for procedure. See Figure 16 for typical filter installation.

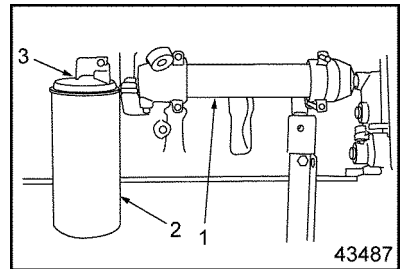

- 1. Oil Cooler Assembly
- 2. Oil Filter
- 3. Oil Filter Header

**Figure 16 Typical Oil Filter Installation**

Make a visual check of all lubricating oil lines for wear and/or chafing. If any indication of wear is evident, replace the oil lines and correct the cause.

Check for oil leaks after starting the engine.

## **Item 11 – Fuel Filter**

### **Fuel Filter and Strainer**

If equipped, drain the fuel/water separator daily.

See Figure 17 for a typical fuel filter and strainer installation. Replace the fuel filter and clean the strainer at the intervals listed in the maintenance tables or every other oil change. For change intervals, refer to Maintenance Intervals. For change procedure, refer to section Replace Fuel Filter and Strainer.

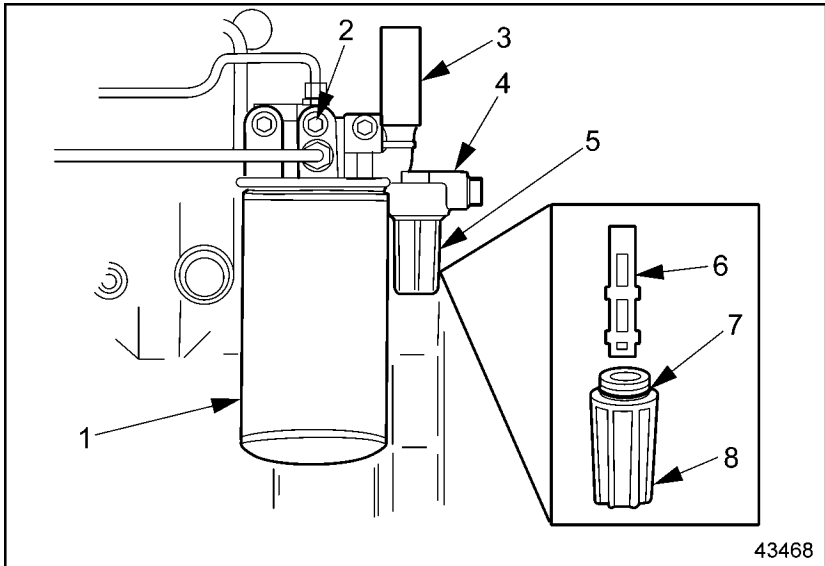

- |                         |                      |
|-------------------------|----------------------|
| 1. Spin-on Fuel Filter  | 5. Strainer Assembly |
| 2. Air Bleed Screw      | 6. Strainer          |
| 3. Air Primer Pump      | 7. O-Ring            |
| 4. Fuel Strainer Header | 8. Body              |

**Figure 17 Typical Fuel Filter and Strainer Installation**

**NOTE:**

Filter change intervals may be shortened to conform with established preventive maintenance schedules, but should never be extended.

no less than 60 psi (414 kPa) at normal operating speed.

Change the fuel filters whenever the fuel pressure at the inlet fitting falls below this level.

One method of determining when filters are plugged to the extent that they need replacing is based on the fuel pressure at the cylinder head fuel inlet fitting. Fuel pressure should be

### Fuel Pro® 382 Filters

Install new Fuel Pro® 382 primary fuel filter elements when the fuel level in the see-thru cover reaches the top of the element or after one year of service, whichever comes first. Refer to section Replace “Fuel Pro® 382/382E” Fuel Filter Element.

## Item 12 – Water Pump and Coolant Inhibitor Element

### Water Pump

**Water Pump Drain Hole** – The water pump drain hole should be inspected every 6 months to make sure it is open. A small chemical build-up or streaking at the drain hole may occur. **This is not an indication of a defective water pump or seal.** Remove the build-up with a mild detergent cleaner and a brush. If coolant does not leak from the drain hole under normal conditions, do not replace the water pump.

### Coolant Inhibitor Element

The coolant must be tested at required intervals and the coolant inhibitor element replaced, if required.

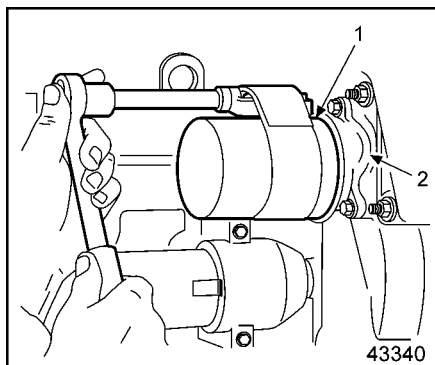

- |                                    |                      |
|------------------------------------|----------------------|
| 1. Spin-on<br>Inhibitor<br>Element | 2. Filter<br>Adaptor |
|------------------------------------|----------------------|

**Figure 18 Installing Coolant Inhibitor Element**

Required test intervals are listed in Table 28 . For SCA test procedures refer to section G. How to Select Coolant and then refer to section SCA Test Procedures in this guide. Use the coolant filter element required. Refer to section *Power Cool Engine Products* for element part number listing. The valves mounted on the filter adaptor head *must* be opened after the element is replaced.

## Item 13 – Cranking Motor

For cranking motor (starter) assembly information, contact an authorized Delco Remy® distributor.

## Item 14 – Air System

All the connections in the air system should be checked to make sure they are tight and leak free. Check all hoses and ducting for punctures, deterioration or other damage and replace, if necessary.

## Item 15 – Exhaust System

Have the exhaust manifold retaining bolts and other connections checked for tightness. Have the exhaust pipe rain cap checked for proper operation, if so equipped.

## Item 16 – Engine (Steam Clean)

Steam clean the engine and engine compartment every 60,000 miles (96,000 km) or 2,100 hours, whichever comes first. Steam clean more frequently, if operating in dusty or dirty environments.

### NOTICE:

Do not apply steam or solvent directly to the battery-charging alternator, starting motor, electronic engine control components, sensors or other electrical components, as damage to electrical equipment may result.

## Item 17 – Radiator

The exterior of the radiator core should be inspected every 30,000 miles (48,000 km), 12 months, or 300 hours (stationary and industrial engines) and cleaned, if necessary.



### CAUTION:

**To avoid injury from flying debris when using compressed air, wear adequate eye protection (face shield or safety goggles) and do not exceed 40 psi (276 kPa) air pressure.**

Use a quality grease solvent, such as mineral spirits, and dry with compressed air. **Fuel oil, kerosene or gasoline should not be used.**

It may be necessary to clean the radiator more frequently if the engine is being operated in extremely dusty or dirty areas.

If the low coolant level sensor is installed in the top tank of the radiator, it should be tested for proper operation every 100,000 miles (160,000 km) or 12 months, whichever comes first. Authorized Detroit Diesel distributors are properly equipped to perform this service.

## Item 18 – Oil Pressure

Under normal operation, oil pressure is noted each time the engine is started. In the event the equipment has warning lights rather than pressure indicators, the pressure should be checked and recorded every 60,000 miles (96,000 km) for vehicle engines or every 600 hours for stationary and industrial engines.

## Item 19 – Battery-Charging Alternator

### General Service Requirements

Terminals should be checked for corrosion and loose connections and wiring inspected for damage and frayed insulation. Have wiring repaired or replaced, as required.

Check torque on alternator mounting bolts and bracketing every 15,000 miles (24,000 km) on coach engines or every 300 hours on all other engines. Retighten, if necessary.

### Alternator Precautions

Precautions must be taken when working on or around the alternator. The diodes and transistors in the alternator circuit are very sensitive and can be easily destroyed.



### CAUTION:

**To avoid injury from battery explosion or contact with battery acid, work in a well-ventilated area, wear protective clothing, and avoid sparks or flames near the battery. Always establish correct polarity before connecting cables to the battery or battery circuit. If you come in contact with battery acid:**

- Flush your skin with water.**
- Apply baking soda or lime to help neutralize the acid.**
- Flush your eyes with water.**
- Get medical attention immediately.**

1. Avoid grounding the output terminal. Grounding an alternator's output wire or terminal (which is always "hot," regardless of whether or not the engine is running) and accidentally reversing the battery polarity will result in equipment damage.
2. Do not reverse battery connections. This can also cause damage.
3. Never disconnect the battery while the alternator is operating.

Disconnecting the battery can result in damage to the battery diodes. In applications which have two (2) sets of batteries, switching from one set to the other while the engine is running will momentarily disconnect the batteries. This can result in equipment damage.

4. If a booster battery is to be used, batteries must be connected correctly (negative to negative, positive to positive) to avoid equipment damage.
5. Never use a fast charger with the batteries connected or as a booster for battery output.

For information on the alternator assembly, contact an authorized Delco Remy® distributor.

## Item 20 – Engine and Transmission Mounts

The engine and transmission mounting bolts and the condition of the mounting pads should be checked every 60,000 miles (96,000 km) or 600 hours. Tighten and/or repair as necessary.

## Item 21 – Crankcase Pressure

The crankcase pressure should be checked and recorded at the intervals in the maintenance schedules. Crankcase pressure should be no

higher than 6 in. water (1.5 kPa) at maximum no-load speed with the breather restrictor tool installed.

## Item 22 – Fan Hub

The fan hub assembly includes a sealed bearing which is not serviceable.

- **Inspection Interval:** Inspect the fan hub for free bearing rotation at the interval shown in the regular maintenance interval table for your engine. If the hub does not spin freely or is noisy (indicating bearings are “dry” or worn), replace the fan hub.
- **Replacement Interval:** Replace the fan hub at the interval shown in the regular maintenance interval table for your engine, regardless of apparent condition.

### Item 23 – Thermostat and Seal

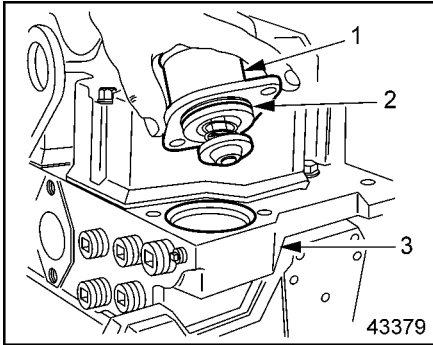

- 1. Thermostat
- 2. Seal
- 3. Cylinder Head

**Figure 19 Typical Thermostat Installation**

Replace the thermostat and seal every 240,000 miles (384,000 km)

on vehicle engines. On non-vehicle engines, replace the thermostat and seal every 4,000 hours or 24 months, whichever comes first.

### Item 24 – Crankcase Breather

The steel mesh breather pad in the valve cover/intake manifold should be removed and washed in clean fuel oil when the valve cover is removed for valve lash measurement and adjustment. These intervals are listed in Table 22.

### Item 25 – Engine Tune-Up

There is no scheduled interval for performing an engine tune-up. However, the valve lash *must* be measured and, if necessary, adjusted at the regular intervals listed in Table 22.

Engine Application	Valve Lash Measurement/ Adjustment Interval
Motor Coach	Every 60,000 Miles (96,000 km) or 24 Months*
Transit Coach	Every 45,000 Miles (72,000 km) or 18 Months*
Stationary, Construction/Industrial, Agricultural, or Generator Set Engines	Every 1,500 Hours or 45,000 Miles (72,000 km)*

\* Whichever comes first.

**Table 22 Valve Lash Measurement/Adjustment Schedule**



## Item 26 – Idler Pulley

The fan belt idler pulley requires periodic inspection and replacement.

- **Inspection Interval:** Inspect the idler pulley for free bearing rotation at 45,000 miles (72,000 km) on vehicle engines and at 450 hours on non-vehicle engines, or whenever the serpentine belt is removed. If the pulley does not spin freely or is noisy (indicating bearings are “dry” or worn), replace the pulley.
- **Replacement Interval:** Replace the idler pulley every 60,000 miles (72,000 km) of operation on vehicle engines or every 9,000 hours of operation on non-vehicle engines, regardless of apparent condition.

## Item 27 – Vibration Damper

All Series 40 engines use rubber-bushed vibration dampers, except generator sets, which use viscous dampers.

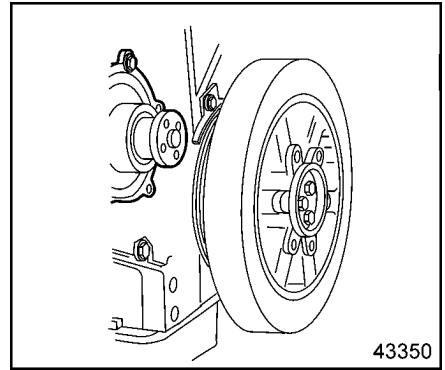

**Figure 20 Typical Rubber-Bushed Vibration Damper**

- **Rubber-Bushed Damper:** Inspect damper (see Figure 20) once a year. Replace if rubber “streaking” on the damper face exceeds guidelines (contact a DDC distributor for guidelines) or if deep splits appear in the rubber member. Deep splits can allow chunks of rubber to break off from the damper (“chunking”), affecting its balance and dampening efficiency.

Heat from normal engine operation will, over a period of time, cause the rubber member in the vibration damper to become brittle as it ages. For this reason the vibration damper *must* be replaced at time of normal major engine overhaul, regardless of apparent condition.

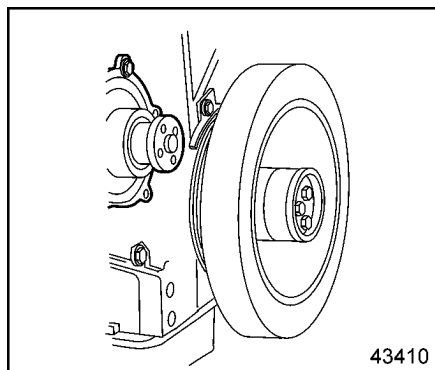

**Figure 21 Typical Viscous Vibration Damper**

- **Viscous Damper:** Inspect damper ( see Figure 21) once a year. Replace if dented or leaking. Heat from normal engine operation may, over a period of time, cause the fluid within the damper to break down and lose its dampening properties. For this reason the viscous damper *must* be replaced at time of normal major engine overhaul, regardless of apparent condition.

### Welding Precaution

#### NOTICE:

**Failure to isolate the electronic engine control system components from high current flow can result in severe ECM (electronic control module) damage.** To avoid damage to vehicle electronic components, disconnect both the positive (+) and the negative (-) battery cables prior to electric welding. Attach the welder's ground cable as close as possible to the joint being welded. If it is necessary to weld close to an electronic component, the component should be temporarily removed.

Whenever welding is done on any part of the vehicle, the batteries *must* be disconnected, both power and ground, which must include all electronic power feeds. The electronic components may easily be damaged by the high voltage used and the RF (radio frequency) energy present in the arc.

## HOW-TO SECTION

This section covers Detroit Diesel's recommendations on how to select lubricating oil, fuel oil, and coolant and includes basic engine maintenance procedures which can be performed by the operator.

### NOTICE:

The manufacturer's warranty applicable to Series 40 engines provides in part that the provisions of such warranty shall not apply to any engine unit that has been subject to misuse, negligence or accident. Accordingly, malfunctions attributable to neglect or failure to follow the manufacturer's fuel or lubricating recommendations may not be within the coverage of the warranty.

## A. How to Select Lubricating Oil

### Lubricant Selection in North America

The selection of the proper lubricating oil is important to achieve the long and trouble-free service which Detroit Diesel engines are designed to provide. The proper lubricating oil for all Detroit Diesel engines is selected based on SAE viscosity grade and API (American Petroleum Institute)

service designation. Only oils licensed to display the API service mark should be used. See Figure 22.

### Lubricant Requirements

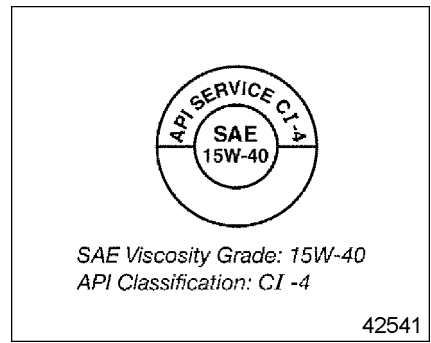

**Figure 22 API Lubricant Service Mark**

API CI-4 or CH-4 oils are recommended for use in all engines.

### Engines Built Prior to 1998

Lubricants meeting API Service Category CG-4 may be used in engines built prior to 1998 when API CI-4 or CH-4 oils are not available.

### NOTE:

The use of CG-4 oils in these engines may require a reduction in oil drain interval, depending upon the application and the fuel sulfur level.

### Cold Weather Starting

At ambient temperatures below  $-4^{\circ}\text{F}$  ( $-20^{\circ}\text{C}$ ) when sufficient starter speed cannot be achieved with SAE 15W-40 oils, the use of 5W-XX oils and 10W-XX oils, where XX is 30 or 40, is allowed to improve startability, provided they are API CI-4 or API CH-4 and have demonstrated field performance in DDC engines. These oils must possess a HT/HS of 3.7 minimum.

#### NOTICE:

**Monograde oils should not be used in Series 40 engines, regardless of API service classification.** Monograde oils gel at lower ambient temperatures, reducing lubricant flow, and they do not provide adequate lubricity at higher engine operating temperatures. These factors can result in severe engine damage.

When the use of high sulfur fuel (greater than 0.05% mass sulfur) is unavoidable, high alkalinity (TBN) lubricants are recommended. High sulfur fuels require modification to oil drain intervals. For further information, refer to publication *Engine Requirements – Lubricating Oil, Fuel and Filters*, 7SE270,

available from authorized Detroit Diesel distributors.

### The Use of Supplemental Additives

Lubricants meeting the Detroit Diesel specifications outlined in this publication already contain a balanced additive treatment. Supplemental additives are generally not necessary and can even be harmful. These additives may be marketed as either oil treatments or engine treatments and are discouraged from use in Detroit Diesel engines. **Engine damage resulting from the use of such materials is not covered by your Detroit Diesel Corporation warranty.** Detroit Diesel will not provide statements beyond this publication relative to their use.

## B. When to Change Oil

### Oil Drain Intervals

 <b>CAUTION:</b>
<p><b>To avoid injury from contact with the contaminants in used engine oil, wear protective gloves and apron.</b></p>

The length of time an engine may operate before an oil change depends upon the lubricant and fuel used, engine oil consumption, and the operating cycle. The maximum

interval at which the engine may operate before the oil and filters must be changed is listed in Table 23. Oil analysis may be used to determine whether this interval should be shortened, but it should not be used to lengthen the interval.

The use of fuels with sulfur content above 0.05 mass percent will require a shortening of drain intervals and/or the use of a higher TBN oil. See the information listed in Table 23. For detailed information refer to publication *Engine Requirements – Lubricating Oil, Fuel and Filters* (7SE270), available from authorized Detroit Diesel distributors.

Engine Application	Drain Interval
Motor Coach, City Transit Coach	12,000 Miles (19,200 km)
Fire Truck or Crash/Rescue Vehicle	6,000 Miles (9,600 km), 300 Hours or 1 Year, whichever comes first
Construction, Industrial or Agriculture	150 Hours, 4,500 Miles (7,200 km) or 1 year, whichever comes first
Stationary Generator Set, Prime Power or Continuous	250 Hours or 3 Months, whichever comes first
Stationary Generator Set, Standby	150 Hours or 1 Year, whichever comes first

**Table 23 Maximum Oil Drain and Filter Change Interval (Fuel Sulfur 0.05 Weight Percent or Less)**

### Disposing of Waste Oil

Dispose of used lubricating oil and filters in an environmentally responsible manner, according to federal (EPA) and/or state recommendations. The disposal of waste oil may be best addressed by the engine oil supplier, who may accept responsibility for proper disposal of this material as part of the business of providing lubricant.

### C. How to Replace the Lube Oil Filter

Filters are an integral part of the lubricating oil system. Proper filter selection and maintenance are important to satisfactory engine performance and service life. Filters should be used to maintain a clean system, not to clean up a contaminated system. Filter part numbers are listed in Table 43 in the **Specifications** section of this guide.

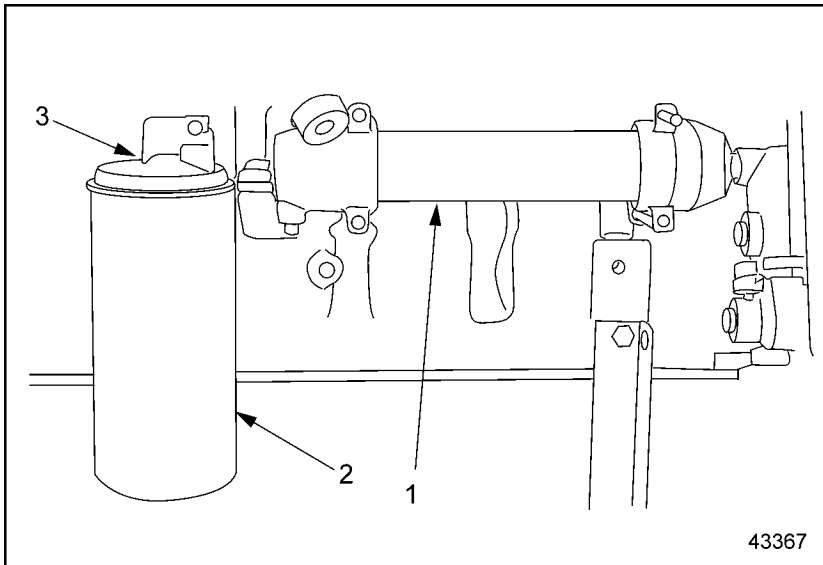

1. Oil Cooler Assembly

3. Oil Filter Header (part of oil cooler assembly)

2. Oil Filter

**Figure 23 Typical Oil Filter Installation**

## Replace Spin-On Type Oil Filter

 <b>CAUTION:</b>
<p><b>To avoid injury from slipping and falling, immediately clean up any spilled liquids.</b></p>

Replace spin-on type filter as follows:

1. Place a suitable container under the engine oil pan, remove the drain plug and drain the lubricating oil. Replace the drain plug and tighten securely.
2. Remove spin-on filter using tool J 29917 or equivalent and a 1/2-in. drive socket wrench and extension. See Figure 24.

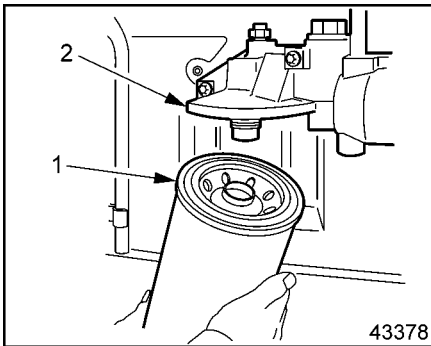

1. Oil Filter                      2. Oil Filter Header

**Figure 24** Removing Oil Filter

3. Dispose of used oil and filter in an environmentally responsible manner, according to federal (EPA) and/or state recommendations.
4. Clean the filter gasket-contact surface of the adaptor head with a clean, lint-free cloth.
5. Fill the new filter with clean lubricating oil and lightly coat the filter gasket with the same oil.

<b>NOTICE:</b>
<p>Do not overtighten filters. Overtightening may crack or distort the filter adaptor.</p>

6. Start the new filter on the adaptor head and tighten by hand until the gasket touches the mounting adaptor head. **Tighten filter an additional one full turn by hand, or as indicated on the filter.**
7. Add oil as required to bring the level to the "Full" or "Operating Range" mark on the dipstick. Refer to Item 1 – Lubricating Oil.



**CAUTION:**

**Diesel engine exhaust and some of its constituents are known to the State of California to cause cancer, birth defects, and other reproductive harm.**

- **Always start and operate an engine in a well ventilated area.**
- **If operating an engine in an enclosed area, vent the exhaust to the outside.**
- **Do not modify or tamper with the exhaust system or emission control system.**

8. Start and run the engine for a short period and check for leaks. After leaks have been corrected, stop the engine long enough for oil from various parts of the engine to drain back to the crankcase (approximately 20 minutes). Add oil as required to bring the level to the “Full” or “Operating Range” mark on the dipstick.

**NOTICE:**

If the engine oil level is constantly above normal and excess lube oil has not been added to the crankcase, consult with an authorized Detroit Diesel service outlet for the cause. Fuel or coolant dilution of lube oil can result in severe engine damage.

## D. How to Select Fuel Oil

### Quality

Fuel quality is an important factor in obtaining satisfactory engine performance, long engine life, and acceptable exhaust emission levels. Detroit Diesel engines are designed to operate on most diesel fuels marketed today.

In general, fuels meeting the properties of ASTM designation D 975 (grades 1-D and 2-D) have provided satisfactory performance.

The fuels used must be clean, completely distilled, stable, and non-corrosive. For more information regarding the significance of these properties and selection of the proper fuel, refer to publication, *Engine Requirements – Lubricating Oil, Fuel and Filters* (7SE270), available from authorized Detroit Diesel distributors.



## Fuel Contamination

Generally, fuel contamination occurs as the result of improper fuel handling. The most common types of contamination are water, dirt, and microbial growth ("black slime"). The formation of varnishes and gums resulting from poor stability or extended storage ("stale fuel") also affects fuel quality. The best treatment for contamination is prevention by maintaining a clean fuel storage system and choosing a reputable fuel supplier.

**Supplemental additives are not recommended due to potential injector system or engine damage.**

Our experience has been that such additives increase operating costs without providing benefit.

The use of supplemental fuel additives does not necessarily void the engine warranty. **However, repair expenses which result from fuel system or engine component malfunctions or damage attributed to their use will not be covered.** These products should be accompanied by performance data supporting their merit. It is not the policy of Detroit Diesel Corporation to test, evaluate, approve or endorse such products.

## Prohibited Additives

**The following fuel additives are not allowed and MUST NOT be mixed with diesel fuel:**

**Used Lubricating Oil** — Detroit Diesel specifically prohibits the use of used lubricating oil in diesel fuel. Used lubricating oil contains combustion acids and particulate materials which can severely erode fuel injector components, resulting in loss of power and increased exhaust emissions. In addition, the use of drained lubricating oil will increase maintenance requirements due to filter plugging and combustion deposits.

## Gasoline —



### CAUTION:

**To avoid increased risk of a fuel fire, do not mix gasoline and diesel fuel.**

**The addition of gasoline to diesel fuel will create a serious fire hazard.**

The presence of gasoline in diesel fuel will reduce fuel cetane number and increase combustion temperatures. Tanks which contain such mixtures should be drained and cleaned as soon as possible.

*Detroit Diesel Corporation will not be responsible for any detrimental effects it determines resulted from adding drained lubricating oil or gasoline to the diesel fuel.*

## E. How to Replace the Fuel Filter

Filters are an integral part of the fuel system. Proper filter selection and maintenance are important to satisfactory engine operation and service life. Filters should be used to maintain a clean system, not to clean up a contaminated system. Refer to the **Specifications** section of this guide for proper filter selection.

A reusable, cylindrical, woven nylon primary fuel strainer element and replaceable spin-on type secondary fuel filter element are used on Series 40 engines. The strainer consists of a cylindrical, woven nylon element that installs onto the strainer header and is protected by a screw-on plastic body with a replaceable seal ring. See Figure 25.

The spin-on secondary filter consists of a shell, element and gasket unitized into a single cartridge and a filter adaptor header which includes threaded inserts to accept the spin-on cartridge. The header also includes a fuel priming pump and air bleed screw for manual priming of the system after filter replacement. See Figure 25.

### NOTE:

An optional fuel/water separator may be installed in the system piping ahead of the fuel strainer.

## Replace Fuel Filter and Strainer



### CAUTION:

**To avoid injury from hot surfaces, allow engine to cool before removing any component. Wear protective gloves.**

Replace spin-on fuel filter element and strainer as follows:

1. Shut down the engine and allow it to cool.
2. With the engine at ambient temperature and cool to the touch, place a suitable container under the filter.
3. A fuel shutoff valve may be installed on the discharge side of the fuel filter adaptor head. If installed, turn the handle on the shutoff valve to the **closed** position (perpendicular to the valve).
4. Using a suitable band type filter wrench, remove the fuel filter. Dispose of the filter in an environmentally responsible manner, according

to federal (EPA) and/or state recommendations. See Figure .

5. Using a 29 mm or 1 1/8-in. deep socket, carefully remove the plastic fuel strainer cover.

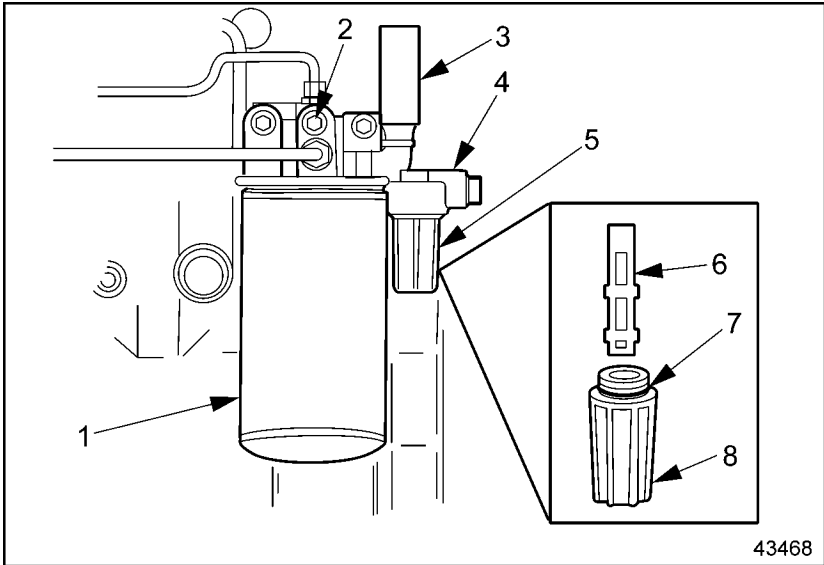

- |                         |                      |
|-------------------------|----------------------|
| 1. Spin-on Fuel Filter  | 5. Strainer Assembly |
| 2. Priming Pump         | 6. Strainer Element  |
| 3. Air Bleed Screw      | 7. Seal Ring         |
| 4. Fuel Strainer Header | 8. See-Through Body  |

**Figure 25 Typical Fuel Filter and Strainer Installation**

6. Inspect the strainer for damage or plugging and clean or replace, as required. Clean the cover. Replace the O-ring, if damaged.

**NOTE:**

Install the strainer into the cover with the open end toward the filter header.

**NOTICE:**

Do not use tools to install the strainer and do not overtighten, since this could distort or crack the plastic cover, resulting in fuel leakage during engine operation.

7. Insert the strainer into the cover with the open end facing UP. With the O-ring in place, install the strainer onto the header. Tighten securely *by hand*.
8. Wipe the filter adaptor header with a clean, lint-free cloth.
9. Fill the new replacement filter with clean diesel fuel and coat the gasket lightly with the fuel.
10. Thread the new filter onto the adaptor insert until the gasket makes full contact with the adaptor header and no side movement is evident. Tighten filter an additional one-half turn **by hand**, or as indicated on the filter.

**NOTICE:**

Do not overtighten the filter. Overtightening may crack or distort the adaptor head.

11. If previously closed, open the fuel shutoff valve.

**NOTICE:**

Failure to disconnect the CMP (camshaft position sensor) before priming the engine may allow the engine to start during priming, which could result in severe engine damage.

12. Refer to Prime the Fuel System and Start the Engine below before starting the engine.

**Prime the Fuel System and Start the Engine**

**NOTICE:**

Failure to disconnect the CMP (camshaft position sensor) before priming the engine may allow the engine to start during priming, which could result in severe engine damage.

Prime the fuel system as follows:

**NOTICE:**

Under no circumstances should the starting motor and fuel pump be used to prime the fuel filter. Prolonged used of the starting motor and fuel pump to prime the fuel system can result in damage to the starter, fuel pump and injectors and cause erratic running of the engine due to the amount of air in the fuel lines and filter.

1. Disconnect the CMP (camshaft position sensor) to prevent the engine from starting. The CMP is installed on the front cover of the engine between the water pump pulley and the fan pulley. See Figure 1.
2. Operate the manual primer pump on the filter header until the primer pump is hard to depress. See Figure 25.
3. Crank the engine three times for 15 seconds each. Reapply the primer pump after each crank cycle.
4. Once the primer pump is hard to depress (usually three crank and hand prime cycles), reconnect the CMP.



**CAUTION:**

**Diesel engine exhaust and some of its constituents are known to the State of California to cause cancer, birth defects, and other reproductive harm.**

- Always start and operate an engine in a well ventilated area.**
- If operating an engine in an enclosed area, vent the exhaust to the outside.**
- Do not modify or tamper with the exhaust system or emission control system.**

**NOTICE:**

To avoid starter damage, do not crank the engine longer than 15 seconds at a time. Allow a 15-second starter cool down interval between starting attempts.

5. Start the engine and check for leaks. Shut down the engine. Correct any leaks with the engine off.

## Replace Fuel/Water Separator Element

If an optional primary filter/water separator is installed in the fuel system piping, replace the element as follows:

1. Shut down the engine and allow it to cool.
2. With the engine at ambient temperature and cool to the touch, place a suitable container under the filter.
3. A fuel shutoff valve may be installed on the discharge side of the fuel/water separator. If installed, turn the handle on the shutoff valve to the **closed** position (perpendicular to the valve).
4. Drain off some fuel by opening the drain valve.
5. Using a strap wrench, remove the element and bowl together, then remove the bowl from the element. The filter and bowl have right-hand threads, so turn counter-clockwise to remove.
6. Clean the bowl and the O-ring seal.
7. Apply a light coating of clean fuel or grease to the O-ring seal, thread the bowl onto the new filter and tighten **by hand**.

### NOTICE:

To avoid damaging the bowl or the filter, do not use tools when tightening.

8. Apply a light coating of clean fuel oil or grease to the new O-ring seal on the top of the replacement filter. Thread the filter and bowl assembly onto the filter header and tighten **by hand** until snug.
9. To eliminate air from the filter, operate the primer pump on the filter header until the fuel purges at the filter assembly.
10. Refer to section Prime the Fuel System and Start the Engine before starting the engine.
11. Shut down the engine. Correct any leaks with the engine off.

## Replace “Fuel Pro® 382/382E” Fuel Filter Element

The Fuel Pro 382/383E diesel fuel filter system consists of a permanently mounted fuel processor, a replaceable filter element and sealing grommet assembly, a filter spring, a see-thru cover and seal, a cover collar, and a vent cap and seal. The Fuel Pro 382E system also includes a fuel heater element, thermostatic switch and wiring harness. See Figure 26.

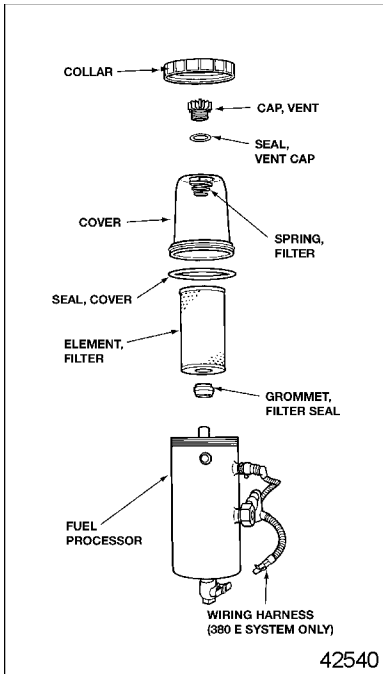

**Figure 26 Fuel Pro 382E Fuel Processor Assembly**

Replace the element as follows:

1. Shut down the engine and allow it to cool.
2. With the engine at ambient temperature and cool to the touch, place a suitable container under the filter.
3. A fuel shutoff valve may be installed on the discharge side of the fuel filter. If installed, turn the handle on the shutoff valve to the **closed** position (perpendicular to the valve).
4. Open the drain valve at the base of the fuel processor and drain the fuel until it is below the bottom of the filter in the see-thru cover. Close the drain valve. The fuel may be returned to the tank.
5. Using filter collar/vent cap wrench part number 232002 or equivalent, remove the collar by turning counter-clockwise. Remove the cover, filter spring and cover seal ring by lifting straight up and over the filter element.
6. Remove the element from the center stud (fuel outlet pipe) by pulling upward and twisting slightly.

**NOTE:**

Current filter elements include an integral sealing grommet. If a former element is replaced, make sure the separate sealing grommet is removed from the center stud before installing the new element.

7. Dispose of the used element and grommet in an environmentally responsible manner, according to federal (EPA) and/or state recommendations.
8. Check to make sure the sealing grommet is included in the base

of the replacement filter element, then install the element onto the center stud by pushing down and twisting slightly.

9. Check to make sure the spring is installed at the top of the cover. If missing, this spring must be replaced to insure proper filter operation. Wipe the cover lip and cover seal clean.

**NOTICE:**

Do not use a wrench of any kind to tighten the collar, since this may lead to overtightening, which can damage the collar and/or the cover.

10. After making sure the seal is properly positioned at the base of the cover, install the cover and collar onto the fuel processor. Tighten the collar **by hand** until secure.
11. Using filter collar/vent cap wrench 232002 or equivalent, remove the vent cap from the top of the cover by turning the cap counter-clockwise. Fill the cover full of clean fuel. After making sure the O-ring seal is installed on the vent cap, reinstall the cap and tighten **by hand**.

**NOTICE:**

To avoid cover or vent cap damage, do not use tools to tighten the vent cap.

12. Open the fuel shutoff valve (if equipped).
13. The fuel system must be primed before starting the engine. Refer to section Prime the Fuel System and Start the Engine.
14. After starting the engine, allow the lubrication system to reach its normal operating pressure, then increase engine speed to high idle for 2 to 3 minutes.

**NOTICE:**

Do not allow the fuel level in the see-thru cover to fall below the top of the collar, since this may lead to interruption of the fuel flow and engine stalling.

15. After the air is purged and with the engine still running, loosen the vent cap. The fuel level in the cover will start falling. When the fuel level falls to the top of the collar, tighten the vent cap quickly **by hand**.
16. Shut down the engine and tighten the collar again **by hand**.



17. Restart the engine and check for leaks. Shut down the engine. Correct any leaks with the engine off.

**NOTE:**

The filter cover will not fill completely during engine operation. It will gradually fill over time, and the fuel level will rise as the filter medium becomes clogged. **The filter element does not require changing until the fuel level has risen to the top of the element, or after one year of service, whichever comes first.**

**F. Engine Out of Fuel — How to Restart**

**NOTICE:**

Under no circumstances should the starting motor and fuel pump be used to prime the fuel filters. Prolonged use of the starting motor and fuel pump to prime the fuel system can result in damage to the starter, fuel pump and injectors and cause erratic running of the engine due to the amount of air in the fuel lines and filters.

When an engine has run out of fuel, there is a definite procedure to follow when restarting it.

**Spin-On Filter** — Use the following procedure for an engine with a spin-on filter.

1. Fill the fuel tank with the recommended grade of fuel. If only partial filling is possible, add a minimum of 10 gallons (38 liters) of fuel to the tank.
2. Close the fuel shutoff valve (if installed) on the filter header and remove the spin-on fuel filter. Fill with clean fuel through the fuel inlet holes (the outer ring of small holes on the element) to insure the fuel is filtered. Thread the element onto the filter header until the gasket makes full contact with the header and no side movement is evident. Tighten filter an additional one-half turn **by hand**, or as indicated on the filter.
3. Open the fuel shutoff valve (if installed).

**NOTICE:**

Failure to disconnect the CMP (camshaft position sensor) before priming the engine may allow the engine to start during priming, which could result in severe engine damage.

4. Prime the fuel system as follows:
  - [a] Disconnect the CMP (camshaft position sensor)

to prevent the engine from starting.

- [b] Operate the manual primer pump on the filter header until the primer pump is hard to depress. See Figure 25.
- [c] Crank the engine three times for 15 seconds each. Reapply the primer pump after each crank cycle.
- [d] Once the primer pump is hard to depress (usually three crank and hand prime cycles), reconnect the CMP.

**NOTICE:**

To avoid starter damage, do not crank the engine longer than 15 seconds at a time. Allow a 15-second starter cool down interval between starting attempts.

- 5. Start the engine and check for leaks.

**Fuel Pro Filters** — Use the following procedure for an engine with Fuel Pro filters.

- 1. Remove the vent cap from the top of the filter by turning counter-clockwise. Fill the cover full of *clean* fuel. After making sure the O-ring seal is installed on the vent plug, reinstall the plug and tighten **by hand** only.

**NOTICE:**

To avoid cover or vent cap damage, do not use tools to tighten the vent cap.

**NOTICE:**

Do not allow the fuel level in the see-thru cover to fall below the top of the collar, since this may lead to interruption of the fuel flow and engine stalling.

- 2. Start the engine and allow the lubrication system to reach its normal operating pressure, then increase engine speed to high idle for 2 to 3 minutes. After the air is purged and with the engine still running, loosen the vent cap on the filter cover. the fuel level in the cover will start falling. When the fuel level falls to the top of the collar on the Fuel Pro cover, tighten the vent cap quickly **by hand**.

**NOTE:**

If the engine fails to start after replacement of fuel filters, the fuel system will require priming with tool J 5956 or equivalent. Authorized Detroit Diesel distributors are properly equipped to perform this service.

## G. How to Select Coolant

### Definitions

This section covers selection of the required coolant for Series 40 engines. To help ensure complete understanding of the information, the definitions of the following terms are provided:

**Antifreeze** — Ethylene glycol or propylene glycol containing a corrosion inhibitor package and which meets an appropriate heavy-duty specification (i.e., TMC RP-329 for ethylene glycol or TMC RP-330 for propylene glycol).

**Coolant** — The fluid mixture circulating in the engine cooling system, typically a mixture of 50% water and 50% antifreeze.

**Drop-Out** — Precipitated sludge or deposit formation on cooling system components.

**Fully Formulated Antifreeze** — Contains all the necessary inhibitors to protect a diesel engine, and does not, therefore, require a pre-charge of SCA before its first use.

**Initial-Fill Coolant** — The coolant that is used in a new or rebuilt engine, or any time the cooling system is emptied and then refilled with coolant.

**OAT** — Organic Acid Technology. An inhibitor system based on

organic acid inhibitors, instead of traditional North American inhibitor formulations.

**SCA** — Supplemental Coolant Additive. SCAs are used in a preventive maintenance program to prevent corrosion, cavitation, and the formation of deposits.

### Approved Coolants

#### NOTICE:

Required specifications for water, ethylene glycol, propylene glycol, inhibitor packages and inhibitor concentration are included in this section. To avoid possible engine damage from inadequate or overconcentrated coolant, this information should be read thoroughly before the coolant is replaced.

The approved and preferred coolants for Series 40 engines are listed in Table 24. Once installed, these coolants should be maintained according to the procedures discussed under **Maintenance** in this section.

Coolant Fill Option	Product
Ethylene Glycol & Water + Corrosion Inhibitors <sup>1</sup>	DDC <i>Power Cool</i>
Commercial Equivalent of DDC <i>Power Cool</i>	Fully Formulated TMC RP-329 Type A Antifreeze & Water
Propylene Glycol & Water + Corrosion Inhibitors <sup>1</sup>	Fully Formulated TMC RP-330 Type A Antifreeze & Water
Ethylene Glycol & Water + OAT Inhibitors	DDC <i>Power Cool Plus</i>
Water Only + Corrosion Inhibitors <sup>2</sup>	Water + DDC <i>Power Cool</i> 3000
Water Only + OAT Inhibitors <sup>2</sup>	Water + DDC <i>Power Cool Plus</i> 6000

<sup>1</sup> Preferred coolant.

<sup>2</sup> Water-only coolant systems offer no freeze protection and should not be used where ambient temperatures can fall to 32° F (0° C).

**Table 24 Initial Fill Coolant Options**

**Ethylene Glycol & Water Plus SCA Inhibitor or Propylene Glycol & Water Plus SCA Inhibitor** —

These products are available as fully formulated, phosphate-free, extended service interval (ESI) coolants. They are commercially available from Detroit Diesel (recommended) and other manufacturers as either a concentrated antifreeze or as a pre-mixed antifreeze. The pre-mixed antifreeze is ready for use, while the concentrated coolant must be mixed with water prior to use.

Detroit Diesel *Power Cool* engine coolant (part number 23512138) is the preferred ethylene glycol coolant. If other commercial brands of ethylene glycol are used, they must be equivalent to the *Power Cool*

(see following paragraph). Detroit Diesel does not market a propylene glycol coolant. If a propylene glycol coolant is used, it must also meet the requirements listed in the following paragraph.

Fully formulated ethylene glycol-based, low silicate antifreeze or coolant must meet TMC RP-329 “Type A” requirements. Fully formulated propylene glycol-based antifreeze or coolant must meet TMC RP-330 “Type A” requirements. *Fully formulated antifreeze does not require a dosage of SCA (supplemental coolant additive) prior to initial use.*

**Mixing EG or PG Antifreeze and Water** —

If a concentrated ethylene glycol (EG) or propylene

glycol (PG) antifreeze is purchased, mix the antifreeze with water meeting the required quality standards listed in Table 27 and fill the cooling system.

**Figure 27 Coolant Freezing and Boiling Temperatures Versus Inhibited Ethylene Glycol (IEG) Concentration (Sea Level)**

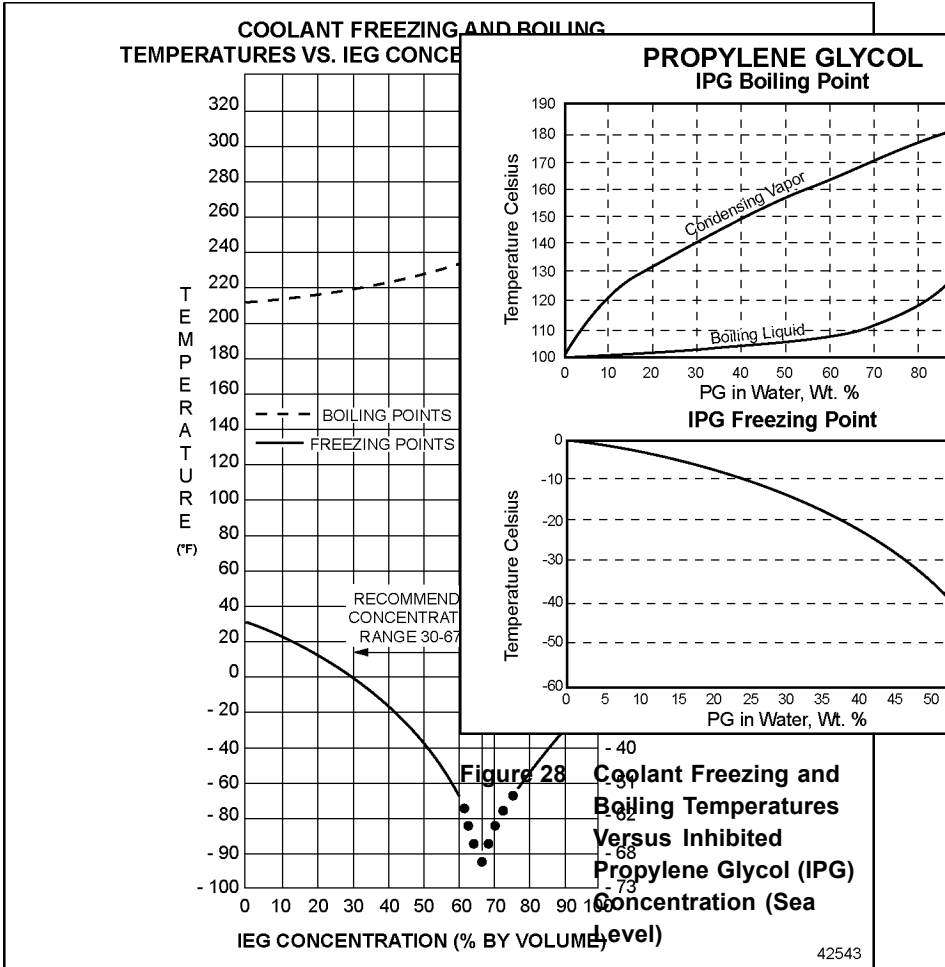

42543

If a pre-diluted, fully formulated coolant is purchased, simply fill the cooling system. For best overall performance, a coolant consisting of 50% concentration of antifreeze (50% antifreeze, 50% water) is *recommended*.

An antifreeze concentration over 67% (67% antifreeze, 33% water) is *not recommended* due to poor heat transfer, reduced freeze protection (IEG only), and possible silicate dropout. An antifreeze concentration below 33% (33% antifreeze, 67% water) offers too little freeze and/or

corrosion protection and is *not recommended*.

See Figure 27 for ethylene glycol-base coolant concentration versus freezing and boiling temperatures. See Figure 28 for propylene glycol-base coolant concentration versus freezing and boiling temperatures.

Always verify that the freeze point and nitrite concentration of the antifreeze/water mixture are correct by using a *POWER Trac*® 3-Way Coolant Test Strip. If chemical analysis is used, elements in the coolant must fall within the limits listed in Table 25.

<b>Fully Formulated Glycol Coolant Concentration Limits</b>	
Boron	125 – 500 PPM
Nitrite	900 – 3200 PPM
Nitrate	200 – 3200 PPM
Silicon	50 – 250 PPM
Phosphorous	0 PPM
pH	8.0 – 11.0

**Table 25 Fully Formulated Glycol Coolant Limits with TMC RP-329, TMC RP-330 Chemistry Type A (50/50 Coolant/Water Mixture)**

**Recycled Antifreeze** — Antifreeze or coolant recycled by reverse osmosis, distillation, and ion exchange, properly re-inhibited to meet TMC RP-329 Type A or TMC RP-330 Type A requirements, has been demonstrated to provide

service equivalent to virgin antifreeze. Recycled antifreeze or coolants of these types are *preferred*. Other recycled coolants, especially coolants recycled through filtration processes, are *not recommended*.

**Ethylene Glycol/Water + OAT Inhibitor or Propylene Glycol/Water + OAT Inhibitor —**

Ethylene glycol and propylene glycol are also available with a (Organic Acid Technology) corrosion package. These coolants require less maintenance over the useful life of the engine. OAT coolants, maintained as detailed in the **Maintenance** section of this guide, may be operated up to 4 years, 600,000 miles (960,000 km), or 10,000 operating hours, whichever comes first. Refer to section Maintenance. The cooling system should either be equipped with a “blank” coolant filter, or the coolant filter and piping may be omitted from the system.

OAT fully formulated antifreezes are available as concentrated and pre-mixed. Concentrated antifreezes should be mixed 50% (50% antifreeze, 50% water).

*OAT coolants should not be mixed with conventional coolants.* If they are mixed, no damage will result, but the long-life advantages of the OAT coolant will be lost. In this event, the coolant should be maintained as a fully formulated IEG coolant, not as an OAT (Organic Acid Technology) coolant.

Detroit Diesel markets a OAT-inhibited ethylene glycol coolant, DDC *Power Cool Plus*, which contains all the required additives.

If a non-DDC OAT antifreeze is used, it must conform to TMC 338 specification. *Do not add extender to new OAT antifreeze or coolant.*

**Water Only + SCA or Water Only + OAT Inhibitor —**

In warm climates a coolant based on water with corrosion inhibitors is approved for use. Water-only systems need to be treated with the proper dosage of corrosion inhibitors. Detroit Diesel-approved SCAs or OAT corrosion inhibitors *must* be added to the water to provide required corrosion and cavitation erosion protection. OAT inhibitors such as *Power Cool Plus 6000* are available for water-only systems. Inhibitor should be mixed at 7.5% – 10% by volume with water. For a list of *Power Cool* products, refer to section *Power Cool Engine Products* in this guide. Traditional SCA (*Power Cool 3000*) can also be used to protect the engine. *Power Cool 3000* concentration limits are listed in Table 26.

**NOTE:**

Do not use Power Trac 3-Way Test Strips to test OAT coolant.

<b>Power Cool 3000 Coolant Concentration Limits</b>	
Boron	125 – 500 PPM
Nitrite	900 – 3200 PPM
Nitrate	0 – 1000 PPM
Silicon	50 – 250 PPM
Phosphorous	0 PPM
pH	8.0 – 11.0

**Table 26 Power Cool 3000 Concentration Limits (5% Power Cool 3000/ 95% Water)**

Power Cool 3000 SCA inhibitors should be mixed at 5% by volume with water. This is 1 quart per 5 gallons of water. These additions can be made by adding liquid SCAs available in a variety of sizes. Coolant filters are also available for different cooling system capacities. These filters release the proper amount of SCA at initial fill.

**Water Requirements —**

Distilled, reverse osmosis-purified,

or de-ionized water which eliminates the adverse effects of minerals in tap water is preferred. High levels of dissolved chlorides, sulfates, magnesium, and calcium in some tap water causes scale deposits and/or corrosion. These deposits have been shown to result in water pump failures and poor heat transfer, resulting in overheating. If tap water is used, the mineral content in the water must be below the maximum allowable limits listed in Table 27.

	<b>Maximum Allowable</b>	
	<b>Parts per Million</b>	<b>Grains per Gallon</b>
Chlorides	40	2.5
Sulfates	100	5.8
Total Dissolved Solids	340	20
Total Hardness – Magnesium and Calcium	170	10

**Table 27 Satisfactory Water Limits – Make-Up Water Only**



**NOTICE:**

Do not add additional SCA to new, fully formulated antifreeze or coolant. This can result in dropout and/or the formation of deposits.

**Coolants Not Recommended**

The following coolants are *not recommended* for use in Detroit Diesel engines:

1. **All antifreezes and coolants containing phosphate** are not recommended. Drop out, overheating and water pump seal failures can result from the use of coolant or inhibitor packages based on phosphate.
2. **Automotive type coolants** generally contain high levels of phosphate and silicate, offer no liner pitting protection, and are *not suitable* for use in Detroit Diesel engines.
3. **Methyl alcohol-based antifreeze** must not be used because of its effect on the non-metallic components of the cooling system and its low boiling point.
4. **Methoxy propanol-based antifreeze** must not be used because it is not compatible with the fluoroelastomer seals found in the cooling system.

5. **Glycol-based coolants formulated for heating/ventilation/air conditioning (HVAC)** should not be used. These coolants generally contain high levels of phosphates, which can deposit on hot internal engine surfaces and reduce heat transfer.

**Additives Not Recommended**

The following additives are *not recommended* for use in Series 40 engines:

1. **Soluble oil additives** are not approved for use in Detroit Diesel engine cooling systems. A small amount of oil adversely affects heat transfer. For example, a 1.25% concentration of soluble oil increases fire deck temperature 6%. A 2.50% concentration increases fire deck temperature 15%. The use of soluble oil additives may result in engine overheating and/or failure.
2. **Chromate additives** are not approved for use in Detroit Diesel engine cooling systems. Chromate additives can form chromium hydroxide, commonly called "green slime." This, in turn, can result in engine damage due to poor heat transfer. Cooling systems operated with chromium-inhibited coolant must be chemically cleaned with *Power*

Cool dry chemical cooling system cleaner/conditioner (or equivalent sulfamic acid/sodium carbonate cleaner) and flushed.

**Coolant Inhibitor Test Intervals**

— The coolant inhibitor level should be checked at the intervals listed in Table 28.

**Maintenance**

This section describes the procedures for maintaining the coolant inhibitor level and proper concentration.

Service Application	Inhibitor Test Interval
Motor Coaches	18,000 Miles (32,000 Kilometers)
City Transit Coaches, Pick-Up and Delivery, Short Trip, and Emergency Vehicles	6,000 Miles (9,600 Kilometers) or 3 Months, whichever comes first
Industrial, Continuous– Duty Generator Set and All Other Applications, except Standby Generator Set	500 Hours or 3 Months, whichever comes first
Stand-By Generator Set	200 Hours or Yearly, whichever comes first

**Table 28 Required Coolant Inhibitor Test Intervals**

 <p><b>CAUTION:</b></p>
<p>To avoid injury from the expulsion of hot coolant, never remove the cooling system pressure cap while the engine is at operating temperature. Remove the cap slowly to relieve pressure. Wear adequate protective clothing (face shield or safety goggles, rubber gloves, apron, and boots).</p>

If topping off is needed, add coolant which is identical to the initial fill coolant.

**Supplemental Coolant Additives for Fully Formulated Coolant**

— The concentrations of some inhibitors will gradually deplete during normal engine operation. SCAs replenish the protection for cooling system components. The coolant *must* be maintained with the proper concentration of SCA. Detroit Diesel *Power Cool* maintenance SCAs are recommended.

The proper application of SCA will provide:

- pH control.
- Restored inhibitor levels to prevent corrosion.
- Water softening to deter formation of mineral deposits.
- Cavitation protection to protect wet sleeve cylinder liners.

**Maintenance Intervals** — Check the nitrite concentration at the regular intervals listed in Table 29 with a *Power Trac* 3-Way Test Strip.

Coolant	Interval <sup>1</sup>	Action
Antifreeze / Water + SCA Inhibitor (DDC <i>Power Cool</i> )	A. 20,000 Miles (32,000 km) or 3 Months* B. 500 Hours or 3 Months*	Test nitrite concentration with test strip. Add SCA or dilute coolant as needed.
	A. 300,000 Miles (480,000 km) B. 2 Years or 4,000 Hours*	Drain and clean system. Refill with new coolant.
Ethylene Glycol / Water + SCA Inhibitor or Propylene Glycol / Water + SCA Inhibitor	A. 20,000 Miles (32,000 km) or 3 Months* B. 500 Hours or 3 Months*	Test nitrite concentration with test strip. Add SCA or dilute coolant as needed.
	A. 300,000 Miles (480,000 km) B. 2 Years or 4,000 Hours*	Drain and clean system. Refill with new coolant.
Ethylene Glycol / Water + OAT Inhibitor or Propylene Glycol / Water + OAT Inhibitor	Test at 1 Year.	—
	A. 300,000 Miles (480,000 km) or 2 Years* B. 5,000 Hours	Add <i>Power Cool</i> Plus Extender
	A. 600,000 Miles (960,000 km) B. 4 Years or 10,000 Hours*	Drain and clean system. Replace with new coolant.
Water Only + SCA Inhibitor	A. 20,000 Miles (32,000 km) or 3 Months* B. 500 Hours or 3 Months*	Test nitrite concentration with test strip. Add SCA or dilute coolant as needed.
	A. 300,000 Miles (480,000 km) B. 2 Years or 4,000 Hours	Drain and clean system. Replace with new coolant.
Water Only + OAT Coolant	A. 300,000 Miles (480,000 km) or 2 Years* B. 5,000 Hours	Add <i>Power Cool</i> Plus Extender
	A. 600,000 Miles (960,000 km) B. 4 Years or 10,000 Hours	Clean and drain. Replace with new coolant.

<sup>1</sup> Maintenance interval based on application. Drain interval dependent on proper maintenance.

**A.** Motor Coaches, City Transit Coaches, Pick-Up and Delivery, Short Trip and Emergency Vehicles

**B.** Industrial, Generator Set and Other Applications

**Table 29 Coolant Maintenance Intervals**

Nitrite levels *must* be within the ranges listed in Table 25.

**NOTICE:**

Failure to properly maintain coolant with SCA can result in damage to the cooling system and its related components. Conversely, over-concentration of SCA inhibitor can result in poor heat transfer, leading to engine damage. Always maintain concentrations at recommended levels. *Do not use traditional SCAs with OAT coolant.*

Additional SCA *must* be added to the coolant when it becomes depleted, as indicated by a nitrite concentration of 900 PPM or less. *If the nitrite concentration is greater than 900 PPM, do not add additional SCA.* If the nitrite concentration is above 3200 PPM, the system is over-inhibited and should be partially drained and filled with a 50/50 mix of water and EG or PG.

In this case the EG or PG should contain no inhibitors and should conform to ASTM D4985. This will dilute the over-concentrated inhibitors.

**NOTE:**

In non-OAT systems, nitrite concentration of 5000 PPM or higher on a Series 40 engine suggests problematic additive

over-concentration. This condition *must* be corrected by immediate draining and flushing of the cooling system. Refill the system with new fully formulated or pre-charged coolant. Check the nitrite concentration level at the next maintenance interval with a Power Trac 3-Way Test Strip.

**SCA Test Procedures**

Detroit Diesel Power Trac 3-Way Coolant Test Strips should be used to measure nitrite and glycol concentrations. Part numbers are listed in Table 55. Cavitation/corrosion is indicated on the strip by the level of nitrite concentration. Freeze/boil over protection is determined by glycol concentration.



**CAUTION:**

**To avoid injury from the expulsion of hot coolant, never remove the cooling system pressure cap while the engine is at operating temperature. Remove the cap slowly to relieve pressure. Wear adequate protective clothing (face shield or safety goggles, rubber gloves, apron, and boots).**

For best results make the test while the coolant is between 50° – 140 °F (10.0° – 60 °C). Wait at least 60, but not longer than 75, seconds before reading the nitrite level. Use the test strips as follows:

1. Dip the strip into coolant for one second. Remove and shake briskly to eliminate excess fluid.
2. Immediately compare the pad end (% glycol) to the color chart on the container.
3. Sixty seconds (one minute) after dipping, compare the nitrite pad to the color chart.
4. Color change of the additive indicator (middle pad) indicates the presence of inhibitor that is not approved by Detroit Diesel.

Promptly replace and tighten the test strip container cap after each use.

Discard unused strips if they have turned light pink or tan.

A factory coolant analysis program is available through authorized Detroit Diesel service outlets. Part numbers are listed in Table 55 in the **Specifications** section. To verify coolant acceptability, submit a sample for coolant analysis every two (2) years, 300,000 miles (480,000 km), or 10,000 operating hours, whichever comes first.

**Need Release Coolant Filters (Non-OAT Systems)**

Spin-on coolant filters are available for Detroit Diesel engines. Membranes in the filters release SCAs before the coolant approaches a corrosive condition, protecting the engine from corrosion. The elements release the SCA charge as needed, as opposed to the maintenance SCA elements, which instantaneously release the SCA charge. Coolant filter elements should be replaced after one (1) year, 120,000 miles (192,000 km) or 2,000 operating hours, whichever comes first.

## Dropout

Excessive amounts of some inhibitors in the coolant can cause a gel or crystalline deposit that reduces heat transfer and coolant flow. The deposit, called “dropout,” takes the color of the coolant when wet, but appears as a white or gray powder when dry. It can pick up solid particles in the coolant and become gritty, causing excessive wear of water pump seals and other cooling system components.



### CAUTION:

**To avoid injury when using caustic cleaning agents, follow the chemical manufacturers usage, disposal, and safety instructions.**

The wet gel can be removed by using a non-acid (alkali) type heavy-duty cleaner, such as Detroit Diesel *Power Cool* On-Line Cleaner (sodium nitrite/sodium tetraborate). Refer to section *POWER COOL COOLING SYSTEM CLEANERS* for part numbers.

#### NOTE:

If the gel is allowed to dry, it is necessary to disassemble the engine and clean it with a caustic solution or physically clean individual components.

## Coolant Extender Inhibitor Additive for “OAT” Coolant

The inhibitors in OAT coolant must also be maintained, but less often than traditional SCA-type coolants. A portable test is available to test the levels of OAT inhibitors in coolant. Where this is not used, fleet testing has determined that a OAT coolant extender package should be added to the coolant at 300,000 miles (480,000 km), two (2) years, or 5,000 hours, whichever comes first. The proper maintenance dosages for all OAT coolants are listed in Table 29, reflecting 0.6% by volume extender. This dosage should be added to the water-only and the glycol systems at the same interval.

The proper application of extender to OAT coolant will provide:

- pH Control
- Restored inhibitor levels to prevent corrosion
- Cavitation protection to protect wet sleeve cylinder liners

#### NOTE:

***Do not use traditional SCAs in OAT coolant, and do not use OAT extender in traditional coolant.***

#### OAT Coolant Drain Interval —

A properly maintained OAT-inhibited coolant will last 600,000 miles

(960,000 km), four (4) years, or 10,000 operating hours, whichever comes first. At this time the coolant should be drained, and the cooling system should be thoroughly cleaned, flushed, and filled with new, properly inhibited OAT coolant.

### **Chronic Coolant System Problems**

The most commonly seen coolant system problems result from maintenance and formulation factors such as:

- Hard water
- Dilution of the coolant by the addition of untreated water
- Over dosage or under dosage of corrosion inhibitors
- Improper corrosion inhibitor (most often phosphated)
- Mixing SCAs
- Improper testing

### **Detroit Diesel Cooling System Maintenance Products**

**Power Cool SCAs** — *Power Cool* SCAs are water-soluble chemical compounds. These products are available in coolant filter elements, liquid packages, and in fully formulated *Power Cool* antifreeze.

#### **NOTE:**

***Power Cool 3000 liquid SCA is more compatible with hard water than Power Cool 2000 SCA.***

#### **Power Cool Coolant Filter Elements**

— *Power Cool* coolant filter elements (spin-on canisters) are available in various sizes suitable for cooling systems of varying capacities. Selection of the proper element size is vital when pre-charging non-fully formulated coolant at initial fill and at maintenance intervals. **A fully formulated antifreeze must not have SCA added at initial fill. Do not use SCA-containing filters with OAT antifreeze or coolant.** The need for maintenance elements is determined by the results of the nitrite concentration test performed at each cooling system interval. *Do not automatically install maintenance elements at maintenance intervals, unless the nitrite concentration falls below 900 parts per million.*

**Power Cool Cleaners** — *Power Cool* Liquid On-Line Cleaner is used for light deposits. *Power Cool* Dry Chemical Cleaner/Conditioner is used for heavy deposits or scale.



## Summary of Coolant Recommendations



### CAUTION:

**To avoid injury from the expulsion of hot coolant, never remove the cooling system pressure cap while the engine is at operating temperature. Remove the cap slowly to relieve pressure. Wear adequate protective clothing (face shield or safety goggles, rubber gloves, apron, and boots).**

1. Always maintain the engine coolant to meet Detroit Diesel specifications.
2. Only use water that meets the specifications listed in Table 27. Distilled, de-mineralized (reverse osmosis) or de-ionized water is preferred.
3. The proper dosage of inhibitors *must* be included in the coolant at initial fill for all Detroit Diesel engines. This dosage is usually included in the fully formulated antifreeze used, or it may need to be added if water alone or if less than 50% antifreeze is used. *The user is urged to refer to the full text of this section to determine the proper dosage.* Mixing of different manufacturers' technologies (brands) could cause cooling system problems.
4. Maintain the inhibitor at the prescribed concentration. Test the nitrite concentration by using a titration kit or Detroit Diesel Power Trac 3-Way Coolant Test Strips. Add SCA only if the nitrite concentration is below 900 PPM. *Do not use SCA in OAT coolant, and do not use Power Trac 3-Way Coolant Test Strips to test OAT coolant.*

#### NOTE:

If the nitrite concentration exceeds 3,200 PPM, the coolant must be drained and replaced with new coolant. A thorough cleaning of the cooling system may be required.

5. Do not use another manufacturer's test kit to measure the SCA concentration of Detroit Diesel maintenance products.
6. Pre-mix coolant makeup solutions to the proper concentration before adding to the cooling system.
7. Do not mix OAT and other coolants in the same engine.
8. Do not use automotive coolants.
9. Where antifreeze/boil over protection is required, use only antifreeze that meets TMC RP-329 "Type A" (EG) or TMC RP-330 "Type A" (PG)

specifications. Always maintain coolant at the proper level.

10. Coolant Life:

- Glycol Coolant. A *properly maintained* cooling system, filled with phosphate-free coolant consisting of a 50/50 mix of antifreeze and water per TMC RP-329 “Type A” (EG) or TMC RP-330 “Type A” (PG) specifications can be operated to the limits recommended. The proper maintenance involves periodic evaluation using Power Trac 3-Way Coolant Test Strips and the addition of SCA as needed, indicated by the strip test. To verify coolant acceptability, submit a sample for coolant analysis every 300,000 miles (480,000 km), three (3) years, or 5,000 operating hours, whichever comes first. Submit the sample in a DDC Power Trac Coolant Test Bottle. Required part numbers are listed in Table 55.
- OAT Coolant. A properly maintained OAT coolant may be operated 600,000 miles (960,000 km), four (4) years, or until overhaul, whichever comes first. At this time the system *must* be completely

drained, thoroughly cleaned, and refilled.

- OAT Coolants require the addition of an extender at 300,000 miles (480,000 km), two (2) years, or 5,000 hours, whichever comes first. Use 1 pint of extender for every 20 gallons of coolant.
- Other Coolants. Other properly maintained coolants may be operated up to 250,000 miles (480,000 km), two (2) years, or 4,000 operating hours, whichever comes first. At this time the system *must* be completely drained, thoroughly cleaned, and refilled.

11. Do not use the following in engine cooling systems:

- Soluble oil
- High silicate, automotive-type antifreeze
- Chromate SCAs
- Methoxy propanol-base coolant
- Methyl alcohol-base coolant
- Sealer additives or coolant containing sealer additives.
- HVAC coolant
- Phosphated coolants

## H. How to Replace the Coolant Filter

The coolant filter is installed on a header mounted at the rear of the gear case just above the oil cooler . Replace the coolant filter as follows:

	<b>CAUTION:</b>
<p><b>To avoid injury from the expulsion of hot coolant, never remove the cooling system pressure cap while the engine is at operating temperature. Remove the cap slowly to relieve pressure. Wear adequate protective clothing (face shield or safety goggles, rubber gloves, apron, and boots).</b></p>	

1. With the engine at ambient temperature and cool to the touch, carefully remove the radiator or deaeration tank pressure cap to relieve pressure in the cooling system.
2. Close the manual shutoff valve on the coolant filter header by turning handle clockwise. In the closed position, the handle will be pointing straight up.
3. Loosen and remove the coolant filter by turning counter-clockwise using a

filter/strap wrench. See Figure 29.

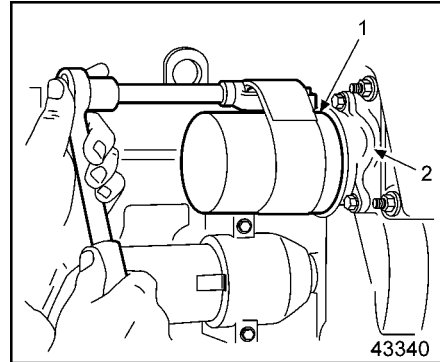

- |   |  |
|---|--|
| <ol style="list-style-type: none"> <li>1. Coolant Filter</li> </ol> | <ol style="list-style-type: none"> <li>2. Coolant Filter Header</li> </ol> |
|---|--|

**Figure 29 Removing Coolant Filter**

4. Lubricate the new coolant filter gasket (1) with clean engine oil and install onto the header (2). See Figure 30.

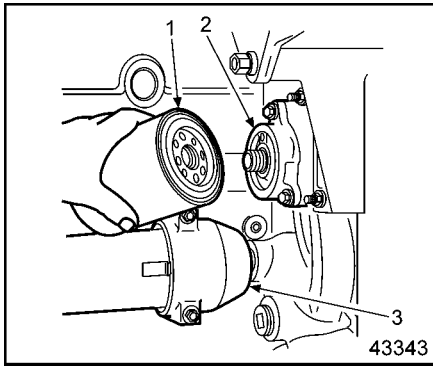

- 1. Coolant Filter Gasket
- 2. Filter Header
- 3. Oil Cooler

**Figure 30** Installing Coolant Filter

5. Tighten filter until gasket makes full contact with the header, then tighten one additional full turn.
6. Inspect the coolant level in the radiator or deaeration tank and top off with required coolant, if necessary. Replace the pressure cap and tighten securely.
7. Open the manual shutoff valve by turning counter-clockwise. In the open position, the handle will be parallel with the filter and pointing rearward.

## I. How to Drain and Flush the Cooling System



### CAUTION:

To avoid injury from the expulsion of hot coolant, never remove the cooling system pressure cap while the engine is at operating temperature. Remove the cap slowly to relieve pressure. Wear adequate protective clothing (face shield or safety goggles, rubber gloves, apron, and boots).

1. With the engine cool, slowly loosen and remove the pressure cap from the radiator or deaeration tank. Place a suitable container under the radiator and drain the previous solution from the engine and radiator. Dispose of the coolant in an environmentally friendly manner, according to state and/or federal (EPA) recommendations.
2. Refill the cooling system with clean, soft water and a good cooling system cleaning compound, such as those listed in Table 54 in the **Specifications** section. If the engine is warm, fill slowly to prevent the rapid cooling and distortion of the metal castings.

3. Start the engine and operate it for fifteen minutes to circulate the solution thoroughly.
4. Stop the engine and allow it to cool.
5. With the engine cool, drain the cooling system completely.
6. Refill the cooling system with clean, soft water and operate it for fifteen minutes.
7. Stop the engine and allow it to cool.
8. With the engine cool, drain the cleaner residue from the cooling system.
9. Refill the system with the required coolant. Refer to section G. How to Select Coolant.
10. Entrapped air must be purged after filling the cooling system. To do this, start the engine and allow it to warm up without the pressure cap installed. With the transmission in neutral, increase engine speed above 1000 RPM and add coolant as required. Install the pressure cap after the coolant level has stabilized at the bottom of the radiator filler neck or the level indicated on the deaeration tank .

**NOTICE:**

If the engine overheats and the coolant level is satisfactory, the cooling system may require cleaning with a descaling solvent and backflushing. Authorized Detroit Diesel service outlets are properly equipped to perform these services.

In addition to the cleaning procedure, other components of the cooling system should be checked periodically to keep the engine operating at peak efficiency.

**Hoses.** Cooling system hoses should be inspected and any hose that shows obvious signs of damage or feels abnormally soft or hard should be replaced. Damaged clamps should also be replaced. All external leaks should be corrected as soon as detected.

**NOTE:**

If Detroit Diesel **Power Cool** antifreeze/coolant (or equivalent fully formulated, precharged antifreeze is used, a precharge element is not required. Coolant inhibitor levels *must* be checked at the intervals listed in Table 28.

## J. When to Service the Dry Type Air Cleaner

Replace dry type air cleaner elements when the maximum allowable air cleaner restriction (20 inches of water or 5.0 kPa) has been reached or annually, whichever comes first.

**Exception:** On engines equipped with boreless turbochargers, such as certain transit bus applications, replace the element when the maximum allowable air cleaner restriction of 15 inches of water (3.7 kPa) has been reached, or annually, whichever comes first.

Some air cleaners are equipped with a restriction indicator which aids in determining the servicing interval.

Cleaning and/or reusing dry paper type air cleaner elements is not recommended unless the cleaning method used removes clogging without damaging the element. Inspection and cleaning of elements *must* be done in accordance with the air cleaner element manufacturer's recommendations, if any.

## **BASIC TROUBLESHOOTING**

This section covers basic troubleshooting of engine operation or performance malfunctions and their probable causes. Hard starting symptoms are listed in Table 30. Objectionable exhaust symptoms are listed in Table 31. Abnormal engine operation symptoms are listed in Table 32. Abnormal operating condition symptoms are listed in Table 33. Abnormal coolant temperature symptoms are listed in Table 34.

	Engine Will Not Rotate	Low Cranking Speed	Engine Cranks But Will Not Start
<b>Probable Causes</b>			
Low Battery Voltage	X	X	
Loose cranking motor connections	X		
Faulty cranking motor	X	X	
Faulty cranking motor switch	X	X	X
Internal seizure	X		
Improper lube oil		X	
Circuit breaker/electronic control malfunction			X
Fuse blown or missing			X
<b>Insufficient Fuel Supply</b>			
Air in fuel			X
Out of fuel			X
Loose fuel connections			X
Cracked fuel lines			X
Obstructed fuel filters/lines			X
Faulty fuel pump			X
Faulty injector operation			X
Restricted fuel fitting missing			X
Electronic control system malfunction			X
Installation/operation of fuel check valve or shutoff valve			X
<b>Low Compression</b>			
Worn intake and exhaust valves			X
Worn piston rings/liners			X



	<b>Engine Will Not Rotate</b>	<b>Low Cranking Speed</b>	<b>Engine Cranks But Will Not Start</b>
<b>Probable Causes</b>			
Leaking cylinder head gasket			X
Improper intake or exhaust valve adjustments			X

**Table 30 Hard Starting Symptoms and Probable Causes**

<b>Probable Causes</b>	<b>Black or Gray Smoke</b>	<b>Blue Smoke</b>	<b>White Smoke</b>
Damaged or dirty air cleaner	X		
Improper grade of fuel	X		
Excessive exhaust back pressure	X		
Misfiring cylinders			X
Lubricating oil not burned in cylinder (being burned in exhaust manifold or turbocharger)		X	
Faulty injector timing	X		
Faulty oil control rings		X	
Excessive installation angle		X	
Excessive oil in crankcase		X	
High ambient temperature	X		
Thin air (high altitude)	X		
Cetane rating of fuel too low			X
Air in the fuel system			X

**Table 31 Objectionable Exhaust Symptoms and Probable Causes**

Probable Causes	Rough Running or Frequent Stalling	Low Power	Detonation
Misfiring cylinder	X	X	
Insufficient fuel	X	X	
High return fuel temperature	X	X	
Low compression	X	X	
Electronic control system malfunction	X	X	
High air inlet restriction/exhaust back pressure		X	
Engine application		X	
High air inlet temperature		X	
High altitude operation		X	
Incorrect engine gear train timing		X	
Low coolant temperature			X
Oil picked up by inlet airstream			X
Faulty injector operation			X
Incorrect injector height setting		X	X

**Table 32 Abnormal Engine Operation Symptoms and Probable Causes**

Probable Causes	High Lube Oil Consumption	Low Oil Pressure
Loose connections	X	
Cracked, leaking oil lines	X	
Damaged gaskets or seal rings	X	
Lube oil loss at breather tube *	X	
Lube oil loss at dipstick tube *	X	
Leaking oil cooler	X	
Leaking valve stem seals	X	
Worn/broken oil control rings	X	
Scored liner and/or piston	X	
Excessive engine installation angle	X	
Crankcase overfilled	X	
Oil in air tanks (air compressor malfunction)	X	
Plugged crankcase breather	X	
Oil level low		X
Improper engine oil viscosity (fuel in the oil)		X
Faulty oil pressure regulator valve		X
Worn crankshaft, camshaft or connecting rod bearings		X
Missing cup plugs in rocker arm shaft		X
Faulty oil pressure relief valve		X
Air leaks in oil pump (suction side)		X
Worn or damaged oil pump		X
Faulty oil pressure gage		X
Faulty electrical components (for gage)		X
Plugged oil line or orifice		X

\* Indicates high crankcase pressure

**Table 33 Abnormal Operating Condition Symptoms and Probable Causes**

<b>Probable Causes</b>	<b>Above Normal</b>	<b>Below Normal</b>
Restricted cooling system passages	X	
Restricted radiator core passages	X	
Slipping fan drive belt	X	
Faulty thermo-modulated fan (failure to engage fan)	X	
Faulty thermo-modulated fan (failure to disengage fan)		X
Obstruction in front of radiator	X	
Low coolant level	X	
Damaged hoses	X	
Faulty thermostat	X	
Faulty water pump	X	
Faulty radiator pressure cap	X	
Air in coolant	X	
Thermostat not fully closed		X
Leakage around thermostat seal		X

**Table 34 Abnormal Coolant Temperature Symptoms and Probable Causes**

## ENGINE STORAGE

### Preparing Engine for Storage

When an engine is to be stored or removed from operation for a period of time, special precautions should be taken to protect the interior and exterior of the engine, transmission and other parts from rust accumulation and corrosion. The parts requiring attention and the recommended preparations are given below.

All rust or corrosion should be removed completely from any exposed part before applying rust preventive compound. Therefore, DDC recommends processing the engine for storage as soon as possible after removing it from service.

The engine should be stored in a building that is dry and can be heated during the winter months. Moisture-absorbing chemicals are available commercially for use when excessive dampness prevails in the storage area.

### Temporary Storage (30 Days or Less)

To protect the engine for a temporary period of time (30 days or less), follow this procedure:

1. With the engine at ambient temperature and cool to the touch,

drain engine crankcase oil into a suitable container. Dispose of the oil in an environmentally friendly manner, according to state and/or federal (EPA) recommendations.

2. Fill the crankcase to the proper level with the recommended viscosity and grade of oil.
3. Fill the fuel tank with the recommended grade of fuel oil. Operate the engine for two (2) minutes at 1200 rpm and no load.  
**Do not drain the fuel system or the crankcase after this run.**
4. Check the air cleaner and service it, if necessary.
5. If freezing weather is expected during the storage period, check the antifreeze/coolant for required freeze and inhibitor protection. Add antifreeze solution to the cooling system in accordance with DDC's recommendations. Refer to section G. How to Select Coolant.

#### NOTE:

If an antifreeze solution is not required during storage, flush the cooling system with a good, soluble oil (3% – 5% by volume) rust inhibitor to prevent rusting of the outside diameter of the cylinder liners.



**CAUTION:**

**To avoid injury from flying debris when using compressed air, wear adequate eye protection (face shield or safety goggles) and do not exceed 40 psi (276 kPa) air pressure.**

6. Clean the exterior of the engine (except electrical parts) with fuel oil and dry with compressed air.
7. Seal all engine openings, including the turbocharger air and exhaust outlets and the valve cover/intake manifold opening. The material used must be waterproof, vaporproof and possess sufficient physical strength to resist puncture and damage from the expansion of entrapped air.

An engine prepared in this manner can be returned to service in a short time by removing the seals at the engine openings and reconnecting piping; by checking the engine coolant, fuel oil, lubricating oil and transmission oil levels; and by priming the fuel system before starting.

**Extended Storage (More than 30 Days)**

To prepare an engine for extended storage (more than 30 days), follow this procedure:

1. Drain the cooling system and flush with clean, soft water. Refill with clean, soft water and add a rust inhibitor to the cooling system.
2. Circulate the coolant by operating the engine until normal operating temperature is reached.
3. Stop the engine.
4. With the engine at ambient temperature and cool to the touch, drain the engine crankcase oil into a suitable container. Remove the oil filter. Dispose of the oil and filter in an environmentally friendly manner, according to state and/or federal (EPA) recommendations. Replace the oil drain plug and tighten to 45 – 50 N·m (33 – 37 lb-ft) torque.
5. Install a new lubricating oil filter. Fill the crankcase to the proper level with Tectyl® 930A preservative lubricating oil or an equivalent 30-weight preservative lubricating oil meeting Mil-L-21260C, Grade 2 Specification.
6. Drain the fuel tank. Refill with enough clean No. 1 diesel fuel

or pure kerosene to permit the engine to operate for about ten (10) minutes. If draining the fuel tank is not convenient, use a separate, portable supply of recommended fuel.

**NOTE:**

If engines are stored where condensation of water in the fuel tank may be a problem, additives containing methyl carbitol or butyl cellusolve may be added to the fuel. Follow manufacturer's instructions for treatment. Where biological contamination of fuel may be a problem, add a biocide such as Biobor® JF (or equivalent) to the fuel. When using a biocide, follow the manufacturer's concentration recommendations and observe all cautions and warnings.

7. Drain the fuel system and remove the fuel filters. Dispose of used filters in an environmentally responsible manner, according to state and/or federal (EPA) recommendations. Fill the new filters with No. 1 diesel fuel or pure kerosene and install on the engine. Prime the fuel system.
8. Start and operate the engine for five (5) minutes to circulate the clean fuel throughout the system and ensure the system is full.

9. Stop the engine and allow to cool. Then disconnect the fuel return line and the inlet line at the fuel filter and securely plug both to retain the fuel in the engine.
10. **Transmission:** Follow the manufacturer's recommendations for prolonged storage.
11. **Power Take-Off:** If equipped, follow manufacturer's recommendations for prolonged storage.
12. Apply a non-friction rust preventive compound to all exposed engine parts. If convenient, apply the rust preventive compound to the engine flywheel. If not, disengage the clutch mechanism to prevent the clutch disc from sticking to the flywheel.

**NOTE:**

Do not apply oil, grease or any wax-base compound to the flywheel. The cast iron will absorb these substances, which can "sweat" out during engine operation and cause the clutch to slip.

13. Drain the engine cooling system.
14. Drain the preservative oil from the engine crankcase. Reinstall and tighten the oil drain plug.



15. Remove and clean the battery and battery cables with a baking soda-water solution and rinse with fresh water. Do not allow the soda solution to enter the battery. Add distilled water to the electrolyte (if necessary) and fully charge the battery. Store the battery in a cool (never below 0 °C or 32 °F) dry place. Keep the battery fully charged and check the level and specific gravity of the electrolyte regularly.
16. Insert heavy paper strips between the pulleys and serpentine drive belt to prevent sticking *or* remove the drive belt and store separately.
17. Seal all engine openings, including the turbocharger air and exhaust outlets and the valve cover/intake manifold opening. Use moisture-resistant tape and cardboard, plywood or metal covers where practical.
18. Clean and dry the exterior painted surfaces of the engine and spray with a suitable liquid automobile body wax, a synthetic resin varnish, or a rust preventive compound.
19. Protect the engine with a good weather-resistant tarpaulin and store it under cover, preferably in a dry building which can be heated during the winter months.

**Outdoor storage of the engine is not recommended.** If units must be kept out of doors, follow the preparation and storage instructions already given. Protect units with quality, weather-resistant tarpaulins (or other suitable covers) arranged to provide for air circulation.

**NOTICE:**

Failure to properly seal off the turbocharger air inlet and exhaust outlet openings before engine storage may permit air drafts to circulate through the turbocharger and rotate the turbine/compressor shaft without an adequate flow of lubricating oil to the center housing bearings. This can result in severe bearing damage.

17. Seal all engine openings, including the turbocharger air and exhaust outlets and the valve cover/intake manifold opening. Use moisture-resistant tape and cardboard, plywood or metal covers where practical.

**NOTICE:**

Do not use plastic sheeting for outdoor storage. Plastic is fine for indoor storage. When used outdoors, however, enough moisture can condense on the inside of the plastic to rust ferrous metal surfaces and pit aluminum surfaces. If a unit is stored outside for any extended period of time, severe corrosion damage can result.

The stored engine should be inspected periodically. If there are any indications of rust or corrosion, corrective steps must be taken to prevent damage to the engine parts. Perform a complete inspection at the end of one year and apply additional treatment as required.

**Restoring an Engine to Service after Extended Storage**

If an engine has been in extended storage, prepare it for service as follows:

1. Remove the covers and tape from all the openings of the engine, fuel tank and electrical equipment. Do not overlook the turbocharger air and exhaust outlets and the valve cover/intake manifold openings.
2. Remove the plugs from the inlet and outlet fuel lines and reconnect the lines to their proper positions.

3. Wash or steam clean the exterior of the engine to remove the rust preventive, if previously applied. **Do not wash or apply steam to electrical components.**
4. Remove the rust preventive from the flywheel. Flush any soluble oil rust inhibitor (if used) in the cooling system.
5. Remove the paper strips from between the pulleys and serpentine drive belt *or* reinstall the drive belt, if previously removed.
6. Fill the crankcase to the proper level with the required grade of lubricating oil. Use a pressure lubricator to insure all bearings and rocker shafts are lubricated.
7. Fill the fuel tank with the required fuel. Prime the fuel system.
8. Close all drain cocks and fill the engine cooling system with clean, soft water and required inhibitors. If the engine is to be exposed to freezing temperatures, install genuine Detroit Diesel **Power Cool** antifreeze or an equivalent ethylene glycol-base or propylene glycol-base antifreeze solution which provides required freeze, boil over, and inhibitor protection. Refer to section G. How to Select Coolant.

9. Install and connect the battery. Make sure the average specific gravity of the battery is 1.260 or higher. Charge the battery, if necessary.
10. Service the air cleaner, if required.
11. **Transmission:** Follow the manufacturer's recommendations covering the return of the transmission to service.
12. **Power Take-Off:** If equipped, follow the manufacturer's recommendations covering the return of the power take-off to service.
13. **Turbocharger:**
  - [a] Remove the tape or covers from the turbocharger air and exhaust outlet connections and the valve cover/intake manifold opening. Reconnect piping as required.
  - [b] Remove the oil inlet tube assembly from the turbocharger center bearing housing. Prelube bearings by pouring approximately five (5) ounces of clean lubricating oil into the opening. Reinstall the oil inlet pipe using a new gasket, and torque inlet pipe flange bolts to specifications.
14. Refer to section Lubrication System Checks in section

*Preparations for Starting the Engine the First Time.*



**CAUTION:**

**Diesel engine exhaust and some of its constituents are known to the State of California to cause cancer, birth defects, and other reproductive harm.**

- Always start and operate an engine in a well ventilated area.**
- If operating an engine in an enclosed area, vent the exhaust to the outside.**
- Do not modify or tamper with the exhaust system or emission control system.**

15. After all preparations are completed, start the engine.

**NOTE:**

The small amount of rust preventive which remains in the fuel system will cause smoky exhaust for a few minutes.

**NOTE:**

Before subjecting the engine to a load or high speed, allow it to reach normal operating temperature. Then monitor the electronic control system diagnostic data link for trouble codes.

## SERVICE PUBLICATIONS

The service manual covering Detroit Diesel Series 40 engines and various reference works which may be of interest to the owner/operator are listed in Table 35.

To purchase a copy of any of these publications, contact an authorize

Detroit Diesel distributor in the U.S. or Canada. Check the Yellow Pages under “Engine, Diesel” or refer to the Distributor and Dealer Directory listed below for the distributor or service outlet nearest you.

<b>Description</b>	<b>Form No.</b>
<i>Series 40 Service Manual</i>	6SE410
<i>Series 40 Troubleshooting Manual</i>	6SE241
<i>U.S. and Canada Distributor/Dealer Directory</i>	6SE280
<i>International Distributor/Dealer Directory</i>	6SE281
<i>Lube Oil, Fuel and Filter Requirements</i>	7SE270
<i>Coolant Requirements for Engine Cooling Systems</i>	7SE298
<i>Technician's Guide – Used Lubricating Oil Analysis</i>	7SE398
<i>Technician's Guide – Turbocharger</i>	7SE374
<i>Technician's Guide – Cooling System</i>	7SE390

**Table 35 Service Publications**

## DETROIT DIESEL CUSTOMER ASSISTANCE

### U.S. and Canada 1-800-445-1980

If you require service for any reason in the U.S. or Canada, you may call the 1-800-445-1980 customer assistance phone number. An operator will assist you in determining what type of service is required. Not all problems are engine related and not all problems are covered by engine warranties.

*YOU MAY BE RESPONSIBLE FOR REPAIR EXPENSES.*

#### **Before calling Customer Assistance, please do the following:**

- Check coolant level.
- Check fuel level.
- Check for fuel leaks
- Make sure manual shutoff valve (if installed) on the fuel filter adaptor, fuel processor body or fuel supply line is open.
- Check the oil level on the dipstick.
- Check diagnostic codes against those listed in section SERIES 40 ELECTRONIC CONTROL SYSTEM.

#### **If you call, have the following information available:**

- Engine serial and model numbers. Refer to section ENGINE MODEL AND SERIAL

NUMBER LOCATIONS for location.

- Vehicle, equipment or generator set make and model
- Accumulated miles/kilometers or hours of operation.
- Vehicle, equipment or generator set owner/company name

### Customer Assistance

The satisfaction and goodwill of the owners of Detroit Diesel engines are of primary concern to Detroit Diesel Corporation and its distributor/dealer organizations. As the owner of a Detroit Diesel product you have a complete network of over 2,000 Detroit Diesel service outlets in the U.S. and Canada, plus many outlets worldwide that are prepared to meet your parts and service needs:

- Service by trained personnel.
- Sales team to help determine your specific power requirements.
- In many areas, emergency service 24 hours a day.
- Complete parts support, including reliabilt® remanufactured components.
- Product information and literature.

We recognize, however, that despite the best intentions of everyone concerned, misunderstandings may occur. Normally, any situation that arises in connection with the sale, operation or service of your product will be handled by the authorized service outlet in your area. In the U.S. and Canada, check the Yellow Pages for the Detroit Diesel service outlet nearest you.

To further assure your complete satisfaction, we have developed the following procedure to be followed in the event you have a problem that has not been handled satisfactorily.

### Step One

Discuss your problem with a member of management from the authorized service outlet. Frequently, complaints are the result of a breakdown in communication and can quickly be resolved by a member of management. If you have already discussed the problem with the Sales or Service Manager, contact the General Manager. If your complaint originates with a dealer, explain the matter to a management member of the distributorship with whom the dealer has a service agreement.

### Step Two

When it appears that your problem cannot be readily resolved at the distributor level without additional

assistance, contact the Detroit Diesel Regional Product Support Manager or Operations Manager responsible for your local distributor. You will be assisted by a member of the manager's staff, depending upon the nature of your problem.

Prior to this contact, have the following information available:

- Engine model number\*  
\_\_\_\_\_
- Engine serial number\*  
\_\_\_\_\_
- Type and make of equipment.
- Engine delivery date and accumulated miles or hours of operation.
- Nature of problem.
- Chronological summary of engine's history.
- Name and location of authorized service outlet.

**\*Important:** Write your engine model number and serial number on the lines provided. They will identify your engine and all service parts, plus provide warranty and extended coverage information. Refer to section ENGINE MODEL AND SERIAL NUMBER LOCATIONS for location of engine model and serial numbers.

**Step Three**

If you are still not satisfied, present the entire matter in writing or by phone to:

**Vice President, Customer Assurance**

Detroit Diesel Corporation  
 13400 Outer Drive, West  
 Detroit, MI 48239-4001  
 Phone: 313-592-7357  
 FAX: 313-592-7888

When contacting the Detroit Diesel regional offices or the DDC/MTU Off-Highway Customer Assurance Center, please keep in mind that ultimately your problem will likely be resolved at the distributorship or dealership, utilizing their facilities, equipment, and personnel. Therefore,

it is suggested that you follow the above steps in sequence when experiencing a problem.

See Figure 31 for the Detroit Diesel NAFTA On-Highway Regions. See Figure 32 for the Detroit Diesel-MTU Off-Highway Sales and Customer Assurance Center.

The addresses and phone/fax numbers for the on-highway regional offices are listed in Table 36. The addresses and phone/fax numbers for the Detroit Diesel-MTU Off-Highway Sales and Customer Assurance Center offices are listed in Table 37. The addresses and phone/fax numbers for Detroit Diesel international regional offices are listed in Table 38.

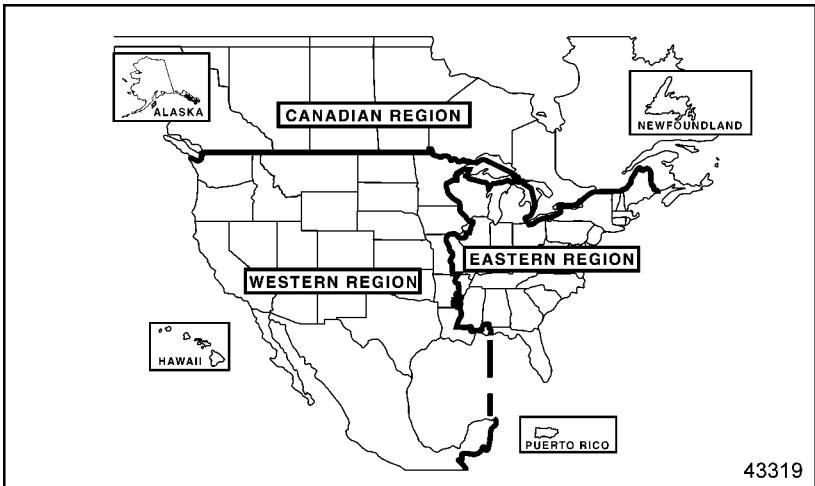

**Figure 31 Detroit Diesel NAFTA On-Highway Regions**

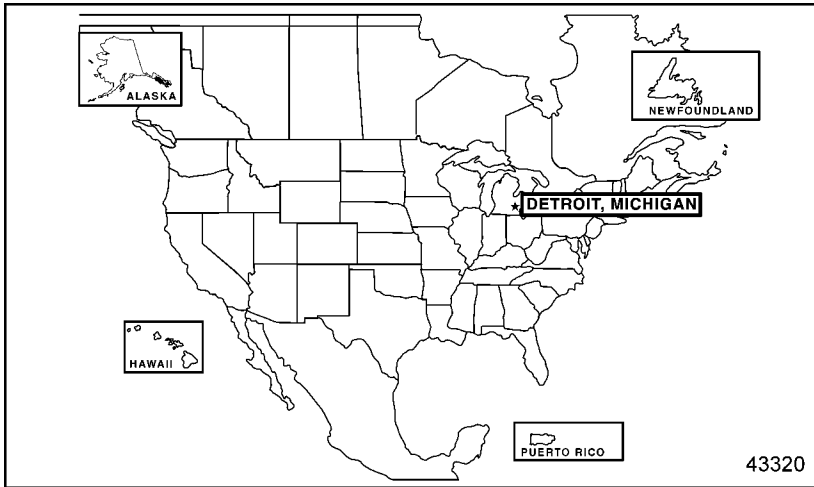

Figure 32 DDC-MTU Off-Highway Sales and Customer Assurance Center

<p><b>WESTERN REGION</b>  <b>Irvine, California</b>                  7700 Irvine Center, Suite 275                  Irvine, CA 92618                  Phone: 949-753-7710                  Fax: 949-753-7711</p>	<p><b>EASTERN REGION</b>  <b>Piscataway, New Jersey</b>                  169 Old New Brunswick Road                  Piscataway, NJ 08854                  Phone: 732-926-9622                  Fax: 732-926-8522</p>
<p><b>CANADIAN REGION</b>  <b>London, Ontario</b>                  Detroit Diesel of Canada, Ltd.                  150 Dufferin Ave., Suite 701                  London, ON N5A 5N6                  Phone: 519-661-0149                  Fax: 519-661-0171</p>	

Table 36 Detroit Diesel North American NAFTA On-Highway Offices



<p><b>Construction, Industrial and Mining Sales (BX7)</b>          13400 Outer Drive, West          Detroit, MI 48239-4001          Telephone: 313-592-5608          Fax: 313-592-5625</p>	<p><b>Marine Sales (BX6)</b>          13400 Outer Drive, West          Detroit, MI 48239-4001          Telephone: 313-592-5124          Fax: 313-592-5137</p>
<p><b>Powergen and Oilfield Sales (BX11)</b>          13400 Outer Drive, West          Detroit, MI 48239-4001          Telephone: 313-592-7459          Fax: 313-592-5158</p>	<p><b>Government Sales (BX11)</b>          13400 Outer Drive, West          Detroit, MI 48239-4001          Telephone: 313-592-5708          Fax: 313-592-5158</p>
<p><b>Customer Assurance (M24)</b>          13400 Outer Drive, West          Detroit, MI 48239-4001          Telephone: 313-592-5550          Fax: 313-592-5717</p>	

**Table 37 DDC-MTU Off-Highway Sales and Customer Assurance Center Offices**

<p><b>EUROPE, MIDDLE EAST, AFRICA (EMA) REGION (On/Off-Highway)</b>  <b>The Netherlands</b>                  Ridderpoort 9                  2984 Ridderkerk                  The Netherlands                  Phone: (31) 180-442-900                  Fax: (31) 180-419-544</p>	<p><b>LATIN AMERICAN REGION (Off-Highway)</b>  <b>Miami, Florida</b>                  2277 N.W. 14th Street                  Latin America Building                  Miami, Florida 33125-0068                  Phone: 305-637-1555                  Fax: 305-637-1580</p>
<p><b>ASIAN REGION (On-Highway)</b>                  13400 Outer Drive, West                  Detroit, Michigan                  Phone: 313-592-5990                  Fax: 313-592-5887</p>	<p><b>ASIA/PACIFIC REGION (Off-Highway)</b>  <b>Singapore</b>                  No. 16 Benoi Crescent                  Singapore 629979                  Phone: (65) 686-15922                  Fax: (65) 686-11550</p>
<p><b>PACIFIC REGION (Off-Highway)</b>  <b>Australia</b>                  11–13 Garling Road                  Kings Park, NSW 2148                  Beaumaris, Victoria 3193                  Australia                  Phone: (612) 8822-7000                  Fax: (612) 8822-7083</p>	<p><b>AUSTRALIAN REGION (On-Highway)</b>                  P.O. Box 1472                  Canterbury, Victoria 3124                  Australia                  Phone: (61) 39-836-0775                  Fax: (61) 39-836-0770</p>
<p><b>MEXICO (On/Off-Highway)</b>                  Detroit Diesel Allison de Mexico, S.A.                  Av. Santa Rosa 58                  Col. Ampliacion Norte                  San Juan Ixtacala, Tlanepantla                  C.P. 54160, Edo de Mexico                  Phone: 525-333-1802                  Fax: 525-333-1870</p>	

**Table 38 Detroit Diesel International Off-Highway Regional Offices**

## LIMITED WARRANTY ON ENGINES USED IN MOTOR COACH, MOTOR HOME AND TRANSIT BUS APPLICATIONS

### TERMS OF COVERAGE

#### Uses

This warranty applies to the first retail purchaser and subsequent owners during the WARRANTY PERIOD of new Detroit Diesel Series 40<sup>®</sup> Engines (referred to as Engine) and attached starting motor, air compressor and alternator (referred to as Accessories) manufactured by Detroit Diesel Corporation and/or supplied by Detroit Diesel Corporation, Detroit Diesel of Canada Limited, or Detroit Diesel Overseas Distribution Corporation (all which are collectively referred to as DDC) which are used in on-highway vehicle applications, including motor coaches, motor homes and transit busses.

#### Defects

This warranty covers Engine REPAIRS to correct any malfunction occurring during the WARRANTY PERIOD resulting from defects in material or workmanship.

#### Repairs

To obtain warranty repairs, you must request the needed repairs within the WARRANTY PERIOD from an authorized DDC service outlet. Only new genuine parts or remanufactured

parts or components supplied or approved by DDC will be used. DDC may, at its discretion, replace rather than repair components. A reasonable time must be allowed to perform the warranty repair after taking the engine to the authorized service outlet. Repairs will be performed during normal business hours.

The owner is responsible for the percentage of repair costs shown in the WARRANTY PERIOD chart below.

#### Warranty Period

The WARRANTY PERIOD begins on the date the engine is delivered to the first retail purchaser or put in use prior to sale at retail, whichever date occurs first, and ends at the time or hour limits listed in Table 39.

LIMITED WARRANTY ON ENGINES USED IN MOTOR COACH, MOTOR HOME AND TRANSIT BUS APPLICATIONS

WARRANTY PERIOD				
Item	Warranty Limitations (Whichever Occurs First)		Repair Charges to Be Paid by Owner	
	MONTHS	MILES/KILO- METERS	PARTS	LABOR
Engine	0 – 12	0 – 50,000 Miles 0 – 80,000 Kilometers	No Charge	No Charge

**Table 39 Warranty Period – Motor Coach, Motor Home and Transit Coach Applications**

**Like Replacement Engine**

Engine(s) supplied by DDC as a replacement for an Engine still under warranty will assume the identity of the Engine being replaced and be entitled to the remaining warranty coverage.

**Service Supplies**

The cost of service supplies such as coolant, oil and filters which are not reusable due to warranted repairs is covered by this warranty.

**Engine Removal and Reinstallation**

Reasonable labor costs for Engine removal and reinstallation, when necessary to make a warranty repair, are covered by this warranty.

**THIS WARRANTY DOES NOT COVER:**

**Repairs Due to Accidents, Misuse, Alteration, Storage Damage, Negligence or Certain Modifications**

Repairs due to an accident, misuse, alteration, misapplication, storage damage, negligence or modification exceeding DDC specifications are not covered by this warranty.

**Braking Devices**

DDC is not responsible for the repair of mechanical braking devices that are not factory-installed or not installed by DDC distributors. Such devices are warranted by the brake manufacturer.

**Maintenance**

DDC is not responsible for the cost of maintenance or repairs due to lack of performance of required maintenance services as recommended by DDC, or the failure to use fuel, oil, lubricants, or coolant meeting DDC-recommended specifications. Performance of the required maintenance and use of proper fuel, oil, lubricants, and coolant are the responsibility of the owner. Refer to section MAINTENANCE SCHEDULES in this guide for details.

### **Incidental or Consequential Damages**

DDC is not responsible for incidental or consequential costs or expenses which the owner may incur as a result of malfunction or failure covered by this warranty, such as communication expenses, meals, lodging, overtime, towing, loss of use of the Engine or vehicle ("downtime"), loss of time, inconvenience, cargo loss or damage and other similar costs and expenses.

### **Other Limitations**

The performance of REPAIRS is the exclusive Owner's remedy under this warranty. DDC does not authorize any person to assume or create for it any other obligation or liability in connection with the Engine or the Accessories.

**THIS LIMITED WARRANTY AND THE EMISSIONS WARRANTY ARE THE ONLY WARRANTIES APPLICABLE TO THE ENGINE**

**AND ACCESSORIES AS USED IN MOTOR COACH, MOTOR HOME AND TRANSIT COACH APPLICATIONS. DETROIT DIESEL CORPORATION MAKES NO OTHER WARRANTIES EXPRESS OR IMPLIED, INCLUDING ANY IMPLIED WARRANTY OF MERCHANTABILITY OR FITNESS FOR A PARTICULAR PURPOSE. DETROIT DIESEL CORPORATION SHALL NOT BE LIABLE FOR ANY INCIDENTAL OR CONSEQUENTIAL DAMAGES AS DESCRIBED ABOVE.**

Some states do not allow the limitation of how long this warranty may last or the limitation or exclusion of incidental or consequential damages, so the above may not apply to you. This warranty gives you specific legal rights, and you may also have other rights which may vary from state to state.

## LIMITED WARRANTY ON ENGINES USED IN FIRE TRUCK OR CRASH VEHICLE APPLICATIONS

### TERMS OF COVERAGE

#### Uses

This warranty applies to the first retail purchaser and subsequent owners during the WARRANTY PERIOD of new Detroit Diesel Series 40<sup>®</sup> Engines (referred to as Engine) manufactured by Detroit Diesel Corporation and/or supplied by Detroit Diesel Corporation, Detroit Diesel of Canada Limited, or Detroit Diesel Overseas Distribution Corporation (all which are collectively referred to as DDC) which are used in fire truck or crash vehicle applications.

#### Defects

This warranty covers Engine REPAIRS to correct any malfunction occurring during the WARRANTY PERIOD resulting from defects in material or workmanship.

#### Repairs

To obtain warranty repairs, you must request the needed repairs within the WARRANTY PERIOD from an authorized DDC service outlet. Only new genuine parts or remanufactured parts or components supplied or approved by DDC will be used. DDC may, at its discretion, replace rather than repair components. A reasonable time must be allowed to perform

the warranty repair after taking the engine to the authorized service outlet. Repairs will be performed during normal business hours.

#### Warranty Period

The WARRANTY PERIOD begins on the date the engine is delivered to the first retail purchaser or put in use prior to sale at retail, whichever date occurs first, and ends at the time or mileage/kilometer limits listed in Table 40.

WARRANTY PERIOD				
Item	Warranty Limitations (Whichever Occurs First)		Repair Charges to Be Paid by Owner	
	MONTHS	MILES/KILO- METERS	PARTS	LABOR
Engine	0 – 60	0 – 50,000 Miles 0 – 80,000 Kilometers	No Charge	No Charge
Accessories	0 – 24	0 – 50,000 Miles 0 – 80,000 Kilometers	No Charge	No Charge

**Table 40 Warranty Period – Fire Truck or Crash Vehicle Applications**

**Like Replacement Engine**

Engine(s) supplied by DDC as a replacement for an Engine still under warranty will assume the identity of the Engine being replaced and be entitled to the remaining warranty coverage.

**Service Supplies**

The cost of service supplies such as coolant, oil and filters which are not reusable due to warranted repairs is covered by this warranty.

**Engine Removal and Reinstallation**

Reasonable labor costs for Engine removal and reinstallation, when necessary to make a warranty repair, are covered by this warranty.

**THIS WARRANTY DOES NOT COVER:**

**Repairs Due to Accidents, Misuse, Alteration, Storage Damage, Negligence or Certain Modifications**

Repairs due to an accident, misuse, alteration, misapplication, storage damage, negligence or modification exceeding DDC specifications are not covered by this warranty.

**Maintenance**

DDC is not responsible for the cost of maintenance or repairs due to lack of performance of required maintenance services as recommended by DDC, or the failure to use fuel, oil, lubricants, or coolant meeting DDC-recommended specifications. Performance of the required maintenance and use of proper fuel, oil, lubricants, and coolant are the responsibility of the owner. Refer to section MAINTENANCE SCHEDULES in this guide for details.

*LIMITED WARRANTY ON ENGINES USED IN FIRE TRUCK OR CRASH  
VEHICLE APPLICATIONS*

---

**Incidental or Consequential  
Damages**

DDC is not responsible for incidental or consequential costs or expenses which the owner may incur as a result of malfunction or failure covered by this warranty, such as communication expenses, meals, lodging, overtime, towing, loss of use of the Engine or vehicle ("downtime"), loss of time, inconvenience, cargo loss or damage and other similar costs and expenses.

**Other Limitations**

The performance of REPAIRS is the exclusive Owner's remedy under this warranty. DDC does not authorize any person to assume or create for it any other obligation or liability in connection with the Engine or the Accessories.

THIS LIMITED WARRANTY AND THE EMISSIONS WARRANTY ARE THE ONLY WARRANTIES APPLICABLE TO THE ENGINE AND ACCESSORIES AS USED IN FIRE TRUCK OR CRASH VEHICLE APPLICATIONS. DETROIT DIESEL CORPORATION MAKES NO OTHER WARRANTIES EXPRESS OR IMPLIED, INCLUDING ANY IMPLIED WARRANTY OF MERCHANTABILITY OR FITNESS FOR A PARTICULAR PURPOSE. DETROIT DIESEL CORPORATION SHALL NOT BE LIABLE FOR ANY INCIDENTAL

OR CONSEQUENTIAL DAMAGES AS DESCRIBED ABOVE.

Some states do not allow the limitation of how long this warranty may last or the limitation or exclusion of incidental or consequential damages, so the above may not apply to you. This warranty gives you specific legal rights, and you may also have other rights which may vary from state to state.



## LIMITED WARRANTY ON ENGINES USED IN CONSTRUCTION/INDUSTRIAL APPLICATIONS

### TERMS OF COVERAGE

#### Uses

This warranty applies to the first retail purchaser and subsequent owners during the WARRANTY PERIOD of new Detroit Diesel Series 40<sup>®</sup> Engines (referred to as Engine) manufactured by Detroit Diesel Corporation and/or supplied by Detroit Diesel Corporation, Detroit Diesel of Canada Limited, or Detroit Diesel Overseas Distribution Corporation (all which are collectively referred to as DDC) which are used in construction/industrial applications.

#### Defects

This warranty covers Engine REPAIRS to correct any malfunction occurring during the WARRANTY PERIOD resulting from defects in material or workmanship.

#### Repairs

To obtain warranty repairs, you must request the needed repairs within the WARRANTY PERIOD from an authorized DDC service outlet. Only new genuine parts or remanufactured parts or components supplied or approved by DDC will be used. DDC may, at its discretion, replace rather than repair components. A reasonable time must be allowed to perform

the warranty repair after taking the engine to the authorized service outlet. Repairs will be performed during normal business hours.

The owner is responsible for the percentage of repair costs shown in the WARRANTY PERIOD chart below.

#### Warranty Period

The WARRANTY PERIOD begins on the date the engine is delivered to the first retail purchaser or put in use prior to sale at retail, whichever date occurs first, and ends at the time or hour limits listed in Table 41.

*LIMITED WARRANTY ON ENGINES USED IN CONSTRUCTION/INDUSTRIAL APPLICATIONS*

<b>WARRANTY PERIOD</b>				
<b>Engine Application</b>	<b>Warranty Limitations (Whichever Occurs First)</b>		<b>Repair Charges to Be Paid by Owner</b>	
	<b>MONTHS</b>	<b>ENGINE HOURS</b>	<b>PARTS</b>	<b>LABOR**</b>
Engine	0 – 12	Unlimited	No Charge	No Charge
Accessories	0 – 12	0 – 2,000	No Charge	No Charge
Upon expiration of the twelve (12) month warranty coverage, but within 12,000 hours of use, the warranty continues to apply as follows:				
Major Components †	13 – 36	0 – 12,000	No Charge	No Charge

† Cylinder block casting, cylinder head casting, crankshaft, camshaft and connecting rods.

**Table 41 Warranty Period Chart – Construction/Industrial Applications**

**Like Replacement Engine**

Engine(s) supplied by DDC as a replacement for an Engine still under warranty will assume the identity of the Engine being replaced and be entitled to the remaining warranty coverage.

**Service Supplies**

The cost of service supplies such as coolant, oil and filters which are not reusable due to warranted repairs is covered by this warranty.

**Mechanic's Travel Expenses**

DDC will pay reasonable travel expenses for the repairing mechanic to travel to and from the repair site.

**Engine Removal and Reinstallation – Construction/Industrial Applications**

Reasonable labor costs for Engine removal and reinstallation, when necessary to make a warranty repair, are covered by this warranty during the first twelve (12) months of service.

**THIS WARRANTY DOES NOT COVER:**

**Repairs Due to Accidents, Misuse, Alteration, Storage Damage, Negligence or Certain Modifications**

Repairs due to an accident, misuse, alteration, misapplication, storage damage, negligence or modification exceeding DDC specifications are not covered by this warranty.

### **Non-DDC Supplied/Manufactured Components**

DDC is not responsible for repair of components and/or assemblies which are manufactured or supplied by another manufacturer, such as non-DDC power take-offs, intake and exhaust systems and fuel storage tanks. Such items are covered by the equipment manufacturer.

### **Maintenance**

DDC is not responsible for the cost of maintenance or repairs due to lack of performance of required maintenance services as recommended by DDC, or the failure to use fuel, oil, lubricants and coolant meeting DDC-recommended specifications. Performance of the required maintenance and use of proper fuel, oil, lubricants, and coolant are the responsibility of the owner. Refer to section MAINTENANCE SCHEDULES in this guide for details.

### **Incidental or Consequential Damages**

DDC is not responsible for incidental or consequential costs or expenses which the owner may incur as a result

of malfunction or failure covered by this warranty, such as communication expenses, meals, lodging, overtime, towing, loss of use of the Engine or vehicle ("downtime"), loss of time, inconvenience, cargo loss or damage and other similar costs and expenses.

### **Other Limitations**

The performance of REPAIRS is the exclusive Owner's remedy under this warranty. DDC does not authorize any person to assume or create for it any other obligation or liability in connection with the Engine or the Accessories.

THIS LIMITED WARRANTY AND THE EMISSIONS WARRANTY ARE THE ONLY WARRANTIES APPLICABLE TO THE ENGINE AND ACCESSORIES AS USED IN CONSTRUCTION/INDUSTRIAL APPLICATIONS. DETROIT DIESEL CORPORATION MAKES NO OTHER WARRANTIES EXPRESS OR IMPLIED, INCLUDING ANY IMPLIED WARRANTY OF MERCHANTABILITY OR FITNESS FOR A PARTICULAR PURPOSE. DETROIT DIESEL CORPORATION SHALL NOT BE LIABLE FOR ANY INCIDENTAL OR CONSEQUENTIAL DAMAGES AS DESCRIBED ABOVE.

*LIMITED WARRANTY ON ENGINES USED IN CONSTRUCTION/INDUSTRIAL APPLICATIONS*

---

Some states do not allow the limitation of how long this warranty may last or the limitation or exclusion of incidental or consequential damages, so the above may not apply to you. This warranty gives you specific legal rights, and you may also have other rights which may vary from state to state.

## LIMITED WARRANTY ON ENGINES USED IN PRIME AND STAND-BY POWER GENERATOR SETS

### TERMS OF COVERAGE

#### Uses

This warranty applies to the first retail purchaser and subsequent owners during the WARRANTY PERIOD of new Detroit Diesel Series 40® Engines (referred to as Engine) manufactured by Detroit Diesel Corporation and/or supplied by Detroit Diesel Corporation, Detroit Diesel of Canada Limited, or Detroit Diesel Overseas Distribution Corporation (all which are collectively referred to as DDC) which are used in prime or stand-by power generators delivered in the U.S. or Canada.

#### Defects

This warranty covers Engine REPAIRS to correct any malfunction occurring during the WARRANTY PERIOD resulting from defects in material or workmanship.

#### Repairs

To obtain warranty repairs, you must request the needed repairs within the WARRANTY PERIOD from an authorized DDC service outlet. Only new genuine parts or remanufactured parts or components supplied or approved by DDC will be used. DDC may, at its discretion, replace rather than repair components. A reasonable

time must be allowed to perform the warranty repair after taking the engine to the authorized service outlet. Repairs will be performed during normal business hours.

The owner is responsible for the percentage of repair costs shown in the WARRANTY PERIOD chart below.

#### Warranty Period

The WARRANTY PERIOD begins on the date the engine is delivered to the first retail purchaser or put in use prior to sale at retail, whichever date occurs first, and ends at the time or hour limits listed in Table 42.

*LIMITED WARRANTY ON ENGINES USED IN PRIME AND STAND-BY POWER GENERATOR SETS*

<b>WARRANTY PERIOD</b>				
<b>Engine Application</b>	<b>Warranty Limitations (Whichever Occurs First)</b>		<b>Repair Charges to Be Paid by Owner</b>	
	<b>MONTHS</b>	<b>ENGINE HOURS</b>	<b>PARTS</b>	<b>LABOR**</b>
Prime Power Generator	0 – 12	Unlimited	No Charge	No Charge
Upon expiration of the 12 month warranty coverage, but within 24 months of delivery date, the warranty continues to apply as follows:				
Major Components †	13 – 24	No Limit	No Charge	100%
Stand-by Power Generator	0 – 12	0 – 400	No Charge	No Charge
** 100% of engine removal and reinstallation labor charge to be paid by owner.				

† Cylinder block casting, cylinder head casting, crankshaft, camshaft and connecting rods.

**Table 42 Warranty Period Chart – Prime Power Generator Set**

**Like Replacement Engine**

Engine(s) supplied by DDC as a replacement for an Engine still under warranty will assume the identity of the Engine being replaced and be entitled to the remaining warranty coverage.

**Service Supplies**

The cost of service supplies such as coolant, oil and filters which are not reusable due to warranted repairs is covered by this warranty.

**Mechanic's Travel Expenses**

DDC will pay reasonable travel expenses for the repairing mechanic to travel to and from the repair site.

**THIS WARRANTY DOES NOT COVER:**

**Repairs Due to Accidents, Misuse, Storage Damage, Negligence or Certain Modifications**

Repairs due to an accident, misuse, misapplication, storage damage, negligence or modification exceeding DDC specifications are not covered by this warranty.

### **Engine Removal and Reinstallation**

Labor costs to gain access or replace the Engine, including removal and reinstallation of items/materials or components in which the Engine is installed, are not covered by this warranty.

### **Non-DDC Supplied/Manufactured Components**

DDC is not responsible for repair of components and/or assemblies which are manufactured or supplied by another manufacturer, such as intake and exhaust systems and fuel storage tanks. Such items are covered by the equipment manufacturer.

### **Maintenance**

DDC is not responsible for the cost of maintenance or repairs due to lack of performance of required maintenance services as recommended by DDC, or the failure to use fuel, oil, lubricants, coolant, cooling air and ventilation meeting DDC-recommended specifications. Performance of the required maintenance and use of proper fuel, oil, lubricants, coolant cooling air and ventilation are the responsibility of the owner. Refer to section MAINTENANCE SCHEDULES in this guide for details.

### **Incidental or Consequential Damage**

This warranty does not cover any economic loss, including without limitation, communication expenses, meals, lodging, loss of use of the Engine, loss of time, inconvenience, overtime, transportation of the Engine or any other cost or expense resulting from a defect covered by this warranty.

### **Other Limitations**

THIS LIMITED WARRANTY IS THE ONLY WARRANTY APPLICABLE TO THE ENGINE AND ACCESSORIES AS USED IN PRIME POWER AND STAND-BY POWER GENERATORS. DETROIT DIESEL CORPORATION MAKES NO OTHER WARRANTIES EXPRESS OR IMPLIED, INCLUDING ANY IMPLIED WARRANTY OF MERCHANTABILITY OR FITNESS FOR A PARTICULAR PURPOSE. DETROIT DIESEL CORPORATION SHALL NOT BE LIABLE FOR ANY INCIDENTAL OR CONSEQUENTIAL DAMAGES AS DESCRIBED ABOVE.

Some states do not allow the limitation of how long this warranty may last or the limitation or exclusion of incidental or consequential damages, so the above may not apply to you. This warranty gives you specific legal rights, and you may also have other rights which may vary from state to state.

**SPECIFICATIONS**

**Fuel and Lubricating Oil Filter Requirements**

<b>FUEL FILTER REQUIREMENTS – Series 40 Regular Service</b>	
<b>Filter Type</b>	<b>Detroit Diesel Part No.</b>
Secondary — Spin-On	1 820 479 C1 (6 In.)
Secondary — Spin-On	23523907
Primary — Fuel Pro 232 Element	23528565
<b>LUBRICATING OIL FILTER REQUIREMENTS</b>	
<b>Filter Type</b>	<b>Detroit Diesel Part No.</b>
Full Flow	23529744

**Table 43 Series 40 Fuel and Lubricating Oil Filter Requirements**

**Engine Oil Capacity**

<b>OIL PAN CAPACITY</b>
All Series 40 off-highway oil pans (front sump and rear sump) require the same amount of engine oil: 22 quarts to the ADD mark ..... Without oil filter 24 quarts to the FULL mark .....Without oil filter
<b>TOTAL OIL CAPACITY OF THE ENGINE</b>
28 quarts to the FULL mark with filter installed and filter and oil galleries charged

**Table 44 Series 40 Engine Oil Capacity**



**Power Cool Engine Products**

**POWER COOL FULLY FORMULATED IEG COOLANT**

Coolant Type	Part Number	Description
Concentrated	23512138	1 Gallon Jug – 6 Per Case
	23512139	55 Gallon Drum
	23529295	330 Gallon Tote
	23512140	Bulk Delivery – 1,000 Gallon Min.
Pre-Blended 50:50	23528203	1 Gallon Jug – 6 Per Case
	23518918	55 Gallon Drum
	23528544	330 Gallon Tote
	23513503	Bulk Delivery – 1,000 Gallon Min.

**Table 45 POWER COOL Fully Formulated IEG Coolant**

**POWER COOL LATIN AMERICAN COOLANT**

Coolant Type	Part Number	Description
Pre-Blended 67:33	23524737	1 Gallon Jug – 6 Per Case
	23524923	55 Gallon Drum
	23524924	Bulk Delivery – 1,000 Gallon Minimum

**Table 46 POWER COOL Latin American Coolant**

**POWER COOL 2000  
SUPPLEMENTAL COOLANT  
ADDITIVE**

Coolant Type	Part Number	Description
For <i>Power Cool</i> IEG Coolant	23507858	Pint Bottle – 12 Per case
	23507859	Half Gallon Jug – 6 Per Case
	23507860	5 Gallon Pail
	23507861	55 Gallon Drum

**Table 47 POWER COOL 2000 Supplemental Coolant Additive**

**POWER COOL 3000  
SUPPLEMENTAL COOLANT  
ADDITIVE**

Coolant Type	Part Number	Description
For <i>POWER COOL</i> IEG Coolant	23507854	Pint Bottle – 12 Per Case
	23507855	Half Gallon Jug – 6 Per Case
	23507856	5 Gallon Pail
	23507857	55 Gallon Drum

**Table 48 POWER COOL 3000 Supplemental Coolant Additive**

**POWER COOL 3000  
SUPPLEMENTAL ADDITIVE  
COOLANT FILTERS**

Coolant Type	Part Number	Description
For <i>POWER COOL</i> IEG Coolant	23507545	4 Ounce (1 Pint Equivalent)
	23508425	8 Ounce (2 Pint Equivalent)
	23508426	12 Ounce (3 Pint Equivalent)
	23507189	16 Ounce (4 Pint Equivalent)
	23508427	32 Ounce (8 Pint Equivalent)
	23508428	53 Ounce (13 Pint Equivalent)

**Table 49 POWER COOL 3000 Supplemental Additive Coolant Filters**

**POWER COOL SUPPLEMENTAL  
ADDITIVE NEED RELEASE  
COOLANT FILTERS**

Coolant Type	Part Number	Description
For <i>POWER COOL</i> IEG Coolant	23516488	For 0 – 8 Gallon Systems
	23516489	For 8 – 20 Gallon Systems

**Table 50 POWER COOL SUPPLEMENTAL ADDITIVE NEED  
RELEASE COOLANT FILTERS**

**POWER COOL PLUS EXTENDED  
LIFE OAT COOLANT**

<b>Coolant Type</b>	<b>Part Number</b>	<b>Description</b>
Concentrated	23519397	1 Gallon Jug – 6 Per Case
	23519394	55 Gallon Drum
	23519395	Bulk Delivery – 1,000 Gallon Min.
Pre-Blended 50:50	23519396	One Gallon Jug – 6 Per Case
	23519398	55 Gallon Drum
	23519399	Bulk Delivery – 1,000 Gallon Min.

**Table 51 POWER COOL Plus Extended Life OAT Coolant**

**POWER COOL PLUS EXTENDER  
FOR USE WITH POWER COOL  
PLUS OAT COOLANT**

<b>Coolant Type</b>	<b>Part Number</b>	<b>Description</b>
For <i>Power Cool Plus</i>	23519400	Quart Bottle – 6 Per Case

**Table 52 POWER COOL Plus Extender for Use with POWER COOL  
Plus OAT Coolant**

**POWER COOL PLUS 6000 OAT  
INHIBITOR FOR WATER-ONLY  
SYSTEMS**

Coolant Type	Part Number	Description
Water Only	23522127	1 Gallon Jug – 6 Per Case
	23522128	5 Gallon Pail

**Table 53 POWER COOL Plus 6000 OAT Inhibitor for Water-Only Systems**

**POWER COOL COOLING  
SYSTEM CLEANERS**

Coolant Type	Part Number	Description
On-Line Cleaner	200164	On-Half Gallon Jug – 6 Per Case
	200105	5 Gallon Pail
	200155	55 Gallon Drum
Twin Pack	201549	Twin Pack – 2 Per Case

**Table 54 Power Cool Cooling System Cleaners**

**POWER TRAC COOLANT  
TESTING AND ANALYSIS  
PRODUCTS**

<b>Application</b>	<b>Part Number</b>	<b>Description</b>
Indicates Nitrite, Molybdate & Glycol Levels	23519401	3-Way Coolant Test Strips (Single Foil Packs)
Indicates Nitrite, Molybdate & Glycol Levels	23519402	3-Way Coolant Test Strips (Bottle of 50)
Indicates Nitrite, Molybdate & Glycol Levels	23522774	3-Way Coolant Test Strips (Bottle of 10)
Complete IEG/IPG Coolant Analysis	23516921	Coolant Analysis Bottle (Carton of 6)
Organic Coolant Analysis	23523398	Laboratory Coolant Analysis Bottle (Carton of 6)

**Table 55 Power Trac Coolant Testing and Analysis Products**