

# **Power Train**

## **Specification**

## **System Operation**

## **Testing & Adjusting**

## **Disassembly & Assembly**

---

**D50S-5, D60S-5, D70S-5, D80S-5, D90S-5**  
**G50S-5, G60S-5, G70S-5**  
**Two Speed Transmission**  
**Drive Axle (OCDB, SHOE)**

# Important Safety Information

Most accidents involving product operation, maintenance and repair are caused by failure to observe basic safety rules or precautions. An accident can often be avoided by recognizing potentially hazardous situations before an accident occurs. A person must be alert to potential hazards. This person should also have the necessary training, skills and tools to perform these functions properly.

**Improper operation, lubrication, maintenance or repair of this product can be dangerous and could result in injury or death.**

**Do not operate or perform any lubrication, maintenance or repair on this product, until you have read and understood the operation, lubrication, maintenance and repair information.**

Safety precautions and warnings are provided in this manual and on the product. If these hazard warnings are not heeded, bodily injury or death could occur to you or other persons.

The hazards are identified by the "Safety Alert Symbol" and followed by a "Signal Word" such as "WARNING" as shown below.



The meaning of this safety alert symbol is as follows :

**Attention! Become Alert! Your Safety is Involved.**

The Message that appears under the warning, explaining the hazard, can be either written or pictorially presented.

Operations that may cause product damage are identified by NOTICE labels on the product and in this publication.

DOOSAN cannot anticipate every possible circumstance that might involve a potential hazard. The warnings in this publication and on the product are therefore not all inclusive. If a tool, procedure, work method or operating technique not specifically recommended by DOOSAN is used, you must satisfy yourself that it is safe for you and others. You should also ensure that the product will not be damaged or made unsafe by the operation, lubrication, maintenance or repair procedures you choose.

The information, specifications, and illustrations in this publication are on the basis of information available at the time it was written. The specifications, torques, pressures, measurements, adjustments, illustrations, and other items can change at any time. These changes can affect the service given to the product.

Obtain the complete and most current information before starting any job. DOOSAN dealers have the most current information available.



# Index

## Specification

General Tightening Torque .....	5
Drive Axle Specification .....	6
Torque Converter.....	7
Transmission Pump .....	7
Drive Axle Mounting.....	8
Differential .....	8
Wheel Bearing and Drive Wheel .....	8
Brake Assembly.....	9
Brake Drum Diameter .....	10
U - joint.....	10

Wheel Brake Adjustment.....	30
Inching Pedal Adjustment.....	32

## Disassembly and Assembly

Drive Shaft and Universal Joint.....	35
Engine, Torque Converter and Transmission .....	36
Transmission Control Valve.....	40
Transmission.....	43
Drive Axle .....	54

## System Operation

General Information .....	11
Power Shift Transmission.....	12
General Information .....	12
Power Flow at Low Speed Forward.....	13
Power Flow at High Speed Forward .....	14
Power Flow at Low Speed Reverse.....	15
Power Flow at High Speed Reverse.....	16
Transmission Control Valve .....	17
Cross-Section View.....	17
Hydraulic Schematic .....	18
Differential and Drive Axles .....	20
Differential .....	20
Wheel Hub.....	20
Brake Components .....	21
Shoe Brake.....	21
Brake Adjuster .....	21
OCDB.....	22

## Testing and Adjusting

Troubleshooting .....	23
Visual Checks .....	23
Checks During Operation .....	23
Check List During Operation .....	23
Check List From Operation Noise.....	25
Check List From Pressure Test .....	26
Differential .....	27
Transmission Pressure .....	28
Converter Stall Test .....	29
Shimming of Transmission Shaft.....	30



# Specification

## General Tightening Torque

### GENERAL TIGHTENING TORQUE FOR BOLTS, NUTS AND TAPERLOCK STUDS

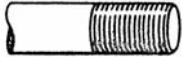
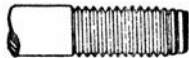

The following charts give the standard torque values for bolts, nuts and taperlock studs of SAE Grade 5 or better quality. Exceptions are given in other sections of Service Manual where needed.

THREAD DIAMETER		STANDARD TORQUE	
inches	millimeters	lb•ft.	N•m*
<b>Standard thread</b> 		Use these torques for bolts and nuts with standard threads (conversions are approximate).	
1/4	6.35	9 ± 3	12 ± 4
5/16	7.94	18 ± 5	25 ± 7
3/8	9.53	32 ± 5	45 ± 7
7/16	11.11	50 ± 10	70 ± 15
1/2	12.70	75 ± 10	100 ± 15
9/16	14.29	110 ± 15	150 ± 20
5/8	15.88	150 ± 20	200 ± 25
3/4	19.05	265 ± 35	360 ± 50
7/8	22.23	420 ± 60	570 ± 80
1	25.40	640 ± 80	875 ± 100
1 1/8	28.58	800 ± 100	1100 ± 150
1 1/4	31.75	1000 ± 120	1350 ± 175
1 3/8	34.93	1200 ± 150	1600 ± 200
1 1/2	38.10	1500 ± 200	2000 ± 275
Use these torques for bolts and nuts on hydraulic valve bodies.			
5/16	7.94	13 ± 2	20 ± 3
3/8	9.53	24 ± 2	35 ± 3
1/2	12.70	60 ± 3	80 ± 4
5/8	15.88	118 ± 4	160 ± 6
<b>Taperlock stud</b> 		Use these torques for studs with Taperlock threads	
1/4	6.35	6 ± 2	8 ± 3
5/16	7.94	13 ± 4	17 ± 5
3/8	9.53	26 ± 4	35 ± 5
7/16	11.11	33 ± 7	45 ± 10
1/2	12.70	48 ± 7	65 ± 10
9/16	14.29	65 ± 11	90 ± 15
5/8	15.88	80 ± 11	110 ± 15
3/4	19.05	125 ± 15	170 ± 20
7/8	22.23	190 ± 22	260 ± 30
1	25.40	300 ± 30	400 ± 40
1 1/8	28.58	370 ± 30	500 ± 40
1 1/4	31.75	480 ± 37	650 ± 50
1 3/8	34.93	550 ± 37	750 ± 50
1 1/2	38.10	640 ± 37	870 ± 50

\*1 newton meter(N•m) is approximately the same as 0.1 mkg.

## Drive Axle Specification

### Shoe Type

Drive Axle	Gear Ratio	Differential	2.636 / D(G) 50/70S-5 3.100 / D80/90S-5
		Planetary	4
		Total	10.545 / D(G) 50/70S-5 12.400 / D80/90S-5
	Axle Oil		SAE #80 or #90
	Oil Volume		12.5 L
Brake	Service Brake		Shoe Brake
	Brake Oil		AZOLLA - ZS10
	Parking Brake		Drum Brake
Differential	Gear Type		Spiral Bevel Gear
	Differential Type		4 Pinions

### OCDB Type

Drive Axle	Gear Ratio	Differential	D(G)50/70S-5 : 2.636 D80/90S-5 : 3.100
		Planetary	4
		Total	D(G)50/70S-5 : 10.545 D80/90S-5 : 12.400
	Axle Oil		MOBIL #424
	Oil Volume		12.5 L
Brake	Service Brake		Oil Cooled Disk Brake
	Brake Oil		AZOLLA - ZS10
	Parking Brake		Drum Brake
Differential	Gear Type		Spiral Bevel Gear
	Differential Type		4 Pinions

## Torque Converter

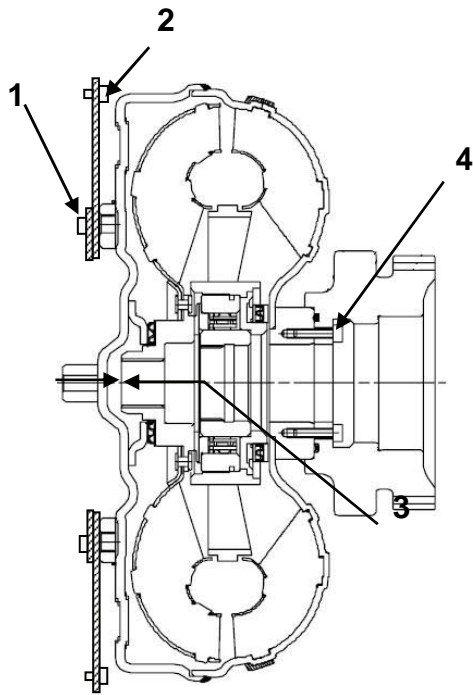

- (1) Torque for bolts (plate to torque converter)  
 .....  $45 \pm 7 \text{ N}\cdot\text{m}$  ( $33 \pm 5 \text{ lb}\cdot\text{ft}$ )  
 Apply LOCTITE NO. 277 sealant to threads of bolts.
- (2) Torque for bolts (plate to flywheel)  
 .....  $25 \pm 7 \text{ N}\cdot\text{m}$  ( $18 \pm 5 \text{ lb}\cdot\text{ft}$ )
- (3) End play of turbine hub (new)  
 .....  $0 \text{ to } 0.99 \text{ mm}$  ( $0 \text{ to } 0.039 \text{ in}$ )  
 Maximum end play of turbine hub (worn)  
 .....  $1.65 \text{ mm}$  ( $0.065 \text{ in}$ )
- (4) Torque for bolts (torque converter to PTO gear)  
 .....  $20 \pm 3 \text{ N}\cdot\text{m}$  ( $15 \pm 2 \text{ lb}\cdot\text{ft}$ )
- Apply LOCTITE NO. 277 sealant to threads of bolts.

**NOTE :** For Torque values not given, see the page of specifications for general tightening torques.

## Transmission Pump

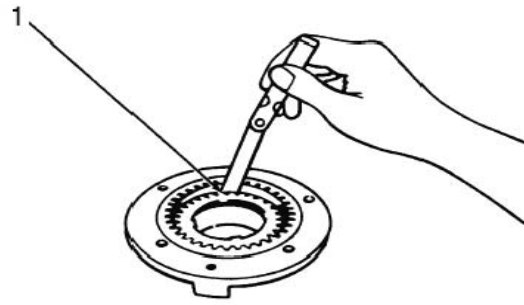

- (1) Clearance between outside of drive gear and crescent  $0.36 \text{ to } 0.43 \text{ mm}$  ( $0.014 \text{ to } 0.017 \text{ in}$ )

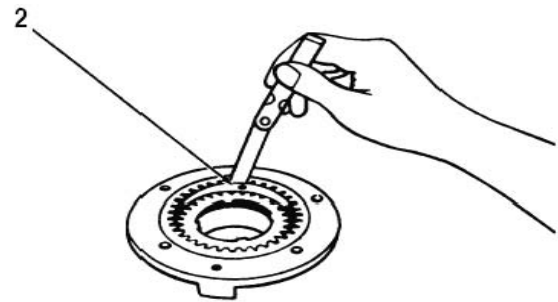

- (2) Clearance between inside of driven gear and crescent  $0.25 \text{ to } 0.33 \text{ mm}$  ( $0.010 \text{ to } 0.013 \text{ in}$ )

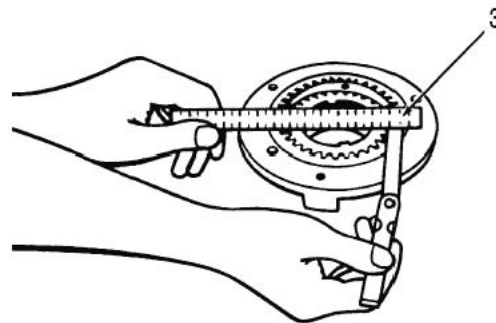

- (3) Gear end play.....  $0.025 \text{ to } 0.064 \text{ mm}$   
 ( $0.0010 \text{ to } 0.0025 \text{ in}$ )



## Drive Axle Mounting

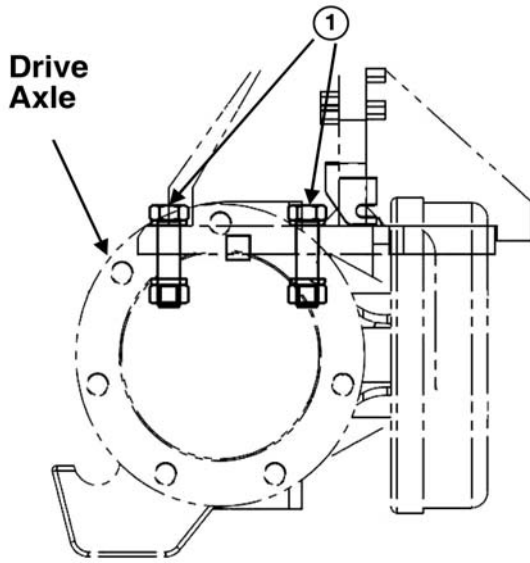

(1) Torque for nuts .....  $800 \pm 50 \text{ N}\cdot\text{m}$  ( $590 \pm 37 \text{ lb}\cdot\text{ft}$ )

Apply LOCTITE NO. 271 sealant to threads of bolts.

## Differential

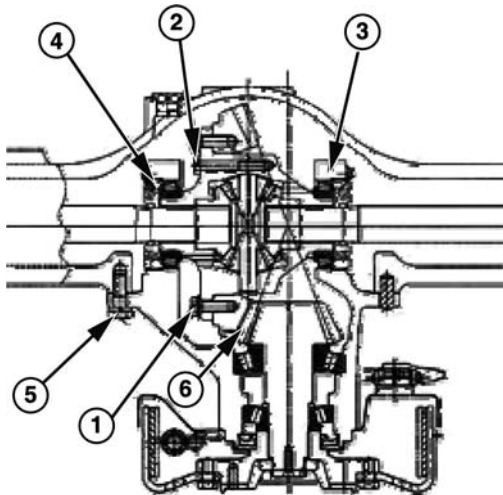

1. Apply Loctite No.271 to threads of bolt. Torque for bolts that hold bevel gear to differential housing is .....  $132 \pm 5 \text{ N}\cdot\text{m}$  ( $98 \pm 4 \text{ lb}\cdot\text{ft}$ ).

2. Apply Loctite No.271 to threads of bolts. Torque for bolts is .....  $59 \pm 5 \text{ N}\cdot\text{m}$  ( $43 \pm 4 \text{ lb}\cdot\text{ft}$ ).

3. Apply Loctite No.271 to threads of bolts. Torque for bolts.....  $157 \pm 5 \text{ N}\cdot\text{m}$  ( $116 \pm 4 \text{ lb}\cdot\text{ft}$ ) Consider same marking on brackets to the housing.

4. Apply Loctite No.271 to threads of bolts. Torque for bolts.....  $10 \pm 2 \text{ N}\cdot\text{m}$  ( $7 \pm 2 \text{ lb}\cdot\text{ft}$ )

5. Apply Loctite No.271 to threads of bolts. Torque for bolts.....  $177 \pm 5 \text{ N}\cdot\text{m}$  ( $130 \pm 4 \text{ lb}\cdot\text{ft}$ )

6. Torsional backlash of bevel gear... 0.18~0.23 mm

## Wheel Bearing and Drive Wheel

### Shoe Axle

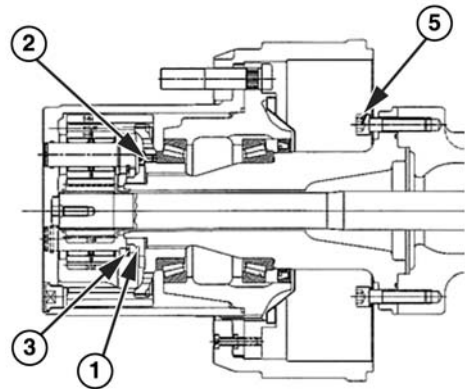

### OCDB Axle

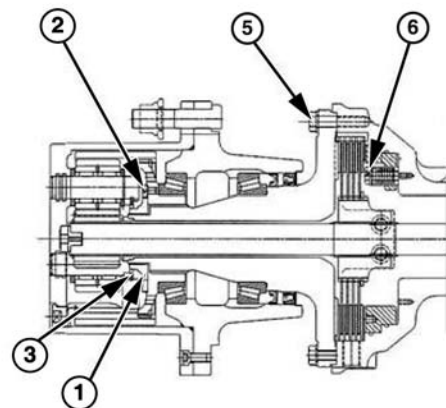

## Slotted nut adjustment

- a. Tighten slotted nut (1) slightly by hand.
- b. Tighten slotted nut (1) to 640 N•m (472 lb•ft).
- c. Rotate wheel hub several times.
- d. Turn back slotted nut (1) slightly and retighten until bearing friction torque reaches to 10~14 N•m (7.4 to 10.3 lb•ft).
- e. Apply Loctite No.271 on the threads of bolt (2). Secure slotted nut (1) with bolt (2) with tightening torque of 19~24 N•m (14~18 lb•ft).
- f. Assemble thrust washer (3) with Loctite # 609.
- g. Torque for Spindle bolt (5) ..... 118 ± 5 N•m  
(87 ± 4 lb•ft)
- h. Torque for Service piston bolt (6) .... 15 ± 0.1 N•m  
(11 ± 0.01 lb•ft)

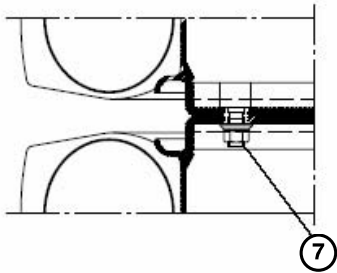

- i. Torque for wheel nut (7) ..... 550 ± 50 N•m  
(406 ± 37 lb•ft)

## Brake Assembly

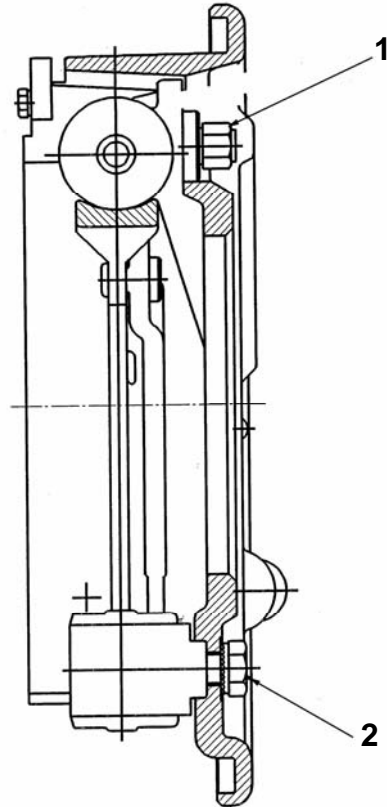

ICPS0005S

Torque for bolts (1) ..... 19 to 22 N•m (14 to 16 lb•ft)

Torque for bolts (2) ..... 120 ± 20 N•m (90 ± 15 lb•ft)

## Brake Drum Diameter

---

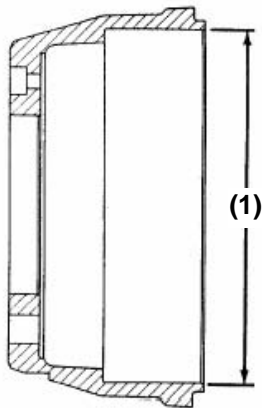

---

Brake drum diameter (1) ..... 315.0 to 315.2 mm  
(12.402 to 12.409 in)

Maximum total diameter of brake drums which can  
be machined from the original diameter..... 2.0 mm  
(0.079 in)

## U - joint

---

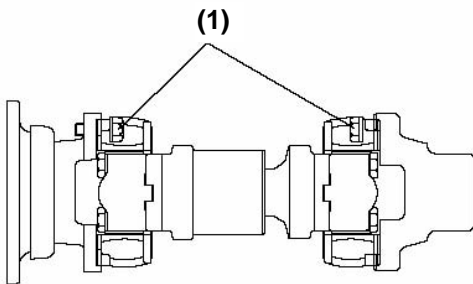

ICPS0007S

---

Torque for bolts (1) .....  $55 \pm 7 \text{ N}\cdot\text{m}$   
( $40 \pm 5 \text{ lb}\cdot\text{ft}$ )

# System Operation

## General Information

---

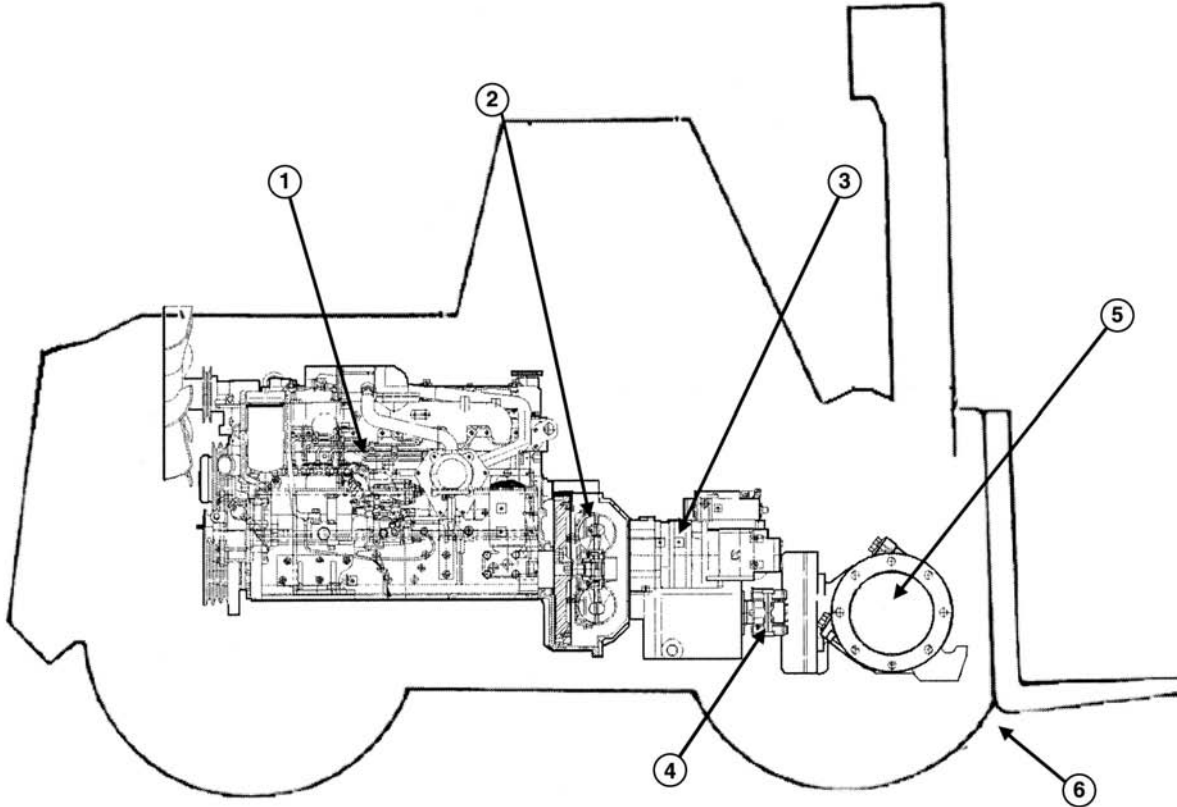

(1) Engine (2) Torque Converter (3) Power Shift Transmission (4) Universal joint (5) Drive Axle (6) Drive Wheels.

The basic components of the power train are: engine (1), torque converter (2), power shift transmission (3), universal joint (4), drive axle (5), drive wheels (6).

Power from the engine flywheel goes from the torque converter to the input shaft of the transmission. The power shift transmission is a constant mesh countershaft type and has four hydraulically operated clutches that are spring released. The transmission has two speeds in forward and two speeds in reverse.

Power from the transmission is sent through its output gear through the drive shaft and reduction gears to the differential. The differential sends power out the axles and to the wheels.

---

### NOTICE

Damage can be caused to the transmission if the truck is moved with the engine not running. There will be no lubrication to the transmission components. Disconnect and remove the universal joint before the truck is moved.

---

# Power Shift Transmission

## General Information

The transmission is a constant mesh power shift transmission and gives two forward and two reverse speeds. The transmission has four clutches that are engaged hydraulically and released by spring force. The direction and speed are changed electrically.

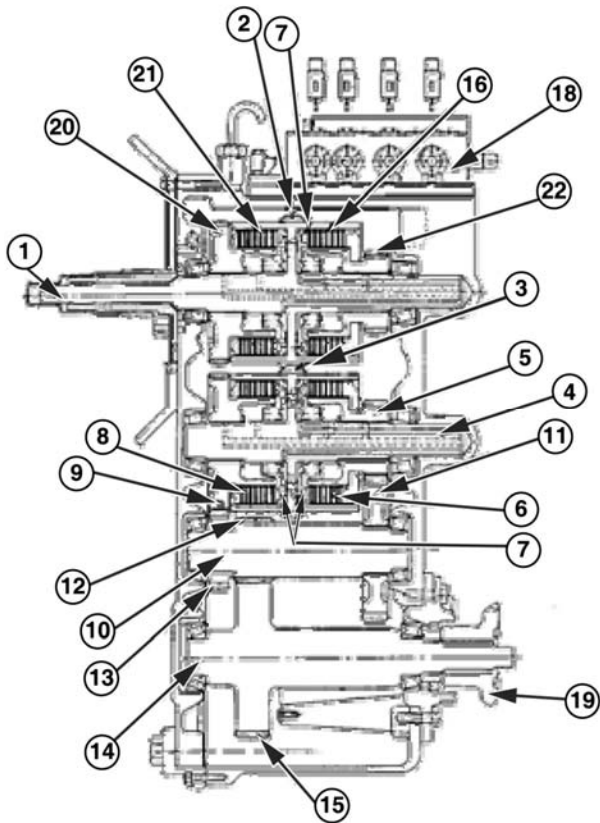

### Power Shift Transmission

- (1) Input Shaft. (2) Cylinder Clutch(Forward)
- (3) Cylinder Clutch(Reverse). (4) Reverse Shaft.
- (5) Gear(Reverse low) (6) Clutch(Reverse low).
- (7) Piston. (8) Clutch(Reverse high).
- (9) Gear(Reverse high). (10) Intermediate Shaft.
- (11) Gear(low). (12) Intermediate Shaft Gear.
- (13) Gear(High) (14) Output Shaft. (15) Output Shaft Gear.
- (16) Clutch(Forward low) (18) Valve Ass'y. (19) Yoke.
- (20) Gear(Forward high). (21) Clutch(Forward high).
- (22) Gear(Forward low).

In the power flow diagrams that follow, the components are shown in a position to make it easier to follow the power flow through the transmission. Illustration shows the transmission from the converter end with the correct location of the components.

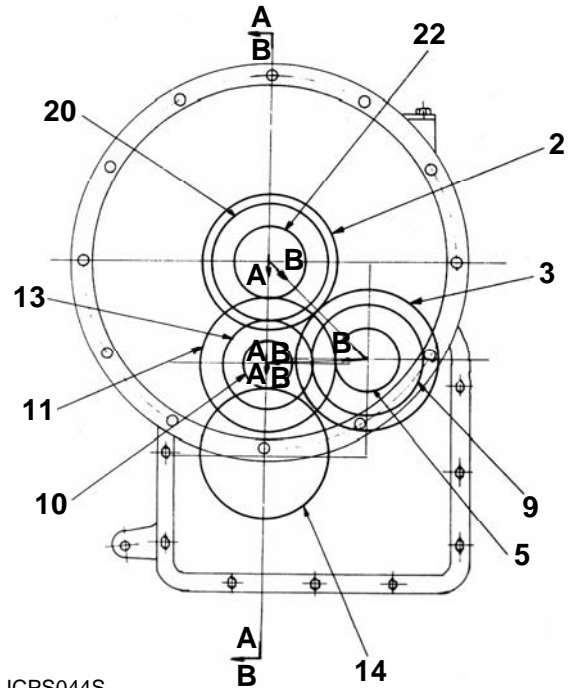

ICPS044S

- (2) Clutch Gear. (3) Clutch Gear. (5) Gear(Reverse low).
- (9) Gear(Reverse high). (10) Intermediate Shaft Gear.
- (11) Gear(Low). (13) Gear(High). (14) Output Shaft Gear.
- (20) Gear(Forward high). (22) Gear(Forward low).

Most all of the components inside the transmission turn when the controls are in either of the FORWARD or REVERSE speeds. Only those components that have been made dark in the diagrams that follow are used in the flow of power through the transmission.

## Power Flow at Low Speed Forward

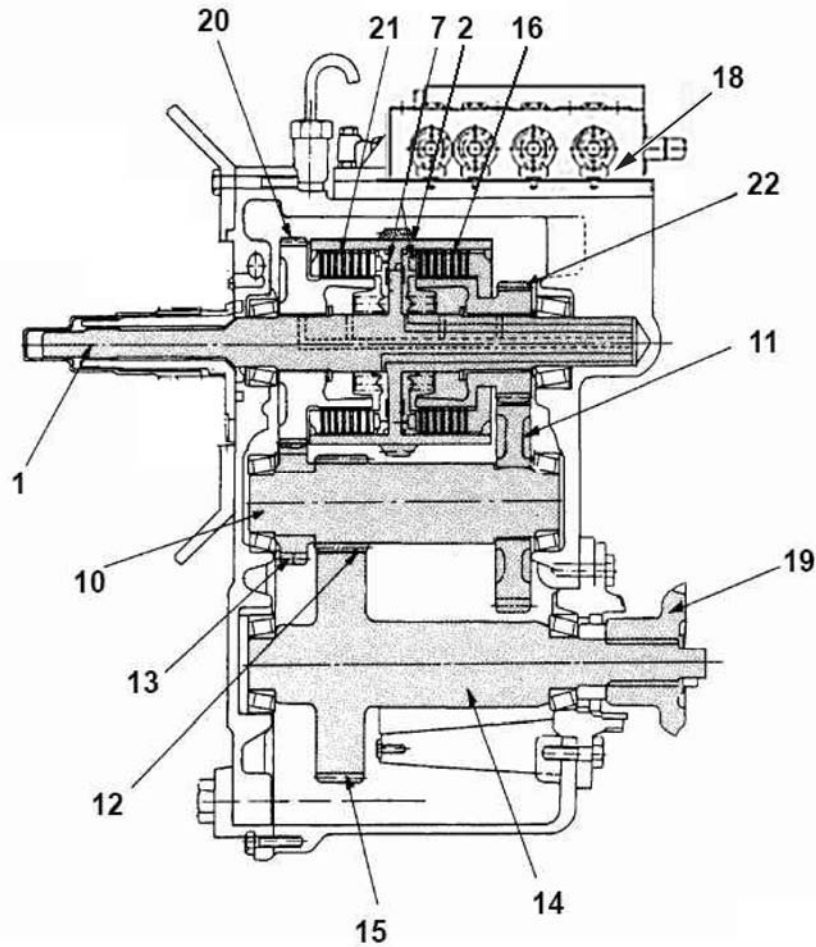

SECTION : A-A

### Power Flow In Low Speed Forward

(1) Input Shaft. (2) Cylinder Clutch(Forward). (7) Piston. (10) Intermediate Shaft. (11) Gear(Low). (12) Intermediate Shaft Gear. (13) Gear(High). (14) Output Shaft. (15) Output Shaft Gear. (16) Clutch(Forward low). (18) Valve Ass'y (19) Yoke. (20) Gear(Forward high). (21) Clutch(Forward high). (22) Gear(Forward low).

Input shaft (1) of the transmission is turned by the turbine of the torque converter. The clutch cylinder (2) for the forward clutches is connected to the input shaft by rivets.

When FORWARD low clutch (16) is engaged, gear (22) is turned through the clutch. Gear (22) is engaged with gear (11) and turns gears (11) and (13) gears (11) and (13) are both connected to shaft (10) by splines. Shaft (10) is engaged with output shaft gear (15) by intermediate shaft gear (12). This sends the power from shaft (10) through output shaft gear (15) into output shaft (14) of the transmission.



## Power Flow at High Speed Forward

---

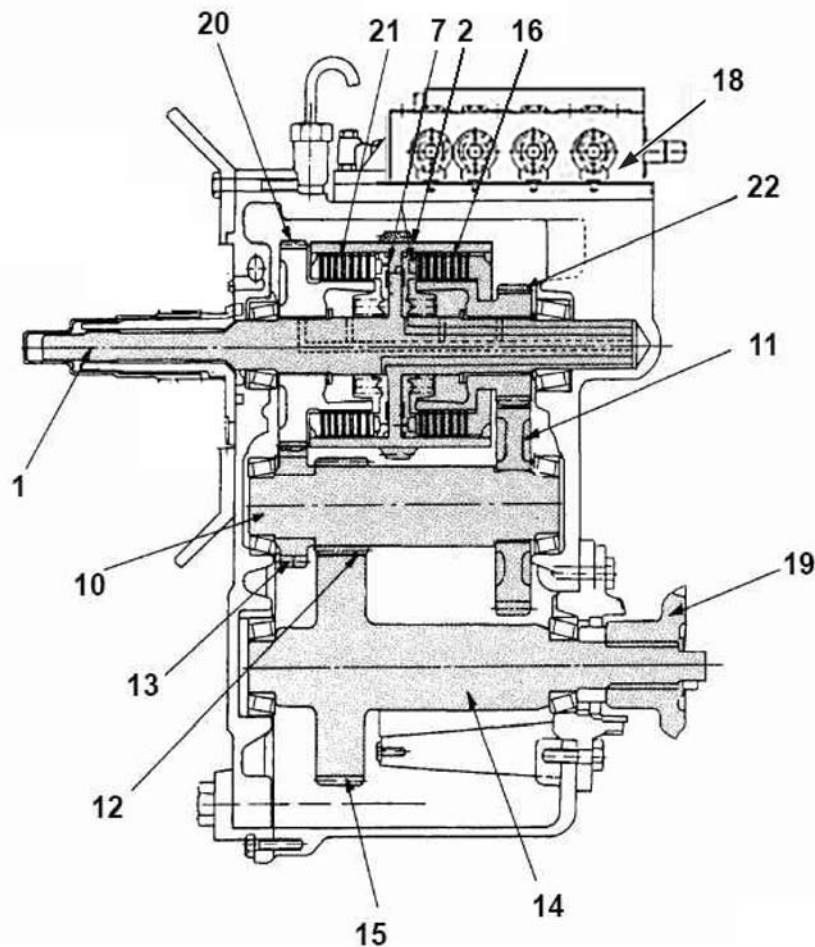

SECTION : A-A

---

### Power Flow In High Speed Forward

(1) Input Shaft. (2) Cylinder Clutch(Forward). (7) Piston. (10) Intermediate Shaft. (11) Gear(Low). (12) Intermediate Shaft Gear. (13) Gear(High). (14) Output Shaft.. (15) Output Shaft Gear. (16) Clutch(Forward low). (18) Valve Ass'y (19) Yoke. (20) Gear(Forward High). (21) Clutch(Forward High). (22) Gear(Forward low).

Input shaft (1) of the transmission is turned by the turbine of the torque converter. The clutch cylinder (2) for the forward clutches is connected to the input shaft by rivets.

When FORWARD high clutch (21) is engaged, gear (2) is turned through the clutch. Gear (20) is engaged with gear (13) and turns gears (13) and (11) gears (13) and (11) are both connected to shaft (10) by splines. Shaft (10) is engaged with output shaft gear (15) by intermediate shaft gear (12). This sends the power from shaft (10) through output shaft gear (15) into output shaft (14) of the transmission.

## Power Flow at Low Speed Reverse

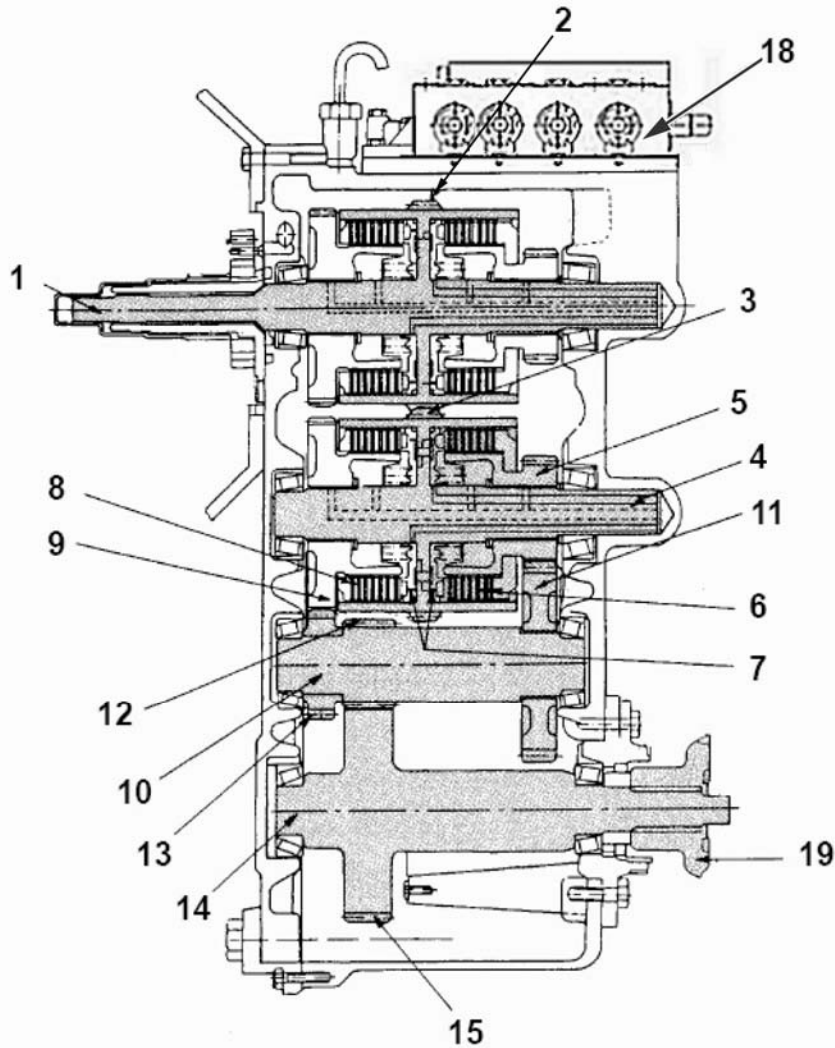

SECTION : B-B

### Power Flow In Low Speed Reverse

(1) Input Shaft. (2) Clutch Cylinder Gear(Forward). (3) Clutch Cylinder Gear(Reverse). (4) Reverse Shaft. (5) Gear(Reverse low). (6) Clutch(Reverse low). (7) Piston. (8) Clutch(Reverse high). (9) Gear(Reverse high). (10) Intermediate Shaft. (11) Gear(Low). (12) Intermediate Shaft Gear. (13) Gear(High). (14) Output Shaft. (15) Output Shaft Gear. (18) Valve Ass'y. (19) Yoke.

Input shaft (1) of the transmission is turned by the turbine of the torque converter. The clutch cylinder (2) for the forward clutches is connected to the input shaft by rivets. Clutch cylinder (2) is engaged with and turns clutch cylinder (3).

When REVERSE low clutch (6) is engaged, gear (5) is turned through the clutch. Gear (5) is engaged with gear (11) and turns gears (11) and (13) gears (11) and (13) are both connected to shaft (10) by splines. Shaft (10) is engaged with output shaft gear (15) by intermediate shaft gear (12). This sends the power from shaft (10) through output shaft gear (15), into output shaft (14) of the transmission.



## Power Flow at High Speed Reverse

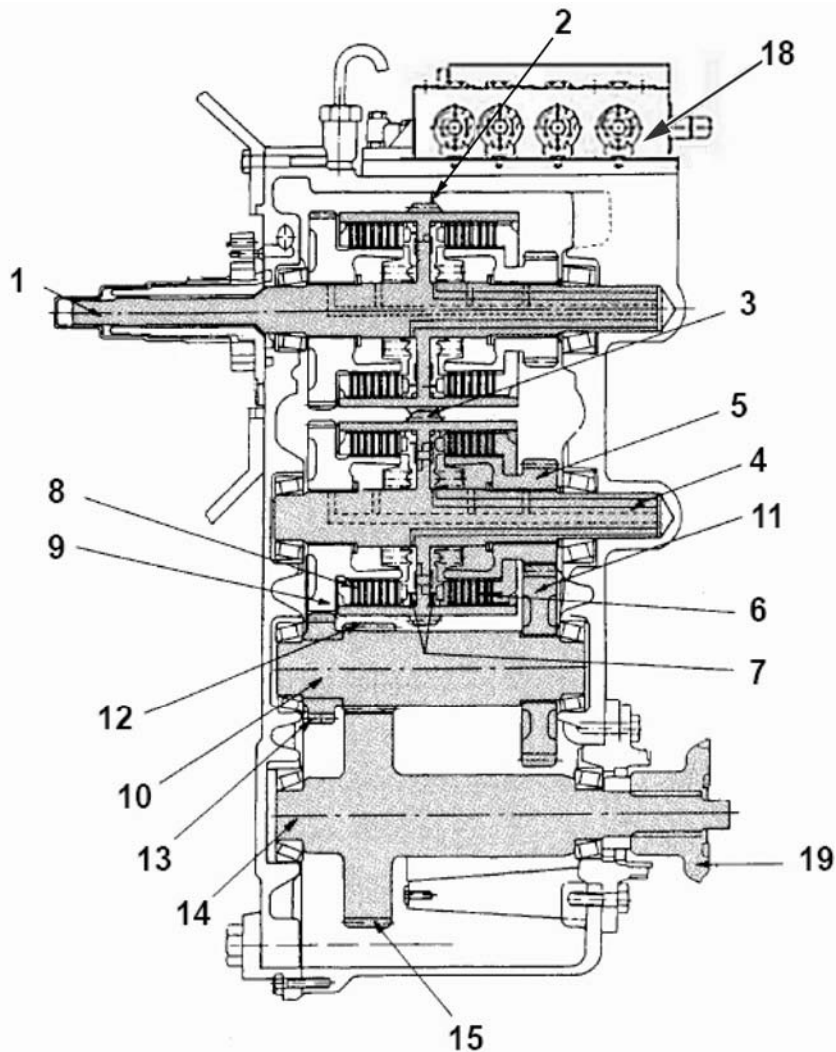

SECTION : B-B

### Power Flow In High Speed Reverse

(1) Input Shaft. (2) Clutch Cylinder Gear (Forward). (3) Clutch Cylinder Gear (Reverse). (4) Reverse Shaft.  
 (5) Gear (Reverse low). (6) Clutch (Reverse low). (7) Piston. (8) Clutch (Reverse high). (9) Gear (Reverse high).  
 (10) Intermediate Shaft. (11) Gear (Low). (12) Intermediate Shaft Gear. (13) Gear (High). (14) Output Shaft.  
 (15) Output Shaft Gear. (18) Valve Ass'y. (19) Yoke

Input shaft (1) of the transmission is turned by the turbine of the torque converter. The clutch cylinder (2) for the forward clutches is connected to the input shaft by rivets. Clutch cylinder (2) is engaged with and turns clutch cylinder (3).

When REVERSE high clutch (8) is engaged, gear (9) is turned through the clutch. Gear (9) is engaged with gear (13) and turns gears (13) and (11) gears (13) and (11) are both connected to shaft (10) by splines. Shaft (10) is engaged with output shaft gear (15) by intermediate shaft gear (12). This sends the power from shaft (10) through output shaft gear (15), into output shaft (14) of the transmission.

# Transmission Control Valve

## Cross-Section View

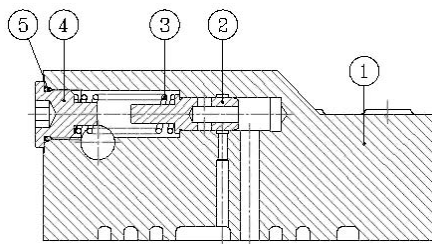
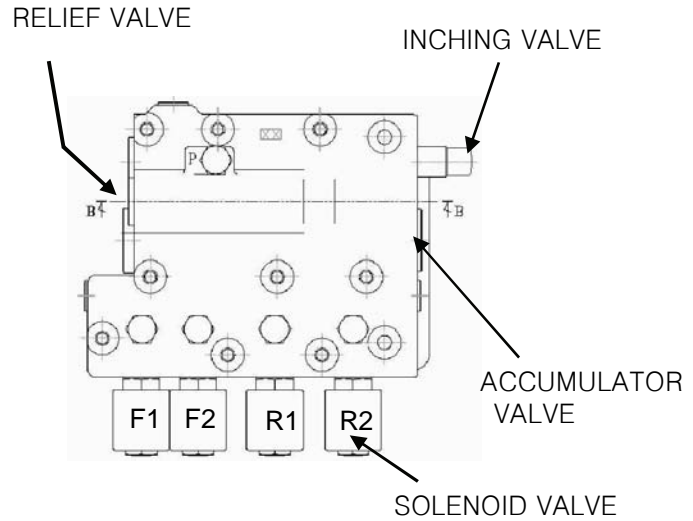
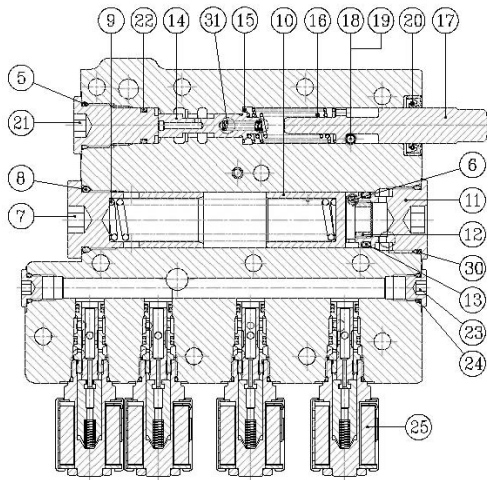

SECTION "B-B"

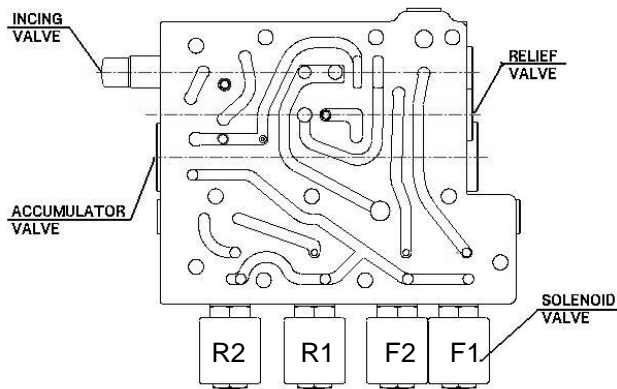
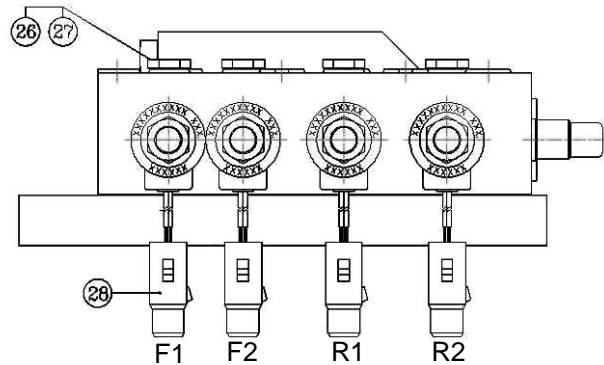

- (1) BODY. (2) SPOOL. (3) SPRING. (4) PLUG. (5) O-RING. (6) ORIFICE. (7) STOPPER. (8) O-RING. (9) SPRING. (10) PISTON. (11) PLUG. (12) FILTER ASS'Y. (13) O-RING. (14) SPOOL. (15) SPRING. (16) SPRING. (17) PLUNGER. (18) PIN. (19) STOP BOL (20) OIL SEAL. (21) PLUG. (22) O-RING. (23) PLUG. (24) O-RING. (25) SOLENOIDE VALVE ASS'Y. (26) PLUG. (27) O-RING. (28) BS CONNECTOR ASS'Y. (29) GASKET. (30) O-RING. (31) SPRING. (32) PLATE. (33) PISTON. (34) GASKET.

# Hydraulic Schematic

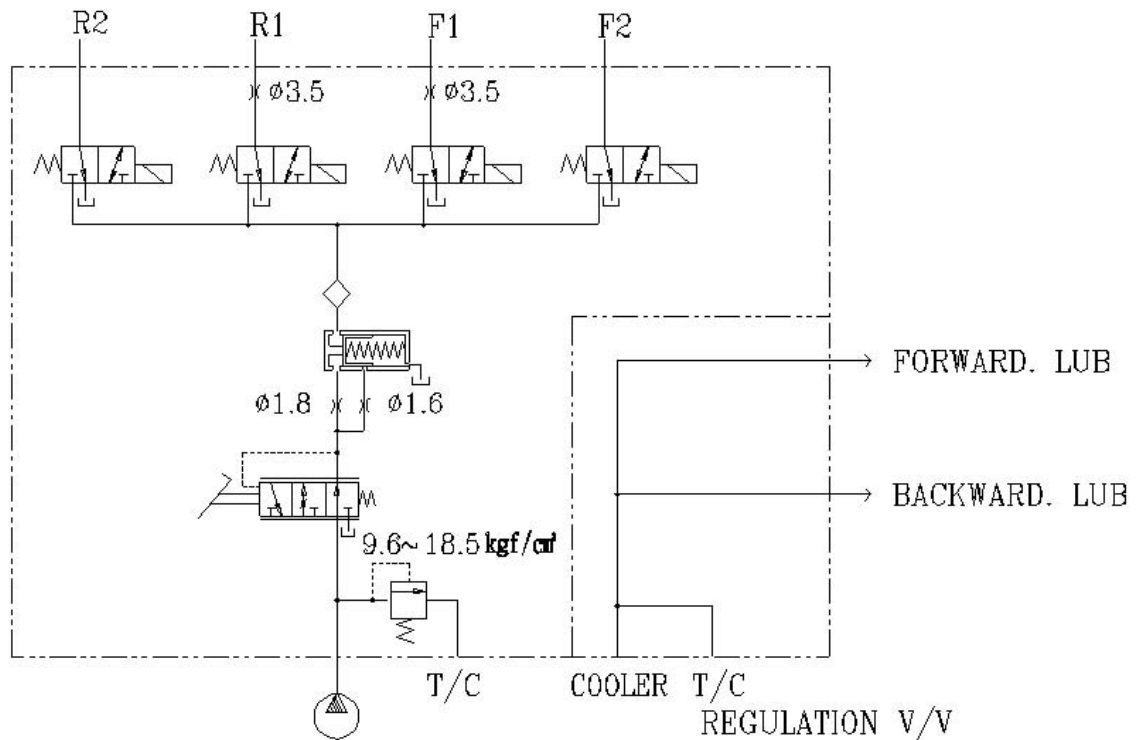

(1) RELIEF VALVE. (2) INCHING VALVE. (3) ACCUMULATOR VALVE. (4) SOLENOID VALVE.

## (1) RELIEF VALVE

◆ **FUNCTION**  
To maintain constant pressure in the CONTROL VALVE, preventing excessive rise or fall of pressure, and supply oil to TORQUE CONVERTER.

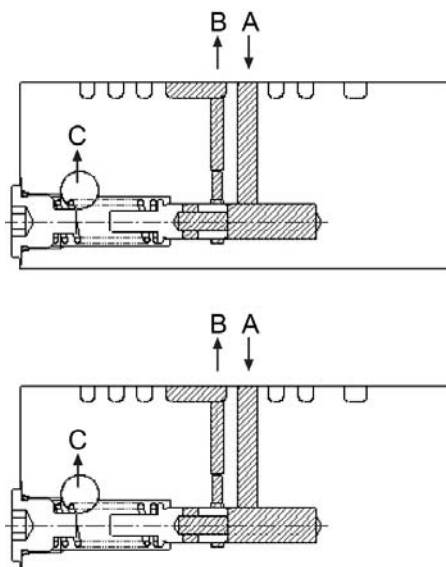

## ◆ OPERATION

The oil from the PUMP is fed to VALVE via "A."  
As pressure rises, the oil through "A" overcomes the spring force and pushes SPOOL to left.

When the SPOOL is pushed to left by oil pressure, "A" and "B" are connected and the oil from "A" enters TORQUE CONVERTER through "B" and pressure falls.

When the pressure fell, PISTON returns reducing the inflow to the TORQUE CONVERTER, raising pressure again. The minimum pressure is maintained by the repeated operation of the SPOOL.

In the event that the pressure is keep rising when oil flows to TORQUE CONVERTER, SPOOL is pushed to right, and at the preset pressure, the oil entered through "A" is drained through "C" preventing the pressure rise higher than the preset value.

(2) INCHING VALVE

◆ FUNCTION

The INCHING VALVE controls the pressure of oil entering CLUTCH and smoothens the CLUTCH contact.

In addition, by enabling the vehicle to move smoothly at high RPM, it provides fast functionality of the implement in low speed.

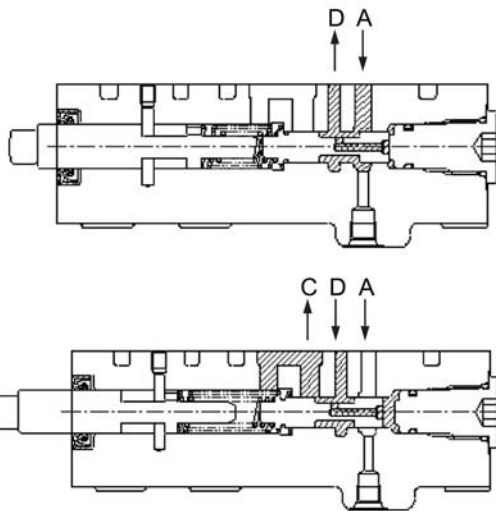

◆ OPERATION

When the INCHING PEDAL is not pressed, the oil from the main pressure line "A" is fed to ACCUMULATOR VALVE through valve and "D."

When the INCHING PEDAL is pressed, SPOOL moves toward left, isolating the main pressure line "A" stopping oil supply. The oil in the ACCUMULATOR is drained through "C" via "D" lowering pressure at CLUTCH.

(3) ACCUMULATOR VALVE

◆ FUNCTION

Smoothens CLUTCH operation by enlarging the time for pressure rise since from the CLUTCH contact and beginning of slip.

◆ OPERATION

When the INCHING PEDAL is pressed and let free, oil enters "E(1st orifice)" from inching to move piston to right. Then, pressure rises slowly to open "F(2nd orifice)." When the piston reaches right side, pressure rises up to the relief setting value.

In the oil path of the accumulator valve plug to solenoid valve is #100 screen which filters foreign material.

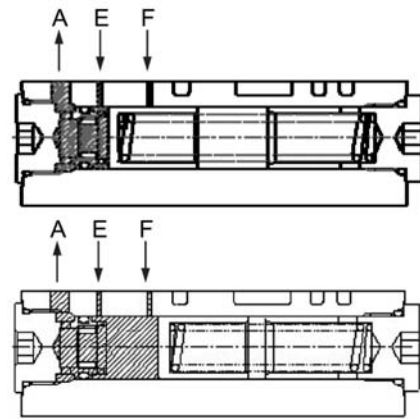

Therefore, wash the plug when replacing the T/M oil.

(4) SOLENIOD VALVE

◆ FUNCTION

Supplies the oil from accumulator to each clutch according to the change of step.

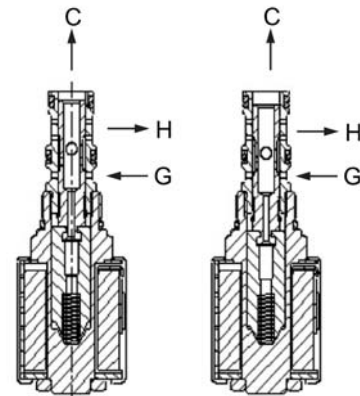

◆ OPERATION

When the shift lever is moved, the spool in the solenoid valve moves toward bottom by electric signal, forming oil path.

The oil from accumulator enters "G", flows through the internal path of solenoid valve, and fed to clutch via "H."

When the shift lever is at neutral position, the electric signal us cut-off, the spool moves upwards by the force of the spring in the solenoid valve, forming an oil path from "G" to "C(tank)" removing residual pressure in the clutch.



# Differential and Drive Axles

## Differential

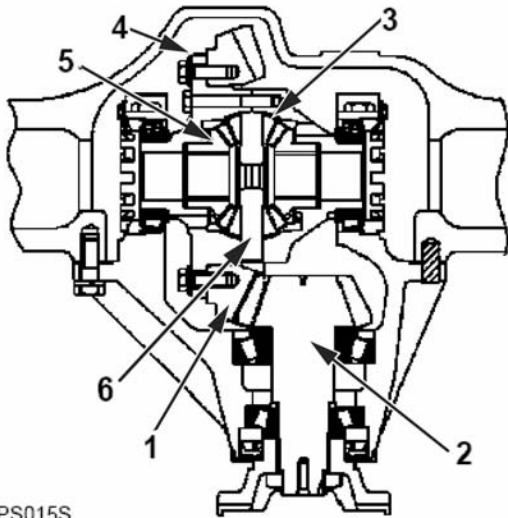

ICPS015S

### Differential

(1) Ring Gear. (2) Pinion Gear. (3) Differential Pinion Gears. (4) Differential. (5) Side Gears. (6) Spider.

Power from the transmission goes to the pinion and ring gear of the differential. The differential turns the axles through the final drive housing.

The drive axles are used to supply torque only. The load bearing hubs on the axle housing are used as a support for the weight of the truck. The axles are connected through planetary gears and carrier to the wheel hubs and drive the wheels.

The differential is used to send the power from the transmission to the wheels. When one wheel is turned slower than the other, the differential lets the inside wheel stop or turn slower in relation to the outside wheel.

The drive shaft from the transmission turns pinion gear (2) which sends the power to the differential. Bevel pinion gear (2) turns ring gear (1) which is fastened to the differential. The differential has four pinions (3), spider (6) and two side gears (5). The connection between four pinions (3) and two side gears (5) is at right angles through a gear mesh. Splines make the connection between side gears (5) and the axles.

When the machine moves straight forward, traction under each wheel is the same, so the torque from each axle is the same and pinions (3) do not turn on spider (6). This gives the same effect as if both wheels were the same axle. In a turn the torque that is sent to the axles is not the same. Thus torques that are not the same are put on opposite sides of the spider (5). The rotation of pinions (3) stops or slows the inside wheel and makes the outside wheel go faster. This moves the machine through a turn under full power.

The differential gets lubrication from oil thrown about inside the housing. A flat surface on each side of spider (6) lets lubricant go to pinions (3) and to the thrust washers.

## Wheel Hub

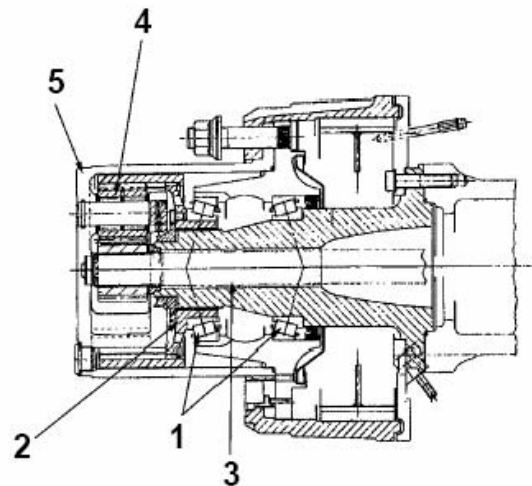

ICPS016S

### Wheel hub

(1) Bearings. (2) Nuts. (3) Axle Shaft. (4) Planetary Gears. (5) Planetary Carrier.

The wheel hubs run on tapered roller bearings (1). The hub bearings are held in position by nuts (2). The hub and bearings are turned by axle shaft (3) and planetary gears (4) through planetary carrier.

# Brake Components

## Shoe Brake

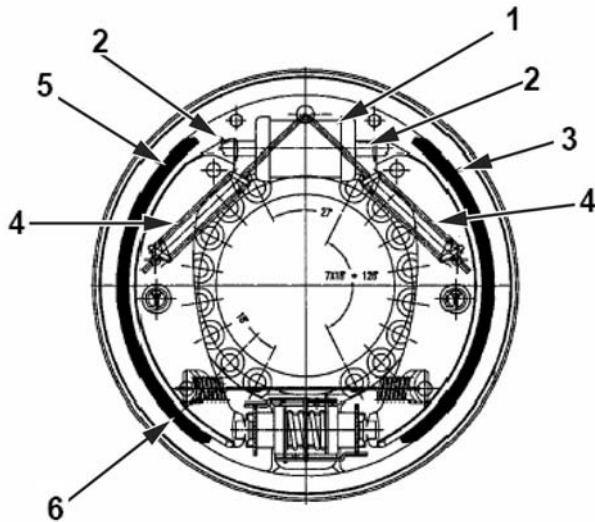

- (1) Wheel Cylinder. (2) Wheel Cylinder Pistons.
- (3) Secondary Shoe. (4) Return Springs. (5) Primary Shoe.
- (6) Return Spring.

When the brake pedal is pushed down the master cylinder sends brake of (hydraulic oil) to wheel cylinder (1). Wheel cylinder pistons (2) are pushed out and move primary shoe (5) and secondary shoe (3). The brake shoes move out until they make contact with brake drum.

When the brake action first starts, primary shoe (5) comes in contact with the rotating brake drum. This contact of the primary shoe puts some force on secondary shoe (3) to help put in position against the drum. As a result, the braking action is increased.

When the brake pedal is released, brake shoe return springs (6) and (4) pull brake shoes (3) and away from the drum surface. They also push wheel cylinder pistons (2) back into wheel cylinder (1).

## Brake Adjuster

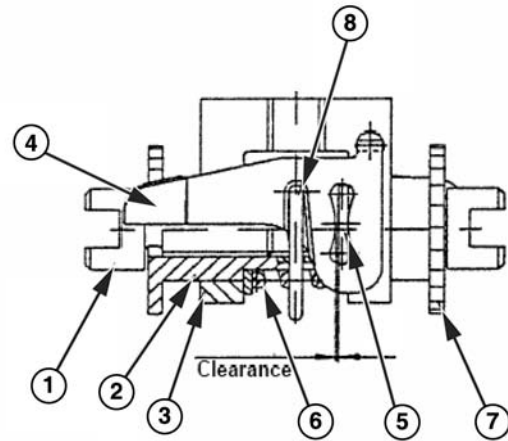

ICPS023S

### Brake Adjuster

- (1) Adjusting Bolt. (2) Sleeve. (3) U-shaped Bracket.
- (4) Adjusting Lever. (5) Adjusting Screw. (6) Spring.
- (7) Adjusting Wheel. (8) Spring.

By means of an adjusting bolt (1), the primary shoe pushes a sleeve (2) through a U-shaped bracket (3), which at the same time acts as the bearing bracket. This thrust movement causes the adjusting lever (4) to be actuated by means of an adjusting disc (5) and to migrate to the side as the result of transmission. As soon as the braking process and the associated movement of the brake shoes have finished, and the shoes have returned to their idle position supported by the compression spring (6) which at the same time serves as a centering point, a toothed adjusting wheel (7) is indexed on as a result of engagement by the adjusting lever which is tensioned by compressed spring (8) and which is restored by the support of the compression spring (6) and the adjusting disc (5). In this way, the adjusting bolt (1), in which the brake shoe is mounted, is unscrewed. This adjusting process per braking action is repeated until the sliding movement of the primary brake shoe is no longer sufficient to overcome a fixed clearance marked in the adjusting lever. This set clearance ensures that the diameter of the brake remains constantly adjustable at a certain dimension.

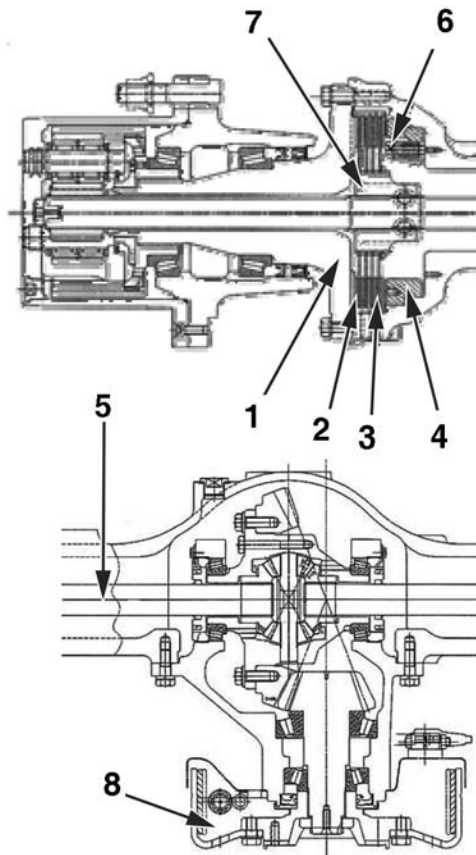

- 
- (1) Spindle. (2) Steel plate. (3) Disk plate. (4) Service piston.
  - (5) Drive shaft. (6) Service piston adjust bolt. (7) Spline collar.
  - (8) Parking brake.

Sealed up structure of hydraulic disk brake system secures good brake performance even in the high humid or dusty area.

Because it is possible to use the brake semi-permanently, there is no need to replace or change the lining as drum type brake do.

Major components are 3 disk plates (3), 4 steel plates (2), service piston (4). Braking force is applied by restricting the driving force from drive shaft (5) and spline collar (7).

# Testing and Adjusting

## Troubleshooting

Troubleshooting can be difficult. A list of possible problems and corrections is on the pages that follow.

Use this as a reference for the location and correction of problems in the transmission. When more testing and adjusting is necessary, use the procedures that are given in Transmission Pressure Tests, Inching Pedal Adjustments and Converter Stall Tests. Always make visual checks first, operation checks second and then make checks on the transmission with instruments.

### WARNING

**When testing and adjusting the power train, move the machine to an area clear of obstructions, and with safe ventilation for the exhaust. To prevent personal injury when drive wheels are off the ground for testing, keep away from wheels that are in rotation.**

Operate the machine in each direction. Make note of all noises that are not normal and find their source. If the operation is not correct, make reference to the troubleshooting chart for “problems” and “probable causes”

## Visual Checks

1. Check the oil level in the transmission with the engine running and with the transmission in NEUTRAL.
2. Check all oil lines, hoses and connections for leaks and damage. Look for oil on the ground under the machine.
3. Move and turn the lever for the speed control and the direction control to all REVERSE and FORWARD positions. The detents must be felt in each position.

4. Check the strainer behind the transmission oil plug and the filter for foreign material.
  - a. Particles of friction paper material give an indication of a clutch failure.
  - b. Metallic(metal) particles in the filter give an indication of wear or mechanical failure in the transmission.
  - c. Rubber particles give an indication of seal or hose failure.
  - d. Aluminum particles give an indication of a torque converter or control valve failure.

If metal or rubber particles are found, all components of the transmission hydraulic system must be flushed. Make a replacement of all parts that show damage.

## Checks During Operation

### NOTICE

Before these checks are started, fill the transmission with oil to the correct level. Improper oil level can cause damage to the transmission components.

With the engine running and brakes on, move the selector lever for transmission speeds to all positions. The detents must be felt in each position. Operate the machine in each direction and in all speeds. Make note of all noises that are not normal and find their sources. If the operation is not correct, make reference to the CHECK LIST DURING OPERATION for “problems” and “probable causes”

## Check List During Operation

**Problem : Transmission does not operate in any speed or does not engage (slips) in all speeds.**

### Probable Cause :

1. Low oil pressure or no oil pressure caused by :
  - a. Low oil, no oil, or thick oil.
  - b. Inching control valve linkage loose, broken or adjustment is not correct.
  - c. Inching valve spool stuck (held) open.
  - d. Failure of the oil pump or a defect in the oil pump.



- e. Converter drive tangs worn off or not engaged into pump.
- f. Main regulator valve stuck open.
- g. Restriction in the oil flow circuit such as dirty oil screen.
- h. Leakage inside the transmission.
  - Control valve gasket has the damage.
  - Worn or broken metal seal rings on clutch shaft.
  - Worn or broken seals around clutch piston.
- i. Control valve gasket is worn that causes leakage.

2. Cooler external lines are not connected correctly.
3. Mechanical failure in the transmission.

**Problem : Transmission does not shift.**

**Probable Cause :**

1. Low oil pressure.
2. Main regulator valve will not move (stuck).
3. Solenoids or related electric components are out of order.

**Problem : Transmission gets hot.**

**Probable Cause :**

1. Restriction in cooling circuit.
2. Oil level too high or too low.
3. Low pump pressure -worn or damaged pump.
4. Converter one way clutch worn and slipping.
5. Air mixed in the oil. Air leaks on the intake side of the pump.
6. Low oil flow through converter.
7. Wrong application for vehicle, (loads are too heavy for the lift truck).
8. Too much inching operation (slipping the clutch plates and discs).

9. Too much stalling of torque converter.
10. Cooler bypass valve stuck (held) open, full oil flow does not go through oil cooler.

**Problem : Clutch engagement is slow or loss of power during engagement.**

**Probable Cause :**

1. Low oil pressure.
2. Low converter pressure.
3. Air mixed in the oil.
  - a. Air leaks on suction side of pump.
  - b. Low oil level also causes aeration.
4. Inching valve linkage adjustment is not correct.

**Problem : Transmission operates in forward speeds only.**

**Probable Cause :**

1. Discs and plates have too much wear in reverse direction clutches.
2. Leakage at the seals.
3. Reverse clutch components have damage.
  - a. Leakage caused by worn or broken metal sealing rings.
  - b. Leakage caused by worn or broken seal around clutch piston.
  - c. Failure of other components.
4. Solenoids or related electric components are out of order.

**Problem : Transmission operates in reverse speeds only.**

**Probable Cause :**

1. Discs and plates have too much wear in forward direction clutches.
2. Leakage at the seals.
3. Forward clutch components have damage.
  - a. Leakage caused by worn or broken seal around metal sealing rings.

b. Leakage caused by worn or broken seal around clutch piston.

c. Failure of other components.

4. Solenoids or related electric components are out of order.

**Problem : Low stall speed.**

**Probable Cause :**

1. Engine performance is not correct.
2. The one-way clutch of the torque converter does not hold.

**Problem : High stall speed in all transmission speeds and directions.**

**Probable Cause :**

1. Low oil level.
2. Air in the oil.
3. Clutches slip(clutch plates slide in relation to one another).
4. Torque converter failure.

**Problem : High stall speed in one speed or one direction.**

**Probable Cause :**

1. There is a leak in that clutch circuit.
2. There is a failure of the clutch in that speed or direction.

**Problem : Clutch engagement is slow and makes rough shifts.**

**Probable Cause :**

1. Inching valve adjustment is not correct.
2. Inching valve is not completely closed or orifice has dirt (plugged).
3. Low main pressure.
4. Low directional clutch pressure.
5. Internal oil leaks.
6. Valve spool springs are weak or have damage.

**Problem : Vehicle operates in one direction and creeps in that direction in NEUTRAL. Engine stalls when shifted to the other direction.**

**Probable Cause :**

1. Failure of clutch in the direction the lift truck moves. Clutch discs or plates are warped (damaged) or held together because of too much heat.
2. Failure of the valve spool in the direction the lift truck moves. The spool stuck(held) in the engaged position possibly caused by metal burrs(particles) or dirt.

**Check List From Operation Noise**

**Problem : Noise in NEUTRAL only.**

**Probable Cause :**

1. Worn bushing in pump assembly.
2. Worn one-way clutch in torque converter.
3. Oil level low.
4. Converter housing or converter tangs not in alignment with engine or transmission pump.

**Problem : Pump noise not normal.**

**Probable Cause :**

1. A loud sound at short time periods gives an indication that foreign material is in the transmission hydraulic system.
2. A constant loud noise is an indication of pump failure.

**Problem : Noise in the transmission that is not normal.**

**Probable Cause :**

1. Converter housing or converter tangs not in alignment with engine or transmission pump.
2. Transmission components have wear or damage.
  - a. Damaged gears.
  - b. Worn teeth or clutch plates and/or clutch discs.
  - c. Slipping clutch plates and discs noise.
  - d. Failure of the thrust washers.
  - e. Other component parts have wear or damage.

**Problem : Noise in the control valve.**

**Probable Cause :**

1. Air in the hydraulic system.
  - a. Air leakage on suction side of the pump.
  - b. Low oil level that causes aeration.
2. Restrictions in oil passage.
3. Valve spools movement has restriction.

**Check List From Pressure Test**

**Problem : Low pressure to FORWARD and REVERSE clutches.**

**Probable Cause :**

1. Inching valve linkage adjustment is not correct.
2. Inching valve spool held (stuck) open.
3. Clutch piston seals cause leakages.
4. A defective regulator valve spring.
5. Low oil pressure, see Probable Cause for Low Oil Pressure.
6. Cooler external lines are not connected correctly.

**Problem : Clutch pressure and main pressure are high.**

**Probable Cause :**

1. Pressure regulator valve is not free to move (stuck).
2. A restriction in the hydraulic circuit.

**Problem : Pressure to one clutch is low.**

**Probable Cause :**

1. Clutch piston seal alignment is not correct, oil leaks through.
2. Seal rings on shaft or clutch piston seals are broken or worn.
3. Control valve surface not flat or gasket has damage.

**Problem : Low main line pressure.**

**Probable Cause :**

1. Low oil level.
2. Main regulator valve movement is restricted.
3. Transmission pump is worn.
4. Inner oil leakage.
5. Low oil pressure.

**Problem : Low lubrication pressure or no lubrication pressure.**

**Probable Cause :**

1. Low oil pressure or no oil pressure caused by :
  - a. Failure of the oil pump or a defect in the oil pump
  - b. Restriction in the oil flow circuit such as a dirt, oil screen.
  - c. Converter drive tangs worn off or not engaged in pump.
  - d. Main regulator valve spool stuck closed.
  - e. Leakage inside of the transmission caused by component defect.

2. Oil cooler has restriction to oil flow.

**Problem : High lubrication pressure.**

**Probable Cause :**

1. High converter inlet pressure.
2. Cooler and oil filter external lines are not connected correctly.

**Problem : High converter pressure.**

**Probable Cause :**

1. Main regulator valve stuck open so most of the flow goes to the converter.
2. A restriction inside the converter assembly.
3. A plugged (restriction) oil flow passage.

**Problem : Low converter pressure.**

**Probable Cause :**

1. Main regulator valve movement is restricted.

**Problem : Converter outlet pressure or cooler inlet pressure is low.**

**Probable Cause :**

1. Low oil pressure.
2. Cooler bypass valve stuck open.

**Problem : Converter outlet pressure or cooler inlet pressure too high.**

**Probable Cause :**

1. Restriction in oil cooler lines or a plugged oil cooler.

## **Differential**

**Problem : Constant noise in differential.**

**Probable Cause :**

1. Lubricant not to the specific level.
2. Wrong type of lubricant.
3. Wheel bearings out of adjustment or have a defect.
4. Drive gear and pinion not in adjustment for correct tooth contact.
5. Teeth of drive gear and pinion have damage or wear.
6. Too much or too little pinion to gear backlash.
7. Loose or worn pinion bearings.
8. Loose or worn side bearing.

**Problem : Noise at different intervals.**

**Probable Cause :**

1. Ring gear does not run even.
  - a. bolts on drive gear not tightened correctly.
  - b. Drive gear has a defect(warped)
2. Loose or broken differential bearings.

**Problem : Noise on turns only.**

**Probable Cause :**

1. Differential pinion gears tight on the spider or the pinion shaft.
2. Side gears tight in differential case.
3. Differential pinion or side gears have a defect.
4. Thrust washers worn or have a damage.
5. Too much clearance (backlash) between side gears and pinions.

**Problem : Leakage of lubricant.**

**Probable Cause :**

1. Loss through axle hub carrier
  - a. Lubricant above specification level.
  - b. Wrong kind of lubricant.
  - c. Restriction of axle housing breather.
2. Loss at pinion shaft.
  - a. Lubricant above specification level.
  - b. wrong kind of lubricant.
  - c. Restriction of axle housing breather.
  - d. Oil seal worn or not installed correctly.
  - e. Universal joint flange loose on the pinion shaft.

# Transmission Pressure

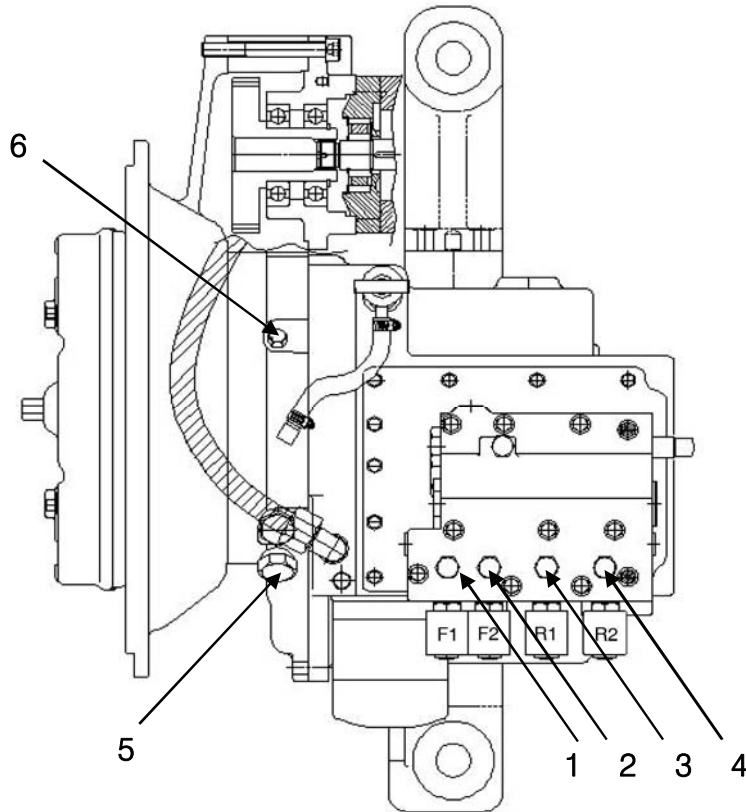

ICPS054S

(1) Forward low clutch pressure tap. (2) Forward high clutch pressure tap. (3) Reverse low clutch pressure tap  
 (4) Reverse high lutch pressure tap. (5) Main line pressure tap. (6) Converter pressure tap.

Transmission Pressure													
Engine RPM	Unit	Main Line (Neutral)		Converter (Neutral)		Forward Low Clutch		Forward High Clutch		Reverse Low Clutch		Reverse High Clutch	
		Min	Max	Min	Max	Min	Max	Min	Max	Min	Max	Min	Max
Idle	psi	62	170	51	113	47	103	47	103	47	103	47	103
1300	psi	103	194	93	187	103	170	103	170	103	170	103	170
2500	psi	103	235	113	235	113	176	113	176	113	176	113	176
Idle	KPa	426	1,175	355	780	324	709	324	709	324	709	324	709
1300	KPa	709	1,337	638	1,287	709	1,175	709	1,175	709	1,175	709	1,175
2500	KPa	709	1,621	780	1,621	780	1,216	780	1,216	780	1,216	780	1,216

## Converter Stall Test

The converter stall test is a test to check engine power. It can also be used to locate a problem in the transmission when the condition of the engine is known. An engine which does not have correct performance will give an indication of a stall speed that is not correct. If the engine performance is correct, and the stall speed is not correct, the problem in the converter or transmission can be found with this test.

**NOTE :** To check the engine performance, see Service Manual for the DB58S Diesel Engines.

The test checks the maximum RPM that the engine, at full throttle, can turn the converter with the turbine held stationary. To hold the converter turbine, engage the brakes with the transmission in either FORWARD or REVERSE and in HIGH speed.

The drive wheels must not turn during the stall test. Put a heavy load on the forks and put the truck in position against a solid object that will not move (such as a loading dock). Engage the parking brake. When the tests are made, the wheel brakes must be engaged with the left foot ; the accelerator pedal can be operated with the right foot. Make sure that the transmission oil is at the correct temperature for operation before tests are made.

Check the high idle setting before the stall test is made. The high idle on the diesel engine is shown in the chart below.

High Idle Setting	
Engine	High Idle RPM
DB58S Diesel	2,600 ± 50
G643(E) LP	2,500 ± 50

### WARNING

**Make tests in a clear, level area only. There must be one operator. Keep all other personnel away from the lift truck. Check to be sure the operation of the brakes is correct before the tests are made.**

1. Connect a tachometer to the engine. Start the engine and move the control levers to the FORWARD direction and HIGH speed.

2. Engage the wheel brakes and push the accelerator pedal down completely. Read the RPM on the tachometer, then release the accelerator pedal. Turn the speed control lever to LOW. Push the accelerator pedal down completely and read the RPM again. Release the accelerator pedal.

### NOTICE

To make sure that the transmission oil does not get too hot, do not hold the transmission in a stall condition for more than ten seconds. After the transmission is stalled, put the controls in NEUTRAL and run the engine at 1200 to 1500 RPM to cool the oil.

3. Repeat the procedure above for both REVERSE speeds.

4. The stall speed is in the chart below.

	Stall Speed	
	Without power Brakes applied	With power Brakes applied
DB58S Diesel	1,690 ± 70	1,590 ± 70
G643(E) LP	1,640 ± 70	1,540 ± 70

Stall speeds that are low are an indication that the engine performance is not correct or the one-way clutch of the torque converter does not hold in reverse direction. If the one-way clutch has a defect, the stall speed will probably be more than 800 RPM low.

The stall speed must be the same in all forward and reverse speeds. If the stall speed is high in all forward and reverse speeds, one or more of the problems that follow can be present ; low oil level, air in the oil, a torque converter failure, or low oil pressure to all clutches.

If the stall speed is high in both speeds in one direction, check the clutch operation for that direction. If the stall speed is high in one speed only, both forward and reverse, check the clutch operation for that speed.

## Shimming of Transmission Shaft

1. Assemble shaft assembly (including taper bearing cone and cup).
2. Insert shaft assembly into transmission case.

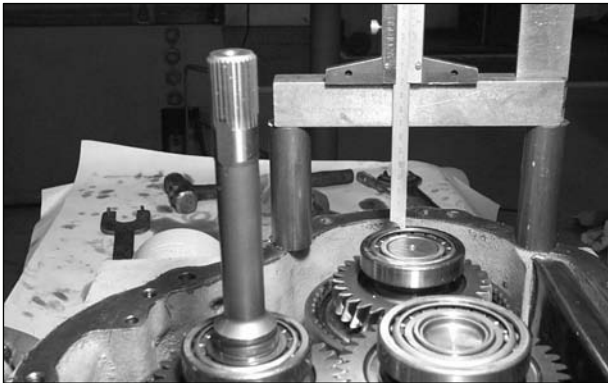

3. Measure the dimension 'X' from surface of transmission case to surface of bearing cup.

**NOTE :** Use depth gage and block gage because the height of bearing cup is higher than surface of transmission case.

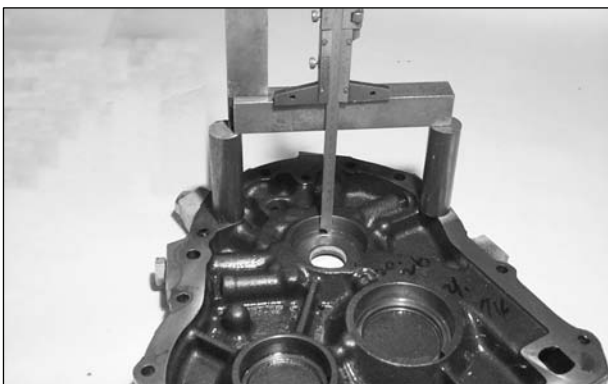

4. Measure the dimension 'Y' from surface of transmission cover to bottom of bore where bearing cup is installed.
5. Calculate required shim thickness as following formula. Required shim thickness 'Z' =  $Y - X + 0.45 \text{ mm}$
6. Select shims to have (-0.04) to 0.11mm (-0.002) to 0.004 in of axial clearance.
7. Assemble transmission case, cover and gasket.
8. Set up transmission assembly vertically.

9. If you reshim input shaft or counter shaft, turn transmission input shaft by hand. It should be turned smoothly. If you reshim intermediate shaft or output shaft, turn output shaft by hand. It should be turned smoothly.
10. If the input shaft or output shaft does not turn smoothly, remove shims about 0.025 - 0.05 mm.

## Wheel Brake Adjustment

### Shoe Brake Axle

The brakes make an adjustment automatically when an application is made in forward and reverse. With each application, there will be an adjustment made, until the lining-to-drum clearance is made small enough to stop the movement of the automatic adjuster.

Brake setting is essential when:

1. Enewing, removing or mounting the automatic adjuster.
2. Mounting new brake shoes and brake drums at all stages of repair.
3. Repair work on the brake, where by the basic setting of the threaded bolts has been altered at the automatic adjuster.

Setting work, as well as checking of the clearance between the brake shoes and brake drum must be carried out when the brake is cold. The driving and parking brake must always be adjusted together.

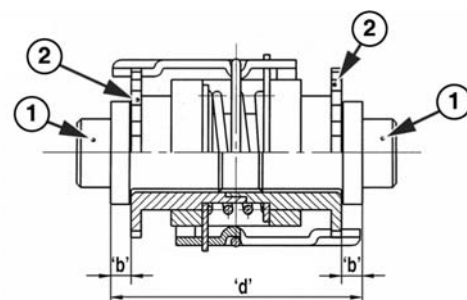

ICPS022S

Brake Adjuster

(1) Adjusting Screws. (2) Adjusting Wheels.



## Setting Procedure

During setting, the parking brake must be released. The cable should not be tensioned.

1. Jack up the vehicle
2. Release the brake cable
3. Remove the brake drum
4. Carefully raise the adjusting lever using a screw driver or similar tool through the opening in the brake plate to permit the adjusting wheel to turn freely.
5. Adjust the brake diameter to meet "diameter =  $\varnothing$  313  $^{+0.2}_0$  mm" by turning the adjusting wheel.

### Remark:

During this setting work, take care to ensure an even distance "b" of the adjusting screws (1) to the relevant adjusting wheel (2).

### Remark:

Precise adjustment of the relevant brake diameter is of decisive importance for the function of the automatic adjuster. An insufficiently high setting could result in damage to the adjuster.

6. Adjust the brake cables in such a way that the relevant brake diameter is not altered.

### Remark:

The brake cables may not be pretensioned, as otherwise it is not possible to guarantee perfect function of the adjuster.

7. Mount the brake drum
8. Release hexagonal for fastening the automatic adjuster.
9. Actuate the brake several times to centre the brake shoes/ the adjuster in the brake drum.
10. Afterwards tighten hexagonal screw to a torque of  $120 \pm 20$  N•m ( $88.6 \pm 14.7$  lb•ft)
11. Tighten the hands brake lever. The wheels should be equally difficult to turn in this setting.

## CAUTION

**Correction of wheels which are not equally difficult to turn may only be carried out at the brake cables and not at the automatic adjuster.**

12. Lower the vehicle
13. Carry out appr. 10 braking processes (not emergency braking) with a starting speed of around 10kph in forward/reverse travel, observing the braking characteristics of the vehicle. The automatic adjuster is then ideally set.

This setting procedure must be carried out always at all the brakes of the vehicle.

## WARNING

**After new adjustment of brake diameter, it will take times until the lining-to-drum clearance is made small enough to stop the movement of the automatic adjuster. So, Please keep enough braking distance to avoid accident.**



## Inching Pedal Adjustment

To check the inching valve adjustment and operation, do the procedure that follows :

### **! WARNING**

When this procedure is used, the lift truck must be in an area clear of obstructions. There must be one operator with all other personnel away from the lift truck. Check the operation of the brakes before the test is made.

1. With the engine at idle speed, put the transmission in FORWARD.

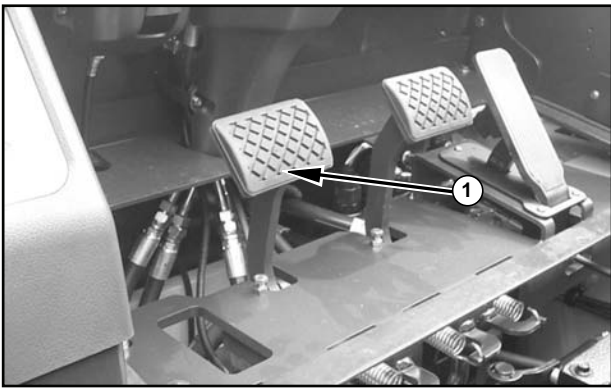

Inching Operation Test  
(1) Inching pedal.

2. Slowly push down on inching pedal (1) until the movement of the brake pedal causes the brake discs (or, shoes) to make contact (small drag) with the brake plates (or, the brake drum).
3. Increase the engine speed to high idle. The truck must not move.

If the operation of the inching valve is not correct, do the procedure that follows.

1. Adjust and bleed the brake system as shown in the Vehicle Systems module.

### **! WARNING**

To prevent personal injury, when the inching pedal is adjusted, move the truck to a clear area that is level. Keep all other personnel away from the lift truck. Use lifting equipment or a safe method to lift the front of the lift truck until the drive wheels are off the floor. Put wood blocks or jack stands of the correct capacity under it to hold it in this position while the inching pedal is adjusted.

2. Raise the front of the lift truck off the floor. Put wood blocks or jack stands of the correct capacity under it while the inching pedal is adjusted.

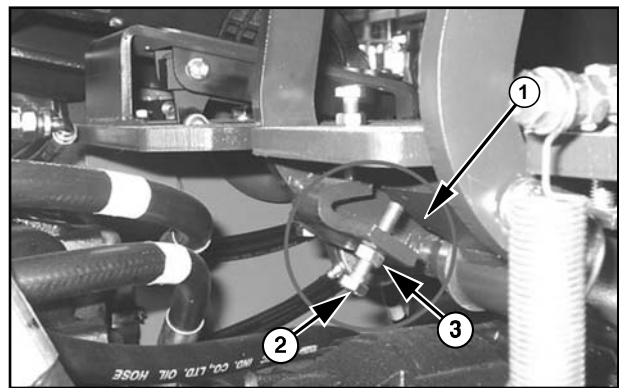

Inching Pedal Adjustment  
(1) Lug. (2) Bolt. (3) Nut.

3. Start the engine and put the transmission FORWARD.
4. With the drive wheels turning, depress inching pedal until the drive wheels stop.
5. Now depress the brake pedal until disc (or, shoe) contact is felt.
6. Loosen nut (3) and adjust bolt (2) to contact lug (1) that rotates the brake control cross shaft. Tighten nut (3).
7. Check the inching valve operation again.
  - a. If something is wrong, inspect all points again one by one very carefully.

The adjusting procedure is as follows. Be sure that the air bleeding of brake system should be done in advance.

< OCDB >

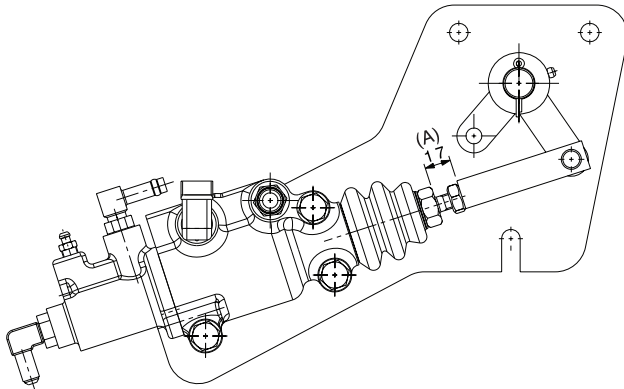

< Shoe Brake >

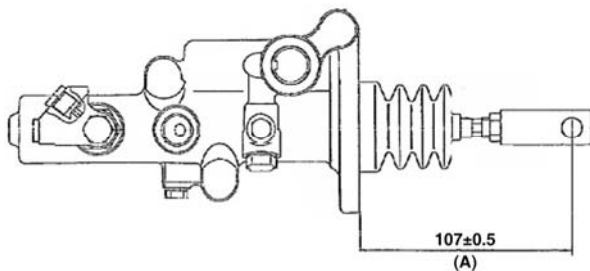

1. Adjust the length (A). Be sure that 1mm of gap between the piston and the rod should exist. In case of no gap, it would result in brake drag or overheating of axle oil. In case of too loose, the performance of service brake become lowered.

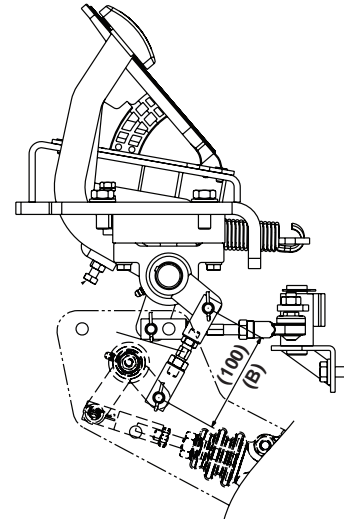

2. Adjust the length (B) of rod by fixing the nuts at both ends. (B) is about 100 mm.

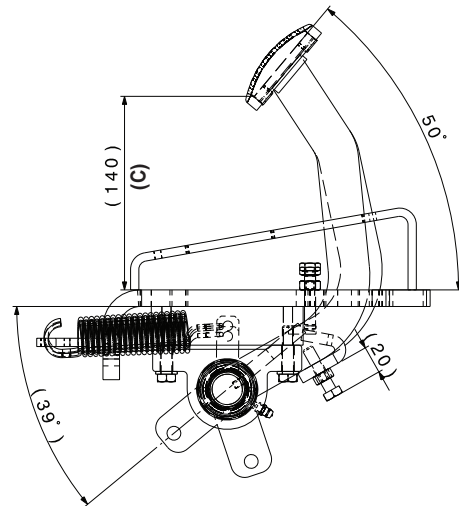

3. Adjust the height (C) of inching pedal and brake pedal by using (2) bolts. (C) is about 140 mm at the same level.

4. Adjust the gap (D) for engaging brake pedal by inching pedal.

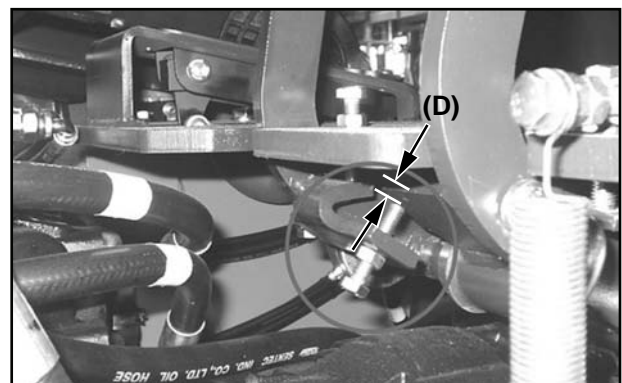

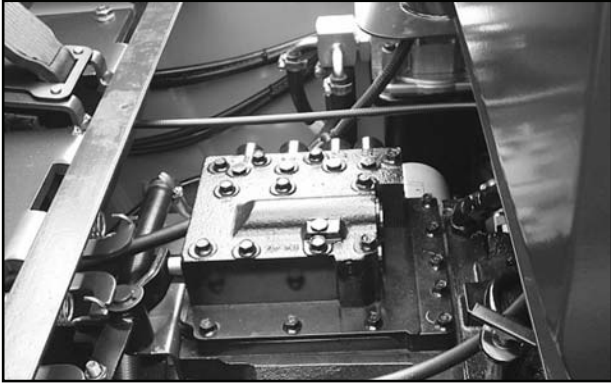

5. The stroke of inching spool when the brake pedal is engaged should be  $3 \pm 1$  mm.
6. Before doing the truck test, inspect again all relevant dimensions.
7. Inspect the service brake and then, inching operation.

# Disassembly and Assembly

## Drive Shaft and Universal Joint

### Remove Drive Shaft and Universal Joint

Start By :

- a. Remove floor plate (front three sections)

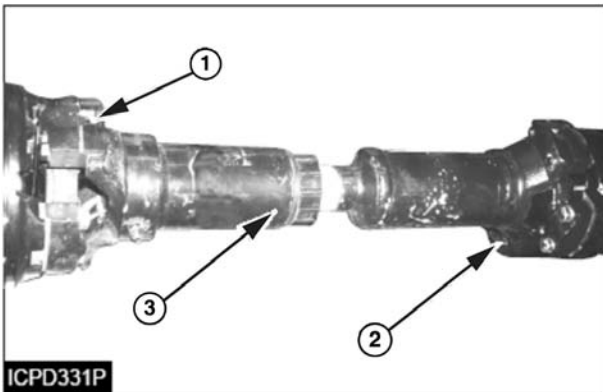

1. Remove four bolts (1) that hold universal joint (3) to the transmission end yoke.
2. Remove four bolts (2) that hold universal joint (3) to the drive axle end yoke. And, remove drive shaft (3) from the machine.

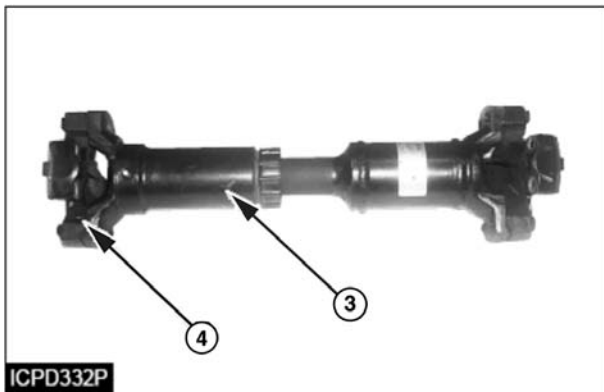

3. Remove eight bolts (4) from drive shaft (3) and remove two universal joints.

**NOTE :** The following steps are for installation of the drive shaft and universal joints.

4. Put two universal joints in position on drive shaft (3) and fasten with eight bolts (4),
5. Put drive shaft (3) in position on drive axle and transmission yoke and, fasten with four bolts.

6. Connect the other of the drive shaft (3) to the transmission yoke (2) and, fasten with four bolts (1).

**NOTE :** Tighten all bolts that fasten universal joints to a torque of  $60 \pm 7 \text{ N}\cdot\text{m}$  ( $45 \pm 5 \text{ lb}\cdot\text{ft}$ ).

End By:

- a. Install floor plate (front three sections).

### Disassemble and Assemble Drive Shaft

Start By:

- a. Remove drive shaft and universal joints.

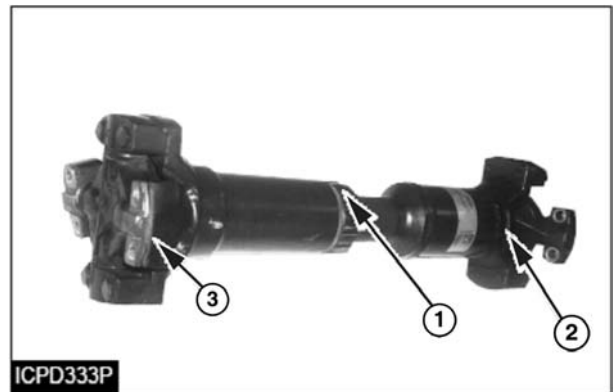

1. Loosen cap (1) and slid off of the yoke (3).
2. Pull yokes (2) and (3) apart from each other.



3. Check all parts of the drive shaft for wear and damage. Use new parts for replacement.

**NOTE :** The following steps are for the assembly of the drive shaft.

---

### NOTICE

The flanges of the two yokes can be assembled out of parallel. Wrong assembly of the universal joint will cause very short joint life. Assemble the spline yoke into the slip yoke. Both flanges must be parallel.

---

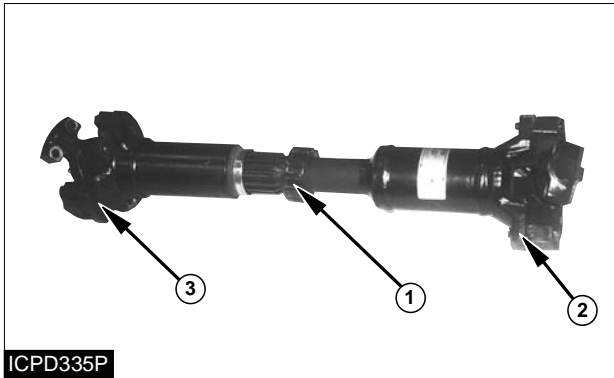

4. Make an alignment of yokes (2) and (3) so that the flanges on the yokes are parallel.
5. Slide yokes (2) and (3) together.
6. Fasten cap (1) to yoke (3) of the drive shaft.

End By:

- a. Install drive shaft and universal joints.

## Engine, Torque Converter and Transmission

### Remove & Install Engine, Torque Converter and Transmission

Start By:

- a. Remove drive shaft and universal joints
- b. Remove hood
- c. Remove counter weight
- d. Remove hydraulic pump drive shaft and universal joints



1. Remove seat and support assembly (1) and floor plate (2),

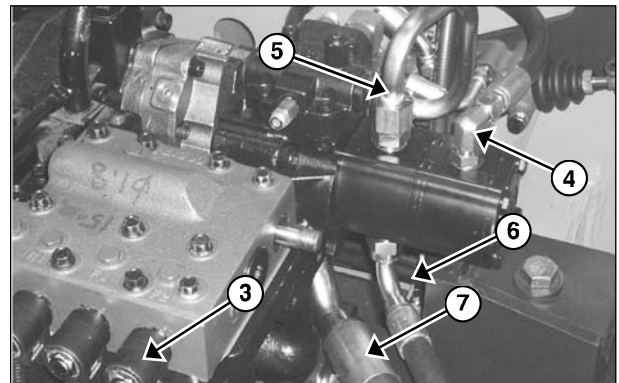

2. Put identification on each of wires to solenoids (3) and, disconnect the wire assemblies at connectors.
3. Disconnect Hyd. Lines (4), (5), (6) & (7) on the pump.



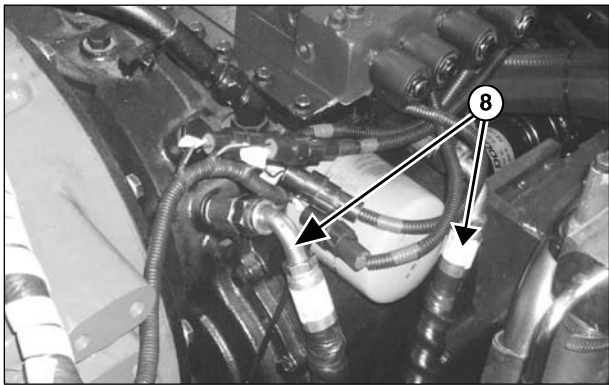

4. Disconnect two cooling lines (8).

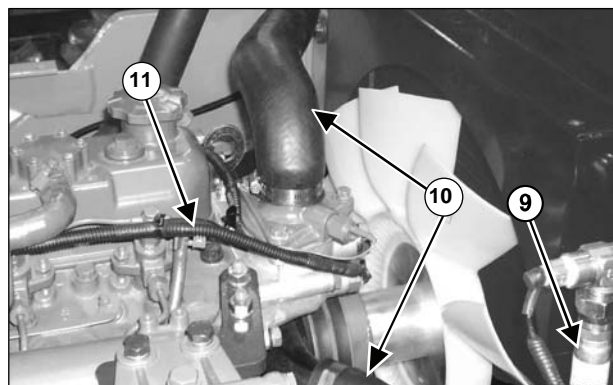
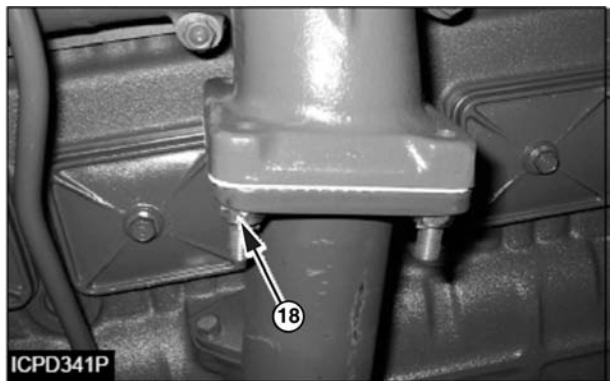
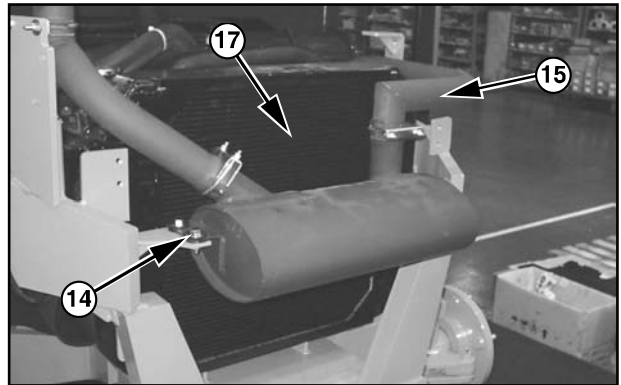

5. Disconnect two cooling lines (9).

6. Remove two water cooling lines (10).

7. Remove engine harness assembly (11).

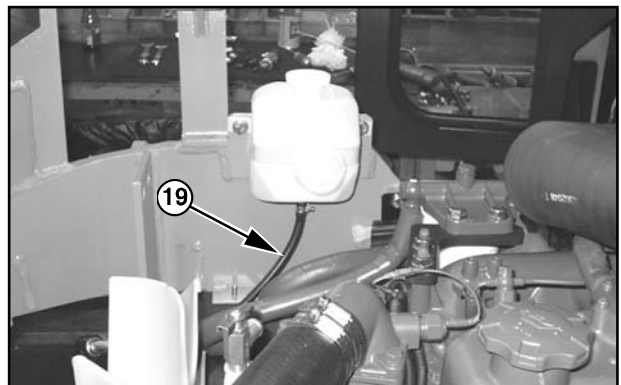

9. Loosen bolts (14) and nuts (18). Remove muffler and exhaust tube assembly (15).

10. Remove radiator reservoir hose (19).

11. Remove radiator assembly (17).

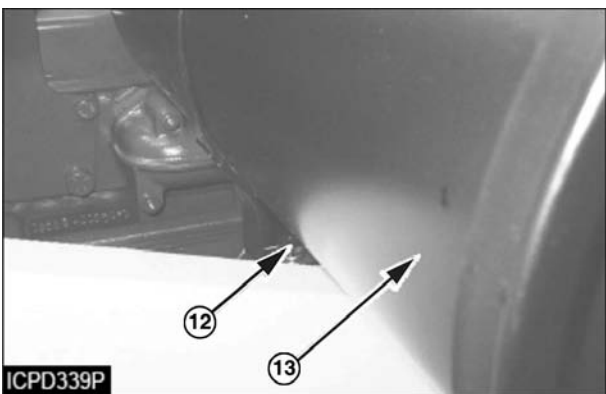

8. Loosen two bolts (12) and remove air cleaner and air intake hose assembly (13).

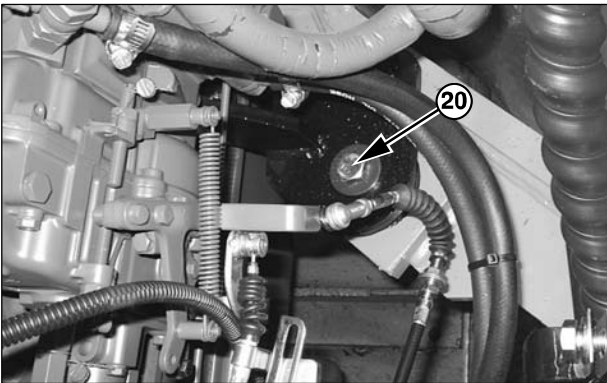
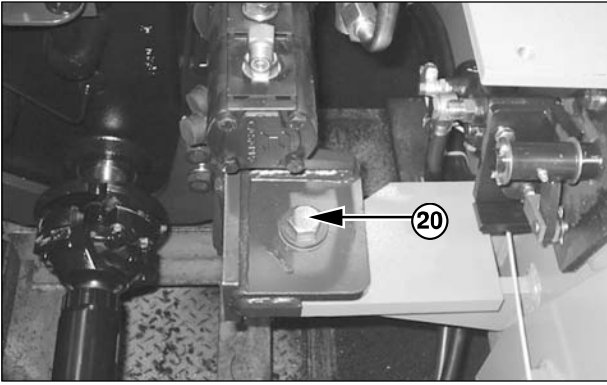

12. Remove bolts (20) and nuts from engine mounts.

---

**NOTICE**

Make sure the engine is supported underneath by suitable wooden blocks. Failure to support engine will result in possible damage.

---

13. Remove engine and transmission with a hoist.

14. Install the engine and transmission in the reverse order of removal.

End By:

- a. Install hydraulic pump drive shaft and universal joints.
- b. Install counter weight.
- c. Install hood.
- d. Install drive shaft and universal joints.

## Separation of Torque Converter and Transmission from Engine

Start By:

- a. Remove engine, torque converter and transmission.

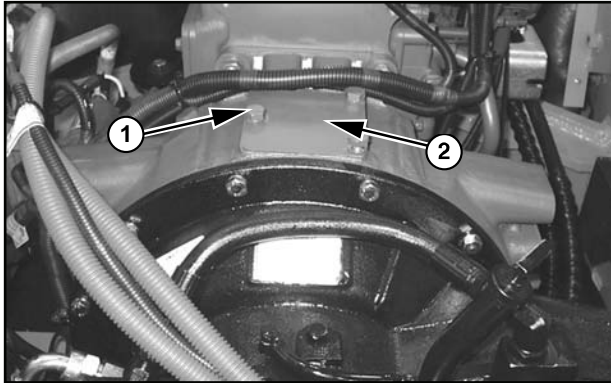

1. Remove bolts (1) and plate (2) from flywheel housing.

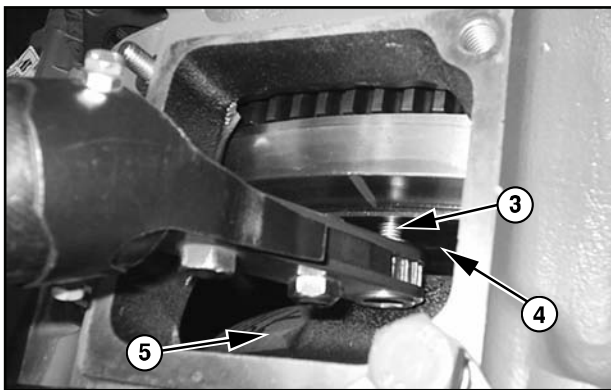

2. Remove six bolts (3) that hold plate (4) to the flywheel.
3. Move plate (4) and torque converter away from the flywheel.
4. Separate transmission and torque converter (5) from the engine.

## Connection of Torque Converter and Transmission to Engine

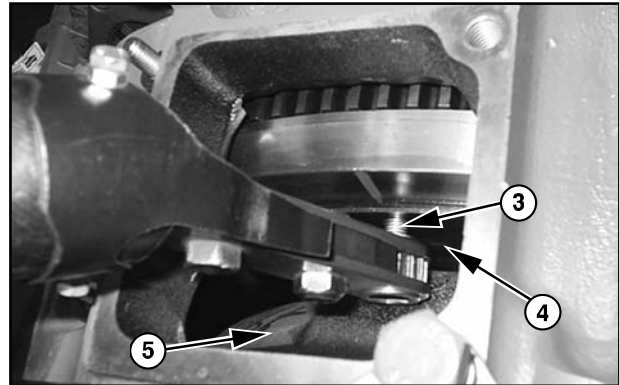

1. Put the transmission and torque converter (5) into position and make a connection of the transmission and torque converter.
2. Move torque converter plate (4) toward flywheel until plate (4) makes contact with the flywheel and check if torque converter turns freely.
3. Install bolts (3) finger tight that hold plate (4) to the flywheel.
4. Turn the flywheel in a counterclockwise direction and tighten the bolts (3) to a torque of  
 $19 \pm 1 \text{ N}\cdot\text{m}$   
 $(14 \pm 1 \text{ lb}\cdot\text{ft})$

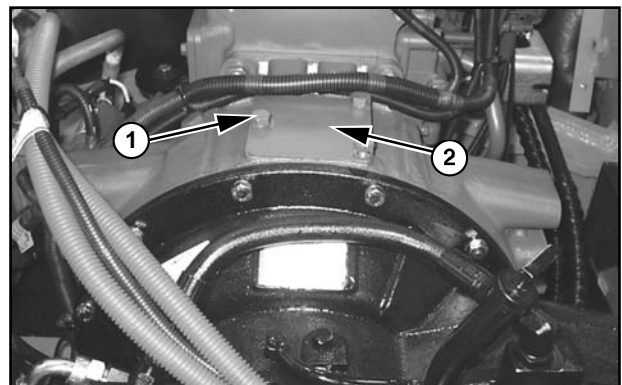

5. Put plate (2) in position and install bolts (1).

End By:

- a. Install engine torque converter and transmission.



# Transmission Control Valve

## Disassembly of Transmission Control Valve

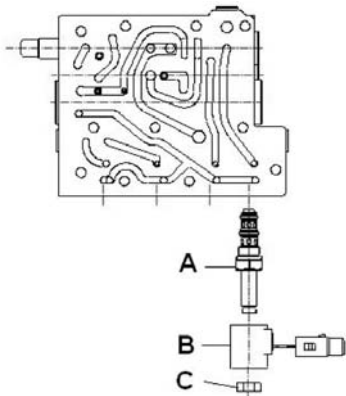

### 1. Disassemble Solenoid Valve

- a. Remove nut (C), remove Coil (B), and disassemble Solenoid Valve body (A).

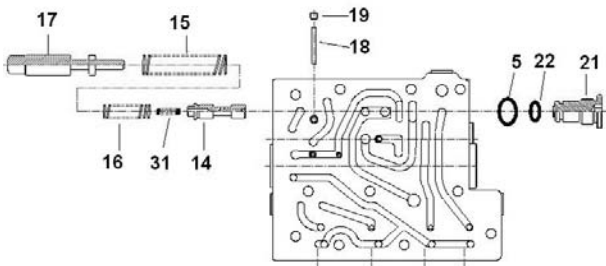

### 2. Disassemble Inching Valve

- a. Disassemble Plug (21) and O-Ring (5),(22) from the main body.
- b. Unscrew STOP Bolt (19), remove Pin (18).
- c. Disassemble Spool (14), Springs (31),(15),(16) and Plunger(17) from the main body.

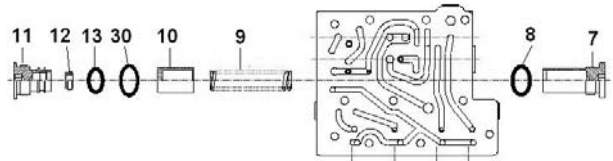

### 3. Disassemble Accumulator Valve

- a. Disassemble the Plug (11) fitted with filter, O-Ring (13)(31), and Spring(9) from main body.
- b. Disassemble Stopper (7) and O-Ring (8) from main body.

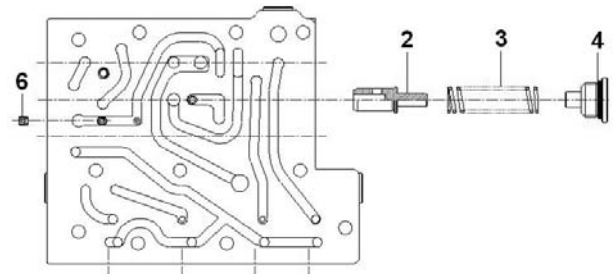

### 4. Disassemble Relief Valve

- a. Disassemble Orifice (6), Plug (4), Spring (3), O-Ring (5) and Spool (2), in the said order

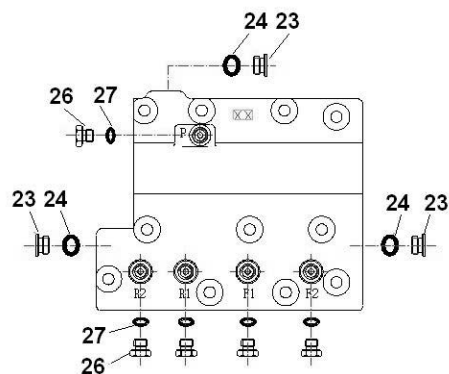

### 5. Disassemble Body Sub

- a. Disassemble Lug (26), O-Ring (27) and Plug (23), O-Ring (24) from the main body.

## Assembly of Transmission Control Valve

### 1. Preparation for Assembling

- a. Refer to the valve disassembling/assembling procedure in advance.
- b. Arrange the work area.
- c. Prepare assembling tools.
- d. Prepare necessary parts according to the number of valves to be assembled.
- e. Wash the parts, put in separate boxes and mark names and part numbers.

### **⚠ WARNING**

When handling the parts, take care not to be injured by sharp edges of body and spool (all the sharp edges must be removed).

Fix the main body when assembling the parts. Otherwise, your hands may be cut).

Take care that wash fluid does not enter eyes when washing the parts. Keep the working area clean to prevent foreign matter. Seals have to be applied with grease or oil to prevent damage.

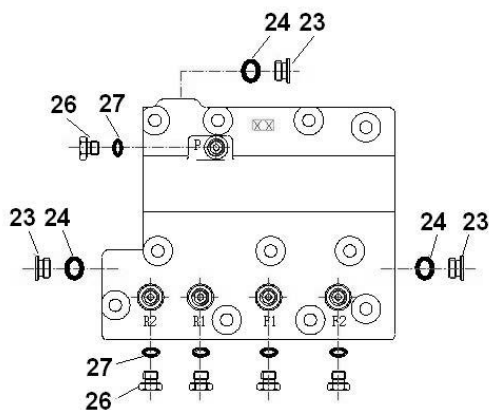

### 2. Assemble Body Sub

- a. Assemble Plug (23) with O-Ring (24), and assemble them with the main body (3 points; torque : 27 N•m)
- b. Assemble Plug (26) with O-Ring (27), and assemble them with the 5 pressure detecting points on the main body (torque : 10 N•m)

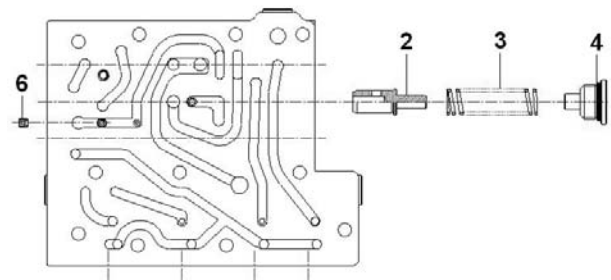

### 3. Assemble Relief Valve

- a. Assemble SPOOL (2) and SPRING (3) in the said order
- b. Assemble O-RING (5) with PLUG (4), and assemble them with the main body (torque: 50 N•m)
- c. Apply Loctite # 603 to ORIFICE (6), and assemble with the main body (check looseness. Conduct caulking when necessary).

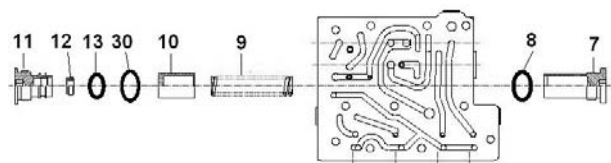

### 4. Assemble Accumulator Valve

- a. Apply Loctite # 609 to Filter Assy (12), and assemble it with Plug (11).
- b. Assemble Stopper (7) with O-Ring (8), and assemble them with the main body (torque : 68 N•m)
- c. Assemble Spring (9) and Piston (11) with the main body.
- d. Assemble Plug (11) fitted with filter with O-Ring (13) and O-Ring (31), and assemble them with the main body. (torque : 100 N•m)

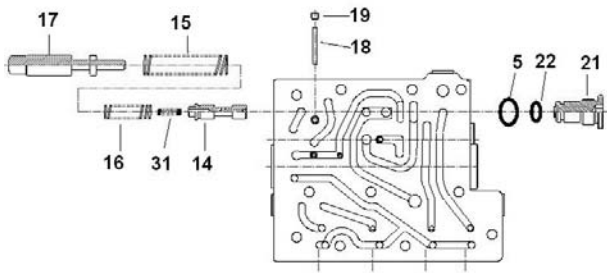

**⚠ CAUTION**  
**Be Sure that the SEAL is not twisted.**

### 5. Assemble Inching Valve

- a. Assemble Body with Spool (14), Spring (31), Spring (15), and Spring (16) in the said order. Insert Plunger and push it down, insert Pin (18) and tighten with Stop Bolt (19). (Stop Bolt must not project from the bottom surface).
- b. Assemble Plug (21) with O-RING (5) and O-RING (23), tighten with the main body (torque : 50 N•m)

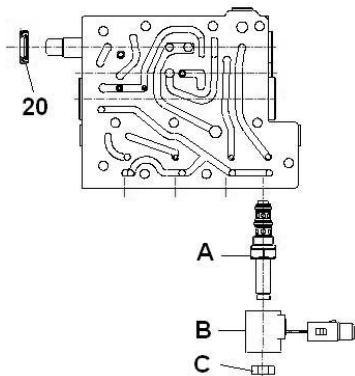

### 6. Assemble Solenoid Valve

- a. Assemble Body with Solenoid Valve body (A) (at 4 points) (torque : 27 N•m)
- b. Insert Coil (B) to the Solenoid Valve body (A), which is assembled with the main body, tighten with Nut (C) (torque : 6.8 N•m)

**⚠ CAUTION**

**The voltage marking on the Coil has to face outwards.**

- c. Insert SEAL (20) into Inching Plunger, and assemble the SEAL with the main body using assembling jig.

# Transmission

## Disassembly of Transmission

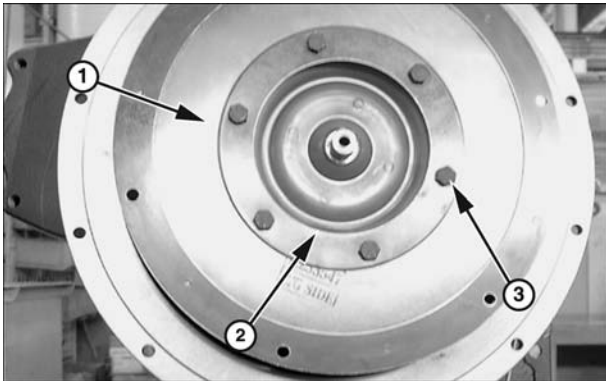

1. Isolate torque converter from housing. Remove 6 bolts (3) from the torque converter, isolate plate(2) and flexible plate (1).

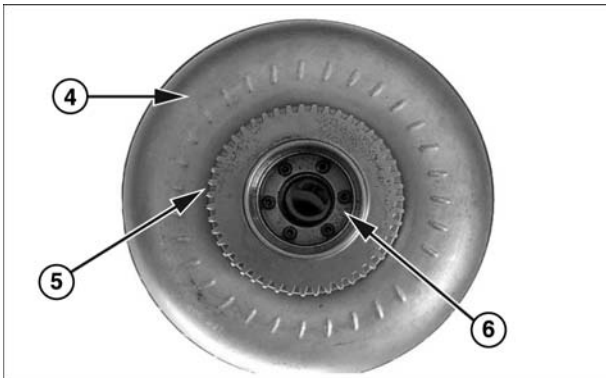

2. From the torque converter (4), unscrew 6 socket bolts (6), disassemble Gear P.T.O Input (5).

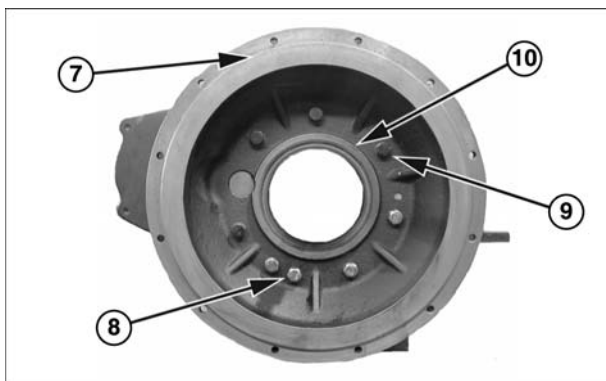

3. From the housing (7), disassemble oil seal (10), 4 bolts (8), 4 bolts (9) and washer.

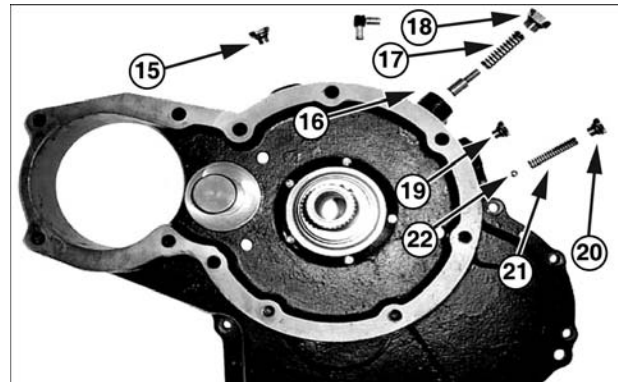

4. Isolate plug (20), O-ring, spring (21) and ball (22) from cover.

5. Disassemble plug (18), O-ring, spring (17) and spool (16).

6. Disassemble plug (15).

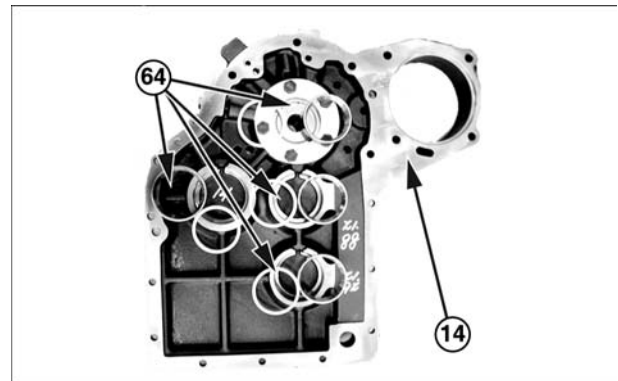

### **⚠ CAUTION**

Bearing cup and seam(64) are inside the cover, or on the shaft in the transmission case. Mark the position on the transmission cover or on the shaft in the transmission case.



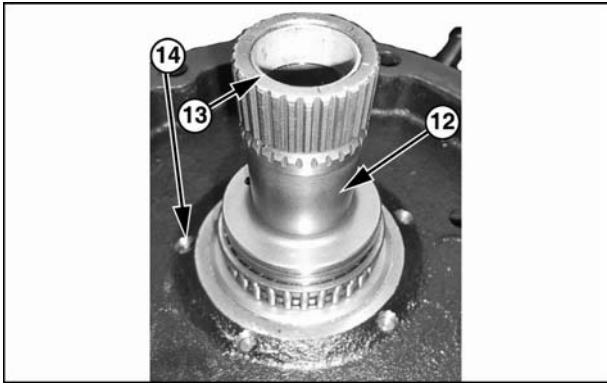

7. Unscrew 5 bolts (11) from the Stator Hub (12) fixed on the Bearing Plate (14), and isolate them from the plate. Use rubber hammer to protect Stator Hub from damage.

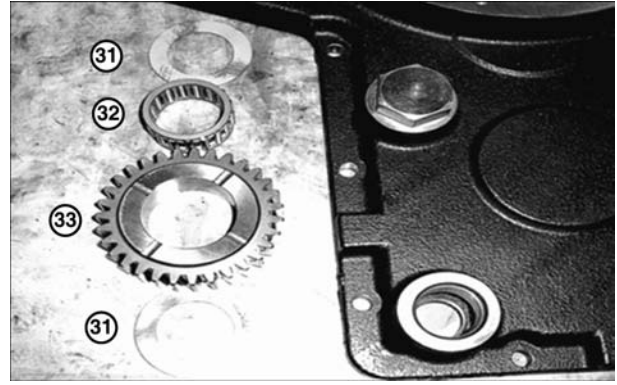

9. From the bearing plate (14), isolate 2 thrust washers (31), needle bearing (32), and Gear-P.T.O Idle (33).

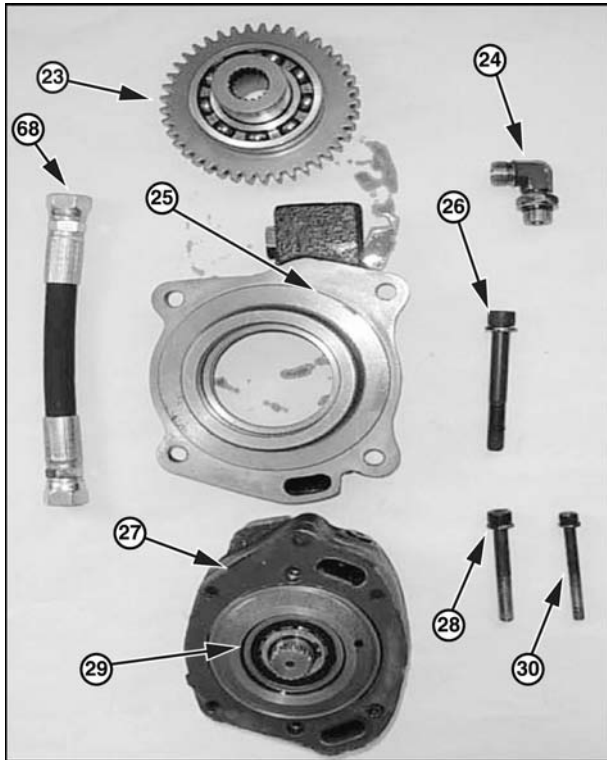

8. Isolate 4 socket bolts (26) from the bearing plate (14), disassemble flange pump (25).

Isolate socket bolt (28) and 4 socket bolts (30) from the flange pump. Isolate charging pump (29) and gasket (27). Disassemble Gear-P.T.O Output (23) and ball bearing, and isolate elbow (24).

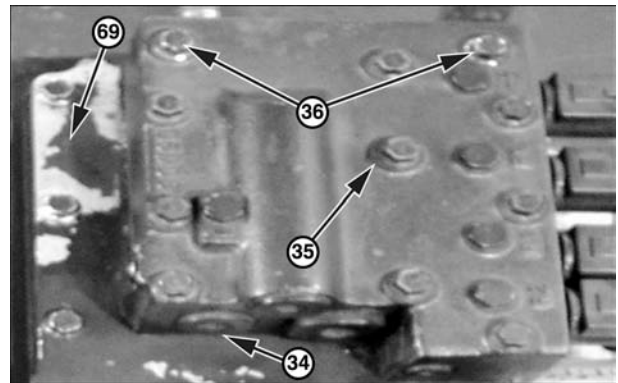

10. Disassemble 2 bolts (35), 9 bolts (36), and valve gasket (34).

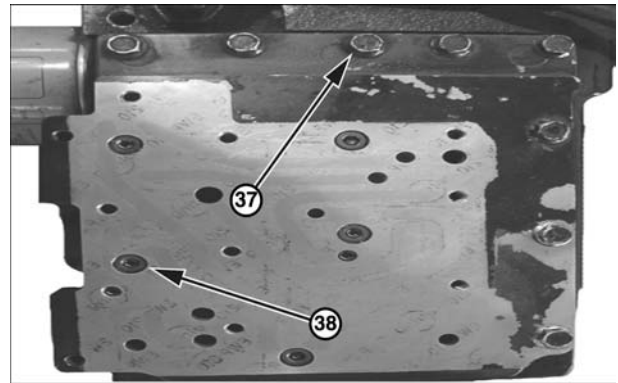

11. Unscrew 8 bolts (37) and 5 socket bolts (38) from transmission. Isolate valve plate (69) slowly

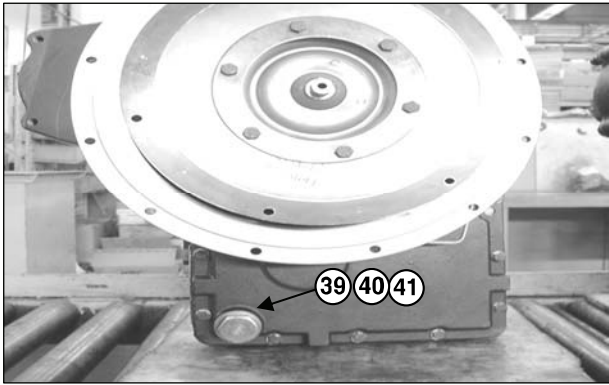

12. Isolate plug (41) and O-ring. Disassemble spring (39) and oil screen (40) from the case

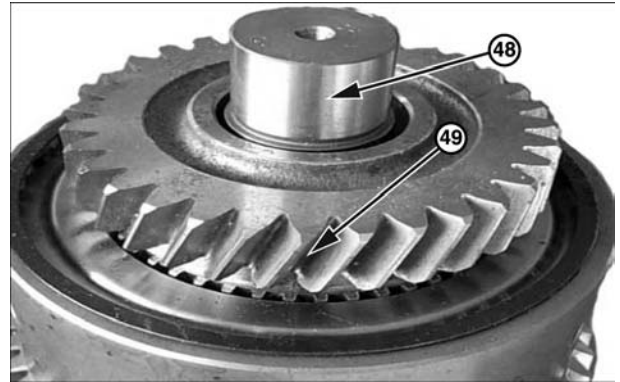

17. Disassemble 2 thrust washers (48) and gear (49)

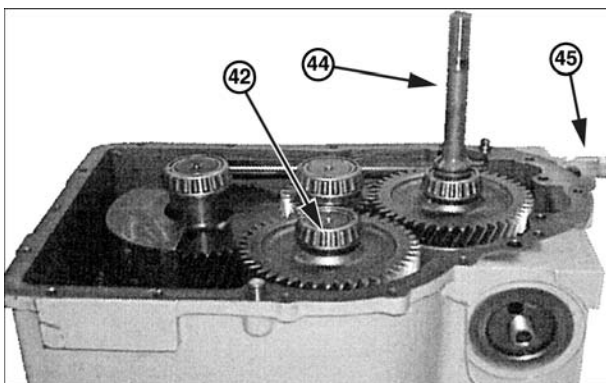

13. Use plastic hammer when pushing-out the tube (45) from transmission case.

14. From the T/M case, disassemble the backward drive shaft assembly (42).

15. Disassemble input shaft assemble (44).

18. Disassemble needle bearing and washer from front shaft of the high speed clutch face



19. Using a screw driver, disassemble snap ring (50) from cylinder.

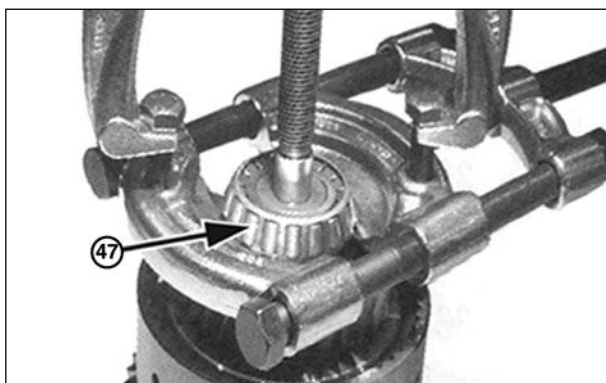

16. Disassemble the bearing cone (47), for high speed backward, in front of the clutch assemble, using gear puller.

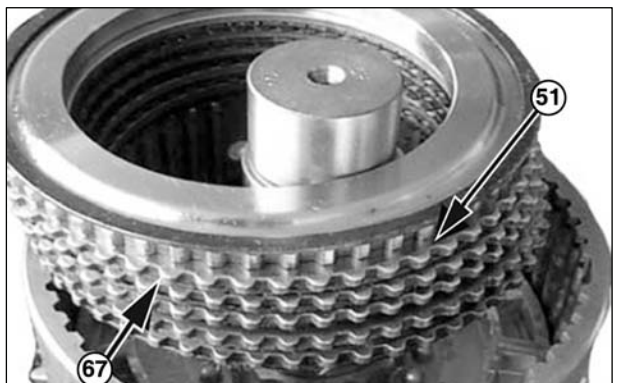

20. Disassemble pressure plate, 7 clutch discs (51), 8 clutch plates, and band plate (67) from the cylinder.

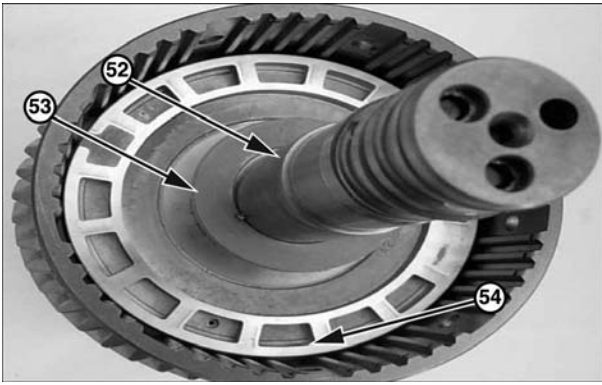

21. Push down the retainer (53) with pressure. Isolate snap ring (52) with a screw driver. Remove the tension force on the assembly slowly.
22. Disassemble retainer (53) and spring assembly from cylinder.
23. Disassemble piston (54) using compressed air. Disassemble O-ring from shaft.

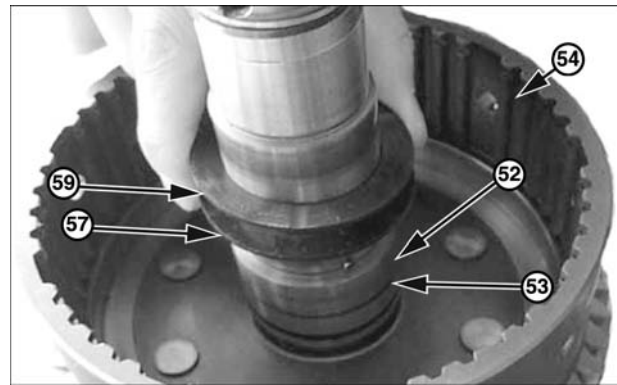

26. Disassemble 2 thrust washers (59) and pin (57).
27. Push retainer (53) down with press and remove snap ring (52). Slowly release the tension force of spring assembly, and remove retainer and spring.
28. Using compressed air, isolate piston (54), and remove O-ring from the shaft.

**⚠ CAUTION**

The disassembling procedure of the input shaft assembly is the same as that of the counter shaft assembly.

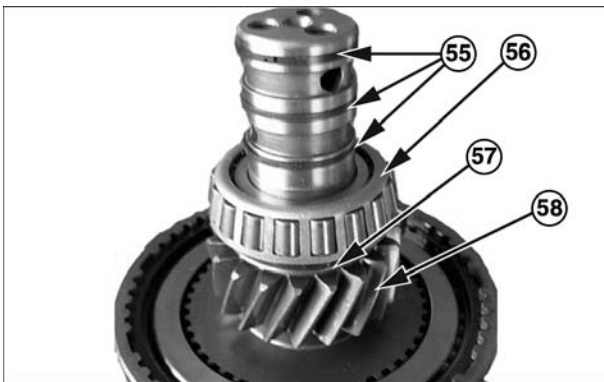

24. Isolate sealing from the low speed forward clutch assembly. Remove bearing (56), thrust washer (57), gear (58), needle bearing, and spacer.

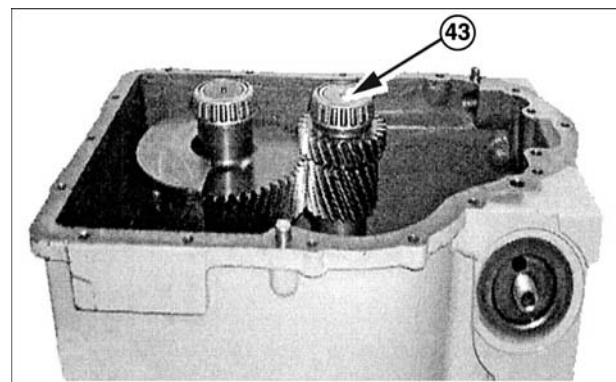

29. First, remove intermediate gear (43) from the transmission case.

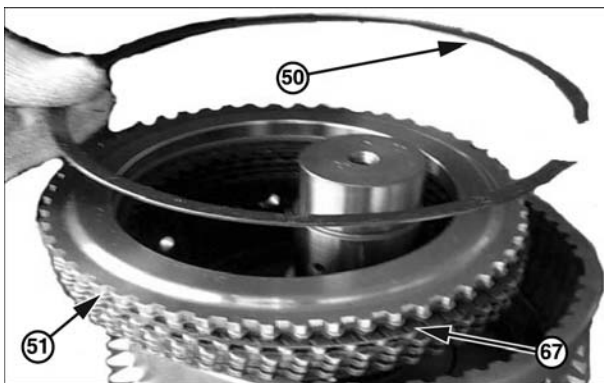

25. Remove snap ring (50), then remove compression plate, 7 clutch discs, 8 clutch plates, and band plate from the cylinder.



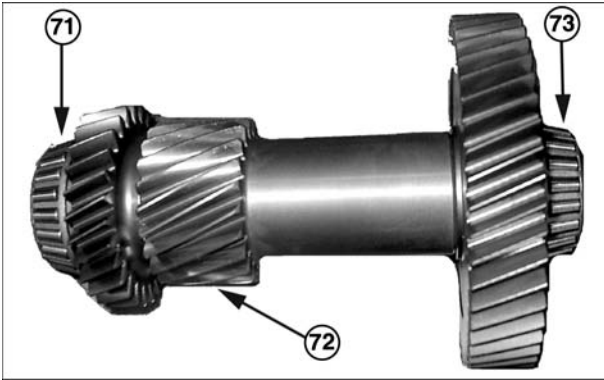

30. Remove bearing cone(71) and gear(72) from the intermediate gear using puller. Remove the bearing cone(73) on the opposite side in the same manner.

**⚠ CAUTION**

Be sure to mark the positions of each gear and bearing.

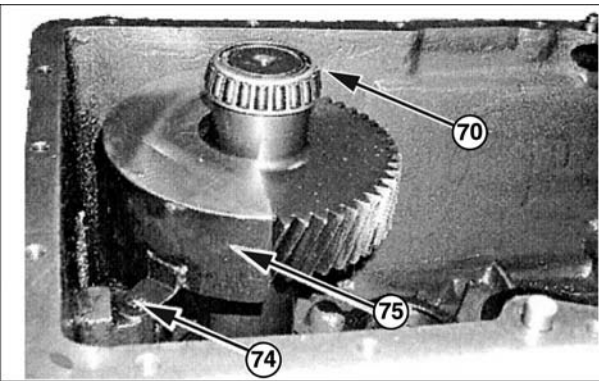

31. Remove the oil collector (75) and bolt (74) from output shaft assembly (70).

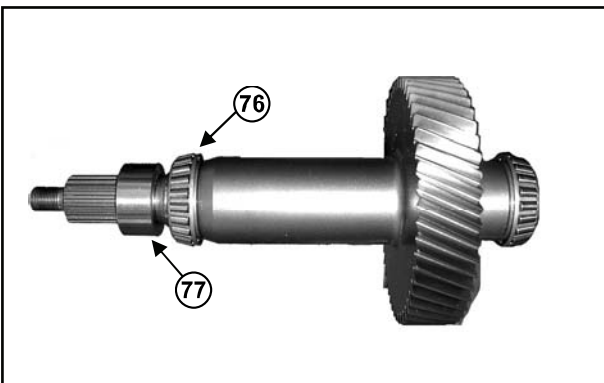

32. Remove spacer (77) and bearing cone (76) from the output shaft assembly.

**⚠ CAUTION**

When removing the spacer, take care not to tear the O-ring in the spacer.

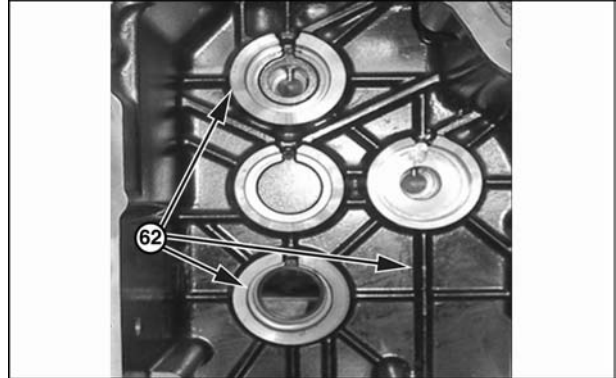

33. Disassemble the bearing cup (62) from the transmission case.

**⚠ CAUTION**

Mark the bearing for identification.



34. Remove lip-shaped oil seal (63) from the gear.



## Assembly of Transmission



1. Wash all the parts clean. Apply transmission oil on all the parts.
2. Assemble oil seal (63) on the transmission case using jig.

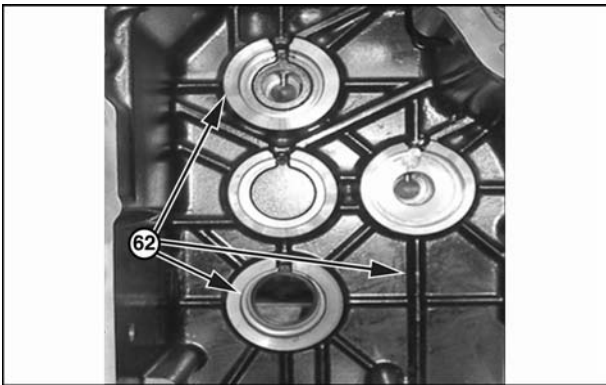

3. Assemble bearing cup (62) on relevant positions on the transmission case.

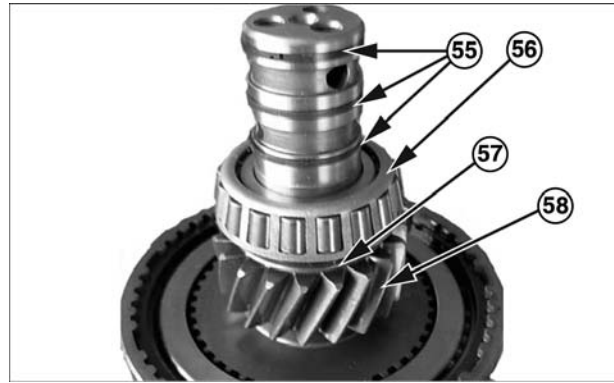
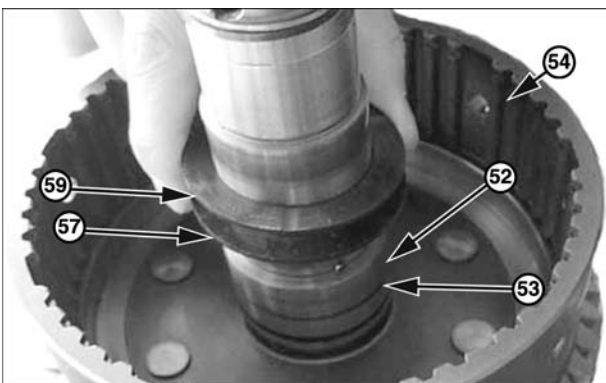

7. Install spring assembly and retainer (53) in the cylinder.
8. Place the shaft assembly on press. Press down the retainer, and assemble snap ring (52) using a screw driver.
9. Assemble pin (57) and 2 thrust washers (59) in the counter shaft of the low speed backward clutch.
10. Assemble needle bearing, spacer, needle bearing, gear (58), thrust washer (59) and bearing (56).



11. Apply clean transmission oil on the clutch discs and plates. Assemble the 7 discs and 8 plates in following order.
  - a. First, install the clutch plate having toothed surface on its outer diameter.
  - b. Then, assemble the clutch disc having toothed surface on the inner diameter.
  - c. Repeat above procedures (1) and (2) to complete the assembling of the clutch discs and plates.
  - d. Assemble the bending plate (67) with the bended part facing downwards.

12. Install the pressure plate at its place in the cylinder.
13. Assemble the pressure plate at its place in the cylinder, mount the snap ring (50) using a screw driver.
14. Assemble 3 seal rings on the shaft.

**⚠ CAUTION**

**Take care not to damage the seal ring in the counter shaft.**

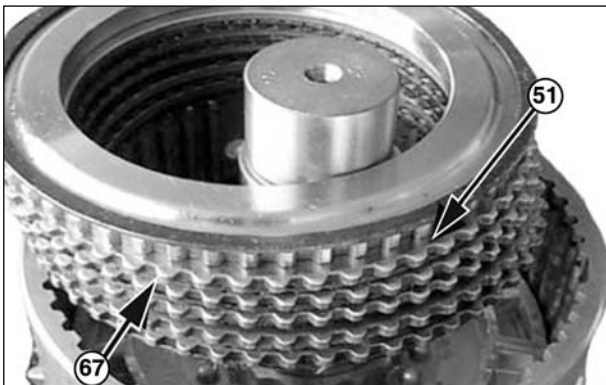

15. Refer clauses 5 through 8 for the opposite side of the shaft assembly.
16. Apply clean transmission oil on the clutch plates and discs. Assemble clutch disc plates in following procedures.
  - a. First, assemble the plate having teeth on outer diameter.
  - b. Next, assemble the clutch disc having teeth on inner diameter.
  - c. Repeat procedures (1) and (2) until all the discs and plates are assembled.
  - d. Assemble the bending plate (67) with its bended part downward.



17. Install the pressure plate in the cylinder.
18. Assemble the snap ring(50) which sets the pressure plate in the cylinder, using a screw driver.
19. Assemble thrust washer and needle bearing on the counter shaft of the high speed clutch.

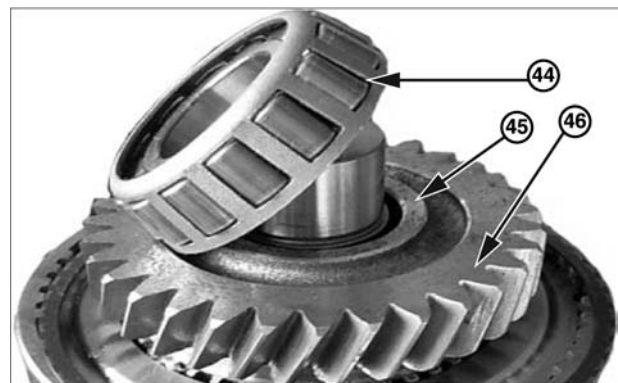

20. Assemble gear (46), thrust washer (45). Adjust bearing cone (44) using assembling jig.

**⚠ CAUTION**

**Do not exert excessive force when assembling gears.**

**Move the gear forward/backward in to the clutch assembly, until the gear spline aligns with the teeth of the disc.**

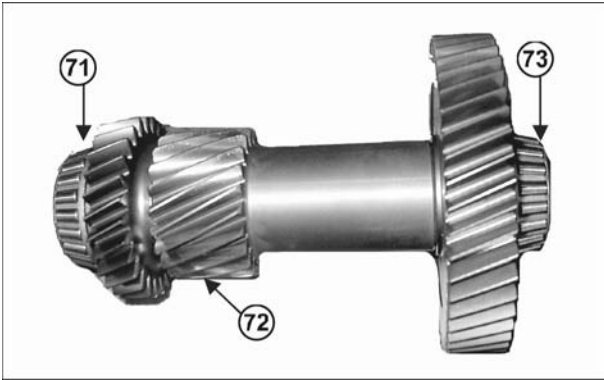

21. Mount gear (72) on the intermediate gear. Assemble bearing cone (71) with press. Assemble the bearing cone (73) on the opposite side in the same manner.

**⚠ CAUTION**

**Bearings and gear must be assembled at their due positions as marked during disassembling.**

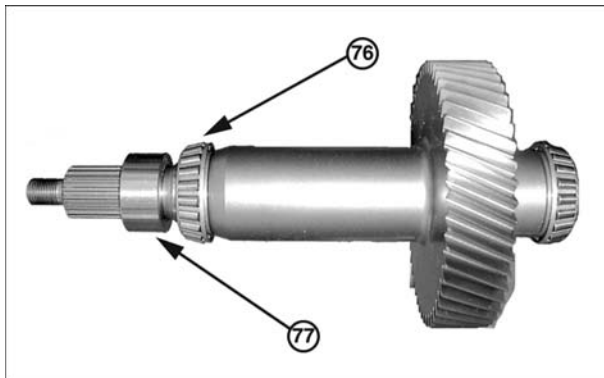

22. Assemble the spacer (77) and bearing cone (76) with the output shaft assembly.

**⚠ CAUTION**

**Take care not to tear O-ring in the spacer when assembling the spacer.**

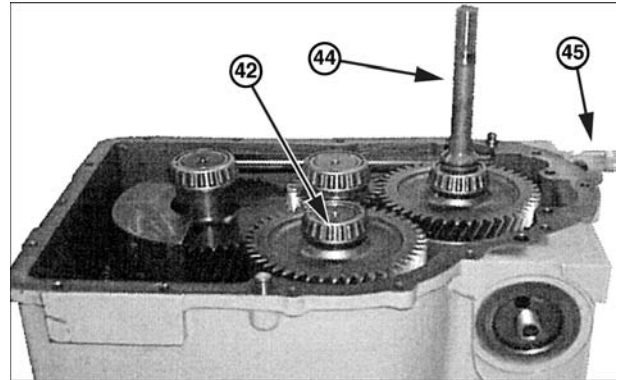

23. Install tube (45) on the transmission case with plastic hammer.
24. Assemble backward shaft and input power shaft in the following procedures.
25. Install the backward driving shaft (42) carefully at its due position of the transmission case.
26. Set the transmission case at correct position, install input power shaft assembly (44) carefully, and turn the gear until the tooth face aligns with the gear on other shaft assembly.

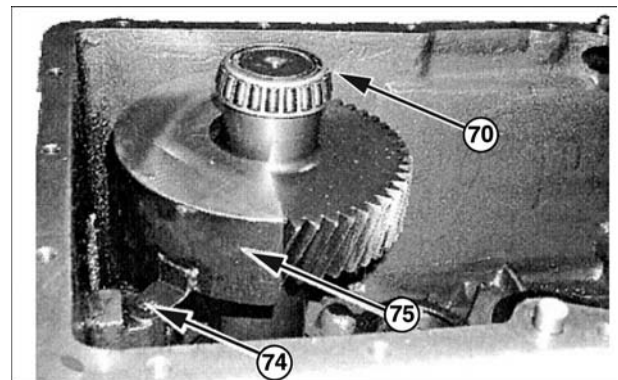

27. Assemble the oil collector and bolt at their due places, in order to install on the output shaft assembly (70).



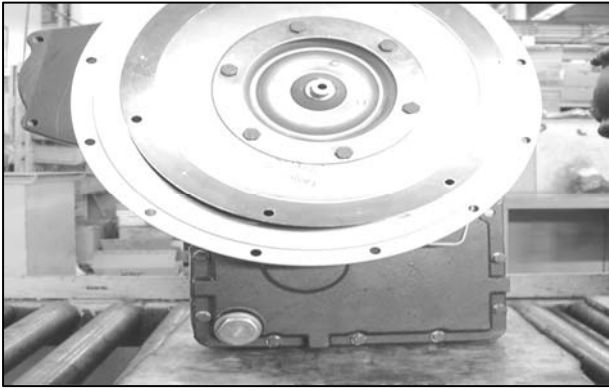

**28.** Assemble the oil screen (40), spring (39), plug (41) and O-ring in the transmission case.

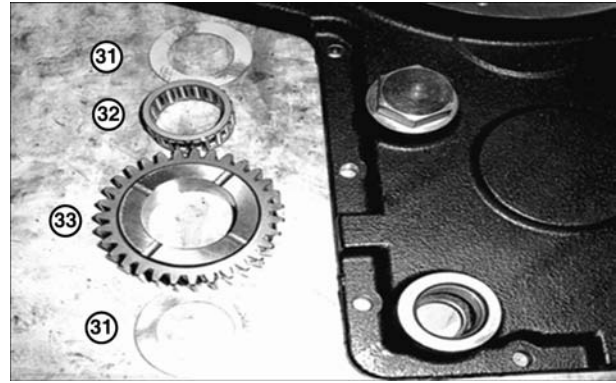

**31.** For the bearing plate (14), assemble thrust 2 washers (31), needle bearing (32), and Gear-P.T.O Idle (33).

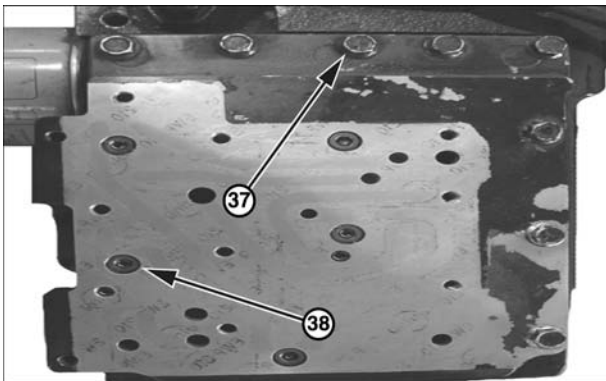

**29.** Apply Loctite #5172 on the gasket surface of the case, and fix it. Assemble the valve plate (69) with 11 bolts (37) and 5 socket bolts (38)

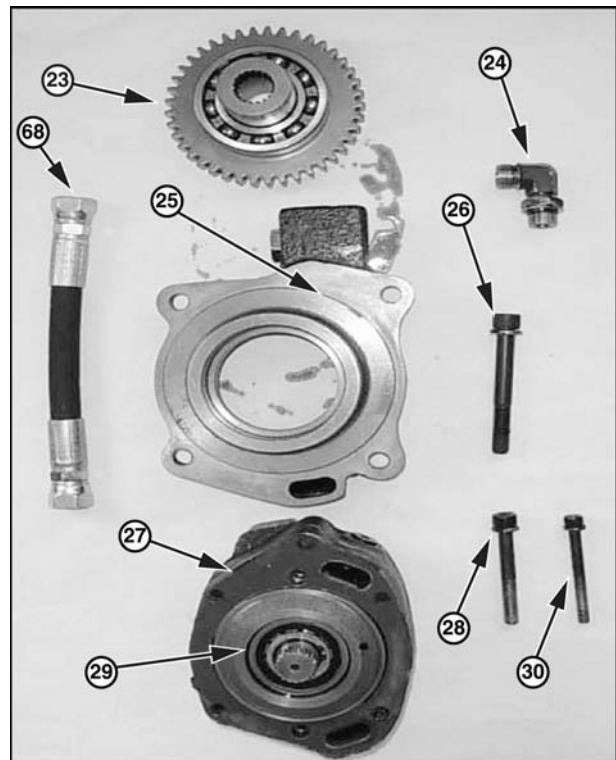

**32.** Assemble flange pump (25) with Gear-P.T.O Output (23) and 2 ball bearings using jigs. Assemble 4 bolts (26) with the bearing plate. Assemble flange pump (25) with charging pump (29) and gasket (27) with bolt (28) and 4 bolts (30). Assemble elbow (24)

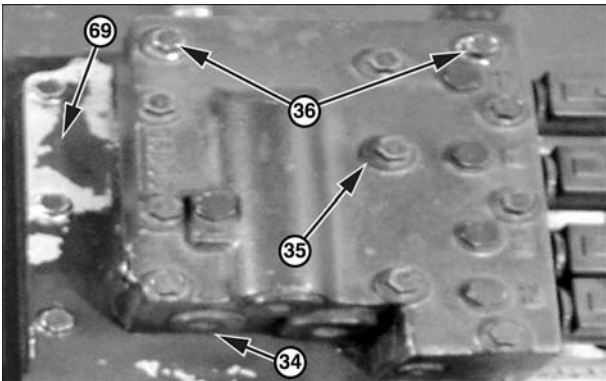

**30.** Place gasket (34), assemble 2 bolts (36) and 9 bolts (35) with the control valve.

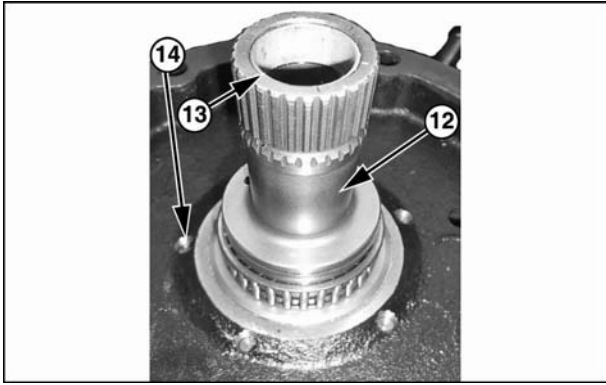

33. Assemble Stator Hub assembly (12), bush (13), piston ring, and 6 bolts (11), and assemble them with the bearing plate (14).

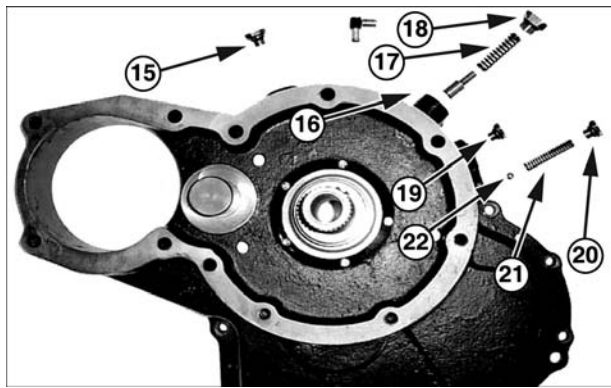

- 34. Assemble plug (15) and O-ring on the transmission cover.
- 35. Assemble valve (16), spring (17), plug (18) and O-ring in the transmission cover.
- 36. Assemble the plug (19).
- 37. In the transmission cover, assemble ball (22), spring(21), plug(20), and O-ring.
- 38. Mount bearing cup and shim on the transmission cover.

**⚠ CAUTION**

The bearing cup and shim have to be installed at correct positions on the transmission cover, in order to be aligned with shaft in the transmission case.

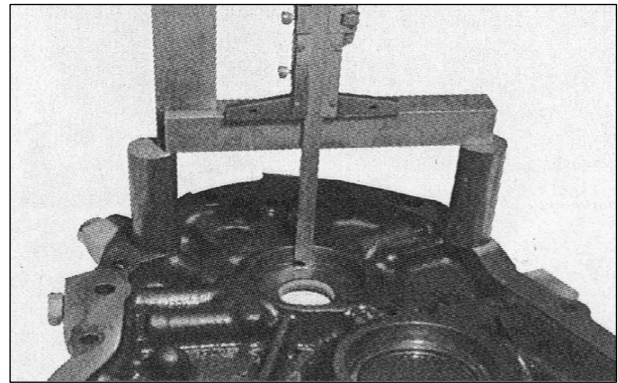
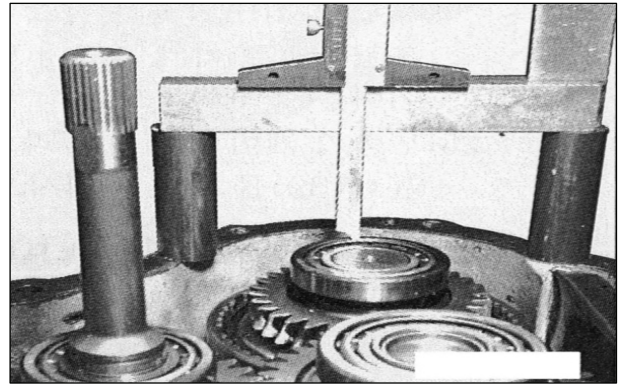

39. When using a new part, calculate the shim thickness as follows.

Measuring method of shim on shaft  
: Transmission cover depth – from transmission case to bearing step rise on shaft assembly

Name	Thickness of shims
Input Shaft	$Y - X - 0.01$
Counter Shaft	$Y - X - 0.05$
Output Shaft	$Y - X - 0.05$

- a. Assemble shaft assembly (including taper bearing cone and cup)
- b. Install shaft assembly on the transmission case.

**⚠ CAUTION**

Since depth gauge and block gauge are used, the height of the bearing cup must be higher than the transmission case surface.

- c. Select the shim of which thickness(0~0.05mm) fits with the shaft.
- d. Assemble cover on the transmission case.

- e. Set the transmission assembly vertically.
- f. Check the shim adjustment on the input and counter shafts. The input shaft of the transmission must be able to rotate freely.
- g. If the input or output shaft does not rotate freely, remove 0.025~0.05mm shim.

**⚠ CAUTION**

**Do not tilt the cover while assembling. Otherwise, the seal ring on the input power shaft may be damaged.**

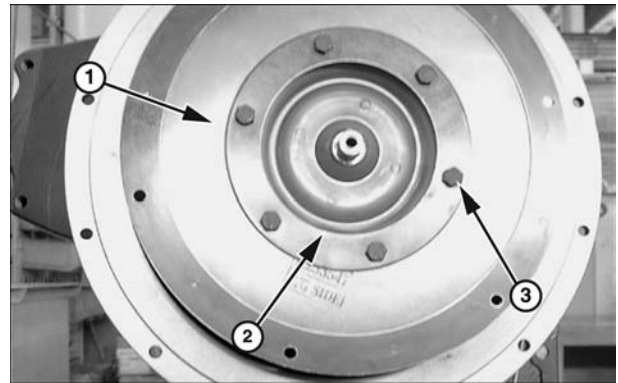

- 42. On the torque converter, assemble plate (2) and flexible plate (1) with 6 bolts (3). Then, assemble torque converter and housing.

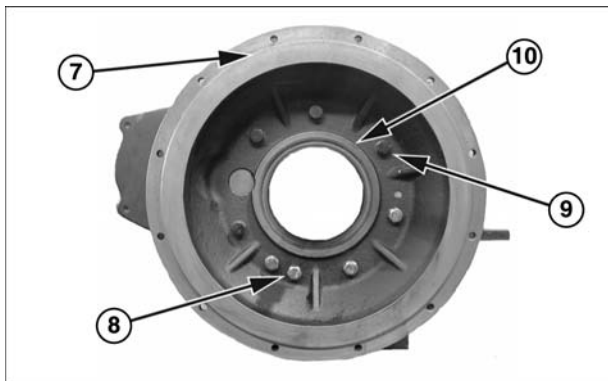

- 40. With the housing (7), assemble oil seal (10), 4 bolts (8), 4 bolts (9) and washer.

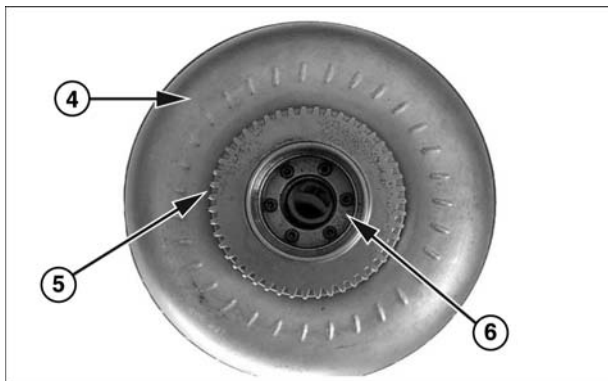

- 41. Mount Gear P.T.O Input (5) on the torque converter (4), assemble with 6 socket bolts (6).



## Drive Axle

### Disassembly



1. Drain oil after loosening drain plug with a torque wrench (1)



2. Loosen and remove two cylindrical bolts from brake drum. Loosen brake drum by beating slightly with a plastic hammer onto the outer diameter and remove it.



3. Loosen oil filler plug on wheel hub and drain oil.

**NOTE:** Same step to be made at the other side !



4. Loosen cylindrical bolts and remove planetary carrier. Detach and remove O-ring from axle hub.

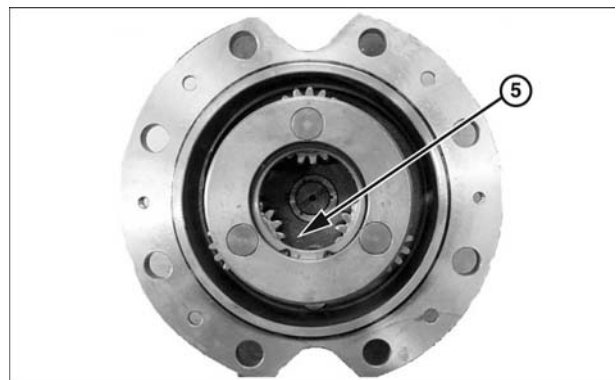

5. Remove snap ring (5) from the housing of planetary

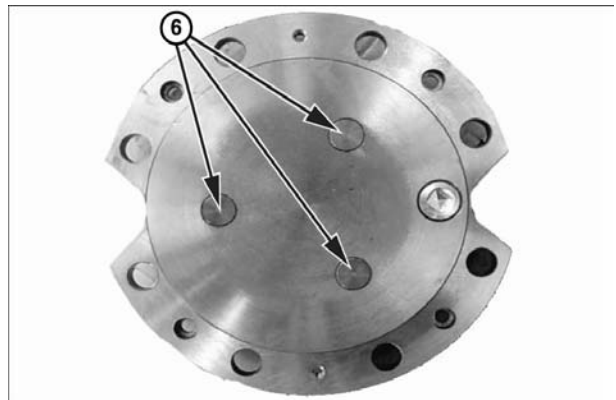

6. Remove 3 pins (6) with a plastic hammer.



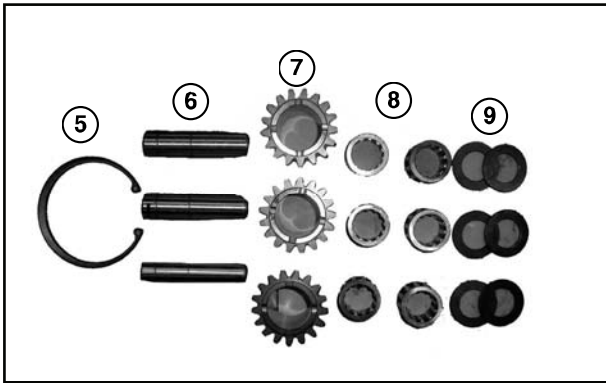

7. Remove needle bearing (8), planetary gear (7) and thrust washer (9).

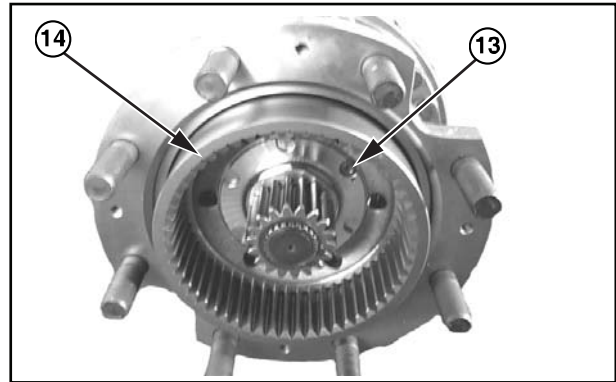

10. After removing bolt (13), remove ring gear (14) and torque plate assembly from the axle tube.

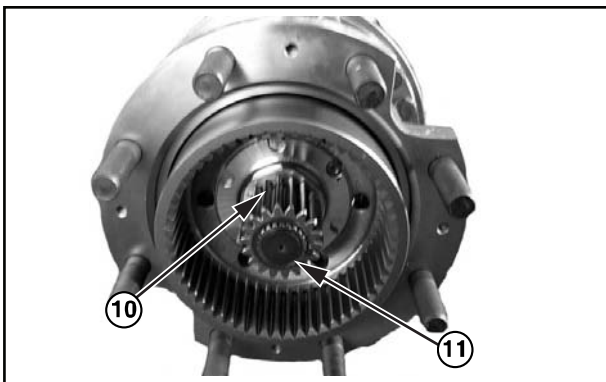

8. Remove sun gear (10) and drive shaft (11).



11. Remove snap ring from the ring gear (14) and disassemble internal gear carrier

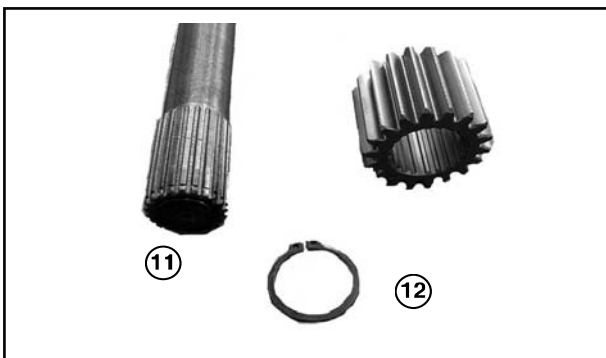

9. Remove snap ring (12) and then, remove sun gear (10) from the shaft (11).



12. Remove bearing cup from the wheel hub by using jig and hammer. Shaft seal will be damaged.

## Removal and Strip Down of Brake

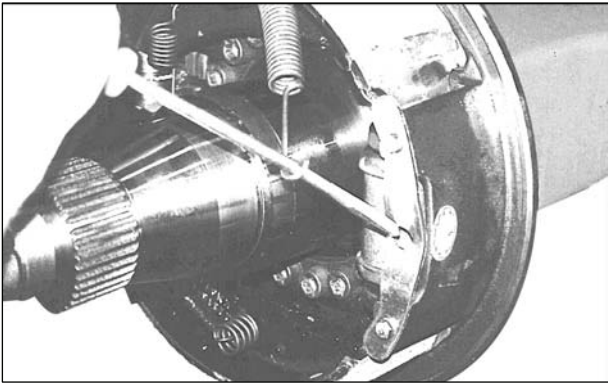

1. Remove 2 tension springs with the aid of pliers or a screwdriver

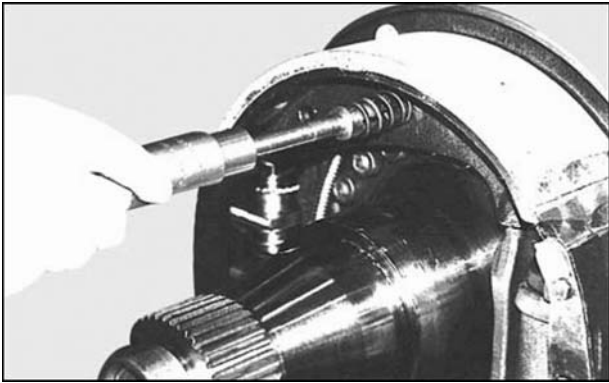

2. Squeeze, unhook and remove compression springs. Remove spring. Unhook and remove the two brake shoes. Then, unhook the brake cable at the pressure rid of the brake shoes and remove it.

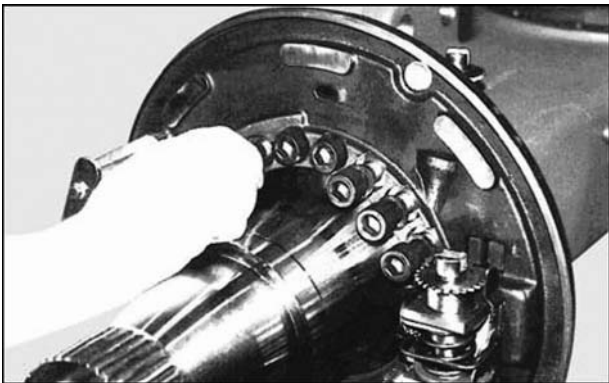

3. Loosen 16 cylindrical bolts. Detach and remove brake plate from axle flange.

**NOTE :** Make the same steps on the second side of the wheel hub if required!

## Removal and Strip Down of Axle Housing

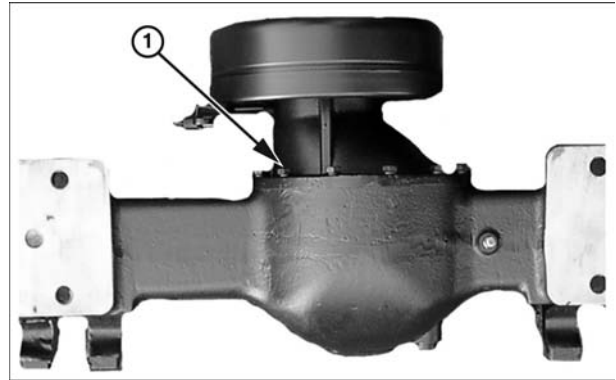

1. Loosen 12 bolts (1) and then, remove carrier from the housing by using a lifting machine.

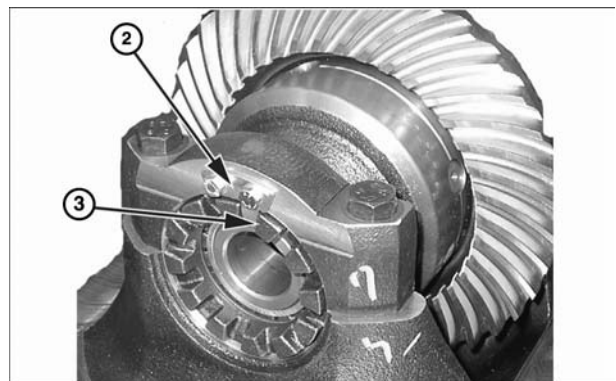

2. For the reassembly, check rolling resistance and record it. After loosening 2 bolt (2), remove backing plate (3).

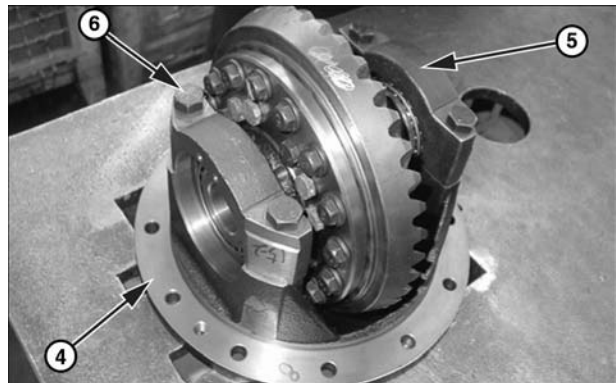

3. Before removing differential assembly from carrier (4), check the location of cap (5) and mark it for reassembly.
4. Remove 4 hexagon bolts (6) and cap (5).



5. Disassemble bearing (7) from the differential housing and remove 12 bolts (8).

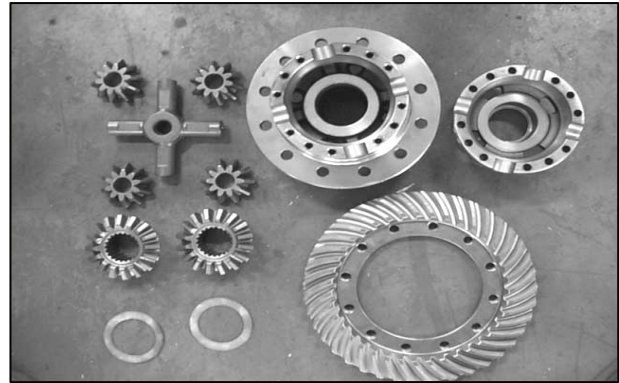

9. Remove thrust washer, side gear, pinion gear and spider and then, place them on the clean bench.



6. Remove differential assembly from the carrier.

7. After removing 12 mounting bolts (9) from the housing, disassemble ring gear.

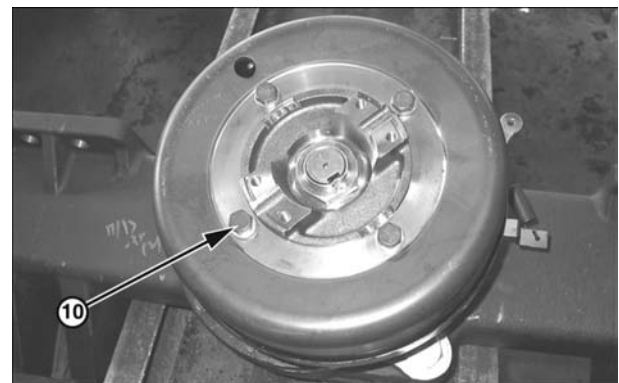

10. Loosen 4 bolts (10) and then, remove Drum from the Parking Brake.



8. Check the mark on the housing and separate the housing from the differential. If there is no mark, be sure to mark on the housing. When reassembling, it must be placed at the same position as before.

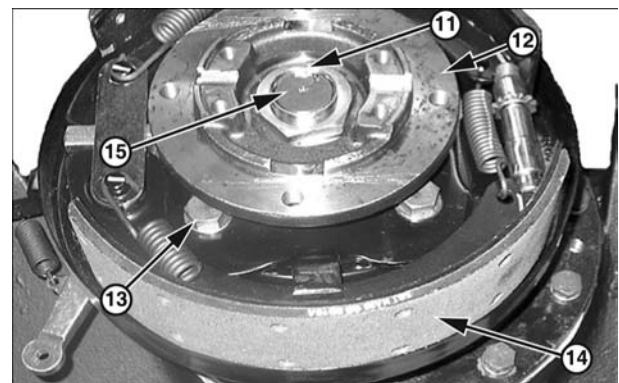

11. After removing lock nut (11), remove yoke (12).

12. Loosen 4 bolts (13) and then, remove Parking Brake (14) from the Carrier housing.

13. Remove carefully drive bevel pinion shaft (15) by using a plastic hammer.



**⚠ CAUTION**

**Be careful not to damage bevel pinion shaft.**

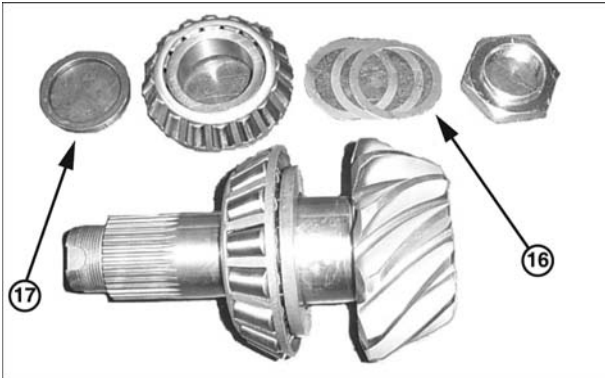

14. Remove shim (16) and spacer (17) from pinion shaft.  
Using a bearing puller, disassemble inner race of taper roller bearing from the pinion shaft.

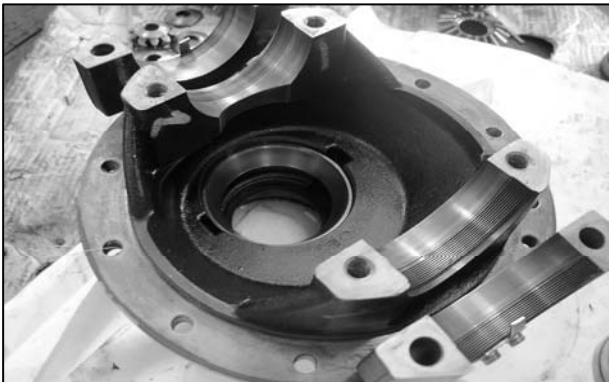

15. Remove outer race of taper roller bearing and shim from the housing by using a jig and hammer.

**⚠ CAUTION**

**Do not reuse damaged shims.**



16. Remove outer race of taper roller bearing from the opposite side.

### Reassembly of Drive Axle

Clean all of the parts with cleanser and then, remove remained loctite.

**⚠ WARNING**

**Be careful not to spill cleanser on your body. Avoid drinking cleanser or breathing its fumes. Wear protective clothing, glasses and gloves. If spilled on the skin, flush your skin with water immediately. If swallowed, get medical attention immediately.**

- Check wear, damage or crack for all the parts and replace if needed.
- If the teeth of gear are damaged, replace it as a set.
- Replace damaged tapered roller bearing.
- Do not reuse deformed shims or worn thrust washers.
- Rasp off the seal contacted surface.

## Adjustment of Bevel Pinion Shaft

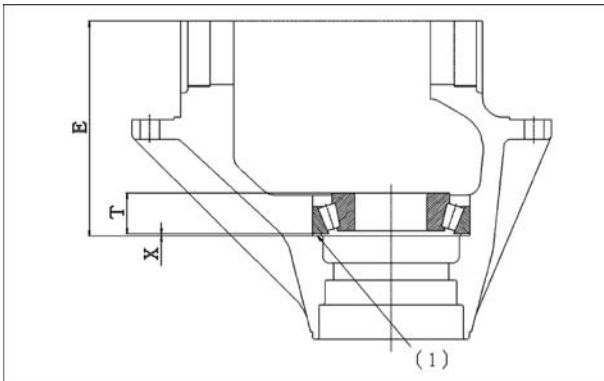

Adjusting shim of bevel pinion shaft.

1. Adjust shim thickness and bevel pinion shaft with following method.

- Measure "E" at the housing.
- By the equation " $X = E - B - T \pm C$ " define the shim thickness (1).

B : Mounting dimension of bevel pinion shaft,  
131.10mm

T : Height of bearing.

C : Dimension of carved seal on the pinion.  
If there's no carved seal  $C=0$ .

Ex : From the housing, "E" = 162.85mm,

B is factory dimension, "B" = 131.10mm,  
Front the bearing, "T" = 31.5mm,  
Carved seal on the pinion, "C" = 0.05mm,

Shim thickness:

"X" =  $162.85 - 131.10 - 31.5 - 0.05 = 0.20$ mm.

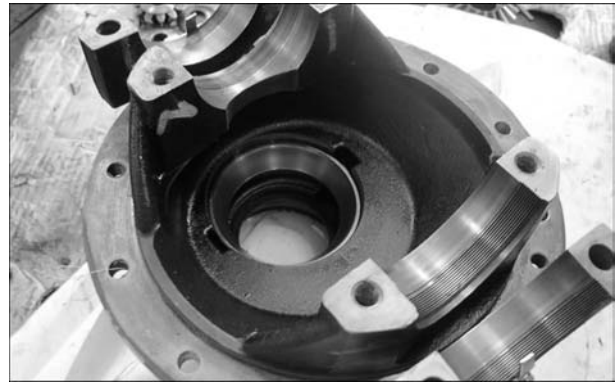

2. Using different kinds of shims, adjust shim thickness as measured by previous equation. Place shims at the bearing place. Using a jig, assemble drive bearing so that the outer race contact with the bearing place.

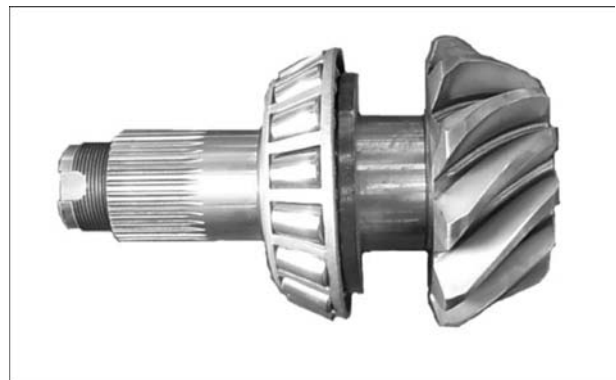

3. Heat inner race of bearing to max 100°C and then, assemble it to the pinion shaft. Also inner race should contact with bearing place.

### CAUTION

If teeth are damaged, replace it as a set. (bevel gear and shaft)

Do not reuse damaged shims and bearings.

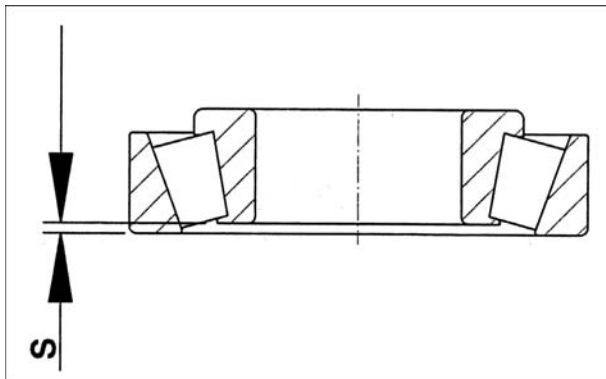
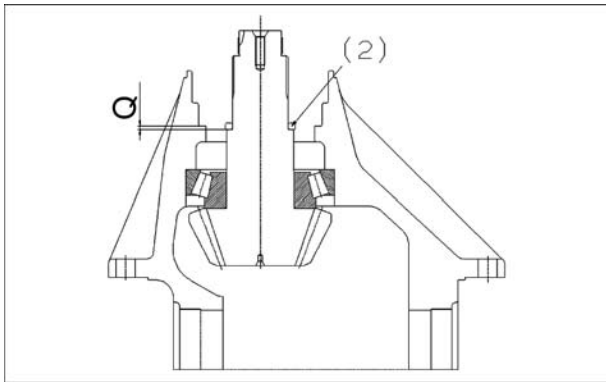

Measure shim thickness by following method.

Dimension "Q" : Distance from bearing outer race surface to spacer surface.

Dimension "S" : Distance from bearing outer race surface to inner race surface.

From the below equation, define required shim thickness "Z" .....  $Z = S + Q$

EX) From the bearing, "S" = 2.25mm  
 From the housing, "Q" = 3.15mm  
 Needed shim thickness "Z",  $Z = 2.25 + 3.15$   
 $= 5.40 \text{ mm}$

(unit : mm)

S	Q	Z
2.25	3.15	5.40
2.30	3.15	5.45
2.35	3.15	5.50
2.40	3.15	5.55
2.45	3.15	5.60

## Adjustment of Pinion Shaft



1. Assemble bearing cup. Assemble spacer to the pinion shaft and then, install measured shims onto the spacer.



2. Insert pinion shaft into the carrier. After assembling bearing cone, Parking Brake and Yoke, assemble lock nut.

Apply grease on the outer bearing. Apply loctite #271 or #277 on the thread of pinion and then, tighten lock nut.

• Tightening torque : ..... 440~500N•m  
 (327~370 lb•ft)

Measure rolling resistance of pinion shaft.

• Rolling resistance : ..... 2~4 N•m (1~3 lb•ft)

Coke lock nut into the slot. of pinion shaft



## Assembly of Differential

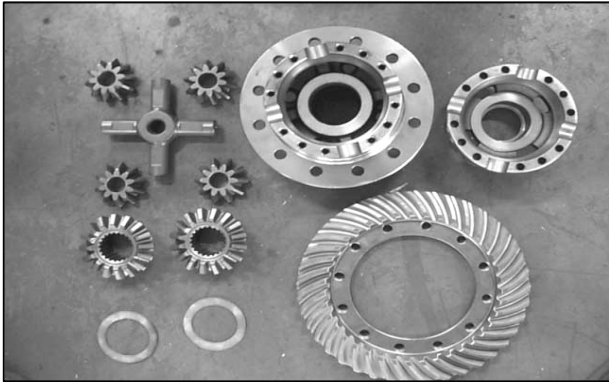

1. Assemble thrust washer, side gear and spider gear and then, install them to the differential housing. Apply grease on the bevel gear and thrust washer.



2. Assemble differential housing.

### CAUTION

Check marks on the housing.  
Match two marks at the same position.



3. Tighten 12 bolts (1) to the differential housing.  
Apply loctite #271 or #277 on the thread of bolt.

- Tightening torque : 49~74 N•m (36~54 lb•ft)



4. Assemble ring gear by tightening 12 bolts (2).  
Apply loctite #271 or #277 on the thread of bolt.

- Tightening torque : 122~142 N•m (91~105 lb•ft)



5. Install differential assembly onto the carrier. Place the bearing cup and screw into the housing.

At this moment, by adjust rotation backlash. By Install the dial gauge on the gear tooth and measure the backlash while rotating bevel gear.

- Rotation backlash : 0.18~0.23 mm

6. Assemble bearing cap.

**CAUTION**

**Fix bearing cap with hexagon bolt.**

- **Tightening torque : 147~167N•m(109~123 lb•ft)**

Measure rolling resistance of tapered roller bearing. The following table shows the relation between preload (P) of bevel pinion shaft and rolling resistance (Z). (calculated at ADJUSTMENT OF PINION SHAFT )

(unit : Kgf•cm)

P	Z
20	44~47
25	49~52
30	55~58
35	59~62

7. Confirm that the screw contacts to bearing closely.
8. After completing assembly of bearing, measure rotation backlash once more and readjust with a screw if needed.
9. Apply loctite #271 to the thread of bearing cap bolt and then, assemble at the tightening torque of ..... 147~167 N•m (109~123 lb•ft)
10. Assemble plate with hexagon bolts. Apply loctite #271 or #277 to the tapped side of bolt and then ,assemble at the tightening torque of ..... 9~12 N•m (6~9 lb•ft)

**CAUTION**

**Assemble oposite side with the same methods.**

11. Apply marking liquid to 3~4 teeth of crown gear and then bring bevel pinion gear contact with the crown gear several times. Check out the contacted shape.

## Assembling Carrier

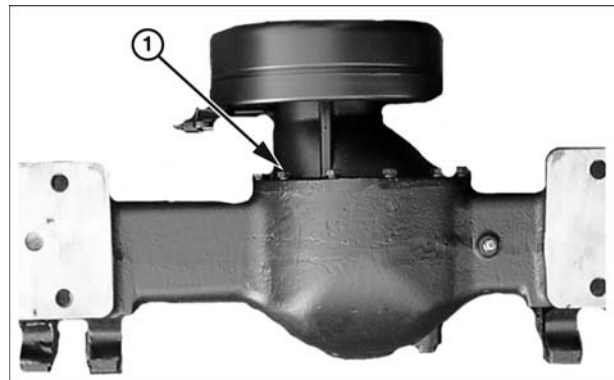

1. Assemble carrier assembly into the axle housing.
2. Fix the carrier assembly with hexagon bolt (1). Apply loctite #271 or #277 to thread of bolt and then, assemble at the tightening torque of 108~127N•m (80~94 lb•ft).

## Assembling Shoe Brake

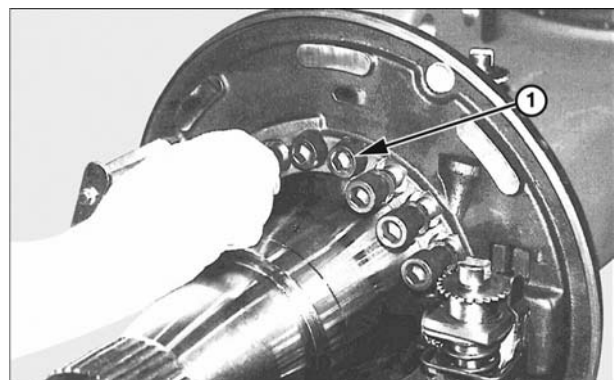

1. Apply Loctite #271 onto threads of the bolts (1). Fasten brake plate and axle flange with cylindrical bolts (1) and lock washers to the axle housing.
- Tightening torque.....200N•m (147 lb•ft)

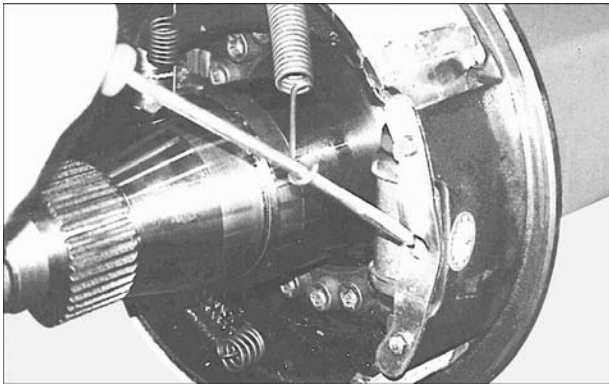

2. Lead brake cable through the provided borehole of the brake carrier and hook it on the pressure rod of the brake shoes. Assemble brake shoes, compression springs and tension springs as described in the Disassembly Section in reverse order.

### Assembling Wheel Hub



1. Insert bearing into wheel hub. Confirm that the bearing and wheel hub contact completely.

#### CAUTION

Apply grease or oil to shaft seal and then, assemble it from the direction of outside of wheel hub.



2. Install wheel hub assembly to the tube flange of axle completely. Install bearing cone.

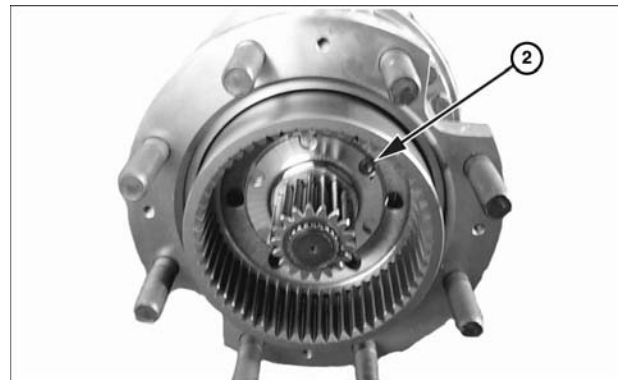

3. Insert shim, fix the torque plate and ring gear with snap ring and assemble them to the axle tube.

Apply loctite #271 or #277 to thread of bolt (2) and then, assemble at the tightening torque of 147~167 N•m (109~123 lb•ft). Apply grease on the bushing

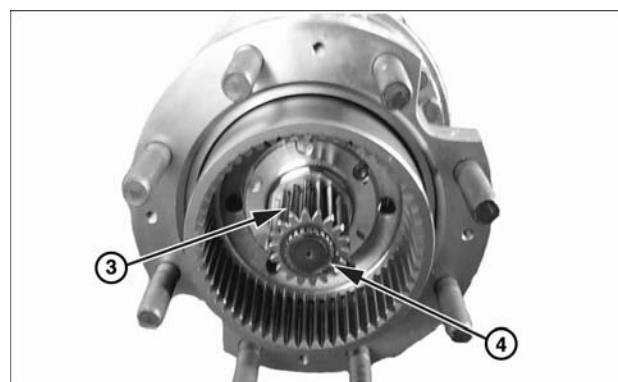

4. Assemble sun gear (3) to axle shaft and fix it with snap ring (4). Assemble axle shaft to the axle assembly. Apply grease on the shaft where bushing contacts. Apply grease to teeth parts of planetary gear.

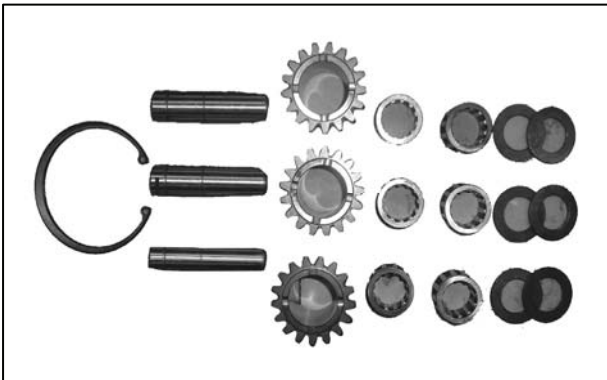

5. Assemble internal components of planetary carrier in the reverse order of disassembly.

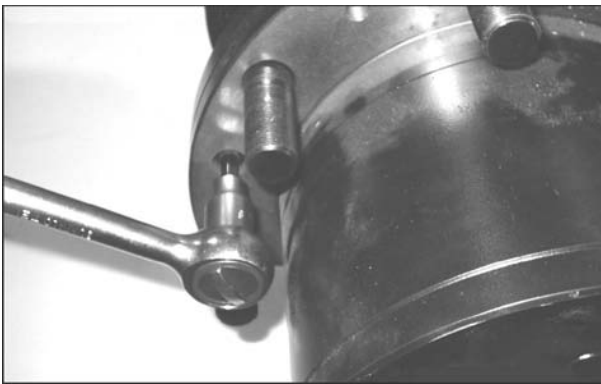

6. Install planetary carrier assembly to wheel hub and tighten bolt.

- Tightening torque : 25~39 N•m (18~29 lb•ft)

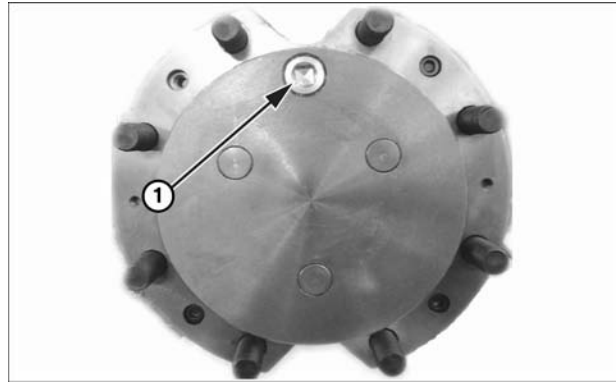

7. Assemble wheel hub and tighten plug (1).

- Tightening torque : 35~59 N•m (25~44 lb•ft)



8. Install brake drum and tighten the bolts.

### Assembling Wheel Hub Ass'y (OCDB)



1. Insert bearing into wheel hub. Confirm that the bearing and wheel hub contact completely.

### ⚠ CAUTION

Apply grease or oil to shaft seal and then, assemble it from the direction of outre side of wheel hub.





2. Install wheel hub assembly to the tube flange of axle completely. Install bearing cone.

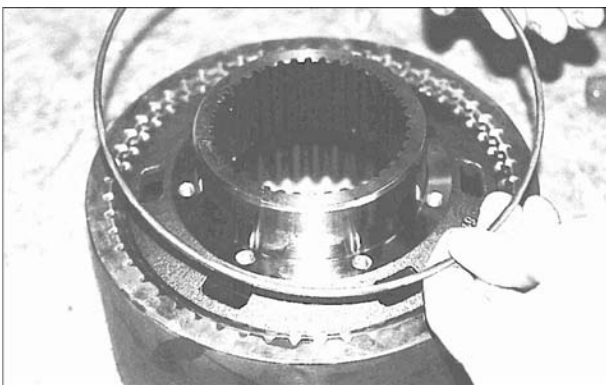

3. Insert flange into ring gear and secure it with circlip.



4. Place heated tapered roller bearing inner race onto flange until contact. Install subsequently until contact after cooling down.



5. Insert shim, fix the torque plate and ring gear with snap ring and assemble them to the axle tube.

Apply loctite #271 or #277 to thread of bolt (2) and then, assemble at the tightening torque of ..... 147~167 N•m (109~123 lb•ft)  
Apply grease on the bushing.

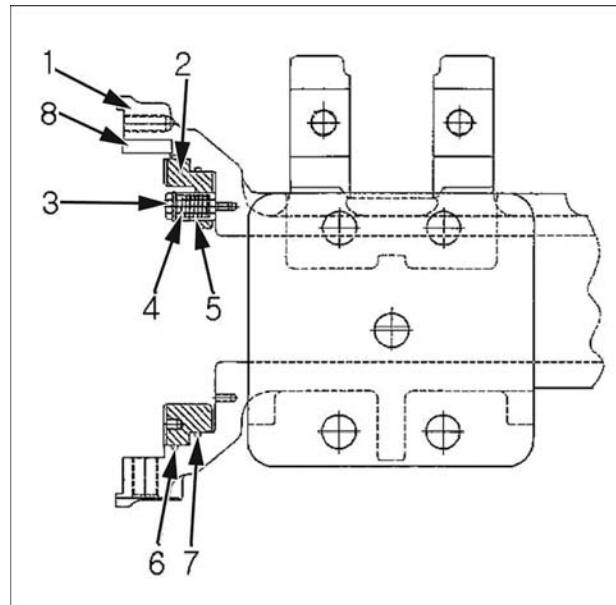

6. Assemble square ring (6),(7) with oil (MOBIL #424) to the Axle housing (1). Assemble bushing (5) to piston (2) and then, assemble piston (2) to axle housing after applying oil sufficiently and applying loctite # 271 to spring (4) and 4 bolts (3).

• Tightening torque : 14~16N•m (10~12 lb•ft)

Assemble 3 brake pins (8) to axle housing.

**⚠ CAUTION**

**Check the status of square ring and replace if damage.**

## Assembling OCD Brake

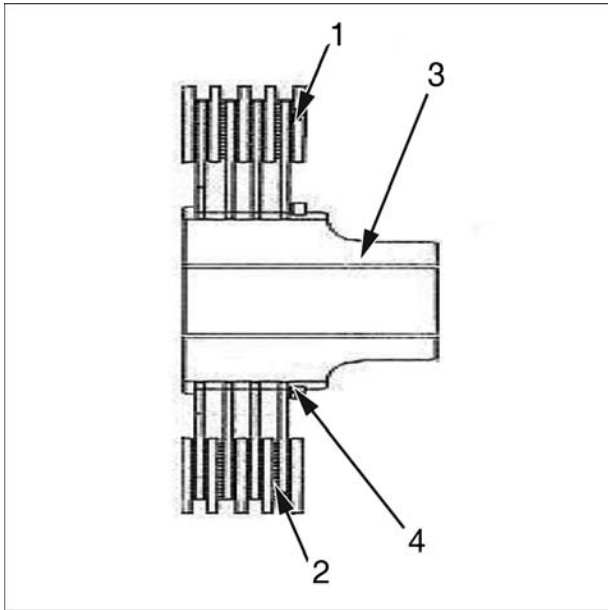

### 7. Assemble Brake plate and disc.

- a. Assemble 5 plates(1) and 4 disks (2) with spline collar (3) and then, lock with snap ring (4).

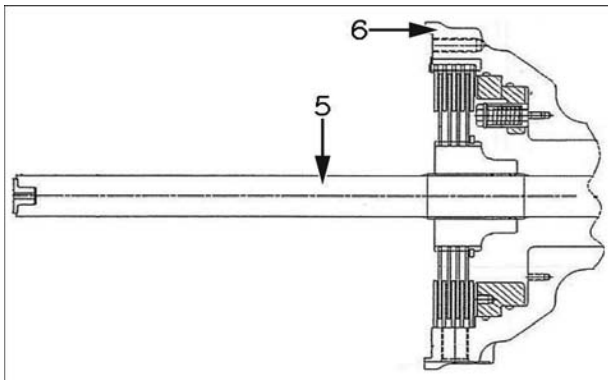

- b. Assemble spline collar joined with plates and disks, and drive shaft (5) to axle housing (6).

- Before assembling, clean all of the parts completely and remove burrs.

- c. After assembling plate and disk, confirm that the tolerance with axle housing surface is 1.3~2.7mm

- d. Apply loctite #5127 on spindle side of axle housing (6).

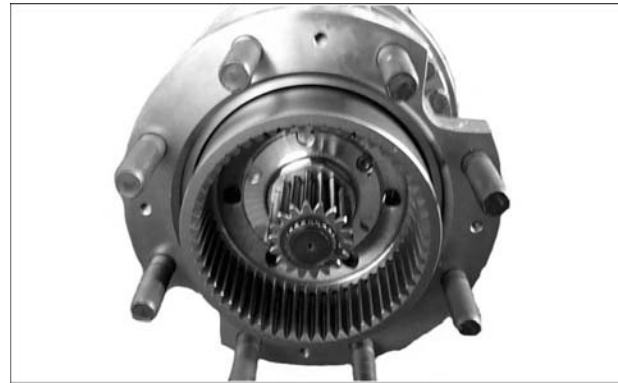

8. After assembling sun gear (9) to axle shaft, fix it with snap ring (10). Assemble axle shaft to the axle assembly.  
Apply grease on the shaft where bushing contacts.  
Apply grease to teeth parts of planetary gear.

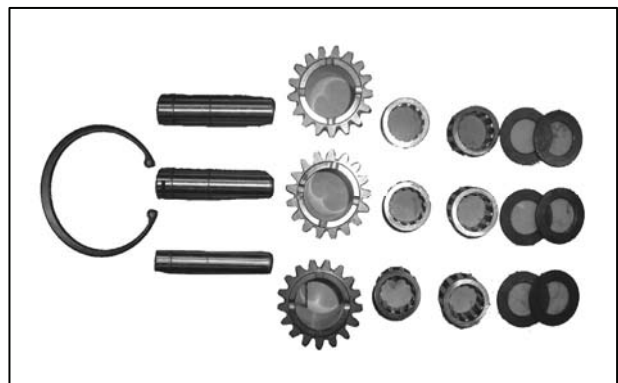

9. Assemble internal components of planetary carrier in the reverse order of disassembly.



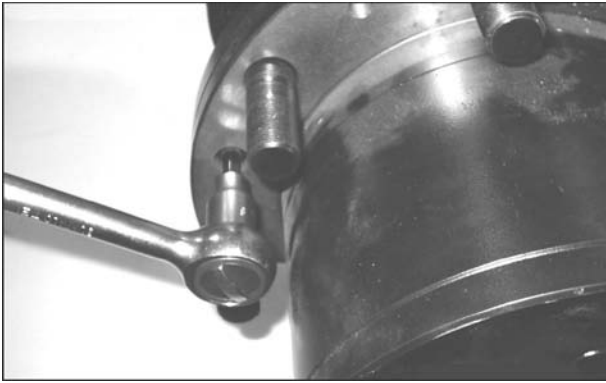

**10.** Install planetary carrier assembly to wheel hub and tighten bolt

\* Tightening torque : 25~39 N•m (18~29 lb•ft)

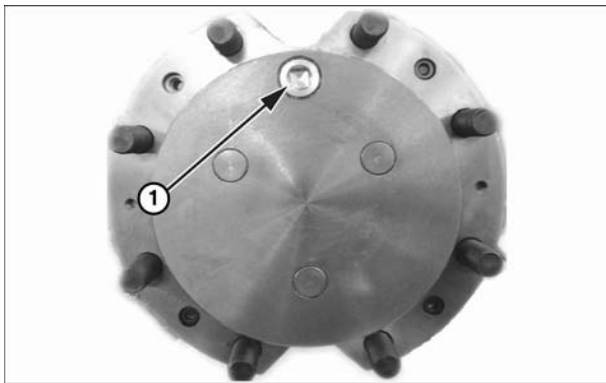

**11.** Assemble wheel hub and tighten plug (1).

• Tightening torque : 35~59 N•m (25~44 lb•ft)