

Operation & Maintenance Manual

UEAM005000

PC600-8 PC600LC-8

HYDRAULIC EXCAVATOR

SERIAL NUMBER

PC600-8 - K50001 and up

PC600LC-8 - K50001 and up



WARNING

Unsafe use of this machine may cause serious injury or death. Operators and maintenance personnel must read this manual before operating or maintaining this machine. This manual should be kept inside the cab for reference and periodically reviewed by all personnel who will come into contact with the machine.

KOMATSU

FOREWORD

FOREWORD

This manual provides rules and guidelines which will help you use this machine safely and effectively. The precautions in this manual must be followed at all times when performing operation and maintenance. Most accidents are caused by the failure to follow fundamental safety rules for the operation and maintenance of machines. Accidents can be prevented by knowing beforehand conditions that may cause a hazard when performing operation and maintenance.

WARNING

Before beginning operation or maintenance, operators and maintenance personnel must always observe the following points.

- Read this manual thoroughly and understand its contents fully.
- Read the safety messages and safety labels given in this manual carefully so that they should be understood fully.
- Keep this manual at the storage location for the Operation and Maintenance Manual given below so that all personnel involved in working on the machine can consult it periodically.
- In case this manual should be lost or damaged, immediately contact Komatsu or your Komatsu distributor to obtain a new copy.
- When you sell the machine, make sure that this manual should be provided to the new owner together with the machine.

In this manual, measurements are expressed in international standard units (SI). For the reference purpose, weight units used in the past are also displayed in ().

Storage location for the Operation and Maintenance Manual:
magazine box on the left side of the operator's seat.

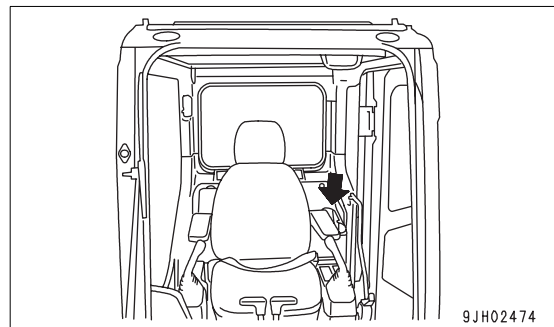

SAFETY INFORMATION

To enable you to use this machine safely, safety precautions and labels are given in this manual and affixed to the machine to give explanations of situations involving potential hazards and of the methods of avoiding such situations.

Signal words

The following signal words are used to inform you that there is a potential hazardous situation that may lead to personal injury or damage.

In this manual and on machine labels, the following signal words are used to express the potential level of hazard.



Indicates an imminently hazardous situation which, if not avoided, will result in death or serious injury.



Indicates a potentially hazardous situation which, if not avoided, could result in death or serious injury.



Indicates a potentially hazardous situation which, if not avoided, may result in minor or moderate injury. This word is used also to alert against unsafe practices that may cause property damage.

Example of safety message using signal word



When standing up from the operator's seat, always place the lock lever in the LOCK position. If you accidentally touch the control levers when they are not locked, this may cause a serious injury or death.

Other signal words

In addition to the above, the following signal words are used to indicate precautions that should be followed to protect the machine or to give information that is useful to know.

NOTICE

This word is used for precautions that must be taken to avoid actions which could shorten the life of the machine.

REMARKS

This word is used for information that is useful to know.

- Safety labels

Safety labels are affixed to the machine to inform the operator or maintenance worker on the spot when carrying out operation or maintenance of the machine that may involve hazard.

This machine uses “Safety labels using words” and “Safety labels using pictograms” to indicate safety procedures.

Example of safety label using words

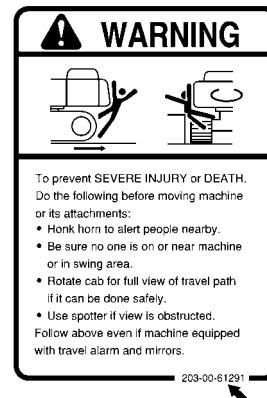

Part No.

Safety labels using pictogram

Safety pictograms use a picture to express a level of hazardous condition equivalent to the signal word. These safety pictograms use pictures in order to let the operator or maintenance worker understand the level and type of hazardous condition at all times.

Safety pictograms show the type of hazardous condition at the top or left side, and the method of avoiding the hazardous condition at the bottom or right side. In addition, the type of hazardous condition is displayed inside a triangle and the method of avoiding the hazardous condition is shown inside a circle.



Part No.

Komatsu cannot predict every circumstance that might involve a potential hazard in operation and maintenance. Therefore, the safety messages in this manual and on the machine may not include all possible safety precautions.

If any procedures or actions not specifically recommended or allowed in this manual are used, it is your responsibility to take the necessary steps to ensure safety.

In no event should you engage in prohibited uses or actions described in this manual.

The explanations, values, and illustrations in this manual were prepared based on the latest information available at that time. Continuing improvements in the design of this machine can lead to changes in detail which may not be reflected in this manual. Consult Komatsu or your Komatsu distributor for the latest available information of your machine or for questions regarding information in this manual.

The numbers in circles in the illustrations correspond to the numbers in () in the text. (For example: ① -> (1))

NOISE

- Sound pressure level at the operator's station, measured according to ISO6396 (Dynamic test method, simulated working cycle).

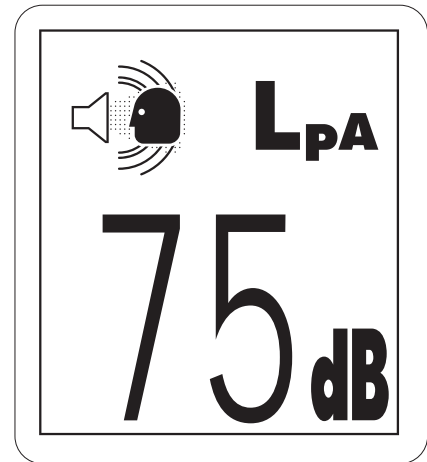

- Sound power level emitted. This is the guaranteed value as specified in the European directive 2000/14/EC



Vibration levels

When used for its intended purpose, levels of vibration for the earth-moving machine transmitted from the operator's seat are lower than or equal to the tested vibrations for the relative machinery class in compliance with ISO 7096.

The actual acceleration value for the hands and arms is less than or equal to 2.5 m/s². The actual acceleration value for the body is less than or equal to 0.5 m/s².

These values were determined using a representative machine and measured during the typical operating condition indicated below according to the measurement procedures that are defined in the standards ISO 2631/1 and ISO 5349.

Operating condition:

Excavating (Digging-loading-rotating-unloading-rotating)

Guide to Reduce Vibration Levels on Machine

The following guides can help an operator of this machine to reduce the whole body vibration levels:

1. Use the correct equipment and attachments.
2. Maintain the machine according to this manual
 - Tension of crawler (for crawler machines)
 - Brake and steering systems
 - Controls, hydraulic system and linkages
3. Keep the terrain where the machine is working and traveling in good condition
 - Remove any large rocks or obstacles
 - Fill any ditches and holes
 - Site manager should provide machine operators with machine and schedule time to maintain terrain conditions
4. Use a seat that meets ISO 7096 and keep the seat maintained and adjusted
 - Adjust the seat and suspension for the weight and size of the operator
 - Wear seat belt
 - Inspect and maintain the seat suspension and adjustment mechanisms
5. Steer, brake, accelerate, and move the attachment levers and pedals slowly so that the machine moves smoothly
6. Adjust the machine speed and travel path to minimize the vibration level
 - When pushing with bucket or blade, avoid sudden loading; load gradually
 - Drive around obstacles and rough terrain conditions
 - Slow down when it is necessary to go over rough terrain
 - Make the curve radius of traveling path as large as possible
 - Travel at low speed when traveling around sharp curves

7. Minimize vibrations for long work cycle or long distance traveling
 - Reduce speed to prevent bounce
 - Transport machines long distances between worksites
8. The following guidelines can be effective to minimize risks of low back pain
 - Operate the machine only when you are in good health.
 - Provide breaks to reduce long periods of sitting in the same posture
 - Do not jump down from the cab or machine
 - Do not repeatedly handle and lift loads

INTRODUCTION

This Komatsu machine is designed to be used mainly for the following work:

- Digging work
- Leveling work
- Ditching work
- Loading work
- Demolition work

See the section "RECOMMENDED APPLICATIONS (3-119)" for further details.

DIRECTIONS OF MACHINE

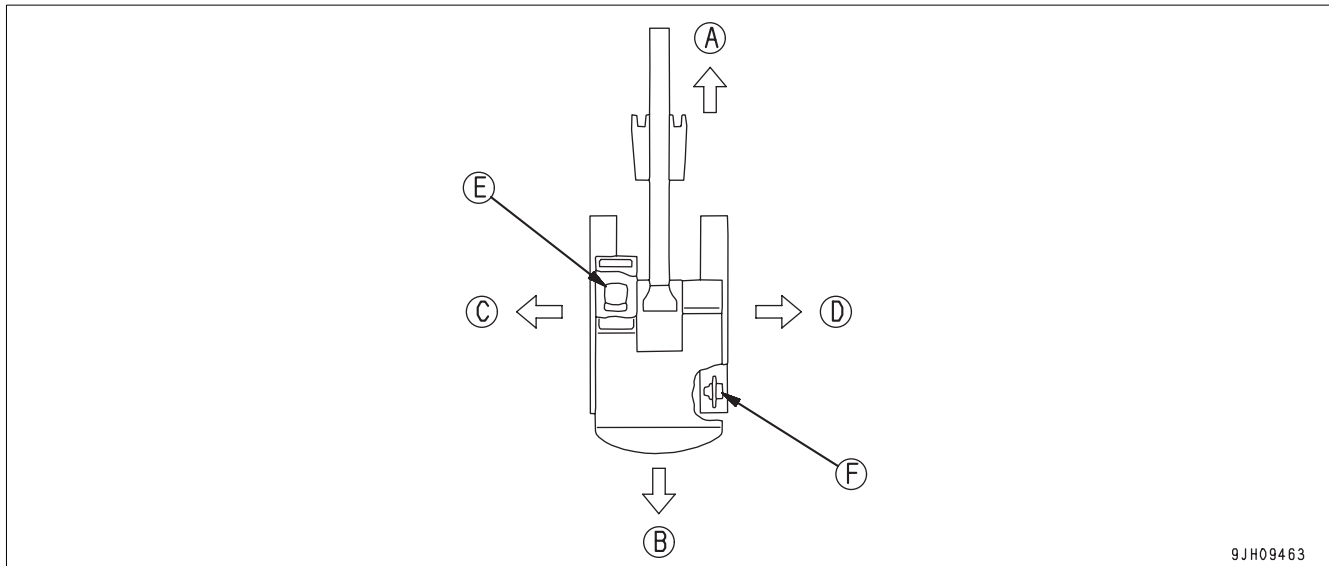

- | | |
|-----------|---------------------|
| (A) Front | (E) Operator's seat |
| (B) Rear | (F) Sprocket |
| (C) Left | |
| (D) Right | |

In this manual, the terms front, rear, left, and right refer to the travel direction as seen from the operator's seat when the operator's seat is facing the front and the sprocket is at the rear of the machine.

VISIBILITY FROM OPERATOR'S SEAT

The visibility standards (ISO 5006) for this machine require a view shown in the diagram below.

PROXIMITY VISIBILITY

The visibility of this machine in the area 1 m from the outside surface of the machine at a height of 1.5 m is shown in the diagram below. The hatched area (A) shows the area where the view is blocked by part of the machine when mirrors or other aids to visibility are installed as standard. Please be fully aware that there are places that cannot be seen when operating the machine.

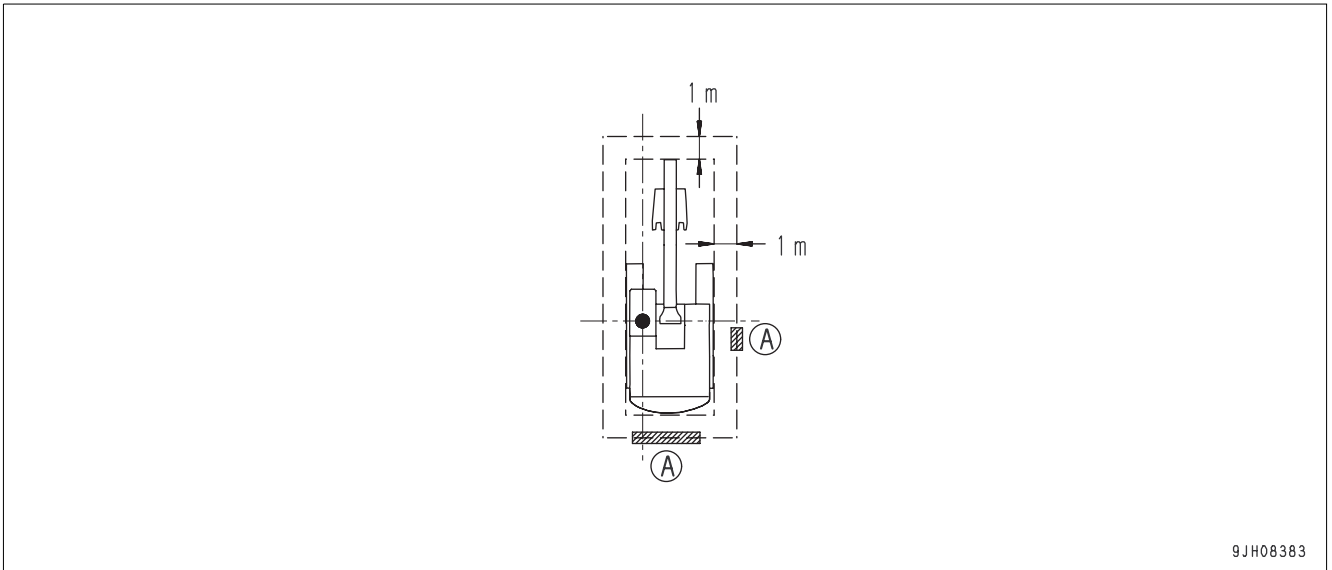

9JH08383

12M CIRCUMFERENCE VISIBILITY

The visibility at a radius of 12 m from the machine is as shown in the diagram below. The hatched areas (B) show the areas where the view is blocked when mirrors or other aids to visibility are installed as standard. Please be fully aware that there are places that cannot be seen when operating the machine.

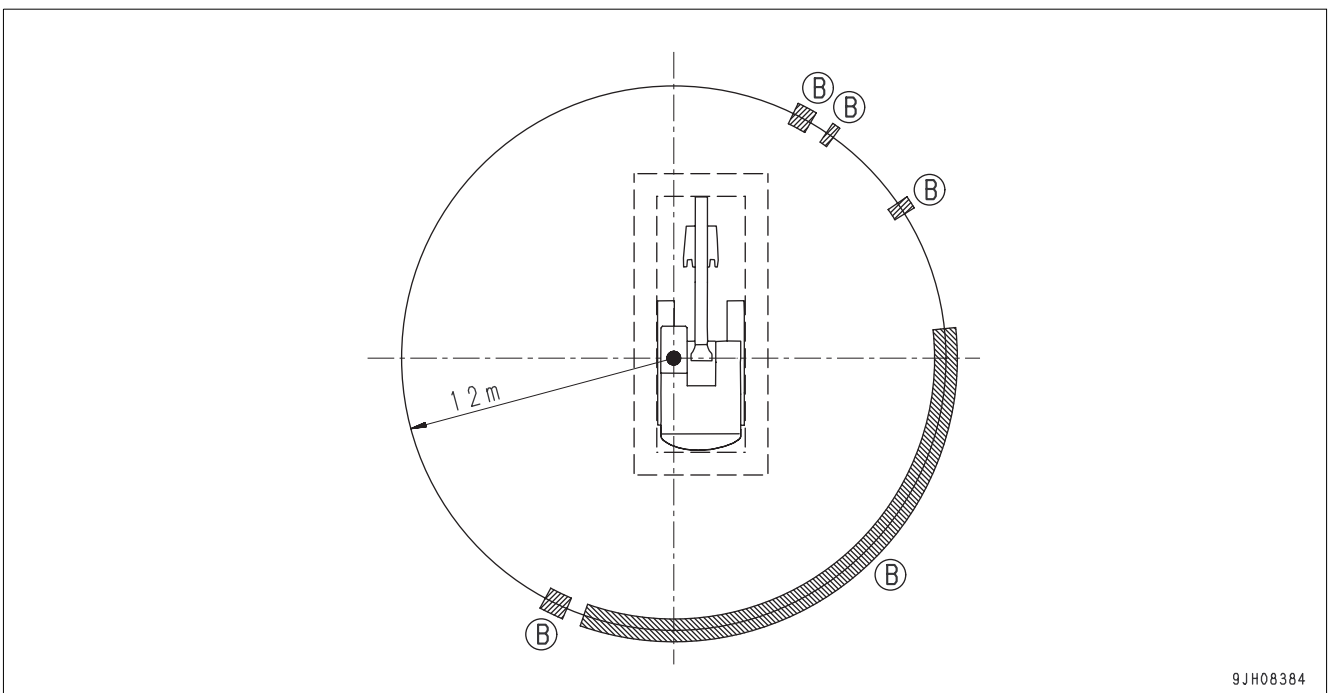

9JH08384

BREAKING-IN THE NEW MACHINE

NOTICE

Your Komatsu machine has been thoroughly adjusted and tested before shipment from the factory. However, operating the machine under full load before breaking the machine in can adversely affect the performance and shorten the machine life.

Be sure to break in the machine for the initial 100 hours (as indicated on the service meter).

Make sure that you fully understand the content of this manual, and pay careful attention to the following points when breaking in the machine.

- Run the engine at idle for 15 seconds after starting it. During this time, do not operate the control levers or fuel control dial.
- Idle the engine for 5 minutes after starting it up.
- Avoid operation with heavy loads or at high speeds.
- Immediately after starting the engine, avoid sudden starts, sudden acceleration, unnecessary sudden stops, and sudden changes in direction.

PRODUCT INFORMATION

When requesting service or ordering replacement parts, please inform your Komatsu distributor of the following items.

PRODUCT IDENTIFICATION NUMBER (PIN)/MACHINE SERIAL NO. PLATE

On the bottom right of the operator's cab

The design of the nameplate differs according to the territory.

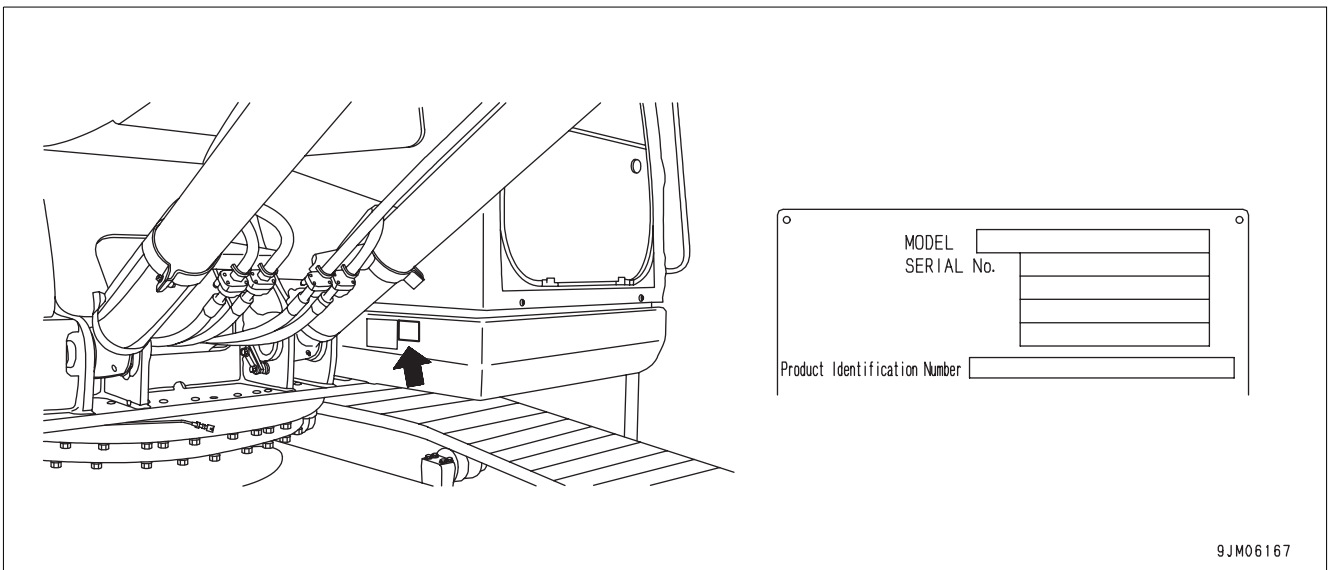

ENGINE SERIAL NUMBER PLATE AND ITS LOCATION

On the upper side of the engine cylinder head cover.

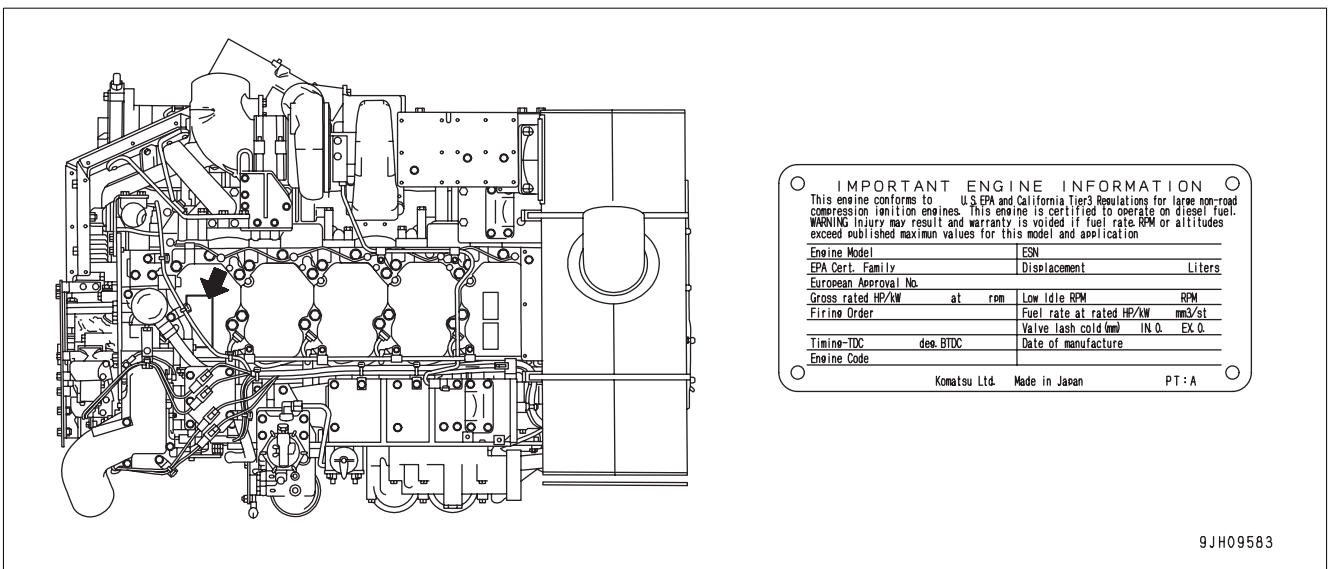

EPA: Environmental Protection Agency, U.S.A.

SERVICE METER LOCATION

On top of the machine monitor

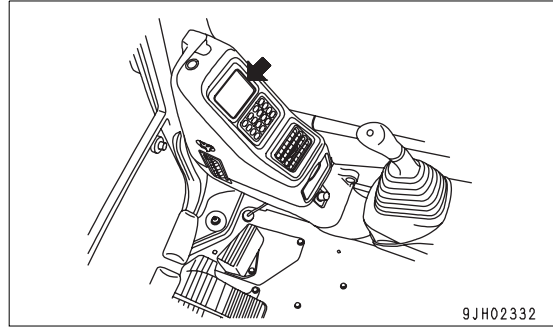

YOUR MACHINE SERIAL NUMBERS AND DISTRIBUTOR

Machine serial No.

Engine serial No.

Product Identification Number

Manufacturers name:	KOMATSU UK Ltd.
Address:	Durham Road Birtley Chester-Le street County Durham DH3 2QX United Kingdom

Distributor
Address

Phone

MACHINE SERIAL PLATE

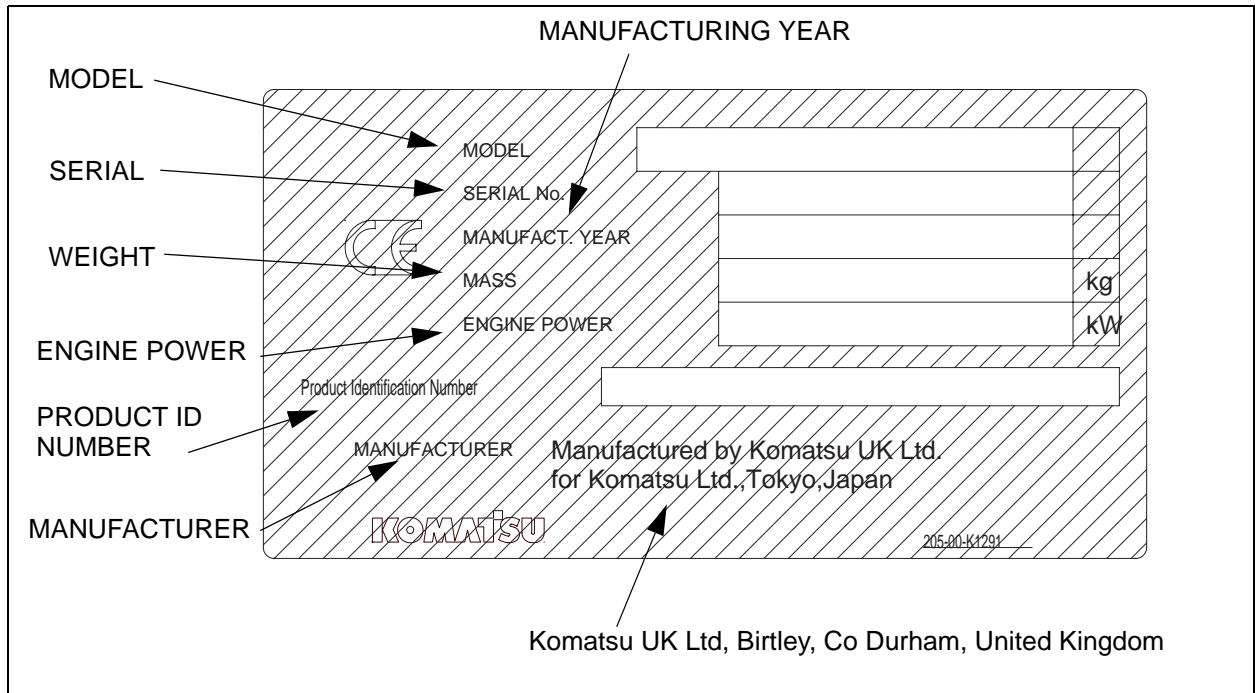

CONTENTS

FOREWORD

FOREWORD	1-2
SAFETY INFORMATION	1-3
SIGNAL WORDS	1-3
EXAMPLE OF SAFETY MESSAGE USING SIGNAL WORD	1-3
OTHER SIGNAL WORDS	1-3
EXAMPLE OF SAFETY LABEL USING WORDS	1-4
SAFETY LABELS USING PICTOGRAM	1-4
NOISE	1-5
Vibration levels	1-6
GUIDE TO REDUCE VIBRATION LEVELS ON MACHINE	1-6
INTRODUCTION	1-8
DIRECTIONS OF MACHINE	1-8
VISIBILITY FROM OPERATOR'S SEAT	1-9
PROXIMITY VISIBILITY	1-9
12M CIRCUMFERENCE VISIBILITY	1-9
BREAKING-IN THE NEW MACHINE	1-10
PRODUCT INFORMATION	1-11
PRODUCT IDENTIFICATION NUMBER (PIN)/MACHINE SERIAL NO. PLATE	1-11
ENGINE SERIAL NUMBER PLATE AND ITS LOCATION	1-11
SERVICE METER LOCATION	1-12
YOUR MACHINE SERIAL NUMBERS AND DISTRIBUTOR	1-12
MACHINE SERIAL PLATE	1-13

SAFETY

SAFETY INFORMATION	2-2
SAFETY LABELS	2-4
LOCATION OF SAFETY LABELS	2-5
SAFETY LABELS	2-6
SAFETY INFORMATION	2-13
SAFETY MACHINE OPERATION	2-22
STARTING ENGINE	2-22
OPERATION	2-24
TRANSPORTATION	2-30
BATTERY	2-31
TOWING	2-32
LIFTING OBJECTS WITH BUCKET	2-33

SAFETY MAINTENANCE INFORMATION	2-34
---	------

OPERATION

MACHINE VIEW ILLUSTRATIONS	3-2
OVERALL MACHINE VIEW.....	3-2
CONTROLS AND GAUGES.....	3-3
DETAILED CONTROLS AND GAUGES	3-5
MONITORING SYSTEM.....	3-5
BASIC OPERATION OF MACHINE MONITOR	3-6
EMERGENCY MONITORS	3-9
CAUTION MONITORS	3-11
BASIC CHECK MONITORS.....	3-13
METER DISPLAY PORTION.....	3-15
MONITOR SWITCHES PORTION	3-20
SWITCHES.....	3-34
CONTROL LEVERS AND PEDALS	3-41
SUN ROOF	3-44
OPENING	3-44
CLOSING.....	3-44
WINDSHIELD	3-45
EMERGENCY EXIT FROM OPERATOR'S CAB	3-50
DOOR LOCK	3-50
CAP WITH LOCK.....	3-51
HOT AND COOL BOX.....	3-52
MAGAZINE BOX.....	3-52
ASHTRAY	3-52
AIR CONDITIONER CONTROLS.....	3-53
AIR CONDITIONER CONTROL PANEL	3-53
METHOD OF OPERATION.....	3-57
USE AIR CONDITIONER WITH CARE	3-63
INSPECTION AND MAINTENANCE OF AIR CONDITIONER EQUIPPED MACHINE.....	3-63
OTHER FUNCTIONS	3-64
CAB RADIO	3-65
USE RADIO WITH CARE.....	3-65
AUXILIARY ELECTRIC POWER.....	3-66
24V POWER SOURCE	3-66
12V POWER SOURCE	3-66
FUSE	3-67
CIRCUIT BREAKER	3-68
CONTROLLER	3-69
TOOL BOX.....	3-69
GREASE PUMP.....	3-70
METHOD OF USE.....	3-70
PRECAUTIONS WHEN USING	3-71
SUPPLYING GREASE	3-71

CONTENTS

ACCUMULATOR 3-73

 RELEASING HYDRAULIC PRESSURE WITH ACCUMULATOR..... 3-73

MACHINE OPERATIONS AND CONTROLS..... 3-74

 BEFORE STARTING ENGINE 3-74

 WALK-AROUND CHECKS..... 3-74

 CHECKS BEFORE STARTING..... 3-75

 ADJUSTMENT..... 3-84

 SEAT BELT 3-87

 OPERATIONS BEFORE STARTING ENGINE 3-88

 STARTING ENGINE 3-91

 AFTER STARTING ENGINE 3-94

 WARMING UP ENGINE 3-94

 WARMING UP HYDRAULIC EQUIPMENT 3-96

 OPERATION AFTER COMPLETION OF WARMING-UP OPERATION 3-100

 STOPPING THE ENGINE 3-101

 MACHINE OPERATION 3-102

 PREPARATIONS FOR MOVING THE MACHINE..... 3-102

 MOVING MACHINE FORWARD 3-103

 MOVING MACHINE BACKWARD..... 3-104

 STOPPING MACHINE..... 3-105

 STEERING THE MACHINE 3-106

 STEERING 3-106

 SWINGING 3-108

 WORK EQUIPMENT CONTROLS AND OPERATIONS 3-109

 WORKING MODE..... 3-110

 PROHIBITED OPERATIONS 3-112

 GENERAL OPERATION INFORMATION 3-114

 TRAVELING ON SLOPES..... 3-116

 ESCAPE FROM MUD..... 3-118

 TRACK ON ONE SIDE STUCK..... 3-118

 TRACKS ON BOTH SIDES STUCK..... 3-118

 RECOMMENDED APPLICATIONS..... 3-119

 DITCHING WORK 3-119

 LOADING WORK 3-119

 BUCKET REPLACEMENT 3-120

 REPLACEMENT..... 3-120

 PARKING MACHINE 3-122

 MACHINE INSPECTION AFTER DAILY WORK 3-123

 LOCKING..... 3-124

 OVERLOAD WARNING DEVICE (option) 3-124

TRANSPORTATION..... 3-125

 PRECAUTIONS FOR TRANSPORTATION 3-125

 LIFTING MACHINE..... 3-125

 SHIPPING MACHINE INFORMATION 3-127

 TRANSPORTATION POSTURE 3-128

 PROCEDURE FOR INCREASING OR REDUCING TRACK FRAME GAUGE..... 3-133

COLD WEATHER OPERATION	3-135
COLD WEATHER OPERATION INFORMATION.....	3-135
FUEL AND LUBRICANTS	3-135
COOLING SYSTEM COOLANT	3-135
BATTERY	3-136
MONITOR.....	3-137
AFTER DAILY WORK COMPLETION.....	3-138
AFTER COLD WEATHER SEASON	3-138
LONG TERM STORAGE	3-139
BEFORE STORAGE.....	3-139
DURING STORAGE	3-139
AFTER STORAGE.....	3-140
STARTING MACHINE AFTER LONG-TERM STORAGE	3-140
TROUBLES AND ACTIONS	3-141
RUNNING OUT OF FUEL	3-141
PHENOMENA THAT ARE NOT FAILURES.....	3-142
TOWING THE MACHINE	3-143
SEVERE JOB CONDITION	3-143
DISCHARGED BATTERY	3-144
BATTERY REMOVAL AND INSTALLATION	3-144
BATTERY CHARGES	3-145
STARTING ENGINE WITH BOOSTER CABLES.....	3-146
OTHER TROUBLE	3-148
ELECTRICAL SYSTEM.....	3-148
CHASSIS.....	3-149
ENGINE	3-150
ELECTRONIC CONTROL SYSTEM.....	3-152
POINT OF CONTACT TO TELEPHONE WHEN ERROR OCCURS	3-153

MAINTENANCE

MAINTENANCE INFORMATION	4-2
OUTLINE OF SERVICE	4-4
HANDLING OIL, FUEL, COOLANT, AND PERFORMING OIL CLINIC	4-4
OIL	4-4
FUEL.....	4-4
COOLING SYSTEM COOLANT	4-5
GREASE.....	4-5
CARRYING OUT KOWA (KOMATSU OIL WEAR ANALYSIS).....	4-6
OIL AND FUEL STORAGE.....	4-7
FILTERS.....	4-7
ELECTRIC SYSTEM MAINTENANCE	4-8
WEAR PARTS	4-9
WEAR PARTS LIST.....	4-9

CONTENTS

LUBRICANTS, FUEL AND COOLANT SPECIFICATIONS	4-10
RECOMMENDED BRANDS, RECOMMENDED QUALITY FOR PRODUCTS OTHER THAN KOMATSU GENUINE OIL.....	4-11
TIGHTENING TORQUE SPECIFICATIONS	4-12
TIGHTENING TORQUE LIST.....	4-12
SAFETY CRITICAL PARTS	4-13
SAFETY CRITICAL PARTS LIST	4-14
MAINTENANCE SCHEDULE	4-15
MAINTENANCE SCHEDULE CHART.....	4-15
MAINTENANCE INTERVAL FOR HYDRAULIC BREAKER.....	4-17
MAINTENANCE PROCEDURE	4-18
INITIAL 100 HOURS MAINTENANCE (ONLY AFTER THE FIRST 100 HOURS).....	4-18
INITIAL 500 HOURS MAINTENANCE (ONLY AFTER THE FIRST 500 HOURS).....	4-18
WHEN REQUIRED	4-19
CHECK, CLEAN AND REPLACE AIR CLEANER ELEMENT.....	4-19
CLEAN INSIDE OF COOLING SYSTEM	4-24
CHECK AND TIGHTEN TRACK SHOE BOLTS.....	4-27
CHECK AND ADJUST TRACK TENSION.....	4-28
REPLACE BUCKET TEETH (HORIZONTAL PIN TYPE).....	4-30
ADJUST BUCKET CLEARANCE	4-31
CHECK WINDOW WASHER FLUID LEVEL, ADD FLUID	4-32
CHECK AND MAINTENANCE AIR CONDITIONER	4-33
CLEAN LINE FILTER, REMOVE DIRT	4-34
REPLACE BREAKER CIRCUIT ADDITIONAL OIL FILTER ELEMENT.....	4-35
CLEAN PILOT LINE FILTER, REMOVE DIRT	4-36
BLEEDING AIR FROM HYDRAULIC SYSTEM.....	4-37
CHECK BEFORE STARTING	4-40
EVERY 10 HOURS MAINTENANCE.....	4-41
LUBRICATING.....	4-41
EVERY 100 HOURS MAINTENANCE.....	4-44
LUBRICATING SWING CIRCLE	4-44
EVERY 250 HOURS MAINTENANCE.....	4-45
CHECK OIL LEVEL IN FINAL DRIVE CASE, ADD OIL	4-45
CHECK LEVEL OF BATTERY ELECTROLYTE	4-46
CHECK AND TIGHTEN TRACK FRAME AND AXLE CONNECTING BOLTS	4-48
CHECK ALTERNATOR DRIVE BELT TENSION, ADJUST	4-49
CHECK AIR CONDITIONER COMPRESSOR BELT TENSION, ADJUST	4-50
EVERY 500 HOURS MAINTENANCE.....	4-51
REPLACE FUEL PRE-FILTER CARTRIDGE.....	4-51
CHECK SWING PINION GREASE LEVEL, ADD GREASE	4-54
CLEAN,CHECK RADIATOR FINS,OIL COOLER FINS,FUEL COOLER FINS,AFTERCOOLER FINS,CONDENSER FINS (MACHINES EQUIPPED WITH AIR CONDITIONER),PTO OIL COOLER FINS.....	4-55
CLEAN FRESH/RECIRC AIR FILTERS OF AIR CONDITIONER (ONLY FOR MACHINES EQUIPPED WITH AIR CONDITIONER)	4-57

CLEAN STRAINER OF P.T.O LUBRICATING OIL FILTER.....	4-58
CHANGE OIL IN ENGINE OIL PAN, REPLACE ENGINE OIL FILTER CARTRIDGE	4-59
EVERY 1000 HOURS MAINTENANCE.....	4-61
REPLACE FUEL MAIN FILTER CARTRIDGE	4-61
REPLACE HYDRAULIC OIL FILTER ELEMENT	4-64
CHANGE OIL IN SWING MACHINERY CASE	4-65
CHANGE OIL IN P.T.O CASE.....	4-66
CHECK ALL TIGHTENING POINTS OF ENGINE EXHAUST PIPE CLAMPS	4-67
REPLACE CORROSION RESISTOR CARTRIDGE	4-67
CHECK WELDED STRUCTURE.....	4-68
REPLACE HYDRAULIC TANK ADDITIONAL BREATHER ELEMENT	4-71
CHECK NITROGEN GAS CHARGE PRESSURE IN ACCUMULATOR (FOR BREAKER).....	4-71
REPLACE BREATHER ELEMENT IN HYDRAULIC TANK	4-72
EVERY 2000 HOURS MAINTENANCE.....	4-73
CHANGE OIL IN FINAL DRIVE CASE	4-73
CLEAN HYDRAULIC TANK STRAINER	4-74
CHECKING CHARGE PRESSURE OF NITROGEN GAS IN ACCUMULATOR (FOR CONTROL CIRCUIT).....	4-75
CHECK ALTERNATOR, STARTING MOTOR	4-78
EVERY 4000 HOURS MAINTENANCE.....	4-79
CHECK WATER PUMP.....	4-79
REPLACE ACCUMULATOR (FOR CONTROL CIRCUIT).....	4-79
CHECK FOR LOOSENESS OF HIGH-PRESSURE PIPING CLAMP, HARDENING OF RUBBER	4-79
CHECK FOR MISSING FUEL SPRAY PREVENTION CAP, HARDENING OF RUBBER.....	4-81
CHECK OPERATING CONDITION OF COMPRESSOR.....	4-81
EVERY 5000 HOURS MAINTENANCE.....	4-82
CHANGE OIL IN HYDRAULIC TANK.....	4-82
EVERY 8000 HOURS MAINTENANCE.....	4-83
REPLACE HIGH-PRESSURE PIPING CLAMP	4-83
REPLACE FUEL SPRAY PREVENTION CAP.....	4-83

SPECIFICATIONS

SPECIFICATIONS.....	5-2
---------------------	-----

ATTACHMENTS AND OPTIONS

GENERAL PRECAUTIONS FOR SAFETY	6-2
PRECAUTIONS WHEN SELECTING	6-2
READ THE INSTRUCTION MANUAL THOROUGHLY	6-2
PRECAUTIONS WHEN REMOVING OR INSTALLING	6-2
PRECAUTIONS WHEN USING	6-3
ATTACHMENT GUIDE	6-4
COMBINATIONS OF WORK EQUIPMENT	6-4
WORKING RANGE DIAGRAM	6-5
TRACK SHOES SELECTION	6-6
HANDLING MACHINES EQUIPPED WITH KOMTRAX	6-7
BASIC PRECAUTIONS	6-7

INDEX

COLOPHON

SAFETY



WARNING

Please read and make sure that you fully understand the precautions described in this manual and the safety labels on the machine. When operating or servicing the machine, always follow these precautions strictly.

SAFETY INFORMATION

SAFETY LABELS..... 2-4
 LOCATION OF SAFETY LABELS 2-5
 SAFETY LABELS..... 2-6

SAFETY INFORMATION

Safety rules 2-13
 If problems are found 2-13
 Working wear and personal protective items 2-13
 Fire extinguisher and first aid kit 2-13
 Safety equipment 2-14
 Keep machine clean..... 2-14
 Keep operator's compartment clean 2-14
 Leaving operator's seat with lock 2-14
 Handrails and steps 2-15
 Mounting and dismounting 2-16
 No persons on attachments 2-16
 Do not get caught in articulated portion 2-16
 Burn prevention..... 2-16
 Fire prevention and explosion prevention 2-17
 Action if fire occurs..... 2-18
 Windshield washer fluid 2-18
 Falling objects, flying objects and intruding objects prevention 2-18
 Attachment installation 2-18
 Attachment combinations..... 2-18
 Cab window glasses 2-19
 Unauthorized modifications 2-19
 Safety at jobsite..... 2-19
 Working on loose ground 2-19
 Distance to high voltage cables 2-20
 Ensure good visibility 2-20
 Ventilation for enclosed area..... 2-21
 Signalman's signal and signs 2-21
 Emergency exit from operator's cab 2-21
 Asbestos dust hazard prevention..... 2-21

SAFETY MACHINE OPERATION	2-22
STARTING ENGINE	2-22
Checks before starting engine	2-22
Safety rules for starting engine	2-23
Starting engine in cold weather.....	2-23
OPERATION	2-24
Checks before operation.....	2-24
Safety rules for changing machine directions	2-24
Safety rules for traveling	2-25
Traveling on slopes.....	2-25
Operations on slopes	2-26
Prohibited operations	2-26
Operations on snow	2-28
Parking machine	2-29
TRANSPORTATION.....	2-30
Loading and unloading	2-30
Shipping the machine	2-30
BATTERY	2-31
Battery hazard prevention.....	2-31
Starting engine with booster cables.....	2-32
TOWING	2-32
Safety rules for towing	2-32
LIFTING OBJECTS WITH BUCKET	2-33
Safety rules for lifting objects	2-33
SAFETY MAINTENANCE INFORMATION.....	2-34
Warning Tag	2-34
Keep Work Place Clean and Tidy	2-34
Appoint Leader when Working with Others.....	2-34
Stop Engine Before Carrying Out Maintenance.....	2-35
Two Workers for Maintenance when Engine is Running	2-35
Proper Tools	2-36
Accumulator	2-36
Personnel.....	2-36
Attachments	2-37
Work Under the Machine	2-37
Noise.....	2-37
When Using Hammer.....	2-37
Welding Works.....	2-37
Removing Battery Terminals.....	2-38
Safety First when Using High-pressure Grease to Adjust Track Tension	2-38
Do Not Disassemble Recoil Springs	2-38
Safety Rules for High-pressure Oil	2-38
Precaution for High Fuel Pressure.....	2-39
Safety Handling High-pressure Hoses.....	2-39
Precaution for High Voltage	2-39
Waste Materials	2-40
Air Conditioner Maintenance.....	2-40
Compressed Air	2-40
Periodic Replacement of Safety Critical Parts	2-40

SAFETY LABELS

The following warning signs and safety labels are used on this machine.

- Be sure that you fully understand the correct position and content of labels.
- To ensure that the content of labels can be read properly, be sure that they are in the correct place and always keep them clean. When cleaning them, do not use organic solvents or gasoline. These may cause the labels to peel off.
- There are also other labels in addition to the warning signs and safety labels. Handle those labels in the same way.
- If the labels are damaged, lost, or cannot be read properly, replace them with new ones. For details of the part numbers for the labels, see this manual or the actual label, and place an order with Komatsu distributor.

LOCATION OF SAFETY LABELS

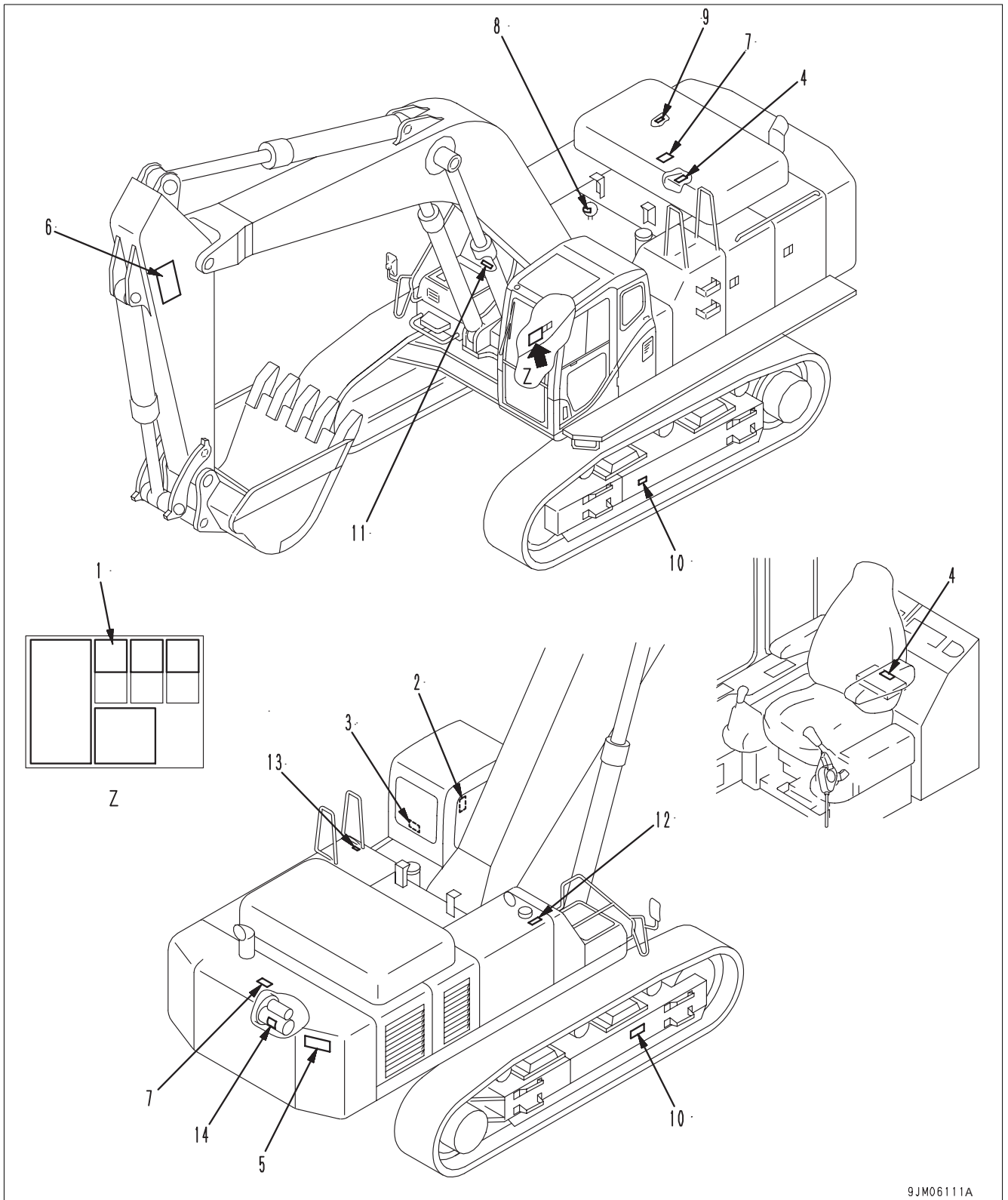

9JM06111A

SAFETY LABELS

1. (207-00-K1951)

- Warnings for operation, inspection and maintenance
- Improper operation and maintenance can cause serious injury or death.
- Read the manual and labels before operation and maintenance.
Follow instructions and warnings in manual and in labels on machine.

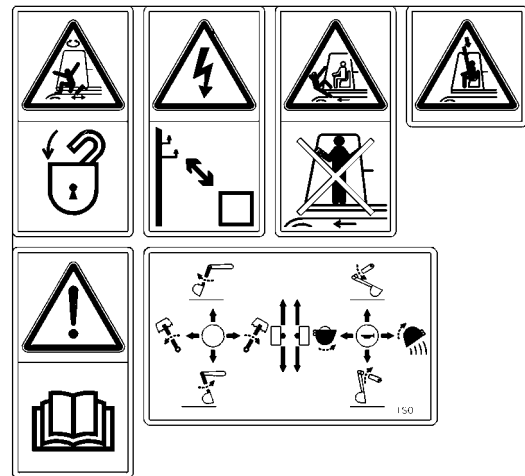

- a. Keep the manual in machine cab near operator.

- Warning!
- Read the manual before operating, maintenance, disassembly, assembly and transportation.

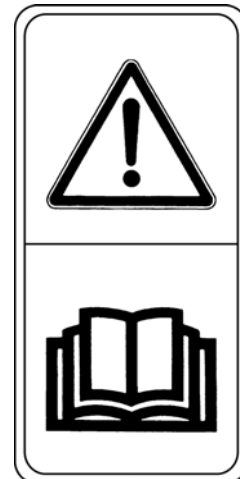

b. Always apply lock when leaving operator's seat.

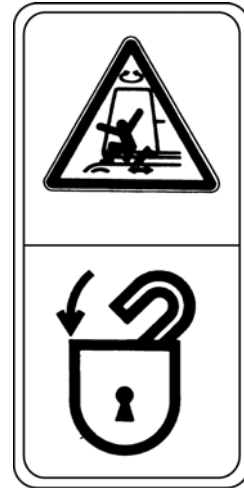

c. WARNING - No passengers

- No passengers allowed to ride on machine while it is moving



d. WARNING - DANGER OF FALLING OBJECTS

- Do not operate where a danger of falling objects exists. Consult your dealer for fitting of FOPS protection



e. HAZARDOUS - Voltage hazard

- Sign indicates an electrocution hazard if the machine is brought too near electric power lines.

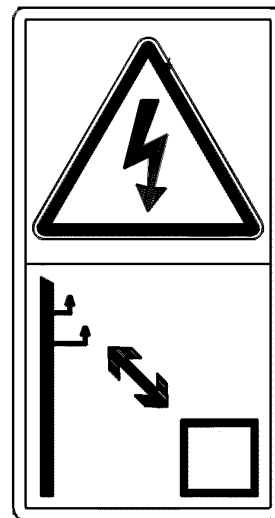

- Keep a safe distance from electric power lines.

f. Control levers operational function diagram.

⚠ WARNING

In order to prevent an accident resulting in injury or death caused by error-operation, confirm the machine motion and indicated operating pattern, when operating machines. Pay attention to the circumference and operate slowly when confirming the machine motion.

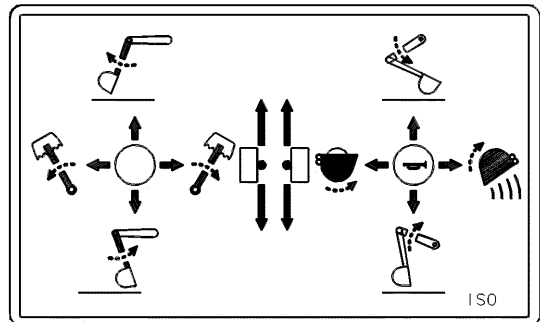

2. (20E-00-K1230)

- Warning when opening front window

- Sign indicates a hazard from falling window.

- After raising window, be sure to lock it in place with lock pins.



3. (20Y-00-K2220)

- Emergency exit
- Read operation manual before operation

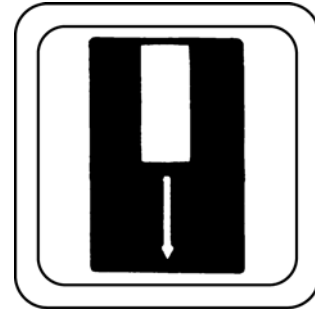

4. (7872-10-1600) Precautions for high voltage.

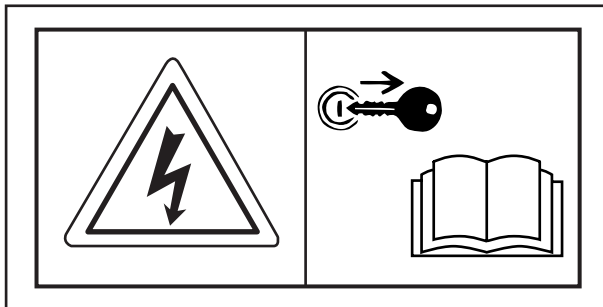

There is a danger of electrocution.

Turn the starting switch OFF before starting inspection or repairs, and read the operation and maintenance manual

5. (20E-00-K1150)

Keeping out of moving area

To prevent SEVERE INJURY or DEATH do the following before moving machine or its attachments:

- Sound horn to alert people nearby.
- Be sure no one is on or near machine or in the swing area.
- Rotate cab for full view of travel path if it can be done safely.
- Use spotter if view is obstructed.

Always follow the above



6. (20E-00-K1140)

Keeping out of working range area.

- Sign indicates a hazard of being hit by the working device of the machine.
- Keep away from machine during operation.



7. (20E-00-K1310)

- Sign indicates a hazard of rotating parts, such as belt.
- Turn off before inspection and maintenance.

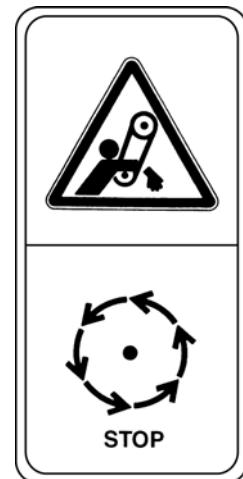

8. (20E-00-K1210) Warning for handling accumulator.

- There is the hazard of explosion causing injury.
- Do not disassemble the accumulator, make holes in it, weld it cut it, hit it, roll it or bring it near flame.
- Read operation manual before operation.

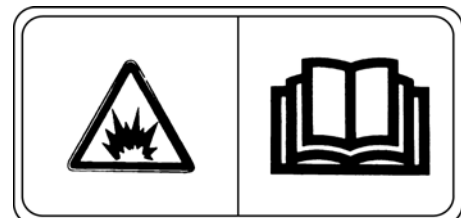

9. (20E-00-K1190)

Warning for high temperature coolant and oil.

- Never remove the cap when the engine is at operating (high) temperature. Steam or high temperature oil blowing up from the radiator or hydraulic tank, will cause personal injury and/or burns.
- Never remove the radiator cap or hydraulic tank oil filler when cooling water or hydraulic oil is at high temperature.

Read operation manual before operation.



10. (09657-A0881)

- Sign indicates a hazard of flying plug from track adjuster that could cause injury.
- Read manual and adjusting track for safe and proper handling.

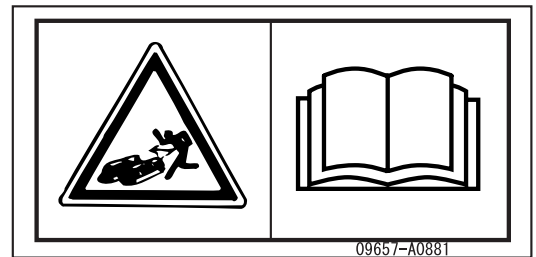

11. (09808-A0881)

- Sign indicates an electric hazard from handling the cable.
- Read manual for safe and proper handling.

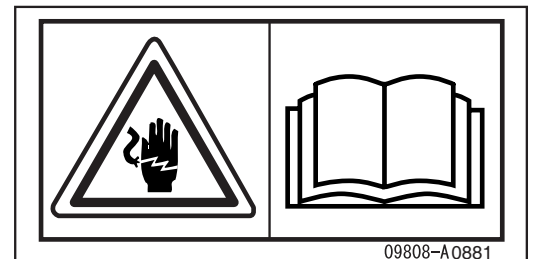

12. (09805-A0881)

- There is the hazard of falling down.
- Do not go close to the edge of the machine by mistake.



13. (09805-C0481)

- Sign indicates a hazard of falling.



- Do not step here!.

14. (09842-A0481) Jump start prohibited

- Start the engine only after sitting down in the operator's seat.
- Do not attempt to start the engine by short-circuiting the engine starting circuit. Such an act may cause a serious bodily injury or fire.



SAFETY INFORMATION

SAFETY RULES

- Only trained and authorized personnel can operate and maintain the machine.
- Follow all safety rules, precautions and instructions when operating or performing maintenance on the machine.
- If you are under the influence of alcohol or medication, your ability to safely operate or repair your machine may be severely impaired putting yourself and everyone else on your jobsite in danger.
- When working with another operator or with a person on worksite traffic duty, be sure that all personnel understand all hand signals that are to be used.

IF PROBLEMS ARE FOUND

If you find any problems in the machine during operation or maintenance (noise, vibration, smell, incorrect gauges, smoke, oil leakage, etc., or any abnormal display on the warning devices or monitor), report to the person in charge and have the necessary action taken. Do not operate the machine until the problem has been corrected.

WORKING WEAR AND PERSONAL PROTECTIVE ITEMS

- Do not wear loose clothing and accessories. There is a hazard that they may catch on control levers or other protruding parts.
- If you have long hair and it hangs out from your hard hat, there is a hazard that it may get caught up in the machine, so tie your hair up and be careful not to let it get caught.
- Always wear a hard hat and safety shoes. If the nature of the work requires it, wear safety glasses, mask, gloves, ear plugs, and safety belt when operating or maintaining the machine.
- Check that all protective equipment functions properly before using it.

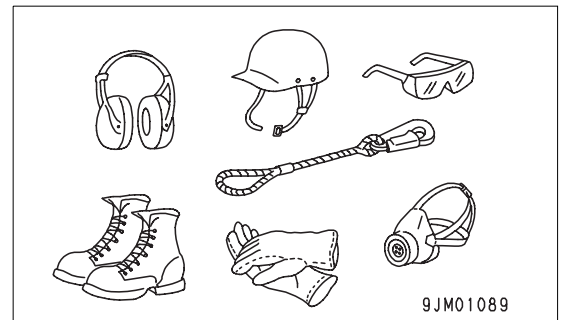

FIRE EXTINGUISHER AND FIRST AID KIT

Always follow the precautions below to prepare for action if any injury or fire should occur.

- Be sure that fire extinguishers have been provided and read the labels to ensure that you know how to use them in emergencies.
- Carry out periodic inspection and maintenance to ensure that the fire extinguisher can always be used.
- Provide a first aid kit in the storage point. Carry out periodic checks and add to the contents if necessary.

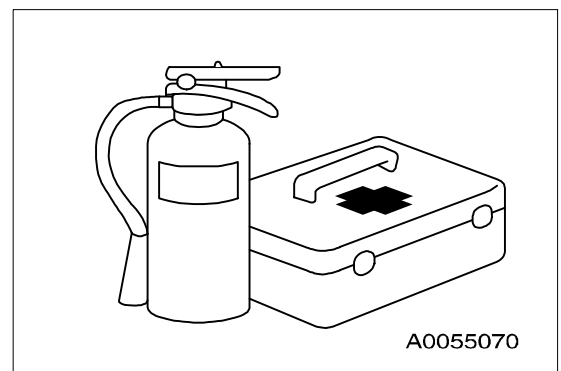

SAFETY EQUIPMENT

- Be sure that all guards and covers are in their proper position. Have guards and covers repaired immediately if they are damaged.
- Understand the method of use of safety features and use them properly.
- Never remove any safety features. Always keep them in good operating condition.

KEEP MACHINE CLEAN

- If water gets into the electrical system, there is a hazard that it will cause malfunctions or misoperation. Do not use water or steam to wash the electrical system (sensors, connectors).
- If inspection and maintenance is carried out when the machine is still dirty with mud or oil, there is a hazard that you will slip and fall, or that dirt or mud will get into your eyes. Always keep the machine clean.

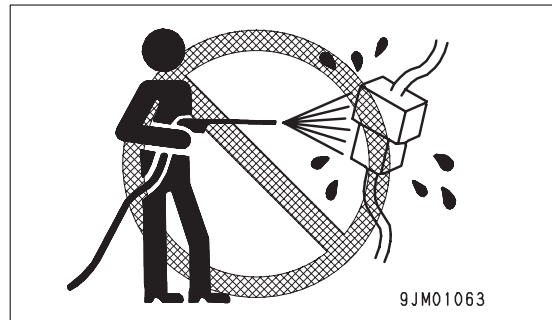

KEEP OPERATOR'S COMPARTMENT CLEAN

- When entering the operator's compartment, always remove all mud and oil from the soles of your shoes.
If you operate the pedal with mud or oil affixed to your shoes, your foot may slip and this may cause a serious accident.
- Do not leave parts or tools lying around the operator's compartment.
- Do not stick suction pads to the window glass. Suction pads act as a lens and may cause fire.
- Do not use cellular telephones inside the operator's compartment when driving or operating the machine.
- Never bring any dangerous objects such as flammable or explosive items into the operator's compartment.

LEAVING OPERATOR'S SEAT WITH LOCK

- Before standing up from the operator's seat (such as when opening or closing the front window or roof window, or when removing or installing the bottom window, or when adjusting the operator's seat), lower the work equipment completely to the ground, set lock lever (1) securely to the LOCK position (L), then stop the engine. If you accidentally touch the levers when they are not locked, there is a hazard that the machine may suddenly move and cause serious injury or property damage.

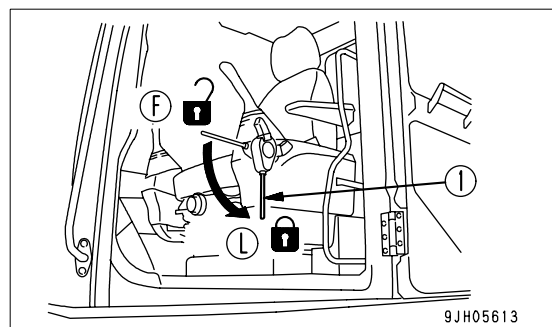

- When leaving the machine, always lower the work equipment completely to the ground, set lock lever (1) securely to the LOCK position (L), then stop the engine. Use the key to lock all the equipment. Always remove the key, take it with you, and keep it in the specified place.

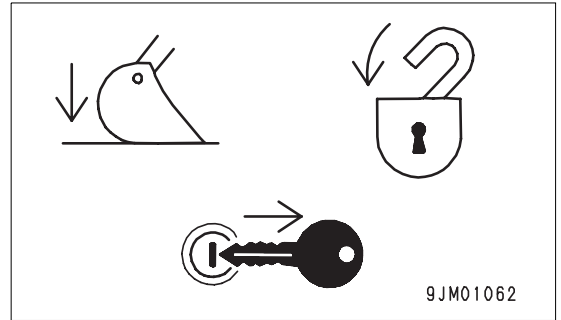

HANDRAILS AND STEPS

To prevent personal injury caused by slipping or falling off the machine, always do as follows.

- Use the handrails and steps marked by arrows in the diagram on the right when getting on or off the machine.

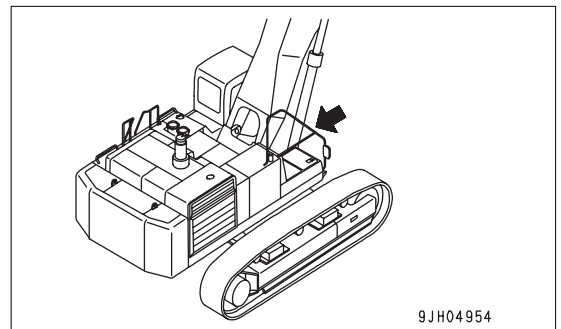
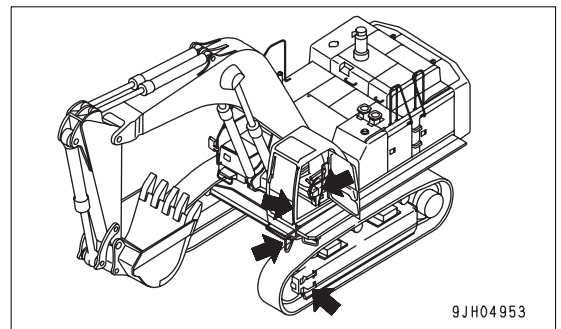

- To ensure safety, always face the machine and maintain three-point contact (both feet and one hand, or both hands and one foot) with the handrails and steps (including the track shoe) to ensure that you support yourself.
- Do not grip the control levers or lock lever when getting on or off the machine.
- Never climb on the engine hood or covers where there are no non-slip pads.
- Before getting on or off the machine, check the handrails and steps (including the track shoe). If there is any oil, grease, or mud on the handrails or steps (including the track shoe), wipe it off immediately. Always keep these parts clean. Repair any damage and tighten any loose bolts.
- Do not get on or off the machine while holding tools in your hand.

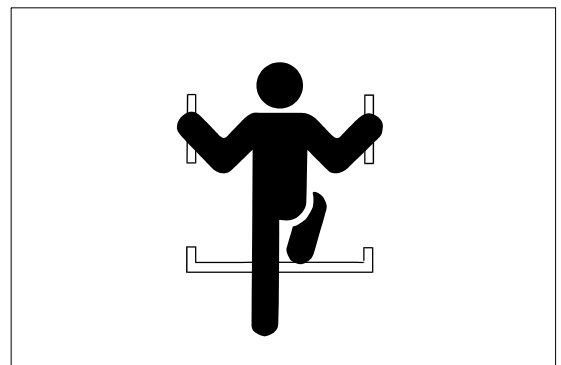

MOUNTING AND DISMOUNTING

- Never jump on or off the machine. Never get on or off a moving machine.
- If the machine starts to move when there is no operator on the machine, do not jump on to the machine and try to stop it.

NO PERSONS ON ATTACHMENTS

Never let anyone ride on the work equipment, or other attachments. There is a hazard of falling and suffering serious injury.

DO NOT GET CAUGHT IN ARTICULATED PORTION

The clearance around the work equipment will change according to the movement of the link. If you get caught, this may lead to serious personal injury. Do not allow anyone to approach any rotating or telescoping part.

BURN PREVENTION

Hot coolant

- To prevent burns from hot water or steam spurting out when checking or draining the coolant, wait for the water to cool to a temperature where it is possible to touch the radiator cap by hand before starting the operation. Even when the coolant has cooled down, loosen the cap slowly to relieve the pressure inside the radiator before removing the cap.

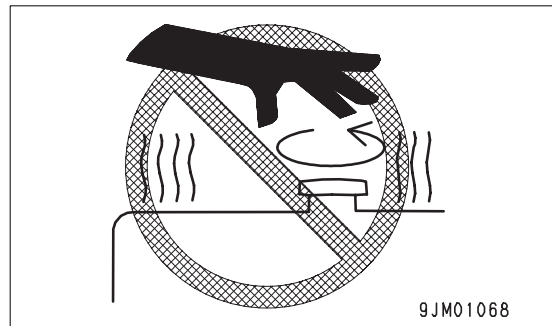

Hot oil

- To prevent burns from hot oil spurting out when checking or draining the oil, wait for the oil to cool to a temperature where it is possible to touch the cap or plug by hand before starting the operation. Even when the oil has cooled down, loosen the cap or plug slowly to relieve the internal pressure before removing the cap or plug.

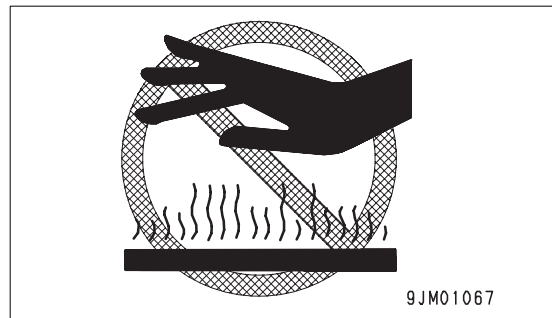

FIRE PREVENTION AND EXPLOSION PREVENTION

- **Fire caused by fuel or oil**

Fuel, oil, antifreeze, and window washer liquid are particularly flammable and can be hazardous. To prevent fire, always observe the following:

- Do not smoke or use any flame near fuel or oil.
- Stop the engine before refueling.
- Do not leave the machine while adding fuel or oil.
- Tighten all fuel and oil caps securely.
- Do not spill fuel on overheated surfaces or on parts of the electrical system.
- Use well-ventilated areas for adding or storing oil and fuel.
- Keep oil and fuel in the determined place and do not allow unauthorized persons to enter.
- After adding fuel or oil, wipe up any spilled fuel or oil.
- When carrying out grinding or welding work on the chassis, move any flammable materials to a safe place before starting.

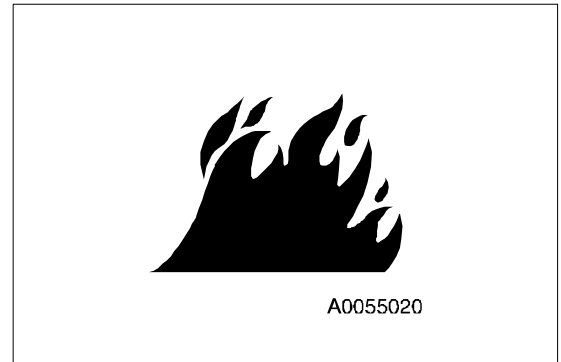

- When washing parts with oil, use a non-flammable oil. Diesel oil and gasoline may catch fire, so do not use them.
- Put greasy rags and other flammable materials into a safe container to maintain safety at the work place.
- Do not weld or use a cutting torch to cut any pipes or tubes that contain flammable liquids.

- **Fire caused by accumulation of flammable material.**

Remove any dry leaves, chips, pieces of paper, dust, or any other flammable materials accumulated or affixed around the engine, exhaust manifold, muffler, or battery, or inside the undercovers.

- **Fire coming from electric wiring**

Short circuits in the electrical system can cause fire.

- Always keep electric wiring connections clean and securely tightened.
- Check the wiring every day for looseness or damage. Tighten any loose connectors or wiring clamps. Repair or replace any damaged wiring.

- **Fire coming from hydraulic line**

Check that all the hose and tube clamps, guards, and cushions are securely fixed in position.

If they are loose, they may vibrate during operation and rub against other parts. This may lead to damage to the hoses, and cause high-pressure oil to spurt out, leading to fire damage or serious injury.

- **Explosion caused by lighting equipment**

When checking fuel, oil, battery electrolyte, window washer fluid, or coolant, always use lighting with antiexplosion specifications. If such lighting equipment is not used, there is danger of explosion that may cause serious injury.

When taking the electrical power for the lighting from the machine itself, follow the instructions in of "AUXILIARY ELECTRIC POWER (3-66)".

ACTION IF FIRE OCCURS

If a fire occurs, escape from the machine as follows.

- Turn the start switch OFF to stop the engine.
- Use the handrails and steps to get off the machine.

WINDSHIELD WASHER FLUID

Use an ethyl alcohol base washer liquid.

Methyl alcohol base washer liquid may irritate your eyes, so do not use it.

FALLING OBJECTS, FLYING OBJECTS AND INTRUDING OBJECTS PREVENTION

On jobsites where there is a hazard that falling objects, flying objects, or intruding objects may hit or enter the operator's cab, consider the operating conditions and install the necessary guards to protect the operator.

- When carrying out demolition or breaker operations, install a front guard and use a laminated coating sheet on the front glass.
- When working in mines or quarries where there is a hazard of falling rock, install FOPS (Falling Objects Protective Structure) and a front guard, and use a laminated coating sheet on the front glass.
- When carrying out the above operations, always close the front window. In addition, always ensure that bystanders are a safe distance away and are not in hazard from falling or flying objects.
- The above recommendations assume that the conditions are for standard operations, but it may be necessary to add additional guards according to the operating conditions on the jobsite. Always contact your Komatsu distributor for advice.

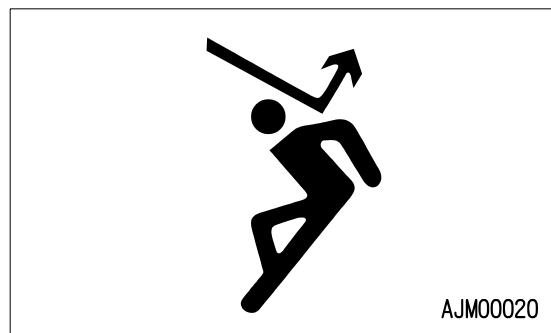
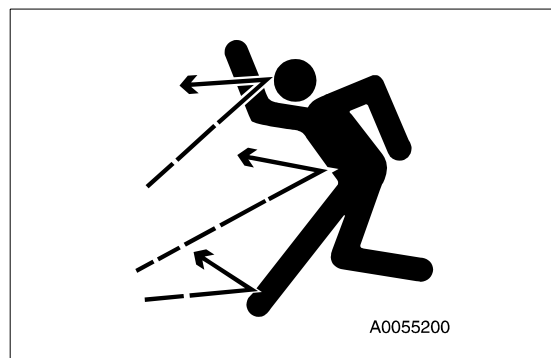

ATTACHMENT INSTALLATION

- When installing optional parts or attachments, there may be problems with safety or legal restrictions. Therefore contact your Komatsu distributor for advice.
- Any injuries, accidents, or product failures resulting from the use of unauthorized attachments or parts will not be the responsibility of Komatsu.
- When installing and using optional attachments, read the instruction manual for the attachment, and the general information related to attachments in this manual.

ATTACHMENT COMBINATIONS

Depending on the type or combination of work equipment, there is a hazard that the work equipment may hit the cab or other parts of the machine. Before using unfamiliar work equipment, check if there is any hazard of interference, and operate with caution.

CAB WINDOW GLASSES

- If a pane of the cab window on the work equipment side is broken, the work equipment may directly hit the operator. In that case, stop the machine immediately and replace the broken pane with new one.
- The ceiling window is made of organic glass (polycarbonate), and as such it is apt to break easily when receiving damage on the surface, thereby deteriorating its protective characteristic. If there is a crack or damage caused by a fallen rock, or when any sign of them is noticed, replace it with a new window.

UNAUTHORIZED MODIFICATIONS

If this machine is modified without permission from Komatsu, there is danger that problems may occur with safety and that this may lead to serious personal injury. Modifications may have an adverse effect on items such as machine strength and visibility. Before making any modifications, please consult your Komatsu distributor. Komatsu cannot take any responsibility for accidents, failures, or damage caused by modifications not authorized by Komatsu.

SAFETY AT JOBSITE

Before starting operations, thoroughly check the area for any unusual conditions that could be dangerous.

- When carrying out operations near combustible materials such as thatched roofs, dry leaves or dry grass, there is a hazard of fire, so be careful when operating.
- Check the terrain and condition of the ground at the worksite, and determine the safest method of operation. Do not operate where there is a hazard of landslides or falling rocks.
- If water lines, gas lines, or high-voltage electrical lines may be buried under the worksite, contact each utility and identify their locations. Be careful not to sever or damage any of these lines.
- Take action to prevent unauthorized people from approaching the jobsite.
- When working on public roads, position flagmen and erect barriers to ensure the safety of passing traffic and pedestrians.
- When traveling or operating in shallow water or on soft ground, check the shape and condition of the bedrock, and the depth and speed of flow of the water before starting operations.

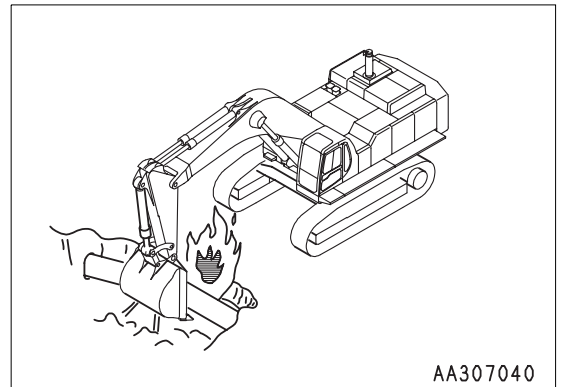

WORKING ON LOOSE GROUND

- Avoid traveling or operating your machine too close to the edge of cliffs, overhangs, and deep ditches. The ground may be weak in such areas. If the ground should collapse under the weight or vibration of the machine, there is a hazard that the machine may fall or tip over. Remember that the soil after heavy rain or blasting or after earthquakes is weak in these areas.
- When working on embankments or near excavated ditches, there is a hazard that the weight and vibration of the machine will cause the soil to collapse. Before starting operations, take steps to ensure that the ground is safe and to prevent the machine from rolling over or falling.

DISTANCE TO HIGH VOLTAGE CABLES

Do not travel or operate the machine near electric cables. There is a hazard of electric shock, which may cause serious injury or property damage. On jobsites where the machine may go close to electric cables, always do as follows.

- Before starting work near electric cables, inform the local power company of the work to be performed, and ask them to take the necessary action.
- Even going close to high-voltage cables can cause electric shock, which may cause serious burns or even death. Always maintain a safe distance (see the table on the right) between the machine and the electric cable. Check with the local power company about safe operating procedure before starting operations.
- To prepare for any possible emergencies, wear rubber shoes and gloves. Lay a rubber sheet on top of the seat, and be careful not to touch the chassis with any exposed part of your body.

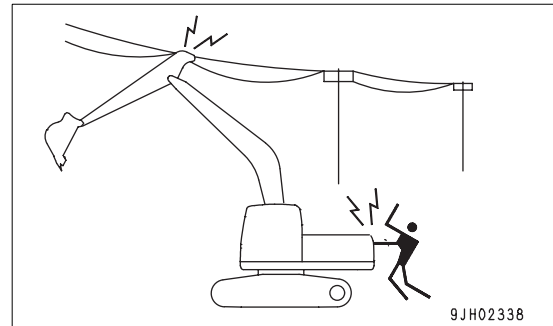

Voltage of Cables	Safety Distance
100 V - 200 V	Over 2 m
6,600 V	Over 2 m
22,000 V	Over 3 m
66,000 V	Over 4 m
154,000 V	Over 5 m
187,000 V	Over 6 m
275,000 V	Over 7 m
500,000 V	Over 11 m

- Use a signalman to give warning if the machine approaches too close to the electric cables.
- When carrying out operations near high voltage cables, do not let anyone near the machine.
- If the machine should come too close or touch the electric cable, to prevent electric shock, the operator should not leave the operator's compartment until it has been confirmed that the electricity has been shut off.

Also, do not let anyone near the machine.

ENSURE GOOD VISIBILITY

This machine is equipped with mirrors to improve the visibility, but even with mirrors, there are places, which cannot be seen from the operator's seat, so always be careful when operating.

When operating or traveling in places with poor visibility, if it is impossible to confirm the condition of the job side or obstacle is in the area around the machine, there is danger that the machine may suffer damage or the operator may suffer serious personal injury. When operating or traveling in places with poor visibility, always observe the following items strictly.

- If the visibility cannot be sufficiently assured, position a flagman if necessary. The operator should pay careful attention to the signs and follow the instructions of the flagman.
- The signals should be given only by one flagman.
- When working in dark places, turn on the working lamps and front lamps of the machine, and if necessary, set up additional lighting in the area.
- Stop operations if there is poor visibility, such as in fog, snow, rain, or sand storms.
- Check the mirrors on the machine before starting operations every day. Clean off any dirt and adjust the view to ensure good visibility.

VENTILATION FOR ENCLOSED AREA

Exhaust fumes from the engine can kill.

- If it is necessary to start the engine within an enclosed area, or when handling fuel, flushing oil, or paint, open the doors and windows to ensure that adequate ventilation is provided to prevent gas poisoning.

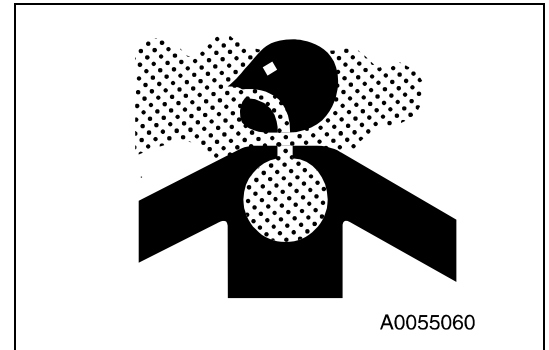

SIGNALMAN'S SIGNAL AND SIGNS

- Set up signs to inform of road shoulders and soft ground. If the visibility is not good, position a signalman if necessary. Operators should pay careful attention to the signs and follow the instructions from the signalman.
- Only one signalman should give signals.
- Make sure that all workers understand the meaning of all signals and signs before starting work.

EMERGENCY EXIT FROM OPERATOR'S CAB

If for some reason, the cab door does not open, use the rear window as an emergency escape. For details, see "EMERGENCY EXIT FROM OPERATOR'S CAB (3-50)" in this manual.

ASBESTOS DUST HAZARD PREVENTION

Asbestos dust in the air can cause lung cancer if it is inhaled. There is danger of inhaling asbestos when working on jobsites handling demolition work or work handling industrial waste. Always observe the following.

- Spray water to keep down the dust when cleaning. Do not use compressed air for cleaning.
- If there is danger that there may be asbestos dust in the air, always operate the machine from an upwind position. All workers should use an approved respirator.
- Do not allow other persons to approach during the operation.
- Always observe the rules and regulations for the work site and environmental standards.

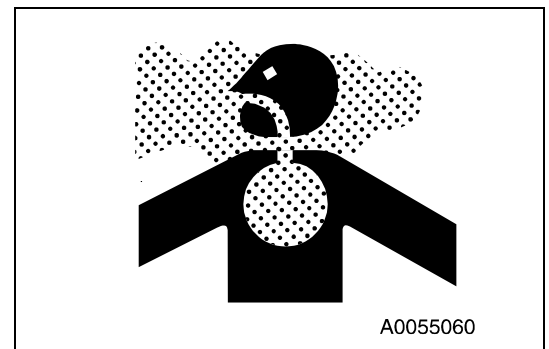

This machine does not use asbestos, but there is a danger that imitation parts may contain asbestos, so always use genuine Komatsu parts.

SAFETY MACHINE OPERATION

STARTING ENGINE

If there is a warning tag hanging from the work equipment control lever, do not start the engine or touch the levers .

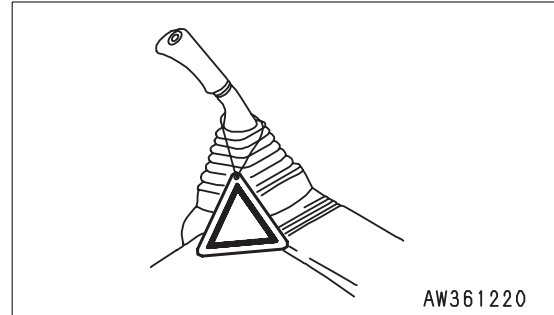

CHECKS BEFORE STARTING ENGINE

Carry out the following checks before starting the engine at the beginning of the day's work.

- Remove all dirt from the surface of the window glass to ensure a good view.
- Remove all dirt from the surface of the lens of the working lamps, and check that they light up correctly.
- Check the coolant level, fuel level, and oil level in engine oil pan, check for clogging of the air cleaner, and check for damage to the electric wiring.
- Adjust the operator's seat to a position where it is easy to carry out operations, and check that there is no damage or wear to the seat belt or mounting clamps.
- Check the operation of the instruments and gauges, check the angle of the mirror, and check that the control levers are all at the Neutral position.
- Before starting the engine, make sure that the lock lever is in the LOCK position.
- Adjust the mirrors so that the rear of the machine can be seen clearly from the operator's seat.
When adjusting, see "Rearview Mirrors (3-86)".
- Check that there are no persons or obstacles above, below, or in the area around the machine.

SAFETY RULES FOR STARTING ENGINE

- Start and operate the machine only while seated.
- Do not attempt to start the engine by short-circuiting the engine starting circuit. Such an act may cause a serious bodily injury or fire.
- When starting the engine, sound the horn as a warning.
- Do not allow anyone apart from the operator to ride on the machine.

STARTING ENGINE IN COLD WEATHER

- Carry out the warming-up operation thoroughly. If the machine is not thoroughly warmed up before the control levers are operated, the reaction of the machine will be slow, and this may lead to unexpected accidents.
- If the battery electrolyte is frozen, do not charge the battery or start the engine with a different power source. There is a hazard that this will ignite the battery and cause the battery to explode.

Before charging or starting the engine with a different power source, melt the battery electrolyte and check that there is no leakage of electrolyte before starting.

OPERATION

CHECKS BEFORE OPERATION

When carrying out the checks, move the machine to a wide area where there are no obstructions, and operate slowly. Do not allow anyone near the machine.

- Always fasten your seat belt.
- Check that the movement of the machine matches the display on the control pattern card. If it does not match, replace it immediately with the correct control pattern card.
- Check the operation of the work equipment, travel system and swing system.
- Check for any problem in the sound of the machine, vibration, heat, smell, or gauges; check also that there is no leakage of oil or fuel.
- If any problem is found, carry out repairs immediately.

SAFETY RULES FOR CHANGING MACHINE DIRECTIONS

- Always operate the machine only when seated.
- Do not allow anyone apart from the operator to ride on the machine.
- For machines equipped with a travel alarm, check that the alarm works properly.
- Always lock the door and windows of the operator's compartment in position (open or closed).
- On jobsites where there is a hazard of flying objects or of objects entering the operator's compartment, check that the door and windows are securely closed.
- If there is an area to the rear of the machine which cannot be seen, position a signal person. Take special care not to hit other machines or people when turning or swinging the machine.
- Before travelling, sound the horn to warn people in the area.
- Before travelling, check again that there is no one in the surrounding area, and that there are no obstacles.
- Before traveling, set the machine so that sprocket (1) is behind the operator's seat.

If sprocket (1) is in front of the operator's cab, the machine moves in the opposite direction from the operation of the lever (front and rear travel is reversed, left and right steering is reversed). Be extremely careful when operating the machine in this situation.

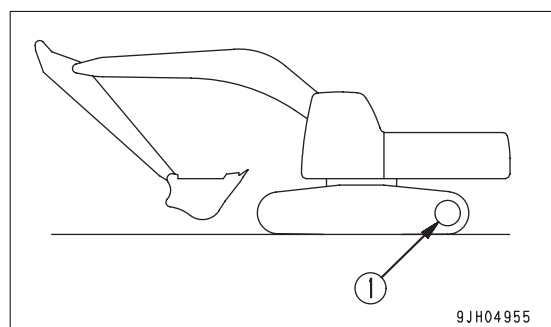
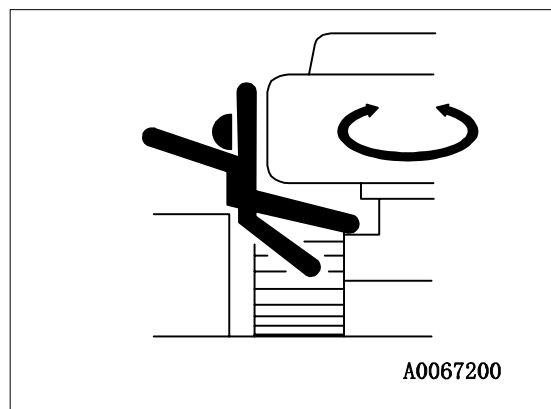
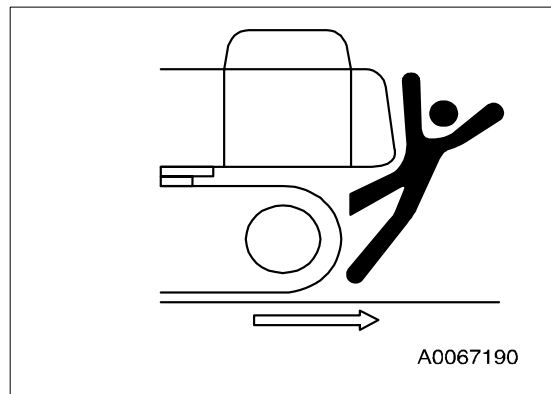

SAFETY RULES FOR TRAVELING

- When traveling on level ground, keep the work equipment at a height of 40 to 50 cm from the ground.
- When traveling on rough ground, travel at low speed and do not operate the steering suddenly. There is danger that the machine may turn over. The work equipment may hit the ground surface and cause the machine to lose its balance, or may damage the machine or structures in the area.
- When traveling on rough ground or steep slopes, if the machine is equipped with auto-deceleration, always turn the auto-deceleration switch OFF (cancel).
- Avoid traveling over obstacles when possible. If the machine has to travel over an obstacle, keep the work equipment close to the ground and travel at low speed. Never travel over obstacles which make the machine tilt strongly to one side.
- When traveling or carrying out operations, always keep a safe distance from people, structures, or other machines to avoid coming into contact with them.
- When passing over bridges or structures, check first that the structure is strong enough to support the weight of the machine.
- When operating in tunnels, under bridges, under electric wires, or other places where the height is limited, operate slowly and be extremely careful not to let the work equipment hit anything.

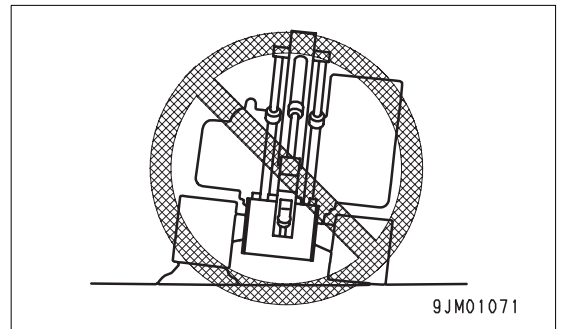
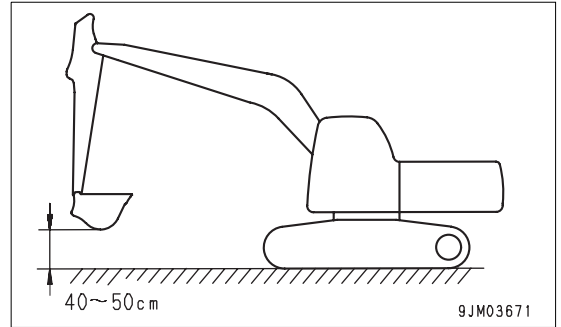

TRAVELING ON SLOPES

To prevent the machine from tipping over or slipping to the side, always do as follows.

- Keep the work equipment approx. 20 to 30 cm above the ground. In case of emergency, lower the work equipment to the ground immediately to help stop the machine.
- When traveling uphill, set the machine with the operator's seat on the uphill side; when traveling downhill, set the operator's seat on the downhill side. Check that the ground under the machine is safe when traveling.

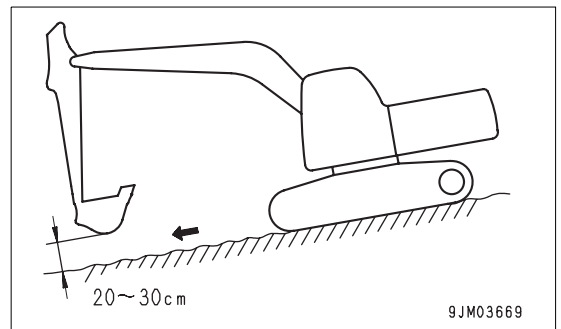
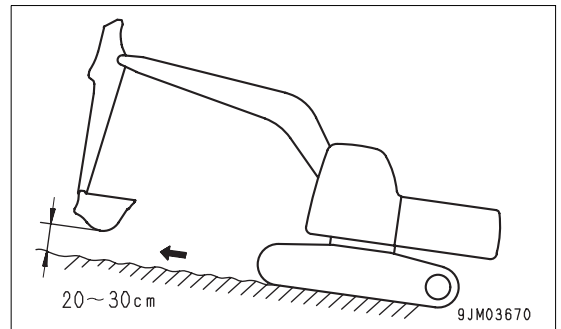

- When traveling up a steep slope, extend the work equipment to the front to improve the balance, keep the work equipment approximately 20 to 30 cm above the ground, and travel at low speed.
- When traveling downhill, lower the engine speed, keep the travel lever close to the neutral position, and travel at low speed.
- Always travel straight up or down a slope. Traveling at an angle or across the slope is extremely dangerous.
- Do not turn on slopes or travel across slopes. Always go down to a flat place to change the position of the machine, then travel on to the slope again.
- Travel on grass, fallen leaves, or wet steel plates with low speed. Even with slight slopes there is a hazard that the machine may slip.

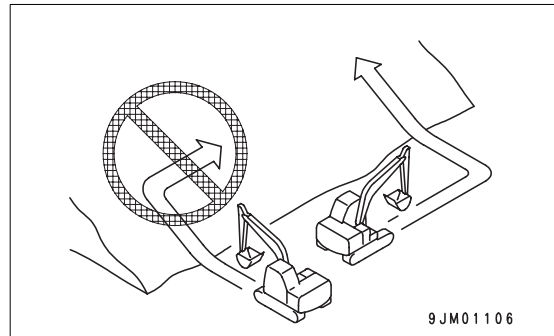
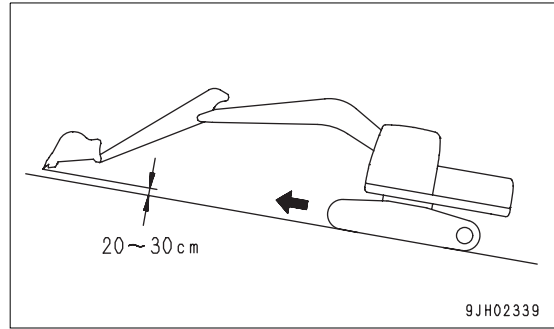

OPERATIONS ON SLOPES

- When working on slopes, there is a hazard that the machine may lose its balance and turn over when the swing or work equipment are operated. This may lead to serious injury or property damage, so always provide a stable place when carrying out these operations, and operate carefully.
- Do not swing the work equipment from the uphill side to the downhill side when the bucket is loaded. This operation is dangerous, and may cause the machine to tip over.
- If the machine has to be used on a slope, pile the soil to make a platform (A) that will keep the machine as horizontal as possible.

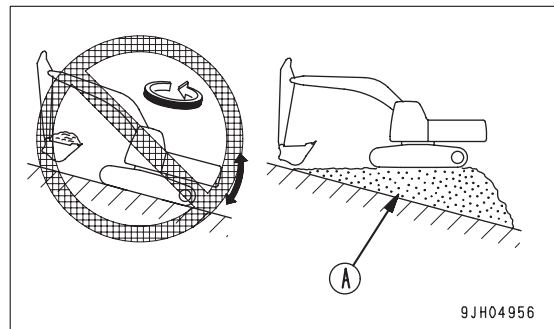

PROHIBITED OPERATIONS

- Never dig the work face under an overhang. There is a hazard that rocks may fall or that the overhang may collapse and fall on top of the machine.

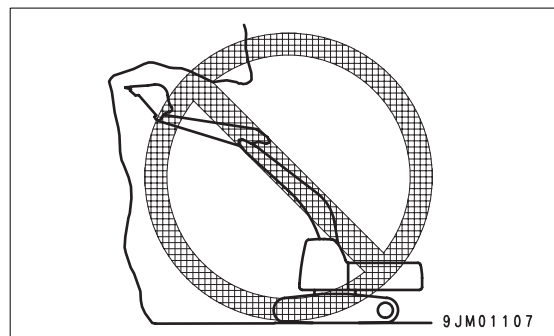

- Do not excavate too deeply under the front of the machine. The ground under the machine may collapse and cause the machine to fall.
- To make it easier to escape if there is any problem, set the tracks at right angles to the road shoulder or cliff with the sprocket at the rear when carrying out operations.
- Do not carry out demolition work under the machine. There is a hazard that the machine may become unstable and tip over.
- When working on or from the top of buildings or other structures, check the strength and the structure before starting operations. There is a hazard of the building collapsing and causing serious injury or damage.
- When carrying out demolition work, do not carry out demolition above your head. There is a hazard of broken parts falling or of the building collapsing and causing serious injury or property damage.
- Do not use the impact force of the work equipment for breaking work. There is a hazard of damage to the work equipment, or a hazard of serious personal injury being caused by flying pieces of broken materials, or of the machine tipping over due to reaction from the impact.
- Generally speaking, the machine is more liable to overturn when the work equipment is at the side than when it is at the front or rear.

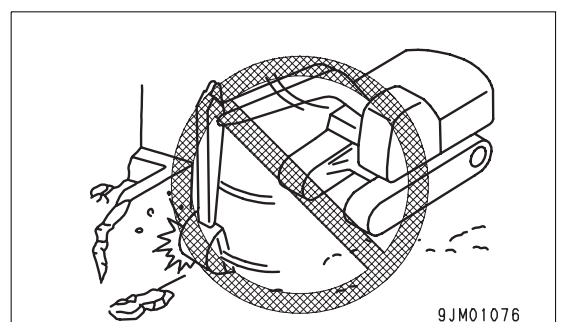
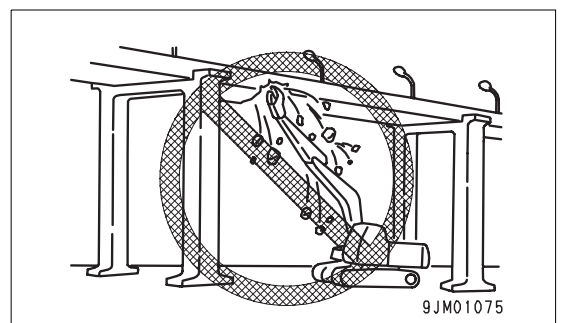
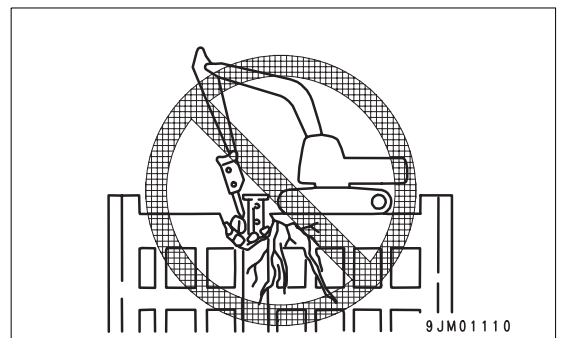
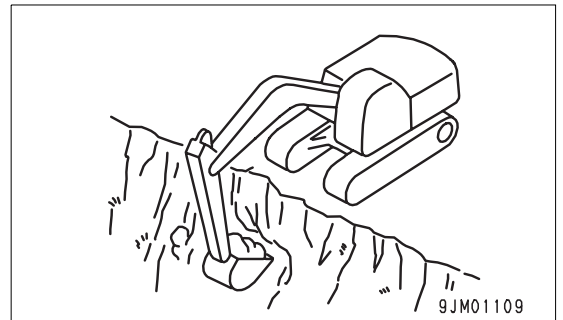
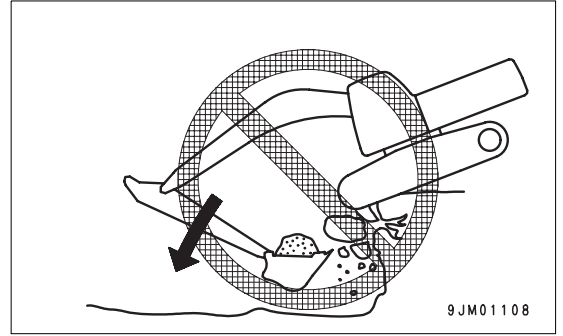

- When using a breaker or other heavy work equipment, there is a hazard of the machine losing its balance and tipping over. When operating on flat ground as well as on slopes.
 - Do not suddenly lower, swing, or stop the work equipment.
 - Do not suddenly extend or retract the boom cylinder. There is a hazard that impact will cause the machine to tip over.
- Do not pass the bucket over the head of other workers or over the operator's seat of dump trucks or other hauling equipment. The load may spill or the bucket may hit the dump truck and cause serious injury or property damage.

OPERATIONS ON SNOW

- Snow-covered or frozen surfaces are slippery, so be extremely careful when traveling or operating the machine, and do not operate the levers suddenly. Even a slight slope may cause the machine to slip, so be particularly careful when working on slopes.
- With frozen ground surfaces, the ground becomes soft when the temperature rises, and this may cause the machine to tip over.
- If the machine enters deep snow, there is a hazard that it may tip over or become buried in the snow. Be careful not to leave the road shoulder or to get trapped in a snow drift.
- When clearing snow, the road shoulder and objects placed beside the road are buried in the snow and cannot be seen. There is a hazard of the machine tipping over or hitting covered objects, so always carry out operations carefully.

PARKING MACHINE

- Park the machine on firm, level ground.
- Select a place where there is no hazard of falling rocks or landslides, or of flooding if the land is low.
- Lower the work equipment completely to the ground.

- When leaving the machine, set lock lever (1) to the LOCK position (L), then stop the engine.
- Always close the operator's cab door, and use the key to lock all the equipment in order to prevent any unauthorized person from moving the machine. Always remove the key, take it with you, and leave it in the specified place.
- If it is necessary to park the machine on a slope, always do as follows.
 - Set the bucket on the downhill side, then dig it into the ground.
 - Put blocks under the tracks to prevent the machine from moving.

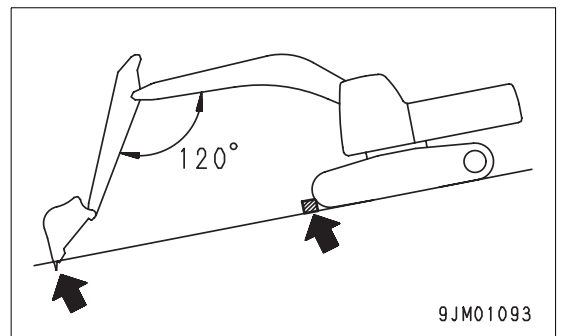
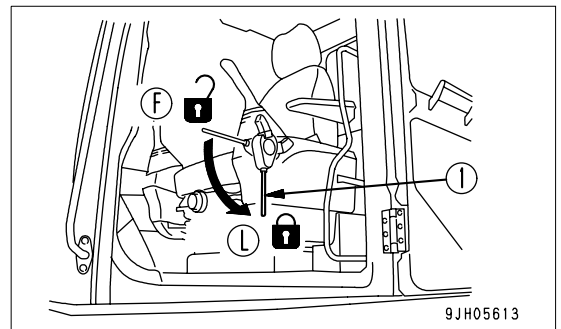
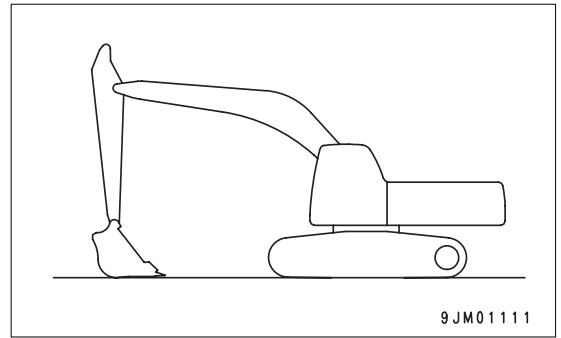

TRANSPORTATION

The machine can be divided into parts for transportation, so when transporting the machine, please contact your Komatsu distributor to have the work carried out.

LOADING AND UNLOADING

When loading or unloading the machine, mistaken operation may bring the hazard of the machine tipping over or falling, so particular care is necessary. Always do as follows.

- Perform loading and unloading on firm, level ground only. Maintain a safe distance from the edge of the road or cliff.
- Never use the work equipment to load or unload the machine. There is danger that the machine may fall or tip over.
- Always use ramps of adequate strength. Be sure that the ramps are wide, long, and thick enough to provide a safe loading slope. Take suitable steps to prevent the ramps from moving out of position or coming off.
- Be sure the ramp surface is clean and free of grease, oil, ice and loose materials. Remove dirt from machine-tracks. On a rainy day, in particular, be extremely careful since the ramp surface is slippery.
- Turn the auto-decelerator switch OFF (auto-deceleration function released).
- Run the engine at low speed and travel slowly.
- When on the ramps, do not operate any lever except for the travel lever.
- Never correct your steering on the ramps. If necessary, drive off the ramps, correct the direction, then enter the ramps again.
- The center of gravity of the machine will change suddenly at the joint between the ramps and the track or trailer, and there is danger of the machine losing its balance. Travel slowly over this point.
- When loading or unloading to an embankment or platform, make sure that it has suitable width, strength, and grade.
- When swinging the upper structure on the trailer, the trailer is unstable, so pull in the work equipment and swing slowly.
- For machines equipped with a cab, always lock the door after boarding the machine. If this is not done, the door may suddenly open during transportation.

Refer to "TRANSPORTATION (3-125)".

SHIPPING THE MACHINE

When shipping the machine on a trailer, do as follows.

- The weight, transportation height, and overall length of the machine differ according to the work equipment, so be sure to confirm the dimensions.
- When passing over bridges or structures on private land, check first that the structure is strong enough to support the weight of the machine. When traveling on public roads, check first with the relevant authorities and follow their instructions.
- For details of the shipping procedure, see "TRANSPORTATION (3-125)" in the OPERATION section.

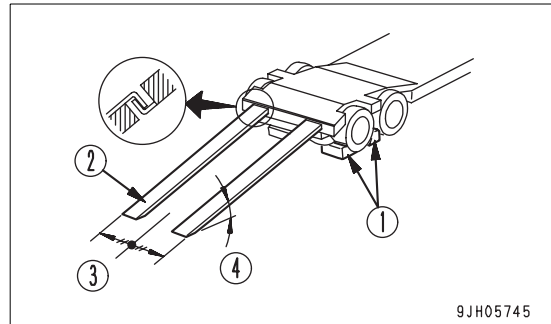

- (1) Blocks
- (2) Ramp
- (3) Centerline of trailer
- (4) Angle of ramps: Max. 15°

BATTERY

BATTERY HAZARD PREVENTION

Battery electrolyte contains sulphuric acid, and batteries generate flammable hydrogen gas, which may explode. Mistaken handling can lead to serious injury or fire. For this reason, always observe the following precautions.

- Do not use or charge the battery if the battery electrolyte level is below the LOWER LEVEL line. This may cause an explosion. Check the battery electrolyte level periodically and add distilled water to bring the electrolyte level to the UPPER LEVEL line.
- When working with batteries, always wear safety glasses and rubber gloves.
- Never smoke or use any flame near the battery.

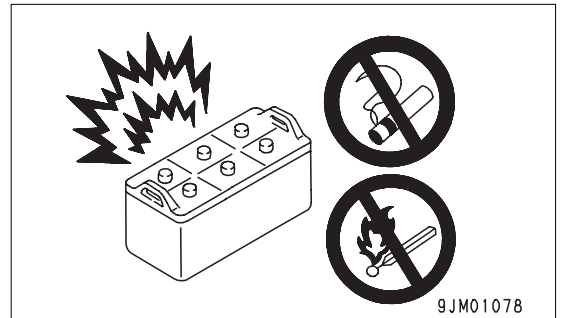

- If you spill acid on your clothes or skin, immediately flush the area with large amount of water.
- If acid gets into your eyes, flush them immediately with large amount of water and seek medical attention.
- Before working with batteries, turn the starting switch to the OFF position.

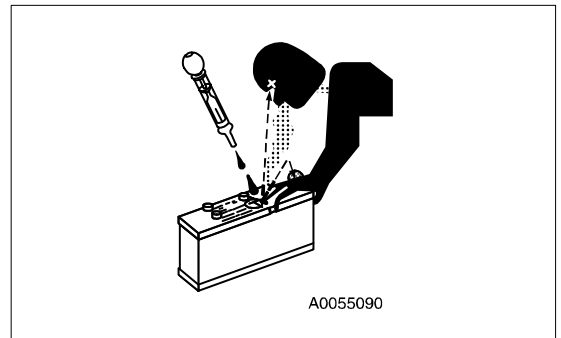

As there is a hazard that sparks will be generated, always do as follows.

- Do not let tools or other metal objects make any contact between the battery terminals. Do not leave tools or other metal objects lying around near the battery.
- Always disconnect the negative (-) terminal (ground side) first when removing the battery; when installing the battery, connect the positive (+) terminal first, and connect the ground last. Tighten the battery terminals securely.
- Flammable hydrogen gas is generated when the battery is charged, so remove the battery from the chassis, take it to a well-ventilated place, and remove the battery caps before charging it.
- Tighten the battery caps securely.
- Install the battery securely to the determined place.

STARTING ENGINE WITH BOOSTER CABLES

If any mistake is made in the method of connecting the booster cables, it may cause the battery to explode, so always do as follows.

- When starting with a booster cable, carry out the starting operation with two workers (one worker sitting in the operator's seat and the other working with the battery).
- When starting from another machine, do not allow the two machines to touch.
- When connecting the booster cables, turn the starting switch OFF position for both the normal machine and problem machine. There is a hazard that the machine will move when the power is connected.
- Be sure to connect the positive (+) cable first when installing the booster cables. Disconnect the negative (-) cable (ground side) first when removing them.
- When removing the booster cables, be careful not to let the booster cable clips touch each other or to let the clips touch the machine.
- Always wear safety glasses and rubber gloves when starting the engine with booster cables.
- When connecting a normal machine to a problem machine with booster cables, always use a normal machine with the same battery voltage as the problem machine.
- For details of the starting procedure when using booster cables, see "Starting Engine with Booster Cables (3-146)" in the OPERATION section.

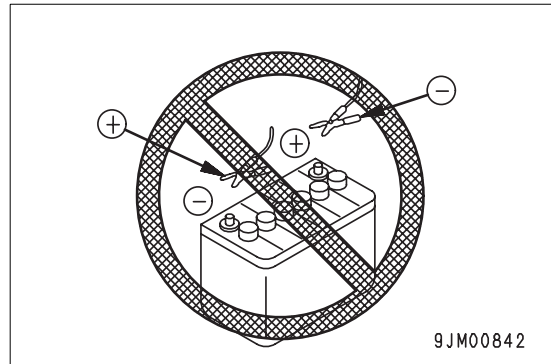

TOWING

SAFETY RULES FOR TOWING

Serious injury or death could result if a disabled machine is towed incorrectly or if there is a mistake in the selection or inspection of the wire rope.

For towing, see "TOWING THE MACHINE (3-143)".

- Always check that the wire rope used for towing has ample strength for the weight of the machine being towed.
- Never use a wire rope which has cut strands (A), reduced diameter (B), or kinks (C). There is danger that the rope may break during the towing operation.
- Always wear leather gloves when handling wire rope.
- Never tow a machine on a slope.
- During the towing operation, never stand between the towing machine and the machine being towed.
- Operate the machine slowly and be careful not to apply any sudden load to the wire rope.

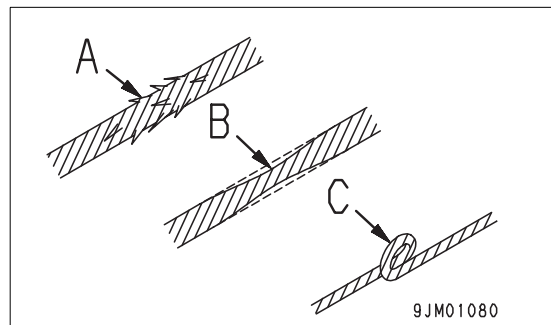

LIFTING OBJECTS WITH BUCKET

SAFETY RULES FOR LIFTING OBJECTS

- Do not carry out lifting work on slopes, soft ground, or other places where the machine is not stable.
- Use wire rope that conforms to the specified standard.
- Always observe the specified lifting load strictly.
- It is dangerous if the load hits any worker or structure. Always check carefully that the surrounding area is safe before swinging or turning the machine.
- Do not start, swing, or stop the machine suddenly. There is a hazard that the lifted load will swing.
- Do not pull the load to the side or in towards the machine.
- Do not leave the operator's seat when there is a raised load.

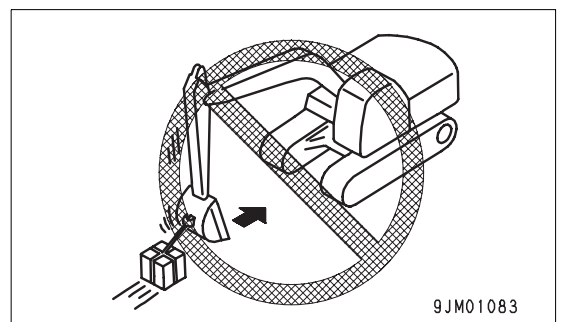
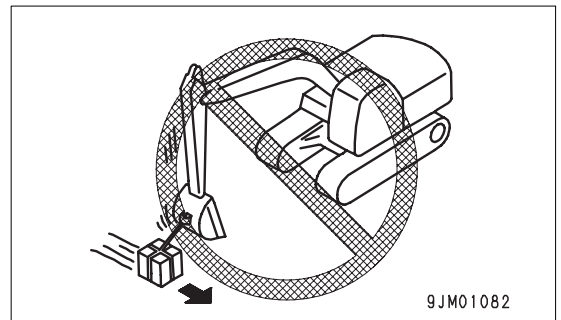

SAFETY MAINTENANCE INFORMATION

WARNING TAG

- Always attach the "DO NOT OPERATE" warning tag to the work equipment control lever in the operator's cab to alert others that you are performing service or maintenance on the machine. Attach additional warning tags around the machine if necessary.

Warning tag Part No. 09963-A1640

Keep this warning tag in the tool box while it is not used. If there is not the tool box, keep the tag in the operation manual pocket.

- If others start the engine, or touch or operate the work equipment control lever while you are performing service or maintenance, you could suffer serious injury or property damage.

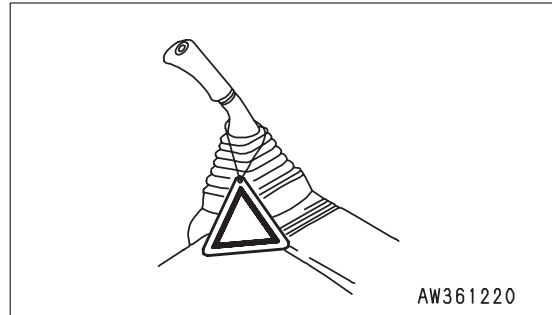

KEEP WORK PLACE CLEAN AND TIDY

- Do not leave hammers or other tools lying around in the work place. Wipe up all grease, oil, or other substances that will cause you to slip. Always keep the work place clean and tidy to enable you to carry out operations safely.

If the work place is not kept clean and tidy, there is the danger that you will trip, slip, or fall over and injure yourself.

- When cleaning the ceiling window which is made of organic glass (polycarbonate), use tap water and avoid use of organic solvents for cleaning. An organic solvent like benzene, toluene or methanol can invite a chemical reaction like dissolution and decomposition on the window glass, deteriorating polycarbonate in use.

APPOINT LEADER WHEN WORKING WITH OTHERS

- When repairing the machine or when removing and installing the work equipment, appoint a leader and follow his instructions during the operation.

STOP ENGINE BEFORE CARRYING OUT MAINTENANCE

- Stop the machine on firm, level ground.
- Select a place where there is no hazard of falling rocks or landslides, or of flooding if the land is low.
- Lower the work equipment completely to the ground and stop the engine.
- Turn the starting switch to the ON position. Operate the work equipment control lever back and forth, left and right at the full stroke 2 to 3 times to eliminate the remaining internal pressure in the hydraulic circuit, and then push up lock lever (1) to the LOCK position (L).

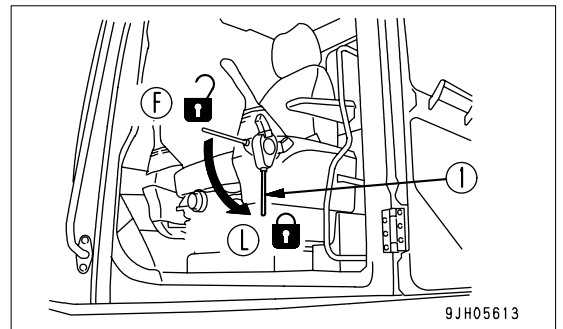
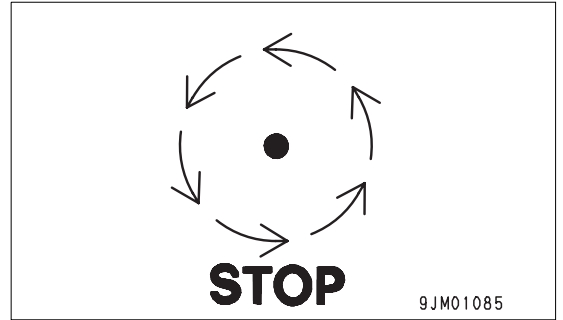

- Put blocks under the track to prevent the machine from moving.

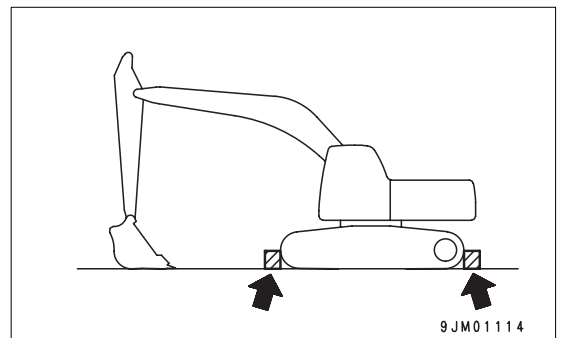

TWO WORKERS FOR MAINTENANCE WHEN ENGINE IS RUNNING

To prevent injury, do not carry out maintenance with the engine running. If maintenance must be carried out with the engine running, carry out the operation with at least two workers and do as follows.

- One worker must always sit in the operator's seat and be ready to stop the engine at any time. All workers must maintain contact with the other workers.
- When carrying out operations near the fan, fan belt, or other rotating parts, there is a hazard of being caught in the parts, so be careful not to come close.
- Never drop or insert tools or other objects into the fan or fan belt. Parts may break or be sent flying.

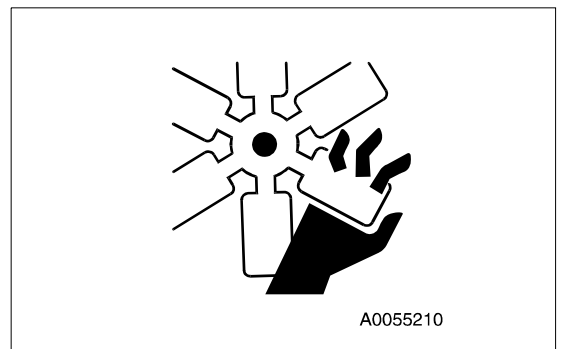

- Set lock lever (1) to the LOCK position (L) to prevent the work equipment from moving.
- Do not touch any control levers. If any control lever must be operated, give a signal to the other workers to warn them to move to a safe place.

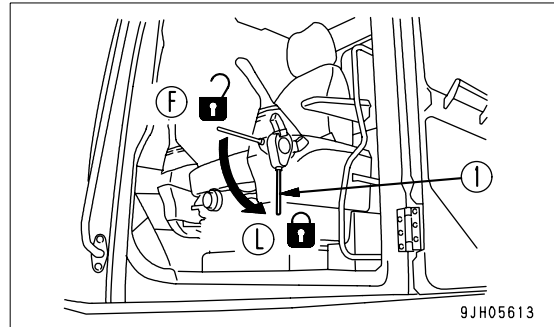

PROPER TOOLS

Use only tools suited to the task and be sure to use the tools correctly. Using damaged, low quality, faulty, makeshift tools or improper use of the tools could cause serious personal injury.

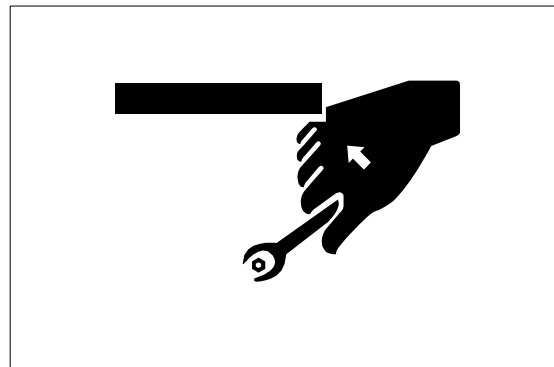

ACCUMULATOR

The accumulator is charged with high-pressure nitrogen gas. When handling the accumulator, careless procedure may cause an explosion which could lead to serious injury or property damage. For this reason, always observe the following precautions.

- Do not disassemble the accumulator.
- Do not bring it near flame or dispose of it in fire.
- Do not make holes in it, weld it, or use a cutting torch.
- Do not hit or roll the accumulator, or subject it to any impact.
- When disposing of the accumulator, the gas must be released. Please contact your Komatsu distributor to have this work performed.



PERSONNEL

Only authorized personnel can service and repair the machine. Do not allow unauthorized personnel into the area. If necessary, employ an observer.

ATTACHMENTS

- Appoint a leader before starting removal or installation operations for attachments.
- Place attachments that have been removed from the machine in a stable condition so that they do not fall. And take steps to prevent unauthorized persons from entering the storage area.



WORK UNDER THE MACHINE

- If it is necessary to go under the work equipment or the machine to carry out service and maintenance, support the work equipment and machine securely with blocks and stands strong enough to support the weight of the work equipment and machine.
- It is extremely dangerous to work under the machine if the track shoes are lifted off the ground and the machine is supported only with the work equipment. If any of the control levers is touched by accident, or there is damage occurring to the hydraulic piping, the work equipment or the machine will suddenly drop. This is extremely dangerous. Never work under the work equipment or the machine.



NOISE

When carrying out maintenance of the engine and you are exposed to noise for long periods of time, wear ear covers or ear plugs while working.

If the noise from the machine is too loud, it may cause temporary or permanent hearing problems.

WHEN USING HAMMER

When using a hammer, pins may fly out or metal particles may be scattered. This may lead to serious injury. Always do as follows.

- If hard metal parts such as pins, bucket teeth, cutting edges, or bearings are hit with a hammer, there is a hazard that pieces might be scattered and cause injury. Always wear safety glasses and gloves.
- When hitting pins or bucket teeth, there is a hazard that broken pieces might be sent flying and injure people in the surrounding area. Always check that there is no one in the surrounding area.
- There is a hazard that the pin hit with strong force may fly out and injure people in the surrounding area.

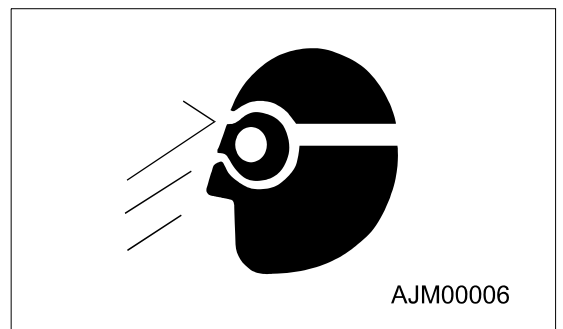

WELDING WORKS

Welding operations must always be carried out by a qualified welder and in a place equipped with proper equipment. There is a hazard of gas, fire, or electrocution when carrying out welding, so never allow any unqualified personnel to carry out welding.

REMOVING BATTERY TERMINALS

When repairing the electrical system or when carrying out electrical welding, remove the negative (-) terminal of the battery to prevent the flow of current.

SAFETY FIRST WHEN USING HIGH-PRESSURE GREASE TO ADJUST TRACK TENSION

- Grease is pumped into the track tension adjustment system under high pressure.

If the specified procedure for maintenance is not followed when making adjustment, grease drain plug (1) may fly out and cause serious injury or property damage.

- When loosening grease drain plug (1) to loosen the track tension, never loosen it more than one turn. Loosen the grease drain plug slowly.
- Never put your face, hands, feet, or any other part of your body close to grease drain plug (1).

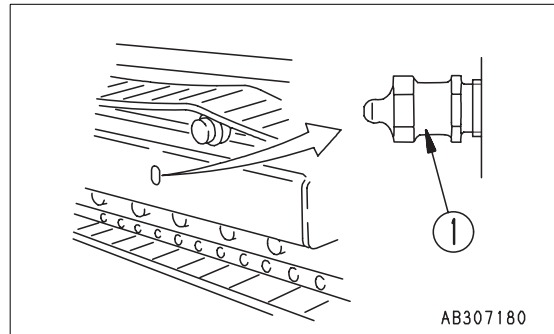

DO NOT DISASSEMBLE RECOIL SPRINGS

Never attempt to disassemble the recoils spring assembly. It contains a spring under high pressure which serves as a shock absorber for the idler. If it is disassembled by mistake, the spring will fly out and cause serious injury. When it becomes necessary to disassemble it, ask your Komatsu distributor to do the work.

SAFETY RULES FOR HIGH-PRESSURE OIL

The hydraulic system is always under internal pressure. When inspecting or replacing piping or hoses, always check that the pressure in the hydraulic circuit has been released. If the circuit is still under pressure, it will lead to serious injury, so always do as follows.

- Release the pressure in the hydraulic circuit. For details, see "METHOD OF RELEASING PRESSURE IN HYDRAULIC CIRCUIT (4-78)". Do not carry out any inspection or replacement work when the hydraulic system is under pressure.
- If there is any leakage from the piping or hoses, the surrounding area will be wet, so check for cracks in the piping and hoses and for swelling in the hoses.

When carry out inspection, wear safety glasses and leather gloves.

- There is a hazard that high-pressure oil leaking from small holes may penetrate your skin or cause blindness if it contacts your eyes directly. If you are hit by a jet of high-pressure oil and suffer injury to your skin or eyes, wash the place with clean water, and consult a doctor immediately for medical attention.

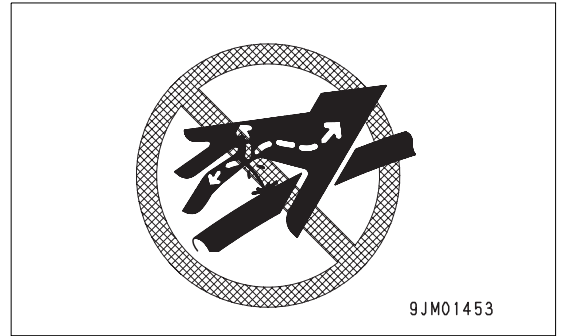

PRECAUTION FOR HIGH FUEL PRESSURE

High pressure is generated inside the engine fuel piping when the engine is running. When carrying out inspection or maintenance of the fuel piping system, wait for at least 30 seconds after stopping the engine to let the internal pressure go down before starting inspection or maintenance.

SAFETY HANDLING HIGH-PRESSURE HOSES

- If oil or fuel leaks from high-pressure hoses, it may cause fire or defective operation, which may lead to serious injury. If any loose bolts are found, stop work and tighten to the specified torque. If any damaged hoses are found, stop operations immediately and contact your Komatsu distributor.

Replace the hose if any of the following problems are found.

- Damaged or leaking hydraulic fitting.
- Frayed or cut covering or exposed reinforcement wire layer.
- Covering swollen in places.
- Twisted or crushed movable portion.
- Foreign material embedded in covering.

PRECAUTION FOR HIGH VOLTAGE

When the engine is running or immediately after it has stopped, high voltage is generated at the injector terminal and inside the engine controller, so there is danger of electrocution. Never touch the injector terminal or the inside of the engine controller.

If it is necessary to touch the injector terminal or the inside of the engine controller, please contact your Komatsu distributor.

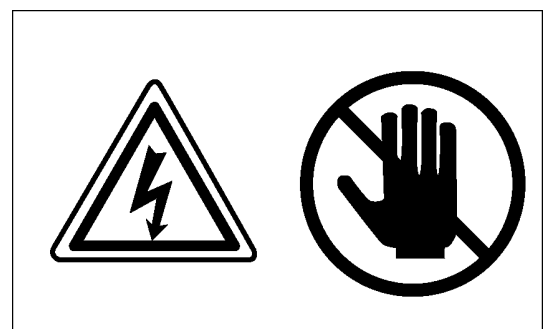

WASTE MATERIALS

To prevent pollution, pay careful attention to the method of disposing of waste materials.

- Always put oil drained from your machine in containers. Never drain oil directly onto the ground or dump into the sewage system, rivers, the sea, or lakes.
- Obey appropriate laws and regulations when disposing of harmful objects such as oil, fuel, coolant, solvent, filters, and batteries.

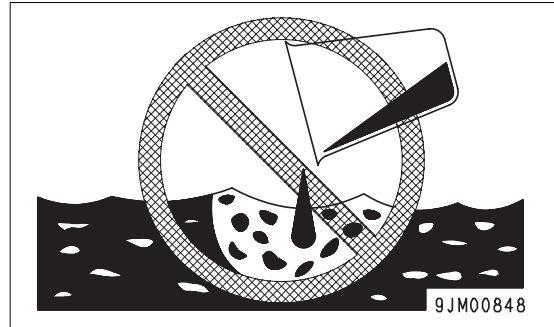

AIR CONDITIONER MAINTENANCE

If air conditioner refrigerant gets into your eyes, it may cause blindness; if it touches your skin, it may cause frostbite.

Never touch refrigerant.

COMPRESSED AIR

- When carrying out cleaning with compressed air, there is a hazard of serious injury caused by flying particles.
- When using compressed air to clean elements or the radiator, always wear safety glasses, dust mask, gloves, and other protective equipment.

PERIODIC REPLACEMENT OF SAFETY CRITICAL PARTS

- For using the machine safely for an extended period of time, replace safety-critical parts like hoses and seat belts periodically.

Replacement of safety-critical parts: See "SAFETY CRITICAL PARTS (4-13)".

- The material of these components naturally changes over time, and repeated use causes deterioration, wear, and fatigue. As a result, there is a hazard that these components may fail and cause serious injury or death. It is difficult to judge the remaining life of these components from external inspection or the feeling when operating, so always replace them at the specified interval.
- Replace or repair safety-critical parts if any defect is found, even when they have not reached the time specified interval.

OPERATION



WARNING

Please read and make sure that you understand the safety volume before reading this section.

MACHINE VIEW ILLUSTRATIONS

OVERALL MACHINE VIEW

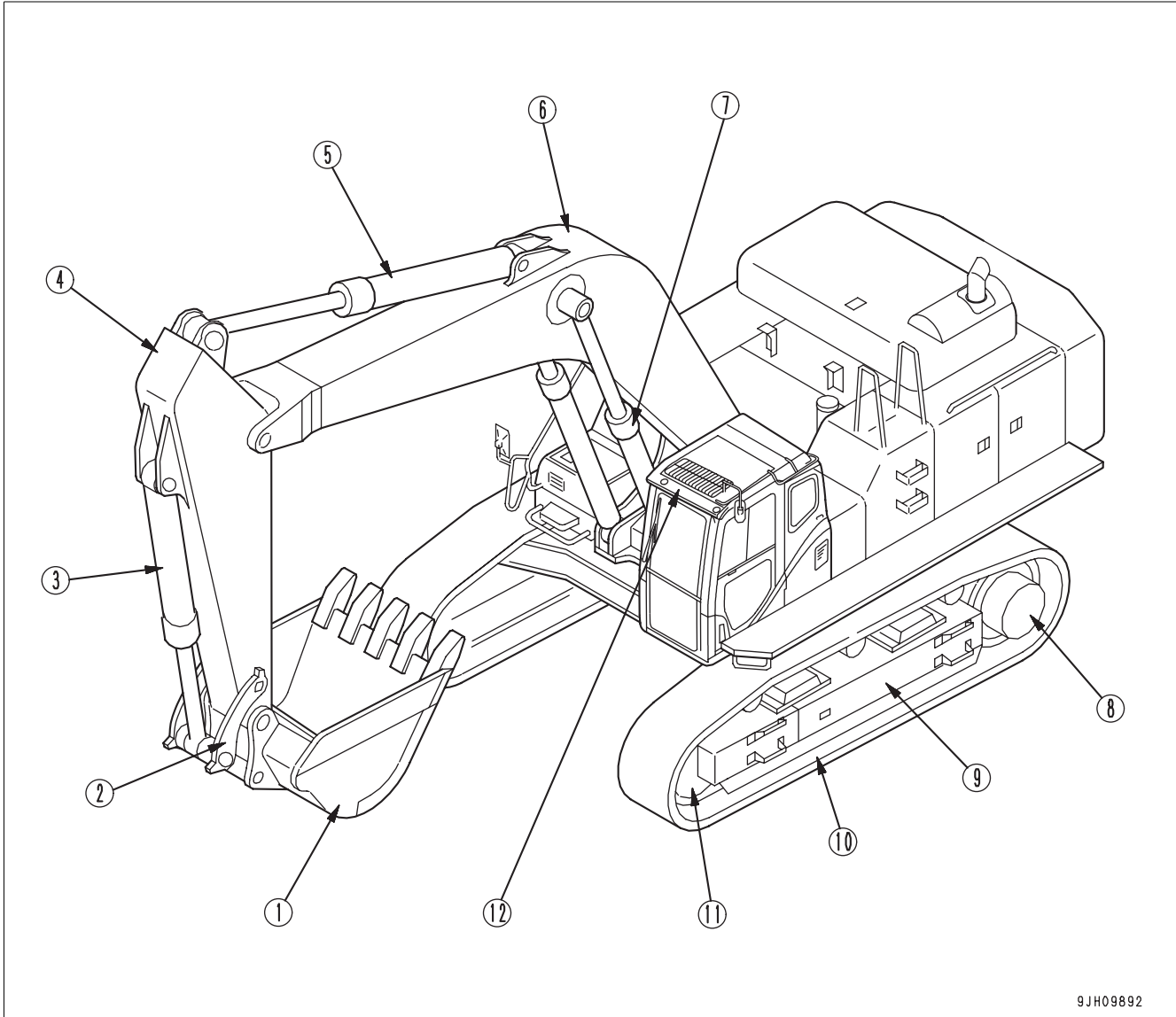

9JH09892

- | | |
|---------------------|--|
| (1) Bucket | (7) Boom cylinder |
| (2) Bucket link | (8) Sprocket |
| (3) Bucket cylinder | (9) Track frame |
| (4) Arm | (10) Track shoe |
| (5) Arm cylinder | (11) Idler |
| (6) Boom | (12) OPG (Operator Protection Guard) (if equipped) |

CONTROLS AND GAUGES

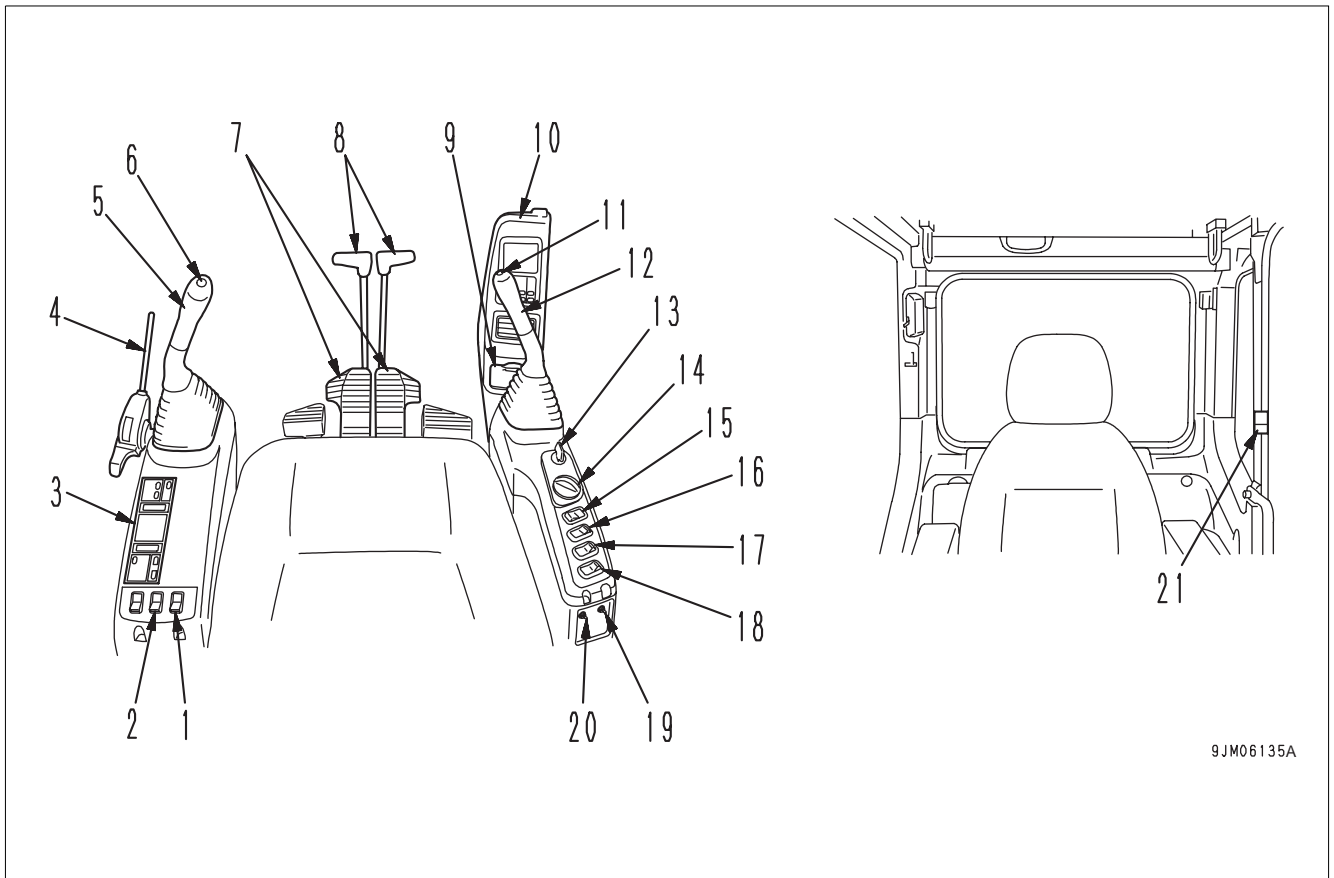

9JM06135A

- | | |
|---|---|
| <ul style="list-style-type: none"> (1) Lower wiper switch (machines with fixed front window cab) or Large capacity airflow air conditioner blower switch (If equipped) (2) Revolving warning lamp switch (option) (3) Air conditioner control switch (4) Safety lock lever (5) L.H. work equipment control lever (6) One-touch power max. switch (7) Travel pedals (8) Travel levers (9) Cigarette lighter (10) Machine monitor | <ul style="list-style-type: none"> (11) Horn switch (12) R.H. work equipment control lever (13) Starting switch (14) Fuel control dial (15) Lamp switch (16) Alarm buzzer stop switch (17) Swing lock switch (18) Machine push-up switch (19) Swing holding brake release switch (20) Emergency pump drive switch (21) Step light switch |
|---|---|

Machine monitors

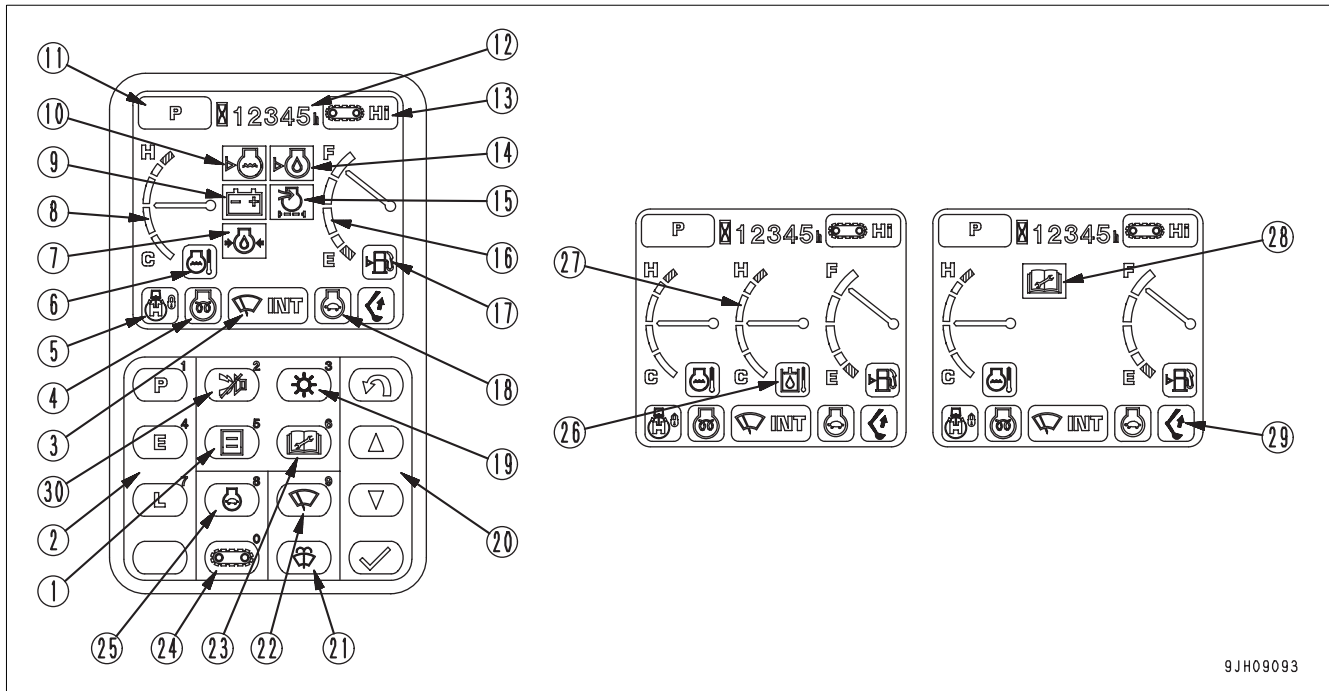

9JH09093

- | | |
|--------------------------------------|--|
| (1) User mode adjustment switch | (16) Fuel gauge |
| (2) Working mode selection switch | (17) Fuel level monitor |
| (3) Wiper monitor | (18) Auto-deceleration monitor |
| (4) Engine pre-heating monitor | (19) Display control switch |
| (5) Swing lock monitor | (20) Input control switch |
| (6) Engine water temperature monitor | (21) Window washer switch |
| (7) Engine oil pressure monitor | (22) Wiper switch |
| (8) Engine water temperature gauge | (23) Maintenance switch |
| (9) Charge level monitor | (24) Travel speed selection switch |
| (10) Radiator coolant level monitor | (25) Auto-deceleration switch |
| (11) Working mode monitor | (26) Hydraulic oil temperature monitor |
| (12) Service meter | (27) Hydraulic oil temperature gauge |
| (13) Travel speed monitor | (28) Maintenance interval monitor |
| (14) Engine oil temperature monitor | (29) One-touch power max. monitor |
| (15) Air cleaner clogging monitor | (30) Alarm buzzer stop switch |

DETAILED CONTROLS AND GAUGES

The following is an explanation of devices needed for operating the machine.

To perform suitable operations correctly and safely, it is important to completely understand methods of operating the equipment, and the meanings of the displays.

MONITORING SYSTEM

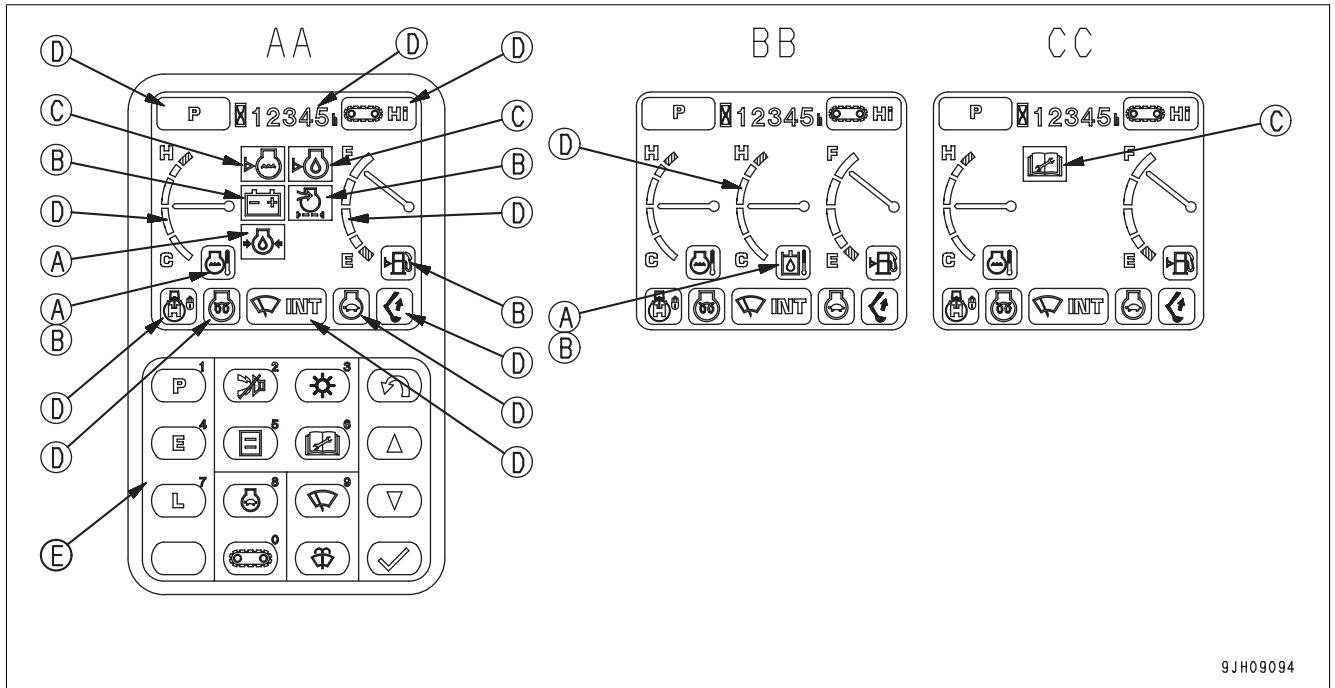

AA: Screen with all lamps lit up

BB: Screen for normal operation

CC: Maintenance time warning screen

- (A) Emergency monitors
- (B) Caution monitors
- (C) Basic check monitors

- (D) Meter display portion
- (E) Monitor switches portion

Basic Operation of Machine Monitor

If There Is Abnormality When Starting Engine

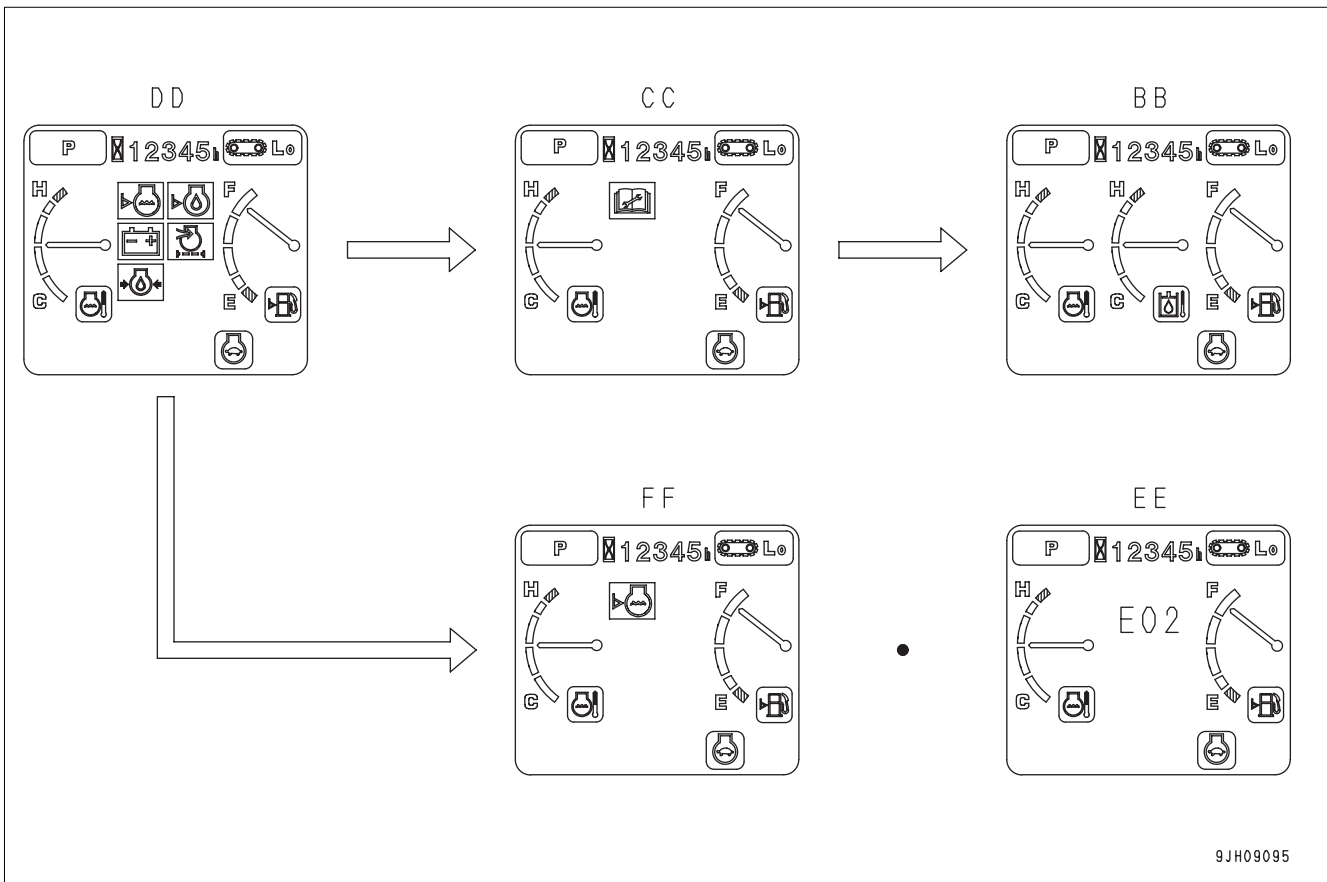

9JH09095

- If there is any abnormality when starting the engine, the check before starting screen DD changes to the maintenance interval warning screen CC, warning screen FF, or error screen EE.
- After displaying the check before starting screen DD for 2 seconds, the screen changes to the maintenance interval warning screen CC.
- After displaying the maintenance interval warning screen CC for 30 seconds, the screen returns to the normal screen BB.
- After displaying the check before starting screen DD for 2 seconds, the screen changes to the warning screen FF or error screen EE.

If Any Abnormality Occurs During Operation

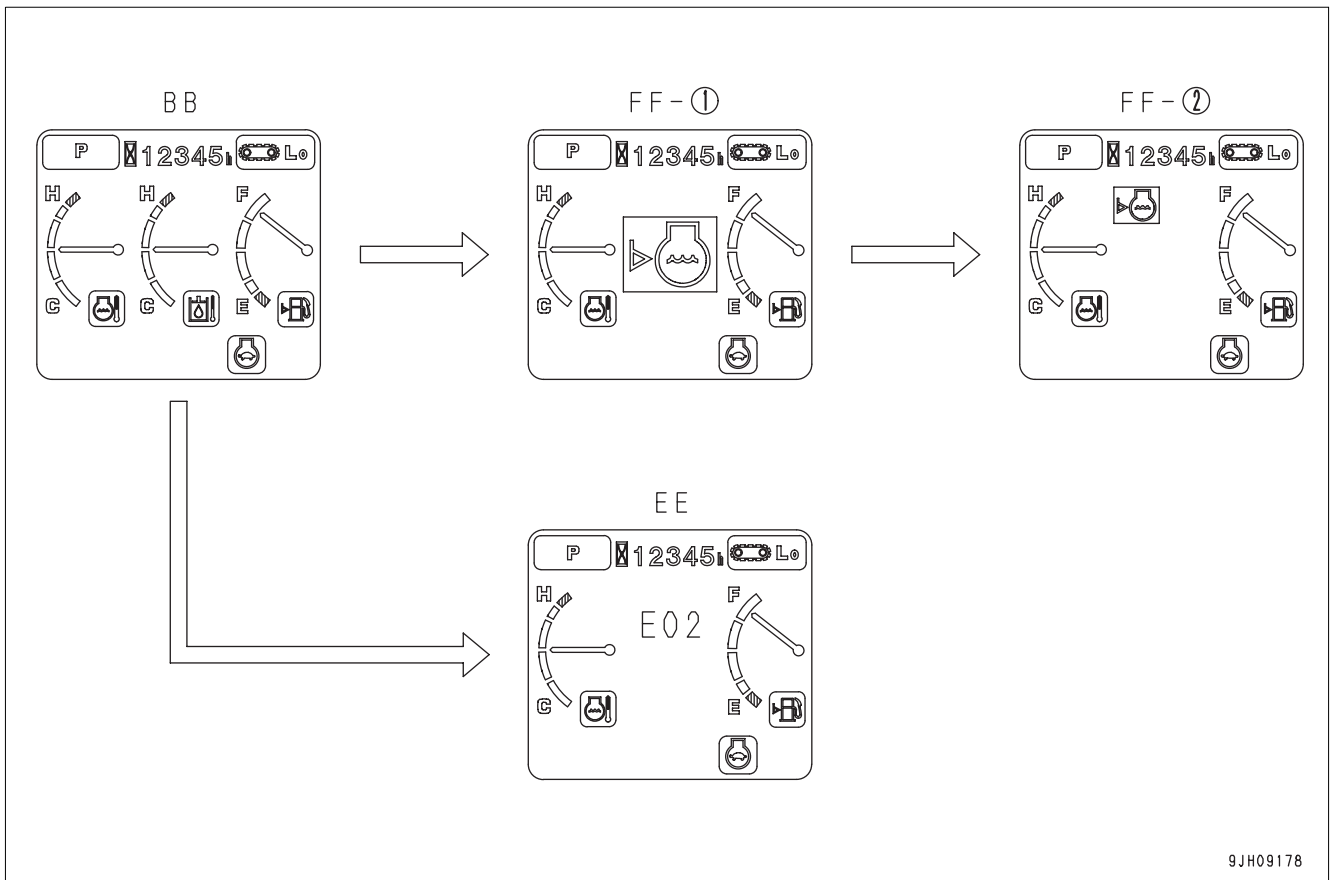

9JH09178

- If any abnormality occurs during operation, the normal operation screen BB changes to warning screen FF-(1) or the error screen EE.
- After displaying warning screen FF-(1) for 2 seconds, the screen automatically changes to warning screen FF-(2).

REMARK

The colors lighting up the monitors related to the emergency stop items, caution items, and basic check items are as follows.

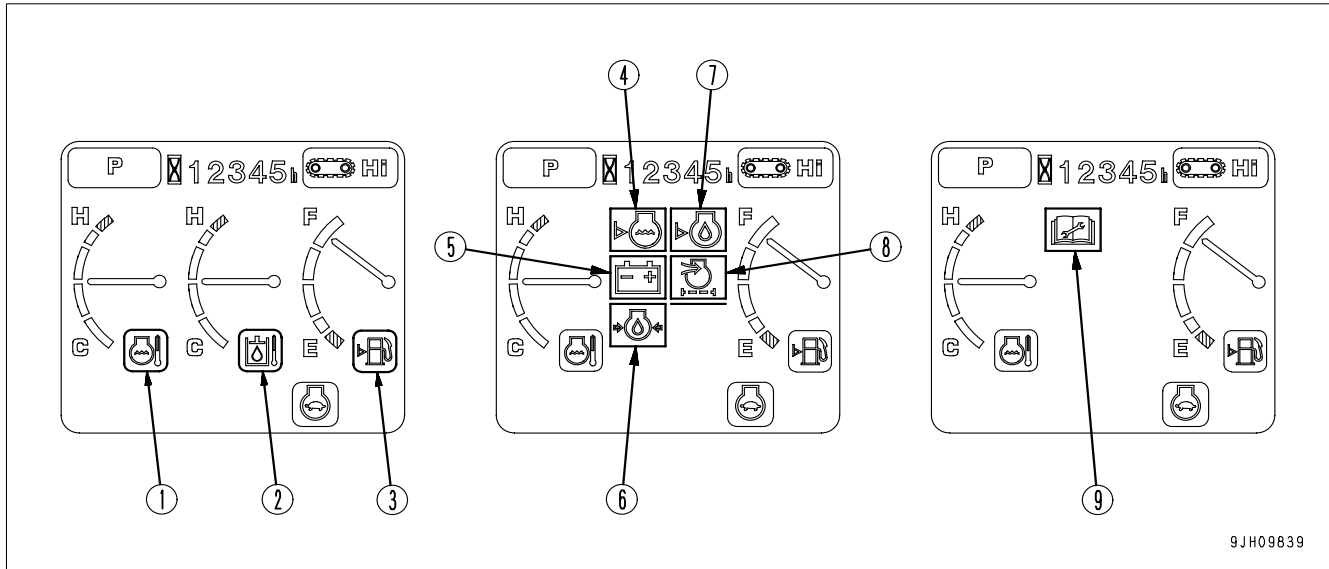

9JH09639

	Type of monitor	Color when monitor lights up		
		When normal	When abnormal	At low temperature
(1)	Engine coolant temperature monitor	Green	Red	White
(2)	Hydraulic oil temperature monitor	Green	Red	White
(3)	Fuel level monitor	Green	Red	-
(4)	Radiator coolant level monitor	OFF	Red	-
(5)	Charge monitor	OFF	Red	-
(6)	Engine oil pressure monitor	OFF	Red	-
(7)	Engine oil level monitor	OFF	Red	-
(8)	Air cleaner clogging monitor	OFF	Red	-
(9)	Maintenance interval monitor	OFF	Red	-

Emergency Monitors

⚠ CAUTION

If the monitor lights up red, stop the engine immediately or run at low idle, check applicable location, then perform necessary actions.

These items should be observed while the engine is running. If there is a problem, the monitor for the abnormal location lights up red and buzzer sounds, perform action immediately.

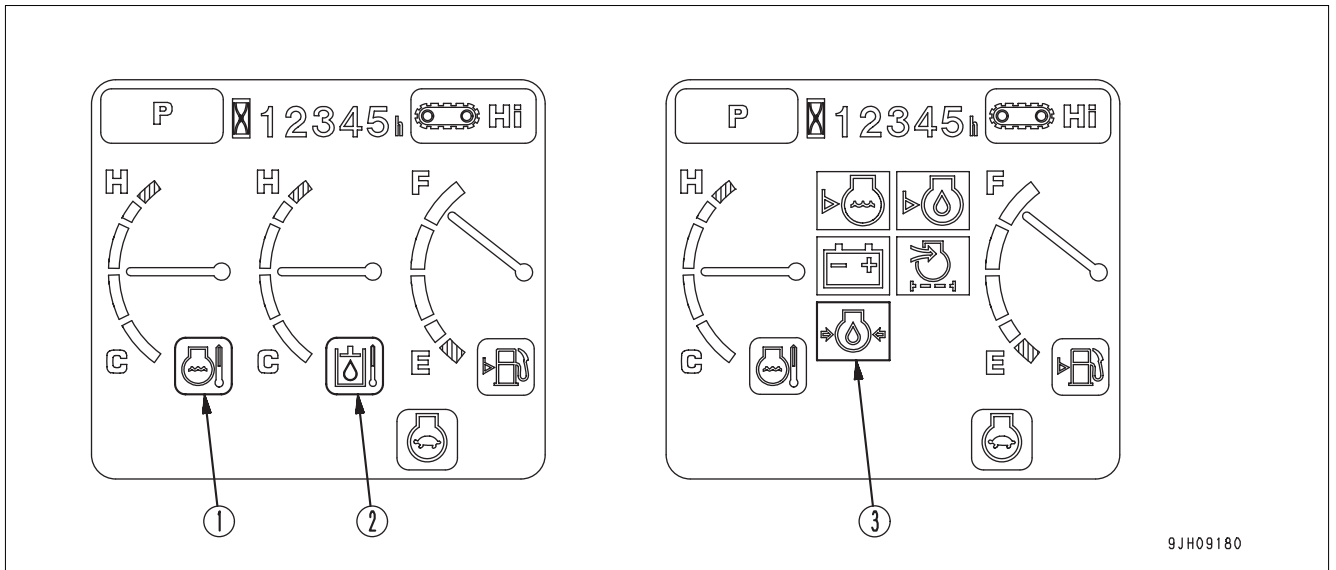

- (1) Engine coolant temperature monitor
- (2) Hydraulic oil temperature monitor

- (3) Engine oil pressure monitor

Engine Coolant Temperature Monitor

Monitor (1) warns operator that the engine coolant temperature has risen.

If engine coolant temperature becomes abnormally high, monitor lights up red, overheat prevention system is automatically actuated, and the engine speed goes down.

Stop operations and run engine at low idle until monitor (1) changes to green.

Check for clogging of the radiator grill or any other problem that will cause overheating.



Hydraulic Oil Temperature Monitor

Monitor (2) warns operator that the hydraulic oil temperature has risen.

If monitor lights up red during operations, run engine at low idle or stop the engine and wait until the oil temperature goes down and monitor (2) changes to green.

Check for clogging of the radiator grill or any other problem that will cause overheating.

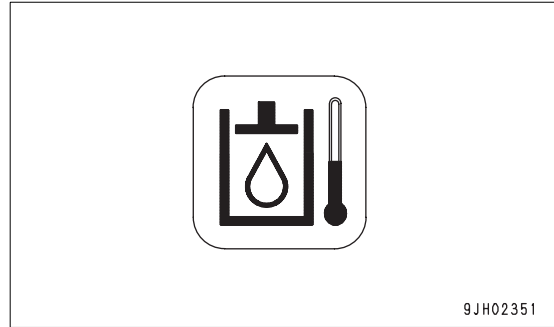

9JH02351

Engine Oil Pressure Monitor

Monitor (3) lights up red if the engine lubrication oil pressure goes below normal level. If monitor lights up red, stop the engine immediately, check the lubrication system and level of oil in the engine oil pan.

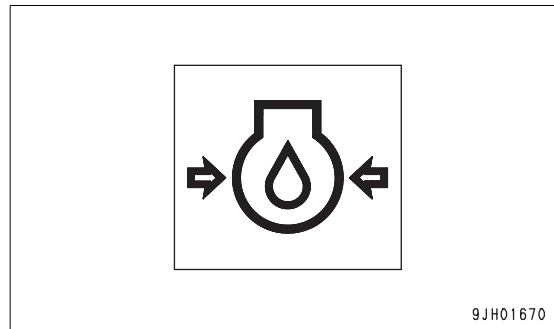

9JH01670

Caution Monitors

⚠ CAUTION

If the warning monitor lights up red, stop operations as soon as possible and perform inspection and maintenance of the applicable location. If the warning is ignored, it may lead to failure.

These are items that should be observed while the engine is running. If any abnormality occurs, the screen displays the item that needs immediate action.

If there is an abnormality, the monitor for the abnormal location lights up red.

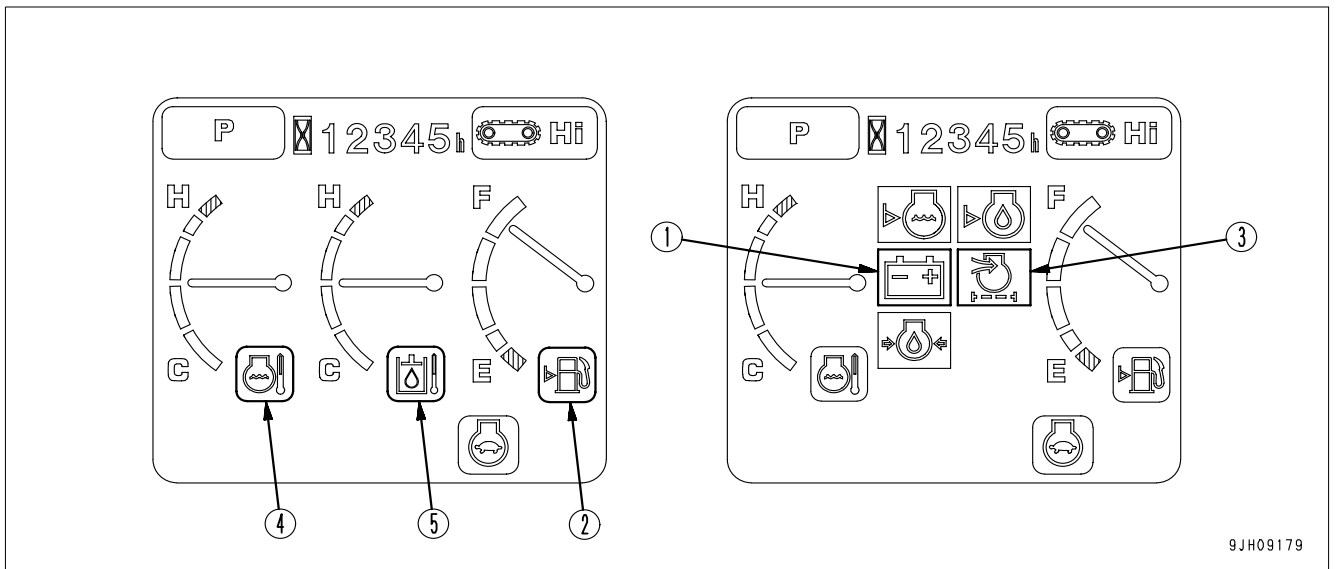

- (1) Charge level monitor
- (2) Fuel level monitor
- (3) Air cleaner clogging monitor
- (4) Engine water temperature monitor
- (5) Hydraulic oil temperature monitor

Charge Level Monitor

Monitor (1) warns the operator of an abnormality in the charging system while the engine is running.

If the battery is not being charged properly while the engine is running, monitor (1) lights up red.

If monitor lights up red, check the V-belt for looseness. If any abnormality is found, perform the necessary actions. For details, see “OTHER TROUBLE (3-148)”.

REMARK

When the engine is started or stopped, the lamp may light momentarily, but this does not indicate any abnormality.

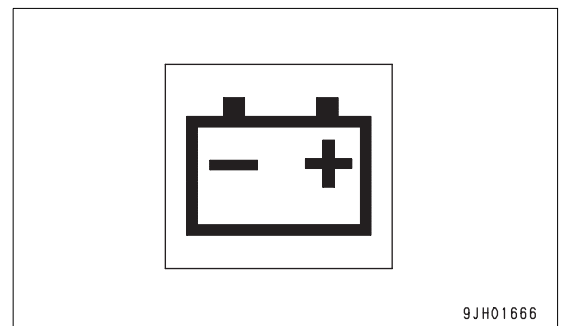

9JH01666

Fuel Level Monitor

Monitor (2) lights up to warn the operator the fuel level in the tank is low.

If the remaining amount of fuel goes down to 101 liters, the light changes from green to red, so add fuel as soon as possible.

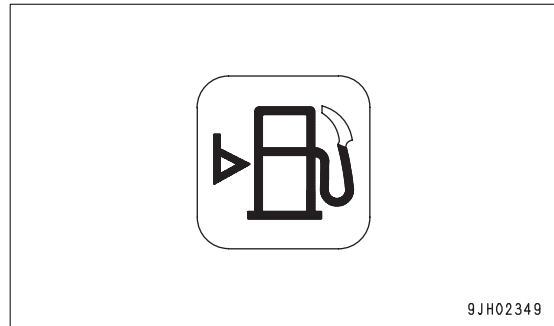

Air Cleaner Clogging Monitor

Monitor (3) warns the operator of a clogged air cleaner.

If the monitor lights up red, stop the engine, inspect and clean the air cleaner. For details, see "CHECK, CLEAN AND REPLACE AIR CLEANER ELEMENT (4-19)".

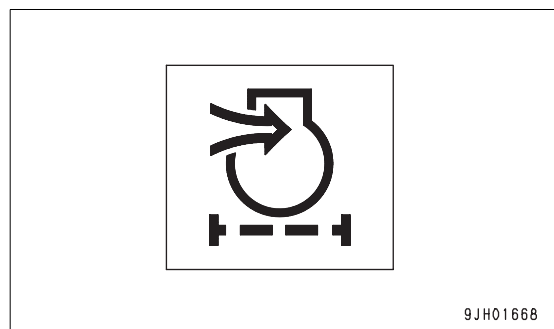

Engine Coolant Temperature Monitor

If monitor (4) lights up white in low temperatures, perform warming-up operation. For details, see "Warming Up Engine (3-94)". Continue warming-up operation until monitor (4) changes to green.

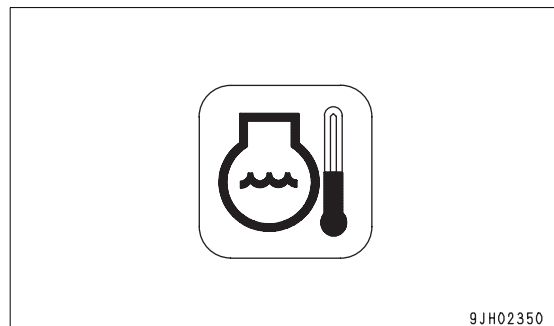

Hydraulic Oil Temperature Monitor

If monitor (5) lights up white in low temperatures, perform warming-up operation. For details, see "Warming Up Hydraulic Equipment (3-96)". Continue warming-up operation until monitor (5) changes to green.

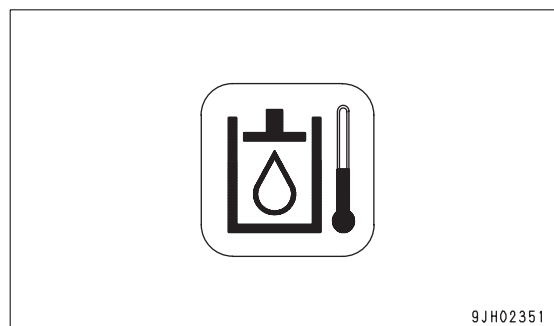

Basic Check Monitors

⚠ CAUTION

These monitors DO NOT ensure that the machine is in good condition. When performing checks before starting (daily checks), do not simply rely on the monitors. Always dismount the machine and check each item directly.

Displays basic items among the check before starting items that must be checked before starting the engine. If there is any abnormality, monitor for the location of abnormality will light up.

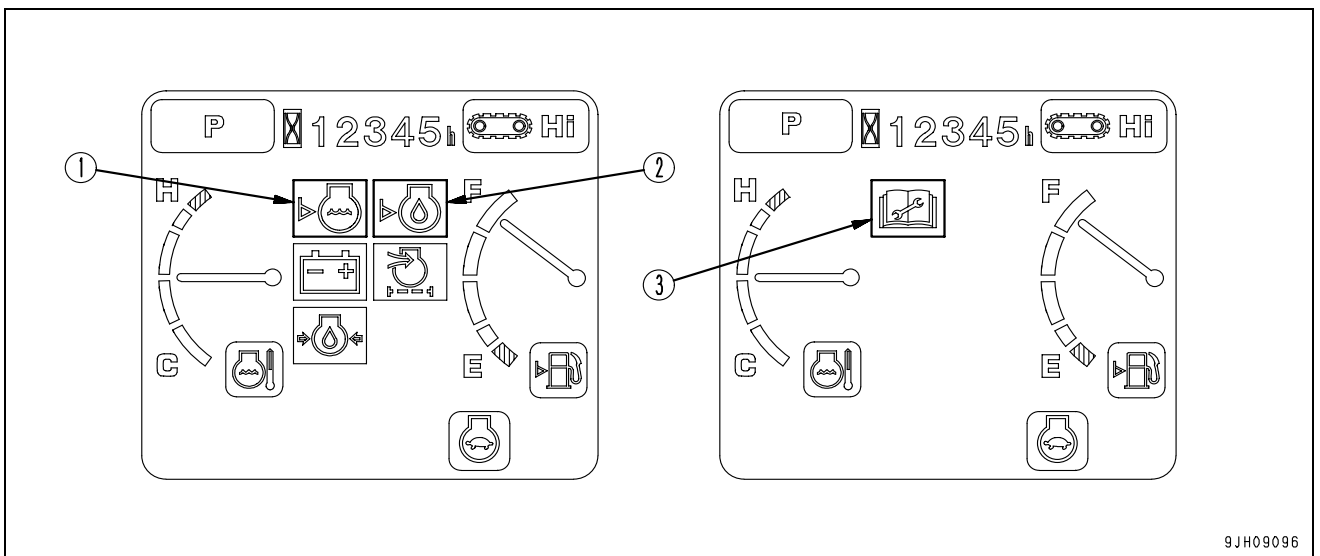

- (1) Radiator coolant level monitor
- (2) Engine oil level monitor

- (3) Maintenance interval monitor

Radiator Coolant Level Monitor

Monitor (1) warns the operator that there has been a drop in the radiator coolant level.

If the radiator coolant is low, the lamp lights up red, so check coolant level in the radiator and subtank, and add coolant.

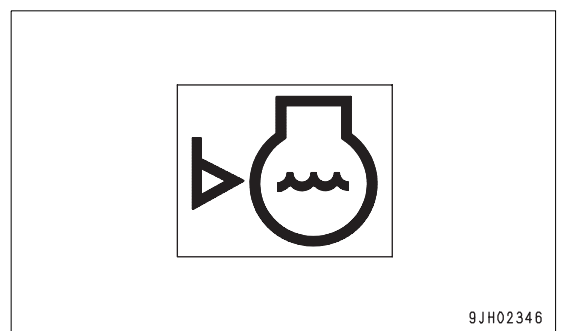

Engine Oil Level Monitor

Monitor (2) warns the operator that the oil level in the engine oil pan has dropped.

If oil level in the engine oil pan is low, the lamp lights up red, so check the oil level, and add oil.

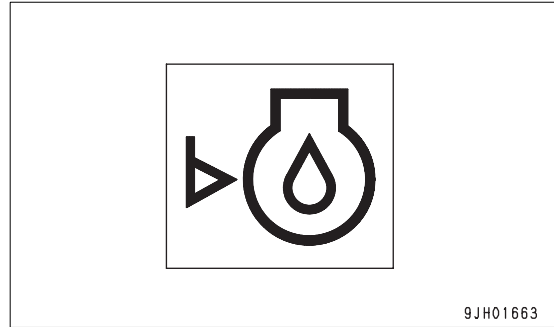

Maintenance Interval Monitor

Monitor (3) lights up to warn the operator that the set time has passed since maintenance was last performed.

This monitor screen goes out after 30 seconds and returns to the normal operation screen.

- For details of the method of checking the maintenance interval, see "Maintenance Switch (3-24)" in the Detailed controls and gauges.

If it is desired to change the maintenance interval settings, have your Komatsu distributor change the interval settings.

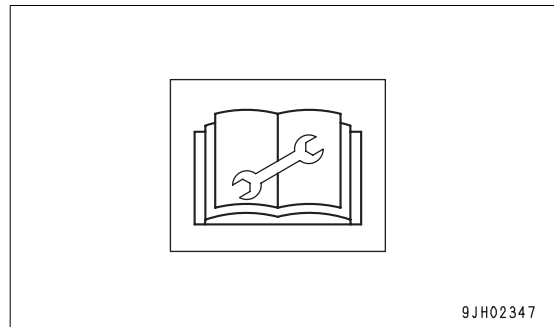

Meter Display Portion

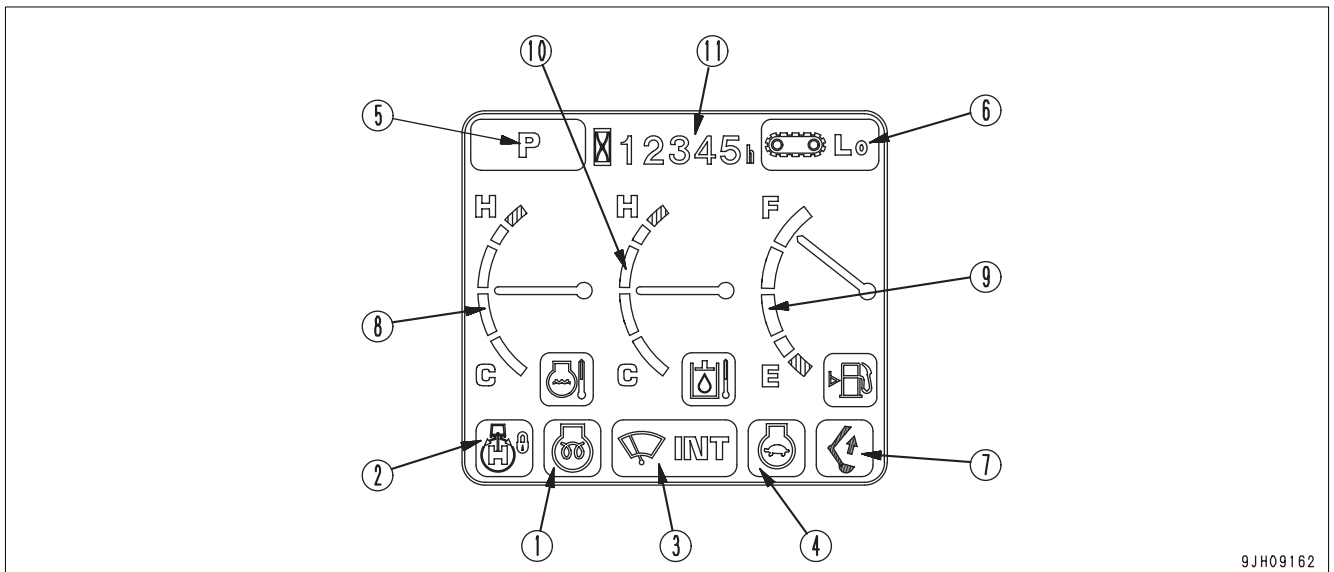

9JH09162

Pilot display

Gauges and Meter

- | | |
|----------------------------------|--------------------------------------|
| (1) Engine pre-heating monitor | (8) Engine coolant temperature gauge |
| (2) Swing lock monitor | (9) Fuel gauge |
| (3) Wiper monitor | (10) Hydraulic oil temperature gauge |
| (4) Auto-deceleration monitor | (11) Service meter |
| (5) Working mode monitor | |
| (6) Travel speed monitor | |
| (7) One-touch power max. monitor | |

Pilot Display

When starting switch is ON, the pilot display lights up when display items are functioning.

Engine Pre-heating Monitor

Monitor lamp (1) indicates pre-heating time required when starting the engine at an ambient temperature below 0°C.

The monitor lamp lights when the ignition switch is turned to the HEAT position and flashes after 30 seconds to show pre-heating is completed. (Monitor lamp will go off after 10 seconds.)



9JH09764

Swing Lock Monitor

Monitor (2) informs the operator that the swing lock is being actuated.

Actuated: Lights up

When the swing lock switch is turned ON (ACTUATED), the monitor lamp lights up.

This monitor flashes when the swing holding brake release switch is turned on.

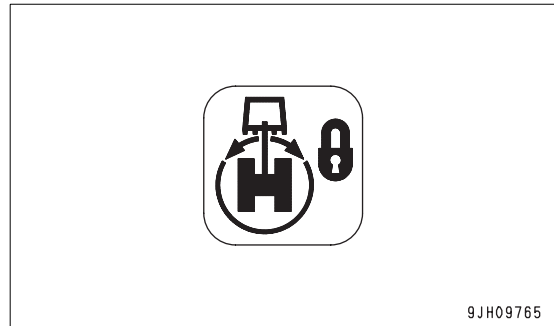

REMARK

The swing motor is equipped with a disc brake that mechanically stops the rotation. When the swing lock monitor is lighted up, the brake remains applied.

Wiper Monitor

Monitor (3) indicates operating status of the wiper.

The monitor display when wiper switch is operated, as follows.

When ON lights up: Wiper moves continuously

When INT lights up: Wiper moves intermittently

OFF: Wiper stops

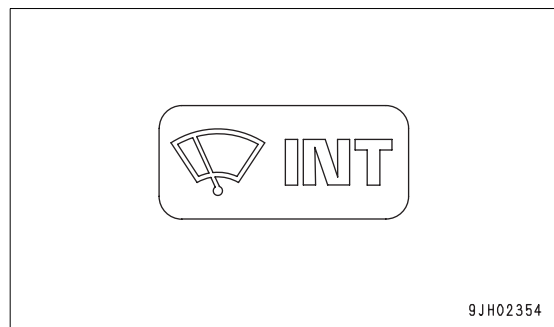

Auto-deceleration Monitor

Monitor (4) shows if the auto-deceleration is being actuated.

The monitor display when auto-deceleration switch is operated, as follows.

Auto-deceleration monitor ON: Auto-deceleration actuated

Auto-deceleration monitor OFF: Auto-deceleration canceled

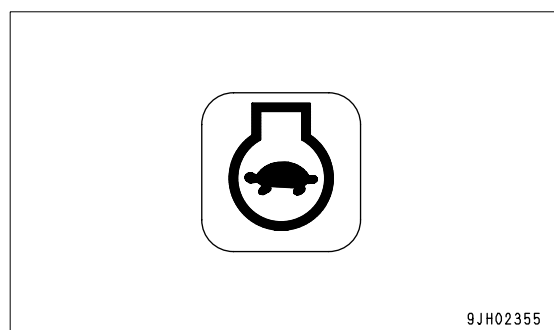

Working Mode Monitor

This monitor (5) displays the working mode setting.

The monitor display when working mode switch is operated is as follows.

P: P mode (for heavy-duty operations)

E: E mode (for operations prioritizing fuel consumption)

L: L mode (for fine-control operations)

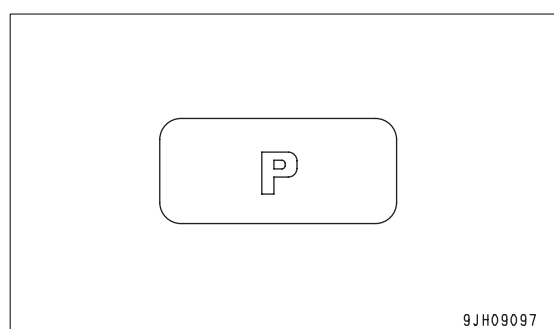

Travel Speed Monitor

Monitor (6) displays set mode for the travel speed.

The monitor display when the travel speed selector switch is operated, as follows.

Lo: Low speed

Hi: High speed

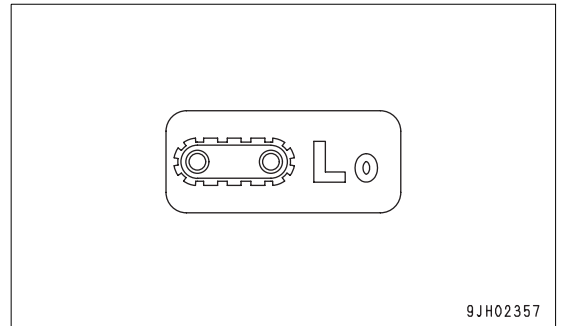

One-Touch Power Max. Monitor

Meter (7) shows if the power max function is being actuated.

The monitor display when the knob switch on the left control lever is operated is as follows.

Monitor lights up: Digging power is increased while knob switch is kept pressed.

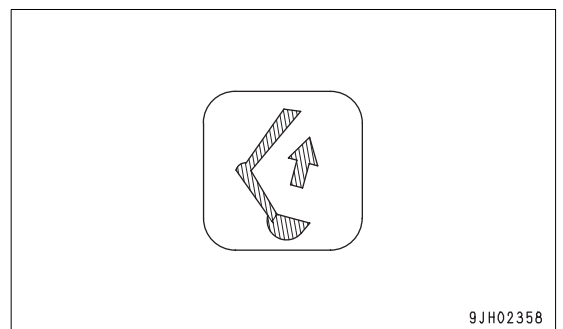

REMARK

The digging power is increased while the knob switch is being pressed only for working modes P and E. Note that even if the knob switch is kept pressed, the increase in power ends after 8.5 seconds.

When the knob switch is pressed, the mode is displayed in the central portion of display GG. After 2 seconds, the monitor in the center goes out and the monitor display changes to screen BB.

Monitor goes out: Power max function stopped

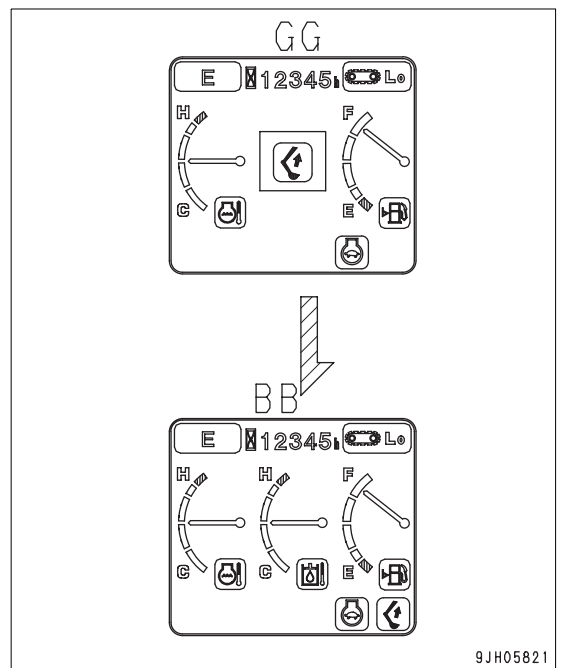

Gauges and Meter

Engine Coolant Temperature Gauge

Gauge (8) indicates the engine coolant temperature.

During normal operations, indicator should be in the black range (A) - (C). If indicator enters the red range (A) - (B) during operations, the overheat prevention system is actuated.

(A) - (B): Red range

(A) - (C): Black range

The overheat prevention system acts as follows.

Red range position (A): Engine water temperature monitor (D) lights up red

Red range position (B): Engine speed is reduced to low idling, engine water temperature monitor (D) lights up red, and the alarm buzzer sounds at same time.

The overheat prevention system remains actuated until the indicator returns to the black range.

When the engine is started, if the indicator is at position (C), engine water temperature monitor (D) lights up white.

In this case, carry out the warming-up operation. For details, see "Warming Up Engine (3-94)".

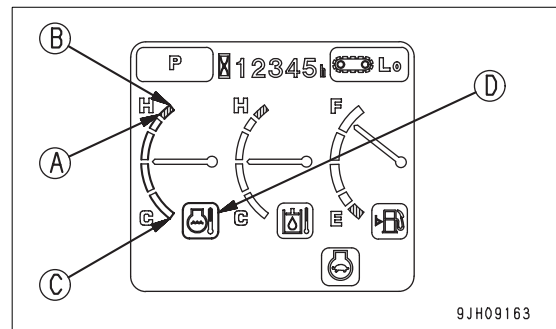

Fuel Gauge

Meter (9) displays the level of fuel in the fuel tank.

During operations, the indicator should be in the black range. If indicator enters red range (A) during operations, there is less than 101 liters of fuel remaining in the tank, check and add fuel.

(A) - (B): Red range

(A) - (C): Black range

REMARK

If the indicator enters red range (B), there is less than 84 liters of fuel remaining. When the indicator is in the red range (A) to (B), fuel level monitor (D) lights up red.

If the indicator enters the red range (A) to (B), do not carry out operations on steep slopes. There is danger of the engine stalling.

The correct fuel level may not be displayed for a short time when the starting switch is turned ON, but this is not an abnormality.

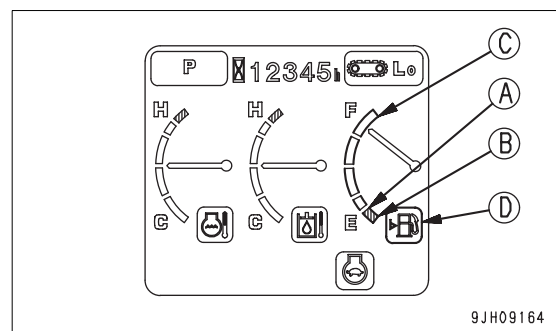

Hydraulic Oil Temperature Gauge

Meter (10) displays the hydraulic oil temperature.

During operations, the indicator should be in the black range (A) to (C).

If the indicator enters red range (A) during operations, the hydraulic oil temperature has gone above 102°C. Stop the engine or run it at low idle and wait for the hydraulic oil temperature to go down.

REMARK

When the indicator is in the red range (A) to (B), the hydraulic oil temperature is as follows.

Red range position (A): More than 102°C

Red range position (B): More than 105°C

When the indicator is in the red range (A) to (B), fuel level monitor (D) lights up red.

If the indicator is at position (C) when the engine is started, the hydraulic oil temperature is 20°C or lower, and hydraulic oil temperature monitor (D) lights up white. In this case, carry out the warming-up operation. For details, see “Warming Up Hydraulic Equipment (3-96)”.

Service Meter

Monitor (11) displays the total time that the machine has been running.

Set the periodic maintenance interval in hour. When the engine is running, the service meter advances even if the machine is not moving. The meter will advance by 1 for each hour of operation regardless of the engine speed.

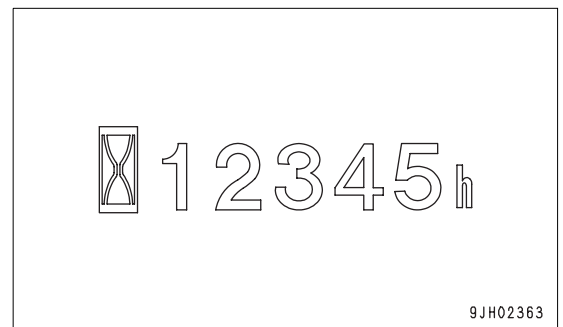
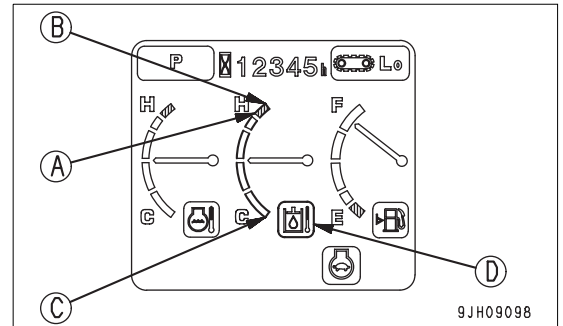

Monitor Switches Portion

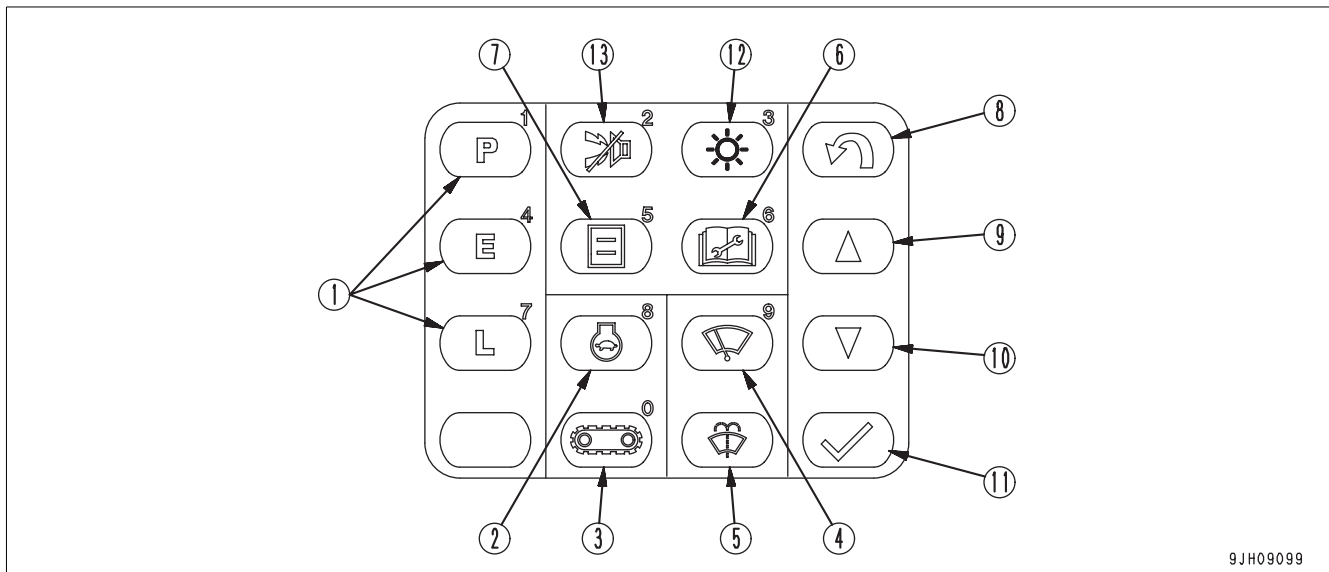

9JH09099

- | | |
|---|--|
| (1) Working mode selector switch (basic switch) | (8) Back switch |
| (2) Auto-deceleration switch (selection switch) | (9) Up switch |
| (3) Travel speed selector switch (selection switch) | (10) Down switch |
| (4) Wiper switch | (11) Input confirmation switch |
| (5) Window washer switch | (12) Adjusting brightness and contrast |
| (6) Maintenance switch | (13) Alarm buzzer stop switch |
| (7) User mode adjustment switch | |

Working Mode Selector Switch (Basic Switch)

This switch (1) is used to set the movement or power for the work equipment. Operations can be carried out more easily by selecting the mode to match the type of operation.

P: P mode (for heavy-duty operations)

E: E mode (for operations prioritizing fuel consumption)

L: L mode (for fine-control operations)

GG mode: Monitor display

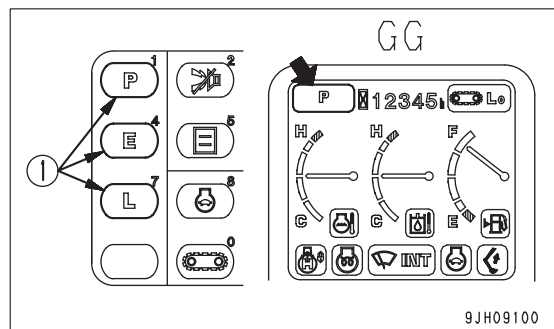

9JH09100

- When the engine is started, the working mode is set automatically to P mode. When the switch is pressed, it is possible to select the other modes. The monitor display GG on the monitor display portion changes for each mode.
- If it is desired to have the working mode set to start automatically in E, L mode (default option setting), have your Komatsu distributor change the setting.

REMARK

When the mode selector switch is pressed, the mode is displayed in the center of monitor display portion (GG), and the screen returns to normal screen (BB) after 2 seconds. (Diagram on the right is an example of display for the E mode.)

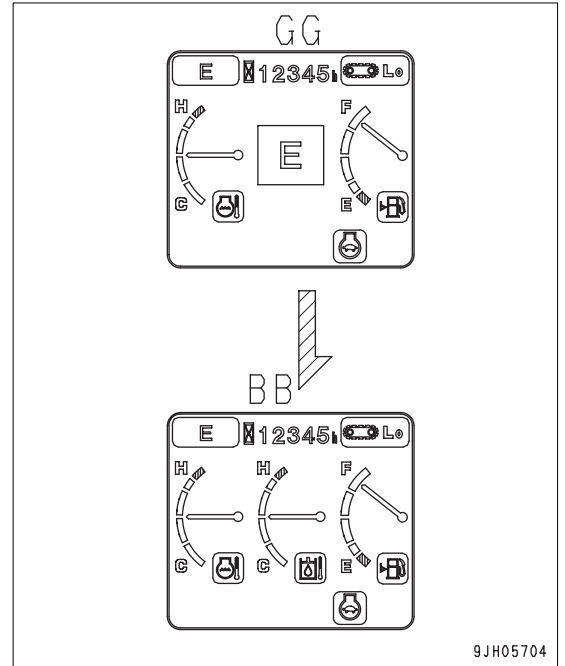

Auto-deceleration Switch (Selection Switch)

When switch (2) is pressed, the auto-deceleration is actuated, if the control levers are in neutral position, the engine speed is automatically lowered to reduce fuel consumption.

Monitor display portion GG ON: Auto-deceleration actuated

Monitor display portion GG OFF: Auto-deceleration canceled

Each time the switch is pressed, auto-deceleration switches between actuated and canceled.

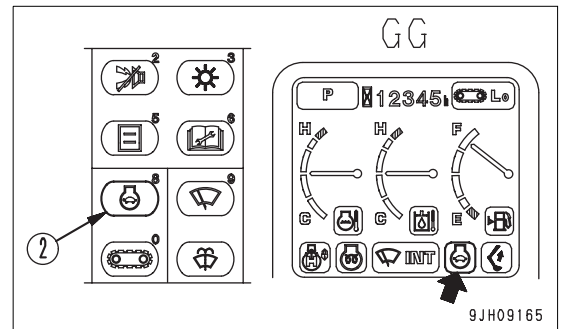

● Auto-deceleration function

When the auto-deceleration function is ON, if the work equipment and travel levers are returned to the N position, the engine speed will drop after 4 seconds from the operating speed to idling speed.

This makes it possible to reduce fuel consumption.

If any lever is operated when the machine is in this condition, engine speed will return to the previous operating speed to make it possible to perform operations.

REMARK

When the auto-deceleration switch is pressed and the auto-deceleration is actuated, the mode is displayed in the center of display portion (GG), and the screen returns to normal screen (BB) after 2 seconds.

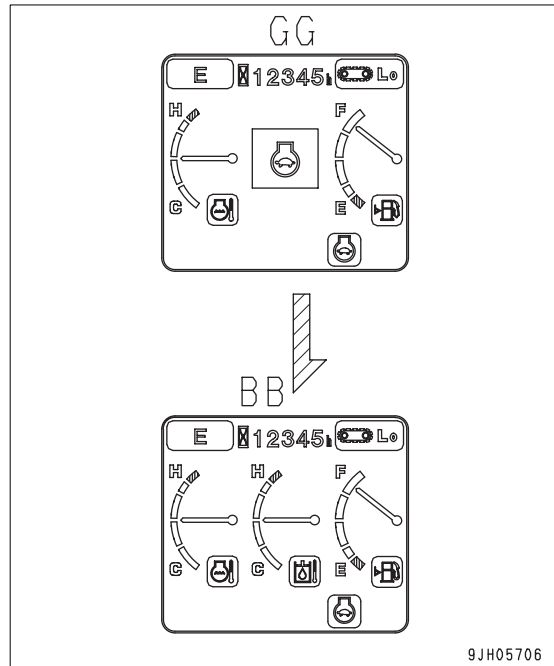

Travel Speed Selector Switch (Selection Switch)

WARNING

- When loading or unloading from a trailer, always travel at low speed (with travel speed selector switch (3) at the Lo position). Never operate travel speed selector switch (3) while loading or unloading.
- If the travel speed is switched between Hi and Lo when the machine is traveling, the machine may deviate to one side, even when traveling in a straight line. Stop the machine before switching the travel speed.

Switch (3) is used to set the travel speed to 3 stages.

Lo lights up: Low-speed travel

Hi lights up: Hi-speed travel

When the engine is started, the speed is automatically set to Lo.

Each time that the switch is pressed, the display changes Lo → Mi → Hi → Lo in turn.

When traveling in high speed (Hi), if travel power is needed, such as when traveling on soft ground or on slopes, the speed automatically switches to low speed (Lo), so there is no need to operate the switch. The monitor display stays at Hi.

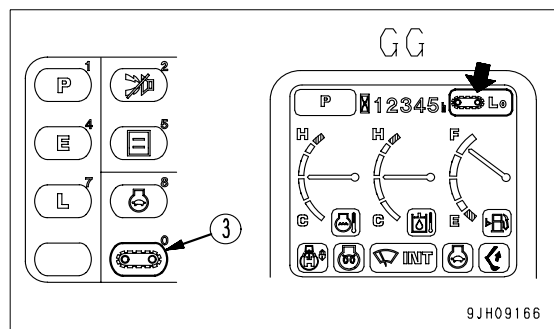

REMARK

Each time that the travel speed selector switch is operated, the mode is displayed in the center of display portion (GG), and the screen returns to normal screen (BB) after 2 seconds.

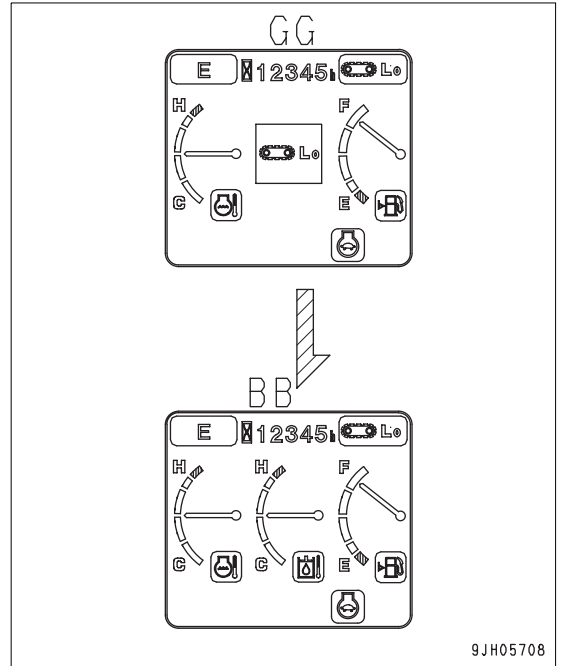

Wiper Switch

Switch (4) operates the wiper for the front glass.

Each time the switch is pressed, it changes ON → INT → stop (OFF).

Monitor display portion GG INT lighted up: Wiper moves intermittently

Monitor display portion GG ON lighted up: Wiper moves continuously

Monitor display portion GG OFF: Wiper stops

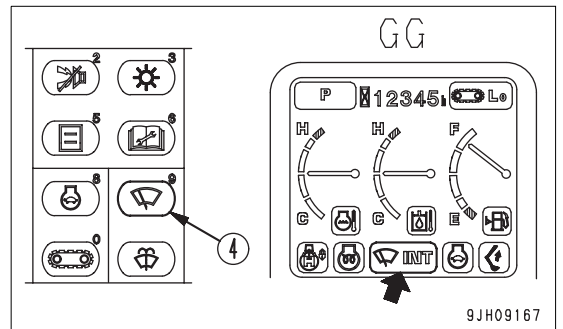

REMARK

Each time that the wiper switch is operated, the mode is displayed in the center of display portion (GG). The screen returns to normal screen (BB) after 2 seconds.

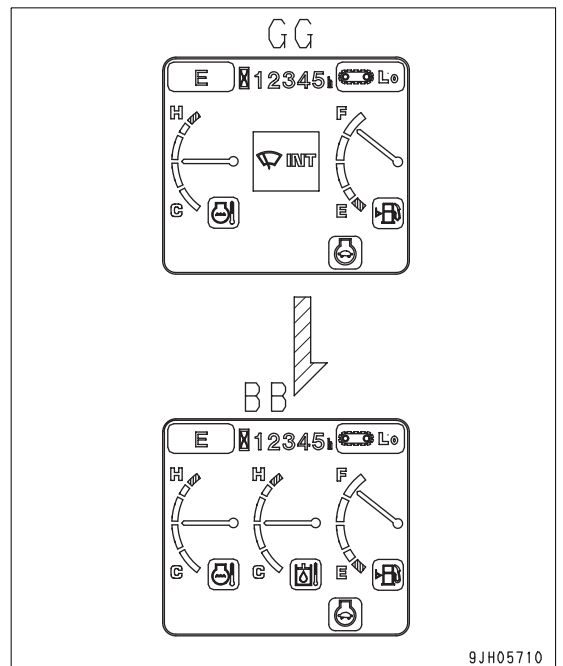

Window Washer Switch

This switch (5) is kept continuously pressed, window washer fluid is sprayed out on the front glass. When the switch is released, the spray stops.

- If switch (5) is kept pressed when the wiper is stopped, the window washer fluid will spray out, and at the same time, the wiper will be actuated continuously. When switch (5) is released, the wiper will continue to operate for 2 cycles, then stop.
- If the wiper is moving intermittently and switch (5) is kept pressed continuously, window washer fluid will spray out, and at the same time, the wiper will be actuated continuously. When switch (5) is released, the wiper will continue to operate for 2 cycles, then return to intermittent operation.

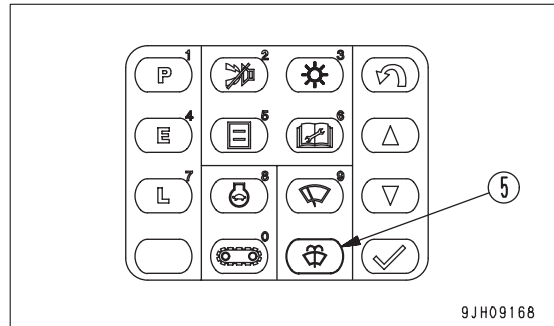

9JH09168

Maintenance Switch

- Switch (6) is used to check the time remaining until maintenance.

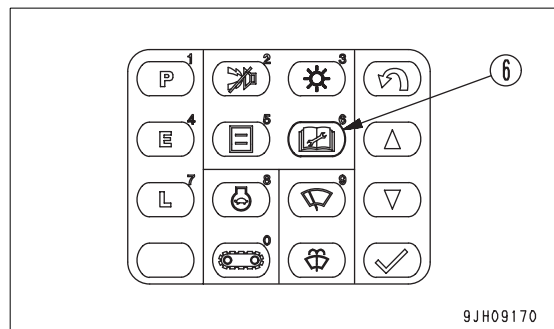

9JH09170

- When switch (6) is pressed, screen on the monitor display changes to the maintenance screen, as shown in diagram on the right.

The time remaining until maintenance is indicated by the color of each monitor display. After confirming the maintenance time, perform the maintenance.

White display: More than 30 hours remaining until maintenance

Yellow display: Less than 30 hours remaining until maintenance

Red display: Maintenance time has already passed

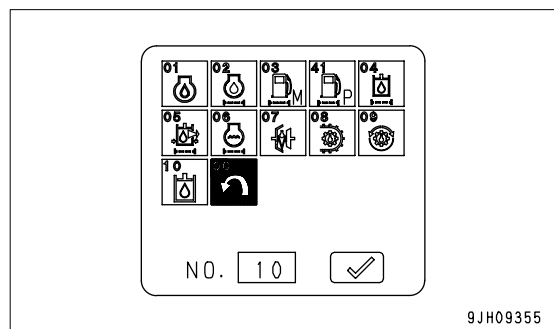

9JH09355

NOTICE

1. If monitor display portion GG changes to the maintenance timing warning screen when the engine is started or when the machine is being operated, stop operations immediately. When this happens, the monitor corresponding to the maintenance time warning screen will light up red.

2. Press switch (6) to display the maintenance screen. Perform maintenance for any location indicated by the monitor that has lighted red.

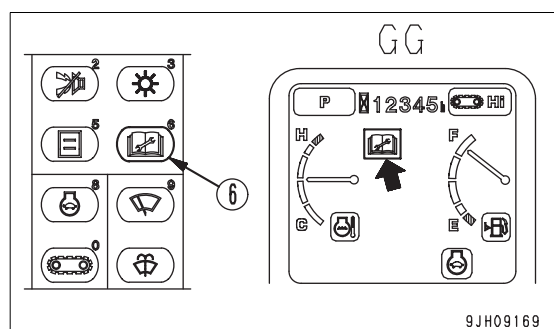

9JH09169

- Maintenance display items are as follows:

Monitor No.	Maintenance item	Default set screen (H)
01	Change engine oil	500
02	Replace engine oil filter	500
03	Fuel main filter cartridge	1000
41	Fuel pre-filter cartridge	500
04	Replace hydraulic oil filter	1000
05	Replace hydraulic tank breather	1000
06	Replace corrosion resistor (option for overseas)	1000
07	Change PTO case oil	1000
08	Change final drive case oil	2000
09	Change swing machinery case oil	1000
10	Change hydraulic oil	5000

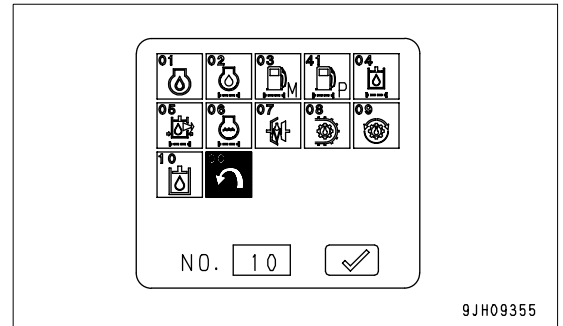

If it is desired to change settings for the maintenance interval, have your Komatsu distributor change the settings.

- The method of checking time remaining until maintenance is as follows:

1. Look at the maintenance screen, press up switch (9) or down switch (10) on the monitor switch portion, and select the item.

(Color of the monitor for selected item is inverted to black.)

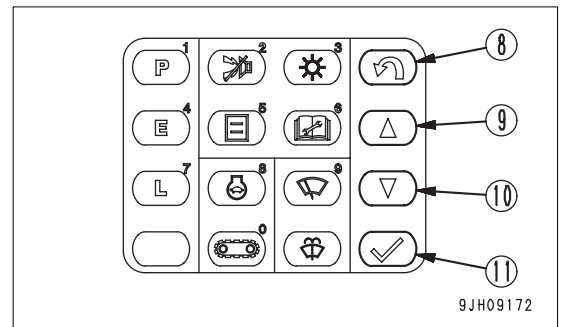

2. After selecting the monitor item, press input confirmation switch (11). Display screen will switch to the time remaining until maintenance.

(Press back switch (8) to return to the previous screen.)

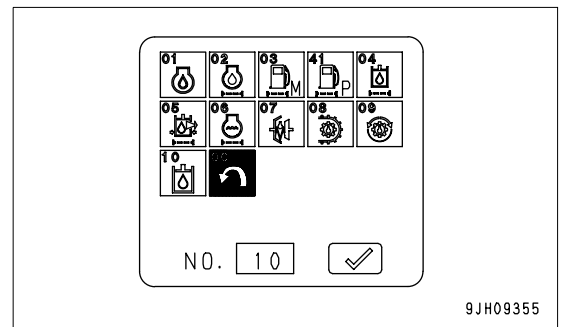

3. Check the time remaining until maintenance.

(a): Time remaining until maintenance

(b): Default setting for maintenance interval

When only checking the time remaining until maintenance, press back switch (8) twice.

The screen will return to the normal operation monitor screen.

When canceling time remaining until maintenance and returning to the default time setting, press inout confirmation switch (11). The screen will switch to the default setting screen.

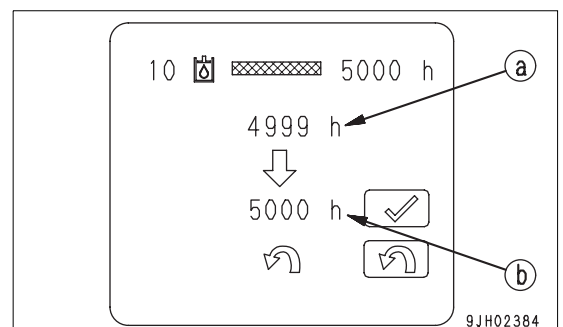

- After checking the time on the default setting screen, press input confirmation switch (11).

The screen will return to the maintenance screen.

(Press back switch (8) to return to the previous screen.)

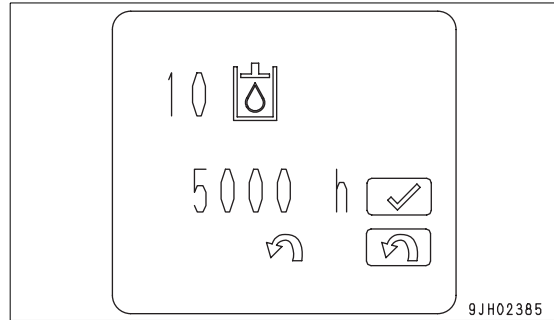

User Mode Adjustment Switch

Press this switch (7) to set to fan reverse rotation and to adjust the set value for the economy mode.

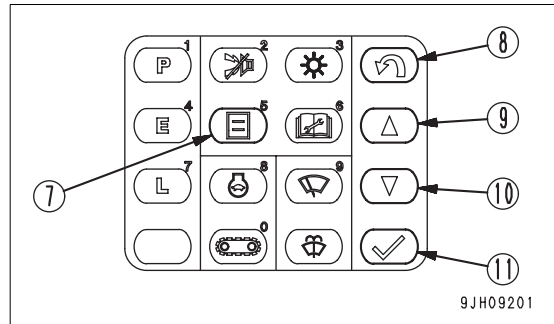

Fan Reverse Rotation

- Press switch (7) and the monitor display screen changes to the fan reverse rotation and economy mode adjustment screen show on the right.

01: Fan reverse rotation menu

02: Economy mode adjustment menu

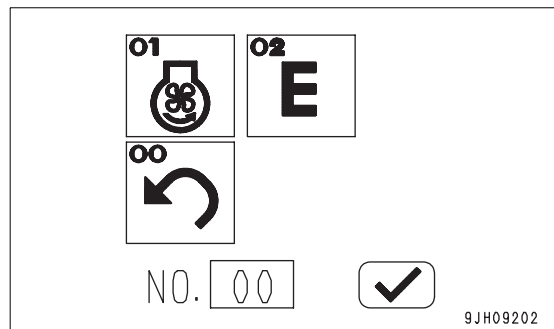

- Fan reverse rotation means that the air from the fan blows to the outside of the machine. This can be used when cleaning to remove insects or dirt stuck to the net.

Check first that there is no flammable or burning material in the surrounding area that will be sucked in, then operate the switch to rotate the fan in reverse.

- Set lock lever (1) securely to LOCK position (L).

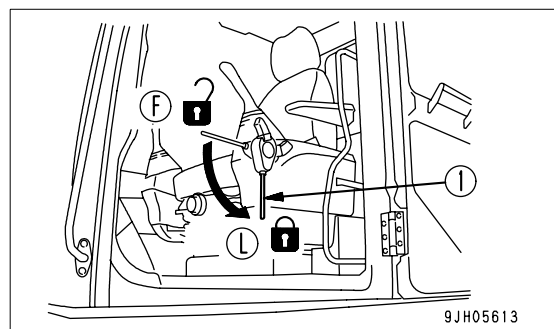

- Use UP switch (9) or DOWN switch (10) to select "01: Fan reverse rotation", then press input confirmation switch (11) to accept the input. The screen changes to the screen on the right (green display). To switch the fan to reverse rotation, press input confirmation switch (11).

(Press Back switch (8) to return to the previous screen.)

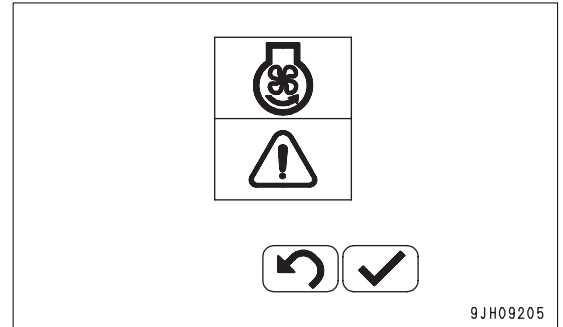

- When the fan rotation is being changed, the screen changes to the waiting screen. The engine is automatically set to low idling, and after approx. 15 seconds, the fan rotates in reverse. After another approx. 4 seconds, the engine speed returns to normal.

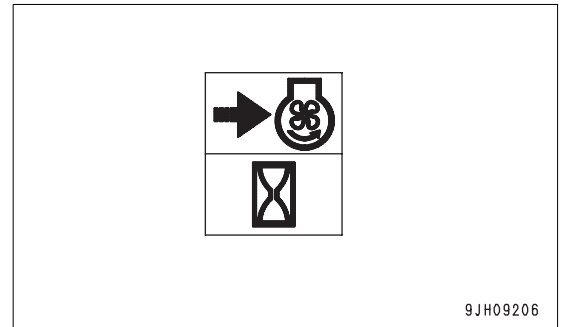

NOTICE

- The fan rotation speed is proportional to the engine speed. When the engine is running at low idling, the fan also rotates at minimum speed. If it is desired to raise the fan rotating speed, use the fuel control dial to raise the engine speed.
- When rotating the fan in reverse with the engine stopped, change to this screen, then turn the starting switch to the START position. This screen does not change until the engine starts, so if it is desired to cancel, turn the starting switch to the OFF position.

- When the fan rotates in reverse, the screen switches automatically to the screen shown on the right (yellow display). While the fan is rotating in reverse, the screen maintains this display.

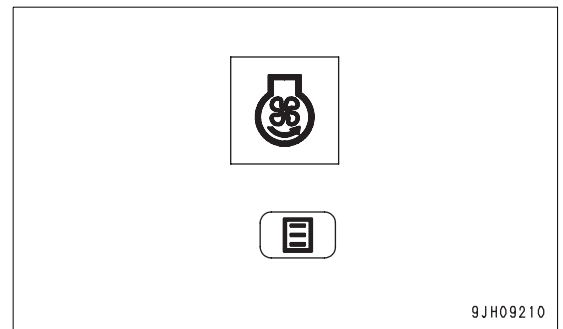

- If any abnormality occurs when the fan is rotating in reverse, a warning monitor is displayed as shown in the diagram on the right. If the warning monitor is displayed, see "MONITORING SYSTEM (3-5)" and follow the instructions.

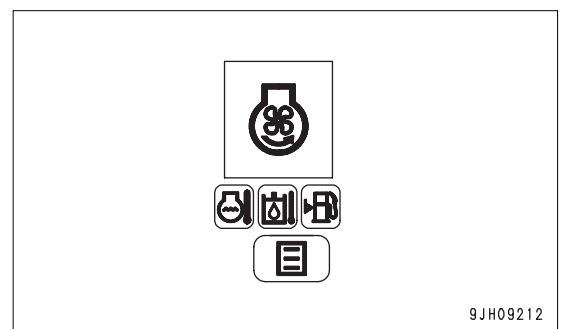

8. When changing the fan rotation direction from reverse direction to the normal direction, press User mode adjustment switch (7).

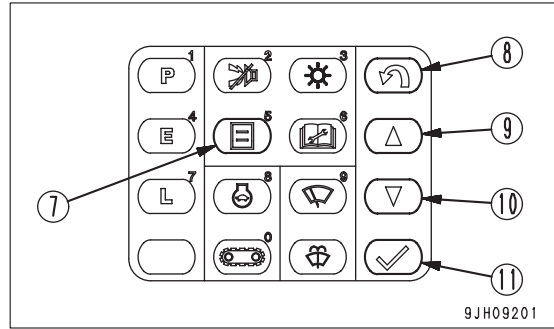

9. When changing the fan rotation direction from reverse direction to the normal direction, press input confirmation switch (11).

(Press Back switch (8) to return to the previous screen.)

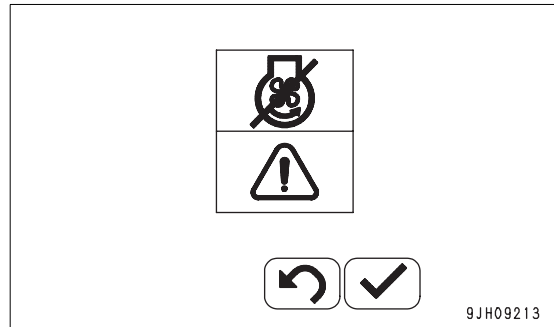

10. When the fan rotation is being changed, the screen changes to the waiting screen. The engine is automatically set to low idling, and after approx. 15 seconds, the fan rotates in the normal direction. After another approx. 4 seconds, the engine speed returns to normal.

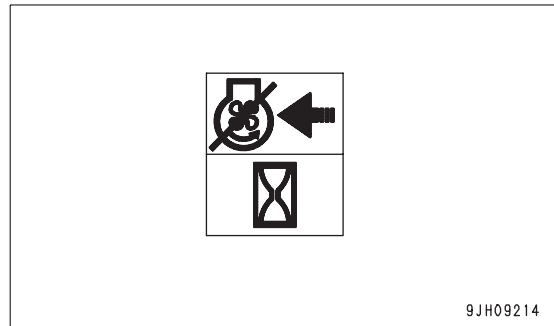

11. When the fan returns to rotating in the normal direction, the display switches automatically to the initial screen.

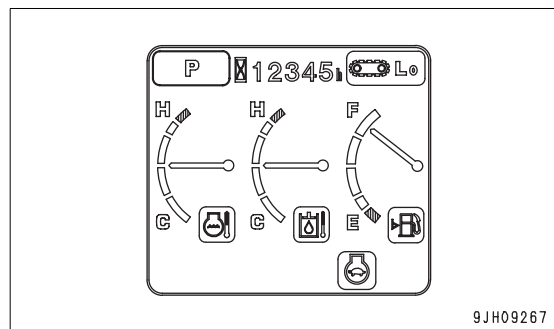

REMARK

In some cases, the screen in Step 1 may switch to the screen on the right (red display) without switching to the screen in Step 4, and the fan may not rotate in reverse. This is designed to protect the equipment and to prevent the fan from rotating in reverse depending on the water temperature and hydraulic oil temperature.

If it is desired to rotate the fan in reverse, press Back switch (8), switch to the initial screen, run the engine at low idling or stop it, then carry out the warming-up or cooling-down operation.

If the water temperature and hydraulic temperature on the initial screen indicates ranges (A) - (B) shown in the diagram on the right, the fan can be rotated in reverse. Carry out the procedure in order from Step 1.

The system is controlled so that when the fan is rotating in reverse, the work equipment makes almost no movement even when the levers are operated. Rotating the fan in reverse is intended for use in cleaning the radiator, so when carrying out operations and moving the work equipment, switch the fan to the normal direction of rotation before starting operations.

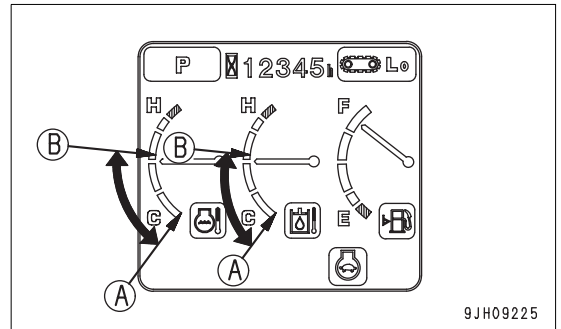
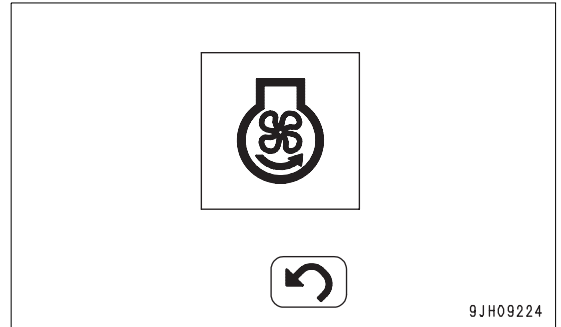

Adjusting Set Value of Economy Mode

1. Press switch (7) and the monitor display screen changes to the fan reverse rotation and economy mode adjustment screen show on the right.

01: Fan reverse rotation menu

02: Economy mode adjustment menu

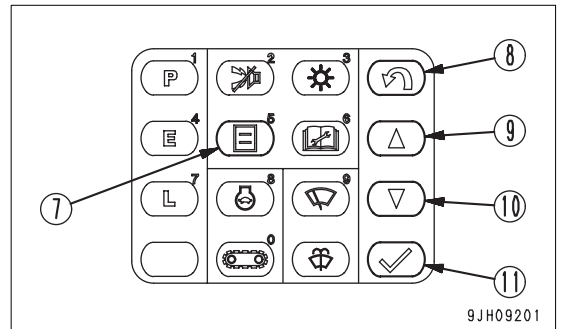

2. When adjusting the set value of the economy mode, adjusting the engine output can provide an improvement in fuel consumption in E mode.

Use UP switch (9) or DOWN switch (10) to select "02: Fan reverse rotation", then press enter switch (11) to accept the input. The screen changes to the screen on the right.

There are four levels that can be set: E0, E1, E2, and E3, as shown in the diagram on the right.

(It is set to E0 when the machine is shipped from the factory.)

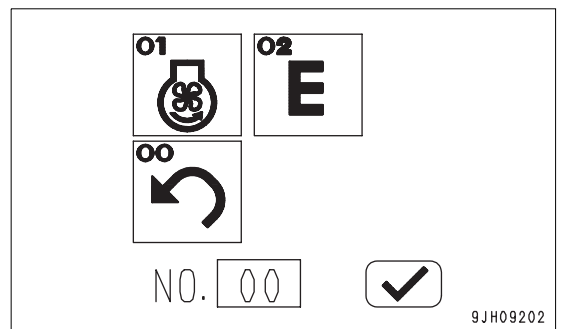

3. Use UP switch (9) or DOWN switch (10) to select E0 - E3.

4. Press input confirmation switch (11).

The relationship between fuel consumption and production is as follows.

E0: Default set value (maximum emphasis on production, not on fuel consumption)

E1: Economy adjustment 1 (emphasis on production)

E2: Economy adjustment 2 (emphasis on fuel consumption)

E3: Economy adjustment 3 (maximum emphasis on fuel consumption, not on production)

For details of productivity in each mode, see “Setting Economy Mode (3-111)”.

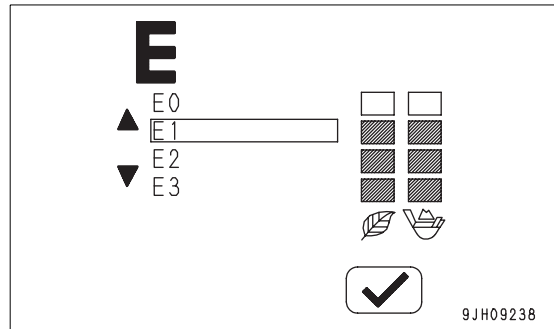

REMARK

The closer the selection is made to E3, the better the fuel consumption becomes, but the production is reduced accordingly.

Back Switch

Press switch (8) when in the maintenance mode, brightness/contrast adjustment mode, or select mode. The screen will return to the previous screen on the monitor display.

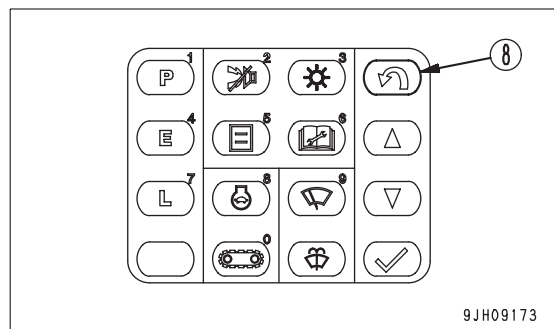

Up Switch, Down Switch

Press up switch (9) or down switch (10) when in the maintenance mode, brightness/contrast adjustment mode, or select mode to move the cursor on the monitor display (colors of selected monitor are inverted) up, down, left, or right.

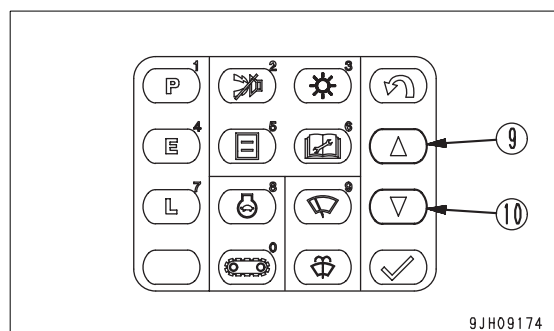

Input Confirmation Switch

Press switch (11) to confirm selected mode when in the maintenance mode, brightness/contrast adjustment mode, or select mode.

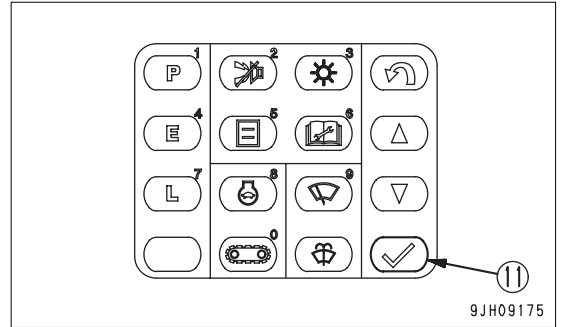

Liquid Crystal Monitor Adjustment Switch

Press switch (12) to adjust the brightness or contrast of the display monitor.

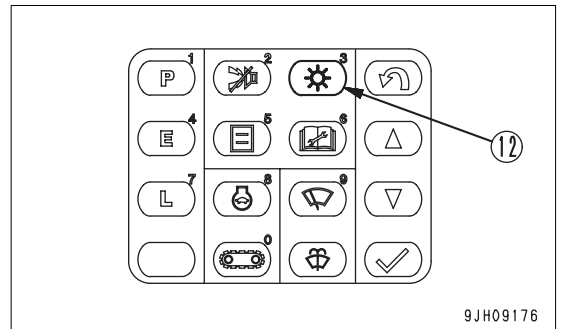

Adjusting Brightness

1. When monitor adjustment switch (12) is pressed, the monitor display screen changes to the brightness/contrast screen shown in the diagram on the right.

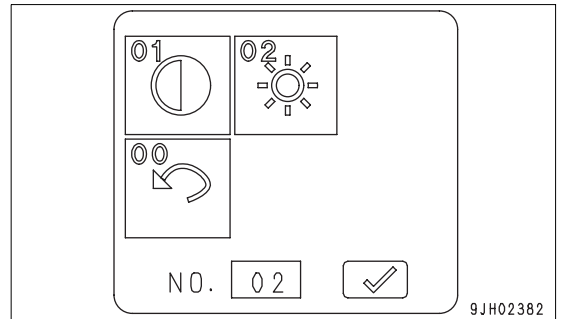

2. Use the brightness/contrast screen and press up switch (9) or down switch (10) to select brightness of the monitor.

(The selected monitor is inverted to black.)

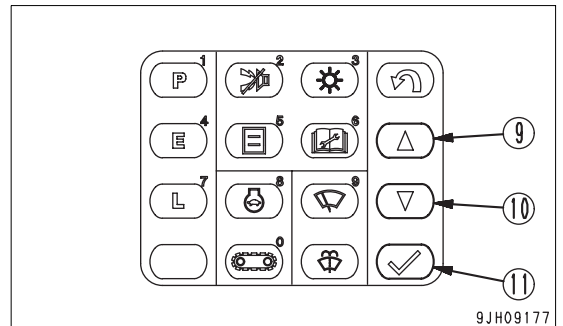

- When the screen changes to the brightness adjustment screen, press up switch (9) or down switch (10) to adjust the brightness.
- After completing adjustment of the brightness, press input confirmation switch (11).

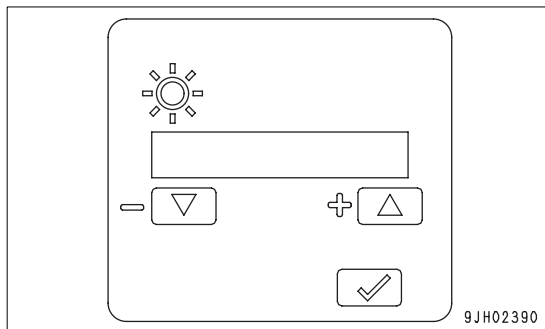

Adjusting Contrast

- When monitor adjustment switch (12) is pressed, the monitor display screen changes to the brightness/contrast screen shown in the diagram on the right.

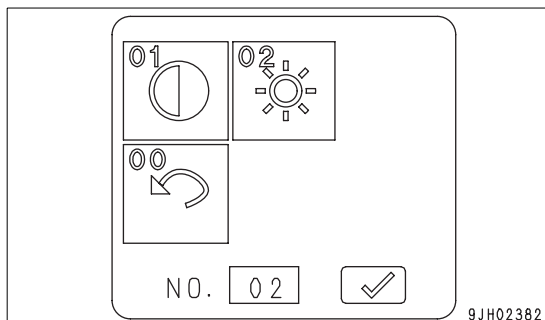

- Use the brightness/contrast screen and press up switch (9) or down switch (10) to select the contrast monitor.

(The selected monitor is inverted to black.)

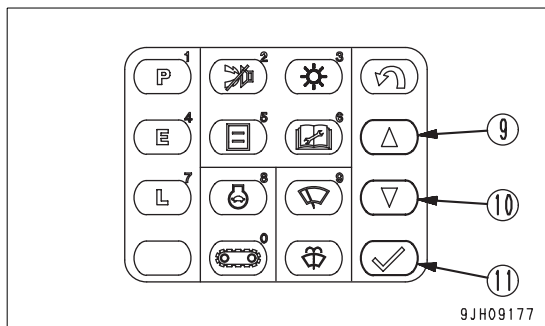

- When the screen changes to the contrast adjustment screen, press up switch (9) or down switch (10) to adjust the contrast.
- After completing adjustment of the contrast, press input confirmation switch (11).

REMARK

When the machine is shipped from the factory, the backlighting is set to the maximum plus (+). The contrast is set to the middle value. After adjusting, even if the starting switch is turned OFF, the adjusted value is retained.

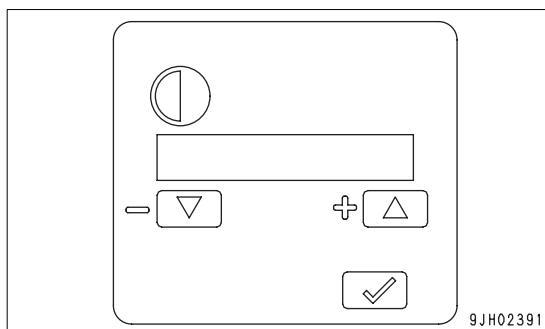

Alarm Buzzer Stop Switch

Use this switch (13) to stop the alarm buzzer when it is sounding during operation to indicate an abnormality in the warning item.

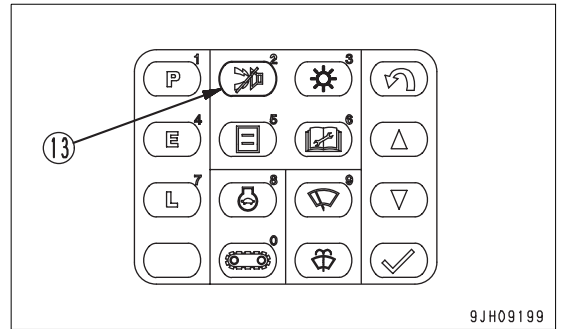

SWITCHES

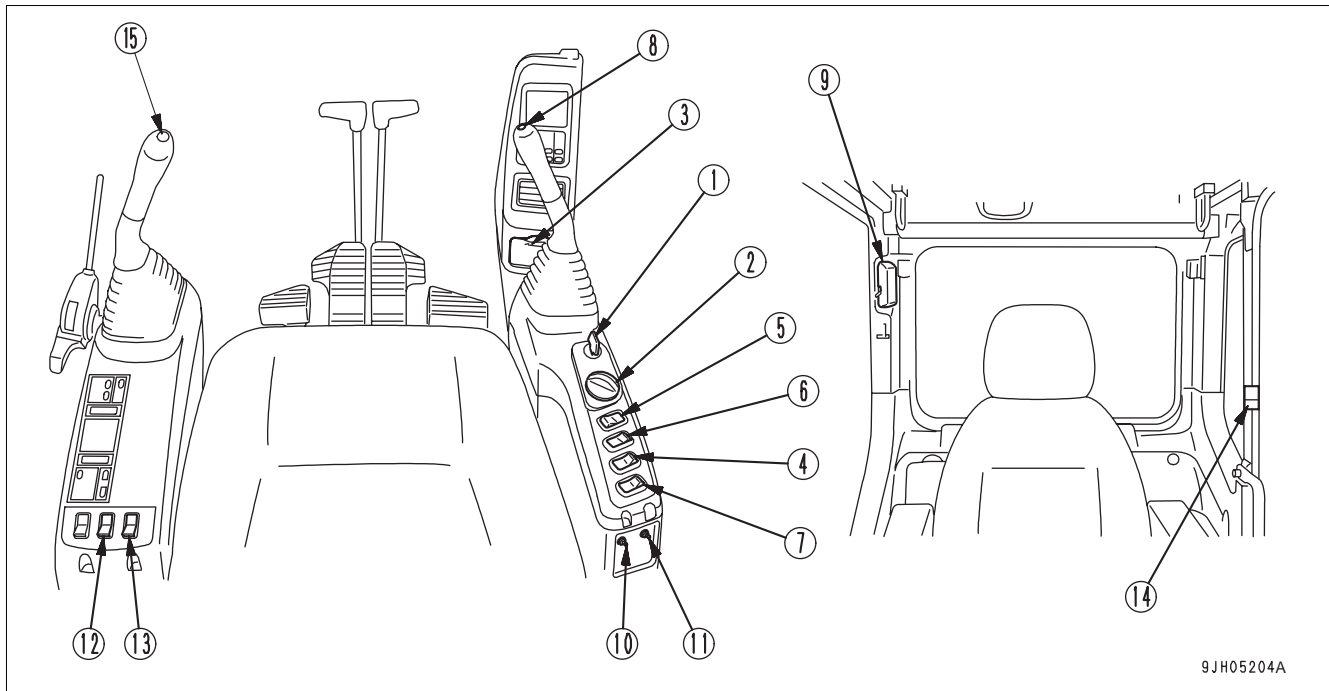

- (1) Starting switch
- (2) Fuel control dial
- (3) Cigarette lighter
- (4) Swing lock switch
- (5) Lamp switch
- (6) Alarm buzzer stop switch
- (7) Machine push-up switch
- (8) Horn switch
- (9) Room lamp switch
- (10) Emergency pump drive switch
- (11) Swing brake cancel switch
- (12) Revolving warning lamp switch
- (13) Lower wiper switch (machines with fixed front window cab) or Large capacity airflow condition blower switch (if equipped)
- (14) Step light switch
- (15) One-touch power max. switch

Starting Switch

Starting switch (1) is used to start or stop the engine.

(A): OFF position

The key can be inserted or withdrawn. Switches for the electrical system (except room lamp), are all turned off and the engine is stopped.

(B): ON position

Electric current flows through the charging and lamp circuits. Keep starting switch key in the ON position while the engine is running.

(C): START position

This is the engine-start position. Keep the key at this position during cranking. Immediately after starting the engine, release the key. It will automatically return to the ON position (B).

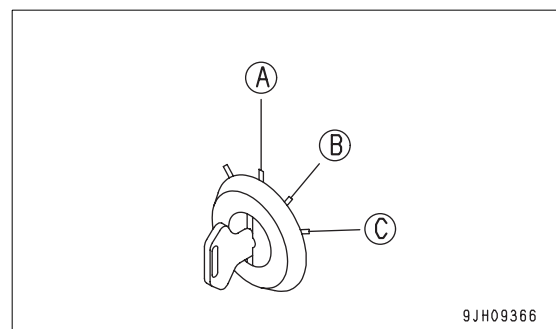

Fuel Control Dial

Dial (2) adjusts the engine speed and output.

- (a) Low idling (MIN): Turned fully to the left
- (b) Full speed (MAX): Turned fully to the right

REMARK

When the fuel control dial is turned, the engine speed does not change for the first few notches from MIN and the last few notches before MAX, but this does not indicate any abnormality.

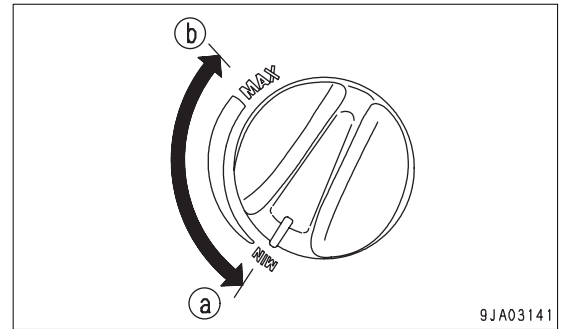

Cigarette Lighter

Lighter (3) is used to light cigarettes.

To use, push the lighter in. After a few seconds it will spring back. Pull out the lighter and light your cigarette.

By removing the cigarette lighter, the socket is available as a power source for the yellow flashing lamp.

Max. current is 85 W (24V x 3.5 A).

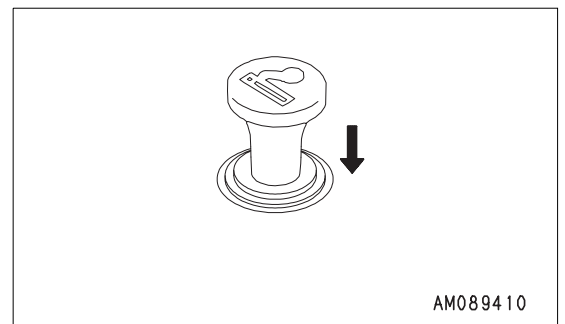

Machine Push-up Switch

⚠ WARNING

When using the boom thrust force to push up the chassis when moving down from a bench, there is danger that the machine may suddenly go down and turn over, so set to the high-pressure setting.

Switch (4) is used to switch the safety valve set pressure at the head of boom cylinder to two levels.

(a) Low pressure setting:

The boom thrust force is weak, so swaying of the chassis is small during digging operations, and digging can be performed smoothly.

This is used for general digging operations on normal ground, soft rock, or blasted rock.

(b) High pressure setting:

The boom thrust force becomes more powerful, so it is easy to twist and swing or escape from soft ground. It is effective in performing digging operations using the bucket and weight of the machine in confined areas.

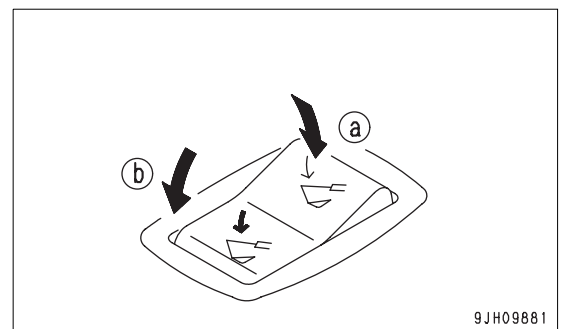

Lamp Switch

Switch (5) is used to turn on the front lamps, working lamps, additional lamps at top front of the cab, and monitor lighting.

- (a) ON: Lamps light up
- (b) OFF: Lamps go off

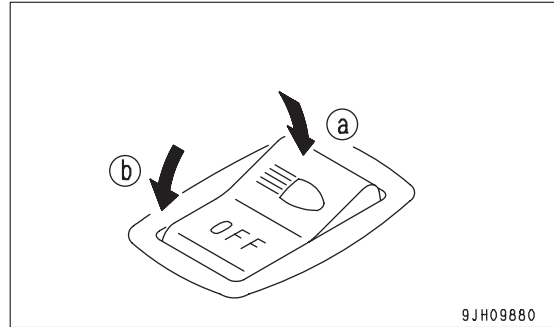

Swing Lock Switch

⚠ WARNING

- When the machine is traveling under its own power, or when the swing is not being operated, always set the switch to the ON position (a).
- On slopes, even when the swing lock switch is at the ON position (a), the weight of the work equipment may cause the upper structure to swing if the swing control lever is operated in the downhill direction.

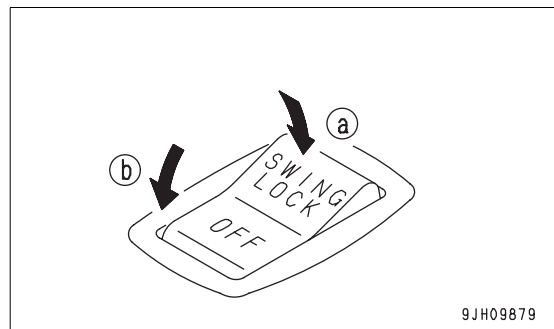

Switch (6) is used to lock the upper structure so it cannot swing.

- (a) ON position (actuated): The swing lock is always applied, and the upper structure will not swing even if the swing is operated. In this condition, the swing lock lamp lights up.
- (b) OFF position (canceled): The swing lock is applied only when all the work equipment control levers are in neutral; when any work equipment control lever is operated, the swing lock is canceled.

The swing lock is actuated approx. 7 seconds after all the control levers are placed in the neutral position.

Boom Shockless Control Switch

(If equipped)

Switch (7) controls the shaking of work equipment when the boom is stopped.

Effect

- The shaking and spillage of load from the bucket is reduced.
- Operator fatigue is reduced when operating for long periods, so operations can be performed safely.

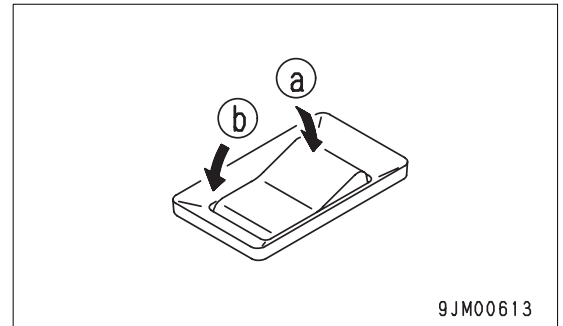

REMARK

When the switch is at the ON position (a) and the boom is stopped, the movement of the boom until it stops will increase slightly.

Be careful when using this operation until you become accustomed to it.

The boom drifts down and it is difficult to position it, so set this switch to the OFF position (b) when carrying out operations with a raised load.

Horn Switch

When the switch (8) at the tip of the right work equipment control lever is pressed, the horn will sound.

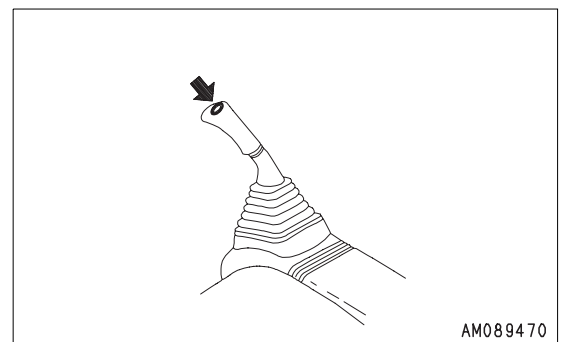

Room Lamp Switch

NOTICE

It is possible to turn on the interior cab room lamp even when starting switch is in the OFF position, do not forget to turn it off.

Use this switch (9) to light up the room lamp.

Position (a) ON: Lights up

Position (b) OFF: Goes out

The room lamp lights up even when the starting switch is in the OFF position.

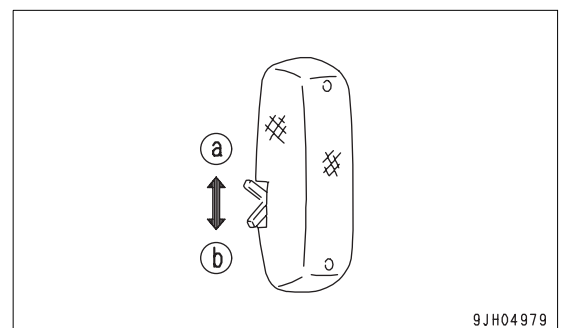

Emergency Pump Drive Switch

NOTICE

Emergency pump drive switch is provided to make it possible to perform work for a short time when there is a failure in the pump control system. It is necessary to repair the abnormal location as soon as possible.

Switch (10) makes it possible to temporarily perform operations should any abnormality occur in the pump control system (when monitor display shows E02).

- (a) When abnormal: Move switch up
- (b) When normal: Move switch down

If the display shows E02, move the switch up to make it possible to carry out work.

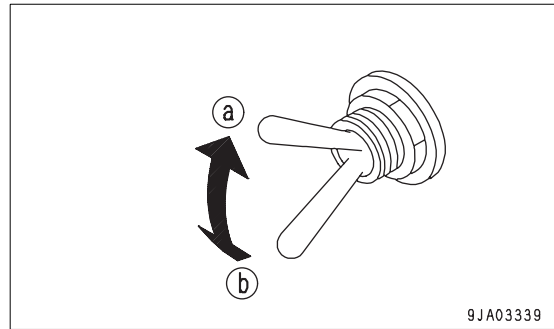

Swing Brake Cancel Switch

NOTICE

This switch makes it possible to perform swing operations for a short even when there is a problem in the swing brake electric system. DO NOT use this switch except in emergencies. Repair the problem as soon as possible.

Switch (11) makes it possible to temporarily perform operations should any abnormality occur in the swing brake system (when monitor display shows E03).

- (a) Release: Position for abnormality (switch moved up)
- (b) Normal: Normal position (switch moved down)
- When the monitor display is "E03", move this switch up to make it possible to perform operations.
- When this switch is set to release position (a), the swing lock monitor flashes.

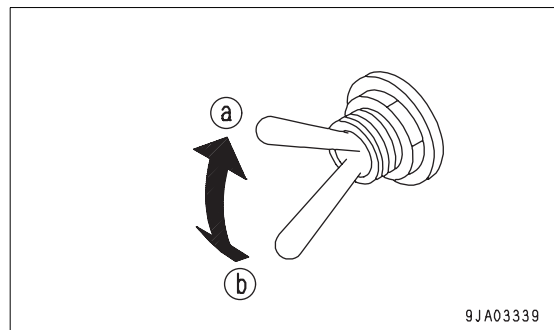

Revolving Warning Lamp Switch

(If equipped)

Switch (12) is used to turn on the yellow rotating lamp located on top of the cab.

- (a) ON: Lamps light up
- (b) OFF: Lamps go off

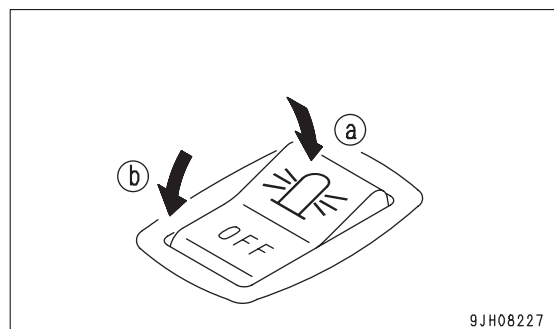

Lower Wiper Switch

(if equipped)

This switch (13) operates the lower wiper (A).

(a) ON position: Lower wiper (A) is actuated

(b) OFF position: Lower wiper (A) stops

If this switch is turned to the ON position at the same time as the wiper switch, the wiper and lower wiper (A) will be actuated in turn.

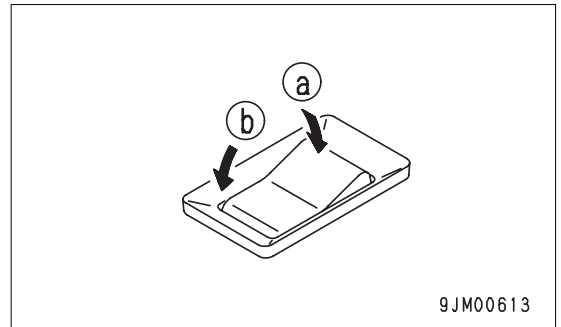

9JM00613

REMARK

If the wiper and lower wiper are being actuated at the same time, lower wiper will not stop even when the wiper switch (monitor) is turned OFF. To stop the lower wiper, turn switch (13) OFF.

When the wiper is under continuous operation at the ON position, if the lower wiper switch is turned ON, the wiper and lower wiper will be actuated in turn.

If the lower wiper switch is at the ON position and is operating continuously, and the wiper is actuated with the machine monitor, the lower wiper (both INT and ON) and wiper will be actuated in turn.

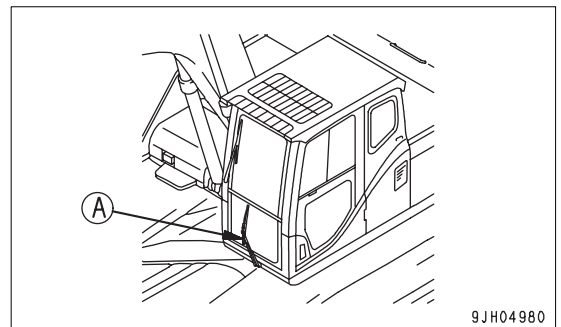

9JH04980

Step Light Switch

(if equipped)

Use this switch (14) when getting off the machine at night.

- When the switch is turned to the ON (a) position, the step light will light up for approx. 60 seconds.
- Even if the starting switch key is at the OFF position, the step light will light up for approx. 60 seconds when the switch is pressed.

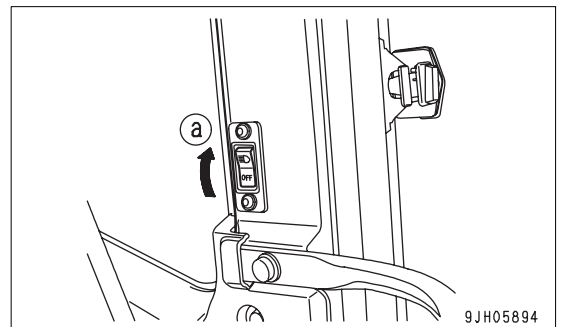

9JH05894

One-Touch Power Max. Switch

This switch (15) on the left work equipment control lever is used to actuate the power max functions.

Press once (single click) and keep the switch pressed. The one-touch power max. function is actuated for a maximum of 8.5 seconds at P and E mode.

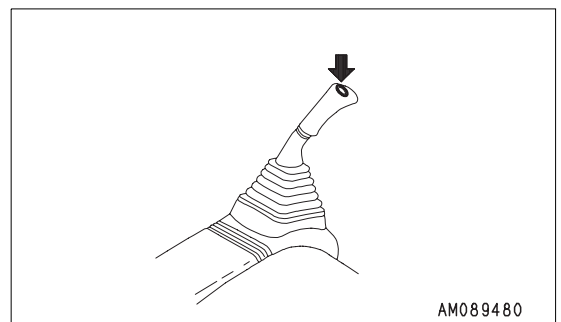

AM089480

Large Capacity Airflow Air Conditioner Blower Switch

(if equipped)

This switch (16) operates the large-capacity airflow air conditioner blower.

(a) ON: Large-capacity air conditioner blower is actuated

(b) OFF: Large-capacity air conditioner blower is stopped

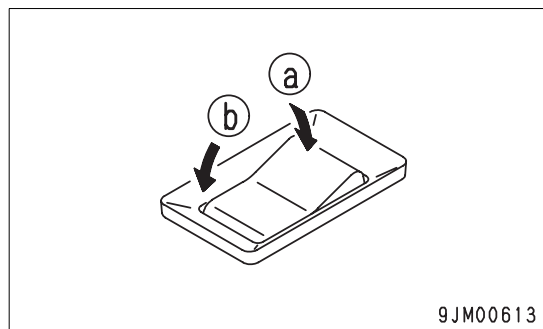

CONTROL LEVERS AND PEDALS

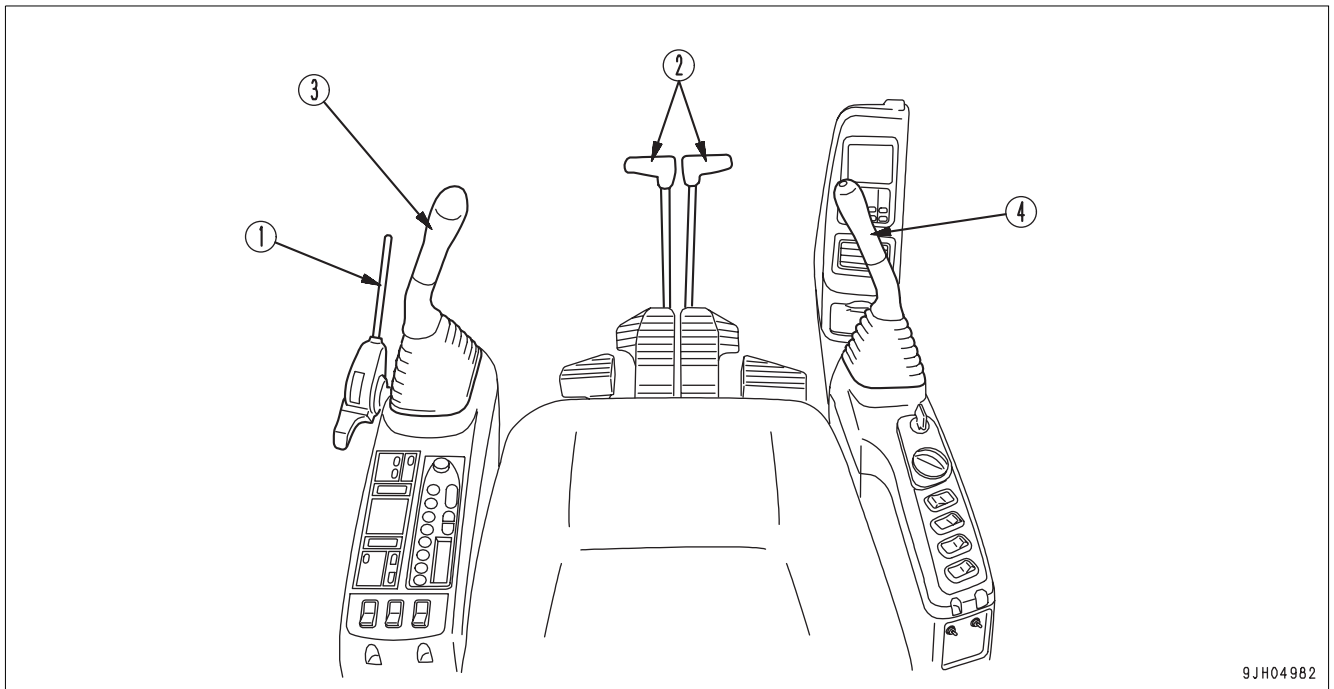

9JH04982

- | | |
|--|---|
| (1) Lock lever | (3) Left work equipment control lever
(with auto-deceleration system) |
| (2) Travel levers
(with pedal and auto-deceleration system) | (4) Right work equipment control lever
(with auto-deceleration system) |

Lock Lever

 **WARNING**

- When standing up from the operator's seat, push lock lever (1) down securely to set it to LOCK position (L). If lock lever (1) is not in LOCK position (L) and the control levers are touched by mistake, it may lead to serious personal injury.
- Check lock lever (1) is placed securely at LOCK position (L).
- Be careful not to touch the work equipment control levers when pulling lock lever (1) up or pushing it down.

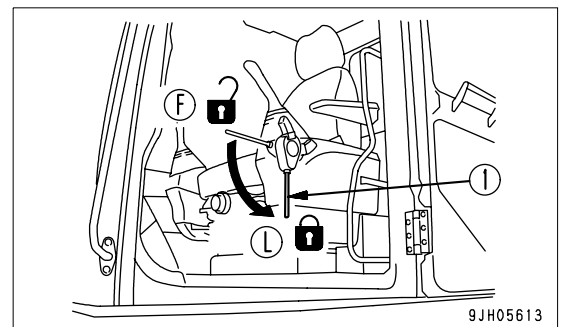

9JH05613

This lever (1) is a device to lock the work equipment, swing, travel, and attachment (if equipped) control levers.

Push the lever (1) down to apply the lock.

This lock lever (1) is a hydraulic lock, even if it is in the lock position (L), the work equipment control lever and travel lever will move, but the work equipment, travel motor, and swing motor will not work.

Travel Levers (with Pedals and Auto-deceleration Device)

⚠ WARNING

- Do not rest your foot on the pedal during operations. If the pedal is depressed by mistake, the machine may suddenly move and cause a serious accident. Be extremely careful when operating the pedal for travel or steering operations. When you are not using the pedal, do not rest your foot on it.
- If the track frame is facing the rear, the direction of travel operations will be reversed when the travel lever is operated. (The machine will travel forward when operated in reverse, and in reverse when operated forward; the left and right directions will also be reversed.)
- When operating the travel levers, check if the track frame is facing the front or the rear. (If the sprocket is at the rear, the track frame is facing the front.)

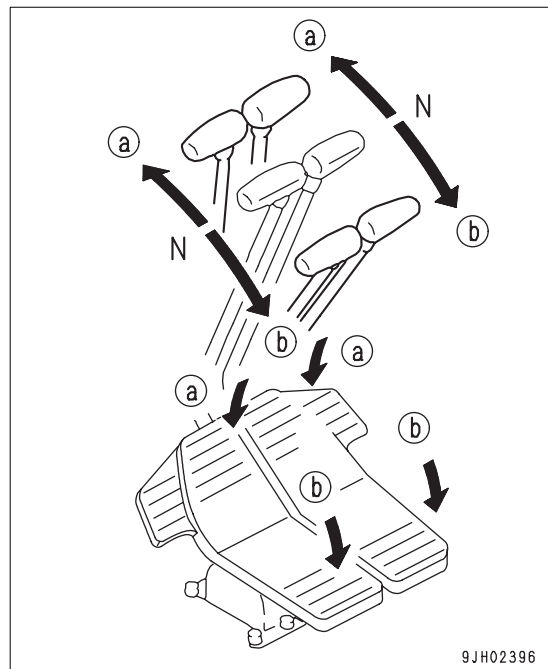

Lever (2) is used to change the direction of travel between forward and reverse. () shows the pedal operation.

(a) FORWARD: The lever is pushed forward

(The pedal is angled forward)

(b) REVERSE: The lever is pulled back

(The pedal is angled back)

N (Neutral): The machine stops

REMARK

If the lever is shifted to the FORWARD or REVERSE position from the Neutral position, the alarm sounds to warn that the machine is starting to move.

Work Equipment Control Lever

Left work equipment control lever (3) is used to operate the arm and upper structure.

Arm operation

(a) Arm OUT

(b) Arm IN

Swing operation

(c) Swing to right

(d) Swing to left

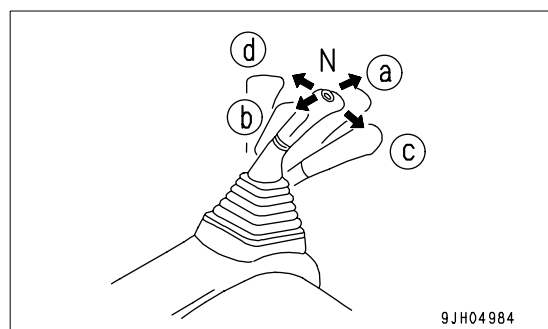

N (Neutral): The upper structure and arm are held in position and do not move.

Right work equipment control lever (4) is used to operate the boom and bucket.

Boom operation

- (a) RAISE
- (b) LOWER

Bucket operation

- (c) DUMP
- (d) CURL

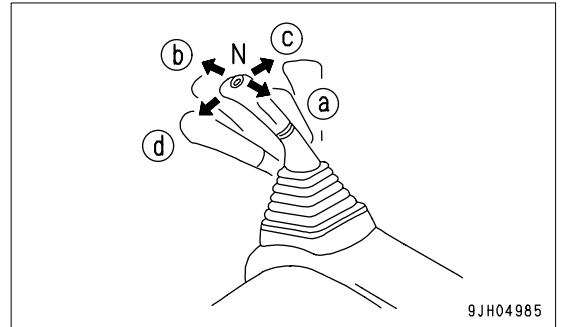

N (Neutral): The boom and bucket are held in position and do not move.

REMARK

The engine speed for all control levers (travel, work equipment, attachment) is changed as follows by the auto-deceleration mechanism.

When the travel lever and work equipment control levers are at the neutral position, even if the fuel control dial is above midrange speed, the engine speed will go down to a midrange speed. If one of these levers is operated, the engine speed will rise to the speed set by the fuel control dial.

If all the control levers are at the neutral position, the engine speed goes down approx. 100 rpm, then after approx. 4 seconds, the engine speed goes down to the deceleration speed (approx. 1400 rpm).

SUN ROOF

(PC600,PC600LC pull up cab specification machine only)

WARNING

When leaving the operator's seat, set the lock lever securely to the LOCK position (L).
 If the lock lever (1) is in the FREE position (F) and the control lever is touched by mistake, this may lead to a serious accident.

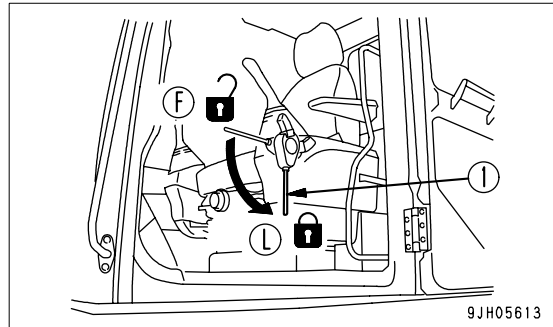

Opening

1. Set lock lever (1) securely to LOCK position (L).
2. Check for any ceiling window movement by pulling lock knob (A) located on front side, then push up and open the ceiling window grasping grip (B).

Closing

Hold grasping grip (B), lower the ceiling window, and apply lock (A). If the lock cannot be applied, open the ceiling window, then pull it in again and apply the lock.

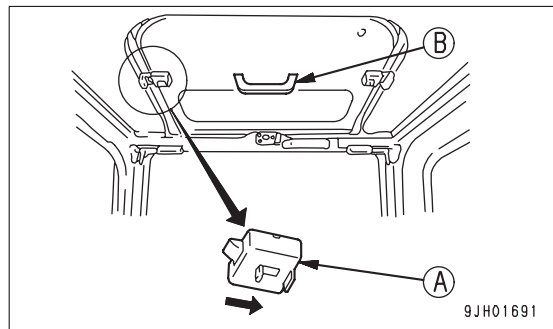

WINDSHIELD

(PC600,PC600LC pull up cab specification machine only)

WARNING

- When opening or closing the front window, bottom window, or door, always set lock lever (1) to LOCK position (L).
If the control levers are not locked and they are touched by accident, this may lead to a serious accident.
- When opening or closing the window at the front of the cab, stop the machine on horizontal ground, lower the work equipment completely to the ground, stop the engine, then carry out the operation.
- When opening the front window, hold the grip securely with both hands, pull up, and do not let go until the automatic lock catch is locked.
- When closing the front window, the window will move quicker under its own weight. Hold the grips securely with both hands when closing it.

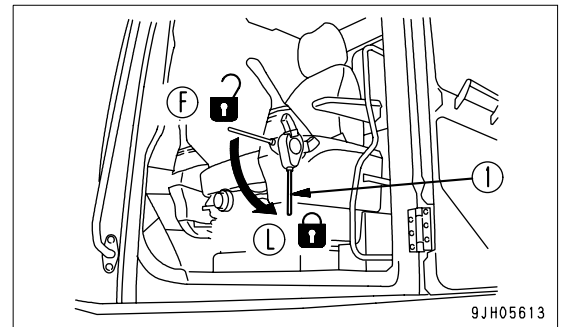

It is possible to stow (pull up) the front window in the roof of the operator's compartment.

Opening

1. Stop the machine on level ground, lower the work equipment completely to the ground, then stop the engine.
2. Push lock lever (1) down to set it securely to LOCK position (L).
3. Check that the wiper blade is stowed in the right stay.

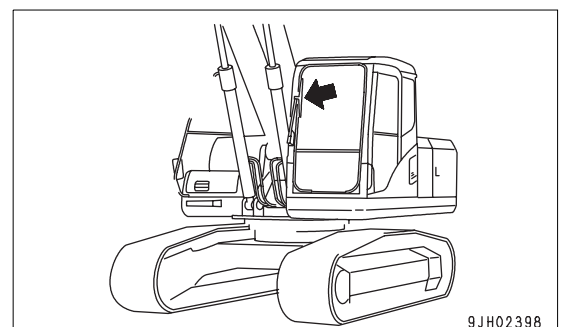
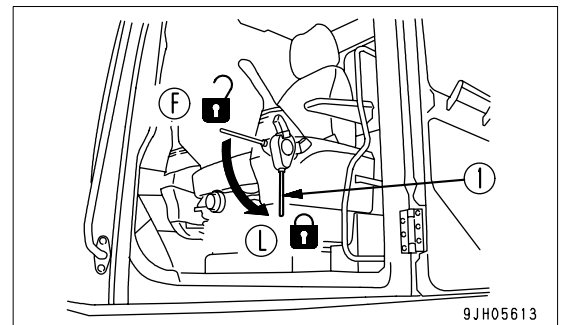

4. Grip handles (A) at the top right and left of the front window, and pull lock lever (B) toward yourself to release the lock at the top of the front window. The top of the front window will come out.

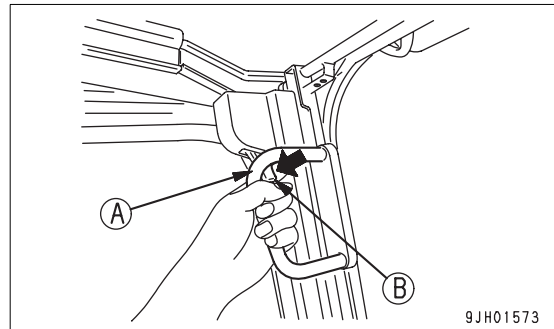
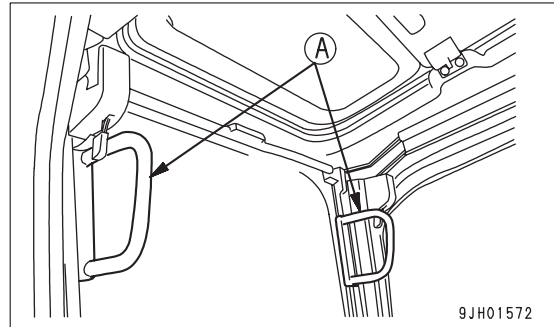

5. Hold lower knob (C) with your left hand from inside the operator's cab, and with your right hand, grip top knob (D), pull it up, and push it against lock catch (E) at the rear of the cab securely to lock the window.

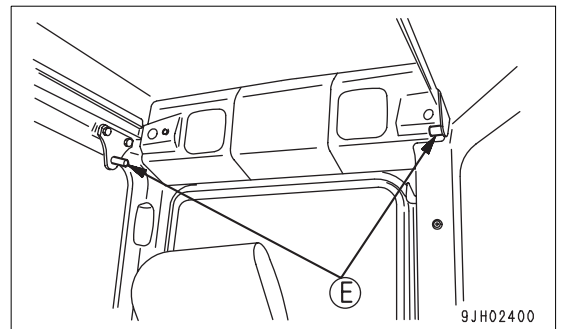
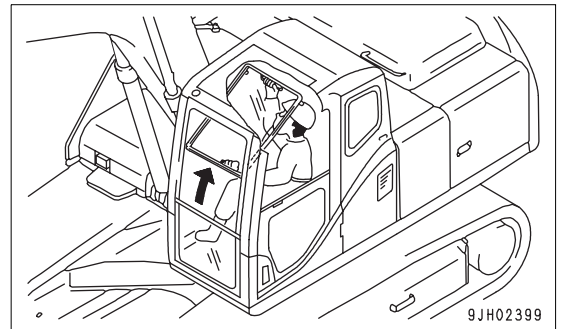
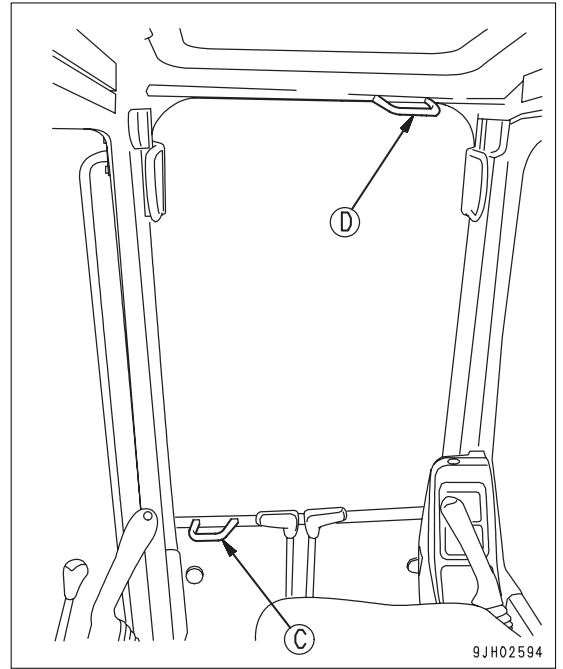

6. Check that lock lever (B) is securely in the LOCK position.
 - The lock is engaged if the arrow on lock case (F) matches the position of the arrow on lock lever (B). Check visually.
 - If the arrow on lock case (F) does not match the position of the arrow on lock lever (B), the lock is not engaged. Repeat the operation in Step 5 to engage the lock.

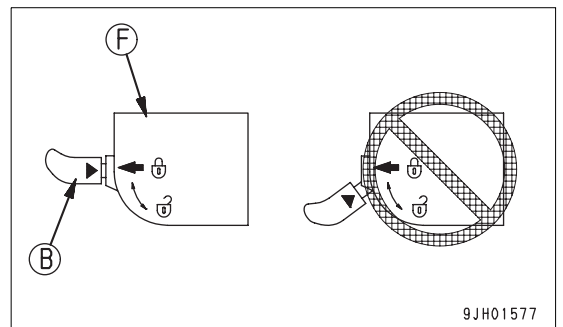

Closing

⚠ WARNING

When closing the window, lower it slowly and be careful not to get your hand caught.

1. Stop the machine on level ground, lower the work equipment completely to the ground, then stop the engine.
2. Push lock lever (1) down to set it securely to LOCK position (L).

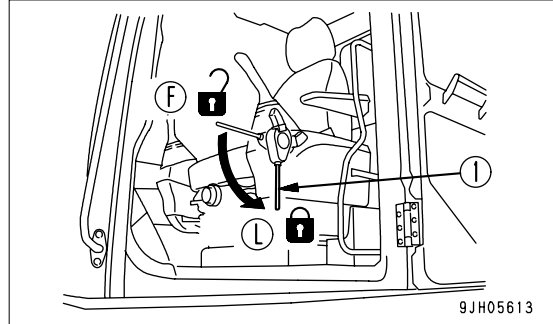

3. Grip left and right handles (A), and pull down lock lever (B) to release the lock.

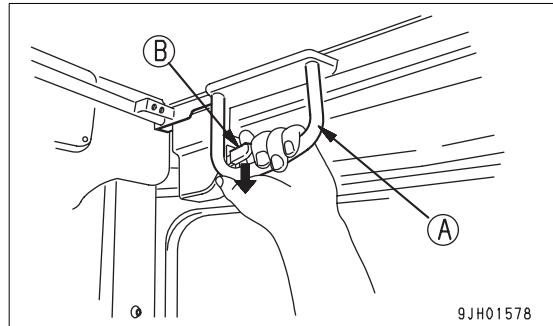

4. Grip handle (C) at the bottom of the front window with your left hand and handle (D) at the top with your right hand, push to the front, then lower slowly.

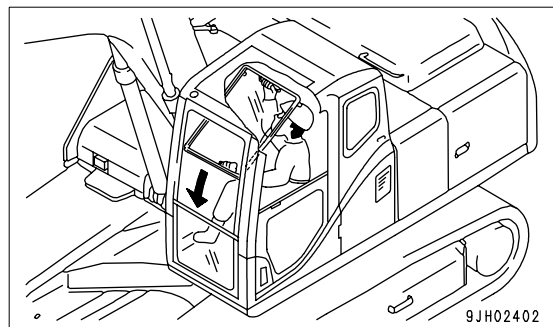
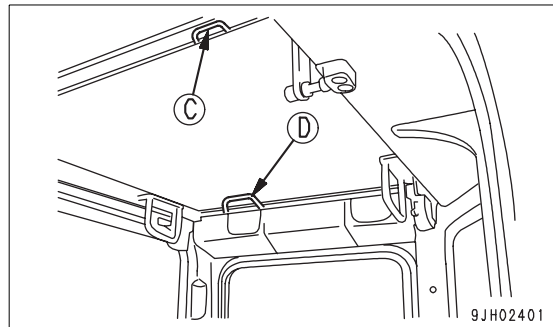

5. When the bottom of the window reaches the top of the bottom window, push the top of the window to the front to push it against left and right lock catches (G) and engage the lock.

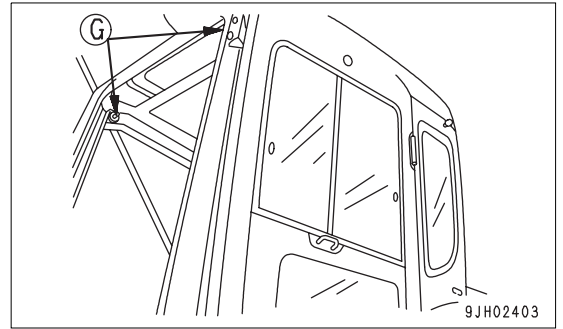

6. Check that lock lever (B) is securely in the LOCK position.
 - The lock is engaged if the arrow on lock case (F) matches the position of the arrow on lock lever (B). Check visually.
 - If the arrow on lock case (F) does not match the position of the arrow on lock lever (B), the lock is not engaged. Repeat the operation in Step 5 to engage the lock.

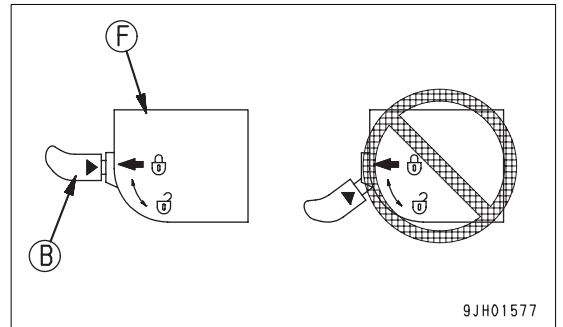

Removing Lower Windshield

1. Open the front window, then hold grip (A), pull up, and remove the bottom window.

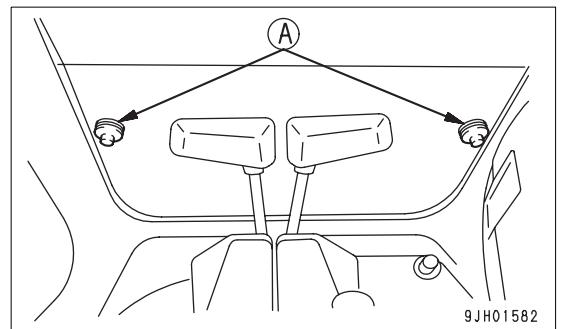

2. After removing the bottom window, store it at the rear of the operator's cab and lock it securely with left and right locks (B).
 - When removing, always hold the glass with one hand and release the lock with the other hand.

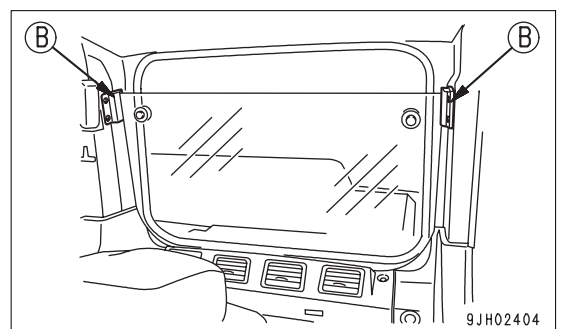

EMERGENCY EXIT FROM OPERATOR'S CAB

- If for some reason, the cab door does not open, remove the rear window and use it as an emergency escape.
- Remove the rear window as follows.
 1. Pull ring (1) and completely remove seal (2) from the rubber core.
 2. With pressure push on corner of the window, the glass will fall outside.
 - Do not remove the rear window except when using it as an emergency exit.

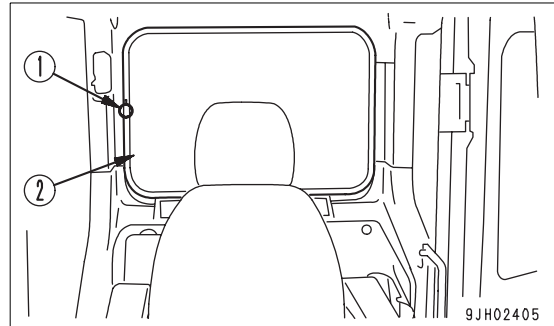

DOOR LOCK

! WARNING

- Before the releasing the door lock, always stop the machine on flat ground. Never release the door lock on a slope. The door may suddenly close and cause injury.
- When releasing the door lock, do not extend your body or hands outside the machine and do not put your hands on the door frame. The door may suddenly close and cause injury.

Use the door lock to fix the door in position after opening it.

1. Push the door against catch (1) to lock it in position.
2. To release the lock, press knob (2) down at the left side of the operator's seat to release the catch.

When fixing the door, fix it firmly to the catch.

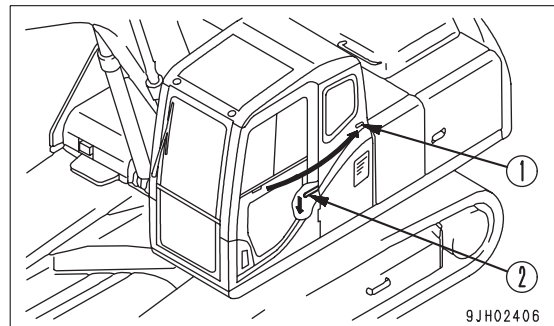

CAP WITH LOCK

Use the starting switch key to open and close the locks on the caps and covers.

For details of the locations of the caps and covers with locks, see "LOCKING (3-124)".

Insert the key as far as it will go to the shoulder (A). If the key is turned before it is inserted all the way, it may break.

Opening and Closing Caps with Lock

Type A is used for the fuel tank cap; type B is used for the hydraulic tank cap.

Opening the Cap

1. Insert the key into the key slot.
2. Turn the key clockwise (counterclockwise for type B), align the key groove with counter mark (3) on the cap, then open the cap.

(1): Open

(2): Lock

Locking the Cap

1. Turn the cap until tight, then insert the key into the key slot.
2. Turn the key counterclockwise (but, for the B type, turn clockwise) and take the key out.

Opening and Closing Cover with Lock

Opening the Cover (Locked Cover)

1. Insert the key into the key slot.
2. Turn the key counterclockwise and open the cover by pulling the cover grip.

(A): Open

(B): Lock

Locking the Cover

1. Close the cover and insert the key into the key slot.
2. Turn the key clockwise and take the key out.

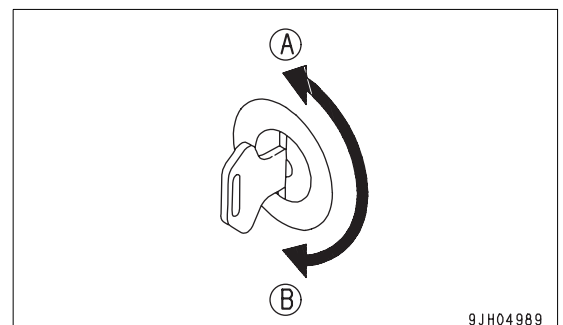
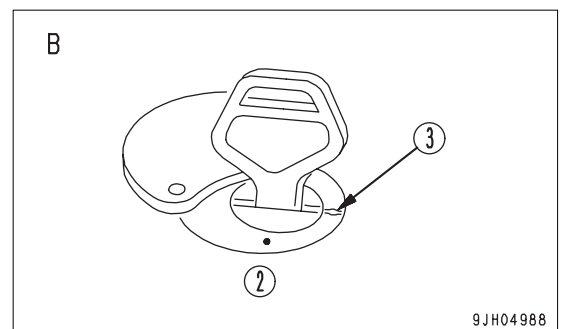
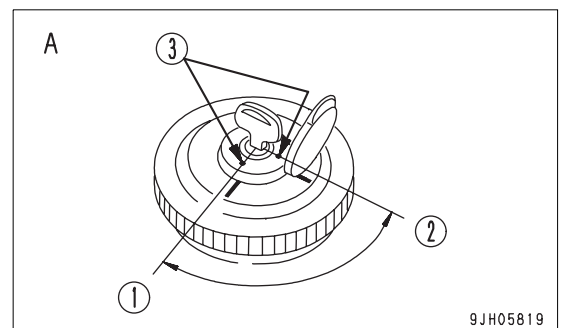
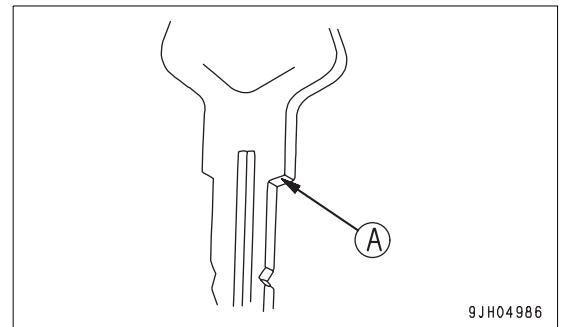

HOT AND COOL BOX

Located on the right side at rear of the operator's seat. It is interconnected with the air conditioner. Box stays warm when the heater is used, and box stays cool when the air conditioning is used.

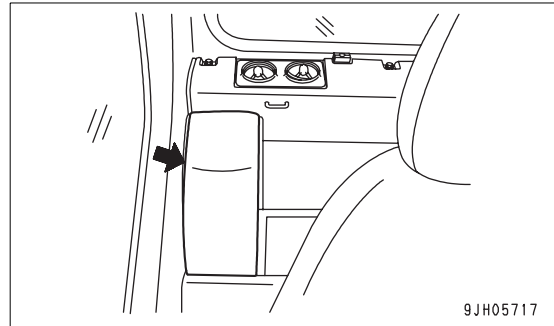

9JH05717

MAGAZINE BOX

(The cup holder is provided separately at the front of the magazine box.)

Located on left side of the operator's seat.

Keep the Operation and Maintenance Manual in this box so that it can be taken out and read whenever necessary.

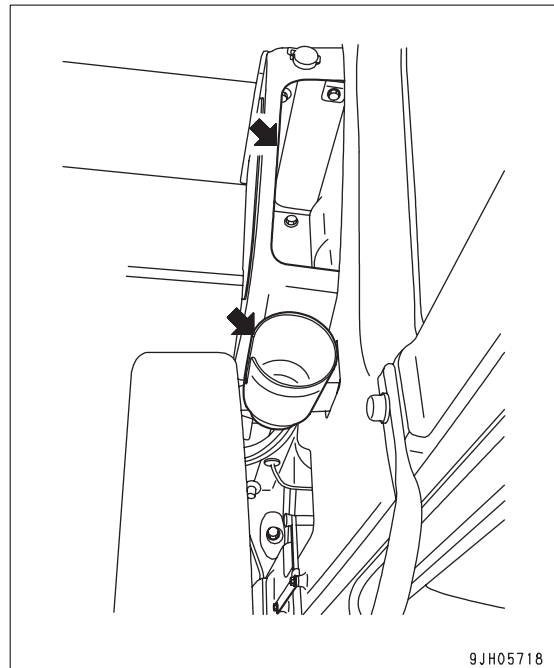

9JH05718

ASHTRAY

This is under the machine monitor at the front right of the operator's compartment.

Always make sure that you extinguish your cigarette, then put it in the ashtray and close the lid.

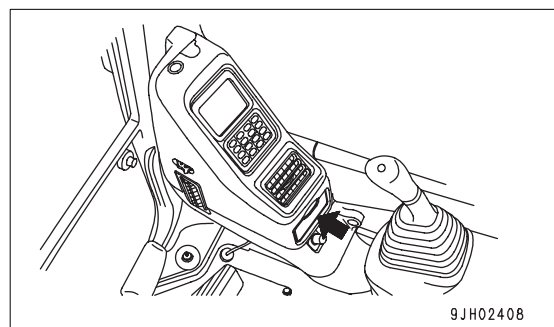

9JH02408

AIR CONDITIONER CONTROLS

Air Conditioner Control Panel

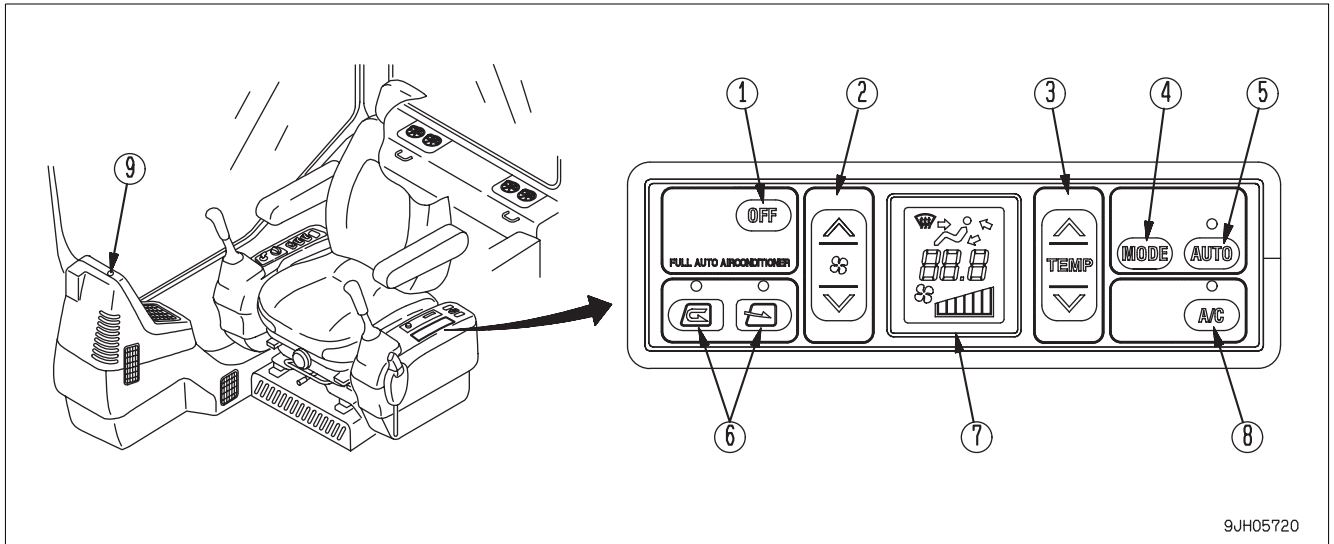

- | | |
|--------------------------------|----------------------------------|
| (1) OFF switch | (6) FRESH/RECIRC selector switch |
| (2) Fan switch | (7) Display monitor |
| (3) Temperature control switch | (8) Air conditioner switch |
| (4) Vent selector switch | (9) Sunlight sensor |
| (5) Auto switch | |

OFF Switch

Switch (1) is used to stop the fan and air conditioner.

- When OFF switch (1) is pressed, the set temperature and air flow display on display monitor (7), the lamps above auto switch (5), and air conditioner (8) go out, and operation stops.

REMARK

When switch (1) is turned to the OFF position, the lamp above FRESH/RECIRC selector switch (6) does not go out, but this is not a problem.



Fan Switch

Switch (2) is used to adjust the air flow.

The air flow can be adjusted to six levels.

- Press the ^ switch to increase the air flow; press the v switch to reduce the air flow.
- During auto operation, the air flow is automatically adjusted.

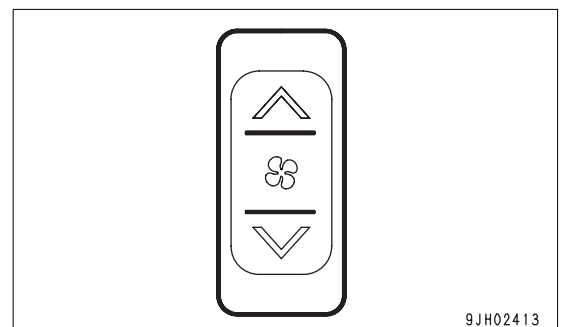

Monitor display and air flow

A: Liquid crystal display

B: Air flow

a: Air flow "low"

b: Air flow "medium 1"

c: Air flow "medium 2"

d: Air flow "medium 3"

e: Air flow "medium 4"

f: Air flow "high"

A	B
	a
	b
	c
	d
	e
	f

Temperature Control Switch

Switch (3) is used to control temperature inside the cab. The temperature can be set between 18°C and 32°C.

- Press the ^ switch to raise the set temperature; press the v switch to lower the set temperature.
- The temperature is generally set at 25°C.
- The temperature can be set in stages of 0.5°C.

<Monitor display and the function>

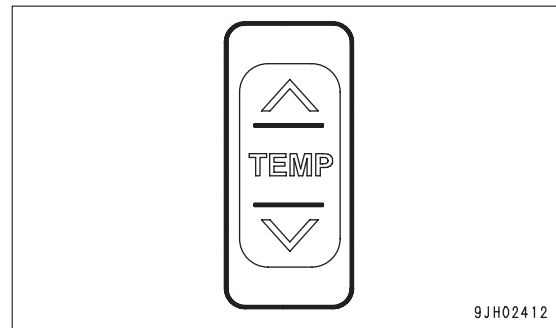

Monitor display (°C)	Set temperature
18.0	Max. cooling
18.5 to 31.5	Adjusts temperature inside cab to set temperature
32.0	Max. heating

REMARK

If the mode is set to auto mode and the temperature setting is set to 18.0 °C and 32.0 °C, the air flow from the fan is always set to HIGH and does not change even when the set temperature is reached.

Vent Selector Switch

Switch (4) is used to select the vents.

- When switch (4) is pressed, the display on monitor display (7) switches and air blows out from the vents displayed.
- During automatic operation, the vents are automatically selected.

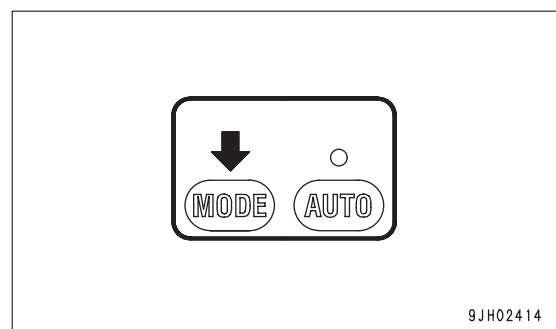

- (A): Rear vent (4 places)
- (B1): Face vent (1 place)
- (C): Foot vent (1 place)
- (D): Front window glass vent (1 place)
- (B2): Front window glass vent (1 place)

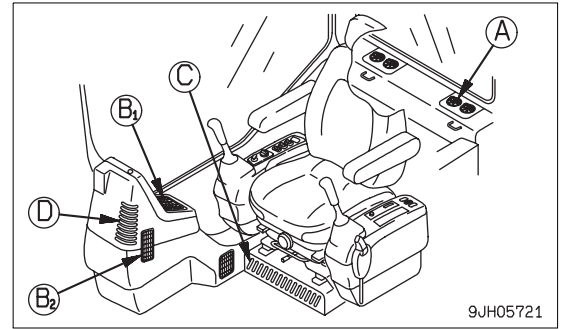

Liquid crystal display	Vent mode	Vent				Remarks
		(A)	(B)	(C)	(D)	
	Front vents		○			Cannot be selected for automatic operation
	Front and rear vents	○	○			-
	Front, rear and foot vents	○	○	○		-
	Foot vent			○		-
	Foot vents Defroster vent)			○	○	Cannot be selected for automatic operation
	Defroster vent				○	Cannot be selected for automatic operation

Note 1: Air blows from vents marked ○

Auto Switch

With switch (5), the air flow, vents, and air source (RECIRC/FRESH) are automatically selected according to the set temperature.

- When auto switch (5) is pressed, the lamp above the auto switch lights up.
- Press switch (5), then use temperature control switch (3) to set the temperature, and run the air conditioner under automatic control.
- When the control is switched from automatic operation to manual operation, it is possible to operate the to change air flow, vents, and air source (RECIRC/FRESH). When manual control is used, lamp above the auto switch goes out.

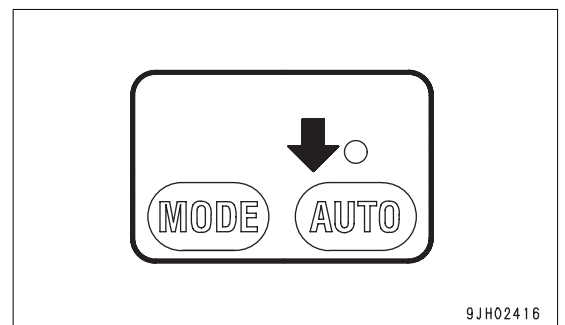

REMARK

When Auto Mode is selected, if the set temperature is set to 18.0 °C and 32.0 °C, the air flow is always set to High, but this is not a problem.

FRESH/RECIRC Selector Switch

Switch (6) is used to switch the air source between recirculation of air inside the cab and intake of from the outside.

- When switch (6) is pressed, the lamp above the selector switch lights up to show that air is being blown out.
- During automatic operation, the selection of inside air (RECIRC) and outside air (FRESH) is performed automatically.

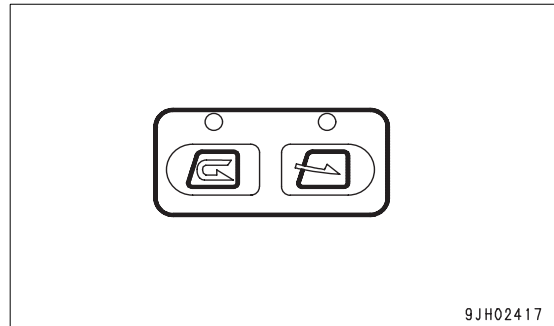

9JH02417

RECIRC	Outside air is shut off and only air inside the cab is circulated. Use this setting to perform rapid cooling of the cab or when outside air is dirty.
FRESH	Outside air is taken into the cab. Use this setting to take in fresh air when performing demisting.

Display Monitor

Monitor (7) displays the status of temperature setting (a), air flow (b), and vents (c).

- When OFF switch (1) is pressed, the display of temperature setting (a) and air flow (b) goes out, and operation stops.

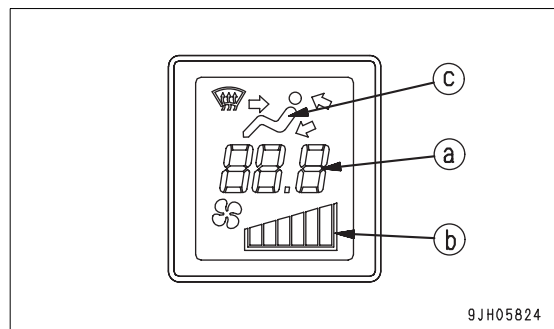

9JH05824

Air Conditioner Switch

Switch (8) is used to turn the air conditioner (cooling, dehumidifying, heating) ON or OFF.

- When the fan is actuated (display (b) is shown) and air conditioner switch (8) is pressed, the air conditioner is switched ON, lamp above the air conditioner switch lights up, and the air conditioner starts.

When switch (8) is pressed again, the air conditioner is switched OFF, lamp above the air conditioner switch goes out, and the air conditioner stops.

- Air conditioner cannot be operated while the fan is off.

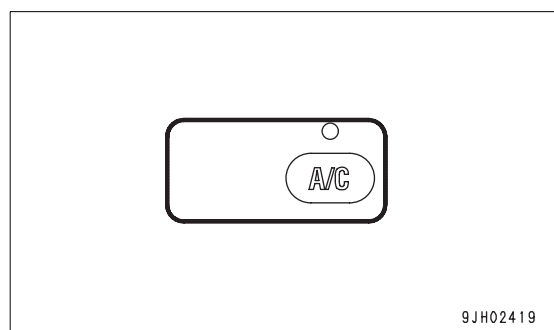

9JH02419

Sunlight Sensor

This sensor (9) automatically adjusts the flow of air from the vents to match the strength of the sun's rays. In addition, it automatically detects changes in the temperature inside the cab caused by changes in the strength of the sun's rays beforehand and automatically adjusts the temperature.

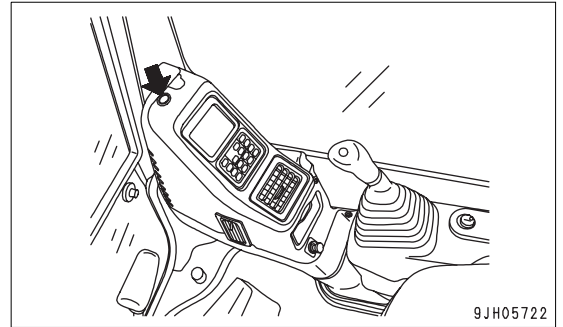

Method of Operation

The air conditioner can be operated automatically or manually. Select the method of operation as desired.

Automatic Operation

1. Turn auto switch (5) ON.
 - The lamp above switch (5) lights up.
 - The set temperature (a) and air flow (b) are displayed on the monitor.

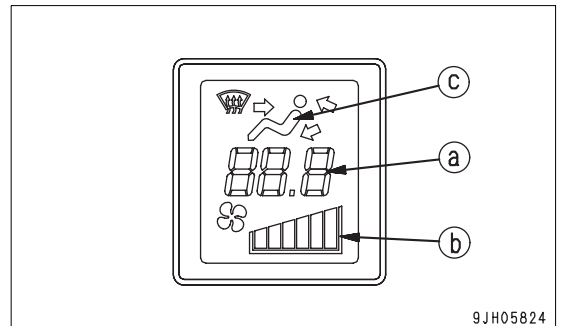
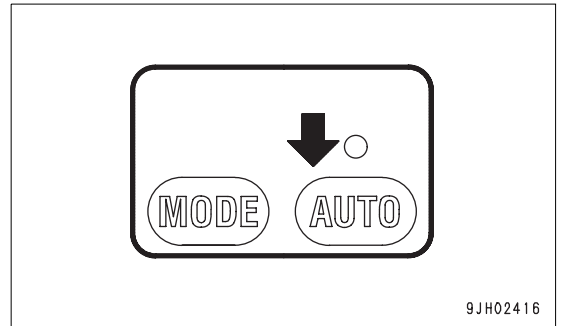

2. Use temperature set switch (3) to set to the desired temperature. The air flow, combination of vents, and selection of fresh or recirculated air is automatically selected according to the set temperature, and the air conditioner is operated automatically to provide the set temperature.

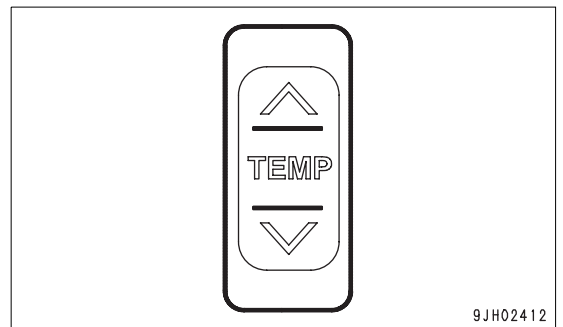

REMARK

When vent display monitor (c) displays (d) or (e), and engine coolant temperature is low, the air flow is automatically limited to prevent cold air from blowing out.

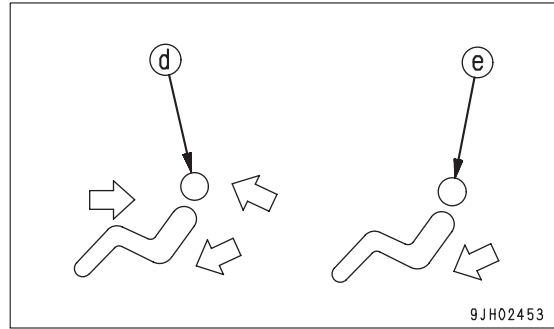

Stopping Automatic Operation

Press OFF switch (1). The displays for temperature setting (a) and air flow (b) on monitor (7), and lamps above auto switch (5) and air conditioner switch (8) go out, the operation stops.



Manual Operation

Press fan switch (2) and adjust the air flow. When doing this, check that temperature setting (a) and air flow (b) are displayed on monitor (7).

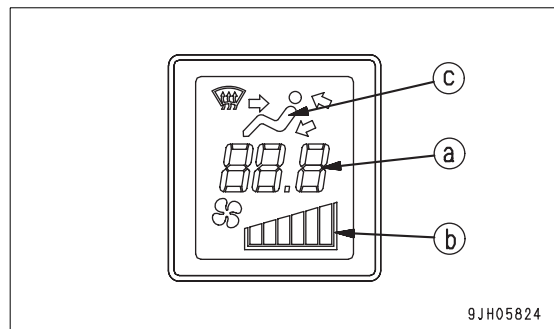
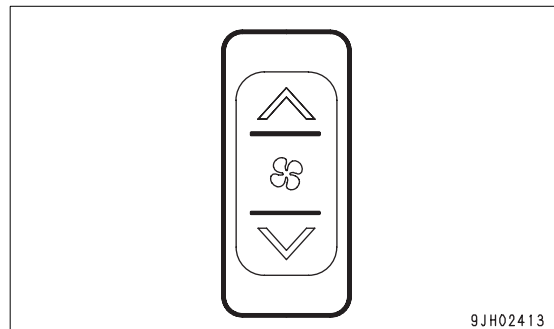

- 3. Turn air conditioner switch (8) ON. Check that the lamp above air conditioner switch lights up.

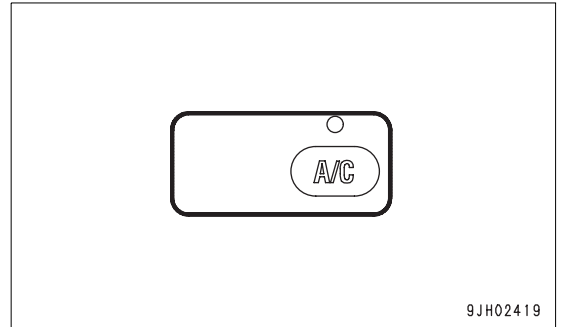

- 4. Press temperature setting switch (3) and adjust temperature inside the cab.

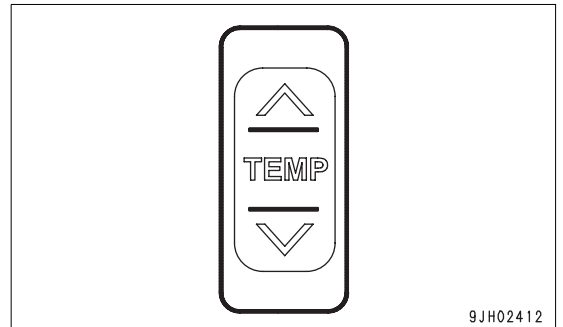

- 5. Press vent selector switch (4) and select the desired vents.
When this is done, the display for vent (c) of the display monitor changes according to the selection.

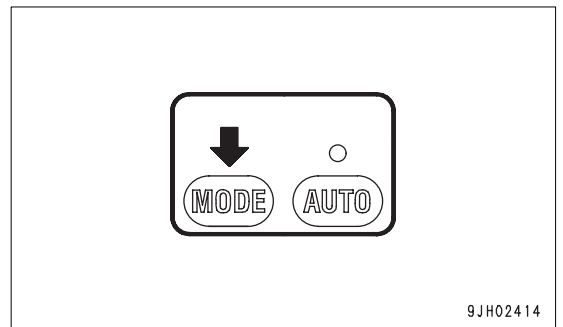

- 6. Press RECIRC/FRESH selector switch (6) and select recirculation of the air inside the cab (RECIRC) or intake of fresh air from outside (FRESH).

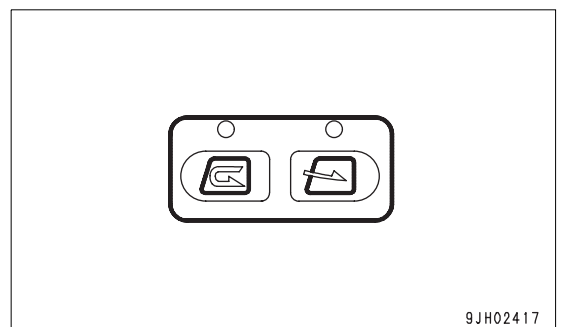
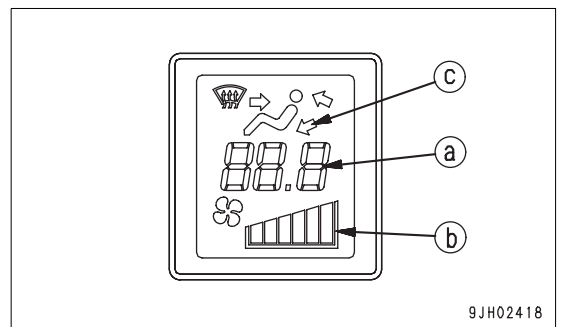

Stopping Manual Operation

Press OFF switch (1). The displays for temperature setting (a) and air flow (b) on monitor (7), and lamps above auto switch (5) and air conditioner switch (8) go out, the operation stops.



Operation with Cold Air to Face and Warm Air to Feet

To operate with cold air blowing to the face and warm air blowing to the feet, set as follows.

1. Press fan switch (2) and adjust the air flow. When doing this, check that temperature setting (a) and air flow (b) are displayed on monitor (7).

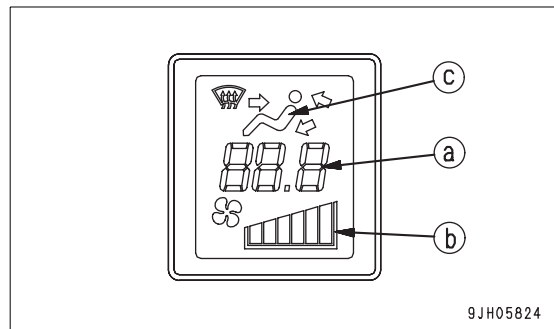
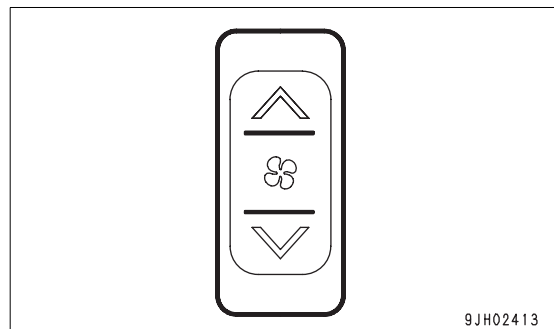

2. Press vent selector switch (4) and set the vent display on the display monitor to the display shown in the diagram on the right.

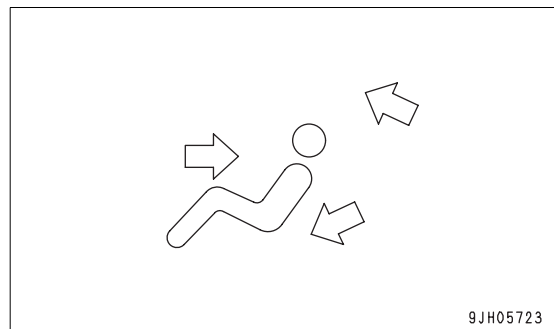

- Turn air conditioner switch (8) ON. Check that the lamp above air conditioner switch lights up.

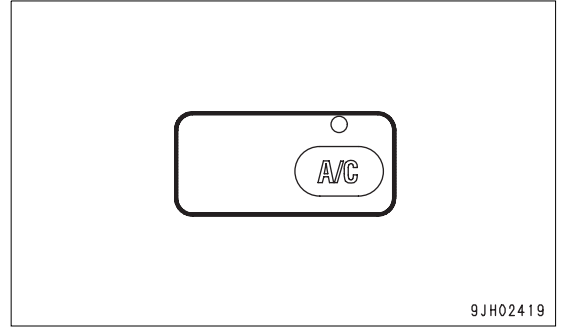

- Adjust fan switch (2), temperature setting switch (3) and RECIRC/FRESH selector switch (6) to the desired positions.

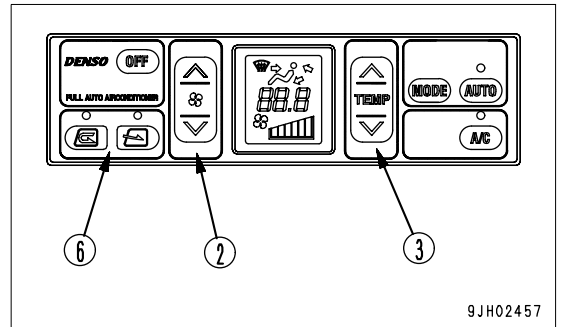

Defroster Operation

- Press fan switch (2) and adjust the air flow. When doing this, check that temperature setting (a) and air flow (b) are displayed on monitor (7).

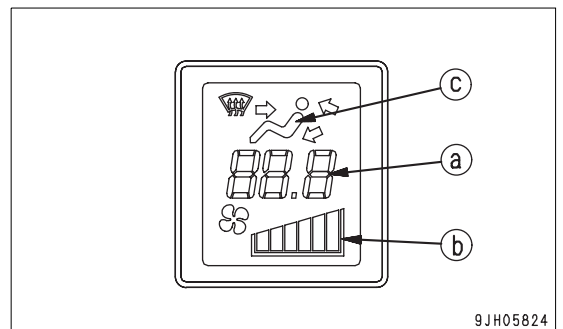
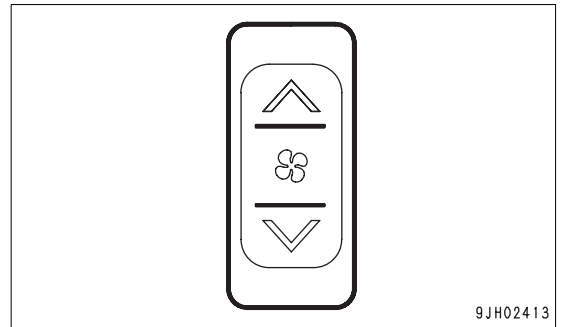

- Press vent selector switch (4) and set vent display on the display monitor to (f) or (g) as shown in diagram on the right.

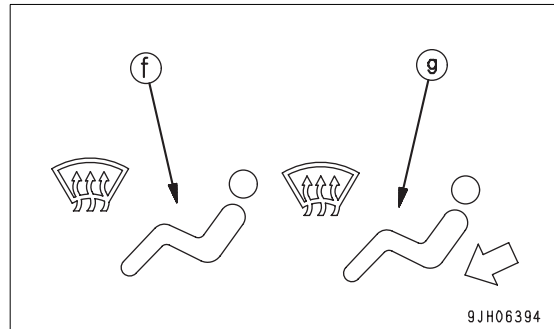
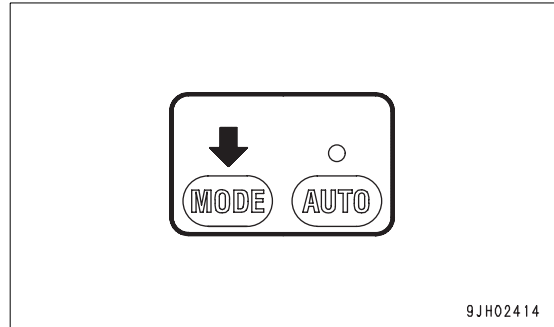

- Press RECIRC/FRESH selector switch (6) and set it to take in fresh air.

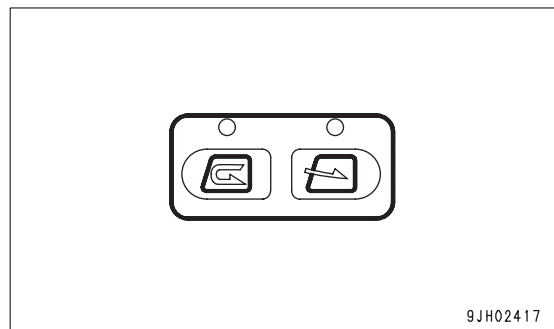

- Press temperature setting switch (3) and set temperature on the display (7) monitor to maximum heating.

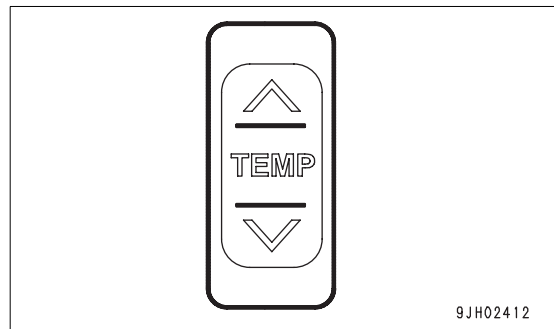

- Adjust vents (A), (B1), and (B2) so that the air blows onto the window glass.

(Vents (C) and (D) are fixed and cannot be adjusted.)

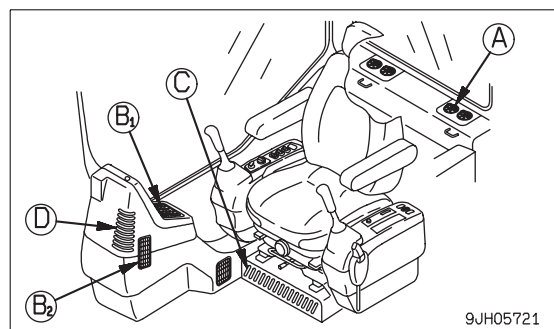

When operating in the rainy season or when it is desired to remove the mist from the window glass or to dehumidify the air, turn air conditioner switch (8) ON.

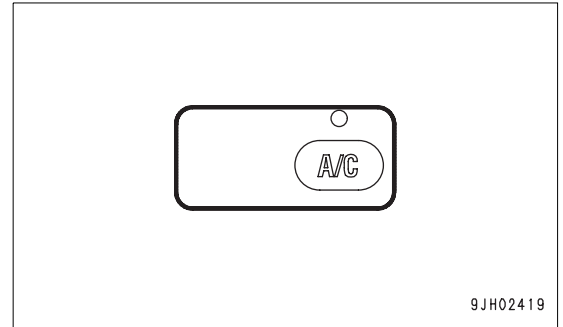

Use Air Conditioner with Care

NOTICE

- When running the air conditioner, always start with the engine running at low speed. Never start the air conditioner when the engine is running at high speed. It will cause failure of the air conditioner.
- If water gets into the control panel or sunlight sensor, it may lead to unexpected failure, be careful not to let water get on these parts. In addition, never bring any flame near these parts.
- For the auto function of the air conditioner to work properly, always keep the sunlight sensor clean and do not leave anything around the sunlight sensor that may interfere with its sensor function.

Ventilation

- When running the air conditioner for a long time, turn the lever to the FRESH position once an hour to carry out ventilation and cooling.
- If you smoke when the air conditioner is on, the smoke may start to hurt your eyes, so open the window and turn the lever to FRESH for a while to remove the smoke while continuing the cooling.

Temperature Control

When the cooler is on, set the temperature so that it feels slightly cool when entering the cab (5 or 6 °C) lower than the outside temperature). This temperature difference is considered to be the most suitable for your health, so always be careful to adjust the temperature properly.

Inspection and maintenance of Air Conditioner Equipped Machine

When carrying out inspection of a machine equipped with an air conditioner, see the "CHECK AND MAINTENANCE AIR CONDITIONER (4-33), CHECK AIR CONDITIONER COMPRESSOR BELT TENSION, ADJUST (4-50), CLEAN FRESH/RECIRC AIR FILTERS OF AIR CONDITIONER (ONLY FOR MACHINES EQUIPPED WITH AIR CONDITIONER) (4-57)" and carry out inspection according to the table.

Other Functions

Self-diagnostic Function

It is possible to perform troubleshooting of various sensors and equipment used on the air conditioner.

1. Turn the starting switch key to the ON (B) position.

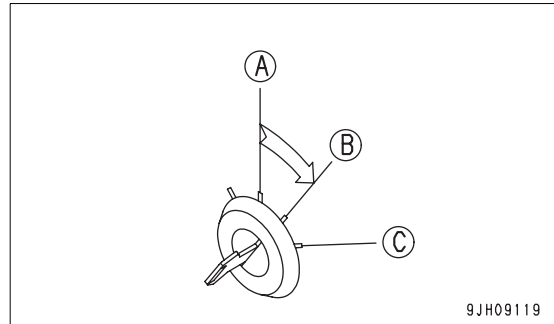

2. Press OFF switch (1). The temperature setting and air flow display on the liquid crystal display portion go out and operation stops.



3. If the “∨” and “∧” parts of temperature setting switch (3) are kept pressed at the same time for at least 3 seconds, the troubleshooting mode is displayed on the liquid crystal display portion.

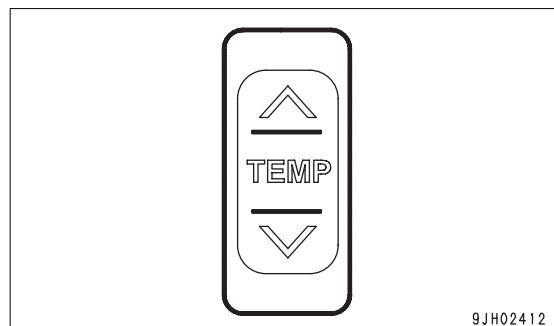

<Monitor display and failure mode>

Display	Failure mode
E--	No failure
E11	Disconnection in RECIRC sensor
E12	Short circuit in RECIRC sensor
E15	Disconnection in water temperature sensor
E16	Short circuit in water temperature sensor
E18	Short circuit in sunlight sensor
E43	Abnormality in vent damper
E44	Abnormality in air mix damper
E45	Abnormality in RECIRC/FRESH damper

- When more than one failure is detected, press the “∨” or “∧” portion of temperature setting switch (3) to display the failures in turn.
- After completing the troubleshooting, press OFF switch (1) again to return to the normal display.

If any problem is detected by the self-diagnostic function, contact your Komatsu distributor to perform inspection and repair.

Function to Switch Set Temperature Display Between Fahrenheit and Celsius

It is possible to switch the set temperature display between °F and °C.

If the “∨” and “∧” portions of temperature setting switch (3) are pressed at the same time for more than 5 seconds while the fan is running, the temperature display will switch between °F and °C.

(Note that the unit is not displayed.)

	Liquid crystal display range
°C	18.0 to 32.0
°F	63 to 91

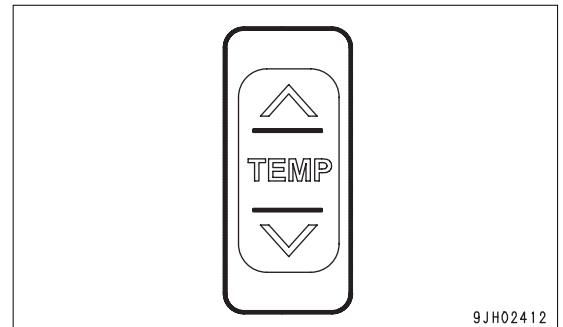

CAB RADIO

Antenna

NOTICE

Before transporting the machine or putting it inside a building, stow the antenna at position (A) to prevent any interference.

Use Radio With Care

- To ensure safety, always keep the sound to a level where it is possible to hear outside sounds during operation.
- If water gets into the speaker case or radio, it may lead to an unexpected failure, so be careful not to get water on the equipment.
- Do not wipe the scales or buttons with benzene, thinner, or any other solvent. Wipe with a soft dry cloth. Use a cloth soaked in alcohol if the equipment is extremely dirty.
- When the battery is replaced, the settings for the preset buttons are all cleared, so set again.

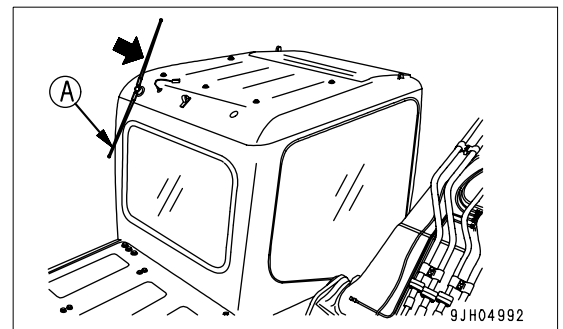

AUXILIARY ELECTRIC POWER

24V power source

NOTICE

Do not use this as the power source for 12 V equipment.

Pull out the connector plug for taking out electric power from the rear side of the panel.

Maximum usable electric power is 85 W (24 V x 3.5 A).

12V power source

(if equipped)

This power source can be used up to a capacity of 60W (12V x 5A).

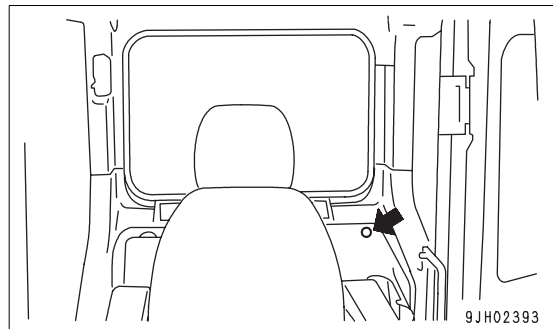
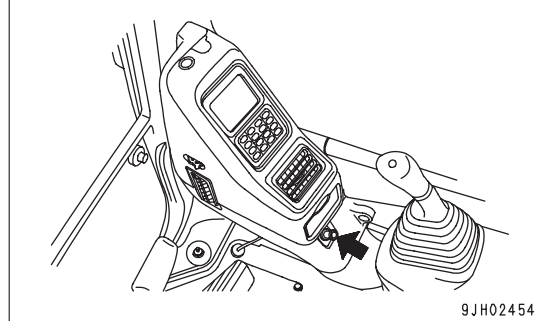

FUSE

NOTICE

Before replacing a fuse, be sure to turn off the starting switch.

The fuses protect the electrical equipment and wiring from burning out.

If the fuse becomes corroded, or white powder can be seen, or the fuse is loose in the fuse holder, replace the fuse.

Replace the fuse with another of the same capacity.

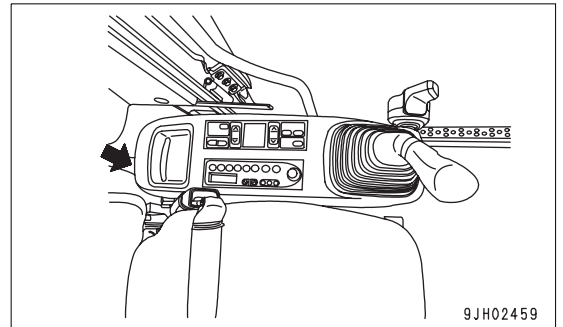

Fuse Capacities and Circuit Names

No.	Fuse Capacity	Circuit Name
(1)	10A	Redundancy,S wing holding brake solenoid
(2)	10A	Solenoid valve
(3)	10A	PPC lock solenoid, Starting motor cut-out relay
(4)	20A	Window washer, Cigarette lighter
(5)	10A	Horn,flashlight (OPT)
(6)	10A	Ribbon heater relay
(7)	10A	Revolving warning lamp (OPT)
(8)	10A	Spare fuse
(9)	10A	Radio, Left knob switch
(10)	20A	Monitors, Buzzer
(11)	25A	Air conditioner unit
(12)	10A	Lower wiper
(13)	20A	Spare fuse
(14)	10A	OPT power supply (1)
(15)	10A	OPT power supply (2), 12V power supply (OPT)
(16)	10A	Radio backup,Room lamp
(17)	10A	Step light (OPT)
(18)	10A	Spare fuse
(19)	10A	Spare fuse
(20)	5A	ACC (ENGINE CON)

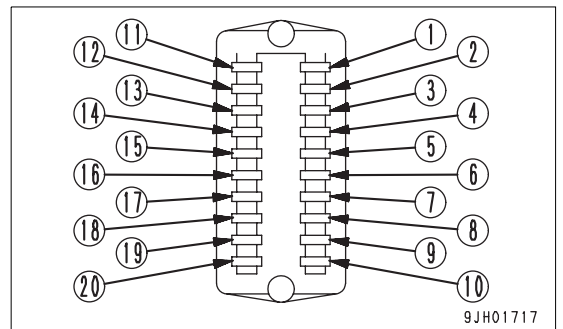

CIRCUIT BREAKER

NOTICE

When resetting the circuit breaker, always turn the starting switch OFF first.

- If the starting switch does not work, even when the starting switch is turned on, open the circuit breaker box inside the grease pump box located at the front right of machine, and perform inspection.
- If an excess current is generated, the circuit breaker cuts off electrical current to protect electrical components and wiring from damage. To return the circuit electrical current to normal after it has been cut off, push in the reset button.

If the electric circuit is working normally, the reset button remains in. If the reset button pops out again immediately after it is pushed in, it is necessary to check the electric circuit.

REMARK

The circuit breaker is a circuit protection device installed to circuits where large current flows. It protects the electrical components and wiring from damage caused by an abnormal current in the same way as a normal fuse. After repairing and restoring the location of the abnormality, there is no need to replace the breaker. It can be used again.

If the starting motor does not work even when the starting switch is turned to the ON position, breaker (6) has probably cut off the circuit, so check and restore circuit breaker (6).

If the electrical equipment does not work even when the fuse is replaced, breaker (1) or (9) has probably cut off the circuit, so check and restore circuit breaker (1) or (9).

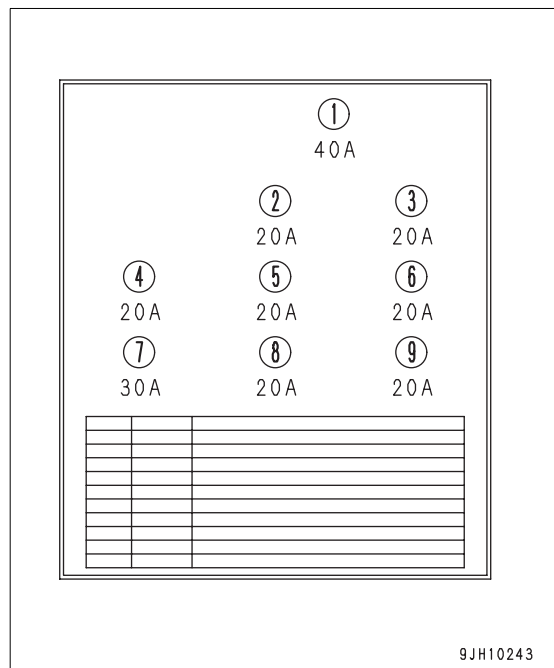
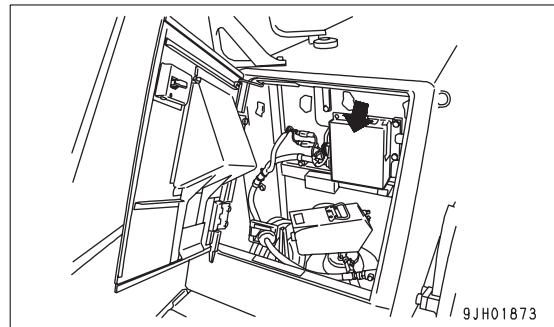

No.	Fuse Capacity	Circuit Name
1	40A	Fuse 1 to 15
2	20A	Work equipment headlamp, right side headlamp
3	20A	Power supply grease pump
4	20A	Pump controller
5	20A	Cab upper headlamp
6	20A	Starting switch, Pump controller
7	30A	Engine controller
8	20A	Monitor, buzzer
9	20A	Fuse 16 to 20

CONTROLLER

Controller installed.

NOTICE

- Be careful not to get water, mud, or juice on the controller. This will cause failure.
- The engine controller has been given moisture prevention treatment, so there is no problem if rain gets on it, but do not spray it with water when washing the machine.
- If any abnormality occurs in the controller, do not disassemble it yourself. Contact your Komatsu distributor for repairs.
- Engine controller

Open the engine hood. It is under the engine oil filter.

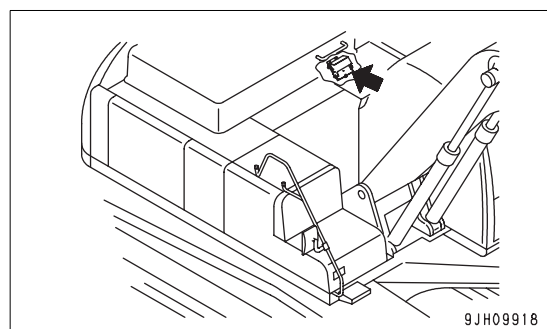

- Pump controller

This is on the right side at the rear of the operator's seat.

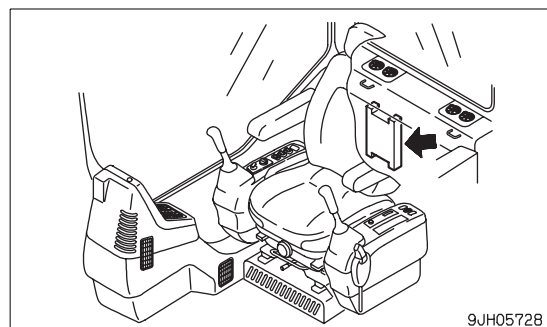

TOOL BOX

(Cloth bag)

This is inside the toolbox at the rear of the cab.

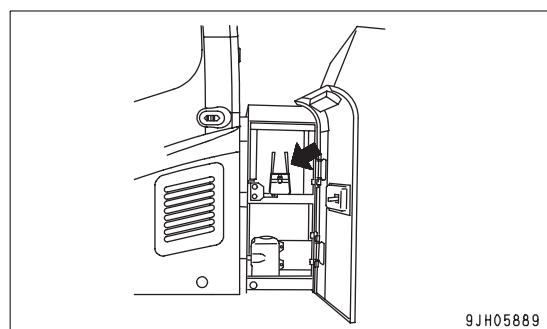

GREASE PUMP

This is stored inside the grease pump box on the right side of the chassis.

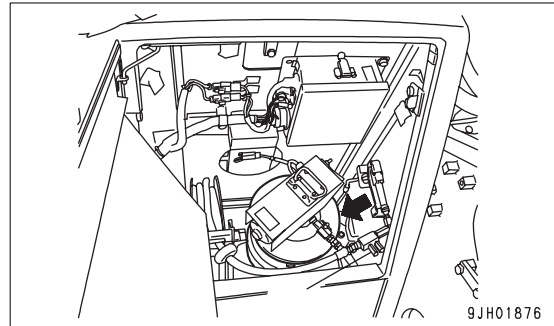

Method of Use

1. When power switch (1) is turned ON, pump (3) is actuated and grease is sent under pressure to grease gun (2).
2. Grease is discharged when lever for grease gun (2) is pulled.

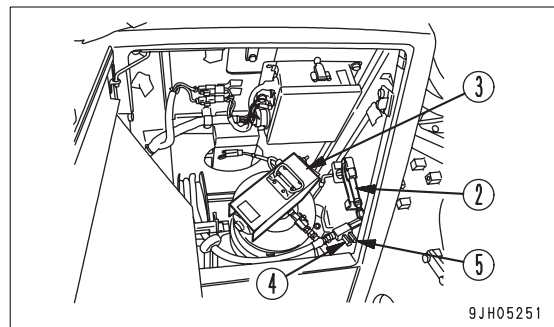
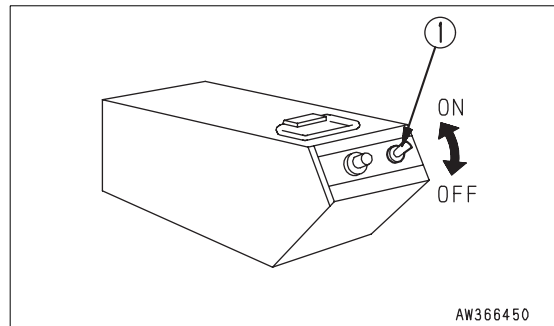

3. The greasing condition can be checked with pressure gauges (4) and (5).
 - (4): green (low pressure)
 - (5): red (high pressure)
4. When the lever of grease gun (2) is released, the supply of grease stops.
5. After using, turn power switch (1) OFF.

Greasing conditions	Pressure gauge	
	Green color (low pressure)	Red color (high pressure)
When grease gun is empty		
Greasing in progress		
When tip is clogged		

Precautions when Using

NOTICE

When not using the grease pump, always turn power switch (1) OFF so that there is no internal pressure on grease gun (2), and release the pressure inside the hose.

- Set so that the nipple and the nozzle at the tip of the grease gun are perpendicular.

- When removing the nozzle at tip of the grease gun from the nipple, carefully angle the tip of nozzle slightly and remove it.

- When there is only a small amount of grease left in the grease can, the pump will not pump out grease, so move grease to the center or fill the can with new grease.

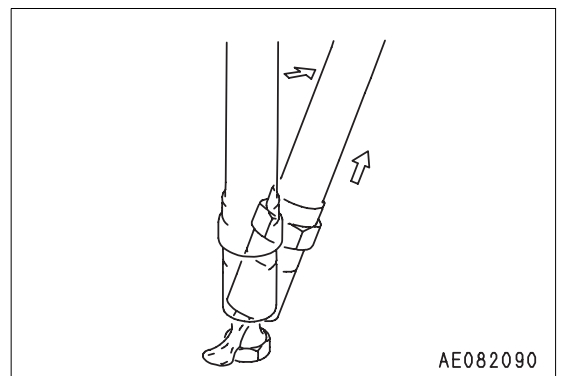
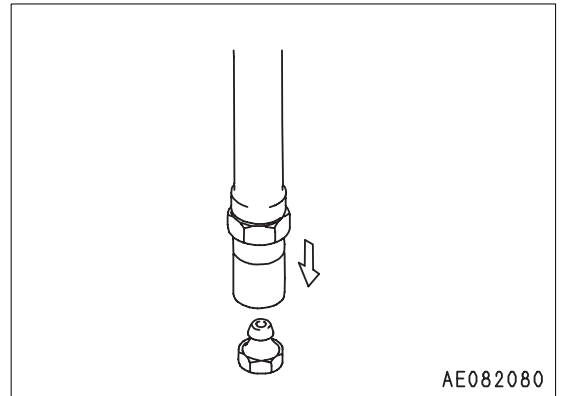

Supplying Grease

1. Remove 3 wing bolts (2) from grease can (1), then remove cover (3) from the pump.
2. Remove follow plate (4) inside the grease can.
3. Fill grease can (1) with fresh grease, set follow plate (4) on top of the grease so that it is horizontal, then push down by hand until grease comes out from the packing in the center of follow plate (4).
 - When setting the follow plate on top of the grease, fill the inside of the raised part in the center of the follow plate with grease. This will make the operation go more smoothly.
4. Insert the pump into the packing at the center of follow plate (4), set cover (3) on grease can (1), then tighten 3 wing bolts (2) uniformly to hold in position.
 - The pump will operate for a short time and then stop, but the first grease includes air inside the pump, so it is cloudy white and not suitable for use.

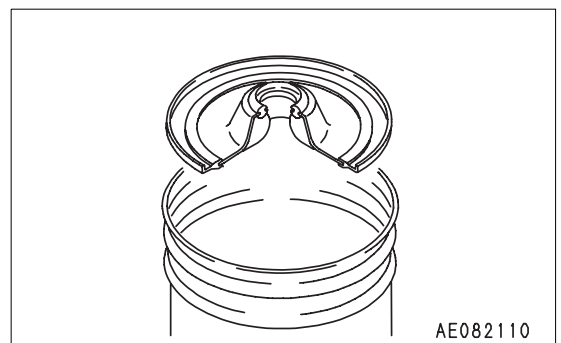
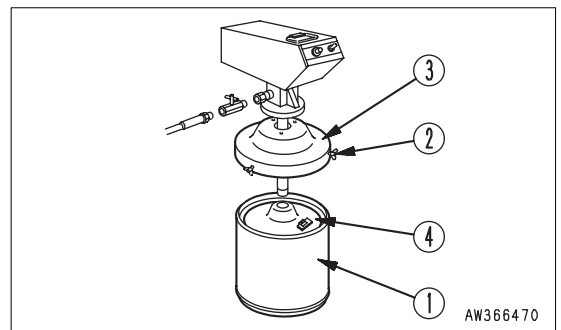

5. Loosen check valve (5), and pump out all the grease which has air in it from hole (6) at the bottom of check valve (5).
6. After bleeding the air, close check valve (5) securely.
7. After bleeding the air inside the pump, pull the lever of the grease gun to completely discharge the grease mixed with air inside the hose and grease gun.
 - When filling with grease, be extremely careful not to let sand or dirt stick to the follow plate or pump suction portion.
 - If there is ample grease, but the pump does not pump out any grease, the follow plate may not be correctly set in position, so set it in position again correctly.
 - The standard grease can contains 16 liters. If an 18 liters can is used, there will be more grease left.

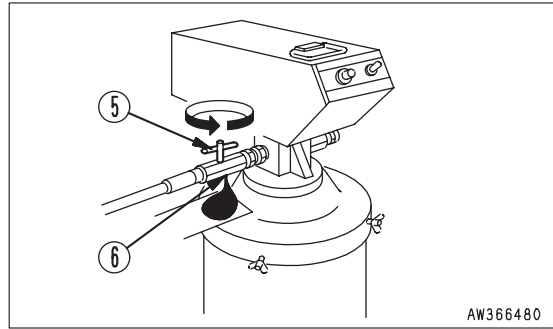

REMARK

Always keep spare grease in the grease can storage box at the rear of the cab.

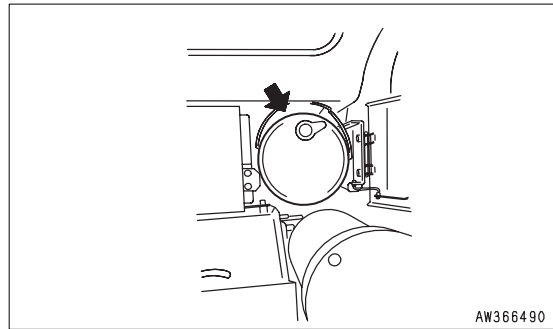

ACCUMULATOR

WARNING

The accumulator is charged with high-pressure nitrogen gas, so mistaken operation may cause an explosion which will lead to serious injury or damage. When handling the accumulator, always do as follows. The pressure in the control circuit cannot be completely removed. When removing the hydraulic equipment, do not stand in the direction that the oil spurts out when carrying out the operation.

Loosen the bolts slowly.

Do not disassemble the accumulator.

Do not bring it near flame or dispose of it in fire.

Do not make holes in it or weld it.

Do not hit it, roll it, or subject it to any impact.

When disposing of the accumulator, the gas must be released. Please contact your Komatsu distributor to have this work carried out.

This machine is equipped with an accumulator in the control circuit. The accumulator is a device to store oil pressure for the control circuit, and when it is installed, the control circuit can be actuated for a short time even after the engine is stopped. Due to this device, the work equipment lowers under its own weight, if the control lever is moved in the lowering direction.

The accumulator is installed to the position shown in the diagram on the right.

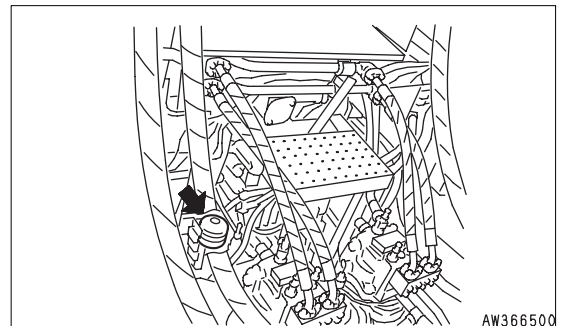

Releasing Hydraulic Pressure With Accumulator

1. Place the work equipment on the ground. Close the crusher attachment jaws, etc.
2. Stop the engine.
3. Turn the key in starting switch to the ON position.
4. Move the safety lock lever to the free position. Move the work equipment control lever and the attachment control pedal to full stroke back and forth, right and left so as to release the pressure in the control circuit.
5. Start the engine again, stop the engine after 2 - 3 seconds, then carry out the operation in Step 3.
6. Continue the operation in Step 4 until the hissing noise of pressure oil can no longer be heard. (Approx. 2 - 3 times)
7. Set the safety lock lever to the LOCK position, and lock the work equipment levers and attachment control pedal. Note that the pressure cannot be completely released, so if the accumulator in the control circuit is removed, loosen the screws slowly, and do not stand in the direction where the oil spurts out.
8. Turn the key in starting switch to the OFF position.

MACHINE OPERATIONS AND CONTROLS

BEFORE STARTING ENGINE

Walk-around Checks

Before starting the engine, look around and under the machine to check for loose nuts and bolts, or leakage of oil, fuel, or coolant, and check condition of the work equipment and hydraulic system. Also check for loose wiring, play, and accumulation of dust at places with high temperatures.

WARNING

Remove any flammable materials from around the battery, engine, muffler, turbocharger, or other high temperature engine parts.

Leakage of fuel or oil will cause the machine to catch fire. Check carefully, be sure to repair any problem, or contact your Komatsu distributor.

Perform the following inspections and cleaning every day before starting engine for the day's work.

1. Check for damage, wear, play in work equipment, cylinders, linkage, hoses
Check for cracks, excessive wear, play in work equipment, cylinders, linkage, and hoses. If any problem is found, repair it.
2. Remove dirt and debris from around the engine, battery, and radiator.
Check for dirt accumulated around the engine and radiator. Also check for flammable material (dry leaves, twigs, etc.) around the battery, engine muffler, turbocharger, or other high temperature engine parts. If any dirt or flammable materials are found, remove them.
3. Check for coolant and oil leakage around the engine
Check for oil leakage from the engine and coolant leaks from the cooling system. If any problem is found, repair it.
4. Check for oil leakage from hydraulic equipment, hydraulic tank, hoses, and joints
Check for oil leakage. If any problem is found, repair the area where oil is leaking.
5. Check the undercarriage (track, sprocket, idler, guard) for damage, wear, loose bolts, or leakage of oil from rollers.
If any problem is found, repair it.
6. Check for problems in handrails, steps, loose bolts.
If any problem is found, repair it. Tighten any loose bolts.
7. Check for problem in gauges, monitor.
Check for problem in the gauges and monitor in the operator's cab. If any problem is found, replace the parts. Clean off any dirt from the surface.
8. Clean, check rear view mirror
Check that there is no damage to the rear view mirror. If it is damaged repair. Clean the surface of the mirror and adjust the angle so that the area at the rear can be seen from the operator's seat.
9. Seat belt and mounting clamps
Check for damage or wear to the seat belt and mounting clamps. If there is any damage, replace with new parts.

Checks Before Starting

Always check the items in this section before starting the engine each day.

Check Coolant Level, Add Coolant

⚠ WARNING

- Do not open the radiator cap unless necessary. Wait for the engine to cool down before checking the coolant in the sub-tank.
- Immediately after the engine is stopped, the coolant is at a high temperature and the radiator is under high internal pressure. If the cap is removed to check the coolant level in this condition, there is a hazard of burns. Wait for the temperature to go down, then turn the cap slowly to release the pressure before removing it.

1. Open cover (1) on top of the pump and check that the level of the coolant inside sub tank (2) is between the FULL and LOW lines. If the coolant level is low, add water through the water filler of sub tank (2) to the FULL line.
2. After adding coolant, tighten the cap securely.
3. If sub tank (2) is empty, check for coolant leakage, then check the coolant level in the radiator. If the coolant level is low, add coolant to the radiator, then add coolant to sub tank (2).

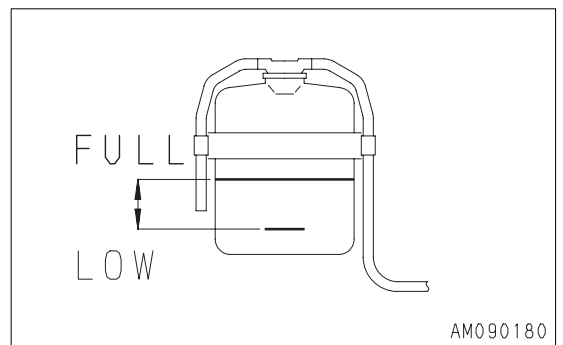
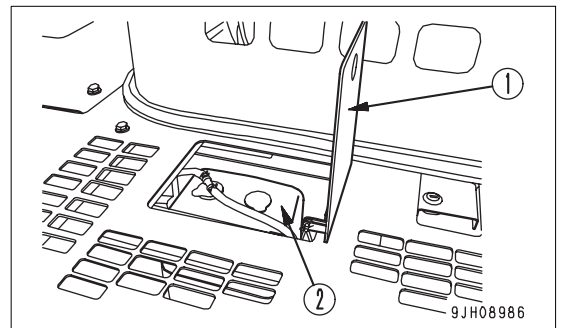

REMARK

Normally, when adding water to the radiator, open the engine hood, slowly loosen cap (3) of the radiator, and check that the pressure has been released. After checking, push in the cap, turn it to loosen it, then remove it.

Check that the coolant level is above shaded portion in diagram on the right. If the level is low, add coolant through the filler.

After adding water, install cap (3) of the radiator.

For the procedure in cold weather, see "COLD WEATHER OPERATION (3-135)".

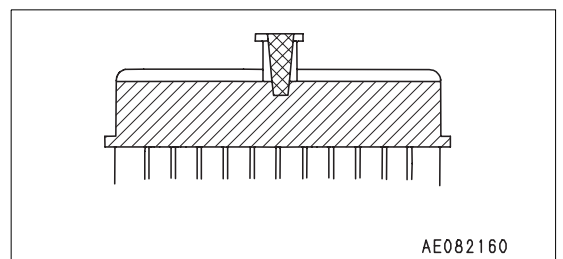
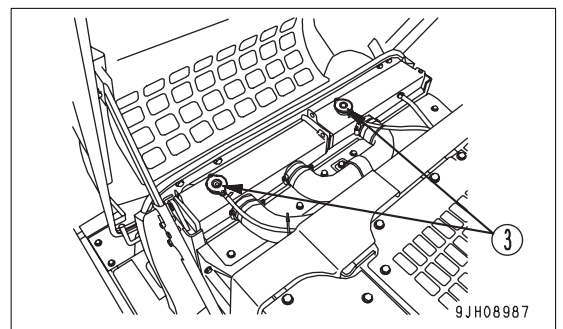

Check Oil Level in Engine Oil Pan, Add Oil

WARNING

Parts and oil are at high temperature immediately after the engine is stopped and may cause serious burns. Wait for the oil temperature to go down before performing this operation.

1. Open the engine hood.
2. Remove dipstick (G), and wipe the oil off with a cloth.
3. Fully insert dipstick (G) into filler pipe (F), then remove it.

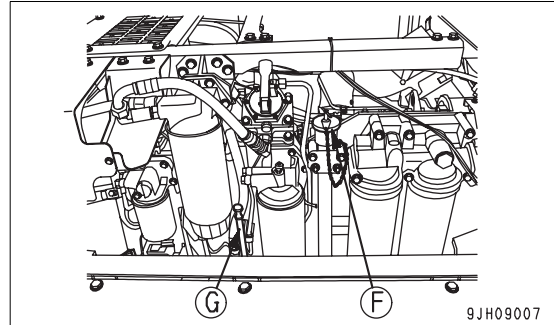

4. The oil level should be between the H and L marks on dipstick (G).

If oil level is below the L mark, add engine oil through filler pipe (F).

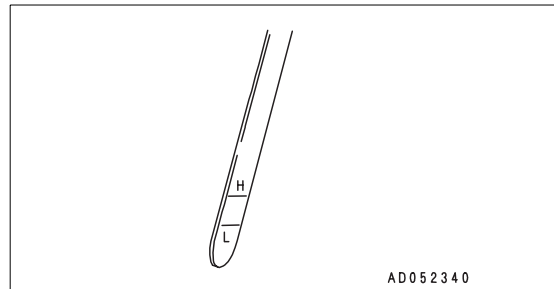

5. If oil is above the H mark, drain the excess engine oil from drain plug (P) at bottom of the engine oil pan, then recheck the oil level.
6. If oil level is correct, securely tighten the oil filler cap and close the engine hood.

REMARK

When checking the oil level after the engine has been operated, wait for at least 15 minutes after stopping the engine before checking.

If the machine is at an angle, make it horizontal before checking.

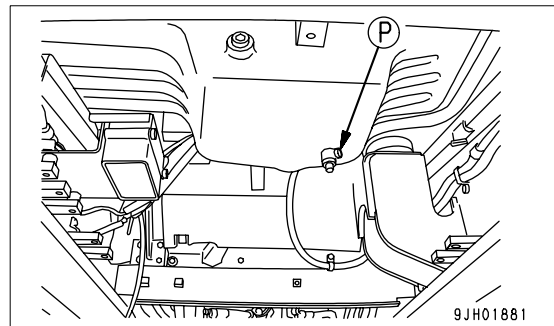

Check Fuel Level, Add Fuel

⚠ WARNING

When adding fuel, never let the fuel overflow. This may cause a fire. If any fuel is spilled, wipe it up completely. Never bring flames near fuel because it is highly flammable and dangerous.

1. Open fuel filler cap (F) of the fuel tank.
2. When fuel filler cap (F) is opened, float gauge (G) comes up in proportion to the remaining fuel level in the tank.

Check that the fuel tank is full.

Inspect the fuel level both visually and with float gauge (G).

3. If the fuel tank is not full, supply fuel through the fuel filler until float gauge (G) rises to the maximum position.

(a: Approx. 50 mm)

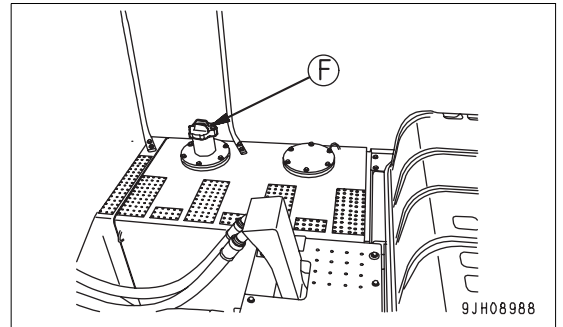

Fuel capacity: 880 liters

4. When refueling is finished, push float gauge (G) straight down along the fuel filler cap (F), then tighten fuel filler cap (F) securely, taking care so that float gauge (G) will not get caught on claw (2) of the cap.

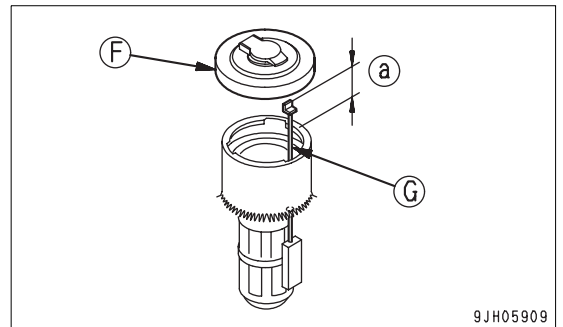

REMARK

If breather hole (1) in the cap is clogged, the pressure in the tank will drop and fuel will not flow. Clean the hole from time to time.

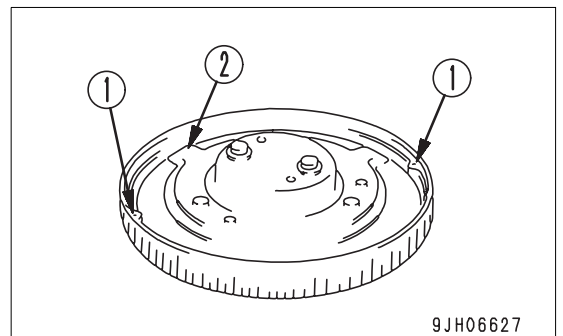

Check for Water and Sediment in Water Separator, Drain Water

The water separator is installed at the bottom of the fuel pre-filter.

1. It is possible to judge the water level and amount of sediment by looking through transparent cap (2). If there is any water or sediment collected at the bottom, set a container to catch the drain water under drain hose (3).
2. Loosen plug (1) and drain the water.
3. When fuel comes out from drain hose (3), tighten plug (1) immediately.

Tightening torque: 0.2 to 0.45 N·m (0.02 to 0.046 kgf·m)

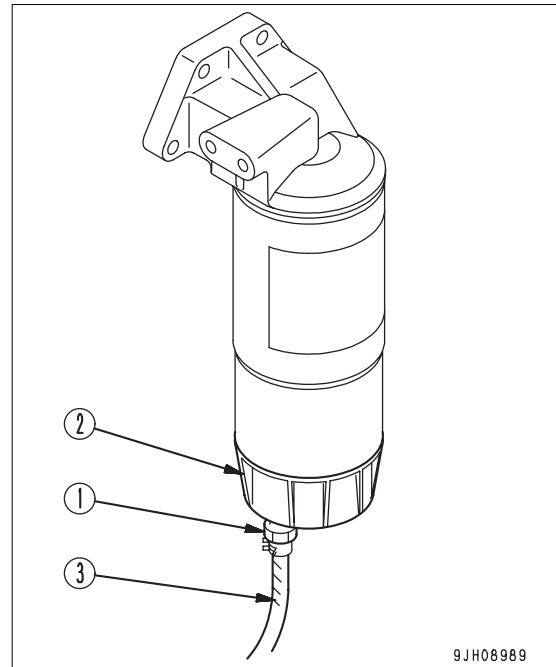

Drain Water And Sediment from Fuel Tank

1. Set the container to catch the fuel under drain port (1) on the front of the fuel tank on the right side of the machine.
2. Open drain valve (2) and drain the sediment and water accumulated at the bottom together with the fuel.
3. When clean fuel comes out, close drain valve (2).

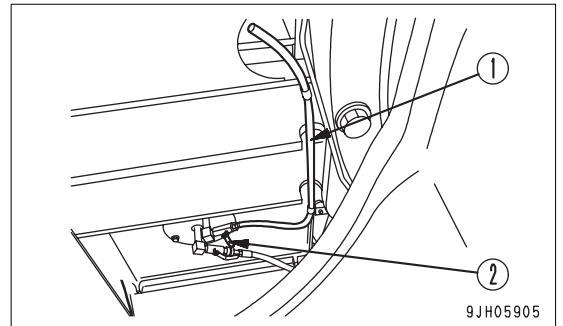

Check Oil Level in Hydraulic Tank, Add Oil

⚠ WARNING

When removing the oil filler cap, oil may spurt out, so turn the cap slowly to release the internal pressure before removing the cap.

1. If the machine is not in the condition shown in the diagram on the right, start the engine, run the engine at low speed, retract the arm and bucket cylinder rods fully, lower the boom, put the bucket teeth in contact with the ground, then stop the engine.
2. Within 15 seconds after stopping the engine, turn starting switch to the ON position, and operate the control levers (work equipment, travel) in each direction to release the internal pressure.

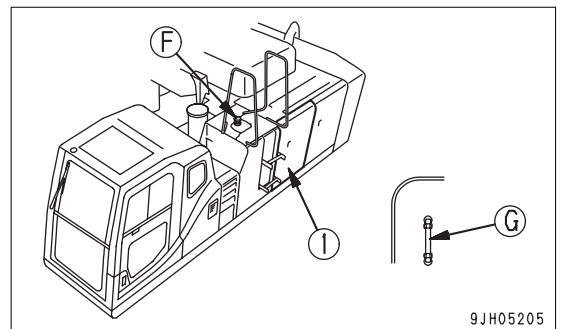
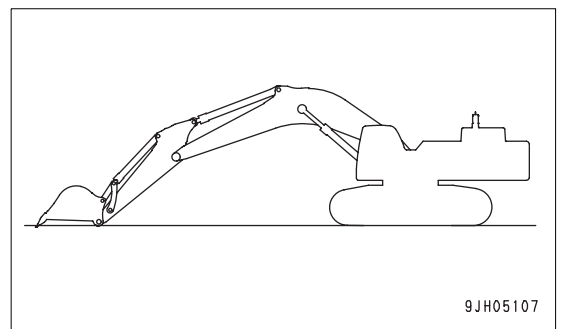

3. Open cover (1) on the left side of the machine and check sight gauge (G). The oil level should be between the H and L marks.

NOTICE

Do not add oil if the level is above the H line. This will damage the hydraulic equipment and cause the oil to spurt out.

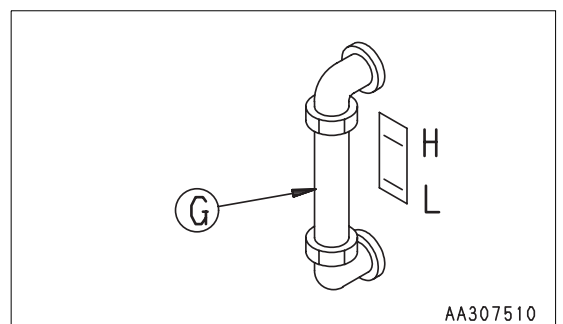

⚠ WARNING

If oil is above the H level, stop the engine, wait for the hydraulic oil to cool down, then drain excess oil from drain plug (P1). When draining the oil, loosen bottom drain plug (P1), then loosen side drain plug (P2) and drain the oil. After draining the oil, tighten plugs (P1) and (P2).

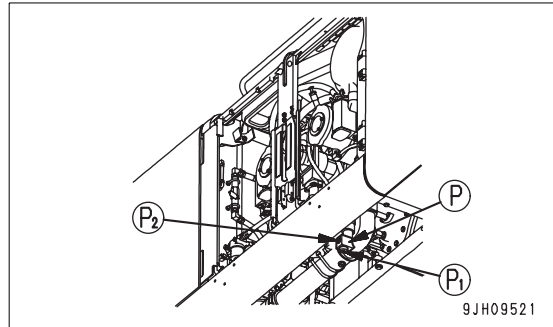

(A): Rear

4. If level is below the L mark, add oil through filler (F) at top of the hydraulic tank.

REMARK

Oil level will vary depending upon the oil temperature. Use the following as a guide:

Before operation: around L level

(Oil temperature 10 to 30°C)

Normal operation: around H level

(Oil temperature 50 to 80°C)

Check Oil Level in Swing Machinery Case, Add Oil

⚠ WARNING

Parts and oil are at high temperature immediately after the engine is stopped and may cause serious burns. Wait for the oil temperature to go down before performing this operation.

1. Remove dipstick (G) and wipe oil from the dipstick with a cloth.
2. Fully insert dipstick (G) into the filler pipe.

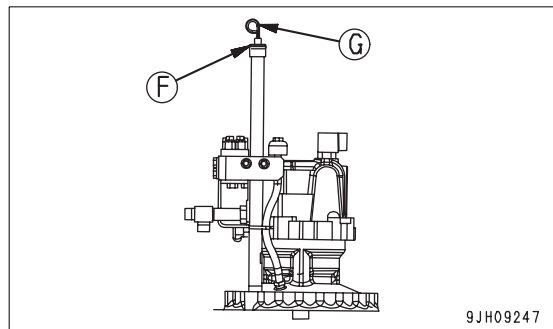

3. The oil level should be between the H and L marks on dipstick (G).

If the oil level is below the L mark, add oil through oil filler (F).

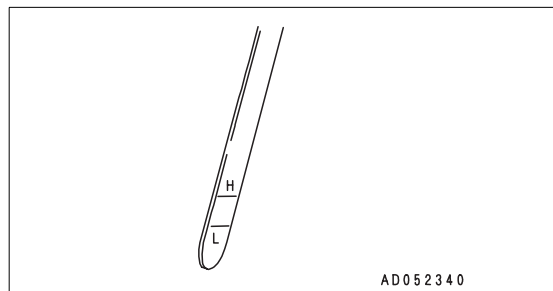

4. If the oil level exceeds the H mark on the dipstick, loosen drain valve (P) to drain the excess oil.
5. After checking oil level or adding oil, fully insert dipstick (G) into the filler pipe.

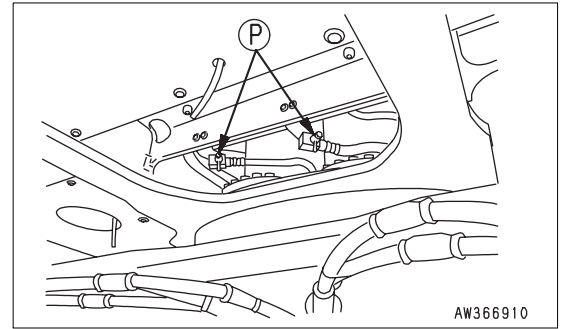

Check Oil Level in P.T.O Case, Add Oil

WARNING

Parts and oil are at high temperature immediately after the engine is stopped and may cause serious burns. Wait for the oil temperature to go down before performing this operation.

NOTICE

Park the machine on flat ground and stop the engine. After waiting for more than 30 minutes after stopping the engine, check the oil level.

1. Open the left side cover and use dipstick (G) to check the oil level.

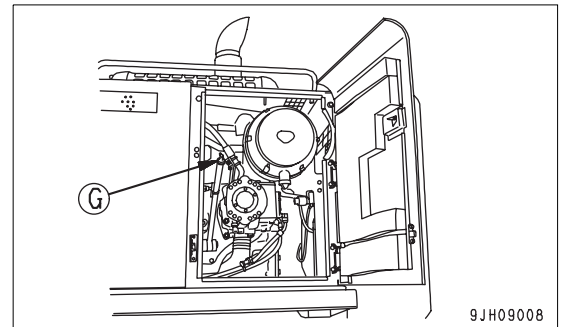

2. The oil on the oil level gauge (G) should be between the H mark and L mark.

If the oil is below the L mark, add oil through the dipstick guide.

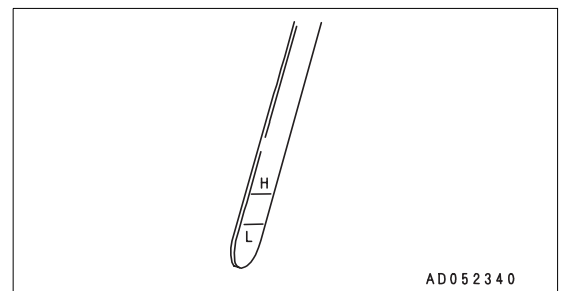

Check Working Lamp Switch

Turn the lamp switch to the ON position and check that the working lamp light up.

If the lamps do not light up, there is probably a broken bulb or disconnection in the wiring, contact your Komatsu distributor for repairs.

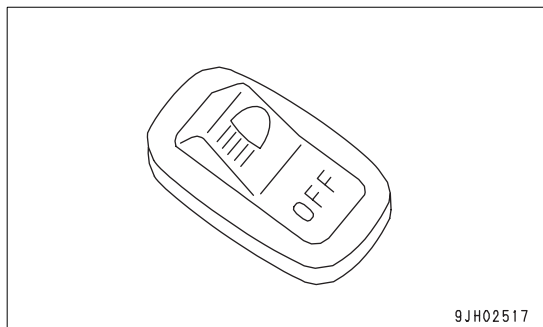

Check Electric Wiring



CAUTION

If fuses are frequently blown or if there are traces of short-circuiting on the electrical wiring, promptly ask your Komatsu distributor to locate the cause and make the repair.

Keep the top surface of the battery clean and check the breather hole in the battery cap. If it is clogged with dirt or dust, wash the battery cap to clear the breather hole.

Check for damage to the fuse, that a fuse of the specified capacity is being used, that there are no signs of any disconnection, breakage, or short circuit in the wiring. Also check for loose terminals, and tighten any loose terminals found.

Be sure to check wiring for the battery, starting motor, and alternator.

In addition, if any flammable material is accumulated around the battery, remove it.

For troubleshooting and repairs, contact your Komatsu distributor.

Check Function of Horn

1. Turn the starting switch to the ON position.
2. Confirm that the horn sounds immediately when the horn button is pressed.

If the horn does not sound, contact your Komatsu distributor for repair.

Adjustment

Seat Adjustment

WARNING

When adjusting the position of the operator's seat, always set the lock lever to the LOCK position to prevent any accidental contact with the control levers.

- Always adjust the operator's seat before starting each operation or when the operators change shift.
- Adjust the operator's seat so control levers and switches can be operated freely and easily with the operator's back against the backrest.

(A) Fore-and-aft adjustment

Pull lever (1) up, set the seat to the desired position, then release the lever.

Fore-and-aft adjustment: 160 mm (16 stages)

(B) Adjusting reclining

NOTICE

The operator's seat can be reclined to a large angle when the seat is completely pushed forward, but the reclining angle is reduced when the seat is moved backward. So return the seat to its upright position before moving the seat to the rear.

Pull up lever (2) and set the backrest to a position that is comfortable for operation, then release the lever.

Sit with your back against the seat backrest when adjusting. If your back is not against the backrest, the backrest may suddenly move forward.

(C) Adjusting seat tilt

● Forward tilt

Push lever (3) down to adjust angle of the front of seat. (4 stages)

- To raise the angle at front of the seat, keep the lever pushed down and apply your weight to the rear of seat.
- To lower the angle at front of the seat, keep the lever pushed down and apply your weight to the front of seat.

● Rear tilt

Pull lever (4) up to adjust angle of the rear of seat. (4 stages)

- To raise the angle at rear of the seat, keep lever (3) pulled up, and stand up slightly to remove your weight from the seat.
- To lower the angle at rear of the seat, keep lever (3) pulled up, and apply your weight to the seat.

Amount of tilt: Up 13°, down 13°

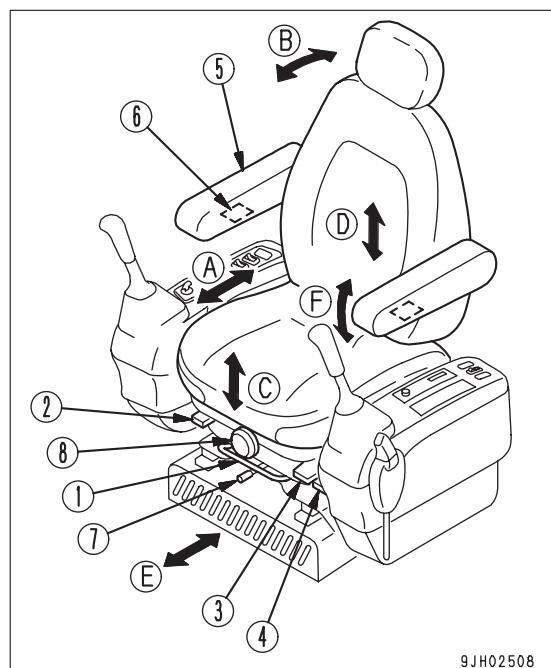

9JH02508

- Adjusting seat height

It is possible to move the seat up or down by combining adjustments forward tilt and rear tilt.

After setting the forward tilt or rear tilt to the desired height, operate the opposite part to set the seat horizontal then secure in position.

Height adjustment: 60 mm

(D) Adjusting armrest angle

Armrest (5) can be made to spring up by hand approx. 90°.

In addition, by turning the bottom (6) of the armrest by hand it is possible to make fine vertical adjustments of the armrest angle.

Armrest adjustment angle: 25°.

REMARK

If the seat back is tipped to the front without raising the armrest (5), armrest will rise automatically.

If the cable at the rear of armrest (5) is tense (when the seat back is tipped to the front), armrest (5) cannot be adjusted by turning dial (6). When adjusting the angle of armrest (5), set the seat back to a position where it is easy to carry out operations, then adjust the armrest.

(E) Overall fore-and-aft adjustment of seat

Move lever (7) to right, set to the desired position, then release the lever. In this case, the operator's seat, left and right control levers, and lock lever all slide together.

Fore-and-aft adjustment: 180 mm (9 stages)

(F) Adjusting suspension - Air seat

In order to function correctly, the seat suspension must be adjusted to suit the drivers weight and is done so by pressing or pulling control knob (8) The seat should be adjusted so that there is equal travel in both upward and downward directions. (weight range 60 ~ 150 Kg).

Rearview Mirrors

⚠ WARNING

Be sure to adjust the mirrors before starting work. If they are not adjusted properly, you cannot secure the visibility and may be injured or may injure someone seriously.

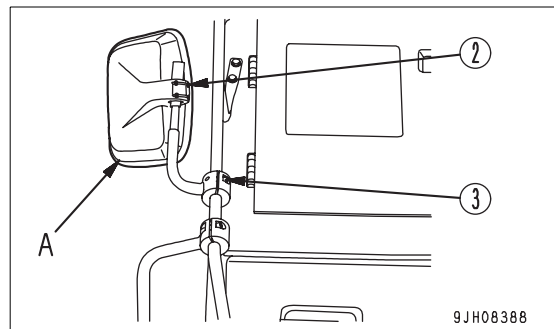
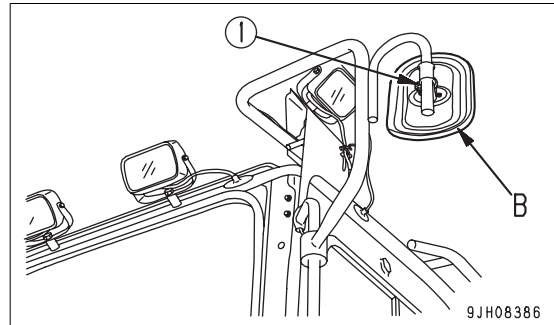

Loosen nut (1), screw (2), and bolt (3) installing the mirror, then adjust the position to give the best view from the operator's seat.

- Adjust the mirror mount so that it is possible to see any person (or object of height 1 m and diameter 30 cm) at the rear left and right of the machine.
- Install the mirror to the mounting position and dimensions shown. The values given below are reference values for the range of view.

Mounting position X : 430 mm

Range of view Y (right side) : 3500mm

Range of view Z (left side) : 2700 mm

Mirror A : must be able to see hatched area (A)

Mirror B : must be able to see hatched area (B)

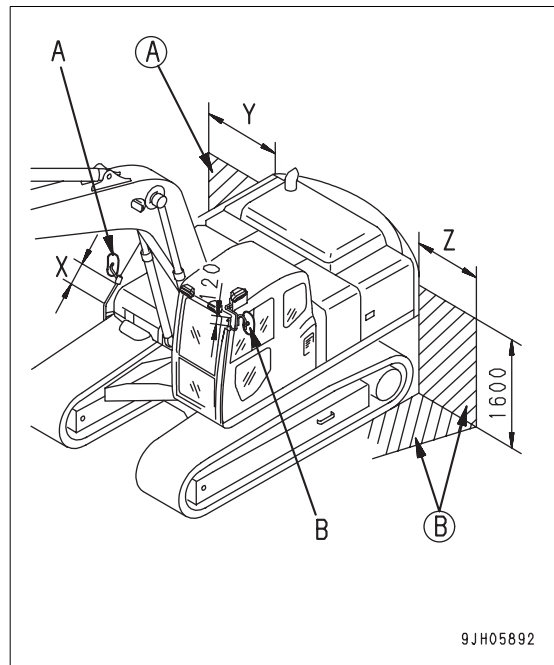

Seat Belt

WARNING

- Before fitting the seat belt, check that there is no problem in the belt mount bracket or mounting belt. If it is worn or damaged, replace the seat belt.
- Even if no problem can be seen in the belt, replace the seat belt every 3 years. The date of manufacture of the belt is shown on the back of the belt.
- Always wear the seat belt during operations.
- Fit the seat belt so that it is not twisted.

Fastening and Removing

This seat belt has a wind-in device, so it is not necessary to adjust the length.

Fastening Seat Belt

Hold grip (2) and pull the belt out from wind-in device (1), check that the belt is not twisted, then insert tongue (3) into buckle (4) securely.

When doing this, pull the belt lightly to check that it is properly locked.

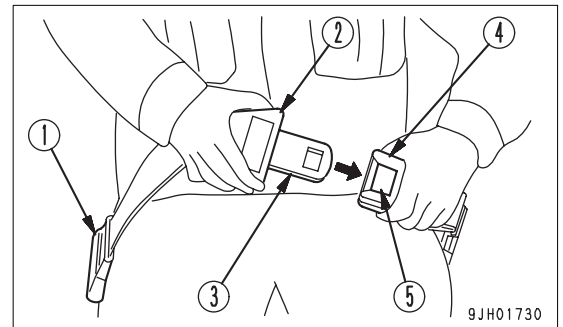

Removing Belt

Press button (5) in buckle (4), and remove tongue (3) from buckle (4).

The belt is automatically wound in, hold grip (2) and return the belt slowly to wind-in device (1).

Operations Before Starting Engine

⚠ WARNING

When starting the engine, check that the lock lever is securely at the LOCK position. If the lock lever is not locked securely and the control levers or control pedal are touched, the machine may move unexpectedly, and this may lead to serious personal injury.

1. Check that lock lever (1) is at the LOCK position (L).
2. Check that each control lever and control pedal is at the Neutral position.

If the control levers and control pedal are not being touched, they will be at the Neutral position.

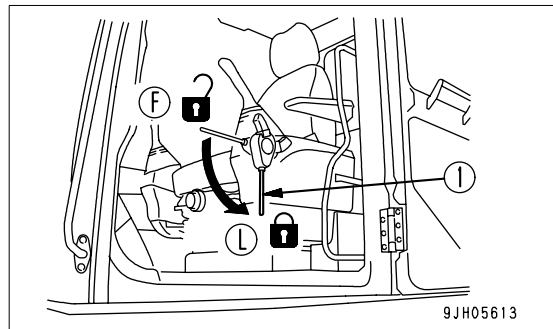
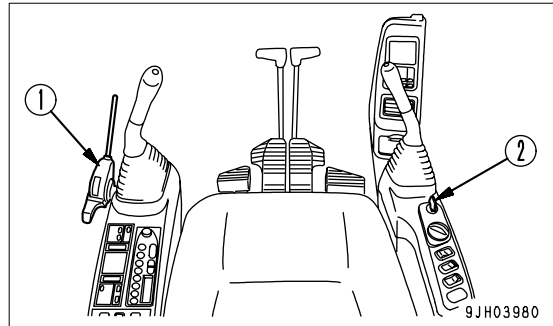

3. Insert key into starting switch (2), turn the key to ON position (B), then perform the following checks.

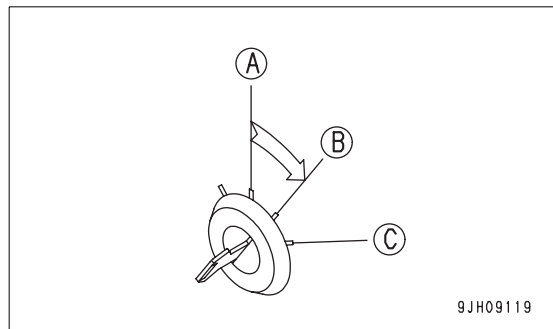

- If a password has been set, the input display screen is shown on the monitor screen.

After inputting the password, press input confirmation switch (3).

REMARK

For details of the method of setting, changing, or canceling the password, see separate "PROCEDURE FOR SETTING, CHANGING, OR CANCELING PASSWORD".

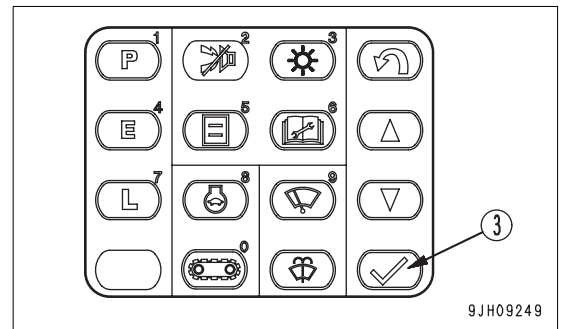
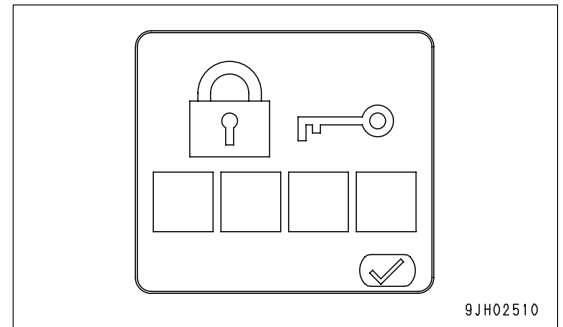

4. The buzzer sounds for approx. 1 second, and the following monitors and meters light up for approx. 3 seconds.

- Radiator coolant level monitor (4)
- Engine oil level monitor (5)
- Charge level monitor (6)
- Fuel level monitor (7)
- Engine coolant temperature monitor (8)
- Engine oil pressure monitor (9)
- Engine coolant temperature gauge (10)
- Fuel gauge (11)
- Air cleaner clogging monitor (12)

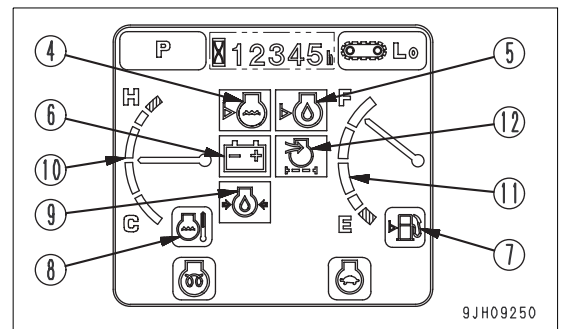

If the monitors do not light up or the buzzer does not sound, there is probably a failure in the monitor, so contact your Komatsu distributor for repairs.

5. After approx. 3 seconds, the screen switches to the working mode/travel speed display monitor. Then it switches to the normal screen.

- Fuel level monitor (7)
- Engine coolant temperature monitor (8)
- Engine coolant temperature gauge (10)
- Fuel gauge (11)
- Hydraulic oil temperature gauge (13)
- Hydraulic oil temperature monitor (14)

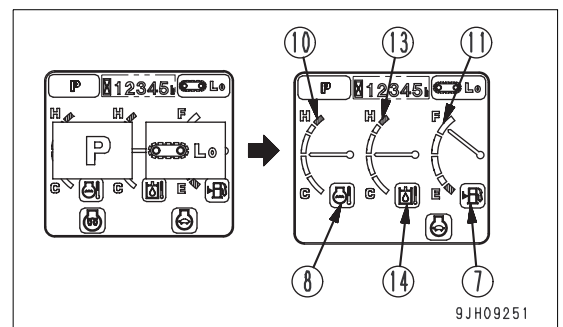

- 6. If the hydraulic oil temperature gauge goes out and caution lamp (15) stays lighted up red, perform inspection immediately for the item which is lighted up red.

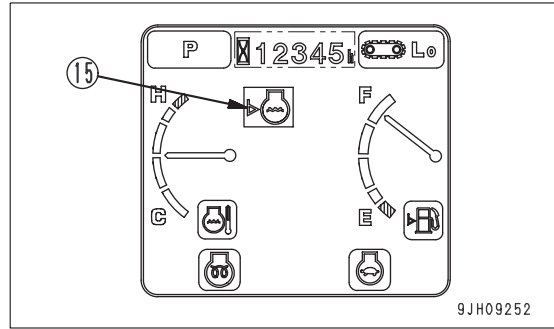

- 7. If there are any items where the maintenance time has passed, maintenance interval monitor (16) lights up for 30 seconds. Press maintenance switch (17), check the item, then perform maintenance immediately.

For details of the method of checking the maintenance interval, see "Maintenance Switch (3-24)" in the Detailed controls and gauges.

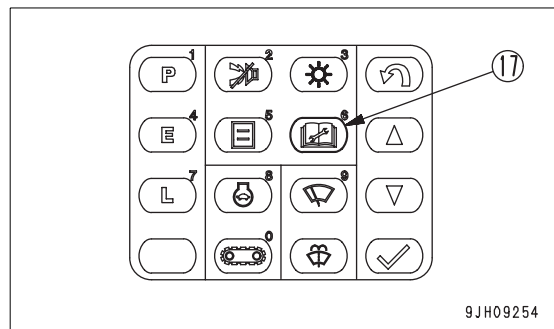
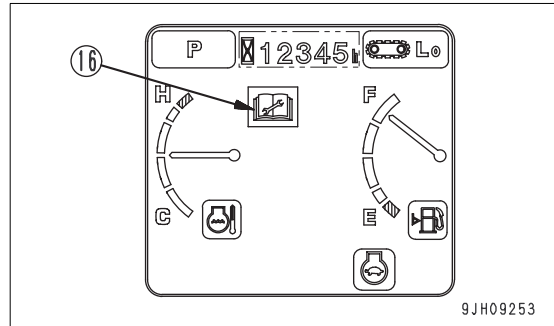

STARTING ENGINE

WARNING

- Start the engine only after sitting down in the operator's seat.
- Do not attempt to start the engine by short-circuiting the engine starting circuit. Such an act may cause a serious bodily injury or fire.
- Check that there are no persons or obstacles in the surrounding area, then sound the horn and start the engine.
- Never use starting aid fluids as they may cause explosions.
- Exhaust gas is toxic. When starting the engine in confined spaces, be particularly careful to ensure good ventilation.

NOTICE

- Before starting the engine, check that fuel control dial (2) is at the low idling (MIN) position. If the fuel control dial is at the full speed (MAX) position, the engine will accelerate suddenly and cause damage to the engine parts.
- Do not keep the key in starting switch (3) at the START position continuously for more than 20 seconds. If the engine does not start, wait for at least 2 minutes, then start again from the beginning.
- After the engine starts, wait for the engine oil pressure monitor to go out. Do not touch the control levers or control pedal while the engine oil pressure monitor is lighted up.

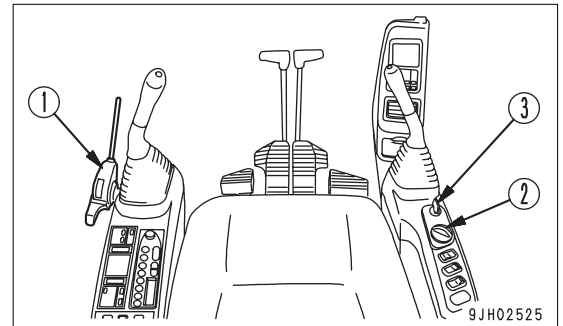

This machine is equipped with an engine automatic preheating device that functions to start the engine preheating automatically.

If the ambient temperature is low, the preheating monitor will light up when the key in starting switch (3) is turned to the ON position to inform the operator that preheating has been started automatically.

1. Check the lock lever (1) is in the LOCK position (L). If the lock lever is in the FREE position (F), the engine does not start.

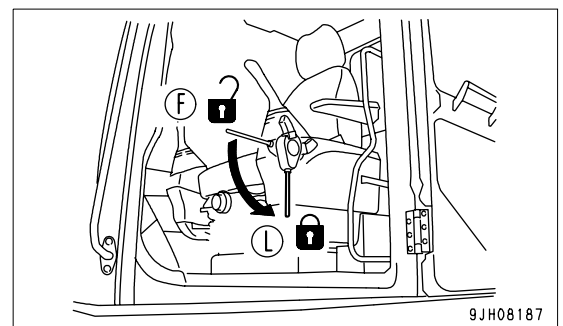

- Set fuel control dial (2) to the low idling (MIN) position.

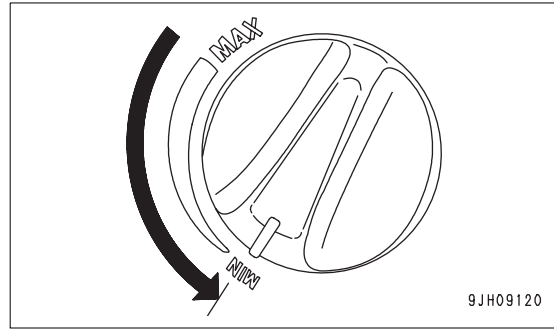

- Turn the key in starting switch (3) to ON position (B).

If the ambient temperature is low, the preheating monitor lights up and automatic preheating is carried out. Keep the key in starting switch (3) at the ON position until the preheating monitor goes out.

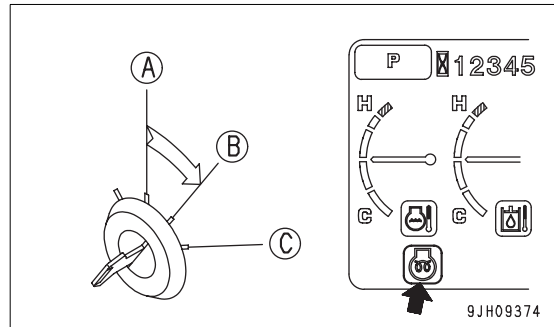

The time that the preheating monitor stays lighted up depends on the ambient temperature as shown in the table on the right.

Ambient temperature	Lighting time
- 5 °C	20 seconds
- 10 °C	25 seconds
- 20 °C	40 seconds

- If the preheating monitor does not light up, or it lights up and then goes out to inform that the engine preheating has been completed, turn the key in starting switch (3) to the START position (C) and start the engine.

REMARK

If the ambient temperature is low, the engine may not start even when the key in the starting switch (3) is kept at the START position for 20 seconds. If this happens, wait for at least 2 minutes, then start again from the beginning.

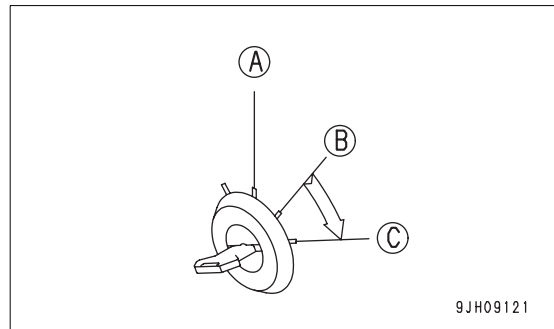

- After the engine starts, release the key in starting switch (3). The key will automatically return to the ON position (B).

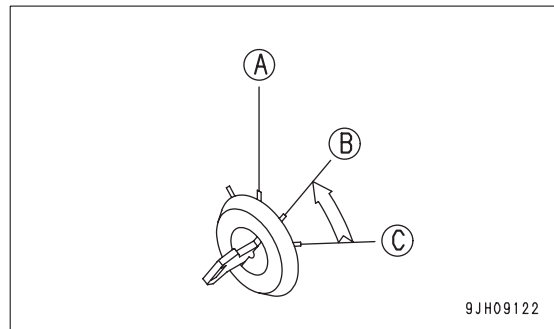

- Even after the engine is started, do not touch the work equipment control levers and the travel pedals, while the engine hydraulic pressure monitor lamp is still lighted.

NOTICE

If the engine oil pressure monitor does not go out even after 4 to 5 seconds have passed, stop the engine immediately. Check the oil level, check for leakage of oil, and take the necessary action.

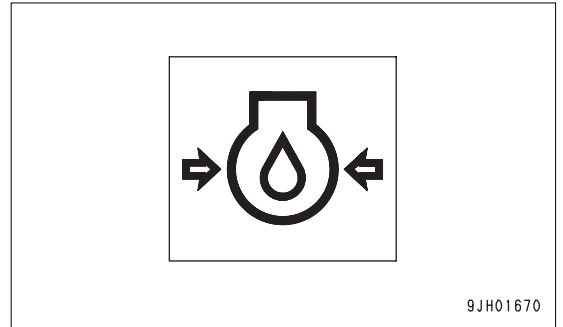

REMARK

Regardless of the ambient temperature, it is possible to start the engine preheating manually.

- Turn the key in starting switch (3) to the left from OFF position (A). The preheating monitor lights up and engine preheating starts. (Preheating continues while the key in starting switch (3) is held at the left position.) During the preheating operation, the preheating monitor lights up to show that preheating is taking place.
- After approx. 18 seconds, the preheating monitor will go out to inform that the preheating has been completed.
- Turn the key in starting switch (3) to START position (C). The engine will start.

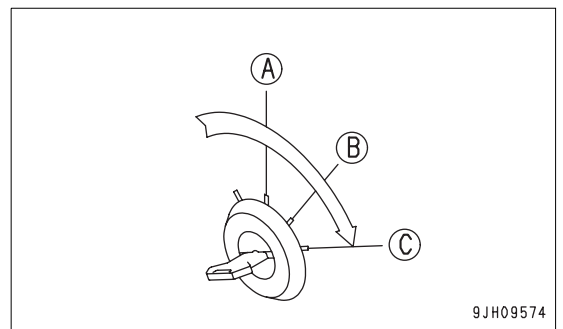
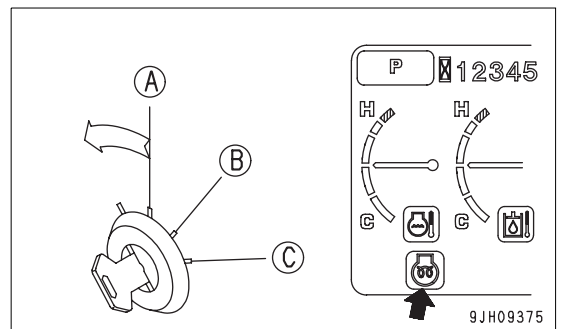

AFTER STARTING ENGINE

WARNING

- **Emergency stop**
If there has been any abnormal actuation or trouble, turn the starting switch key to the OFF position.
- **Do not carry out operations or operate the levers or pedals suddenly while the hydraulic oil is at low temperature. Always carry out the warming-up operation for the hydraulic equipment until the hydraulic oil temperature monitor is displayed green.**
- **If the warming-up operation for the hydraulic equipment is not carried out thoroughly, and the machine is moved, the reaction of the control levers and pedals will be slow and the movement may not be what the operator intended. Always warm up the hydraulic equipment. In particular, in cold areas, always warm up the hydraulic equipment thoroughly.**

There are two types of warming-up operation: warming up the engine and warming up the hydraulic equipment. In addition, depending on the environment, the method of carrying out the warming-up operation may differ, so carry out the warming-up operation according to the items given in the appropriate section.

(When only the engine is warmed up, the hydraulic equipment is not warmed up, so always carry out the warming-up operation for the hydraulic equipment separately from the warming-up operation for the engine. Warming up the hydraulic equipment thoroughly ensures that the hydraulic oil is warmed up and that warm hydraulic oil circulates in all the control circuits.)

Warming Up Engine

NOTICE

- **Do not accelerate the engine suddenly until the warming-up operation has been completed.**
- **Do not run the engine at low idling or high idling under no load for more than 20 minutes. This will have an adverse effect on the environment, and will also have an adverse effect on the internal structure of the engine. If it is necessary to run the engine at idling for more than 20 minutes, apply a load from time to time or run at a mid-range speed.**

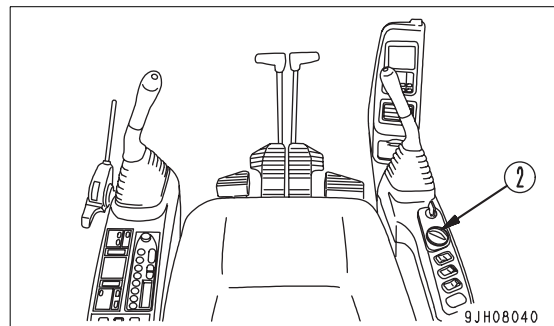

After the engine starts, do not start operating the machine immediately. First, carry out the following operations and checks.

1. This machine is equipped with an automatic engine warming-up system, so if the engine water temperature is below 30 °C after the engine is started, the engine warming-up operation starts automatically. When the engine automatic warming-up operation starts, the engine speed is maintained at a speed higher than the normal low idling speed.

If the engine water temperature goes above 30 °C or if the warming-up operation has been continued for more than 10 minutes, the automatic warming-up operation is cancelled and the engine speed drops to the normal low idling speed.

2. Check that engine water temperature monitor (1) displays green.

If it displays white, use the procedure in Step 3 to carry out additional warming up of the engine until the monitor displays green.

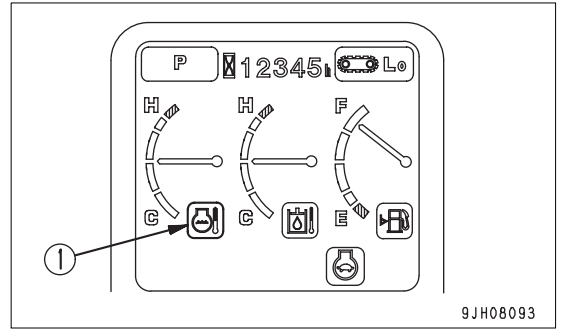

3. Turn fuel control dial (2) to a point midway between low idling (MIN) and full speed (MAX), run the engine at a mid-range speed, and run under no load until engine water temperature monitor (1) displays green.

If the engine water temperature monitor displays green, the engine warming-up operation is completed.

After checking that the engine water temperature monitor displays green, carry out the warming-up operation for the hydraulic equipment.

NOTICE

Canceling automatic warming-up operation

If it becomes necessary in an emergency to cancel the automatic warming-up operation or to lower the engine speed to low idle, do as follows.

4. Turn fuel control dial (2) to the full speed (MAX) position and hold it for 3 seconds.

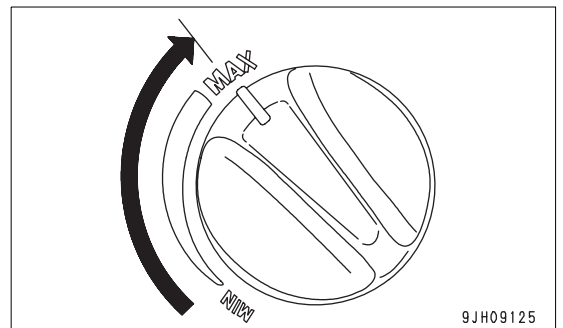
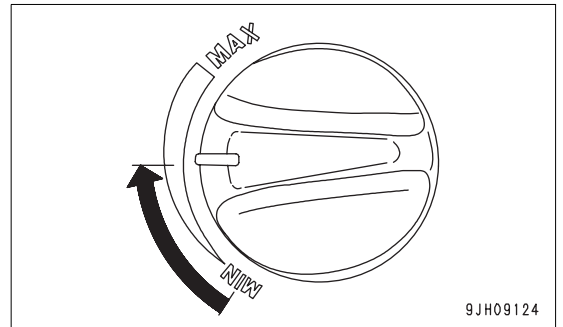

5. When fuel control dial (2) is returned to the low idle (MIN) position, the engine speed will drop.

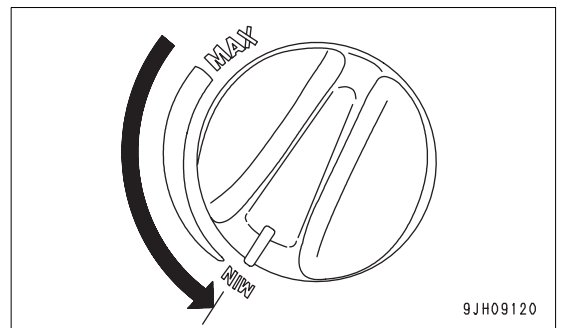

Warming Up Hydraulic Equipment

⚠ WARNING

- Before carrying out the warming-up operation for the hydraulic equipment, turn the swing lock switch ON, check on the monitor that the swing lock is actuated, then start the warming-up operation.
- When warming up the hydraulic equipment, check that there is no person or obstacle in the surrounding area, then sound the horn and start the operation.
- Carry out the warming-up operation for the hydraulic equipment until the hydraulic oil temperature monitor displays green.
- The warming-up operation for the hydraulic equipment is necessary not only for the circuit between the pump and cylinders and between the pump and motor, but also for all the control circuits. Do not carry out the operation just for one cylinder or motor, or the operation just in one direction. Carry out the operation in both directions for the work equipment (boom, arm, bucket), swing, travel, and attachment (if equipped).

1. Check that engine water temperature monitor (1) displays green.

If it displays white, carry out additional warming up of the engine until engine water temperature monitor (1) displays green.

For details of the procedure, see “Warming Up Engine (3-94)”.

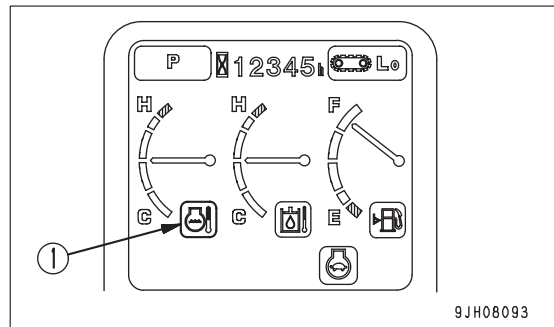

2. Turn swing lock switch (2) ON and check that the swing lock monitor lights up.

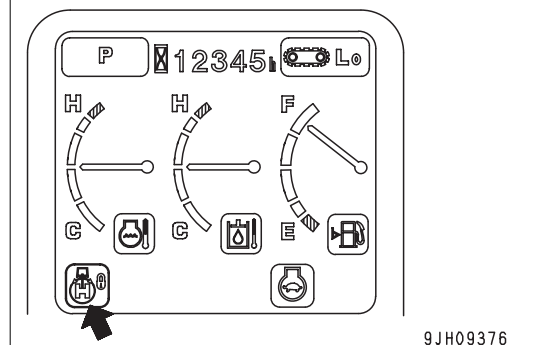
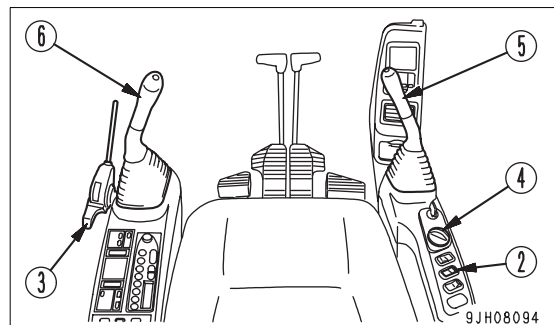

- To complete the warming-up operation of the hydraulic equipment more quickly, set the working mode to P mode (heavy-duty mode).

For details of the procedure for setting the working mode, see "Working Mode Selector Switch (Basic Switch) (3-20)".

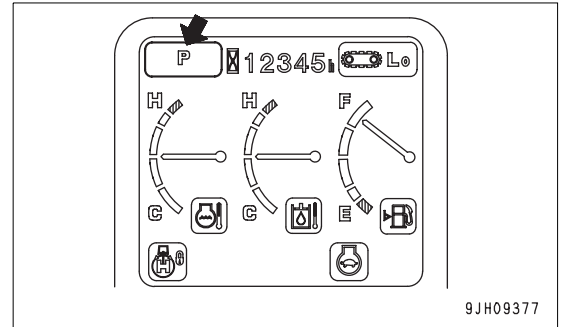

- Move lock lever (3) slowly to the FREE position (F), then raise the bucket from the ground.

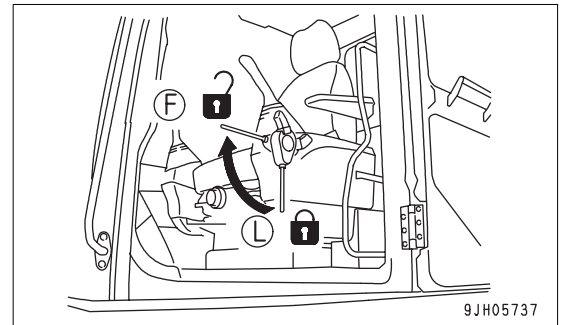

- Turn fuel control dial (4) to a point midway between low idling (MIN) and full speed (MAX).

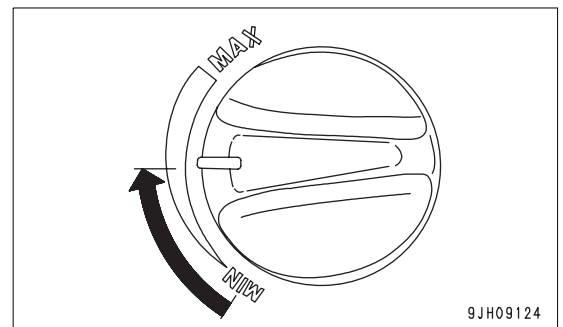

NOTICE

When the work equipment is retracted, take care that it does not interfere with the machine body or ground.

- Move right work equipment control lever (5) slowly in the direction to pull in the bucket (D). Operate the lever to the end of its travel and hold it in position for 30 seconds.
- Move right work equipment control lever (5) slowly in the direction to push out the bucket (C). Operate the lever to the end of its travel and hold it in position for 30 seconds.
- Next, move left work equipment control lever (6) slowly in the direction to pull in the arm (B). Operate the lever to the end of its travel and hold it in position for 30 seconds.
- Move left work equipment control lever (6) slowly in the direction to push out the arm (A). Operate the lever to the end of its travel and hold it in position for 30 seconds.
- Repeat the operation in Steps 6 to 9 for 5 minutes.

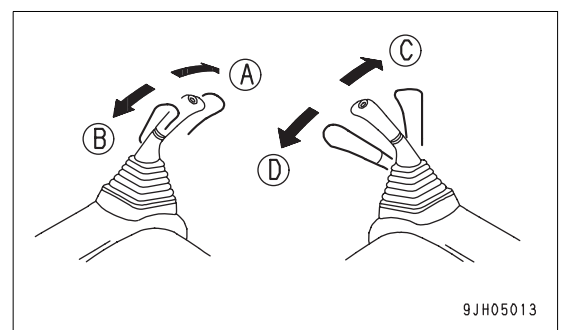

11. Check that hydraulic oil temperature monitor (7) is displaying green.

If the hydraulic oil temperature monitor is not displaying green (it is displaying white), repeat Steps 6 to 10 until the display is green.

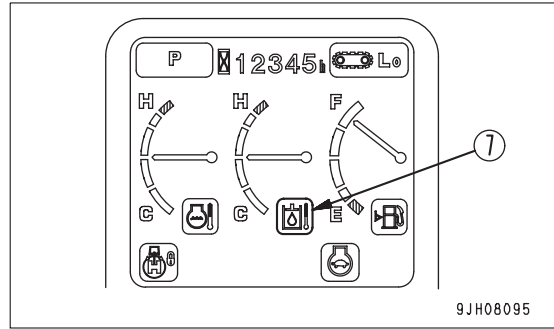

12. Check that engine water temperature monitor (1) displays green.

If it displays white, carry out additional warming up of the engine until engine water temperature monitor (1) displays green.

For details of the procedure, see “Warming Up Engine (3-94)”.

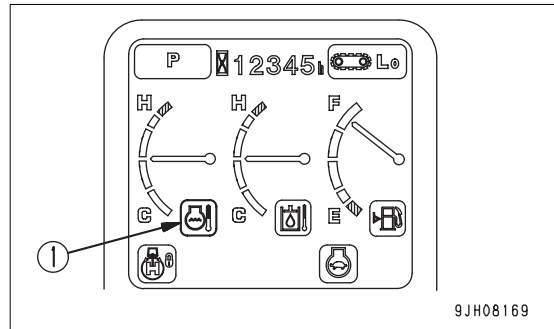

13. Check that the hydraulic oil temperature monitor and engine water temperature monitor are displaying green, then check that all the gauges and caution monitors on the machine monitor our in the following status.

- Radiator coolant level monitor (8): OFF
- Charge level monitor (9): OFF
- Engine oil pressure monitor (10): ON
- Engine oil level monitor (11): OFF
- Air cleaner clogging monitor (12): OFF
- Engine pre-heating lamp (13): OFF
- Engine water temperature gauge (14): Indicator in green range
- Engine water temperature monitor (1): Green display
- Hydraulic oil temperature gauge (15): Indicator in green range
- Hydraulic oil temperature monitor (7): Green display
- Fuel gauge (16): Indicator in green range
- Fuel level monitor (17): Green display

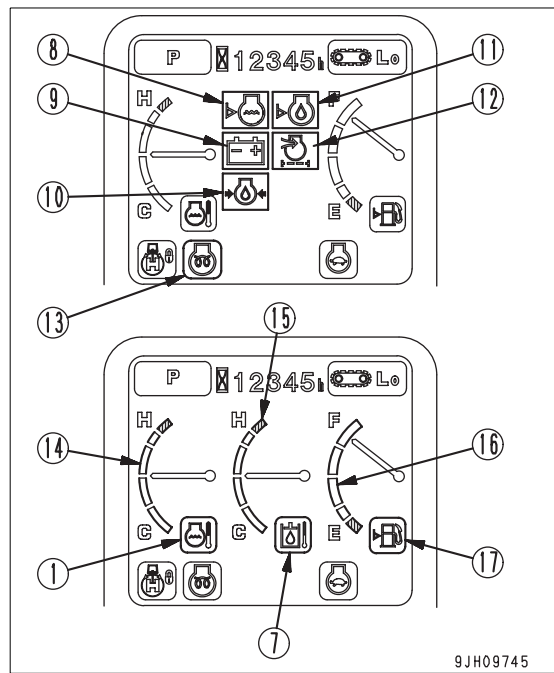

14. Check for abnormal exhaust gas color, noise, or vibration. If any problem is found, contact your Komatsu distributor.

In cold temperatures (ambient temperature below 0°C), even when the hydraulic oil temperature monitor displays green, carry out additional Step 15 to warm up all the hydraulic equipment.

15. Turn fuel control dial (4) to the full speed (MAX) position, repeat Steps 6 to 9 for 3 to 5 minutes, then check again that the hydraulic oil temperature monitor is displaying green.

If it is not displaying green, repeat Steps 6 to 9 for 3 to 5 minutes until hydraulic oil temperature monitor (7) displays green.

For both normal temperatures and cold temperatures, carry out the following operation.

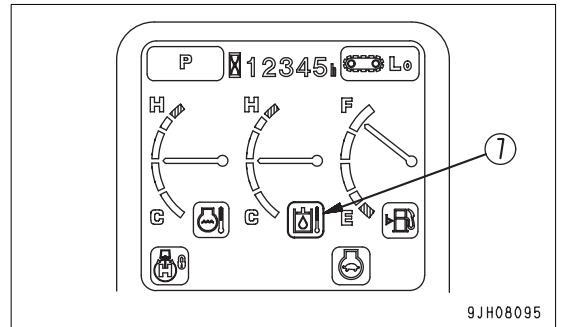
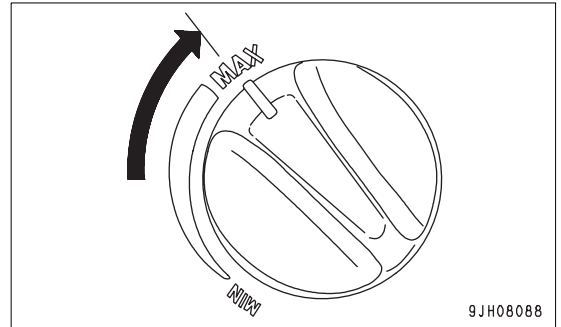

16. Check that fuel control dial (4) is at a point midway between low idling (MIN) and full speed (MAX).

If it is not at the midway position, set it to the midway position and run the engine at a mid-range speed before operating.

17. Before starting operations, repeat the following operations slowly 3 to 5 times to circulate warm oil through the control circuits.

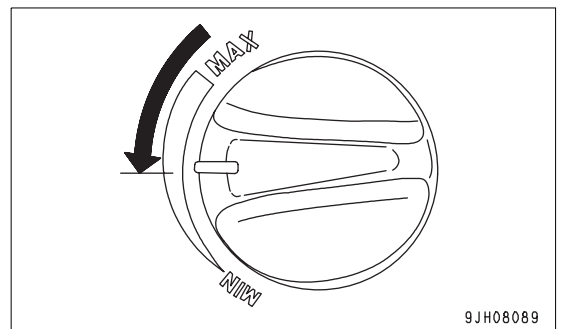

- Boom operation RAISE (E) ↔ LOWER (F)
- Arm operation IN (B) ↔ OUT (A)
- Bucket operation CURL (D) ↔ DUMP (C)

When carrying out swing operations, release swing lock switch (2), check that swing lock monitor (18) goes out, then operate the swing.

- Swing operation Left (G) ↔ Right (H)

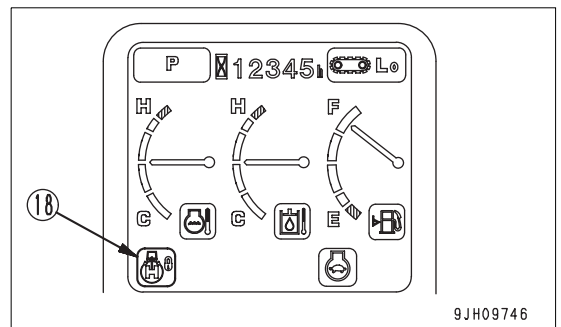
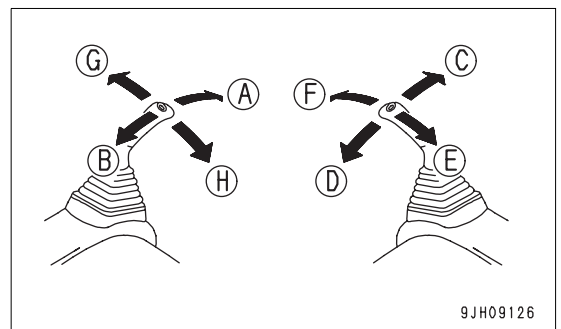

- Travel (Lo) operation FORWARD (A) ↔ REVERSE (B)

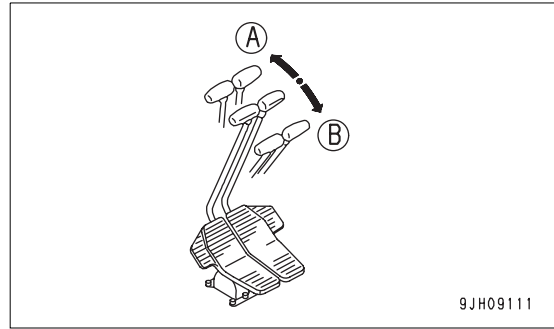

18. Check that hydraulic oil temperature monitor (7) is displaying green.

If the hydraulic oil temperature monitor is not displaying green (it is displaying white), repeat Steps 6 to 10 until the display is green.

If the hydraulic oil temperature monitor displays green, the hydraulic equipment warming-up operation is completed.

After confirming that the hydraulic oil temperature monitor displays green, carry out the following procedure.

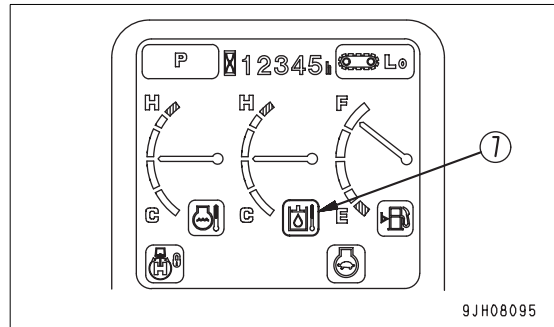

Operation After Completion Of Warming-Up Operation

1. Check that hydraulic oil temperature monitor (7) displays green.

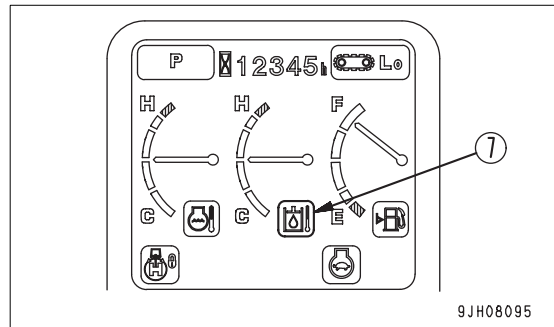

2. Push working mode selector switch (19) of the machine monitor to select the working mode to be used.

For details of the procedure for selecting the working mode, see “Working Mode Selector Switch (Basic Switch) (3-20)”.

- Working mode monitor display

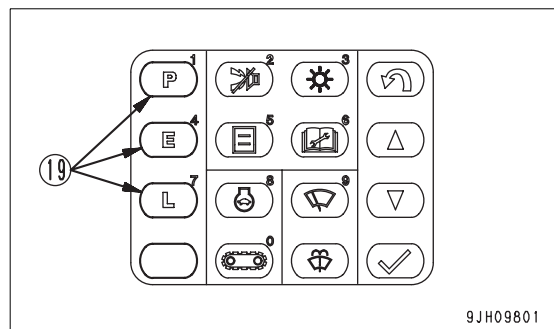

1) P mode

For heavy-duty operations

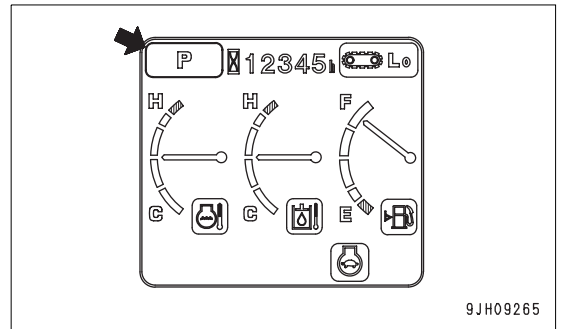

2) E mode

For operations with emphasis on fuel economy

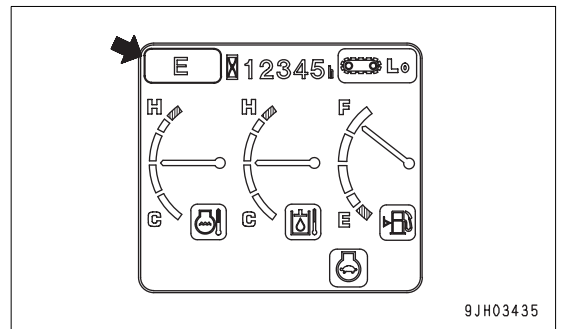

3) L mode

For operations requiring fine control

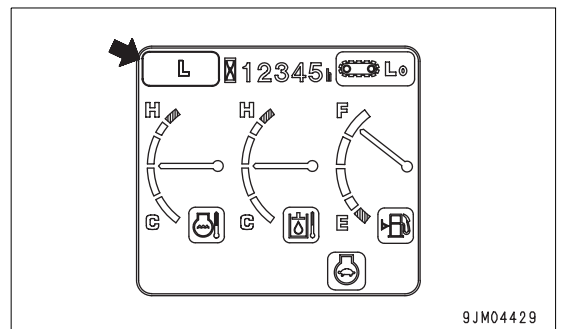

STOPPING THE ENGINE

NOTICE

If the engine is stopped suddenly, there is danger that the life of the engine parts will be reduced. Do not stop the engine suddenly except in emergencies.

If the engine has overheated, do not stop the engine immediately. Run the engine at low idling to cool the engine down gradually, then stop the engine.

1. Run the engine at low idle for about 5 minutes to cool down gradually.

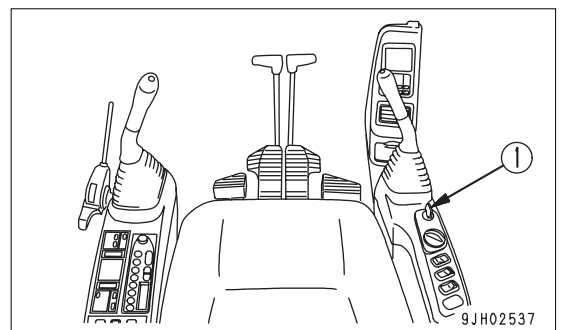

2. Turn the key in starting switch (1) to the OFF position (A) and stop the engine.
3. Remove the key from starting switch (1).

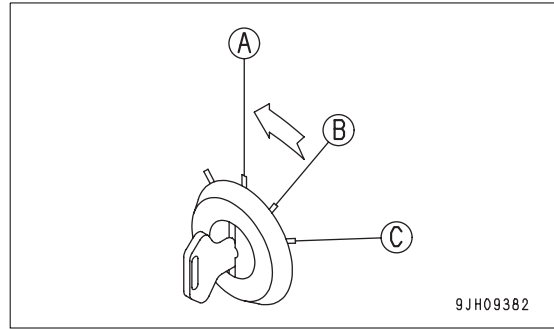

MACHINE OPERATION

WARNING

- Before operating the control lever, check the direction of the track frame. If the track frame is facing the rear (if the sprocket is at the front), the machine moves in the opposite direction from the operation of the travel lever (front and rear travel is reversed, left and right steering is reversed).
- Before starting the machine off, check that the area around the machine is safe, and sound the horn.
- Do not allow anyone to enter the area around the machine.
- Clear any obstacles from the travel path.
- There is a blind spot at the rear of the machine, so be particularly careful when traveling in reverse.
- If the control lever is operated when the auto deceleration is being actuated, the engine speed will suddenly rise, so be careful when operating.
- Before starting the machine off, check that the travel alarm sounds normally.

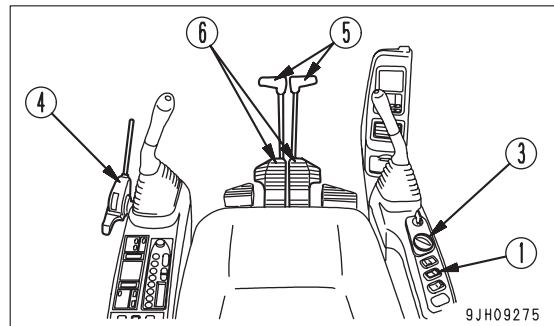

Preparations for Moving the Machine

1. Set swing lock switch (1) to the ON (actuated) position and confirm that swing lock monitor lamp (2) lights up.

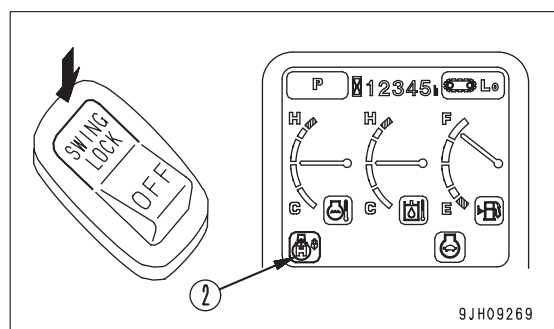

- Turn fuel control dial (3) towards the full speed position to increase the engine speed.

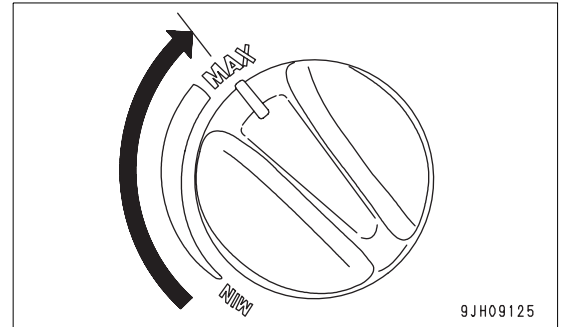

Moving Machine Forward

- Set lock lever (4) in the FREE position (F), fold the work equipment, and raise it 40 to 50 cm from the ground.
- Operate the right and left travel levers (5), or the right or left travel pedals (6) as follows:

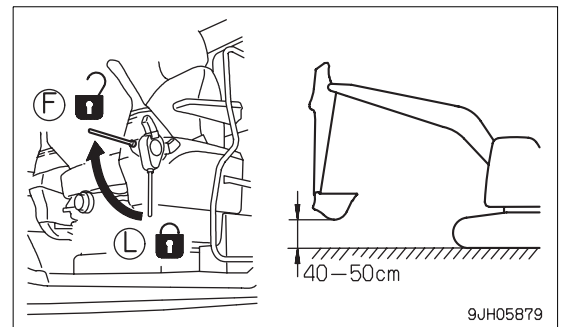

- When sprocket (A) is at the rear of the machine:
Slowly push the levers (5) forward, or slowly depress the front part of the pedals (6) to move the machine forward.

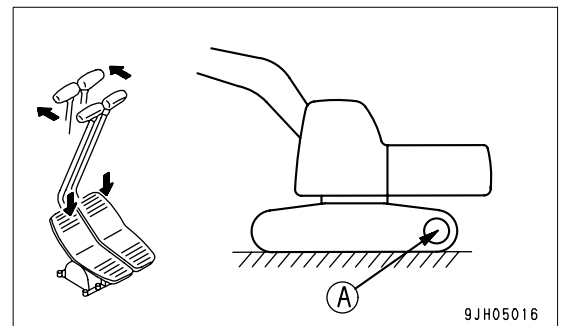

- When sprocket (A) is at the front of the machine:
Slowly pull the levers (5) backward, or slowly depress the rear part of the pedals (6) to move the machine forward.
- Check that the travel alarm sounds properly. If the travel alarm does not sound, please contact your Komatsu distributor for repair.

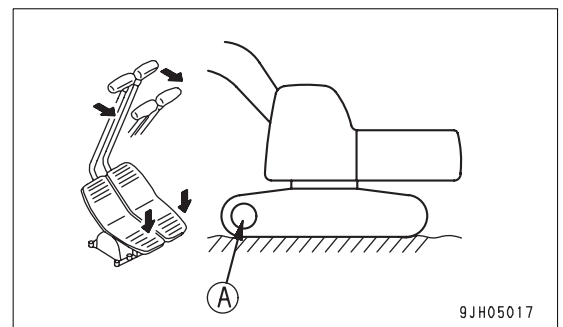

REMARK

In cold temperatures, if the machine travel speed is not normal, thoroughly perform the warming-up operation.
In addition, if the undercarriage is clogged with mud and the machine travel speed is not normal, remove the soil and mud from the undercarriage.

Moving Machine Backward

1. Set lock lever (4) to FREE position (F), set the work equipment to the travel posture, then raise it 40 to 50 cm from the ground.
2. Operate the right and left travel levers (5), or the right or left travel pedals (6) as follows:

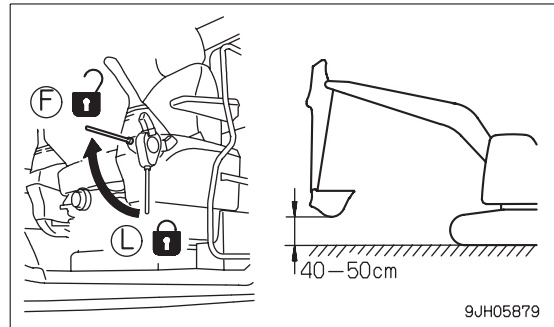

- When sprocket (A) is at the rear of the machine:
Slowly pull the levers (5) backward, or slowly depress the rear part of the pedals (6) to move the machine backward.

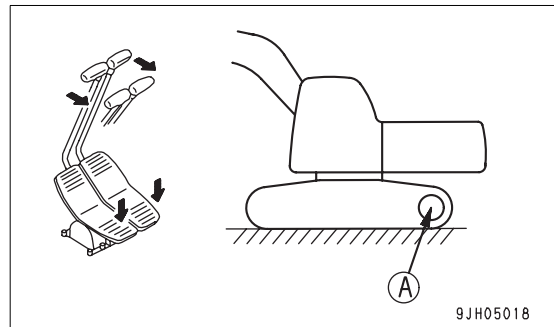

- When sprocket (A) is at the front of the machine:
Slowly push the levers (5) forward, or slowly depress the front part of the pedals (6) to move the machine backward.

3. Check that the travel alarm sounds properly. If the travel alarm does not sound, please contact your Komatsu distributor for repair.

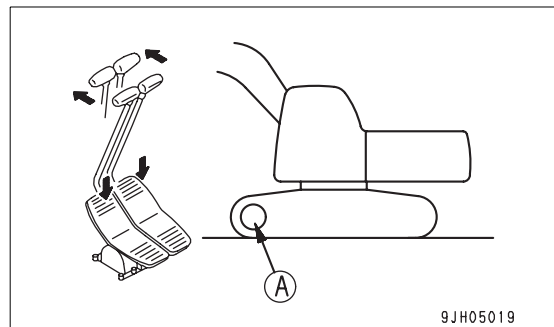

Stopping Machine

Avoid stopping suddenly. Give yourself ample room when stopping.

1. Put the left and right travel levers (1) in the neutral position, then stop the machine.

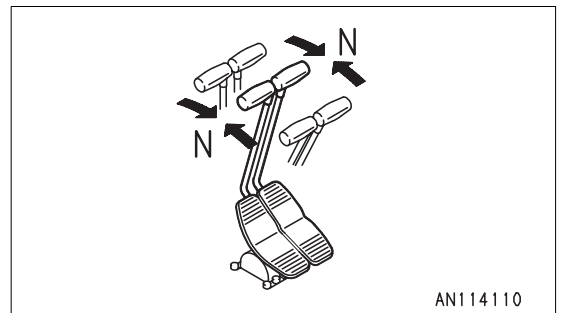
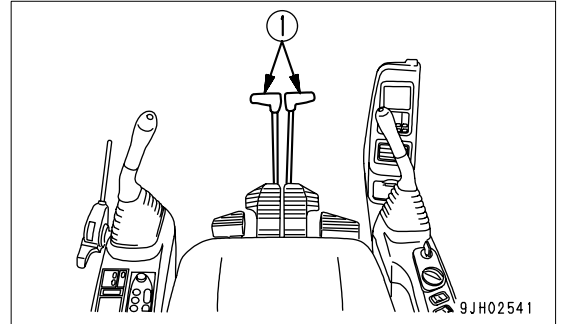

STEERING THE MACHINE

Steering

WARNING

Before operating the travel levers, check the direction of the track frame (the position of the sprocket). If the sprocket is at the rear, the machine moves in the reverse direction to the operation of the travel levers.

Use the travel levers to change direction.

Avoid sudden changes of direction as much as possible. Especially when performing counter-rotation (spin turn), stop the machine before turning.

Operate two travel levers (1) as follows.

Steering the Machine when Stopped

When turning to the left:

Push the right travel lever forward to turn to the left when traveling forward; and pull it back to turn left when traveling in reverse.

(A): Forward left turn

(B): Reverse left turn

REMARK

When turning to the right, operate the left travel lever in the same way.

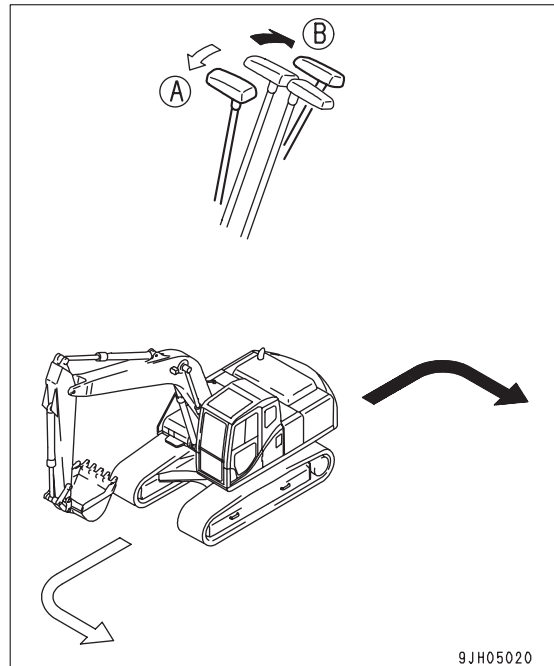
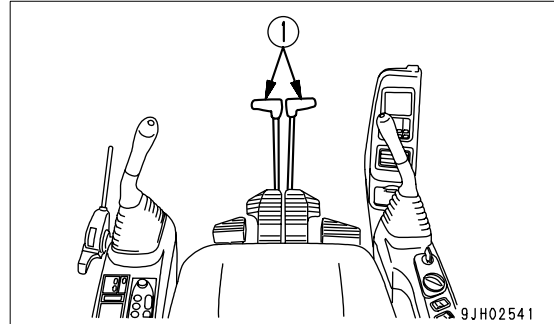

Changing Direction of the Machine

When turning to the left:

If the left travel lever is returned to the neutral position, the machine will turn to the left.

(A): Forward left turn

(B): Reverse left turn

REMARK

When turning to the right, operate the right travel lever in the same way.

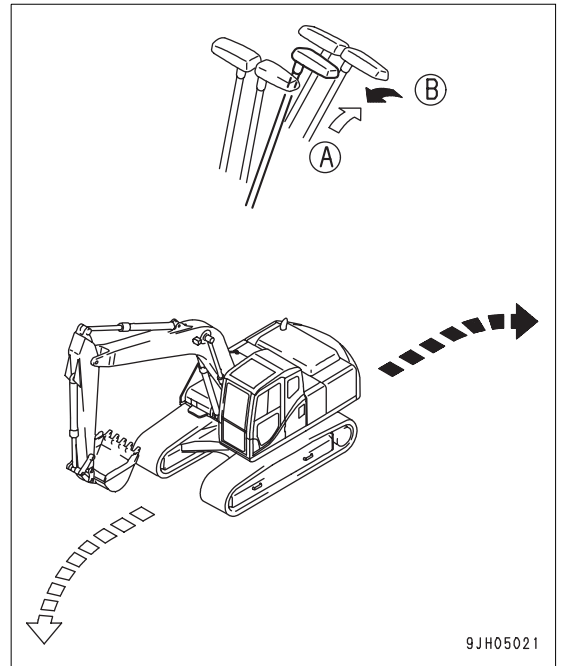

Counter-rotation Turn (Spin Turn)

When using counter-rotation (spin turn) to turn left, pull the left travel lever back and push the right travel lever forward.

REMARK

When using counter-rotation to turn right, pull the right travel lever back and push the left travel lever forward.

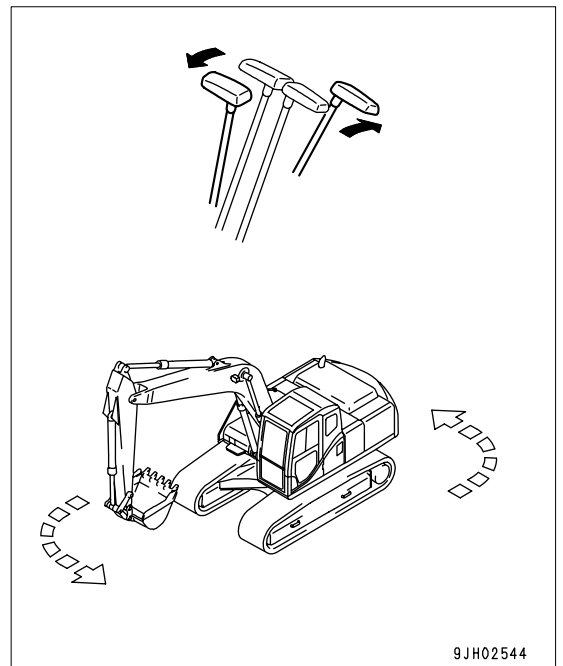

SWINGING

WARNING

The tail of the machine extends outside the tracks. Before operating the swing, check that the area around the machine is safe.

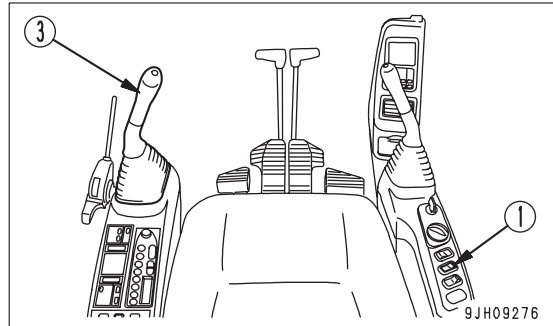

1. Before starting the swing operation, turn swing lock switch (1) OFF and check that swing lock monitor (2) has gone out.

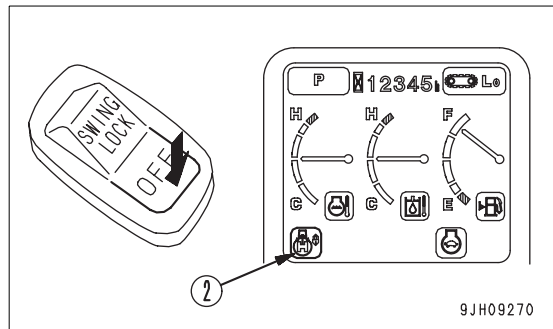

2. Operate left work equipment control lever (3) to swing the upper structure.

(A): Left swing

(B): Right swing

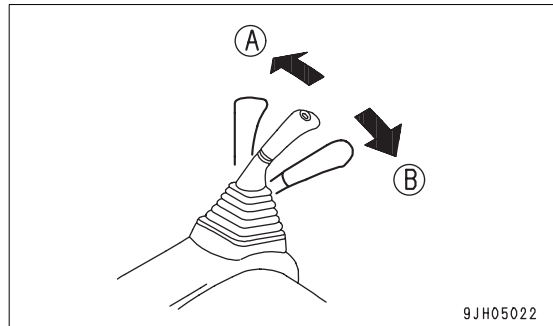

3. When not using the swing, turn swing lock switch (1) ON. Check that swing lock monitor (2) lights up.

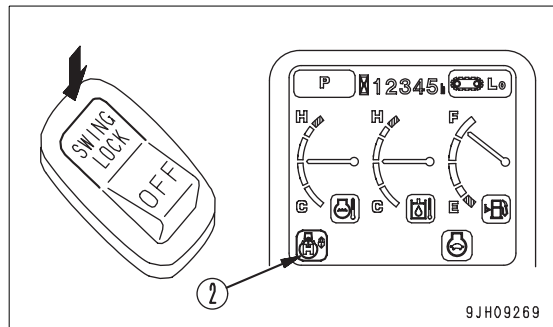

WORK EQUIPMENT CONTROLS AND OPERATIONS

WARNING

If the lever is operated when the engine speed has been lowered by the auto-deceleration function, the engine speed will suddenly rise, so operate the levers carefully.

Use the control levers to operate the work equipment.

Note that when the levers are released, they return to the HOLD position and the work equipment is held in that position.

- If the work equipment control levers are returned to the neutral position when the machine is stopped, even if the fuel control dial is set to FULL, the auto-deceleration mechanism will act to reduce the engine speed to a mid-range speed.

REMARK

With this machine, an accumulator is installed in the operating circuit, if less than 15 seconds has passed since the engine was stopped, when the starting switch is turned to the ON position even with the engine stopped, it is possible to operate the levers to lower work equipment to the ground.

In addition, this operation can also be used to release the remaining pressure in the hydraulic cylinder circuit or to lower the boom after the machine has been loaded onto a trailer.

- Arm control

Move the left work equipment control lever to the front or rear to operate the arm.

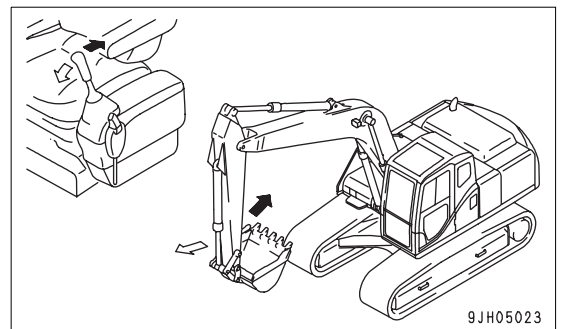

- Swing control

Move the left work equipment control lever to the left or right to swing the upper structure.

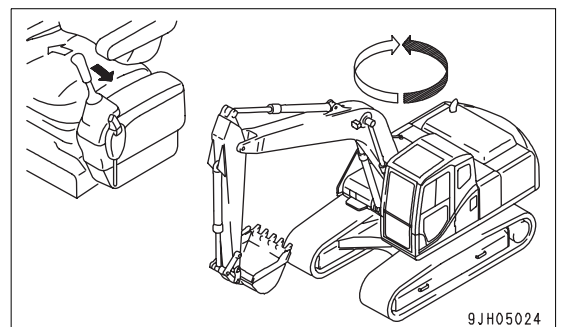

- Boom control

Move the right work equipment control lever to the front or rear to operate the boom.

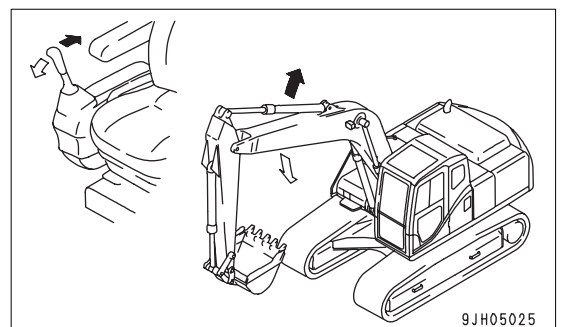

- Bucket control

Move the right work equipment control lever to the left or right to operate the bucket.

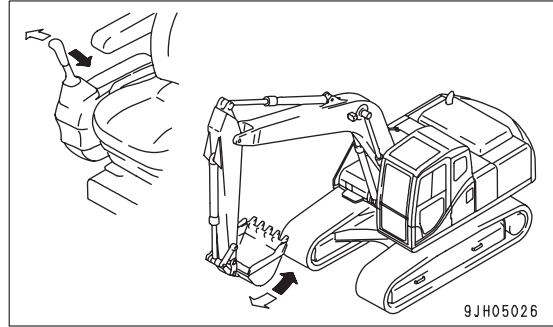

9JH05026

WORKING MODE

Working Mode

The mode selector switch can be used to switch the mode to match operating conditions and purpose, thereby enabling work to be performed efficiently.

Make effective use of each mode as follows.

When the starting switch is turned to the ON position, the working mode is set to P mode (digging).

Use the working mode switch to set the mode to the most efficient mode to match the type of work.

Working mode	Applicable operations
P mode	Normal digging, loading operations (Operations with emphasis on productivity)
E mode	Normal digging, loading operations (Operations with emphasis on fuel economy)
L mode	When positioning work equipment exactly (Fine-control operations)

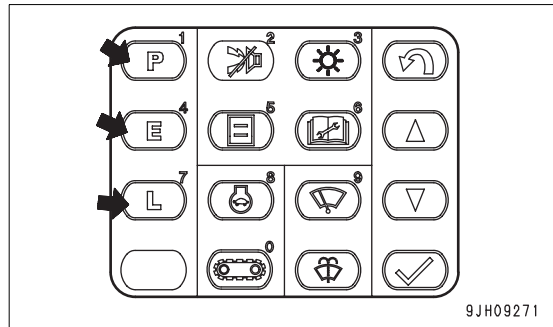

9JH09271

Setting Economy Mode

We recommend adjusting the economy mode settings to give the fuel consumption and production in the table below.

REMARK

The closer the selection is made to E3, the better the fuel consumption becomes, but the production is reduced accordingly.

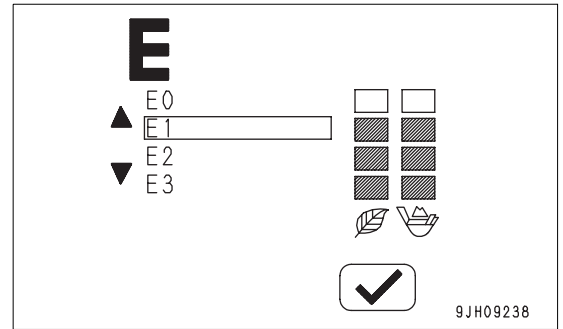

Mode	Dumping and loading		Handling overburden		Excavated and blasted rock	Pit excavation	Handling remaining walls	Trenching		Lifting work
	Blasted rock	Loosened sandy soil	Soft rock	Sandy bed-rock				Soft rock	Sandy bed-rock	
E0	○	○	●	○	●	●	●	●	●	○
E1	●	●	●	●	△	△	△	△	△	○
E2	△	●	△	△	×	×	×	×	△	●
E3	×	△	×	×	×	×	×	×	×	●

○: Work possible without problem (can carry out that operation without problem)

●: Work possible (can carry out operation with some minor problems)

△: Work possible (can carry out operation but there are many problems)

×: Work impossible (too many problems, cannot carry out operation)

PROHIBITED OPERATIONS

WARNING

- If it is necessary to operate the work equipment control lever when the machine is traveling, stop the machine, then operate the control lever.
- If any lever is operated when the auto-deceleration is being actuated, the engine speed will suddenly increase, so be careful when operating.

Operations Using Swing Force

Do not use the swing force to compact soil or break objects. This is not only dangerous, but will also drastically reduce the life of the machine.

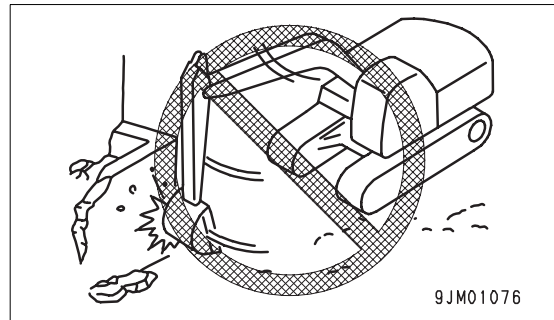

Operations Using Travel Force

Do not dig the bucket into the ground and use the travel force to carry out excavation. This will damage the machine or work equipment.

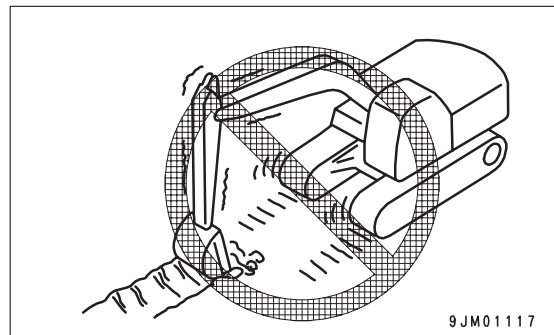

Prohibition of Operations Using Hydraulic Cylinders to Stroke Ends

If the work equipment is used with the cylinder rod operated to its stroke end, and given impact by some external force, the hydraulic cylinders will be damaged, causing personal injury. Avoid operations with the hydraulic cylinder fully retracted or fully extended.

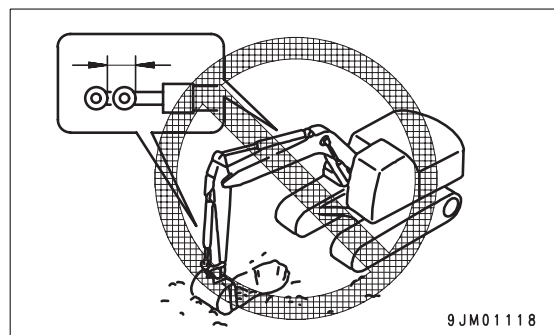

Operations Using Bucket Dropping Force

Do not use the dropping force of the machine for digging, or use the dropping force of the bucket as a pickaxe, breaker, or pile driver. This will drastically reduce the life of the machine.

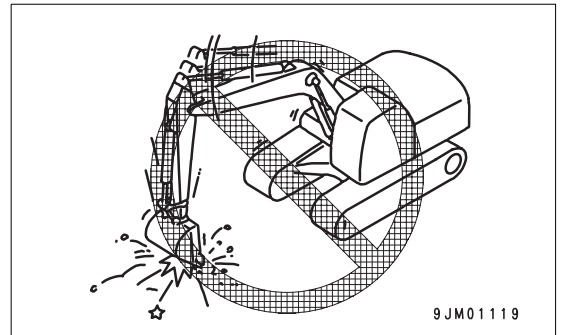

Operations Using Machine Dropping Force

Do not use the dropping force of the machine for digging.

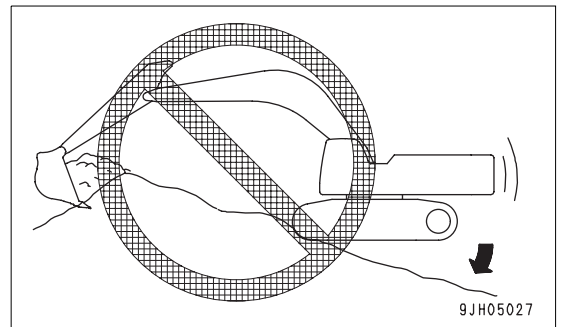
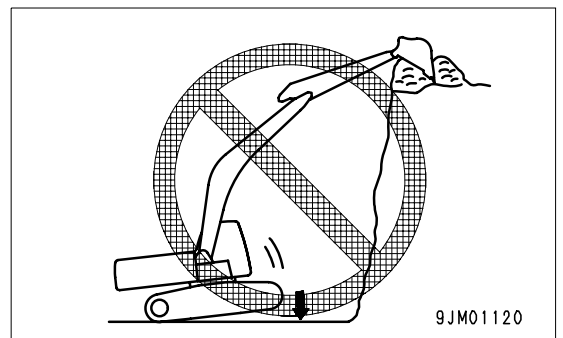

Digging Hard Rocky Ground

Do not attempt to directly excavate hard rocky ground with the work equipment. It is better to excavate it after breaking up by some other means. This will not only save the machine from damage but will make for better economy.

Sudden Lever Shifting High Speed Travel

- (1) Never carry out sudden lever shifting as this may cause sudden starting.
- (2) Avoid sudden lever shifting from forward (A) to reverse (B) (or from reverse (B) to forward (A)).
- (3) Avoid sudden lever shifting change such as sudden stopping from near top speed (lever release operation).

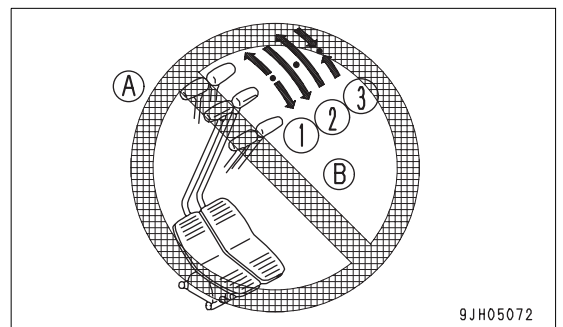

GENERAL OPERATION INFORMATION

Traveling

Traveling over boulders, tree stumps, or other obstacles will cause a big shock to the chassis (and in particular to the tracks), and this will cause damage to the machine. For this reason, always remove any obstacles or travel around them, or take other steps to avoid traveling over such obstacles as far as possible.

If there is no way to avoid traveling over an obstacle, reduce the travel speed, keep the work equipment close to the ground, and try to travel so that the center of the track passes over the obstacle.

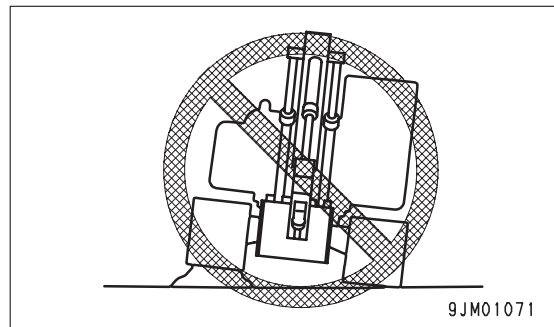

High Speed Travel

On uneven roadbeds such as rock beds or uneven roads with large rocks, travel at Lo speed. When traveling at high speed, set the idler in the forward direction.

- To switch the travel speed, press travel speed selector switch (1). The travel speed is displayed as Lo, Mi, or Hi on the monitor display.

Precautions when Carrying Out Operations Continually with the Work Equipment in the Same Posture

Precautions when carrying out operations continually with the work equipment in the same posture.

When operations are carried out continuously with the cylinder operated slightly, operate the cylinder occasionally by a large amount to ensure greasing of the work equipment pins. This will prevent loss of grease at the pins.

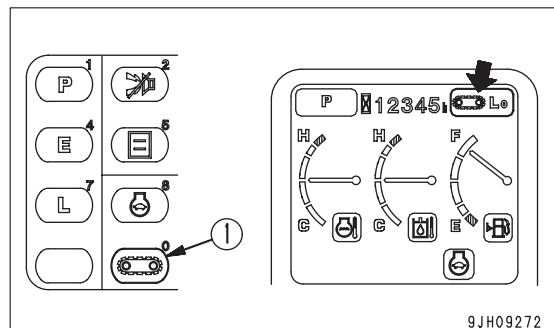

Permissible Water Depth**NOTICE**

When driving the machine out of water, if the angle of the machine exceeds 15°, the rear of the upper structure will go under water, and water will be thrown up by the radiator fan. This may cause the fan to break.

Be extremely careful when driving the machine out of water.

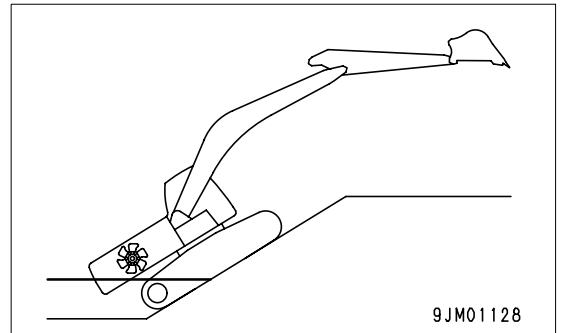

Do not drive the machine in water deeper than the center of carrier roller (1).

Supply grease to the parts which have been under water for a long time until the used grease is projected out of the bearings (around the bucket pin, in particular).

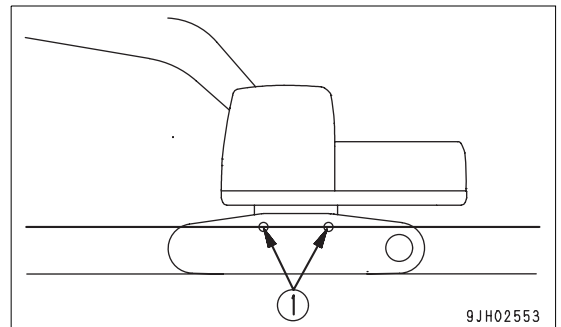

TRAVELING ON SLOPES

⚠ WARNING

- Turning or operating the work equipment when working on slopes may cause the machine to lose its balance and turn over, so avoid such operations. It is particularly dangerous to swing downhill when the bucket is loaded. If such operations have to be performed, pile soil to make a platform (A) on the slope so the machine is kept horizontal during operation.
- Do not travel up or down steep slopes. There is a danger that the machine may turn over.
- When traveling, raise the bucket approx. 20 to 30 cm from the ground. Do not travel downhill in reverse.
- Never turn on slopes or travel across slopes. Always go down to a flat place to perform these operations. It may be longer, but it will ensure safety.
- Always operate or travel in such a way that it is possible to stop safely at any time if the machine slips or becomes unstable.
- When traveling uphill, if the shoes slip or it is impossible to travel uphill using only the force of the tracks, do not use the pulling force of the arm to help the machine travel uphill. There is danger that the machine may turn over.

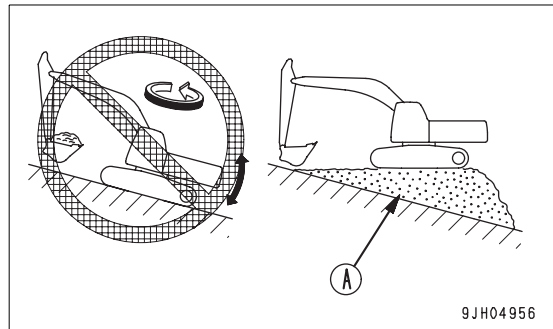
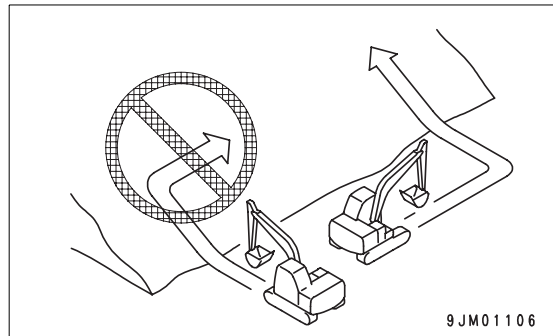

1. When traveling down steep hills, use the travel lever and fuel control lever to keep the travel speed low.

When traveling down slopes of more than 15°, set the work equipment in the posture shown in the figure on the right, and lower the engine speed.

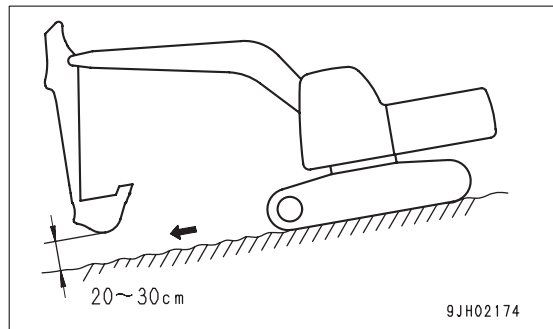

2. When traveling up a steep hill of more than 15°, set the work equipment to the posture shown in the diagram on the right.

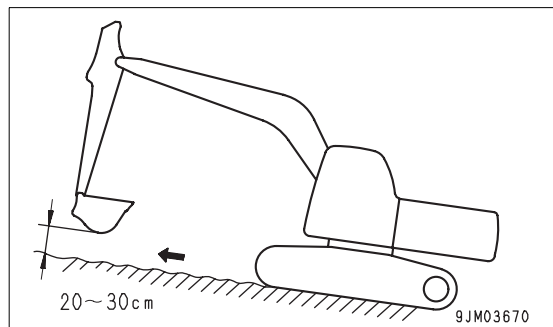

- When traveling up a steep slope, extend the work equipment to the front to improve the balance, keep the work equipment approximately 20 to 30 cm above the ground, and travel at low speed.

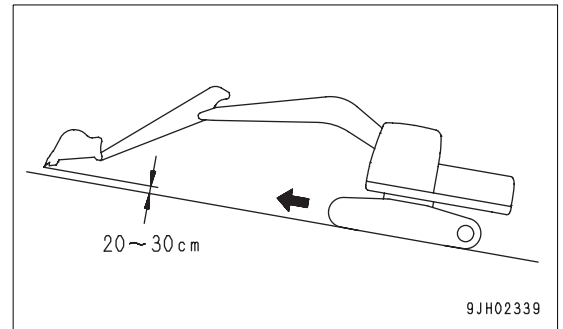

Traveling Downhill

Put the travel lever in the neutral position. This will cause the brake to be automatically applied.

Engine Stopped on Slope

If the engine stops when traveling uphill, move the travel levers to the neutral position, lower the bucket to the ground, stop the machine, then start the engine again.

Cab Doors on Slope



WARNING

Do not open or close the door when the machine is on a slope. The operating effort may suddenly change. Always keep the door locked in position when it is open and when it is closed.

- If the engine stops when the machine is on a slope, never use the left work equipment control lever to carry out swing operations. The upper structure will swing under its own weight.

ESCAPE FROM MUD

When operating, be careful not to get stuck in mud. If the machine gets stuck in mud, do as follows to get the machine out.

- Place the machine push-up switch at high-pressure set position (b). This will increase the pushing power of the boom and make it easier to escape.

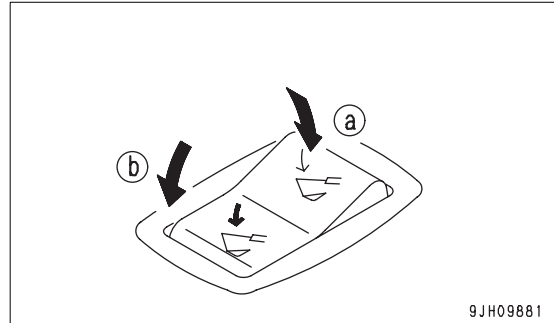

Track on One Side Stuck

NOTICE

When using the boom or arm to raise the machine, always have the bottom of the bucket in contact with the ground. The angle between the boom and arm should be 90° to 110°.

The same applies when using the bucket installed in the reverse direction.

When only one side is stuck in mud, use the bucket to raise the track, then lay boards or logs and drive the machine out.

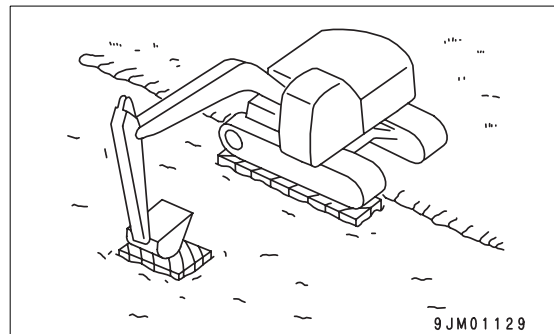

Tracks on Both Sides Stuck

When the tracks on both sides are stuck in mud and they slip, making it impossible for the machine to move, lay boards or logs as explained above, and dig the bucket into the ground in front. Then pull in the arm as in normal digging operations and put the travel levers in the FORWARD position to pull the machine out.

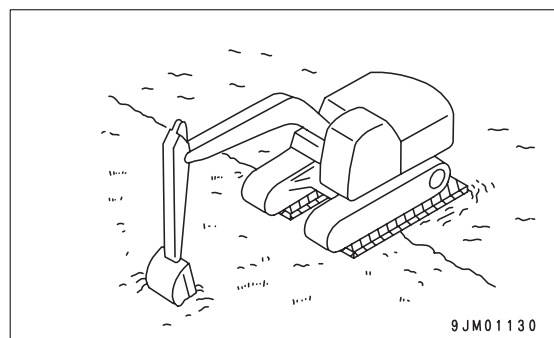

RECOMMENDED APPLICATIONS

In addition to the following, it is possible to further increase the range of applications by using various attachments.

Backhoe Work

A backhoe is suitable for excavating areas that are lower than the machine.

When the condition of the machine is as shown in the diagram on the right (angle between [bucket cylinder and link] and [arm cylinder and arm] is 90°), the maximum excavation force is obtained from the pushing force of each cylinder.

When excavating, use this angle effectively to optimize your working efficiency.

The range for excavating with the arm is from a 45° angle away from the machine to a 30° angle towards the machine.

There may be some differences depending on the excavation depth, but try to stay within the above range rather than operating the cylinder to the end of its stroke.

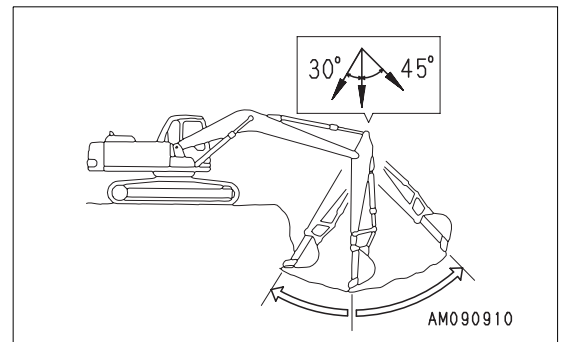
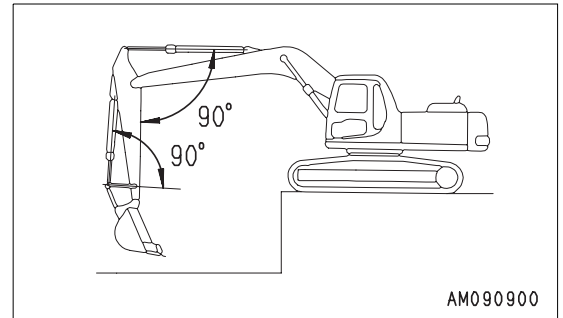

Ditching Work

Ditching work can be performed efficiently by attaching a bucket which matches the digging operation and then setting the tracks parallel to the line of the ditch to be excavated.

To excavate a wide ditch, first dig both sides and then finally remove the center portion.

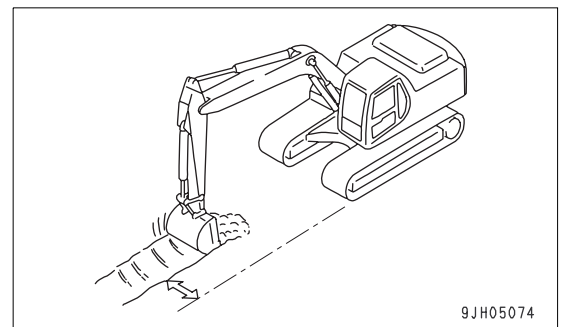

Loading Work

In places where the swing angle is narrow, work efficiency can be enhanced by locating the dump truck in a place easily visible to the operator.

Loading is easier and capacity greater if you begin from the front of the dump truck body than if loading is done from the side.

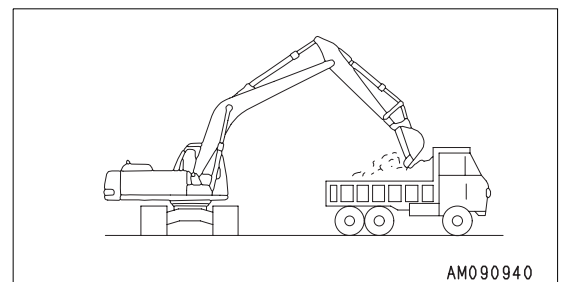

BUCKET REPLACEMENT

WARNING

- When pins are knocked in with a hammer, pieces of metal may fly and cause serious injury. When carrying out this operation, always wear goggles, hard hat, gloves, and other protective equipment.
- When the bucket is removed, place it in a stable condition.
- If pins are hit with a strong force, there is a hazard that the pin may fly out and injure people in the surrounding area. Make sure that there is no one in the surrounding area before starting the operation.
- When removing the pins, do not stand behind the bucket. In addition, be extremely careful not to put your foot under the bucket while standing at the side for the work.
- When removing or inserting pins, be extremely careful not to get your fingers caught.
- Never insert your fingers into the pin holes when aligning the holes.

Stop the machine on a firm and flat surface and do the work. When performing joint work, appoint a lead and follow that person's instructions and signals.

Replacement

1. Place the bucket in contact with a flat surface.

REMARK

When removing the pins, place the bucket so that it is in light contact with the ground.

If the bucket is lowered strongly to the ground, the resistance will be increased and it will be difficult to remove the pins.

2. Remove the stopper at the end of the pin, then pull out pins (A) and (B) and remove the bucket.

NOTICE

After removing the pins, make sure that mud or sand does not get on them. Dust seals are fitted at both ends of the bushings, be careful not to damage them.

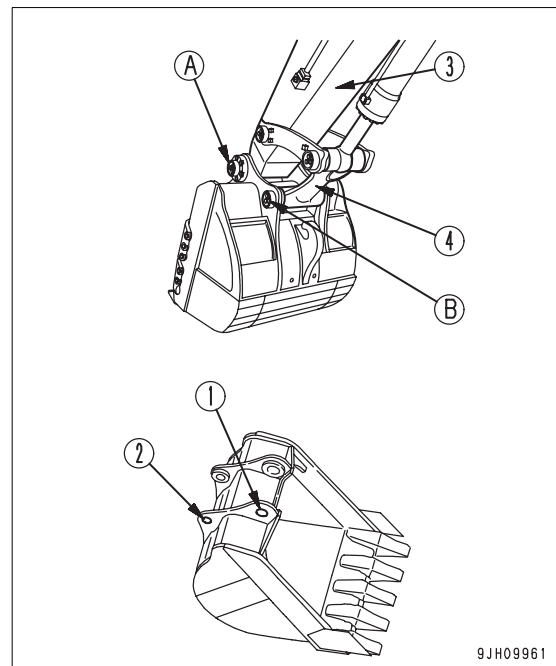

- Align the arm (3) with holes (1) of the replacement bucket and the link (4) with holes (2) , then insert grease-coated pins (A) and (B) into hole (1) and hole (2) respectively.

REMARK

Carry out installation in the reverse order to removal.

When installing bucket (5), it is easy to damage the O-ring (6), so fit O-ring (6) to bucket (5) in the position shown in diagram on the right. After inserting pin, fit the O-ring correctly in the groove.

Install the stopper bolts and nuts for each pin, then grease the pin.

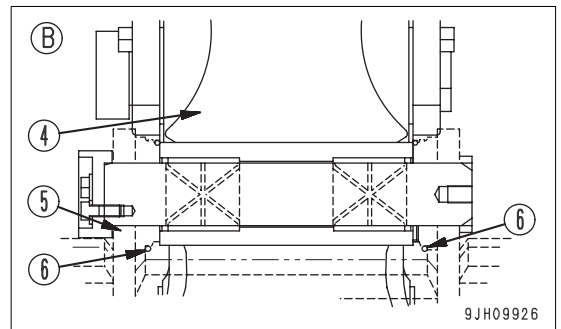
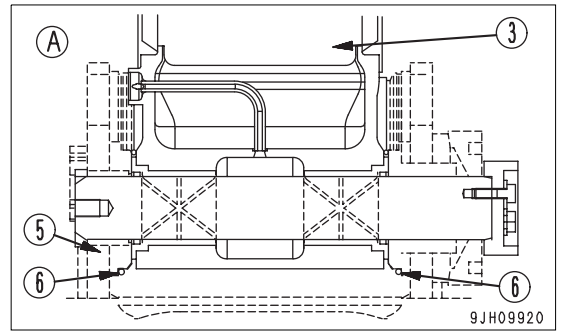

PARKING MACHINE

WARNING

- Avoid stopping suddenly. Give yourself ample room when stopping.
- When stopping the machine, select flat hard ground and avoid dangerous places.
If it is unavoidably necessary to park the machine on a slope, insert blocks underneath the track shoes. As an additional safety measure, thrust the bucket into the ground.
- If the control lever is touched by accident, the machine may move suddenly, and this may lead to a serious accident.
Before leaving the operator's compartment, always set the lock lever securely to LOCK position.

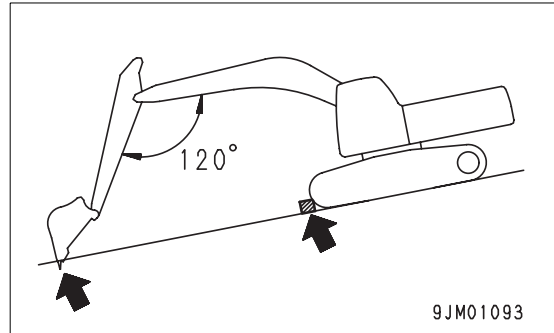

1. Put left and right travel levers (1) in the neutral position.

The machine stops.

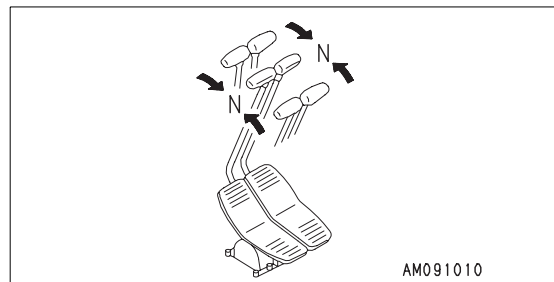
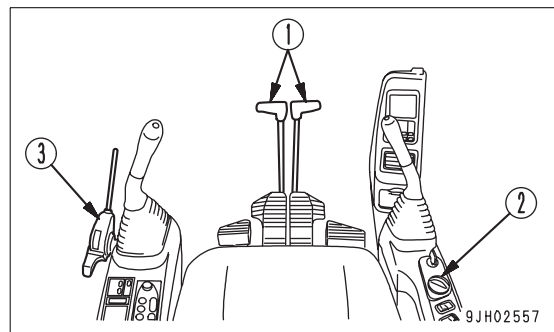

2. Turn fuel control dial (2) to lower the engine speed to low idle.

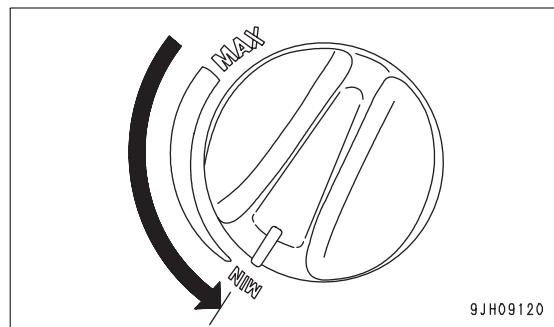

- Lower the bucket horizontally until the bottom touches the ground.

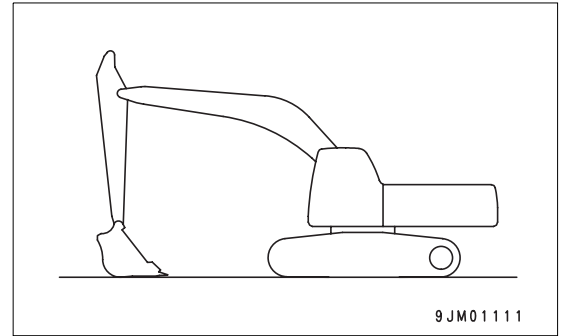

- Set lock lever (3) in the LOCK position.

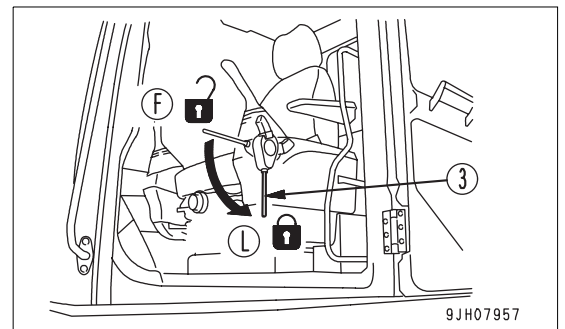

- Use the machine monitor to check the engine water temperature, engine oil pressure, and fuel level.

- If the coolant temperature gauge is in the red range, allow it to cool until the indicator enters the black range, then stop the engine. For details of the inspection and action to take, see "TROUBLES AND ACTIONS (3-141)".
- If the engine oil pressure monitor lights up, stop the engine immediately. For details of the inspection and action to take, see "TROUBLES AND ACTIONS (3-141)".

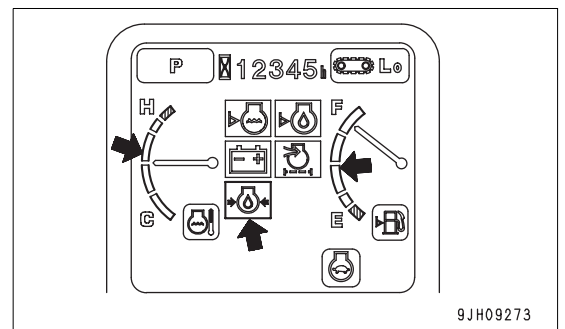

- Stop the engine. For details on the procedure for stopping the engine, see "STOPPING THE ENGINE (3-101)".

MACHINE INSPECTION AFTER DAILY WORK

- Walk around the machine and check the work equipment, machine exterior, and undercarriage, also check for any leakage of oil or coolant. If any problems are found, repair them.
- Fill the fuel tank.
- Check the engine compartment for paper and debris. Clean out any paper and debris to avoid a fire hazard.
- Remove any mud affixed to the undercarriage.

LOCKING

Always lock the following places.

(1) Door of operator's cab

Always remember to close the window.

(2) Fuel tank filler port

(3) Engine hood

(4) Battery box cover

(5) Left side door of the machine (2 places)

(6) Tool box side door

(7) Hydraulic tank filler port

(8) Spare pail cover

(9) Grease pump box cover

REMARK

Use the starting switch key to open and close all these places.

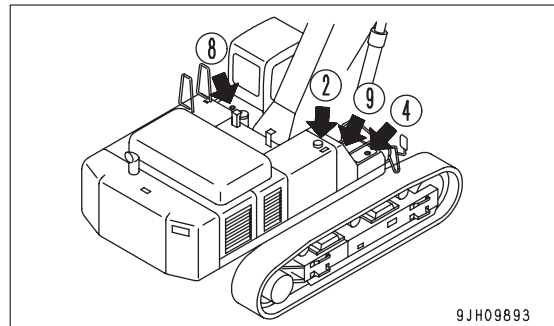
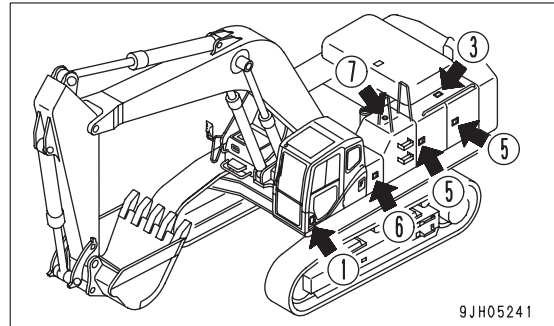

OVERLOAD WARNING DEVICE (option)

The machine is fitted with this device to warn the operator when tipping over is a risk while lifting loads.

During lifting operations ensure switch (A) is depressed to activate warning (switch will illuminate when actuated)



TRANSPORTATION

When transporting the machine, observe all related laws and regulations, and be careful to assure safety.

PRECAUTIONS FOR TRANSPORTATION



WARNING

**This machine must be divided into several units for transportation.
When transporting the machine, please consult your Komatsu distributor.**

LIFTING MACHINE



WARNING

**The operator carrying out the lifting operation using a crane must be a properly qualified crane operator.
Never raise the machine with any worker on it.
Always make sure that the wire rope is of ample strength for the weight of this machine.
When lifting, keep the machine horizontal.
When carrying out lifting operations, set the lock lever to the LOCK position to prevent the machine from moving unexpectedly.
Never enter the area under or around a raised machine.
Never try to lift the machine in any posture other than the posture given in the procedure below or using lifting equipment other than in the procedure below.
There is a hazard that the machine may lose its balance.**

NOTICE

**The lifting procedure applies to machines with standard specifications.
The method of lifting differs according to attachments and options actually installed on the machine. For the proper lifting procedures, contact your Komatsu distributor.**

For details of the weight, see "SPECIFICATIONS (5-2)".

When lifting the machine, carry out the operation on flat ground as follows.

1. Pass wire ropes between the 1st and 2nd track rollers from the front and between the 1st and 2nd track rollers from the rear.

However, for machines equipped with a full roller guard for the track roller, pass the wire rope under the track.

2. The mark for the center of gravity installed to the machine shows the position of the center of gravity in the condition shown in the diagram on the right.
 3. Set the lifting angle (A) of the wire rope to 30° to 40° , then lift the machine slowly.
 4. After the machine comes off the ground, stop the lifting operation and wait for the machine to stabilize, then lift the machine slowly.
- The lifting load is 35 tons.

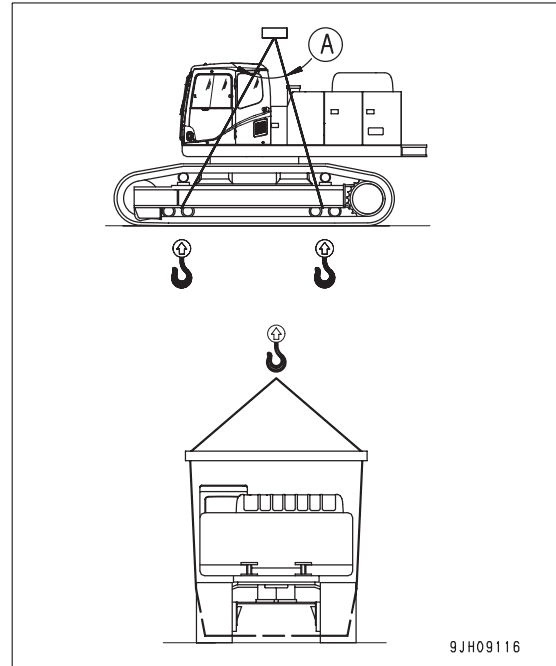

SHIPPING MACHINE INFORMATION**⚠ WARNING**

- When loading the machine, choose firm level ground. Keep well away from the road shoulder.
- Run the engine at low speed and operate slowly.

After placing the machine on the specified position of the trailer, secure it according to the following procedure.

1. Set all the control levers securely at LOCK position (L) with lock lever (1).
2. Stop the engine and pull out the starting switch key.
3. Lock the window glass, roof window, front window, operator's seat door, side cover, engine hood, and battery box cover securely.
4. When transporting the machine, place a rectangular block under the front and rear track shoes to prevent the machine from moving. Furthermore fasten the machine with chains or wire ropes of sufficient strength. Make sure particularly that the machine will not slip sideways.

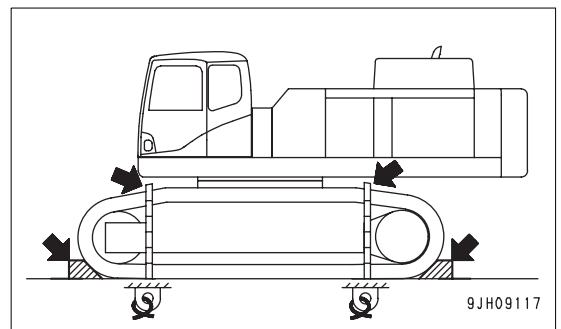
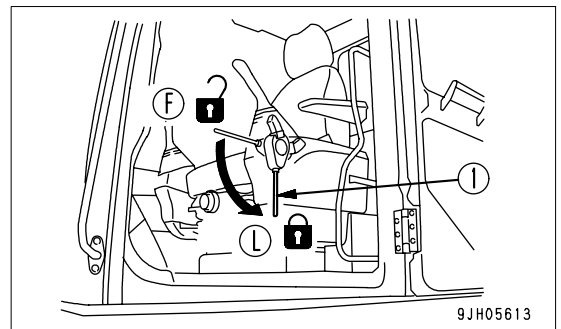

TRANSPORTATION POSTURE

This machine can be divided into three units or four units for transportation. When transporting the machine please contact your Komatsu distributor.

Three units for transportation

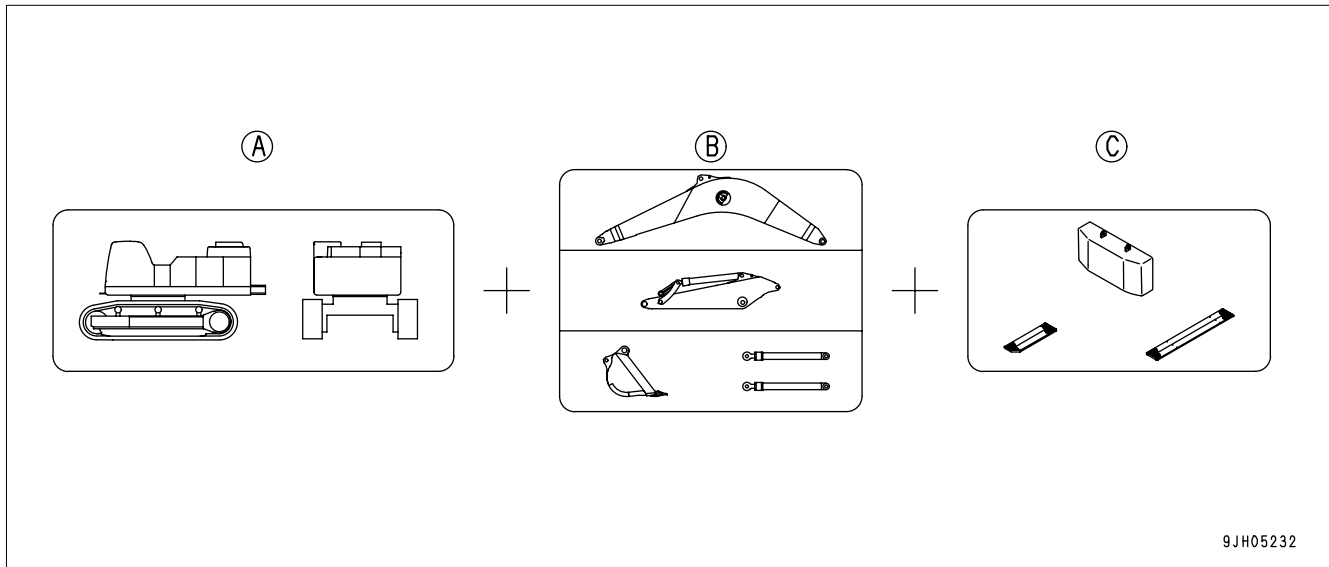

(A) Upper structure + Undercarriage

(B) Work equipment

(C) Other

Posture for Each Unit

Upper Structure + Undercarriage

Unit		PC600	PC600LC
Overall width	mm	3,195	3,195
A	mm	3,330	3,330
B	mm	6,170	6,340
Weight	kg	34,240	35,240

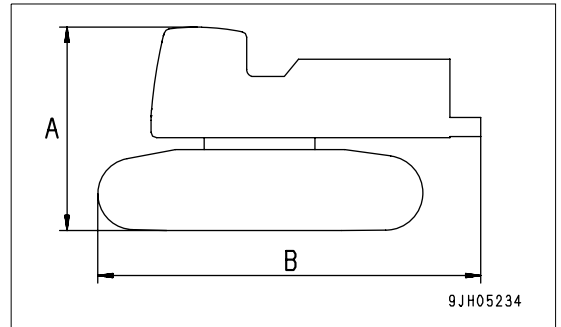

Upper Structure

Secure the upper structure to the platform with a chain and block.

Item	Unit	PC600, PC600LC
Overall width	mm	3,195
A	mm	2,500
B	mm	5,070
Weight	kg	16,800

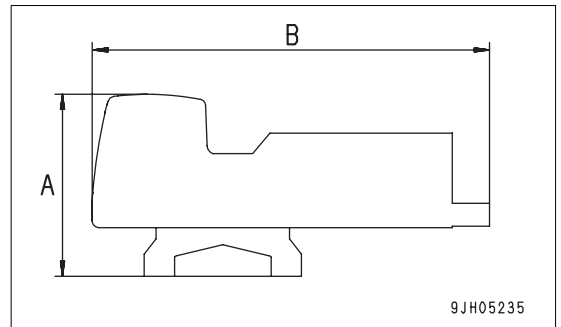

Undercarriage

If there is a warning tag hanging on the work equipment control lever, do not start the engine.

Item	Unit	PC600	PC600LC
Quantity	-	2	2
A	mm	1,260	1,260
B	mm	5,340	5,690
C	mm	875	875
Weight	kg	16,400	17,400

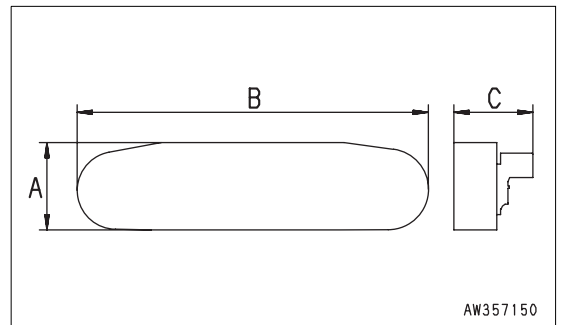

Work Equipment

● Boom

Item	Unit	PC600,PC600LC
A	mm	7,920
B	mm	2,040
Overall width	mm	1,190
Weight	kg	4,820

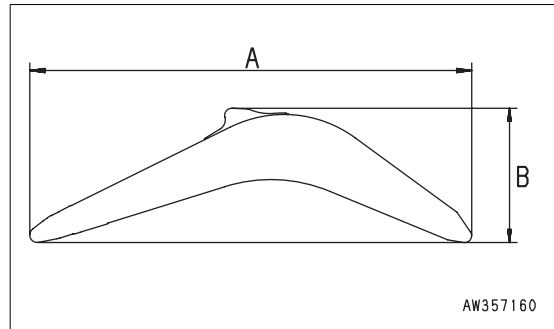

● Arm

Item	Unit	PC600,PC600LC
A	mm	4,870
B	mm	1,270
Overall width	mm	480
Weight	kg	3,240

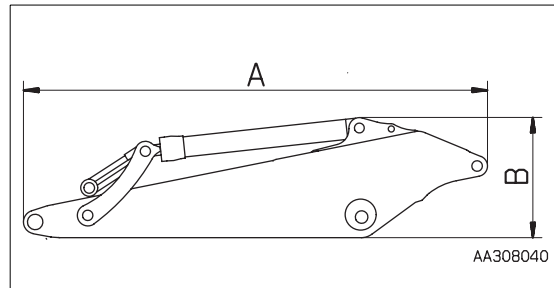

● Bucket (with side cutter, shroud)

Item	Unit	PC600,PC600LC
A	mm	2,040
B	mm	1,870
Overall width	mm	1,790
Weight	kg	2,510

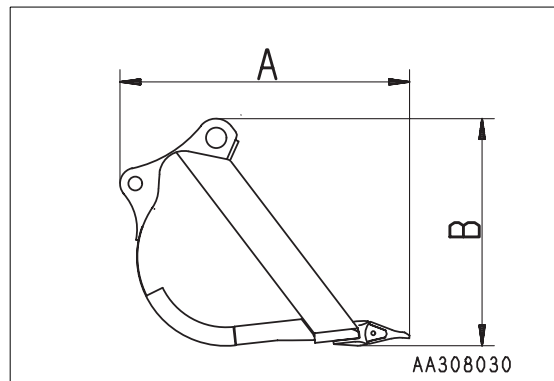

● Boom cylinder (same for all models)

Item	Unit	PC600,PC600LC
Quantity	-	2
A	mm	2,672
Weight	kg	1,040

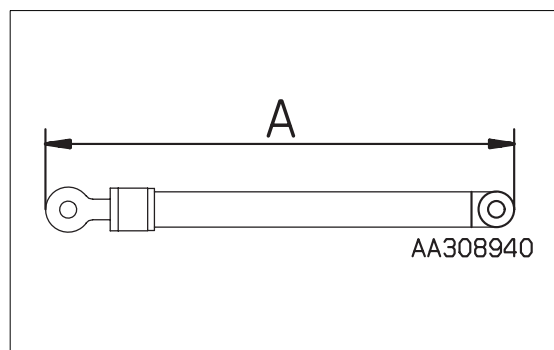

- Arm cylinder

Item	Unit	PC600,PC600LC
A	mm	3,108
Weight	kg	770

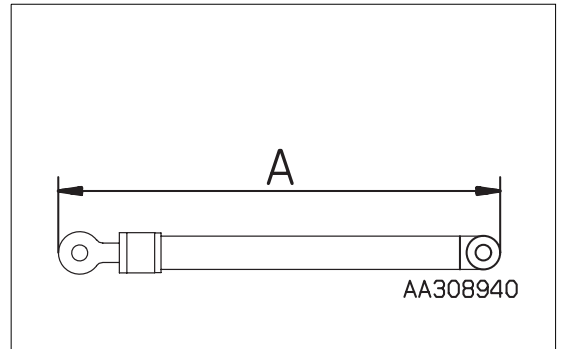

Others

- Counterweight

Item	Unit	PC600,PC600LC
A	mm	1,320
B	mm	3,195
C	mm	780
Weight	kg	10,750

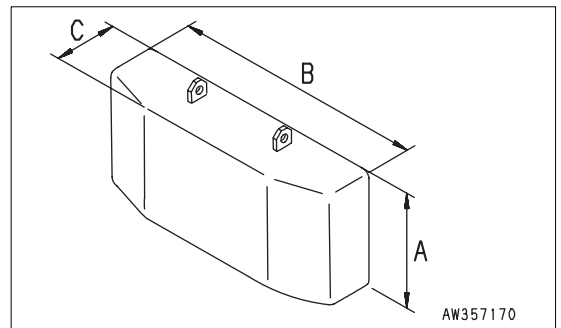

- Head guard (if equipped)

Item	Unit	PC600,PC600LC
A	mm	1,816
B	mm	215
C	mm	980
Weight	kg	55

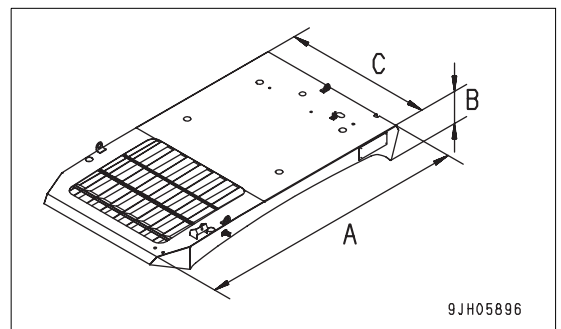

● Catwalk (1) (same for all models)

Item	Unit	PC600,PC600LC
A	mm	1,910
B	mm	500
Weight	kg	32

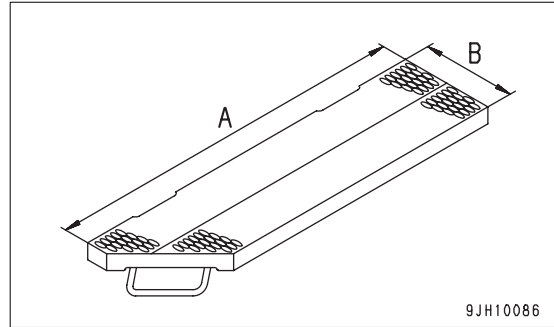

● Catwalk (2) (same for all models)

Item	Unit	PC600,PC600LC
A	mm	2,310
B	mm	500
Weight	kg	37

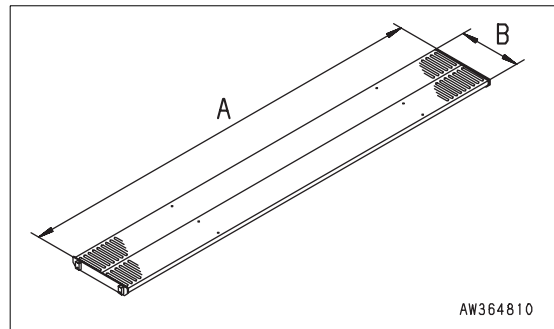

PROCEDURE FOR INCREASING OR REDUCING TRACK FRAME GAUGE

WARNING

Never use the machine for operations with the track frame retracted.

Reducing Track Gauge

1. Remove center frame mounting bolts (1). (one side, front + rear: 16 bolts)
2. Swing the upper structure so that it is at 90° on the side of track frame (A) to be retracted, then use the work equipment to jack up the track frame.
3. Set blocks (B) (20 to 30 cm wooden blocks) towards the outside of track frame (A), then use the boom cylinder to lower the machine slowly. The track frame (A) will slide and stop when it contacts the stopper.
4. Lower the machine carefully and install bolts (2). (one side, front + rear: 8 bolts out of bolts (1))
5. Tightening torque: 1960 - 2450 N·m (200 - 250 kgf·m)
6. Follow the same procedure to retract the track frame on the other side.

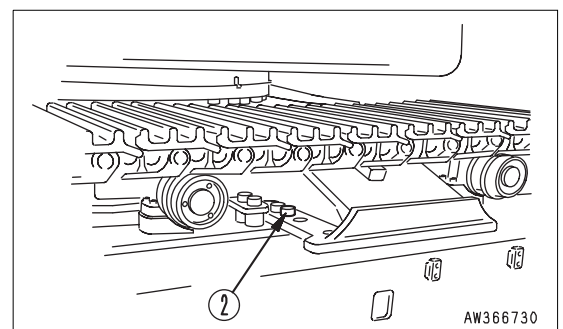
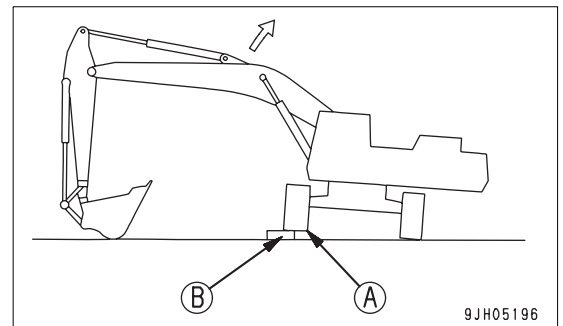
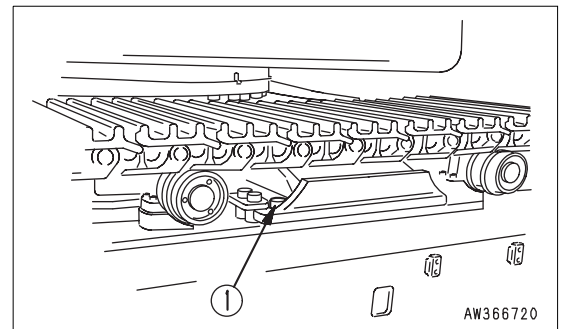

Increasing Track Gauge

1. Remove center frame mounting bolts (2) (one side, front + rear: 8 bolts) from the front and rear of the track frame on the side to be extended.

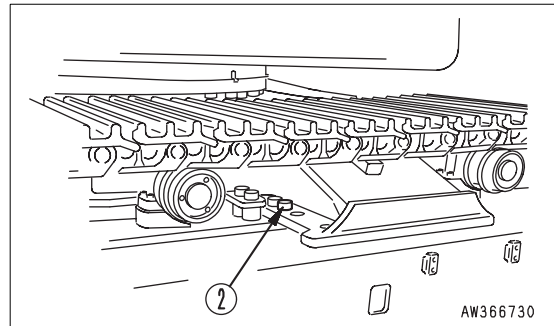

2. Swing the upper structure so that it is at 90° on the opposite side to track frame (A) to be extended.

REMARK

Height H of the track frame being raised should be less than 50 mm. Take care not to raise the track frame so much that the stopper bolt is distorted.

3. Using the arm, pull the machine to the front.
The track frame will slide.

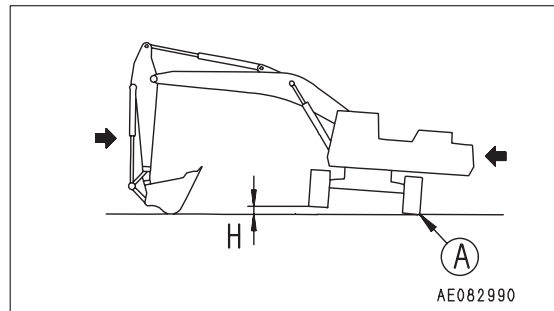

4. Extend the track frame until it comes into contact with the stopper, then lower the machine slowly to the ground. Install bolts (1) (one side, front + rear: 16 bolts) and tighten to specified torque.

5. Tightening torque: 1960 - 2450 N·m (200 - 250 kgf·m)

6. Follow the same procedure to retract the track frame on the other side.

- Stop the machine on firm level ground when extending or retracting the track frame gauge width.
- Never operate the cylinders suddenly when extending or retracting the track frame gauge width. It is dangerous if they are operated suddenly.

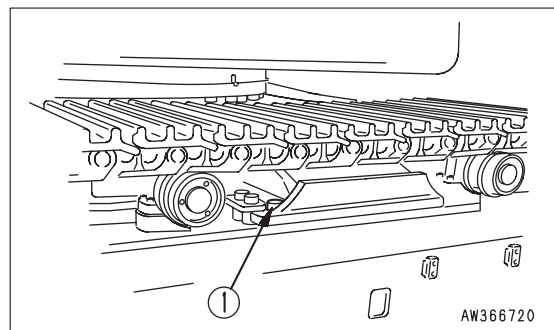

COLD WEATHER OPERATION

COLD WEATHER OPERATION INFORMATION

If the temperature becomes low, it becomes difficult to start the engine, and the coolant may freeze, so do as follows.

Fuel and Lubricants

Change to fuel and oil with low viscosity for all components. For details of the specified viscosity, see "LUBRICANTS, FUEL AND COOLANT SPECIFICATIONS (4-10)".

Cooling System Coolant

WARNING

- Antifreeze is toxic. Be careful not to get it into your eyes or on your skin. If it should get into your eyes or on your skin, wash it off with large amounts of fresh water and see a doctor at once.
- When changing the coolant or when handling coolant containing antifreeze that has been drained when repairing the radiator, please contact your Komatsu distributor or request a specialist company to carry out the operation. Antifreeze is toxic. Do not let it flow into drainage ditches or spray it onto the ground surface.
- Antifreeze is flammable. Do not bring any flame close. Do not smoke when handling antifreeze.

NOTICE

- Never use methanol, ethanol, or propanol-based antifreeze.
- Never use any water-leakage prevention agent or any antifreeze containing such an agent.
- Do not mix different types of antifreeze.

For details of the antifreeze mixture when changing the coolant, see "CLEAN INSIDE OF COOLING SYSTEM (4-24)".

Use a Permanent Antifreeze (ethylene glycol mixed with corrosion inhibitor, antifoam agent, etc.) meeting the standard requirements as shown below. With permanent antifreeze, no change of coolant is required for a year. If it is doubtful that an available antifreeze meets the standard requirements, ask the supplier of that antifreeze for information.

Standard requirements for permanent antifreeze

- SAE J1034
- FEDERAL STANDARD O-A-548D

REMARK

In areas where permanent antifreeze is not available, it is possible to use antifreeze whose main component is ethylene glycol and does not contain any corrosion inhibitor. (Such antifreeze can be used for the winter season only.) However, in such a case, the coolant must be changed twice a year (spring and autumn), so use permanent antifreeze when possible.

Battery

 WARNING

- The battery generates flammable gas. Do not bring fire or sparks near the battery.
- Battery electrolyte is dangerous. If it gets in your eyes or on your skin, wash it off with a large amount of water and consult a doctor.
- Battery electrolyte dissolves paint. If it gets on the bodywork, wash it off immediately with water.
- If the battery electrolyte is frozen, do not charge the battery or start the engine with a different power source. There is danger that the battery may explode.
- Battery electrolyte is toxic. Do not let it flow into drainage ditches or spray it on to the ground surface.

When the ambient temperature drops, the capacity of the battery will also drop. If the battery charge ratio is low, the battery electrolyte may freeze. Maintain the battery charge as close as possible to 100%. Insulate it against cold temperature to ensure the machine can be started easily the next morning.

REMARK

Measure the specific gravity and calculate the charging rate from the following conversion table.

Charging Rate (%)	Electrolyte Temperature (°C)			
	20	0	-10	-20
100	1.28	1.29	1.30	1.31
90	1.26	1.27	1.28	1.29
80	1.24	1.25	1.26	1.27
75	1.23	1.24	1.25	1.26

- As the battery capacity drastically drops in low temperatures, cover or remove the battery from the machine, store the battery in a warm place, and install it again the next morning.
- If the electrolyte level is low, add distilled water in the morning before beginning work. Do not add water after the day's work to prevent diluted electrolyte in the battery from freezing during the night.

Monitor

A feature of the liquid crystal monitor is that the screen becomes dark and is difficult to read in cold weather (particularly with the starting switch ON).

In this case, adjust the brightness and contrast of the screen.

For details, see “Liquid Crystal Monitor Adjustment Switch (3-31)”.

If the screen is dark, increase the brightness and contrast (extend the scale in the + Δ direction) to make the screen brighter and easier to read.

Brightness

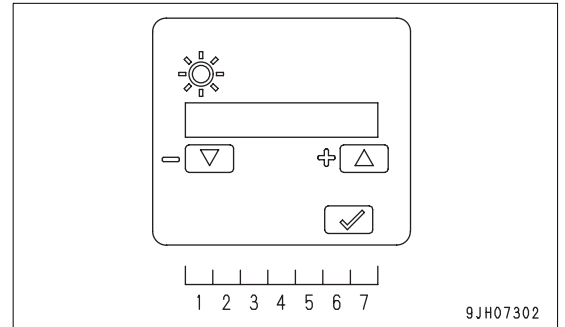

Contrast

Guideline for bar display for brightness and contrast in cold weather

Ambient temperature	Brightness	Contrast
-10°C	7 (max)	5 - 4
-20°C	7	7 - 6

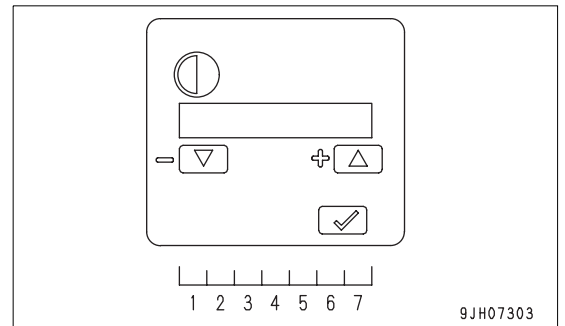

AFTER DAILY WORK COMPLETION

WARNING

Performing idle-running of the tracks is dangerous, stay well away from the tracks.

To prevent mud, water, or the undercarriage from freezing and making it impossible for the machine to move on the following morning, observe the following precautions.

- Remove all the mud and water from the machine body. In particular, wipe the hydraulic cylinder rods clean to prevent damage to the seal caused by mud, dirt, or drops of water on the rod from getting inside the seal.
- Park the machine on hard, dry ground.

If this is impossible, park the machine on boards.

The boards prevent the tracks from freezing to the ground, and allow the machine to be moved the next morning.

- Open the drain valve and drain any water collected in the fuel system to prevent it from freezing.
- Fill the fuel tank to capacity. This minimizes moisture condensation in the tank when the temperature drops.
- After operation in water or mud, remove water from undercarriage as described below to extend undercarriage service life.

1. Swing 90° with engine at low idle and bring the work equipment to the side of the track.
2. Jack up the machine until the track is raised slightly from the ground. Rotate the track under no load. Repeat this procedure on both the left and right sides.

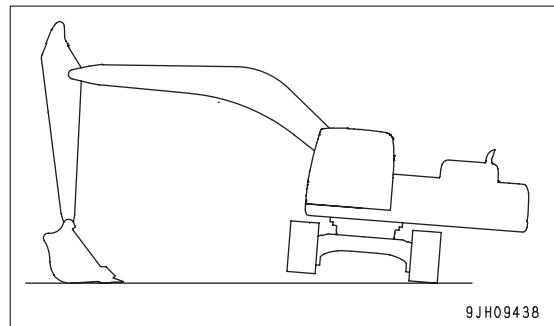

AFTER COLD WEATHER SEASON

When the season changes and the weather becomes warmer, do as follows.

- Replace all fuel and oil with the specified fuel and oil.

For details, see “LUBRICANTS, FUEL AND COOLANT SPECIFICATIONS (4-10)”.

LONG TERM STORAGE

BEFORE STORAGE

NOTICE

To protect the hydraulic cylinder piston rod while in storage, keep the work equipment in the posture shown at right.

(This prevents rust from developing on the piston rod)

When putting the machine in storage for a long time (more than one month), do as follows.

- Clean and wash all parts, then store the machine indoors. If the machine has to be stored outdoors, select level ground and cover the machine with canvas.
- Completely fill the fuel tank. This prevents moisture from collecting.
- Lubricate and change the oil before storage.
- Coat the exposed portion of the hydraulic cylinder piston rod with grease.
- Disconnect the negative terminals of the battery and cover it or remove it from the machine and store it separately.
- Lock each control lever and pedal with the lock lever and pedal lock.
- Set the stop valve to the LOCK position on machines ready for attachments. Install the blind plugs to the elbows.
- Set the selector valve on the machines which can install attachments to the "Where no attachment is mounted" position.

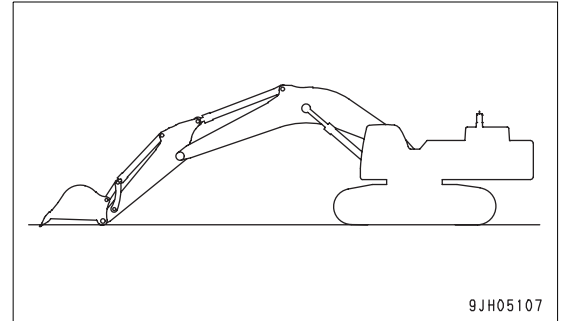

DURING STORAGE

WARNING

If it is necessary to perform the rust-prevention operation while the machine is indoors, open the doors and windows to improve ventilation and prevent gas poisoning.

- During storage, operate and move the machine for a short distance once a month so that a new film of oil will coat moving parts. At the same time, also charge the battery.
- For machines equipped with an air conditioner, operate the air conditioner for three to five minutes once a month to circulate lubricant to all parts of its compressor. Be sure to idle the engine at low speed and operate the air conditioner. Also check the quantity of refrigerant twice a year.
- When operating the work equipment, wipe off all the grease from the hydraulic cylinder rods.
- If the machine is equipped with an air conditioner, operate the air conditioner for 3 to 5 minutes once a month to lubricate all parts of the air conditioner compressor. Always run the engine at low idle when doing this. In addition, check the refrigerant level twice a year.

AFTER STORAGE

NOTICE

If the machine has been stored without carrying out the monthly rust-prevention operation, consult your Komatsu distributor before using it.

When using the machine after long-term storage, do as follows before using it.

- Wipe off the grease from the hydraulic cylinder rods.
- Add oil and grease at all lubrication points.
- When the machine is stored for a long period, moisture in the air will mix with the oil. Check the oil before and after starting the engine. If there is water in the oil, change all the oil.

STARTING MACHINE AFTER LONG-TERM STORAGE

When starting the engine after the machine has been in storage for a long time, carry out the warming-up operation thoroughly. For details, see "Warming Up Engine (3-94)".

TROUBLES AND ACTIONS

RUNNING OUT OF FUEL

When starting the engine again after running out of fuel, fill with fuel, then bleed the air from the fuel system before starting the engine.

Always watch the fuel level and be careful not to run out of fuel.

If the engine has stopped because of lack of fuel, it is necessary to use the priming pump to bleed the air completely from the fuel circuit.

Procedure for Bleeding Air



CAUTION

This engine consists of higher precision parts than on the conventional fuel injection pump and nozzle, so if dirt gets in, it will cause problems. If there is any dirt stuck to the fuel line, use fuel to wash it off completely.

Be careful when opening the air bleed plug for the fuel filter head. If there is any remaining pressure, the fuel may spurt out.

When bleeding the air immediately after the engine has run out of fuel, the area around the engine is extremely hot, so be careful not to burn yourself.

1. Loosen plug (A) at the top of fuel main filter head (1).

NOTICE

Do not loosen the plug of the fuel pre-filter head. This is at the suction end, so if it is loosened, it will be impossible to bleed the air.

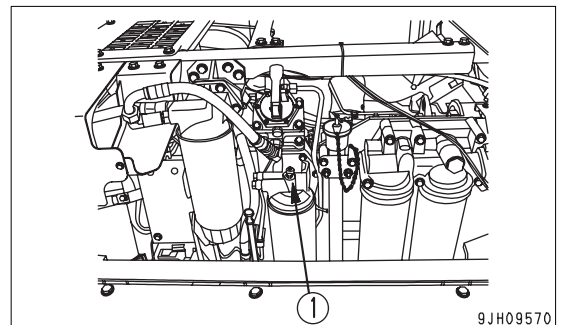

2. Loosen butterfly nut (2) holding the lever of the priming pump.
3. Operate the lever of the priming pump to prime with fuel. Fuel will come out from plug (A) at the top of the fuel main filter head. When no more bubbles come out with the fuel, operate the priming pump lever more slowly. Tighten plug (A).

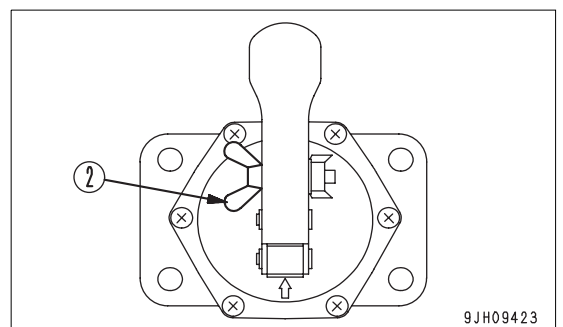
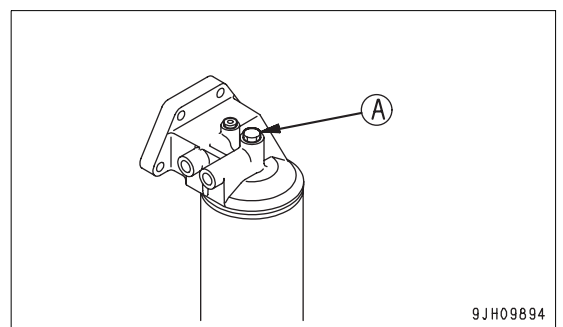

4. Carry out priming approx. 50 times with priming pump (3) of the supply pump.
5. Tighten butterfly nut (2) holding the lever of the priming pump securely.
Target tightening torque: 11.80 N·m (1.2 kgf·m)
6. Turn the key in the starting switch to the START position.
The engine will start.

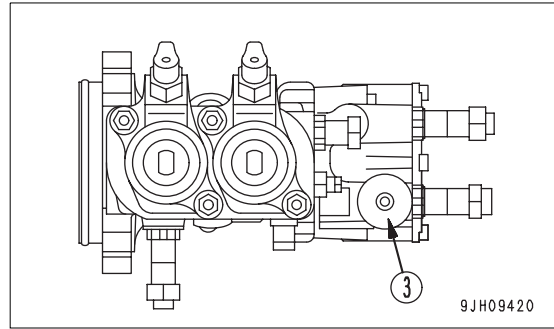

PHENOMENA THAT ARE NOT FAILURES

Note that the following phenomena are not failures:

- When the arm control lever is operated to the IN position and the work equipment is lowered under no load from a high position, the arm speed will drop momentarily when the arm is more or less at the vertical position.
- When the bucket control lever is operated to the CURL position and the work equipment is lowered under no load from a high position, the bucket speed will drop momentarily when the bucket teeth are more or less at the horizontal position.
- The bucket or arm will fluctuate by itself during heavy-duty digging operations.
- When starting or stopping the swing, noise will be emitted from the brake valve.
- When going down a steep slope at low speed, a noise will be emitted from the travel motor brake valve.

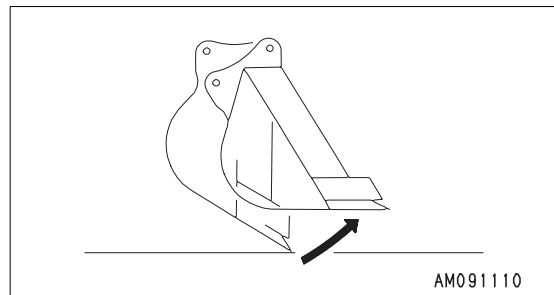
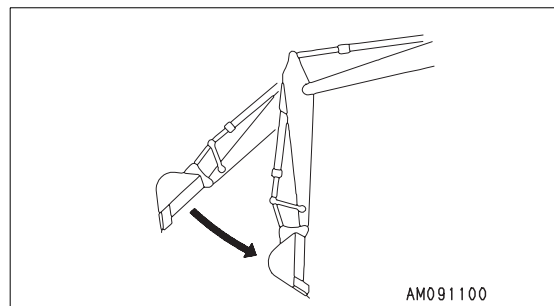

TOWING THE MACHINE

WARNING

Serious injury or death could result if a disabled machine is towed incorrectly or if there is a mistake in the selection or inspection of the wire rope.

Always check that the wire rope used for towing has ample strength for the weight of the machine being towed.

Never use a wire rope which has cut strands (A), reduced diameter (B), or kinks (C). There is danger that the rope may break during the towing operation.

Always wear leather gloves when handling wire rope.

Never tow a machine on a slope.

During the towing operation, never stand between the towing machine and the machine being towed.

Operate the machine slowly and be careful not to apply any sudden load to the wire rope.

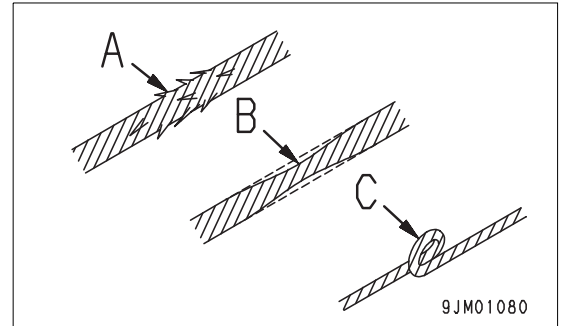

NOTICE

The maximum towing capacity for this machine is 412,000N (42,000kgf).

Always carry out towing operations within the maximum towing capacity.

- If the machine sinks in mud and cannot get out under its own power, or if the drawbar pull of the excavator is being used to tow a heavy object, use a wire rope as shown in the diagram on the right.
- Place pieces of wood between wire ropes and body to prevent damage to ropes and body.
- Hold the wire rope level and direct it straight to the track frame.
- When towing a machine, travel at a speed of less than 1 km/h for a distance of only a few meters to a place that is suitable for carrying out repairs.

This is for use only in emergencies.

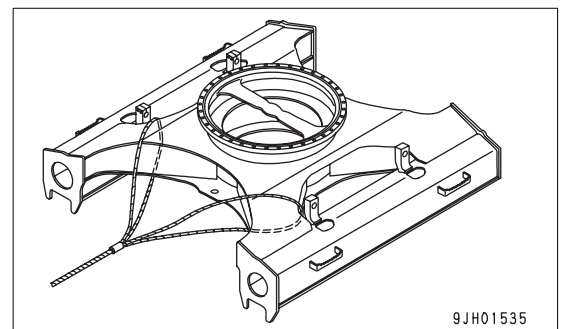
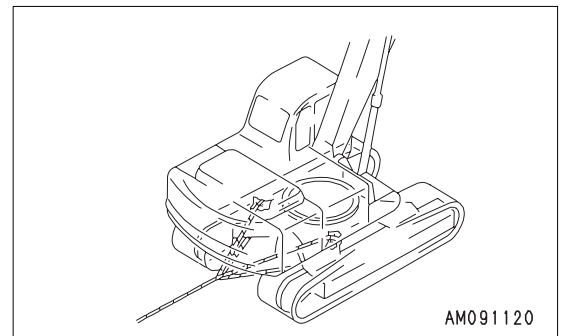

SEVERE JOB CONDITION

- When carrying out digging operations in water, if the work equipment mounting pin goes into the water, carry out greasing every time the operation is carried out.
- For heavy-duty operations and deep digging, carry out greasing of the work equipment mounting pins every time before operation.

After greasing, operate the boom, arm and bucket several times, then grease again.

DISCHARGED BATTERY

WARNING

- It is dangerous to charge a battery when mounted on a machine. Make sure that it is dismantled before charging.
- When checking or handling the battery, stop the engine and turn the starting switch key to the OFF position.
- The battery generates hydrogen gas, so there is a hazard of explosion. Do not bring lighted cigarettes near the battery, or do anything that will cause sparks.
- Battery electrolyte is dilute sulfuric acid, and it will attack your clothes and skin. If it gets on your clothes or on your skin, immediately wash it off with a large amount of water. If it gets in your eyes, wash it out with fresh water and consult a doctor.
- When handling batteries, always wear safety glasses and rubber gloves.
- When removing the battery, first disconnect the cable from the ground (normally the negative (-) terminal). When installing, install the positive (+) terminal first. If a tool touches the positive terminal and the chassis, there is danger that it will cause a spark, so be extremely careful.
- If the terminals are loose, there is danger that the defective contact may generate sparks that will cause an explosion.
- When removing or installing the terminals, check which is the positive (+) terminal and which is the negative (-) terminal.

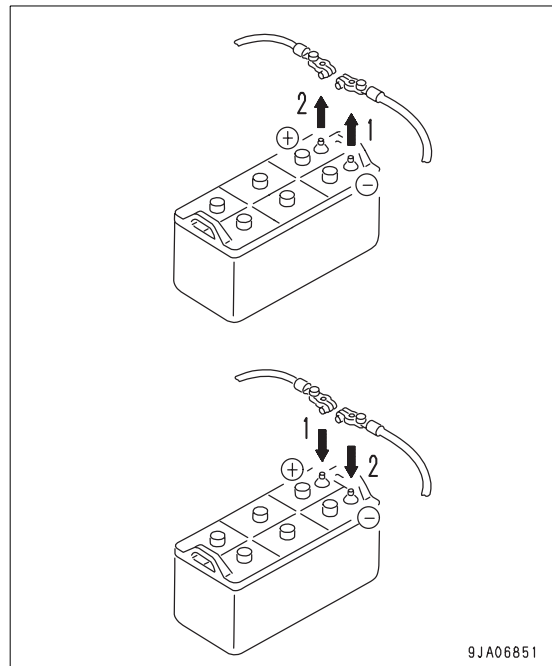

Battery Removal and Installation

- Before removing the battery, remove the ground cable (normally connected to the negative (-) terminal).
If any tool touches between the positive terminal and the chassis, there is a hazard of sparks being generated.
- When installing the battery, connect the ground cable last.
- When replacing the battery, fix the battery securely in position with the battery mounting clamp.
Tightening torque of mounting bolt: 9.8 to 19.6 N·m (1.0 to 2.0 kgf·m)

Battery Charges

When charging the battery, if the battery is not handled correctly, there is a hazard that the battery may explode. Always follow the instructions of "DISCHARGED BATTERY (3-144)" and the instruction manual accompanying the charger, and do as follows.

- Set the voltage of the charger to match the voltage of the battery to be charged. If the correct voltage is not selected, the charger may overheat and cause an explosion.
- Connect the positive (+) charger clip of the charger to the positive (+) terminal of the battery, then connect the negative (-) charger clip of the charger to the negative (-) terminal of the battery. Be sure to attach the clips securely.
- Connect the positive (+) charger clip of the charger to the positive (+) terminal of the battery, then connect the negative (-) charger clip of the charger to the negative (-) terminal of the battery. Be sure to attach the clips securely.
- Set the charging current to 1/10 of the value of the rated battery capacity; when carrying out rapid charging, set it to less than the rated battery capacity.

If the charger current is too high, the electrolyte will leak or dry up, and this may cause the battery to catch fire and explode.

- If the battery electrolyte is frozen, do not charge the battery or start the engine with a different power source. There is a danger that this will ignite the battery electrolyte and cause the battery to explode.
- Do not use or charge the battery if the battery electrolyte level is below the LOWER LEVEL line. This may cause an explosion. Check the battery electrolyte level periodically and add distilled water to bring the electrolyte level to the UPPER LEVEL line.

Starting Engine with Booster Cables

When starting the engine with a booster cable, do as follows:

Connecting and Disconnecting Booster Cables

WARNING

- When connecting the cables, never contact the positive (+) and negative (-) terminals.
- When starting the engine with a booster cable, always wear safety glasses.
- Be careful not to let the normal machine and problem machine contact each other. This prevents sparks from generating near the battery which could ignite the hydrogen gas given off by the battery. If hydrogen gas explodes, it could cause serious injury.
- Be careful not to make a mistake when connecting a booster cable. In the last connection (to the upper structure frame), a spark will be caused, connect the cable to a spot as far away from the battery as possible. (Avoid the work equipment, however, because it is not a good conductor)
- When removing the booster cable, exercise good care so that the booster cable clips may not contact each other, or they contact the chassis.

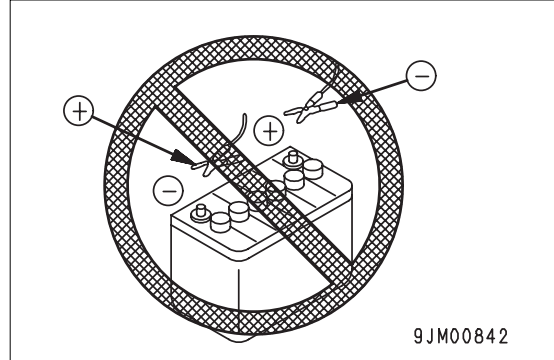

NOTICE

- The starting system for this machine uses 24V. For the normal machine, also use a 24V battery.
- The size of the booster cable and clip should be suitable for the battery size.
- The battery of the normal machine must be the same capacity as that of the engine to be started.
- Check the cables and clips for damage or corrosion.
- Make sure that the cables and clips are firmly connected.
- Check that the lock levers of both machine are in the LOCK position.
- Check that each lever is in the NEUTRAL position.

Booster Cable Connection

Keep the starting switch of the normal machine and problem machine in the OFF position.

Connect the booster cable as follows, in the order of the numbers marked in the diagram.

1. Connect the clip of booster cable (A) to the positive (+) terminal of battery (C) on the problem machine.
2. Connect the clip at the other end of booster cable (A) to the positive (+) terminal of battery (D) on the normal machine.
3. Connect the clip of booster cable (B) to the negative (-) terminal of battery (D) on the normal machine.
4. Connect the other clip of booster cable (B) to the revolving frame (E) of the problem machine.

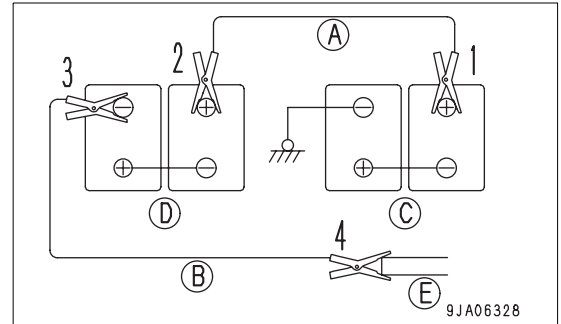

Starting the Engine

⚠ WARNING

Always check that the lock lever is set to the LOCK position, regardless of whether the machine is working normally or has failed. Check also that all the control levers are in the neutral position.

1. Make sure the clips are firmly connected to the battery terminals.
2. Start engine of the normal machine and run it at high idle speed.
3. Turn the starting switch of the problem machine to the START position and start the engine.

If the engine doesn't start at first, try again after 2 minutes or so.

Booster Cable Disconnection

After the engine has started, disconnect booster cables in the reverse order in which they were connected.

1. Remove one clip of booster cable (B) from the revolving frame (E) of the problem machine.
2. Remove the clip of booster cable (B) from the negative (-) terminal of battery (D) on the normal machine.
3. Remove the clip of booster cable (A) from the positive (+) terminal of battery (D) on the normal machine.
4. Remove the clip of booster cable (A) from the positive (+) terminal of battery (C) on the problem machine.

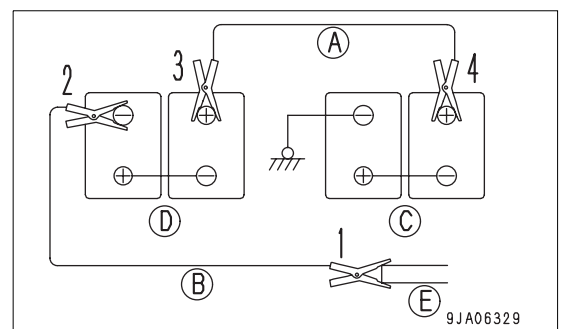

OTHER TROUBLE

Electrical System

- (): Always contact your Komatsu distributor when dealing with these items.
- In cases of problems or causes which are not listed below, contact your Komatsu distributor for repairs.

Problem	Main causes	Remedy
Lamp does not glow brightly even when the engine runs at high speed	<ul style="list-style-type: none"> •Defective wiring •Deteriorated battery 	<ul style="list-style-type: none"> (•Check, repair loose terminals,disconnections) (•Replace battery)
Lamp flickers while engine is running	<ul style="list-style-type: none"> •Defective adjustment of V belt tension 	<ul style="list-style-type: none"> •Check, adjust V belt tension For details, see EVERY 250 HOURS SERVICE
Charge level monitor does not go out even when engine is running	<ul style="list-style-type: none"> •Defective alternator •Defective wiring 	<ul style="list-style-type: none"> (•Replace) (•Check, repair)
Abnormal noise is generated from alternator	<ul style="list-style-type: none"> •Defective alternator 	<ul style="list-style-type: none"> (•Replace)
Starting motor does not crank when Starting switch is turned ON	<ul style="list-style-type: none"> •Defective wiring •Defective starting motor •Insufficient battery charge •Defective safety relay •Defective engine controller 	<ul style="list-style-type: none"> (•Check, repair) (•Replace) •Charge (•Replace) (•Replace)
Pinion of starting motor keeps going in and out	<ul style="list-style-type: none"> •Insufficient battery charge •Defective safety relay (direct starting motor) 	<ul style="list-style-type: none"> •Charge (•Replace)
Starting motor turns engine sluggishly	<ul style="list-style-type: none"> •Insufficient battery charge •Defective starting motor 	<ul style="list-style-type: none"> •Charge (•Replace)
Starting motor disengages before engine starts	<ul style="list-style-type: none"> •Defective wiring,defective ring gear pinion •Insufficient battery charge 	<ul style="list-style-type: none"> (•Check, repair) •Charge
Pre-heating monitor does not light	<ul style="list-style-type: none"> •Defective wiring •Defective heater relay •Defective monitor 	<ul style="list-style-type: none"> (•Check, repair) (•Replace) (•Replace)
Oil pressure monitor does not light up when engine is stopped (starting switch at ON position)	<ul style="list-style-type: none"> •Defective monitor •Defective sensor •Defective wiring 	<ul style="list-style-type: none"> (•Replace) (•Replace) (•Check, repair)
Charge level monitor does not light up when engine is stopped (starting switch at ON position)	<ul style="list-style-type: none"> •Defective monitor •Defective wiring 	<ul style="list-style-type: none"> (•Replace) (•Check, repair)

Chassis

- (): Always contact your Komatsu distributor when dealing with these items.
- In cases of problems or causes which are not listed below, contact your Komatsu distributor for repairs.

Problem	Main causes	Remedy
Speed of travel, swing, boom, arm, bucket is slow	•Lack of hydraulic oil	•Add oil to specified level, see CHECK BEFORE STARTING
Pump generates abnormal noise	•Clogged element in hydraulic tank strainer •Loose suction hose •Lack of hydraulic oil	•Clean, see EVERY 2000 HOURS SERVICE •Retighten •Add oil to specified
Excessive rise in hydraulic oil temperature	•Dirty oil cooler •Lack of hydraulic oil	•Clean, see EVERY 500 HOURS SERVICE •Add oil to specified level, see CHECK BEFORE STARTING
Track comes off Abnormal wear of sprocket	•Track too loose	•Adjust track tension, see WHEN REQUIRED
Bucket rises slowly, does not rise	•Lack of hydraulic oil	•Add oil to specified level, see CHECK BEFORE STARTING
Does not swing	•Swing lock switch still applied	•Turn swing lock switch OFF

Engine

- (): Always contact your Komatsu distributor when dealing with these items.
- In cases of problems or causes which are not listed below, contact your Komatsu distributor for repairs.

Problem	Main causes	Remedy
Engine oil pressure monitor lights up	<ul style="list-style-type: none"> •Engine oil pan oil level is low (sucking in air) •Clogged oil filter cartridge •Defective tightening of oil pipe joint, oil leakage from damaged part •Disconnection, broken wiring to sensor •Defective sensor •Defective Monitor 	<ul style="list-style-type: none"> •Add oil to specified level, see CHECK BEFORE STARTING •Replace cartridge, see EVERY 500 HOURS SERVICE (•Check, repair) (•Repair, connect wiring) (•Replace) (•Replace)
Steam is emitted from top part of radiator (pressure valve)	<ul style="list-style-type: none"> •Coolant level low •Loosen fan belt 	<ul style="list-style-type: none"> •Add coolant, repair, see leakage CHECK BEFORE STARTING •Check fan belt tension, see EVERY 500 HOURS SERVICE (• Replace water level sensor)
Radiator coolant level monitor lights up	<ul style="list-style-type: none"> •Defective water level sensor •Dirt or scale accumulated in cooling system 	<ul style="list-style-type: none"> •Change coolant, clean inside of cooling system, see WHEN REQUIRED •Clean or repair, see EVERY 500 HOURS SERVICE (•Replace engine water temperature gauge° (•Replace thermostat° (•Replace thermostat seal° •Tighten cap or replace packing
Engine water temperature gauge is in red range	<ul style="list-style-type: none"> •Clogged radiator fin or damaged fin •Defective engine water temperature gauge 	<ul style="list-style-type: none"> •Clean or repair, see EVERY 500 HOURS SERVICE (•Replace engine water temperature gauge° (•Replace thermostat° (•Replace thermostat seal° •Tighten cap or replace packing
Engine water temperature monitor lights up	<ul style="list-style-type: none"> •Defective thermostat •Defective thermostat seal •Loose radiator filler cap (high altitude operation) •Disconnection, broken wiring to sensor 	<ul style="list-style-type: none"> (•Repair, connect wiring)
Engine water temperature gauge display stays at lowest level and does not rise	<ul style="list-style-type: none"> •Defective water temperature gauge monitor •Defective thermostat •In cold weather, cold wind is blowing strongly against engine 	<ul style="list-style-type: none"> (•Replace water temperature gauge monitor) •Replace thermostat (•Install radiator curtain)
Engine does not start even when starting motor is turned	<ul style="list-style-type: none"> •Lack of fuel •Air in fuel system •No fuel in fuel filter •Starting motor cranks engine too slowly •Starting motor does not turn •Defective valve clearance (defective compression) 	<ul style="list-style-type: none"> •Add fuel, see CHECK BEFORE STARTING (•Repair place where air is sucked in) •Fill filter with fuel. See EVERY 500 HOURS SERVICE. •See ELECTRICAL SYSTEM •See ELECTRICAL SYSTEM (•Adjust valve clearance)
Fuel stops from time to time	<ul style="list-style-type: none"> •Fuel tank cap 	<ul style="list-style-type: none"> (•Clean or replace fuel tank cap)

Problem	Main causes	Remedy
Excessive oil consumption	<ul style="list-style-type: none"> •Oil leakage •Excessive oil in il pan 	<ul style="list-style-type: none"> (•Check, repair) •Add oil to specified level. See CHECK BEFORE STARTING.
Exhaust gas is white or blue	<ul style="list-style-type: none"> •Worn piston, ring, cylinder liner •Improper fuel •Defective turbocharger 	<ul style="list-style-type: none"> (•Replace) •Replace with specified fuel (•Check, replace)
Exhaust gas is black	<ul style="list-style-type: none"> •Clogged air cleaner element •Worn piston, ring, cylinder liner •Defective compression •Defective turbocharger •Defective injector 	<ul style="list-style-type: none"> •Clean or replace. See WHEN REQUIRED. (•Check, repair) •See adjustment of clearance above (•Check, replace) (•Check, adjust, repair)
Engine hunts	<ul style="list-style-type: none"> •Air entering suction side of fuel line 	<ul style="list-style-type: none"> (•Check, repair)
Abnormal noise generated (combustion or mechanical)	<ul style="list-style-type: none"> •Low-grade fuel being used •Overheating 	<ul style="list-style-type: none"> •Change to specified fuel •Refer to“Radiator water level monitor lights up“ as above
Error code is displayed on monitor	Contact your Komatsu distributor	
Alarm buzzer sounds		
Engine suddenly loses power (entered delayed mode)		

Electronic Control System

If an error code is displayed on the machine monitor display, follow the self-diagnostic remedy table below.

Machine Monitoring System

Monitor display	Failure mode	Remedy
E02	TVC valve system error	When emergency pump drive switch is up, normal operations become normal, but carry out inspection immediately. (*)
E03	Swing brake system error	Turn the swing holding brake release switch is up to release the brake. When applying the swing brake, operate it manually with the swing lock switch. Depending on the cause of the problem, it may not be possible to release it. In any case, have it inspected immediately. (*)
E10	Abnormality in electronic governor system (engine stopped)	Carry out inspection immediately.
E11	Abnormality in electronic governor system (abnormality in engine protection output)	It is possible to carry out normal working operations, but have inspection carried out immediately.
E14	Abnormality in throttle (abnormality in fuel control dial)	Move machine to a safe posture, and carry out inspection immediately.
E15	Abnormality in electronic governor system	It is possible to carry out normal driving operations, but have inspection carried out immediately.
E0E	Abnormality in network	<ul style="list-style-type: none"> •If the engine can be operated, set the machine to a safe posture, then have inspection carried out immediately. •If the engine is operated and stalls, turn the emergency pump drive switch is up set the machine to a safe posture, then have inspection carried out immediately. •Even if the engine is stopped, have inspection carried out immediately.
CALL	Operation cannot be continued	Move machine to a safe posture, and carry out inspection immediately.
If no error code is displayed but work equipment or swing cannot be operated		Carry out inspection immediately.

(*): For details of handling the emergency pump drive switch and swing holding brake cancel switch, see "SWITCHES (3-34)".

Point of Contact to Telephone when Error Occurs

If an error screen is displayed on the monitor, the screen changes as follows each time input confirmation switch (1) is pressed.

Error screen -> screen A -> screen B -> screen C -> error screen

Check the point of contact telephone number on screen B.

REMARK

If the point of contact telephone number has not been registered, screen B is not displayed.

If it is necessary to register the point of contact telephone number, ask your Komatsu distributor to register it.

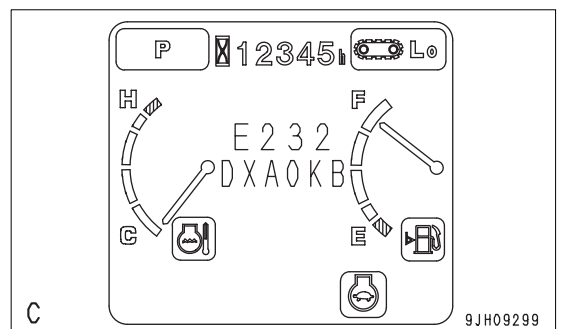
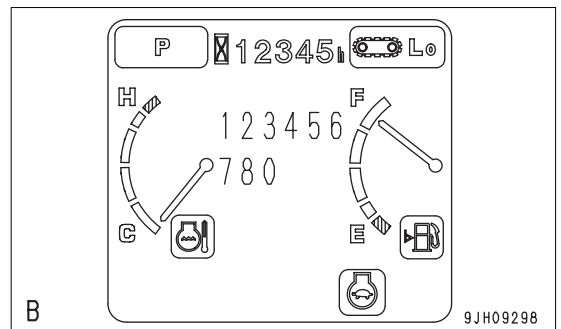
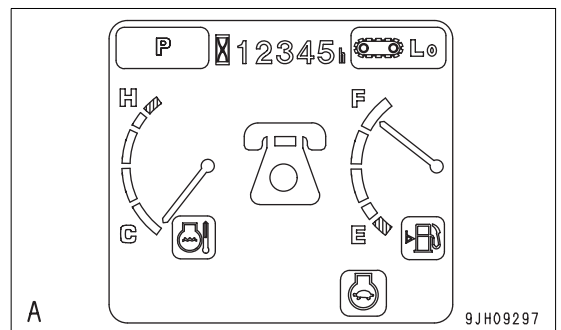
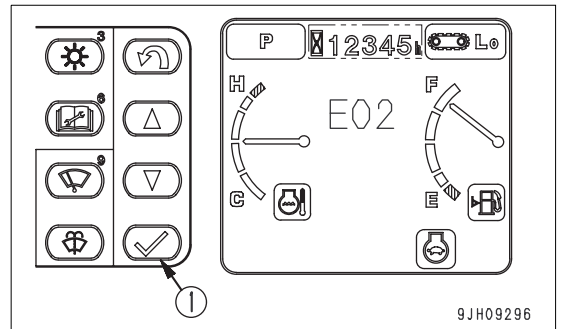

MAINTENANCE



WARNING

Please read and make sure that you understand the safety volume before reading this section.

MAINTENANCE INFORMATION

Do not perform any inspection and maintenance operation that is not found in this manual.

Service Meter Reading

Check the service meter reading every day to see if the time has come for any necessary maintenance to be performed.

Komatsu Genuine Replacement Parts

Use Komatsu genuine parts specified in the Parts Book as replacement parts.

Komatsu Genuine Lubricants

Use Komatsu genuine oils and grease. Choose oils and grease with proper viscosities specified for ambient temperature.

Windshield Washer Fluid

Use automobile window washer fluid, and be careful not to let any dirt get into it.

Fresh and Clean Lubricants

Use clean oil and grease. Also, keep the containers of the oil and grease clean. Keep foreign materials away from oil and grease.

Check Drained Oil and Used Filter

After oil is changed or filters are replaced, check the old oil and filters for metal particles and foreign materials. If large quantity of metal particles or foreign materials are found, always report to the person in charge, and carry out suitable action.

Fuel Strainer

If your machine is equipped with a fuel strainer, do not remove it while fueling.

Welding Instructions

- Turn off the engine starting switch.
- Do not apply more than 200 V continuously.
- Connect grounding cable within 1 m of the area to be welded. If grounding cable is connected near instruments, connectors, etc., the instruments may malfunction.
- If a seal or bearing happens to come between the part being welded and grounding point, change the grounding point to avoid such parts.
- Do not use the area around the work equipment pins or the hydraulic cylinders as the grounding point.

Do not Drop Things Inside Machine

- When opening inspection windows or the oil filler port of the tank to carry out inspection, be careful not to drop nuts, bolts, or tools inside the machine.

If such things are dropped inside the machine, it may cause damage and/or malfunction of the machine, and will lead to failure. If you drop anything inside the machine, always remove it immediately.

- Do not put unnecessary things in your pockets. Carry only things which are necessary for inspection.

Dusty Jobsite

When working at dusty worksites, do as follows:

- Clean the radiator fins and other parts of the heat exchange equipment more frequently, and take care not to let the fins become clogged.
- Replace the fuel filter more frequently.
- Clean electrical components, especially the starting motor and alternator, to avoid accumulation of dust.
- When checking and replacing the oil or filters, move the machine to a place where there is no dust and take care to prevent dust from entering the system.

Avoid Mixing Lubricants

If a different brand or grade of oil has to be added, drain the old oil and replace all the oil with the new brand or grade of oil. Never mix different brand or grade of oil.

Locking the Inspection Covers

Lock inspection cover securely into position with the lock bar. If inspection or maintenance is performed with inspection cover not locked in position, there is a danger that it may be suddenly blow shut by the wind and cause injury to the worker.

Hydraulic System - Air Bleeding

When hydraulic equipment has been repaired or replaced, or the hydraulic piping has been removed and installed again, the air must be bled from the circuit. For details, see "BLEEDING AIR FROM HYDRAULIC SYSTEM (4-37)".

Hydraulic Hose Installation

- When removing parts at locations where there are O-rings or gasket seals, clean the mounting surface, and replace with new parts.
When doing this, be careful not to forget to assemble the O-rings and gaskets.
- When installing the hoses, do not twist them or bend them sharply. If they are installed so, their service life will be shortened extremely and they may be damaged.

Checks After Inspection and Maintenance Works

If you forget to perform the checks after inspection and maintenance, unexpected problems may occur, and this may lead to serious injury or property damage. Always do the following:

- Checks after operation (with engine stopped)
 - Have any inspection and maintenance points been forgotten?
 - Have all inspection and maintenance items been performed correctly?
 - Have any tools or parts been dropped inside the machine? It is particularly dangerous if parts are dropped inside the machine and get caught in the lever linkage mechanism.
 - Are there any leakage of coolant or oil? Have all nuts and bolts been tightened?
- Checks when operating engine
 - For details of the checks when operating the engine, see "TWO WORKERS FOR MAINTENANCE WHEN ENGINE IS RUNNING (2-35)" and pay careful attention to safety.
 - Are the inspection and maintenance items working properly?
 - Is there any leakage of fuel or oil when the engine speed is raised?

OUTLINE OF SERVICE

HANDLING OIL, FUEL, COOLANT, AND PERFORMING OIL CLINIC

Oil

- Oil is used in the engine and hydraulic equipment under extremely severe conditions (high temperature, high pressure), and deteriorates with use.

Always use oil that matches the grade and maximum and minimum ambient temperatures recommended in the Operation and Maintenance Manual. Even if the oil is not dirty, always change the oil at the specified interval.

- Oil corresponds to blood in the human body, always be careful when handling it to prevent any impurities (water, metal particles, dirt, etc.) from getting in.

The majority of problems with the machine are caused by the entry of such impurities.

Take particular care not to let any impurities get in when storing or adding oil.

- Never mix oils of different grades or brands.
- Always add the specified amount of oil.

Having too much oil or too little oil are both causes of problems.

- If the oil in the work equipment is not clear, there is probably water or air getting into the circuit. In such cases, please contact your Komatsu distributor.
- When changing the oil, always replace the related filters at the same time.
- We recommend you have an analysis made of the oil periodically to check the condition of the machine. For those who wish to use this service, please contact your Komatsu distributor.
- When using commercially available oil, it may be necessary to reduce the oil change interval.

We recommend that you use the Komatsu oil clinic to carry out a detailed checks of the characteristics of the oil.

Fuel

- After completing the day's operations, fill the fuel tank to force out any air containing moisture. This will prevent the moisture from condensing and mixing with the fuel.
- The fuel pump is a precision instrument, and if fuel containing water or dirt is used, it cannot work properly.
- Be extremely careful not to let impurities get in when storing or adding fuel.
- Always use the fuel specified in the Operation and Maintenance Manual.

Fuel may congeal depending on the temperature when it is used (particularly in low temperature below -15°C). It is necessary to use the fuel that is suitable for the temperature.

- Before starting the engine, or when 10 minutes have passed after adding fuel, drain the sediment and water from the fuel tank.
- If the engine runs out of fuel, or if the filters have been replaced, it is necessary to bleed the air from the circuit.
- If there is any foreign material in the fuel tank, wash the tank and fuel system.

NOTICE

Always use diesel oil for the fuel.

To ensure good fuel consumption characteristics and exhaust gas characteristics, the engine mounted on this machine uses an electronically controlled high-pressure fuel injection device. This device requires high precision parts and lubrication, so if low viscosity fuel with low lubricating ability is used, the durability may drop markedly.

Cooling System Coolant

- River water contains large amount of calcium and other impurities, so if it is used, scale will stick to the engine and radiator, and this will cause defective heat exchange and overheating.

Do not use water that is not suitable for drinking.

- When using antifreeze, always observe the precautions given in the Operation and Maintenance Manual.
- Komatsu machines are supplied with Komatsu original anti-freeze in the coolant when the machine is shipped.

This anti-freeze is effective in preventing corrosion of the cooling system.

The anti-freeze can be used continuously for two years or 4000 hours. Therefore, it can be used as it is even in hot areas.

- Antifreeze is flammable, so be extremely careful not to expose it to flame or fire.
- The proportion of anti-freeze to water differs according to the ambient temperature.
For details of the mixing proportions, see "CLEAN INSIDE OF COOLING SYSTEM (4-24)".
- If the engine overheats, wait for the engine to cool before adding coolant.
- If the coolant level is low, it will cause overheating, and will also cause problems with corrosion due to air entering the coolant.

Grease

- Grease is used to prevent seizure and noises at the joints.
- This construction equipment is used under heavy-duty conditions. Always use the recommended grease and follow the change intervals and recommended ambient temperatures given in this Operation and Maintenance Manual.
- The nipples not included in the maintenance section are nipples for overhaul, so they do not need grease.

If any part becomes stiff after being used for long time, add grease.

- Always wipe off all of the old grease that is pushed out when greasing.

Be particularly careful to wipe off the old grease in places where sand or dirt sticking in the grease would cause wear of the rotating parts.

Carrying Out KOWA (Komatsu Oil Wear Analysis)

KOWA is a maintenance service that makes it possible to prevent machine failures and downtime. With KOWA, the oil is periodically sampled and analyzed. This enables early detection of wear of the machine drive parts and other problems.

We strongly recommend you to use this service. The oil analysis is carried out at actual cost, so the cost is low, and the results of the analysis are reported together with recommendations which will reduce repair costs and machine downtime.

KOWA Analysis Items

- Measurement of density of metal wear particles

This uses an ICP (Inductively Coupled Plasma) analyzer to measure the density of iron, copper, and other metal wear particles in the oil.

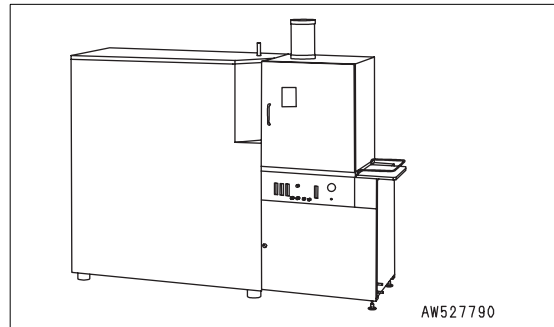

- Measurement of quantity of particles

This uses a particle quantifier index measurement machine to measure the quantity of iron particles of 5μ or more, enabling early detection of failures.

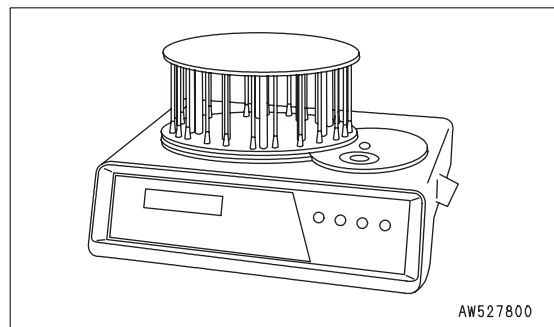

- Others

Measurements are made of items such as the ratio of water in the oil, density of the antifreeze coolant, ratio of fuel in the oil, and dynamic viscosity, enabling a highly precise diagnosis of the machine's health.

Oil Sampling

- Sampling interval

250 hours: Engine

500 hours: Other components

- Precautions when sampling

- Make sure that the oil is well mixed before sampling.
- Perform sampling at regular fixed intervals.
- Do not perform sampling on rainy or windy days when water or dust can get into the oil.

For further details of KOWA, please contact your Komatsu distributor.

Oil and Fuel Storage

- Keep indoors to prevent any water, dirt, or other impurities from getting in.
- When keeping drum cans for a long period, put the drum on its side so that the filler port of the drums is at the side to prevent moisture from being sucked in.

If drums have to be stored outside, cover them with a waterproof sheet or take other measures to protect them.

- To prevent any change in quality during long-term storage, be sure to use in the order of first in - first out (use the oldest oil or fuel first).

Filters

- Filters are extremely important safety parts. They prevent impurities in the fuel and air circuits from entering important equipment and causing problems.

Replace all filters periodically. For details, see the Operation and Maintenance Manual.

However, when working in severe conditions, replace the filters at shorter intervals according to the oil and fuel (sulfur content) being used.

- Never try to clean the filters (cartridge type) and use them again. Always replace with new filters.
- When replacing oil filters, check if any metal particles are attached to the old filter. If any metal particles are found, contact your Komatsu distributor.
- When replacing the engine oil filter, fill the new filter with fresh, clean specified oil before installing.
- Do not open packs of spare filters until just before they are to be used.
- Always use Komatsu genuine filters.

ELECTRIC SYSTEM MAINTENANCE

- It is extremely dangerous if the electrical equipment becomes wet or the covering of the wiring is damaged. This will cause an electrical short circuit and may lead to malfunction of the machine. Do not wash the inside of the operator's cab with water. When washing the machine, be careful not to let water get into the electrical components.
- Service relating to the electric system is checking fan belt tension, checking damage or wear to the fan belt and checking battery fluid level.
- Never install any electric components other than those specified by Komatsu.
- External electro-magnetic interference may cause malfunction of the control system controller, before installing a radio receiver or other wireless equipment, contact your Komatsu distributor.
- When working at the seashore, carefully clean the electric system to prevent corrosion.
- When installing electrical equipment, connect it to the special power source connector.
Do not connect the optional power source to the fuse, starting switch, or battery relay.

WEAR PARTS

Replace wear parts such as the filter element or air cleaner element at the time of periodic maintenance or before they reach the wear limit. The wear parts should be replaced correctly in order to ensure more economic use of the machine. When replacing parts, always use Komatsu genuine parts.

As a result of our continuous efforts to improve product quality, the part number may change, so inform your Komatsu distributor of the machine serial number and check for the latest part number when ordering parts.

WEAR PARTS LIST

The parts in parentheses are to be replaced at the same time.

Item	Part No.	Part Name	Q'ty	Change interval
Hydraulic oil filter	209-60-77531 (07000-05180)	Element (O-ring)	1 (1)	Every 1000 hours
Engine oil filter	600-211-1340	Cartridge	2	Every 500 hours
Fuel main filter	600-319-3520	Cartridge	1	Every 1000 hours
Fuel pre-filter	600-319-3440	Cartridge	1	Every 500 hours
Corrosion resistor (if equipped)	600-411-1151	Cartridge	1	Every 1000 hours
Air conditioner RECIRC filter	20Y-979-6261	Filter	1	Every one year
Air conditioner FRESH filter	17M-911-3530	Element	1	Every one year
Air cleaner	600-185-6100	Element assembly	1	-
	600-185-6110 (600-184-1671)	Outer element assembly (O-ring)	1 (1)	
Bucket	21M-939-2280 (21M939-2290)	KMAX Tooth Tooth (Pin)	5 (5)	-
	209-70-14181 209-70-14191 (209-70-14210)	Side cutter (left) Side cutter (right) (Bolt)	1 1 (12)	
	(21T-32-11320) (01643-33080)	(Nut) (Washer)	(12) (12)	
	427-70-13610 21N-939-3330 (209-939--7110) (209-939--7120)	Side Shroud (Pin) (Shim) (Shim)	4 (8) (16) (8)	
Hydraulic tank breather	20Y-60-21470	Element	1	Every 1000 hours
	285-62-17320	Element	1	
Line filter	07063-21200	Element	2	-
	(07000-13038)	(O-ring)	(2)	
	(07000-12055)	(O-ring)	(2)	
	(07002-11023)	(O-ring)	(4)	
Pilot strainer	704-28-00751	Strainer	1	-
	(07002-13334)	(O-ring)	(1)	
Additional filter for breaker (if equipped)	21M-970-1380	Element	1	-
	(07000-12011)	(O-ring)	(1)	
	(07000-12125)	(O-ring)	(1)	

LUBRICANTS, FUEL AND COOLANT SPECIFICATIONS

Reservoir	Kind of fluid	AMBIENT TEMPERATURE		Type
		Min	Max	
Engine oil pan	Engine oil	0° C -20° C -15° C -20° C	40° C 10° C 50° C 40° C	SAE 30 SAE 10W SAE 15W-40 SAE 10W-30
P.T.O. case		0° C -30° C	40° C 10° C	SAE 30 SAE10W
Swing machinery case		-30° C	40° C	SAE 30
Final drive case				
Hydraulic system		-30° C -20° C -15° C	40° C 40° C 40° C	SAE 10W SAE 10W-30 SAE 15W-40
Fuel tank	Diesel fuel (2)	-10° C -30° C	50° C -10° C	ASTM D975 No. 2 ASTM D975 No. 1 (for winter use)
Cooling sytem	Water	Add antifreeze		
Grease fitting	Grease	-30° C	40° C	NLGI No. 2

*1: ASTM D975 No.1

*2: Use only diesel fuel.

NOTICE

Use only diesel fuel.

The engine mounted on this machine employs electronic control and a high-pressure fuel injection device to obtain good fuel consumption and good exhaust gas characteristics. For this reason, it requires high precision for the parts and good lubrication.

If kerosene or other fuel with low lubricating ability is used, there will be a big drop in durability.

		Engine Oil pan	P.T.O case	Swing machinery case (Each of right and left)	Final drive case (Each of right and left)	Hydraulic oil system	Fuel tank	Cooling system
Specified oil amount	Liter	45	7.2	13	10.5	520	880	58
Refill oil amount	Liter	40	7.2	13	10	360	-	-

REMARK

When fuel sulphur content is less than 0.5%, change oil in the oil pan according to the periodic maintenance hours described in this manual.

Change oil according to the following table if fuel sulfur content is above 0.5%.

When starting the engine with an atmospheric temperature of lower than 0°C, be sure to use engine oil of SAE10W, SAE10W-30 and SAE15W-40, even though the atmospheric temperature goes up to 10°C more or less during the day.

Use API classification CD as engine oil and if API classification CC, reduce the engine oil change interval to half.

There is no problem if single grade oil is mixed with multigrade oil (SAE10W-30, 15W-40), but be sure to add single grade oil that matches the temperature range in the table.

We recommend Komatsu genuine oil which has been specifically formulated and approved for use in engine and hydraulic work equipment applications.

Specified capacity: Total amount of oil including oil for components and oil in piping.

Refill capacity: Amount of oil needed to refill system during normal inspection and maintenance.

ASTM: American Society of Testing and Material

SAE: Society of Automotive Engineers

API: American Petroleum Institute

Fuel sulfur content	Engine oil change interval
0.5 to 1.0%	1/2 of regular interval
Above 1.0%	1/4 of regular interval

RECOMMENDED BRANDS, RECOMMENDED QUALITY FOR PRODUCTS OTHER THAN KOMATSU GENUINE OIL

When using commercially available oils other than Komatsu genuine oil, or when checking the latest specifications, consult your Komatsu distributor.

TIGHTENING TORQUE SPECIFICATIONS

TIGHTENING TORQUE LIST

⚠ CAUTION

If nuts, bolts, or other parts are not tightened to the specified torque, it will cause looseness or damage to the tightened parts, and this will cause failure of the machine or problems with operation. Always pay careful attention when tightening parts.

Unless otherwise specified, tighten the metric nuts and bolts to the torque shown in the table below.

If it is necessary to replace any nut or bolt, always use a Komatsu genuine part of the same size as the part that was replaced.

Thread diameter of bolt (a)(mm)	Width across flats (b)(mm)	Tightning torque [N·m (kgf·m)]	
		Target value	Permissible range
6	10	13.2 (1.35)	11.8 - 14.7 (1.2 - 1.5)
8	13	31 (3.2)	27 - 34 (2.8 - 3.5)
10	17	66 (6.7)	59 - 74 (6.0 - 7.5)
12	19	113 (11.5)	98 - 123 (10.0 - 12.5)
14	22	177 (18.0)	157 - 196 (16.0 - 20.0)
16	24	279 (28.5)	245 - 309 (25.0 - 31.5)
18	27	382 (39.0)	343 - 425 (35.0 - 43.5)
20	30	549 (56.0)	490 - 608 (50.0 - 62.0)
22	32	745 (76.0)	662 - 829 (67.5 - 84.5)
24	36	927 (94.5)	824 - 1030 (84.0 - 105.0)
27	41	1320 (135.0)	1180 - 1470 (120.0 - 150.0)
30	46	1720 (175.0)	1520 - 1910 (155.0 - 195.0)
33	50	2210 (225.0)	1960 - 2450 (200.0 - 250.0)
36	55	2750 (280.0)	2450 - 3040 (250.0 - 310.0)
39	60	3280 (335.0)	2890 - 3630 (295.0 - 370.0)
42	65	3830 (390.0)	3430 - 4220 (350.0 - 430.0)

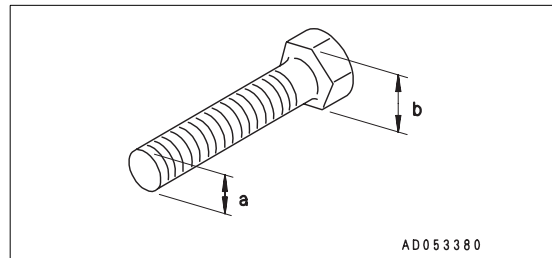

Apply the following table for Hydraulic Hose.

Nominal No. of hose	Width across flat b(mm)	Tightening torque [N·m (kgf·m)]	
		Target value	Permissible range
02	19	44 (4.5)	35 - 54 (3.5 - 5.5)
03	22	74 (7.5)	54 - 93 (5.5 - 9.5)
04	27	103 (10.5)	84 - 132 (8.5 - 13.5)
05	32	157 (16.0)	128 - 186 (13.0 - 19.0)
06	36	216 (22.0)	177 - 245 (18.0 - 25.0)
10	41	215 (22)	176 - 234 (18 - 24)

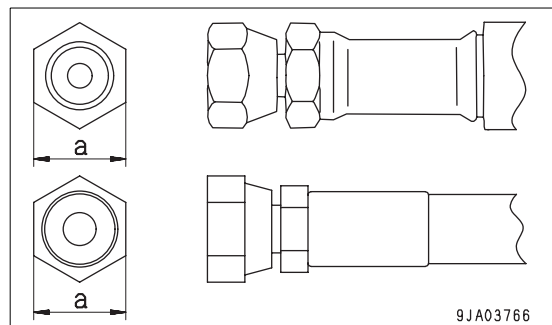

SAFETY CRITICAL PARTS

For using the machine safely for an extended period of time, you are required to periodically replace the safety (critical and fire prevention) related parts listed in the table of important parts on the following page.

Material quality of these parts can change as time passes and they are likely to wear out or deteriorate. However, it is difficult to determine the extent of wear or deterioration at the time of periodic maintenance. Hence, it is required to replace them with new ones regardless of their condition after a certain period of usage. This is important to ensure that these parts maintain their full performance at all times.

Furthermore, should anything abnormal be found on any of these parts, replace it with a new one even if the periodic replacement time for the part has not yet arrived.

If any of the hose clamps show deterioration like deformation or cracking, replace the clamps at the same time as the hoses.

Also perform the following checks with hydraulic hoses which need to be replaced periodically. Tighten all loose clamps and replace defective hoses, as required.

When replacing hoses, always replace O-rings, gaskets, and other such parts at the same time.

Have your Komatsu distributor replace the critical parts.

SAFETY CRITICAL PARTS LIST

NO.	Periodical exchange parts	Q'ty	Change interval
1	Fuel hose (fuel tank to fuel pre-filter)	1	Every 2 years or 4,000 hours, whichever come first
2	Fuel hose (fuel pre-filter to priming pump)	1	
3	Fuel return hose (injection pump to fuel cooler)	1	
4	Fuel return hose (fuel cooler to fuel tank)	1	
5	Fuel spill hose (engine to fuel tank)	1	
6	Fuel drain hose	1	
7	Heater hose (heater to engine)	2	
8	Front pump outlet hose	2	
9	Rear pump outlet hose	2	
10	Pump branch hose	2	
11	In-line filter to valve hose	2	
12	Swing hose	4	
13	Suction hose	4	
14	Boom cylinder line hose (B/H)	4	
15	Arm cylinder line hose (B/H)	4	
16	Bucket cylinder line hose (B/H)	4	
17	Boom cylinder line hose (L/S)	4	
18	Arm cylinder line hose (L/S)	2	
19	Bucket cylinder line hose (L/S)	6	
20	Bottom dump cylinder line hose (L/S)	10	
21	Fan pump outlet hose	1	Every 8 hours
22	Accumulator (for control circuit)	1	
23	High-pressure piping clamp	15	
24	Fuel spray prevention cap	16	Every 3 years
25	Seat belt	1	

MAINTENANCE SCHEDULE

- If the machine is equipped with a hydraulic breaker, the maintenance schedule for some parts will be different. For details, see “MAINTENANCE INTERVAL FOR HYDRAULIC BREAKER (4-17)” to confirm the correct maintenance schedule when carrying out maintenance.

MAINTENANCE SCHEDULE CHART

INITIAL 100 HOURS MAINTENANCE (ONLY AFTER THE FIRST 100 HOURS)

CLEAN STRAINER OF P.T.O LUBRICATING OIL FILTER 4-58

INITIAL 500 HOURS MAINTENANCE (ONLY AFTER THE FIRST 500 HOURS)

CHANGE OIL IN SWING MACHINERY CASE 4-65
 CHANGE OIL IN P.T.O CASE 4-66
 CHANGE OIL IN FINAL DRIVE CASE 4-73

WHEN REQUIRED

CHECK, CLEAN AND REPLACE AIR CREANER ELEMENT 4-19
 CLEAN INSIDE OF COOLING SYSTEM 4-24
 CHECK AND TIGHTEN TRACK SHOE BOLTS 4-27
 CHECK AND ADJUST TRACK TENSION 4-28
 REPLACE BUCKET TEETH (KMAX) 4-30
 ADJUST BUCKET CREARANCE 4-31
 CHECK WINDOW WASHER FLUID LEVEL, ADD FLUID 4-32
 CHECK AND ADJUST AIR CONDITIONER 4-33
 CLEAN LINE FILTER, REMOVE DIRT 4-34
 REPLACE BREAKER CIRCUIT ADDITIONAL OIL FILTER ELEMENT 4-35
 CLEAN PILOT LINE FILTER, REMOVE DIRT 4-36
 BLEEDING AIR FROM HYDRAULIC SYSTEM 4-37

CHECKS BEFORE STARTING

EVERY 10 HOURS MAINTENANCE

LUBRICATING 4-41

EVERY 100 HOURS MAINTENANCE

LUBRICATING SWING CIRCLE 4-44

EVERY 250 HOURS MAINTENANCE

CHECK OIL LEVEL IN FINAL DRIVE CASE, ADD OIL 4-45
 CHECK LEVEL OF BATTERY ELECTROLYTE 4-46
 CHECK AND TIGHTEN TRACK FRAME AND AXLE CONNECTING BOLTS 4-48
 CHECK ALTERNATOR DRIVE BELT TENSION, ADJUST 4-49
 CHECK AIR CONDITIONER COMPRESSOR BELT TENSION, ADJUST (ONLY FOR MACHINES EQUIPPED WITH AIR CONDITIONER) 4-50

EVERY 500 HOURS MAINTENANCE

REPLACE FUEL PRE-FILTER CARTRIDGE 4-51
 CHECK SWING PINION GREASE LEVEL, ADD GREASE 4-54
 CLEAN, CHECK RADIATOR FINS, OIL COOLER FINS, FUEL COOLER FINS,
 AFTERCOOLER FINS, CONDENSER FINS (machines equipped with air conditioner),
 PTO OIL COOLER FINS..... 4-55
 CLEAN FRESH/RECIRC AIR FILTERS OF AIR CONDITIONER (ONLY FOR MACHINES EQUIPPED WITH AIR
 CONDITIONER)..... 4-57
 CLEAN STRAINER OF P.T.O LUBRICATING OIL FILTER 4-58
 CHANGE OIL IN ENGINE OIL PAN, REPLACE ENGINE OIL FILTER CARTRIDGE..... 4-59

EVERY 1000 HOURS MAINTENANCE

REPLACE FUEL MAIN FILTER CARTRIDGE..... 4-61
 REPLACE HYDRAULIC OIL FILTER ELEMENT 4-64
 CHANGE OIL IN SWING MACHINERY CASE 4-65
 CHANGE OIL IN P.T.O CASE 4-66
 CHECK ALL TIGHTENING POINTS OF ENGINE EXHAUST PIPE CLAMPS 4-67
 REPLACE CORROSION RESISTOR CARTRIDGE (IF EQUIPPED)..... 4-67
 CHECK WELDED STRUCTURE 4-68
 REPLACE HYDRAULIC TANK ADDITIONAL BREATHER ELEMENT 4-71
 CHECK NITROGEN GAS CHARGE PRESSURE IN ACCUMULATOR (FOR BREAKER) 4-71
 REPLACE BREATHER ELEMENT IN HYDRAULIC TANK..... 4-72

EVERY 2000 HOURS MAINTENANCE

CHANGE OIL IN FINAL DRIVE CASE 4-73
 CLEAN HYDRAULIC TANK STRAINER..... 4-74
 Checking Charge Pressure of Nitrogen Gas in Accumulator (For Control Circuit)..... 4-75
 CHECK ALTERNATOR, STARTING MOTOR..... 4-78

EVERY 4000 HOURS MAINTENANCE

CHECK WATER PUMP 4-79
 Replace Accumulator (For Control Circuit) 4-79
 CHECK FOR LOOSENESS OF HIGH-PRESSURE PIPING CLAMP, HARDENING OF RUBBER..... 4-79
 CHECK FOR MISSING FUEL SPRAY PREVENTION CAP, HARDENING OF RUBBER 4-81
 CHECK OPERATING CONDITION OF COMPRESSOR 4-81

EVERY 5000 HOURS MAINTENANCE

CHANGE OIL IN HYDRAULIC TANK..... 4-82

EVERY 8000 HOURS MAINTENANCE

REPLACE HIGH-PRESSURE PIPING CLAMP 4-83
 REPLACE FUEL SPRAY PREVENTION CAP 4-83

MAINTENANCE INTERVAL FOR HYDRAULIC BREAKER

For machine equipped with a hydraulic breaker, the hydraulic oil deteriorates faster than for normal bucket digging operations, so set the maintenance intervals as follows.

REPLACE HYDRAULIC OIL FILTER ELEMENT

- **Replace hydraulic filter element**

On a new machine, replace the element after the first 100 to 150 hours, then carry out further replacement of the element according to the table on the right.

- **Change oil in hydraulic tank**

Change the oil according to the table on the right.

- **Replacing additional filter element for breaker (if equipped)**

Use a guideline of 250 hours for use of the breaker (operating ratio for the breaker: 50 % or more), and replace the element according to the table on the right.

X : Breaker operating ratio (%)

Y : Replacement interval (H)

(A): Hydraulic filter element

(B): Hydraulic oil

(C): Additional filter element

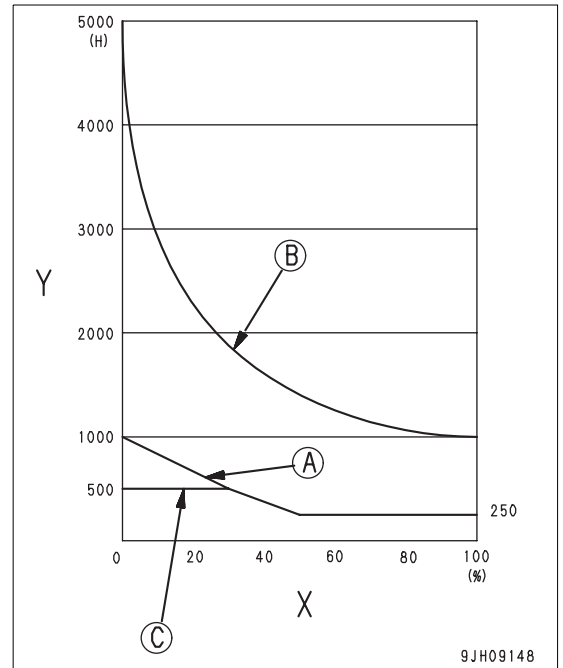

CHANGE OIL IN HYDRAULIC TANK

- **Change the oil according to the table on the right.**

REPLACE ADDITIONAL FILTER ELEMENT FOR BREAKER

- **Use a guideline of 250 hours for use of the breaker (operating ratio for the breaker: 50 % or more), and replace the element according to the table on the right.**

MAINTENANCE PROCEDURE

INITIAL 100 HOURS MAINTENANCE (ONLY AFTER THE FIRST 100 HOURS)

Perform the following maintenance only after the first 100 hours.

- Clean strainer of P.T.O lubricating oil filter

For details of the method of maintaining, see EVERY 500 HOURS MAINTENANCE.

INITIAL 500 HOURS MAINTENANCE (ONLY AFTER THE FIRST 500 HOURS)

Carry out the following maintenance only after the first 500 hours.

- Change oil in swing machinery case
- Change oil in P.T.O case
- Change oil in final drive case

Special tools are needed for the inspection and maintenance, have your Komatsu distributor perform this work.

For details of the method of replacing or maintaining, see EVERY 1000 HOURS and EVERY 2000 HOURS SERVICE.

WHEN REQUIRED

CHECK, CLEAN AND REPLACE AIR CLEANER ELEMENT

WARNING

- When using compressed air, there is danger of dirt flying and causing personal injury. Always wear protective glasses, dust mask, or other protective equipment.
- When removing the outer element from the air cleaner body, it is dangerous to pull it out by force. When working in high places or where the foothold is poor, be careful not to fall because of the reaction when pulling out the outer element.

NOTICE

- Do not clean the air cleaner element until the air cleaner clogging monitor on the monitor panel flashes. If the element is cleaned frequently before the clogging monitor flashes, the air cleaner will not be able to display its performance fully, and the cleaning efficiency will also go down. In addition, during the cleaning operation, more dirt stuck to the element will fall inside the inner element.
- If inspection, cleaning, or maintenance is carried out with the engine running, dirt will enter the engine and cause damage to the engine. Always stop the engine before carrying out these operations.

Checking

If air cleaner clogging monitor (1) of the monitor panel flashes, clean the air cleaner element.

Replacing

- Replacing element, O-ring
If one year has passed since installing the element or if air cleaner clogging monitor (1) on the monitor panel flashes immediately after the element is cleaned, replace the outer element, inner element, and O-ring.
- Replacing evacuator valve
Replace it if it is damaged or the rubber is markedly deformed.

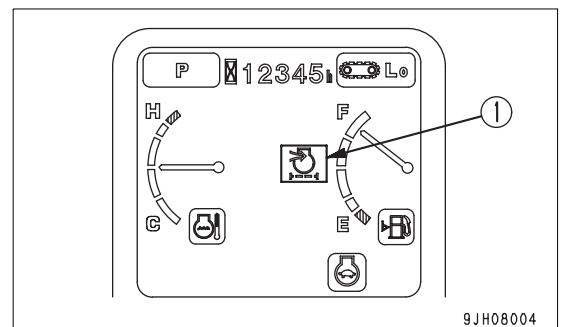

Cleaning or Replacing Outer Element

NOTICE

Before and after cleaning the element, do not leave or keep it in direct sunlight.

1. Open the cover at the left side of the machine, remove 6 hooks (2), then remove cover (3).

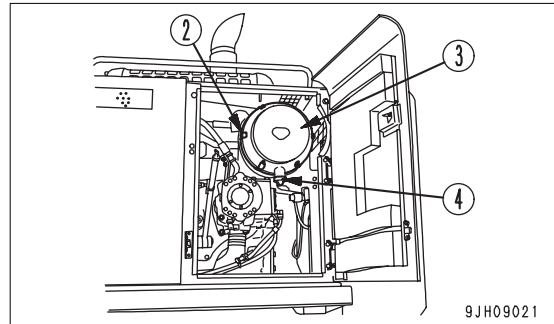

NOTICE

- Never remove the inner element (6). It will allow dirt to enter and cause failure of the engine.

- Do not use a screwdriver or other tool.

2. Hold the outer element (5), rock it lightly up and down and to the left and right, and rotate the element to the left and right to pull it out.
3. When the outer element (5) has been removed, check that the inner element has not come out of position and is not at an angle. If it is at an angle, insert your hand and push it in straight.
4. After removing the outer element (5), cover the inner element (6) with a clean cloth or tape to prevent dirt or dust from entering.
5. Wipe off or brush off the dirt stuck to cover (3) and the inside of the air cleaner body (7).
6. Remove any dirt or dust that is accumulated to evacuator valve (4) installed to cover (3).

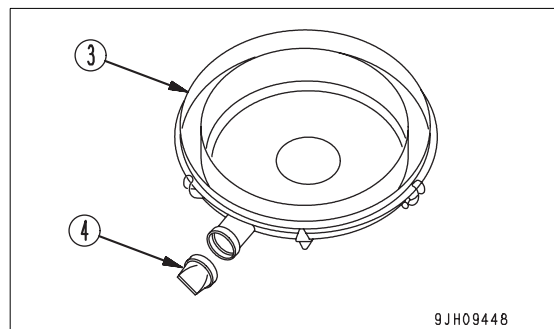
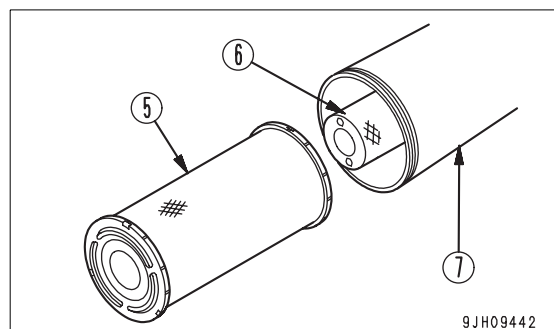

NOTICE

When cleaning the element, do not hit or beat it against anything.

7. Direct dry compressed air (less than 0.69 MPa (7 kgf/cm²)) to the outer element from inside along its folds, then direct it from outside along its folds and again from inside.
8. Replace the outer element which has been cleaned 6 times repeatedly or used throughout a year. Replace the inner element at the same time.
9. Replace both inner and outer elements when the monitor (1) lights up soon after installing the cleaned outer element even though it has not been cleaned 6 times.

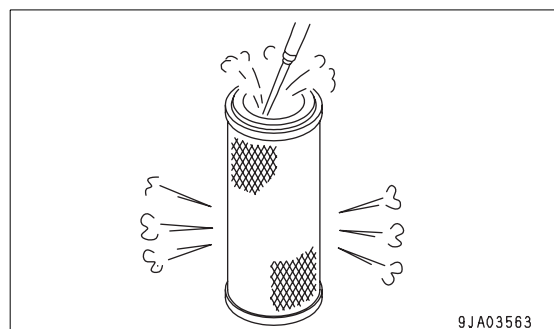

10. If small holes or thinner parts are found on the element when it is checked by shining a light through it after cleaning, replace the element.
11. Remove the cloth or tape covering inner element (6).

NOTICE

- **Do not use an element whose folds or gasket or seal are damaged.**
- **If the element or O-ring are cleaned and used again after they have been used for more than one year, it will cause problems. Do not use them again.**

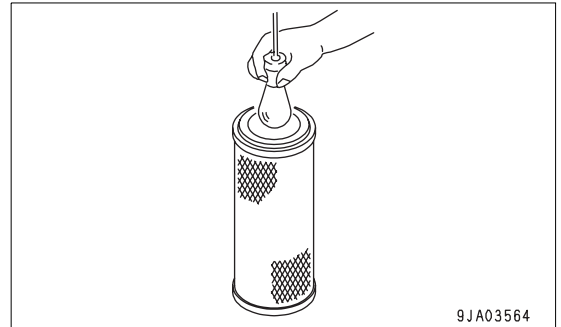

12. Check that there is no dirt or oil stuck to the seal portion of the new element or cleaned element. Wipe off any dirt or oil.
13. Push the outer element in straight with your hand when installing it to the air cleaner body.

If the outer element is held and rocked lightly up and down and to the left and right while pushing it in, the outer element can be inserted easily.

NOTICE

When inserting the element, if the rubber at the tip is swollen or the outer element is not pushed in straight, and cover (3) is assembled by force to hook (2), there is danger that the hook and air cleaner body may be damaged, so be careful when assembling.

14. Install cover (3) as follows.
15. Align cover (3) with the element.
16. Hook the tip of hook (2) to the protruding part of the air cleaner body and lock it in position.
17. When locking hooks (2) in position, apply the hooks in turn on opposite sides (top, bottom, left, right) in the same way as when tightening bolts.
18. Always install cover (3) so that the evacuator (4) is facing the ground (A).
19. When cover (3) is installed, check that the clearance between the air cleaner body and cover (3) is not too large. If it is too large, install again.
20. When replacing the element, push the indicator button at the bottom of the air cleaner to reset it.

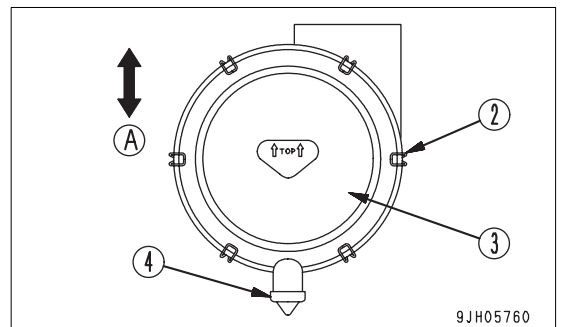
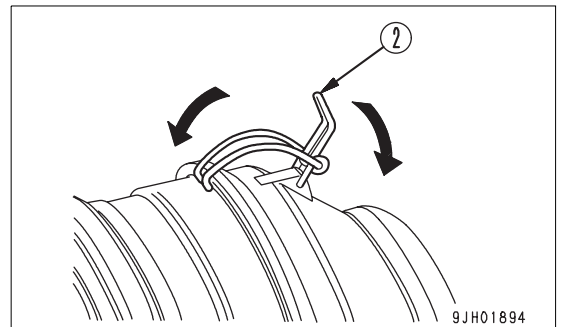

Install Air Cleaner Element

1. Open the cover at the left side of the machine, remove 6 hooks (2), then remove cover (3).

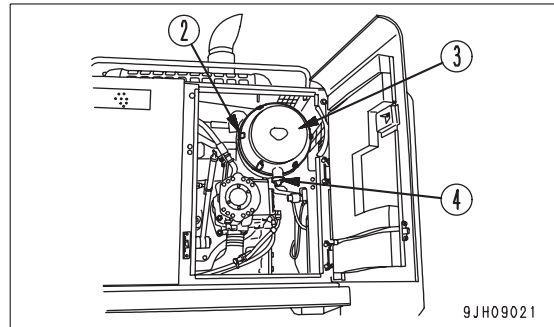

2. Hold the outer element (5), rock it lightly up and down and to the left and right, and rotate the element to the left and right to pull it out.

Do not remove inner element (6) when doing this.

3. When the outer element (5) has been removed, check that the inner element has not come out of position and is not at an angle. If it is at an angle, insert your hand and push it in straight.

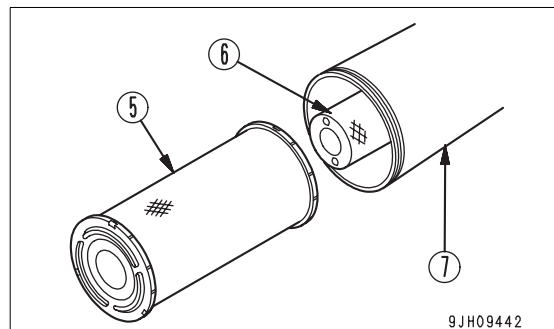

4. Wipe off or brush off the dirt stuck to cover (3) and the inside of the air cleaner body (7).

5. Remove any dirt or dust that is accumulated to evacuator valve (4) installed to cover (3).

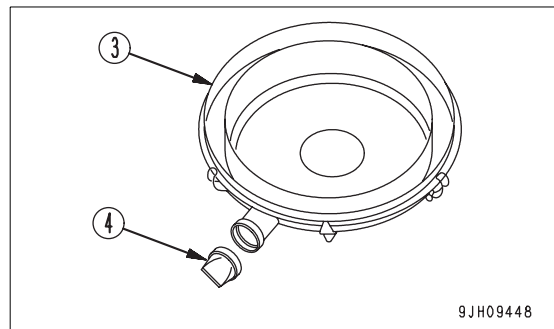

NOTICE

- The inner element must not be cleaned and used again. When replacing the outer element, replace the inner element at the same time.
- If the inner element is not installed properly and the outer element and cover are installed, there is danger that the outer element will be damaged.
- The seal portion on imitation parts lacks precision, and allows the entry of dust, which leads to damage of the engine. Do not use such imitation parts.

6. Remove inner element (6), then quickly install the new inner element.

Insert the inner element securely so that it does not move.

7. Push the new outer element (5) in straight with your hand when installing it to the air cleaner body.

If the element is held and rocked lightly up and down and to the left and right while pushing it in, the element can be inserted easily.

- Replace O-ring (8) of cover (3) with a new part.

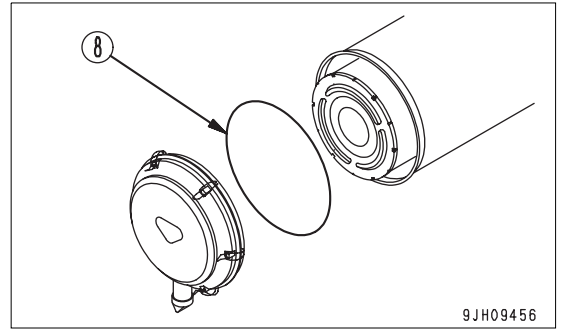

NOTICE

When inserting the element, if the rubber at the tip is swollen or the outer element is not pushed in straight, and cover (3) is assembled by force to hook (2), there is danger that the hook and air cleaner body may be damaged, so be careful when assembling.

- Install cover (3) as follows.
- Align cover (3) with the element.
- Hook the tip of hook (2) to the protruding part of the air cleaner body and lock it in position.
- When locking hooks (2) in position, apply the hooks in turn on opposite sides (top, bottom, left, right) in the same way as when tightening bolts.
- Always install cover (3) so that the evacuator (4) is facing the ground (A).
- When cover (3) is installed, check that the clearance between the air cleaner body and cover (3) is not too large. If it is too large, install again.
- After replacing the element, press reset button (9) of the dust indicator to return the yellow display to its original position.

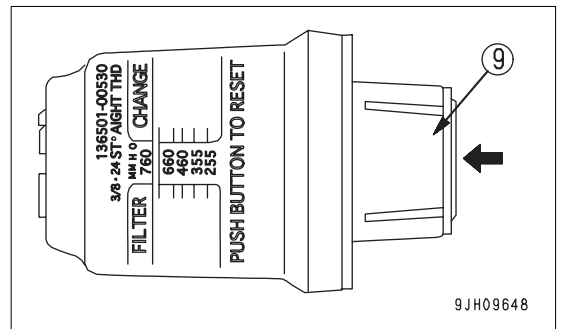
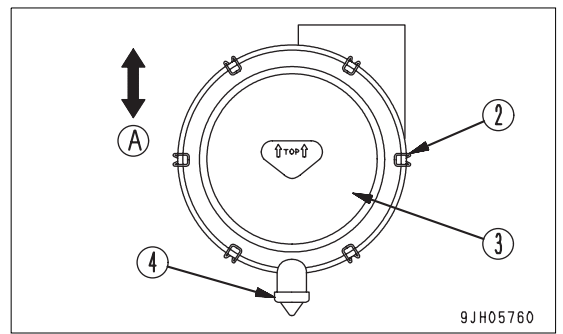
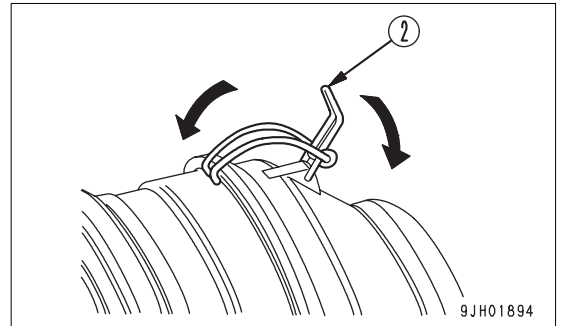

CLEAN INSIDE OF COOLING SYSTEM

⚠ WARNING

- **Immediately after the engine is stopped, the coolant is at a high temperature and the radiator is under high internal pressure. If the cap is removed to drain the coolant in this condition, there is a hazard of burns. Wait for the temperature to go down, then turn the cap slowly to release the pressure before removing it.**
- **Cleaning is carried out with the engine running. When standing up or leaving the operator's seat, set the lock lever to the LOCK position.**
- **For details of starting the engine, see "BEFORE STARTING ENGINE (3-74)" and "STARTING ENGINE (3-91)" in the OPERATION section.**
- **There is danger of touching the fan if the undercover is left removed. Never enter behind the machine when the engine is running.**

Clean the inside of the cooling system, change the coolant and replace the corrosion resistor according to the table below.

Kind of coolant	Cleaning inside of cooling system and changing coolant	Replacing corrosion resistor
Permanent type antifreeze (All season type)	Every year (autumn) or every 2000 hours, whichever comes first	Every 1000 hours and when cleaning the inside of the cooling system and when changing coolant
Non permanent type antifreeze containing ethylene glycol (winter, one season type)	Every 6 months (spring, autumn) (Drain antifreeze in spring, add antifreeze in autumn)	
When not using antifreeze	Every 6 months or every 1000 hours, whichever come first	

Stop the machine on level ground when cleaning or changing the coolant.

Use a permanent type of antifreeze.

If, for some reason, it is impossible to use permanent type antifreeze, use an antifreeze containing ethylene glycol. Super Coolant (AF-ACL) has an anti-corrosion effect as well as an antifreeze effect.

The ratio of antifreeze to water depends on the ambient temperature, but to obtain the corrosion resistance effect, a minimum ratio of 30% by volume is necessary.

When deciding the ratio of antifreeze to water, check the lowest temperature in the past, and decide from the mixing rate table given below.

It is actually better to estimate a temperature about 10°C lower when deciding the mixing rate.

Mixing rate of water and antifreeze

Min. atmospheric temperature	°C	-10	-15	-20	-25	-30	-35	-40
Amount of antifreeze	liter	17.4	20.9	23.8	26.7	29	31.3	33.6
Amount of water	liter	30.6	37.1	34.2	31.3	29	26.7	24.4
Volume ratio (%)		30	36	41	46	50	54	58

⚠ WARNING

**Antifreeze is flammable, so keep it away from flame.
Antifreeze is toxic. When removing the drain plug, be careful not to get water containing antifreeze on you. If it gets in your eyes, flush your eyes with large amount of fresh water and see a doctor at once.**

Use city water for the coolant.

If river water, well water or other such water supply must be used, contact your Komatsu distributor.

We recommend use of an antifreeze density gauge to control the mixing proportions.

Min 58 liters capacity.

1. Stop the engine, close valve (1) on corrosion resistor (2).
(Machines equipped with corrosion resistor)
 2. Turn cap (3), (4) of the radiator water filler slowly.
 3. Remove covers (5), (6), and (7), then place containers to catch the drained coolant under water drain valves (8) and (9) under the radiator, and under engine coolant drain valve (10) at the top of the engine oil pan.
 4. Open drain valves (8), (9) and (10) drain the water.
 5. After draining the antifreeze solution, close drain valves (8), (9) and (10), then fill with clean water. After the radiator is filled with water, start and run the engine at low idling speed. After the water temperature rises above 90°C, run the engine for about 10 minutes.
 6. Stop the engine and open drain valves (8), (9), and (10) to drain the water.
 7. After draining the water, clean the radiator with detergent.
- When carrying out the flushing operation, follow the instructions given with the flushing agent.
8. Replace the corrosion resistor, and open valve (1).

For details of the method for replacing the corrosion resistor cartridge, see "REPLACE CORROSION RESISTOR CARTRIDGE (4-67)".
 9. Close drain valves (8), (9), and (10).
 10. Install undercovers (5), (6), and (7).
 11. Add coolant until it overflows from the water filler.

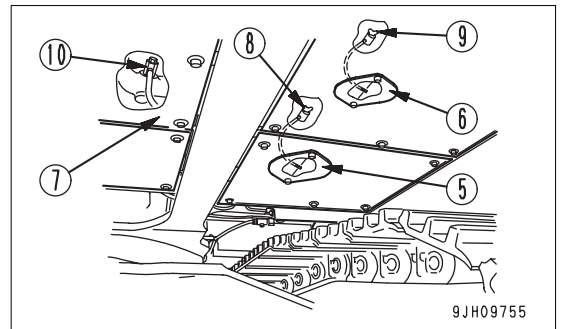
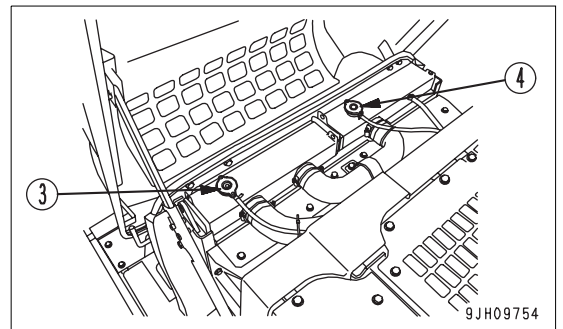
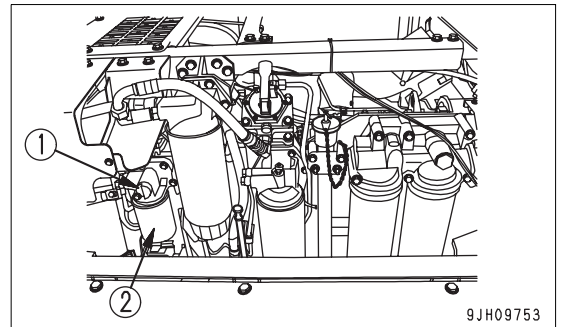

Decide the proportions of antifreeze and water according to the table for the mixing rate of water and antifreeze.

12. Run the engine at low idling for 5 minutes to remove the air from the water, then run at high idling for 5 minutes. (Leave radiator cap (3) removed when doing this.)

13. After draining off the coolant of sub tank (11), clean the inside of the sub tank and refill the water between FULL and LOW level.
14. Stop the engine, wait for 3 minutes, add city water until the water level reaches near the water filler port, then tighten the cap (3).

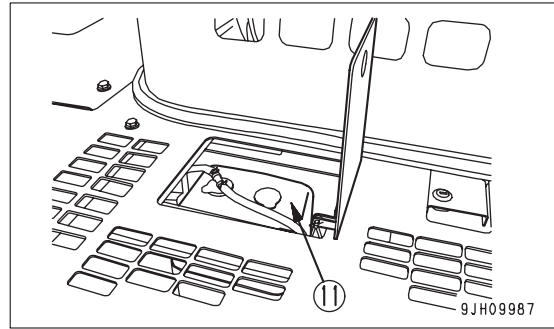

CHECK AND TIGHTEN TRACK SHOE BOLTS

If the machine is used with track shoe bolts (1) loose, they will break, so tighten any loose bolts immediately.

Tightening

1. First, tighten to a tightening torque of 784 ± 78 N·m (80 ± 8 kgf·m), then check that the nut and shoe are in tight contact with the link mating surface.
2. After checking, further tighten to the tightening torque of $120^\circ \pm 10^\circ$.

Order for Tightening

Tighten the bolts in the order shown in the diagram on the right. After tightening, check that the nut and shoe are in close contact with the link mating surface.

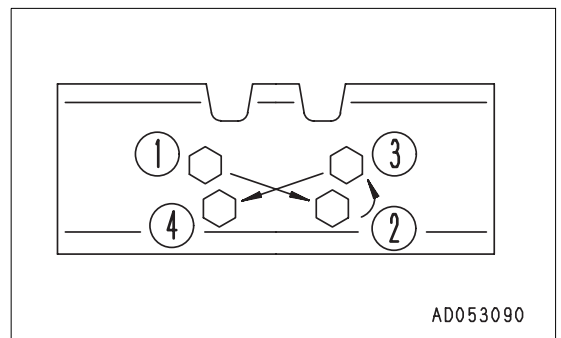
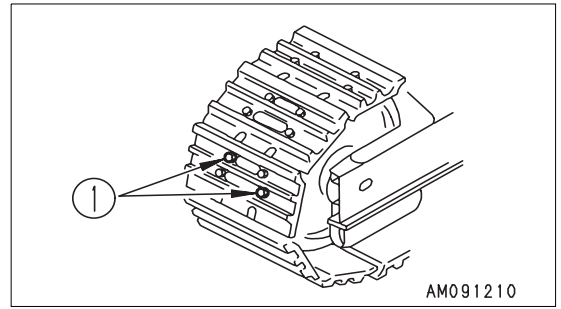

CHECK AND ADJUST TRACK TENSION

⚠ WARNING

For details of starting the engine and operating the work equipment, see “BEFORE STARTING ENGINE (3-74)”, “STARTING ENGINE (3-91)”, “AFTER STARTING ENGINE (3-94)”, and “WORK EQUIPMENT CONTROLS AND OPERATIONS (3-109)” in the OPERATION section.

The wear of the pins and bushings on the undercarriage will vary with the working conditions and type of soil, so inspect the track tension frequently in order to maintain the standard tension.

Stop the machine on firm, horizontal ground when carrying out the inspection and maintenance.

Checking

1. Run the engine at low idle, then move the machine forward for a distance equal to the track length on ground, and slowly stop the machine.
2. Place wooden bar (3) on top of the track from No. 2 roller (1) to No. 3 roller (2).
3. Measure the maximum deflection between bottom surface of the wooden bar and top surface of the track shoe.

Deflection “a” should be 10 - 30 mm.

If the track tension is not at the standard value, adjust it in the following manner.

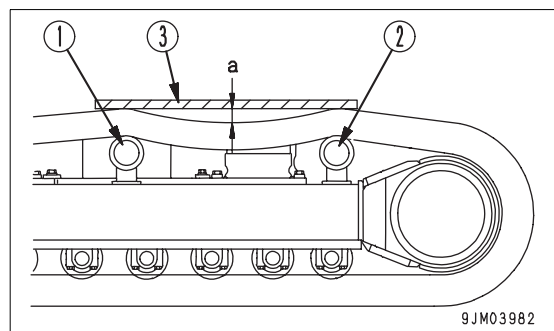

Adjustment

⚠ WARNING

Grease inside the adjusting mechanism is under high pressure. Grease coming from plug (1) under pressure can penetrate the body, causing injury or death. For this reason, do not loosen plug (1) more than one turn.

Do not loosen any part other than plug (1). Furthermore, do not bring your face in front of the plug (1). If track tension is not relieved by this procedure, contact your Komatsu distributor for repairs.

Increasing Track Tension

Prepare a grease pump.

1. Pump in grease through valve (1) using a grease gun.
2. To check that the tension is correct, move the machine slowly forward and in reverse.
3. Check the track tension again, and if the tension is not correct, adjust it again.

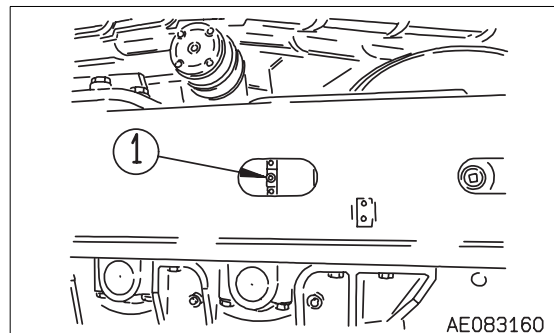

4. Continue to pump in grease until (S) becomes 48 mm. If the tension is still loose, the pin and bushing are excessively worn, so they must be either turned or replaced. Please contact your Komatsu distributor.

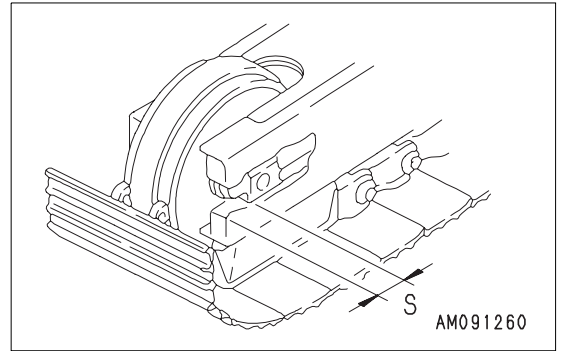

Loosening Track Tension

⚠ WARNING

It is extremely dangerous to release the grease by any method except the procedure given below. If track tension is not relieved by this procedure, contact your Komatsu distributor for repairs.

1. Loosen plug (1) gradually to release the grease.
2. Turn plug (1) a maximum of one turn.
3. If the grease does not come out smoothly, move the machine forwards and backwards a short distance.
4. Tighten plug (1).
5. To check that the tension is correct, move the machine slowly forward.
6. Check the track tension again, and if the tension is not correct, adjust it again.

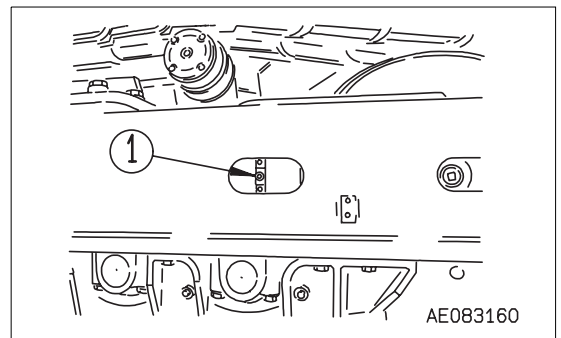

REPLACE BUCKET TEETH (HORIZONTAL PIN TYPE)

Replace the teeth before the wear reaches the adapter.

⚠ WARNING

- ✘ It is dangerous if the work equipment is mistakenly moved when replacing the teeth. Set the work equipment in a stable condition, stop the engine, then set safety lock lever (1) securely to the LOCK position (L).
- If the locking pin is knocked out with force, there is danger that the pin may fly out. Check that there is no one near the machine.
- Broken pieces may fly during the replacement operation, so always wear safety glasses, gloves, or other protective equipment.

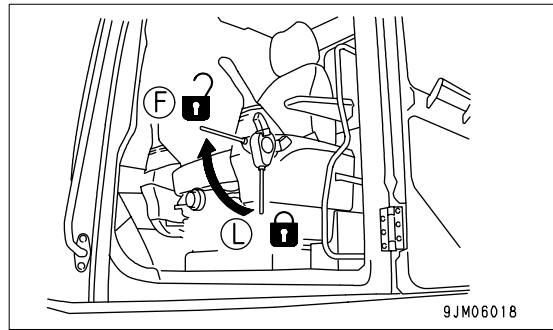

1. Set a block (3) under the bottom face of the bucket so that pin (1) can be removed. Turn the starting switch to the ON position within 15 seconds after stopping the engine, operate the control levers fully, check that the work equipment is stable, then set the safety lock lever to the LOCK position (L).

Set so that the bottom face of the bucket is horizontal.

2. Place a bar on the head of pin (1), hit the bar with a hammer to knock out the pin, then remove tooth (2).

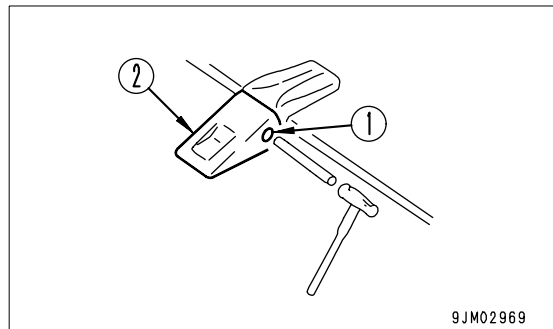

REMARK

If it cannot be removed by this method, for safety reasons, always contact your Komatsu distributor to have the replacement carried out.

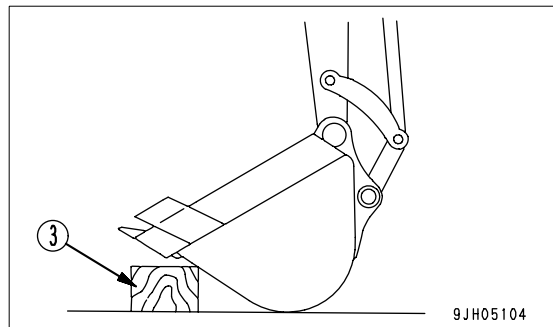

3. Clean the mounting face. Fit a new tooth (2) in the adapter, push in pin (1) partially by hand, then lock it with a hammer to install the tooth to the bucket.

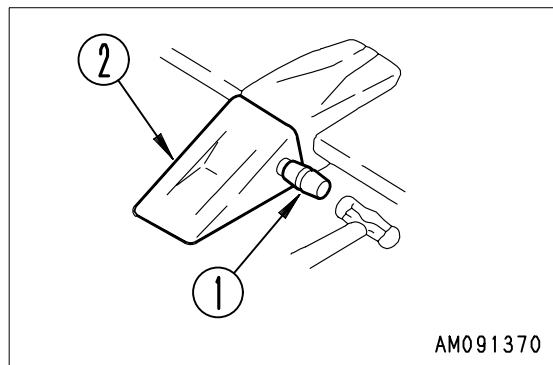

ADJUST BUCKET CLEARANCE

⚠ WARNING

It is dangerous if the work equipment is mistakenly moved when adjusting the bucket clearance. Set the work equipment in a stable condition, stop the engine, then set safety lock lever securely to the LOCK position (L).

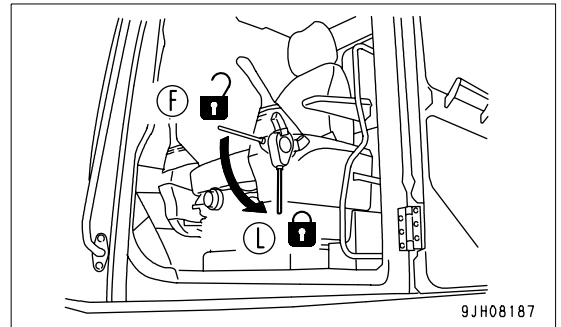

1. Set the work equipment in the position shown in the diagram on the right, then stop the engine and set the lock lever to the LOCK position.

2. Shift O-ring (1) and measure the amount of play "a".

Measurement is easier if you move the bucket to one side so that all the play can be measured at one place (the left side in the diagram).

Use a clearance gauge for easy and accurate measurement.

3. Loosen 4 plate mounting bolts (2), and loosen plate (3).

The shim is a split type, so the operation can be carried out without removing the bolts.

4. Remove shim (4) corresponding to the amount of play "a" measured above.

[Example]

In the case of play of 3 mm, remove two 1.0 mm shims and one 0.5 mm shim. Play becomes 0.5 mm. For shim (4), two types of 1.0 mm and 0.5 mm are used.

When play "a" is smaller than one shim, do not carry out any maintenance.

5. Tighten the four bolts (2).

If the bolts (2) are too stiff to tighten, pull out pin stopper bolt (5) for easier tightening.

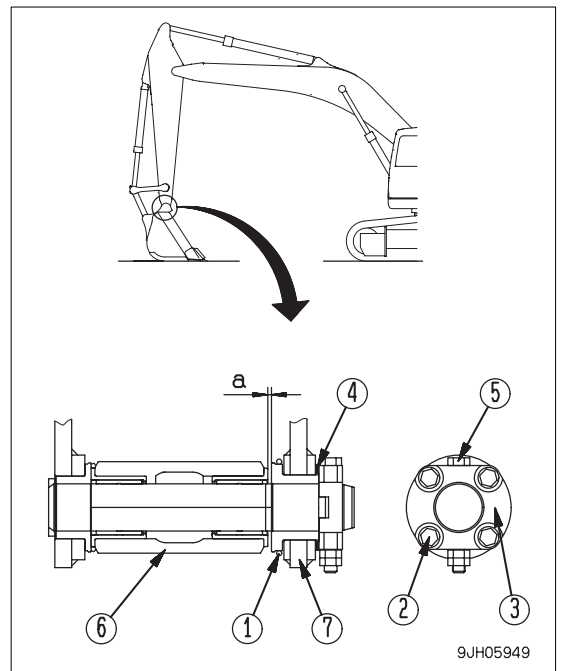

- (6) Arm
- (7) Bucket

CHECK WINDOW WASHER FLUID LEVEL, ADD FLUID

If there is air in the window washer fluid, check the level of the fluid in window washer tank (1), and if it is low, add automobile window washer fluid.

When adding fluid, be careful not to let any dust get in.

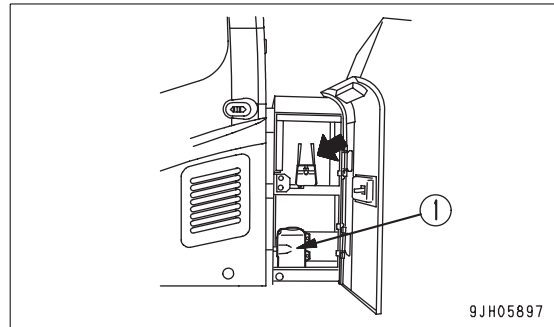

Mixture Ratio of Pure Washer Fluid and Water

The proportion differs according to the ambient temperature, so dilute the washer fluid with water to the following proportions before adding.

Operation area and season	Mixture ratio	Freezing temperature
Normal	Pure washer fluid 1/3: water 2/3	- 10°C
Winter in cold region	Pure washer fluid 1/2: water 1/2	- 20°C
Winter in extremely cold region	Pure washer fluid	- 30°C

There are two types depending on the freezing temperature:

-10°C (general use) and -30°C (cold area use), select according to the area and season.

CHECK AND MAINTENANCE AIR CONDITIONER

(Only for machines equipped with air conditioner)

Check Level of Refrigerant (gas)

⚠ WARNING

If the refrigerant used in the air conditioner gets into your eyes or on your hands, it may cause loss of sight or frostbite. Do not touch the refrigerant. Never loosen any part of the refrigerant circuit. Do not bring any flame close to any point where the refrigerant gas is leaking.

If the level of the refrigerant (gas) is low, the cooling effect will be reduced. Run the engine at high idle, and check the flow of the refrigerant gas (R134a) in the refrigerant circuit through the sight glass (2) (inspection window) of the receiver (1) when the cooler is running at high speed.

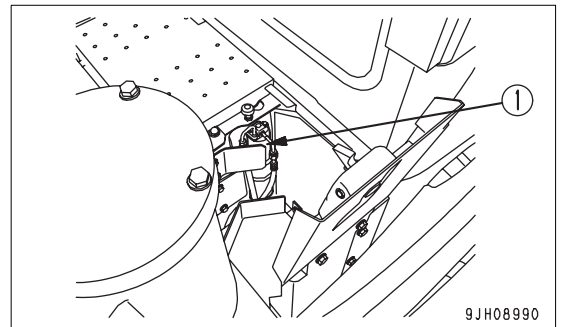

- (A) No bubbles in refrigerant flow: Suitable
- (B) Some bubbles in flow (bubbles pass continuously): Lack of refrigerant
- (C) Colorless, transparent: No refrigerant

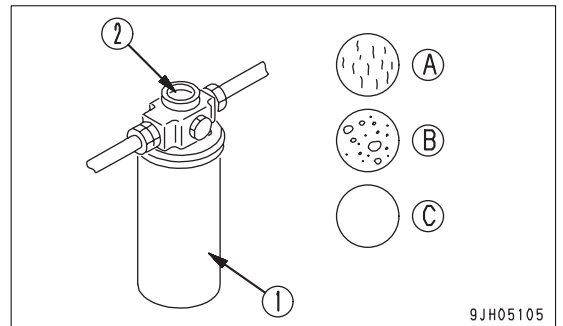

REMARK
When there are bubbles, the refrigerant gas level is low, so contact your Komatsu distributors to have refrigerant added. If the air conditioner is run with the refrigerant gas level low, it will cause damage to the compressor.

Inspection During Off Season

Even during the off-season, operate the air conditioner for 3 to 5 minutes once a month to maintain the oil film at all parts of the compressor.

Inspection and Maintenance Items

Check, maintenance items	Content of check, maintenance	Guideline for maintenance interval
Refrigerant (gas)	Charge amount	Twice a year (spring, autumn)
Condenser	Clogged fins	Every 500 hours
Compressor	Operating condition	Every 4000 hours
V-belt	Damage, tension	Every 250 hours
Blower motor, fan	Operating condition (does it make abnormal noise?)	When required
Control mechanism	Operating condition (does it function normally?)	When required
Piping mounts	Mounting condition, looseness at tightening or connecting portions, leakage of gas, damage	When required

CLEAN LINE FILTER, REMOVE DIRT

If there is any abnormality in the pump or other hydraulic equipment, remove the dirt from inside the line filter as follows.

Before removing the line filter, release the pressure inside the hydraulic circuit. For details, see "METHOD OF RELEASING PRESSURE IN HYDRAULIC CIRCUIT (4-78)".

1. Remove the cover on top of the pump.
2. Remove 4 bolts (1), then remove flange (2).
3. Remove 4 bolts (3), then temporarily screw 2 of the bolts into the temporary insertion holes (5) in cover (4).
4. Remove cover (4) and wash filter (6). When washing the filter, remove plug (7) and clean out all the dirt stuck to the side face of the case.
5. After washing filter (6), install it again. When installing the filter, cover, and flange again, replace backup ring (8) and O-rings (9), (10), and (11) with new parts.

After assembling the filter again, bleed the air. For details, see "BLEEDING AIR FROM HYDRAULIC SYSTEM (4-37)".

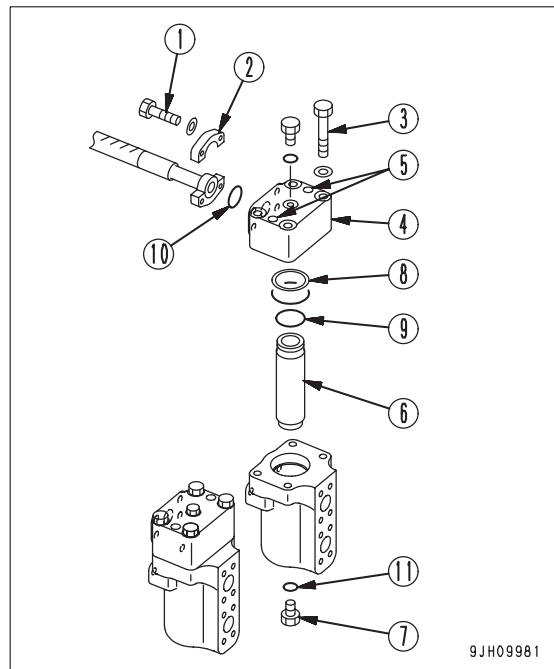
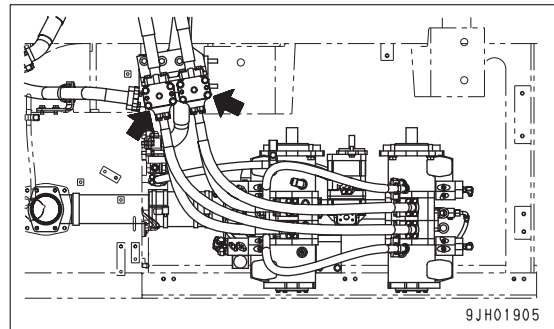

REPLACE BREAKER CIRCUIT ADDITIONAL OIL FILTER ELEMENT

(If equipped)

⚠ WARNING
Parts and oil are at high temperature immediately after the engine is stopped and may cause serious burns. Wait for the oil temperature to go down before performing this operation.

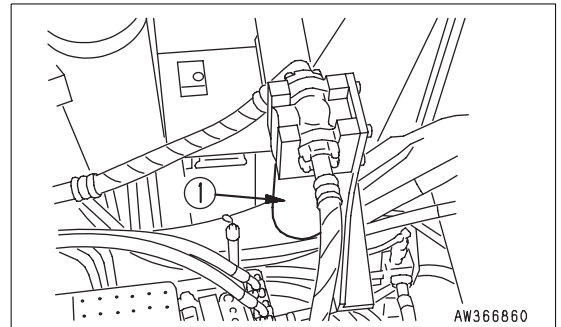

- Prepare a container to catch the oil.
1. Place a container under the filter element to catch the oil.
 2. Remove plug (3) from filter case (1) and drain the oil from the case.
 3. Turn filter case (1) to the left to remove it, then take out element (2).
 4. Clean the removed parts, then install new element (2) and O-ring (4).
 5. When installing, bring the case into contact with the filter holder, then tighten a further 1/2 turns.

NOTICE
For details of the replacement interval for the element, “MAINTENANCE INTERVAL FOR HYDRAULIC BREAKER (4-17)”.

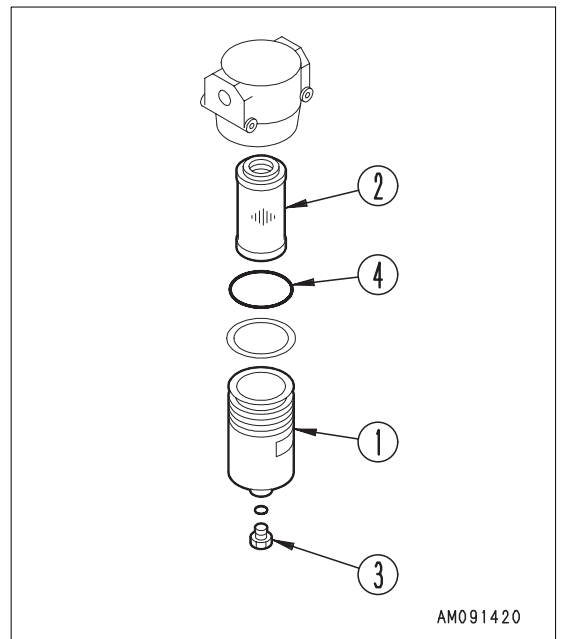

CLEAN PILOT LINE FILTER, REMOVE DIRT

Prepare a container to catch drained fuel.

1. Place a container under the pilot line filter to catch the oil.
2. Remove plug (1).
3. Remove strainer (2) and wash it.
4. Replace O-ring (3) with new one.
5. Install the washed strainer (2). Tightening torque for a strainer 8.83 to 9.81 N·m (0.9 to 1.0 kgf·m) Fix two positions of the cylinder.
6. Install the O-ring (3) and the plug (1). Tightening torque for a plug 108.0 to 147.0 N·m (11 to 15 kgf·m)

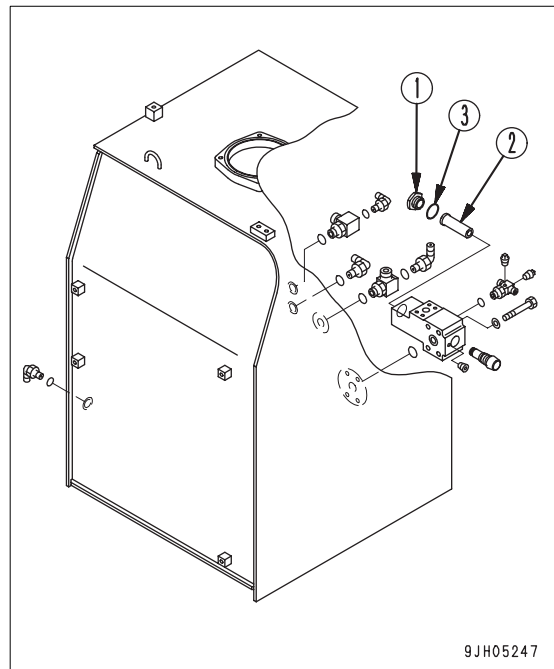

BLEEDING AIR FROM HYDRAULIC SYSTEM

For details of the procedure when starting the engine, see “STARTING ENGINE (3-91)”. If necessary, refer to the OPERATION volume for the sections for starting the engine, moving the machine off, steering, and stopping.

CAUTION

When starting the engine to bleed the air, cancel the automatic warming-up operation before starting.

NOTICE

- **Bleed the air as follows.**
 1. Pump (work equipment, swing)
 2. Work equipment circuit
- Run the engine at less than 1000 rpm, and operate the cylinders slowly.
- Do not suddenly stop and cause the cylinder pressure to rise or operate to the end of the stroke.
- When operating the cylinder for the first stroke (extending and retracting), operate particularly slowly.
- When operating the cylinder for the first stroke, there is a large amount of air inside the circuit, so the work equipment will not move for at least 10 seconds. Be careful not to operate the lever to the end of the stroke.
- Use clean oil of NAS7 class or above when filling the pump. Be sure to use a clean oil can.

Carry out Steps 1 - 3 below to bleed the air. If necessary, carry out Steps 4 - 6 in addition.

1. Bleeding air from pump
2. Loosen air bleed plug (1) and check that oil oozes out from air bleeder (2).
3. If oil does not ooze out, remove the drain hose and elbow from the pump case, and fill the pump case with hydraulic oil through drain port (3).
If the mouthpiece is lower than the oil level in the hydraulic tank, oil will come out from the drain hose when it is removed. To prevent this, fix the mouthpiece of the hose at a position higher than the oil level in the hydraulic tank.
4. After completing the air bleed operation, tighten air bleed plug (1) and install the drain hose.

NOTICE

If the drain hose is installed first, oil will spurt out from plug (1) hole. If the pump is operated without filling the pump case with hydraulic oil, abnormal heat will be generated and this may cause premature damage to the pump.

5. Starting engine

Cancel the automatic warming-up operation before starting the engine. Run the engine at low idling for 10 minutes after starting it, then go on to the next operation.

6. Bleeding air from cylinders
7. Run the engine at low idle, and extend and retract each cylinder 4 to 5 times, taking care that a cylinder is not moved to the end of its stroke. (Stop the cylinder approx. 100 mm short of its stroke end)
8. Next, operate each cylinder 3 to 4 times to the end of its stroke.

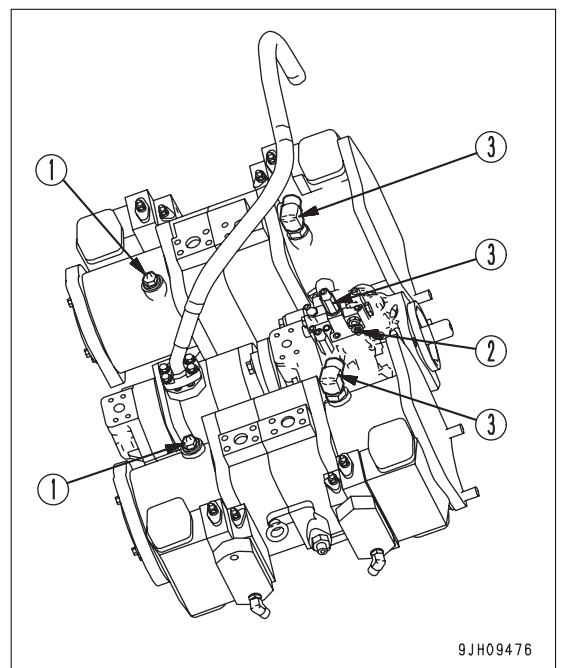

9. Finally, operate each cylinder 4 to 5 times to the end of its stroke to completely remove the air.

NOTICE

If the engine is run at high speed immediately after startup or a cylinder is pushed up to its stroke end, air taken inside the cylinder may cause damage to the piston packing.

10. Bleeding air from swing motor (bleed the air only when the oil inside the swing motor case has been drained)

- When oil has been drained from inside swing motor case

11. Run the engine at low idling, loosen hose (1) at port S, and check that oil oozes out from port S hose (1).

NOTICE

When doing this, do not operate the swing.

12. If oil does not ooze out, stop the engine, remove port S hose (1), and fill the inside of the motor case with hydraulic oil.

13. After completely bleeding the air, tighten port S hose (1).

14. Run the engine at low idle, and slowly swing the upper structure at least 2 times uniformly to the left and right.

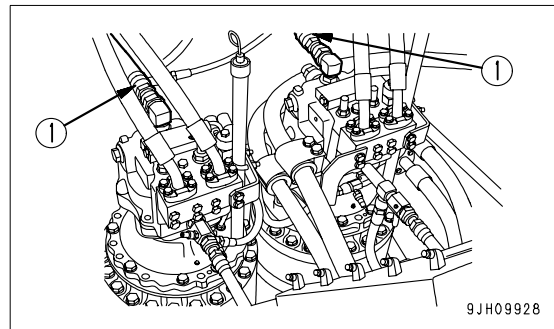

NOTICE

- **If the air is not bled from the swing motor, the motor bearings may be damaged.**
- **Use the above procedure also to bleed the air when the swing motor safety valve has been replaced.**

15. Bleeding air from attachment (when installed)

If an attachment has been installed, run the engine at low idling and operate the attachment pedal repeatedly (approx. 10 times) until the air has been bled from the attachment and circuit.

NOTICE

- **If the method of bleeding the air from the attachment itself is specified by the manufacturer, bleed the air according to the specified procedure.**
- **After completing the air bleeding operation, stop the engine, and leave the machine for 5 minutes before starting operations. This will remove the air bubbles in the oil inside the hydraulic cylinders.**
- **Check that there is no leakage of oil and wipe off any oil that has been spilled.**

16. Bleeding air from travel motor circuit

If the piping has been removed from the travel motor circuit, bleed the air after reassembling. To bleed the air, run the engine at low idling and do as follows.

17. Start the engine and run at low idling.
18. Remove travel motor cover (1), then loosen air bleed plug (2) one turn.

NOTICE

Do not loosen plug (2) more than one turn.

19. When no more cloudy white oil comes out from air bleed plug (2), tighten air bleed plug (2).
20. Carry out fine operation of the travel lever and set to FORWARD and REVERSE 4 - 5 times.
21. Install the travel motor cover.

Operation

22. After completing the air bleed operation, stop the engine and wait for at least 5 minutes before starting operations. This will allow the bubbles in the oil inside the tank to escape.
23. Check that there is no leakage of oil, and wipe up any oil that has been spilled.

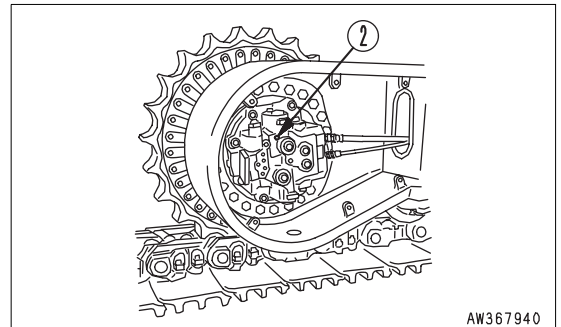
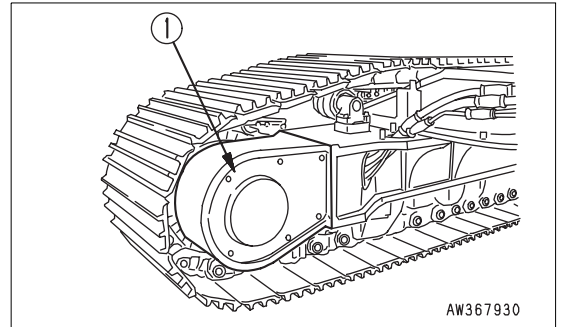

CHECK BEFORE STARTING

For details of the following items, see "Checks Before Starting (3-75)" in the OPERATION section.

- Check coolant level, add coolant
- Check oil level in engine oil pan, add oil
- Check fuel level, add fuel
- Check water separator, drain water and sediment
- Drain water and sediment from fuel tank
- Check oil level in hydraulic tank, add oil
- Check oil level in swing machinery case, add oil
- Check oil level in P.T.O case, add oil
- Check working lamp switch
- Check electric wiring
- Check function of horn

EVERY 10 HOURS MAINTENANCE

LUBRICATING

1. Set to the greasing posture below, lower the work equipment to the ground, then stop the engine.
2. Using a grease pump, pump in grease through the grease fittings shown by arrows.
3. After greasing, wipe off any old grease that was pushed out.

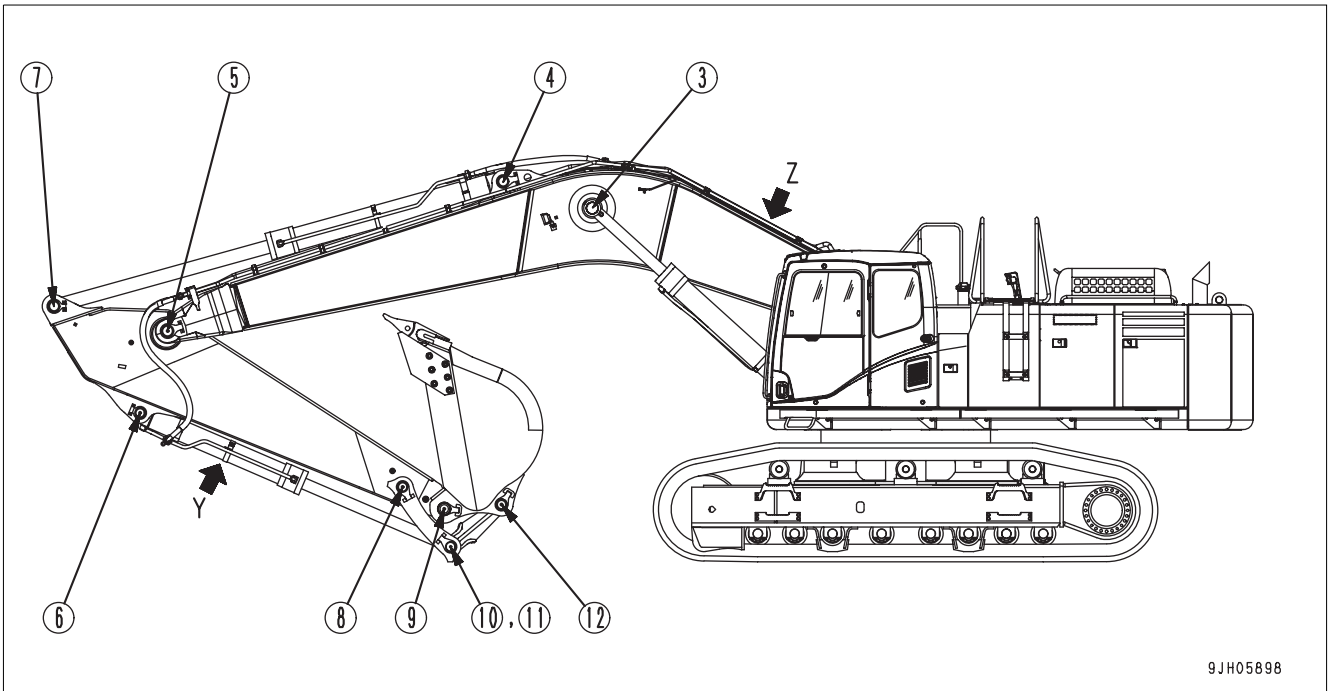

9JH05898

(1) Boom cylinder foot pin (2 places)

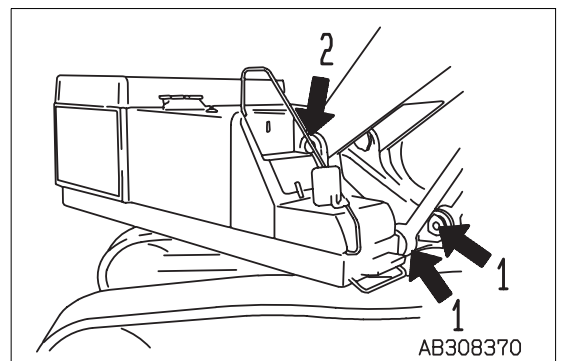

AB308370

- (2) Boom foot pin (2 places)
- (3) Boom cylinder rod end pin (2 places)
- (4) Arm cylinder foot pin (1 place)

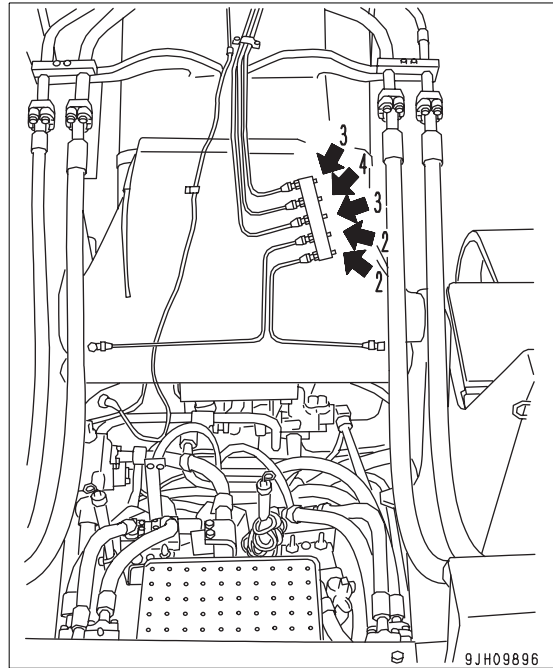

- (5) Boom-Arm coupling pin (1 place)
- (6) Bucket cylinder foot pin (1 place)
- (7) Arm cylinder rod pin (1 place)

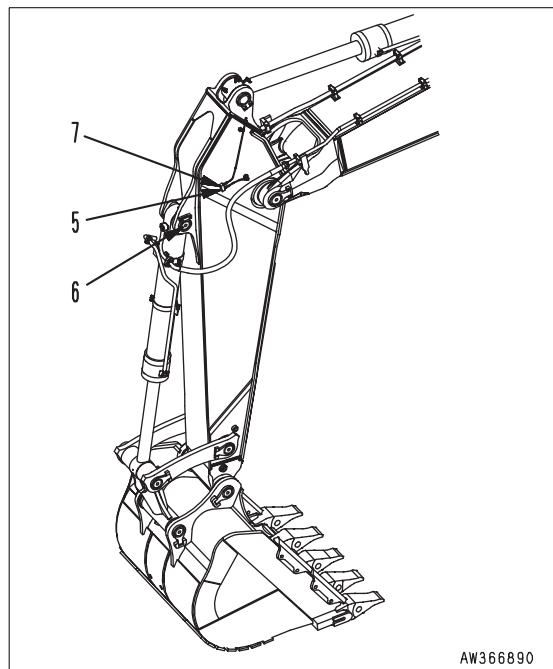

- (8) Arm-Link coupling pin (1 place)
- (9) Arm-Bucket coupling pin (1 place)

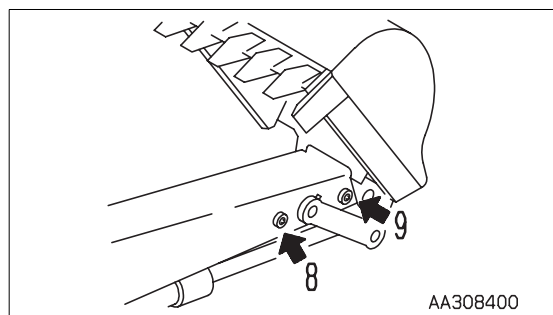

- (10) Link coupling pin (2 places)
- (11) Bucket cylinder rod pin (1 place)
- (12) Bucket-Link coupling pin (1 place)

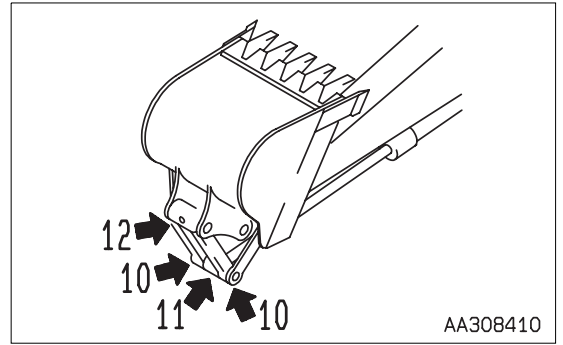

EVERY 100 HOURS MAINTENANCE

Maintenance for every 10 hours service should be carried out at the same time.

LUBRICATING SWING CIRCLE

3 places

1. Lower the work equipment to the ground.
2. Using a grease pump, pump in grease through the grease fittings shown by arrows.
3. After greasing, wipe off any old grease that was pushed out.

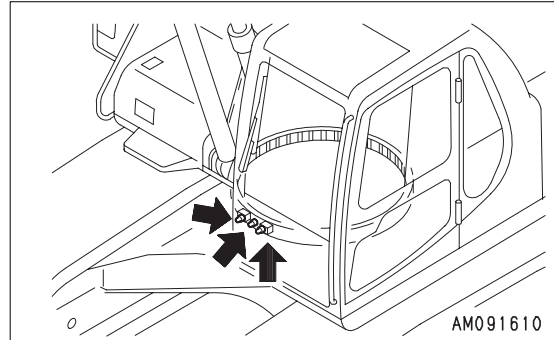

EVERY 250 HOURS MAINTENANCE

Maintenance for every 10 hours of service should be performed at the same time.

CHECK OIL LEVEL IN FINAL DRIVE CASE, ADD OIL

 **WARNING**

- The parts and oil are at high temperature immediately after the engine is stopped, and may cause serious burns. Wait for the temperature to go down before starting the operation.
- If there is still pressure remaining inside the case, the oil or plug may fly out. Loosen the plug slowly to release the pressure.

- Prepare a handle.
1. Set the TOP mark at the top, with the UP mark and plug (P) perpendicular to the ground surface.
 2. Using a handle, remove plug (F) and check that the oil level is within a range of 10 mm below the bottom edge of the plug hole.
 3. If the oil level is low, check again. Install plug (F), operate the travel lever, travel in FORWARD or REVERSE, and rotate the sprocket one turn. Perform inspection for Procedure 2 again.
 4. If the oil level is low, add engine oil through plug hole (F) until the oil overflows from plug hole (F).
 5. After checking, install plug (F).

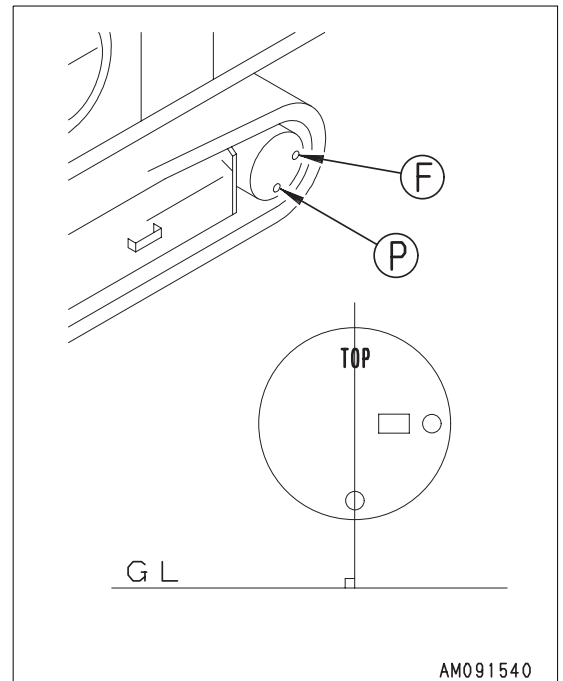

CHECK LEVEL OF BATTERY ELECTROLYTE

Perform this check before operating the machine.

WARNING

- Do not use the battery if the battery electrolyte level is below the LOWER LEVEL line. This will accelerate deterioration of the inside of the battery and reduce the service life of the battery. In addition, it may cause an explosion.
- The battery generates flammable gas and there is danger of explosion, do not bring fire or sparks near the battery.
- Battery electrolyte is dangerous. If it gets in your eyes or on your skin, wash it off with a large amount of water and consult a doctor.

NOTICE

- When adding distilled water to the battery, do not allow the battery electrolyte to go above the UPPER LEVEL line. If the electrolyte level is too high, it may leak and cause damage to the paint surface or corrode other parts.
- When adding distilled water in cold weather, add it before starting operations in the morning to prevent the electrolyte from freezing.

Inspect the battery electrolyte level at least once a month and follow the basic safety procedures given below.

Open cover (1) at the rear left side of the machine. The batteries are installed at (A) part.

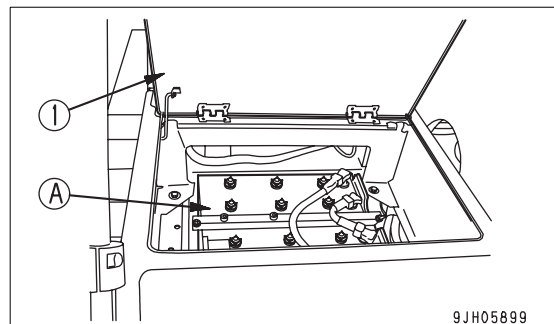

9JH05899

When Checking Electrolyte Level from Side of Battery

If it is possible to check the electrolyte level from the side of the battery, check as follows.

1. Use a wet cloth to clean the area around the electrolyte level lines and check that the electrolyte level is between the UPPER LEVEL (U.L.) and LOWER LEVEL (L.L.) lines.

If the battery is wiped with a dry cloth, static electricity may cause a fire or explosion.

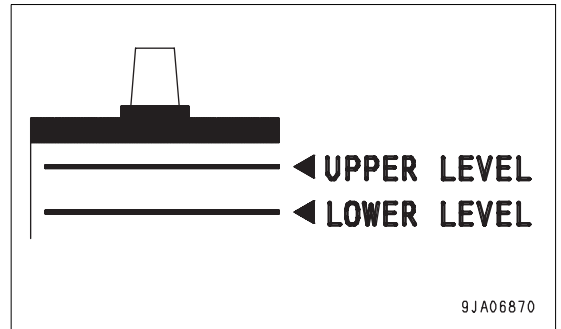

2. If the electrolyte level is below the midway point between the UPPER LEVEL (U.L.) and LOWER LEVEL (L.L.) lines, remove cap (2) and add distilled water to the U.L. line.
3. After adding distilled water, tighten cap (2) securely.

REMARK

If distilled water is added to above the UPPER LEVEL (U.L.) line, use a syringe to lower the level to the UPPER LEVEL (U.L.) line. Neutralize the removed fluid with baking soda (sodium bicarbonate), then flush it away with a large amount of water or consult your Komatsu distributor or battery maker.

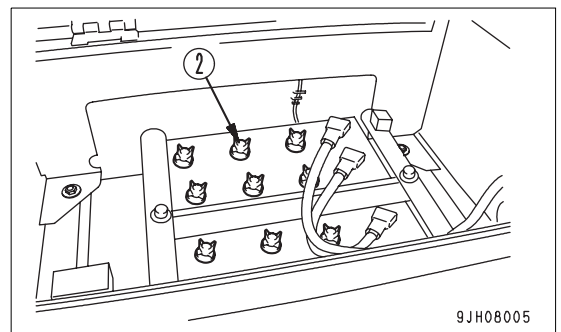

When it is Impossible to Check Electrolyte Level from Side of Battery

If it is impossible to check the electrolyte level from the side of the battery, or there is no display of the UPPER LEVEL line on the side of the battery, check as follows.

1. Remove cap (2) at the top of the battery, look through the water filler port (3), and check the electrolyte surface. If the electrolyte does not reach the sleeve (4), add distilled water so that the level reaches the bottom of the sleeve (UPPER LEVEL line) without fail.

- (A) Suitable level: Electrolyte level is up to bottom of sleeve, so surface tension causes electrolyte surface to bulge and poles appear bent.
- (B) Low: Electrolyte level is not up to bottom of sleeve, so poles appear straight and not bent.

2. After adding distilled water, tighten cap (2) securely.

REMARK

If distilled water is added to above the bottom of the sleeve, use a syringe to lower the level to the bottom of the sleeve. Neutralize the removed fluid with baking soda (sodium bicarbonate), then flush it away with a large amount of water or consult your Komatsu distributor or battery maker.

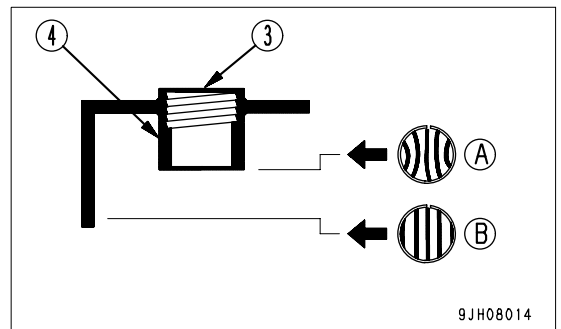
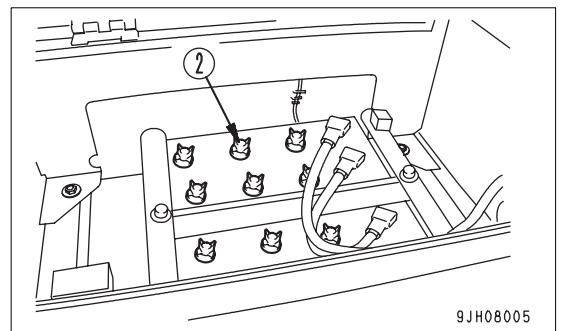

When it is Possible to Use Indicator to Check Electrolyte Level

If it is possible to use an indicator to check the electrolyte level, follow the instructions given.

CHECK AND TIGHTEN TRACK FRAME AND AXLE CONNECTING BOLTS

Bolts (1) connecting the track frame and axle will break if they remain loose, so loose bolts must always be retightened.

- Tightening torque: 2649 ± 294 N·m
(270 ± 30 kgf·m)

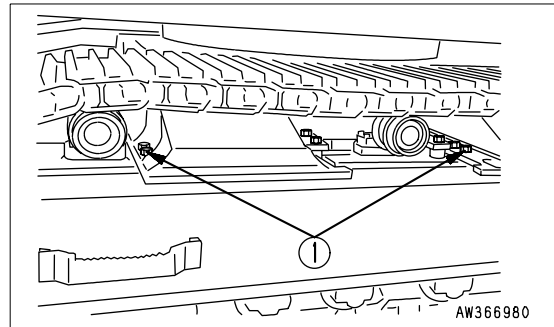

CHECK ALTERNATOR DRIVE BELT TENSION, ADJUST

Checking

1. Remove cover (1).
2. If you push the belt at the center between the alternator (2) and the drive pulley (3) with your thumb [approximately 98.1N (10 kgf)] and you get deflection of (A), it is normal.

(A): 13 to 16 mm

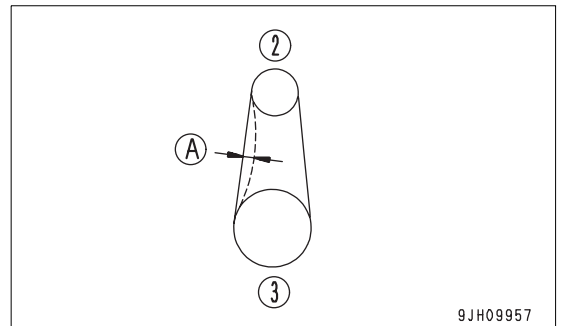
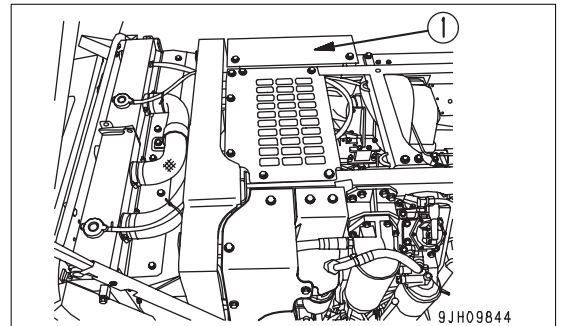

Adjustment

1. Loosen bolts and nuts (4) - (6) in number order.
 - If nut (7) is tightened, the belt tension will increase. If nut (7) is loosened, the belt tension will be relieved.
2. After adjusting the belt, tighten bolts and nuts (4) - (6) in the reverse order to their number order.
 - Check each pulley for damage, wear of the V-groove, and wear of the V-belt. Check in particular that the V-belt does not contact the bottom of the V-groove.
 - If the V-belt is elongated and there is no more allowance for adjustment, or if the belt is cracked or cut, replace the belt.
 - When the V-belt has been replaced, adjust again after running for 1 hour.
3. Install cover (1).

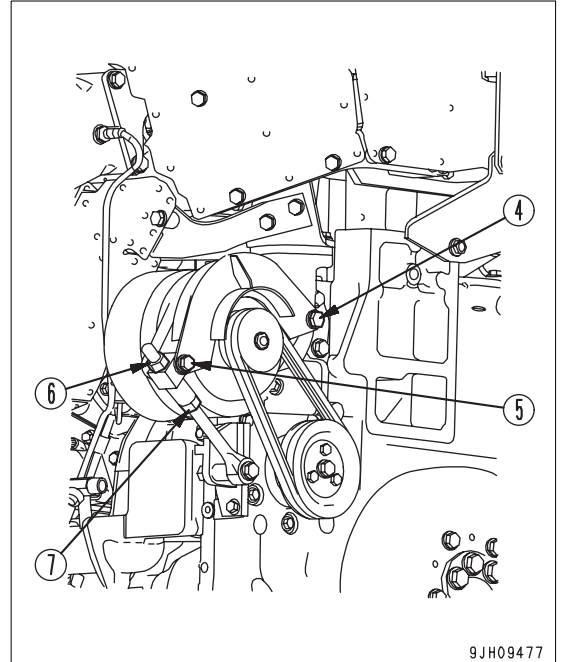

CHECK AIR CONDITIONER COMPRESSOR BELT TENSION, ADJUST

Checking

1. Remove 4 bolts (2), then remove cover (1).
2. The standard deflection for the drive belt is of (A) when pressed with a thumb [at approx.98.1 N (approximately 10kgf)] at a point midway between the drive pulley (3) and the air conditioner compressor pulley (4).

(A): 10 mm

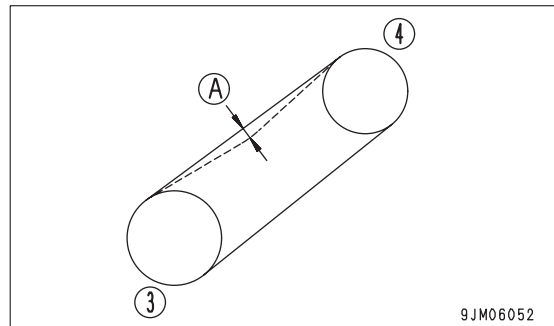
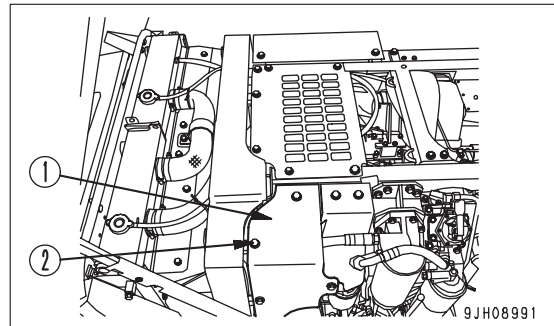

Adjustment

1. Loosen bolts and nuts (5) - (7) in number order, and move the compressor to the side.
 - If nut (8) is tightened, the belt tension will increase. If nut (8) is loosened, the belt tension will be relieved.
2. After adjusting the belt, tighten bolts and nuts (5) - (7) in the reverse order to their number order.
 - Check each pulley for damage, wear of the V-groove, and wear of the V-belt. Check in particular that the V-belt does not contact the bottom of the V-groove.
 - If the V-belt is elongated and there is no more allowance for adjustment, or if the belt is cracked or cut, replace the belt.
 - When the V-belt has been replaced, adjust again after running for 1 hour.
3. Install cover (1).

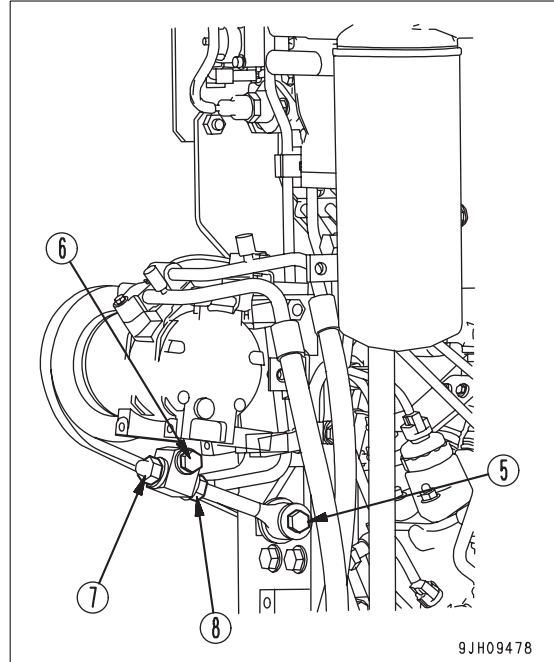

EVERY 500 HOURS MAINTENANCE

Maintenance for every 10, 100, and 250 hours of service should be performed at the same time.

REPLACE FUEL PRE-FILTER CARTRIDGE

WARNING

- After the engine has been operated, all parts are at high temperature, so do not replace the filter immediately. Wait for all parts to cool down before starting the operation.
- High pressure is generated inside the engine fuel piping system when the engine is running. When replacing the filter, wait for at least 30 seconds after stopping the engine to let the internal pressure go down before replacing the filter.
- Do not bring any fire or flame close.
- Be careful when opening the air bleed plug in the fuel filter head. It is still under pressure, so fuel may spurt out.

NOTICE

- Genuine Komatsu fuel filter cartridges use a special filter that has highly efficient filtering ability. When replacing the filter cartridge, always use a genuine Komatsu part.
 - The common rail fuel injection system used on this machine consists of more precise parts than the conventional injection pump and nozzle. If any part other than a genuine Komatsu filter cartridge is used, dust or dirt may get in and cause problems with the injection system. Always avoid using substitute parts.
 - When carrying out inspection or maintenance of the fuel system, pay more attention than normal to the entry of dirt. If dirt is stuck to any part, use fuel to wash it off completely.
- Container to catch the oil
 - Prepare a filter wrench
 1. Turn valve (1) at the bottom of the fuel tank to the right to close it.

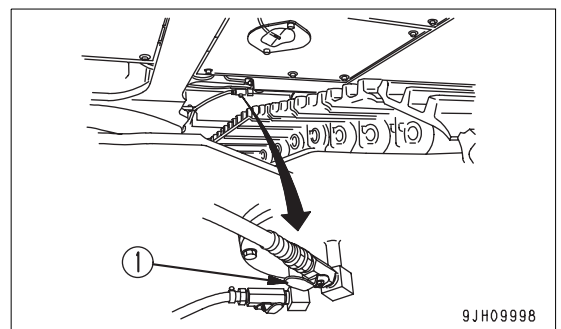

2. Set a container under fuel pre-filter cartridge (2) to catch the drained fuel.
3. Turn transparent cap (3) of the water separator installed to the bottom of the cartridge to the left to remove it. (The transparent cap is used again.)
4. Using a filter wrench, turn filter cartridge (2) counterclockwise to remove it.

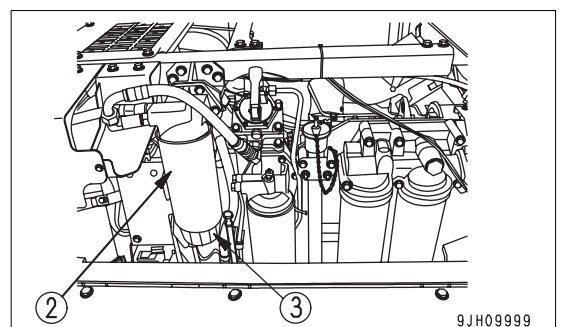

5. Install transparent cap (3) to the bottom of the new fuel pre-filter cartridge. (When doing this, always replace the seal with a new part.)

Tightening torque for transparent cap: 10.0 N·m (1.0 kgf·m)

6. Clean the filter holder, coat the packing surface of the new filter cartridge thinly with oil, then install the filter cartridge to the filter holder.

NOTICE

- **When adding fuel, do not remove cap (B). Always add fuel from the 8 small holes (A) on the dirty side.**
- **After adding fuel, remove cap (B) and install the fuel filter.**
- **Always fill with clean fuel. Be careful not to let any dirt or dust get into the fuel. In particular, center portion is the clean side, so do not remove cap (B) when adding fuel. Be careful not to let dirt or dust get into center portion on the clean side.**

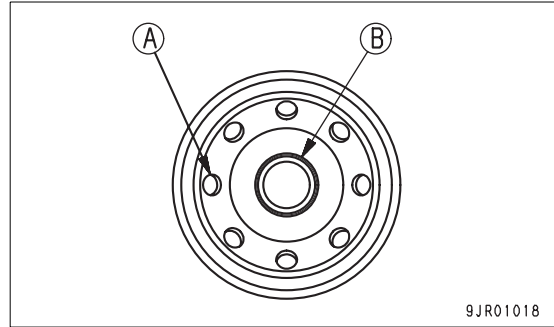

7. When installing, tighten until the packing surface contacts the seal surface of the filter holder, then tighten it 3/4 of a turn.

If the filter cartridge is tightened too far, the packing will be damaged and this will lead to leakage of fuel. If the filter cartridge is too loose, fuel will also leak from the packing, so always tighten the correct amount.

- When tightening with a filter wrench, be extremely careful not to dent or damage the filter.

8. Check that drain plug (5) at the bottom of transparent cap (3) is tightened securely.

Tightening torque: 0.2 to 0.45 N·m (0.02 to 0.046 kgf·m)

9. After completing the replacement of fuel pre-filter cartridge (2), bleed the air.

Bleed the air as follows:

10. Loosen plug (A) at the top of fuel main filter cartridge (4).

NOTICE

Do not loosen the plug of the fuel pre-filter head. This is at the suction end, so if it is loosened, it will be impossible to bleed the air.

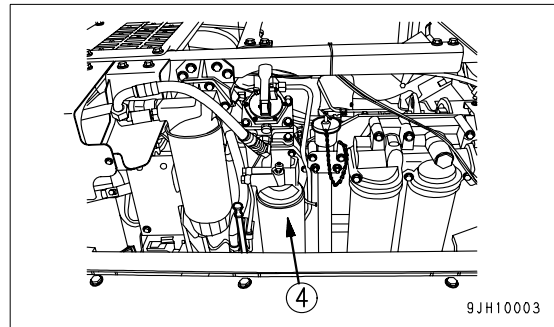

11. Loosen butterfly nut (5) holding the lever of the priming pump.
12. Operate the lever of the priming pump to prime with uel. Fuel will come out from plug (A) at the top of the fuel main filter head. When no more bubbles come out wih the fuel, operate the priming pump lever more slowly. Tighten plug (A).

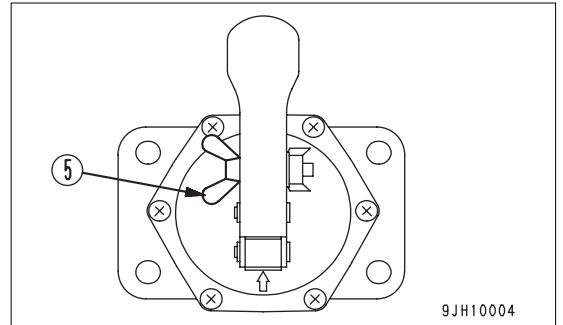
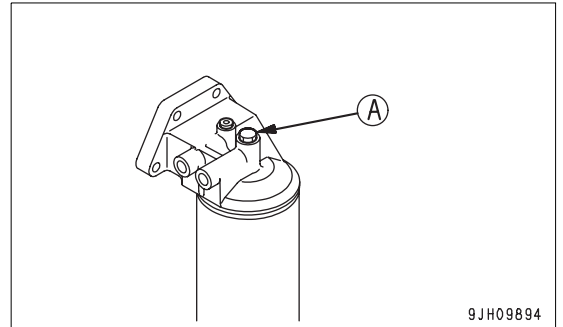

13. Carry out priming approx. 50 times with priming pump (6) of the supply pump.
14. Tighten butterfly nut (5) holding the lever of the priming pump securely.
15. Target tightening torque: 11.80 N·m (1.2 kgf·m)
16. Turner valve (1) at the bottom of the fuel tank to the left to open it.
17. Start the engine, check that there is no leakage of fuel from the filter seal surface or water separator mounting surface, then run for approx. 10 minutes at low idling.

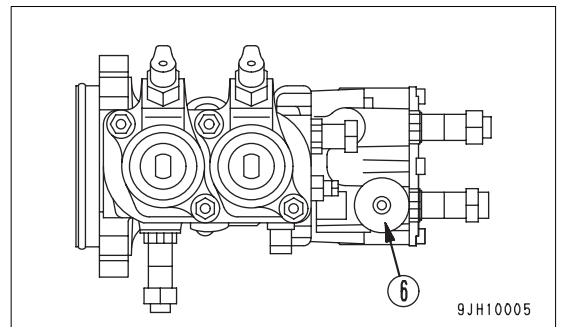

CHECK SWING PINION GREASE LEVEL, ADD GREASE

- Prepare a scale.
- 1. Before starting the inspection, swing 2 times to the right or left, then lower the work equipment to the ground and stop the engine.
- 2. Remove bolts (1) (2 bolts) on the top of the revolving frame and remove cover (2).
- 3. Insert a scale into the grease and check that the depth of the grease is approx. 60 mm. Add grease if necessary.

Insert the scale (A) in the position shown in the diagram on the right when measuring.

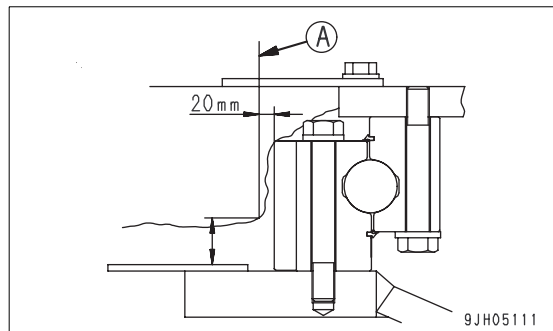
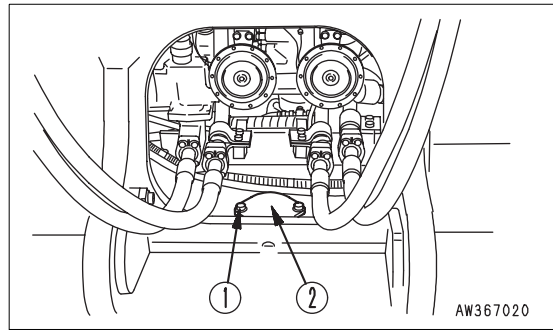

If the grease is particularly milky due to ingress of water, etc., then remove bolts (3) and cover (4) from the bottom of the track frame and remove the grease. Replace all of the grease with new grease.

The total amount of grease is 31 liters (28 kg).

- 4. Install cover (2) with bolts (1).

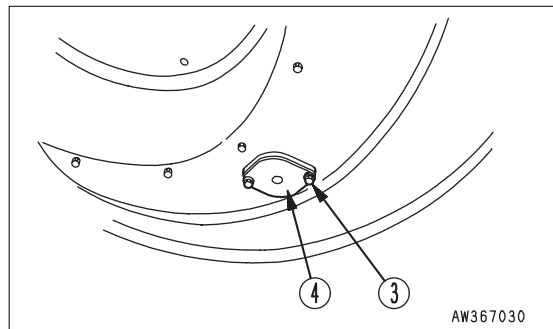

CLEAN,CHECK RADIATOR FINS,OIL COOLER FINS,FUEL COOLER FINS,AFTER-COOLER FINS,CONDENSER FINS (machines equipped with air conditioner),PTO OIL COOLER FINS

⚠ WARNING

If compressed air, high-pressure water, or steam hit your body directly, or they cause dirt or dust to be blown up, there is a hazard of serious injury. Always use safety glasses, dust mask, or other protective equipment.

NOTICE

When using compressed air, use from a distance to prevent damage to the fins.

In particular, with the fuel cooler and aftercooler, blow with compressed air at an angle of 45° with the nozzle at a distance of at least 300 mm.

Never blow the compressed air at right angles to the core. If the fins are damaged, it may cause coolant leakage or overheating. On dusty jobsites, check the fins daily, irrespective of the maintenance interval.

1. Open the engine hood and rear duct (1) on the right side of the machine.

REMARK

Insert the pin of the bar supporting the engine hood again to keep the hood fully open.

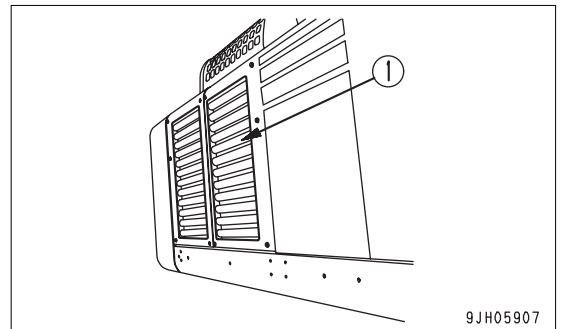

2. Loosen screw (2) and pull up net (3).
3. Clean net (3). (it is to be installed again, as instructed in the step 8.)
4. Loosen bolts (5) of top cover (4) on the engine side, then slide cover (4) to the rear.
5. Check the front face and rear face of oil cooler fins (6), radiator fins (7), aftercooler fins (8), condenser fins (9), and fuel cooler fins (10). If there are any leaves, mud, or dirt, blow off with compressed air.

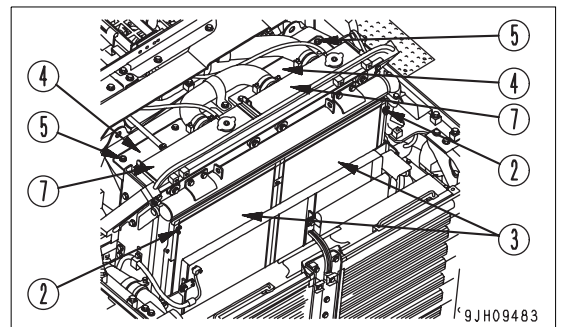

Steam or water can be used instead of compressed air, or the fan can be rotated in reverse to carry out cleaning.

For details of the method for rotating the fan in reverse, see "MONITORING SYSTEM (3-5)"

6. Check the rubber hose. Replace with a new one if the hose is found to have cracks or to be hardened by aging. In addition, check the hose clamps for looseness.

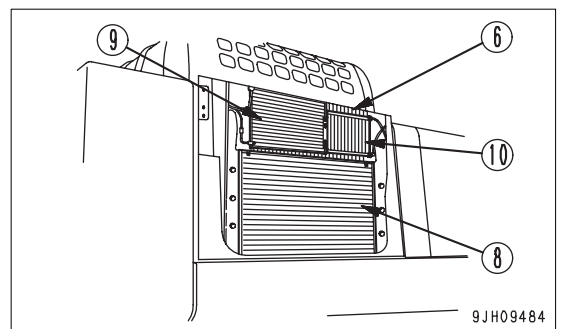

7. Remove undercover (11) and (12), then evacuate all mud, dirt, or leaves to the outside of the machine.
8. Push in cleaned net (3) back to the original place and secure it with screw (2).
9. Install cover (4) with bolts (5).
10. Install the undercover (11) and (12).

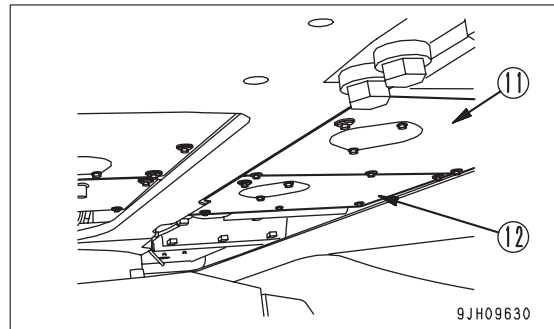

Next, clean and check the PTO oil cooler, too.

11. Open the door at the rear left of the machine.
12. Check the front face and rear face of PTO oil cooler (13), and use compressed air to blow off any mud, dirt, or leaves stuck to the cooler.

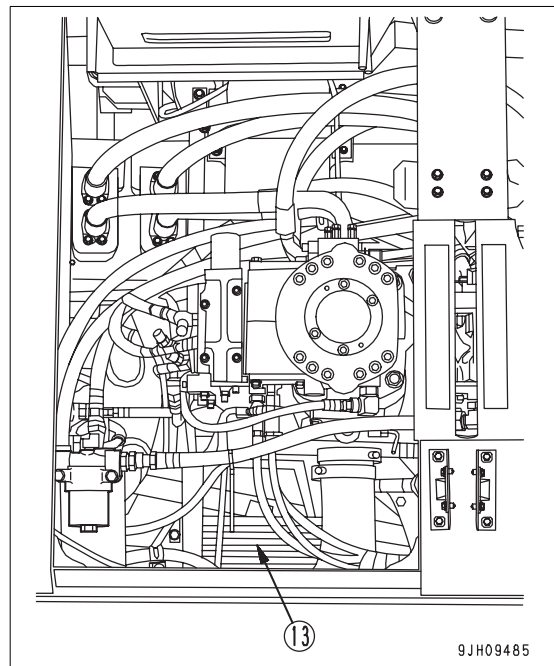

13. Remove undercover (14), then evacuate all mud, dirt, or leaves to the outside of the machine.
14. Install undercover (14).

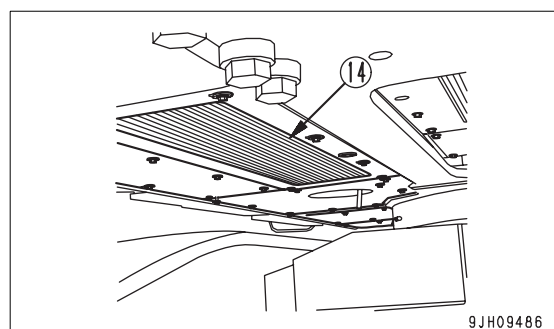

CLEAN FRESH/RECIRC AIR FILTERS OF AIR CONDITIONER (ONLY FOR MACHINES EQUIPPED WITH AIR CONDITIONER)

⚠ WARNING

If compressed air is used, there is danger that dirt may fly and cause personal injury. Always wear protective glasses, dust mask, and other protective equipment.

NOTICE

As a guideline, the filters should be cleaned every 500 hours, but on dusty jobsites, clean the filters more frequently.

REMARK

If the filter becomes clogged, the air flow will be reduced, and there will be an abnormal noise from the air conditioner unit.

CLEAN RECIRC AIR FILTER

1. Remove wing bolts (1) from the inspection window at the bottom rear left on the inside of the operator's cab, then take out the recirculated air filter.
2. Clean the filter with compressed air. If there is oil on the filter, or if the filter is extremely dirty, wash it in a neutral agent. After rinsing it in water, dry it thoroughly before using it again.

If the clogging of the filter cannot be removed by blowing with air or washing in water, replace the filter with a new part.

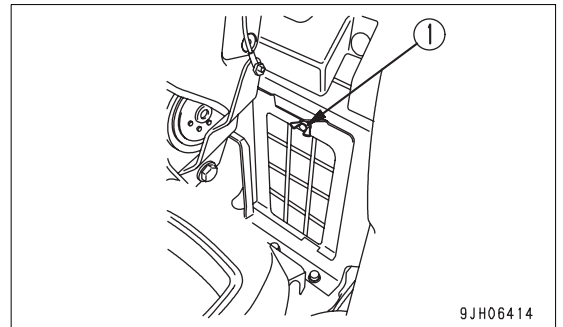

CLEAN FRESH AIR FILTER

1. Use the starting switch key to open cover (2) at the rear left of the operator's cab, then open cover (2) by hand and remove filter (3) inside the cover.
2. Clean the filter with compressed air. If there is oil on the filter, or if the filter is extremely dirty, wash it in a neutral agent. After rinsing it in water, dry it thoroughly before using it again.

Replace the filter with a new part every year. If the clogging of the filter cannot be removed by blowing with air or washing in water, replace the filter immediately.

3. After cleaning, return filter (3) to its original position and close the cover. Use the starting switch key to lock the cover. Do not forget to remove the starting switch key.

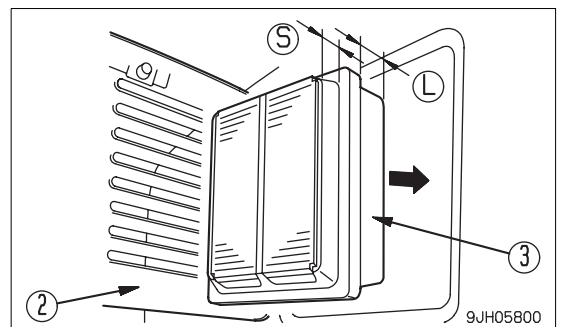
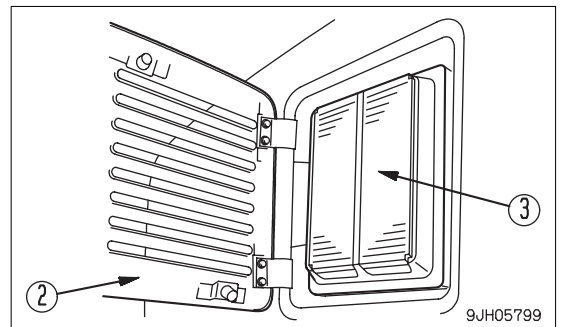

REMARK

The FRESH filter must be installed facing in the correct direction. When installing, insert the long (L) end of filter (3) into the filter case first. If the short (S) end is installed first, cover (2) will not close.

CLEAN STRAINER OF P.T.O LUBRICATING OIL FILTER**⚠ WARNING**

Start the engine, run it for approx. 10 minutes at low idling, and check for any leakage of fuel from the filter seal mounting surface.

1. Remove filter case (1).
2. Take out the strainer, remove any dirt stuck to the strainer, then wash it in flushing oil.

If the strainer or O-ring are damaged, replace with a new part.

3. Install the strainer and filter case (1).

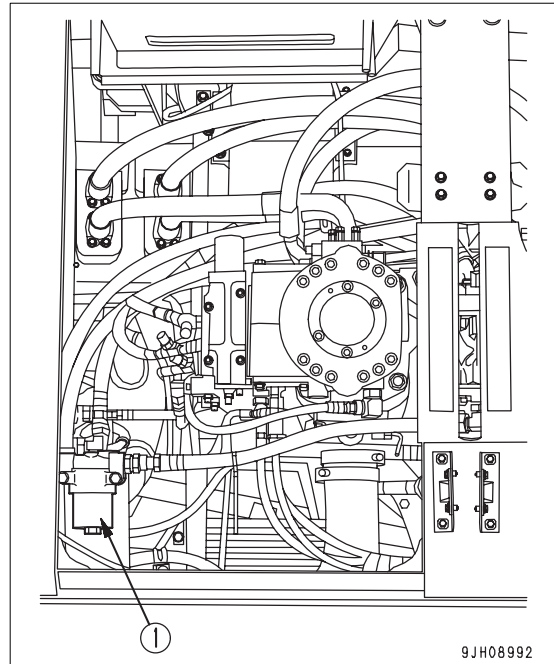

CHANGE OIL IN ENGINE OIL PAN, REPLACE ENGINE OIL FILTER CARTRIDGE

⚠ WARNING
Parts and oil are at high temperature immediately after the engine is stopped and may cause serious burns. Wait for the oil temperature to go down before performing this operation.

- Oil pan refill capacity: 40 liters
 - Prepare a filter wrench
1. Remove cover (1) at the bottom of the engine, then set a container immediately under drain valve (2) to catch the drained oil.

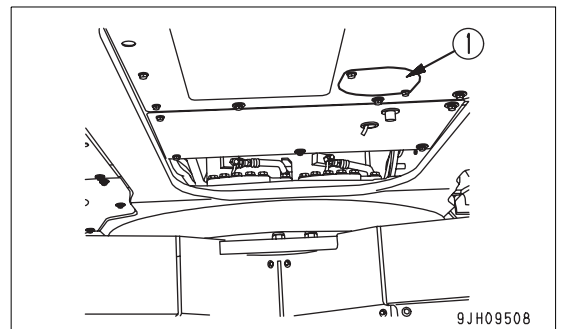

2. Be careful not to get oil on yourself. Move lever (3) of the drain valve down slowly to drain the oil, and after draining the oil, raise the lever to close it.

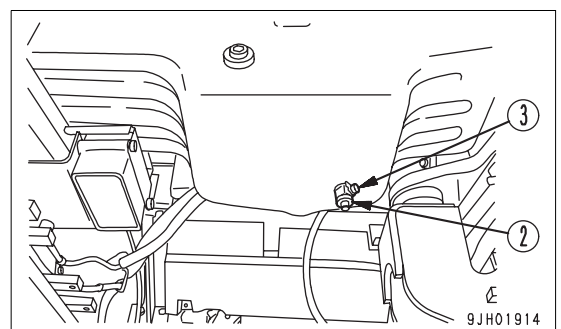

3. Open the cover of the engine hood, use a filter wrench from the top of the engine, turn filter cartridge (4) to the left, and remove it.
4. Clean the filter holder, fill the new filter cartridge with clean engine oil, coat the thread and packing surface of the new filter cartridge with clean engine oil (or coat it thinly with grease), then install it to the filter holder.

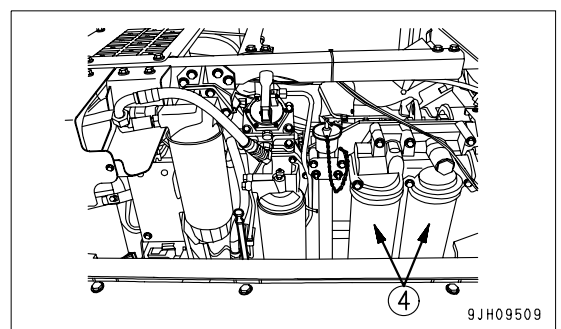

REMARK
 Check that there is no old packing stuck to the filter holder. If there is any old packing stuck to the filter, it will cause leakage of oil.

5. When installing, bring the packing surface into contact with the seal surface of the filter holder, then tighten a further 3/4 - 1 turn.
- When using a filter wrench for tightening, be extremely careful not to damage the filter or cause dents.

6. After replacing the filter cartridge, add engine oil through oil filler port (F) so that the oil level is between the H and L marks on dipstick (G).
7. Run the engine for a short time at low idling, then stop the engine. Check that the oil level gauge is between the H and L marks. For details, see "Check Oil Level in Engine Oil Pan, Add Oil (3-76)".

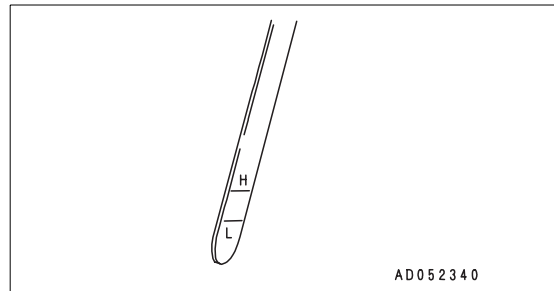
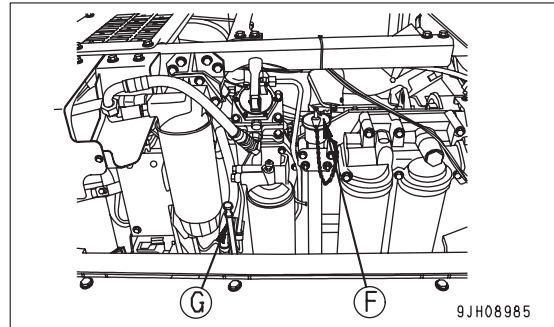

EVERY 1000 HOURS MAINTENANCE

Maintenance for every 10, 100, 250, and 500 hours of service should be performed at the same time.

REPLACE FUEL MAIN FILTER CARTRIDGE

WARNING

- After the engine has been operated, all parts are at high temperature, so do not replace the filter immediately. Wait for all parts to cool down before starting the operation.
- High pressure is generated inside the engine fuel piping system when the engine is running. When replacing the filter, wait for at least 30 seconds after stopping the engine to let the internal pressure go down before replacing the filter.
- Do not bring any fire or flame close.
- Be careful when opening the air bleed plug in the fuel filter head. It is still under pressure, so fuel may spurt out.

NOTICE

- Genuine Komatsu fuel filter cartridges use a special filter that has highly efficient filtering ability. When replacing the filter cartridge, always use a genuine Komatsu part.
 - The common rail fuel injection system used on this machine consists of more precise parts than the conventional injection pump and nozzle. If any part other than a genuine Komatsu filter cartridge is used, dust or dirt may get in and cause problems with the injection system. Always avoid using substitute parts.
 - When carrying out inspection or maintenance of the fuel system, pay more attention than normal to the entry of dirt. If dirt is stuck to any part, use fuel to wash it off completely.
 - Container to catch the oil
 - Prepare a filter wrench
1. Turn valve (1) at the bottom of the fuel tank to the right to close it.

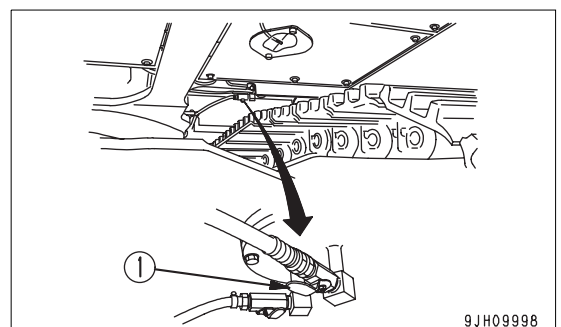

2. Set the container to catch the fuel under the filter cartridge.
3. Using a filter wrench, turn filter cartridge (2) counterclockwise to remove it.
4. Clean the filter holder, coat the packing surface of the new filter cartridge thinly with oil, then install the filter cartridge to the filter holder.

NOTICE

- Do not fill the fuel filter cartridge with fuel.
- Remove cap (B) and install the fuel filter.

5. When installing, tighten until the packing surface contacts the seal surface of the filter holder, then tighten it 3/4 of a turn.

If the filter cartridge is tightened too far, the packing will be damaged and this will lead to leakage of fuel. If the filter cartridge is too loose, fuel will also leak from the packing, so always tighten the correct amount.

- When tightening with a filter wrench, be extremely careful not to dent or damage the filter.

6. After completing the replacement of fuel main filter cartridge (2), bleed the air.

Bleed the air as follows:

7. Loosen plug (A) at the top of fuel main filter cartridge (2).

NOTICE

Do not loosen the plug of the fuel pre-filter head. This is at the suction end, so if it is loosened, it will be impossible to bleed the air.

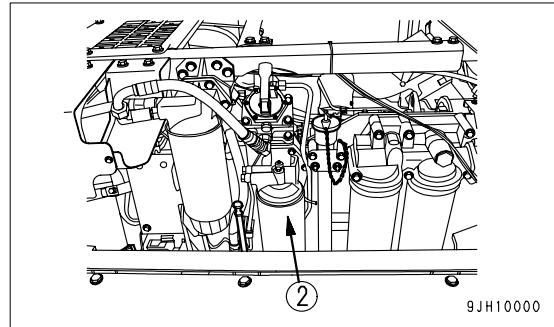

9JH10000

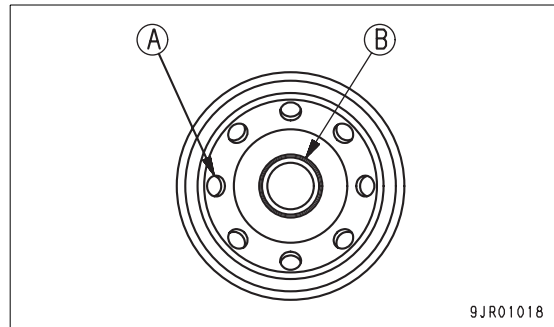

9JR01018

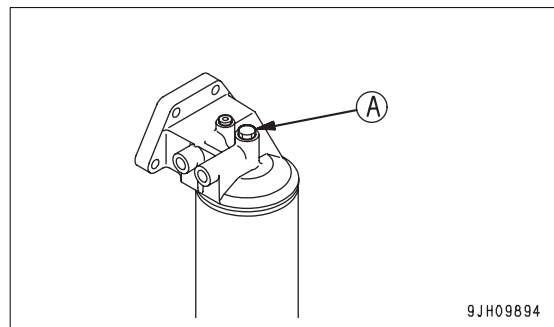

9JH09894

8. Loosen butterfly nut (3) holding the lever of the priming pump.
9. Operate the lever of the priming pump to prime with uel. Fuel will come out from plug (A) at the top of the fuel main filter head. When no more bubbles come out wih the fuel, operate the priming pump lever more slowly. Tighten plug (A).
10. Carry out priming approx. 50 times with priming pump (4) of the supply pump.
11. Tighten butterfly nut (3) holding the lever of the priming pump securely.
Target tightening torque: 11.80 N·m (1.2 kgf·m)
12. Turner valve (1) at the bottom of the fuel tank to the left to open it.
13. Start the engine, run it for approx. 10 minutes at low idling, and check for any leakage of fuel from the filter seal mounting surface.

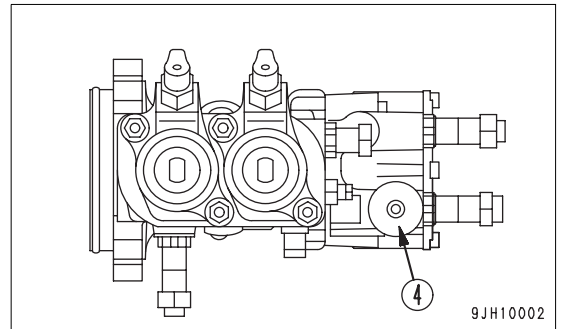
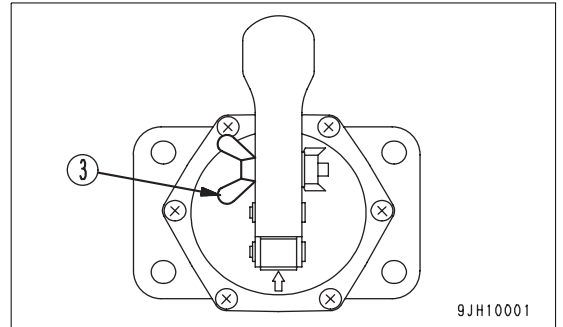

REPLACE HYDRAULIC OIL FILTER ELEMENT

⚠ WARNING

- The parts and oil are at high temperature immediately after the engine is stopped, and may cause burns. Wait for the temperature to go down before starting the work.
- When removing the oil filler cap, turn it slowly to release the internal pressure, then remove it.

1. Set the work equipment on the hard and flat ground in the maintenance posture as shown in the figure, then lower it to the ground and stop the engine.
2. Remove the cap from oil filler (F) on top of the hydraulic tank, and release the internal pressure.
3. Loosen 4 bolts, then remove cover (1).

When doing this, the cover may fly out under the force of spring (2), hold the cover down when removing the bolts.

4. After removing spring (2), valve (3) and strainer (5), take out element (4).

- If there are metal particles or foreign material inside strainer (5), contact your Komatsu distributor.

5. Clean the removed parts in diesel oil.
6. Install the new element in the place where old element (4) was installed.
7. Set valve (3), strainer (5) and spring (2) on top of the element.
8. Set cover (1) in position, push it down by hand, and install the cover with the mousing bolts.
9. Install the cap of oil filler port (F).
10. To bleed the air, start the engine according to "Warming Up Engine (3-94)" and run the engine at low idle for 10 minutes.
11. Stop the engine.

REMARK

Operate the machine after halting for more than 5 minutes to eliminate bubbles in the oil inside the tank.

12. Check for oil leakage and wipe off any spilled oil.

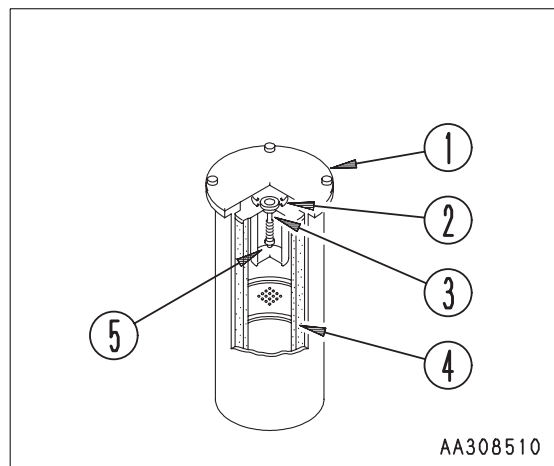
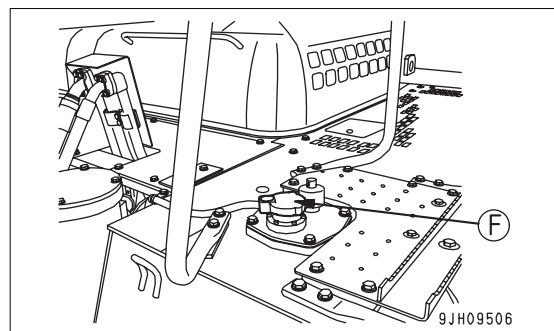
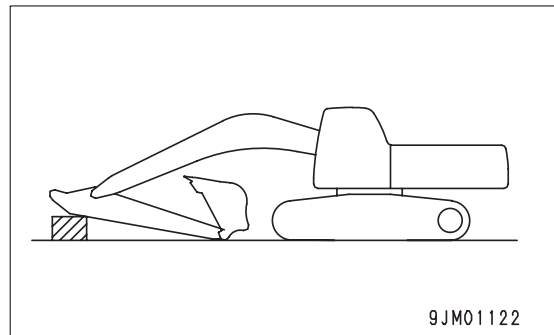

CHANGE OIL IN SWING MACHINERY CASE

⚠ WARNING

Parts and oil are at high temperature immediately after the engine is stopped and may cause serious burns. Wait for the oil temperature to go down before performing this operation.

- Refill capacity: Each 13 liters
- 1. Set a container under drain hose under the machine body to catch the oil.
- 2. Loosen drain valve (P) under the machine body, drain the oil, then tighten the drain plug again.
- 3. Replace breather (1) at the same time when changing the oil.
- 4. Add the refill capacity of oil through the dipstick guide of dipstick (G).
- 5. Wipe off the oil on the dipstick with a cloth.
- 6. Fully insert dipstick (G) into filler pipe (F), then remove it.
- 7. The oil level should be between the H and L marks on dipstick (G).
If the oil level is below the L mark, add oil through oil filler (F).
- 8. If the oil is above the H mark, drain the excess oil from drain plug (P) at bottom of machine, and check the oil level again.
- 9. Immediately after changing the oil, oil level is variable.
So operate for one hour, then check the oil level again.

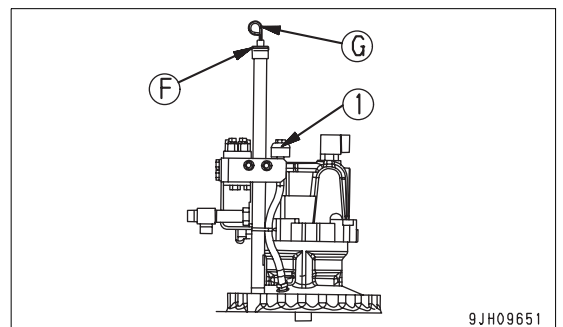
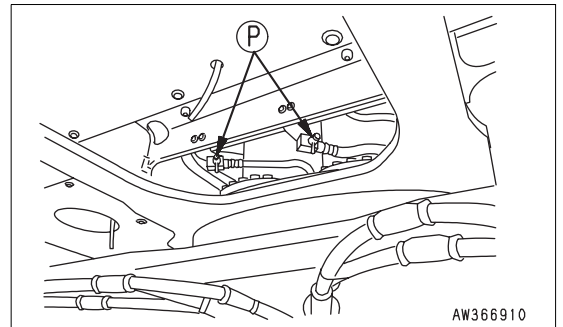

CHANGE OIL IN P.T.O CASE

⚠ WARNING

Parts and oil are at high temperature immediately after the engine is stopped and may cause serious burns. Wait for the oil temperature to go down before performing this operation.

NOTICE

Park the machine on flat ground and stop the engine. After waiting for more than 30 minutes after stopping the engine, check the oil level.

- Refill capacity: 7.2 liters
- 1. Remove undercover (1).
- 2. Remove drain plug (P1) from the bottom of the PTO case.
- 3. Loosen drain plug (P2) and drain the oil from (P1).
- 4. After draining the oil, tighten plug (P2), then install plug (P1).
- 5. Refill the specified quantity of oil through oil filler (F).
- 6. Install undercover (1).

NOTICE

If excess oil is supplied, drain it to the specified amount to avoid overheating.

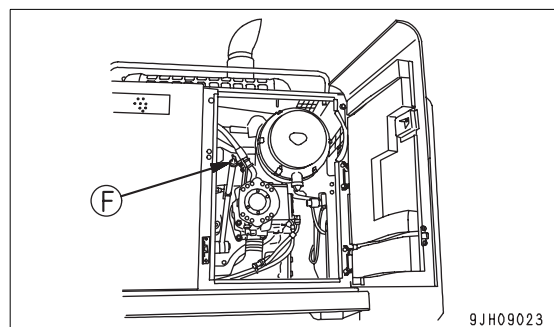
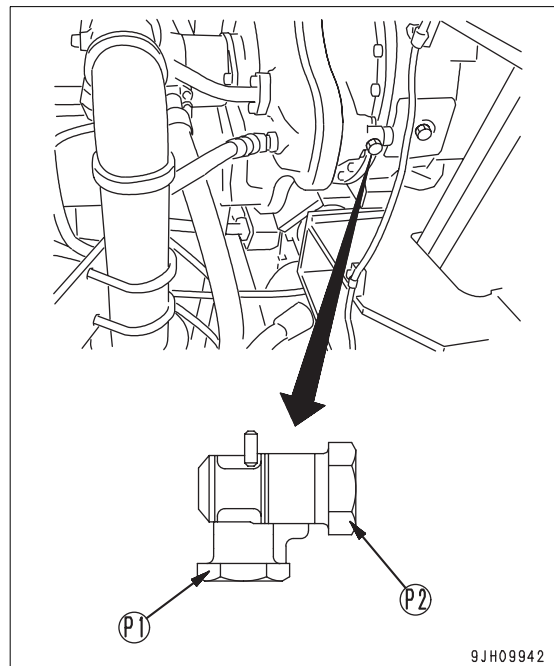
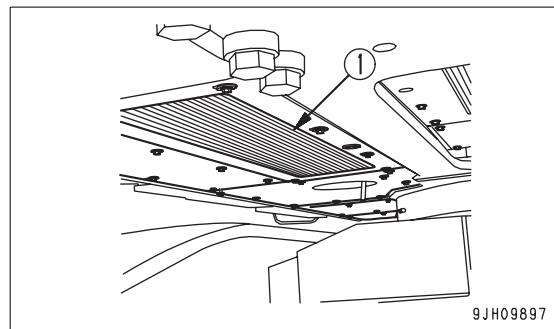

CHECK ALL TIGHTENING POINTS OF ENGINE EXHAUST PIPE CLAMPS

Please ask your Komatsu distributor to check the tightening of the clamps between the air cleaner - turbocharger - aftercooler - engine.

REPLACE CORROSION RESISTOR CARTRIDGE

(If equipped)

 **WARNING**

The oil is at high temperature after the engine has been operated, so never replace the cartridge immediately after finishing operations.

Wait for the oil to cool down before replacing cartridge.

- Container to catch coolant
 - Prepare a filter wrench
1. Turn valve (1) of corrosion resistor (2) to the CLOSE stopper position.
 2. Set a container under the cartridge to catch the coolant.
 3. Using a filter wrench, turn cartridge (2) to the left to remove it.
 4. Clean the filter holder, coat the seal surface of the new cartridge thinly with engine oil, then install the cartridge.
 - Always use a genuine Komatsu part for the cartridge.

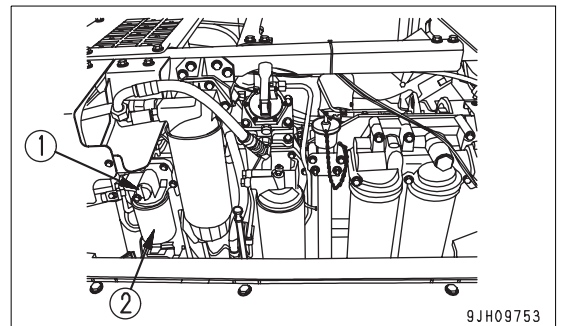

5. When installing the cartridge, bring the packing surface into contact with the seal surface of the filter holder, then tighten a further 2/3 times.

If the filter cartridge is tightened too far, the gasket will be damaged and coolant will leak. If it is too loose, coolant will leak from the gap in the gasket, so always keep the proper tightening angle.

6. Turn valve (1) of corrosion resistor (2) to the OPEN stopper position.
7. After replacing the cartridge, run the engine, and check for any leakage of water from the filter seal surface. If any water leakage is found, check the tightening of the filter cartridge.

CHECK WELDED STRUCTURE

(Color check)

Cracks in welded structures can be seen easily with a color check. Check the revolving frame, center frame, boom, and arm every 1000 hours.

In particular, carry out a color check on the important check points (marked with a circle).

The procedure for the color check is as follows.

1. Prepare the materials needed for the color check. (Detergent, penetrating agent, developing solution)
2. Spray with detergent and wash to remove all the dirt and oil from the place to be checked.
3. After washing, dry the area, then spray with penetrating agent and leave for 5 - 20 minutes.
4. Spray with detergent, then clean the surface with a cloth.
5. Clean the surface again, then spray with developing solution.
6. Leave for 15 - 20 minutes, then check visually for cracks.

If there are any cracks, color can be seen.

7. If there are any cracks, carry out the repair procedure to repair.

(A): Important check points

(F): Front

- Revolving frame

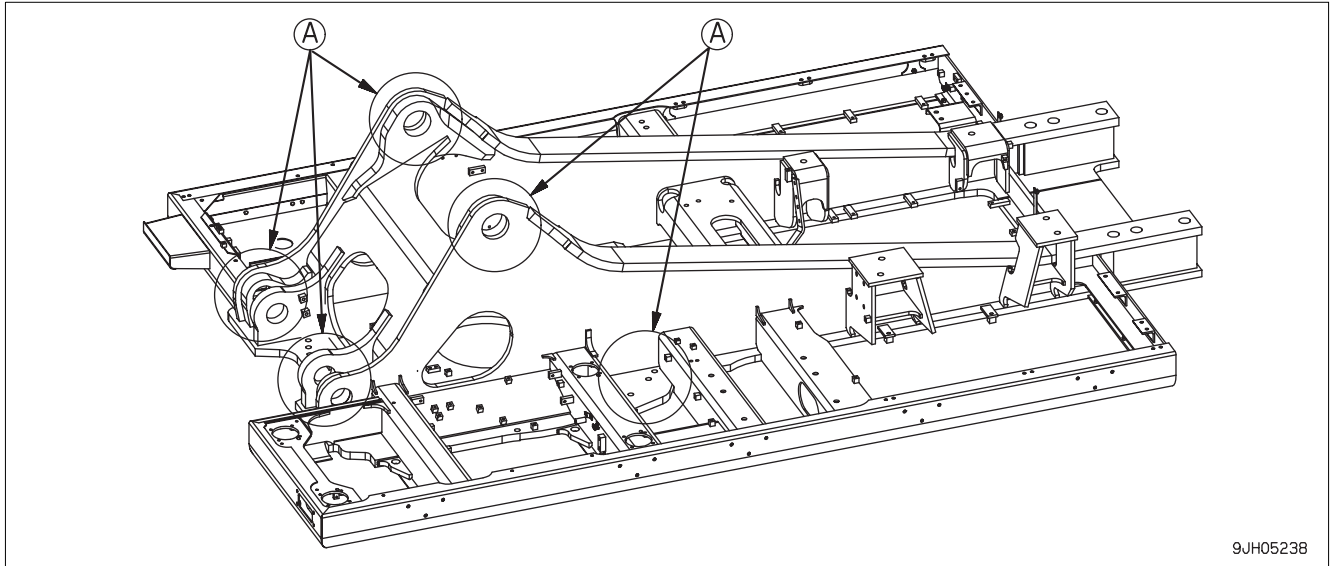

9JH05238

- Center frame

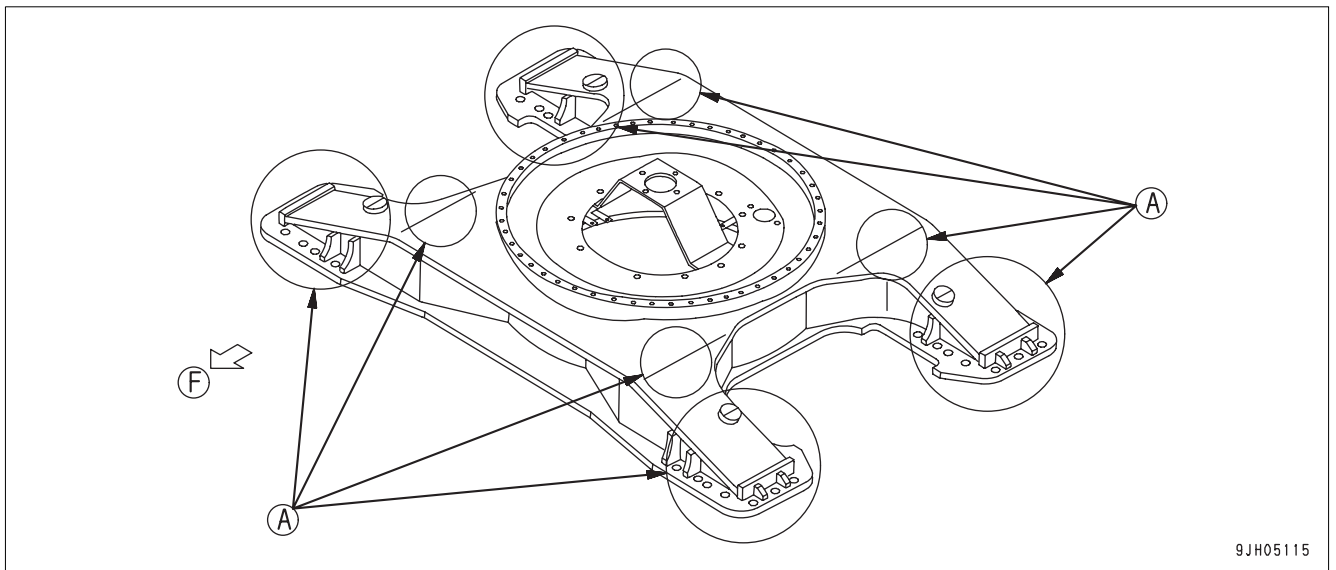

9JH05115

(A): Important check points

- Boom

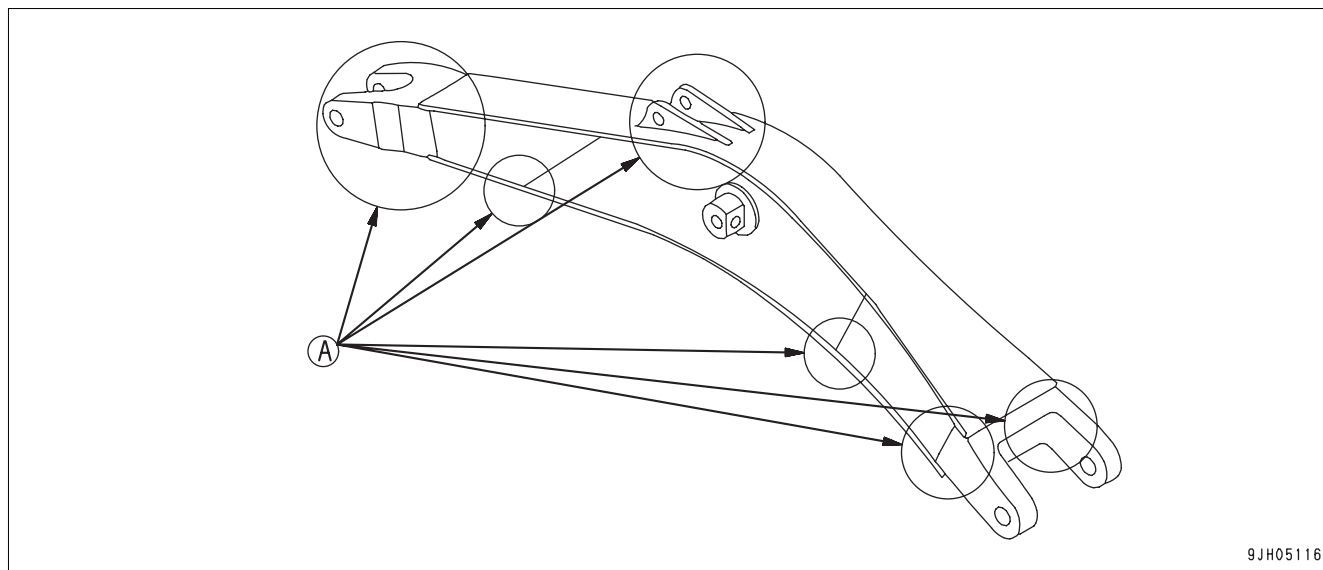

- Arm

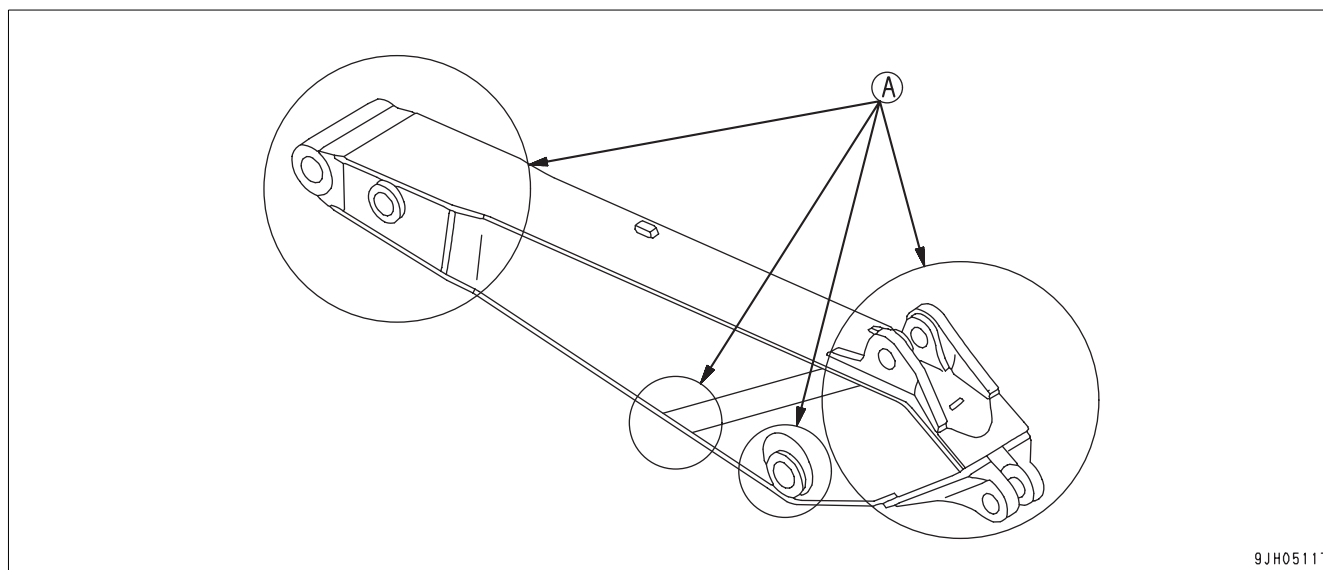

REPLACE HYDRAULIC TANK ADDITIONAL BREATHER ELEMENT

⚠ WARNING

- The parts and oil are at high temperature immediately after the engine is stopped, and may cause burns. Wait for the temperature to go down before starting the work.
- When removing the oil filler cap, turn it slowly to release the internal pressure, then remove it.

1. Pull out snap ring (2) of breather assembly (1) at the top of the hydraulic tank, then remove cover (3).
2. Replace filter element (4) with a new element.
3. Install cover (3) and snap ring (2).

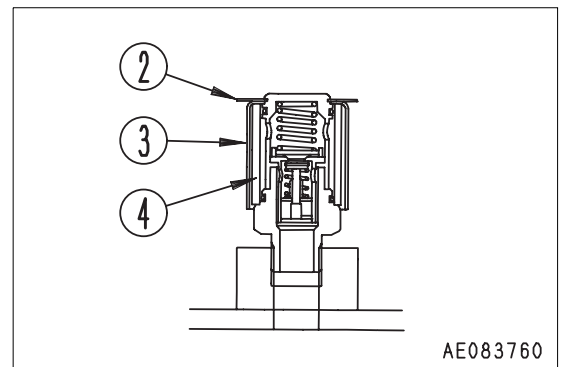
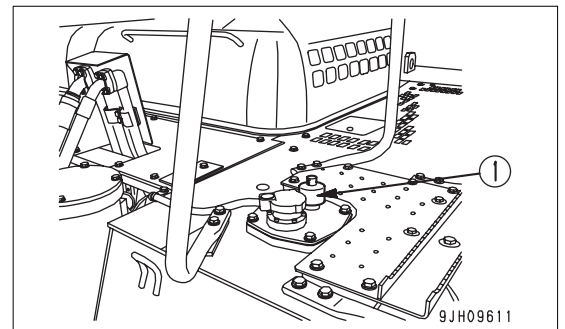

CHECK NITROGEN GAS CHARGE PRESSURE IN ACCUMULATOR (for breaker)

(If equipped)

A special tool is needed for inspecting and charging with nitrogen gas.

Have your Komatsu distributor inspect and charge the accumulator.

REPLACE BREATHER ELEMENT IN HYDRAULIC TANK**⚠ WARNING**

- The parts and oil are at high temperature immediately after the engine is stopped, and may cause burns. Wait for the temperature to go down before starting the work.
- When removing the oil filler cap, turn it slowly to release the internal pressure, then remove it.

1. Remove the cap of oil filler (F) at the top of the hydraulic tank.

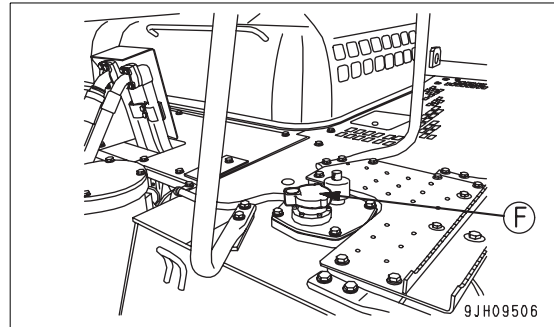

2. Replace element (1) inside the cap.

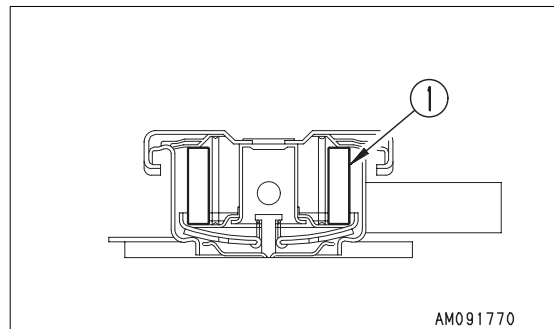

EVERY 2000 HOURS MAINTENANCE

Maintenance for every 10, 100, 250, 500, and 1000 hours of service should be performed at the same time.

CHANGE OIL IN FINAL DRIVE CASE

⚠ WARNING

- The parts and oil are at high temperature immediately after the engine is stopped, and may cause serious burns. Wait for the temperature to go down before starting the operation.
- If there is still pressure remaining inside the case, the oil or plug may fly out. Loosen the plug slowly to release the pressure.

- Refill capacity: each 10 liters
 - Prepare a handle.
1. Set the TOP mark at the top, with the TOP mark and plug (P) perpendicular to the ground surface.
 2. Remove plugs (P) and (F) with the handle and drain the oil.

REMARK

Check the O-rings in the plugs for damage. If necessary, replace with new ones.

3. Tighten plug (P).
4. Add oil through the hole of plug (F).
5. When the oil overflows from the hole of plug (F), install plug (F).

Tightening torque of plugs (P) and (F) : $68.6 \pm 9.8 \text{ N}\cdot\text{m}$ ($7 \pm 1 \text{ kgf}\cdot\text{m}$)

When the oil overflows from the hole of plug (F), install plug (F). Tighten plugs (P) and (F).

Tightening torque of plugs (P) and (F) : $68.6 \pm 9.8 \text{ N}\cdot\text{m}$ ($7 \pm 1 \text{ kgf}\cdot\text{m}$)

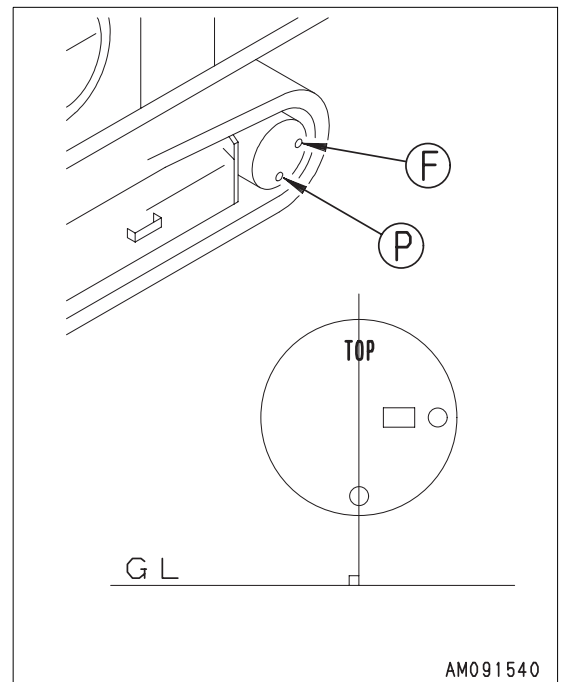

CLEAN HYDRAULIC TANK STRAINER

⚠ WARNING

- After the engine is stopped, the parts and oil are at high temperature, so there is danger of burns. Wait for the temperature to go down before starting the operation.
- When the cap of the oil filler port is removed, oil may spurt out, so turn it slowly to release the internal pressure, then remove it carefully.
- When removing cover (1), the cover may fly off under the force of spring (2), so loosen the 4 bolts slowly.

1. Remove the cap from oil filler (F) on top of the hydraulic tank.
2. Remove cover (1) and lift up the top of rod (3) from above to take out spring (2) and strainer (4).
3. Remove any dirt stuck to strainer (4), then wash it in clean diesel oil or flushing oil. If strainer (4) is damaged, replace it with a new part.
4. When installing, insert strainer (4) into protruding part (5) of the tank, and assemble.
5. Assemble so that the protruding part at the bottom of cover (1) holds spring (2), then tighten with the bolt.

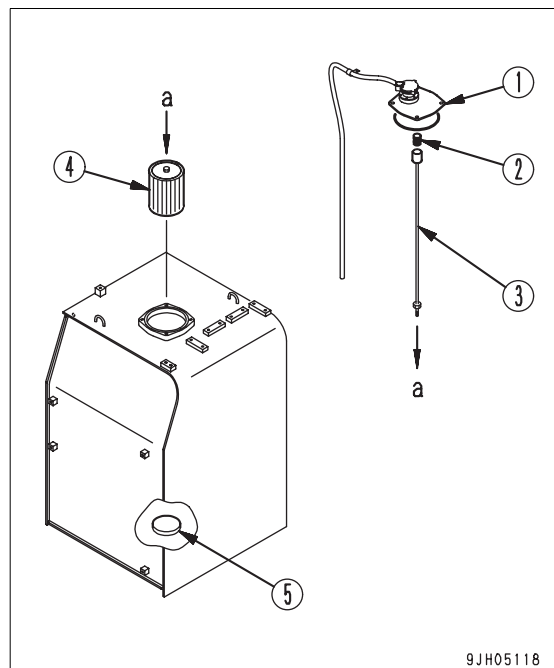
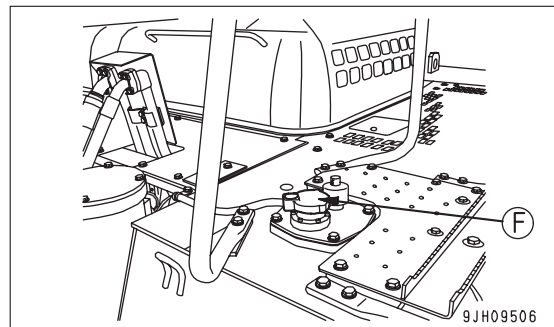

CHECKING CHARGE PRESSURE OF NITROGEN GAS IN ACCUMULATOR (FOR CONTROL CIRCUIT)

WARNING

The accumulator is charged with high-pressure nitrogen gas, so mistaken operation may cause an explosion, which will lead to serious injury or damage. When handling the accumulator, always do as follows. The pressure in the hydraulic circuit cannot be completely removed. When removing the hydraulic equipment, do not stand in the direction that the oil spurts out when carrying out the operation. In addition, loosen the bolts slowly when carrying out the operation.

Do not disassemble the accumulator.

Do not bring it near flame or dispose of it in fire.

Do not make holes in it or weld it.

Do not hit it, roll it, or subject it to any impact.

When disposing of the accumulator, the gas must be released. Please contact your Komatsu distributor to have this work carried out.

NOTICE

If the nitrogen gas charge pressure in the accumulator is low and operations are continued, it will become impossible to release the remaining pressure inside the hydraulic circuit if a failure occurs on the machine.

FUNCTION OF ACCUMULATOR

The accumulator stores the pressure in the control circuit. Even after the engine is stopped, the control circuit can be operated, so the following actions are possible.

- If the control lever is operated in the direction to lower the work equipment, it is possible for the work equipment to go down under its own weight.
- The pressure in the hydraulic circuit can be released.

The accumulator is installed to the position shown in the diagram on the right.

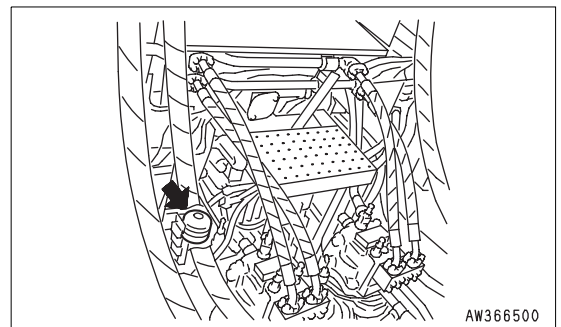

CHECKING FUNCTION OF ACCUMULATOR

⚠ CAUTION

When carrying out the inspection, check first that there is no person or obstacle in the surrounding area.

Check the nitrogen gas charge pressure as follows.

1. Stop the machine on firm, level ground.
2. Hold the work equipment in the maximum reach posture (arm fully out, bucket fully dumped) at a height (A) 1.5 m from the ground.

Carry out Steps 3 - 5 within 15 seconds.

When the engine is stopped, the pressure in the accumulator gradually goes down. For this reason, the check can only be carried out immediately after the engine is stopped.

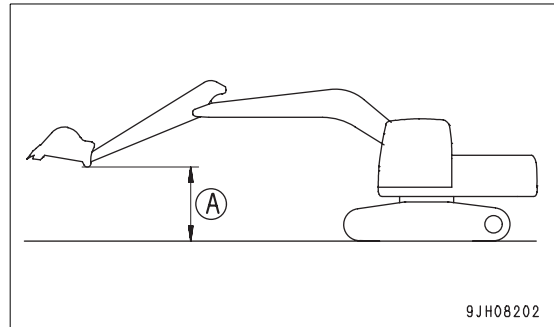

3. Keep the work equipment at the maximum reach, turn the starting switch to the OFF position (A), and stop the engine.

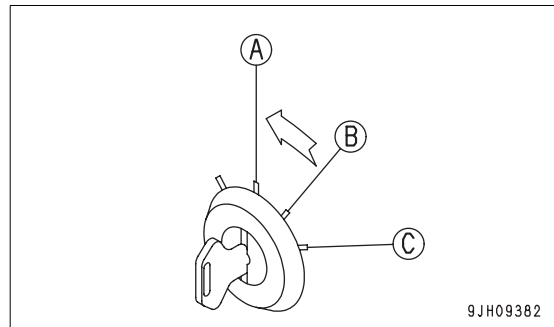

4. Turn the starting switch to the ON position (B).

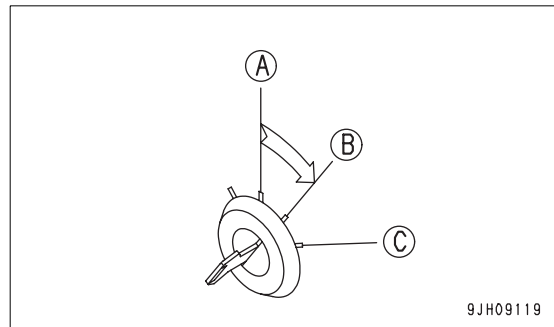

5. With the lock lever at the FREE position (F), operate the work equipment control levers fully in the LOWER direction and check that the work equipment is lowered to the ground.

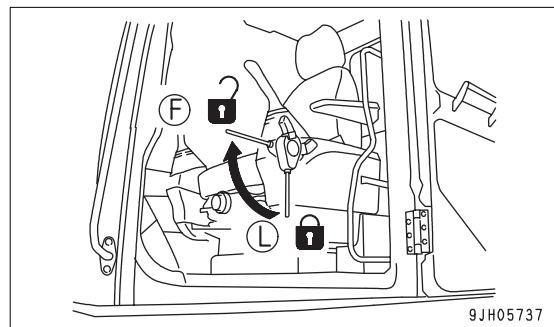

6. If the work equipment goes down under its weight and contacts the ground, the accumulator is normal.

If the work equipment does not go down or stops in mid-way, the charged pressure of the gas in the accumulator for the hydraulic circuit has probably dropped.

Please contact your Komatsu distributor for inspection.

7. This completes the inspection. After completion of the inspection, set the lock lever to the LOCK position and turn the starting switch to the OFF position.

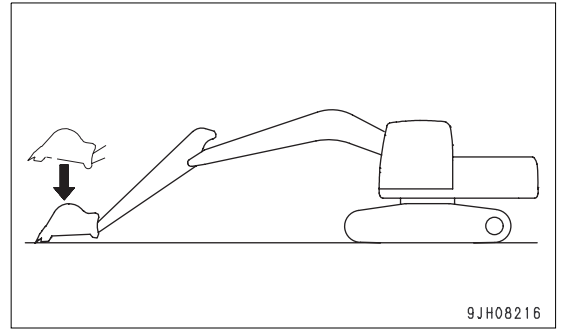

METHOD OF RELEASING PRESSURE IN HYDRAULIC CIRCUIT

⚠ WARNING

- The hydraulic system is always under internal pressure, so when inspecting or replacing the piping or hoses, always release the pressure in the circuit before starting. If the pressure is not released, high pressure oil may spurt out and cause serious personal injury.
- The parts and oil are at high temperature after the engine is stopped, and may cause serious burns. Wait for the temperature to go down before starting the operation.
- When the oil filler cap is removed, oil may spurt out, so turn the cap slowly to release the pressure before removing the cap.

1. Stop the machine on firm horizontal ground, lower the work equipment to the ground as shown in the diagram on the right, then stop the engine.
 - Set the lock lever at the FREE position (F).
2. Operate each work equipment control lever to the full stroke within 5 - 6 seconds after stopping the engine.
 - Leave the starting switch at the ON position.
3. Remove the cap of the hydraulic tank.
4. Start the engine, run for approx. 10 seconds, then stop the engine again.
 - Do not run the engine at more than 1000 rpm.
 - Set the work equipment control levers to the HOLD position.
5. Operate each work equipment control lever to the full stroke within 5 - 6 seconds after stopping the engine.
 - Repeat Steps 4 - 5 three times.

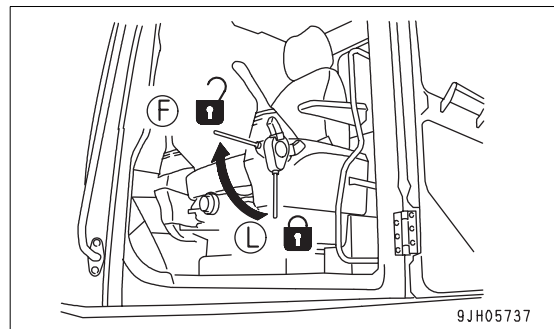
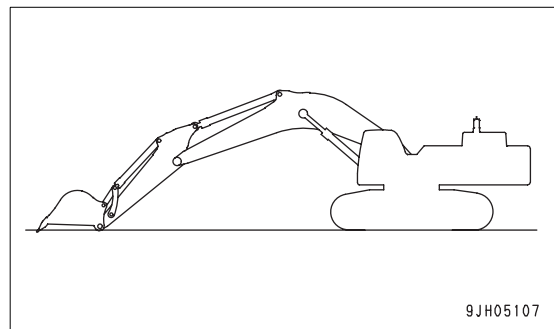

CHECK ALTERNATOR, STARTING MOTOR

There is a possibility that the bearing is short of grease. Call your Komatsu distributor for inspection and repair.

If the engine is started frequently, ask for the inspection every 1000 hours of operation.

EVERY 4000 HOURS MAINTENANCE

Maintenance for every 10, 100, 250, 500, 1000, and 2000 hours of service should be performed at the same time.

CHECK WATER PUMP

Check for leakage of oil or water. If any problem is found, ask your Komatsu distributor to carry out disassembly and repair or replacement.

REPLACE ACCUMULATOR (FOR CONTROL CIRCUIT)

Replace the accumulator every 2 years or every 4000 hours, whichever comes sooner.

WARNING

The accumulator is charged with high-pressure nitrogen gas, so mistaken operation may cause an explosion, which will lead to serious injury or damage. When handling the accumulator, always do as follows. The pressure in the hydraulic circuit cannot be completely removed. When removing the hydraulic equipment, do not stand in the direction that the oil spurts out when carrying out the operation. In addition, loosen the bolts slowly when carrying out the operation.

Do not disassemble the accumulator.

Do not bring it near flame or dispose of it in fire.

Do not make holes in it or weld it.

Do not hit it, roll it, or subject it to any impact.

When disposing of the accumulator, the gas must be released. Please contact your Komatsu distributor to have this work carried out.

If operations are continued after the performance of the accumulator has dropped, it will be impossible to release the remaining pressure in the hydraulic circuit if there should be a failure on the machine. Please ask your Komatsu distributor to replace the accumulator.

The accumulator is installed to the position shown in the diagram on the right.

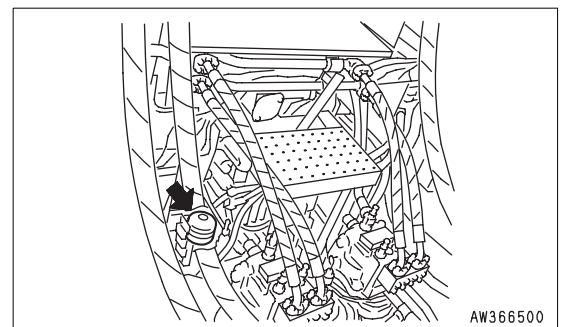

CHECK FOR LOOSENESS OF HIGH-PRESSURE PIPING CLAMP, HARDENING OF RUBBER

Check for any looseness in the high-pressure clamp mounting bolts (1) to (15) in the drawing in the illustrations below. Check visually and feel with your finger to check that the rubber has not hardened. If there is any problem, the problem part must be replaced. Contact your Komatsu distributor for part replacement.

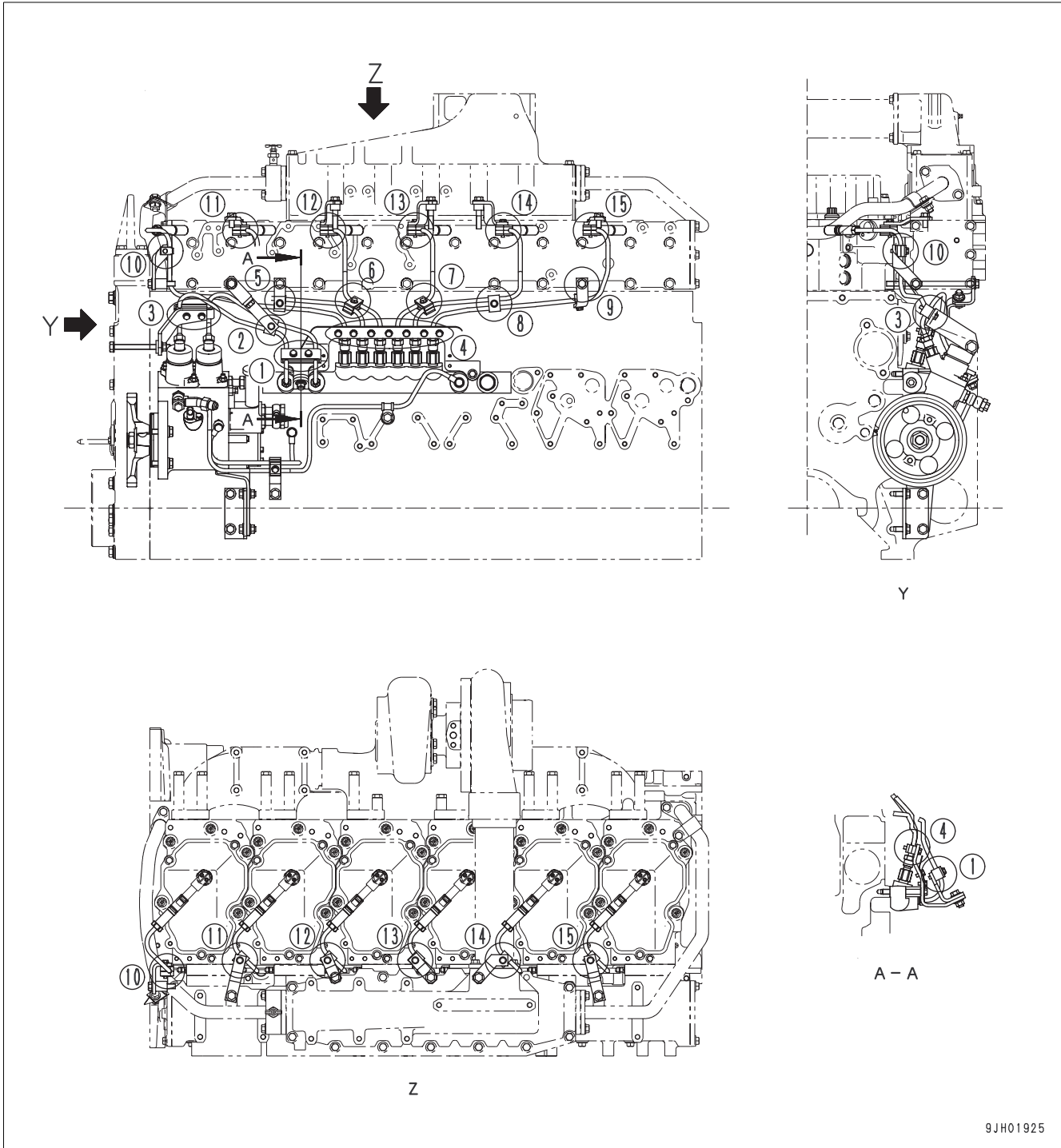

9JH01925

NOTICE

If the engine continues to be used when there are loose bolts, hardened rubber, or missing parts, there is danger of damage or breakage occurring due to vibration and wear at the connections of high-pressure piping. Always check that the proper high-pressure piping clamps are correctly installed.

CHECK FOR MISSING FUEL SPRAY PREVENTION CAP, HARDENING OF RUBBER

Fuel spray prevention caps (1) - (16) and fuel spray prevention cover (17) are protective parts installed to prevent fire caused by fuel leaking and spraying out on to high temperature parts of the engine. Check visually that there are no missing caps or loose bolts, and feel with your finger to check that the rubber has not hardened. If there is any problem, the problem part must be replaced. Contact your Komatsu distributor for part replacement.

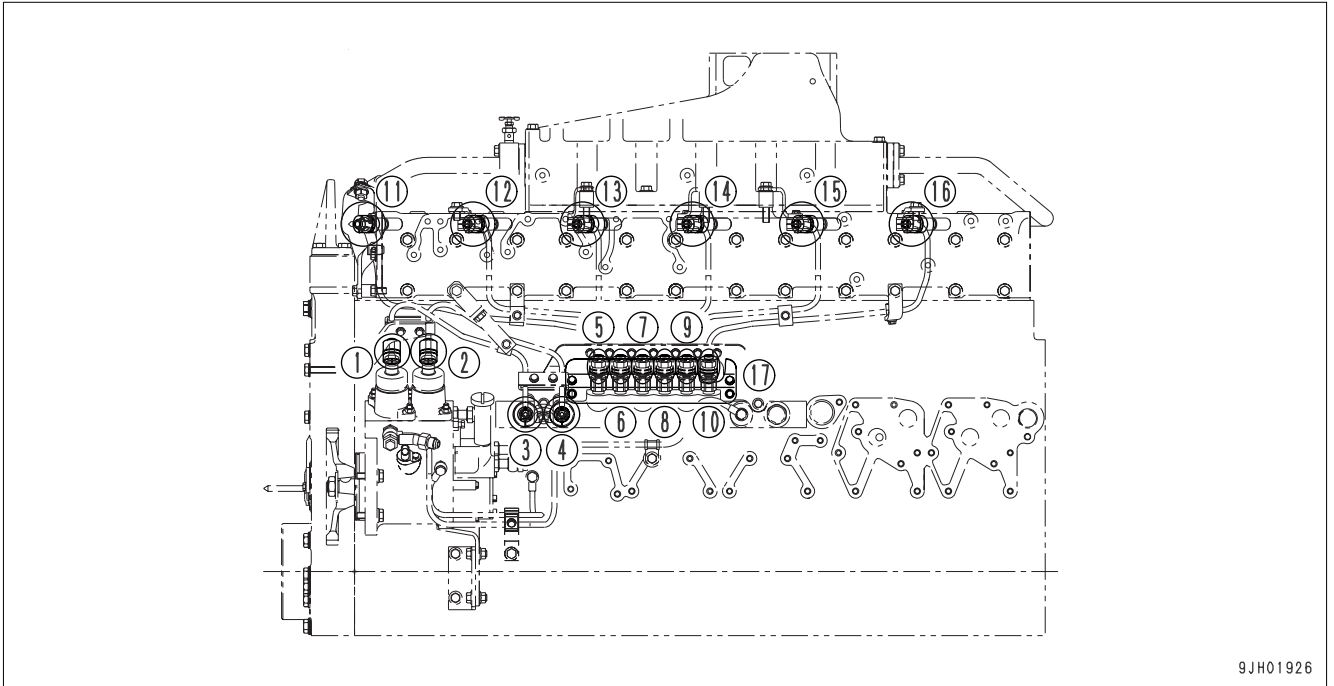

9JH01926

CHECK OPERATING CONDITION OF COMPRESSOR

Ask your Komatsu distributor to carry out the inspection.

EVERY 5000 HOURS MAINTENANCE

Maintenance for every 10, 100, 250, 500, 1000, and 2000 hours of service should be performed at the same time.

CHANGE OIL IN HYDRAULIC TANK

WARNING

- The parts and oil are at high temperature immediately after the engine is stopped, and may cause burns. Wait for the temperature to go down before starting the work.
- When removing the oil filler cap, turn it slowly to release the internal pressure, then remove it.

- Refill capacity: 360 liters
 - Prepare a handle for socket wrench set
1. Swing the upper structure 45° to the left so that drain plugs (P1), (P2) under the tank and the bottom of the pump suction tube are in the middle between the left and right tracks.
 2. Retract the arm and bucket cylinders, then lower the boom and put the teeth in contact with the ground.
 3. Set the lock lever to the LOCK position and stop the engine.
 4. Remove the undercover under drain plug (P).

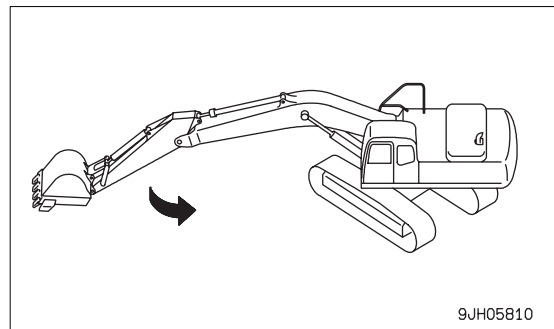

5. Remove the cap of oil filler port (F) at the top of the hydraulic tank.
6. Set a container under the drain plug to catch the drained oil.

Remove (P1) of drain plug (P), then loosen (P2) and drain the oil. After draining the oil, tighten drain plugs (P1) and (P2).

- Tightening torque: $68.6 \pm 9.8 \text{ N}\cdot\text{m}$ ($7 \pm 1 \text{ kgf}\cdot\text{m}$)

When loosening drain plug (P2) be careful not to get oil on yourself.

7. Add the replacement amount of oil through oil filler (F). Check that the oil level is between the H and L lines on the sight gauge.

For details of oil level check, see "Check Oil Level in Hydraulic Tank, Add Oil (3-79)".

8. Bleed the air from the circuit after cleaning or replacing the filter element or strainer, or after changing the oil.
9. Install the undercover under drain plug (P).

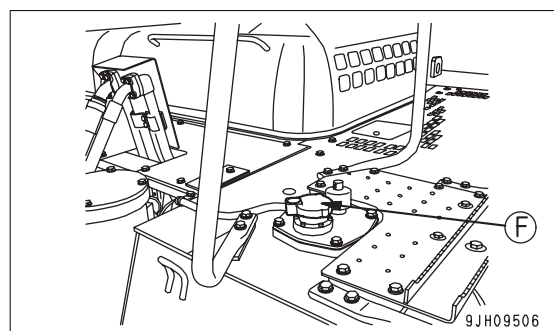
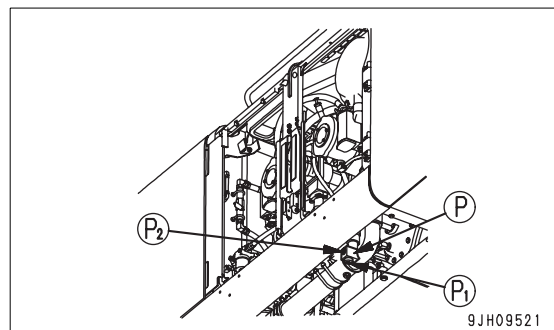

EVERY 8000 HOURS MAINTENANCE

Maintenance for every 10, 100, 250, 500, 1000, 2000, and 4000 hours of service should be performed at the same time.

REPLACE HIGH-PRESSURE PIPING CLAMP

Contact your Komatsu distributor to have the engine high-pressure clamps replaced.

REPLACE FUEL SPRAY PREVENTION CAP

Contact your Komatsu distributor to have the fuel spray prevention cap replaced.

SPECIFICATIONS

SPECIFICATIONS

Item	Unit	PC600-8	PC600LC-8
Operating weight (including one person)	kg	57,640	58,640
Bucket capacity	m ³	2.7	2.7
Name of engine	-	KOMATSU SAA6D140E-5 deisel engine	
Rated horsepower of engine	kW (HP)/rpm	317 (425)/1,800	317 (425)/1,800
A Overall length	mm	11,830	12,440
B Overall height	mm	4,600	4,300
C Overall width	mm	4,210	4,210
D Track shoe width	mm	600	600
E Height of cab	mm	3,290	3,290
F tail swing radius	mm	3,800	3,800
G Overall length of track	mm	5,340	5,690
H Tumbler center distance	mm	4,250	4,600
Min. ground clearance	mm	780	780
Traveling speed (low/high)	km/h	3.0/4.9	3.0/4.9
Swing speed	rpm	8.3	8.3

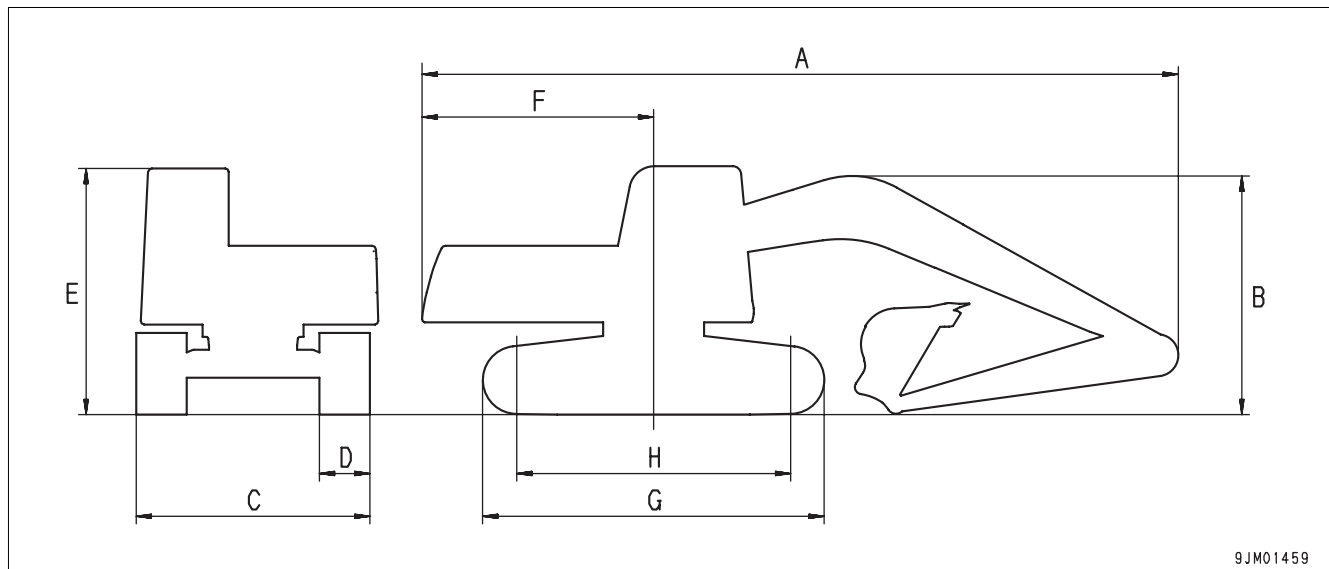

9JM01459

Working ranges	Unit	PC600-8	PC600LC-8
A Max. digging reach	mm	13,020	13,020
B Max. digging depth	mm	8,490	8,490
C Max. digging height	mm	11,880	11,880
D Maximum vertical wall digging depth	mm	7,510	7,510
E Max. dumping height	mm	7,960	7,960
F Max. digging reached at ground level	mm	12,800	12,800

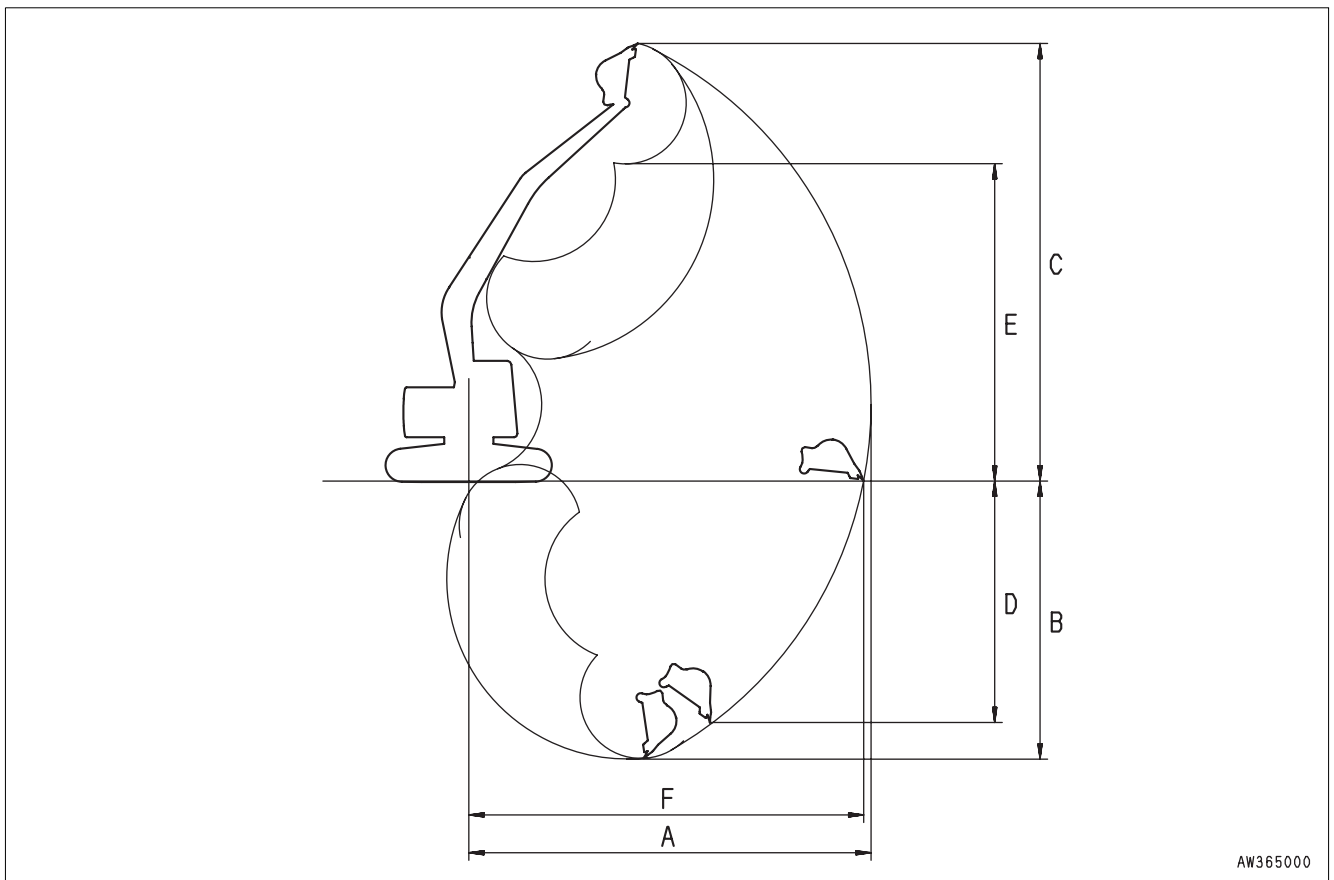

ATTACHMENTS AND OPTIONS



WARNING

Please read and make sure that you understand the safety volume before reading this section.

GENERAL PRECAUTIONS FOR SAFETY

When installing attachments or options to the machine, it is necessary to pay attention to safety. Please obey the following precautions strictly when selecting, installing, or using attachments or options.

PRECAUTIONS WHEN SELECTING

- Please consult your Komatsu distributor before installing attachments or options to the machine. Depending on the type of attachment or option, it may be necessary to install a front guard, overhead guard, or other safety structure to the machine. There may also be problems of the attachment or option hitting the operator's cab.
- Install only attachments or options authorized by Komatsu. Komatsu cannot accept any responsibility for any accident, damage, or failure caused by the use of attachments or options not authorized by Komatsu.

READ THE INSTRUCTION MANUAL THOROUGHLY

- Before using or starting the operation to remove or install any attachment or optional device, read the instruction manual for the machine itself and for the attachment or optional device thoroughly.
- If you lose the instruction manual or it is damaged, always obtain a new copy from the attachment manufacturer or your Komatsu distributor.

PRECAUTIONS WHEN REMOVING OR INSTALLING

When removing or installing the attachment or option, obey the following precautions, and take care to ensure safety during the operation.

- Carry out the removal and installation operation on a flat, firm ground surface.
- When the operation is carried out by two or more workers, choose the leader and follow his instructions.
- Use a crane when handling heavy objects (more than 25 kg). (The crane must be operated by a qualified operator.)
- Never go under a load raised by the crane.
- Do not carry out operations with the load kept raised by the crane. Always use a stand to prevent the load from falling.
- When removing a heavy part, consider the balance after it is removed. To prevent the machine from tipping over, set a support in position if necessary before removing the part.
- Before installing or after removing the attachment or option, set it in a stable condition to prevent it from falling over.
- For details of the removal or installation operation, please consult your Komatsu distributor.

PRECAUTIONS WHEN USING

When long or heavy work equipment is installed, remember the following precautions. Before starting operations, move the machine to a safe place and carry out a test operation to make sure that you fully understand the movement, center of gravity, and working range of the machine.

- Do not swing the work equipment if the machine is at an angle. If the work equipment is swung with the machine at an angle, there is danger that the machine will tip over.
- Always maintain a safe distance from obstacles in the surrounding area when operating. If long work equipment is installed, the working range becomes larger.
- If heavy work equipment is installed, pay careful attention to the following precautions.
 - The swing overrun (the distance the work equipment moves before completely stopping after the swing brake is applied) will be greater. There is danger of hitting objects if the swing overrun is miscalculated, so allow extra space to the swing position when swinging.
 - The hydraulic drift of the work equipment (the amount of the work equipment moves down under its own weight when it is stopped in a raised position) also becomes greater. Do not stop the work equipment in a raised position; always lower it to the ground.
 - Do not swing, lower, or stop the work equipment suddenly. There is danger that the machine may tip over.
 - Do not suddenly extend or retract the boom cylinder. The shock may cause the machine to tip over.

ATTACHMENT GUIDE

WARNING

- Please read the instruction manual for the attachment and the sections of this manual related to attachments and options.
- When installing any attachment or option, there may be problems with safety, so please contact your Komatsu distributor before installing.
- Installing attachments or options without consulting your Komatsu distributor may not only cause problems with safety, but may also have an adverse effect on the operation of the machine and the life of the equipment.
- Any injuries, accidents, or damage resulting from the use of unauthorized attachments or options will not be the responsibility of Komatsu.

COMBINATIONS OF WORK EQUIPMENT

WARNING

Depending on the type or combination of work equipment, there is danger that the work equipment may hit the cab or machine body.

When using unfamiliar work equipment for the first time, check before starting if there is any danger of interference, and operate with caution.

Select the combination of boom, arm, and bucket from the combinations shown in the table below.

Bucket name	Capacity m ³	Bucket width mm		7.6 m boom		7.3 m boom		6.6 m boom
		Side cutter (Excluding side shroud)	Side cutter (Including side shroud)	3.5m arm	2.9m arm	3.5m arm	2.9m arm	SE arm 2.9 m
Narrow	2.4	1,320	1,400	○	○	○	○	○
Standard	2.7	1,600	1,680	●	○	○	○	○
Stone crushing (strengthened)	2.8	1,655	1,705	×	●	●	●	○
Wide (SE)	3.5	1,850	1,900	×	×	×	×	●

●: for standard operations

○: Possible to use only light work

×: Impossible to use

Working Range Diagram

	Working ranges	Unit	PC600 Standard arm 3.5 m	PC600 Semi-long arm 4.3 m	PC600 Long arm 5.2 m	PC600 SE arm 2.9 m
A	Max. digging reach	mm	13,020	13,740	14,630	11,550
B	Max. digging depth	mm	8,490	9,275	10,255	7,060
C	Max. digging height	mm	11,880	12,180	12,560	11,140
D	Maximum vertical wall digging depth	mm	7,510	8,375	9,275	5,630
E	Max. dumping height	mm	7,960	8,245	8,600	7,210
F	Max. digging reached at ground level	mm	12,800	13,555	14,435	11,330

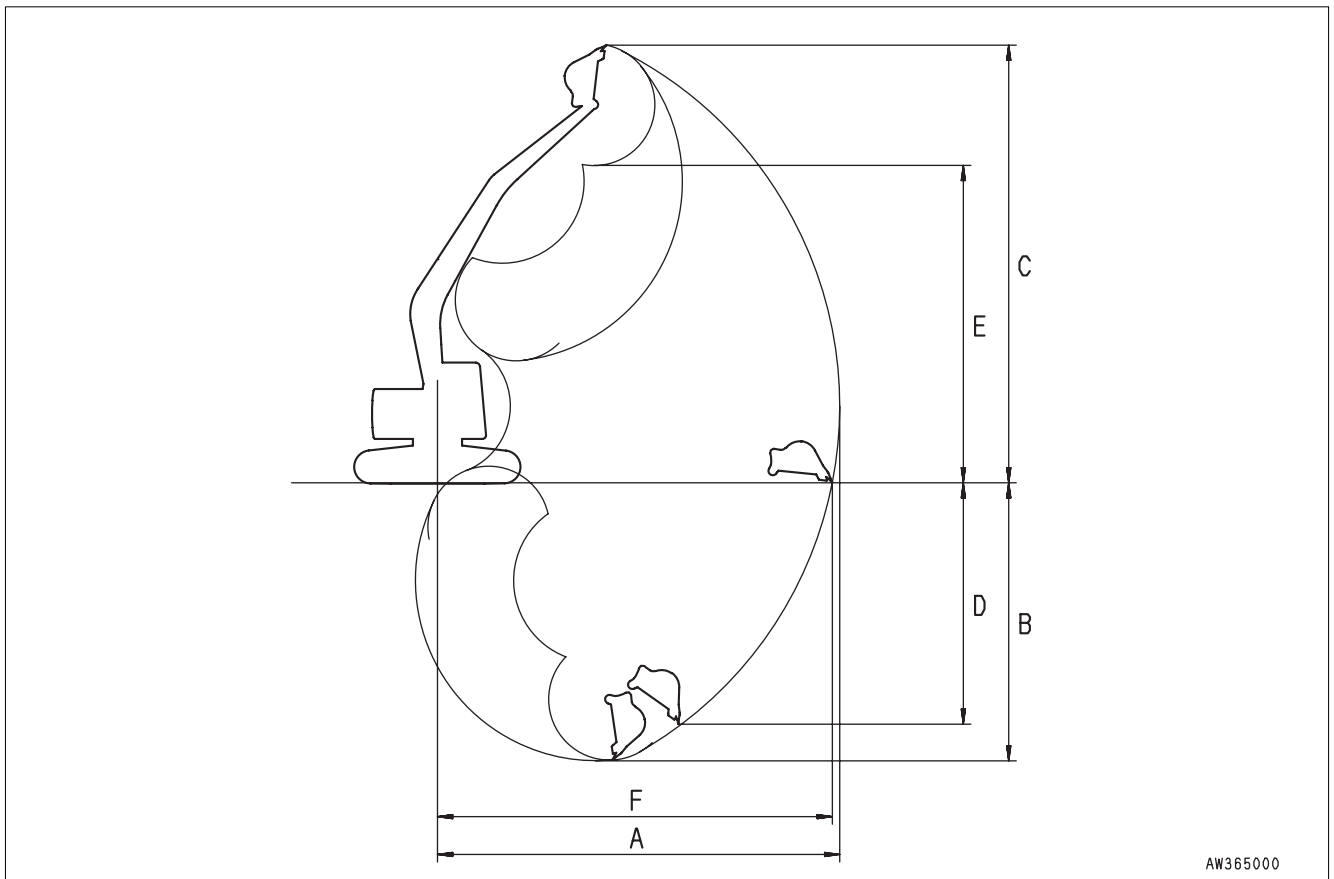

TRACK SHOES SELECTION

Select the appropriate track shoe to match the operating conditions.

Selection

Check the category from the uses in the table below, then select the shoes from the table below that.

- Category of use B is the wide shoe, so there are limits on the use. Check the precautions for use, examine the conditions of use thoroughly, and use the optimum shoes for the situation.
- When selecting the shoe width, choose the narrowest shoes possible to bring the machine within the range where there is no problem regarding the machine flotation and ground contact pressure. If wider shoes than necessary are used, the load on the track shoe will increase, so this may cause problems such as bending of the shoe, cracking of the link, damage of the pin, and looseness of the shoe bolts.

Category	Use	Precautions when using
A	Rocky ground, riverbeds, normal soil	<ul style="list-style-type: none"> ● On rough ground with large obstacles such as boulders or fallen trees, travel at low speed.
B	Normal soil, soft ground	<ul style="list-style-type: none"> ● These shoes cannot be used on rough ground where there are large obstacles such as boulders or fallen trees. ● Travel at Hi or Mi speed only on flat ground, and if it is impossible to avoid going over obstacles, shift down and travel at half speed in Lo.

	PC600	PC600LC
	Specifications	Classification
Standard	600 mm triple	A
Option	700 mm triple	B
	750 mm triple	

HANDLING MACHINES EQUIPPED WITH KOMTRAX

- KOMTRAX is a machine management system that uses wireless communications.
- A contract with your Komatsu distributor is necessary before the KOMTRAX system can be used. Any customers desiring to use the KOMTRAX system should consult their Komatsu distributor.
- The KOMTRAX equipment is a wireless device using radio waves, so it is necessary to obtain authorization and conform to the laws of the country or territory where the machine equipped with KOMTRAX is being used. Always contact your Komatsu distributor before selling or exporting any machine equipped with KOMTRAX.
- When selling or exporting the machine or at other times when your Komatsu distributor considers it necessary, it may be necessary for your Komatsu distributor to remove the KOMTRAX equipment or to carry out action to stop communications.
- If you do not obey the above precautions, neither Komatsu nor your Komatsu distributor can take any responsibility for any problem that is caused or for any loss that results.

BASIC PRECAUTIONS

WARNING

- **Never disassemble, repair, modify, or move the communications terminal, antenna, or cables. This may cause failure or fire on the KOMTRAX equipment or the machine itself. (Your Komatsu distributor will carry out removal and installation of KOMTRAX.)**
- **Do not allow cables or cords to become caught; do not damage or pull cables or cords by force. Short circuits or disconnected wires may cause failure or fire on the KOMTRAX equipment or the machine itself.**
- **For anyone wearing a pacemaker, make sure that the communications antenna is at least 22 cm from the pacemaker. The radio waves may have an adverse effect on the operation of the pacemaker.**

NOTICE

- **Even when the key in the starting switch of the KOMTRAX system is at the OFF position, a small amount of electric power is consumed. When putting the machine into long-term storage, take the action given in "LONG TERM STORAGE (3-181)".**
- **Please contact your Komatsu distributor before installing a top guard or other attachment that covers the cab roof.**
- **Be careful not to get water on the communications terminal or wiring.**

REMARK

The KOMTRAX system uses wireless communications, so it cannot be used inside tunnels, underground, inside buildings, or in mountain areas where radio waves cannot be received. Even when the machine is outside, it cannot be used in areas where the radio signal is weak or in areas outside the wireless communication service area.

REMARK

There is absolutely no need to inspect or operate the KOMTRAX communications terminal, but if any abnormality is found, please consult your Komatsu distributor.

INDEX

INDEX

<A>

Air Conditioner Controls	3-53
Ashtray	3-52
Attachment Guide	6-4
Combinations of Work Equipment	6-4
Auxiliary Electric Power.....	3-66

Breaking-In The New Machine.....	1-10
Bucket Replacement.....	3-120

<C>

Cap with Lock.....	3-51
Circuit Breaker	3-68
Cold Weather Operation	3-135
After Cold Weather Season.....	3-138
After Daily Work Completion	3-138
Cold Weather Operation Information.....	3-135
Control Levers and Pedals.....	3-41
Controller.....	3-69
Controls and Gauges	3-3

<D>

Detailed Controls and Gauges.....	3-5
Direction of Machine	1-8
Door Lock.....	3-50

<E>

Electric System Maintenance.....	4-8
Emergency Exit from OperatorsCab'	3-50
Engine After Starting.....	3-94
Engine Before Starting.....	3-74
Engine Serial No. Plate and Its Location.....	1-11
Engine, Starting.....	3-91
Engine, Stopping the.....	3-101
Escape from Mud.....	3-118

<F>

Fire Extinguisher	3-53
Foreword.....	1-2
Fuse	3-67

<G>

General Operation Information.....	3-114
General Precautions for Safety.....	6-2
Precautions when Removing or Installing	6-2
Precautions when Selecting	6-2
Precautions when Using.....	6-3
Read the Instruction Manual Thoroughly.....	6-2
Grease Pump.....	3-70

<H>

Handling Oil, Fuel, Coolant, and Performing Oil Clinic 4-4	
Hot and cool box.....	3-52

<I>

Introduction.....	1-8
-------------------	-----

<L>

Locking	3-124
Long term storage.....	3-139
After Storage.....	3-140
Before Storage.....	3-139
During Storage.....	3-139
Starting machine after long-term storage.....	3-140
Lubricants, Fuel and Coolant Specifications.....	4-10

<M>

Machine Inspection After Daily Work.....	3-123
Machine Operation	3-102
Machine Operations and Controls	3-74
Machine View Illustrations	3-2
Machine, Steering the.....	3-106
Magazine Box	3-52
Maintenance Information	4-2
Maintenance Procedure.....	4-18
Check before starting.....	4-40
Every 10 hours.....	4-41
Every 100 hours.....	4-44
Every 1000 hours.....	4-61
Every 2000 hours.....	4-73
Every 250 hours.....	4-45
Every 4000 hours.....	4-79
Every 500 hours.....	4-51
Every 5000 hours.....	4-82
Every 8000 hours.....	4-83
Initial 100 Hours	4-18
Initial 500 Hours	4-18
When Required	4-19
Maintenance Schedule	4-15
Maintenance Interval for Hydraulic Breaker	4-17
Maintenance Schedule Chart.....	4-15
Monitoring System.....	3-5

<O>

Outline of Service	4-4
Overall Machine View.....	3-2

<P>

Parking Machine.....	3-122
----------------------	-------

Product Identification Number (PIN)/Machine Serial
No. Plate 1-11
Product Information 1-11
Prohibited Operations 3-112

Wear Parts List..... 4-9
Windshield 3-45
Work Equipment Controls and Operations 3-109
Working Mode..... 3-110

<R>

Radio 3-65
Recommended Applications 3-119

<Y>

Your Machine Serial Numbers And Distributor 1-12

<S>

Safety Critical Parts..... 4-13
 Safety Critical Parts List 4-14
Safety Information 1-3,2-2,2-13
Safety Labels 2-4
 Location of Safety Labels 2-5
 Safety Labels..... 2-6
Safety Machine Operation..... 2-22
 Battery 2-31
 Lifting Objects with Bucket 2-33
 Operation 2-24
 Starting Engine 2-22
 Towing 2-32
 Transportation 2-30
Safety Maintenance Information 2-34
Service Meter Location 1-12
Specifications 5-2
Sun Roof 3-44
Swinging..... 3-108
Switches..... 3-34

<T>

Tightening Torque Specifications 4-12
 Tightening Torque List..... 4-12
Tool Box 3-69
Transportation 3-125
 Lifting Machine 3-125
 Precautions for Transportation 3-125
 Procedure for Increasing or Reducing Track Frame
 Gauge 3-133
 Shipping Machine Information 3-127
 Transportation Posture 3-128
Traveling on Slopes 3-116
Troubles and Actions 3-141
 Battery, Discharged 3-144
 Other Trouble 3-148
 Phenomena that are not failures 3-142
 Running Out of Fuel 3-141
 Severe Job Condition 3-143
 Towing the Machine 3-143

<V>

Visibility From OperatorsSeat' 1-9

<W>

Wear Parts 4-9

COLOPHON

PC600-8, PC600LC-8 GALEO HYDRAULIC EXCAVATOR

Form No. UEAM005001

© 2005 KOMATSU
All Rights Reserved
Printed in Belgium 12-05