

OMTD40C98/1E

OPERATOR'S MANUAL

TD-40C

SERIAL NUMBERS
1501 AND UP

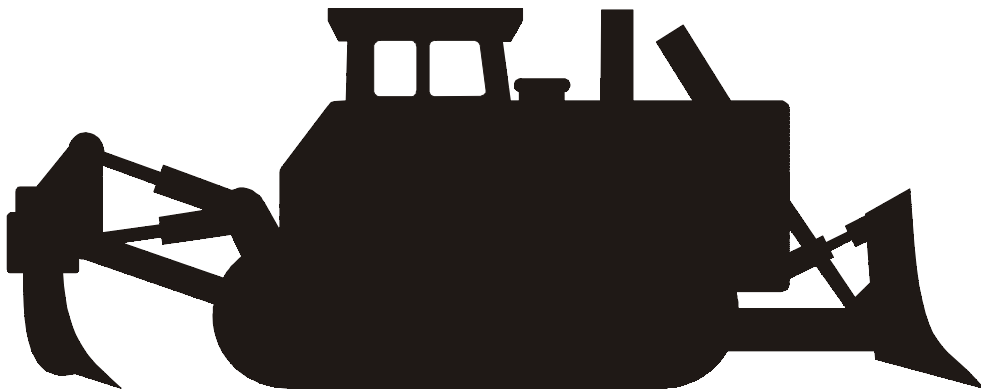

DRESSTA Co. Ltd.



FOREWORD

***Welcome to the growing group of value-conscious people who operate
DRESSTA machines!***

This manual covers the instructions for safe operation, lubrications, adjustments and maintenance for normal daily care. These instructions are divided into six sections to simplify your reference to the information most important to you. Refer to the contents page at the beginning of the section for a complete list of the subjects covered except for Section 1, which should be read entirely.

This manual has been prepared to help you operate and maintain your machine with utmost efficiency and safety. Read this manual thoroughly and learn your machine before you attempt to operate it.

It is our policy to improve our products whenever it is possible and practical to do so. We reserve the right to make changes or add improvements at any time without incurring any obligation to install such changes on products sold previously.

Due to this continuous program of research and development, periodic revisions may be made to this publication. It is recommended that customers contact their distributor for information on the latest revision.

We hope you enjoy operating Dressta machines.

DRESSTA Co. Ltd.

THIS MATERIAL IS PROPRIETARY USED, OR DISCLOSED EXCEPT FROM DRESSTA Co. Ltd. NOT TO BE REPRODUCED, USED, OR DISCLOSED EXCEPT IN ACCORDANCE WITH WRITTEN AUTHORIZATION FROM DRESSTA Co. Ltd.

IT IS OUR POLICY TO IMPROVE OUR PRODUCTS WHENEVER IT IS POSSIBLE AND PRACTICAL TO DO SO. WE RESERVE THE RIGHT TO MAKE CHANGES OR ADD IMPROVEMENTS AT ANY TIME WITHOUT INCURRING ANY OBLIGATION TO INSTALL SUCH CHANGES ON PRODUCTS SOLD PREVIOUSLY.

DUE TO THIS CONTINUOUS PROGRAM OF RESEARCH AND DEVELOPMENT, PERIODIC REVISIONS MAY BE MADE TO THIS PUBLICATION. IT IS RECOMMENDED THAT CUSTOMERS CONTACT THEIR DISTRIBUTOR FOR INFORMATION ON LATEST REVISION.

CONTENTS

1. INTRODUCTION
2. SAFETY PRECAUTIONS
3. MACHINE TRANSPORT AND STORAGE
4. OPERATING
5. MAINTENANCE
6. SPECIFICATIONS

SECTION INDEX

SECTION 1 – INTRODUCTION

This section discusses the use of this manual, serial number locations.

SECTION 2 – SAFETY PRECAUTIONS

This section lists safety rules concerning personal safety. Read this section carefully! Maintain this manual and review it frequently for continuing safe operation and instructing new operators.

SECTION 3 – MACHINE TRANSPORT AND STORAGE

This section discusses how to ship or store this machine.

SECTION 4 – OPERATING

The front portion of this section provides you with instructions for trouble free operation of the machine, machine precautions and a universal symbol chart, text and illustrations for instruments and controls. The instrument and controls area is designed to tell you “where it is, what it does and how to use it”. Read this area carefully. The remaining portion of this section outlines and illustrates the step-by-step procedures for starting, operating and stopping the machine and discusses a few operating suggestions and techniques and simple ideas to help ease the work and lengthen the useful life of your machine.

SECTION 5 – MAINTENANCE

The beginning of this section outlines a complete scheduled maintenance program, which helps to reduce down-time and expense, and increase the profit and work from your machine. Read and use this area. Following the maintenance program are the lubrication recommendations and requirements for the machine. The remainder of the section is devoted to clearly explaining the “how to” of the many maintenance and adjustment procedures listed in the maintenance program. The explanations are prepared in an easy style to help you “do it yourself” and get it right.

SECTION 6 – SPECIFICATIONS

This section covers the diagrams, general dimensions and weights, refill capacities, ground speeds and the standard and special torque values.

SECTION CONTENTS

1. INTRODUCTION

1.1. Introduction.....	3
1.2. Serial Numbers.....	3

2. SAFETY PRECAUTIONS

2.1. General.....	3
2.2. Before Starting the Engine	4
2.3. Operation.....	5
2.4. Maintenance.....	6
2.5. Shutdown.....	9
2.6. Safety Product Graphic	10

3. MACHINE TRANSPORT AND STORAGE

3.1. Machine Transport	3
3.2. Lifting Machine on Slings	4
3.3. Moving a Disabled Machine	4
3.4. Machine Storage	5

4. OPERATING

4.1. Machine Precautions.....	3
4.2. Universal Symbols for Instruments and Controls.....	4
4.3. Universal Symbols.....	5
4.4. Instrument Panel	6
4.5. Cab Controls	11
4.6. Controls and Adjustment.....	12
4.7. Starting the Engine.....	18
4.8. Stopping the Engine.....	22
4.9. Driving the Machine.....	23
4.10. Shifting the Transmission.....	24
4.11. Converter Overheating.....	25
4.12. Steering the Machine	25
4.13. Locking both Tracks	26
4.14. Downgrade Operation	26
4.15. Operating Over an Obstruction	26
4.16. Stopping the Machine	26
4.17. Parking the Machine.....	27
4.18. Operating Mounted Equipment.....	28
4.19. Operating Techniques.....	31
4.20. Economical Operation of the Machine.....	40

5. MAINTENANCE

5.1. Service Precautions	3
5.2. Scheduled Maintenance Guide.....	4
5.3. Maintenance and Service Chart.....	7
5.4. Lubrication.....	10
5.5. Seasonal Preparation.....	14
5.6. Air Cleaning System.....	15
5.7. Belts.....	19

5.8. Cooling System.....	22
5.9. Fan and Fan Hub.....	27
5.10. Electrical System	28
5.11. Engine.....	32
5.12. Fuel System	35
5.13. Hydraulic System	38
5.14. Lubrication Fittings	43
5.15. Mounted Equipment	44
5.16. Safety Belt.....	51
5.17. Final Drives.....	51
5.18. Transmission System	52
5.19. Undercarriage	57
5.20. Adjusting Hand and Foot Controls	62
5.21. Cab and ROPS.....	63

6. SPECIFICATIONS

6.1. Application	3
6.2. Technical Description	3
6.3. Cinematic Diagram	5
6.4. Mounted Equipment Hydraulic Diagram.....	6
6.5. Transmission System Hydraulic Diagram	9
6.6. Electrical Diagram.....	10
6.7. Specifications.....	14
6.8. Special Torques.....	17
6.9. Standard Metric Fasteners	19
6.10. Torque Values for Standard English Fasteners	20
6.11. Torque Values for Split Flange Connections	21
6.12. Torque Values for Hydraulic Tubes and Fittings.....	21
6.13. Torque Values for Hose Clamps	21
6.14. Torque Values for Air Conditioning Tubes and Fittings	22
6.15. Torque Values for Air Conditioning O-Ring Connections	22

SECTION 1
INTRODUCTION

SECTION CONTENTS

1.1. Introduction3
1.2. Serial Numbers3

1.1. INTRODUCTION

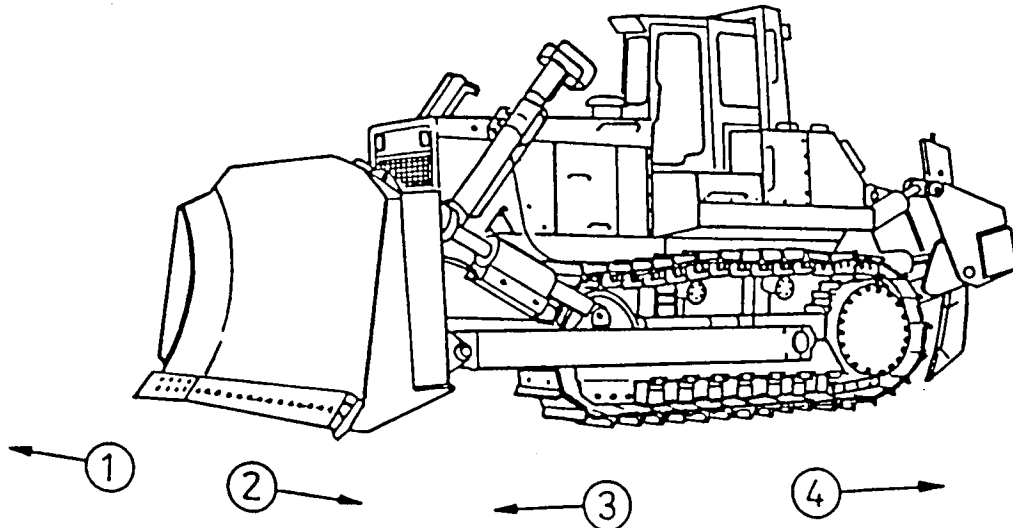

Fig. 1.1. TD-40 Series C Crawler Tractor Equipped with Bulldozer Blade and Cab

- | | |
|------------------------------------|--------------------------|
| ① – Right Hand Side of the Machine | ③ – Front of the Machine |
| ② – Left Hand Side of the Machine | ④ – Rear of the Machine |

General

Throughout this manual there will be two types of cross-references. One type is to a heading in another section. The other is to a heading within the same section. Unless it is otherwise stated, references will be to the same section. Refer to the section contents page at the beginning of the individual sections for specific page numbers. Some illustrations are of general application of this model and may not show your machine accurately in all details.

Throughout this manual the use of the terms “left”, “right”, “front”, and “rear” must be understood to avoid confusion when following instructions. “Left” and “right” indicate the left and right sides of the machine when facing forward in the operator’s seat. See Fig. 1.1.

1.2. SERIAL NUMBERS

The product identification number (P.I.N.) is stamped on a plate attached to the front wall of the control console at the left hand side of the operator’s seat (Fig. 1.2). It is also stamped on the rear face of the rear frame in the upper right hand corner (Fig. 1.3).

The bulldozer model designation is stamped on the back of the blade, near the top right hand corner (Fig. 1.4).

All other components having serial numbers are each equipped with a separate serial number plate.

Use serial numbers when requesting information or ordering parts and proper numbers from Parts Catalogue.

1.2. SERIAL NUMBERS

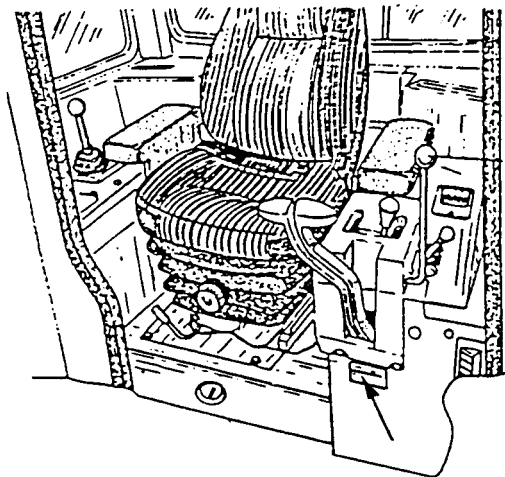

Fig. 1.2. Product Identification Number (P.I.N.)

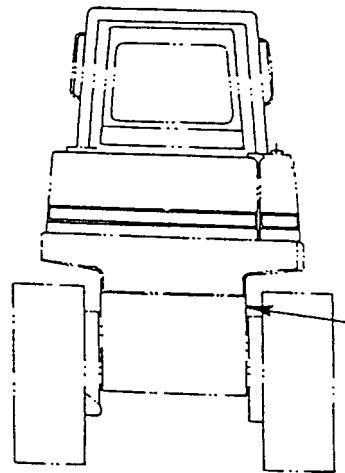

Fig. 1.3. Product Identification Number (P.I.N.)

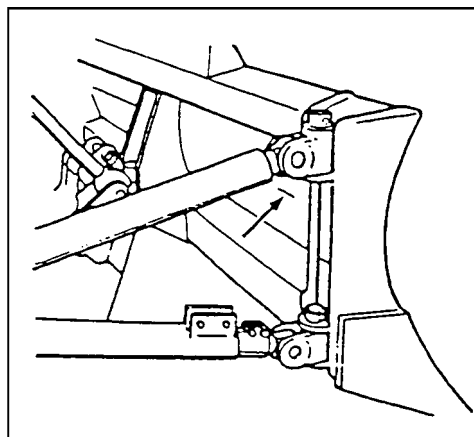

Fig. 1.4. Serial Number Designation of Blade

SECTION 2
SAFETY PRECAUTIONS

SECTION CONTENTS

2.1. General3
2.2. Before Starting the Engine5
2.3. Operation6
2.4. Maintenance8
2.5. When Parking 11
2.6. Safety Product Graphic Location 12
 2.6.1. Safety Product Graphs 13

2.1. GENERAL

WORK SAFELY – FOLLOW THESE RULES



This symbol and text with bold letters is used throughout this manual to call your attention to instructions concerning your personal safety. Observe and follow these instructions. Be certain anyone operating and servicing this machine is aware of these rules. Failure to follow these rules may result in injury or death.



WARNING: The machine can only be operated by a person who is familiar with this manual, knows operation of the machine and its mechanisms, experienced and properly licensed to operate such machines. Carefully observe and follow all instructions provided in this manual.

The instructions and information given in this section do not cover all you ought to know to operate the machine safely. Detailed instructions regarding operational safety appear in the following sections of this manual.

Human error is an important factor in most equipment-related injuries. Haste, carelessness and lack of training are the primary causes of injuries.

Most operating injuries occur because of excessive speed, loss of control, failure to observe warning signs, slipping or falling while entering for dismounting, a lack of barriers on roadways or piles, lack of a ROPS or seat belt, or not watching in the direction of travel.

Most maintenance injuries occur during welding or when using hammers or wrenches. The most common faults are improper work position, a slipped tool, missed aim, a broken tool, flying chips and no welding hood.

Think before you act. A careful operator or maintenance man is the best insurance against an accident.

Always wear proper safety equipment.

Avoid wearing jewelry and loose fitting clothing; they could catch on moving parts, which could result in serious injury or death. Hard hat, sturdy rough-soled work shoes or safety shoes, ear protectors, reflective clothing, safety glasses and heavy gloves may be required. Consult your employer for specific safety equipment requirements.

Each job site and application may have personal safety requirements. Carefully evaluate your particular application and machine for equipment such as heater and defroster, all windshield wipers, warning lights, side view and rearview mirrors, back-up alarms, fire extinguisher, rotating beacons and additional lights. If in doubt, contact your distributor.

The machine should be equipped with a fully charged fire extinguisher. All personnel should be instructed in fire extinguisher proper usage. Recharge immediately after use.

If a machine is equipped with a GRAMMER operator's seat, the fire extinguisher is placed in a operator's cab to right of his seat. Fig. 2.1 shows the fire extinguisher location.

GENERAL

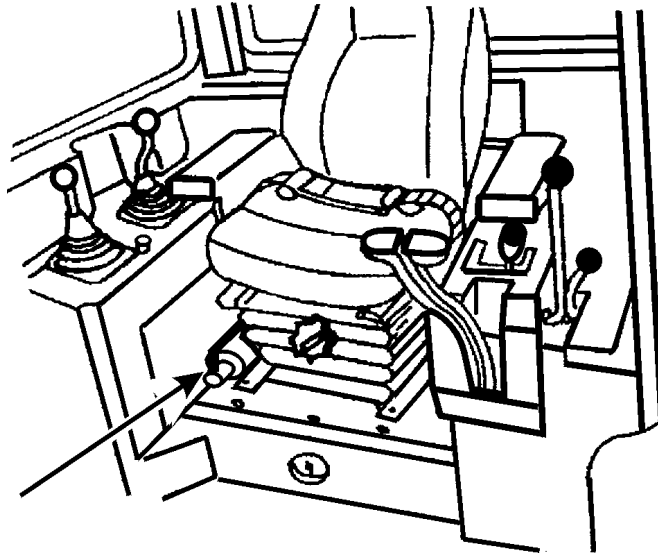

Fig.2.1. Fire extinguisher location in a machine equipped with GRAMMER operator's seat

If a machine is equipped with a operator's seat other than GRAMMER one, the fire extinguisher is placed on the left hand side of a machine on the ROPS structure. Fig. 2.1A shows the fire extinguisher location.

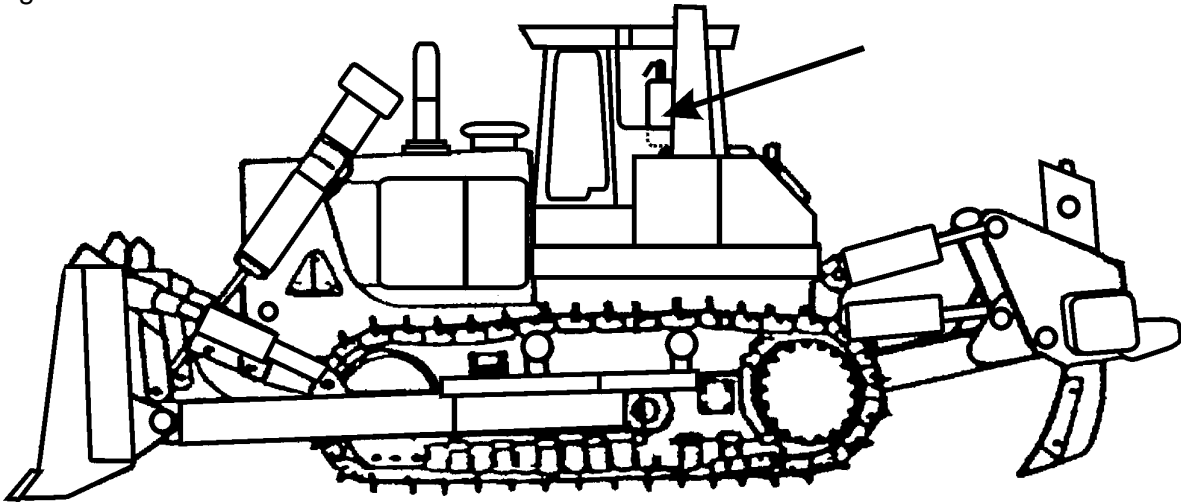

Fig.2.1A. Fire extinguisher location in a machine equipped with different operator's seat than GRAMMER seat.

The machine is equipped with a powder fire extinguisher, placed in a fire extinguisher holder that prevents its movement the machine operation. In case of fire the extinguisher is easy to remove. The fire extinguisher is provided with an instruction label that gives how to use it and its application. The machine operator is to be familiarized with the fire extinguisher servicing.

Electrical system is 24-volt negative ground.

Each machine is equipped with a booster receptacle socket that is to be used during the engine start up with a booster battery. When the use of the booster receptacle socket is impossible in out-of-normal situations, follow the precautions given below to prevent chances of injury or damage to electrical circuits.

GENERAL

1. Turn the electrical master switch to the OFF position.
2. Attach one end of jumper cable to the positive terminal of booster battery and other end to the positive terminal of machine battery.
3. Attach one end of second cable to the negative terminal of booster battery and other end to the machine's frame away from the battery.
4. To remove cables, reverse above sequence exactly to avoid sparks near the battery.

A frozen battery can explode when the booster cables are attached.

NEVER check battery charge by placing a metal object across the battery posts. The sparks could cause an explosion. Use a voltmeter or areometer for checking. Every machine is factory equipped with a fire extinguisher, first aid kit and safety belt.

2.2. BEFORE STARTING THE ENGINE

Never start the engine indoors unless proper exhaust ventilation is provided to remove deadly exhaust gases. Once the engine is operating, move the machine outdoors as soon as possible. Exhaust gases are dangerous and can cause unconscious-ness and death.

Always place the gear selector in neutral, apply neutral safety lock and lock the parking brake before starting the engine.

The operator must be alert, physically fit and free from the influences of alcohol, drugs or medications that might affect his eyesight, hearing, reactions or judgement.

Observe and know the use of alternate exits from the operator compartment.

Safety must always be the operator's most important concern. He must refuse to operate when he knows it is unsafe and consult his supervisor when safety is in doubt. The best safety device is a safe operator.

Do not use controls or hoses as hand holds when climbing on or off the machine. Hoses and controls can move and do not provide solid support. Movement of the controls may cause inadvertent and unexpected movement of the machine or its equipment.

Follow all machine-mounted safety signs before starting, operating, maintaining or servicing the machine.

Be sure the area of the operator's compartment, all mounting steps and grab handles are free of oil, grease, loose objects, ice and mud to lessen the possibility of slipping. Remove or secure all maintenance and personal items so they will not interfere with the operator or jam the controls.

Perform a visual check of the machine before starting the engine. Look for such things as improper fluid levels, oil leaks, and loose, damaged or missing parts. Do not start the engine until any unsafe conditions are corrected. Secure all caps and filler plugs.

Know and understand the traffic flow patterns of your job and obey flagman, signs and signals.

BEFORE STARTING THE ENGINE

Before entering the operator's compartment, clear the immediate area surrounding the machine of personnel and obstructions. Walk completely around the machine. After entering the operator's compartment, sound the horn to clear the immediate area of the machine.

Due to the danger of fire and explosion, never check or fill fuel tank or batteries near lighted smoking materials or open flame or sparks.

Check work area for hazardous conditions. Be alert for soft ground conditions, especially when working on slopes, near drop-offs or excavations or fill material, which could lead to sudden tipping of the machine. At night and times of poor visibility, carefully check the work area before moving in with the machine. Use all lights provided.

2.3. OPERATION

Check the work area for hazardous conditions. Be alert for soft ground conditions, especially when working on slopes, near drop-offs or excavations or fill material, which could lead to sudden land collapse and tipping of the machine.

At night and at times of poor visibility, carefully check the work area before moving in with the machine. Use all lights provided.

Keep the windshield, windows and mirrors (if equipped) clean.

Before starting the engine, be sure you understand all control functions. Check all controls, including the brakes, decelerator, steering and transmission. Check all gauges, warning lights and safety devices. Correct any malfunctions.

Only one person, the operator, should be permitted to ride on the machine when it is in operation.

Perform an operational check of the machine in a safe area before putting it to work.

Keep operating controls, hands and shoes free of grease, water and mud to insure positive control functions.

If the machine is ROPS equipped, for your personal protection, wear your seat belt.

Before driving the machine, adjust the seat and fasten the seat belt. Adjust the seat belt to fit snugly and flow around the hips to lessen the chance and severity of injury in the event of an accident. Never wear the seat belt across the abdomen.

Check overhead clearance carefully before operating the machine in areas with low overhead clearance, such as guy wires, power lines, bridges, low-hanging tree branches and building entrances or exits. These overhead obstructions could cause an accident.

After starting the engine, but before moving the machine, warn nearby personnel by giving a couple of short horn blasts.

Be sure that the rear screen is securely fastened to the ROPS structure before operating the winch. Operating without correctly installed screen could result in serious injuries. Operate the winch from the driver's seat only. Always engage the parking brake before winching, if the machine is stopped. Use caution when installing or removing cable from the winch. Keep all persons clear of a cable under tension. Never use a cable that is damaged. Failure to follow these instructions could result in serious injuries.

OPERATION

Never mix gasoline, gasohol and/or alcohol with diesel fuel. This practice creates an extreme fire hazard and under certain conditions an explosion, which could result in personal injury or death.

Do not smoke when refueling or servicing the machine. A fire could result.
Never place gasoline or diesel fuel in open pan.

Never remove the fuel tank filler caps or refill the fuel tanks while the engine is running or hot or when the machine is indoors. Fumes are dangerous, a spark or flame could result in a fire or explosion.

On machines equipped with a suction fan or a reversible fan in the suction position, periodically check the engine exhaust system for leaks. Exhaust gases are dangerous to the operator.

Do not operate the machine in a condition of extreme fatigue or illness.

Be sure that the rear screen is securely fastened to the ROPS structure.

Be sure chains or cables and their anchor points are strong enough to handle the expected load. Inspect carefully chains and cables for flaws before using them.

Always wear gloves when handling cables and chains. Avoid looping or knotting a cable or chain.

Do not pull with a kinked chain or cable as excessively high stress in bent area may cause chain or cable failure. Cables or chains for towing or winching should be fastened to attachment points designed to this purpose only.

Be sure the attachment pins are securely inserted immediately before pulling with the chain or cable.

Stand clear of chains or cables under load.

Keep engine exhaust system and exhaust manifold clear of combustible material for your personal protection.

Know the locations of underground cables, water mains, gas lines, etc. A ruptured gas line or cut electrical cable could result in personal injury or death.

When leaving the machine unattended for any length of time, make sure the transmission shift lever is positioned and locked in neutral (N), the blade is completely lowered, the engine is stopped, the parking brake is applied, and the electrical master switch is in the "off" position. If the machine is equipped with a cab make sure that the cab is locked.

Before operating the machine read and know the Operator's Manual and all Safety Product Graphic.

The roll-over protective structure (ROPS) provides the operator's protection in the event of machine rollover or upset. This structure is designed to bend during rollover to protect the operator from sudden impact loads.

When operating the machine, look in the intended direction of travel and the immediate machine operational area to be sure personnel or allied equipment does not interfere with the machine work pattern.

Never try to get on or off the machine while it is moving. A serious injury or death could result.

OPERATION

Never shift the transmission into neutral (N) when traveling downhill. The machine may go out of control and a rollover could result or the transmission, torque converter or engine could be damaged when the transmission is again placed in gear. Always put the transmission in low range position before starting downhill. Use the decelerator and brake pedal to slow the machine.

Avoid side hill travel whenever possible. Drive straight up and down the slope. If the machine starts slipping sideways on a grade, turn downhill immediately.

If possible avoid crossing obstacles such as ridges, rocks or logs. If you can't avoid them, reduce speed and ease over the obstacle at an angle.

A machine's weight and the vibration it creates can cause the edge of a high wall to collapse. Keep your machine away from the edges of banks and excavations. If it is not possible to avoid turn the machine front towards the bank edge or excavation.

Travel slowly in congested areas or on rough ground, slopes or near drop-offs or on snow, ice or slippery surfaces.

Maintain a safe distance between your machine and other vehicles according to the condition of the road and load.

Never hold the hydraulic controls in their extreme position after the equipment has reached its maximum travel. This could cause overheating of the hydraulic system.

Do not adjust the seat position while the machine is in motion. A loss of control may result. Completely stop the machine, apply and lock the parking brake and then adjust the seat.

Never use the blade as a brake except in an emergency.

Carry the blade low for maximum stability and visibility.

Where noise exposure exceeds levels defined by proper health and safety authorities and applicable standards wear authorized ear protective equipment.

2.4. MAINTENANCE

Servicemen and their helpers only are allowed to remain at operator' s post while maintaining or repairing the machine.

Authorized personnel only is allowed to control, maintain or repair a machine.

Do not hurry. Haste could result in accident.

Load things into the machine from the ground level before mounting the machine.

Loosen the radiator cap slowly to relieve all pressure in the system and use caution when removing the caps.

MAINTENANCE

Loosen the filler cap slowly to relieve the pressure to prevent possible injury. Always vent the hydraulic system before working on any hydraulic component.

Have all equipment resting on the ground and relieve all hydraulic system pressure by moving control lever in various directions before removing any hydraulic component.

Never work beneath the blade and/ or ripper without proper blocking. Improper blocking could result in serious injuries.

When service or maintenance requires access to areas that cannot be reached from the ground, use a ladder or platform. If such ladders or platforms are not available, use the machine hand holds and steps provided. Perform all service or maintenance carefully.

Use only approved parts for repairs and maintenance show in your parts catalog. Failure to do so could compromise your personal safety and machine performance and reliability.

Never align holes with fingers or hands. Use a proper aligning tool.

Be sure all used tools are in good condition. Do not use tools which are worn, bent or have mushroomed heads. Use the proper tool for the job. Remove sharp edges and burrs from reworked parts.

For field service, move machine to level ground if possible and blocks the tracks. If work is absolutely necessary on an incline, block the machine and its attachments securely. Move the machine to level ground as soon as possible

Before working on the machine, turn OFF the electrical system master switch and remove the starting switch key so no one will start it unexpectedly.

Do not carry loose objects in pockets that might catch on the machine or fall unnoticed into open compartments.

Before working on any part of the engine or electrical system, disconnect the battery ground cable. Tag the cable and all controls to alert personnel that work is in progress.

When it is necessary to make any checks or adjustments with the engine operating, always use two people. One trained person must be in the operator's seat to safeguard the second person making the checks or adjustment.

As an added precaution, when making checks or adjustments with the engine operating, make sure the transmission shift lever is locked in neutral (N), and the parking brake is locked.

Never stand on the tracks or near the blade while the engine is operating.

If the engine is running and the side doors are open or removed be careful of rotating parts such as the fan and belts that can cause serious injury.

Use a non-toxic, nonflammable commercial solvent for cleaning parts, unless otherwise specified. Never use gasoline, diesel fuel, kerosene or other flammable solvents for cleaning part.

MAINTENANCE

Excessive or repeated skin contact with sealant or solvents may cause skin irritation. In case of skin contact, remove sealant or solvent promptly by washing with soap and water. Follow the manufacturer's advice whenever cleaning agents or other chemicals are used.

Lower blade and ripper before making hydraulic adjustments. To prevent personal injury, be sure no personnel are standing in the way of the blade and/or ripper when it is being lowered. Never allow anyone to walk under or be near unblocked raised equipment.

Provide proper ventilation when operating in a closed building to avoid danger of exhaust gases. Exhaust gases are dangerous and can cause unconsciousness and death.

Hydraulic fluid escaping under pressure from a very small hole can be almost invisible, yet have sufficient force to penetrate the skin. Use a piece of cardboard or wood to search for suspected leaks. Do not use hands. If injured by escaping fluid, see a doctor at once. Serious infection or reaction can occur if proper medical treatment is not administered immediately.

Wear proper protective equipment such as goggles or safety glasses with side shields, hard hat, safety shoes and heavy gloves when metal or other particles are apt to fly or fall.

Lift and handle all heavy parts with a lifting device of proper capacity. Be sure parts are secured by proper slings and hooks. Use lifting eyes if provided. Warn people in the area to stand clear.

Do not attempt to repair a protective structure after an accident. Repaired structures do not provide the original strength and protection. Contact your distributor for information on structure replacement. Do not operate the machine again until the ROPS has been replaced.

When using compressed air for cleaning parts, wear goggles or safety glasses with side shields. Use a air nozzle, which limits the pressure to 200 kPa.

Do not use an open flame to check for leaks or fluid levels anywhere around the machine.

Keep work area clean and dry. Remove oil and water spills immediately.

Do not pile up oily or greasy rags. They are a fire hazard. Store them in an approved, closed metal container.

Use a soft iron or nonferrous hammer to install or remove ripper teeth. It is dangerous to hammer on the teeth. Wear safety glasses with side shields or goggles to reduce the chances of injury.

Batteries give off a highly inflammable gas. Never allow sparks or open flame near the batteries. A fire or explosion could occur. Do not charge batteries in a closed area. Provide proper ventilation to guard against accidental explosion of an accumulation of the explosive gas given off in the charging process.

When installing batteries, be sure the electrical master switch is in the "off" position. Be sure to connect the positive cable to the positive terminal and the negative (ground) cable to the negative terminal.

Ether starting fluid is flammable. Follow the precautions printed on the container. An explosion can result if sparks or flame contact the ether in the container or if the container is stored in an area in which the temperature exceeds 70°C. Observe the following precautions:

MAINTENANCE

1. Follow the correct method for starting the engine. Refer to "STARTING THE ENGINE" in Section 3.
2. Do not use the ether injector when the ambient temperature is above freezing.
3. For your own personal safety, always remove the ether container when welding, grinding or fusing a torch on the machine.
4. Do not let ether come in contact with your skin, as it can cause localized freezing.
5. Do not breathe the hazardous ether vapor.
6. Keep the fluid container out of the reach of children.
7. Never puncture the fluid container or put it into a fire. Dispose of empty container properly.
8. Do not store fluid containers in the operator's compartment.

Never mix gasoline, gasohol or alcohol with diesel fuel. This creates an extreme fire or explosion hazard, which could result in personal injury or death.

Do not use bleach, color dye or solvents on the seat belt webbing. This may cause a severe loss of tensile strength. This could cause the webbing to break resulting in personal injury. It is recommended that the seat belt be cleaned only with warm water and mild detergent.

2.5. WHEN PARKING

If parking on or near traffic lanes cannot be avoided, provide appropriate flags, barriers, flares and warning signals. Also provide advance-warning signals in the traffic lane for approaching traffic. Park the machine in a non-operating and non-traffic area. Park machine on level ground whenever possible. If you must park on a slope, park at right angles to the slope. Apply and lock the brake pedal.

Never leave the machine unattended with the engine running.

When leaving the machine unattended, slowly lower the hydraulic equipment to the ground, shift the transmission into neutral and lock the neutral lock lever, shut off the engine, apply and lock the parking brake. Relieve any pressure in the hydraulic system by moving the controls in both directions. Turn off the electrical system master switch and take it out. Always lock up machine when leaving it unattended, including any anti-vandalism attachments.

Do not jump off the machine.

When operating in bad weather and storm lightening is nearby, dismount and seek shelter away from the machine. Lightening will be attracted to the machine and can cause serious injury or death.

When the machine is to be loaded onto a transport truck and trailer do so carefully. Load only when the trailer is level. The steel track shoes will slide easily on the trailer. When the machine is properly positioned chain it securely and block with wooden pieces so it can not move on the trailer.

Keep your head, body, legs, hand, fingers away from the blade and ripper when they are in a raised position.

Do not allow the hydraulic system to support the mounted equipment without its proper blocking when leaving the machine unattended, to eliminate the possibility of an expected drop of the blade or ripper.

2.6. SAFETY PRODUCT GRAPHIC LOCATION

INCLUDEPICTUREEMERGEFORMAT

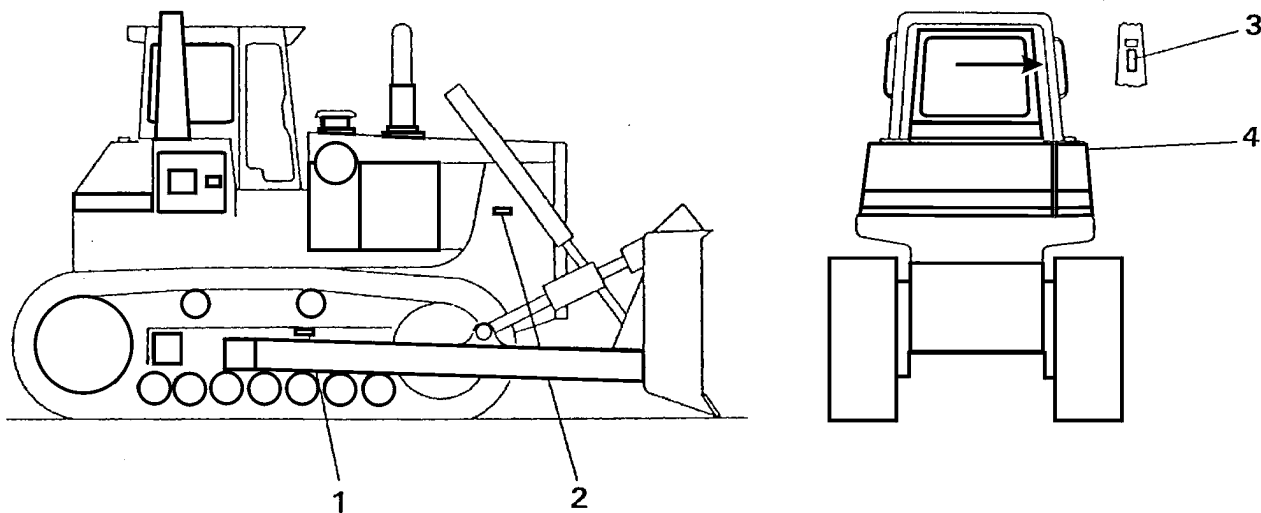

Fig. 2.2. Safety Product Graphic Location – Machine

- 1. Track Adjuster Caution
- 2. Engine Door Caution
- 3. ROPS Caution
- 4. Pressurized Reservoir Caution

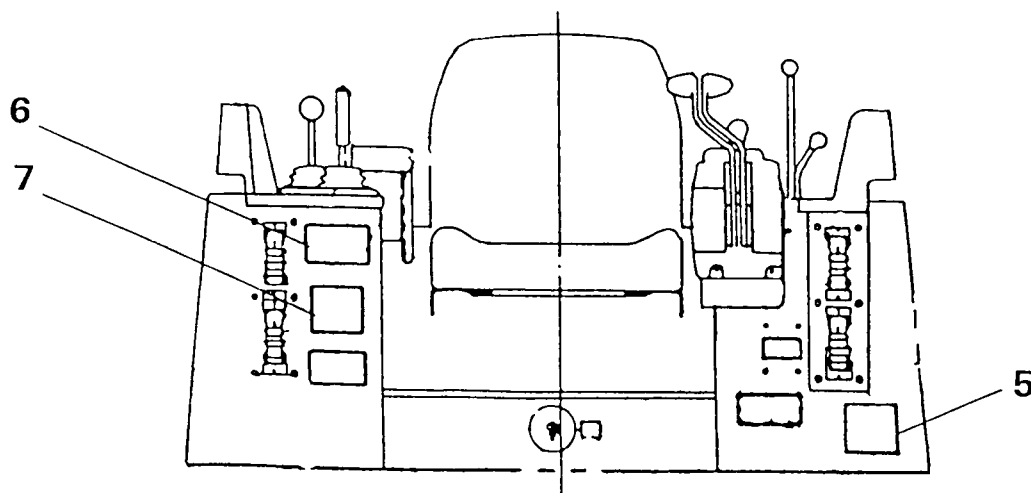

Fig. 2.3. Safety Product Graphic Location – Cab

- 5. General Caution
- 6. Instruction Caution
- 7. Safety Caution

SAFETY PRODUCT GRAPHIC LOCATION

2.6.1. SAFETY PRODUCT GRAPHICS



Decal 1



Decal 2

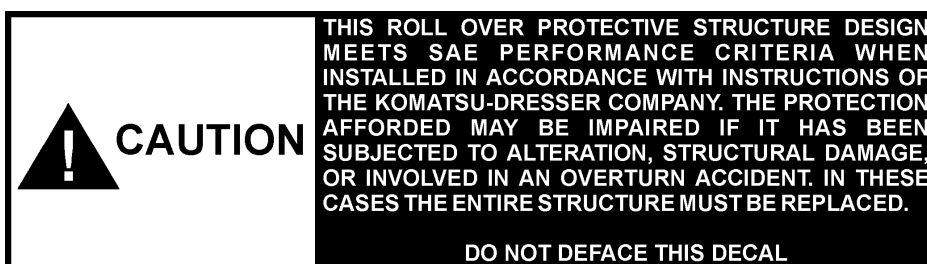

Decal 3



Decal 4

SAFETY PRECAUTIONS

SAFETY PRODUCT GRAPHIC LOCATION



Decal 5

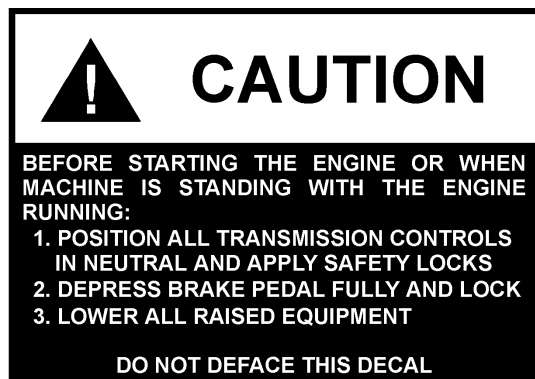

Decal 6



Decal 7

SECTION 3
MACHINE TRANSPORT AND STORAGE

SECTION CONTENTS

3.1. Machine Transport 3
3.2. Lifting on Slings 4
3.3. Moving a Disabled Machine 4
3.4. Machine Storage 5
 3.4.1. Preparing for Storage 5
 3.4.2. Servicing Machine During Storage 7
 3.4.3. Preparing for Operation 7

3.1. MACHINE TRANSPORT

Truck

When shipping this machine by truck learn obligatory regulations. Contact local authorities for the proper shipping and loading regulations.

When preparing to transport the machine by truck, have truck and trailer level.



WARNING! Use caution when loading and unloading machine.

1. Use ramps or loading dock to maintain stability
2. Drive the machine in its lower gear
3. Use the lowest engine speed that will move the machine and not stall the engine
4. The machine can be "inched" into place by holding the steering hand levers back and slowly moving them forward into the drive position. (Be careful and move the levers simultaneously otherwise the machine will turn).
5. Pulling the steering hand levers back will disconnect the drive. Pulled back part way will permit the machine to roll freely.
6. When the machine is properly located, stop the engine, place transmission controls in Neutral, apply the Neutral Safety Lever and apply and lock the brakes.
7. Tie the machine down securely to prevent unintentional movement.



WARNING! Failure to secure the machine to the truck during transporting can result in property damage, personal injury or death.

Railroad Flatcar

Respective railroad loading rules and specifications must be followed when shipping this machine on open top railroad cars.

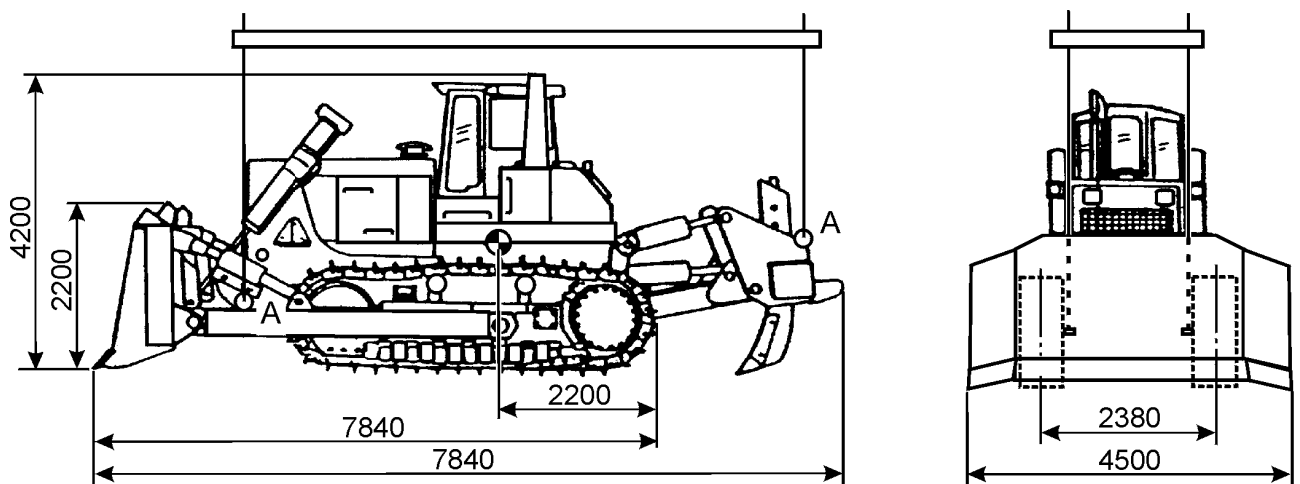

Fig. 3.1. Lifting Machine on Slings

MOVING A DISABLED MACHINE

If the tractor can be towed but the engine and/or steering hydraulic system is inoperable proceed as follows:

1. Lock the transmission shift lever in "NEUTRAL".
2. Release brake and decelerator pedal.
3. Pump sufficient grease into one of the valve (1 or 2 in Fig. 3.2.) to release the brakes. The amount of grease required depends on the amount of pressure dissipation in the system.
4. Use a towing cable of sufficient strength. During the tow, it may be necessary to pump more grease into the right brake fitting to replace loss of pressure.
5. Depressing the brake pedal will relieve hydraulic pressure and apply the brakes.
6. After towing is completed, actuate the steering levers until all grease is purged from the system. There should be no pressure in the brake system (when measured at brake port) with the brake and decelerator pedal applied or the steering levers in the pivot position.

3.4. MACHINE STORAGE**3.4.1. PREPARING FOR STORAGE**

When a machine is taken out of service and stored for more than 30 days, steps must be taken to protect the machine. Leaving equipment outdoors exposed to the elements will materially shorten its life. An enclosure will protect the machine from rapid temperature changes and lesson the amount of condensation that forms in hydraulic components, engine, fuel tank and final drives. If it is not possible to put the machine in an enclosure, cover it with a tarpaulin.

After the machine has been positioned for storage and the engine shutdown, perform the following operations:

1. Visually inspect the machine for external leakage and other defects.
2. Clean the radiator, refer to "COOLING SYSTEM."
3. Thoroughly clean the machine be sure to rinse off any corrosive residue.
4. Correct any defects found. Consult Authorized Distributor of Construction Equipment.
5. Clean or replace the air cleaner filter elements. Refer to "AIR CLEANING SYSTEM".
6. The cooling system should be completely drained, chemically flushed, and refilled with a conditioned water/antifreeze solution suitable for the lowest temperature anticipated. Refer to "COOLING SYSTEM" for the proper antifreeze and conditioner concentrations.

IMPORTANT: *Under no circumstances should the vehicle be stored with a dry cooling system.*

7. Drain the water from the fuel tank.
8. Remove, empty, and reinstall the fuel filters. Refer to "FUEL SYSTEM".
9. It is recommended to use a fuel stabilizer quantity as instructed by the manufacturer. The stabilizer will prevent the degrading of the fuel, sludge buildup and stops the growth of bacteria in the fuel during storage. The fuel stabilizer may be purchased from:

**FIRE PREP 1000
NALCO CHEMICAL COMPANY
2901 BUTTERFIELD ROAD
OAK BROOK, ILLINOIS 60521, USA
or from Authorized Distributor of Construction Equipment**

MACHINE STORAGE

10. Add 120 [ml] of volatile corrosion inhibitor "VCI" for each 100 liters of total fuel capacity to the fuel tank. The "VCI" provides corrosion protection by contact with the metal, and in a closed system, the vapors provide sufficient protection for areas that are not in contact with the oil. The "VCI" may be purchased from:

**NOX RUST VCI # 105 OIL
DAUBERT CHEMICAL COMPANY
1200 JORIES BLVD
OAK BROOK, ILLINOIS 60521, USA
or from Authorized Distributor of Construction Equipment**



WARNING! Rust inhibitors are volatile and flammable. Prepare machine in a well-ventilated place. Keep away from open flame or sparks DO NOT SMOKE. Store container in a secure, cool, well ventilated place.



WARNING! Due to the volatile nature of "VCI", irritation of eyes and skin may occur. Prolonged exposure to the vapors or oil should be avoided.

11. Vent the fuel system. Refer to "FUEL SYSTEM" in Section 4.
12. Start the engine and run at 1400 – 1600 [RPM], no load for approximately 4 minutes and stop the engine.
13. Lubricate all points of the machine as outlined in the "SERVICE GUIDE".

NOTE: *Be sure to oil or grease all linkage connections, joints, nuts, pins, shafts, and bushings not covered in the "SERVICE GUIDE".*

14. Drain the crankcase oil from the engine, replace the lubricating oil filters and refill with the specified oil. Refer to "ENGINE".
15. Add 15 [ml] of "VCI" for each liter of engine oil capacity to the crankcase. (Example: if the total crankcase capacity is 10 liters, add 150 [ml] of VCI to the crankcase).



WARNING! Due to the volatile nature of "VCI", irritation of eyes and skin may occur. Avoid prolonged exposure to the vapors or oil.

16. Start the engine and run at 1400 – 1600 [RPM], no load, for approximately 30 seconds and stop the engine.
17. Remove the air intake cap.
18. Seal all external openings (i.e. engine exhaust outlet, crankcase and hydraulic breathers, fuel vent line, etc.) with waterproof tape wide enough to cover the opening.

NOTE: *When sealing with tape, be sure to extend tape approximately 25 [mm] beyond opening to insure a good seal.*

19. Pour 120 [ml] of "VCI" into the intake manifold to provide sufficient corrosion protection for the area between the top of the piston and the bottom of the cylinder head.
20. Add 350 [ml] of VCI to the hydraulic reservoir.
21. Remove the batteries and store them in a cool, clean, dry, well ventilated place away from areas storing or dispensing fuel and oil, not near any heat source and preferably where the temperature range is between 0 [°C] to +21 [°C].
Be sure the batteries are fully charged.

MACHINE STORAGE

NOTE: Do not leave batteries on a concrete floor or in freezing temperatures

IMPORTANT: If the machine is stored with dry-charged batteries or no batteries, the alternator output lead must be disconnected and insulated. Failure to do so may result in permanent damage to the alternator. Connect the output lead only after the batteries have been activated with electrolyte. Refer to "ELECTRICAL SYSTEM".

22. If the blade is detached for storage, secure the cylinders to the machine to avoid damage.

23. Coat all machined unpainted surfaces with chassis grease to prevent rust.

3.4.2. SERVICING MACHINE DURING STORAGE

ONE-MONTH REPETITIVE SERVICE PERIOD

MACHINES WITH MAINTENANCE-FREE BATTERIES:

Check if batteries are fully charged. Never allow batteries to run down below $\frac{3}{4}$ full charge.

SIX MONTH REPETITIVE SERVICE PERIOD

1. Visually inspect the engine and radiator for leakage and other defects. Correct all defects; consult Authorized Distributor of Construction Equipment.
2. Remove all storage seals from the machine. (i.e. crankcase and hydraulic breathers, engine air intake, fuel tank vent lines, etc.).
3. Install fully charged batteries. Refer to "ELECTRICAL SYSTEM".

IMPORTANT: Check that batteries are level in the holders and securely held. The hold-down fasteners should hold the batteries firmly but not tight enough to warp or damage either the hold-down bar or batteries.



WARNING! Lay the cables so they do not chafe against the hold-down bar their fasteners. Always connect the negative ground cable last to minimize the chance of sparks or an explosion.

4. Check the coolant level in the radiator and add proper concentrations of antifreeze and coolant conditioners, if required. Refer to "COOLING SYSTEM".

NOTE: If excessive loss of coolant is detected, the problem should be corrected. Refer to "COOLING SYSTEM".

5. Follow steps 7 through 23 of "PREPARING FOR STORAGE".

3.4.3. PREPARING FOR OPERATION

1. Visually inspect the machine for external leakage and other defects.
2. Clean the radiator; refer to "COOLING SYSTEM".
3. Thoroughly clean the machine.
4. Correct any defects found. Consult Authorized Distributor of Construction Equipment if necessary.
5. Remove all storage seals from the machine (i.e. crankcase and hydraulic breathers, engine air intake, fuel tank vent lines, etc.).

MACHINE STORAGE

6. Replace the air cleaner filter elements. Refer to "AIR CLEANING SYSTEM".
7. Remove and discard fuel filters and replace with new. Refer to "FUEL SYSTEM".
8. Fill the fuel tank with approved diesel fuel. Refer to "FUEL SYSTEM".
9. Lubricate all points of the machine as outlined in the "SERVICE GUIDE".

NOTE: *Be sure to oil or grease all linkage connections, joints, nuts, pins, shafts, and bushings not covered on the "SERVICE GUIDE".*

10. Drain engine oil from the crankcase and replace the engine lubricating oil filters. Refer to "ENGINE".
11. Install fully charged batteries. Refer to "ELECTRICAL SYSTEM".

NOTE: *Check that batteries are level in the holders and securely held. The hold-down fasteners should hold the batteries firmly but not tight enough to warp or damage either the hold-down bar or batteries.*

NOTE: *Lay the cables so they do not chafe against the hold-down bar or the fasteners. Always connect the negative round cable last to minimize the chance of sparks and possible explosion.*

12. Prime the turbocharger by placing the engine position and cranking the engine for approximately 30 seconds. Continue to crank the engine for 30-second periods until an oil pressure reading is indicated on the engine oil pressure gauge. This should provide an adequate amount of oil to lubricate the turbocharger.

IMPORTANT: *Crank the engine for a period of 30 seconds the, allow the cranking motor to cool for two minutes before cranking again to avoid damaging the cranking motor.*



WARNING! Never start the engine indoors unless proper exhaust ventilation is provided. Once the engine is running, move the machine outdoors as soon as possible.

13. Start the engine; refer to "STARTING THE ENGINE". Observe all the gauges on the instrument panel for proper operation of engine.
14. Perform an engine diagnostic test.

SECTION 4
OPERATING

SECTION CONTENTS

4.1. Machine Precautions.....3
4.2. Universal Symbols for Instruments and Controls.....4
4.3. Universal Symbols5
4.4. Instrument Panel.....6
4.5. Cab Controls 11
4.6. Controls and Adjustment..... 12
4.7. Starting the Engine 18
4.8. Stopping the Engine.....22
4.9. Driving the Machine23
4.10. Shifting the Transmission.....24
4.11. Converter Overheating.....25
4.12. Steering the Machine25
4.13. Locking Both Tracks26
4.14. Downgrade Operation26
4.15. Operating Over an Obstruction26
4.16. Stopping the Machine26
4.17. Parking the Machine27
4.18. Operating Mounted Equipment28
4.19. Operating Techniques.....31
4.20. Economical Operation of the Machine40

4.1. MACHINE PRECAUTIONS

During operation stay alert and watch what you are doing. Use common sense and do not operate when fatigued.

Know your machine. For your personal safety read this manual carefully and follow all instructions and precautions. Refer to and read Section 2 carefully and follow all precautions.

Before starting or operating this tractor, read the following general precautions. These are listed there to help you protect the machine and to remind you of protection for yourself and those around you. Sound judgment and observance of these rules will help make your job a safer one. Visually check out the machine for leaks and broken, missing or malfunctioning parts. Be sure all caps, dipsticks, battery covers, etc. are secure before starting. Correct any problems before operating the machine.

Keep the transmission in low gear when going downhill. Never coast downhill with the transmission in neutral. The machine could go out of control and tip over. Always drive the machine slowly when on hillsides, ramps or rough terrain. Be extremely careful when working around trenches or banks. Failure to do so could cause the machine to roll over.

Before starting operation, check the machine for correct function of steering controls, brake controls, hydraulic controls, instruments and safety equipment. Make all necessary repairs or adjustments before operating the machine.

Do not place the tractor under load without the proper engine oil pressure and operating temperature. After starting the engine, move the engine speed control lever to the low idle position.

Allow the engine to run at low idle for 3 to 5 minutes at 1000 RPM until normal oil pressure registers on the gauge to obtain complete distribution of the lubricating oil.

Oil pressure after 15 seconds must be correct. To prevent any possible damage to the alternator, the electrical system master switch must be in the "ON" position when the engine is running. The switch must be in the "OFF" position only when the engine is shut down at the end of each day or when the operator leaves the tractor unattended.

If the tractor is left outside during cold weather and the tracks become frozen to the ground, do not attempt to jerk them free with the power of the engine. Start the tractor slowly and, if the tracks do not break free, pry them loose. To prevent the tracks from freezing in the ground, park the tractor on planks.

In freezing weather thoroughly clean all ice and mud from the track system after each day's operation to prevent freeze-up of the system. Be sure to clean the seal area off the sprocket drives, front idlers, top idlers and rollers.

Never pour cold coolant into the radiator if the engine is very hot unless conditions make it absolutely necessary. Use extreme caution as hot coolant could burn you. Keep face away from filler neck. Under such conditions, start the engine and let it idle while slowly pouring the coolant into the radiator. Allow the engine to cool down to 50°C.

Pouring cold coolant into the engine may result in damage to cast components of the engine.

Never use water alone in the cooling system.

Fill the fuel tank at the end of each day's work to reduce moisture condensation in the tank.

When using a long chain or cable to hitch the tractor to the load, drive the tractor forward slowly until all slack is taken out.

Before shutting down, operate the engine at half speed (no load) for three to five minutes. This will aid in cooling the engine and turbocharger.











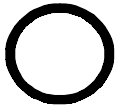





























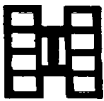













4.2. UNIVERSAL SYMBOLS FOR INSTRUMENTS AND CONTROLS

The use of universal symbols will pictorially identify various instruments and controls. These symbols are an effort to overcome language differences for all operators in a positive way, thus enhancing their safety through quicker recognition of the instruments and controls while operating the equipment.

Study the following symbols so you will know their meaning immediately and at a glance.

NOTE: *Some symbols may not pertain to your machine.*

4.3. UNIVERSAL SYMBOLS

 ON (GENERAL)	 OFF (GENERAL)	 FWD or UP	 REVERSE or DOWN	 FWD or REVERSE	 Hourmeter	 Caution	 Caution high pressure
 Variable slide control	 Variable rotation control	 Next speed (straight-line)	 Next speed (rotation)	 NEUTRAL position	 A/C	 Electrical receptacle	 Lighter
 Battery isolator	 Voltmeter	 Lights	 Dome light	 Windshield wiper	 Rear window wiper	 Window washer	 Fan
 Horn	 Fuel filler	 Fuel level	 Air cleaner	 Coolant level	 Coolant temperature	 Engine	 Engine RPM
 Oil pressure	 Starting aid	 Drive train oil filler	 Oil pressure	 Oil filter	 Oil level	 Oil temperature	 Oil pressure diagnostic point
 Hydraulic oil filter	 Hydraulic oil level	 Undercarriage	 Vehicle FWD or REVERSE	 LH Track driven	 RH Track driven	 RH Track brake	 LH Track brake
 Hydraulic filter	 Blade	 Raise	 Hold	 Lower	 Float	 Tilt left	 Tilt right
 Angle left	 Angle right	 Pitch FWD	 Pitch AFT	 Ripper	 Raise	 Hold	 Lower
 Pitch FWD	 Pitch AFT	 Coolant filler	 Grease lubricant	 Brake (GENERAL)	 Parking brake	 Brake ON	 Lift or lift point

The above symbols are used in crawler dozers manufactured by HSW, however not all of them must be used on this machine.

4.4. INSTRUMENT PANEL

General

This section covers the location and function of the various instruments and controls. More detailed information regarding operation of controls can be found in the following text within this section. Regardless of previous experience as an operator; you must be thoroughly familiar with the location and use of all instruments and controls before operating the machine.

IMPORTANT: Understand all control functions before starting the engine.

IMPORTANT: After starting and while operating observe instruments and warning lights frequently.

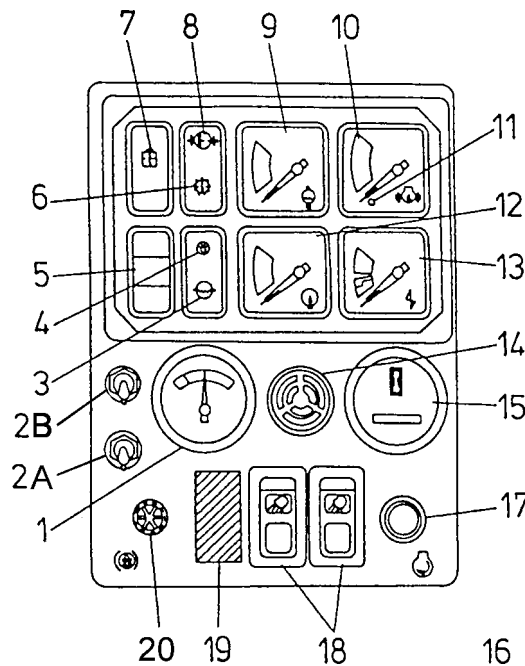

Fig. 4.2. Instrument Panel for Machine Equipped with QSK-19 Engine

- 1. Fuel Level Gauge
- 2A. Engine ECM Failure Code Display Selector Switch
- 2B. Engine ECM Memory Activation Diagnostics Switch
- 3. Engine Coolant Level Warning Light
- 4. Air Cleaner Filter Warning Light
- 5. Engine ECM Failure Code Warning Lights
- 6. Transmission Oil Pressure Filters Warning Light
- 7. Hydraulic Oil Filters Warning Light
- 8. Low Transmission Main Pressure and Clutch Low Oil Pressure Warning Light
- 9. Engine Coolant Temperature Gauge
- 10. Engine Oil Pressure Gauge
- 11. Low Engine Oil Pressure Warning Light
- 12. Torque Converter Oil Temperature Gauge
- 13. Voltmeter
- 14. Engine Coolant Low Level and Low Oil Engine Pressure Alarm
- 15. Hourmeter
- 16. Starting Button and Warning Light
- 17. Light Switches
- 18. Ether Injector Switch
- 19. Brake Lock

INSTRUMENT PANEL

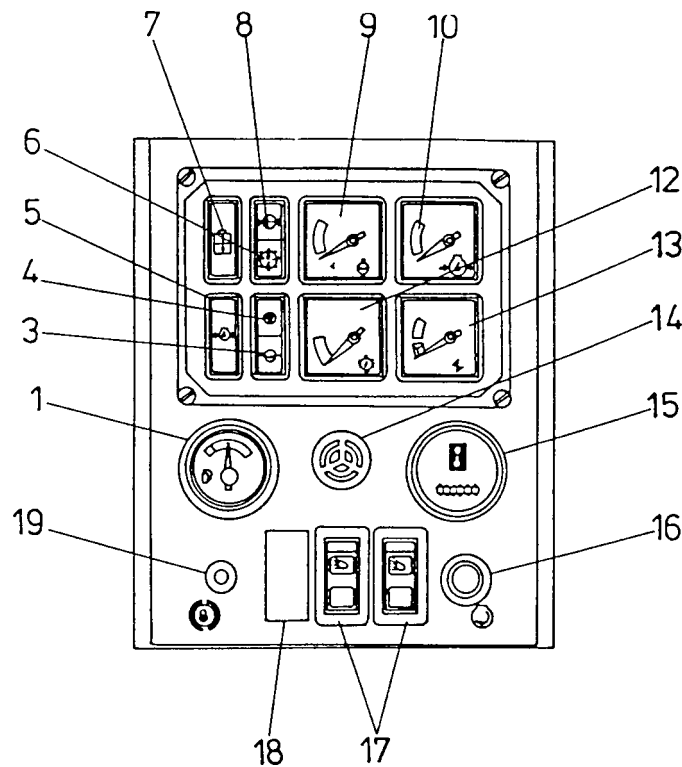

Fig. 4.3. Instrument Panel for Machine Equipped with KTA-19C Engine

1. Fuel Level Gauge
3. Engine Coolant Level Warning Light
4. Air Cleaner Filter Warning Light
5. Low Engine Oil Pressure Warning Light for KTA-19C
6. Transmission Oil Pressure Filters Warning Light
7. Hydraulic Oil Filters Warning Light
8. Transmission Main Low Pressure and Clutch Low Oil Pressure Warning Light
9. Engine Coolant Temperature Gauge
10. Engine Oil Pressure Gauge
12. Torque Converter Oil Temperature Gauge
13. Voltmeter
14. Low Engine Coolant Low Level and Low Oil Pressure Alarm
15. Hourmeter
16. Starting Button and Warning Light Check
17. Light Switches
18. Ether Injector Switch
19. Brake Lock

1. FUEL LEVEL GAUGE

The gauge indicates quantity of fuel available for operation in fuel tank.

2A. ENGINE ECM FAILURE CODE DISPLAY SELECTOR SWITCH (QSK-19 engine only)

This selector switch has three positions. In its upper and lower position it enables to display engine failure codes (in succession). The selector switch reverses automatically to its home-central position.

INSTRUMENT PANEL

2B. ENGINE ECM MEMORY ACTIVATION DIAGNOSTICS SWITCH (QSK-19 engine only)

This is a two-position switch: upper – normal (working) position and lower position for engine failures capture (memory activated).

3. ENGINE COOLANT LEVEL WARNING LIGHT

The engine coolant level indicator will glow if coolant level drops below operating level, this light is supplemental to low engine coolant and oil pressure alarm (14) on instrument panel.

4. AIR CLEANER FILTER WARNING LIGHT

The air cleaner filter warning light will glow amber when the filter element reaches the maximum allowable restriction. When this happens, filter element service is required.

5. ENGINE OIL PRESSURE WARNING LIGHT (KTA –19C engine only)

The engine oil pressure warning light will glow when engine oil pressure is low.

5. ENGINE ECM FAILURE CODE WARNING LIGHTS (QSK-19 engine only)

If any of monitored engine performance characteristics is not within specified range or sensor is damaged, it will be stored in the ECM memory and then signaled by warning lights. This is first information for the operator of incorrect engine performance characteristic. If so, read failure code per Engine Manual.

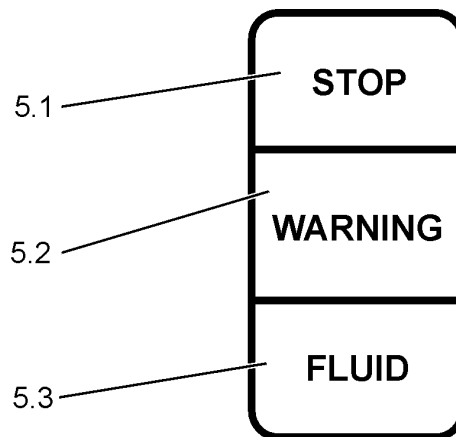

Fig. 3A. Warning lamps.

5.1 WARNING LAMP (RED)

This light indicates a serious malfunction of the engine. Stop the engine immediately or the ECM module will stop the engine.

5.2 WARNING LAMP (YELLOW)

This light indicates a less serious malfunction of the engine. It can be operated but to its protection the ECM may reduce the engine performance (power, rpm). This failure should be corrected as soon as possible.

5.3 WARNING LAMP (AMBER)

This indicator shows low engine coolant level. The low engine coolant level extending over a longer period will reduce engine performance and eventually, stop the engine.

6. TRANSMISSION OIL PRESSURE FILTERS WARNING LIGHT

The transmission oil filter indicator will glow amber when the oil filter element reaches the maximum allowable restriction. When this happens, respective transmission pressure filter service is required.

INSTRUMENT PANEL

7. HYDRAULIC OIL FILTERS WARNING LIGHT

The hydraulic oil filter warning light will glow amber when the oil filter element reaches the maximum allowable restriction. When this happens, respective filter service is required.

8. TRANSMISSION MAIN LOW PRESSURE AND CLUTCH LOW OIL PRESSURE WARNING LIGHT

The transmission clutch low oil pressure warning light will glow when there is insufficient oil pressure in neutral position or insufficient oil pressure available for the transmission clutches with transmission in gear. When warning light is activated stop the engine and clean transmission system suction filter and check oil level in rear frame. Refer to "TRANSMISSION SYSTEM" in Section 5. If the light continues to glow stop the engine and consult Authorized Distributor of Construction Equipment before operating the machine.

9. ENGINE COOLANT TEMPERATURE GAUGE

This gauge shows the temperature of the coolant circulating through the engine. After the engine has operated a sufficient length of the time, the pointer of the gauge must be in the GREEN area of the gauge.

During normal operation the gauge readings may vary between the minimum and maximum indicated by the GREEN area of the gauge.

Continuous engine operating below the minimum temperature is harmful to the engine. Low coolant temperatures will also cause exhaust smoke and increase the rate of fuel consumption.

NOTE: *In cold weather, if no louver is mounted, it may be necessary to cover part of the radiator to maintain the minimum coolant temperature indicated at the lower end of the GREEN area.*

The engine temperature under full load should remain in the GREEN of the gauge.

10. ENGINE OIL PRESSURE GAUGE

This gauge shows the pressure at which the lubricating oil is circulating through the engine. The pointer must register in the green area during operation of the engine.

The gauge only QSK-19C is equipped with red warning light. When red warning light is on, the engine must be immediately be stopped.

11. LOW ENGINE OIL PRESSURE WARNING LIGHT (ENGINE QSK-19)

The warning light will glow red when engine lubricating oil pressure drops below permissible minimum value. If so, stop operating the machine and stop the engine.

12. TRANSMISSION SYSTEM OIL TEMPERATURE GAUGE

This gauge shows the temperature of oil in transmission system. The pointer of the gauge must be in the GREEN area of the gauge.

13. VOLTMETER

The voltmeter indicates the condition of the batteries. At low idle speed, the gauge pointer should be within the green with white stripe area, which indicates a good battery charge. If the voltage drops below this area, the batteries should be checked.

With the engine operating above low idle speed, the pointer should be within the upper green area, which is the normal operating range. If the pointer drops below or exceeds this area, the battery, alternator or wiring may be at fault.

14. LOW ENGINE COOLANT AND LOW OIL PRESSURE ALARM

This alarm will sound when lubricating engine oil pressure or coolant level in radiator drops below normal. If so, stop the machine and find out which warning light glows and check gauge indication.

INSTRUMENT PANEL

15. HOURMETER

The hourmeter electrically records the actual hours of engine operation. The purpose of the hourmeter is to indicate when to perform the recommended maintenance and lubrication operations. The hourmeter will register only when the engine is running.

16. START SWITCH BUTTON AND WARNING LIGHTS CHECK

The button is used to crank the engine. Place the transmission neutral lock in neutral and the transmission electrical system master switch to the ON position.

IMPORTANT: To prevent damage to the starter motor and avoid low battery output, do not continuously crank the engine for more than 30 second intervals. Allow 2 to 3 minute recovery period between cranking.

Prior to starting the engine move the engine speed and shut down lever fully forward (OFF position), depress the starting switch and check if all warning lights glow. If any warning light doesn't glow that indicates that the bulb is defective or its circuit is broken.

17. STARTING SWITCH (only QSK-19 engine)

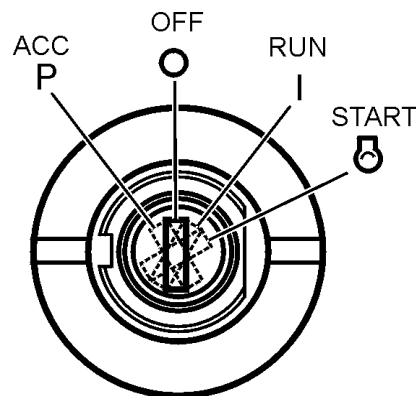

Fig. 3B. Starting switch-key positions

The starting switch equipped with a key is used to connect and disconnect electric circuits and for starting and stopping the machine engine.

Starting switch key positions:

ACC – to the left – for future used,

OFF – after inserting the key – disconnects electrical circuits,

RUN – to the right – activates electrical circuits,

START - to the right with automatic return to RUN on key release – engine startup.

18. LIGHTS SWITCHES

Work lights switches are rocker type switches. Activation of the switches turns on front and/or rear work lights.

19. ETHER INJECTOR SWITCH

This switch controls the ether injector for cold weather starting. Refer to "STARTING THE ENGINE" for proper operation of this switch.

20. BRAKE LOCK

This handle locks the brake pedal in the applied position for parking the machine. To lock the brake pedal, fully depress the pedal, pull out the lock handle and remove your foot from the pedal. To release the brake, simultaneously depress the brake pedal and push in the lock handle.

4.5. CAB CONTROLS

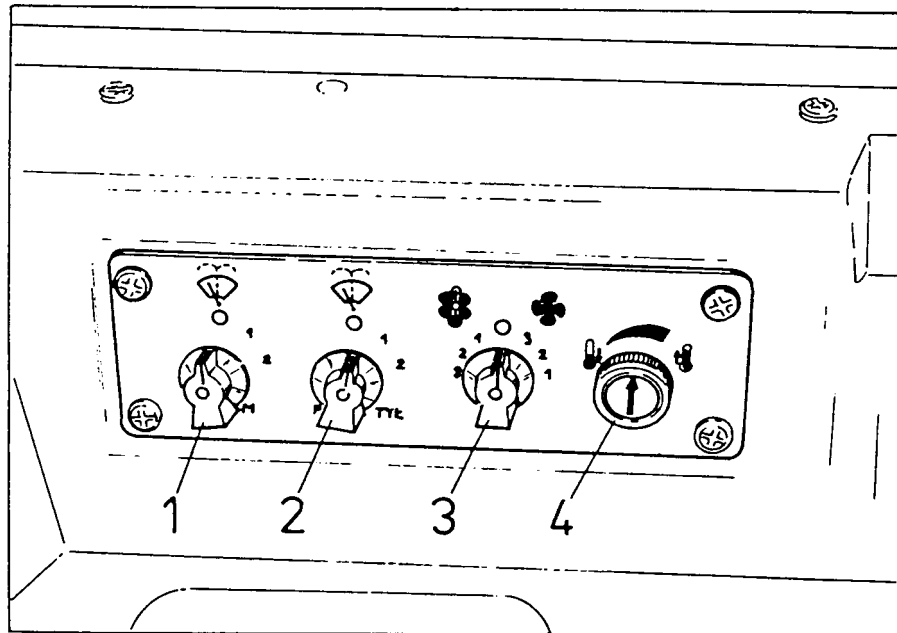

Fig. 4.4. Air Conditioner, Heater and Accessories Controls

1. Door Wiper Knob and Washer Pushbutton
2. Window Wiper Knob and Washer Pushbutton
3. Heater and/or Cooler Pressurized Control Knob
4. Temperature Control Knob

DOME LIGHT

Dome light is switched on with switch mounted in the light.

CAB VENTILATION

NOTE: For maximum cooling turn the temperature control knob fully to the left.

1. DOOR WIPER KNOB

This knob activates window wipers and washers. Principle of operation is similar to wiper timing knob and washer.

2. WINDOW WIPER KNOB

This knob activates window wipers and washers. The switch enables two-speed selection of the wipers, low and high speed when turn to the left and push the washer button to spray washer fluid.

3. HEATER AND/OR COOLING PRESSURIZER FAN SPEED CONTROL KNOB

This knob controls the speed of the fan circulating air inside the cab. It has three speed settings low, medium and high. Turn the knob to the left for three fan speed selections when cooling the air, i.e. low, medium and high.

Turn the knob to right for three fan speed selections when heating air i.e. low, medium and high. To turn the fan off, turn knob to center position.

CAB CONTROLS

4. TEMPERATURE CONTROL KNOB

This knob is used to control temperature inside the cab. To decrease temperature turn the knob to the left position and to increase temperature turn the knob to the right position.

4.6. CONTROLS AND ADJUSTMENT

4.6.1. SEAT

SEAT ADJUSTMENT LEVERS

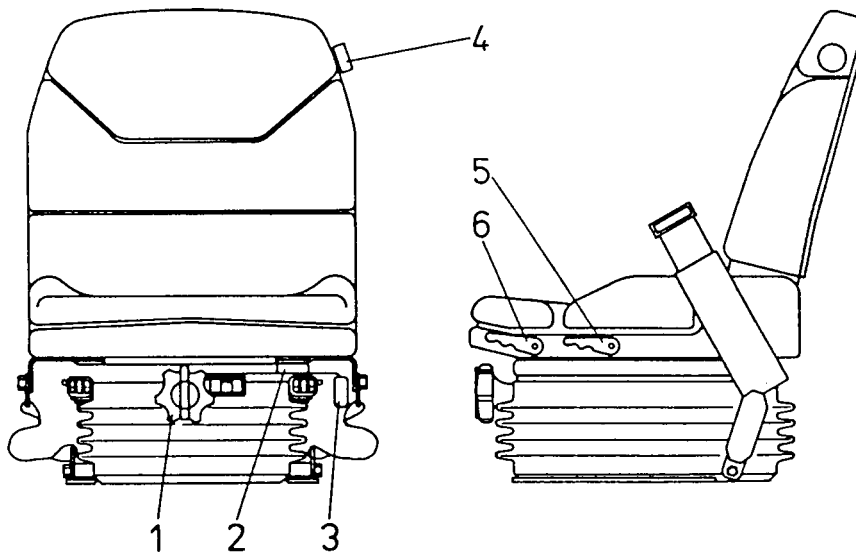

Fig. 4.5. Seat

1. Weight Adjustment Lever
2. Seat Travel Lever
3. 15° Swivel to the Right Lever
4. Back Rest Cushion Adjustment knob
5. Back Cushion Tilt Lever
6. Seat Adjustment Knob

The operator's seat is adjusted as follows:

Press tilt lever 5 to adjust required angle of back cushion.

Turn the knob 1 to adjust to own weight. Move lever 2 forward to slide the seat back or forth.

Turn the knob 4 located on the left side to adjust backrest angle.

For ripping operations lift lever 3 to swivel the seat 15° to the right.

4.6.2. SEAT BELT



WARNING! Before driving the machine adjust the seat belt and fasten the seat belt. Adjust the belt to fit snugly and low around the hips to lessen the chance and severity of injury in the event of an accident. Never wear the belt across the abdomen.

CONTROLS AND ADJUSTMENT

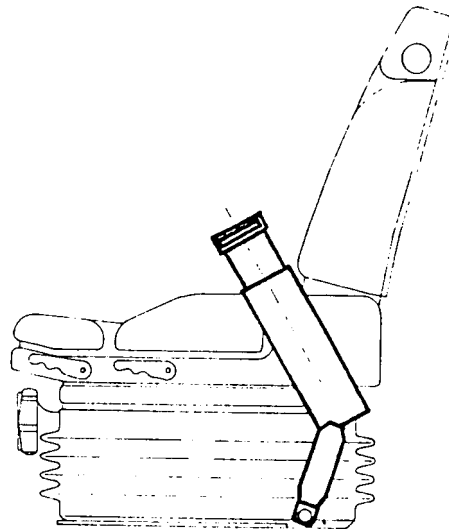

Fig. 4.6. Seat Belt

To buckle, insert the tongue portion of the buckle into the locking portion.



WARNING! Do not bleach, color dye or solvents on the seat belt webbing, this may cause a severe loss of tensile strength. This could cause the webbing to break resulting in personal injury, it is recommended that the seat belt be cleaned only with warm water and a mild detergent.

Keep belt flat to avoid twisting and roping when not being used. Do not place heavy or sharp object on the belts.

4.6.3. ENGINE SPEED AND SHUT DOWN LEVER

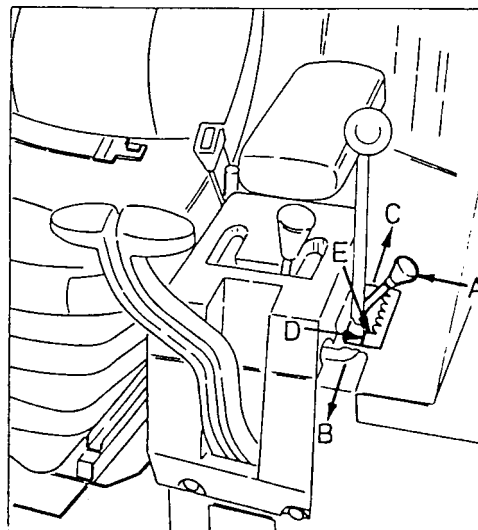

Fig. 4.7. Engine Speed and Shut Down Lever

- A – Engine Speed and Shut Down Lever
- B – Lever Forward to Decrease Speed
- C – Lever Back to Increase Speed
- D – Large Cutout for Engine Shut Down
- E – Engine start and Low Idle Speed

CONTROLS AND ADJUSTMENT

This lever (A) is used to start the engine, control this speed of the engine or to shut it off. Push this lever forward (B) to decrease engine speed. Pull the lever back (C) to increase engine speed. Position lever in this large cutout (D) to shut down the engine.

For machine equipped with QSK-19 engine – see “STOPPING THE ENGINE”

4.6.4. TRANSMISSION NEUTRAL LOCK LEVER

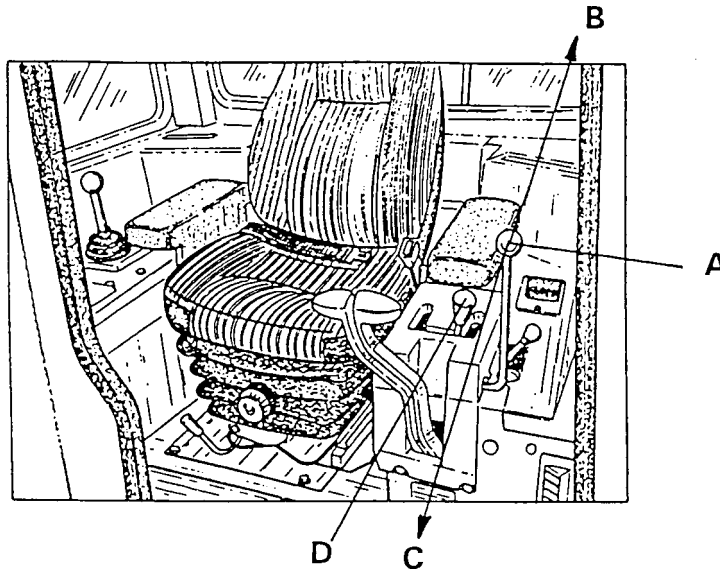

Fig. 4.8. Transmission Controls

- A – Transmission Neutral Lock Lever
- B – Lever Rearward to Lock Shift Lever
- C – Lever forward to release shift lever
- D – Transmission Shift Lever

This lever (A) is used to lock the transmission shift lever in “NEUTRAL.” Move the lever backward (B) (ON position) to lock the shift lever, or forward (C) (OFF position) to release. When starting or idling the engine with the transmission in NEUTRAL place the lock lever in the ON position.

4.6.5. TRANSMISSION SHIFT LEVER

This lever is used to select the various transmission gear ranges. Refer to “DRIVING THE MACHINE.”

NOTE: When the shift lever is placed in one of the reverse positions, the back-up alarm will automatically sound.

CONTROLS AND ADJUSTMENT

4.6.6. HAND STEERING LEVERS

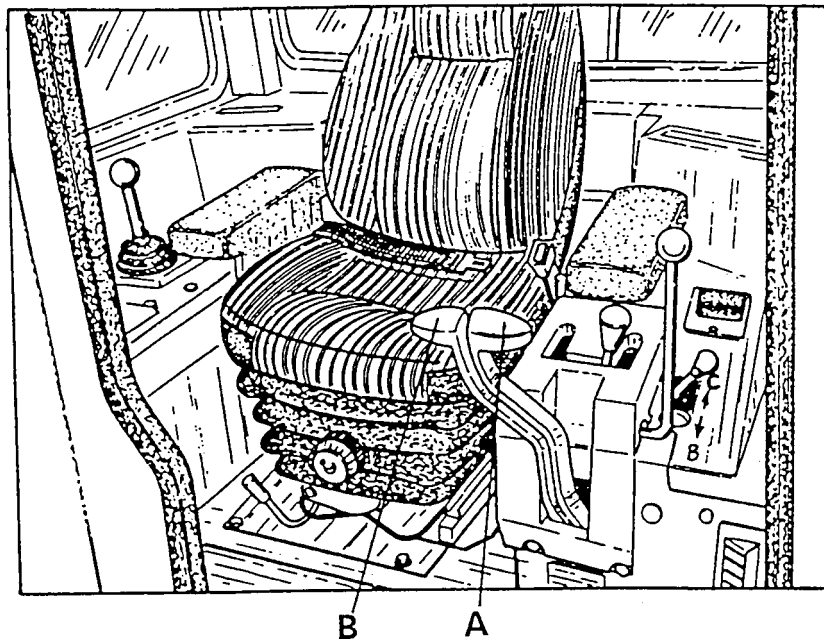

Fig. 4.9. Hand Steering Levers

- A – Left Hand Steering Lever
- B – Right Hand Steering Lever

These levers steer the machine by controlling engine power to the tracks and by applying and releasing respective speed range clutch packs and brake clutch packs. The left-hand steering lever (A) controls the left track with the right hand steering lever (B) controlling the right track.

4.6.7. BRAKE AND DECELERATOR PEDAL

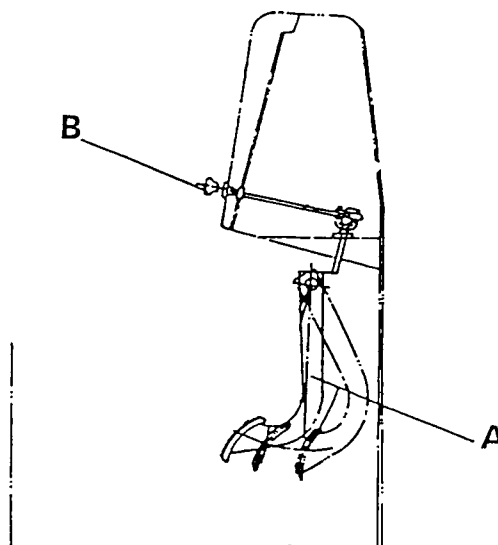

Fig.10. Brake and Decelerator Pedal and Pedal Lock

- A – Brake and Decelerator Pedal
- B – Brake Lock

CONTROLS AND ADJUSTMENT

This pedal overrides the engine speed control lever setting. Partial depression of the pedal decreases engine speed for smoother changes in machine direction and to ease the machine up to a load. Release the pedal to accelerate the engine speed control lever setting. This pedal stops the machine when fully depressed. It also serves as a parking brake when the brake pedal lock is applied and brake pedal lock knob is pulled.

Periodic adjustment of the pedal might be required. Refer to Authorized Distributor of Construction Equipment if pedal values are not within those shown in Fig. 4.11.

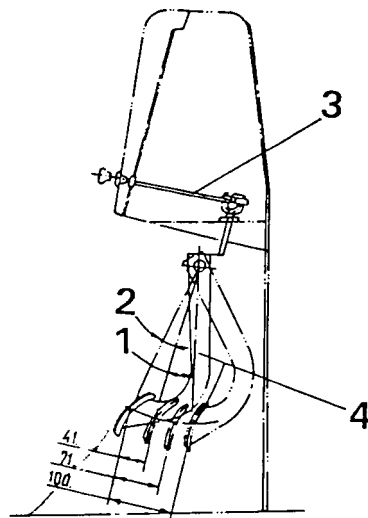

Fig. 4.11. Brake and Decelerator Pedal Adjustment

1. Deceleration Angle (10°)
2. Braking Angle (14°)
3. Brake Lock Linkage
4. Brake and Decelerator Pedal

4.6.8. BRAKE AND DECELERATOR PEDAL LOCK

This lock secures the brake and decelerator pedal in the applied position for parking the machine. To lock the brake and decelerator pedal fully depress the pedal, pull out the lock and remove your foot from the brake and decelerator pedal. To release the brake, depress the brake and decelerator pedal and push the lock.

IMPORTANT: Release the brake pedal lock before moving the machine. The brakes could burn or be damaged if the machine is driven with partially applied brakes.

4.6.9. ELECTRICAL SYSTEM MASTER SWITCH

Turn the key clockwise to connect the battery ground circuit. Turn the key counterclockwise to disconnect the battery ground circuit.

IMPORTANT: Keep the switch on while the engine is running.

CONTROLS AND ADJUSTMENT

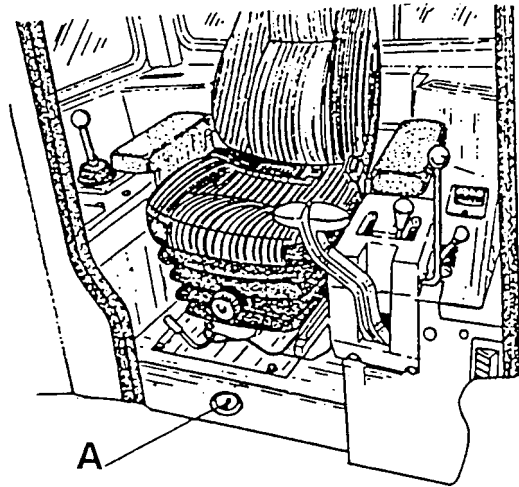

Fig. 4.12. Electrical System Master Switch

A – Electrical System Master Switch Key

4.6.10. EQUIPMENT CONTROL LEVERS

BLADE CONTROL LEVER

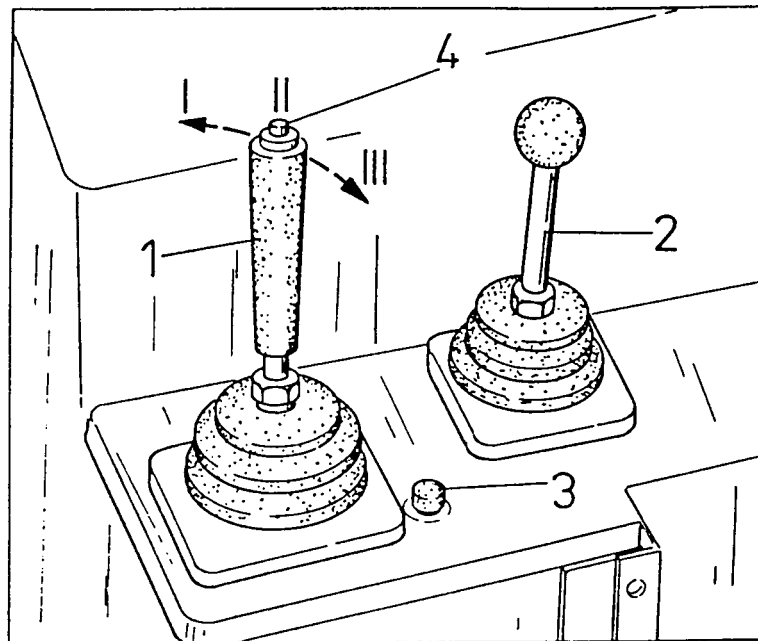

Fig. 4.13. Equipment Control Levers

- 1. Blade Raise, Lift, Tilt and Pitch Control Lever
- 2. Ripper Control Lever
- 3. Horn Button
- 4. Blade Pitch Button
 - I - Decreasing Suction Angle
 - II - Hold
 - III - Increasing Suction Angle

CONTROLS AND ADJUSTMENT

RIPPER CONTROL LEVER

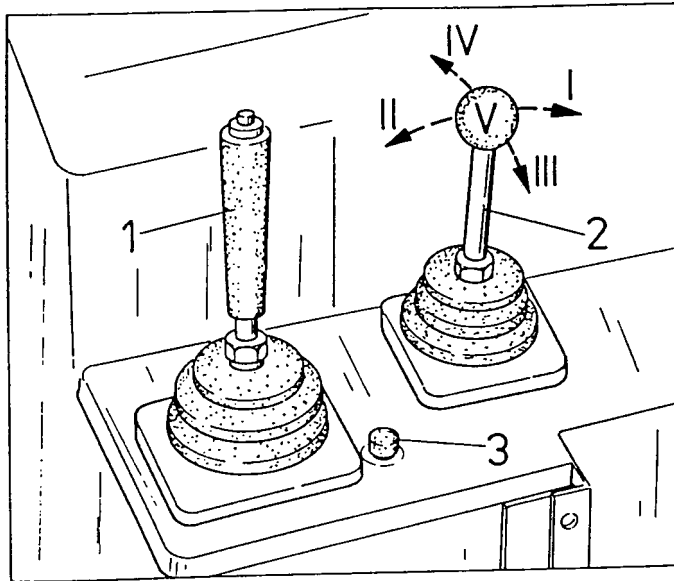

Fig. 4.14. Ripper Control Lever (2)

- | | |
|-------------------------|--------------------------|
| 1. Blade Control Lever | I - Ripper Pitch Forward |
| 2. Ripper Control Lever | II - Ripper Pitch Aft |
| 3. Horn Button | III - Ripper Raise |
| | IV - Ripper Lower |
| | V - Hold |

NOTE: For proper control of ripper control lever and observation of working tool swivel the operator seat 15° to the right.

4.7. STARTING THE ENGINE

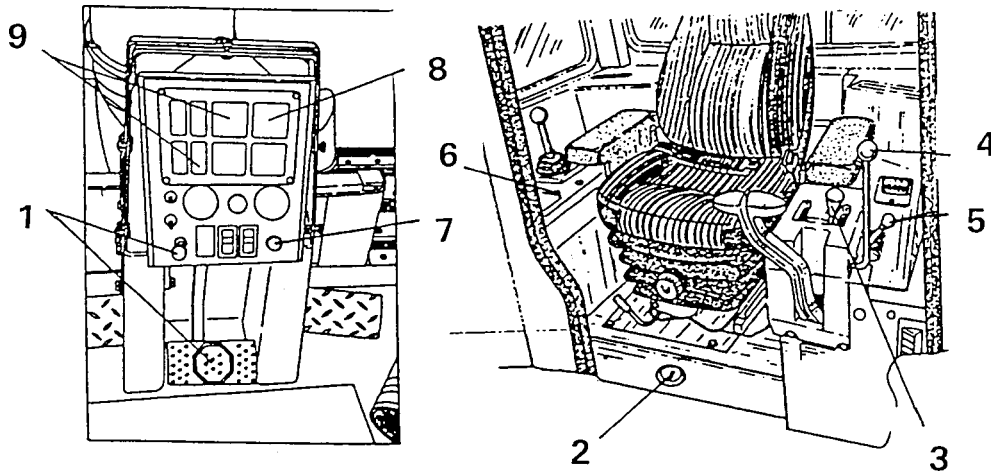

Fig. 4.15. Starting the Engine

- | | | |
|--|-------------------------------------|---|
| 1. Brake and Decelerator Pedal and Brake Lock Knob | 4. Transmission Neutral Lock Lever | 7. Start Switch Button-Starting Switch (for QSK-19 engine only) |
| 2. Electrical System Master Switch | 5. Engine Speed and Shut Down Lever | 8. Engine Oil Pressure gauge |
| 3. Transmission Shift Lever | 6. Horn | 9. Engine Coolant Gauge and Light |

STARTING THE ENGINE

NOTE: Before operating the machine perform each of the 10 hour maintenance requirements referred to in Section 5.2. SCHEDULED MAINTENANCE. This engine cannot be started by towing, pushing or coasting the machine.



WARNING! Before entering the operator's compartment, walk completely around the machine and clear the area of personnel and obstructions.



WARNING! Read all product graphics before starting, operating, maintaining, or repairing the machine.



WARNING! Before starting the engine or when the machine is standing with the engine running, lock the transmission shift lever in neutral, apply brake lock and lower all raised equipment:



WARNING! Understand all control functions before starting the engine.



WARNING! Never start the engine indoors unless proper exhaust ventilation is provided to remove deadly exhaust gases. Once the engine is running, move the machine outdoors as soon as possible. Exhaust gases are hazardous and can cause unconsciousness and death.



WARNING! Be sure all personnel are clear of the machine before starting the engine. Sound the horn.



WARNING! Make sure the operator's seat is adjusted properly and fasten the safety seat belt.

4.7.1. NORMAL START (temperature above 0°C)

1. Apply and lock the brake and decelerator pedal.
2. Place transmission shift levers in neutral.
3. Place the neutral lock lever in vertical "ON" position.
4. Move the engine speed control lever to idle speed position (Fig. 4.16).
5. Turn on electrical system master switch ("ON").
6. QSK-19 engine only. Turn the starting switch key from the OFF position to the RUN position (Fig. 3B). With the key in this position warning lights 5.1, 5.2 and 5.3 on the instrument panel will be on (Fig. 3A). After two seconds the warning light 5.2 will turn off followed by the light 5.1 and 5.3. This means that the engine self-detection feature disclosed no ECM failure. If the ECM detects engine system failure (sensor damage, low oil pressure, low coolant level, etc.) it will be stored in ECM memory as an active failure. Turn the starting switch key into the OFF position, the diagnostics switch (2B, Fig.2) into its upper position and then turn the key into the RUN position to read active failure codes. Turn the 2A selector switch (Fig.2) into its upper and lower position to display the failure code.

STARTING THE ENGINE

Failure code display (example): 115 (Fig. 15A)

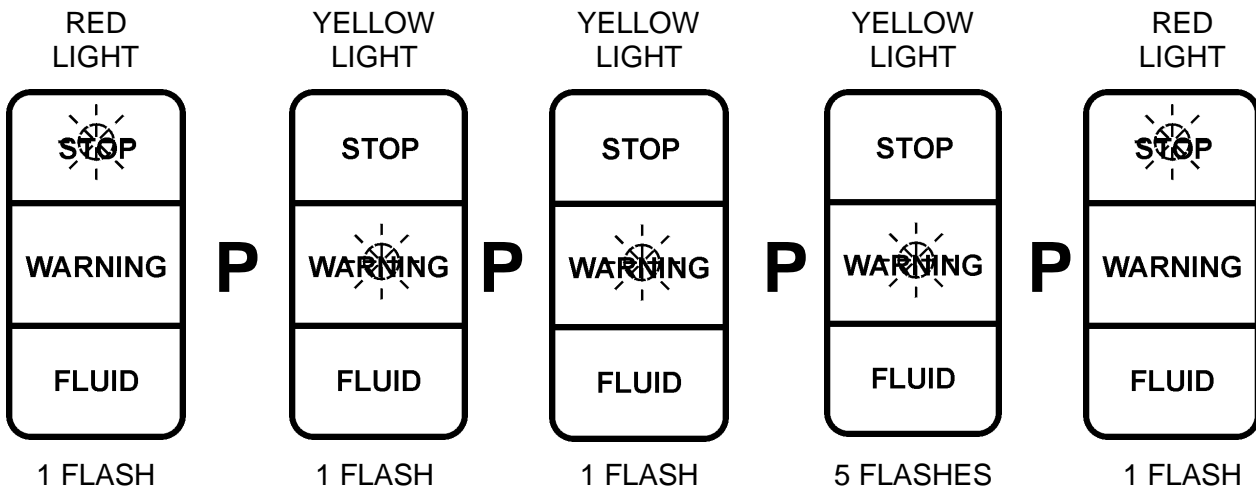

Fig. 15A. Failure code display (example)

P.- one second interval

Failure code 115 – engine rpm sensor damage

For failure code – refer to QSK-19 ENGINE MANUAL

Contact an Authorized Construction Equipment Distributor in case you find out any active engine failures.

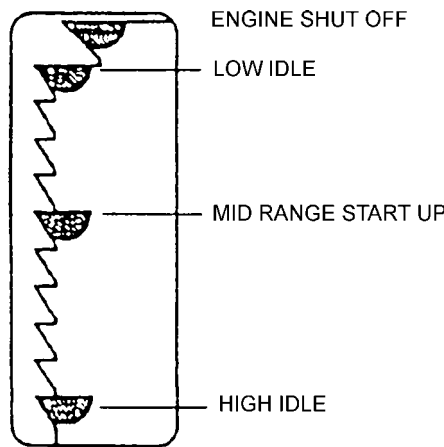

Fig. 4.16. Engine Speed and Shut Down Control Lever

6. Sound the horn to clear all personnel from the immediate area.
7. Crank the engine.
 - press the start switch button (KTA-19C engine)
 - turn the starting switch key to the right to the START position (QSK-19 engine)
8. Check oil pressure. Stop the engine immediately if gauge fails to show correct pressure after 15 seconds. Allow the engine to idle for 3 to 5 minutes (app.1000 RPM.) before increasing the engine speed and placing under load.
9. Check indications of all instruments to ensure that machine is operating correctly. Refer to INSTRUMENT PANEL.

IMPORTANT: It is not recommended to run the engine at low idle over 10 minutes due to possibility of accelerated wear of engine components.

STARTING THE ENGINE

4.7.2. ETHER INJECTOR START (temperatures below 0°C)



WARNING! Ether starting fluid is highly flammable. Follow the precautions on the container. An explosion can result if sparks or flame contact the ether or when storing ether container when the air temperature is above 70°C.

Observe the following precautions:

- Do not use the ether injector when the air temperature is above 0°C.
- Do not use open flame when using ether starting fluid.
- Do not store fluid containers in the operator's compartment.
- Store the containers in a cool, well ventilated place. Keep the fluid containers out reach of children.
- Do not breathe the hazardous ether vapor.
- Do not let ether contact you skin, because it can cause frostbite.
- Never puncture the fluid container or put it into a fire
- Dispose of empty containers per instructions printed on the container
- For your safety, remove the ether container when welding, grinding, or using a torch on the machine.
- Follow the correct method for starting the engine.
- Before any attempt to start the engine, check the ether container or insure that a supply of starting fluid is available under pressure and the system is in working condition.
- Pressing the switch in the instrument panel makes ether injection.



WARNING! Ether injector is to be used only for starting. Misuse of ether injector while engine is running can result in serious damage to engine.

1. Follow the steps described in the Items 1 through 5. Refer to NORMAL START (temperature above 0°C).
 - Crank the engine
 - press the start switch button (KTA-19C engine)
 - turn the starting switch key to the right to the START position (QSK-19 engine)

Press both the engine button and the ether injector switch simultaneously. Allow one to two seconds for chamber in the valve to fill in then, with the engine cranking, release the ether injector switch to inject a measured shot of starting fluid into the engine. If temperature is below –18°C, additional ether shots may be required. If the engine does not fire with 4 injections maximum, determine the cause of the engine failure to start and correct it before any another attempt to restart the engine.

IMPORTANT: Crank engine for 30 seconds at a time. If engine does not start, allow cranking motor to cool two or three minutes before cranking again.

4.7.3. ENGINE START AFTER OIL CHANGE OR PROLONGED STANDSTILL (over 5 days)

1. Follow the steps described in the Items 1 through 6. Refer to NORMAL START.
2. Shift the engine speed control lever to OFF position (Fig. 4.16).
3. QSK-19 engine. Unplug the male part of the ESP engine RPM sensor connector. Refer to Fig. 16A.
4. Crank the engine
 - - press the start switch button (KTA-19C engine)
 - turn the starting switch key to the right to the START position (QSK-19 engine) (Fig. 3B)

Continue to crank the engine until oil gauge registers oil pressure or low oil pressure warning light goes off.

OPERATING

STARTING THE ENGINE

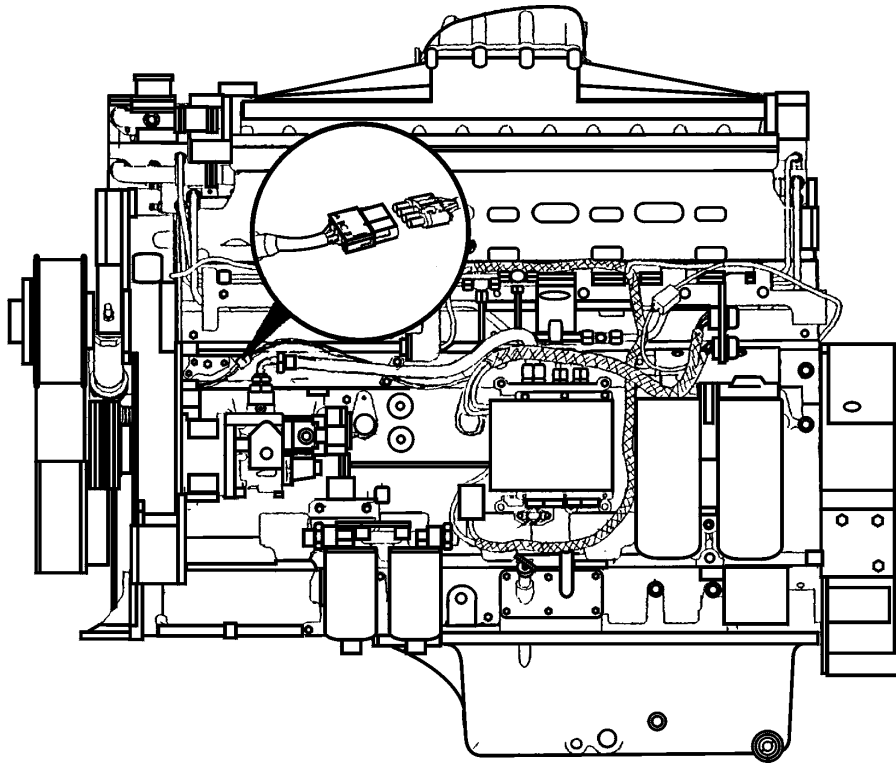

Fig. 16A. ESP engine RPM sensor connector.

5. QSK-19 engine. Replace the male part of the ESP engine RPM sensor connector. Follow the steps described in the Items 7 through 10. Refer to NORMAL START.

4.8. STOPPING THE ENGINE

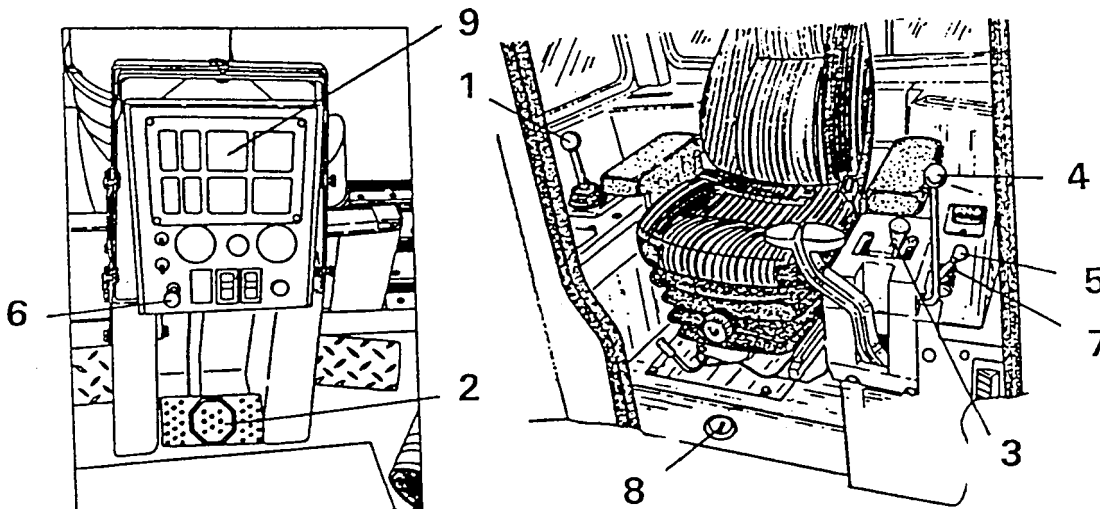

Fig. 4.17. Stopping the Engine

- 1. Ripper Control Lever
- 2. Brake and Decelerator Pedal
- 3. Transmission Shift Lever
- 4. Transmission Neutral Lock Lever
- 5. Engine Speed and Shut Down Lever
- 6. Brake Lock Knob
- 7. Starting Switch (QSK-19 engine)
- 8. Electrical System Master Switch
- 9. Engine Coolant Temperature Gauge

STOPPING THE ENGINE

1. Using control lever (1) lower all mounted equipment to the ground. Depress the brake and decelerator pedal (2) and place transmission shift lever (3) into NEUTRAL.
2. Apply transmission neutral lock lever (4).
3. If engine operated under load, operate the engine at idle speed for 3 to 5 minutes to allow the engine to cool down in gradual and uniform manner.
4. Depress and lock brake and decelerator pedal.

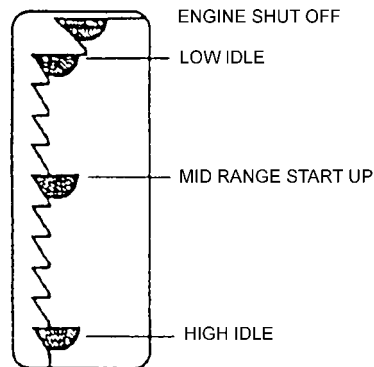

Fig. 4.18. Engine Speed and Shut Down Control Lever

IMPORTANT: Immediate engine shut down after operation under load may result in engine damage.

5. Shift the engine speed and shut down lever to large notched OFF position – the electrovalve will shut down the engine. (KTA-19C engine only)
6. QSK-19 engine only: Turn the starting switch key to the left to the OFF position (Fig. 3B). The engine will be shut off.
7. Turn the electrical master switch to the OFF position.

4.9. DRIVING THE MACHINE

IMPORTANT: Read the SAFETY PRECAUTIONS in Section 2 before operating the machine.

IMPORTANT: Before operating check all instruments.



WARNING! Never haul passengers. Only the operator should be on the machine when it is moving.



WARNING! Sit in the operator seat before operating the controls. Keep hands and footwear free of grease, water and mud to insure positive control movements.



WARNING! Before operating the machine adjust the seat to allow full access of all controls and fasten the seat belt. Failure to do so could result in serious injuries or death.



WARNING! Never get on or off the machine while it is moving because serious injury or death could result.

DRIVING THE MACHINE

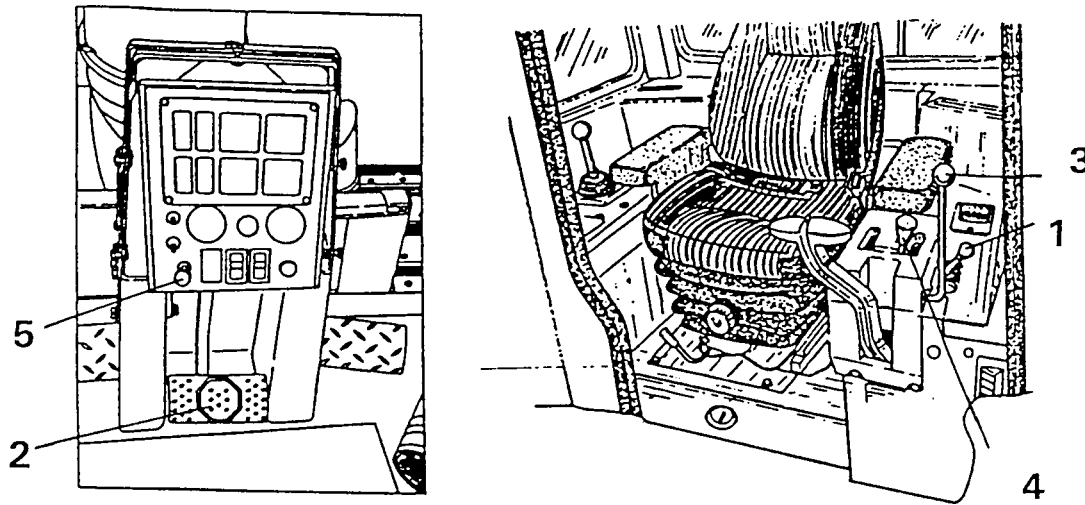

Fig. 4.19. Driving the Machine

1. Engine Speed and Shut Down Lever
2. Brake and Decelerator Pedal
3. Transmission Neutral Lock Lever
4. Transmission Shift Lever
5. Brake Lock Lever

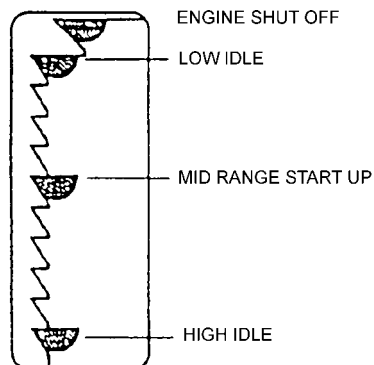

Fig. 4.20. Engine Speed and Shut Down Control Lever

1. Place the engine speed and shut down control lever in the high idle position.
2. Depress the decelerator pedal to decrease engine speed.
3. Move forward the neutral lock lever (3) from ON to OFF position.
4. Place the transmission shift lever in the desired range.
5. Gradually release the brake and decelerator pedal.

4.10. SHIFTING THE TRANSMISSION

The transmission has three speeds in both the forward and reverse ranges. The ranges and speeds are controlled by the transmission shift lever. The machine is equipped with automatic system reducing travel speed appropriately to shifted range when changing direction of travel from reverse to forward. The system is designed to reduce dynamic load and consequently to prolong drive train service life.

4.11. CONVERTER OVERHEATING

If the pointer of the torque converter oil temperature gauge moves out of the RUN area of the dial during operation, the transmission may be in a gear range which is too high for the load. Shift down into the next lower gear range. The temperature should reduce; if not, downshift again. If the dial pointer remain out of the RUN range in first gear, stop the machine, shift into neutral and run the engine at 1000 RPM until the gauge pointer moves into the RUN area. If the converter still remains overheated, stop the engine and consult Authorized Distributor of Construction Equipment before operating the machine.

4.12. STEERING THE MACHINE

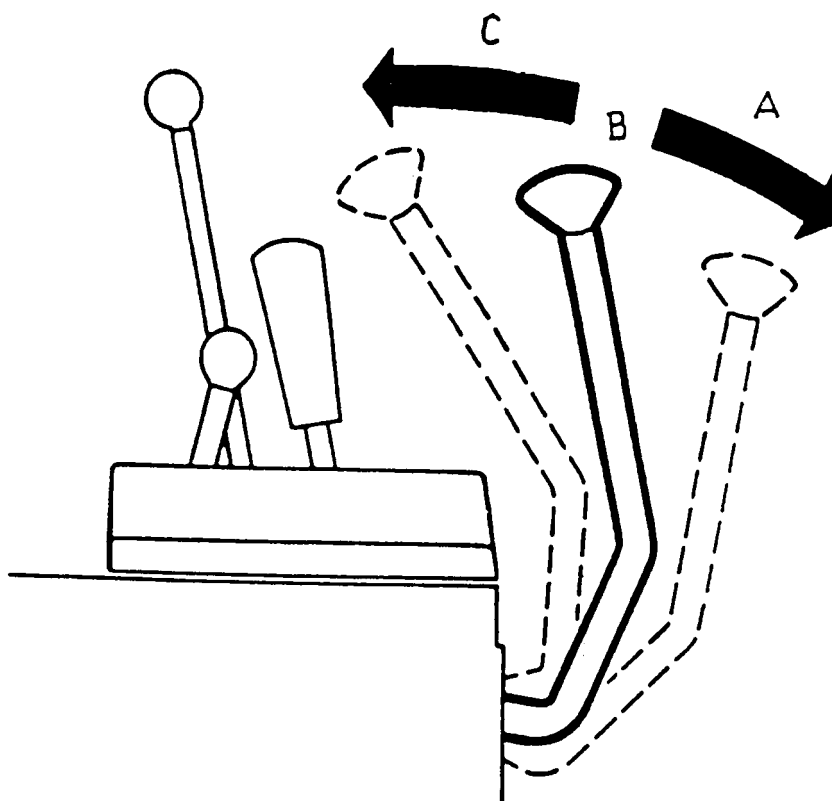

Fig. 4.21. Steering Levers

A – High Range B – Low Range C – Pivot

Steering is accomplished with the two steering levers. Each of the two levers function in three positions as shown in Fig. 4.21.

- in forward position A transmits power to the track in high range
- in middle position B transmits the power to the track in low range
- in rearward position C disconnects the power and applies the brake

To turn to the right or left pull back the steering lever on the side toward which the turn is to be made. Pull lever back just enough to make the desired turn. To make a pivot turn pull the lever all the way back.

To make a gradual left turn proceed as follows:

With steering lever in high range move LH steering in low range. When both steering levers are in low range, move RH steering lever in high range. To make a gradual right turn proceed in similar manner.

4.13. LOCKING BOTH TRACKS

When both steering levers are pulled simultaneously all the way back, the braking action stops both tracks.



WARNING! Never pull both steering levers all the way back to stop the machine unless the machine is moving very slowly. Use the foot brake to slow down or stop the machine.

4.14. DOWNGRADE OPERATION



WARNING! When operating a machine downhill, always put the transmission in the low range position. Use the brake pedal to slow the machine. Never go downhill with the transmission control in neutral. Failure to do so could result in losing control of the machine and rollover could result.

Before going downgrade, select the range which will provide full tractor control without overspeeding the engine.

4.15. OPERATING OVER AN OBSTRUCTION

When crossing a log or ditch bank, use the decelerator pedal to slow the machine; and when possible, cross at an angle. Then gradually increase the power to the tracks as the machine moves forward, over, and down. If the load is light, it may also be necessary to use the brake pedal to avoid abrupt movements.

4.16. STOPPING THE MACHINE

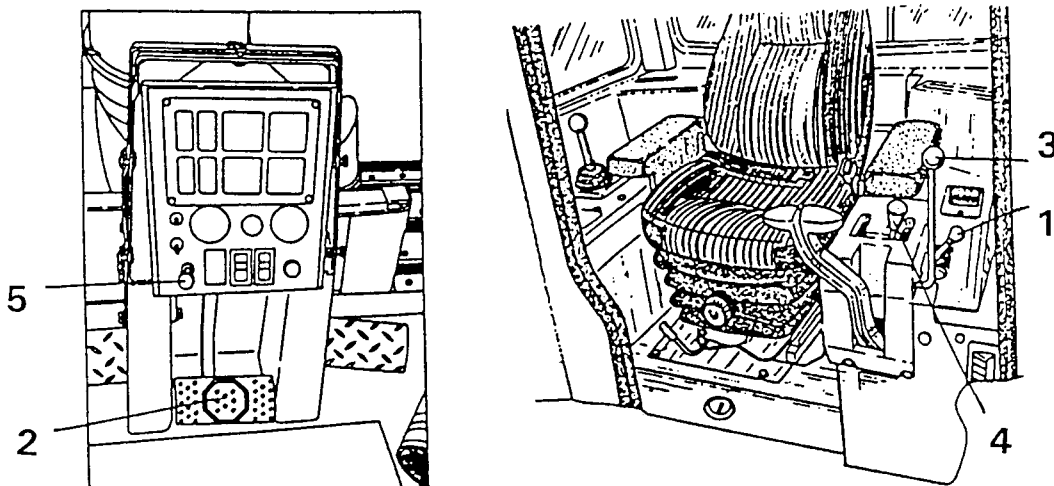

Fig. 4.22. Stopping the Machine

- | | |
|-------------------------------------|-----------------------------|
| 1. Engine Speed and Shut Down Lever | 4. Transmission Shift Lever |
| 2. Brake and Decelerator Pedal | 5. Brake Lock Lever |
| 3. Transmission Neutral Lock Lever | |

STOPPING THE MACHINE

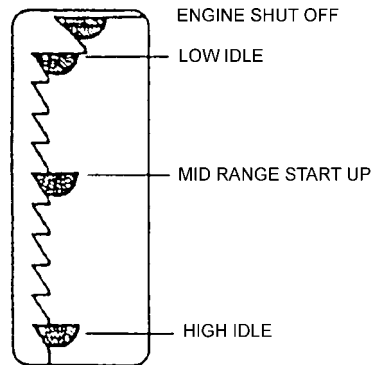

Fig. 4.23. Engine Speed and Shut Down Control Lever

1. Depress the brake and decelerator pedal until the machine is stopped.
2. Move the engine speed and shut down control lever to the low idle position.
3. Place the transmission shift lever in NEUTRAL.
4. Place the neutral lock lever in ON position.
5. Lock the brake and decelerator pedal.

4.17. PARKING THE MACHINE

A few DO suggestions to protect both lives and equipment when parking. DO park tractor on planks in freezing weather to prevent tracks from freezing to ground. Do lower hydraulically operated tractor equipment to the ground to reduce injury possibilities and to gain tractor stability.



WARNING! Never leave the machine unattended while the engine is running.

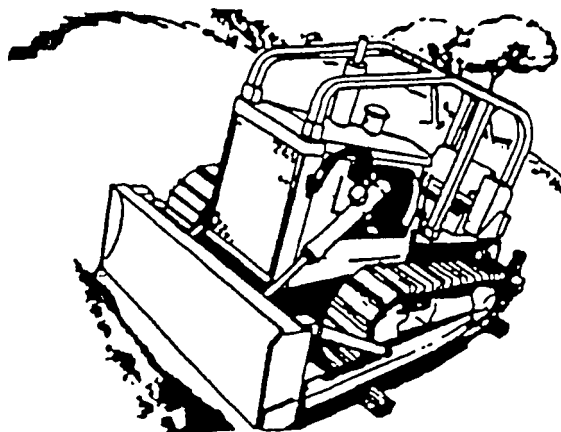

Fig. 4.24. Parking on a Slope

Parking on a slope is not recommended. Do park tractor on level ground, if at all possible to:

- a) Avoid unexpected movement
- b) Obtain accurate coolant, lubricant and fuel level checks

Avoid parking on a slope because unexpected machine movement may occur. However if necessary, park at a right angle and secure the tracks with blocks (front and rear).

4.18. OPERATING MOUNTED EQUIPMENT

General

The hydraulic system provides power for the blade equipment, ripper or various other types of equipment. Specific instructions for the operation of the blade and ripper are included in this section.

IMPORTANT: Holding a control lever in any position except HOLD or FLOAT for an extended period off time after the hydraulic cylinder rod has reached the limit of its travel will produce excessive heat in the hydraulic system which may affect equipment performance.

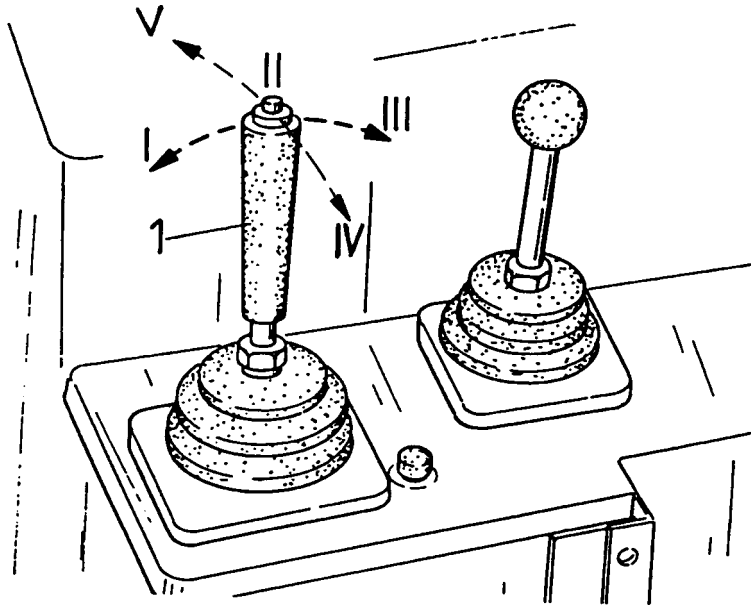

Fig. 4.25. Blade Control Lever Positions

I – Lower II - Hold III - Raise IV - LH Tilt V - RH Tilt

4.18.1. HOLD

When the lever is released from any position except “Float”, the lever automatically returns to the hold position. The blade height will remain the same, as it was when the lever was released.

4.18.2. RAISE

Pull the control lever back to raise the blade to desired height. When released the lever will return to the hold position.

4.18.3. LOWER

Push the control lever forward to lower the blade. When released the lever will return to the hold position.

4.18.4. FLOAT

With the control lever in the float position, the blade is free to follow the contour of the ground. To place the control lever in the float position, push all the way forward to its detented position in direction I in Fig.25. The lever will remain in this position until it is manually returned to the hold position.

OPERATING MOUNTED EQUIPMENT

4.18.5. TILT

LH TILT

Pull the control lever to the left to lower the left hand corner of the blade. The lever will return to the hold position when released.

RH TILT

Push the control lever to the right to lower the right hand corner of the blade. The lever will return to the hold position when released.

4.18.6. PITCHING THE BLADE

1. To pitch the blade backward (decrease suction angle) press the button 4 and push the blade control lever to the right (outward I direction).
2. To pitch the blade forwards (increase suction angle) press the button 4 and pull the blade control lever to the left (inward III direction).

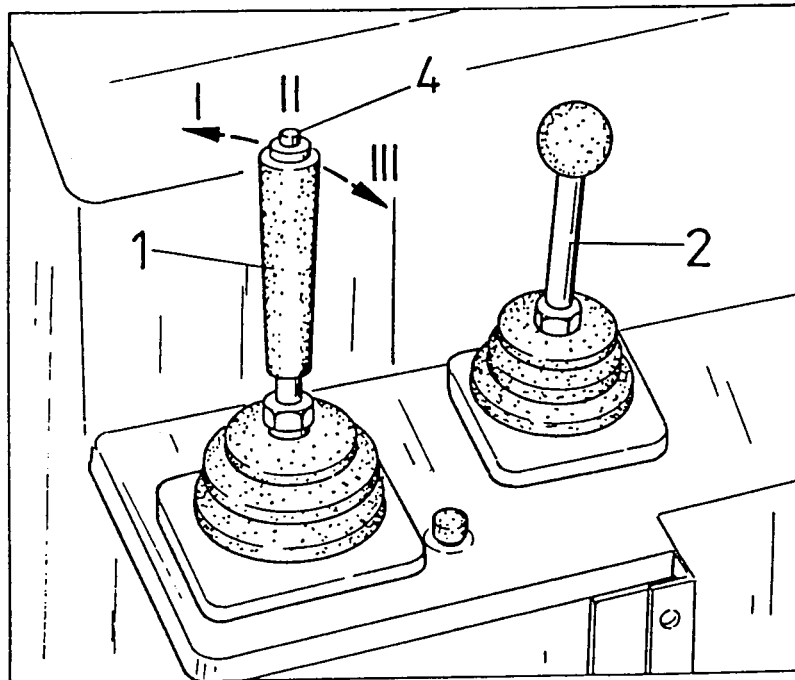

Fig. 4.26. Pitching the Blade

- 1. Blade Control Lever
- 2. Ripper Control Lever
- 4. Blade Pitch Button
- I - Blade Pitch Aft
- II - Neutral
- III - Blade Pitch Forward

4.18.7. RIPPER CONTROL LEVER

NOTE: For proper operation of ripper control lever and observation of working tool it is necessary to swivel the operator's seat 15° to the right.

OPERATING MOUNTED EQUIPMENT

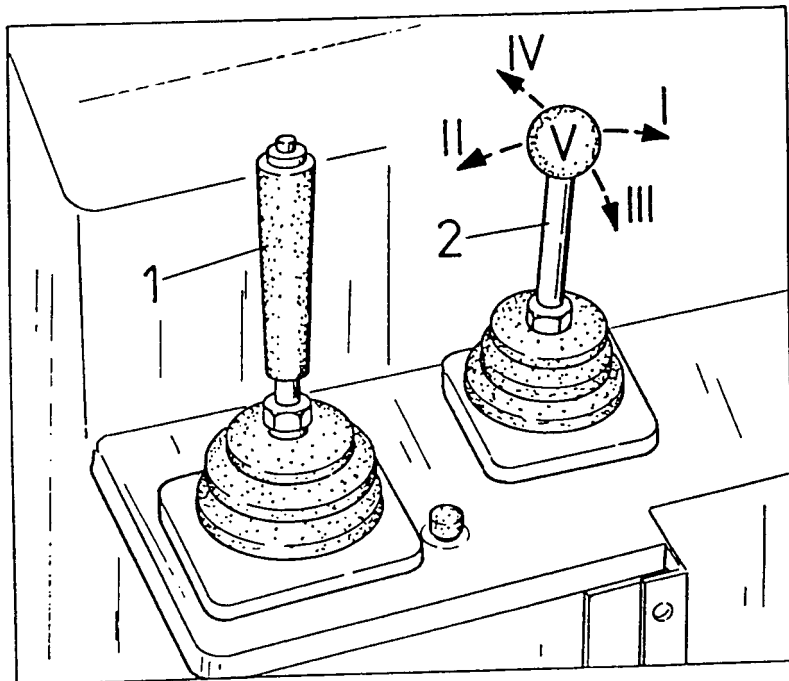

Fig. 4.27. Ripper Control Lever

- | | |
|-------------------------|--------------------------|
| 1. Blade Control Lever | I - Ripper Pitch Forward |
| 2. Ripper Control Lever | II - Ripper Pitch Aft |
| | III - Ripper Raise |
| | IV - Ripper Lower |
| | V - Hold |

1. Ripper Pitch (forward or aft)

To change angle of ripper tooth move the ripper control lever:

- a) Ripper point forward – move the lever to “I” position.
- b) Ripper point aft – move the lever to “II” position.

The control lever will return automatically to HOLD position when released (from “I” to “V” position)

2. Ripper Raise

To raise the ripper to required height move the lever in “III” position. The control lever will return automatically to HOLD position “V” when released.

3. Ripper Lower

To lower the ripper moves the lever in “IV” position. The control lever will return automatically to HOLD position “V” when released.

NOTE: Holding the control lever in any position except HOLD for an extended period of time will produce excessive heat in the hydraulic system which may affect equipment performance.

4.18.8. HYDRAULIC PIN PULLER

The pin puller control lever will return automatically to hold when released. Push the lever to the right to remove the shaft pin, pull to the left to install the shaft pin. Raise or pitch ripper shank during those operations to facilitate pin movement in hole.

OPERATING MOUNTED EQUIPMENT

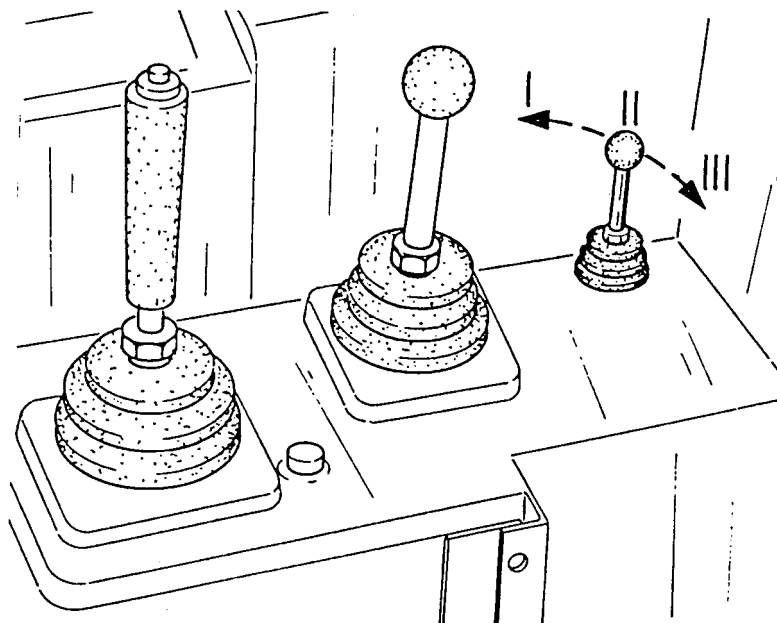

Fig. 4.28. Hydraulic Pin Puller Control Lever

- I - Shank Pin Removal
- II - Shank Pin Installation
- III - Hold

4.19. OPERATING TECHNIQUES



WARNING! Before operating the machine, be sure the area of the operator's compartment, all mounting steps and grab handles are free of oil, grease, loose objects, ice, snow and mud to lessen the possibility of slipping. Remove or secure all maintenance and personal items so they will not interfere with the operator or jam the controls. Failure to follow these instructions may result in serious injury.

When the blade is held hydraulically it becomes a rigid part of the tractor, except when the valve is in "FLOAT" position, and will follow all movements of the tractor. When rough terrain encountered it will be necessary to vary the height of the blade while pitching to obtain a smooth cut. When possible, start all jobs from relatively level ground. If necessary, level an area large enough to provide sufficient working space for the tractor. This prevents back and forth pitch of the tractor and will result in easier digging.

Avoid track spinning whenever possible; this wastes effort and converts a relatively smooth working area into ruts and piles that pitch and tilt a tractor. In cold weather this material can freeze and cause additional difficulty the following day.

Crossing ditches, ridges, rock or logs should be done slowly and, at an angle. This slows the fall, lessens the danger of upsetting the machine and reduces the fall jolt, which can be harmful to the operator and machine.

4.19.1. DIGGING AND CLEARING



WARNING! Prior to operating know the locations of gas lines, utility lines, sewers, overhead and buried power lines, and the other obstructions or hazards are known. A ruptured gas line or cut electrical line could result in personal injury.

OPERATING TECHNIQUES

Always feed the blade into the ground gradually until the desired depth of cut is obtained. When selecting the gear range and determining the depth of cut, allow for an increase in resistance as the load increases. When raising the blade at the end of a cut, do it gradually to avoid an abrupt ridge or bump in the path of the tractor. Move material downgrade whenever possible to take advantage of the reduced effort required (Fig. 4.29).



Fig. 4.29. Moving Material Downgrade

Two methods of cutting down a pile or hill are shown in Fig. 4.30. Type of material and local conditions may dictate which method is preferred. Further information is included in "BREAKING PILES AND SPREADING" When using Method 1, never allow the high face to become a hazard to the operator or machine. With the tractor at right angles to the face, raise the blade and dislodge the high bank before returning to the original direction of cut. When using Method 2, make the cut wide enough to avoid trapping the tractor.



WARNING! Avoid high overhangs. Ramp up and remove the top layers first. Avoid high banks. Operate the machines as far away from the trench as possible or cave-in may result.

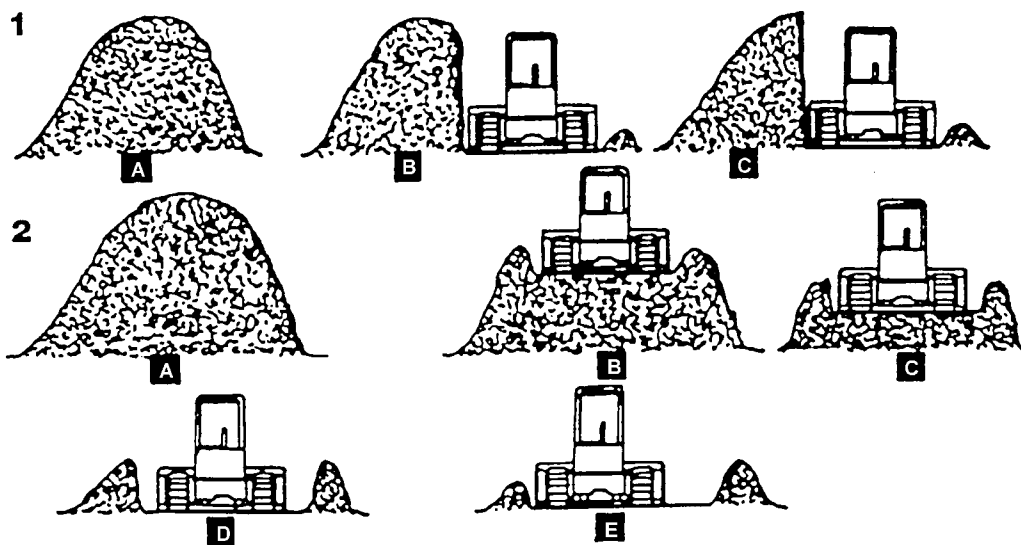

Fig. 4.30. Cutting Down a Pile or Hill

1 – Method 1 2 – Method 2

OPERATING TECHNIQUES

A side-hill cut can be started more easily if a small bench cut is first made as shown in Fig. 4.31. Then, when digging as in Fig. 4.32, keep the inside (uphill) surface slightly lower to gain greater tractor stability. Tilting the blade will provide this type of cut with less effort on the operator's part.

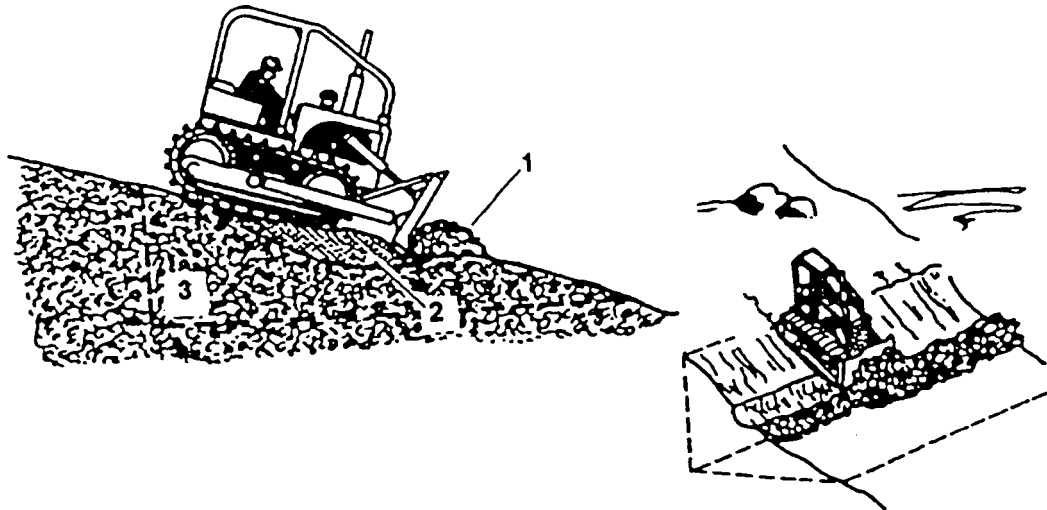

Fig. 4.31. Side-Hill Cut

1. Cut I 2. Cut II 3. Cut III

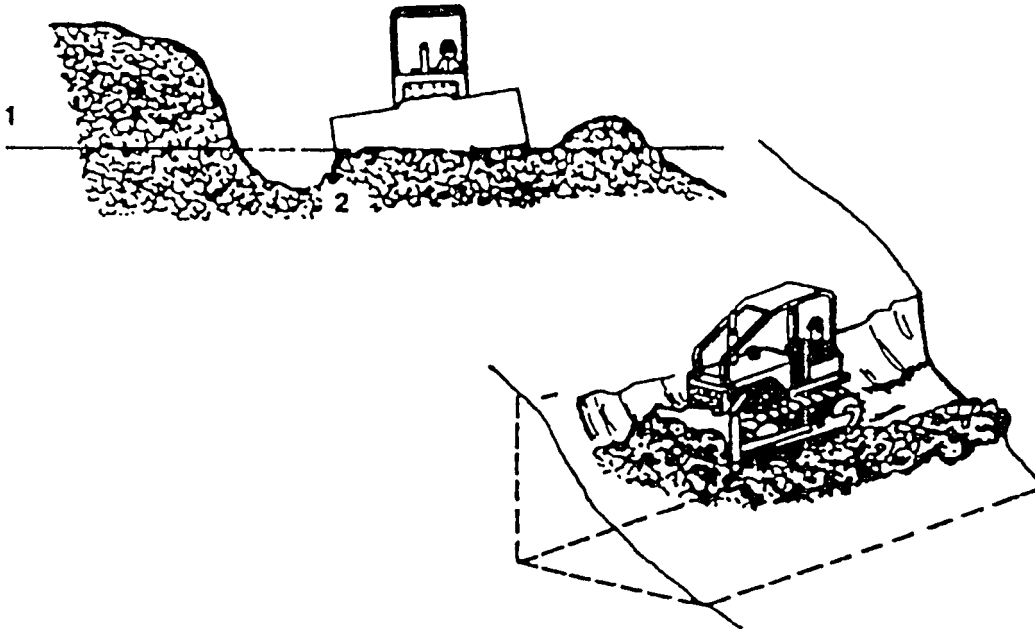

Fig. 4.32. Side Hill Cut

1. Level 2. Lower Surface

Always cut the shelf wide enough to provide solid support for equipment using it later. If possible, move the material downhill to gain the advantage of gravity, reduced effort and increased tractor stability. Soft soil or shallow slopes may allow the side hill cut to be made as shown in Fig. 4.33. Increased stability is realized by running the uphill track inside the ridge left by the first cut. Cuts 3, 4 and 5 illustrate the completion of the shelf.

OPERATING

OPERATING TECHNIQUES

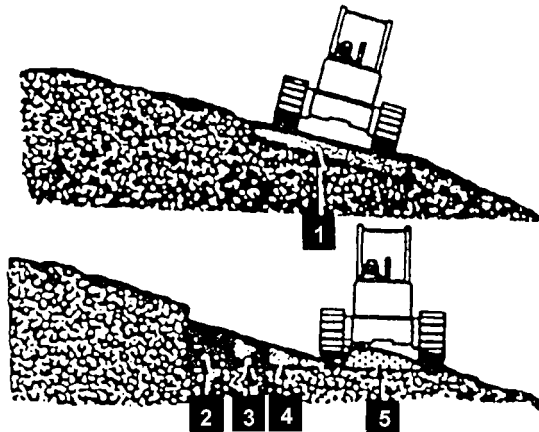

Fig. 4.33. Shallow Slope Side Hill Cut

Once again, pushing the loosened material to the lower side of the slope will normally reduce time and cost. Do not push material beyond the point required to retain firm track support.



Fig. 4.34. Slope Edge Operation

When backing up, do not raise the blade as this puts extra weight on the front idlers causing greater track penetration. Let the blade float as you back away from the edge of soft fills. Initial work on steep hillsides can be safer by either securing the tractor with a winch to a suitable uphill anchor point or by operating a tandem arrangement as shown in Fig. 4.35.

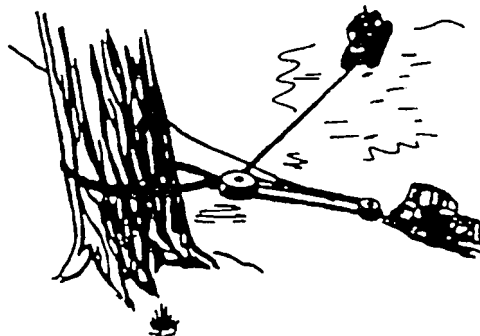

Fig. 4.35. Operating a Tandem Arrangement

OPERATING TECHNIQUES

When clearing trees, raise the blade high to gain leverage and make contact gently to reduce possible harm to the operator and machine (Fig. 4.36).

Heavy roots of large trees may require pushing and digging or cutting from several sides of the tree. Use a cable to topple and remove trees from soft ground (Fig. 4.37).



Fig. 4.36. Machine Equipped with Sweeps



Fig. 4.37. Using Cable to Remove Trees



WARNING! Falling trees and dead limbs can cause injuries. When clearing trees, operator protection must be used.

When clearing a rocky area, remove the small and loose rocks first, large and solid rocks can then be loosened and moved with less difficulty. When loosening large or solid rocks, greater force and penetration can be obtained by tilting the blade and prying under the rock with the lower edge of the blade (Fig. 4.38). Lifting the rock with the blade while pushing will increase traction and reduce track spinning

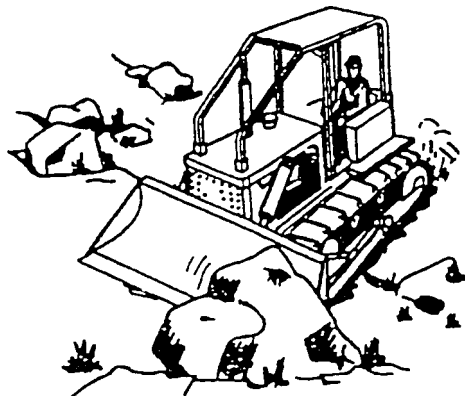

Fig. 4.38. Loosening Rocks with Lower Edge of the Blade

OPERATING TECHNIQUES

Penetration on hard, frozen or rocky ground can be made easier by tilting the blade. This will add weight and power to the lower cutting edge. When the ground is frozen and the area must be ripped before it can be worked, rip a relatively small section and work it to grade before enlarging the cut. This will require ripping each section only once, not every morning after the ground has refrozen. Snow can act as an insulating blanket and reduce or eliminate the need for a ripper. Therefore, remove snow only from the area to be worked each day; leave the rest to insulate the ground.

4.19.2. TRANSPORTING, PILING OR LOADING

The transporting of material with a bulldozer is not always a most economical method. Natural ridges, a window formed by side blade spillage on earlier passes or side-by-side, dozing will improve the productivity (Fig 4.39). Where the quantity of material or distance involved becomes excessive, a loader, scraper or truck should be considered.

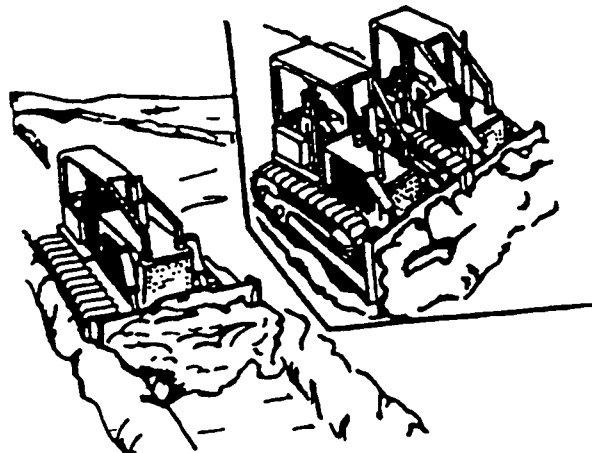

Fig. 4.39. Side-by-Side Dozing

A usual method of piling is shown in Fig. 4.40. When the piling reaches stages "D" or "E" the operator may elect to continue one of the other depending on height or area desired. When the tractor is used as a pusher, aiding scraper loading (Fig. 4.41), the tractor power must be carefully controlled. Excessive "push" effort can cause the scraper unit to "jackknife", with resulting injury or damage. On turns, be sure the blade of the pusher tractor does not come in contact with the rear wheels of the scraper.

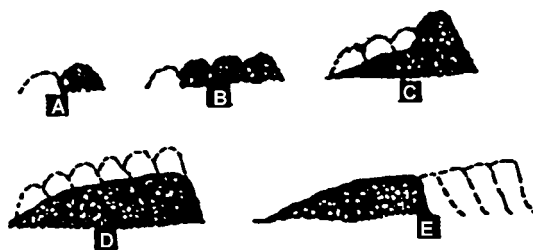

Fig. 4.40. A Usual Method of Piling

OPERATING TECHNIQUES

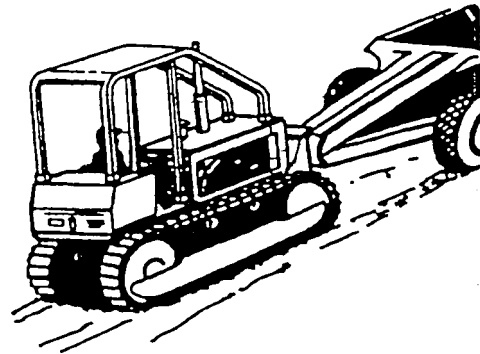

Fig. 4.41. Aiding Scraper Loading

The bulldozer can be used directly as a loader if the method shown in Fig. 4.42 is used.

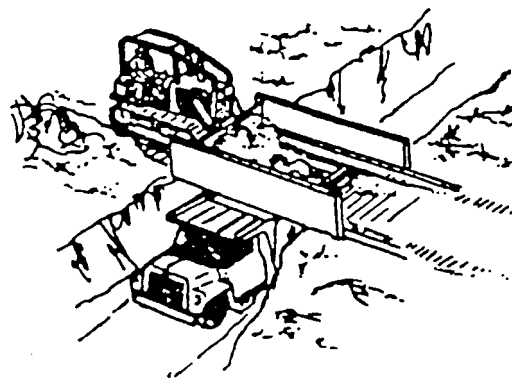
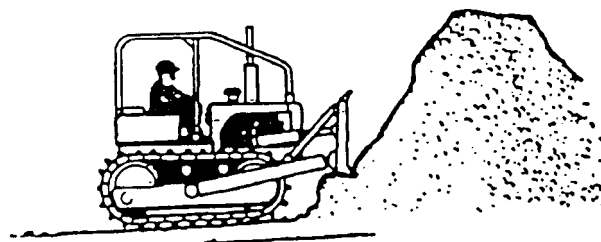

Fig. 4.42. Loading Directly

4.19.3. BREAKING PILES AND SPREADING

Two methods of breaking down a pile are shown in Fig. 4.43. When spreading is to be in several directions or if the pile is large or hard, Method 1 is usually desired. When using Method 1, cut into the side of the pile from different angles. When Method 2 is used, and access to the top of the pile is difficult, a slot may be started as shown below. Loosen material at the base and form a dirt "ramp" to provide a decreased angle of approach and cut.



Method 1

OPERATING

OPERATING TECHNIQUES

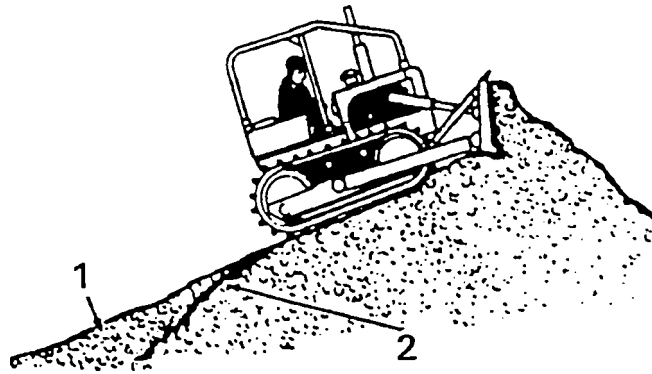

Method 2

Fig. 4.43. Breaking Down a Pile

1. Ramp
2. Original Slope

When trucks or wagons are used for hauling, bulldozers are ideal spreading tools at the fill (Fig. 4.44). Blade should be kept in a straight position so that material is drifted directly under the cutting edge (Fig. 4.45). When finishing in non-solid materials, such as earth, drag the blade backward for a smooth job as shown in Fig. 4.45. Rock, of course, may damage the blade base, therefore, such practice is not recommended where abrasive material is common.

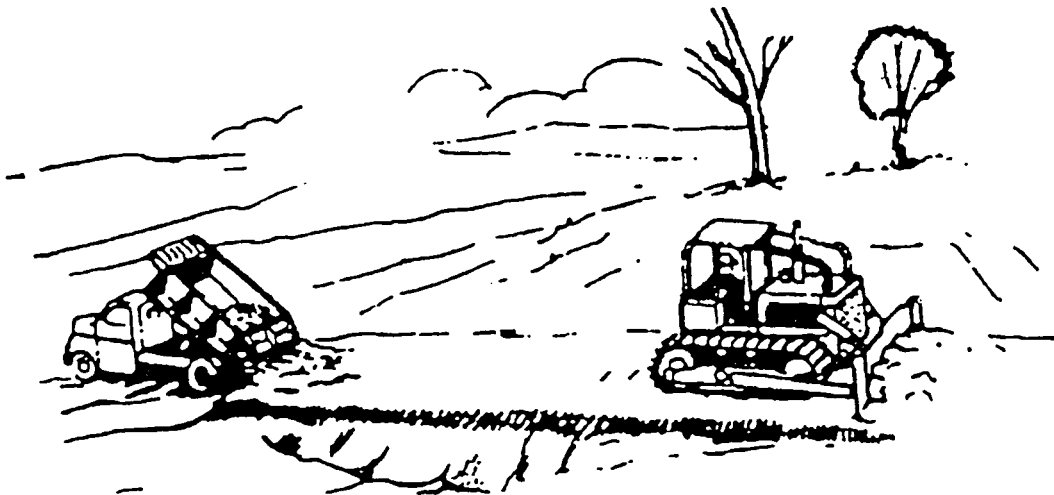

Fig. 4.44. Spreading Material Forward

OPERATING TECHNIQUES

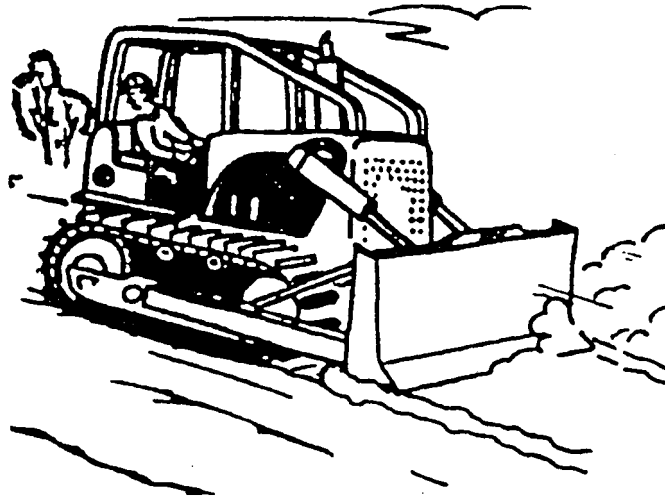

Fig. 4.44. Backdragging

4.19.4. RIPPING**4.19.4.1. Prior to Operation**

Before operating the ripper proceed as follows:

1. Check all mounting hardware for torque.
2. Check hydraulic connections for leaks.
3. Check the condition of the ripper, bits, mounting hardware for completeness and torque.

4.19.4.2. Ripping Techniques

When starting ripping lower the ripper teeth slowly to required depth. Ripping of rock material must be performed in direction of easier ripping what may be established by carrying out test ripping in various directions and under various angle of inclination of the shanks. During test ripping lower the shank to half of working depth. Machine efficiency can be improved when several centimeters of loose material is left on solid rock. Ripping should be performed at a depth the best results are obtained without overloading the engine. Keep loose ground level and horizontal as much as possible. Never make turns with the machine with ripper teeth are at full depth in rocky ground. Use the common sense when working in hard ground not to damage the ripper and the machine. Do not accelerate the machine and simultaneously lower the ripper teeth into the ground – this will damage the ripper.

Pay attention not to allow rear of the machine to lift off the ground during ripping operations, as this decreases traction and accelerates wear of track system. Use new and sharp bits for hard ground.

4.19.5. COLD WEATHER OPERATION

Start the engine as described in “STARTING THE ENGINE” and then proceed as follows:

- move slightly and slowly ripper control to warm oil in hydraulic cylinders.
- raise the ripper at max. height and then lower it slowly until it rests on the ground.
- increase gradually pressure in ripper cylinders by keeping the control lever in LOWER position until rear of the machine is off the ground.

OPERATING TECHNIQUES

- prior to normal ripping operations operate the ripper at low depth for a couple of minutes to warm shank bits.
- protect shank and bits when parking the machine.

4.20. ECONOMICAL OPERATION OF THE MACHINE

Fuel consumption during operation of the dozer depends on many factors as: engine characteristics, load, terrain, operator's skill and experience, manner of operation.

Relatively of fuel consumption is quantity on moved material per unit of consumed fuel. To reach the most favorable value of this ratio observe the following principles of dozer operation:

- Avoid long distance transporting of material.
- Loading and pushing of material must be performed at gear which ensures maximum drawbar pull (1st or 2nd gear) with high blade fill ratio without losing material in blade.
- Reverse travel at top gear but keep engine speed above medium, not maximum.
- Avoid stopping machine due stall of the engine.
- Avoid track slippage.
- For digging hard material pitch the blade forward, for transportation of material pitch the blade backward.

SECTION 5
MAINTENANCE

SECTION CONTENTS

5.1. Service Precautions 3
5.2. Scheduled Maintenance 4
5.3. Maintenance and Service Chart 7
5.4. Lubrication 10
5.5. Seasonal Preparation 14
5.6. Air Cleaning System 15
5.7. Belts..... 19
5.8. Cooling System..... 22
5.9. Fan and Fan Hub 27
5.10. Electrical System 28
5.11. Engine 32
5.12. Fuel System 35
5.13. Hydraulic System 38
5.14. Lubrication Fittings..... 43
5.15. Mounted Equipment 44
5.16. Safety Belt 51
5.17. Final Drives 51
5.18. Transmission System..... 52
5.19. Undercarriage 57
5.20. Adjusting Hand and Foot Controls 62
5.21. Cab and ROPS 63

5.1. SERVICE PRECAUTIONS

WARNING! Only authorized personnel, thoroughly trained with design and operation of all assemblies and mechanisms may be allowed to service this machine.

WORK SAFELY – FOLLOW THESE RULES

A CAREFUL OPERATOR IS THE BEST INSURANCE AGAINST AN ACCIDENT.

GENERAL SERVICE PRECAUTIONS

The procedures in this section contain many notes and precautions, which should be followed along with standard safety procedures to minimize the possibility of personal injury or improper service. Improper service could compromise the machine's safety or cause it to function improperly, which could result in personal injury or death. Review the precautions listed in Section 2 "SAFETY PRECAUTIONS".

Do not attempt to do repairs you do not understand. Use your „Service Manual” or consult your Authorized Distributor for information.

Do not jump on or off the machine. When working under the machine or servicing in the area of the engine fan or belts, turn off the electrical system master switch, apply and lock parking brake and tag controls to warn against starting the machine.

Whenever servicing, take care to prevent accidental cranking of the engine. Turn off the electrical master switch and remove the key. It is not possible to anticipate all conceivable ways or conditions under which the machine may be serviced or to provide precautions for all the possible hazards that may result. Safety is always the most important rule.

Constantly be aware of dangers involved in working on the machine and take proper precautions.

Standard and accepted safety precautions and equipment should be used. This machine is assembled using high strength fasteners.

Do not substitute. Replacement fasteners must be of the same size and strength as the originals (refer to Section 6). Tighten fasteners to the proper torque value specified in Section 6, unless otherwise specified.

Refer to Spare Parts Catalogue for all replacement parts.

Use safety goggles, hard hats, safety shoes, heavy duty gloves and other protection during cutting, grinding, chiseling, prying or any other process which could cause material removal or projectiles.

Many machined parts are hardened and can chip.

Use the proper size and type of tool for the job being done. Select a wrench or that fits and be sure it is on straight. Keep your tools clean and in good condition.

Some procedures require the use of tools specially designed for that specific purpose.

Before substituting another tool or procedure, you must be completely satisfied that neither personal safety nor the performance of the machine will be endangered.

Scheduled maintenance is the normal maintenance necessary to provide proper and efficient equipment operation.

5.2. SCHEDULED MAINTENANCE GUIDE

Every 10 Hours of Operation (Every Day)

1. Clean windows, lights and instrument panel.
2. Check engine oil level. Refer to 5.11.1.
3. Check radiator coolant level. Refer to 5.8.5
4. Check hydraulic system oil level. Refer to 5.13.1.
5. Check and clean precleaner screen, if necessary. Refer to 5.6.4.1.
6. Check level in window washer reservoir. Refer to 5.21
7. Carry out ground level inspection. Refer to 5.2.1.
8. Drain water from fuel filters prior to starting the work. Refer to 5.12.7.
9. Visually check the condition of drive belts. Refer to 5.7. and fan Refer to 5.9.
10. Check instruments and warning lights for operation. Refer to 4.3.
11. Refill fuel tank at the end of each day's operation. Refer to 5.12.1.
- 12*. Check torque:
 - track shoe bolts. Refer to 5.19.1.
 - blade cutting edge and end bit bolts. Refer to 5.15.
 - trunnion cap bolts and trunnion mounting bolts. Refer to 5.15.

* – after initial 10 hours of operation only.

Every 50 Hours of Operation

1. Check oil level in rear mainframe. Refer to 5.18.1.
2. Clean radiator core (for QSK – 19 Engine clean also fuel cooler). Refer to 5.8.4.2.
3. Check and adjust track tension, if necessary. Refer to 5.19.3. and 5.19.4.
4. Check air intake system for leaks (hoses and clamps). Refer to 5.6.4.2.
5. Lubricate lift cylinder bearings. Refer to 5.14.
6. Lubricate ripper cylinder bearings. Refer to 5.14.
- 7*. Replace hydraulic system return filters. Refer to 5.13.3.
- 8*. Replace transmission system pressure filters. Refer to 5.18.3.
- 9*. Clean transmission system suction strainer. Refer to 5.18.4.
- 10*. Replace equipment pilot filter. Refer to 5.13.3.

* – after initial 50 hours of operation only.

Every 250 Hours of Operation

1. Change engine crankcase oil. Refer to 5.11.2.
2. Change engine crankcase oil filters (2 filters for QSK – 19 and 3 filters for KT – 19C). Refer to 5.11.2.
3. Replace fuel filters (2 filters) (replace fuel filters earlier when drop in engine power is noticed). Refer to 5.12.4.2.
4. Check coolant for DCA concentration and replace coolant filter. Refer to 5.8.3.
5. Check engine crankcase breather hoses. Refer to 5.11.1.
6. Check alternator belt and air compressor (if equipped) belt tension. Refer to 5.7.2.
7. Reverse fan blade (if equipped). Refer to 5.9.
8. Check final drive oil level. Refer to 5.17.1.
9. Lubricate upper struts and joints. Refer to 5.14.
10. Lubricate lower struts and joints. Refer to 5.14.
11. Lubricate gimbal crosstube. Refer to 5.14.
12. Lubricate fan idler arm (only QSK-19 if equipped). Refer to 5.9.

5.2. SCHEDULED MAINTENANCE GUIDE**Every 500 Hours of Operation**

1. Check oil level in pivot shaft housing. Refer to 5.19.6.
2. Lubricate equalizer bar pin. Refer to 5.19.7.

Every 1000 Hours of Operation

1. Change oil level in rear mainframe. Refer to 5.18.2.
2. Clean transmission system suction strainer. Refer to 5.18.4.
3. Clean transmission scavenger suction strainer. Refer to 5.18.6.
4. Replace transmission system pressure filters. Refer to 5.18.3.
5. Replace rear mainframe breather. Refer to 5.18.5.
6. Change final drive oil. Refer to 5.17.2.
7. Check sprocket bolt torque's. Refer to 5.19.
8. Replace hydraulic system return filters. Refer to 5.13.5.
9. Clean hydraulic reservoir breather. Refer to 5.13.5.
10. Lubricate gimbal crosstube. Refer to 5.14.

Periodic (at least once a year or as required)

1. Clean air cleaner elements or replace if necessary. Refer to 5.6.
2. Clean fuel tank filler strainer. Refer to 5.12.2.
3. Clean cab air filters. Refer to 5.21.
4. Drain water and sediment from fuel tank sediment bowl. Refer to 5.12.5.
5. Lubricate hand and foot linkage, check for operation and adjust if necessary. Refer to 5.20.
6. Lubricate equipment pilot valve plunger – to – plate surfaces. Refer to 5.20.
7. Check engine RPM with depressed decelerator. Refer to 5.20.
8. Check operation of brake lock. Refer to 5.20.
9. Check undercarriage components for wear. Refer to 5.19.
10. Check track frames guide clearance and adjust if necessary, lubricate track frame guides. Refer to 5.19.5.
11. Check clearance in blade socket and diagonal struts. Refer to 5.15.1.2 ÷ 5.15.1.3.
12. Check the condition and amount of charge of batteries. Refer to 5.10.2.
13. Check the condition of electrical wires and connections. Refer to 5.10.
14. Check the condition of safety belt. Refer to 5.16.
15. Check torque:
 - cab and ROPS mounting bolts. Refer to 5.21.
 - track shoe mounting bolts. Refer to 5.19.1.
 - blade cutting edge and end bit bolts. Refer to 5.15.
 - trunnion cap bolts and trunnion mounting bolts. Refer to 5.15.2.
16. Check cutting edges and end bits for wear. Refer to 5.15.3.
17. Check ripper points for wear. Refer to 5.15.3.
18. Check front wheel guide clearance. Refer to 5.19.8.

**Every 1500 Hours of Operation or every year
(Per Engine Operator's Manual)**

1. Steam cleans the engine.
- 2*. Check and adjust valve and injectors.
3. Lubricate fan hub (for QSK – 19 engine only).
4. Check bypass oil filter and cooling system hoses and replace if necessary.
5. Check cold start aids (seasonal).

5.2. SCHEDULED MAINTENANCE GUIDE

6. Check crankshaft end clearance.
7. Clean crankcase breather element and replace if necessary.
8. Check engine mounting bolts and nuts and torque if necessary.

* – after initial 1500 hours and then every 6000 hours of operation.

Every 2000 hours of operation

1. Replace equipment pilot filter. Refer to 5.13.3.
2. Change hydraulic system oil. Refer to 5.13.2.
3. Clean hydraulic system suction strainer. Refer to 5.13.4.

Every 6000 Hours of Operation or every 2 years (Per Engine Operator's Manual)

1. Clean and calibrate injectors.
2. Clean and calibrate fuel pump (KTA – 19C)
3. Inspect the following engine assemblies:
 - Turbocharger
 - Vibration dumper
 - fan hub and fan idler pulley
 - water pump for oil and coolant leaks
4. Drain and flush cooling system. Change coolant. Refer to 5.8.6.

5.2.1. GROUND LEVEL INSPECTION

1. Tractor operational equipment for damage and state of proper fastening.
2. Radiator: for damage, evidence of leakage and condition of grill.
3. Hydraulic components for damage or leakage.
4. Track system: rollers, front idlers, sprockets, track shoes for cracks, excessive wear, loose components and leaks.
5. Transmission system and final drives: for possible leakage.
6. Engine compartment for fuel, oil and coolant leaks.
7. Guards: for damage or missing.
8. ROPS: general condition (no ROPS defects are permissible that may adversely affect its protection in case of machine rollover).





WARNING! To ensure personal protection performs all maintenance services in accordance with Scheduled Maintenance Guide and Instructions.

To prolong the service life of your equipment follows the scheduled maintenance listed in Scheduled Maintenance Guide.

5.3. MAINTENANCE AND SERVICE CHART

(Always use clean containers and lubricators)

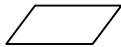
SERVICE INTERVAL	REF. No	POINT OF SERVICE	SERVICE POINTS	LUBRICANT	SERVICE
Every 10 Hours 	1 2 21 29	Radiator Coolant Level Engine crankcase Oil Level Fuel Filter Water Separator Hydraulic Reservoir Oil Level Ground Level Inspection	1 1 2 1	E01 HDTF/E02	Check Check Drain Check Check
Every 50 Hours 	11 23 30	Rear Frame Oil Level Hydraulic Cylinder Lube Fittings Ripper Lube Fittings	1 2 12	HDTF MPG MPG	Check Lube Lube
Every 250 Hours 	3 4 10 21 20 22 24 33 34	Engine Coolant Filter Engine Crankcase Oil Level Final Drive Oil Level Fuel Filter Engine Crankcase Oil Filters Upper Struts Upper Strut Balls KT-19C Engine Bypass Filter Crankcase Breather	1 1 2 2 2 4 2 1 3	E01 MPL E01 MPG MPG E01	Change Change Check Change Change Lube Lube Change Change
Every 500 Hours	5	Pivot Shaft Housing	2	HDTF	Check
Every 1000 Hours 	7 8 14 15 16 17 26 28 31	Transmission System Suction Strainer Rear frame Breather Transmission System Oil Final Drive Oil Transmission System Pressure Filter Element Gimbal Crosstube Hydraulic Tank Breather Hydraulic System Return Filters Battery Terminals	1 1 1 2 2 2 1 2	HDTF MPL MPG	Clean Change Change Change Change Lube Clean Change Check
Every 2000 Hours	9 27 36	Hydraulic System Oil Hydraulic Oil Suction Strainer Hydraulic Control System Filter	1 1 1	HDTF/E02	Change Clean Change
Periodic or at Least Once a Year	6 12 13 18 19 25 35	Transmission Scavenger Strainer Fuel Tank Strainer Fuel Tank Sediment Bowl Hand and Foot Control Linkage Air Cleaner Element Pilot Control Valve Hydraulic Tank Strainer	1 1 1 10 1 1 1	MPG MPG	Clean Clean Drain Lube Clean Clean Clean
Every 6000 Hours or Two Years	32	Engine Coolant	1		Change

5.3. MAINTENANCE AND SERVICE CHART

- E01 - Engine Oil
- E02 - Multigrade Transmission Oil
- MPG - Multi-Purpose Grease
- HDTF - Hydraulic Transmission Fluid for Heavy Condition
- MPL - Multigrade Gear Oil

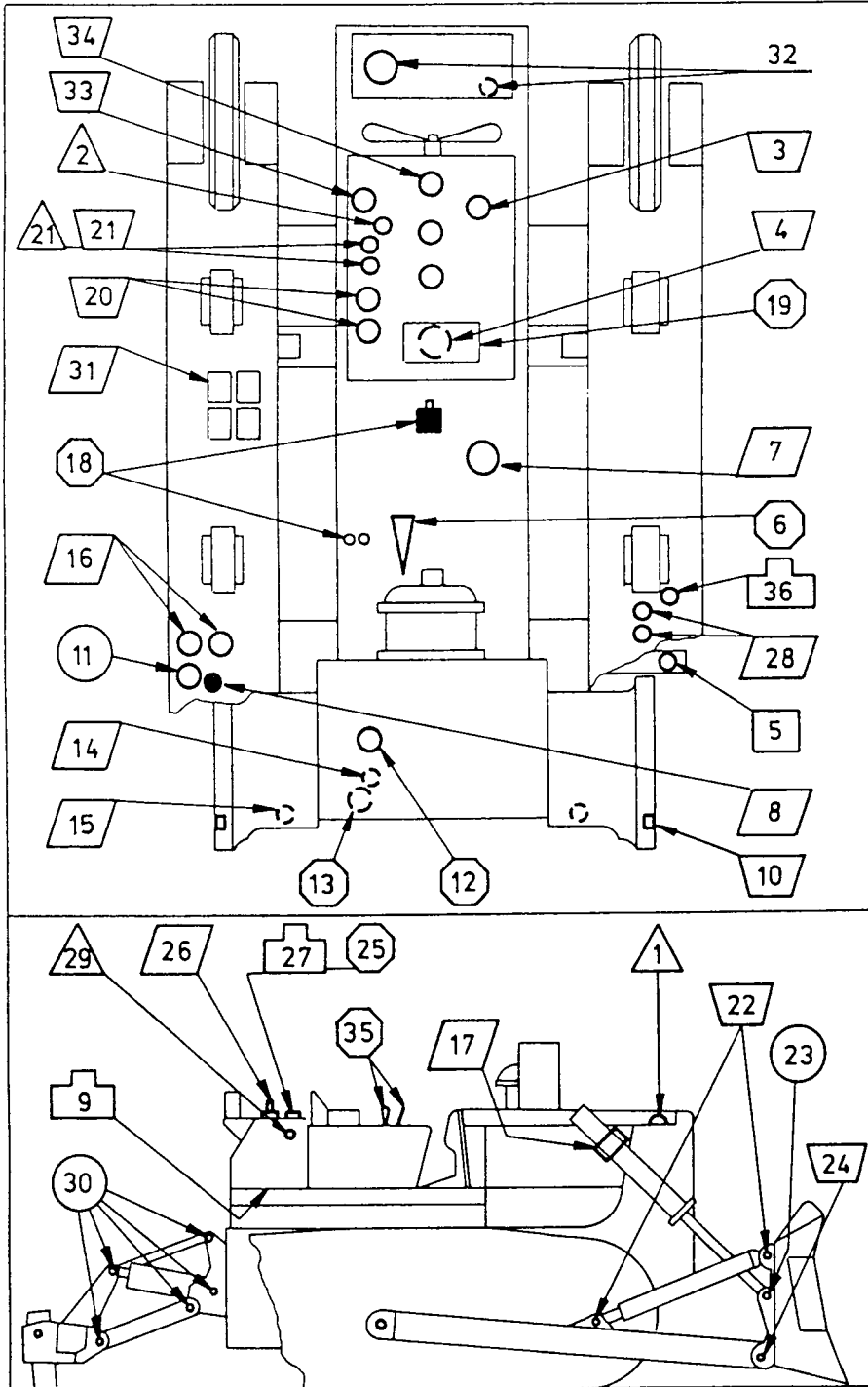

Fig. 5.1. Service Guide

5.3.1. REFILL SPECIFICATIONS AND CAPACITIES CHART

MODEL	LUBRICATION POINT			REFILL CAPACITY	TYPE	AIR TEMPERATURE +40 – +7°C	AIR TEMPERATURE +21 – -23°C	TEMPERATURE -12 – -34°C	TEMPERATURE -12 – -54°C
TD-40C	Final Drive – Each			85 l	MPL	SAE 85W-140	SAE 85W-140	SAE 80W-90	MPL – ARCTIC ARCTIC GRADE 75 per HMS-B22-0003
	Engine Crankcase with Filter Change			67 l (QSK-19C) 50 l (KT-19C)	E01	SAE 15W40	SAE 10W-30	SAE 5W-20 or SAE 5W-30	E01 - ARCTIC MULTI - PURPOSE ARCTIC OIL per HMS-B21-0001
	Transmission System			270 l	HDTF	SAE 10W		SAE 5W-30 or SAE 5W-20	
	Track Roller (each)	Life Time Lubrication	If Rebuilt	1.0 l	HDTF or E02*	SAE 30			
	Top Idler (each)			0.5 l					
	Front Idler (each)			1.4 l					
	D-2 Equipment Hydraulic System			265 l	HDTF or E02*	SAE 10W			
	D-2 and Ripper Equipment Hydraulic System			355 l					
	Cooling System			98 l (QSK-19C) 95 l (KT-19C)		ANTI-FREEZE SOLUTION 0° – -37°C -37° – -54°C 50% Anti-freeze 62% Anti-freeze 50% Water 38% Water			62% Anti-freeze 38% Water
	Fuel Tank			1340 l		above - 12°C Diesel Fuel # 2D below - 12°C Diesel Fuel # 1D			Diesel Fuel VV-F-800DF-A

5.3. MAINTENANCE AND SERVICE CHART

DESCRIPTION:**HDTF:**

Severe Service Transmission Fluid per HMS B21-0006 or equivalent and passing formula C-4 and TO-4. Should not contain viscosity-improving agent.

Arctic selection: per HMS B21-0001

EO1:

Engine Oil per HMS B21-0002 or multigrade diesel engine oil CE, CF-4 per API, MIL-L-2104 with sulphated ash of 1.5% maximum.

Arctic selection: per HMS B21-0001

EO2: for service only

Multi – purpose engine oil per HMS B21-0003 or engine oil CD per MIL-L-2104C passing TO-2 and C-3 test with 0.10% minimum zinc.

Arctic selection: per HMS B21-0001

MPL:

Multi – purpose gear lubricant per HMS B22-0003 or API GL-5, MIL-L-2105C

Arctic selection: grade 75 per HMS B22-0003

EO:

Multi – purpose arctic selection per HMS B21-0001 or MIL-L-46167

MPG:

Multi – purpose grease 251 HEPM per HMS B27-0002 or NLGI grade #2 multi-purpose lithium grease with 3% minimum molybdenum disulfide (MoS₂).

Arctic selection: per HMS B27-0003 or MIL-L-10924D

ANTI-FREEZE:

Single Phase, ethylene glycol base per HMS B1-0001 or equivalent.

DISEL FUEL:

Per HMS B32-0001 or ASTM D-973

Arctic selection: per VV-F-800DF-A

NOTE: *Maintenance/lubricant change service intervals are based on average operating conditions. Under unusually severe conditions of operations, reduce the interval of time between services. All inspection (maintenance) service must be carried out according to schedule, but at least once a year.*

5.4. LUBRICATION

5.4.1. WHEN SHIPPED

This machine has been lubricated at the factory for operation in an air temperature range of +21°C to – 23°C. If this tractor is to be operated above or below this range, change to the correct lubricants.

Unless an exception is shown below, all lubricants can be used (within above temperature range) until regular scheduled (normal) change intervals occur. Refer to "MAINTENANCE AND SERVICE CHART" for the scheduled (normal) change intervals and to "REFILL SPECIFICATIONS AND CAPACITIES CHART" for the proper oil grades for ambient temperatures.

5.4. LUBRICATION

Front idlers, track idlers and track rollers are permanently lubricated with a SAE30, API CD or MIL-L-2104C engine oil.

A level check of these compartments is not required.

5.4.2. WHEN SERVICED



WARNING! When you service the machine, always follow the Operator's or Service Manual. Never grease, oil or perform any maintenance alone with the engine running. Always have another experienced person helping in the operator's compartment when maintenance must be done with the engine running. Block up all attachments securely. Do not leave the operator's seat with the engine running. Failure to follow these instructions could result in serious injury or death.

The life and performance of a tractor and its equipment depends on the service that it is given. Proper lubrication is an important part of the maintenance service. Thorough lubrication service performed at specified intervals will aid in prolonging the life of the tractor and its equipment and in reducing operating expense. The type of work being done, load, ground and weather conditions are all factors to consider in frequency of lubrication.

The scheduled intervals between lubrication periods shown on the "SERVICE CHART" are approximate, based on average operating conditions. It may be necessary to lubricate after shorter working periods under severe operating conditions such as extremely dusty, low engine temperatures, intermittent operation, excessively heavy loads with high oil temperatures, or when diesel fuel with a high sulfur content is used. However, the time intervals between lubrication periods must never exceed those indicated in this manual.

5.4.3. SELECTION

The selection of the proper type (specification) and the grade (weight or viscosity) of lubricant is important. Many tests have been made to determine the correct lubricants for this tractor and its equipment.

5.4.4. VISCOSITIES

During cold weather, base the selection of a crankcase lubricating oil viscosity on the lowest anticipated temperature for the day to make starting easier.

For hot weather operation, base the selection on the highest anticipated temperature. Refer to the "REFILL SPECIFICATIONS AND CAPACITIES CHART".

IMPORTANT: After changing oil or break in operation for more than 5 days follow the below specified procedure to start the engine:

1. QSK-19C – Engine Procedure
 - Disconnect EPS¹⁾ connector of engine electrical system as shown in Engine Manual
 - crank the engine until the gauge registers pressure or engine oil pressure warning light goes off
 - reconnect EPS
 - start the engine per normal method for starting procedure

¹⁾ EPS – Engine Position Sensor

5.4. LUBRICATION

2. KTA-19C Starting Procedure

- cut off fuel supply with engine speed and shut down control lever (forward position)*
- crank the engine until the gauge registers pressure or engine oil pressure warning light goes off*
- start the engine per normal method for starting procedure*

5.4. LUBRICATION

5.4.5. RECOMMENDED LUBRICANT CHART

RECOMMENDED LUBRICANT	EQUIVALENT LUBRICANT			TYPE
	POLISH	SHELL	TEXACO	
Engine oil per HMS B21-0002 or API CE, CF or CD or MIL-L02104C with sulfated ash of 1.65% maximum SAE 15W/40	LOTS DIESEL CE/SF SAE 15W/40 SUPEROL FALCO CD. 15W/40	MYRINA TX 15W/40 RIMULA X 15W/40	URSA SUPER LA 15W/40	E01
Engine oil per HMS B21-0003 or CD MIL-L02104C/ SAE 10W, SAE 30	SUPEROL CD. SAE 10W SUPEROL CD. SAE 30	ROTELLA TX 10W ROTELLA TX 30	URSA SUPER LA 10W URSA SUPER LA 30	E02
Transmission Fluid HDTF per HMS B21-0006 passing formula C-4 and TO-4, SAE 10W, SAE 30	GERAX TKD 10W GERAX TKD 30	DONAX TC 10 DONAX TC 30	TEXTRAN HD 10W TEXTRAN HD 30	HDTF
Gear Lube per HMS B22-0003 or API GL-5 or MIL-L-2105C SAE 85W/140 SAE 80W/90	HIPOL 85W/140 HIPOL 80W/90	SPIRAX HD 85W/140 SPIRAX HD 80W/90	GEARTEX EP-C 85W/140 GEARTEX EP-C 80W/90	MPL
Multi-purpose grease per HMS B27-0002 or NLGI grade #2 Multi-purpose lithium grease with 3% minimum molybdenum disulfide (MoS ₂)	LITMOS EP-23	RETINAX EPX2	MOLYTEX EP-2	MPG
Anti-freeze, ethylene glycol base per HMS B1-0001	ERGOFRYZ	GLYCOSHELL DILUTED	ANTIFREEZE ETX 6042	
Arctic oil, synthetic 75W per HMS B22-0003			SYN-STAR 75W CODE 2080	MPL ARCTIC
Arctic grease per HMS B27-0003 or MIL-L-10924D		SRI grease manufactured by CONOCO Grease 2816 manufactured by EMERY Ind.		MPG ARCTIC
Arctic engine Oil, synthetic per HMS B-21-0001 or MIL-L-46167	CHEVRON SUB-ZERO Fluid OW-30 Manufactured by CHEVRON or FRIGID-GO 2809A Manufactured by EMERY Ind.			EO ARCTIC
Diesel Fuel Per HMS-B32-0001	Diesel fuel per Polish Standard PN-C-96051:1992 DL above 0°C DP above -12°C DZ above -20°C IZ-40 above -30°C For temperatures below -30°C add pour point depressant			

5.5. SEASONAL PREPARATION

General

Mechanical efficiency is enhanced during seasonal air temperature changes, when these instructions are followed.

Outside source of heat

Machines left outside for prolonged periods in sub-zero weather will suffer from "cold-soak." Lubricants become viscous and incapable of lubricating moving parts. Extreme wear could result to the engine, transmission and final drives unless proper precautions are taken.

A source of outside heat is necessary under these conditions. There are electric as well as propane-fired engine coolant heaters available. Gas-fired forced air heaters may also be obtained to heat the transmission and final drives.

When using such heaters follow manufacturer's safety instructions.



WARNING! For your personal safety, use caution and follow the manufacturer's instructions when using engine block heaters to warm the coolant or external heaters to warm the tractor

5.5.1. FUEL SYSTEM

Refer to "FUEL SYSTEM" for the diesel fuels selection, which will give the most satisfactory performance.

5.5.2. COOLING SYSTEM

Prepare the cooling system as follows:

1. Check the entire engine system for leaks.
2. Inspect the condition of all hoses and replace the hose and hose clamps as necessary.
3. Clean cooling system. Refer to "CLEANING THE SYSTEM."
4. Check the drive belt tension and adjust tension or replace belt. Refer to "ENGINE MANUAL".
5. Remove all debris from the radiator core using air or water under pressure. Direct the flow through the core, opposite the normal direction of air flow.



WARNING! For your personal protection, water pressure should not exceed 275 kPa and air pressure should not exceed 210 kPa. Use safety goggles.

6. Clean the radiator guard and outside of the core.
7. Protect your cooling system from damage by using approved antifreeze and coolant. *Refer to "FILLING THE DRAINED SYSTEM".*
8. Keep your cooling system clean and minimize corrosion by changing the coolant filter at correct intervals. Refer to "COOLING SYSTEM."
9. Check the condition of fan blades. Lubricate fan hub (QSK-19 Engine)

5.5.3. ELECTRICAL SYSTEM

Clean batteries and remove all corrosion from the battery terminals and cables. Repair or replace all wires, which have worn, cracked or frayed insulation and broken or loose wires. Service the batteries.

5.6. AIR CLEANING SYSTEM

5.6.1. AIR CLEANER

This machine has a „dry-type” cleaner with replaceable elements.

The cleaner has two elements: primary and safety. The primary can be cleaned for a limited number of times before replacement is necessary, however, the safety element must be replaced when plugged. Detailed service procedures for this air cleaner are covered in the following text.

IMPORTANT: *As a precaution against dirt entering the engine, all gasket and rubber hoses between the air cleaner, turbocharger and intake manifold, and between the manifold and cylinder head must be in good condition and the joints or connections must be tight. Never operate the engine unless a filter element is in place and filter end gasket is installed. Never remove the element from the air cleaner or service the air cleaner while the engine is running.*

5.6.2. PRIMARY FILTER ELEMENT

Service

The air cleaner primary element must be serviced whenever indicated by the air cleaner filter warning light. Refer to "AIR CLEANER FILTER WARNING LIGHT".

If after performed cleaning of primary filter element the air cleaner filter-warning light continues to glow, check for allowable restriction, precleaner screen. If the warning continues to glow replace safety filter element. If with cleaned primary filter element and replaced safety filter element the warning light still continues to glow, check air cleaner service indicator. The primary element can be cleaned by either of two methods: washing or compressed air. Washing is the preferred method as it removes more dust and soot and restore the element to an almost new condition.

The result being better performance and longer intervals between required element service. It is recommended that a spare element be obtained for use while the serviced element is drying.

IMPORTANT: *The primary filter element must be replaced after six washing.*

Cleaning the element with compressed air is not considered an entirely satisfactory method. Some dust will remain in the element causing more frequent servicing of the element. Cleaning with compressed air should be used only as a temporary measure until sufficient time is available to clean the element by washing. Engine air intake system (hoses, clamps, rubber connectors) is recommended to be checked for leaks ever 50 hours of operation.

IMPORTANT: *After cleaning, if an element is to be stored for later use, place it in a plastic bag and store in an element-shipping container to protect against dirt and damage.*

Removal (Fig. 5.2)

1. Stop the engine. Lower equipment on the ground. Open left engine access door. Remove all dust from the element removal end of the air cleaner body
2. Release tree lock straps and remove cover (8) from the air cleaner body (1), unscrew the wing nut (5) remove gasket (9) and carefully remove the primary element from the body not to dislodge dust from the dirty element onto the primary element (2).

MAINTENANCE

5.6. AIR CLEANING SYSTEM

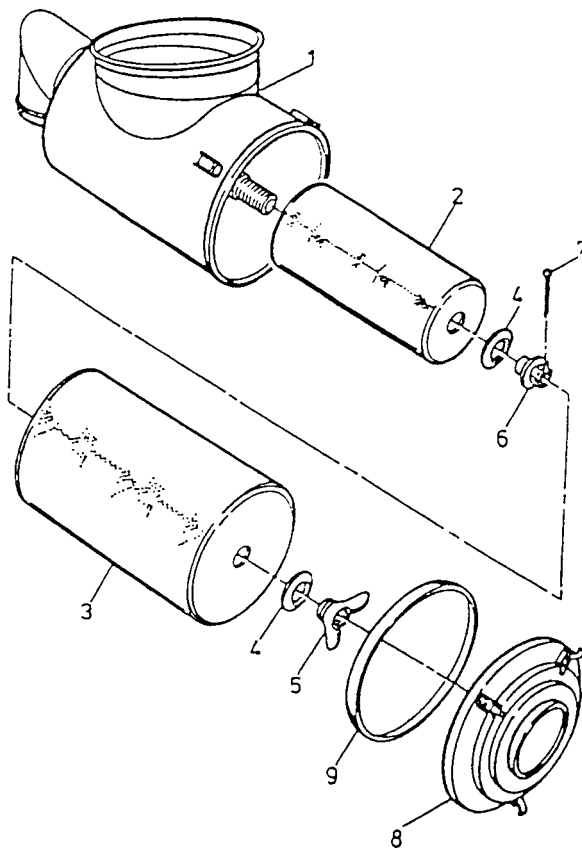

Fig. 5.2. Air Cleaner Assembly

- | | |
|--------------------|----------------|
| 1. Body | 6. Slotted Nut |
| 2. Safety Element | 7. Cotter Key |
| 3. Primary Element | 8. Cover |
| 4. Washer | 9. Gasket |
| 5. Wing Nut | |

3. Check the condition of the gasket on the end of the outer element (3). If the gasket is damaged or missing, replace the primary element. Remove all dirt from inside the air cleaner body with a damp cloth. A small amount of nonsudsing detergent added to the water will remove the soot.

Washing

IMPORTANT: Never wash element in fuel, oil, gas or solvent. DO NOT OIL ELEMENTS. Do not tap the element against a hard surface; this will damage the element.

1. Carefully tap the side or end of the element against the palm of your hand to remove loose dust.
2. Wash the element in clean, warm water 20°C to 40°C. A small amount of nonsudsing detergent added to the water will remove the soot.
3. Rinse the element in clear water (if a hose is used, do not exceed 275 kPa). Shake the element carefully to remove excess water.

5.6. AIR CLEANING SYSTEM

IMPORTANT: Do not use compressed air to speed the drying of the element; the air pressure will rupture the wet element.

4. Lay the element on its side and allow it to air-dry before reinstalling. Overnight drying is usually sufficient. When drying the element, protect it from dirt and/or freezing

NOTE: If no spare element is available, the wet element, after excess water has been shaken out, may be installed in the air cleaner and the engine operated at idle for 10 minutes before operating the tractor.

5. Inspect for damage. Refer to “INSPECTION.”

Inspection

1. Inspect the filter element for leaks or damage by placing a bright light inside the element. Inspection of the element on the outside will disclose any holes where concentrated light shines through. The slightest rupture requires replacement of the filter element.
2. Inspect the contact surfaces of the air cleaner body. If faulty or damaged surfaces are noted, correct these conditions immediately.

Installation (Fig. 5.2)

1. Insert the open end of the primary element (3) into the air cleaner body (1) and secure with the washer (4) and wing nut (5). Install cover (8) with gasket (9) onto the air cleaner body. Secure the cover to the body with locking clamps making sure cover is not cocked.
2. Inspect and tighten all air cleaner connections before resuming operation. Start the engine. If the air cleaner, filter warning light indicates air restriction, replace primary or primary and safety filter elements.

5.6.3. SAFETY FILTER ELEMENT

Service

Replace the safety element with every third change of the primary element or when plugged, as shown by the filter warning light.

Removal (Fig. 5.2.)

1. Remove primary element. Refer to 5.6.2.
2. Remove cotter key (7), nut (6) and washer (4) and pull safety element from body. Clean inside of body (1) with a damp cloth. Check the condition of gasket on the end of the safety element. If the gasket is damaged or missing, replace the gasket.

Installation (Fig. 5.2.)

1. Install new safety element (2) into the body and secure with nut (6) and washer (4). Secure bolt with cotter key (7).
2. Install primary filter element. Refer to 5.6.2.

5.6. AIR CLEANING SYSTEM

5.6.4. AIR INTAKE SYSTEM

5.6.4.1. Precleaner

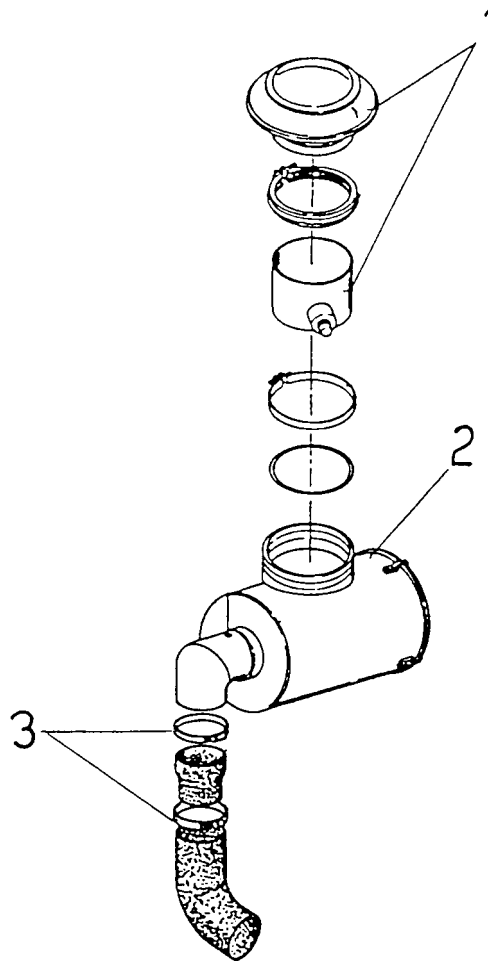

Fig. 5.3. Precleaner Assembly

1. Precleaner Filter
2. Air Cleaner
3. Tube Clamps

The dome of the precleaner hood serves as a rain shield and the screen prevents chaff and coarse dirt from getting into the air cleaner. Keep this screen clean from all chaff, oil or dust. Clogged holes in the screen will reduce the power of the engine by restricting the flow of air.

Loosen the clamp screw on the precleaner hood. Twist and pull upward to remove the cap. Use compressed air to clean the screen. If compressed air is not available, wash in clean hot water or water containing a small amount of nonsudsing detergent.

Never wash precleaner installed on the machine as water may penetrate to the engine.

5.6.4.2. Checking air intake system for leaks

1. Remove cover from the air cleaner body.
2. Remove primary element.

5.6. AIR CLEANING SYSTEM

3. Mask the entire perforated metal outside diameter of safety element (smaller) with the duct tape and reinstall. Sealing must be airtight. Connect regulated compressed air supply to one of existing connecting ports on air intake manifold. Connect pressure gauge to other connecting port on intake manifold or to warning light switch.
4. Check if underpressure of 0.14 – 0.21 kG/cm² has been obtained by reading the pressure. If improper pressure is seen, adjust pressure to 0.14 – 0.21 kG/cm² by cranking the engine crankshaft to a position where minimum leakage occurs past engine valves.
5. Coat the following areas with soap solution and check for leaks. Leaks will cause air bubbles to form.
 - a) air cleaner body surface around the outlet pipe to app. the outside diameter of safety element
 - b) air cleaner outlet to turbocharger inlet hose to air cleaner body junction
 - c) orifice and tubing from the air cleaner
 - d) all clamped hose and gasket connections between air cleaner outlet and intake manifold. This includes connections at turbocharger
 - e) surface of all air induction piping and hoses air cleaner and air intake manifold including the manifold gasket area
6. No leakage is permitted between air cleaner and intake manifold (the entire air induction system).

Test frequency

Air intake system leakproof tests must be performed after each Disassembly of intake system or if necessary (leaks or loosens clamps).

5.7. BELTS

General



WARNING! Keep clear of fan and fan belts when the engine is running. Rotating fan and belt contact can cause injury.

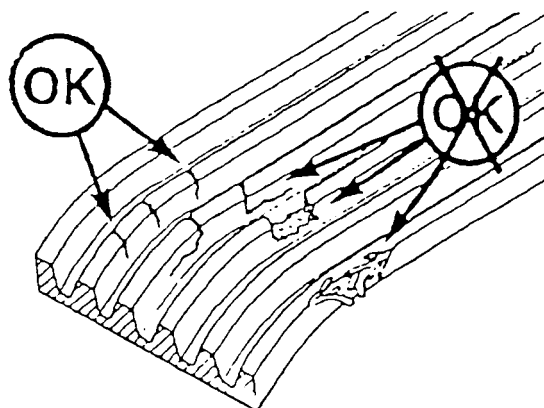

Fig. 5.4. Belt Inspection

5.7. BELTS

Replace badly worn, greasy or cracked belts immediately. These conditions prevent proper belt function.

Visually inspect the drive belts for intersecting cracks. Transverse (across the belt width) cracks are acceptable. Longitudinal (direction of belt length) cracks that intersect with transverse cracks are not acceptable. Replace the belt if it is frayed or has pieces of material missing.

5.7.1. CHECKING TENSION AND ADJUSTMENT

Checking tension

The engine is equipped with an automatic belt tensioner that maintains correct tension on the drive belt. To check belt tension a Borroughs type gauge must be used.

Adjustment

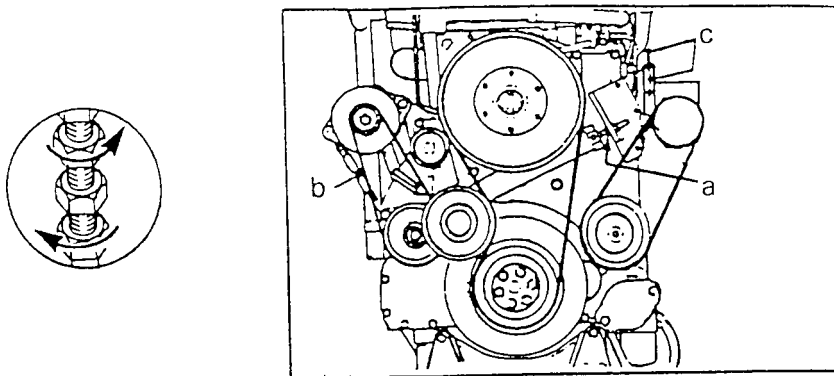

Fig. 5.5. Belt Tension Adjustment

- a – Fan Belt Tension Adjustment (only for QSK-19C Engine)
- b – Alternator Belt Tension Adjustment
- c – Air Conditioner Compressor Belt Tension Adjustment

Belt tension adjustment:

1. Alternator belt – tighten or loosen nuts and adjusting bolt “b” until tension value specified in chart is obtained.
2. Air conditioner compressor belt- tighten or loosen nuts and adjusting bolt “c” until tension value specified in chart is obtained.
3. Fan belt (chart enclosed) – loosen locknut and relive belt tension. Move fan idler until it contacts with the belt. Turn locknut by hand until snug. Turn the locknut by full 9 turns using wrench. Then torque the locknut to 81 Nm.

5.7.2 BELT TENSION CHART

BELT WIDTH	GAUGE		NEW BELT TENSION		USED BELT TENSION*	
	CLICK	BORROUGHS	N	Lbf	Lbf	N
0.38"	3822524		140	620	60 – 110	270 – 490
0.44"	3822524		140	620	60 – 110	270 – 490
1/2"	3822524	ST-1138	140	620	60 – 110	270 – 490
11/16"	3822524	ST-1138	140	620	60 – 110	270 – 490
3/4"	3822524	ST-1138	140	620	60 – 110	270 – 490
7/8"	3822524	ST-1138	140	620	60 – 110	270 – 490
4-groove	3822524	ST-1138	140	620	60 – 110	270 – 490
5-groove	3822524	ST-1138	150	670	60 – 120	270 – 530
6-groove	3822525	ST-1293	160	710	65 – 130	290 – 580
8-groove	3822525	ST-1293	200	890	80 – 160	360 – 710
10-groove	3822525	3823138	250	1110	100 – 200	440 – 890
12-groove	3822525	3823138	300	1330	120 – 240	530 – 1070
15-groove K	3822525	3823138	375	1670	150 – 300	670 – 1340
16-groove L	-----	3376344	560	2490	260 – 520	1160 – 2315
20-groove L	-----	3823772	700	3115	330 – 650	1470 – 2890

* belt is considered used if it has been run at least 10 minutes. If belt is used for a shorter period of time, apply maximum tension value specified for used belt. Groove width for type K belt is 3.5 mm and 4.3 mm for type L.

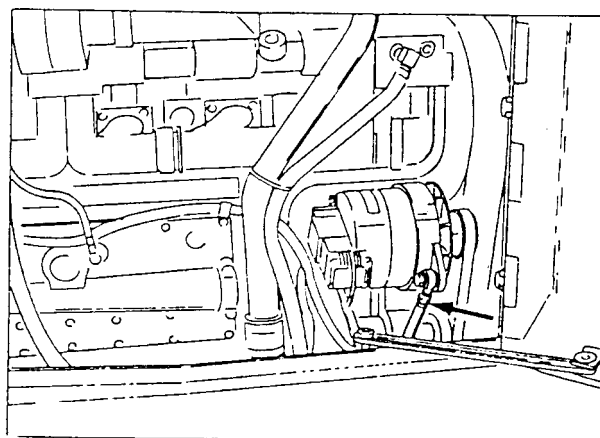

Fig. 5.6. Alternator Belt Adjusting Screw

5.8. COOLING SYSTEM

General

The cooling system operates under pressure. The water pump circulates the coolant through the oil cooler, engine block, cylinder heads, and radiator. Circulation is controlled by the thermostats, which prevent coolant flow through the radiator until the engine reaches operating temperature. Proper cooling is assured only when the system is sealed, radiator cap and gasket in good condition, thermostats operate properly, system is free of coolant and/or air flow restrictions and is filled to proper level.

Selection and maintenance of the system coolant is important to long engine life. The following information provides recommendations for selecting the engine coolant, maintaining the coolant inhibitors, and servicing the cooling system. This system will operate with a water/antifreeze mixture or inhibited water as a coolant. Never use water alone because water will allow rust, scale deposits, and corrosion to occur within the system.

5.8.1. WATER

Use water, which has a low mineral content. Water used in conjunction with antifreeze, coolant filters and inhibited water must meet the following standards:

Total hardness: Not to exceed 170 parts per million to prevent scale deposits. Water containing dissolved magnesium and calcium (the usual reason for water hardness) above the specified amount will cause scale deposits to develop in the engine.

Chlorides – Not to exceed 40 parts per million to prevent corrosion.

Sulfites – Not to exceed 100 parts per million to prevent corrosion.

Dissolved solids – Not to exceed 340 parts per million to minimize sludge deposits, scale deposits and corrosion.

If any of the requirements cannot be met, use distilled de-ionized or de-mineralized water. To determine if local water supplies meet these standards, water treatment laboratories can test water samples. Softened water that is prepared using common salt (sodium chloride) contains excessive amounts of chlorides and should not be used.

5.8.2. ANTIFREEZE

Low silicate ethylene glycol antifreeze is recommended. The antifreeze should contain no more than 0.1% anhydrous alkali metasilicate. Low silicate antifreeze is recommended to avoid the formation of silica gel (hydro-gel). This gel formation can occur when cooling system contains an over concentration of high silicate antifreeze and/or supplemental coolant additive. DO NOT use methanol or alcohol as antifreeze because of its low boiling point. Antifreeze may retain its freeze protection for more than one season but coolant conditioners must be added to maintain corrosion protection. Antifreeze formulated with methoxy propanol, or propylene glycol is not recommended for this system.

IMPORTANT: Do not mix types of antifreeze solutions. Mixed solutions make it impossible to determine the protection against freezing. Antifreeze containing sealer or anti-leak additives should not be used in this system. Sealer or anti-leak additives will plug the coolant filter and cause plugging problems in the cooling system.

5.8. COOLING SYSTEM

Table included in Engine Manual shows percentage of antifreeze concentration required for various temperatures.

5.8.3. INHIBITORS / CONDITIONERS

1. All cooling system inhibitors, including those in antifreeze solutions, become depleted through normal operation. If the inhibitors in antifreeze are allowed to become depleted, the antifreeze becomes corrosive and attacks and coats the metallic surfaces of the cooling system which reduces heat transfer. Cooling system conditioners, which contain these inhibitors, must be added to maintain corrosion protection.
2. SOLUBLE OIL IS NOT RECOMMENDED for use in the engine as its use will reduce heat transfer.

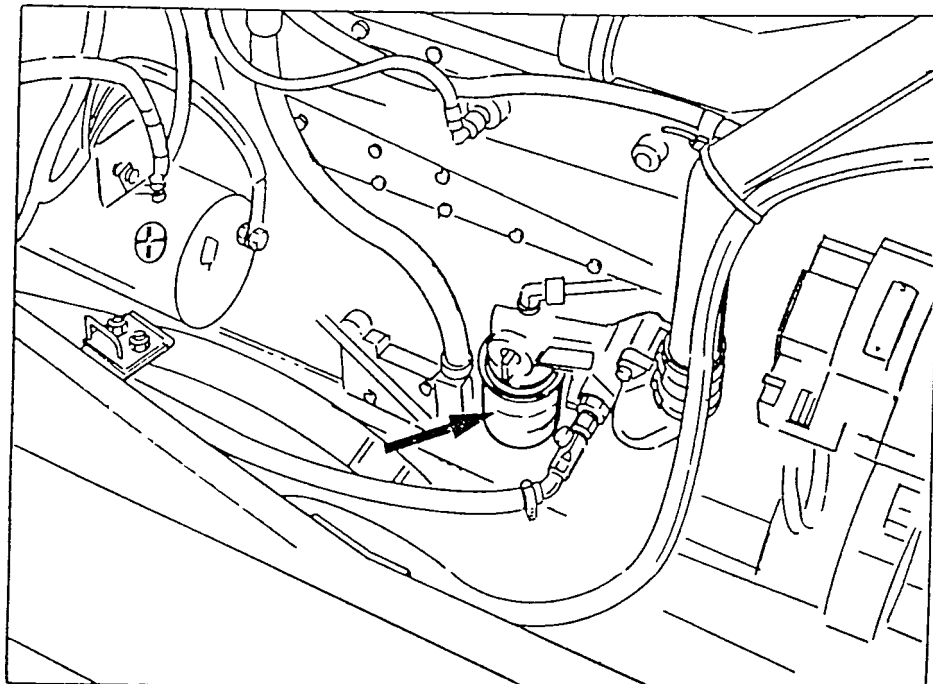

Fig. 5.7. Coolant Filter

Replenishing coolant conditioner

Replenishing coolant conditioner is performed by periodical replacement of filters (Fig. 5.6) containing DCA4 inhibitor protecting cooling system against corrosion and cavitation erosion of cylinder sleeves and coolant pump blades.

Coolant testing for conditioner concentration

Coolant testing for DCA4 concentration should be performed periodically before coolant filter replacement for determines proper capacity of filter to be applied. CC2626 test kit of filter manufacturer is designed for this purpose. Test procedure is included in Engine Manual.

Prior to installation of new coolant filter close the shut-off valve (Fig. 5.6) OFF position. Upon installation of new coolant filter open the shut-off valve – ON position.

NOTE: *Mixing of DCA4 and other supplemental coolant additives is not recommended because there is currently no test kit available to measure concentration levels with mixed chemical solutions.*

5.8. COOLING SYSTEM

5.8.4. RADIATOR

5.8.4.1. Radiator Cap

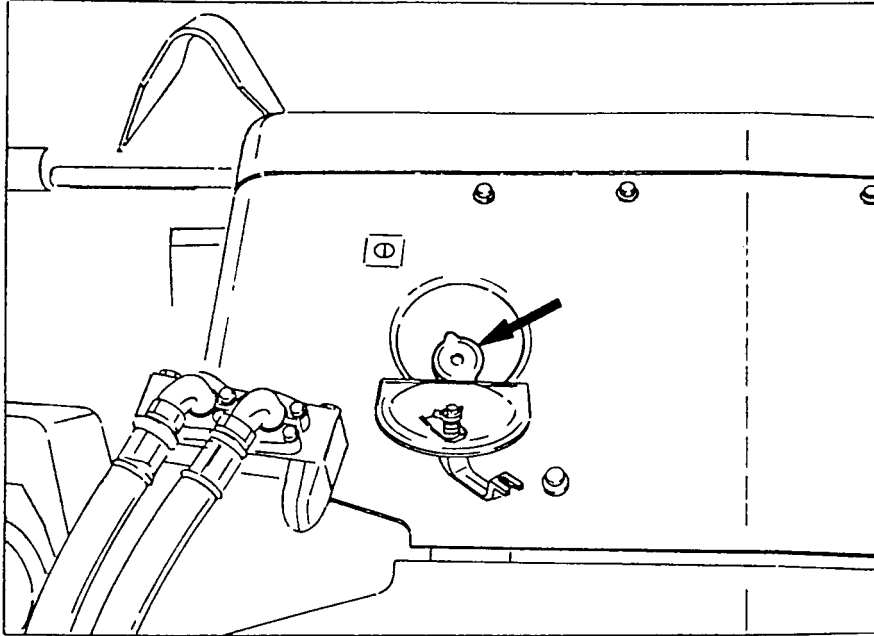

Fig. 5.8. Radiator Cap

General

The radiator cap seals the coolant filler opening of the radiator. Positive sealing requires a cap gasket and its contacting surfaces in good condition, and a properly tightened cap.

The radiator cap incorporates a pressure relief valve that keeps the pressure of the coolant at 40 – 55 kPa in top tank of the radiator.

NOTE: *Operating the machine without a radiator cap, or with a cap without a relief valve set to operate at the correct pressure can cause damage.*

Removal



WARNING! Hot, scalding coolant can spray out if the radiator cap is removed suddenly. Relieve system pressure by slowly turning the cap to the first notch or lifting the safety lever. Remove the cap only after the pressure is relieved.



WARNING! Use extreme caution when adding coolant to a hot radiator to avoid being burned. Wear gloves and goggles and keep face away from the filler neck.

To remove the cap turn the cap to the left or counterclockwise up to the safety stop until all pressure is released. Then press down on the cap and continue to turn until the cap is free to be removed.

5.8. COOLING SYSTEM

Installation

When installing the cap, gasket and contacting surfaces must be clean. Turn the cap to the right or clockwise until snug.

5.8.4.2. Cleaning the Radiator Core

Every 50 hours of operation remove dirt from the radiator core. Refer to 5.5.2 for radiator core cleaning procedure. Air conditioner cooler core must also be cleaned (if installed). For machines equipped with QSK-19C engine clean also fuel cooler.

5.8.5. CHECKING COOLANT LEVEL

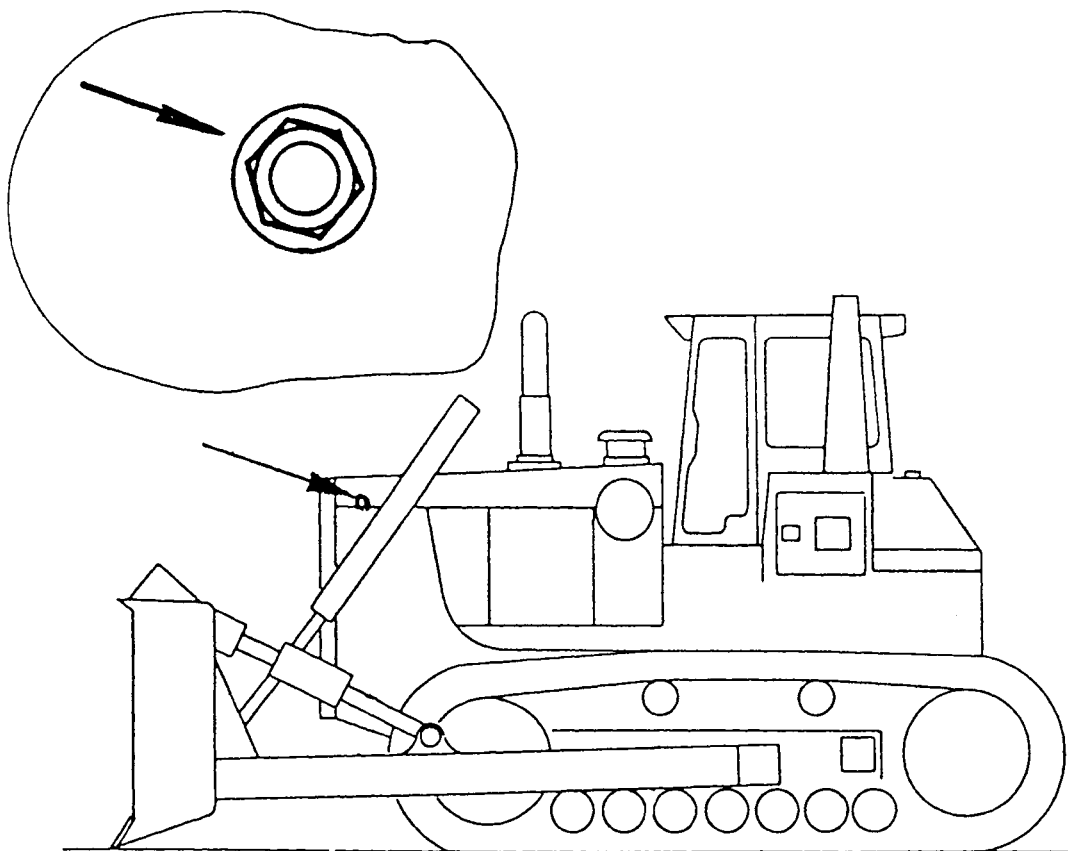

Fig. 5.9. Radiator Sight Gauge

Check the coolant level daily before starting the engine.

For checking the coolant level place the machine on the level ground and lower the mounted equipment on the ground.

Coolant level must be seen in the radiator sight gauge.

After replenishing coolant in the radiator check and correct concentration of DCA4.

IMPORTANT: Never add coolant when engine is hot. This may result in damage to the engine. Allow the engine to cool down below 50°C prior to replenishing coolant in the radiator.

5.8. COOLING SYSTEM

5.8.6. CHANGING THE COOLANT

Open L.H. side engine access door. Cooling system fast fill receiver is mounted to L.H. side of mainframe.

To drain cooling system remove protective cover from the receiver and install drain pump adapter. Drain the system.

Fill the cooling system using the same fast fill receiver "1"

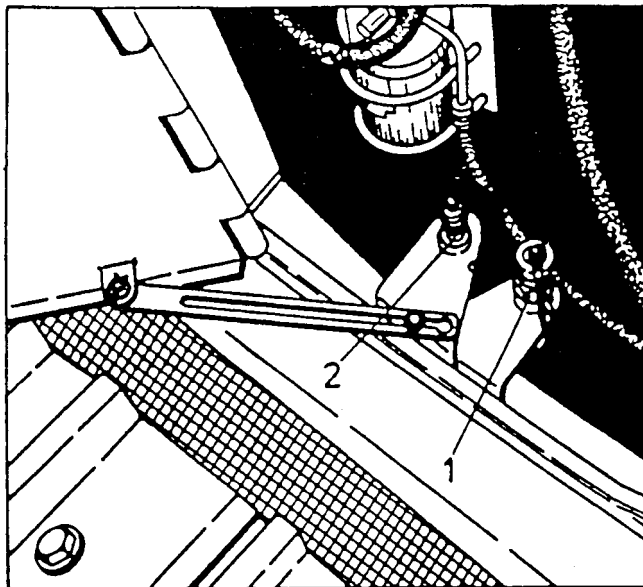

Fig. 5.10. Fast Filling Engine Systems

1. Cooling System Fast Fill And Drain Receiver
2. Engine Crankcase Oil Fast Fill And Drain Receiver

5.8.7. CHANGING COOLANT

Every 250 hours of operation change coolant filter and check coolant for DCA concentration. Procedure is shown in Engine Operation Manual. After 6000 hours of operation or every 2 years clean the cooling system as described in Engine Operation Manual.

5.8.8. CHANGING COOLANT (for machines without fast fill systems)

5.8.8.1. Draining the System

1. Run the engine until it reaches operating temperature, then stop the engine
2. Remove the radiator cap. Refer to "RADIATOR CAP"
3. Open the oil cooler drain valve located on the bottom of the oil cooler
4. Open two crankcase drain valves, located at each side of the rear part of the crankcase
5. Open radiator drain valve located on lower tank on R.H. side of the machine. Access to the valve is gained after removal of front bottom guard.
6. Open coolant filter shut-off valve
7. Allow the system to drain completely; do not let drain outlets plug up from foreign material.

5.8. COOLING SYSTEM

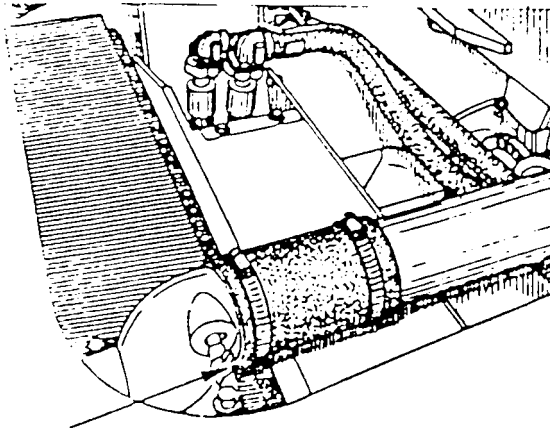

Fig. 5.11. Crankcase Coolant Drain Plug

5.8.8.2. Filling the Drained System

1. Close the oil cooler drain valve, radiator drain valve and two crankcase drain valves and coolant filter shut-off.
2. Fill the cooling system slowly. This allows more air to escape and the system to be filled to maximum capacity. The percentage of antifreeze to add for freeze protection can be determined from the antifreeze and coolant chart. Refer to "ANTIFREEZE".
3. Start engine and run until normal operating temperature is reached; adding coolant when needed to keep proper level of 25 mm above the baffle.
4. After all air is removed and level remains fixed, install the radiator cap.

5.9. FAN AND FAN HUB

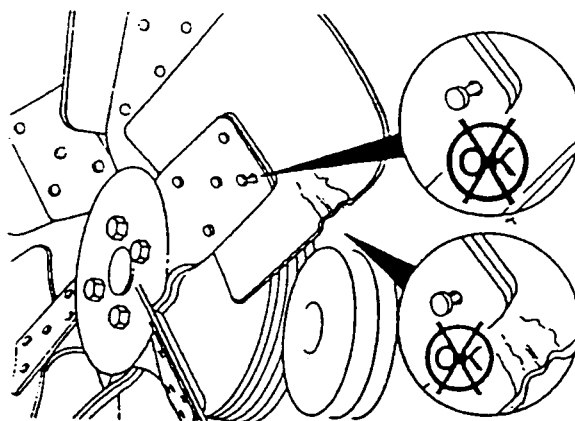

Fig. 5.12. Fan



WARNING! Keep clear of fan and fan belts when engine is running. Rotating fan and belt contact can cause injury.

MAINTENANCE

5.9. FAN AND FAN HUB

1. Check the condition of fan blades (cracks, damaged, rivets, loosen mounting bolts) and bearing of idler pulley (lubrication of idler hub is not applicable for QSK-19)
2. Reversible fan blades (if equipped) should be after every 250 hours reversed to prevent excessive contamination in engine and cooler compartment. After reversing the blades adjust them in required position.

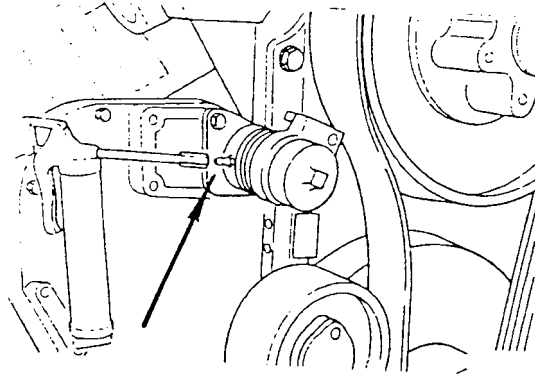

Fig. 5.13. Idler Arm Lube Fitting

3. Lubricate fan idler arm every 250 hours

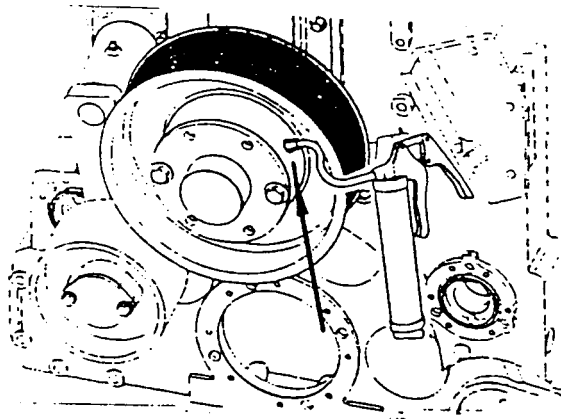

Fig.14. Fan Hub Lube Fitting

4. Lubricate QSK-19 fan hub every 1500 hours or once a year.

5.10. ELECTRICAL SYSTEM

Precautions



WARNING! BEFORE WORKING ON THE ENGINE OR ELECTRICAL SYSTEM, turn off the electrical system master switch and remove the key. All terminals must be clean and fastened securely. Replace frayed, cracked, and poorly insulated wiring.

5.10. ELECTRICAL SYSTEM

The surface under all terminals must be clean, and good electrical connections must be established after any reassembly. Also, all clips must grip cables tightly to prevent vibrations and rapid cable wear. All clips and straps must be closed in a workmanlike manner, so as not to damage the insulation.

Batteries can only be charged using receptacle locate close to the engine on the left hand side of the machine. Receptacle can also be used to connect additional source of supply, e.g. for engine starting. Batteries can be only be charged using this receptacle, which also can be used to for connection of additional source of power to start the engine under extreme conditions.

5.10.1. AUTOMATIC RESET CIRCUIT BREAKER

Electrical circuits are protected by automatic reset circuit breakers mounted on the underside of the instrument panel. In the event of a short circuit or ground, the circuit breaker will open and close until trouble clears or is corrected. The circuit breaker will then return and stay in its normal closed position.

5.10.2. BATTERIES

General

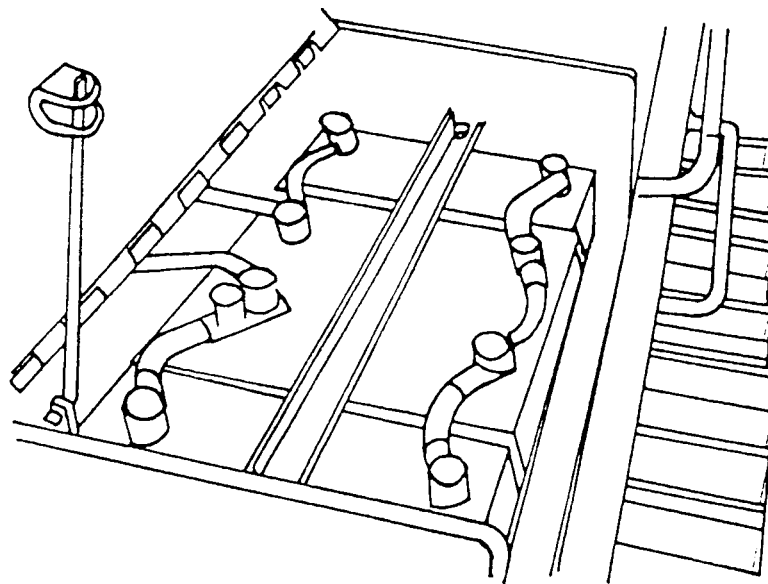

Fig. 5.15. Location of Batteries

The machine is equipped with two 12-volt battery. They are located in L.H. fender. Access is provided upon removal of three bolts and lifting the cover. Never allow a battery to stand on concrete, ground or a metal support unless proper insulation is provided. A wooden platform or board is sufficient insulation. Be sure the battery is fastened securely to avoid damage from vibration.



WARNING! A battery gives off highly flammable gas. Never allow sparks, open flame or lighted smoking material near the battery. Avoid spilling any electrolyte on hands or clothing. Always wear safety glasses when working on a battery.

5.10. ELECTRICAL SYSTEM



WARNING! Never check the battery charge by placing a metal object across the terminals. The sparks could cause a battery explosion. Use a voltmeter or hydrometer to measure charge.



WARNING! Be sure the electrical system master switch is off when connecting or disconnecting the battery to minimize the chance of sparks and explosion.

Maintenance

Proper battery maintenance will assure maximum service. Following are a few simple rules: Keep battery cable terminals clean and tight. Keep filler cap vent holes unplugged. Replace worn, cracked, broken or corroded cables. Keep battery fastened securely in frame.

NOTE: *Excessive tightening can warp or crack battery case.*

Maintain the correct battery electrolyte level. Refer to "Electrolyte Level". Always charge the battery in a ventilated area. Keep the battery clean. Refer to "Cleaning the Battery".

The following precautions must be taken when working around batteries:

Use a battery carrier to avoid spilling electrolyte on clothing. Wearing rubber aprons and gloves is advisable.

Be careful that tools or other metallic objects do not fall across the battery terminals.

Never break a live circuit at the terminals. This could cause sparks. Make sure charger cable clamps or booster leads are clean and making good contact. If it becomes necessary to prepare electrolyte of a desired specific gravity, always pour the acid into the water.

Always turn the charger to the OFF position before connecting or removing charger leads to the battery.

When charging a battery, it is recommended that the caps be left on. A damp cloth should be placed on top of the caps.

Cleaning the Batteries

If the top of a battery is dirty, it may be cleaned with a brush dipped in ammonia or soda solution.

Electrolyte Level

The electrolyte in each cell must be at the proper level (21 to 27 mm above the plates) at all times to prevent battery failure. Check the level of the electrolyte.

When the electrolyte is below this level, pure distilled water must be added. Never use hydrant water or any water which has been in a metal container. A skilled battery man must never add except acid or electrolyte. Under no circumstances add any special battery solutions or powders.

It is especially important to keep the battery at full charge for cold weather operation. Add distilled water to the battery in freezing temperatures only when the engine is to operate for several hours, to thoroughly mix the water and the electrolyte, or damage to the battery may occur.

Charging Fully Discharged Batteries

When a machine is not in use for an extended period, the maintenance-free battery can become discharged. For this reason, when a machine will not be used for over 30 days, it is recommended that the negative ground terminal cable be disconnected. Prior to starting up a machine that has been idle, always make a visual inspection of the battery and take an open circuit voltage test. A reading of 12.3 volts (75% of full charge) or less indicates a state of discharge and battery should be charged.

5.10. ELECTRICAL SYSTEM

Check amount of charge of batteries:

100% of full charge	1.26 – 1.28 g/cm ³
75% of full charge	1.23 – 1.25 g/cm ³
50% of full charge	1.20 – 1.22 g/cm ³
Fully discharged	1.11 – 1.13 g/cm ³

5.11. ENGINE

5.11.1. CHECKING THE CRANKCASE OIL

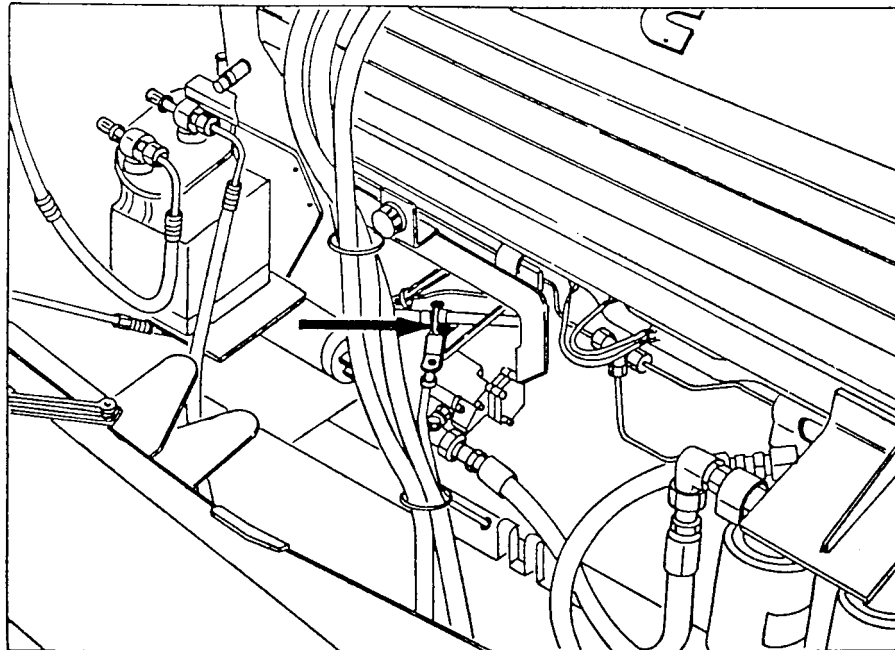

Fig. 5.16. Oil Level Gauge



WARNING! Park the machine on level ground, stop the engine, lower all mounted equipment to the ground, lock the transmission shift lever in neutral, apply the brake pedal lock, turn off the electrical system master switch.

Stop the engine and check level. For an accurate reading wait for the oil to drain into the crankcase pan. Open hood side access door.

Remove the oil level gauge and wipe it clean. Reinsert the gauge completely. Remove the gauge and check the oil level. If the level is at or below the ADD mark, add oil through the fast fill receiver to bring the level up to the FULL mark on the gauge. Refer to “REFILL SPECIFICATIONS AND CAPACITIES CHART” for type and viscosity of oil specified. Reinstall the level gauge.

NOTE: Never run the engine if the level of the oil is at or below the ADD mark on the oil level gauge.

1. Every 250 hours of operation check and clean crankcase breather hoses (3 pcs). For cleaning remove crankcase breather housing and clean with compressed air in reverse direction to that of normal operation. Damaged breather must not be used.
2. Check the engine for leaks.

MAINTENANCE

5.11. ENGINE

5.11.2. CHANGING THE CRANKCASE OIL AND OIL FILTERS

5.11.2.1. Changing the Crankcase Oil (for machines without fast fill system)



WARNING! Hot parts – wear gloves. Fire hazards – do not smoke.

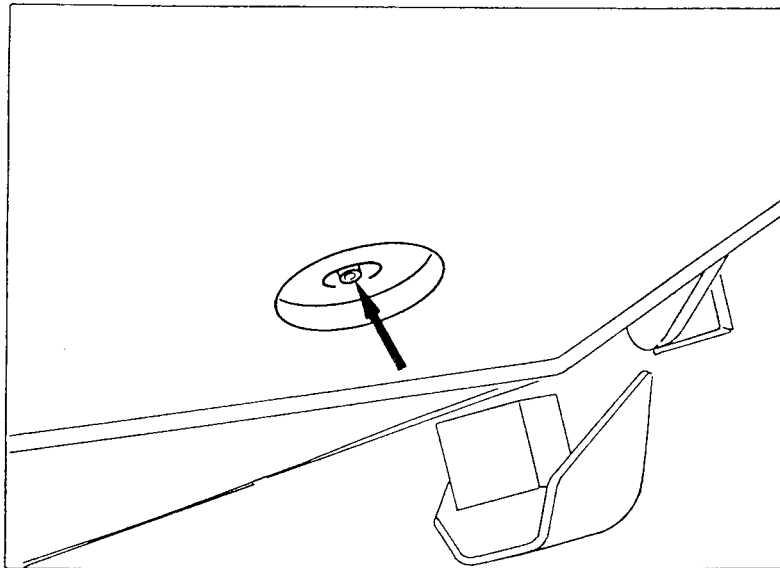

Fig. 5.17. Crankcase Oil Drain Plug Cover Location (Remove for Machines Without Fast Fill System)



WARNING! Whenever working under the machine, turn off the electrical system master switch, remove the key and tag the controls to prevent inadvertent starting.

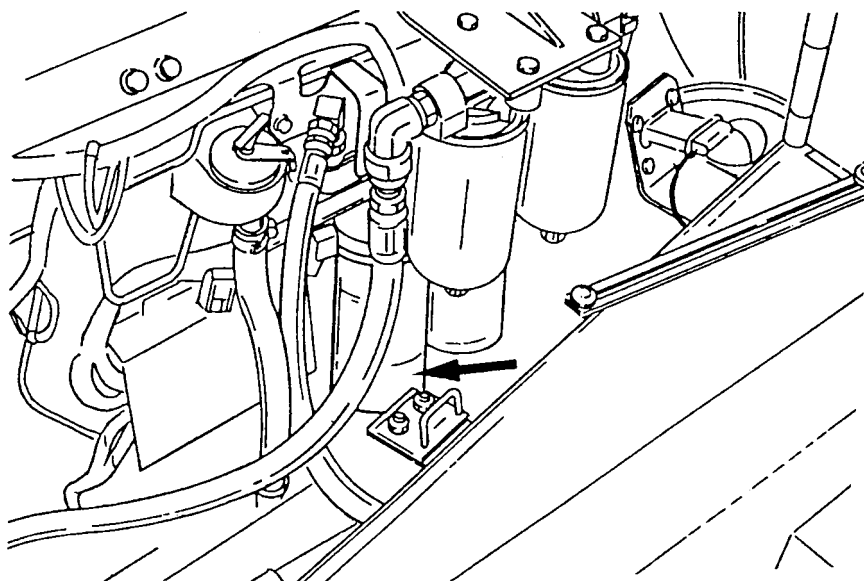

Fig. 5.18. Lubricating Oil Filter (QSK-19C Engine)

5.11. ENGINE

NOTE: Use only recommended filters available from Authorized Distributor of Construction Equipment.

1. When coolant reaches the temperature of app. 60°C, stop the engine and drain the crankcase oil.
2. Clean the filters and filter head. Remove spin-on filters.
3. Clean filter head in spin-on filter seal contact area.
4. Apply a little clean engine oil to the seal of new filter (2 pcs for replacement for QSK-19 Engine and 3 pcs for replacement for KT-19C Engine), fill the filter with engine oil and thread the filter on by hand per instructions specified on the filter.

IMPORTANT: Thread the filters by hand. Do not use any tools to install the filters because this can damage the filter.

5. Fill the crankcase with fresh oil. Refer to the “REFILL SPECIFICATION AND CAPACITIES CHART.”

5.11.2.2. Crankcase Fast Fill System

For fast draining crankcase oil, remove protective cover from receiver and connect drain pump nozzle. For draining oil must be warm. For filling the system connect fill pump nozzle to the receiver and fill the crankcase with oil.

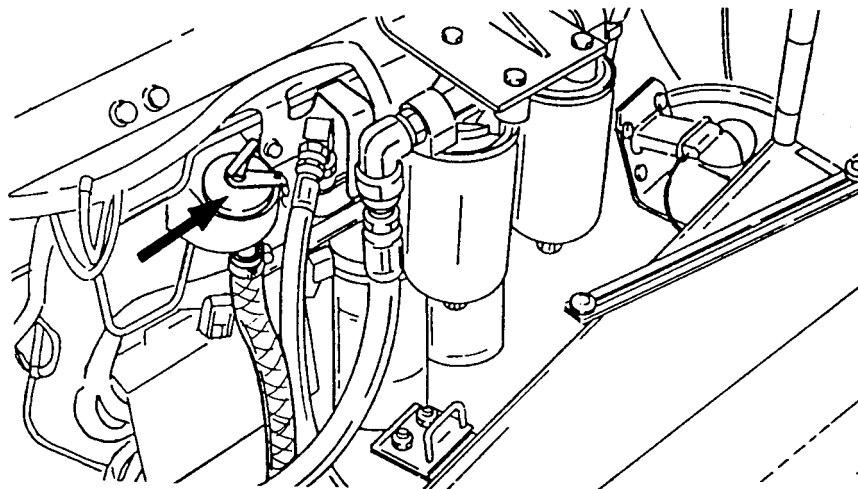

Fig. 5.19. Oil Fill Tube

5.11. ENGINE

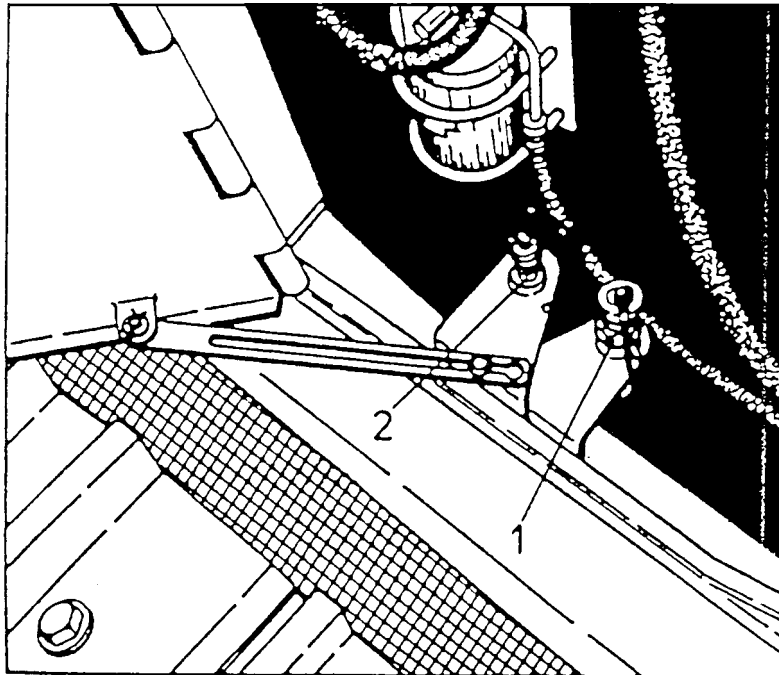

Fig. 5.20. Filling the Crankcase

- 1.Cooling System Fast Fill Receiver
- 2.Crankcase System Fast Fill Receiver

5.11.3. ETHER INJECTOR (if equipped)

Precautions



WARNING! Ether starting fluid is highly flammable.

Follow the precautions on the container. An explosion can result if sparks or flame contact the ether.

Observe the following precautions:

Do not use the ether injector when the air temperature is above 0°C.

Do not use open flame when using ether-starting fluid.

Do not store fluid containers in the operator's compartment. Store the containers in a cool, well-ventilated place.

Keep the fluid containers out of unauthorized personnel.

Do not breathe the hazardous ether vapor.

Do not let ether contact your skin, because it can cause frostbite.

Never puncture the fluid container or put it into a fire. Dispose of empty containers properly.

For your safety, remove the ether container when welding, grinding, or using a torch on the machine.

Follow the correct method for starting the engine. Refer to "STARTING THE ENGINE" in this manual.

NOTE: *The ether starting valve inlet must be sealed against the entry of dirt at all times by having a fluid container installed or by installing the dust cap provided with the valve.*

5.11. ENGINE

Inspection and Cleaning

Make certain that ether is available under pressure. To do so, remove the ether container and check if a good spray is obtained.

Test the ether injector as follows:

1. Disconnect the ether tube at the spray nozzle in the engine manifold. Remove the spray nozzle.
2. Reconnect the nozzle to the tube. Direct the nozzle away from the engine and actuate the ether injector. Dribbling or no spray indicates a blocked spray nozzle or tube. If necessary, clean or replace spray nozzle and/or tube.

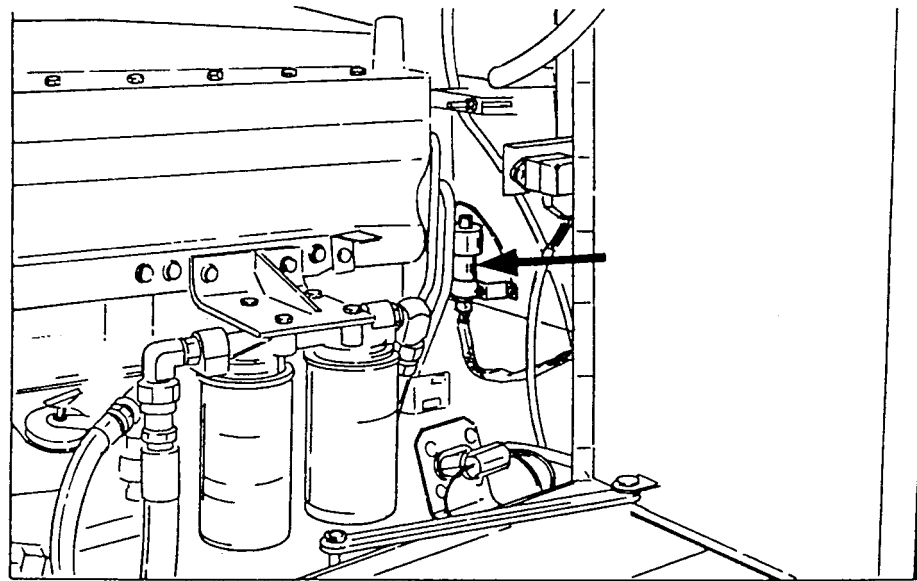

Fig. 5.21. Ether Fluid Container

Changing the Fluid Container

1. Loosen the nuts securing the fluid container support saddle.
2. Unscrew and discard the container from the ether starting valve in a suitable, closed refuse container.
3. Install the new container in the valve.
4. Secure the container in place by tightening the saddle nuts. Do not over tighten the nuts.

5.12. FUEL SYSTEM

General

Cleanliness of diesel fuel determines the service life of the fuel components. Water and contaminants, allowed to reach precision components, cause rapid wear and poor performance. Clean fuel and regular servicing of the fuel tank and fuel filtering components are necessary for long service life. Always clean the area around the fuel tank filler cap before refueling.



WARNING! Fire hazard – never mix gasoline and/or alcohol with diesel fuel. This practice creates an extreme fire hazard and under certain conditions an explosion, which could result in personal injury or death.

5.12. FUEL SYSTEM



WARNING! Never remove the fuel tank filler cap or refill the fuel tank while the engine is running or hot or when the machine is indoors. Fumes are dangerous, a spark or flame could result in a fire or explosion.

5.12.1. FILLING THE FUEL TANK

Be sure fuel tank is full. Fill the tank at the end of each day's operation to reduce condensation of moisture (Fig. 5.22).

5.12.2. FUEL TANK FILLER STRAINER

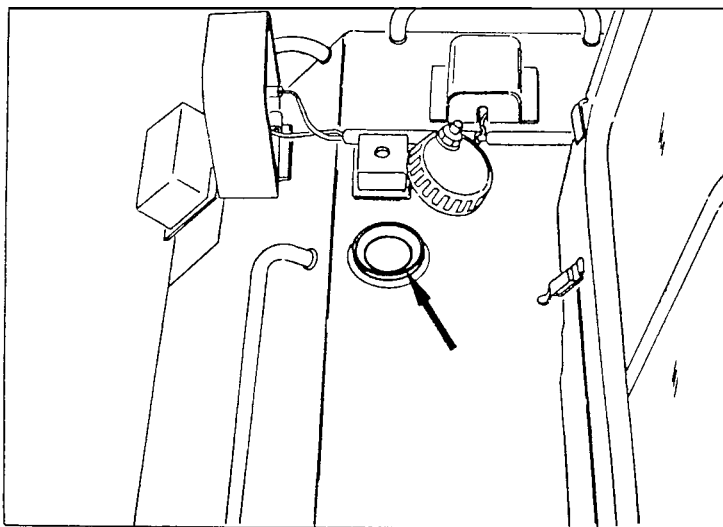

Fig. 5.22. Fuel Tank Filler Strainer

This screen filters the fuel entering the tank and eases the job of the fuel filters. Remove and clean the screen with a nonflammable commercial cleaning solvent.

5.12.3. FUEL TANK SHUTOFF VALVE

Be sure the shutoff valve is open.

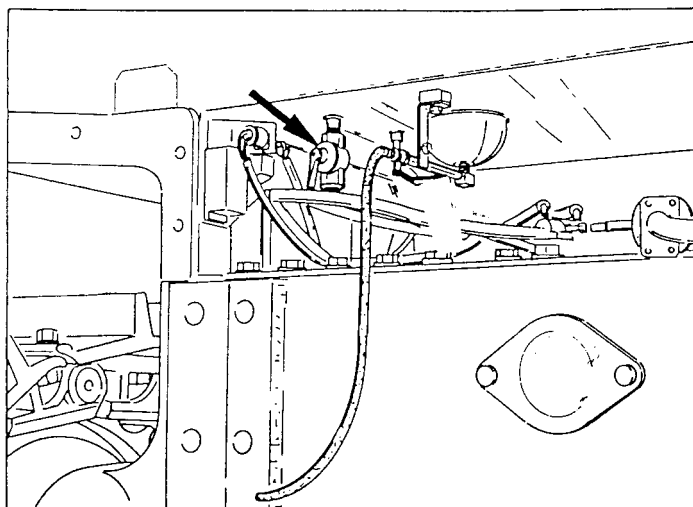

Fig. 5.23. Fuel Tank Shutoff Valve

5.12. FUEL SYSTEM

5.12.4. FUEL FILTERS

5.12.4.1. Fuel Filter Water Separator Drain Valve

Spin-on fuel filters equipped with water separator are used in fuel system. Water and foreign materials separated from fuel, which settle to the bottom of the filter, are drained from the fuel thru drain valve located in lower part of the filter.

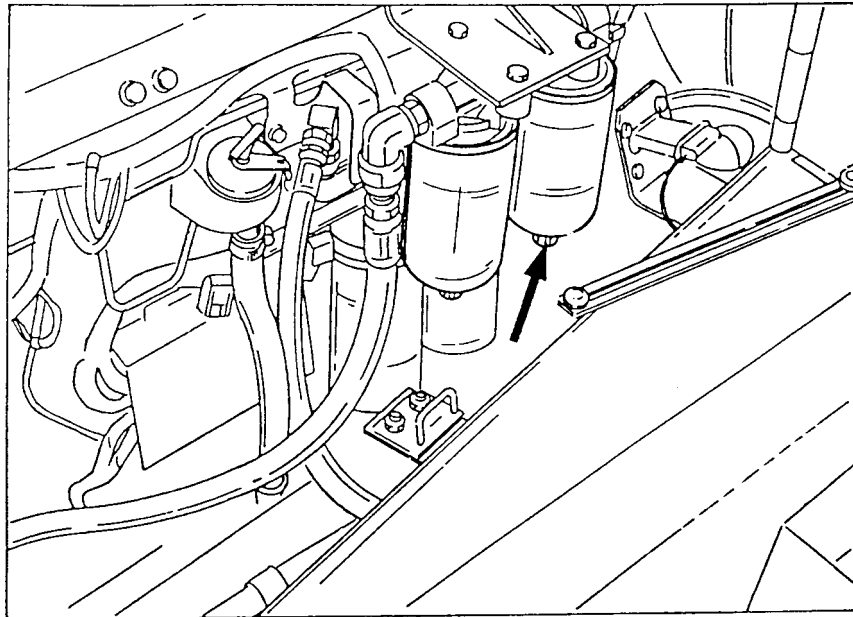

Fig. 5.24. Fuel Filters (Water and Sediment Fuel Filter Drain Valve Shown by Arrow)

Open the valve and drain water and sediment from the filter until clean diesel fuel appears. Close the valve.

NOTE: *Water contaminated with sediment and fuels as well as oil are detrimental to environment. Drain water to suitable container and utilize in appropriate area.*

5.12.4.2. Replacing the Fuel Filter

Replace fuel filter when the engine is misfiring, loss of power is evident or after 250 hours. Keep the new filter in the original package until ready for installation. Before loosening the filter, clean the filter head to prevent dirt or foreign material from entering the system.

1. Close the fuel shutoff valve under the fuel tank.
2. Remove the fuel filters from the filter header using a filter removal wrench.
3. Thoroughly clean the filter header to prevent dirt or foreign material from entering the system.
4. Fill fuel filter with clean fuel.
5. Apply a light coating of clean engine oil to the seal surface on the new filter.
6. Install the new filter, turning it until the seal just contacts the filter head and tighten the filter an additional 1/2 to 3/4 turn.

NOTE: *Thread the filters by hand. Do not use any tools to install the filters because this can damage the filter.*

5.12. FUEL SYSTEM

NOTE: Use only recommended filters available from Authorized Distributor of Construction Equipment.

5.12.5. DRAINING FUEL TANK

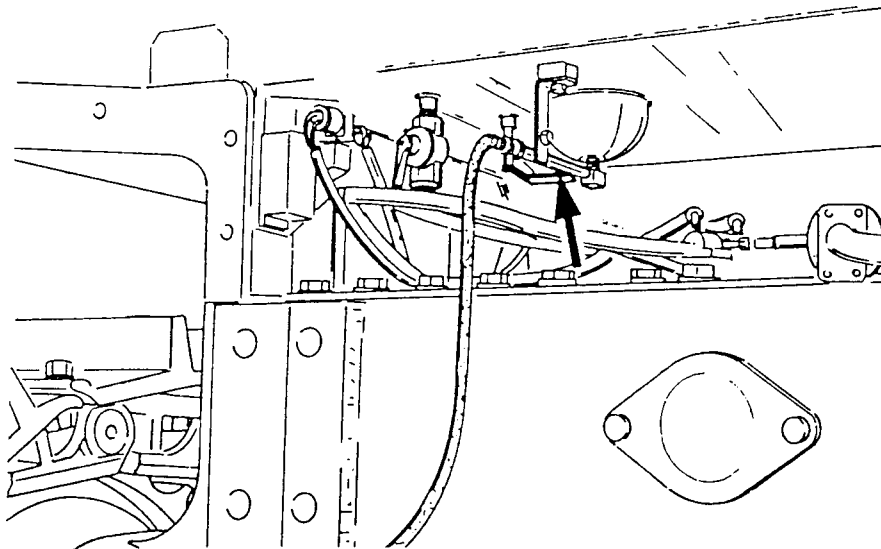

Fig. 5.26. Fuel Tank Drain Valve

Periodically open the valve and drain water and sediment from the fuel tank until clean diesel fuel appears. Close the valve.

5.13. HYDRAULIC SYSTEM

General



WARNING! Always lower all mounted equipment to the ground before performing work on the hydraulic system. With all mounted equipment lowered to the ground and the engine off, cycle all hydraulic controls in all directions to relieve trapped pressure. Slowly loosen the hydraulic reservoir filler cap to relieve trapped reservoir pressure.

5.13.1. CHECKING OIL LEVEL

1. Park the machine on level ground lower the blade and the ripper to the ground and stop the engine.
2. Check oil level at sight gauge on the side of the reservoir. Add oil if level is below the center line of the gauge. Refer to "OIL CHANGE".

NOTE: Before removing any components from the reservoir or servicing, wipe the top surface of the reservoir, using clean kerosene or a commercial cleaning solvent.

5.13. HYDRAULIC SYSTEM

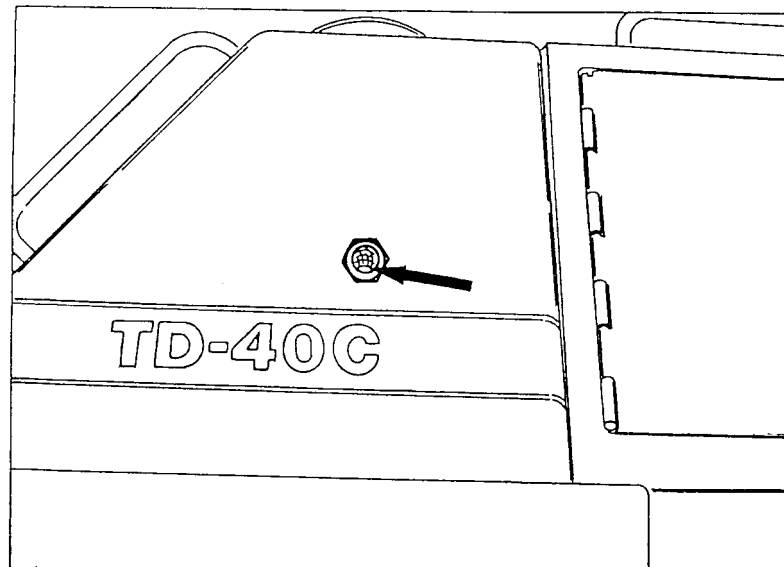

Fig. 5.27. Hydraulic Reservoir Sight Gauge

5.13.2. CHANGING HYDRAULIC OIL

1. Start the engine and operate the blade to warm the oil for easy draining.
2. Park the machine on level ground, lower the blade and the ripper to the ground.
3. Stop the engine. Shift to neutral and apply the neutral lock lever. Apply and lock the parking brake. Turn the electrical system master switch to OFF and remove the key. Slowly loosen reservoir filler plug to relieve reservoir pressure.
4. Drain the reservoir into a suitable container by removing the filler plug and the drain plug (Fig. 5.28).
5. Replace two return filters of hydraulic system and equipment hydraulic control circuit filter. Refer to "SERVICING THE RETURN FILTER". Service the suction strainer as described under "SERVICING THE SUCTION STRAINER". Service fuel tank filler strainer.

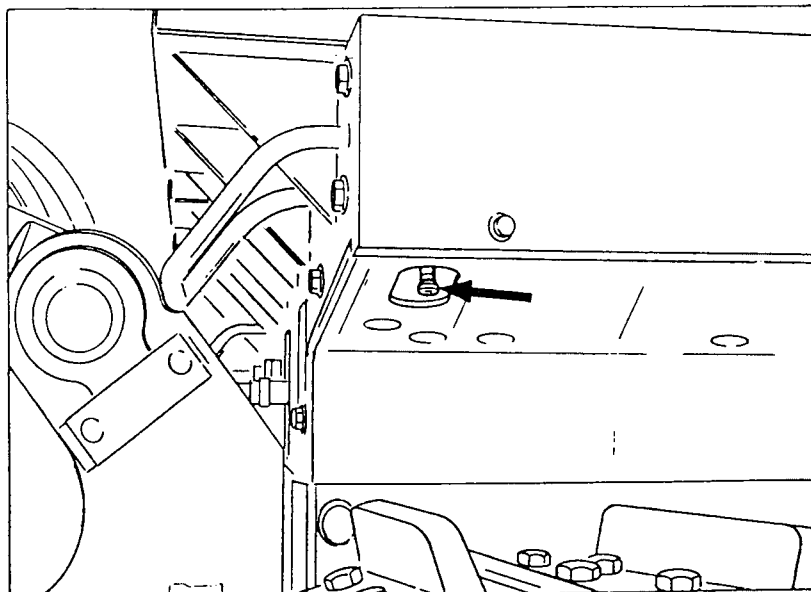

Fig. 5.28. Hydraulic Reservoir Drain Plug

5.13. HYDRAULIC SYSTEM

NOTE: Use clean oil from a clean container. Maintain all packaging and fittings so as to prevent leakage.

1. Reinstall the drain plug. Fill the reservoir with lubricant up to the center line of the sight gauge. Refer to 6.8.2. "REFILL CAPACITIES" chart for the quantity oil specified. Reinstall the filler cap.
2. Vent the system. Refer to "VENTING THE SYSTEM".

5.13.3. SERVICING THE RETURN FILTER AND EQUIPMENT HYDRAULIC CONTROL SYSTEM FILTER

NOTE: The hydraulic reservoir does not have to be drained in order to service this filter.

NOTE: If the filters warning light on the instrument panel, remains on at operating oil temperature with the engine running, the filter must be changed.

Two hydraulic return filters and one pilot filter change according SCHEDULED MAINTENANCE GUIDE as described below:

1. Park the machine on level ground lower the blade to the ground and stop the engine. Turn the electrical master switch to OFF.
2. With the engine stopped, operate the equipment lever several times in all directions to relieve any pressure. Remove return filters side cover located at R.H. side in front of the hydraulic reservoir, remove all outside dirt from filters.
3. Using a filter wrench remove the spin-on filter. Wipe the filter base, removing all of the old oil from the seal area.
4. Coat the seal on the new filter element with clean oil. Install the new element by threading it onto the filter base until the seal contacts the base, turn the filter by hand an additional 1/4 to 1/2 turn. Check the oil level in the system as outlined under CHECKING THE OIL LEVEL.

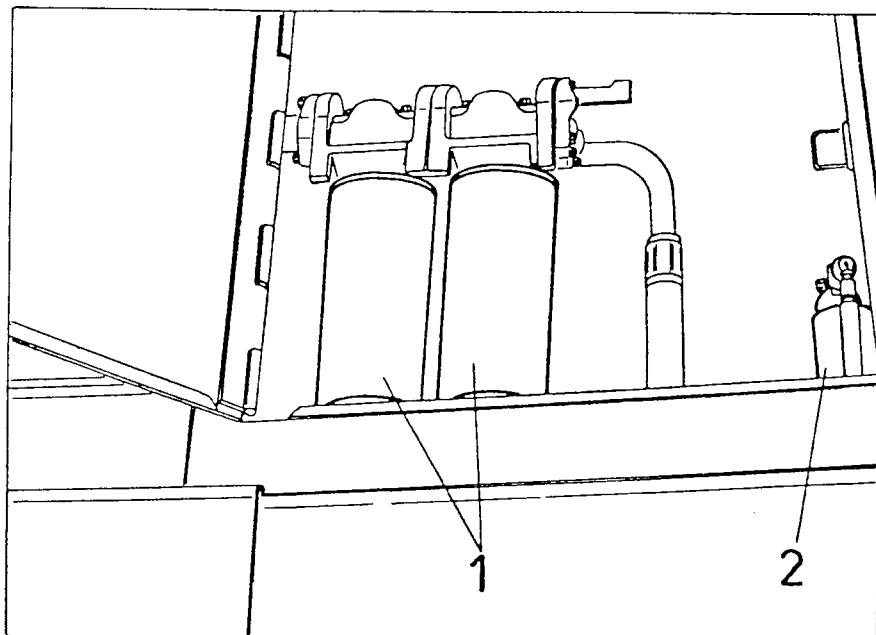

Fig. 5.29. Return Filters

1. Hydraulic System Filters
2. Equipment Hydraulic Control System Filter

5.13. HYDRAULIC SYSTEM

5.13.4. SERVICING THE SUCTION STRAINER

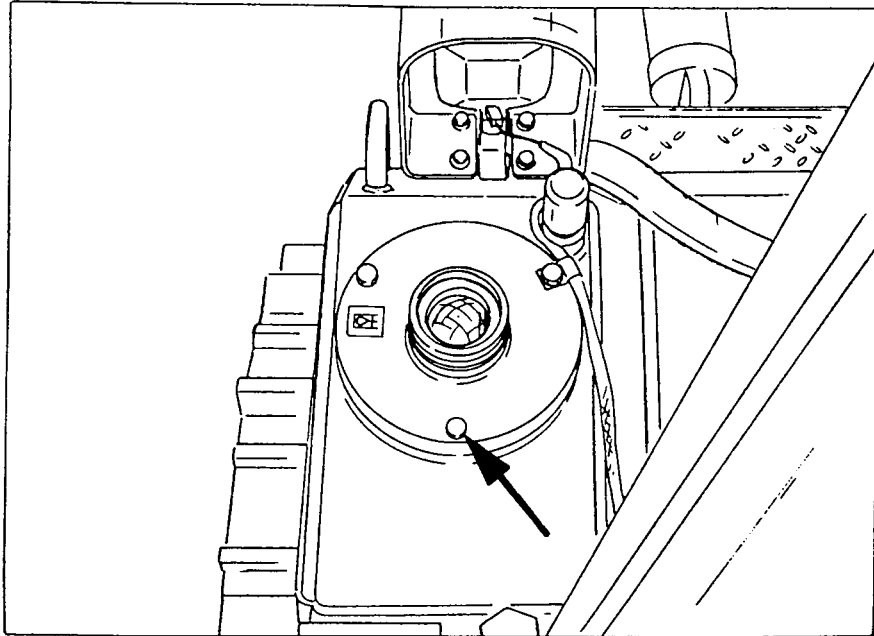

Fig.30. Hydraulic Oil Suction Strainer (Inside Hydraulic Reservoir) and Filler Strainer

1. Park the machine on level ground, lower the blade to the ground and stop the engine. Turn the electrical master switch to OFF. With the engine stopped, operate the equipment lever several times to relieve any pressure. Drain the hydraulic system. Refer to CHANGING HYDRAULIC OIL.
2. Remove 3 bolts and remove cover of hydraulic reservoir. Remove the strainer from the reservoir and discard the O-ring and replace with new.
3. Clean the suction strainer in a nonflammable commercial solvent and dry thoroughly. Thoroughly clean the interior of the reservoir being sure all particles are removed from the corners.



WARNING! Fire hazard – do not use kerosene, diesel fuel or flammable liquids to clean parts. A spark or a flame could cause a fire or an explosion. Use a nonflammable commercial solvent.

4. Install the strainer with new O-ring and connect elbow. Fill the system, refer to CHANGING HYDRAULIC OIL.

MAINTENANCE

5.13. HYDRAULIC SYSTEM

5.13.5. SERVICING THE RESERVOIR BREATHER

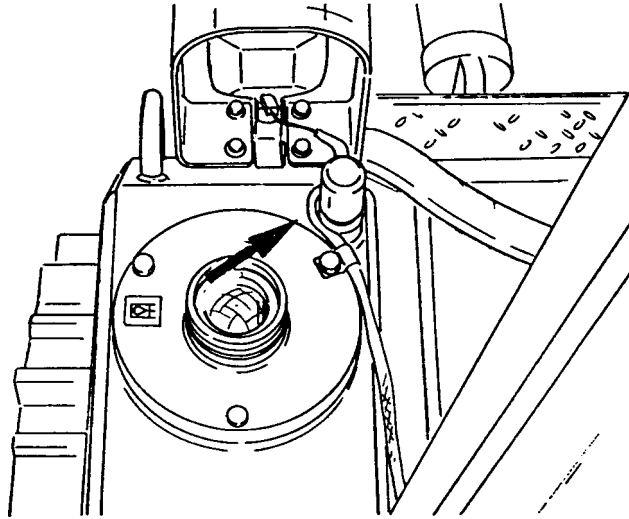

Fig. 5.31. Hydraulic Reservoir Breather Location

1. Park the machine on level ground, lower the blade to the ground and stop the engine. Turn the electrical master switch to OFF and remove the key. With the engine stopped, operate the equipment lever several times to relieve any pressure. Remove all outside dirt from breather.
2. Slowly loosen the filler plug on the reservoir in order to relieve any pressure in the reservoir.



WARNING! Pressurized Reservoir. Always loosen the filler plug slowly in case there is still some pressure in the system.

3. Remove the breather (Fig. 5.31) from the reservoir. Remove the lock ring (1), cover (2), element (3) and clean in a nonflammable commercial solvent. Dry thoroughly. Check O-ring (4) for wear or deterioration. Replace if necessary. Reinstall filter (3) and cover (2). Secure with lock ring (1). Reinstall the filler cap.

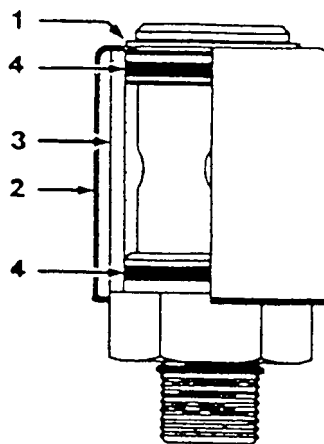

Fig. 5.32. Hydraulic Reservoir Breather

1. Lock Ring
2. Element Cover
3. Breather Element
4. O-Ring

5.13. HYDRAULIC SYSTEM

5.13.6. VENTING THE HYDRAULIC SYSTEM

The hydraulic system has to be vented of air if:

The system has been drained and filled hydraulic lines have been disconnected or tightened after noting hydraulic leaks the hydraulic system has been operated with excessively low oil level.

1. Start the engine and run it at low idle speed. Operate all the controls through all positions four or five times so the cylinders are filled with oil and air expelled.
2. Check the oil level as described under CHECKING OIL LEVEL. Repeat this procedure until the fluid level remains at the specified level in the reservoir.

5.14. LUBRICATION FITTINGS

General

The following lubrication fittings are to be greased at the intervals indicated on the MACHINE SERVICE GUIDE.

- brake and throttle linkage (8 fittings)
- hand steering levers (2 fittings)

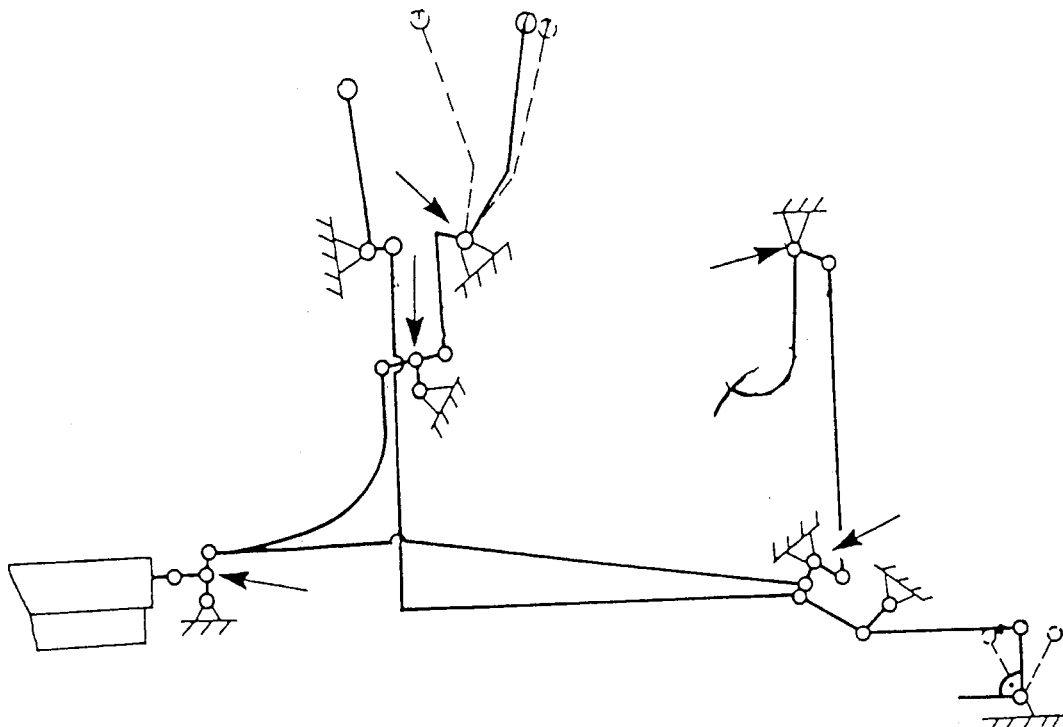

Fig. 5.33. Hand and Foot Control Linkage Lubrication Fittings

Mounted equipment fittings:

- Lift cylinder trunnion (4 fittings)
- Blade w/tilt (6 fittings)
- Blade w/o tilt (7 fittings)

MAINTENANCE

5.14. LUBRICATION FITTINGS

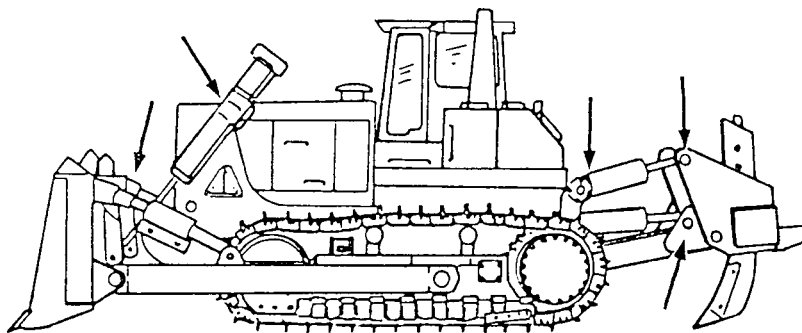

Fig. 5.34. Mounted Equipment Fittings

Apply grease until clean lubricant is visible. Always use a clean lubricator and wipe dirt from fittings before fresh grease is applied. If grease fails to go through the fitting, determine the cause and correct it.

Cross tube (lubrication with lube lines). Apply grease until clean lubricant is visible.

The ripper contains 12 lube fittings (ripper w/hydraulic pin puller contains 14 lube fittings).

5.15. MOUNTED EQUIPMENT

5.15.1. COMPLETE BALDE REMOVAL AND INSTALLATION

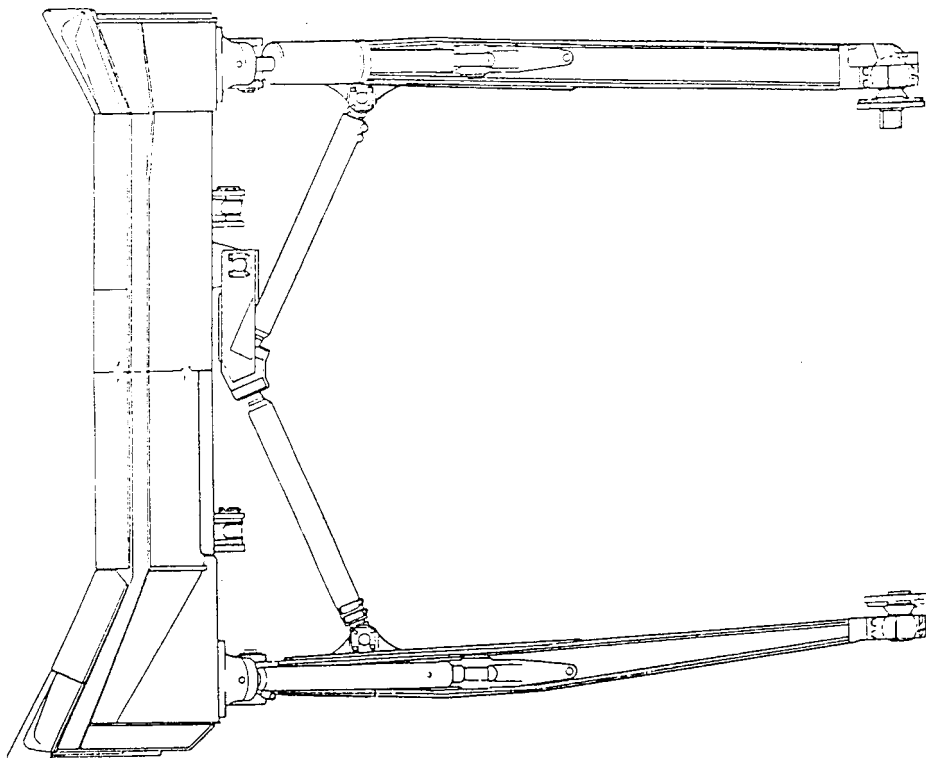

Fig. 5.35. Complete Semi-U/U-Blade

If for any reason the complete blade is to be removed from the tractor; proceed as follows:

1. Place the blade on level ground and block up the ends of the push arms close to the trunnions. This will maintain a proper height for reassembly.

5.15. MOUNTED EQUIPMENT

2. For machines with hydraulic tilt:
Remove the bolts and remove cover (1). Remove hose clamp securing the hoses to the trunnion.

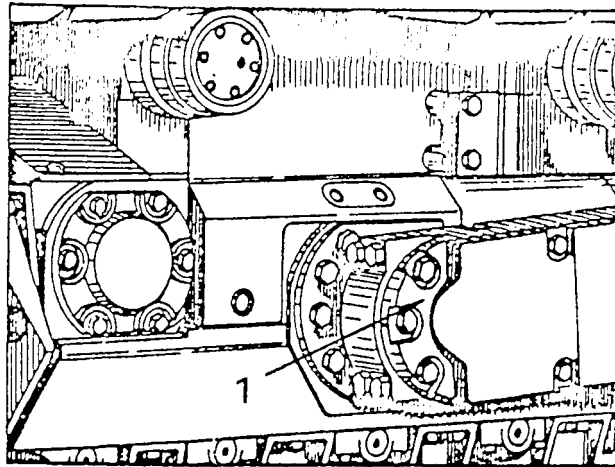

Fig. 5.36. Blade Tilt Hoses Connection Location

1. Cover

3. Remove the pins securing the lift cylinder piston rods to the blade lift brackets at the back of the blade. Retract the piston rods fully into the cylinders. Secure the rods to the tractor using shipping hanger bars to prevent damage to the piston rods.
4. Remove 4 trunnion bearing cap bolts and remove caps and shims of R.H. and L.H. side trunnion from push arms.
5. Back the tractor straight out and away from the push arms.
6. Reassemble shims and bearing caps to the push arms and secure with bearing cap bolts to prevent their damage or being lost. If the blade is to be stored outdoors, grease to prevent corrosion.

To reassemble the blade perform the above in reverse order.

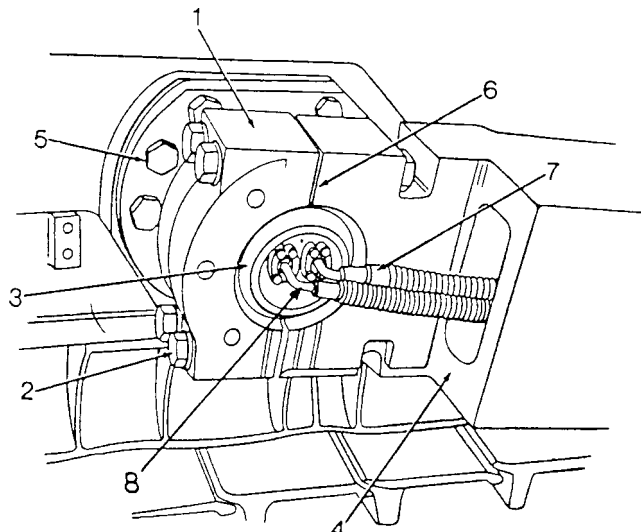

Fig. 5.37. Push Arm Mounting

- | | | |
|-------------------------|----------------------------|------------------------------------|
| 1. Trunnion Bearing Cap | 4. Push Arm | 7. Tilt Cylinder Hose (rod end) |
| 2. Cap Bolts | 5. Trunnion Mounting Bolts | 8. Tilt Cylinder Hose (piston end) |
| 3. Trunnion Ball | 6. Shims | |

5.15. MOUNTED EQUIPMENT

- 7. Check if the blade is positioned symmetrically to machine axis. Operating with blade non-symmetrical to machine axis results in damage to the blade.

5.15.1.1. Leveling the Blade

- 1. Place the lowest corner of the blade on a flat surface.
- 2. Hold the control lever in position on the side to which the blade is to be lowered until the blade is even along the flat surface.

5.15.1.2. Lower Diagonal Strut Adjustment

The diagonal strut stress reliever lever adjustment must be checked occasionally to ensure it is remaining parallel with the back of the blade.

Adjust as follows:

With the blade on the ground, remove the pin at the push arm bracket connection.

Move the stress reliever lever (3) away from the blade until it is parallel with the back of the blade.

Block between the lever (3) and the back of the blade to maintain this parallelism during lower strut adjustment. Remove the four (4) cap screws securing the lower strut cap (5) to the stress reliever lever. Attach a suitable lifting device with sling to the lower strut to support the strut during shimming adjustment.

Slide the strut (1) with cap (5) back to disengage the strut ball from the lever socket. Remove all shims (2), which were present and reassembly, the strut into the lever socket. Install the four cap screws (4) and torque to 400 Nm.

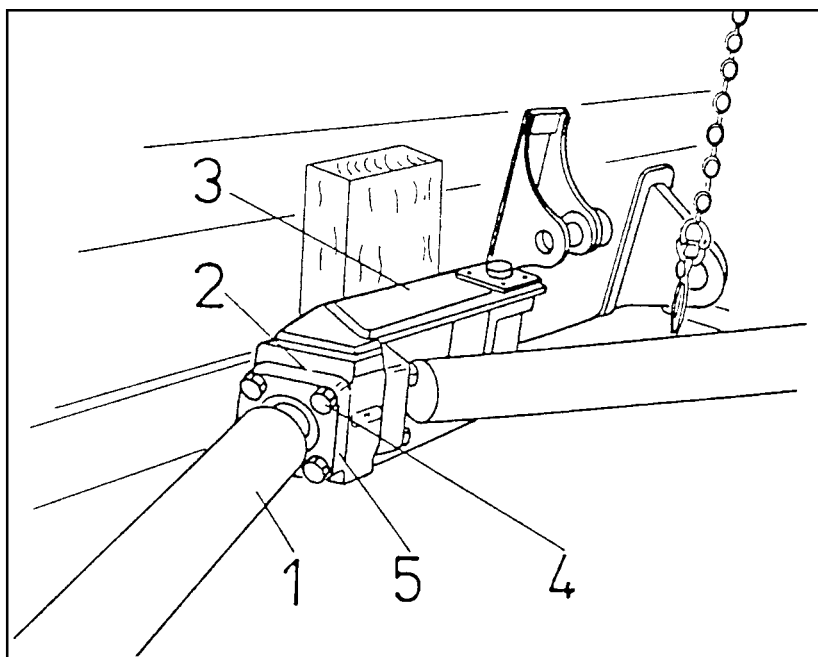

Fig. 5.38. Blocking the Stress Reliever Lever Parallel to the Blade

- 1. Diagonal Strut
- 2. Shims
- 3. Stress Reliever Lever
- 4. Cap Screws
- 5. Strut Cap

5.15. MOUNTED EQUIPMENT

Using the removal shims (Fig. 38) determine the maximum amount of shims which will fit the gap between the cap (5) and lever (3) gap. Check if the gap is equal on all sides between the cap (5) and lever (3).

When the correct shim pack for the gap between the strut cap (5) and lever (3) is determined add one shim to provide clearance. Each shim is 0.75 mm.

Prior to final assembly clean all shims (2) and mating surfaces of all foreign material, dirt and paint.

Clean the threaded holes in the lever (3) and cap screw (4) threads and coat with LOCTITE "T" primer.

Insert the shims (2) over the strut ball and install the strut with shims to the lever (3)

Apply LOCTITE 262-thread locker to the cap screws (4) and torque to 1500 Nm.

Hoist the strut (1) into position in the strut bracket on the push arm. While maintaining the stress relieve parallelism to the back of the blade check the misalignment between the bracket bore and strut eye bore.

To lengthen or shorten the strut for pin bore alignment, loosen the clamp bolts securing the strut eye.

Adjust the bore in the strut eye to align with the bore in the push arm bracket.

Insert the strut pin and lock. Repeat this procedure for the opposite side while continuing to maintain stress reliever lever (3) parallelism with the back off the blade.

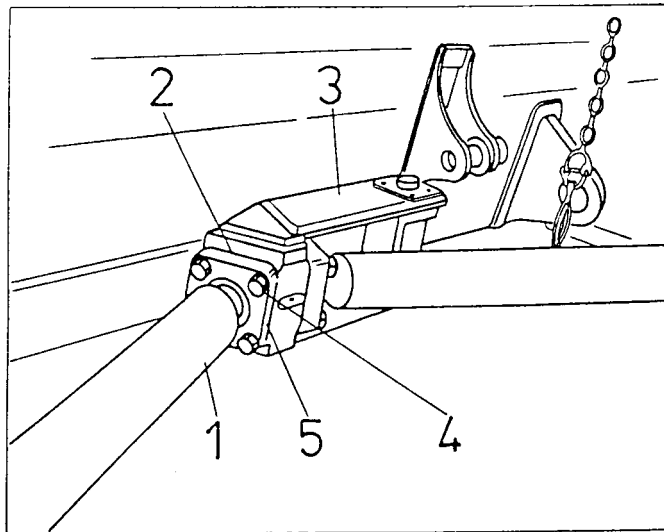

Fig. 5.39. Diagonal Strut Adjustment

- 1. Diagonal Strut
- 2. Shims
- 3. Stress Reliever Lever
- 4. Cap Screws
- 5. Strut Cap

5.15. MOUNTED EQUIPMENT

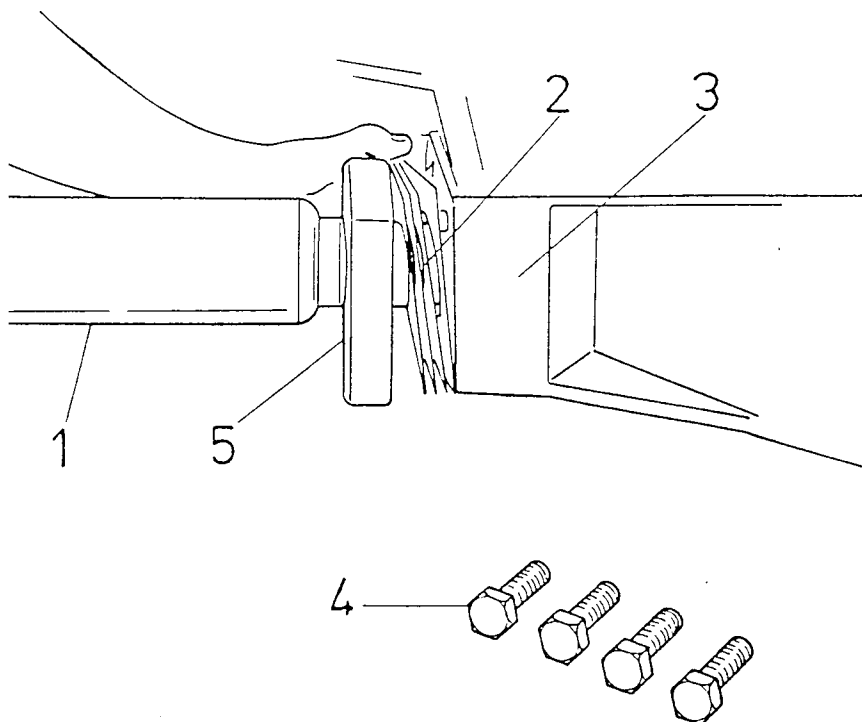

Fig. 5.40. Diagonal Shimming

1. Diagonal Strut
2. Shims
3. Stress Reliever Lever
4. Cap Screws
5. Strut Cap

5.15.1.3. Upper Strut and Tilt Cylinder Adjustment

The upper strut and tilt cylinder sockets must be checked occasionally to ensure excessive movement does not occur between the cap and blade socket. When movement exceeding 1.3 mm is detected readjustment is necessary.

Adjust as follows:

- Attach a suitable hoist and sling to the upper stud or tilt cylinder (1). Remove cap screws (2) securing cap (5) to blade socket (4).

Retract upper strut or tilt cylinder (1) while supporting the assembly with the hoist and sling.

Remove shims (3). Re-extend strut or tilt cylinder (1) until the ball on the strut or tilt cylinder bottoms in the blade socket (4).

Reinstall cap (5) with four cap screws (2). Torque cap screws (2) to 270 Nm evenly to ensure the cap is not cocked on the strut ball.

Using the removed shims (Fig. 5.41) determine the maximum amount of shims which will fill the gap between the cap (5) and socket (4). When the correct shim pack for the gap between the strut cap (5) and socket (4) is determined add one shim to provide clearance. Each shim is 0.75 mm.

Prior to final assembly clean all shims (3), mating surfaces of strut caps (5) and socket (4) mating surfaces of all foreign material, dirt and paint. Insert the shims over the strut or tilt cylinder ball and extend until the ball bottoms in the blade socket. Install all cap screws (2) and torque to 850 Nm. Readjust blade strut to desired blade angle.

5.15. MOUNTED EQUIPMENT

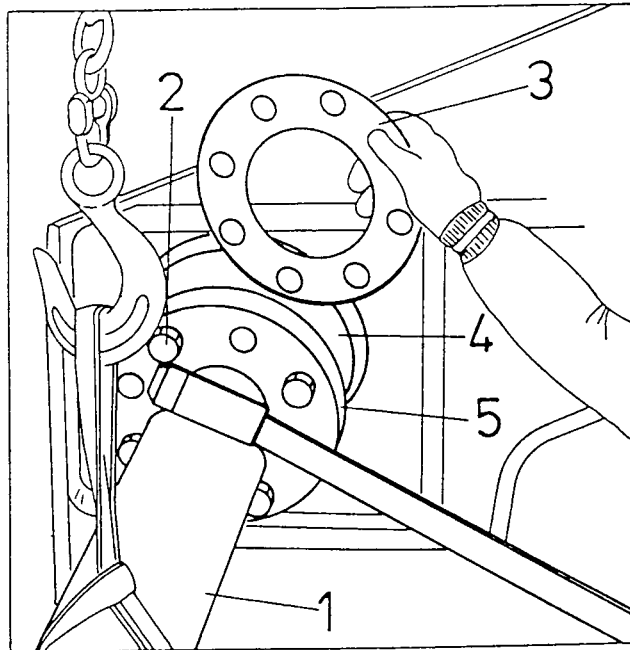

Fig. 5.41. Adjusting the Upper Strut and Tilt Cylinder

1. Upper Strut
2. Cap Screws
3. Shims
4. Blade Socket
5. Strut Cap

5.15.1.4. Adjusting Blade Pitch Cylinder

If blade pitch cylinder is installed instead of upper strut follow to adjust movement between cap and blade socket follow the procedure given for Upper strut and tilt cylinder adjustment.

5.15.2. TRUNNION, COVER, BLADE CUTTING EDGE AND END BITS MOUNTING BOLTS.

Check torque of trunnion mounting bolts, bearing cap screws and cutting edge and end bits bolts after initial 10 hours of operation, and then periodically. Refer to "SPECIAL TORQUES".

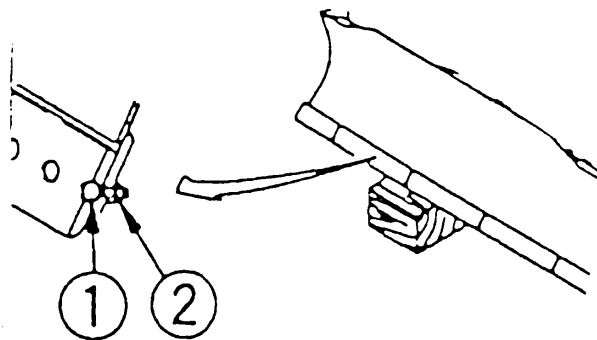

Fig. 5.42. Tightening Blade Cutting Edge and End Bits Bolts

1. Bolt
2. Nut

5.15. MOUNTED EQUIPMENT



WARNING! Never work beneath the blade without securing it by wooden blocks

5.15.3. ALLOWABLE WEAR OF CUTTING EDGE AND END BITS AND RIPPER POINTS

Reverse or replace the cutting edge and end bits before the mounting plate is worn or damaged. To replace the cutting edge and end bits:

1. Raise the blade about 300 mm above the ground and set the pilot valve lever in "HOLD" position. Prop up the push arms and stop the engine.



WARNING! Never work beneath the blade without securing it by wooden blocks

2. Remove the cutting edge and end bits mounting bolts.
3. Install the cutting edge or the end bits and tighten the bolts to the torque specified in "SPECIAL TORQUES" in Section 6.
4. Authorized Distributor of Construction Equipment can supply these specially heat-treated bolts.

NOTE: Do not substitute bolts. Loosening of bolts mounting cutting edge and end bits may result in tear off cutting edge or end bits and blade damage as well as injury.

5.15.3.1. Servicing the Ripper

Prior to each day's work carry out ripper inspection and remedy if any malfunction is found. Operating defective ripper results in reduced job efficiency and may cause its damage. The following table specifies services to be carried out during inspection:

POINT OF SERVICE	SERVICE DESCRIPTION
Ripper Assy	Visually check for cracks, breakage, loose parts and completeness
Hydraulic hoses and connections	Check for leaks and remedy, if any.
Hydraulic reservoir	Check hydraulic reservoir oil level. Refer to Hydraulic System
Ripper pins	Check if pins are secured correctly and tighten loosened bolts if necessary.
Ripper shank point	Check for wear. Replace, if 1/3 of point is worn. Excessively worn shank point makes ripping difficult.

Replace ripper shank point as follows:

1. Raise ripper tooth about 300 mm above ground and prop up to prevent ripper tooth from lowering during service.
2. Stop the engine.
3. Remove point mounting pin.
4. Install new point and mounting pin.

5.15. MOUNTED EQUIPMENT

5.15.3.2. Lubrication

Apply lubricant to ripper lube fittings. Service interval of 50 hours refers to average operating conditions. Under unusually severe operating conditions reduce the interval of time between services. Always use clean lubricators and containers. Apply sufficient lubricant to force out old lubricant and dirt.

5.16. SAFETY BELT



WARNING! Seat belt – do not clean with solvents or bleach or redye color of webbing as this may cause a severe loss of strength. This could cause the webbing to break and result in personal injury. Wash in warm water with a mild detergent.

Keep belt flat to avoid twisting and roping when not being used. Do not place heavy or sharp objects on belt.

The entire seat belt assembly should be inspected periodically for corrosion, wear, fraying or wear spots. The seat belt mounting bolts should also be periodically inspected for tightness.

5.17. FINAL DRIVES

5.17.1. CHECKING THE OIL LEVEL

Position the machine on level ground so the “OIL LEVEL” mark on the final drive housing is positioned horizontally. Remove the magnetic filler and level plug, check the lubricant and, if the lubricant is low, fill to the level of the plug opening. Also, check the plug for metallic particles that may be present. If this condition continues after periodic checks, consult Authorized Distributor of Construction Equipment. Reinstall the plug and tighten.

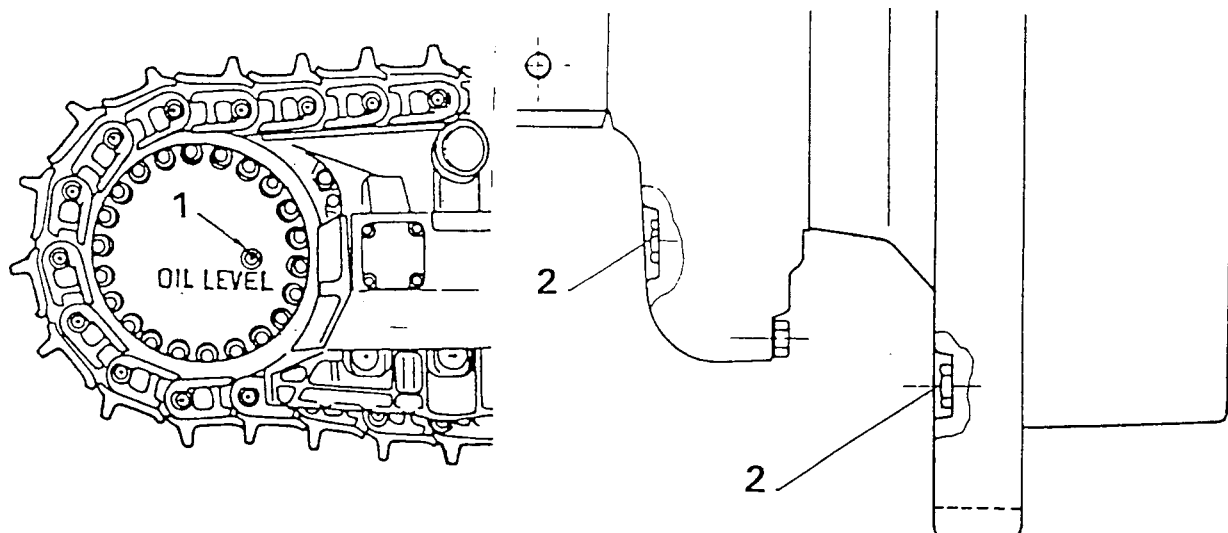

Fig. 5.43. Checking the Lubricant Level

- 1. Filler and Level Plug
- 2. Drain Plug

5.17. FINAL DRIVES

5.17.2. CHANGING THE OIL

1. While the oil is at operating or warm ambient temperature, park the machine on level ground so the "OIL LEVEL" mark on the final drive housing is positioned horizontally. Remove the drain plugs (2) and levels plugs (1) and allow the lubricant to drain into a suitable container. Remove metal particles from the magnetic plugs. Install and tighten the drain plugs. Fill app.8 liters of fuel oil up to the housing and install the plugs.
2. Operate the machine in low gear (with no load) for a few minutes. Remove the drain plugs and thoroughly drain the fuel oil into a suitable container. Reinstall and tighten the drain plugs. Remove the filler and level plugs. Fill the housing with fresh oil up to the bottom of the filler and level plug opening. Refer to the REFILL SPECIFICATIONS AND CAPACITIES chart for grade of lubricant specified. Reinstall and tighten the filler and level plugs.

5.18. TRANSMISSION SYSTEM

General

The rear frame is the common oil reservoir for the transmission, torque converter and hydraulic steering drive. The system has a pressure filters and a suction strainer which require service.

5.18.1. CHECKING THE OIL LEVEL

1. With the engine shutdown open L.H. side access door, unscrew the T handle of the oil level gauge, remove the gauge and wipe it clean.

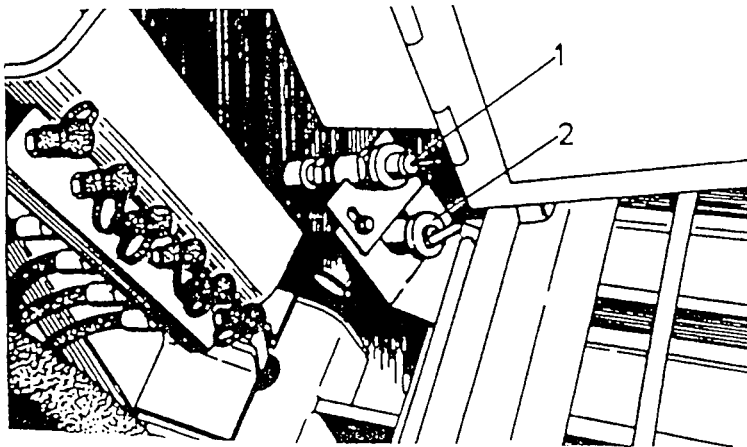

Fig. 5.44. Rear Frame Oil Level

1. Rear Frame Drain and Fill Receiver (if equipped) and Breather
2. Oil Level Gauge

2. Insert the gauge fully into the filler sleeve. Do not tighten. Remove the gauge and check the lubricant level. If necessary, add oil through the filler to bring the level. Reinstall and secure the gauge. The gauge has two marks: LO for low oil level and HI for high oil level for HOT oil on one side and two marks: LO for low oil level and HI for high oil level for COLD oil on the other. Check oil level with engine stopped.

NOTE: *Never operate the machine if the level of the oil is at or below the LOW mark on the oil level gauge.*

5.18. TRANSMISSION SYSTEM

5.18.2. CHANGING TRANSMISSION SYSTEM OIL

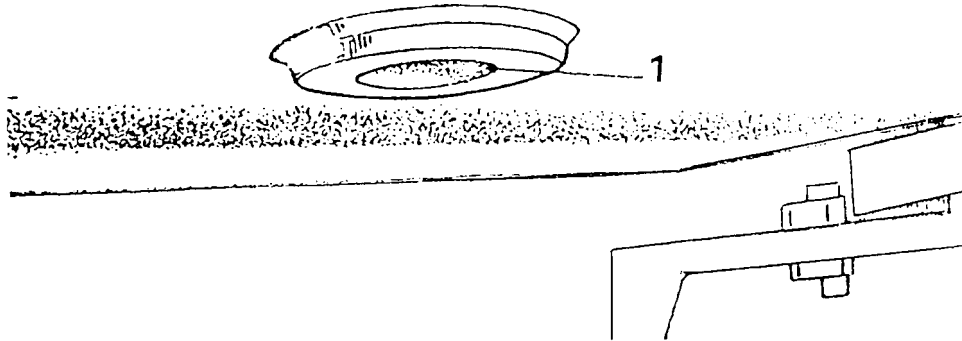

Fig. 5.45. Rear Frame drain Plug

1. Drain Plug

The transmission system lubricant must be changed at least once a year, even if the 1000 hours operational period has not elapsed.

1. To drain oil, remove the drain plug in the rear frame. For environmental safe draining the transmission system oil remove protective cover of receiver (Fig. 5.44) and connect nozzle of oil draining pump.
2. Remove oil level gauge with cover. Pump out used oil and pour lubricant into the rear frame through the receiver to bring the level up to the FULL mark on the gauge.
3. Reinstall protective cover on the receiver.

5.18.3. SERVICING THE PRESSURE FILTERS

NOTE: *If the pressure filter warning light on the instrument panel remains on at operating oil temperature with engine running, the restricted pressure filter must be changed.*

1. With the engine stopped, operate the steering levers several times to relieve any pressure. Open the L.H. side access door. Remove all outside dirt from filter and using a filter wrench remove spin-on filters, first "M" main pressure circuit filter and then Torque Converter circuit filter. Wipe the filter base, removing all of the old oil from the seal area.

MAINTENANCE

5.18. TRANSMISSION SYSTEM

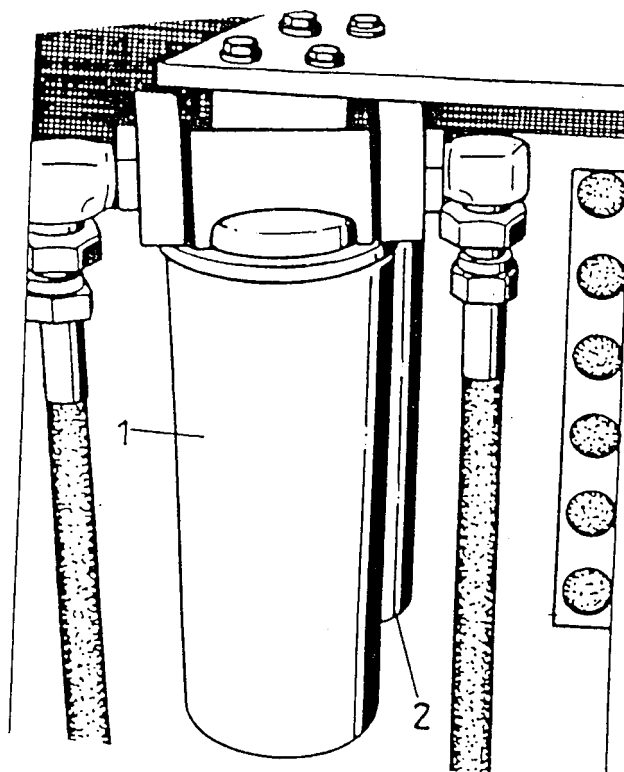

Fig. 5.46. Transmission Pressure Filters

1. "M" Main Pressure Filter
2. Torque Converter Pressure Filter

2. Coat the seals on the new filters with clean oil. Install the filter by threading it onto the filter base until the seal contacts the base, turn the filter by hand an additional 1/4 to 1/2 turn. Start the engine and let it idle for approximately 5 minutes. During this time operate the steering levers several times, check filters for leaks and remove leaks if any.
3. Check oil level in the transmission system.

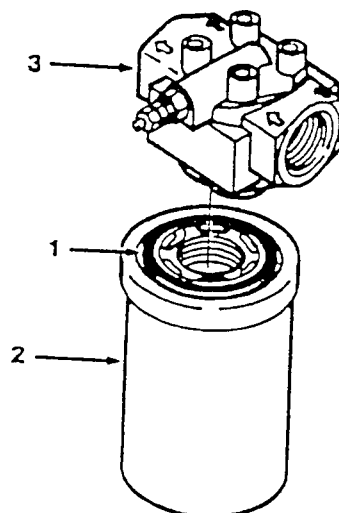

Fig. 5.47. Transmission Pressure Filter

1. Filter Seal
2. Filter Element
3. Filter Base

5.18. TRANSMISSION SYSTEM

5.18.4. SERVICING THE SUCTION STRAINER

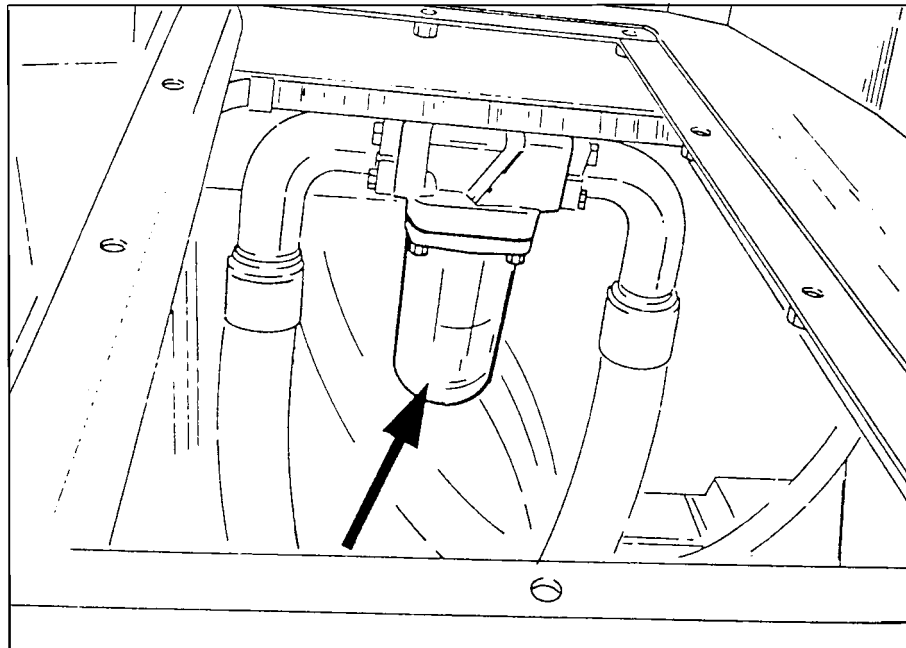

Fig. 5.48. Suction Strainer

1. Remove the operators compartment floor board to gain access to suction strainer located on R.H. side under the board.
2. Remove four bolts and separate the housing from the base. Remove the element with magnets and O-ring.
3. Wash the element and housing in a commercial solvent and dry thoroughly. Replace O-ring. Remove all dirt from the inside of the base using a cloth dampened with solvent.
4. Check that the new O-ring is in place in the groove in the element. Slip the non O-ring end of the element into the housing. Secure the housing to the base with the hardware previously removed.
5. Start the engine and let it idle for approximately five minutes. During this time, check the strainer for leaks. Correct all leaks no matter how minor. Then check the level in the transmission system as outlined under "CHECKING THE OIL LEVEL". Reinstall the operators compartment floor board.

5.18.5. SERVICING THE BREATHER

NOTE: To prevent dirt from entering the critical areas of the transmission system, keep the breather clean. Replace the breather as indicated when changing oil in the rear frame.

The breather is located on the transmission system filler tube. Unscrew the breather from the reducer nipple. Install the new breather on the nipple.

5.18. TRANSMISSION SYSTEM

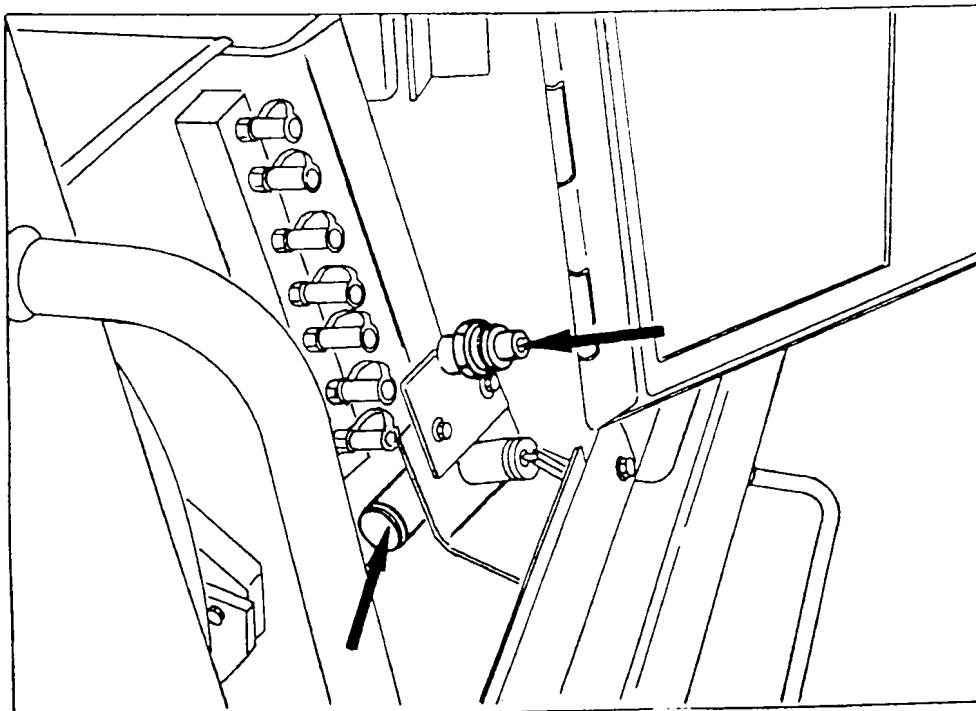

Fig. 5.49. Transmission System Breather and Oil Drain Receiver Location

5.18.6. SERVICING TRANSMISSION SCAVENGER STRAINER

NOTE: With the transmission system drained after 1000 hours of operation, remove the scavenger oil strainer and clean as described below.

1. To gain access to the oil strainer first removes the transmission guard.
2. Disconnect the transmission scavenger hose from the transmission.

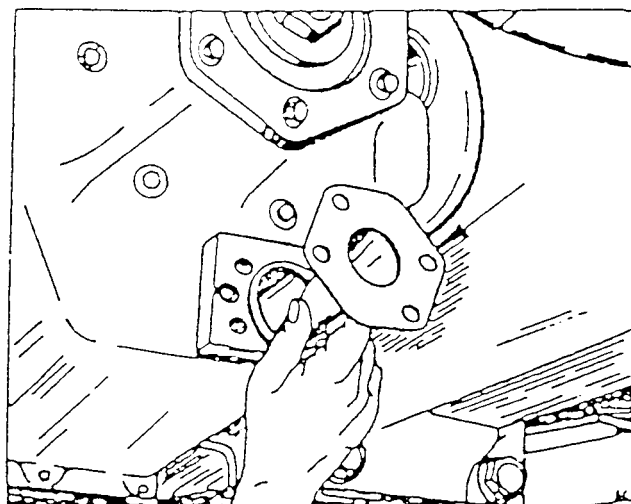

Fig. 5.50. Transmission Scavenger Oil Strainer

3. Remove the strainer from the transmission housing.
4. Clean the strainer with a nonflammable commercial cleaning solvent.
5. Install the strainer into the transmission.

5.18. TRANSMISSION SYSTEM

6. Reinstall the transmission scavenger hose.
7. Reinstall the transmission guard.

5.19. UNDERCARRIAGE

Periodically make observation checks on your undercarriage components. Check tracks, track rollers, track idlers, front idlers etc. for abnormal wear. Make adjustments to these problems before damages to these components occur. Once the wear on these components drops below zero percentage the option to recondition will also be lost. Refer to TD-40C Service Manual for dimensions indicating percentage of allowable wear. If this Service Manual is not available contact Authorized Distributor of Construction Equipment.

Clean mud and debris should from the undercarriage so components can perform properly. Every 1000 hours of operation check torque of sprocket mounting bolts and tighten if necessary.



WARNING! Special knowledge and equipment are required to service lubricated track systems and their components. Unless you are completely familiar with servicing lubricated track systems do not make any attempt to remove them. Disconnecting the master link could cause the chain to whip off the front idler causing serious personal injury.

Improper track tension and loose track shoes will cause damage and premature wear to the track. When new tracks or track shoes are installed, track tension and track shoe bolts should be checked after initial 10 hours of operation and adjusted if necessary.

5.19.1. TRACK SHOE BOLTS

The bolts used for attaching the track shoes to the tracks are heat-treated alloy bolts and will stand a considerable tightening strain. Ordinary bolts must not be used. Nuts must be assembled so that washer face is not against track link. Radius side of nuts must be against track link.

Coat bolt threads and area under the head with engine oil. Torque value is 2400 Nm.

5.19.1. EFFECT OF TRACK ADJUSTMENT ON UNDERCARRIAGE WEAR

Tracks adjusted too tightly increase operating loads on final drives and accelerate wear on undercarriage components, especially in packing conditions.

A machine in forward operation with correctly adjusted tracks will experience track loads only along the ground from the front idler to where the bushings engage the sprocket.

Lubricated track systems are to be adjusted to provide a sag in the track chain between to front top idler and the front idler. Correct tension reduces stress levels throughout the undercarriage system.

5.19. UNDERCARRIAGE

5.19.3. CHECKING THE TENSION

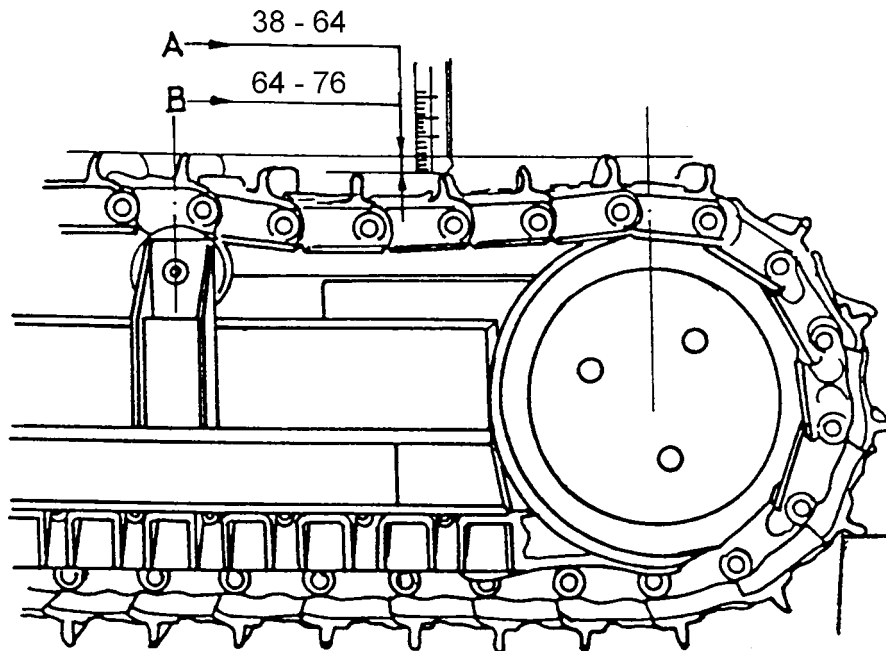

Fig. 5.51. Checking Track Tension

A - Track Sag for Normal Operations
 B - Track Sag for Mud and Snow Packing

1. Place a wooden block, ~300 mm in height, under the front most track shoe lug. Drive the machine forward until the track chain is tight along the ground and around the sprocket. Apply and lock the brake pedal, lock the transmission shift lever in the NEUTRAL position and stop the engine.
2. Stand on the track between the front idler and the first track idler in order to accumulate all the chain slack at this point.
3. Place a straightedge on the track so the ends rest over the front idler and track idler. Measure the clearance between the bottom of the straightedge and the top of the shoe grouser with a ruler at the midway point between the idlers. If the distance is more than 64 mm or less than 38 mm, adjust the track tension.
4. For mud and snow packing conditions track should be adjusted so sag is 64 – 76 mm.

5.19.4. ADJUSTING TENSION

The track chains are adjusted by hydraulic pressure. When lubricant is introduced into the front idler fork through the lubrication fitting, it acts upon the piston within the front idler fork forcing the front idler fork and front idler forward for track adjustment.



WARNING! To avoid possible injury, always stand to the side of the bleeder plug when making track adjustment. The pressure in the front idler fork is held by the bleeder plug and check valve. A loose or improper thread fit of either of these parts can allow them to be ejected by the pressure of the lubricant, causing possible injury. When increasing track tension, be sure the bleeder plug and check valve are properly torqued. When relieving track tension, never loosen the bleeder plug and check valve more than 2 – 2 1/2 turns.

5.19. UNDERCARRIAGE

1. Remove the bolts and track adjuster cover.



WARNING! Before adding lubricant for track adjustment, be sure the ball check and relief valves are properly torqued to 61 – 75 Nm.

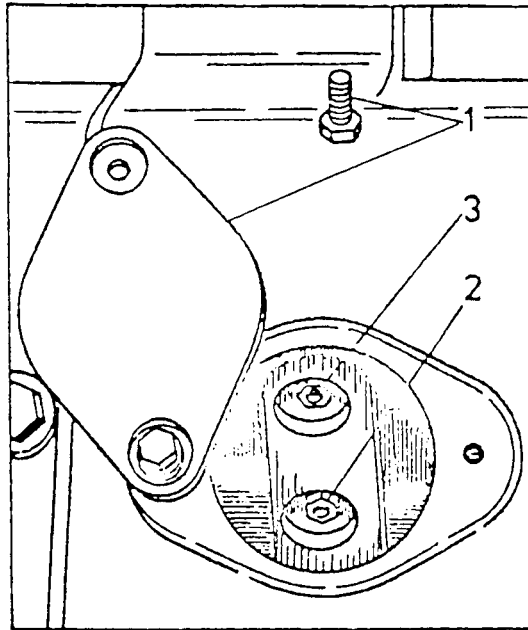

Fig. 5.52. Track Adjuster

1. Track Adjuster Cover
2. Relief Valve
3. Lubrication Fitting (Ball Check Valve)

2. To increase track tension, connect a lubricator nozzle to the lubrication fitting (3). Determine the amount of adjustment necessary, and add lubricant to obtain the proper track chain tension. It is advisable to move the machine forward and backward slightly to be sure the correct tension has been obtained.
3. To reduce track tension, loosen the relief valve (2) 1/2 to 1 full turn to allow the pressurized lubricant to escape through the relief passage. If lubricant does not appear, loosen the check valve (located under the lubrication fitting) 1/2 to one full turn to allow the pressurized lubricant to escape from a second relief passage.
4. If lubricant still does not appear, use the following emergency method. Should the relief passages still be blocked, unscrew the ball check and/or relief valve an additional 1 1/2 to 2 turns (2 1/2 total turns).



WARNING! Use extreme care when relieving pressure with the following emergency method. If loosened excessively, the cylinder pressure can eject the ball check or relief valve. NEVER loosen these parts more than a total of 2 1/2 turns.

5. When the proper tension has been obtained, tighten the ball check and/or relief valve to 61 – 75 Nm. Install the cover and secure with removed hardware.

NOTE: Never remove one link to bring a stretched track to within the range of proper track adjustment. A track that is worn badly enough to take up the length of one link, will be so far out of pitch that the increased wear on the sprocket will far more than offset the saving obtained by the removal of one link in the track chain.

MAINTENANCE

5.19. UNDERCARRIAGE

5.19.5. TRACK FRAME GUIDE

To avoid excessive wear of undercarriage components and track frame suspension points, the track frame guide must be checked periodically.

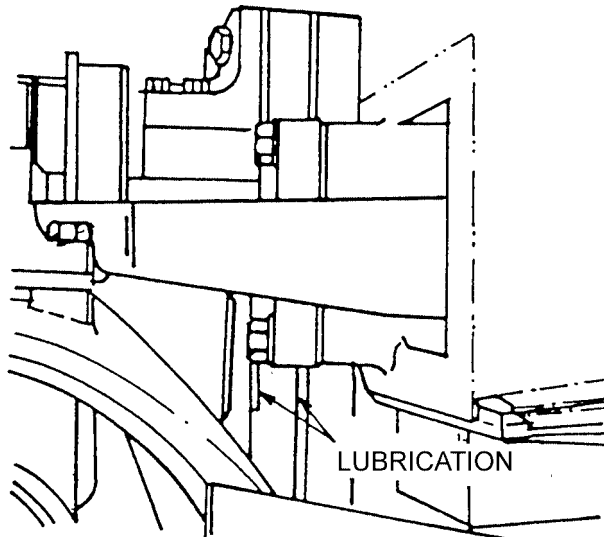

Fig. 5.53. Track Frame Guide Lubrication

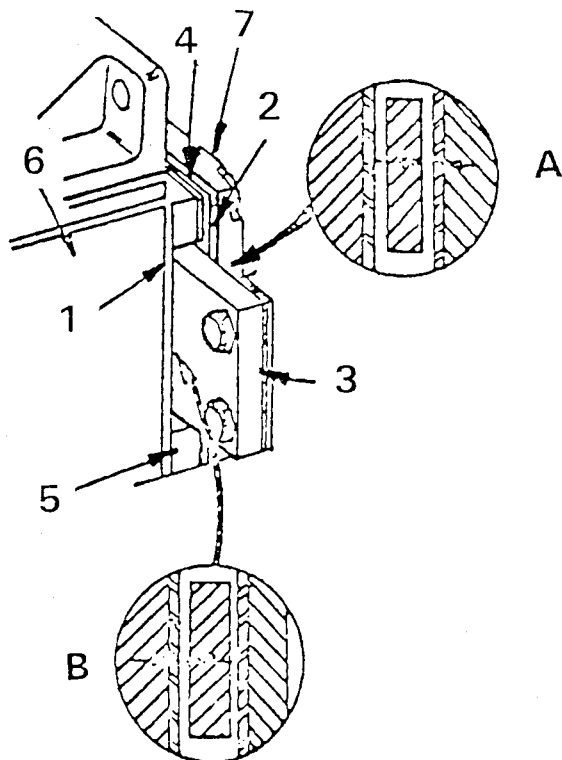

Fig. 5.54. Track Frame Guide

- | | | |
|---------------------|--------------------|----------------------------|
| 1. Outer Wear Plate | 4. Shims | 6. Track Frame |
| 2. Inner Wear Plate | 5. Guide Bar Block | 7. Track Frame Guide Plate |
| 3. Guide Plate | | |

5.19. UNDERCARRIAGE

Measure clearances "A" and "B". If the total is 6.5 mm or more, adjust by removing shims (4) from between the spacer blocks (5) and inner wear plate (2). Remove enough shims to reduce the total clearance (A+B) to 0.8 mm. Keep the removed shims for future use.

If removal of all the shims (4) will not provide a total clearance of less than 6.5 mm, replace the wear plates (1 and 2) worn guide plate (3), as required. Reinstall the shims and repeat the check. Lubricate track frame guides.

5.19.6. PIVOT SHAFT

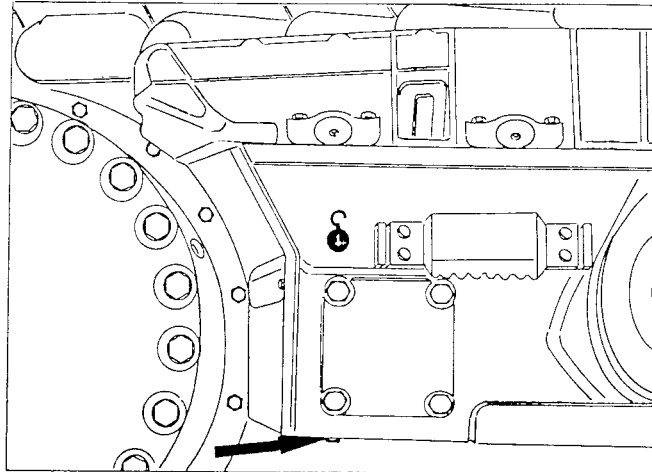

Fig. 5.55. Track Frame Oil Filler Plug

Remove the plug (one at each side), check oil level and if the lubricant is low, fill to the level of the plug opening. Reinstall and tighten the plug.

NOTE: Refer to the "REFILL SPECIFICATIONS AND CAPACITIES" chart for grade of lubricant specified.

5.19.7. EQUALIZER BAR

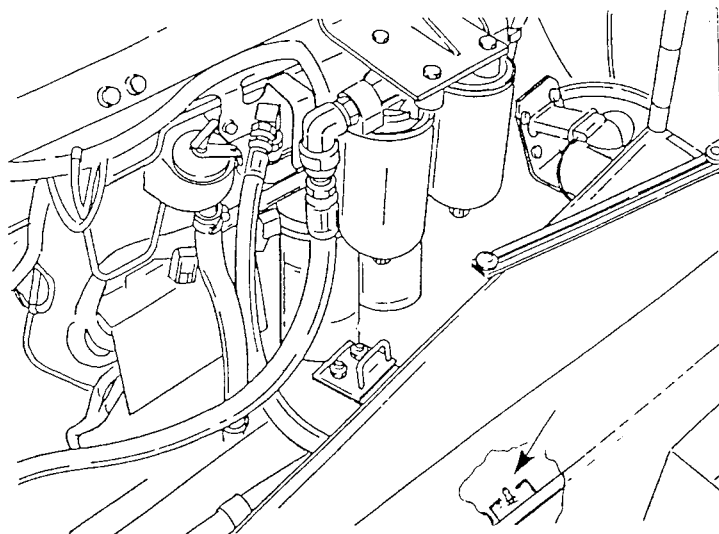

Fig. 5.56. Equalizer Bar Pivot Pin Lubrication Fitting

5.19. UNDERCARRIAGE

Lubricate equalizer bar pivot pin every 500 hours of operation or earlier if necessary. Lubrication line fitting is remotely located in upper part of front mainframe as shown in the drawing. Periodically check the condition of wear pads that support equalizer bar ends in track frame rebound brackets.

Replace pads if any cracks are found.

5.19.8. FRONT WHEEL

Check the thickness of front wheel guides. If they are weared (min. thickness is 27 mm) cut off them and weld new.

5.20. ADJUSTING HAND AND FOOT CONTROLS

Check engine high and deceleration RPM. If RPM values are incorrect proceed as follows:

Check adjustment of hand levers and foot pedals per below given drawing.

- a) Adjust lever "4" to vertical position of the lever for high idle speed (2305 RPM) During the adjustment the lever "1" must be placed in its foremost position.
- b) Adjust lever "2" to maintain the dimension 202 mm and 9 mm.
- c) Adjust foot pedal "3" to maintain the dimensions in mm (Refer to Fig. 5.57):

I - Engine high speed position (2305 RPM)

II - End of deceleration (1200 ± 100 RPM)

III - Beginning of braking

IV - Full brake

After adjustment made lubricate linkage and fill bearings with grease thru lubrication fittings (refer to "LUBRICATION FITTINGS") and check if the machine is stopped with applied Decelerator- Brake pedal (refer to 3.3. for brake operation principle). Perform brake test as follows:

- start the engine and bring transmission system to operating temperature
- shift to 2nd speed with engine at top speed and brake the machine for a while

With correct adjustment made the machine should stop. If in doubt contact Authorized Distributor of Construction Equipment. Periodically lubricate plate-to-plunger contact area of blade and ripper pilot valves.

5.20. ADJUSTING HAND AND FOOT CONTROLS

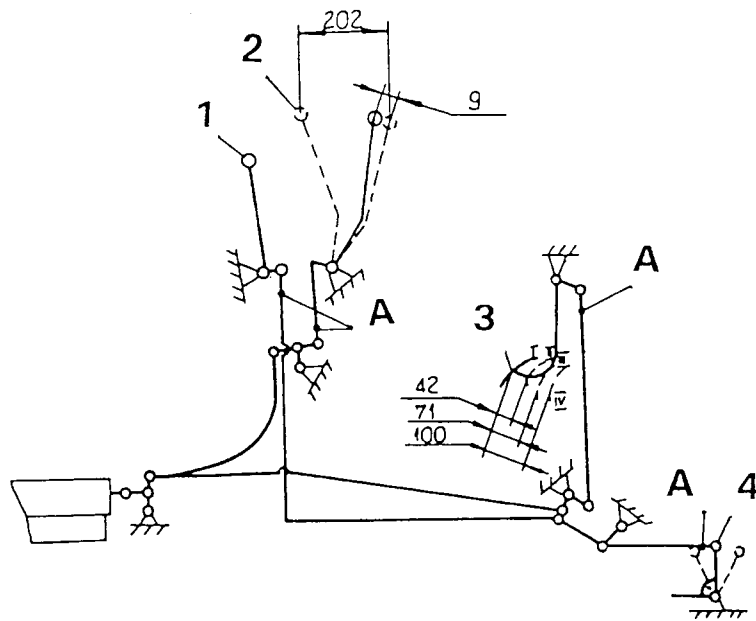

Fig. 5.57. Hand and Foot Controls

- | | |
|------------------------|--------------------------------|
| 1. Engine Speed Lever | 3. Decelerator and Brake Pedal |
| 2. Hand Steering Lever | A – Controls for Adjustment |
| | 4. Fuel Pump Lever |

5.21. CAB AND ROPS

The dozer can be equipped with ROPS protective structure with canopy or cab with separate ROPS protective structure.

Open three latches and remove the filter. Clean the filter with compressed air directing air in reverse direction to that of normal operation. Clean filter housing.

Reinstall the filter and secure cover with latches.

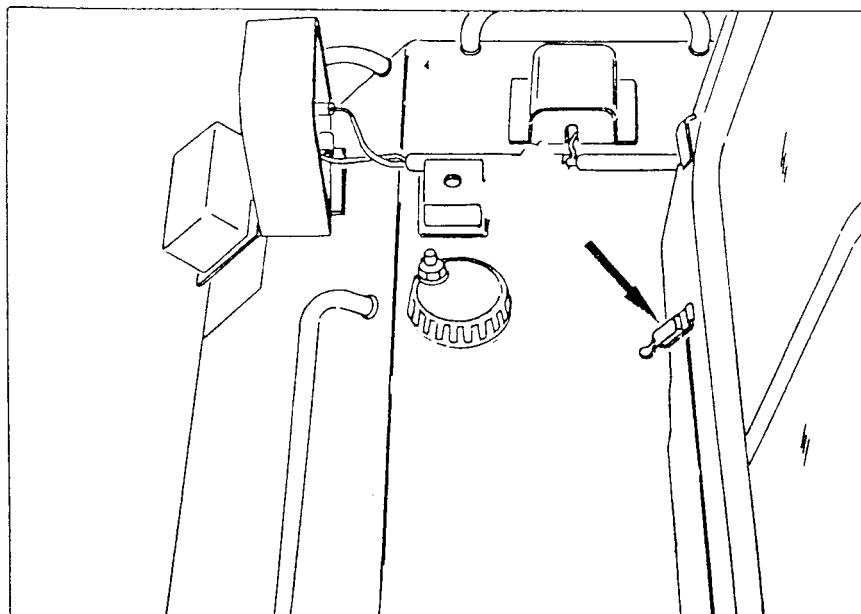

Fig. 5.58. Air Conditioner Filter Cover

MAINTENANCE

5.21. CAB AND ROPS

Periodically check torque of ROPS and operator's platform mounting bolts, clean air conditioner filters and check instruments and controls for proper operation, tighten or adjust mounting bolts of mirrors, wipers and shields.

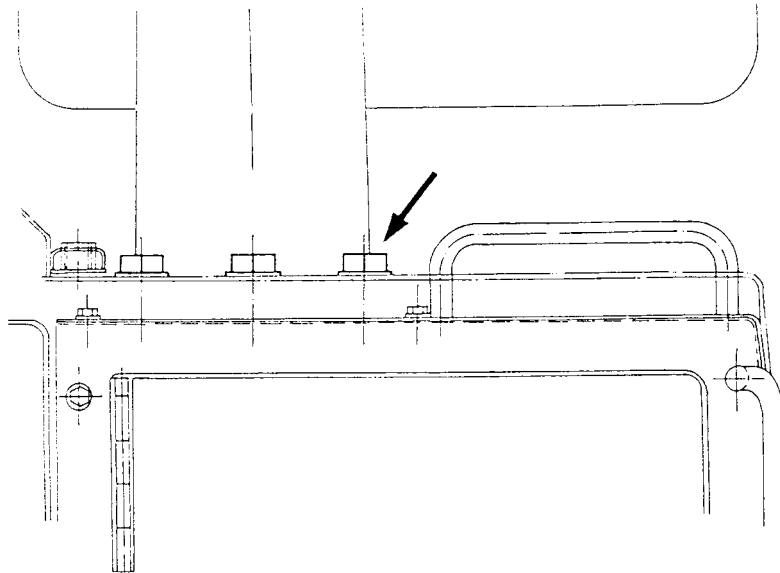

Fig. 5.59. ROPS Mounting Bolts

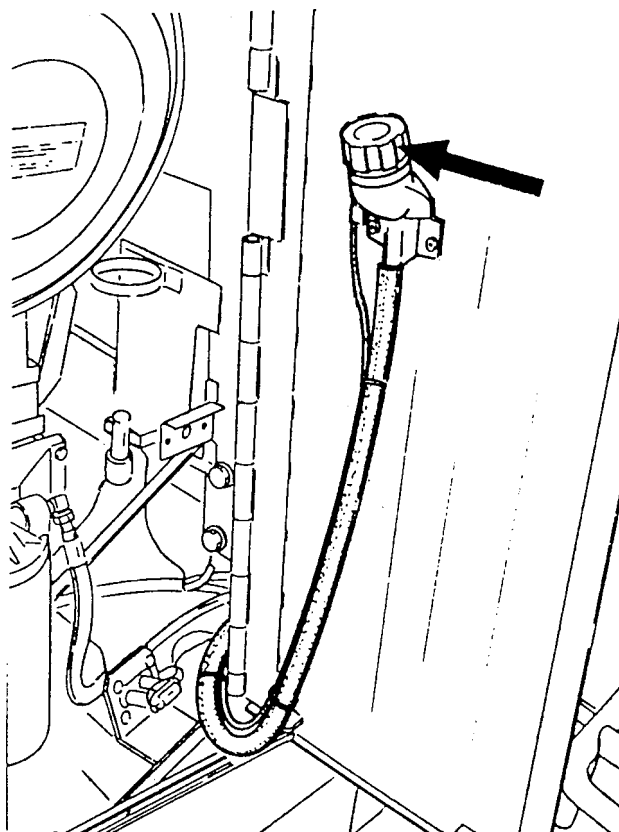

Fig. 5.60. Window Washer Reservoir Filler Spout.

SECTION 6
SPECIFICATIONS

SECTION CONTENTS

6.1. Application3
6.2. Technical Description.....3
6.3. Cinematic Diagram5
6.4. Equipment Hydraulic System Diagram.....6
6.5. Transmission Hydraulic System Diagram.....9
6.6. Wiring Diagram.....10
6.7. Specifications.....17
6.8. Special Torque's20
6.9. Standard Metric Fasteners.....22
6.10. Torque Values for Standard English Fasteners.....23
6.11. Torque Values for Split Flange Connections.....24
6.12. Torque Values for Hydraulic Tubes and Fittings24
6.13. Torque Values for Hose Clamps24
6.14. Torque Values for Air Conditioning Tubes and Fittings24
6.15. Torque Values for Air Conditioning O-Ring Connections25

6.1. APPLICATION

Td-40C Crawler dozer has been designed to perform many different jobs at medium and large construction sites in variety of soils, bulk materials, etc. Principal range of application covers:

- transporting materials at short distances
- grading and clearing
- digging
- piling
- breaking piles and spreading
- other jobs with blade, ripper and drawbar

The TD-40C dozer is easy in operation and maintenance.

The blades have been specially designed for various applications.

Arctic version of TD-40C is specially adapted for operation in ambient temperature range +40 to -50 [°C] (conforming to Russian HL Specifications)

6.2. TECHNICAL DESCRIPTION

TD-40C Crawler Dozer features powershift speed changes and hydraulic control of all mounted equipment.

TD-40C includes the following main assemblies/ systems:

- undercarriage
- superstructure
- drive train
- transmission hydraulic system
- mounted equipment
- equipment hydraulic system

Undercarriage

Undercarriage includes two box section track frames with track rollers, track idlers and front idlers. Track chains with track shoes, sprockets.

Track tension can be hydraulically increased to force forces the front idler forward for track chain adjustment by use of a common grease gun and released by turning pressure relief valve located under an easily removed plate.

Track frames are attached to the mainframe by the pivot shaft and to flexible equalizer bar attached to the saddle in the front mainframe.

Superstructure

Superstructure includes one-piece weldment consisting of front and rear frame. The mainframe is mounting base for radiator, coolers, engine, transmission and final drive. Superstructure includes engine hood, instrument panel, fenders, fuel tank, battery box, hydraulic reservoir, operator's platform and operator's seat.

The TD-40C Crawler Dozer is equipped with cab with air conditioner and can also be equipped with external individually mounted ROPS.

TECHNICAL DESCRIPTION**Drive train:**

Drive train includes the following components:

- Engine with Radiator
- Torque Converter
- U-Joint
- Transmission
- Pinion/Bevel Gear Set and Steering Drive
- Final Drives

Engine power is transmitted through torque converter, U-joint, transmission, pinion /bevel gear set and steering drive to two final drives with mounted sprockets.

Three-speed powershift transmission combined with two-speed steering gives 6 speeds forward and 6 speeds reverse.

Steering is accomplished by application of clutch packs in steering drive. Drive train is equipped with automatic system of speed control for FORWARD – REVERSE directional changes to protect the drive train against dynamic overload.

Transmission system

Transmission system includes oil tank which is rear frame, 10 μ suction filter of torque converter mounted pump, main regulator valve, rate of rise valve, range selector valve and transmission and steering drive control valves.

Mounted equipment

- Semi-U Blade
- Full-U Blade
- Single-Shank and Multi-Shank Ripper
- Drawbar

Blade lift and lower movements are accomplished with two blade lift cylinders.

Blade tilt to the right and left is accomplished with one tilt cylinder.

Multi-shank ripper – 3 shanks, tool beam raised and lowered with hydraulic cylinder, ripper shanks are equipped with hydraulic pitch and can be adjusted in two vertical positions.

Single-shank ripper is equipped with hydraulic pin puller.

Fixed drawbar with vertical pin.

Equipment hydraulic system

Equipment hydraulic system consists of hydraulic reservoir with sight gauge and breather, suction filter, hydraulic pump, pilot control valve, control valve with pressure relief valve supplying hydraulic cylinders and return filters. Hydraulic cylinder operating pressure is 15.5 [Mpa].

6.3. CINEMATIC DIAGRAM

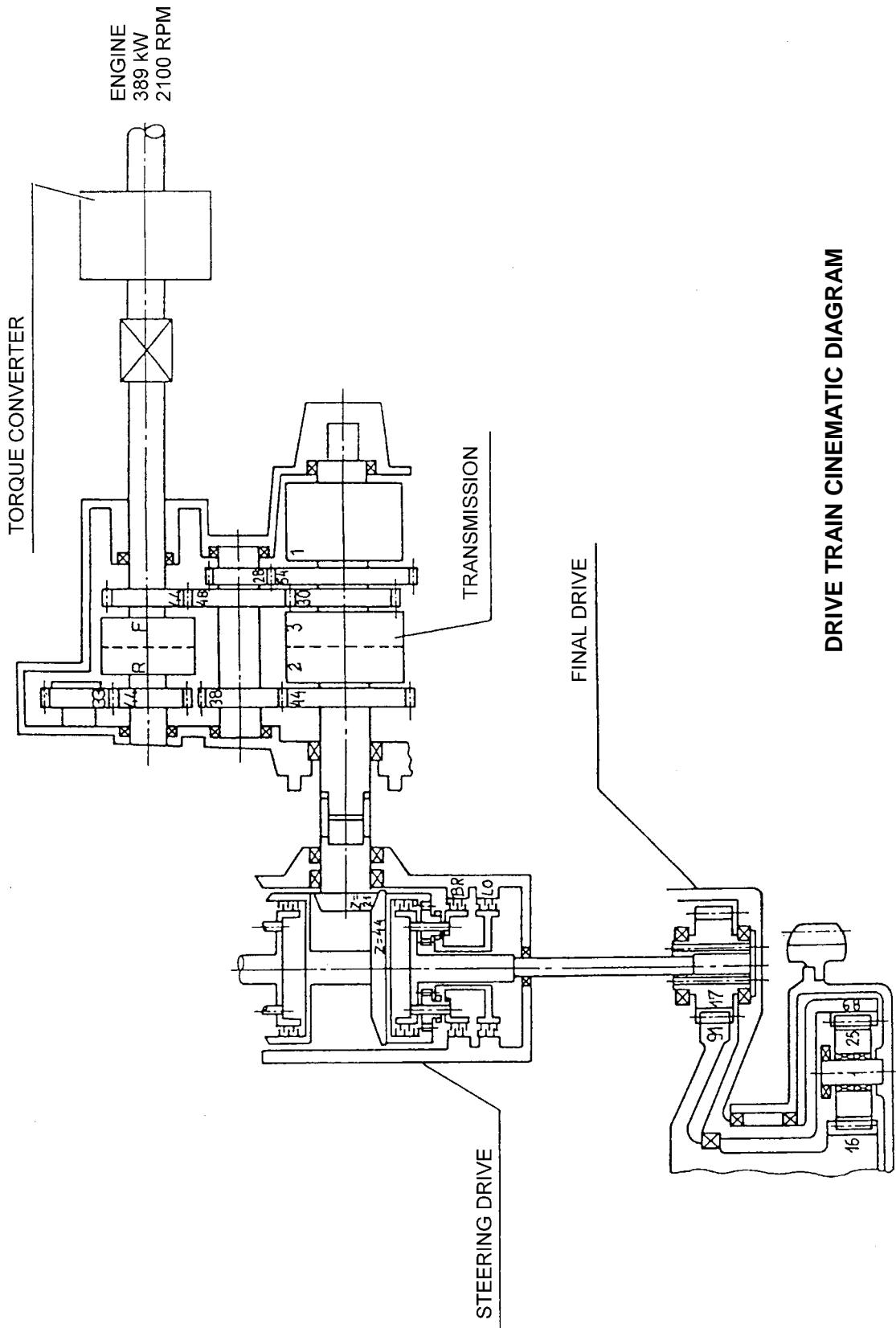

DRIVE TRAIN CINEMATIC DIAGRAM

6.4. EQUIPMENT HYDRAULIC SYSTEM DIAGRAM

Legend to equipment hydraulic system diagram

1. Ripper Lift Cylinders
2. Ripper Pitch Cylinders
3. Blade Lift Cylinders
4. Blade Tilt Cylinder
5. Main Control Valve
6. Quick Drop Valve
7. Unloading Valve
8. Tilt Control Valve
9. Directional Valves
10. Ripper Pilot Control Valve
11. Blade Pilot Control Valve
12. Directional Valve
13. Pressure Regulator
14. Return Filters
15. Breather
16. Hydraulic Pilot System Filter
17. Hydraulic Reservoir
18. Tandem Pump
19. Tilt and Pitch Cylinders
20. Tilt and Pitch Control Valve
21. Solenoid Valve
22. Hydraulic Control System Pump

6.5. TRANSMISSION HYDRAULIC SYSTEM DIAGRAM

Legend to transmission hydraulic system

1. Transmission
2. Suction Filter
3. Charge Pump
4. Scavenger Pump
5. Pressure Filters
6. Torque Converter
7. Oil Cooler
8. Solenoid Valve
9. Steering Unit Speed Solenoid Valve Switch
10. Rear Frame
11. Steering Valve
12. Transmission Control Valve
13. Range Selector Valve
14. Rate of Rise Valve
15. Main Regulator Valve
16. Pressure Diagnostic Center
17. Steering Drive

TRANSMISSION HYDRAULIC SYSTEM DIAGRAM

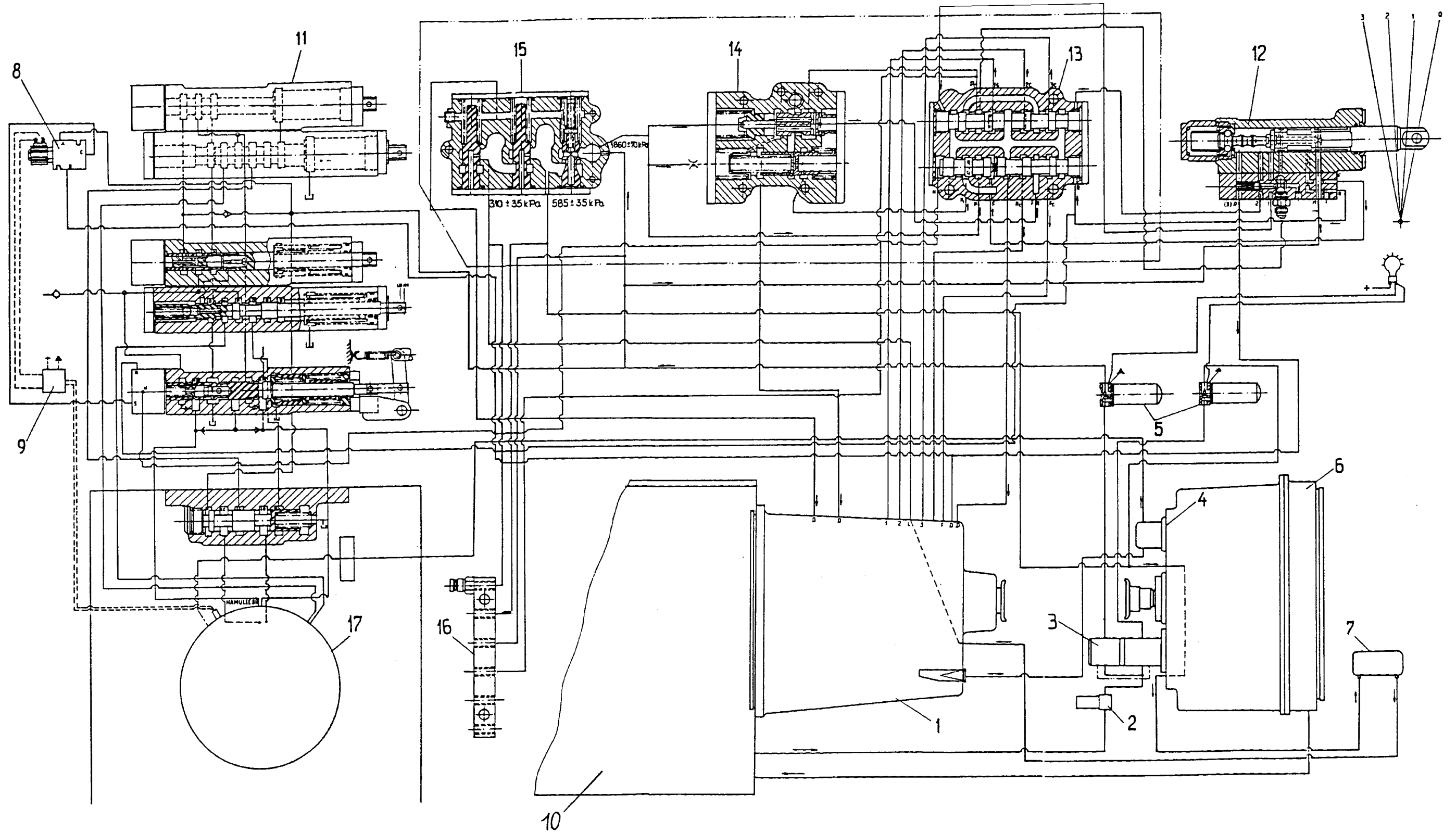

TRANSMISSION HYDRAULIC SYSTEM SCHEMATIC

SPECIFICATIONS

6.6. WIRING DIAGRAM

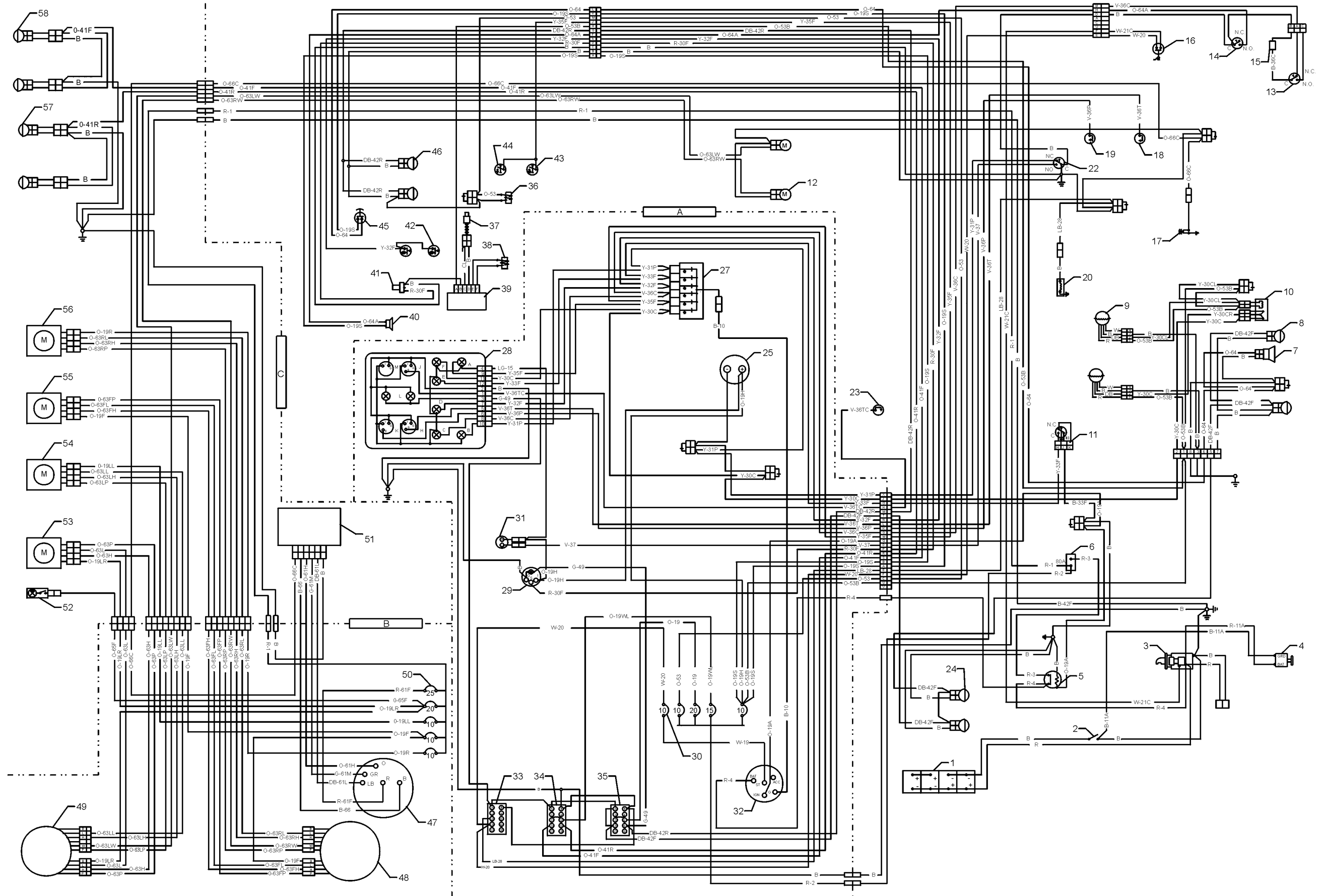

WIRING DIAGRAM (QSK-19C ONLY)

WIRING DIAGRAM

CUMMINS ENGINE 21 PIN CONNECTOR (QSK-19C ONLY)

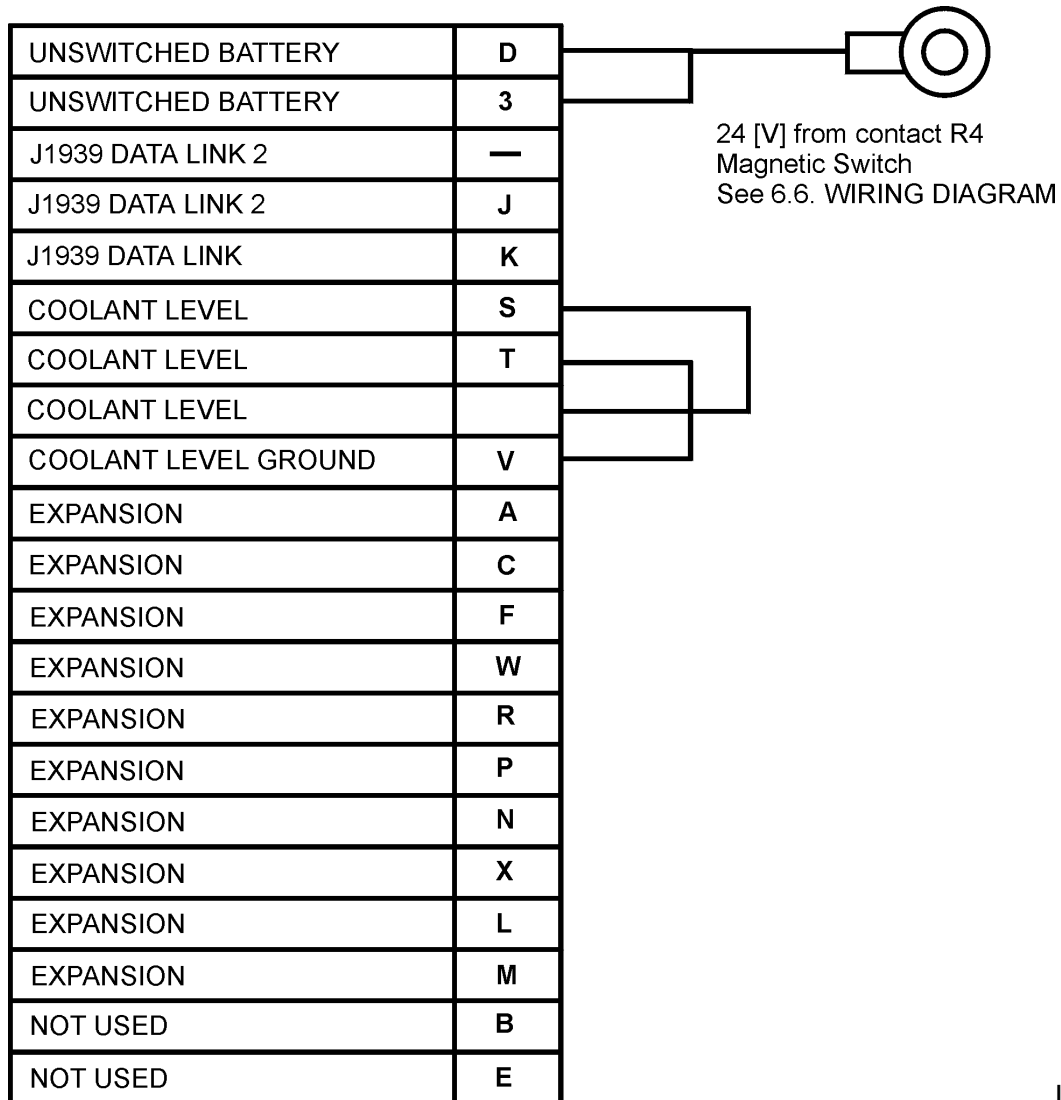

EMERGEFORMAT

INCLUDEPICTUR

SPECIFICATIONS

WIRING DIAGRAM

CUMMINS ENGINE 31 PIN CONNECTOR (QSK-19C ONLY)

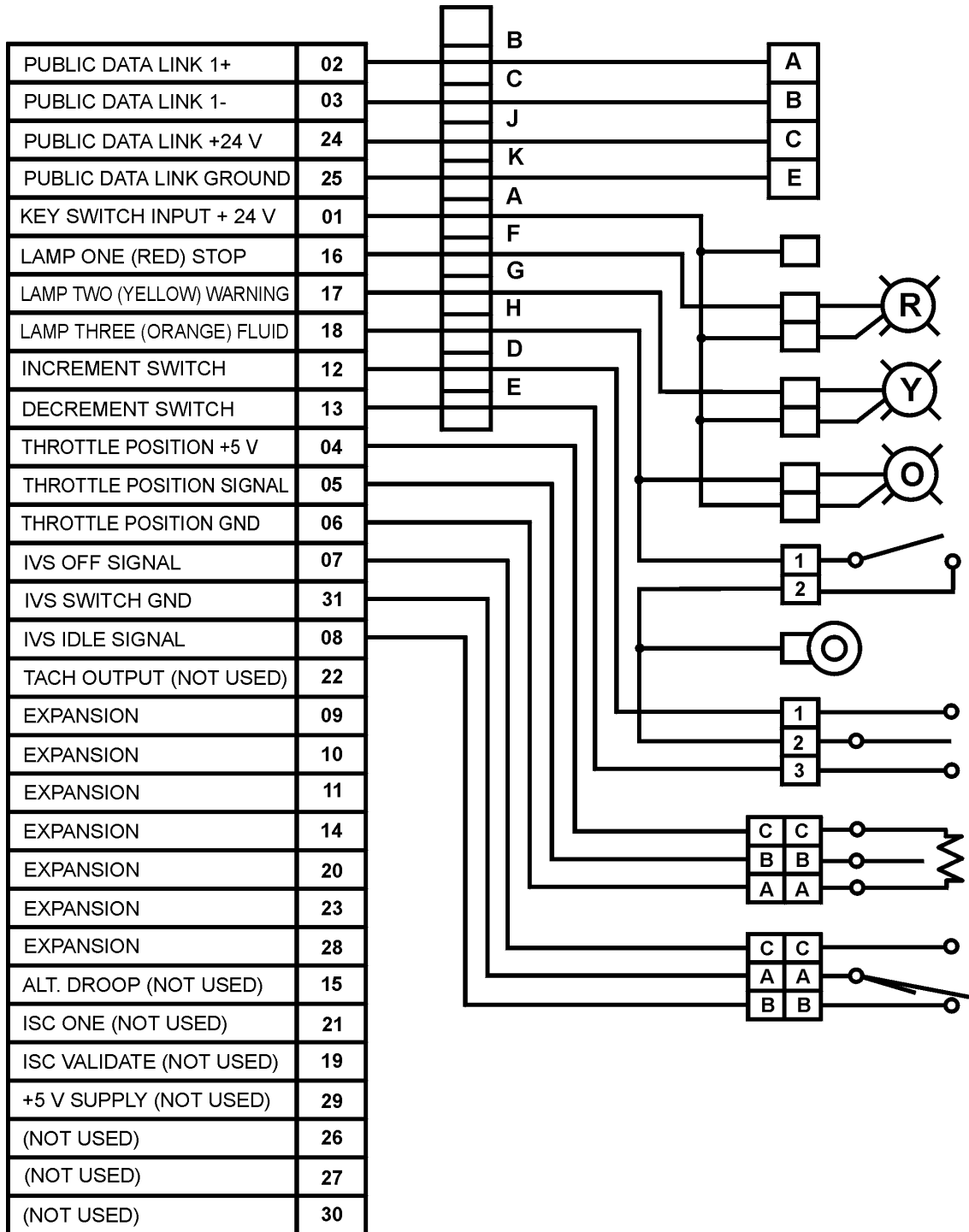

WIRING DIAGRAM

Legend for Wiring Diagram (QSK-19C ONLY)

- A - Machine Instrument Panel
- B - Cab Instrument Panel
- C - Cab Electric system

- 1. Battery
- 2. Master Switch
- 3. Cranking Motor
- 4. Alternator
- 5. Magnetic Switch
- 6. Main Circuit Breaker
- 7. Horn
- 8. Front Machine Headlamps
- 9. Coolant Level Sensors
- 10. Coolant Level Relay
- 11. Air Filter Vacuum Warning Light Switch
- 12. Window Washer Pumps
- 13. Transmission Main Low Pressure and Clutch Low Oil Pressure Warning Light Switch
- 14. Back-Up Oil Alarm Pressure Switch
- 15. Warning Light Delay Relay
- 16. Neutral Safety Switch
- 17. A/C Electromagnetic Clutch
- 18. Coolant Temperature Sensor
- 19. Engine Oil Pressure Sensor
- 20. Ether Solenoid Valve
- 22. Hourmeter Pressure Switch
- 23. Torque Converter Temperature Sensor
- 24. Front Fender Headlights
- 25. Audible Alarm (Low Engine Oil Pressure or Low Coolant Level)
- 27. Diode Assy
- 28. Gauge Cluster y
- 29. Fuel Level Gauge
- 30. Machine Circuit Breakers
- 31. Hourmeter
- 32. Starting Switch
- 33. Ether Start Switch
- 34. Cab Headlights Switch
- 35. Tractor Headlights Switch
- 36. Pilot Valve Float Position Solenoid
- 37. Steering Drive Speed Magnetic Sensor
- 38. Steering Drive Brake Solenoid Valve
- 39. Steering Unit Speed Solenoid Valve Switch
- 40. Back-Up Alarm
- 41. Fuel Level Sensor
- 42. Pressure Filters Warning Light Switch
- 43. Pilot Oil Filter Warning Light Switch
- 44. Hydraulic Oil Filters Warning Light Switch
- 45. Horn Pushbutton
- 46. Rear Headlamps
- 47. A/C and Heater Switch
- 48. Front and Rear Wiper Switch
- 49. Door Wipers Switch
- 50. Cab Circuit Breakers
- 51. A/C Heater Unit
- 52. Cab Light
- 53. RH Door Wiper Motor
- 54. LH Door Wiper Motor
- 55. Front Wiper Motor
- 56. Rear Wiper Motor
- 57. Cab Rear Headlamps
- 58. Cab Front Headlamps

Gauge Cluster Components:

- A – Hydraulic Oil Filter Warning Light
- B – Engine Oil Low Pressure Warning Light
- C – Main and Speed Clutches Oil Pressure Warning Light
- D – Transmission Oil Filters Warning Light
- E – Air Filter Vacuum Warning Light
- F – Coolant Low Level Warning Light
- H – Coolant Temperature Gauge
- J – Torque Converter Temperature Gauge
- K – Engine Oil Pressure Gauge
- L – Gauges Lamps
- M - Voltmeter

SPECIFICATIONS

WIRING DIAGRAM

Legend for Wiring Diagram (KTA-19C ONLY)

- | | |
|---|---|
| <ul style="list-style-type: none"> A - Machine Instrument Panel B - Cab Instrument Panel C - Cab Electric system <ul style="list-style-type: none"> 1. Battery 2. Master Switch 3. Cranking Motor 4. Alternator 5. Magnetic Switch 6. Main Circuit Breaker 7. Horn 8. Front Machine Headlamps 9. Coolant Level Sensors 10. Coolant Level Relay 11. Air Filter Vacuum Warning Light Switch 12. Window Washer Pumps 13. Transmission Main Low Pressure and Clutch Low Oil Pressure Warning Light Switch 14. Back-Up Oil Alarm Pressure Switch 15. Fuel Electrovalve Switch 16. Neutral Safety Switch 17. A/C Electromagnetic Clutch 18. Coolant Temperature Sensor 19. Engine Oil Pressure Sensor 20. Ether Solenoid Valve 21. Fuel Solenoid Valve 22. Hourmeter Pressure Switch 23. Torque Converter Temperature Sensor 24. Front Fender Headlights 25. Audible Alarm (Engine Oil Pressure or Low Coolant Level) 26. Warning Light Relay 27. Diode Assy 28. Indicators Assembly 29. Fuel Level Gauge 30. Machine Circuit Breakers 31. Hourmeter 32. Starting Button 33. Ether Start Switch 34. Cab Headlights Switch 35. Tractor Headlights Switch 36. Pilot Valve Float Position Solenoid 37. Steering Drive Speed Magnetic Sensor 38. Steering Drive Brake Electrovalve 39. Steering Unit Speed Electrovalve Switch 40. Back-Up Alarm 41. Fuel Level Sensor 42. Pressure Filter Warning Light Switch 43. Pilot Oil Filter Warning Light Switch 44. Hydraulic Oil Filters Warning Light Switch | <ul style="list-style-type: none"> 45. Horn Pushbutton 46. Rear Headlamps 47. A/C and Heater Switch 48. Front and Rear Wiper Switch 49. Door Wipers Switch 50. Cab Circuit Breakers 51. A/C Heater Unit 52. Cab Light 53. RH Door Wiper Motor 54. LH Door Wiper Motor 55. Front Wiper Motor 56. Rear Wiper Motor 57. Cab Rear Headlamps 58. Cab Front Headlamps <p>Gauge cluster components:</p> <ul style="list-style-type: none"> A – Hydraulic Oil Filter Warning Light B – Engine Oil Low Pressure Warning Light C – Main and Speed Clutches Oil Pressure Warning Light D – Transmission Oil Filters Warning Light E – Air Filter Vacuum Warning Light F – Coolant Low Level Warning Light H – Coolant Temperature Gauge J – Torque Converter Temperature Gauge K – Engine Oil Pressure Gauge L – Gauges Lamps M - Voltmeter |
|---|---|

WIRING DIAGRAM

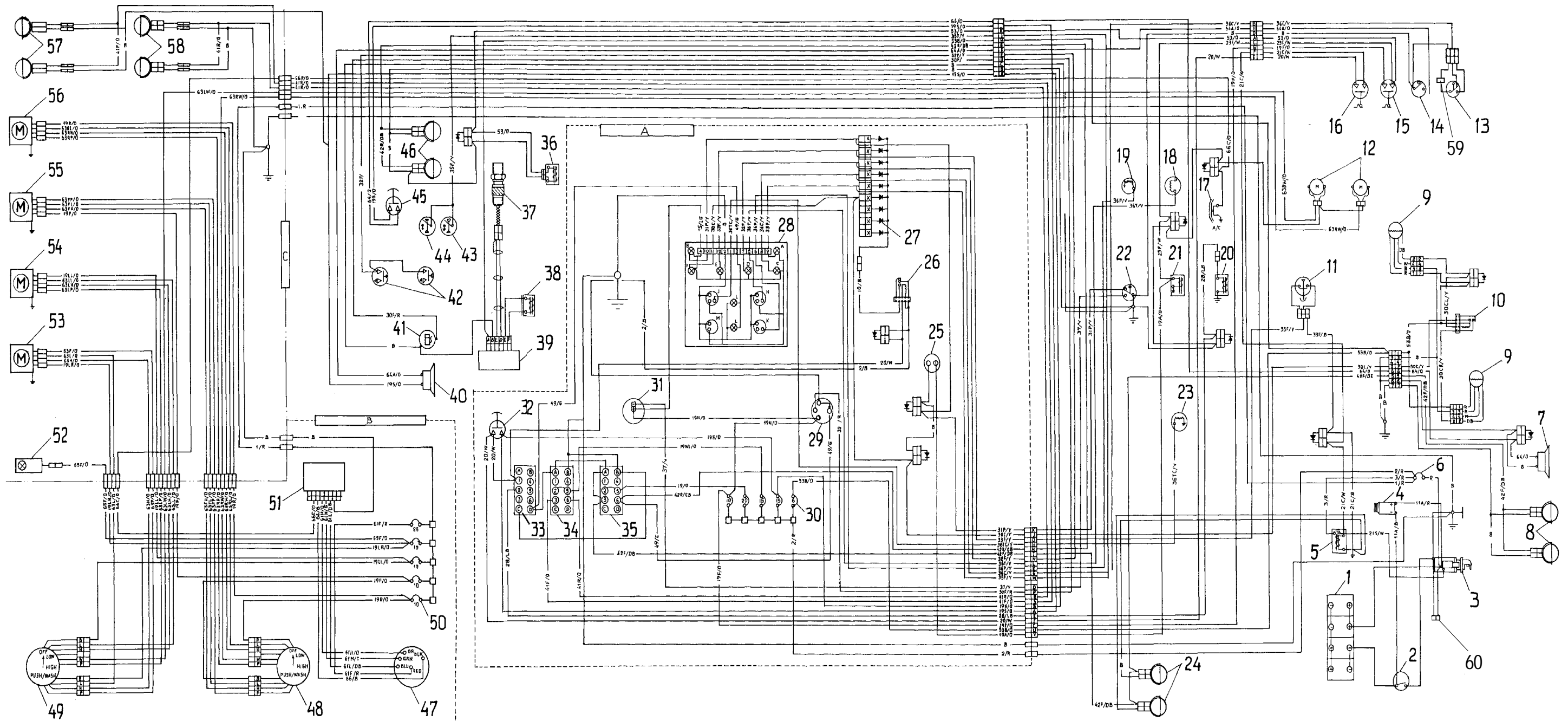

WIRING DIAGRAM (KTA-19C ONLY)

6.7. SPECIFICATIONS

6.7.1. OVERALL DIMENSIONS

Length:

Machine without mounted equipment	5.65 [m]
Machine with Semi-U blade	7.52 [m]

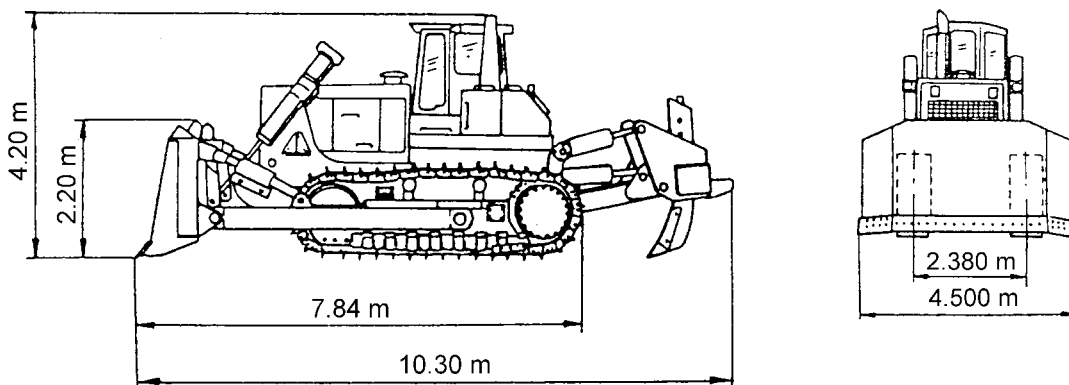

Fig. 6.1. Dimensions

Width:

1. Machine without mounted equipment with 660 [mm] track shoes	3.04 [m]
2. Machine without mounted equipment (over trunnions)	3.57 [m]
3. Machine with Semi-U blade	4.5 [m]

Height:

1. Height without ROPS.....	3.65 [m]
-----------------------------	----------

6.7.2. REFILL CAPACITIES

Fuel tank	1 340 liters
Cooling system	KT-19C..... 95 liters QSK-19 98 liters
Crankcase with filters	KT-19C..... (Full) 50 liters QSK-19 ... (Full) 67 liters
Transmission system.....	270 litersRear frame (HI) 160 liters
Final drive (each).....	85 liters
Track roller (each)	1.0 liter
Track idler (each)	0.5 liter
Front idler (each).....	1.4 liter
Pivot shaft reservoir (each)	9.0 liters

Equipment hydraulic system:

Model D2 (Equipped with hydraulic tilt).....	265 liters Reservoir 140 liters
Model D2 Blade & Ripper (Equipped with hydraulic tilt).....	355 liters Reservoir 140 liters
Air conditioning refrigerant	1.22 [kg]

Track rollers, track idlers and front idlers are permanently lubricated with SAE 30 engine oil when assembled and do not require any additional lubrication except when reconditioned.

SPECIFICATIONS

6.7.3. TRACKS

Gauge	2.38 [m]
Track on ground	3.61 [m]
Track shoe width, standard	610 [mm]
Track shoe width, max.	800 [mm]
Track shoes each side	39

6.7.4. ENGINE

Make and model.....	Cummins QSK – 19C or KTA-19C
Type	4-cycle diesel, turbocharged
No of cylinders	6
Bore	158.75 [mm]
Stroke	158.75 [mm]
Displacement	18.9 liters
Net flywheel power @2100 RPM.....	388 [Kw]

Engine speed

Full load governed.....	2100 [RPM]
Low idle	750 ± 50 [RPM]
Decelerator.....	1200 ± 50 [RPM]

6.7.5. TORQUE CONVERTER

Make and Type.....	Rockford, single-stage with rotating housing
Venting	Self-venting thru breather
Oil operating temperature range	82 – 121 [°C]

6.7.7. TRAVEL SPEEDS

Forward:

1 st , low range	0 – 3.2 [km/h]
1 st , high range	0 – 4.2 [km/h]
2 nd , low range	0 – 5.4 [km/h]
2 nd , high range.....	0 – 7.0 [km/h]
3 rd , low range.....	0 – 9.8 [km/h]
3 rd , high range	0 – 12.4 [km/h]

Reverse:

1 st , low range	0 – 3.8 [km/h]
1 st , high range	0 – 5.0 [km/h]
2 nd , low range	0 – 6.3 [km/h]
2 nd , high range.....	0 – 8.2 [km/h]
3 rd , low range.....	0 – 11.8 [km/h]
3 rd , high range	0 – 15.2 [km/h]

SPECIFICATIONS

6.7.8. WEIGHT (APPROXIMATE)

Machine without mounted equipment, 10% fuel, ROPS, track roller guard, sprocket rock deflector, crankcase and transmission guards, pull hook and lights 50698 [kg].

Machine with cab, Semi-U blade and single shank ripper 66540 [kg]

Mounted equipment

Semi-U Blade Max. track shoe width 800 [mm]

Semi-U blade

Length (over end bits) 4.5 [m]

Height 2.2 [m]

Max. lift:

Blade straight 1.65 [m]

Max. drop below ground level 0.65 [m]

Max. tilt adjustment 1.20 [m]

Max. pitch adjustment 10 [°]

Moldboard construction full closed back

Cutting edges (3) reversible) heat treated high alloy steel:

Length 1064 [mm]

Width 330 [mm]

Thickness 32 [mm]

End bits (2) reversible) heat-treated high alloy steel:

Length 785 [mm]

Width 380 [mm]

Thickness 35 [mm]

Hydraulic system

Pump type gear

Cylinders (double acting)

Bore and stroke 160 x 1600 [mm]

6.7.9. ELECTRICAL SYSTEM

System voltage 24 [V], negative ground

Batteries (maintenance-free) four 12 [V] or six 12 [V]

Alternator 80 [A]

6.7.10. FUEL CONSUMPTION

During intensive slot dozing tests in sandy soil (soil density app. 1.6 [t/m³]) average fuel consumption amounted to app. 100 [l/h].

Average operational fuel consumption

The above specified fuel consumption value refers to short period of intensive operation of the machine only. However, taking into consideration actual longer periods of machine operation fuel consumption value is considerably lower and can estimated at the level of app. 80 [l/h].

6.8. SPECIAL TORQUES

Rear harness to steering valve manifold screw	0.7 [Nm]
Main harness to pod at rear of LH console	0.7 [Nm]
Audio alarm terminal (on instrument panel)	0.7 [Nm]
Fuel sender terminal	0.7 [Nm]
Horn switch terminal (on RH console)	2–3 [Nm]
Neutral start & engine shutdown switch terminal	2 [Nm]
Hourmeter switch terminal (on engine)	1 [Nm]
Back-up alarm terminal	2 [Nm]
Back-up alarm terminal (in LH console)	1 [Nm]
Cab dome light mounting screw	2 [Nm]
Gauge cluster mounting screw (on instrument panel).....	2 [Nm]
Transmission filter indicator light	1–2 [Nm]
Equipment filter indicator switch	1–2 [Nm]
Equipment pilot filter indicator light	2 [Nm]
Water temperature sender terminal.....	2 [Nm]
Circuit breaker mounting screw (on hood support)	2 [Nm]
Circuit breaker mounting screw (on instrument panel).....	2 [Nm]
Circuit breaker terminal (on instrument panel)	2 [Nm]
Engine oil pressure sender (on engine).....	2 [Nm]
Magnetic switch terminal	2–3 [Nm]
Fuel sender mounting screw	2 [Nm]
Fuel level gauge terminal	2 [Nm]
Fuel level gauge mounting screw	1–1.5 [Nm]
Cranking motor switch terminal (DELCO).....	2–3 [Nm]
Torque converter temperature sender terminal	2 [Nm]
Ventilation louver mounting screw	2 [Nm]
Washer bottle spout mounting screw	7 [Nm]
Hourmeter terminal and mounting bracket screw	
Cab plastic trim mounting screw.....	5 [Nm]
Circuit breaker terminal (on hood support)	6 [Nm]
Alternator to battery (+) terminal (DELCO)	6–8 [Nm]
Magnetic switch terminal	5–8 [Nm]
Headliner mounting bolt	14 [Nm]
Transmission internal tube mounting bolt	60 [Nm]
Battery terminal nut	30 [Nm]
Freon compressor mounting bolt	60 [Nm]
Freon compressor adapter mounting bolt	50 [Nm]
Pipe plug track roller, top roller and front idler shaft	20 [Nm]
Master disconnect terminal	10 [Nm]
Transmission internal tube bolt	60 [Nm]
Transmission internal tube retaining clamp bolt.....	60 [Nm]
Track idler cover bolt	60 [Nm]
Battery hold down bolt	9 [Nm]
Track frame side door bolt	110 [Nm]
Radiator side mounting bolt.....	110 [Nm]
Final drive pinion bearing cover bolt	90 [Nm]
Final drive oil seal bolt	90 [Nm]
Final drive ring gear retainer bolt	90 [Nm]
Track frame rear cover door bolt	110 [Nm]
Quick drop valve mounting bolt	60–70 [Nm]
Torque converter ring gear to flywheel bolt	110 [Nm]
Cranking motor terminal	30–35 [Nm]

SPECIAL TORQUES

Alternator mounting hardware	80–100 [Nm]
Engine to trunnion support bolt.....	220 [Nm]
Flywheel to engine bolt.....	220–300 [Nm]
Track adjuster relief valve	70 [Nm]
Track adjuster check valve- Lube fitting	70 [Nm]
Alternator pulley nut	100–110 [Nm]
Starting switch nut.....	5 [Nm]
Horn switch nut	5 [Nm]
Track roller bushing retainer bolt	220 [Nm]
Front idler bushing retainer bolt	220 [Nm]
U-joint to torque converter yoke bolt.....	270 [Nm]
U-joint to transmission yoke bolt	270 [Nm]
Equipment floating pin retainer plate bolt	270 [Nm]
Stress reliever pin retainer plate bolt	270 [Nm]
Final drive pinion bearing housing bolt	220 [Nm]
Lift cylinder rod bearing retainer bolt	270 [Nm]
Tilt hose guard flange bolt	270 [Nm]
Master switch mounting nut.....	50 [Nm]
NEUTRAL, START and ENGINE SHUTOFF switch nut.....	50 [Nm]
Pivot shaft hose cover bolt	520 [Nm]
Track spring housing cover bolt	520 [Nm]
Tilt hose cover mounting bolt.....	520 [Nm]
Track frame step bolt	520 [Nm]
Final drive bearing retainer plate bolt	440 [Nm]
Fuel tank and hydraulic reservoir mounting bolt	520 [Nm]
Sprocket upper rock deflector bolt	520 [Nm]
Fender to frame bolts	520 [Nm]
Radiator top stabilizer bolt.....	370 [Nm]
Rock deflector wear bar bolt.....	850 [Nm]
Pivot shaft cover bolt	850 [Nm]
Track roller shield mounting bolt	850 [Nm]
Steering drive mounting bolt (top)	760 [Nm]
Steering drive mounting bolt (bottom)	760 [Nm]
Rear mainframe cover mounting bolt	850 [Nm]
Rear engine to frame mounting bolt	850 [Nm]
Front engine to frame mounting bolts.....	850 [Nm]
Transmission mounting bolt	760 [Nm]
Tilt plumbing guard mounting bolt (at trunnion)	850 [Nm]
Diagonal strut cap bolt.....	850 [Nm]
Upper strut and tilt cylinder cap bolts.....	850 [Nm]
Sprocket mounting nut	1400±70 [Nm]
Pivot shaft thrust plate bolt.....	850 [Nm]
Equalizer bar pin retainer plate bolt	850 [Nm]
Rebound bracket mounting bolt	850 [Nm]
Track roller bracket bolt.....	850 [Nm]
Front track idler bracket bolt	850 [Nm]
Rear track idler mounting block bolt	850 [Nm]
Front idler fork mounting bolt.....	850 [Nm]
Track frame front cover plate bolt	850 [Nm]
Chain guide wear plate bolt	850 [Nm]
Sprocket rock deflector rear bolt	850 [Nm]

SPECIFICATIONS

SPECIAL TORQUES

Sprocket rock deflector mounting bolt	850 [Nm]
Front idler tapered pin retainer plug.....	270 [Nm]
Track shoe bolt.....	2400 (ref) [Nm]
Track chain split link bolt	2400 (ref) [Nm]
Audio alarm mounting nut (on instrument panel)	finger tight [Nm]
Trunnion assembly bolt	1500 [Nm]
Lift cylinder yoke bushing block bolt	1500 [Nm]
Cutting edge and end bit nuts.....	1500 [Nm]
Trunnion bearing cap bolt	1500 [Nm]
Track frame guide plate mounting bolt	1500 [Nm]
Guide plate spacer bolt	1500 [Nm]
Final drive planet carrier mounting bolt	1500 [Nm]
Final drive cover mounting bolt (to frame)	1500 [Nm]
Final drive wear guard mounting bolt	1500 [Nm]
Pivot shaft dipstick	24 [Nm]
Ripper mounting frame bolt	2800 [Nm]
Ripper mounting frame bolts	3600 [Nm]
Pivot shaft lock pin retainer plug	280 [Nm]

6.9. STANDARD METRIC FASTENERS

This chart provides tightening torque for general-purpose applications using original equipment standard hardware. Original equipment standard hardware is defined as coarse thread metric class 10.9 bolts and class 10.0 nuts and thru hardened flat washers (Rockwell "C" 38-45), all phosphate coated and assembled without supplemental lubrication (as received) condition. The torques shown below apply to phosphate coated bolts designed for 60% yield strength.

The torques shown below also apply to phosphate coated bolts used with phosphate coated prevailing torque nuts, phosphate coated bolts used with copper plated weld nuts.

NOMINAL THREAD DIAMETER	STANDARD TORQUE ±10%
[mm]	[Nm]
6	10
7	16
8	23
10	46
12	80
14	125
16	200
18	275
20	385
22	530
24	670
27	980
30	1330
33	1790
36	2325

6.10. TORQUE VALUES FOR STANDARD ENGLISH FASTENERS

This chart provides tightening torque for general purpose applications using original equipment standard hardware as listed in the Parts Catalog for the machine involved. **DO NOT SUBSTITUTE.** Original equipment standard hardware is defined as Type 8, coarse thread bolts and nuts and thru hardened flat washers (Rockwell "C" 38-45), all phosphate coated and assembled without supplemental lubrication (as received) condition. Phosphate coated bolts used in tapped holes in steel or gray iron. 2. Phosphate coated bolts used with phosphate coated prevailing torque nuts (nuts with distorted threads or plastic inserts). Phosphate coated bolts used with copper plated weld nuts.

Markings on bolt heads or nuts indicate material grade **ONLY** and are **NOT** to be used to determine required torque.

NOMINAL THREAD DIAMETER	STANDARD TORQUE ±10%
[in]	[Nm]
1/4	10
5/16	21
3/8	38
7/16	60
1/2	92
9/16	130
5/8	180
3/4	325
7/8	520
1	780
1-1/8	1110
1-1/4	1565
1-3/8	2050
1-1/2	2720
1-3/4	3380
2	5080

6.11. TORQUE VALUES FOR SPLIT FLANGE CONNECTIONS

The following chart provides the tightening torques for split flange connections used in hydraulic systems. Split flanges and fitting shoulders should fit squarely. Install all bolts, finger tight and then torque evenly. Over torquing bolts will damage the flanges and/or bolts, which may cause leakage.

Bolt size	Flange size	Torque Value
[in]	[in]*	[Nm]
1/2	5/16	20–24
3/4	3/8	30–37
1	3/8	37–47
1-1/4	7/16	47–61
1-1/2	1/2	62–79
2	1/2	75–88
2-1/2	1/2	107–123
3	5/8	187–203
3-1/2	5/8	159–180

* – Inside diameter of hydraulic tube or hose fitting.

6.12. TORQUE VALUES FOR HYDRAULIC TUBES AND FITTINGS

Size	Tubing o.d. in inches	Thread size in inches	Torque values for 37 [°] flared fittings	Torque values for O-ring boss plugs, locknuts and 37 [°] flared fittings
4	1/4	7/16-20	12-16	8-14
5	5/16	1/2 -20	16-20	14-20
6	3/8	9/16-18	29-33	20-27
8	1/2	3/4 -16	47-54	34-42
10	5/8	7/8-14	72-79	47-54
12	3/4	1-1/16-12	104-111	81-95
14	7/8	1-3/16-12	122-138	95-109
16	1	1-5/16-12	149-163	108-122
20	1-1/4	1-5/8-12	190-204	129-156
24	1-1/2	1-7/8-12	217-237	163-190
32	2	2-1/2-12	305-325	339-407

Above torque figures are recommended for plain, cadmium or zinc plated fittings, dry or wet installations. These torques are not recommended for tube with wall thickness of 0.889 [mm] or less

6.13. TORQUE VALUES FOR HOSE CLAMPS

The following chart provides the tightening torques for hose clamps used in all rubber applications (radiator, air cleaner, operating lever boots, hydraulic system, etc.).

CLAMP TYPE AND SIZE	TORQUE ± 0.6 [Nm]	
	Radiator, Air Cleaner, Boots, etc [Nm]	Hydraulic System [Nm]
"T" Bolt (any diameter)	6.2 -7.3	—
Worm Drive – 1-3/4 [in]. Open Diameter & Under	2.2 - 3.3	4.5 - 5.6
Worm Drive – Over 1-3/4 [in]. Open Diameter	4.5 - 5.6	—
Worm Drive – All "Ultra-tite"	10.7 - 11.8	4.5 - 5.6

6.14. TORQUE VALUES FOR AIR CONDITIONING TUBES AND FITTINGS

SWAGED 45 [°] CONNECTIONS

SIZE	THREAD SIZE [in]	TORQUE VALUES FOR MATERIALS [Nm]			
		STEEL-STEEL	BRONZE -STEEL	COPPER-STEEL	ALUMINUM-STEEL
1/4	7/16-20	16 - 23	15 - 20	15 - 20	12 - 18
3/8	5/8-18	27 - 33	23 - 38	23 - 38	20 - 25
1/2	3/4-16	47 - 54	38 - 46	38 - 46	28 - 36
5/8	7/8-14	61 - 68	45 - 53	45 - 53	34 - 42
3/4	1-1/16-12	72 - 80	49 - 57	49 - 57	45 - 53
	1-1/16-14	72 - 80	49 - 57	49 - 57	45 - 53

6.15. TORQUE VALUES FOR AIR CONDITIONING O-RING CONNECTIONS

SIZE	THREAD SIZE [in]	TORQUE VALUES FOR MATERIALS [Nm]
		STEEL-STEEL
1/4	7/16-20	15 – 25
3/8	5/8-18	27 – 33
1/2	3/4-16	40 – 48
5/8	7/8-14	47 – 54
3/4	1-1/16-12	54 – 61
	1-1/16-14	54 – 61