

OMTD25H00-1E

# OPERATOR'S MANUAL

# TD-25H

SERIAL NUMBERS  
73001 AND UP

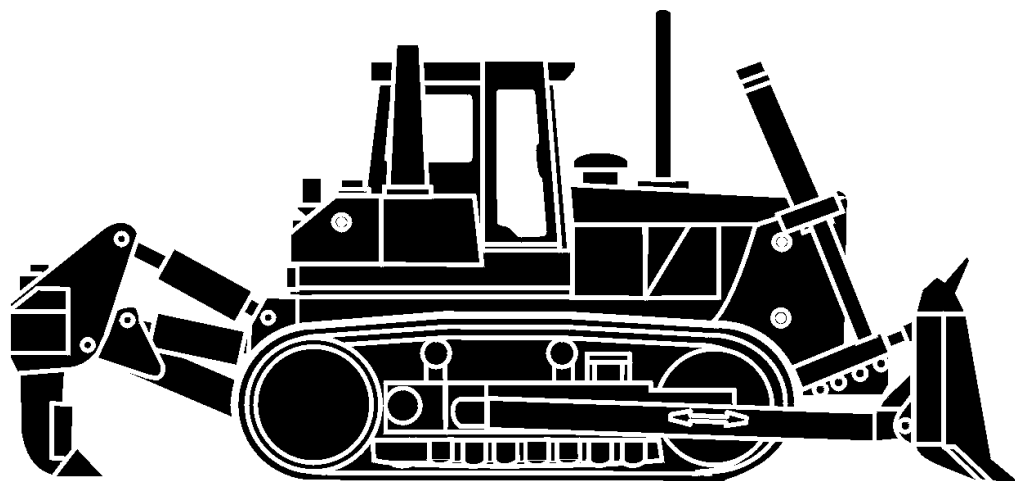

DRESSTA Co. Ltd.

---

---

---

## CONTENTS

1. INTRODUCTION
2. SAFETY PRECAUTIONS
3. MACHINE TRANSPORT AND STORAGE
4. OPERATING
5. MAINTENANCE
6. SPECIFICATIONS



## FOREWORD

***Welcome to the growing group of value-conscious people who operate DRESSTA machines.***

This manual covers the instructions for safe operation, lubrications, adjustments and maintenance for normal daily care. These instructions are divided into six sections to simplify your reference to the information most important to you. Refer to the contents page at the beginning of the section for a complete list of the subjects covered except for Section 2, which should be read entirely.

This manual has been prepared to help you operate and maintain your machine with utmost efficiency and safety. Read this manual thoroughly and learn your machine before you attempt to operate it.

It is our policy to improve our products whenever it is possible and practical to do so. We reserve the right to make changes or add improvements at any time without incurring any obligation to install such changes on products sold previously.

Due to this continuous program of research and development, periodic revisions may be made to this publication. It is recommended that customers contact their distributor for information on the latest revision.

**We hope you enjoy operating Dressta machines.**

**DRESSTA Co. Ltd.**

THIS MATERIAL IS PROPRIETARY TO DRESSTA Co. Ltd. AND IS NOT TO BE REPRODUCED, USED, OR DISCLOSED EXCEPT IN ACCORDANCE WITH WRITTEN AUTHORIZATION FROM DRESSTA Co. Ltd.

## **SECTION INDEX**

### **SECTION 1 - INTRODUCTION**

This section discusses the use of this manual, serial number locations.

### **SECTION 2 - SAFETY PRECAUTIONS**

This section lists safety rules concerning personal safety. Read this section carefully! Maintain this manual and review it frequently for continuing safe operation and instructing new operators.

### **SECTION 3 - MACHINE TRANSPORT AND STORAGE**

This section discusses how to ship or store this machine.

### **SECTION 4 - OPERATING**

The front portion of this section provides you with instructions for trouble free operation of the machine, machine precautions and a universal symbol chart, the text and illustrations for instruments and controls. The instrument and controls area is designed to tell you „where it is, what it does and how to use it". Read this area carefully. The remaining portion of this section outlines and illustrates the step-by-step procedures for starting, operating and stopping the machine and discusses a few operating suggestions and techniques and simple ideas to help ease work and lengthen the useful life of your machine.

### **SECTION 5 - MAINTENANCE**

The beginning of this section outlines a complete scheduled maintenance program, which helps to reduce down-time and expense, and increase the profit and work from your machine. Read and use this area. Following the maintenance program are the lubrication recommendations and requirements for the machine. The remainder of the section is devoted to clearly explaining the "how to" of the many maintenance and adjustment procedures listed in the maintenance program. The explanations are prepared in an easy style to help you "do it yourself" and get it right.

### **SECTION 6 - SPECIFICATIONS**

This section covers the diagrams, general dimensions and weights, refill capacities, ground speeds and the standard and special torque values.

## SECTION CONTENTS

### 1. INTRODUCTION

|                           |   |
|---------------------------|---|
| 1.1. Introduction .....   | 3 |
| 1.2. Serial Numbers ..... | 4 |

### 2. SAFETY PRECAUTIONS

|  |    |
|--|----|
| 2.1. General .....                         | 3  |
| 2.2. Before Starting the Engine .....      | 4  |
| 2.3. Operation .....                       | 5  |
| 2.4. Maintenance .....                     | 8  |
| 2.5. Shutdown .....                        | 10 |
| 2.6. Safety Product Graphic Location ..... | 11 |

### 3. MACHINE TRANSPORT AND STORAGE

|                                      |   |
|--------------------------------------|---|
| 3.1. Machine Transport .....         | 3 |
| 3.2. Lifting Machine on Slings ..... | 4 |
| 3.3. Moving a Disabled Machine ..... | 4 |
| 3.4. Machine Storage .....           | 6 |

### 4. OPERATING

|   |    |
|---|----|
| 4.1. Machine Precautions.....                             | 3  |
| 4.2. Universal Symbols for Instruments and Controls ..... | 4  |
| 4.3. Instrument Panel .....                               | 6  |
| 4.4. Cab Controls .....                                   | 9  |
| 4.5. Control and Adjustment .....                         | 10 |
| 4.6. Starting the Engine .....                            | 17 |
| 4.7. Stopping the Engine .....                            | 20 |
| 4.8. Tips for Engine Safeguarding .....                   | 21 |
| 4.9. Driving the Machine .....                            | 21 |
| 4.10. Shifting the Transmission .....                     | 22 |
| 4.11. Converter Overheating .....                         | 23 |
| 4.12. Steering the Machine .....                          | 23 |
| 4.13. Downgrade Operation .....                           | 24 |
| 4.14. Operating Over an Obstruction .....                 | 24 |
| 4.15. Stopping the Machine .....                          | 25 |
| 4.16. Parking the Machine .....                           | 25 |
| 4.17. Operating the Mounted Equipment .....               | 26 |
| 4.18. Blade Positions .....                               | 30 |
| 4.19. Operating Techniques .....                          | 32 |
| 4.20. Economical Operation of the Machine .....           | 40 |

### 5. MAINTENANCE

|  |    |
|--|----|
| 5.1. Service Precautions .....                   | 3  |
| 5.2. Scheduled Maintenance Guide .....           | 4  |
| 5.3. Maintenance and Service Chart .....         | 7  |
| 5.4. Lubrication .....                           | 10 |
| 5.5. Seasonal Preparation .....                  | 13 |
| 5.6. Air Cleaning System .....                   | 14 |
| 5.7. Belts .....                                 | 17 |
| 5.8. Cooling System .....                        | 19 |
| 5.9. Fan .....                                   | 24 |
| 5.10. Electrical System .....                    | 25 |
| 5.11. Engine .....                               | 28 |
| 5.12. Fuel System .....                          | 32 |
| 5.13. Hydraulic System .....                     | 35 |
| 5.14. Lubricating Fittings .....                 | 40 |
| 5.15. Mounted Equipment .....                    | 45 |
| 5.16. Safety Belt .....                          | 51 |
| 5.17. Final Drives .....                         | 51 |
| 5.18. Transmission System .....                  | 52 |
| 5.19. Undercarriage .....                        | 58 |
| 5.20. Adjusting the Hand and Foot Controls ..... | 64 |
| 5.21. Cab and ROPS .....                         | 65 |

## 6. SPECIFICATIONS

|   |    |
|---|----|
| 6.1. Application .....  | 3  |
| 6.2. Technical Description .....                                  | 3  |
| 6.3. Specifications .....   | 5  |
| 6.4. Refill Capacities .....                                      | 8  |
| 6.5. Special Torque.....  | 9  |
| 6.6. Torque Values for Standard Metric Fasteners .....            | 10 |
| 6.7. Torque Values for Standard English Fasteners .....           | 10 |
| 6.8. Torque Values for Split Flange Connections .....             | 11 |
| 6.9. Torque Values for Hydraulic Tubes and Fittings .....         | 11 |
| 6.10. Torque Values for Hose Clamps .....                         | 12 |
| 6.11. Torque Values for Air Conditioning Tubes and Fittings ..... | 12 |
| 6.12. Torque Values for Air Conditioning O-Ring Connections ..... | 12 |
| 6.13. List of Service Tools .....                                 | 13 |
| 6.14. Drive Train Schematic .....                                 | 14 |
| 6.15. Transmission Hydraulic System Diagram .....                 | 15 |
| 6.16. Equipment Hydraulic System Diagram .....                    | 17 |
| 6.17. Wiring Diagram .....  | 18 |
| 6.18. Cab Wiring Diagram .....                                    | 21 |

**SECTION 1**  
**INTRODUCTION**



**SECTION CONTENTS**

1.1. Introduction ..... 3  
1.2. Serial Numbers ..... 4

## 1.1. INTRODUCTION

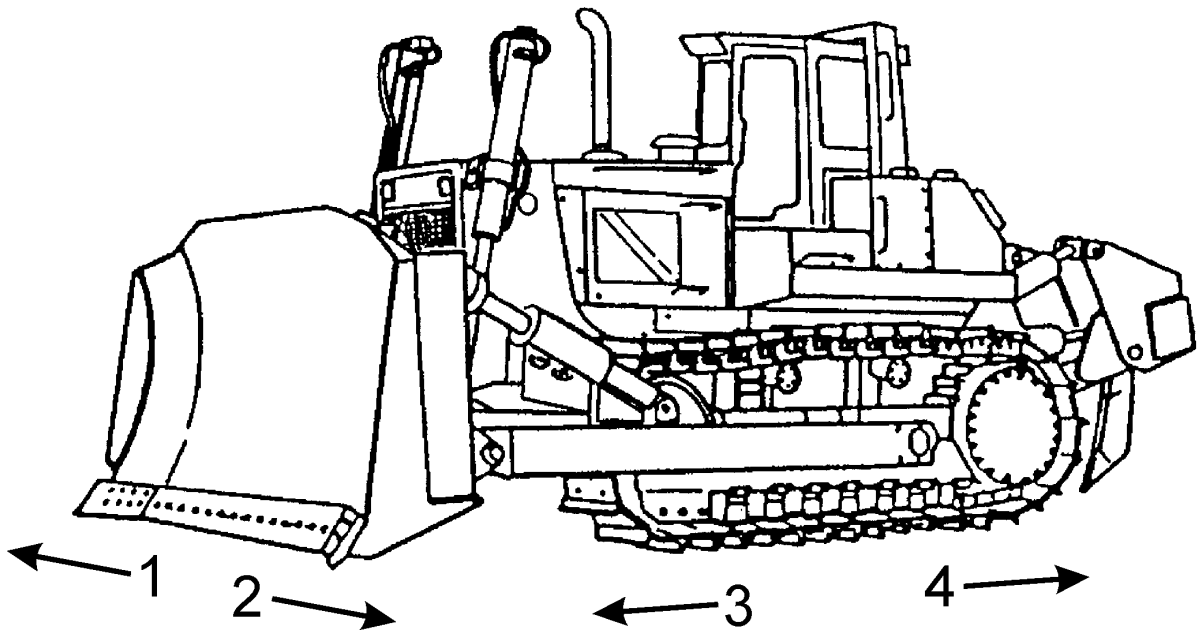

Fig. 1.1. TD-25 Series H Crawler Tractor Equipped with Bulldozer Blade

- |                                   |                         |
|-----------------------------------|-------------------------|
| 1. Right Hand Side of the Machine | 3. Front of the Machine |
| 2. Left Hand Side of the Machine  | 4. Rear of the Machine  |

### GENERAL

Throughout this manual there will be two types of cross references. One type is to a heading in another section. The other is to a heading within the same section. Unless it is otherwise stated, references will be to the same section. Refer to the section contents page at the beginning of the individual sections for specific page numbers.

Some illustrations are of general application and may not show your machine accurately in all details.

Throughout this manual the use of the terms "left", "right", "front", and "rear" must be understood to avoid confusion when following instructions. "Left" and "right" indicate the left and right sides of the machine when facing forward in the operator's seat. See Fig. 1.1.

The three following symbols and text in bold letters are used throughout this manual to call your attention to instructions concerning your personal safety:



**DANGER!** It indicates an emergency which, if not avoided, may result in injury or death. This sign calls your attention to a most serious danger.



**WARNING!** This sign indicates an emergency which, if not avoided, may result in injury or death.



**CAUTION!** This sign indicates an emergency which, if not avoided, may result in minor injury.

## INTRODUCTION

The two following signs and text in italics are used throughout this manual to call your attention to important procedures or steps having influence on the right functioning of a machine. Failure to follow such instructions may result in the damage of a machine or affect machine life time.

***IMPORTANT:*** This sign and text in italics is used throughout this manual to call your attention to key problems for machine operation. Failure to follow such instructions may result in damage of a machine and heavy material losses.

***NOTE:*** This sign and text in italics is used throughout this manual to call your attention to an important function having influence on the right functioning of a machine or for informational purposes.

## 1.2. SERIAL NUMBERS

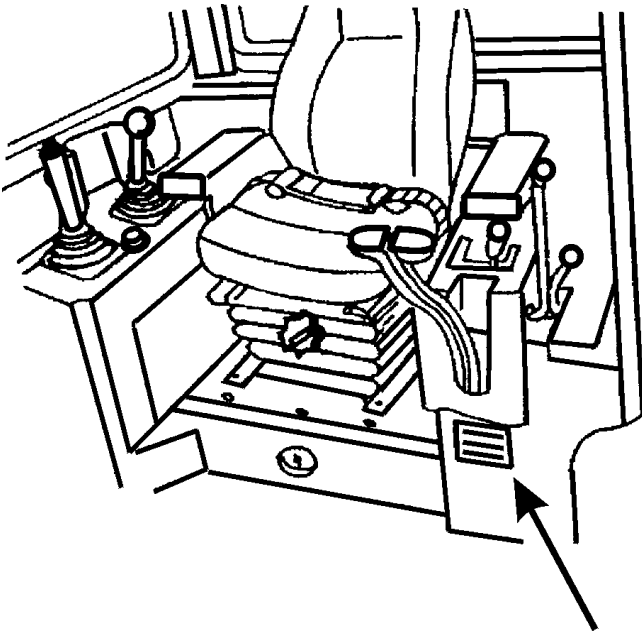

Fig. 1.2. Product Identification Number (P.I.N.)

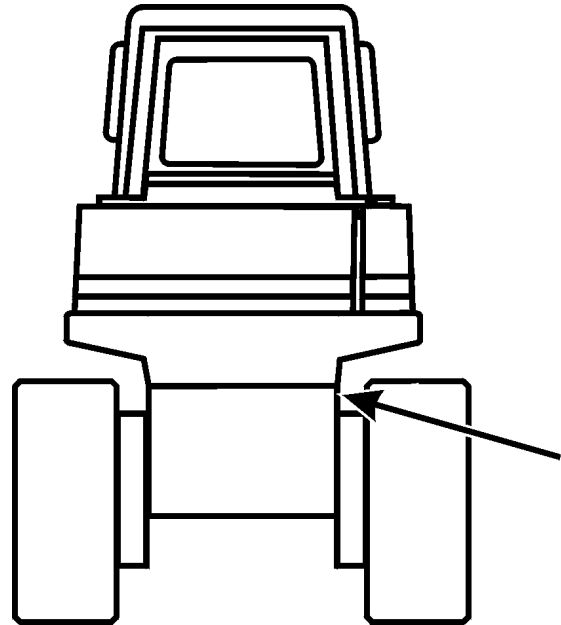

Fig. 1.3. Product Identification Number (P.I.N.) on RMF

The product identification number (P.I.N.) is stamped on a plate attached to the front wall of the control console at the left hand side of the operator's seat (Fig. 1.2). It is also stamped on the rear frame in the upper right hand corner under the fender (Fig. 1.3).

## SERIAL NUMBERS

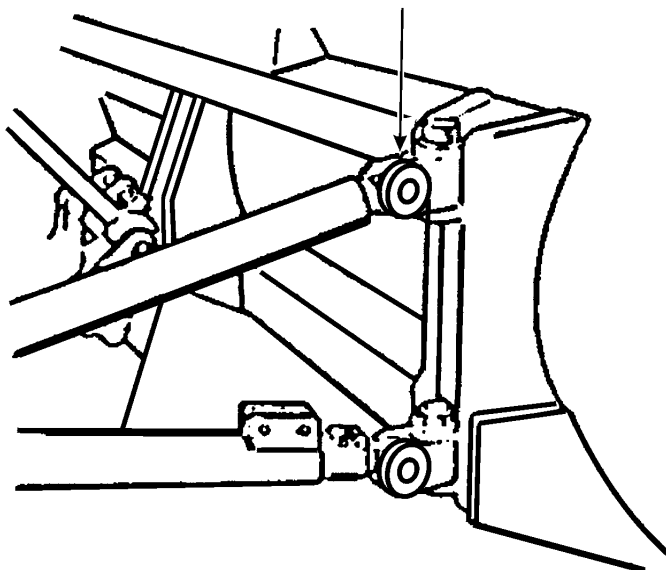

Fig. 1.4. Serial Number Designation of Blade

The bulldozer model designation is stamped on the back of the blade, near the top right hand corner (Fig. 1.4).

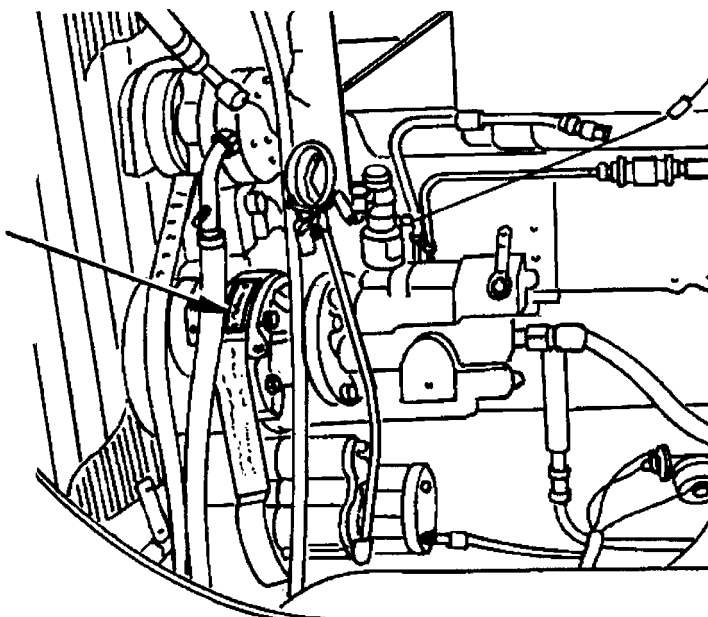

Fig. 1.5. Engine serial number plate

The engine serial number and rating are designated on a plate attached to the front of the engine on the left hand side (Fig. 1.5).

All other components having serial numbers are equipped with a separate serial number plate.

Use machine serial numbers when requesting information or ordering parts and proper numbers from the Parts Catalogue.

**SECTION 2**  
**SAFETY PRECAUTIONS**

## SECTION CONTENTS

|  | PAGE |
|--|------|
| 2.1. General .....                         | 3    |
| 2.2. Before Starting the Engine .....      | 4    |
| 2.3. Operation .....                       | 5    |
| 2.4. Maintenance .....                     | 8    |
| 2.5. Shutdown .....                        | 10   |
| 2.6. Safety Product Graphic Location ..... | 11   |
| 2.6.1. Safety Product Graphic .....        | 12   |

## 2.1. GENERAL

### WORK SAFELY – FOLLOW THESE RULES



**This symbol and text with bold letters is used throughout this manual to call your attention to instructions concerning your personal safety. Observe and follow these instructions. Be certain anyone operating and servicing this machine is aware of these rules. Failure to follow these rules may result in injury or death.**



**WARNING!: The machine can only be operated by a person who is familiar with this manual, knows operation of the machine and its mechanisms, experienced and properly licensed to operate such machines. Carefully observe and follow all instructions provided in this manual.**

The instructions and information given in this section do not cover all you ought to know to operate the machine safely. Detailed instructions regarding operational safety appear in the following sections of this manual.

Human error is a contributing factor in most equipment-related injuries. Haste, carelessness and lack of training are the primary causes of injuries.

Most operating injuries occur because of excessive speed, loss of control, failure to observe warning signs, slipping or falling while entering or dismounting, a lack of bars on roadways or piles, lack of a ROPS or seat belt, or not watching in the direction of travel.

Most maintenance injuries occur during welding or when using hammers or wrenches. The most common faults are improper work position, a slipped tool, missed aim, a broken tool, flying chips and no welding hood.

Think before you act. A careful operator or maintenance man is the best insurance against an accident.

Always wear proper safety equipment. Avoid wearing jewelry and loose fitting clothing; they could catch on moving parts, which could result in serious injury or death. Hard hat, sturdy rough-soled work shoes or safety shoes, ear protectors, reflective clothing, safety glasses and heavy gloves may be required. Consult your employer for specific safety equipment requirements.

Each job site and application may have personal safety requirements. Carefully evaluate your particular application and machine for equipment such as heater and defroster, all windshield wipers, warning lights, side view and rearview mirrors, back-up alarms, fire extinguisher, rotating beacons and additional lights. If in doubt, contact your distributor.

The machine should be equipped with a fully charged fire extinguisher. All personnel should be instructed in proper usage. Recharge immediately after use. A dry powder fire extinguisher is placed in the cab on the right hand side of the operator's seat (Grammer seat, Fig. 2.1). It is placed in a holder preventing uncontrolled movement during machine operation. In case of a fire the extinguisher can be easily removed from the holder. The extinguisher is provided with a label containing the instructions of its use and application. The operator should be familiar with these instructions.

# SAFETY PRECAUTIONS

## GENERAL

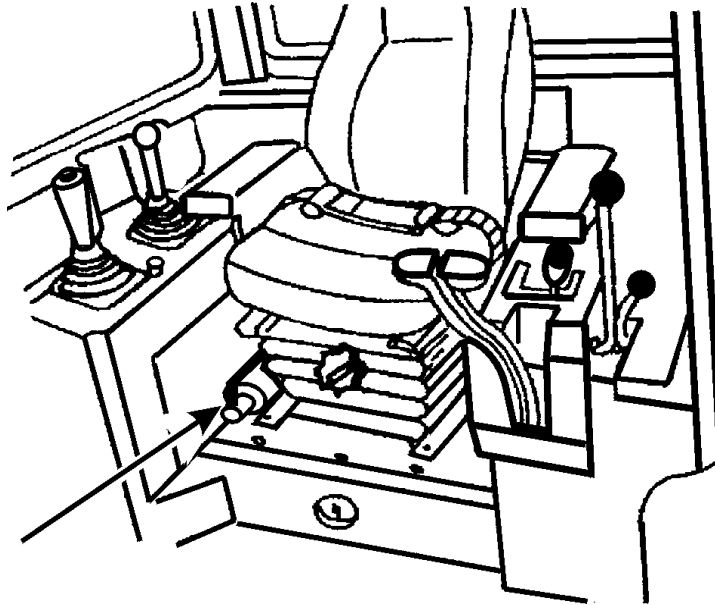

Fig. 2.1. Fire Extinguisher Location

Do not jump on or off the machine. Keep two hands and one foot or two feet and one hand in contact with the steps and grab handles and rails at all times.

Electrical system is 24-volt negative ground. Each machine is equipped with a starting receptacle. It should be used when starting the machine using booster batteries. In case the receptacle cannot be used the following precautions must be taken to minimize chances of injury or damage to electrical parts.

1. Turn the system master switch to the OFF position.
2. Attach one end of the jumper cable to the positive terminal of the booster battery and the other end to the positive terminal of the machine battery.
3. Attach one end of the second cable to the negative terminal of the booster battery and the other end to the machine's frame away from the battery.
4. To remove the cables, reverse the above sequence exactly to avoid sparks near the battery.

A frozen battery can explode when the booster cables are attached.

NEVER check battery charge by placing a metal object across the battery posts. Sparks can cause an explosion. Use a voltmeter or hydrometer for checking.

Each new machine is equipped with a fire extinguisher, first aid kit and safety belt.

## 2.2. BEFORE STARTING THE ENGINE

Never start the engine indoors unless proper exhaust ventilation is provided to remove deadly exhaust gases. Once the engine is operating, move the machine outdoors as soon as possible. Exhaust gases are dangerous and can cause unconsciousness and death.

Always place the transmission shift lever in neutral, apply the transmission neutral safety lock and lock the parking brake before starting.



## BEFORE STARTING THE ENGINE

The operator must be alert, physically fit and free from the influences of alcohol, drugs or medications that might affect his eyesight, hearing, reactions or judgment.

Observe and know the use of alternative exits from the operator compartment.

Safety must always be the operator's most important concern. He must refuse to operate when he knows it is unsafe and consult his supervisor when safety is in doubt. The best safety device is a safe operator.

Do not use controls or hoses as hand holds when climbing on or off the machine. Hoses and controls can move and do not provide solid support. Movement of the controls may cause inadvertent and unexpected movement of the machine or its equipment.

Follow all machine-mounted safety signs before starting, operating, maintaining or servicing the machine.

Be sure the area of the operator's compartment, all mounting steps and grab handles are free of oil, grease, loose objects, ice and mud to lessen the possibility of slipping. Remove or secure all maintenance and personal items so they will not interfere with the operator or jam the controls.

Perform a visual check of the machine before starting the engine. Look for such things as improper fluid levels, oil leaks, and loose, damaged or missing parts. Do not start the engine until any unsafe conditions are corrected. Secure all caps and filler plugs.

Know and understand the traffic flow patterns of your job and obey flagman, signs and signals.

Before entering the operator's compartment, clear the immediate area surrounding the machine of personnel and obstructions. Walk completely around the machine. After entering the operator's compartment, sound the horn to clear the immediate area of the machine.

Due to the danger of fire and explosion, never check or fill fuel tank or batteries near lighted smoking materials or open flame or sparks.

## 2.3. OPERATION

Check work area for hazardous conditions. Be alert for soft ground conditions, especially when working on slopes, near drop-offs or excavations or fill material, which could lead to sudden tipping of the machine.

At night and times of poor visibility, carefully check the work area before moving in with the machine. Use all lights provided.

Keep the windshield, windows and mirrors (if equipped) clean.

Before starting the engine, be sure you understand all control functions. Check all controls, including the brakes, decelerator, steering and transmission. Check all gauges, warning lights and safety devices. Correct any malfunctions.

Only one person, the operator, should be permitted to ride on the machine when it is in operation.

Perform an operational check of the machine in a safe area before putting it to work.

**OPERATION**

Keep operating controls, hands and shoes free of grease, water and mud to insure positive control functions.

If the machine is ROPS equipped, for your personal protection, wear your seat belt. Before driving the machine, adjust the seat and fasten the seat belt. Adjust the seat belt to fit snugly and flow around the hips to lessen the chance and severity of injury in the event of an accident. Never wear the seat belt across the abdomen.

Check overhead clearance carefully before operating the machine in areas with low overhead clearance, such as guy wires, power lines, bridges, low-hanging tree branches and building entrances or exits. These overhead obstructions could cause an accident.

After starting the engine, but before moving the machine, warn nearby personnel by giving a couple of short horn blasts.

Be sure that the rear screen is securely fastened to the ROPS structure before operating the winch. Operating without properly installed screen could result in serious injuries. Operate the winch from the driver's seat only. Always engage the parking brake before winching, if the machine is stopped. Use caution when installing or removing cable from the winch. Keep all persons clear of a cable under tension. Never use a cable that is damaged. Failure to follow these precautions could result in serious injuries.

Never mix gasoline, gasohol and/or alcohol with diesel fuel. This practice creates an extreme fire hazard and under certain conditions an explosion, which could result in personal injury or death.

Do not smoke when refueling or servicing the machine. A fire could result.

Never place gasoline or diesel fuel in an open pan.

Never remove the fuel tank filler cap or refill the fuel tank while the engine is running or hot or when the machine is indoors. Fumes are dangerous, a spark or flame could result in a fire or explosion.

On machines equipped with a suction fan or a reversible fan in the suction position, periodically check the engine exhaust system for leaks. Exhaust gases are dangerous to the operator.

Do not operate the machine in the condition of extreme fatigue or illness.

Be sure that the rear screen is securely fastened to the ROPS structure. Be sure chains or cables and their anchor points are strong enough to handle the expected load. Inspect carefully for flaws before using.

Always wear gloves when handling cables and chains. Avoid looping or knotting a cable or chain. Do not pull with kinked chain or cable as excessively high stress in the area of bending may cause a failure in the kinked area. Cables or chains for towing or winching should be fastened to the designated to this purpose attachment points only. Be sure the pins are attached securely before pulling. Stand clear of chains or cables under load.

Keep the engine exhaust system and exhaust manifold clear of combustible material for your personal protection.

Know the locations of underground cables, water mains, gas lines, etc. A ruptured gas line or cut electrical cable could result in personal injury or death.

## OPERATION

When leaving a machine unattended for any length of time, make sure the transmission shift lever is positioned and locked in neutral (N), the blade is completely lowered, the engine is stopped, the parking brake is applied, and the electric master switch is in the "off" position. If the machine is equipped with a cab make sure that the cab is locked.

Before operating a machine read and know the Operator's Manual and all Safety Product Graphic.

The roll-over protective structure (ROPS) provides the operator's protection in the event of machine rollover or upset. This structure is designed to bend during a rollover to protect the operator from sudden impact loads.

When operating a machine, look in the intended direction of travel to be sure personnel or allied equipment does not interfere with the machine work pattern.

Never try to get on or off a machine while it is moving. A serious injury or death could result.

Never shift the transmission into neutral (N) when traveling downhill. The machine may go out of control and a rollover could result or the transmission, torque converter or engine could be damaged when the transmission is again placed in gear. Always put the transmission in low range position before starting downhill. Use the decelerator and brake pedal to slow the machine.

Avoid side hill travel whenever possible. Drive straight up and down the slope. If the machine starts slipping sideways on a grade, turn downhill immediately.

If possible avoid crossing obstacles such as ridges, rocks or logs. If you can't avoid them, reduce speed and ease over the obstacle at an angle.

Machine's weight and the vibration it creates can cause the edge of a high wall to collapse. Keep your machine back from the edges of banks and excavations. If it cannot be avoided drive the machine at the straight angle to the edge.

Travel slowly in congested areas or on rough ground, slopes or near drop-offs or on snow, ice or slippery surfaces.

Maintain a safe distance between your machine and other vehicles according to the condition of the road and load.

Never hold the hydraulic controls in their extreme position after the equipment has reached its maximum travel. This could cause overheating of the hydraulic system.

Do not adjust the seat position while the machine is in motion. A loss of control may result. Completely stop the machine, apply and lock the parking brake and then adjust the seat.

Never use the blade as a brake except in an emergency.

Carry the blade low for maximum stability and visibility.

Where noise exposure exceeds the levels defined by proper health and safety authorities and applicable standards wear authorized ear protective equipment.

**2.4. MAINTENANCE**

Trained personnel in machine operation and their helpers only are allowed to take the operator's seat while doing maintenance or repairs on a machine. Authorized personnel only is allowed to control, maintain or repair a machine.

Do not hasten. It may cause accidents.

Put objects onto a machine standing on the level ground before you climb on the machine.

Loosen the radiator cap slowly to relieve all pressure in the system and use caution when removing the cap to prevent possible injury.

Have all equipment resting on the ground or blocked before removing any hydraulic component. Actuate the control levers in opposite directions to relieve all pressure from the system.

Never work beneath a blade or ripper without proper blocking. Improper blocking could result in serious injuries.

When service or maintenance requires access to areas that cannot be reached from the ground, use a ladder or platform. If such ladders or platforms are not available, use the machine's hand holds and steps provided. Perform all service or maintenance carefully.

Use only approved parts for repairs and maintenance shown in your parts catalog. Failure to do so could compromise your personal safety and machine's performance and reliability.

Never align holes with fingers or hands. Use a proper aligning tool.

Be sure all tools are in good condition. Do not use tools which are worn, bent or have mushroomed heads. Use the proper tool for the job. Remove sharp edges and burrs from reworked parts.

For field service, move the machine to the level ground, if possible and block the tracks. If work is absolutely necessary on an incline, block the machine and its attachments securely. Move the machine to the level ground, as soon as possible.

Before working on a machine, turn OFF the electric system master switch and take the key out so no one will start it unexpectedly.

Do not carry loose objects in your pockets that might catch on the machine or fall unnoticed into open compartments.

Before working on any part of the engine or electric system, disconnect the battery ground cable. Tag the cable and all controls to alert personnel that work is in progress.

When it is necessary to make any checks or adjustments with the engine running, always use two people. One trained person must be in the operator's seat to safeguard the second person making the checks or adjustments.

As an additional precaution, when making checks or adjustments with the engine running, make sure the transmission shift lever is locked in neutral (N), and the parking brake is locked.

Never stand on the tracks or near the blade while the engine is running.

## MAINTENANCE

If the engine is running and the side doors are open or removed be careful of rotating parts such as the fan and belts that can cause serious injury.

Never operate the engine when cleaning or lubricating the machine. Serious injury could result from contacting moving parts.

Use a non-toxic, nonflammable commercial solvent for cleaning parts. Never use gasoline, diesel fuel, kerosene or other flammable solvents for cleaning a part.

Excessive or repeated skin contact with sealant or solvents may cause skin irritation. In case of skin contact, remove sealant or solvent promptly by washing with soap and water. Follow the manufacturer's advice whenever cleaning agents or other chemicals are used.

Lower the blade and/or the ripper before making hydraulic adjustments. To prevent personal injury, be sure the personnel are standing out of the way of the blade when it is being lowered. Never allow anyone to walk under or be near unblocked raised equipment.

Provide proper ventilation when operating in a closed building to avoid danger of exhaust gases. Exhaust gases are dangerous and can cause poisoning, unconsciousness and death.

Hydraulic fluid escaping under pressure from a very small hole can be almost invisible, yet have sufficient force to penetrate the skin. Use a piece of cardboard or wood to search for suspected leaks. Do not use hands. If injured by escaping fluid, see a doctor at once. Serious infection or reaction can occur if proper medical treatment is not administered immediately.

Wear proper protective equipment such as goggles or safety glasses with side shields, hard hat, safety shoes and heavy gloves when metal or other particles are apt to fly or fall. Many of a machine's parts are hardened and can chip.

Lift and handle all heavy parts with a lifting device of proper capacity. Be sure parts are secured by proper slings and hooks. Use lifting eyes if provided. Warn people in the area to stand clear.

Do not attempt to repair a ROPS protective structure after an accident. Repaired structures do not provide the original strength and protection. Contact your distributor for information on structure replacement. Do not operate the machine again until the ROPS has been replaced.

Do not cut, grind, weld, drill or tap holes in the ROPS. This could weaken the structure, or affect the overall energy absorption capabilities.

When using compressed air for cleaning parts, wear goggles or safety glasses with side shields. Use a nozzle, which limits the pressure to 200 [kPa].

Do not use an open flame to check for leaks or fluid levels anywhere around a machine.

Keep work area clean and dry. Remove oil and water spills immediately. Do not pile up oily or greasy rags. They are a fire hazard. Store them in an approved, closed metal container.

Use a soft iron or nonferrous hammer to install or remove ripper teeth. It is dangerous to hammer on teeth. Wear safety glasses with side shields or goggles to reduce the chances of injury.

Batteries give off a highly flammable gas. Never allow sparks or open flame near the batteries. A fire or explosion could occur. Do not charge batteries in a closed area. Provide proper ventilation to guard against accidental explosion of an accumulation of the explosive gas given off in the charging process. When installing batteries, be sure the electric master switch is in the "OFF" position. Be sure to connect the positive cable to the positive terminal and the negative (ground) cable to the ground of the machine.

**MAINTENANCE**

Ether starting fluid is flammable. Follow the precautions printed on the container. An explosion can result if sparks or flame contact ether in a container or if a container is stored in an area where the temperature exceeds 70 [°C]. Observe the following precautions:

1. Follow the correct method for starting the engine. Refer to "STARTING THE ENGINE", Section 4.
2. Do not use the ether injector when the ambient temperature is above freezing.
3. For your own personal safety, always remove the ether container when welding, grinding or using a torch on a machine.
4. Do not let ether come in contact with your skin, as it can cause local freezing.
5. Do not breathe in hazardous ether vapor.
6. Keep a fluid container out of reach of children.
7. Never puncture a fluid container or put it into fire. Dispose of an empty container properly.
8. Do not store fluid containers in the operator's compartment.

Never mix gasoline or alcohol with diesel fuel. This creates an extreme fire or explosion hazard, which could result in personal injury or death.

Do not use bleach, color dye or solvents on the seat belt webbing. This may cause a severe loss of tensile strength. This could cause the webbing to break resulting in personal injury. It is recommended that the seat belt be cleaned only with warm water and mild detergent.

**2.5. SHUTDOWN**

If parking on or near traffic lanes cannot be avoided, provide appropriate flags, barriers, flares and warning signals. Also provide advance-warning signals in the traffic lane for approaching traffic. Park the machine in a non-operating and non-traffic area. Park the machine on level ground whenever possible. If you must park on a slope, park at the right angle to the slope. Apply and lock the brake pedal.

Never leave a machine unattended with the engine running.

When leaving a machine unattended, slowly lower the hydraulic equipment to the ground, shift the transmission into neutral and lock the neutral lock lever, shut off the engine, apply and lock the parking brake. Relieve any pressure in the hydraulic system by moving the controls in both directions. Turn off the electric system master switch and take the key out. Always lock up the machine when leaving it unattended, including any anti-vandalism attachments.

Do not jump off a machine.

When operating in bad weather and storm lightening is nearby, dismount and seek shelter away from the machine. Lightening will be attracted to the machine and can cause serious injury or death.

When a machine is to be loaded onto a transport truck and trailer do so carefully. Load only when the trailer is level. The steel track shoes will slide easily on the trailer. When the machine is properly positioned chain it securely so it can not move on the trailer.

Keep away your head, body, feet, hands and fingers from a blade or ripper when they are in a raised position.

## SHUTDOWN

Do not allow the hydraulic system to support the mounted equipment when leaving a machine unattended, to eliminate possibility of an unexpected drop of the blade or ripper.

### 2.6. SAFETY PRODUCT GRAPHIC LOCATION

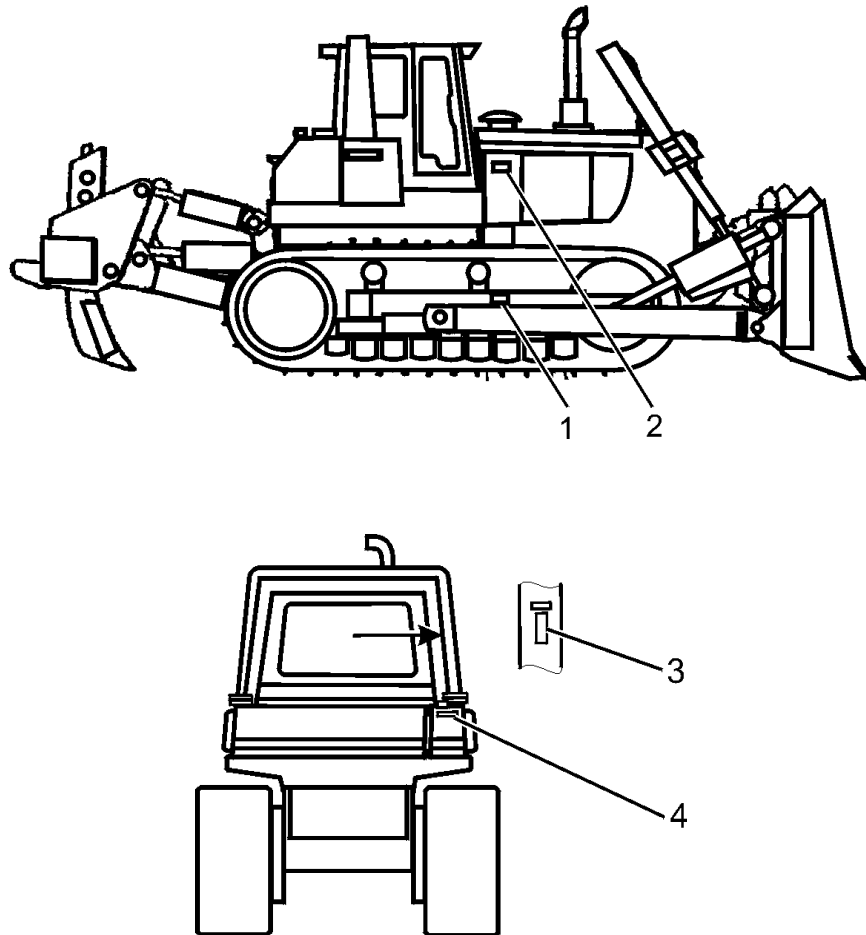

Fig. 2.2. Safety Product Graphic Location – Machine

1. Track Adjuster Decal
2. Door Decal
3. ROPS Decal
4. Pressurized Reservoir Decal

# SAFETY PRECAUTIONS

## SAFETY PRODUCT GRAPHIC LOCATION

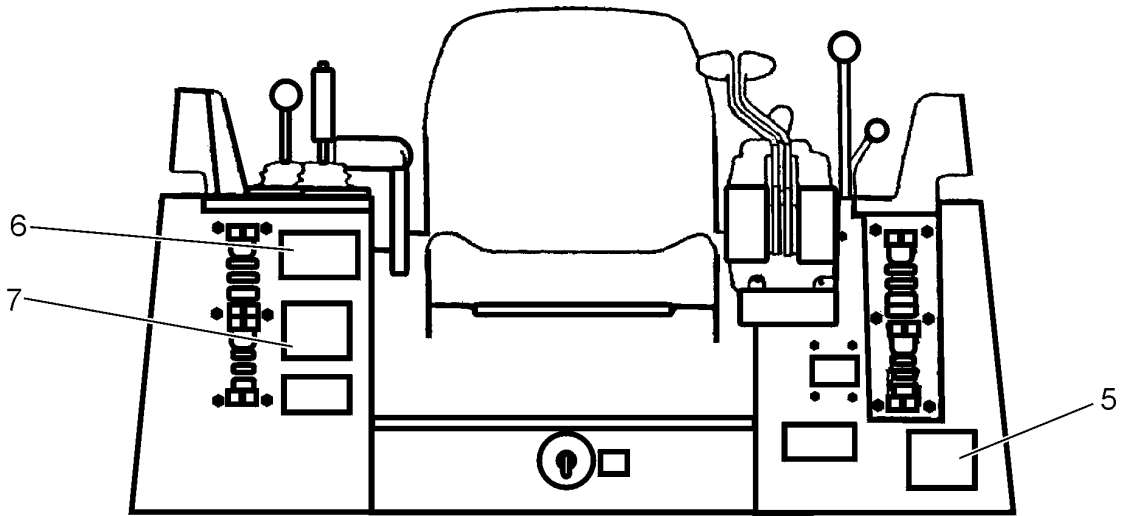

Fig. 2.3. Safety Product Graphic Location – Cab

- 5. General Decal
- 6. Instruction Decal for locking the lever to prevent incidental movement of a machine.
- 7. Safety Decal

### 2.6.1. SAFETY PRODUCT GRAPHICS



Decal 1



Decal 2



## SAFETY PRODUCT GRAPHIC LOCATION

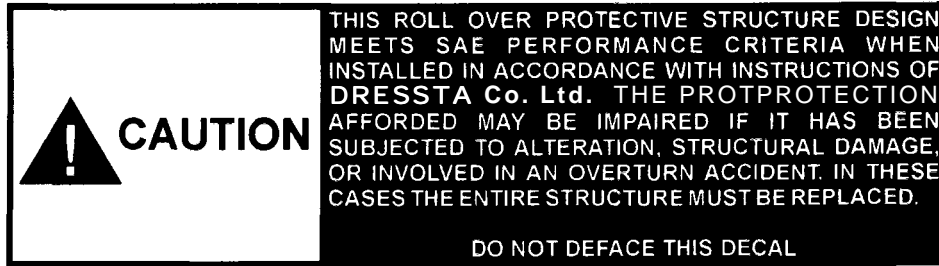

Decal 3



Decal 4



Decal 5

# SAFETY PRECAUTIONS

## SAFETY PRODUCT GRAPHIC LOCATION

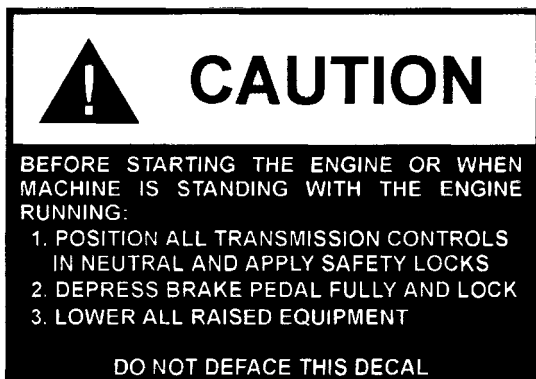

Decal 6



Decal 7

**SECTION 3**  
**MACHINE TRANSPORT AND STORAGE**

## SECTION CONTENTS

|  | PAGE |
|--|------|
| 3.1. Machine Transport .....                       | 3    |
| 3.1.1. General .....                               | 3    |
| 3.1.2. Truck .....                                 | 3    |
| 3.1.3. Railroad Flat Car .....                     | 3    |
| 3.2. Lifting a Machine on Slings .....             | 4    |
| 3.3. Moving a Disabled Machine .....               | 4    |
| 3.4. Machine Storage .....                         | 6    |
| 3.4.1. Preparing for Storage .....                 | 6    |
| 3.4.2. Servicing Machine During Storage .....      | 8    |
| 3.4.3. Preparing for Operation after Storage ..... | 8    |

### 3.1. MACHINE TRANSPORT

#### 3.1.1. GENERAL

**IMPORTANT:** When shipping this machine by high-speed means of transport secure the air intake cap and the exhaust outlet to protect the turbocharger from damage. Turn the system master switch to the OFF position.



**WARNING!** When transporting a machine, use caution when loading and unloading. Load and unload a machine in a level area which fully supports the machine and the transport vehicle so it cannot move. Use loading ramps of adequate strength, low angle and proper height.

#### 3.1.2. TRUCK

When shipping this machine by truck learn obligatory regulations. Contact local authorities for the proper shipping and loading regulations.

When preparing to transport a machine by truck, have the truck and trailer level.

1. Use ramps or loading dock to maintain stability.
2. Drive the machine in its lower gear.
3. Use the lowest engine speed that will move the machine and without stalling the engine.
4. The machine can be "inched" into place by holding the steering hand levers back and slowly moving them forward into the driving position. (Be careful and move the levers simultaneously otherwise the machine will turn).
5. Pulling the steering hand levers back will disconnect the drive. Pulled back part way they will permit the machine to roll freely.
6. When the machine is properly located, stop the engine, place the transmission control in Neutral (N), apply the Transmission Neutral lock Lever, apply and lock the brakes and turn the master switch OFF.
7. Tie the machine down securely by ropes or wires and by wooden blocks to prevent unintentional movement.



**DANGER!** Failure to secure the machine to the truck in a proper way during transporting can result in property damage, personal injury or death.

#### 3.1.3. RAILROAD FLAT CAR

Respective railroad loading rules and specifications must be followed when shipping this machine on open top railroad cars.

## SECTION 3 MACHINE TRANSPORT AND STORAGE

Page 4

### 3.2. LIFTING MACHINE ON SLINGS

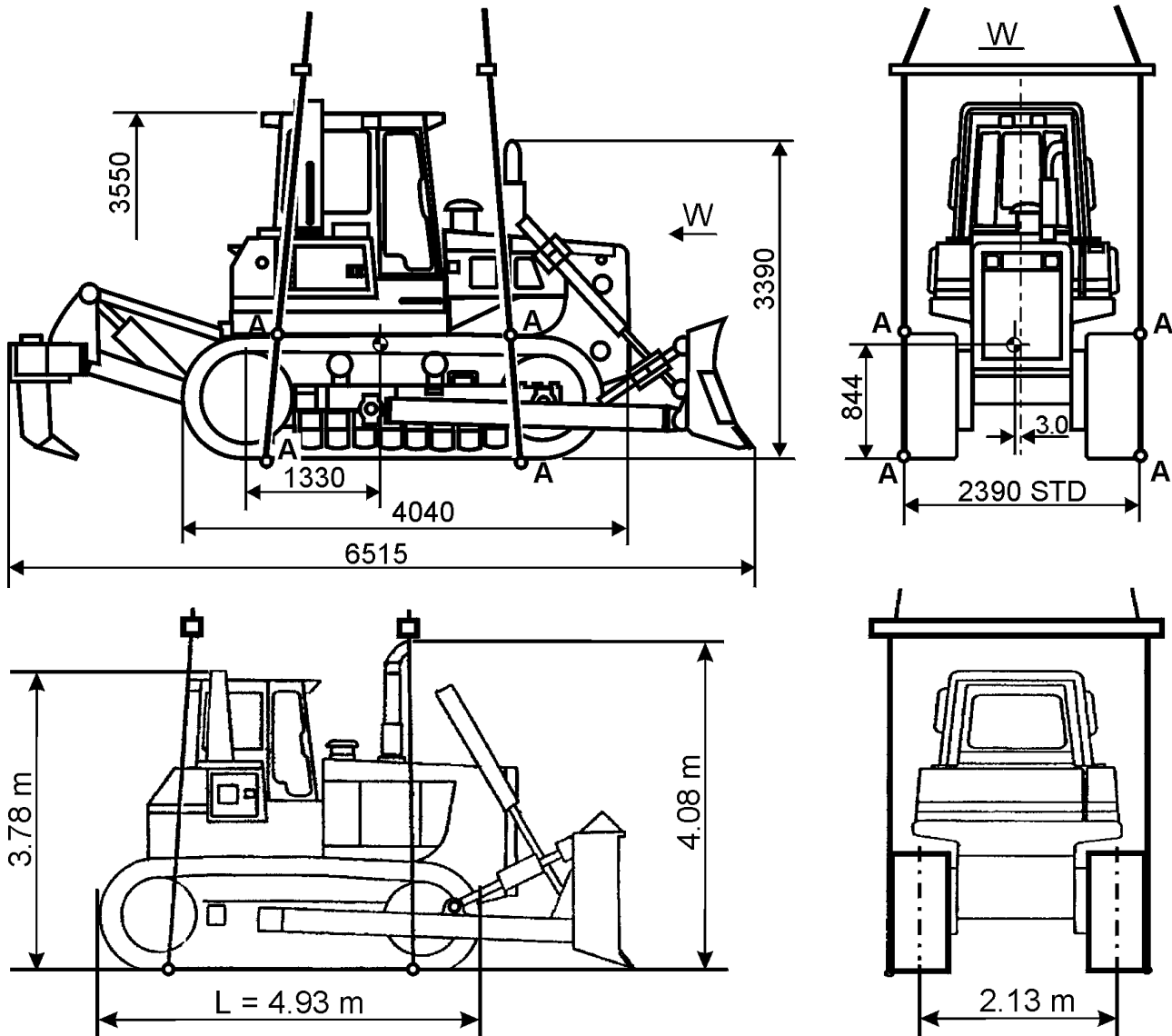

Fig. 3.1. Lifting Machine on Slings

1. Use slings of sufficient strength for machine weight.
2. Attach slings under the machine as shown in the drawing in the places marked by the letter „A” in the way preventing sliding of the sling from the track shoe and moving the track itself.
3. Attach spreader bars to the lifting slings to prevent them from slipping off.
4. Standard machine weight with a cab, ROPS structure, air conditioner, blade and ripper is 38,620 [kg].

### 3.3. MOVING A DISABLED MACHINE



**CAUTION!** When using a chain or cable, be sure it is strong enough for the expected load and is properly secured to the drawbar pins or tow hooks (if equipped).



**WARNING!** When pulling with a chain or cable, take up the slack slowly to avoid jerking. A chain or cable which fails under load can whip and cause serious injury. Stand clear. Do not pull or tow unless the operator's compartment is guarded against or out of reach of a whipping chain or cable. Attach only to the machine tow hook or drawbar. Failure to follow these instructions could cause serious injury.

***IMPORTANT!*** A machine ***MUST NOT*** be towed if the steering drive, final drive or their parts or subassemblies are out of order. It must be transported to avoid further damage.

To avoid a possibility of power train damage, limit towing to a distance of 1 [km] at speeds less than 2 [km/h]. The brakes on this machine are spring applied automatically when the engine is stopped or the steering hydraulic system fails, and can only be released hydraulically.

## SECTION 3 MACHINE TRANSPORT AND STORAGE

Page 6

### MOVING A DISABLED MACHINE

The diagnostic center (Fig. 3.2) has a quick couplers  $R_B$  and  $L_B$  for application of external hydraulic pressure to the LH and RH brake spools to release them prior to towing as described in the procedure specified below.

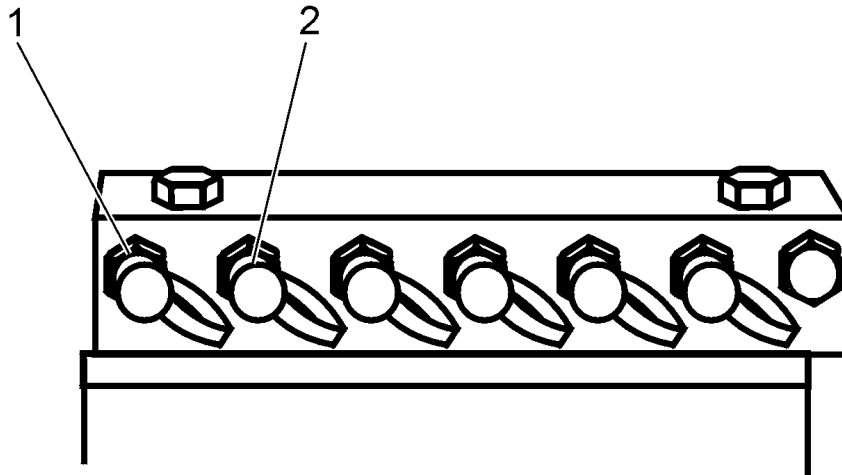

Fig. 3.2. Diagnostic Center – Tow and Pressure Check Ports

1. Right Brake Quick Coupler
2. Left Brake Quick Coupler

If the tractor can be towed and the engine and steering hydraulic system can be operated, proceed as follows:

1. Shift the transmission shift lever in "NEUTRAL" and lock it with the lever (A, Fig. 4.7)
2. Start the engine.
3. Release the brake and decelerator pedal.
4. Use a towing cable of sufficient strength. Keep the engine running in the middle range of the idle speed and hold transmission shift lever locked in "NEUTRAL" during the tow.

If the tractor can be towed but the engine and/or steering hydraulic system is inoperable proceed as follows:

1. Shift the transmission shift lever in "NEUTRAL" and lock it with the lever (A, Fig. 4.7)
2. Open the diagnostic center cover on the LH side of the machine and connect a lubricating fitting and pressure gauge to one of the quick couplers (port 1 or 2, Fig. 3.2).
3. Release the decelerator and brake pedal.
4. Pump sufficient grease into one of the ports to release the brakes. The connected pressure gauge should show a pressure of 830 - 1030 [kPa]. The amount of grease required depends on the amount of pressure dissipation in the system.
5. Use a towing cable of sufficient strength. During the tow, it may be necessary to pump more grease into the quick coupling to make up for the loss of pressure.
6. Depressing the decelerator and brake pedal will relieve hydraulic pressure and apply the brakes.
7. After towing is completed, actuate the steering levers until all grease is purged from the system and the pressure drops to zero (as measured on the brake port) while the decelerator and brake pedal is depressed and the steering levers are in the braking position.
8. Close the diagnostic center cover after disconnecting the lubricating fitting.



## 3.4. MACHINE STORAGE

### 3.4.1. PREPARING FOR STORAGE

When a machine is taken out of service and stored for more than 30 days, steps must be taken to protect the machine. Leaving the equipment outdoors exposed to the elements will materially shorten its life. An enclosure will protect a machine from rapid temperature changes and lessen the amount of condensation that forms in hydraulic components, engine, fuel tank and final drives. If it is not possible to put a machine in an enclosure, cover it with a tarpaulin.

After a machine has been positioned for storage and the engine shutdown, perform the following operations:

1. Visually inspect the machine for external leakage and other defects.
2. Clean the radiator, refer to "COOLING SYSTEM", Section 5.
3. Thoroughly clean the machine, be sure to rinse off any corrosive residue.
4. Correct any defects found. Consult Authorized Distributor of Construction Equipment, if necessary.
5. Clean or replace the air cleaner filter elements. Refer to "AIR CLEANING SYSTEM", Section 5.
6. The cooling system should be completely drained, chemically flushed, and refilled with a conditioned water/antifreeze solution suitable for the lowest temperature anticipated. Refer to "COOLING SYSTEM", Section 5 for the proper antifreeze and conditioner concentrations.

**IMPORTANT:** Under no circumstances should a vehicle be stored with a dry cooling system.

7. Drain the condensation water from the fuel tank. Refer to "FUEL SYSTEM", Section 5.
8. Remove and reinstall new fuel filters. Refer to "FUEL SYSTEM", Section 5.
9. It is recommended to use fuel stabilizer in the quantity as instructed by the manufacturer. Stabilizer will prevent degradation of fuel, sludge buildup and stops the growth of bacteria in fuel during storage. Fuel stabilizer may be purchased from:

**FUEL PREP 1000  
NALCO CHEMICAL COMPANY  
2901 BUTTERFIELD ROAD  
OAK BROOK, ILLINOIS 60521, USA  
or machines distributor**

10. Add 120 [ml] of volatile corrosion inhibitor "VCI" for each 100 liters of total fuel capacity to the fuel tank. "VCI" provides corrosion protection by contact with metal, and in a closed system, the vapors provide sufficient protection for areas that are not in contact with fuel. "VCI" may be purchased from:

**NOX RUST VCI # 105 OIL  
DAUBERT CHEMICAL COMPANY  
1200 JORIES BLVD  
OAK BROOK, ILLINOIS 60521, USA  
or machines distributor**



**WARNING!** Rust inhibitors are volatile and flammable. Prepare the machine in a well ventilated place. Keep away from open flame or sparks. **DO NOT SMOKE.** Store the container in a secure, cool, well ventilated place.

## SECTION 3 MACHINE TRANSPORT AND STORAGE

Page 8

### MACHINE STORAGE



**CAUTION!** Due to the volatile nature of "VCI", irritation of eyes and skin may occur. Prolonged exposure to the vapors or oil should be avoided.

11. Start the engine and run in the middle range of idle speed, no load, for approximately 4 minutes and then stop the engine.

12. Lubricate all points of the machine as outlined in the "SERVICE GUIDE", Section 5.

**NOTE:** Be sure to oil or grease all linkage connections, joints, nuts, pins, shafts, and bushings not covered in the "SERVICE GUIDE".

13. Drain the crankcase oil from the engine, replace the lubricating oil filter and refill with the specified oil. Refer to "ENGINE", Section 5.

14. Add 15 [ml] of "VCI" for each liter of engine oil capacity to the crankcase. (Example: if the total crankcase capacity is 10 liters, add 150 [ml] of VCI to the crankcase).

15. Start the engine and run it in the middle range of idle speed, no load, for approximately 30 seconds and then stop the engine.

16. Remove the air intake cap.

17. Pour 120 [ml] of "VCI" into the intake manifold to provide sufficient corrosion protection for the area between the top of the piston and the bottom of the cylinder head.

18. Add 350 [ml] of VCI to the hydraulic reservoir.

19. Seal all external openings (i.e. engine exhaust outlet, crankcase and hydraulic breathers, fuel vent line, air intake, etc.) with waterproof tape wide enough to cover the opening regardless of its size.

**NOTE:** When sealing with tape, be sure to extend the tape approximately 25 mm beyond opening to insure a good seal.

20. Remove the batteries and store them in a cool, clean, dry, well ventilated place away from areas of storing or dispensing fuel and oil, not near any heat source and preferably where the temperature range is between 0 [°C] to +21 [°C]. Be sure the batteries are fully charged.

**IMPORTANT:** Do not leave batteries on a concrete floor or in freezing temperatures.

**IMPORTANT:** If a machine is stored with dry-charged batteries or no batteries, the alternator output lead must be disconnected and insulated. Failure to do so may result in permanent damage to the alternator. Connect the output lead only after the batteries have been activated with electrolyte. Refer to "ELECTRICAL SYSTEM", Section 5.

21. If the blade is detached for storage, secure the cylinders to the machine to avoid damage.

22. Coat all machined, unpainted surfaces with chassis grease to prevent rust.

## MACHINE STORAGE

### 3.4.2. SERVICING MACHINE DURING STORAGE

#### ONE-MONTH REPETITIVE SERVICE PERIOD

#### MACHINES EQUIPPED WITH MAINTENANCE-FREE BATTERIES

Check if batteries are fully charged. Never allow batteries to run down below  $\frac{3}{4}$  full charge.

#### SIX-MONTH REPETITIVE SERVICE PERIOD

1. Visually inspect the engine and radiator for leakage and other defects. Correct all defects. If necessary, consult Authorized Distributor of Construction Equipment.
2. Remove all storage seals from the machine. (i.e. crankcase and hydraulic breathers, engine air intake, fuel tank vent lines, etc.).
3. Install fully charged batteries. Refer to "ELECTRICAL SYSTEM", Section 5.

**IMPORTANT:** Check that batteries are level in the holder and securely held. The hold-down fasteners should hold the batteries firmly but not tight enough to warp or damage either the hold-down bar or batteries.



**WARNING!** The battery cable shoes should be so arranged that access to the plugs is ensured. Lay the cables so that the wires should not rub hold-down bars or its fasteners. Always connect the negative ground cable last to minimize the chance of sparks or explosion.

4. Check the coolant level in the radiator and add proper concentrations of antifreeze and coolant conditioners, if required. Refer to "COOLING SYSTEM", Section 5.

**NOTE:** If excessive loss of coolant is detected, the problem should be corrected. Refer to "COOLING SYSTEM", Section 5.

5. Perform steps 7 through 22 of "PREPARING FOR STORAGE".

### 3.4.3. PREPARING FOR OPERATION AFTER STORAGE

1. Visually inspect the machine for external leakage and other defects.
2. Clean the radiator, refer to "COOLING SYSTEM", Section 5.
3. Thoroughly clean and wash the machine.
4. Correct any defects found. Consult Authorized Distributor of Construction Equipment if necessary.
5. Remove all storage seals from the machine (i.e. crankcase and hydraulic breathers, engine air intake, fuel tank vent lines, etc.).
6. Replace the air cleaner filter elements. Refer to "AIR CLEANING SYSTEM", Section 5.
7. Remove and discard fuel filters and replace with new ones. Refer to "FUEL SYSTEM", Section 5.
8. Fill the fuel tank with approved diesel fuel. Refer to "REFILL SPECIFICATIONS AND CAPACITIES CHART", Section 5.
9. Lubricate all points of the machine as outlined in the "SERVICE GUIDE", Section 5.

## SECTION 3 MACHINE TRANSPORT AND STORAGE

Page 10

### MACHINE STORAGE

**NOTE:** Be sure to oil or grease all linkage connections, joints, nuts, pins, shafts, and bushings not covered in the "SERVICE GUIDE".

10. Drain the engine oil from the crankcase and replace the engine lubricating oil filter. Refer to "ENGINE", Section 5.

11. Install fully charged batteries. Refer to "ELECTRICAL SYSTEM", Section 5.

**IMPORTANT:** Check that the batteries are level in the holder and securely held. The hold-down fasteners should hold the batteries firmly but not tight enough to warp or damage either the hold-down bar or batteries.



**WARNING!** Battery cable shoes are arranged in a way that access to the battery plugs is ensured. Battery cables should not rub hold-down bars or its fasteners. Always connect the negative ground cable last to minimize the chance of sparks or explosion.

12. Start the engine, refer to "ENGINE START AFTER OIL CHANGE OR PROLONGED STANDSTILL", Section 4. Observe all the gauges on the instrument panel for proper operation of the engine.



**WARNING!** Never start an engine indoors unless proper exhaust ventilation is provided. Once the engine is running, move the machine outdoors as soon as possible.

**IMPORTANT:** Crank the engine for a period of 30 seconds then allow the cranking motor to cool for two or three minutes before cranking again to avoid damaging the cranking motor.

**SECTION 4**  
**OPERATING**



SECTION CONTENTS

|  | PAGE |
|--|------|
| 4.1. Machine Precautions.....                                      | 3    |
| 4.2. Universal Symbols for Instruments and Controls .....          | 4    |
| 4.3. Instrument Panel .....  | 6    |
| 4.4. Cab Controls .....  | 9    |
| 4.5. Controls and Adjustment .....                                 | 10   |
| 4.5.1. Seat .....  | 10   |
| 4.5.2. Seat Belt .....   | 11   |
| 4.5.3. Engine Speed and Shut Down Lever .....                      | 12   |
| 4.5.4. Transmission Neutral Lock Lever .....                       | 13   |
| 4.5.5. Transmission Shift Lever .....                              | 13   |
| 4.5.6. Hand Steering Levers .....                                  | 14   |
| 4.5.7. Brake and Decelerator Pedal .....                           | 14   |
| 4.5.8. Brake and Decelerator Pedal Lock .....                      | 15   |
| 4.5.9. Electric System Master Switch .....                         | 15   |
| 4.5.10. Equipment Control Levers .....                             | 16   |
| 4.6. Starting the Engine .....                                     | 17   |
| 4.6.1. Normal Start .....  | 18   |
| 4.6.2. Ether Injector Start .....                                  | 19   |
| 4.6.3. Engine Start after Oil Change or Prolonged Standstill ..... | 20   |
| 4.7. Stopping the Engine .....                                     | 20   |
| 4.8. Tips for Engine Safeguarding .....                            | 21   |
| 4. 9. Driving the Machine .....                                    | 21   |
| 4.10. Shifting the Transmission .....                              | 22   |
| 4.11. Converter Overheating .....                                  | 23   |
| 4.12. Steering the Machine .....                                   | 23   |
| 4.12.1. Gradual Turn .....   | 24   |
| 4.12.2. Pivot Turn .....   | 24   |
| 4.13. Downgrade Operation .....                                    | 24   |
| 4.14. Operating Over an Obstruction .....                          | 24   |
| 4.15. Stopping the Machine .....                                   | 25   |
| 4.16. Parking the Machine .....                                    | 25   |
| 4.17. Operating Mounted Equipment .....                            | 26   |
| 4.17.1. Blade Control Lever .....                                  | 26   |
| 4.17.1.1. Hold .....   | 27   |
| 4.17.1.2. Raise .....  | 27   |
| 4.17.1.3. Lower .....  | 27   |
| 4.17.1.4. Float.....   | 27   |
| 4.17.1.5. Tilt .....   | 28   |
| 4.17.1.6. Pitch .....  | 28   |

|   |    |
|---|----|
| 4.17.2. Ripper Control Levers .....             | 28 |
| 4.17.2.1. Ripper Shank Pitch .....              | 29 |
| 4.17.2.2. Ripper Raise and Lower .....          | 29 |
| 4.17.2.3. Pin Puller Control Lever .....        | 29 |
| 4.18. Blade Positions .....                     | 30 |
| 4.18.1. Bulldozer Blade Positions .....         | 30 |
| 4.18.1.1. Tilting the Blade .....               | 30 |
| 4.18.1.2. Pitching the Blade .....              | 31 |
| 4.18.1.3. Levelling the Blade .....             | 31 |
| 4.19. Operating Techniques .....                | 32 |
| 4.19.1. Digging and Clearing .....              | 33 |
| 4.19.2. Transporting, Piling or Loading .....   | 37 |
| 4.19.3. Breaking Piles and Spreading .....      | 38 |
| 4.19.4. Ripping .....                           | 39 |
| 4.19.4.1. Prior to Operation .....              | 39 |
| 4.19.4.2. Ripping Techniques .....              | 40 |
| 4.19.4.3. Cold Weather Operation .....          | 40 |
| 4.20. Economical Operation of the Machine ..... | 40 |



**4.1. MACHINE PRECAUTIONS**

During operation stay alert and watch what you are doing. Use common sense and do not operate when fatigued.

Know your machine.

For your personal safety read this manual carefully and follow all instructions and precautions. Refer to and read Section 2 carefully and follow all precautions.

Before starting or operating this tractor, read the following general precautions. These are listed there to help you protect the machine and to remind you of protection for yourself and those around you. Sound judgment and observance of these rules will help make your job a safer one. Visually check out the machine for leaks and broken, missing or malfunctioning parts. Be sure all caps, dipsticks, battery caps, etc. are secure before starting. Correct any problems before operating the machine.

Before starting operation, check the machine for correct function of steering controls, brake controls, hydraulic controls, instruments and safety equipment. Make all necessary repairs or adjustments before operating the machine.

Keep the transmission in low gear when going downhill. Never coast downhill with the transmission in neutral. The machine could go out of control and tip over. Always drive the machine slowly when on hillsides, ramps or rough terrain. Be extremely careful when working around trenches or banks. Failure to do so could cause the machine to roll over.

Do not place the tractor under load without the proper engine oil pressure and operating temperature. After starting the engine, move the engine speed control lever to the low idle position. Allow the engine to run at low idle for 3 to 5 minutes at 1000 [RPM] until normal oil pressure registers on the gauge to obtain complete distribution of the lubricating oil. Oil pressure after 15 seconds must be correct. Do not idle the engine for more than 10 minutes.

To prevent any possible damage to the alternator, the electric system master switch must be in the "ON" position when the engine is running. The switch must be in the "OFF" position only when the engine is shut down at the end of each day or when the operator leaves the tractor unattended.

If the tractor is left outside during cold weather and the tracks become frozen to the ground, do not attempt to jerk them free with the power of the engine. Start the tractor slowly and, if the tracks do not break free, pry them loose. To prevent the tracks from freezing in the ground, park the tractor on planks.

In freezing weather thoroughly clean all ice and mud from the track system after each day's operation to prevent freeze-up of the system. Be sure to clean the seal area of the final drives, front idlers, top idlers and rollers.

Never pour cold coolant into the radiator, if the engine is very hot unless the conditions make it absolutely necessary. Use extreme caution as hot coolant could burn you. Keep your face away from the filler neck. Under such conditions, start the engine and let it idle while slowly pouring the coolant into the radiator. Allow the engine to cool down to 50 [°C].

Pouring cold coolant into an engine may result in damage to the cast components of the engine.

Never use water alone in the cooling system. Fill the fuel tank at the end of each day's work to reduce moisture condensation in the tank.

**MACHINE PRECAUTIONS**

When using a long chain or cable to hitch the tractor to the load, drive the tractor forward slowly until all slack is taken out. Before shutting down, operate the engine at half speed (no load) for three to five minutes. This will aid in cooling the engine and turbocharger.

**4.2. UNIVERSAL SYMBOLS FOR INSTRUMENTS AND CONTROLS**

The use of universal symbols will pictorially identify various instruments and controls. These symbols are an effort to overcome language differences for all operators in a positive way, thus enhancing their safety through quicker recognition of the instruments and controls while operating the equipment.

Study the following symbols so you will know their meaning immediately and at a glance.

UNIVERSAL SYMBOLS FOR INSTRUMENTS AND CONTROLS

The bellow symbols are used in crawler dozers, however, not all of them must be used on this machine.

























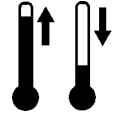
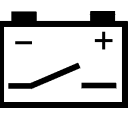



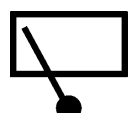





















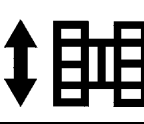
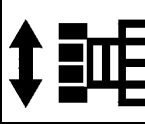
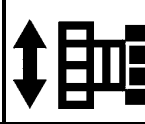



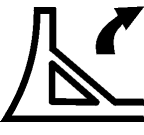



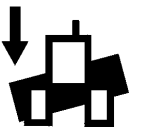
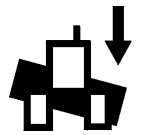

|  |   |   |  |   |  |   |   |
|--|---|---|--|---|--|---|---|
| ON<br>(GENERAL)<br>           | OFF<br>(GENERAL)<br>             | FWD or UP<br>                          | REVERSE<br>or DOWN<br>            | FWD<br>or REVERSE<br>    | HOURLY METER<br>            | DANGER<br>WARNING<br>        | Caution high<br>pressure<br>           |
| Variable slide<br>CONTROL<br> | Variable rotation<br>CONTROL<br> | Next speed<br>(straight-line)<br>2<br> | Next speed<br>(rotation)<br>1<br> | NEUTRAL<br>position<br>  | A/C<br>                     | Electrical<br>receptacle<br> | Temperature<br>check<br>               |
| Battery<br>switch<br>         | Voltmeter<br>                    | Lights<br>                             | Dome<br>lights<br>                | Windshield<br>Wiper<br>  | Rear window<br>wiper<br>    | Window<br>washer<br>         | Fan<br>                                |
| Horn<br>                     | Fuel filler<br>                 | Fuel level<br>                        | Air cleaner<br>                  | Coolant level<br>       | Coolant<br>temperature<br> | Engine<br>                  | Engine RPM<br>                        |
| Oil pressure<br>            | Starting aid<br>               | Drive train<br>oil filler<br>        | Oil pressure<br>                | Oil filler<br>         | Oil level<br>             | Oil<br>temperature<br>     | Oil pressure<br>diagnostic point<br> |
| Hydraulic<br>oil filler<br> | Hydraulic<br>oil level<br>     | Undercarriage<br>                    | Vehicle FWD<br>or REVERSE<br>   | LH Track<br>driven<br> | RH Track<br>driven<br>     | RH Track<br>brake<br>      | LH Track<br>brake<br>                |
| Hydraulic filter<br>        | Blade<br>                      | Raise<br>                            | Hold<br>                        | Lower<br>              | Float<br>                 | Left Tilt<br>              | Right Tilt<br>                       |
| Left Angle<br>              | Right Angle<br>                | FWD Pitch<br>                        | AFT Pitch<br>                   | Ripper<br>             | Raise<br>                 | Hold<br>                   | Lower<br>                            |
| FWD Pitch<br>               | AFT Pitch<br>                  | Coolant filler<br>                   | Grease<br>Lubricant<br>         | Engine<br>Start<br>    | Parking Brake<br>         | Brake ON<br>               | Lift or lift point<br>               |

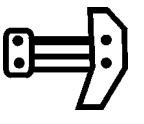
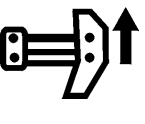
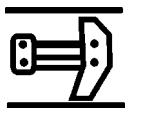
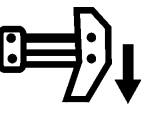
Fig. 4.1. Universal Symbols for Instruments and Controls

4.3. INSTRUMENT PANEL

**General**

This section covers the location and function of the various instruments and controls. More detailed information regarding operation of controls can be found in the following text within this section. Regardless of previous experience as an operator; you must be thoroughly familiar with the location and use of all instruments and controls before operating a machine.



**CAUTION!** Understand all control functions before starting the engine.

**IMPORTANT:** After starting and while operating observe instruments and warning lights frequently.

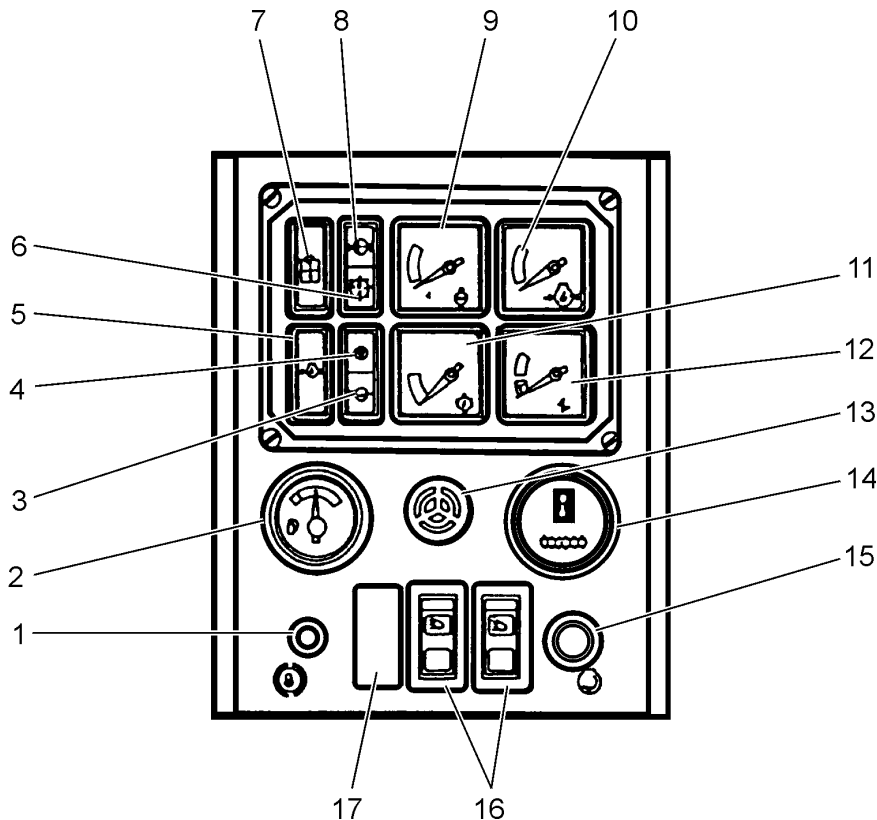

Fig. 4.2. Instrument Panel

- 1. Brake Lock
- 2. Fuel Level Gauge
- 3. Engine Coolant Level Warning Light
- 4. Air Cleaner Filter Warning Light
- 5. Low Engine Oil Pressure Warning Light
- 6. Transmission Oil Pressure Filters Warning Light
- 7. Hydraulic Oil Filters Warning Light
- 8. Transmission Main Low Oil Pressure and Clutch Low Oil Pressure Warning Light
- 9. Engine Coolant Temperature Gauge
- 10. Engine Oil Pressure Gauge
- 11. Torque Converter Oil Temperature Gauge
- 12. Voltmeter
- 13. Engine Coolant Low Level and Engine Low Oil Pressure Alarm
- 14. Hourmeter
- 15. Starting Button and Warning Light Check
- 16. Lights Switches
- 17. Ether Injector Switch

## INSTRUMENT PANEL

## 1. BRAKE LOCK

This handle locks the brake and decelerator pedal in the applied position for parking the machine. To lock the brake and decelerator pedal, fully depress the pedal, pull out the lock handle and remove your foot from the pedal. To release the brake, simultaneously depress the brake pedal and push in the lock handle.

## 2. FUEL LEVEL GAUGE

The gauge indicates quantity of fuel available for operation in the fuel tank.

## 3. ENGINE COOLANT LEVEL WARNING LIGHT

The engine coolant level indicator will glow, if coolant level drops below the operating level. This light is supplemental to low engine coolant and oil pressure alarm (13) on instrument panel.

## 4. AIR CLEANER FILTER WARNING LIGHT

The air cleaner filter warning light will glow amber when the filter element reaches the maximum allowable restriction. When this happens, filter element service is required and examining the problem. Refer to "AIR INTAKE SYSTEM".

## 5. LOW ENGINE OIL PRESSURE WARNING LIGHT

The engine oil pressure warning light will glow and the audible alarm will sound when engine oil pressure is low. When this happens stop the engine immediately and investigate the problem.

## 6. TRANSMISSION OIL PRESSURE FILTERS WARNING LIGHT

The transmission oil filter indicator will glow amber when one of the oil filter element reaches the maximum allowable restriction. When this happens, transmission pressure filter change is required.

## 7. HYDRAULIC OIL FILTERS WARNING LIGHT

The hydraulic oil filter warning light will glow amber when the oil filter element reaches the maximum allowable restriction. When this happens, filter change is required.

## 8. TRANSMISSION MAIN LOW PRESSURE AND CLUTCH LOW OIL PRESSURE WARNING LIGHT

The transmission clutch low oil pressure warning light will glow when there is insufficient oil pressure in neutral position or insufficient oil pressure available for the transmission clutches with transmission in gear. When warning light is activated stop the engine and clean transmission system suction filter and check oil level in rear frame. Refer to "TRANSMISSION SYSTEM" in Section 5. If the light continues to glow stop the engine and consult Authorized Distributor of Construction Equipment before operating the machine.

## 9. ENGINE COOLANT TEMPERATURE GAUGE

This gauge shows the temperature of the coolant circulating through the engine. After the engine has operated a sufficient length of time, the pointer of the gauge must be in the GREEN area of the gauge. During normal operation the gauge readings may vary between the minimum and maximum indicated by the GREEN area of the gauge.

Continuous engine operating above the maximum temperature is harmful to the engine. Low coolant temperatures will also cause exhaust smoke and increase the rate of fuel consumption.

**NOTE:** *In cold weather, if no louver is mounted, it may be necessary to cover part of the radiator to maintain the minimum coolant temperature indicated at the lower end of the GREEN area.*

The engine temperature under full load should remain in the GREEN of the gauge.

## INSTRUMENT PANEL

## 10. ENGINE OIL PRESSURE GAUGE

This gauge shows the pressure at which the lubricating oil is circulating through the engine. The pointer must register in the GREEN area during operation of the engine. If the red light of the gauge starts glowing stop the engine immediately.

## 11. TORQUE CONVERTER OIL TEMPERATURE GAUGE

This gauge shows the temperature of oil in the torque converter. The pointer of the gauge must be in the GREEN area of the gauge. If the pointer is above the GREEN area of the gauge check the following:

- whether the transmission is not in a gear range too high for the load handled,
- the oil level in the rear main frame,
- the radiator for cleanness,
- suction filter for cleanness and suction line for leaks.

If the pointer still remains beyond the GREEN area, consult an Authorized Distributor of Construction Equipment.

## 12. VOLTMETER

The voltmeter indicates the condition of the batteries. At low idle speed, the gauge pointer should be within the GREEN area with white stripe, which indicates a good battery charge. If the voltage drops below this area, the batteries should be checked.

With the engine operating above low idle speed, the pointer should be within the upper GREEN area, which is the normal operating range. If the pointer drops below or exceeds this area, the battery, alternator or wiring may be at fault.

## 13. LOW ENGINE COOLANT AND LOW OIL PRESSURE ALARM

This alarm will sound when engine lubricating oil pressure or coolant level in the radiator drops below normal. If so, stop the machine and find out which warning light glows and check the gauge indication.

## 14. HOURMETER

The hourmeter electrically records actual hours of engine operation. The purpose of the hourmeter is to indicate when to perform the recommended maintenance and lubrication operations. The hourmeter will register only when the engine is running.

## 15. STARTING AND WARNING LIGHTS CHECK BUTTON

The button is used to crank the engine.

**IMPORTANT:** To prevent damage to the starter motor and avoid low battery output, do not continuously crank the engine for a period longer than 30-second. Allow 2 to 3 minute recovery intervals between cranking.

Before starting the engine place the transmission neutral lock in neutral (OFF) and the electric system master switch in the ON position. Depress the starting button and check if all warning lights glow. If any warning light doesn't glow that indicates that the bulb is defective or its circuit is broken.

## 16. LIGHTS SWITCHES

The work light switches are the rocker type switches. When activated they turn on the front and/or the rear work lights.

## 17. ETHER INJECTOR SWITCH

This switch controls the ether injector for cold weather starting. Refer to "STARTING THE ENGINE" for proper operation of this switch.

## 4.4. CAB CONTROLS

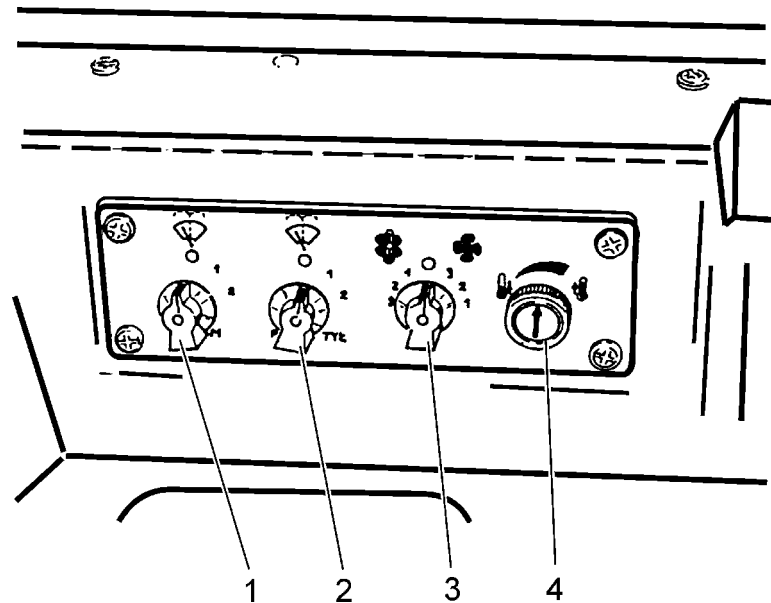

Fig. 4.3. Air Conditioner, Heater and Accessories Controls

1. Door Wipers Switch and Washer Push-button
2. Windows Wiper Switch and Washer Push-button
3. Heater and/or Cooler Pressurizer Control Switch
4. Temperature Control Knob

#### DOME LIGHT

Dome light is switched on with a switch mounted in the light.

#### CAB VENTILATION

**NOTE:** For maximum cooling turn the temperature control knob fully to the left.

##### 1. DOOR WIPERS SWITCH

This switch activates window wipers and washers. The switch enables two-speed selection of the wipers that is: low (position 1) and high (position 2). Push the washer button to spray washer fluid.

##### 2. WINDOW WIPERS SWITCH

This switch activates window wipers and washers. The switch enables two-speed selection of the wipers that is: low (position 1) and high (position 2). Push the washer button to spray washer fluid.

##### 3. HEATER AND/OR COOLING PRESSURIZER CONTROL SWITCH

This switch controls the speed of the fan circulating the air inside the cab. It has three speed settings: low, medium and high. Turn the knob to the left for three fan speed selections when cooling the air, i.e. low, medium and high.

Turn the knob to the right for three fan speed selections when heating air i.e. low, medium and high. To turn the fan off, turn the knob to the central position.

##### 4. TEMPERATURE CONTROL KNOB

To supply cool air into the cab, turn the temperature control knob off (completely to left). The rate of cooling can be adjusted by selection of fan speed as required.

To increase the temperature of the air, turn the temperature control knob to the right. A turn of the knob opens the valve which lets more coolant through the heater and increases the temperature of the air entering the cab.

## 4.5. CONTROLS AND ADJUSTMENT

## 4.5.1. SEAT

## SEAT ADJUSTMENT LEVERS

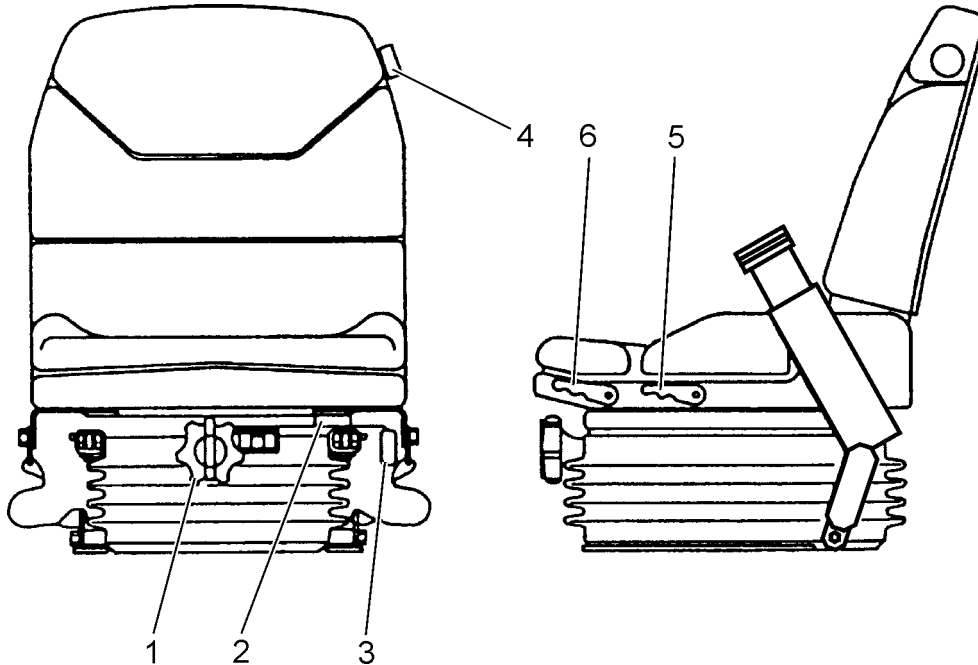

Fig. 4.4. Seat

1. Operator' s Weight Adjustment Knob
2. Seat Travel Lever
3. 15 [°] Swivel to Right Lever
4. Back Rest Profile Adjustment Knob
5. Back Cushion Tilt Lever
6. Seat Adjustment Lever

The operator's seat is adjusted as follows:

Press tilt lever (5) to adjust the required angle of the back cushion.

Turn knob (1) to adjust to your own weight. Move lever (2) forward to slide the seat back or forth.

Turn knob (4) located on the left side of the back rest to adjust the back rest profile.

For ripping operations lift lever (3) to swivel the seat 15[°] to the right.



## CONTROLS AND ADJUSTMENT

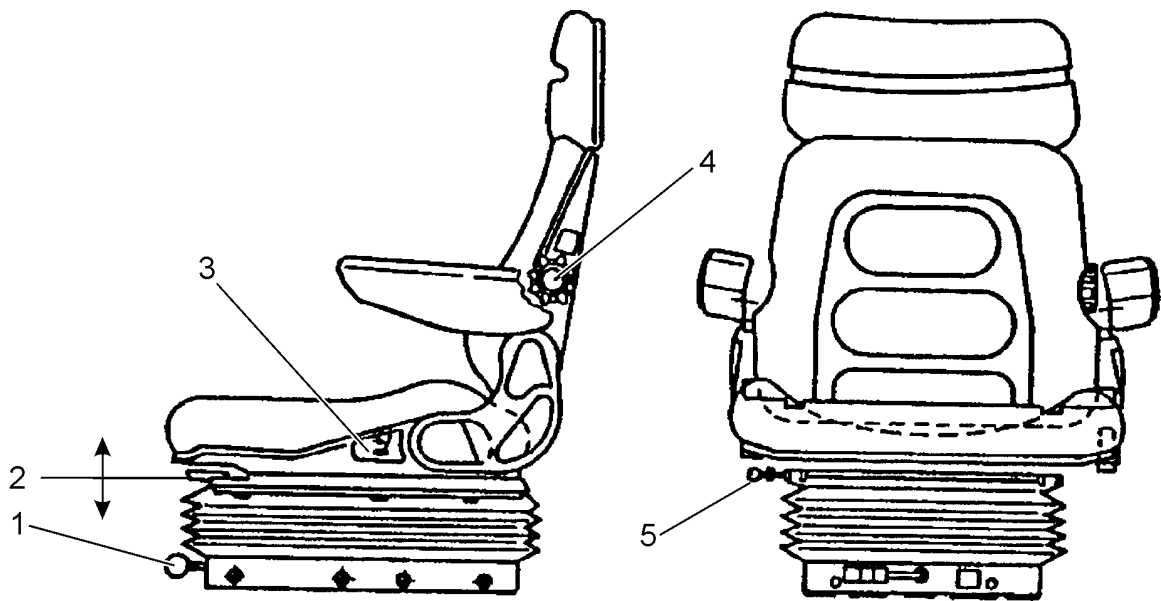

Fig. 4.4A. GRAMMER Seat (if equipped)

1. Operator's Weight Adjustment Lever
2. Seat Height Adjustment Lever
3. Back Rest Angle Adjustment Lever
4. Back Rest Profile Adjustment Knob
5. Seat Travel Lever

This is a suspension seat with several adjustments to provide maximum comfort to the operator.

Set with lever (1) the initial load according to the operator's weight.

The seat cushion can be set in one of the following three positions: "low", "medium" and "high". To change the position press the cushion down or lift it up as necessary.

Turn knob (4) to adjust the backrest profile.

Pull lever (5) forward and slide the seat forward or rearward to the desired positions and lock with the lever.

The backrest angle can be adjusted with lever (3).

The seat is equipped with arm rests and safety belt. The seat belt is the emergency type and does not need to be adjusted.

#### 4.5.2. SEAT BELT



**WARNING!** Before driving a machine adjust the seat and fasten the seat belt. Adjust the belt to fit snugly and low around the hips to lessen the chance and severity of injury in the event of an accident. Never wear the belt across the abdomen.

# OPERATING

## CONTROLS AND ADJUSTMENT

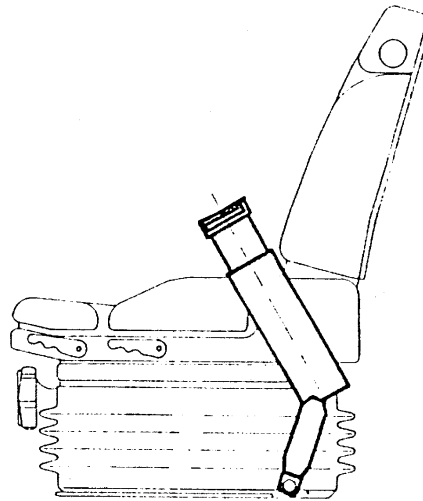

Fig. 4.5. Seat Belt

To buckle, insert the tongue portion of the buckle into the locking portion.



**WARNING! Do not use bleach, color dye or solvents on the seat belt webbing. This may cause a severe loss of tensile strength. This could cause the webbing to break resulting in personal injury.**

It is recommended that the seat belt be cleaned only with warm water and a mild detergent. Keep belt flat to avoid twisting and roping when not being used. Do not place heavy or sharp object on the belt.

### 4.5.3. ENGINE SPEED AND SHUT DOWN LEVER

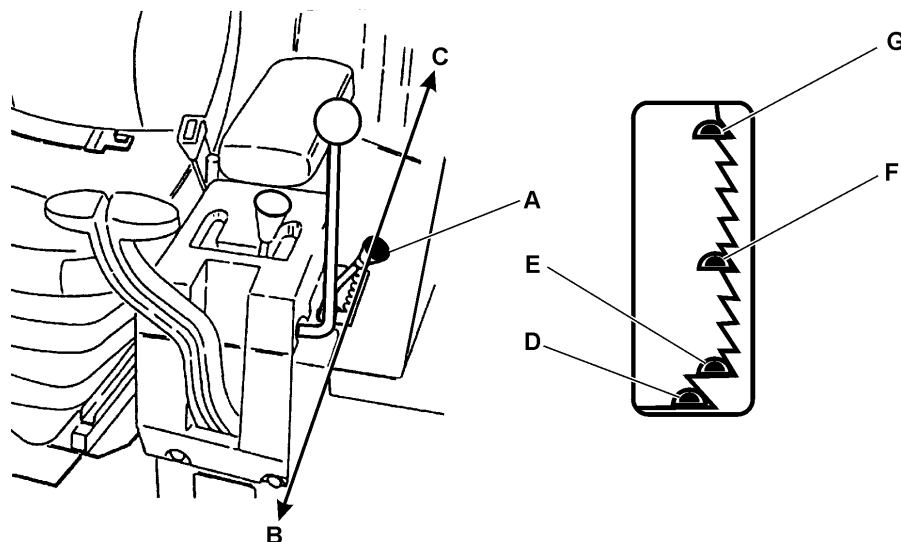

Fig. 4.6. Engine Speed and Shut Down Lever

- |                                      |   |
|--------------------------------------|---|
| A. Engine Speed and Shut Down Lever  | E. Cutout for Engine Start and Low Idle Speed |
| B. Lever Forward to Decrease Speed   | F. Medium Idle Speed                          |
| C. Lever Back to Increase Speed      | G. High Idle Speed                            |
| D. Large Cutout for Engine Shut Down |   |

## CONTROLS AND ADJUSTMENT

This lever (A) is used to start the engine, control speed of the engine or to shut it off. Push this lever forward (B) to decrease engine speed. Pull the lever back (C) to increase engine speed. Position lever in this large cutout (D) to shut down the engine.

## 4.5.4. TRANSMISSION NEUTRAL LOCK LEVER

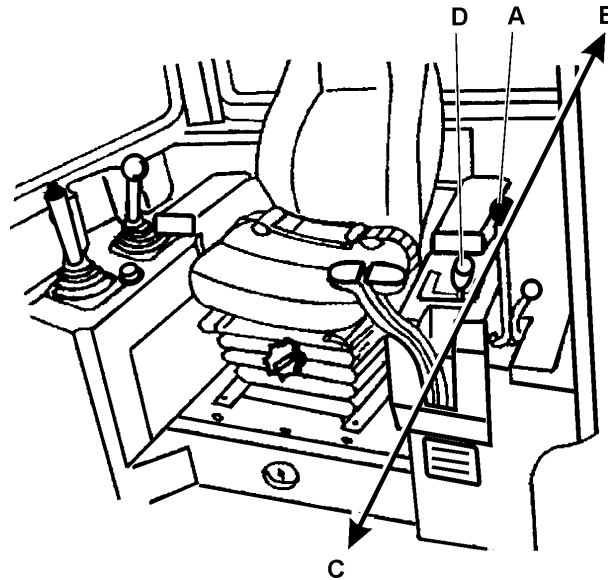

Fig. 4.7. Transmission Neutral Lock Lever

- |                                       |   |
|---------------------------------------|---|
| A. Transmission Neutral Lock Lever    | C. Lever Forward to Release Shift Lever |
| B. Lever Rearward to Lock Shift Lever | D. Transmission Shift Lever             |

This lever (A) is used to lock the transmission shift lever in "NEUTRAL." Move the lever backward (B) (ON position) to lock the shift lever, or forward (C) (OFF position) to release. When starting the engine place the transmission shift lever in "NEUTRAL" and the transmission neutral lock lever in the position (B) (ON).

## 4.5.5. TRANSMISSION SHIFT LEVER

Lever (D, Fig. 4.7) is used to select the various transmission gear ranges and directional ranges. Refer to "SHIFTING THE TRANSMISSION – 4.10"

**NOTE:** When the shift lever is placed in one of the reverse positions, the back-up alarm will sound automatically.

# OPERATING

## CONTROLS AND ADJUSTMENT

### 4.5.6. HAND STEERING LEVERS

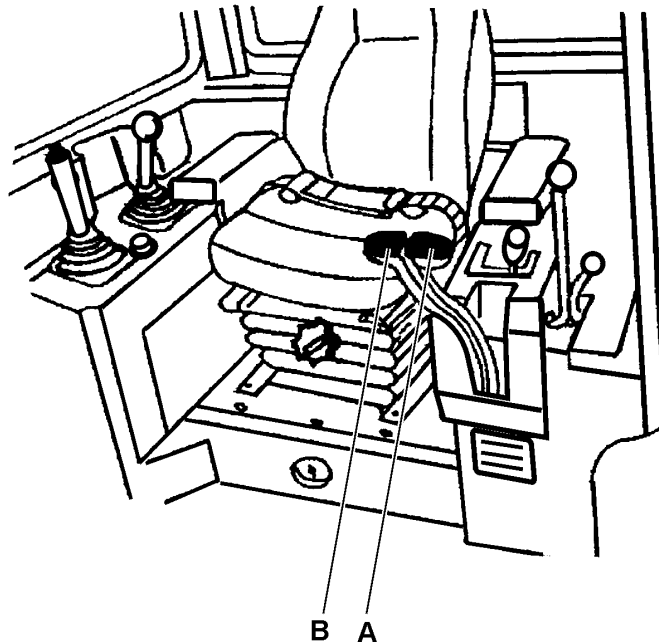

Fig. 4.8. Hand Steering Levers

- A. Left Hand Steering Lever
- B. Right Hand Steering Lever

These levers steer the machine by controlling engine power to the tracks and by applying and releasing respective speed range clutch packs and brake clutch packs. The left hand steering lever (A) controls the left track with the right hand steering lever (B) controlling the right track. Refer to "STEERING THE MACHINE".

### 4.5.7. BRAKE AND DECELERATOR PEDAL

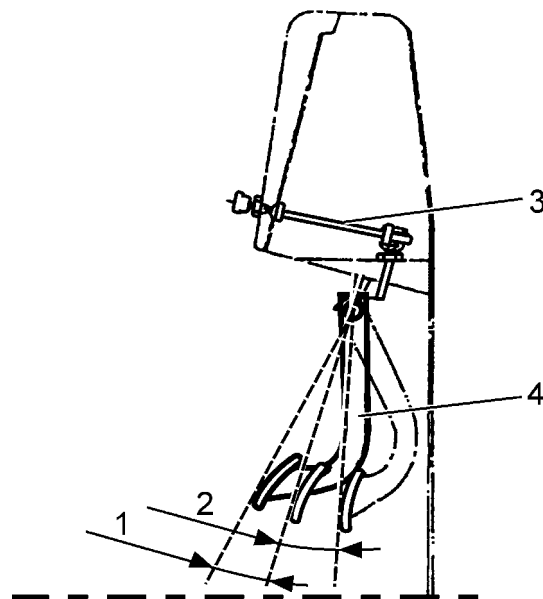

Fig. 4.9. Brake and Decelerator Pedal Adjustment

- 1. Deceleration Angle (10 [°])
- 2. Braking Angle (14 [°])
- 3. Brake Lock Linkage
- 4. Brake and Decelerator Pedal

## CONTROLS AND ADJUSTMENT

This pedal overrides the engine speed control lever setting. Partial depression of the pedal decreases engine speed for smoother changes in machine direction and to ease the machine up to a load. Release the pedal to accelerate the engine speed control lever setting. This pedal stops the machine when fully depressed. It also serves as a parking brake when the brake pedal lock is applied and brake pedal lock knob is pulled out.

Periodic adjustment of the pedal might be required. If the adjustment values are not within those shown in Fig. 4.9 contact an Authorized Distributor of Construction Equipment.

## 4.5.8. BRAKE AND DECELERATOR PEDAL LOCK

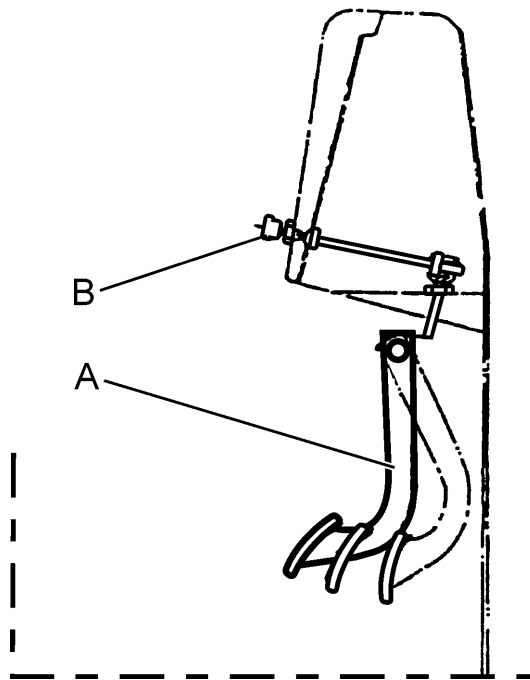

Fig. 4.10. Brake and Decelerator Pedal and Lock

- A. Brake and Decelerator Pedal
- B. Brake Lock

This lock secures the brake and decelerator pedal in the applied position for parking a machine. To lock the brake and decelerator pedal fully depress the pedal, pull out the lock and remove your foot from the brake and decelerator pedal. To release the brake, depress the brake and decelerator pedal and push the lock. Then release the pedal.

**IMPORTANT:** Release the brake pedal lock before moving a machine. The brakes could burn or steering clutches be damaged if a machine is driven with partially applied brakes.

## 4.5.9. ELECTRIC SYSTEM MASTER SWITCH

Turn the key clockwise to connect the battery ground circuit. Turn the key counterclockwise to disconnect the battery ground circuit.

**IMPORTANT:** Keep the switch on while the engine is running.

## OPERATING

### CONTROLS AND ADJUSTMENT

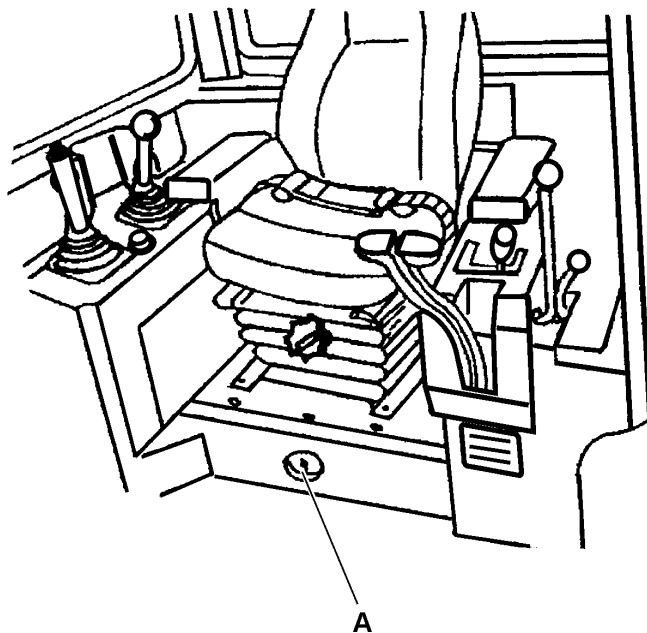

Fig. 4.11. Electric System Master Switch  
A. Electric System Master Switch Key

#### 4.5.10. EQUIPMENT CONTROL LEVERS

The levers are used to control the mounted equipment such as blade and/or ripper. Refer to "OPERATING THE MOUNTED EQUIPMENT"

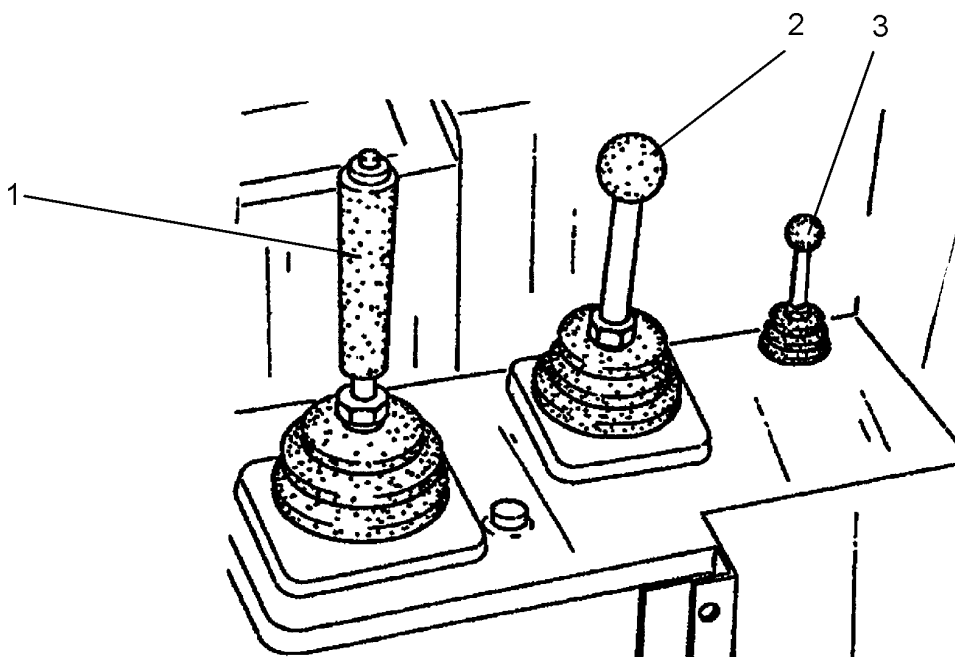

Fig. 4.12. Equipment Control Lever

1. Blade Control Lever
2. Ripper Control Lever
3. Pin Puller Control Lever (if equipped)

## CONTROLS AND ADJUSTMENT

## BLADE CONTROL LEVER

The blade can be lifted or lowered, tilted or pitched by shifting the blade control lever to the required position.

## RIPPER CONTROL LEVER

The ripper can be lifted, lowered, or pitched by shifting the ripper control lever to the required position.

## PIN PULLER CONTROL LEVER (if equipped)

This lever controls installation or removal of the pin securing the ripper shank in the tool beam.

**NOTE:** For proper control of the ripper control lever and observation of working tool swivel the operator seat 15[°] to the right.

## 4.6. STARTING THE ENGINE

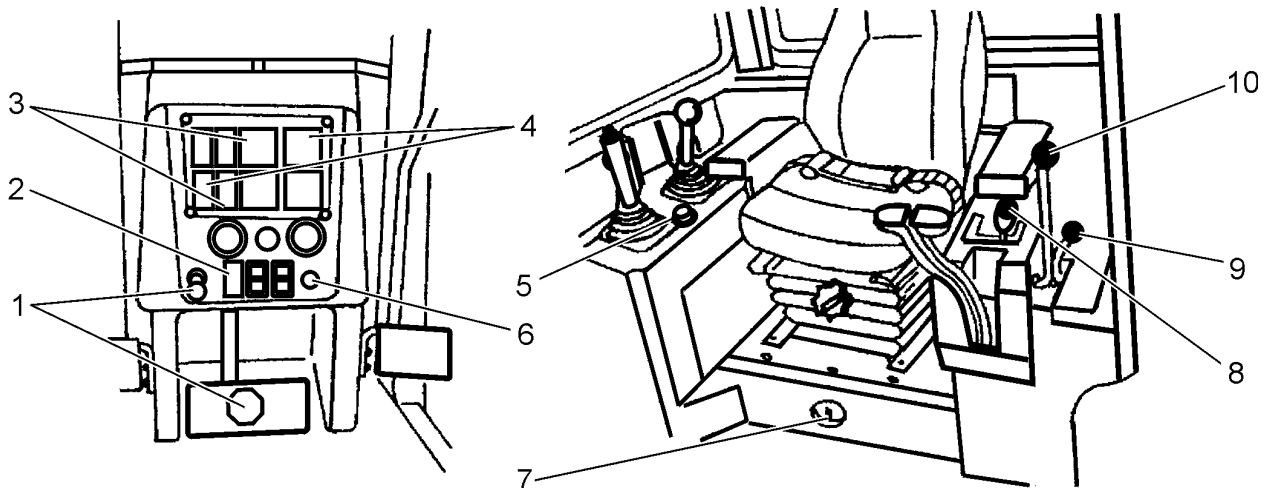

Fig. 4.13. Starting the Engine

1. Brake and Decelerator Pedal and Brake Lock Knob
2. Ether Start Button
3. Engine Coolant Gauge and Light
4. Engine Oil Pressure Gauge and Light
5. Horn Button
6. Starting Button
7. Electric system Master Switch
8. Transmission Shift Lever
9. Engine Speed and Shut Down Lever
10. Transmission Neutral Lock Lever

**IMPORTANT:** Before operating a machine perform each of the 10 hour maintenance requirements shown in Section 5.2., SCHEDULED MAINTENANCE. This engine cannot be started by towing, pushing or coasting the machine.

# OPERATING

## STARTING THE ENGINE



**WARNING!** Before entering the operator's compartment, walk completely around the machine and clear the area of personnel and obstructions.



**CAUTION!** Understand all control functions before starting the engine.



**WARNING!** Read all product graphics before starting, operating, maintaining, or repairing a machine.



**WARNING!** Never start an engine indoors unless proper exhaust ventilation is provided to remove deadly exhaust gases. Once the engine is running, move the machine outdoors as soon as possible. Exhaust gases are hazardous and can cause unconsciousness and death.



**WARNING!** Be sure all personnel are clear of the machine before starting the engine. Sound the horn.



**WARNING!** Make sure the operator's seat is adjusted properly and fasten the safety seat belt.

### 4.6.1. NORMAL START (temperature above 0 [°C]) (Fig. 4.13)

1. Apply and lock the brake and decelerator pedal.
2. Place the transmission shift lever (8) in neutral.
3. Place the transmission neutral lock lever (10) in vertical "ON" position.
4. Move the engine speed and shut down lever (9) to low speed (idle) position E (Fig. 4.14).
5. Turn the electric system master (7) switch to "ON".

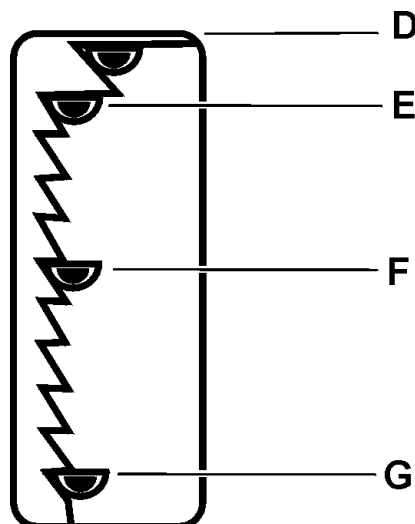

Fig. 4.14. Engine Speed and Shut Down Control Lever Positions

D. Large Cutout for Engine Shut Off

E. Cutout for Engine Start and Low Idle Speed

F. Medium Engine Speed

G. High Idle Speed



## STARTING THE ENGINE

6. Sound horn (5) to clear all personnel of the immediate area.
7. Crank the engine with button (6).

**IMPORTANT:** Do not crank an engine for more than 30 seconds at a time. If the engine does not start, allow the cranking motor to cool two or three minutes before cranking again.

8. Check the oil pressure. Stop the engine immediately, if the gauge fails to show the correct pressure after 15 seconds.
9. Allow the engine to idle for 3 to 5 minutes (app.1000 [RPM]) before increasing engine speed and placing under load.
10. Check the indications of all instruments to ensure that the machine is operating correctly. Refer to "INSTRUMENT PANEL".

**IMPORTANT:** It is not recommended to run the engine at low idle over 10 minutes due to a possibility of increased wear of engine components.

#### 4.6.2. ETHER INJECTOR START (temperatures below 0 [°C]) (Fig. 4.13).



**WARNING!** Ether starting fluid is highly flammable. Follow the precautions on the container. An explosion can result if sparks or flame contact ether or when storing an ether container when the air temperature is above 70 [°C].

Observe the following precautions:

- Do not use the ether injector when the air temperature is above 0 [°C].
- Do not use open flame when using ether starting fluid.
- Do not store fluid containers in the operator's compartment.
- Store containers in a cool, well ventilated place.
- Keep fluid containers out reach of children.
- Do not breathe hazardous ether vapor.
- Do not let ether contact your skin, because it can cause frostbite.
- Never puncture a fluid container or put it into a fire.
- Dispose of an empty container per instructions printed on the container.
- For your safety, remove the ether container when welding, grinding, or using a torch on a machine.
- Follow the correct method for starting the engine.
- Before any attempt to start the engine, check the ether container or insure that a supply of starting fluid is available under pressure and the system is in working condition.

Pressing the switch in the instrument panel makes ether injection.

**IMPORTANT:** The ether injector is to be used for engine starting only. Misuse of the ether injector while the engine is running can result in a serious damage to the engine.

1. Perform all steps as described in items 1 through 6. Refer to "NORMAL START" (temperature above 0 [°C]).
2. Press the starting button (6) and during engine cranking press the ether injector switch. Allow one to two seconds for the chamber in the valve to fill then, with the engine cranking, release the ether injector switch to release a measured shot of starting fluid into the engine.

## OPERATING

## STARTING THE ENGINE

If the temperature is below  $-18$  [ $^{\circ}\text{C}$ ], additional ether may be required. Allow a 10 second interval between two successive injections. If the engine does not fire with a maximum of 4 injections, determine the cause and correct before restarting the engine.

**IMPORTANT:** Do not crank an engine for more than 30 seconds at a time. If it does not start, allow the cranking motor to cool two or three minutes before cranking again.

3. Perform steps from items 8 through 10. Refer to "NORMAL START"

#### 4.6.3. ENGINE START AFTER OIL CHANGE OR PROLONGED STANDSTILL (over 5 days) (Fig. 4.13).

1. Perform all steps as described in items 1 through 3 and 5 through 6. Refer to "NORMAL START".
2. Place the engine speed and shut down lever in the OFF position (Fig. 4.14).
3. Press the engine starting button (6) on the instrument panel. Crank the engine until oil gauge (4) registers oil pressure or the low oil pressure warning light goes off. Release the starting button (6).
4. Move the engine speed and shut down lever to the idle position E (Fig. 4.14).
5. Perform all steps as described in items 7 through 10. Refer to "NORMAL START".

#### 4.7. STOPPING THE ENGINE (Fig. 4.15)

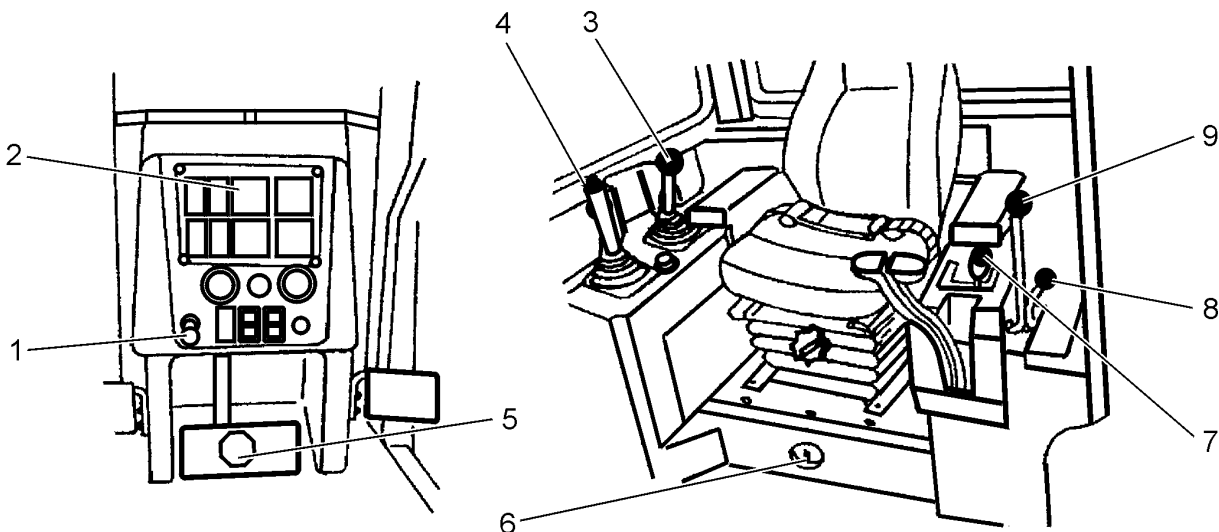

Fig. 4.15. Stopping the Engine

- |                                     |                                     |
|-------------------------------------|-------------------------------------|
| 1. Brake Lock Knob                  | 6. Electric System Master Switch    |
| 2. Engine Coolant Temperature Gauge | 7. Transmission Shift Lever         |
| 3. Ripper Control Lever             | 8. Engine Speed and Shut Down Lever |
| 4. Blade Control Lever              | 9. Transmission Neutral Lock Lever  |
| 5. Brake and Decelerator Pedal      |                                     |

1. Using control levers (3 and 4) lower all mounted equipment to the ground. Depress the brake and decelerator pedal (5) and place the transmission shift lever (7) into NEUTRAL.
2. Apply the transmission neutral lock lever (9).
3. If the engine has been operated under load, operate it at idle speed for 3 to 5 minutes to allow the engine to cool down in a gradual and uniform manner.

**IMPORTANT:** Immediate engine shut-down after operation under load may result in engine damage.

## STOPPING THE ENGINE

4. Depress and lock brake and decelerator pedal (5).
5. Move engine speed and shut down lever (8) to the large notched OFF position (Fig. 4.14).
6. Turn the electric master switch (6) into OFF position.

### 4.8. TIPS FOR ENGINE SAFEGUARDING

1. Do not operate the engine with the engine speed and shut down lever shifted into high speed position, if the engine speed drops below the speed providing the maximal torque (1400 [RPM] for N14-C350 engine for TD-25H dozer) for a period longer than 30 seconds.
2. If the engine has been operated under load, operate it at idle speed for 3 to 5 minutes to allow the engine and the turbocharger to cool down in a gradual and uniform manner.
3. Do not put the engine under load before the coolant temperature grows up to 60 [°C] or it has exceeded 100 [°C].

Do not operate the engine under load if the coolant temperature is below 60 [°C].

4. If the coolant temperature reaches the maximum permissible level of 100 [°C] reduce the load of the engine (either decrease the engine speed or reduce the gear or both) until it has dropped down to the working range.
5. Stop the engine if the oil pressure either drops below the minimum or grows above the maximum the value of the working range.
6. Most malfunctions can be detected at an early stage. Observe any changes in engine operation such as:

- uneven and intermittent operation,
- excessive vibrations,
- unusual engine drone,
- sudden changes of coolant temperature, or pressure
- excessive exhaust smoke,
- drop of the engine power,
- excessive oil consumption,
- excessive fuel consumption,
- oil, fuel or coolant leaks.

### 4.9. DRIVING THE MACHINE (Fig. 4.16)



**CAUTION!** *Read the SAFETY PRECAUTIONS in Section 2 before operating a machine.*

**IMPORTANT:** *Before operating check all instruments.*



**WARNING!** *Never haul passengers. Only the operator should be on a machine when it is moving.*



**WARNING!** *Sit in the operator's seat before operating the controls. Keep your hands and footwear free of grease, water and mud to insure positive control movements.*



**WARNING!** *Before operating a machine adjust the seat to allow full access to all controls and fasten the seat belt. Failure to do so could result in serious injuries or death.*

## OPERATING

## DRIVING THE MACHINE

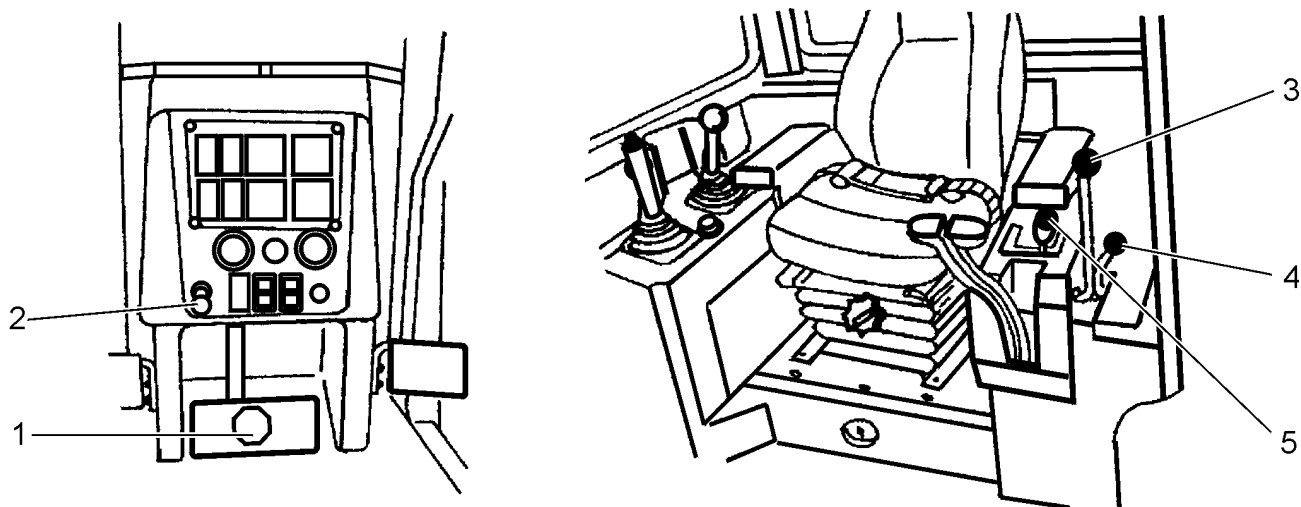

Fig. 4.16. Driving the Machine

1. Brake and Decelerator Pedal
2. Brake Lock Knob
3. Transmission Neutral Lock Lever
4. Engine Speed and Shut Down Lever
5. Transmission Shift Lever



**WARNING! Never get on or off a machine while it is moving because serious injury or death could result.**

1. Place engine speed and shut down control lever (4) in the high idle position (G, Fig. 4.14).
2. Depress brake and decelerator pedal (1) to decrease engine speed.
3. Move forward transmission neutral lock lever (3) from ON to OFF position.
4. Place transmission shift lever (5) in the desired range. Refer to "SHIFTING THE TRANSMISSION".
5. Gradually release brake and decelerator pedal (1).

#### 4.10. SHIFTING THE TRANSMISSION

Three speeds of the transmission, controlled by the transmission shift lever and the high and low speed ranges of the steering drive, controlled by the steering levers provide six speeds for both forward and reverse travel. With the steering levers in the low range and the transmission shift lever in any speed position the machine can be put into second speed by moving the steering levers into the high range. It is not necessary to stop the machine when shifting from one to another gear range or from forward to reverse (or reverse to forward). Shifting can be performed with the machine in motion.

## SHIFTING THE TRANSMISSION

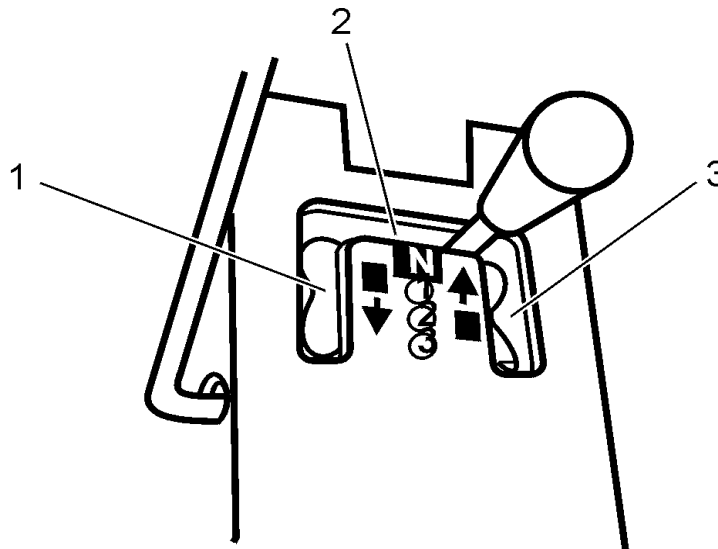

Fig.4.17. Transmission Shift Lever Position

1. Rear Gears
2. Neutral Position
3. Front Gears

## 4.11. CONVERTER OVERHEATING

If the pointer of the torque converter oil temperature gauge (refer to "INSTRUMENT PANEL") moves out of the RUN area of the dial during operation, the transmission may be in a gear range which is too high for the load. Shift down into the next lower gear range. The temperature should reduce; if not, downshift again. If the dial pointer remains out of the RUN range in the first gear, stop the machine, shift into neutral and run the engine at 1000 [RPM] until the gauge pointer moves into the RUN area.

If the converter remains overheated, stop the engine, check transmission oil level, clean the oil radiator and the oil suction filter.

If the converter still remains overheated, stop the engine and consult an Authorized Distributor of Construction Equipment before operating the machine.

## 4.12. STEERING THE MACHINE

Steering is accomplished with two steering levers. Each of the two levers functions in three positions as shown in Fig. 4.18.

- in forward position A: transmits the power to the track in the high range
- in middle position B: transmits the power to the track in the low range
- in rearward position C: disconnects the power and applies the brake



**WARNING! Never pull both steering levers all the way back to stop a machine. Use the foot brake (Brake & Decelerator Pedal) to slow down or stop the machine.**

## OPERATING

### STEERING THE MACHINE

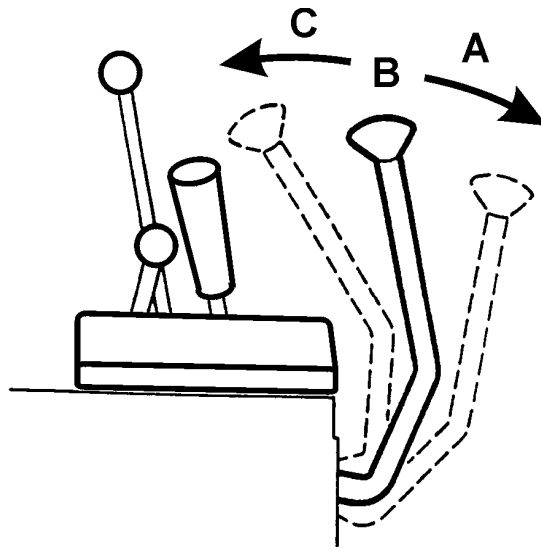

Fig. 4.18. Steering Levers

A. High Range      B. Low Range      C. Pivot Turn

#### 4.12.1. GRADUAL TURN

To make a gradual left turn proceed as follows:

With the steering lever in the high range "A" move the LH steering into the low range "B". With the steering lever in the low range "B" move the RH steering into the high range "A". When both steering levers are in the low range, move the RH steering lever into the high range "A". To make a gradual right turn proceed in the similar manner.

#### 4.12.2. PIVOT TURN

To make a pivot turn slow the machine down, then with both lever in either high "A" or low "B" range pull the lever on the side toward which the turn is to be made all the way back (position "C").

### 4.13. DOWNGRADE OPERATION



**WARNING!** When operating a machine downhill, always put the transmission in the low range position. Use the brake pedal to slow the machine. Never go downhill with the transmission control in neutral. Failure to do so could result in losing control of the machine and rollover could result.

Before going downgrade, select the range, which will provide full tractor control without overspeeding the engine.

**NOTE:** When going downhill control the speed of the machine using the brake and decelerator pedal.

#### 4.14. OPERATING OVER AN OBSTRUCTION

When crossing a log or ditch bank, use the decelerator pedal to slow the machine; and when possible, cross at an angle. Then gradually increase the power to the tracks as the machine moves forward, over, and down. If the load is light, it may also be necessary to use the brake pedal to avoid abrupt movements.

**4.15. STOPPING THE MACHINE (Fig. 4.19)**

Fig. 4.19. Stopping the Machine

- |                                    |                                     |
|------------------------------------|-------------------------------------|
| 1. Brake and Decelerator Pedal     | 4. Engine Speed and Shut-down Lever |
| 2. Brake Lock Knob                 | 5. Transmission Shift Lever         |
| 3. Transmission Neutral Lock Lever |                                     |

To stop a machine proceed as follows:

1. Depress the brake and decelerator pedal (1) until the machine is stopped.
2. Move the engine speed and shut down lever (4) to the low idle position (E, Fig. 4.14).
3. Place the transmission shift lever (5) in NEUTRAL.
4. Place the transmission neutral lock lever (3) in the ON position (rearmost position).
5. Lock the brake and decelerator pedal (1) with the brake lock knob (2).
6. Lower the mounted equipment to the ground.

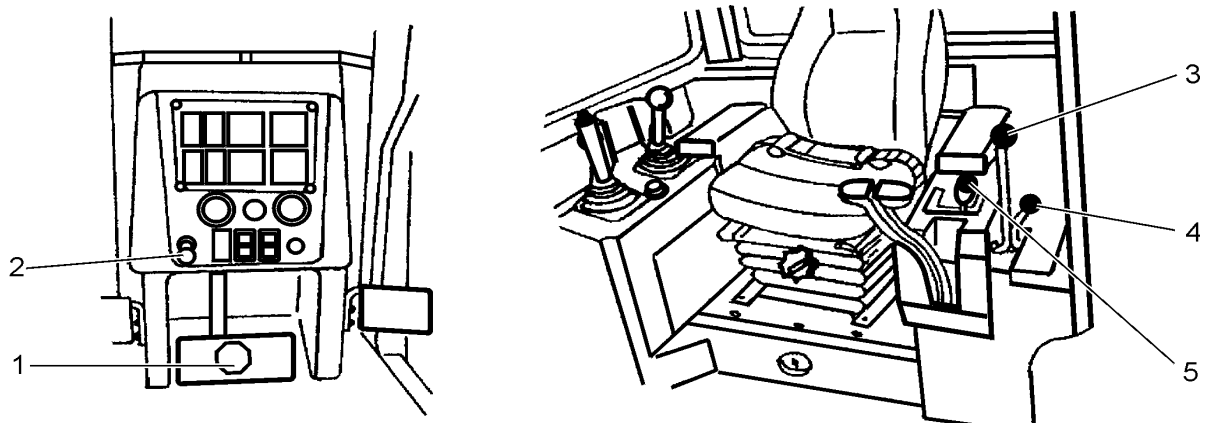

**WARNING! Never leave a machine unattended with the engine running.**

**4.16. PARKING THE MACHINE**

A few DO suggestions to protect both lives and equipment when parking.

DO park tractor on planks in freezing weather to prevent the tracks from freezing to the ground.

DO lower the hydraulically operated tractor equipment to the ground and relieve the pressure in the hydraulic system to reduce injury possibilities and to gain tractor stability.

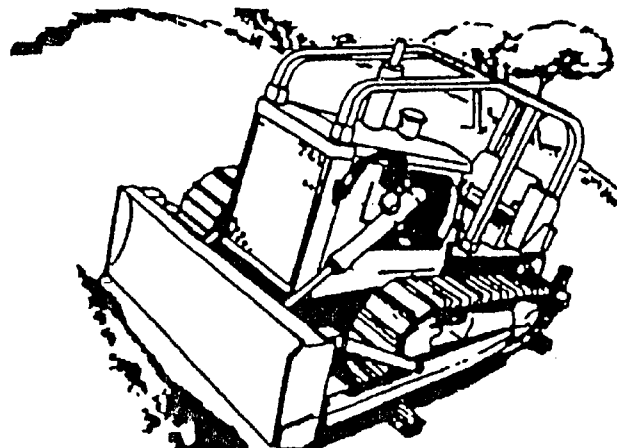

Fig. 4.20. Parking on a Slope

# OPERATING

## PARKING THE MACHINE

Parking on a slope is not recommended. Do park a tractor on a level ground, if at all possible to:

- a) Avoid unexpected movement,
- b) Obtain accurate coolant, lubricant and fuel level checks.

Avoid parking on a slope because unexpected machine movement may occur. However, if necessary, park at the right angle and secure the tracks with blocks (front and rear) (Fig. 4.20).

### 4.17. OPERATING MOUNTED EQUIPMENT

#### General

The hydraulic system provides power for the blade equipment, ripper or various other types of equipment. Specific instructions for the operation of the blade and ripper are included in this section.

**IMPORTANT:** Holding a control lever in any position except HOLD or FLOAT for an extended period of time after the hydraulic cylinder rod has reached the limit of its travel will produce excessive heat in the hydraulic system which may affect equipment performance.

#### 4.17.1. BLADE CONTROL LEVER (Fig. 4.21)

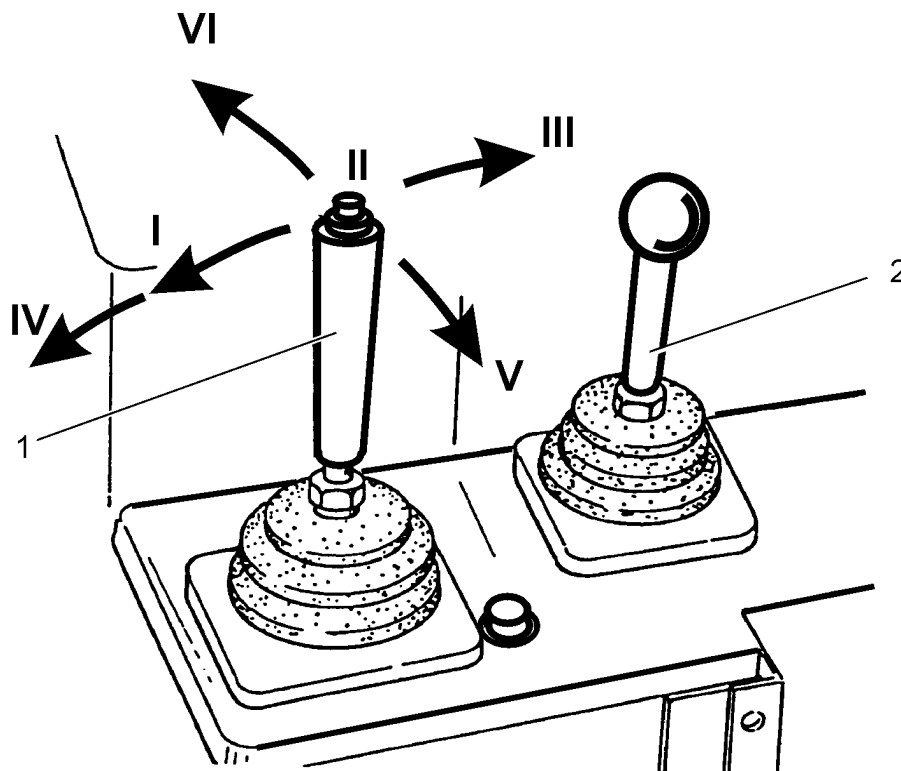

Fig. 4.21. Blade Control Lever Positions (1)

- |                         |            |             |
|-------------------------|------------|-------------|
| 1. Blade Control Lever  | I. Lower   | IV. Float   |
| 2. Ripper Control Lever | II. Hold   | V. LH Tilt  |
|                         | III. Raise | VI. RH Tilt |



## OPERATING MOUNTED EQUIPMENT

**4.17.1.1. HOLD**

When the lever is released from any position except "Float", the lever automatically returns to the "Hold" position. The blade height will remain the same, as it was when the lever was released.

**4.17.1.2. RAISE**

Pull the control lever back (position III) to raise the blade to the desired height. When released the lever will return to the "Hold" position.

**4.17.1.3. LOWER**

Push the control lever forward (position I) to lower the blade. When released the lever will return to the "Hold" position.

**4.17.1.4. FLOAT**

With the control lever in the "Float" position, the blade is free to follow the contour of the ground. To place the control lever in the float position, push all the way forward to its detented position IV in Fig. 4.21. The lever will remain in this position until it is manually returned to the "Hold" position.

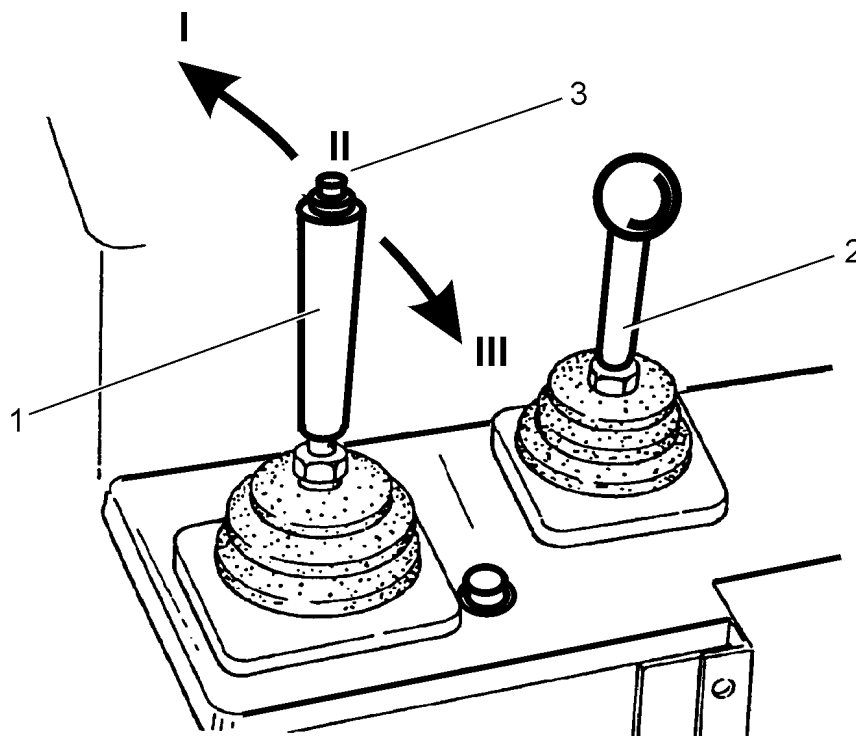

Fig. 4.22. Blade Pitch Control Lever Positions (1)

1. Blade Control Lever
2. Ripper Control Lever
3. Pitch Button

- I. Aft
- II. Hold
- III. Forward

OPERATING MOUNTED EQUIPMENT

4.17.1.5. TILT

LH TILT

Pull the control lever to the left (position V) to lower the left-hand corner of the blade. The lever will return to the "Hold" position when released.

RH TILT

Push the control lever to the right (position VI) to lower the right-hand corner of the blade. The lever will return to the "Hold" position when released.

4.17.1.6. PITCH (FORWARD OR AFT) (Fig. 4.22)

1. To pitch the blade aft (decreased angle of suction) depress button (3) and hold it down while shifting the blade control lever to the right (position I). The lever will return to the "Hold" position when released.

2. To pitch the blade forward (increased angle of suction) depress button (3) and hold it down while shifting the blade control lever to the left (position III). The lever will return to the "Hold" position when released.

4.17.2. RIPPER CONTROL LEVER

**NOTE:** For proper operation of the ripper control lever and observation of working tool it is necessary to swivel the operator's seat 15 [°] to the right.

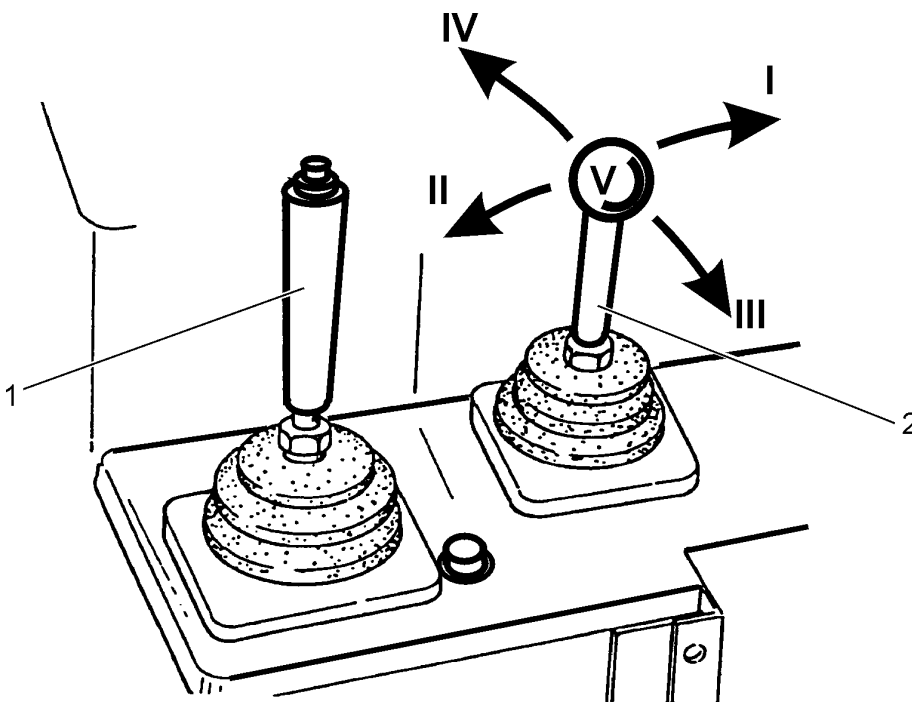

Fig. 4.23. Ripper Control Lever (2)

- |                         |                        |
|-------------------------|------------------------|
| 1. Blade Control Lever  | I. Shank Forward Pitch |
| 2. Ripper Control Lever | II. Shank Aft Pitch    |
|                         | III. Ripper Raise      |
|                         | IV. Ripper Lower       |
|                         | V. Hold                |

OPERATING MOUNTED EQUIPMENT

4.17.2.1. SHANK PITCH (FORWARD OR AFT)

To pitch the ripper shank shift ripper control lever (2) as follows:

- a. into position "I" to pitch the shank forward,
- b. into position "II" to pitch the shank aft,

The lever will return to the "Hold" position ("V") when released.

4.17.2.2. RIPPER RAISE AND LOWER

RIPPER RAISE

To raise the ripper to the required height, move the lever into position "III". The control lever will return automatically to HOLD position ("V") when released.

RIPPER LOWER

To lower the ripper move the lever into position "IV". The control lever will return automatically to HOLD position ("V") when released.

**IMPORTANT:** Holding the control lever in any position except HOLD for an extended period of time will produce excessive heat in the hydraulic system which may affect equipment performance

4.17.2.3. PIN PULLER CONTROL LEVER

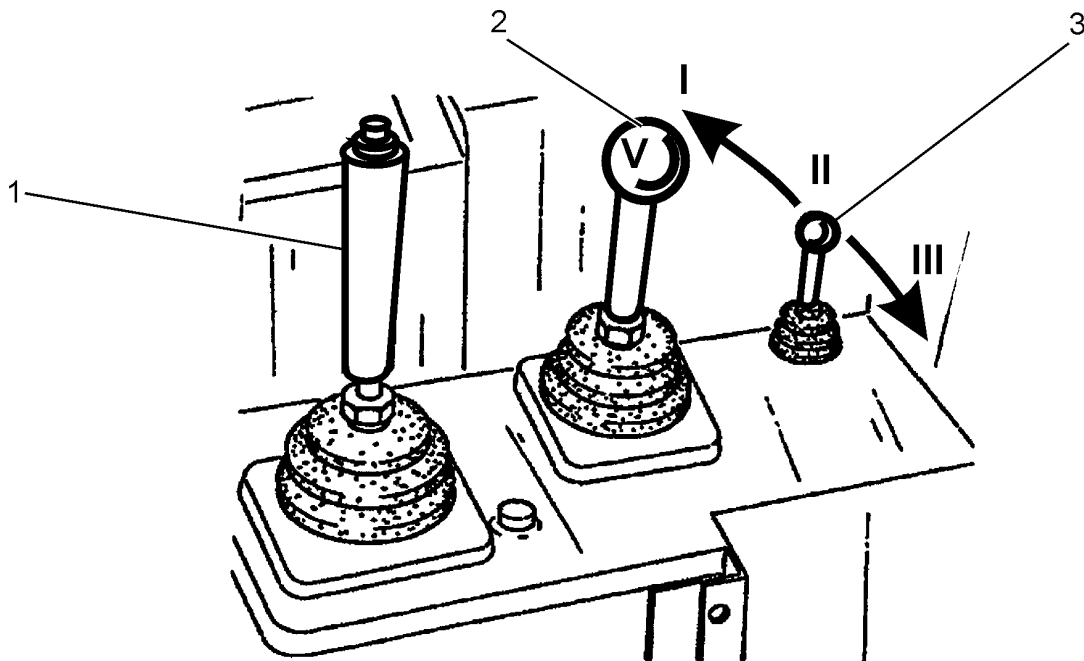

Fig. 4.24. Pin Puller Control Lever (3)

- |                             |                       |
|-----------------------------|-----------------------|
| 1. Blade Control Lever      | I. Pin Removal        |
| 2. Ripper Control Lever     | II. Hold              |
| 3. Pin Puller Control Lever | III. Pin Installation |

PIN REMOVAL

Push the control lever to the right, position "III" to remove the shank pin from the tool beam. Simultaneous raising or pitching of the tooth will facilitate the removal of the pin. The control lever will return automatically to the hold position when released.

## OPERATING MOUNTED EQUIPMENT

## PIN INSTALLATION

Push the control lever to the left, position "I" to install the shank pin into the shank mounting hole. Simultaneous raising or pitching of the tooth will facilitate the installation of the pin. The control lever will return automatically to the hold position when released.

## 4.18. BLADE POSITIONS

## 4.18.1. BULLDOZER (D-2) BLADE POSITIONS

## 4.18.1.1. TILTING THE BLADE

## TILTING THE BLADE WITH MECHANICAL TILT

1. Raise the blade above the ground and shut off the engine. Refer to "STOPPING THE ENGINE".
2. Remove the strut locking pin and adjust the upper strut on the side to be raised. Extend the strut by the value equal approximately to half of required blade tilt.

**IMPORTANT:** Do not expose any portion of the eyebolt threads.

3. Adjust the opposite side to get the desired tilt by shortening the strut by the value equal to the remaining part of desired tilt. Reinstall the locking pin.

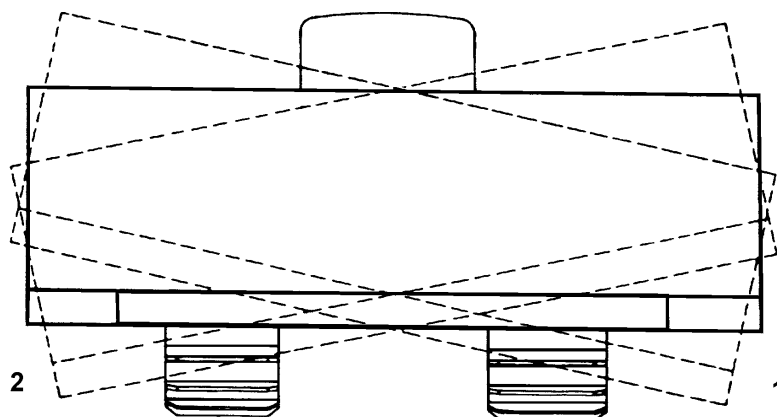

Fig. 4.25. Blade tilt

1. RH Tilt      2. LH Tilt

## TILTING THE BLADE WITH HYDRAULIC TILT

Proceed as follows:

1. Raise the blade off the ground.
2. Hold the tilt control lever in the tilt position on the side to which the blade is to be tilted until the desired tilt is obtained. Maximum tilt is 500 [mm].

## BLADE POSITIONS

## 4.18.1.2. PITCHING THE BLADE

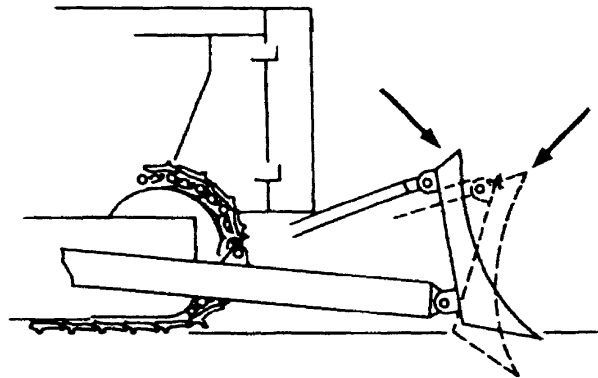

Fig. 4.26. Blade Pitch

## PITCHING THE BLADE (MECHANICAL PITCH)

1. To pitch the blade forward (increasing the suction angle), raise the blade several centimeters off the ground. Shut off the engine. Refer to „STOPPING THE ENGINE“. Then extend the upper struts on each side of the blade an equal amount.

**IMPORTANT:** Do not expose any portion of the eyebolt threads.

2. To pitch the blade backward (decreasing the suction angle), the upper struts must be shortened on each side of the blade an equal amount.

**NOTE:** When the suction angle either increases or decreases the upper struts must be relatively extended or shortened by the same value on both sides.

3. After making the adjustments, secure the upper strut with the locking pin so it will not rotate.

## PITCHING THE BLADE (HYDRAULIC PITCH)

1. To pitch the blade forward (increasing the suction angle), raise the blade several centimeters off the ground. Then depress button (3, Fig. 4.22) and hold it down while shifting the blade control lever to left (inwards) until the desired pitch is obtained.
2. To pitch the blade backward (decreasing the suction angle), raise the blade several centimeters off the ground. Then depress button (3, Fig. 4.22) and hold it down while shifting the blade control lever to right (outwards) until the desired pitch is obtained.

Maximum pitch is 10 [°] (the difference between the minimum and maximum suction angle).

## 4.18.1.3. LEVELLING THE BLADE

## LEVELLING THE BLADE WITH MECHANIC TILT (Fig. 4.27)

1. Lift the blade a few centimeters off the ground. Stop the engine. Refer to „STOPPING THE ENGINE“.
2. Remove locking pins. Adjust both upper struts so that the gap ("A") between the shoulder of eye bolt (1) and strut body (2) is 35 [mm]. This will position the blade in its neutral pitch position. If the blade is not level a half rotation of strut body (2) in either direction will level the blade.

## OPERATING

### BLADE POSITIONS

3. After the blade is level, raise the blade 300 [mm] off the ground. Adjust both struts to align the holes of the brackets and struts to allow installation of the mounting/ locking pins.

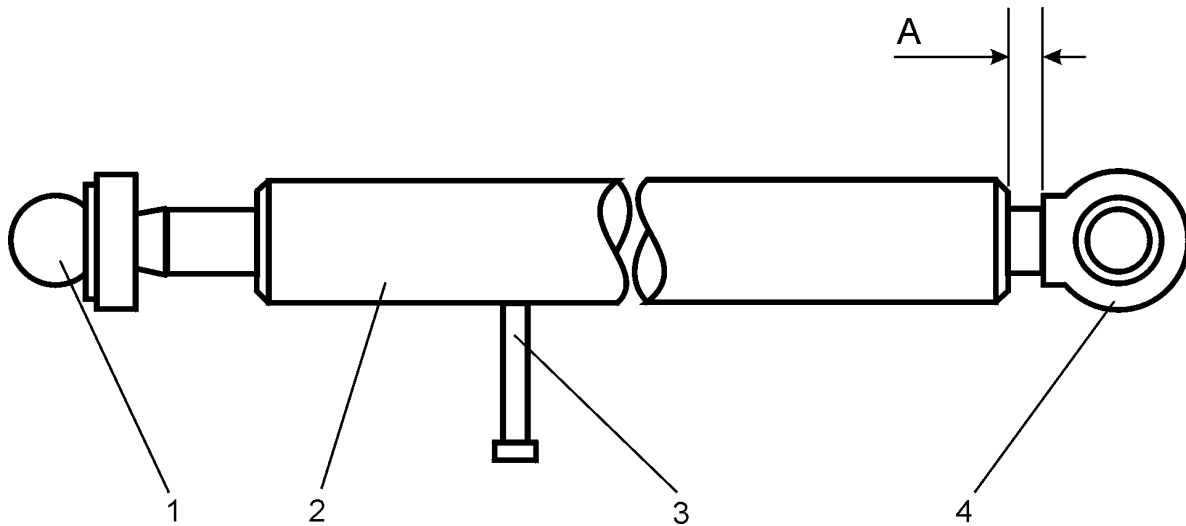

Fig. 4.27. Upper strut.

- |               |                 |
|---------------|-----------------|
| 1. Strut Ball | 3. Locking Pins |
| 2. Strut Body | 4. Eyebolt      |

#### LEVELLING THE BLADE WITH HYDRAULIC TILT

1. Place the lowest corner of the blade on a flat surface.
2. Shift the control lever to the side to which the blade is to be lowered until the blade is even along the flat surface.

**NOTE:** If the tilt cylinders are to be vented refer to “VENTING THE HYDRAULIC SYSTEM”, section 5.

#### 4.19. OPERATING TECHNIQUES



**WARNING!** Before operating a machine, be sure the area of the operator's compartment, all mounting steps and grab handles are free of oil, grease, loose objects, ice, snow and mud to lessen the possibility of slipping. Remove or secure all maintenance and personal items so they will not interfere with the operator or jam the controls. Failure to follow these instructions may result in serious injury.

When the blade is held hydraulically, it becomes a rigid part of the tractor, except when the valve is in the “FLOAT” position, and will follow all movements of the machine. When rough terrain is encountered it will be necessary to vary the height of the blade while pitching to obtain a smooth cut. When possible, start all jobs from a relatively level ground. If necessary, level an area large enough to provide sufficient working space for the machine. This prevents back and forth pitch of the machine and will result in easier digging.

## OPERATING TECHNIQUES

Avoid track spinning whenever possible; this wastes effort and converts a relatively smooth working area into ruts and piles that pitch and tilt a tractor. In cold weather this material can freeze and cause additional difficulty the following day.

Crossing ditches, ridges, rock or logs should be done slowly and, at an angle. This slows the fall, lessens the danger of upsetting the machine and reduces the fall jolt, which can be harmful to the operator and the machine.

### 4.19.1. DIGGING AND CLEARING



**WARNING!** Prior to operating know the locations of gas lines, utility lines, sewers, overhead and buried power lines, and the other obstructions or hazards are known. A ruptured gas line or cut electrical line could result in personal injury.

Always feed the blade into the ground gradually until the desired depth of cut is obtained. When selecting the gear range and determining the depth of cut, allow for an increase in resistance as the load increases. When raising the blade at the end of a cut, do it gradually to avoid an abrupt ridge or bump in the path of the tractor. Move material downgrade whenever possible to take advantage of the reduced effort required (Fig. 4.29).



Fig. 4.29. Moving Material Downgrade

Two methods of cutting down a pile or hill are shown in Fig. 4.30. Type of material and local conditions may dictate which method is preferred. Further information is included in "BREAKING PILES AND SPREADING". When using Method 1 never allow the high face to become a hazard to the operator or machine. With the tractor at the right angle to the face, raise the blade and dislodge the high bank before returning to the original direction of cut. When using Method 2, make a cut wide enough to avoid trapping the tractor.

# OPERATING

## OPERATING TECHNIQUES

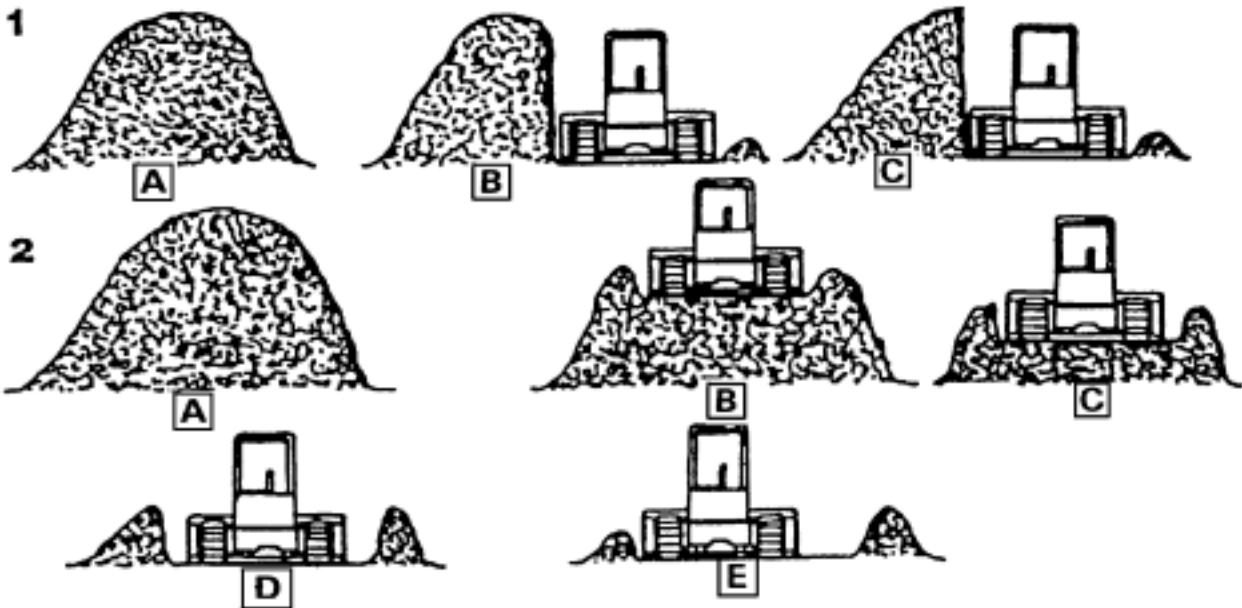

Fig. 4.30. Cutting Down a Pile or Hill  
1. Method 1      2. Method 2



**WARNING!** Avoid high overhangs. Ramp up and remove the top layers first. Avoid high banks. Operate the machine as far away from the trench as possible or cave-in may result.

A hillside cut can be started more easily if a small bench cut is first made as shown in Fig. 4.31.

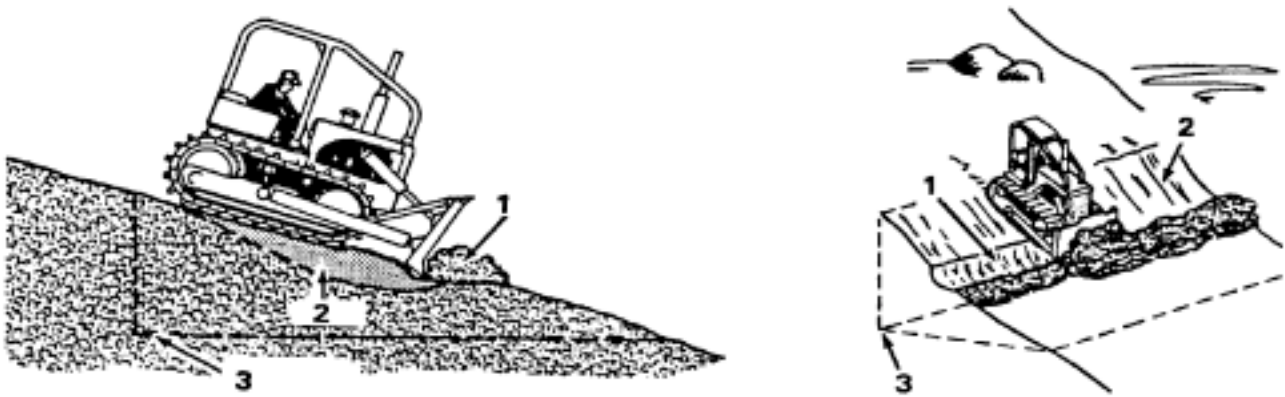

Fig. 4.31. Hillside Cut  
1. Cut I      2. Cut II      3. Final level

Then, when digging as in Fig. 4.32, keep the inside (uphill) surface slightly lower to gain greater tractor stability. Tilting the blade will provide this type of cut with less effort on the operator's part. Always cut a shelf wide enough to provide solid support for equipment used later. If possible, move the material downhill to gain the advantage of gravity, reduced effort and increased tractor stability. Soft soil or shallow slopes may allow the side hill cut to be made as shown in Fig. 4.33. Increased stability is realized by running the uphill track inside the ridge left by the first cut. Cuts 3, 4 and 5 illustrate the completion of the shelf.



OPERATING TECHNIQUES

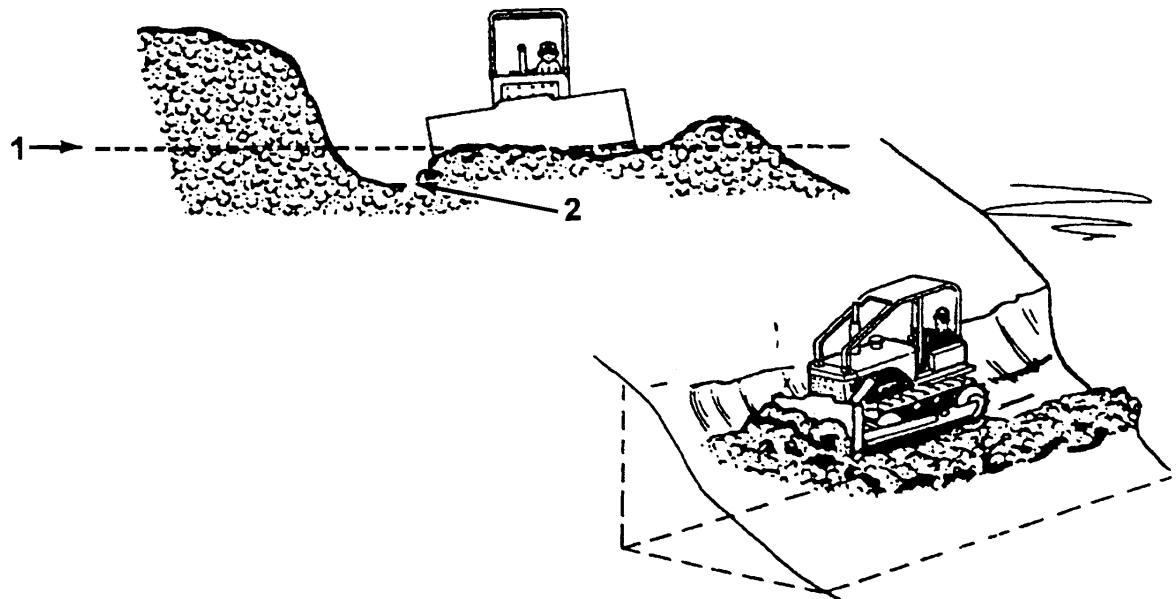

Fig. 4.32. Hillside Cut

1. Level I      2. Lower Surface

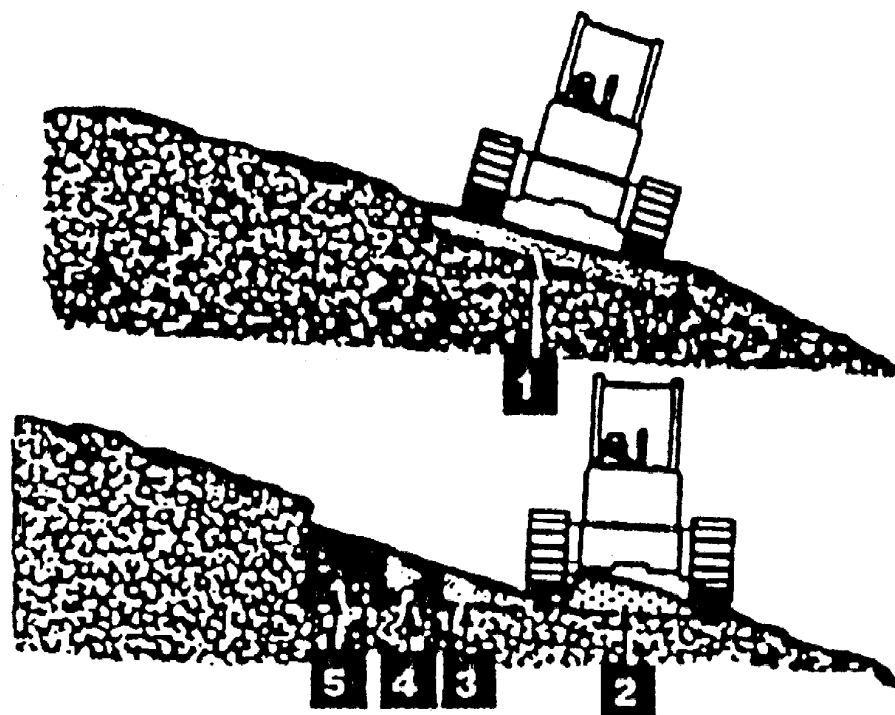

Fig. 4.33. Shallow Slope Hillside Cut

Once again, pushing loosened material to the lower side of the slope Fig. 4.34 will normally reduce time and cost. Do not push material beyond the point required to retain firm track support.

OPERATING TECHNIQUES



Fig. 4.34. Slope Edge Operation

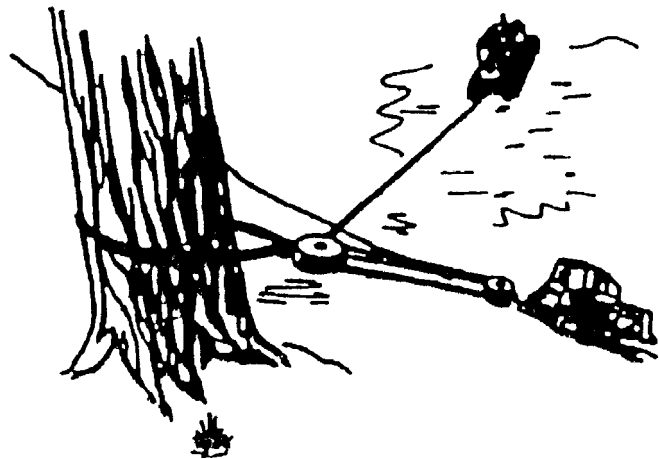

Fig. 4.35. Operating a Tandem Arrangement

When backing up, do not raise the blade as this puts extra weight on the front idlers causing greater track penetration. Let the blade float as you back away from the edge of soft fills. Initial work on steep hillsides can be safer by either securing the tractor with a winch to a suitable uphill anchor point or by operating a tandem arrangement as shown in Fig. 4.35.

When clearing trees, raise the blade high to gain leverage and make contact gently to reduce possible harm to the operator and machine (Fig. 4.36). Heavy roots of large trees may require pushing and digging or cutting from several sides of the tree. Use a cable to topple and remove trees from soft ground (Fig. 4.37).



Fig. 4.36. Machine Equipped with Sweeps



Fig. 4.37. Using Cable to Remove Trees



**CAUTION! Falling trees and dead limbs can cause injuries. When clearing trees, operator protection must be used.**

When clearing a rocky area, remove the small and loose rocks first, large and solid rocks can then be loosened and moved with less difficulty. When loosening large or solid rocks, greater force and penetration can be obtained by tilting the blade and prying under the rock with the lower edge of the blade (Fig. 4.38). Lifting the rock with the blade while pushing will increase traction and reduce track spinning.

## OPERATING TECHNIQUES

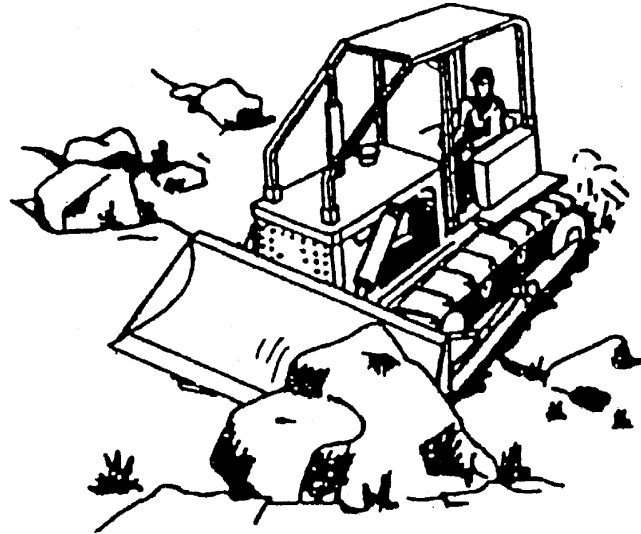

Fig. 4.38. Loosening Rocks with Lower Edge of the Blade

Penetration on hard, frozen or rocky ground can be made easier by tilting the blade. This will add weight and power to the lower cutting edge. When the ground is frozen and the area must be ripped before it can be worked, rip a relatively small section and work it to grade before enlarging the cut. This will require ripping each section only once, not every morning after the ground has refrozen. Snow can act as an insulating blanket and reduce or eliminate the need for a ripper. Therefore, remove snow only from the area to be worked each day; leave the rest to insulate the ground.

#### 4.19.2. TRANSPORTING, PILING OR LOADING

Transporting of material with a bulldozer or bullgrader is not always a most economical method. Natural ridges, a window formed by side blade spillage on earlier passes or side-by-side, dozing will improve the productivity (Fig 4.39). Where the quantity of material or distance involved becomes excessive, a loader, scraper or truck should be considered.

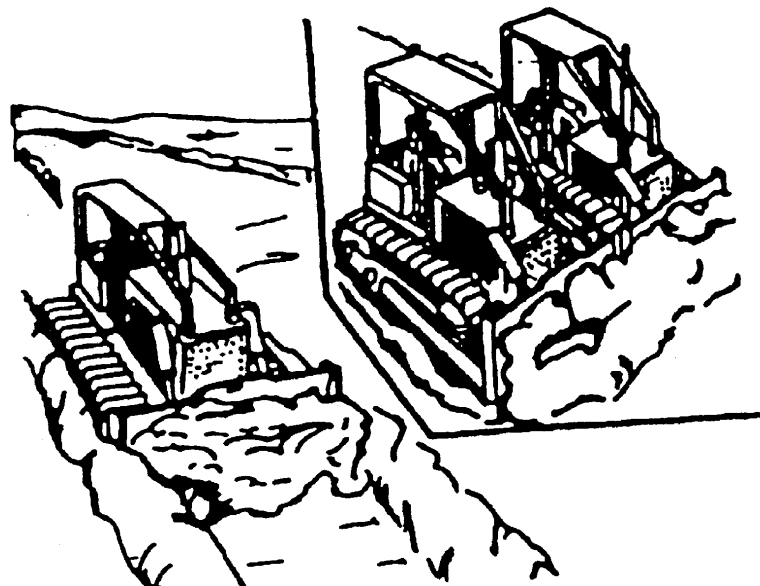

Fig. 4.39. Side-by-Side Dozing

# OPERATING

## OPERATING TECHNIQUES

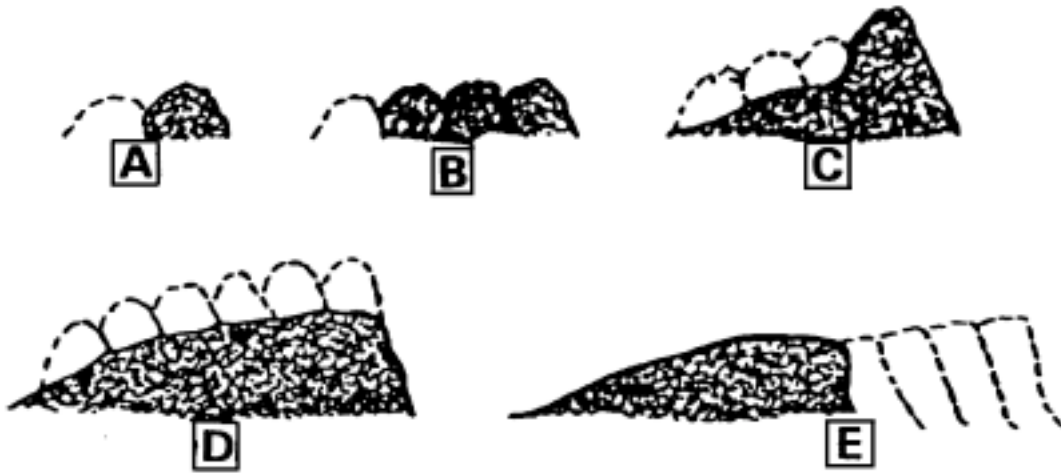

Fig. 4.40. A Usual Method of Piling

A usual method of piling is shown in fig. 4.40. When the piling reaches stages “D” or “E” the operator may elect to continue one or the other depending on the height or area desired. When the machine is used as a pusher, aiding scraper loading (Fig. 4.41), the machine power must be carefully controlled. Excessive “push” effort can cause the scraper unit to “jackknife”, with resulting injury or damage. On turns, be sure the blade of the pusher tractor does not come in contact with the rear wheels of the scraper.

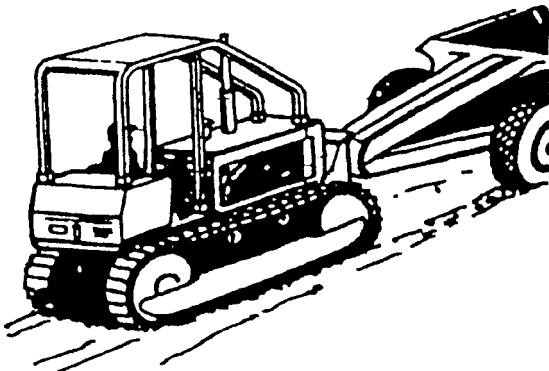

Fig. 4.41. Aiding Scraper Loading

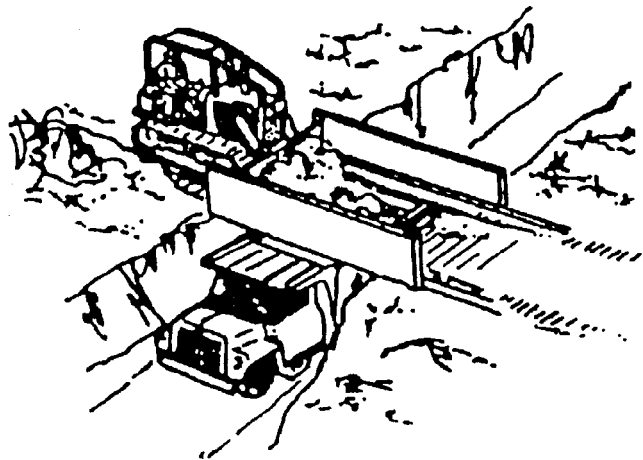

Fig. 4.42. Loading Directly

A bulldozer can be used directly as a loader if the method shown in Fig. 4.42 is used.

### 4.19.3. BREAKING PILES AND SPREADING

Two methods of breaking down a pile are shown in Fig. 4.43. When spreading is to be done in several directions or if the pile is large or hard, Method 1 is usually desired. When using Method 1, cut into the side of the pile from different angles. When Method 2 is used, and access to the top of the pile is difficult, a slot may be started as shown below. Loosen the material at the base and form a dirt “ramp” to provide a decreased angle of approach and cut.

## OPERATING TECHNIQUES

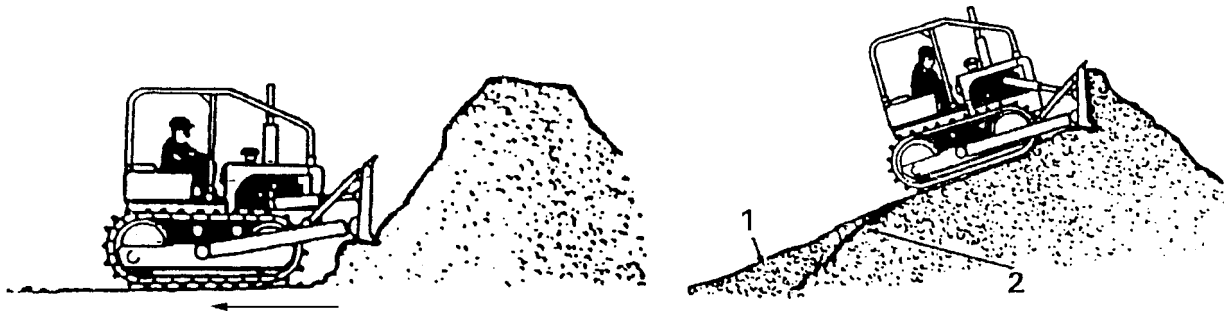

Fig. 4.43. Breaking Down a Pile

Method 1

Method 2

1. Ramp 2. Original Slope

When trucks or wagons are used for hauling, bulldozers are ideal spreading tools at the fill (Fig. 4.43). Blade should be kept in the straight position so that the material is drifted directly under the cutting edge (Fig. 4.44). When finishing in non-solid materials, such as earth, drag the blade backward for a smooth job as shown in Fig. 4.45. Rock, of course, may damage the blade base, therefore, such practice is not recommended where abrasive material is common.



Fig. 4.44. Spreading Material Forward

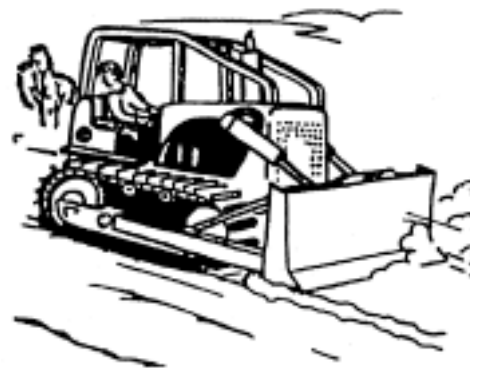

Fig. 4.45. Back Dragging

**4.19.4. RIPPING****4.19.4.1. Prior to Operation**

Before operating the ripper proceed as follows:

1. Check all mounting hardware for torque.
2. Check the hydraulic connections for leaks.
3. Check the condition of the ripper, bits, mounting hardware for completeness and torque.

## OPERATING TECHNIQUES

### 4.19.4.2. Ripping Techniques

When starting ripping lower the ripper teeth slowly to the required depth. Ripping of rock material must be performed in direction of easier ripping which may be established by carrying out test ripping in various directions and under various angles of inclination of the shanks. During test ripping lower the shank to the half of working depth. Machine efficiency can be improved when several centimeters of loose material is left on solid rock. Ripping should be performed at a depth the best results are obtained without overloading the engine. Keep loose ground level and horizontal as much as possible. Never make turns with the machine with ripper teeth at full depth in rocky ground. Use common sense when working in hard ground not to damage the ripper and the machine. Do not accelerate the machine and simultaneously lower the ripper teeth into the ground – this will damage the ripper.

Pay attention not to allow the rear of the machine to lift off the ground during ripping operations, as this decreases traction and accelerates wear of the track system. Use new and sharp bits for hard ground.

### 4.19.4.3. Cold Weather Operation

Start the engine as described in “STARTING THE ENGINE” and then proceed as follows:

- Move slightly and slowly ripper control lever to warm the oil in the hydraulic cylinders.
- Raise the ripper at the max. height and then lower it slowly until it rests on the ground.
- Increase gradually pressure in the ripper cylinders by keeping the control lever in LOWER position until the rear of the machine is off the ground.
- Prior to normal ripping operations operate the ripper at low depth for a couple of minutes to warm the shank bits.
- Protect the shank and bits when parking the machine.

## 4.20. ECONOMICAL OPERATION OF THE MACHINE

Fuel consumption during operation of a dozer depends on many factors as: engine characteristics, load, terrain, operator's skill and experience, the manner of operation.

A relatively conclusive indicator of fuel consumption is the quantity of moved material per unit of consumed fuel. To reach the most favorable value of this ratio observe the following principles of dozer operation:

- Avoid long distance transporting of material.
- Loading and pushing of material must be performed at the gear which ensures maximum drawbar pull (1<sup>st</sup> or 2<sup>nd</sup> gear) with high blade fill ratio without losing the material in blade.
- Reverse travel at top gear but keep engine speed above medium, not maximum.
- Avoid stopping the machine due to stall of the engine.
- Avoid track slippage.
- For digging hard material pitch the blade forward, for transportation of material pitch the blade backward.

**SECTION 5**  
**MAINTENANCE**





**SECTION CONTENTS**

|          |   |    |
|----------|---|----|
| 5.1.     | Service Precautions .....                                   | 3  |
| 5.2.     | Scheduled Maintenance Guide .....                           | 4  |
| 5.2.1.   | Ground Level Inspection .....                               | 6  |
| 5.3.     | Maintenance and Service Chart .....                         | 7  |
| 5.3.1.   | Refill Specifications and Capacities Chart .....            | 9  |
| 5.4.     | Lubrication .....   | 10 |
| 5.4.1.   | When Shipped .....  | 10 |
| 5.4.2.   | When Serviced .....   | 11 |
| 5.4.3.   | Selection .....   | 11 |
| 5.4.4.   | Viscosities .....   | 11 |
| 5.4.5.   | Recommended Lubricant Chart .....                           | 12 |
| 5.5.     | Seasonal Preparation.....                                   | 13 |
| 5.5.1.   | Fuel System .....   | 13 |
| 5.5.2.   | Cooling System .....  | 13 |
| 5.5.3.   | Electric System .....                                       | 13 |
| 5.6.     | Air Cleaning System .....                                   | 14 |
| 5.6.1.   | Air Pre-cleaner .....                                       | 14 |
| 5.6.2.   | Air Cleaner .....   | 14 |
| 5.6.2.1. | Primary Filter Element .....                                | 15 |
| 5.6.2.2. | Safety Filter Element .....                                 | 16 |
| 5.6.3.   | Checking Air Intake System for Leaks .....                  | 17 |
| 5.7.     | Belts .....   | 17 |
| 5.7.1.   | Visual Inspection .....                                     | 17 |
| 5.7.2.   | Checking Tension and Adjustment .....                       | 18 |
| 5.7.2.1. | Checking Tension and Adjustment of A/C Compressor Belt..... | 19 |
| 5.7.2.2. | Checking Tension and Adjustment of Alternator Belt .....    | 19 |
| 5.7.3.   | Belt Replacement .....                                      | 19 |
| 5.8.     | Cooling System .....  | 19 |
| 5.8.1.   | Water .....   | 20 |
| 5.8.2.   | Antifreeze .....  | 20 |
| 5.8.3.   | Inhibitors / Conditioners .....                             | 20 |
| 5.8.4.   | Radiator Cap .....  | 21 |
| 5.8.4.1. | Radiator Cap Cover .....                                    | 21 |
| 5.8.4.2. | Cleaning the Radiator Core .....                            | 22 |
| 5.8.5.   | Checking Coolant Level .....                                | 22 |
| 5.8.6.   | Changing Coolant.....                                       | 23 |
| 5.8.6.1. | Draining the System .....                                   | 23 |
| 5.8.6.2. | Filling the Drained System.....                             | 23 |
| 5.8.7.   | Changing the Coolant Filter .....                           | 24 |
| 5.9.     | Fan .....   | 24 |
| 5.10.    | Electric System .....                                       | 25 |
| 5.10.1.  | Electric Wires and Connections .....                        | 25 |
| 5.10.2.  | Automatic Reset Circuit Breaker .....                       | 25 |
| 5.10.3.  | Batteries .....   | 25 |
| 5.11.    | Engine .....  | 28 |
| 5.11.1.  | Checking the Crankcase Oil .....                            | 28 |
| 5.11.2.  | Changing the Crankcase Oil and Oil Filter .....             | 28 |
| 5.11.3.  | Ether Injector .....  | 30 |

|   |    |
|---|----|
| 5.12. Fuel System .....   | 32 |
| 5.12.1. Filling the Fuel Tank .....   | 32 |
| 5.12.2. Fuel Tank Filler Strainer .....                                       | 32 |
| 5.12.3. Fuel Tank Shutoff Valve .....   | 33 |
| 5.12.4. Fuel Filters .....  | 33 |
| 5.12.4.1. Fuel Filter Water Separator Drain Valve .....                       | 33 |
| 5.12.4.2. Replacing the Fuel Filters .....                                    | 34 |
| 5.12.5. Draining Fuel Tank .....  | 34 |
| 5.13. Hydraulic System .....  | 35 |
| 5.13.1. Checking Oil Level .....  | 35 |
| 5.13.2. Changing Hydraulic Oil .....  | 35 |
| 5.13.3. Replacement the Return Filters and Pilot Filter .....                 | 37 |
| 5.13.4. Servicing the Suction Strainer and Filler Strainer .....              | 38 |
| 5.13.5. Servicing the Reservoir Breather .....                                | 39 |
| 5.13.6. Venting the Hydraulic System .....                                    | 40 |
| 5.14. Lubricating Fittings .....  | 40 |
| 5.15. Mounted Equipment .....   | 45 |
| 5.15.1. Complete Blade Removal and Installation .....                         | 45 |
| 5.15.2. Diagonal Struts Adjustment .....                                      | 46 |
| 5.15.3. Upper Strut and Tilt Cylinder Adjustment .....                        | 47 |
| 5.15.4. Pitch Cylinder Loose Adjustment .....                                 | 49 |
| 5.15.5. Checking the Blade Condition .....                                    | 49 |
| 5.15.5.1. Trunnion and Cap Mounting Bolts .....                               | 49 |
| 5.15.5.2. Blade Cutting Edge and End Bits Mounting Bolts .....                | 50 |
| 5.15.5.3. Allowable Wear of Cutting Edge and End Bits and Ripper Points ..... | 50 |
| 5.15.6. Servicing the Ripper .....  | 51 |
| 5.16. Safety Belt .....   | 51 |
| 5.17. Final Drives .....  | 51 |
| 5.17.1. Checking the Oil Level .....  | 51 |
| 5.17.2. Changing the Oil .....  | 52 |
| 5.18. Transmission System .....   | 52 |
| 5.18.1. Checking the Oil Level in RMF .....                                   | 52 |
| 5.18.2. Changing Transmission System Oil .....                                | 53 |
| 5.18.3. Servicing the Transmission Pressure Filters .....                     | 54 |
| 5.18.4. Servicing the Suction Strainer.....                                   | 55 |
| 5.18.5. Servicing Transmission Scavenger Strainer .....                       | 57 |
| 5.18.6. Servicing the Breather .....  | 57 |
| 5.19. Undercarriage .....   | 58 |
| 5.19.1. Track Shoe Bolts .....  | 58 |
| 5.19.2. Effect of Track Adjustment on Undercarriage Wear .....                | 58 |
| 5.19.3. Checking the Tension .....  | 59 |
| 5.19.4. Adjusting Tension .....   | 59 |
| 5.19.5. Track Frame Guide .....   | 61 |
| 5.19.6. Pivot Shaft Housing .....   | 62 |
| 5.19.7. Front Wheel Guides .....  | 63 |
| 5.20. Adjusting Hand and Foot Controls .....                                  | 64 |
| 5.21. Cab and ROPS .....  | 65 |
| 5.21.1. ROPS Cab/Canopy and Mounted Equipment Mounting Hardware .....         | 65 |
| 5.21.2. Air Conditioning Cleaning .....                                       | 65 |
| 5.21.3. Windshield Washer Reservoir.....                                      | 66 |

**5.1. SERVICE PRECAUTIONS**



**CAUTION! Only authorized personnel, thoroughly trained with the design and operation of all assemblies and mechanisms may be allowed to service this machine.**

WORK SAFELY – FOLLOW THESE RULES



**CAUTION! If a machine is operated in any circumstances involving dust as in coalmines, wash the engine compartment and check the fuel lines and electric wires at least once a week.**

A CAREFUL OPERATOR IS THE BEST INSURANCE AGAINST AN ACCIDENT.

**GENERAL SERVICE PRECAUTIONS**

The procedures in this section contain many notes and precautions, which should be followed along with standard safety procedures to minimize a possibility of personal injury or improper service. Improper service could compromise a machine's safety or cause it to function improperly, which could result in personal injury or death. Review the precautions listed in Section 2, "SAFETY PRECAUTIONS".

Do not attempt to do repairs you do not understand. Use your "Service Manual" or consult your Authorized Distributor for information.

Do not jump on or off a machine.

When working under a machine or servicing in the area of the engine fan or belts, turn the electric system master switch OFF, apply and lock the parking brake and tag controls to warn against starting the machine.

Whenever servicing, take care to prevent accidental cranking of the engine. Turn the electric master switch OFF and remove the key. It is not possible to anticipate all conceivable ways or conditions under which a machine may be serviced or to provide precautions for all the possible hazards that may result. Safety is always the most important rule.

Constantly be aware of dangers involved in working on a machine and take proper precautions.

Standard and accepted safety precautions and equipment should be used.

This machine is assembled using high strength fasteners. Do not substitute. Replacement fasteners must be of the same size and strength as the originals (refer to Section 6). Tighten fasteners to the proper torque value specified in Section 6, unless otherwise specified.

Refer to Spare Parts Catalogue for all replacement parts.

Use safety goggles, hard hats, safety shoes, heavy duty gloves and other protection during cutting, grinding, chiseling, prying or any other process which could cause material removal or projectiles. Many machined parts are hardened and can chip.

Use the proper size and type of tool for the job being done. Select a wrench that fits and be sure it is on straight. Keep your tools clean and in good condition.

Some procedures require the use of tools specially designed for that specific purpose.

Before substituting another tool or procedure, you must be completely satisfied that neither personal safety nor the performance of the machine will be endangered.

**5.2. SCHEDULED MAINTENANCE GUIDE**

Scheduled maintenance is the normal maintenance necessary to provide proper and efficient equipment operation and to prolong of your machine's service life.

**Every 10 Hours of Operation (Every Day)**

1. Clean windows, lights and instrument panel.
2. Drain water from fuel filters prior to starting the work. Refer to 5.12.4.1.
3. Check engine oil level. Refer to 5.11.1.
4. Check hydraulic system oil level. Refer to 5.13.1.
5. Visually check the condition of drive belts. Refer to 5.7.1.
6. Visually check the condition of fan. Refer to 5.9.
7. Check radiator coolant level. Refer to 5.8.5
8. Check and clean precleaner screen, if necessary. Refer to 5.6. 1.
9. Check level in window washer reservoir. Refer to 5.21.3.
10. Carry out ground level inspection. Refer to 5.2.1.
11. Check instruments and warning lights for operation. Refer to 4.3.
12. Refill fuel tank at the end of each day's operation. Refer to 5.12.1.
- 13.\* Check torque:
  - track shoe bolts. Refer to 5.19.1.
  - blade cutting edge and end bit bolts. Refer to 5.15.5.2.
  - trunnion cap bolts and trunnion mounting bolts. Refer to 5.15.5.1.

\* – after initial 10 hours of operation only.

**Every 50 Hours of Operation**

1. Check oil level in rear mainframe. Refer to 5.18.1.
2. Clean radiator cores. Refer to 5. 8.4.2.
3. Check and adjust tracks tension, if necessary. Refer to 5.19
4. Check air intake system for leaks (hoses and clamps). Refer to 5.6.3.
5. Lubricate ripper bearings. Refer to 5.14.
6. Lubricate lift cylinder piston rod bearings. Refer to 5.14.
- 7\*. Replace hydraulic system return filters. Refer to 5.13.3.
- 8\*. Replace transmission system pressure filters. Refer to 5.18.3.
- 9\*. Replace equipment pilot filter. Refer to 5.13.3.

\* – after initial 50 hours of operation only.

**Every 100 Hours of Operation**

1. Lubricate blade lift cylinders yoke bearings. Refer to 5.14.

**Every 250 Hours of Operation or every 6 months**

1. Replace fuel filters (2 filters). Refer to 5.12.4.2.
2. Change engine oil filters (2 filters). Refer to 5.11.2.
3. Check coolant for DCA concentration and replace coolant filter. Refer to 5.8.7.
4. Change engine crankcase oil. Refer to 5.11.2.
5. Check fan, alternator and water pump belt and air compressor or air conditioner (if equipped) belt tension. Refer to 5.7.2.
6. Check the condition of the fan (if equipped reverse the reversible fan blades) Refer to 5.9.
7. Check final drive oil level. Refer to 5.17.1.
8. Lubricate upper struts and joints. Refer to 5.14.
9. Lubricate diagonal struts and joints. Refer to 5.14.

**SCHEDULED MAINTENANCE GUIDE****Every 500 Hours of Operation or every year**

1. Check oil level in pivot shaft housing. Refer to 5.19.6

**Every 1000 Hours of Operation**

1. Change final drive oil. Refer to 5.17.2.
2. Change oil in rear mainframe. Refer to 5.18.2.
3. Replace transmission suction strainer. Refer to 5.18.4.
4. Replace transmission system pressure filter. Refer to 5.18.3.
5. Clean transmission system scavenger suction strainer. Refer to 5.18.5.
6. Replace hydraulic system return filter. Refer to 5.13.3.
7. Replace rear mainframe breather. Refer to 5.18.6.
8. Clean hydraulic reservoir breather. Refer to 5.13.5.
9. Lubricate gimbal crosstube. Refer to 5.14.
10. Check sprocket bolt torques. Refer to 5.19.

**Periodic (at least once a year or as required)**

1. Lubricate hand and foot linkage, check for operation and adjust if necessary. Refer to 5.20. and 5.14.
2. Check condition and state-of-charge of batteries. Refer to 5.10.3.
3. Clean air cleaner elements or replace if necessary. Refer to 5.6.2.1. and 5.6.2.2.
4. Clean fuel tank filler strainer. Refer to 5.12.2.
5. Drain water and sediment from fuel tank sediment bowl. Refer to 5.12.5.
6. Clean hydraulic system filler strainer. Refer to 5.13.4.
7. Lubricate the equipment pilot valve plunger – to – plate surfaces. Refer to 5.14.
8. Clean the air conditioner outside filter. Refer to 5.21.2.
9. Check engine RPM with depressed decelerator. Refer to 5.20.
10. Check operation of brake and decelerator pedal. Refer to 5.20.
11. Check undercarriage components for wear. Refer to 5.19.
12. Check track frames guide clearance and adjust if necessary, lubricate track frame guides. Refer to 5.19.5.
13. Check clearance in blade sockets of diagonal struts, upper struts and pitch cylinder and adjust if necessary. Refer to 5.15.2., 5.15.3.
14. Check condition of electrical wires and connections. Refer to 5.10.1.
15. Check condition of safety belt. Refer to 5.16.
16. Check torque:
  - cab and ROPS mounting bolts. Refer to 5.21.1.
  - track shoe mounting bolts. Refer to 5.19.1.
  - blade cutting edge and end bit bolts. Refer to 5.15.5.2.
  - trunnion cap bolts and trunnion mounting bolts. Refer to 5.15.5.1.
17. Check the cutting edges and end bits for wear. Refer to 5.15.5.3.
18. Check the ripper points for wear. Refer to 5.15.6.
19. Wash the machine inside by water stream.
20. Check front wheel guide clearance. Refer to 5.19.7.

**SCHEDULED MAINTENANCE GUIDE****Every 1500 Hours of Operation or every year  
(Per Engine Operator's Manual)**

1. Clean or replace crankcase breather tube if necessary.
2. Adjust engine valves and injectors.
3. Steam clean the engine.
4. Check and replace engine hoses if necessary.
5. Check engine mounting bolts and nuts and torque if necessary.
6. Check turbocharger mounting nuts.

**Every 2000 hours of operation**

1. Change radiator coolant. Refer to 5.8.6.
2. Replace system pilot filter. Refer to 5.13.3.
3. Change hydraulic system oil. Refer to 5.13.2.
4. Clean hydraulic system suction strainer. Refer to 5.13.4.

**Every 6000 Hours of Operation or every 3 years  
(Per Engine Operator's Manual)**

- 1\*. Calibrate injectors and fuel pump.
  2. Check and clean crankcase breather tube.
  3. Drain and flush cooling system. Change coolant and replace coolant filter.
  4. Inspect condition of fan and fan hub.
  5. Inspect condition of coolant pump idler pulley
  6. Inspect condition of coolant pump.
  7. Inspect condition and end play of turbocharger.
  8. Inspect condition of vibration dumper.
- \* – after initial 1500 hours of operation and then each 6000 hours only.

**5.2.1. GROUND LEVEL INSPECTION**

1. Tractor operational equipment for damage and state of proper fastening.
2. Radiator: for damage, evidence of leakage and condition of grill.
3. Hydraulic components for damage or leakage.
4. Track system: rollers, front idlers, sprockets, track shoes for: cracks, excessive wear, loose components and leaks.
5. Transmission system and final drives: for possible leakage.
6. Engine compartment for fuel, oil and coolant leaks.
7. Guards: for damage or missing.
8. ROPS: general condition (no ROPS defects are permissible that may adversely affect its protection in case of machine rollover).











**CAUTION! To ensure personal protection perform all maintenance services in accordance with Scheduled Maintenance Guide and Instructions**

To extend the service life of your equipment follow the scheduled maintenance listed in Scheduled Maintenance Guide.

**5.3. MAINTENANCE AND SERVICE CHART**

**(Always use clean containers and lubricators)**

| SERVICE INTERVAL  | REF. No               | POINT OF SERVICE                          | SERVICE POINTS | LUBRICANT                | SERVICE       |
|---|-----------------------|---|----------------|--------------------------|---------------|
| <br>Every 10 Hours                     | 8                     | Fuel Filter Water Separator               | 2              | EO1<br>HDTF/EO2          | Drain         |
|   | 12                    | Engine Crankcase Oil Level                | 1              |                          | Check         |
|   | 25                    | Hydraulic Reservoir Oil Level             | 1              |                          | Check         |
|   | 32                    | Radiator Coolant Level                    | 1              |                          | Check         |
|   |                       | Ground Level Inspection                   |                |                          | Check         |
| <br>Every 50 Hours                     | 20                    | Transmission System Oil Level             | 1              | HDTF                     | Check         |
|   | 23                    | Ripper Bearings and Pins Cylinder         | 12             | MPG                      | Lube          |
|   | 34                    | Lift Cylinder Piston Rod Bearings         | 2              | MPG                      | Lube          |
| <br>Every 100 Hours                    | 31                    | Blade Lift Cylinders Yoke Bearings        | 4              | MPG                      | Lube          |
| <br>Every 250 Hours or 3 Months        | 8                     | Fuel Filter                               | 2              | EO1<br>MPL<br>MPG<br>MPG | Change        |
|   | 9                     | Engine Crankcase Oil Filter               | 2              |                          | Change        |
|   | 11                    | Engine Coolant Filter, DCA- Concentration | 1              |                          | Check, Change |
|   | 13                    | Engine Crankcase Oil Level                | 1              |                          | Change        |
|   | 18                    | Final Drive Oil Level                     | 2              |                          | Check         |
|   | 33                    | Upper Struts                              | 4              |                          | Lube          |
| 35  | Diagonal Strut Socket | 2   | Lube           |                          |               |
| <br>Every 500 Hours or 6 Month       | 17                    | Pivot Shaft Housing Oil Level             | 2              | HDTF                     | Check         |
| <br>Every 1000 Hours or 12 Month     | 1                     | Final Drive Oil                           | 2              | MPL                      | Change        |
|   | 2                     | Transmission System Oil                   | 1              | HDTF                     | Change        |
|   | 3                     | Transmission Suction Strainer             | 1              |                          | Change        |
|   | 4                     | Transmission System Pressure Filter       | 2              |                          | Change        |
|   | 14                    | Transmission System Scavenger Strainer    | 1              |                          | Clean         |
|   | 15                    | Hydraulic System Return Filter            | 2              |                          | Change        |
|   | 19                    | Rear Frame Breather                       | 1              |                          | Change        |
|   | 26                    | Hydraulic Reservoir Breather              | 1              |                          | Clean         |
| 30  | Gimbal Crosstube      | 2   | MPG            | Lube                     |               |
| <br>Every 2000 Hours                 | 10                    | Engine Coolant                            | 1              | HDTF/EO2                 | Change        |
|   | 16                    | System Pilot Filter                       | 1              |                          | Change        |
|   | 24                    | Hydraulic System Oil                      | 1              |                          | Change        |
|   | 27                    | Hydraulic Oil Suction Strainer            | 1              |                          | Clean         |
| <br>Periodic or at Least Once a Year | 5                     | Hand and Foot Control Linkage             | all            | MPG                      | Lube          |
|   | 6                     | Batteries                                 |                |                          | Inspect       |
|   | 7                     | Air Cleaner Element                       | 1+1            |                          | Clean/Change  |
|   | 21                    | Fuel Tank Strainer                        | 1              |                          | Clean         |
|   | 22                    | Fuel Tank Sediment Bowl                   | 1              |                          | Drain         |
|   | 28                    | Hydraulic Filler Strainer                 | 1              |                          | Clean         |
|   | 29                    | Pilot Valve Plunger – to – Plate Surfaces | 2              | MPG                      | Lube          |

**Lubricant Key:**

EO1 - Engine Oil

HDTF - Heavy Duty Hydraulic Transmission Fluid

EO2 - Multi-purpose Engine Oil

MPL - Multi-purpose Transmission Oil

MPG - Multi-purpose Grease

# MAINTENANCE

## MAINTENANCE AND SERVICE CHART



**CAUTION!** Intervals of time between services are based on average operating conditions. Under unusually severe conditions of operation, reduce the intervals of time between services. Service a machine according to Scheduled Maintenance Guide Instructions.

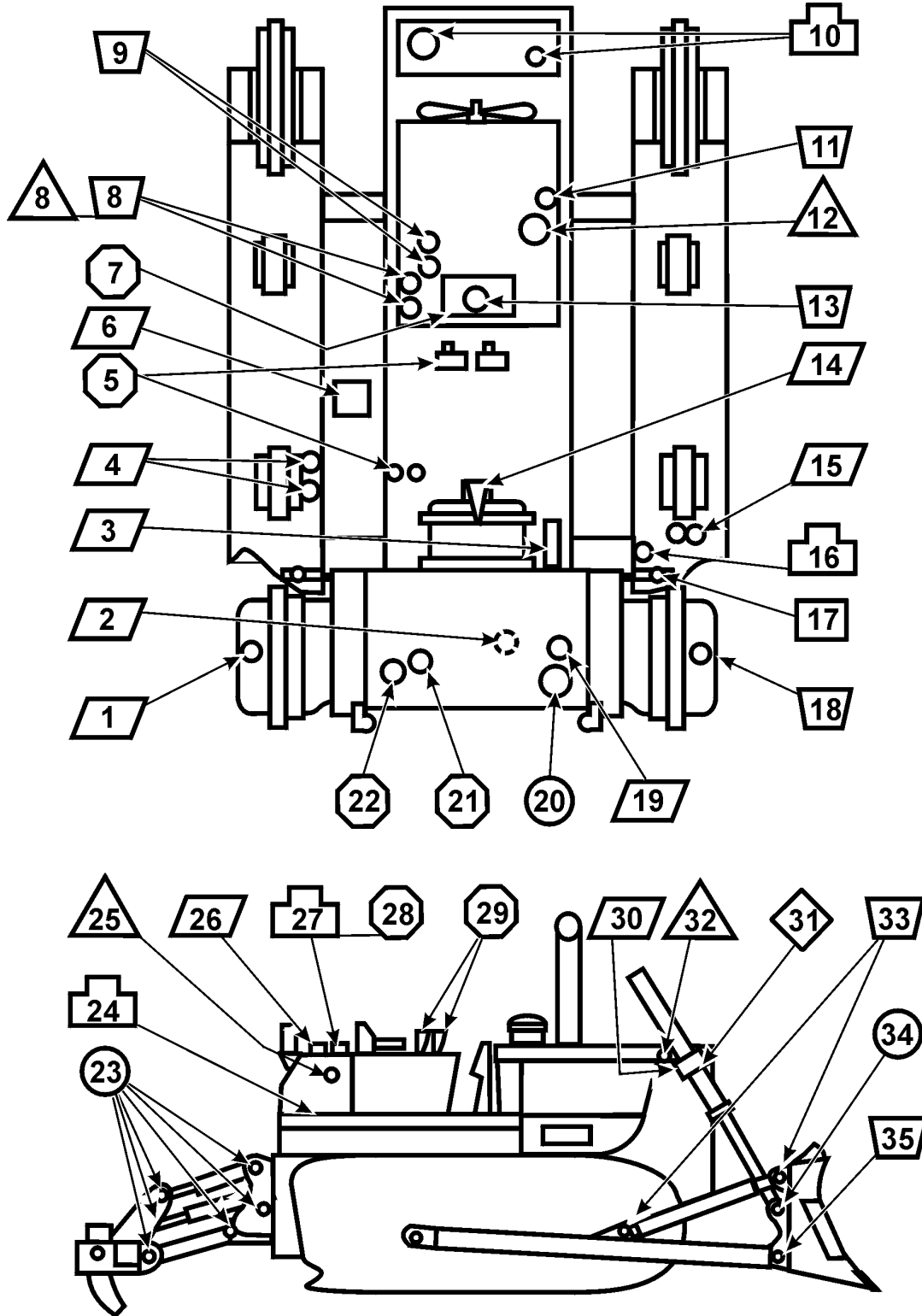

Fig. 5.1. Service Guide



**MAINTENANCE AND SERVICE CHART**

**5.3.1. REFILL SPECIFICATION AND CAPACITIES CHART**

| <b>MODEL TD-25H</b>                     |                       |                 |                           |   |                                |                            |   |   |
|---|-----------------------|-----------------|---------------------------|---|--------------------------------|----------------------------|---|---|
| Lubrication Point                       |                       | Refill capacity | Type                      | Air Temperature +49 – -7 [°C]   | Air Temperature +21 – -23 [°C] | Temperature -12 – -34 [°C] | Temperature -12 – -54 [°C]                    |   |
| Final Drive - Each                      |                       | 46 [l]          | MPL                       | SAE 85W-140   | SAE 85W-140 or SAE 80W - 90    | SAE 80W-90                 | MPL - ARCTIC ARCTIC GRADE 75 per HMS-B22-0003 |   |
| Pivot Shaft Housing - Each              |                       | 4.5 [l]         | MPL                       |   |                                |                            |   |   |
| Engine Crankcase with Filter Change     |                       | 42 [l]          | EO1                       | SAE 15W-40  | SAE 10W-30 or SAE 15W-40       | SAE 5W-20 or SAE 5W-30     | EO - ARCTIC MULTI – PURPOSE per HMS-B21-0001  |   |
| Transmission System (RMF)               |                       | 220[l]          | HDTF                      | SAE 10W   |                                |                            |   |   |
| Track Roller (each)                     | Life Time Lubrication | If Rebuilt      | 0.9 [l]                   | HDTF or EO2*  | SAE 30                         |                            |   |   |
| Top Idler (each)                        | Life Time Lubrication | If Rebuilt      | 1.1 [l]                   |   |                                |                            |   |   |
| Front Idler (each)                      | Life Time Lubrication | If Rebuilt      | 0.8 [l]                   |   |                                |                            |   |   |
| Lubricated track chain link (each)      | Life Time Lubrication | If Rebuilt      | 0.03 [l] approx.. (each). | MPL   | SAE 85W                        |                            |   | MPL - ARCTIC ARCTIC GRADE 75 per HMS-B22-0003 |
| D-2 Equipment Hydraulic System          |                       | 130 [l]         | HDTF or EO2*              | SAE 10W   |                                |                            | EO ARCTIC OIL PER HMS-B21-0001                |   |
| D-2 Equipment Hydraulic System w/Ripper |                       | 165 [l]         | HDTF or EO2*              | SAE 10W   |                                |                            | EO ARCTIC OIL PER HMS-B21-0001                |   |
| Cooling System                          |                       | 92 [l]          |                           | ANTI-FREEZE SOLUTION<br>0° – -37 [°C]<br>50 [%] Anti-freeze<br>50 [%] Water |                                |                            | 62 [%] Anti-freeze<br>38 [%] Water            |   |
| Fuel Tank                               |                       | 825 [l]         |                           | above -12 [°C] Diesel Fuel # 2D<br>below - 12 [°C] Diesel Fuel # 1D         |                                |                            | Diesel Fuel VV-F-800DF-A                      |   |

\* - for servicing only

## MAINTENANCE AND SERVICE CHART

**DESCRIPTION:****HDTF:**

Heavy Duty Transmission Fluid per HMS B21-0006 or equivalent and passing formula C-4 and TO-4. Should not contain viscosity-improving agent.

**EO1:**

CF-4 or SG-4 Engine Oil meeting API requirements, or per MIL-L-2104D Standard and per HMS B21-0002 with sulfated ash of 1.85% maximum.

**EO2:**

Multi – purpose engine oil per HMS B21-0003 or CD engine oil meeting API requirements, or MIL-L-2104C Standard and passing TO-2 and C-3 test with 0.10% minimum zinc.

**EO:**

**Arctic selection:** multi-purpose oil per HMS B21-0001 or MIL-L-46167

**MPL:**

Multi – purpose gear lubricant per HMS B22-0003 or API GL-5 or MIL-L-2105C

**Arctic selection:** grade 75 per HMS B22-0003

**MPG:**

Multi – purpose grease 251 HEPM per HMS B27-0002 or NLGI grade #2 - lithium grease with 3% minimum molybdenum disulfide (MoS<sub>2</sub>) contents.

**Arctic selection:** per HMS B27-0003 or MIL-L-10924D

**ANTI-FREEZE:**

Single phase, ethylene glycol base per HMS B01-0001.

**DIESEL FUEL:**

Per HMS B32-0001 or ASTM 2975

**Arctic selection:** per VV-F-800DF-A

**IMPORTANT:** *Intervals of time between services are based on average operating conditions. Under unusually severe conditions of operation, reduce the intervals of time between services. Service a machine according to Scheduled Maintenance Guide Instructions at least once a year.*

**5.4. LUBRICATION****5.4.1. WHEN SHIPPED**

This machine has been lubricated at the factory for operation in an air temperature range of +21 [°C] to – 23 [°C]. If this tractor is to be operated above or below this range, change to the correct lubricants.

Unless an exception is shown below, all lubricants can be used (within above temperature range) until regular scheduled (normal) change intervals occur. Refer to "MAINTENANCE AND SERVICE CHART" for the scheduled (normal) change intervals and to "REFILL SPECIFICATIONS AND CAPACITIES CHART" for the proper oil grades for ambient temperatures.

Front idlers, track idlers and track rollers are permanently lubricated with a SAE 30, API CD or MIL-L-2104C engine oil. Lubricated track chain links are permanently lubricated with SAE 85W multi-purpose lubricant. Level check of these compartments is not required.

## LUBRICATION

## 5.4.2. WHEN SERVICED



**WARNING!** When you service a machine, always follow the Operator's or Service Manual. Never grease, oil or perform any maintenance alone with the engine running. Always have another experienced person helping in the operator's compartment when maintenance must be done with the engine running. Block up all attachments securely. Do not leave the operator's seat with the engine running. Failure to follow these instructions could result in serious injury or death.

The life and performance of a tractor and its equipment depends on the service that it is given. Proper lubrication is an important part of maintenance service. Thorough lubrication service performed at specified intervals will aid in prolonging the life of the tractor and its equipment and in reducing operating expense. The type of work being done, load, ground and weather conditions are all factors to consider in frequency of lubrication.

The scheduled intervals between lubrication periods shown on the "SERVICE CHART" are approximate, based on average operating conditions. It may be necessary to lubricate after shorter working periods under severe operating conditions such as extreme dust, low engine temperatures, intermittent operation, excessively heavy loads with high oil temperatures, or when diesel fuel with a high sulfur content is used. However, the time intervals between lubrication periods must never exceed those indicated in this manual.

## 5.4.3. SELECTION

The selection of the proper type (specification) and the grade (weight or viscosity) of lubricant is important. Many tests have been made to determine the correct lubricants for this tractor and its equipment. Refer to "REFILL SPECIFICATION AND CAPACITIES CHART" for the recommended time intervals and grades of lubricants.

## 5.4.4. VISCOSITIES

During cold weather, base the selection of crankcase lubricating oil viscosity on the lowest anticipated temperature for the day to make starting easier. For hot weather operation, base the selection on the highest anticipated temperature. Refer to the "REFILL SPECIFICATIONS AND CAPACITIES CHART".

**IMPORTANT:** After the oil has been replaced, start the engine according to the instructions specified in Section 4, "ENGINE START AFTER OIL CHANGE OR PROLONGED STANDSTILL".

## LUBRICATION

## 5.4.5. RECOMMENDED LUBRICANT CHART

| RECOMMENDED LUBRICANT   | EQUIVALENT LUBRICANT   |  |   | TYPE       |
|---|--|--|---|------------|
|   | POLISH   | SHELL  | TEXACO                                      |            |
| Engine oil per HMS B21-0002 or API CF-4 or SG-4 per MIL-L-2104D with sulfated ash of 1.85% maximum<br>SAE 15W/40<br><br>SAE 10W/30<br>SAE 5W/40 | AQUILA DIESEL TURBO CE/CF-4/SG SAE 15W/40<br><br>HELIUS SAE 5W/40  | RIMULA TX 15W/40<br><br>MYRINA TX 10W/30   | URSA SUPER LA 15W/40<br><br>URSA TDX 10W/30 | EO1        |
| Engine oil per HMS B21-0003 or CD MIL-L-2104C<br>SAE 10W<br><br>SAE 30  | SUPEROL CD SAE 10W<br>SUPEROL CD SAE 30  | ROTELLA TX 10W<br><br>ROTELLA TX 30  | URSA SUPER LA 10W<br>URSA SUPER LA 30       | EO2        |
| Transmission Fluid HDTF per HMS B21-0006 passing formula C-4 and TO-4 tests<br>SAE 10W<br>SAE 30  | GERAX TKD 10W<br>GERAX TKD 30  | DONAX TC 10W<br>DONAX TC 30  | TEXTRAN HD 10W<br>TEXTRAN HD 30             | HDTF       |
| Gear Lube per HMS B22-0003 or API GL-5 or MIL-L-2105C<br>SAE 85W/140<br><br>SAE 80W/90  | HIPOL 85W/140<br><br>HIPOL 80W/90  | SPIRAX HD 85W/140<br>SPIRAX HD 80W/90  | GEARTEX EP-C 85W/14<br>GEARTEX EP-C 80W/90  | MPL        |
| Multi-purpose grease per HMS B27-0002 or NLGI lithium grease grade #2 with 3% MoS <sub>2</sub>  | LITOMOS EP-23  | RETINAX EPX2   | MOLYTEX EP-2                                | MPG        |
| Anti-freeze, ethylene glycol base per HMS B1-0001   | ERGOFRYZ   | GLYCOSHELL DILUTED   | ANTIFREEZE ETX 6042                         |            |
| Arctic oil, synthetic 75W per HMS B22-0003  | -----  | -----  | SYN-STAR 75W CODE 2080                      | MPL ARCTIC |
| Arctic engine Oil, synthetic per HMS B21-0001 or MIL-L-46167  | -----  | CHEVRON SUB-ZERO Fluid OW-30 manufactured by CHEVRON or FRIGID-GO 2809A manufactured by EMERY Ind. |   | EO ARCTIC  |
| Arctic grease per HMS B27-0003 or MIL-L-10924D  | -----  | SRI grease manufactured by CONOCO Grease 2816 manufactured by EMERY Ind.                           |   | MPG ARCTIC |
| Diesel Fuel Per HMS-B32-0001  | Diesel fuel per Polish Standard PN-C-96051:1992<br>DL above 0[°C]<br>DP above -12[°C]<br>DZ above -20[°C]<br>IZ-40 above -30[°C]<br>For temperatures below -30[°C] add pour point depressant |  |   |            |

## 5.5. SEASONAL PREPARATION

### General

Mechanical efficiency is enhanced during seasonal air temperature changes, when these instructions are followed.

### Outside source of heat

Machines left outside for prolonged periods in sub-zero weather will suffer from "cold-soak." Lubricants become viscous and incapable of lubricating moving parts. Extreme wear could result to the engine, transmission and final drives unless proper precautions are taken.

A source of outside heat is necessary under these conditions. There are electric as well as propane-fired engine coolant heaters available. Gas-fired forced air heaters may also be obtained to heat the transmission and final drives.

When using such heaters follow manufacturer's safety instructions.



**WARNING! For your personal safety, use caution and follow the manufacturer's instructions when using engine block heaters to warm the coolant or external heaters to warm the tractor.**

### 5.5.1. FUEL SYSTEM

Refer to "RECOMMENDED LUBRICANT CHART " for the diesel fuels selection, which will give the most satisfactory performance in the ambient temperature.

### 5.5.2. COOLING SYSTEM

Prepare the cooling system as follows:

1. Check the entire engine system for leaks.
2. Inspect the condition of all hoses and replace the hose and hose clamps as necessary.
3. Check the drive belts tension and adjust tension or replace a faulty belt. Refer to "CHECKING TENSION AND ADJUSTMENT".
4. Remove all debris from the radiator core using air or water under pressure. Direct the flow through the core, opposite the normal direction of air flow.



**WARNING! For your personal protection, water pressure should not exceed 270 [kPa] and air pressure should not exceed 210 [kPa]. Use safety goggles.**

5. Clean the radiator guard and the outside of the core.
6. Protect your cooling system from damage by using approved antifreeze and coolant. Refer to "CHANGING COOLANT".
7. Keep your cooling system clean and minimize corrosion by adding VCI at the correct intervals. Refer to "COOLING SYSTEM".
8. Check the condition of the fan blades.

### 5.5.3. ELECTRIC SYSTEM

Clean the batteries and remove all corrosion from the battery terminals and cables. Repair or replace all wires, which have worn, cracked or frayed insulation and broken or loose wires. Service the batteries. Refer to "BATTERIES".

5.6. AIR CLEANING SYSTEM

5.6.1. PRE-CLEANER (Fig. 5.2)

The air pre-cleaner consists of the pre-cleaner hood (8) with a screen. Hood (8) of the pre-cleaner hood serves as a rain shield and the screen prevents chaff and coarse dirt from getting into the air cleaner. Keep this screen clean from all chaff, oil or dust. Clogged holes in the screen will reduce the power of the engine by restricting the flow of air.

Loosen clamp (10) on the pre-cleaner hood (8) securing it to the pre-cleaner (9). Twist and pull upward to remove the hood. Use compressed air to clean the screen. If compressed air is not available, wash the screen in a clean hot water or water containing a small amount of non-sudsing detergent.

**IMPORTANT:** Never wash the pre-cleaner installed on a machine as water may penetrate to the engine and cause a serious damage.

5.6.2. AIR CLEANER (Fig. 5.2)

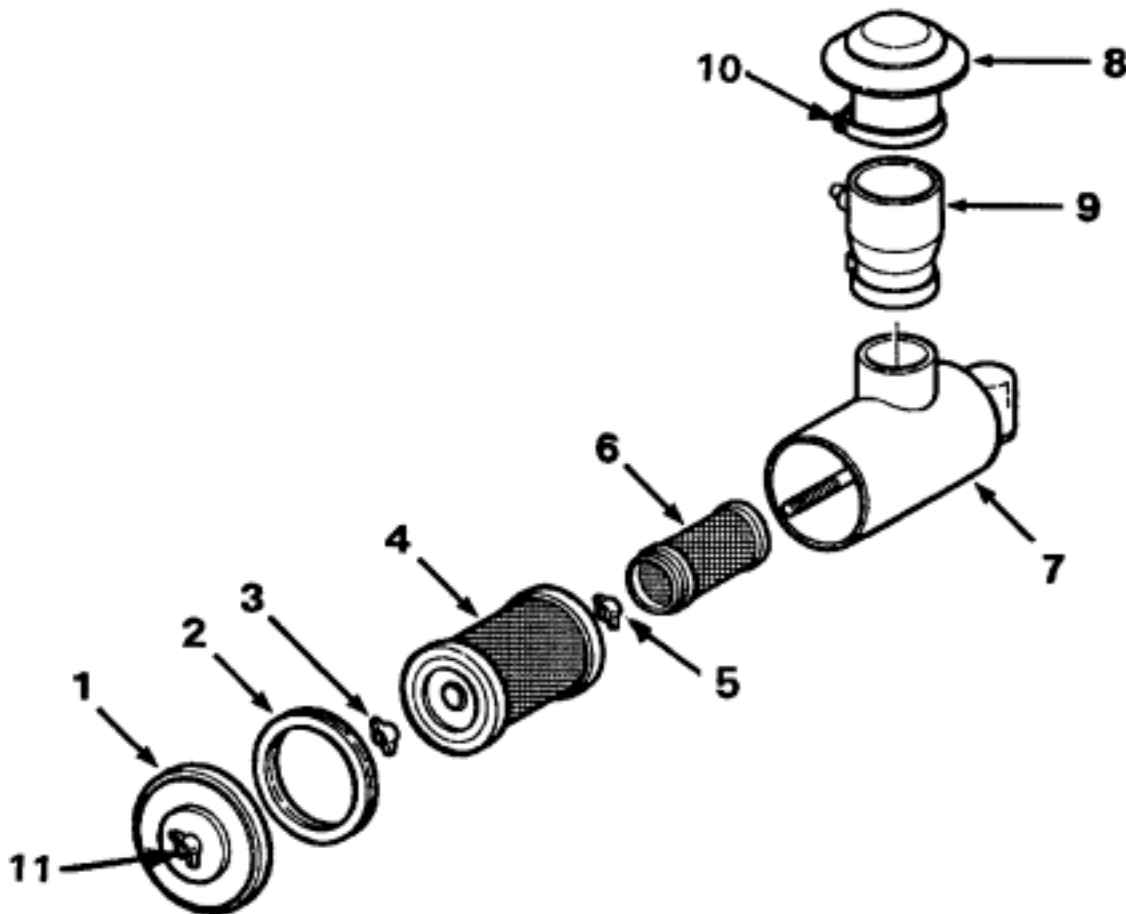

Fig. 5.2. Air Cleaner with Connections (exploded view)

- |                    |                     |                     |
|--------------------|---------------------|---------------------|
| 1. Cover           | 5. Lock Nut         | 9. Pre-Cleaner Body |
| 2. Cover Gasket    | 6. Safety Element   | 10. Clamp           |
| 3. Wing Nut        | 7. Cleaner Body     | 11. Wing Nut        |
| 4. Primary Element | 8. Pre-Cleaner Hood |                     |

**AIR CLEANING SYSTEM**

This machine has a "dry-type" cleaner with replaceable elements.

The cleaner has two elements: primary and safety. The primary element can be cleaned for a limited number of times before replacement is necessary. However, the safety element must be replaced when plugged. Detailed service procedures for the air cleaner are covered in the following text.

**IMPORTANT:** *As a precaution against dirt entering the engine, all gasket and rubber hoses between the air cleaner, turbocharger and intake manifold, and between the manifold and cylinder head must be in good condition and the joints or connections must be tight. Never operate the engine unless a filter element is in place and filter end gasket is installed. Never remove the element from the air cleaner or service the air cleaner while the engine is running*

**5.6.2.1. PRIMARY FILTER ELEMENT (Fig. 5.2)****Service**

The air cleaner primary element must be serviced whenever indicated by the air cleaner filter warning light. Refer to "AIR CLEANER FILTER WARNING LIGHT", Section 4.

If after cleaning of the primary filter element the air cleaner filter warning light continues to glow, check the pre-cleaner screen for allowable restriction. If the warning light continues to glow, replace the safety filter element. If, with the cleaned primary filter element and replaced safety filter element, the warning light still continues to glow, check the air cleaner service indicator. The primary element can be cleaned by either of two methods: washing or cleaning with compressed air. Washing is the preferred method as it removes more dust and soot and restores the element to an almost new condition.

The result being better performance and longer intervals between required element service. It is recommended that a spare element be obtained for use while the serviced element is drying.

**NOTE:** *The primary filter element must be replaced after six washings.*

Cleaning an element with compressed air is not considered an entirely satisfactory method. Some dust will remain in the element causing more frequent servicing of it. Cleaning with compressed air should be used only as a temporary measure until sufficient time is available to clean the element by washing.

**NOTE:** *After cleaning, if the element is to be stored for later use, place it in a plastic bag and store in the element-shipping container to protect against dirt and damage.*

**Removal (Fig. 5.2)**

1. Stop the engine, lower the equipment to the ground. Open the left engine access door. Remove all dust from the element removable end of the air cleaner body (7).
2. Unscrew the wing nut (11) and remove the cover (1) and the cover gasket (2) from the air cleaner body (7). Unscrew the wing nut (3) and carefully remove the primary element (4) from the body taking care not to dislodge dust from the dirty element onto the safety element (6).
3. Check the condition of the gasket on both sides of the primary element (4). If the gasket is damaged or missing, replace the primary element.
4. Remove all dirt from the inside air cleaner body (7) with a damp cloth. A small amount of non-sudsing detergent added to the water will remove the soot.

## AIR CLEANING SYSTEM

## Washing

**IMPORTANT:** Never wash element in flammable liquids such as: fuel, oil, gas or solvent. DO NOT OIL ELEMENTS. Do not tap the element against a hard surface; this will damage the element.

1. Carefully tap the side or end of the element against the palm of your hand to remove loose dust.
2. Wash the element in clean, warm water 20 [°C] to 40 [°C]. A small amount of non-sudsing detergent added to water will remove the soot.
3. Rinse the element in clear water (if a hose is used, do not exceed 270 [kPa]). Shake the element carefully to remove excess water.

**NOTE:** Do not use compressed air to speed the drying of an element; air pressure will rupture a wet element.

4. Lay the element on its side and allow it to air-dry before reinstalling. Overnight drying is usually sufficient. When drying an element, protect it from dirt and/or freezing.

**NOTE:** If no spare element is available, the wet element, after excess water has been shaken out, may be installed in the air cleaner and the engine operated at idle for 10 minutes before operating the tractor.

5. Inspect for damage. Refer to "INSPECTION" below.

## Inspection

1. Inspect a filter element for leaks or damage by placing a bright light inside the element. Inspection of the element on the outside will disclose any holes where concentrated light shines through. The slightest rupture requires replacement of the filter element.
2. Inspect the contact surfaces of the air cleaner body. If faulty or damaged surfaces are noted, correct these conditions immediately.

## Installation (Fig. 5.2)

1. Insert the open end of the primary element (4) into the air cleaner body (7) and secure it with the wing nut (3). Install the cover (1) with the gasket (2) onto the air cleaner body (7). Secure the cover to the body with the wing nut (11) making sure the cover is not cocked.
2. Inspect and tighten all air cleaner connections before resuming operation. Start the engine. If the air cleaner filter warning light indicates air restriction, replace the primary or primary and safety filter elements.

## 5.6.2.2. SAFETY FILTER ELEMENT

## Service

Replace the safety element with every third change of the primary element or when plugged, as shown by the filter warning light.



AIR CLEANING SYSTEM

Removal (Fig. 5.2.)

1. Remove the primary element as described in 5.6.2.1.
2. Unscrew nut (5). Pull safety the element (6) out. Clean the inside of body (7) with a damp cloth. Check the condition of the gasket at the end of safety element (6). If the gasket is damaged or missing, replace the element.

Installation (Fig. 5.2.)

1. Install a new safety element (6) into the body (7) and secure it with the nut (5).
2. Install the primary filter element as described in 5.6.2.1.

5.6.3. CHECKING AIR INTAKE SYSTEM FOR LEAKS

Check the air intake system for hose cracks, loose clamps. Tighten loose connection, replace broken parts to eliminate leaks, which may damage or impair the engine.

**NOTE:** No leakage is permitted between the air cleaner and the engine intake manifold (the entire air induction system).

5.7. BELTS

General



**WARNING!** Keep clear of the fan and fan belt when the engine is running. Rotating fan and belt contact can cause injury.

5.7.1. Visual Inspection

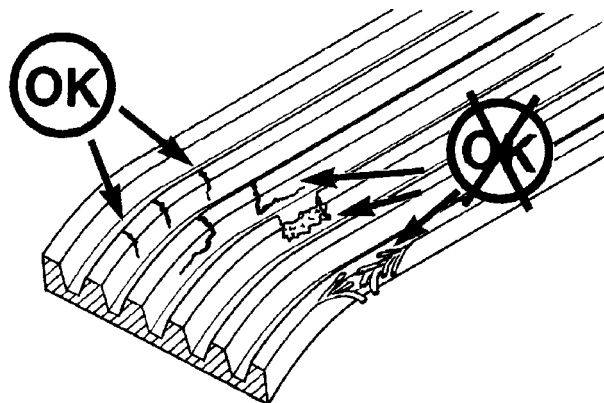

Fig. 5.3. Belt Inspection

Replace badly worn, greasy or cracked belts immediately. These conditions prevent proper belt function.

Visually inspect the drive belts for intersecting cracks. Transverse (across the belt width) cracks are acceptable. Longitudinal (direction of belt length) cracks that intersect with transverse cracks are not acceptable. Replace a belt if it is frayed or has pieces of material missing.

BELTS

5.7.2. CHECKING TENSION AND ADJUSTMENT

Belts on new machines and replacement belts lose their tension as they seat into the pulley grooves. The tension of the fan, alternator and water pump belts must be checked and adjusted. Refer to Engine Maintenance Schedule. To check belt tension an ST-1293 Borroughs type gauge must be used. Adjust the tension according to the „Belt Tension Chart”.

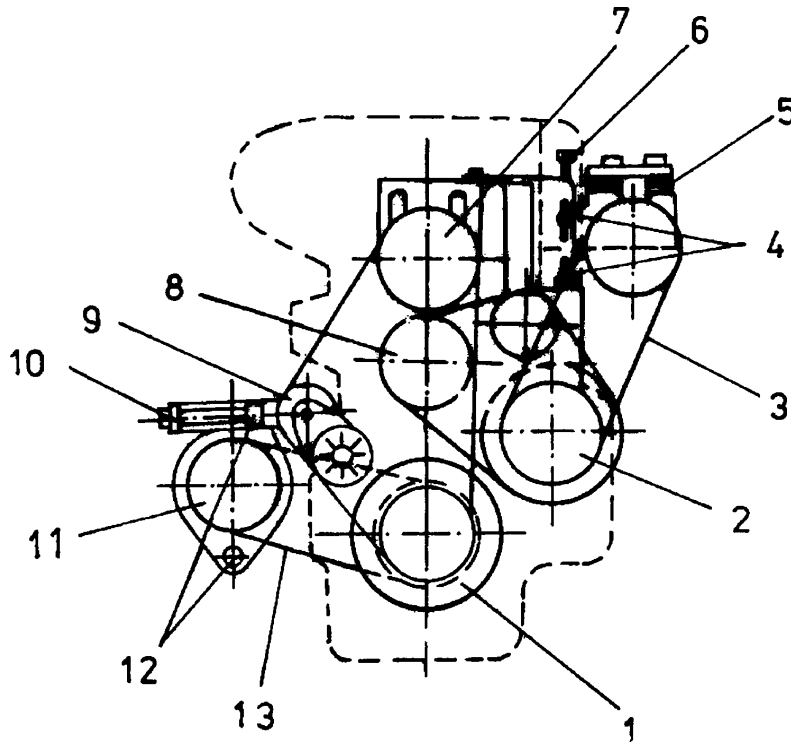

Fig. 5.4. Belt Tension Adjustment

- 1. Crankshaft pulley
- 2. A/C Compressor Pulley
- 3. A/C Compressor Belt
- 4. Mounting Bolts
- 5. A/C Compressor
- 6. A/C Compressor Belt Adjusting Bolt
- 7. Fan Pulley
- 8. Water Pump Pulley
- 9. Fan Belt Tensioner
- 10. Alternator Belt Adjusting Bolt
- 11. Alternator Pulley
- 12. Alternator Mounting Bolts
- 13. Alternator Belt

| DRIVE               | NEW BELT TENSION | USED BELT TENSION* |
|---------------------|------------------|--------------------|
|                     | [N]              | [N]                |
| ALTERNATOR BELT     | 620              | 270 - 490          |
| FAN BELT            | 620              | 270 - 490          |
| AIR COMPRESSOR BELT | 620              | 270 - 490          |
| WATER PUMP BELT     | 710              | 290 - 580          |

\* A belt is considered as used after at least 10 minutes of operation

## BELTS

### 5.7.2.1. AIR CONDITIONING COMPRESSOR BELT ADJUSTMENT (Fig. 5.4)

To adjust belt tension of air conditioning compressor proceed as follows:

1. Loosen mounting bolts (4).
2. Turn in or out the adjusting bolt (6) to increase or decrease belt (3) tension.
3. Tighten mounting bolts (4).
4. Tighten the adjusting bolt (6) with a standard torque.

### 5.7.2.2. ALTERNATOR BELT ADJUSTMENT (Fig. 5.4)

To adjust belt (13) tension of the air conditioning compressor proceed as follows:

1. Loosen mounting bolts (12).
2. Turn in or out the adjusting bolt (10) to increase or decrease belt tension to the standard value of 270-490 [N].
3. Tighten mounting bolts (12).

### 5.7.3. BELT REPLACEMENT

In case of a replacement always inspect all the belts and, if necessary, replace all belts that need to be replaced. All pulley supports, bearings, shafts, pulleys and brackets must be in working order. Prior to installing a new belt make sure all pulley grooves are clean and not worn. All impurities must be removed. If a pulley is damaged or its grooves are worn, it must be replaced. When replacing belts and pulleys, the pulley alignment must be checked. A misalignment that can be detected with a naked eye is detrimental to the belt performance.

During a belt installment, do not force the belt into the pulley grooves by prying with a screwdriver or pry bar. This will damage the belt side cords, which causes the belt to turn and results in complete destruction of the belt in operation.

## 5.8. COOLING SYSTEM

### General

The cooling system operates under pressure controlled by a pressure relief valve in the radiator cap. The water pump circulates the coolant through the oil cooler, engine block, cylinder heads, and radiator. Circulation is controlled by a thermostat, which prevents coolant flow through the radiator until the engine reaches the operating temperature. Proper cooling is assured only when the system is sealed, the radiator cap and gasket in good condition, the thermostat operates properly, the system is free of coolant and/or air flow restrictions and is filled to the proper level.

The selection and maintenance of the system coolant is important to long engine life. The following information provides recommendations for selecting engine coolant, maintaining coolant inhibitors, and servicing the cooling system. This system will operate with a water/antifreeze mixture or inhibited water as coolant. Never use water alone because water will allow rust, scale deposits, and corrosion to occur within the system.

## COOLING SYSTEM

## 5.8.1. WATER

Use water, which has a low mineral content. Water used in conjunction with antifreeze, coolant filters and inhibited water must meet the following standards:

**Total hardness:** Not to exceed 170 parts per million to prevent scale deposits. Water containing dissolved magnesium and calcium (the usual reason for water hardness) above the specified amount will cause scale deposits to develop in the engine.

**Chlorides** – Not to exceed 40 parts per million to prevent corrosion.

**Sulfites** – Not to exceed 100 parts per million to prevent corrosion.

**Dissolved solids** – Not to exceed 340 parts per million to minimize sludge deposits, scale deposits and corrosion.

If any of the requirements cannot be met, use distilled, de-ionized or de-mineralized water. To determine if local water supplies meet these standards, water treatment laboratories can test water samples. Softened water that is prepared using common salt (sodium chloride) contains excessive amounts of chlorides and should not be used.

## 5.8.2. ANTIFREEZE

Low silicate ethylene glycol antifreeze is recommended. The antifreeze should contain no more than 0.1% anhydrous alkali metasilicate. Low silicate antifreeze is recommended to avoid the formation of silica gel (hydro-gel). This gel formation can occur when cooling system contains an over concentration of high silicate antifreeze and/or supplemental coolant additive. DO NOT use methanol or alcohol as antifreeze because of its low boiling point. Antifreeze may retain its freeze protection for more than one season but coolant conditioners must be added to maintain corrosion protection. Antifreeze formulated with methoxy propanol, or propylene glycol is not recommended for this system.

**IMPORTANT:** Do not mix different types of antifreeze solutions. Mixed solutions make it impossible to determine the protection against freezing.

**IMPORTANT:** Antifreeze containing sealer or anti-leak additives should not be used in this system. Sealer or anti-leak additives will plug the coolant filter and cause plugging problems in the cooling system.

A table included in Engine Operation and Maintenance Manual shows percentage of antifreeze concentration required for various temperatures.

## 5.8.3. INHIBITORS / CONDITIONERS

All cooling system inhibitors, including those in antifreeze solutions, become depleted through normal operation. If the inhibitors in antifreeze are allowed to become depleted, the antifreeze becomes corrosive and attacks and coats the metallic surfaces of the cooling system. If the concentration is too high it causes plugging problems in the cooling system, which reduces heat transfer. Cooling system conditioners, which contain these inhibitors, must be added or filters replaced to maintain corrosion protection.

## COOLING SYSTEM

**Replenishing coolant conditioner**

Replenishing coolant conditioner is performed by periodical replacement of filters containing DCA-4 inhibitor protecting the cooling system against corrosion and cavitation erosion of the cylinder sleeves and coolant pump blades.

**Coolant testing for conditioner concentration**

Coolant testing for DCA-4 concentration should be performed periodically before coolant filter replacement to determine the proper capacity of the filter to be applied. CC2626 test kit of the filter manufacturer is designed for this purpose. The testing procedure is included in Engine Operation and Maintenance Manual.

**NOTE:** *Mixing of DCA-4 and other supplemental coolant additives is not recommended because there is currently no test kit available to measure concentration levels with mixed chemical solutions.*

**5.8.4. RADIATOR CAP****5.8.4.1 RADIATOR CAP COVER**

Fig. 5.5. Radiator Cap

COOLING SYSTEM

General

The radiator cap seals the coolant filler opening of the radiator. Positive sealing requires a cap gasket and its contacting surfaces in good condition, and a properly tightened cap.

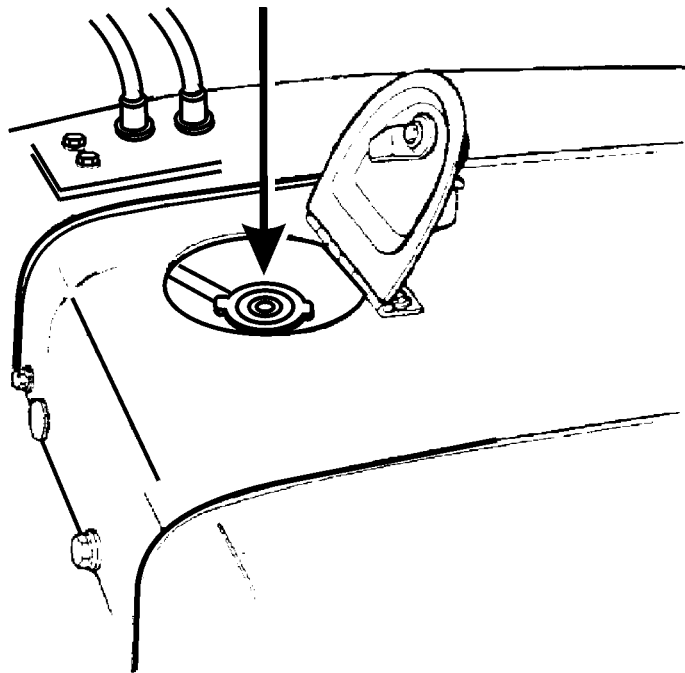
The radiator cap incorporates a pressure relief valve that keeps the pressure of the coolant at 40 – 55 [kPa] in the top tank of the radiator.

**IMPORTANT:** *Operating a machine without a radiator cap, or with a cap without a relief valve set to operate at the correct pressure can cause damage.*

Removal



**WARNING!** Hot, scalding coolant can spray out if the radiator cap is removed suddenly. Relieve the system pressure by slowly turning the cap to the first notch or lifting the safety lever (if equipped). Remove the cap only after the pressure is relieved. Wait until the coolant temperature drops below 50 [°C] before removing the cap or adding coolant.



**WARNING!** Use extreme caution when adding coolant to a hot radiator to avoid being burned. Wear gloves and goggles and keep face away from the filler neck.

To remove the cap turn the cap to the left or counterclockwise up to the safety stop and wait until all pressure is released. Then press down on the cap and continue to turn until the cap is free to be removed.

Installation

When installing the cap, gasket and contacting surfaces must be clean. Turn the cap to the right or clockwise until snug.

5.8.4.2. CLEANING THE RADIATOR CORE

Every 50 hours of operation remove dirt from the radiator core. Refer to “COOLING SYSTEM”. Air conditioning radiator core (if equipped) should be cleaned as well.

5.8.5. CHECKING COOLANT LEVEL

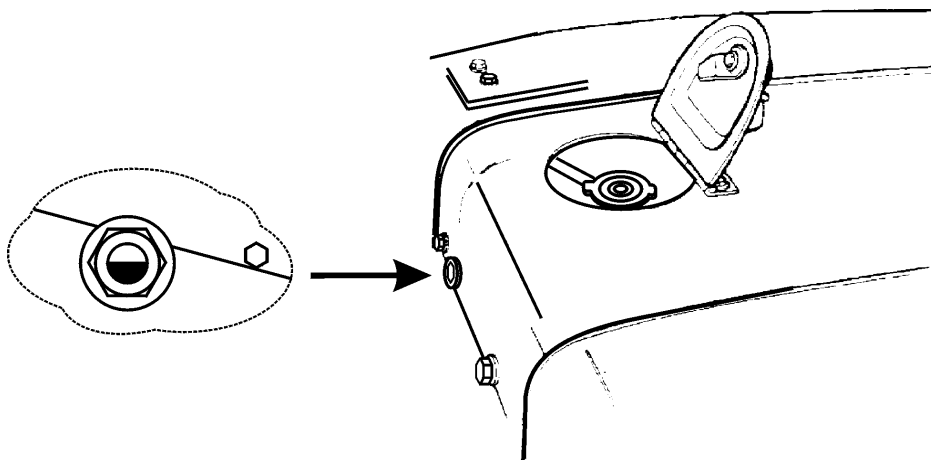

Fig. 5.6. Radiator Sight Gauge

COOLING SYSTEM

Check the coolant level daily to be sure that the level is proper. For checking coolant level place the machine on the level ground and lower the mounted equipment to the ground. Coolant level must be seen in the sight gauge. If coolant has to be added check and replenish DCA-4.

5.8.6. CHANGING COOLANT

5.8.6.1. Draining the System (Fig. 5.7)

1. Position the machine on level ground.
2. Run the engine until it reaches the temperature of 50 [°C] then stop the engine.
3. Remove the radiator cap. Refer to "RADIATOR CAP".
4. Open radiator drain valve (1) located in the radiator lower tank on the right hand side of the machine. Access to the valve is gained after the removal of the front bottom guard.
5. Open engine drain cock (2) on the cylinder block.
6. Open oil cooler drain cock (3) located on the bottom of the oil cooler.
7. Open the shutoff valve at the cooling filter head.
8. Allow the system to drain completely; do not let drain outlets plug up from foreign material.
9. Change coolant filter. Install a filter of greater capacity. (Procedure is shown in Engine Operation Manual).

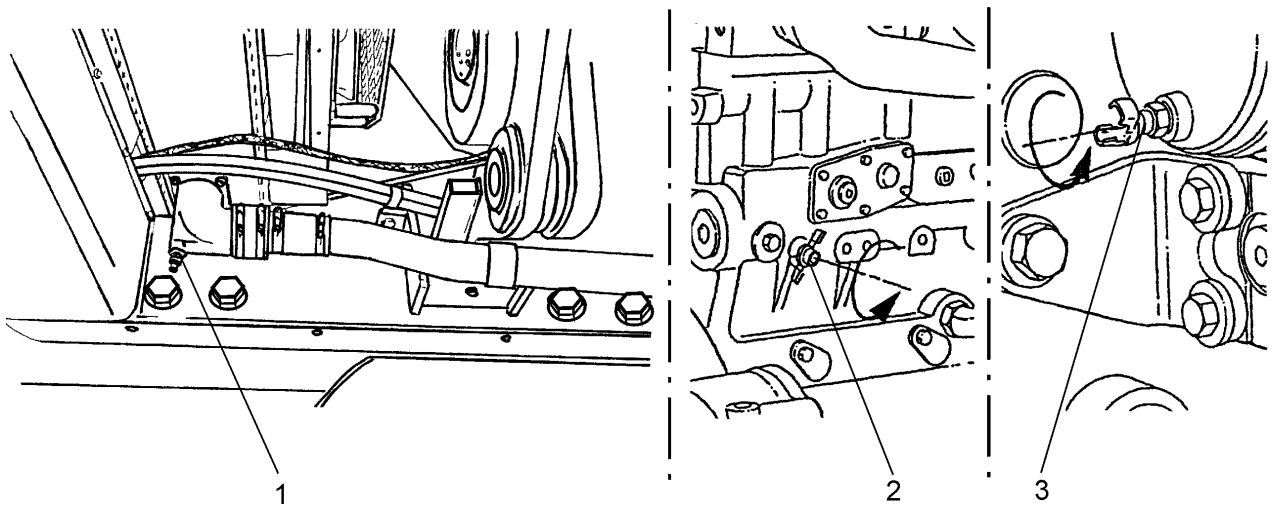

Fig. 5.7. Water Coolant Drain Valves.

1. Radiator Drain Valve
2. Engine Draincock on the Cylinder Block
3. Oil Cooler Draincock

5.8.6.2. FILLING THE DRAINED SYSTEM

**IMPORTANT:** Do not fill a cooling system with water alone. Use antifreeze and water solution in proportions as specified in "REFILL SPECIFICATIONS AND CAPACITIES CHART" according to the ambient temperature.

1. Close the radiator drain valve, the engine oil cooler draincock, the draincock on the cylinder block and the coolant filter shutoff valve.

## COOLING SYSTEM

2. Fill the cooling system slowly. This allows more air to escape and the system to be filled to maximum capacity. Install the radiator cap.
3. Start the engine and run it until normal operating temperature is reached. Add coolant when needed to keep proper level. Refer to "CHECKING THE COOLANT LEVEL". Check the system for leaks.

## 5.8.7. CHANGING THE COOLANT FILTER

Every 250 hours of operation the coolant filter should be replaced and DCA-4 conditioner level should be checked. Refer to the ENGINE OPERATION MANUAL. Every 2000 hours of operation or every 2 years the whole cooling system should be cleaned. Refer to the ENGINE OPERATION MANUAL.

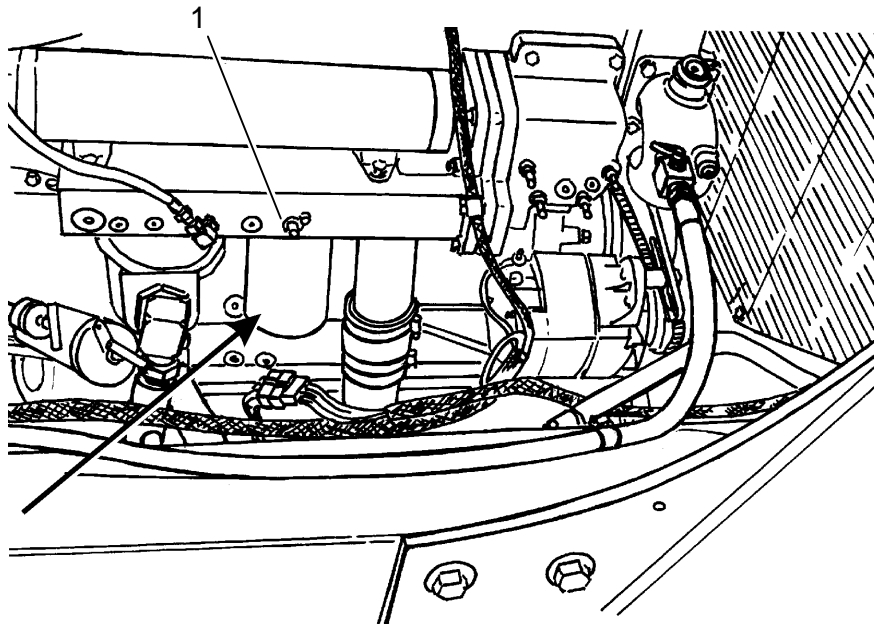

Fig. 5.8. Coolant Filter

1. Shut-off Valve

Prior to installation of a new coolant filter close the shut-off valve (1, Fig. 5.8) at the cooling system filter. Upon installation of new the coolant filter open the shut-off valve.

## 5.9. FAN AND FAN HUB



**WARNING!** Keep clear of fan and fan belts when engine is running. Rotating fan and belt contact can cause injury.

1. Check the condition of the fan blades (cracks, damaged rivets, loose mounting bolts).
2. Reversible fan blades (if equipped) should be reversed every 250 hours of operation to clean the radiator and engine compartment. At the times of engine overhaul, remove the hub cover and apply NLGI 2 lithium grease to the blade bracket.



FAN AND FAN HUB

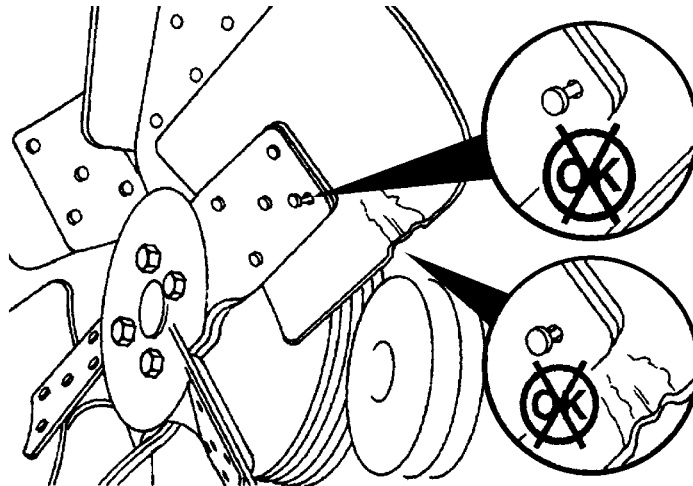

Fig. 5.9. Fan

5.10. ELECTRIC SYSTEM

PRECAUTIONS



**WARNING!** Before working on an engine or electric system, turn off the electric system master switch and remove the key. All terminals must be clean and fastened securely. Replace frayed, cracked, and poorly insulated wiring. The electric system shall not be tampered with. Wrongly made alterations may cause machine damage or fire.

5.10.1. ELECTRIC WIRES AND CONNECTIONS

The contact surface under all terminals must be clean, and good electrical connections must be established after any reassembly. Also, all clips must grip cables tightly to prevent vibrations and rapid cable wear. All clips and straps must be closed in a workmanlike manner, so as not to damage the insulation.

5.10.2. AUTOMATIC RESET CIRCUIT BREAKER

Electric circuits are protected by automatic reset circuit breakers mounted on the underside of the instrument panel. In the event of a short circuit or ground, the circuit breaker will open and close until trouble clears or is corrected. The circuit breaker will then return and stay in its normal closed position.

5.10.3. BATTERIES

**General**

Batteries can only be charged using receptacle located close to the engine on the left hand side of the machine. The receptacle can also be used to connect additional source of supply, e.g. for engine starting. This receptacle can also be used to connect additional source of power to start the engine under extreme conditions.

## MAINTENANCE

## ELECTRIC SYSTEM

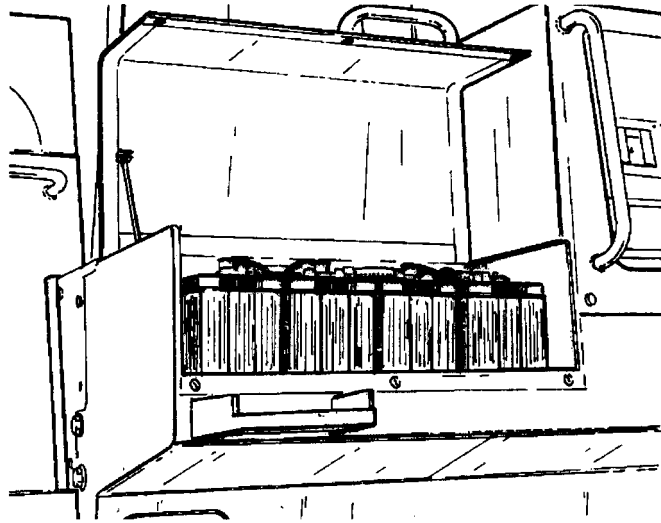

Fig. 5.10. Location of Batteries

A machine is equipped with four 12-volt batteries. Access is provided upon removal of three bolts and lifting the cover.

Batteries can only be charged through a receptacle located on the L.H. side of the machine near the engine. The receptacle can be used to connect a booster battery as in the case of starting the engine in severe conditions.

Never allow a battery to stand on concrete, ground or a metal support unless proper insulation is provided. A wooden platform or board is a sufficient insulation. Be sure the battery in a machine is fastened securely to avoid damage from vibration.



**WARNING!** A battery gives off highly flammable gas (hydrogen). Never allow sparks, open flame or lighted smoking material near the battery. Avoid spilling any electrolyte on hands or clothing. Always wear safety glasses when working on a battery.



**WARNING!** Never check a battery charge by placing a metal object across the terminals. The sparks could cause a battery explosion. Use a voltmeter or hydrometer to measure the charge.



**WARNING!** Be sure the electric system master switch is off when connecting or disconnecting a battery to minimize the chance of sparks and explosion.

### Maintenance

Proper battery maintenance will assure maximum service. Following are a few simple rules: Keep battery cable terminals clean and tight. Keep the filler cap vent holes unplugged. Replace worn, cracked, broken or corroded cables. Keep the battery fastened securely in the frame.

**IMPORTANT:** Excessive tightening can warp or crack the battery case.

Maintain the correct battery electrolyte level. Refer to "ELECTROLYTE LEVEL" below. Always charge a battery in a ventilated area. Keep a battery clean. Refer to "CLEANING THE BATTERIES" below.

ELECTRIC SYSTEM

**CAUTION!** The following precautions must be taken when working around batteries:



- Use a battery carrier to avoid spilling electrolyte on clothing. Wearing rubber aprons and gloves is advisable.
- Be careful that tools or other metallic objects do not fall across the battery terminals.
- Never break a live circuit at the terminals. This could cause sparks.
- Make sure charger cable clamps or booster leads are clean and making good contact.
- If it becomes necessary to prepare electrolyte of a desired specific gravity, always pour acid into water.
- Always turn the charger to the OFF position before connecting or removing charger leads to a battery.
- Be sure the electric system master switch is off when connecting or disconnecting a battery to minimize the chance of sparks and explosion.

**Cleaning the Batteries**

If the top of a battery is dirty, it may be cleaned with a brush dipped in ammonia or soda solution and then rinsed with water.

**Electrolyte Level**

The electrolyte in each cell must be at the proper level (21 to 27 [mm] above the plates) at all times to prevent battery failure. Check periodically the level of electrolyte.

When the electrolyte is below this level, pure distilled water must be added. Never use hydrant water or any water which has been in a metal container. A skilled battery man must never add except acid or electrolyte. Under no circumstances add any special battery solutions or powders.

It is especially important to keep a battery at full charge for cold weather operation. Add distilled water to the battery in freezing temperatures only when the engine is to operate for several hours, to thoroughly mix the water and the electrolyte, or damage to the battery may occur.

**Battery Charge**

When a machine is not in use for an extended period, the maintenance-free battery can become discharged. For this reason, when a machine is not to be used for over 30 days, it is recommended that the negative ground terminal cable be disconnected. Prior to starting up a machine that has been idle, always make a visual inspection of the battery and take the open circuit voltage test. A reading of 12.4 volts (75% of full charge) or less indicates a state of discharge and the battery should be charged.

Check the state-of charge of batteries (specific gravity of electrolyte):

|                     |                                  |
|---------------------|----------------------------------|
| 100% of full charge | 1.26 – 1.28 [g/cm <sup>3</sup> ] |
| 75% of full charge  | 1.23 – 1.25 [g/cm <sup>3</sup> ] |
| 50% of full charge  | 1.20 – 1.22 [g/cm <sup>3</sup> ] |
| Fully discharged    | 1.11 – 1.13 [g/cm <sup>3</sup> ] |

## 5.11. ENGINE

## 5.11.1. CHECKING THE CRANKCASE OIL

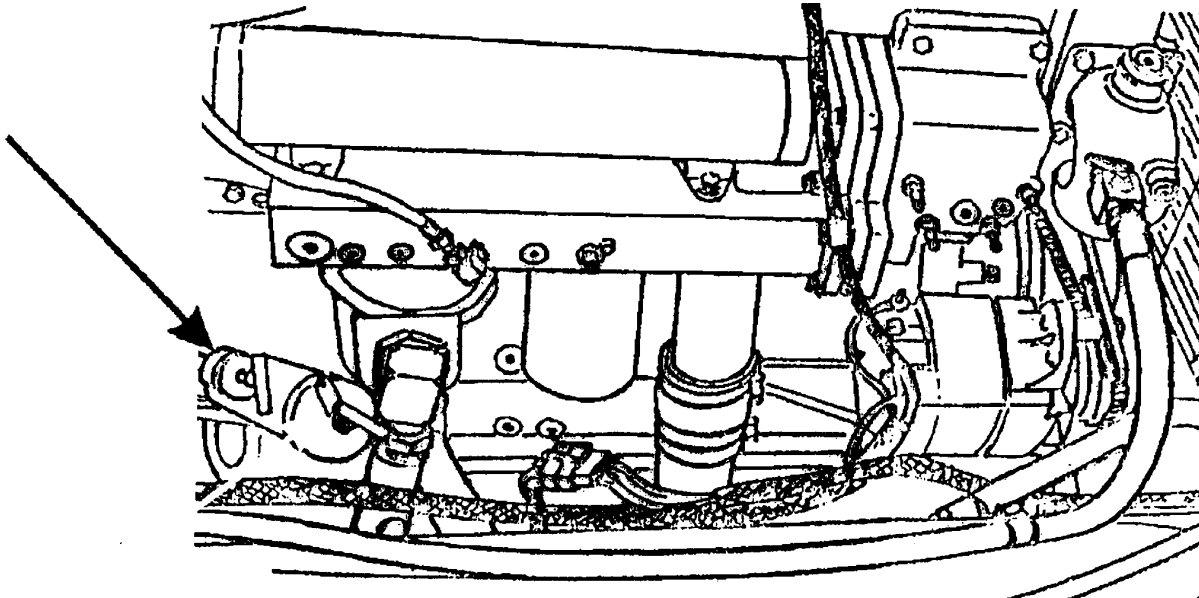

Fig. 5.11. Oil Level Gauge



**WARNING!** Park the machine on level ground, stop the engine, lower all mounted equipment to the ground, lock the transmission shift lever in neutral, apply the brake pedal lock, turn off the electric system master switch.

Stop the engine and check the oil level. For an accurate reading wait a few minutes for the oil to drain into the crankcase pan. Open the side access door. Remove the oil dipstick and wipe it clean. Reinsert the dipstick completely. Remove the dipstick and check the oil level. If the level is at or below the MIN (ADD) mark, add oil through the fast fill receiver to bring the level up to the MAX (FULL) mark on the dipstick. Refer to "REFILL SPECIFICATIONS AND CAPACITIES CHART" for type and viscosity of oil specified. Reinstall the level gauge.

**IMPORTANT:** Never run an engine, if the level of oil is at or below the MIN (ADD) mark on the oil dipstick.

## 5.11.2. CHANGING THE CRANKCASE OIL AND OIL FILTER

Change the engine oil and oil filters every 250 hours.



**CAUTION!** Hot parts – wear gloves. Fire hazards – do not smoke.



**WARNING!** Whenever working under a machine, turn off the electric system master switch, remove the key and tag the controls to prevent inadvertent starting.

ENGINE

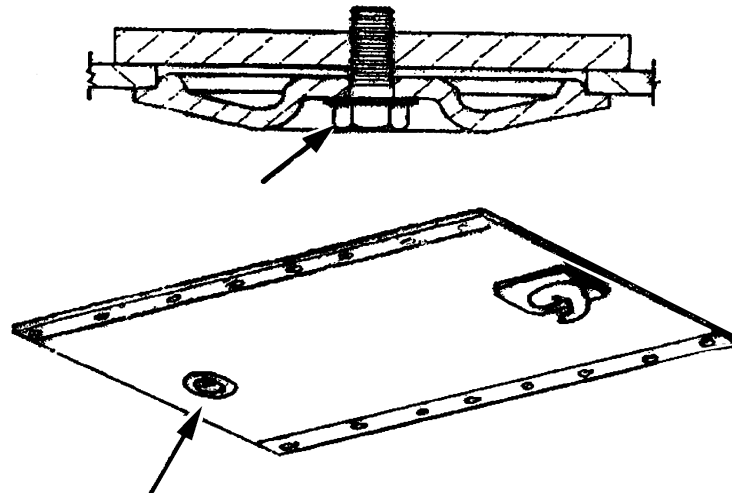

Fig. 5.12. Location of Oil Drain Plug Cover in Crankcase Guard

1. If the engine is cool start it and run it until it reaches 60 [°C]. Then stop the engine.
2. Remove the oil drain plug cover bolts to gain access to the crankcase oil pan drain plug. Remove the drain plug and allow the oil to drain completely into a suitable container.
3. Clean the oil filter and filter header. Remove the filters.
4. Clean the filter header in the seal contact area.

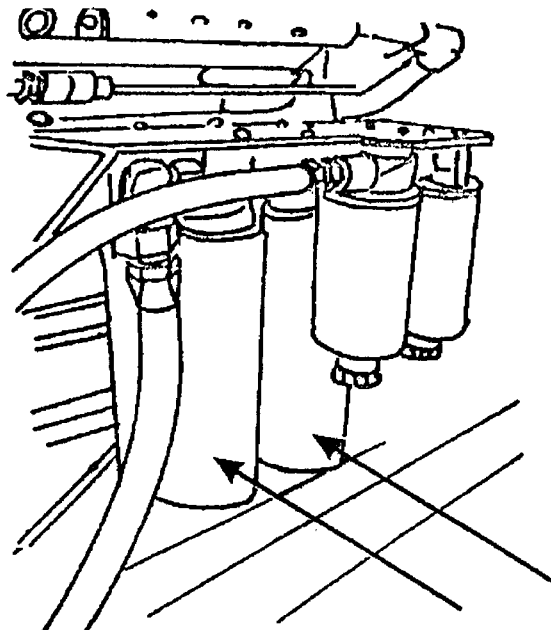

Fig. 5.13. Lubricating Oil Filters

**IMPORTANT:** Use only recommended filters available from Authorized Distributor of Construction Equipment.

5. Apply a little clean engine oil to the seal of a new filter, fill the filter with engine oil and thread the filter on by hand per instructions specified on the filter.

**IMPORTANT:** Thread filters by hand. Do not use any tools to install a filter because this can damage it.

## ENGINE

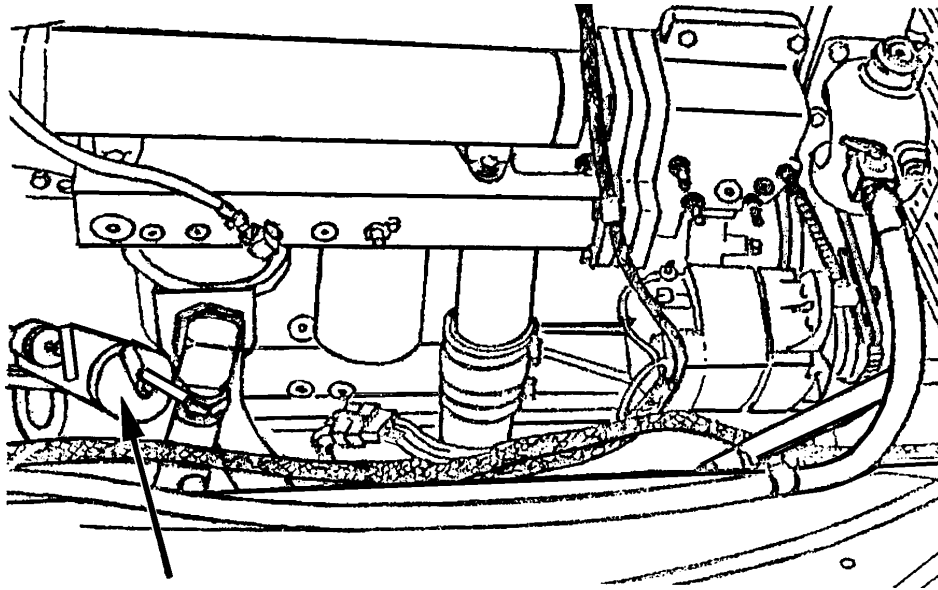

Fig. 5.14. Engine Oil Filler

5. Fill the crankcase with fresh oil (Fig. 5.14). Refer to the "REFILL SPECIFICATION AND CAPACITIES CHART".
6. Check the oil level with the oil dipstick as described in 5.11.1.

**IMPORTANT:** After the oil has been replaced, start the engine according to the instructions specified in Section 4 "ENGINE START AFTER OIL CHANGE OR PROLONGED STANDSTILL".

### 5.11.3. ETHER INJECTOR (if equipped)

#### Precautions

**WARNING!** Ether starting fluid is highly flammable.

Explosion can result if sparks or flame contact ether or a container is stored in temperature above 70 [°C].

Follow the precautions on the container.

Observe the following precautions:

- Do not use the ether injector when air temperature is above 0 [°C].
- Do not use open flame when using ether starting fluid.
- Do not store fluid containers in the operator's compartment.
- Store containers in a cool, well ventilated place.
- Keep fluid containers out of reach of unauthorized personnel.
- Do not breathe hazardous ether vapor.
- Do not let ether contact your skin, because it can cause frostbite.
- Never puncture a fluid container or put it into fire. Dispose of empty containers properly.
- For your safety, remove the ether container when welding, grinding, or using a torch on a machine.



Follow the correct method of starting the engine. Refer to "STARTING THE ENGINE" in this manual.

ENGINE

**IMPORTANT:** An ether starting valve inlet must be sealed against the entry of dirt at all times by having a fluid container installed or by installing the dust cap provided with the valve.

**INSPECTION AND CLEANING**

Make certain that ether is available under pressure. To do so, remove the ether container and check if a good spray is obtained.

Test the ether injector as follows:

1. Disconnect the ether tube at the spray nozzle in the engine manifold. Remove the spray nozzle.
2. Reconnect the nozzle to the tube. Direct the nozzle away from the engine and actuate the ether injector. Dribbling or no spray indicates a blocked spray nozzle or tube. If necessary, clean or replace spray nozzle and/or tube.

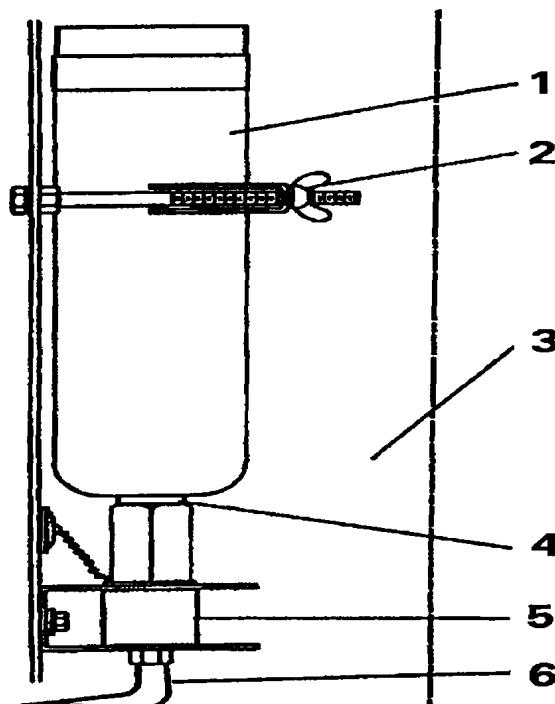

Fig. 5.15. Ether Fluid Container

- |                    |                   |
|--------------------|-------------------|
| 1. Ether Container | 4. Seal Ring      |
| 2. Clamp Wing Nuts | 5. Injector       |
| 3. Support Saddle  | 6. Injection Tube |

**CHANGING THE FLUID CONTAINER**

1. Loosen clamp wing nuts (2) securing the fluid container in the support saddle.
2. Unscrew and discard container (1) from ether starting valve (5) in a suitable, closed refuse container.
3. Install new container (1) in valve (5).
4. Secure the container in support saddle (3) by tightening clamp wing nuts (2). Do not over tighten the clamp wing nuts (2).

## 5.12. FUEL SYSTEM

**GENERAL**

Cleanness of diesel fuel determines the service life of the fuel system components. Water and contaminants, allowed to reach precision components, cause rapid wear and poor performance. Clean fuel and regular servicing of the fuel tank and fuel filtering components are necessary for long service life. Always clean the area around the fuel tank filler cap before refueling.



**WARNING!** Fire hazard – never mix gasoline and/or alcohol with diesel fuel. This practice creates an extreme fire hazard and under certain conditions could cause explosion, which could result in personal injury or death.



**WARNING!** Never remove the fuel tank filler cap or refill the fuel tank while the engine is running or hot or when a machine is indoors. Fumes are dangerous, a spark or flame could result in a fire or explosion.

## 5.12.1. FILLING THE FUEL TANK

Be sure the fuel tank is full. Fill the tank at the end of each day's operation to reduce condensation of moisture.

## 5.12.2. FUEL TANK FILLER STRAINER

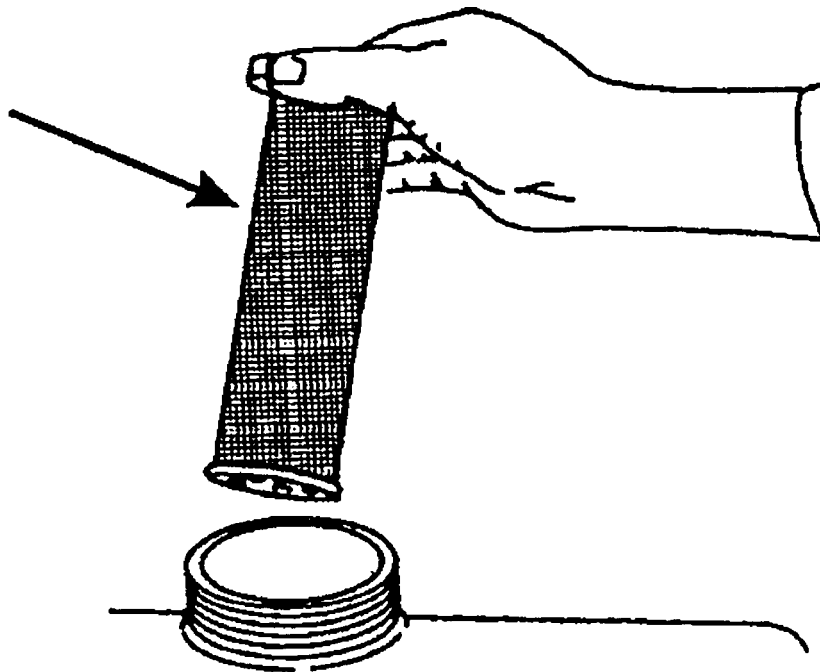

Fig. 5.16. Fuel Tank Filler Strainer

This screen filters the fuel entering the tank and eases the job of the fuel filters. Remove and clean the screen with nonflammable commercial cleaning solvent.



FUEL SYSTEM

5.12.3. FUEL TANK SHUTOFF VALVE

Be sure the shutoff valve is open.

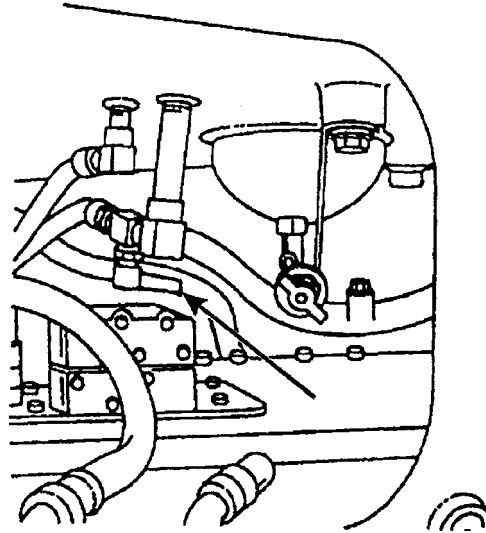

Fig. 5.17. Fuel Tank Shutoff Valve

5.12.4. FUEL FILTERS

5.12.4.1. Fuel Filter Water Separator Drain Valve

The fuel filters used in the fuel system are spin-on type and are equipped with a water separator. Water and foreign materials separated from fuel, which settle at the bottom of the filter, are drained from the fuel through drain valve located in the lower part of the filter.

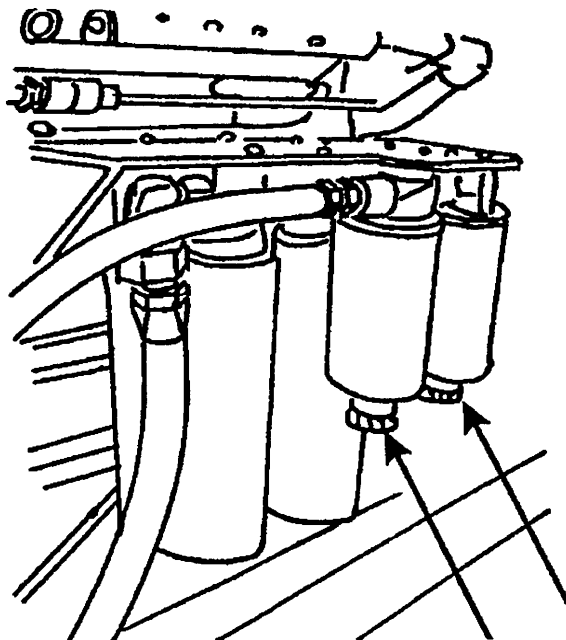

Fig. 5.18. Fuel Filters with Water Separator Drain Valves

## FUEL SYSTEM

Open the valve and drain water and sediment from the filter until clean diesel fuel appears. Close the valve.

**IMPORTANT:** *Water contaminated with sediment and fuel as well as oil are detrimental to environment. Drain water into a suitable container and utilize in the appropriate area.*

**5.12.4.2. Replacing Fuel Filters**

Replace fuel filters if the engine works unevenly or power loss is evident or after 250 hours of operation.

Keep new filters in their original packages until ready for installation. Before loosening the filter, clean the filter header to prevent dirt or foreign material from entering the system.

1. Close the fuel shutoff valve under the fuel tank.
2. Remove the fuel filter from the filter header using a filter wrench.
3. Thoroughly clean the filter header to prevent dirt or foreign material from entering the system.
4. Fill the fuel filter with clean fuel.
5. Apply a light coating of clean engine oil to the seal surface of the new filter.
6. Install the new filter, turning it until the seal just contacts the filter header and tighten the filter an additional 1/2 to 3/4 turn.

**IMPORTANT:** *Thread the filters by hand. Do not use any tools to install a filter because this can damage it.*

**NOTE:** *Use only recommended filters available from Authorized Distributor of Construction Equipment.*

**5.12.5. DRAINING FUEL TANK**

Fig. 5.19. Fuel Tank Drain Valve

Periodically open the valve and drain water and sediment from the fuel tank until clean diesel fuel appears. Close the valve.

5.13. HYDRAULIC SYSTEM

General

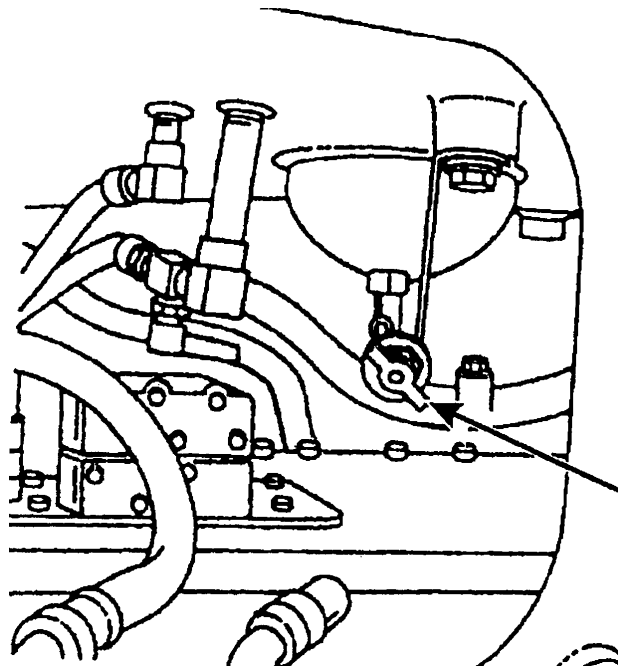

**WARNING!** Always lower all mounted equipment to the ground before performing work on the hydraulic system. With all mounted equipment lowered to the ground and the engine off, cycle all hydraulic controls in all directions to relieve trapped pressure.

Slowly loosen the hydraulic reservoir filler cap to relieve trapped reservoir pressure.

5.13.1. CHECKING OIL LEVEL

1. Park the machine on level ground, lower the blade and the ripper to the ground and stop the engine.
2. Check the oil level at the sight gauge on the side of the reservoir. Add oil if the level is below the centerline of the gauge. Refer to "CHANGING HYDRAULIC OIL".

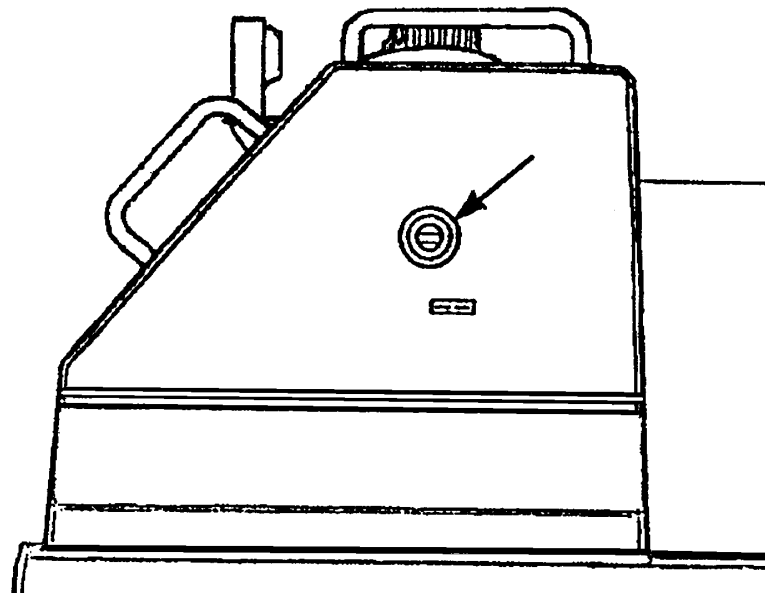

Fig. 5.20. Hydraulic Reservoir Sight Gauge

**IMPORTANT:** Before removing any components from the reservoir or servicing, wipe the top surface of the reservoir, using clean kerosene or a commercial cleaning solvent.

5.13.2. CHANGING HYDRAULIC OIL

1. Start the engine and operate the blade to warm the oil for easy draining.
2. Park the machine on level ground, lower the blade and the ripper to the ground.
3. Stop the engine. Shift the transmission lever to neutral and apply the neutral lock lever. Apply and lock the parking brake. Turn the electric system master switch to OFF and remove the key. Slowly loosen the reservoir filler plug to relieve reservoir pressure.
4. Drain the reservoir into a suitable container by removing the filler plug and the drain plug (Fig. 5.21). If the reservoir is equipped with a drain valve (Fig. 5.21.A), remove **safety plug** (1) of the drain valve and thread hose (2) into the plug opening and drain the oil into a suitable container. When threaded in, drain hose (2) opens the drain valve and allows the oil to flow out.

# MAINTENANCE

## HYDRAULIC SYSTEM

- 5. Replace the two return filters of the hydraulic system and equipment pilot filter. Refer to "SERVICING THE RETURN FILTER". Service the suction strainer as described in "SERVICING THE SUCTION STRAINER". Service hydraulic reservoir filler strainer.

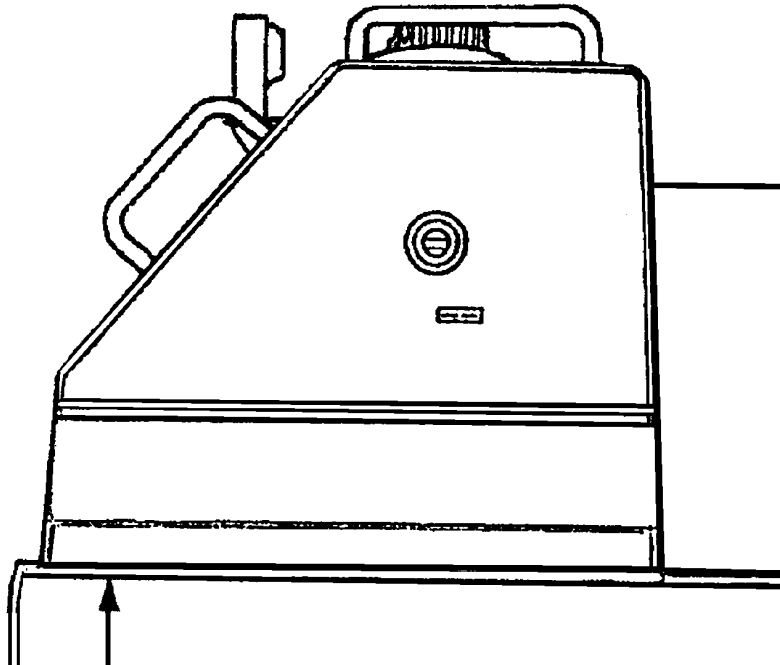

Fig. 5.21. Hydraulic Reservoir Drain Plug Location

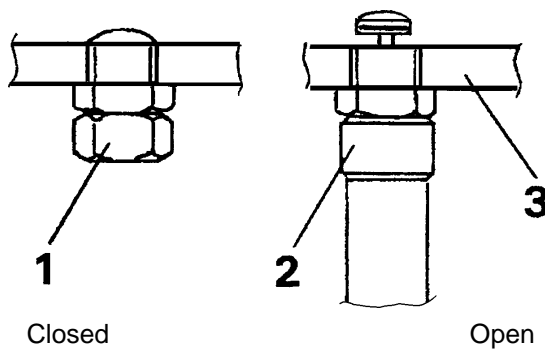

Fig. 5.21A. Hydraulic Reservoir Drain Valve (if equipped)

- 1. Safety Plug
- 2. Drain Hose
- 3. Reservoir Bottom

**IMPORTANT:** Use clean oil from a clean container. Maintain all packaging and fittings so as to prevent leakage.

- 6. Reinstall the drain plug. Fill the reservoir with hydraulic oil up to the center line of the sight gauge. Refer to Section 6, " REFILL SPECIFICATIONS AND CAPACITIES" for the quantity oil specified. Reinstall the filler cap.
- 7. Vent the system. Refer to "VENTING THE HYDRAULIC SYSTEM".

HYDRAULIC SYSTEM

5.13.3. REPLACEMENT THE RETURN FILTERS AND PILOT FILTER

**NOTE:** *The hydraulic reservoir does not have to be drained in order to replace these filters.*

**IMPORTANT:** *If the filter warning light on the instrument panel, remains on at the operating oil temperature with the engine running, the appropriate filter must be replaced.*

Two hydraulic return filters and equipment pilot filter must be replaced according the "MAINTENANCE SCHEDULE GUIDE" as described below:

1. Park the machine on level ground, lower the blade to the ground and stop the engine. Turn the electric master switch to OFF.
2. With the engine stopped, operate the equipment lever several times in all directions to relieve any pressure. Remove the return filters side cover located on the R.H. side in front of the hydraulic reservoir, remove all outside dirt from the filters.
3. Using a filter wrench, remove the filters. Wipe the filter head, removing all of the old oil from the seal area.
4. Coat the seal on the new filter element with clean oil. Install the new element by threading it onto the filter head until the seal contacts the head, turn the filter by hand an additional 1/4 to 1/2 turn. Check the oil level in the system as outlined in "CHECKING THE OIL LEVEL".

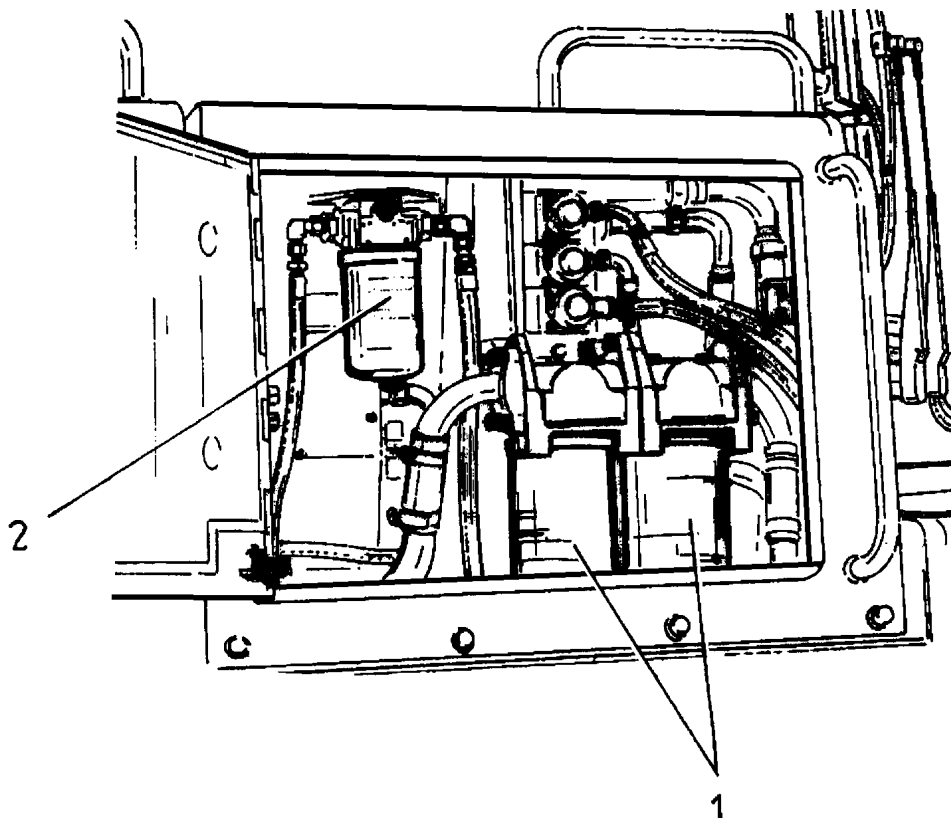

Fig. 5.22. Hydraulic System Filters

1. Hydraulic Return Filters

2. Equipment Pilot Filter

## HYDRAULIC SYSTEM

## 5.13.4. SERVICING THE SUCTION STRAINER AND FILLER STRAINER

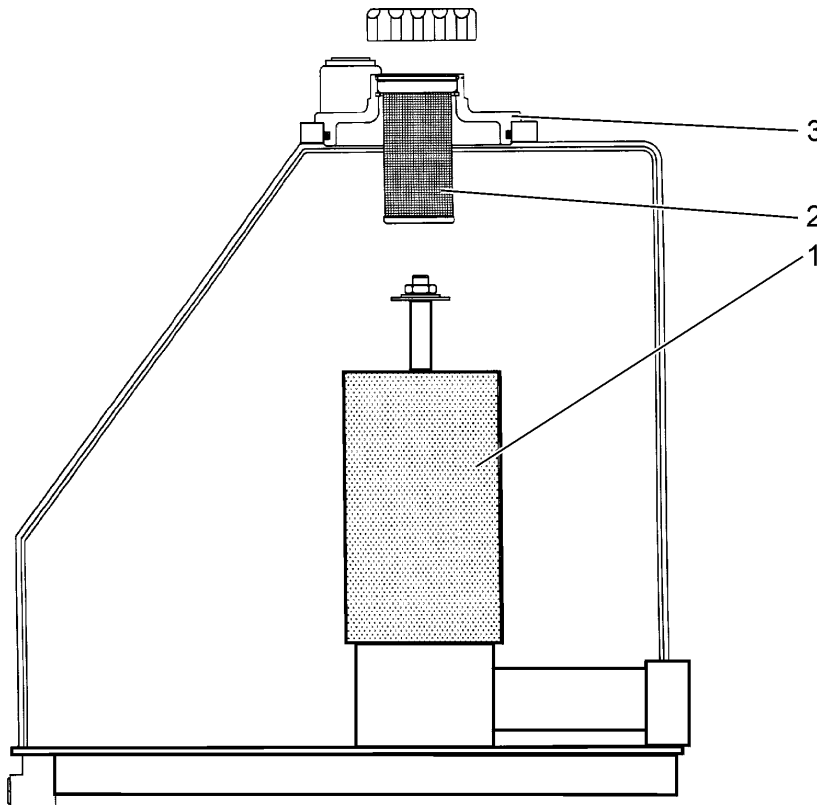

Fig. 5.23. Strainers inside Hydraulic Reservoir

1. Suction Strainer

2. Filler Strainer

3. Cover

1. Park the machine on level ground lower the blade to the ground and stop the engine. Turn the electric master switch OFF. With the engine stopped, operate the equipment lever several times to relieve any pressure. Drain the hydraulic system. Refer to "CHANGING HYDRAULIC OIL".
2. Remove three bolts and remove cover (3) of the hydraulic reservoir. Remove the nut securing the suction strainer (1). Remove the strainer from the reservoir.
3. Remove the snap ring securing filler strainer (2) in reservoir cover (3). Remove the filler strainer. Clean and dry the strainer and install it in the reservoir cover.
4. Clean the suction strainer in nonflammable commercial solvent and dry thoroughly. Thoroughly clean the interior of the reservoir being sure all particles are removed from the corners.



**WARNING! Fire hazard – do not use kerosene, diesel fuel or flammable liquids to clean parts. A spark or a flame could cause a fire or an explosion. Use a nonflammable commercial solvent.**

5. Install the suction strainer, secure it with the nut. Install the reservoir cover with a new O-ring.
6. Fill the system, refer to "CHANGING HYDRAULIC OIL".

HYDRAULIC SYSTEM

5.13.5. SERVICING THE RESERVOIR BREATHER

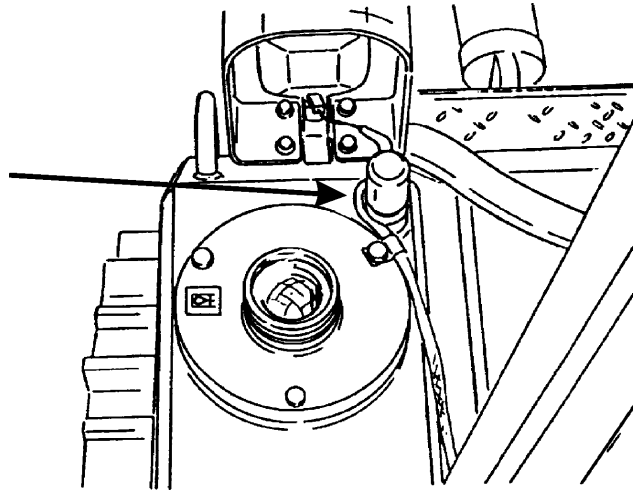

Fig. 5.24. Hydraulic Reservoir Breather Location

1. Park the machine on level ground, lower the blade to the ground and stop the engine. Turn the electric master switch to OFF and remove the key. With the engine stopped, operate the equipment lever several times to relieve any pressure. Remove all outside dirt from the breather.
2. Slowly loosen the filler plug on the reservoir in order to relieve any pressure in the reservoir.



**CAUTION! Pressurized Reservoir. Always loosen the filler plug slowly in case there is still some pressure in the system.**

3. Remove the breather (Fig. 5.25) from the reservoir. Remove snap ring (1), cover (2), element (3) and clean in a nonflammable commercial solvent. Dry thoroughly. Check O-rings (4) for wear or deterioration. Replace if necessary. Reinstall the filter (3) and the cover (2). Secure with the snap ring (1). Reinstall the breather and the filler cap.

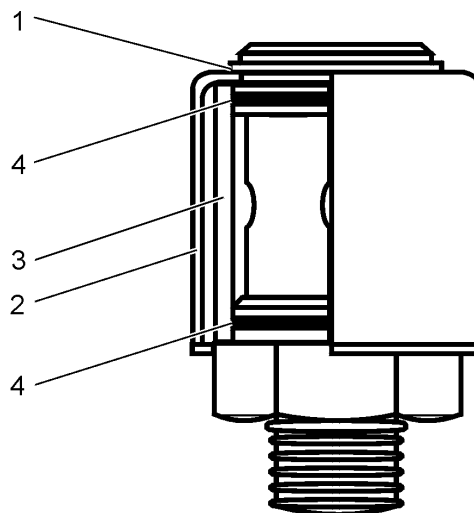

Fig. 5.25. Hydraulic Reservoir Breather

1. Snap Ring    2. Element Cover    3. Breather Element    4. O-Ring

## HYDRAULIC SYSTEM

## 5.13.6. VENTING THE HYDRAULIC SYSTEM

The hydraulic system has to be vented of air if:

- the system has been drained and filled,
  - the hydraulic lines have been disconnected or tightened,
  - after noting hydraulic leaks,
  - the hydraulic system has been operated with excessively low oil level.
1. Start the engine and run it at low idle speed. Operate all the controls through all positions four or five times so the cylinders are filled with oil and air expelled.
  2. Check the oil level as described in "CHECKING OIL LEVEL". Repeat this procedure until the fluid level remains at the specified level in the reservoir.

## 5.14. LUBRICATING FITTINGS



**WARNING!** Before starting any maintenance service lower all mounted equipment to the ground, place all control levers in their neutral position, lock the transmission shift lever in neutral, apply the brake pedal lock, turn the electric system master switch off.

**General**

The following lubrication fittings are to be greased at the intervals indicated in the SCHEDULED MAINTENANCE GUIDE. Apply grease until clean lubricant is visible. Always use a clean lubricator and wipe dirt from the fittings before fresh grease is applied. If grease fails to go through a fitting, determine the cause and correct it.

**Foot Pedals and Throttle Linkage**

Remove the middle cover to get access to the lubricating fittings.

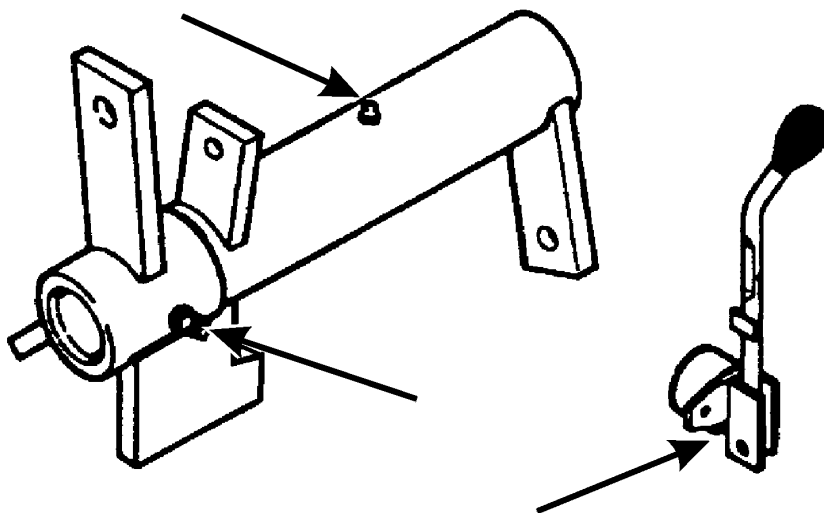

Fig. 5.26. Foot Pedals and Throttle Linkage Fittings



LUBRICATION FITTINGS

Steering Lever Bearings (2 fittings) and Pilot Valves (2 plates)

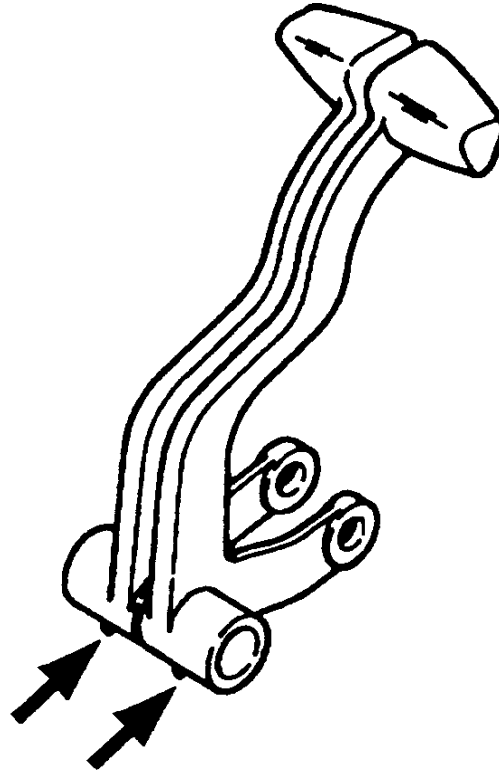
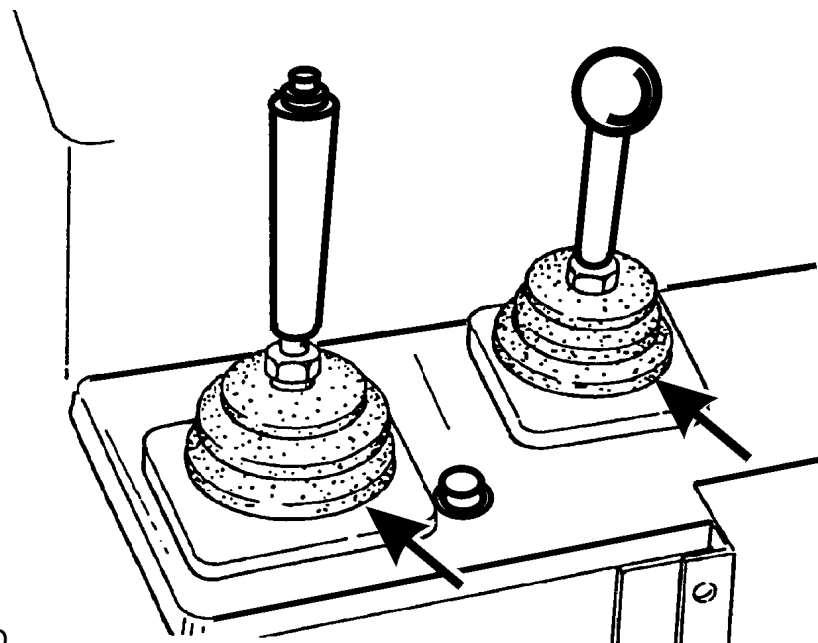

Fig. 5.27. Steering Lever Bearing Fittings



EMBED

Fig. 5.28. Lubricating the Ends of Plungers

LUBRICATION FITTINGS

**Cylinder Pin of the Blade Lift Cylinder Piston Rod Fittings**  
One lubricating fitting in each cylinder.

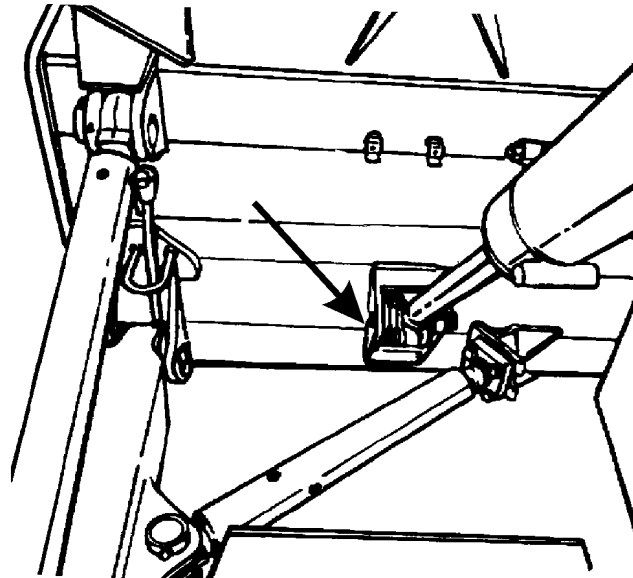

Fig. 5.29. Cylinder Pin of Blade Lift Cylinder Piston Rod Fittings

**Blade Lift Cylinder Yokes (4 fittings)**

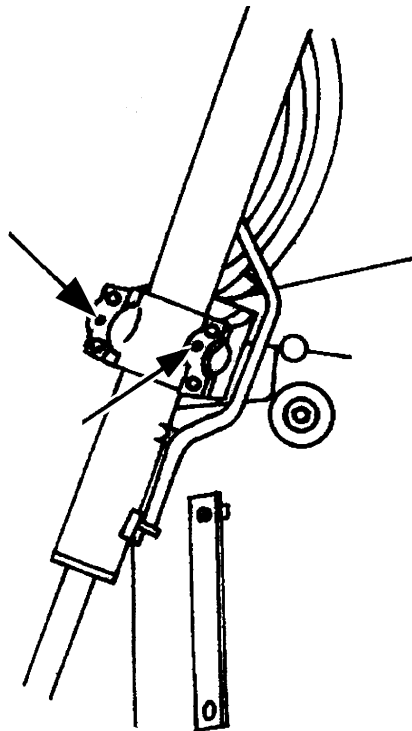

Fig. 5.30. Blade Lift Cylinder Yoke Fittings

LUBRICATION FITTINGS

**Gimbal Crosstube**

Apply grease until fresh grease flows out of the breather.

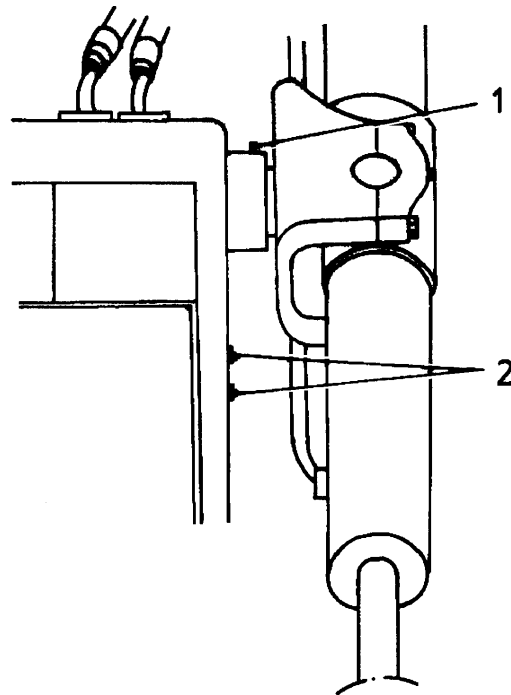

Fig. 5.31. Blade Lift Cylinder Yoke Fittings

1. Breather

2. Lubricating fittings

**D-2 Dozer Blade**

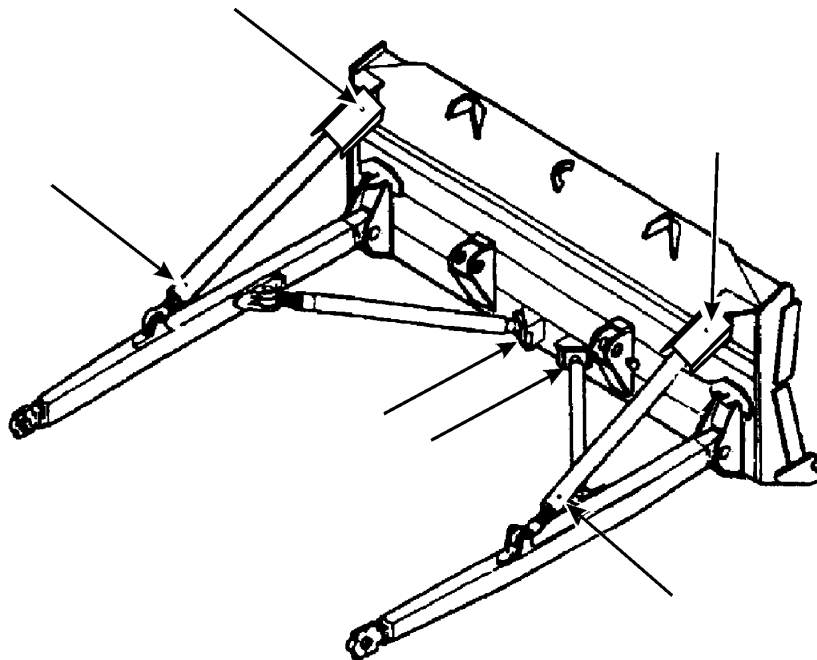

Fig. 5.32. D-2 Dozer Blade Strut Fittings (mechanical tilt)

# MAINTENANCE

## LUBRICATION FITTINGS

### D-2 Grader Blade

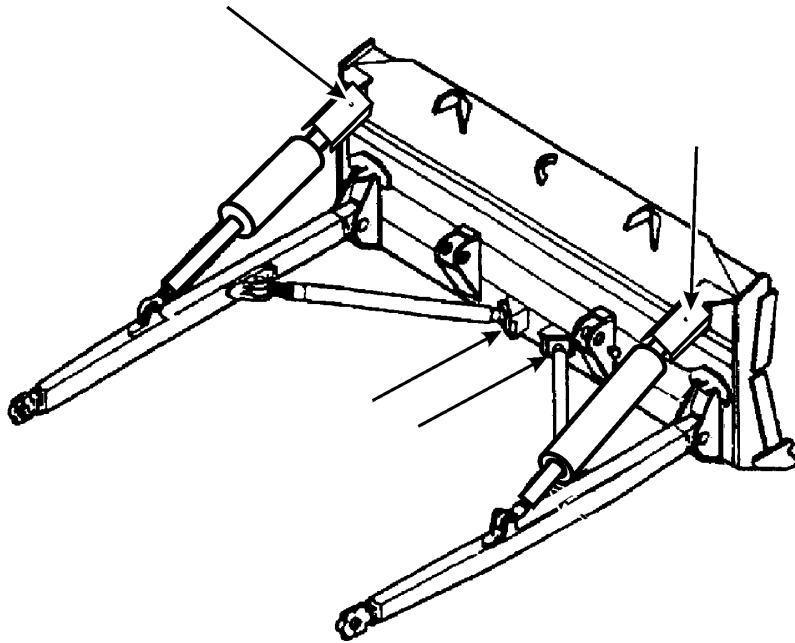

Fig. 5.33. D-2 Grader Strut Lubricating Fittings (hydraulic tilt)

### Ripper (12 fittings)

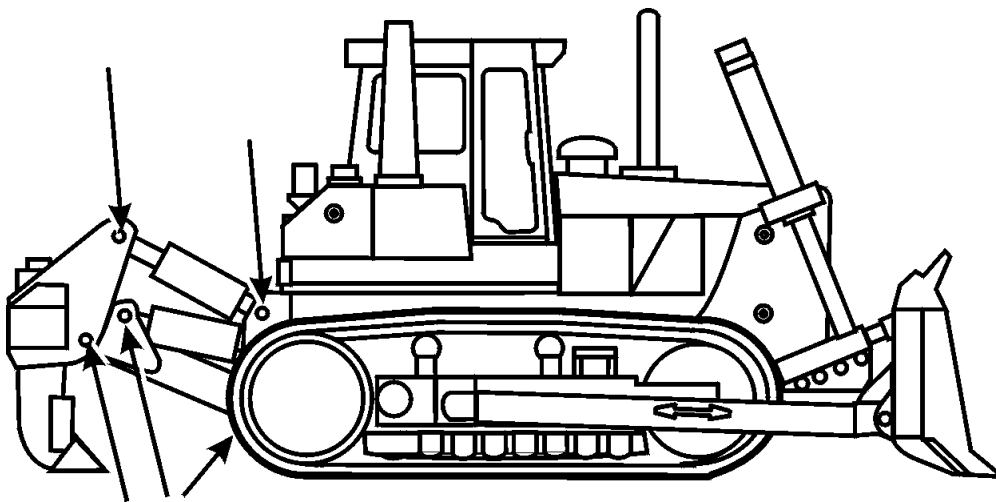

Fig. 5.34. Ripper Bearing Lubricating Fittings

5.15. MOUNTED EQUIPMENT

5.15.1. COMPLETE BLADE REMOVAL AND INSTALLATION

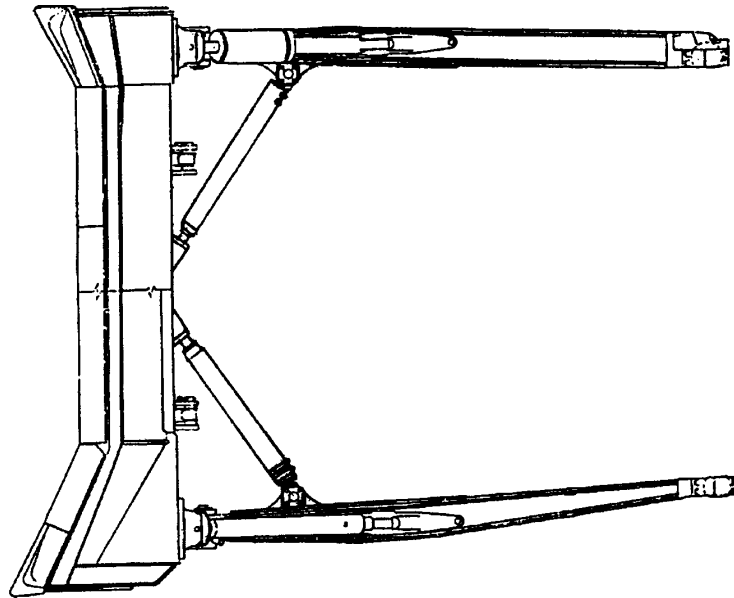

Fig. 5.35. Complete Semi-U Blade

If for any reason the complete blade is to be removed from the tractor proceed as follows:

1. Place the blade on level ground and block up the ends of the push arms or C-frame close to the trunnions. This will maintain the proper height for reassembly.

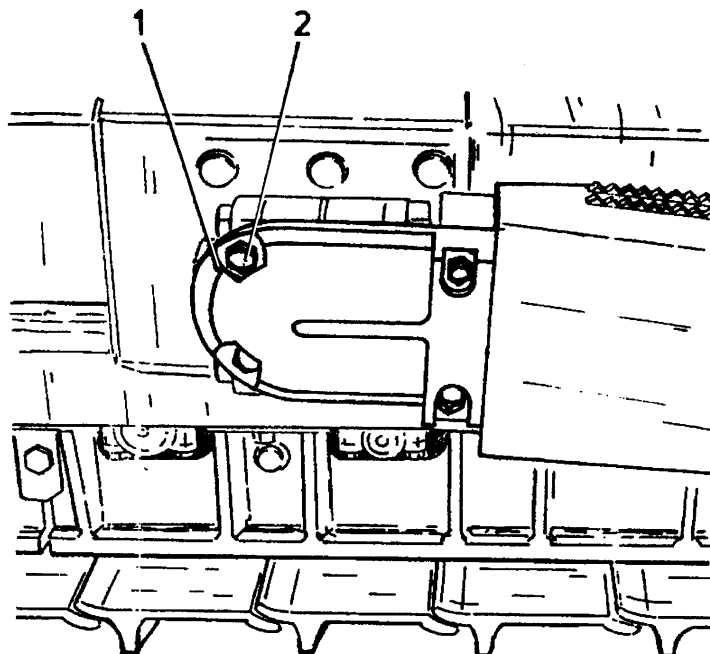

Fig. 5.36. Blade Tilt Hoses Connection Cover and Trunnion Bearing Cap

1. Blade Tilt Hoses Connection Cover

2. Cover Bolts

## MOUNTED EQUIPMENT

2. Remove bolts (2, Fig. 5.36) and tilt hoses connection cover (1).
3. Remove the pins securing the lift cylinder piston rods to the blade lift brackets at the back of the blade. Retract the piston rods fully into the cylinders. Secure the rods to the tractor using shipping hanger bars to prevent damage to the piston rods.
4. Remove two trunnion bearing cap bolts (3) and remove caps (2) and shims (7) of the R.H. and L.H. side trunnion (1) located at the back of the push arms (6).
5. Back the tractor straight out and away from the push arms.
6. Reassemble shims and bearing caps to the push arms and secure with the bearing cap bolts to prevent their damage or being lost. If the blade is to be stored outdoors, grease to prevent corrosion. To reassemble the blade, perform the above in reverse order.

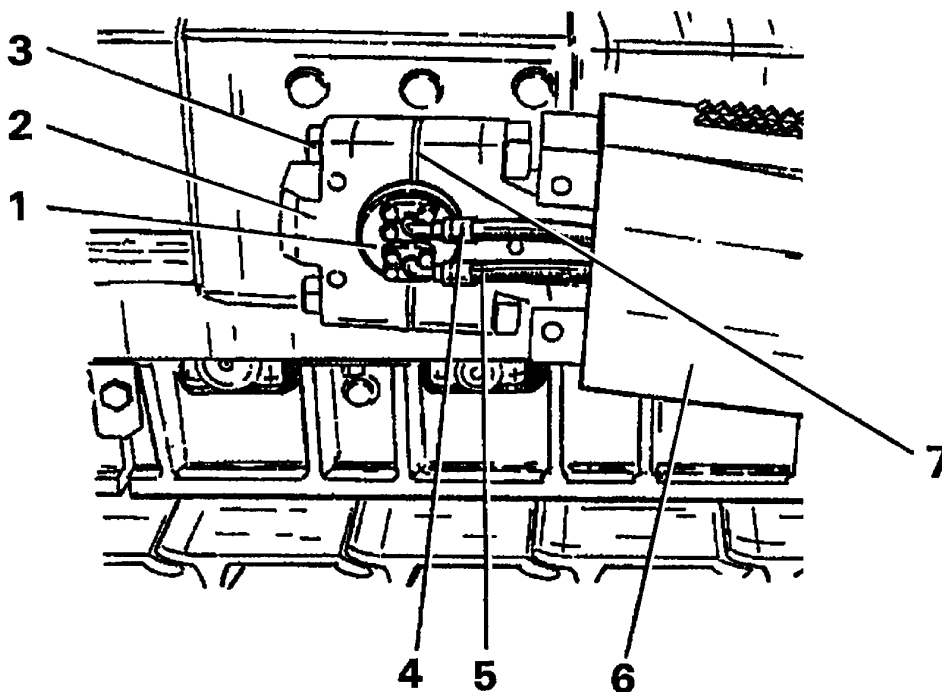

Fig. 5.37. Push Arm Mounting

- |                              |                               |
|------------------------------|-------------------------------|
| 1. Trunnion                  | 5. Hydraulic Hose (underside) |
| 2. Trunnion Bearing Cap      | 6. Push Arm                   |
| 3. Cap Bolts                 | 7. Shims                      |
| 4. Hydraulic Hose (overside) |                               |

7. Check if the blade is positioned symmetrically to the machine axis. Operating with a blade non-symmetrical to the machine axis results in damage to the blade.

**5.15.2. DIAGONAL STRUTS ADJUSTMENT (Fig. 5.38)**

The diagonal strut adjustment must be checked periodically to maintain the proper compression load of the strut with the straight positioned blade. If there is compression load on the pusharms the struts should be adjusted as follows: With the blade on the ground and the engine stopped, remove the strut pin (1) at the push arm bracket connection. Loosen clamping bolts (2) Adjust the strut length until the holes in the strut eye (1) and push arm bracket align.

MOUNTED EQUIPMENT

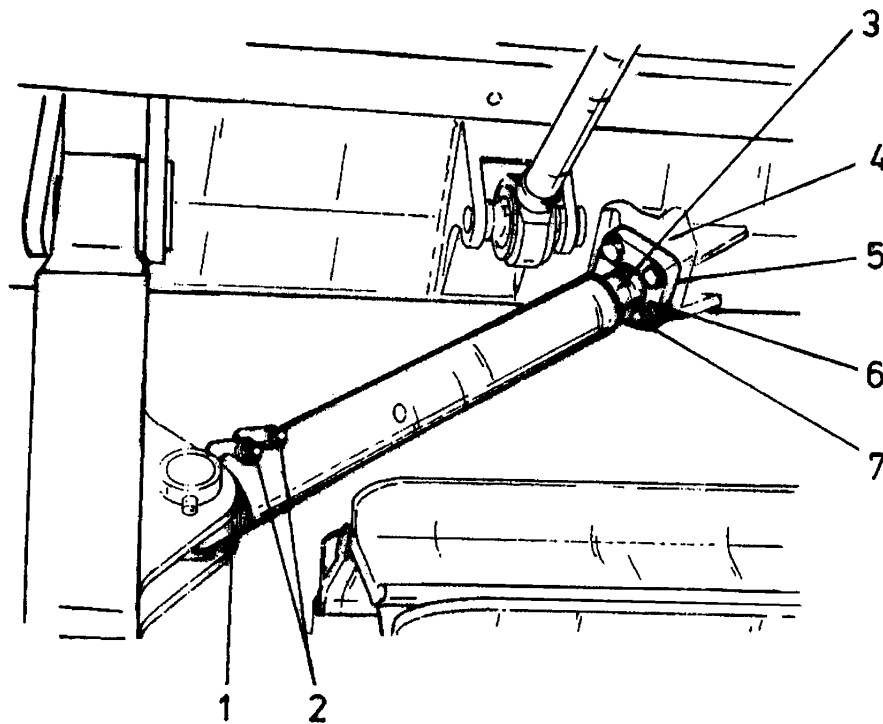

Fig. 5.38. Installing the Diagonal Strut

- |                           |                 |
|---------------------------|-----------------|
| 1. Diagonal Strut Eyebolt | 5. Socket Shims |
| 2. Clamping Bolts         | 6. Strut Cap    |
| 3. Strut Ball             | 7. Cap Bolts    |
| 4. Blade Socket           |                 |

Make the strut as long as possible, still permitting the pin installation. Install and secure the pin at the bracket connection on the arm beam and tighten the clamping bolt to prevent the bolt turning.

When making this adjustment be certain that the distance between inner surface of blade beam and a fixed point on the track frame remains the same on each side.

Insert the ball end (3) into the blade socket (4) without shims. Install and tighten the strut cap (6) with four cap bolts (7) so that collar of the cap is firmly and evenly seated against the ball.

Determine the number of shims (5) necessary for the existing gap. Be sure the gap is equal on all sides between the strut cap (2) and the socket (4). Add one shim to provide clearance.

Remove the strut(1) and install the number of shims determined earlier. Reinstall the strut(1) and give it an additional half a turn to get the compression needed. Then tighten the cap bolts (2). Torque the bolts (7) to 1050 [Nm].

**5.15.3. UPPER STRUT AND TILT CYLINDER ADJUSTMENT (Fig. 5.39)**

The upper strut and tilt (tilt and tilt/pitch) cylinder adjustment must be checked periodically to maintain the proper gap between the strut ball and the socket. Adjustment is necessary if the clearance exceeds a value of 1.3 [mm].

## MOUNTED EQUIPMENT

To remove excessive clearance proceed as follows:

1. Attach a hoist of adequate capacity to the upper strut or tilt cylinder (1).
2. Remove the bolts (2) securing the cover (5) to the socket (4) on the blade.
3. Swing the upper strut out or retract the cylinder rod (1) while lifting them with the hoist.
4. Remove the shims (3).
5. Push in the upper strut or tilt cylinder (1) so, that strut or cylinder balls enter and seat in the blade socket (4).
6. Push the strut ball cap (5) against the blade socket (4) and torque it evenly with four bolts (2) to 270 [Nm]. Make sure the ball cap (5) is not distorted around the strut ball.
7. Using replaceable shims (3) determine the maximal number of shims to fill the gap between the ball cap (5) and the socket (4).
8. To ensure adequate clearance between the ball cap (5) and the socket (4) add one more shim to the shims already placed in the gap. Each shim is 0.75 [mm] thick.
9. Before the final assembly clean the shims (3) and the matching surfaces of the cap (5) and the socket (4) of foreign matter, dirt and paint.
10. Slide the shims over and past the strut ball or the lift cylinder and press down the cylinder rod so that the strut ball is seated in the socket(4).
11. Torque the cap bolts (2) to 845 [Nm].
12. Adjust the strut to the desired blade tilt.

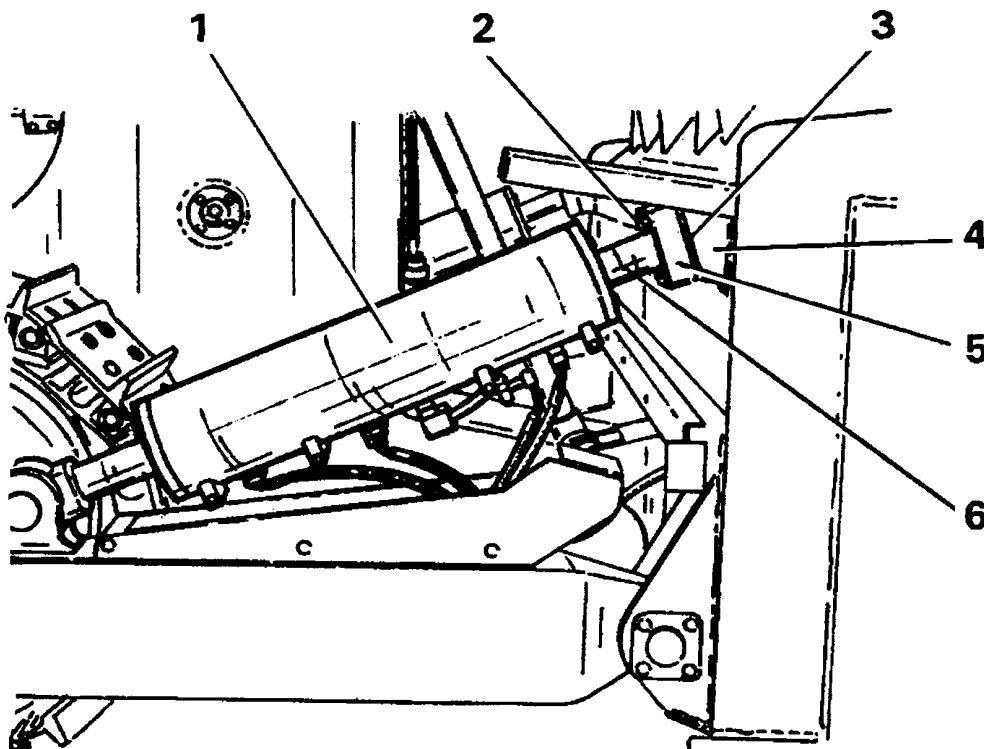

Fig. 5.39. Adjustment of Upper Strut and Tilt Cylinder (Machines with Pitch Cylinder)

- |                  |                              |
|------------------|------------------------------|
| 1. Tilt Cylinder | 4. Mounting Bracket on Blade |
| 2. Cap Bolts     | 5. Strut Ball Cap            |
| 3. Shims         | 6. Strut Ball                |



MOUNTED EQUIPMENT

5.15.4. PITCH CYLINDER CLEARANCE ADJUSTMENT

If the left hand upper strut is replaced with the pitch cylinder the clearance of strut ball shall be adjusted in the same way as the adjustment of the upper strut and the blade tilt cylinder.

5.15.5. CHECKING THE BLADE CONDITION

5.15.5.1. TRUNNION AND CAP MOUNTING BOLTS (Fig. 5.40)

Check the torque of the trunnion mounting bolts, push arm bearing cap bolts after the initial 10 hours of operation, and then periodically.

Tighten trunnion bolts (1) to a torque of 1050 [Nm].

Tighten cap bolts (2) to a torque of 2100 [Nm].

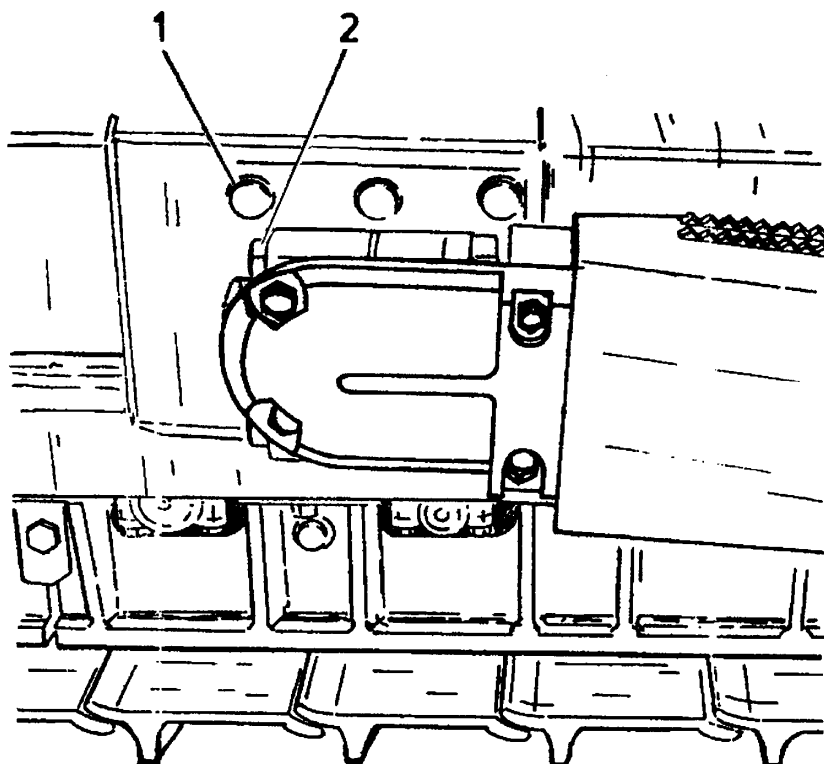

Fig. 5.40. Tightening Trunnion and Pusharm Bearing Cap Bolts

- 1. Trunnion Bolts
- 2. Cap Bolts

## MOUNTED EQUIPMENT

## 5.15.5.2. BLADE CUTTING EDGE AND END BITS MOUNTING BOLTS.

Check the torque of the blade cutting edges and end bit bolts after the initial 10 hours of operation and then periodically. Lift the blade off the ground and block it. Stop the engine. Turn the electric system master key OFF and remove it.

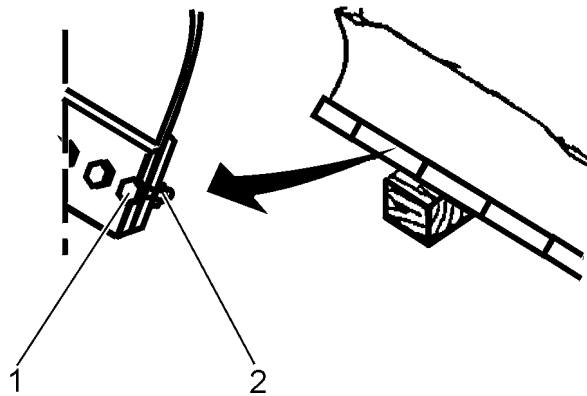

Fig. 5.41. Tightening Blade Cutting Edge Bolts

1. Bolt      2. Nut



**WARNING! Never work beneath the blade without proper blocking it.**

Tighten the cutting edges and end bits bolts to 1050 [Nm].

## 5.15.5.3. ALLOWABLE WEAR OF CUTTING EDGE AND END BITS AND RIPPER POINTS

Reverse or replace the cutting edge and end bits before the mounting plate is worn or damaged. If the distance between the cutting edge mounting bolt axis and the cutting edge bottom edge is smaller than 85 [mm] the cutting edge should be reversed or replaced if it had already been reversed before. An end bit should be replaced if the distance between the axis of a mounting bolt in the lower row and the bottom edge is smaller than 95 [mm]. To replace a cutting edge and end bits proceed as follows:

1. Raise the blade about 300 [mm] above the ground and set the pilot valve lever in "HOLD" position. Prop up the pusharms and stop the engine.



**WARNING! Never work beneath the blade without proper blocking it.**

2. Remove the cutting edge and end bits mounting bolts.
3. Install the cutting edge or the end bits and tighten the bolts to a torque of 1050 [Nm] .

Authorized Distributor of Construction Equipment can supply these specially heat-treated bolts.



**CAUTION! Do not substitute bolts. Loosening of the bolts securing a cutting edge and end bits may result in tearing off of the cutting edge or end bits and blade damage or personal injury.**

**MOUNTED EQUIPMENT**

**5.15.6. SERVICING THE RIPPER**

Prior to each day’s work carry out ripper inspection and remedy if any malfunction is found. Operating defective ripper results in reduced job efficiency and may cause its damage. The following table specifies services on the ripper to be carried out during the ripper inspection:

| <b>POINT OF SERVICE</b>         | <b>SERVICE DESCRIPTION</b>  |
|---------------------------------|---|
| Ripper assembly                 | Visually check for cracks, breakage, loose parts and completeness.  |
| Hydraulic hoses and connections | Check for leaks and remedy, if any.   |
| Ripper pins                     | Check if pins are secured correctly and tighten loosened bolts if necessary.  |
| Ripper shank points             | Check for wear. Replace, if the total length of the point is smaller than 210 [mm]. Excessive ripper shank point wear is detrimental to ripper operation. |

Replace a ripper shank point as follows:

1. Raise the ripper tooth about 300 [mm] above the ground and prop it up to prevent the ripper tooth from lowering during service.
2. Stop the engine.
3. Remove the point mounting pin.
4. Install a new point and a mounting pin.

**5.16. SAFETY BELT**



**WARNING! Seat belt – do not clean with solvents or bleach or re-dye color of webbing as this may cause a severe loss of strength. This could cause the webbing to break and result in personal injury. Wash in warm water with mild detergent.**

Keep the belt flat to avoid twisting and roping when not being used. Do not place heavy or sharp objects on the belt.

The entire seat belt assembly should be inspected periodically for corrosion, wear, fraying or weak spots. The seat belt mounting bolts should also be periodically inspected for tightness.

**5.17. FINAL DRIVES (Fig. 5.42)**

**5.17.1. CHECKING THE OIL LEVEL**

Position the machine on level ground so that the "OIL LEVEL" mark on the final drive housing is positioned horizontally. Remove the magnetic filler and level plug (1), check the lubricant and, if the lubricant is low, fill to the level of the plug opening. Also, check the plug for metallic particles that may be present. If this condition continues after periodic checks, consult Authorized Distributor of Construction Equipment. Reinstall the plug and tighten.

## FINAL DRIVES

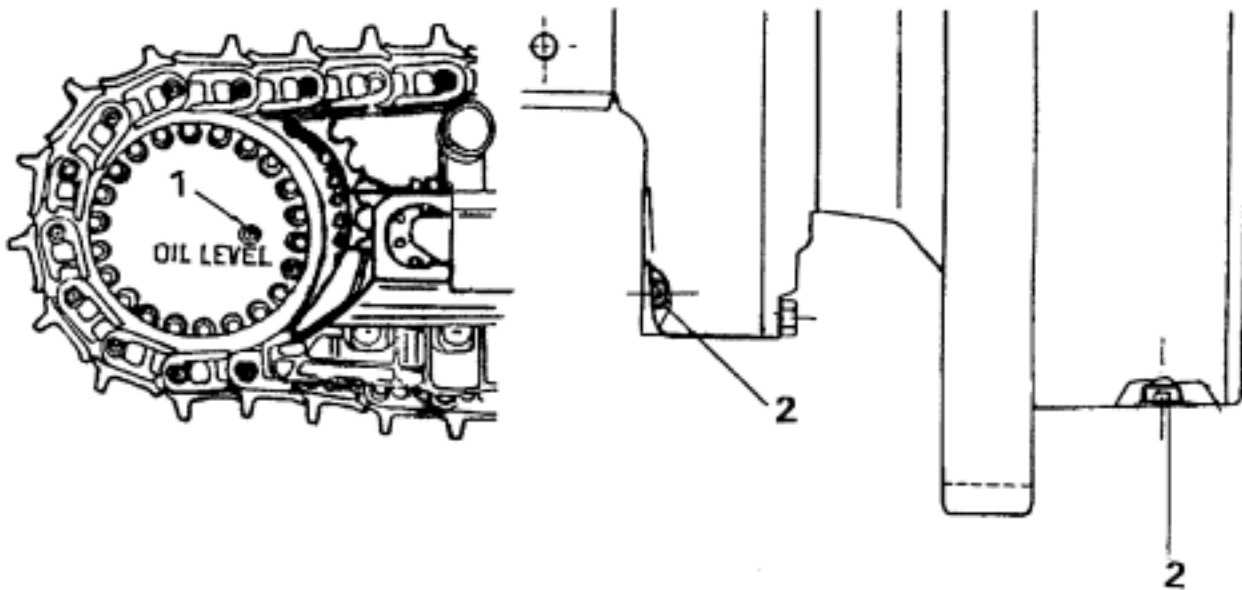

Fig. 5.42. Checking the Lubricant Level

1. Filler and Level Plug      2. Drain Plugs

## 5.17.2. CHANGING THE OIL

1. While the oil is at operating temperature, park the machine on level ground so that filler and level plug (1) is in topmost position. Remove the drain plugs (2) and the level plug (1) and allow the lubricant to drain into a suitable container. Remove metal particles from the magnetic plugs. Install and tighten the drain plugs. Fill app. 8 liters of fuel oil up to the housing and install the plugs.
2. Operate the machine in low gear (with no load) for a few minutes. Position the machine so that the "OIL LEVEL" mark on the final drive housing is positioned horizontally. Remove the drain plugs and thoroughly drain the fuel oil into a suitable container. Reinstall and tighten the drain plugs. Install and tighten the filler and level plugs. Fill the housing with fresh oil up to the bottom of the filler and level plug opening. Refer to the "REFILL SPECIFICATIONS AND CAPACITIES" for the grade of lubricant specified. Reinstall and tighten the filler and level plugs.

## 5.18. TRANSMISSION SYSTEM

**General**

The rear frame is the common oil reservoir for the transmission, torque converter and hydraulic steering drive. The system has pressure filters and a suction strainer that require service.

## 5.18.1. CHECKING THE OIL LEVEL IN REAR MAIN FRAME (Fig. 5.43)

1. With the engine shut down open the L.H. side rear access door, unscrew the T handle of the oil dipstick, remove the dipstick (1) and wipe it clean.

TRANSMISSION SYSTEM

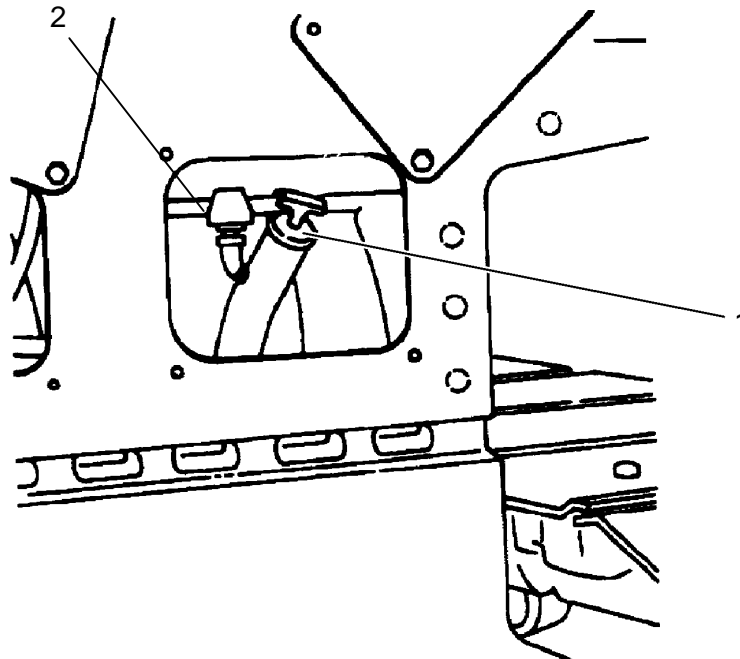

Fig. 5.43. Rear Main Frame Oil Level

- 1. Oil Dipstick and Oil Filler in RMF
- 2. Breather

2. Insert the dipstick fully into the filler sleeve. Do not tighten. Remove the dipstick and check the lubricant level. If necessary, add oil through the filler to bring the level up. Reinstall and secure the dipstick . The dipstick has two marks: the LO for low oil level and the HI for high oil level for HOT oil on one side and two marks: the LO for low oil level and the HI for high oil level for COLD oil on the other side. Check the oil level with the engine stopped.

**IMPORTANT:** Never operate a machine if the oil level is at or below the LOW mark on the oil dipstick.

5.18.2. CHANGING TRANSMISSION SYSTEM OIL (Fig. 5.44)

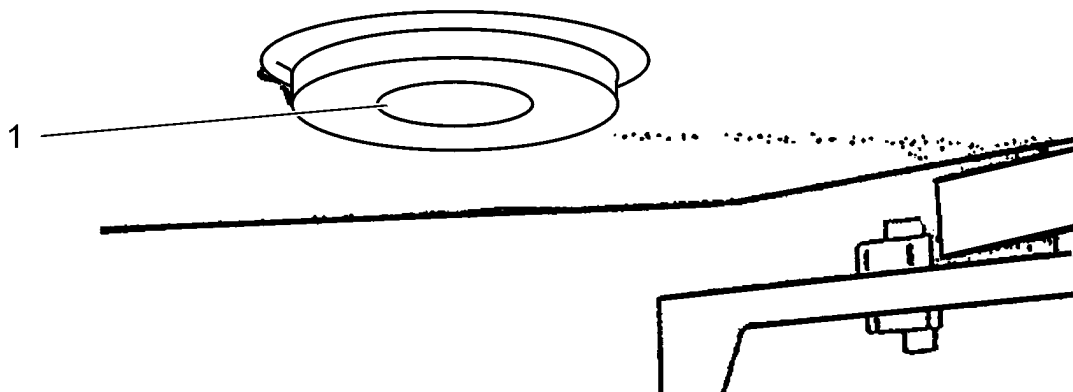

Fig. 5.44. Rear Frame drain Plug

- 1. Drain Plug

## TRANSMISSION SYSTEM

The transmission system lubricant must be changed at least once a year, even if the 1000 hours operational period has not elapsed.

1. To drain oil, warm it and remove the drain plug in the rear frame.
2. Remove the oil dipstick with the cover. Drain out the used oil and pour lubricant into the rear frame through the filler tube (Fig. 5.43) to bring the level up to the FULL mark on the dipstick.
3. Check the oil level and reinstall the dipstick.

## 5.18.3. SERVICING THE TRANSMISSION SYSTEM PRESSURE FILTERS

**IMPORTANT:** If the pressure filter warning light on the instrument panel remains on at the operating oil temperature with the engine running, the restricted pressure filters must be changed.

1. With the engine stopped, operate the steering levers several times to relieve any pressure. Open the L.H. side access door. Remove all outside dirt from the filters and using a filter wrench remove the filters; first in the main pressure system "M", then in the torque converter system. Wipe the filter head, removing all of the old oil from the seal area.

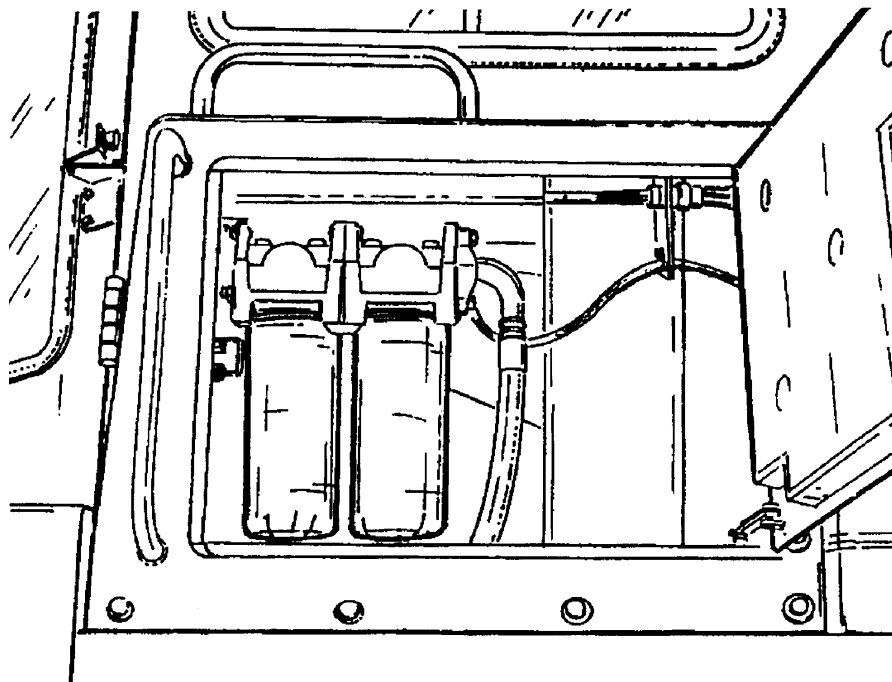

Fig. 5.45. Transmission System Pressure Filters.

2. Coat the seal on the new filters with clean oil. Install the filters by threading them onto the filter head until the seal contacts the head, turn the filters by hand an additional 1/4 to 1/2 turn. Start the engine and let it idle for approximately 5 minutes. Operate the steering levers several times, check filters for leaks and remove leaks, if any.
3. Check the oil level in the transmission system.

TRANSMISSION SYSTEM

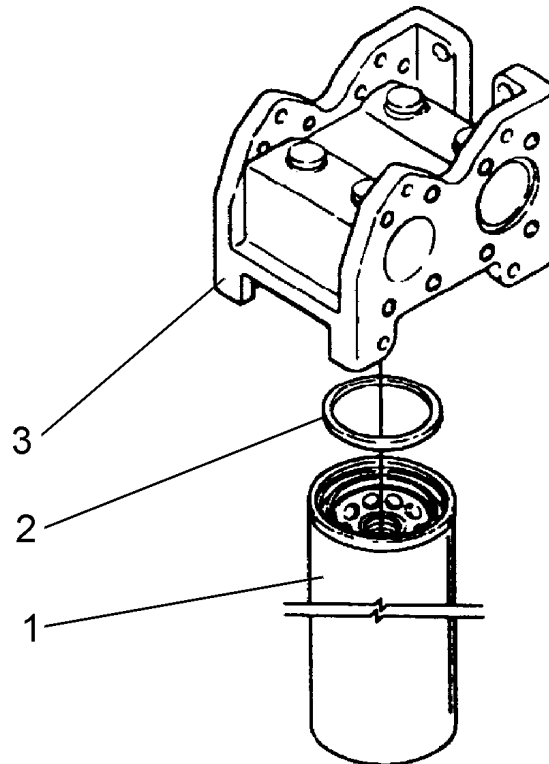

Fig. 5.46. Transmission Pressure Filter

1. Filter Seal                      2. Filter Element      3. Filter Head

**5.18.4. SERVICING THE SUCTION STRAINER (Fig. 5.47)**

The filter should be replaced with every change of transmission system oil in rear main frame.

1. To gain access to the oil strainer, first remove the transmission guard and put it down on the ground.
2. Remove bolts (5) of the filter saddle and remove the clamp (6) from the filter housing (7).
3. Remove bolts (3) from the tubing collars (2) at the filter housing. (7).
4. Press the filter housing down and remove the O-ring (8) from the tubing collars . (2). Keep the ring.

**IMPORTANT:** *Keep the disassembled parts clean. Protect the filter from dirt.*

5. Remove bolts (1, Fig. 5.48) securing filter base (3) and inner/hold-down cover/retainer (4) and spring (5). Remove O-ring (2) and keep it for reassemble. Remove filter element (6). Clean the filter housing (7).

MAINTENANCE

TRANSMISSION SYSTEM

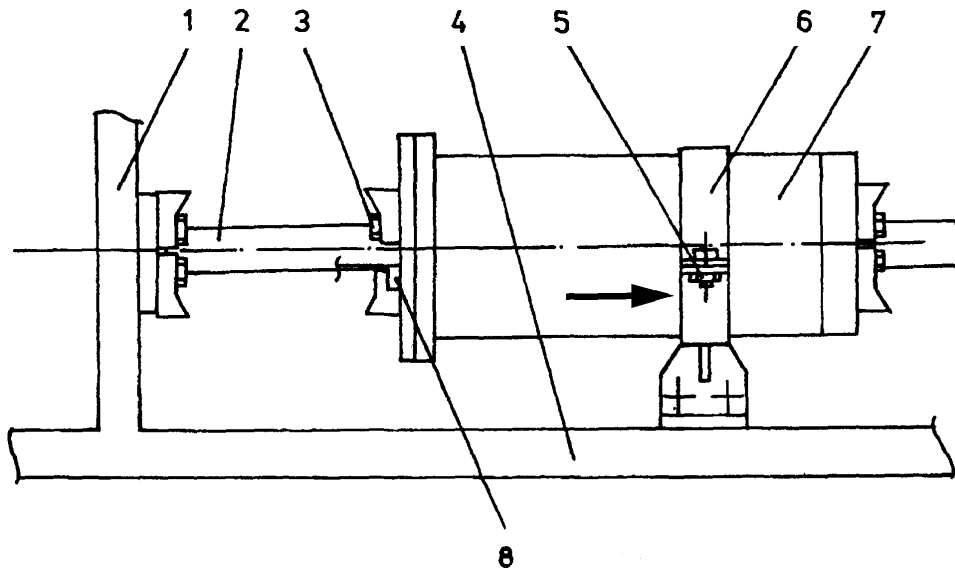

Fig. 5.47. Suction Strainer

- |                    |                        |                   |
|--------------------|------------------------|-------------------|
| 1. Rear Main Frame | 4. RH Front Frame Rail | 7. Filter Housing |
| 2. Tubing          | 5. Clamping Bolt       | 8. O-ring         |
| 3. Bolt            | 6. Filter Clamp        |                   |

**IMPORTANT:** Keep the disassembled parts clean. Protect the filter from dirt.

6. Replace the filter element (6, Fig. 5.48). Check and replace the O-ring (2) with a new one if damaged before its installation. Put the new filter element (6) into the filter housing (7). Install the O-ring (2), install the filter base (3), the inner/hold-down cover/retainer (4), spring (5) and secure it with bolts (1).

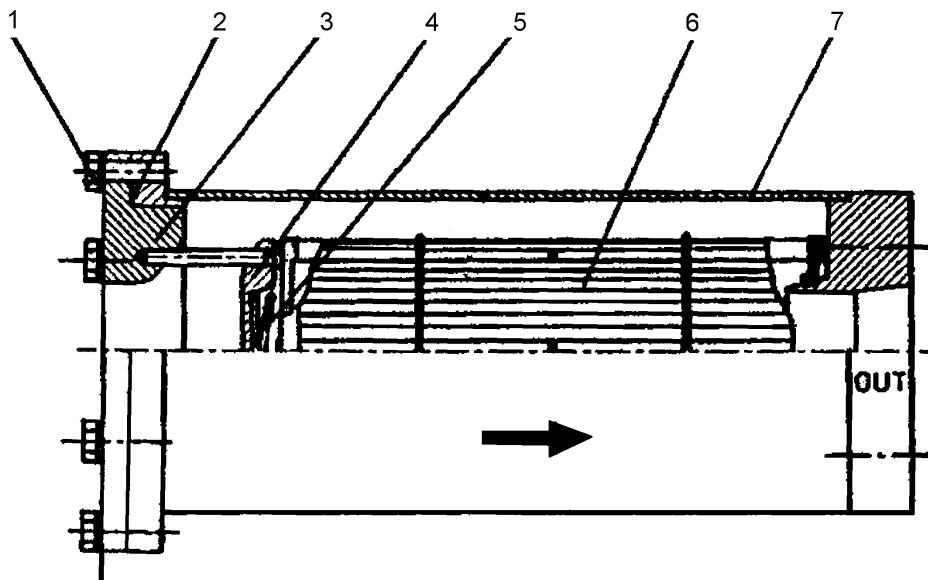

Fig. 5.48. Suction Strainer (cross section)

- |               |                                    |                   |
|---------------|------------------------------------|-------------------|
| 1. Cover Bolt | 3. Filter Base                     | 5. Spring         |
| 2. O-ring     | 4. Inner/Hold-down Cover /Retainer | 6. Filter Element |
|               |                                    | 7. Housing        |



TRANSMISSION SYSTEM

**IMPORTANT:** When installing the filter element follow the arrow pointing the direction of oil flow.

7. Connect the suction strainer to the tubing (2, Fig. 5.47). Insert the O-ring (8) into the flange groove, install the two halves of the collar and secure them with bolts (3).
8. Reinstall the transmission guard.

**5.18.5. SERVICING THE TRANSMISSION SCAVENGER STRAINER (Fig. 5.49)**

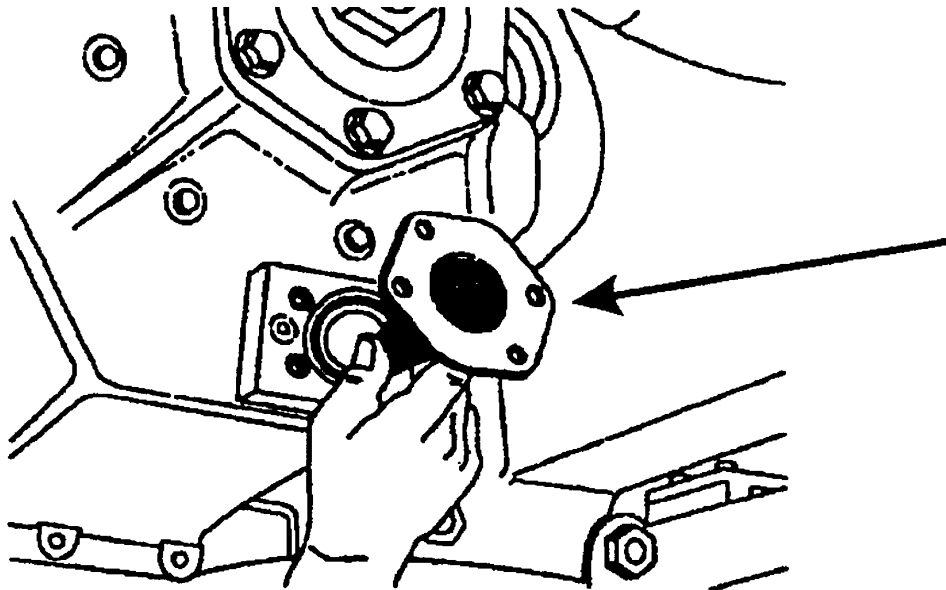

Fig. 5.49. Transmission Scavenger Oil Strainer

With the transmission system drained after 1000 hours of operation as described in the "Maintenance Schedule", remove the scavenger oil strainer and clean as described below:

1. To gain access to the oil strainer first remove the transmission guard.
2. Disconnect the transmission scavenger hose from intake pipe.
3. Remove the strainer from the transmission housing.
4. Clean the strainer with nonflammable commercial cleaning solvent.
5. Reinstall the strainer into the transmission housing.
6. Reinstall the transmission scavenger hose to pipe.
7. Reinstall the transmission guard.

**5.18.6. SERVICING THE BREATHER**

**IMPORTANT:** To prevent dirt from entering the critical areas of the transmission system, keep the breather clean.

Change the breather when changing oil in the rear frame. The breather is located next to the rear frame filler tube. Unscrew the breather from the reducer nipple. Install the new breather on the nipple.

## 5.19. UNDERCARRIAGE

### CHECKING THE UNDERCARRIAGE CONDITION

Periodically make observation checks on your undercarriage components. Check the tracks, track rollers, track idlers, front idlers etc. for abnormal wear. Make adjustments to these problems before damage to the components occurs. Once the wear on these components drops below zero percentage the option to recondition will also be lost. Refer to "SERVICE MANUAL" for dimensions indicating percentage of allowable wear. If this Service Manual is not available contact Authorized Distributor of Construction Equipment.

Clean mud and debris from the undercarriage so components can perform properly. After each 1000 hours of operation check the torque of the sprocket wheel rim mounting hardware and torque to 900 [Nm], if necessary.



**WARNING! Special knowledge and equipment are required to service lubricated track systems and their components. Unless you are completely familiar with servicing lubricated track systems do not make any attempt to remove them. Disconnecting the master link could cause the chain to whip off the front idler causing serious personal injury.**

Improper track tension and loose track shoes will cause damage and premature wear to the track. When new tracks or track shoes are installed, track tension and track shoe bolts should be checked after initial 10 hours of operation and adjusted; if necessary.

#### 5.19.1. TRACK SHOE BOLTS

The bolts used for attaching the track shoes to the tracks are heat-treated alloy bolts and will stand a considerable tightening strain. Ordinary bolts must not be used. Nuts must be assembled so that washer face is not against track link. Radius side of nuts must be against track link.

If removed or new, coat bolt threads and area under the head with engine oil. Torque value is 1100 [Nm]. Check the bolts torque for 700 [Nm]. The full torque is obtained by torquing a bolt to a value of  $650 \pm 70$  [Nm] and then turning the bolt an additional 120 degrees.

#### 5.19.2. EFFECT OF TRACK ADJUSTMENT ON UNDERCARRIAGE WEAR

Tracks adjusted too tightly increase operating loads on final drives and accelerate wear on undercarriage components, especially in packing conditions.

A machine in forward operation with correctly adjusted tracks will experience track loads only along the ground from the front idler to where the bushings engage the sprocket.

Lubricated track systems are to be adjusted to provide a sag in the track chain between the front top idler and the front idler. Correct tension reduces stress levels throughout the undercarriage system.

UNDERCARRIAGE

5.19.3. CHECKING THE TENSION

1. Place a wooden block, ~300 [mm] in height, under the foremost track shoe lug. Drive the machine forward until the track chain is tight along the ground and around the sprocket. Apply and lock the brake pedal, lock the transmission shift lever in NEUTRAL position and stop the engine, turn the master switch OFF and remove the key.
2. Stand on the track between the front idler and the first track idler in order to accumulate all the chain slack at this point.
3. Place a straightedge on the track so the ends rest over the front idler and track idler. Measure the clearance between the bottom of the straightedge and the top of the shoe grouser with a ruler at the midway point between the idlers. If the distance is more than 64 [mm] or less than 38 [mm] for lubricated chain and over 38 [mm] or less than 25 [mm] for non-lubricated chain, adjust the track tension .
4. For mud and snow packing conditions lubricated and non-lubricated track should be adjusted so its sag is 64 to 76 [mm] and 38 to 50 [mm], respectively.

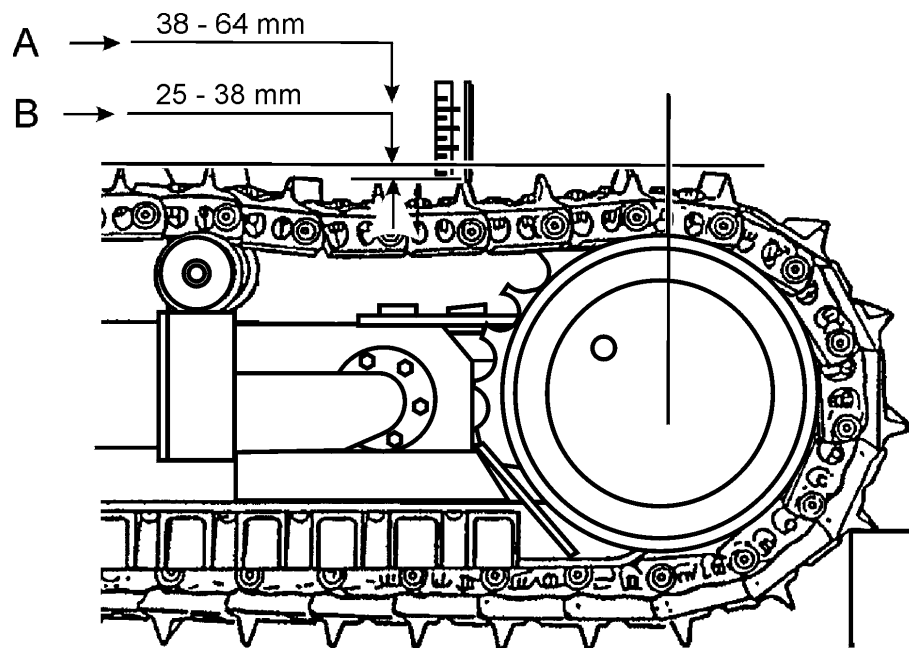

Fig. 5.50. Checking Track Tension

A. Track Sag for Lubricated Track System

B. Track Sag for Non-Lubricated Track System

5.19.4. ADJUSTING TENSION (Fig. 5.51)

The track chains are adjusted by hydraulic pressure. When lubricant is introduced into the front idler fork through the lubrication fitting, it acts upon the piston within the front idler fork forcing the front idler fork and front idler forward for track adjustment.

## UNDERCARRIAGE



**WARNING!** To avoid possible injury, always stand to the side of the bleeder plug when making track adjustment. The pressure in the front idler fork is held by the relieve and ball check valves. A loose or improper thread fit of either of these parts can allow them to be ejected by the pressure of lubricant, causing possible injury. When relieving track tension, never loosen the bleeder plug and check valve more than 2 – 2 ½ turns.

1. Remove the bolts and track adjuster cover.



**WARNING!** Before adding lubricant for track adjustment, be sure the ball check and relief valves are properly torqued to 61 – 75 [Nm] .

2. To increase track tension, connect a lubricator nozzle to lubrication fitting (2). Determine the amount of adjustment necessary, and add lubricant to obtain the proper track chain tension. It is advisable to move the machine forward and backward slightly to be sure the correct tension has been obtained.
3. To reduce track tension, loosen relief valve (1) ½ to 1 full turn to allow the pressurized lubricant to escape through the relief passage. If lubricant does not appear, loosen the ball check valve (located under lubricating fitting (2)) by ½ to one full turn to allow the pressurized lubricant to escape from the second relief passage.

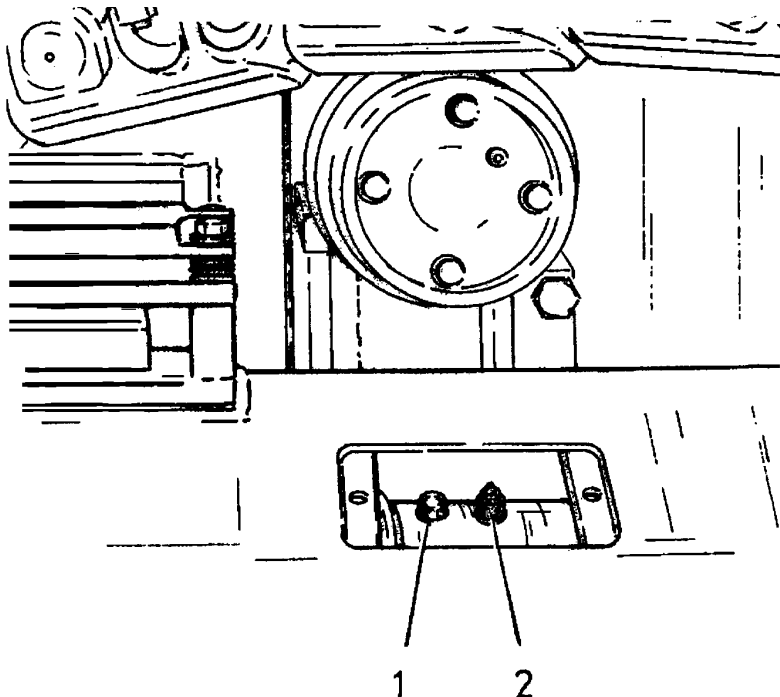

Fig. 5.51. Track Adjuster

1. Relief Valve
2. Lubrication Fitting (Ball Check Valve)

4. If lubricant still does not appear, use the following emergency method. Should the relief passages still be blocked, unscrew the ball check and/or relief valve an additional 1 to 2 turns – (2 ½ turns in total).

UNDERCARRIAGE



**WARNING!** Use extreme care when relieving pressure with the following emergency method. If loosened excessively, the cylinder pressure can eject the ball check or relief valve. NEVER loosen these parts more than a total of 2 ½ turns.

5. When the proper tension has been obtained, tighten the ball check and/or relief valve to 61 – 75 [Nm]. Install the cover and secure with the removed hardware.

**IMPORTANT:** Never remove one link to bring a stretched track to within the range of proper track adjustment. A track that is worn badly enough to take up the length of one link, will be so far out of pitch that the increased wear on the sprocket will far more than offset the saving obtained by the removal of one link in the track chain.

**5.19.5. TRACK FRAME GUIDE**

To avoid excessive wear of undercarriage components and track frame suspension points, the track frame guide must be lubricated, checked and adjusted periodically.

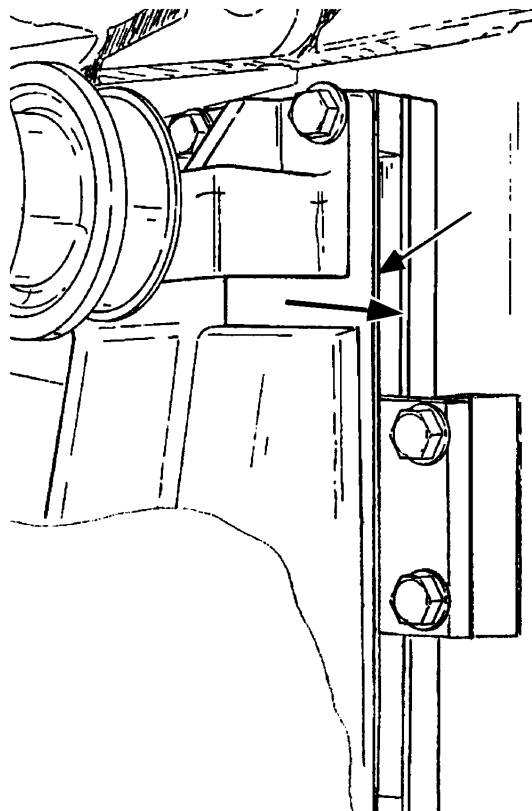

Fig. 5.52. Track Frame Guide Lubrication Points

# MAINTENANCE

## UNDERCARRIAGE

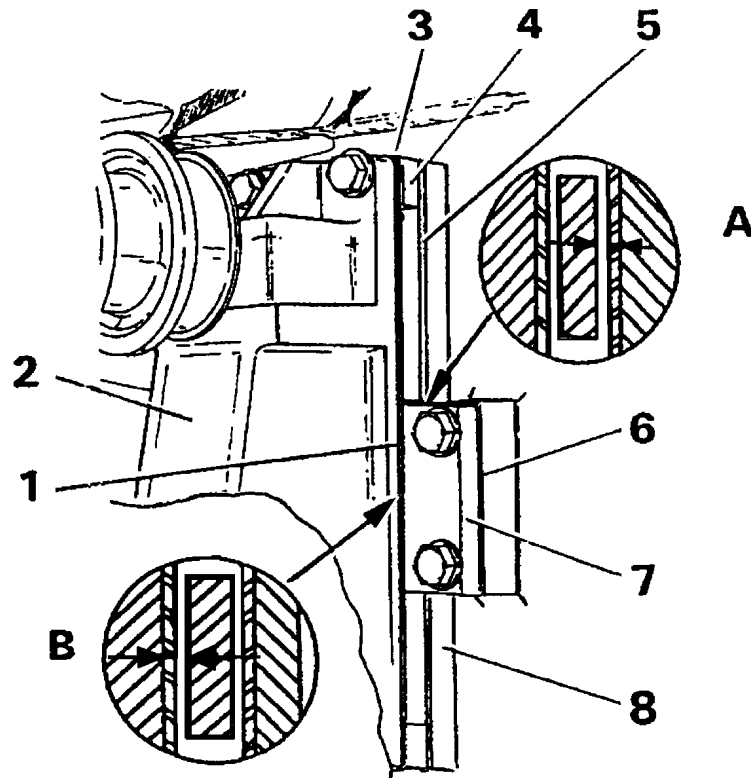

Fig. 5.53. Track Frame Guide

- |                     |                            |
|---------------------|----------------------------|
| 1. Outer Wear Plate | 5. Inner Wear Plate        |
| 2. Track Frame      | 6. Guide Plate Shims       |
| 3. Shims            | 7. Guide Plate             |
| 4. Guide Bar Block  | 8. Track Frame Guide Plate |

Measure clearances "A" and "B". If the total is 6.5 [mm] or more, adjust by removing shims (3) from between spacer blocks (4) and inner/outer wear plate (5/1). Remove enough shims to reduce the total clearance (A+B) to 0.8 [mm]. Keep the removed shims for future use.

If the removal of all shims (3) will not provide a total clearance of less than 6.5 [mm], replace wear plates (1 and 5), worn guide plate (7), as required. Reinstall the shims and repeat the check. Lubricate track frame guides. Apply grease into clearance "A" and "B".

### 5.19.6. PIVOT SHAFT HOUSING

Remove the plug (one at each side), check the oil level in the pivot shaft housing and if the lubricant is low, fill to the level of the plug opening. Reinstall and tighten the plug.

**NOTE:** Refer to the "REFILL SPECIFICATIONS AND CAPACITIES" chart for grade of lubricant specified.

UNDERCARRIAGE

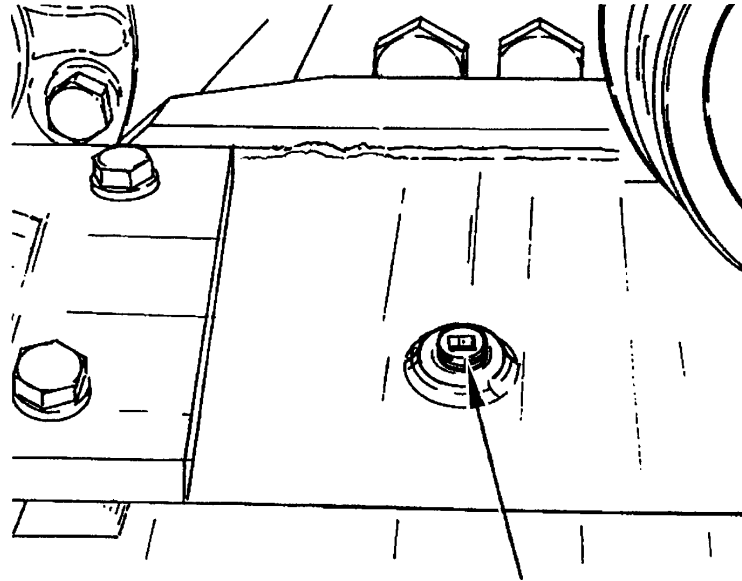

Fig. 5.54. Track Frame Pivot Shaft Housing Oil Filler Plug

5.19.7. FRONT WHEEL GUIDES

Periodically check the clearance between the front idler blocks and track frame guide and wear bars. If they are worn, measure thickness of the bars. The minimal thickness of the bars must not drop below 20.3 [mm]). If it is smaller replace the bar and grease it.

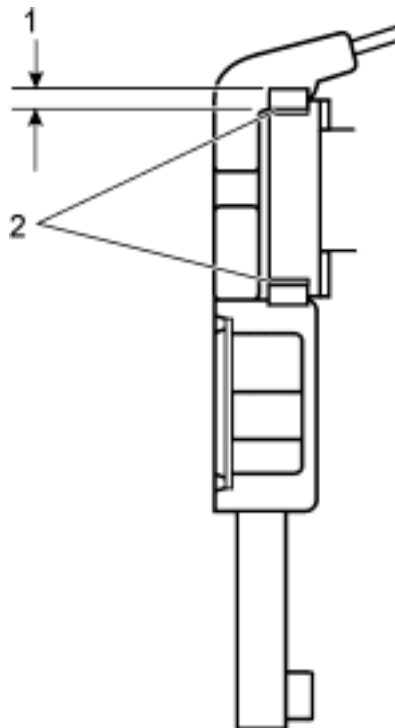

Fig. 5.55. Front Wheel Guide Clearance

1. Minimum Guide Thickness 20.3 [mm]

2. Lubricating Points

5.20. ADJUSTING HAND AND FOOT CONTROLS

Check the engine high and deceleration RPM. If RPM values are incorrect proceed as follows:  
 Check the adjustment of the hand levers and foot pedals as described below:

- a) Adjust the lever (4) to the vertical position of the lever for engine high idle speed (2200 to 2400 [RPM]). During adjustment the lever (1) must be placed in its rearmost position.
- b) Adjust the lever (2) to maintain the dimension 200 [mm] and 36 [mm].
- c) Adjust the foot pedal (3) to maintain the dimensions in [mm]
  - I - Engine high speed position (2200 to 2400 [RPM])
  - II - End of deceleration (1000 to 1200 SYMBOL[RPM])
  - III - Beginning of braking
  - IV - Full braking

After the adjustment has been made lubricate linkage and fill bearings with grease through the lubricating fittings (refer to "LUBRICATING FITTINGS") and check if the machine is stopped with the Decelerator–Brake pedal applied. Perform a brake test as follows:

- start the engine and bring the transmission system to the operating temperature,
- shift the engine speed and shut down lever to the 2nd speed with the engine at high speed and bring the machine to a temporary halt by applying the decelerator and brake pedal and brake lock.

With the correct adjustment made the machine should stop. If in doubt, contact Authorized Distributor of Construction Equipment.

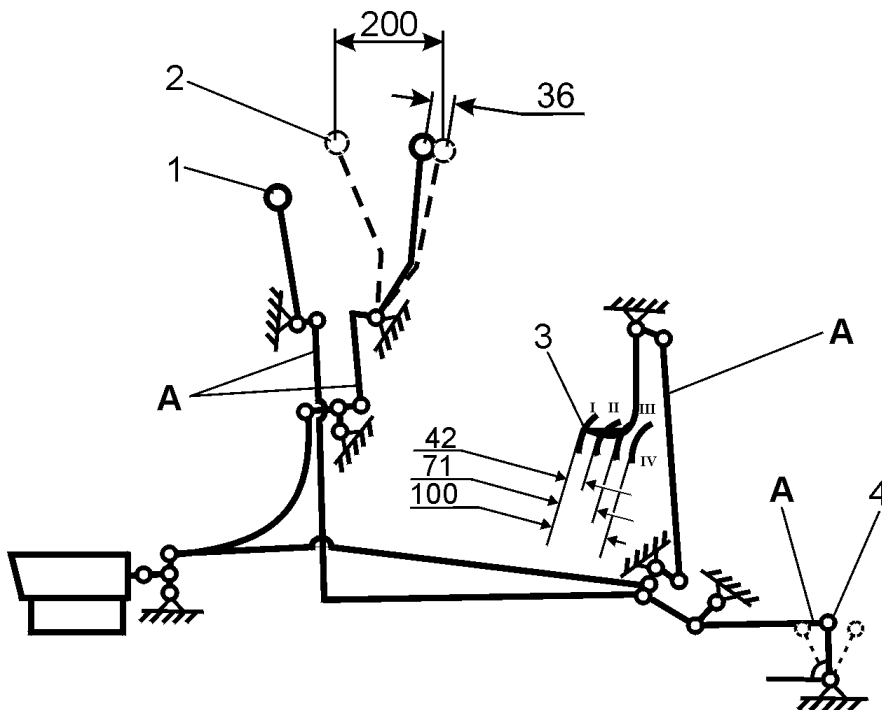

Fig. 5.56. Hand and Foot Controls

- |                                     |                                 |
|-------------------------------------|---------------------------------|
| 1. Engine Speed and Shut Down Lever | 3. Brake and Decelerator Pedal  |
| 2. Hand Steering Lever              | 4. Fuel Pump Lever              |
|                                     | A – Adjustable Control Elements |

Periodically lubricate plate to plungers contact area of pilot valve.



5.21. CAB AND ROPS

5.21.1. ROPS CAB/CANOPY AND MOUNTED EQUIPMENT MOUNTING HARDWARE (Fig. 5.57)

A dozer can be equipped with a ROPS protective structure with a canopy or a cab with a separate ROPS protective structure.

Periodically check the torque of ROPS and operator's platform mounting bolts, and check instruments and controls for proper operation, tighten or adjust the mounting bolts of the mirrors, wipers and shields. ROPS bolts should be torqued to 1500 [Nm].

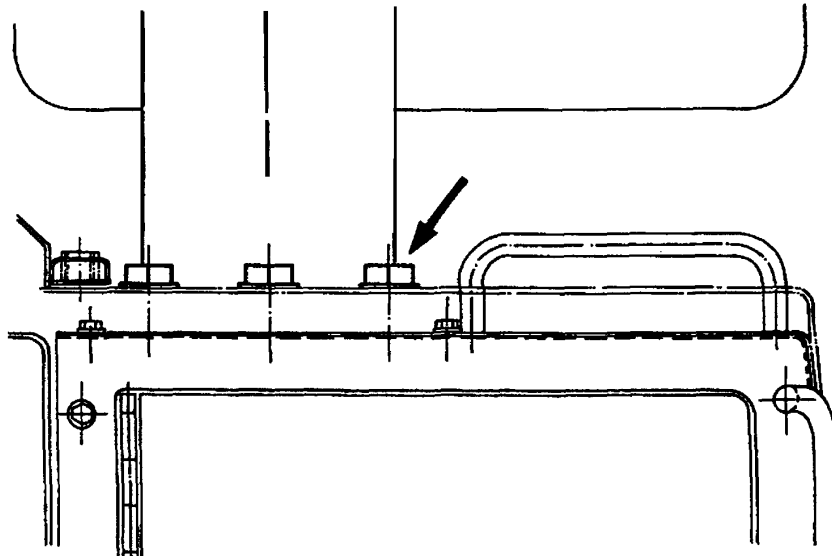

Fig. 5.57. ROPS Mounting Bolts

5.21.2. AIR CONDITIONER FILTER CLEANING (Fig. 5.58)

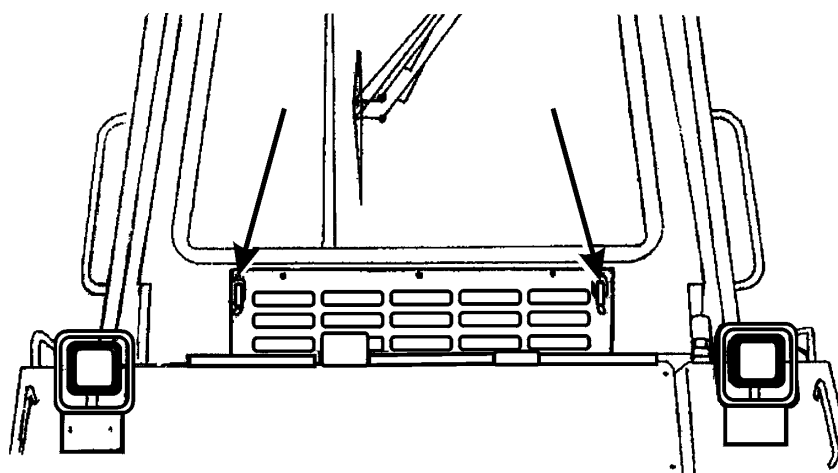

Fig. 5.58. Air Conditioner Filter Cover (Latches)

Periodically clean the air conditioner filter.

Open two latches and remove the filter. Clean the filter with compressed air directing the air in the reverse direction to that of normal operation. Clean the filter housing.

Reinstall the filter and secure the cover with the latches.

CAB AND ROPS

5.21.3. WINDSHIELD WASHER RESERVOIR (Fig. 5.59)

Refill the reservoir with washer liquid daily.

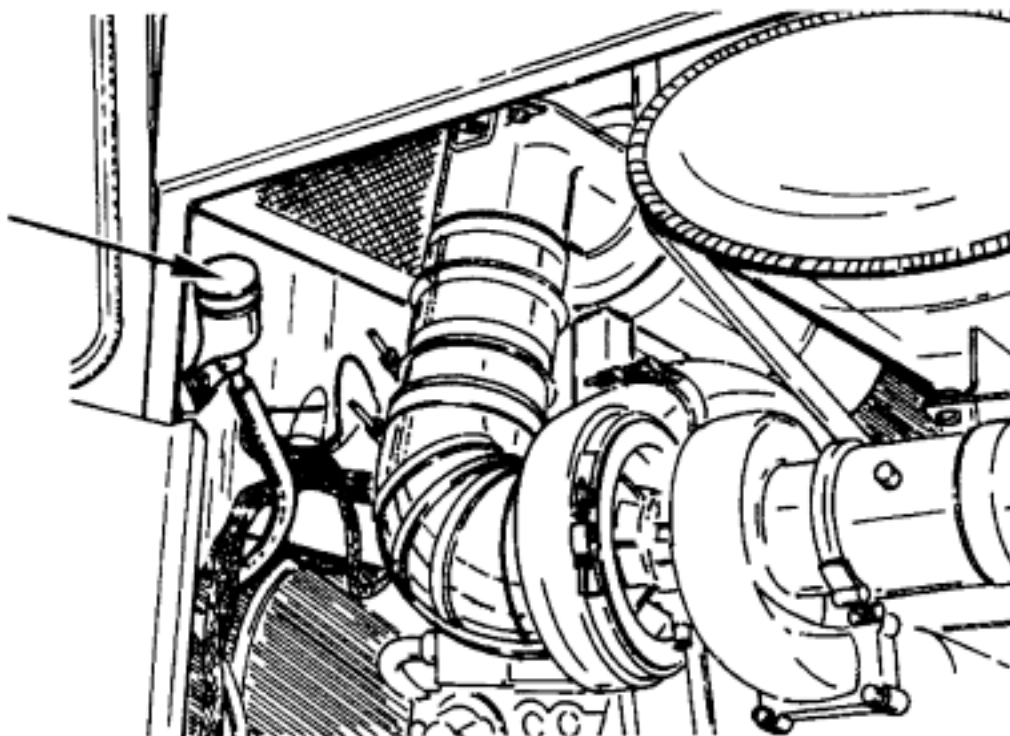

Fig. 5.59. Windshield Washer Reservoir Filler Spout.

**SECTION 6**  
**SPECIFICATIONS**



**SECTION CONTENTS**

|   | PAGE |
|---|------|
| 6.1. Application .....  | 3    |
| 6.2. Technical Description .....                                  | 3    |
| 6.3. Specifications .....   | 5    |
| 6.3.1. Overall Dimensions of Dozers .....                         | 5    |
| 6.3.2. Engine.....  | 6    |
| 6.3.3. Electrical System.....                                     | 6    |
| 6.3.4. Torque Converter .....                                     | 6    |
| 6.3.5. Travel Speeds .....  | 6    |
| 6.3.6. Transmission.....  | 6    |
| 6.3.7. Steering Drive .....                                       | 7    |
| 6.3.8. Final Drives Operation Weights .....                       | 7    |
| 6.3.9. Track Frames.....  | 7    |
| 6.3.10. Track Chains.....   | 7    |
| 6.3.11. Fuel Consumption .....                                    | 7    |
| 6.3.12. Weight (Approximate) .....                                | 7    |
| 6.3.12.1 Maximum Pull Force.....                                  | 8    |
| 6.3.13. Blade.....  | 8    |
| 6.3.14. Ripper .....  | 8    |
| 6.4. Refill Capacities .....                                      | 8    |
| 6.5. Special Torques.....   | 9    |
| 6.6. Torque Values for Standard Metric Fasteners .....            | 10   |
| 6.7. Torque Values for Standard English Fasteners .....           | 10   |
| 6.8. Torque Values for Split Flange Connections .....             | 11   |
| 6.9. Torque Values for Hydraulic Tubes and Fittings .....         | 11   |
| 6.10. Torque Values for Hose Clamps .....                         | 12   |
| 6.11. Torque Values for Air Conditioning Tubes and Fittings ..... | 12   |
| 6.12. Torque Values for Air Conditioning O-Ring Connections ..... | 12   |
| 6.13. List of Service Tools .....                                 | 13   |
| 6.14. Drive Train Schematic .....                                 | 14   |
| 6.15. Drive Train Hydraulic System Diagram .....                  | 15   |
| 6.16. Equipment Hydraulic System Diagram .....                    | 17   |
| 6.17. Wiring Diagram .....  | 18   |
| 6.18. Cab Wiring Diagram.....                                     | 21   |



**6.1. APPLICATION**

The TD-25H Crawler dozer has been designed to perform many different jobs at housing and industrial construction sites in a variety of soils, bulk materials, etc. The principal range of application covers:

- transporting materials at short distances
- digging and piling
- grading and clearing
- other jobs with blade, ripper and drawbar and mounted equipment

The TD-25H dozer is designed for operation in a mild climate. It can also be fitted for operation in the temperature range of +40 [°C] to -50 [°C].

**6.2. TECHNICAL DESCRIPTION**

The TD-25H includes the following main assemblies / systems:

- undercarriage
- main frame
- superstructure
- drive train
- transmission hydraulic system
- mounted equipment
- equipment hydraulic system
- electrical system

**Undercarriage**

The undercarriage includes two box section track frames with track rollers, track idlers, front idlers and track chains with track shoes, sprockets. Track frames are attached by a track frame pivot shaft to the rear frame and to a flexible equalizer bar attached to the saddle in the front mainframe. A track chain with track shoes is installed around the sprocket wheel, front idler, top idlers and track rollers. Track tension can be hydraulically increased to force the front idler forward for track chain adjustment by use of a common grease gun and released by turning pressure relief valve located under an easily removed plate.

**Mainframe**

The mainframe includes one-piece weldment consisting of a front and rear frame. The main frame is a mounting base for the radiator, cooler, engine, transmission, final drives and the superstructure components.

**Superstructure**

The superstructure includes an engine hood and side doors, instrument panel, fenders, fuel tank, hydraulic reservoir, operator's platform and operator's seat, battery box. The TD-25H crawler dozer is equipped with a cab with an air conditioner and can also be equipped with external individually mounted ROPS.

## TECHNICAL DESCRIPTION

### Drive train:

The drive train includes the following components:

- Engine with Radiator
- Torque Converter
- Universal Joint
- Transmission
- Pinion / Bevel Gear Set and Steering Drive
- Final Drives

Engine power is transmitted thru a torque converter, universal joint, transmission, pinion/bevel gear set and steering drive to two final drives with mounted sprockets.

A three-speed powershift transmission combined with two-speed steering gives six speeds forward and six speeds reverse.

Steering is accomplished by the application of clutch packs in the steering drive.

### Hydraulics of transmission system

The transmission system includes an oil tank, which is the rear frame, double gear pump, suction filter, pressure filters, main regulator valve, rate of rise valve, transmission, range selector valve and transmission and steering drive control valves.

### Mounted equipment

- Semi-U Blade
- Full U Blade
- Single/Multi-shank ripper
- Fixed drawbar

The blade is lowered or raised with two blade cylinders and tilted with a tilt cylinder. It can also be pitched either with two pitch cylinders or mechanically.

Multi-shank ripper can be equipped with 3 shanks installed on a draft frame raised and lowered with hydraulic cylinders. The shanks can be hydraulically pitched and adjusted in two vertical positions for shallow and deep penetration.

Single-shank ripper is equipped with a hydraulic pin puller for adjustment of the shank length for shallow and deep penetration.

Drawbar with vertical pin.

### Equipment hydraulic system

The equipment hydraulic system consists of:

- hydraulic oil reservoir with a sight gauge and vacuum pressure valve
- suction filter
- triple vane pump
- pilot valves
- control valves
- hydraulic cylinders
- return filters
- multiple valves



6.3. SPECIFICATIONS

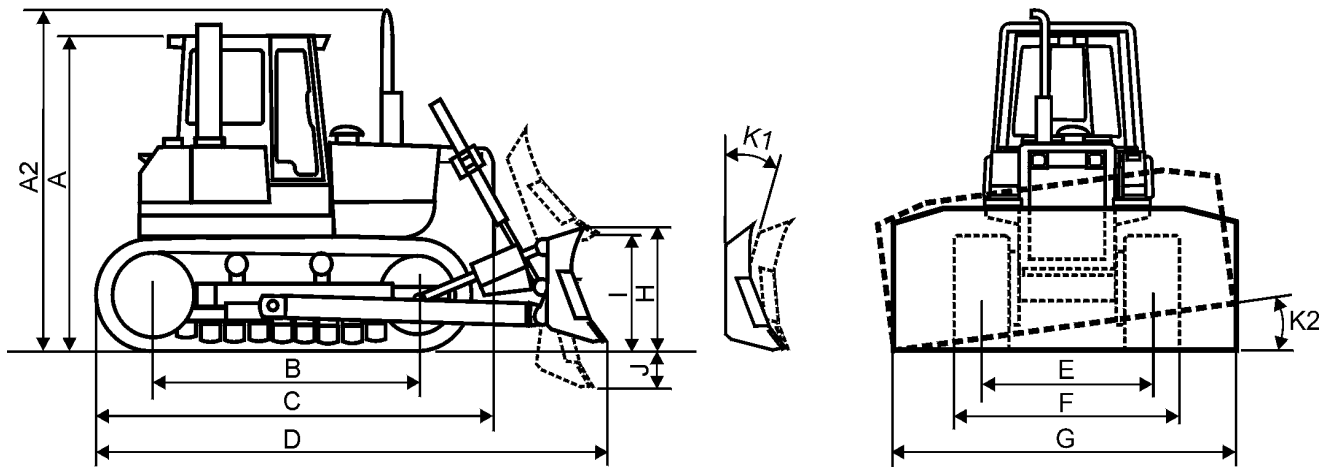

Fig. 6.1. Dimensions of Dozers

6.3.1. OVERALL DIMENSIONS OF DOZERS:

| Dimensions:  | TD-25H<br>[mm] |
|--|----------------|
| A. Height with cab .....                           | 3650           |
| A1. Height with ROPS .....                         | 3780           |
| A2. Height to exhaust pipe .....                   | 4080           |
| B. Distance between sprocket and front idler ..... | 3150           |
| C. Length without mounted equipment .....          | 5230           |
| D. Length with straight semi-U blade .....         | 6680           |
| (for TD-25H with std drawbar)                      |                |
| D1. Length with blade and ripper .....             | 8360           |
| E. Gauge .....                                     | 2130           |
| F. Width (with track shoes)                        |                |
| 560 [mm] .....                                     | 2750           |
| 610 [mm] .....                                     | 2800           |
| 660 [mm] .....                                     | 2850           |
| 864 [mm] .....                                     | ----           |
| F1. Machine width including trunnions .....        | 3230           |
| G. Straight blade width (Model D-2) .....          | 4030           |
| H. Blade height (Model D-2)                        |                |
| - struts in central position .....                 | 1730           |
| I. Max. blade raise                                |                |
| - straight blade .....                             | 1460           |
| J. Max. blade drop below the ground level          |                |
| - straight blade (Model D-2) .....                 | 600            |
| K. Blade tilt                                      |                |
| - straight blade (Model D-2) .....                 | 500            |
| K1. Max. pitching angle .....                      | 10 [°]         |
| K2. Blade angle .....                              | 25 [°]         |

**SPECIFICATIONS**

**6.3.2. ENGINE**

|                                 |  |
|---------------------------------|--|
| Make and model                  | CUMMINS N14-C 350                              |
| Type                            | 4-cycle diesel, turbocharged, direct injection |
| Net flywheel power @ 2100 [RPM] | 238 [kW]                                       |
| Max. torque at 1400 [RPM]       | 1600 [Nm]                                      |
| No of cylinders                 | 6  |
| Displacement                    | 14 [dm <sup>3</sup> ]                          |
| Engine speed:                   |  |
| High idle                       | 2200 – 2400 [RPM]                              |
| Low idle                        | 800 – 850 [RPM]                                |
| Deceleration                    | 1000 – 1200 [RPM]                              |

\* Net flywheel power is the power at the engine output shaft for the engine equipped with the standard equipment, that is: fan, air cleaner, alternator, water pump, lubricating pump, fuel pump @29.4 [°C] and air pressure 99.2 [kPa]

**6.3.3. ELECTRIC SYSTEM**

|                              |                         |
|------------------------------|-------------------------|
| System voltage               | 24 [V], negative ground |
| Batteries (maintenance-free) | 12 [V], four or six     |
| Alternator                   | 50 [A] or 80 [A]        |

**6.3.4. TORQUE CONVERTER**

|                           |  |
|---------------------------|--|
| Type                      | Rockford, single-stage, single-range, engine-mounted |
| Effective diameter (size) | 406.4 [mm]   |
| Torque ratio              | 2.7 : 1  |

**6.3.5. TRAVEL SPEEDS**

|                              |                 |
|------------------------------|-----------------|
| Forward:                     |                 |
| 1 <sup>st</sup> , low range  | 0 – 3.0 [km/h]  |
| 1 <sup>st</sup> , high range | 0 – 4.0 [km/h]  |
| 2 <sup>nd</sup> , low range  | 0 – 5.2 [km/h]  |
| 2 <sup>nd</sup> , high range | 0 – 6.7 [km/h]  |
| 3 <sup>rd</sup> , low range  | 0 – 8.1 [km/h]  |
| 3 <sup>rd</sup> , high range | 0 – 10.4 [km/h] |
| Reverse:                     |                 |
| 1 <sup>st</sup> , low range  | 0 – 3.7 [km/h]  |
| 1 <sup>st</sup> , high range | 0 – 4.9 [km/h]  |
| 2 <sup>nd</sup> , low range  | 0 – 6.2 [km/h]  |
| 2 <sup>nd</sup> , high range | 0 – 8.1 [km/h]  |
| 3 <sup>rd</sup> , low range  | 0 – 9.7 [km/h]  |
| 3 <sup>rd</sup> , high range | 0 – 12.4 [km/h] |

**6.3.6. TRANSMISSION**

|               |  |
|---------------|--|
| Type          | Modular Countershaft Hydraulically Power Shifted |
| No of speeds: | 3 forward, 3 reverse                             |

**SPECIFICATIONS**

**6.3.7. STEERING DRIVE**

Type: 2-speed with a planet gear on each side and hydraulic powered multiple-disc clutches and brakes

Steering: with 2 independent hand levers; one for each side.

Brake actuation: automatically applied on engine shutdown.

**6.3.8. FINAL DRIVES**

Type : 2-stage, planet

Sprocket rim: 8-part set

**6.3.9. TRACK FRAMES**

|  |                      |
|--|----------------------|
| No of track rollers on each side: . . . . .                          | 7                    |
| No of top idlers on each side: . . . . .                             | 2                    |
| All rollers and front idlers: . . . . .                              | life time lubricated |
| Track frame pivot swing amplitude at the front idler axis: . . . . . | 406 [mm]             |

**6.3.10. TRACK CHAINS**

Track chain with standard split link:

|  |                        |
|--|------------------------|
| Std shoe width: . . . . .  | 560 [mm]               |
| Optional shoes width: . . . . .                                  | 610, 660, 710 [mm]     |
| No of shoes per side: . . . . .                                  | 38                     |
| Shoe contact surface with the ground for the std shoe: . . . . . | 3.52 [m <sup>2</sup> ] |
| Grouser height: . . . . .  | 76 [mm]                |
| Tension adjustment: . . . . .                                    | hydraulic              |

**6.3.11. FUEL CONSUMPTION**

- During intensive slot dozing tests of a tractor equipped with a semi-U dozer blade, the average fuel consumption amounted to:
  - in sandy soil (soil density app. 1.6 [t/ m<sup>3</sup>]): 50 [l/h]
  - in firm ground (clay, soil density app. 1.9 [t/m<sup>3</sup>]): 55 [l/h]
- During longer periods of machine operation fuel consumption value can be estimated at the level of app. 45 [l/h].

**6.3.12. OPERATIONAL WEIGHTS**

- machine without mounted equipment, 10% full fuel, ROPS structure, track roller shields, sprocket rock deflector, crankcase and transmission guards, drawbar and headlamps: . . . . . 28000 [kg]
- machine with semi-U frontal blade equipment and drawbar: . . . . . 35550 [kg]
- machine with blade equipment and ripper. . . . . 40650 [kg]

## SPECIFICATIONS

## SPECIFICATIONS

## 6.3.12.1. Maximum Pull Force

The machine 1 low speed maximum pull force at the maximum engine RPM is 888<sup>+/-5</sup> [kN]

## 6.3.13. BLADE (Fig 6.1)

| Type   | full U                  | semi-U                 |
|--|-------------------------|------------------------|
| Max capacity acc to SAE J1265                          | 11.47 [m <sup>3</sup> ] | 9.56 [m <sup>3</sup> ] |
| Max effective shoe width                               | 710 [mm]                | 710 [mm]               |
| Blade dimensions                                       |                         |                        |
| • width (bit to bit)                                   | 4.52 [m]                | 4.03 [m]               |
| • height "A"   | 1.73 [m]                | 1.73 [m]               |
| Max. blade rise  |                         |                        |
| • in frontal position "B"                              | 1.46 [m]                | 1.46 [m]               |
| Max. blade drop (below the ground level, position "C") | 0.6 [m]                 | 0.6 [m]                |
| Max. blade tilt "D"                                    | 0.5 [m]                 | 0.5 [m]                |
| Max. blade pitch angle "E"                             | 10 [°]                  | 10 [°]                 |
| Average blade lift rate (@ nominal engine) RPM         | 0.40 [m/s]              | 0.40 [m/s]             |
| Blade equipment weight                                 | 7150 [kg]               | 6850 [kg]              |

## 6.3.14. RIPPER

| Type                          | multi-shank  | single-shank | single-shank |
|-------------------------------|--------------|--------------|--------------|
| Type of shank                 | std dig      | std dig      | deep dig     |
| Draft frame                   |              |              |              |
| • width                       | 2462 [mm]    | 1245 [mm]    | 1245 [mm]    |
| • section (height x width)    | 380x478 [mm] | 400x500 [mm] | 400x550 [mm] |
| Clearance under tool beam     |              |              |              |
| • with fully raised shank     | 1544 [mm]    | 1565 [mm]    | 1565 [mm]    |
| • with lowered shank          | 171 [mm]     | 154 [mm]     | 154 [mm]     |
| Teeth                         |              |              |              |
| • max. number of teeth        | 3            | 1            | 1            |
| • shank spacing               | 1067 [mm]    | -            | -            |
| • max. penetration            | 760 [mm]     | 1250 [mm]    | 1700 [mm]    |
| • clearance when fully raised | 868 [mm]     | 770 [mm]     | 760 [mm]     |
| • no of pitch positions       | 2            | 4            | 6            |
| Total weight                  |              |              |              |
| • with single shank           | 5100 [kg]    | 5280 [kg]    | 5370 [kg]    |
| • each additional tooth       | 320 [kg]     | -            | -            |

## 6.4. REFILL CAPACITIES

|                              |             |
|------------------------------|-------------|
| Fuel tank                    | 825 liters  |
| Cooling system               | 92.5 liters |
| Crankcase with filter        | 42 liters   |
| Transmission system (RMF)    | 220 liters  |
| Final drive (each)           | 46 liters   |
| Track roller (each)          | 0.9 liter   |
| Top idler (each)             | 1.1 liter   |
| Front idler (each)           | 0.8 liter   |
| Track Chain link             | 0.03 liters |
| Pivot shaft reservoir (each) | 4.5 liters  |

**REFILL CAPACITIES**

Equipment hydraulic system:

|                                |            |
|--------------------------------|------------|
| Hydraulic reservoir, Model D-2 | 130 liters |
| Blade tilt:                    | 12 liters  |
| Ripper with hydraulic tilt     | 75 liters  |
| Ripper without tilt            | 52 liters  |

**6.5. SPECIAL TORQUES**

| No | Description of tightening place                  | Size of thread | Torque [Nm] |
|----|--|----------------|-------------|
| 1  | Cab Dome Light Mounting Screw                    | 8-32           | 2           |
| 2  | Cluster Gauge Mounting Screw                     | 10-24          | 2           |
| 3  | Air Pre-Cleaner Clamp Bolts                      | 5/16-18        | 15          |
| 4  | Battery Terminal Nuts                            | 3/8-16         | 31          |
| 5  | Battery Hold Down Bolts                          | 1/2-13         | 7           |
| 6  | Alternator Mounting Bolts                        | 1/2-13         | 81-95       |
| 7  | Lamp Stud Nuts                                   | 1/2-20         | 51          |
| 8  | Lift Cylinder Rod Bearing Plate Bolts            | 1/2            | 130         |
| 9  | Track Adjuster Relief Valve                      | 5/8-18         | 68          |
| 10 | Track Adjuster Check Valve                       | 5/8-18         | 68          |
| 11 | Alternator Pulley Nut                            | 5/8-18         | 95-108      |
| 12 | Rear Main Frame Cover Bolts                      | 3/4-10         | 455         |
| 13 | Lift Cylinder Yoke Bearing Cap Bolts             | 3/4            | 450         |
| 14 | Diagonal Strut Eye Clamping Bolts                | 3/4            | 450         |
| 15 | Sprocket Dirt (Rock Deflector Mounting Bolts     | M20            | 522         |
| 16 | Track Frame Pivot Shaft Mounting Bolts           | M20            | 522         |
| 17 | Equalizer Bar Rebound Bracket Mounting Bolt      | M20            | 522         |
| 18 | Sprocket Rim Bolts                               | 7/8-14         | 900±5%      |
| 19 | Track Shoe Bolt                                  | 7/8-14         | 1100 INF    |
| 20 | Track Roller Shield Nuts                         | M24            | 845         |
| 21 | Track Roller Shield and Sprocket Wheel Bolts     | M24            | 845         |
| 22 | Rock Deflector Mounting Bolts                    | M24            | 845         |
| 23 | Track Roller Shaft Bracket Bolts                 | M24            | 845         |
| 24 | Final Drive to Rear Main Frame Mounting Bolts    | 1"-8           | 920         |
| 25 | Steering Drive to Rear Main Frame Mounting Bolts | 1"-8           | 920         |
| 26 | Transmission Mounting Bolts                      | 1"-8           | 920         |
| 27 | Engine Front Support Bar Bolts                   | 1"-8           | 920         |
| 28 | Engine Rear Trunnion Shafts Bolts                | 1"-8           | 1110        |
| 29 | Cutting Edge and End Bit Nuts                    | 1              | 1050        |
| 30 | Diagonal Strut Socket Cap Bolt                   | 1              | 1050        |
| 31 | Trunnion Mounting Bolts                          | 1              | 1050        |
| 32 | Pusharm Bearing Cap Bolts                        | 1-1/4          | 2100        |
| 33 | Ripper Mounting Frame Stud Nuts                  | 1-1/2          | 3100        |
| 34 | Counterweight and Drawbar Mounting Bolts         | 1-1/2 – 12     | 3100±5%     |
| 35 | Ripper Mounting Frame Bolts                      | 1-1/2 – 6      | 3100±5%     |
| 36 | Track Frame Guide Plate                          | M30            | 1500        |
| 37 | Track Frame Guide Wear Plates                    | M30            | 1500        |
| 38 | ROPS Structure Support Bolts                     | M30            | 1500        |

**6.6. TORQUES VALUES FOR STANDARD METRIC FASTENERS**

This chart provides tightening torque for general-purpose applications using original equipment standard hardware. Original equipment standard hardware is defined as coarse thread metric class 10.9 bolts and class 10.0 nuts and thru hardened flat washers (Rockwell "C" 38-45), all phosphate coated and assembled without supplemental lubrication (as received condition). The torques shown below apply to phosphate coated bolts designed for 60% yield strength.

The torques shown below also apply to phosphate coated bolts used with phosphate coated prevailing torque nuts, phosphate coated bolts used with copper plated weld nuts and are applied to steel and cast iron parts.

| NOMINAL THREAD DIAMETER<br>[mm] | STANDARD TORQUE ±10%<br>[Nm] |
|---------------------------------|------------------------------|
| 6                               | 10                           |
| 7                               | 16                           |
| 8                               | 23                           |
| 10                              | 46                           |
| 12                              | 80                           |
| 14                              | 125                          |
| 16                              | 200                          |
| 18                              | 275                          |
| 20                              | 385                          |
| 22                              | 530                          |
| 24                              | 670                          |
| 27                              | 980                          |
| 30                              | 1330                         |
| 33                              | 1790                         |
| 36                              | 2325                         |
| 39                              | 3010                         |

**6.7. TORQUE VALUES FOR STANDARD ENGLISH FASTENERS**

| NOMINAL THREAD DIAMETER<br>[in] | STANDARD TORQUE ±10%<br>[Nm] |
|---------------------------------|------------------------------|
| ¼                               | 10                           |
| 5/16                            | 21                           |
| 3/8                             | 38                           |
| 7/16                            | 60                           |
| ½                               | 92                           |
| 9/16                            | 130                          |
| 5/8                             | 180                          |
| ¾                               | 325                          |
| 7/8                             | 520                          |
| 1                               | 780                          |
| 1-1/8                           | 1110                         |
| 1-1/4                           | 1565                         |
| 1- 3/8                          | 2050                         |
| 1- 1/2                          | 2720                         |
| 1- 3/4                          | 3380                         |
| 2                               | 5080                         |

**TORQUE VALUES FOR STANDARD ENGLISH FASTENERS**

This chart provides tightening torque for general purpose applications using original equipment standard hardware as listed in the Parts Catalog for the machine involved. **DO NOT SUBSTITUTE.** Original equipment standard hardware is defined as Type 8, coarse thread bolts and nuts and thru hardened flat washers (Rockwell "C" 38-45), all phosphate coated and assembled without supplemental lubrication (as received condition). Phosphate coated bolts used in tapped holes in steel or gray iron, phosphate coated bolts used with phosphate coated prevailing torque nuts (nuts with distorted threads or plastic inserts). Phosphate coated bolts used with copper plated weld nuts.

Markings on bolt heads or nuts indicate material grade **ONLY** and are **NOT** to be used to determine required torque.

**6.8. TORQUE VALUES FOR SPLIT FLANGE CONNECTIONS**

The following chart provides the tightening torques for split flange connections used in hydraulic systems. Split flanges and fitting shoulders should fit squarely. Install all bolts, finger tight and then torque evenly. Over torqued bolts will damage the flanges and/or bolts, which may cause leakage.

| Flange size<br>[in]* | Bolt size<br>[in] | Torque Value<br>[Nm] |
|----------------------|-------------------|----------------------|
| 1/2                  | 5/16              | 20–24                |
| 3/4                  | 3/8               | 30–37                |
| 1                    | 3/8               | 37–47                |
| 1- 1/4               | 7/16              | 47–61                |
| 1- 1/2               | 1/2               | 62–79                |
| 2                    | 1/2               | 75–88                |
| 2- 1/2               | 1/2               | 107–123              |
| 3                    | 5/8               | 187–203              |
| 3- 1/2               | 5/8               | 159–180              |

\* – Outside diameter of hydraulic tube or hose fitting.

**6.9. TORQUE VALUES FOR HYDRAULIC TUBES AND FITTINGS**

| Size | Tubing O. D.<br>in inches | Thread size in<br>inches | Torque values for<br>37 [°] flared fittings | Torque values for O-ring boss<br>plugs, locknuts and 37 [°] flared<br>JIC fittings |
|------|---------------------------|--------------------------|---|--|
| 4    | ¼                         | 7/16–20                  | 12–16                                       | 8–14   |
| 5    | 5/16                      | 1/2 –20                  | 16–20                                       | 14–20  |
| 6    | 3/8                       | 9/16–18                  | 29–33                                       | 20–27  |
| 8    | 1/2                       | 3/4 –16                  | 47–54                                       | 34–41  |
| 10   | 5/8                       | 7/8–14                   | 72–79                                       | 47–54  |
| 12   | 3/4                       | 1-1/16–12                | 104–111                                     | 81–95  |
| 14   | 7/8                       | 1-3/16–12                | 122–138                                     | 95–109   |
| 16   | 1                         | 1-5/16–12                | 149–163                                     | 108–122  |
| 20   | 1- 1/4                    | 1-5/8–12                 | 190–204                                     | 129–156  |
| 24   | 1- 1/2                    | 1-7/8–12                 | 217–237                                     | 163–190  |
| 32   | 2                         | 2-1/2–12                 | 305–325                                     | 339–407  |

Above torque figures are recommended for plain, cadmium or zinc plated fittings, dry or wet installations. These torques are not recommended for tube with wall thickness of 0.89 [mm] or less.

**6.10. TORQUE VALUES FOR HOSE CLAMPS**

The following chart provides the tightening torques for hose clamps used in all rubber applications (radiator, air cleaner, operating lever boots, hydraulic system, etc.).

| CLAMP TYPE AND SIZE                          | TORQUE ± 0.6 [Nm]                       |                       |
|--|---|-----------------------|
|  | Radiator, Air Cleaner, Boots, etc. [Nm] | Hydraulic System [Nm] |
| "T" Bolt (any diameter)                      | 6.2 – 7.3                               | —                     |
| Worm Drive – 1-3/4 ["] Open Diameter & Under | 2.2 – 3.3                               | 4.5 – 5.6             |
| Worm Drive – Over 1-3/4 ["] Open Diameter    | 4.5 – 5.6                               | —                     |
| Worm Drive – "Ultra-title"                   | 10.7 – 11.8                             | 4.5 – 5.6             |

**6.11. TORQUE VALUES FOR AIR CONDITIONING TUBES AND FITTINGS**

SWAGED 45 [°] CONNECTIONS

| SIZE | THREAD SIZE ["] | TORQUE VALUES FOR MATERIALS [Nm] |               |              |                |
|------|-----------------|----------------------------------|---------------|--------------|----------------|
|      |                 | STEEL-STEEL                      | BRONZE –STEEL | COPPER-STEEL | ALUMINUM-STEEL |
| 1/4  | 7/16–20         | 16 – 23                          | 15 – 20       | 15 – 20      | 12 – 18        |
| 3/8  | 5/8–18          | 27 – 33                          | 23 – 38       | 23 – 38      | 20 – 25        |
| 1/2  | 3/4–16          | 47 – 54                          | 38 – 46       | 38 – 46      | 28 – 36        |
| 5/8  | 7/8–14          | 61 – 68                          | 45 – 53       | 45 – 53      | 34 – 42        |
| 3/4  | 1-1/16–12       | 72 – 80                          | 49 – 57       | 49 – 57      | 45 – 53        |
|      | 1-1/16–14       | 72 – 80                          | 49 – 57       | 49 – 57      | 45 – 53        |

**6.12. TORQUE VALUES FOR AIR CONDITIONING O-RING CONNECTIONS**

| SIZE | THREAD SIZE ["] | TORQUE VALUES FOR MATERIALS [Nm] |
|------|-----------------|----------------------------------|
|      |                 | STEEL-STEEL                      |
| 1/4  | 7/16–20         | 15 – 25                          |
| 3/8  | 5/8–18          | 27 – 33                          |
| 1/2  | 3/4–16          | 40 – 48                          |
| 5/8  | 7/8–14          | 47 – 54                          |
| 3/4  | 1-1/16–12       | 54 – 61                          |
|      | 1-1/16–14       | 54 – 61                          |



**6.13. LIST OF SERVICE TOOLS**

| <b>Item</b> | <b>Tool-wrench size</b>    | <b>Type of tool</b> | <b>Service (removal and installation)</b>                                |
|-------------|----------------------------|---------------------|--|
| 1           | 7/16 ["]                   | End Wrench          | Ether Injector Nozzle  |
| 2           | ¾ ["]                      | End Wrench          | Battery Removal  |
|             |                            |                     | Transmission System Suction Strainer Cleaning (Filter Body Removal)      |
|             |                            |                     | Transmission System Scavenger Strainer Cleaning (Platform Cover Removal) |
|             |                            |                     | Coolant Shut-off Valve (Coolant Filter)<br>Alternator Mounting Hardware  |
| 3           | 15/16 ["]                  | Socket              | Track Tension Adjustment (Relief and Check Valve)                        |
|             |                            | End Wrench          | Lower Strut Adjustment   |
| 4           | 1-1/8 ["]                  | End Wrench          | Blade Edges and End Bits   |
|             |                            | Socket              | Track Chain Shoes  |
|             |                            | End Wrench          | RMF Oil Replacement (Plug)   |
|             |                            | End Wrench          | Final Drive Oil Replacement (Plug)                                       |
| 5           | 1-1/2 ["]                  | End Wrench          | Blade Removal (Pusharm Trunnion Cap Bolts)                               |
|             |                            | Socket              | ROPS Mounting Bolts  |
| 6           | 1-11/16 ["]                | Socket              | Ripper Frame Removal   |
|             |                            |                     | Drawbar Removal  |
| 7           | 10 [mm]                    | End Wrench          | Fuel Line Venting  |
| 8           | 14 [mm]                    | End Wrench          | Battery Terminal Cleaning  |
|             |                            |                     | Transmission Suction Strainer Cover                                      |
|             |                            | T-Handle            | Track Frame Oil Filler Plug  |
| 9           | 17 [mm]                    | End Wrench          | RMF Breather Replacement   |
| 10          | 19 [mm]                    | End Wrench          | Battery Box Cover  |
| 11          | 22 [mm]                    | End Wrench          | Alternator Mounting Hardware   |
| 12          | 32 [mm]                    | End Wrench          | Crankcase Oil Drain Plug   |
| 13          | 38 [mm]                    | End Wrench          | Hydraulic Reservoir Breather Replacement                                 |
| 14          | ST-1293 Gauge              |                     | Drive Belt Tension Adjustment  |
| 15          | Flat Screwdriver 1x6.5     |                     | Air Pre-Cleaner Clamp  |
| 16          | Filter Wrench 90-95 [mm]   |                     | Coolant Filter   |
|             |                            |                     | Fuel Filter and Water Separator  |
| 17          | Filter Wrench 118-131 [mm] |                     | Engine Crankcase Oil Filter  |
|             |                            |                     | Hydraulic Return Filter  |
|             |                            |                     | Transmission System Pressure Filter                                      |

# SPECIFICATIONS

## 6.14. DRIVE TRAIN SCHEMATIC

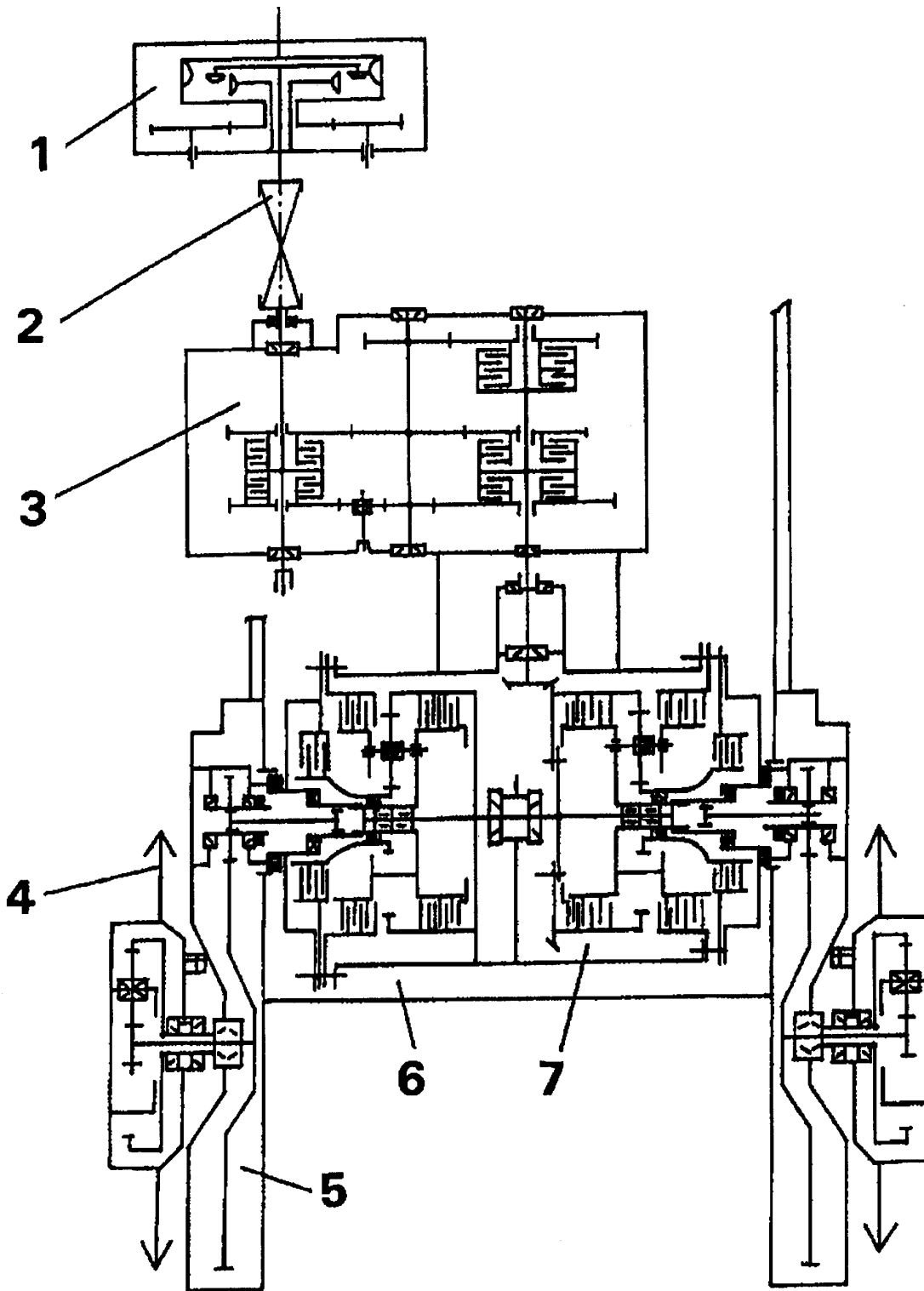

Fig. 6.2. Drive Train Schematic

- |                     |                    |
|---------------------|--------------------|
| 1. Torque Converter | 5. Final Drive     |
| 2. Universal Joint  | 6. Rear Main Frame |
| 3. Transmission     | 7. Steering Drive  |
| 4. Sprocket Wheel   |                    |

6.15. DRIVE TRAIN HYDRAULIC SYSTEM DIAGRAM

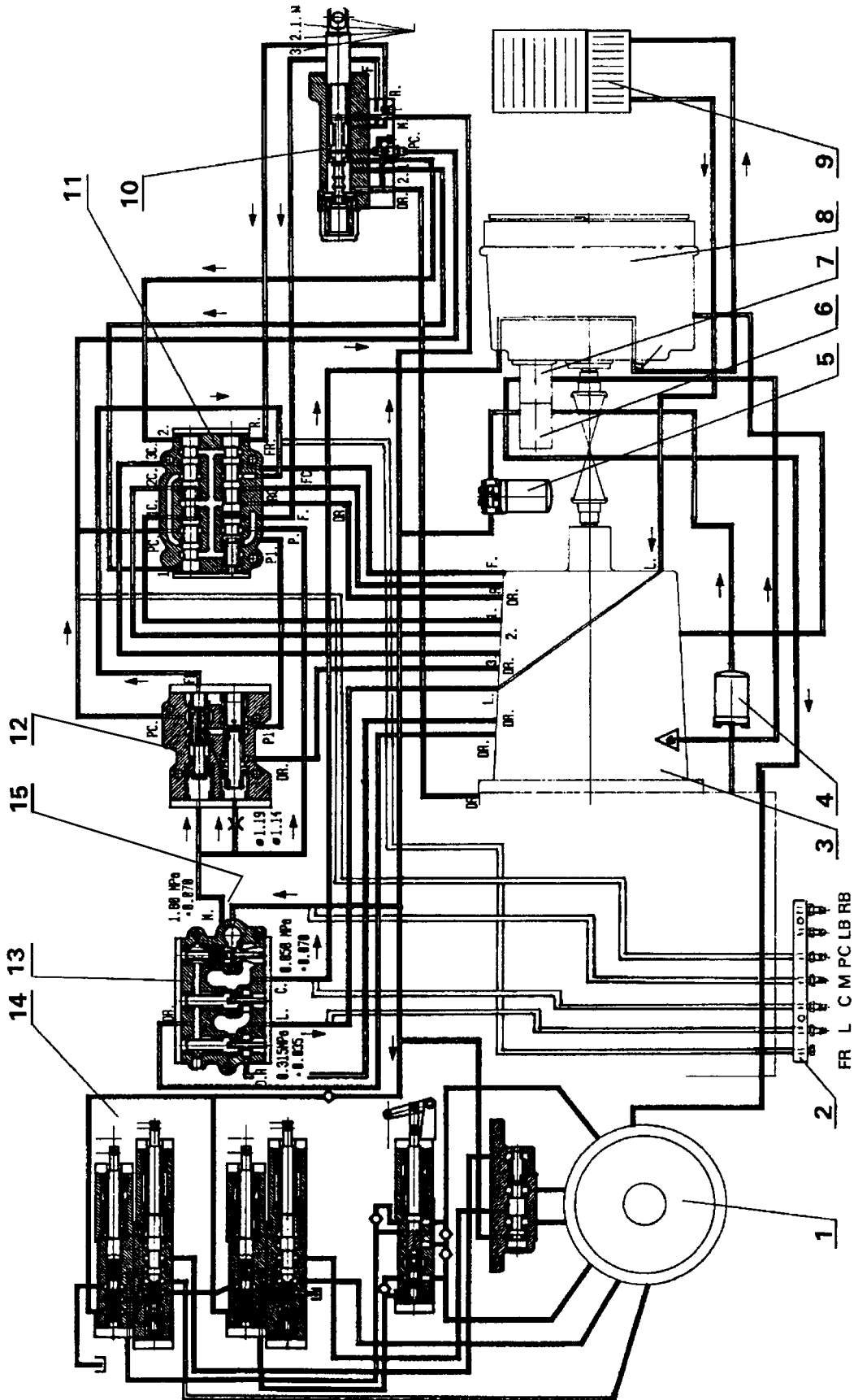

Fig. 6.3. Drive Train Hydraulic System Diagram

**DRIVE TRAIN HYDRAULIC SYSTEM DIAGRAM**

Key to the drive train hydraulic system:

1. Steering Drive
2. Diagnostic Center
3. Transmission
4. Suction Strainer
5. Pressure Filters (2 pcs)
6. Charge Pump
7. Scavenger Pump
8. Torque Converter
9. Oil Cooler
10. Transmission Control Valve
11. Range Selector Valve
12. Rate-of-Rise Valve
13. Main Regulator Valve
14. Steering Drive Valve
15. Supply to Cylinder for Ripper Shank Pin Puller

- 1C. Range Clutch 1 Oil Pressure
- 2C. Range Clutch 2 Oil Pressure
- 3C. Range Clutch 3 Oil Pressure
- FC. Forward Clutch Oil Pressure
- RC. Reverse Clutch Oil Pressure
  1. Range Clutch 1 Pilot Pressure
  2. Range Clutch 2 Pilot Pressure
  3. Range Clutch 3 Pilot Pressure
- F. Forward Clutch Pilot Pressure
- R. Reverse Clutch Pilot Pressure
- PC. Range Clutch Oil Pressure
- M. Main Pressure
- FR. Direction Clutch Oil Pressure
- C. Torque Converter Oil Pressure
- L. Lubricating Pressure
- P1. Rate-of-Rise Valve Pilot Pressure
- DR. Drain (Return to the Reservoir)
- LB. LH Brake Quickcoupling
- RB. RH Brake Quickcoupling

6.16. EQUIPMENT HYDRAULIC SYSTEM DIAGRAM

CONTROL OF PULLER FOR RIPPER SHANK PIN

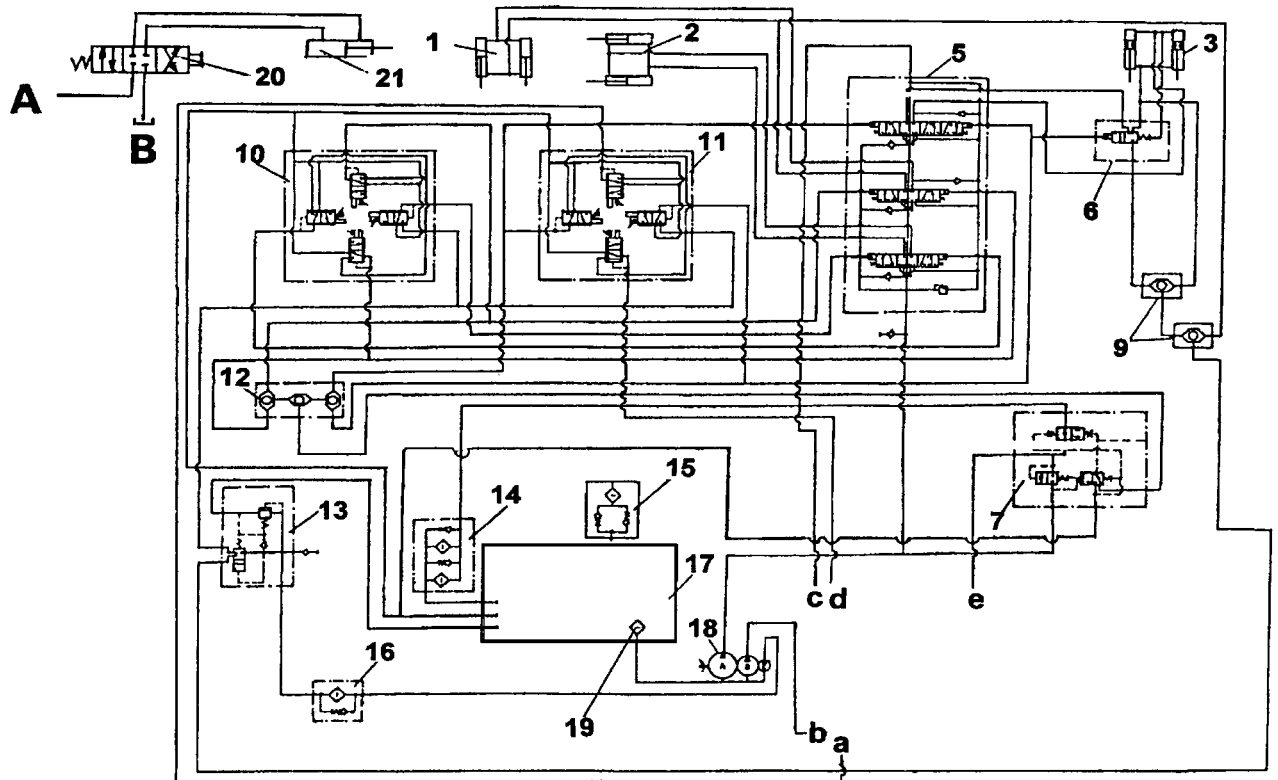

BLADE TILT CONTROL

BLADE TILT & PITCH CONTROL

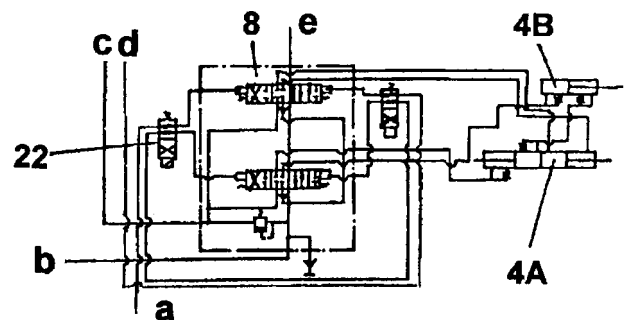
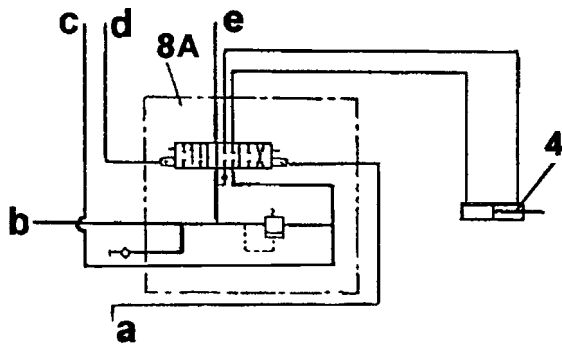

Fig. 6.4. Equipment Hydraulic System Diagram

- |                                   |  |
|-----------------------------------|--|
| 1. Ripper Lift Cylinders          | 12. Directional Valve                          |
| 2. Ripper Pitch Cylinders         | 13. Pilot Supply Valve                         |
| 3. Blade Lift Cylinders           | 14. Return Filters with Bypass Valve           |
| 4. Blade Tilt Cylinder            | 15. Vacuum Pressure Relief Valve               |
| 4A. Blade Tilt/Pitch Cylinder     | 16. Equipment Pilot Filter                     |
| 4B. Blade Pitch Cylinder          | 17. Hydraulic Reservoir                        |
| 5. Main Control Valve             | 18. Hydraulic Triple Pump                      |
| 6. Quick Drop Valve               | 19. Suction Strainer                           |
| 7. Relief Valve                   | 20. Control Valve for Ripper Shank Pin Control |
| 8. Blade Tilt/Pitch Control Valve | 21. Cylinder for Ripper Shank Pin Puller       |
| 8A. Pitch Control Valve           | 22. Solenoid Valve                             |
| 9. Directional Valve              | A. Steering Drive Supply                       |
| 10. Ripper Control Valve          | B. Drain (Rear Frame)                          |
| 11. Blade Control Valve           |  |

## 6.17. WIRING DIAGRAM

1. Horn
2. Front Tractor Headlamps
3. Alternator
4. Cranking Motor
5. Magnetic Switch
6. Main Automatic Reset Breaker
7. Air Filter Vacuum Warning Light Switch
8. A/C Electromagnetic Clutch
9. Ether Solenoid Valve
10. Fuel Solenoid Valve
11. Engine Oil Pressure Sensor
12. Engine Low Oil Pressure Switch
13. Coolant Temperature Sensor
14. Window Washers Pump Motor
15. Torque Converter Oil Temperature Sensor
16. Electric System Master Switch
17. Battery
18. Transmission Main Low Pressure and Range Clutches Pressure Warning Light Switch
19. Warning Lamp Delay Relay
20. Back up Alarm Pressure Switch
21. Fuel Solenoid Valve Switch
22. Transmission Neutral Lock Lever Switch
23. Transmission Filter Warning Light Switch
24. Rear Headlamp
25. Back up Alarm
26. Fuel Level Sensor
27. Horn Pushbutton
28. Hydraulic Filter Warning Light Switch
29. Gauge Cluster
30. Diode Assembly
31. Warning Lamp Check Relay
32. Fuel Level Gauge
33. Audible Alarm (Engine Oil Pressure or Low Coolant Level)
34. Hourmeter
35. Start Button
36. Ether Solenoid Valve Switch
37. Cab Switch
38. Tractor Headlamp Switch
39. Automatic Circuit Breakers
40. Blade Float Detent Solenoid
41. Blade Pitch Pushbutton
42. Tilt/Pitch Solenoid Valves
43. Coolant Level Sensors
44. Coolant Level Sensors Relay
45. Receptacle

**Gauge cluster components:**

- A – Hydraulic Oil Filter Warning Light  
 B – Engine Low Oil Pressure Switch  
 C – Main and Speed Clutches Oil Pressure Warning Light  
 D – Transmission Oil Pressure Filters Warning Light  
 E – Air Filter Vacuum Warning Light  
 F – Coolant Low Level Warning Light  
 H – Coolant Temperature Gauge  
 J – Torque Converter Temperature Gauge  
 K – Engine Oil Pressure Gauge  
 L – Gauges Lamps  
 M – Voltmeter

**Wire color code:**

- |            |                  |
|------------|------------------|
| R - red    | O - orange       |
| T - amber  | P - pink         |
| W - white  | V - violet       |
| Y - yellow | DB - dark blue   |
| B - black  | LB - light blue  |
| BR - brown | DG - dark green  |
| G - gray   | LG - light green |

**Wire cable marking:**

- 42/DB
- 42 - cable designation
  - DB - color code



# **SPECIFICATIONS**

## **WIRING DIAGRAM**



6.18. CAB WIRING DIAGRAM

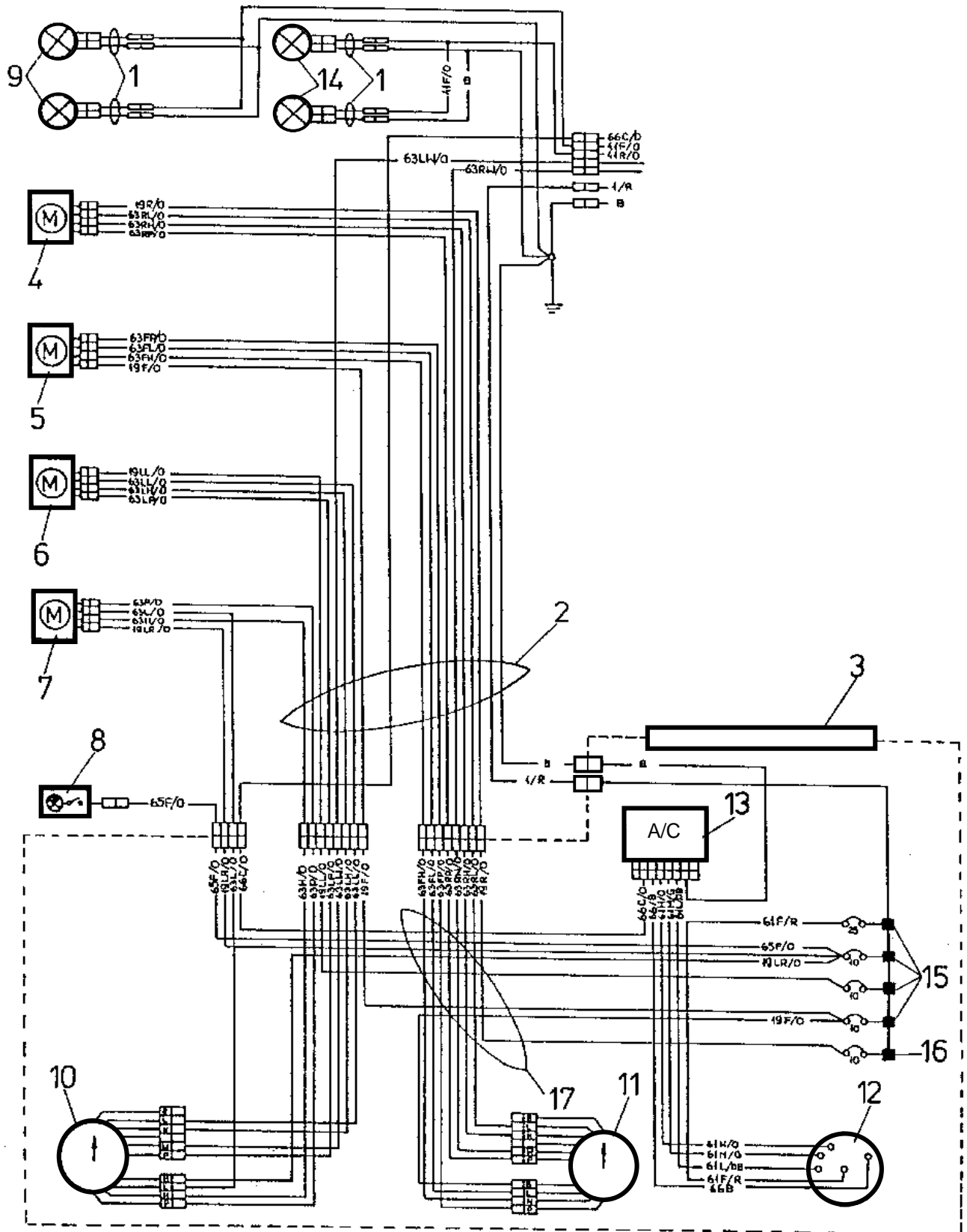

EMBED

Fig. 6.6. Cab Wiring Diagram

**CAB WIRING DIAGRAM**

## Key to the Cab Wiring System

1. Cab Headlamps Harness
2. Cab Harness
3. Cab Instrument Panel
4. Rear Wiper
5. Front Wiper
6. L.H. Wiper
7. R.H. Wiper
8. Dome Lamp
9. Cab Front Headlamp
10. Left and Right Wiper and Washer Switch
11. Front and Rear Wiper and Washer Switch
12. Air Conditioner Switch
13. Air Conditioner
14. Cab Rear Headlamp
15. Automatic Circuit Breaker 10 [A]
16. Automatic Circuit Breaker 20 [A]
17. Instrument Panel Harness