

en

Operating Manual

Wheel Loader
L507 Speeder - 787 from 12800

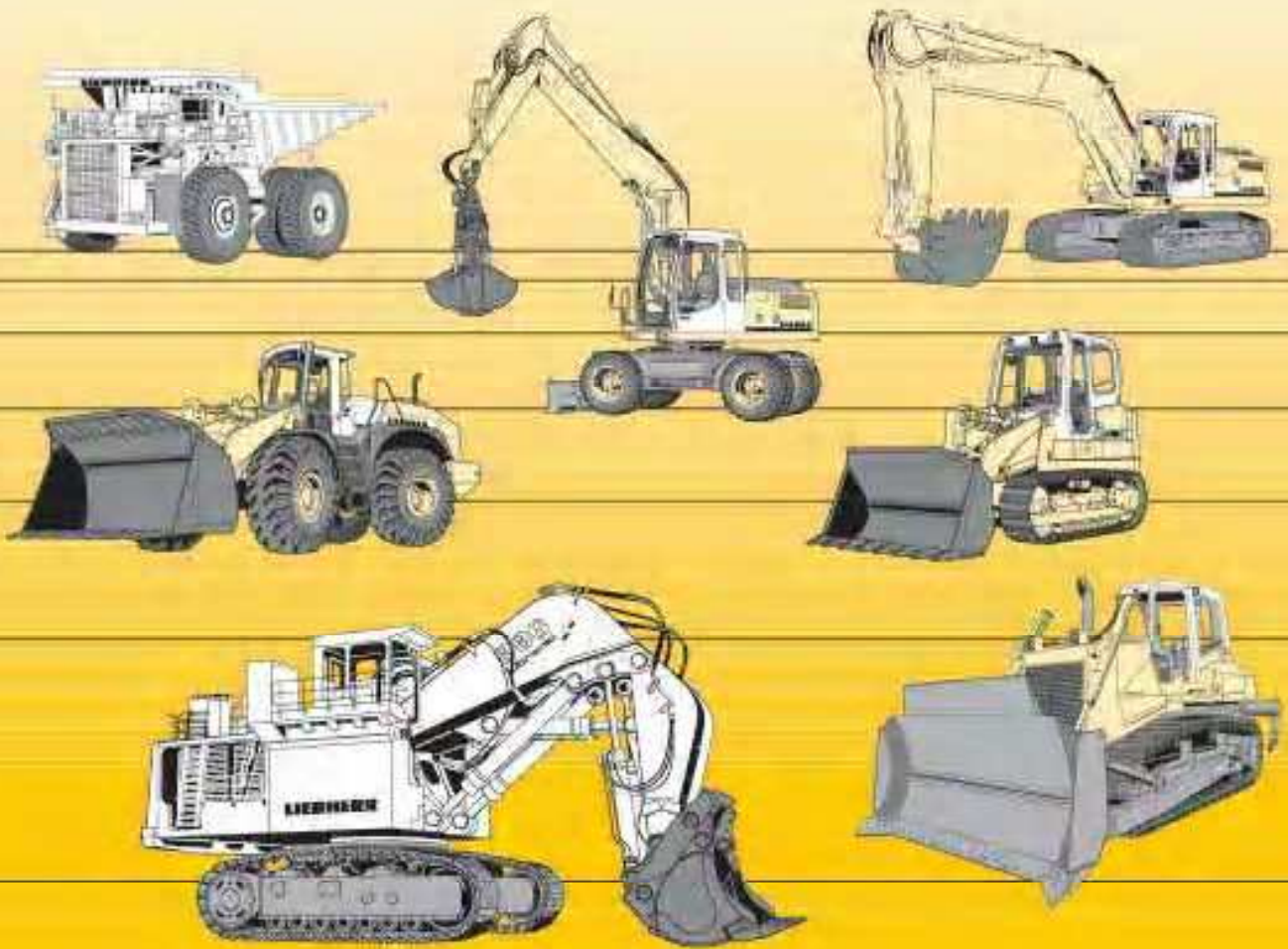

LIEBHERR

en

Operating Manual

Wheel Loader

L507 Speeder - 787 from 12800

Document identification

Order number: 10097534
Version: 02 / 2006
Document version: 02
Valid for: L507 Speeder - 787 from 12800
Author: LBH – Technical Documentation Department

Product identification

Type: L507 Speeder
Type no.: 787
Serial number: from 12800
Conformity:



Address

Address: LIEBHERR-WERK BISCHOFSHOFEN GMBH
Dr. Hans Liebherr – Straße 4
A – 5500 BISCHOFSHOFEN

Manufacturer

Address: LIEBHERR-WERK BISCHOFSHOFEN GMBH

Machine data:

Please enter the following details on receipt of your vehicle: *You will find these details on the vehicle type plate. They will be useful when ordering spare parts.

*** Serial no.**

VATZ ZZB

*** Year of manufacture**

.

Initial start-up date

. . / . . / . .

This operating manual has been written for the **driver** and for the **maintenance personnel** of the machine.

It describes:

- Chapter 1 - Product description
- Chapter 2 - Safety regulations
- Chapter 3 - Operation and handling
- Chapter 4 - Malfunctions
- Chapter 5 - Maintenance

This operating manual must be carefully read before initial operation and should be read and used later at regular intervals by anyone responsible for working on the machine.

Working with or on the machine includes:

- **Operation**, including equipping, troubleshooting during operation, removing production debris, maintenance, removing operating and auxiliary materials.
- **Servicing**, including maintenance, inspection and repairs.
- **Transport** or loading the machine.

This manual helps the driver to become acquainted with the machine and prevents malfunctions due to improper operation.

Observation of the operating manual by maintenance staff:

- Increases reliability during operation
- Extends the service life of your machine
- Reduces repair costs and downtime

This manual must be kept with the machine. Place a copy within easy reach in the glove compartment in the driver's cab.

In addition to the operating manual follow the instructions based on existing national accident prevention and environmental protection regulations.

In addition to the operating manual and applicable national and local legal accident prevention rules, observe the recognised technical regulations for safe and proper operation.

This operating manual contains all the information you need to operate and service your machine.

If you should, however, require more detailed explanations or information, our technical information and customer services departments will be happy to provide assistance.

You will understand that we cannot accept warranty claims for damage due to improper use, insufficient maintenance, use of non-approved consumables or failure to follow the safety instructions.

LIEBHERR will cancel without prior notice all obligations such as warranty agreements and service contracts entered into by **LIEBHERR** and/or its agents if spare parts other than genuine **LIEBHERR** parts or those purchased from **LIEBHERR** are used for maintenance and repairs.

In extreme conditions, maintenance may be required more often than stated in the inspection schedule.

Modifications, conditions, copyright:

- We reserve the right to alter the technical details of the machine regardless of the specifications and illustrations in these documents.
- The warranty and liability terms contained in LIEBHERR's general conditions of trade are not affected by the information in the manual.
- The information and illustrations in this manual may not be reproduced, distributed or used for commercial purposes. All rights under copyright laws are expressly reserved.

Abbreviations used:

CPU = central processing unit
Hydr. = hydraulic
LCD = liquid crystal display
LED = light emitting diode
LECU = Liebherr Electronic Control Unit
LFD = Liebherr ride control
LH = Liebherr
LKW = truck
MC = microcontroller
MV = solenoid valve
NLP = emergency steering pump
P-kinematics = kinematic version of the lift arms
SKW = heavy lorry
SW = quick-change device
UEC = universal earth mover controller
Z-kinematics = kinematic version of the lift arms

Symbols and pictograms:

Direction of operation or movement



bsym0059



bsym0066



bsym0065



bsym0029



bsym0049



bsym0061



bsym0060



bpik0006



bsym0063

Reply form

We need your help to continually improve our documentation. Please copy this page and fax it or e-mail it to us with your comments, ideas and suggestions for improvement.

To: Liebherr Werk Bischofshofen GmbH
Dr. Hans Liebherr Strasse 4
5500 Bischofshofen / Austria

Fax: 0043 6462 888 287

E-mail: roland.weber@liebherr.com

Ideas, comments (please state the page number):

Overall, how would you judge this document?

Excellent	
Very good	
Good	
Satisfactory	
Poor	

Your data: Machine / serial number: _____

Company: _____

Name: _____

Address: _____

Telephone number: _____

Dealer: _____

Thank you for your help.

LBH/02/003801/0003/2.06/en

Contents

1	Product description	1 - 1
1.1	Technical data	1 - 2
1.1.1	Complete machine with bucket	1 - 2
1.1.2	Engine	1 - 3
1.1.3	Electrical system	1 - 4
1.1.4	Travel drive	1 - 4
1.1.5	Axles	1 - 4
1.1.6	Braking	1 - 5
1.1.7	Steering	1 - 5
1.1.8	Working hydraulics	1 - 5
1.1.9	Working attachment	1 - 6
1.1.10	Driver's cab	1 - 7
1.1.11	Heating and ventilation	1 - 7
1.1.12	Sound emission	1 - 7
1.1.13	Towing device	1 - 8
1.1.14	Tyres	1 - 8
1.1.15	Air-conditioning system	1 - 10
1.1.16	Snow chains or guard chains	1 - 11
1.1.17	Soot particle filter	1 - 11
1.1.18	Light material bucket with undercut blade	1 - 13
1.1.19	4 in 1 bucket	1 - 15
1.1.20	Forklift	1 - 17
2	Safety regulations	2 - 1
2.1	Introduction	2 - 1
2.2	General safety regulations	2 - 1
2.3	Proper use	2 - 3
2.4	Decals on the machine	2 - 3
2.4.1	Location of decals	2 - 4

2.4.2	Safety decals	2 - 4
2.4.3	Information decals	2 - 6
2.4.4	Type plates	2 - 10
2.5	Instructions on preventing crushing injuries and burns	2 - 10
2.6	Instructions on preventing fires and explosions	2 - 11
2.7	Safety instructions for start-up	2 - 12
2.8	Safety precautions during start-up	2 - 12
2.9	Instructions for safe working	2 - 13
2.10	Safety instructions for driving on slopes	2 - 14
2.11	Parking safely	2 - 14
2.12	Transporting the machine safely	2 - 15
2.13	Towing the machine safely	2 - 15
2.14	Measures for ensuring safe maintenance	2 - 16
2.15	Safety instructions for maintenance work on machines with hydro accumulators	2 - 18
2.16	Safety instructions for welding work on the machine	2 - 19
2.17	Instructions for working safely on the working attachment	2 - 19
2.18	Safety instructions for transporting the machine by crane	2 - 20
2.19	Safe maintenance of hydraulic hoses and hose lines	2 - 20
2.20	Attachments and accessories	2 - 21
2.21	Protection against vibrations	2 - 21
3	Operation, Handling	3 - 1
3.1	Layout of control elements	3 - 1
3.2	Operation	3 - 2
3.2.1	Battery main switch	3 - 2
3.2.2	Cab access	3 - 2
3.2.3	Emergency exit	3 - 4
3.2.4	Driver's seat with mechanical suspension	3 - 5
3.2.5	Driver's seat with pneumatic suspension	3 - 10
3.2.6	Seat belt	3 - 14
3.2.7	Steering column and steering wheel	3 - 16

3.2.8	Ignition switch	3 - 17
3.2.9	Steering column switch	3 - 17
3.2.10	Lighting	3 - 19
3.2.11	Interior cab lighting	3 - 20
3.2.12	Display unit	3 - 22
3.2.13	Switches on the side console	3 - 27
3.2.14	LIEBHERR control lever	3 - 33
3.2.15	Control lever for additional working functions and quick-change device	3 - 36
3.2.16	Heating and ventilation	3 - 38
3.2.17	Air-conditioning system	3 - 40
3.2.18	Interior and exterior mirrors	3 - 41
3.2.19	Sun visor	3 - 42
3.2.20	Radio	3 - 42
3.2.21	Windshield wiper and washer system	3 - 43
3.2.22	Windshield washer fluid reservoir	3 - 45
3.3	Handling	3 - 46
3.3.1	Daily start-up	3 - 46
3.3.2	Starting the diesel engine	3 - 48
3.3.3	Driving	3 - 52
3.3.4	Shutting down the machine	3 - 62
3.3.5	Operating the lift arms	3 - 65
3.3.6	Working methods	3 - 73
3.3.7	Soot particle filter	3 - 86
3.3.8	Quick-change device - fitting and removing the working attachment	3 - 88
3.3.9	4 in 1 bucket	3 - 97
3.3.10	Forklift	3 - 98
3.3.11	Transporting the machine	3 - 100
3.4	Emergency operation	3 - 106
3.4.1	Towing the machine	3 - 106
3.4.2	Jump starting	3 - 112
4	Malfunctions	4 - 1
4.1	Service Code Table	4 - 1

4.1.1	Service code indication on the display	4 - 2
4.1.2	Visible and audible warning signals	4 - 8
4.1.3	Troubleshooting	4 - 10
4.2	Eliminating malfunctions	4 - 13
4.2.1	Replacing fuses	4 - 13
5	Maintenance	5 - 1
5.1	Maintenance and inspection schedule	5 - 1
5.2	Lubricant chart, filling quantities	5 - 5
5.2.1	Table of filling quantities	5 - 5
5.2.2	Lubricant chart	5 - 6
5.3	Maintenance tasks	5 - 8
5.3.1	Preparatory tasks for maintenance	5 - 8
5.3.2	Checking the machine for external damage	5 - 12
5.3.3	Making sure the bolted connections are tight	5 - 12
5.3.4	Sealing leaks	5 - 12
5.3.5	Checking the engine oil level	5 - 13
5.3.6	Changing the engine oil	5 - 14
5.3.7	Changing the engine oil filter	5 - 15
5.3.8	Changing the fuel pre-filter	5 - 16
5.3.9	Changing the fuel fine filter	5 - 17
5.3.10	Draining off condensate from the fuel fine filter	5 - 18
5.3.11	Cleaning the air filter service cap and dust extraction valve	5 - 19
5.3.12	Changing the air filter main element when indicated by the vacuum switch	5 - 19
5.3.13	Checking and draining the soot particle filter condensate separator	5 - 21
5.3.14	Checking the coolant level	5 - 21
5.3.15	Checking the coolant antifreeze concentration	5 - 22
5.3.16	Cleaning the cooling system	5 - 24
5.3.17	Checking the oil level in the hydraulic tank	5 - 25
5.3.18	Checking that the steering is working	5 - 25
5.3.19	Lubricating the bearing points on the steering cylinders	5 - 26

5.3.20	Checking the service brake and parking brake	5 - 26
5.3.21	Checking the gap and wear on the service brake linings	5 - 27
5.3.22	Checking the oil level in the equalising reservoir of the brake system	5 - 28
5.3.23	Checking the indicator lamps and lighting	5 - 28
5.3.24	Checking the tightness of the wheels (once after 50, 100 and 250 h)	5 - 29
5.3.25	Greasing the rear axle kingpin bearings	5 - 30
5.3.26	Checking and lubricating the cardan shaft(s)	5 - 31
5.3.27	Checking the tyre pressure	5 - 32
5.3.28	Lubricating the articulation bearing and rear oscillating bearing	5 - 32
5.3.29	Greasing the contact faces of articulation stops	5 - 33
5.3.30	Checking whether metered quantities are adequate at the bearing points (grease collars) of the central lubrication system	5 - 34
5.3.31	Checking the pipes, hoses and lubrication points of the lubrication system	5 - 35
5.3.32	Greasing the cab door hinges	5 - 35
5.3.33	Cleaning or replacing the fresh air and recirculated air filter	5 - 35
5.3.34	Lubricating the lift arms and attachment	5 - 35
5.3.35	Checking the lift arm bearing bushings	5 - 36
5.3.36	Lubricating and testing the quick-change device	5 - 37
5.3.37	Cleaning the machine	5 - 39
5.3.38	Corrosion protection	5 - 40
5.4	Lubricants and fuels	5 - 41
5.4.1	Lubricating oils for diesel engines	5 - 42
5.4.2	Diesel fuels	5 - 43
5.4.3	Coolants for diesel engines	5 - 45
5.4.4	Hydraulic oils	5 - 46
5.4.5	Lubricating oils for the transmission	5 - 48
5.4.6	Brake oil	5 - 48
5.4.7	Grease for general lubrication points	5 - 49

1 Product description

Equipment layout

Standard version

This section contains an overview of the machine and the names of the components shown.

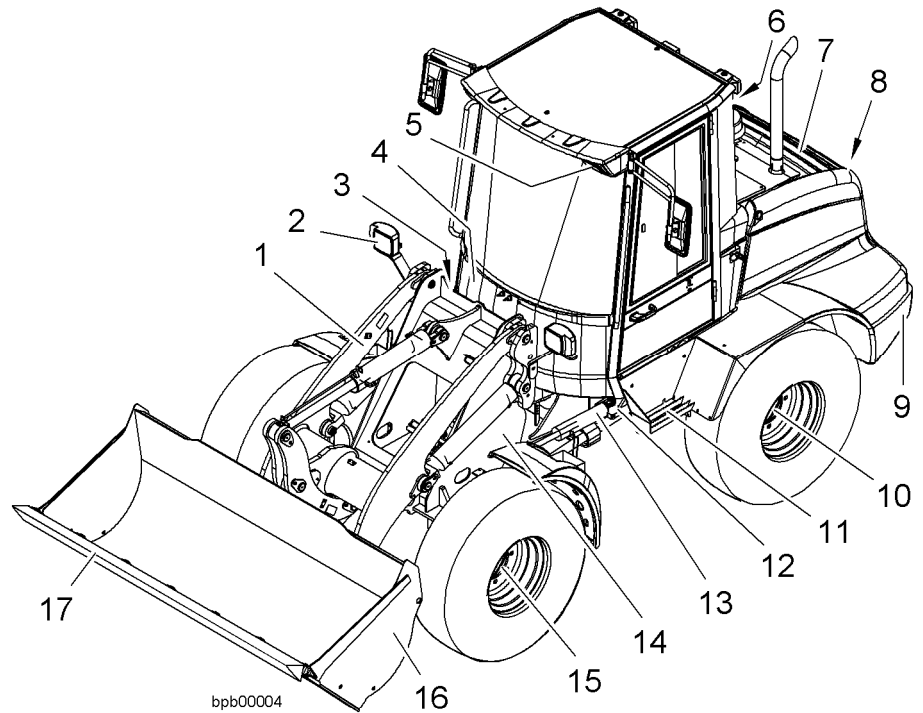

Left view of machine

- | | |
|---------------------------|----------------------|
| 1 Lift arm | 10 Rear axle |
| 2 Lighting | 11 Cab access |
| 3 Articulation lock | 12 Rear section |
| 4 Driver's cab | 13 Steering cylinder |
| 5 Working floodlight | 14 Front section |
| 6 Battery compartment | 15 Front axle |
| 7 Engine compartment hood | 16 Bucket |
| 8 Towing device | 17 Tooth guard |
| 9 Ballast weight | |

1.1 Technical data

1.1.1 Complete machine with bucket



The values stated refer to the machine:

- In its standard version
- With 365/70R18 tyres
- Including all lubricants
- With a full tank
- With ROPS/FOPS cab and driver

Tyre sizes and additional attachments affect the operating weight and tipping load.

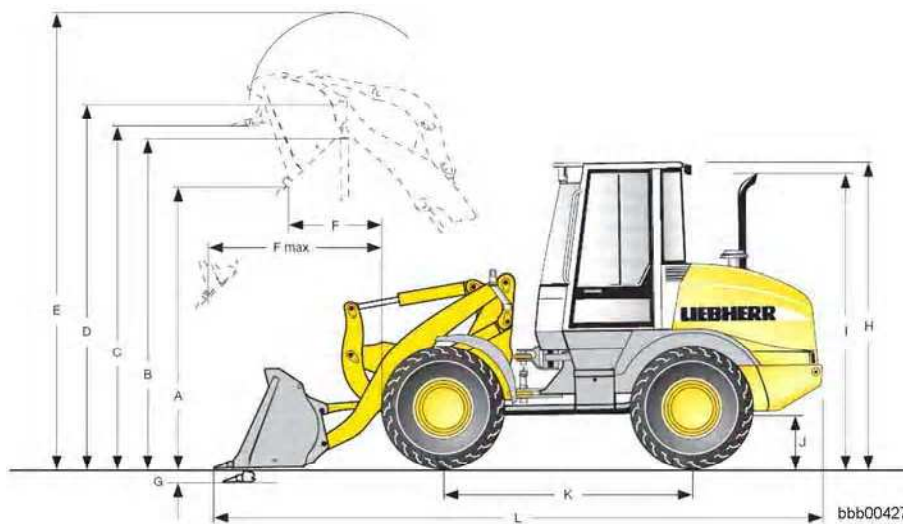

Dimensions

Name	Value	Units
Bucket capacity (ISO 7546) ¹⁾	0.9	m ³
Bucket width	2050	mm
Specific material weight	1.8	t/m ³
A - Dump height at maximum lifting height and 42° tilt-out angle	2550	mm
B - Dump height	2872	mm
C - Maximum bucket base height	3011	mm
D - Maximum bucket pivot point height	3211	mm
E - Maximum bucket top height	4040	mm
F - Reach at maximum lifting height and 42° tilt-out angle	818	mm
F max - Maximum reach at 42° tilt-out angle	1517	mm
G - Digging depth	80	mm

LBH/02/003801/0003/2.06/en

Name	Value	Units
H - Height above the cab	2725	mm
I - Height above exhaust	2600	mm
J - Ground clearance	295	mm
K - Wheel base	2150	mm
L - Overall length	5295	mm
Turning radius over bucket outer edge	3755	mm
Lifting force (SAE)	44	kN
Breakout force (SAE)	48	kN
Tipping load when straight	3836	kg
Articulated tipping load	3501	kg
Operating weight	5240	kg
Tractive force	4603	daN

¹⁾In practice, the bucket capacity can be around 10 % greater than as calculated using the ISO 7546 method. This depends on the type of material.

1.1.2 Engine



bpik0027

Water-cooled Liebherr diesel engine with turbocharger.

The exhaust emissions are below the threshold levels in EU directive 97/68/EC – Stage II.

Name	Value	Units
Diesel engine	D404T-01	
Number of cylinders	4	Pc.
Combustion	Pump-jet	
Rated power according to ISO 9249 at 2800 min ⁻¹	46	kW
Maximum torque at 1680 min ⁻¹	227	Nm
Cylinder capacity	2.44	litres
Idle speed	min.850 ^{±50} max.3040 ⁺⁸⁰	min ⁻¹ min ⁻¹
Longitudinal / traverse inclinability	30	°

1.1.3 Electrical system



bpik0028

Name	Value	Units
Battery voltage	12	V
Battery capacity	100	Ah
Number of batteries	1	Pc.
Operating voltage	12	V
Alternator	12/65	V/ A
Starter	12/2.2	V / kW

Battery fastening

Name	Value	Units
Tightening torque	10	Nm

1.1.4 Travel drive



bpik0029

Continuously variable hydrostatic travel drive

Travel drive controlled by gas pedal and combined inch/brake pedal.

The inch pedal allows you to smoothly adapt the tractive and thrust force to the terrain and conditions.

Forward and reverse travel are selected using the Liebherr control lever

Speed data:

- For forward and reverse travel
- With standard tyres

Name	Value	Units
Travel range 1	0 – 7.0	km/h
Travel range 2	0 – 30.0	km/h

1.1.5 Axles



bpik0030

Front axle

Rigidly mounted planetary axle

Name	Value	Units
Width	1486	mm
Manually activated differential lock	100	%

Rear axle Oscillating planetary axle
Open differential, kingpin steering

Name	Value	Units
Width	1486	mm
Angle of articulation to each side	5	°

1.1.6 Braking



bpik0031

The braking system complies with the roadworthiness certification regulations.

Service brake Two-circuit brake system, drum brake and wet disc brake in the front axle.

Parking brake Negative brake system in the front axle acting on the wet disc brakes.

1.1.7 Steering



bpik0033

“Stereo steering”, central articulation joint with absorbers in combination with kingpin steering on the rear axle.

Name	Value	Units
Angle of articulation to each side	30	°
Angle of articulation of articulated joint to each side	5	°
Maximum operating pressure	180	bar

1.1.8 Working hydraulics



bpik0034

Single lever control with Liebherr control lever, hydraulic pilot control.

Design:

- Gear pump and pressure cut-off

Name	Value	Units
Maximum flow	65	l/min
Maximum operating pressure	230	bar

LBH/02/003801/0003/2.06/en

1.1.9 Working attachment



Lift arm Bearing points – lathed, thick-walled bushings with lubricating grooves

Z kinematics:

- Standard version
- With standard hydraulic quick-change device

Bucket

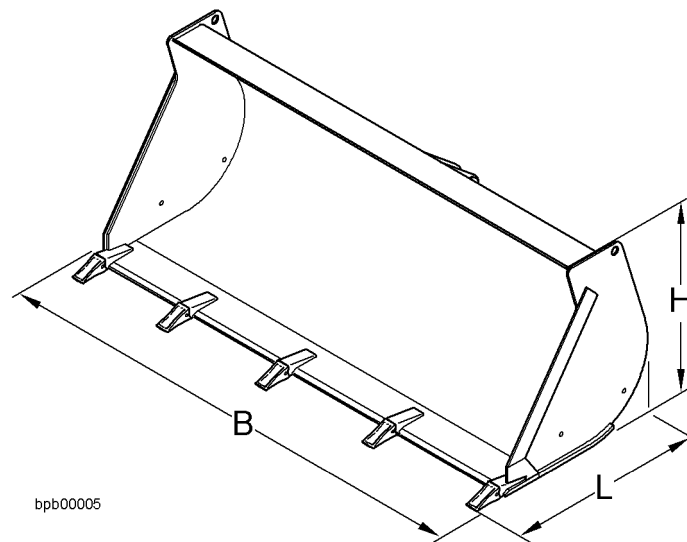

Dimensions

Name	Value	Units
Bucket capacity (ISO 7546)	0.9	m ³
Specific material weight	1.8	t/m ³
B – bucket width	2050	mm
H – height	863	mm
L – length with teeth	910	mm
Weight	321	kg
Teeth – UNI-Z-2000	7	Pc.

LBH/02/003801/0003/2.06/en

1.1.10 Driver's cab



On elastic bearing on rear section, soundproof ROPS/FOPS cab.

Design:

- 2 detachable doors
- The right door is the emergency exit.
- Left door with sliding window
- Tinted windows made of hardened single-glazed safety glass
- ROPS rollover protection in accordance with DIN/ISO 13510/ EN 474-3.
- FOPS stone impact protection in accordance with DIN/ISO 13627/ EN 474-1.

Driver's seat

Alternative versions:

- Driver's seat with mechanical suspension
 - Driver's seat with pneumatic suspension.
- This equipment is optional.

1.1.11 Heating and ventilation

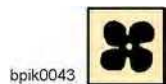

Driver's cab with defroster, fresh air filter, circulated air filter and warm water heating.

Name	Value	Units
Number of blower levels	3	
Heating power	11.3	kW

1.1.12 Sound emission



Sound pressure

Name	Value	Units
ISO 6396 – L _{pA} (in driver's cab)	70	dB (A)

Sound output

You can read the level on the decal on the machine.
See the section on decals on the machine in chapter 2.

LBH/02/003801/0003/2.06/en

1.1.13 Towing device



The towing device is attached to the back of the machine.

Purpose:

- For towing the machine out of a danger area
See the section on emergency operation in chapter 3.
- For lifting the machine by crane
See the section on transporting the machine in chapter 3.

Note



It may not be used for attaching a trailer. The manufacturer/supplier will not be held liable for damage resulting from this.

! See the instructions on proper use and safely towing the machine in chapter 2.

1.1.14 Tyres



The driving performance of the machine depends, among other things, on the tyres.

The same tyre size must be used for all four wheels.

When changing the tyres or if there is increasing wear on the tyres, make sure that the difference in diameter between the tyres on the front and rear axles is no more than 3 %.

Otherwise the axles may be damaged.

The correct tyre pressure is a decisive factor for the proper performance of the machine and for a long tyre lifetime.

You will find the following specifications in the table below:

- Recommended tyre sizes
- Tyre tread
- Tyre pressure

Abbreviations:

- **p – Max.** = maximum permissible air pressure
- **VA** = front axle
- **HA** = rear axle

The air pressure specifications refer to:

- Basic air pressure recommendations - as set when delivered from the factory
- Cold tyres
- Machine ready for operation - basic machine with standard equipment and permissible load



Note

For special uses such as industrial timber handling or other uses where heavier loads may be expected, a higher tyre pressure is recommended, depending on the specific load. However, the tyre pressure may not be greater than the maximum permitted by the tyre manufacturer's specifications.

! Check and adjust the tyre pressure, see the maintenance tasks in chapter 5.

Dunlop tyres Air pressure table for the standard machine

Tyre size	Tyre tread	Air pressure (bar)		
		VA	HA	p – Max.
365/70R18EM ¹⁾	SPT9-TL	3.75	2.50	3.75
405/70R18EM	SPT9-TL	3.00	2.00	3.75
335/80R20EM	SPT9-TL	3.75	2.50	3.75
365/80R20EM	SPT9-TL	3.00	2.00	3.75
405/70R20EM	SPT9-TL	2.75	2.00	3.75

¹⁾Standard tyres

Michelin tyres Air pressure table for the standard machine

Tyre size	Tyre tread	Air pressure (bar)		
		VA	HA	p – Max.
375/75R20EM	XZSL-TL	2.25	1.60	3.80
375/75R20EM	XM27-TL	2.25	1.60	3.80
405/70R20EM	XZSL-TL	2.25	1.60	3.80
405/70R20EM	XM27-TL	2.25	1.60	3.80

Goodyear tyres Air pressure table for the standard machine

Tyre size	Tyre tread	Air pressure (bar)		
		VA	HA	p – Max.
400/70R18EM	IT 520-TL	3.00	2.00	4.00

Bridgestone tyres Air pressure table for the standard machine

Tyre size	Tyre tread	Air pressure (bar)		
		VA	HA	p – Max.
365/80R20EM	VUT-TL	3.30	2.60	3.75
405/70R20EM	VUT-TL	3.20	2.50	3.75

Mitas tyres Air pressure table for the standard machine

Tyre size	Tyre tread	Air pressure (bar)		
		VA	HA	p – Max.
365/80R18	EM-01-TL	4.60	2.80	4.60

LBH/02/003801/0003/2.06/en

Special tyres Air pressure table for machines with special tyres:

Tyre size	Tyre tread	Air pressure (bar)		
		VA	HA	p – Max.
1)				
2)				
2)				

The specifications should be entered in the tables as follows:

- 1) By the manufacturer, if the machine is delivered ex-works with special tyres.
- 2) By the machine operator, if the machine is retrofitted by the machine operator.

Tyres for machines with optional accessories

Table 1 is for the type of optional accessory

Air pressure table 2 is for machines with optional accessories

Specifications	Type of optional accessory
1)	
2)	
2)	

Table 1

Tyre size	Tyre tread	Air pressure (bar)		
		VA	HA	p – Max.
1)				
2)				
2)				

Air pressure table 2

The specifications should be entered in the tables as follows:

- 1) By the manufacturer, if the machine is delivered ex-works with optional accessories.
- 2) By the machine operator, if the machine is retrofitted by the machine operator.

1.1.15 Air-conditioning system



bpik0045

This equipment is optional.

Name	Value	Units
Refrigerant	R134a	
Cooling power	6.4	kW

LBH/02/003801/0003/2.06/en

1.1.16 Snow chains or guard chains



This equipment is optional.

When snow chains or guard chains are used, they must be attached to all four wheels.



Note

Failure to do this can damage the drive system.
 ! See the section on attachments and accessories in chapter 2.

1.1.17 Soot particle filter

This equipment is optional.

Name	Value	Units
Filter medium	Ceramic block made from cordierite with catalytic coating	
Maximum exhaust gas counterpressure	0.2	bar

1.1.18 Light material bucket with undercut blade

This equipment is optional.

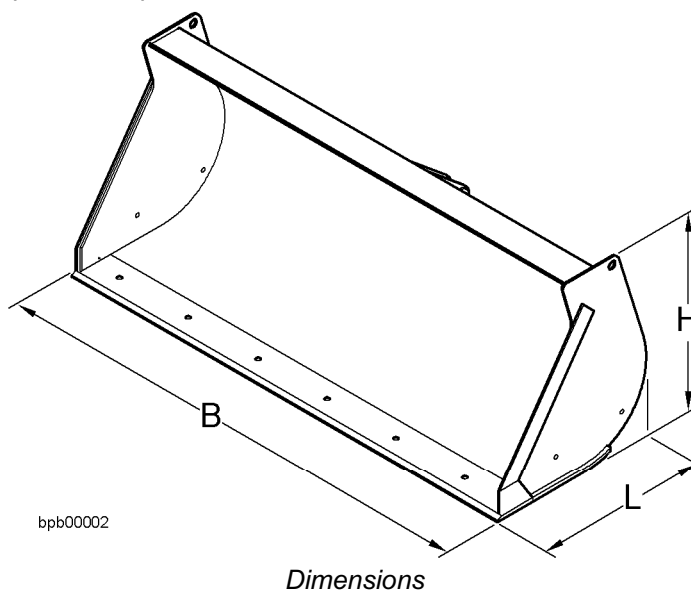

	Description	Unit	Value	
	Bucket capacity as per ISO 7546	m ³	1.2	1.6
	Specific material weight	t/m ³	1.4	1.0
B	Bucket width	mm	2330	2400
H	Height	mm	915	1065
L	Length	mm	1062	993
	Weight	kg	420	498

LBH/02/003801/0003/2.06/en

Complete machine with light material bucket

The values stated refer to the machine:

- With 365/70R18 tyres
- Including all lubricants
- With a full tank
- With ROPS/FOPS cab and driver

Tyre sizes and additional attachments affect the operating weight and tipping load.

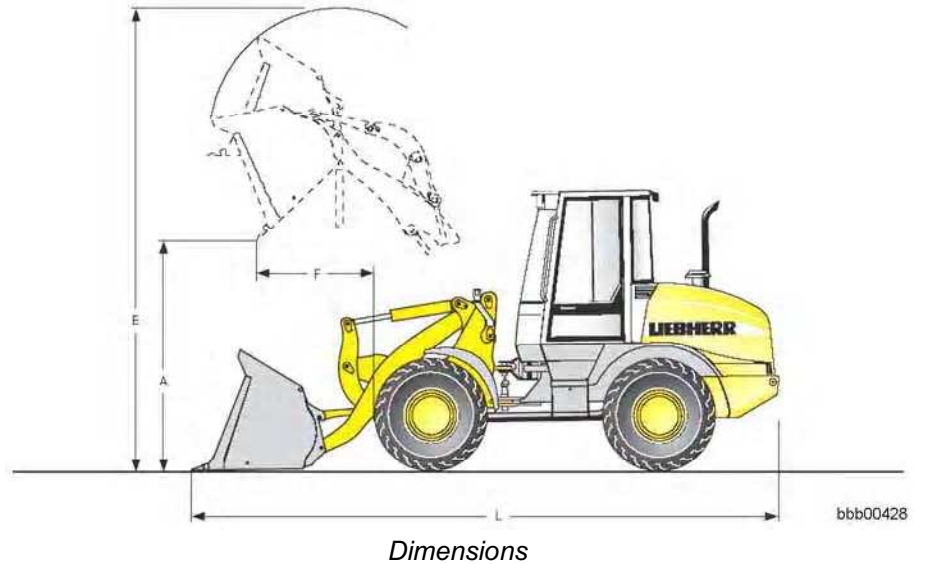

	Description	Unit	Value	
	Bucket capacity as per ISO 7546	m ³	1.2	1.6
	Bucket width	mm	2330	2400
	Specific material weight	t/m ³	1.4	1.0
A	Dump height at maximum lifting height	mm	2511	2420
E	Maximum height above bucket top	mm	4123	4196
F	Reach at maximum lifting height	mm	866	890
L	Overall length	mm	5355	5410
	Tipping load when straight	kg	3818	3702
	Articulated tipping load	kg	3485	3379
	Operating weight	kg	5341	5417

LBH/02/003801/0003/2.06/en

1.1.19 4 in 1 bucket



This equipment is optional.

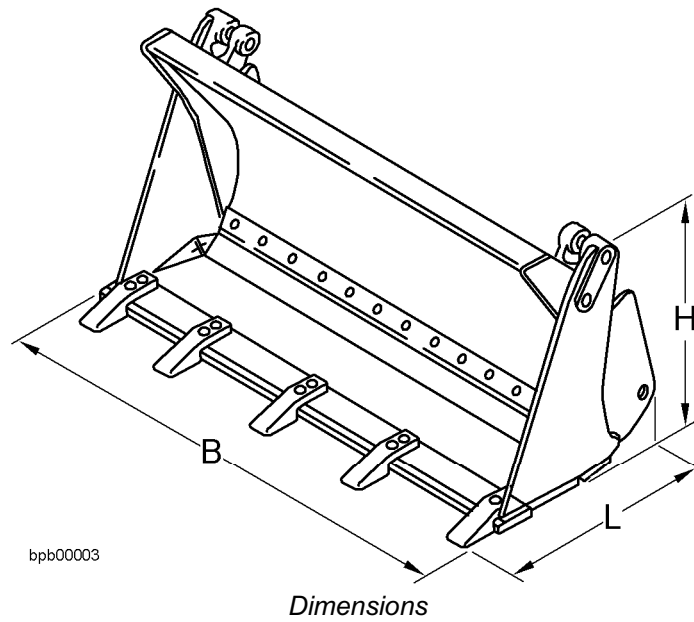

Name	Value	Units
Bucket capacity (ISO 7546)	0.8	m ³
Specific material weight	1.8	t/m ³
B – bucket width	2100	mm
H – height	918	mm
L – length with teeth	1011	mm
Weight	581	kg
Teeth – UNI-Z-2000	7	Pc.
Maximum hydraulic operating pressure	250	bar

LBH/02/003801/0003/2.06/en

Complete machine with 4-in-1 bucket

The values stated refer to the machine:

- With 365/70R18 tyres
- Including all lubricants
- With a full tank
- With ROPS/FOPS cab and driver

Tyre sizes and additional attachments affect the operating weight and tipping load.

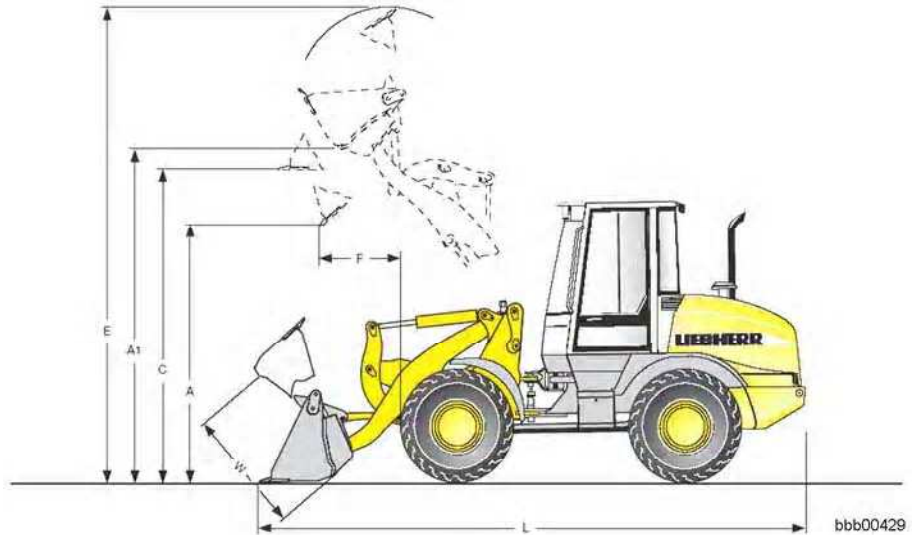

Dimensions

Name	Value	Units
A - Dump height at maximum lifting height and 42° tilt-out angle	2532	mm
A1 - Maximum dump height with bucket flap open	3203	mm
C - Maximum bucket base height	2946	mm
E - Maximum bucket top height	4714	mm
F - Reach at maximum lifting height and 42° tilt-out angle	890	mm
L - Overall length	5390	mm
W - Flap opening	1008	mm
Turning radius over bucket outer edge	3907	mm
Tipping load when straight	3427	kg
Articulated tipping load	3128	kg
Operating weight	5499	kg

LBH/02/003801/0003/2.06/en

1.1.20 Forklift

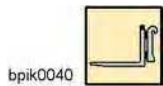

This equipment is optional.

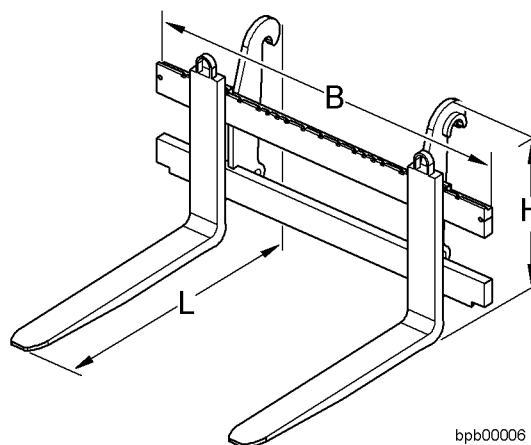

Dimensions

bpb00006

Name	Value	Units
Fork carrier prong size	FEM II	
Prong length	1200	mm
L – Length (fork carrier + prongs)	1585	mm
B – Fork carrier width	1245	mm
H – Height (fork carrier + prongs)	860	mm
Weight (fork carrier + prongs)	255	kg

LBH/02/003801/0003/2.06/en

Complete machine with forks

The values stated refer to the machine:

- With 365/70R18 tyres
- With FEM II forks
- Including all lubricants
- With a full tank
- With ROPS/FOPS cab and driver
- In accordance with EN 474-3 and ISO 8313.

Tyre sizes and additional attachments affect the operating weight and tipping load.

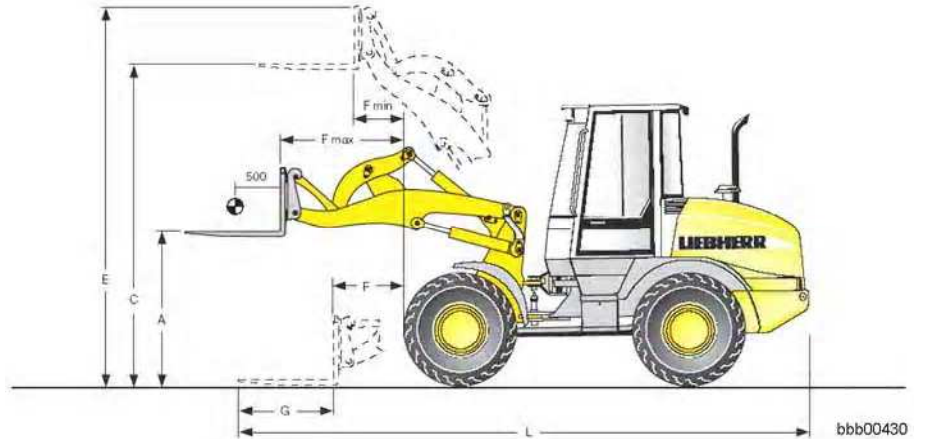

Dimensions

Name	Value	Units
A - Lifting height at maximum reach	1452	mm
C - Maximum lifting height	3039	mm
E - Maximum height above fork carrier	3714	mm
F - Reach in loading position	741	mm
F max - Maximum reach	1258	mm
F min - Reach at maximum lifting height	550	mm
G - Fork prong length	1200	mm
L - Overall length of basic machine	5805	mm
Tipping load when straight	2905	kg
Articulated tipping load	2652	kg
Maximum payload on uneven terrain = 60 % of the static tipping load articulated	1591	kg
Maximum payload on even terrain = 80 % of the static tipping load articulated	2121	kg
Operating weight	5170	kg

LBH/02/003801/0003/2.06/en

Load bearing tables for forklift operation

The loads (rated payloads) are calculated according to the EN 474-3 safety norm.

The permissible load is stated as a percentage of the tipping load as per ISO 8313 with the fork prongs in the horizontal position.

The following values may not be exceeded:

- On even and firm terrain – 80% of the tipping load with forklift
- On uneven terrain – 60% of the tipping load with forklift

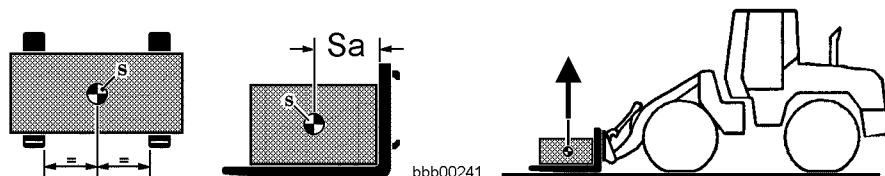

The following tables specify the permitted loads on various types of terrain and at various distances to the centre of gravity **Sa**.

All calculated values refer to the original LIEBHERR equipment (fork carrier and prongs).

Lift arms with Z kinematics								
Even and firm terrain Load = 80% of the tipping load	Loads in kg with different distances to the centre of gravity - Sa in mm							
Tyres	500	600	700	800	900	1000	1100	1200
365/70R18EM Dunlop SPT9-TL ²⁾	2121	1950 ¹⁾	1730 ¹⁾	1550 ¹⁾	1410 ¹⁾	1290 ¹⁾	1190 ¹⁾	1110 ¹⁾
365/80R20EM Dunlop SPT9-TL	2149	1950 ¹⁾	1730 ¹⁾	1550 ¹⁾	1410 ¹⁾	1290 ¹⁾	1190 ¹⁾	1110 ¹⁾
405/70R18EM Dunlop SPT9-TL	2138	1950 ¹⁾	1730 ¹⁾	1550 ¹⁾	1410 ¹⁾	1290 ¹⁾	1190 ¹⁾	1110 ¹⁾
405/70R20EM Dunlop SPT9-TL	2157	1950 ¹⁾	1730 ¹⁾	1550 ¹⁾	1410 ¹⁾	1290 ¹⁾	1190 ¹⁾	1110 ¹⁾
335/80R18EM Dunlop SPT9-TL	2118	1950 ¹⁾	1730 ¹⁾	1550 ¹⁾	1410 ¹⁾	1290 ¹⁾	1190 ¹⁾	1110 ¹⁾
335/80R20EM Dunlop SPT9-TL	2127	1950 ¹⁾	1730 ¹⁾	1550 ¹⁾	1410 ¹⁾	1290 ¹⁾	1190 ¹⁾	1110 ¹⁾
405/70R20EM Dunlop PG 75R-TL	2234	1950 ¹⁾	1730 ¹⁾	1550 ¹⁾	1410 ¹⁾	1290 ¹⁾	1190 ¹⁾	1110 ¹⁾
375/75R20EM Michelin XZSL-TL	2162	1950 ¹⁾	1730 ¹⁾	1550 ¹⁾	1410 ¹⁾	1290 ¹⁾	1190 ¹⁾	1110 ¹⁾
375/75R20EM Michelin XM27-TL	2139	1950 ¹⁾	1730 ¹⁾	1550 ¹⁾	1410 ¹⁾	1290 ¹⁾	1190 ¹⁾	1110 ¹⁾
405/70R20EM Michelin XZSL-TL	2177	1950 ¹⁾	1730 ¹⁾	1550 ¹⁾	1410 ¹⁾	1290 ¹⁾	1190 ¹⁾	1110 ¹⁾
335/80R18EM Michelin XZSL-TL	2138	1950 ¹⁾	1730 ¹⁾	1550 ¹⁾	1410 ¹⁾	1290 ¹⁾	1190 ¹⁾	1110 ¹⁾
335/80R20EM Michelin XM27-TL	2127	1950 ¹⁾	1730 ¹⁾	1550 ¹⁾	1410 ¹⁾	1290 ¹⁾	1190 ¹⁾	1110 ¹⁾
400/70R18EM Good Year IT 530-TL	2148	1950 ¹⁾	1730 ¹⁾	1550 ¹⁾	1410 ¹⁾	1290 ¹⁾	1190 ¹⁾	1110 ¹⁾
400/70R18EM Good Year IT 520-TL	2143	1950 ¹⁾	1730 ¹⁾	1550 ¹⁾	1410 ¹⁾	1290 ¹⁾	1190 ¹⁾	1110 ¹⁾
335/80R20EM Bridgestone VUT-TL	2133	1950 ¹⁾	1730 ¹⁾	1550 ¹⁾	1410 ¹⁾	1290 ¹⁾	1190 ¹⁾	1110 ¹⁾
365/80R20EM Bridgestone VUT-TL	2150	1950 ¹⁾	1730 ¹⁾	1550 ¹⁾	1410 ¹⁾	1290 ¹⁾	1190 ¹⁾	1110 ¹⁾
405/70R20EM Bridgestone VUT-TL	2168	1950 ¹⁾	1730 ¹⁾	1550 ¹⁾	1410 ¹⁾	1290 ¹⁾	1190 ¹⁾	1110 ¹⁾
365/70R18 Mitas EM-01-TL	2125	1950 ¹⁾	1730 ¹⁾	1550 ¹⁾	1410 ¹⁾	1290 ¹⁾	1190 ¹⁾	1110 ¹⁾

Payload with FEM II fork carrier and prongs (standard version) limited to 2500 kg.

¹⁾Hydraulics restricted by tilt cylinders of Z-kinematics.

²⁾Standard tyres

Lift arms with Z kinematics								
Uneven terrain Load = 60% of the tipping load	Loads in kg with different distances to the centre of gravity - Sa in mm							
	Tyres	500	600	700	800	900	1000	1100
365/70R18EM Dunlop SPT9-TL ²⁾	1591	1523	1461	1403	1350	1290 ¹⁾	1190 ¹⁾	1110 ¹⁾
365/80R20EM Dunlop SPT9-TL	1612	1543	1480	1422	1368	1290 ¹⁾	1190 ¹⁾	1110 ¹⁾
405/70R18EM Dunlop SPT9-TL	1604	1535	1472	1415	1361	1290 ¹⁾	1190 ¹⁾	1110 ¹⁾
405/70R20EM Dunlop SPT9-TL	1618	1549	1485	1427	1373	1290 ¹⁾	1190 ¹⁾	1110 ¹⁾
335/80R18EM Dunlop SPT9-TL	1589	1521	1459	1401	1348	1290 ¹⁾	1190 ¹⁾	1110 ¹⁾
335/80R20EM Dunlop SPT9-TL	1595	1527	1465	1407	1354	1290 ¹⁾	1190 ¹⁾	1110 ¹⁾
405/70R20EM Dunlop PG 75R-TL	1676	1604	1539	1478	1410 ¹⁾	1290 ¹⁾	1190 ¹⁾	1110 ¹⁾
375/75R20EM Michelin XZSL-TL	1622	1553	1489	1431	1376	1290 ¹⁾	1190 ¹⁾	1110 ¹⁾
375/75R20EM Michelin XM27-TL	1604	1536	1473	1415	1362	1290 ¹⁾	1190 ¹⁾	1110 ¹⁾
405/70R20EM Michelin XZSL-TL	1633	1563	1499	1440	1386	1290 ¹⁾	1190 ¹⁾	1110 ¹⁾
335/80R18EM Michelin XZSL-TL	1604	1536	1473	1415	1361	1290 ¹⁾	1190 ¹⁾	1110 ¹⁾
335/80R20EM Michelin XM27-TL	1595	1527	1465	1407	1354	1290 ¹⁾	1190 ¹⁾	1110 ¹⁾
400/70R18EM Good Year IT 530-TL	1611	1543	1479	1421	1368	1290 ¹⁾	1190 ¹⁾	1110 ¹⁾
400/70R18EM Good Year IT 520-TL	1608	1539	1476	1418	1365	1290 ¹⁾	1190 ¹⁾	1110 ¹⁾
335/80R20EM Bridgestone VUT-TL	1600	1532	1469	1411	1358	1290 ¹⁾	1190 ¹⁾	1110 ¹⁾
365/80R20EM Bridgestone VUT-TL	1613	1544	1481	1423	1369	1290 ¹⁾	1190 ¹⁾	1110 ¹⁾
405/70R20EM Bridgestone VUT-TL	1626	1557	1493	1434	1380	1290 ¹⁾	1190 ¹⁾	1110 ¹⁾
365/70R18 Mitas EM-01-TL	1594	1526	1463	1406	1353	1290 ¹⁾	1190 ¹⁾	1110 ¹⁾

¹⁾Hydraulics restricted by tilt cylinders of Z-kinematics.

²⁾Standard tyres

2 Safety regulations

Working on the machine poses safety risks to the operator, driver or maintenance engineers. You can prevent risks and accidents by regularly reading and observing the various safety instructions.

This is especially important for personnel who only occasionally work on the machine, for example, carrying out rigging or maintenance work.

The safety regulations listed below, if conscientiously followed, will ensure your own safety and that of others, and will prevent the machine from being damaged.

Whenever tasks which could cause danger to personnel or damage to the machine are described, the necessary safety precautions are explained in this manual.

These are indicated by the headings **Danger**, **Warning** or **Caution**.

2.1 Introduction

1. The symbols below have the following meanings:



Danger

Warning that without appropriate precautions, certain operational procedures could result in fatal accidents.



Warning

Warning that without appropriate precautions, certain operational procedures could result in severe physical injuries.



Caution

Warning that without appropriate precautions, certain operational procedures could result in minor physical injuries or damage to the machine.

2. **Observance of these instructions does not exempt you from following any additional rules and guidelines that may apply**

The following should also be observed:

- The safety rules in force at the operating site
- Legally enforceable road traffic regulations
- Guidelines issued by trade associations

2.2 General safety regulations

1. Familiarise yourself with the **operating manual** before starting up the machine.

Make sure that you are in possession of and have read and understood additional instructions applicable to any special equipment installed on your machine.

2. Only expressly authorised personnel may operate, service or repair the machine.

Observe the legal minimum ages.

3. Only trained or instructed personnel may operate the machine. Clearly assign responsibility for operation, rigging, maintenance and repair work.

4. Clearly establish the driver's responsibilities (also with respect to traffic regulations) and authorise him to refuse to carry out unsafe instructions from third parties.
5. Personnel undergoing training, instruction or who are not yet fully qualified may only be allowed to work on the machine under constant supervision by an experienced person.
6. Now and again check that your personnel are working safely and are aware of possible dangers in observance of the **operating manual**.
7. Wear safe working clothes when working on the machine.
Do not wear rings, wristwatches, ties, scarves, unbuttoned jackets, loose clothing or similar garments, as they can become caught in the machinery and cause injury.
Certain tasks require safety goggles, safety boots, hard hats, gloves, reflective vests, ear protection etc.
8. Ask the site manager about any special safety regulations in force on the site.
9. Do not hold onto the steering column, the control panel or the control levers when getting on or off the machine.
You might inadvertently trigger movements which could lead to accidents.
10. Never jump down from the machine. Use the steps, ladders and platforms provided for getting on and off.
11. Familiarise yourself with the emergency exit through the right cab door and/or the rear window.
12. Unless there are other instructions, perform maintenance and repair work as follows:
Procedure:
 - Park the machine on firm, level ground and lower the working attachment to the ground.
 - Move all control levers to neutral.
 - Shut down the engine and take out the ignition key.
13. Before starting any work on the hydraulic circuit, you must also press the working hydraulics lockout button and actuate all pilot control units (joystick and pedals) in both directions in order to reduce the control pressure and accumulated pressure in the operating circuits. You must then reduce the internal tank pressure.
14. Lock the working hydraulics to prevent accidental actuation before leaving the driver's cab.
Lock the working hydraulics in accordance with the instructions in the **operating manual**.
15. Secure all loose parts of the machine.
16. Never start up a machine without first making a thorough tour of inspection and checking if any warning signs are missing or illegible.
17. Observe all signs with warnings or safety instructions.
18. Special safety apparatus must be fitted to the machine for certain applications. If this is the case, only work with this apparatus fitted and in working order.
19. Do not make any modifications, extensions or conversions to the machine with possible safety implications without the approval of the supplier. This also applies to installing and adjusting safety apparatus and valves, as well as to welding load-bearing components.

2.3 Proper use

1. When fitted with the standard bucket, forklift or grabber equipment, the wheel loader is solely to be used for loosening, picking up, transferring, loading and dumping earth, stone, rock fragments or other materials and loading it onto trucks, ships, conveyor belts or crushers.
2. Any other use, such as breaking rock, hammering in posts, transporting people or towing is deemed improper.
The manufacturer/supplier will not be held liable for damage resulting from this.
The operator bears sole liability.
3. Vehicles used for lifting purposes are subject to special conditions and must also be equipped with the prescribed safety equipment.
4. Proper use also includes observance of the **operating manual** and adherence to the inspection and maintenance conditions.

2.4 Decals on the machine

1. There are several types of decal attached to the machine.

Decal types:

- Safety decals
- Information decals
- Type plates

The order numbers can be found in the spare parts list.

2.4.1 Location of decals

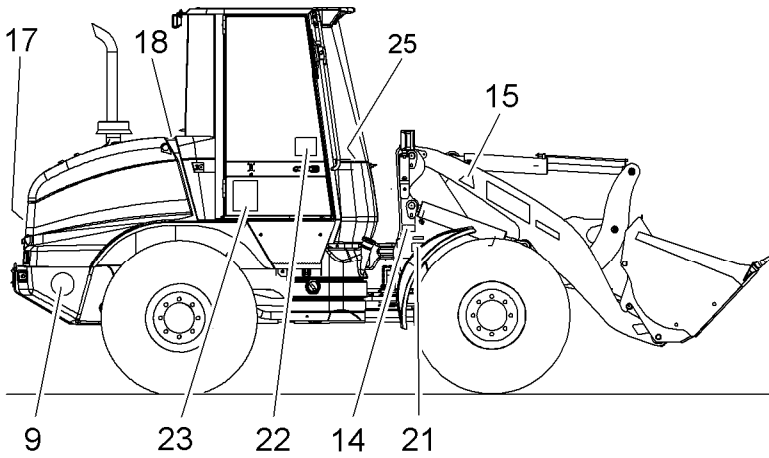
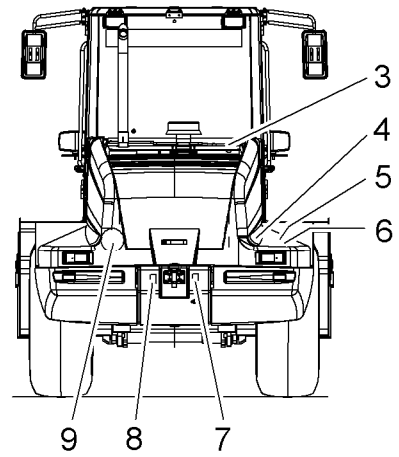
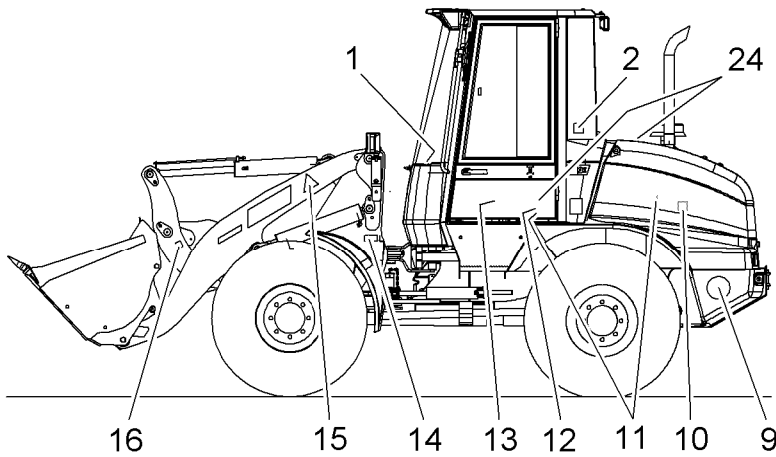

bsich001

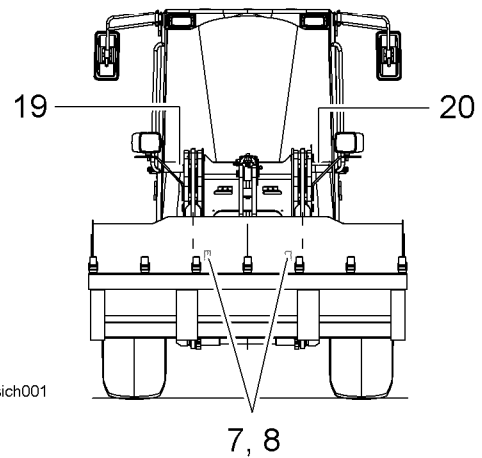

Location of decals

- | | | |
|--|--|------------------------------------|
| 1 Steering decal | 11 Accident prevention decal | 19 Working hydraulics decal |
| 2 Noise output decal – L _{WA} | 12 Wheel lugs decal | 20 Parking brake open/closed decal |
| 3 Cooler decal | 13 ROPS decal | 21 Machine type plate |
| 4 Voltage decal | 14 Articulation area warning decal | 22 Bearing load table decal |
| 5 System voltage decal | 15 Keep clear decal | 23 Lubrication chart |
| 6 Tightening torque decal | 16 Hydraulic quick-change device open/closed decal | 24 Bio oil decal |
| 7 Lashing point decal | 17 Engine standstill decal | 25 Pipe break decal |
| 8 Slinging and lifting point decal | 18 Brake fluid decal | |
| 9 Speed decal | | |
| 10 Windscreen water decal | | |

2.4.2 Safety decals

The section on the location of decals describes where they are attached. Failure to obey the safety decals can lead to severe or even fatal injuries. The safety decals should be continuously checked for completeness and legibility.

Replace any missing or illegible safety decals immediately.

LBH/02/003801/0003/2.06/en

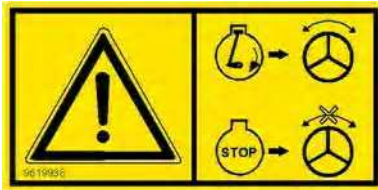

03sc05ab

Steering decal

Warns of the risk of accidents, possibly resulting in severe or even fatal injuries.

Meaning: **The steering is only operational when the engine is running**



03sc03ab

Accident prevention decal

Refers to instructions in the operating manual for preventing accidents.

Meaning: **Strictly observe the accident prevention instructions in the operating manual when operating the machine**



bsich007

Articulation area decal

Warns of the risk of accidents, possibly resulting in severe or even fatal injuries.

Meaning: **Keep out of the articulation area when it is not locked**



03sc01ab

Keep clear decal

Warns of the risk of accidents, possibly resulting in severe or even fatal injuries.

Meaning: **Keep out of the danger area**



03sc04ab

Engine standstill decal

Warns of the risk of accidents, possibly resulting in severe injuries.

Meaning: **Only open when the engine is shut down**



bsich009

Pipe break decal

Valid for:

- L507- 787 from 0101
- L509-789 from 0101

This equipment is optional.

Warns of the risk of accidents, possibly resulting in severe or even fatal injuries.

Meaning: **The pipe break function is deactivated when ride control is selected.**

LBH/02/003801/0003/2.06/en

2.4.3 Information decals

The section on the location of decals describes where they are attached. The information decals indicate information on operating, servicing and properties of the machine.

Noise output decal – L_{WA}

States the noise output level (L_{WA}) of the machine in decibels. You can read the level on the decal on the machine.

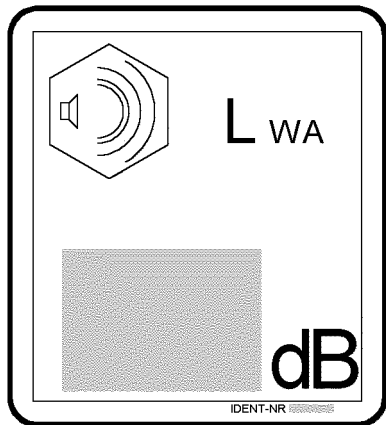

03sc24ab

Cooler decal

Refers to cleaning the cooling system.

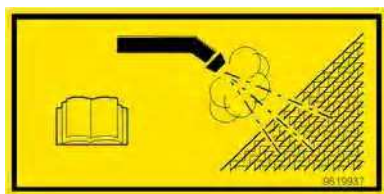

03sc07ab

Voltage decal

Refers to the battery main switch.

Meaning: **The electrical system is energised when the battery main switch is turned on.**



bsich005

System voltage decal

This equipment is optional.

Refers to the system voltage of the electrical system.



b4670007

Tightening torque decal

Refers to tightening torque of the battery fastening.

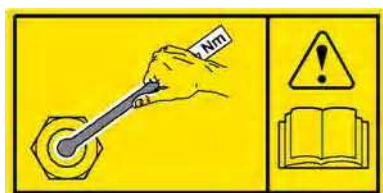

bsch0005

Lashing point decal

Refers to the lashing points on the machine.



03sc16ab

Slinging and lifting point decal

Refers to the slinging and lifting points on the machine.



03sc17ab

Speed decal

Refers to the permitted speed limit for the machine.

You can find the applicable data for the machine:

- In the technical data section in chapter 1.
- On the machine, see the section on the location of decals.

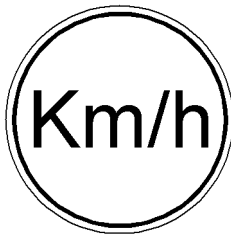

bsich008

Windscreen water decal

Indicates the reservoir for the windscreen washer fluid.



03sc13ab

LBH/02/003801/0003/2.06/en

Decals on the machine

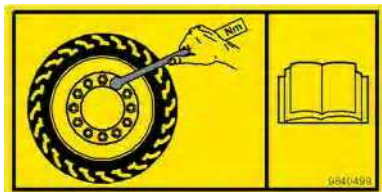

bsch0001

Wheel lugs decal

Refers to the service interval for checking the tightness of the wheel lugs specified in the operating manual.

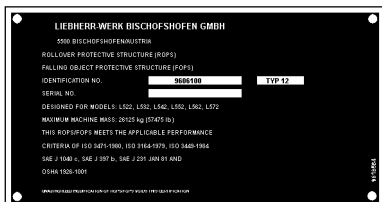

035c09ab

ROPS decal

States the maximum load of the roll-over protection system.

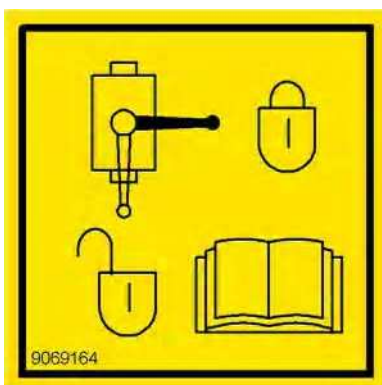

bsich004

Hydraulic quick-change device open/closed decal

Indicates the directions for opening and closing the changeover valve of the hydraulic quick-change device.

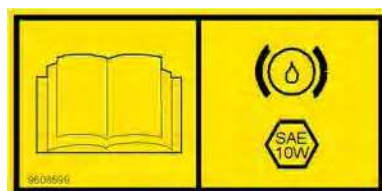

b4270076

Brake fluid decal

Refers to the brake fluid specifications. Only use SAE 10W mineral hydraulic oil.

Working hydraulics decal

Indicates the directions in which the LH control lever can be moved.

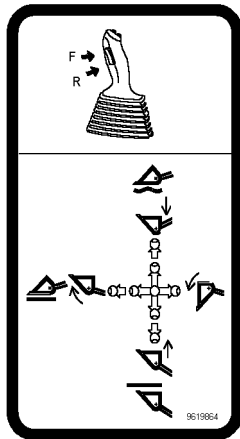

03sc06at

Parking brake open/closed decal

Indicates the directions for opening and closing the parking brake.

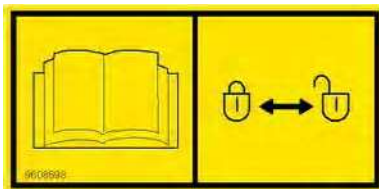

b4270056

Bearing load table decal

Indicates the maximum permissible load in forklift operation.

The loads stated on the decal refer to machines with standard tyres.

XXXX	XXXX	XXXX	XXXX	XXXX
xxxxkg	xxxxkg	xxxxkg	*xxxxkg	*xxxxkg
xxxxkg	xxxxkg	xxxxkg	xxxxkg	xxxxkg
* FEM II: max. xxxkg				
ISO 8313		ID.:XXXXXXXX		

bsich006

Lubrication chart decal

Indicates the maintenance points and intervals in relation to lubricants and consumables for the machine.

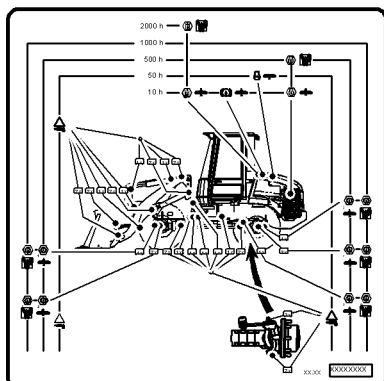

bsich002

LBH/02/003801/0003/2.06/en

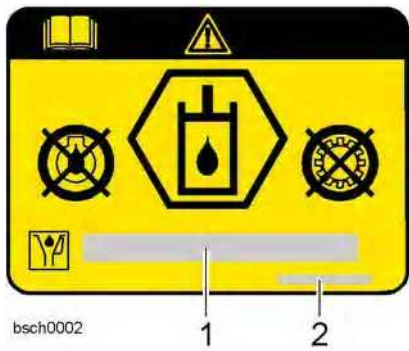

Bio oil decal

This equipment is optional.

- 1 Bio oil type
- 2 ID number

Indicates that the hydraulic system is filled with bio oil.

States that bio oil cannot be used for lubricating the engine and gearbox.

The field 1 contains the exact designation of the bio oil in the hydraulic system.

2.4.4 Type plates

The section on the location of decals describes where they are attached. The machine and all its components, such as the engine, gearbox and axles, have type plates affixed to them.

Machine type plate

Information on the type plate:

- Type
- Vehicle ID No.
- Maximum total weight
- Year of construction
- Maximum front axle load
- Maximum rear axle load
- Engine power
- Maximum speed
- Homolog. no. ¹⁾
- Maximum trailer weight ¹⁾

¹⁾ Italian version only

The total weight and axle loads stated refer to operation of the machine on roads.

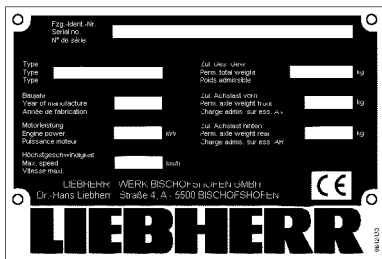

typ00001

Type plate

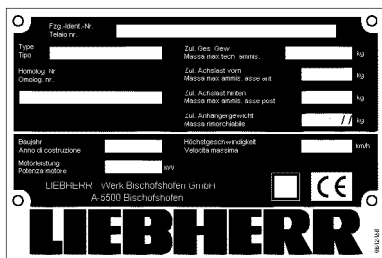

typit001

Italian version of machine type plate

2.5 Instructions on preventing crushing injuries and burns

1. Do not work under the attachment if it is not resting on the ground or supported.

2. Do not use any ropes or chains which are damaged or which have insufficient load bearing capacity.
Wear protective gloves when handling wire ropes.
3. When working with the attachment, never align the boreholes with your fingers, instead, use a suitable mandrel for this purpose.
4. Make sure no objects come into contact with the fan when the engine is running.
Objects which fall or project into the fan will be thrown back out or destroyed and could damage the fan.
5. When the machine is near operating temperature, the engine cooler system is hot and pressurised.
Do not touch parts carrying cooling water.
This can lead to burns.
6. Only check the coolant level once the cap on the expansion tank has cooled down enough to touch.
Carefully open the cap to let out excess pressure.
7. When running at or near the operating temperature, the engine oil and hydraulic oil are hot.
Avoid touching hot oil or parts which carry oil.
8. Wear goggles and safety gloves when working on the battery.
Avoid sparks and naked lights.
9. Never let anyone move the bucket or other working attachments into position by hand.
10. Any time you open the engine compartment, prevent the compartment doors from falling shut using the struts provided.
11. Before starting up the machine, close and lock the engine compartment doors and the battery compartment cover.
12. Never lie under the machine when it is raised using the working attachment, unless the undercarriage is securely supported using wooden beams.

2.6 Instructions on preventing fires and explosions

1. When refuelling, the engine must be turned off. Switch off the auxiliary heater, if installed.
2. Do not smoke. Avoid naked flames when refuelling or where batteries are being recharged.
3. Always follow the instructions in the **operating manual** when starting the engine.
4. Check the electrical system.
Immediately eliminate all faults such as loose connections, worn cables or burnt out fuses and bulbs.
5. Do not carry combustible fluids on the machine outside the tanks provided.
6. Regularly check all lines, hoses and bolted connections for leaks and damage.
7. Repair the leaks immediately and replace the damaged components.
Oil escaping from leaks can easily cause fires.
8. Make sure that all brackets and protective plates are properly installed to prevent vibrations, abrasion and heat build-up.
9. Starting agent (ether) is a particularly dangerous fire hazard.
Never use ether starting agent near head sources, naked lights (such as cigarettes) or in poorly ventilated spaces.

10. Do not use starting agents containing ethers to start diesel engines with preglow or flame glow systems.
Otherwise there is a risk of **explosions**.
11. Familiarise yourself with the location and use of fire extinguishers and find out about fire alarm and firefighting facilities on site.

2.7 Safety instructions for start-up

1. Each time you start up the machine, make a thorough tour of inspection.
2. Check the machine for loose bolts, cracks, wear, leaks and deliberate damage.
3. Never start up a damaged machine.
4. Make sure the damage is rectified immediately.
5. Ensure that all hoods and covers are closed and locked. Check that all the warning and instruction decals are in place.
6. Clean the windows and interior and exterior mirrors, and secure the doors and windows against inadvertent movement.
7. Make sure no-one is working on or underneath the machine. Warn any bystanders before you start up the machine.
8. After getting into the driver's cab, adjust the seat, the inside and outside mirrors, the control lever and the seat belt so that you can work comfortably.
9. Sound insulation equipment on the machine must be in place during operation.

2.8 Safety precautions during start-up

1. Before starting, check that all control lamps and instruments are working properly.
Move all control levers to neutral.
2. Before starting the engine, briefly sound the horn to warn anyone else in the vicinity of the machine.
3. Only start the machine when sitting in the driver's seat.
4. Unless otherwise instructed, start the engine in accordance with the instructions in the **operating manual**.
5. Start the engine and then check all display and monitoring equipment.
6. Only run the engine in enclosed spaces when there is sufficient ventilation. If necessary, open the windows and doors to ensure adequate fresh air.
7. Run the engine until both it and the hydraulic oil are at operating temperature. Low oil temperatures lead to sluggish performance.
8. Check that the attachment controls are working properly.
9. Carefully drive the machine to open ground and check the service brake, the steering, the signals and lighting.

2.9 Instructions for safe working

1. Before starting work, familiarise yourself with the features of the site, as well as any special regulations and warning signals.
The working environment includes obstacles in the working area and on access roads, the firmness of the terrain and any protective barriers to prevent the public from entering the site.
 2. Always keep a safe distance from overhangs, drops, slopes and unsafe terrain.
 3. Be especially careful with variable terrain conditions, poor visibility and changeable weather.
 4. Find out where the supply pipes to the site are, and be especially careful when working near them. If necessary, notify the relevant authorities.
 5. Keep a safe distance away from overhead power lines.
When working near overhead power lines, keep the attachment well away from them.
 - There is a risk of **fatal injury**.
 - Find out about the safety clearances to be observed.
- If the machine comes into contact with live power lines:**
- Do not get out of the machine.
 - If possible, move the machine to a safe distance away from the danger area.
 - Warn any bystanders not to approach or touch the machine.
 - Arrange for the power to be switched off.
 - Only get out of the machine when you are sure that the power line you have touched or damaged has been switched off.
6. Before driving or working with the machine, check that the accessories are safely stowed away.
 7. When driving on public roads, paths and spaces, observe the traffic regulations, and make sure the machine is in a fit condition to use public roads if this is not already the case.
 8. Always switch on the lights in darkness and poor visibility.
 9. Do not take passengers on the machine.
 10. Only work seated and wearing a safety belt.
 11. Report any malfunctions and make sure that any necessary repairs are carried out immediately.
 12. Take personal care to ensure that no-one is endangered when the machine starts moving.
 13. Before starting work, check the brake system as instructed in the **operating manual**.
 14. Never get out of the driver's seat when the machine is still in motion.
 15. Never leave the machine unattended with the engine running.
 16. When driving the machine, lower the working attachment to the transport position and carry the load as close as possible to the ground.
 17. Avoid movements which could cause the machine to tip over.
If the machine does start to tip over or slide sideways, put down the attachment immediately and point the machine downhill.
Wherever possible, work up or downhill and not sideways to the slope.
 18. Drive carefully on rocky or slippery terrain and on slopes.
 19. Only drive downhill within the permitted speed limit, otherwise you could lose control of the machine.

The engine must be running at the rated speed and you should only reduce the travel speed using the pedals.

Shift down to a lower gear before reaching the slope. Do not wait until you are actually on it.

20. When loading a truck, insist on the driver getting out of his cab, even if it is protected against stone impact.
21. When performing work such as demolition work, clearance and crane operation, always use the protective equipment provided for these specific tasks.
22. Have someone direct you when vision is restricted and whenever else it is necessary.
Only let one person give you signals.
23. Only allow experienced personnel to sling loads and direct crane drivers.
The person giving directions must remain in sight of the operator or at least be in spoken contact with him.

2.10 Safety instructions for driving on slopes

1. On downward slopes, always drive carefully and never at top speed, as you could otherwise lose control over the machine.

Travel speeds:

- Never exceed the speed limits specified in the **operating manual**.
 - Exceeding the maximum speed causes the permitted limits to be exceeded for all rotating parts, including the drive motor, the drive shaft, all gears including axles and ultimately the diesel engine itself.
2. Before driving onto a slope, therefore select a travel range (gear) in which you can safely negotiate the whole slope without endangering yourself, the machine and other people.
 3. Also, take your foot off the gas pedal when driving onto a slope.

2.11 Parking safely

1. When possible, always park the machine on flat, firm ground.
If you have to park on a slope, use wheel wedges to prevent the machine from moving.
2. If the machine has articulated steering, engage the articulation lock.
This only applies to wheel loaders with articulated steering.
3. Lower the digging attachment so that it is lightly anchored in the ground.
4. Move all control levers to the neutral position and engage the parking brake.
5. Shut down the engine in accordance with the instructions in the **operating manual**.
6. Lock the working hydraulics before leaving the driver's cab.
Lock the working hydraulics in accordance with the instructions in the **operating manual**.
7. Lock up the machine, take out all keys and secure it against unauthorised use and vandalism.

2.12 Transporting the machine safely

1. Only use suitable transport equipment and lifting gear with sufficient load capacity.
2. Park the machine on flat ground and use wedges to secure the tracks or wheels.
3. If necessary, dismantle the working attachment for the duration of transport.
4. The ramp for driving onto the low-bed truck should not be more than 30° steep, and should be covered with wooden boards to prevent slipping.
5. Clean the machine tracks or wheels of snow, ice and mud before driving onto the ramp.
6. Before driving on, secure the upper carriage to the undercarriage with the locking pin.
Procedure: does not apply to wheel loaders.
7. Align the machine precisely with the loading ramp.
8. Attach the hand lever to the pedals for sensitive driving.
Procedure: does not apply to wheel loaders.
9. Have someone give signals to direct the driver.
Drive carefully onto the ramp and then on to the transport vehicle itself.
10. Have wedges ready to prevent the machine from rolling back when driving on.
11. Tilt the attachment in and drive onto the ramp.
Keep the attachment close to the loading area.
12. After driving on, lower the working attachment onto the loading area.
Apply the articulation lock (this only applies to wheel loaders with articulated steering).
13. Secure the machine and the remaining individual components against slipping using chains and wedges.
14. Relieve the pressure lines, take out the ignition key, lock the cab door and side panels, and get out of the machine.
15. Acquaint yourself with the route before transport, especially as regards the width, height and weight limits you will encounter.
16. Make a special note of any overhead power lines, bridges and tunnels along the route.
17. Apply the same care when driving off.

Procedure:

- Remove all chains and wedges.
- Start the engine in accordance with the instructions in the **operating manual**.
- Carefully drive off the loading area using a ramp.
- Keep the attachment close to the ground.
- Have someone give you directions.

2.13 Towing the machine safely

1. Always observe the correct procedure as described in the **operating manual**. See the section on towing the machine in chapter 3.
2. The machine may only be towed in exceptional circumstances, for example to move it away from a dangerously exposed position for repairs.
3. Before pulling or towing the machine, check that all attachments and towing equipment are safe and secure.

4. The rope or bar used for towing must have sufficient tensile strength and be fastened to the holes provided on the front section.
In no event are damage or accidents resulting from towing covered by the manufacturer's guarantee.
Instructions on towing by rope:
 - Make sure no-one is near the taut rope when towing.
 - Keep the rope taut and avoid kinks.
 - Carefully pull the rope taut.
 - Sudden jerks can cause a slack rope to tear.
5. When towing, keep to the prescribed transport position, speed limit and route.
6. When starting the machine up again, follow the instructions in the **operating manual**.

2.14 Measures for ensuring safe maintenance

1. Never attempt maintenance and repair work unless you are qualified to do so.
2. Observe the prescribed periods for regular checks and inspections or those specified in the **operating manual**.
A suitably equipped workshop is absolutely necessary in order to perform repair work.
3. The table at the end of this **operating manual** states exactly who may carry out each job.
The jobs listed under **daily / weekly** in the maintenance schedule can be carried out by the driver or by service personnel.
The other jobs may only be carried out by suitably qualified specialist staff.
4. Spare parts must meet the technical requirements specified by the manufacturer. This is guaranteed if you use genuine spares.
5. Wear safety overalls for maintenance work. Certain jobs not only require a hard hat and safety boots, but also goggles and safety gloves.
6. Keep unauthorised persons away from the machine during maintenance.
7. Set up an extended cordon around the maintenance area as necessary.
8. Notify the operating personnel before starting repairs or other special jobs. Nominate a supervisor.
9. Unless otherwise specified in the **operating manual** carry out all maintenance work on the machine on firm, level ground with the engine off.
10. Afterwards always re-tighten any bolts loosened during maintenance and repair work.
11. If safety equipment has to be dismantled for rigging, maintenance and repair work, it must be re-installed and checked as soon as the job is finished.
12. When undertaking maintenance jobs, especially under the machine, attach a warning sign marked **DO NOT SWITCH ON** to the ignition where it is clearly visible. Take out the ignition key.
13. Before starting maintenance or repairs, clean any oil, fuel or service fluids from the machine, especially connections and bolted joints. Do not use abrasive cleaning agents. Use fibre-free cloths.
14. Before welding, burning and sanding, clean any dust from the machine and the area around it, and ensure adequate ventilation.
Otherwise there is a risk of **explosions**.

15. Before cleaning the machine with water, steam jet (high-pressure cleaner) or other cleaning agents, cover or tape up all openings where water, steam and cleaning agent may not penetrate for safety reasons. Electric motors, control cabinets and battery compartments are at particular risk.

Further procedure:

- Make sure that during cleaning work on the machine housings, the temperature sensors for the fire alarm and extinguisher systems do not come into contact with hot cleaning agent. Otherwise the fire extinguishing system could be activated.
 - After cleaning, completely remove the covers and tape.
 - After cleaning, check all fuel, engine oil and hydraulic oil lines for leaks, loose connections, abrasion and damage.
 - Repair any defects immediately.
16. Follow the safety instructions for the product in question when handling oil, grease and other chemical substances.
 17. Dispose of spare parts and consumables in a safe, environmentally sound manner.
 18. Take care when handling hot operating and auxiliary materials (danger of burns and scalding).
 19. Only operate combustion engines and fuel-powered heaters in sufficiently ventilated rooms. Before starting the engine inside a building, make sure the room is well ventilated. Follow the local regulations in force at the site.
 20. Only carry out welding, burning and grinding work when it is expressly allowed, as otherwise you may cause fires or explosions.
 21. Do not try to lift heavy parts. Only use suitable equipment with sufficient load capacity.

Procedure:

- When replacing individual parts and larger assemblies, carefully fasten and secure them to the lifting gear so that no danger can arise.
- Only use suitable lifting gear in perfect order, and slinging equipment with sufficient load capacity.

Keep out from under suspended loads.

22. Do not use ropes which are damaged or of insufficient load bearing capacity. Wear protective gloves when handling wire ropes.
23. Only allow experienced personnel to sling loads and direct crane drivers. The person giving directions must remain in sight of the operator or at least be in spoken contact with him.
24. When carrying out fitting work above head height, use the safety climbing aids and working platforms provided or equivalent. Do not use parts of the machine for climbing. Wear a safety harness when working at height. Keep all handles, steps, rails, gangways, platforms and ladders free from dirt, snow and ice.
25. When working on the attachment (for example replacing teeth), make sure it is properly supported. Avoid direct metal-to-metal contact.
26. Never lie under the machine when it is raised using the working attachment, unless the undercarriage is securely supported using wooden beams.
27. Always support the machine on blocks, so that it cannot become unbalanced by any shift in weight. Avoid metal-to-metal contact.
28. Only trained specialist staff may perform work on the chassis, brake and steering systems.
29. If you have to repair the machine on a slope, secure the wheels with wedges. Move the working attachment to the maintenance position and engage the articulation lock.

30. Only personnel with the requisite skills and experience may work on hydraulic equipment.
31. Wear protective gloves when looking for leaks. Under pressure, a thin jet of liquid can pierce the skin.
32. Never release hydraulic lines or bolts before setting down the working attachment and shutting down the engine.
Before starting any work on the hydraulic circuit, you must also press the working hydraulics lockout button and actuate all pilot control units (joystick and pedals) in both directions in order to reduce the control pressure and accumulated pressure in the operating circuits. You must then reduce the internal tank pressure.
33. Regularly check all hydraulic oil lines, hoses and bolted connections for leaks and visible damage. Repair all damage immediately. Oil escaping under pressure can cause injury and fires.
34. Before beginning repair work, depressurise the system sections and pressurised lines (hydraulics, compressed air) which are to be opened, as instructed in the assembly descriptions.
35. Lay and fit hydraulic and compressed air lines in the proper manner. Do not switch the connections. Fittings, as well as the length and quality of the hose lines, must match the manufacturer's requirements.
Only use LIEBHERR spare parts.
36. Replace hydraulic hose lines at appropriate intervals, even if there are no apparent defects which may impair safety.
37. Work on the machine's electrical equipment may only be carried out by a qualified electrician or by instructed persons under the direction and supervision of a qualified electrician, in accordance with the recognised electrical engineering rules.
38. Only use original fuses with the stated current ratings. If there are malfunctions in the electrical power supply, switch off the machine immediately.
39. Inspect and test the machine's electrical equipment regularly. Immediately rectify all faults, such as loose connections, scorched or worn cables or burnt out fuses and bulbs.
40. If you have to carry out work on live components, have a second person assist you, who can throw the emergency stop or main switch in an emergency. Cordon off the working area with a red and white safety chain and a warning sign. Only use insulated tools.
41. When working on high-voltage assemblies after they have been isolated from the power supply, short the supply cable and the components, such as capacitors, with an earthing rod.
42. First, check that the isolated parts are not live, connect them to earth and then short them. Isolate any neighbouring live parts.

2.15 Safety instructions for maintenance work on machines with hydro accumulators

1. Only qualified staff may carry out work on the hydraulic and pneumatic connections of the membrane accumulator.
Serious accidents could result from inexperienced fitting and operation.
The hydraulic system must be depressurised before work can be carried out on it.
Do not carry out any welding or soldering work on the membrane accumulator.

There is a risk of explosion during welding or soldering work.

The accumulator may burst during machining, resulting in the loss of the operating permit.

Hydro accumulators may only be filled with nitrogen, not with oxygen or air - otherwise there is a **risk of explosion**.

The accumulator can heat up, causing burns.

Do not use membrane accumulators which have been damaged during transportation.

New membrane accumulators must be filled with nitrogen before they are used. Remove the sealing caps on the fluid side.

The minimum and maximum operating data are permanently marked on the membrane accumulator. The marking must remain visible.

2.16 Safety instructions for welding work on the machine

1. Main components for power transmission (such as the vehicle frame and attachment components) . . . may only be welded by the manufacturer or an authorised workshop.

Disconnect the battery when working on the electrical system or when carrying out arc welding on the machine.

Always disconnect the negative terminal first and reconnect it last.

On machines with electronic gearbox control units:

- Also disconnect the multi-pin plug on the electronic gearbox control unit before starting any welding work on the machine.

The earth cable of the welding device should be attached as close as possible to the actual welding location, so that it is not possible for the welding current to flow through components or sealing elements such as the slewing ring, joints, bearings, bushes, rubber components . . . and seals.

2.17 Instructions for working safely on the working attachment

1. Do not work under the attachment if it is not resting on the ground or supported.
2. When replacing attachment components (decals, cutting edge, teeth), . . . do not let metal rest on metal.
3. Do not try to lift heavy parts. Only use suitable equipment with sufficient load capacity.
4. Always wear gloves when working with wire ropes.
5. Never release hydraulic lines or bolts before setting down the working attachment and shutting down the engine.

Before starting any work on the hydraulic circuit, you must also press the working hydraulics lockout button and actuate all pilot control units (joystick and pedals) in both directions in order to reduce the control pressure and accumulated pressure in the operating circuits. You must then reduce the internal tank pressure.

6. Ensure that all lines and threaded couplings are reconnected and re-tightened on completion of the job.

7. Be especially careful when removing or inserting bolts and pins made of hardened steel, as they can splinter, causing serious injury.
Wear safety gloves and goggles.
Whenever possible use special tools (such as mandrels, extractors, . . . etc.)

2.18 Safety instructions for transporting the machine by crane

1. Lower the working attachment and tilt back the loading equipment to its limit.
2. Apply the articulation lock (this only applies to wheel loaders with articulated steering).
3. Move all control levers to the neutral position and engage the parking brake.
4. Shut down the engine in accordance with the instructions in the **operating manual**.
5. Lock the working hydraulics before leaving the driver's cab.
Lock the working hydraulics in accordance with the instructions in the **operating manual**.
6. Lock all doors, covers and hoods on the machine.
7. Only allow experienced personnel to sling loads and direct crane drivers. The person giving directions must remain in sight of the operator or at least be in spoken contact with him.
8. Attach the lifting tackle to the lugs and bore holes provided on the machine.
9. Make sure the lifting tackle is long enough.
10. Carefully lift the machine.
11. **CAUTION! Keep out from under the machine when it is raised.**
12. When restarting the machine, proceed strictly according to the **operating manual**.

2.19 Safe maintenance of hydraulic hoses and hose lines

1. Never attempt to repair hydraulic lines and hydraulic hoses.
2. All hoses, hose lines and threaded couplings must be checked regularly, at the very least once a year, for leaks and visible signs of damage.
Replace damaged parts immediately. Oil escaping under pressure can cause injury and fires.
3. Even when properly stored and subjected to normal load, hoses and hose lines are subject to natural ageing. This limits their service life.
4. Improper storage, mechanical damage and excess strain are the main causes of damage.
5. Hose lines should not be used for longer than six years, including storage of no longer than two years (note the date of manufacture on the hoses).
6. Using the hoses close to their maximum strain can shorten their service life (e.g. high temperatures, frequent movement, extremely high impulse frequencies and multiple shift operation).

7. Hoses and hose lines must be replaced when inspections reveal the following.
Criteria:
 - Damage to the outer layer penetrating to the inner layer (e.g. abrasion, cuts and cracks)
 - Embrittlement of the outer layer (cracks in the hose material)
 - Deformation of the natural shape of the hose or the hose line, both when pressurised and depressurised, or at bends, e.g. layer separation, blistering
 - Leaks
 - Failure to observe installation requirements
 - Damage or deformation of the hose fittings, which reduces the strength of the fittings or the connection between the fitting and the hose
 - Slippage of the hose out of the fitting
 - Corrosion of the fitting, impairing its function and strength
 - Exceeded storage time or service life
8. Only use genuine spare parts to replace hoses and hose lines.
9. Lay and fit hoses and hose lines in the proper manner. Do not switch the connections.

2.20 Attachments and accessories

1. Attachments and accessories produced by third-party manufacturers or those which have not been generally approved by LIEBHERR for installation or for external fitting may not be installed or fitted on the machine without prior written consent from LIEBHERR.
2. The appropriate technical documentation should be made available to LIEBHERR for this purpose.
3. When adding or converting equipment or tyres, the stability of the machine must be tested and ensured in accordance with **EN 474**.
See also the technical data section in chapter 1.

2.21 Protection against vibrations

1. The vibrations to which mobile construction machines are subjected are mainly due to the way they are used.
The following parameters in particular have a great effect:
 - Terrain conditions: bumps and potholes.
 - Operating methods: speed, steering, braking, use of the controls while driving and while working.
2. The amount of vibration depends to a large extent on the machine operator, because he determines the speed, gear ratio, working methods and distance covered.
This results in a wide range of different vibrations for the same type of machine.
3. The machine operator can reduce overall vibration by following these recommendations:

- Select a suitable machine, equipment and accessories for the job.
- Use a machine equipped with a suitable seat (i.e. for earthworking machines, a seat which complies with EN ISO 7096).
- Keep the seat in good condition and adjust it as follows:
 - Adjust the seat and its suspension according to the height and weight of the driver.
 - Regularly check the suspension and adjustment mechanisms of the seat and make sure the seat is kept in the condition specified by the manufacturer.
- Check the service condition of the machine, especially the tyre pressure, brakes, steering, mechanical connections etc.
- Do not steer, brake, accelerate, shift gears or load the working attachment of the machine suddenly.
- Adjust the speed of the machine to the distance to be driven in order to reduce vibrations.
 - Slow down when driving over difficult terrain.
 - Drive around obstacles and avoid difficult terrain.
- Keep the area on which the machine is operated in a tidy condition.
 - Remove any large rocks and obstacles.
 - Fill in any trenches or holes.
 - Have machines available to maintain good terrain and plan sufficient time to do so.
- Travel over longer distances (e.g. public roads) at a suitable (medium) speed.
- For machines which are often driven on open roads, use a special additional system (if available) to reduce vibrations during this type of use.

If such systems are not available, control your speed to stop the machine from shaking.

3 Operation, Handling

3.1 Layout of control elements

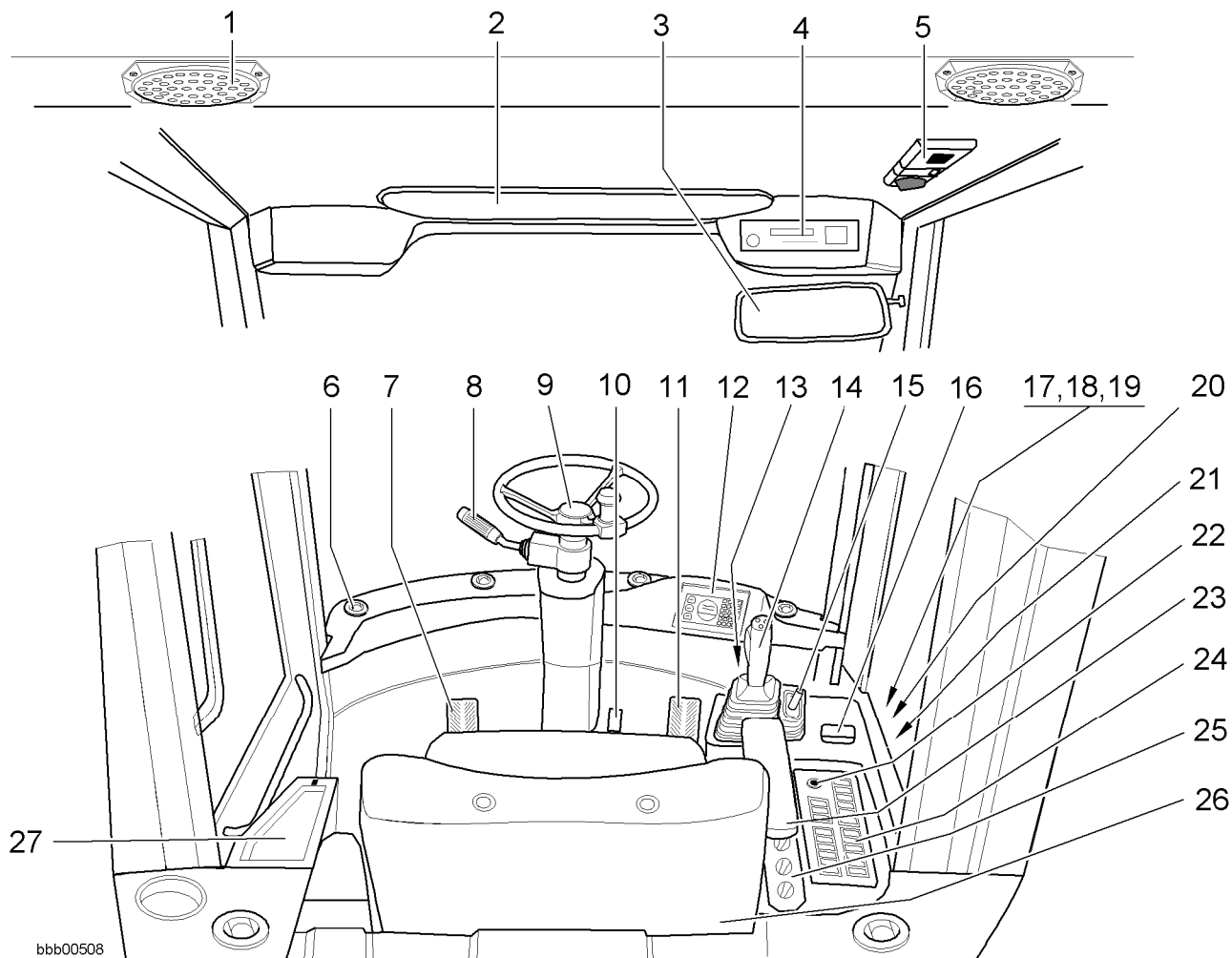

Inside view of the driver's cab

- | | | |
|---|---|---|
| 1 Radio speaker | 10 Steering column adjustment lever (optional) | 18 Control electronics |
| 2 Sun visor | 11 Gas pedal | 19 Control relay |
| 3 Interior mirror | 12 Instrument panel display unit | 20 Diagnostic plug |
| 4 Radio compartment | 13 Operating manual compartment | 21 Socket |
| 5 Interior lights with switch | 14 LIEBHERR control lever | 22 Ignition switch |
| 6 Heater/ventilation/air-conditioning outlet nozzles (optional) | 15 Control lever for additional working functions | 23 Adjustable arm rest |
| 7 Inch/brake pedal | 16 Ashtray | 24 Switches on the side console (control panel) |
| 8 Steering column switch | 17 Fuses | 25 Heating/ventilation switch |
| 9 Steering column with steering wheel | | 26 Driver's seat |
| | | 27 Glove compartment |

3.2 Operation

3.2.1 Battery main switch

You must turn on the battery main switch before you can start the machine.

The battery main switch is located at the rear right of the engine compartment.

Switching the battery main switch on and off

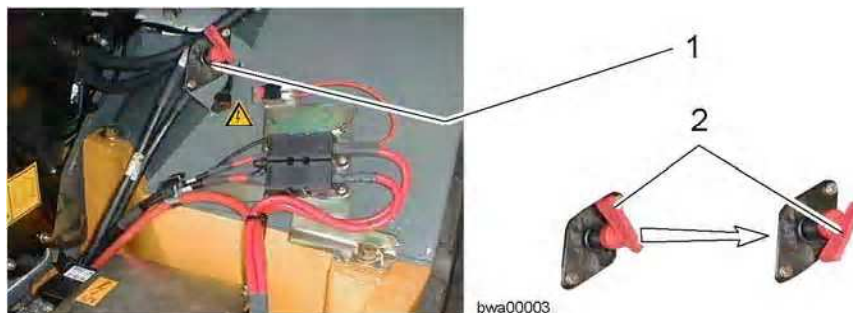

Switching the battery main switch on and off

1 Battery main switch

2 Key

- Turn the battery main switch 1 on and off using the key 2.

3.2.2 Cab access

Only get on and off the machine using the access aids provided.

Normally, the driver's cab must be entered and exited through the left-hand driver's cab door.

The right-hand driver's cab door is provided as an emergency exit and therefore should only be used in this event.

Familiarise yourself with the emergency exit through the right cab door. See the section on the emergency exit.

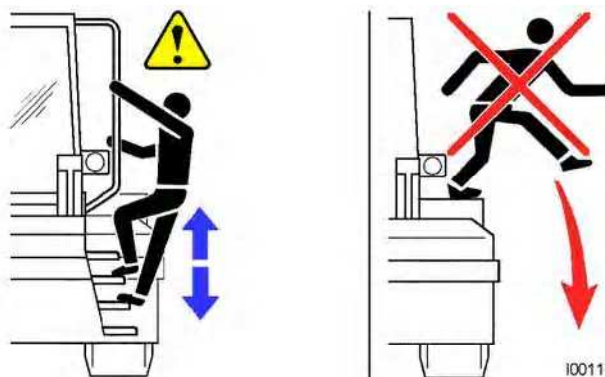

Warning



You risk injury if you jump or fall off the machine.

! Use the steps, ladders and handles provided for getting on and off.

! Never jump down from the machine.

Warning



You could be injured if the machine suddenly moves.

! Do not hold onto the steering column, the control panel or the control levers when getting on or off.

Entering the driver's cab

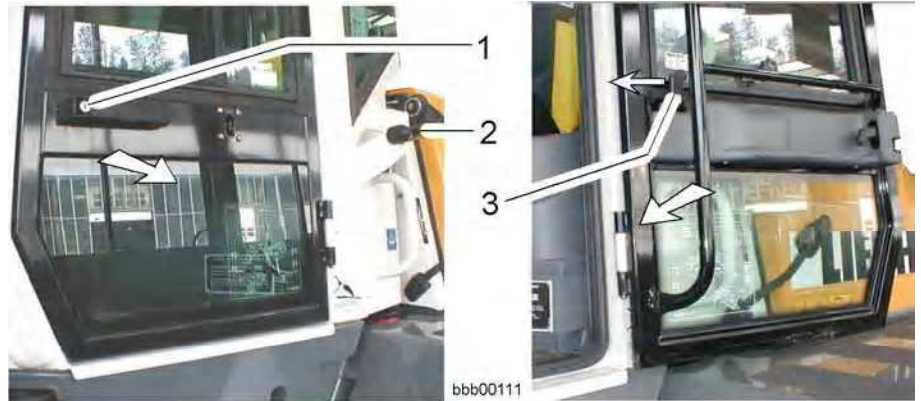

Entering the cab

1 Handle with lock
2 Door holder

3 Door holder lever

- Open the lock of the cab door with the ignition key.
- Open the cab door with the door handle **1** until it latches in the door holder **2**.
- Enter the cab.
- Use the door holder lever **3** to lock and unlock the cab door.

Leaving the driver's cab

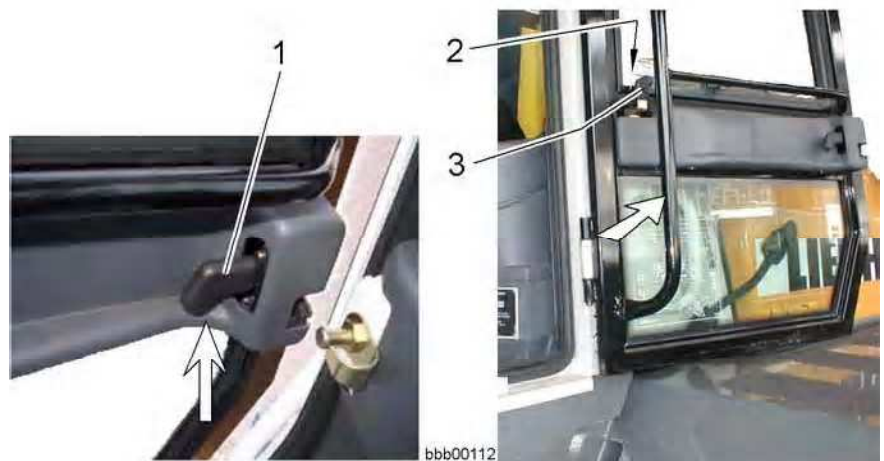

Leaving the cab

1 Door opener lever
2 Door holder

3 Door holder lever

- Open the cab door with the door opener lever **1** until it latches in the door holder **2**.

LBH/02/003801/0003/2.06/en

- Leave the cab.
- Use the door holder lever **3** to lock and unlock the cab door.
- Lock the cab door with the ignition key.

3.2.3 Emergency exit



The right-hand driver's cab door is provided as an emergency exit and therefore should only be used in this event.

Before starting up the machine, check that you can exit the cab through the right-hand door from inside without any hindrance.

Leaving the driver's cab through the emergency exit



bbb00237

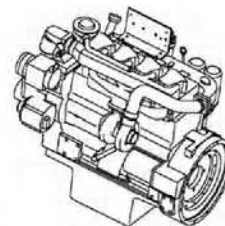

Switching off the engine

Warning



There is a risk of accidents if you leave the engine running. If you leave the cab by the emergency exit with the engine running, it increases the risk of accidents for the driver and any auxiliary staff.
! Deactivate the driving and working functions.

- Turn off the engine.

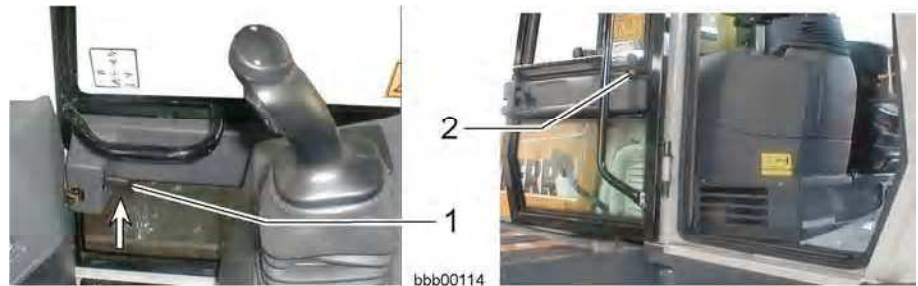

Opening the emergency exit

- Open the right cab door with the door opener lever **1** until it latches in the door holder **2**.
- Leave the cab.

Opening the emergency exit from outside

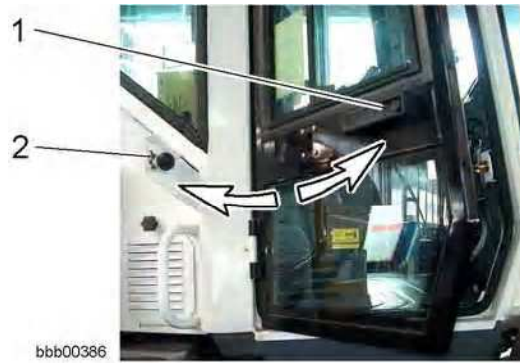

Opening the emergency exit

- Open the right cab door with the door handle **1** until it latches in the door holder **2**.

3.2.4 Driver's seat with mechanical suspension

The ergonomically designed driver's seat offers a high degree of comfort. The adjustable seat surface, back rest, suspension and arm rest mean that the driver can adjust the seat for maximum individual comfort.

Vibration damping:

The seat installed in the machine complies with ISO 7096.

When the machine is used correctly, the vibrations transmitted by the driver's seat are less than or equal to the vibrations simulated in test conditions for the corresponding machine class in accordance with ISO 7096 class EM3.

The vibration acceleration values (a_{zw}), measured in accordance with ISO 2631, Part 1, thus meet the standards for protection against overall body vibrations in EN 474-1.

Layout

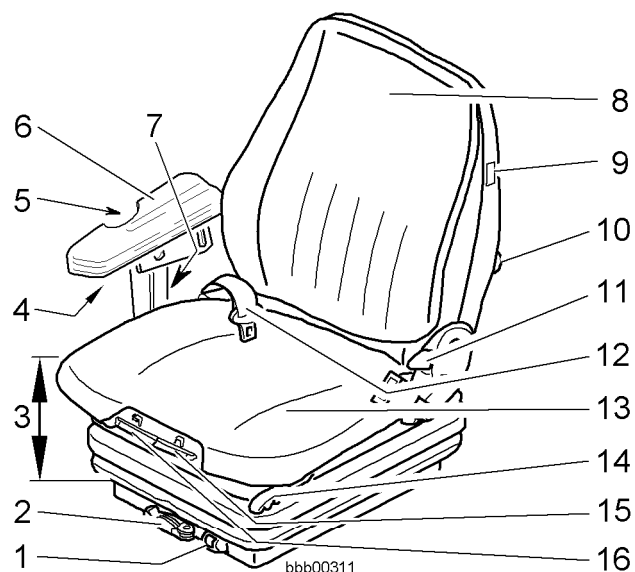

Main components and adjustable elements of the driver's seat

1 Weight display

2 Weight adjustment

LBH/02/003801/0003/2.06/en

- | | |
|---|--|
| 3 Height adjustment | 10 Lumbar support knob |
| 4 Locking screw for arm rest horizontal adjustment | 11 Back rest adjustment lever |
| 5 Locking screw for arm rest inclination adjustment | 12 Seat belt |
| 6 Arm rest | 13 Seat surface |
| 7 Locking screw for arm rest height adjustment | 14 Driver's seat horizontal adjustment lever |
| 8 Back rest | 15 Seat surface inclination adjustment lever |
| 9 Seat heating switch (optional) | 16 Seat surface horizontal adjustment lever |

Adjusting the driver's seat

The seat can be adjusted to the driver's individual requirements to provide the highest possible degree of comfort.

Adjusting the driver's seat for driving on roads

Warning



There is a risk of injuries if the driver's seat is not properly adjusted.

! When driving on public roads, the driver's seat may only be adjusted when the machine is at a standstill.

- Adjust the driver's seat before starting the machine.

Adjusting the driver's seat horizontally

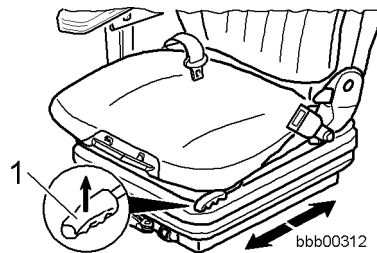

Horizontal adjustment

Adjust backward or forward:

- Using the lever 1.
- Pull the lever 1 in the direction of the arrow.
- Adjust the driver's seat horizontally.
- Let go of the lever.

Adjusting the driver's seat surface horizontally

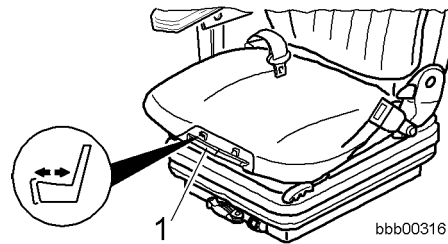

Horizontal adjustment of the seat surface

Adjust backward or forward:

- Using the lever 1.
- Push up the lever 1.
- Adjust the surface of the driver's seat horizontally.
- Let go of the lever.

Adjusting the inclination of the seat surface

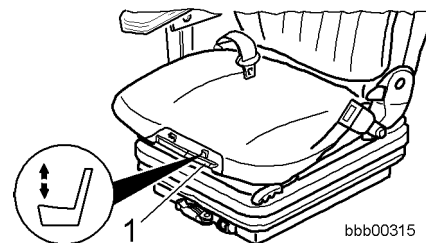

Adjusting the inclination of the seat surface

Adjust up or down:

- Using the lever 1.
- Push up the lever 1.
- Adjust the seat surface of the driver's seat up or down.
- Let go of the lever.

Adjusting the seat suspension

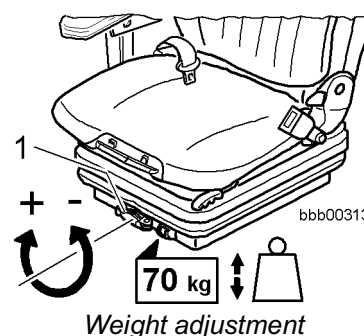

Weight adjustment

The seat suspension can be adjusted to the driver's individual body weight.

- Set the body weight using the knob 1.

The setting is shown beside the knob.

Adjusting the seat height

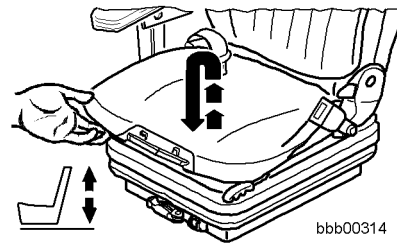

Seat height adjustment

Adjust the seat height by lifting up the seat with your hand. The height can be adjusted to several levels.

- Lift up the seat as necessary until you hear it catch.
- Lift the driver's seat above the final level (limit stop): The driver's seat sinks to the lowest position.

Adjusting the back rest

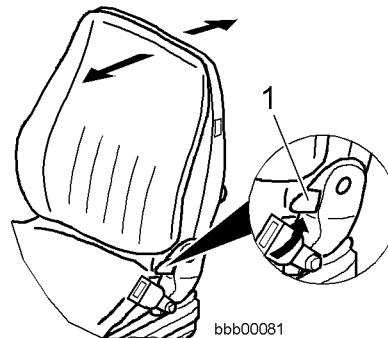

Inclination of the back rest

The back rest can be adjusted:

- Using the lever 1.
- Raise the lever 1.
- Move the back rest to the angle required.
- Let go of the lever.

Adjusting the lumbar support

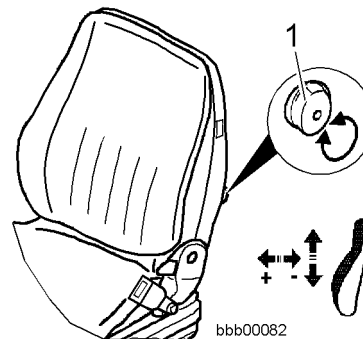

Lumbar support

The lumbar support improves seat comfort.

- Turn the hand wheel 1 to the left or right: This adjusts the height and size of the bulge in the back upholstery.

Adjusting the arm rest

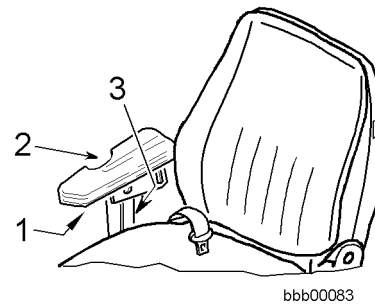

Arm rest adjustment

The height, inclination and horizontal position of the arm rests can be adjusted.

- Height adjustment:
Loosen the clamp screw **3**, adjust the height and lock it in place.
- Inclination adjustment:
Loosen the clamp screw **2**, adjust the inclination and lock it in place.
- Horizontal adjustment:
Loosen the clamp screw **1**, adjust the arm rest horizontally and lock it in place.

3.2.5 Driver's seat with pneumatic suspension

This equipment is optional.

The ergonomically designed driver's seat offers a high degree of comfort. The adjustable seat surface, back rest, suspension and arm rest mean that the driver can adjust the seat for maximum individual comfort.

Vibration damping:

The seat installed in the machine complies with ISO 7096.

When the machine is used correctly, the vibrations transmitted by the driver's seat are less than or equal to the vibrations simulated in test conditions for the corresponding machine class in accordance with ISO 7096 class EM3.

The vibration acceleration values (a_{zw}), measured in accordance with ISO 2631, Part 1, thus meet the standards for protection against overall body vibrations in EN 474-1.

Layout

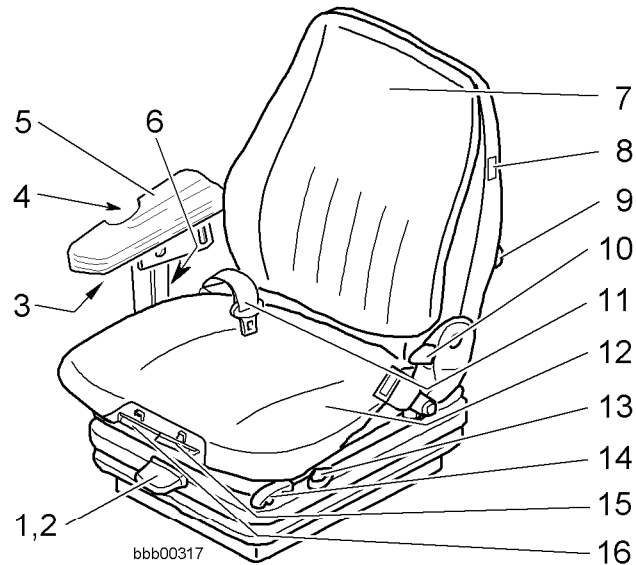

Main components and adjustable elements of the driver's seat

- | | |
|---|--|
| 1 Weight adjustment | 10 Back rest adjustment lever |
| 2 Height adjustment | 11 Seat belt |
| 3 Locking screw for arm rest horizontal adjustment | 12 Seat surface |
| 4 Locking screw for arm rest inclination adjustment | 13 Lever for horizontal suspension |
| 5 Arm rest | 14 Lever for horizontal adjustment |
| 6 Locking screw for arm rest height adjustment | 15 Seat surface inclination adjustment lever |
| 7 Back rest | 16 Seat surface horizontal adjustment lever |
| 8 Seat heating switch (optional) | |
| 9 Lumbar support knob | |

Adjusting the driver's seat

The seat can be adjusted to the driver's individual requirements to provide the highest possible degree of comfort.

Adjusting the driver's seat for driving on roads

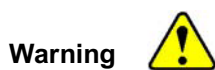

There is a risk of injuries if the driver's seat is not properly adjusted.
 ! When driving on public roads, the driver's seat may only be adjusted when the machine is at a standstill.

- Adjust the driver's seat before starting the machine.

Adjusting the driver's seat horizontally

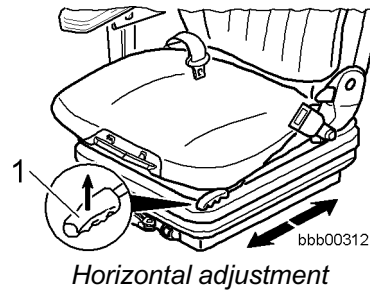

Adjust backward or forward:

- Using the lever 1.
- Pull the lever 1 in the direction of the arrow.
- Adjust the driver's seat horizontally.
- Let go of the lever.

Adjusting the driver's seat surface horizontally

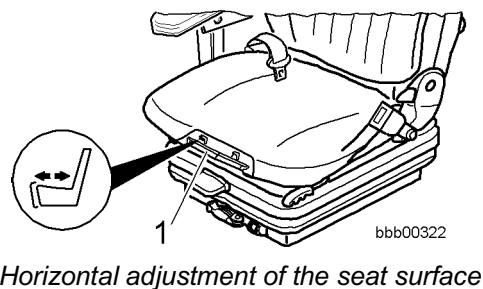

Adjust backward or forward:

- Using the lever 1.
- Push up the lever 1.
- Adjust the surface of the driver's seat horizontally.
- Let go of the lever.

Adjusting the inclination of the seat surface

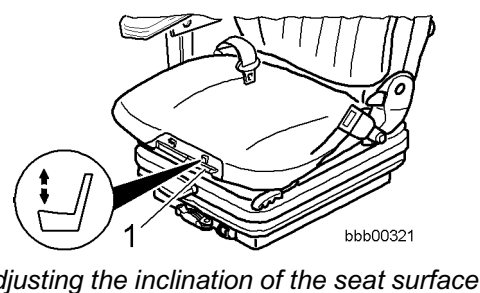

Adjust up or down:

- Using the lever 1.
- Push up the lever 1.
- Adjust the seat surface of the driver's seat up or down.
- Let go of the lever.

Activating and deactivating horizontal suspension on the driver's seat

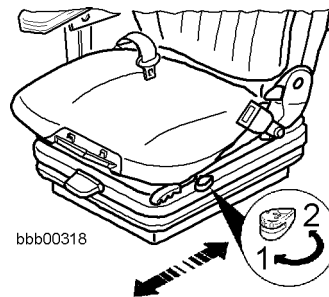

Horizontal suspension

Under certain conditions you can increase comfort by activating the horizontal suspension.

Advantage: The driver's seat can better absorb shocks in the direction of travel.

- Position 1 = on
- Position 2 = off

Adjusting the seat suspension

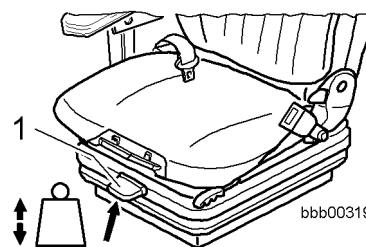

Weight adjustment

The seat suspension can be adjusted to the driver's individual body weight.

Note



For adjustment:

! The driver must be sitting in the normal position.

- Set the body weight by briefly pulling the lever 1.

Adjusting the seat height

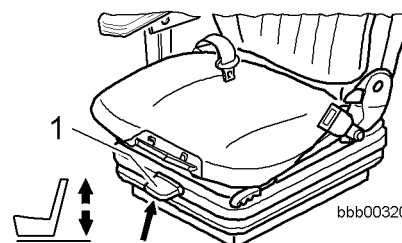

Seat height adjustment

The seat height can be continuously adjusted using air springs.

- Push or pull the lever 1 as far as it will go.

When it reaches the top or bottom limit, the height is adjusted automatically.

The minimum required suspension is ensured.

Note

To avoid damage:
! Do not actuate the compressor for more than 1 minute.

Adjusting the back rest

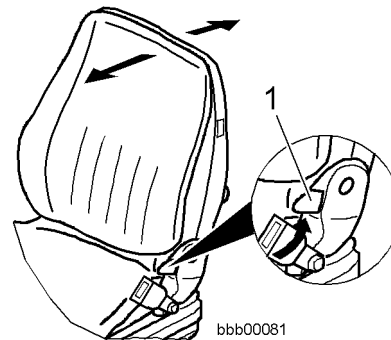

Inclination of the back rest

The back rest can be adjusted:

- Using the lever 1.
- Raise the lever 1.
- Move the back rest to the angle required.
- Let go of the lever.

Adjusting the lumbar support

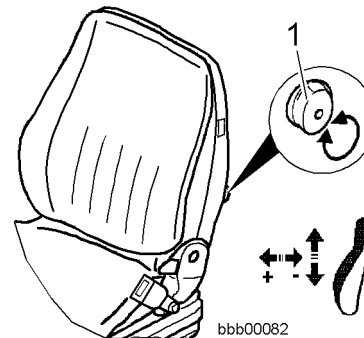

Lumbar support

The lumbar support improves seat comfort.

- Turn the hand wheel 1 to the left or right:
This adjusts the height and size of the bulge in the back upholstery.

Adjusting the arm rest

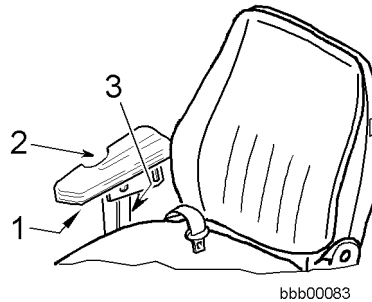

bbb00083

Arm rest adjustment

The height, inclination and horizontal position of the arm rests can be adjusted.

- Height adjustment:
Loosen the clamp screw **3**, adjust the height and lock it in place.
- Inclination adjustment:
Loosen the clamp screw **2**, adjust the inclination and lock it in place.
- Horizontal adjustment:
Loosen the clamp screw **1**, adjust the arm rest horizontally and lock it in place.

3.2.6 Seat belt

Safety aspects of the seat belt

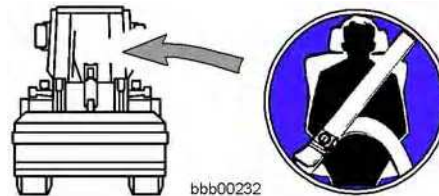

bbb00232

Always wear a seat belt

The driver's cab is equipped with roll-over protection (**ROPS**).

The ROPS roll-over protection system can only protect the driver if the seat belt has been fastened.

This section describes the safety considerations for wearing the seat belt.

Danger



There is a risk of injuries if the seat belt is not fastened.

If the machine tips or rolls over, the driver could suffer fatal injuries if he is not wearing a seat belt.

If the machine is braked or stops abruptly, the driver may suffer severe injuries if he is not wearing a seat belt.

! It is essential that you fasten your seat belt before starting up the machine.

- To guarantee your safety, regularly check the condition, function and fastening of the seat belt.
- Immediately replace damaged parts.
- Do not twist the seat belt.

Fastening the seat belt

The seat belt is an automatic belt.
You do not need to adjust the belt length.

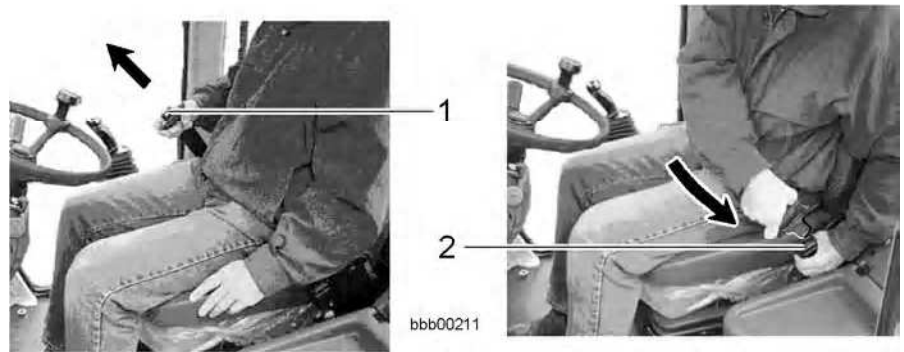

Fastening the seat belt

- Pull the belt buckle **1** over your body at hip level and plug it into the snap lock **2**.

Note



The roller may lock if you pull out the belt suddenly.

! Pull the belt smoothly out of the roller.

- Check that the snap lock is engaged by pulling the clasps.

Releasing the seat belt

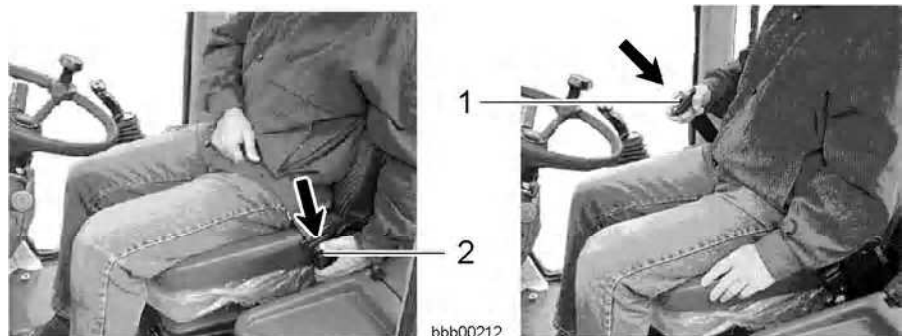

Releasing the seat belt

- Push down the lock button on the snap lock **2**.
- Let the belt buckle **1** slowly wind up the roller.

3.2.7 Steering column and steering wheel

Layout

The steering column with the steering wheel and steering column switch is integrated in the steering console.

Adjusting the steering column

This equipment is optional.

The steering wheel can be adjusted to suit the driver by adjusting the steering column.

The steering wheel can be adjusted progressively.

Warning



There is a risk of injuries if the steering column is not properly adjusted.
! Never adjust the steering column when the vehicle is moving.

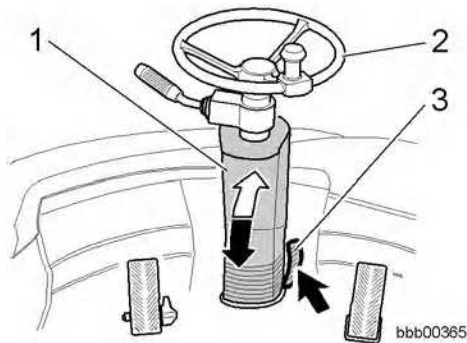

Adjusting the steering column

- 1 Steering column
- 2 Steering wheel
- 3 Lever

- Press down the lever **3** with your foot in the direction of the arrow.
- Pull or push the steering wheel **2** to adjust the steering column **1** as required.
- Release the lever **3** to lock the steering column **1** in the selected position.

3.2.8 Ignition switch



Ignition switch position

- 1 Ignition switch

The ignition switch is equipped with a repeat start lock.

The ignition key can be removed when it is in the 0 position with the engine switched off.

When the ignition key is in the 0 position or parking position, the following units on the instrument panel can be switched on:

- Parking and driving light
- Hazard warning system
- Interior lighting
- Front working floodlights
- Rear working floodlight (optional)
- Flashing beacon (optional)

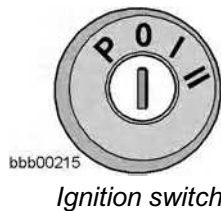

Layout

Switch positions:

P – Parking position

0 – 0 position / engine off

I – Contact, operating and preglow position

II – Starting position



Switching the electrical system on and off

Make sure that the battery main switch is on.

- Switch the electrical system on or off with the ignition key.

3.2.9 Steering column switch

The steering column switch is mounted on the steering column.

Layout

The steering columns switch consists of the following controls:

- Travel direction indicators
- High beam
- Horn and headlight flasher
- Front windscreen wiper
- Front windshield wiper and washer system

Function description

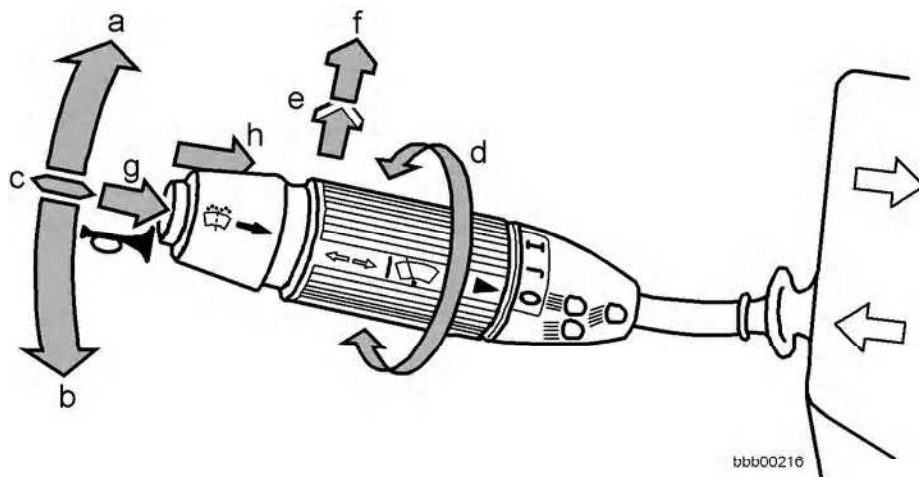

Steering column switch

Functions of the steering column switch when activated in each direction:

- a** – Direction display: right indicators
- b** – Direction display: left indicators
- c** – Centre position: neutral position
- d** – Windshield wiper: front windscreen
 - **0** – Level 0
 - **J** – Interval
 - **I** – Level I
- e** – Visual warning indicator: headlight flasher
- f** – High beam: driving light
- g** – Audible warning indicator: horn
- h** – Windshield wiper / washer system: front windscreen

3.2.10 Lighting



Make sure that the electrical system is switched on.

Switching off the parking light / driving light

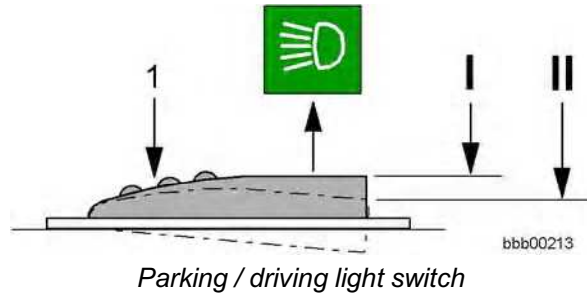

- Turn the parking / driving light switch to position **I**.
The parking light lights up.
The parking light also works after you take out the ignition key.
- Turn the parking / driving light switch to position **II**.
The driving light lights up.
The driving lights work when the key is in position **I** or **II**.
- To switch off the parking light and driving light, push the switch to position **1**.
All functions are switched off.

Caution

Risk of damage to the battery
If the battery is in a discharged condition over a long period of time (e.g. longer than one month), the battery can no longer be recharged.
! Avoid discharging the battery accidentally.

- When you leave the driver's cab:
Make sure that you have not left the parking / driving light on.

Switching on high beam

Make sure that the driving light is switched on.

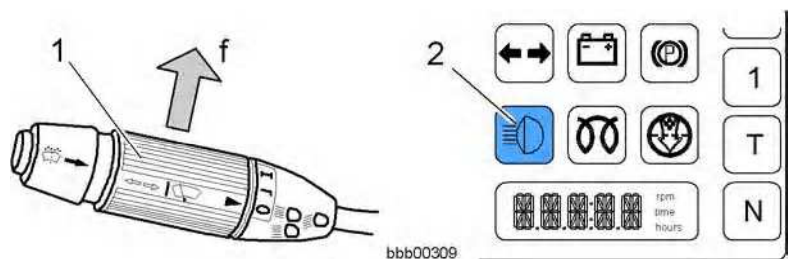

1 Steering column switch

2 High beam symbol field

- Push the steering column switch **1** in direction **f**.
The symbol field **2** for high beam lights up.
High beam is activated.

LBH/02/003801/0003/2.06/en

Switching off high beam

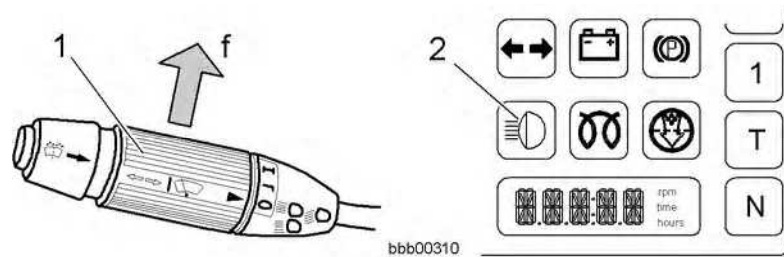

Steering column switch and display unit

1 Steering column switch

2 High beam symbol field

- To switch back to low beam, push the steering column switch **1** in direction **f**.

The symbol field **2** for high beam goes out.
The driving light lights up.

3.2.11 Interior cab lighting

The interior lighting is mounted in the top of the cab above the right cab door.

Switching the interior lighting on and off

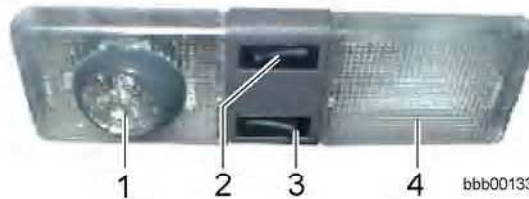

Interior lighting

1 Reading lamp

2 Reading lamp switch

3 Interior lighting switch

4 Interior lighting

- To switch the interior lighting **4** on or off, press the switch **3**.
- To switch the reading lamp **1** on or off, press the switch **2**.
- Set the beam of the reading lamp **1** as required by turning the reading lamp.

3.2.12 Display unit

The layout and function of the display unit are described in this section. The display unit is mounted on the right at the front of the instrument panel.

It consists of the display (symbol LCD) and the backlighting. Each symbol field is either red, yellow, green or blue.

Layout

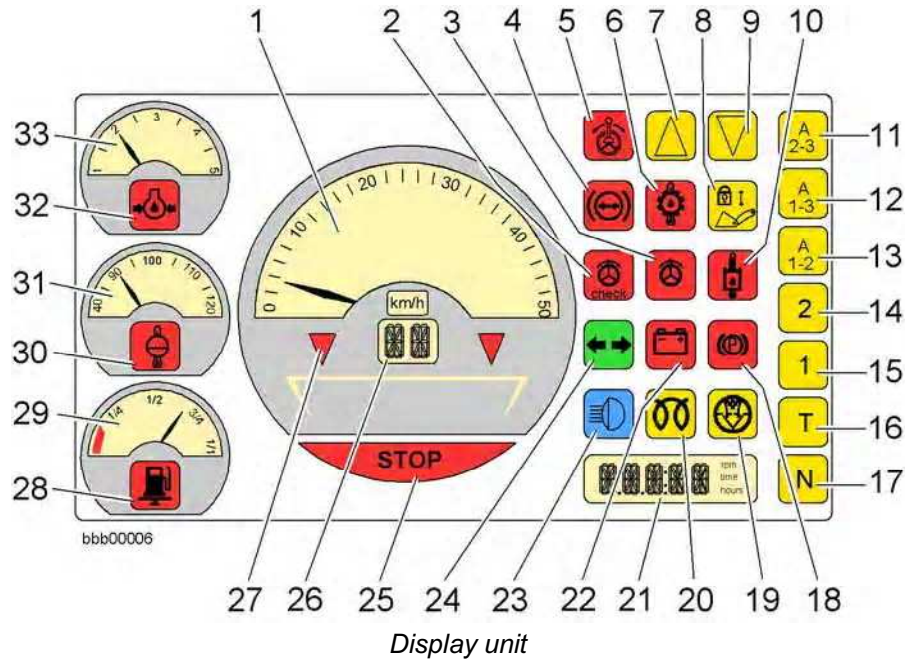

- | | |
|--|--|
| 1 Travel speed display | 16 Tempomat T symbol field (not activated) |
| 2 Emergency steering check symbol field (not activated) | 17 Neutral position N symbol field |
| 3 Emergency steering symbol field (not activated) | 18 Parking brake symbol field |
| 4 Brake system accumulator pressure symbol field (not activated) | 19 Air filter contamination symbol field |
| 5 Joystick steering symbol field | 20 Preglow monitor symbol field |
| 6 Gear oil overheating symbol field (not activated) | 21 Segment display for software version, engine speed, clock and service hours |
| 7 Forward travel direction symbol field | 22 Battery charge (charge control) symbol field |
| 8 Working hydraulics lockout symbol field | 23 High beam symbol field |
| 9 Reverse travel direction symbol field | 24 Direction indicator system symbol field |
| 10 Hydraulic oil overheating symbol field | 25 Stop symbol field |
| 11 Automatic travel range 2-3 symbol field (not activated) | 26 Machine type display |
| 12 Automatic travel range 1-3 symbol field (not activated) | 27 Overspeed protection display (not activated) |
| 13 Automatic travel range 1-2 symbol field (not activated) | 28 Fuel supply symbol field |
| 14 Fixed gear 2 symbol field | 29 Fuel supply display |
| 15 Fixed gear 1 symbol field | 30 Engine overheating and coolant level symbol field |
| | 31 Coolant temperature display |
| | 32 Engine oil pressure symbol field |
| | 33 Engine oil pressure display |

LBH/02/003801/0003/2.06/en

Function description

Travel speed display

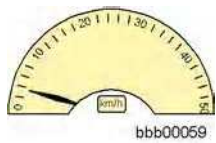

bbb00059
Segment display

Travel speed display

Display function:

- Shows the machine's travel speed.

Joystick steering indicator



bbb00020

This equipment is optional.

Joystick steering symbol field

Symbol field colour – red

Lights up during operation with joystick steering.

Forward travel direction indicator



bbb00017

Forward travel direction symbol field

Symbol field colour – yellow

Displays that the selected travel direction of the machine is forwards.

Working hydraulics lockout indicator



bbb00010

Working hydraulics lockout symbol field

Symbol field colour – yellow

Lights up when the working hydraulics lockout is activated.

Reverse travel direction indicator



bbb00018

Reverse travel direction symbol field

Symbol field colour – yellow

Displays that the selected travel direction of the machine is reverse.

Hydraulic oil overheating indicator



04ml11ab

Hydraulic oil overheating symbol field

Symbol field colour – red

Lights up when the hydraulic oil temperature is too high.



bptk0012

Warning sequence:

- The symbol field lights up and a warning message is issued if the hydraulic oil temperature exceeds 95°C.
- The warning function of the symbol field is accompanied by a tone sounding at intervals.
Tone sequence: 1 second on, 9 seconds off
- The travel hydraulics are switched to travel range 1.

Travel range 2 indicator



bbb00024

Travel range 2 symbol field

Symbol field colour – yellow

Displays that the selected travel range of the machine is 2.



Travel range 1 indicator

Travel range 1 symbol field
 Symbol field colour – yellow
 Displays that the selected travel range of the machine is 1.



Neutral travel direction indicator

Neutral travel direction symbol field
 Symbol field colour – yellow
 Displays that the selected travel direction of the machine is neutral.



Parking brake activation indicator

Parking brake symbol field
 Symbol field colour – red
 Warning functions:
 – Lights up when the ignition key is turned to contact, operating and preglow position I.
 – Lights up when the parking brake is engaged.
 The symbol field goes out when the parking brake is released.



Air filter contamination indicator

Air filter contamination symbol field
 Symbol field colour – yellow
 Lights up when the air filter is heavily contaminated.



Preglow monitoring

Preglow monitor symbol field
 Symbol field colour – yellow
 Lights up when the ignition key is turned to the ignition, operation and preglow position - I and in the starting position II.
 The symbol field goes out at the end of the preglow period and when the engine is started.

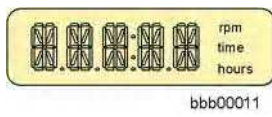

Software version, engine speed, clock and service hours indicator

Segment display for software version, engine speed, service hours or clock
 Field colour – white

Requirement: the required function must be selected on the control unit.

Display functions:
 – The software version (e.g. V 1012) is shown for 3 seconds when you switch the ignition on.
 – Engine speed
 – Service hours of the machine
 The service hours are used as the basis for the maintenance intervals.
 – Clock

LBH/02/003801/0003/2.06/en



04mi09ab

Battery charge control indicator

Battery charge (charge control) symbol field

Symbol field colour – red

Warning functions:

- Lights up when the ignition key is in the ignition position I. The symbol field goes out when the engine is started.
- It lights up, for instance, if the V-ribbed drive belt of the alternator tears.



04mi08ab

High beam activation indicator

High beam symbol field

Symbol field colour – blue

Lights up when the high beam is activated.



04mi12ab

Direction indicator system activation indicator

Direction indicator system symbol field

Symbol field colour – green

Warning functions:

- Flashes when the steering column switch is actuated to display the travel direction.
- Flashes when the hazard warning system is activated.



bbb00016

Machine stop indicator

Stop symbol field

Symbol field colour – red

Lights up:

- If there is a service code message which means that the machine must be shut down.
- If the engine overheats.
- If the engine oil pressure is too low.

Note



The cause of the fault must be analysed and corrected immediately.

! See also the malfunctions described in chapter 4.

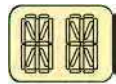

bbb00019

Machine type indicator

Machine type display

Field colour – white

Shows the machine type for 3 seconds when you switch the ignition on.



04mi23ab

Low fuel supply indicator

Fuel supply symbol field

Symbol field colour – red

Flashes when the diesel fuel is down to reserve level.



bbb00007

Fuel supply tank content indicator

Fuel supply display

Field colour – white (limit range with reserve – red)

Shows the content of the diesel fuel tank.



04ml24ab

Engine overheating indicator

Engine overheating symbol field

Symbol field colour – red

Warning functions:

- Lights up when the coolant temperature in the engine is too high.



bbb00660



Warning sequence:

- The symbol field lights up and a warning message is issued if the coolant temperature exceeds 108°C.
- The warning function of the symbol field is accompanied by a continuous tone.
- The travel hydraulics are switched to travel range 1.
- The STOP symbol field lights up.



bbb00008

Coolant temperature indicator

Coolant temperature display

Field colour – white

Shows the coolant temperature in °C.

A warning message is issued if the temperature in the coolant circuit reaches 103°C:

- A warning buzzer with interval tone sounds.
Tone sequence: 1 second on, 9 seconds off
- The travel hydraulics are switched to travel range 1.



04ml25ab

Engine oil pressure indicator

Engine oil pressure symbol field

Symbol field colour – red

Warning functions:

- Lights up when the ignition key is in the ignition position I.
The symbol field goes out when the engine is started.
- Flashes when the engine oil pressure drops.

Requirement: the diesel engine must be running.



bbb00660



Warning sequence:

- When a warning is received, the symbol field lights up.
- The warning function of the symbol field is accompanied by a continuous tone.
- The STOP symbol field lights up.



bbb00009

Engine oil pressure display

Engine oil pressure display

Field colour – white

Shows engine oil pressure in bar.

LBH/02/003801/0003/2.06/en

3.2.13 Switches on the side console

The switches are built into the side console.

The switches have indicator lamps. These light up when the switches are activated.

Layout

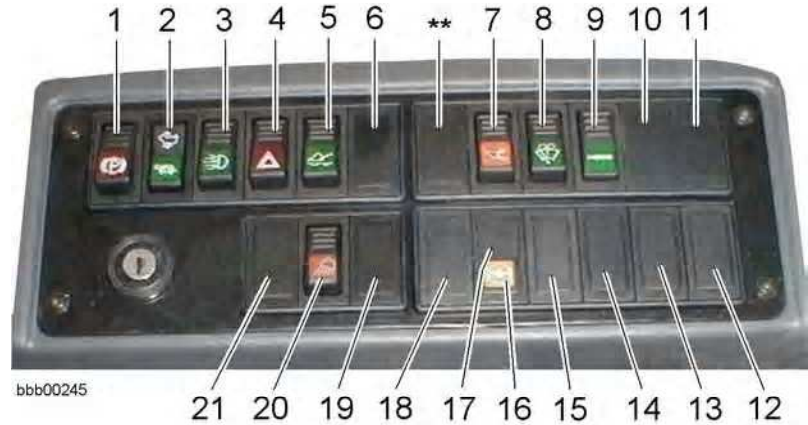

Switches on the side console

- | | |
|---|--|
| 1 Parking brake button | 12 Mirror heating switch (optional)
* |
| 2 Travel range button | 13 Reverse alarm deactivation
switch (optional) * |
| 3 Parking / driving light switch | 14 Comfort control switch (option-
al) * |
| 4 Hazard warning system switch | 15 Ride control button (optional) * |
| 5 Float position switch | 16 100% differential lockout signal
lamp |
| 6 Bucket return-to-dig switch
(optional) * | 17 Hydraulic quick-change device
signal lamp (optional) * |
| 7 Working hydraulics lockout
button | 18 Hydraulic quick-change device
switch (optional) * |
| 8 Rear windshield wiper and
washer system switch | 19 Rear working floodlight switch
(optional) * |
| 9 MODE button – engine speed,
service hours and clock
display | 20 Front working floodlight switch |
| 10 Software selection button (op-
tional) * | 21 Flashing beacon switch (op-
tional) * |
| 11 Air conditioning switch (option-
al) * | ** Dummy plug |

* The illustration above shows dummy plugs in the place of optional equipment.

Function description

Activating and deactivating the parking brake



bbb00247

Parking brake button

Field colour – red

Engages or releases the parking brake.

The parking brake can only be deactivated when the engine is running.

Deactivating the parking brake:

- Press the parking brake button
The parking brake symbol field goes out.

Engaging the parking brake:

- Press the parking brake button
The parking brake symbol field lights up.

If you press the parking brake button while the machine is moving, the parking brake will only close when the speed falls below 2 km/h.

If you press the parking brake switch while accelerating, the parking brake closes immediately.

Selecting travel ranges

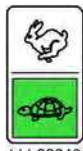

bbb00246

Travel range button

Field colour – green

For selecting travel ranges **1** and **2**.

- Press the tortoise symbol on the button to switch the travel range down to **1**.
- Press the hare symbol on the button to switch the travel range up to **2**.

Switching on the parking light or driving light



b4270067

Parking / driving light switch

Field colour – green

Function for parking light – switch position **I**:

Switches the parking light on or off.

When the switch is in position **I** the following lights on the machine must light up:

- Left/right driving headlights (parking light)
- Left/right tail lights

Function for driving light – switch position **II**:

Switches the driving light on or off.

When the switch is in position **II** the following lights on the machine must light up:

- Left/right driving headlights (driving light)
- Left/right tail lights

The parking light also works after you take out the ignition key.

The driving lights work when the key is in position **I** or **II**.



Switching on the hazard warning system

Hazard warning system switch

Field colour – red

Switches the hazard warning system on or off.

When you press the switch:

If the hazard warning system field is flashing, all flashing lights on the machine are on.

If the hazard warning system field goes out, all the flashing lights on the machine go out.

The switch also works when the ignition key is in the 0 position or parking position.



Activating and deactivating the float position

Float position switch

Field colour – green

Switches the float position function on or off.

This function is only available once the engine has started.

When you press the switch, a solenoid on the pilot control device is activated.

The LIEBHERR control lever is held in the float position by magnetic force.



Activating and deactivating the bucket return-to-dig function

This equipment is optional.

Bucket return-to-dig switch

Field colour – green

Switches the automatic bucket return-to-dig function on or off.

This function is only available once the engine has started.

When you press the switch, a solenoid on the pilot control device is activated.

The LIEBHERR control lever is held in the bucket tilt-in position by magnetic force until the limit switch on the tilt cylinder switches off the solenoid in the pilot control device.



Activating and deactivating the working hydraulics lockout

Working hydraulics lockout button

Field colour – orange

Disables and enables the working hydraulics functions.

Press the button to activate or deactivate the working hydraulics lockout.



Button function with the ignition switched off:

- When you press the button **a** and at the same time operate the LH control lever, you can lower the lift arms and tilt out the bucket while the ignition is switched off.

Switching the rear windshield wiper and washer system on and off



bbb00258

Rear windshield wiper and washer system switch

Field colour – green

Switches the windshield wiper and washer system for the rear window on or off.

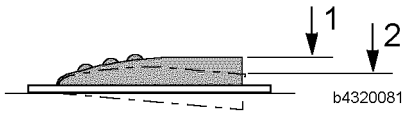

b4320081

The switch has a switch function **1** and a button function **2**.

Switch functions:

- Switch to position **1** for wiping
- Press to position **2** for washing

LCD brightness setting and engine speed, service hours and clock display

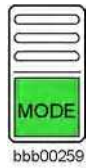

bbb00259

MODE button – LCD brightness setting and engine speed, service hours and clock display

Field colour – green

Adjusts the brightness and switches the LCD between the engine speed, service hours and clock.

LCD brightness setting

Press the button **b** to set one of various brightness levels for the LCD.

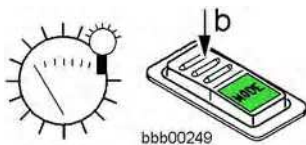

bbb00249

Engine speed indicator

Press the button **a** to switch the LCD to show the engine speed.



bbb00251

Service hours indicator

Press the button **a** to switch the LCD to show the service hours.



bbb00250

Clock display

Press the button **a** to switch the LCD to show the time.

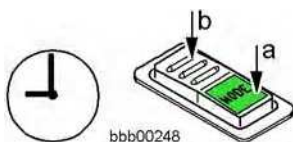

bbb00248

Setting the clock:

The digital display may not show an error if you want to activate clock setting mode.

Press the button **a** for longer than 5 seconds – the digital display starts to flash and the following functions are available.

- Button: **a**
Accept the numerical value shown and move to the next unit. The units are moved through as follows:
Year-month-day-hour-minute-second-apply values entered
- Button: **b**
Add up the number displayed.

Changing the software selection

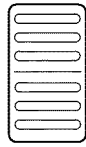

bbb00260

This equipment is optional.
 LCD software selection button
 Field colour – green
 Changes the LCD software

Switching the air-conditioning on and off



b4320082

This equipment is optional.
 Air-conditioning switch
 Switches the air-conditioning system on or off.

Switching the mirror heating on and off



bbb00164

This equipment is optional.
 Exterior mirror heating switch
 Field colour – green
 Switches the exterior mirror heating on or off.

Switching the reverse alarm on and off



bbb00196

This equipment is optional.
 Reverse alarm off switch
 Field colour – green
 Switches the reverse alarm on or off.

Switching comfort control on and off



bbb00268

This equipment is optional.
 Comfort control switch
 Switches the comfort control function on or off.

Switching ride control (LFD system) on or off



b4320084

This equipment is optional.
 Ride control button
 Switches the ride control system on or off.
 – Display “LFD 0” or “LFD 1”.

Functions:
 – SPEED (activation/deactivation according to speed)
 – ONOFF (manual activation/deactivation)

To switch from “SPEED” to “ONOFF” and back:
 – Press the button for 2 seconds.

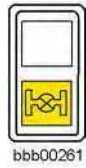

bbb00261

Differential lock indicator

100% differential lockout signal lamp

Field colour – yellow

Display function:

- When you press the button on the LH control lever, the signal lamp lights up.

Quick-change device indicator

This equipment is optional.

Hydraulic quick-change device control lamp

Field colour – red

Display function:

- When you press the hydraulic quick-change device switch, the control lamp lights up.



bbb00262

Activating and deactivating the quick-change device

This equipment is optional.

Hydraulic quick-change device switch

Field colour – red

Switches the hydraulic quick-change device function on or off.

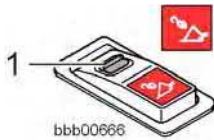

bbb00666

Note



This function is only available once the engine has started. The switch is secured with a lock to prevent actuation by mistake. ! Before actuation, release the lock 1.



bpik0006

When you press the switch:

- A warning signal in the side console sounds.

Switching on the rear working floodlights

This equipment is optional.

Rear working floodlight switch

Field colour – orange

Switches the rear working floodlights on or off.

Press the switch to switch the rear working floodlights on and off.

The switch also works when the ignition key is in the 0 position or parking position.



b4670031

Switching on the front working floodlights

Field colour – orange

Switches the front working floodlights on or off.

Press the switch to switch the front working floodlights on and off.

The switch also works when the ignition key is in the 0 position or parking position.



b4670030

Flashing beacon



This equipment is optional.

Flashing beacon switch

Field colour – orange

Switches the flashing beacon on and off.

The switch also works when the ignition key is in the 0 position or parking position.

Dummy plug



Dummy plug

Reserved for additional functions.

3.2.14 LIEBHERR control lever

This section describes the design and function of the LIEBHERR control lever.

Layout



LH control lever

- | | |
|------------------------------------|---|
| 1 LH control lever | 4 Button for optional attachments (optional third control circuit) |
| 2 Travel direction switch | 5 Button for optional attachments (optional fourth control circuit) |
| 3 100% differential lockout button | |

Function description

Use the LIEBHERR control lever (LH control lever) to control the travel direction and movements of the working attachment, the 100% differential lockout and optional attachments.

Switching the travel direction

The travel direction cannot be selected while the parking brake is engaged. You can switch travel direction using the button **1** on the LH control lever. See the section on driving in chapter 3.

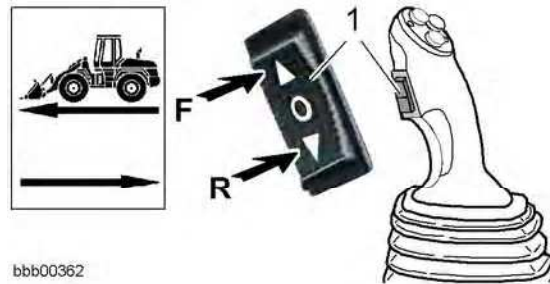

bbb00362

LH control lever

- 1 Travel direction switch
- 0 = Neutral travel direction
- F = Forward travel direction
- R = Reverse travel direction

- Selecting the travel direction:
Press the switch **1** according to the direction you want to travel in. Symbol fields are used to show the selected travel direction on the instrument panel in the display unit. See the section on the display unit in chapter 3.

Controlling the working attachment

The grip of the LH control lever is mechanically linked to the pilot control device directly underneath it.

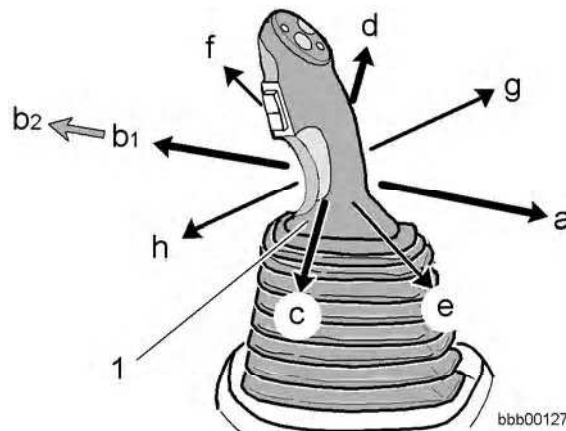

bbb00127

Directions of movement of the LH control lever

- a Back
- b1 Forward to action point
- b2 Forward to limit
- c Left
- d Right
- e-h Diagonal

- Control the working attachment by moving the LH control lever **1**.

LBH/02/003801/0003/2.06/en

Movements of the LH control lever and associated functions:

- a** – Raises the lift arm
- b1** – Normal lowering function – the lift arm is lowered slowly
- b2** – Fast lowering function – the lift arm is lowered quickly
- c** – Tilts the bucket in
- d** – Tilts the bucket out
- e** – Raises the lift arm while tilting the bucket in
- f** – Lowers the lift arm while tilting the bucket out
- g** – Raises the lift arm while tilting the bucket out
- h** – Lowers the lift arm while tilting the bucket in

Differential lock



100% differential lockout

1 LH control lever

2 100% differential lockout button

- Press and hold down the button to activate the 100% differential lockout.
- The 100% differential lockout is indicated by a signal lamp on the switch bar.

Comfort control

This equipment is optional.

- It controls an additional hydraulic function, such as the high dump bucket.
- It is operated using a button and the tilt-in and tilt-out function of the LH control lever.
- You can keep your hand on the LH control lever.
- It provides very accurate fine control.

Warning 

Incorrect operation can lead to injuries.

! The tilt-in and tilt-out function (tilt cylinder) cannot be used at the same time as comfort control.

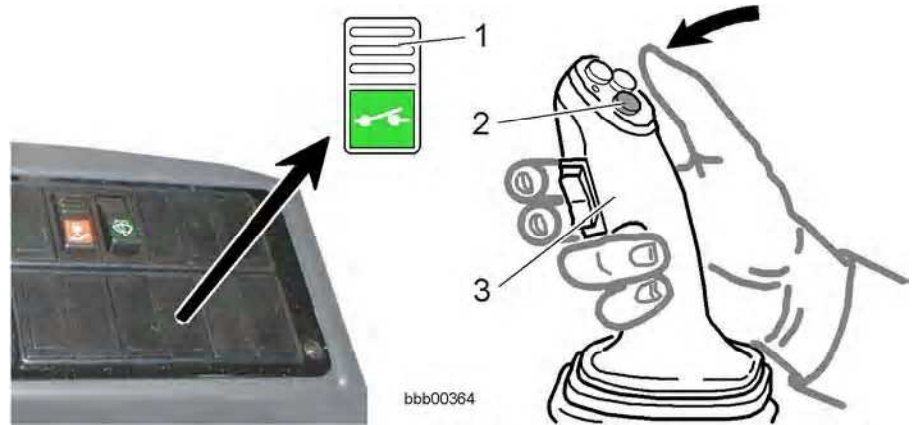

Comfort control

- 1 Comfort control switch
- 2 Comfort control button

- 3 LH control lever

- Activate the switch **1**.
- Press the button **2** and hold it down.
- Use the tilt-in or tilt-out function of the LH control lever **3** to move the working attachment via the additional control circuit.

An example of this is tilting the high dump bucket in or out using the bucket cylinder.

- If you let go of the button **2**, control of an additional hydraulic function is interrupted.

The working attachment is thus moved via the control circuit of the working hydraulics.

An example of this is tilting the attachment in or out using the tilt cylinder.

Button control

This equipment is optional.

- It controls an additional hydraulic function, such as the high dump bucket.
- It is operated by buttons.
- You can keep your hand on the LH control lever.
- Fine control is not possible.

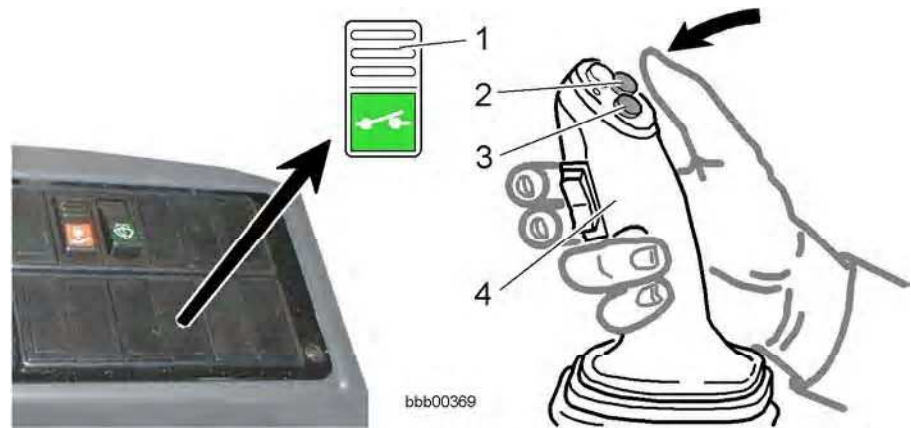

Button operation

- | | |
|------------------------------|-------------------------------|
| 1 Button control switch | 3 Hydraulic retraction button |
| 2 Hydraulic extension button | 4 LH control lever |

- Activate the switch 1.
- Use button 2 or 3 to move the working attachment or the additional control circuit.

An example of this is tilting the high dump bucket in or out using the bucket cylinder.

- If you let go of button 2 or 3, control of an additional hydraulic function is interrupted.

3.2.15 Control lever for additional working functions and quick-change device

The control lever for additional working functions and the quick-change device (additional control lever) is installed to the right of the LH control lever in the control panel.

Function description

If an optional attachment with an independent control circuit is attached to the lift arm, it is controlled by the additional control lever.

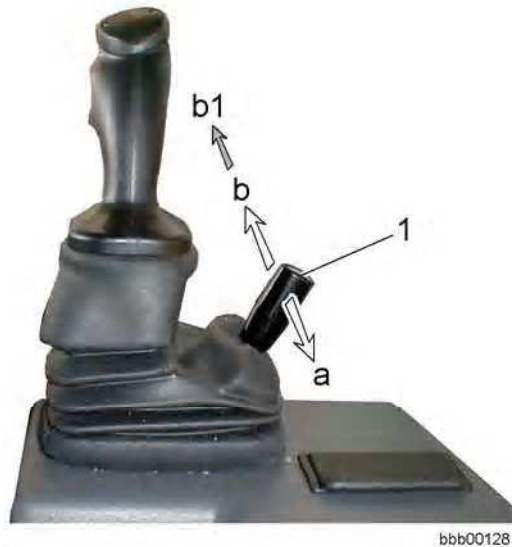

Directions of movement of the additional control lever

- | | |
|----------------------------|--|
| 1 Additional control lever | b1 – Forward beyond the action point (fixed position for continuous operation) |
| a – Back | |
| b – Forward | |

The optional equipment is controlled by moving the additional control lever **1**.

Movements of the additional control lever and associated functions:

- a** – The function depends on the type of optional equipment attached.
- b** – The function depends on the type of optional equipment attached.
- b1** – The fixed position for continuous operation depends on the type of optional equipment attached.

Make sure you are familiar with the operation of the optional attachment installed.

Refer to the section on operation or to the operating manual for additional equipment.

Operating the hydraulic quick-change device:

See the section on the hydraulic quick-change device - fitting and removing the working attachment

LBH/02/003801/0003/2.06/en

3.2.16 Heating and ventilation

The driver's cab is equipped with a warm water heating system.

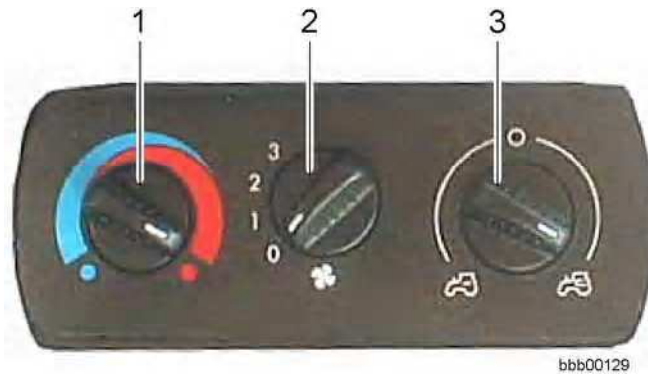

Heating and ventilation

1 Temperature knob
2 Blower motor knob

3 Air supply knob

Make sure that:

- The machine's electrical system is switched on.
- The nozzles for the air flow are open.
For example towards the driver, front windshield or rear window.

Regulating the temperature

The temperature can be adjusted progressively.

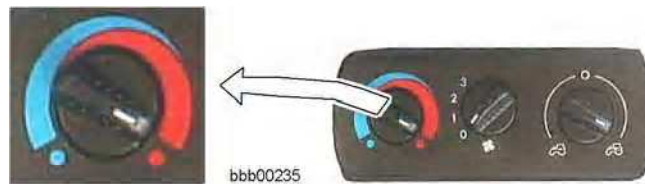

Temperature knob

- To regulate the temperature: turn the temperature knob to the required position.

Knob position:

- Blue for cold air
- Red for hot air

- To speed up the warming process:

Turn the temperature knob all the way to the right. At the same time, turn the air supply knob to the circulated air position and turn the blower motor knob to position **3**. See also the sections on regulating the blower and the air supply.

Adjusting the blower

The blower motor knob switches the blower on and off.

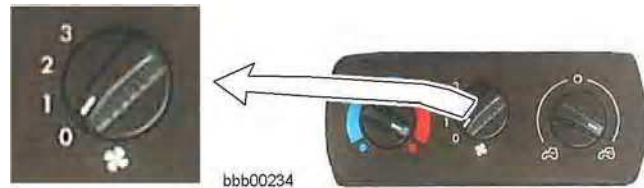

bbb00234
Blower motor knob

Blower speeds:

- Position 0 – Off
- Position 1 – Weak air flow
- Position 2 – Medium air flow
- Position 3 – Strong air flow

- Turn the blower motor knob to the required position.
- The air is blown into the cab through nozzles.

Regulating the air supply

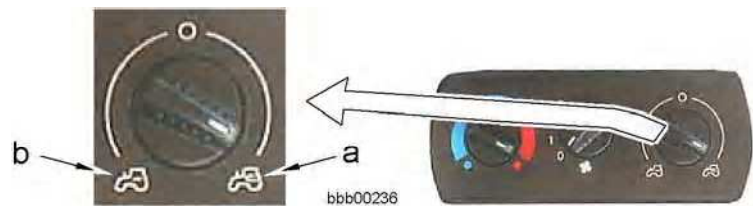

bbb00236
Air supply knob

Switch positions:

- Position a – Circulated air
- Position b – Fresh air

- To switch between fresh air and circulated air, turn the air supply knob to the required position.

3.2.17 Air-conditioning system

This equipment is optional.

The intake air is filtered through a serviceable dry filter cartridge and directed into the cab via the evaporator, heat exchanger and adjustable outlet nozzles.

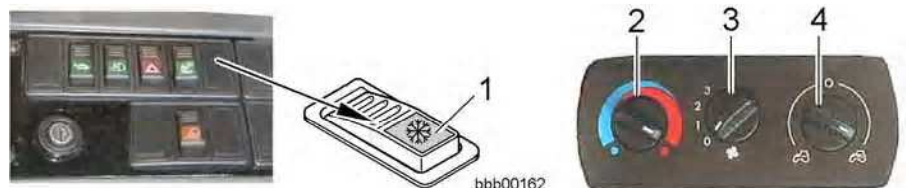

bbb00162
Air-conditioning system

1 Air-conditioning switch

2 Temperature knob

LBH/02/003801/0003/2.06/en

3 Blower motor knob

4 Air supply knob

Using the air-conditioning system

In order to ensure that the air-conditioning system remains in good working order, it is advisable to switch it on every 14 days.

When the air-conditioning system is in use, the shaft seal ring in the air-conditioning compressor is lubricated. This prevents coolant escaping from the air-conditioning compressor.

In order to switch on the air-conditioning system:

- The engine must be running.
- The blower knob must be set to at least position 1.
- The temperature in the cab must be above +1 °C (below this temperature, the thermostat in the evaporator is switched off).

Switching on the air-conditioning system

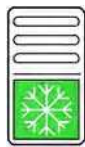

b4320082

- Press the air-conditioning switch.

The switch symbol lights up to indicate that the function is active.

Regulating the temperature

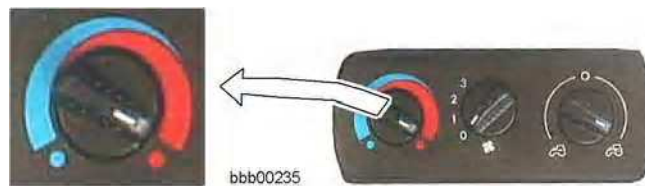

bbb00235

Temperature knob

The cab temperature is regulated by mixing in hot air supplied by the heater.

- Set the heater knob as required.

Turn clockwise = warmer

Turn anticlockwise = colder

Cooling the air in the cab

- If heat has built up in the cab, first air the cab thoroughly.

To achieve maximum cooling in the cab, take the following steps:

- Set the highest blower speed
- Turn the temperature knob all the way to the left
- Close the cab doors and windows
- Turn the air supply knob to circulated air
- Turn on the air-conditioning system using the air-conditioning switch.

Re-heat mode

On cold, damp days, you can use the air-conditioning system to dehumidify the cab air.

- To dehumidify the cab air, switch on the air-conditioning system in addition to the heater.

This stops the windows from misting up:

- The damp air condenses on the evaporator
- It is then drained outside into the drip pan.

Switching off the air-conditioning system

- To switch off the air-conditioning system, press the air-conditioning system switch.

When the function is switched off, the light in the switch symbol goes out.



3.2.18 Interior and exterior mirrors

The driver's cab is equipped with one interior and two exterior mirrors.

Adjusting the mirrors

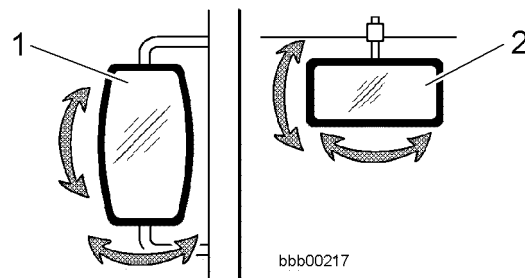

Adjusting the mirrors

1 Exterior mirror

2 Interior mirror

- All mirrors can be adjusted individually.

3.2.19 Sun visor

The driver's cab is equipped with a sun visor.

Adjusting the sun visor

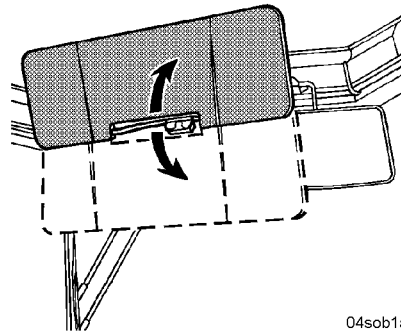

Adjusting the sun visor

- Adjust the sun visor according to your individual requirements by pulling it up or down.

3.2.20 Radio

This equipment is optional.

Functions:

- Also works when the ignition key is in the 0 position or parking position.

Switching on and using the radio



- To use the radio:
See the radio manufacturer's operating manual supplied.

3.2.21 Windshield wiper and washer system

Layout

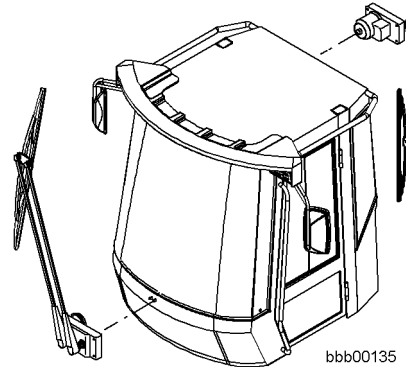

The machine has an electric windshield washer and wiper system for the front and rear windshields.

Essentially it consists of the controls, the windshield wipers, the reservoir and pumps, and the outlet nozzles for the washing fluid.

The wiper and washer systems for the front and rear windshield use a shared washer fluid reservoir.

Non-return valves are fitted in the washing fluid hoses to the outlet nozzles.

The switches for the front washer and wiper system are on the steering column switch.

The switches for the rear washer and wiper system are in the right-hand side console. There is a spring-action button for activating the washer fluid pump.

Activating the windshield wiper and washer system

Make sure that the electrical system is switched on before using the wiper and washer system.

Using the front windshield wiper and washer system

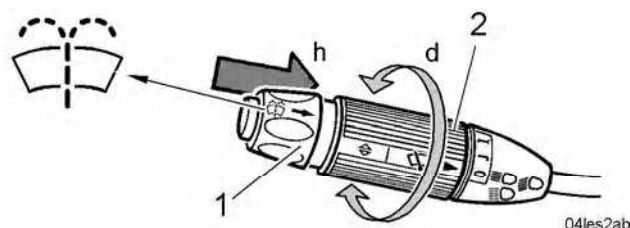

Steering column switch

- 1 Button
- 2 Handle
- d Windshield wiper activation
- h Windshield wiper and washer system activation

- To wipe the window, turn the handle **2** to the required position **J – I**.
- To wash the window, press the button **1** on the steering column switch.

Washer fluid is sprayed onto the front windscreen through the outlet nozzles.

LBH/02/003801/0003/2.06/en

Using the rear windshield wiper and washer system

Switch on the windshield wiper and washer system by pressing the switch **1** .

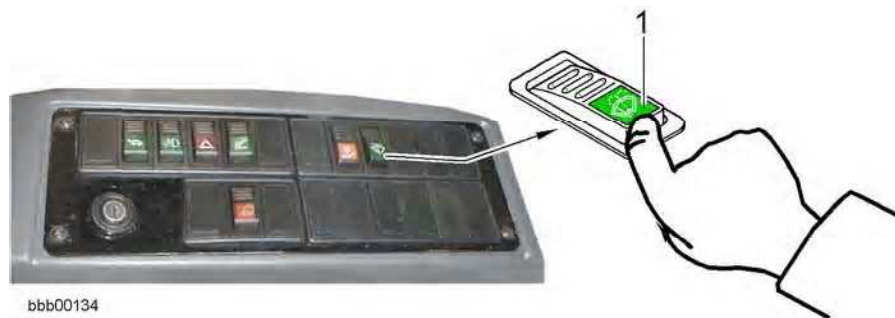

bbb00134

Switches on the side console

1 Rear windshield wiper and washer system switch

- To wipe the window, press the switch **1** once. The rear windshield wiper is activated.
- To wipe and wash the window, press the switch **1** again and hold it down.

Washer fluid is sprayed onto the rear windscreen through an outlet nozzle.

- To switch off the windscreen washer, release the switch **1** .
- To switch off the windscreen wiper, push the switch **1** back.

3.2.22 Windshield washer fluid reservoir

Layout

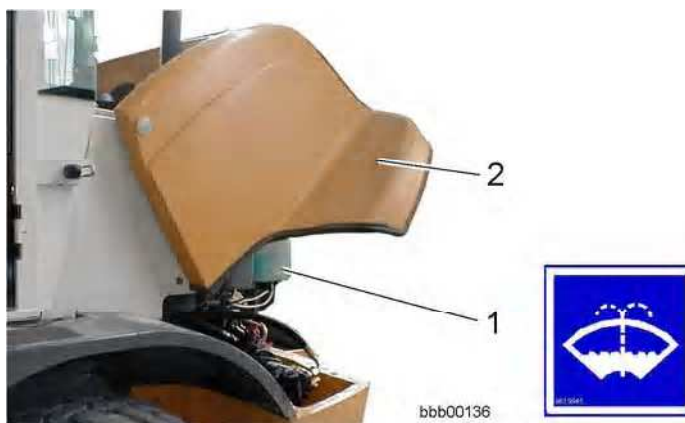

bbb00136

Windshield washer fluid reservoir

1 Reservoir with filling inlet 2 Engine compartment rear hatch

The reservoir **1** is on the left of the engine compartment.

LBH/02/003801/0003/2.06/en

Topping up washer fluid

The filling quantity is 3.5 litres.

- Open the engine compartment rear hatch **2**.
- Top up with standard windshield washer fluid as necessary.

Caution



Ice can damage the windshield wiper and washer system. Icing up can damage the windscreen wiper and washer system and cause it to fail. A dirty front or rear windscreen is a safety hazard.

! Scrape snow and ice from the windshield before driving.

! You must protect the windshield wiper and washer system using anti-freeze.



04sy02ab

- Use commercially available windscreen antifreeze.
- Top up with an appropriate quantity of antifreeze before the winter starts.

3.3 Handling

3.3.1 Daily start-up

Make sure that:

- The maintenance tasks to be carried out daily or every 10 service hours have been performed.
See the maintenance and inspection schedule in chapter 5.
- Enough diesel fuel is available for the daily workload.
See the section on refuelling with diesel fuel.

Operating position

This is how to put the machine into the operating position.

Turning on the battery main switch

The battery main switch is located at the rear right of the engine compartment.



Battery main switch

1 Battery main switch

2 Main switch key

- Switch on the battery main switch.
- Close all service doors, hatches and hoods, and lock them if possible.

Closing the service doors, hatches and hoods

Releasing the articulation lock

Warning

There is a risk of accidents if the steering is locked.
When the articulation lock is engaged, no steering functions are possible.
! Release the articulation lock.

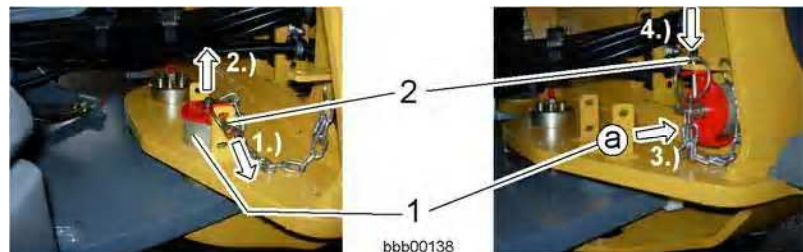

Articulation lock

1 Pin

2 Spring clip

LBH/02/003801/0003/2.06/en

- Push the pin 1 towards the arrow to position a.
- Secure the pin 1 using the spring clip 2.

Putting the machine in the starting position

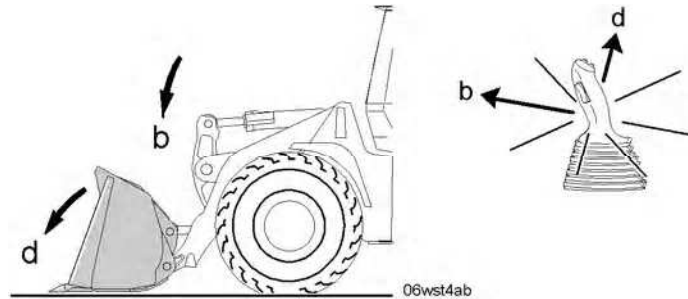

Starting position

- Set the bucket down flat on the ground.

Refuelling with diesel fuel

Make sure that the electrical system is switched on.

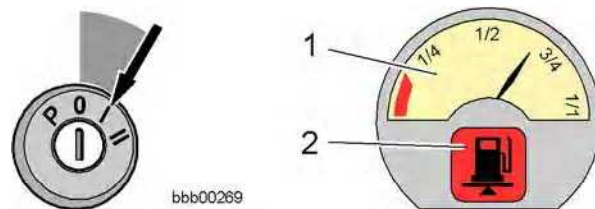

Diesel fuel display

1 Fuel supply display

2 Fuel supply symbol field

- Look at the fuel supply display field 1 to see if there is sufficient diesel in the tank.

If there is too little fuel, the fuel supply symbol field 2 lights up. See also the section on the display unit.

In this case, there are 10 litres left in the tank.



Safety while refuelling

LBH/02/003801/0003/2.06/en



Danger

There is a risk of fires and explosions.

! Do not smoke. Make sure there are no naked lights when refuelling.

! Only refuel with the engine switched off.



Fuel tank

- It is essential to observe the safety regulations for refuelling. See also the safety regulations in chapter 2.
- Only use clean diesel fuel.
- Carefully clean around the tank cap 1 before taking it off.
- Push off the cap 2.
- Release the tank lock and remove the tank cap.
- Refuel with diesel fuel as necessary.
- If possible, refuel at the end of the working day to prevent condensation from accumulating in the tank.

The machine is ready for operation.

3.3.2 Starting the diesel engine

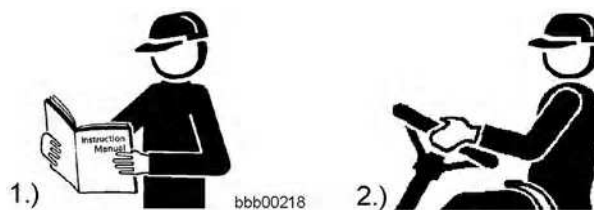

Operating manual

1.) Make sure you have read and understood the operator's manual

2.) Then you are ready to use the machine

Only ever operate the machine once you have read and understood the operating manual.



Note

The machine is equipped with a hydrostatic travel drive.

! You cannot start the engine by bump-starting it or towing it.

Starting precautions

The following precautions must be taken before starting the machine. First make sure that the machine is in its operating position. See the section on the operating position.

Starting procedure

Lamp check

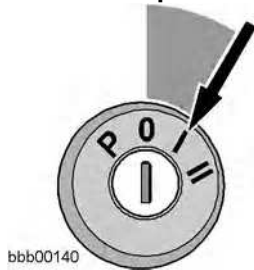

During the lamp check, the control electronics test all the symbol fields.

- Switch on the electrical system by turning the ignition key to position I.

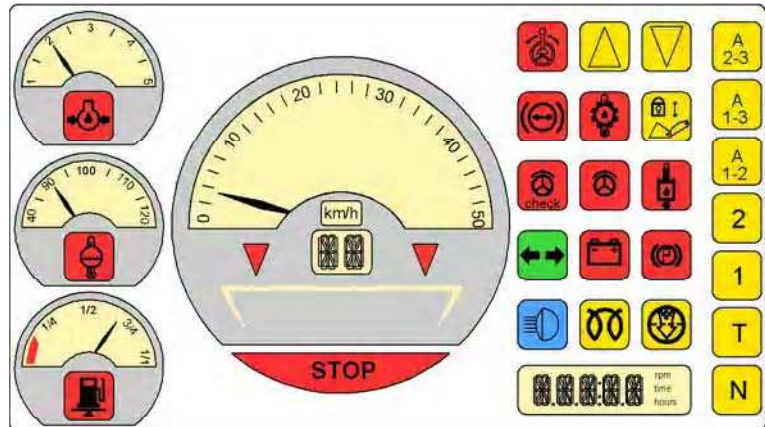

bbb00270

Display unit during the lamp check

All symbol fields light up for 3 seconds.

For the indications and function of the symbol fields, see the section on the display unit.

After the check is completed, the following symbol fields must still light up with the key in position I:

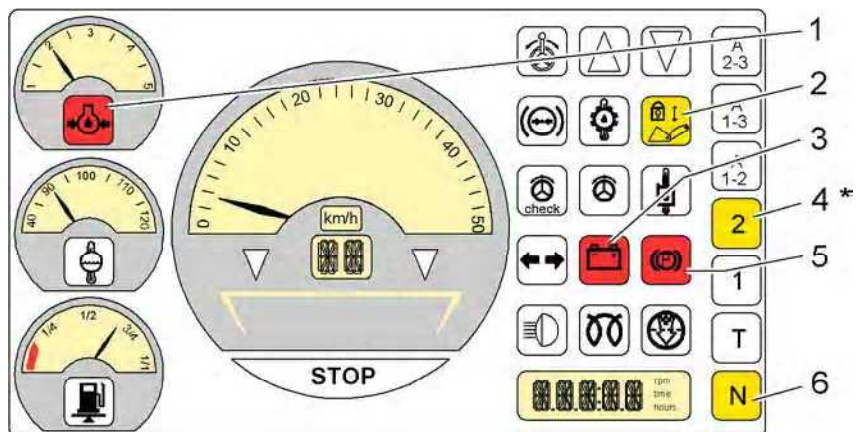

bbb00271

Display unit after the lamp check

- | | |
|--|---|
| 1 Engine oil pressure symbol field | 4 Travel range 2 symbol field |
| 2 Working hydraulics lockout symbol field | 5 Parking brake symbol field |
| 3 Battery charge (charge control) symbol field | 6 Neutral travel direction symbol field |

* Depending on the selected travel range, the symbol field for either travel range 1 or travel range 2 lights up.

Preglowing the engine

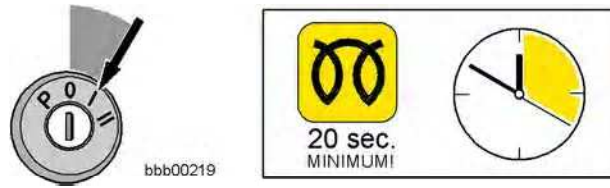

Ignition key contact and preglow positions

The preglow time depends on the outside temperature and the electrical starting conditions.

The minimum is 20 seconds and at extremely low temperatures it can be more than 120 seconds.

If the engine is warm and at high ambient temperatures, you do not need to wait for the preglow time.

Note: do not preglow the engine if it is already at operating temperature.

- Switch on the electrical system by turning the ignition key to position I.

The following symbol fields must light up:

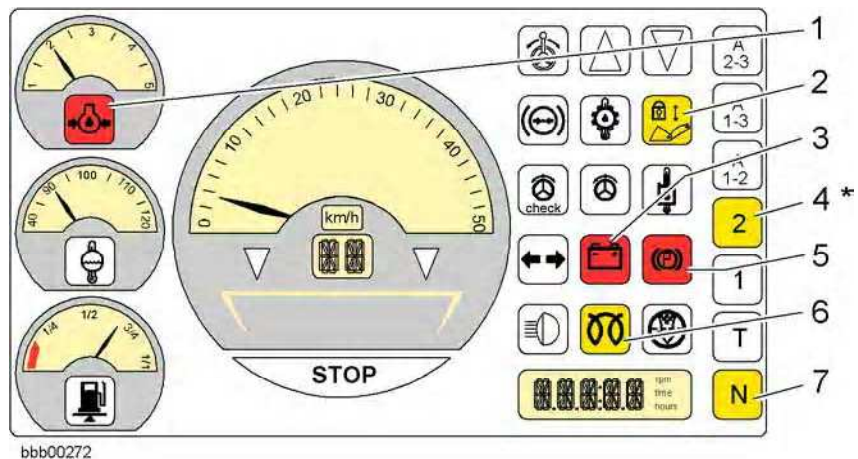

Display unit while preglowing the engine

- | | |
|--|---|
| 1 Engine oil pressure symbol field | 4 Travel range 2 symbol field |
| 2 Working hydraulics lockout symbol field | 5 Parking brake symbol field |
| 3 Battery charge (charge control) symbol field | 6 Preglow monitor symbol field |
| | 7 Neutral travel direction symbol field |

* Depending on the position of the travel range switch, the symbol field for either travel range 1 or travel range 2 lights up.

Starting the engine

- Wait until the symbol field for the preglow monitor goes out.

The preglow time is over when the symbol field goes out.

The engine is ready to start.



Ignition switch starting position

- Turn the ignition key to the starting position II and keep it in there until the engine starts.
- **Do not hold the key in the starting position for more than 10 seconds at a time.**
- If the engine does not start:
Turn the ignition key back to the 0 position.

Troubleshooting

The engine will not start.

- Wait two minutes and try to start the engine again.
- If the engine does not start after two attempts, find the cause in the troubleshooting table and rectify it. See the section on troubleshooting in chapter 4.

- Let go of the ignition key as soon as the engine starts running.

The ignition key automatically returns to the operating position.

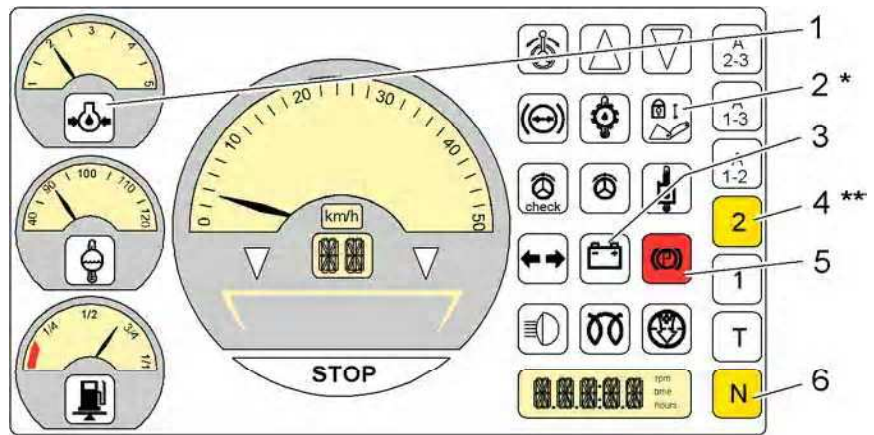

bbb00273

Display unit

- | | |
|--|---|
| 1 Engine oil pressure symbol field | 4 Travel range 2 symbol field |
| 2 Working hydraulics lockout symbol field | 5 Parking brake symbol field |
| 3 Battery charge (charge control) symbol field | 6 Neutral travel direction symbol field |

* Depending on whether the working hydraulics lockout is activated, the working hydraulics lockout symbol field either lights up or goes out.

** Depending on the selected travel range, the symbol field for either travel range 1 or travel range 2 lights up.

When the engine starts, the following symbol fields must go out:

- Engine oil pressure
- Battery charge (charge control)

When the engine starts, the following symbol fields must light up:

- Travel range 2
- Parking brake
- Neutral travel direction

LBH/02/003801/0003/2.06/en

Troubleshooting

The symbol fields **1, 3** do not go out.

- Switch off the engine and rectify the problem as described in the section on malfunctions.

- Regulate the engine speed using the gas pedal.

Starting precautions at cold temperatures

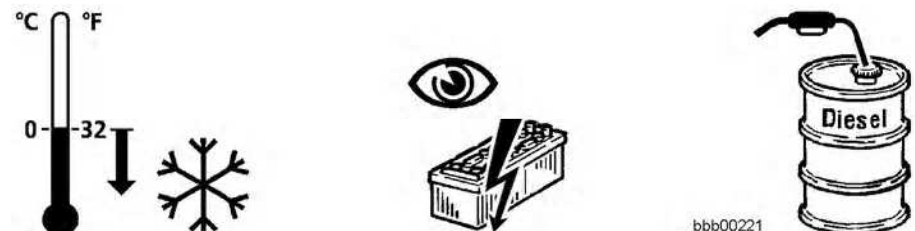

Winter operation

The following precautions help you start the engine at cold temperatures.

Precautions:

- Check the battery charge
If necessary, recharge the battery.
- Use winter-grade fuel
See the section on diesel fuels in chapter 5.

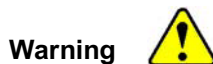

There is a risk of explosion with the diesel engine.
There is a risk of explosions when using volatile fluids for starting diesel engines with preglow systems.

! Do not use starting agents containing ethers.

- Carry out the precautions listed for starting at temperatures below freezing.

3.3.3 Driving



- This is the situation after the electrical system is switched on:
- When the parking brake is engaged, the travel lockout is active.
 - The travel direction cannot be preselected.
 - The travel direction can be selected.

Preparing for driving

Carry out the preparations for driving in the following order.
First make sure that the machine is in its operating position.
See the section on the operating position.

Checking the lights

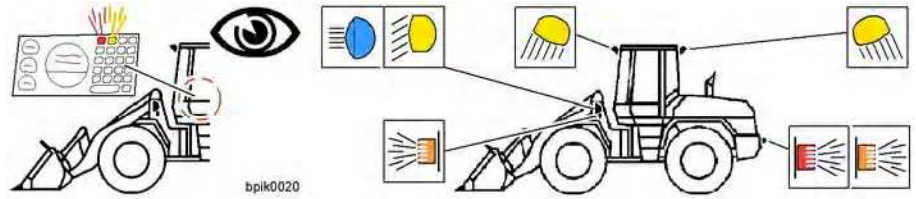

bpik0020

Lighting equipment

- Check all of the lighting equipment.
- Adjust the headlights if necessary.

Checking the interior and exterior mirrors

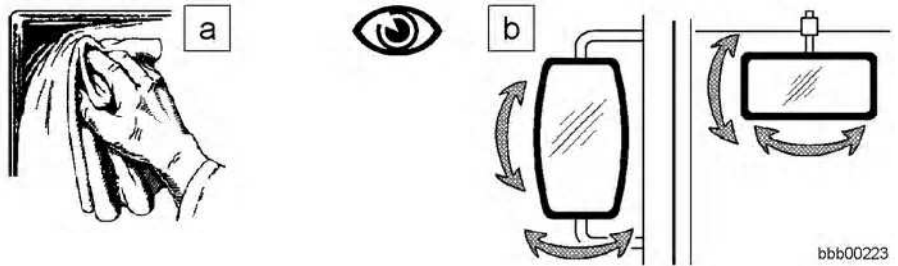

bbb00223

Interior and exterior mirrors

- Clean the interior and exterior mirrors.
- Adjust the interior and exterior mirrors.
- Turn the ignition key to the starting position II and keep it in there until the engine starts.
See also the starting procedure in the section on starting the diesel engine.

Starting the machine

Putting the working attachment into position

For detailed information, see the sections on the LIEBHERR control lever and using the lift arms.

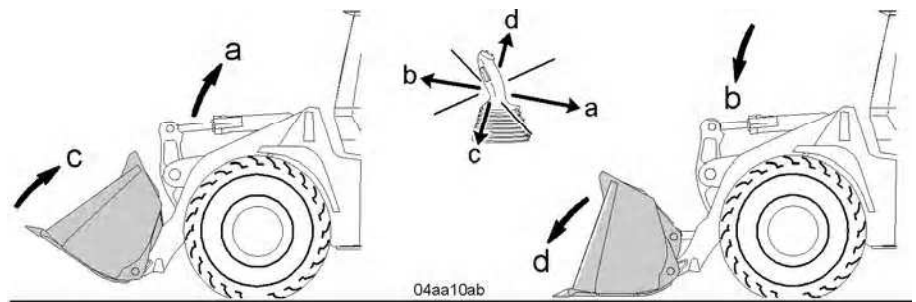

04aa10ab

Bucket position

- Raise or lower the lift arm to the starting position.
- Move the bucket into position.

LBH/02/003801/0003/2.06/en

Releasing the parking brake

When the parking brake is engaged, the travel lockout is active. The travel direction cannot be preselected.

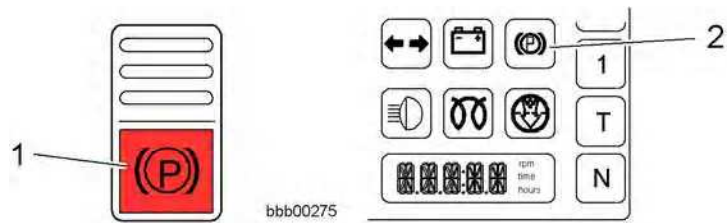

Display unit and parking brake lever

1 Parking brake button

2 Parking brake symbol field

- To release the parking brake, press the button 1. The symbol field 2 for the parking brake goes out.

Selecting the travel direction

You can now select forward or reverse travel by pushing the rocker switch.



Rocker switch and display unit

1 Travel direction switch

2 Forward travel direction

3 Neutral travel direction

4 Reverse travel direction

5 Neutral travel direction symbol field

6 Forward travel direction symbol field

7 Reverse travel direction symbol field

- Depending on the operation, set the switch 1 to forward or reverse travel direction.

The selected travel direction is shown by symbol field 6 or 7 in the display unit.

Selecting travel ranges

Select the travel range using the travel range switch. See also the section on switches in the side console.

The selected travel range is shown on the instrument panel in the display unit. See also the section on the display unit.

You can shift to another travel range at any speed. If you shift down at a high speed, the machine is hydrostatically braked.

You can select the following travel ranges:

- Travel range 1 for slow driving (e.g. on steep slopes).
- Travel range 2 for normal working operation.

Travel speeds: See the section on the travel drive in chapter 1.
 The maximum tractive force is reached in both travel range 1 and travel range 2.

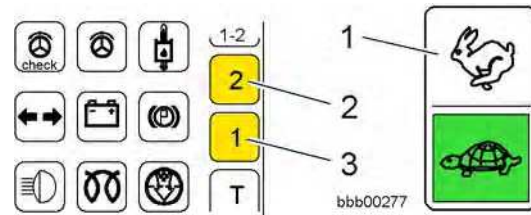

Selecting travel ranges

- 1 Travel range switch
- 2 Travel range 2 symbol field
- 3 Travel range 1 symbol field

- Depending on the operation, set the switch **1** to travel range **1** or **2**. The selected travel range is shown by symbol field **2** or **3** in the display unit.

Setting off

Make sure that you have carried out all the preparations for driving.
 See also the section on preparing for driving.

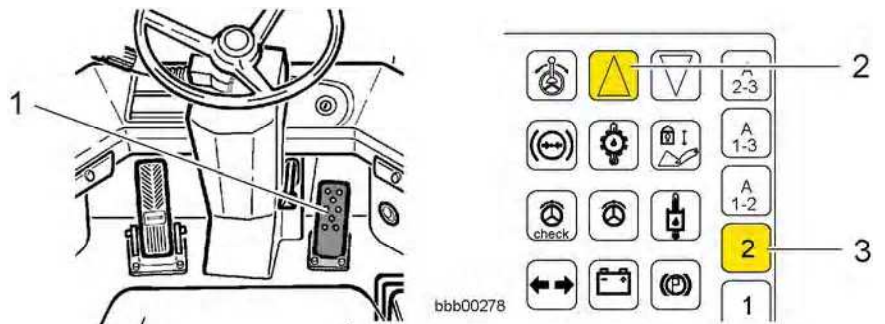

Gas pedal

- 1 Gas pedal
- 2 Travel direction symbol field
- 3 Travel range 2 symbol field

- Push down the gas pedal **1**. The machine starts moving.
- Control the travel speed using the gas pedal.

LBH/02/003801/0003/2.06/en

Driving

You will find descriptions of work operations, driving, transport and transferring bulk material in the section on general working methods.

Just after you set off, check that the steering and brakes are working properly.

See the section on maintenance tasks in chapter 5.

Reversing

The machine can be reversed in either travel direction and at any travel speed.

If you change travel direction at a high speed, the machine is hydrostatically braked.

This results in smooth reversing action.



Rocker switch and display unit

- | | |
|----------------------------|---|
| 1 Travel direction switch | 5 Forward travel direction symbol field |
| 2 Forward travel direction | 6 Reverse travel direction symbol field |
| 3 Neutral travel direction | |
| 4 Reverse travel direction | |

- Depending on the operation, set the switch 1 to forward or reverse travel direction.

The selected travel direction is shown by symbol field 5 or 6 in the display unit.

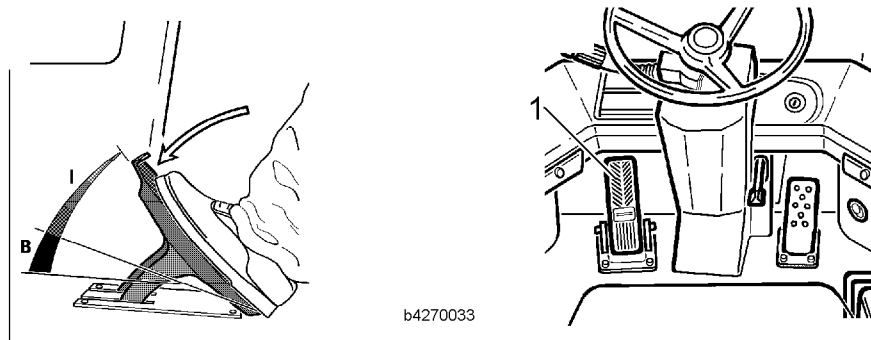

Inch/brake pedal

You can support the reversing procedure by easing off the gas pedal or by gently pressing the inch/brake pedal.

- Support the reversing procedure if necessary.**

This results in smooth reversing action.

Driving on public roads

Before driving on public roads, find out about the route (roads, bridges, tunnels, underpasses, bottlenecks etc.) as regards the weight limit, bridge load, width and height restrictions.

Wheel loaders which are limited by design to a maximum speed of 20 km/h and have no official registration number must be labelled on both sides with the operating company's address and require an operational liability insurance certificate.

The wheel loader may only be driven on public roads when unloaded.

Before driving on public roads, find out the following:

- Ask the vehicle owner whether the necessary conditions for permission to drive on public roads have been met.
 - "Operating permit"
 - "Special license"
- The appropriate safety regulations.
- See the following sections in chapter 2:
 - "Safety instructions for driving on slopes"
 - "Instructions for safe working"

Make sure that you have carried out all the preparations for driving.

Preparing for driving on roads

Make sure that the safety devices listed below are all stowed on board, in accordance with the provisions of the **Roadworthiness Certification**.

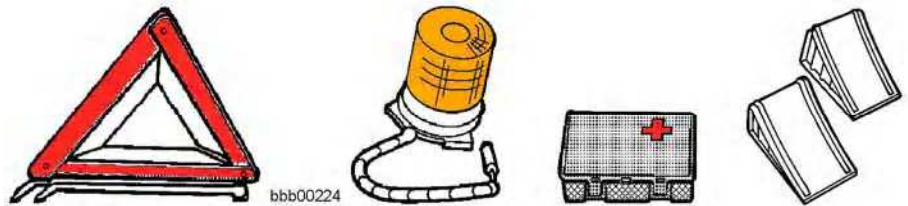

- Warning triangle
- Flashing beacon
- First aid kit
- Wheel wedges

Also make sure that you have carried out all the tasks listed below.

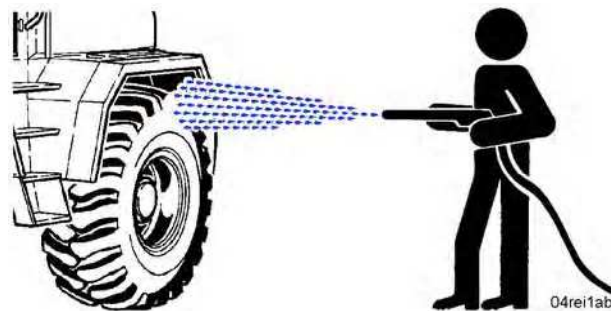

Washing

LBH/02/003801/0003/2.06/en

- Remove coarse dirt from the machine and clean the tyre treads.
See the section on cleaning the machine in chapter 5.
- Close all service doors, hatches, covers and hoods and where possible lock them.

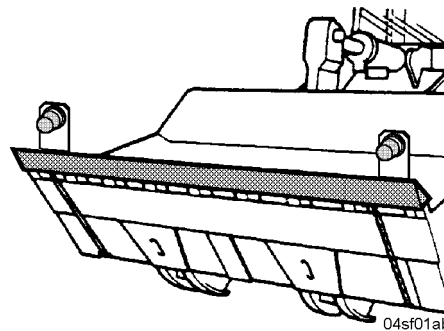

Bucket tooth guard and side lamps

- Attach the tooth guard to the bucket.
- Attach the side lamps.
- Plug in the cables for the side lights.

Driving

You will find descriptions of work operations, driving, transport and transferring bulk material in the section on general working methods.

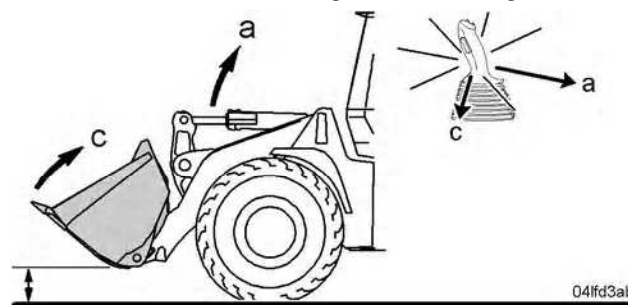

Transport height

Make sure that:

- The bucket is in the transport position when driving.
The transport position means that the bucket pivot point is about 40 cm above the ground.
- The bucket is tipped up as far as it will go.

Make sure that the working hydraulics are locked so that the working attachment cannot be moved inadvertently.

See also the section on locking the working hydraulics.

- Always drive with due care.
- Observe the highway code.

Braking

There are two ways to brake the machine:

- With the hydrostatic circuit only.
- With the hydrostatic circuit and the service brake.

Hydrostatic braking

You can brake the machine hydrostatically by reducing the engine speed. The hydrostatic travel drive system of the machine also acts as a service brake in the deceleration phase.

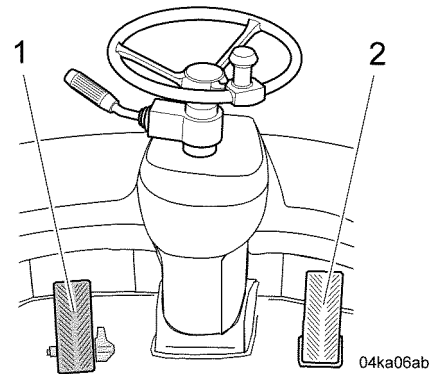

Inch/brake pedal and gas pedal

1 Inch/brake pedal

2 Gas pedal

- Reduce the speed of the diesel engine with the gas pedal **2**.

Service brake

If hydrostatic braking is not sufficient, you must brake the machine using the inch/brake pedal **1**.

Braking with the inch/brake pedal

During braking, there are two actuation ranges for the inch/brake pedal:

- Range **I** for hydrostatic braking only.
- Range **B** for braking with the hydrostatic circuit and the service brake.

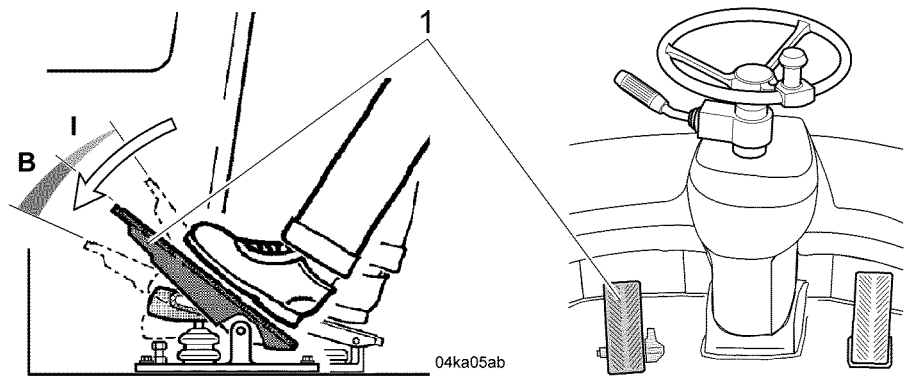

Inch/brake pedal

1 Inch/brake pedal
I Inching range

B Braking range

LBH/02/003801/0003/2.06/en

Danger



There is a risk of accidents when braking.
If you brake the machine, you may suffer severe injuries if your seat belt is not properly fastened.

! It is essential that you fasten your seat belt before starting up the machine.

! For full braking in emergencies, push the inch/brake pedal all the way down.

- Braking with the hydrostatic circuit only: Actuate the inch/brake pedal **1** in range **I**.

or

- With the hydrostatic circuit and the service brake. Actuate the inch/brake pedal **1** in range **B**.

The machine is braked accordingly.

Troubleshooting

Little or no braking effect.

- Shut down the machine immediately.
- Contact LIEBHERR CUSTOMER SERVICE.

Braking in emergencies

Danger



There is a risk of accidents when braking.
If you brake the machine, you may suffer severe injuries if your seat belt is not properly fastened.

! It is essential that you fasten your seat belt before starting up the machine.

! For full braking in emergencies, push the inch/brake pedal all the way down.

- Press the inch/brake pedal **1** in range **B** as far as it will go.

This brakes the machine suddenly.

After the machine stops

If you leave the machine with the engine running, take the following precautions.

Engaging the parking brake

Do not engage the parking brake until the machine has come to a full standstill.

When you engage the parking brake the travel direction is automatically switched to neutral.

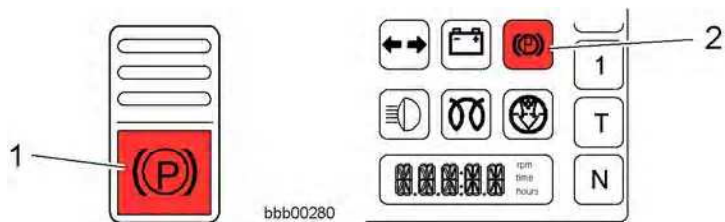

Display unit and parking brake switch

1 Parking brake button

2 Parking brake symbol field

- Activate the parking brake with the button 1. The symbol field 2 for the parking brake lights up. The parking brake is engaged and the travel direction is switched to neutral.

Locking the working hydraulics

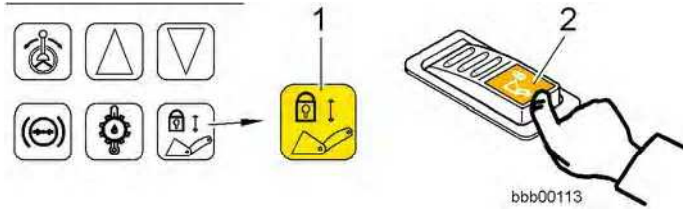

Working hydraulics lockout

1 Working hydraulics lockout symbol field

2 Working hydraulics lockout switch

- Press the switch 2 for the working hydraulics lockout to prevent inadvertent activation of the working attachment. The symbol field 1 lights up. The working hydraulics are no longer operational.

Securing the machine

The following precautions should be taken when the machine is to be parked for a prolonged period on a slope.

Danger



There is a risk of accidents if the machine rolls away.
! Secure the machine against rolling away.

- Take the wedges out of their holders.

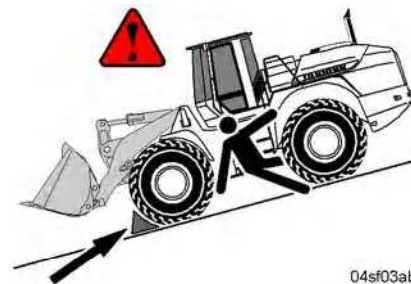

Downhill slope

- Use the wedges to secure the machine against rolling away.

3.3.4 Shutting down the machine

Take the following precautions before you switch off the engine and leave the machine.

LBH/02/003801/0003/2.06/en

Lowering the working attachment

Make sure that the bucket is empty.

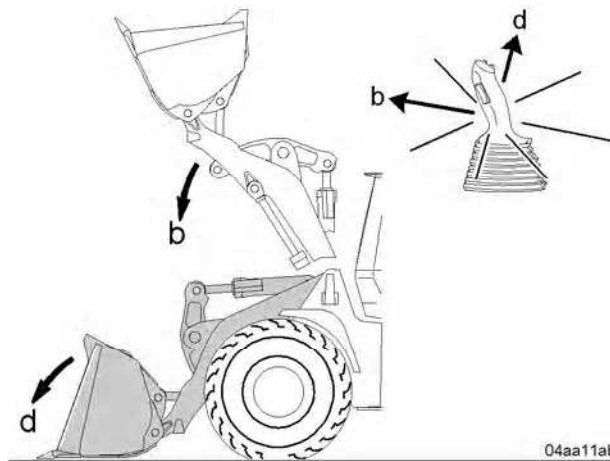

04aa11ab

Bucket arm movement

- Lower the lift arms by moving the control lever in direction **b**.
- Set down the bucket flat on the ground by moving the control lever in direction **d**.

Engaging the parking brake

When you engage the parking brake the travel direction is automatically switched to neutral.

Do not engage the parking brake until the machine has come to a full standstill.

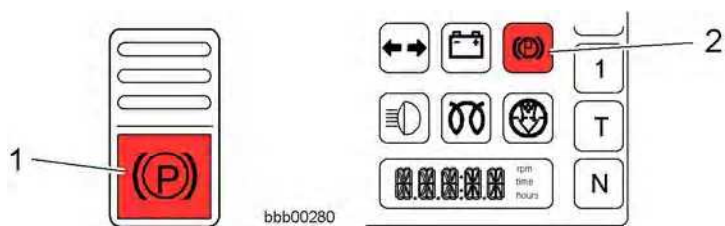

bbb00280

Control unit

1 Parking brake button

2 Parking brake symbol field

- Activate the parking brake with the button **1**.
The symbol field **2** for the parking brake lights up.

Locking the working hydraulics

The working hydraulics lockout is activated automatically when you switch off the ignition.

This is how to activate the working hydraulics lockout before switching off the ignition.

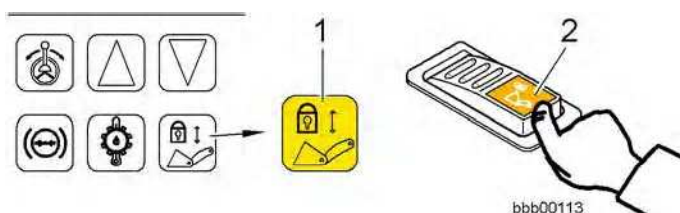

bbb00113

Control unit

1 Working hydraulics lockout symbol field

2 Working hydraulics lockout button

- **If necessary**, press the button **2** for the working hydraulics lockout to prevent inadvertent activation of the working attachment.

The symbol field **1** for the working hydraulics lockout lights up. The working hydraulics are no longer operational.

Switching off the engine

Note



Do not switch off the engine suddenly when it is running at full speed. This is especially important with turbo engines.

! If you suddenly switch off the motor, the turbocharger continues running for a while with no oil supply.

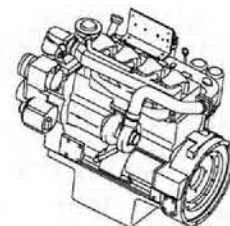

bbb00237

Switching off the engine

- Reduce the engine speed to idle running speed by taking your foot off the gas pedal.
- Let the engine continue idling briefly - for 10 to 15 seconds.
- Turn the ignition key to the **0** position and pull it out.

All the symbol fields go out.

Turning off the battery main switch

The battery main switch is located at the rear right of the engine compartment.

See the section on turning off the battery main switch in chapter 5.

If you are leaving the machine unattended:

Caution



There is a risk of damaging the electrical system.

! Do not turn off the battery main switch while the engine is running.

See the section on turning off the battery main switch in chapter 5.

- If you turn off the battery main switch:
First turn off the engine and then turn off the battery main switch.
- To secure the machine against unauthorised use, pull out the main switch key.



bpik0024

Securing the machine

The following precautions should be taken when the machine is to be parked for a prolonged period on a slope.

Danger



There is a risk of accidents if the machine rolls away.
! Secure the machine against rolling away.

- Take the wedges out of their holders.

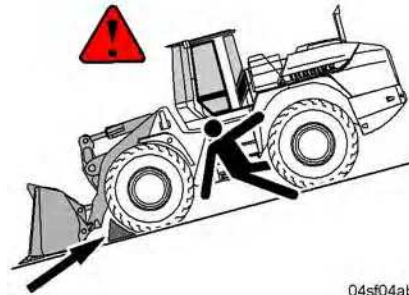

Downhill slope

- Use the wedges to secure the machine against rolling away.

Parking position

The ignition key cannot be pulled out in the parking position **P**.

- Turn the ignition key to the parking position **P**.
- You can keep the battery main switch turned on when parking the machine on public roads.



bbb00226

Ignition switch parking position

The consumer units listed below are ready for operation:

- Parking and driving light
- Interior lighting
- Hazard warning system
- Socket/cigarette lighter
- Front working floodlights

The following optional accessories are also ready for operation, if fitted.

- Flashing beacon
- Radio
- Rear working floodlights

Danger



If unauthorised people are on the machine it can put the maintenance personnel in extreme danger.

! Secure the machine against access by unauthorised persons.

- When leaving the machine:
Turn the ignition key to the **0** position and pull it out.

Any power consumers which are still required can be switched on at the instrument panel.

See the section on the ignition switch.

3.3.5 Operating the lift arms

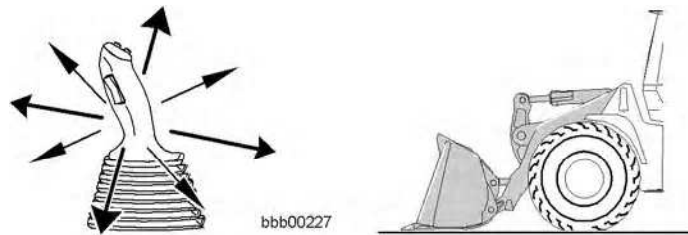

LH control lever

The movements of the lift arms and the working attachment (bucket) are controlled by the LH control lever.

See also the section on the LIEBHERR control lever.

Releasing the working hydraulics

The working hydraulics are automatically ready for operation when you switch on the ignition.

- If you have previously engaged the working hydraulics lockout: Release the working hydraulics for operation.

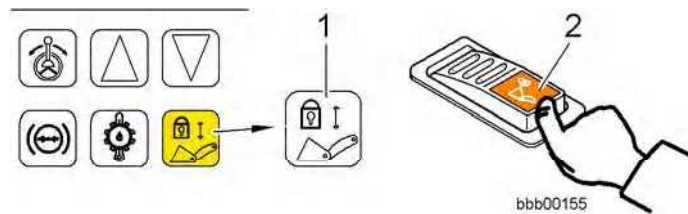

Deactivating the working hydraulics lockout

1 Working hydraulics lockout symbol field

2 Working hydraulics lockout button

- Deactivate the working hydraulics lockout by pressing the button 2. The symbol field 1 for the working hydraulics lockout goes out. The working hydraulics are now operational. You can operate the working attachment.

Operating the lift cylinders

The lift cylinders raise and lower the lift arms.

Raising or lowering the lift arms

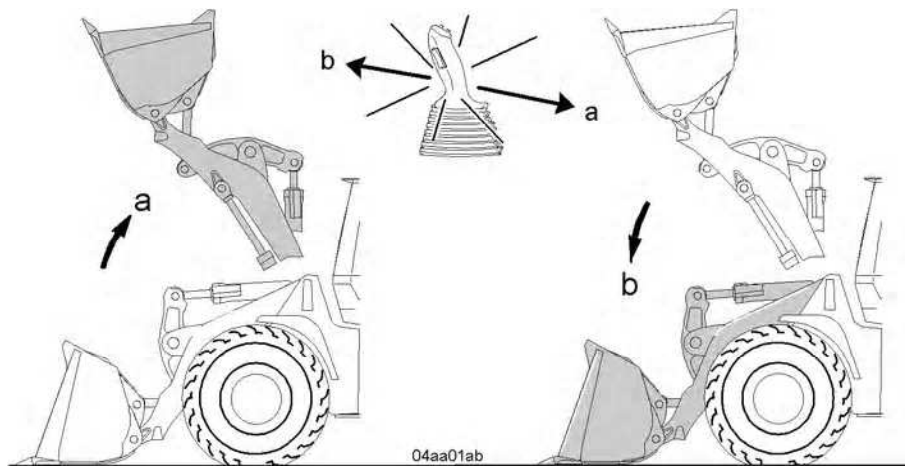

Raising or lowering the lift arms

LBH/02/003801/0003/2.06/en

- Move the LH control lever in direction **a**.
The lift arms are raised.

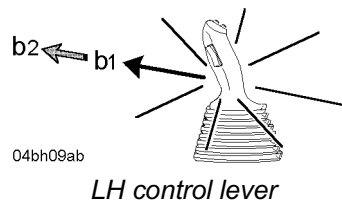

There are two ways to lower the lift arms:

- Slowly, using the normal lowering functions - **b1**
- Quickly, using the quick drop function - **b2**

- To actuate the normal lowering function, move the LH control lever in the direction **b1** up to the action point.

The lift arms are slowly lowered.

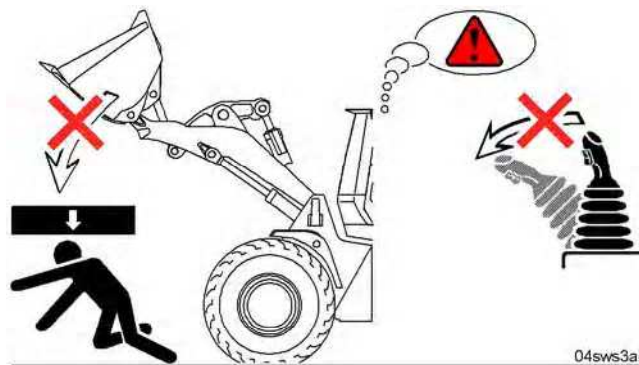

Danger

Danger



There is a risk of accidents when the working attachment is lowered quickly.

The raised working attachment is lowered quickly when you actuate the quick drop function.

Anyone standing under the working attachment will be crushed.

! Keep out of the danger area.

- To actuate the quick drop function, move the LH control lever in direction **b2** through the action point to its limit.

The lift arms are quickly lowered.

Operating the tilt cylinders

The tilt cylinder tilts the bucket in and out.

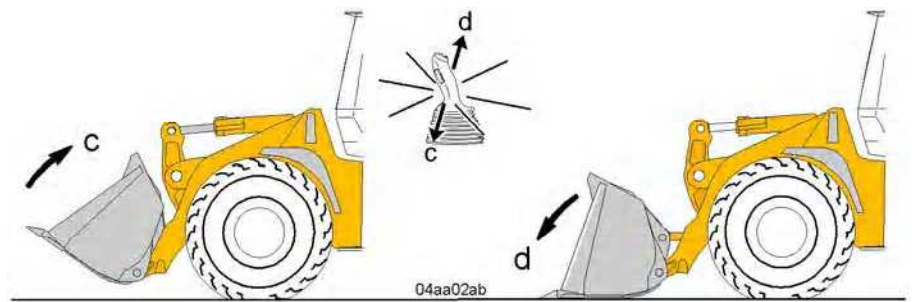

Tilting the bucket in and out

Tilting the bucket in or out

- Move the LH control lever in direction **c**.
The bucket is tilted in.
- Move the LH control lever in direction **d**.
The bucket is tilted out.

Operating the lift and tilt cylinders simultaneously

You can extend or retract the lift and tilt cylinders simultaneously by moving the LH control lever diagonally.

Raising the lift arms while tilting the bucket in or out

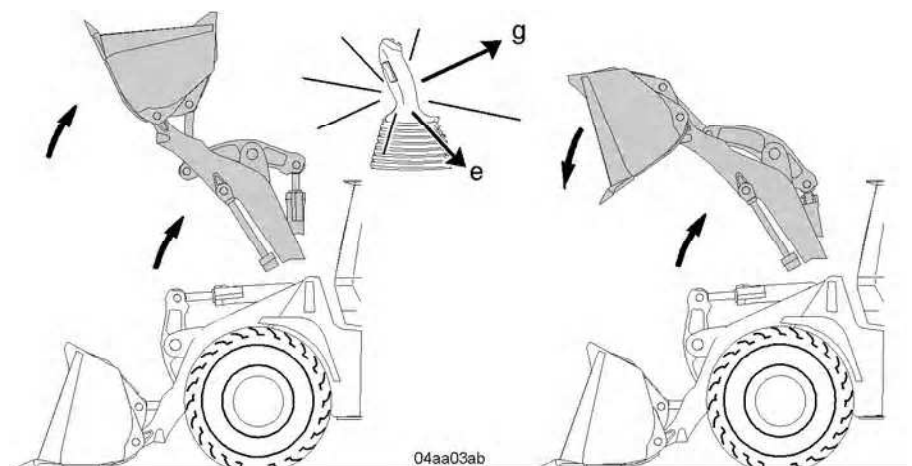

Working movements

- Move the LH control lever in direction **e**.
The lift arms are raised while the bucket is tilted in.
- Move the LH control lever in direction **g**.
The lift arms are raised while the bucket is tilted out.

LBH/02/003801/0003/2.06/en

Lowering the lift arms while tilting the bucket in or out

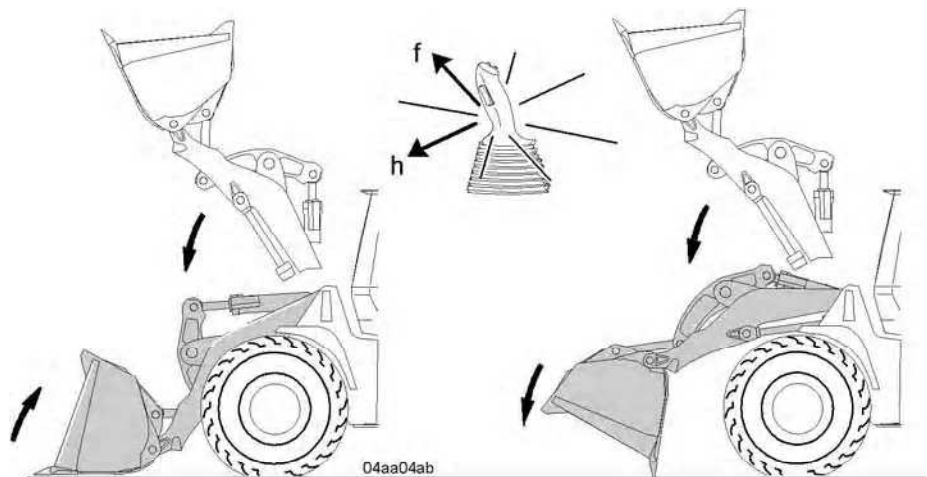

Working movements

- Move the LH control lever in direction **h**.
The lift arms are lowered while the bucket is tilted in.
- Move the LH control lever in direction **f**.
The lift arms are lowered while the bucket is tilted out.

Float position

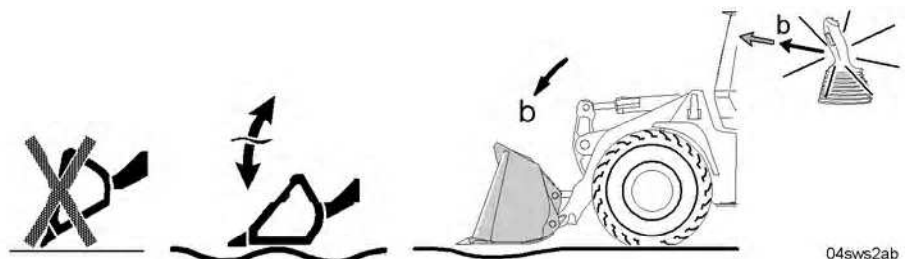

Bucket in float position

The float position allows the bucket to lie on the ground under its own weight and to move freely on uneven ground.

Activating float position

This is how to activate the float position.

Make sure the lift arms are lowered and the bucket is lying flat on the ground.

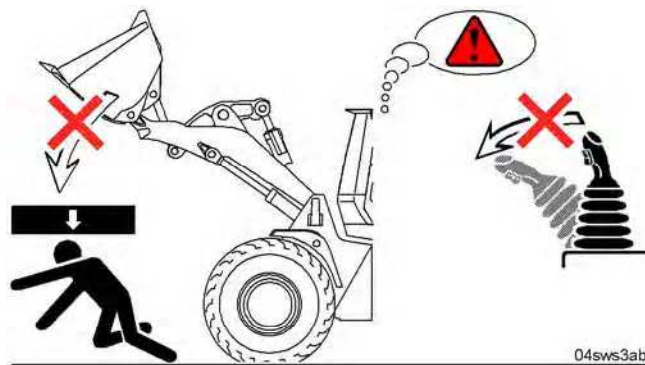

Danger

LBH/02/003801/0003/2.06/en

Danger 

There is a risk of accidents when the working attachment is lowered quickly.
 The working attachment is lowered quickly when the float position is activated.
 Anyone standing under the working attachment will be crushed.
! Keep out of the danger area.

- Do not activate the float position function when the working attachment is raised.

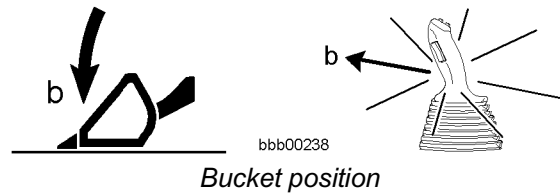

- Lower the lift arm and lay the bucket down flat on the ground.

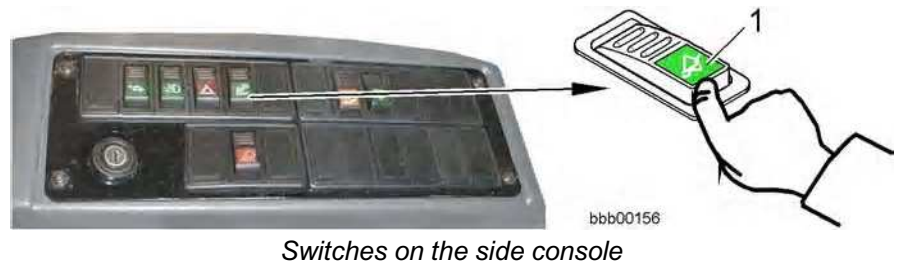

1 Float position switch

Press the float position switch **1** to enable the function.

- Press the float position switch **1**.

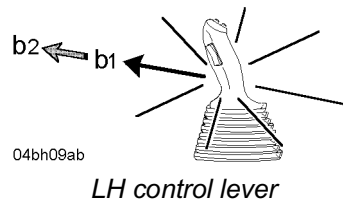

- Move the LH control lever in direction **b2** through the action point as far as it will go and then release it.

The LH control lever is held in this position by magnetic force.

The float position function is now active.

Activating the manual bucket return-to-dig function

To be used on machines with Z kinematics and standard buckets.

Using the manual bucket return-to-dig function

The indicator **1** for the bucket position shows whether the bucket base is parallel to the ground.

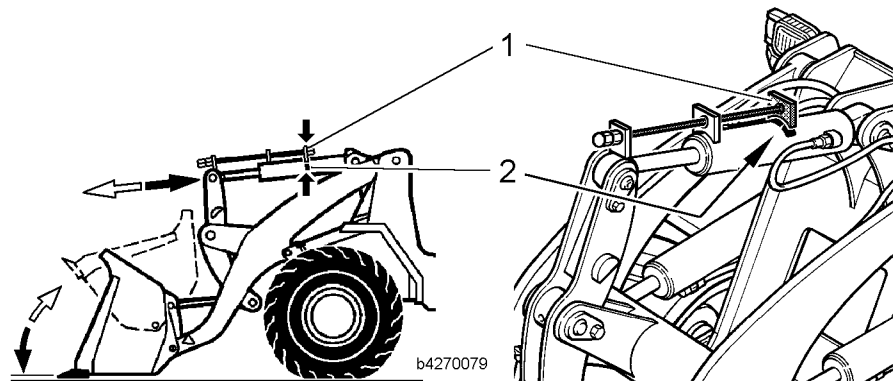

Bucket position indicator

- Using the tilt cylinder, tilt the bucket in or out until the indicator **1** covers the marking **2** on the tilt cylinder.

See also the section on operating the tilt cylinders.

Automatic bucket return-to-dig function

This equipment is optional.

You can use the automatic bucket return-to-dig function for loading jobs which require a certain digging position.

Activating the automatic bucket return-to-dig function

The procedure for activating the automatic bucket return-to-dig function is as follows:



Switches on the side console

1 Bucket return-to-dig switch

- Press the bucket return-to-dig switch **1**.

The automatic bucket return-to-dig function is now activated.

Using the automatic bucket return-to-dig function

Make sure the automatic bucket return-to-dig function is activated.

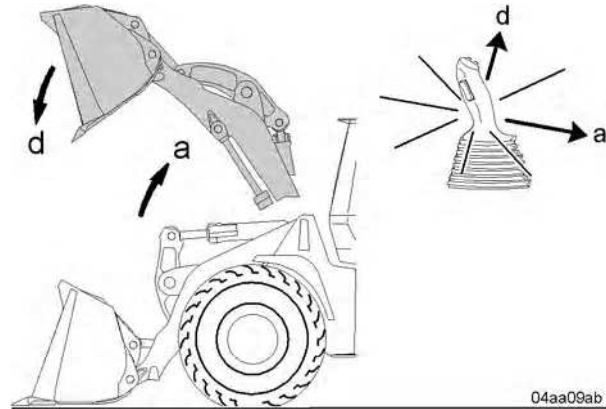

Working movements

- Raise the lift arm by moving the LH control lever in direction **a**.
- Tilt the bucket out in the raised position by moving the LH control lever in direction **d**.

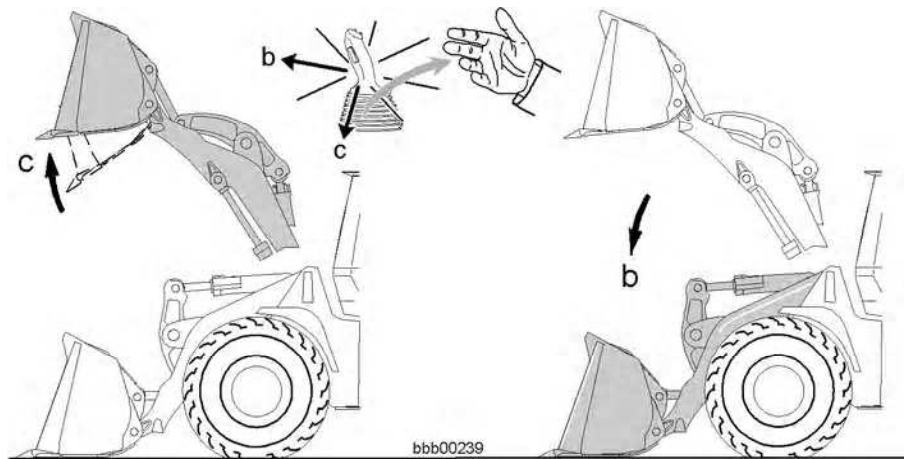

Working movements

- Tilt in the loading bucket in the raised position by moving the LH control lever in direction **c** through the action point as far as it will go and releasing it.

The LH control lever is held in this position by magnetic force.

This moves the bucket into the preliminary position for the digging position.

As soon as the bucket reaches the preliminary position, the solenoid releases the LH control lever.

- Lower the lift arms by moving the LH control lever in direction **b**. This moves the loading bucket into the digging position on the ground.

LBH/02/003801/0003/2.06/en

Setting the digging position

The proximity switch for the automatic bucket return-to-dig function is set at the factory.

If necessary, the proximity switch can be re-adjusted.

The procedure for re-adjusting the proximity switch is as follows.

Rough adjustment

Make sure that the lift arms are lowered and the bucket is empty.

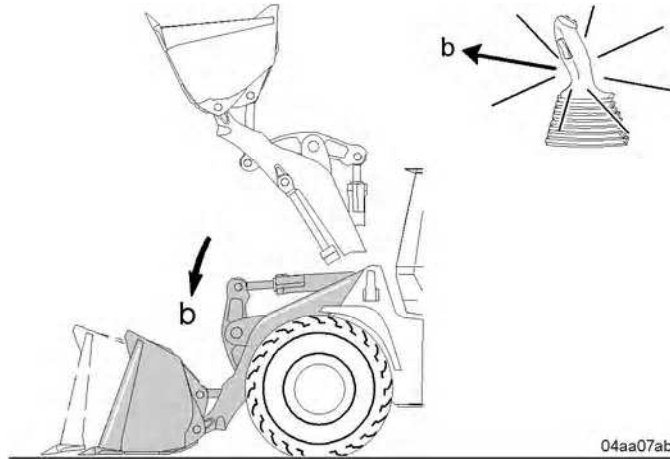

Rough digging position

- Using the LH control lever, move the loading bucket to the required digging position.

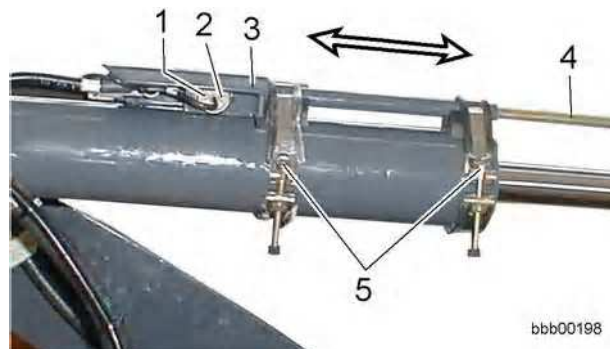

Setting up bucket return-to-dig

- | | |
|--------------------|-----------------|
| 1 Proximity switch | 4 Shift linkage |
| 2 LED | 5 Screws |
| 3 Bracket | |

- Loosen the screws **5**.
Horizontally adjust the bracket **3** until the shift linkage **4** covers half the contact surface of the proximity switch **1**.
When the shift linkage enters the contact area of the proximity switch, the LED **2** on the proximity switch lights up.
- Tighten the screws on the bracket again.
The rough adjustment of the required digging position is now complete.
- Test the rough adjustment: The procedure is described in the section on using the automatic bucket return-to-dig function.
- If required, carry out a fine adjustment.

Fine adjustment

Carry out several tests to perform the fine adjustment.

LBH/02/003801/0003/2.06/en

- Using the LH control lever, move the loading bucket to the exact digging position.
- Re-adjust the proximity switch as detailed in the section on rough adjustment.
- Test the fine adjustment. The procedure is described in the section on using the automatic bucket return-to-dig function.

3.3.6 Working methods

This section describes the routine working methods.

Picking up and moving material

The following procedure is recommended to avoid any possible loss of traction.

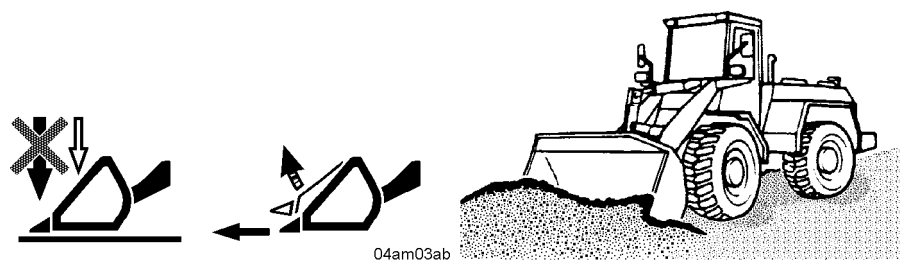

- Do not work with a strong downwards pressure on the bucket.
- If the flow of the bulk material into the bucket needs to be assisted when driving into the material, gently tip the bucket up and down.

Pressing the inch/brake pedal reduces tractive force, which makes loading easier.

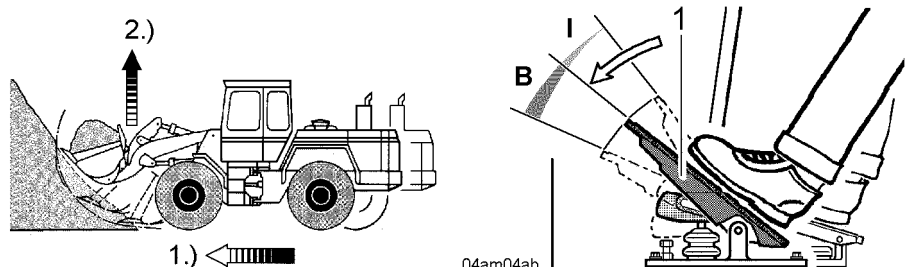

Power distribution by inching

1 Inch/brake pedal
I Inching range

B Braking range

- Also press down the inch/brake pedal 1 in range I with the required force.

The power is adjusted:

- 1.) The power of the travel hydraulics is reduced.
- 2.) The power of the working attachment is reduced.

Power adjustment has the following advantages:

- The wheels no longer spin
- The fuel consumption is reduced.

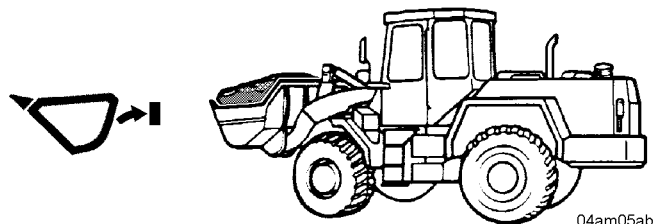

04am05ab

- Tilt in the loaded bucket as far as it will go and raise the lift arms.

Transporting and moving material

The bucket should be moved into the transport position to improve the machine's stability and to ensure good viewing conditions when transporting and transferring bulk materials.

The transport position means that the bucket pivot point is roughly 40 cm above the ground.

Transport position

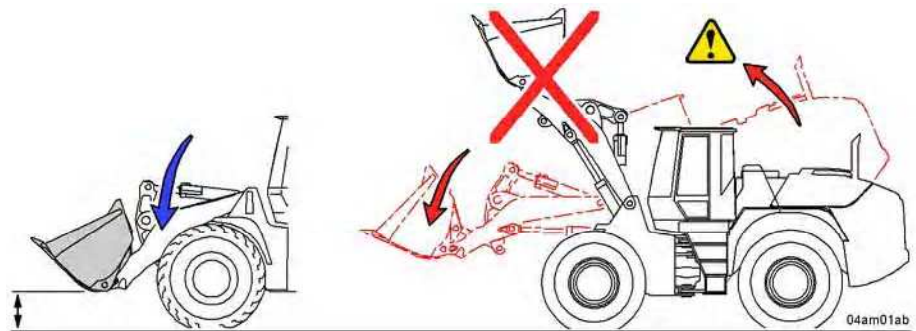

04am01ab

Bucket position

Warning

There is a risk of the machine tipping over. The machine might tip over when the lift arms are raised due to the shift in the centre of gravity.

! Observe the maximum permitted bulk material weight and the specified tipping loads.

- Move the loaded bucket to the transport position.

Transporting the load on a slope

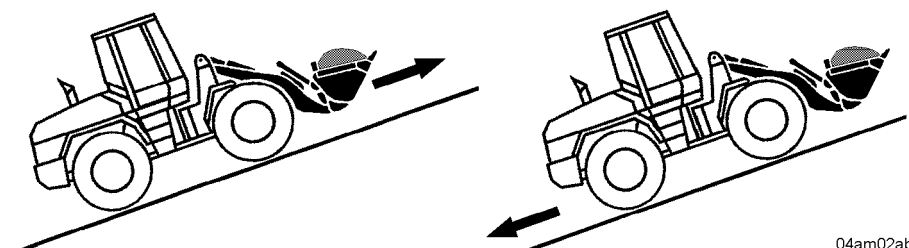

04am02ab

Direction of travel during transport

LBH/02/003801/0003/2.06/en

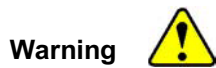

There is a risk of the machine tipping over.

! Hold the loaded bucket low when transporting a load on steep terrain.



- Do not turn the machine on steep slopes.
- Drive forwards up the slope.
- Drive backwards down the slope.
- Do not drive on slopes with the working attachment raised.

Driving on slopes

You must observe the safety instructions when driving on slopes. See the safety instructions for driving on slopes in chapter 2.

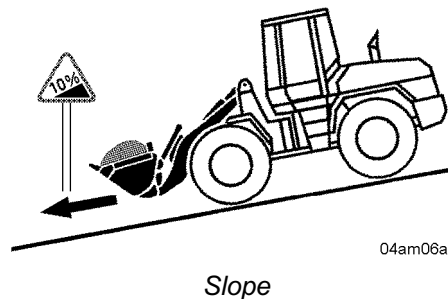

There is a risk of the machine tipping over.

The machine can tip over more easily when driving on sloping ground.

! Always keep the loaded bucket low during transport.

! Do not suddenly change direction or brake abruptly.

- Ease off the gas pedal before driving onto the slope.
- Drive downhill carefully.
- If necessary, apply the service brake.

or

If driving on a long, steep downhill slope:

- First switch to travel range I. See also in the information on changing travel ranges in the driving mode section.

Grading work

Keep the bucket base horizontal when grading.

Grading The following procedure is recommended to avoid any possible loss of traction.

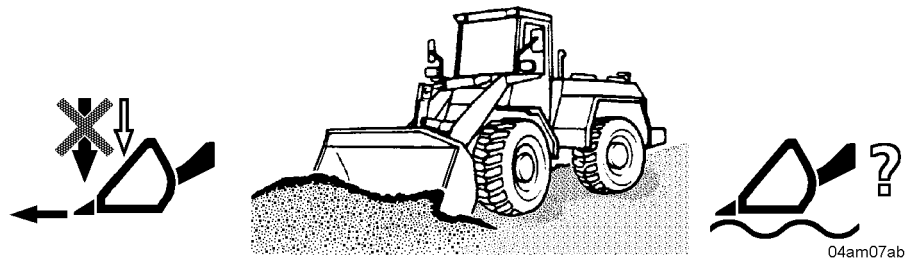

Procedure for grading

- Do not work with a strong downwards pressure on the bucket.

or

- Use the float position function. See also the sections on operating the lift arms and the float position function.

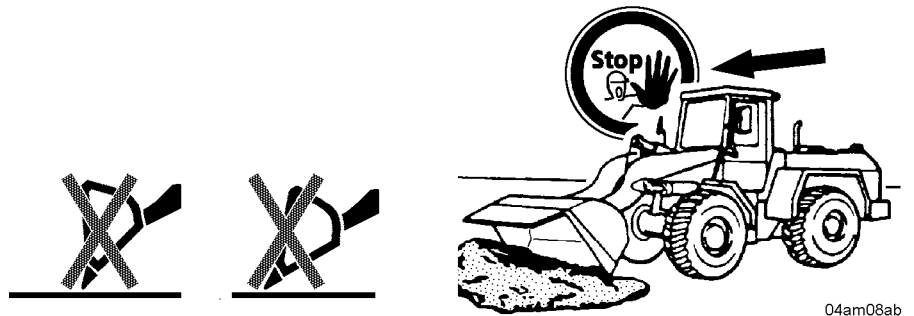

Impermissible bucket positions

Caution 

There is a risk of damage to the machine.

The machine may be damaged during grading work if the bucket hits a hard object when it is tipped down while the machine is moving forward.

! Do not grade in the forward travel direction with the bucket tipped down.

- Keep the base of the bucket parallel to the ground.

or

- Gently set the bucket base down.

Scraping off material

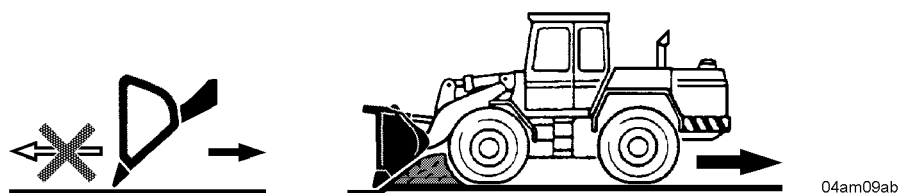

- Tilt the bucket down and drive backwards.

Loading a heap

Picking up material

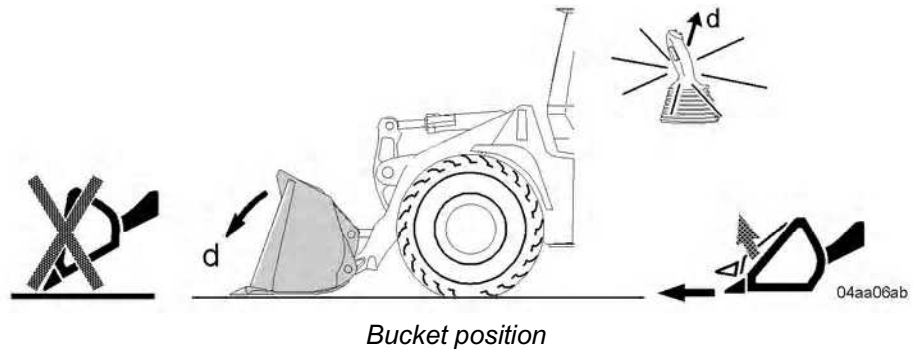

Caution

There is a risk of damage to the machine. The lift arms may be damaged if you hit a hard obstacle at speed when clearing away bulk material in the forward travel direction with the bucket tipped down.

! When clearing away bulk material, do not drive into the pile with the bucket tipped down.

- Lower the bucket horizontally to the ground.
- Drive into the material, slightly tipping the bucket in the process.
- If the flow of the bulk material into the bucket needs to be assisted gently tip the bucket up and down when driving into the material.
- Also press down the inch/brake pedal. See the section on picking up and moving material.

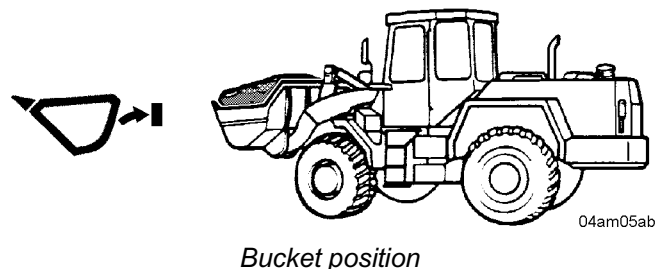

- Tilt in the loaded bucket as far as it will go and raise the lift arms.

Transporting material

Keep the loaded bucket low during transport in order to improve the machine's stability and to ensure good viewing conditions.

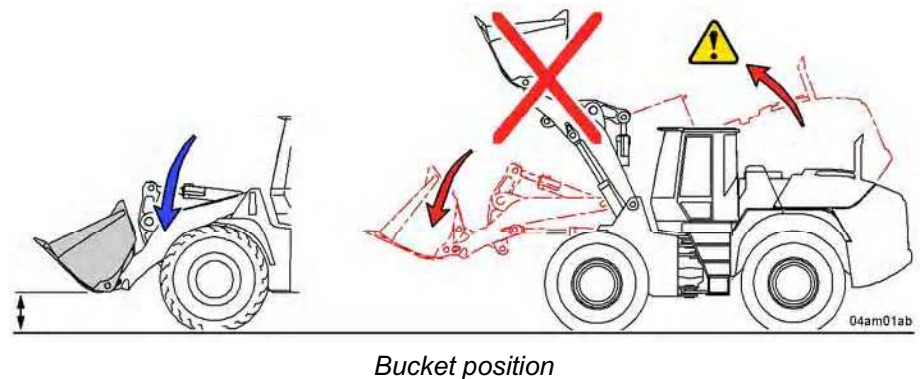

LBH/02/003801/0003/2.06/en

Make sure that the bucket is in the transport position.

The transport position means that the bucket pivot point is roughly 40 cm above the ground.

- Move the bucket to the transport position.

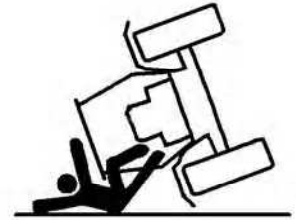
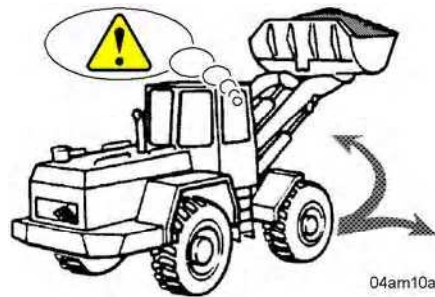

The machine may tip over

Warning 

There is a risk of the machine tipping over.

The machine might tip over when the lift arms are raised due to the shift in the centre of gravity.

! Do not suddenly change direction or brake abruptly when the bucket is raised.

- Do not raise the lift arm until just before reaching the unloading point.

Dumping

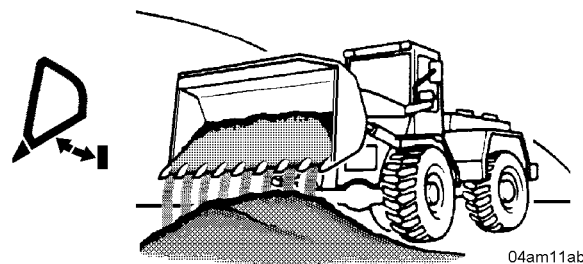

Dumping

- Tip out the bucket.
- To loosen material adhering to the bucket, quickly tilt the bucket in and out, briefly jolting against the bucket arm stops.

Removing material from a slope or wall

Removing material from a slope

This is how to remove normal material such as sand or gravel.

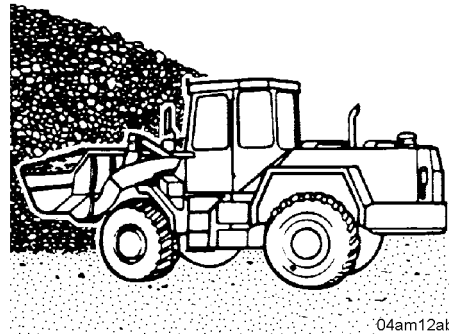

04am12ab

Removing bulk material 1

- Start at the foot of the slope and work upwards.

Removing material from a wall

This is how to remove unusually hard material such as rock.

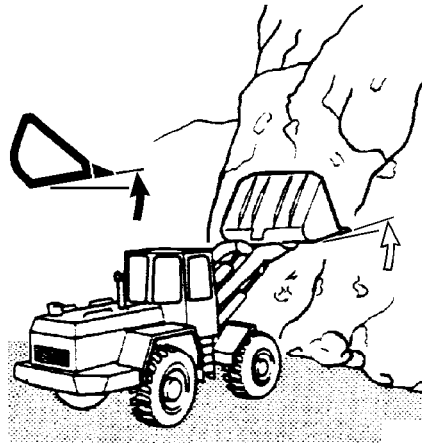

04am13ab

Removing bulk material 2

- Slightly tilt up the bucket base.
- Start removing material at the top and work downwards.

Warning



There is a risk of accidents due to falling material.
 ! Do not work under overhangs.

- Remove overhangs first and then look out for slippage.

Loading a transport vehicle

Transport routes

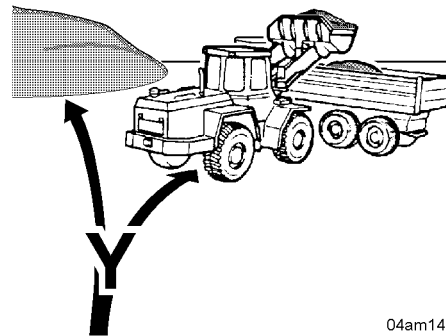

04am14ab

Y movement

The vehicle to be loaded should be parked so that the transport distance for the machine is as short as possible.

If possible make a **Y movement**. See also in the information on reversing in the driving mode section.

Loading procedure

In order to speed up the loading procedure, brake the machine in front of the truck with the inch/brake pedal.

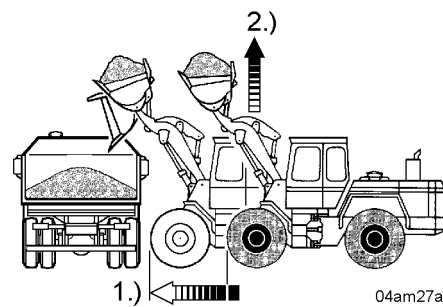

04am27ab

Unloading point

This achieves the following:

- 1.) Sensitive speed adjustment
- 2.) Optimum power adjustment for the working attachment

See the section on picking up and moving material.

- Put the machine in the unloading position. Do not raise the lift arms until just before reaching the unloading point.

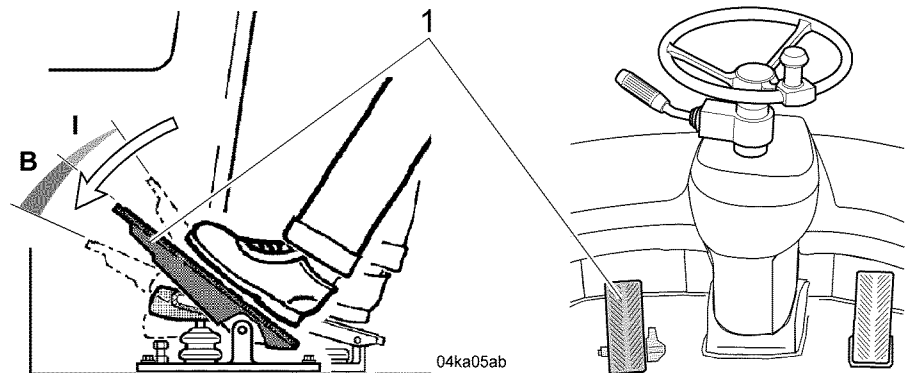

04ka05ab

Inch/brake pedal

1 Inch/brake pedal
I Inching range

B Braking range

LBH/02/003801/0003/2.06/en

- Brake the machine by pushing down the inch/brake pedal **1** in range I with the required force.

Warning



There is a risk of accidents due to falling material.

! The driver may only swing the working attachments over occupied driver cabs, operating and working stations of other machines if they are protected by reinforced roofs (FOPS).

! If the driver's cab is not equipped to provide the necessary degree of protection, then the driver of the machine in question must leave his cab during overhead operations.

- Load the truck so that the material falls into the middle of the skip.
- Load long transport vehicles from front to back.

When working near overhead power lines:

Danger



There is a risk of accidents through contact with overhead power lines. There is a risk of **fatal injury**.

! Obtain information about the safety clearances to be observed.



- Keep the machine a sufficient distance away.
- Do not go near power lines with the attachment.
- Also read the instructions for safe working in the chapter on safety regulations.

Loading large rocks

Make sure that the loading surface of the transport vehicle can withstand the impact of large rocks.

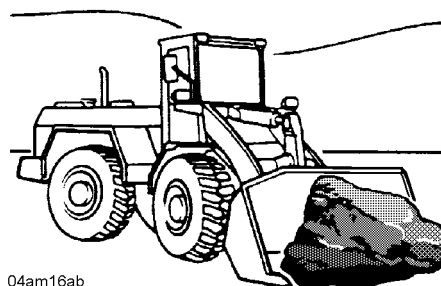

Loading the bucket

- First put a bucket load of smaller rocks in the transport vehicle.
- Carry on loading the transport vehicle.

LBH/02/003801/0003/2.06/en

Loading sticky material

You can use the automatic bucket return-to-dig function for loading jobs which require a certain digging position.

See also the sections on operating the lift arms and the automatic float position function.

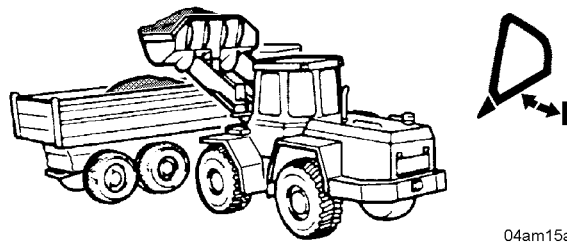

04am15ab

Dumping

- Tip out the bucket.



There is a risk of damage to the machine.

Unnecessary jolting when tipping up and down against the bucket arm stops can increase wear on the bolts and bushes on the kinematics.

! Avoid unnecessary jolting.

- To loosen material adhering to the bucket, quickly tilt the bucket in and out, briefly jolting against the bucket arm stops.

Moving the machine back

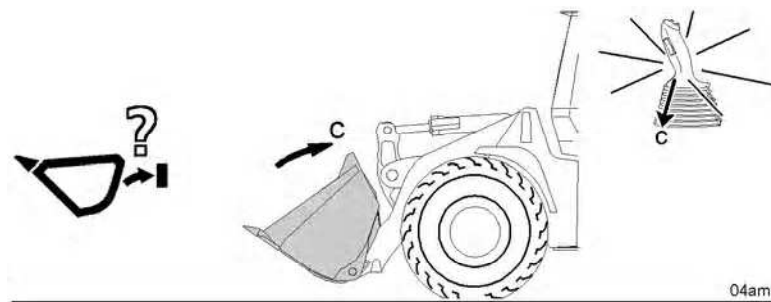

04am17ab

Bucket position



There is a risk of damage to the machine.

Unnecessary jolting when tipping up and down against the bucket arm stops can increase wear on the bolts and bushes on the kinematics.

! Avoid unnecessary jolting.

- Tilt the bucket in.

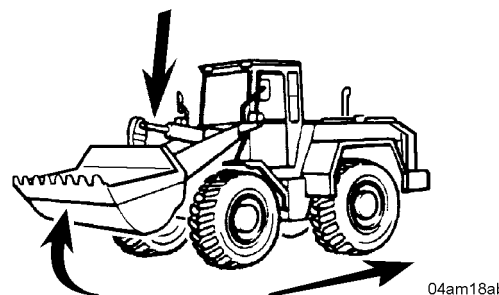

04am18ab

Lift arm position.

- Lower the lift arm when driving back.

Excavation

Lifting out soft material This is how to excavate soft material.

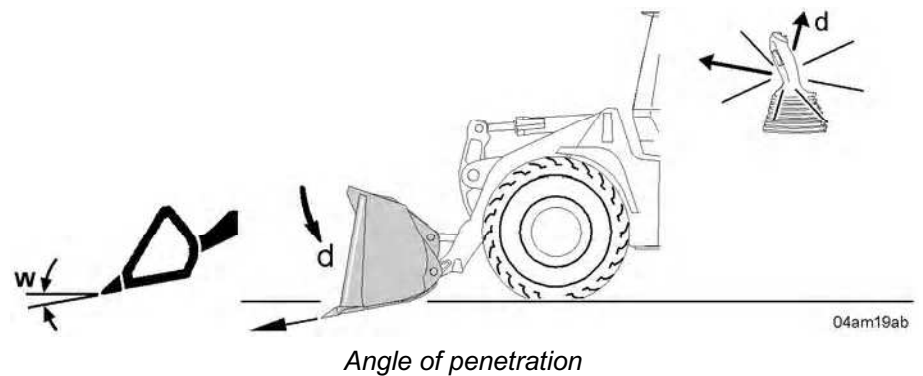

- Lower the bucket to the ground.
- Set a small cutting angle **W** of no more than 10°.

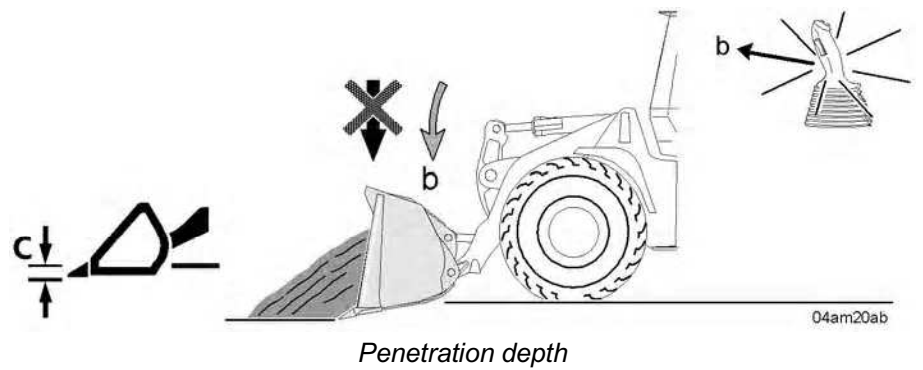

- When approaching with the machine, simultaneously press the lift arms down, until a sufficient penetration depth **C** is reached.
- The following procedure is recommended to avoid any possible loss of traction. Do not work with a strong downwards pressure on the bucket.

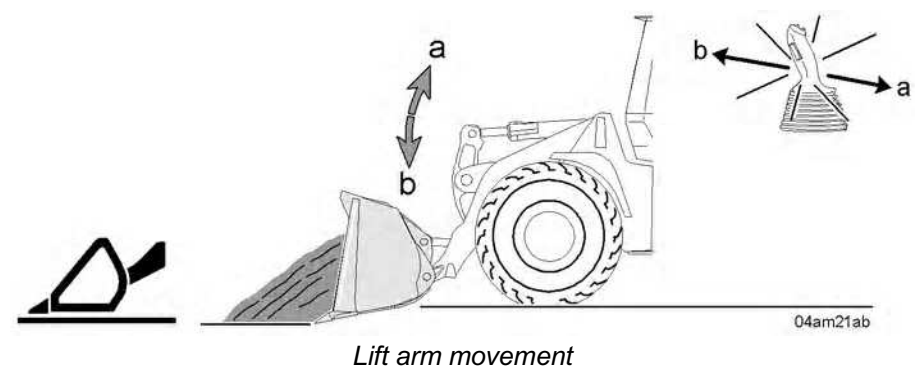

- Make horizontal cuts when driving forward.
- Raise and lower the lift arms to make the work easier.

LBH/02/003801/0003/2.06/en

Lifting out hard material Use a bucket with teeth for excavating hard material.

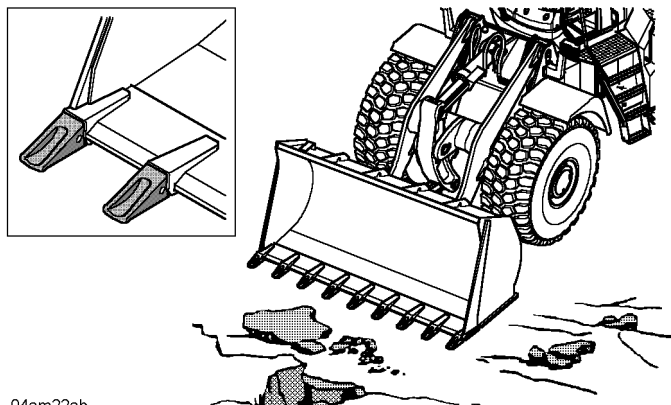

04am22ab

Working attachment

- For the subsequent procedure: See the section on lifting out soft material.

Example of foundation excavation

This is how to excavate foundations.

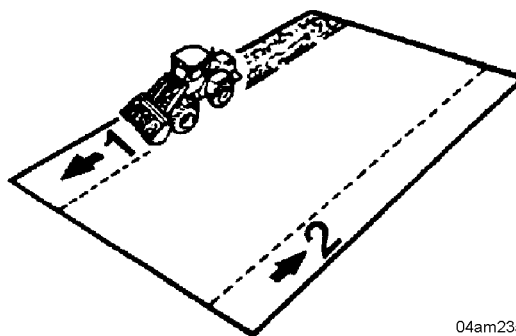

04am23ab

Lengthways cuts

- Use the bucket to make a first trench along the side of the pit.
- When the first trench is down to a depth of 1 metre, start a second trench along the opposite side.
- Excavate the area between to the same depth as the two side trenches.

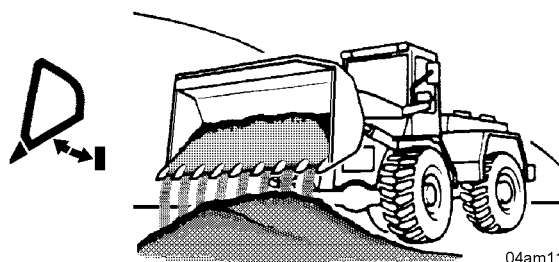

04am11ab

Heaping material

- Heap the material in one corner, leaving the sides of the foundations clear.

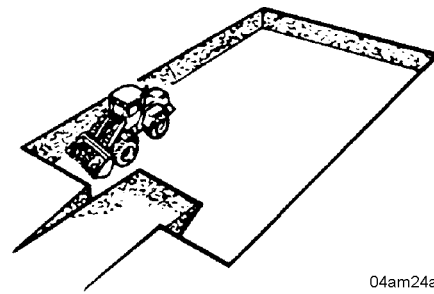

04am24ab

Pit corner

- When the foundations have been excavated to the required depth, dig out the corners and transport the material out of the pit.

Driving out of the pit

You must make a ramp so that you can drive the machine out of the pit.

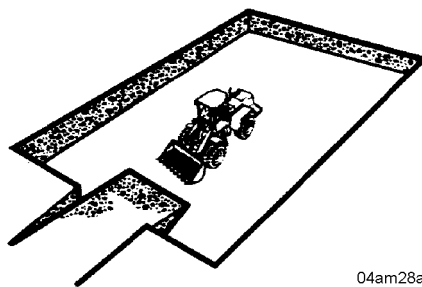

04am28ab

Exit ramp and transport direction

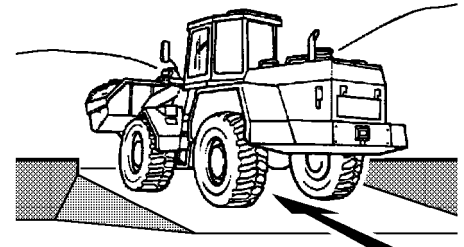

- To make an exit for the machine dig out the centre of the ramp.
- Keep the loaded bucket low during transport.
- Drive forwards out of the pit.

3.3.7 Soot particle filter

This equipment is optional.

Tasks of the soot particle filter:

- It reduces the emission of soot particles.
- It eliminates most of the carbon monoxide (CO) and hydrocarbons (HC) from the exhaust.
- It regenerates itself during normal operation.

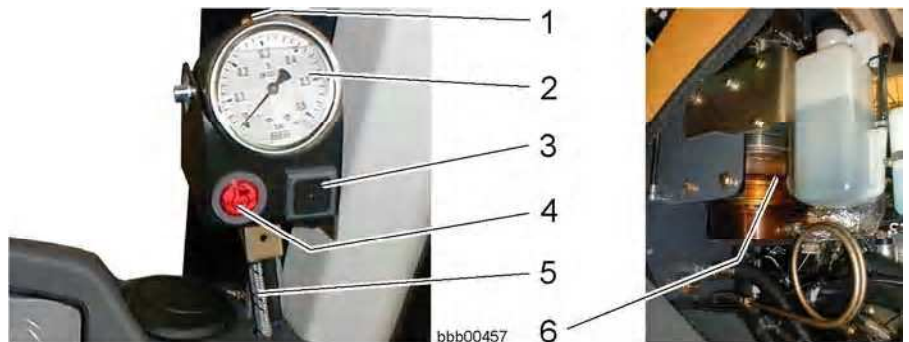

Soot particle filter exhaust counterpressure indicator

LBH/02/003801/0003/2.06/en

- | | |
|---|--|
| 1 Bleeder valve | 4 Visual exhaust counterpressure monitor |
| 2 Exhaust counterpressure indicator | 5 Pressure line |
| 3 Audible exhaust counterpressure monitor | 6 Soot particle filter |

Exhaust counterpressure indicator

Task:

- To display the contamination status of the particle filter system.



Incorrect values displayed
 ! The bleeder valve must be open, as otherwise incorrect values will be displayed.



There is a risk of damage to the engine.
 ! The counter-pressure may not exceed 0.2 bar.

Audible/visual exhaust counterpressure monitor

Task:

- To give an audible and visible warning to the operator when the maximum counterpressure is exceeded.
- To save the data measured by the counterpressure monitor electronically.

Counterpressure warning sequence:

- If the counterpressure exceeds 0.15 bar for longer than 60 seconds
 The exhaust counterpressure monitor **2** lights up.
- If the counterpressure exceeds 0.2 bar for longer than 60 seconds
 The audible exhaust counterpressure monitor **3** is also activated.



There is a risk of damage to the soot particle filter and the diesel engine. If the machine idles for prolonged periods or is run in the lower load range, the maximum counterpressure may be exceeded.
 ! Avoid letting the machine idle for prolonged periods or run in the lower load range.

If excessive exhaust counterpressure is indicated:

- Take action to reduce the counterpressure.

If analysis of the measured data shows that no action was taken to reduce the counterpressure, the manufacturer's warranty becomes invalid for any component damaged or destroyed by excess counterpressure.

Lowering the exhaust counterpressure

If the counterpressure is above 0.15 bar:

- Run the diesel engine at high speed. This means operating at full load for approximately 5 minutes, for example pushing against a wall.

or

- Lower and raise the lift arms with a fully loaded bucket at full throttle until the counterpressure is clearly below 0.15 bar.

Troubleshooting

If the counterpressure cannot be reduced using these measures:

Excess exhaust counterpressure can also be caused by a blocked counterpressure line. If the display indicates excess counterpressure, in addition to cleaning the filter, inspect and service the counterpressure line.

- Shut down the machine immediately.
 - Contact LIEBHERR CUSTOMER SERVICE.
-

Exhaust gas tests

Information on exhaust measurements by the machine operator

For operation in Switzerland:

- The machine is marked with the VERT filter label and test label. BUWAL and BauRLL prescribe test measurements to be logged in the exhaust maintenance document at least every 24 months.
- The exhaust maintenance document is created by the main importer and provided with the machine.

For operation in the EU:

- TRGS 554 prescribes test measurements for vehicles in industrial use. These must be carried out and documented annually or every 1500 service hours. For vehicles used underground the intervals are 6 months or every 600 service hours.

3.3.8 Quick-change device - fitting and removing the working attachment

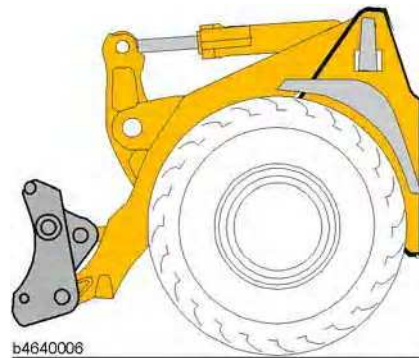

Quick-change device

Quick-change device version:

- Mechanical activation and deactivation using switch lever.
- Electrical activation and deactivation using switch (optional version).

Note



Information on attachments and accessories:

Attachments and accessories produced by third-party manufacturers or those which have not been generally approved by LIEBHERR for installation or for external fitting may not be installed or fitted on the machine without prior written consent from LIEBHERR.

! The appropriate technical documentation should be made available to LIEBHERR for this purpose.

Activating the quick-change device

This is how to activate the quick-change device.

Make sure that:

- The lift arm is lowered to just above the ground.
- Where a working attachment with an independent hydraulic supply is mounted, all cylinders, valves etc. are in the initial position or closed.
- Where a working attachment is fitted, make sure that it is tilted in.

Mechanically activating the quick-change device

The quick-change device is activated and deactivated by manually actuating the changeover valve using the switch lever.

Danger 

There is a risk of accidents if the working attachment drops.
 ! Never operate the switch lever when the working attachment is raised.

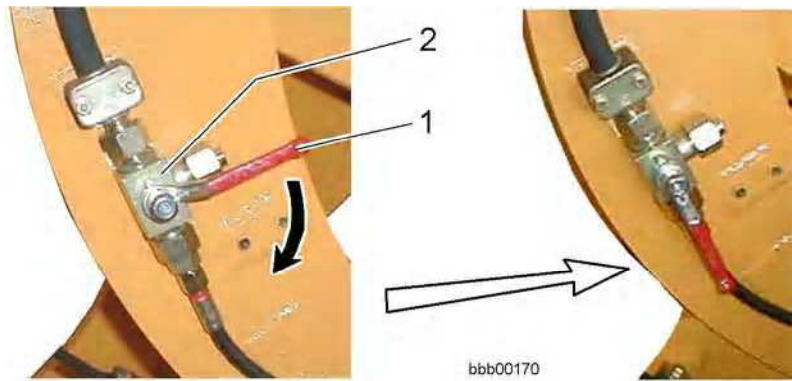

Mechanical activation

1 Switch lever

2 Changeover valve

- Lift the switch lever 1 and turn it in the direction of the arrow. This enables the function for extending and retracting the locking pin.

Electrically activating the quick-change device

This equipment is optional.

The quick-change device is activated and deactivated using the quick-change device switch. See also the section on switches in the side console.

Danger 

There is a risk of accidents if the working attachment drops.
 ! Do not activate the lockable switch when the working attachment is raised.



Electrical activation

1 Quick-change device switch

- Start the engine
- Release the activation lock in the direction of the arrow and simultaneously push the switch 1 forwards.



When you press the switch you will hear a warning signal from the side console (control panel).

This enables the function for extending and retracting the locking pin.

LBH/02/003801/0003/2.06/en

Extending and retracting the locking pins

This is how to extend and retract the locking pins for the working attachment.

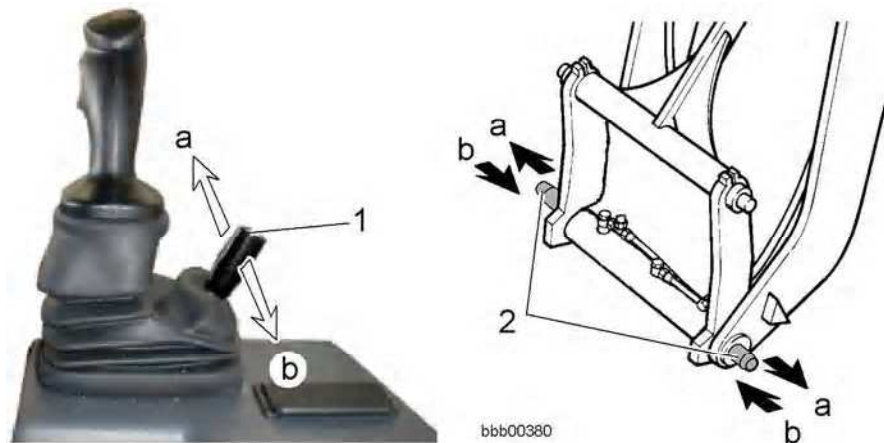

Extending or retracting the pins on the quick-change device

1 Control lever for additional working functions

2 Locking pins

- At medium motor speed, move the control lever 1 in direction a as far as it will go.
- The pins 2 on the quick-change device are extended (for locking).
- At medium motor speed, move the control lever 1 in direction b as far as it will go.
- The pins 2 on the quick-change device are retracted (for unlocking).

Connecting the working attachment to the quick-change device

Picking up and connecting the working attachment

This is the procedure for attaching and connecting the working attachment. Make sure that the quick-change device is completely unlocked.

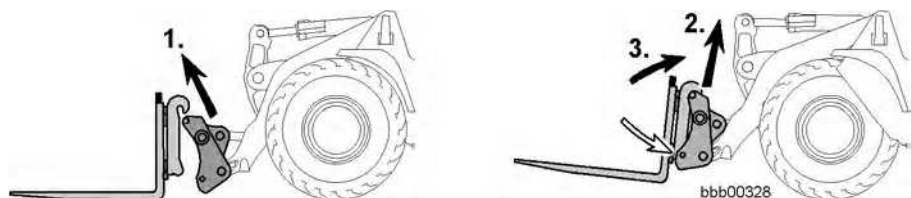

- Carefully put the quick-change device in the adapter holder at the top of the working attachment.
 - Slightly raise and tilt in the working attachment.
- The working attachment must be fully engaged in the quick-change device.

Locking the working attachment

This is how to lock the working attachment.

Make sure that:

- The working attachment is completely engaged in the quick-change device, so that the working attachment can be locked in place with the locking pins.

LBH/02/003801/0003/2.06/en

Danger 

There is a risk of accidents if the working attachment drops.
 ! Check whether the working attachment is fully engaged in the quick-change device.

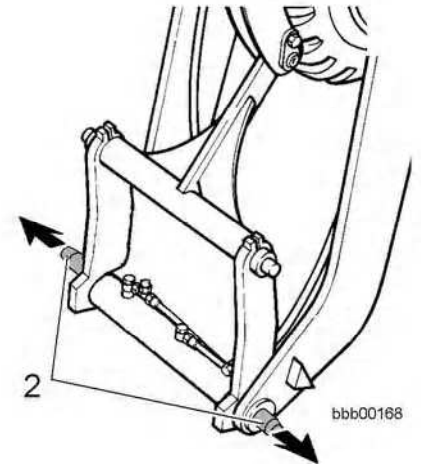

Locking the working attachment

1 Control lever for additional working functions

2 Locking pins on quick-change device

- At medium motor speed, move the control lever **1** in direction **a** as far as it will go.

The pins **2** on the quick-change device are extended.

The working attachment is locked.

This is how to check after locking.

Make sure that the quick-change device is in a suitable position for inspection.

Checking that the working attachment is locked

Danger 

There is a risk of accidents if the working attachment drops.

! Do not carry out any working movements of the attachment before checking whether it is locked.

! Check whether the working attachment is securely locked to the quick-change device.

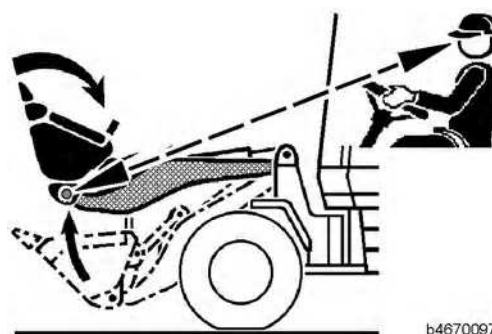

- Raise the lift arms until you can see the quick-change device from the cab.
- Check that the locking pins have actually locked the working attachment on both sides.

You can see that it is properly locked when locking pins protrude at the sides.

LBH/02/003801/0003/2.06/en

Danger



There is a risk of accidents if the working attachment drops.
 If the quick-change device is unintentionally unlocked, both personnel and the working attachment will be endangered.
 ! Always deactivate the quick-change device after the locking procedure is finished.

- Do not carry out any movements with the working attachment until you have inspected and deactivated the quick-change device.

Mechanically deactivating the quick-change device

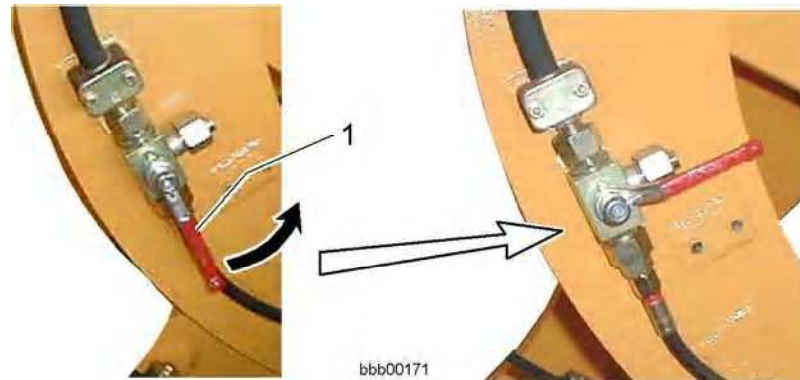

Mechanical deactivation

- Lift the switch lever 1 and turn it in the direction of the arrow. The function for unlocking the quick-change device is thus disabled. This equipment is optional.

Electrically deactivating the quick-change device



Electrical deactivation

- Push back the quick-change device switch 1. The function for unlocking the quick-change device is thus disabled.

Connecting the hydraulic lines

If the working attachment has an independent hydraulic circuit, the hydraulic supply lines must be connected.
 This is how to disconnect the hydraulic lines.

Warning



There is a risk of accidents from hydraulic lines under pressure.
 ! Depressurise the hydraulic circuits before connecting or disconnecting hydraulic lines and couplings.

- Depressurise the hydraulic lines, see the section on depressurising the operating circuits.
- Take the caps off the line couplings.
- Connect the hydraulic lines according to their function.

Note the following points when connecting:

- Clean the line couplings before connecting.
 - Do not connect the wrong ends of the hydraulic lines.
 - Lay the hydraulic lines so that they cannot become caught in the working attachment during operation.
 - Use any hose retainers provided when laying the lines.
- Check the hydraulic lines for leaks after connecting them.

Depressurising the operating circuits

The hydraulic lines and couplings of the working attachment which have their own hydraulic supply may be pressurised.



There is a risk of accidents from hydraulic lines under pressure.
 ! Depressurise the hydraulic circuits before connecting or disconnecting hydraulic lines and couplings.

Depressurising – standard version

This is how to depressurise the lines.

- Start the engine and let it run for 10 seconds.
- Shut down the diesel engine.
- Switch on the ignition.



Reducing the operating pressure

1 Working hydraulics lockout switch

2 Control lever for additional working functions

- Press and hold down the button **a** on the working hydraulics lockout switch.

At the same time:

- Move the control lever for additional working functions several times in directions **b** and **c**.

- The hydraulics of the working attachments are now depressurised.

LBH/02/003801/0003/2.06/en

Depressurising using comfort or button control

This equipment is optional.
This is how to depressurise the lines.

- Start the engine and let it run for 10 seconds.
- Shut down the diesel engine.
- Switch on the ignition.

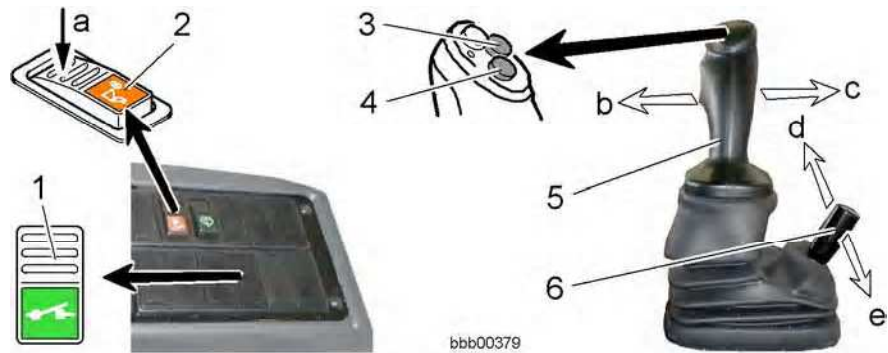

Reducing the operating pressure

- | | |
|-------------------------------------|--|
| 1 Comfort control button | 4 Button |
| 2 Working hydraulics lockout switch | 5 LH control lever |
| 3 Button | 6 Control lever for additional working functions |

- Activating the comfort control button
- Press and hold down the button **a** on the working hydraulics lockout switch.

At the same time:

- Press the button **3** while moving the LH control lever several times in directions **b** and **c**.
- Press the button **4** while moving the LH control lever several times in directions **b** and **c**.
- Move the control lever for additional working functions several times in directions **d** and **e**.

- The hydraulics of the working attachments are now depressurised.

Removing the working attachment from the quick-change device

Disconnecting hydraulic lines

If the working attachment has an independent hydraulic circuit, the hydraulic supply lines must be disconnected.

The procedure for disconnecting the hydraulic lines is as follows.

Warning 

There is a risk of accidents from hydraulic lines under pressure.
 ! Depressurise the hydraulic circuits before connecting or disconnecting hydraulic lines and couplings.

- Depressurise the hydraulic lines, see the section on depressurising the operating circuits.
- Release the hydraulic lines and quick-release couplings from the machine.
- Make sure that no hydraulic oil leaks onto the ground.

Take any contaminated soil for disposal, because hydraulic oil can pollute rivers and groundwater.

- Seal the line couplings with a cap.
- Place the hydraulic lines in the hose retainer.

Unlocking the quick-change device

The procedure for unlocking the quick-change device is as follows.
 Make sure that the quick-change device is activated.

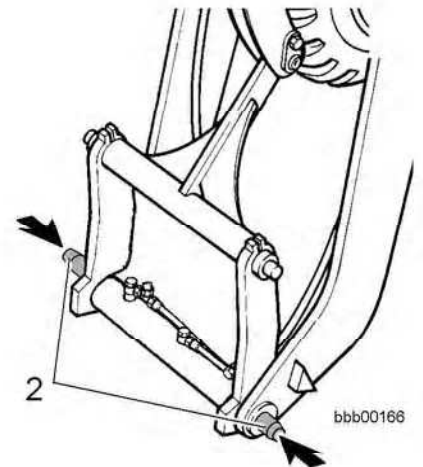

Unlocking the quick-change device

1 Control lever for additional working functions

2 Locking pins on quick-change device

- At medium motor speed, move the control lever **1** in direction **b** as far as it will go.

The pins **2** on the quick-change device are retracted.
 The working attachment is unlocked.

Disconnecting the working attachment

This is the procedure for detaching the working attachment.

If the working attachment has an independent hydraulic circuit, make sure the hydraulic supply lines have been disconnected.

LBH/02/003801/0003/2.06/en



There is a risk of accidents if the working attachment is incorrectly set down.

! Never set down the working attachment in unsecured areas (roadways etc.).

- Set down the working attachment flat on firm, even ground.

If the working attachment has an independent hydraulic supply, set down the working attachment in such a way that the hydraulic lines are not subjected to any strain.

- Secure the working attachment against tipping over.

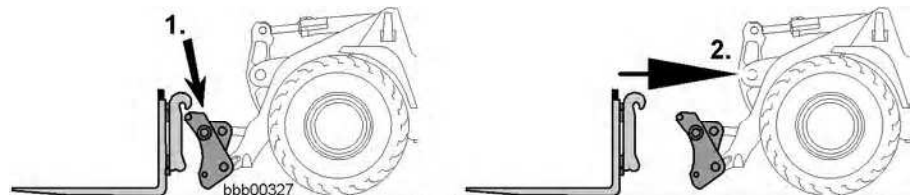

- Carefully remove the quick-change device from the adapter holder at the top of the working attachment.

The working attachment is now disconnected.

3.3.9 4 in 1 bucket

This equipment is optional.

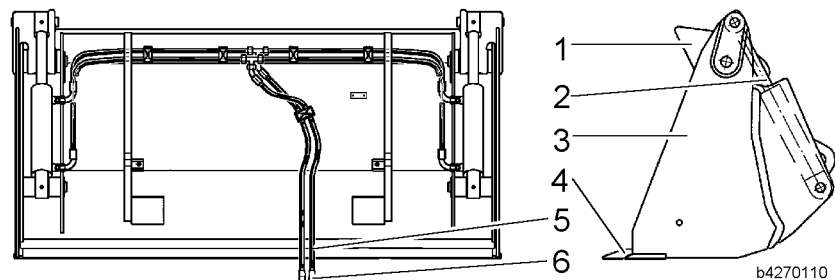

4 in 1 bucket

- | | |
|----------------------|-----------------------------|
| 1 Back of bucket | 4 Teeth |
| 2 Hydraulic cylinder | 5 Hydraulic line connection |
| 3 Bucket flap | 6 Quick-action couplings |

Opening and closing the bucket flap

This is how to open and close the bucket flap:

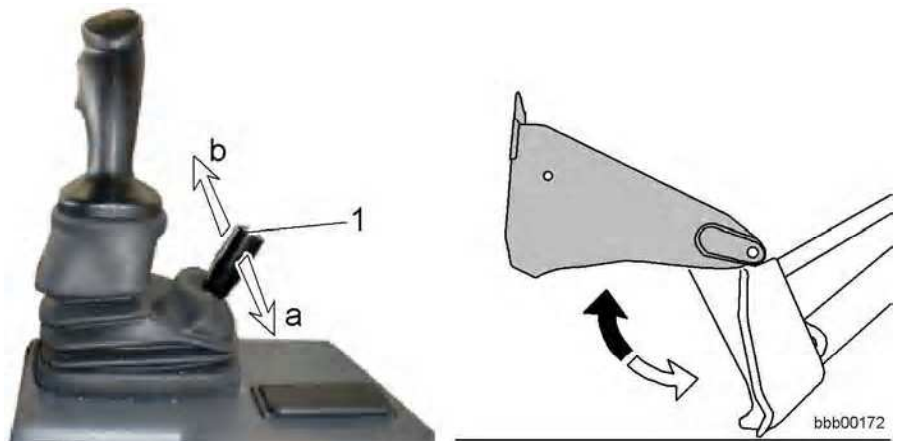

Opening and closing the bucket flap

Warning



There is a risk of accidents due to falling material. Make sure the opening and closing of the bucket flap function properly. ! Operate the bucket once while it is empty to check whether the hydraulics are correctly connected.

- To open the bucket flap, move the control lever **1** for additional working functions in direction **b**.
- To close the bucket flap, move the control lever **1** for additional working functions in direction **a**.

Different uses of the 4 in 1 bucket

The 4 in 1 bucket may only be used for the following purposes, with material weighing no more than 1.8 t/m³.

- Shifting, scraping and loading material
- All excavation jobs
- Gripping bulky objects
- Tipping while open
- Grading
- As a scraper
- For great dump heights

The manufacturer will not be held liable for damage caused by improper use (such as, for example, breaking off rocks, hammering in posts or attaching lifting gear).

3.3.10 Forklift

This equipment is optional.

The forklift consists of the fork carrier and adjustable fork prongs.

The forklift is mounted using the quick-change device.

Use the forklift for picking up, transporting and transferring pallets, and for stacking.

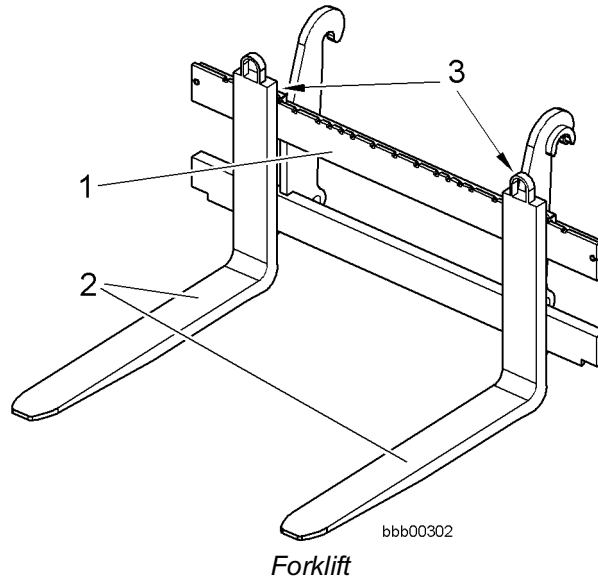

1 Fork carrier
2 Fork prongs

3 Fork lock

Adjusting the prongs on the fork carrier

The fork prongs are attached to the fork carrier and are secured against slipping with the fork lock on the upper fork hook.

This is how to adjust the prongs on the fork carrier:

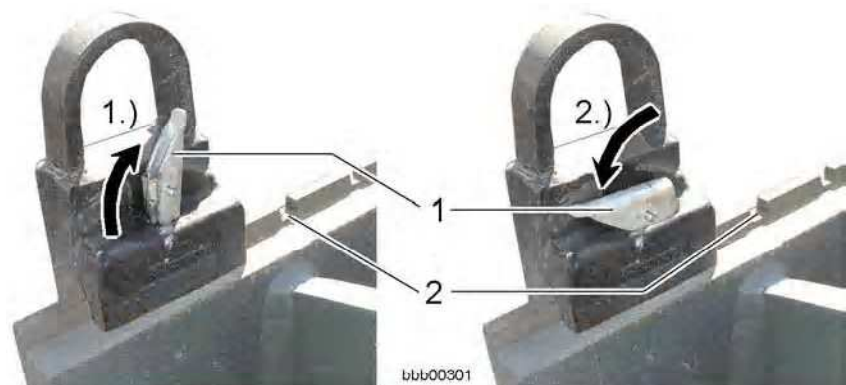

1 Fork lock
2 Groove

1.) Opening the fork lock
2.) Closing the fork lock

- Open the fork lock **1**.
- Push the prongs to the correct position.
- When closing the fork lock **1** let it latch in the groove **2**.

The prongs are held tight.

Jobs for the forks

When lifting in forklift mode, the load is not parallel to the ground.

- This means that with a parallel initial position of the forks of 0° to the ground, the attachment tilts in during the lift movement up to 2/3 of the maximum lift height and then tilts out again, but does not tilt down forwards.

Warning



There is a risk of accidents if the forklift tilts out forward. If the forklift is not parallel to the ground (0°) in its starting position, it may tilt out forward.

! Avoid incorrect operation during forklift operation.

- The lever ratio of the kinematics in the topmost lifting range means that the load bearing capacity may be restricted. See the load tables for forklift operation in chapter 1.

This is how to work in forklift mode.

Make sure that the working attachment and the quick-change device are safely locked.

The procedure for locking the quick-change device is described in the section on the quick-change device - fitting and removing the working attachment

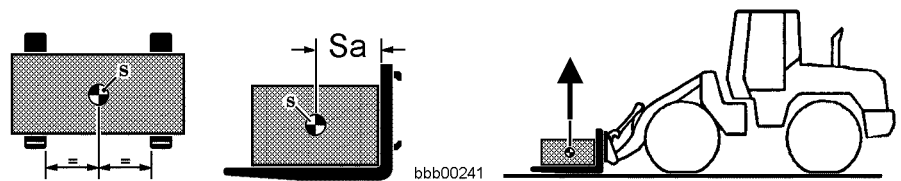

Distance from centre of gravity

S Centre of gravity

Sa Distance from centre of gravity

Caution



There is a risk of damage to the load and the machine. During forklift operation, only use forks with prongs of suitable length and make sure that these do not project beyond the load. Otherwise goods or pallets lying in front of the forks could be damaged.

! Avoid incorrect operation during forklift operation.

- When you pick up the load, make sure that the load is resting as close as possible to the vertical limb of the fork prong. Pick up the load. Make sure that the centre of gravity **Sa** of the load is correctly positioned.

Warning

There is a risk of the machine tipping over.

! Avoid incorrect operation during forklift operation.

- Raise the lift arms to the transport position (30–40 cm above the ground).
- When driving unloaded, tilt the forklift slightly in and carry it low.
- When driving with a load, tilt the forklift slightly in and carry the load low.
- When driving on slopes, always keep the load uphill.
- Never drive across slopes.
- Never turn on slopes.
- If a high unloading position is required:
Do not raise the lift arms until just before reaching the unloading point.
- If a low unloading position is required:
Do not lower the lift arms until just before reaching the unloading point.

3.3.11 Transporting the machine

Lifting the machine by crane

It is essential to observe the accident prevention regulations when lifting the machine by crane.

See section on safety regulations when lifting the machine by crane in chapter 2.

Take the following precautions before lifting the machine by crane.

Precautions:

- Lower the working attachment and tilt back the loading equipment to its limit.
- Engage the articulation lock.
- Move all control levers to neutral.
- Engage the parking brake.
- Lock the working hydraulics.
- Shut down the engine.
- Close and lock all doors, hatches and hoods on the machine.

For detailed descriptions, see the section on operation and handling.

Find out about:

- The weight and collision masses of the machine: See the technical data section in chapter 1.
- The required load bearing capacity and lengths of the lifting tackle.

Loading for lorry, rail or sea transport

This is carried out when the machine has to be loaded by crane.

Necessary equipment:

- Lifting tackle **1**: minimum rope length 6.0 m
- Loading device **2**: available as accessory, order no. 9842905

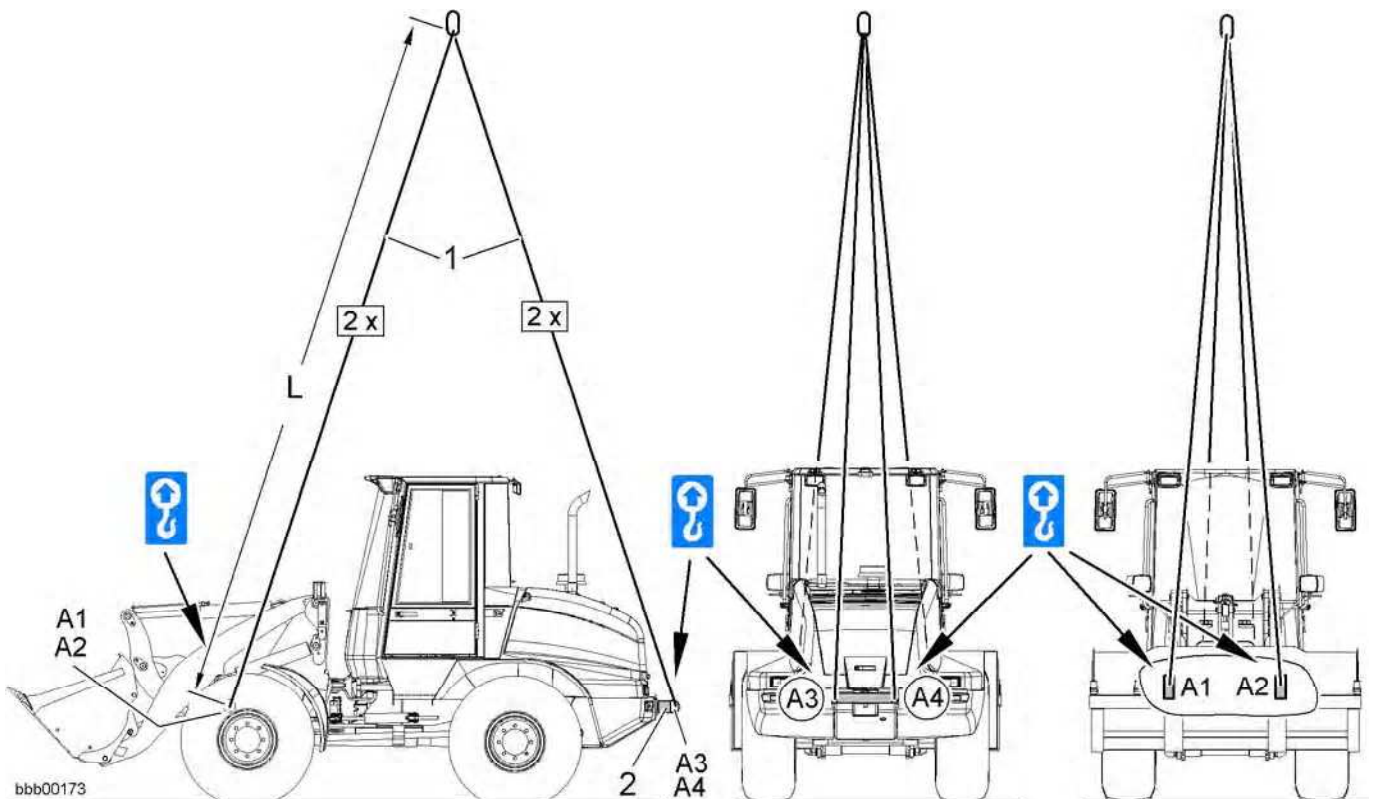

Loading diagram

- 1 Lifting tackle – 4-strand rope
- 2 Loading device
- A1 Front right slinging and lifting point
- A2 Front left slinging and lifting point

- A3 Rear left slinging and lifting point
- A4 Rear right slinging and lifting point

- A4 Rear right slinging and lifting point

Danger



There is risk of accidents if the suspended load falls.
 ! Never stand under the machine when it is suspended.

- Attach the lifting tackle to the slinging and lifting points **A1**, **A2**, **A3**, **A4** provided on the machine.
- Carefully lift the machine and load it.



- Do not allow anyone under the raised machine.

LBH/02/003801/0003/2.06/en

Transporting the machine by lorry or rail

Before driving onto the loading area

The following precautions must be taken before driving onto the loading area.

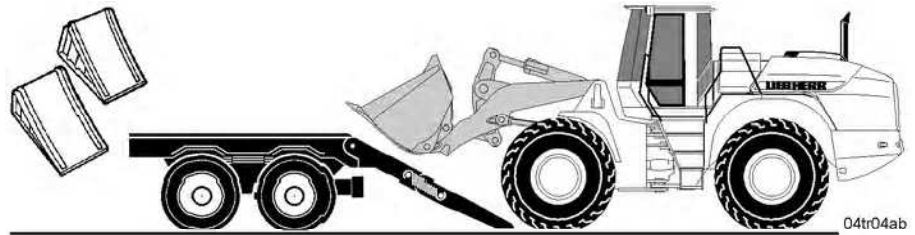

04tr04ab
Loading the machine

Precautions:

- Have wheel wedges ready.
- Have suitable tensioning ropes or chains ready to lash the machine down.

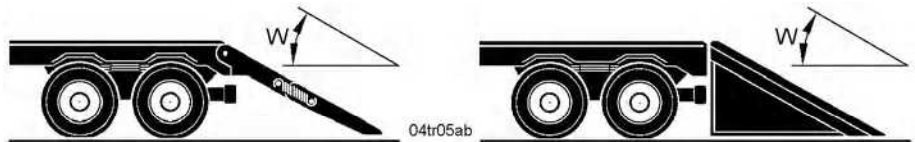

04tr05ab
Ramp inclination

A ramp should be provided for driving the machine onto the loading area. The inclination of the ramp **W** may not exceed 30°.

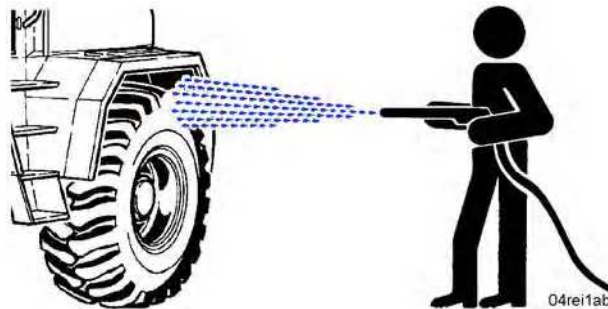

04rei1ab
Washing

Clean the tyres of snow, ice and mud before driving up the ramp.

Driving onto the loading area

For detailed descriptions, see the section on operation and handling.



04tr03ab

When driving onto the loading area have someone direct you.

Make sure there is someone to give the driver the necessary signals.

Persons giving directions must always take up a position to one side of the machine.

This is the procedure for driving onto the loading area:

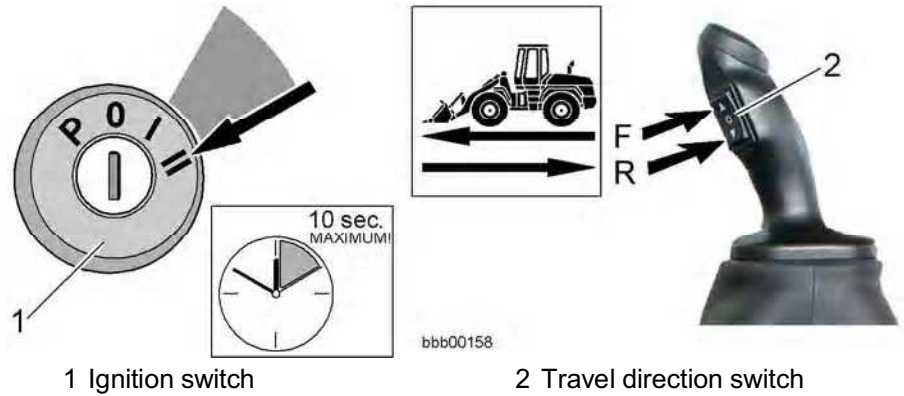

- Start the engine.

This is the situation after the machine has been started:

- When the parking brake is engaged, the travel lockout is active.
- The travel direction cannot be preselected.
- The travel direction can be selected.

See also the sections on starting the diesel engine and driving mode.

- Release the parking brake.
- Select the travel direction.

Warning

There is a risk of accidents if the machine is driven without due care. Reckless driving can endanger those loading, directing and driving the machine.

! Always drive with due care when loading the machine.

Caution

There is a risk of damage if the machine is not driven with due care. Reckless driving can damage the transport vehicle and the machine.

! Always drive with due care when loading the machine.

- Push down the gas pedal carefully.
- Carefully drive the machine to the loading area and stop.

After driving onto the loading area

For detailed descriptions, see the section on operation and handling.

Make sure that the air stream produced during transport cannot enter the exhaust pipe opening.

This is especially important for rail transport, since the direction of travel cannot be known in advance.



Engaging the parking brake

1 Parking brake

2 Parking brake symbol field

LBH/02/003801/0003/2.06/en

- Activate the parking brake with the button 1. The symbol field 2 lights up.

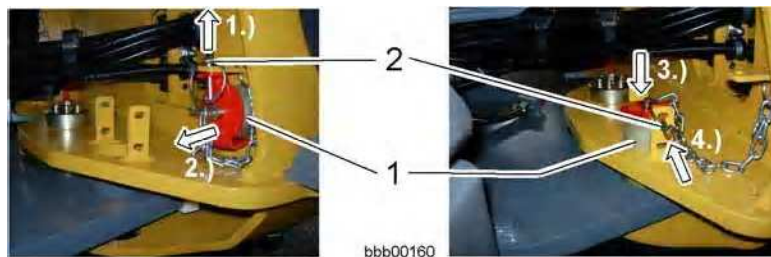

Engaging the articulation lock

- 1 Articulation lock pin
- 2 Spring clip

- Engage the articulation lock.
- Lower the lift arms and lay the bucket down flat on the loading area.



Working hydraulics lockout

- 1 Working hydraulics lockout symbol field
- 2 Working hydraulics lockout button

- Lock the working hydraulics.
- Turn off the engine.
- Close and lock all doors, hatches and hoods on the machine.

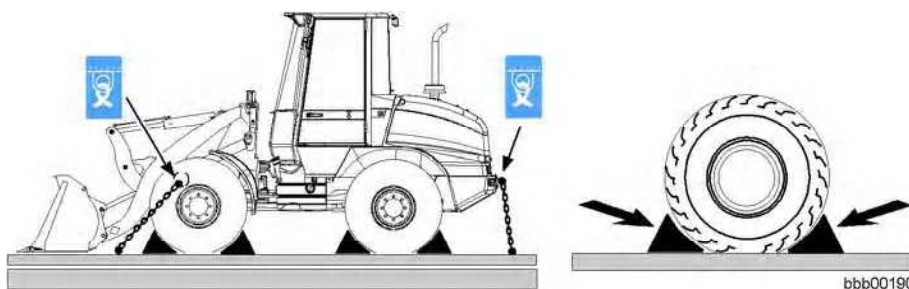

Lashing points

- Secure the machine against sliding using wheel wedges and tensioning ropes or chains.
- Fasten the ropes and chains securely to the indicated lashing points.

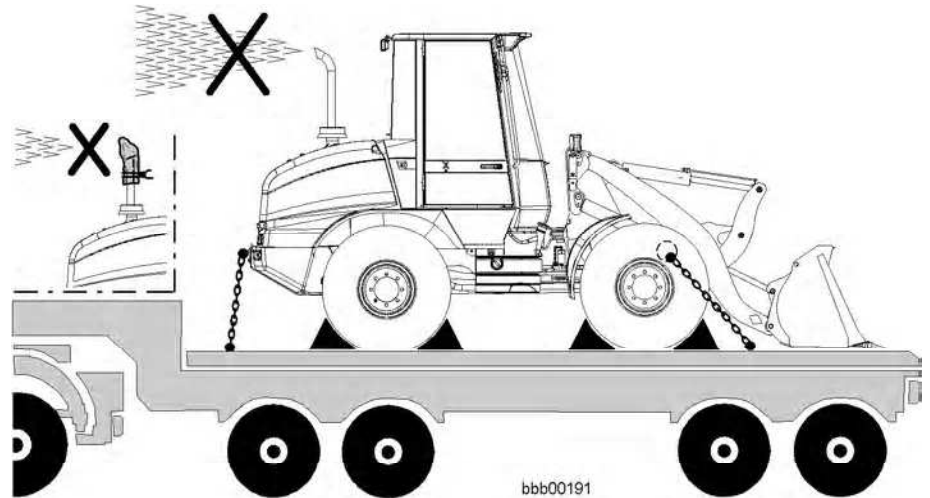

Exhaust pipe covering

If the machine is being transported facing backwards, air can blow into the exhaust pipe opening.
Take the following precaution to prevent damage during transport.

Caution

There is a risk of damage to the turbocharger.
If air blows into the exhaust pipe opening, it causes the turbocharger of the diesel engine to rotate.
The turbocharger is not lubricated when the engine is not running.
The turbocharger can be damaged if it is not lubricated.
! Prevent the air stream produced during transport from entering the exhaust.

- To block off the exhaust pipe opening, climb onto the machine via the cab access, making sure that you have secure footing.

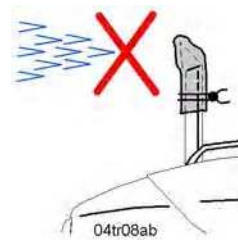

Blocking off the exhaust pipe opening

- Block off the exhaust pipe opening using airtight material which cannot slip.

3.4 Emergency operation

This section describes the emergency operations of the machine.

Emergency operations:

- Towing the machine
- Jump starting

3.4.1 Towing the machine

If the machine breaks down, you may have to tow it away from a hazardous area.

The following towing instructions only apply to exceptional situations where a machine incapable of independent movement has to be taken to a place where it can be repaired or transported.

Towing speed and towing distance:

- Maximum towing speed 2 km/h
- Only short distances are permitted, in order to move the machine away from a danger area.

The machine must always be put on a transporter for longer distances.

Safety instructions for towing

Towing the machine can be difficult and is therefore entirely the responsibility of the operator.

In no event can damage or accidents resulting from towing be covered by the manufacturer's guarantee.

See the section on safely towing the machine in chapter 2.



Danger



Incorrect towing can cause accidents.

When a machine incapable of independent movement is not properly towed, the result could be severe or even fatal injuries.

! Always secure the machine against rolling away before releasing the brakes for towing.

- Follow all specified safety regulations and the following instructions when towing.

Towing with the engine running

The travel drive must be switched to free circulation before you can tow the machine.

Switching the travel drive to free circulation impairs the braking effect.

There is no hydrostatic braking force.

You can no longer brake the machine using the brake pedal or the main brake cylinder.

The following precautions must be taken before towing the machine.

Precautions:

- Put the machine in the towing position.
- Deactivate all travel functions
- Release the parking brake.

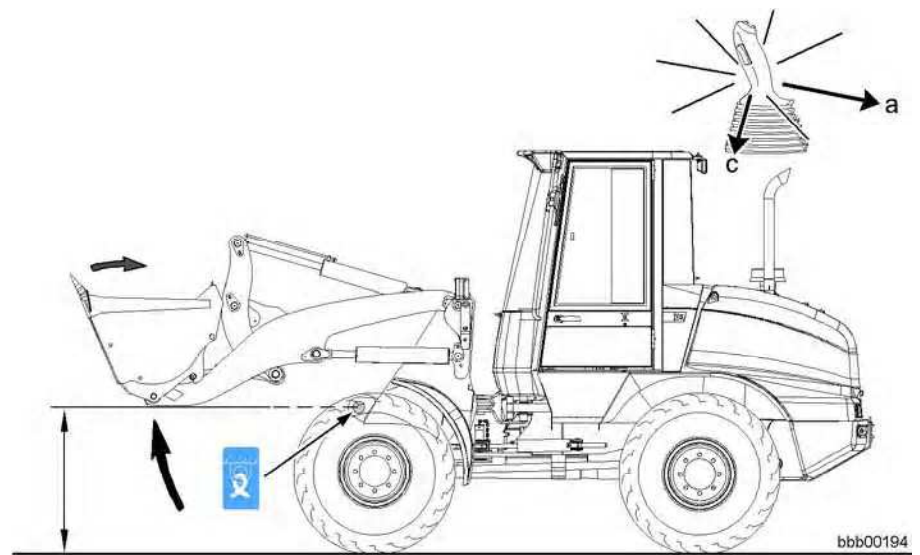

Towing position

- **Put the machine in the towing position.**
Raise the lifting gear above the towing drill hole.
- If the working attachment can be hydraulically operated, tilt in the bucket as far as it will go.



Caution

There is a risk of accidents if the braking effect is impaired. Switching the travel drive to free circulation impairs the braking effect. You can no longer brake the machine using the brake pedal or the main brake cylinder.

! Always drive carefully when in tow.

• **Switching the travel drive to free circulation:**

Release the valve insert of the high pressure relief valves 2, 3.

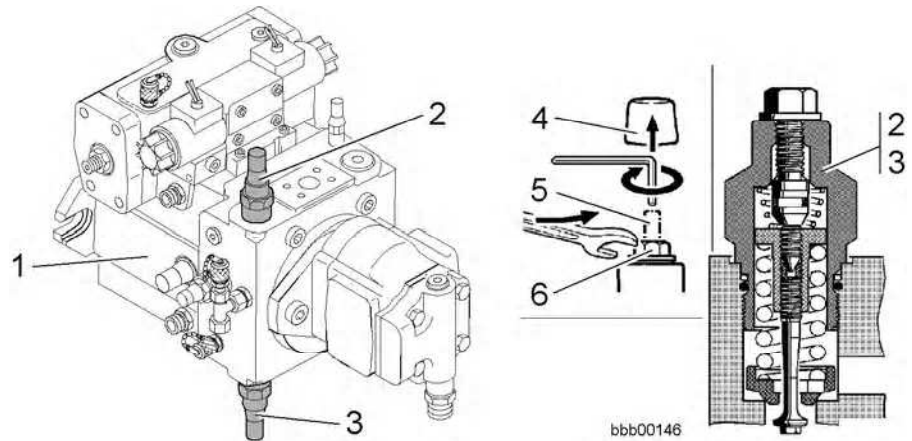

High pressure relief valves

- | | |
|--|-------------------|
| 1 Travel hydraulics variable adjustment pump | 4 Cap |
| 2 High pressure relief valve | 5 Adjusting screw |
| 3 High pressure relief valve | 6 Counter nut |

- Remove the cap 4.
- Loosen the counter nut 6.
- Tighten the adjusting screw 5 until it is flush with the counter nut 6.
- Tighten the counter nut 6 again.

This allows the oil to circulate freely.

The machine's travel functions are now out of operation.

Activating the working hydraulics lockout:

If necessary, lock the working hydraulics to prevent the working attachment from being operated inadvertently.

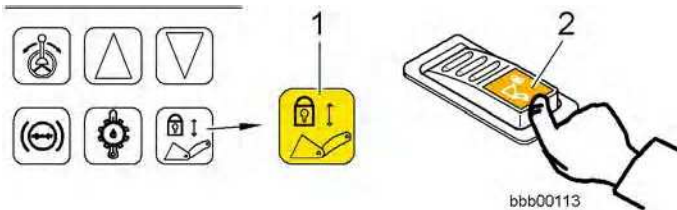

Working hydraulics lockout button

- | | |
|---|-------------------------------------|
| 1 Working hydraulics lockout symbol field | 2 Working hydraulics lockout button |
|---|-------------------------------------|

- Press the working hydraulics lockout button 2.

The symbol field 1 for the working hydraulics lockout must light up. The working hydraulics are no longer operational.

Release the parking brake:

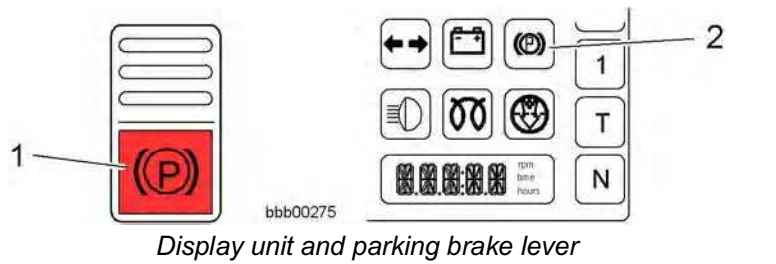

1 Parking brake button 2 Parking brake symbol field

- Press the button 1.
- The symbol field 2 for the parking brake goes out. The parking brake is released and the machine can now be towed.

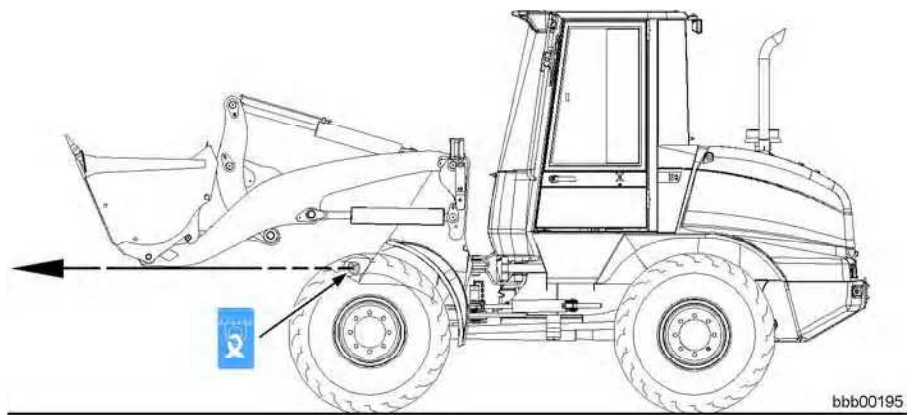

Towing

- Feed the two towing ropes through the bore holes in the front section and secure them.
- Tow the machine out of the danger area.

When towing has been completed:

Re-tighten the valve insert of the high pressure limiting valves 2, 3.

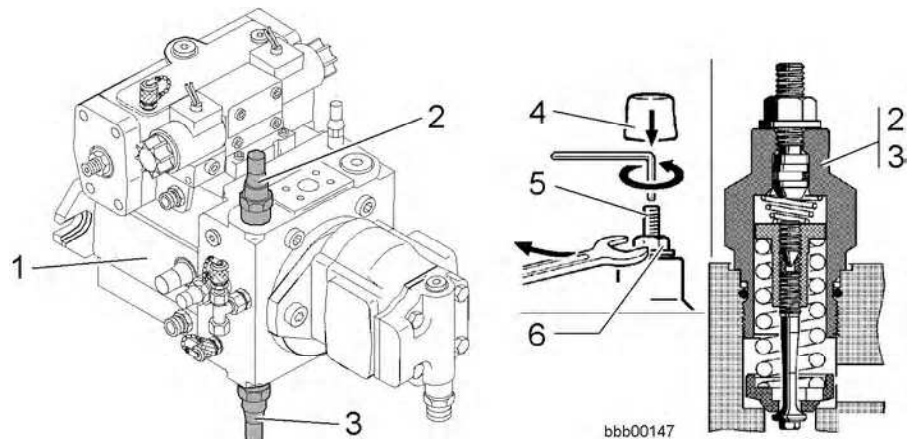

High pressure relief valves

- | | |
|--|-------------------|
| 1 Travel hydraulics variable adjustment pump | 4 Cap |
| 2 High pressure relief valve | 5 Adjusting screw |
| 3 High pressure relief valve | 6 Counter nut |

LBH/02/003801/0003/2.06/en

- Loosen the counter nut **6**.
- Unscrew the adjusting screw **5** as far as it will go.
- Tighten the counter nut **6** again.
- Attach the cap **4**.

The original set value of the high pressure limiting valves is thus restored.

Towing with the engine not running

If the machine has suffered a serious breakdown such as engine failure, the braking and steering functions will be impaired.

Switching the travel drive to free circulation impairs the braking effect.

There is no hydrostatic braking force.

You can no longer brake the machine using the brake pedal or the main brake cylinder.

The following precautions must be taken before towing the machine.

Precautions:

- Switch on the machine's electrical system
- Put the machine in the transport position
- Deactivate all travel functions
- Release the parking brake mechanically.

This is how to tow the machine without the engine running.

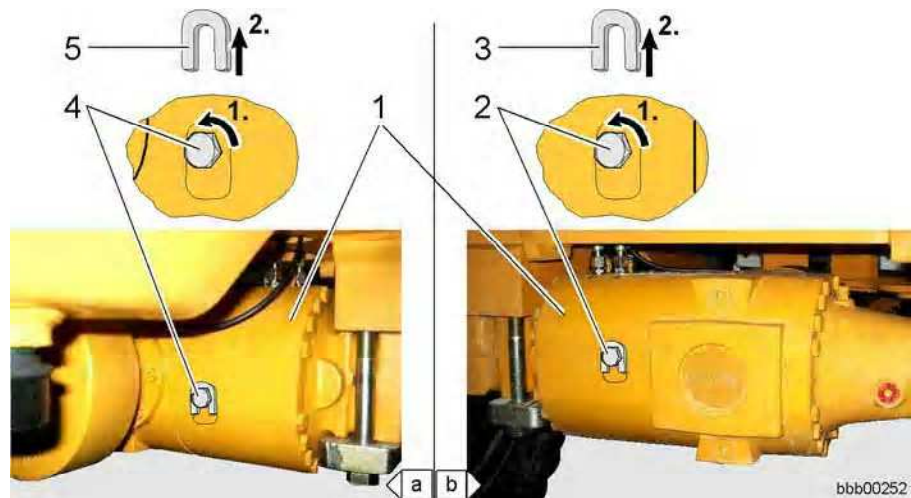

Front axle differential

- | | |
|----------------------------|------------|
| a View from axle drive end | 3 Spacer |
| b View from axle exterior | 4 Hex bolt |
| 1 Front axle differential | 5 Spacer |
| 2 Hex bolt | |

LBH/02/003801/0003/2.06/en

- Loosen the hex bolt **2** and **4** (24 mm).
- Remove the spacer **3** and **5**.

This allows the parking brake to be released.

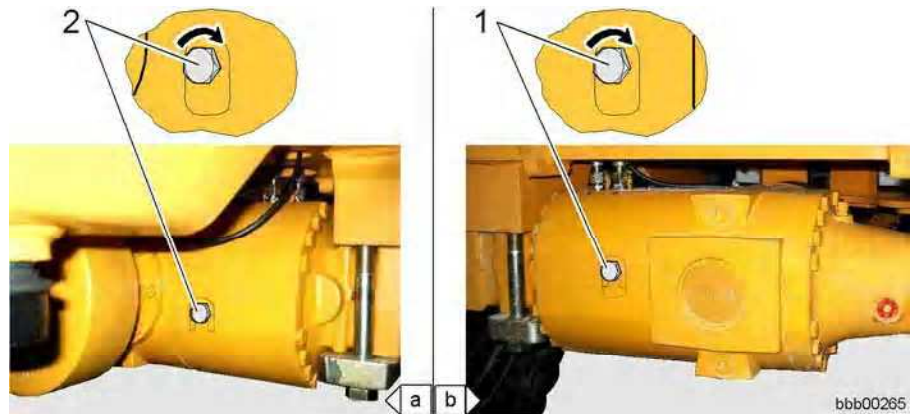

Front axle differential

- Fully tighten the hex bolt **1** and **2** alternately, step by step.
- The parking brake is released and the machine can now be towed.

Warning

There is a risk of accidents when the machine is in tow.
 ! The steering function is restricted.

- Switch on the ignition by turning the key to position I.
- Feed the two towing ropes through the bore holes in the front section and secure them.
- Tow the machine out of the danger area.

When towing has been completed:

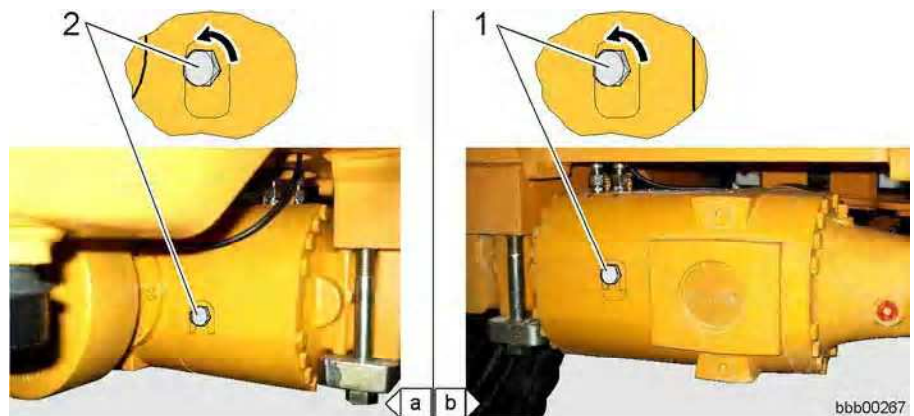

Front axle differential

LBH/02/003801/0003/2.06/en

- Unscrew the hex bolt 1 and 2 alternately, step by step.

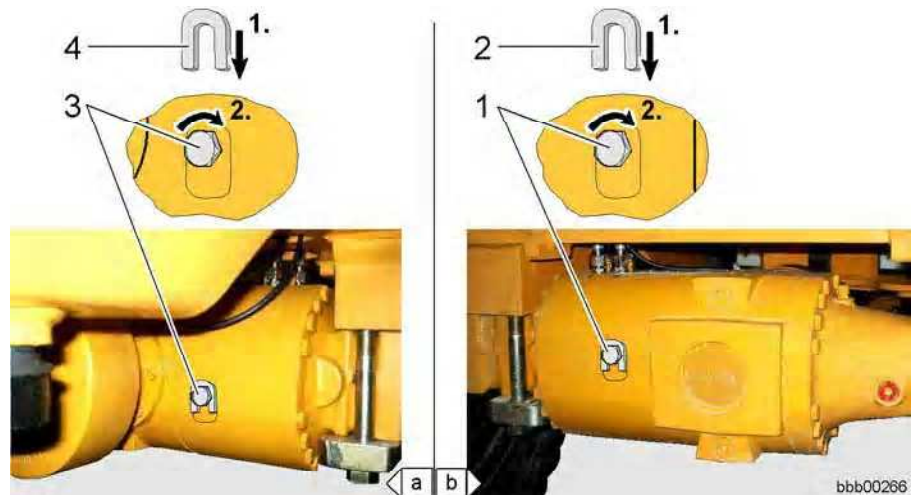

Front axle differential

- Put in the spacer 2 and 4.
 - Fully tighten the hex bolt 1 and 3.
Tightening torque 95–115 Nm
- The parking brake is adjusted again.

3.4.2 Jump starting

If you have problems starting because the batteries are flat, the machine can be jump started with external batteries. Make sure you have taken all the following safety precautions.

Connecting an external battery

How to jump start the machine.

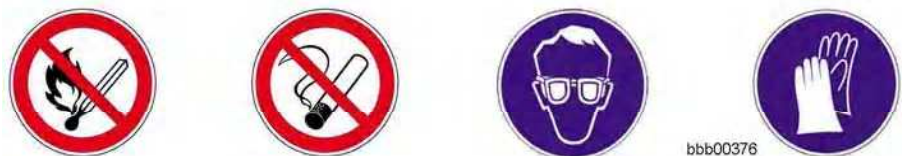

Danger



There is a risk of accidents due to incorrect or careless jump starting. Excess gas can form when you connect an external battery to old batteries. There is a risk of explosions.

- ! Therefore avoid naked flames and sparks near the batteries.
- ! Wear protective gloves and goggles when jump starting.
- ! Only use sufficiently thick jump leads.
- ! Make sure you connect and disconnect the jump leads in the right order.

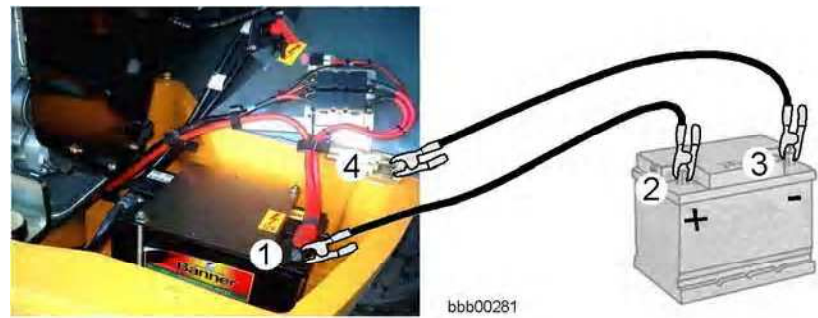

Jump starting

- | | |
|---|---|
| 1 Positive terminal of the flat battery | 3 Negative terminal of external battery |
| 2 Positive terminal of external battery | 4 Earth point on the machine |

- First connect one jump lead to the positive terminal **1** of the flat battery and then to the positive terminal **2** of the external battery.
- Connect the second jump lead to the negative terminal **3** of the external battery and then to the earth point **4** on the machine.
- Start up the engine. See the section on starting the engine.

Disconnecting the external battery

Before removing the jump leads, you must shift the engine to low idling speed.

Excess voltage can be avoided by switching on major consumers such as floodlights.

- First disconnect the jump lead from the earth point **4** on the machine and then from the earth point **3** on the external battery.
- Then remove the second jump lead from the positive terminal **1** of the flat battery and then from the positive terminal **2** of the external battery.

4 Malfunctions

Warning and error messages

- Various faults are indicated by the corresponding symbol fields (visually) or by display instruments on the instrument panel.
See the section on the display unit in chapter 3.
- Some warning functions are accompanied by audible warning signals.

Finding and eliminating errors and malfunctions

- Faults can often be traced back to incorrect operation or servicing of the machine.

Therefore, carefully read the appropriate section of the operating manual each time a fault occurs.

- **Analyse the cause of the fault and correct it immediately.**
- Describe the fault and all related circumstances as accurately as possible if you contact **LIEBHERR CUSTOMER SERVICE**.
Precise information helps to locate and eliminate the cause of the fault. This means that the exact type and serial number of the machine need to be stated.
- Never perform any work for which you have not been trained or instructed.

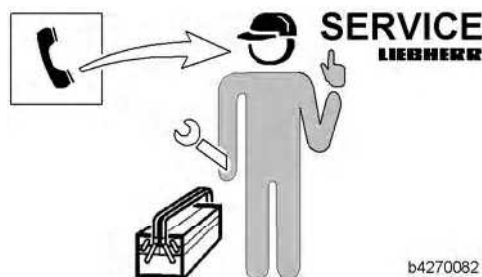

Note



If you cannot recognise the cause of the fault using the service code tables or cannot rectify the fault:
! Contact LIEBHERR CUSTOMER SERVICE.

4.1 Service Code Table

4.1.1 Service code indication on the display

The UEC3 (Universal Earth Mover Controller 3) monitors many of the machine's functions.

It monitors for short circuits, cable rupture, external voltage and incorrect input and output signals.

In addition, the UEC3 continuously checks the program sequence and communication with the display unit.

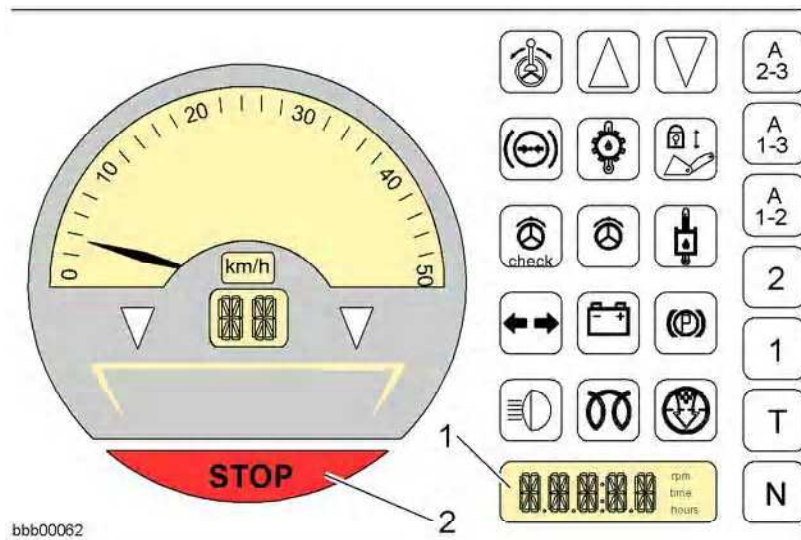

bbb00062

Display unit

1 Service code display

2 STOP display

If a fault occurs while you are setting up or operating the machine, it is shown on the display unit and stored in the service code memory.

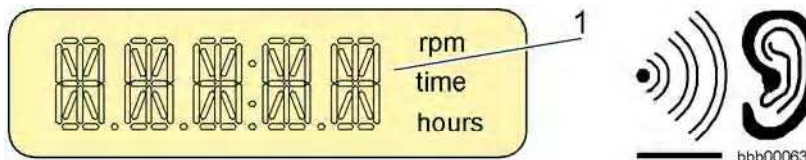

bbb00063

Error indicator

The following must be taken into account:

- The service codes are displayed in the segment field 1.
- Most service codes are accompanied by a warning beep
- If the service codes A00F, A002, A012, A013 or A016 are displayed, the UEC3 must be replaced

The service codes are classed in the following groups:

- **FATAL:**
This is a fault in the UEC3 which shuts down the machine.
- **CRITICAL:**
This is a fault in the emergency steering pump, its associated components or wiring.
- **ERROR:**
This is a fault in the various electrical components or wiring.

Malfunctions and their effects

Every malfunction has a defined effect. This is specified in the “Effect” column of the service code table. Restricted driving is usually still possible.

If malfunctions occur which can damage the machine:

- The machine is shut down.
- Neutral travel direction is automatically selected and the machine coasts to a halt.
- This is indicated by the STOP display 2 on the display unit.

Make a note of the service code, as it disappears from the segment field of the display unit when the ignition is switched off.

Have LIEBHERR CUSTOMER SERVICE rectify the fault.

FATAL service code

This is a fault in the UEC3.

- Continuous warning buzzer
- The machine is shut down

Service-Code	Symptom	Cause	Solution
EA001	Incorrect code executed	Occasional/constant fault in hardware, incorrect software programmed	Contact LIEBHERR CUSTOMER SERVICE
EA003	Outputs cannot be activated with defective watchdog	Occasional/constant hardware fault, faulty external current to DA5 output or short circuit from DA5 to GND	Contact LIEBHERR CUSTOMER SERVICE
EA014	The affected output can no longer be switched off in the normal manner	Occasional/constant hardware fault, external fault current	Contact LIEBHERR CUSTOMER SERVICE
EA015	Important outputs can be switched off	Occasional/constant hardware fault	Contact LIEBHERR CUSTOMER SERVICE

ERROR service code

This is a fault in the various electrical components or wiring.

- 1 second warning tone

Service-Code	Symptom	Cause	Solution
EA00A	Outputs: LFD solenoid, parking brake, forward travel, reverse travel and reversing light do not work.	UEC3: No power supply to fuse F23; defective fuse or broken wire	Check fuse F23; contact LIEBHERR CUSTOMER SERVICE
EA00B	Outputs: MV option 3, engine stop relay and preglow relay do not work.	UEC3: No power supply to fuse F22; defective fuse or broken wire	Check fuse F22; contact LIEBHERR CUSTOMER SERVICE

LBH/02/003801/0003/2.06/en

Service-Code	Symptom	Cause	Solution
EA00C	Outputs: Solenoid valves option 1 and 2 do not work.	UEC3: No power supply to fuse F24; defective fuse or broken wire	Check fuse F24; contact LIEBHERR CUSTOMER SERVICE
EA017	Possibly unacceptable fan speeds	UEC3: Defective internal voltage VCCEXT; occasional/constant hardware fault, external contact from pin X3-25 to GND or positive	Contact LIEBHERR CUSTOMER SERVICE
EA105	Entries (e.g. BH) cannot be added or modified in the Tuple chain.	UEC3: Tuple pages synchronisation failed; problem with controller hardware	Contact LIEBHERR CUSTOMER SERVICE
E2002	Travel direction cannot be selected; parking brake active indicator.	Parking brake status pressure switch B5 does not correspond to the UEC3 output signal; faulty wiring, solenoid valve, hydraulics or pressure switch; controller hardware fault	Contact LIEBHERR CUSTOMER SERVICE
E3000	No speed signal; no speed-dependent control functions possible (such as directional change lockout)	Faulty speed sensor or wiring, hardware fault	Contact LIEBHERR CUSTOMER SERVICE
E3001	No speed signal; no speed-dependent control functions possible (such as directional change lockout)	Power take-off speed sensor B1 shorted to earth; faulty speed sensor or wiring, hardware fault	Contact LIEBHERR CUSTOMER SERVICE
E3002	No speed signal; no speed-dependent control functions possible (such as directional change lockout)	Power take-off speed sensor B1 shorted to positive; faulty speed sensor or wiring, hardware fault	Contact LIEBHERR CUSTOMER SERVICE
E3003	No information on current hydraulic temperature available; fan running at high speed	Interruption to hydraulic oil temperature sensor B8; faulty sensor, wire, plug or controller	Contact LIEBHERR CUSTOMER SERVICE
E3004	No information on current hydraulic temperature available; fan running at high speed	Hydraulic oil temperature sensor B8 shorted to earth; sensor, wire, plug or controller earth fault	Contact LIEBHERR CUSTOMER SERVICE

Service-Code	Symptom	Cause	Solution
E3005	No information on current coolant temperature available; fan running at high speed	Interruption to coolant temperature sensor B21; faulty sensor, wire, plug or controller	Contact LIEBHERR CUSTOMER SERVICE
E3006	No information on current coolant temperature available; fan running at high speed	Coolant temperature sensor B21 shorted to earth; sensor, wire, plug or controller earth fault	Contact LIEBHERR CUSTOMER SERVICE
E3007	Fan runs at full speed because there is no information on the current engine temperature	Interruption to coolant temperature sensor B20; faulty sensor, wire, plug or controller	Contact LIEBHERR CUSTOMER SERVICE
E3008	Fan runs at full speed because there is no information on the current engine temperature	Coolant temperature sensor B20 shorted; faulty sensor, wire, plug or controller	Contact LIEBHERR CUSTOMER SERVICE
E3009	Fuel level cannot be identified. Minimum filling level is displayed	Fuel level sensor B25 shorted to earth; faulty level sensor or wiring; controller hardware fault	Contact LIEBHERR CUSTOMER SERVICE
E3010	Engine oil pressure symbol field H4 goes out after the lamp check; low engine pressure cannot be detected	Engine oil pressure switch: B7 shorted to positive; fault in pressure switch B7, wiring; controller hardware fault	Contact LIEBHERR CUSTOMER SERVICE
E3011	The engine oil pressure symbol field H4 remains on even when the engine is running; low engine pressure cannot be detected.	Engine oil pressure switch: B7 shorted to earth; faulty pressure switch or wiring; controller hardware fault	Contact LIEBHERR CUSTOMER SERVICE
E3012	The engine oil pressure symbol field H4 remains on even when the engine is running; normal condition cannot be detected.	Engine pressure switch B7 not activated after engine starts; faulty pressure switch or wiring; controller hardware fault; no engine oil pressure at switch	Contact LIEBHERR CUSTOMER SERVICE

LBH/02/003801/0003/2.06/en

Service-Code	Symptom	Cause	Solution
E3013	Parking brake symbol field H11 lights up even when the engine is running and the parking brake switch is pressed; condition of the parking brake cannot be detected.	Parking brake pressure switch B5 shorted to earth; fault in pressure switch B7, wiring; controller hardware fault	Contact LIEBHERR CUSTOMER SERVICE
E4000	Forward travel not possible	Forward MV Y2 shorted; consumer or wiring shorted to earth	Contact LIEBHERR CUSTOMER SERVICE
E4001	Forward travel not possible	Forward MV Y2 interrupted; interruption in consumer or wiring	Contact LIEBHERR CUSTOMER SERVICE
E4002	Reverse travel not possible.	Reverse MV Y3 or travel direction detection Y26 shorted; consumer or wiring shorted to earth	Contact LIEBHERR CUSTOMER SERVICE
E4003	Reverse travel not possible.	Reverse MV Y3 or direction detection Y26 interrupted; power interrupted in consumer or wiring	Contact LIEBHERR CUSTOMER SERVICE
E4004	Travel not possible because the parking brake cannot be released	Parking brake MV Y10 shorted to earth; consumer or wiring shorted	Contact LIEBHERR CUSTOMER SERVICE
E4005	Travel not possible because the parking brake cannot be released	Parking brake MV Y10 interrupted; interruption in consumer or wiring	Contact LIEBHERR CUSTOMER SERVICE
E4006	Fan always at top speed	Fan motor MV Y13 shorted to earth; consumer or wiring shorted	Contact LIEBHERR CUSTOMER SERVICE
E4007	Fan always at top speed	Fan motor MV Y13 interrupted; interruption in consumer or wiring	Contact LIEBHERR CUSTOMER SERVICE
E4008	Travel range 1 not possible	Travel range MV Y6 shorted to earth; consumer or wiring shorted	Contact LIEBHERR CUSTOMER SERVICE
E4009	Travel range 1 not possible	Travel range MV Y6 interrupted; interruption in consumer or wiring	Contact LIEBHERR CUSTOMER SERVICE

Service-Code	Symptom	Cause	Solution
E4010	Option II cannot be activated	Option II MV Y11 shorted to earth; consumer or wiring shorted	Contact LIEBHERR CUSTOMER SERVICE
E4012	Option III cannot be activated	Option III MV Y12 shorted to earth; consumer or wiring shorted	Contact LIEBHERR CUSTOMER SERVICE
E300A	Fuel level cannot be identified	Fuel level sensor B25 shorted to positive; faulty level sensor or wiring; controller hardware fault	Contact LIEBHERR CUSTOMER SERVICE
E300B	Possible machine malfunction or incorrect charge indicator	Signals at terminal 61 (D+) and engine speed terminal W do not match; no engine speed signal at terminal W but D+ signal active; faulty wiring, generator or controller	Contact LIEBHERR CUSTOMER SERVICE
E300C	Possible machine malfunction or incorrect charge indicator	Signals at terminal 61 (D+) and engine speed terminal W do not match; no terminal 61 (D+) but speed signal terminal W signal active; faulty wiring, generator or controller	Contact LIEBHERR CUSTOMER SERVICE
E300D	Air filter contamination cannot be detected	Air filter contamination pressure switch B4 shorted to positive; faulty wiring; controller hardware fault	Contact LIEBHERR CUSTOMER SERVICE
E300E	No reliable detection of air filter contamination possible	Air filter contamination pressure switch B4 activated although engine is not running; faulty pressure switch or wiring; controller hardware fault; pressure switch dirty	Contact LIEBHERR CUSTOMER SERVICE
E300F	Machine stops; travel direction cannot be selected.	LH control lever S2 in invalid switching condition; faulty control lever or wiring; controller hardware fault	Check fuse F15; contact LIEBHERR CUSTOMER SERVICE
E400A	Working hydraulics lockout cannot be lifted	Working hydraulics lockout MV Y14, quick-change device MV Y53 shorted; consumer or wiring shorted to earth	Contact LIEBHERR CUSTOMER SERVICE
E400B	Working hydraulics lockout cannot be lifted	Working hydraulics lockout MV Y14, quick-change device MV Y53 interrupted; consumer or wiring interrupted	Contact LIEBHERR CUSTOMER SERVICE

Service-Code	Symptom	Cause	Solution
E400D	At cold temperatures, engine starts with difficulty or not at all	Preglow output K04 shorted or interrupted; short circuit or interruption in consumer or wiring	Contact LIEBHERR CUSTOMER SERVICE
EA018	Service hours counter currently very high; provides information that the machine's service hours could not be loaded from the Tuple chain.	UEC3: Service hours could not be read; incorrect data in the EEPROM, faulty CRC, hardware fault	Contact LIEBHERR CUSTOMER SERVICE
EA019	Commands are not displayed; monitor does not react to queries, no communication with this module.	No communication with monitor possible; problem with CAN bus or monitor not working (power supply, hardware)	Check fuse F15; contact LIEBHERR CUSTOMER SERVICE

4.1.2 Visible and audible warning signals



The following table contains the warning signals which have an additional audible tone or which are only displayed visually, along with their causes and remedies.

There are two different audible warning signals:

- Continuous tone
- Interval tone sequence: 1 second on, 9 seconds off

Warning signal	Cause	Remedy
A buzzer sounds when you select the travel direction	The parking brake is engaged	Release the parking brake
Hydraulic oil overheating symbol field (H23) lights up, interval warning buzzer sounds, travel hydraulics are switched to travel range 1	Hydraulic oil temperature (B8) above 95°C	Clean the cooling system of operate the machine at low load until the hydraulic oil temperature falls again.
	Fault in the hydraulic system	Contact LIEBHERR CUSTOMER SERVICE
	Fault in the electrical system (temperature sensor (B8) defective, faulty wiring)	Contact LIEBHERR CUSTOMER SERVICE
Interval warning buzzer sounds, travel hydraulics are switched to travel range 1.	Coolant temperature (B21) above 103°C	Clean the cooling system of operate the machine at low load until the coolant temperature falls again.
	Fault in the hydraulic system	Contact LIEBHERR CUSTOMER SERVICE
	Fault in the electrical system (temperature sensor (B21) defective, faulty wiring)	Contact LIEBHERR CUSTOMER SERVICE
Engine oil overheating symbol field (H13) lights up, travel hydraulics are switched to travel range 1, continuous buzzer sounds, STOP symbol field lights up	Coolant temperature (B20) above 108°C	Clean the cooling system of operate the machine at low load until the coolant temperature falls again.
	Fault in the electrical system (temperature switch (B20) defective, faulty wiring)	Contact LIEBHERR CUSTOMER SERVICE
	Thermostat defective (will not open)	Contact LIEBHERR CUSTOMER SERVICE
Engine oil pressure symbol field (H4) lights up, continuous warning buzzer sounds, STOP symbol field lights up	Engine oil pressure too low, insufficient engine oil	Check the oil level and top up if necessary
	Pressure switch defective – faulty wiring	Contact LIEBHERR CUSTOMER SERVICE
	Error in the diesel engine lubricating oil supply	Contact LIEBHERR CUSTOMER SERVICE
	Fault in the electrical system	Contact LIEBHERR CUSTOMER SERVICE
Battery charge symbol field (H6) lights up, buzzer sounds briefly twice, driving not possible	Torn V-belt	Replace the V-belt
	Defective alternator	Contact LIEBHERR CUSTOMER SERVICE
	Fault in the electrical system	Contact LIEBHERR CUSTOMER SERVICE

4.1.3 Troubleshooting

Diesel engine		
Malfunction / error	Cause	Remedy
Diesel engine will not start	Battery main switch is turned off	Turn on the battery main switch
	Main fuse defective	Check the main fuse, have it replaced by an electrician
	Battery defective or not charged	Have battery checked and fault rectified by a qualified person
	Battery connections loose	Grease battery terminals and tighten connections
	Starter defective	Contact LIEBHERR CUSTOMER SERVICE
Diesel engine turns over but does not start	The engine is too cold	Preglow sufficiently before starting
	The fuel tank is empty	Refuel
	Wrong fuel for the ambient temperature	Use winter diesel appropriate to the outside temperature
	The fuel filter or pre-filter is dirty	Replace the fuel filter and clean the fuel pre-filter
	The start/stop solenoid will not switch	Check the fuses F17 and F15 and replace them if necessary
The diesel engine does not reach full power	Insufficient fuel supply to the engine	Clean the fuel pre-filter Replace the fuel filter
	Insufficient air supply to the engine	Check the air filter and replace it if necessary
	The maximum engine speed is not reached (the speed adjusting lever does not reach the full load position when the gas pedal is fully pressed down)	Adjust the Bowden cable
The engine overheats	The cooler is dirty	Clean the cooler
	The thermostat in the engine is defective	Contact LIEBHERR CUSTOMER SERVICE
	The fan motor is running too slowly or not at all	Contact LIEBHERR CUSTOMER SERVICE
The battery charge control lamp does not go out	The engine speed is too low after starting	Apply the gas pedal until the lamp goes out
	Torn V-belt	Replace the V-belt

Travel hydraulics / driving		
Malfunction / error	Cause	Remedy
The travel direction cannot be selected	The parking brake is engaged	Release the parking brake and select the travel direction
	Defective fuse	Check the fuse F15 and replace if necessary
	The travel direction switch is defective	Contact LIEBHERR CUSTOMER SERVICE
The parking brake is released, but the parking brake signal lamp does not go out	The parking brake switch is defective	Check and adjust the switch, replace it if necessary
The machine does not move although the engine is running, you have pressed the parking brake switch and the travel direction can be selected	The hydraulic oil is too viscous a) The oil is too cold b) The oil is unsuitable for the ambient temperature	a) Let the machine warm up b) Use suitable oil
The hydraulic oil overheats	The hydraulic oil cooler is dirty	Clean the oil cooler
	The fan motor is running too slowly or not at all	Contact LIEBHERR CUSTOMER SERVICE

Working hydraulics / working attachment		
Malfunction / error	Cause	Remedy
The working attachment does not move when you operate the control lever	The working hydraulics lockout is activated	Switch off the working hydraulics lockout
	Defective fuse	Check the fuse F28 and replace if necessary

Steering system		
Malfunction / error	Cause	Remedy
Steering is not possible	Insufficient hydraulic oil	Check the oil level in the hydraulic tank and top up if necessary
	The articulation lock is engaged	Put the locking bar in the top position

Brake system		
Malfunction / error	Cause	Remedy
The service brake has insufficient effect or none at all	Insufficient brake oil in the system	– Check the brake system for leaks – Check the brake oil level in the reservoir (if necessary top up with SAE 10W brake oil)
	Air in the brake system.	Contact LIEBHERR CUSTOMER SERVICE
	The brake linings are severely worn	Contact LIEBHERR CUSTOMER SERVICE

LBH/02/003801/0003/2.06/en

Electrical system		
Malfunction / error	Cause	Remedy
Some of the lights do not work	Defective fuse	Check the fuse(s) and replace if necessary
	Defective bulb	Replace the bulb Check the connections

Heating		
Malfunction / error	Cause	Remedy
The heating does not work	The water supply to the heating is interrupted	Check the water valve
The heating/air-conditioning blower does not work	Defective fuse	Check the fuse F19 and replace if necessary

4.2 Eliminating malffunctions

4.2.1 Replacing fuses



There is a risk of damaging the electrical system.

! In order to prevent damage to the electrical system, only use fuses with the correct rating.

Make sure that:

- The electrical circuit has been checked before changing the fuse.
- For safety reasons, after checking the circuit, that the machine's electrical system has been switched off.



Danger of electrocution

If you touch live parts you can be electrocuted.

! Switch off the machine's electrical system before working on live components.

! The battery main switch 1 is located at the rear right of the engine compartment.

Fuses in the engine compartment (Maxi and Mega fuses)

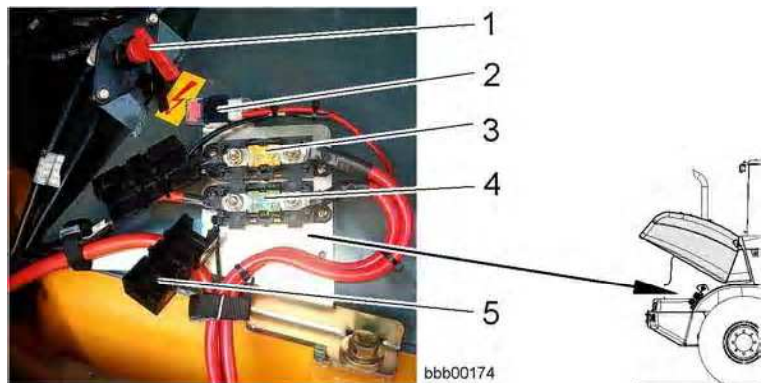

Main fuse box

- | | |
|-----------------------|----------------------------|
| 1 Battery main switch | 4 Fuse F01 |
| 2 Fuse F07 | 5 Fuse box cover (removed) |
| 3 Fuse F02 | |

Fuse	Value	Unit	Designation/function	Location
F07	10.0	A	Hazard warning lights	Rear right of engine compartment

Assignment of Maxi fuses

Fuse	Value	Unit	Designation/function	Location
F01	125	A	Main fuse	Rear right of engine compartment
F02	100	A	Preglow	Rear right of engine compartment

Assignment of Mega fuses

LBH/02/003801/0003/2.06/en

- Remove the cover **5** of the fuse box.
- Use the table above to identify the defective fuse.
- Take out the defective fuse and replace it with a new one with the same rating.

Fuses in the driver's cab

The plug-in fuses **F1 – F32** for the functions listed in the table below are located in the fuse box on the right in the control panel.



Fuse box with A4 control board

1 Control panel
2 Fuse box

3 A4 control board

- Open the emergency exit door from outside.
- Take off the cover of the fuse box on the right in the control panel.

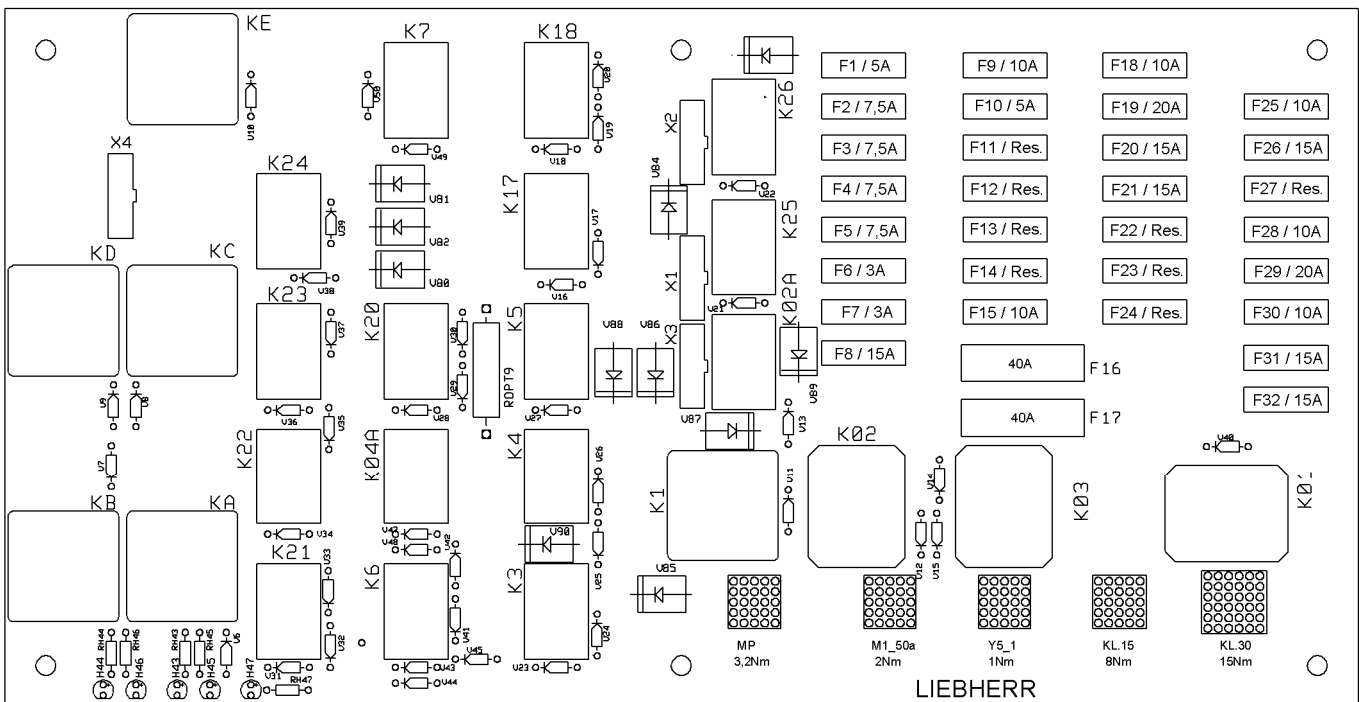

A4 control board

bbb00240

LBH/02/003801/0003/2.06/en

Key:

T = terminal

LFD = Liebherr ride control

LECU1 = Liebherr Electronic Control Unit 1

UEC3 = Universal Earth Mover Controller 3

Fuse	Value	Unit	Designation/function
F1	5.0	A	Quick-change device when the working hydraulics are activated
F2	7.5	A	Left high beam
F3	7.5	A	Right high beam
F4	7.5	A	Right driving light
F5	7.5	A	Left driving light
F6	3.0	A	Right parking light
F7	3.0	A	Left parking light
F8	15.0	A	Radio, seat compressor, socket
F9	10.0	A	LH control lever options, fast / slow, parking brake button, parking brake pressure switch
F10	3.0	A	100% lockout
F11	--	A	Spare fuse
F12	--	A	Spare fuse
F13	--	A	Spare fuse
F14	--	A	Spare fuse
F15	10.0	A	Brake light, analogue display, LECU1, UEC3, LH control lever, travel direction, tank pipe sensor, D+ function, K4/86, LFD, S100, S101, S102; emergency steering option
F16	40.0	A	Starter solenoid
F17	40.0	A	Engine stop
F18	10.0	A	Rear wipe motor/washer pump, indicator function at T 15 only
F19	20.0	A	Heating/air-conditioning, lower switch lighting
F20	15.0	A	Front wiper motor/washer pump, horn
F21	15.0	A	Driving light, top switch lighting
F22	15.0	A	UEC3
F23	15.0	A	UEC3
F24	15.0	A	UEC3
F25	10.0	A	Flashing beacon
F26	15.0	A	LECU1, UEC3
F27	--	A	Spare fuse
F28	10.0	A	Working hydraulics, analogue display, float position, bucket return-to-dig
F29	20.0	A	Ignition/starter lock release
F30	10.0	A	Radio T 30
F31	15.0	A	Front working floodlights
F32	15.0	A	Rear working floodlights, interior lighting

Assignment of fuses on A4 control board

- Use the table above to identify the defective fuse.
- Take out the defective fuse and replace it with a new one with the same rating.

5 Maintenance

5.1 Maintenance and inspection schedule

The following abbreviations are used in this section:

- h = service hours

Various symbols (solid or empty circles, boxes and stars) are used to indicate the maintenance tasks, which fall into two main types.

	●	●				✦
		■				

bsym0039

The symbols have the following meanings:

Table with solid circle, box or star

- Responsibility for carrying out the maintenance work lies with the machine operator or his maintenance personnel.
This affects the maintenance intervals every 10 and 50 service hours (h) and non-scheduled intervals.

□		○	○	○	✦
		□	○	○	250h

bsym0040

The symbols have the following meanings:

Table with empty circle, box or star, or service hours (h)

- The maintenance and inspection work must be performed or supervised by authorised engineers from LIEBHERR or its authorised dealers.
This affects the maintenance intervals on delivery, every 500, 1000, 2000 service hours (h), and at unscheduled times.

You will find a list of the spare parts needed for maintenance and inspection work in the service package of the spare parts list.

Customer: Machine type: Serial No.: Oper. hours: Date :

Maintenance/inspection according to operating hours							TASKS TO BE PERFORMED	
On delivery	Every 10	Every 50	Every 500	Every 1000	Every 2000	Special intervals	By maintenance personnel ■ One-off activity ● Repetition interval † If necessary * Annually at the start of the cold season	By authorised qualified personnel □ One-off activity ○ Repetition interval † If necessary
Complete machine								
<input type="checkbox"/>								Have the driver lubricate the machine in accordance with the lubrication chart and instruct him on proper maintenance
<input type="checkbox"/>								Instruct the driver in the operation of all functions
<input type="checkbox"/>	●	●	○	○	○			Check the machine for external damage
							†	Make sure the bolted connections are tight
<input type="checkbox"/>							†	Seal any leaks
				○	○			Check the hydraulic pressure according to the testing and adjustment plan - see the service manual
Diesel engine								
<input type="checkbox"/>	●	●	○	○	○			Check the engine oil level
				○	○	○		Change the engine oil (note: the operating hours stated here only apply to the appropriate engine oil quality / for complicating factors see the lubricants and fuels section)
				○	○	○		Change the engine oil filter
				○	○	○		Check the V-ribbed belt
							†	Change the fuel pre-filter
				○	○	○	†	Change the fuel fine filter
		●	○	○	○		†	Drain off condensate from the fuel filter
		●	○	○	○		†	Clean the air filter service cap and dust extraction valve
				○	○			Check that the air filter vacuum switch works
							†	Replace the air filter primary element if indicated by the vacuum switch (replace the secondary element after having replaced the primary element 3 times)
				○	○	○		Check the air suction hoses for leaks and tight fitting
				○	○	○		Check the exhaust lines for leaks and tight fitting
Soot particle filter (optional)								
				○	○	○		Check the soot particle filter pressure monitor for function, leaks and blockages
				○	○	○	†	Check and drain the soot particle filter condensate separator
				○	○			Change the soot particle filter condensate separator
				○	○		†	Clean the soot particle filter
Cooling system								
<input type="checkbox"/>	●	●	○	○	○			Check the coolant level

LBH/02/003801/0003/2.06/en

Customer: Machine type: Serial No.: Oper. hours: Date :

Maintenance/inspection according to operating hours							TASKS TO BE PERFORMED	
On delivery	Every 10	Every 50	Every 500	Every 1000	Every 2000	Special intervals	By maintenance personnel ■ One-off activity ● Repetition interval † If necessary * Annually at the start of the cold season	By authorised qualified personnel □ One-off activity ○ Repetition interval † If necessary
			○	○	○	*		Check the coolant antifreeze concentration
						†		Clean the cooling system
					○			Replace the coolant and antifreeze (or every 2 years)
Working hydraulics								
□	●	●	○	○	○			Check the hydraulic tank oil level (take an oil sample every 500 hours for bio oil)
					○			Change the hydraulic tank oil
				○	○			Change the hydraulic tank return suction filter
					○			Change the hydraulic tank bleeder filter
			○	○				Lubricate the pilot control device solenoids, universal joints and tappets
Steering system								
□	●	●	○	○	○			Check that the steering is working
□		●	○	○	○			Lubricate the bearing points on the steering cylinders
Brake system								
□	●	●	○	○	○			Check the service brake and parking brake
				○	○			Check the gap and wear on the service brake linings
□		●	○	○	○			Check the oil level in the equalising reservoir of the brake system
Electrical system								
□	●	●	○	○	○			Check the indicator lamps and lighting
			○	○	○			Check the batteries, fluid level and terminals
Transfer gear								
□			○	○	○			Check the transfer gear oil level
			□	○	○			Change the transfer gear oil
Axles and tyres								
□		■	○	○	○			Check the tightness of the wheels (once after 50, 100 and 250 h)
			□		○			Check the tightening torque of the front axle fastening bolts
□			○	○	○			Check the axle oil levels
			□	○	○			Change the axle oil
□		●	○	○	○			Grease the rear axle kingpin bearings
				○	○			Check the fitting of the rear axle kingpin bearings
□		●	○	○	○			Check and lubricate the cardan shaft(s)
□						†		Check the tyre pressure

LBH/02/003801/0003/2.06/en

Customer: Machine type: Serial No.: Oper. hours: Date :

Maintenance/inspection according to operating hours							TASKS TO BE PERFORMED	
On delivery	Every 10	Every 50	Every 500	Every 1000	Every 2000	Special intervals	By maintenance personnel ■ One-off activity ● Repetition interval † If necessary * Annually at the start of the cold season	By authorised qualified personnel □ One-off activity ○ Repetition interval † If necessary
Machine frame and ballast weight								
<input type="checkbox"/>		●	○	○	○			Lubricate the articulation bearing and rear oscillating bearing
						†		Grease the contact faces of the articulation stops
			□		○			Check the tightening torque of the bolts on the two pressure flanges of the articulation bearing
				○	○			Check that the taper connection of the steering rods is tight
Lubrication system (optional)								
<input type="checkbox"/>		●	○	○	○			Check whether metered quantities are adequate at the bearing points (grease collars) of the central lubrication system
<input type="checkbox"/>		●	○	○	○			Check the pipes, hoses and lubrication points of the lubrication system
Cab, heating and air-conditioning								
						†		Grease the cab door hinges
						†		Clean or replace the fresh air and recirculated air filter
			○	○	○			Check the indicator and filling level beads in the dryer-collector unit (optional) of the air conditioner
Lift arms and quick-change device								
<input type="checkbox"/>		●	○	○	○	†		Lubricate the lift arms and attachment
				○	○	†		Check the lift arm bearing bushings
				○	○			Check the lift arms and bucket stops
<input type="checkbox"/>	●	●	○	○	○			Lubricate and test the quick-change device

LBH/02/003801/0003/2.06/en

5.2 Lubricant chart, filling quantities









5.2.1 Table of filling quantities

Specifications in the medium column:





- The standard lubricants and fuels required for central European climate conditions are stated here.
- **Before you change or top up the oil in the hydraulic system (hydraulic tank), always check if it is filled with petroleum or bio oil.**
- For more detailed information about the required lubricants and service fuels, see the section on lubricants and fuels.

Specifications in the dosage column:

- The values stated for the filling quantities in the table are only guidelines.
- The dipstick and level markings are always mandatory.
- Each time the oil is replaced or topped up, check the level in the unit in question.

	Name	Medium	Dosage	Units
 06sy05ab	Diesel engine (with filter change)	Engine oil SAE 10W -40	8.0	l
 06sy04ab	Diesel engine cooling system total capacity	Coolant	10.0	l
 06sy03ab	Hydraulic system total capacity	Engine oil SAE 20W -20	90.0	l
 06sy03ab	Hydraulic tank	Engine oil SAE 20W -20	55.0	l
 bsym0027	Brake system total capacity	HLPD hydraulic oil (mineral oil) SAE 10W	0.8	l
 5 06sy18ab	Transfer gear	Gear oil SAE 90 LS	0.7	l
 1 06sy14ab	Front axle differential	Gear oil SAE 90 LS	4.0	l
 2 06sy15ab	Front axle wheel hubs	Gear oil SAE 90 LS	2 x 0.9	l

LBH/02/003801/0003/2.06/en

	Name	Medium	Dosage	Units
 3 06sy16ab	Rear axle differential	Gear oil SAE 90 LS	4.1	l
 4 06sy17ab	Rear axle wheel hubs	Gear oil SAE 90 LS	2 x 0.9	l
 bsym0057	Fuel tank	Diesel	80.0	l
 bsym0029	Air-conditioning system	Refrigerant R 134a – ca.	1400	g

5.2.2 Lubricant chart

The lubrication chart provides an overview of the location of the maintenance points on the machine and of the maintenance intervals.

You will find detailed information in the maintenance and inspection schedule, as well as in the individual descriptions in the section on maintenance tasks.

For more detailed information about the required lubricants and service fuels, see the section on lubricants and fuels.





For information about the required filling quantities, see the tables of filling quantities.

Key:

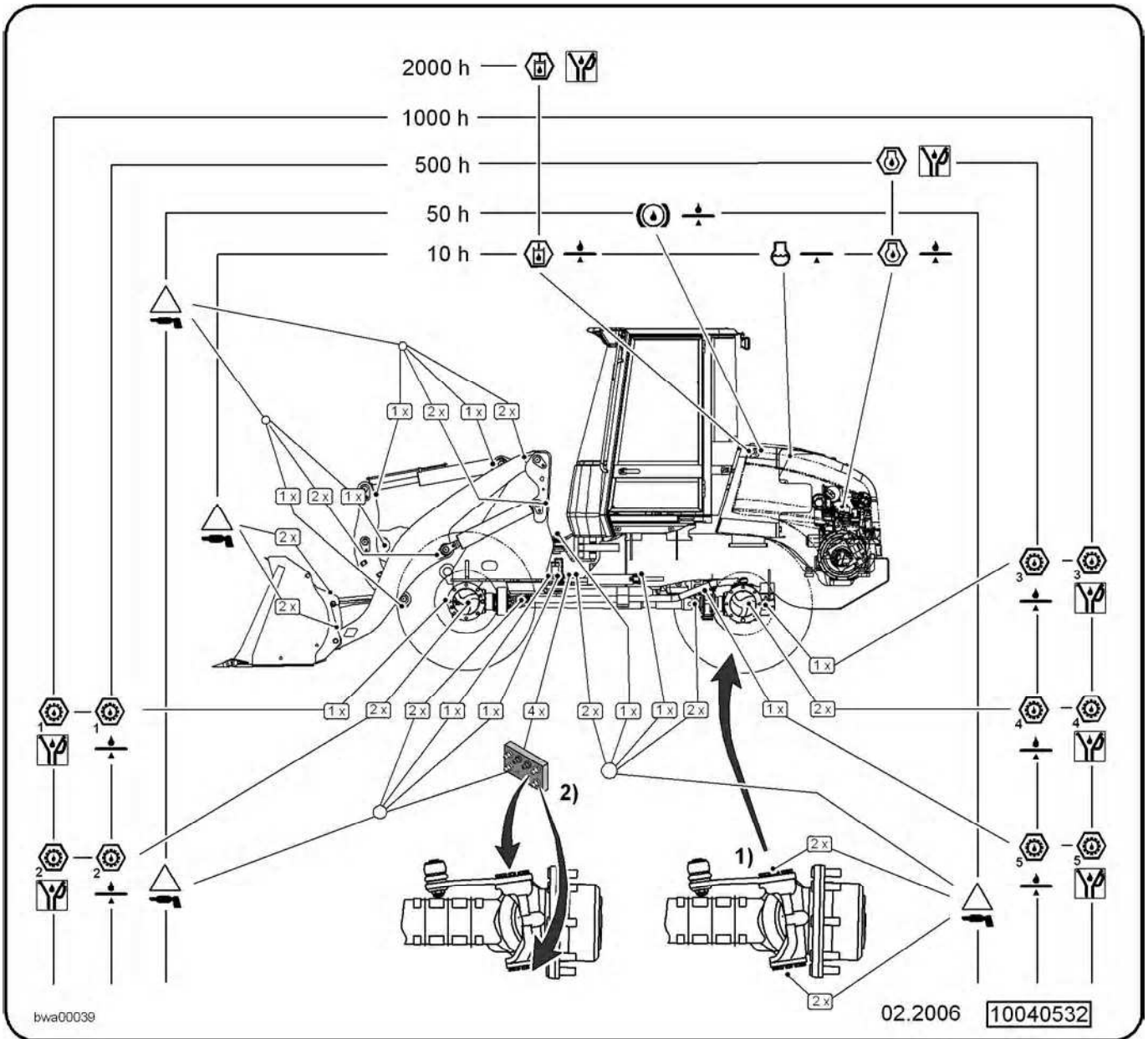
1) = Standard version

2) = This equipment is optional.



Symbol	Name	Symbol	Name
 06sy09ab	General lubrication points	 06sy01ab	Lubrication
 06sy13ab	Check the oil level	 06sy21ab	Check the coolant level
 06sy11ab	Oil change		

LBH/02/003801/0003/2.06/en

5.3 Maintenance tasks

On completion of servicing, the machine should be returned to the operating position.

See the section on the operating position in chapter 3.

5.3.1 Preparatory tasks for maintenance

Before performing the various maintenance tasks, move the machine to maintenance position unless otherwise explicitly specified in the description.

The various maintenance tasks include:

- Lubricating the lift arms
- Checking the oil level or changing the oil in the engine, gears, axles, hydraulic tank, etc.
- Replacing filters as well as adjustment and repair work on the hydraulic system

Safety precautions for maintenance

Always observe the accident prevention regulations during maintenance work.

See the measures to ensure safe maintenance on chapter 2.

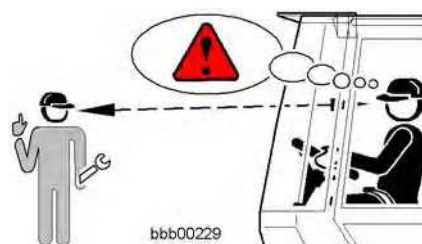

Visual contact

Make sure that visual contact between the operator in the cab and maintenance personnel is always maintained.

Danger



There is a risk of accidents for maintenance personnel.

The presence of unauthorised persons on the machine can place the maintenance personnel in extreme danger.

! Never enter a dangerous area of the machine without making your presence known.

- Make sure you can be clearly seen before entering one of the machine's danger areas.

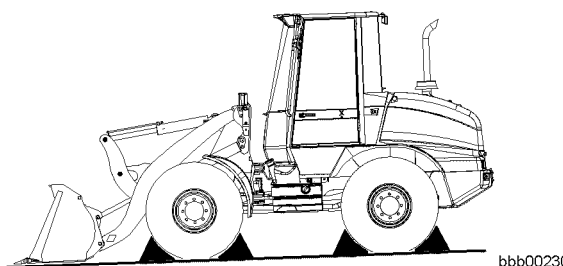

Wheel wedges

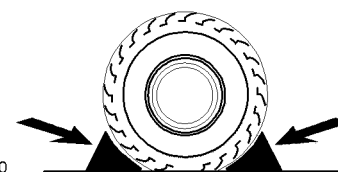

- Secure the machine against rolling away with wheel wedges.

Maintenance positions

The maintenance position depends on the maintenance task to be performed.

The two basic maintenance positions 1 and 2 are described below. They enable you to access the individual maintenance points.

Maintenance position 1

To move the machine into maintenance position 1 proceed as follows.

For a detailed description of the individual procedures, see the section on operation in chapter 3.

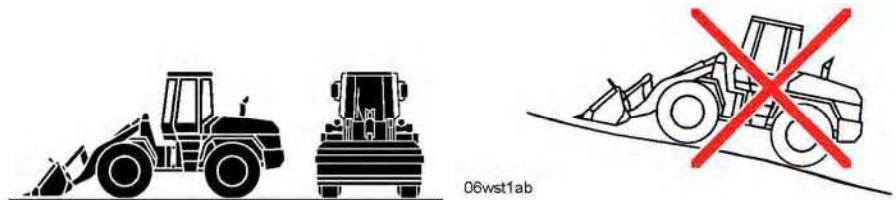

Maintenance position 1

- Park the machine on level ground.
- Lower the lift arms.
- Set the bucket down flat on the ground.
- Engage the parking brake
- Turn off the diesel engine.
- Take out the ignition key.

Maintenance position 2

To move the machine into maintenance position 2 proceed as follows.

For a detailed description of the individual procedures, see the section on operation in chapter 3.

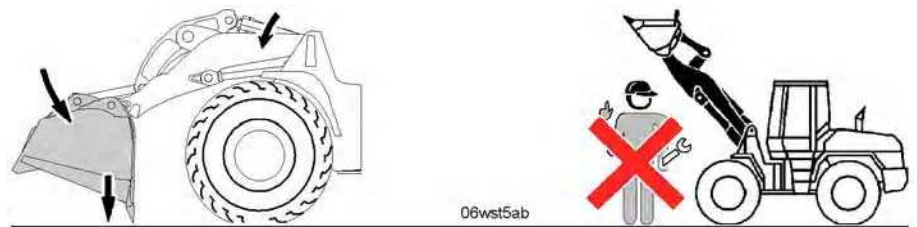

Maintenance position 2

- Park the machine on level ground.
- Engage the articulation lock.
- Lower the lift arms.
- Tilt the bucket out and set it down on the ground on its teeth or cutting edge.
- Engage the parking brake
- Turn off the diesel engine.
- Take out the ignition key.

Opening the engine compartment hood and the cooler grille

Opening the engine compartment hood

When the hood is open, you can access the following units:

- Diesel engine
- Air filter
- Hydraulic pumps
- Cooling system
- Battery



Engine compartment hood

1 Engine compartment hood
2 Handle with lock

3 Gas-filled springs

Warning



Engine parts which are in motion can cause injury. Rotating or moving engine parts, such as the fan blades or V-belts, can cause injury.

! Only open the engine compartment hood when the engine is shut down.

- Open the lock with the ignition key.
- Open the engine compartment hood **1** using the handle **2** and lift it all the way up.

The hood is held in this position by two gas-filled springs **3**.

Warning



There is a risk of injuries if the hood falls shut.

! Check that the gas-filled springs securely hold the hood fully open.

- If not, rectify the problem immediately.

Troubleshooting

The function is not assured

- Contact LIEBHERR CUSTOMER SERVICE.

Removing the cooling system grille

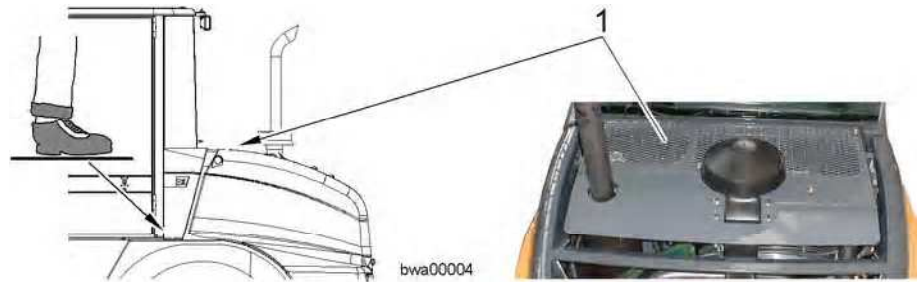

Cooling system grille

When the grille 1 is removed, you can access the following units:

- Cooling system
- Hydraulic tank
- Brake system equalising reservoir

Warning

The hot exhaust system can cause injury.

! When performing checks or maintenance, be careful if the exhaust system is hot.

- To remove or fit the grille, climb onto the machine via the cab access, making sure that you have secure footing.
- Undo the screws and take off the grille.

Turning off the battery main switch

The battery main switch is located at the rear right of the engine compartment.

For certain maintenance jobs, the battery main switch must first be turned off.

Look at the relevant descriptions of maintenance tasks to find out if the battery main switch has to be turned on or off. See the section on maintenance tasks.

Switch on the battery main switch after completing these maintenance tasks.



Turning off the battery main switch

1 Battery main switch

2 Key

Danger

There is a risk of accidents for maintenance personnel.
If unauthorised people are on the machine it can put the maintenance personnel in extreme danger.

! For safety reasons, it is essential that the battery main switch is turned off.

! Pull out the key for safety reasons.

- Turn the battery main switch **1** off using the key **2**.

5.3.2 Checking the machine for external damage

Make sure that the machine is in maintenance position 1.

Procedure



- Before starting up the machine, check for external damage which might impair safe operation.
- Repair any damage with safety implications immediately.

5.3.3 Making sure the bolted connections are tight

Make sure that:

- The machine is in maintenance position 2.
- The appropriate service doors, hatches and hoods are open.

Procedure

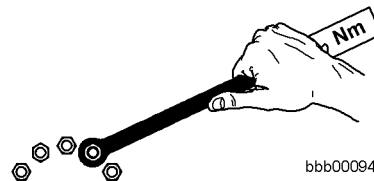

- Check that all bolts and screws are tight.
- Tighten any loose screws or bolts with the required tightening torque.

5.3.4 Sealing leaks

Make sure that:

- The machine is in maintenance position 2.
- The appropriate service doors, hatches and hoods are open.

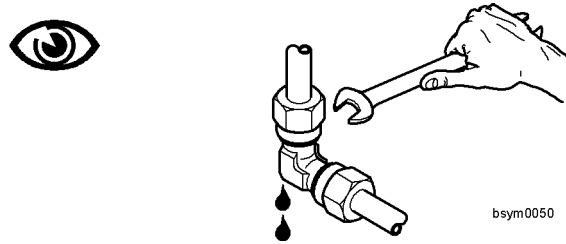
Procedure

bsym0050

- Check the entire hydraulic system for leaks.
- Replace any damaged hydraulic seals.
- Tighten any loose hydraulic couplings.
- See also the section on safe maintenance of hydraulic hoses and hose lines in chapter 2.

5.3.5 Checking the engine oil level

The oil filler neck is on the top of the engine on the valve cover.

Make sure that:

- The machine is in maintenance position 1.
- The engine compartment hood is open.
- The engine is level and has not been running for 2 - 3 minutes.

Procedure

bwa00005

Engine oil dipstick

- Pull out the dipstick **1**, wipe it clean, and re-insert it.
- Pull out the dipstick once again and read off the oil level.

The oil level must be within the cross hatching **2**.

- If the oil level is in the range **3** or below:
Top up with engine oil.

5.3.6 Changing the engine oil

Make sure that:

- The machine is in maintenance position 1.
- The engine compartment hood is open.
- The engine is level.
- The engine is warm.
- A suitable receptacle, an oil drain hose and the specified engine oil are at hand.

See the table of filling quantities for the required capacity of the receptacle.

Procedure



Changing the engine oil

- Remove the plastic plug 7.
- Unscrew the cap of the oil drain valve 2 on the oil pan.
- Screw the oil drain hose 1 to the oil drain valve 2.
- Drain off the oil into the receptacle.
- Unscrew the oil drain hose 1.
- Screw the cap onto the oil drain valve 2.
- Put in the plastic plug 7.
- **When changing the engine oil and the oil filter:**
Change the filter as described in the section on changing the oil filter.
- Top up the oil via the oil filler neck 4 to the top marking 5 on the cross hatching of the dipstick 6 (for the oil quality, see the section on lubricants and fuels).
- Clean the filler cap 3, place it on the oil filler neck 4 and tighten it.
- Start the engine and check the oil pressure.
- Turn off the engine and after 1 - 2 minutes, check the oil level on the dipstick 6.
- The oil level must be within the cross hatching 5.

5.3.7 Changing the engine oil filter

Make sure that:

- The machine is in maintenance position 1.
- The engine compartment hood is open.
- The engine oil has been drained off.
- A strap wrench and a suitable container are in place.
- Only use genuine LIEBHERR spare parts.
(1 oil filter cartridge)

Procedure



Unscrewing the oil filter

- Release the oil filter cartridge **2** with a strap wrench **3** and unscrew it.
- Clean the seal surfaces of the filter bracket **1**, if necessary remove the old filter seal and anything left of it.
- Lightly coat the filter seal on the new oil filter cartridge **2** with engine oil.
- Screw the new oil filter cartridge onto the filter bracket **1** until the seal touches the filter bracket **1**. Tighten it another half to three-quarter turn.
- **Top up with oil as described in the section on engine oil.**

5.3.8 Changing the fuel pre-filter

Make sure that:

- The machine is in maintenance position 1.
- The engine compartment hood is open.
- You have a LIEBHERR fuel pre-filter cartridge ready.

Changing the fuel pre-filter



Changing the fuel pre-filter

- Release the hose clips and remove the fuel pre-filter 1.
- Fit a new fuel pre-filter 1.

Bleeding the fuel system



Bleeding the fuel system

- Undo the bleeder screw 1 by two turns.
- Push the hand pump lever 2 until bubble-free fuel comes out of the bleeder screw 1.
- Tighten the bleeder screw 1.
- Push the hand pump lever 2 until the pump resistance subsides. Carry on pumping and undo the bleeder screw 1 (the remaining air escapes under pressure and the pump resistance increases again).
- Close the bleeder screw 1 and push the hand pump lever 2 until the pump resistance subsides again.
- If you can feel no resistance accumulate while pushing the hand pump lever 2 or if no fuel comes out of the bleeder screw 1:

Briefly turn over the diesel engine with the starter, because the lever of the fuel pump is probably at the top of the cam.

5.3.9 Changing the fuel fine filter

Make sure that:

- The machine is in maintenance position 1.
- The engine compartment hood is open.
- You have a LIEBHERR fuel fine filter cartridge ready.

Procedure for changing the fuel fine filter

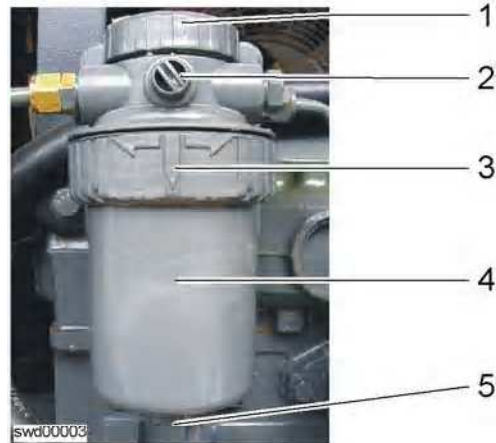

- Carefully clean the fuel fine filter and the area around it.
- Place a receptacle under the fuel fine filter.
If necessary, connect a drain hose to the drain valve.
- Open the drain screw **5** on the fuel fine filter by two or three turns:
Drain off the condensate into a suitable receptacle.
- Unscrew the retaining ring **3** on the fuel fine filter anticlockwise:
(Use a strap wrench if necessary), take off the retaining ring and pull out the filter cartridge **4**.
- Clean the seal on the filter head.
- Oil the seal on the new filter cartridge.

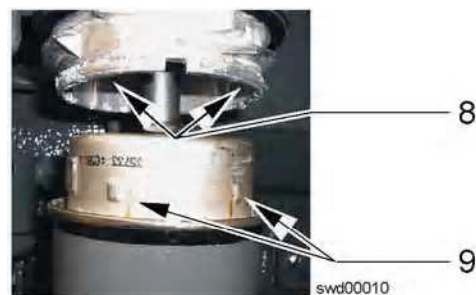

- Fit a new filter cartridge **4** on the filter base.
Make sure that the slot **8** in the filter base and the lugs **9** on the filter element are lined up.
- Fit the snap ring **3** and tighten it by 1/3 turn clockwise.
The snap ring clicks into the notch.

Bleeding the fuel system

Procedure: see the section on changing the fuel pre-filter.

5.3.10 Draining off condensate from the fuel fine filter

Make sure that:

- The machine is in maintenance position 1.
- The engine compartment hood is open.

Draining off condensate



Draining off condensate

- Place a receptacle under the fuel fine filter.
- Unscrew the drain plug 1 and drain the condensate into the receptacle until clean fuel starts to flow.
- Tighten the drain plug 1 again.

Bleeding the fuel system

Procedure: see the section on changing the fuel pre-filter.

5.3.11 Cleaning the air filter service cap and dust extraction valve

Important: With the engine running at lower idle speed, you should clearly feel air pulsating at the dust extraction valve.

If the valve is damaged, the dust extraction function is impaired and the filters become clogged more quickly.

Make sure that:

- The machine is in maintenance position 1.
- The engine compartment hood is open.

Cleaning the dust extraction valve

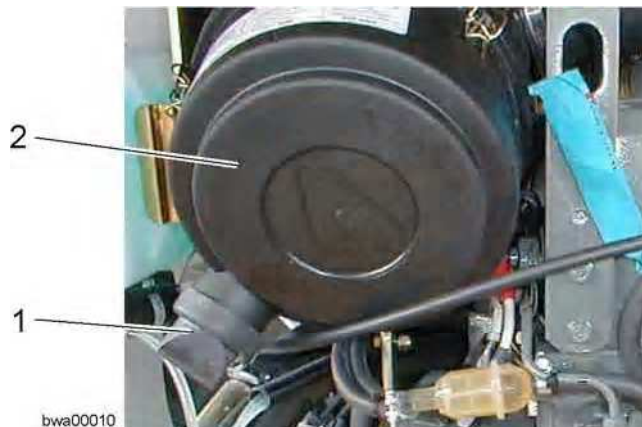

Cleaning the dust extraction valve

- Press the rubber seal on the dust extraction valve **1** several times to remove the dust from the service cap **2**.
- When working in dusty conditions, check and empty the dust extraction valve **1** more often.
- If the dust extraction valve is damaged or stays open:
Replace the dust extraction valve.

Cleaning the service cap

- Open the fixing clips on the service cap **2** and take the cap off.
- Clean the service cap.
- Put the service cap back on the filter housing. The dust extraction valve **1** must face down.

Only when the lid completely covers the filter housing can you close the fixing clips without excessive force.

- Close the fixing clips.

5.3.12 Changing the air filter main element when indicated by the vacuum switch

The primary element **2** should be cleaned or replaced when the air filter contamination symbol field on the display unit lights up.

If the air filter contamination symbol field remains lit after the primary element **2** has been serviced then the secondary element **1** must also be replaced.

Make sure that:

- The machine is in maintenance position 1.
- The engine compartment hood is open.

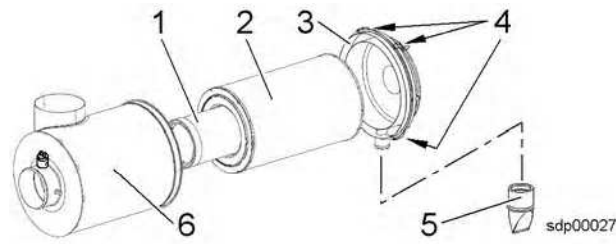
Procedure*Air filter*

- | | |
|---------------------|-------------------------|
| 1 Secondary element | 4 Fixing clips |
| 2 Primary element | 5 Dust extraction valve |
| 3 Service cap | 6 Air filter housing |

- Open the fixing clips **4** on the service cap **3** and take the cap off.
 - Remove the primary element **2** and the secondary element **1**.
To loosen the seal: pull or twist the elements slightly up, down or sideways.
 - Make sure that all dirt has been removed from the filter housing before you put in a new or cleaned filter element.
 - The secondary element **1** should be replaced every third time the main filter element **2** is replaced.
 - Lightly oil the seal surfaces before installing the filter elements (for the primary element **2** this is on the inside, for the secondary element **1** on the outside).
 - Re-insert filter elements **1** and **2** and make sure that they are correctly fitted.
 - Clean the service cap **3** and put it on the filter housing with the dust extraction valve **5** facing down.
- Only when the lid completely covers the filter housing can you close the fixing clips without excessive force.
- Close the fixing clips **4**.

5.3.13 Checking and draining the soot particle filter condensate separator

This equipment is optional.

The condensate separator is part of the soot particle filter system.

The filter/drain unit 1 is mounted on the left side under the cab.

Make sure that the machine is in maintenance position 1.



Main components

- | | |
|------------------------|--|
| 1 Filter/drain unit | 5 Exhaust gas counterpressure display line |
| 2 Counterpressure line | 6 Data logger line |
| 3 Condensate container | |
| 4 Drain plug | |

- **At regular intervals (daily or as required):**
Check the filling level of the filter/drain unit.
- **If the condensate container is over half full with condensation water:**
Drain off the accumulated condensation water.
 - To do this, unscrew the drain plug **4** from the condensate container **3**.
 - Pour out the condensation water.
 - Screw the drain plug **4** back onto the condensate container **3**.
- Check the filter insert (visible in the sight glass) of the filter/drain unit **1** for dirt.
- **If the filter insert is too dirty:**
The filter insert must be replaced.

NOTE The condensate separator should be completely replaced after 1000 operating hours.

This must be done when cleaning the filter (every 1000 operating hours as prescribed).

- Contact LIEBHERR CUSTOMER SERVICE.

5.3.14 Checking the coolant level

Make sure that:

- The machine is in maintenance position 1.
- The engine compartment hood is open.

Procedure*Checking the coolant level*

- Check the coolant level in the equalising reservoir **1**; the coolant level must be within the marking **3**.
- If the coolant level is below the marking **3**:
Top up with coolant via the filler neck **2**.

5.3.15 Checking the coolant antifreeze concentration

All year round, the coolant must contain at least 50 % by volume of concentrated antifreeze, but not more than 60% by volume. This protects against freezing down to around -37 °C.

Make sure that:

The machine is in maintenance position 1.

The engine compartment hood is open.

You have the optical density tester or strip test kit ready.

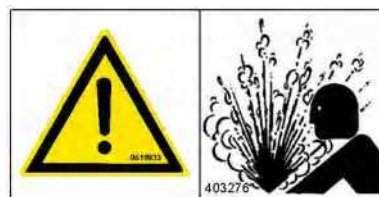
Checking the antifreeze concentration**Procedure****Caution**

There is a danger of scalding due to coolant escaping under pressure. Only open the sealing cap once the engine has cooled down.

! Carefully open the sealing cap on the filler neck and let the pressure escape from the cooling system.

- Take a sample of the coolant and check the antifreeze concentration using the test tool or strip test kit.
- If the antifreeze concentration is too low:
Correct the mixing ratio of the antifreeze in the coolant.

Correcting the antifreeze concentration

- If the antifreeze concentration is too low:
Drain off the coolant and top up with pure antifreeze according to the following diagram.



There is a risk of damage to the diesel engine.
Too much antifreeze and corrosion protection agent impairs the cooling effect.
This eventually causes damage to the diesel engine.
! Never use more than 60% antifreeze and corrosion protection agent.

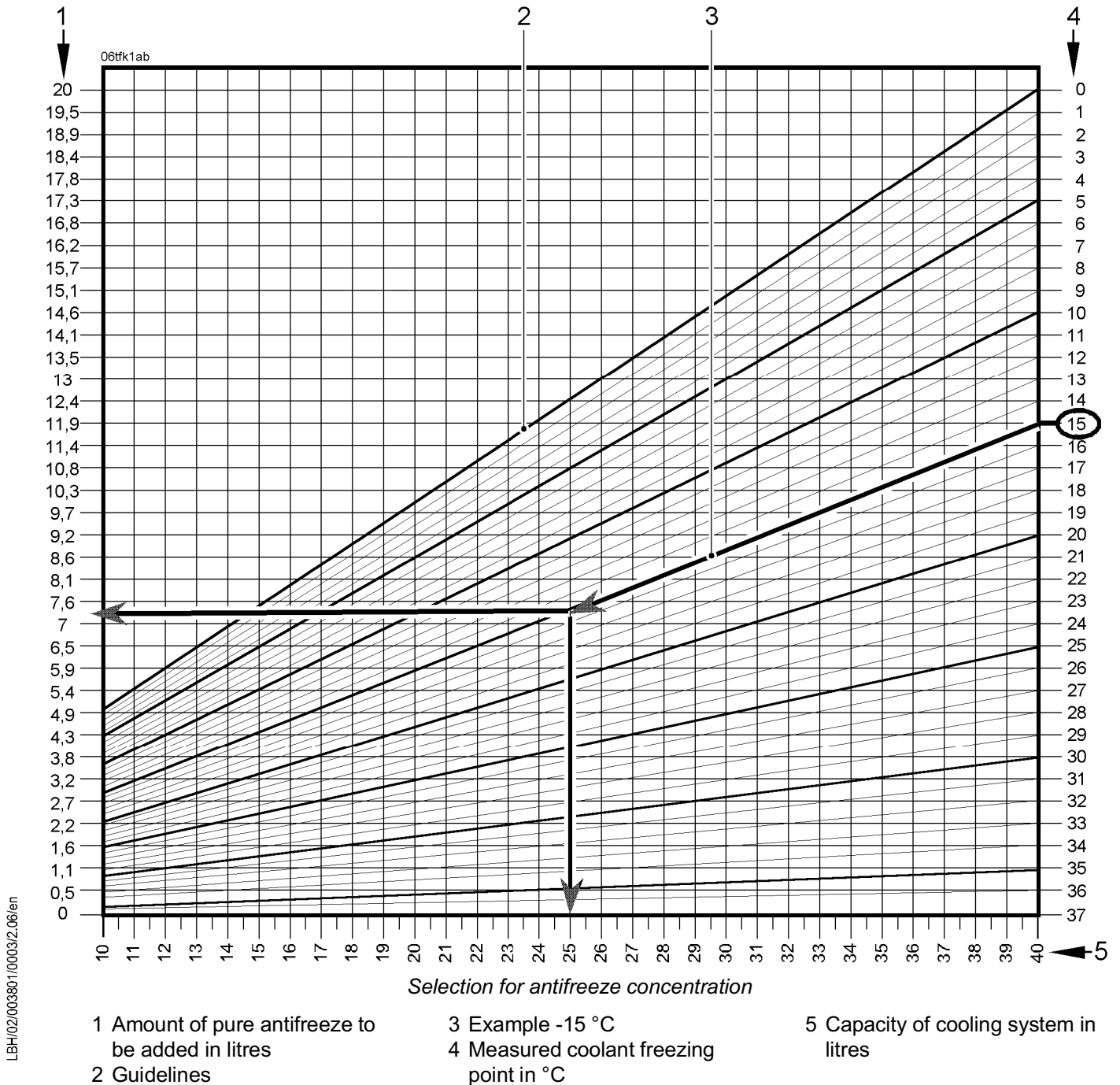

LBH/02/003801/0003/2.06/en

- **Procedure for the example -15 °C:**

If you measure a temperature of -15 °C in the cooling system, follow the guideline 3 (starting from the measured temperature) to the left down to the vertical line indicating the filling quantity for the cooling system 5 and from this point horizontally to the left edge.

This gives you the topping up quantity of pure antifreeze and corrosion protection agent 1 to be added in order to achieve protection down to -37° C.

- To restore the correct mixing ratio, you must drain off at least the previously calculated quantity from the cooling system.
- Top up with the correct quantity of pure antifreeze and corrosion protection agent.
- The coolant previously drained off can be used if necessary to restore the required coolant level.

5.3.16 Cleaning the cooling system

Clean the cooler whenever necessary in order to ensure proper cooling. In dusty environments, check the cooler every day and clean it if necessary. Dirty cooler units result in overheating. The consequence is an audible and visual warning with simultaneous power reduction of the travel drive. Dust and other contaminants can be removed from the cooling fins with water jets, steam or compressed air. Compressed air is preferable.

Make sure that:

- The machine is in maintenance position 1.
- The cooling system grille has been removed.

Procedure



Cleaning the cooler units

Caution



Risk of damage to the cooling system

Careless handling can damage the cooler fins.

! Do not use hard objects or excessive water pressure for cleaning.

- Clean the cooler units 1 with compressed air, steam or water.

5.3.17 Checking the oil level in the hydraulic tank

Make sure that:

- The machine is cold.
- The machine is in maintenance position 1.
- The engine compartment hood is open.

Warning 

The hot exhaust system can cause injury.

! When performing checks or maintenance, be careful if the exhaust system is hot.

Procedure

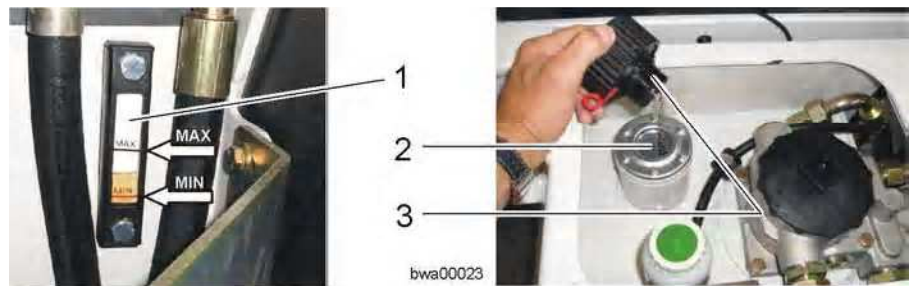

Checking the oil level

The **MIN - MAX** marking shows the correct oil level.

- Check the oil level in the sight glass 1.
- If the oil level is too low:
Top up with hydraulic oil.

The hydraulic oil may only be poured in through the filler strainer 2.

- Remove the cooling system grille.
- Unscrew the bleeder filter 3.
- Top up with hydraulic oil to within the **MIN - MAX** marking.
- Put the bleeder filter 3 on and tighten it.
- Fit the cooling system grille.

5.3.18 Checking that the steering is working

Procedure

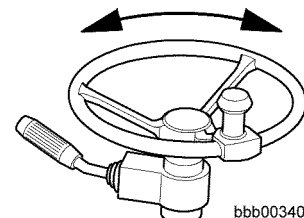
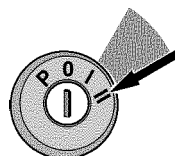

- Start the diesel engine.
- Without moving the machine, turn the steering in both directions and check that it is functioning properly.

LBH/02/003801/0003/2.06/en

5.3.19 Lubricating the bearing points on the steering cylinders

Make sure that the machine is in maintenance position 1.

Procedure



Steering cylinder lubrication points

- Lubricate the bearing points on the steering cylinders.

5.3.20 Checking the service brake and parking brake

Make sure that there is enough room to check the service brake and parking brake.

Checking the service brake

Warning



There is a danger of driving into bystanders or obstacles.

- ! Do not allow anyone into the danger area while these tests are being conducted.
- ! Perform the test on level ground with no obstacles.

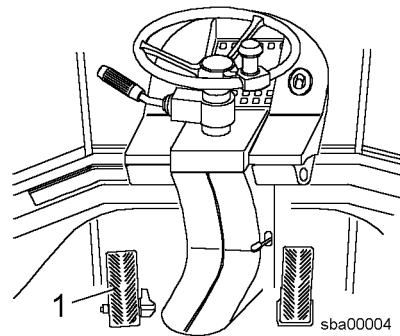

- Start the machine, and drive it forwards at around 8 km/h.
- While moving, push the inch/brake pedal **1** all the way down. The machine must come to an **abrupt** stop.

Troubleshooting

If the braking effect is too slight or entirely absent:

- Contact LIEBHERR CUSTOMER SERVICE.

Checking the parking brake



There is a danger of driving into bystanders or obstacles.
 ! Do not allow anyone into the danger area while these tests are being conducted.
 ! Perform the test on level ground with no obstacles.

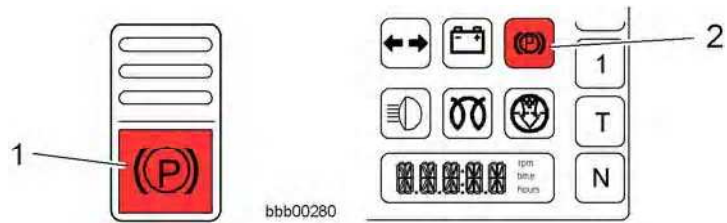

- Start the machine, select travel range 1 and forward travel direction.
- Drive the machine forwards at around 3 km/h and press the parking brake button 1.

The symbol field 2 for the parking brake lights up.

The machine must come to an abrupt halt.

Troubleshooting

If the braking effect is too slight or entirely absent:

- Contact LIEBHERR CUSTOMER SERVICE.

5.3.21 Checking the gap and wear on the service brake linings

Make sure that the machine is in maintenance position 1.

Procedure



Drum brake

- Remove the plugs from the measuring openings 1 on the drum brake.
- Shine a torch into the measuring opening.
- Check the gap (min. 0.2 mm / max 0.5 mm) and wear on the brake linings (min. 2 mm at the thinnest point).
- If the gap or wear on the brake linings is outside the permissible range, contact LIEBHERR customer service.

5.3.22 Checking the oil level in the equalising reservoir of the brake system

Make sure that the machine is in maintenance position 1.



To avoid damaging the brake system, only use suitable hydraulic oil (mineral oil).

! Make sure that only suitable oils are used for topping up (see the section on lubricants and fuels).

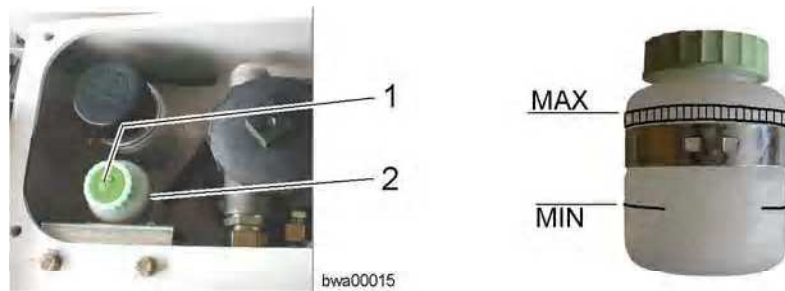

Brake system equalising reservoir

- Check the oil level in the equalising reservoir **2** from the driver's seat. The oil level must be between the **MIN** and **MAX** markings.



The hot exhaust system can cause injury.

! When performing checks or maintenance, be careful if the exhaust system is hot.

If the oil level is lower:

- Remove the cooling system grille
- Remove the cap **1** and top up with oil.
- Screw the cap **1** onto the equalising reservoir **2**.
- Fit the cooling system grille.

5.3.23 Checking the indicator lamps and lighting

Make sure that:

- The machine is in maintenance position 1.
- The machine's electrical system is switched on.

Procedure

- When you switch on the ignition, the lamps on the display unit are tested.
- All symbol fields light up for three seconds.
See the section on starting the engine in chapter 3.

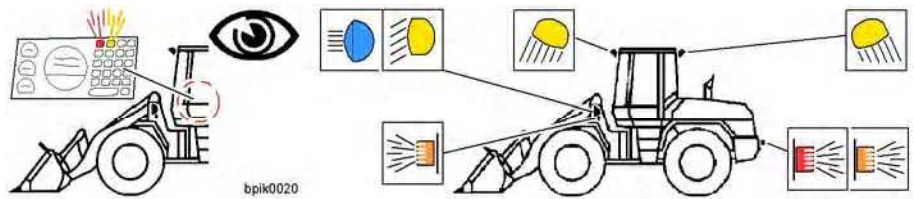

- Switch on the ignition.
- Check that the symbol fields on the display unit light up.
- Check that all lights are working.

5.3.24 Checking the tightness of the wheels (once after 50, 100 and 250 h)

Make sure that:

- The machine is in maintenance position 1.
- A torque wrench with a measuring range of over 450 Nm is available.

Procedure

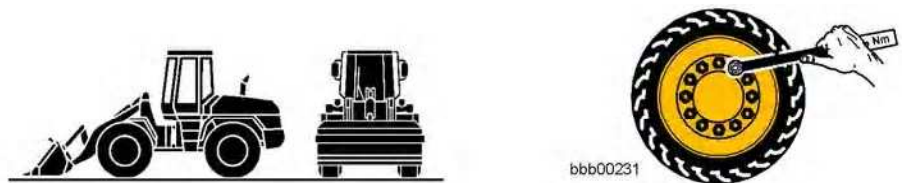

Note  Check the tightness of the wheels according to the specified intervals.
! This one-off maintenance task scheduled for 50, 100 and 250 service hours must be performed every time the wheels are changed.

Note



Installing or changing the working attachment or tyres.
 ! See the section on attachments and accessories in chapter 2.

- Check that the nuts and bolts on all four wheels have been tightened with the required torque.

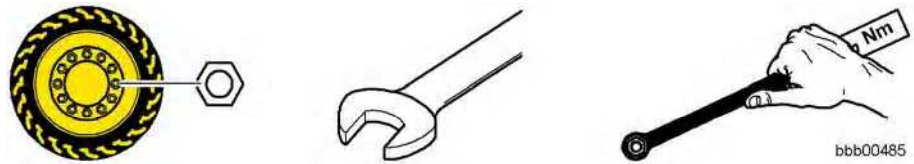

Wheel fastening:

Description	Value	Unit
Wheel lug tightening torque	450	Nm
Wheel lug spanner size	30	mm

Wheel lug tightening torque and spanner size

5.3.25 Greasing the rear axle kingpin bearings

Make sure the machine is on level ground.

Procedure

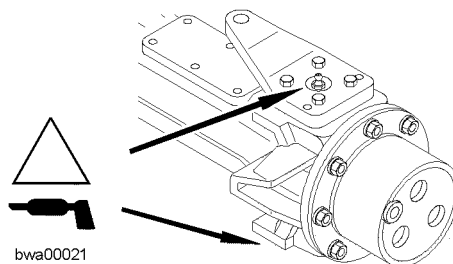

- Turn the steering to the right.
- **Activate the parking brake and shut down the machine.**
- Grease the lubrication points on the left axle kingpin bearing.
- Turn the steering to the left.
- **Activate the parking brake and shut down the machine.**
- Grease the lubrication points on the right axle kingpin bearing.

This equipment is optional.

Make sure that:

- The machine is in maintenance position 1.
- The articulation lock is engaged.

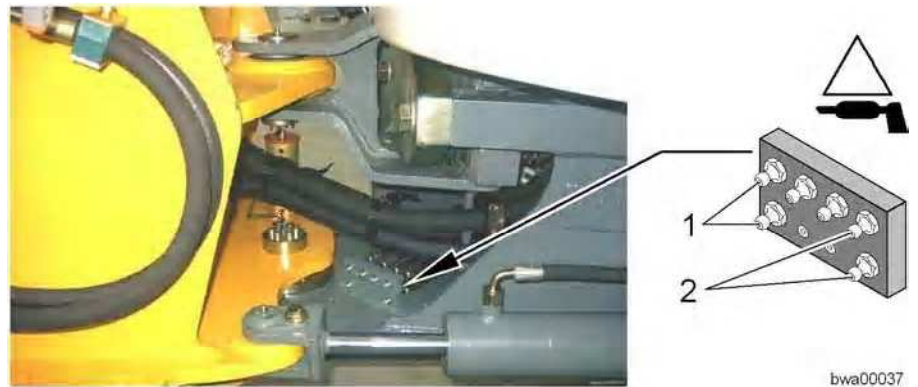

Lubricating points on the rear axle kingpin bearings

1 Right axle king pin bearing lubrication points

2 Right axle king pin bearing lubrication points

- Lubricate the axle kingpin bearing on the right: Grease the lubricating points **1**.
- Lubricate the axle kingpin bearing on the left: Grease the lubricating points **2**.

5.3.26 Checking and lubricating the cardan shaft(s)

Make sure the machine is on level ground.

Procedure

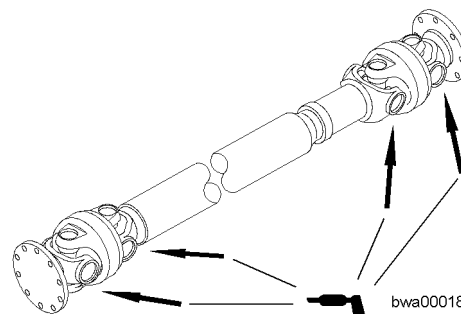

Checking and lubricating the drive shaft

- Drive the machine into a position where the grease fittings are facing diagonally downwards.
- **Activate the parking brake and shut down the machine.**
- Grease the 4 lubricating points on the drive shaft.
- Check the play of the drive shaft in the bearings.
- Check the rubber sleeve for leaks and damage.

LBH/02/003801/0003/2.06/en

5.3.27 Checking the tyre pressure

The air pressure in the tyres has a significant influence on the overall operating performance of the machine.

The tyre pressure depends on the following factors:

- The tyres used
- The purpose the machine is used for
- The attachment installed

For special uses where heavier loads may be expected, a higher tyre pressure is recommended.

However, the tyre pressure **may not be greater than the maximum permitted** by the tyre manufacturer's specifications.

Make sure that:

- The machine is in maintenance position 1.
- The correct tyre pressures are available.
See the section on tyres in chapter 1.

The tyre pressures stated refer to cold tyres.

Procedure



Checking and adjusting the tyre pressure

Warning



Exploding tyres can cause serious injury.

If the tyre inflation equipment is incorrectly or carelessly used or if the tyre pressure is too high, the tyres may burst or the rims may come off, causing severe, or possibly even fatal injuries.

To check and adjust the tyre pressure:

- ! Use a sufficiently long hose with a self-locking adapter for filling the tyres.
- ! Do not stand in the danger zone.

- Check the air pressure in all the tyres and adjust if necessary.

5.3.28 Lubricating the articulation bearing and rear oscillating bearing

Make sure that:

- The machine is in maintenance position 1.
- The articulation lock is engaged.

Procedure



Lubricating points on the articulated oscillating bearing and the rear oscillating bearing

1 Lubricating points on the articulated oscillating bearing

2 Lubricating points on the rear oscillating bearing

- Lubricate the articulated oscillating bearing: Grease the lubricating points **1**.
- Lubricate the rear oscillating bearing: Grease the lubricating points **2**.

This equipment is optional.

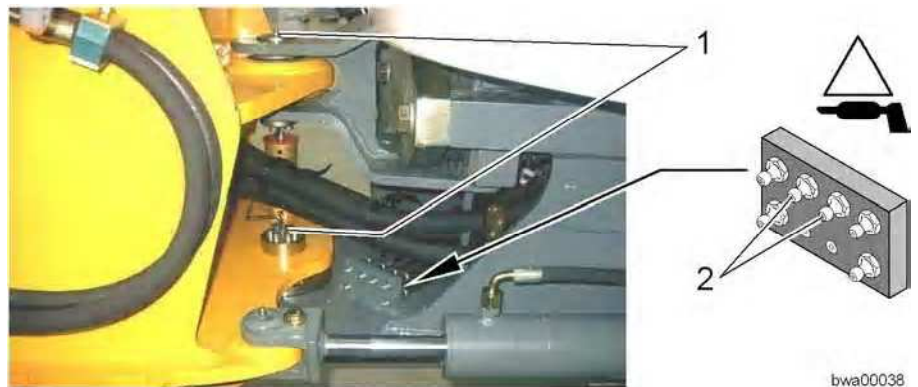

Lubricating points on the articulated oscillating bearing and the rear oscillating bearing

1 Lubricating points on the articulated oscillating bearing

2 Lubricating points on the rear oscillating bearing

- Lubricate the articulated oscillating bearing: Grease the lubricating points **1**.
- Lubricate the rear oscillating bearing: Grease the lubricating points **2**.

5.3.29 Greasing the contact faces of articulation stops

Make sure that:

- The machine is in maintenance position 1.
- The articulation lock is engaged.

LBH/02/003801/0003/2.06/en

Procedure

Lubricating the articulation bearing and rear oscillating bearing

1 Lubricating points on the articulation stops

- Apply grease to the stop faces of the plastic covers.
For lubricant specifications, see the section on lubricants and fuels.

5.3.30 Checking whether metered quantities are adequate at the bearing points (grease collars) of the central lubrication system

This equipment is optional.

Make sure that the machine is in maintenance position 1.



- Visually examine whether metered quantities are adequate at the bearing points.
- If the bearing points are not sufficiently lubricated, locate the problem and rectify it.

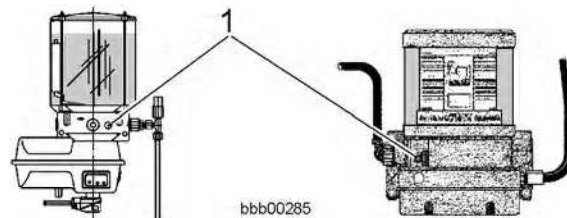

Regularly check the grease quantity in the reservoir.

Stay within the minimum and maximum lubricant levels.

The reservoir has a sight glass where the rubber stripper on the agitator can be seen. You can check how much grease is left here.

Depending on the version of the central lubrication system:

- If necessary, fill the reservoir via the grease fitting or the filling coupling **1**.

For lubricant specifications, see the section on lubricants and fuels.

5.3.31 Checking the pipes, hoses and lubrication points of the lubrication system

This equipment is optional.

Make sure that the machine is in maintenance position 1.



bsym0049

- Visually examine the hose lines for defects.
- In case of any defects, locate and rectify the problem.

5.3.32 Greasing the cab door hinges

Make sure that the machine is in maintenance position 1.

Procedure



bsym0053

- Lubricate the door hinges with a grease gun.
For lubricant specifications, see the section on lubricants and fuels.

5.3.33 Cleaning or replacing the fresh air and recirculated air filter

The fresh air filter is on the left of the cab below the driver's seat.

Make sure that the machine is in maintenance position 1.

Procedure

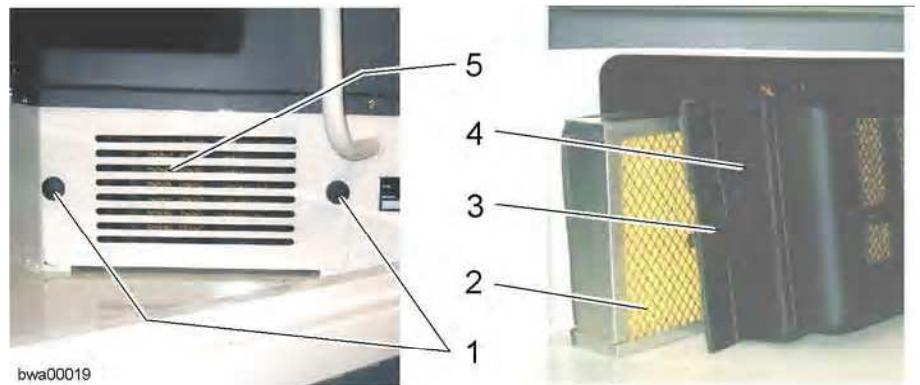

- Undo the screws **1** and take off the ventilation grille **5**.
- Open the filter bracket **4** using the flap **3** and turn it to the right.
- Take out the filter element **2** and clean or replace it.
- Carefully remove any dust which has collected in the air filter duct. (The area behind the filter must be completely clean.)
- Put in a clean or new filter element **2**. Make sure it is correctly fitted.
- Close the filter bracket **4** and fasten it using the flap **3**.
- Put in the ventilation grille **5** and fasten it with the screws **1**.

5.3.34 Lubricating the lift arms and attachment

Make sure that the machine is in maintenance position 1.

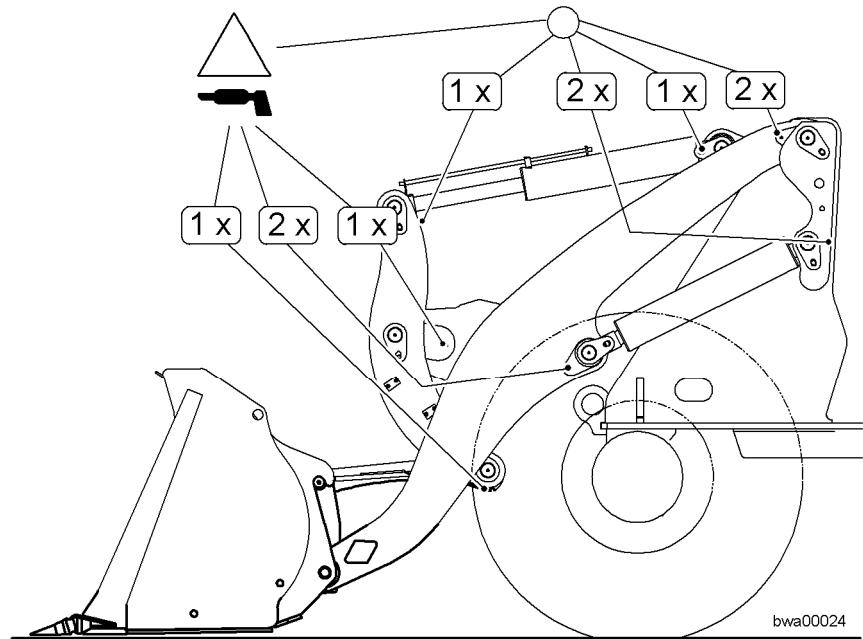
Procedure

Bearing and lubrication points on the lift arms

- Move the lift arms and the attachment to the position shown.
- Secure the machine against rolling away with wheel wedges.
- Grease all the bearing and lubrication points on the lift arms.
- If fitted, grease the lubrication points on the attachment.

5.3.35 Checking the lift arm bearing bushings

Dirt or insufficient lubrication can cause wear on the bearing bushings. The increased play between the pin and bearing bushing causes noises. Replace the bearing bushings in good time to prevent damage to the material of the bucket arm.

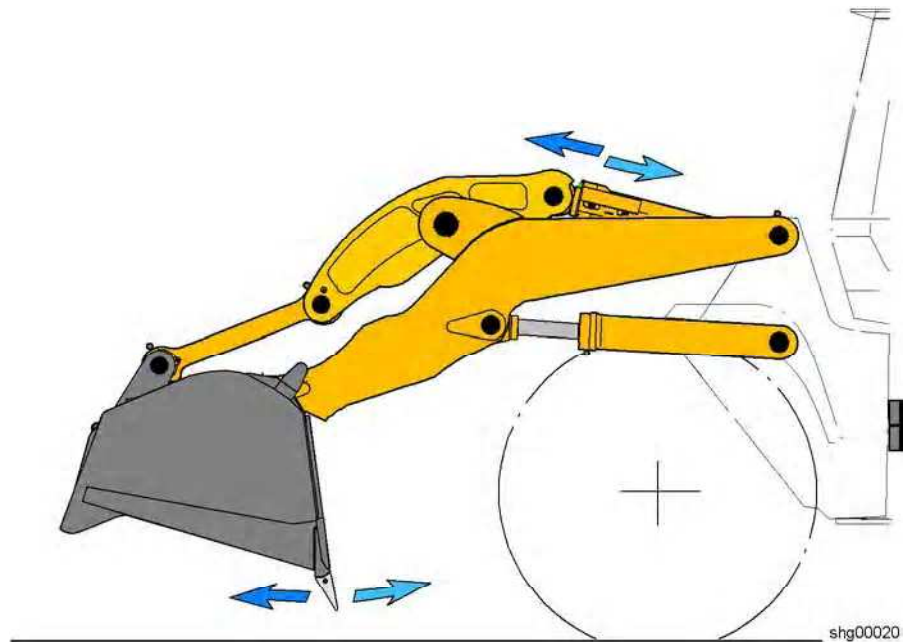
Procedure

Checking the lift arm bearing bushings

- Move the lift arms and the bucket to the position shown.
- Gently and rapidly tilt the bucket in and out, and check the bearing points for noise and play.
- If there is significant play at the bearing points or loud noise:
Replace the bearing bushings. Contact LIEBHERR CUSTOMER SERVICE.

5.3.36 Lubricating and testing the quick-change device**Lubricating the quick-change device**

Make sure that the machine is in maintenance position 1.

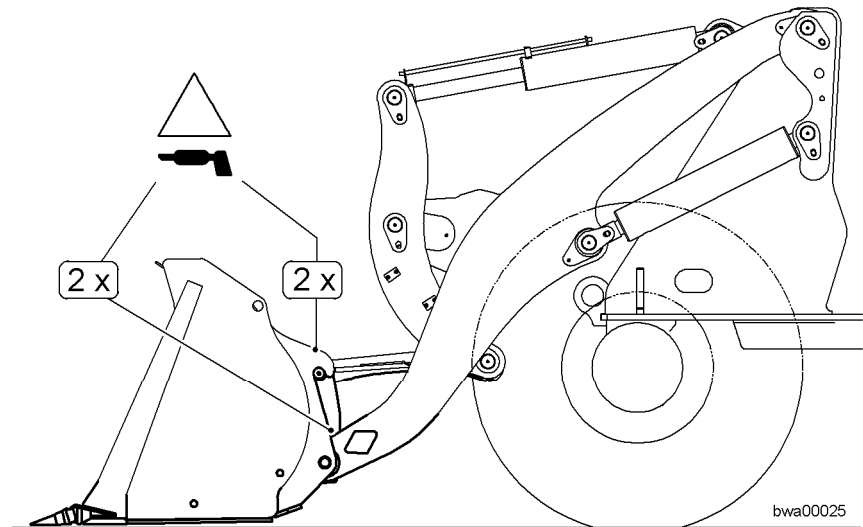
Procedure

Lubricating points on the quick-change device

- Move the lift arms and the attachment to the position shown.
- Secure the machine against rolling away with wheel wedges.
- Grease all lubricating points on the quick-change device.
- If fitted, grease the lubrication points on the attachment.

Testing the quick-change device

Make sure that:

- The engine has been started.
- The lift arms have been lowered.
- The working attachment is tilted in.

Procedure

The operation of the quick-change device can vary according to the version or the type of machine.

Danger



Failure to use the quick-change device properly can cause accidents.

! See the section on operation in chapter 3 for how to use the quick-change device.

! Follow the safety instructions.

- To check that it is working properly:
Unlock the quick-change device and lock it again.

This prevents the locking pins from jamming and preventing the quick-change device from being released.

- To make sure, check:
That the quick-change device is properly locked again.

5.3.37 Cleaning the machine

Washing the machine

Cleaning the machine

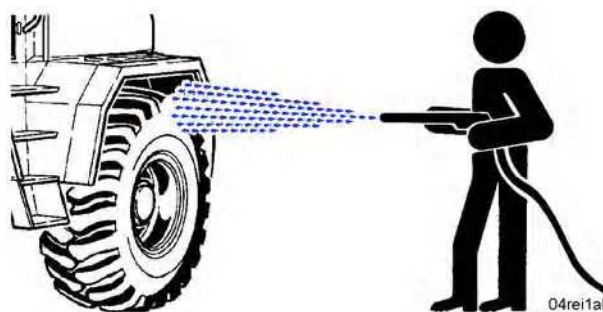

Washing

Electrical devices such as the emergency steering pump, refuelling pump, sensors and electric components in the cab are not watertight.

Be careful when cleaning the machine with a high-pressure cleaner.

Every time you clean the machine with a high-pressure cleaner, regrease all lubrication points on the machine.

Caution

Freshly painted surfaces may be damaged. High-pressure cleaning [more than 1379 kPa (13.8 bar)] can damage freshly painted surfaces.

! When a new machine is delivered, let the paint dry in the air for at least 30 days before you wash it or parts of it with a high-pressure cleaner.

! Until this 30 day period has passed, only use a low-pressure cleaner for washing.

Caution

Risk of damaging the soundproofing mats. The soundproofing mats can be damaged if you clean them with high pressure.

Damaged soundproofing mats increase the sound output level above that guaranteed by the manufacturer.

! Do not expose soundproofing mats to water or steam jets.

Caution

There is a risk of damaging electrical devices. When using a high-pressure cleaner, you may damage electrical devices such as the emergency steering pump, refuelling pump, sensors and electrical components in the cab.

! Do not expose electrical devices to water or steam jets.

- Wash the machine.
- Regrease all lubrication points on the machine.

Cleaning the diesel engine

When washing the engine using water or steam jet, take care not to expose electronic devices such as the starter, alternator, sensors and oil pressure switches directly to the jet.

After cleaning, start up the engine to allow it to dry out.

LBH/02/003801/0003/2.06/en



There is a risk of damaging the engine and its electric components. Moisture penetration can cause corrosion and electrical malfunctions.

! Do not expose devices such as the starter, alternator, sensors and oil pressure switches to water or steam jets.

- Carefully clean the engine.

5.3.38 Corrosion protection

If the machine is not used for more than 4 weeks, especially on sea journeys, the following measures must be taken.

Protecting the piston rods from corrosion

Use a non-acidic corrosion protection grease to protect against corrosion.

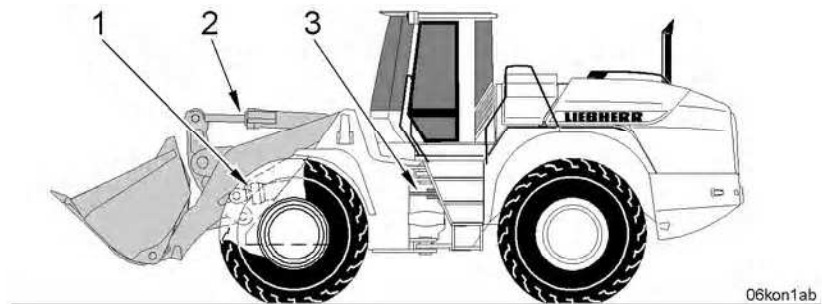

1 Lift cylinder
2 Tilt cylinder

3 Steering cylinder

- Shut down the machine so that all piston rods are retracted as far as possible in their cylinders.
- Smear all exposed piston rods with a thick layer of oxygen-free anti-corrosion grease.
- If the cylinder piston rods are not coated with hydraulic oil for a prolonged period:
The piston rods must be coated with non-acidic corrosion protection grease.

When moving a machine thus protected for loading or transport, the scraper removes the grease from the piston rods in the cylinders.

- If the machine is transported:
Check the corrosion protection on the piston rods once again after loading.

Protecting the fuel tank from corrosion

If the machine is not used for a long time, condensation can collect in the tank.

Condensation in the tank leads to rust.

- If the machine is not used for more than 2 months:
Fill up the fuel tank with diesel.

5.4 Lubricants and fuels

Conscientious observance of the regulations for handling lubricants and fuels will increase the reliability and service life of the machine.

It is especially important that the specified lubricant qualities are observed. You can find the various specifications about the prescribed intervals in the maintenance and inspection schedule and the lubrication chart.

You can find details on lubrication, checking the oil level and changing operating fluids in the maintenance section under maintenance tasks.

Follow the rules on handling lubricants and fuels, especially the environmental regulations.

Filling quantities and specifications:

- The filling quantities listed in the tables are only guidelines. The dipstick and level markings are always mandatory.
- Each time the lubricant or fuel is replaced or topped up, check the level in the unit in question.
- For more detailed information about the required lubricants, fuels and filling quantities, see the filling quantities in the lubrication chart and the section on lubricants and fuels.

Environmental protection

- Always implement and observe environmental protection measures.
- Observe national regulations.
- Ensure that liquids can be properly disposed of before draining them.

Disposing of used materials

This applies to the following types of used materials and hazardous waste:

- Oils, lubricants, brake fluids, etc.
- Coolant
- Fuels
- Filters, oil cartridges etc.
- Rubber, tyres, insulating materials etc.
- Batteries

Procedure

Caution 

Environmental and health hazard

! Observe the local regulations for protecting the environment when disposing of used materials.

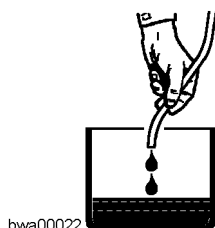

Disposal

- Always collect and store used materials separately in suitable containers.
- Dispose of used materials properly at the official collection points.

Converting the hydraulic system from petroleum to environmentally compatible hydraulic fluids

For the operation of LIEBHERR earth moving machines with environmentally compatible hydraulic fluids we recommend **PANOLIN HLP SYNTH 46**. **Machines filled at factory with environmentally compatible hydraulic fluids have an appropriate sign (CAUTION) attached to the driver's cab and hydraulic tank.**

Procedure for conversion:



Beware of damaging the machine's hydraulic system. Mixing environmentally harmless hydraulic fluids with mineral oils produces a vigorous reaction that can damage the hydraulic system.

! Avoid mixing environmentally harmless hydraulic fluids with mineral oils.

- If you intend to convert the machine to environmentally-compatible hydraulic fluid, you **must** first consult LIEBHERR CUSTOMER SERVICE.
- It is essential that you order the **INSTRUCTION SHEET** and the **CONVERSION GUIDELINES** from LIEBHERR and that you observe them.

5.4.1 Lubricating oils for diesel engines



06sy05ab

Lubricating oil quality

Only high-alloy lubricating oils are used in modern diesel engines. They consist of basic oils blended with additives. The lubricating oil regulation for LIEBHERR diesel engines is based on the following specifications and regulations.

Description	Specifications
API classification (American Petroleum Institute)	CH-4, CI-4
ACEA classification (Association des Constructeurs Européens de l'Automobile)	E3, E4, E5

Specifications and regulations for diesel engine lubricating oils

Lubricating oil viscosity

The lubricating oil viscosity is selected according to the SAE (Society of Automotive Engineers) classification. The decisive factor for the selection of the correct SAE class is the ambient temperature.

The selection of the SAE classification does not affect the quality of a lubricant oil.

If the viscosity is too high, starting can be difficult. If it is too low, lubricant efficiency may be impaired.

The temperature ranges detailed in the following diagram are guidelines - short-term deviations are permissible.

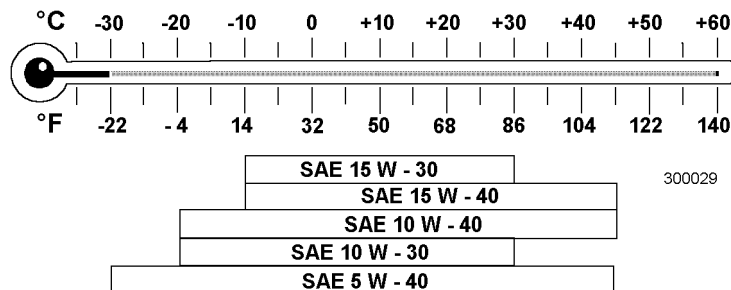

Selection of the SAE class according to temperature

Lubricant oil changing intervals

Changing intervals:

- Change the oil according to climate zone, sulphur content in the fuel and oil quality as shown in the following table.

Even if the specified number of service hours (h) is not reached in a given year, the engine oil and filter should be replaced at least once a year.

Complicating factors

Various complicating factors or harsh operating conditions can affect the maintenance intervals.

Complicating factors or harsh operating conditions include:

- Frequent cold starts
- A sulphur content above 0.5% in the fuel
- Outside operating temperatures below -10 °C

If working under difficult conditions, the oil change intervals defined in the maintenance and inspection schedule must be reduced by half, as shown in the table below.

Complicating factor		Oil quality	
		E3 CH-4, CI-4	E4, E5
Outside temperature	Sulphur content in fuel	Interval	
Normal climate, down to -10 °C	Up to 0.5%	250 h	500 h
	Above 0.5%	125 h	250 h
Below -10 °C	Up to 0.5%	125 h	250 h
	Above 0.5%	-	125 h

Oil change intervals in service hours (h)

5.4.2 Diesel fuels



06sy02ab

Specifications

The diesel fuels must meet the minimum requirements in the fuel specifications listed below.

LBH/02/003801/0003/2.06/en

Authorised fuel specifications:

- DIN EN 590
- ASTM D 975-89a - 1D and 2D

The sulphur content should not exceed 0.5% by weight. Higher sulphur content affects the oil change intervals and the engine lifetime.

Lubricity

The reduction of the sulphur content in diesel fuels has raised the problem of lubricity. It has been found that diesel fuels which comply with the European limit of 0.005 % sulphur by weight can cause wear in injection systems, especially distributor injection pumps.

Branded fuels (in Germany) contain these lubricant additives as part of their additives package. The fuel lubricity must be <400µm according to the HFRR (60°) test.

The additives should be added by the supplier in his capacity as agent responsible for fuel quality. Addition of secondary lubricity additives by the customer is not recommended.

Diesel fuel at very low temperatures

When outside temperatures fall below 0°C, the flow performance of summer diesel fuel may be insufficient as a result of paraffin separation. The same problem arises with winter diesel fuels below -15 °C.

Diesel fuel containing additives for operating temperatures down to -20 °C is also often available.

To avoid breakdowns, the diesel fuel must be mixed with two star petrol or paraffin at low temperatures. Blending in two star petrol must be viewed as an emergency remedy and it may not exceed 30% by volume.

Four star petrol may not be used for blending.

The engine power can drop in relation to the additive mixture used for cold conditions. Blending in additives should therefore be kept to a minimum, taking into account the outside temperatures.

For safety reasons, the fuel may only be mixed in a fuel container. When refuelling, pour in the fuel additive with lower specific gravity before the diesel fuel. The engine should then be run until the fuel mixture is circulating throughout the entire fuel system.

Diesel fuel mixing ratio (% vol.)

Outside temperature °C	Summer diesel fuel %	Additive %
0 to -10	70	30
-10 to -15	50	50 *

Mixing ratio for summer diesel fuel

* If an additive of 50% is necessary, only paraffin may be used (not two-star petrol).

Outside temperature °C	Winter diesel fuel %		Additive %	
	-15 °C	-20 °C	-15 °C	-20 °C
0 to -10	100	100	--	--
-10 to -15	100	100	--	--
-15 to -20	70	100	30	--
-20 to -25	50	70	50 *	30

Mixing ratio for winter diesel fuel

* If an additive of 50% is necessary, only paraffin may be used (not two-star petrol).

Additives for diesel fuel (flow improvers)

Flow improvers available on the market will also improve the cold weather performance of the diesel fuel. Their use requires the observance of quantity and application recommendations stipulated by the manufacturer.

LBH/02/003801/0003/2.06/en

5.4.3 Coolants for diesel engines

General recommendations



06sy04ab

The cooling system only functions reliably when it is working in a pre-pressurised condition. Therefore it is essential that it is kept clean and leakproof, that the cooling plug and operating valves function properly and that the necessary coolant level is maintained.

The antifreeze and corrosion protection agents approved by us ensure sufficient protection against cold, corrosion and cavitation, do not corrode seals and hoses and do not foam.

Coolants which contain unsuitable antifreeze and corrosion protection or which have been insufficiently or incorrectly prepared can cause units or components in the coolant circuit to malfunction as a result of cavitation or corrosion damage.

Also, heat-insulating deposits can occur on heat-conducting components which can result in overheating and cause the engine to break down.

Fresh water regulations

Drinking tap water is suitable with the following restrictions.

Appearance: colourless, clear, free of visible impurities.

Sea water, brackish water, salt water and industrial waste water are not suitable.

Description	Value and unit
Water hardness	0.6 to 2.7 mmol/l (3 to 15°d)
pH value at 20 °C	6.5 to 8.0
Chloride ion content	max. 80 mg/l
Sulphate ion content	max. 80 mg/l

Fresh water quality

Coolant

The cooling system must contain at least 50% by volume antifreeze and corrosion protection agent all year round. This protects against freezing down to around -37 °C. When coolant loss occurs, make sure that the proportion of antifreeze has not dropped below the 50% by volume limit.

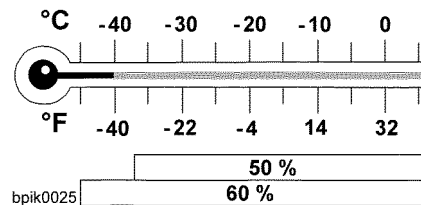

Proportion in % of antifreeze and corrosion protection agent



Caution

There is a risk of damage to the diesel engine.

Too much antifreeze and corrosion protection agent impairs the cooling effect. This eventually causes damage to the diesel engine.

! Do not use more than 60% antifreeze and corrosion protection agent.

When carrying out maintenance work, check the concentration of anti-freeze and anti-corrosion agent and correct it if necessary.

The prescribed interval for changing the coolant is 2 years.

LBH/02/003801/0003/2.06/en

Approved antifreeze and corrosion protection agents

Approved antifreeze and corrosion protection agent for diesel engine cooling systems		
Product designation		Manufacturer
A	Agip Antifreeze Plus	Agip
	Aral Kühler-Frostschutz A	Aral
	AVIA Frostschutz APN (G48-00)	AVIA
C	Caltex Engine Coolant DB	Caltex
	Caltex Extended Life Coolant	Caltex
	Castrol Anti-Freeze O	Castrol
	Chevron DEX-COOL Extended Life Anti-Freeze/Coolant	Chevron Texaco
D	DEUTZ Kühlschutzmittel 0101 1490	DEUTZ
E	Esso Kühlerfrostschutz	Esso
F	Frostschutz Motorex (G 48-00)	Bucher + Cie
G	Glysantin (G48-00)	BASF
H	Havoline XLC	ARTECO
	Havoline DEX-COOL Extended Life Anti-Freeze/Coolant	Chevron Texaco
O	Organifreeze	Total
T	Total Antigel S-MB 486	Total
	Total Frostfrei	Total

Approved antifreeze and corrosion protection agents (50:50 premix)		
Product designation		Manufacturer
C	Caltex Extended Life Coolant Pre-Mixed 50/50 (ready-to-use-version)	Caltex
	Chevron DEX-COOL Extended Life Prediluted 50/50 Antifreeze coolant	Chevron Texaco
H	Havoline XLC, 50/50	ARTECO
	Havoline DEX-COOL Extended Life Prediluted 50/50 Antifreeze coolant	Chevron Texaco
L	Liebherr Anti-Freeze APN Mix Id.Nr. 8611045 – 20 l drum	LIEBHERR
O	Organicool 50/50	Total

Operating in hot climates

The engines are designed for use with glycol-based coolants.

Always use a recommended glycol-based engine coolant, even when operating the machine in a region where anti-freeze protection is not required.

5.4.4 Hydraulic oils



06sy03ab

Specifications

Only engine oils (mineral oils) meeting the following specifications and regulations are permitted.

Description	Specifications
API classification (American Petroleum Institute)	CF-4, CG-4, CH-4
ACEA classification (Association des Constructeurs Européens de l'Automobile)	E2 , E3 , E4

Specifications and regulations for hydraulic oil

Viscosity

The viscosity is selected according to the SAE (Society of Automotive Engineers) classification.

The decisive factor for the selection of the correct SAE class is the ambient temperature.

The selection of the SAE classification has no bearing on the quality of a hydraulic oil.

The temperature ranges presented in the diagram are merely guidelines.

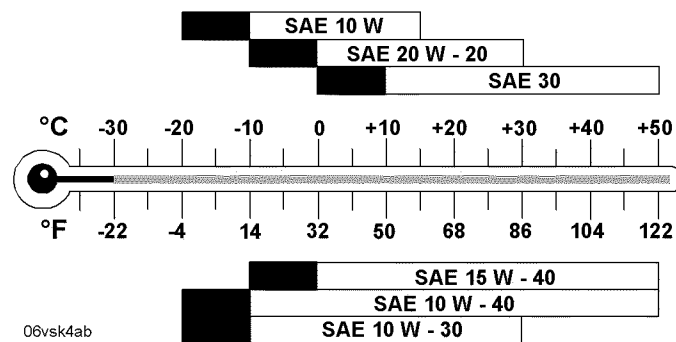

Selection of the SAE class according to temperature

Warming up

For temperatures up to 10 °C below the specified limit:

- Adjust the diesel engine to roughly half speed after starting.
- Activate the hydraulic cylinders and engines and briefly move the cylinders to their stops.
- Warming up takes roughly 10 minutes.

At even lower temperatures:

- Before starting the engine, prewarm the oil tank.

Environmentally compatible hydraulic fluids

When operating LIEBHERR earth moving machines with environmentally compatible hydraulic fluids, we recommend **PANOLIN HLP SYNTH 46** with the viscosity specified by LIEBHERR.

Conversion of the hydraulic system to an environmentally compatible hydraulic fluid:

- See the section on conversion from mineral oils to environmentally harmless hydraulic fluids.

Note



Environmentally-compatible hydraulic fluids must be checked every 500 operating hours at regular intervals.

! LIEBHERR recommends that the oil analysis is carried out by WEAR-CHECK.

Oil change:

- Not at the interval stated in the maintenance and inspection schedule.
- At the interval specified by WEAR-CHECK.

LBH/02/003801/0003/2.06/en



Note

Do not mix environmentally-compatible hydraulic fluid from different manufacturers or with mineral oils.
! See also the customer service information.

Monitoring hydraulic oil - changing according to oil samples - analysis and laboratory report:

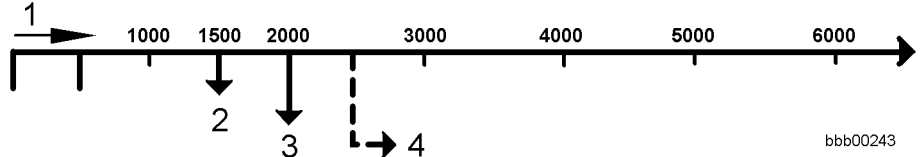

bbb00243

Oil change intervals according to sample analysis and laboratory report

- 1 Service hours
- 2 First oil sample
- 3 Second oil sample
- 4 Further oil samples every 500 operating hours

5.4.5 Lubricating oils for the transmission



06sy08ab

Axles and transfer gear

Gear oils must comply with the API GL-5 and MIL-L 2105 B, C or D specifications and the viscosity class **SAE 90 LS ***.



06sy08ab

* = Gear oil with limited slip additives for disc brakes and self-locking differentials.

For the viscosity class SAE 90 LS, an oil of the viscosity class SAE 80 W 90 LS can also be used.

5.4.6 Brake oil



bsym0027



Caution

Brake fluids and engine oils can damage the seals in the brake circuit.
! Do not use brake fluids and engine oils.

Service brake

Only the following may be used as brake oil:

HLPD hydraulic oil (mineral oil) SAE 10W for all ambient temperatures.

Description	ID no.	Quantity
AVIA FLUID HVD 520	10218008	1 litre

LBH/02/003801/0003/2.06/en

5.4.7 Grease for general lubrication points



This grease must meet the **KP2k** specification – consistency 2 of the NL GI class according to DIN 51818 and DIN 51825 or EP 2 according to NF-T-60 132.

The grease must be made of a lithium complex with a four ball tester (VKA) value of at least 2300 N according to DIN 51350 or ASTM D 2596.

Application:

- Grease for all lubrication points (according to the lubrication schedule)
- Lubricant grease for bolt fitting
- Grease for the automatic lubrication system

Approved lubricants

LIEBHERR 9610 special grease is a milling-resistant, ageing-resistant lithium grease, providing protection against corrosion with excellent lubricity over a wide temperature range.

Its molecular composition yields high degrees of shearing and milling stability and good flow properties in long pipes.

Description	ID no.	Quantity
LH 9610 special grease	8613 02908	400 g (cartridge)
LH 9610 special grease	8613 01308	10 kg (drum)
LH 9610 special grease	8613 04508	25 kg (drum)

Grease for the automatic lubrication system

Greases with high-pressure additives (EP greases) are recommended. Only use greases with the same type of saponification.



Note



Greases with solid lubricant particles such as graphite are not suitable.
! Do not use this type of grease.

Index

4

4 in 1 bucket **1-14, 3-96**

A

Accident prevention decal **2-5**
Activating and deactivating horizontal suspension on the driver's seat **3-12**
Activating and deactivating the bucket return-to-dig function **3-28**
Activating and deactivating the float position **3-28**
Activating and deactivating the parking brake **3-27**
Activating and deactivating the quick-change device **3-31**
Activating and deactivating the working hydraulics lockout **3-28**
Activating float position **3-68**
Activating the automatic bucket return-to-dig function **3-70**
Activating the manual bucket return-to-dig function **3-70**
Activating the quick-change device **3-88**
Activating the windshield wiper and washer system **3-43**
After driving onto the loading area **3-103**
After the machine stops **3-60**
Air-conditioning system **1-10, 3-39**
Air filter contamination indicator **3-23**
Additives for diesel fuel (flow improvers) **5-44**
Adjusting the arm rest **3-9, 3-14**
Adjusting the back rest **3-8, 3-13**
Adjusting the blower **3-39**
Adjusting the inclination of the seat surface **3-7, 3-11**
Adjusting the lumbar support **3-8, 3-13**
Adjusting the mirrors **3-41**
Adjusting the prongs on the fork carrier **3-98**
Adjusting the driver's seat for driving on roads **3-6, 3-10**
Adjusting the driver's seat **3-6, 3-10**
Adjusting the driver's seat horizontally **3-6, 3-11**
Adjusting the driver's seat surface horizontally **3-7, 3-11**
Adjusting the seat height **3-8, 3-12**
Adjusting the seat suspension **3-7, 3-12**
Adjusting the steering column **3-16**
Adjusting the sun visor **3-42**
Approved antifreeze and corrosion protection agents **5-46**
Approved lubricants **5-49**
Articulation area decal **2-5**
Attachments and accessories **2-21**
Audible/visual exhaust counterpressure monitor **3-86**
Automatic bucket return-to-dig function **3-70**
Axles and transfer gear **5-48**
Axles **1-4**

B

Battery charge control indicator **3-24**
Battery fastening **1-4**
Battery main switch **3-2**
Bearing load table decal **2-9**
Before driving onto the loading area **3-102**
Bio oil decal **2-10**
Bleeding the fuel system **5-16, 5-17, 5-18**
Brake fluid decal **2-8**
Brake oil **5-48**
Braking **1-5**
Braking **3-59**
Braking in emergencies **3-60**
Braking with the inch/brake pedal **3-59**
Bridgestone tyres **1-9**
Bucket **1-6**
Button control **3-36**

C

Cab access **3-2**
Changing the air filter main element when indicated by the vacuum switch **5-19**
Changing the engine oil filter **5-15**
Changing the engine oil **5-14**
Changing the fuel fine filter **5-17**
Changing the fuel pre-filter **5-15**
Changing the fuel pre-filter **5-16**
Changing the software selection **3-30**
Checking and lubricating the cardan shaft(s) **5-31**
Checking and draining the soot particle filter condensate separator **5-21**
Checking that the steering is working **5-25**
Checking that the working attachment is locked **3-91**
Checking the antifreeze concentration **5-22**
Checking the coolant antifreeze concentration **5-22**
Checking the coolant level **5-21**
Checking the engine oil level **5-13**
Checking the gap and wear on the service brake linings **5-27**
Checking the indicator lamps and lighting **5-28**
Checking the interior and exterior mirrors **3-53**
Checking the lift arm bearing bushings **5-36**
Checking the lights **3-53**
Checking the machine for external damage **5-12**
Checking the oil level in the equalising reservoir of the brake system **5-28**
Checking the oil level in the hydraulic tank **5-25**
Checking the parking brake **5-27**
Checking the pipes, hoses and lubrication points of the lubrication system **5-35**
Checking the service brake and parking brake **5-26**
Checking the service brake **5-26**
Checking the tightness of the wheels (once after 50, 100 and 250 h) **5-29**
Checking the tyre pressure **5-32**

Checking whether metered quantities are adequate at the bearing points (grease collars) of the central lubrication system **5-34**
 Cleaning or replacing the fresh air and recirculated air filter **5-35**
 Cleaning the air filter service cap and dust extraction valve **5-18**
 Cleaning the cooling system **5-24**
 Cleaning the diesel engine **5-39**
 Cleaning the machine **5-39**
 Cleaning the machine **5-39**
 Cleaning the service cap **5-19**
 Cleaning the dust extraction valve **5-19**
 Clock display **3-29**
 Closing the service doors, hatches and hoods **3-46**
 Comfort control **3-34**
 Complete machine with 4-in-1 bucket **1-15**
 Complete machine with bucket **1-2**
 Complete machine with forks **1-17**
 Complete machine with light material bucket **1-13**
 Complicating factors **5-43**
 Connecting an external battery **3-112**
 Connecting the hydraulic lines **3-92**
 Connecting the working attachment to the quick-change device **3-90**
 Control lever for additional working functions and quick-change device **3-36**
 Controlling the working attachment **3-33**
 Converting the hydraulic system from petroleum to environmentally compatible hydraulic fluids **5-42**
 Coolant **5-45**
 Coolants for diesel engines **5-45**
 Coolant temperature indicator **3-25**
 Cooler decal **2-6**
 Cooling the air in the cab **3-40**
 Correcting the antifreeze concentration **5-23**
 Corrosion protection **5-40**

D

Daily start-up **3-46**
 Decals on the machine **2-3**
 Depressurising – standard version **3-93**
 Depressurising the operating circuits **3-93**
 Depressurising using comfort or button control **3-94**
 Diesel fuel at very low temperatures **5-44**
 Diesel fuel mixing ratio (% vol.) **5-44**
 Diesel fuels **5-43**
 Differential lock **3-34**
 Differential lock indicator **3-31**
 Different uses of the 4 in 1 bucket **3-97**
 Direction indicator system activation indicator **3-24**
 Disconnecting hydraulic lines **3-94**
 Disconnecting the external battery **3-113**
 Disconnecting the working attachment **3-95**
 Display unit **3-20**
 Disposing of used materials **5-41**
 Draining off condensate from the fuel fine filter **5-18**
 Draining off condensate **5-18**

Driver's cab **1-7**
 Driver's seat **1-7**
 Driver's seat with mechanical suspension **3-5**
 Driver's seat with pneumatic suspension **3-9**
 Driving **3-52**
 Driving **3-56, 3-58**
 Driving on public roads **3-57**
 Driving on slopes **3-75**
 Driving onto the loading area **3-102**
 Driving out of the pit **3-85**
 Dummy plug **3-32**
 Dumping **3-78**
 Dunlop tyres **1-9**

E

Electrically activating the quick-change device **3-89**
 Electrically deactivating the quick-change device **3-92**
 Electrical system **1-4**
 Eliminating malfunctions **4-13**
 Emergency exit **3-4**
 Emergency operation **3-106**
 Engaging the parking brake **3-62**
 Engine **1-3**
 Engine oil pressure indicator **3-25**
 Engine oil pressure display **3-25**
 Engine overheating indicator **3-25**
 Engine speed indicator **3-29**
 Engine standstill decal **2-5**
 Entering the driver's cab **3-3**
 Environmentally compatible hydraulic fluids **5-47**
 Environmental protection **5-41**
 ERROR service code **4-3**
 Example of foundation excavation **3-84**
 Excavation **3-83**
 Exhaust counterpressure indicator **3-86**
 Exhaust gas tests **3-87**
 Extending and retracting the locking pins **3-90**

F

Fastening the seat belt **3-15**
 FATAL service code **4-3**
 Flashing beacon **3-32**
 Float position **3-68**
 Forklift **1-16, 3-98**
 Forward travel direction indicator **3-22**
 Fresh water regulations **5-45**
 Front axle **1-4**
 Fuel supply tank content indicator **3-25**
 Fuses in the engine compartment (Maxi and Mega fuses) **4-13**
 Fuses in the driver's cab **4-14**

G

General recommendations **5-45**
 General safety regulations **2-1**
 Goodyear tyres **1-9**
 Grading **3-76**

Grading work **3-76**
 Grease for general lubrication points **5-49**
 Grease for the automatic lubrication system **5-49**
 Greasing the cab door hinges **5-35**
 Greasing the contact faces of articulation stops **5-33**
 Greasing the rear axle kingpin bearings **5-30**

H

Handling **3-46**
 Heating and ventilation **1-7, 3-38**
 High beam activation indicator **3-24**
 Hydraulic oil overheating indicator **3-22**
 Hydraulic oils **5-46**
 Hydraulic quick-change device open/closed decal **2-8**
 Hydrostatic braking **3-59**

I

Ignition switch **3-16**
 Index **6-1**
 Information decals **2-6**
 Instructions for safe working **2-13**
 Instructions for working safely on the working attachment **2-19**
 Instructions on preventing crushing injuries and burns **2-10**
 Instructions on preventing fires and explosions **2-11**
 Interior and exterior mirrors **3-41**
 Interior cab lighting **3-20**
 Introduction **2-1**

J

Jobs for the forks **3-99**
 Joystick steering indicator **3-22**
 Jump starting **3-112**

K

Keep clear decal **2-5**

L

Lamp check **3-49**
 Lashing point decal **2-7**
 Layout of control elements **3-1**
 LCD brightness setting and engine speed, service hours and clock display **3-29**
 LCD brightness setting **3-29**
 Leaving the driver's cab **3-3**
 Leaving the driver's cab through the emergency exit **3-4**
 LIEBHERR control lever **3-32**
 Lift arm **1-6**
 Lifting out hard material **3-84**
 Lifting out soft material **3-83**
 Lifting the machine by crane **3-100**
 Lighting **3-18**
 Light material bucket with undercut blade **1-12**

Load bearing tables for forklift operation **1-18**
 Loading a heap **3-77**
 Loading a transport vehicle **3-80**
 Loading for lorry, rail or sea transport **3-100**
 Loading large rocks **3-81**
 Loading procedure **3-80**
 Loading sticky material **3-82**
 Location of decals **2-4**
 Locking the working attachment **3-90**
 Locking the working hydraulics **3-62**
 Lowering the exhaust counterpressure **3-87**
 Lowering the lift arms while tilting the bucket in or out **3-68**
 Lowering the working attachment **3-62**
 Low fuel supply indicator **3-24**
 Lubricant chart, filling quantities **5-5**
 Lubricant chart **5-6**
 Lubricant oil changing intervals **5-43**
 Lubricants and fuels **5-41**
 Lubricating and testing the quick-change device **5-37**
 Lubricating oil quality **5-42**
 Lubricating oils for diesel engines **5-42**
 Lubricating oils for the transmission **5-48**
 Lubricating oil viscosity **5-42**
 Lubricating the articulation bearing and rear oscillating bearing **5-32**
 Lubricating the bearing points on the steering cylinders **5-26**
 Lubricating the lift arms and attachment **5-35**
 Lubricating the quick-change device **5-37**
 Lubrication chart decal **2-9**
 Lubricity **5-44**

M

Machine stop indicator **3-24**
 Machine type indicator **3-24**
 Machine type plate **2-10**
 Maintenance and inspection schedule **5-1**
 Maintenance **5-1**
 Maintenance position 1 **5-9**
 Maintenance position 2 **5-9**
 Maintenance positions **5-9**
 Maintenance tasks **5-8**
 Making sure the bolted connections are tight **5-12**
 Malfunctions and their effects **4-3**
 Malfunctions **4-1**
 Measures for ensuring safe maintenance **2-16**
 Mechanically activating the quick-change device **3-88**
 Mechanically deactivating the quick-change device **3-92**
 Michelin tyres **1-9**
 Mitas tyres **1-9**
 Moving the machine back **3-82**

N

Neutral travel direction indicator **3-23**
 Noise output decal – L WA **2-6**

O

Opening and closing the bucket flap **3-97**
 Opening the emergency exit from outside **3-5**
 Opening the engine compartment hood and the cooler grille **5-10**
 Opening the engine compartment hood **5-10**
 Operating in hot climates **5-46**
 Operating position **3-46**
 Operating the lift and tilt cylinders simultaneously **3-67**
 Operating the lift arms **3-65**
 Operating the lift cylinders **3-65**
 Operating the tilt cylinders **3-67**
 Operation **3-2**
 Operation, Handling **3-1**

P

Parking brake activation indicator **3-23**
 Parking brake **1-5**
 Parking brake open/closed decal **2-9**
 Parking position **3-64**
 Parking safely **2-14**
 Picking up and connecting the working attachment **3-90**
 Picking up and moving material **3-73**
 Picking up material **3-77**
 Pipe break decal **2-5**
 Preglowing the engine **3-50**
 Preglow monitoring **3-23**
 Preparatory tasks for maintenance **5-8**
 Preparing for driving **3-52**
 Preparing for driving on roads **3-57**
 Procedure for changing the fuel fine filter **5-17**
 Procedure **5-25**
 Proper use **2-3**
 Protecting the fuel tank from corrosion **5-40**
 Protecting the piston rods from corrosion **5-40**
 Protection against vibrations **2-21**
 Product description **1-1**
 Putting the machine in the starting position **3-47**
 Putting the working attachment into position **3-53**

Q

Quick-change device - fitting and removing the working attachment **3-88**
 Quick-change device indicator **3-31**

R

Radio **3-42**
 Raising or lowering the lift arms **3-65**
 Raising the lift arms while tilting the bucket in or out **3-67**

Rear axle **1-5**
 Refuelling with diesel fuel **3-47**
 Regulating the air supply **3-39**
 Regulating the temperature **3-38, 3-40**
 Re-heat mode **3-41**
 Releasing the articulation lock **3-46**
 Releasing the parking brake **3-54**
 Releasing the seat belt **3-15**
 Releasing the working hydraulics **3-65**
 Removing material from a slope **3-79**
 Removing material from a slope or wall **3-79**
 Removing material from a wall **3-79**
 Removing the cooling system grille **5-11**
 Removing the working attachment from the quick-change device **3-94**
 Replacing fuses **4-13**
 Reverse travel direction indicator **3-22**
 Reversing **3-56**
 ROPS decal **2-8**

S

Safe maintenance of hydraulic hoses and hose lines **2-20**
 Safety aspects of the seat belt **3-14**
 Safety decals **2-4**
 Safety instructions for maintenance work on machines with hydro accumulators **2-18**
 Safety instructions for driving on slopes **2-14**
 Safety instructions for start-up **2-12**
 Safety instructions for towing **3-106**
 Safety instructions for transporting the machine by crane **2-20**
 Safety instructions for welding work on the machine **2-19**
 Safety precautions for maintenance **5-8**
 Safety precautions during start-up **2-12**
 Safety regulations **2-1**
 Scraping off material **3-76**
 Sealing leaks **5-12**
 Seat belt **3-14**
 Securing the machine **3-63**
 Selecting the travel direction **3-54**
 Selecting travel ranges **3-27, 3-54**
 Service brake **1-5, 3-59, 5-48**
 Service code indication on the display **4-2**
 Service Code Table **4-1**
 Service hours indicator **3-29**
 Setting off **3-55**
 Setting the digging position **3-72**
 Shutting down the machine **3-61**
 Slings and lifting point decal **2-7**
 Snow chains or guard chains **1-11**
 Software version, engine speed, clock and service hours indicator **3-23**
 Soot particle filter **1-11, 3-85**
 Sound emission **1-7**
 Sound output **1-7**
 Sound pressure **1-7**

Special tyres **1-10**
 Specifications **5-43, 5-46**
 Speed decal **2-7**
 Starting precautions at cold temperatures **3-52**
 Starting precautions **3-48**
 Starting procedure **3-49**
 Starting the engine **3-50**
 Starting the diesel engine **3-48**
 Starting the machine **3-53**
 Steering column and steering wheel **3-15**
 Steering column switch **3-17**
 Steering decal **2-5**
 Steering **1-5**
 Sun visor **3-41**
 Switches on the side console **3-26**
 Switching comfort control on and off **3-30**
 Switching off high beam **3-20**
 Switching off the air-conditioning system **3-41**
 Switching off the engine **3-63**
 Switching off the parking light / driving light **3-19**
 Switching on and using the radio **3-42**
 Switching on high beam **3-19**
 Switching on the air-conditioning system **3-40**
 Switching on the front working floodlights **3-31**
 Switching on the hazard warning system **3-28**
 Switching on the parking light or driving light **3-27**
 Switching on the rear working floodlights **3-31**
 Switching ride control (LFD system) on or off **3-30**
 Switching the air-conditioning on and off **3-30**
 Switching the battery main switch on and off **3-2**
 Switching the electrical system on and off **3-17**
 Switching the interior lighting on and off **3-20**
 Switching the mirror heating on and off **3-30**
 Switching the rear windshield wiper and washer system on and off **3-29**
 Switching the reverse alarm on and off **3-30**
 Switching the travel direction **3-33**
 System voltage decal **2-6**

T

Table of filling quantities **5-5**
 Technical data **1-2**
 Testing the quick-change device **5-38**
 Tightening torque decal **2-6**
 Tilting the bucket in or out **3-67**
 Topping up washer fluid **3-45**
 Towing device **1-8**
 Towing the machine **3-106**
 Towing the machine safely **2-15**
 Towing with the engine not running **3-110**

Towing with the engine running **3-107**
 Transporting and moving material **3-74**
 Transporting material **3-77**
 Transporting the load on a slope **3-74**
 Transporting the machine by lorry or rail **3-102**
 Transporting the machine **3-100**
 Transporting the machine safely **2-15**
 Transport position **3-74**
 Transport routes **3-80**
 Travel range 1 indicator **3-23**
 Travel range 2 indicator **3-22**
 Travel drive **1-4**
 Travel speed display **3-22**
 Troubleshooting **4-10**
 Turning off the battery main switch **3-63, 5-11**
 Turning on the battery main switch **3-46**
 Type plates **2-10**
 Tyres for machines with optional accessories **1-10**
 Tyres **1-8**

U

Unlocking the quick-change device **3-95**
 Using the air-conditioning system **3-40**
 Using the automatic bucket return-to-dig function **3-71**
 Using the front windshield wiper and washer system **3-43**
 Using the manual bucket return-to-dig function **3-70**
 Using the rear windshield wiper and washer system **3-44**

V

Viscosity **5-47**
 Visible and audible warning signals **4-8**
 Voltage decal **2-6**

W

Warming up **5-47**
 Washing the machine **5-39**
 Wheel lugs decal **2-8**
 Windscreen water decal **2-7**
 Windshield washer fluid reservoir **3-44**
 Windshield wiper and washer system **3-43**
 Working attachment **1-6**
 Working hydraulics decal **2-9**
 Working hydraulics **1-5**
 Working hydraulics lockout indicator **3-22**
 Working methods **3-73**

Liebherr-Hydraulikbagger GmbH

Hans-Liebherr-Straße 12
D-88457 Kirchdorf/Iller
☎ + 49 7354 80-0
Fax + 49 7354 80-72 94
www.liebherr.com
E-Mail: info@lhb.liebherr.com

Liebherr-France SAS

2, Avenue Joseph Rey, B.P. 287
F-68005 Colmar Cedex
☎ + 33 389 21 30 30
Fax + 33 389 21 37 93
www.liebherr.com
E-Mail: info@lfr.liebherr.com

Liebherr-Werk Telfs GmbH

Hans-Liebherr-Straße 35
A-6410 Telfs
☎ + 43 5262 6 00-0
Fax + 43 5262 6 00-72
www.liebherr.com
E-Mail: info@lwt.liebherr.com

Liebherr-Werk Bischofshofen GmbH

Postfach 49
A-5500 Bischofshofen
☎ + 43 6462 8 88-0
Fax + 43 6462 8 88-3 85
www.liebherr.com
E-Mail: info@lbh.liebherr.com