

en

## Operating Manual

2plus2 Wheel Loader  
L580 -459 from 11780



# LIEBHERR

en

## Operating Manual

2plus2 Wheel Loader  
L580 - 459 from 11780

### Document identification

**Order number:** 10323762  
**Version:** 05 / 2006  
**Document version:** 03  
**Valid for:** L580 - 459 from 11780  
**Author:** LBH – Technical Documentation Department

### Product identification

**Type:** L580  
**Type no.:** 459  
**Serial number:** from 11780  
**Conformity:**



### Address

**Address:** LIEBHERR-WERK BISCHOFSHOFEN GMBH  
Dr. Hans Liebherr – Straße 4  
A – 5500 BISCHOFSHOFEN

### Manufacturer

**Address:** LIEBHERR-WERK BISCHOFSHOFEN GMBH

This operating manual has been written for the **driver** and for the **maintenance personnel** of the machine.

It describes:

- Chapter 1 - Product description
- Chapter 2 - Safety regulations
- Chapter 3 - Operation and handling
- Chapter 4 - Malfunctions
- Chapter 5 - Maintenance

This operating manual must be carefully read before initial operation and should be read and used later at regular intervals by anyone responsible for working on the machine.

Working with or on the machine includes:

- **Operation**, including equipping, troubleshooting during operation, removing production debris, maintenance, removing operating and auxiliary materials.
- **Servicing**, including maintenance, inspection and repairs.
- **Transport** or loading the machine.

This manual helps the driver to become acquainted with the machine and prevents malfunctions due to improper operation.

Observation of the operating manual by maintenance staff:

- Increases reliability during operation
- Extends the service life of your machine
- Reduces repair costs and downtime

**This manual must be kept with the machine. Place a copy within easy reach in the glove compartment in the driver's cab.**

In addition to the operating manual follow the instructions based on existing national accident prevention and environmental protection regulations.

In addition to the operating manual and applicable national and local legal accident prevention rules, observe the recognised technical regulations for safe and proper operation.

This operating manual contains all the information you need to operate and service your machine.

If you should, however, require more detailed explanations or information, our technical information and customer services departments will be happy to provide assistance.

You will understand that we cannot accept warranty claims for damage due to improper use, insufficient maintenance, use of non-approved consumables or failure to follow the safety instructions.

**LIEBHERR** will cancel without prior notice all obligations such as warranty agreements and service contracts entered into by **LIEBHERR** and/or its agents if spare parts other than genuine **LIEBHERR** parts or those purchased from **LIEBHERR** are used for maintenance and repairs.

In extreme conditions, maintenance may be required more often than stated in the inspection schedule.





### Modifications, conditions, copyright:

- We reserve the right to alter the technical details of the machine regardless of the specifications and illustrations in these documents.
- The warranty and liability terms contained in LIEBHERR's general conditions of trade are not affected by the information in the manual.
- The information and illustrations in this manual may not be reproduced, distributed or used for commercial purposes. All rights under copyright laws are expressly reserved.

### Abbreviations used:

CAN = controller area network  
CPU = central processing unit  
Hydr. = hydraulic  
LCD = liquid crystal display  
LED = light emitting diode  
LH-ECU = Liebherr electronic control unit  
LFD = Liebherr ride control  
LH = Liebherr  
LKW = truck  
MC = microcontroller  
MV = solenoid valve  
NLP = emergency steering pump  
P-kinematics = kinematic version of the lift arms  
PWM = pulse width modulated outputs (proportional solenoid)  
REF = reference (comparison)  
SKW = heavy lorry  
SW = quick-change device  
Ubat = battery power supply (terminal 30)  
UEC = universal earth mover controller  
Z-kinematics = kinematic version of the lift arms

### Symbols and pictograms:

 bsym0059	Direction of operation or movement
 bsym0066	Stop movement
 bsym0065	Do not do this
 bsym0029	Air conditioning, winter, low temperatures
 bsym0049	Visual inspection
 bsym0061	Closed, locked
 bsym0060	Open, unlocked
 bpik0006	Audible signal, warning tone

---

# Reply form

We need your help to continually improve our documentation. Please copy this page and fax it or e-mail it to us with your comments, ideas and suggestions for improvement.

**To:** Liebherr Werk Bischofshofen GmbH  
Dr. Hans Liebherr Strasse 4  
5500 Bischofshofen / Austria

**Fax:** 0043 6462 888 287

**E-mail:** roland.weber@liebherr.com

Ideas, comments (please state the page number):

---

---

---

---

---

---

---

---

---

---

Overall, how would you judge this document?

Excellent	
Very good	
Good	
Satisfactory	
Poor	

**Your data:** Machine / serial number: \_\_\_\_\_

Company: \_\_\_\_\_

Name: \_\_\_\_\_

Address: \_\_\_\_\_

Telephone number: \_\_\_\_\_

Dealer: \_\_\_\_\_

**Thank you for your help.**

LBH/03/003801/0003/5.06/en

---

# Contents

<b>1</b>	<b>Product description</b>	<b>1 - 1</b>
1.1	Technical data	1 - 2
1.1.1	Complete machine with bucket	1 - 2
1.1.2	Engine	1 - 3
1.1.3	Electrical system	1 - 4
1.1.4	Travel drive	1 - 5
1.1.5	Axles	1 - 5
1.1.6	Braking	1 - 6
1.1.7	Ballast weight	1 - 6
1.1.8	Tyres	1 - 7
1.1.9	Snow chains or guard chains	1 - 9
1.1.10	Tyres with foam	1 - 10
1.1.11	Steering	1 - 10
1.1.12	Working hydraulics	1 - 11
1.1.13	Working attachment	1 - 11
1.1.14	Driver's cab	1 - 15
1.1.15	Sound emission	1 - 15
1.1.16	Towing device	1 - 16
1.1.17	Soot particle filter	1 - 16
1.1.18	Light material bucket	1 - 18
1.1.19	High dump bucket	1 - 20
1.1.20	Forklift	1 - 22
1.1.21	Timber grabber	1 - 25
<b>2</b>	<b>Safety regulations</b>	<b>2 - 1</b>
2.1	Introduction	2 - 1
2.2	General safety regulations	2 - 2
2.3	Proper use	2 - 3
2.4	Decals on the machine	2 - 4

2.4.1	<u>Safety decals</u>	2 - 4
2.4.2	<u>Information decals</u>	2 - 7
2.4.3	<u>Type plates</u>	2 - 12
2.5	<u>Instructions on preventing crushing injuries and burns</u>	2 - 12
2.6	<u>Instructions on preventing fires and explosions</u>	2 - 13
2.7	<u>Safety instructions for start-up</u>	2 - 14
2.8	<u>Safety precautions during start-up</u>	2 - 14
2.9	<u>Instructions for safe working</u>	2 - 14
2.10	<u>Safety instructions for driving on slopes</u>	2 - 16
2.11	<u>Parking safely</u>	2 - 16
2.12	<u>Transporting the machine safely</u>	2 - 16
2.13	<u>Towing the machine safely</u>	2 - 17
2.14	<u>Measures for ensuring safe maintenance</u>	2 - 18
2.15	<u>Safety instructions for maintenance work on machines with hydro accumulators</u>	2 - 20
2.16	<u>Safety instructions for welding work on the machine</u>	2 - 21
2.17	<u>Instructions for working safely on the working attachment</u>	2 - 21
2.18	<u>Safety instructions for transporting the machine by crane</u>	2 - 21
2.19	<u>Safe maintenance of hydraulic hoses and hose lines</u>	2 - 22
2.20	<u>Attachments and accessories</u>	2 - 23
2.21	<u>Protection against vibrations</u>	2 - 23
<b>3</b>	<b><u>Operation, Handling</u></b>	<b>3 - 1</b>
3.1	<u>Layout of control elements</u>	3 - 1
3.2	<u>Operation</u>	3 - 2
3.2.1	<u>Battery main switch</u>	3 - 2
3.2.2	<u>Cab access</u>	3 - 2
3.2.3	<u>Right hinged window</u>	3 - 4
3.2.4	<u>Emergency exit</u>	3 - 5
3.2.5	<u>Driver's seat with mechanical suspension</u>	3 - 7
3.2.6	<u>Driver's seat with pneumatic suspension</u>	3 - 12
3.2.7	<u>Seat belt</u>	3 - 17

3.2.8	Steering column and steering wheel	3 - 18
3.2.9	Control panel	3 - 19
3.2.10	Ignition switch	3 - 20
3.2.11	Electronic immobiliser	3 - 21
3.2.12	Steering column switch	3 - 23
3.2.13	Lighting	3 - 24
3.2.14	Interior cab lighting	3 - 28
3.2.15	Display unit	3 - 30
3.2.16	Mechanical service hours counter	3 - 38
3.2.17	Control units	3 - 39
3.2.18	Optional buttons on the side console	3 - 53
3.2.19	Optional switches on the side console	3 - 54
3.2.20	LIEBHERR control lever	3 - 56
3.2.21	Control lever for additional working functions	3 - 60
3.2.22	Heating and ventilation	3 - 61
3.2.23	Air-conditioning system	3 - 63
3.2.24	Interior and exterior mirrors	3 - 65
3.2.25	Sun visor	3 - 66
3.2.26	Radio	3 - 66
3.2.27	Windshield wiper and washer system	3 - 67
3.2.28	Windshield washer fluid reservoir	3 - 69
3.2.29	LIEBHERR automatic lubrication system	3 - 70
3.2.30	Audible reverse warning device (back-up alarm)	3 - 74
3.2.31	Visible reverse warning device	3 - 75
3.2.32	Reversible fan drive	3 - 77
3.3	Handling	3 - 79
3.3.1	Daily start-up	3 - 79
3.3.2	Starting the diesel engine	3 - 82
3.3.3	Driving	3 - 86
3.3.4	Shutting down the machine	3 - 104
3.3.5	Operating the lift arms	3 - 107
3.3.6	Working methods	3 - 117
3.3.7	Soot particle filter	3 - 131



3.3.8	Filling the tank using the filling pump	3 - 135
3.3.9	Hydraulically actuated quick-change device	3 - 137
3.3.10	Combined electro-hydraulically actuated quick-change device	3 - 144
3.3.11	Electro-hydraulically actuated quick-change device with comfort control.	3 - 149
3.3.12	Forklift	3 - 154
3.3.13	Using the high dump bucket	3 - 156
3.3.14	Timber handling	3 - 159
3.3.15	Transporting the machine	3 - 160
3.4	Emergency operation	3 - 166
3.4.1	Towing the machine	3 - 166
3.4.2	Jump starting	3 - 170
<b>4</b>	<b>Malfunctions</b>	4 - 1
4.1	Service Code Table	4 - 2
4.1.1	Service code indication on the display	4 - 2
4.1.2	Visible and audible warning signals	4 - 18
4.2	Eliminating malfunctions	4 - 21
4.2.1	Replacing fuses	4 - 21
<b>5</b>	<b>Maintenance</b>	5 - 1
5.1	Maintenance and inspection schedule	5 - 1
5.2	Lubricant chart, filling quantities	5 - 5
5.2.1	Table of filling quantities	5 - 5
5.2.2	Lubricant chart	5 - 6
5.3	Lubricants and fuels	5 - 8
5.3.1	Lubricating oils for diesel engines	5 - 9
5.3.2	Diesel fuels	5 - 11
5.3.3	Coolants for diesel engines	5 - 12
5.3.4	Hydraulic oils	5 - 17
5.3.5	Lubricating oils for the transmission	5 - 19
5.3.6	Grease for general lubrication points	5 - 20
5.4	Maintenance tasks	5 - 21
5.4.1	Preparatory tasks for maintenance	5 - 21

5.4.2	Removing loose parts, dirt, ice and snow from the machine	5 - 28
5.4.3	Checking the machine for external damage	5 - 29
5.4.4	Making sure the bolted connections are tight	5 - 29
5.4.5	Sealing leaks	5 - 29
5.4.6	Checking the engine oil level	5 - 30
5.4.7	Changing the engine oil	5 - 30
5.4.8	Changing the engine oil filter	5 - 32
5.4.9	Checking the diesel engine heating flange	5 - 33
5.4.10	Changing the fuel pre-filter	5 - 33
5.4.11	Changing the fuel fine filter	5 - 35
5.4.12	Draining off condensate from the fuel pre-filter	5 - 36
5.4.13	Bleeding the fuel system	5 - 38
5.4.14	Draining off condensate and sediment from the fuel tank	5 - 40
5.4.15	Cleaning the air filter service cap and dust extraction valve	5 - 42
5.4.16	Changing the air filter main element when indicated by the vacuum switch	5 - 42
5.4.17	Changing the air filter secondary element	5 - 43
5.4.18	Checking the oil level in the pump distributor gear	5 - 44
5.4.19	Checking and draining the soot particle filter condensate separator	5 - 45
5.4.20	Checking the coolant antifreeze concentration	5 - 47
5.4.21	Cleaning the cooling system	5 - 51
5.4.22	Changing coolant with antifreeze	5 - 52
5.4.23	Checking the oil level in the hydraulic tank	5 - 54
5.4.24	Checking and cleaning the magnetic rod on the hydraulic tank	5 - 55
5.4.25	Checking that the steering is working	5 - 57
5.4.26	Lubricating the bearing points on the steering cylinders	5 - 57
5.4.27	Checking the service brake and parking brake	5 - 58
5.4.28	Checking the gap and wear on the parking brake linings	5 - 59

5.4.29	Checking the indicator lamps and lighting	5 - 60
5.4.30	Checking the transfer gear oil level	5 - 61
5.4.31	Checking the tightness of the wheels (once after 50, 100 and 250 h)	5 - 63
5.4.32	Lubricating the bevel gear seals of the front and rear axles	5 - 63
5.4.33	Checking and lubricating the cardan shaft(s)	5 - 64
5.4.34	Checking the tyre pressure	5 - 65
5.4.35	Greasing the oscillating axle frame and articulation lock	5 - 65
5.4.36	Checking whether metered quantities are adequate at the bearing points (grease collars) of the central lubrication system	5 - 66
5.4.37	Checking the pipes, hoses and lubrication points of the lubrication system	5 - 67
5.4.38	Greasing the cab door hinges	5 - 67
5.4.39	Cleaning and replacing the fresh air and recirculated air filter	5 - 68
5.4.40	Lubricating the lift arms and attachment	5 - 70
5.4.41	Checking the bucket bearing seals and the bearing bushings on the lift arms	5 - 71
5.4.42	Lubricating and testing the quick-change device	5 - 73
5.4.43	Cleaning the machine	5 - 74
5.4.44	Corrosion protection	5 - 75
<b>6</b>	<b>Index</b>	<b>6 - 1</b>

# 1 Product description

## Equipment layout

### Standard version

This section contains an overview of the machine and the names of the components shown.

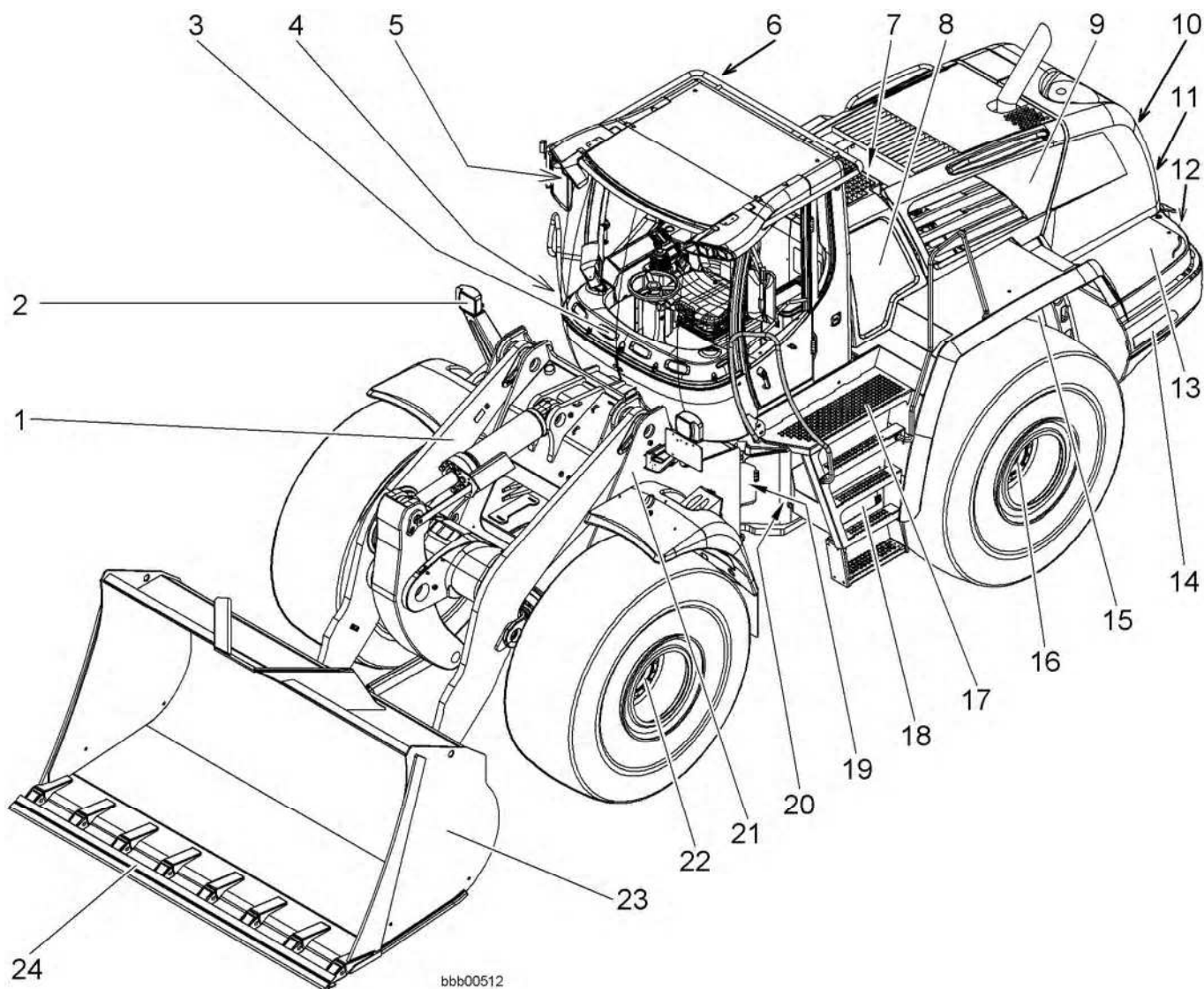

*Left view of machine*

- |                                      |                              |                      |
|--------------------------------------|------------------------------|----------------------|
| 1 Lift arm                           | 9 Engine compartment hood    | 18 Tool box          |
| 2 Front lighting                     | 10 Engine compartment hatch  | 19 Steering cylinder |
| 3 Driver's cab                       | 11 Towing device             | 20 Articulation lock |
| 4 Fuel tank                          | 12 Rear lighting             | 21 Front section     |
| 5 Front working floodlights          | 13 Battery compartment cover | 22 Front axle        |
| 6 Rear working floodlight (optional) | 14 Ballast weights           | 23 Bucket            |
| 7 Cooling system                     | 15 Rear section              | 24 Tooth guard       |
| 8 Cooling system hood                | 16 Rear axle                 |                      |
|                                      | 17 Cab access                |                      |

## 1.1 Technical data

### 1.1.1 Complete machine with bucket



- The values stated refer to the machine:
- In its standard version
  - With Z lift arms = 3050 mm
  - Without a hydraulic quick-change device
  - With 26.5 R25 Michelin XHA tyres.
  - Including all lubricants
  - With a full tank
  - With ROPS/FOPS cab and driver

Tyre sizes and additional attachments affect the operating weight and tipping load.



Bucket versions

Key to the table:

Z = Welded tooth holder with plug-in teeth

U= Four-section, reversible undercut blade

1)Rear loading bucket with angled base

2)Rock bucket with delta blade and overflow grille

3)In practice, the bucket capacity can be around 10% greater than as calculated using the ISO 7546 method.

This depends on the type of material.

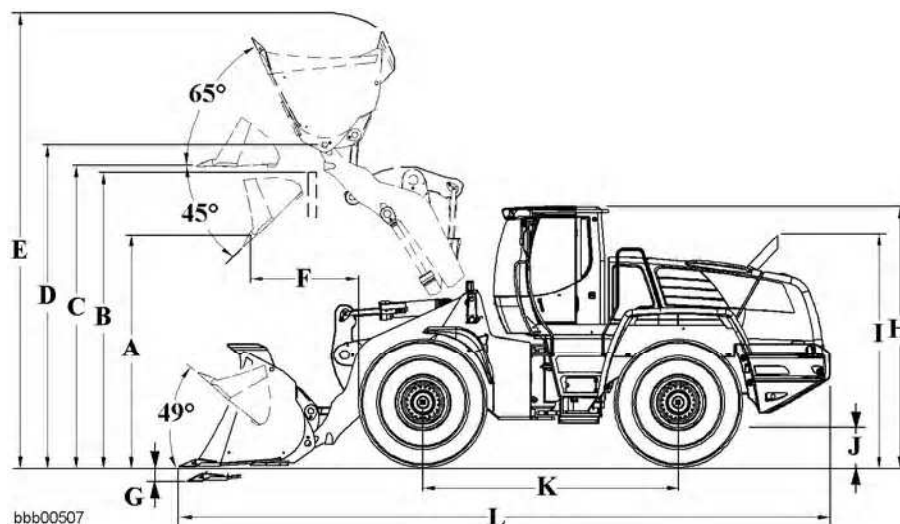

Dimensions

LBH/03/003801/0003/5.06/en

	Description	Unit	Value				
			Z <sup>1)</sup>	U <sup>1)</sup>	Z <sup>1)</sup>	U <sup>1)</sup>	DZ <sup>2)</sup>
	Cutting tool		Z <sup>1)</sup>	U <sup>1)</sup>	Z <sup>1)</sup>	U <sup>1)</sup>	DZ <sup>2)</sup>
	Bucket capacity as per ISO 7546 <sup>3)</sup>	m <sup>3</sup>	5.0	5.0	5.5	5.5	4.0 m <sup>3</sup>
	Bucket width	mm	3300	3300	3300	3300	3200
	Specific material weight	t/m <sup>3</sup>	1.8	1.8	1.6	1.6	1.8
A	Dump height at maximum lifting height and 45° tilt-out angle	mm	3320	3320	3250	3250	3265
B	Dump height	mm	4100	4100	4100	4100	4100
C	Maximum bucket base height	mm	4270	4270	4270	4270	4310
D	Maximum bucket pivot point height	mm	4580	4580	4580	4580	4620
E	Maximum bucket top height	mm	6340	6340	6420	6420	6195
F	Reach at maximum lifting height and 45° tilt-out angle	mm	1150	1150	1220	1220	1205
G	Digging depth	mm	100	100	100	100	80
H	Height above the cab	mm	3550	3550	3550	3550	3590
I	Height above exhaust	mm	3100	3100	3100	3100	3140
J	Ground clearance	mm	565	565	565	565	565
K	Wheel base	mm	3700	3700	3700	3700	3700
L	Overall length	mm	9300	9120	9400	9220	9425
	Turning radius over bucket outer edge	mm	7420	7370	7450	7400	7390
	Lifting force (SAE)	kN	250	250	248	248	246
	Breakout force (SAE)	kN	175	175	160	160	160
	Tipping load when straight	kg	20470	20022	19991	19672	19781
	Tipping load articulated at 37°	kg	18409	18006	17978	17691	17789
	Tipping load articulated at 40°	kg	18076	17680	17653	17371	17467
	Operating weight	kg	24580	24780	24730	24980	26140
	Tractive force	kN	173.3	173.3	173.3	173.3	173.3

### 1.1.2 Engine



Type: 6-cylinder in-line engine, water-cooled with turbocharger and charge air cooling.

Air filter system: Dry air filter with primary and secondary element, separator, LCD service display

The exhaust emissions are below the threshold levels in EU directive 97/68/EC – Tier III A.

Name	Value	Units
Diesel engine	D 936 L A6	
Number of cylinders	6	Pc.
Rated power according to ISO 9249 at 2000 min <sup>-1</sup>	200 / 272	kW / PS
Maximum torque at 1000 min <sup>-1</sup> up to 1500 min <sup>-1</sup>	1270	Nm
Cylinder capacity	10.5	litres

LBH/03/003801/0003/5.06/en

Name	Value	Units
Lower idle speed	830 $\pm 30$	min <sup>-1</sup>
Upper idle speed	2060 $+30$	min <sup>-1</sup>
Longitudinal / traverse inclinability	45 / 45	°

### 1.1.3 Electrical system



bpik0028

Protected by:

- Main fuse
- Fuses for preglow system, starter, emergency steering pump
- Fuses on the relay and fuse board

Batteries:

- Connected in series
- Installed in the left ballast weight

Battery main switch: Rear left of engine compartment

Name	Value	Units
Battery voltage	12	V
Battery capacity	2 x 170	Ah
Number of batteries	2	Pc.
Operating voltage	24	V
Three-phase current alternator	28 / 80	V / A
Starter	24 / 6.6	V / kW

#### Battery fastening

When fitting or changing the battery:

Name	Value	Units
Tightening torque	10	Nm

### 1.1.4 Travel drive

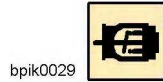

Continuously variable hydrostatic travel drive

Type: 2plus2:

- Swash plate variable displacement pump and two axial piston motors in a closed circuit  
With a transfer gear
- Forward and reverse travel by switching the flow direction of the variable displacement pump.

Travel drive control:

- By gas pedal and tractive force control pedal (inch pedal).
- The tractive force control pedal facilitates continuous adjustment of tractive or thrust force at full engine speed.
- Forward and reverse travel are selected using the Liebherr control lever
- The travel ranges are selected using the buttons on the control unit.

Speed data:

- For forward and reverse travel
- With standard tyres

Name	Value	Units
Travel range 1	0–10.0	km/h
Travel range 2	0–20.0	km/h
Travel range A1-2 (automatic)	0–20.0	km/h
Travel range A1-3 (automatic)	0–40.0	km/h
Travel range A2–3 (automatic)	0–40.0	km/h

### 1.1.5 Axles



Automatically acting self-locking differential in both axles.

#### Front axle

Rigidly mounted planetary axle

Name	Value	Units
Width	2230	mm
Differential lock	45	%

LBH/03/003801/0003/5.06/en



**Rear axle** Oscillating planetary axle

Name	Value	Units
Width	2230	mm
Differential lock	45	%
Angle of articulation to each side	13	°
Height of obstacles which can be driven over	560	mm

**1.1.6 Braking**



bpiik0031

The braking system complies with the roadworthiness certification regulations.

**Service brake** Self-arrest of hydrostatic travel drive, acting on all four wheels. Additional pump accumulator brake system with wet disc brakes in the wheel hubs (two separate brake circuits).

**Parking brake** Electrohydraulic spring accumulator brake system on the gearbox.

**1.1.7 Ballast weight**

The factory supplies the machine with the type of ballast stated in the order.



**Note**

Installing or changing the working attachment or tyres.  
! See the section on attachments and accessories in chapter 2.

**Key:**

- LR = Air tyres
- LR+RA = Air tyres with foam
- LR+K = Air tyres with chains
- x = Required ballast

Description	LR	LR+RA	LR+K
Ballast weight –	Standard ballast	x	--
	Special ballast	--	x
	Road ballast	x	--

Selection table

LBH/03/003801/0003/5.06/en

### 1.1.8 Tyres



The driving performance of the machine depends, among other things, on the tyres.



**Note**

Use the same tyre size for all four wheels.  
When changing the tyres or if there is increasing wear on the tyres, make sure that the difference in diameter between the tyres on the front and rear axles is no more than 3%.

! Otherwise the axles may be damaged.

The correct tyre pressure is crucial for:

- Reliable behaviour of the machine in use
- Long tyre lifetime

You will find the following specifications in the table below:

- Recommended tyre sizes
- Tyre tread
- Tyre pressure

Abbreviations:

- **p – Max.** = maximum permissible air pressure
- **VA** = front axle
- **HA** = rear axle

The air pressure specifications refer to:

- Basic air pressure recommendations - as set when delivered from the factory
- Cold tyres
- Machine ready for operation - basic machine with standard equipment and permissible load



**Note**

For special uses such as industrial timber handling or other uses where heavier loads may be expected, we recommend a higher tyre pressure, depending on the specific load.

However, the tyre pressure may not be greater than the maximum permitted by the tyre manufacturer's specifications.

! Check and adjust the tyre pressure, see the maintenance tasks in chapter 5.

**Michelin tyres**

Air pressure table 1 for the standard machine

Air pressure table 2 for machines used for industrial timber handling

Tyre size	Tyre tread	Air pressure bar		
		VA	HA	p – Max.
26.5 R25EM	XHA * L3	4.30	2.50	5.50
26.5 R25EM	XLD D1A * L4	4.30	2.50	5.50
26.5 R25EM	XLD D2A * L5	4.30	2.50	5.50
26.5 R25EM	XMine D2 * L5	4.30	2.50	5.50

*Air pressure table 1*

LBH/03/003801/0003/5.06/en

Tyre size	Tyre tread	Air pressure bar		
		VA	HA	p – Max.
26.5 R25EM	XLD D1A * L4	5.00	3.30	5.50

Air pressure table 2

**Goodyear tyres** Air pressure table 1 for the standard machine  
Air pressure table 2 for machines used for industrial timber handling

Tyre size	Tyre tread	Air pressure bar		
		VA	HA	p – Max.
26.5 R25EM	GP-2B * L2	4.30	2.50	5.00
26.5 R25EM	RT-3B * L3	4.30	2.50	5.00
26.5 R25EM	TL-3A * + L3	4.30	2.50	5.00
26.5 R25EM	GP-4D * L4	4.30	2.50	5.00
26.5 R25EM	RL 5K * L5	4.30	2.50	5.00

Air pressure table 1

Tyre size	Tyre tread	Air pressure bar		
		VA	HA	p – Max.
26.5 R25EM	GP-4D ** 4S	6.00	3.00	6.50

Air pressure table 2

**Bridgestone tyres** Air pressure table for the standard machine

Tyre size	Tyre tread	Air pressure bar		
		VA	HA	p – Max.
26.5 R25EM	VMT * L3	4.50	3.50	5.00
26.5 R25EM	VSDT * L5	5.00	3.50	5.00
26.5 R25EM	VSDL * L5	5.00	3.50	5.00

**Special tyres** Air pressure table for machines with special tyres:

Tyre size	Tyre tread	Air pressure bar		
		VA	HA	p – Max.
1)				
2)				
2)				

The specifications should be entered in the tables as follows:

- 1) By the manufacturer, if the machine is delivered ex-works with special tyres.
- 2) By the machine operator, if the machine is retrofitted by the machine operator.

**Tyres for machines with optional accessories**

Table 1 is for the type of optional accessory  
Air pressure table 2 is for machines with optional accessories

Specifications	Type of optional accessory
1)	
2)	
2)	

Table 1

Tyre size	Tyre tread	Air pressure bar		
		VA	HA	p – Max.
1)				
2)				
2)				

Air pressure table 2

**The specifications should be entered in the tables as follows:**

- 1) By the manufacturer, if the machine is delivered ex-works with optional accessories.
- 2) By the machine operator, if the machine is retrofitted by the machine operator.

**1.1.9 Snow chains or guard chains**



This equipment is optional.

When snow chains or guard chains are used, they must be attached to all four wheels.



**Note**

Failure to do this can damage the drive system.  
! See the section on attachments and accessories in chapter 2.

Valid for L556 to L580:

If you attach snow chains or guard chains, you must adjust the ballast weight.

See the section on the ballast weight in chapter 1.



**Note**

Installing or changing the working attachment or tyres.  
! See the section on attachments and accessories in chapter 2.

LBH/03/003801/0003/15.06/en

### 1.1.10 Tyres with foam

This equipment is optional.

When tyres with foam are used, they must be attached to all four wheels.

Valid for L556 to L580:

If you fill the tyres with foam, you must adjust the ballast weight.

See the section on the ballast weight in chapter 1.



#### Note

Installing or changing the working attachment or tyres.

! See the section on attachments and accessories in chapter 2.

### 1.1.11 Steering



bpik0033

Type:

- Load sensing swash plate variable displacement pump with pressure cut-off and flow regulator.
- Central articulated joint with two dual-action steering cylinders with shock absorbers.

Emergency steering: Electrohydraulic emergency steering system

Name	Value	Units
Angle of articulation to each side	40	°
Angle of articulation to each side	13	°
Maximum operating pressure	210	bar

### 1.1.12 Working hydraulics

bpik0034



Type:

Load sensing swash plate variable displacement pump with power controller and pressure cut-off.

Cooling:

Hydraulic oil cooling with thermostatically controlled fan and oil cooler

Filtration:

Return filter in the hydraulic tank.

Control:

Single-lever control, hydraulic servo system.

Control block:

Pressure cut-off, LUDV version (load-independent flow distribution).

Lifting cycle:

- Lifting, neutral, lowering
- Float position using lockable Liebherr control lever.
- Automatic lift kick-out.

Tilting cycle:

- Tilt out, neutral, tilt in
- Automatic bucket return-to-dig function.

Name	Value	Units
Maximum flow	290	l/min
Maximum operating pressure	350	bar

### 1.1.13 Working attachment

bpik0035



**Lift arm**

Length (distance – holes) = 3050 mm

Z kinematics with one tilt cylinder.

Sealed bearing points.

Working cycle time at rated load:

Name	Value	Units
Lifting	5.6	sec.
Tilting out	2.0	sec.
Lowering (empty)	3.5	sec.

LBH/03/003801/0003/5.06/en

**Bucket**

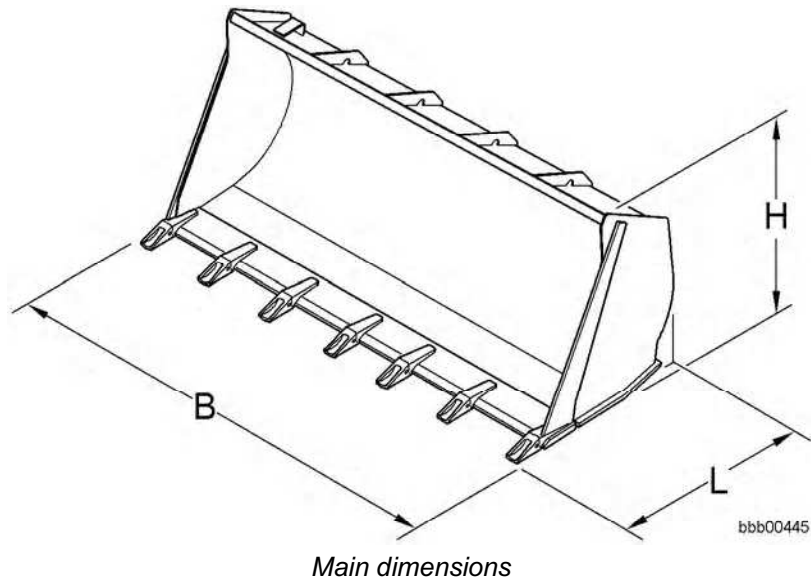

Rear loading bucket:

- With angled base
- For lift arms without hydraulic quick-change device.

Name	Value	Units
Bucket capacity as per ISO 7546	5.0	m <sup>3</sup>
Specific material weight	1.8	t/m <sup>3</sup>
B – bucket width	3300	mm
H – height	1675	mm
L - length	1900	mm
Weight	2340	kg

Name	Value	Units
Bucket capacity as per ISO 7546	5.5	m <sup>3</sup>
Specific material weight	1.6	t/m <sup>3</sup>
B – bucket width	3300	mm
H – height	1760	mm
L - length	2000	mm
Weight	2500	kg

LBH/03/003801/0003/5.06/en

Rear loading bucket:

- Version with undercut blade.
- With angled base
- For lift arms without hydraulic quick-change device.

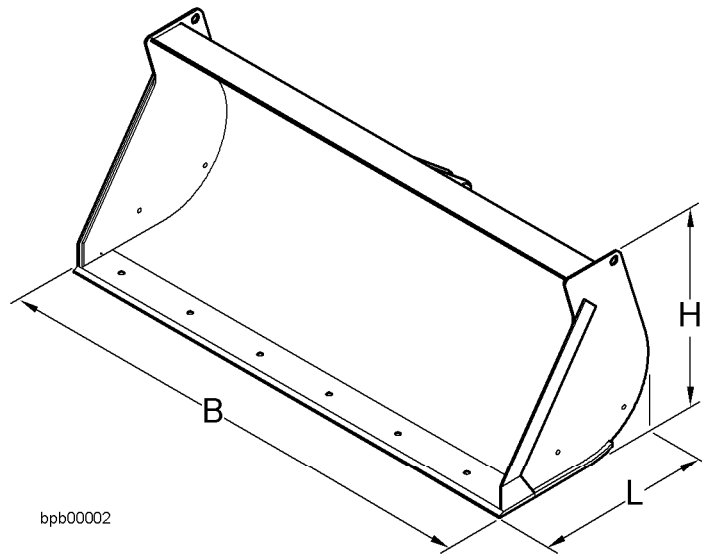

bpb00002

Main dimensions

Name	Value	Units
Bucket capacity as per ISO 7546	5.0	m <sup>3</sup>
Specific material weight	1.8	t/m <sup>3</sup>
B – bucket width	3300	mm
H – height	1710	mm
L - length	1725	mm
Weight	2500	kg

Name	Value	Units
Bucket capacity as per ISO 7546	5.5	m <sup>3</sup>
Specific material weight	1.6	t/m <sup>3</sup>
B – bucket width	3300	mm
H – height	1800	mm
L - length	1825	mm
Weight	2700	kg

LBH/03/003801/0003/5.06/en



Rock bucket:

- With delta blade and overflow grille.
- For lift arms without hydraulic quick-change device.

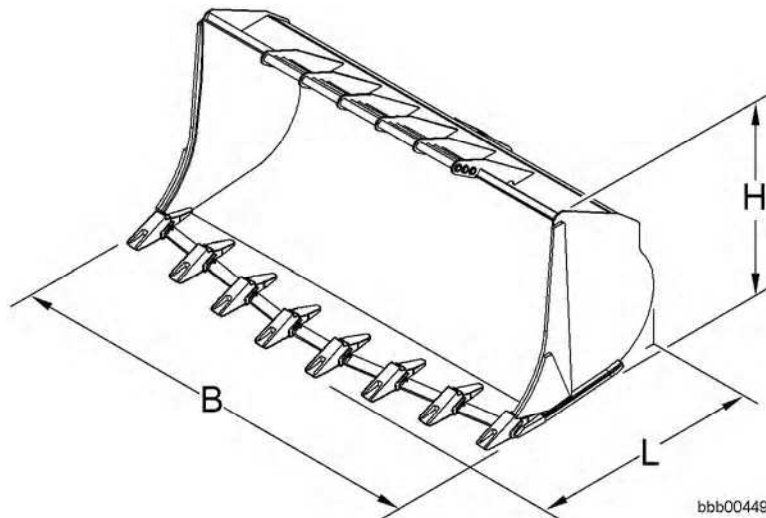

bbb00449

Name	Value	Units
Bucket capacity as per ISO 7546	4.5	m <sup>3</sup>
Specific material weight	1.8	t/m <sup>3</sup>
B – bucket width	3200	mm
H – height	1650	mm
L - length	2025	mm
Weight	3200	kg

**Hydraulic quick-change device**

This equipment is optional.

Alternative versions:

- Hydraulically actuated quick-change device
- Combined, electro-hydraulically actuated quick-change device
- Electro-hydraulically actuated quick-change device with comfort control

LBH/03/003801/0003/5.06/en

### 1.1.14 Driver's cab



On elastic bearing on rear section, soundproof ROPS/FOPS cab.

Design:

- Detachable left door  
Optional sliding window
- Hinged right window
- Tinted windows made of hardened single-glazed safety glass
- Adjustable steering column and control panel
- ROPS rollover protection in accordance with DIN/ISO 13510/ EN 474-3.
- FOPS stone impact protection in accordance with DIN/ISO 13627/ EN 474-1.

#### Driver's seat

Alternative versions:

- Driver's seat with gas-filled spring suspension.
  - Driver's seat with pneumatic suspension.
- This equipment is optional.

#### Heating, ventilation, air conditioning

Driver's cab with:

- Air direction on 4 levels
- Hot water heater
- Defroster and air conditioning using electronic valve control  
Electronic fresh/recirculated air control
- Filter system with prefilter, fresh air filter and recirculated air filter
- Air-conditioning system  
Automatic air conditioning is optional.

Name	Value	Units
Number of blower levels	3	
Heating power	11	kW
Cooling power	9.7	kW

### 1.1.15 Sound emission



#### Sound pressure

Name	Value	Units
ISO 6396 – LpA (in driver's cab)	69	dB (A)

#### Sound output

You can read the level on the decal on the machine.  
See the section on decals on the machine in chapter 2.

LBH/03/003801/0003/15.06/en

### 1.1.16 Towing device

bpik0041



The towing device is attached to the back of the machine.

Purpose:

- For towing the machine out of a danger area  
See the section on emergency operation in chapter 3.
- For lifting the machine by crane  
See the section on transporting the machine in chapter 3.



#### Note

It may not be used for attaching a trailer. The manufacturer/supplier will not be held liable for damage resulting from this.

! See the instructions on proper use and safely towing the machine in chapter 2.

### 1.1.17 Soot particle filter

This equipment is optional.

Name	Value	Units
Filter medium	Ceramic block made from cordierite with catalytic coating	
Maximum exhaust gas counterpressure	0.2	bar

**1.1.18 Light material bucket**



This equipment is optional.  
Version with undercut blade.

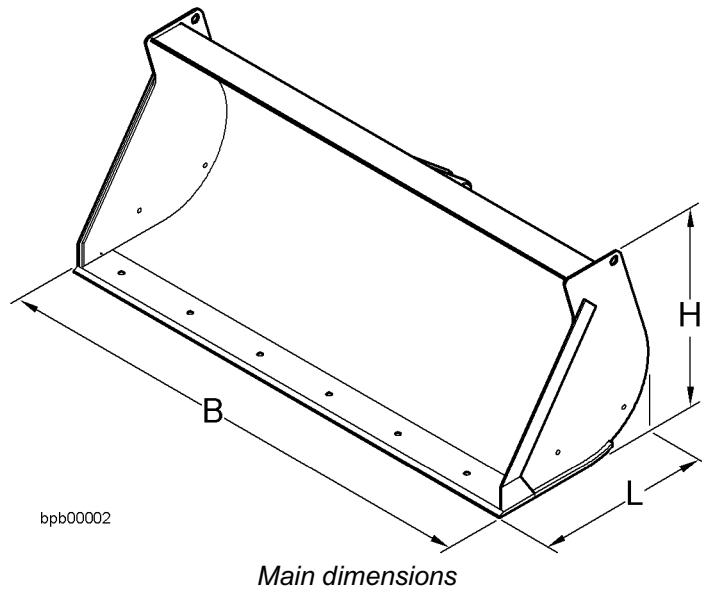

Light material bucket for direct attachment:

Name	Value	Units
Bucket capacity as per ISO 7546	6.5	m <sup>3</sup>
Specific material weight	1.2	t/m <sup>3</sup>
B – bucket width	3200	mm
H – height	1840	mm
L - length	1830	mm
Weight	2580	kg

Name	Value	Units
Bucket capacity as per ISO 7546	8.5	m <sup>3</sup>
Specific material weight	1.0	t/m <sup>3</sup>
B – bucket width	3500	mm
H – height	1960	mm
L - length	1920	mm
Weight	2890	kg

LBH/03/003801/0003/5.06/en

**Complete machine with light material bucket**

The values stated refer to the machine:

- With Z lift arms = 3050 mm
- Without a hydraulic quick-change device
- With 26.5 R25 Michelin XHA tyres.
- Including all lubricants
- With a full tank
- With ROPS/FOPS cab and driver

Tyre sizes and additional attachments affect the operating weight and tipping load.

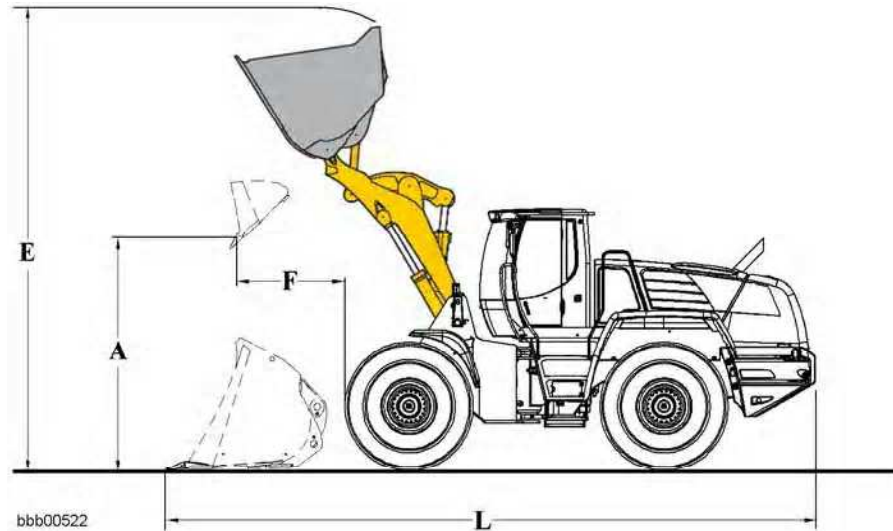

*Dimensions*

	Description	Unit	Value	
			6.5	8.5
	Bucket capacity as per ISO 7546	m <sup>3</sup>	6.5	8.5
	Bucket width	mm	3200	3500
	Specific material weight	t/m <sup>3</sup>	1.2	1.0
A	Dump height at maximum lifting height	mm	3195	3050
E	Maximum bucket top height	mm	6450	6650
F	Reach at maximum lifting height	mm	1205	1355
L	Overall length	mm	9170	9375
	Tipping load when straight	kg	19639	19040
	Articulated tipping load	kg	17342	16813
	Operating weight	kg	24860	25170

**1.1.19 High dump bucket**



This equipment is optional.  
Version with undercut blade.

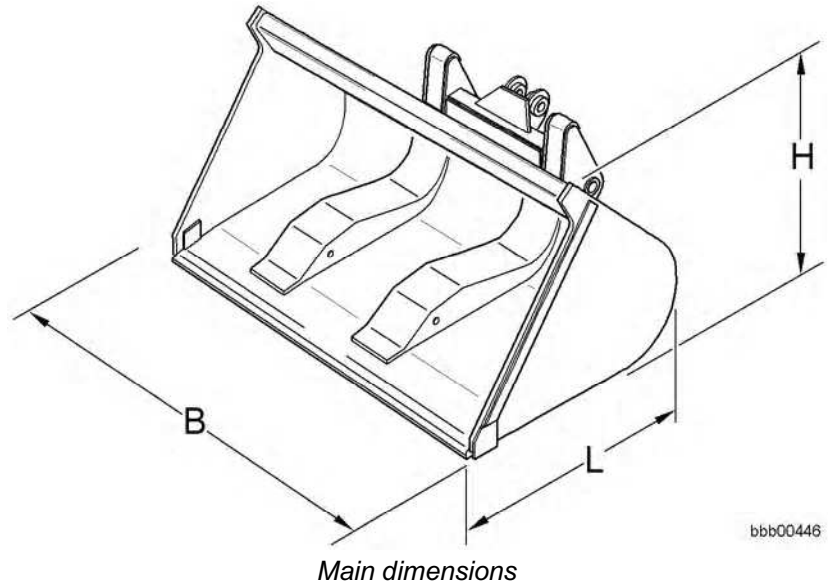

High dump bucket for direct attachment:

Name	Value	Units
Bucket capacity as per ISO 7546	6.5	m <sup>3</sup>
Specific material weight	1.0	t/m <sup>3</sup>
B – bucket width	3200	mm
H – height	2000	mm
L – length with blade	2500	mm
Weight	4000	kg
Maximum operating pressure for attachment hydraulics	250	bar

**Complete machine with high dump bucket**

The values stated refer to the machine:

- With Z lift arms = 3050 mm
- Without a hydraulic quick-change device
- With 26.5 R25 Michelin XHA tyres.
- Including all lubricants
- With a full tank
- With ROPS/FOPS cab and driver

Tyre sizes and additional attachments affect the operating weight and tipping load.

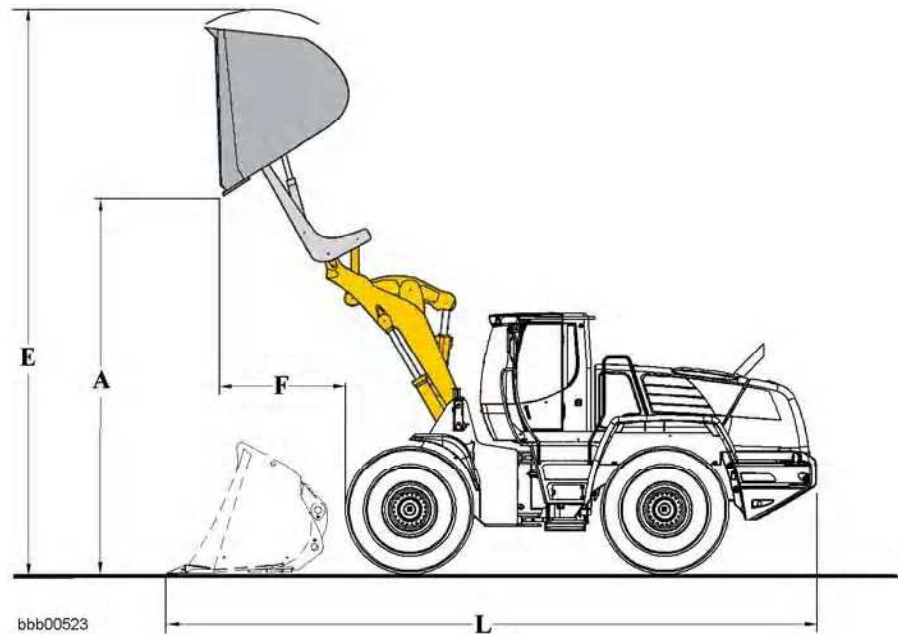

*Dimensions*

Name	Value	Units
Bucket capacity as per ISO 7546	6.5	m <sup>3</sup>
Bucket width	3200	mm
Specific material weight	1.0	t/m <sup>3</sup>
A Dump height at maximum lifting height	5540	mm
E Maximum height at bucket top edge	7820	mm
F Reach at maximum lifting height	1655	mm
L Overall length	9780	mm
Tipping load when straight	16786	kg
Articulated tipping load	14823	kg
Operating weight	26380	kg

LBH/03/003801/0003/5.06/en

**1.1.20 Forklift**

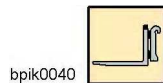

This equipment is optional.

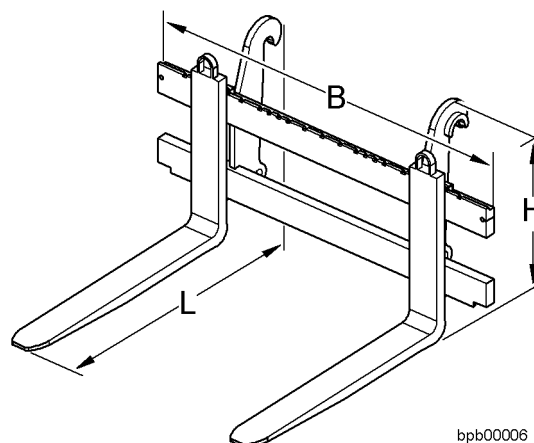

Dimensions

bpb00006

Name	Value	Units
Fork carrier prong size	FEM IV	
Prong length	1800	mm
L – Length (fork carrier + prongs)	2220	mm
K – Fork carrier width	2050	mm
H – Height (fork carrier + prongs)	1270	mm
Weight (fork carrier + prongs)	1160	kg



**Complete machine with forks**

The values stated refer to the machine:

- With Z lift arms = 3050 mm
- With hydraulic quick-change device
- With a FEM IV fork
- With specified tyres  
(See footnote)
- Including all lubricants
- With a full tank
- With ROPS/FOPS cab and driver
- In accordance with EN 474-3 and ISO 8313.

Tyre sizes and additional attachments affect the operating weight and tipping load.

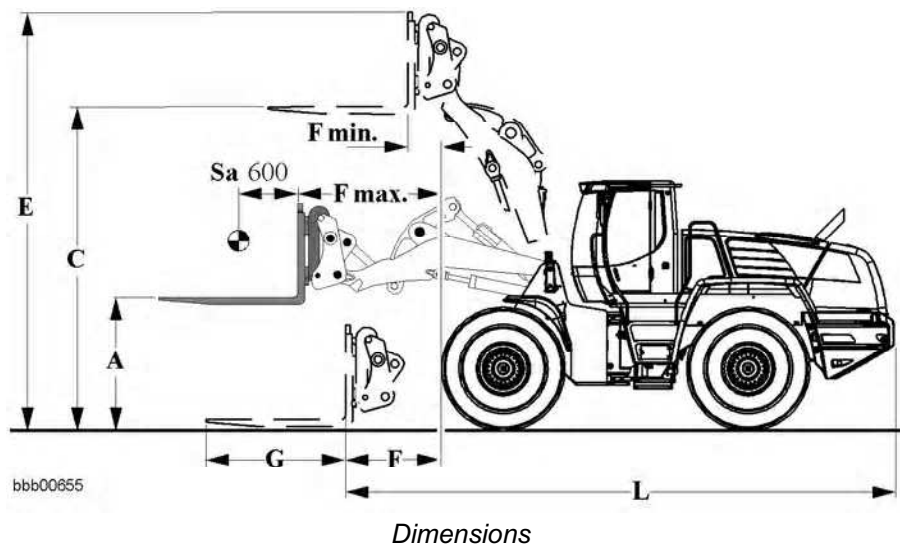

Lift arm		Standard 3050 mm			
Load geometry		Z kinematics		Z kinematics	
Fork attachment for quick-change device		FEM IV forklift 1800 mm		FEM IV forklift 1800 mm	
Description		Value <sup>1)</sup>	Unit	Value <sup>2)</sup>	Unit
A	Lifting height at maximum reach	1985	mm	1985	mm
C	Maximum lifting height	4350	mm	4350	mm
E	Maximum height above fork carrier	5540	mm	5540	mm
F	Reach in loading position	1300	mm	1300	mm
F max.	Maximum reach	1970	mm	1970	mm
F min.	Reach at maximum lifting height	840	mm	840	mm
G	Fork prong length	1800	mm	1800	mm
L	Overall length of basic machine	8100	mm	8100	mm
	Tipping load when straight	14140 <sup>1)</sup>	kg	14350 <sup>2)</sup>	kg
	Articulated tipping load	12280 <sup>1)</sup>	kg	12600 <sup>2)</sup>	kg
	Operating weight	24285 <sup>1)</sup>	kg	24945 <sup>2)</sup>	kg

<sup>1)</sup>With 26.5 R25 Michelin XHA tyres

<sup>2)</sup>With 26.5 R25 Michelin XLD-D2 tyres

**Load bearing tables for forklift operation**

Basis for determining bearing loads (rated payloads):

- Safety norm EN 474-3

The maximum bearing load is calculated as follows:

- As a percentage of the tipping load according to ISO 8313
- Fork prongs in horizontal position

The following values may not be exceeded:

- On even and firm terrain – 80% of the tipping load with forklift.
- On uneven terrain – 60% of the tipping load with forklift.

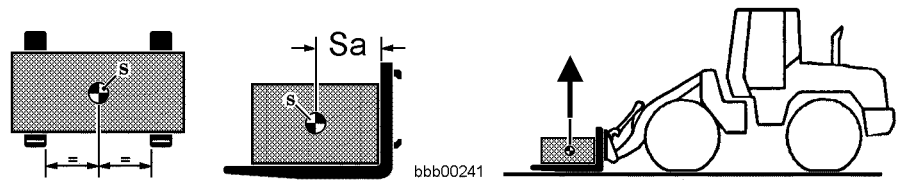

Specifications with permissible bearing loads:

- On different surfaces
- With different distances from the centre of gravity **Sa**

See the following tables.

All calculated values refer to genuine LIEBHERR equipment (fork carriers and prongs).

**Lift arms with Z kinematics**

Maximum permissible load for lift arms with quick change device.

Even and firm terrain Load = 80% of the tipping load		Load values in kg at different distances from the centre of gravity - Sa in mm							
Tyres	Tyre fill- ing	500	600	700	800	900	1000	1100	1200
26.5 R25 Michelin XHA <sup>2)</sup>	--	9670 <sup>1)</sup>	8840 <sup>1)</sup>	8150 <sup>1)</sup>	7550 <sup>1)</sup>	7040 <sup>1)</sup>	6590 <sup>1)</sup>	6200 <sup>1)</sup>	5850 <sup>1)</sup>
26.5 R25 Michelin XHA	1500 kg	9670 <sup>1)</sup>	8840 <sup>1)</sup>	8150 <sup>1)</sup>	7550 <sup>1)</sup>	7040 <sup>1)</sup>	6590 <sup>1)</sup>	6200 <sup>1)</sup>	5850 <sup>1)</sup>
26.5 R25 Michelin XLD-D2	--	9670 <sup>1)</sup>	8840 <sup>1)</sup>	8150 <sup>1)</sup>	7550 <sup>1)</sup>	7040 <sup>1)</sup>	6590 <sup>1)</sup>	6200 <sup>1)</sup>	5850 <sup>1)</sup>
26.5 R25 Michelin X-Mine	--	9670 <sup>1)</sup>	8840 <sup>1)</sup>	8150 <sup>1)</sup>	7550 <sup>1)</sup>	7040 <sup>1)</sup>	6590 <sup>1)</sup>	6200 <sup>1)</sup>	5850 <sup>1)</sup>
26.5.R25 Goodyear GP-4B	--	9670 <sup>1)</sup>	8840 <sup>1)</sup>	8150 <sup>1)</sup>	7550 <sup>1)</sup>	7040 <sup>1)</sup>	6590 <sup>1)</sup>	6200 <sup>1)</sup>	5850 <sup>1)</sup>
26.5 R25 Goodyear RL-5K	--	9670 <sup>1)</sup>	8840 <sup>1)</sup>	8150 <sup>1)</sup>	7550 <sup>1)</sup>	7040 <sup>1)</sup>	6590 <sup>1)</sup>	6200 <sup>1)</sup>	5850 <sup>1)</sup>

<sup>1)</sup>Payload restricted by tilt cylinders of Z-kinematics.

<sup>2)</sup>Standard tyres

Uneven terrain Load = 60% of the tipping load		Load values in kg at different distances from the centre of gravity - Sa in mm							
Tyres	Tyre filling	500	600	700	800	900	1000	1100	1200
26.5 R25 Michelin XHA <sup>2)</sup>	--	7724	7500	7288	7088	6899	6590 <sup>1)</sup>	6200 <sup>1)</sup>	5850 <sup>1)</sup>
26.5 R25 Michelin XHA	1500 kg	8571	8322	8088	7550 <sup>1)</sup>	7040 <sup>1)</sup>	6590 <sup>1)</sup>	6200 <sup>1)</sup>	5850 <sup>1)</sup>

LBH/03/003801/0003/15.06/en

Technical data

Uneven terrain Load = 60% of the tipping load		Load values in kg at different distances from the centre of gravity - Sa in mm							
Tyres	Tyre fill- ing	500	600	700	800	900	1000	1100	1200
26.5 R25 Michelin XLD-D2	--	7918	7688	7472	7267	7040 <sup>1)</sup>	6590 <sup>1)</sup>	6200 <sup>1)</sup>	5850 <sup>1)</sup>
26.5 R25 Michelin X-Mine	--	8039	7806	7586	7377	7040 <sup>1)</sup>	6590 <sup>1)</sup>	6200 <sup>1)</sup>	5850 <sup>1)</sup>
26.5.R25 Goodyear GP-4B	--	7792	7566	7352	7150	6959	6590 <sup>1)</sup>	6200 <sup>1)</sup>	5850 <sup>1)</sup>
26.5 R25 Goodyear RL-5K	--	8015	7783	7563	7356	7040 <sup>1)</sup>	6590 <sup>1)</sup>	6200 <sup>1)</sup>	5850 <sup>1)</sup>

<sup>1)</sup>Payload restricted by tilt cylinders of Z-kinematics.

<sup>2)</sup>Standard tyres

### 1.1.21 Timber grabber



This equipment is optional.

**Complete machine for timber handling**

- The values stated refer to the machine:
- With Z lift arms 3050 mm
  - With tilt cylinder support (Holzknecht)
  - With hydraulic quick-change device
  - With 26.5 R25 Goodyear GP4B tyres
  - Including all lubricants
  - With a full tank
  - With ROPS/FOPS cab and driver

Tyre sizes and additional attachments affect the operating weight and tipping load.

Key to the table:

ZKK = Z kinematics with tilt cylinder support and hydraulic quick-change device (Holzknecht)

<sup>1)</sup>Data includes water-filled rear tyres.

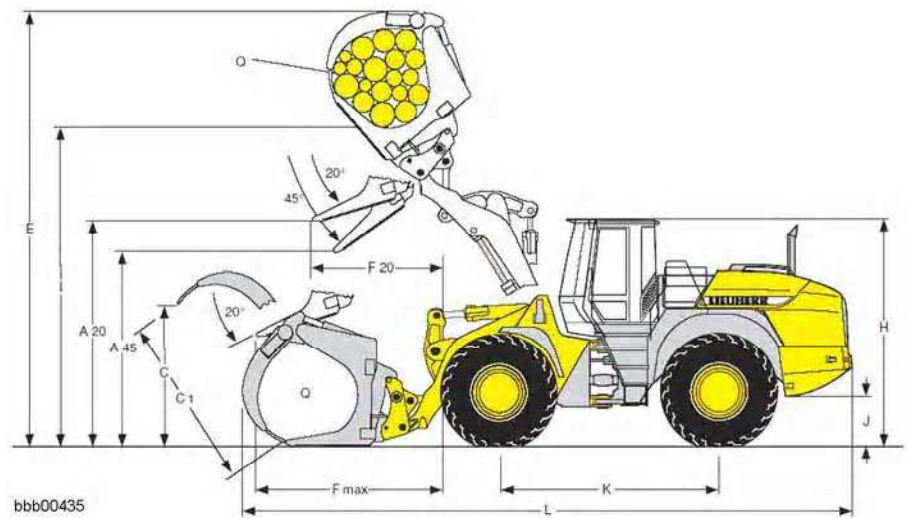

Dimensions

Name	Value	Units
Load geometry	ZKK	
A20 Unloading height at 20°	3630	mm
A45 Unloading height at 45°	2880	mm
C Maximum grabber opening in loading position	3370	mm
C1 Maximum grabber opening	3650	mm
E Maximum height	7800	mm
F20 Reach at maximum lifting height and 20° tilt-out angle	2230	mm
F45 Reach at maximum lifting height and 45° tilt-out angle	1660	mm
Fmax. Maximum reach	3340	mm
H Height above cab	3580	mm
I Manipulation height	5400	mm
J Ground clearance	565	mm
K Wheel base	3700	mm
L Overall length	9980	mm

LBH/03/003801/0003/15.06/en

<b>Name</b>	<b>Value</b>	<b>Units</b>
Machine width under tyres	2930	mm
Q Grabber cross section	3.5	m <sup>2</sup>
Grabber width	1850	mm
Payload	9200 <sup>1)</sup>	kg
Operating weight	27850 <sup>1)</sup>	kg

# 2 Safety regulations

Working on the machine poses safety risks to the operator, driver or maintenance engineers. You can prevent risks and accidents by regularly reading and observing the various safety instructions.

This is especially important for personnel who only occasionally work on the machine, for example, carrying out rigging or maintenance work.

The safety regulations listed below, if conscientiously followed, will ensure your own safety and that of others, and will prevent the machine from being damaged.

Whenever tasks which could cause danger to personnel or damage to the machine are described, the necessary safety precautions are explained in this manual.

These are indicated by the headings **Danger**, **Warning** or **Caution**.

## 2.1 Introduction

1. The symbols below have the following meanings:



---

### **Danger**

Risk of personal injury.

Denotes an impending dangerous situation which can lead to serious injury or death if not avoided.

! Note the warning.

---



---

### **Warning**

Risk of personal injury.

Denotes a potentially dangerous situation which can lead to serious injury or death if not avoided.

! Note the warning.

---



---

### **Caution**

Risk of personal injury.

Denotes a potentially dangerous situation which can lead to slight injury if not avoided.

! Note the warning.

---

---

### **Caution**

Risk of damage to the machine.

Denotes actions or circumstances which may result in damage to the machine.

! Note the warning.

---

**Note**

Useful information

Denotes information on correctly handling the machine and the lubricants and fuels used.

! Observe the instructions.

2. **Observance of these instructions does not exempt you from following any additional rules and guidelines that may apply**

The following should also be observed:

- The safety rules in force at the operating site
- Legally enforceable road traffic regulations
- Guidelines issued by trade associations

## 2.2 General safety regulations

1. Familiarise yourself with the **operating manual** before starting up the machine.  
Make sure that you are in possession of and have read and understood additional instructions applicable to any special equipment installed on your machine.
2. Only expressly authorised personnel may operate, service or repair the machine.  
Observe the legal minimum ages.
3. Only trained or instructed personnel may operate the machine. Clearly assign responsibility for operation, rigging, maintenance and repair work.
4. Clearly establish the driver's responsibilities (also with respect to traffic regulations) and authorise him to refuse to carry out unsafe instructions from third parties.
5. Personnel undergoing training, instruction or who are not yet fully qualified may only be allowed to work on the machine under constant supervision by an experienced person.
6. Now and again check that your personnel are working safely and are aware of possible dangers in observance of the **operating manual**.
7. Wear safe working clothes when working on the machine.  
Do not wear rings, wristwatches, ties, scarves, unbuttoned jackets, loose clothing or similar garments, as they can become caught in the machinery and cause injury.  
Certain tasks require safety goggles, safety boots, hard hats, gloves, reflective vests, ear protection etc.
8. Ask the site manager about any special safety regulations in force on the site.
9. Do not hold onto the steering column, the control panel or the control levers when getting on or off the machine.  
You might inadvertently trigger movements which could lead to accidents.
10. Never jump down from the machine. Use the steps, ladders and platforms provided for getting on and off.
11. Familiarise yourself with the emergency exit through the right cab door and/or the rear window.
12. Unless there are other instructions, perform maintenance and repair work as follows:

## Procedure:

- Park the machine on firm, level ground and lower the working attachment to the ground.
  - Move all control levers to neutral.
  - Shut down the engine and take out the ignition key.
13. Before starting any work on the hydraulic circuit, you must also press the working hydraulics lockout button and actuate all pilot control units (joystick and pedals) in both directions in order to reduce the control pressure and accumulated pressure in the operating circuits. You must then reduce the internal tank pressure.
  14. Lock the working hydraulics to prevent accidental actuation before leaving the driver's cab.  
Lock the working hydraulics in accordance with the instructions in the **operating manual**.
  15. Secure all loose parts of the machine.
  16. Never start up a machine without first making a thorough tour of inspection and checking if any warning signs are missing or illegible.
  17. Observe all signs with warnings or safety instructions.
  18. Special safety apparatus must be fitted to the machine for certain applications. If this is the case, only work with this apparatus fitted and in working order.
  19. Do not make any modifications, extensions or conversions to the machine with possible safety implications without the approval of the supplier. This also applies to installing and adjusting safety apparatus and valves, as well as to welding load-bearing components.

## 2.3 Proper use

1. When fitted with the standard bucket, forklift or grabber equipment, the wheel loader is solely to be used for loosening, picking up, transferring, loading and dumping earth, stone, rock fragments or other materials and loading it onto trucks, ships, conveyor belts or crushers.
2. Any other use, such as breaking rock, hammering in posts, transporting people or towing is deemed improper.  
The manufacturer/supplier will not be held liable for damage resulting from this.  
The operator bears sole liability.
3. Vehicles used for lifting purposes are subject to special conditions and must also be equipped with the prescribed safety equipment.
4. Proper use also includes observance of the **operating manual** and adherence to the inspection and maintenance conditions.



## 2.4 Decals on the machine

1. There are several types of decal attached to the machine.

Decal types:

- Safety decals
- Information decals
- Type plates

The order numbers can be found in the spare parts list.

### 2.4.1 Safety decals

1. Failure to obey the safety decals can lead to severe or even fatal injuries. The safety decals should be continuously checked for completeness and legibility. Replace any missing or illegible safety decals immediately.

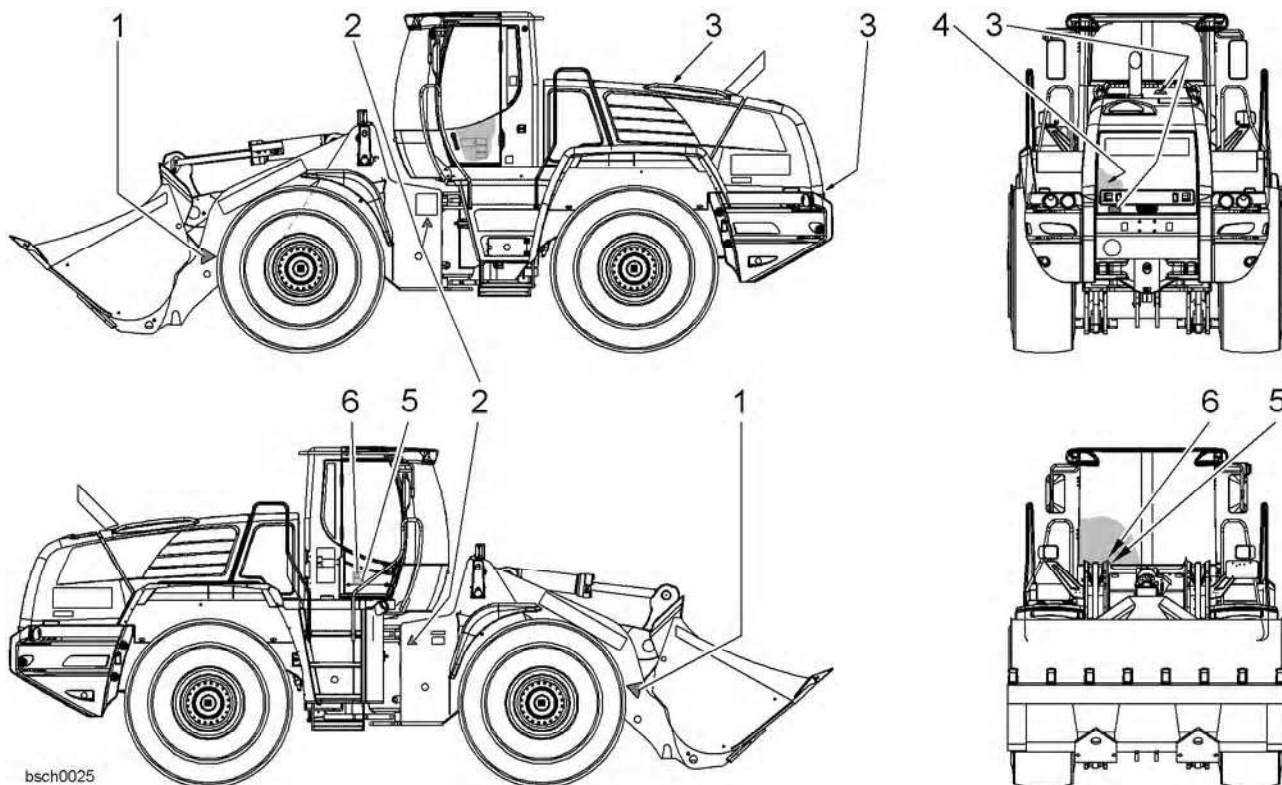

bsch0025

Arrangement of safety decals

- 1 Keep clear decal
- 2 Articulation area warning decal

- 3 Engine standstill decal
- 4 Voltage decal
- 5 Accident prevention decal

- 6 Steering decal

**Keep clear decal**



03sc01ab

Warns of the risk of accidents, possibly resulting in severe or even fatal injuries.

Meaning: **Keep out of the danger area**

**Articulation area decal**



bsich007

Warns of the risk of accidents, possibly resulting in severe or even fatal injuries.

Meaning: **Keep out of the articulation area when it is not locked**

**Engine standstill decal**



03sc04ab

Warns of the risk of accidents, possibly resulting in severe injuries.

Meaning: **Only open when the engine is shut down**

**Voltage decal**



bsich005

Refers to the battery main switch.

Meaning: **The electrical system is energised when the battery main switch is turned on.**

LBH/03/003801/0003/5.06/en

**Accident prevention decal**



03sc03ab

Refers to instructions in the operating manual for preventing accidents.  
 Meaning: **Strictly observe the accident prevention instructions in the operating manual when operating the machine**

**Steering decal**



03sc05ab

Warns of the risk of accidents, possibly resulting in severe or even fatal injuries.  
 Meaning: **The steering is only operational when the engine is running**

### 2.4.2 Information decals

- The information decals indicate information on operating, servicing and properties of the machine.

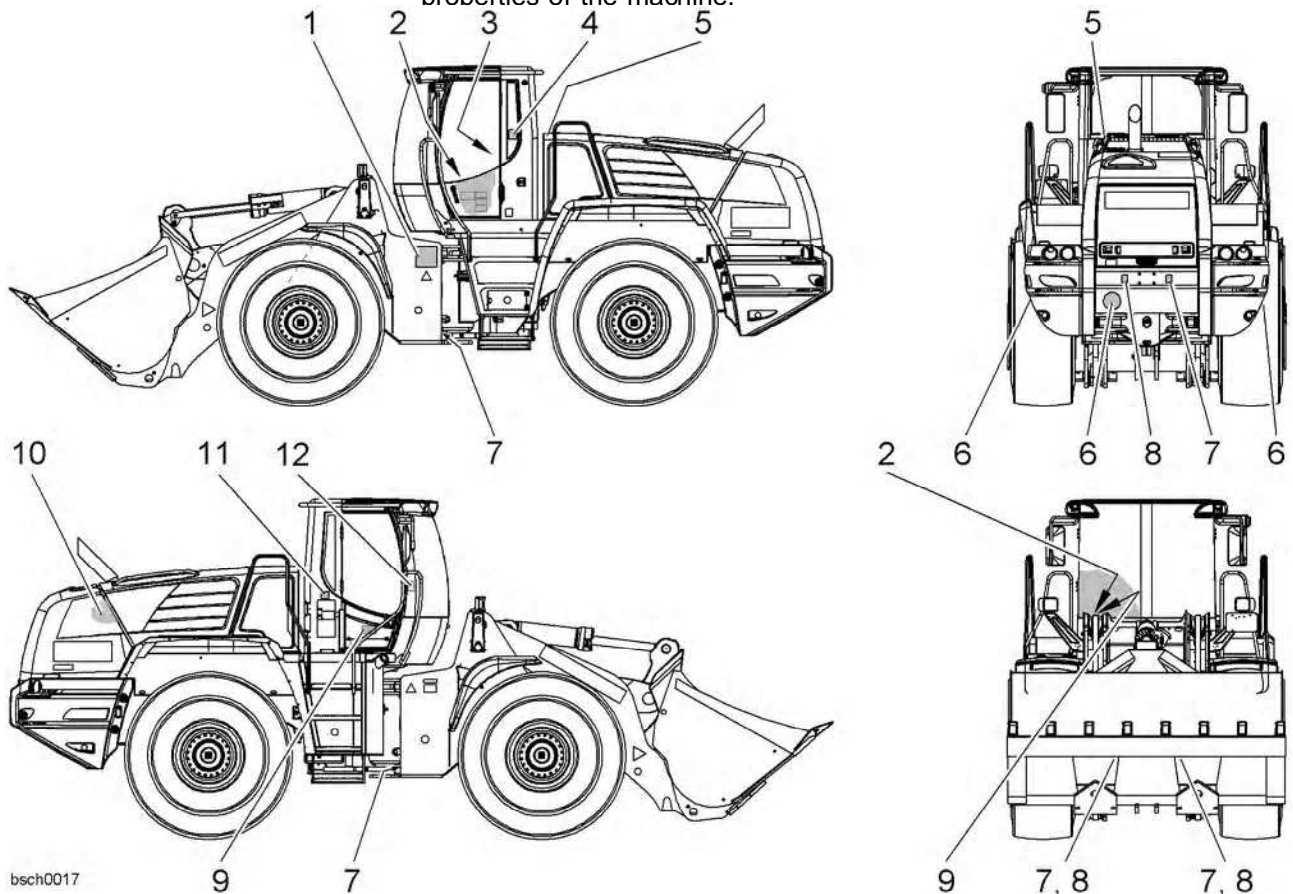

bsch0017

bsch002

Arrangement of information decals

- |  |                                    |                             |
|--|------------------------------------|-----------------------------|
| 1 Lubrication chart                    | 5 Cooler decal                     | 9 ROPS decal                |
| 2 Wheel lugs decal                     | 6 40 km/h speed limit decal        | 10 Oil level decal          |
| 3 Operating manual decal               | 7 Lashing point decal              | 11 Windscreen water decal   |
| 4 Noise output decal – L <sub>WA</sub> | 8 Slinging and lifting point decal | 12 Working hydraulics decal |

### Lubrication chart decal

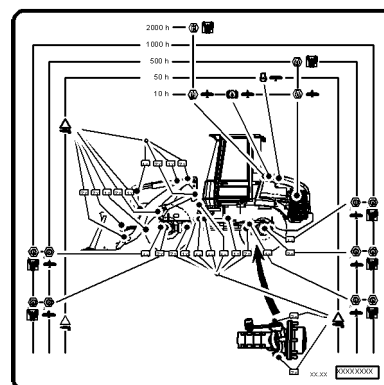

Indicates the maintenance points and intervals in relation to lubricants and consumables for the machine.

LBH/03/003801/0003/15.06/en

**Wheel lugs decal**

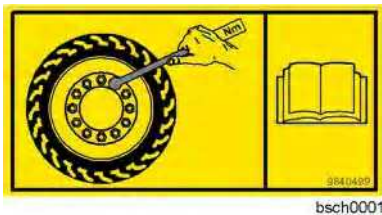

Refers to the service interval for checking the tightness of the wheel lugs specified in the operating manual.

**Operating manual decal**

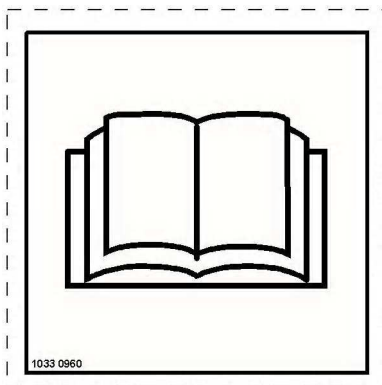

Indicates where the operating manual is kept.

**Noise output decal – L<sub>WA</sub>**

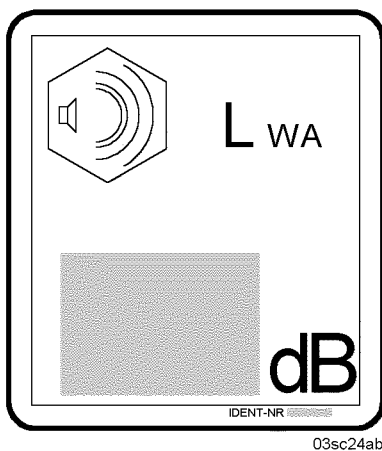

States the noise output level (L<sub>WA</sub>) of the machine in decibels. You can read the level on the decal on the machine.

**Cooler decal**

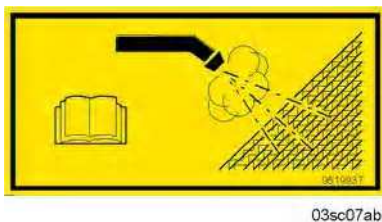

Refers to cleaning the cooling system.

LBH/03/003801/0003/5.06/en

### 40 km/h decal



03sc08ab

Refers to the permitted speed limit for the machine.

### Lashing point decal



03sc16ab

Refers to the lashing points on the machine.

### Slinging and lifting point decal



03sc17ab

Refers to the slinging and lifting points on the machine.

### ROPS decal

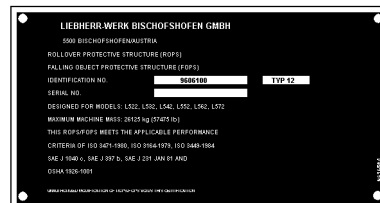

03sc09ab

States the maximum load of the roll-over protection system.

LBH/03/003801/0003/15.06/en

### Oil level decal



03sc11ab

It indicates the oil level in the hydraulic tank.

### Windscreen water decal

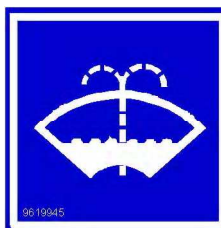

03sc13ab

Indicates the reservoir for the windscreen washer fluid.

### Working hydraulics decal

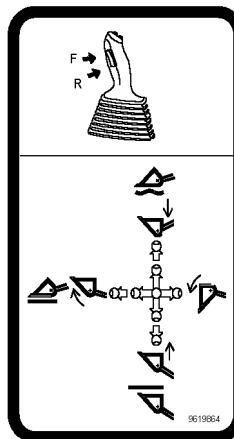

03sc06at

Indicates the directions in which the LH control lever can be moved.

### Bio oil decal

This equipment is optional.

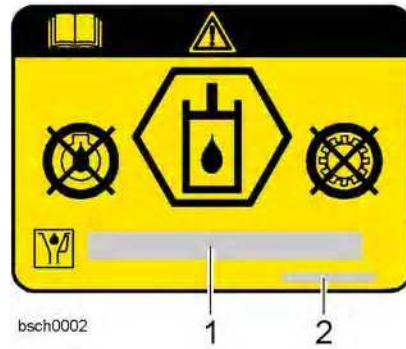

- 1 Bio oil type
- 2 ID number

Indicates that the hydraulic system is filled with bio oil.

**States that bio oil cannot be used for lubricating the engine and gearbox.**

The field 1 contains the exact designation of the bio oil in the hydraulic system.

### Bearing load table decal

This equipment is optional.

	L544	L554	L564	L574	L574S	L580
	5800 kg	6500 kg	7845 kg	8840 kg	8840 kg	8840 kg
	4550 kg	4875 kg	5885 kg	6630 kg	6960 kg	7500 kg

bsch0006

Indicates the maximum permissible load in forklift operation.

### 2.4.3 Type plates

1. The machine and all its components, such as the engine, gearbox and axles, have type plates affixed to them.

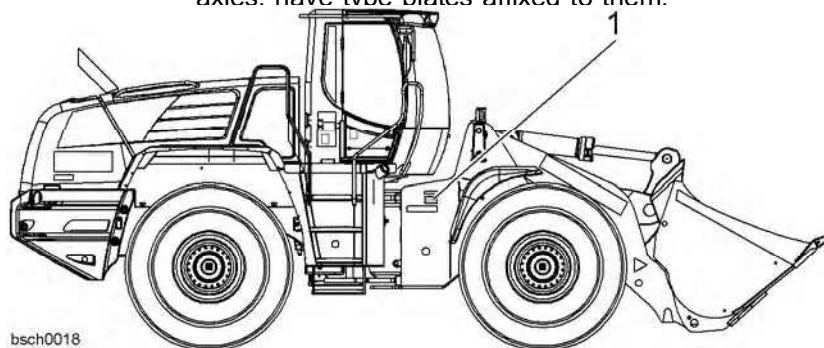

bsch0018

Arrangement of type plates

- 1 Machine type plate

LBH/03/003801/0003/5.06/en



### Machine type plate



typ00001

Type plate

Information on the type plate:

- Type
- Vehicle ID No.
- Maximum total weight
- Year of construction
- Maximum front axle load
- Maximum rear axle load
- Engine power
- Maximum speed
- Homolog. no. <sup>1)</sup>
- Maximum trailer weight <sup>1)</sup>



typit001

Italian version of machine type plate

<sup>1)</sup> Italian version only

## 2.5 Instructions on preventing crushing injuries and burns

1. Do not work under the attachment if it is not resting on the ground or supported.
2. Do not use any ropes or chains which are damaged or which have insufficient load bearing capacity.  
Wear protective gloves when handling wire ropes.
3. When working with the attachment, never align the boreholes with your fingers, instead, use a suitable mandrel for this purpose.
4. Make sure no objects come into contact with the fan when the engine is running.  
Objects which fall or project into the fan will be thrown back out or destroyed and could damage the fan.

5. When the machine is near operating temperature, the engine cooler system is hot and pressurised.  
Do not touch parts carrying cooling water.  
This can lead to burns.
6. Only check the coolant level once the cap on the expansion tank has cooled down enough to touch.  
Carefully open the cap to let out excess pressure.
7. When running at or near the operating temperature, the engine oil and hydraulic oil are hot.  
Avoid touching hot oil or parts which carry oil.
8. Wear goggles and safety gloves when working on the battery.  
Avoid sparks and naked lights.
9. Never let anyone move the bucket or other working attachments into position by hand.
10. Any time you open the engine compartment, prevent the compartment doors from falling shut using the struts provided.
11. Before starting up the machine, close and lock the engine compartment doors and the battery compartment cover.
12. Never lie under the machine when it is raised using the working attachment, unless the undercarriage is securely supported using wooden beams.

## 2.6 Instructions on preventing fires and explosions

1. When refuelling, the engine must be turned off. Switch off the auxiliary heater, if installed.
2. Do not smoke. Avoid naked flames when refuelling or where batteries are being recharged.
3. Always follow the instructions in the **operating manual** when starting the engine.
4. Check the electrical system.  
Immediately eliminate all faults such as loose connections, worn cables or burnt out fuses and bulbs.
5. Do not carry combustible fluids on the machine outside the tanks provided.
6. Regularly check all lines, hoses and bolted connections for leaks and damage.
7. Repair the leaks immediately and replace the damaged components.  
Oil escaping from leaks can easily cause fires.
8. Make sure that all brackets and protective plates are properly installed to prevent vibrations, abrasion and heat build-up.
9. Starting agent (ether) is a particularly dangerous fire hazard.  
Never use ether starting agent near head sources, naked lights (such as cigarettes) or in poorly ventilated spaces.
10. Do not use starting agents containing ethers to start diesel engines with preglow or flame glow systems.  
Otherwise there is a risk of **explosions**.
11. Familiarise yourself with the location and use of fire extinguishers and find out about fire alarm and firefighting facilities on site.

## 2.7 Safety instructions for start-up

1. Each time you start up the machine, make a thorough tour of inspection.
2. Check the machine for loose bolts, cracks, wear, leaks and deliberate damage.
3. Never start up a damaged machine.
4. Make sure the damage is rectified immediately.
5. Ensure that all hoods and covers are closed and locked. Check that all the warning and instruction decals are in place.
6. Clean the windows and interior and exterior mirrors, and secure the doors and windows against inadvertent movement.
7. Make sure no-one is working on or underneath the machine. Warn any bystanders before you start up the machine.
8. After getting into the driver's cab, adjust the seat, the inside and outside mirrors, the control lever and the seat belt so that you can work comfortably.
9. Sound insulation equipment on the machine must be in place during operation.

## 2.8 Safety precautions during start-up

1. Before starting, check that all control lamps and instruments are working properly.  
Move all control levers to neutral.
2. Before starting the engine, briefly sound the horn to warn anyone else in the vicinity of the machine.
3. Only start the machine when sitting in the driver's seat.
4. Unless otherwise instructed, start the engine in accordance with the instructions in the **operating manual**.
5. Start the engine and then check all display and monitoring equipment.
6. Only run the engine in enclosed spaces when there is sufficient ventilation. If necessary, open the windows and doors to ensure adequate fresh air.
7. Run the engine until both it and the hydraulic oil are at operating temperature. Low oil temperatures lead to sluggish performance.
8. Check that the attachment controls are working properly.
9. Carefully drive the machine to open ground and check the service brake, the steering, the signals and lighting.

## 2.9 Instructions for safe working

1. Before starting work, familiarise yourself with the features of the site, as well as any special regulations and warning signals.  
The working environment includes obstacles in the working area and on access roads, the firmness of the terrain and any protective barriers to prevent the public from entering the site.
2. Always keep a safe distance from overhangs, drops, slopes and unsafe terrain.
3. Be especially careful with variable terrain conditions, poor visibility and changeable weather.
4. Find out where the supply pipes to the site are, and be especially careful when working near them. If necessary, notify the relevant authorities.

5. Keep a safe distance away from overhead power lines.  
When working near overhead power lines, keep the attachment well away from them.
  - There is a risk of **fatal injury**.
  - Find out about the safety clearances to be observed.

**If the machine comes into contact with live power lines:**

  - Do not get out of the machine.
  - If possible, move the machine to a safe distance away from the danger area.
  - Warn any bystanders not to approach or touch the machine.
  - Arrange for the power to be switched off.
  - Only get out of the machine when you are sure that the power line you have touched or damaged has been switched off.
6. Before driving or working with the machine, check that the accessories are safely stowed away.
7. When driving on public roads, paths and spaces, observe the traffic regulations, and make sure the machine is in a fit condition to use public roads if this is not already the case.
8. Always switch on the lights in darkness and poor visibility.
9. Do not take passengers on the machine.
10. Only work seated and wearing a safety belt.
11. Report any malfunctions and make sure that any necessary repairs are carried out immediately.
12. Take personal care to ensure that no-one is endangered when the machine starts moving.
13. Before starting work, check the brake system as instructed in the **operating manual**.
14. Never get out of the driver's seat when the machine is still in motion.
15. Never leave the machine unattended with the engine running.
16. When driving the machine, lower the working attachment to the transport position and carry the load as close as possible to the ground.
17. Avoid movements which could cause the machine to tip over.  
If the machine does start to tip over or slide sideways, put down the attachment immediately and point the machine downhill.  
Wherever possible, work up or downhill and not sideways to the slope.
18. Drive carefully on rocky or slippery terrain and on slopes.
19. Only drive downhill within the permitted speed limit, otherwise you could lose control of the machine.  
The engine must be running at the rated speed and you should only reduce the travel speed using the pedals.  
Shift down to a lower gear before reaching the slope. Do not wait until you are actually on it.
20. When loading a truck, insist on the driver getting out of his cab, even if it is protected against stone impact.
21. When performing work such as demolition work, clearance and crane operation, always use the protective equipment provided for these specific tasks.
22. Have someone direct you when vision is restricted and whenever else it is necessary.  
Only let one person give you signals.
23. Only allow experienced personnel to sling loads and direct crane drivers.  
The person giving directions must remain in sight of the operator or at least be in spoken contact with him.

## 2.10 Safety instructions for driving on slopes

1. On downward slopes, always drive carefully and never at top speed, as you could otherwise lose control over the machine.

Travel speeds:

- Never exceed the speed limits specified in the **operating manual**.
  - Exceeding the maximum speed causes the permitted limits to be exceeded for all rotating parts, including the drive motor, the drive shaft, all gears including axles and ultimately the diesel engine itself.
2. Before driving onto a slope, therefore select a travel range (gear) in which you can safely negotiate the whole slope without endangering yourself, the machine and other people.
  3. Also, take your foot off the gas pedal when driving onto a slope.

## 2.11 Parking safely

1. When possible, always park the machine on flat, firm ground.  
If you have to park on a slope, use wheel wedges to prevent the machine from moving.
2. If the machine has articulated steering, engage the articulation lock.  
This only applies to wheel loaders with articulated steering.
3. Lower the digging attachment so that it is lightly anchored in the ground.
4. Move all control levers to the neutral position and engage the parking brake.
5. Shut down the engine in accordance with the instructions in the **operating manual**.
6. Lock the working hydraulics before leaving the driver's cab.  
Lock the working hydraulics in accordance with the instructions in the **operating manual**.
7. Lock up the machine, take out all keys and secure it against unauthorised use and vandalism.

## 2.12 Transporting the machine safely

1. Only use suitable transport equipment and lifting gear with sufficient load capacity.
2. Park the machine on flat ground and use wedges to secure the tracks or wheels.
3. If necessary, dismantle the working attachment for the duration of transport.
4. The ramp for driving onto the low-bed truck should not be more than 30° steep, and should be covered with wooden boards to prevent slipping.
5. Clean the machine tracks or wheels of snow, ice and mud before driving onto the ramp.
6. Before driving on, secure the upper carriage to the undercarriage with the locking pin.  
Procedure: does not apply to wheel loaders.
7. Align the machine precisely with the loading ramp.

8. Attach the hand lever to the pedals for sensitive driving.  
Procedure: does not apply to wheel loaders.
9. Have someone give signals to direct the driver.  
Drive carefully onto the ramp and then on to the transport vehicle itself.
10. Have wedges ready to prevent the machine from rolling back when driving on.
11. Tilt the attachment in and drive onto the ramp.  
Keep the attachment close to the loading area.
12. After driving on, lower the working attachment onto the loading area.  
Apply the articulation lock (this only applies to wheel loaders with articulated steering).
13. Secure the machine and the remaining individual components against slipping using chains and wedges.
14. Relieve the pressure lines, take out the ignition key, lock the cab door and side panels, and get out of the machine.
15. Acquaint yourself with the route before transport, especially as regards the width, height and weight limits you will encounter.
16. Make a special note of any overhead power lines, bridges and tunnels along the route.
17. Apply the same care when driving off.  
Procedure:
  - Remove all chains and wedges.
  - Start the engine in accordance with the instructions in the **operating manual**.
  - Carefully drive off the loading area using a ramp.
  - Keep the attachment close to the ground.
  - Have someone give you directions.

## 2.13 Towing the machine safely

1. Always observe the correct procedure as described in the **operating manual**. See the section on towing the machine in chapter 3.
2. The machine may only be towed in exceptional circumstances, for example to move it away from a dangerously exposed position for repairs.
3. Before pulling or towing the machine, check that all attachments and towing equipment are safe and secure.
4. The rope or bar used for towing must have sufficient tensile strength and be fastened to the holes provided on the front section.  
In no event are damage or accidents resulting from towing covered by the manufacturer's guarantee.  
Instructions on towing by rope:
  - Make sure no-one is near the taut rope when towing.
  - Keep the rope taut and avoid kinks.
  - Carefully pull the rope taut.
  - Sudden jerks can cause a slack rope to tear.
5. When towing, keep to the prescribed transport position, speed limit and route.
6. When starting the machine up again, follow the instructions in the **operating manual**.

## 2.14 Measures for ensuring safe maintenance

1. Never attempt maintenance and repair work unless you are qualified to do so.
2. Observe the prescribed periods for regular checks and inspections or those specified in the **operating manual**.  
A suitably equipped workshop is absolutely necessary in order to perform repair work.
3. The table at the end of this **operating manual** states exactly who may carry out each job.  
The jobs listed under **daily / weekly** in the maintenance schedule can be carried out by the driver or by service personnel.  
The other jobs may only be carried out by suitably qualified specialist staff.
4. Spare parts must meet the technical requirements specified by the manufacturer. This is guaranteed if you use genuine spares.
5. Wear safety overalls for maintenance work. Certain jobs not only require a hard hat and safety boots, but also goggles and safety gloves.
6. Keep unauthorised persons away from the machine during maintenance.
7. Set up an extended cordon around the maintenance area as necessary.
8. Notify the operating personnel before starting repairs or other special jobs. Nominate a supervisor.
9. Unless otherwise specified in the **operating manual** carry out all maintenance work on the machine on firm, level ground with the engine off.
10. Afterwards always re-tighten any bolts loosened during maintenance and repair work.
11. If safety equipment has to be dismantled for rigging, maintenance and repair work, it must be re-installed and checked as soon as the job is finished.
12. When undertaking maintenance jobs, especially under the machine, attach a warning sign marked **DO NOT SWITCH ON** to the ignition where it is clearly visible. Take out the ignition key.
13. Before starting maintenance or repairs, clean any oil, fuel or service fluids from the machine, especially connections and bolted joints. Do not use abrasive cleaning agents. Use fibre-free cloths.
14. Before welding, burning and sanding, clean any dust from the machine and the area around it, and ensure adequate ventilation.  
Otherwise there is a risk of **explosions**.
15. Before cleaning the machine with water, steam jet (high-pressure cleaner) or other cleaning agents, cover or tape up all openings where water, steam and cleaning agent may not penetrate for safety reasons.  
Electric motors, control cabinets and battery compartments are at particular risk.  
Further procedure:
  - Make sure that during cleaning work on the machine housings, the temperature sensors for the fire alarm and extinguisher systems do not come into contact with hot cleaning agent. Otherwise the fire extinguishing system could be activated.
  - After cleaning, completely remove the covers and tape.
  - After cleaning, check all fuel, engine oil and hydraulic oil lines for leaks, loose connections, abrasion and damage.
  - Repair any defects immediately.
16. Follow the safety instructions for the product in question when handling oil, grease and other chemical substances.

17. Dispose of spare parts and consumables in a safe, environmentally sound manner.
18. Take care when handling hot operating and auxiliary materials (danger of burns and scalding).
19. Only operate combustion engines and fuel-powered heaters in sufficiently ventilated rooms. Before starting the engine inside a building, make sure the room is well ventilated. Follow the local regulations in force at the site.
20. Only carry out welding, burning and grinding work when it is expressly allowed, as otherwise you may cause fires or explosions.
21. Do not try to lift heavy parts. Only use suitable equipment with sufficient load capacity.

Procedure:

- When replacing individual parts and larger assemblies, carefully fasten and secure them to the lifting gear so that no danger can arise.
- Only use suitable lifting gear in perfect order, and slinging equipment with sufficient load capacity.

**Keep out from under suspended loads.**

22. Do not use ropes which are damaged or of insufficient load bearing capacity. Wear protective gloves when handling wire ropes.
23. Only allow experienced personnel to sling loads and direct crane drivers. The person giving directions must remain in sight of the operator or at least be in spoken contact with him.
24. When carrying out fitting work above head height, use the safety climbing aids and working platforms provided or equivalent. Do not use parts of the machine for climbing. Wear a safety harness when working at height. Keep all handles, steps, rails, gangways, platforms and ladders free from dirt, snow and ice.
25. When working on the attachment (for example replacing teeth), make sure it is properly supported. Avoid direct metal-to-metal contact.
26. Never lie under the machine when it is raised using the working attachment, unless the undercarriage is securely supported using wooden beams.
27. Always support the machine on blocks, so that it cannot become unbalanced by any shift in weight. Avoid metal-to-metal contact.
28. Only trained specialist staff may perform work on the chassis, brake and steering systems.
29. If you have to repair the machine on a slope, secure the wheels with wedges. Move the working attachment to the maintenance position and engage the articulation lock.
30. Only personnel with the requisite skills and experience may work on hydraulic equipment.
31. Wear protective gloves when looking for leaks. Under pressure, a thin jet of liquid can pierce the skin.
32. Never release hydraulic lines or bolts before setting down the working attachment and shutting down the engine.  
Before starting any work on the hydraulic circuit, you must also press the working hydraulics lockout button and actuate all pilot control units (joystick and pedals) in both directions in order to reduce the control pressure and accumulated pressure in the operating circuits. You must then reduce the internal tank pressure.
33. Regularly check all hydraulic oil lines, hoses and bolted connections for leaks and visible damage. Repair all damage immediately. Oil escaping under pressure can cause injury and fires.
34. Before beginning repair work, depressurise the system sections and pressurised lines (hydraulics, compressed air) which are to be opened, as instructed in the assembly descriptions.



35. Lay and fit hydraulic and compressed air lines in the proper manner. Do not switch the connections. Fittings, as well as the length and quality of the hose lines, must match the manufacturer's requirements.  
**Only use LIEBHERR spare parts.**
36. Replace hydraulic hose lines at appropriate intervals, even if there are no apparent defects which may impair safety.
37. Work on the machine's electrical equipment may only be carried out by a qualified electrician or by instructed persons under the direction and supervision of a qualified electrician, in accordance with the recognised electrical engineering rules.
38. Only use original fuses with the stated current ratings. If there are malfunctions in the electrical power supply, switch off the machine immediately.
39. Inspect and test the machine's electrical equipment regularly. Immediately rectify all faults, such as loose connections, scorched or worn cables or burnt out fuses and bulbs.
40. If you have to carry out work on live components, have a second person assist you, who can throw the emergency stop or main switch in an emergency. Cordon off the working area with a red and white safety chain and a warning sign. Only use insulated tools.
41. When working on high-voltage assemblies after they have been isolated from the power supply, short the supply cable and the components, such as capacitors, with an earthing rod.
42. First, check that the isolated parts are not live, connect them to earth and then short them. Isolate any neighbouring live parts.

## 2.15 Safety instructions for maintenance work on machines with hydro accumulators

1. Only qualified staff may carry out work on the hydraulic and pneumatic connections of the membrane accumulator.  
Serious accidents could result from inexpert fitting and operation.  
The hydraulic system must be depressurised before work can be carried out on it.  
Do not carry out any welding or soldering work on the membrane accumulator.  
**There is a risk of explosion during welding or soldering work.**  
The accumulator may burst during machining, resulting in the loss of the operating permit.  
Hydro accumulators may only be filled with nitrogen, not with oxygen or air - otherwise there is a **risk of explosion**.  
The accumulator can heat up, causing burns.  
Do not use membrane accumulators which have been damaged during transportation.  
New membrane accumulators must be filled with nitrogen before they are used. Remove the sealing caps on the fluid side.  
The minimum and maximum operating data are permanently marked on the membrane accumulator. The marking must remain visible.

## 2.16 Safety instructions for welding work on the machine

1. Main components for power transmission (such as the vehicle frame and attachment components) . . may only be welded by the manufacturer or an authorised workshop.

Disconnect the battery when working on the electrical system or when carrying out arc welding on the machine.

Always disconnect the negative terminal first and reconnect it last.

### **On machines with electronic gearbox control units:**

- Also disconnect the multi-pin plug on the electronic gearbox control unit before starting any welding work on the machine.

The earth cable of the welding device should be attached as close as possible to the actual welding location, so that it is not possible for the welding current to flow through components or sealing elements such as the slewing ring, joints, bearings, bushes, rubber components . . and seals.

## 2.17 Instructions for working safely on the working attachment

1. Do not work under the attachment if it is not resting on the ground or supported.
2. When replacing attachment components (decals, cutting edge, teeth), . . do not let metal rest on metal.
3. Do not try to lift heavy parts. Only use suitable equipment with sufficient load capacity.
4. Always wear gloves when working with wire ropes.
5. Never release hydraulic lines or bolts before setting down the working attachment and shutting down the engine.

Before starting any work on the hydraulic circuit, you must also press the working hydraulics lockout button and actuate all pilot control units (joystick and pedals) in both directions in order to reduce the control pressure and accumulated pressure in the operating circuits. You must then reduce the internal tank pressure.

6. Ensure that all lines and threaded couplings are reconnected and re-tightened on completion of the job.
7. Be especially careful when removing or inserting bolts and pins made of hardened steel, as they can splinter, causing serious injury.

Wear safety gloves and goggles.

Whenever possible use special tools (such as mandrels, extractors, . . etc.)

## 2.18 Safety instructions for transporting the machine by crane

1. Lower the working attachment and tilt back the loading equipment to its limit.
2. Apply the articulation lock (this only applies to wheel loaders with articulated steering).

3. Move all control levers to the neutral position and engage the parking brake.
4. Shut down the engine in accordance with the instructions in the **operating manual**.
5. Lock the working hydraulics before leaving the driver's cab.  
Lock the working hydraulics in accordance with the instructions in the **operating manual**.
6. Lock all doors, covers and hoods on the machine.
7. Only allow experienced personnel to sling loads and direct crane drivers. The person giving directions must remain in sight of the operator or at least be in spoken contact with him.
8. Attach the lifting tackle to the lugs and bore holes provided on the machine.
9. Make sure the lifting tackle is long enough.
10. Carefully lift the machine.
11. **CAUTION! Keep out from under the machine when it is raised.**
12. When restarting the machine, proceed strictly according to the **operating manual**.

## 2.19 Safe maintenance of hydraulic hoses and hose lines

1. Never attempt to repair hydraulic lines and hydraulic hoses.
2. All hoses, hose lines and threaded couplings must be checked regularly, at the very least once a year, for leaks and visible signs of damage.  
Replace damaged parts immediately. Oil escaping under pressure can cause injury and fires.
3. Even when properly stored and subjected to normal load, hoses and hose lines are subject to natural ageing. This limits their service life.
4. Improper storage, mechanical damage and excess strain are the main causes of damage.
5. Hose lines should not be used for longer than six years, including storage of no longer than two years (note the date of manufacture on the hoses).
6. Using the hoses close to their maximum strain can shorten their service life (e.g. high temperatures, frequent movement, extremely high impulse frequencies and multiple shift operation).
7. Hoses and hose lines must be replaced when inspections reveal the following.

### Criteria:

- Damage to the outer layer penetrating to the inner layer (e.g. abrasion, cuts and cracks)
- Embrittlement of the outer layer (cracks in the hose material)
- Deformation of the natural shape of the hose or the hose line, both when pressurised and depressurised, or at bends, e.g. layer separation, blistering
- Leaks
- Failure to observe installation requirements
- Damage or deformation of the hose fittings, which reduces the strength of the fittings or the connection between the fitting and the hose
- Slippage of the hose out of the fitting
- Corrosion of the fitting, impairing its function and strength
- Exceeded storage time or service life

8. Only use genuine spare parts to replace hoses and hose lines.
9. Lay and fit hoses and hose lines in the proper manner. Do not switch the connections.

## 2.20 Attachments and accessories

1. Attachments and accessories produced by third-party manufacturers or those which have not been generally approved by LIEBHERR for installation or for external fitting may not be installed or fitted on the machine without prior written consent from LIEBHERR.
2. The appropriate technical documentation should be made available to LIEBHERR for this purpose.
3. When adding or converting equipment or tyres, the stability of the machine must be tested and ensured in accordance with **EN 474**.  
See also the technical data section in chapter 1.

## 2.21 Protection against vibrations

1. The vibrations to which mobile construction machines are subjected are mainly due to the way they are used.  
  
The following parameters in particular have a great effect:
  - Terrain conditions: bumps and potholes.
  - Operating methods: speed, steering, braking, use of the controls while driving and while working.
2. The amount of vibration depends to a large extent on the machine operator, because he determines the speed, gear ratio, working methods and distance covered.  
This results in a wide range of different vibrations for the same type of machine.
3. The machine operator can reduce overall vibration by following these recommendations:

- Select a suitable machine, equipment and accessories for the job.
- Use a machine equipped with a suitable seat (i.e. for earthworking machines, a seat which complies with EN ISO 7096).
- Keep the seat in good condition and adjust it as follows:
  - Adjust the seat and its suspension according to the height and weight of the driver.
  - Regularly check the suspension and adjustment mechanisms of the seat and make sure the seat is kept in the condition specified by the manufacturer.
- Check the service condition of the machine, especially the tyre pressure, brakes, steering, mechanical connections etc.
- Do not steer, brake, accelerate, shift gears or load the working attachment of the machine suddenly.
- Adjust the speed of the machine to the distance to be driven in order to reduce vibrations.
  - Slow down when driving over difficult terrain.
  - Drive around obstacles and avoid difficult terrain.
- Keep the area on which the machine is operated in a tidy condition.
  - Remove any large rocks and obstacles.
  - Fill in any trenches or holes.
  - Have machines available to maintain good terrain and plan sufficient time to do so.
- Travel over longer distances (e.g. public roads) at a suitable (medium) speed.
- For machines which are often driven on open roads, use a special additional system (if available) to reduce vibrations during this type of use.

If such systems are not available, control your speed to stop the machine from shaking.

# 3 Operation, Handling

## 3.1 Layout of control elements

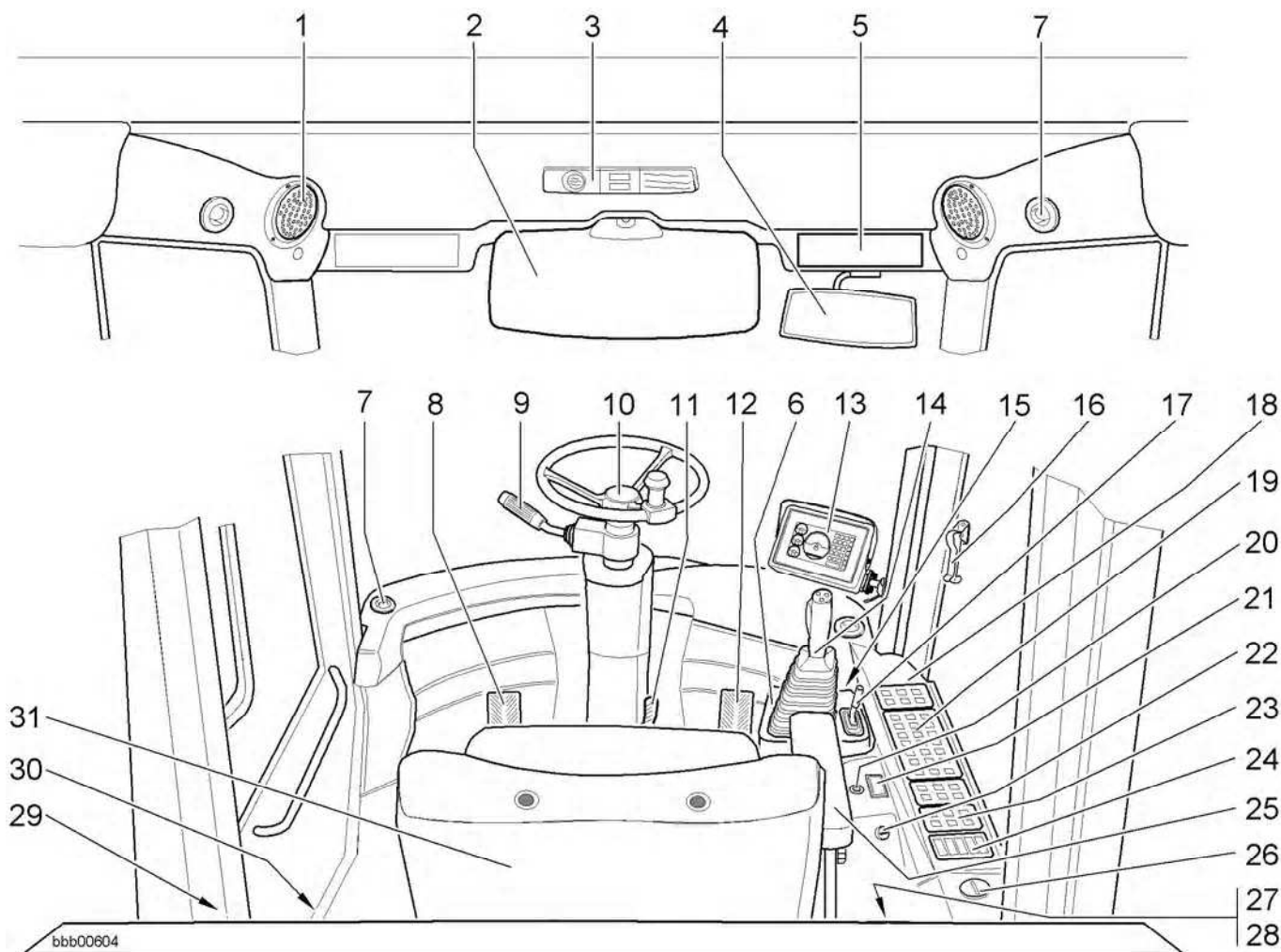

*Inside view of the driver's cab*

- |  |   |                          |
|--|---|--------------------------|
| 1 Radio speaker                                      | 11 Steering column adjustment lever                     | 21 Ashtray               |
| 2 Sun visor  | 12 Gas pedal  | 22 Ignition switch       |
| 3 Interior lighting                                  | 13 Display unit   | 23 Optional button       |
| 4 Interior mirror                                    | 14 LIEBHERR control lever                               | 24 Optional switch       |
| 5 Radio compartment                                  | 15 Panel adjustment pedal                               | 25 Adjustable arm rest   |
| 6 Control panel                                      | 16 Window opener lever                                  | 26 Mechanical hour meter |
| 7 Heater/ventilation/air-conditioning outlet nozzles | 17 Control lever fitting for optional working functions | 27 Diagnostic plug       |
| 8 Inch/brake pedal                                   | 18 Instrument panel                                     | 28 Emergency hammer      |
| 9 Steering column switch                             | 19 Control units  | 29 Glove compartment     |
| 10 Adjustable steering column with steering wheel    | 20 Cigarette lighter socket                             | 30 Fuse box              |
|  |   | 31 Driver's seat         |

LBH/03/003801/0003/15.06/en

## 3.2 Operation

### 3.2.1 Battery main switch

You must turn on the battery main switch before you can start the machine.

The battery main switch is located at the rear left of the engine compartment.

#### Turning on the battery main switch

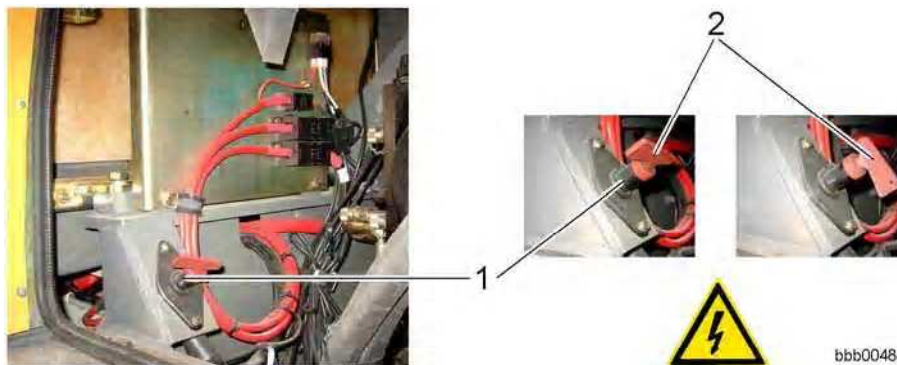

Battery main switch

1 Battery main switch

2 Main switch key

Before you enter the cab, make sure that:

- The battery main switch is turned on.

### 3.2.2 Cab access

Only get on and off the machine using the access aids provided.

Normally, the driver's cab must be entered and exited through the left-hand driver's cab door.

The right window is hinged.

Familiarise yourself with the emergency exit through the right window or the rear window. See the section on the emergency exit.

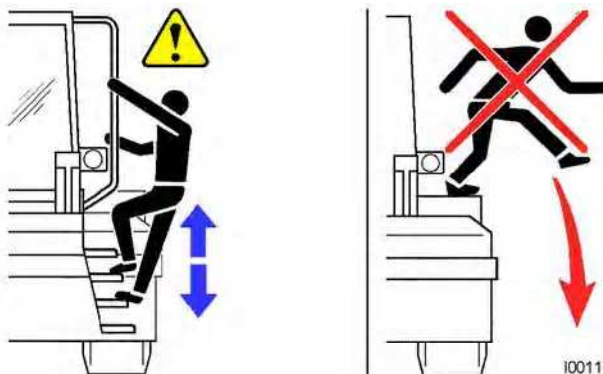

LBH/03/003801/0003/5.06/en



**Warning**

You risk injury if you jump or fall off the machine.

- ! Use the steps, ladders and handles provided for getting on and off.
- ! Never jump down from the machine.



**Warning**

You could be injured if the machine suddenly moves.

It is dangerous if the cab door is open and the engine is running.

- ! Do not hold onto the steering column, the control panel or the control levers when getting on or off.

**Entering the driver's cab**

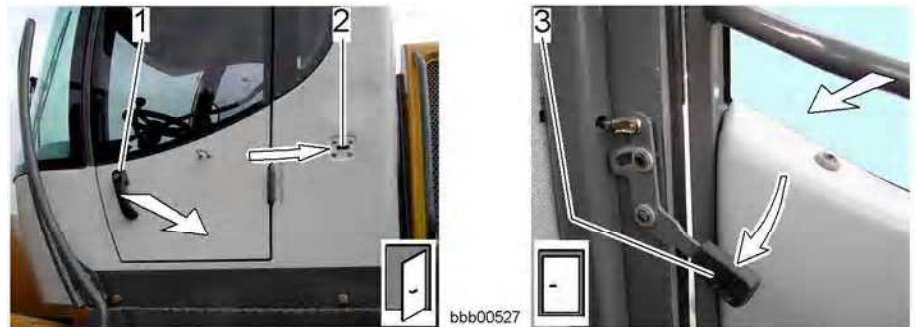

*Entering the cab*

- 1 Handle with lock
- 2 Door holder

- 3 Door holder lever

- Open the lock of the cab door with the ignition key.
- Open the cab door with the door handle 1 until it latches in the door holder 2.
- Enter the cab.
- Use the door holder lever 3 to lock and unlock the cab door.

**Leaving the driver's cab**



*Leaving the cab*

- 1 Door opener lever
- 2 Door holder

- 3 Door holder lever

- Open the cab door with the door opener lever 1 until it latches in the door holder 2.

LBH/03/003801/0003/15.06/en



- Leave the cab.
- Use the door holder lever **3** to lock and unlock the cab door.
- Lock the cab door with the ignition key.

### 3.2.3 Right hinged window

The right window is hinged.

#### Opening and closing the hinged window

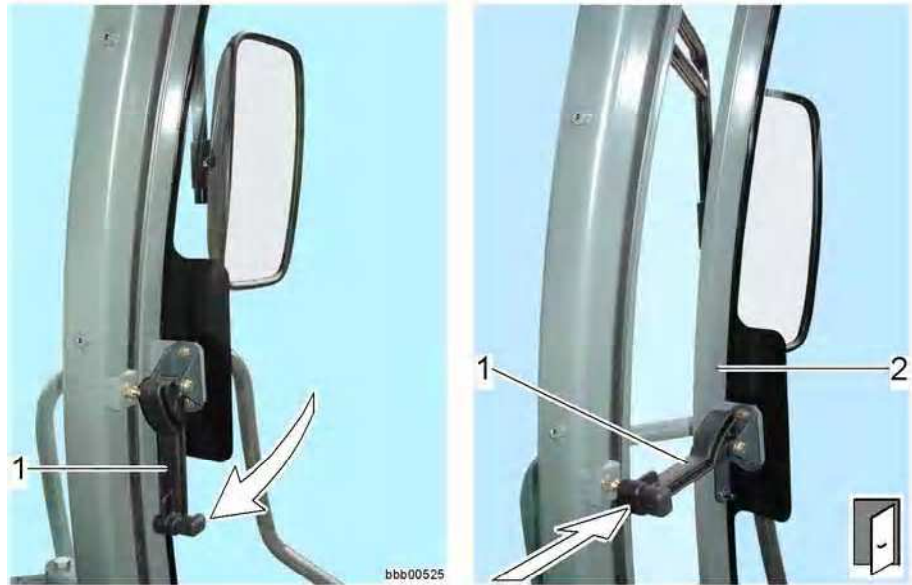

*Hinged window*

1 Window opener lever

2 Hinged window

- To open the window:  
Push up the lever 1.

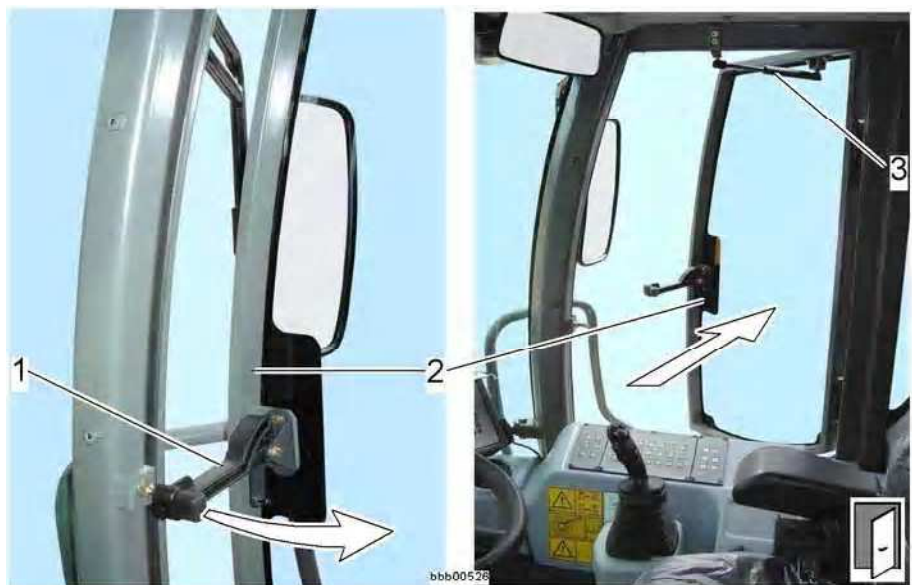

*Hinged window*

1 Window opener lever

2 Hinged window

LBH/03/003801/0003/5.06/en

### 3 Gas-filled springs

- Release the window opener lever **1** from the retaining pin.
- Let go of the window opener lever

The gas-filled spring **3** opens the window.

- To close the window:  
Use the window opener lever **1** to close the window.
- Move the window opener lever **1** over the retaining pin.
- Pull the window opener lever until the window is closed.
- To lock the window:  
Push up the window opener lever **1** down.



### 3.2.4 Emergency exit

The right window and the rear window are designed as emergency exits and therefore should only be used in this event.

Before starting the machine, make sure there is an emergency hammer in the cab.

### Using the emergency hammer



bbb00237

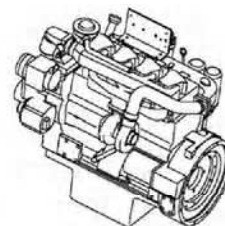

Switching off the engine



#### Warning

There is a risk of accidents if you leave the engine running. If you leave the cab by the emergency exit with the engine running, it increases the risk of accidents for the driver and any auxiliary staff because the travel and working functions may be activated unintentionally.  
! Deactivate the driving and working functions.

- Turn off the engine.  
All functions are switched off.



bbb00677

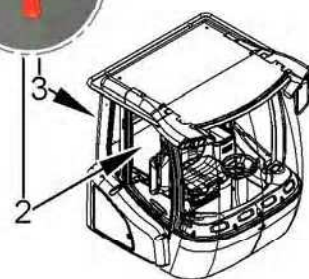

1 Emergency hammer  
2 Hinged window

3 Rear windscreen



#### Note

Using the emergency hammer. If you need to make an emergency exit:  
! Break the window with the emergency hammer.



bbb00654

- Break the right window or the rear window, depending on the situation.
- Leave the cab through the broken window.

### 3.2.5 Driver's seat with mechanical suspension

The ergonomically designed driver's seat offers a high degree of comfort. The adjustable seat surface, back rest, suspension and arm rest mean that the driver can adjust the seat for maximum individual comfort.

#### Shock absorption:

The seat installed in the machine complies with ISO 7096.

When the machine is used correctly, the vibrations transmitted by the driver's seat are less than or equal to the vibrations simulated in test conditions for the corresponding machine class in accordance with ISO 7096 class EM3.

The vibration acceleration values ( $a_{zw}$ ), measured in accordance with ISO 2631, Part 1, thus meet the standards for protection against overall body vibrations in EN 474-1.

#### Layout

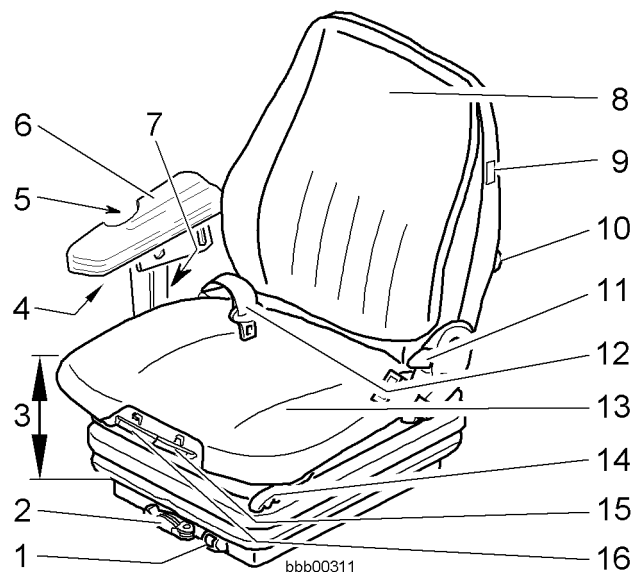

Main components and adjustable elements of the driver's seat

- |   |  |
|---|--|
| 1 Weight display                                    | 9 Seat heating switch (optional)             |
| 2 Weight adjustment                                 | 10 Lumbar support knob                       |
| 3 Height adjustment                                 | 11 Back rest adjustment lever                |
| 4 Locking screw for arm rest horizontal adjustment  | 12 Seat belt                                 |
| 5 Locking screw for arm rest inclination adjustment | 13 Seat surface                              |
| 6 Arm rest  | 14 Driver's seat horizontal adjustment lever |
| 7 Locking screw for arm rest height adjustment      | 15 Seat surface inclination adjustment lever |
| 8 Back rest   | 16 Seat surface horizontal adjustment lever  |

#### Adjusting the driver's seat

The seat can be adjusted to the driver's individual requirements to provide the highest possible degree of comfort.

LBH/03/003801/0003/5.06/en

## Adjusting the driver's seat for driving on roads



### Warning

There is a risk of injuries if the driver's seat is not properly adjusted.

! When driving on public roads, the driver's seat may only be adjusted when the machine is at a standstill.

- Adjust the driver's seat before starting the machine.

### Adjusting the driver's seat horizontally

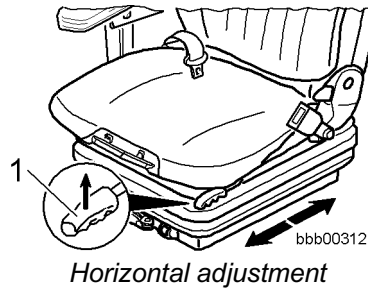

Adjust backward or forward:

- Using the lever 1.
- Pull the lever 1 in the direction of the arrow.
- Adjust the driver's seat horizontally.
- Let go of the lever.

### Adjusting the driver's seat surface horizontally

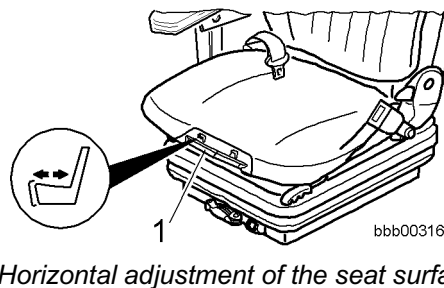

Adjust backward or forward:

- Using the lever 1.
- Push up the lever 1.
- Adjust the surface of the driver's seat horizontally.
- Let go of the lever.

## Adjusting the inclination of the seat surface

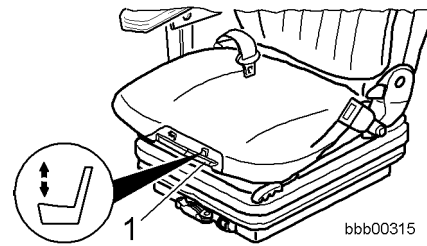

*Adjusting the inclination of the seat surface*

Adjust up or down:

- Using the lever 1.
- Push up the lever 1.
- Adjust the seat surface of the driver's seat up or down.
- Let go of the lever.

## Adjusting the seat suspension

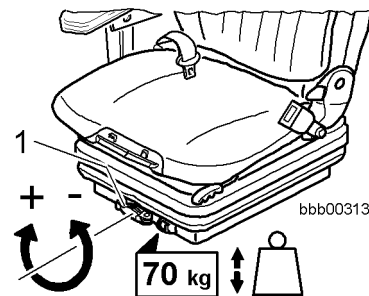

*Weight adjustment*

The seat suspension can be adjusted to the driver's individual body weight.

- Set the body weight using the knob 1.

The setting is shown beside the knob.

## Adjusting the seat height

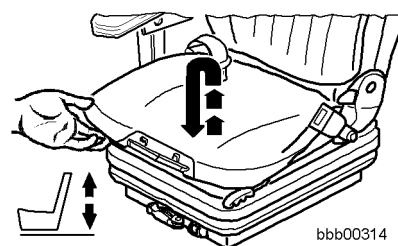

*Seat height adjustment*

Adjust the seat height by lifting up the seat with your hand.

The height can be adjusted to several levels.

- Lift up the seat as necessary until you hear it catch.
- Lift the driver's seat above the final level (limit stop):  
The driver's seat sinks to the lowest position.

### Adjusting the back rest

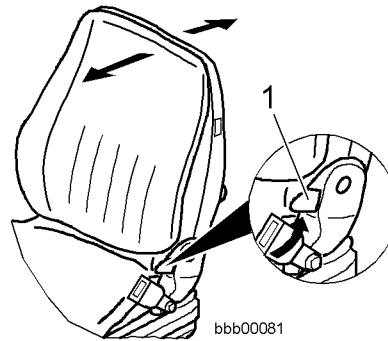

*Inclination of the back rest*

The back rest can be adjusted:

- Using the lever 1.
- Raise the lever 1.
- Move the back rest to the angle required.
- Let go of the lever.

### Adjusting the lumbar support

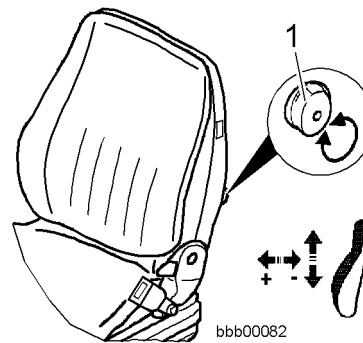

*Lumbar support*

The lumbar support improves seat comfort.

- Turn the hand wheel 1 to the left or right:  
This adjusts the height and size of the bulge in the back upholstery.

## Adjusting the arm rest

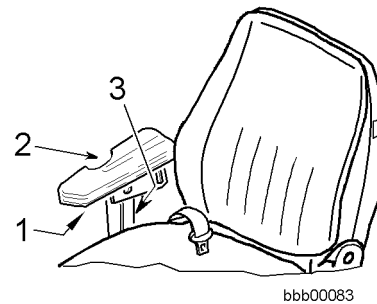

*Arm rest adjustment*

The height, inclination and horizontal position of the arm rests can be adjusted.

- Height adjustment:  
Loosen the clamp screw **3**, adjust the height and lock it in place.
- Inclination adjustment:  
Loosen the clamp screw **2**, adjust the inclination and lock it in place.
- Horizontal adjustment:  
Loosen the clamp screw **1**, adjust the arm rest horizontally and lock it in place.

### 3.2.6 Driver's seat with pneumatic suspension

This equipment is optional.

The ergonomically designed driver's seat offers a high degree of comfort. The adjustable seat surface, back rest, suspension and arm rest mean that the driver can adjust the seat for maximum individual comfort.

#### **Shock absorption:**

The seat installed in the machine complies with ISO 7096.

When the machine is used correctly, the vibrations transmitted by the driver's seat are less than or equal to the vibrations simulated in test conditions for the corresponding machine class in accordance with ISO 7096 class EM3.

The vibration acceleration values ( $a_{zw}$ ), measured in accordance with ISO 2631, Part 1, thus meet the standards for protection against overall body vibrations in EN 474-1.



### Layout

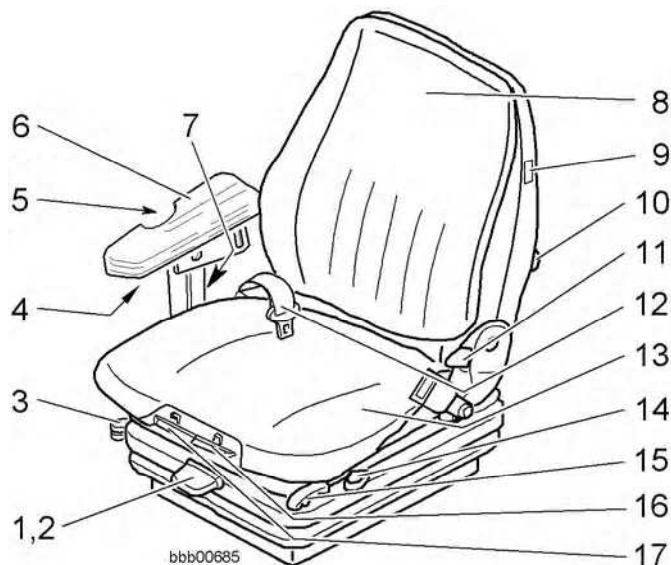

*Main components and adjustable elements of the driver's seat*

- |   |  |
|---|--|
| 1 Weight adjustment                                 | 10 Lumbar support knob                       |
| 2 Height adjustment                                 | 11 Back rest adjustment lever                |
| 3 Shock absorber lever                              | 12 Seat belt                                 |
| 4 Locking screw for arm rest horizontal adjustment  | 13 Seat surface                              |
| 5 Locking screw for arm rest inclination adjustment | 14 Lever for horizontal suspension           |
| 6 Arm rest  | 15 Lever for horizontal adjustment           |
| 7 Locking screw for arm rest height adjustment      | 16 Seat surface inclination adjustment lever |
| 8 Back rest   | 17 Seat surface horizontal adjustment lever  |
| 9 Seat heating switch (optional)                    |  |

### Adjusting the driver's seat

The seat can be adjusted to the driver's individual requirements to provide the highest possible degree of comfort.

### Adjusting the driver's seat for driving on roads



#### **Warning**

There is a risk of injuries if the driver's seat is not properly adjusted.

! When driving on public roads, the driver's seat may only be adjusted when the machine is at a standstill.

- Adjust the driver's seat before starting the machine.

### Adjusting the driver's seat horizontally

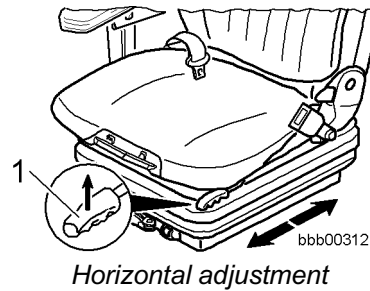

Adjust backward or forward:

- Using the lever 1.
- Pull the lever 1 in the direction of the arrow.
- Adjust the driver's seat horizontally.
- Let go of the lever.

### Adjusting the driver's seat surface horizontally

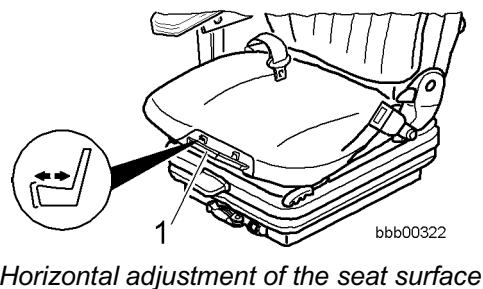

Adjust backward or forward:

- Using the lever 1.
- Push up the lever 1.
- Adjust the surface of the driver's seat horizontally.
- Let go of the lever.

### Adjusting the inclination of the seat surface

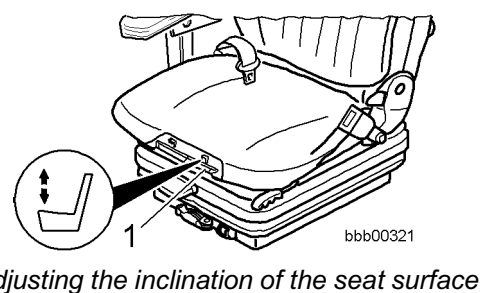

Adjust up or down:

- Using the lever 1.
- Push up the lever 1.
- Adjust the seat surface of the driver's seat up or down.
- Let go of the lever.

### Activating and deactivating horizontal suspension on the driver's seat

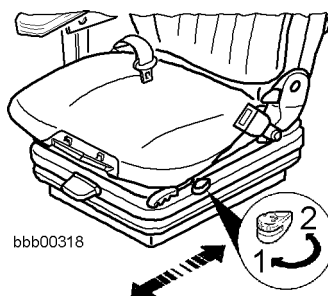

Horizontal suspension

Under certain conditions you can increase comfort by activating the horizontal suspension.

**Advantage:** The driver's seat can better absorb shocks in the direction of travel.

- Position 1 = on
- Position 2 = off

### Adjusting the seat suspension

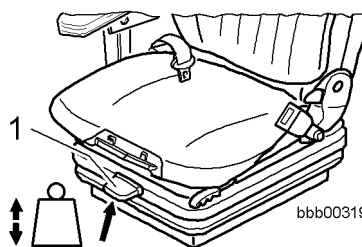

Weight adjustment

The seat suspension can be adjusted to the driver's individual body weight.



**Note**

For adjustment:

! The driver must be sitting in the normal position.

- Set the body weight by briefly pulling the lever 1.

### Adjusting the driver's seat shock absorber

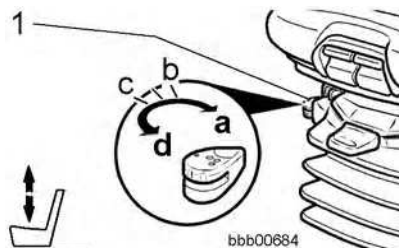

Adjusting the vertical absorber

Adjust the shock absorber individually to the track or terrain.

**Note**

For adjustment:

! The driver must be sitting in the normal position.

- Turn the lever **1** to the required position and let go.

Lever positions and adjustment:

- **a** = soft
- **b, c** = medium
- **d** = hard

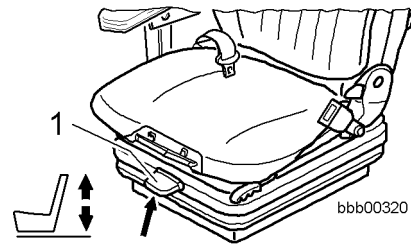
**Adjusting the seat height**

*Seat height adjustment*

The seat height can be continuously adjusted using air springs.

- Push or pull the lever **1** as far as it will go.

When it reaches the top or bottom limit, the height is adjusted automatically.

The minimum required suspension is ensured.

**Caution**

To avoid damage:

! Do not actuate the compressor for more than 1 minute.

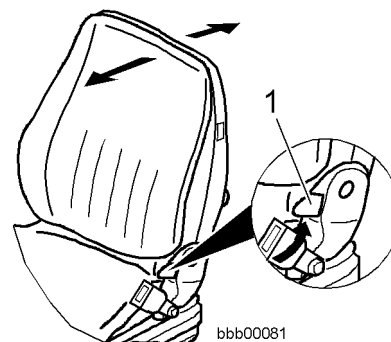
**Adjusting the back rest**

*Inclination of the back rest*

The back rest can be adjusted:

- Using the lever **1**.
- Raise the lever **1**.
- Move the back rest to the angle required.
- Let go of the lever.

### Adjusting the lumbar support

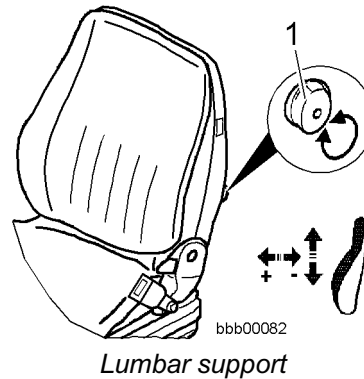

*Lumbar support*

The lumbar support improves seat comfort.

- Turn the hand wheel **1** to the left or right:  
This adjusts the height and size of the bulge in the back upholstery.

### Adjusting the arm rest

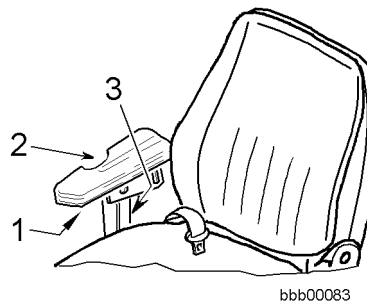

*Arm rest adjustment*

The height, inclination and horizontal position of the arm rests can be adjusted.

- Height adjustment:  
Loosen the clamp screw **3**, adjust the height and lock it in place.
- Inclination adjustment:  
Loosen the clamp screw **2**, adjust the inclination and lock it in place.
- Horizontal adjustment:  
Loosen the clamp screw **1**, adjust the arm rest horizontally and lock it in place.

### 3.2.7 Seat belt

#### Safety aspects of the seat belt

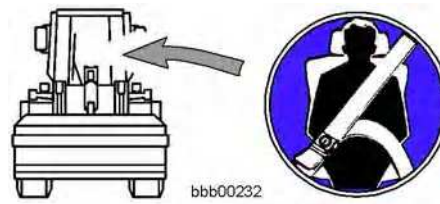

bbb00232

*Always wear a seat belt*

The driver's cab is equipped with roll-over protection (**ROPS**).

**The ROPS roll-over protection system can only protect the driver if the seat belt has been fastened.**

This section describes the safety considerations for wearing the seat belt.



#### Danger

There is a risk of injuries if the seat belt is not fastened.

If the machine tips or rolls over, the driver could suffer fatal injuries if he is not wearing a seat belt.

If the machine is braked or stops abruptly, the driver may suffer severe injuries if he is not wearing a seat belt.

! It is essential that you fasten your seat belt before starting up the machine.

- To guarantee your safety, regularly check the condition, function and fastening of the seat belt.
- Immediately replace damaged parts.
- Do not twist the seat belt.

#### Fastening the seat belt

The seat belt is an automatic belt.

You do not need to adjust the belt length.

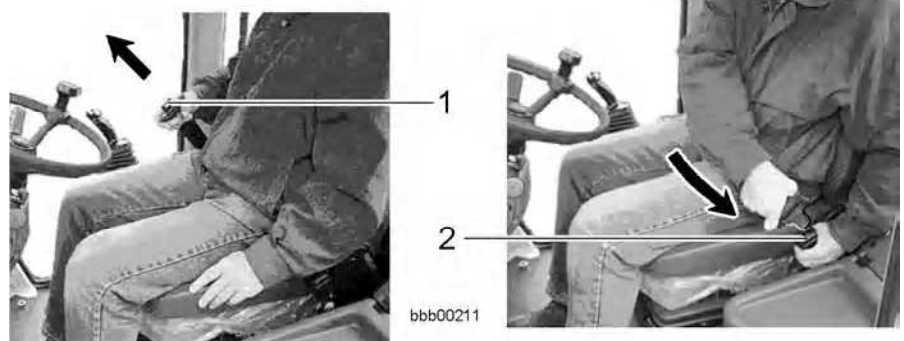

bbb00211

*Fastening the seat belt*

- Pull the belt buckle **1** over your body at hip level and plug it into the snap lock **2**.



**Note**

The roller may lock if you pull out the belt suddenly.  
 ! Pull the belt smoothly out of the roller.

- Check that the snap lock is engaged by pulling the clasps.

**Releasing the seat belt**

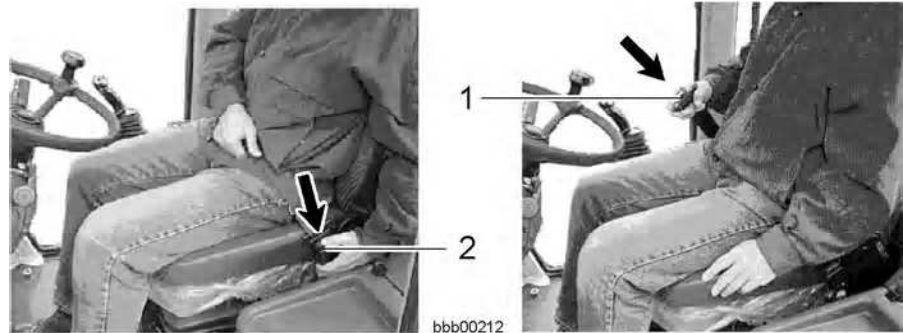

*Releasing the seat belt*

- Push down the lock button on the snap lock 2.
- Let the belt buckle 1 slowly wind up the roller.

**3.2.8 Steering column and steering wheel**

**Layout**

The steering column with the steering wheel and steering column switch is integrated in the steering console.

**Adjusting the steering column**

The steering wheel can be adjusted to suit the driver by adjusting the steering column.

The steering wheel can be adjusted progressively.



**Warning**

There is a risk of injuries if the steering column is not properly adjusted.

! Never adjust the steering column when the vehicle is moving.

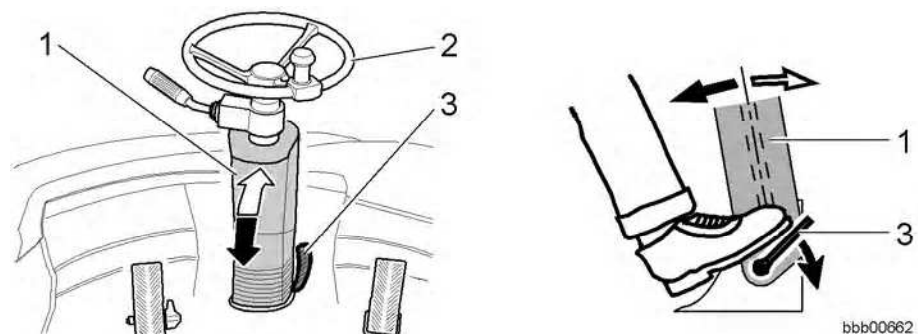

*Adjusting the steering column*

1 Steering column

2 Steering wheel

LBH/03/003801/0003/5.06/en

3 Lever

- Press down the lever **3** with your foot in the direction of the arrow.
- Pull or push the steering wheel **2** to adjust the steering column **1** as required.
- Release the lever **3** to lock the steering column **1** in the selected position.

**3.2.9 Control panel**

The control panel is mounted on the cab floor to the right of the driver's seat.

The control panel can be adjusted to suit the seat position and arm length of the driver.

Adjusting the position of the control panel provides maximum comfort - and therefore safety - for the driver.

**Adjusting the control panel to the seat position and arm length of the driver**



Control panel

1 Control panel

2 Pedal



**Warning**

The working attachment can cause accidents if it is accidentally actuated.

! Only adjust the control panel when the vehicle is not moving.

! Set down the attachment flat on the ground.

- Push the pedal **2**.

The control panel moves back.

- Adjust the control panel **1**.

- Release the pedal **2**.

The control panel is fixed.

LBH/03/003801/0003/5.06/en



### 3.2.10 Ignition switch



Ignition switch position

bbb00678

#### 1 Ignition switch

The ignition switch is equipped with a repeat start lock.

The ignition key can be removed when it is in the 0 position with the engine switched off.

When the ignition key is in the 0 position or parking position, the following units on the instrument panel can be switched on:

- Hazard warning system
- Interior lighting
- With the ignition key in the parking position
- Working floodlight
- Flashing beacon (optional)
- Radio (optional)

#### Layout

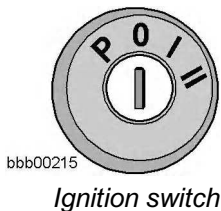

bbb00215

Ignition switch

Switch positions:

P – Parking position

0 – 0 position / engine off

I – Contact, operating and preglow position

II – Starting position

#### Switching the electrical system on and off

Make sure that the battery main switch is on.

- Switch the electrical system on or off with the ignition key.



bpik0024

### 3.2.11 Electronic immobiliser

This equipment is optional.

The electronic immobiliser is automatically activated.

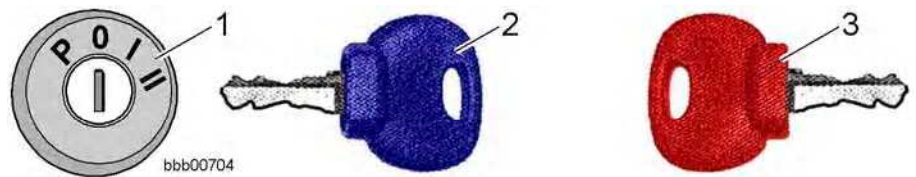

*Electronic immobiliser*

The electronic immobiliser includes:

- A starter switch **1** and antenna
- An electronic controller
- At least one mechanical key **2** (blue grip) with tag
- One electronic master key **3** (red grip).



#### Note

Always keep the master key separately for reasons of security.

The master key is only used for programming tag keys.

! Only start the machine with a programmed key.

See the manufacturer's operating manual for a detailed description.

### Deactivating the electronic immobiliser



#### Note

Only start the machine with a programmed key.

Otherwise the security function will be activated.

If more than five keys with different codes are used in the ignition lock in the space of one minute, the immobiliser is activated for 15 minutes.

The immobiliser will not even accept valid keys during this time.

! See the manufacturer's operating manual for a detailed description.

- Switch on the electrical system using the ignition key **2** (blue).
- Start the machine as necessary.  
See the section on starting the engine.

### Activating the electronic immobiliser

The electronic immobiliser is activated automatically after 5 seconds in the following cases:

- The ignition key is in the 0 position / engine off
- The ignition key is removed



#### Note

The immobiliser is activated and remains active if the key is left in the 0 position.

! See the manufacturer's operating manual for a detailed description.

- Take out the ignition key.

## Further information on the electronic immobiliser



**Note**

This section only contains brief summaries of the following topics.  
! See the manufacturer's operating manual for a detailed description.

### Programming new keys

New keys are programmed using the master key.



**Note**

There is only one master key for each immobiliser.  
The immobiliser cannot be activated using the master key.  
! See the manufacturer's operating manual for a detailed description of the programming procedure.

### Deleting programmed keys

Programmed keys need to be deleted if they are lost.



**Note**

The deletion procedure deletes all programmed keys.  
After deletion, you can reprogram all the keys again.  
! See the manufacturer's operating manual for a detailed description of the deletion procedure.

## Security functions



**Note**

If more than five keys with different codes are used in the ignition lock in the space of one minute, the immobiliser is activated for 15 minutes.  
The immobiliser will not even accept valid keys during this time.  
! See the manufacturer's operating manual for a detailed description.

## Tamper protection



**Note**

The immobiliser cannot be deactivated by tampering with it.  
! See the manufacturer's operating manual for a detailed description.

## Troubleshooting

Simple description of problems and how to solve them:

Cause:	Remedy:
Immobiliser does not work	– Use a programmed key
Keys cannot be programmed.	– No master key or wrong master key used previously – Master key left in ignition too long or not long enough – The key has no tag

LBH/03/003801/0003/5.06/en

Cause:	Remedy:
	<ul style="list-style-type: none"> <li>– Key not long enough in ignition for programming</li> </ul>
Programmed keys cannot be deleted	<ul style="list-style-type: none"> <li>– No master key or wrong master key used</li> <li>– Master key not long enough in ignition</li> </ul>

- See the manufacturer's operating manual for a detailed description.

**Troubleshooting**

If you are unable to solve the problem as described above, it must have a different cause.

- Contact LIEBHERR CUSTOMER SERVICE.

**3.2.12 Steering column switch**

The steering column switch is mounted on the steering column.

**Layout**

The steering columns switch consists of the following controls:

- Travel direction indicators
- High beam
- Horn and headlight flasher
- Front windscreen wiper
- Front windshield wiper and washer system

LBH/03/003801/0003/15.06/en

**Function description**

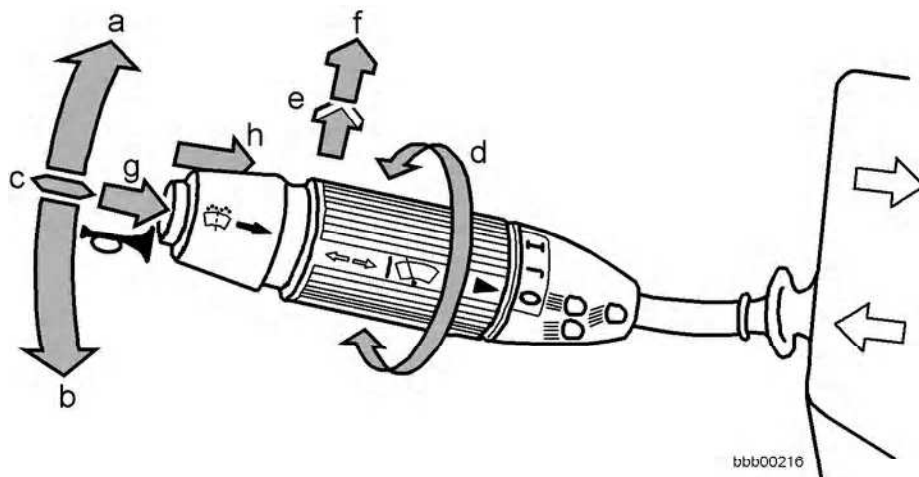

Steering column switch

Functions of the steering column switch when activated in each direction:

- a – Direction display: right indicators
- b – Direction display: left indicators
- c – Centre position: neutral position
- d – Windscreen wiper: front windscreen
  - 0 – Level 0
  - J – Interval
  - I – Level I
- e – Visual warning indicator: headlight flasher
- f – High beam: driving light
- g – Audible warning indicator: horn
- h – Windscreen wiper and washer system: front windscreen

**3.2.13 Lighting**



Make sure that the electrical system is switched on.



**Switching off the parking light / driving light**

- Press the button once.  
The parking light lights up.  
The LED on the left lights up.
- Press the button again.  
The driving light lights up.  
The LEDs on the left and right light up.
- To switch off the parking light and driving light, press the button a third time.

All functions are switched off.  
The LEDs on the button go out.  
See also the section on control units.

LBH/03/003801/0003/5.06/en

**Caution**

Risk of damage to the battery

If the battery is in a discharged condition over a long period of time (e.g. longer than one month), the battery can no longer be recharged.

! Avoid discharging the battery accidentally.

- When you leave the driver's cab:  
Make sure that you have not left the parking / driving light on.

**Switching on high beam**

Make sure that the driving light is switched on.

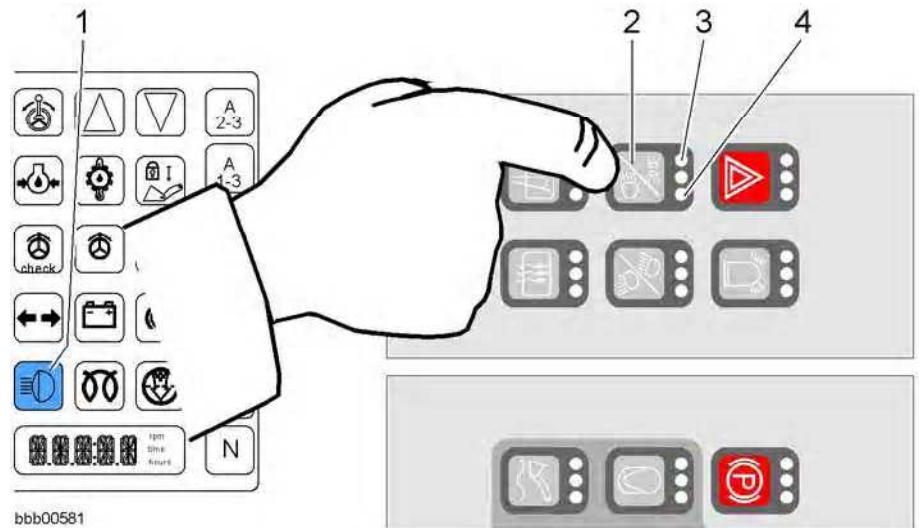

bbb00581

Control unit

- 1 High beam symbol field
- 2 Parking light/driving light button
- 3 Parking light LED
- 4 Driving light LED



bbb00541

- Press the button 2 for the parking light/driving light twice.

The LEDs 3 and 4 light up.

See also the section on control units.

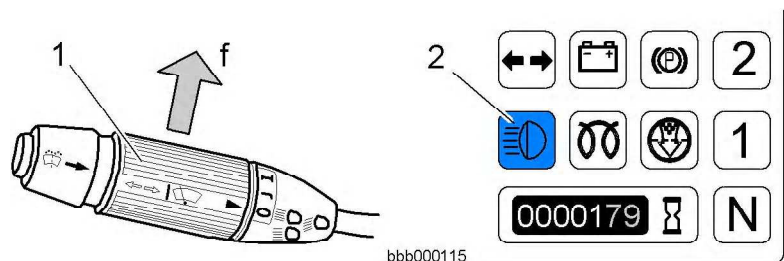

bbb000115

Steering column switch and display unit

- 1 Steering column switch
- 2 High beam symbol field

- Push the steering column switch 1 in direction f.

The symbol field 2 for high beam lights up.

High beam is activated.

LBH/03/003801/0003/5.06/en

### Switching off high beam

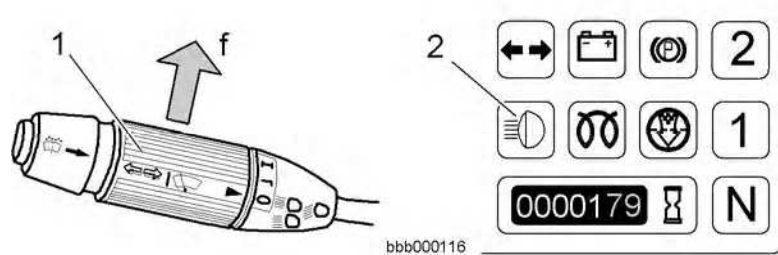

Steering column switch and display unit

1 Steering column switch

2 High beam symbol field

- To switch back to low beam, push the steering column switch **1** in direction **f**.

The symbol field **2** for high beam goes out.

The driving light lights up.

### Front working floodlights

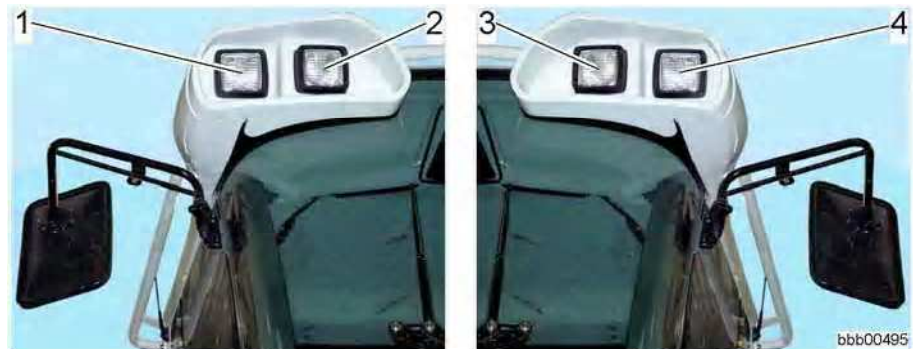

1 Front right working floodlight  
2 Front right working floodlight

3 Front left working floodlight  
4 Front left working floodlight

The front working floodlights **1** and **4** are also available as XENON versions.

- To switch on the front working floodlights:**

Press the working floodlight button once.

The LED on the left **1** lights up.

See also the section on control units.

- To switch off the front working floodlights:**

Press the working floodlight button a fourth time.

No LEDs on the button light up.

See also the section on control units.



bbb00659

### Rear lighting

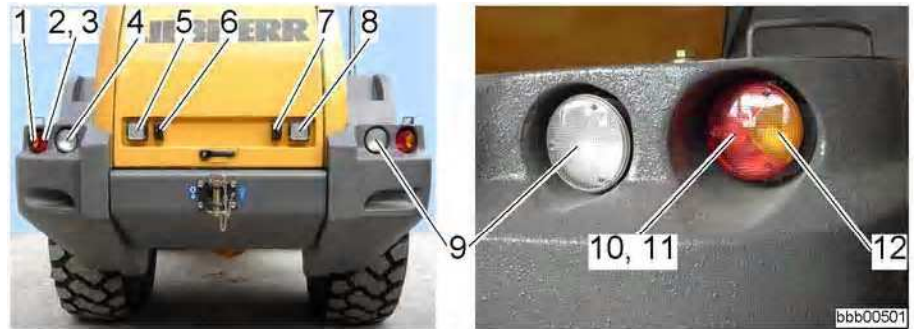

Rear lighting

- |                           |                            |
|---------------------------|----------------------------|
| 1 Left flashing light     | 7 Right number plate light |
| 2 Left brake light        | 8 Right working floodlight |
| 3 Left tail light         | 9 Right reversing light    |
| 4 Left reversing light    | 10 Right brake light       |
| 5 Left working floodlight | 11 Right tail light        |
| 6 Left number plate light | 12 Right flashing light    |

- The reversing lights **4** and **9** automatically light up when the machine is reversing.

### Rear working floodlights

The top rear working floodlights **2** and **3** are optional.

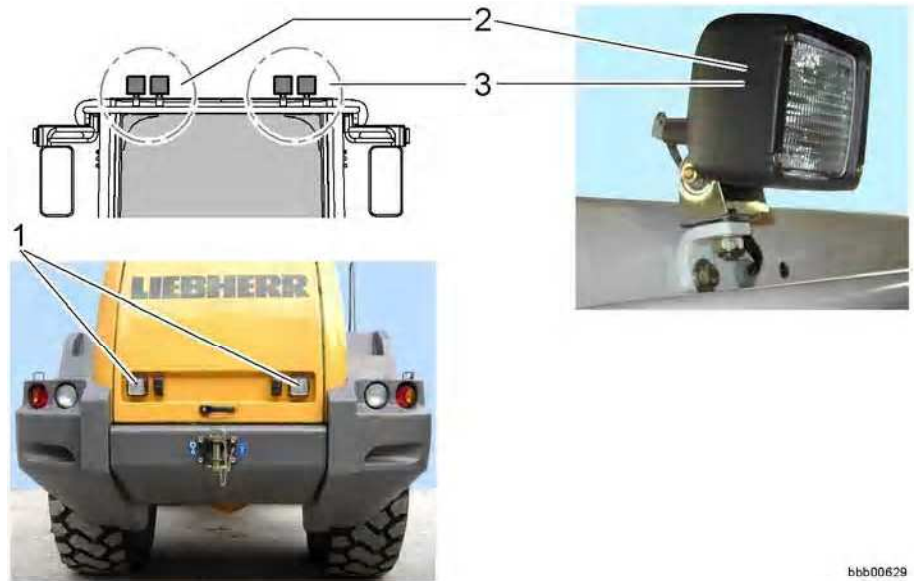

- |                               |                                |
|-------------------------------|--------------------------------|
| 1 Rear working floodlights    | 3 Top right working floodlight |
| 2 Top left working floodlight |                                |



- **To switch on the rear working floodlights:**  
Press the working floodlight button a third time.  
The right LED **2** on the button lights up.  
See also the section on control units.
- **To switch off the rear working floodlights:**  
Press the working floodlight button a fourth time.  
No LEDs on the button light up.  
See also the section on control units.

LBH/03/003801/0003/5.06/en



### Flashing beacon

This equipment is optional.

Functions:

- Also works when the ignition key is in the 0 position or parking position.

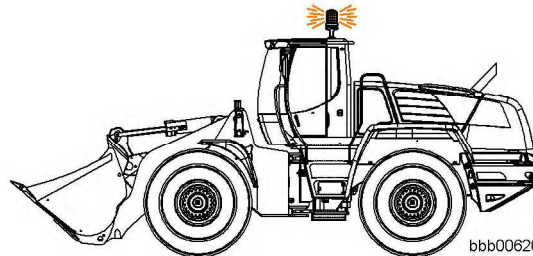

bbb00620



bbb00546

- To switch the flashing beacon on and off:  
Press the flashing beacon button.
- Function on – all three LEDs on the button light up.
- Function off – all three LEDs on the button go out.

See also the section on control units.

### 3.2.14 Interior cab lighting

The interior lighting is mounted centrally in the top of the cab.

#### Switching the interior lighting on and off

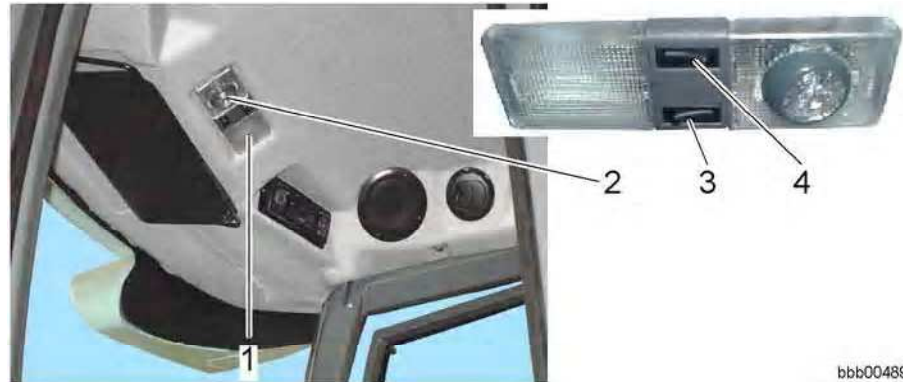

bbb00489

Interior lighting

- |                     |                            |
|---------------------|----------------------------|
| 1 Interior lighting | 3 Interior lighting switch |
| 2 Reading lamp      | 4 Reading lamp switch      |

- To switch the interior lighting **1** on or off, press the switch **3**.
- To switch the reading lamp **2** on or off, press the switch **4**.
- Set the beam of the reading lamp **2** as required by turning the reading lamp.

### 3.2.15 Display unit

The layout and function of the display unit are described in this section.

#### Layout



Display unit

- |                        |                  |
|------------------------|------------------|
| 1 Instrument panel     | 4 Visor          |
| 2 Display unit         | 5 Swivel console |
| 3 Display (symbol LCD) |                  |

The display unit is mounted on the front right on the frame. You can adjust the position of the display unit using the swivel console. It consists of the display (symbol LCD) and the backlighting. Each symbol field is either red, yellow, green or blue.

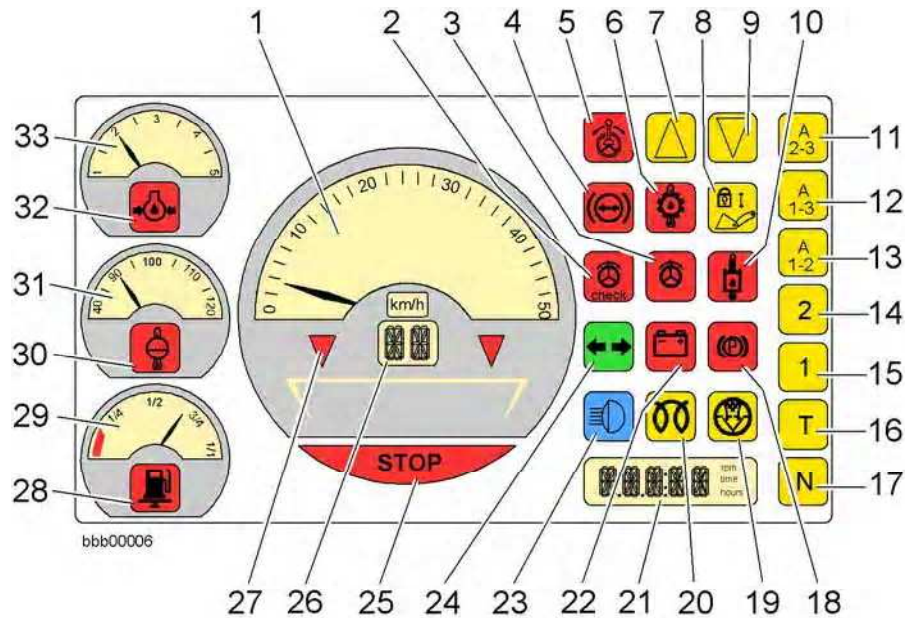

Display unit

- |   |  |
|---|--|
| 1 Travel speed display                  | 4 Brake system accumulator pressure symbol field |
| 2 Emergency steering check symbol field | 5 Joystick steering symbol field                 |
| 3 Emergency steering symbol field       | 6 Gear oil overheating symbol field              |

LBH/03/003801/0003/5.06/en

- |  |  |
|--|--|
| 7 Forward travel direction symbol field    | 20 Preglow monitor symbol field  |
| 8 Working hydraulics lockout symbol field  | 21 Segment display for engine speed, time, operating hours segment and service codes |
| 9 Reverse travel direction symbol field    | 22 Battery charge (charge control) symbol field                                      |
| 10 Hydraulic oil overheating symbol field  | 23 High beam symbol field  |
| 11 Automatic travel range 2-3 symbol field | 24 Direction indicator system symbol field   |
| 12 Automatic travel range 1-3 symbol field | 25 Stop symbol field   |
| 13 Automatic travel range 1-2 symbol field | 26 Selected gear and tractive force control display                                  |
| 14 Fixed gear 2 symbol field               | 27 Overspeed protection display  |
| 15 Fixed gear 1 symbol field               | 28 Fuel supply symbol field  |
| 16 Tempomat T Vmax symbol field            | 29 Fuel supply display   |
| 17 Neutral position N symbol field         | 30 Engine overheating and coolant level symbol field                                 |
| 18 Parking brake symbol field              | 31 Coolant temperature display   |
| 19 Air filter contamination symbol field   | 32 Engine oil pressure symbol field  |
|  | 33 Engine oil pressure display   |

**Function description**

**Travel speed display**

Travel speed display

Display function:

- Shows the machine's travel speed.

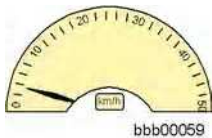

bbb00059

Segment display



04ml13ab

**Emergency steering check indicator**

Emergency steering check symbol field

Symbol field colour – red

The symbol field:

- Lights up briefly after the engine is started.
- Goes out once the check has successfully taken place.
- Does not go out if the emergency steering check is not successful.



bbb00016

If the emergency steering check is not successful:

- The stop symbol field also lights up.
- The machine must be shut down.
- The cause of the fault must be analysed and corrected immediately. See also the malfunctions described in chapter 4.



04ml14ab

### Emergency steering indicator

Emergency steering symbol field

Symbol field colour – red

Warning functions – the symbol field lights up:

- If the engine shuts down while the machine is moving
- If the steering pump fails

In both cases the emergency steering pump is activated for approximately 40 seconds.



bpik0006

bbb00016

The warning function of the symbol field is accompanied:

- Audibly, by a continuous tone

- Visibly, by the stop symbol field lighting up

The cause of the fault must be analysed and corrected immediately.

See also the malfunctions described in chapter 4.

The emergency steering symbol field remains lit:

- If the emergency steering button to start the emergency steering pump has been pressed.

The maximum duration of the emergency steering function is 10 seconds.

See also the sections on the control unit and emergency operation.



bbb00015

### Brake system accumulator pressure indicator

Brake system accumulator pressure symbol field

Symbol field colour – red

Lights up when the brake accumulator pressure is too low.

Warning sequence:

- When a warning is received, the symbol field lights up.
- The warning function of the symbol field is accompanied after 2 minutes by a continuous tone.



bbb00020

### Joystick steering indicator

Joystick steering symbol field

Symbol field colour – red

Lights up during operation of the machine with optional joystick steering.



04ml18ab

### Gear oil overheating indicator

Gear oil overheating symbol field

Symbol field colour – red

Lights up when the gear oil temperature is too high.



bbb00017

### Forward travel direction indicator

Forward travel direction symbol field

Symbol field colour – yellow

Displays that the selected travel direction of the machine is forwards.

Flashes when the ignition key is in position **I** or **II**:

If the travel direction switch is set to forward.

Flashes when the ignition key is in position **II**:

When the parking brake button has been pressed.



bpik0006

The flashing symbol field is accompanied by a warning beep.



bbb00010

### Working hydraulics lockout indicator

Working hydraulics lockout symbol field

Symbol field colour – yellow

Lights up when the working hydraulics lockout is activated.



bbb00018

### Reverse travel direction indicator

Reverse travel direction symbol field

Symbol field colour – yellow

Displays that the selected travel direction of the machine is reverse.

Flashes when the ignition key is in position **I** or **II**:

If the travel direction switch is already or is still set to reverse.

Flashes when the ignition key is in position **II**:

When the parking brake button has been pressed.



bpik0006

The flashing symbol field is accompanied by a warning beep.



04ml11ab

### Hydraulic oil overheating indicator

Hydraulic oil overheating symbol field

Symbol field colour – red

Lights up when the hydraulic oil temperature is too high.

Warning sequence:

- When a warning is received, above a hydraulic oil temperature of 95 °C the symbol field first lights up.  
Above 95 °C the service code **E 2013** appears in the display.
- The warning function of the symbol field is accompanied by a tone sounding at intervals.



bpik0012

Audible warning:

- When the hydraulic oil temperature exceeds 95 °C  
Tone sequence: 1 second tone followed by 10 seconds pause.



bbb00021

### Travel range 2-3 indicator

Travel range 2-3 symbol field

Symbol field colour – yellow

Displays that the selected travel range is 2-3.



bbb00022

**Travel range 1-3 indicator**

Travel range 1-3 symbol field  
 Symbol field colour – yellow  
 Displays that the selected travel range is 1-3.



bbb00023

**Travel range 1-2 indicator**

Travel range 1-2 symbol field  
 Symbol field colour – yellow  
 Displays that the selected travel range is 1-2.



bbb00024

**Fixed gear 2 indicator**

Travel range 2 symbol field  
 Symbol field colour – yellow  
 Displays that the selected travel range of the machine is 2.



bbb00025

**Fixed gear 1 indicator**

Travel range 1 symbol field  
 Symbol field colour – yellow  
 Displays that the selected travel range of the machine is 1.



bbb00026

**Tempomat T Vmax indicator**

Tempomat T Vmax symbol field  
 Symbol field colour – yellow  
 The machine keeps to the travel speed at the time the function is activated.



bbb00027

**Neutral position N indicator**

Neutral position N symbol field  
 Symbol field colour – yellow  
 The travel drive is switched to neutral.

Flashes when the ignition key is in position **I** or **II**:  
 If the travel direction switch is set to forward or reverse.

Flashes when the ignition key is in position **II**:  
 When the parking brake button has been pressed.



04ml10ab

**Parking brake activation indicator**

Parking brake symbol field  
 Symbol field colour – red

Warning functions:

- Lights up when the ignition key is turned to contact, operating and preglow position **I**.
- Lights up when the parking brake is engaged.  
 The symbol field goes out when the parking brake is released.



04mi06ab

**Air filter contamination indicator**

Air filter contamination symbol field  
 Symbol field colour – yellow  
 Lights up when the air filter is heavily contaminated.



04ml05ab

### Preglow monitoring

Preglow monitor symbol field

Symbol field colour – yellow

Lights up when the ignition key is turned to the ignition, operation and preglow position - I and in the starting position II.

The symbol field goes out at the end of the preglow period and when the engine is started.

### Engine speed, time, operating hours and service code indicator



bbb00011

Segment display for engine speed, real time, operating hours segment or service codes

Field colour – grey

**Condition:** the required function must be selected on the control unit.

Display functions:

- Displays the time.
- Displays the engine speed.
- Shows how many hours the machine has been in operation.
- Displays the service code in the event of malfunction.

The service hours are used as the basis for the maintenance intervals.

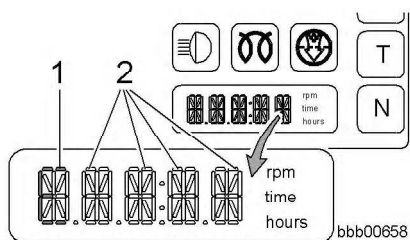

Additional display functions, for example:

- Ride control status
  - Temperature setting on automatic air conditioning (optional)
- For several seconds when the temperature control button is pressed.

### Service code structure:

Field 1 = E plus Field 2 = service code number. **E2000** or **E502C**

The service code display is accompanied by a beep.

Tone sequence: immediately after the service code is displayed, 1 second long, once only.

When a service code is displayed which means the machine has to be stopped, the STOP symbol field also lights up.

See the section on the machine stop indicator.

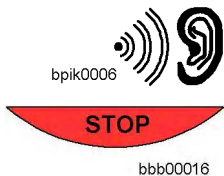

bpik0006

bbb00016



### Note

**The segment display goes out when the ignition is switched off.**

! If necessary, first note the service code which is displayed.

### Battery charge control indicator



04ml09ab

Battery charge (charge control) symbol field

Symbol field colour – red

Warning functions:

- Lights up when the ignition key is in the ignition position I.
- The symbol field goes out when the engine is started.
- It lights up, for instance, if the V-ribbed drive belt of the alternator tears.



04ml08ab

### High beam activation indicator

High beam symbol field

Symbol field colour – blue

Lights up when the high beam is activated.



04ml12ab

### Direction indicator system activation indicator

Direction indicator system symbol field

Symbol field colour – green

Warning functions:

- Flashes when the steering column switch is actuated to display the travel direction.
- Flashes when the hazard warning system is activated.

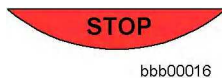

bbb00016

### Machine stop indicator

Stop symbol field

Symbol field colour – red

Lights up:

- If there is a service code message which means that the machine must be shut down.
- If the emergency steering check is not successful.
- If the emergency steering is automatically activated.
- If the engine overheats.
- If the engine oil pressure is too low.
- If the coolant temperature is too high.
- If the coolant level is too low.



### Note

**The cause of the fault must be analysed and corrected immediately.**

! See also the malfunctions described in chapter 4.

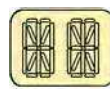

bbb00019

### Travel range or tractive force control indicator

Segment display for gear and tractive force control

Field colour – yellow

Display functions:

- Shows the selected gear – **G1, G2, G3**.
- Shows the selected tractive force between 70% and 100% in 5% increments.
- Shows the adjustable time interval of 5 to 90 minutes for the fan drive reversal option.



bbb00060

### Overspeed protection indicator

Overspeed protection segment display

Overspeed protection field 1

Symbol field colour – red

Warning message:

- Flashes if the machine is operated at too high a speed.
- The warning function of the symbol field is accompanied by a single beep.

LBH/03/003801/0003/15.06/en





04ml23ab

### Low fuel supply indicator

Fuel supply symbol field

Symbol field colour – red

Flashes when the diesel fuel is down to reserve level.



bbb00007

### Fuel supply tank content indicator

Fuel supply display

Field colour – grey (limit range with reserve – red)

Shows the content of the diesel fuel tank.



04ml24ab

### Engine overheating and coolant level indicator

Engine overheating and coolant level symbol field

Symbol field colour – red

Warning functions:

- Lights up when the coolant temperature exceeds. 100 °C .
- Lights up when the coolant level is too low.

#### Warning message when the coolant temperature exceeds 100 °C :

- When a warning is issued, the symbol field flashes first.
- The warning function of the symbol field is accompanied by a continuous tone.
- The stop symbol field lights up.  
The cause of the fault must be analysed and corrected immediately.  
See also the malfunctions described in chapter 4.

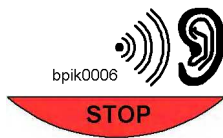

bpik0006

bbb00016

#### Warning message when the coolant level is too low:

- When a warning is received, the symbol field lights up.
- The warning function of the symbol field is accompanied by a continuous tone.
- The stop symbol field lights up.  
The cause of the fault must be analysed and corrected immediately.  
See also the malfunctions described in chapter 4.

### Coolant temperature indicator

Coolant temperature display

Field colour – grey

Shows the coolant temperature in °C.



bbb00008



04ml25ab

### Engine oil pressure indicator

Engine oil pressure symbol field

Symbol field colour – red

Warning functions:

- Lights up when the ignition key is in the ignition position I. The symbol field goes out when the engine is started.
- Flashes when the engine oil pressure drops.

**Condition:** the diesel engine must be running.

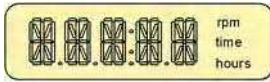

bbb00011

Warning sequence:

- When a warning is received, the symbol field lights up. The service code **E 6017** also appears in the display.
- The warning function of the symbol field is accompanied after 10 seconds by a continuous tone.



bpik0006

bbb00016

The stop symbol field lights up.

The cause of the fault must be analysed and corrected immediately.

See also the malfunctions described in chapter 4.



bbb00009

### Engine oil pressure display

Engine oil pressure display

Field colour – grey

Shows engine oil pressure in bar.

## 3.2.16 Mechanical service hours counter

This equipment is optional.

### Layout



bbb00622

Service hours counter

The mechanical service hours counter 1 is in the instrument panel to the right of the driver's seat.

**Function description**

**Machine service hours indicator**

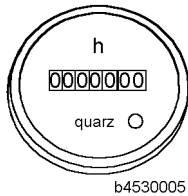

Mechanical service hours counter

Shows how many hours the machine has been in operation.

The service hours are used as the basis for the maintenance intervals.

**3.2.17 Control units**

The layout and function of the controls are described in this section.

**Layout**

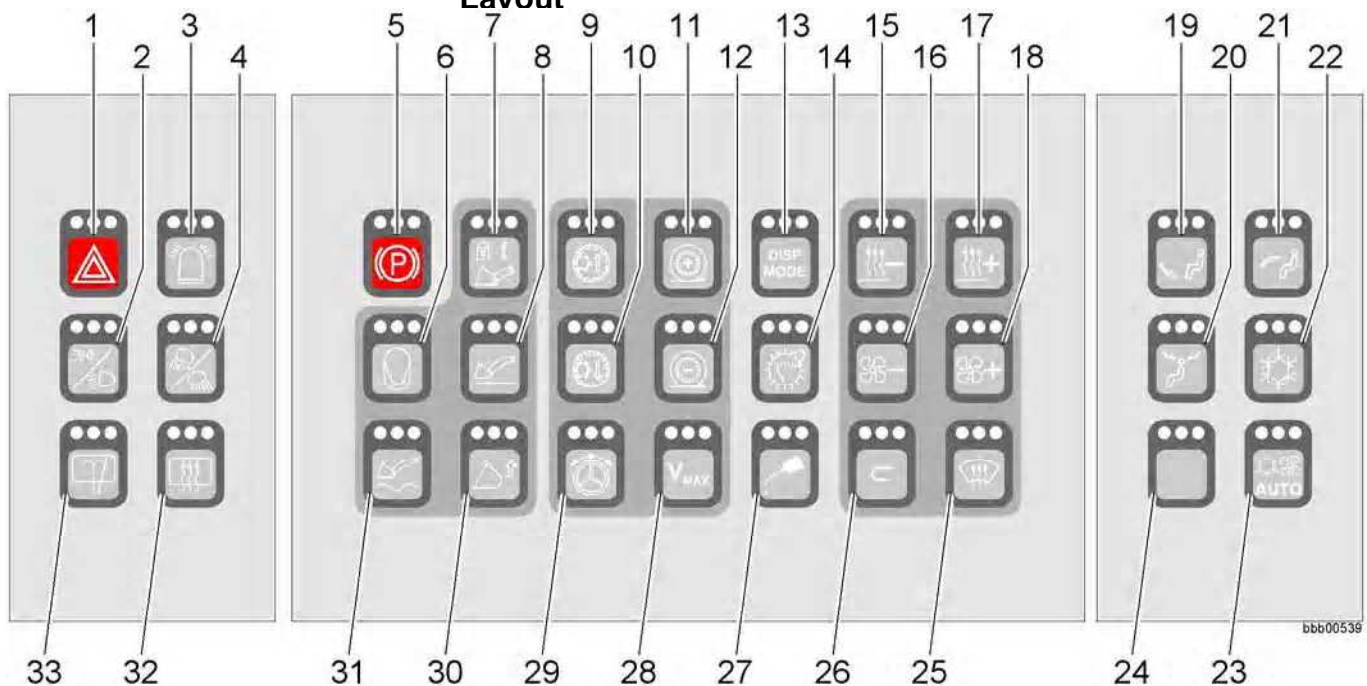

Control unit (view rotated by 90°)

- |   |   |   |
|---|---|---|
| 1 Hazard warning system button          | 13 Display mode button                        | 22 Air conditioning ECO mode button               |
| 2 Profile lights and low beam button    | 14 Display unit brightness control button     | 23 Air conditioning auto mode button              |
| 3 Flashing beacon button                | 14 Engine bleeding button (special function)  | 24 Spare button                                   |
| 4 Front/rear working floodlights button | 15 Temperature down button                    | 25 Defrost button                                 |
| 5 Parking brake button                  | 16 Blower speed down button                   | 26 Recirculated air button                        |
| 6 Ride control (LFD system) button      | 17 Temperature up button                      | 27 Central lubrication system button (optional)   |
| 7 Working hydraulics lockout button     | 18 Blower speed up button                     | 28 Vmax button                                    |
| 8 Bucket return-to-dig button           | 19 Blower duct (footwell) selection button    | 29 Emergency steering button                      |
| 9 Travel range up button                | 20 Blower duct (head area) selection button   | 30 Lift kick-out button                           |
| 10 Travel range down button             | 21 Blower duct (middle area) selection button | 31 Float position button                          |
| 11 Increase tractive force button       |   | 32 Rear window heater button                      |
| 12 Reduce tractive force button         |   | 33 Rear windshield wiper and washer system button |

LBH/03/003801/0003/15.06/en

The control unit is in the instrument panel to the right of the driver's seat.  
All the buttons on the control units have LEDs.  
When you press a button to select its function, the LED lights up.  
When you press the button again to switch its function off, the LED goes out.

## Function description

### Hazard warning system



bbb00540

Hazard warning system button

Switches the hazard warning system on or off.

When you press the button for the first time:

- Function ON
  - The direction indicator symbol field lights up
  - All four direction indicator lights on the machine flash
  - All three LEDs on the button light up

When you press the button a second time:

- Function OFF
  - The direction indicator symbol field goes out
  - All four direction indicator lights on the machine go out
  - All three LEDs on the button go out

The button is also functional when the ignition key is in the 0 position or parking position.

### Profile lights and low beam



bbb00541

Profile lights and low beam button

When you press the button for the first time:

- Profile lights (parking lights) function ON
- The profile lights (parking lights) light up
- The LED on the left lights up

When you press the button a second time:

- Low beam (driving light) function ON
- Driving light low beam is activated.
- The LEDs on the left and right light up.

When you press the button a third time:

- All functions OFF
- The LEDs on the button go out.

The button is also functional when the ignition key is in the 0 position or parking position.

### Flashing beacon



bbb00546

This equipment is optional.

Flashing beacon button

Switches the flashing beacon on and off.

When you press the button for the first time:

- Function ON – the flashing beacon lights up
- All three LEDs on the button flash.

When you press the button a second time:

- Function OFF – the flashing beacon goes out
- All three LEDs on the button go out

The button is also functional when the ignition key is in the 0 position or parking position.

### Front/rear working floodlights



bbb00547

Front/rear working floodlights button

To switch on or off:

- Front working floodlights
- Front and rear working floodlights
- Rear working floodlights

When you press the button for the first time:

- The front working floodlights light up.
- The left LED on the button lights up.

When you press the button a second time:

- The front and rear working floodlights light up.
- The left and right LEDs on the button light up.

When you press the button a third time:

- The rear working floodlights light up.
- The right LED on the button lights up.

Press the button a fourth time to switch off all the functions.

The button is also functional when the ignition key is in the 0 position or parking position.

### Parking brake



bbb00548

Parking brake button

Engages or releases the parking brake.

When you press the button for the first time:

- Function ON  
The parking brake is activated.  
All three LEDs on the button light up.

When you press the button a second time:

- Function OFF  
The parking brake is deactivated.  
All three LEDs on the button go out



### Switching ride control (LFD system) on or off

Ride control (LFD system) button

Switches the ride control system on or off.

When you press the button for the first time:

- Function ON – ride control is activated.
- All three LEDs on the button flash.

When you press the button a second time:

- Function OFF – ride control is deactivated.
- All three LEDs on the button go out



#### Note

The function remains active after the ignition is switched off.

! This means the function is still active when the ignition is switched on again.



### Working hydraulics lockout

Working hydraulics lockout button

Disables and enables the working hydraulics functions.

When you press the button for the first time:

- Function ON  
The working hydraulics lockout is activated.  
All three LEDs on the button light up.

When you press the button a second time:

- Function OFF  
The working hydraulics lockout is deactivated.  
All three LEDs on the button go out



#### Note

The function remains active after the ignition is switched off.

! This means the function is still active when the ignition is switched on again.

The working hydraulics lockout remains active as long as the engine is not running.

You can temporarily deactivate the working hydraulics lockout by pressing the button.



bbb00551

### Bucket return-to-dig

Bucket return-to-dig button

Switches the automatic bucket return-to-dig function on or off.

When you press the button for the first time:

- Function ON  
A solenoid on the pilot control device is activated.  
All three LEDs on the button light up.

When you press the button a second time:

- Function OFF  
A solenoid on the pilot control device is deactivated.  
All three LEDs on the button go out

The LIEBHERR control lever is held in the bucket tilt-in position by magnetic force.



#### Note

The function remains active after the ignition is switched off.

! This means the function is still active when the ignition is switched on again.



bbb00552

### Selecting a higher travel range

Travel range up button

Selects a higher travel range.

The selected travel range is indicated on the display unit.

When you press the button:

- The travel range is shifted up.
- All three LEDs on the button briefly light up.



bbb00553

### Selecting a lower travel range

Travel range down button

Selects a lower travel range.

The selected travel range is indicated on the display unit.

When you press the button:

- The travel range is shifted down.
- All three LEDs on the button briefly light up.



bbb00554

### Increasing the tractive force

Increase tractive force button

Increases the tractive force of the machine.

The tractive force is shown as a percentage (between 70% and 100% in 5% increments) on the display unit.

If the tractive force is set at 100%, the function is deactivated.

When you press the button:

- The tractive force is increased.
- The LEDs on the button light up according to the set tractive force.



bbb00555

### Reducing the tractive force

Reduce tractive force button

Reduces the tractive force of the machine.

If the tractive force is set at less than 100%, the tractive force reduction is activated accordingly.

The tractive force is shown as a percentage (between 70% and 100% in 5% increments) on the display unit.

When you press the button:

- The tractive force is reduced.
- The LEDs on the button light up according to the set tractive force.



bbb00556

### Switching the display mode

Display mode button

For activating the display between:

- Engine speed (rpm)
- Time
- Service hours

If a service code is displayed, you can press the button to hide it.

When you press the button:

- The display mode is changed. This is shown in the segment display of the unit.
- All three LEDs on the button briefly light up.

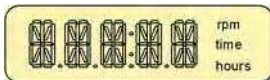

bbb00011

Functions of the segment display:

- See the section on the display unit.



bbb00557

### Display unit brightness control

Display unit brightness control button

Adjusts the brightness of the display unit.

When you press the button:

- The brightness of the display unit background lighting is increased.
- All three LEDs on the button briefly light up.

If you press the button ten times the background lighting is switched off.



#### Note

This button also has a special function.

! See the section on the engine bleeding button (special function)



bbb00557

### Engine bleeding button (special function)

Engine bleeding button (special function)

This bleeds the fuel system of the diesel engine.

It is necessary when the fuel tank has run completely empty.

When the fuel tank is empty there is air in the fuel system.

You can remove some of the air from the fuel system by bleeding the fuel filter.

You can bleed the air between the injection pump and the injection nozzle by activating engine bleeding mode.





**Note**

Activation sequence:

! See the section on bleeding the fuel system in chapter 5.

**Lowering the temperature**

Temperature down button

For adjusting the temperature on the (automatic) air conditioning.

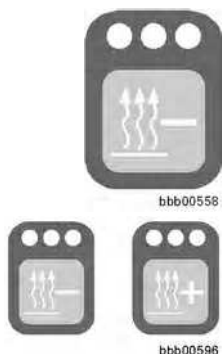

The temperature setting (reduction) takes place:

- On the manual air conditioning system in % increments  
From 100% to 0%.
- On the automatic air conditioning system in °C ,  
From 28 °C to 16 °C .

See also the sections on heating, ventilation and air conditioning.

When you press the button, the LEDs light up according to the temperature level.

Set temperature display:

- On the automatic air conditioning (optional)  
The temperature is displayed for a few seconds after it is adjusted.

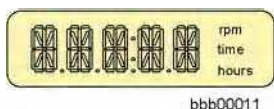

**Note**

The function remains active after the ignition is switched off.

! This means the function is still active when the ignition is switched on again.

**Increasing the temperature**

Temperature up button

For adjusting the temperature on the (automatic) air conditioning.

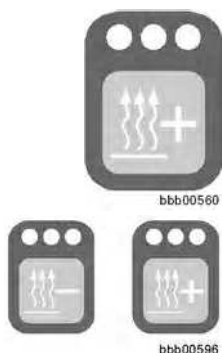

The temperature setting (increase) takes place:

- On the manual air conditioning system in % increments  
From 0% to 100%.
- On the automatic air conditioning system in °C ,  
From 16 °C to 28 °C .

See also the sections on heating, ventilation and air conditioning.

When you press the button, the LEDs light up according to the temperature level.

Set temperature display:

- On the automatic air conditioning (optional)  
The temperature is displayed for a few seconds after it is adjusted.

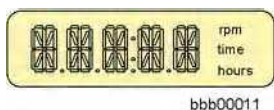



**Note**

The function remains active after the ignition is switched off.  
 ! This means the function is still active when the ignition is switched on again.

**Reducing the blower speed**

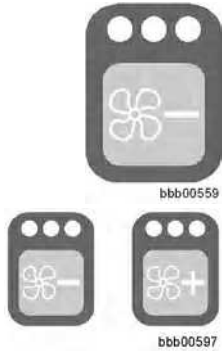

Blower speed down button  
 For regulating (reducing) the blower speed on 6 levels.

From 100% to 0%.

When you press the button, the LEDs light up according to the blower speed.

At blower speed 0 the air conditioning is switched off.



**Note**

The function remains active after the ignition is switched off.  
 ! This means the function is still active when the ignition is switched on again.

**Increasing the blower speed**

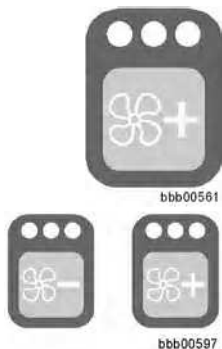

Blower speed up button  
 For switching on the air conditioning system.  
 For regulating (increasing) the blower speed on 6 levels.

From 0% to 100%.

Each time you press the button, the LEDs light up according to the blower speed.



**Note**

The function remains active after the ignition is switched off.  
 ! This means the function is still active when the ignition is switched on again.



### Selecting the blower ducts (footwell)

Blower duct (footwell) selection button

For opening and closing the flaps for the required blower direction.

Blowing towards the feet.

When you press the button:

- Function ON – all three LEDs on the button light up.  
The flaps are opened.
- Function OFF – all three LEDs on the button go out.  
The flaps are closed.

You can also combine blowing directions.

When the flaps are open, the three LEDs for that direction light up.

Selecting a blower direction deactivates any previous automatic air conditioning setting.



---

#### Note

The function remains active after the ignition is switched off.

! This means the function is still active when the ignition is switched on again.

---



### Selecting the blower ducts (head area)

Blower duct (head area) selection button

For opening and closing the flaps for the required blower direction.

Blowing towards the head.

When you press the button:

- Function ON – all three LEDs on the button light up.  
The flaps are opened.
- Function OFF – all three LEDs on the button go out.  
The flaps are closed.

You can also combine blowing directions.

When the flaps are open, the three LEDs for that direction light up.

Selecting a blower direction deactivates the automatic air conditioning setting.



---

#### Note

The function remains active after the ignition is switched off.

! This means the function is still active when the ignition is switched on again.

---



### Selecting the blower ducts (middle area)

Blower duct (middle area) selection button

For opening and closing the flaps for the required blower direction.  
Blowing towards the body.

When you press the button:

- Function ON – all three LEDs on the button light up.  
The flaps are opened.
- Function OFF – all three LEDs on the button go out.  
The flaps are closed.

You can also combine blowing directions.

When the flaps are open, the three LEDs for that direction light up.

Selecting a blower direction deactivates the automatic air conditioning setting.



#### Note

The function remains active after the ignition is switched off.

! This means the function is still active when the ignition is switched on again.



### Air conditioning ECO mode

Air conditioning ECO mode button

For activating ECO mode.

Switches the air-conditioning system on and off.

When you press the button for the first time:

- Function ON – all three LEDs on the button light up.  
The air conditioning compressor is activated if necessary.  
No ECO mode.

When you press the button a second time:

- Function OFF – all three LEDs on the button go out.  
The air conditioning system is turned off.  
ECO mode.



#### Note

The function remains active after the ignition is switched off.

! This means the function is still active when the ignition is switched on again.



**Air conditioning auto mode**

Air conditioning auto mode button

For switching on and off:

- The manual air conditioning system
  - The automatic air conditioning.
- This equipment is optional.

**Manual air conditioning**

When you press the button:

- Function ON – all three LEDs on the button light up.  
The air conditioning system is switched on.
- Exception: the LEDs do not light up in defrost mode.
- Function OFF – all three LEDs on the button go out.  
The air conditioning system is switched off.

**Automatic air conditioning**

This equipment is optional.

When you press the button:

- Function ON – all three LEDs on the button light up.  
The air conditioning system is in automatic mode.
- Function OFF – all three LEDs on the button go out.  
The air conditioning system is switched off.



**Note**

The function remains active after the ignition is switched off.  
! This means the function is still active when the ignition is switched on again.



**Spare**

Spare button (unassigned)

For activating an optional function.



**Defrost mode**

Defrost button

Switches defrost mode on and off.

When you press the button:

- Function ON – all three LEDs on the button light up.  
The air conditioning system is in defrost mode.  
In defrost mode, the entire air flow is directed at the windscreen.
- Function off – all three LEDs on the button go out.



**Note**

The function remains active after the ignition is switched off.  
! This means the function is still active when the ignition is switched on again.



bbb00569

### Recirculated air

Recirculated air button

Switches the recirculated air flap on and off.

All three LEDs light up when recirculated air is activated.

When you press the button:

- Function ON – all three LEDs on the button light up.  
No fresh air is taken in.
- Function off – all three LEDs on the button go out.



---

#### Note

The function remains active after the ignition is switched off.

! This means the function is still active when the ignition is switched on again.

---



bbb00570

### Central lubrication system

Central lubrication system button (optional)

For selecting the central lubrication system mode:

- Press briefly:  
(Non-scheduled lubrication)
- Press longer:  
(Light – medium– heavy duty).

If there is a fault in the system, all three LEDs light up.

All three LEDs light up when the grease supply is used up.

With the ignition on, the following light up depending on mode:

- Left LED = light duty
- Middle LED = medium duty
- Right LED = heavy duty

When the pump is running (during automatic lubrication), the following flash, depending on mode:

- Left LED = light duty
- Middle LED = medium duty
- Right LED = heavy duty



### Vmax

Vmax button

For restricting the speed.

**This function is only available when travelling forward in fixed gears 1 and 2.**

If activated while the machine is moving:

- The machine keeps to the travel speed (Vmax) at the time the function is activated.  
The speed thus set is the maximum speed.

If activated while the machine is at a standstill:

- The machine travels at the minimum speed of the selected gear.  
Gear level 1: approx. 4 km/h  
Gear level 2: approx. 10 km/h

When you press the button:

- Function on – all three LEDs on the button light up.
- Function off – all three LEDs on the button go out.

The function is deactivated in the following conditions:

- If you press the reverse travel direction switch.  
The control electronics switch to automatic travel range **A1-3**.

Deactivate the function by pressing the Vmax button again or changing the travel range.



### Emergency steering

Emergency steering button

Starts the emergency steering pump for up to 10 seconds emergency steering.

With the ignition on and the button pressed:

- The emergency steering pump runs until the button is pressed.  
The maximum duration is 10 seconds.
- All three LEDs on the button light up as long as the emergency steering pump is running.

See also the sections on the display unit and towing the machine when the steering system has broken down.



### Lift kick-out

Lift kick-out button

Switches the lift kick-out function on and off.

**Note**

The button function is available:  
 When the machine is equipped with the option light kickout function.  
 The function remains active after the ignition is switched off.  
 ! This means the function is still active when the ignition is switched on again.

When you press the button for the first time:

- Function ON  
 A solenoid on the pilot control device is activated.  
 All three LEDs on the button light up.

When you press the button a second time:

- Function OFF  
 A solenoid on the pilot control device is deactivated.  
 All three LEDs on the button go out

The LIEBHERR control lever is held in the raised lift arm position by magnetic force.

**Float position**

Float position button

Switches the float position function on or off.



When you press the button for the first time:

- Function ON  
 A solenoid on the pilot control device is activated.  
 All three LEDs on the button light up.

When you press the button a second time:

- Function OFF  
 A solenoid on the pilot control device is deactivated.  
 All three LEDs on the button go out

After the LIEBHERR control lever is actuated, it is held in the lower lift arm position by magnetic force.

**Note**

The memory function of the float position switch is optional.  
 The function remains active after the ignition is switched off.  
 ! This means the function is still active when the ignition is switched on again.





bbb00575

### Rear window heater

Rear window heater button

Switches the rear window heater on or off.

This function is only available when the ignition is on.

When you press the button for the first time:

- Function ON
- All three LEDs on the button light up.

When you press the button a second time:

- Function OFF
- All three LEDs on the button go out

The function remains active after it is switched on:

- Until the rear window heater is switched off
- Or for a maximum 20 minutes (to protect the battery).



bbb00576

### Rear windshield wiper and washer system

Rear windshield wiper and washer system button

Switches the windshield wiper and washer system for the rear window on or off.

Press the button once:

- Interval wipe
- The LED on the left lights up.

Press the button a second time:

- Constant wiping on
- The LEDs on the left and right light up.

Press the button a third time:

- Function OFF
- All the LEDs go out.

Hold the button down:

- Rear windscreen washer pump ON
- Rear wiper ON
- (Continues wiping for several seconds).

## 3.2.18 Optional buttons on the side console

The layout and function of the buttons on the side console for additional working functions are described in this section.

**Layout**

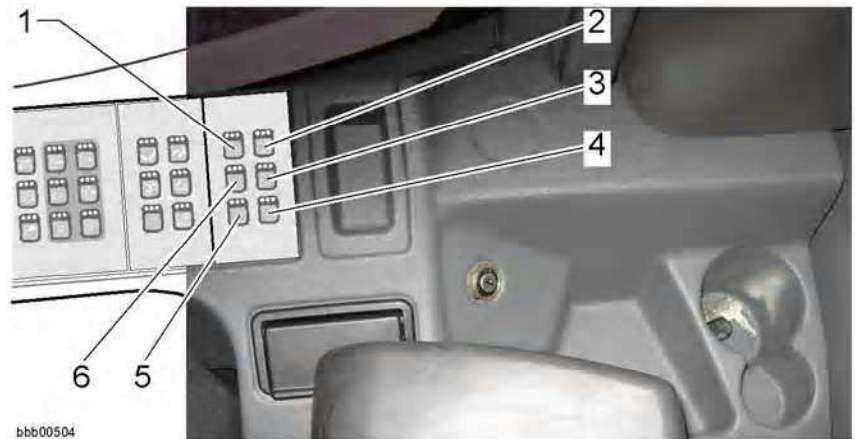

bbb00504

Side console

- |  |                          |
|--|--------------------------|
| 1 Reversible fan drive button and indicator lamp | 4 Spare                  |
| 2 Joystick steering button                       | 5 Spare                  |
| 3 Spare  | 6 2-in-1 steering button |

**Function description**

**Reversible fan drive**



bbb00646

This equipment is optional.

Reversible fan drive button and indicator lamp

For a detailed description, see the section on the reversible fan drive.

**Joystick steering**



bbb00647

This equipment is optional.

Joystick steering button

For a detailed description, see the operation manual for optional equipment.

**Spare**



bbb00567

Spare button (unassigned)

For activating an optional function.

LBH/03/003801/0003/15.06/en



bbb00647

### 2-in-1 steering

This equipment is optional.

2-in-1 steering button

For a detailed description, see the operation manual for optional equipment.

### 3.2.19 Optional switches on the side console

The layout and function of the switches on the side console for additional working functions are described in this section.

#### Layout



bbb00621

Side console

- |                                     |  |
|-------------------------------------|--|
| 1 Back-up alarm deactivation button | 3 Hydraulic quick-change device switch |
| 2 Comfort control switch            | 4 Dummy plug                           |
|                                     | 5 Dummy plug                           |

#### Function description

##### Switching off the back-up alarm

This equipment is optional.

Back-up alarm deactivation button

Field colour – orange

For switching off the back-up alarm

For a detailed description see the following sections:

- Audible reverse warning device (back-up alarm)
- Visible reverse warning device



bbb00688

### Comfort control or quick change control

This equipment is optional.

Comfort control or quick change control switch

Field colour – green

For detailed descriptions see the sections on comfort control and electro-hydraulic actuation of the quick-change device.

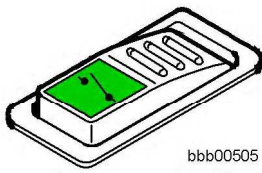

### Activating and deactivating the quick-change device

This equipment is optional.

Quick-change device switch

Field colour – red

Switches the hydraulic quick-change device function on or off.

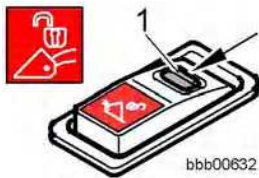

#### Note

This function is only available once the engine has started.

The switch is secured with a lock to prevent actuation by mistake.

! Before actuation, release the lock 1.



When you press the switch:

- A solenoid valve is activated.
- A warning signal in the side console also sounds.
- Activating the working hydraulics in addition causes the locking mechanism of the quick-change device to retract.

### Dummy plug

Dummy plug

Reserved for additional functions.

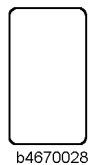

### 3.2.20 LIEBHERR control lever

This section describes the design and function of the LIEBHERR control lever.

#### Layout

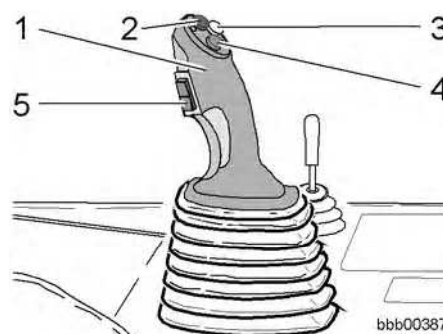

LH control lever

LBH/03/003801/0003/5.06/en

- 1 LH control lever
- 2 Kick-down button
- 3 Additional equipment button <sup>1)</sup>
- 4 Comfort control switch <sup>2)</sup>
- 5 Travel direction switch

**Integrated controls:**

- Lever with pilot control unit for controlling the working attachment
- Button for kick-down shifting
- Button for controlling an additional hydraulic function  
<sup>1)</sup>e.g. optional additional equipment (high dump bucket)
- Comfort control button  
<sup>2)</sup>e.g. optional hydraulic quick-change device
- Switch for changing travel direction between forward and reverse.

**Function description**

Use the LIEBHERR control lever (LH control lever) to control the travel direction and movements of the working attachment.

**Switching the travel direction**

The travel direction cannot be selected while the parking brake is engaged. You can change the travel direction using switch 1 on the LH control lever. See the section on driving in chapter 3.

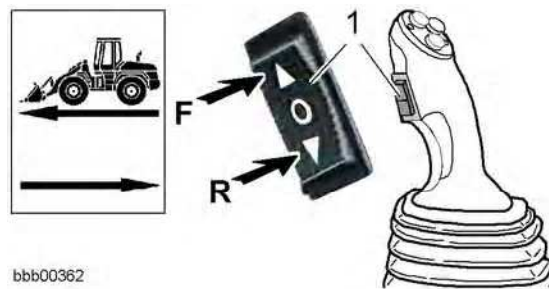

bbb00362

LH control lever

- 1 Travel direction switch
- 0 = Neutral travel direction
- F = Forward travel direction
- R = Reverse travel direction

- Selecting the travel direction:  
 Press the switch 1 according to the direction you want to travel in. Symbol fields are used to show the selected travel direction on the instrument panel in the display unit. See the section on the display unit in chapter 3.

### Activating the kick-down function

When the electrical system is switched on, the automatic travel range **A1-3** is selected and the travel drive is set to neutral **N**.

Both are shown in the display unit.

The kick-down function can only be selected when the machine is moving. Kick-down shifting is possible while moving forwards or reversing in the following travel ranges: **2, A1-2, A1-3, A2-3** and at every travel speed.

**Use:** See the section on kick-down shifting in the driving section.

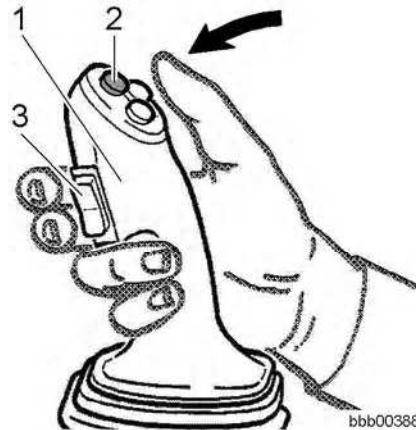

LH control lever

1 LH control lever  
2 Kick-down button

3 Travel direction switch

#### Selection procedures for kick-down shifting:

- When you press the button **2** the machine is automatically hydrostatically braked. The gearbox automatically shifts to first gear. This means that the gear is automatically shifted from 3 to 2 and then from 2 to 1.
- When you drive without resistance, first gear is active for 10 seconds from the time the button **2** is pressed. The machine then automatically shifts to second gear when the speed increases again.
- When driving into the pile, first gear remains selected as long as there is resistance.

As long as the kick-down function is activated, you cannot drive faster in first gear than 8 km/h .

- To deactivate the kick-down function:  
Press the switch **3** according to the direction you want to travel in.

### Controlling the working attachment

The grip of the LH control lever is mechanically linked to the pilot control device directly underneath it.

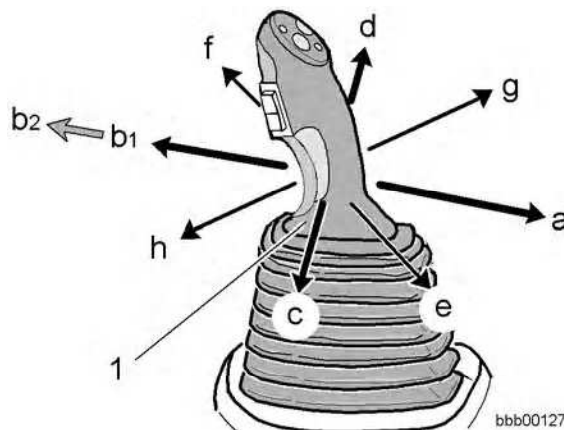

Directions of movement of the LH control lever

- a Back
- b1 Forward to action point
- b2 Forward to limit
- c Left
- d Right
- e-h Diagonal

- Control the working attachment by moving the LH control lever 1.

Movements of the LH control lever and associated functions:

- a – Raises the lift arm
- b1 – Normal lowering function – the lift arm is lowered slowly
- b2 – Fast lowering function – the lift arm is lowered quickly
- c – Tilts the bucket in
- d – Tilts the bucket out
- e – Raises the lift arm while tilting the bucket in
- f – Lowers the lift arm while tilting the bucket out
- g – Raises the lift arm while tilting the bucket out
- h – Lowers the lift arm while tilting the bucket in

### Comfort control

This equipment is optional.



Comfort control

- 1 Comfort control switch

LBH/03/003801/0003/5.06/en

Functions:

- It controls an additional hydraulic function, such as the high dump bucket.

Operation:

- Using a button and the tilt-in and tilt-out function of the LH control lever.

Advantage:

- You can keep your hand on the LH control lever. Very good fine control is possible.



**Warning**

Incorrect operation can lead to injuries.

! The tilt-in and tilt-out function (tilt cylinder) cannot be used at the same time as comfort control.

Activate the comfort control function using the comfort control switch 1. See the section on electrohydraulic operation of the quick-change device in the operation section.

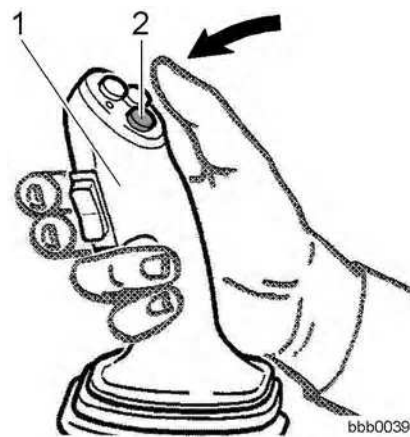

LH control lever

1 LH control lever

2 Comfort control button

- Press and hold down the comfort control button 2.
- Use the LH control lever 1 to move the working attachment via the additional control circuit (accessory kit).

An example of this is tilting the high dump bucket in or out using the bucket cylinder.

- When you release the comfort control button 2, the additional hydraulic control function is interrupted.

The working attachment is thus moved via the control circuit of the working hydraulics.

An example of this is tilting the attachment in or out using the tilt cylinder.



### 3.2.21 Control lever for additional working functions

This equipment is optional.

The control lever for additional working functions (additional control lever) is installed to the right of the LH control lever in the instrument panel.

#### Controlling the optional attachment

If an optional attachment with an independent control circuit is attached to the lift arm, it is controlled by the additional control lever.

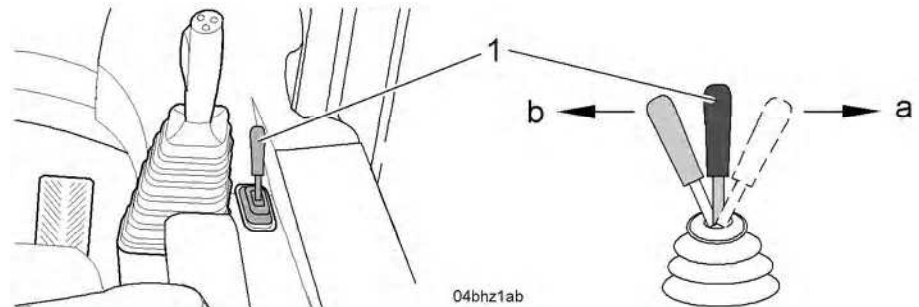

*Directions of movement of the additional control lever*

a – Back

b – Forward

- You can control the optional attachment using the additional control lever 1.

Movements of the additional control lever and associated functions:

a– (function depends on the type of optional equipment attached)

b– (function depends on the type of optional equipment attached)

- **Make sure you are familiar with the operation of the optional attachment installed.**

Refer to the section on operation or to the operating manual for additional equipment.

### 3.2.22 Heating and ventilation

The driver's cab is equipped with a warm water heating system.

The controls are located on the control unit in the right of the cab.

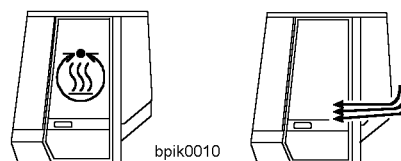

The intake air is filtered through two serviceable dry filter cartridges and directed to the adjustable air flow nozzles in the cab through the heating/air-conditioning unit.

Make sure that:

- The shut-off valves on the thermostat housing of the diesel engine are open.
- The machine's electrical system is switched on.
- The nozzles for the air flow are open.

For example towards the driver, front windshield or rear window.

### Regulating the temperature

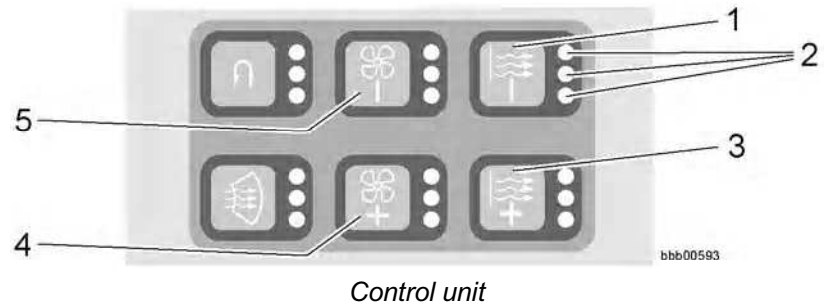

- 1 Temperature down button
- 2 LEDs
- 3 Temperature up button
- 4 Blower speed up button
- 5 Blower speed down button



- Set the inside temperature using the buttons 1 and 3:
  - Temperature up button = warmer
  - Temperature down button = cooler

#### Regulating the temperature with manual air conditioning:

The temperature is set in %:

Six temperature levels from 0% to 100% are available.

The temperature ranges are indicated by the number of LED which light up on the keypad.

#### Regulating the temperature with automatic air conditioning:

This equipment is optional.

The temperature is set in °C and can be adjusted in 1°C increments:



- 1 Temperature down button
- 2 LED
- 3 Temperature up button
- 4 Segment display

Set temperature display:

- This is shown in the segment display 4 for a few seconds after you adjust the temperature.

To read the temperature on the display you must press the temperature up or down button.



- **To speed up the warming process:**

Press the temperature up button (+) to the highest level.

Set temperature display:

- With manual air conditioning
  - The LEDs light up according to the temperature level.
- With automatic air conditioning
  - Briefly in the segment display.

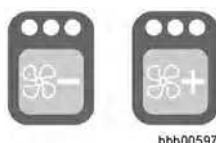

- Press the blower speed up button (+) to the highest level.

When you press the button, the LEDs light up according to the blower speed.

LBH/03/003801/0003/5.06/en

### Adjusting the blower

The filters of the heating/air-conditioning unit must be regularly serviced in order to ensure good ventilation.

The air flow is impaired if the filter is dirty.

See the section on maintenance tasks in chapter 3.

The air outlet nozzles in the cab must also be open.

---

#### Caution

The evaporator may be damaged if the recirculated air filter is not present. If there is no recirculated air filter or fresh air filter, the closely meshed, deep evaporator fins will quickly become dirty.

It is then necessary to replace the evaporator as cleaning is no longer possible.

! Never operate the heater/air-conditioning unit without filters.

---

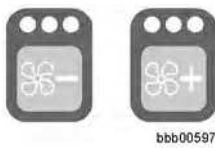

- **To switch on the blower:**

Press the blower speed up button (+).

Fresh air and circulating air is automatically blown into the cab.

- Set the air flow using the blower speed buttons.

Available blower speeds:

From 0% to 100%.

When you press the button, the LEDs light up according to the blower speed.

- **To switch off the blower:**

Press the blower speed down button (-) to reduce the blower speed to 0.

- At blower speed 0 the blower is switched off.

### Selecting the blower direction

You can direct the air flow as you require.

You select the following blowing directions.

- Towards your feet
- Towards your face
- Towards your body

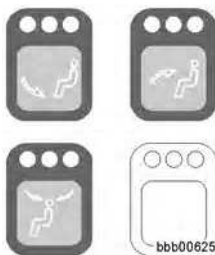

- **To select the blower direction:**

Press the button for the corresponding ducts ( . . . ).

You can also combine blowing directions.

Selecting a blower direction deactivates the automatic air conditioning setting.

See also the description of selecting blower ducts in the section on control units..

### 3.2.23 Air-conditioning system



The standard driver's cab is fitted with a manual air-conditioning unit.

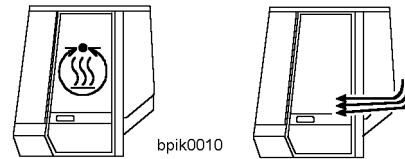

The intake air is filtered through two serviceable dry filter cartridges and directed into the cab via the evaporator, heat exchanger and adjustable outlet nozzles.

#### Using the air-conditioning system

In order to ensure that the air-conditioning system remains in good working order, it is advisable to switch it on every 14 days.

When the air-conditioning system is in use, the shaft seal ring in the air-conditioning compressor is lubricated. This prevents coolant escaping from the air-conditioning compressor.

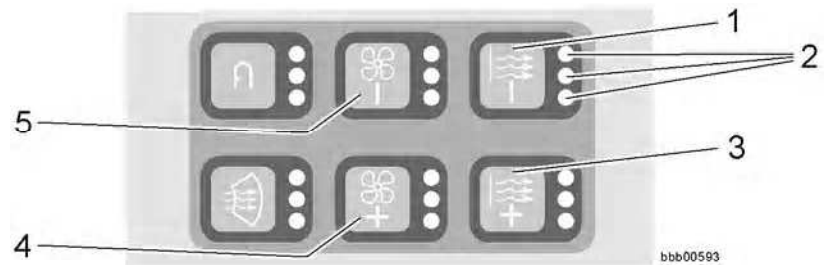

Control unit

- 1 Temperature down button
- 2 LEDs
- 3 Temperature up button
- 4 Blower speed up button
- 5 Blower speed down button

In order to switch on the air-conditioning system:

- The engine must be running
- The blower button **3** must be set to at least level **1**.

#### Switching on the air-conditioning system

- To switch on the air-conditioning system, Press the automatic air-conditioning ECO mode button.

When you press the button:

- Function ON – all three LEDs on the button light up. The air conditioning compressor is activated if necessary. No ECO mode.





### Activating air-conditioning auto mode

- To switch on the air-conditioning system, Press the automatic air-conditioning auto mode button.

### Manual air conditioning

When you press the button:

- Function ON – all three LEDs on the button light up. The air conditioning system is switched on.
- Exception: the LEDs do not light up in defrost mode.

### Automatic air conditioning

This equipment is optional.

When you press the button:

- Function ON – all three LEDs on the button light up. The air conditioning system is in automatic mode.

### Regulating the temperature

The cab temperature is regulated by mixing in hot air supplied by the heater.



- Set the inside temperature using the buttons **1** and **3**:
  - Temperature up button = warmer
  - Temperature down button = cooler

### Regulating the temperature with manual air conditioning:

The temperature is set in %:

Six temperature levels from 0% to 100% are available.

The temperature ranges are indicated by the number of LED which light up on the keypad.

### Regulating the temperature with automatic air conditioning:

This equipment is optional.

The temperature is set in °C and can be adjusted in 1°C increments:



- 1 Temperature down button
- 2 LED

- 3 Temperature up button
- 4 Segment display

Set temperature display:

- This is shown in the segment display **4** for a few seconds after you adjust the temperature.

- To read the temperature on the display: Press the temperature control up or down button.

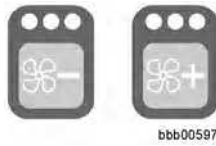

### Cooling the air in the cab

- If heat has built up in the cab, first air the cab thoroughly.

To achieve maximum cooling in the cab, take the following steps:

- Press the blower speed up button (+) to set the highest level.

When you press the button, the LEDs light up according to the blower speed.

- Press the temperature down button 1 to the lowest level.
- Close the cab doors and windows.
- Direct the outlet nozzles away from the windows.

### Re-heat mode

On cold, damp days, you can use the air-conditioning system to de-humidify the cab air.

- To dehumidify the cab air, switch on the air-conditioning system in addition to the heater.

This stops the windows from misting up:

- The damp air condenses on the evaporator
- It is then drained outside into the drip pan.

### Switching off the air-conditioning system

- To switch off the air-conditioning system, Press the air-conditioning ECO mode button.



When you press the button a second time:

- Function OFF – all three LEDs on the button go out. The air conditioning system is turned off. ECO mode.

## 3.2.24 Interior and exterior mirrors

The driver's cab is equipped with one interior and two exterior mirrors.

### Adjusting the mirrors

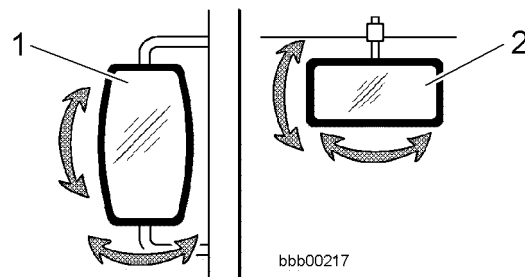

Adjusting the mirrors

1 Exterior mirror

2 Interior mirror

- All mirrors can be adjusted individually.

### 3.2.25 Sun visor

The driver's cab is equipped with a sun visor.

#### Adjusting the sun visor

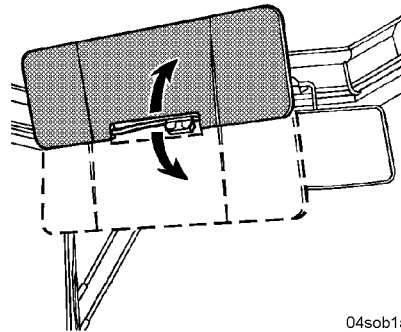

04sob1ab

*Adjusting the sun visor*

- Adjust the sun visor according to your individual requirements by pulling it up or down.

### 3.2.26 Radio

This equipment is optional.

Functions:

- Also works when the ignition key is in the 0 position or parking position.

#### Switching on and using the radio

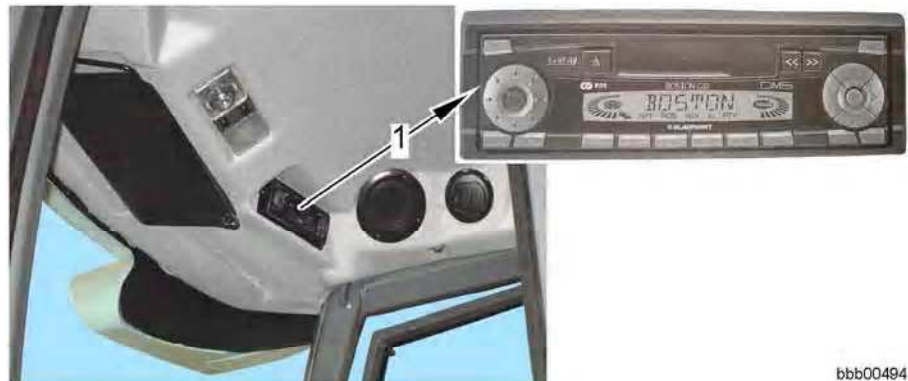

bbb00494

- To use the radio:  
See the radio manufacturer's operating manual supplied.

### 3.2.27 Windshield wiper and washer system

#### Layout

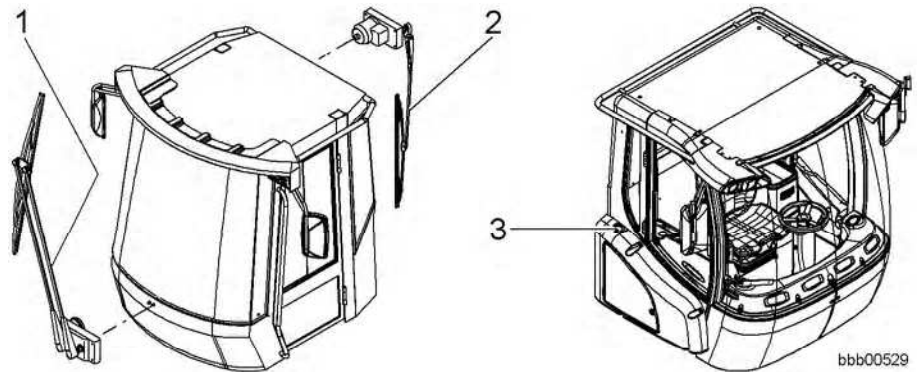

Windshield wiper and washer system

- 1 Front windshield wiper and washer system
- 2 Rear windshield wiper and washer system

- 3 Windshield washer fluid reservoir

The machine has an electric windshield washer and wiper system for the front and rear windshields.

Essentially it consists of the controls, the windshield wipers, the reservoir and pumps, and the outlet nozzles for the washing fluid.

The wiper and washer systems for the front and rear windshield use a shared washer fluid reservoir.

Non-return valves are fitted in the washing fluid hoses to the outlet nozzles.

The switches for the front washer and wiper system are on the steering column switch.

The switches for the rear washer and wiper system are in the right-hand side console.



#### Activating the windshield wiper and washer system

Make sure that the electrical system is switched on before using the wiper and washer system.



#### Caution

Impaired vision can cause accidents.

A dirty front or rear windscreen is a safety hazard.

! Scrape snow and ice from the windshield before driving.



### Using the front windshield wiper and washer system

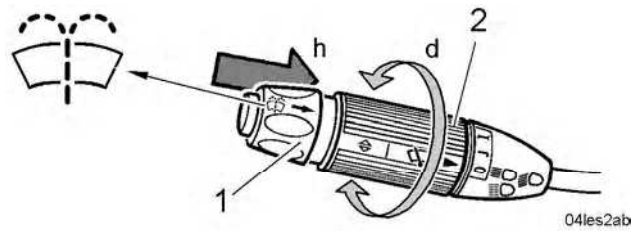

Steering column switch

- 1 Button
- 2 Handle
- d Windshield wiper activation
- h Windshield wiper and washer system activation

- To wipe the window, turn the handle **2** to the required position **J – I**.
- To wash the window, press the button **1** on the steering column switch. Washer fluid is sprayed onto the front windscreen through the outlet nozzles.

### Using the rear windshield wiper and washer system

Switch on the windshield wiper and washer system by pressing the button **1**.

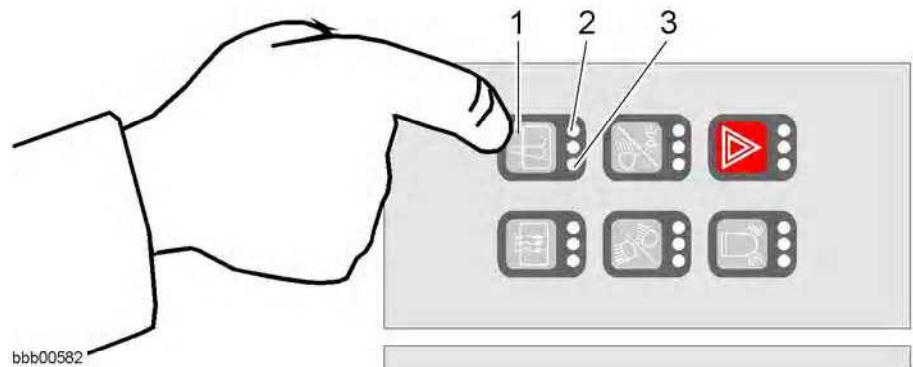

Control unit

- 1 Rear windshield wiper and washer system button
- 2 Interval LED
- 3 Constant wiping ON LED

- Interval wipe: press the button **1** once. The left LED on the button lights up.
- Constant wiping on: press the button **1** a second time. The left and right LEDs on the button light up.
- To switch off the windscreen washer: press the button **1** a third time. All the LEDs on the button go out.
- To switch on the windscreen washer, press the button **1** once.
  - The LED on the left lights up as long as the button is pressed.
  - Rear windscreen washer pump ON  
Washer fluid is sprayed onto the rear windscreen through an outlet nozzle.
  - Rear wiper ON  
(Continues wiping for several seconds).

LBH/03/003801/0003/5.06/en

### 3.2.28 Windshield washer fluid reservoir

#### Layout

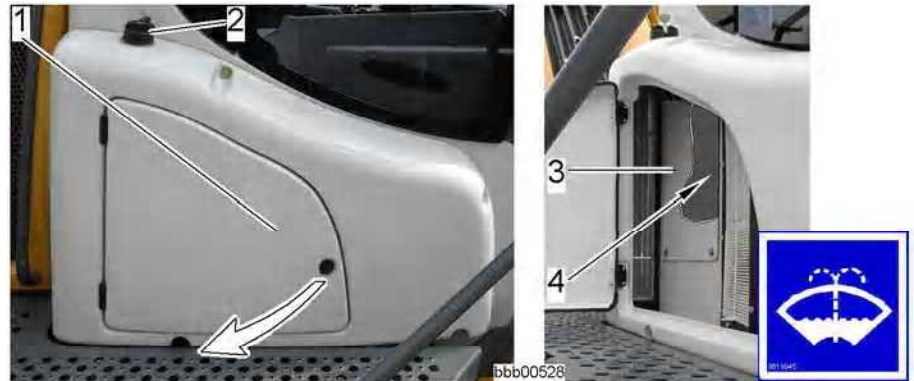

Windshield washer fluid reservoir

- |                 |                                     |
|-----------------|-------------------------------------|
| 1 Door          | 4 Windshield washer fluid reservoir |
| 2 Reservoir cap |                                     |
| 3 Cover         |                                     |

The reservoir with filling inlet is mounted on the right-hand side of the driver's cab.

#### Topping up washer fluid

Filling quantity 3.5 litres .

- Unlock the cap on the reservoir and take it off.
- Top up with standard windshield washer fluid as necessary.

---

#### Caution

Ice can damage the windshield wiper and washer system.

Icing up can damage the windscreen wiper and washer system and cause it to fail.

! You must protect the windshield wiper and washer system using anti-freeze.



04sy02ab

- Use commercially available windscreen antifreeze.
- Top up with an appropriate quantity of antifreeze before the winter starts.

### 3.2.29 LIEBHERR automatic lubrication system

This equipment is optional.

The central lubrication system greases all the connected lubrication points in succession.

**Note**

All lubrication points not connected to the automatic central lubrication system, for example:  
 on the cardan shaft(s)  
 on optional equipment (such as the quick-change device)  
 ! must be lubricated manually.

**Layout**

The central lubrication pump with its transparent reservoir is installed on the left-hand side of the machine.

The button is in the right of the instrument panel.

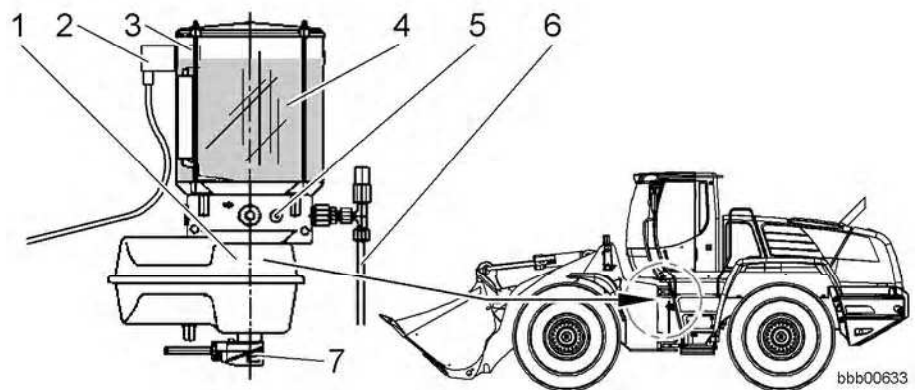

*Automatic central lubrication system*

- |                            |                                |
|----------------------------|--------------------------------|
| 1 Central lubrication pump | 5 Grease fitting               |
| 2 Electrical connector     | 6 Lubricant supply lines       |
| 3 Filling level sensor     | 7 Electrical connector (motor) |
| 4 Transparent container    |                                |

**Other components of the automatic central lubrication system:**

- Central lubrication system button (in the driver's cab)
- LEDs for monitoring functions
- One main progressive distributor
- Several secondary progressive distributors
- Motor

**Function description****Basic function**

The LIEBHERR automatic central lubrication system is a progressive system.

It lubricates progressively, i.e. all connected lubricating points in succession.

The central grease pump pumps the lubricant through all the supply lines and through one main and several secondary distributors to the lubrication points.

A pressure relief valve monitors the lubrication of all points.

After starting the engine and releasing the parking brake, lubrication is activated.

The connected lubrication points are lubricated at the set intervals. Lubrication stops when the transparent reservoir is empty.

**Function of the LEDs**

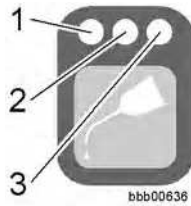

- LED 1 – light-duty operation
- LED 2 – medium-duty operation
- LED 3 – heavy-duty operation

the functions of the central lubrication system is indicated by the LEDs on the central lubrication system button.

LED	Function
One LED lights up	Mode 1, 2 or 3 has been set
One LED flashes	Pump is lubricated in mode 1, 2 or 3
All 3 LEDs light up	Grease reservoir is empty
All 3 LEDs flash	Fault in the central lubrication system

**Lubrication, cycle and idle times**

The main electronics system (MASTER) controls the central lubrication system.

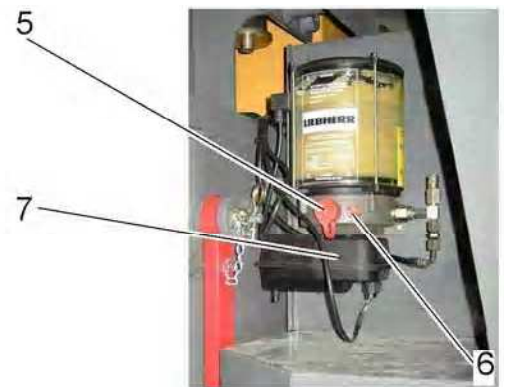
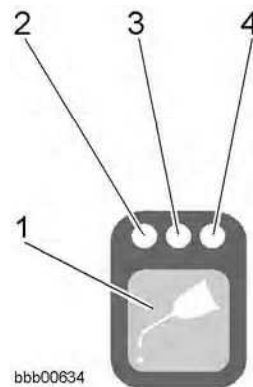

*Automatic central lubrication system*

- 1 Central lubrication system button
- 2 Left LED – mode 1 (light-duty operation)
- 3 Middle LED – mode 2 (medium-duty operation)
- 4 Right LED – mode 3 (heavy-duty operation)
- 5 Filling coupling (fast filling)
- 6 Grease fitting
- 7 Central lubrication pump

All further lubrication cycles follow automatically in a pattern determined by the set idle time.

During lubrication, if the ignition is switched off (engine stop) or the parking brake is engaged, the controller stops lubrication.

After starting the engine and releasing the parking brake, lubrication is continued at the point where it was interrupted.

LBH/03/003801/0003/5.06/en

Description	Value	Unit
Default lubrication time	24	Cycles
Default idle time	30	Min.
Adjustable lubrication time <sup>1)</sup>	min. 3 max. 10	Cycles Cycles

*Standard mode*

<sup>1)</sup>This setting can only be changed by LIEBHERR CUSTOMER SERVICE.

**Setting the idle times**



bbb00570

If the central lubrication button is pressed for longer than 2 seconds, setting mode is activated.

If the button remains pressed, the mode is changed every second or with every press of the button.

If the button is not pressed for 3 seconds, the last mode is stored.

Mode level	LED	Dead time
Mode 1	The LED on the left lights up	Idle time 45 min.
Mode 2	The LED in the middle lights up	Idle time 30 min. (can be changed)
Mode 3	The LED on the right lights up	Idle time 20 min.

Mode 2 can be set:

- In a range from 5 to 60 minutes
- By LIEBHERR CUSTOMER SERVICE at the request of the customer.

**Operating the central lubrication system**



bbb00570

Using the central lubrication system button, you can perform non-scheduled lubrication at any time when the ignition is switched on.

The default settings for the lubrication time and cycle times can be found in the section on lubrication, cycle and idle times.

- To start a non-scheduled lubrication:  
press the button briefly (for less than 2 seconds).

The pump is switched on until the specified lubrication quantity (24 cycles) has been attained.

Afterwards, the system waits for the set idle time until a new lubrication cycle starts.

### Cycle error

Causes of cycle errors:

- Engine is defective
- Lubrication point, lubricant supply line or distributor blocked.

If the set cycles set could not be performed in the time specified:

- All three LEDs on the central lubrication system button flash.

A service code is shown in the display in the event of a cycle error.

See the service code tables in chapter 4.

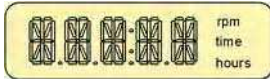

bbb00011

- To rectify the fault:  
Contact LIEBHERR CUSTOMER SERVICE.

### Grease level in reservoir too low

If the grease in the reservoir container is too low, all 3 LEDs on the central lubrication system button light up.

### Filling the reservoir

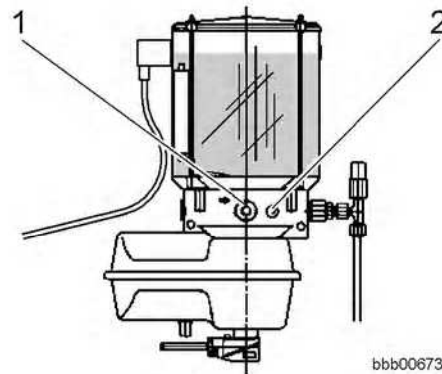

bbb00673

- Fill the reservoir:  
Via the filling coupling **1** (fast filling) or the grease fitting **2**.

**Grease specifications:** see the lubricants and fuels listed in chapter 5.



06sy09ab

### 3.2.30 Audible reverse warning device (back-up alarm)

This equipment is optional.

This equipment comes as standard with the tunnel version of the machine. In the driver's cab there is an additional warning shield with information to be observed regarding the reverse warning device.

The audible reverse warning system warns anyone standing behind the machine while it is reversing.

### Activating the reverse warning device



bbb00058

LH control lever and display unit

The reverse warning system is electrically actuated when the travel direction switch is in the reversing position.

An alarm sounds when you move the switch **1** to the **R** position for reversing.



#### Danger

There is a risk of accidents when reversing the machine.

Obstructed vision when reversing can cause accidents resulting in serious injury or death to bystanders.

! When reversing, make sure you have a clear view and observe the safety regulations.

#### Caution

There is a risk of damage when reversing the machine.

Obstructed vision while reversing can cause accidents resulting in damage to property.

! When reversing, make sure you have a clear view and observe the safety regulations.

- Press the switch **1** for **R = REVERSE** travel direction.

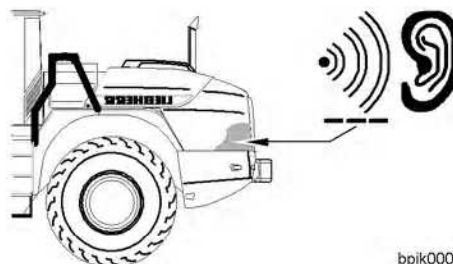

bpik0005

The reverse warning device, which is mounted at the back of the machine, on the left side in the engine compartment, emits an alarm tone of around 60 pulses per minute.

The alarm tone is roughly 5 decibels louder than the ambient noise.

#### Deactivating the back-up alarm

This equipment is optional.



**Danger**

There is an increased risk of accidents if you deactivate the back-up alarm.

! Only do so if it is absolutely necessary.



bbb00687

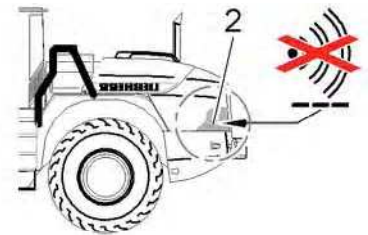

bbb00688

- For switching off the back-up alarm  
Press the back-up alarm deactivation button 1.
- Be especially carefully when reversing.

**3.2.31 Visible reverse warning device**

This equipment is optional.

The machine can also be equipped with a visual reverse warning device, in addition to the audible one.

Depending on the model, the following may be mounted on the rear of the vehicle:

- Two red warning lights
- A yellow flashing beacon

The visual reverse warning system warns anyone standing behind the machine while it is reversing.

**Activating the reverse warning device**

The warning lamps are electrically actuated when the travel direction switch is in the reversing position.



**Danger**

There is a risk of accidents when reversing the machine.

Obstructed vision when reversing can cause accidents resulting in serious injury or death to bystanders.

! When reversing, make sure you have a clear view and observe the safety regulations.



**Caution**

There is a risk of damage when reversing the machine. Obstructed vision while reversing can cause accidents resulting in damage to property.

! When reversing, make sure you have a clear view and observe the safety regulations.



bbb00058

LH control lever and display unit

- Press the switch 1 for R = **REVERSE** travel direction.

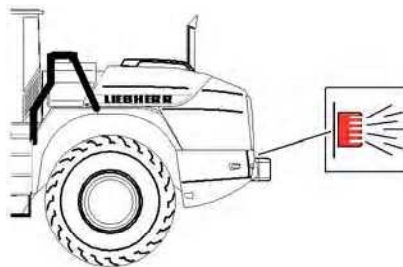

bbb00672

Depending on the version:

- The two warning lights flash
- The beacon lights up

**Deactivating the back-up alarm**

This equipment is optional.



**Danger**

There is an increased risk of accidents if you deactivate the back-up alarm.

! Only do so if it is absolutely necessary.



bbb00686

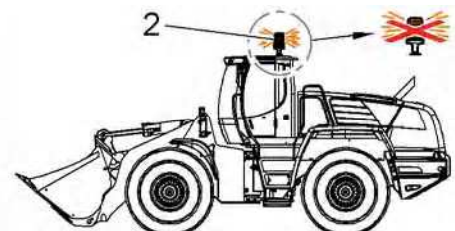

bbb00689

- For switching off the back-up alarm Press the back-up alarm deactivation switch 1.
- Be especially carefully when reversing.

LBH/03/003801/0003/5.06/en

### 3.2.32 Reversible fan drive

This equipment is optional.

The fan can be reversed to clean the cooler.

The interval for reversing the fan drive is adjustable because the need for cleaning depends on the conditions of use.

#### Setting the fan reversal interval

The interval for reversing the fan drive can be adjusted according to the conditions of use and need for cleaning.

The interval for reversing the fan can be set between 5 and 90 minutes.

The default setting for fan reversal is:

- Fan runs for 20 seconds
- The interval is 30 minutes

Make sure that the electrical system is switched on.

#### Procedure

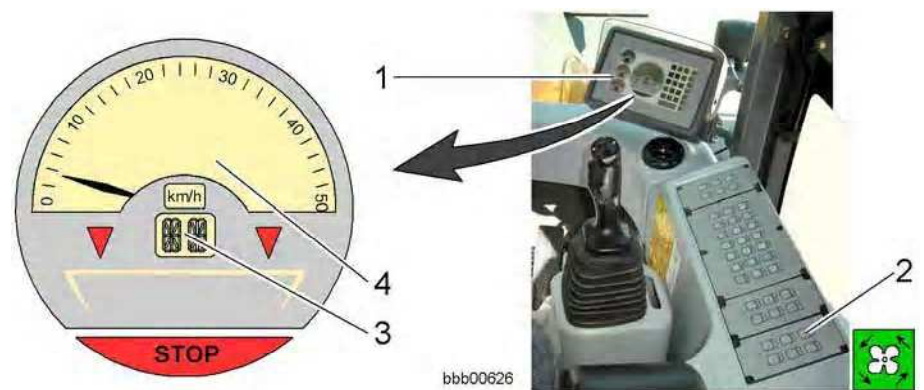

Reversible fan drive display and button

- |  |   |
|--|---|
| 1 Display unit                                     | 3 Reversible fan drive interval display <sup>1)</sup> |
| 2 Reversible fan drive button and indicator lamp   | <sup>1)</sup> This function is optional.              |
| 3 Selected gear and tractive force control display | 4 Travel speed display                                |



- Press the button **2** for the reversible fan drive for longer than 2 seconds.

The left LED glows as long as the fan reversal is active.

- Then press the button several times to alter the interval in increments.

The set interval is shown on the display unit **1**.

See reversible fan drive interval display **3**.

The display remains for approx. 3 seconds after you release the button. After 3 seconds with no button pressed or if the electrical system is switched off, the set time is applied and saved.

## Switching on the fan reversal

### Procedure

- Press the button **2** for the reversible fan drive for less than 2 seconds. The fan reversal function is activated with the interval you set.

The reversible fan drive interval display displays the following information:

\* = if fan reversal is activated

X = meaning the reversible fan drive is activated



### Note

The function remains active after the ignition is switched off.

! This means the function is still active when the ignition is switched on again.

---

## Switching off the fan reversal

### Procedure

- Press the button **2** for the reversible fan drive for less than 2 seconds.

### 3.3 Handling

#### 3.3.1 Daily start-up

Make sure that:

- The maintenance tasks to be carried out daily or every 10 service hours have been performed.  
See the maintenance and inspection schedule in chapter 5.
- Enough diesel fuel is available for the daily workload.  
See the section on refuelling with diesel fuel.

#### Operating position

This is how to put the machine into the operating position.

##### Turning on the battery main switch

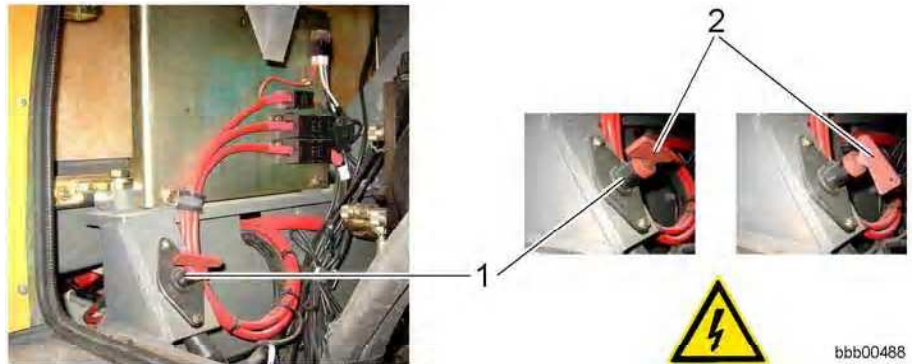

Battery main switch

1 Battery main switch

2 Main switch key

- Switch on the battery main switch.
- Close all service doors, hatches and hoods, and lock them if possible.

##### Closing the service doors, hatches and hoods

##### Releasing the articulation lock



**Warning**

There is a risk of accidents if the steering is locked.  
 When the articulation lock is engaged, no steering functions are possible.  
 ! Release the articulation lock.

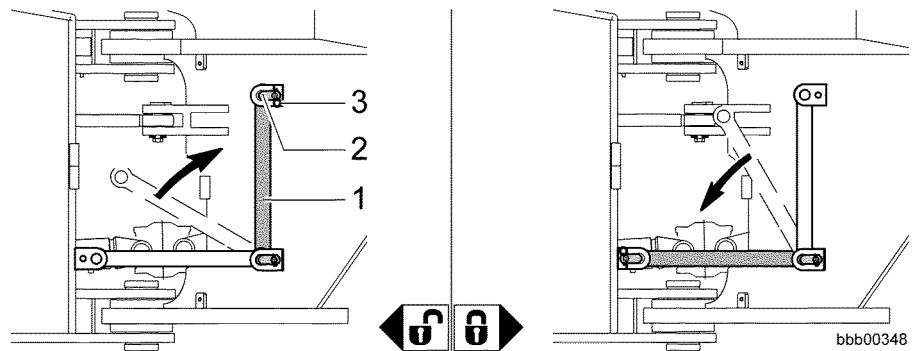

Articulation lock open / closed

1 Locking bar  
 2 Pin

3 Spring clip

- Pin the locking bar **1** in the top position.
- Secure the pin **2** from falling out using the spring clip **3**.

**Putting the machine in the starting position**

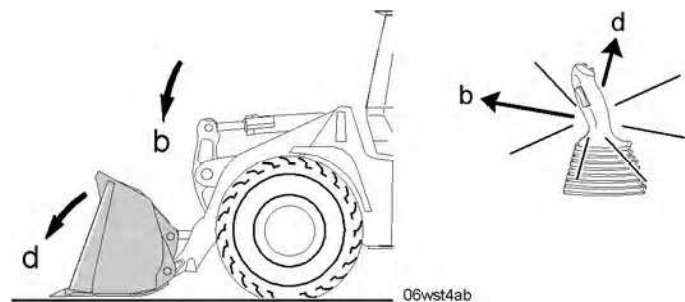

Starting position

- Set the bucket down flat on the ground.

**Refuelling with diesel fuel**

Make sure that the electrical system is switched on.

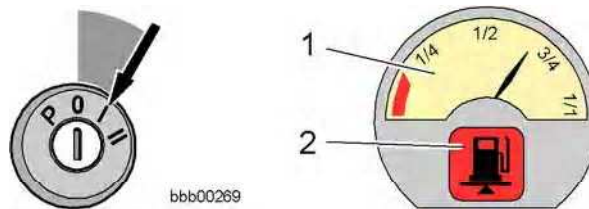

Diesel fuel display

1 Fuel supply display

2 Fuel supply symbol field

- Look at the fuel supply segment field **1** to see if there is sufficient diesel in the tank.

LBH/03/003801/0003/5.06/en

If there is too little fuel, the fuel supply symbol field 2 flashes.  
See also the section on the display unit.  
There is a residual quantity of approx. 35 litres in the tank.



Safety while refuelling



**Danger**

There is a risk of fires and explosions.

- ! Do not smoke. Make sure there are no naked lights when refuelling.
- ! Only refuel with the engine switched off.



Fuel tank

1 Tank cap

2 Cap

- It is essential to observe the safety regulations for refuelling. See also the safety regulations in chapter 2.
- Only use clean diesel fuel. See the section on diesel fuels in chapter 5.
- Carefully clean around the tank cap before taking it off.
- Refuel with diesel fuel as necessary.
- If possible, refuel at the end of the working day to prevent condensation from accumulating in the tank.

The machine is ready for operation.

**3.3.2 Starting the diesel engine**

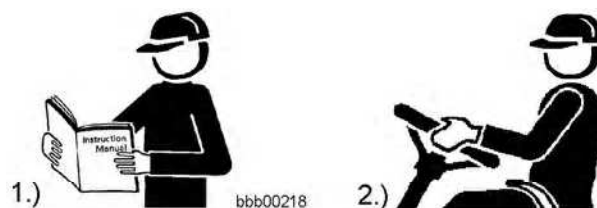

Operating manual

LBH/03/003801/0003/5.06/en

- 1.) Make sure you have read and understood the operator's manual
- 2.) Then you are ready to use the machine

Only ever operate the machine once you have read and understood the operating manual.



**Note**

Information about the machine's travel drive system:  
 The machine is equipped with a hydrostatic travel drive.  
 ! You cannot start the engine by bump-starting it or towing it.

**Starting precautions**

The following precautions must be taken before starting the machine. First make sure that the machine is in its operating position. See the section on the operating position.

**Starting procedure**

**Switch on the ignition.**



- Switch on the electrical system by turning the ignition key to position I. The master electronics are booted up.

**Boot phase of the main electronics (master)**

Boot phase process.

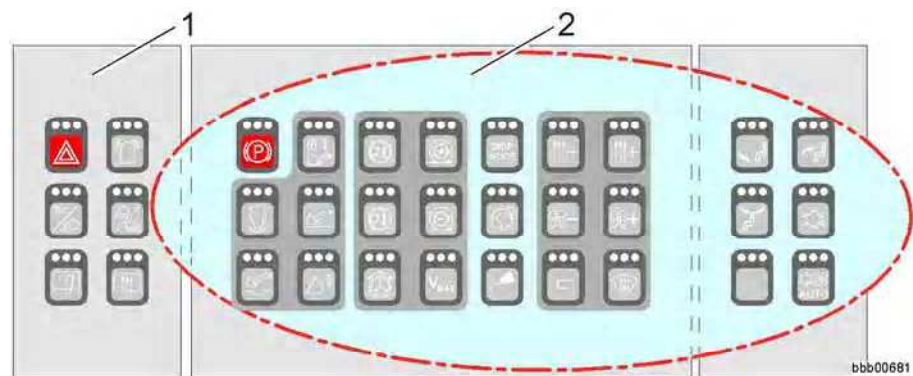

Control units

1 Electrical system, keypad

2 CAN bus control unit

The control system (CAN bus) is started up during the boot phase. During the boot phase, all the LEDs on all buttons of the CAN bus control unit 2 briefly light up.

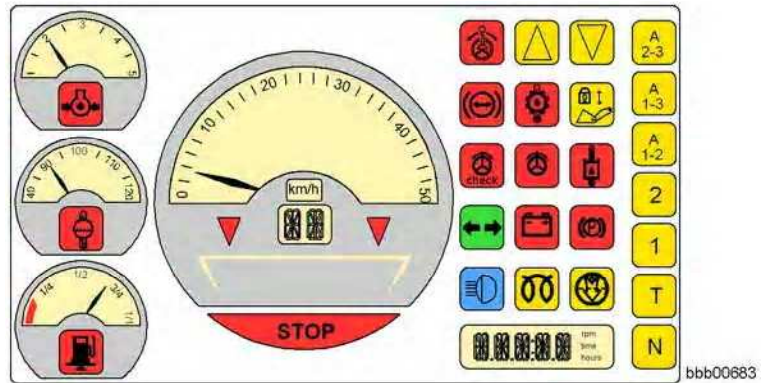

**Main electronics (master) standby**

At the same time, all the segment and symbol fields on the display unit briefly light up.

Standby for starting the engine is indicated as follows.

The LEDs on most of the buttons go out.



The LEDs on the following buttons do not go out.

- Parking brake button 1
- Working hydraulics lockout button 2
- All buttons with a memory function (if they have been active since the last start-up)  
(See the section on control units.)

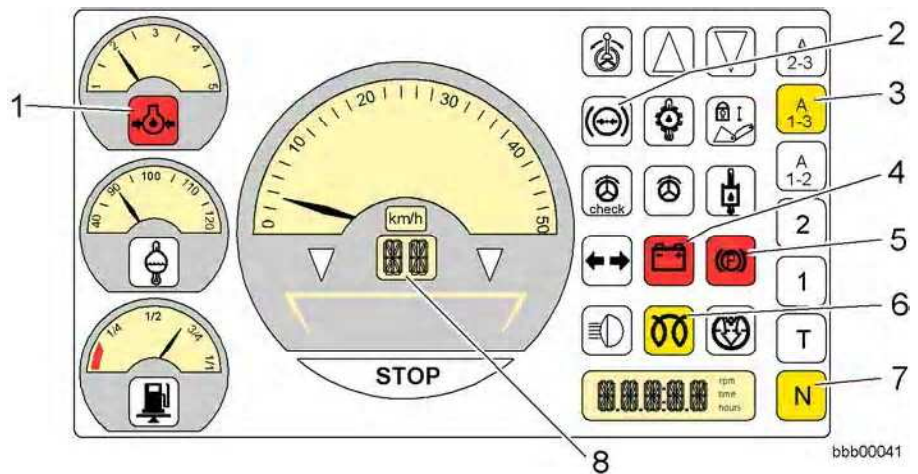

Display unit

- |  |  |
|--|--|
| 1 Engine oil pressure symbol field               | 5 Parking brake symbol field                       |
| 2 Brake system accumulator pressure symbol field | 6 Preglow monitor symbol field <sup>1)</sup>       |
| 3 Automatic travel range 1-3 symbol field        | 7 Neutral position N symbol field                  |
| 4 Battery charge (charge control) symbol field   | 8 Selected gear and tractive force control display |

LBH/03/003801/0003/5.06/en



After the check is completed, the following symbol fields must still flash or light up with the key in position I:

- 1 Engine oil pressure (red) flashes
  - 2 Brake system accumulator (red):  
. Lights up when the brake accumulator pressure is too low.
  - 3 Automatic travel range 1-3 (yellow) lights up
  - 4 Battery charge (red) lights up
  - 5 Parking brake (red) lights up
  - 6 Preglow monitor <sup>1)</sup>(yellow):  
. Lights up at temperatures below + 5 °C .
- Wait for the preglow period if necessary:  
See the section on the preglowing the engine.
- 7 Neutral N (yellow) lights up
  - 8 Selected gear and tractive force control  
. 1 indicates that gear 1 is selected.

### Preglowing the engine

The preglow time depends on the outside temperature.

At positive temperatures above 5 °C preglowing does not take place.

- At temperatures below + 5 °C :  
Wait until the symbol field **6** for the preglow monitor goes out.



At temperatures below + 5 °C :

- The engine controller regulates the preglow period until the engine is ready to start.
- Depending on the temperature, preglowing takes from 0 to 20 seconds.

### Starting the engine

The engine is ready to start, as soon as:

- The control system (CAN bus) is started up
- The usual symbols such as the parking brake light up on the display unit
- The indicators on the analogue instruments are clearly visible
- The preglow monitor symbol field **6** has gone out

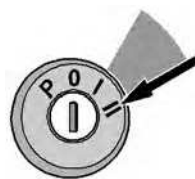

bbb00674

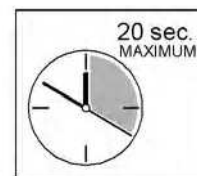

*Ignition switch starting position*

- Turn the ignition key to the starting position **II** and keep it in there until the engine starts.
- **Do not hold the key in the starting position for more than 20 seconds at a time.**
- If the engine does not start:  
Turn the ignition key back to the 0 position.

**Troubleshooting**

The engine will not start.

- Wait 60 seconds and try to start the engine again.
- If the motor does not start after three attempts, find the cause and rectify it.  
See the service code tables in chapter 4.

- Let go of the ignition key as soon as the engine starts running.

The ignition key automatically returns to the operating position.

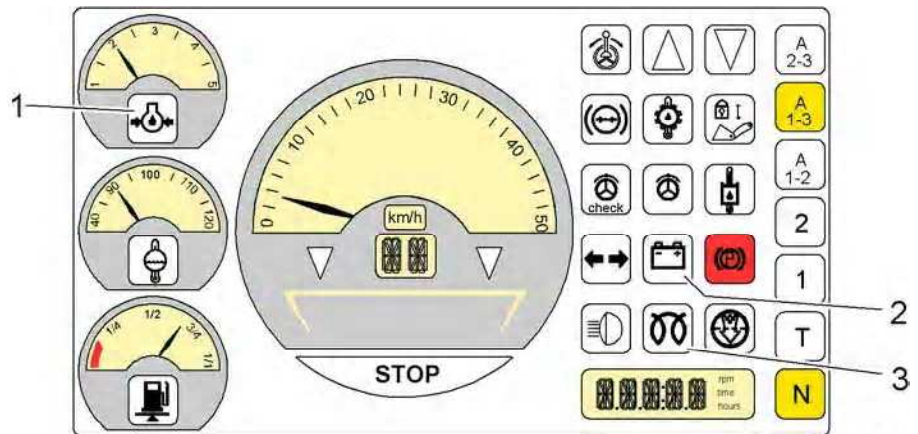

bbb00042

Display unit

- |                                    |  |
|------------------------------------|--|
| 1 Engine oil pressure symbol field | 2 Battery charge (charge control) symbol field |
|                                    | 3 Preglow monitor symbol field                 |

**When the engine starts, the following symbol fields must go out:**

- 1 Engine oil pressure (red)
- 2 Battery charge (red)
- 3 Preglow monitor (yellow)



**Note**

When the engine is being preheated, the symbol field 3 goes out when the preglow time has elapsed, i.e. when the engine is ready.  
! Even at extremely low temperatures, preglowing does not take more than 20 seconds.

**Troubleshooting**

The symbol fields 1, 2 and 3 do not go out.

- Switch off the engine and rectify the problem as described in the section on malfunctions.
- Once the engine has started, decrease the engine speed to a medium speed.
- Briefly let the engine warm up by actuating the working attachments at medium load.
- Then gradually increase to full load.

LBH/03/003801/0003/5.06/en

### Starting precautions at cold temperatures



Winter operation

The following precautions help you start the engine at cold temperatures.

Precautions:

- Check the battery charge  
If necessary, recharge the battery.
- Use winter-grade fuel  
See the section on diesel fuels in chapter 5.
- Use an auxiliary engine preheating system heating (cooling water):  
If required, the machine can be equipped with an auxiliary engine prewarming system (cooling water).  
The auxiliary engine prewarming system is optionally available from your LIEBHERR dealer.



#### Warning

There is a risk of explosion with the diesel engine.  
There is a risk of explosions when using volatile fluids for diesel engines with preglow systems.  
**!** Do not use starting agents containing ethers.

- Carry out the precautions listed for starting at temperatures below freezing.

### 3.3.3 Driving



This is the situation after the electrical system is switched on:

- After the electrical system has been turned on, automatic travel range **A1-3** is automatically selected.  
The segment display in the display unit indicates gear level **1**.
- The parking brake is automatically activated.
- When the parking brake is engaged, the travel lockout is active.
- The travel direction cannot be preselected.

#### Preparing for driving

Carry out the preparations for driving in the following order.  
First make sure that the machine is in its operating position.  
See the section on the operating position.

**Checking the lights**

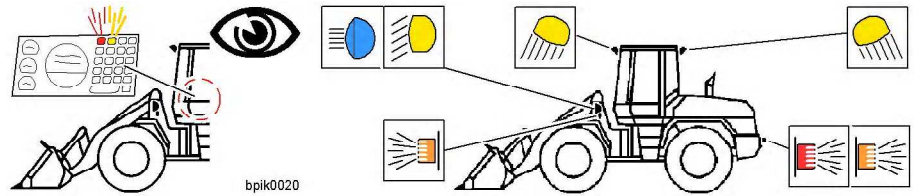

bpik0020

*Lighting equipment*

- Check all of the lighting equipment.
- Adjust the headlights if necessary.

**Checking the interior and exterior mirrors**

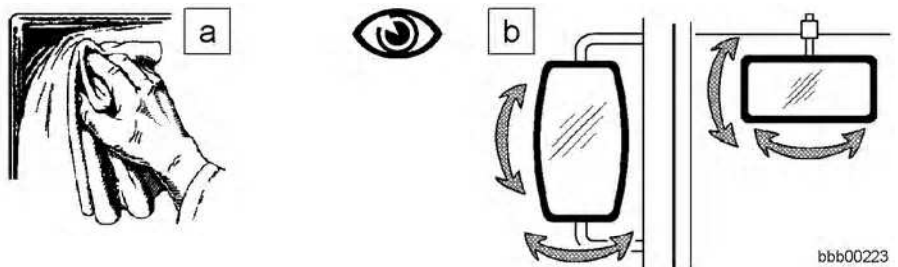

bbb00223

*Interior and exterior mirrors*

- Clean the interior and exterior mirrors.
- Adjust the interior and exterior mirrors.

**Starting the machine**

- Turn the ignition key to the starting position II and keep it in there until the engine starts.  
See also the starting procedure in the section on starting the diesel engine.

**Putting the working attachment into position**

For detailed information, see the sections on the LIEBHERR control lever and using the lift arms.

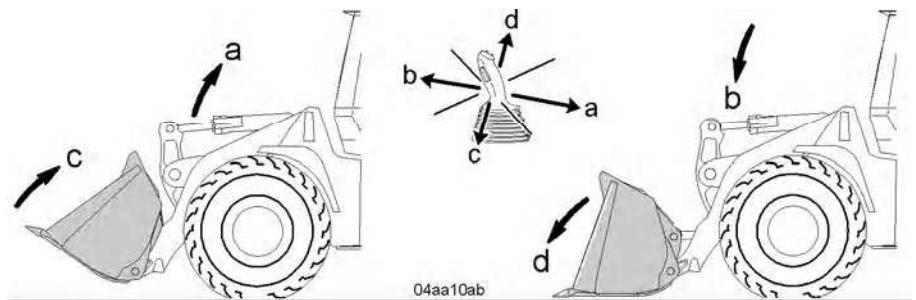

04aa10ab

*Bucket position*

- Raise or lower the lift arm to the starting position.
- Move the bucket into position.

LBH/03/003801/0003/5.06/en

**Releasing the parking brake**

When the parking brake is engaged, the travel lockout is active. The travel direction cannot be preselected.

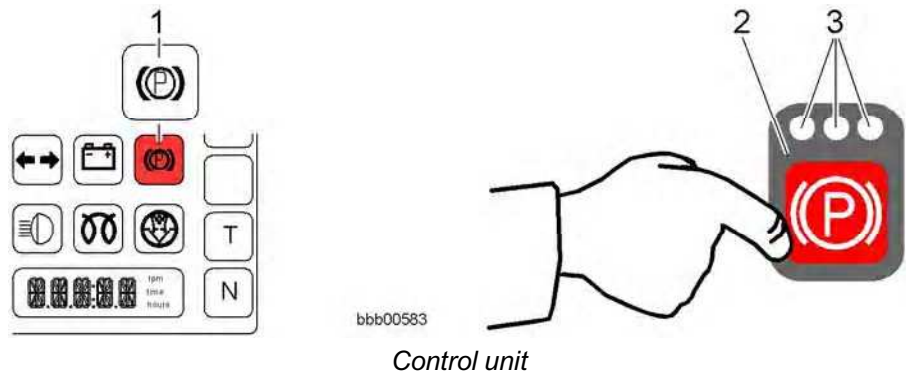

- 1 Parking brake symbol field
- 2 Parking brake button
- 3 LEDs

- Press the button 2 to release the parking brake. All 3 LEDs on the button go out. The symbol field 1 for the parking brake goes out.

**Selecting the travel direction**

This might be the situation after the electrical system is switched on.

**The forward or reverse travel direction symbol field flashes:**

- When the ignition key is in position I or II  
If the travel direction switch is set to forward or reverse.
- When the ignition key is in position II  
When the parking brake button has been pressed.



The flashing symbol field is accompanied by a warning beep.

- If this is the situation:  
Move the travel direction switch to the middle, neutral position. You can now preselect forward or reverse travel again by pushing the travel direction switch.

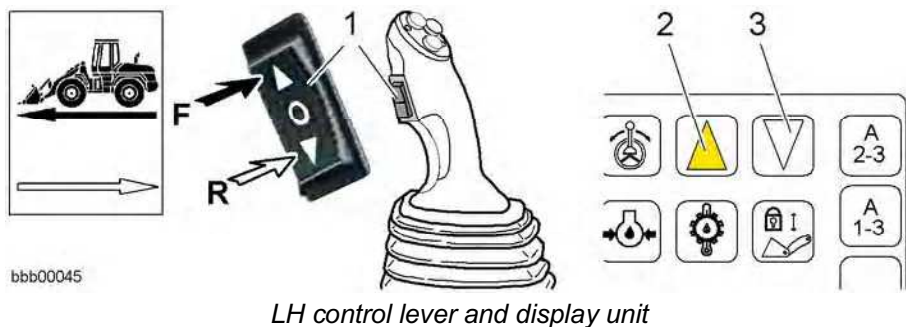

- 1 Travel direction switch
- 2 Forward travel direction symbol field
- 3 Reverse travel direction symbol field

- Press the switch 1 for F = FORWARD travel direction.
- or
- Press the switch 1 for R = REVERSE travel direction. Depending on the switch position, the symbol field for forward travel 2 or for reverse travel 3 lights up.

LBH/03/003801/0003/5.06/en

**Selecting travel ranges**

When the electrical system is switched on, the automatic travel range **A1-3** is selected and the travel drive is set to neutral **N**.

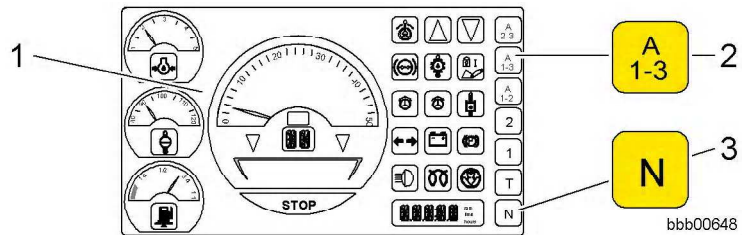

Both travel ranges are shown by symbol field **2** or **3** in the display unit **1**.

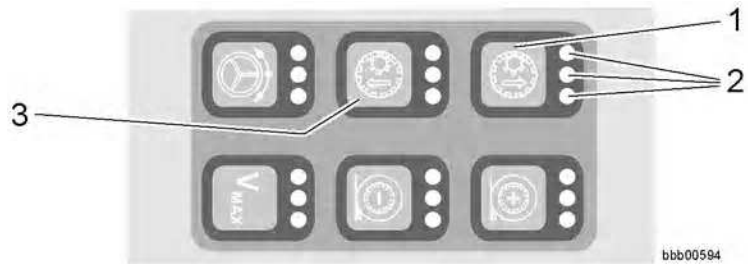

Control unit

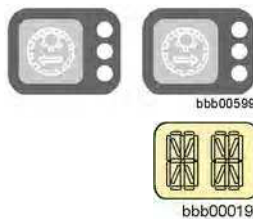

You can select the travel ranges using the buttons **1** and **3** on the control unit.

All three LEDs **2** light up briefly when the buttons are pressed.

The segment display (see display unit) shows the gear level selected.

You can shift to another travel range at any speed.

If you shift down at too high a speed:

- The machine is first braked hydrostatically.
- The travel range is then automatically shifted down.

**You can select the following travel ranges:**



bbb00025

Fixed gear **1** for slow driving (on steep slopes).

- This shifts the gears to gear level **1**.
- The segment display shows gear level **1**.



bbb00024

Fixed gear **2** for normal working operation.

- This shifts the gears to gear level **2**.
- The segment display shows gear level **2**.

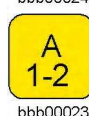

bbb00023

Automatic travel range **A1-2** for normal working operation.

- This shifts the gears to gear level **1** or **2**.
- If the gears are shifted when the machine is stationary, the segment display shows gear **1**.
- If the gears are shifted when the machine is moving, the segment display shows the gear level depending on the travel speed.



bbb00022

Automatic travel range **A1-3** for all kinds of operation.

- This shifts the gears to gear level **1**, **2** or **3**.
- If the gears are shifted when the machine is stationary, the segment display shows gear **1**.
- If the gears are shifted when the machine is moving, the segment display shows the gear level depending on the travel speed.

LBH/03/003801/0003/15.06/en



- Automatic travel range A2-3** for driving on public roads or for transport.
- This shifts the gears to gear level **2** or **3**.
  - If the gears are shifted when the machine is stationary, the segment display shows gear **2**.
  - If the gears are shifted when the machine is moving, the segment display shows the gear level depending on the travel speed.



- Tempomat T** when slow travel is required.
- The machine keeps to the travel speed at the time the function is activated.
  - The segment display shows gear **1** or **2** depending on the selected fixed gear.



- Neutral position N** for shifting the travel direction to neutral.
- The travel drive is switched to neutral.
  - The segment display shows gear level **1**.

**Shifting gear in automatic travel ranges:**

- Gear levels **1**, **2** and **3** are automatically shifted according to the the gas pedal position, the travel speed and the rate of acceleration or deceleration.

Travel speeds: see the technical data section.

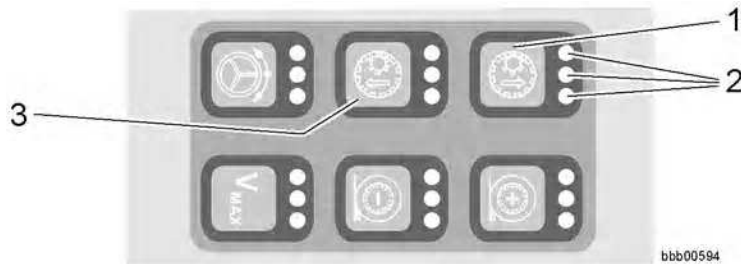

Control unit

- Depending on the type of use, press the button **1** or **3** to select the required travel range.

All three LEDs **2** light up briefly when the buttons are pressed. The segment display (see display unit) shows the gear level selected.

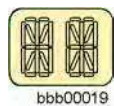

**Setting off**

After the electrical system has been turned on, automatic travel range **A1-3** is automatically selected.

The segment display in the display unit indicates gear level **1**.

Make sure that you have carried out all the preparations for driving.

See also the section on preparing for driving.

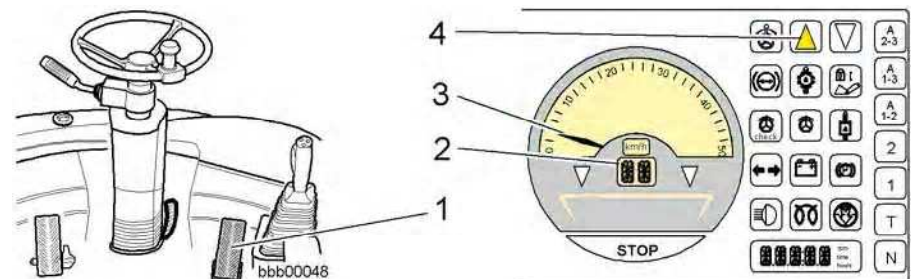

Gas pedal and travel speed display

1 Gas pedal

2 Gear level LCD

LBH/03/003801/0003/5.06/en

3 Travel speed display

4 Travel direction symbol field

- Push down the gas pedal **1**.

The machine starts moving.

- Control the travel speed using the gas pedal.

The gear selected when setting off is displayed in the LCD field **2**.

The travel speed is indicated by the travel speed display **3**.

### Driving

You will find descriptions of work operations, driving, transport and transferring bulk material in the section on general working methods.

Just after you set off, check that the steering and brakes are working properly.

See the section on maintenance tasks in chapter 5.

### Overspeed protection

The diesel engine and variable displacement motors can overspeed when driving down a steep slope.

The machine has an overspeed protection system to prevent injury and damage.

However, the overspeed protection system does not provide protection against deliberately reckless driving down steep slopes.

### Driving on even terrain

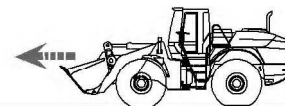

bbb00204

When a certain speed is reached in each travel range (forward and reverse), the pump flow of the working hydraulics pump is reduced.

This speed is slightly above the stated maximum speed in each travel range.

This prevents the machine from exceeding the maximum permitted speed on even terrain.

The overspeed protection system is not activated.

### Driving on a steep downhill slope

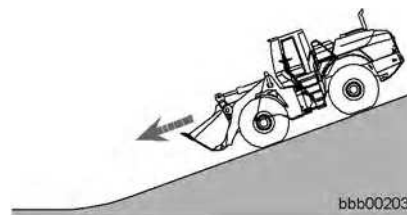

bbb00203

When a certain speed is reached in each travel range (forward and reverse), the pump flow of the working hydraulics pump is reduced.

The machine is braked hydrostatically.

If the steep slope causes the machine to greatly exceed the stated maximum speed in each travel range (forwards and reverse), the overspeed protection system is activated.

### Overspeed protection functions:

Protects against excessive output speed

Protects the diesel engine from overspeed

Activates the rear axle brake

Protects from rolling downhill

LBH/03/003801/0003/5.06/en



**Overspeed causes the following actions:**

- The automatic rear axle brake is activated.
- The warning buzzer sounds for one second.



**Warning**

Danger can be caused by deliberately or recklessly driving down steep slopes.

When driving down a steep slope without due care, the diesel engine and the variable displacement motors can overspeed.

! Do not drive recklessly down steep slopes.

**Deliberately reckless driving down slopes means:**

- The driver drives downhill too fast
- The automatic rear axle brake (overspeed) is active for more than 3 seconds due to excess engine speed or travel speed.

• **If driving on a long, steep downhill slope:**

First activate kick-down mode (see the section on driving with kick-down shifting).

The machine is automatically hydrostatically braked and the mains electronics (MASER) switches to first gear (travel range I).

The machine remains in first gear until you press the gas pedal.

- If the speed continues to increase due to the steepness of the downhill slope:

Operate the brake pedal.

**Driving with kick-down shifting**

The kick-down function allows temporary manual shifting to first gear.

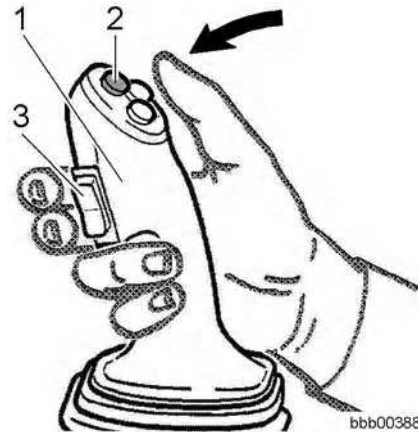

LH control lever

- 1 LH control lever
- 2 Kick-down button

- 3 Travel direction switch

**Kick-down shifting is used in the following situations:**

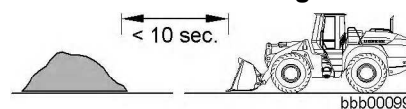

**a) When approaching the pile**

This allows you to work on the pile in first gear.

The kick-down function hydrostatically brakes the machine, and it switches down to first gear.

While pushing into the pile, first gear remains selected as long as the resistance is high.

Kick-down mode is deactivated when you change travel direction.

- If you want to use kick-down shifting:  
Press the kick-down button **2** on the LH control lever **1**.

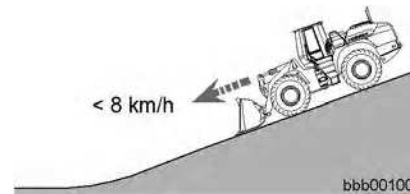
**b) Driving onto a steep downhill slope**

Before driving onto a steep slope, you can also use the kick-down function to shift to travel range I (first gear).

The machine remains in first gear until you press the gas pedal.

In kick-down mode, the maximum travel speed is 8 km/h .

- If driving on a long, steep downhill slope:  
First activate kick-down mode.

The machine is automatically hydrostatically braked and the main electronics (MASTER) switches to first gear.

At high travel speeds, the machine automatically shifts from third to second gear, and then to first gear.

The machine remains in first gear until you press the gas pedal.

When you press the gas pedal, the main electronics (MASTER) automatically switches to second and third gear.

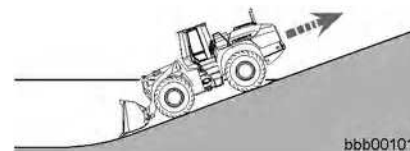
**c) Driving backwards up a steep slope**

When you select the travel direction, the machine drives off in second gear.

If steep terrain prevents this, the main electronics (MASTER) automatically switches to first gear after 0.8 seconds.

- If you cannot wait 0.8 seconds:  
You can switch to first gear immediately using the kick-down function.
- If you want to use kick-down shifting:  
Set the travel direction switch **3** to reverse and at the same time press the kick-down button **2** on the LH control lever **1**.

**Driving with the Vmax (Tempomat) function**

When slow driving is necessary, the Vmax (Tempomat) function can be activated.

**This function is only available when travelling forward in fixed gears 1 and 2.**

If activated while the machine is moving:

- The machine keeps to the travel speed (Vmax) at the time the function is activated.  
The speed thus set is the maximum speed.

If activated while the machine is at a standstill:

- The machine travels at the minimum speed of the selected gear.  
Gear level 1: approx. 4 km/h  
Gear level 2: approx. 10 km/h

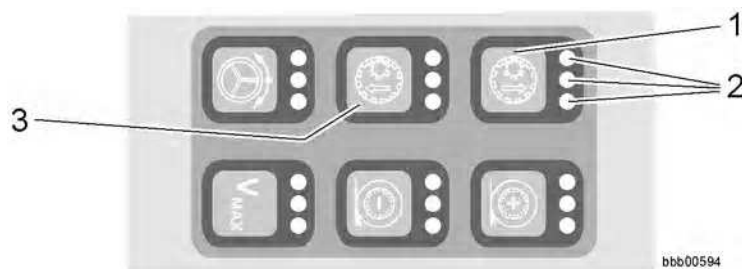

Control unit

- **To drive off at the desired speed (select fixed gear 1 or 2):**  
Press button 1 or 3.

All three LEDs 2 light up briefly when the buttons are pressed. The segment display (see display unit) shows the gear level selected.



- Press the button 1 for Vmax (Tempomat).  
All 3 LEDs on the pressed button flash.
- Put your foot down on the gas pedal to attain the desired speed:

The function is deactivated in the following conditions:

- If you press the reverse travel direction switch.
- The control electronics switch to automatic travel range **A1-3**.

- **Switching off Vmax (Tempomat):** Press the button 1 again.  
All 3 LEDs on the button go out.

or

- Select a different travel range.

**Driving without LFD**

The LFD system is the Liebherr ride control system.

If you travel long distances without LFD you may experience vibrations while driving.

Therefore, the LFD system should be activated for all applications which require significant distances to be covered.

- Improve driving comfort by activating the LFD system.

**Driving with LFD**

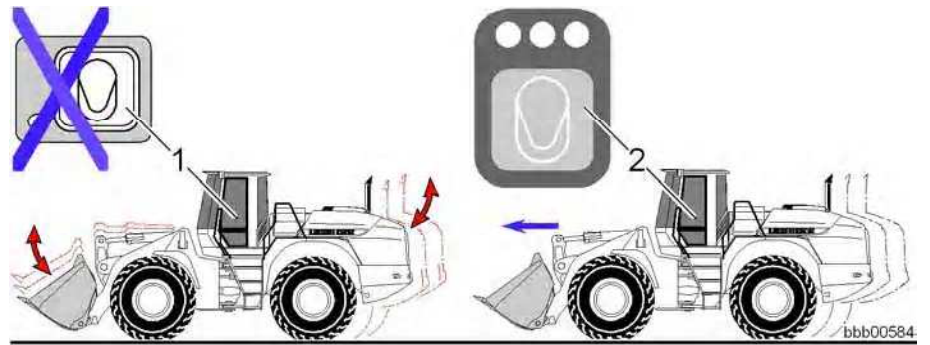

1 Driving without LFD

2 Driving with LFD

The LFD system improves driver comfort in nearly all situations by reducing vibrations.

Therefore, the LFD system should be activated for all applications which require significant distances to be covered.

**Activating the LFD system**

If you have activated the LFD system, it is automatically switched on when the machine reaches a certain speed.

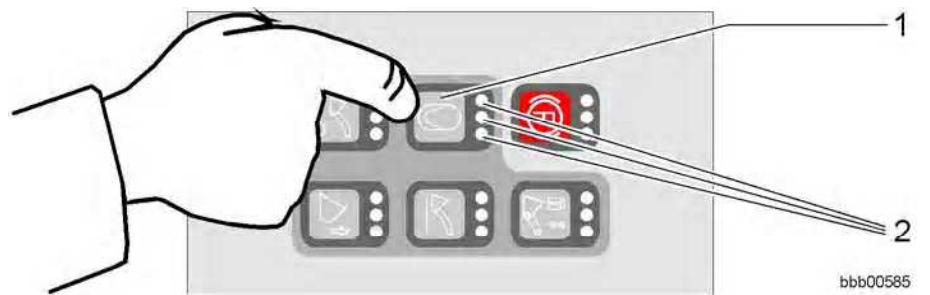

1 Ride control button

2 LEDs



Press the button 1 for ride control (LFD system) to prepare the function.

- Press the button 1 for ride control (LFD system).

All 3 LEDs on the pressed button flash.

The LFD system is now activated.

The LFD system automatically switches on when the machine speed is more than 10 km/h .

**Reversing**

The machine can be reversed in either travel direction and at any travel speed.

**Shifting process when reversing**

- When reversing in travel ranges **A1-2** (automatic), **A1-3** (automatic) or **A2-3** (automatic) the machine does not shift back automatically to gear level 1.
- The system only shifts to gear level 1 when it is not possible to drive off in gear level 2.

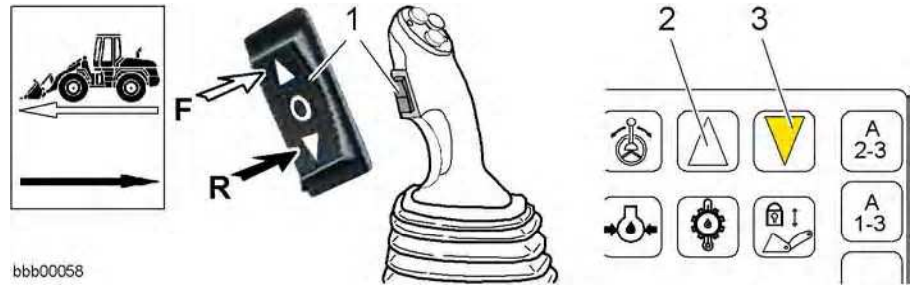

bbb00058

*Travel direction switch and display unit*

- |   |   |
|---|---|
| 1 Travel direction switch               | 3 Reverse travel direction symbol field |
| 2 Forward travel direction symbol field |   |

- To change the travel direction, press the switch 1. Depending on the switch position, the symbol field for forward travel 2 or for reverse travel 3 lights up.

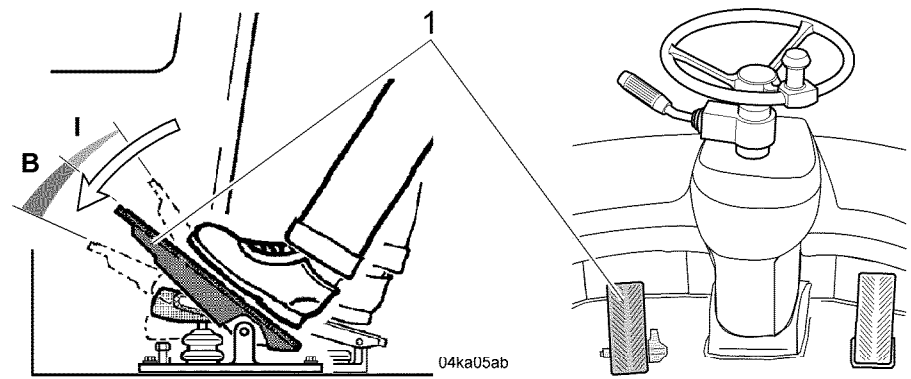

04ka05ab

*Inch/brake pedal*

- **If a gentle reverse action is required:**  
Support the reversing procedure by easing off the gas pedal or by gently pressing the inch/brake pedal. This results in smooth reversing action.

**Tractive force adjustment**



You can adjust the maximum tractive force of the machine for special working conditions such as on loose sand. This prevents the wheels from spinning on sandy ground.

See also the section on control units.

**The tractive force is adjusted:**

- When the button for tractive force adjustment has been pressed.
- Only in the forward travel direction.
- If the the machine's travel speed is less than 3 km/h .
- Only in gear 1.

**Reducing the tractive force:**

Switch the button for tractive force adjustment to the required level.

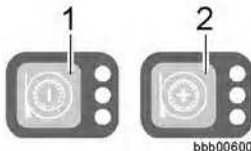

**1** Less tractive force (< 100% to 70%)

If the tractive force is set at less than 100%, the tractive force reduction is activated accordingly.

**2** More tractive force (> 70% to 100%)

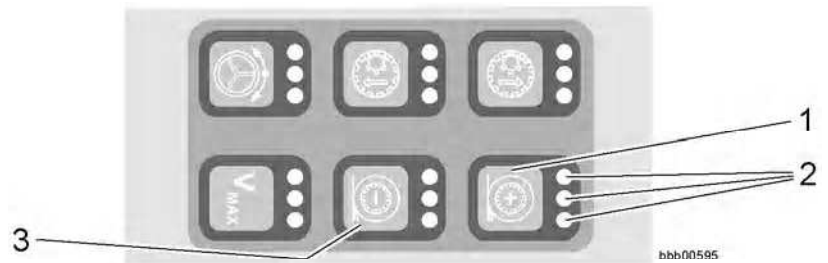

Control unit

- 1 Increase tractive force button
- 2 LEDs
- 3 Reduce tractive force button

- To reduce the tractive force (< 100% to 70%):

Press the button **3** to reduce the tractive force.

The tractive force adjustment function is now activated.

The tractive force is now only 95%.

Each time you press the button **3** the tractive force is reduced further.

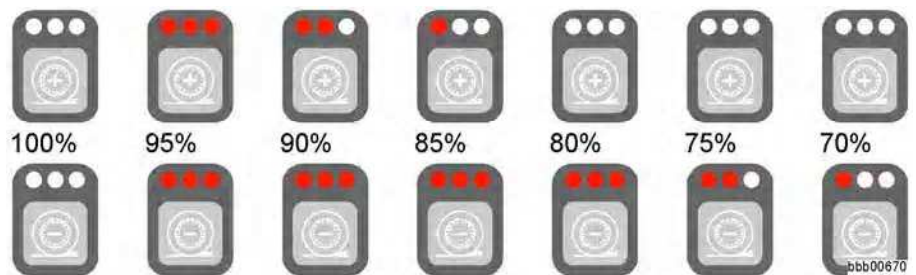

The LEDs **2** on the two buttons **1** and **3** light up according to the set tractive force.

The value set previously for the tractive force is shown for one and a half seconds on the segment display unit (see display unit).

The newly set value is shown as a percentage (between 70% and 100% in 5% increments) on the display unit.

**Increasing the tractive force:**

- To increase the tractive force (> 70% to 100%):

Press the button **1** to increase the tractive force.

Each time you press the button **1** the tractive force is increased further.

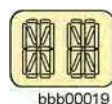

LBH/03/003801/0003/5.06/en



The LEDs **2** on the two buttons **1** and **3** light up according to the set tractive force.

If the tractive force is set at 100%, the function is deactivated.

No LEDs light up.

- **When you no longer need tractive force adjustment:  
Switch the tractive force button to increase to 100%.**

If the tractive force is set at 100%, the function is deactivated.

Otherwise you cannot reach the maximum tractive force.

### Driving on public roads

Before driving on public roads, find out about the route (roads, bridges, tunnels, underpasses, bottlenecks etc.) as regards the weight limit, bridge load, width and height restrictions.

Wheel loaders which are limited by design to a maximum speed of 20 km/h and have no official registration number must be labelled on both sides with the operating company's address and require an operational liability insurance certificate.

**The wheel loader may only be driven on public roads when unloaded.**

Before driving on public roads, find out the following:

- Ask the vehicle owner whether the necessary conditions for permission to drive on public roads have been met.
  - “Operating permit”
  - “Special license”
- The appropriate safety regulations.
- See the following sections in chapter 2:
  - “Safety instructions for driving on slopes”
  - “Instructions for safe working”

Make sure that you have carried out all the preparations for driving.

**Preparing for driving on roads**

Make sure that the safety devices listed below are all stowed on board, in accordance with the provisions of the **Roadworthiness Certification**.

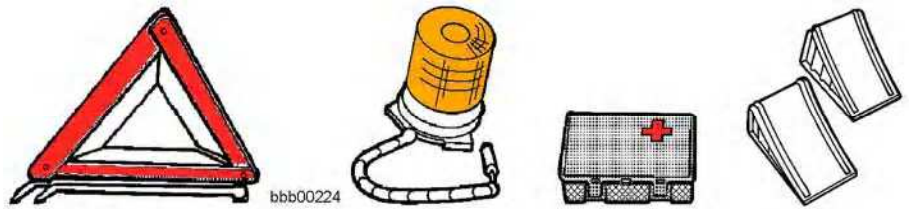

- Warning triangle
- Flashing beacon
- First aid kit
- Wheel wedges

Also make sure that you have carried out all the tasks listed below.

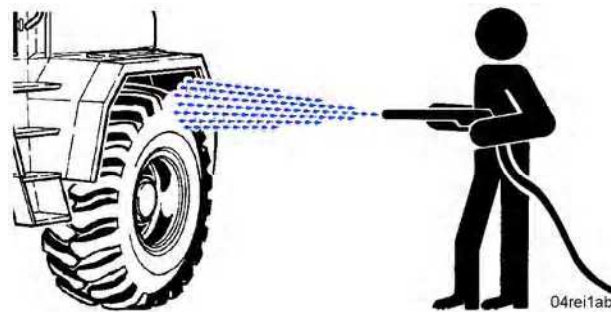

*Washing*

- Remove coarse dirt from the machine and clean the tyre treads.
- See the section on cleaning the machine in chapter 5.
- Close all service doors, hatches, covers and hoods and where possible lock them.

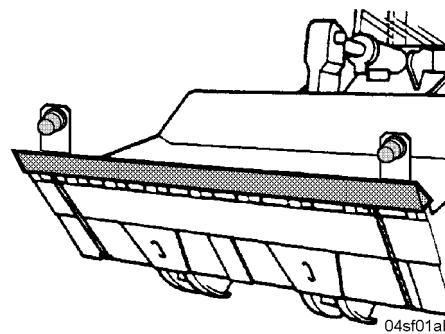

*Bucket tooth guard and side lamps*

- Attach the tooth guard to the bucket.
- Attach the side lamps.
- Plug in the cables for the side lights.

LBH/03/003801/0003/5.06/en



**Driving** You will find descriptions of work operations, driving, transport and transferring bulk material in the section on general working methods.

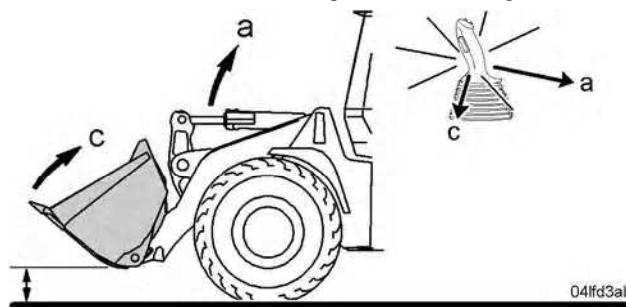

Transport height

Make sure that:

- The bucket is in the transport position when driving.  
The transport position means The bucket pivot point must be approximately 40 cm above the ground.
- The bucket is tipped up as far as it will go.



bbb00550

Make sure that the working hydraulics are locked so that the working attachment cannot be moved inadvertently.

See also the section on locking the working hydraulics.

- Always drive with due care.
- Observe the highway code.

**Braking**

There are two ways to brake the machine:

- With the hydrostatic circuit only.
- With the hydrostatic circuit and the disc brake.

**Hydrostatic braking**

You can brake the machine hydrostatically by reducing the engine speed. The hydrostatic travel drive system of the machine also acts as a service brake in the deceleration phase.

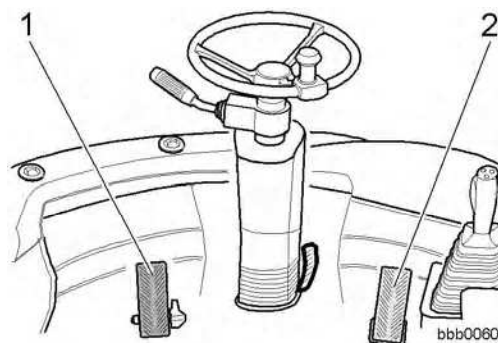

Inch/brake pedal and gas pedal

1 Inch/brake pedal

2 Gas pedal

- Reduce the speed of the diesel engine with the gas pedal 2.

**Service brake**

If hydrostatic braking is not sufficient, you must brake the machine using the inch/brake pedal 1.

LBH/03/003801/0003/5.06/en

**Braking with the inch/brake pedal**

- During braking, there are two actuation ranges for the inch/brake pedal:
- Range **I** for hydrostatic braking only.
  - Range **B** for braking with the hydrostatic circuit and with the wet disc brakes in the wheel hubs.

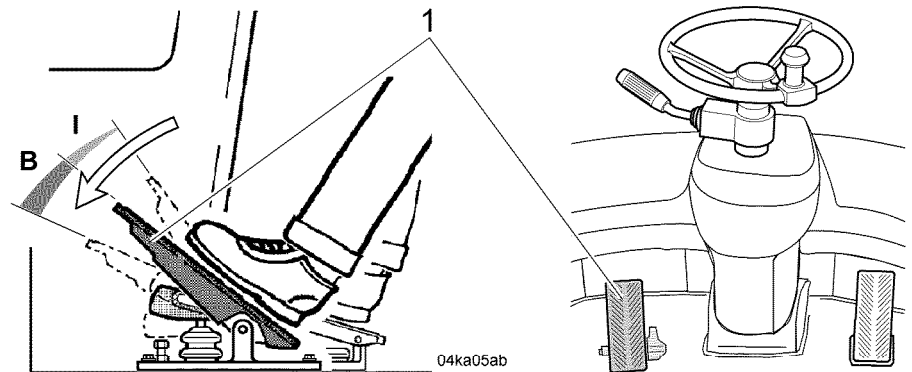

*Inch/brake pedal*

1 Inch/brake pedal  
I Inching range

B Braking range



**Danger**

There is a risk of accidents when braking. If you brake the machine, you may suffer severe injuries if your seat belt is not properly fastened.

- ! It is essential that you fasten your seat belt before starting up the machine.
- ! For full braking in emergencies, push the inch/brake pedal all the way down.

- Braking with the hydrostatic circuit only: Press the inch/brake pedal **1** in range **I**.

or

- Braking with the hydrostatic circuit and the disc brake: Press the inch/brake pedal **1** in range **B**. The machine is braked accordingly.

**Troubleshooting**

Little or no braking effect.

- Shut down the machine immediately.
- Contact LIEBHERR CUSTOMER SERVICE.

**Braking in emergencies**

LBH/03/003801/0003/5.06/en



**Danger**

There is a risk of accidents when braking.

If you brake the machine, you may suffer severe injuries if your seat belt is not properly fastened.

! It is essential that you fasten your seat belt before starting up the machine.

! For full braking in emergencies, push the inch/brake pedal all the way down.

- Press the inch/brake pedal **1** in range **B** as far as it will go.

This brakes the machine suddenly.

**After the machine stops**

If you leave the machine with the engine running, take the following precautions.

**Engaging the parking brake**

Do not engage the parking brake until the machine has come to a full standstill.

When you engage the parking brake the travel direction is automatically switched to neutral.

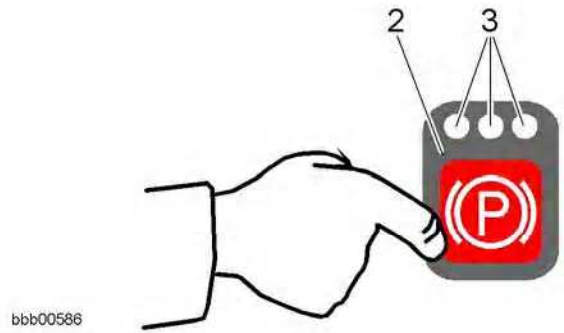
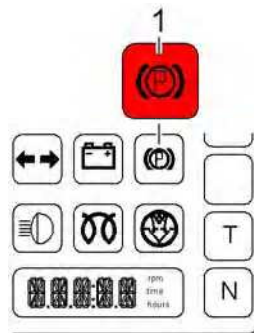

bbb00586

Control unit

- 1 Parking brake symbol field
- 2 Parking brake button

3 LEDs

- Activate the parking brake with the button **2**.

All three LEDs **3** on the pressed button flash.

The symbol field **1** for the parking brake lights up.

The parking brake is engaged and the travel direction is switched to neutral.

**Locking the working hydraulics**

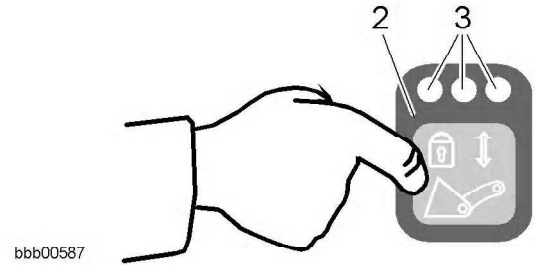
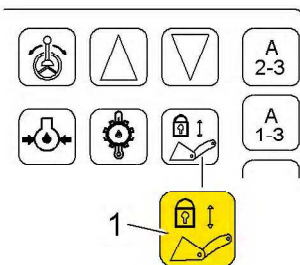

bbb00587

Control unit

- 1 Working hydraulics lockout symbol field

- 2 Working hydraulics lockout button
- 3 LEDs

LBH/03/003801/0003/5.06/en

- Press the button **2** for the working hydraulics lockout to prevent inadvertent activation of the working attachment.

All three LEDs **3** on the pressed button flash.

The symbol field **1** for the working hydraulics lockout lights up.

The working hydraulics are no longer operational.

### Securing the machine

The following precautions should be taken when the machine is to be parked for a prolonged period on a slope.



---

#### Danger

There is a risk of accidents if the machine rolls away.

! Secure the machine against rolling away.

---

- Take the wedges out of their holders.

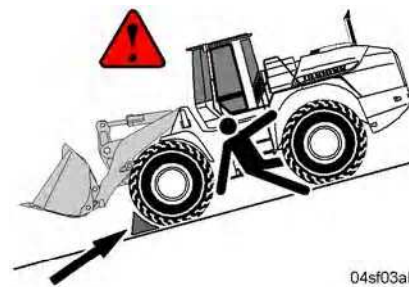

*Downhill slope*

- Use the wedges to secure the machine against rolling away.

### 3.3.4 Shutting down the machine

Take the following precautions before you switch off the engine and leave the machine.

### Lowering the working attachment

Make sure that the bucket is empty.

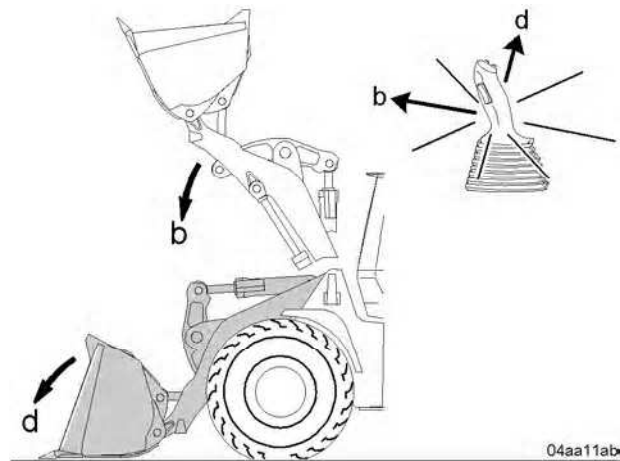

04aa11ab

Bucket arm movement

- Lower the lift arms by moving the control lever in direction **b**.
- Set down the bucket flat on the ground by moving the control lever in direction **d**.

### Engaging the parking brake

The parking brake is automatically engaged when you switch off the ignition.

This is how to engage the parking brake before switching off the ignition:

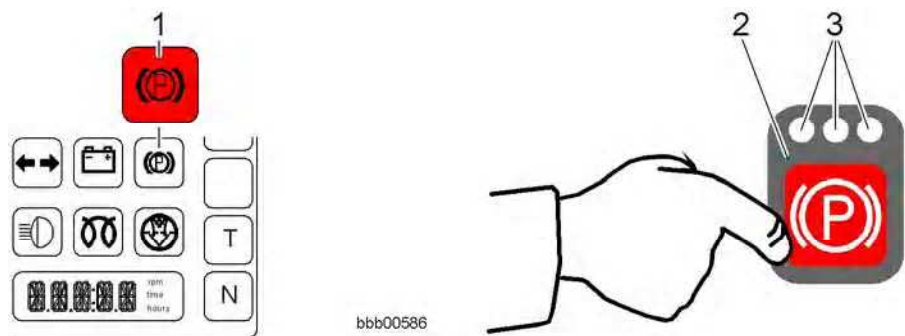

bbb00586

Control unit

- 1 Parking brake symbol field
- 2 Parking brake button
- 3 LEDs

- **If necessary**, engage the parking brake by pressing the button **2**.

All three LEDs **3** on the pressed button flash.

The symbol field **1** for the parking brake lights up.

When you engage the parking brake the travel direction is automatically switched to neutral.

### Locking the working hydraulics

The working hydraulics lockout is activated automatically when you switch off the ignition.

This is how to activate the working hydraulics lockout before switching off the ignition.

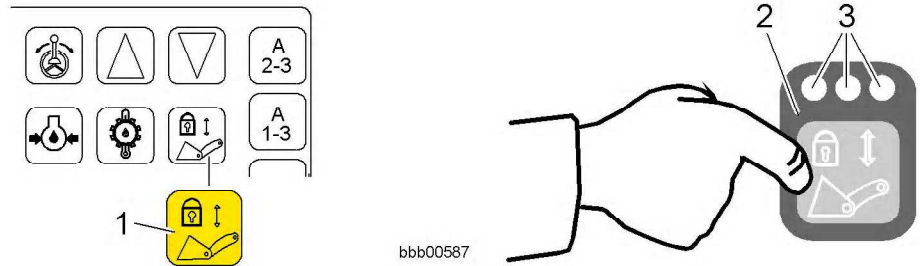

bbb00587

Control unit

1 Working hydraulics lockout symbol field

2 Working hydraulics lockout button  
3 LEDs

- **If necessary**, press the button **2** for the working hydraulics lockout to prevent inadvertent activation of the working attachment.

All three LEDs **3** on the pressed button flash.

The symbol field **1** for the working hydraulics lockout lights up.

The working hydraulics are no longer operational.

### Switching off the engine

#### Caution

There is a risk of damaging the engine

This is especially important with turbo engines.

If you suddenly switch off the motor, the turbocharger continues running for a while with no oil supply.

**!** Do not switch off the engine suddenly when it is running at full speed.

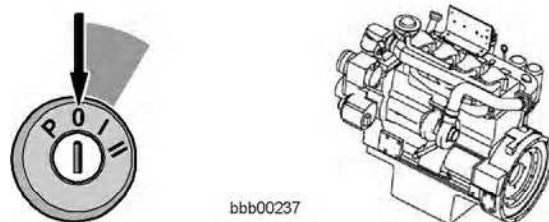

bbb00237

Switching off the engine

- Reduce the engine speed to idle running speed by taking your foot off the gas pedal.
- Let the engine continue idling briefly - for 10 to 15 seconds.
- Turn the ignition key to the **0** position and pull it out.

All the symbol fields go out.

### Turning off the battery main switch

The battery main switch is located at the rear left of the engine compartment.

**If you are leaving the machine unattended:**

**Caution**

There is a risk of damaging the electrical system.

! Do not turn off the battery main switch while the engine is running.

See the section on turning off the battery main switch in chapter 5.



- If you turn off the battery main switch:  
First turn off the engine and then turn off the battery main switch.
- To secure the machine against unauthorised use,  
pull out the main switch key.

**Securing the machine**

The following precautions should be taken when the machine is to be parked for a prolonged period on a slope.



**Danger**

There is a risk of accidents if the machine rolls away.

! Secure the machine against rolling away.

- Take the wedges out of their holders.

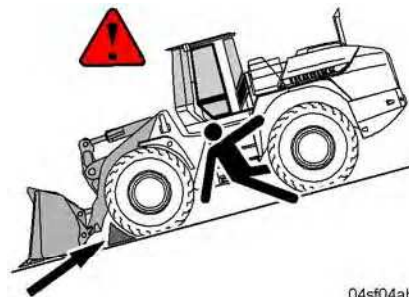

Downhill slope

- Use the wedges to secure the machine against rolling away.

**Parking position**

The ignition key cannot be pulled out in the parking position **P**.

- Turn the ignition key to the parking position **P**.
- You can keep the battery main switch turned on when parking the machine on public roads.



Ignition switch parking position

The consumer units listed below are ready for operation:

- Interior lighting
- Hazard warning system
- Socket/cigarette lighter
- Working floodlight

The following optional accessories are also ready for operation, if fitted.

- Flashing beacon
- Radio



**Danger**

If unauthorised people are on the machine it can put the maintenance personnel in extreme danger.

! Secure the machine against access by unauthorised persons.

- When leaving the machine:

Turn the ignition key to the **0** position and pull it out.

Any power consumers which are still required can be switched on at the instrument panel.

See the section on the ignition switch.

**3.3.5 Operating the lift arms**

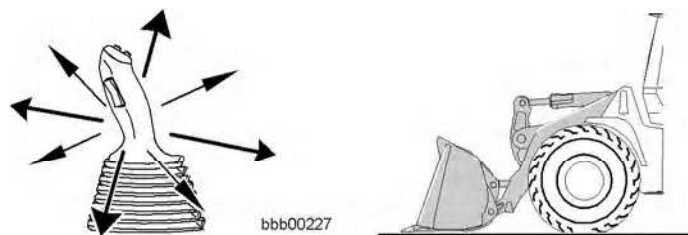

bbb00227

LH control lever

The movements of the lift arms and the working attachment (bucket) are controlled by the LH control lever.

See also the section on the LIEBHERR control lever.

**Releasing the working hydraulics**

The working hydraulics are automatically ready for operation when you switch on the ignition.

- **If you have previously engaged the working hydraulics lockout: Release the working hydraulics for operation.**

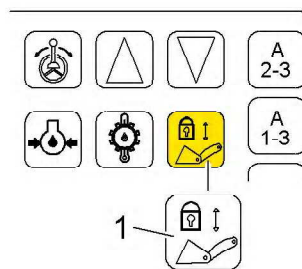

1 Working hydraulics lockout symbol field

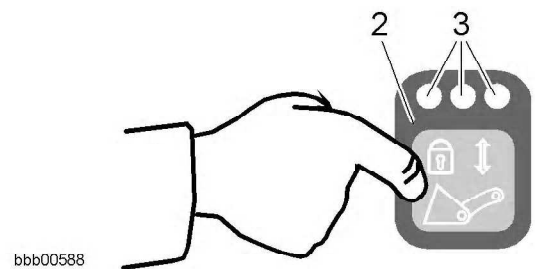

bbb00588

Control unit

2 Working hydraulics lockout button  
3 LEDs

- Deactivate the working hydraulics lockout by pressing the button **2**.

All three LEDs **3** on the pressed button go out.

The symbol field **1** for the working hydraulics lockout goes out.

The working hydraulics are now operational.

You can operate the working attachment.

LBH/03/003801/0003/5.06/en



### Operating the lift cylinders

The lift cylinders raise and lower the lift arms.

#### Raising or lowering the lift arms

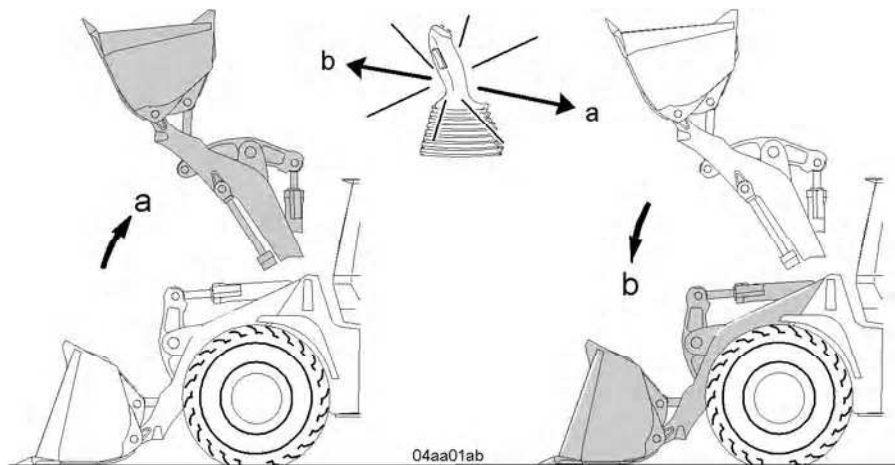

Raising or lowering the lift arms

- Move the LH control lever in direction **a**.  
The lift arms are raised.  
There are two ways to lower the lift arms:

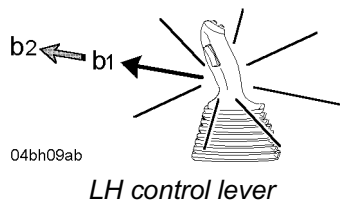

LH control lever

- Slowly, using the normal lowering function.  
Lever position **b1**
- Quickly, using the quick drop function.  
Lever position **b2**
- To actuate the normal lowering function, move the LH control lever in the direction **b1** up to the action point.

The lift arms are slowly lowered.

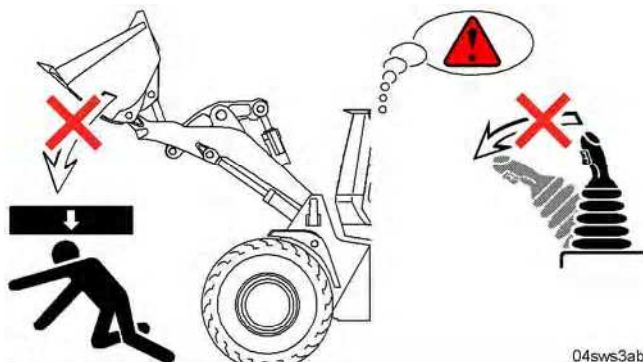

Danger



**Danger**

There is a risk of accidents when the working attachment is lowered quickly.

The raised working attachment is lowered quickly when you actuate the quick drop function.

Anyone standing under the working attachment will be crushed.

! Keep out of the danger area.

- To actuate the quick drop function, move the LH control lever in direction **b2** through the action point to its limit.

The lift arms are quickly lowered.

**Operating the tilt cylinders**

The tilt cylinder tilts the bucket in and out.

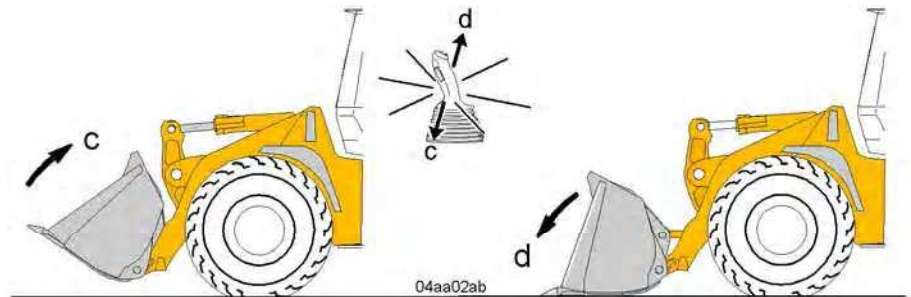

*Tilting the bucket in and out*

**Tilting the bucket in or out**

- Move the LH control lever in direction **c**.  
The bucket is tilted in.
- Move the LH control lever in direction **d**.  
The bucket is tilted out.

**Operating the lift and tilt cylinders simultaneously**

You can extend or retract the lift and tilt cylinders simultaneously by moving the LH control lever diagonally.

**Raising the lift arms while tilting the bucket in or out**

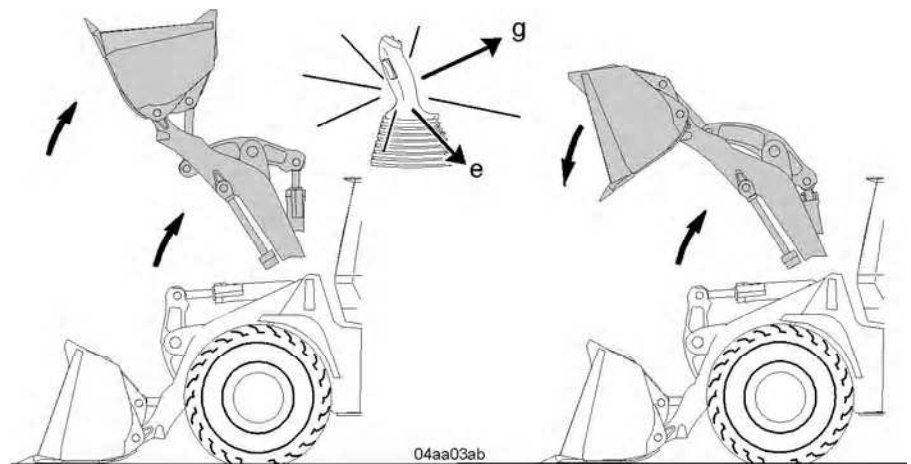

*Working movements*

LBH/03/003801/0003/5.06/en

- Move the LH control lever in direction **e**.  
The lift arms are raised while the bucket is tilted in.
- Move the LH control lever in direction **g**.  
The lift arms are raised while the bucket is tilted out.

**Lowering the lift arms while tilting the bucket in or out**

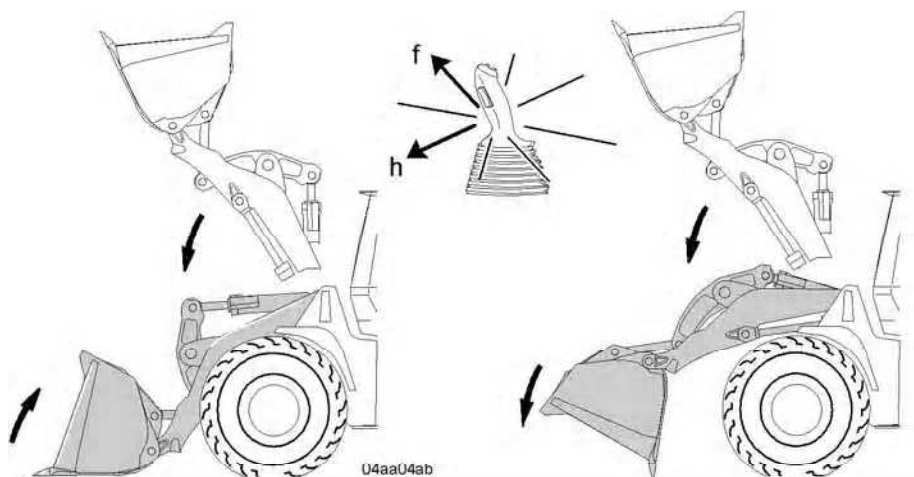

*Working movements*

- Move the LH control lever in direction **h**.  
The lift arms are lowered while the bucket is tilted in.
- Move the LH control lever in direction **f**.  
The lift arms are lowered while the bucket is tilted out.

**Float position**

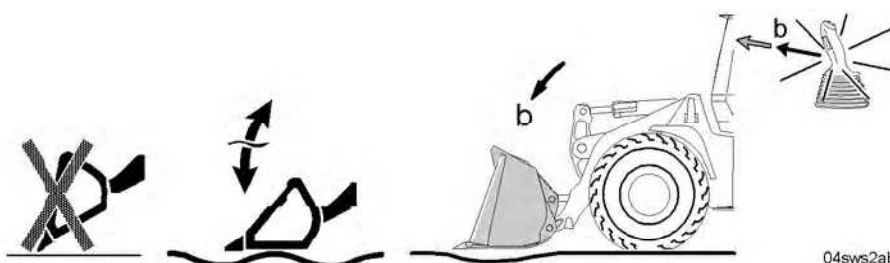

*Bucket in float position*

The float position allows the bucket to lie on the ground under its own weight and to move freely on uneven ground.

**Activating float position**

This is how to activate the float position.

Make sure the lift arms are lowered and the bucket is lying flat on the ground.

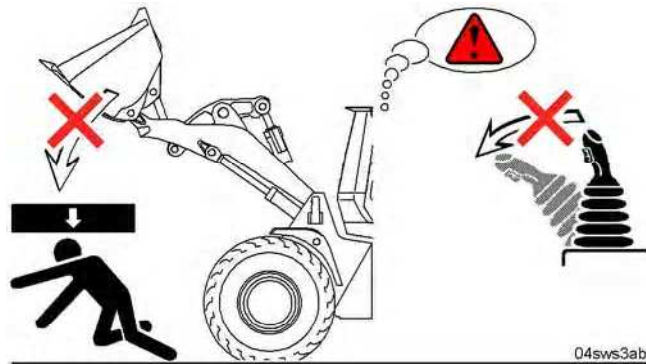

Danger



**Danger**

There is a risk of accidents when the working attachment is lowered quickly.

The working attachment is lowered quickly when the float position is activated.

Anyone standing under the working attachment will be crushed.

! Keep out of the danger area.

- Do not activate the float position function when the working attachment is raised.



Bucket position

- Lower the lift arm and lay the bucket down flat on the ground.

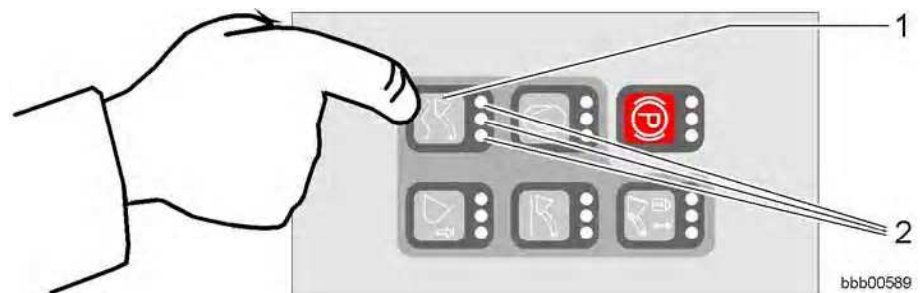

Control unit

1 Float position button

2 LEDs



Press the float position button **1** to enable the function.

- Press the float position button **1**.

All three LEDs **2** on the pressed button flash.

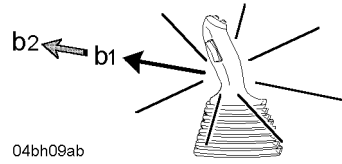

LH control lever

- Move the LH control lever in direction **b2** through the action point as far as it will go and then release it.

The LH control lever is held in this position by magnetic force.

The float position function is now active.

### Using the automatic lift kick-out function

This equipment is optional.

The automatic lift kick-out function prevents the lift arm coming to an abrupt halt at the upper lift limit.

This protects both the machine and the driver from unnecessary jolting.

The procedure for activating the automatic lift kick-out is as follows:

#### Activating the automatic lift kick-out function

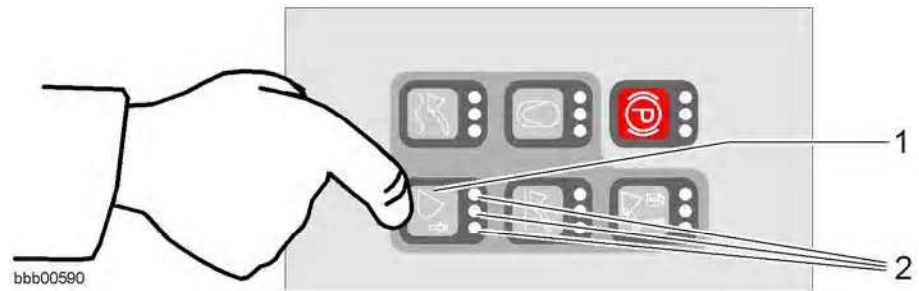

Control unit

1 Lift kick-out button

2 LEDs



- Press the button **1** for lift kick-out.

All three LEDs **2** on the pressed button flash.

The lift kick-out function is now active.

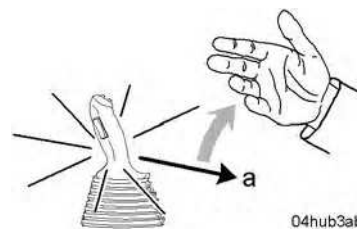

LH control lever

- Move the LH control lever in direction **a** through the action point as far as it will go and then release it.

The LH control lever is held in this position by magnetic force.

This means that the lift arm is only raised as far as the switching point for the lift kick-out.

The lifting procedure is automatically stopped at this point.

#### Lift kick-out for reduced dumping height

You can also use the proximity switch to set a reduced dumping height.



**Caution**

There is a risk of accidents when working close to a height limit. When working close to a height limit, there is a risk of accidents if the lift kick-out is overrun.

! When working near to a height limit, proceed with extreme caution.

**Setting the lift kick-out for reduced dumping height**

- Set the lift kick-out for a reduced dumping height.

The proximity switch for the automatic lift kick-out is set at the factory.

If necessary, the proximity switch can be re-adjusted.

The procedure for re-adjusting the proximity switch is as follows.

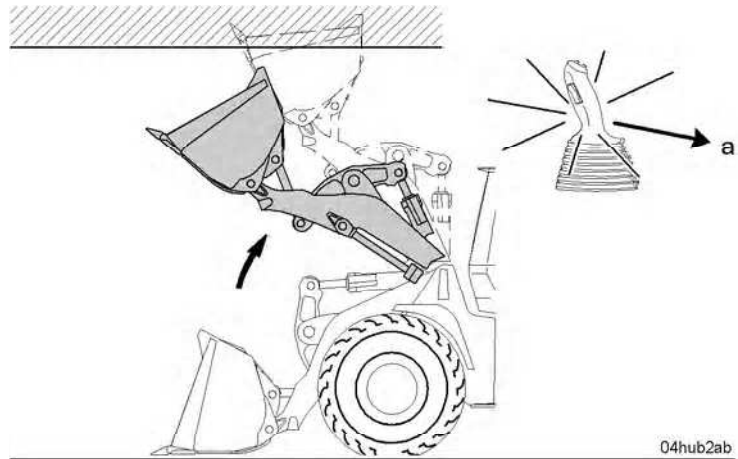

Reduced dumping height

- Raise the lift arms to the required dumping height.

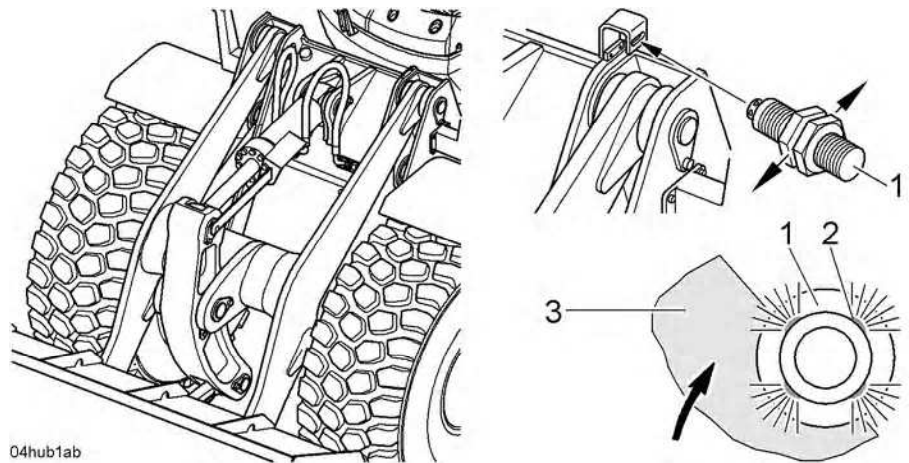

04hub1ab

Proximity switch

1 Proximity switch for automatic lift kick-out

2 LED

3 Bucket arm

- Release the fixing nuts of the proximity switch.

Horizontally adjust the proximity switch 1 until the bucket arm 3 covers up to half the contact surface of the proximity switch.

When the bucket arm enters the actuation range of the proximity switch, the four LEDs 2 on the proximity switch light up.

LBH/03/003801/0003/5\_06/en

- Tighten the fixing nuts on the proximity switch again.

The proximity switch has been reset and the automatic lift kick-out is once more ready for operation.

- Test the setting and re-adjust it if necessary.

**Automatic bucket return-to-dig function**

You can use the automatic bucket return-to-dig function for loading jobs which require a certain digging position.

**Activating the automatic bucket return-to-dig function**

The procedure for activating the automatic bucket return-to-dig function is as follows:



Control unit

- 1 Bucket return-to-dig button
- 2 LEDs

- Press the bucket return-to-dig button 1.

All three LEDs 2 on the pressed button flash.

The automatic bucket return-to-dig function is now activated.



**Using the automatic bucket return-to-dig function**

Make sure the automatic bucket return-to-dig function is activated.

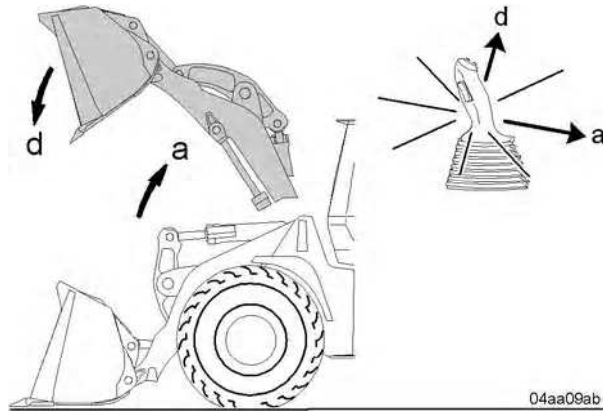

Working movements

LBH/03/003801/0003/5.06/en

- Raise the lift arm by moving the LH control lever in direction **a**.
- Tilt the bucket out in the raised position by moving the LH control lever in direction **d**.

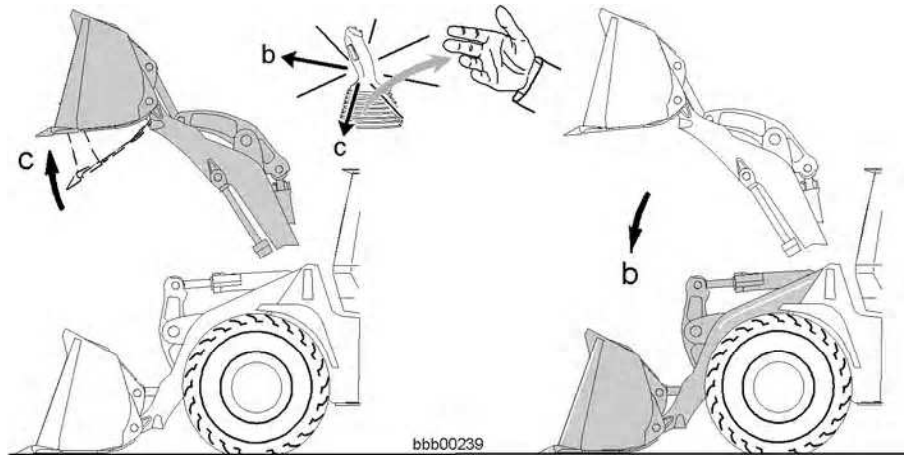

*Working movements*

- Tilt in the loading bucket in the raised position by moving the LH control lever in direction **c** through the action point as far as it will go and releasing it.

The LH control lever is held in this position by magnetic force.

This moves the bucket into the preliminary position for the digging position.

As soon as the bucket reaches the preliminary position, the solenoid releases the LH control lever.

- Lower the lift arms by moving the LH control lever in direction **b**.

This moves the loading bucket into the digging position on the ground.

**Setting the digging position**

The proximity switch for the automatic bucket return-to-dig function is set at the factory.

If necessary, the proximity switch can be re-adjusted.

The procedure for re-adjusting the proximity switch is as follows.

**Rough adjustment**

Make sure that the lift arms are lowered and the bucket is empty.

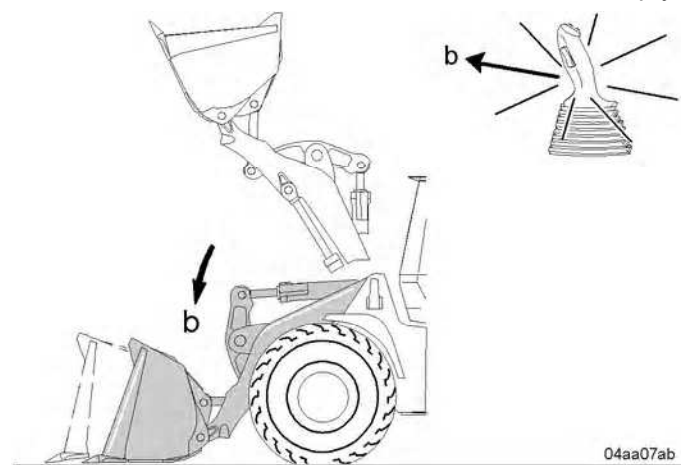

*Rough digging position*

LBH/03/003801/0003/5.06/en



- Using the LH control lever, move the loading bucket to the required digging position.

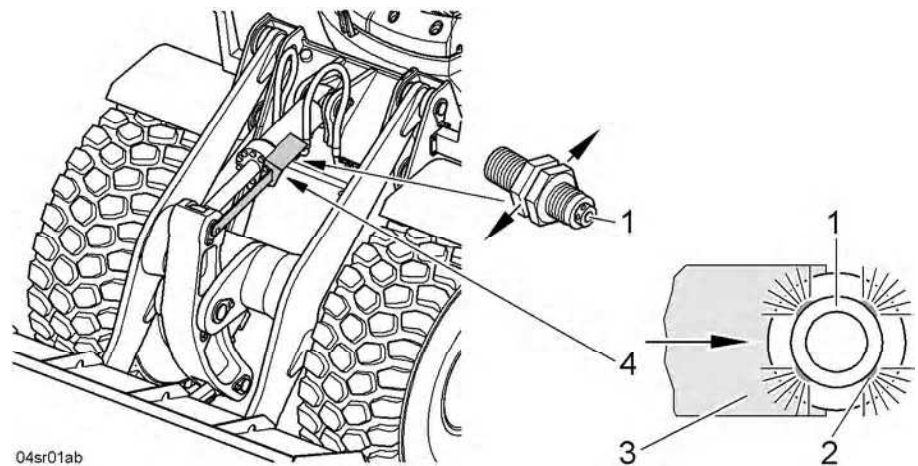

Setting up bucket return-to-dig

- |   |                               |
|---|-------------------------------|
| 1 Proximity switch for automatic bucket return-to-dig | 3 Positioning curve           |
| 2 LED   | 4 LFD system proximity switch |

- Release the fixing nuts of the proximity switch 1. Horizontally adjust the proximity switch 1 until the positioning curve 3 covers up to half the contact surface of the proximity switch. When the positioning curve enters the contact area of the proximity switch, the four LEDs 2 on the proximity switch light up.
- Tighten the fixing nuts on the proximity switch 1 again. The rough adjustment of the required digging position is now complete.
- Test the rough adjustment: The procedure is described in the section on using the automatic bucket return-to-dig function.
- If required, carry out a fine adjustment.

**Fine adjustment**

Carry out several tests to perform the fine adjustment.

- Using the LH control lever, move the loading bucket to the exact digging position.
- Re-adjust the proximity switch as detailed in the section on rough adjustment.
- Test the fine adjustment. The procedure is described in the section on using the automatic bucket return-to-dig function.

**3.3.6 Working methods**

This section describes the routine working methods.

LBH/03/003801/0003/5.06/en

### Picking up and moving material

The following procedure is recommended to avoid any possible loss of traction.

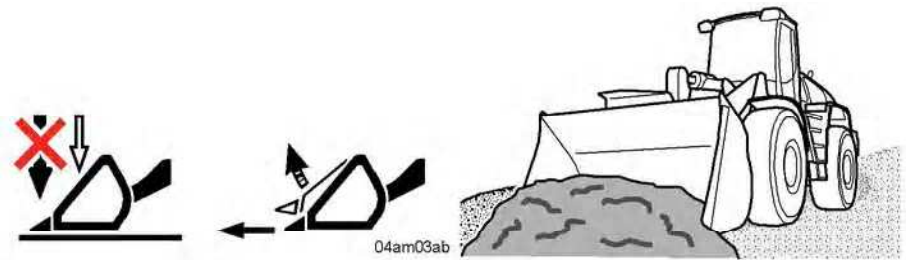

- Do not work with a strong downwards pressure on the bucket.
- If the flow of the bulk material into the bucket needs to be assisted when driving into the material, gently tip the bucket up and down.

Pressing the inch/brake pedal reduces tractive force, which makes loading easier.

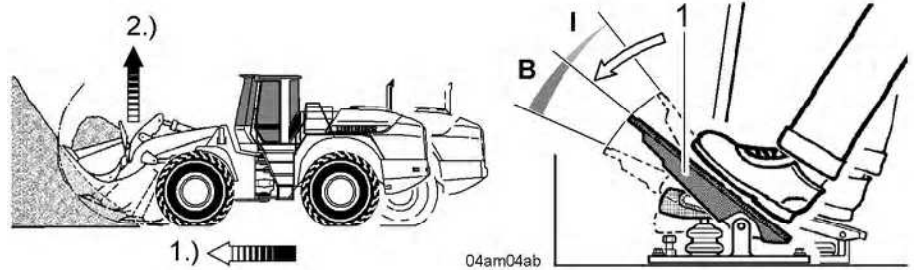

Power distribution by inching

1 Inch/brake pedal  
I Inching range

B Braking range

- Also press down the inch/brake pedal 1 in range I with the required force.

The power is adjusted:

- 1.) The power of the travel hydraulics is reduced.
- 2.) The power of the working attachment is reduced.

Power adjustment has the following advantages:

- The wheels no longer spin
- The fuel consumption is reduced.

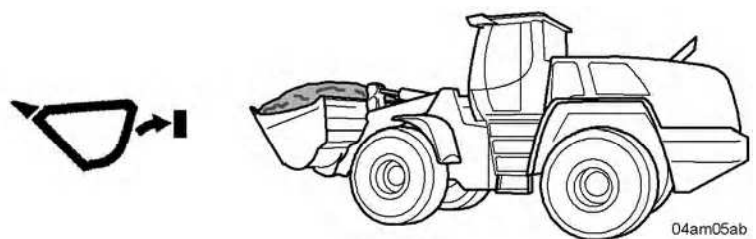

- Tilt in the loaded bucket as far as it will go and raise the lift arms.

### Transporting and moving material

The bucket should be moved into the transport position to improve the machine's stability and to ensure good viewing conditions when transporting and transferring bulk materials.

The transport position means that the bucket pivot point is approximately 40 cm above the ground.

#### Transport position

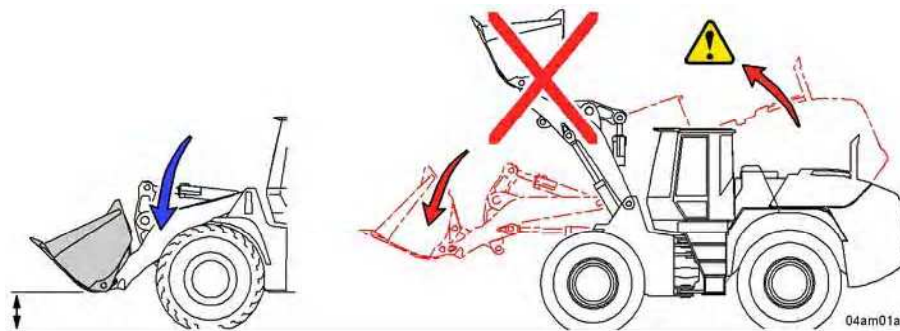

*Bucket position*



#### Warning

There is a risk of the machine tipping over.

The machine might tip over when the lift arms are raised due to the shift in the centre of gravity.

! Observe the maximum permitted bulk material weight and the specified tipping loads.

- Move the loaded bucket to the transport position.

#### Transporting the load on a slope

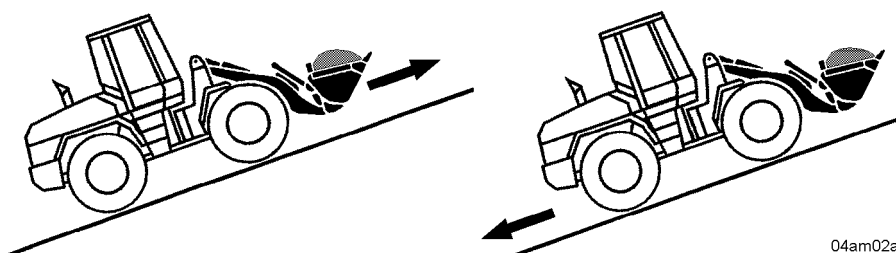

*Direction of travel during transport*

**Warning**

There is a risk of the machine tipping over.

! Hold the loaded bucket low when transporting a load on steep terrain.



- Do not turn the machine on steep slopes.
- Drive forwards up the slope.
- Drive backwards down the slope.
- Do not drive on slopes with the working attachment raised.

**Driving on slopes**

You must observe the safety instructions when driving on slopes. See the safety instructions for driving on slopes in chapter 2.

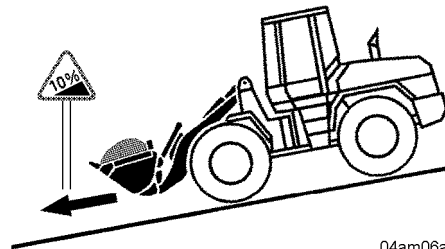

04am06ab

Slope

**Warning**

There is a risk of the machine tipping over.

The machine can tip over more easily when driving on sloping ground.

! Always keep the loaded bucket low during transport.

! Do not suddenly change direction or brake abruptly.

- Ease off the gas pedal before driving onto the slope.
- Drive downhill carefully.
- If necessary, apply the service brake.

or

If driving on a long, steep downhill slope:

- First switch to travel range I. See also in the information on changing travel ranges in the driving mode section.

### Grading work

Keep the bucket base horizontal when grading.

#### Grading

The following procedure is recommended to avoid any possible loss of traction.

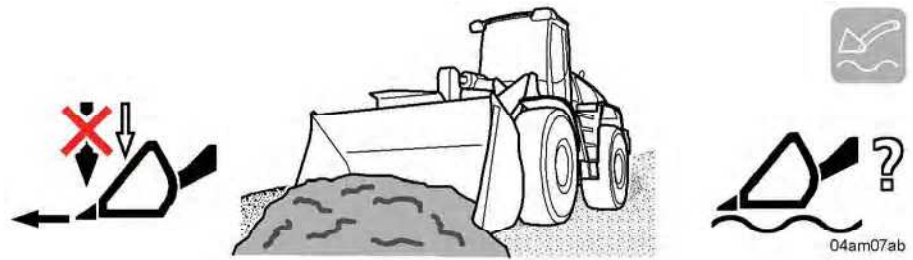

*Procedure for grading*

- Do not work with a strong downwards pressure on the bucket.

or

- Use the float position function. See also the sections on operating the lift arms and the float position function.



*Impermissible bucket positions*

### Caution

There is a risk of damage to the machine.

The machine may be damaged during grading work if the bucket hits a hard object when it is tipped down while the machine is moving forward.

! Do not grade in the forward travel direction with the bucket tipped down.

- Keep the base of the bucket parallel to the ground.

or

- Gently set the bucket base down.

#### Scraping off material



- Tilt the bucket down and drive backwards.

### Loading a heap

#### Picking up material

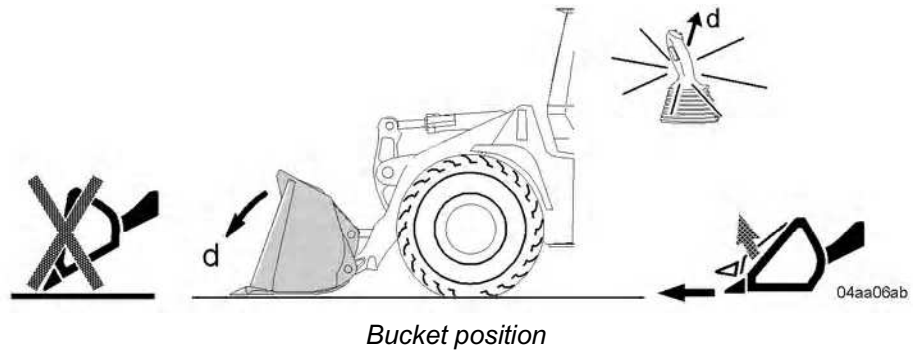

#### Caution

There is a risk of damage to the machine.

The lift arms may be damaged if you hit a hard obstacle at speed when clearing away bulk material in the forward travel direction with the bucket tipped down.

! When clearing away bulk material, do not drive into the pile with the bucket tipped down.

- Lower the bucket horizontally to the ground.
- Drive into the material, slightly tipping the bucket in the process.
- If the flow of the bulk material into the bucket needs to be assisted gently tip the bucket up and down when driving into the material.
- Also press down the inch/brake pedal. See the section on picking up and moving material.

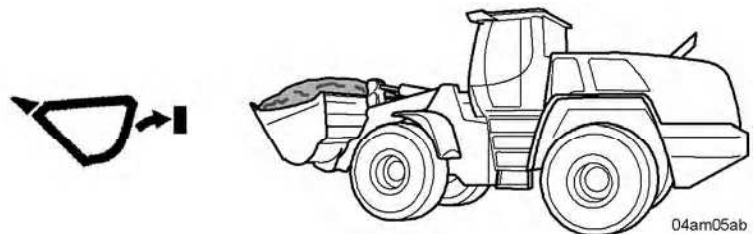

Bucket position

- Tilt in the loaded bucket as far as it will go and raise the lift arms.

#### Transporting material

Keep the loaded bucket low during transport in order to improve the machine's stability and to ensure good viewing conditions.

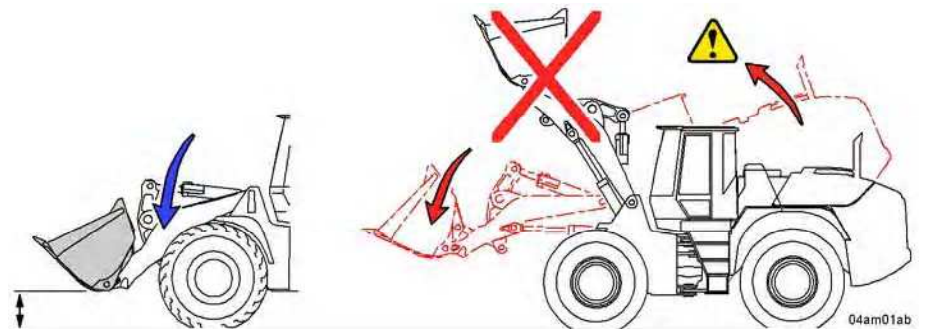

Bucket position

LBH/03/003801/0003/15.06/en

Make sure that the bucket is in the transport position.

The transport position means that the bucket pivot point is approximately 40 cm above the ground.

- Move the bucket to the transport position.

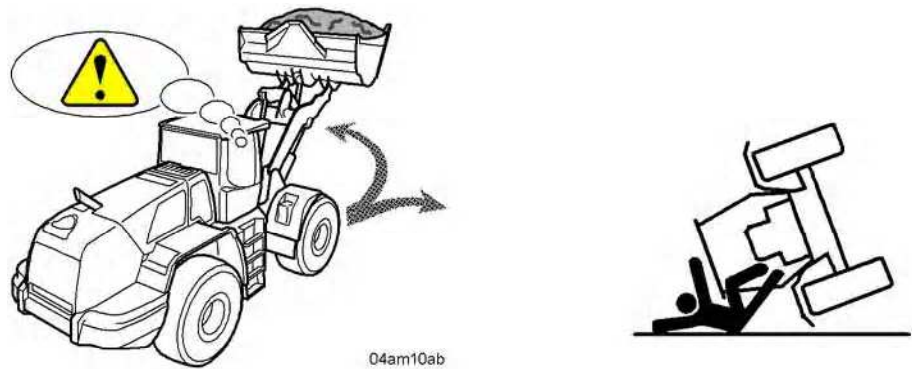

*The machine may tip over*



**Warning**

There is a risk of the machine tipping over.

The machine might tip over when the lift arms are raised due to the shift in the centre of gravity.

! Do not suddenly change direction or brake abruptly when the bucket is raised.

- Do not raise the lift arm until just before reaching the unloading point.

**Dumping**

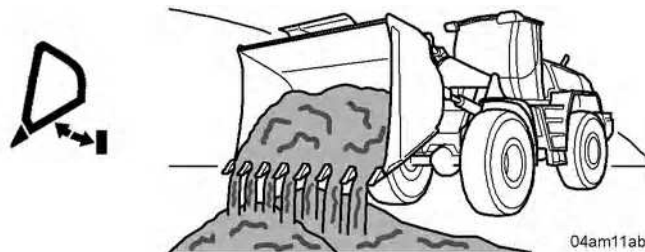

*Dumping*

- Tip out the bucket.
- To loosen material adhering to the bucket, quickly tilt the bucket in and out, briefly jolting against the bucket arm stops.

### Removing material from a slope or wall

#### Removing material from a slope

This is how to remove normal material such as sand or gravel.



*Removing bulk material 1*

- Start at the foot of the slope and work upwards.

#### Removing material from a wall

This is how to remove unusually hard material such as rock.

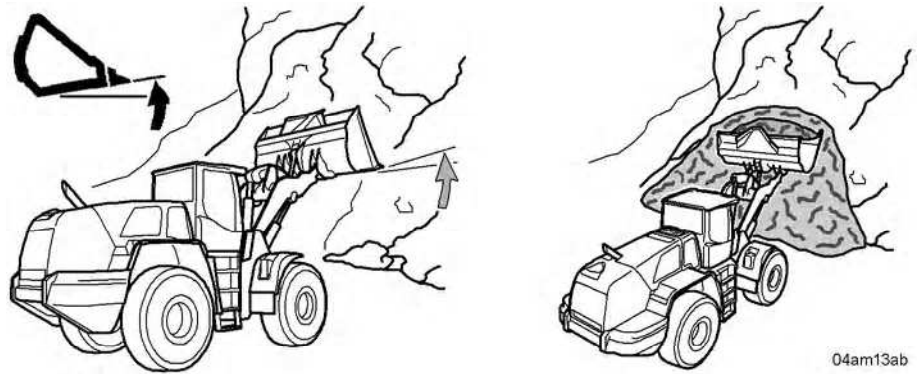

*Removing bulk material 2*

- Slightly tilt up the bucket base.
- Start removing material at the top and work downwards.



#### **Warning**

There is a risk of accidents due to falling material.

! Do not work under overhangs.

- Remove overhangs first and then look out for slippage.



### Loading a transport vehicle

#### Transport routes

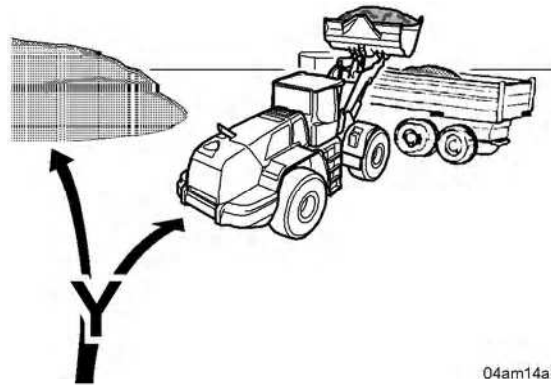

04am14ab

Y movement

The vehicle to be loaded should be parked so that the transport distance for the machine is as short as possible.

If possible make a **Y movement**. See also in the information on reversing in the driving mode section.

#### Loading procedure

In order to speed up the loading procedure, brake the machine in front of the truck with the inch/brake pedal.

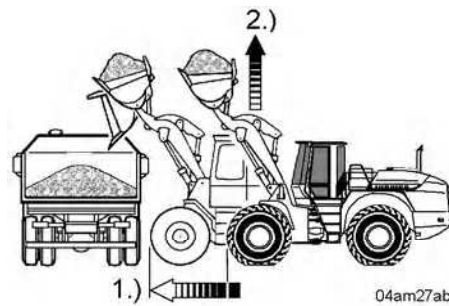

04am27ab

Unloading point

This achieves the following:

- 1.) Sensitive speed adjustment
- 2.) Optimum power adjustment for the working attachment

See the section on picking up and moving material.

- Put the machine in the unloading position. Do not raise the lift arms until just before reaching the unloading point.

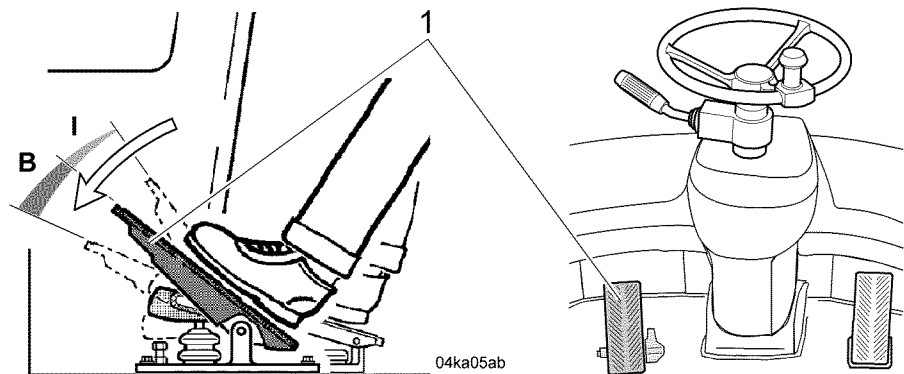

04ka05ab

Inch/brake pedal

1 Inch/brake pedal

I Inching range

LBH/03/003801/0003/5.06/en

B Braking range

- Brake the machine by pushing down the inch/brake pedal **1** in range **I** with the required force.



**Warning**

There is a risk of accidents due to falling material.

- ! The driver may only swing the working attachments over occupied driver cabs, operating and working stations of other machines if they are protected by reinforced roofs (FOPS).
- ! If the driver's cab is not equipped to provide the necessary degree of protection, then the driver of the machine in question must leave his cab during overhead operations.

- Load the truck so that the material falls into the middle of the skip.
- Load long transport vehicles from front to back.

**When working near overhead power lines:**



**Danger**

There is a risk of accidents through contact with overhead power lines. There is a risk of **fatal injury**.

- ! Obtain information about the safety clearances to be observed.



- Keep the machine a sufficient distance away.
- Do not go near power lines with the attachment.
- Also read the instructions for safe working in the chapter on safety regulations.

**Loading large rocks**

Make sure that the loading surface of the transport vehicle can withstand the impact of large rocks.

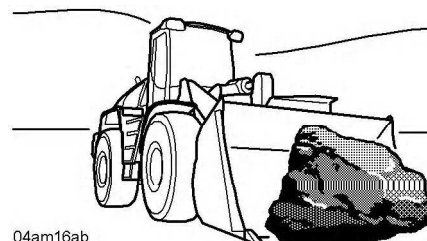

*Loading the bucket*

- First put a bucket load of smaller rocks in the transport vehicle.
- Carry on loading the transport vehicle.

LBH/03/003801/0003/5.06/en

**Loading sticky material**

You can use the automatic bucket return-to-dig function for loading jobs which require a certain digging position.

See also the sections on operating the lift arms and the automatic float position function.



04am15ab

*Dumping*

- Tip out the bucket.

---

**Caution**

There is a risk of damage to the machine.

Unnecessary jolting when tipping up and down against the bucket arm stops can increase wear on the bolts and bushes on the kinematics.

! Avoid unnecessary jolting.

---

- To loosen material adhering to the bucket, quickly tilt the bucket in and out, briefly jolting against the bucket arm stops.

**Moving the machine back**

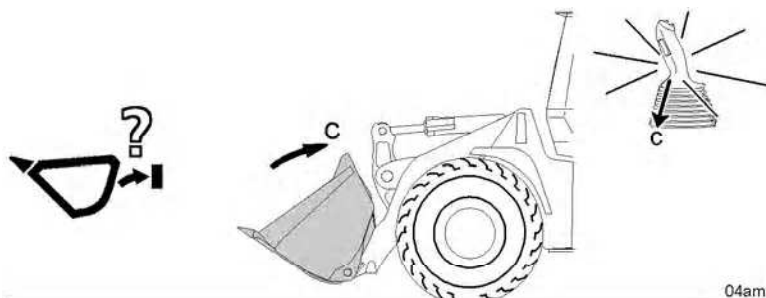

04am17ab

*Bucket position*

**Caution**

There is a risk of damage to the machine. Unnecessary jolting when tipping up and down against the bucket arm stops can increase wear on the bolts and bushes on the kinematics. ! Avoid unnecessary jolting.

- Tilt the bucket in.

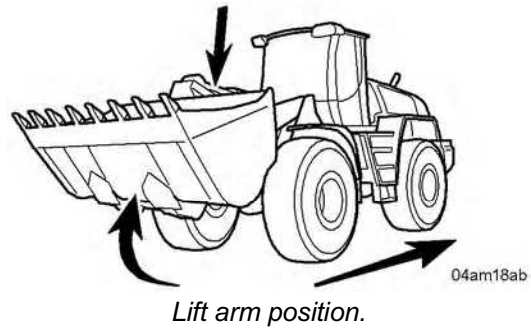

- Lower the lift arm when driving back.

**Excavation**

**Lifting out soft material** This is how to excavate soft material.

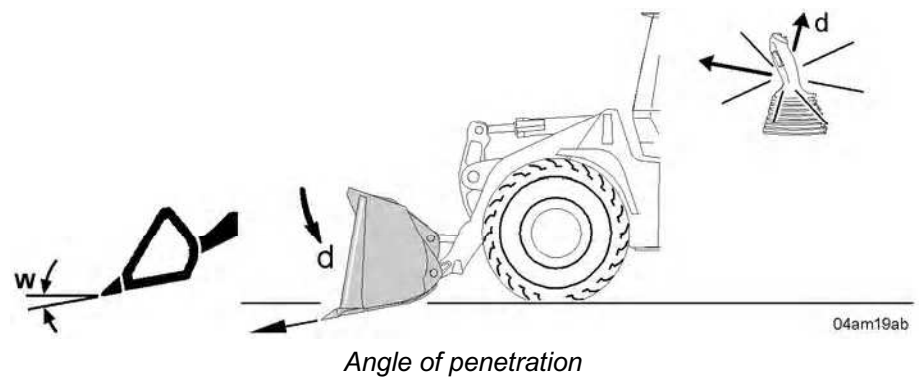

- Lower the bucket to the ground.
- Set a small cutting angle **w** of no more than 10°.

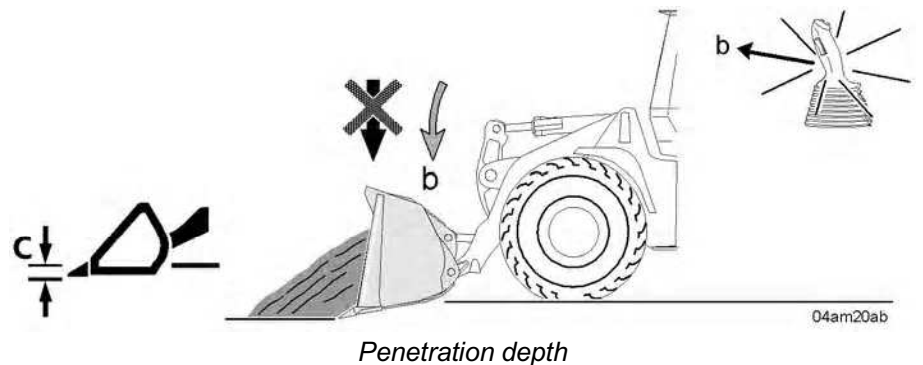

LBH/03/003801/0003/5.06/en

- When approaching with the machine, simultaneously press the lift arms down, until a sufficient penetration depth **C** is reached.
- The following procedure is recommended to avoid any possible loss of traction. Do not work with a strong downwards pressure on the bucket.

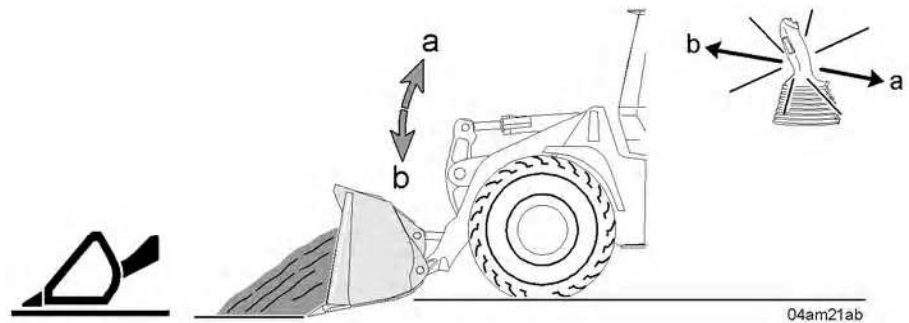

Lift arm movement

- Make horizontal cuts when driving forward.
- Raise and lower the lift arms to make the work easier.

**Lifting out hard material**

Use a bucket with teeth for excavating hard material.

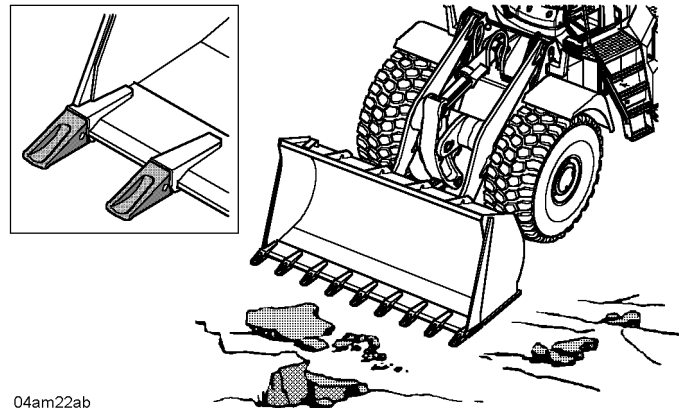

04am22ab

Working attachment

- For the subsequent procedure: See the section on lifting out soft material.

**Example of foundation excavation**

This is how to excavate foundations.

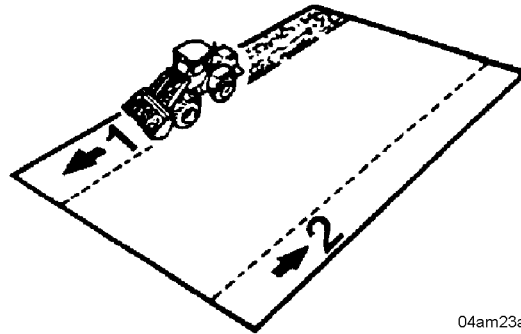

04am23ab

*Lengthways cuts*

- Use the bucket to make a first trench along the side of the pit.
- When the first trench is down to a depth of 1 metre : start a second trench along the opposite side.
- Excavate the area between to the same depth as the two side trenches.

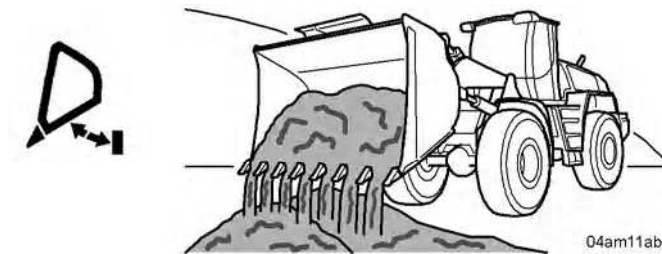

04am11ab

*Heaping material*

- Heap the material in one corner, leaving the sides of the foundations clear.

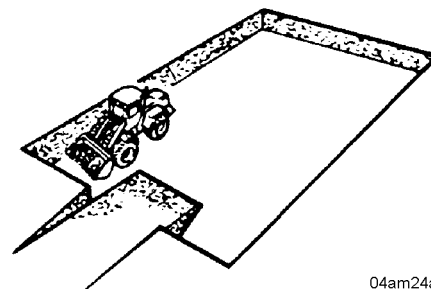

04am24ab

*Pit corner*

- When the foundations have been excavated to the required depth, dig out the corners and transport the material out of the pit.

LBH/03/003801/0003/5.06/en

**Driving out of the pit** You must make a ramp so that you can drive the machine out of the pit.

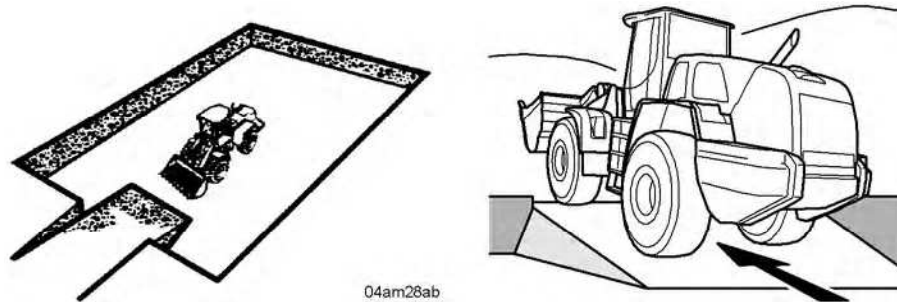

04am28ab

Exit ramp and transport direction

- To make an exit for the machine dig out the centre of the ramp.
- Keep the loaded bucket low during transport.
- Drive forwards out of the pit.

### 3.3.7 Soot particle filter

This equipment is optional.

**Tasks of the soot particle filter:**

- It reduces the emission of soot particles.
- It eliminates most of the carbon monoxide (CO) and hydrocarbons (HC) from the exhaust.
- It regenerates itself during normal operation.

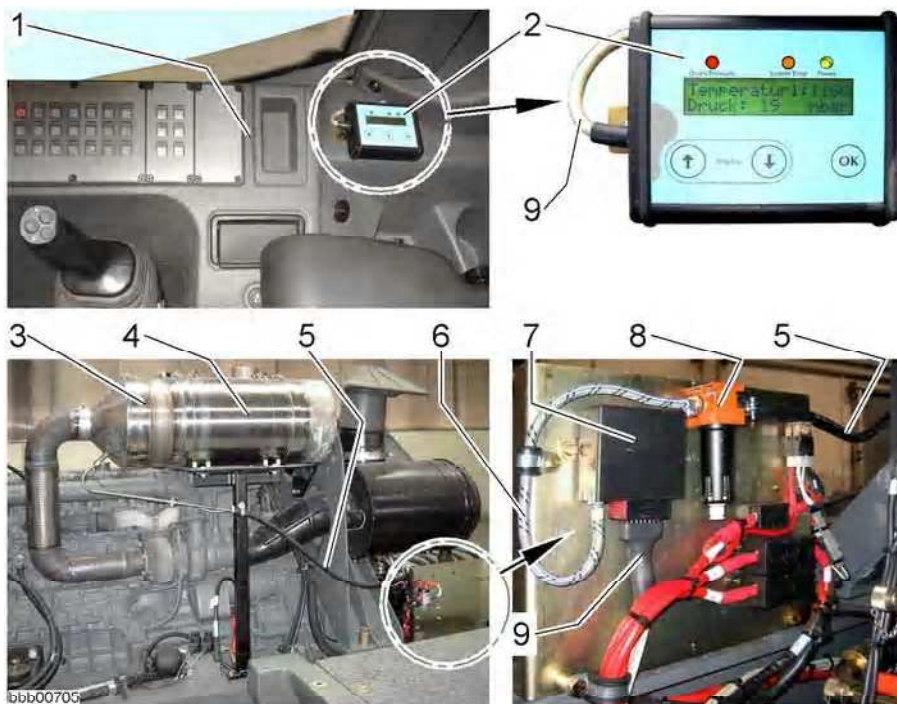

Soot particle filter system

- |  |                     |
|--|---------------------|
| 1 Instrument panel                                 | 5 Pressure line 1   |
| 2 Exhaust counterpressure display and control unit | 6 Pressure line 2   |
| 3 Soot particle prefilter                          | 7 Data logger       |
| 4 Soot particle main filter                        | 8 Filter/drain unit |
|  | 9 Data cable        |

LBH/03/003801/0003/5.06/en

The exhaust counterpressure is recorded by the data logger. The data logger transfers the information via the data cable to the exhaust counterpressure display and control unit.

### Exhaust counterpressure display and control unit

Task:

- To monitor and display the status of the particle filter system
- To give an audible and visible warning to the operator when the maximum exhaust counterpressure is exceeded
- To save the data measured by the counterpressure monitor electronically



**Note**

With turbocharged engines a counterpressure of 0.2 bar may not be exceeded.

! The exhaust counterpressure display and control unit indicates excessive levels with visible and audible signals.

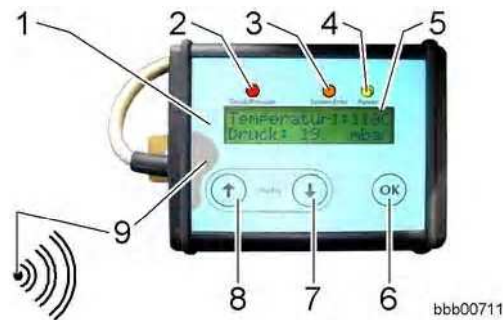

Display and control unit

- |                            |                          |
|----------------------------|--------------------------|
| 1 Display and control unit | 6 Acknowledgement button |
| 2 Red pressure LED         | 7 Menu button            |
| 3 Orange system error LED  | 8 No function            |
| 4 Green power LED          | 9 Buzzer (in housing)    |
| 5 LC display               |                          |

- For activating the display:  
Press the menu button 7 for 2 seconds.

Display:

- Exhaust counterpressure (mbar)
- Exhaust temperature (°C)
- Speed (rpm)

Action:	Display:
After engine start	Exhaust counterpressure
Press the menu button 7	Exhaust counterpressure Exhaust temperature 1
Press the menu button 7 again	Exhaust counterpressure Exhaust temperature 2
Press the menu button 7 again	Exhaust counterpressure Engine speed
Press the menu button 7 again	Exhaust counterpressure = engine start

LBH/03/003801/0003/15.06/en



**If a system fault is displayed:**

- The green LED 4 lights up
- The orange LED 3 lights up
- The buzzer 9 emits a continuous tone

In this case there is a system fault.  
there are various instances with system faults.

- See the manufacturer's operating manual for how to remedy the fault.

**If a counterpressure alarm is displayed:**

- The green LED 4 lights up
- The red LED 2 lights up or flashes
- The buzzer 9 emits an interval tone

In this case there is an excess exhaust counterpressure alarm.

There are various levels of counterpressure alarm:

- The red LED 2 and the green LED 4 light up  
The exhaust counterpressure has reached the level for a preliminary alarm
- The red LED 2 flashes, the green LED 4 lights up and the buzzer 9 emits an interval tone  
The exhaust counterpressure has reached the level for a full alarm
- See the manufacturer's operating manual for how to remedy the fault.

**If a filter break or blocked line is displayed:**

- The green LED 4 flashes
- The orange LED 3 flashes
- The red LED 2 flashes
- The buzzer 9 emits an interval tone

In this case there is either a filter break (bypass), or a blocked or leaking pressure line.

- See the manufacturer's operating manual for how to remedy the fault.

**If service is displayed:**

- The LC display 5 shows the message "Call service".

The filter needs to be serviced or cleaned (the service interval has elapsed).

- See the manufacturer's operating manual for a detailed description.

**Audible/visual exhaust counterpressure monitor**

Counterpressure warning sequence:

- If a counterpressure of 0.15 bar is exceeded for longer than 60 seconds  
The red LED 2 lights up
- If a counterpressure of 0.2 bar is exceeded for longer than 60 seconds  
The audible buzzer 9 is also activated.

**Note**

Information on counterpressure monitoring:

! After the counterpressure monitor is activated, you must take action to reduce the counterpressure.

**If excessive exhaust counterpressure is indicated:**

- Excess exhaust counterpressure can also be caused by a blocked counterpressure line.
- If the display indicates excess counterpressure, in addition to cleaning the filter, inspect and service the counterpressure line.
- The counterpressure monitor must be inspected and serviced every **500 service hours**.

See the section on the soot particle filter in the maintenance and inspection schedule in chapter 5.

- Contact LIEBHERR CUSTOMER SERVICE.

**Caution**

There is a risk of damage to the soot particle filter and the diesel engine. If the machine idles for prolonged periods or is run in the lower load range, the maximum counterpressure may be exceeded.

! Avoid letting the machine idle for prolonged periods or run in the lower load range.

- If the counterpressure is too high:  
Take action to reduce it.

**Note**

Information on counterpressure monitoring:

! The data measured by the counterpressure monitor is saved electronically.

- If the evaluation of the measured data shows that no action was taken to reduce the counterpressure:  
The manufacturer's warranty becomes invalid for any component damaged or destroyed by excess counterpressure.

**Lowering the exhaust counterpressure****Action to reduce the counterpressure:**

- If the counterpressure is above 0.15 bar :  
Run the diesel engine at high speed.
- **This means:** drive at full load for approx. 5 minutes.  
e.g. working against a wall.

or

Lower and raise the lift arms with a fully loaded bucket at full throttle

- Until the counterpressure is significantly lower than 0.15 bar .

---

### Troubleshooting

**If the counterpressure cannot be reduced using these measures:**

Excess exhaust counterpressure can also be caused by a blocked counterpressure line. If the display indicates excess counterpressure, in addition to cleaning the filter, inspect and service the counterpressure line.

- Shut down the machine immediately.
  - Contact LIEBHERR CUSTOMER SERVICE.
- 



---

### Note

The soot particle filter must be cleaned once a year, or at least once every 1000 service hours.

! See the maintenance and inspection schedule in chapter 5.

---

- The cleaning must be done using suitable equipment, so that the ash can be collected for disposal.
- 

### Caution

There is a risk of damage to the soot particle filter and the diesel engine. When refitting the filter module after cleaning, make sure the filter module is fitted with the exhaust in the right direction.

! Do not fit the filter module in the opposite direction.

---

- For additional information:  
Contact LIEBHERR CUSTOMER SERVICE.
- 

### Exhaust gas tests

For operation in Switzerland:

- The machine is marked with the VERT filter label and test label. BUWAL and BauRLL prescribe test measurements to be logged in the exhaust maintenance document at least every 24 months.
- The exhaust maintenance document is created by the main importer and provided with the machine.

For operation in the EU:

- TRGS 554 prescribes test measurements for vehicles in industrial use. These must be carried out and documented annually or every 1500 service hours. For vehicles used underground the intervals are 6 months or every 600 service hours.

### 3.3.8 Filling the tank using the filling pump

This equipment is optional.

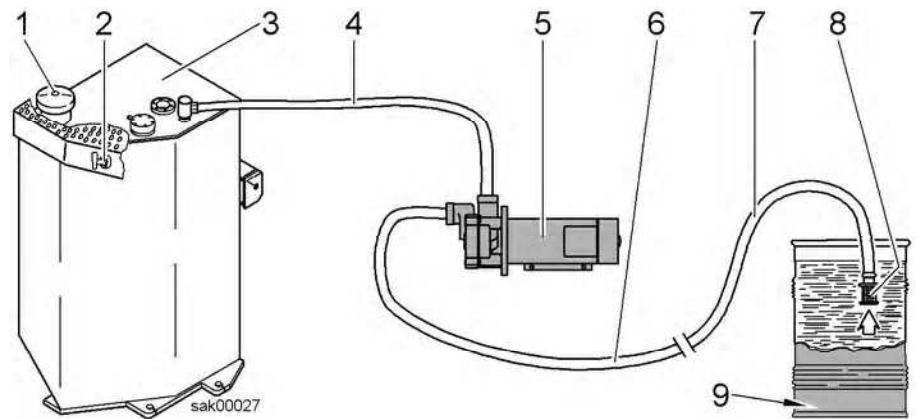

Make sure that:

- The machine is in maintenance position 1.
- The suction line extension 7 (with suction strainer) is connected to the suction line 6 behind the engine compartment door.  
The suction strainer 8 is not damaged, otherwise the refuelling pump 5 is not protected against foreign particles.
- The suction line extension 7 with the suction strainer 8 reaches to the bottom of the tank 9 (so that the tank can be completely drained).
- The battery main switch is turned on.
- The key for the refuelling pump switch 2 (next to the tank filler cap) is inserted.

#### Starting up the filling pump



#### Warning

There is a risk of burns and explosions.

! Never allow naked flames or lighted cigarettes in the vicinity during the refuelling procedure.



Fuel tank

1 Tank cap

2 Cap

LBH/03/003801/0003/5.06/en

- Open the tank cap 1 on the filler neck.



bbb00627

Fuel tank

- Take off the protective cap 3 from the switch 2.
- Turn the key 4 in the switch 2 to the ON position.

Refuelling begins.

Description	Value	Unit
Flow rate	50	l/min
Max. duty cycle	15	min
Max. suction height	4	m



**Warning**

There is a danger due to the fuel overflowing from the filler neck. The refuelling pump does not switch off automatically, which means fuel can overflow from the filler neck.

! Watch the filling process via the fuel tank filler neck 1.

! Never allow naked flames or lighted cigarettes in the vicinity during the refuelling procedure.

- At the end of the filling process:  
Turn the key 4 in the switch 2 to the OFF position and take it out.
- Close the fuel tank cap 1.
- Disconnect the suction line extension 7 (with suction strainer) from the suction line 6 and seal the lines with dummy plugs.

### 3.3.9 Hydraulically actuated quick-change device

This equipment is optional.

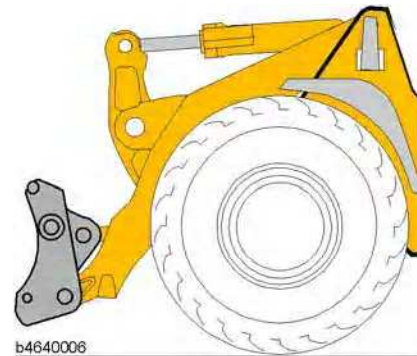

Quick-change device

Quick-change device version:

- Hydraulic activation and deactivation using changeover valve.
- Hydraulic operation using the additional control lever.
- Mechanical locking indicator of the quick-change device.



**Note**

Information on attachments and accessories:

Attachments and accessories produced by third-party manufacturers or those which have not been generally approved by LIEBHERR for installation or for external fitting may not be installed or fitted on the machine without prior written consent from LIEBHERR.

! The appropriate technical documentation should be made available to LIEBHERR for this purpose.

#### Activating the quick-change device

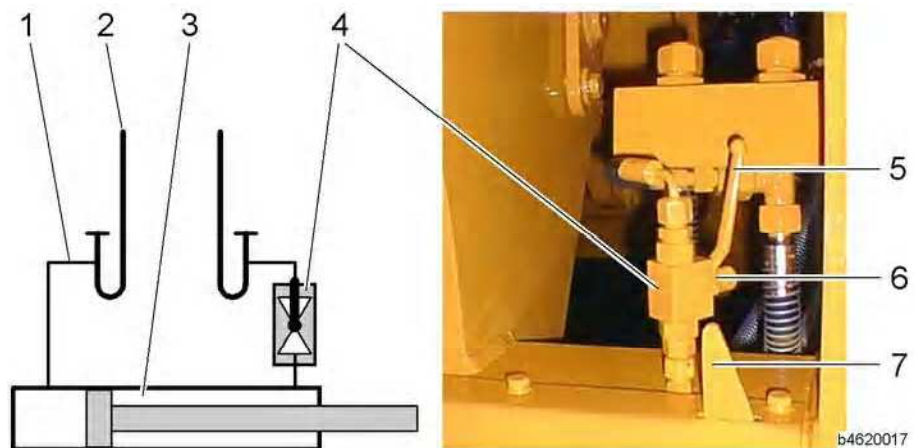

Hydraulic quick-change device

- |   |  |
|---|--|
| <p>1 Supply line for quick-change device</p> <p>2 Supply line for accessory kit</p> <p>3 Hydraulic cylinder</p> | <p>4 Changeover valve</p> <p>5 Switch lever</p> <p>6 Anti-twist lock</p> <p>7 Mechanical indicator</p> |
|---|--|

LBH/03/003801/0003/15.06/en

The hydraulic quick-change device is activated (enabled) or deactivated (blocked) using the changeover valve 4.

The switch lever 5 is secured with an anti-twist lock 6 to prevent actuation by mistake.

This is how to activate the quick-change device.

Make sure that:

- The lift arm is lowered to just above the ground.
- Where a working attachment with an independent hydraulic supply is mounted, all cylinders, valves etc. are in the initial position or closed.
- Where a working attachment is fitted, make sure that it is tilted in.



**Danger**

There is a risk of accidents if the working attachment drops.

! Do not activate the quick-change device when the working attachment is raised.

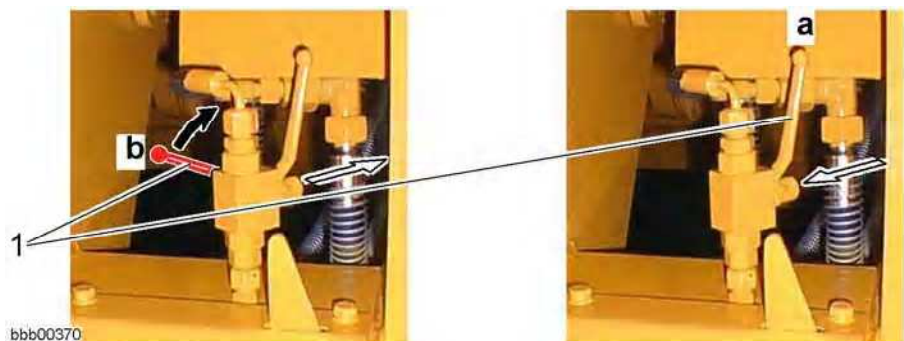

Changeover valve

The picture shows two lever positions (open/closed).

Activate (release) the hydraulic quick-change device with the changeover valve.

- If you want to activate the quick-change device:  
Move the switch lever 1 to position a and engage the anti-twist lock.

This opens the changeover valve.

The position of the lever shows the direction in which the hydraulic oil flows.

The function for unlocking the quick-change device is thus enabled.

### Unlocking the quick-change device

The procedure for unlocking the quick-change device is as follows. Make sure the quick-change device has been activated (enabled) by means of the changeover valve 4.

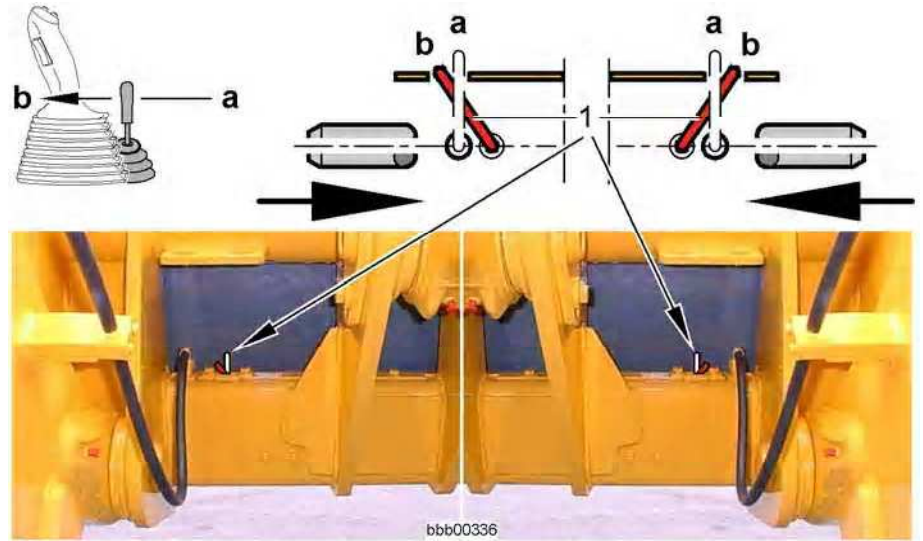

*Quick-change device as seen from the driver's cab*

1 Mechanical indicator

b Unlocked position

a Locked position

- Completely retract the locking pins  
Move the additional control lever in direction **b** as far as it will go and hold it there.

The locking pins for the quick-change device are retracted.

The position (retracted) of the locking pins is indicated mechanically by the display 1.

### Disconnecting the working attachment

This is the procedure for detaching the working attachment.

If the working attachment has an independent hydraulic circuit, make sure the hydraulic supply lines have been disconnected.



**Warning**

There is a risk of accidents if the working attachment is incorrectly set down.

! Never set down the working attachment in unsecured areas (roadways etc.).

- Set down the working attachment flat on firm, even ground.

If the working attachment has an independent hydraulic supply, set down the working attachment in such a way that the hydraulic lines are not subjected to any strain.

- Secure the working attachment against tipping over.

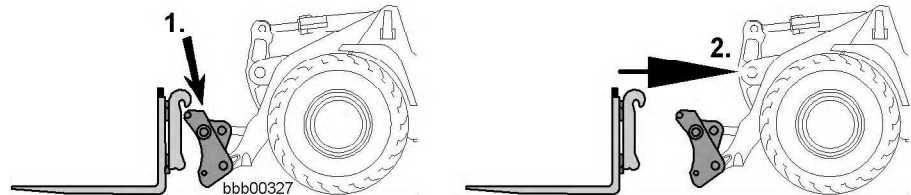

- Carefully remove the quick-change device from the adapter holder at the top of the working attachment.

The working attachment is now disconnected.

**Disconnecting hydraulic lines**

If the working attachment has an independent hydraulic circuit, the hydraulic supply lines must be disconnected.

The procedure for disconnecting the hydraulic lines is as follows.

**Depressurising the operating circuits****Warning**

There is a risk of accidents from hydraulic lines under pressure.

! Depressurise the hydraulic circuits before connecting or disconnecting hydraulic lines and couplings.

- Turn off the engine.
- Switch on the electrical system using the ignition key.
- Operate all pilot control devices in both directions using the control lever.

**Disconnecting hydraulic lines**

- Release the hydraulic lines and quick-release couplings from the machine.

- Make sure that no hydraulic oil leaks onto the ground.

Take any contaminated soil for disposal, because hydraulic oil can pollute rivers and groundwater.

- Seal the line couplings with a cap.
- Place the hydraulic lines in the hose retainer.

### Picking up and connecting the working attachment

This is the procedure for attaching and connecting the working attachment. Make sure that the quick-change device is completely unlocked.

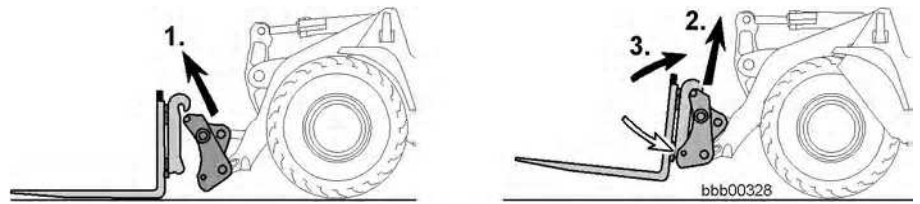

- Carefully put the quick-change device in the adapter holder at the top of the working attachment.
- Slightly raise and tilt in the working attachment.

The working attachment must be fully engaged in the quick-change device.

### Locking the quick-change device

The procedure for locking the quick-change device is as follows.

Make sure that:

- The working attachment is completely engaged in the quick-change device, so that the working attachment can be locked in place with the locking pins.
- The quick-change device has been activated by means of the changeover valve **4**.



#### Danger

There is a risk of accidents if the working attachment drops.

! Check whether the working attachment is fully engaged in the quick-change device.

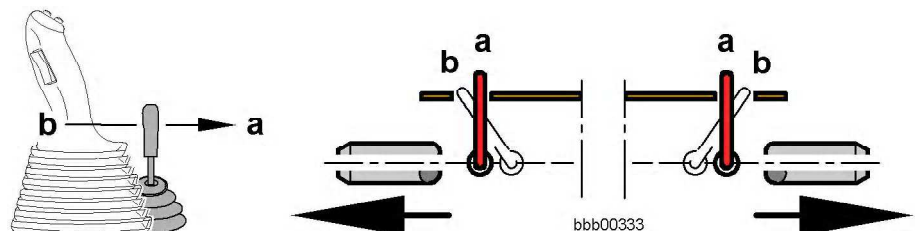

- Completely extend the locking pins  
Move the additional control lever in direction **a** as far as it will go and hold it there.

The locking pins for the quick-change device are extended.

The working attachment is now connected.

### Checking that the working attachment is locked

This is how to check after locking.

Make sure that the quick-change device is in a suitable position for inspection.



**Danger**

There is a risk of accidents if the working attachment drops.

! Do not carry out any working movements of the attachment before checking whether it is locked.

! Check whether the working attachment is securely locked to the quick-change device.

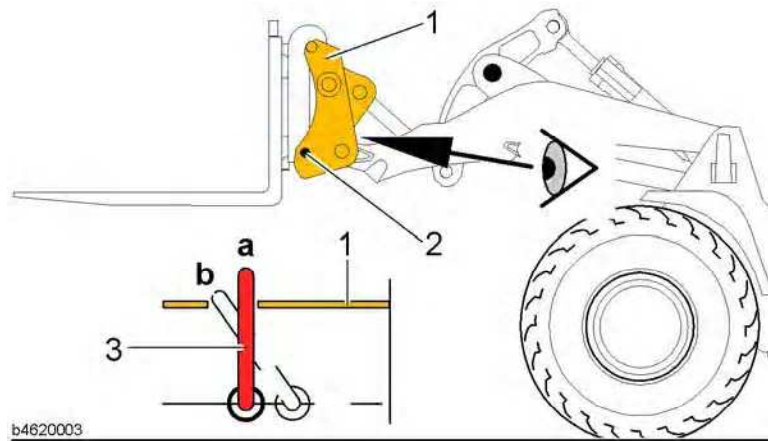

*Visual inspection of quick-change device*

- |                        |                     |
|------------------------|---------------------|
| 1 Quick-change device  | a Locked position   |
| 2 Locking pin          | b Unlocked position |
| 3 Mechanical indicator |                     |

- Move the lift arm up until it is possible to see the display 3.
- Get out of the machine and visually check that the locking pins 2 have actually locked the working attachment.
- Carry out the inspection on both sides of the machine.

**You can see that it is properly locked when the indicator 3 is upright. In addition, the locking pins 2 must have been inserted all the way to the outer borehole of the quick-change device 1.**



**Danger**

There is a risk of accidents if the working attachment drops.

If the quick-change device is unintentionally unlocked, both personnel and the working attachment will be endangered.

! It is essential that the changeover valve is locked again after the locking procedure is finished.

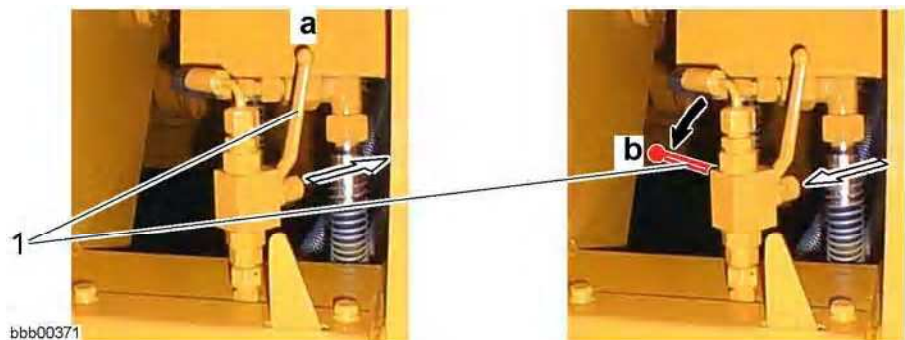

*Changeover valve*

LBH/03/003801/0003/5.06/en

The picture shows two lever positions (open/closed).

Deactivate (block) the quick-change device with the changeover valve.

- Close the changeover valve by taking the switch lever **1** out of the anti-twist lock and setting it to the position **b**.

This closes the changeover valve.

The function for unlocking the hydraulic quick-change device is thus blocked.

- Do not carry out any movements with the working attachment until you have inspected and deactivated the quick-change device.
- For operating a working attachment with its own control circuit, see the description in chapter 3 on the control lever for additional working functions and working with optional equipment (e.g. Using the high dump bucket).

### Connecting the hydraulic lines

If the working attachment has an independent hydraulic circuit, the hydraulic supply lines must be connected.



---

#### Warning

There is a risk of accidents from hydraulic lines under pressure.

! Depressurise the hydraulic circuits before connecting or disconnecting hydraulic lines and couplings.

---

- Take the caps off the line couplings.
- Connect the hydraulic lines according to their function.

Note the following points when connecting:

- Clean the line couplings before connecting.
  - Do not connect the wrong ends of the hydraulic lines.
  - Lay the hydraulic lines so that they cannot become caught in the working attachment during operation.
  - Use any hose retainers provided when laying the lines.
- Check the hydraulic lines for leaks after connecting them.

### 3.3.10 Combined electro-hydraulically actuated quick-change device

This equipment is optional.

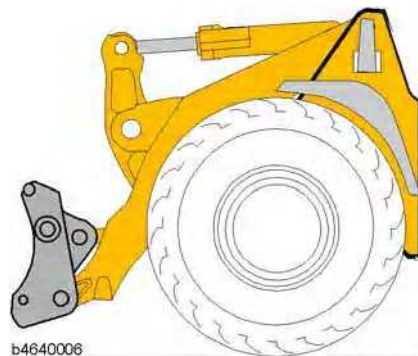

Quick-change device version:

- Combined electrohydraulic version.  
Electric activation and deactivation using switch.  
Hydraulic operation using the additional control lever.
- Mechanical locking indicator of the quick-change device.



#### Note

Information on attachments and accessories:  
Attachments and accessories produced by third-party manufacturers or those which have not been generally approved by LIEBHERR for installation or for external fitting may not be installed or fitted on the machine without prior written consent from LIEBHERR.

! The appropriate technical documentation should be made available to LIEBHERR for this purpose.

### Activating the quick-change device



Hydraulic quick-change device

- |                                       |   |
|---------------------------------------|---|
| 1 Supply line for quick-change device | 3 Switch for hydraulic quick-change device (optional) |
| 2 Hydraulic cylinder                  |   |



The combined, electro-hydraulically operated quick-change device is activated and deactivated using the switch **3** for the hydraulic quick-change device.

This is how to activate the quick-change device.

Make sure that:

- The lift arm is lowered to just above the ground.
- Where a working attachment with an independent hydraulic supply is mounted, all cylinders, valves etc. are in the initial position or closed.
- Where a working attachment is fitted, make sure that it is tilted in.

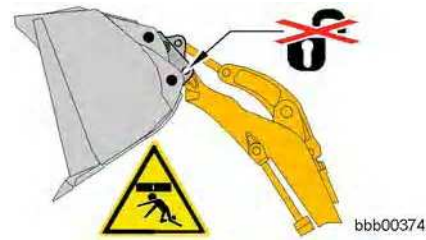

**Danger**

There is a risk of accidents if the working attachment drops.

! Do not activate the lockable switch when the working attachment is raised.

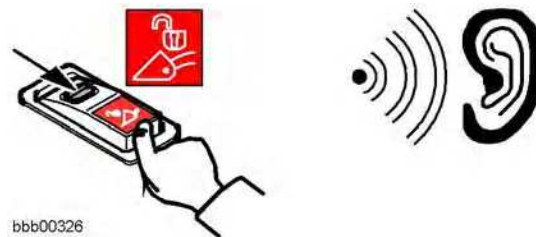

- Loosen the activation lock in the direction of the arrow and simultaneously push the switch forwards.

When you press the switch you will hear a warning signal from the instrument panel.

The function for unlocking the quick-change device is thus enabled.

**Unlocking the quick-change device**

The procedure for unlocking the quick-change device is as follows.

Make sure that the switch for the hydraulic quick-change device has been pressed.

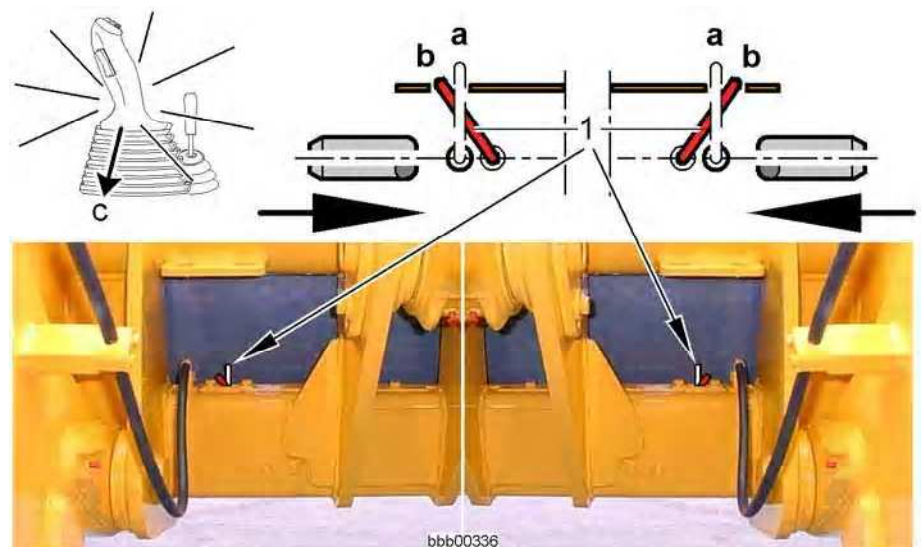

*Quick-change device as seen from the driver's cab*

LBH/03/003801/0003/5.06/en

1 Mechanical indicator  
a Locked position

b Unlocked position

- Completely retract the locking pins by moving the LH control lever in direction **c** (to tilt in the working attachment) to the stop and holding it in this position.

The locking pins for the quick-change device are retracted.

The position (retracted) of the locking pins is indicated mechanically by the display 1.

### Disconnecting the working attachment

This is the procedure for detaching the working attachment.

If the working attachment has an independent hydraulic circuit, make sure the hydraulic supply lines have been disconnected.



#### Warning

There is a risk of accidents if the working attachment is incorrectly set down.

! Never set down the working attachment in unsecured areas (roadways etc.).



- Deactivate the quick-change device by pushing back the hydraulic quick-change device switch.

When you press the switch the warning signal from the instrument panel stops.

- Set down the working attachment flat on firm, even ground.

If the working attachment has an independent hydraulic supply, set down the working attachment in such a way that the hydraulic lines are not subjected to any strain.

- Secure the working attachment against tipping over.

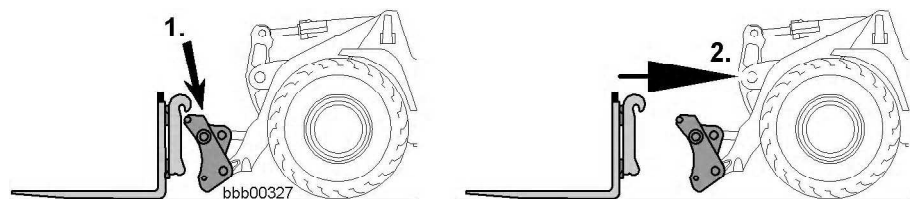

- Carefully remove the quick-change device from the adapter holder at the top of the working attachment.

The working attachment is now disconnected.

### Disconnecting hydraulic lines

Procedure: as described in the section on operating the hydraulic quick-change device.

LBH/03/003801/0003/5.06/en

## Picking up and connecting the working attachment

Procedure: as described in the section on operating the hydraulic quick-change device.

## Locking the quick-change device

The procedure for locking the quick-change device is as follows.

Make sure that:

- The working attachment is completely engaged in the quick-change device, so that the working attachment can be locked in place with the locking pins.
- The switch for the hydraulic quick-change device is turned off.



### Danger

There is a risk of accidents if the working attachment drops.

! Check whether the working attachment is fully engaged in the quick-change device.

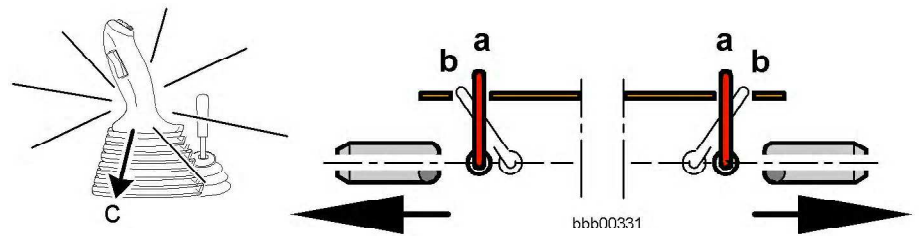

- Completely extend the locking pins by moving the LH control lever in direction **c** (to tilt in the working attachment) to the stop and holding it in this position.

The locking pins for the quick-change device are extended.

The working attachment is now connected.

## Checking that the working attachment is locked

This is how to check after locking.

Make sure that the quick-change device is in a suitable position for inspection.





**Danger**

There is a risk of accidents if the working attachment drops.

- ! Do not carry out any working movements of the attachment before checking whether it is locked.
- ! Check whether the working attachment is securely locked to the quick-change device.

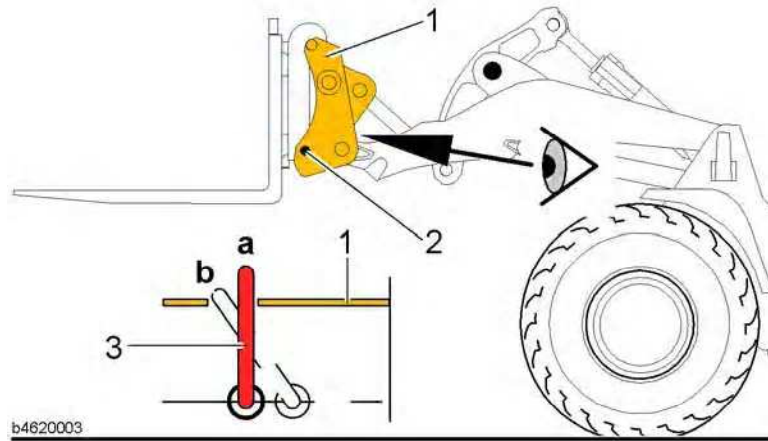

*Visual inspection of quick-change device*

- |                        |                     |
|------------------------|---------------------|
| 1 Quick-change device  | a Locked position   |
| 2 Locking pin          | b Unlocked position |
| 3 Mechanical indicator |                     |

- Move the lift arm up until it is possible to see the display 3.
- Get out of the machine and visually check that the locking pins 2 have actually locked the working attachment.
- Carry out the inspection on both sides of the machine.

**You can see that it is properly locked when the indicator 3 is upright. In addition, the locking pins 2 must have been inserted all the way to the outer borehole of the quick-change device 1.**

- Do not carry out any working movements of the attachment before performing the check.
- For operating a working attachment with its own control circuit, see the description in chapter 3 on the control lever for additional working functions and working with optional equipment (e.g. Using the high dump bucket).

**Connecting the hydraulic lines**

Procedure: as described in the section on operating the hydraulic quick-change device.

### 3.3.11 Electro-hydraulically actuated quick-change device with comfort control.

This equipment is optional.

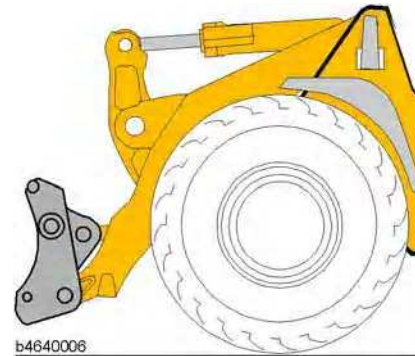

Quick-change device version:

- Combined electrohydraulic version with comfort control.  
Electrical activation and deactivation using changeover valve and switch.
- Hydraulic operation using the LH control lever.
- Mechanical locking indicator of the quick-change device.



#### Note

Information on attachments and accessories:

Attachments and accessories produced by third-party manufacturers or those which have not been generally approved by LIEBHERR for installation or for external fitting may not be installed or fitted on the machine without prior written consent from LIEBHERR.

! The appropriate technical documentation should be made available to LIEBHERR for this purpose.

#### Activating the quick-change device

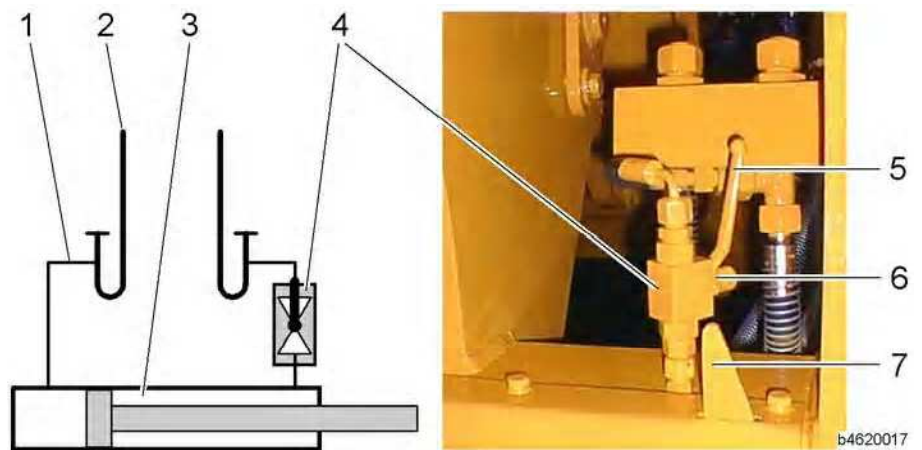

Hydraulic quick-change device

- |                                       |                        |
|---------------------------------------|------------------------|
| 1 Supply line for quick-change device | 4 Changeover valve     |
| 2 Supply line for accessory kit       | 5 Switch lever         |
| 3 Hydraulic cylinder                  | 6 Anti-twist lock      |
|                                       | 7 Mechanical indicator |

LBH/03/003801/0003/15.06/en



Comfort control

1 Comfort control switch

The combined, electro-hydraulically operated quick-change device with comfort control is activated and deactivated using the switch 1. This is how to activate the quick-change device.

Make sure that:

- The lift arm is lowered to just above the ground.
- Where a working attachment with an independent hydraulic supply is mounted, all cylinders, valves etc. are in the initial position or closed.
- Where a working attachment is fitted, make sure that it is tilted in.
- The changeover valve 4 is open.

See the description of activating the quick-change device in the section on operating the hydraulic quick-change device (version 1).



**Danger**

There is a risk of accidents if the working attachment drops.  
! Do not actuate switch when the working attachment is raised.

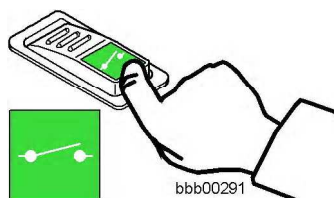

- Press the switch forwards.

The function for unlocking the quick-change device is thus enabled.

## Unlocking the quick-change device

The procedure for unlocking the quick-change device is as follows. Make sure that the quick-change device has been activated using the comfort control switch 1.

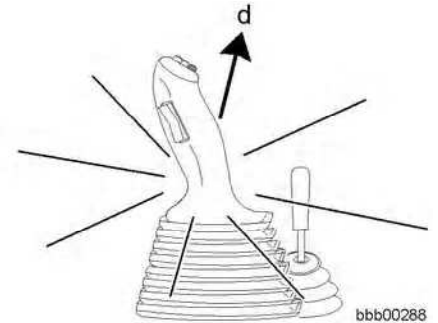
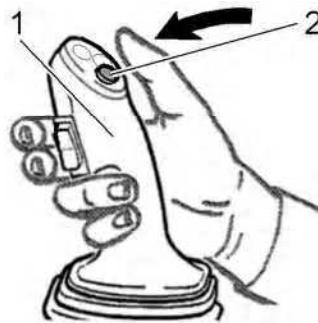

LH control lever

- 1 LH control lever
- 2 Comfort control button

- d Direction of movement

- Press the button 2 and hold it down. Press the button 2 to disable the function for operating the lift and tilt cylinders.

- Completely retract the locking pins by moving the LH control lever 1 in direction d (to tilt out the working attachment) to the stop and keep it in this position.

The locking pins for the quick-change device are retracted.

- When the locking pins are completely retracted: Release the button 2 and the LH control lever 1 again.

Release the button 2 to enable the function for operating the lift and tilt cylinders again.

## Disconnecting the working attachment

Procedure: as described in the section on operating the hydraulic quick-change device for Z lift arms.

## Disconnecting hydraulic lines

Procedure: as described in the section on operating the hydraulic quick-change device for Z lift arms.

## Picking up and connecting the working attachment

Procedure: as described in the section on operating the hydraulic quick-change device for Z lift arms.

## Locking the quick-change device

The procedure for locking the quick-change device is as follows.

Make sure that:

- The working attachment is completely engaged in the quick-change device, so that the working attachment can be locked in place with the locking pins.
- The quick-change device is activated using the comfort control switch 1.



**Danger**

There is a risk of accidents if the working attachment drops.

! Check whether the working attachment is fully engaged in the quick-change device.

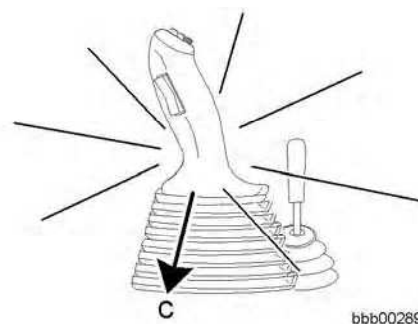
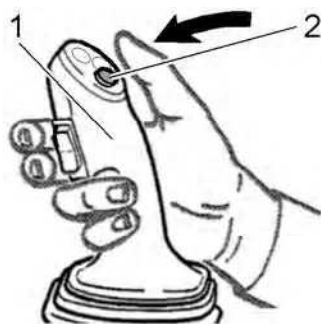

LH control lever

- 1 LH control lever
- 2 Comfort control button

c Direction of movement

- Press the button **2** and hold it down.

Press the button **2** to disable the function for operating the lift and tilt cylinders.

- Completely extend the locking pins  
Move the LH control lever **1** in direction **c** (to tilt in working attachment) to the stop and keep it in this position.

The locking pins for the quick-change device are extended.

- When the locking pins are completely extended:  
Release the button **2** and the LH control lever **1** again.

Release the button **2** to enable the function for operating the lift and tilt cylinders again.

The working attachment is now connected.



**Danger**

There is a risk of accidents if the working attachment drops.

If the quick-change device is unintentionally unlocked, both personnel and the working attachment will be endangered.

! It is essential that the changeover valve is locked again after the locking procedure is finished.

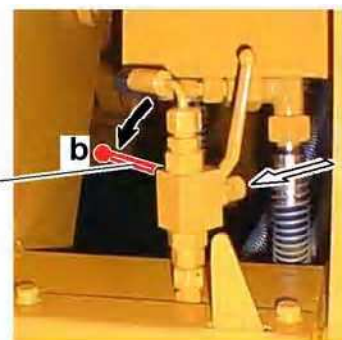
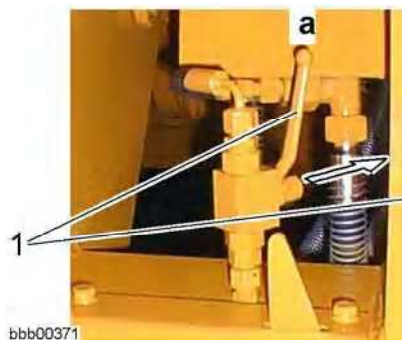

Changeover valve

bbb00371

LBH/03/003801/0003/5.06/en

- After the locking procedure:  
Deactivate (block) the quick-change device with the changeover valve.

### Checking that the working attachment is locked

Procedure: as described in the section on operating the hydraulic quick-change device.

### Connecting the hydraulic lines

Procedure: as described in the section on operating the hydraulic quick-change device.

## 3.3.12 Forklift

This equipment is optional.

The forklift consists of the fork carrier and adjustable fork prongs.

The forklift is mounted using the quick-change device.

Use the forklift for picking up, transporting and transferring pallets, and for stacking.

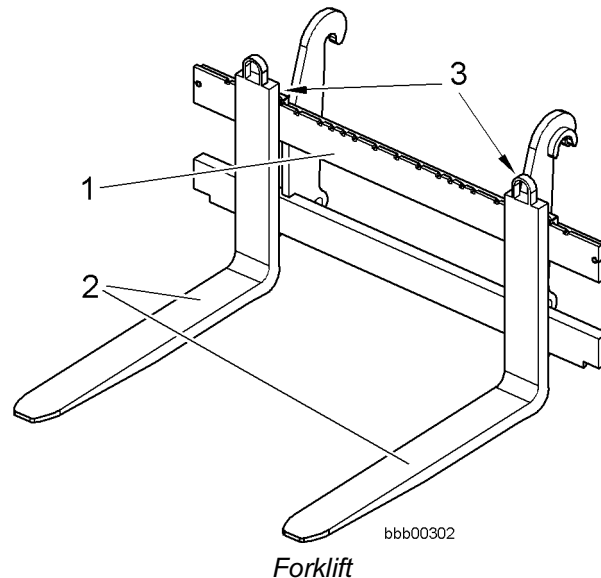

1 Fork carrier  
2 Fork prongs

3 Fork lock

#### For forklift operation with a P-kinematics lift arm:

- This only applies for machines with a P-lift arm attached.  
The parallel kinematics permit parallel guidance of the load over the entire lifting range during lifting or lowering.

#### For forklift operation with lift arms with Z-kinematics:

- Parallel load movement is not guaranteed with lift arms with Z-kinematics.  
This means that the attachment tilts in during the lift movement up to 2/3 of the maximum lift height and then tilts out again, but does not tilt down forwards.
- The less favourable lever ratio of the Z-kinematics in the topmost lifting range means that the load bearing capacity may be restricted.  
See the load tables for forklift operation in chapter 1.

### Adjusting the prongs on the fork carrier

The fork prongs are attached to the fork carrier and are secured against slipping with the fork lock on the upper fork hook. This is how to adjust the prongs on the fork carrier:

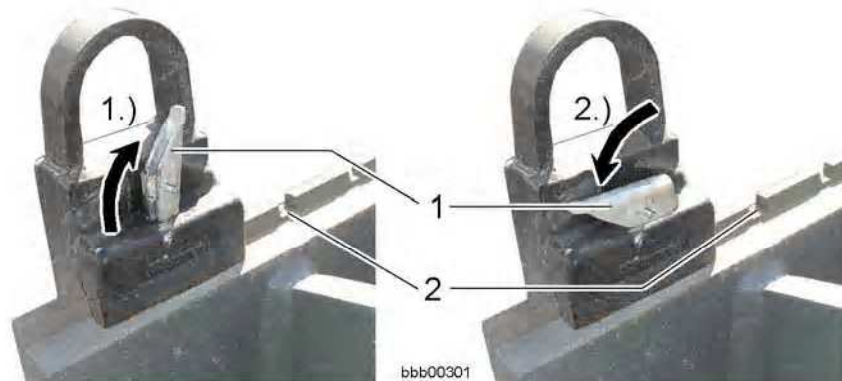

1 Fork lock  
2 Groove

1.) Opening the fork lock  
2.) Closing the fork lock

- Open the fork lock 1.
  - Push the prongs to the correct position.
  - When closing the fork lock 1 let it latch in the groove 2.
- The prongs are held tight.

### Jobs for the forks



#### Warning

There is a risk of accidents if the forklift tilts out forward. If the forklift is not parallel to the ground (0°) in its starting position, it may tilt out forward.

! Avoid incorrect operation during forklift operation.

When lifting in forklift mode, the load is not parallel to the ground.

This means when the forks are initially parallel (0° to the ground), when they are lifted two thirds of the full height:

- the attachment tilts in
- if lifted further, they tilt back out, but not forward.

The lever ratio of the kinematics in the topmost lifting range means that the load bearing capacity may be restricted.

See the load tables for forklift operation in chapter 1.

This is how to work in forklift mode.

**Make sure that the working attachment and the quick-change device are safely locked.**

See the description in the sections on operating the quick-change device . . and checking if the working attachment is locked.

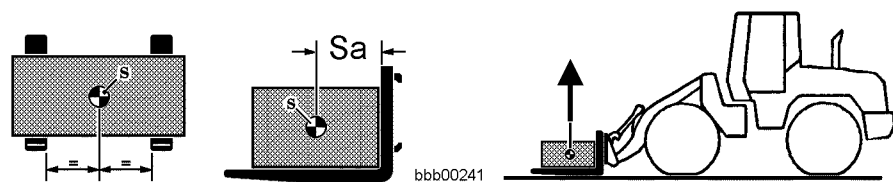

Distance from centre of gravity

LBH/03/003801/0003/5.06/en

S Centre of gravity

Sa Distance from centre of gravity

---

**Caution**

There is a risk of damage to the load and the machine.

During forklift operation, only use forks with prongs of suitable length and make sure that these do not project beyond the load. Otherwise goods or pallets lying in front of the forks could be damaged.

! Avoid incorrect operation during forklift operation.

---

- When you pick up the load, make sure that the load is resting as close as possible to the vertical limb of the fork prong.

Pick up the load. Make sure that the centre of gravity **Sa** of the load is correctly positioned.



---

**Warning**

There is a risk of the machine tipping over.

! Avoid incorrect operation during forklift operation.

---

- Raise the lift arms to the transport position (approx. 30–40 cm above the ground).
- When driving unloaded, tilt the forklift slightly in and carry it low.
- When driving with a load, tilt the forklift slightly in and carry the load low.
- When driving on slopes, always keep the load uphill.
- Never drive across slopes.
- Never turn on slopes.
- If a high unloading position is required:  
Do not raise the lift arms until just before reaching the unloading point.
- If a low unloading position is required:  
Do not lower the lift arms until just before reaching the unloading point.



### 3.3.13 Using the high dump bucket

The high dump bucket is equipped with its own hydraulic circuit for the high dumping function.



This high dumping function means that the buckets are especially suitable for work requiring a great dump height, such as loading high-sided wagons.

It can be used for light materials such as wood shavings, sawdust and cereals.



#### The high dump bucket may not be used:

- To lift or transport persons.
- To carry lifting equipment (in other words, you may not attach crane hooks or similar items).
- For handling material heavier than the specific material weight.  
See the technical data section in chapter 1.
- For breaking up rocks.
- For hammering in posts.
- Underground.

The manufacturer will not be held liable for damage caused by improper use (such as, for example, breaking off rocks, hammering in posts or attaching lifting gear).

#### Function test

**Make sure that the working attachment and the quick-change device are safely locked.**

See the description in the sections on operating the quick-change device .  
. and checking if the working attachment is locked.

Before starting work:

- Carry out a function test without any load.
- Familiarise yourself with the operation of the high dump bucket.



**Caution**

There is a risk of accidents if the hydraulic circuit is incorrectly connected.  
! Check to see that bucket tilts in and out properly.

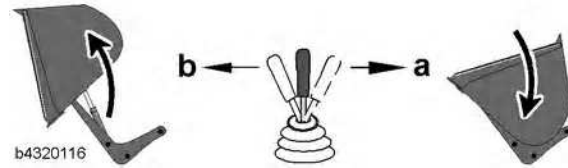

- Actuate the high dump bucket with the additional control lever to check if the hydraulic circuit of the high dump bucket is correctly connected.

**Tilting the high dump bucket in and out**

The high dump bucket is controlled using the additional control lever. See also the section on the control lever for additional working functions.

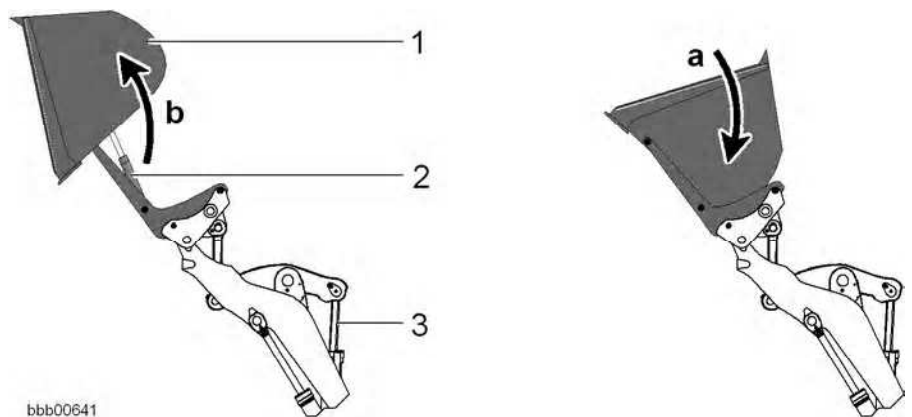

High dump bucket

- 1 Bucket body
- 2 Hydraulic cylinder for high dump bucket

- 3 Tilt cylinder for lift arm

**Caution**

There is a risk of damage to the machine and the vehicle to be loaded. If the high dump bucket is not properly used, the side of the lorry, for example, may be damaged.

! When loading lorries or similar vehicles, only tip out the material using the hydraulic circuit of the high dump bucket.

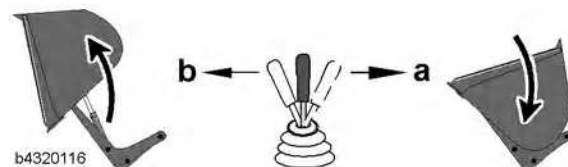

- **Tilting out the high dump bucket:**  
Move the additional control lever in direction **b**.  
The high dump bucket is tilted out.
- **Tilting in the high dump bucket:**  
Move the additional control lever in direction **a**.  
The high dump bucket is tilted in.

LBH/03/003801/0003/5.06/en

### Loading using the high dump bucket

For high dump bucket operations such as loading light material, see the section on working methods.

#### 3.3.14 Timber handling

An optional attachment is available for transferring timber.



*Tilt cylinder support*

- |                    |                    |
|--------------------|--------------------|
| 1 Z-bar linkage    | 4 Support fork     |
| 2 Tilt cylinder    | 5 Lubricating line |
| 3 Support cylinder |                    |

The support fork and the two support cylinders provide the necessary torque in the unloading position when carrying heavy equipment and loads. For the maximum payload, see the technical data section in chapter 1. This is how to transfer timber.

**Make sure that the working attachment and the quick-change device are safely locked.**

See the description in the sections on operating the quick-change device . and checking after locking.

### Operating the timber grabber

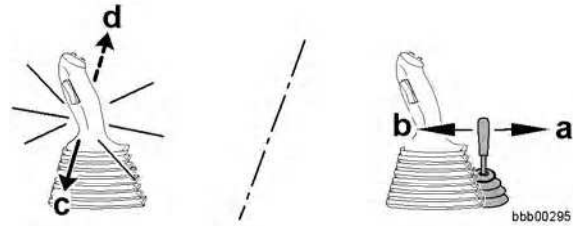

The operation of the timber grabber can vary according to its design.

Versions:

- Operation using the additional control lever
- Operation using the comfort control switch and LH control lever  
See also the section on the LIEBHERR control lever.

- **Before starting work:**

Carry out a function test without any load.

- Familiarise yourself with the operation of the attachment.
- For details on the function, operation and maintenance of the attachment:  
See the manufacturer's operating manual.



---

#### Caution

There is a risk of accidents if the hydraulic circuit is incorrectly connected.  
! Test the function of the attachment.

---

- Operate the attachment to check if the hydraulic circuit of the timber grabber is correctly connected.

#### Transferring timber

- **When you pick up the load:**

Make sure that the centre of gravity of the load is correctly positioned.



**Warning**

There is a risk of the machine tipping over.

! Avoid incorrect operation when transferring timber.

- Raise the lift arms to the transport position (approx. 30–40 cm above the ground).
- When driving unloaded, tilt the attachment slightly in and carry it low.
- When driving with a load, tilt the attachment slightly in and carry the load low.
- When driving on slopes, always keep the load uphill.
- Never drive across slopes.
- Never turn on slopes.

See also the section on working methods.

- If a high unloading position is required:  
Do not raise the lift arms until just before reaching the unloading point.
- If a low unloading position is required:  
Do not lower the lift arms until just before reaching the unloading point.

### 3.3.15 Transporting the machine

#### Lifting the machine by crane

**It is essential to observe the accident prevention regulations when lifting the machine by crane.**

See section on safety regulations when lifting the machine by crane in chapter 2.

Take the following precautions before lifting the machine by crane.

**Note**

To ensure safe machine transport:

Always clean the machine before transporting it by road, rail or sea.

! Remove any loose parts, coarse dirt, mud, ice, snow etc.

Further precautions:

- Lower the working attachment and tilt back the loading equipment to its limit.
- Engage the articulation lock.
- Move all control levers to neutral.
- Engage the parking brake.
- Lock the working hydraulics.
- Shut down the engine.
- Close and lock all doors, hatches and hoods on the machine.

For detailed descriptions, see the section on operation and handling.

Find out about:

- The weight and collision masses of the machine: See the technical data section in chapter 1.
- The required load bearing capacity and lengths of the lifting tackle.

**Loading for lorry, rail or sea transport**

This is carried out when the machine has to be loaded by crane.

Necessary equipment:

- Towing device/yoke **1**  
Minimum length **b1** = 0.85 m  
Minimum length **b2** = 0.35 m  
Minimum length **l** = 5.85 m
- Lifting tackle **2**: minimum rope length = 2.7 m
- Lifting tackle **3**: minimum rope length = 2.9 m

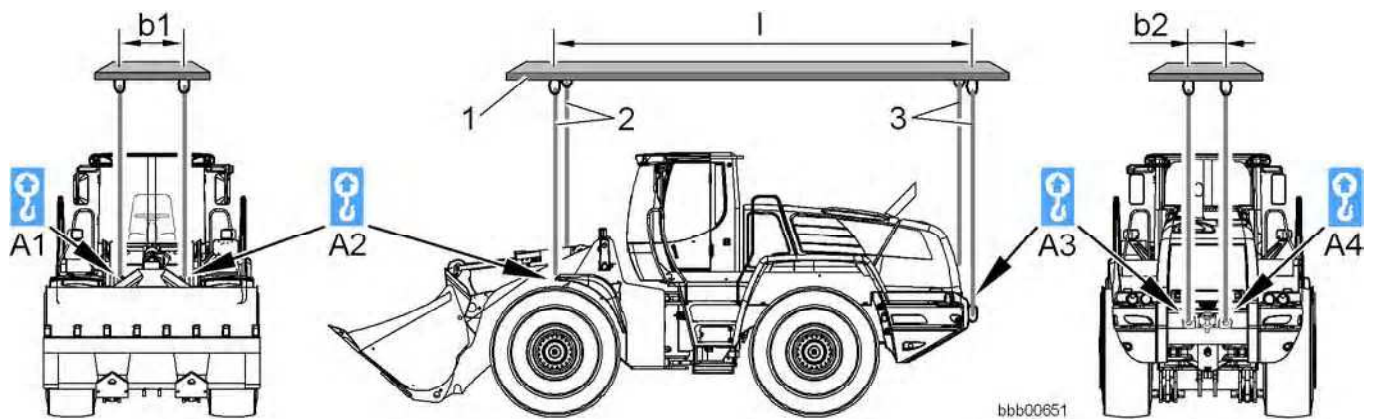

- 1 Towing device/yoke
- 2 Front lifting tackle
- 3 Rear lifting tackle

- A1 Front right slinging and lifting point
- A2 Front left slinging and lifting point

- A3 Rear left slinging and lifting point
- A4 Rear right slinging and lifting point



**Danger**

There is risk of accidents if the suspended load falls.  
! Never stand under the machine when it is suspended.

- Attach the lifting tackle to the slinging and lifting points **A1**, **A2**, **A3**, **A4** provided on the machine.
- Carefully lift the machine and load it.



- Do not allow anyone under the raised machine.

LBH/03/003801/0003/15.06/en

### Transporting the machine by lorry or rail

#### Before driving onto the loading area

The following precautions must be taken before driving onto the loading area.

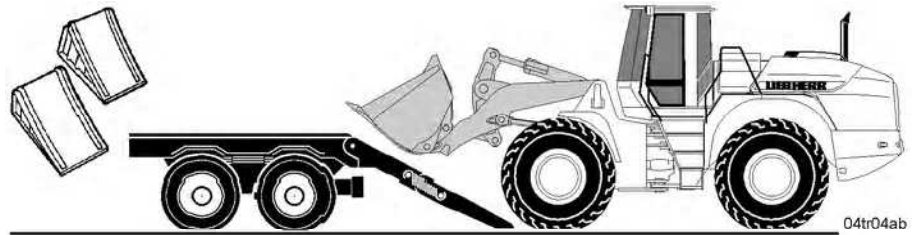

Loading the machine

Precautions:

- Have wheel wedges ready.
- Have suitable tensioning ropes or chains ready to lash the machine down.

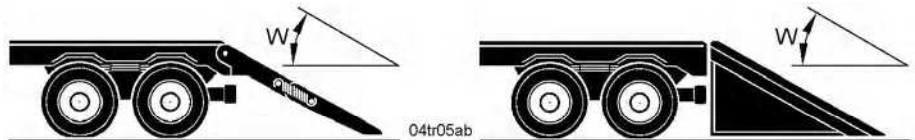

Ramp inclination

A ramp should be provided for driving the machine onto the loading area. The inclination of the ramp **W** may not exceed 30°.

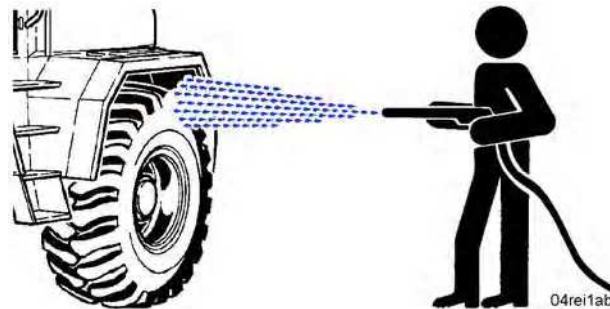

Washing

Clean the tyres of snow, ice and mud before driving up the ramp.

#### Driving onto the loading area

For detailed descriptions, see the section on operation and handling.



When driving onto the loading area have someone direct you. Make sure there is someone to give the driver the necessary signals.



#### Warning

There is a risk of injury to the person giving directions.

! The person giving directions must remain in sight of the operator or at least be in spoken contact with him.

! People giving directions must always stand to one side of the machine.

This is the procedure for driving onto the loading area:

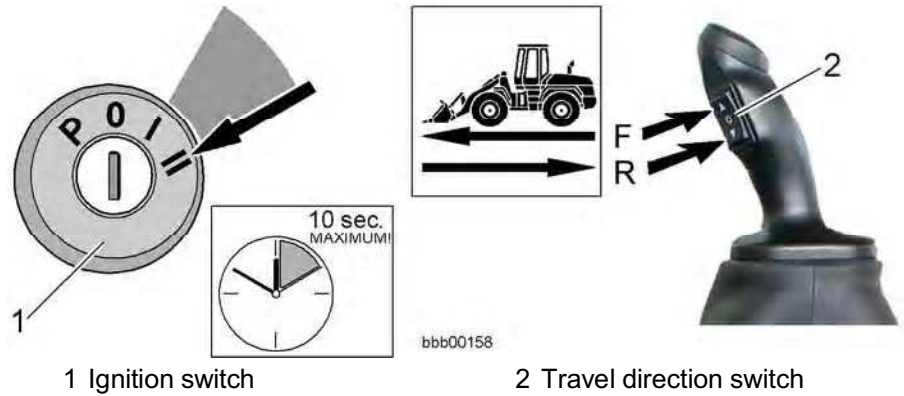

- Start the engine.

This is the situation after the machine has been started:

- The default settings are the automatic travel range **A1-3** and the travel drive set to neutral **N**.  
These are both indicated by the symbol field on the display unit.
- The parking brake is automatically activated.

See also the sections on starting the diesel engine and driving.

- Release the parking brake.
- Select the travel direction.



#### Warning

There is a risk of accidents if the machine is driven without due care. Reckless driving can endanger those loading, directing and driving the machine.

! Always drive with due care when loading the machine.

#### Caution

There is a risk of damage if the machine is not driven with due care. Reckless driving can damage the transport vehicle and the machine.

! Always drive with due care when loading the machine.

- Push down the gas pedal carefully.
- Carefully drive the machine to the loading area and stop.



**After driving onto the loading area**

For detailed descriptions, see the section on operation and handling. Make sure that the air stream produced during transport cannot enter the exhaust pipe opening. This is especially important for rail transport, since the direction of travel cannot be known in advance.

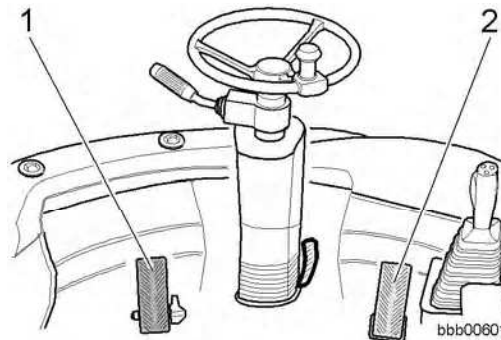

*Inch/brake pedal and gas pedal*

1 Inch/brake pedal

2 Gas pedal

- Stop the machine.

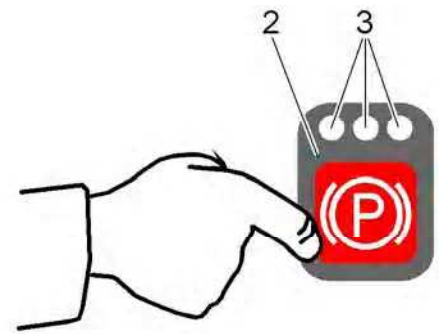

bbb00586

*Parking brake*

- Engage the parking brake.

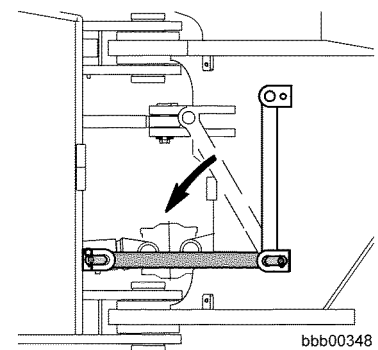
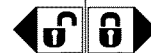
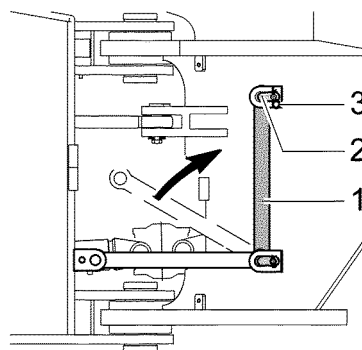

bbb00348

*Articulation lock open / closed*

- Engage the articulation lock.
- Bolt the locking bar 1 in the bottom position.

- Secure the pin **2** from falling out using the spring clip **3**.
- Lower the lift arms and lay the bucket down flat on the loading area.
- Turn off the engine.
- Close and lock all doors, hatches and hoods on the machine.

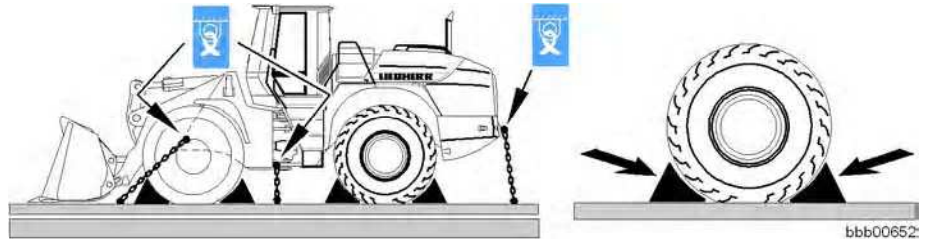

Lashing points

- Secure the machine against sliding using wheel wedges and tensioning ropes or chains.
- Fasten the ropes and chains securely to the indicated lashing points.

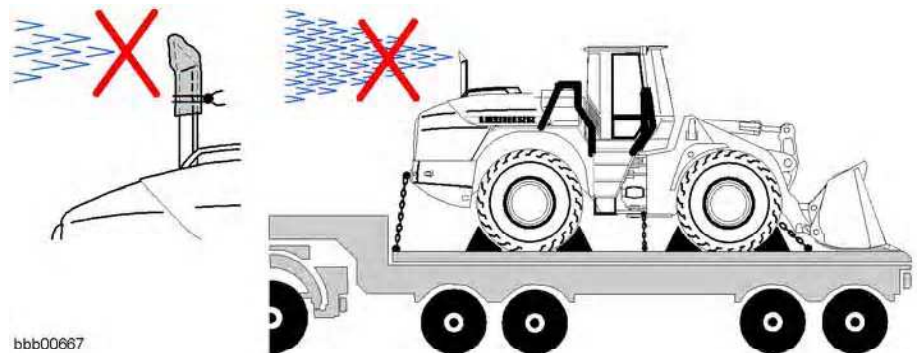

Blocking off the exhaust pipe opening

If the machine is being transported facing backwards, air can blow into the exhaust pipe opening.

Take the following precaution to prevent damage during transport.

---

**Caution**

There is a risk of damage to the turbocharger.

If air blows into the exhaust pipe opening, it causes the turbocharger of the diesel engine to rotate.

The turbocharger is not lubricated when the engine is not running.

The turbocharger can be damaged if it is not lubricated.

! Prevent the air stream produced during transport from entering the exhaust.

---

- To block off the exhaust pipe opening, climb onto the machine via the cab access, making sure that you have secure footing.
- Block off the exhaust pipe opening using airtight material which cannot slip.

## 3.4 Emergency operation

This section describes the emergency operations of the machine.

### Emergency operations:

- Towing the machine
- Jump starting

### 3.4.1 Towing the machine

If the machine breaks down, you may have to tow it away from a hazardous area.

The following towing instructions only apply to exceptional situations where a machine incapable of independent movement has to be taken to a place where it can be repaired or transported.

#### Towing speed and towing distance:

- Maximum towing speed 2 km/h ,
- Only short distances are permitted, in order to move the machine away from a danger area.

#### Safety instructions for towing

Towing the machine can be difficult and is therefore entirely the responsibility of the operator.

In no event can damage or accidents resulting from towing be covered by the manufacturer's guarantee.

See the section on safely towing the machine in chapter 2.



#### Danger

Incorrect towing can cause accidents.

When a machine incapable of independent movement is not properly towed, the result could be severe or even fatal injuries.

! Always secure the machine against rolling away before releasing the brakes for towing.

- Follow all specified safety regulations and the following instructions when towing.

#### Towing with the engine running

The following precautions must be taken before towing the machine.

#### Precautions:

- Put the machine in the towing position.
- Deactivate all travel functions
- Release the parking brake.

This is how to tow the machine with the engine running.

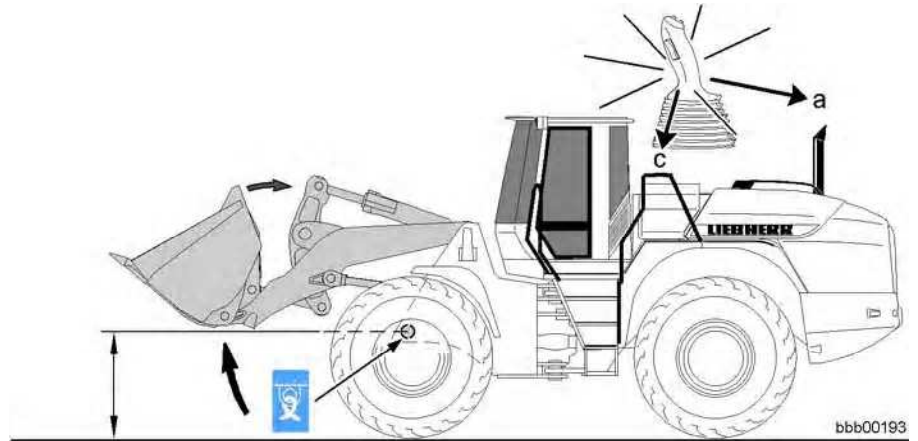

Towing position

- **Put the machine in the towing position.**  
Raise the lifting gear above the towing drill hole.
- If the working attachment can be hydraulically operated, tilt in the bucket as far as it will go.

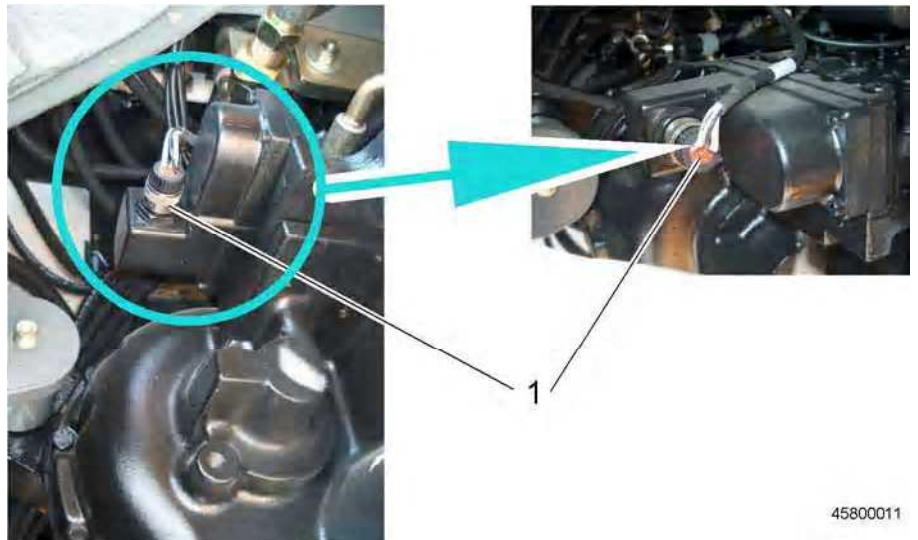

Transfer gear

- Put all travel functions out of operation by removing the plug 1 from the transfer gear.

This disconnects the solenoid valve on the gearbox from the electronics. The machine's travel functions are now out of operation.

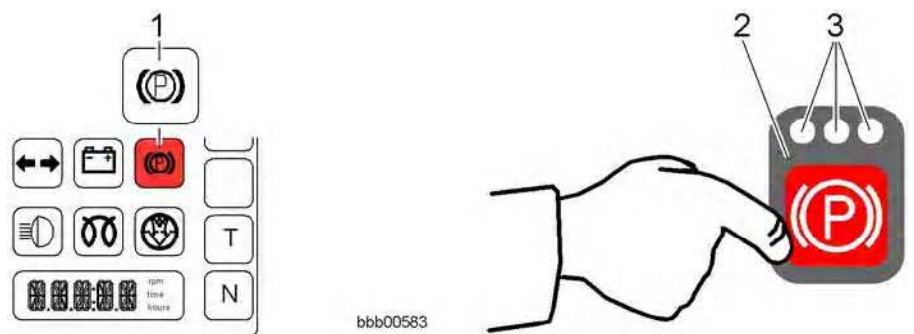

Control unit

LBH/03/003801/0003/5.06/en

- 1 Parking brake symbol field
- 2 Parking brake button
- 3 LEDs

- Press the button **2** to release the parking brake.
- All 3 LEDs on the button go out.  
 The symbol field **1** for the parking brake goes out.  
 The parking brake is released and the machine can now be towed.

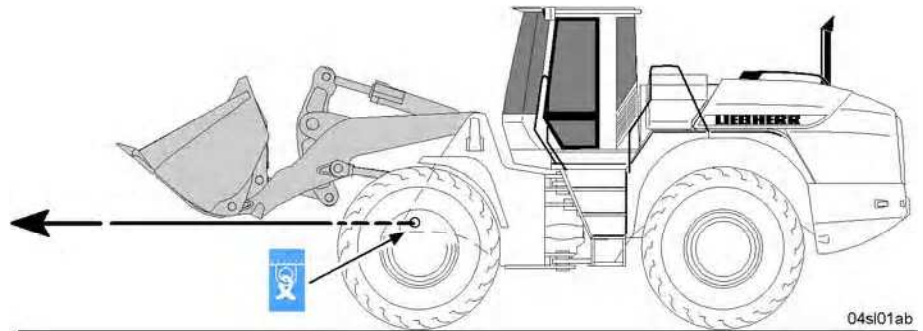

Towing

- Feed the two towing ropes through the bore holes in the front section and secure them.
- Tow the machine out of the danger area.



Transfer gear

- **When towing has been completed:**  
 Reattach the plug **1** to the powershift section **2** of the transmission **3**.  
 This connects the solenoid valve on the gearbox to the electronics.  
 The machine's travel functions are operational again.

### Towing with the engine not running

If the machine has suffered a serious breakdown such as engine failure, the braking and steering functions will be impaired.



**Note**

The brake accumulator is not filled if the engine is not running:  
 ! The service brake becomes ineffective after it is applied several times.

Make sure that the parking brake has been mechanically released before towing the machine away.

**This is how to tow the machine without the engine running.**



### Danger

There is a risk of accidents if the machine suddenly rolls away.

! Secure the machine against rolling away.

- Release the parking brake mechanically.
- Take off the cover.

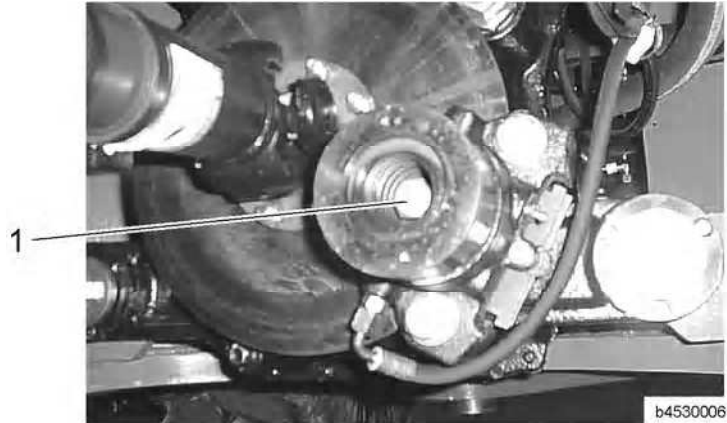

*Parking brake*

- Loosen the counter nut.
- Loosen the adjusting screw 1 until the brake pad no longer touches the brake disc.

This releases the parking brake.



### Warning

There is a risk of accidents when the machine is in tow.

Since the steering function is restricted, there is a risk of accidents when the machine is being towed.

! When towing the machine, use the emergency steering function.

- See the section on towing the machine when the steering system has failed.
- Only tow the machine using the tow bar.
- **When towing has been completed:**  
Correctly reset the parking brake.

See chapter 5 in the section on checking the gap and wear on the parking brake linings.

### Towing the machine when the steering system has failed

If the ignition is on, you can steer using the emergency steering function for up to 10 seconds.



bbb00572



bbb00214

Make sure that the electrical system is switched on.

#### Procedure for starting the emergency steering pump.

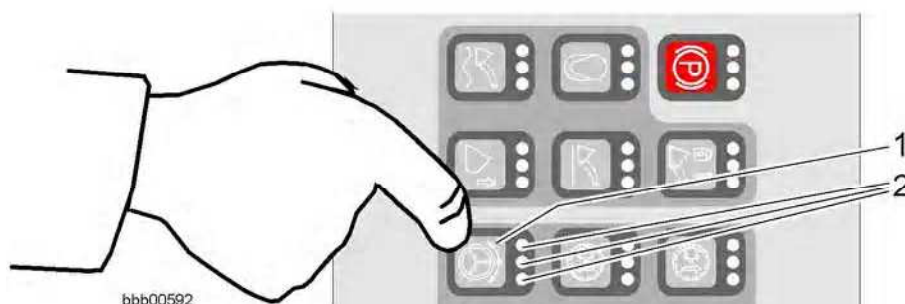

bbb00592

Control unit

1 Emergency steering button      2 LEDs

If you need to turn the steering wheel while towing:

- For emergency steering up to 10 seconds:  
Press and hold down the emergency steering button 1.

The emergency steering pump is activated for a maximum of 10 seconds .

All three LEDs 2 on the button light up as long as the emergency steering pump is running.

The emergency steering symbol field lights up when the emergency steering function is activated.

See also the description of the display unit in the section on operation.



bbb00572



04ml14ab

### 3.4.2 Jump starting

If you have problems starting because the batteries are flat, the machine can be jump started with external batteries.

Make sure you have taken all the following safety precautions.

#### Connecting an external battery

How to jump start the machine.



bbb00376



**Danger**

There is a risk of accidents due to incorrect or careless jump starting. Excess gas can form when you connect an external battery to old batteries. There is a risk of explosions.

- ! Therefore avoid naked flames and sparks near the batteries.
- ! Wear protective gloves and goggles when jump starting.
- ! Only use sufficiently thick jump leads.
- ! Make sure you connect and disconnect the jump leads in the right order.

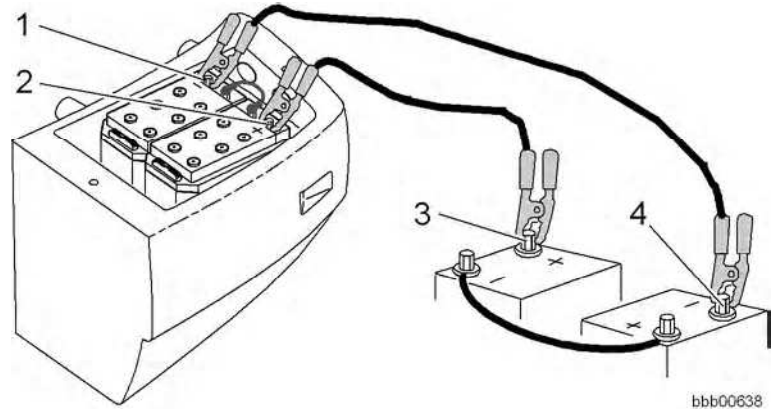

*Jump starting*

- |   |   |
|---|---|
| 1 Earth point of the flat battery       | 3 Positive terminal of the external battery |
| 2 Positive terminal of the flat battery | 4 Earth point of the external battery       |

- First connect one jump lead to the positive terminal of the flat battery **2** and then to the positive terminal of the external battery **3**.
- First connect the second jump lead to the earth point of the external battery/batteries **4** and then to the earth point on the discharged battery **1**.
- Start up the engine. See the section on starting the engine.

**Disconnecting the external battery**



**Note**

Before disconnecting the jump leads:

- ! Make sure the engine is at lower idling speed.

Excess voltage can be avoided by switching on major consumers such as floodlights.

- First disconnect the jump lead from the earth point of the discharged battery **1** and then from the earth point on the external battery/batteries **4**.
- Then remove the second jump lead from the positive terminal of the external battery **3** and then from the positive terminal of the flat battery **2**.

LBH/03/003801/0003/5.06/en



# 4 Malfunctions

## Warning and error messages

- Various faults are indicated by the corresponding symbol fields (visually) or by display instruments on the instrument panel.  
See the section on the display unit in chapter 3.
- Some warning functions are accompanied by audible warning signals.

## Finding and eliminating errors and malfunctions

- Faults can often be traced back to incorrect operation or servicing of the machine.

**Therefore, carefully read the appropriate section of the operating manual each time a fault occurs.**

- **Analyse the cause of the fault and correct it immediately.**
- Describe the fault and all related circumstances as accurately as possible if you contact **LIEBHERR CUSTOMER SERVICE**.  
Precise information helps to locate and eliminate the cause of the fault. This means that the exact type and serial number of the machine need to be stated.
- Never perform any work for which you have not been trained or instructed.



---

### Note

If you cannot recognise the cause of the fault using the service code tables or cannot rectify the fault:

! Contact LIEBHERR CUSTOMER SERVICE.

---



### Malfunctions and their effects

Every malfunction has a defined effect.

See the Effects column in the service code table.

Depending on the cause of the fault, restricted driving may still be possible.

If malfunctions occur which can seriously damage the machine:

- The machine is shut down.
- Neutral travel direction is automatically selected and the machine coasts to a halt.
- This is indicated by the STOP display **2** on the display unit.



**Note**

Note the service code.

! After switching off the ignition, the service code in the segment display (see display unit) is deleted.

Have LIEBHERR CUSTOMER SERVICE rectify the fault.

Service-Code	Symptom	Cause	Solution
E 2000	No emergency steering function.	Emergency steering pump: Pressure switch B3 is closed even though the engine is not running	Contact LIEBHERR CUSTOMER SERVICE
E 2001	No emergency steering function.	Emergency steering pump: Pressure switch B3 does not switch after the engine starts	Contact LIEBHERR CUSTOMER SERVICE
E 2002	No emergency steering function.	Emergency steering pump: Test failed (B3a emergency steering pump check pressure switch did not switch)	Contact LIEBHERR CUSTOMER SERVICE
E 2003	No emergency steering function.	Emergency steering pump: Emergency steering pump pressure switch check B3a closed without check	Contact LIEBHERR CUSTOMER SERVICE
E 2013	The output of the travel pump is reduced	The hydraulic oil (B8) has overheated to more than 95 °C	Clean the cooling system, contact LIEBHERR CUSTOMER SERVICE
E 2016	Symbol field H19 glows, after 2 mins the warning beep sounds constantly, travel direction cannot be selected	Brake accumulator pressure: pressure too low	Contact LIEBHERR CUSTOMER SERVICE
E 2017	All three LEDs on the control unit switch light up, central lubrication system does not work	Central lubrication system: Electrical fault at output (cable rupture) of grease supply line fault	Check the distributor, grease supply lines and lubrication points, contact LIEBHERR CUSTOMER SERVICE

LBH/03/003801/0003/5.06/en

Service-Code	Symptom	Cause	Solution
E 2018	Gerotor steering (2 in 1 steering) is deactivated	Gerotor steering (2 in 1 steering): Signal at output does not correspond to the activation	Contact LIEBHERR CUSTOMER SERVICE
E 2020	Output module 1 Vcc Bank 2 has no power supply	No voltage response from the output, defective wiring or fuse	Contact LIEBHERR CUSTOMER SERVICE
E 2022	Output module 2 Vcc Bank 2 has no power supply	No voltage response from the output, defective wiring or fuse	Contact LIEBHERR CUSTOMER SERVICE
E 201A	The enabled options have no function	Wrong options enabled	Contact LIEBHERR CUSTOMER SERVICE
E 201B	Output module 2 DO 1 has no power supply	No voltage response from the output, defective wiring or fuse	Contact LIEBHERR CUSTOMER SERVICE
E 201C	Output module 2 DO 2 has no power supply	No voltage response from the output, defective wiring or fuse	Contact LIEBHERR CUSTOMER SERVICE
E 201D	Output module 1 DO 1 has no power supply	No voltage response from the output, defective wiring or fuse	Contact LIEBHERR CUSTOMER SERVICE
E 201E	Output module 1 DO 2 has no power supply	No voltage response from the output, defective wiring or fuse	Contact LIEBHERR CUSTOMER SERVICE
E 201F	Output module 1 Vcc Bank 1 has no power supply	No voltage response from the output, defective wiring or fuse	Contact LIEBHERR CUSTOMER SERVICE
E A005	Display unit (A13) does not work	CAN: Display unit (A13) time out, display unit (A13) hardware defective, error in CAN wiring	Contact LIEBHERR CUSTOMER SERVICE
E A006	Air conditioning does not work	CAN: Air conditioning module timeout, air conditioning hardware defective, error in CAN wiring	Contact LIEBHERR CUSTOMER SERVICE
E A007	Option output module does not work	CAN: Option output module timeout, output module hardware defective, error in CAN wiring	Contact LIEBHERR CUSTOMER SERVICE
E A008	Option input module does not work	CAN: Option input module timeout, input module hardware defective, error in CAN wiring	Contact LIEBHERR CUSTOMER SERVICE
E A010	Heater/air conditioning keypad does not work	CAN: Heater/air conditioning keypad, keypad hardware defective, error in CAN wiring	Contact LIEBHERR CUSTOMER SERVICE

Service-Code	Symptom	Cause	Solution
E A011	Option keypad does not work	CAN: Option keypad timeout, keypad hardware defective, error in CAN wiring	Contact LIEBHERR CUSTOMER SERVICE
E A020	Depends on the fault	Calculation error options, input module 1, module has sent an internal error code	Contact LIEBHERR CUSTOMER SERVICE
E A021	Depends on the fault	Calculation error options, output module 1, module has sent an internal error code	Contact LIEBHERR CUSTOMER SERVICE
E A023	Depends on the fault	Calculation error, option keypad module has sent an internal error code	Contact LIEBHERR CUSTOMER SERVICE
E A024	Depends on the fault	Calculation error, main keypad (A11) module has sent an internal error code	Contact LIEBHERR CUSTOMER SERVICE
E A025	Depends on the fault	Calculation error, display unit (A13) module has sent an internal error code.	Contact LIEBHERR CUSTOMER SERVICE
E A026	Depends on the fault	Calculation error, output module 2 (A17b), module has sent an internal error code	Contact LIEBHERR CUSTOMER SERVICE
E A027	Depends on the fault	Calculation error, output module 1 (A17a), module has sent an internal error code	Contact LIEBHERR CUSTOMER SERVICE
E A028	Depends on the fault	Calculation error, input module 2, module has sent an internal error code.	Contact LIEBHERR CUSTOMER SERVICE
E A029	Depends on the fault	Calculation error, input module 1, module has sent an internal error code.	Contact LIEBHERR CUSTOMER SERVICE
E A02A	Depends on the fault	Calculation error, A 15 master unit module has sent an internal error code.	Contact LIEBHERR CUSTOMER SERVICE
E A02B	Calculation error depends on the fault	Calculation error, CAN module has sent an internal error code for a CAN user.	Contact LIEBHERR CUSTOMER SERVICE
E A02C	Calculation error depends on the fault	General calculation error, module has sent an internal error code for a CAN user.	Contact LIEBHERR CUSTOMER SERVICE

Service-Code	Symptom	Cause	Solution
E 3000	STOP symbol field H24 flashes, no emergency steering function available	Emergency steering pump: Pressure switch B3a check - shorted to earth	Contact LIEBHERR CUSTOMER SERVICE
E 3001	STOP symbol field H8 flashes, no emergency steering function available	Emergency steering pump: Pressure switch B3 - shorted to earth	Contact LIEBHERR CUSTOMER SERVICE
E 3002	Symbol field H19 lights up, condition of the parking brake cannot be detected	Brake accumulator pressure: Pressure switch B19 - shorted to earth	Contact LIEBHERR CUSTOMER SERVICE
E 3003	No float position available	Float position: Pressure switch B32 - shorted to earth	Contact LIEBHERR CUSTOMER SERVICE
E 3004	No inching function available	Inching angle sensor: Channel 1 electrical fault (overcurrent >20mA)	Contact LIEBHERR CUSTOMER SERVICE
E 3005	No inching function available	Inching angle sensor: Channel 1 electrical fault (undercurrent <4mA)	Contact LIEBHERR CUSTOMER SERVICE
E 3006	Travel direction cannot be selected	Control lever S2, forwards travel direction signal: Channel 1 shorted to earth	Contact LIEBHERR CUSTOMER SERVICE
E 3007	Travel direction cannot be selected	Control lever S2, reverse travel direction signal: Channel 1 shorted to earth	Contact LIEBHERR CUSTOMER SERVICE
E 3008	No lift kick-out available	Lift kick-out: Inductive switch B17 shorted to earth	Contact LIEBHERR CUSTOMER SERVICE
E 3009	No bucket return-to-dig available	Bucket return-to-dig: Inductive switch B15 shorted to earth	Contact LIEBHERR CUSTOMER SERVICE
E 300A	Gear oil symbol field (H14) lights up	Gear oil: Overheated, overheating switch B14 shorted to earth	Clean the cooler, contact LIEBHERR CUSTOMER SERVICE
E 300B	Fuel filling level not detected - minimum filling level displayed	Tank sensor B25: Electrical fault (undervoltage <1V)	Contact LIEBHERR CUSTOMER SERVICE
E 300C	Fuel filling level not detected - minimum filling level displayed	Tank sensor B25: Electrical fault (overvoltage >4V)	Contact LIEBHERR CUSTOMER SERVICE
E 300D	Engine cannot be started	S1 ignition switch: Start signal KI 50a shorted to earth	Contact LIEBHERR CUSTOMER SERVICE

Service-Code	Symptom	Cause	Solution
E 300E	Engine speed cannot be changed, driving not possible	Gas pedal angle sensor R5: Channel 1, current too high at the input of the input module (>20mA)	Contact LIEBHERR CUSTOMER SERVICE
E 300F	Engine speed cannot be changed, driving not possible	Gas pedal angle sensor R5: Channel 1, current too low at the input of the input module (<4mA)	Contact LIEBHERR CUSTOMER SERVICE
E 3010	Symbol field H23 lights up, incorrect fan speed calculated, driving only possible in fixed gear 1 or 2	Hydraulic oil: Temperature sensor B8 shorted to earth	Contact LIEBHERR CUSTOMER SERVICE
E 3011	Symbol field H23 lights up, incorrect fan speed calculated, driving only possible in fixed gear 1 or 2	Hydraulic oil: Temperature sensor B8 cable rupture	Contact LIEBHERR CUSTOMER SERVICE
E 3012	Continued driving is only possible in fixed gear 2	Variable displacement motor 1: Inductive sensor B2 shorted to earth	Contact LIEBHERR CUSTOMER SERVICE
E 3013	Continued driving is only possible in fixed gear 2	Variable displacement motor 1: Inductive sensor B2 cable rupture	Contact LIEBHERR CUSTOMER SERVICE
E 3014	No speed display (output speed) available.	Output speed: Inductive sensor B1 shorted to earth	Contact LIEBHERR CUSTOMER SERVICE
E 3015	No speed display (output speed) available.	Output speed: Inductive sensor B1 cable rupture	Contact LIEBHERR CUSTOMER SERVICE
E 3016	None	Driving light: Wiring shorted to earth at input of the input module	Contact LIEBHERR CUSTOMER SERVICE
E 3017	Symbol field H12 flashes, high beam symbol not triggered on monitor	High beam: Wiring shorted to earth at input of the input module	Contact LIEBHERR CUSTOMER SERVICE
E 3018	Symbol field H10 lights up, indicator symbol not triggered on monitor	Indicator signal: Wiring shorted to earth at input of the input module	Contact LIEBHERR CUSTOMER SERVICE
E 3019	Ride control not available	Ride control: Pressure switch B28 shorted to earth	Contact LIEBHERR CUSTOMER SERVICE

Service-Code	Symptom	Cause	Solution
E 301A	Travel direction cannot be selected	Control lever S2: Forwards travel direction signal channel 2 shorted to earth	Contact LIEBHERR CUSTOMER SERVICE
E 301B	Travel direction cannot be selected	Control lever S2: Reverse travel direction signal channel 2 shorted to earth	Contact LIEBHERR CUSTOMER SERVICE
E 301C	No inching function available	Inching angle sensor R1: Channel 2 electrical fault (overcurrent >20mA)	Contact LIEBHERR CUSTOMER SERVICE
E 301D	No inching function available	Inching angle sensor R1: Channel 2 electrical fault (undercurrent <4mA)	Contact LIEBHERR CUSTOMER SERVICE
E 301E	Engine speed cannot be changed, driving not possible	Gas pedal angle sensor R6: Channel 2 electrical fault (overcurrent >20mA)	Contact LIEBHERR CUSTOMER SERVICE
E 301F	Engine speed cannot be changed, driving not possible	Gas pedal angle sensor R6: Channel 2 electrical fault (undercurrent <4mA)	Contact LIEBHERR CUSTOMER SERVICE
E 3020	Kick-down function not available	Control lever kick-down button S12: shorted to earth	Contact LIEBHERR CUSTOMER SERVICE
E 3021	Option 2 function not available	Control lever option 2 button S12a: shorted to earth	Contact LIEBHERR CUSTOMER SERVICE
E 3022	Option 3 function not available	Control lever option 3 button S12b: shorted to earth	Contact LIEBHERR CUSTOMER SERVICE
E 3023	No audible warning signals, H40 beeper cannot be triggered by an external function	H40 beeper: Input shorted to earth	Contact LIEBHERR CUSTOMER SERVICE
E 3024	Central lubrication system not available	Central lubrication system filling level: Inductive switch B44 shorted to earth	Contact LIEBHERR CUSTOMER SERVICE
E 3025	Particle filter cannot be monitored	Particle filter: Input 1 electrical fault (shorted to earth)	Contact LIEBHERR CUSTOMER SERVICE
E 3026	Particle filter cannot be monitored	Particle filter input 2 electrical fault (shorted to earth)	Contact LIEBHERR CUSTOMER SERVICE
E 3027	Joystick steering not available	Joystick steering: Left input signal electrical fault (overcurrent >20mA)	Contact LIEBHERR CUSTOMER SERVICE



Service-Code	Symptom	Cause	Solution
E 3028	Joystick steering not available	Joystick steering: Left input signal electrical fault (undercurrent <4mA)	Contact LIEBHERR CUSTOMER SERVICE
E 3029	No driving function available	Variable displacement motor 2: Inductive sensor B2a shorted to earth	Contact LIEBHERR CUSTOMER SERVICE
E 302A	No driving function available	Variable displacement motor 2: Inductive sensor B2a cable rupture	Contact LIEBHERR CUSTOMER SERVICE
E 302B	Central lubrication system not available	Central lubrication cycle: Inductive sensor B43 shorted to earth	Contact LIEBHERR CUSTOMER SERVICE
E 302C	Central lubrication system not available	Central lubrication cycle: Inductive sensor B43 cable rupture	Contact LIEBHERR CUSTOMER SERVICE
E 302D	Joystick steering not available	Joystick steering: Right input signal electrical fault (overcurrent >20mA)	Contact LIEBHERR CUSTOMER SERVICE
E 302E	Joystick steering not available	Joystick steering: Right input signal electrical fault (undercurrent <4mA)	Contact LIEBHERR CUSTOMER SERVICE
E 302F	Joystick steering not available	Joystick steering: Pressure switch 1 shorted to earth	Contact LIEBHERR CUSTOMER SERVICE
E 3030	Joystick steering not available	Joystick steering: Pressure switch 2 shorted to earth	Contact LIEBHERR CUSTOMER SERVICE
E 3031	Basket mode - emergency off function not available	Emergency off: Input signal 1 shorted to earth	Contact LIEBHERR CUSTOMER SERVICE
E 3032	Basket mode - emergency off function not available	Emergency off: Input signal 2 shorted to earth	Contact LIEBHERR CUSTOMER SERVICE
E 3033	Basket mode function not available	Basket mode: Input signal 1 shorted to earth	Contact LIEBHERR CUSTOMER SERVICE
E 3034	Basket mode function not available	Basket mode: Input signal 2 shorted to earth	Contact LIEBHERR CUSTOMER SERVICE
E 3035	Joystick steering not available	Joystick steering: Activation button shorted to earth	Contact LIEBHERR CUSTOMER SERVICE
E 3036	Joystick steering not available	Joystick steering: Arm rest inductive switch shorted to earth	Contact LIEBHERR CUSTOMER SERVICE

Service-Code	Symptom	Cause	Solution
E 4000	Symbol field H11 flashes, parking brake cannot be released, driving not possible	Parking brake: Electrical fault at output (short circuit)	Contact LIEBHERR CUSTOMER SERVICE
E 4001	Symbol field H11 flashes, parking brake cannot be released, driving not possible	Parking brake: Electrical fault at output (interruption)	Contact LIEBHERR CUSTOMER SERVICE
E 4002	Working hydraulics lockout cannot be lifted	Working hydraulics lockout: Fault at output (short circuit)	Contact LIEBHERR CUSTOMER SERVICE
E 4004	No bucket return-to-dig available	Bucket return-to-dig: Fault at output (short circuit)	Contact LIEBHERR CUSTOMER SERVICE
E 4006	No lift kick-out available	Lift kick-out: Fault at output (short circuit)	Contact LIEBHERR CUSTOMER SERVICE
E 4008	No float position available	Float position: Fault at output (short circuit)	Contact LIEBHERR CUSTOMER SERVICE
E 4013	Range A2-3 activated, kick-down not possible	1st gear solenoid: Electrical fault at output (interruption)	Contact LIEBHERR CUSTOMER SERVICE
E 4015	Fixed gear 1 is engaged and variable displacement motor 1 is set to a wide angle to prevent overspeed	2nd gear solenoid: Fault at output (interruption)	Contact LIEBHERR CUSTOMER SERVICE
E 4017	Fixed gear 2 is engaged	3rd gear solenoid: Electrical fault at output (interruption)	Contact LIEBHERR CUSTOMER SERVICE
E 4019	Coupling damage	Modulation solenoid: Electrical fault at output (interruption)	Contact LIEBHERR CUSTOMER SERVICE
E 4023	Only reverse travel possible	Pump 1 forward direction valve: Electrical fault at output (interruption)	Contact LIEBHERR CUSTOMER SERVICE
E 4025	Only reverse travel possible	Pump 1 forward direction valve: Electrical fault at output (interruption)	Contact LIEBHERR CUSTOMER SERVICE
E 4027	No rear axle brake available at overspeed	Overspeed protection: Electrical fault at output (interruption)	Contact LIEBHERR CUSTOMER SERVICE
E 4037	No ride control available	Ride control: Electrical fault at output (interruption)	Contact LIEBHERR CUSTOMER SERVICE

Service-Code	Symptom	Cause	Solution
E 400A	Fan does not work (full speed)	Fan: Fault at output (short circuit)	Contact LIEBHERR CUSTOMER SERVICE
E 400B	Fan does not work (full speed)	Fan: Fault at output (short circuit)	Contact LIEBHERR CUSTOMER SERVICE
E 400C	Fan does not work (full speed)	Fan: Fault at output (fault current)	Contact LIEBHERR CUSTOMER SERVICE
E 400D	Fan does not work (full speed)	Fan: Fault at output (deviation) The measured return current does not match the output current	Contact LIEBHERR CUSTOMER SERVICE
E 400E	Buzzer cannot be activated	Buzzer: Fault at output (short circuit)	Contact LIEBHERR CUSTOMER SERVICE
E 4010	Possible gearbox damage, coupling damage during longer trips	Swivel angle restriction: Electrical fault at output (short circuit)	Contact LIEBHERR CUSTOMER SERVICE
E 4012	Range A2-3 activated, kick-down not possible	1st gear solenoid: Fault at output (short circuit)	Contact LIEBHERR CUSTOMER SERVICE
E 4014	Fixed gear 1 is engaged and variable displacement motor 1 is set to a wide angle to prevent overspeed	2nd gear solenoid: Fault at output (short circuit)	Contact LIEBHERR CUSTOMER SERVICE
E 4016	Fixed gear 2 is engaged	3rd gear solenoid: Fault at output (short circuit)	Contact LIEBHERR CUSTOMER SERVICE
E 4018	Coupling damage	Modulation solenoid: Fault at output (short circuit)	Contact LIEBHERR CUSTOMER SERVICE
E 401A	Fixed gear 2 engaged, kick-down not possible	Variable displacement motor 1: Fault at output (short circuit)	Contact LIEBHERR CUSTOMER SERVICE
E 401B	Fixed gear 2 engaged, kick-down not possible	Variable displacement motor 1: Fault at output (interruption)	Contact LIEBHERR CUSTOMER SERVICE
E 401C	Fixed gear 2 engaged, kick-down not possible	Variable displacement motor 1: Fault at output (fault current)	Contact LIEBHERR CUSTOMER SERVICE

Service-Code	Symptom	Cause	Solution
E 401D	Fixed gear 2 engaged, kick-down not possible	Variable displacement motor 1: Electrical fault at output (deviation) The measured return current does not match the output current	Contact LIEBHERR CUSTOMER SERVICE
E 401E	Fixed gear 1 is engaged and variable displacement motor 1 is set to a wide angle to prevent overspeed	Variable displacement motor 2: Fault at output (short circuit)	Contact LIEBHERR CUSTOMER SERVICE
E 401F	Fixed gear 1 is engaged and variable displacement motor 1 is set to a wide angle to prevent overspeed	Variable displacement motor 2: Electrical fault at output (interruption)	Contact LIEBHERR CUSTOMER SERVICE
E 4020	Fixed gear 1 is engaged and variable displacement motor 1 is set to a wide angle to prevent overspeed	Variable displacement motor 2: Electrical fault at output (fault current)	Contact LIEBHERR CUSTOMER SERVICE
E 4021	Fixed gear 1 is engaged and variable displacement motor 1 is set to a wide angle to prevent overspeed	Variable displacement motor 2: Electrical fault at output (deviation) The measured return current does not match the output current	Contact LIEBHERR CUSTOMER SERVICE
E 4022	Only reverse travel possible	Travel pump 1 forward direction valve: Electrical fault at output (short circuit)	Contact LIEBHERR CUSTOMER SERVICE
E 4024	Only forward travel possible	Travel pump 1 reverse direction valve, electrical fault at output (short circuit)	Contact LIEBHERR CUSTOMER SERVICE
E 4026	No rear axle brake available at overspeed	Overspeed protection: Fault at output (short circuit)	Contact LIEBHERR CUSTOMER SERVICE
E 4028	Quick change device not available	Quick-change device: Fault at output (short circuit)	Contact LIEBHERR CUSTOMER SERVICE
E 402A	Driving is not possible	Proportional valve control pressure travel pump 1: Fault at output (short circuit)	Contact LIEBHERR CUSTOMER SERVICE
E 402B	Driving is not possible	Proportional valve control pressure travel pump 1: Fault at output (interruption)	Contact LIEBHERR CUSTOMER SERVICE

Service-Code	Symptom	Cause	Solution
E 402C	Driving is not possible	Proportional valve control pressure travel pump 1: Fault at output (fault current)	Contact LIEBHERR CUSTOMER SERVICE
E 402D	Driving is not possible	Proportional valve control pressure travel pump 1: Fault at output (deviation) The measured return current does not match the output current	Contact LIEBHERR CUSTOMER SERVICE
E 402E	Driving is not possible	(L586 only) proportional valve control pressure travel pump 2: Fault at output (short circuit)	Contact LIEBHERR CUSTOMER SERVICE
E 402F	Driving is not possible	(L586 only) proportional valve control pressure travel pump 2: Fault at output (interruption)	Contact LIEBHERR CUSTOMER SERVICE
E 4030	Driving is not possible	(L586 only) proportional valve control pressure travel pump 2: Fault at output (fault current)	Contact LIEBHERR CUSTOMER SERVICE
E 4031	Driving is not possible	(L586 only) proportional valve control pressure travel pump 2: Fault at output (deviation) The measured return current does not match the output current	Contact LIEBHERR CUSTOMER SERVICE
E 4032	No emergency steering	Emergency steering pump: Fault at output (short circuit)	Contact LIEBHERR CUSTOMER SERVICE
E 4034	No fan reversal available	Fan reversal: Fault at output (short circuit)	Contact LIEBHERR CUSTOMER SERVICE
E 4036	No ride control available	Ride control: Fault at output (short circuit)	Contact LIEBHERR CUSTOMER SERVICE
E 4038	No ride control, float position function available	Ride control / float position: Fault at output (short circuit)	Contact LIEBHERR CUSTOMER SERVICE
E 403A	Only reverse travel possible	(L586 only) travel direction valve travel pump 2 forwards: Fault at output (short circuit)	Contact LIEBHERR CUSTOMER SERVICE
E 403B	Only reverse travel possible	Travel pump 2 forward direction valve: Electrical fault at output (interruption)	Contact LIEBHERR CUSTOMER SERVICE
E 403C	Only forward travel possible	(L586 only) travel direction valve travel pump 2 reverse, fault at output (short circuit)	Contact LIEBHERR CUSTOMER SERVICE

Service-Code	Symptom	Cause	Solution
E 403D	Only forward travel possible	Travel pump 2 forward direction valve: Electrical fault at output (interruption)	Contact LIEBHERR CUSTOMER SERVICE
E 403E	Additional equipment 1 cannot be activated	Additional equipment 1: Fault at output (short circuit)	Contact LIEBHERR CUSTOMER SERVICE
E 4040	Additional equipment 2 cannot be activated	Additional equipment 2: Fault at output (short circuit)	Contact LIEBHERR CUSTOMER SERVICE
E 4042	No joystick steering available	Joystick steering, left: Fault at output (short circuit)	Contact LIEBHERR CUSTOMER SERVICE
E 4044	No joystick steering available	Joystick steering, right: Fault at output (short circuit)	Contact LIEBHERR CUSTOMER SERVICE
E 4046	No 2in1 steering (Gerotor steering) available	Gerotor steering: Fault at output (short circuit)	Contact LIEBHERR CUSTOMER SERVICE
E 4048	Joystick steering not available	2. Joystick steering lockout 2 deactivated: Fault at output (short circuit)	Contact LIEBHERR CUSTOMER SERVICE
E 404A	Travel pump 2 not available	2. Travel pump 2 lockout 2 deactivated: Fault at output (short circuit)	Contact LIEBHERR CUSTOMER SERVICE
E 404C	Central lubrication system does not work	Central lubrication system motor: Fault at output (short circuit)	Contact LIEBHERR CUSTOMER SERVICE
E 404E	Flashing back-up alarm does not work	Flashing back-up alarm: Fault at output (short circuit)	Contact LIEBHERR CUSTOMER SERVICE
E 4050	Travel pump 1 not available	2. Deactivation stage travel pump 1: Fault at output (short circuit)	Contact LIEBHERR CUSTOMER SERVICE
E 4052	Gearbox not available	2. Gearbox lockout: Fault at output (short circuit)	Contact LIEBHERR CUSTOMER SERVICE
E 4054	Reversing light does not work	Reversing light E1, E5: Fault at output (short circuit)	Contact LIEBHERR CUSTOMER SERVICE
E 4056	Back-up alarm does not work	Back-up alarm B16: Fault at output (short circuit)	Contact LIEBHERR CUSTOMER SERVICE
E 4058	Comfort control does not work	Comfort control fault at output (short circuit)	Contact LIEBHERR CUSTOMER SERVICE
E 405A	Output option: Electrical fault at output	Electrical fault in consumer or wiring, option does not work	Contact LIEBHERR CUSTOMER SERVICE

Service-Code	Symptom	Cause	Solution
<b>E 502A</b>	Driving only possible in 1st gear	Implausible signal of B1 output speed sensor, output speed does not correspond to hydromotor speed (monitoring only in 1st gear)	Contact LIEBHERR CUSTOMER SERVICE
<b>E 502B</b>	No kick-down function available	Kick-down button is pressed longer than 10 secs. (or jammed) after ignition or pressed longer than 2 minutes (or jammed) in normal operation	Check kick-down button, contact LIEBHERR CUSTOMER SERVICE
<b>E 502C</b>	No inching function available	Inching angle sensor below 100%, inch pedal constantly less than 100% for longer than 2 minutes (inch pedal dirty)	Clean the inch pedal so that it moves properly
<b>E 5022</b>	Travel slow or impossible	Variable displacement motor current balance failed	Contact LIEBHERR CUSTOMER SERVICE
<b>E 5023</b>	Engine does not take up fuel	Gas pedal angle sensor R5: Balance not ended or not concluded with parameter	Contact LIEBHERR CUSTOMER SERVICE
<b>E 5024</b>	Inching function not available	Inch pedal angle sensor R1: Balance not ended or not concluded with parameter	Contact LIEBHERR CUSTOMER SERVICE
<b>E 5025</b>	Couplings open --> driving is not possible, no hydrostatic brake effect	Variable displacement motor current balance not ended or not concluded with parameter	Contact LIEBHERR CUSTOMER SERVICE
<b>E 5026</b>	Engine speed cannot be changed, driving not possible	Error in angle sensor R5 gas pedal, values of sensor 1 and sensor 2 differ	Contact LIEBHERR CUSTOMER SERVICE
<b>E 5027</b>	No inching function available	Error in angle sensor R1 inch pedal, values of sensor 1 and sensor 2 differ	Contact LIEBHERR CUSTOMER SERVICE
<b>E 5028</b>	Limits the speed to 20 km/h , driving only possible in 1st or 2nd gear	Gear oil thermo switch B14 has triggered, gear temperature above 120 °C , oil level too high, temperature switch defective	Clean cooling system, check oil level, contact LIEBHERR CUSTOMER SERVICE
<b>E 5029</b>	None	Rear axle brake error: rear axle brake activated for longer than 3 seconds at a time or for more than 16% intermittently	Contact LIEBHERR CUSTOMER SERVICE

Service-Code	Symptom	Cause	Solution
E 5034	Engine damage	Engine oil pressure too low: Fault in pressure sensor B701 or the wiring	Check engine oil level, contact LIEBHERR CUSTOMER SERVICE
E 5035	Travel direction selection cannot be clearly detected	LH control lever S2: Invalid switching condition	Contact LIEBHERR CUSTOMER SERVICE
E 5036	The motor retains the old value	Variable displacement motor balance 1 maximum current too low	Contact LIEBHERR CUSTOMER SERVICE
E 5037	The motor retains the old value	Variable displacement motor balance 1 maximum current too high	Contact LIEBHERR CUSTOMER SERVICE
E 5038	The motor retains the old value	Variable displacement motor balance 1 minimum current too high	Contact LIEBHERR CUSTOMER SERVICE
E 5039	The motor retains the old value	Variable displacement motor balance 1 minimum current too low	Contact LIEBHERR CUSTOMER SERVICE
E 503A	The motor retains the old value	Variable displacement motor balance 2 maximum current too low	Contact LIEBHERR CUSTOMER SERVICE
E 503B	The motor retains the old value	Variable displacement motor balance 2 maximum current too high	Contact LIEBHERR CUSTOMER SERVICE
E 503C	The motor retains the old value	Variable displacement motor balance 2 minimum current too high	Contact LIEBHERR CUSTOMER SERVICE
E 503D	The motor retains the old value	Variable displacement motor balance 2 minimum current too low	Contact LIEBHERR CUSTOMER SERVICE
E 503E	Look at STOP symbol field for difference between engine speed 1 and take-off speed in gear 1	Difference between engine speed 1 and take-off speed in gear 1	Contact LIEBHERR CUSTOMER SERVICE
E 503F	Look at STOP symbol field for difference between engine speed 2 and take-off speed in gear 1	Difference between engine speed 2 and take-off speed in gear 1	Contact LIEBHERR CUSTOMER SERVICE



Service-Code	Symptom	Cause	Solution
<b>E 5040</b>	Look at STOP symbol field for difference between engine speed 2 and take-off speed in gear 2	Difference between engine speed 2 and take-off speed in gear 2	Contact LIEBHERR CUSTOMER SERVICE
<b>E 5041</b>	Look at STOP symbol field for difference between engine speed 1 and take-off speed in gear 3	Difference between engine speed 1 and take-off speed in gear 3	Contact LIEBHERR CUSTOMER SERVICE
<b>E 6000</b>	Coolant temperature symbol field (H13) flashes, STOP symbol field lights up, continuous warning buzzer sounds	Coolant temperature above 100 °C , t >3 sec. (B708)	Contact LIEBHERR CUSTOMER SERVICE
<b>E 6001</b>	Warning buzzer sounds	Charge air temperature above 75 °C , t >3 sec. (B707)	Contact LIEBHERR CUSTOMER SERVICE
<b>E 6002</b>	Warning buzzer sounds	Fuel temperature above 75 °C , t >3 sec. (B709)	Contact LIEBHERR CUSTOMER SERVICE
<b>E 6003</b>	Warning buzzer sounds	Water in fuel prefilter (B710)	Contact LIEBHERR CUSTOMER SERVICE
<b>E 6004</b>	Engine oil pressure symbol field (H4) lights up, STOP symbol field (H36) lights up, continuous warning buzzer after 10 sec.	Engine oil pressure too low (B701)	Contact LIEBHERR CUSTOMER SERVICE
<b>E 600B</b>	Engine running at too high a speed	Engine speed too high while braking > 2500 rpm	Contact LIEBHERR CUSTOMER SERVICE
<b>E 600C</b>	Calculation error depends on the fault	Always given for an additional service code	Contact LIEBHERR CUSTOMER SERVICE
<b>E 600D</b>	Engine shuts down	Emergency shutdown, speed encoder 1 and 2 (B711 and B712) defective	Contact LIEBHERR CUSTOMER SERVICE
<b>E 600E</b>	Engine not running smoothly	Defective injector	Contact LIEBHERR CUSTOMER SERVICE
<b>E 600F</b>	Engine shuts down	Engine controller detected internal error	Contact LIEBHERR CUSTOMER SERVICE
<b>E 6010</b>	Engine has reduced power	Power reduction active	Contact LIEBHERR CUSTOMER SERVICE

Service-Code	Symptom	Cause	Solution
E 6011	Engine has reduced power	Peak power reduction active	Contact LIEBHERR CUSTOMER SERVICE
E 6012	Emergency shutdown imminent. Engine cannot be started	The emergency shutdown can be triggered by the following service codes: E 500C, E 500D, E 500E, E 500F	Contact LIEBHERR CUSTOMER SERVICE
E 6016	Charge control lamp symbol field (H6) lights up, parking brake cannot be released	Alternator not supplying power	Contact LIEBHERR CUSTOMER SERVICE
E 6017	Depends on the fault	Calculation error, diesel engine module has sent an internal error code. This is shown in the display unit instead of the engine service code.	Contact LIEBHERR CUSTOMER SERVICE
E 6018	CAN failure	CAN failure due to insufficient battery voltage, below 8V for longer than 100 ms	Contact LIEBHERR CUSTOMER SERVICE

#### 4.1.2 Visible and audible warning signals



The following table contains the warning signals which have an additional audible tone or which are only displayed visually, along with their causes and remedies.

##### There are four different audible warning signals:

- Continuous tone
- Interval tone 1/10 (1 second tone followed by 10 second pause)
- Interval tone 2/3 (2 second tone followed by 3 second pause)
- Single 1 second beep

Warning signal	Cause	Remedy
Service code E A02A Coolant temperature symbol field (H13) flashes	Coolant temperature above 97 °C (B708)	Clean the cooling system
Service code E A02A, E 6000, E 6012 Coolant temperature symbol field (H13) flashes STOP symbol field light up, continuous warning buzzer	Coolant temperature above 104 °C (B708) Error in the cooling or electrical system	Clean the cooling system Contact LIEBHERR CUSTOMER SERVICE
Service code E 6008, E 6012 Coolant temperature symbol field (H13) lights up STOP symbol field light up, continuous warning buzzer	Coolant level too low (B710) Fault in the electrical system	Check the coolant level Contact LIEBHERR CUSTOMER SERVICE
Hydraulic oil overheating symbol field (H23) lights up	Hydraulic oil temperature above 90 °C (B8)	Clean the cooling system
Service code E A02A Hydraulic oil overheating symbol field (H23) lights up, interval tone 1/10 The output of the travel pump is reduced	Hydraulic oil temperature above 95 °C (B8) Fault in the cooling / hydraulic / electrical system	Clean the cooling system Contact LIEBHERR CUSTOMER SERVICE
Service code E 2002 Emergency steering check symbol field (H24) lights up	Emergency steering pump check not successfully completed (B3a) Error in the electrical / hydraulic system	Contact LIEBHERR CUSTOMER SERVICE
Service code E 2001 Emergency steering symbol field (H8) lights up, warning buzzer with 40 sec. tone	Emergency steering function activated due to failure of steering pump (B3) Error in the electrical / hydraulic system	Contact LIEBHERR CUSTOMER SERVICE
Service code E 6004, E 5034, E A02A, E 6012 Engine oil pressure symbol field (H4) lights up Stop symbol field (H36) lights up After 10 seconds continual warning buzzer	Insufficient engine oil pressure (B701) Error in the diesel engine lubricating oil supply Fault in the electrical system	Check the oil level Contact LIEBHERR CUSTOMER SERVICE
Service code E 300A	Gear oil temperature above 120 °C (B14)	Clean the gear oil cooler

Service Code Table

<b>Warning signal</b>	<b>Cause</b>	<b>Remedy</b>
Gear oil overheating symbol field (H14) lights up Driving is only possible at reduced speed (approx. 20 km/h )	Oil level too high	Correct the oil level
	Fault in the electrical system	Contact LIEBHERR CUSTOMER SERVICE
Service code E 2016  Accumulator pressure symbol field (H19) lights up No travel direction can be selected, after 2 minutes continual warning buzzer	Brake accumulator pressure too low (B19)	Start the engine: the brake accumulators are filled while the engine runs
	Error in the electrical / hydraulic system	Contact LIEBHERR CUSTOMER SERVICE
Service code E 6016 Battery charge symbol field (H6) lights up The parking brake cannot be released	Torn V-belt	Fit a new V-belt
	Defective alternator	Contact LIEBHERR CUSTOMER SERVICE
Service code segment display (P7) shows the service code, single 1-second beep		See the service code tables
		Contact LIEBHERR CUSTOMER SERVICE

## 4.2 Eliminating malfunctions

### 4.2.1 Replacing fuses

---

#### Caution

There is a risk of damaging the electrical system.

! In order to prevent damage to the electrical system, only use fuses with the correct rating.

---

Make sure that:

- The electrical circuit has been checked before changing the fuse.
  - For safety reasons, after checking the circuit, that the machine's electrical system has been switched off.
- 



#### Caution

Danger of electrocution

If you touch live parts you can be electrocuted.

! Switch off the machine's electrical system before working on live components.

! For safety reasons, turn off the battery main switch.

---

#### Mega fuses

- If you need to access the fuses:  
Open the rear hatch.
- Remove the cover of the fuse boxes **6**.

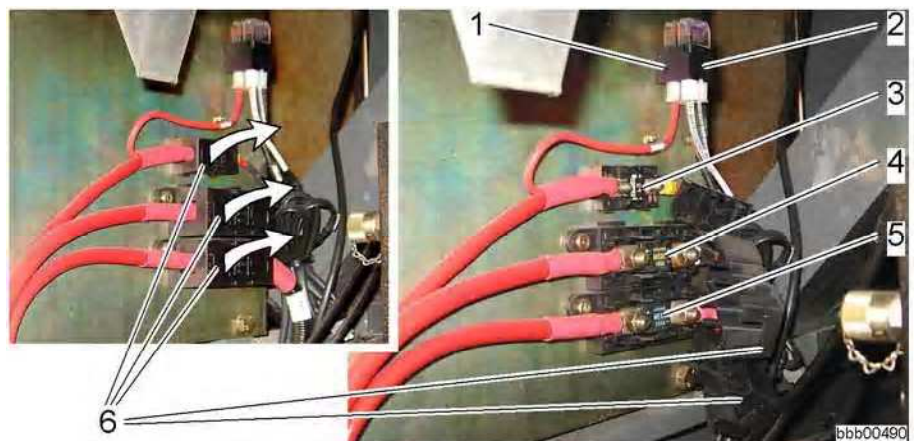

Main fuse

1 Fuse F07  
2 Fuse F010  
3 Fuse F02

4 Fuse F01  
5 Fuse F03  
6 Fuse box cover (removed)

Fuse	Value	Unit	Designation/function	Location
F02	60	A	Preglow	Rear left of engine compartment
F03	200	A	Emergency steering pump	Rear left of engine compartment
F07	10	A	Hazard warning system	Rear left of engine compartment
F010	5	A	Info. heating flange	Rear left of engine compartment
F01	100	A	Main fuse	Rear left of engine compartment

#### Fuses in the engine compartment

- Use the table above to identify the defective fuse.
- Take out the defective fuse and replace it with a new one with the same rating.

#### Plug-in fuses on the relay and fuse board

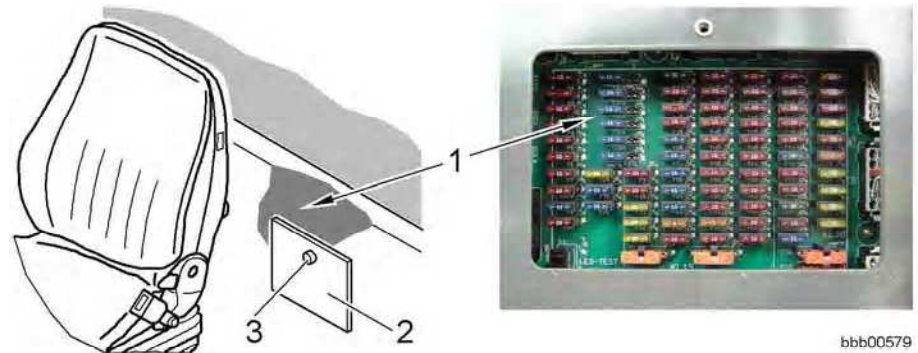

Fuse box

1 Fuse box  
2 Cover

3 Screw

The circuit board and the relay as well as the plug-in fuses are located behind the driver's seat.

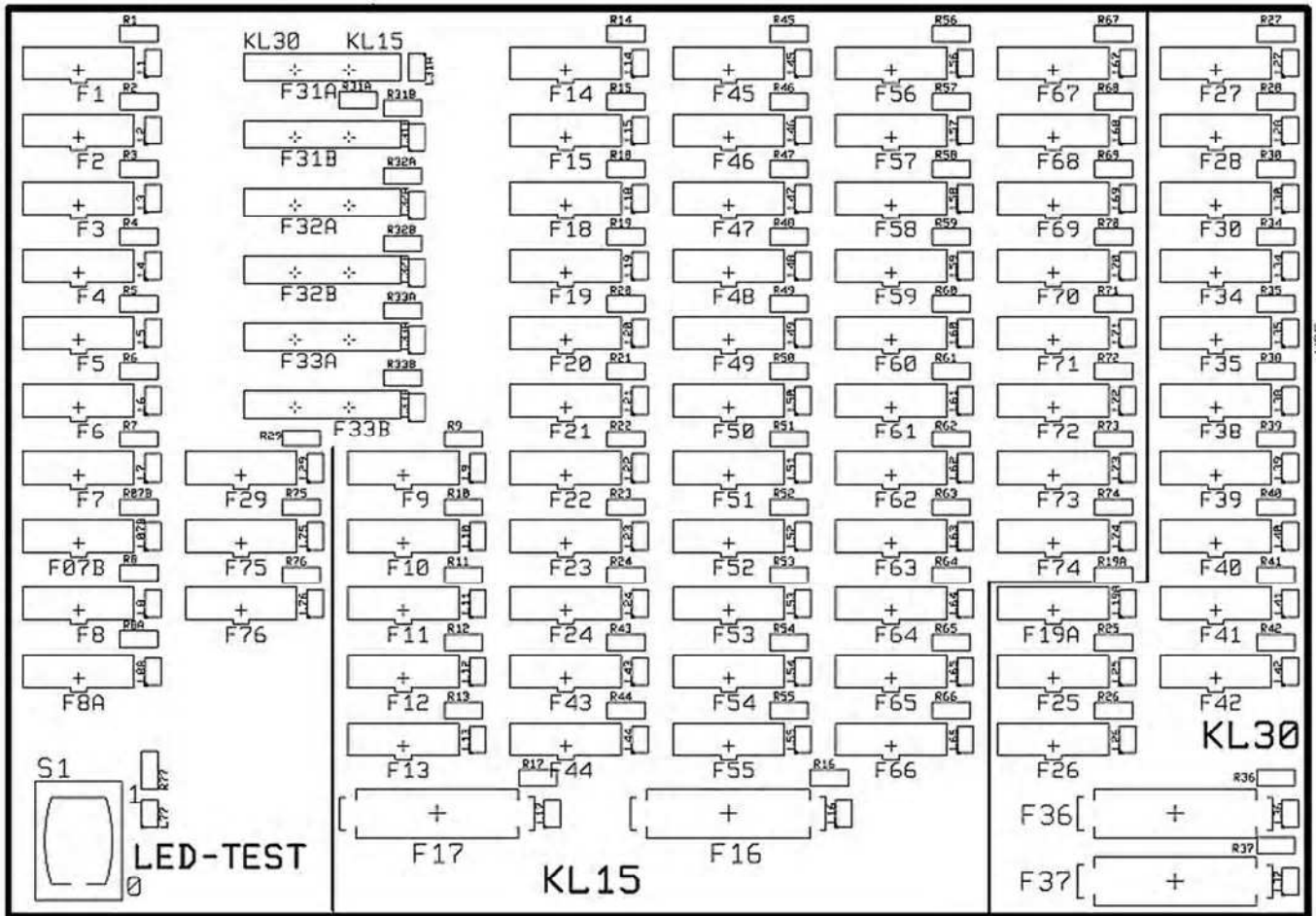

bbb00538

Relay and fuse board

Fuse	Value	Unit	Designation/function	Location
F1	10	A	Spare	in the fuse box
F2	7.5	A	Left high beam	- II -
F3	7.5	A	Right high beam	- II -
F4	7.5	A	Left low beam	- II -
F5	7.5	A	Right low beam	- II -
F6	3	A	Left profile light/parking light	- II -
F7	3	A	Right profile light/parking light	- II -
F07b	10	A	Hazard warning lights	- II -
F8	15	A	Seat compressor (optional), (radio) cigarette lighter (X70)	- II -
F8a	10	A	Interior lighting	- II -
F9	10	A	LH control lever button, air conditioning system, optional keyboard	- II -
F10	5	A	Display unit	- II -
F11	10	A	Pressure switches B32, B28, B3, B3a	- II -
F12	20	A	Groeneveld central lubrication system	- II -
F13	20	A	Spare	- II -
F14	15	A	Fuel preheater	- II -
F15	10	A	LH control lever V (forward) - N - R (reverse) excitation G3, simulation D+	- II -
F16	40	A	Terminal 15 (MAXI fuse)	- II -

LBH/03/003801/0003/5.06/en

## Eliminating malfunctions

Fuse	Value	Unit	Designation/function	Location
F17	40	A	Terminal 15 (MAXI fuse)	– II –
F18	10	A	Wiper motor, rear washer pump, dust filter monitor	– II –
F19	10	A	Heater, air conditioning system, terminal 15	– II –
F19A	20	A	Heater, air conditioning system, terminal 30	– II –
F20	15	A	Front windshield wiper/washer pump, horn	– II –
F21	10	A	Low beam, high beam	– II –
F22	7.5	A	Switch lighting, brake light	– II –
F23	15	A	Puri tech particle filter, reversing sensor	– II –
F24	10	A	Ignition ON, engine ECU	– II –
F25	10	A	Flashing beacon	– II –
F26	10	A	Diagnostic plug, KAT immobiliser	– II –
F27	10	A	Profile light, parking light	– II –
F28	10	A	Spare	– II –
F29	25	A	Ignition start lock relief	– II –
F30	15	A	Vcc voltage converter, radio, 12 V socket	– II –
F31a	10	A	Front left working floodlight	– II –
F31b	10	A	Front right working floodlight	– II –
F32a	10	A	Left working floodlight, rear hatch	– II –
F32b	10	A	Right working floodlight, rear hatch	– II –
F33a	10	A	Left working floodlight, rear cab roof (optional)	– II –
F33b	10	A	Right working floodlight, rear cab roof (optional)	– II –
F34	20	A	Refuelling pump (optional)	– II –
F35	10	A	Vcc master terminal 30	– II –
F36	40	A	A14.B1 LH-ECU-UP/CR A14.B2 LH-ECU-UP/CR (MAXI fuse) terminal 30	– II –
F37	40	A	Reserve (MAXI fuse) terminal 30	– II –
F38	5	A	LH-ECU-UP/CR Vcc Controller	– II –
F39	10	A	Clock, auxiliary heater	– II –
F40	20	A	Vcc auxiliary heater terminal 30	– II –
F41	20	A	Dust filter excess pressure system	– II –
F42	20	A	Spare	– II –
F43	5	A	Logic input 1+2, Logic output 1+2	– II –
F44	10	A	Input module 1 Vcc	– II –
F45	10	A	Input module 2 Vcc	– II –
F46	10	A	Input module 3 Vcc, joystick steering	– II –
F47	10	A	Output module 1 – Bank 1 Y10, Y14, Y9, Y17	– II –
F48	10	A	Output module 1 – Bank 2 Y18, Y13, H40, Y57 (optional)	– II –
F49	10	A	Vcc DO 4 reverse warning system – optical, flashing red	– II –
F50	10	A	Spare	– II –
F51	10	A	Output module 1 – DO 1 output module 2 – Y51, Y52	– II –
F52	10	A	Output module 1 – DO 2 output module 2 – Y2a, Y3a, Y11, Y12	– II –
F53	10	A	Output module 1 – DO 3 Y62 LH central lubrication system	– II –
F54	5	A	Terminal 15 master	– II –
F55	10	A	Output module 2 – Bank 1 Y16, Y53, Y15, Y15a	– II –
F56	10	A	Output module 2 – Bank 2 K11/50, Y50, Y20, Y21	– II –
F57	10	A	Spare	– II –
F58	10	A	Spare	– II –
F59	10	A	Output module 2 – DO 1 output module 1 – YEP1, YEP2, Y2, Y3	– II –
F60	10	A	Output module 2 – DO 2 output module 1 – MO1, Y6.1.2.3	– II –



Fuse	Value	Unit	Designation/function	Location
F61	10	A	Output module 2 – DO 3 E1, E5 reversing light	– II –
F62	10	A	Output module 2 – DO 4 B16 back-up alarm	– II –
F63	10	A	Output module 3 Vcc Bank 1	– II –
F64	10	A	Output module 3 Vcc Bank 2	– II –
F65	10	A	Output module 3 Vcc Bank 3	– II –
F66	10	A	Output module 3 Vcc Bank 4	– II –
F67	10	A	Output module 3 Vcc DO 1	– II –
F68	10	A	Output module 3 Vcc DO 2	– II –
F69	10	A	Output module 3 Vcc DO 3	– II –
F70	10	A	Output module 3 Vcc DO 4	– II –
F71	10	A	Vcc keyboards terminal 15	– II –
F72	30	A	Spare	– II –
F73	10	A	Spare	– II –
F74	15	A	Rear window heating, mirror heating (optional)	– II –
F75	10	A	Radio terminal 58, 12 V socket	– II –
F76	10	A	Radio terminal 30	– II –

*Fuses in the driver's cab*

- Remove the cover 2.
- Use the table above to identify the defective fuse.
- Take out the defective fuse and replace it with a new one with the same rating.

**LED test for checking the plug-in fuses**

There is an LED next to every plug-in fuse.

The LEDs glow to show that the fuse is intact during the LED test.

**Procedure for checking the plug-in fuses**

The following LED test is possible:

- With the ignition OFF:  
All plug-in fuses (terminal 30) are tested.
- With the ignition OFF:  
All plug-in fuses (terminal 15, terminal 30 and terminal 58) are tested.
- With the ignition ON and a function switched on:  
All plug-in fuses affected by the corresponding function are tested.

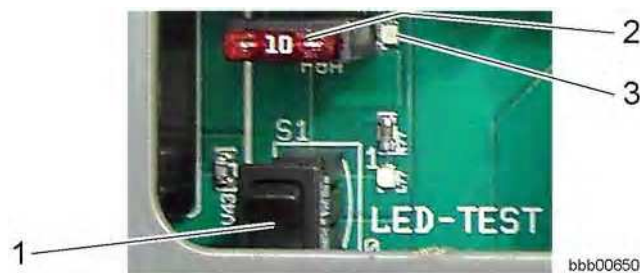

1 Button LED test  
2 Fuse (example)

3 LED (example)

- With the ignition ON and a function switched on:  
The button LED test 1 checks the fuse(s) function is switched on.  
If the fuse is intact, the corresponding LED lights up.

LBH/03/003801/0003/5.06/en

# 5 Maintenance

## 5.1 Maintenance and inspection schedule

The following abbreviations are used in this section:

- h = service hours

Various symbols (solid or empty circles, boxes and stars) are used to indicate the maintenance tasks, which fall into two main types.

	●	●					✦
		■					

bsym0039

The symbols have the following meanings:

Table with solid circle, box or star

- Responsibility for carrying out the maintenance work lies with the machine operator or his maintenance personnel.  
This affects the maintenance intervals every 10 and 50 service hours (h) and non-scheduled intervals.

□			○	○	○	✦	
			□	○	○	250h	

bsym0040

The symbols have the following meanings:

Table with empty circle, box or star, or service hours (h)

- The maintenance and inspection work must be performed or supervised by authorised engineers from LIEBHERR or its authorised dealers.  
This affects the maintenance intervals on delivery, every 500, 1000, 2000 service hours (h), and at unscheduled times.

You will find a list of the spare parts needed for maintenance and inspection work in the service package of the spare parts list.

Customer: ..... Machine type: ..... Serial No.: ..... Oper. hours: ..... Date : .....

Maintenance/inspection according to operating hours							TASKS TO BE PERFORMED	
On delivery	Every 10	Every 50	Every 500	Every 1000	Every 2000	Special intervals	<b>By maintenance personnel</b> ■ One-off activity ● Repetition interval † If necessary ❄ Annually at the start of the cold season	<b>By authorised qualified personnel</b> □ One-off activity ○ Repetition interval † If necessary
<b>Complete machine</b>								
<input type="checkbox"/>								Have the driver lubricate the machine in accordance with the lubrication chart and instruct him on proper maintenance
<input type="checkbox"/>								Instruct the driver in the operation of all functions
	●	●	○	○	○			Remove loose parts, dirt, ice and snow from the machine
<input type="checkbox"/>	●	●	○	○	○			Check the machine for external damage
							†	Make sure the bolted connections are tight
<input type="checkbox"/>							†	Seal any leaks
			□	○	○			Check the hydraulic pressure according to the testing and adjustment plan - see the service manual
<b>Diesel engine and pump distributor gear</b>								
<input type="checkbox"/>	●	●	○	○	○			Check the engine oil level
			○	○	○			Change the engine oil (or every year at the latest): NOTE See the section on lubricants and fuels for the engine oil quality and complicating factors.
			○	○	○			Change the engine oil filter
			○	○	○			Check the V-ribbed belt
			○	○				Check the engine valve play
							❄	Check the diesel engine heating flange
					○			Lightly grease the ring gear on the engine starter flywheel
			○	○				Change the engine oil separator filter insert
			○	○			†	Replace the fuel pre-filter (or in the event of a lack of output)
			○	○			†	Replace the fuel fine filter (or in the event of a lack of output)
	●	●	○	○	○		†	Drain off condensate from the fuel pre-filter (or if the monitor light glows)
							†	Bleed air from fuel system (CAUTION do not loosen injection lines)
<input type="checkbox"/>	●	○	○	○			†	Drain off condensate and sediment from the fuel tank
	●	○	○	○			†	Clean the air filter service cap and dust extraction valve
			○	○				Check that the air filter vacuum switch works
							†	Change the main air filter element when indicated by the vacuum switch (or every year at the latest)
							†	Clean or replace the air filter secondary element (after replacing the main element 3 times or every year at the latest)
			○	○	○			Check the air suction hoses for leaks and tight fitting
			○	○	○			Check the exhaust lines for leaks and tight fitting
<input type="checkbox"/>	●	○	○	○				Check the oil level in the pump distributor gear
			□	○	○			Change the pump distributor gear oil

LBH/03/003801/0003/5\_06/en

Customer: ..... Machine type: ..... Serial No.: ..... Oper. hours: ..... Date : .....

Maintenance/inspection according to operating hours							TASKS TO BE PERFORMED	
On delivery	Every 10	Every 50	Every 500	Every 1000	Every 2000	Special intervals	<b>By maintenance personnel</b> ■ One-off activity ● Repetition interval † If necessary * Annually at the start of the cold season	<b>By authorised qualified personnel</b> □ One-off activity ○ Repetition interval † If necessary
							<b>Soot particle filter (optional)</b>	
			○	○	○		Check the soot particle filter pressure monitor for function, leaks and blockages	
			○	○	○	†	Check and drain the soot particle filter condensate separator	
			○	○			Change the soot particle filter condensate separator	
			○	○		†	Clean the soot particle filter	
							<b>Cooling system</b>	
			○	○	○	*	Check the coolant antifreeze concentration	
						†	Clean the cooling system	
						3000h	Replace the coolant and antifreeze (or every 2 years)	
							<b>Working hydraulics</b>	
□	●	●	○	○	○		Check the hydraulic tank oil level (take an oil sample every 500 hours for bio oil)	
			○	○	○		Drain off condensate and sediment from the hydraulic tank	
					○		Change the oil in the hydraulic tank and check the return strainer	
□	■	○	○	○	○	250h	Check and clean the magnetic rod on the hydraulic tank	
			○	○	○		Change the hydraulic tank return suction filter	
			○	○			Change the hydraulic tank bleeder filter	
			○	○			Lubricate the pilot control device solenoids, universal joints and tappets	
							<b>Steering system</b>	
□	●	●	○	○	○		Check that the steering is working	
□	●	○	○	○	○		Lubricate the bearing points on the steering cylinders	
							<b>Brake system</b>	
□	●	●	○	○	○		Check the service brake and parking brake	
			○	○			Check the gap and wear on the parking brake linings	
							<b>Electrical system</b>	
□	●	●	○	○	○		Check the indicator lamps and lighting	
			○	○	○		Check the batteries, fluid level and terminals	
							<b>Transfer gear</b>	
□	●	○	○	○	○		Check the transfer gear oil level	
			□	○	○		Change the transfer gear oil	
			□	○	○		Change the transmission oil filter	
							<b>Axles and tyres</b>	
□	■	○	○	○	○		Check the tightness of the wheels (once after 50, 100 and 250 h)	

LBH/03/003801/0003/15.06/en

Customer: ..... Machine type: ..... Serial No.: ..... Oper. hours: ..... Date : .....

Maintenance/inspection according to operating hours							TASKS TO BE PERFORMED	
On delivery	Every 10	Every 50	Every 500	Every 1000	Every 2000	Special intervals	<b>By maintenance personnel</b> ■ One-off activity ● Repetition interval † If necessary * Annually at the start of the cold season	<b>By authorised qualified personnel</b> □ One-off activity ○ Repetition interval † If necessary
<input type="checkbox"/>			<input type="checkbox"/>	<input type="checkbox"/>	<input type="checkbox"/>		Check the axle oil levels	
			<input type="checkbox"/>	<input type="checkbox"/>	<input type="checkbox"/>		Change the axle oil	
<input type="checkbox"/>				<input type="checkbox"/>	<input type="checkbox"/>	†	Lubricate the bevel gear seal on the front and rear axles (if necessary, for example, if used in water every day) (only applies to L580 -459; L586 -461).	
<input type="checkbox"/>		●	<input type="checkbox"/>	<input type="checkbox"/>	<input type="checkbox"/>		Check and lubricate the cardan shaft(s)	
<input type="checkbox"/>						†	Check the tyre pressure	
<b>Machine frame and ballast weight</b>								
<input type="checkbox"/>		●	<input type="checkbox"/>	<input type="checkbox"/>	<input type="checkbox"/>		Lubricate the articulation bearing and rear oscillating bearing	
<b>Lubrication system (optional)</b>								
<input type="checkbox"/>		●	<input type="checkbox"/>	<input type="checkbox"/>	<input type="checkbox"/>		Check whether metered quantities are adequate at the bearing points (grease collars) of the central lubrication system	
<input type="checkbox"/>		●	<input type="checkbox"/>	<input type="checkbox"/>	<input type="checkbox"/>		Check the pipes, hoses and lubrication points of the lubrication system	
<b>Cab, heating and air-conditioning</b>								
						†	Grease the cab door hinges	
						†	Clean or replace the fresh air and recirculated air filter	
			<input type="checkbox"/>	<input type="checkbox"/>	<input type="checkbox"/>		Check the indicator and filling level beads in the dryer-collector unit (optional) of the air conditioner	
<b>Lift arms and quick-change device</b>								
<input type="checkbox"/>		●	<input type="checkbox"/>	<input type="checkbox"/>	<input type="checkbox"/>	†	Lubricate the lift arms and attachment	
				<input type="checkbox"/>	<input type="checkbox"/>	†	Check the bucket bearing seals and the bearing bushings on the lift arms	
				<input type="checkbox"/>	<input type="checkbox"/>		Check the lift arms and bucket stops	
<input type="checkbox"/>	●	●	<input type="checkbox"/>	<input type="checkbox"/>	<input type="checkbox"/>		Lubricate and test the quick-change device	

LBH/03/003801/0003/5.06/en

## 5.2 Lubricant chart, filling quantities









### 5.2.1 Table of filling quantities

**Specifications in the medium column:**

- The standard lubricants and fuels required for central European climate conditions are stated here.
- **Before you change or top up the oil in the hydraulic system (hydraulic tank), always check if it is filled with petroleum or bio oil.**
- For more detailed information about the required lubricants and service fuels, see the section on lubricants and fuels.

**Specifications in the dosage column:**

- The values stated for the filling quantities in the table are only guidelines.
- The dipstick and level markings are always mandatory.
- Each time the oil is replaced or topped up, check the level in the unit in question.

	Name	Medium	Dosage	Units
 06sy05ab	Diesel engine (with filter change)	Engine oil SAE 10W -40	43.0	l
 06sy08ab	Pump distributor gear	Gear oil SAE 90 LS	2.5	l
 06sy04ab	Diesel engine cooling system total capacity	Coolant	52.0	l
 06sy03ab	Hydraulic system total capacity	Engine oil SAE 20W -20	240	l
 06sy03ab	Hydraulic tank	Engine oil SAE 20W -20	135	l
 1 06sy14ab	Transfer gear	ATF oil	11.5	l
 2 06sy15ab	Front axle	Gear oil SAE 90 LS	48.0	l
 3 06sy16ab	Rear axle	Gear oil SAE 90 LS	50.0	l

LBH/03/003801/0003/5.06/en



Name	Medium	Dosage	Units
Fuel tank	Diesel	400	l
Air-conditioning system	Refrigerant R 134a	1800	g

## 5.2.2 Lubricant chart

The lubrication chart provides an overview of the location of the maintenance points on the machine and of the maintenance intervals.

You will find detailed information in the maintenance and inspection schedule, as well as in the individual descriptions in the section on maintenance tasks.

For more detailed information about the required lubricants and service fuels, see the section on lubricants and fuels.

For information about the required filling quantities, see the tables of filling quantities.

Key:

1 = transmission

2 = front axle

3 = rear axle

1) = central lubricating rail, front section



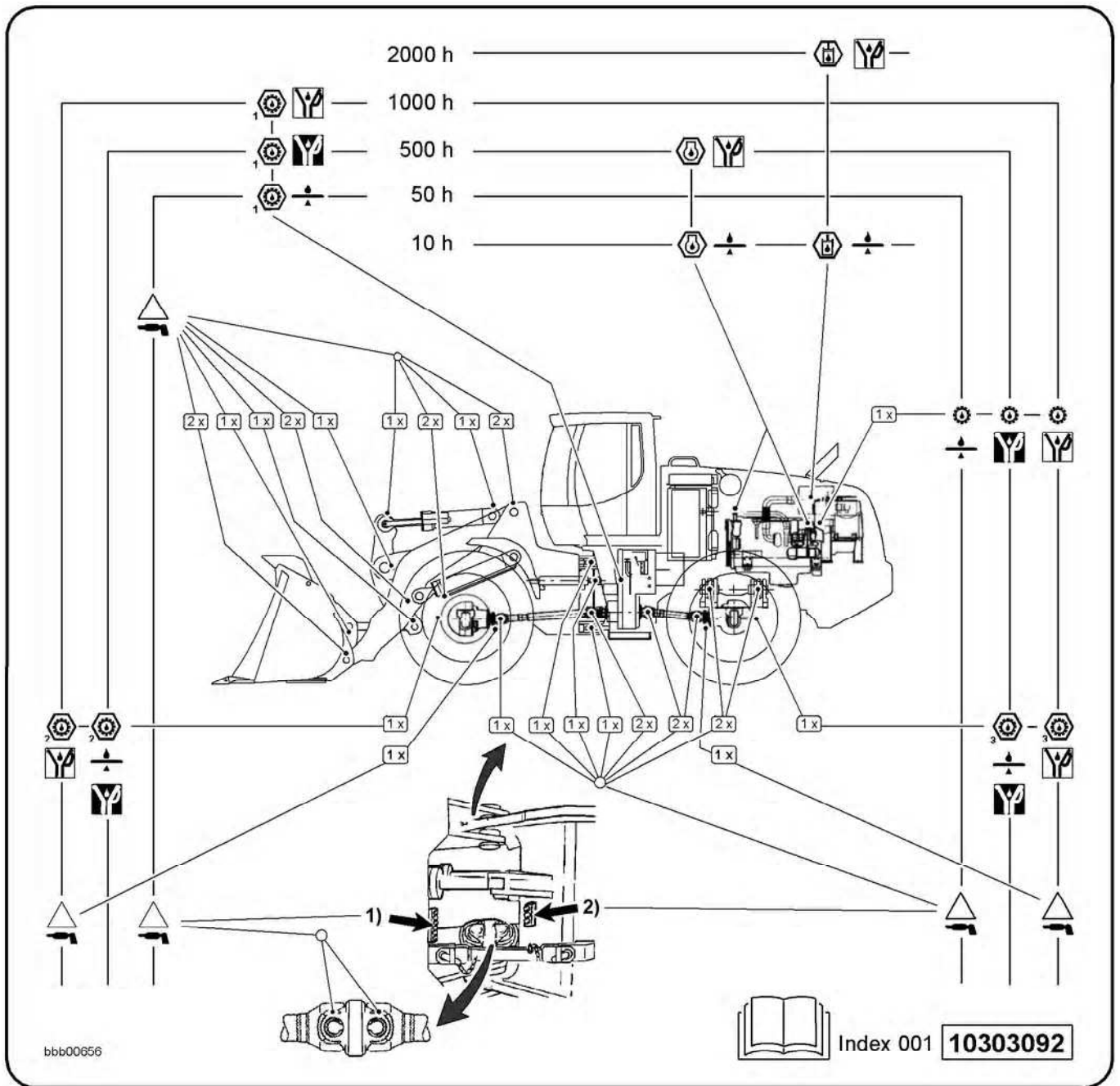

2) = central lubricating rail, rear section

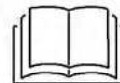

bbb00656



Index 001 **10303092**

Symbol	Name	Symbol	Name
 06sy09ab	General lubrication points	 06sy01ab	Lubrication
 06sy13ab	Check the oil level	 06sy11ab	Oil change
 06sy12ab	First oil change		

LBH/03/003801/0003/5.06/en



## 5.3 Lubricants and fuels

Conscientious observance of the regulations for handling lubricants and fuels will increase the reliability and service life of the machine.

It is especially important that the specified lubricant qualities are observed.

You can find the various specifications about the prescribed intervals in the maintenance and inspection schedule and the lubrication chart.

You can find details on lubrication, checking the oil level and changing operating fluids in the maintenance section under maintenance tasks.

Follow the rules on handling lubricants and fuels, especially the environmental regulations.

### Filling quantities and specifications:

- The filling quantities listed in the tables are only guidelines. The dipstick and level markings are always mandatory.
- Each time the lubricant or fuel is replaced or topped up, check the level in the unit in question.
- For more detailed information about the required lubricants, fuels and filling quantities, see the filling quantities in the lubrication chart and the section on lubricants and fuels.

### Environmental protection

- Always implement and observe environmental protection measures.
- Observe national regulations.
- Ensure that liquids can be properly disposed of before draining them.

### Disposing of used materials

This applies to the following types of used materials and hazardous waste:

- Oils, lubricants, brake fluids, etc.
- Coolant
- Fuels
- Filters, oil cartridges etc.
- Rubber, tyres, insulating materials etc.
- Batteries

### Procedure



#### Note

Environmental and health hazard

! Observe the local regulations for protecting the environment when disposing of used materials.

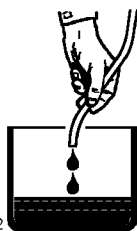

bwa00022

Disposal

- Always collect and store used materials separately in suitable containers.
- Dispose of used materials properly at the official collection points.

### Converting the hydraulic system from petroleum to environmentally compatible hydraulic fluids

For the operation of LIEBHERR earth moving machines with environmentally compatible hydraulic fluids we recommend **PANOLIN HLP SYNTH 46**. **Machines filled at factory with environmentally compatible hydraulic fluids have an appropriate sign (CAUTION) attached to the driver's cab and hydraulic tank.**

**Procedure for conversion:**

---

#### Caution

Beware of damaging the machine's hydraulic system.

Mixing environmentally harmless hydraulic fluids with mineral oils produces a vigorous reaction that can damage the hydraulic system.

**!** Avoid mixing environmentally harmless hydraulic fluids with mineral oils.

---

- If you intend to convert the machine to environmentally-compatible hydraulic fluid, you **must** first consult LIEBHERR CUSTOMER SERVICE.
- It is essential that you order the **INSTRUCTION SHEET** and the **CONVERSION GUIDELINES** from LIEBHERR and that you observe them.

### 5.3.1 Lubricating oils for diesel engines



06sy05ab

#### Lubricating oil quality

Only high-alloy lubricating oils are used in modern diesel engines. They consist of basic oils blended with additives.

The lubricating oil regulation for LIEBHERR diesel engines is based on the following specifications and regulations.

Description	Specifications
ACEA classification (Association des Constructeurs Européens de l'Automobile)	E4, E5, E7
API classification (American Petroleum Institute)	Observe CH-4, CI-4 special oil changing interval

#### *Specifications and regulations for diesel engine lubricating oils*

#### Lubricating oil viscosity

The lubricating oil viscosity is selected according to the SAE (Society of Automotive Engineers) classification.

The decisive factor for the selection of the correct SAE class is the ambient temperature.

LBH/03/003801/0003/5.06/en

The selection of the SAE classification does not affect the quality of a lubricant oil.

If the viscosity is too high, starting can be difficult. If it is too low, lubricant efficiency may be impaired.

The temperature ranges detailed in the following diagram are guidelines - short-term deviations are permissible.

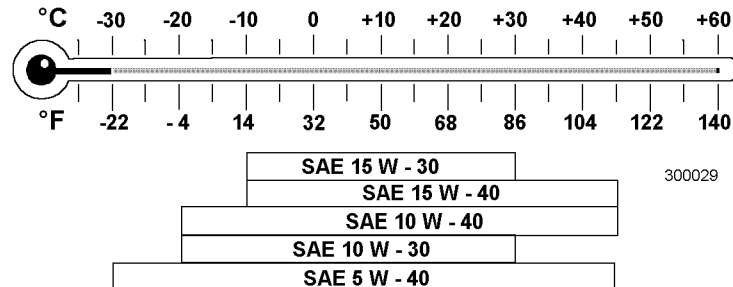

Selection of the SAE class according to temperature

The following diesel engine oil is recommended (for ambient temperatures of -20 °C to + 45 °C :

**LIEBHERR diesel engine oil**

- SAE 10W-40 / specification ACEA E4
- ID no. 8600033 – 20 litres drum

**Lubricant oil changing intervals**

Changing intervals:

- Change the oil according to climate zone, sulphur content in the fuel and oil quality as shown in the following table.

Even if the specified number of service hours (h) is not reached in a given year, the engine oil and filter should be replaced at least once a year.

**Complicating factors**

Various complicating factors or harsh operating conditions can affect the maintenance intervals.

Complicating factors or harsh operating conditions include:

- Frequent cold starts
- A sulphur content above 0.5% in the fuel
- Operating temperature below -10 °C

If working under difficult conditions, the oil change intervals defined in the maintenance and inspection schedule must be reduced by half, as shown in the table below.

Complicating factor		Oil quality	
		CH-4	CI-4
			E4
			E5
			E7
Operation conditions	Sulphur content in fuel	Interval	
Normal climate, down to -10 °C	Up to 0.5%	250 h	500 h
	Above 0.5%	125 h	250 h
Under -10 °C	Up to 0.5%	125 h	250 h
	Above 0.5%		125 h

Oil change intervals in service hours (h)

LBH/03/003801/000315.06/en

### 5.3.2 Diesel fuels



06sy02ab

#### Specifications

The diesel fuels must meet the minimum requirements in the fuel specifications listed below.

Authorised fuel specifications:

- DIN EN 590
- ASTM D 975 (89a) 1D and 2D

The sulphur content should not exceed 0.5% by weight. Higher sulphur content affects the oil change intervals and the engine lifetime.

#### Sulphur content in diesel fuel

DIN EN 590 allows no more than 50 mg/kg = max. 0.005 % by weight of sulphur.

Low-sulphur diesel fuels with a sulphur content below 0.05% are only suitable with additives to ensure lubricity.

The maximum fuel lubricity according to the HFRR (60) test is 460 µm.

**If you use diesel fuels with a sulphur content above 0.5 % by weight, the oil change intervals must be halved.**

**Diesel fuels with a sulphur content above 1% are not permitted.**



#### Note

In some cases, approval may be given, depending on the quality of the diesel engine lubricating oil.

! The ASTM D 975 fuel norm does not include lubricity testing for fuels. Written confirmation from the fuel supplier must be requested. The additives should be added by the supplier in his capacity as agent responsible for fuel quality. Addition of secondary lubricity additives by the customer is not recommended.

- ASTM D 975 requires a **cetane number of at least 45** for fuels. A cetane number above 50 is preferable, especially at temperatures below 0 °C .

#### Diesel fuel at low temperatures (winter operation)

Paraffin crystals form in diesel fuel as the temperature falls; these increase the flow resistance in the fuel filter to such an extent that the fuel supply of the diesel engine is no longer guaranteed.

In temperate climates, cold flow is guaranteed up to:

0 °C from 15.04. - 30.09.

-10 °C from 01.10. - 15.11./1.3. 14.04.

-20 °C from 16.11. - 29.02.

according to DIN EN 590.

If the cold flow properties of the diesel fuel are insufficient or the outside temperature is lower than -20 °C , we recommend using a heater for the fuel filter.

Other approved diesel fuels:

Diesel fuel complying with DIN EN 590 with up to 5% vol. FAME.

### 5.3.3 Coolants for diesel engines

#### General recommendations

The cooling system only functions reliably when it is working in a pre-pressurised condition. Therefore it is essential that it is kept clean and leakproof, that the cooling plug and operating valves function properly and that the necessary coolant level is maintained.

The antifreeze and corrosion protection agents approved by us ensure sufficient protection against cold, corrosion and cavitation, do not corrode seals and hoses and do not foam.

The cooling systems for the engines must be filled all year round with a mixture of 50% water and 50% antifreeze/corrosion inhibitor, providing protection against freezing down to -37 °C .

#### Coolant

Coolants which contain unsuitable antifreeze and corrosion protection or which have been insufficiently or incorrectly prepared can cause units or components in the coolant circuit to malfunction as a result of cavitation or corrosion damage. Also, heat-insulating deposits can occur on heat-conducting components which can result in overheating and cause the engine to break down.

For permanent, trouble-free operation of Liebherr diesel engines, the coolant must consist of 50% water and 50% antifreeze and corrosion protection. In special cases, corrosion inhibitors can be used. Emulgating anti-corrosion oils may never be used.

#### Mixing ratio of water and antifreeze/corrosion protection agent

	°C	°F	Water %	Antifreeze/corrosion protection %
Outside temperature	-37	-35	50	50
Outside temperature	-50	-58	40	60

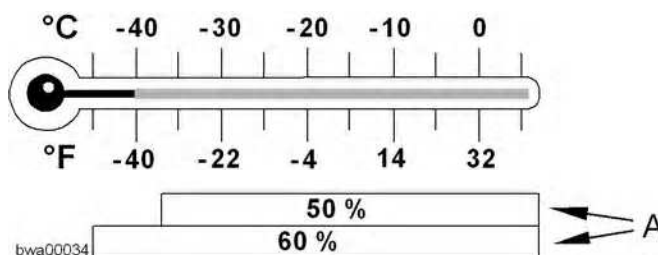

Mixing ratio of antifreeze and corrosion protection agent according to temperature

A = Proportion in % of antifreeze

#### Checking and replacing the coolant

- Always top up the coolant with a mixture of water and at least 50 vol. % antifreeze and corrosion protection agent.
- Never let the concentration of antifreeze and corrosion protection agent fall below 50 vol. %.
- Do not use more than 60% antifreeze and corrosion protection agent, as this impairs the cooling effect and antifreeze protection.

LBH/03/003801/0003/5.06/en

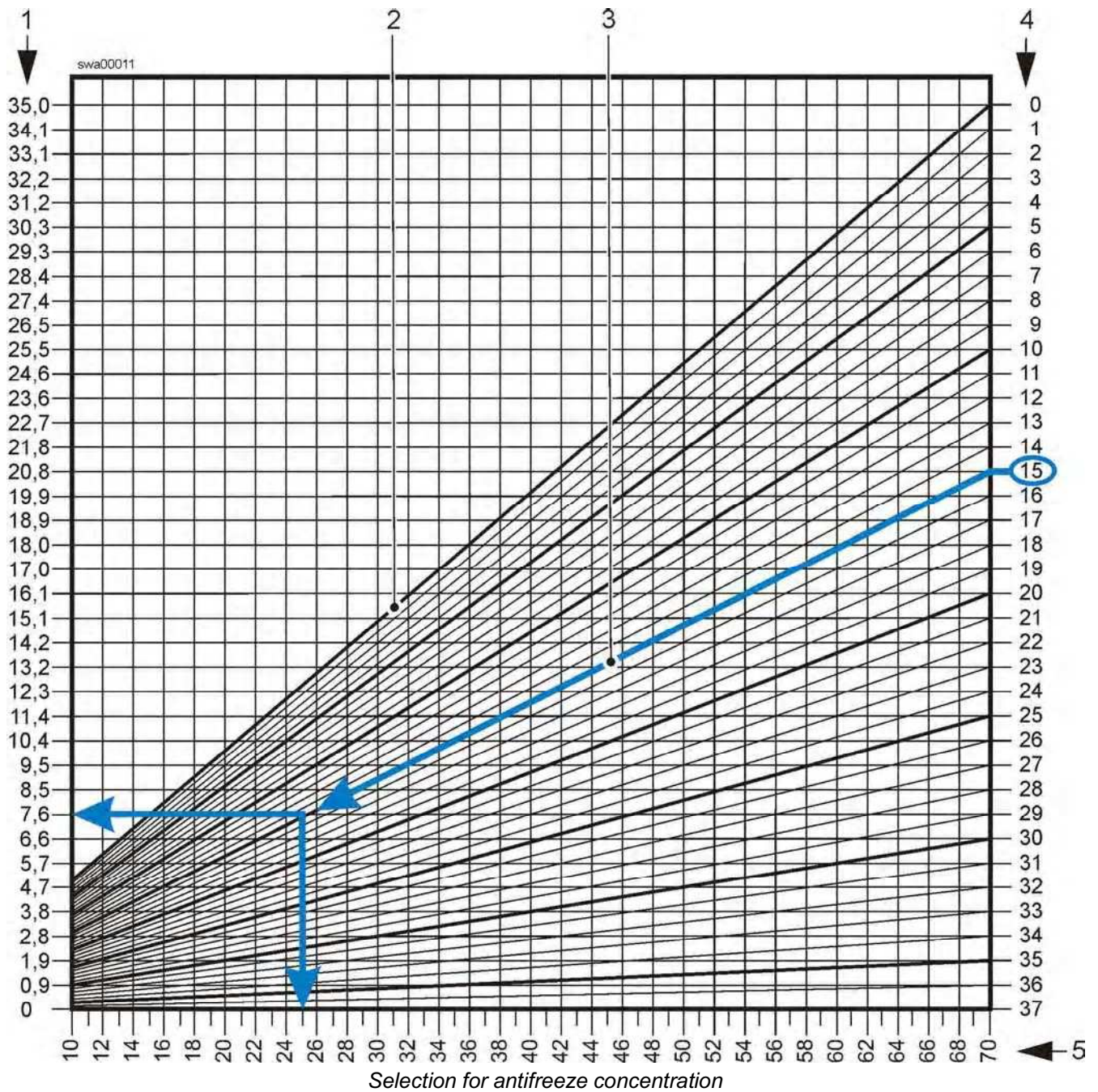

**Procedure for the example -15 °C :**

- If a temperature of -15 °C is measured in the cooling system, follow the guideline 3 (starting from the measured temperature) to the left down to the vertical line indicating the filling quantity for the cooling system 5 and from this point horizontally to the left edge.

This gives you the quantity of pure antifreeze and corrosion protection agent 1 to be added for protection to -37 °C .

- To restore the correct mixing ratio, you must drain off at least the previously calculated quantity from the cooling system.
- Top up with the correct quantity of pure antifreeze and corrosion protection agent.
- The coolant previously drained off can be used if necessary to restore the required coolant level.

LBH/03/003801/0003/5.06/en

**Fresh water** Colourless, clear, clean drinking tap water is suitable with the following restrictions.

**Sea water, brackish water, salt water and industrial waste water are not suitable.**

Description	Value and unit
Water hardness	0.6 to 3.6 mmol/dm <sup>3</sup> (3 to 20° d)
pH value at 20 °C	6.5 to 8.5
Chloride ion content	max. 80 mg/dm <sup>3</sup>
Sulphate ion content	max. 100 mg/dm <sup>3</sup>

*Fresh water quality when using antifreeze and corrosion protection agent*

Description	Value and unit
Water hardness	0.6 to 2.7 mmol/dm <sup>3</sup> (3 to 15° d)
pH value at 20 °C	6.5 to 8.0
Chloride ion content	max. 80 mg/dm <sup>3</sup>
Sulphate ion content	max. 80 mg/dm <sup>3</sup>

*Fresh water quality when using DCA -4 corrosion protection agent*

Ask the local authority for drinking water analyses.

**Anti-corrosion agent (inhibitors)** Use liquid DCA-4.



**Note**

In exceptional cases and when outside temperatures never fall below freezing, such as tropical zones, where it is demonstrable that no approved antifreeze and corrosion protection agent is available:

! DCA-4 may be used in the coolant.

**DCA -4 (Diesel Coolant Additives 4) without antifreeze**

In the exceptional cases, check the concentration of DCA -4 and correct it if necessary when carrying out maintenance work.

The Fleetguard CC 2602 M test kit is recommended for testing.

The DCA -4 concentration must be between 0.6 and 1.06 units per litre.

**Caltex / Chevron Texaco / Havoline / Total without antifreeze**

When carrying out maintenance work, check the mixing ratio when using Caltex / Chevron Texaco / Havoline / Total and correct it if necessary.

The Gefo 2710 refractometer is recommended for testing.

The mixing ratio must be 7.5% corrosion inhibitor and 92.5% water.

**Checking the mixing ratio with a refractometer**



bbb00602



RE120464

*Gefo refractometer no. 2710*

LBH/03/003801/0003/5.06/en

Refractometer

- Screw for adjusting to zero line (water line)
- The focus is set by turning the eyepiece.
- Soft eyepiece flap.
- Sturdy metal housing
- Reinforced rubber grip

Test procedure

- Clean the cover and the prism carefully
- Place 1 or 2 drops of test fluid on the prism.
- The fluid is distributed by closing the prism.
- Look through the eyepiece against a light background and focus the scale.
- Read off the values on the blue line.

Conversion diagram

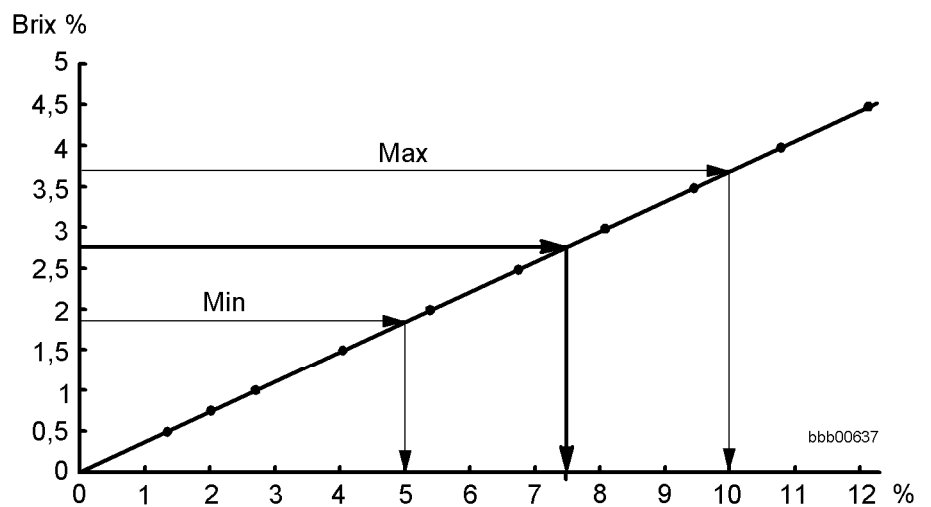

Concentration measured with a Brix refractometer for

- Chevron Texaco Heavy Duty Extended Life Corrosion Inhibitor Nitrite Free / Chevron Texaco
- Havoline Extended Life Corrosion Inhibitor (XLI) / ARTECO
- Caltex CL Corrosion Inhibitor Concentrate / Caltex
- Total WT Supra / Total

Approved water-soluble corrosion protection agent (concentrate) for diesel engine cooling systems

	Product designation	Manufacturer
D	DCA -4 Diesel Coolant Additives	Fleetguard
C	Caltex CL Corrosion Inhibitor Concentrate	Caltex
	Chevron Texaco Heavy Duty Extended Life Corrosion Inhibitor Nitrite Free	Chevron Texaco
H	Havoline Extended Life Corrosion Inhibitor (XLI)	ARTECO
T	Total WT Supra	Total

**The coolant must be replaced once a year.**

When changing from antifreeze and corrosion protection agent to corrosion inhibitor or vice versa, drain off all the coolant.

LBH/03/003801/0003/5.06/en



**Disposing of antifreeze and corrosion protection agents**

Undiluted antifreeze and corrosion protection agents must be treated as hazardous waste. When disposing of used coolant fluids (mixtures with water) follow the instructions of the authorities responsible.

**Approved antifreeze and corrosion protection agent for diesel engine cooling systems**

	Product designation	Manufacturer
A	Agip Antifreeze Plus	Agip Petroli S-P.A., Rome/Italy
	Agip Langzeit-Frostschutz	Autol-Werke GmbH, Würzburg/Germany
	Antigel DB 486	Sotragal SA, St-Priest/France
	Aral Kühler-Frostschutz A	Aral AG, Bochum/Germany
	AVIA Frostschutz APN (G48-00)	Deutsche AVIA-Mineral-Oel-Ges.mbH Munich/Germany
B	BP anti frost X 2270 A	Deutsche BP AG, Hamburg/Germany
	BP Nappgel C 2270/1	BP Chemicals Ltd., London/UK
C	Caltex Engine Coolant DB	Caltex (UK) Ltd., London/UK
	Caltex Extended Life Coolant	Caltex
	Castrol Anti-Freeze O	Deutsche Castrol Vertriebsges.mbH, Hamburg
	Century F.L. Antifreeze	Century Oils, Hanley, Stoke-on-Trent/UK
	Chevron DEX-COOL Extended Life Anti-Freeze/Coolant	Chevron Texaco
D	DEUTZ Kühlschutzmittel 0101 1490	DEUTZ Service Intl. GmbH (DSI), Cologne/Germany
E	Esso Kühlerfrostschutz	Esso AG, Hamburg/Germany
F	Fricofin	Fuchs Mineralölwerke GmbH, Mannheim/Germany
	Frostschutz Motorex (G 48-00)	Bucher + Cie, Langenthal/Switzerland
	Frostschutz 500	Mobil Oil AG, Hamburg/Germany
G	Glacelf Auto Supra	Total
	Glycoshell AF 405	Shell
	Glycoshell N	Shell
	Glystantin (G48-00)	BASF AG, Ludwigshafen/Germany
H	Havoline XLC	ARTECO
	Havoline DEX-COOL Extended Life Anti-Freeze/Coolant	Chevron Texaco
I	Igol Antigel Type DB	Igol France, Paris/France
L	Labo FP 100	Labo Industrie, Nanterre/France
M	Motul Anti-Freeze	Motul SA, Aubervilliers Cedex/France
O	OMV-Frostschutzmittel	OMV AG, Schwechat/Austria
	Organifreeze	Total
	OZO Frostschutz S	Total Deutschland GmbH, Düsseldorf/Germany
T	Total Antigel S-MB 486	Total Deutschland GmbH, Düsseldorf/Germany
	Total Frostfrei	Total Deutschland GmbH, Düsseldorf/Germany

	Product designation	Manufacturer
V	Veedol Antifreeze O	Deutsche Veedol GmbH, Hamburg/Germany
W	Wintershall Kühlerschutz	Wintershall Mineralöl GmbH, Düsseldorf/Germany

**LIEBHERR antifreeze and corrosion protection agents (50:50 premix) for diesel engine cooling systems**

**LIEBHERR Anti-Freeze APN Mix**  
ID no. 8611045 – 20 litres drum

**Approved antifreeze and corrosion protection agents (50:50 premix) for diesel engine cooling systems**

	Product designation	Manufacturer
C	Caltex Extended Life Coolant Pre-Mixed 50/50 (ready-to-use-version)	Caltex
	Chevron DEX-COOL Extended Life Prediluted 50/50 Antifreeze coolant	Chevron Texaco
H	Havoline XLC, 50/50	ARTECO
	Havoline DEX-COOL Extended Life Prediluted 50/50 Antifreeze coolant	Chevron Texaco
O	Organicool 50/50	Total

### 5.3.4 Hydraulic oils



06sy03ab

#### Specifications

Only engine oils (mineral oils) meeting the following specifications and regulations are permitted.

Description	Specifications
API classification (American Petroleum Institute)	CF-4, CG-4, CH-4
ACEA classification (Association des Constructeurs Européens de l'Automobile)	E2 , E3 , E4

*Specifications and regulations for hydraulic oil*

LBH/03/003801/0003/15.06/en

**Viscosity** The viscosity is selected according to the SAE (Society of Automotive Engineers) classification.

The decisive factor for the selection of the correct SAE class is the ambient temperature.

The selection of the SAE classification has no bearing on the quality of a hydraulic oil.

The temperature ranges presented in the diagram are merely guidelines.

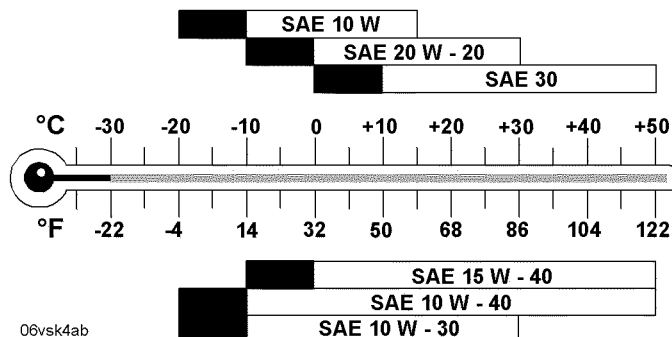

*Selection of the SAE class according to temperature*

### Warming up

At temperatures up to 10 °C below the stated limit:

- Adjust the diesel engine to roughly half speed after starting.
- Activate the hydraulic cylinders and engines and briefly move the cylinders to their stops.
- Warming up takes roughly 10 minutes.

At even lower temperatures:

- Before starting the engine, prewarm the oil tank.

### Environmentally compatible hydraulic fluids

When operating LIEBHERR earth moving machines with environmentally compatible hydraulic fluids, we recommend **PANOLIN HLP SYNTH 46** with the viscosity specified by LIEBHERR.

#### Converting the hydraulic system to an environmentally compatible hydraulic fluid:

- See the section on conversion from mineral oils to environmentally compatible hydraulic fluids.



#### Note

Environmentally-compatible hydraulic fluids must be checked every 500 operating hours at regular intervals.

! LIEBHERR recommends that the oil analysis is carried out by WEAR-CHECK.

#### Oil change:

- Not at the interval stated in the maintenance and inspection schedule.
- At the interval specified by WEAR-CHECK.



**Note**

Do not mix environmentally-compatible hydraulic fluid from different manufacturers or with mineral oils.

! See also the customer service information.

**Monitoring hydraulic oil - changing according to oil samples - analysis and laboratory report:**

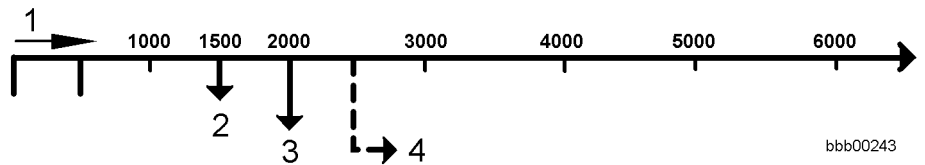

*Oil change intervals according to sample analysis and laboratory report*

- 1 Service hours
- 2 First oil sample
- 3 Second oil sample
- 4 Further oil samples every 500 operating hours

**5.3.5 Lubricating oils for the transmission**



06sy08ab

**Pump distributor gear and axles**

Gear oils must comply with the API GL-5 and MIL-L 2105 B, C or D specifications and the viscosity class SAE 90 LS \*.

\* = Gear oil with limited slip additives for disc brakes and self-locking differentials.



06sy06ab

**LS = limited slip additive:**

- Not required for pump distributor gears
- Required for axles

For the viscosity class SAE 90 LS, an oil of the viscosity class SAE 80 W 90 LS can also be used.

**Transfer gear**

An ATF oil compliant with the DEXTRON II D specification should be used as lubrication oil for the axle transfer gear.

Factory filling:

ATF 86 AVIA-FLUID DEXRON II D



06sy07ab

Description	ID no.	Quantity
ATF 86 AVIA-FLUID DEXRON II D	861012601	210 l
ATF 86 AVIA-FLUID DEXRON II D	10009964	20 l

LBH/03/003801/0003/5.06/en

### 5.3.6 Grease for general lubrication points



This grease must meet the **KP2k** specification – consistency 2 of the NL GI class according to DIN 51818 and DIN 51825 or EP 2 according to NF-T-60 132.

The grease must be made of a lithium complex with a four ball tester (VKA) value of at least 2300 N according to DIN 51350 or ASTM D 2596.

**Application:**

- Grease for all lubrication points (according to the lubrication schedule)
- Lubricant grease for bolt fitting
- Lubricant grease for automatic central lubrication systems

**Approved lubricants**

LIEBHERR 9610 special grease is a milling-resistant, ageing-resistant lithium grease, providing protection against corrosion with excellent lubricity over a wide temperature range.

Its molecular composition yields high degrees of shearing and milling stability and good flow properties in long pipes.

Description	ID no.	Quantity
LH 9610 special grease	8613 02908	400 g (cartridge)
LH 9610 special grease	8613 01308	10 kg (drum)
LH 9610 special grease	8613 04508	25 kg (drum)

**Lubricant grease for automatic central lubrication systems**



Greases with high-pressure additives (EP greases) are recommended.

Only use greases with the same type of saponification.



**Note**

Greases with solid lubricant particles such as graphite are not suitable.  
! Do not use this type of grease.

## 5.4 Maintenance tasks

On completion of servicing, the machine should be returned to the operating position.

See the section on the operating position in chapter 3.



bpik0050

Make sure you are wearing safe working clothing.

Certain jobs not only require a hard hat and safety boots, but also goggles and safety gloves.

### 5.4.1 Preparatory tasks for maintenance

Before performing the various maintenance tasks, move the machine to maintenance position unless otherwise explicitly specified in the description.

See the section on maintenance positions.

The various maintenance tasks include:

- Lubricating the lift arms
- Checking the oil level or changing the oil in the engine, gears, axles, hydraulic tank, etc.
- Replacing filters as well as adjustment and repair work on the hydraulic system

### Safety precautions for maintenance

**Always observe the accident prevention regulations during maintenance work.**

See the measures to ensure safe maintenance on chapter 2.



*Visual contact*

Make sure that visual contact between the operator in the cab and maintenance personnel is always maintained.



### Danger

There is a risk of accidents for maintenance personnel.

The presence of unauthorised persons on the machine can place the maintenance personnel in extreme danger.

! Never enter a dangerous area of the machine without making your presence known.

- Make sure you can be clearly seen before entering one of the machine's danger areas.

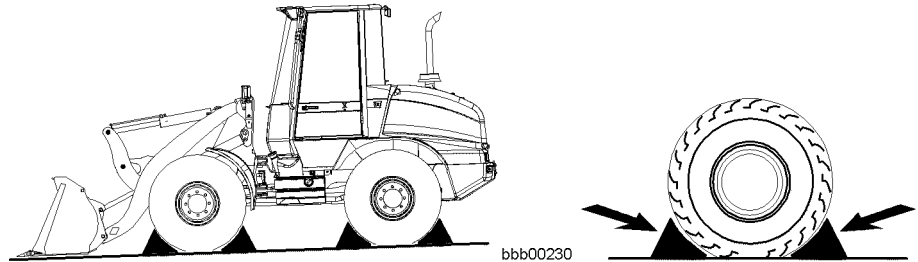

*Wheel wedges*

- Secure the machine against rolling away with wheel wedges.

### Maintenance positions

The maintenance position depends on the maintenance task to be performed.

The two basic maintenance positions 1 and 2 are described below.

They enable you to access the individual maintenance points.

#### Maintenance position 1

To move the machine into maintenance position 1 proceed as follows.

For a detailed description of the individual procedures, see the section on operation in chapter 3.

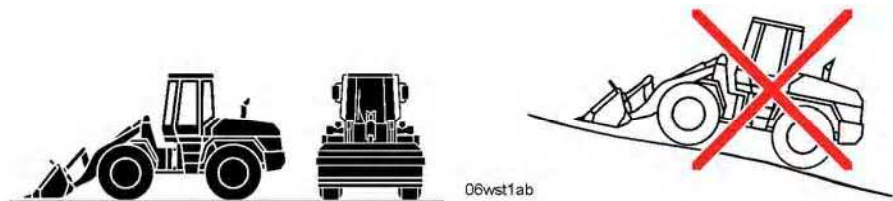

*Maintenance position 1*

- Park the machine on level ground.
- Lower the lift arms.
- Set the bucket down flat on the ground.
- Engaging the parking brake
- Turn off the diesel engine.
- Take out the ignition key.

**Maintenance position 2**

To move the machine into maintenance position 2 proceed as follows.  
For a detailed description of the individual procedures, see the section on operation in chapter 3.

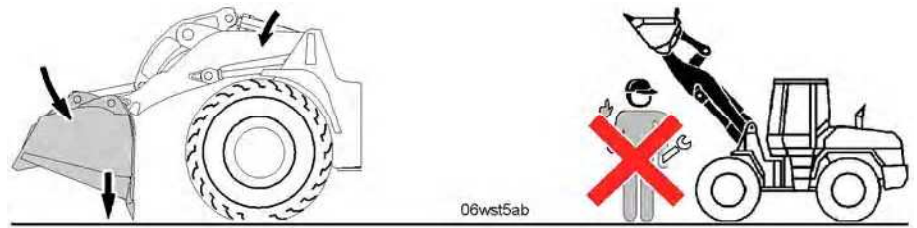

Maintenance position 2

- Park the machine on level ground.
- Engage the articulation lock.
- Lower the lift arms.
- Tilt the bucket out and set it down on the ground on its teeth or cutting edge.
- Engaging the parking brake
- Turn off the diesel engine.
- Take out the ignition key.

**Opening the service hatches, doors and hoods**

**Opening the engine compartment hatch**

Open the hatch if you need to access the following units or components:

- Hydraulic pumps
- Hydraulic tank
- Hydraulic tank shut-off valve
- Air filter
- Battery main switch



Engine compartment hatch

- 1 Engine compartment hatch
- 2 Handle with lock

- 3 Gas-filled springs

LBH/03/003801/0003/5.06/en



**Warning**

There is a risk of injury if the flap falls shut.

! Check that the gas-filled springs securely hold the hood fully open.

**Closing the engine compartment hatch**

- Open the lock with the ignition key.
  - Completely open the hatch **1** with the handle **2**.
- Two gas-filled springs **3** hold the open hatch in this position.
- Completely close the hatch **1** with the handle **2**.
  - Lock the hatch with the ignition key.

**Opening the engine compartment hood**

When the hood is open, you can access the following units:

- Diesel engine
- Pump distributor gear
- Cooling system
- Hydraulic tank



*Engine compartment hatch and hood cable*

- Open the engine compartment hatch.



**Warning**

Engine parts which are in motion can cause injury. Rotating or moving engine parts, such as the fan blades or V-belts, can cause injury.

! Only open the engine compartment hood when the engine is shut down.

- Pull the cable **1** for unlocking the engine compartment hood until the lock is open.

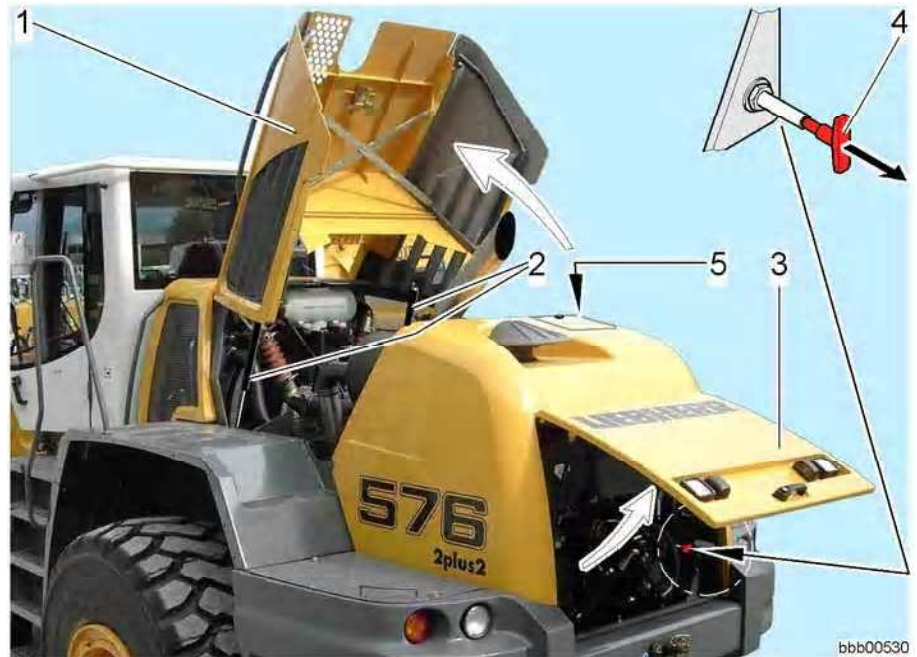

*Engine compartment hood*

- |                            |                        |
|----------------------------|------------------------|
| 1 Engine compartment hood  | 4 Cable lock           |
| 2 Gas-filled springs       | 5 Hydraulic tank cover |
| 3 Engine compartment hatch |                        |

The lock releases the engine compartment hood **1**. The hood is automatically opened and held in position by two gas-filled springs **2**.

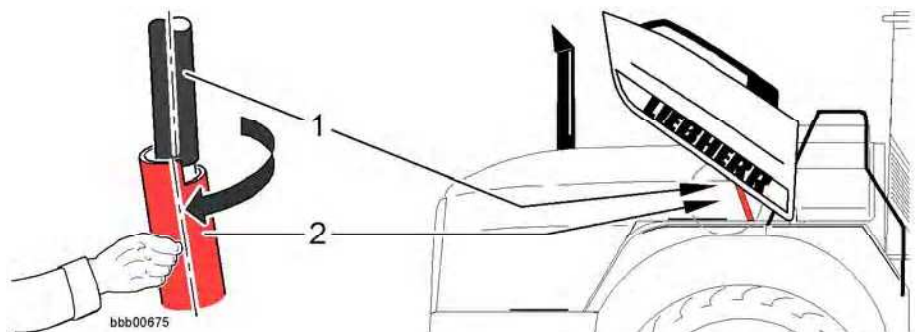

- Turn the securing pipe **2** in the direction of the arrow (position shown). The gas-filled spring **1** is now blocked. The engine compartment hood cannot be opened.

LBH/03/003801/0003/5.06/en

**Warning**

There is a risk of injuries if the hood falls shut.

! Check that the gas-filled springs securely hold the hood fully open.

- Check the function.

**Troubleshooting**

If not, rectify the problem immediately.

- Contact LIEBHERR CUSTOMER SERVICE.

### Closing the engine compartment hood

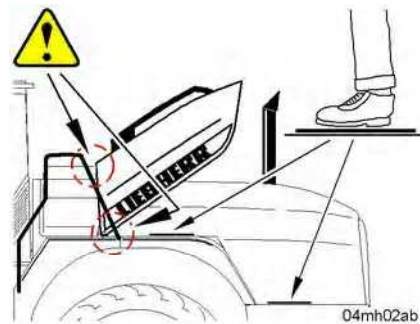

*Foot plate*

- Close the hood:  
Climb onto the machine via the cab access, making sure that you have secure footing.

**Caution**

There is a risk of accidents when opening or closing the hood.

You can injure your feet when opening and closing the hood.

! Make sure your feet are in a safe place when opening or closing the hood.

- Stand to one side of the hood with both feet on the foot plates provided.
- Open the hydraulic tank cover **5** if necessary.  
Close the cover and lock it.

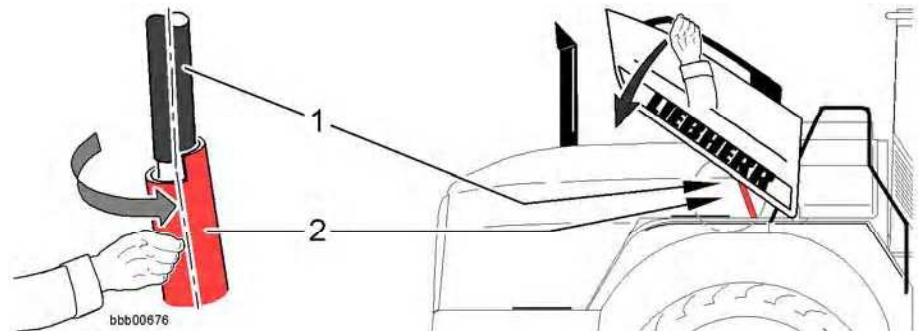

- Turn the securing pipe **2** in the direction of the arrow (position shown).

**Opening the cooling system hood**

The gas-filled spring **1** is now released.  
The engine compartment hood can be closed.

- Close the hood:  
Push down the hood handle until the hood engages in the lock.

When the hood is open, you can access the cooling system.  
Make sure that the left or right cab door is closed as necessary.

- When opening or closing the hood, climb onto the machine via the cab access, making sure that you have secure footing.

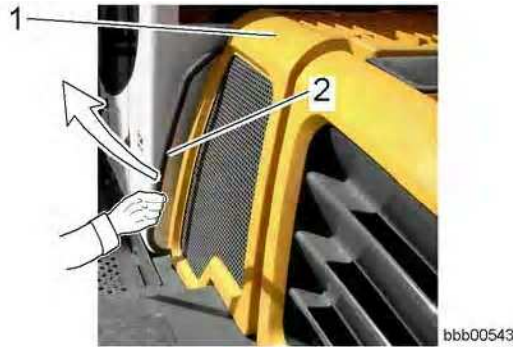

Cooling system hood

1 Left cooling system hood                      2 Handle

- Completely open the hood **1** by pulling up the handle.



Cooling system hood

1 Left cooling system hood                      3 Gas-filled springs  
2 Right cooling system hood

- Completely open the hood **2** by pulling up the handle.  
The hood is held in this position by the gas-filled spring **3**.



**Warning**

There is a risk of injuries if the hood falls shut.  
**!** Check that gas-filled spring holds it completely open.

- If not, rectify the problem immediately.

**Troubleshooting**

The function is not assured

- Contact LIEBHERR CUSTOMER SERVICE.

LBH/03/003801/0003/5.06/en

### Turning off the battery main switch

The battery main switch is located at the rear left of the engine compartment.

**For certain maintenance jobs, the battery main switch must first be turned off.**

Find out from the descriptions of the relevant maintenance tasks whether the battery main switch must be turned on or off. See the section on maintenance tasks.

Switch on the battery main switch after completing these maintenance tasks.

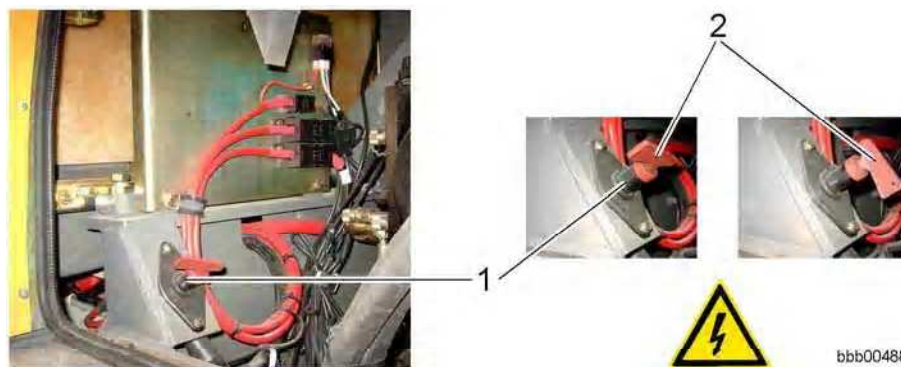

Battery main switch

1 Battery main switch

2 Main switch key



#### Danger

There is a risk of accidents for maintenance personnel.

If unauthorised people are on the machine it can put the maintenance personnel in extreme danger.

! For safety reasons, it is essential that the battery main switch is turned off.

! Take out the key.

- Turn off the battery main switch **1** by turning the key **2** to the **0** position.

### 5.4.2 Removing loose parts, dirt, ice and snow from the machine

Make sure that the machine is in maintenance position 1.

#### Procedure



#### Note

To ensure safe machine transport and easy maintenance:  
Clean the machine after everyday work and before starting maintenance tasks.

! Remove any loose parts, coarse dirt, mud, ice, snow etc.

- Be careful when cleaning the machine with a high-pressure cleaner. See the section on cleaning the machine.

### 5.4.3 Checking the machine for external damage

Make sure that the machine is in maintenance position 1.

#### Procedure



bsym0049

- Before starting up the machine, check for external damage which might impair safe operation.
- Immediately repair any damage which may impair safety.

### 5.4.4 Making sure the bolted connections are tight

Make sure that:

- The machine is in maintenance position 2.
- The appropriate service doors, hatches and hoods are open.

#### Procedure

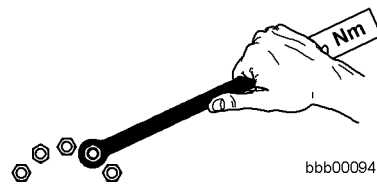

bbb00094

- Check that all bolts and screws are tight.
- Tighten any loose screws or bolts with the required tightening torque.

### 5.4.5 Sealing leaks

Make sure that:

- The machine is in maintenance position 2.
- The appropriate service doors, hatches and hoods are open.

#### Procedure

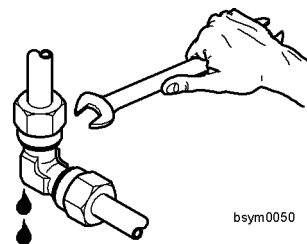

bsym0050

- Check the entire hydraulic system for leaks.
- Replace any damaged hydraulic seals.
- Tighten any loose hydraulic couplings.
- See also the section on safe maintenance of hydraulic hoses and hose lines in chapter 2.

### 5.4.6 Checking the engine oil level

Make sure that:

- The machine is in maintenance position 1.
- The engine compartment hood is open.
- The engine is level and has not been running for 2 - 3 minutes.

#### Procedure



*Diesel engine*

- Pull out the dipstick **1**, wipe it clean, and re-insert it.
- Pull out the dipstick once again and read off the oil level.

The oil level must be between the MIN and MAX markings.

- If the oil level is too low:  
Remove the sealing cap from the filler neck **2** and top up with oil.

Necessary oil quality: see the section on lubricants and fuels.

- Top up with oil via the oil filler neck **2**.
- Clean the sealing cap, place it on the filler neck **2** and tighten it.

### 5.4.7 Changing the engine oil

Make sure that:

- The machine is in maintenance position 1.
- The engine compartment hood is open.
- The engine is level.
- The engine is warm.
- A suitable receptacle, an oil drain hose and the specified engine oil are at hand.

See the table of filling quantities for the required capacity of the receptacle.

**Procedure**

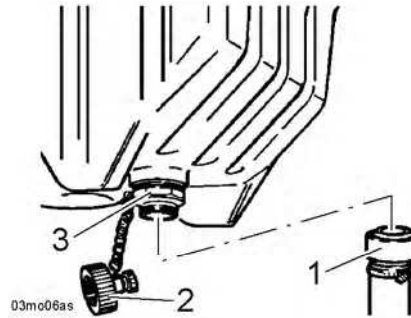

*Diesel engine*

1 Oil drain hose  
2 Cap

3 Oil drain valve

- Unscrew the cap of the oil drain valve on the oil pan.
- Screw the oil drain hose to the oil drain valve.
- Drain off the oil into the receptacle.
- Unscrew the oil drain hose.
- Screw the cap onto the oil drain valve.
- **When changing the engine oil and the oil filter:**  
Change the filter as described in the section on changing the oil filter.



*Diesel engine*

- Pour the new oil into the filler neck **2** to between the MIN and MAX markings on the dipstick **1**.
- Clean the filler cap, place it on the filler neck **2** and tighten it.
- Start the engine and check the oil pressure.
- Turn off the engine and after 1 or 2 minutes, check the oil level on the dipstick.
- Top up with oil if necessary.

LBH/03/003801/0003/5.06/en



### 5.4.8 Changing the engine oil filter

Make sure that:

- The machine is in maintenance position 1.
- The engine compartment hood is open.
- The engine oil has been drained off.
- A strap wrench and a suitable container are in place.
- Only use genuine LIEBHERR spare parts.  
(2 oil filter cartridges)

#### Procedure

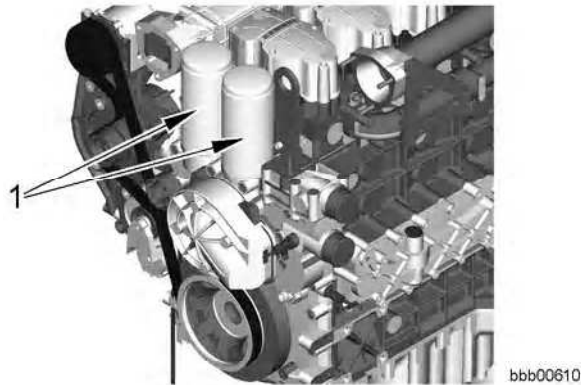

- Place a suitable container under the diesel engine.



#### Note

Protect the V-ribbed-belt against emerging oil when changing the oil filter cartridges.

! After changing the oil filter, remove all traces of oil on the diesel engine, also behind the vibration damper so that this is not diagnosed as a leak in the leakage in the radial shaft seal at a later stage.

- Release the filter cartridges 1 with a strap wrench and unscrew them.
- Clean the seals on the filter bracket.
- Lightly coat the rubber gaskets on the new oil filter cartridges with engine oil.
- Screw on the new oil filter cartridge until the sealing ring touches the filter bracket.
- When the sealing ring touches the filter bracket:  
Tighten the oil filter cartridge by a half to three-quarter turn. (Do not use a tool for tightening).
- Start the diesel engine:  
Check the oil pressure in the engine oil pressure display (see display unit).
- Shut down the diesel engine:  
Check the seals on the oil filters and the oil level.
- After 2 to 3 minutes, check the oil level on the dipstick.



#### Troubleshooting

Is the oil level between the min. and max. levels?

- Correct the oil level.

### 5.4.9 Checking the diesel engine heating flange

Make sure that:

- The machine is in maintenance position 1.
- The engine compartment hood is open.
- You have an ohmmeter or a multimeter ready.

#### Procedure

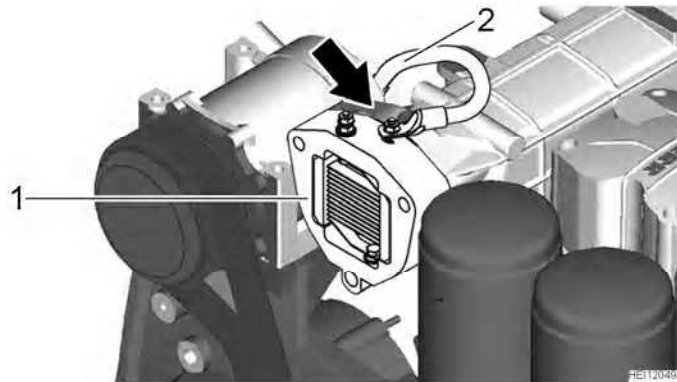

- Turn off the battery main switch.
- Disconnect the electric connection cable **2** on the heating flange **1**.
- Connect the ohmmeter or multimeter to the terminal and check the resistance.

#### Troubleshooting

If the resistance is not 250 Ohms +/- 10% at 20 °C :

- Replace the heating flange.
- 
- Disconnect the electric connection cable on the heating flange.
  - Turn on the battery main switch

### 5.4.10 Changing the fuel pre-filter

On the right side of the diesel engine you can find:

- Fuel pre-filter  
with water separator  
with fuel preheating, depending on the equipment of the diesel engine.
- Water level probe
- Integrated fuel hand pump.

Bleeding the water of the fuel prefilter must be conducted after the water level probe activates.

Make sure that:

- The machine is in maintenance position 1.
- The engine compartment hood is open.
- You have a suitable receptacle ready.
- Only use genuine LIEBHERR spare parts.  
(1 fuel pre-filter cartridge)

## Procedure



### Danger

There is a risk of fire and explosions.

- ! Do not smoke.
- ! Avoid naked flames.
- ! Only work with the engine switched off and cooled down.

- Place a receptacle under the fuel pre-filter.
- Carefully clean the fuel pre-filter and the area around it.

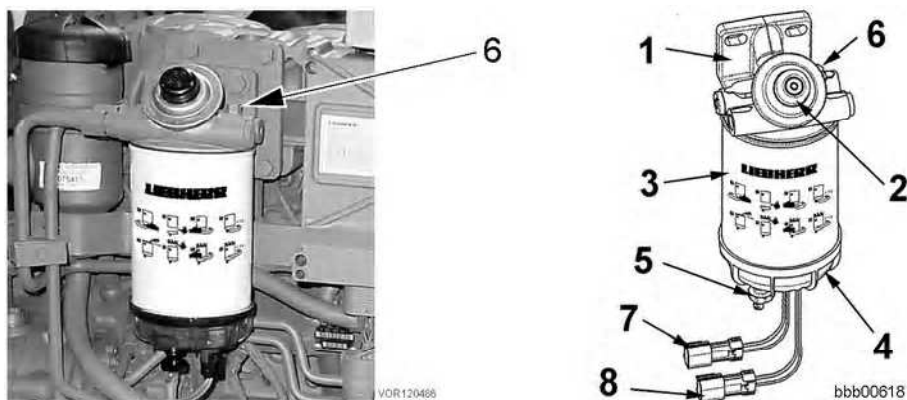

*Fuel prefilter cartridge*

- Disconnect the electrical connections of the water level probe **8** and the fuel preheater **7**.
- Drain the fuel:  
Unscrew the bleeder screw **6** and drain plug **5**.
- Release the filter cartridges **3** with a strap wrench or similar tools and unscrew them.

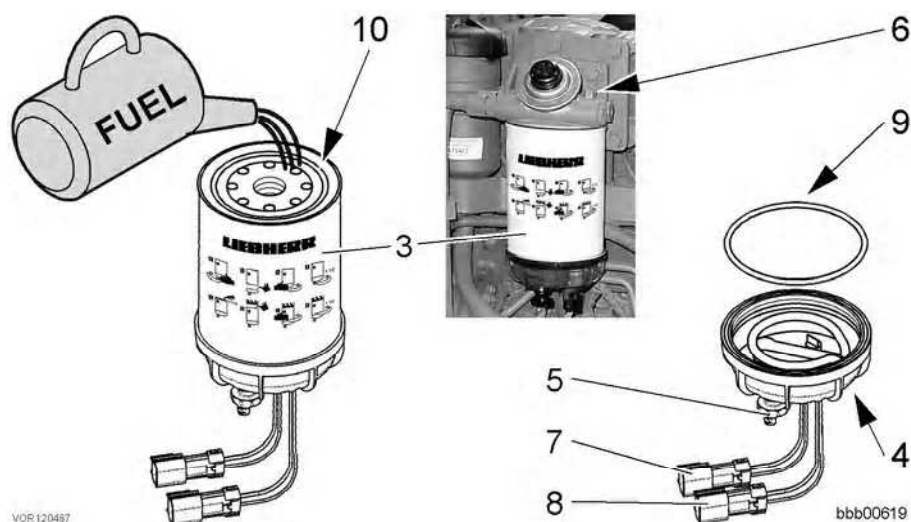

*Filter cartridge, water separator container*

- Unscrew the water separator container **4** from the filter cartridge **3**.
- Dispose of the old filter cartridge.
- Wash the water separator container and dry it with compressed air.
- Lubricate the O-ring **9** of the water separator container lightly.

- Screw the water separator container to the new filter cartridge until the O-ring touches the filter cartridge.
- Tighten the water separator container half a turn by hand.
- Screw in the drain plug **5**.
- Check the filter head is clean and ensure that the thread adapter is firmly in the filter head.
- If the filter head is dirty:  
Clean the filter head.
- Lubricate the sealing ring **10** of the new filter cartridge with clean fuel.
- Fill the filter cartridge and screw it on until the sealing ring lies on the filter head.
- Tighten the filter cartridge **3** half a turn by hand.
- Reconnect the electrical connections of the water level probe **8** and fuel prewarming unit **7**.
- Close the bleeder screw **6**.
- Bleed the fuel system.  
See the section on bleeding the fuel system.

#### 5.4.11 Changing the fuel fine filter

Make sure that:

- The machine is in maintenance position 1.
- The engine compartment hood is open.
- You have a suitable receptacle ready.
- Only use genuine LIEBHERR spare parts.  
(1 fuel fine-filter cartridge)

## Procedure



### Danger

There is a risk of fire and explosions.

- ! Do not smoke.
- ! Avoid naked flames.
- ! Only work with the engine switched off and cooled down.

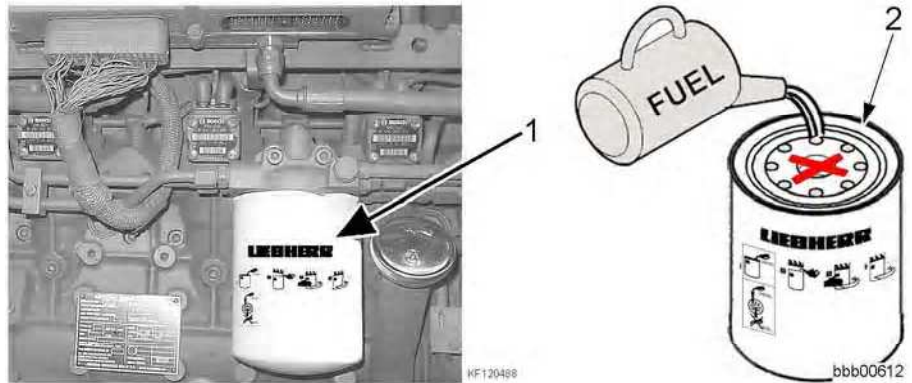

- Place a receptacle under the fuel fine filter.
- Carefully clean the fuel fine filter and the area around it.
- Screw off the fuel fine filter 1.  
(Use a suitable filter strap)
- Dispose of the old filter cartridge.
- Check the filter base is clean and ensure that the thread adapter is firmly in the filter base.
- If the filter base is dirty:  
Clean the filter base.
- Lubricate the sealing ring 2 of the new filter cartridge with clean fuel.
- Fill the filter cartridge and screw it on until the sealing ring lies on the filter head.
- Tighten the filter cartridge 1/2 a revolution by hand with a filter wrench.
- Bleed the fuel system.  
See the section on bleeding the fuel system.

### 5.4.12 Draining off condensate from the fuel pre-filter

After integrated water level probe in the fuel prefilter activates (control lamp glows), the water collector tank must be drained.

**Danger**

There is a risk of fire and explosions.

! Do not smoke.

! Avoid naked flames.

! Only work with the engine switched off and cooled down.

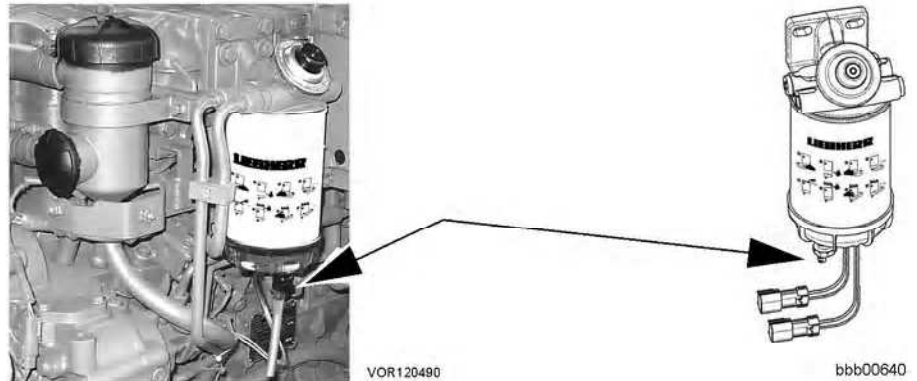

*Draining the fuel pre-filter*

- Do not start the diesel engine.
- Place a receptacle under the fuel pre-filter.  
If necessary attach a drainage hose.
- Open the drain plug, drain the water until fuel emerges without bubbles.
- When fuel emerges:  
Tighten the drain plug.
- Bleed the fuel system.  
See the section on bleeding the fuel system.

### 5.4.13 Bleeding the fuel system

Bleeding the fuel filter is necessary after:

- Changing the fuel filter  
See the section on bleeding the fuel filter.

Bleeding the fuel system is necessary after:

- Emptying the fuel tank  
See the section on bleeding the fuel filter with the engine bleeding function.

Make sure that:

- The machine is in maintenance position 1.
- A receptacle is ready for the fuel.

## Bleeding the fuel filter

### Procedure



#### Danger

There is a risk of fire and explosions.

! Do not smoke.

! Avoid naked flames.

! Only work with the engine switched off and cooled down.



*Bleeder screw on the head of the fuel prefilter*

- Unscrew the bleeder screw 1 on the filter top of the fuel prefilter by 2 to 3 turns.
- Activate the hand pump 2.
- If fuel flows out of the bleeder screw without bubbles:  
Tighten the bleeder screw 1.
- Continue to activate the hand pump until you feel strong resistance.

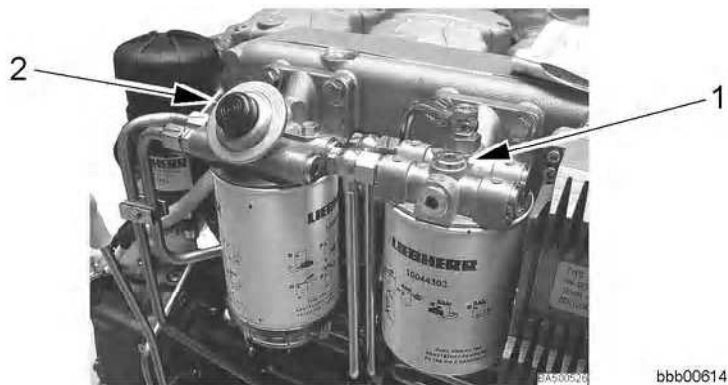

*Bleeder screw on the head of the fuel fine filter*

- Unscrew the bleeder screw **1** on the filter top of the fuel fine filter by 2 to 3 turns.
- Activate the hand pump **2**.
- If fuel flows out of the bleeder screw without bubbles:  
Tighten the bleeder screw **1**.
- Continue to activate the hand pump until you feel strong resistance.

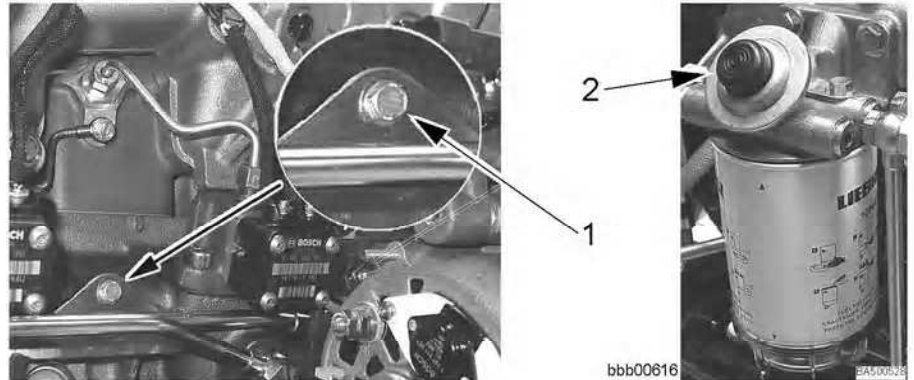

*Bleeder screw on the crankcase*

- Unscrew the bleeder screw **1** on the crankcase (if present) by 2 to 3 revolutions.
- Activate the hand pump **2**.
- If fuel flows out of the bleeder screw without bubbles:  
Tighten the bleeder screw **1**.
- Continue to activate the hand pump until you feel strong resistance.

### **Bleeding the fuel filter with the engine bleeding function**

It is necessary when the fuel tank has run completely empty.

When the fuel tank is empty there is air in the fuel system.

You can remove some of the air from the fuel system by bleeding the fuel filter.

You can bleed the air between the injection pump and the injection nozzle by activating engine bleeding mode.

See the section on the engine bleeding button (special function) in chapter 3



## Procedure

---



### Danger

There is a risk of fire and explosions.

- ! Do not smoke.
  - ! Avoid naked flames.
  - ! Only work with the engine switched off and cooled down.
- 



- Bleed the fuel filter:  
See the section on bleeding the fuel filter.
- Activate the engine bleeding function.

Activation sequence:

- Turn the ignition on
  - With the engine standing, press the button for 10 seconds
  - All 3 LEDs on the button light up when the engine bleeding function is activated.
- Turn the ignition key to the starting position **II** and keep it in there until the engine starts.
  - **Do not hold the key in the starting position for more than 20 seconds at a time.**

The ECU ends the engine bleeding function automatically as soon as the engine starts again.

---

### Troubleshooting

If the engine does not start again within 20 seconds:

- Turn the ignition key back to the 0 position.
- 
- Wait a minute and repeat the procedure.  
In the meantime, continue to operate the hand pump until you feel strong resistance.

## 5.4.14 Draining off condensate and sediment from the fuel tank

Make sure that the machine is in maintenance position 1.

**Procedure**

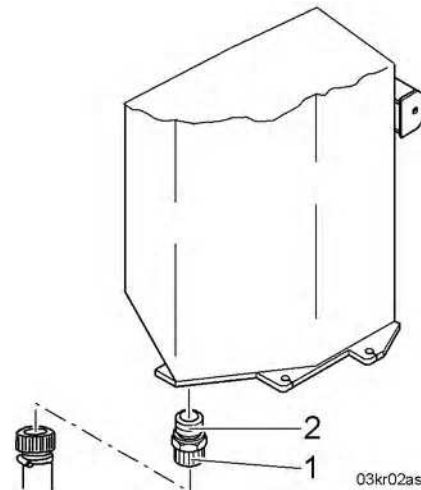

- Unscrew the sealing cap 1 on the drain valve 2 on the bottom of the diesel tank.
- Screw the drain hose onto the drain valve 2.
- Drain the condensation and sediment into a suitable receptacle until clean fuel begins to flow.
- Unscrew the oil drain hose.
- Screw the cap 1 onto the drain valve 2 and tighten it.

**5.4.15 Cleaning the air filter service cap and dust extraction valve**



**Note**

If the valve is damaged, the dust extraction function is impaired and the filters become clogged more quickly.

! With the engine running at lower idle speed, you should clearly feel air pulsating at the dust extraction valve.



*Engine compartment hatch*

- 1 Engine compartment hatch
- 2 Handle with lock

- 3 Gas-filled springs

LBH/03/003801/0003/15.06/en

Make sure that:

- The machine is in maintenance position 1.
- The engine compartment hatch is open.
- The battery main switch is switched off and the main switch key is removed.

### Cleaning the dust extraction valve

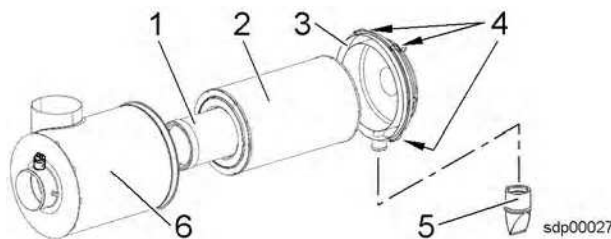

- Press the rubber seal on the dust extraction valve **5** several times to remove the dust from the service cap **3**.
- When working in dusty conditions, check and empty the dust extraction valve **5** more often.
- If the dust extraction valve is damaged or stays open:  
Replace the dust extraction valve.

### Cleaning the service cap

- Open the fixing clips **4** on the service cap **3** and take the cap off.
- Clean the service cap **3**.
- Put the service cap **3** back on the filter housing **6**.

The dust extraction valve **5** must face down.

- Make sure the cap is placed properly on the filter housing **6**.  
Only then can you close the fixing clips **4** without excessive force.
- Close the fixing clips **4**.

## 5.4.16 Changing the air filter main element when indicated by the vacuum switch

The primary element **2** should be cleaned or replaced when the air filter contamination symbol field on the display unit lights up or at least every 1000 service hours.

If the air filter contamination symbol field remains lit after the primary element **2** has been serviced then the secondary element **1** must also be replaced.

Make sure that:

- The machine is in maintenance position 1.
- The engine compartment hatch is open.
- The battery main switch is switched off and the main switch key is removed.

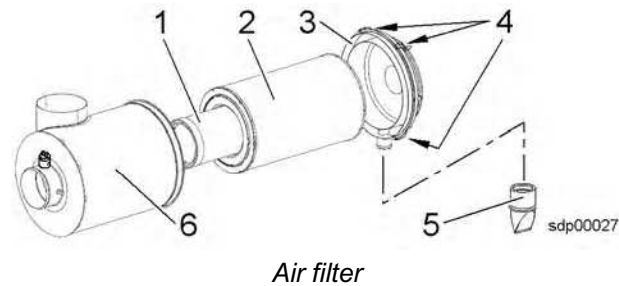
**Procedure**

- |                     |                         |
|---------------------|-------------------------|
| 1 Secondary element | 4 Fixing clips          |
| 2 Primary element   | 5 Dust extraction valve |
| 3 Service cap       | 6 Air filter housing    |

- Open the fixing clips **4** on the service cap **3** and take the cap off.
  - Remove the primary element **2** and the secondary element **1**.  
To loosen the seal: pull or twist the elements slightly up, down or sideways.
  - Make sure that all dirt has been removed from the filter housing before you put in a new or cleaned filter element.
  - The secondary element **1** should be replaced every third time the main filter element **2** is replaced.
  - Before installing the filter elements, lightly oil the seal surfaces.  
(On the primary element **2** this is the inside, on the secondary element **1** it is the outside).
  - Re-insert filter elements **1** and **2** and make sure that they are correctly fitted.
  - Clean the service cap **3** and put it on the filter housing with the dust extraction valve **5** facing down.
- Only when the lid completely covers the filter housing can you close the fixing clips without excessive force.
- Close the fixing clips **4**.

**5.4.17 Changing the air filter secondary element**

If the air filter contamination symbol field remains lit after the primary element **2** has been serviced then the secondary element **1** must also be replaced.

After replacing the primary element three times or at the latest after one year, the secondary element must be replaced.

Make sure that:

- The machine is in maintenance position 1.
- The engine compartment door is open.
- The battery main switch is switched off and the main switch key is removed.

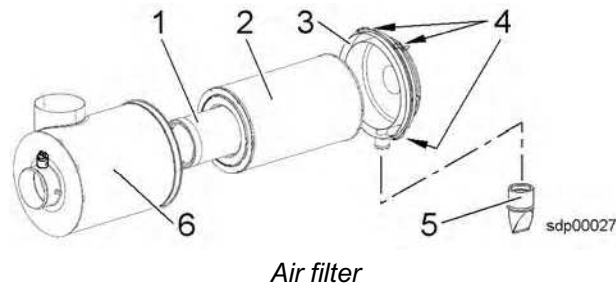
**Procedure**

- |                     |                         |
|---------------------|-------------------------|
| 1 Secondary element | 4 Fixing clips          |
| 2 Primary element   | 5 Dust extraction valve |
| 3 Service cap       | 6 Air filter housing    |

- Open the fixing clips **4** on the service cap **3** and take the cap off.
  - Remove the secondary element **1**.  
To loosen the seal: Pull or twist the elements slightly up, down or sideways.
  - Make sure that all dirt has been removed from the filter housing before you put in a new or cleaned filter element.
  - Before installing the filter element, lightly oil the seal surface. (On the secondary element **1** this is the outside).
  - Re-insert the filter elements **1** make sure that it is correctly fitted.
  - Clean the service cap **3** and put it on the filter housing with the dust extraction valve **5** facing down.
- Only when the lid completely covers the filter housing can you close the fixing clips without excessive force.
- Close the fixing clips **4**.

**5.4.18 Checking the oil level in the pump distributor gear**

The dipstick **3** and the oil inlet pipe **2** are located in the engine compartment directly beside the hydraulic tank.

Access is from above the engine on the right-hand side.

Make sure that:

- The machine is in maintenance position 1.
- The engine compartment hood is open.

**Procedure**

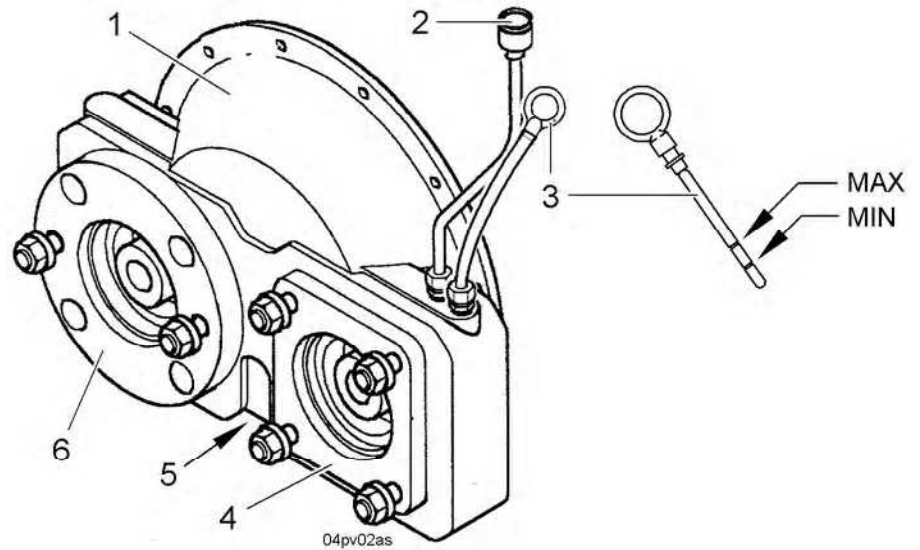

*Pump distributor gear*

- Pull out the dipstick **3**, wipe it clean, and re-insert it.
- Pull out the dipstick **3** once again and read off the oil level. The oil level must be between the MIN and MAX markings.
- If the oil level is too low:  
Remove the sealing cap from the oil filling tube **2** and top up with oil. For the oil quality, see the gear lubricants listed in chapter 5.
- Clean the sealing cap for the oil filling tube **2**, put it on the oil filling tube **2** on the pump distributor gear, and then tighten it up.

**5.4.19 Checking and draining the soot particle filter condensate separator**

This equipment is optional.

**The condensate separator is part of the soot particle filter system.**

The filter/drain unit **1** is mounted on the rear left in the engine compartment.

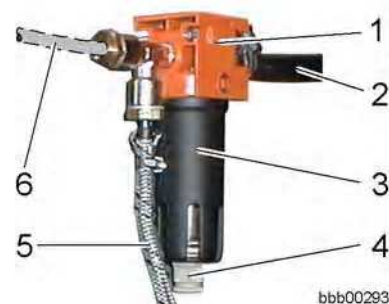

*Main components*

- |                        |  |
|------------------------|--|
| 1 Filter/drain unit    | 5 Exhaust gas counterpressure display line |
| 2 Counterpressure line | 6 Data logger line                         |
| 3 Condensate container |  |
| 4 Drain plug           |  |

LBH/03/003801/0003/15.06/en

- **At regular intervals (daily or as required):**  
Check the filling level of the filter/drain unit.
- **If the condensate container is over half full with condensation water:**  
Drain off the accumulated condensation water.
- To do this, open the drain plug **4** of the condensate container **3**.
- Tighten the drain plug **4** again.
- Check the filter insert (visible in the sight glass) of the filter/drain unit **1** for dirt.
- **If the filter insert is too dirty:**  
The filter insert must be replaced.

**Note**

The condensate separator should be completely replaced after 1000 operating hours.

! This must be done when cleaning the filter (every 1000 operating hours as prescribed).

- Contact LIEBHERR CUSTOMER SERVICE.

#### 5.4.20 Checking the coolant antifreeze concentration

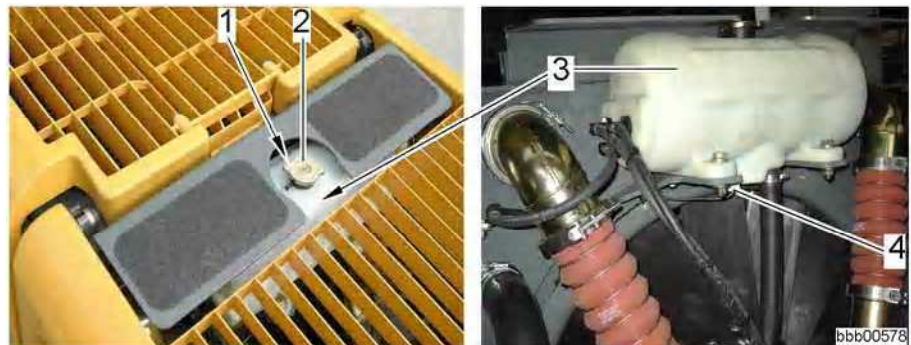

*Coolant equalizing reservoir*

1 Filler neck  
2 Cap

3 Coolant equalizing reservoir  
4 Coolant level sensor

The coolant must contain at least 50% by volume but not more than 60% by volume of antifreeze concentrate.

This protects against freezing down to around -37 °C .

Make sure that:

- The machine is in maintenance position 1.
- The optical density tester or antifreeze tester is ready.

## Checking the antifreeze concentration

### Procedure



### Caution

There is a danger of scalding due to coolant escaping under pressure. Only open the cap on the filler neck once the engine has cooled down.  
! Check the coolant temperature.



- See the coolant temperature on the display unit.  
The coolant temperature display should be in the bottom third of the display.
- Carefully open the sealing cap on the filler neck 1.
- Take a sample of the coolant and check the antifreeze concentration using the test tool.
- If the antifreeze concentration is too low:  
Refill with pure antifreeze until the required value is attained.  
See the section on correcting the antifreeze concentration.

## Correcting the antifreeze concentration

### Procedure

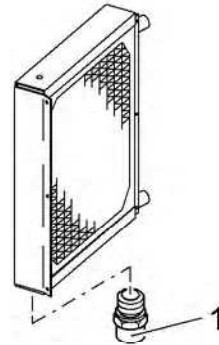

1 Cooler drain valve

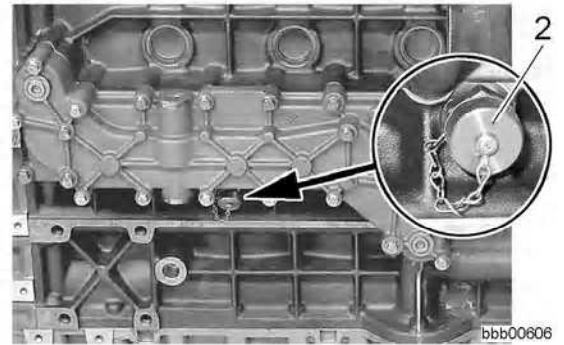

2 Diesel engine drain plug

- If the antifreeze concentration is too low:  
Drain off the coolant and top up with pure antifreeze according to the following diagram.



**Caution**

There is a risk of damage to the diesel engine.  
Too much antifreeze and corrosion protection agent impairs the cooling effect.

This eventually causes damage to the diesel engine.

! Never use more than 60% antifreeze and corrosion protection agent.

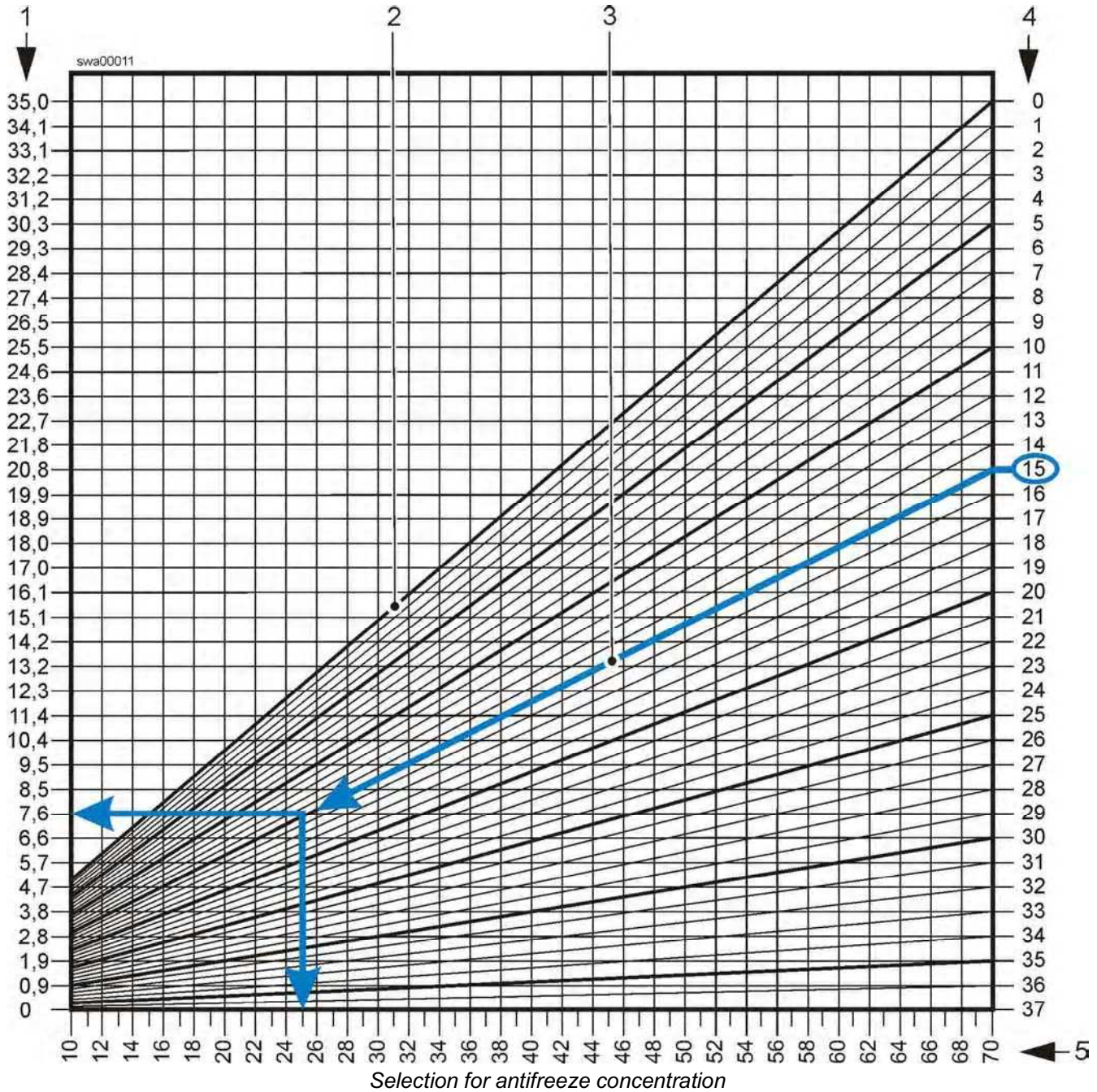

1 Amount of pure antifreeze to be added in litres  
2 Guidelines

3 Example -15 °C  
4 Measured coolant freezing point in °C

5 Total capacity of cooling system in litres

LBH/03/003801/0003/5.06/en

**Procedure for the example -15 °C**

- If, at a total filling level of 25 litres, a temperature of -15 °C is measured in the cooling system:

Follow the guideline **3** (starting from the measured temperature) to the left down to the vertical line indicating the total filling quantity for the cooling system **5** and from this point horizontally to the left edge.

This gives you the topping up quantity of pure antifreeze and corrosion protection agent **1** to be added in order to attain antifreeze protection to -37 °C.

- To restore the correct mixing ratio, you must drain off at least the previously calculated quantity from the cooling system.
- Top up with the correct quantity of pure antifreeze and corrosion protection agent.
- The coolant previously drained off can be used if necessary to restore the required coolant level.

**Using anti-corrosion agent without antifreeze**

In exceptional cases and when outside temperatures never fall below freezing, such as tropical zones, where it is demonstrable that no approved antifreeze and corrosion protection agent is available, corrosion inhibitors may be used.

The coolant must be replaced once a year.

The mixing ratio must consist of 7.5% corrosion inhibitor and 92.5% water.

The Gefo 2710 refractometer is recommended for testing.

See the lubricants and fuels section under coolants for diesel engines.

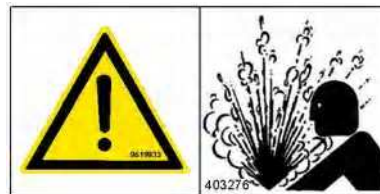
**Procedure for checking the coolant antifreeze concentration****Caution**

There is a danger of scalding due to coolant escaping under pressure. Only open the cap on the filler neck once the engine has cooled down.

! Check the coolant temperature.

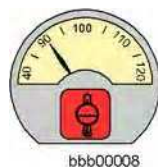

- See the coolant temperature on the display unit.  
The coolant temperature display should be in the bottom third of the display.
- Carefully open the sealing cap on the filler neck.
- Check the antifreeze concentration with a 2710 refractometer from the GEFO company.

## Checking the mixing ratio with a refractometer

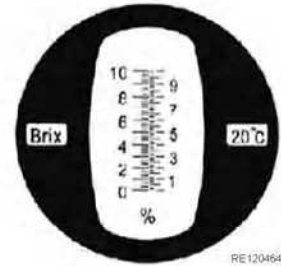

Gefo refractometer no. 2710

- The focus is set by turning the eyepiece.

### Test procedure

- Clean the cover and the prism carefully.
- Place 1 or 2 drops of test fluid on the prism.

The fluid is distributed by closing the prism.

- Look through the eyepiece against a light background and focus the scale.
- Read off the value on the blue line.

Brix %

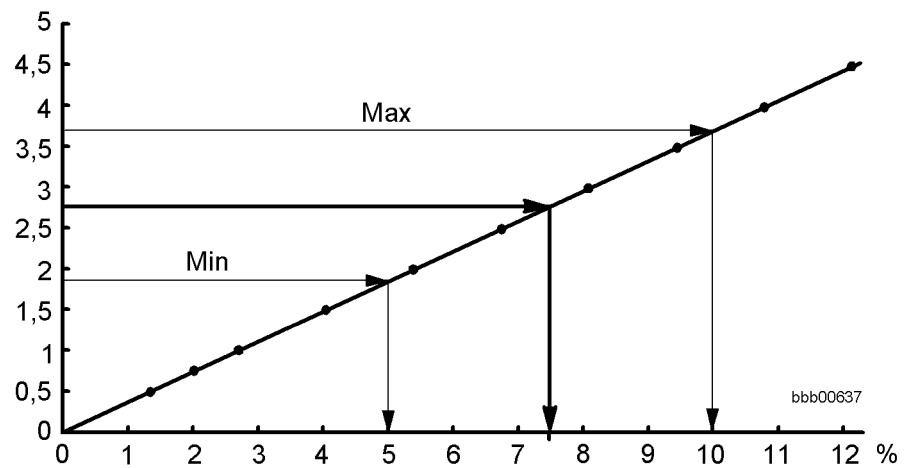

Conversion diagram from Brix to corrosion inhibitor concentration (%vol)

- Convertt the value using the conversion diagram to find the actual corrsion inhibitor conventration.

### 5.4.21 Cleaning the cooling system



Cooling system hood

- 1 Left cooling system hood
- 2 Right cooling system hood
- 3 Gas-filled springs

Clean the cooler whenever necessary in order to ensure proper cooling. In dusty environments, check the cooler every day and clean it if necessary. Dirty cooler units result in overheating. The consequence is an audible and visual warning with simultaneous power reduction of the travel drive. Dust and other contaminants can be removed from the cooling fins with water jets, steam or compressed air. Compressed air is preferable.

Make sure that:

- The machine is in maintenance position 1.
- The left and right cooling system hoods are open.

#### Procedure

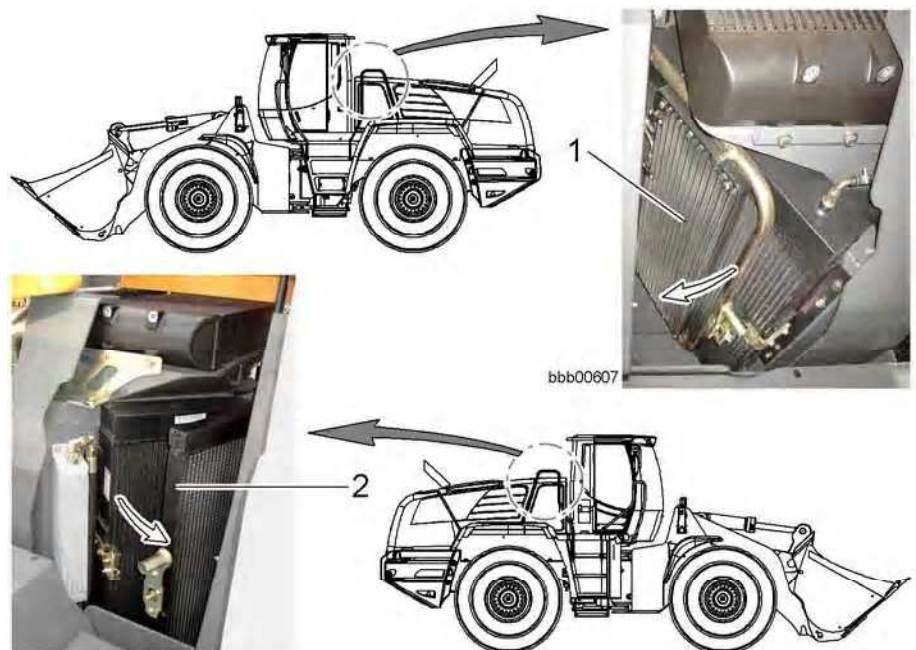

Cooling system

- Swing out the condensor 1.
- Swing out the condensor 2.
- Clean the cooler units with compressed air, steam or water.

LBH/03/003801/0003/5.06/en

**Caution**

Risk of damage to the cooling system

Careless handling can damage the cooler fins.

! Do not use hard objects or excessive water pressure for cleaning.

- Close the condenser **1** again.
- Close the fuel cooler **2** again.
- Close the cooling system hood(s) (left/right) again; shut the cab doors beforehand.

**5.4.22 Changing coolant with antifreeze**

Use clean, fresh water with a Ph value between 6.5 and 8.5 and a low sulphate / chlorine content for preparing the coolant.

The coolant must be prepared outside the cooling system.

Always dispose of any coolant which you have drained off but no longer need according to the applicable regulations.

Make sure that:

- The machine is in maintenance position 1.
  - A receptacle for coolant with a capacity of at least 25 l and a drain hose are ready.
  - The mixing ratio of the new coolant must be correct.
- See also the section on checking the coolant antifreeze concentration.
- The shut-off valves on the heating hoses are open.

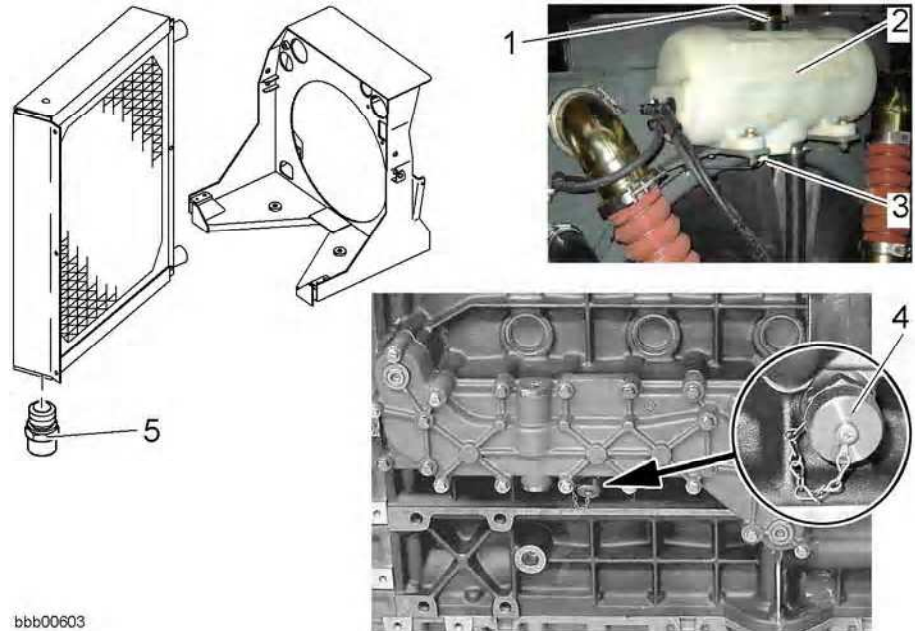
**Procedure**

*Cooling system*

- |                                |                            |
|--------------------------------|----------------------------|
| 1 Filler neck                  | 4 Diesel engine drain plug |
| 2 Coolant equalizing reservoir | 5 Cooler drain valve       |
| 3 Coolant level sensor         |                            |



**Caution**

There is a danger of scalding due to coolant escaping under pressure. Only open the cap on the filler neck once the engine has cooled down.

! Check the coolant temperature.

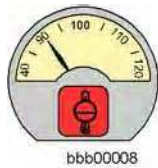

- See the coolant temperature on the display unit.  
The coolant temperature display should be in the bottom third of the display.
- Open the sealing cap on the filler neck **1**.
- Unscrew the sealing cap on the cooler drain valve **5** and unscrew the drain hose. Drain the coolant into the receptacle.
- Take off the drain hose, screw the sealing cap onto the cooler drain valve **5** and tighten it.
- Also drain the coolant from the diesel engine:  
Open the drain plug **4** and let the coolant flow into the receptacle.
- Screw the drain plug **4** back in and tighten it.

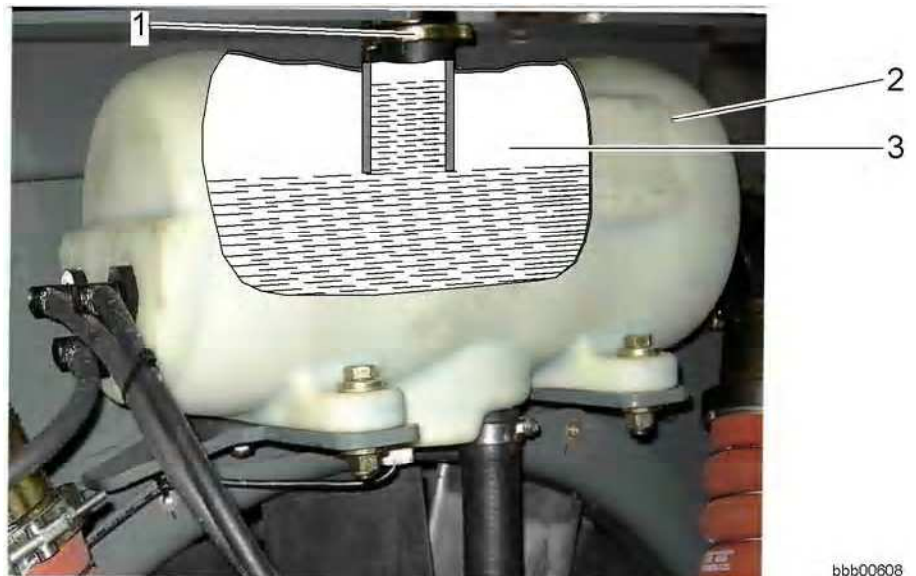

*Cooling system*

- 1 Cap
- 2 Coolant equalizing reservoir
- 3 Filler neck

- Fill in coolant in the equalizing reservoir **2**:  
Until you can see coolant in the filler neck **3**.
- Screw the cap **1** on the filler neck **3**.
- Start the engine.
- Allow the engine to run at lower idling speed.

LBH/03/003801/0003/5.06/en

- Set the heater to warm.

#### Procedure for correcting the coolant level

- Fill in coolant in the equalizing reservoir **2**:  
Until you can see coolant in the filler neck **3**.
- If the coolant level is correct:  
Screw the cap **1** on the filler neck **3**.

### 5.4.23 Checking the oil level in the hydraulic tank

Make sure that:

- The machine is cold.
- The machine is in maintenance position 1.
- The engine compartment hood is open.

#### Checking the hydraulic oil level

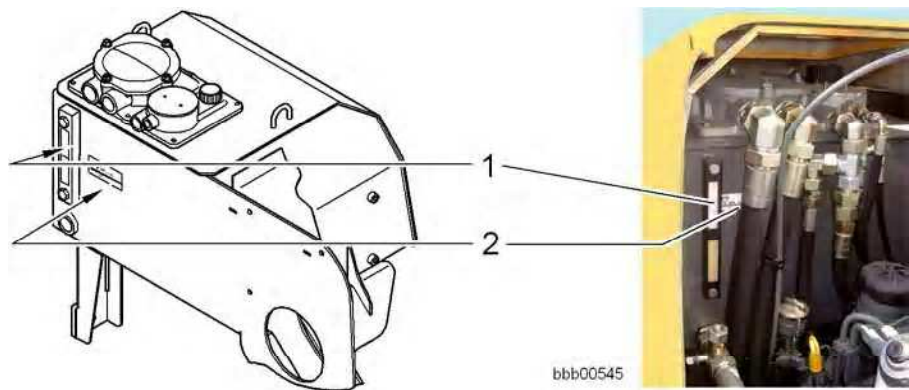

Hydraulic tank

1 Sight glass

2 Maximum oil level marking

The red maximum oil level marking shows the correct oil level.

- Check the oil level in the sight glass **1**.
- If the oil level is too low:  
Top up with hydraulic oil.

### Topping up with hydraulic oil

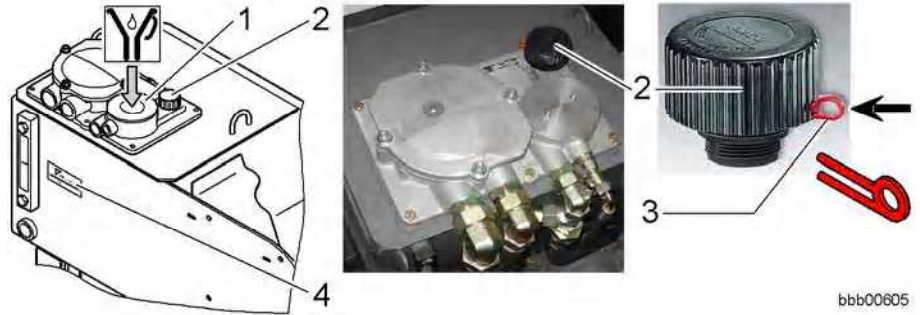

bbb00605

- If there is a plug **3** (to protect against vandalism):  
Connect it to the bleeder filter.
- The anti-twist lock of the bleeder filter is released.
- Release the tank pre-pressure:  
Unscrew the bleeder filter **2** on the hydraulic tank by two turns.



#### Note

The hydraulic oil may only be poured in through the return strainer.  
! For oil specifications, see the section on lubricants and fuels.

- Open the cover **1** of the return strainer.
- Top up with hydraulic oil up to the oil level marking **4**.
- Put the cover **1** on the housing and tighten it up.
- Screw on the bleeder filter.

#### 5.4.24 Checking and cleaning the magnetic rod on the hydraulic tank

Make sure that:

- The machine is in maintenance position 1.
- The engine compartment hood is open.

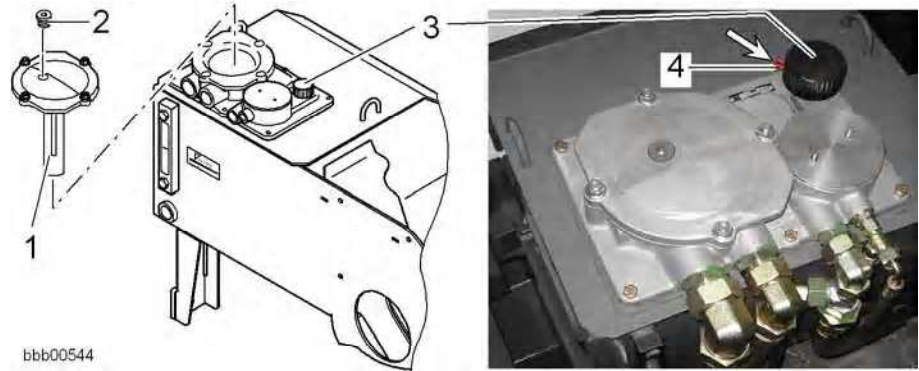

**Procedure**

bbb00544

- If there is a plug 4 (to protect against vandalism):  
Connect it to the bleeder filter.  
The anti-twist lock of the bleeder filter is released.
  - Release the tank pre-pressure:  
Unscrew the bleeder filter 3 on the hydraulic tank by two turns.
  - Unscrew the plug 2.
- The oil level sinks.
- Release the bolts on the lid and slowly lift the lid with the magnetic rod 1.

**Troubleshooting**

Serious contamination or large metal fragments on the magnetic rod may indicate damage to the hydraulic system.

- In this event, locate the problem and rectify it.
- Contact LIEBHERR CUSTOMER SERVICE.

- Carefully clean the magnetic rod.
- **After cleaning:**  
Place the O-ring and cover with the magnetic rod on the housing.
- Tighten the screws on the cover.
- Screw in the plug 2.

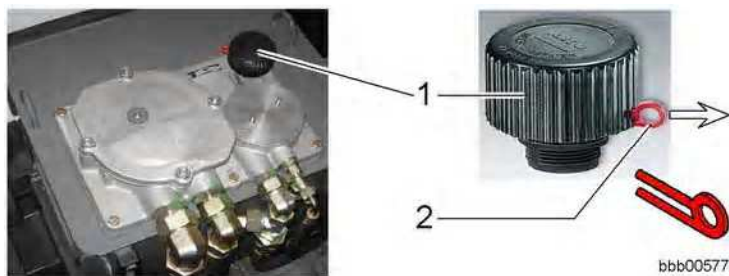

bbb00577

- Undo the bleeder filter 1 by two turns.
- To protect against vandalism:  
Remove the plug 2 on the bleeder filter and store it safely.  
This protects against unauthorised opening.

### 5.4.25 Checking that the steering is working

Make sure that:

- The working attachment is in the transport position
- The articulation lock is open
- There is enough space to test the steering

#### Procedure

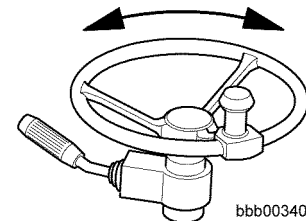
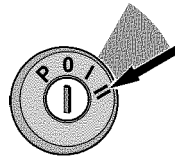

- Start the engine.
- Without moving the machine, turn the steering in both directions and check that it is functioning properly.

### 5.4.26 Lubricating the bearing points on the steering cylinders

Make sure that:

- The machine is in maintenance position 1.
- The articulation lock is engaged if possible.

#### Procedure

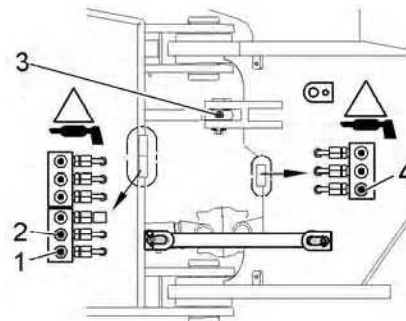

*Steering cylinder lubrication points*

- 1 Lubrication point at base of right-hand steering cylinder
- 2 Lubrication point at base of left-hand steering cylinder

- 3 Lubrication point on the piston rod end of left-hand steering cylinder
- 4 Lubrication point on the piston rod end of right-hand steering cylinder

- Lubricate the bearing points on the steering cylinders.

LBH/03/003801/0003/5.06/en

### 5.4.27 Checking the service brake and parking brake

Make sure that there is enough room to check the service brake and parking brake.

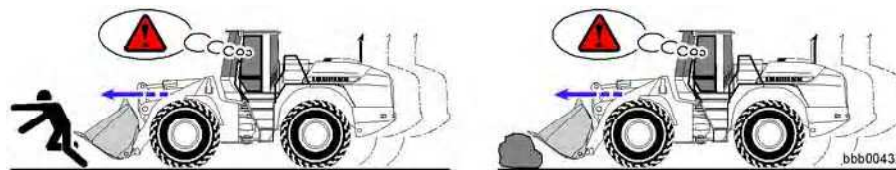

#### Warning

There is a danger of driving into bystanders or obstacles.

! Do not allow anyone into the danger area while these tests are being conducted.

! Perform the test on level ground with no obstacles.

#### Checking the service brake

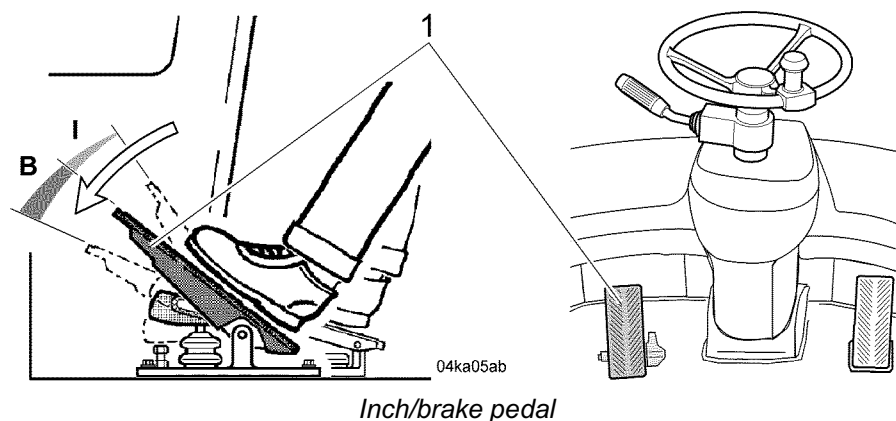

1 Inch/brake pedal  
I Inching range

B Braking range

- Start the machine, and drive it forward at around 8 km/h .
- Push the inch/brake pedal all the way down. The machine must come to an **abrupt** stop.

#### Troubleshooting

If the braking effect is too slight or entirely absent:

- Contact LIEBHERR CUSTOMER SERVICE.

#### Checking the parking brake

- Start the machine, and drive it forward at around 5 km/h .
- Press the parking brake button while travelling.

The machine must come to an **abrupt** halt.

#### Troubleshooting

If the braking effect is too slight or entirely absent:

- Contact LIEBHERR CUSTOMER SERVICE.



bbb00548

### 5.4.28 Checking the gap and wear on the parking brake linings

Friction can change the gap X1 and X2 and the thickness of the brake lining.

Make sure that:

- The machine is in maintenance position 2.

#### Procedure



#### Warning

There is a risk of injuries due to machine rolling away.

! Make sure that the machine is secured against rolling away when carrying out work on the parking brake.

- Secure the machine against rolling away with wheel wedges.

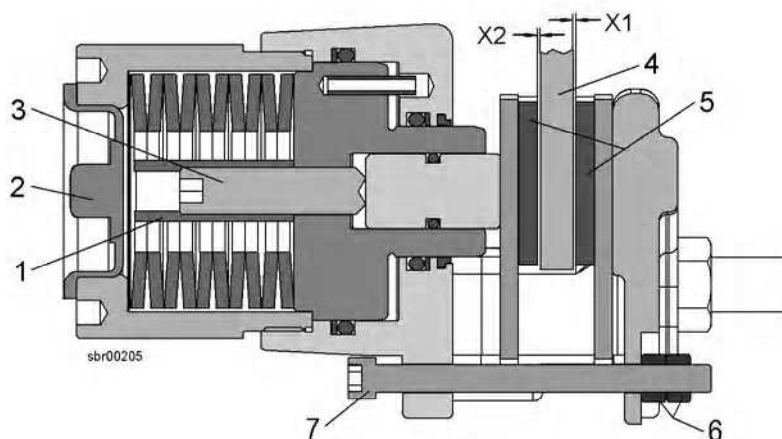

Disc brake (shown in open position)

- |                   |               |
|-------------------|---------------|
| 1 Lock nut        | 6 Counter nut |
| 2 Plug            | 7 Hex bolt    |
| 3 Adjusting screw | X1 Gap        |
| 4 Brake disc      | X2 Gap        |
| 5 Brake lining    |               |

- Start the diesel engine and press the button to release the parking brake.
- Test the brake lining thickness.
- If the brake lining is thinner than 1.0 mm :  
Replace the brake linings **5**.
- Check the gap X1 and X2.
- If the gap X1 + X2 is more than 1.5 mm :  
Adjust the gap.
- Loosen the counter nut **6** and use the hex bolt **7** to adjust the gap X1 to 0.3 mm .

- Tighten the counter nut **6**.
- Unscrew the sealing cap **2** and loosen the lock nut **1**.
- Use the adjusting screw **3** to set the gap X2 0.3 mm .
- Tighten the lock nut **1**.
- Engage the parking brake several times and test it again.
- Screw on the sealing cap **2** and tighten it.

### 5.4.29 Checking the indicator lamps and lighting

Make sure that:

- The machine is in maintenance position 1.
- The machine's electrical system is switched on.

#### Checking the indicator lamps and lighting

- When you switch on the ignition, the lamps on the display unit are tested.
- All symbol fields light up for three seconds.  
See the section on starting the engine in chapter 3.

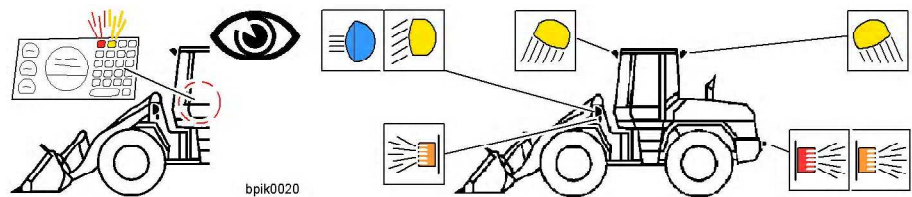

- Switch on the ignition.
- Check that the symbol fields on the display unit light up.
- Check that all lights are working.

#### Adjusting the working floodlights



Front/rear working floodlights

Versions:

- **1** front working floodlight  
Single-chamber headlight
- **2** rear working floodlight  
Single-chamber headlight  
This equipment is optional.

The front working floodlights cannot be adjusted.

**Adjusting the rear working floodlight**

This equipment is optional.

Adjust the working floodlights as required:

- Either for close range lighting
- or for long range lighting.

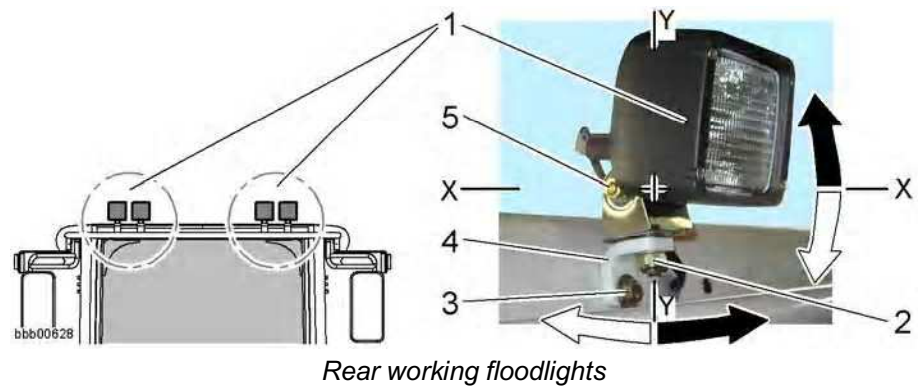

- 1 Floodlight
- 2 Fixing screw
- 3 Fixing screws

- 4 Bracket
- 5 Adjusting screw

**Horizontal Y axis adjustment:**

- Loosen the screw 2.
- Move the left and right floodlights as required.
- Tighten the screw again.

**Vertical X axis adjustment:**

- Loosen the screw 5.
- Move the left and right floodlights as required.
- Tighten the screw again.

**5.4.30 Checking the transfer gear oil level**

Make sure that:

- The machine is in maintenance position 1.
- The articulation lock is engaged.

**Procedure**

- Start the engine and let it run at low idling speed.

Check the oil level with the engine running and at a gear oil temperature of  $20 \pm 10 \text{ }^\circ\text{C}$ .

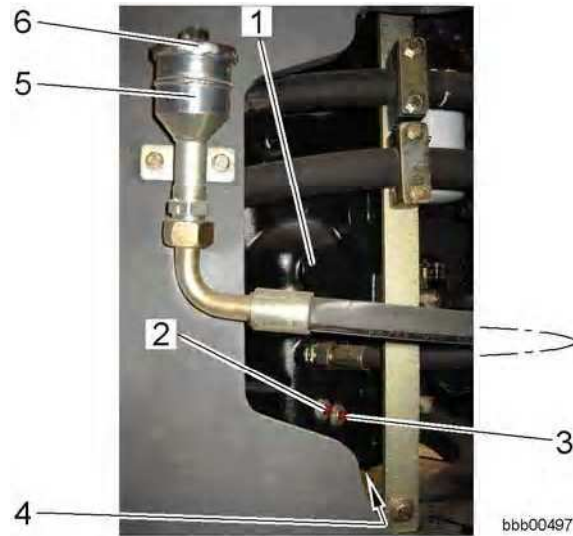

*Transfer gear*

- |                      |                |
|----------------------|----------------|
| 1 Transfer gear      | 4 Drain plug   |
| 2 Top sight glass    | 5 Filling tube |
| 3 Bottom sight glass | 6 Plug         |

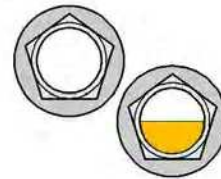

b4430002

- Check the oil level in the sight glasses **2, 3**.  
The oil level must be within the bottom sight glass **3**.

**Troubleshooting**

If the oil level is too low:

- Switch off the engine and top up with the required amount of gear oil.  
For the oil quality, see the section gear lubricants in the lubricants and fuels section.

- Repeat the check.

**Troubleshooting**

If the oil level is too high:

- Contact LIEBHERR CUSTOMER SERVICE.

### 5.4.31 Checking the tightness of the wheels (once after 50, 100 and 250 h)

Make sure that:

- The machine is in maintenance position 1.
- A torque wrench with a measuring range of over 750 Nm is available.

#### Procedure

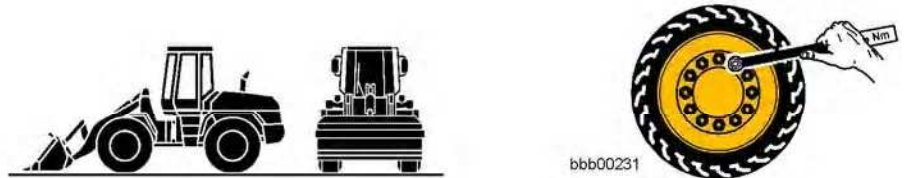

#### Note

Check the tightness of the wheels according to the specified intervals.  
 ! This one-off maintenance task scheduled for 50, 100 and 250 service hours must be performed every time the wheels are changed.



#### Note

Installing or changing the working attachment or tyres.  
 ! See the section on attachments and accessories in chapter 2.

- Check that the nuts and bolts on all four wheels have been tightened with the required torque.

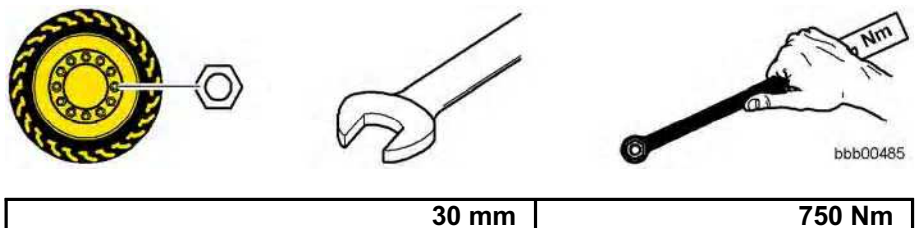

30 mm	750 Nm
-------	--------

Wheel lug tightening torque and spanner size

### 5.4.32 Lubricating the bevel gear seals of the front and rear axles

The bevel gear seals should be lubricated as necessary, and when operating the machine in water, every day.

Make sure that the machine is in maintenance position 1.



**Procedure**

- Grease the bevel gear seals of the front and rear axles.  
Grease specifications: See the lubricants and fuels listed in chapter 5.

**5.4.33 Checking and lubricating the cardan shaft(s)**

Make sure that:

The machine is in maintenance position 1.

Wedges are in place to secure the machine against rolling away.

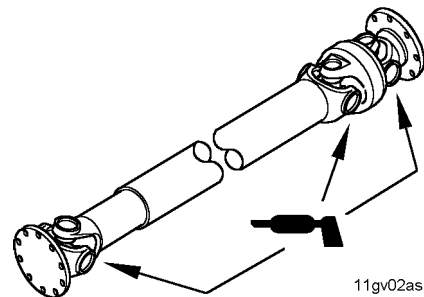
**Checking and lubricating the front drive shaft****Procedure**

- Lubricate the drive shaft at both universal joints.
- Check the play of the drive shaft in the bearings.
- Check the rubber sleeve for leaks and damage.

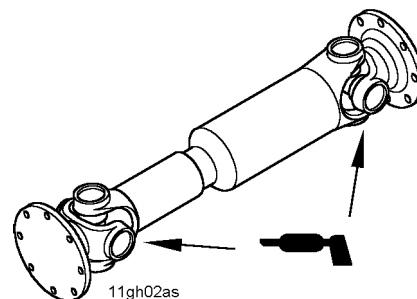
**Checking and lubricating the rear drive shaft****Procedure**

- Lubricate the drive shaft at both universal joints.
- Check the play of the drive shaft in the bearings.

### 5.4.34 Checking the tyre pressure

The air pressure in the tyres has a significant influence on the overall operating performance of the machine.

The tyre pressure depends on the following factors:

- The tyres used
- The purpose the machine is used for
- The attachment installed

For special uses where heavier loads may be expected, a higher tyre pressure is recommended.

However, the tyre pressure **may not be greater than the maximum permitted** by the tyre manufacturer's specifications.

Make sure that:

- The machine is in maintenance position 1.
- The correct tyre pressures are available.  
See the section on tyres in chapter 1.

The tyre pressures stated refer to cold tyres.

#### Procedure



Checking and adjusting the tyre pressure



#### Danger

Exploding tyres can cause serious injury.

If the tyre inflation equipment is incorrectly or carelessly used or if the tyre pressure is too high, the tyres may burst or the rims may come off, causing severe, or possibly even fatal injuries.

To check and adjust the tyre pressure:

- ! Use a sufficiently long hose with a self-locking adapter for filling the tyres.
- ! Do not stand in the danger zone.

- Check the air pressure in all the tyres and adjust if necessary.

### 5.4.35 Greasing the oscillating axle frame and articulation lock

Make sure that:

- The machine is in maintenance position 1.
- The articulation lock is engaged.

**Procedure**

Grease the lubricating points for the oscillating axle frame and articulation lock.

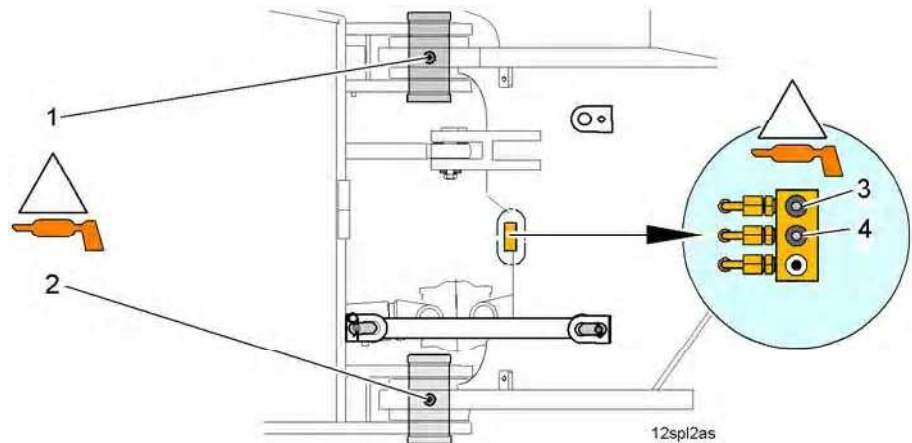

*Lubrication points on the right-hand side of the central lubricating rail*

- |                               |                                |
|-------------------------------|--------------------------------|
| 1 Top articulation bearing    | 3 Front oscillating axle mount |
| 2 Bottom articulation bearing | 4 Rear oscillating axle mount  |

- Grease the lubricating point for the oscillating axle frame and articulation lock.

#### 5.4.36 Checking whether metered quantities are adequate at the bearing points (grease collars) of the central lubrication system

This equipment is optional.

Make sure that the machine is in maintenance position 1.



- Visually examine whether metered quantities are adequate at the bearing points.
- If the bearing points are not sufficiently lubricated, locate the problem and rectify it.

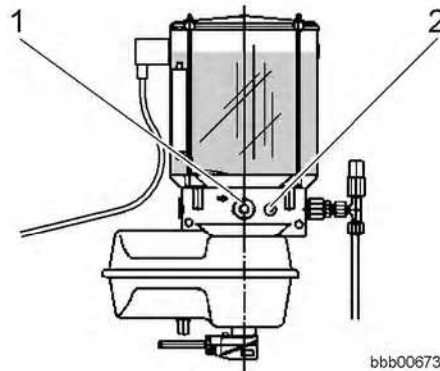

Regularly check the grease quantity in the reservoir. Stay within the minimum and maximum lubricant levels. The reservoir has a sight glass where the rubber stripper on the agitator can be seen. You can check how much grease is left in the sight glass.

- Top up the reservoir if necessary. Via the filling coupling **1** (fast filling) or the grease fitting **2**. Grease specifications: see the section on lubricants and fuels.



### 5.4.37 Checking the pipes, hoses and lubrication points of the lubrication system

This equipment is optional. Make sure that the machine is in maintenance position 1.



- Visually examine the hose lines for defects.
- In case of any defects, locate and rectify the problem.

### 5.4.38 Greasing the cab door hinges

Make sure that the machine is in maintenance position 1.

**Procedure**



- Lubricate the door hinges with a grease gun. For lubricant specifications, see the section on lubricants and fuels.

### 5.4.39 Cleaning and replacing the fresh air and recirculated air filter

Make sure that the machine is in maintenance position 1.

LBH/03/003801/0003/5.06/en

### Cleaning and changing the fresh air filter

#### Procedure

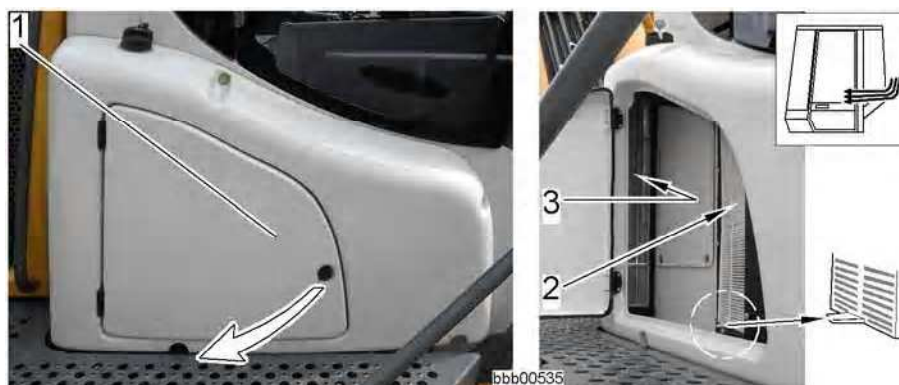

Fresh air filter

- 1 Door
- 2 Fresh air filter

- 3 Ventilation lint filter

- Open the door 1.
- Unscrew the fresh air filter 2 at the bottom on the front lug.

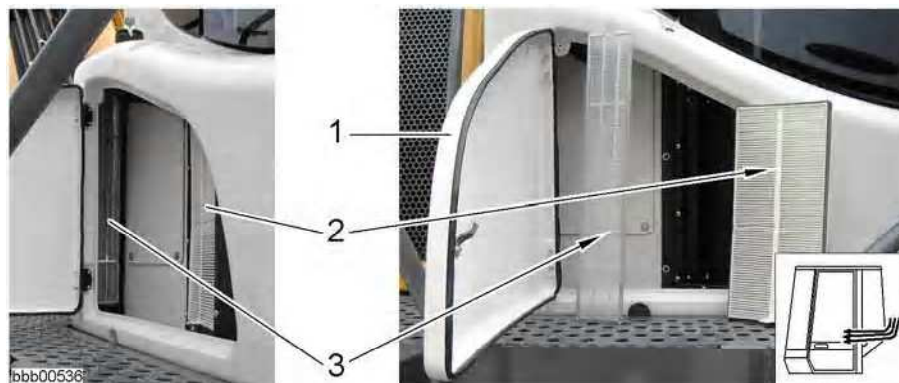

Fresh air filter

- Clean the fresh air filter 2 (blow out or wash) or change if necessary.
- Remove the lint filter 3.
- Clean (blow out) or replace the lint filter.

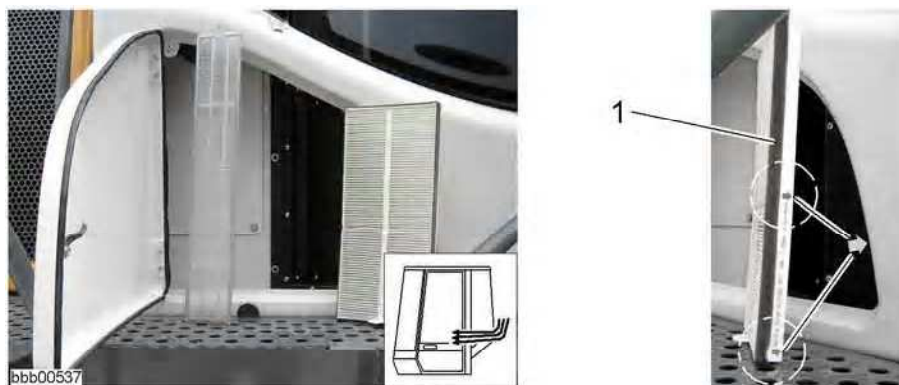

Fresh air filter

LBH/03/003801/0003/5.06/en

- Insert the cleaned or new filters, making sure they are correctly fitted (the arrows moulded on the filter frame point towards the air taken in).
- Close the door again.

### Cleaning and replacing the recirculated air filter

#### Procedure

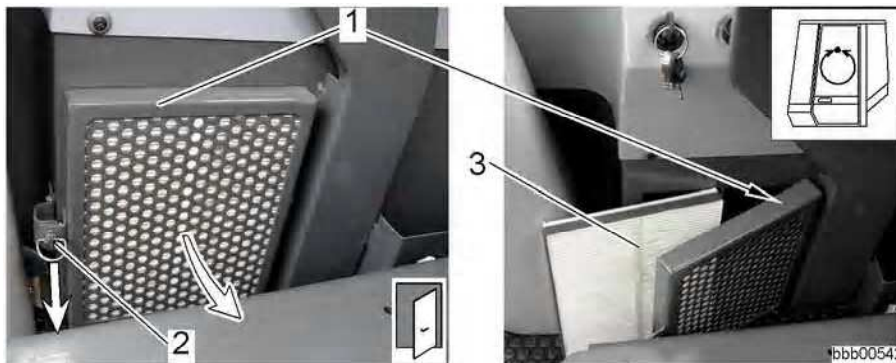

*Recirculation filter*

1 Door  
2 Pin

3 Recirculation filter

- Remove the pin 2.
- Open the door 1.
- Clean the recirculation air filter 3 (blow out or wash) or change if necessary.
- Put in a clean or new filter.
- Close the door again.

#### 5.4.40 Lubricating the lift arms and attachment

Make sure that the machine is in maintenance position 2.

### Lubricating standard lift arms and attachment

#### Procedure

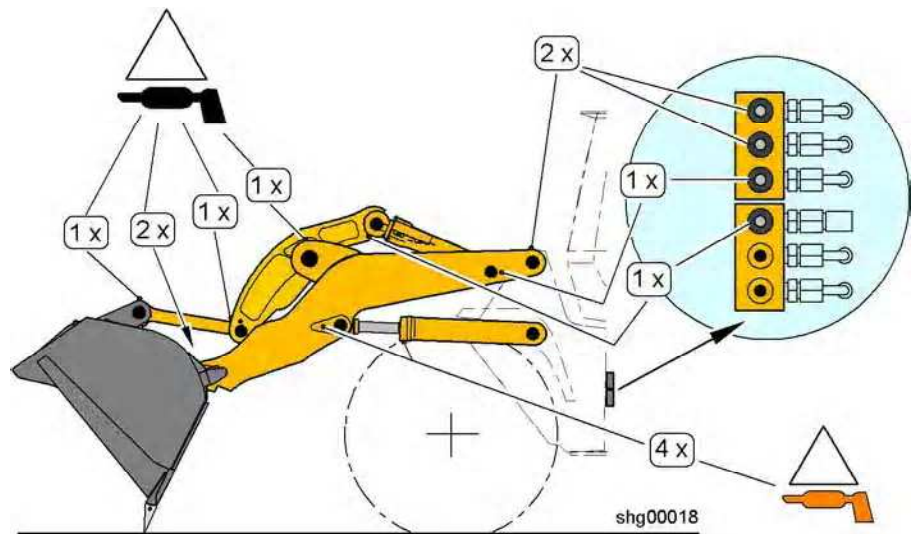

*Bearing and lubrication points on the lift arms*

- Move the lift arms and the bucket to the position shown.
- Secure the machine against rolling away with wheel wedges.
- Grease all the bearing and lubrication points on the lift arms.
- If fitted, lubricate the optional quick-change device.
- If fitted, grease the lubrication points on the attachment.
- The lower bucket bearings should be lubricated daily if necessary.

### Lubricating the tilt cylinder support for timber transfer

This equipment is optional.

#### Procedure

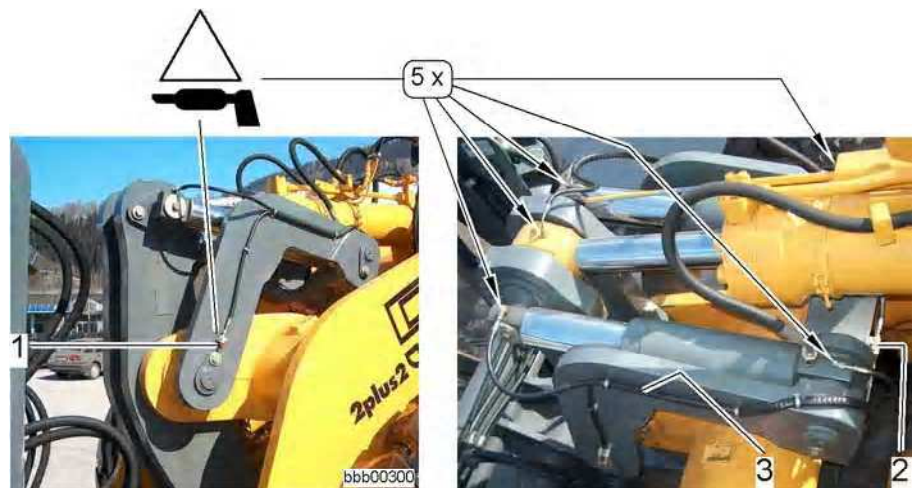

*Tilt cylinder support*

- 1 Grease fitting
- 2 Distributor block

- 3 Lubricating line

LBH/03/003801/0003/5.06/en

- Grease the lubrication points via the grease fitting **1**.  
The lubricant is pumped via the distributor block **2** and the lubricating lines **3** to the lubricating points.
- If fitted, grease the lubrication points on the timber grabber.  
For detailed information on maintenance for the attachment, see the manufacturer's instructions.

### 5.4.41 Checking the bucket bearing seals and the bearing bushings on the lift arms

The bucket bearing seal **3** prevents dirt from entering the bearing, thus increasing the lifetime of the bearing bushings. Depending on the type of application, wear occurs on the sealing lips **5** and on the dirt guard **6**. If the bucket bearing seal **3** is in any way damaged or worn, it must be replaced.

#### Procedure for checking the bucket bearing seal

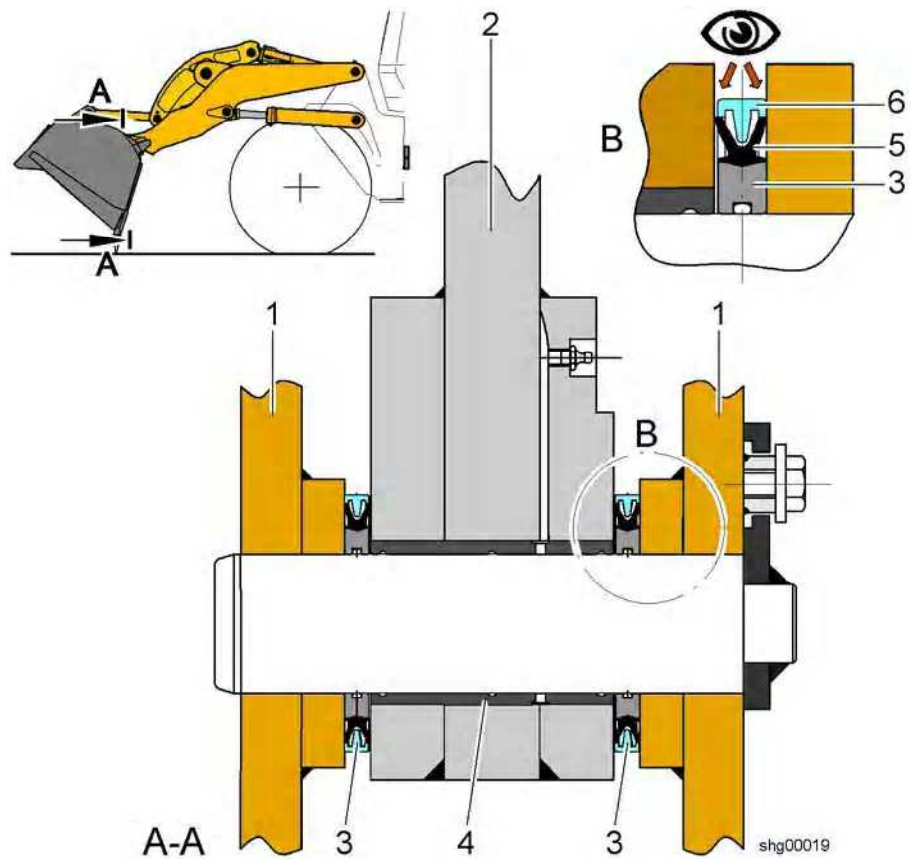

Bucket bearing seal

- |                        |                   |
|------------------------|-------------------|
| 1 Bucket bearing plate | 4 Bearing bushing |
| 2 Bucket arm           | 5 Sealing lips    |
| 3 Bucket bearing seal  | 6 Dirt guard      |

- Move the lift arms and the bucket to the position shown.
- Clean the bucket bearing seal **3** using a steam jet.

LBH/03/003801/0003/15.06/en



- Visually check whether the sealing lips **5** touch the sides of the lift arms and the bucket.
- If there is a gap between the sealing lips **5** and the bucket arm **2** or the bucket bearing plate **1**, or if the bucket bearing seal is damaged:  
Replace the bucket bearing seal as described in the service manual in the section on lift arms and quick change device.

#### Procedure for checking the bearing bushings for wear

Dirt or insufficient lubrication can cause wear on the bearing bushings.

The increased play between the pin and bearing bushing causes noises.

Replace the bearing bushings in good time to prevent damage to the material of the bucket arm.

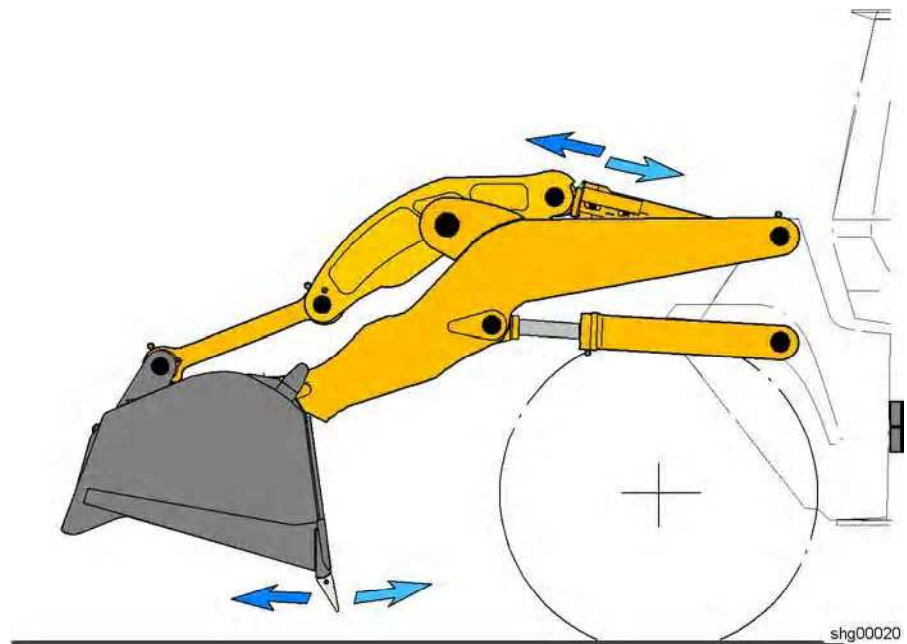

*Lift arm bearing bushings*

- Move the lift arms and the bucket to the position shown.
- Gently and rapidly tilt the bucket in and out, and check the bearing points for noise and play.
- If there is significant play at the bearing points or loud noise:  
Replace the bearing bushings. Contact LIEBHERR CUSTOMER SERVICE.

### 5.4.42 Lubricating and testing the quick-change device

#### Lubricating the quick-change device

Make sure that:

- The machine is in maintenance position 2.

If the lubricating points near the bucket coupling are poorly accessible:

- Make sure the working attachment is disconnected.

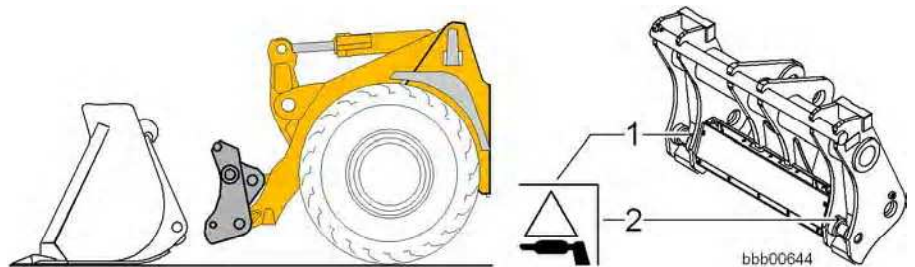

Quick-change device lubrication points

- Lubricate the quick-change device.  
For lubricant specifications, see the section on lubricants and fuels.

#### Testing the quick-change device

Make sure that:

- The engine has been started.
- The lift arms have been lowered.
- The working attachment is tilted in.

#### Procedure

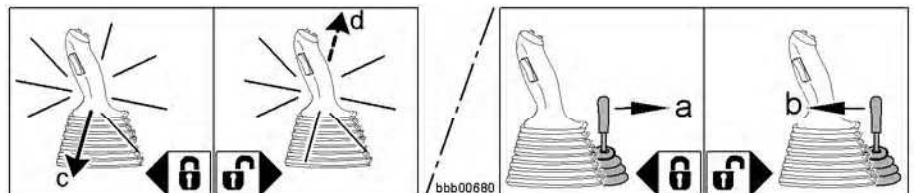

The operation of the quick-change device can vary according to the version or the type of machine.



#### Danger

Failure to use the quick-change device properly can cause accidents.

- ! See the section on operation in chapter 3 for how to use the quick-change device.
- ! Follow the safety instructions.

- To check that it is working properly:  
Unlock the quick-change device and lock it again.

This prevents the locking pins from jamming and preventing the quick-change device from being released.

- To make sure, check:  
That the quick-change device is properly locked again.

## 5.4.43 Cleaning the machine

### Washing the machine

#### Cleaning the machine

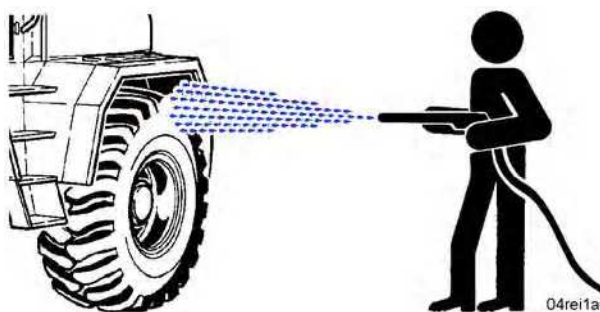

Washing

Electrical devices such as the emergency steering pump, refuelling pump, sensors and electric components in the cab are not watertight.

Be careful when cleaning the machine with a high-pressure cleaner.

Every time you clean the machine with a high-pressure cleaner, regrease all lubrication points on the machine.

---

#### Caution

Freshly painted surfaces may be damaged.

During high-pressure cleaning [more than 1379 kPa ( 13.8 bar )] freshly painted surfaces can be damaged.

! When a new machine is delivered, let the paint dry in the air for at least 30 days before you wash it or parts of it with a high-pressure cleaner.

! Until this 30 day period has passed, only use a low-pressure cleaner for washing.

---



---

#### Caution

Beware of damaging the soundproofing mats.

The soundproofing mats can be damaged if you clean them with high pressure.

Damaged soundproofing mats increase the sound output level above that guaranteed by the manufacturer.

! Do not expose soundproofing mats to water or steam jets.

---



---

#### Caution

There is a risk of damaging electrical devices.

When using a high-pressure cleaner, you may damage electrical devices such as the emergency steering pump, refuelling pump, sensors and electrical components in the cab.

! Do not expose electrical devices to water or steam jets.

---

- Wash the machine.
- Regrease all lubrication points on the machine.

**Cleaning the diesel engine**

When washing the engine using water or steam jet, take care not to expose electronic devices such as the starter, alternator, sensors and oil pressure switches directly to the jet.

After cleaning, start up the engine to allow it to dry out.

**Caution**

There is a risk of damaging the engine and its electric components. Moisture penetration can cause corrosion and electrical malfunctions.

! Do not expose devices such as the starter, alternator, sensors and oil pressure switches to water or steam jets.

- Carefully clean the engine.

**5.4.44 Corrosion protection**

If the machine is not used for more than 4 weeks, especially on sea journeys, the following measures must be taken.

**Protecting the piston rods from corrosion**

Use a non-acidic corrosion protection grease to protect against corrosion.

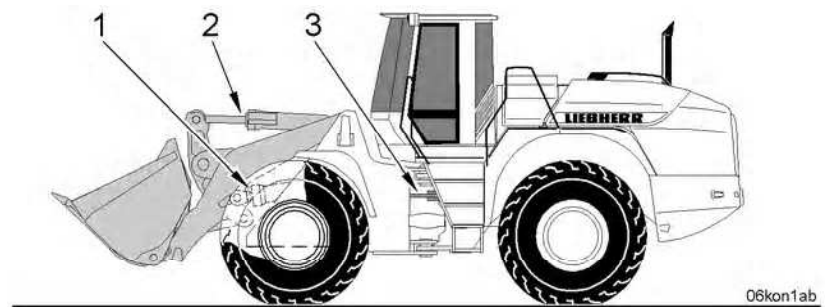

1 Lift cylinder  
2 Tilt cylinder

3 Steering cylinder

- Shut down the machine so that all piston rods are retracted as far as possible in their cylinders.
- Smear all exposed piston rods with a thick layer of oxygen-free anti-corrosion grease.
- If the cylinder piston rods are not coated with hydraulic oil for a prolonged period:  
The piston rods must be coated with non-acidic corrosion protection grease.

When moving a machine thus protected for loading or transport, the scraper removes the grease from the piston rods in the cylinders.

- If the machine is transported:  
Check the corrosion protection on the piston rods once again after loading.

# Index

## 2

2-in-1 steering **3-54**

## 4

40 km/h decal **2-9**

## A

Accident prevention decal **2-6**  
Activating air-conditioning auto mode **3-64**  
Activating and deactivating horizontal suspension on the driver's seat **3-14**  
Activating and deactivating the quick-change device **3-55**  
Activating float position **3-111**  
Activating the automatic bucket return-to-dig function **3-114**  
Activating the automatic lift kick-out function **3-112**  
Activating the electronic immobiliser **3-21**  
Activating the kick-down function **3-57**  
Activating the quick-change device **3-137, 3-144, 3-149**  
Activating the reverse warning device **3-74, 3-75**  
Activating the windshield wiper and washer system **3-67**  
After driving onto the loading area **3-164**  
After the machine stops **3-102**  
Air conditioning auto mode **3-48**  
Air conditioning ECO mode **3-47**  
Air-conditioning system **3-63**  
Air filter contamination indicator **3-33**  
Adjusting the arm rest **3-11, 3-16**  
Adjusting the back rest **3-10, 3-15**  
Adjusting the blower **3-62**  
Adjusting the control panel to the seat position and arm length of the driver **3-19**  
Adjusting the inclination of the seat surface **3-9, 3-13**  
Adjusting the lumbar support **3-10, 3-16**  
Adjusting the mirrors **3-65**  
Adjusting the prongs on the fork carrier **3-154**  
Adjusting the rear working floodlight **5-61**  
Adjusting the driver's seat for driving on roads **3-8, 3-12**  
Adjusting the driver's seat **3-7, 3-12**  
Adjusting the driver's seat horizontally **3-8, 3-13**  
Adjusting the driver's seat shock absorber **3-14**  
Adjusting the driver's seat surface horizontally **3-8, 3-13**  
Adjusting the seat height **3-9, 3-15**  
Adjusting the seat suspension **3-9, 3-14**  
Adjusting the steering column **3-18**  
Adjusting the sun visor **3-66**  
Adjusting the working floodlights **5-60**  
Anti-corrosion agent (inhibitors) **5-14**  
Approved antifreeze and corrosion protection agent

for diesel engine cooling systems **5-16**  
Approved antifreeze and corrosion protection agents (50:50 premix) for diesel engine cooling systems **5-17**  
Approved lubricants **5-20**  
Approved water-soluble corrosion protection agent (concentrate) for diesel engine cooling systems **5-15**  
Articulation area decal **2-5**  
Attachments and accessories **2-23**  
Audible reverse warning device (back-up alarm) **3-73**  
Audible/visual exhaust counterpressure monitor **3-132**  
Automatic bucket return-to-dig function **3-114**  
Axles **1-5**

## B

Ballast weight **1-6**  
Basic function **3-70**  
Battery charge control indicator **3-34**  
Battery fastening **1-4**  
Battery main switch **3-2**  
Bearing load table decal **2-11**  
Before driving onto the loading area **3-162**  
Bio oil decal **2-11**  
Bleeding the fuel filter **5-38**  
Bleeding the fuel filter with the engine bleeding function **5-39**  
Bleeding the fuel system **5-37**  
Boot phase of the main electronics (master) **3-82**  
Brake system accumulator pressure indicator **3-31**  
Braking **1-6**  
Braking **3-100**  
Braking in emergencies **3-101**  
Braking with the inch/brake pedal **3-101**  
Bridgestone tyres **1-8**  
Bucket **1-12**  
Bucket return-to-dig **3-42**

## C

Cab access **3-2**  
Central lubrication system **3-49**  
Changing coolant with antifreeze **5-52**  
Changing the air filter main element when indicated by the vacuum switch **5-42**  
Changing the air filter secondary element **5-43**  
Changing the engine oil filter **5-32**  
Changing the engine oil **5-30**  
Changing the fuel fine filter **5-35**  
Changing the fuel pre-filter **5-33**  
Checking and cleaning the magnetic rod on the hydraulic tank **5-55**  
Checking and lubricating the cardan shaft(s) **5-64**  
Checking and lubricating the front drive shaft **5-64**  
Checking and lubricating the rear drive shaft **5-64**  
Checking and draining the soot particle filter con-

densate separator **5-45**  
 Checking and replacing the coolant **5-12**  
 Checking that the steering is working **5-57**  
 Checking that the working attachment is locked **3-141, 3-147, 3-153**  
 Checking the antifreeze concentration **5-47**  
 Checking the bucket bearing seals and the bearing bushings on the lift arms **5-71**  
 Checking the coolant antifreeze concentration **5-46**  
 Checking the engine oil level **5-30**  
 Checking the gap and wear on the parking brake linings **5-59**  
 Checking the hydraulic oil level **5-54**  
 Checking the diesel engine heating flange **5-33**  
 Checking the indicator lamps and lighting **5-60**  
 Checking the indicator lamps and lighting **5-60**  
 Checking the interior and exterior mirrors **3-87**  
 Checking the lights **3-87**  
 Checking the machine for external damage **5-29**  
 Checking the mixing ratio with a refractometer **5-14, 5-50**  
 Checking the oil level in the hydraulic tank **5-54**  
 Checking the oil level in the pump distributor gear **5-44**  
 Checking the parking brake **5-58**  
 Checking the pipes, hoses and lubrication points of the lubrication system **5-67**  
 Checking the service brake and parking brake **5-58**  
 Checking the service brake **5-58**  
 Checking the tightness of the wheels (once after 50, 100 and 250 h) **5-63**  
 Checking the transfer gear oil level **5-61**  
 Checking the tyre pressure **5-65**  
 Checking whether metered quantities are adequate at the bearing points (grease collars) of the central lubrication system **5-66**  
 Cleaning and changing the fresh air filter **5-68**  
 Cleaning and replacing the fresh air and recirculated air filter **5-67**  
 Cleaning and replacing the recirculated air filter **5-69**  
 Cleaning the air filter service cap and dust extraction valve **5-41**  
 Cleaning the cooling system **5-51**  
 Cleaning the diesel engine **5-75**  
 Cleaning the machine **5-74**  
 Cleaning the machine **5-74**  
 Cleaning the service cap **5-42**  
 Cleaning the dust extraction valve **5-42**  
 Closing the engine compartment hatch **5-24**  
 Closing the engine compartment hood **5-26**  
 Closing the service doors, hatches and hoods **3-79**  
 Combined electro-hydraulically actuated quick-change device **3-144**  
 Comfort control **3-58**  
 Comfort control or quick change control **3-55**  
 Complete machine for timber handling **1-25**  
 Complete machine with bucket **1-2**  
 Complete machine with forks **1-22**

Complete machine with high dump bucket **1-20**  
 Complete machine with light material bucket **1-18**  
 Complicating factors **5-10**  
 Connecting an external battery **3-170**  
 Connecting the hydraulic lines **3-143, 3-148, 3-153**  
 Control lever for additional working functions **3-60**  
 Controlling the optional attachment **3-60**  
 Controlling the working attachment **3-58**  
 Control panel **3-19**  
 Control units **3-38**  
 Conversion diagram **5-15**  
 Converting the hydraulic system from petroleum to environmentally compatible hydraulic fluids **5-9**  
 Coolant **5-12**  
 Coolants for diesel engines **5-12**  
 Coolant temperature indicator **3-36**  
 Cooler decal **2-8**  
 Cooling the air in the cab **3-65**  
 Correcting the antifreeze concentration **5-47**  
 Corrosion protection **5-75**  
 Cycle error **3-73**

## D

Daily start-up **3-79**  
 Deactivating the back-up alarm **3-74, 3-76**  
 Deactivating the electronic immobiliser **3-21**  
 Decals on the machine **2-4**  
 Defrost mode **3-48**  
 Deleting programmed keys **3-22**  
 Depressurising the operating circuits **3-140**  
 Diesel fuel at low temperatures (winter operation) **5-11**  
 Diesel fuels **5-11**  
 Direction indicator system activation indicator **3-35**  
 Disconnecting hydraulic lines **3-140, 3-146, 3-151**  
 Disconnecting the external battery **3-171**  
 Disconnecting the working attachment **3-139, 3-146, 3-151**  
 Display unit brightness control **3-43**  
 Display unit **3-29**  
 Disposing of antifreeze and corrosion protection agents **5-16**  
 Disposing of used materials **5-8**  
 Draining off condensate and sediment from the fuel tank **5-40**  
 Draining off condensate from the fuel pre-filter **5-36**  
 Driver's cab **1-15**  
 Driver's seat **1-15**  
 Driver's seat with mechanical suspension **3-7**  
 Driver's seat with pneumatic suspension **3-11**  
 Driving **3-86**  
 Driving **3-91, 3-100**  
 Driving on public roads **3-98**  
 Driving on slopes **3-119**  
 Driving onto the loading area **3-162**  
 Driving out of the pit **3-130**  
 Driving with kick-down shifting **3-92**  
 Driving with LFD **3-95**

Driving without LFD **3-94**  
 Driving with the Vmax (Tempomat) function **3-94**  
 Dummy plug **3-55**  
 Dumping **3-122**

## E

Electrical system **1-4**  
 Electro-hydraulically actuated quick-change device with comfort control. **3-149**  
 Electronic immobiliser **3-21**  
 Eliminating malfunctions **4-21**  
 Emergency exit **3-5**  
 Emergency operation **3-166**  
 Emergency steering check indicator **3-30**  
 Emergency steering **3-50**  
 Emergency steering indicator **3-31**  
 Engaging the parking brake **3-104**  
 Engine bleeding button (special function) **3-43**  
 Engine **1-3**  
 Engine oil pressure indicator **3-37**  
 Engine oil pressure display **3-37**  
 Engine overheating and coolant level indicator **3-36**  
 Engine speed, time, operating hours and service code indicator **3-34**  
 Engine standstill decal **2-5**  
 Entering the driver's cab **3-3**  
 Environmentally compatible hydraulic fluids **5-18**  
 Environmental protection **5-8**  
 Example of foundation excavation **3-129**  
 Excavation **3-127**  
 Exhaust counterpressure display and control unit **3-131**  
 Exhaust gas tests **3-134**

## F

Fastening the seat belt **3-17**  
 Filling the reservoir **3-73**  
 Filling the tank using the filling pump **3-135**  
 Fixed gear 1 indicator **3-33**  
 Fixed gear 2 indicator **3-33**  
 Flashing beacon **3-28, 3-40**  
 Float position **3-51, 3-110**  
 Forklift **1-21, 3-153**  
 Forward travel direction indicator **3-32**  
 Fresh water **5-14**  
 Front axle **1-5**  
 Front/rear working floodlights **3-40**  
 Front working floodlights **3-26**  
 Fuel supply tank content indicator **3-36**  
 Function of the LEDs **3-71**  
 Function test **3-156**  
 Further information on the electronic immobiliser **3-22**

## G

Gear oil overheating indicator **3-31**  
 General recommendations **5-12**  
 General safety regulations **2-2**

Goodyear tyres **1-8**  
 Grading **3-120**  
 Grading work **3-120**  
 Grease for general lubrication points **5-20**  
 Grease level in reservoir too low **3-73**  
 Greasing the cab door hinges **5-67**  
 Greasing the oscillating axle frame and articulation lock **5-65**

## H

Handling **3-79**  
 Hazard warning system **3-39**  
 Heating and ventilation **3-60**  
 Heating, ventilation, air conditioning **1-15**  
 High beam activation indicator **3-35**  
 High dump bucket **1-19**  
 Hydraulically actuated quick-change device **3-137**  
 Hydraulic oil overheating indicator **3-32**  
 Hydraulic oils **5-17**  
 Hydraulic quick-change device **1-14**  
 Hydrostatic braking **3-100**

## I

Ignition switch **3-20**  
 Increasing the blower speed **3-45**  
 Increasing the temperature **3-44**  
 Increasing the tractive force **3-42**  
 Index **6-1**  
 Information decals **2-7**  
 Instructions for safe working **2-14**  
 Instructions for working safely on the working attachment **2-21**  
 Instructions on preventing crushing injuries and burns **2-12**  
 Instructions on preventing fires and explosions **2-13**  
 Interior and exterior mirrors **3-65**  
 Interior cab lighting **3-28**  
 Introduction **2-1**

## J

Jobs for the forks **3-154**  
 Joystick steering **3-53**  
 Joystick steering indicator **3-31**  
 Jump starting **3-170**

## K

Keep clear decal **2-5**

## L

Lashing point decal **2-9**  
 Layout of control elements **3-1**  
 Leaving the driver's cab **3-3**  
 LED test for checking the plug-in fuses **4-25**  
 LIEBHERR antifreeze and corrosion protection agents (50:50 premix) for diesel engine cooling systems **5-17**  
 LIEBHERR automatic lubrication system **3-69**

LIEBHERR control lever **3-55**  
 Lift arm **1-11**  
 Lift arms with Z kinematics **1-23**  
 Lifting out hard material **3-128**  
 Lifting out soft material **3-127**  
 Lifting the machine by crane **3-160**  
 Lift kick-out for reduced dumping height **3-112**  
 Lift kick-out **3-50**  
 Lighting **3-24**  
 Light material bucket **1-17**  
 Load bearing tables for forklift operation **1-23**  
 Loading a heap **3-121**  
 Loading a transport vehicle **3-124**  
 Loading for lorry, rail or sea transport **3-161**  
 Loading large rocks **3-125**  
 Loading procedure **3-124**  
 Loading sticky material **3-126**  
 Loading using the high dump bucket **3-158**  
 Locking the quick-change device **3-141, 3-147, 3-151**  
 Locking the working hydraulics **3-105**  
 Lowering the exhaust counterpressure **3-133**  
 Lowering the lift arms while tilting the bucket in or out **3-110**  
 Lowering the temperature **3-44**  
 Lowering the working attachment **3-104**  
 Low fuel supply indicator **3-36**  
 Lubricant chart, filling quantities **5-5**  
 Lubricant chart **5-6**  
 Lubricant grease for automatic central lubrication systems **5-20**  
 Lubricant oil changing intervals **5-10**  
 Lubricants and fuels **5-8**  
 Lubricating and testing the quick-change device **5-73**  
 Lubricating oil quality **5-9**  
 Lubricating oils for diesel engines **5-9**  
 Lubricating oils for the transmission **5-19**  
 Lubricating oil viscosity **5-9**  
 Lubricating standard lift arms and attachment **5-70**  
 Lubricating the bearing points on the steering cylinders **5-57**  
 Lubricating the bevel gear seals of the front and rear axles **5-63**  
 Lubricating the lift arms and attachment **5-69**  
 Lubricating the quick-change device **5-73**  
 Lubricating the tilt cylinder support for timber transfer **5-70**  
 Lubrication chart decal **2-7**  
 Lubrication, cycle and idle times **3-71**

## M

Machine service hours indicator **3-38**  
 Machine stop indicator **3-35**  
 Machine type plate **2-12**  
 Main electronics (master) standby **3-83**  
 Maintenance and inspection schedule **5-1**  
 Maintenance **5-1**

Maintenance position 1 **5-22**  
 Maintenance position 2 **5-23**  
 Maintenance positions **5-22**  
 Maintenance tasks **5-21**  
 Making sure the bolted connections are tight **5-29**  
 Malfunctions and their effects **4-3**  
 Malfunctions **4-1**  
 Measures for ensuring safe maintenance **2-18**  
 Mechanical service hours counter **3-37**  
 Mega fuses **4-21**  
 Michelin tyres **1-7**  
 Mixing ratio of water and antifreeze/corrosion protection agent **5-12**  
 Moving the machine back **3-126**

## N

Neutral position N indicator **3-33**  
 Noise output decal – L WA **2-8**

## O

Oil level decal **2-10**  
 Opening and closing the hinged window **3-4**  
 Opening the cooling system hood **5-27**  
 Opening the engine compartment hatch **5-23**  
 Opening the engine compartment hood **5-24**  
 Opening the service hatches, doors and hoods **5-23**  
 Operating manual decal **2-8**  
 Operating position **3-79**  
 Operating the central lubrication system **3-72**  
 Operating the lift and tilt cylinders simultaneously **3-109**  
 Operating the lift arms **3-107**  
 Operating the lift cylinders **3-108**  
 Operating the tilt cylinders **3-109**  
 Operating the timber grabber **3-159**  
 Operation **3-2**  
 Operation, Handling **3-1**  
 Optional buttons on the side console **3-52**  
 Optional switches on the side console **3-54**  
 Overspeed protection **3-91**  
 Overspeed protection indicator **3-35**

## P

Parking brake activation indicator **3-33**  
 Parking brake **1-6, 3-40**  
 Parking position **3-106**  
 Parking safely **2-16**  
 Picking up and connecting the working attachment **3-141, 3-147, 3-151**  
 Picking up and moving material **3-117**  
 Picking up material **3-121**  
 Plug-in fuses on the relay and fuse board **4-22**  
 Preglowing the engine **3-84**  
 Preglow monitoring **3-34**  
 Preparatory tasks for maintenance **5-21**  
 Preparing for driving **3-86**  
 Preparing for driving on roads **3-99**  
 Profile lights and low beam **3-39**



Programming new keys **3-22**  
 Proper use **2-3**  
 Protecting the fuel tank from corrosion **5-76**  
 Protecting the piston rods from corrosion **5-75**  
 Protection against vibrations **2-23**  
 Product description **1-1**  
 Pump distributor gear and axles **5-19**  
 Putting the machine in the starting position **3-80**  
 Putting the working attachment into position **3-87**

## R

Radio **3-66**  
 Raising or lowering the lift arms **3-108**  
 Raising the lift arms while tilting the bucket in or out **3-109**  
 Rear axle **1-6**  
 Rear lighting **3-27**  
 Rear window heater **3-52**  
 Rear windshield wiper and washer system **3-52**  
 Rear working floodlights **3-27**  
 Recirculated air **3-49**  
 Refuelling with diesel fuel **3-80**  
 Regulating the temperature **3-61, 3-64**  
 Re-heat mode **3-65**  
 Releasing the articulation lock **3-79**  
 Releasing the parking brake **3-88**  
 Releasing the seat belt **3-18**  
 Releasing the working hydraulics **3-107**  
 Removing loose parts, dirt, ice and snow from the machine **5-28**  
 Removing material from a slope **3-123**  
 Removing material from a slope or wall **3-123**  
 Removing material from a wall **3-123**  
 Replacing fuses **4-21**  
 Reducing the blower speed **3-45**  
 Reducing the tractive force **3-43**  
 Reverse travel direction indicator **3-32**  
 Reversible fan drive **3-77**  
 Reversible fan drive **3-53**  
 Reversing **3-95**  
 Right hinged window **3-4**  
 ROPS decal **2-9**

## S

Safe maintenance of hydraulic hoses and hose lines **2-22**  
 Safety aspects of the seat belt **3-17**  
 Safety decals **2-4**  
 Safety instructions for maintenance work on machines with hydro accumulators **2-20**  
 Safety instructions for driving on slopes **2-16**  
 Safety instructions for start-up **2-14**  
 Safety instructions for towing **3-166**  
 Safety instructions for transporting the machine by crane **2-21**  
 Safety instructions for welding work on the machine **2-21**  
 Safety precautions for maintenance **5-21**

Safety precautions during start-up **2-14**  
 Safety regulations **2-1**  
 Scraping off material **3-120**  
 Sealing leaks **5-29**  
 Seat belt **3-17**  
 Securing the machine **3-106**  
 Security functions **3-22**  
 Selecting a higher travel range **3-42**  
 Selecting a lower travel range **3-42**  
 Selecting the blower direction **3-62**  
 Selecting the blower ducts (footwell) **3-46**  
 Selecting the blower ducts (head area) **3-46**  
 Selecting the blower ducts (middle area) **3-47**  
 Selecting the travel direction **3-88**  
 Selecting travel ranges **3-89**  
 Service brake **1-6, 3-100**  
 Service code indication on the display **4-2**  
 Service Code Table **4-2**  
 Setting off **3-90**  
 Setting the fan reversal interval **3-77**  
 Setting the digging position **3-115**  
 Setting the idle times **3-72**  
 Setting the lift kick-out for reduced dumping height **3-113**  
 Shutting down the machine **3-103**  
 Slinging and lifting point decal **2-9**  
 Snow chains or guard chains **1-9**  
 Soot particle filter **1-16, 3-130**  
 Sound emission **1-15**  
 Sound output **1-15**  
 Sound pressure **1-15**  
 Spare **3-48, 3-53**  
 Special tyres **1-8**  
 Specifications **5-11, 5-17**  
 Starting precautions at cold temperatures **3-86**  
 Starting precautions **3-82**  
 Starting procedure **3-82**  
 Starting the engine **3-84**  
 Starting the diesel engine **3-81**  
 Starting the machine **3-87**  
 Starting up the filling pump **3-135**  
 Steering column and steering wheel **3-18**  
 Steering column switch **3-23**  
 Steering decal **2-6**  
 Steering **1-10**  
 Sulphur content in diesel fuel **5-11**  
 Sun visor **3-66**  
 Switching off high beam **3-26**  
 Switching off the air-conditioning system **3-65**  
 Switching off the back-up alarm **3-54**  
 Switching off the engine **3-105**  
 Switching off the fan reversal **3-78**  
 Switching off the parking light / driving light **3-24**  
 Switching on and using the radio **3-66**  
 Switching on high beam **3-25**  
 Switching on the air-conditioning system **3-63**  
 Switching on the fan reversal **3-78**  
 Switching ride control (LFD system) on or off **3-41**  
 Switching the electrical system on and off **3-20**

Switching the interior lighting on and off **3-28**  
 Switching the display mode **3-43**  
 Switching the travel direction **3-56**  
 Switch on the ignition. **3-82**

## T

Table of filling quantities **5-5**  
 Tamper protection **3-22**  
 Technical data **1-2**  
 Tempomat T Vmax indicator **3-33**  
 Testing the quick-change device **5-73**  
 Tilting the bucket in or out **3-109**  
 Tilting the high dump bucket in and out **3-157**  
 Timber grabber **1-24**  
 Timber handling **3-158**  
 Topping up washer fluid **3-69**  
 Topping up with hydraulic oil **5-55**  
 Towing device **1-16**  
 Towing the machine **3-166**  
 Towing the machine safely **2-17**  
 Towing the machine when the steering system has failed **3-170**  
 Towing with the engine not running **3-168**  
 Towing with the engine running **3-166**  
 Tractive force adjustment **3-97**  
 Transfer gear **5-19**  
 Transferring timber **3-159**  
 Transporting and moving material **3-118**  
 Transporting material **3-121**  
 Transporting the load on a slope **3-118**  
 Transporting the machine by lorry or rail **3-162**  
 Transporting the machine **3-160**  
 Transporting the machine safely **2-16**  
 Transport position **3-118**  
 Transport routes **3-124**  
 Travel range 1-2 indicator **3-33**  
 Travel range 1-3 indicator **3-33**  
 Travel range 2-3 indicator **3-32**  
 Travel range or tractive force control indicator **3-35**  
 Travel drive **1-5**  
 Travel speed display **3-30**  
 Troubleshooting **3-22**  
 Turning off the battery main switch **5-28, 3-105**

Turning on the battery main switch **3-2, 3-79**  
 Type plates **2-11**  
 Tyres for machines with optional accessories **1-9**  
 Tyres **1-7**  
 Tyres with foam **1-10**

## U

Unlocking the quick-change device **3-139, 3-145, 3-151**  
 Using anti-corrosion agent without antifreeze **5-49**  
 Using the air-conditioning system **3-63**  
 Using the automatic bucket return-to-dig function **3-114**  
 Using the automatic lift kick-out function **3-112**  
 Using the emergency hammer **3-6**  
 Using the front windshield wiper and washer system **3-68**  
 Using the high dump bucket **3-156**  
 Using the rear windshield wiper and washer system **3-68**

## V

Viscosity **5-18**  
 Visible and audible warning signals **4-18**  
 Visible reverse warning device **3-75**  
 Vmax **3-50**  
 Voltage decal **2-5**

## W

Warming up **5-18**  
 Washing the machine **5-74**  
 Wheel lugs decal **2-8**  
 Windscreen water decal **2-10**  
 Windshield washer fluid reservoir **3-69**  
 Windshield wiper and washer system **3-67**  
 Working attachment **1-11**  
 Working hydraulics decal **2-10**  
 Working hydraulics **1-11**  
 Working hydraulics lockout **3-41**  
 Working hydraulics lockout indicator **3-32**  
 Working methods **3-116**

**Liebherr-Hydraulikbagger GmbH**

Hans-Liebherr-Straße 12  
D-88457 Kirchdorf/Iller  
☎ + 49 7354 80-0  
Fax + 49 7354 80-72 94  
www.liebherr.com  
E-Mail: info@lhb.liebherr.com

**Liebherr-France SAS**

2, Avenue Joseph Rey, B.P. 287  
F-68005 Colmar Cedex  
☎ + 33 389 21 30 30  
Fax + 33 389 21 37 93  
www.liebherr.com  
E-Mail: info@lfr.liebherr.com

**Liebherr-Werk Telfs GmbH**

Hans-Liebherr-Straße 35  
A-6410 Telfs  
☎ + 43 5262 6 00-0  
Fax + 43 5262 6 00-72  
www.liebherr.com  
E-Mail: info@lwt.liebherr.com

**Liebherr-Werk Bischofshofen GmbH**

Postfach 49  
A-5500 Bischofshofen  
☎ + 43 6462 8 88-0  
Fax + 43 6462 8 88-3 85  
www.liebherr.com  
E-Mail: info@lbh.liebherr.com