

en

Operating Manual

Welding dozer
SR 712 B Litronic

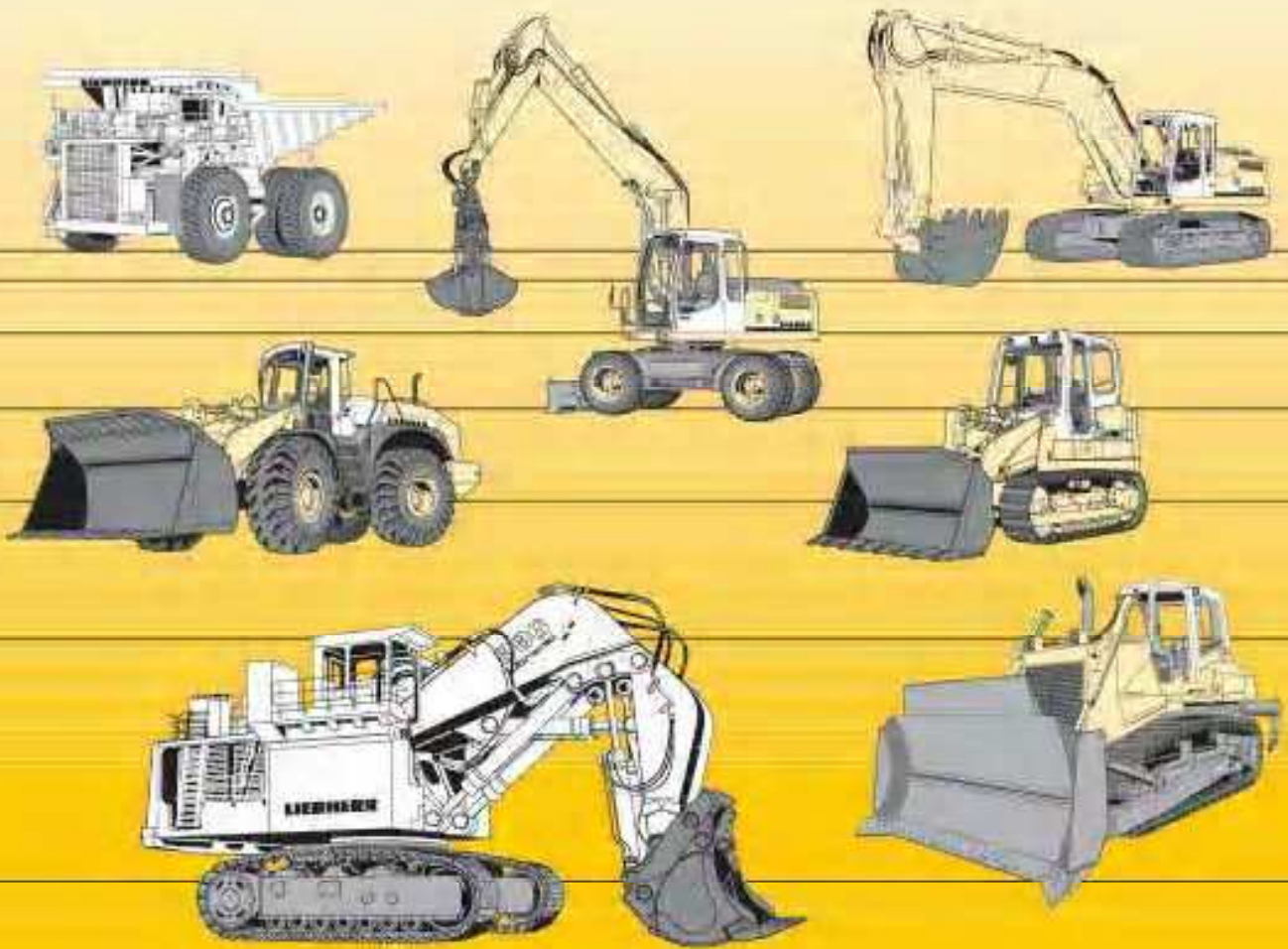

LIEBHERR

Operating manual

Welding dozer
SR 712 B Litronic

Document identification

Id. No.: 9084562
Issue: 04/2003
Valid for: SR 712B from S/N 5500
Author: LWT / Technical Documentation Dept.

Product identification

Manufacturer: LIEBHERR Werk Telfs GMBH
Product group: Crawler dozer
Type: SR 712B

Address

Address: LIEBHERR Werk Telfs GMBH
Hans LIEBHERR - Straße 35,
A - 6410 TELFS Austria

Machine data

We recommend that you fill in the following information in the space provided as soon as you receive your machine:

This information will also be helpful when ordering parts.

Machine S/N: *

Year: CE *

Delivery date: .. / .. / ..

* This information is found on the data tag of your machine, on the left front of the main frame.

Noise level

Sound pressure level LpA SR712B max. 80 dB(A) at the work station according to ISO 6396

Sound emission level LWA SR712B max. 108 dB(A) emitted to the surrounding area, according to EU guide line 2000 / 14 / EG

Foreword

This operating manual has been written for the **operator** and for the **maintenance personnel** of this machine.

This manual contains descriptions for:

- Technical Data
- Safety information
- Operating instructions and guidelines
- Maintenance
- Instructions for special / optional equipment

This operating manual should be given to the operator and the maintenance personnel and any other person who works on the machine, who should read it carefully at regular intervals and before operating or servicing the machine.

Work with or on the machine is, for example:

- **Operation**, including set up, trouble shooting during operation, removal of debris, service, removal of oil, lubricants, fuels and operating fluids.
- **Maintenance**, including inspection, upkeep and / or repair.
- **Transportation** or loading the machine.

Reading this manual will familiarize the operator with the machine and prevent problems due to improper operation.

Following the operation and maintenance guidelines by maintenance personnel will:

- increase reliable service,
- increase the service life expectancy of your machine,
- reduce repair costs and downtime.

The Operating Manual is part of the machine. Keep a copy of this manual in the glove compartment in the operator's cab to assure that it can be consulted and referred to at any time.

Any existing federal, state and local safety requirements governing accident prevention and environmental safety must be added to this Operating Manual, in addition to safety and accident prevention regulations applicable to the country and job site you operate in, including any technical rules and regulations to assure safe and proper operation must be followed.

This Operating Manual includes the necessary information to operate and maintain your machine.

- Some illustrations in this manual might show details and machines which differ from your machine.
- For some illustrations, covers and protective devices were removed to provide a better view.
- Continuing improvements on our machines might result in changes, which are not reflected in this Operation and Maintenance Manual.

If you need any additional information and / or clarification, please don't hesitate to contact LIEBHERR's Technical Documentation Department, Customer Service School or Service Department.

We hope you understand that LIEBHERR cannot honor warranty claims resulting from improper operation, inadequate maintenance, use of wrong and unauthorized oils, lubricants, fuels and operating fluids and / or from disregard of safety information and guidelines.

LIEBHERR reserves the right to reject any warranty claims, service contracts or agreements established by **LIEBHERR** and / or any of its dealers without prior notice if any other than Original **LIEBHERR** parts or parts sold by **LIEBHERR** are being or have been used for maintenance and repair.

Under extreme conditions, it might be necessary to increase maintenance intervals as compared to those listed in the inspection schedule.

Changes, conditions, copyright:

- We reserve the right to make changes of technical details on the machine which differ from the wording and illustrations in this manual.
- No part of this manual, technical or otherwise, may be reproduced nor copied in any form or used for competitive purposes in the market place. All rights reserved.
- Above and the following remarks will not expand LIEBHERR's general business conditions regarding warranties and liability.

Table of contents

1.	Product description	1 - 1
1.1	Technical Data	1 - 2
1.1.1	Air conditioning system	1 - 3
1.2	Tightening torques	1 - 5
1.2.1	Preload values and tightening torques for screws with standard metric threads according to	1 - 6
1.2.2	Preload force and tightening torque for screws with fine metric thread according to factor	1 - 7
2.	Safety guidelines, decals	2 - 1
2.1	Introduction	2 - 1
2.2	Proper and intended use	2 - 1
2.3	Decals on the machine	2 - 2
2.3.1	Safety decals	2 - 2
2.3.2	Reference decals	2 - 5
2.3.3	Data tags	2 - 9
2.4	Safety guidelines	2 - 9
2.4.1	General Safety Guidelines	2 - 9
2.4.2	Crushing and burn prevention	2 - 11
2.4.3	Fire and explosion prevention	2 - 11
2.4.4	Machine start up safety	2 - 12
2.4.5	Engine start up safety	2 - 12
2.4.6	Machine operating safety	2 - 13
2.4.7	Machine parking safety	2 - 14
2.4.8	Machine transporting safety	2 - 15
2.4.9	Machine towing safety	2 - 15
2.4.10	Machine maintenance safety	2 - 16
2.4.11	Safety guidelines to be observed when welding on the machine	2 - 19
2.4.12	Safety guidelines to be observed when working on the attachment	2 - 19
2.4.13	Safety guidelines to be observed when loading the machine with a crane	2 - 20
2.4.14	Safe maintenance of hydraulic hoses and lines	2 - 20
2.4.15	Roll over protection (ROPS) and falling object protection (FOPS)	2 - 21
2.4.16	Attachments and installations	2 - 21
3.	Control, instrumentation	3 - 1
3.1	Location of controls and instrumentation	3 - 1
3.1.1	Operator's cab	3 - 1
3.1.2	Controls and instrumentation on the instrument panel	3 - 3
3.1.3	Controls on the instrument panel	3 - 6
3.1.4	Controls and indicators in the roof console	3 - 8
3.2	Operation	3 - 9
3.2.1	Entry	3 - 9

3.2.2	Emergency exit	3 - 10
3.2.3	Door lock	3 - 11
3.2.4	Operator's seat	3 - 12
3.2.5	Operator's seat - air cushioned	3 - 15
3.2.6	Arm rests	3 - 18
3.2.7	Seat belt	3 - 18
3.2.8	Heater, ventilation	3 - 20
3.2.9	Air conditioning system	3 - 22
3.2.10	Sliding window	3 - 24
3.2.11	Sun shade	3 - 24
3.2.12	Cab interior lighting	3 - 24
3.2.13	Rear view mirror	3 - 25
3.2.14	Electric windshield wiper and washer system	3 - 25
3.2.15	Reservoir for windshield washer fluid	3 - 26
3.2.16	Compartment for machine documentation	3 - 27
3.2.17	Back up alarm	3 - 27
3.2.18	Fire extinguisher	3 - 28
3.2.19	Beacon	3 - 28
3.3	Operation	3 - 29
3.3.1	Daily operation	3 - 29
3.3.2	Machine operation in low ambient temperatures	3 - 31
3.3.3	Start the Diesel engine	3 - 31
3.3.4	Travel operation	3 - 37
3.3.5	Travel	3 - 39
3.3.6	Brakes	3 - 41
3.3.7	Machine shut down	3 - 43
3.3.8	Guidelines for working in water	3 - 46
3.3.9	Transporting the machine	3 - 46
3.3.10	Loading the machine with a crane	3 - 52
3.4	Emergency operation	3 - 53
3.4.1	Towing the machine	3 - 54
3.4.2	Auxiliary starting procedure	3 - 59
4.	Operating problems	4 - 1
4.1	Problems and remedy	4 - 2
4.2	Problem remedy	4 - 5
4.2.1	Change fuse	4 - 5
5.	Maintenance	5 - 1
5.1	Maintenance and inspection schedule	5 - 2
5.2	Lubrication chart	5 - 6
5.3	Lubricants and service fluids	5 - 8
5.3.1	Handling lubricants and service fluids	5 - 8
5.3.2	Lubricants and service fluid specification, quantities	5 - 8
5.3.3	Change from mineral oils to environmentally friendly hydraulic fluids	5 - 14

	5.3.4	Proper oil diagnostics analysis	5 - 15
5.4		Preparations for maintenance	5 - 19
	5.4.1	Maintenance position	5 - 19
	5.4.2	Electrical system	5 - 22
5.5		Diesel engine	5 - 22
	5.5.1	Check the engine oil level	5 - 22
	5.5.2	Check the engine oil pressure	5 - 23
	5.5.3	Engine compartment	5 - 24
	5.5.4	Change the engine oil	5 - 24
	5.5.5	Change the lube oil filter	5 - 26
	5.5.6	Check / change the V-belt	5 - 27
	5.5.7	Check the Diesel engine area for leaks and condition	5 - 28
	5.5.8	Check the mounting of intake and exhaust lines	5 - 28
	5.5.9	Oil separator	5 - 29
5.6		Cooling system	5 - 29
	5.6.1	Check the coolant level	5 - 30
	5.6.2	Clean the cooling system	5 - 31
	5.6.3	Check the cooling system for leaks	5 - 32
	5.6.4	Change the coolant filter	5 - 33
	5.6.5	Check the antifreeze and DCA-4 concentration in the coolant	5 - 33
	5.6.6	Change the coolant	5 - 34
5.7		Fuel system	5 - 36
	5.7.1	Drain the fuel separator condensation	5 - 36
	5.7.2	Drain water and contaminants in the fuel tank	5 - 37
	5.7.3	Empty the fuel tank	5 - 38
	5.7.4	Change the fuel filter elements	5 - 39
	5.7.5	Bleed the fuel system	5 - 41
5.8		Air filter system	5 - 42
	5.8.1	Clean / change the air filter	5 - 42
5.9		Hydraulic system	5 - 44
	5.9.1	Oil level in hydraulic tank	5 - 45
	5.9.2	Clean the magnetic rod on the hydraulic tank.	5 - 47
	5.9.3	Change the return filter insert	5 - 48
	5.9.4	Change the replenishing oil filter	5 - 50
	5.9.5	Check the hydraulic system for function and leaks	5 - 50
	5.9.6	Clean the oil cooler	5 - 51
	5.9.7	Change the hydraulic oil	5 - 52
5.10		Splitterbox	5 - 53
	5.10.1	Check oil level	5 - 53
	5.10.2	Change the gear oil	5 - 54
5.11		Electrical system	5 - 55
	5.11.1	Check indicator lights and illumination	5 - 56
	5.11.2	Batteries	5 - 57
	5.11.3	Change bulbs	5 - 58
5.12		Heating and fresh air system, air conditioning system	5 - 60

5.12.1	Check the heater for function and for leaks	5 - 60
5.12.2	Heater - fresh air filter	5 - 61
5.12.3	Air conditioning system	5 - 62
5.13	Travel gear	5 - 65
5.13.1	Check the condition of the travel gear	5 - 65
5.13.2	Check oil level	5 - 66
5.13.3	Change the gear oil	5 - 66
5.13.4	Travel gear - lifetime seal area	5 - 67
5.14	Track components	5 - 73
5.14.1	Check the screws on nuts on the track components for tight seating	5 - 73
5.14.2	Check the seal on the carrier rollers, track rollers and idlers	5 - 74
5.14.3	Idler guide	5 - 74
5.14.4	Chain tension	5 - 77
5.14.5	Changing the chain	5 - 79
5.14.6	Clean the tracks	5 - 86
5.14.7	Check track wear	5 - 87
5.15	Total machine	5 - 87
5.15.1	Check the machine for external damage	5 - 87
5.15.2	Windshield wiper	5 - 88
5.15.3	Taking the machine out of service	5 - 88
5.16	Cab - tilting device	5 - 88
5.16.1	Raise the cab	5 - 88
5.16.2	Lower the cab	5 - 90

1. Product description

Design - Overview

This paragraph shows an overview of the machine with description of the displayed components.

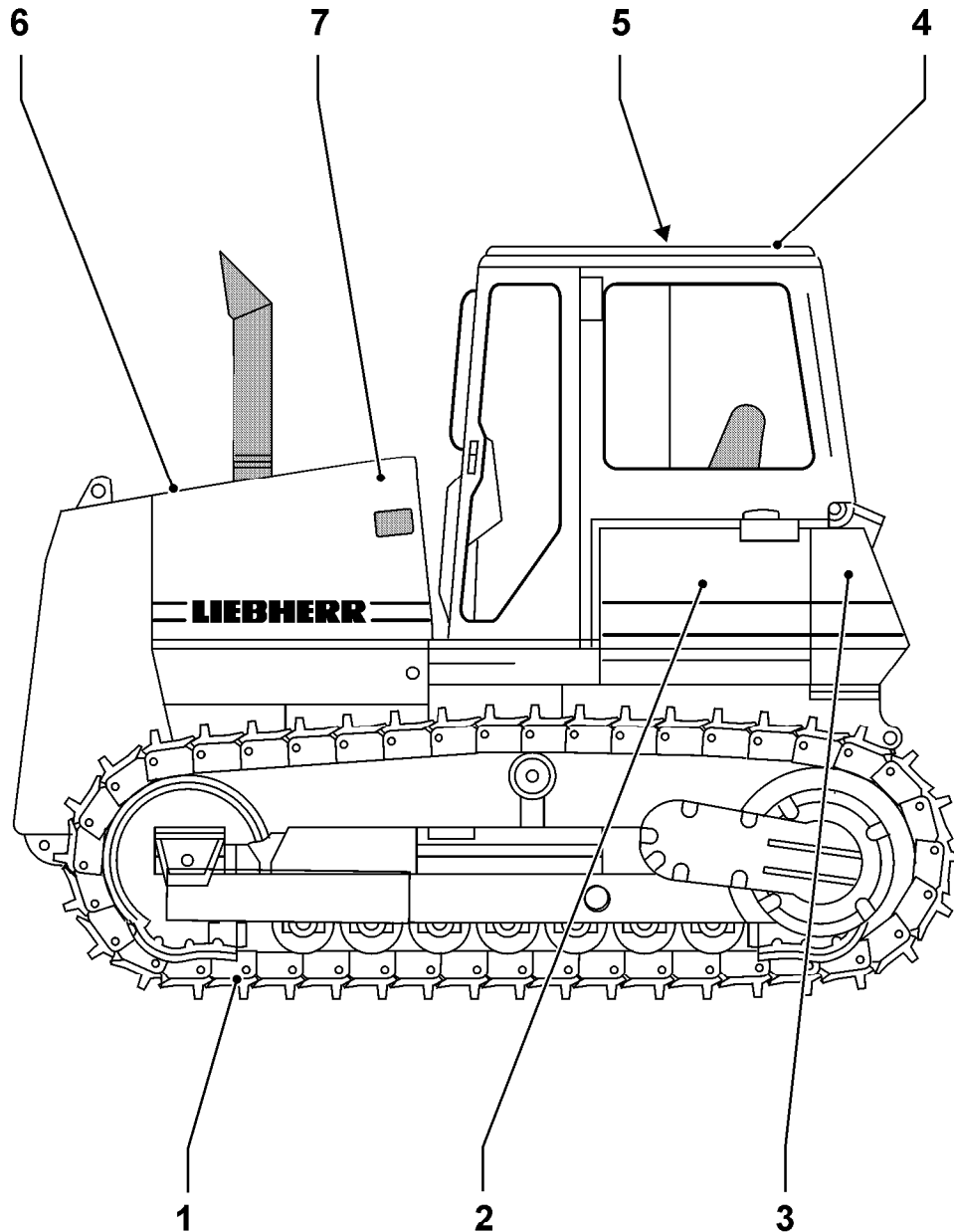

Complete machine - left view

- | | |
|------------------|------------------------------------|
| 1 Roller frame | 5 Battery box |
| 2 Hydraulic tank | 6 Covers |
| 3 Fuel tank | 7 Diesel engine with pump assembly |
| 4 Operator's cab | |

404171

1.1 Technical Data

The most important technical data can be found in the enclosed technical description.

Technical Description

Welding Tractor

SR712 BM
Litronic[®]

Engine output 120 kW/163 HP

Operating weight 16.9 – 17.5 t/37,300 – 38,600 lb

Hydrostatic travel drive with electronic steering control



LIEBHERR

The Better Machine.

The decisive economical factors of the SR 712 BM:

1. The construction machine engine

- High operational safety
- Low engine RPM
- Low fuel consumption
- Low emissions

2. The hydrostatic travel drive

- Permanently high ratio of efficiency
- Optimal overload protection
- Excellent precision controls
- Stepless regulation of speed
- Exact straight travel
- High manoeuvrability including turning on the spot

3. The innovative track frame concept

- Low ground pressure
- High stability
- Excellent climbing ability
- High shock absorption

4. The economical working attachments

- Hydraulically driven generator
- Hydraulically driven compressor
- Hydraulically driven loading crane
- All aggregates are driven by the standard diesel engine of the welding tractor.
- Up to 6 modular welding positions
- Welding and power cable premounted to crane

5. The practical and comfortable working environment

- Available with canopy as well as with fully enclosed cab
- Optimal visibility of work area
- Single joystick control of basic machine
- Control for crane and compressor located next to operator's seat
- Electrical isolation monitoring



The Advantage: Total economical efficiency



y.

Functional design

The modern SR 712 BM welding tractor is especially remarkable due to its functionality as carrier machine for the equipment necessary for pipeline welding.

The standard diesel engine of the welding tractor is used for driving the welding generator, the hydraulic crane and the air compressor - an additional diesel engine is not necessary for this purpose. Thus noise emissions are reduced, fuel consumption made more efficient and maintenance work on additional components is eliminated.

The long tracks and the high ground clearance also make it possible to use the machine in difficult ground conditions optimally. The added, extremely low ground pressure guarantees safe operation even on soft ground, as is especially the case on pipeline sites.

Easy and safe operation

One decisive aspect when operating a crawler welder is easy control. Above all the hydrostatic travel drive is remarkable due to its single lever control. This lever controls all travel movements of the machine.

Control of the generator, loading crane as well as the compressor are located next to the operator's seat. The operator can concentrate fully on the work area from the operator's seat and can guarantee safe handling of the machine even at construction sites with tight quarters.



Single joystick control as well as the possibilities of a canopy and a fully enclosed cab make the Liebherr operator post remarkable.

Control of the loading crane and the compressor is ergonomically located next to the operator's seat.



The SR 712 BM Welding Tractor: Versatile,



A hydraulically driven air compressor fills the large air tank.

The electric generator is driven hydraulically for constant weld quality.

The welding tractor can be equipped with 6 welding positions.



precise and economical.



Engine

Liebherr-Diesel Engine	D 924 T-E
Rating per ISO 3046	163 HP (120 kW) at 2000 RPM
Displacement	6,7 l (409 cu.in)
Bore/stroke	122/142 mm (4.8/5.9 in)
Design	4 cylinder, in-line, water-cooled, turbo-charged, engine individual cylinder heads, wet cylinder bushings, maintenance-free drive for fan and water pump
Injection	direct fuel injection with distributor injection pump, mechanical regulator
Fuel filtration	pre-filter with water separator and micro filter
Air filtration	combustion air pre-filter with automatic dust ejection, dry air filter system with main and safety element
Lubrication	pressurized lubrication system with main flow filters and integrated oil cooler, deep oil pan for inclinations, engine lubrication to an inclination of up to 45° to each side
Operating voltage	24 V
Alternator	55 A DC
Starter	5,4 kW (7.3 HP)
Central fuse box	35 A
Batterie	110 Ah



Travel Drive

Design	independent hydrostatic drive of travel gear
Pump flow	max. 125 l/min (32 gpm)
Max. pressure	adjusted to 420 bar (6090 PSI)
Travel speed	0 - 11 km/h (0 - 6.8 mph) infinitely variable, forward and reverse
Steering	hydrostatic
Service brake	hydrostatic
Parking/emergency brake	automatic multi disc brake in final drives
Cooling system	hydraulic oil cooler with separate cooling circuit with gear pump and front mounted cooler
Filter system	cartridge fine filters in the cooling circuit
Final drive	2-stage planetary reduction gear with hydraulic travel motor



Track Frame

Design	maintenance-free crawler travel gear
Mount	fixed over pre-mounted support axles and bridge
Chains	sealed, chain tension via spring loaded tensioner and hydraulic cylinders, single grouser pads
Chain links	44
Sprockets	2 replaceable segments
Track rollers	7
Carrier rollers	2



Travel Control

1 Joystick lever	with electronic control for all travel functions: travel direction, speed, steering and counter-rotation
Low speed range	for the total joystick deflection range for the travel speed from 0 - 5 km/h (0 - 3.1 mph)
Electronic engine speed sensing control	electronic regulation assures a constant balance between travel speed and necessary drawbar pull through engine speed sensing avoiding engine overload, even in partial load range
Straight line travel	electronically controlled
Parking/emergency brake	automatically applied after the joystick lever is put in neutral position
Safety lever	inactivates complete travel hydraulic circuit and automatically activates the parking brake
Emergency shut off	push button on instrument panel immediately activates parking and emergency brake



Implement Hydraulic

Hydraulic system	on demand (load sensing) control, swash plate type variable displacement pump and pressure cut-off for generator drive and separate circuits for compressor- and crane drive
Max. pump flow	max. 300 + 38 + 38 l/min
Pressure limitation	adjusted to 280 bar
Filter system	return filter with magnetic rod in hydraulic tank



Operator's Platform

Mount	resiliently mounted
Operator's seat	fully adjustable swing seat, adjustable to operator weight
Monitor	comprehensive instrument panel on the right hand side of the operator's seat



Refill Capacities

Fuel tank	310 l
Cooling system	52 l
Engine oil	18 l
Splitterbox	2,5 l
Hydraulic tank	178 l
Final drive, each	5,5 l



Generator

Design	hydraulic powered Stamford electric generator in protection skid (IP 45)
Rating	125 kVA
Voltage	231/400 V - 50 Hz
Switch box	integrated switch box with Amp., Hz., and Volt gauges and service hour indicator; insulation monitoring device
Plug sockets	4 x shuko 231 V 4 x CEE 400 V
Operation	push button on instrument panel

Technical Data



Compressor

Design	hydraulic powered heavy duty Quincy air compressor, skid mounted
Model	QR-25 basic two-stage compressor model 370 LVD
Rating	1.245 l/min @ 14 bar
Airreceiver	500 l; 16 bar
Operation	control lever at operator's platform



Crane

Design	fully hydraulic powered HIAB crane with 400° slewing angle; front mounted; complete with service lead supports and hook for lifting of welding tent
Model	071 AW
Capacity	70,6 kNm (7.2 tm)
Max. reach	7,2 meter (full hydraulic)
Operation	control levers and emergency switch at operator's platform



Welding Equipment

Design	4 pos. electric powered welding sources mounted in protection housings on customers request
Model	
Operation	remote control on welding spot, service lead two meters longer than max. reach of crane

Working Attachment

- Lockable toolbox
- Gasbottle support for two propane gasbottles
- Working lights at front, left and rear side of the machine

Optionals

- Cabin
- Airconditioning
- Trackguard
- Swamp undercarriage
- Air compressor Quincy 390 LVD
- 6 welding positions
- Preparation for automatic welding
- Salt chains
- Different Generator
- Different Compressor
- Different Crane

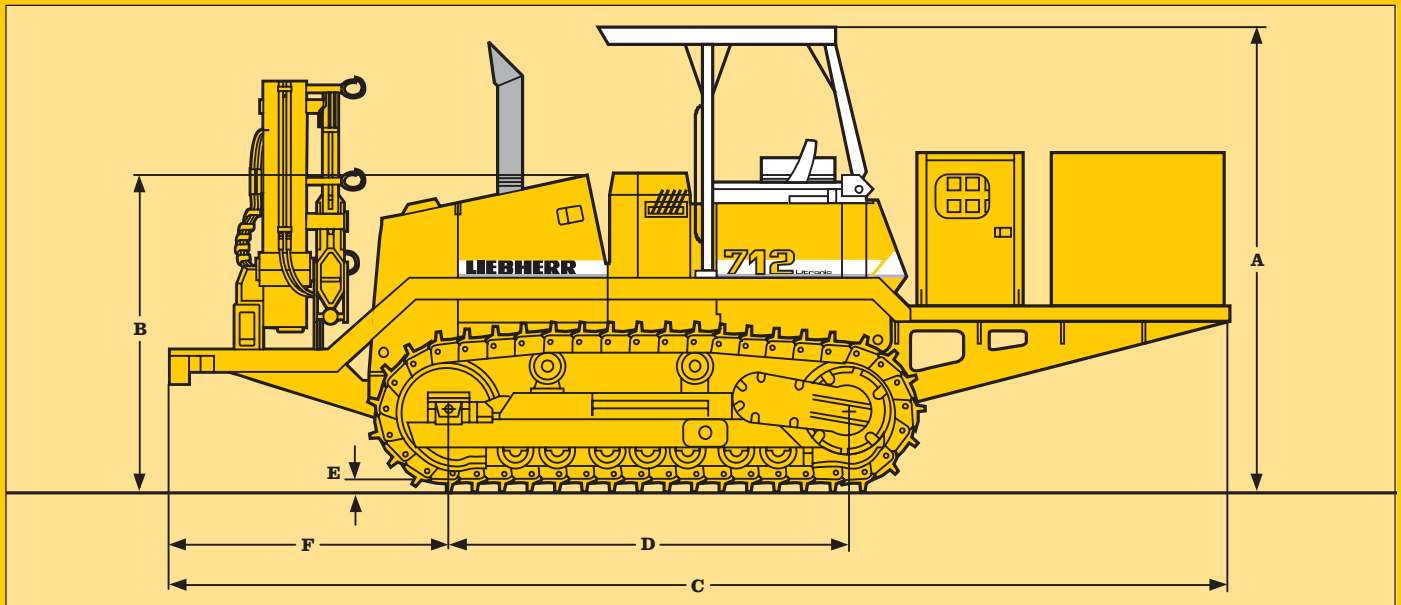

Dimensions

	ft-in/mm
A Height over canopy	10'2"/3100
B Height over engine cover	6'11"/2100
C Overall length	22'9"/6934
D Distance idler/sprocket center	8'7"/2615
E Height of grouser	2"/56
F Additional length frontside from idler cutter	5'8"/1719
Overall width with pad size 24"/610 mm	4944 sq.in/3.19 m ²
28"/711 mm	5766 sq.in/3.72 m ²
30"/762 mm	6184 sq.in/3.99 m ²
34"/864 mm	7006 sq.in/4.52 m ²

Technical Data/Dimensions

1.1.1 Air conditioning system

The especially robust heat and air conditioning system, which is installed in Liebherr machines, heats and cools the operator's cab.

Technical data

Refrigerant	R134a
Nominal voltage	24 V
Operating voltage	24 V
Fan	3-stage
Filling quantity of complete system	Refrigerant R134a = 1700g
Oil quantity - air conditioner compressor	200 ccm

Components of the air conditioning system

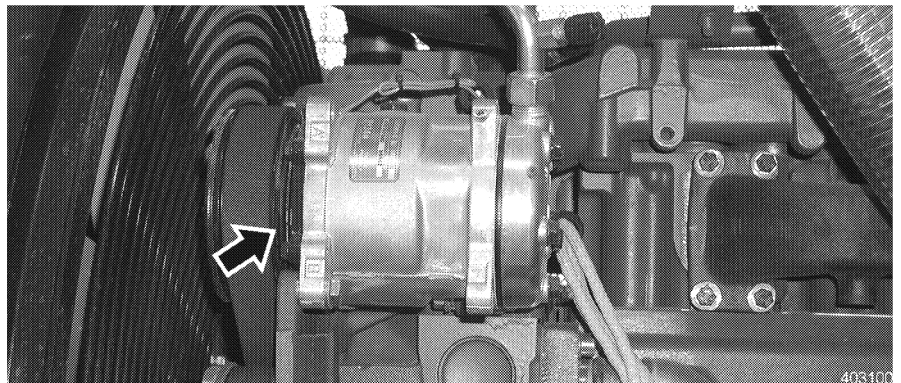

Air conditioner compressor

Air conditioner compressor

The air conditioner compressor is installed in the engine compartment.

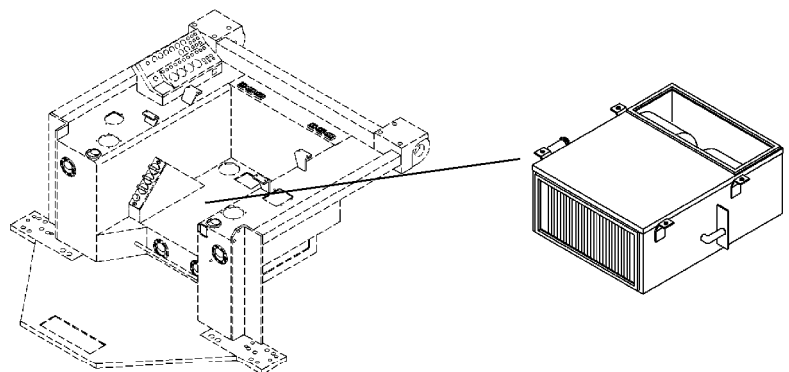

Heating unit

Heating unit

The heating unit is located under the seat console in the floorboard area of the operator's cab.

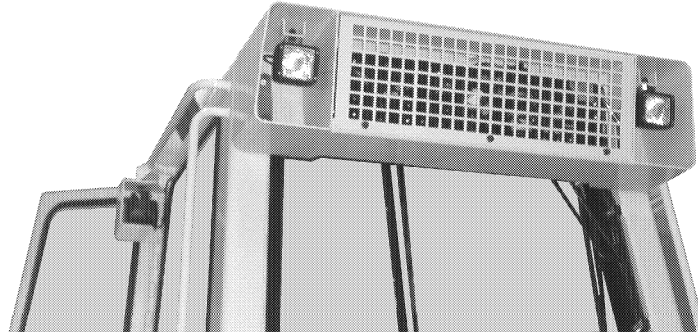

403466

Evaporator unit

Evaporator unit The evaporator unit is installed on rear on the roof of the operator's cab.

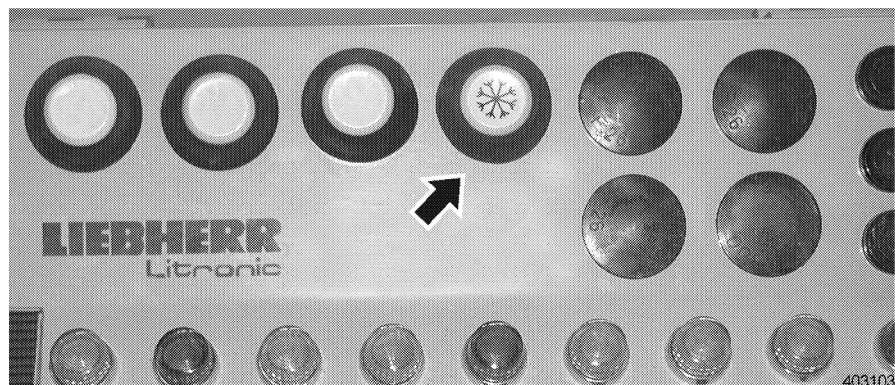

Main air conditioner switch

Control elements of the air conditioning system

Main switch

The main air conditioner switch is installed in the instrument panel (marked with the air conditioner star).

Control element

The control element is located on the right hand side of the operator's seat.

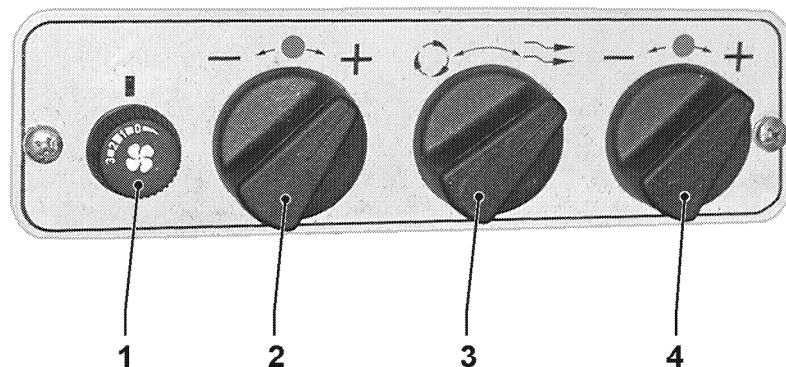

403104

Control element

- 1 Blower switch 3-stage
- 2 Turn regulator - heater
- 3 Turn regulator - air vent

- 4 Turn regulator - air conditioning system

1.2 Tightening torques

Installation preload F_M and tightening torques M_A for shank screws with metric standard or fine threads according to DIN ISO 262 and DIN ISO 965 T2 (replacement for DIN 13 part 13) and head dimensions of hex head screws with shank DIN EN 24014 (replacement for DIN 931 part 1) or Allan head screws DIN EN ISO 4762 (replacement for DIN 912)

The chart values are valid for screws with "black" surface or phosphated, zinc-plated and DACROMET 500. Screws and nuts with "black" surface, phosphated or galvanized, lightly lubricated. Medium friction $\mu_G = 0,10$.

Any tightening torque values given in drawings / parts lists, instructions or component descriptions and / or tightening procedures must always be used and observed before using the factory standard values.

Beginning with grade 10.9, the use of lock washers does no longer provide any safety actions.

Always use a torque wrench of the correct size - the torque momentum according to the chart should be in the upper third of the present test range.

When using impact wrenches, care must be taken that the given torque values are retained - use a torque wrench for prechecks and intermediate checks.

1.2.1 Preload values and tightening torques for screws with standard metric threads according to factory standard WN 4037 G

Standard metric thread	Preload value F_M based on grades in N			Tightening torques M_A based on grades in Nm			Wrench size for hex head screws		Wrench size for socket head screws	
	8.8	10.9	12.9	8.8	10.9	12.9	mm	Inch	mm	Inch
M 4 x 0,7	4 200	6 200	7 300	2.5	3.7	4,3	7	9/32	3	--
M 5 x 0,8	6 900	10 100	11 900	4.9	7.3	8.5	8	5/16	4	5/32
M 6 x 1	9 700	14 300	16 700	8.5	12.5	14.5	10	--	5	--
M 7 x 1	14 200	20 900	24 500	14	20.5	24	11	--	--	--
M 8 x 1,25	17 900	26 000	30 500	20.5	30	35	13	1/2	6	--
M 10 x 1,5	28 500	42 000	49 000	41	60	71	(17)16	(11/16)	8	5/16
M 12 x 1,75	41 500	61 000	71 000	71	104	121	(19) 18	(3/4)	10	--
M 14 x 2	57 000	84 000	98 000	113	165	195	(22) 21	(7/8)	12	--
M 16 x 2	78 000	115 000	134 000	170	250	300	24	--	14	9/16
M 18 x 2,5	98 000	140 000	164 000	245	350	410	27	1 - 1/16	14	9/16
M 20 x 2,5	126 000	180 000	210 000	350	490	580	30	1 - 3/16	17	--
M 22 x 2,5	157 000	224 000	260 000	470	670	780	(32) 34	--	17	--
M 24 x 3	182 000	260 000	305 000	600	850	1 000	36	1 - 7/16	19	3/4
M 27 x 3	239 000	340 000	400 000	880	1 250	1 450	41	1 - 5/8	19	3/4
M 30 x 3,5	290 000	415 000	485 000	1 190	1 700	2 000	46	1 - 13/16	22	7/8
M 33 x 3,5	360 000	520 000	600 000	1 600	2 300	2 700	50	2	24	--
M 36 x 4	425 000	600 000	710 000	2 100	3 000	3 500	55	2 - 3/16	27	1 - 1/16
M 39 x 4	510 000	730 000	850 000	2 700	3 800	4 500	60	2 - 3/8	27	1 - 1/16

1.2.2 Preload force and tightening torque for screws with fine metric thread according to factory standard WN 4037 G

Fine metric thread	Preload value F_M based on grades in N			Tightening torque M_A based on grades in Nm			Wrench size for hex head screws		Wrench size for socket head screws	
	8.8	10.9	12.9	8.8	10.9	12.9	mm	Inch	mm	Inch
M 8 x 1	19 600	28 500	33 500	22	32	38	13	1/2	6	--
M 9 x 1	25 500	38 000	44 000	32	46	54	--	--	--	--
M 10 x 1	32 500	48 000	56 000	45	67	78	17	11/16	8	5/16
M 10 x 1,25	30 500	45 000	53 000	43	64	74	17	11/16	8	5/16
M 12 x 1,25	46 500	68 000	80 000	77	112	130	19	3/4	10	--
M 12 x 1,5	44 000	65 000	76 000	74	108	125	19	3/4	10	--
M 14 x 1,5	63 000	92 000	108 000	121	175	205	22	7/8	12	--
M 16 x 1,5	85 000	125 000	147 000	180	270	310	24	--	14	9/16
M 18 x 1,5	114 000	163 000	191 000	270	390	450	27	1 - 1/16	14	9/16
M 18 x 2	106 000	151 000	177 000	260	370	430	27	1 - 1/16	14	9/16
M 20 x 1,5	144 000	206 000	240 000	380	540	630	30	1 - 3/16	17	--
M 22 x 1,5	177 000	255 000	295 000	510	720	840	32	--	17	--
M 24 x 1,5	215 000	306 000	358 000	700	990	1 170	36	1 - 7/16	19	3/4
M 24 x 2	203 000	290 000	340 000	640	920	1 070	36	1 - 7/16	19	3/4
M 27 x 1,5	276 000	394 000	461 000	1 010	1 440	1 690	41	1 - 5/8	19	3/4
M 27 x 2	265 000	375 000	440 000	940	1 350	1 550	41	1 - 5/8	19	3/4
M 30 x 1,5	346 000	493 000	576 000	1 410	2 000	2 340	46	1 - 13/16	22	7/8
M 30 x 2	332 000	472 000	553 000	1 370	1 940	2 270	46	1 - 13/16	22	7/8
M 33 x 1,5	423 000	603 000	705 000	1 880	2 670	3 130	50	2	24	--
M 33 x 2	410 000	580 000	680 000	1 750	2 500	2 900	50	2	24	--
M 36 x 1,5	508 000	724 000	847 000	2 450	3 490	4 090	55	2 - 3/16	27	1 - 1/16
M 36 x 3	455 000	650 000	760 000	2 200	3 100	3 600	55	2 - 3/16	27	1 - 1/16
M 39 x 1,5	601 000	857 000	1002 000	3 140	4 470	5 230	60	2 - 3/8	27	1 - 1/16
M 39 x 3	550 000	780 000	910 000	2 800	4 000	4 700	60	2 - 3/8	27	1 - 1/16

2. Safety guidelines, decals

Working on earth moving machinery can be dangerous, it could result in injury or death for operator, driver or maintenance personnel. We urge you to read these safety notes repeatedly and carefully and to observe them to prevent danger and accidents.

This is especially important for any personnel that works on the machine only occasionally, such as during set up and / or maintenance on the machine.

Careful adherence to the below listed safety information will insure safe operation and maintenance and potentially prevent personal injury to yourself and others and possible damage to your machine.

Important safety notes are used throughout this manual when describing tasks, which could endanger personnel or machine.

They are marked with the notes - **Danger** or **Caution**.

2.1 Introduction

In this Operation and Maintenance Manual, the notes are defined as follows:



"Danger"

Denotes an extreme intrinsic hazard, which could result in a high probability of death or serious injury if proper precautions are not taken.



"Caution"

Denotes a reminder of safety practices or directs attention to unsafe practices if proper precaution are not taken, which could result in personal injury and / or damage or destruction of the machine.

Following these notes does not relieve you of your obligation to observe all additional regulations and guidelines!

In addition, the following must be observed:

- all safety regulations which are valid at the job site,
- any federal, state, and local governing travel on public highways,
- any guidelines issued by trade and professional associations.

2.2 Proper and intended use

1. With the standard dozer attachment, the machine may only be used to loosen, move and dump dirt, gravel, broken rocks or other similar material.
2. Other usage, for which this machine is not designed, such as breaking rocks, demolishing buildings, driving piles, transporting personnel, etc. is considered to be improper and unsafe use. Neither the manufacturer nor the dealer can be held responsible for any damage or accident resulting from such unauthorized use of the machine. Any risk in improperly using this machine is the sole responsibility of the user.
3. Machines used in special applications are subject to special conditions, among others, they must be equipped with the appropriate safety devices.

4. The proper and intended use also includes the strict adherence to the operating and maintenance guidelines issued in this Operation and Maintenance manual and careful adherence to the inspection and maintenance schedules and guidelines.

2.3 Decals on the machine

1. Several types of decals are attached to your machine.

Type of decals:

- Safety decals
- Reference decals
- Data tags

Their contents and location are described, as follows.
The Id. No. can be found in the spare parts list.

2.3.1 Safety decals

1. Nonobservance of safety decals can result in severe injuries or death. The safety decals must be checked regularly to insure they are still complete and legible. Missing or illegible safety decals must be replaced immediately.



Warning label - Stay clear

Warning label - Stay clear

This decal is attached to the outside, on the left and right hand side of the machine.

Warns that a dangerous accident could occur which could result in death or severe injury.

Meaning: No one may remain in the danger zone, everyone must stay clear of the machine!

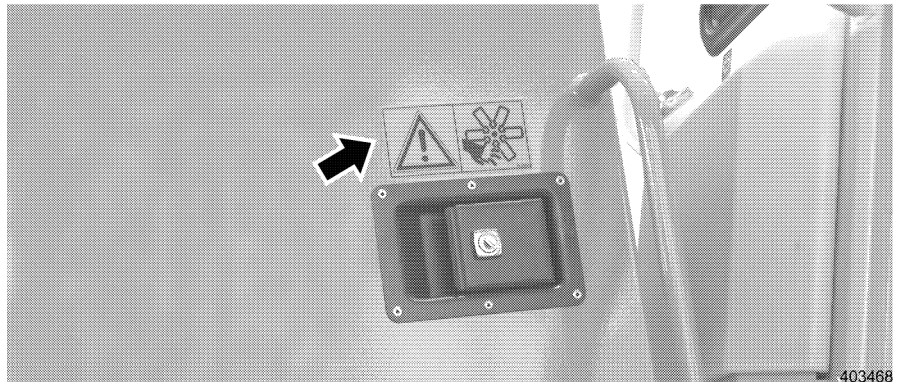

Decal - Engine standstill

Decal - Engine standstill

The decal is installed on the left and right hand side on the engine compartment doors.

Warns that a dangerous accident could occur which could result in severe injury.

Meaning: Open only when the engine is not running!

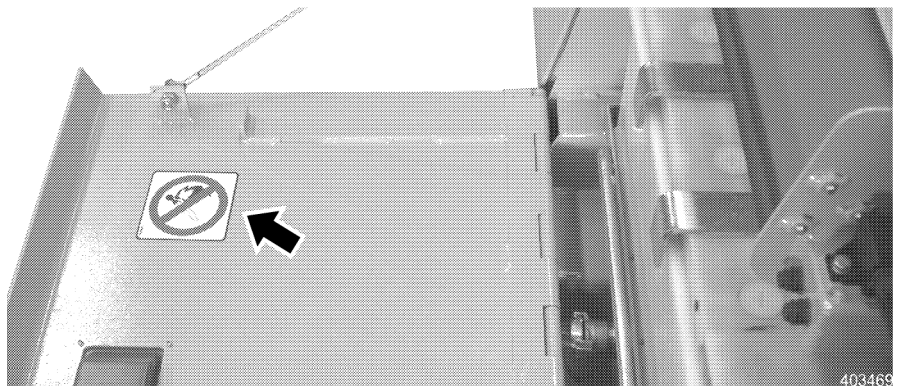

Decal - Battery

Decal - Battery

The decal is installed in the battery compartment.

Warns that a dangerous accident could occur which could result in severe injury.

Meaning: Do not smoke or keep an open flame near batteries.

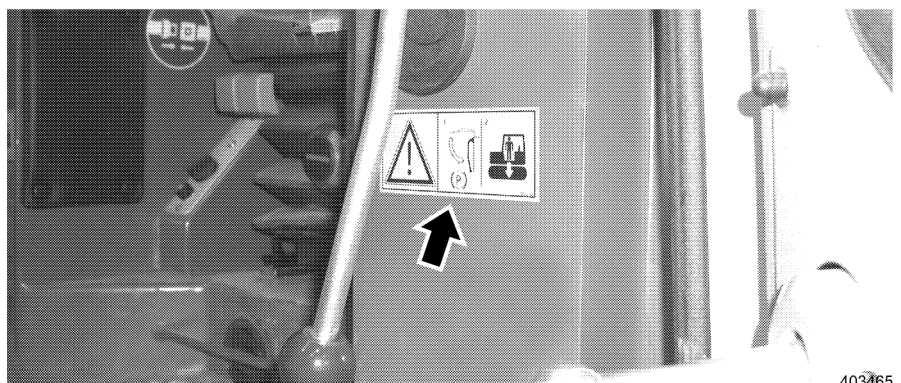

Decal - Safety lever

Decal - Safety lever

The decal is installed on the left and right hand side of the operator's seat.

Warns that a dangerous accident could occur which could result in death or severe injury!

Meaning: Before leaving the operator's seat, place the safety lever down. In dangerous situations, immediately lower the attachment, then the safety lever.

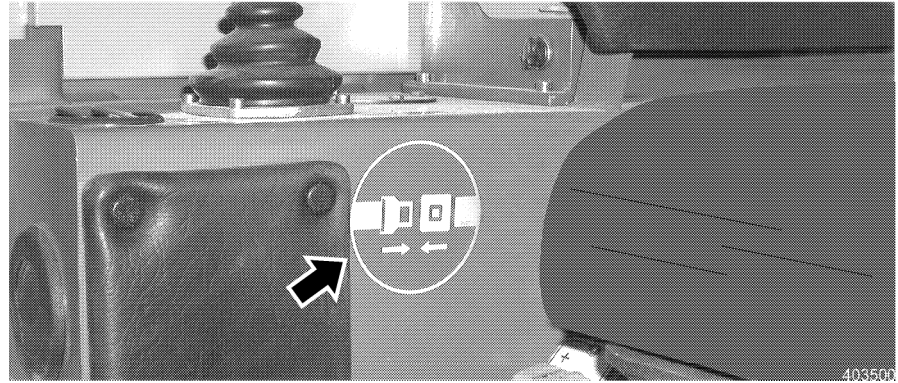

Decal - Seat belt

Decal - Seat belt

The decal is installed on the right hand side of the operator's seat.

Notes the importance of wearing a seat belt.

Meaning: Always wear a seat belt before operating the machine.

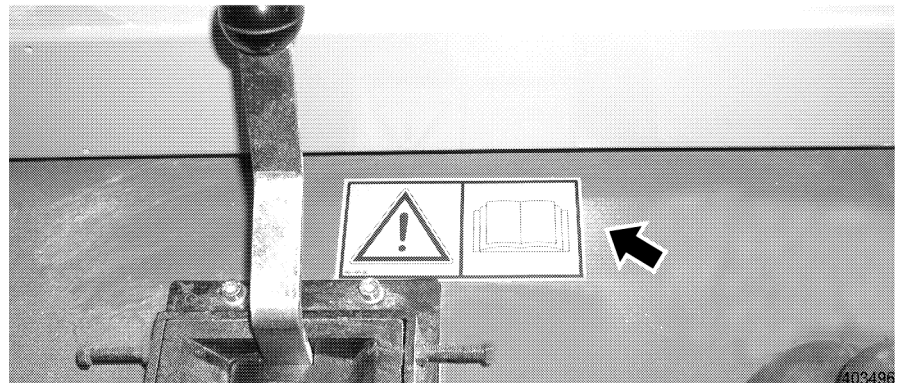

Decal - Accident prevention

Decal - Accident prevention

The decal is installed on the left hand side of the operator's seat, near the travel joystick.

Reminds the operator to read the Operation and Maintenance Manual and to read and observe the safety guidelines to prevent accidents.

Meaning: Operate the machine only if you have read and understand the instructions given in the Operation and Maintenance Manual.

When operating the machine, the accident prevention guidelines printed in the Operation and Maintenance Manual must be strictly observed!

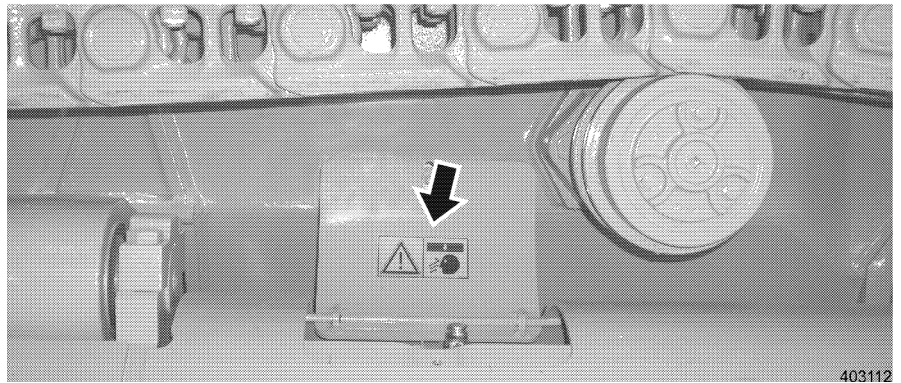

Decal - Chain tension

Decal - Chain tension

The decal is installed on the left and right hand side of the track roller frame near the grease cylinder.

Warns that a dangerous accident could occur which could result in severe injuries.

Meaning: When releasing the chain tension, keep your head clear of the track roller frame - the chain might drop and the grease can squirt out.

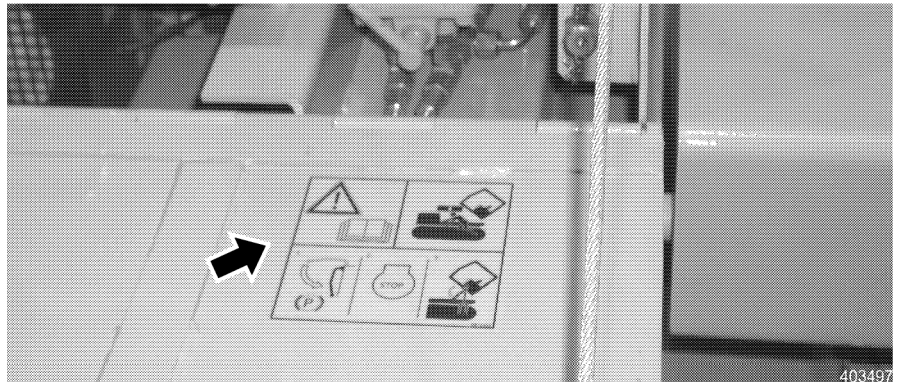

Decal - Operator's cab tilt device

Decal - Operator's cab tilt device

The decal is installed in the battery compartment near the hydraulic hand pump.

Warns that a dangerous accident could occur which could result in death or severe injuries.

Meaning: Do not stand under the cab unless the safety bar is placed to secure the tilted cab. The machine may not be started or driven when the cab is tilted, the safety lever must always remain in the lowest position (safety lever down).

2.3.2 Reference decals

The reference decals show certain points regarding operation, maintenance and machine characteristics.

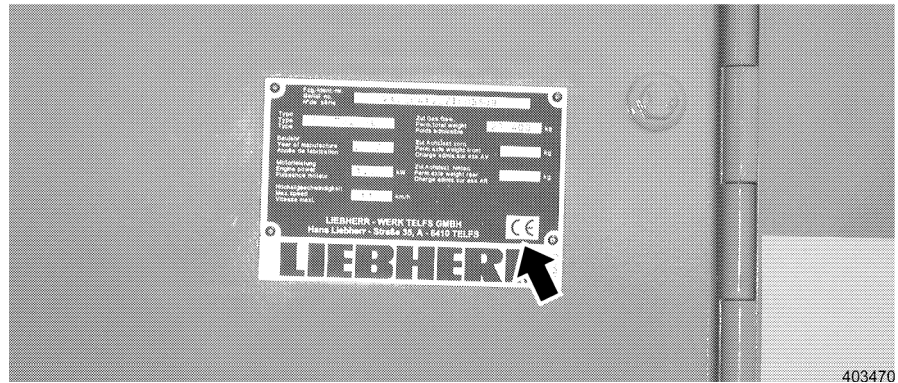

CE mark

Decal - Conformity mark - CE

This mark is included in the date tag on the left hand side on the main frame.
Shows conformity to the regulations of EU machine guidelines.

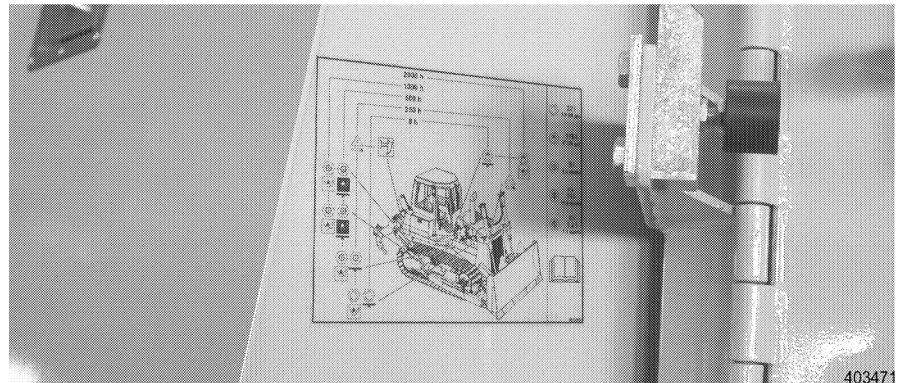

Decal - Lubrication chart

Decal - Lubrication chart

The decal is installed on the right hand side on the battery compartment. The lubrication chart illustrations show all components, which use oil or grease as well as the inspection and change intervals for these parts.

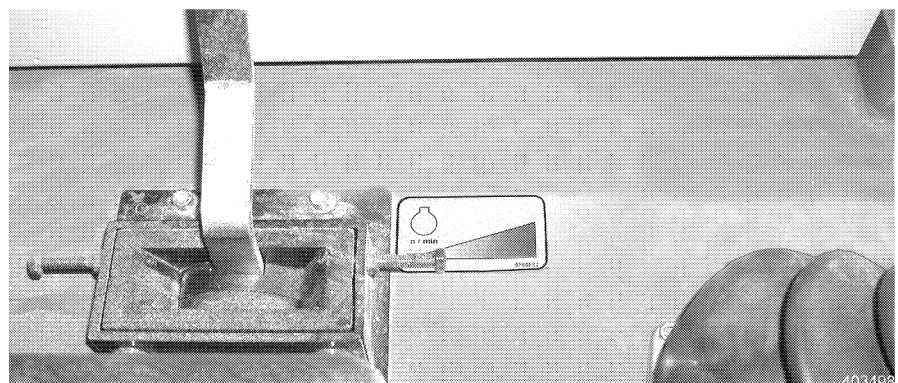

Decal - Engine operation

Decal - Engine operation

The decal is installed on the left hand side on the operator's seat. Shows the operation of the throttle control lever for the Diesel engine.

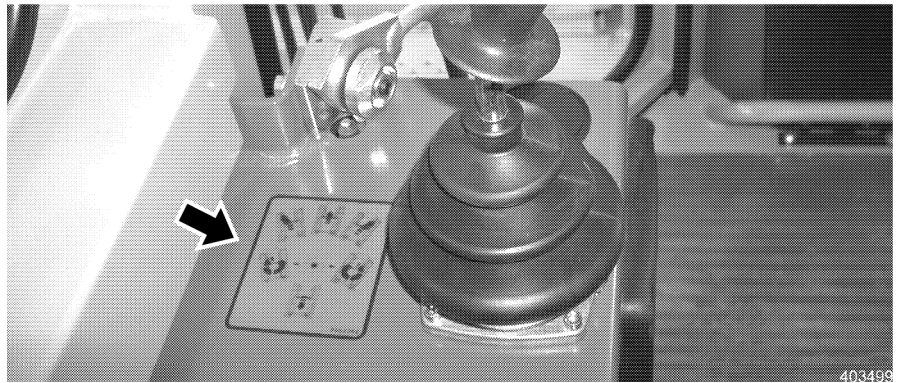

Decal - Travel hydraulic

Decal - Travel hydraulic

The decal is installed on the left hand side of the operator's seat. Shows the operation of the travel joystick for the travel functions of the machine.

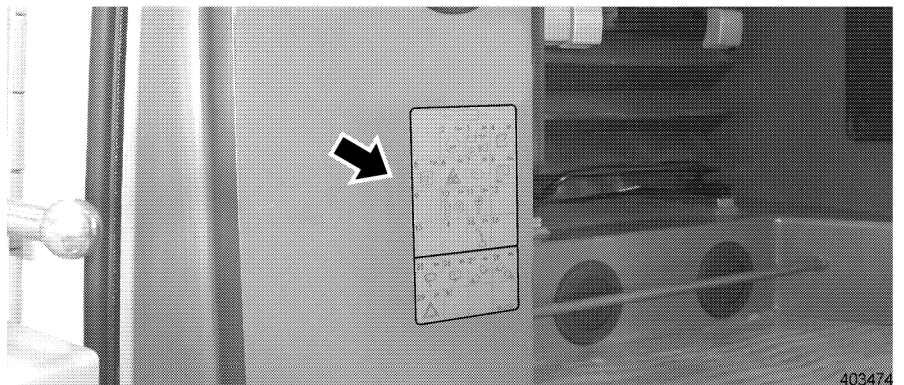

Decal - Fuses

Decal - Fuses

The decal is installed on the front of the operator's seat. Shows the location and rating of the fuses.

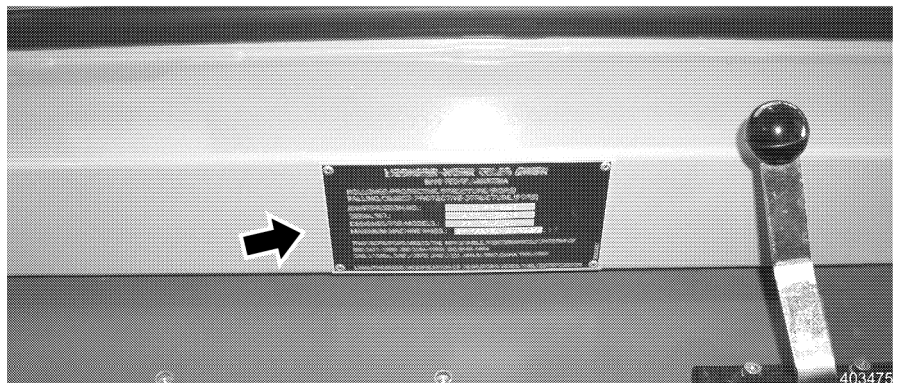

Decal - Rops - Fops

Decal - Rops - Fops

The decal is installed on the operator's cab, on the left hand side of the operator's seat. Shows the maximum load for roll-over protection.

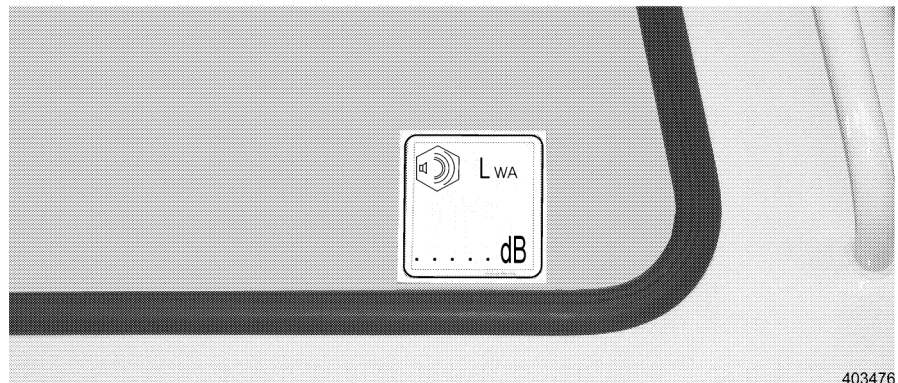

403476

Decal - Sound protection

Decal - Sound protection

The decal is installed on the inside of the window pane in the operator's cab.

LWA = Sound emission level (sound emission level emitted to the surrounding area)

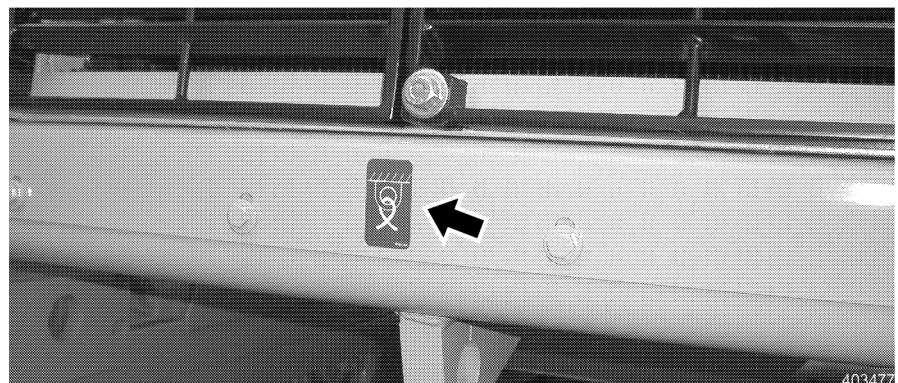

403477

Decal - Rigging points

Decal - Rigging points

The decal is installed on the rigging points of the machine. Shows the rigging points of the machine.

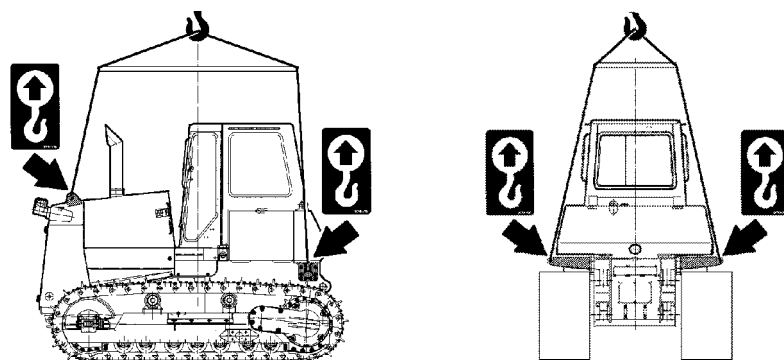

403501

Decal - Lifting points

Decal - Lifting points

The decal is installed on the lifting points of the machine. Shows the lifting points of the machine.

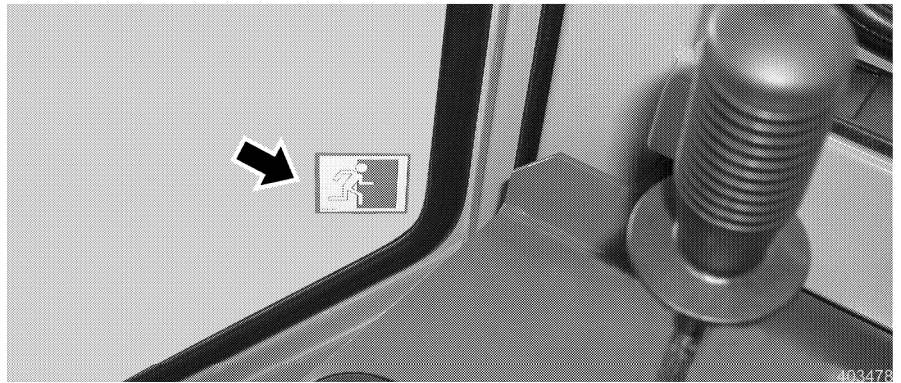

Decal - Emergency exit

Decal - Emergency exit

The decal is installed on the right door of the operator's cab. Shows the emergency exit.

2.3.3 Data tags

The machine and components, such as Diesel engine, gear, pumps etc. are marked with a data tag, which shows the serial numbers for the individual components.



Data tag - Machine

Data tag - Machine

The data tag is installed on the left front of the main frame. Data noted on the tag:

- Type
- Vehicle Id. No.
- Permissible total weight
- Year
- Engine output
- Maximum speed

2.4 Safety guidelines**2.4.1 General Safety Guidelines**

1. Study the Operation and Maintenance Manual before operating the machine.
 - Make certain that you have additional information for the special attachments of your machine, read it and make sure you understand it.

2. Only trained and authorized personnel may operate, maintain, service and repair this machine.
 - Make sure you are aware of the permissible minimum age requirements, as stated by law.
3. Utilize only trained or specially instructed personnel, make sure everyone is aware of the person / persons responsible for the operation, installation of attachments, maintenance and repair of the machine.
4. Determine the responsibility of the operator (to include adherence to traffic regulations) and permit him to refuse to carry out unsafe instructions and practices given by a third person.
5. Do not allow any personnel, either still to be trained or already in training to work on the machine unless that person is under constant supervision of an experienced instructor or operator.
6. Periodically check to see if all persons observe all safety guidelines and work cautiously, as noted in the "**Operation and Maintenance Manual**".
7. Always wear proper clothing when operating or working on the machine.
 - Avoid wearing rings, watches, bracelets, ties, scarves, open jackets, loose clothing, such as unbuttoned or unzipped jackets, etc. they are dangerous as they could get caught in the machinery resulting in serious injury.
 - Wear proper safety equipment for certain work, such as safety glasses, safety shoes, hard hats, gloves, reflective vests, ear protection,...
8. Consult your employer or supervisor for specific safety equipment requirements and safety regulations applicable to the job site.
9. Never use the safety lever, control levers or joysticks as handholds when entering or leaving the cab. This could trigger inadvertent movement of the machine and cause serious accidents.
10. Never jump off the machine! Climb on and off the machine only by using the steps, rails and handles provided. When climbing on or off the machine, use both hands for support and face the machine.
11. Keep steps, ladders and handrails and handles free of oil, grease, mud, snow and ice. These precautions will minimize the danger of slipping, stumbling or falling.
12. Familiarize yourself with the emergency exit route through the right cab door.
13. If no other instructions were given, proceed as follows for maintenance and repairs:

Procedure:

 - Park the machine on firm and level ground and lower the attachment to the ground.
 - Bring all operating and control levers into neutral position.
 - Turn the engine off, leave the ignition key in contact position.
 - Actuate the operating lever / joystick several times to relieve the pressure in the hydraulic lines.
 - Bring all operating and control levers into neutral position.
 - Place the safety lever in the full down position before leaving the machine.
 - Remove the ignition key.
14. Before any work on the hydraulic circuit, you must also - with the ignition key in contact position - actuate all pilot controls (joysticks and pedals) in both directions to relieve pressure in the servo and hydraulic circuit. Then relieve the hydraulic tank pressure.
15. The safety lever must always be placed in the full down position before leaving the operator's seat and the cab.
16. Secure all loose parts on the machine.

17. Never operate the machine until you have performed a complete walk-around inspection. Also check if all warning decals are on the machine and if all of them are legible.
18. Check and follow all instructions on the warning and safety decals.
19. The machine must be equipped with specific safety devices for use in special applications. Utilize the machine only if they are installed and fully functioning.
20. Never change, add or modify anything on the machine which could influence the safety of the machine without explicit written permission of the manufacturer. This also applies to the installation and adjustment of safety devices and valves as well as for any welding on load carrying machine parts or sections.

2.4.2 Crushing and burn prevention

1. Never work underneath the attachment unless it is safely placed on the ground or properly blocked and supported.
2. Never use damaged or insufficient load carrying devices, such as chains, ropes, ...). Always wear gloves when handling wire rope or cables.
3. When working on the attachment, never align bores with your fingers, always use proper alignment tools when installing, changing or servicing attachments.
4. When the engine is running, make sure that no objects touch the radiator fan. Rotating fans will swirl and throw out objects which can become very dangerous and in addition to damaging the fan, they can cause severe injury to yourself and others.
5. Avoid contact with components containing coolant. At or near operating temperature, the engine coolant is hot and under pressure and could cause severe burns.
6. Check the coolant level only after the radiator cap is cool enough to touch. Remove the cap slowly to relieve pressure.
7. Do not allow your skin to come into contact with hot oil or components containing hot oil. At or near operating temperature, engine and hydraulic oil is hot and can be under pressure.
8. Always wear safety glasses and protective gloves when handling batteries. Make sure there are no sparks and open flames in the vicinity.
9. Never permit anyone to hand-guide the attachment into its proper position.
10. Secure the engine compartment doors in open position to avoid unwanted closing. Use the supports installed for this purpose.
11. Insure that all engine and battery compartment doors are closed and locked before operating the machine.
12. Never work underneath the machine if the machine has been raised with its attachment. Prior to working underneath, the machine and / or its attachment must always be properly blocked and supported with wooden blocks. Do not use steel on steel support.

2.4.3 Fire and explosion prevention

1. Always shut the engine off before refueling.
 - In addition, the heater must also be turned off before refueling.

2. Never smoke or allow an open flame in refueling areas and / or where batteries or flammable materials are being charged or stored.
3. Always use the proper engine starting procedure, as described in the **"Operating Manual"**.
4. Check the electrical system frequently. Correct any defects, such as loose connections, chafed wiring, or burnt out fuses and bulbs immediately.
5. Never store or carry any flammable fluids on the machine, except in the storage tank intended for machine operation.
6. Regularly check all components, lines, tubes, and hoses for oil and fuel leaks and / or damage. Replace or repair damaged components immediately.
 - Oil and fuel leaks can cause fires.
7. Be certain that all clamps, guards and heat shields are installed. These components prevent vibration, rubbing and heat build up. Install tie wraps to fasten hoses and wires, as required.
8. Cold start ether is extremely flammable! Never use cold start ether near heat sources, open flames, or near anyone who is smoking cigarettes. Use only in well ventilated area and as directed.
9. Never use the flame glow plug or preheat system when you use an ether cold start aid. Danger of explosion!
10. Know the location of the fire extinguishers, make sure you know how to use them properly. Check out the location of where to report a fire and inform yourself about fire fighting capabilities on the job site before you start to work.

2.4.4 Machine start up safety

1. Before starting the machine, perform a thorough walk-around inspection.
2. Check the machine for loose bolts, cracks, wear, leaks and any evidence of vandalism.
3. Never start or operate an unsafe or damaged machine.
4. Be certain that all defects are taken care of immediately.
5. Make sure that all covers and doors are closed and locked. Check if all warning and safety decals are on the machine, make sure that all of them are legible.
6. Clean all windows and mirrors, secure all doors and windows to prevent any inadvertent movement.
7. Always enter and leave the cab through the left door. Use the right door only in emergencies.
8. Make sure that no one is on or under the machine. Warn all personnel in the surrounding area on the job site before operating the machine.
9. After entering the operator's cab, adjust the operator's seat, the mirrors, the arm rests and the seat belt so you can work comfortably.
10. All noise level protection devices on the machine must be operational when operating the machine.
11. Never operate the machine without a cab or canopy.

2.4.5 Engine start up safety

1. Before starting the engine, check all indicator lights and instruments for proper function. Place all operating and control levers into neutral position.
2. Before starting the engine, warn any personnel in the surrounding area by sounding the horn.
3. Start the machine only while seated in the operator's seat.
4. If no other instructions were given, follow the engine starting instructions are outlined in the "**Operating Manual**".
5. Start the engine and check all indicator lights, gauges, instruments and controls.
6. Start the engine only in a well ventilated area. If necessary, open doors and windows to assure a sufficient fresh air supply
7. Warm up the engine and hydraulic system to bring the engine and hydraulic oil to operating temperature, as low oil temperatures cause the machine to be unresponsive.
8. Check that all attachment functions are operating properly.
9. Move the machine slowly and carefully into an open area and check the travel and brake functions, the steering function as well as the turn signals and lights.

2.4.6 Machine operating safety

1. Make sure that you are aware of any special circumstances on the jobsite, make sure you are familiar with any special guidelines and warning signals. Familiarize yourself with the jobsite before starting to work, any special hindrances and obstacles influencing the operation or movement, the ground conditions and any special protection required to secure the job site from public highway traffic.
2. Always keep a safe distance from overhangs, walls, drop offs and unstable ground.
3. Make sure you are especially aware of changing ground conditions, visibility or weather conditions.
4. Make sure you know the location of utility lines. Be aware of underground cables, gas and water lines. You must be especially careful when working near supply lines. If necessary, contact the appropriate utility company for information and location of utility lines.
5. Keep sufficient distance from electrical lines with the attachment. Avoid working near high voltage electrical lines.
 - There is a **DANGER OF LOSS OF LIFE!**
 - You must inform yourself of proper distances to assure your safety while working.
6. **If you do touch an electrical line with the attachment or machine, proceed as follows:**
 - Do not leave the machine!
 - If possible, move the machine a sufficient distance away from the danger area.
 - Warn all personnel in the surrounding area not to come close to the machine and / or touch the machine.
 - Instruct somebody to turn the electrical power off.
 - Do not leave the machine until you are assured that the electrical line which has been touched or damaged is no longer energized, and the power has been turned off!
7. Before moving or working, make sure you always check that the attachments can be operated safely.

8. When traveling or moving the machine on public roads, highways or properties make sure to observe all applicable laws, rules and regulations. After moving a machine it may become necessary to reassemble it and to bring it back to proper operating conditions.
9. Always turn on the lights if visibility is poor or as dusk approaches.
10. Never allow another person to ride along on the machine.
11. Always work while seated in the operator's seat and with the seat belt secured.
12. In the event the machine should tip, remain in the operator's seat with the seat belt securely fastened. Experience has shown that it is safer to remain in the cab in the event of an overturn.
13. Report any functional problems or defects immediately and make sure that all necessary repairs are completed before resuming operation.
14. Be certain that no one is endangered by moving the machine.
15. Do not get up from the operator's seat as long as the machine is still moving.
16. Never leave the machine unattended with the engine running.
17. When traveling, make sure that the attachment is in transport position and keep the load as close to the ground as possible.
18. Avoid any working movement, which could cause the machine to tip over or overturn. However, if the machine does begin to tip or slide or slip on a grade, immediately lower the attachment and load to the ground and turn the machine downhill. If possible, work downhill or uphill, never sideways on a slope.
19. Always move slowly on rocky, rough or slippery ground or on a slope.
20. Always adapt your travel speed to working conditions.
21. Never travel on slopes that exceed the maximum permissible gradeability of the machine.
22. Never travel downhill at maximum speed, always at low speed to prevent loss of control. The engine must be at high idle and the speed must be reduced by preselecting the low speed range. Always change to low speed range before reaching the slope, never move onto a slope and then change the speed range.
23. When loading a truck, the driver must leave the cab, even if the cab is FOPS protected.
24. The machine must always be equipped with proper protective devices designed for the specific purposes. The machine must be equipped with proper protection when it is utilized in demolition work, land clearing, crane operation, etc.
25. Always have another person guide you if visibility is restricted. Always take signals from one person only.
26. Utilize only experienced personnel to attach loads and direct operators. The person giving signals must be visible to the operator or be equipped with two way radios.

2.4.7 Machine parking safety

1. Park the machine only on firm and level ground. If it becomes necessary to park the machine on a grade, it must be properly blocked with wedges to secure it and prevent any unintentional movement.
2. Lower the attachment to the ground and lightly anchor it in the ground.

3. Bring all operating levers and controls into neutral position, place the safety lever in full down position and turn the engine off, as outlined in the Operation and Maintenance Manual, before you leave the operator's seat.
4. Lock the machine, remove all keys and secure the machine against vandalism and unauthorized use.
5. Never park the machine in such a way as to block access to entrances, exits, ramps, fire hydrants, etc.

2.4.8 Machine transporting safety

1. Use only safe transportation and lifting devices with adequate carrying load capacity.
2. Park the machine on level ground and use wedges to hold chains or wheels.
3. If necessary, remove part of the attachment of the machine for transport.
4. Never use a ramp that is steeper than 30° to move the machine onto the transporting vehicle, the ramp should be covered with wooden planks to prevent slipping.
5. Before moving onto the ramp, remove any snow, ice and / or mud from chains or wheels.
6. Align the machine with the ramp.
7. Use another person as a guide to signal you, the operator. Move very slowly and carefully towards the ramp and the transporting vehicle.
8. Raise the attachment and move onto the ramp. Hold the attachment as close as possible to the loading platform.
9. After the loading procedure, lower the attachment onto the trailer platform.
10. Secure the machine and all remaining parts with chains and wedges to prevent any slipping or movement during transport.
11. Relieve pressures from hydraulic liens and hoses, remove the ignition key, lock the operator's cab and covers before leaving the machine.
12. Carefully check out the transporting route beforehand, check any regulations regarding width, height and weight.
13. Make sure that there is enough clearance underneath all bridges and underpasses, utility lines and tunnels.
14. During off loading, use the same care and caution as during the loading procedure.
Proceed as follows:
 - Remove all chains, wedges and blocks. Start the engine as noted in the Operating Manual.
 - Carefully move from the trailer platform down the ramp.
 - Hold the attachment as close as possible above the ground.
 - Use a guide to signal you.

2.4.9 Machine towing safety

1. Always follow the correct procedure as noted in the "**Operating Manual**", see "Towing the machine".
2. Tow the machine only in exceptional cases, such as removing the machine from a dangerous area to have the machine repaired.
3. Be sure that all towing and pulling devices, such as cables, hooks, etc. are safe and adequate.

4. The cable or towing bar, which is used to tow the machine, must be adequate to pull the machine and must be connected to the appropriate bores or couplers. Any damage or accident which is the direct result of towing this machine is expressly excluded from the manufacturer's and / or LIEBHERR warranty.

Notes for towing with a cable:

- Make sure that no one is near the tensioned cable when pulling or towing the machine.
 - Keep the cable tight and free of kinks.
 - Carefully pull the cable tight, do not jerk!
 - A sudden jerk can cause a slack cable to snap.
5. When towing, keep the machine in the correct transport position, and maintain the permissible speed and route.
 6. When returning the machine to operation, proceed as noted in the Operating Manual.
 7. After towing the machine, and before continuing operation, be certain to return the machine to a safe operating condition.

2.4.10 Machine maintenance safety

1. Never perform any maintenance or repairs for which you are not qualified or you do not understand.
2. Any maintenance and inspection should be performed in the intervals noted in the Operation and Maintenance Manual.
To perform any repairs, make sure you have the proper tools.
3. Maintenance work should be performed according to the chart at the end of this Operation and Maintenance Manual. It is also noted who should or may perform what type of work. The operator should only perform items marked OM on the maintenance and inspection chart. The remaining work should only be performed by trained personnel.
4. All spare parts must conform to the technical requirements set forth by the manufacturer. This is only assured if Original LIEBHERR spare parts are used.
5. Always wear proper and safe work clothing. For certain jobs, in addition to hard hats and safety shoes, additional safety equipment is required, such as safety glasses and gloves.
6. Keep unauthorized personnel from the machine during maintenance and repair work.
7. Secure the maintenance area, as necessary.
8. Inform operators if any special tasks or maintenance work is required. Appoint one supervisory person to assure that this work has been done properly.
9. Perform all maintenance work with the machine parked on firm and level ground and with the engine turned off, unless otherwise specified in the Operation and Maintenance Manual.
10. The cab may only be raised if the machine is parked and the engine is turned off! Before raising the cab, make sure no personnel is within the proximity of the cab. Always secure the raise cab with the safety bar before working under the raised cab. The machine may **NEVER** be moved when the cab is raised! The safety lever must always remain in the full down position!
11. After any maintenance and repair work on the machine, make sure that all screw connections or fittings, which had to be loosened, are retightened.

12. If it becomes necessary to remove any safety devices during maintenance and repair, the safety devices, which were removed, must be reinstalled immediately and then be inspected for proper function.
13. Before servicing the machine, especially when working under the machine, attach an easily visible warning label **DO NOT OPERATE** to the ignition switch. Remove the ignition key.
14. Before any maintenance or repair, clean off any oil, fuel or service fluids from connections and couplings. Do not use harsh cleaning fluids. Use lint free cleaning rags.
15. To clean the machine, do not use flammable fluids.
16. Before any welding, cutting or grinding, clean the machine and surrounding area of dust, and assure adequate ventilation.
 - Otherwise, there is a **DANGER OF EXPLOSION**.
17. Before cleaning the machine with water, steam (high pressure cleaning systems) or other cleaning fluids, cover or tape all openings, make sure that no water, steam or cleaning fluids enters these openings for safety and functional reasons.
Electrical motors, switch boxes, and battery compartments are especially endangered.

In addition:

- Make sure that during cleaning work, the temperature sensors for the fire warning and sprinkler system do not come in contact with the hot cleaning fluid, or the sprinkler system could be actuated
 - After the cleaning procedure, completely remove all covers and tapes.
 - After cleaning the machine, check all fuel, engine oil, and hydraulic lines for leaks, for loose connections, for chafed and damaged areas.
 - All problems must be remedied immediately.
18. Adhere to the product safety instructions issued for handling oils, grease and other chemical substances.
 19. Make sure to dispose of any operating and service fluids as well as replacement parts properly and in an environmentally sound manner.
 20. Be very careful when handling any hot components or fluids on the machine as there is a danger of burns and scalding.
 21. Use combustion motors and fuel operated heaters only in areas with adequate ventilation. Before start up, make sure that the ventilation is adequate. Follow and adhere to any local regulations and guidelines and instructions pertaining to the present jobsite.
 22. Perform any welding, cutting or grinding work on the machine only if this work has been explicitly authorized, as there can be a danger of fire and / or explosion.
 23. The window panes in the operator's cab are made of safety glass. Always replace damaged window panes in the operator's cab immediately.
 - The window panes in the operator's cab must be made of safety glass.
 - Use only Original LIEBHERR spare parts.
 24. Do not try to lift heavy parts. Always use appropriate lifting aids and devices with sufficient load carrying capacity.
Procedure:

- To lift spare parts and component assemblies for replacement on the machine, they must be securely mounted and secured onto the lifting device to prevent accidents.
 - Use only suitable and flawless lifting devices as well as hooks, ropes, slings, shackles, etc. with sufficient load carrying capacity.
 - **Do not allow anybody to work or remain underneath a suspended load.**
25. Do not use damaged or insufficient wire ropes. Always wear gloves when handling wire ropes and cables.
 26. Only experienced personnel may attach loads and signal the operator. The person used as a guide must be visible by the operator or be in direct voice contact with the operator via a two way radio.
 27. When installing parts higher up or when working overhead, always use safe scaffolding, ladders or working platforms. Do not step on any parts to get closer to the work area. You must wear safety harnesses or similar safety equipment when working higher up. Make sure that all handles, steps, walk ways, cat walks, and ladders etc. are always free of dirt, snow and ice.
 28. When working on or changing any part of the attachment, for example when changing the teeth, make sure that the attachment is properly supported. Never use metal on metal supports.
 29. Never work underneath the machine if the machine has been raised by its attachment. Prior to working underneath, the machine and / or its attachment must always be properly blocked and supported with wooden blocks.
 30. Always block the machine in such a way that any change in the center of gravity will not endanger its stability. Never use metal on metal support.
 31. Only authorized, trained personnel may work on the travel gear, brake and steering system.
 32. If the machine must be repaired while parked on a slope, the track chains or wheels must be blocked with wedges to prevent any movement. The attachment must be brought to proper maintenance position.
 33. Only authorized personnel who have received specialized training may work on the hydraulic system.
 34. Always wear gloves when checking for leaks. Never check for leaks with your bare hands. A thin stream of fluid escaping from as small hole can have enough force to penetrate the skin.
 35. Never loosen the hydraulic lines or connections until the attachment has been lowered to the ground, the engine has been turned off - with the ignition key in contact position - all servo controls (joysticks and pedals) have been actuated in both directions to release any servo pressure and to release all pressures in the working circuit and the tank pressure has been release by slowly opening the bleeder screw.
 36. Regularly check all hydraulic lines, hoses and connections for any leaks and damage. Any defects must be repaired immediately. Any escaping fluid can cause serious injury and fire.
 37. Before beginning repairs, you must also make sure that all air pressures are relieved in any of the systems you need to gain access to. To be certain, refer to the description for the various component groups and assemblies.

38. Route and install all hydraulic and air pressure lines properly. Mark and check all connections to prevent any mix ups. All the fittings, including length and quality or type of hoses used must match the requirements set forth by the manufacturer.
For that reason, use only Original LIEBHERR spare parts.
39. Replace hydraulic hoses and lines in regular intervals, as stated, even if no defects can be seen.
40. Work on the electrical components of the machine may only be performed by a certified electrician or by a person working under the guidance and supervision of such a licensed electrician and according to electro-technical procedures, rules and regulations.
41. Use only Original fuses with the same amperage. In case of problems in the electrical power supply, turn the machine off immediately.
42. Inspect / check the electronic components of the machine regularly. Repair any problems or defects, such as loose connections or chafed wires and replace any burnt out fuses and bulbs immediately.
43. If any work is necessary on energized, voltage carrying parts a second person must be utilized to disconnect the main battery switch in case a problem should arise. Rope off the working area with a red / white safety chain and a warning sign. Use only insulated tools.
44. When working on high voltage carrying components or sections, turn off the power supply, then connect the power supply cable to the ground wire and use the grounding rod to ground these parts, such as the condenser, for example.
45. Check the disconnected parts first to see if they are really voltage free, ground them and then close them off. Insulate the voltage carrying parts close by.

2.4.11 Safety guidelines to be observed when welding on the machine

1. Disconnect the battery, when working on the electrical system or before any arc welding on the machine.
 - Disconnect the negative (- minus) terminal first, and reconnect it last.
 - **In addition, before any welding, always remove the electronic box.**

2.4.12 Safety guidelines to be observed when working on the attachment

1. Never work underneath the attachment unless it is securely placed on the ground or is properly supported.
2. When replacing or changing any part of the attachment, such as blade, cutting edges, teeth, ...) never use metal on metal support.
3. Never try to lift heavy parts. Always select and use appropriate lifting devices with sufficient lifting capacity.
4. When handling wire ropes, always wear gloves!
5. Do not disconnect any lines or hoses or remove fittings, caps or covers before the attachment has been placed down and the engine has been turned off. To release pressures - with the ignition key in contact position - move all servo controls (joystick and pedals) in both directions to release the servo pressure and any pressure remaining in the hydraulic circuit, then release the tank pressure by turning the bleeder screw.

6. After completion of all maintenance and repairs, make sure that all lines and hoses and fittings are properly connected and retightened.
7. Removing and installing the steel pins with a hammer can be very dangerous. Metal chips can cause injury.
 - Always wear gloves and safety glasses.If possible, use appropriate tools for the job, such as pin pullers, punches, etc.).

2.4.13 Safety guidelines to be observed when loading the machine with a crane

1. Lower the attachment to the ground.
2. Bring all operating and control levers into neutral position.
3. Turn the engine off, as described in the Operating Manual and place the safety lever in the full down position before you leave the operator's seat.
4. Securely close all doors, covers and hoods.
5. Utilize only experienced personnel to attach loads and direct the crane operator. The person giving signals must be visible by the operator or be equipped with a two way radio.
6. Install the shackles and hooks to the appropriate and designated brackets / bore holes on the machine.
7. Make sure the length of the lifting device is sufficient.
8. Carefully lift the machine.
9. **DANGER! Make sure no one is near or underneath the raised machine.**
10. When the machine is placed back in service, proceed according to the guidelines given in the Operation and Maintenance Manual.

2.4.14 Safe maintenance of hydraulic hoses and lines

1. Hydraulic hoses and lines may never be repaired!
2. All hoses, lines and fittings must be checked regularly, but at least once a year for leaks and any externally visible damage! Any damaged sections must be replaced immediately! Escaping oil can cause injuries and fire.
3. Even if hoses and lines are stored and used properly, they undergo a natural aging process. For that reason, their service life is limited.
4. Improper storage, mechanical damage and improper use are the most frequent causes of hose failures.
5. The service life of a hose may not exceed six years, including a storage period of no more than two years (always check the manufacturing date on the hoses).
6. Using hoses and lines close to the limit ranges of permitted use can shorten the service life (for example at high temperatures, frequent working cycles, extremely high impulse frequencies, multi-shift or around the clock operation).
7. Hoses and lines must be replaced if any of the following points are found during an inspection:
Criteria:
 - Damage on the external layer into the inner layer (such as chafing, cuts and rips);
 - Brittle outer layers (crack formation of the hose material);

- Changes in shape, which differ from the natural shape of the hose or line, when under pressure or when not under pressure, or in bends or curves, such as separation of layers, blisters or bubble formation;
 - Leaks;
 - Non-observance of installation requirements;
 - Damage or deformation of hose fittings, which might reduce the strength of the fitting or the connection between the hose and the fitting;
 - Any movement of the hose away from the fitting;
 - Corrosion on the fittings, which might reduce the function or the strength of the fitting;
 - Storage or service life has been exceeded.
8. When replacing hoses or lines, use only Original replacement parts.
 9. Route and install the hoses and lines properly. Do not mix up the connections.

2.4.15 Roll over protection (ROPS) and falling object protection (FOPS)

These are protective devices, which are integrated in the operator's cab. To reduce a weakening of the roll over or falling object protection, always check with your LIEBHERR dealer or Service Department before making any changes.

- Do not attach fire extinguishers, first aid kits, floodlights or similar objects to these protective structures.
 - Welding points or drilling of holes could weaken the structure. For similar work, always consult with your LIEBHERR dealer.
1. Any changes, which have not been explicitly approved by LIEBHERR would invalidate the roll over or falling object protection permit.
 - Damage to the structure can also be caused by a roll over accident or falling objects, etc.

2.4.16 Attachments and installations

1. Attachments and installations from other sources or parts which have not been approved by LIEBHERR for installation may not be installed on the machine without prior written permission by LIEBHERR.
2. The necessary technical documentation must be forwarded to LIEBHERR.

3. Control, instrumentation

3.1 Location of controls and instrumentation

3.1.1 Operator's cab

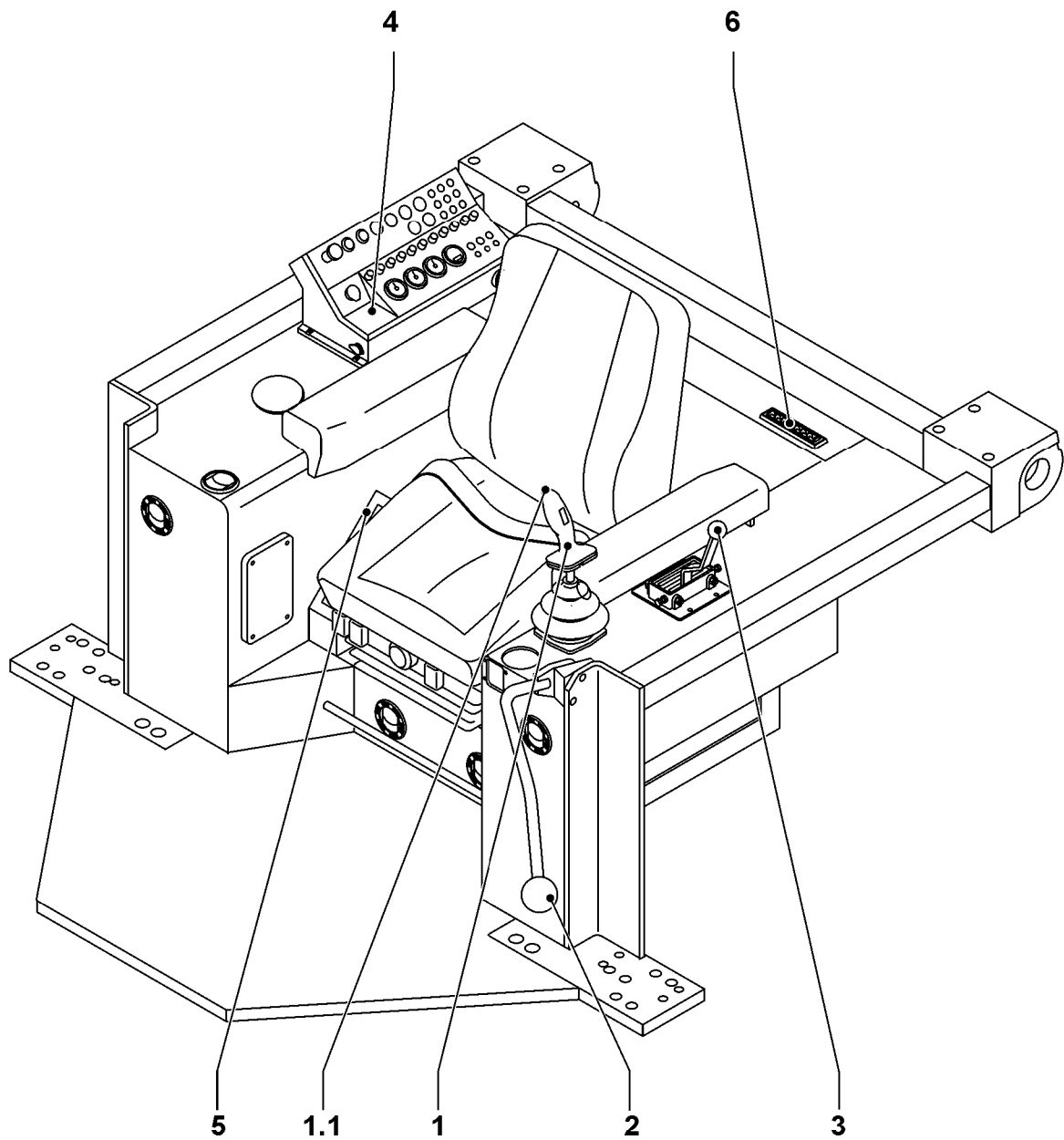

Interior view - Operator's cab

404172

1 Travel joystick
1.1 Push button for "counter rotation"

2 Safety lever
3 Engine throttle control
4 Instrument panel

5 Heater control
6 Heater vents

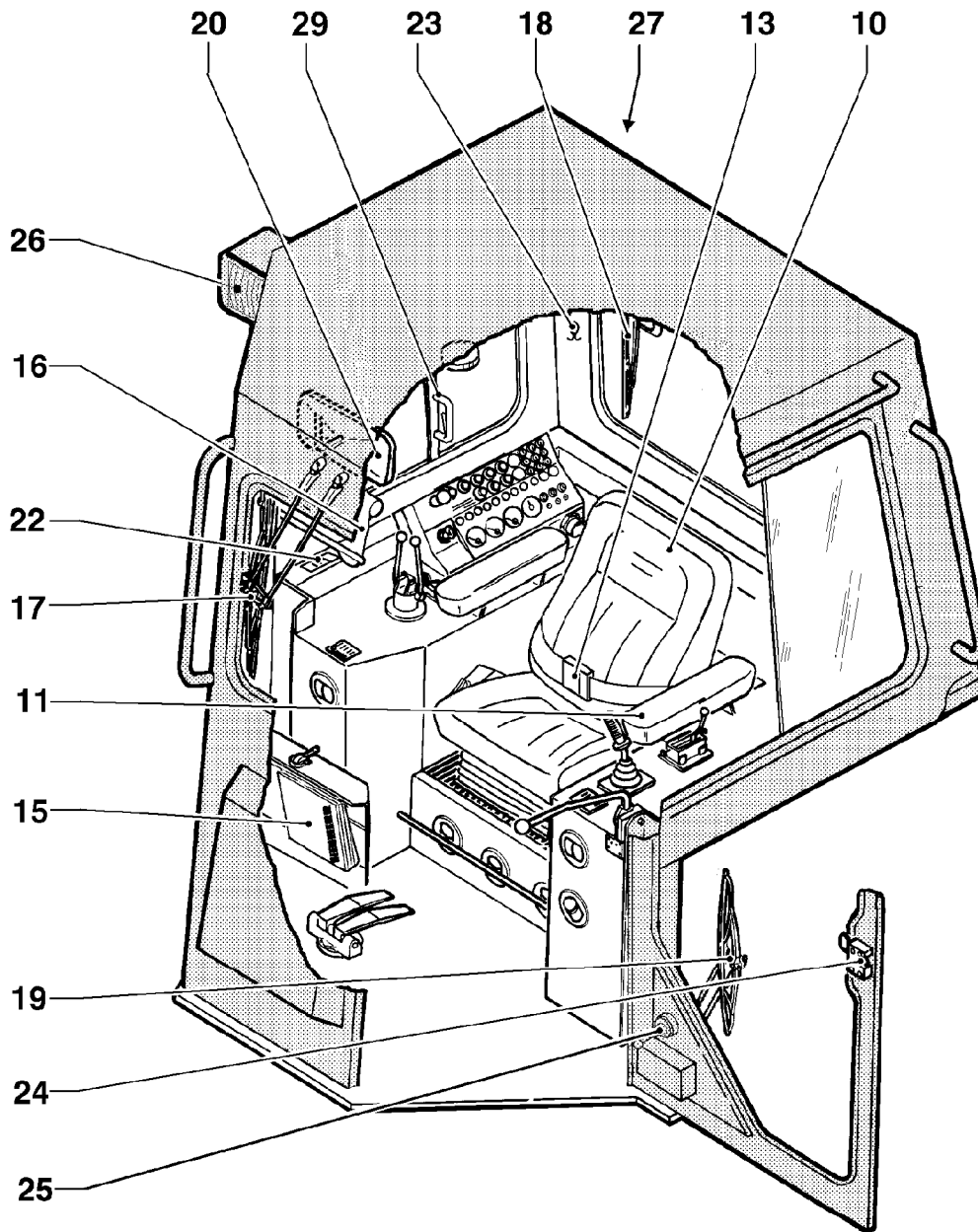

404173

Interior view - Operator's cab

- | | | |
|--|------------------------------------|-----------------------|
| 10 Operator's seat | 17 Windshield wiper - front window | 23 Coat hanger |
| 11 Arm rest | 18 Windshield wiper - rear window | 24 Door lock |
| 13 Seat belt | 19 Windshield wiper - doors | 25 Door latch |
| 15 Compartment for machine documentation | 20 Rear view mirror | 26 Floodlight - front |
| 16 Sun visor | 22 Ashtray | 27 Floodlight - rear |
| | | 29 Window lock |

3.1.2 Controls and instrumentation on the instrument panel

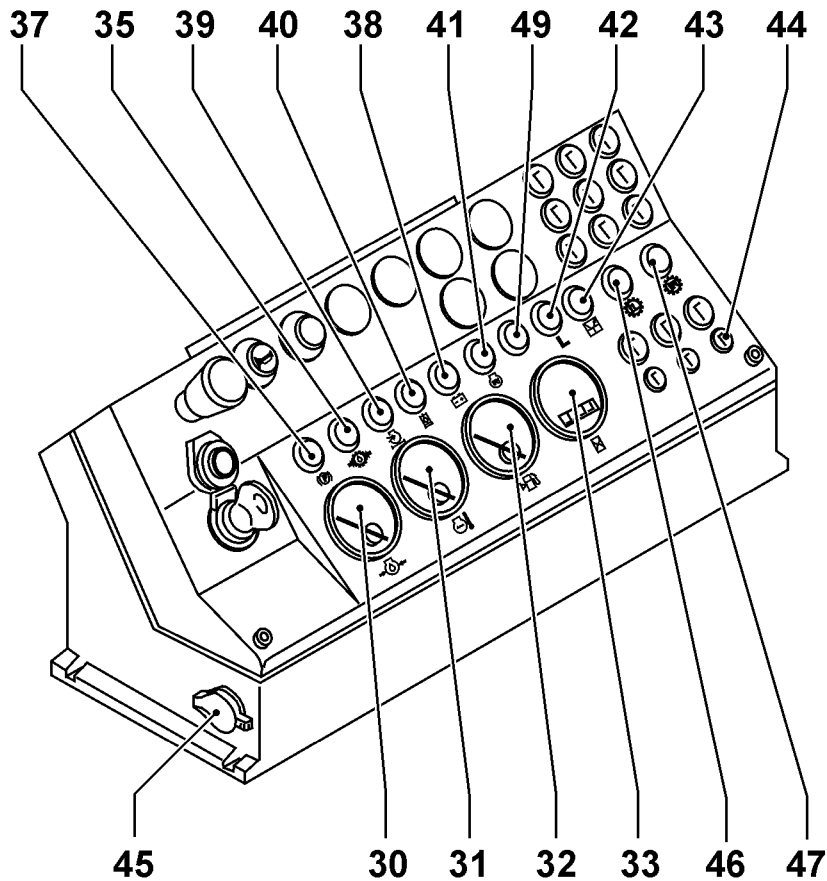

Controls and instrumentation on the instrument panel

404169

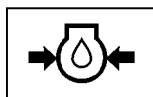

30 Engine oil pressure gauge

Shows the oil pressure of the Diesel engine.

The oil pressure may not drop below the following values:

At low idle: 1 bar

At full load: 3,5 bar

If the engine oil pressure drops below these values, turn the engine off immediately and check for and correct the problem (change the engine oil and filter, if necessary).



31 Coolant temperature gauge

Shows the coolant temperature of the Diesel engine.

If the coolant temperature stays consistently above 100°C, turn the engine off and correct the problem (clean the cooler, add coolant, check for leaks or check the water pump).



32 Fuel gauge

Shows the fuel quantity in the fuel tank.
To reduce condensation, always maintain a high fuel level in the tank.



33 Hour meter

Shows the number of hours the machine has been in operation.
Use the number of hours to schedule maintenance according to the inspection schedule.

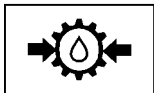

35 Indicator light - Replenishing oil pressure

Color: red

- Lights up if there is a drop in replenishing oil pressure.

Should the light come on after the engine is running, turn the engine off immediately, check for and correct the problem.



37 Indicator light - Parking brake

Color: yellow

- Lights up if the parking brake is applied.
- Lights up if the safety lever is in the down position.
- Lights up if there is a drop in replenishing oil pressure.



38 Indicator light - Battery charge

Color: red

Turns off after the Diesel engine has been started.

- Lights up, for example in case of a broken V-belt.

If the indicator light lights up, turn the Diesel engine off, check for and fix the problem.



39 Indicator light - Air filter contamination

Color: yellow

- Lights up if the air filter is contaminated.

Perform air filter maintenance.



40 Indicator light - Return filter

Color: yellow

- Lights up if the return filter element for the hydraulic oil is dirty.
(Hydraulic oil at operating temperature)

Perform return filter maintenance.



41 Indicator light - Preglow system

Color: yellow

- Lights up for approx. 20 seconds when the ignition key is in preglow position.

As soon as the indicator light turns off, continue to turn the ignition key to start the Diesel engine.



42 Indicator light - Reduced travel speed range

Color: yellow

- Lights up in reduced travel speed range.

The travel speed of the machine is reduced by switching the switch on the joystick to position II or I.



43 Indicator light - Electronic

Color: red

- Lights up when there is a problem in the electrical system.

If the indicator light comes on, turn the machine off and restart. If the indicator light does not turn off or lights up again, contact Liebherr Service.



44 Fuses

The location as well as the fuse ratings are described later in this manual.



45 Electrical outlet 24 V

- Additional electrical users (maximum 10A) can be connected via the 24V electrical outlet.

Current is available only if the ignition key is in contact position.



46 Indicator light - Travel gear - Lifetime seal area, left

Color: red

- Lights up if the oil level in the lifetime seal area is too low.
- Lights up for approx. 3 seconds when the ignition key is in contact position (self check).

If the indicator light lights up, turn the machine off, check the travel gear externally for leaks.

Contact Liebherr Service.

- To be able to continue work in the meantime, add oil to bring the oil level to normal level.



47 Indicator light - Travel gear - Lifetime seal area, right

Color: red

- Lights up if the oil level in the lifetime seal area is too low.
- Lights up for approx. 3 seconds when the ignition key is in contact position (self check).

If the indicator light lights up, turn the machine off, check the travel gear externally for leaks.

Contact Liebherr Service.

- To be able to continue work in the meantime, add oil to bring the oil level to normal level.

49 Indicator light - Welding generator

Color: yellow

- Lights up if the welding generator is turned on.

3.1.3 Controls on the instrument panel

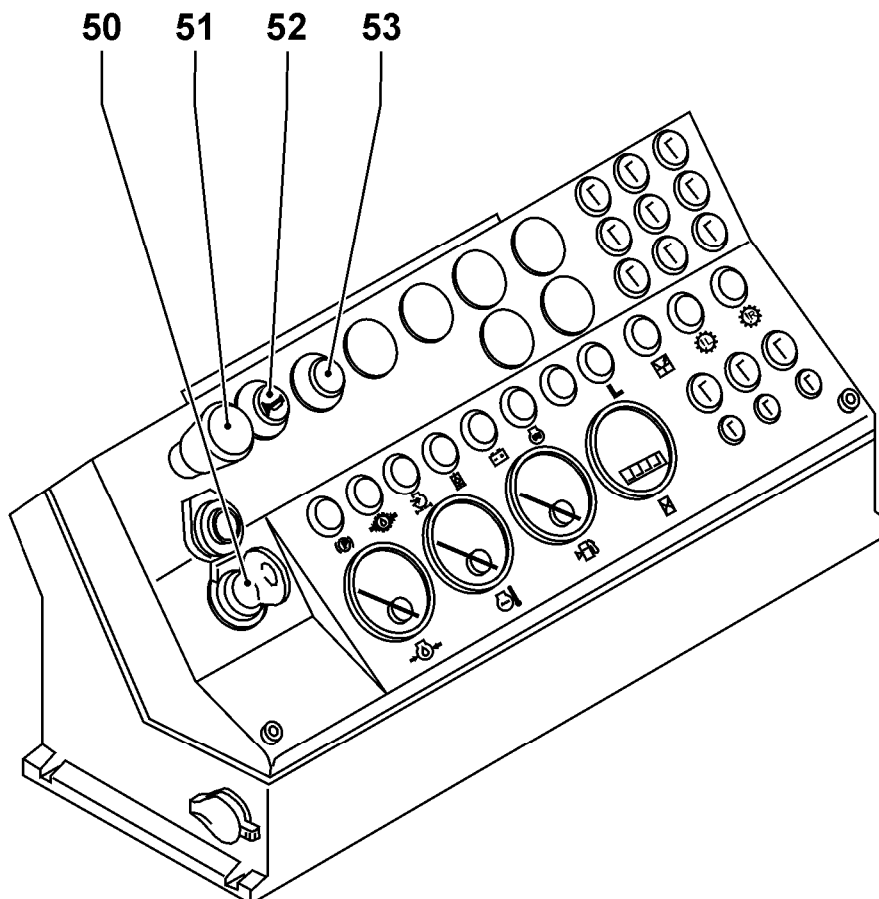

Controls on the instrument panel

404170

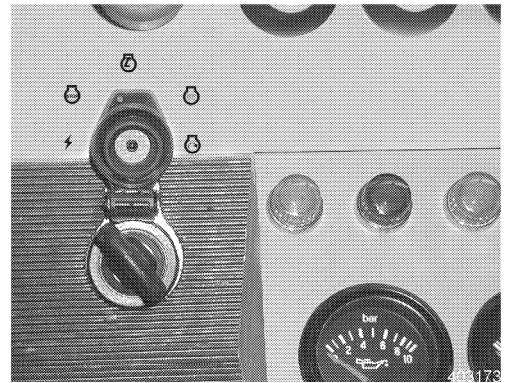
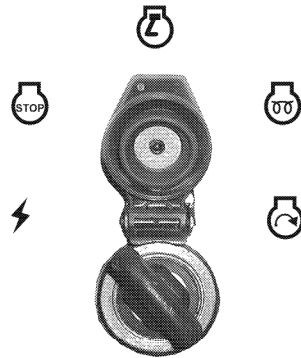

Starter switch

**50.0 Off position****50.1 Contact position****50.2 Preglow position****50.3 Starting position****50.4 Parking position****51 Emergency shut off button**

- The machine stops immediately when the emergency shut off button is pushed in.
The attachments can still be operated.

**52 Horn**

- Push the button to activate the horn.

53 Welding generator

- Push the switch to turn the welding generator on or off.

3.1.4 Controls and indicators in the roof console

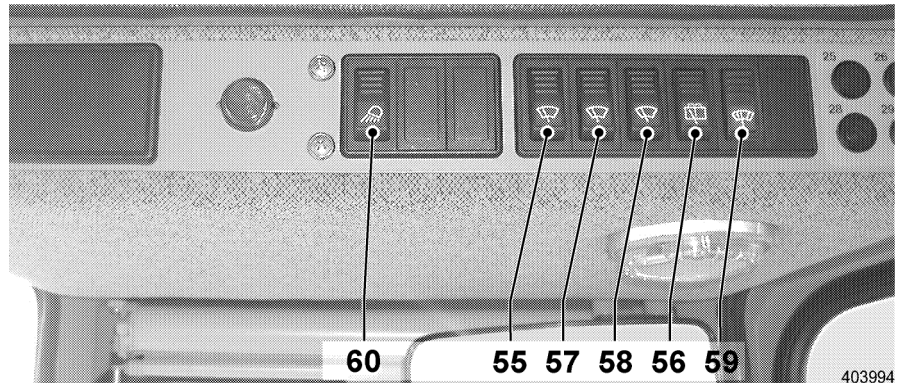

Roof console



55 Switch - Windshield wiper, left door

turn on - off



56 Switch - Windshield wiper / washer system, rear

turn on - off



57 Switch - Windshield wiper, front

turn on - off



58 Switch - Windshield wiper, right door

turn on - off



59 Switch - Windshield wiper - intermittent / washer system

Stage 1 (press on top): button - windshield washer system

Stage 2 (center position): continuous wipe

Stage 3 (press on bottom): intermittent wipe

– The windshield wiper, turned on with switches 55, 57 and 58, is changed over from continuous wipe to intermittent wipe.



60 Switch - floodlight

turn on - off

Press the switch to turn the floodlights on or off.

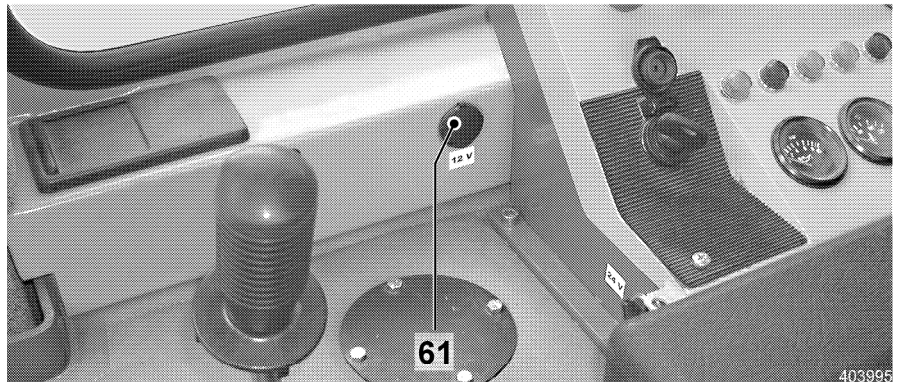

Electrical socket 12V



61 Electrical socket

Additional items can be connected via the integrated 12V electrical socket (max. load 10A).

Can only be used if the ignition key is in contact position.

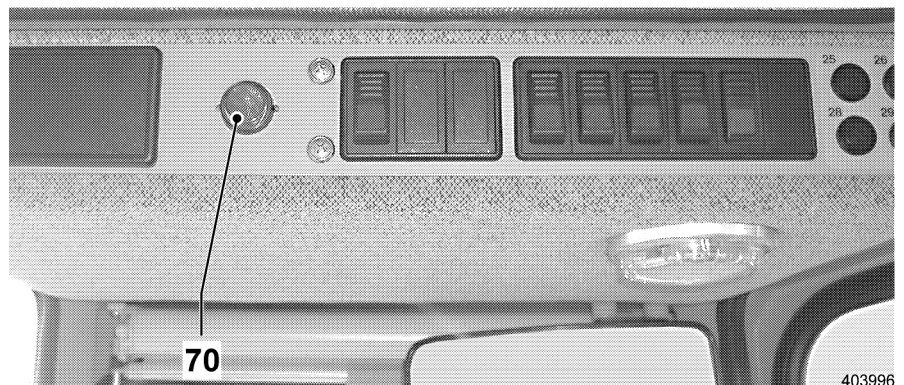

Warning light - operator's cab



70 Warning light - operator's cab

The warning light lights up:

- at increased Diesel engine coolant temperature
- at a drop of Diesel engine oil pressure
- at a drop of replenishing pressure
- if the starter switch is in contact position and the Diesel engine is not yet running.

If the warning light - operator's cab lights up, turn the Diesel engine off and remedy the problem.

3.2 Operation

3.2.1 Entry

Entering and leaving the operator's cab

Always use the steps, rails and handles provided to enter and leave the cab.

Make sure the steps and chains are cleaned before stepping on them.

Always enter and leave the operator's cab through the left door of the operator's cab.

Make yourself familiar with the emergency exit through the right door in the operator's cab.

See also "Emergency exit".



403132

Entering and leaving the operator's cab

Caution



Do not jump off the machine, danger of injuries due to falling or jumping off the machine!

! Always use the steps, ladders or rails provided to enter or leave the cab.

! Never jump off the machine.

Caution



Danger of injuries due to inadvertent movement of the machine!

! When entering or leaving the machine, never grasp the safety lever or the control levers and use them as handholds.

- Enter the machine only via the left side.

3.2.2 Emergency exit

The operator's cab must be entered and exited through the left door in the operator's cab.

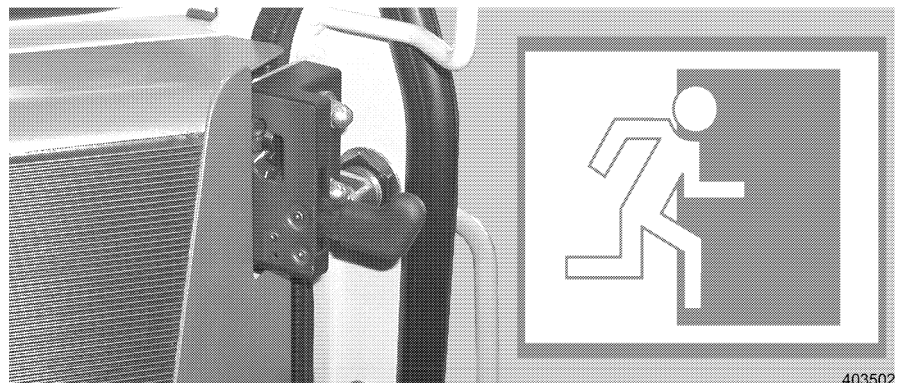

403502

Emergency exit

In case of an emergency, leave the operator's cab through the emergency exit

The right door in the operator's cab is intended as the emergency exit and may only be used in emergency situations.

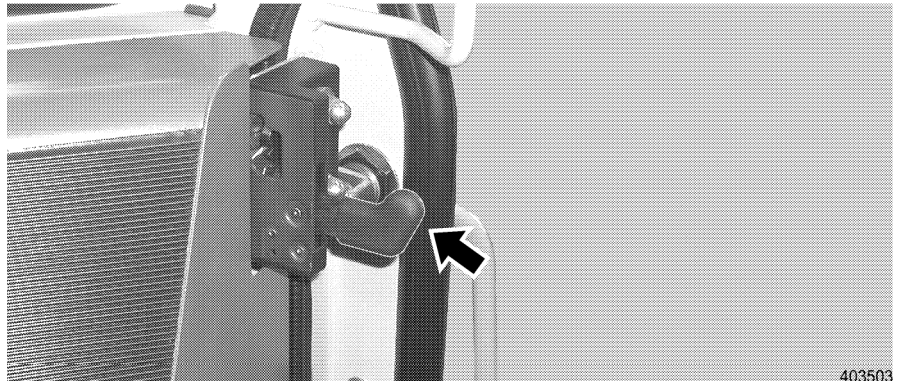

Open the right door in the operator's cab

- Before putting the machine into service, check if the operator's cab can be exited without any problems from inside through the right door.
- To open the door of the operator's cab: push the lever on the door lock down.

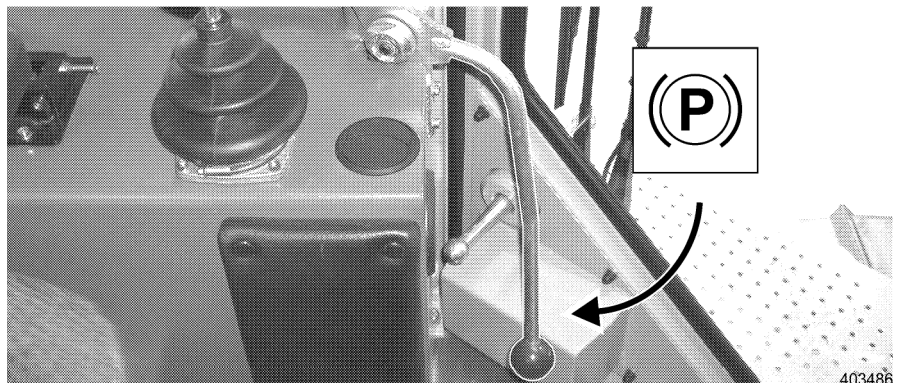

Safety lever down

- Before leaving the operator's cab, always place the safety lever down.
 - The indicator light - travel brake must light up.

3.2.3 Door lock

The door of the operator's cab are held closed by the door lock.

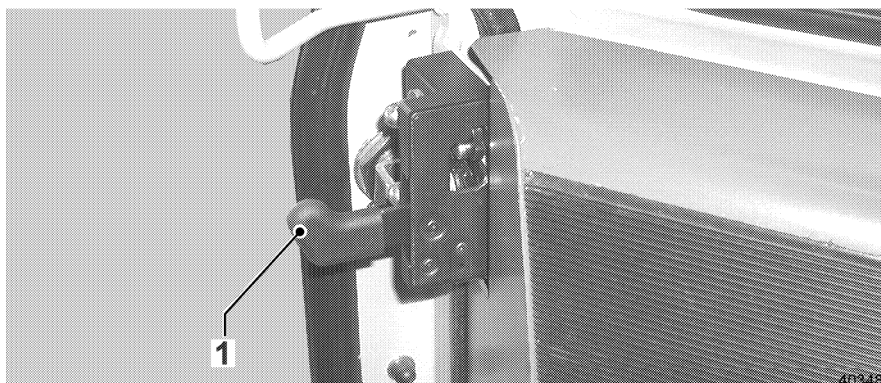

Open the operator's cab door

Open the operator's cab door from the inside

- Push lever 1 on the door lock down.

Door latch

The fully opened doors in the operator's cab are held in this position by the door latch 1.



Release the door latch

- Release the door latch: Push lever 1 down.

3.2.4 Operator's seat

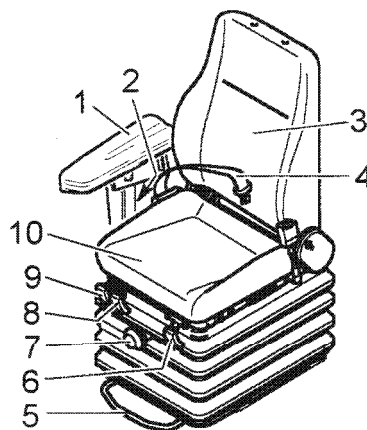

Operator's seat - main components and control elements

- 1 Armrest
- 2 Arm rest adjustment
- 3 Backrest
- 4 Seat belt
- 5 Lever - horizontal adjustment
- 6 Lever - backrest adjustment
- 7 Knob - seat suspension
- 8 Lever - incline adjustment forward
- 9 Lever - incline adjustment backward
- 10 Seat surface

Individual adjustment for ergonomic seat position

The operator's seat can be adjusted for optimum operator comfort.

Horizontal adjustment

The seat can be moved forward or backward with the lever 2 on the front of the operator's seat.

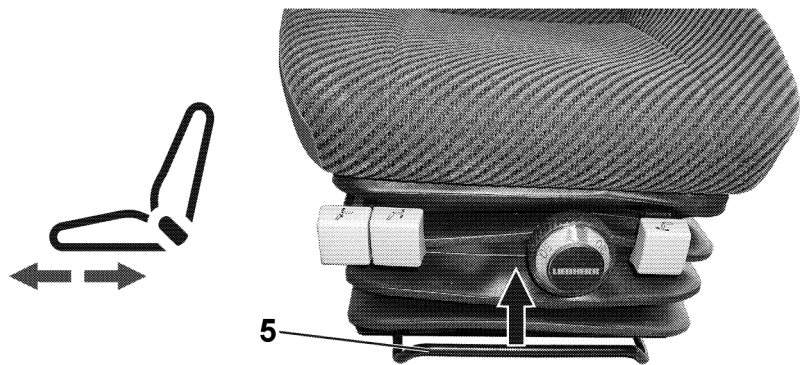

403030

Horizontal adjustment

5 Lever - Horizontal adjustment

- Pull the lever 5 in direction of the arrow.
- Bring the operator's seat to the desired horizontal position and release the lever.

Adjustment of seat surface incline

The adjustment can be made with lever 8 and lever 9 on the right front of the operator's seat.

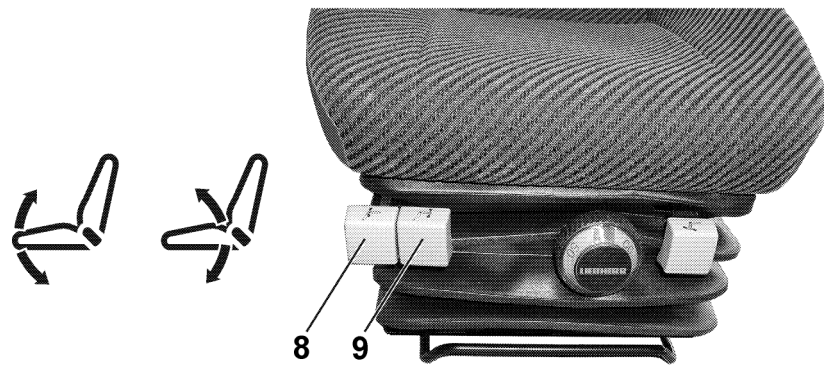

403032

Adjustment of seat surface, height

- 8 Lever - incline adjustment to the rear
- 9 Lever - incline adjustment to the front

- Incline adjustment, rear: Lift lever 8 in direction of the arrow, adjust the incline and release the lever.
- Incline adjustment, front: Lift lever 9 in direction of the arrow, adjust the incline and release the lever.

Adjustment of seat height

The height of the seat can be adjusted with lever 8 and lever 9 on the right side of the operator's seat.

- Lift lever 8 and lever 9 at the same time.
- Raise the seat to the desired height and release both levers.

Backrest adjustment

The incline of the backrest can be adjusted with lever 3 on the left hand side of the operator's seat.



403033

Adjustment - backrest

- 3 Lever - backrest adjustment

- Lift lever 3.
- Bring the backrest to the desired incline and release the lever.

Adjustment of seat suspension

The seat suspension can be set to the bodyweight of the operator. The adjustment is made via the knob on the front of the operator's seat. The knob shows the adjusted weight in kg.

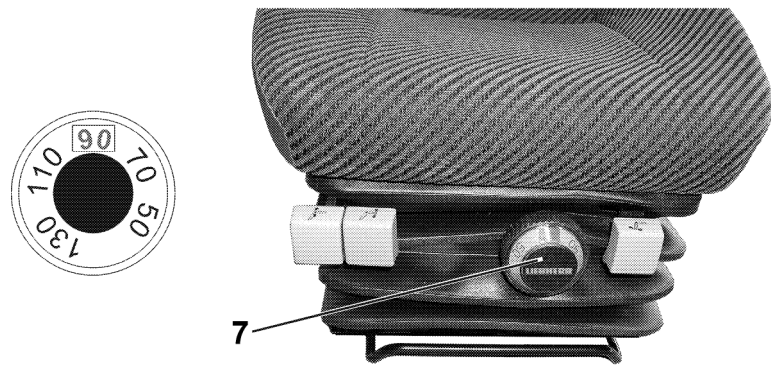

403031

Adjustment - seat suspension

7 Knob - Seat suspension

- Set the body weight of the operator with knob 7.

Operator's seats, which meet ISO 7096 ensure that the swing accelerations (measured according to ISO 2631 part 1) in earthmoving machinery, which is used as intended, fulfill the requirements for full body vibration protection.

3.2.5 Operator's seat - air cushioned

(Optional equipment)

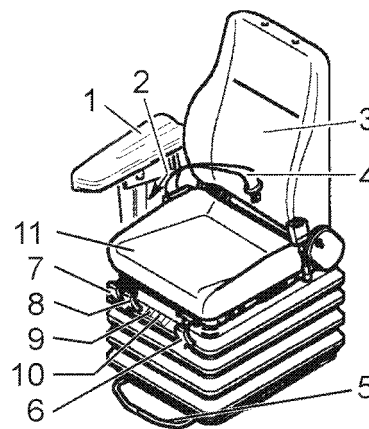

403040

Operator's seat - main components and control elements

- | | |
|---------------------------------|------------------------------------|
| 1 Armrest | 7 Lever - incline position - front |
| 2 Adjustment - armrest | 8 Lever - incline position- rear |
| 3 Backrest | 9 Button - seat suspension |
| 4 Seatbelt | 10 Button - back support |
| 5 Lever - horizontal adjustment | 11 Seat surface |
| 6 Lever - adjustment - backrest | |

Individual adjustment for ergonomic seat position

The operator's seat can be adjusted for optimum operator comfort.

Horizontal adjustment

The seat can be moved forward or backward with the lever 5 on the front of the operator's seat.

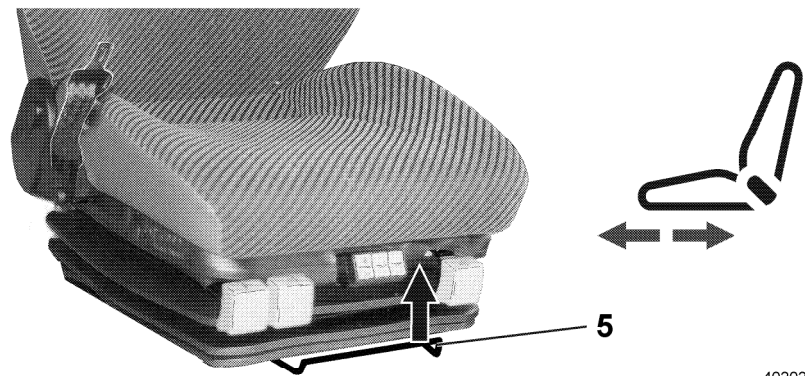

403035

Horizontal adjustment

5 Lever - Horizontal adjustment

- Pull lever 5 in direction of the arrow,
- Set the operator's seat in horizontal position and release the lever.

Seat surface incline

The adjustment can be made with lever 7 and lever 8 on the right front of the operator's seat.

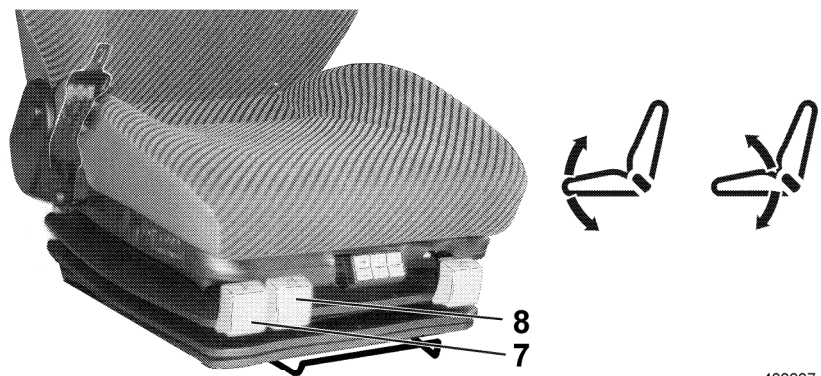

403037

Adjustment - seat surface, height

- 7 Lever - incline position on the rear
- 8 Lever - incline position on the front

- Incline adjustment on the rear: Lift lever 7 in direction of the arrow, set the incline and release the lever.
- Incline adjustment on the front: Lift the lever 8 in direction of the arrow, set the incline and release the lever.

Adjustment of seat height

The height of the seat can be adjusted with lever 7 and lever 8 on the right hand side of the operator's seat.

- Lift lever 7 and lever 8 at the same time.
- Move the seat to the desired height and release both levers.

Backrest adjustment

The incline of the backrest can be set with lever 6 on the left side of the operator's seat.

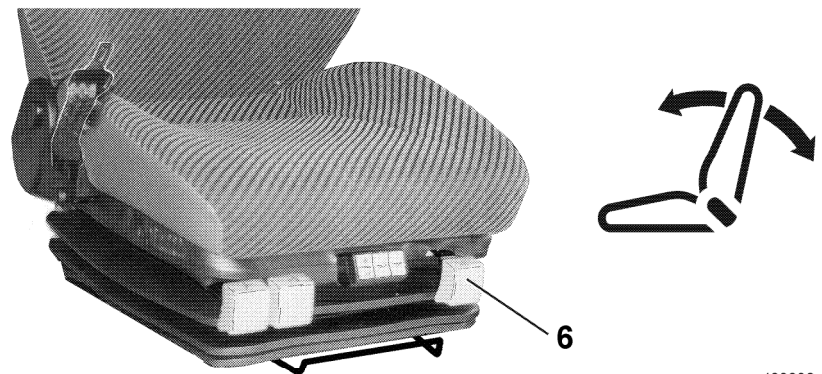

403038

*Adjustment - backrest***6 Lever - adjustment - backrest**

- Lift lever 6.
- Bring the backrest into the desired incline and release the lever.

Adjust the seat suspension

The seat suspension can be set to the bodyweight of the operator. The adjustment is made with the button on the front side of the operator's seat.

Press the button in "+" or "-" direction until the desired seat suspension is set.

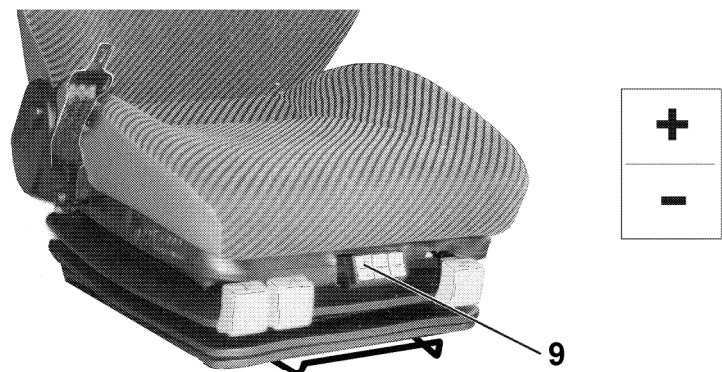

403036

*Adjustment - seat suspension***9 Button - seat suspension**

- Press button 9 to set the corresponding bodyweight.

Adjustment of back support

The lower back supports in the backrest can be individually adjusted. Two lower back supports are installed in the backrest: one in the upper and one in the lower area of the backrest.

The adjustment is made via buttons 1 and 2.

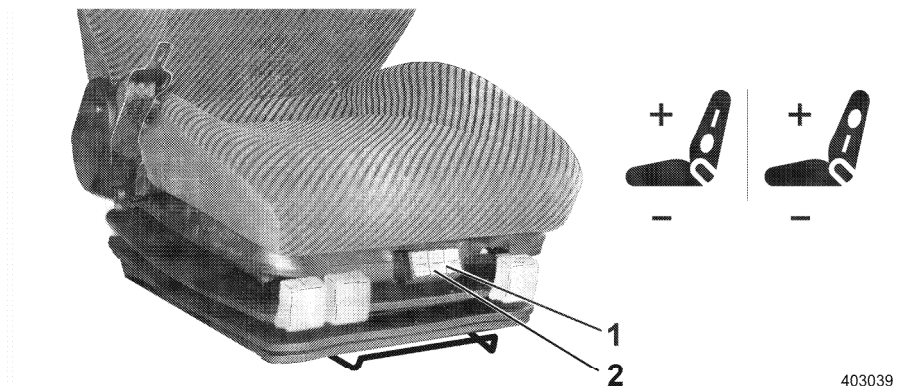

Adjustment - back support

- Adjust the back support with buttons 1 and 2.

3.2.6 Arm rests

The height of the arm rest can be adjusted individually.

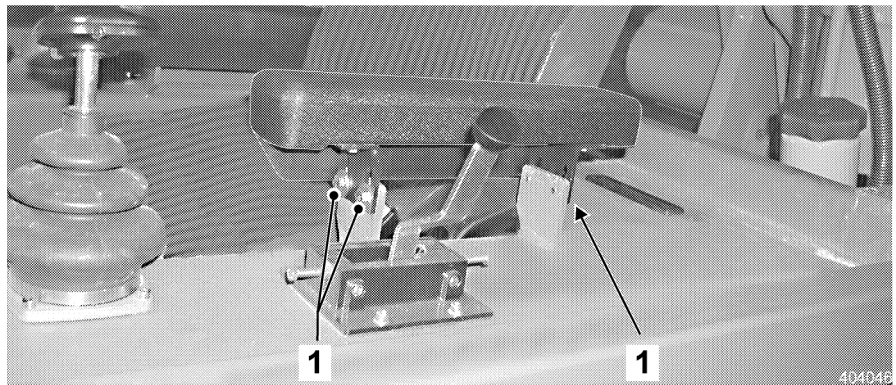

Adjustment - arm rest

- Adjustment: Loosen the hex head screws 1, adjust the height and tighten.

3.2.7 Seat belt

Observation of safety aspects

The operator's cab of the machine is equipped with a rollover protection - ROPS.

The rollover protection - ROPS can only provide its safety function for the operator if he wears the seatbelt.

This chapter describes the safety aspects for wearing the seat belt.

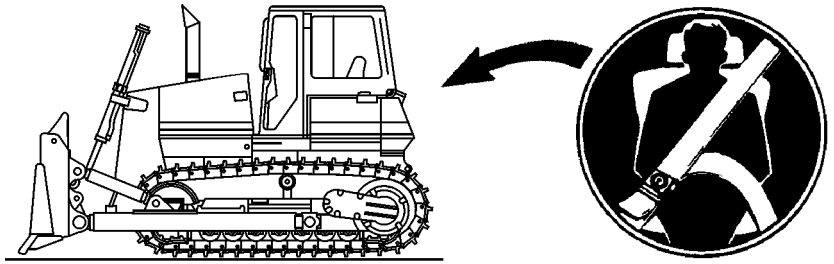

403490

*Seatbelt requirement***Caution**

Danger of injury if seatbelt is not fastened! If the machine is slowed down or stopped abruptly, a serious accident with severe injuries can occur if the seatbelt is not fastened!

! Always fasten the seatbelt before operating the machine.

Danger

Danger of injuries if the seatbelt is not fastened! If the machine tips or rolls over, a deadly accident can occur if the seatbelt is not fastened!

! Always fasten the seatbelt before operating the machine!

- To ensure safety: check the condition, function and mounting of the belt frequently and replace worn, damaged or defective parts immediately.
- Make sure that the seatbelt is not twisted when in use.

Apply the seatbelt

The seatbelt is adjusted automatically to the correct length.

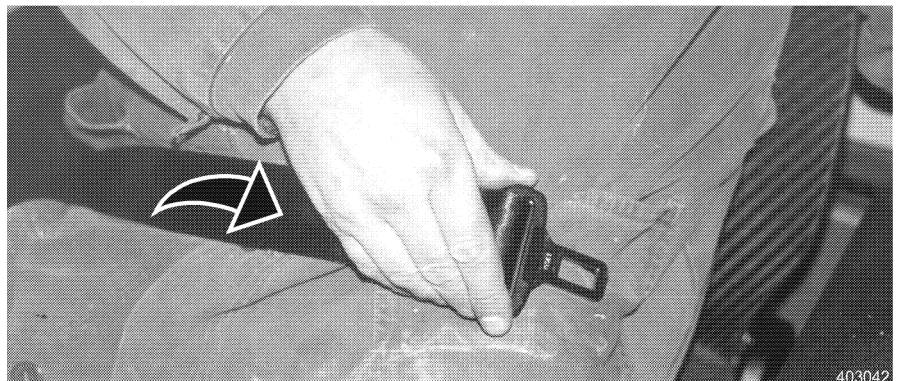

403042

Apply the belt

- Hold the belt buckle with the right hand and slowly pull the belt from the housing.

NOTE: Pull the seatbelt slowly from the housing or the lock mechanism will be triggered.

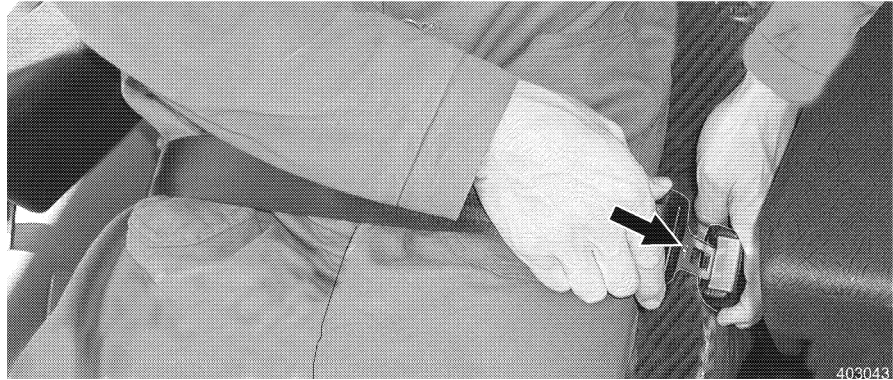

Close the belt

- Hold the lock with the left hand and pull the belt over your lap.
- Insert the buckle into the lock and pull the belt to make sure that the lock is engaged.

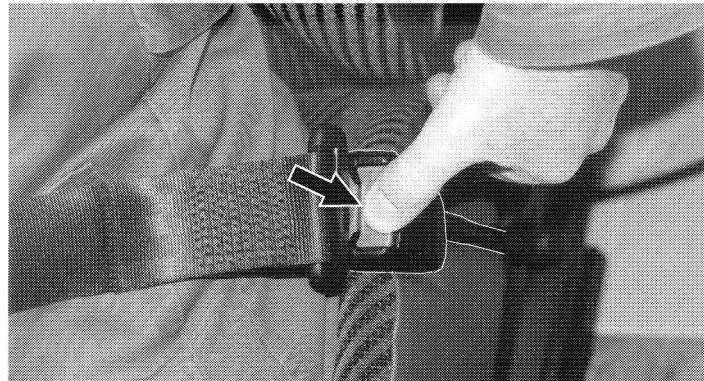

Release the seatbelt

Release the seatbelt

- Release the seatbelt: Push the button on the lock downward with your thumb.

3.2.8 Heater, ventilation

The operator's cab is equipped with a warm water heater. The operator's cab can also be equipped with an air conditioning system, if desired.

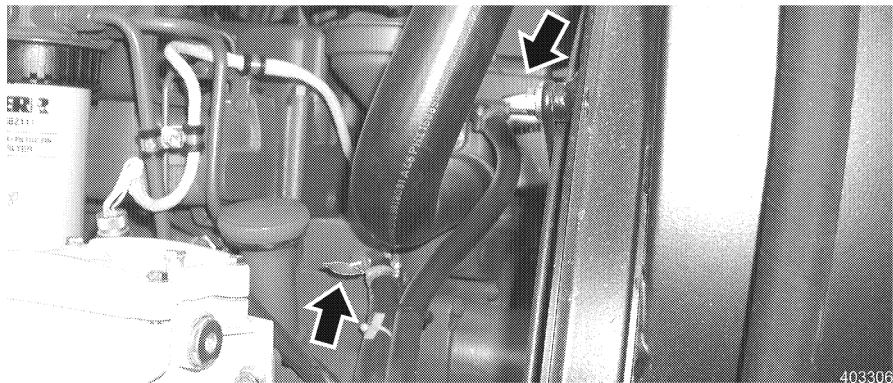

Shut off valves

The operator's cab can only be heated if the Diesel engine is at operating temperature and the shut off valves are open.

To turn the heater on / off

Control elements on the heater:

- 1 - Knob - Fan
2 - Regulating knob - Temperature

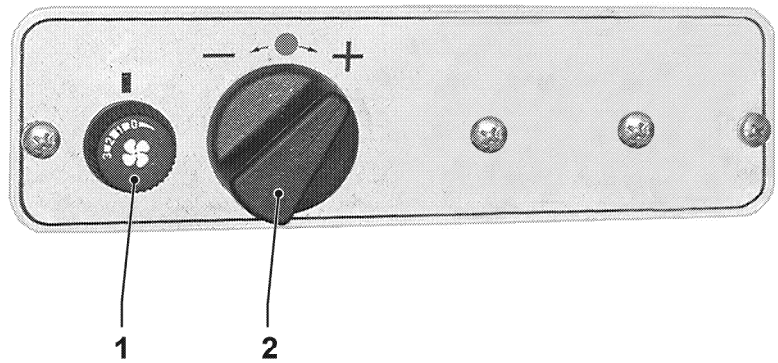

403136

Heater control elements

Make sure that

- the electrical system on the machine is turned on,
- the air vents are open to direct the air flow, as desired, to the body, to the front window or to the rear window.
- To turn the heater on: Turn the knob 1 to stage 1. The air flow is blown into the operator's cab via the air vents.

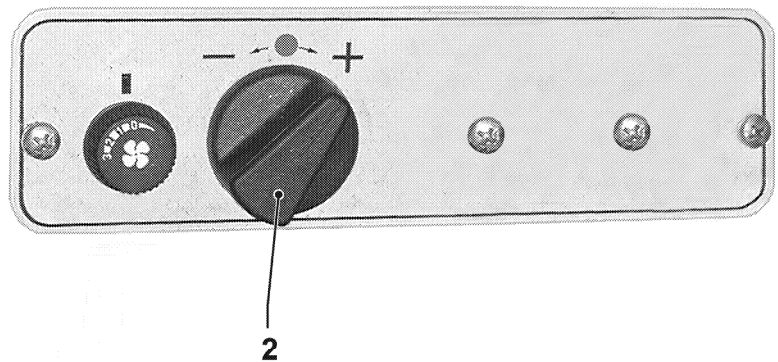

403145

Temperature regulator

The temperature can be regulated steplessly: Turn the regulating knob 2 in clockwise direction for warm, in counter clockwise direction for cold.

- To regulate the temperature: Turn the regulating knob 2 in the desired direction.

To regulate the blower Turn the blower on or off with knob 1.

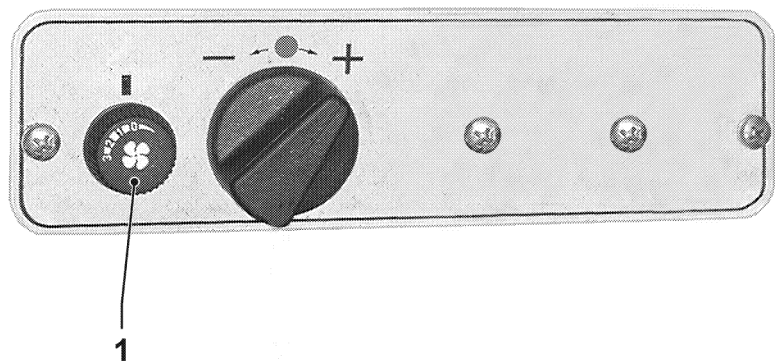

403144

Blower - knob

Blower stages:

Stage 0 - position - OFF

Stage 1 - slight air flow

Stage 2 - medium air flow

Stage 3 - strong air flow

- Turn the knob 1 to the desired setting.

The air flow is blown via the air vents into the operator's cab.

3.2.9 Air conditioning system

To ensure the function of the air conditioning system, we recommend to turn the system on at least once every 2 weeks.

The shaft seal ring in the compressor is lubricated during operation of the air conditioning system to prevent refrigerant leakage from the compressor.

On damp days, the air conditioner can be used to dehumidify the air in the cab (operator the heater and air conditioner).

Then use the heater to compensate the cooling to obtain a comfortable temperature setting and to prevent the windows from fogging up.

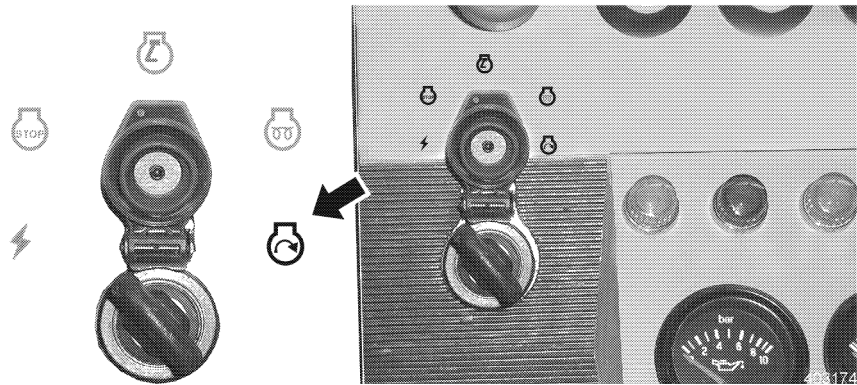

Start the Diesel engine

Turn on the air conditioning system

The air conditioning system can only be operated if the Diesel engine is running.

- Start the Diesel engine.

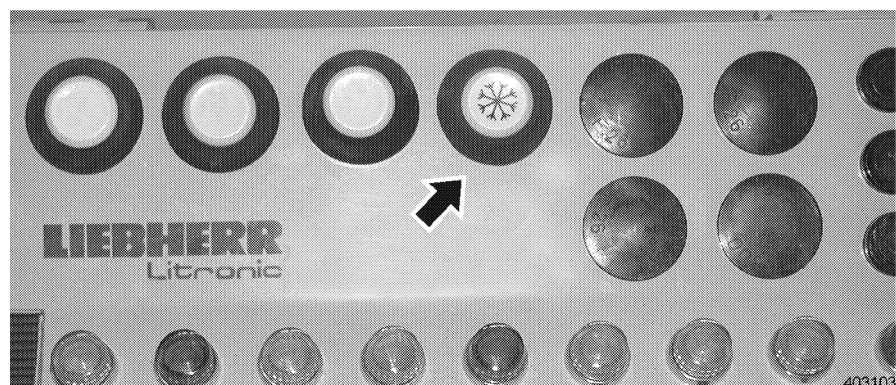

Main air conditioner switch

- Push the main air conditioner switch on the instrument panel.

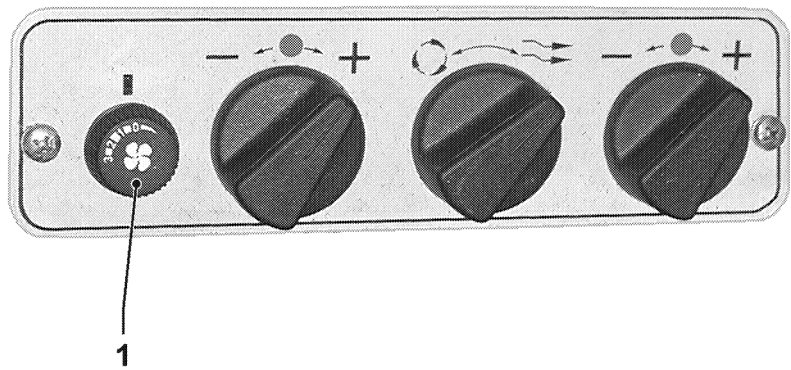

Blower switch

403137

- Set the blower switch at least to stage 1.

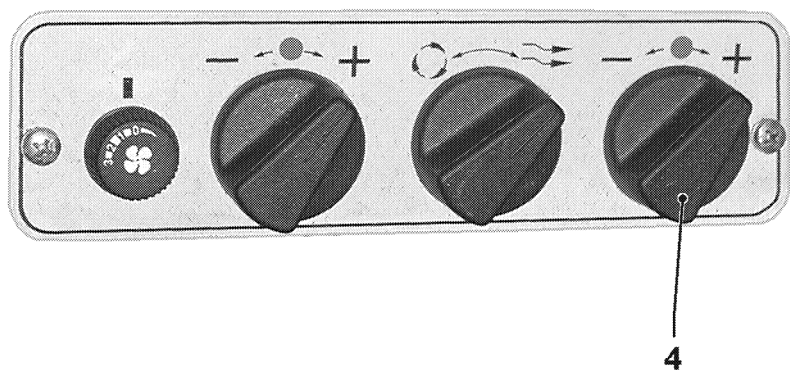

Regulating knob - Air conditioning system

403138

- Select the desired temperature with the regulating knob for the air conditioning system.

Turn the knob in clockwise direction to increase the output of the air conditioning system, the temperature in the operator's cab drops.

The higher the cooling output is set, the higher the blower stage setting must be set.

Due to the integrated de-icing protection, the evaporator will not ice up.

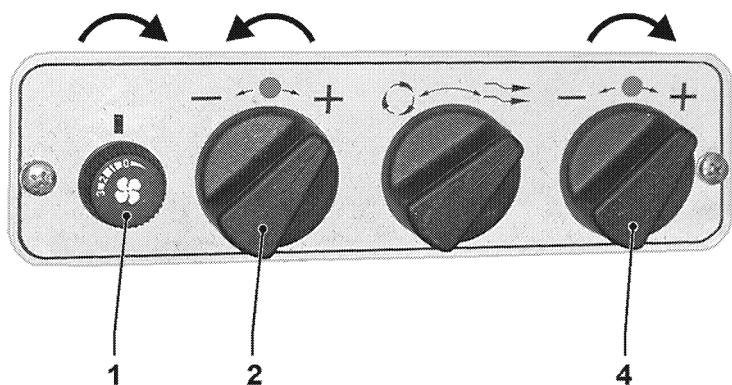

Air conditioning system - full power

403139

Air conditioning system - full power

The greatest cooling output is reached:

- By turning the regulating knob for the air conditioning system in clockwise direction to the stop.

- Set the highest blower stage.
- Turn the heater off.
- Close the windows.

3.2.10 Sliding window

The sliding windows in the operator's cab can be opened by pulling the handle and locked in position at several points.

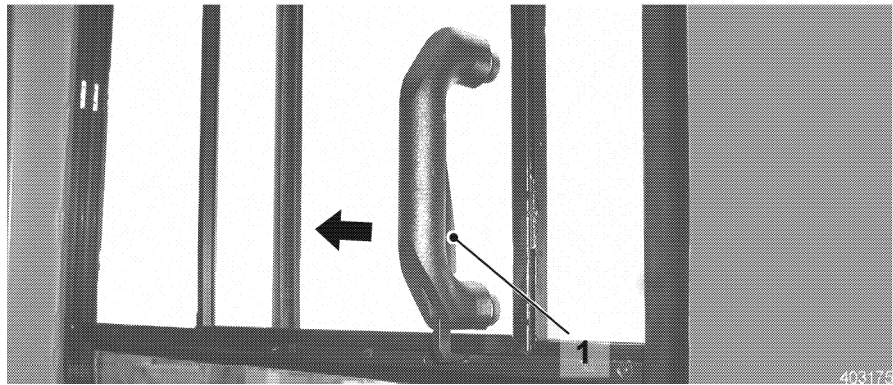

To open and close the sliding window

- Push the lever 1 on the handle and move the sliding window to the desired position.
- Lock the window in the notches on the window frame.

3.2.11 Sun shade

Adjustment of sun shade

The operator's cab is equipped with a sun shade.

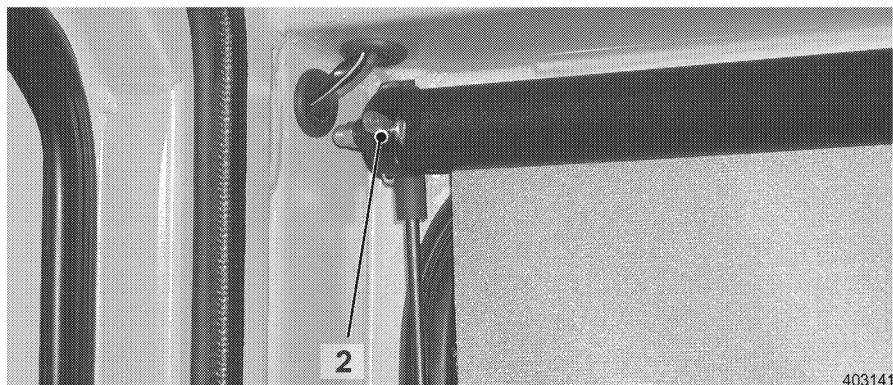

Adjustment - Sun shade

- Adjust the sun shade by pulling it down to the desired level.
- To roll up, pull the lever 2 on the left hand side of the sun shade down.

3.2.12 Cab interior lighting

Turn the interior lights on / off

The interior light is located in the roof of the operator's cab on the right hand side of the operator's seat.



Interior light

- Turn the interior light on: Turn the light cover 1 to the right.
- Turn the interior light off: Turn the light cover 1 to the left.

3.2.13 Rear view mirror

Adjustment of mirror

The operator's cab is equipped with a rear view mirror.

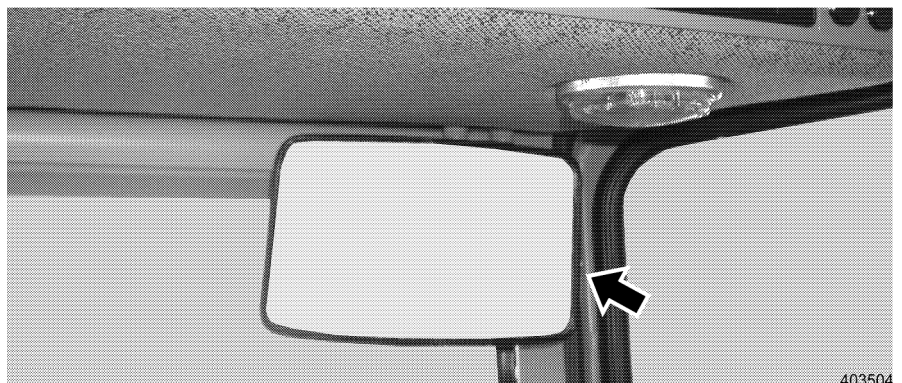

Adjustment - Mirror

- Adjust the mirror before starting to work, so you can see the complete rear area.

3.2.14 Electric windshield wiper and washer system

The machine is equipped with an electric windshield washer system for the front and rear window as well as for the doors.

It consists of control elements, windshield wipers, reservoir and nozzles for the windshield washer fluid.

Make sure that the electrical system of the machine is turned on before operating the windshield wiper and washer system.

Operation of windshield wiper and washer system

The windshield wiper system can be operated with switches 1, 2, 3, 4.

Press switch 5 to use the windshield washer system and the intermittent control.

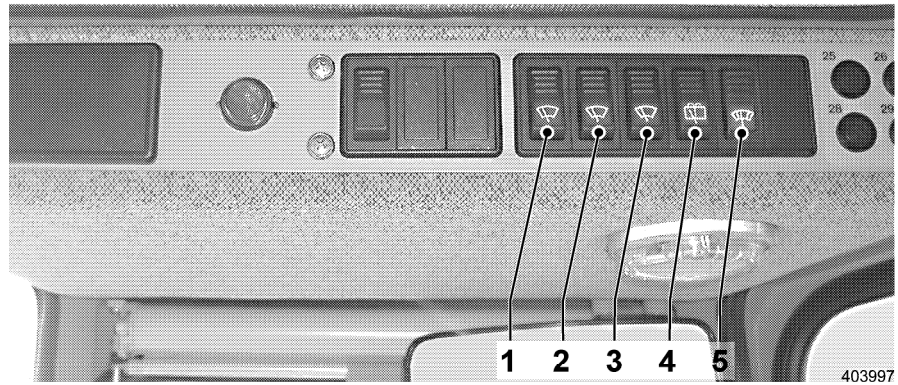

Switch - Windshield wiper and washer system

- | | |
|---|---|
| 1 Switch - Windshield wiper system - left door | 4 Switch - Windshield wiper and washer system - rear window |
| 2 Switch - Windshield wiper system - front window | 5 Switch - Intermittent control / windshield washer system |
| 3 Switch - Windshield wiper system - right door | |

- To wipe the window: Press switch 1, 2, 3 or 4. The selected windshield wiper will be activated.
- Windshield wiper - intermittent control: Move switch 5 to stage 3 (press on bottom). The windshield wiper, turned on with switches 1, 2, 3 is changed over from continuous wipe to intermittent wipe.
- To wash the window: Press switch 5 on top and hold down. The windshield washer fluid is sprayed onto the window through the nozzles.
- To turn the windshield washer system off: Release switch 5.
- To turn the windshield wiper - intermittent control off: Set switch 5 to center position.
- To turn the windshield wiper system off: Press switch 1, 2, 3 or 4 on the rear.

3.2.15 Reservoir for windshield washer fluid

The reservoir is integrated on the front in the operator's cab.

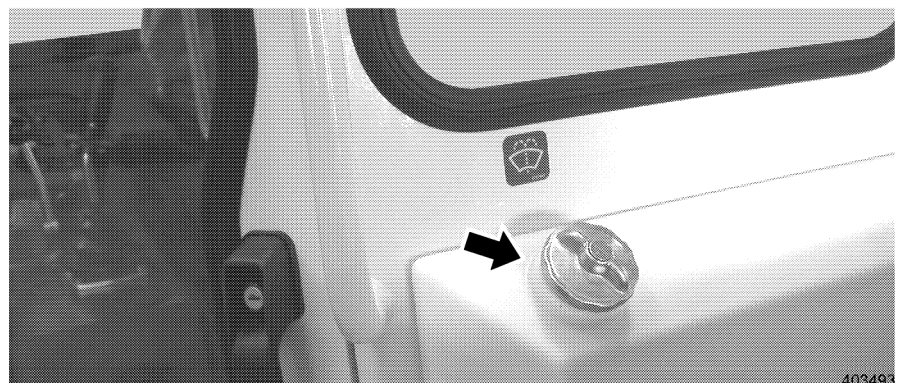

Reservoir - windshield washer fluid

Add windshield washer fluid

- Open the cover.
- If necessary, add commercially available windshield washer fluid. For quantity, see "Lubricants and service fluids".

Caution

Danger of damage to the windshield wiper and washer system due to ice formation!

Ice can destroy or damage the windshield wiper and washer system. A dirty front or rear window is a safety risk!

! Make sure to protect the windshield wiper and washer system to avoid ice formation!

- Use commercially available antifreeze for window cleaners.
- Add the correct amount of antifreeze for window cleaners before the start of the cold season.

3.2.16 Compartment for machine documentation

On the front in the operator's cab is a compartment for the machine documentation.

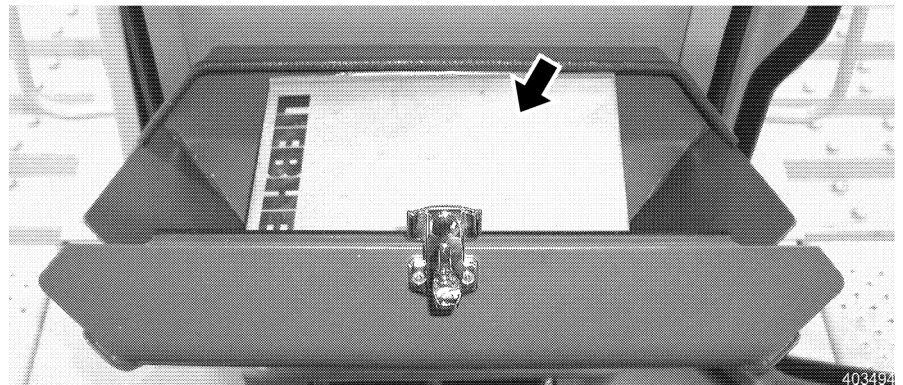

Compartment for machine documentation

Open the compartment for machine documentation

- Pull the lever on the latch up and open the cover.

A copy of the machine documentation (operating manual, spare parts list) should always be stored in the compartment.

One set of the machine documentation is part of the machine!

3.2.17 Back up alarm

(Optional equipment)

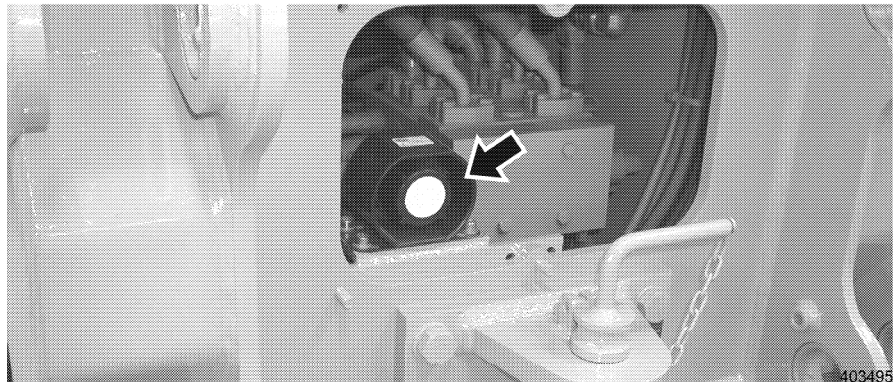

Back up alarm

The back up alarm sounds if the travel lever is moved to the position for "Reverse travel".

- Any persons behind the machine will be warned by the sound of the horn.

The back up alarm is located in the rear of the machine. The sound level is automatically set.

3.2.18 Fire extinguisher

(Optional equipment)

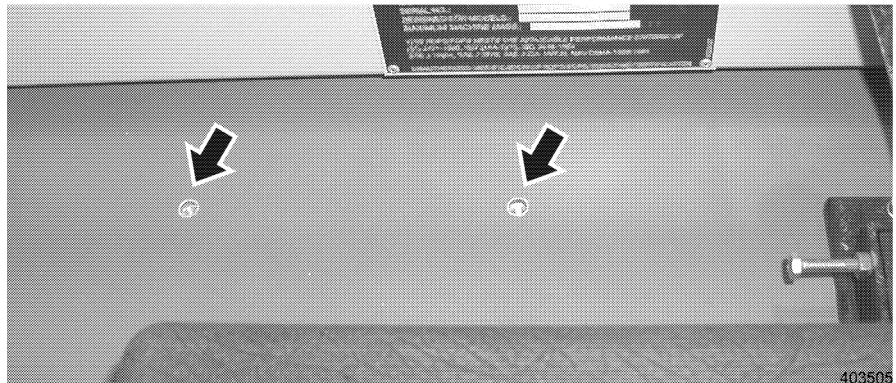

Location - fire extinguisher

Location - fire extinguisher

A mounting location is available for retrofit installation of a fire extinguisher, on the left hand side behind the operator's seat.

- Contact your Liebherr dealer for the installation kit - fire extinguisher.

3.2.19 Beacon

(Optional equipment)

Your machine is also prepared for the retrofit installation of a beacon.

- For the installation kit of the beacon, contact your LIEBHERR dealer.

3.3 Operation

3.3.1 Daily operation

Before operating the machine, carry out the "Maintenance tasks for every 8 - 10 operating hours". See "Maintenance and inspection schedule".

After completing the "Maintenance tasks for every 8 - 10 operating hours", bring the machine in operating position. See "Operating position". Make sure that:

- All "Maintenance tasks for every 8 - 10 operating hours" have been completed before daily operation.
- The machine is refueled. See "Add Diesel fuel".

Operating position

To bring the machine into operating position, proceed as follows.

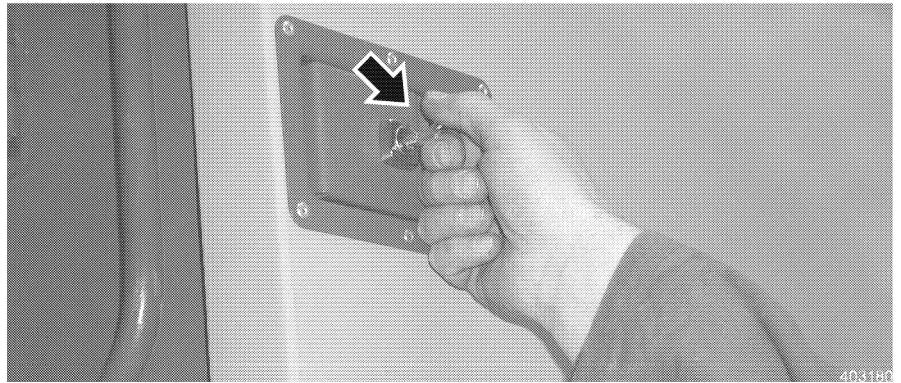

Lock doors

Close all service access doors and hoods

- Close all service access doors and hoods and lock, if possible.

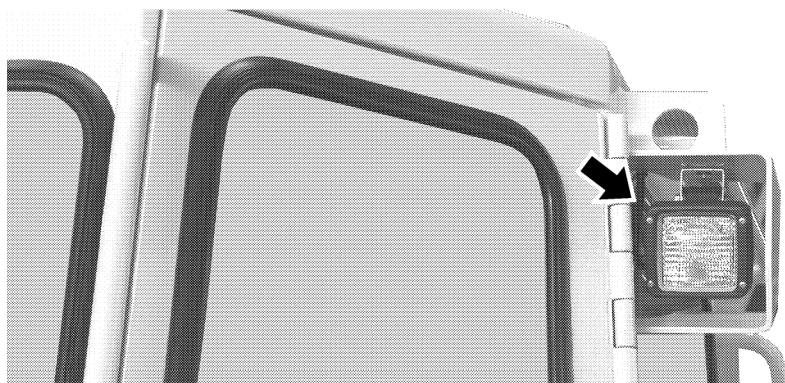

Headlight adjustment

Check the lighting system

- Check the lighting system.
- If necessary, adjust the headlights.

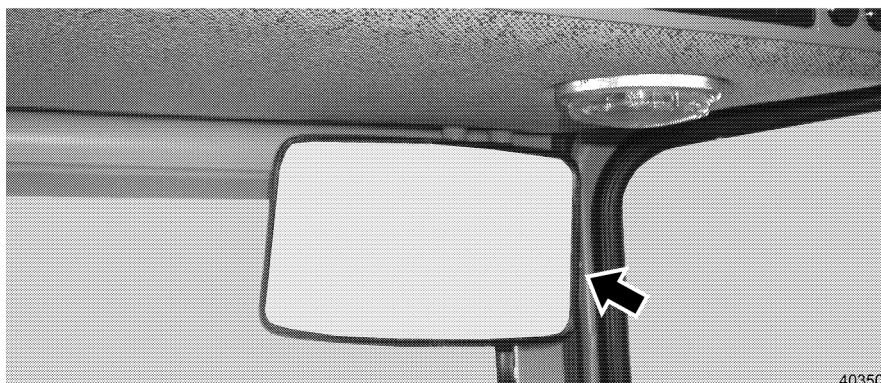

403504

Rear view mirror

Adjust the rear view mirror

- Adjust the rear view mirror.

Add Diesel fuel

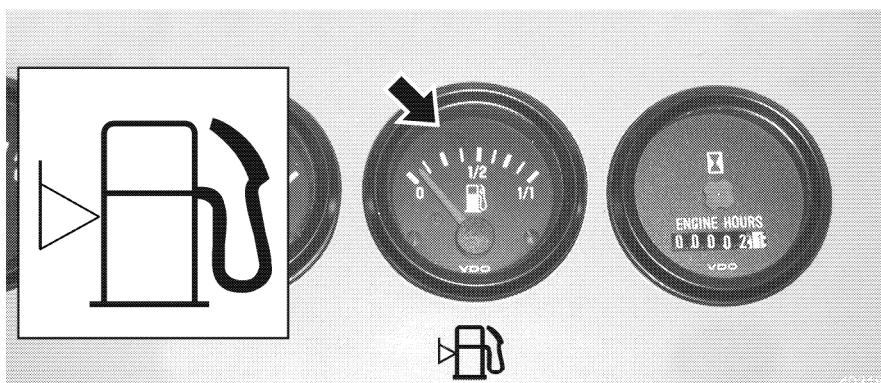

403482

Fuel gauge

Fuel gauge

- Set the starter switch to contact position.
- Check the fuel gauge to see if there is sufficient Diesel fuel in the tank.

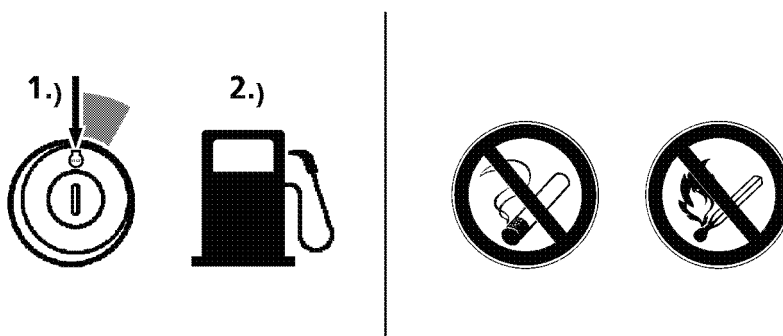

Refueling safety

403183

Danger

When refueling, there is a danger of fire and explosion.
 ! Do not smoke or allow an open flame in refueling areas.
 ! Refuel only when the Diesel engine is turned off.

- Make sure to observe all safety guidelines for refueling. See also the chapter - Safety Guidelines.

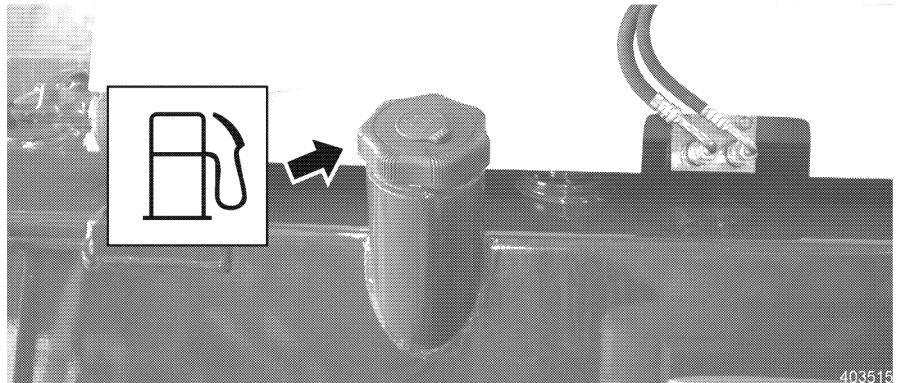

Tank cover

- Remove the tank cover.
 - Refuel only with clean Diesel fuel.
 - Add Diesel fuel only via the installed strainer.
- To prevent condensation in the fuel tank, maintain a high fuel level, always add fuel after a work day or shift change.

3.3.2 Machine operation in low ambient temperatures

Your machine can be operated without additional special equipment to an ambient temperature of -22°C .

If the ambient temperatures remain constantly below -22°C , then special equipment should be installed to ensure proper operation.

When using the machine below -22°C , contact your LIEBHERR service or the manufacturer directly.

3.3.3 Start the Diesel engine

1.)

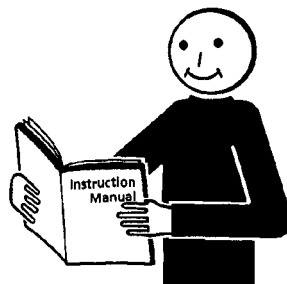

2.)



Operating manual

- 1.) read and understand
- 2.) drive and work

Operate the machine only if you have read and understood the operating manual!

Notes regarding the machine's travel drive:

- The machine is equipped with a hydrostatic travel drive.
- The Diesel engine cannot be started by pushing or towing the machine.

Starting procedure

Before starting the machine, do the following:
Make sure that the machine is in operating position.
See "Operating position".

Caution



- The engine can only be started if the safety lever is in the full down position
- If the engine can be started with the safety lever in any other position, check for and correct the defect.

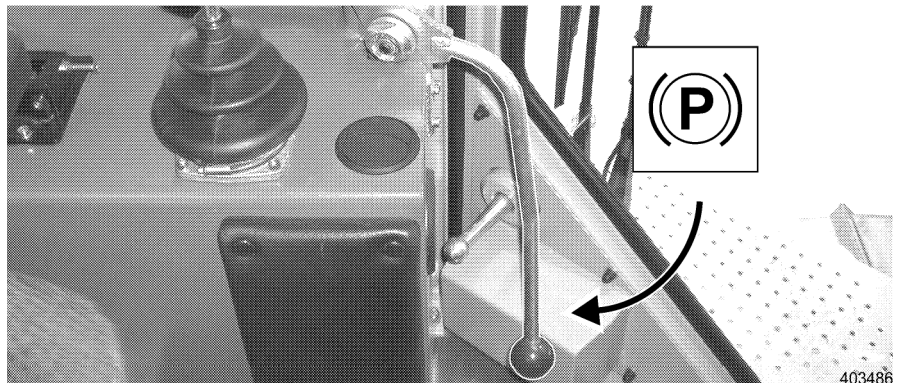

Safety lever down

- Move the safety lever down.
- The joystick must be in neutral position.

Check the travel joystick position

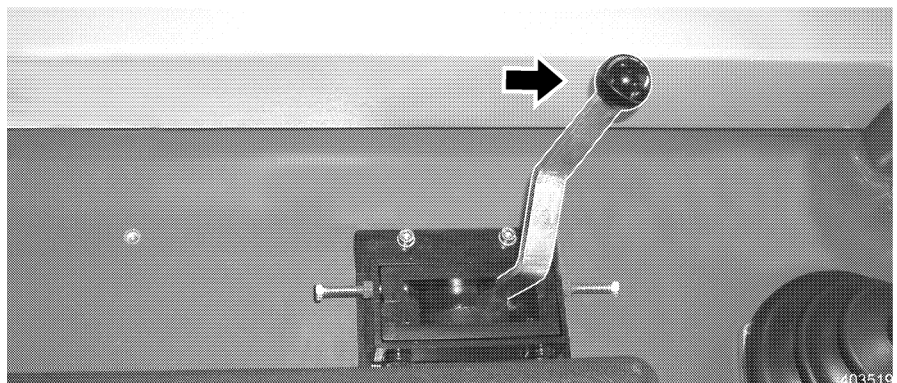

Throttle control lever - full load

- Set the throttle control lever to full load.
- Push the throttle control lever forward.

Starting procedure

Check the indicator lights

When the ignition key is in contact position, the electronic control checks the indicator lights.

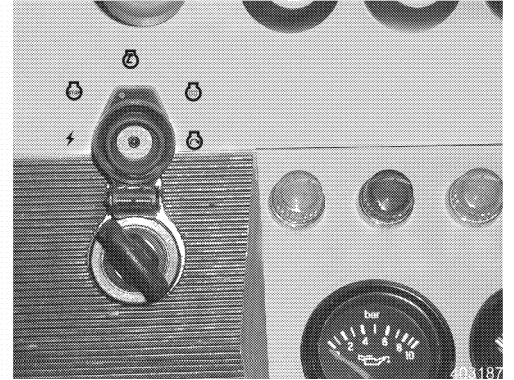
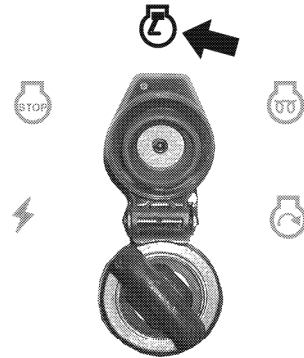

Starter switch - Contact position

- Set the ignition key to contact position.
The following indicator lights light up for a short time (for 2.5 - 3 seconds).

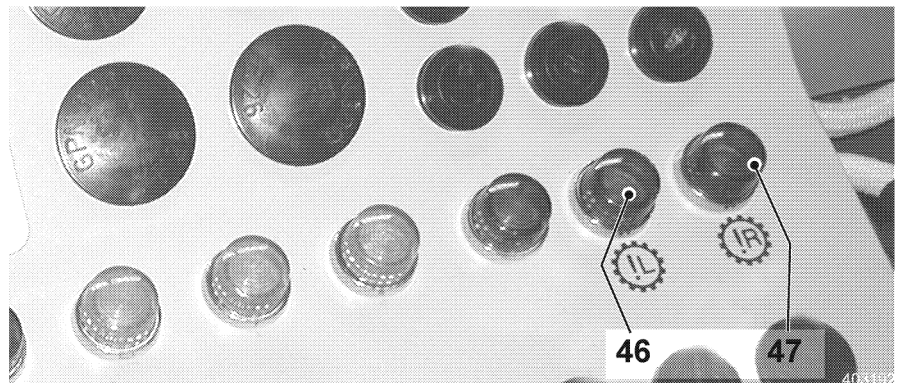

Indicator lights

- 46 Indicator light - Lifetime seal area left
- 47 Indicator light - Lifetime seal area right

The following indicator lights must still be on:

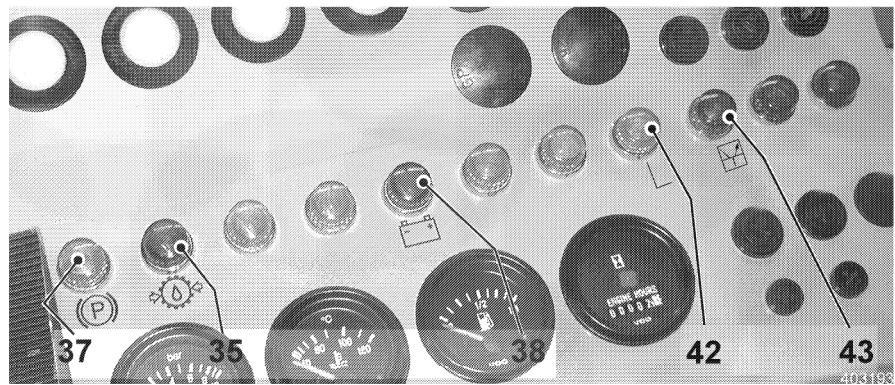

Indicator lights

- | | |
|--|--------------------------------------|
| 35 Indicator light - Replenishing oil pressure | 42 Indicator light - Low speed range |
| 37 Indicator light - Travel brake | 43 Indicator light - Electronic |
| 38 Charge indicator light | |



Warning light - Operator's cab

Preglow the engine

The preglow time depends on the ambient temperature and the electric starting conditions.

It is at least 20 seconds and can take more than 120 seconds at extremely low temperatures.

If the Diesel engine is warm and the ambient temperatures are high, then the preglow procedure is not necessary!

Note: Do not preglow the Diesel engine if it is already at operating temperature!

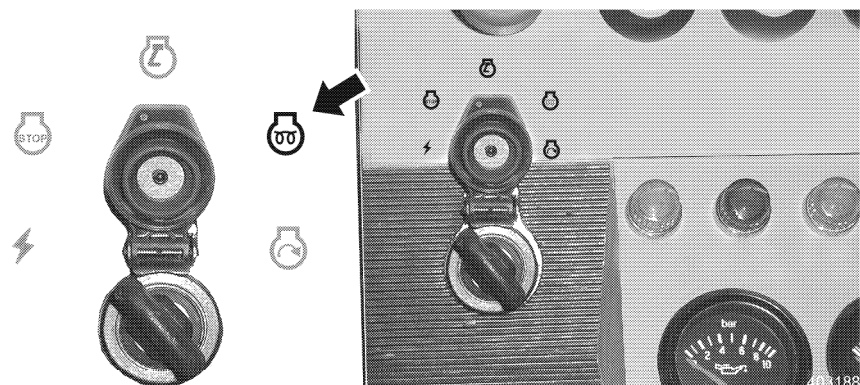

Starter switch - Preglow position

Start the engine

- Wait until the indicator light - preglow system turns off. When the indicator light turns off, the preglow time is over.
- The engine is ready to start.

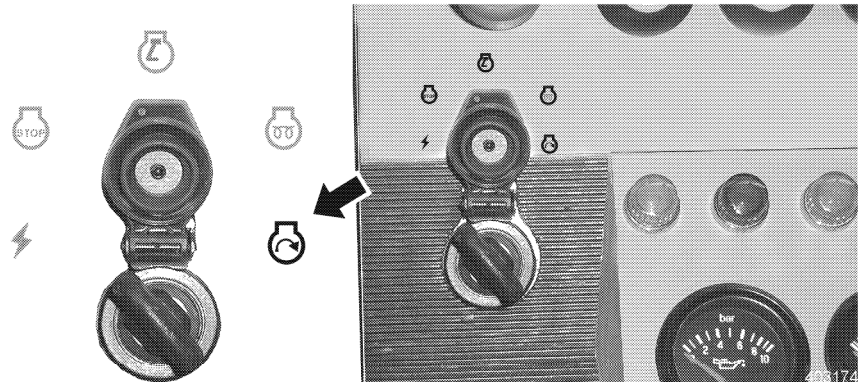

Starter switch - starting position

- Turn the starter switch to starting position and hold it in this position until the engine starts.
 - Do not crank the starter switch for more than 10 seconds.
- If the engine does not start:
- Return the starter switch to the Off position.

Troubleshooting

The engine does not start?

- Wait for 120 seconds, then repeat the starting procedure.
- If the engine does not start after two starting attempts, check the troubleshooting chart (see "Operating problems") and fix the problem.

- As soon as the engine is running, release the starter switch. The starter switch returns automatically to the operating position.

As soon as the engine is running, the following indicator lights must turn off:

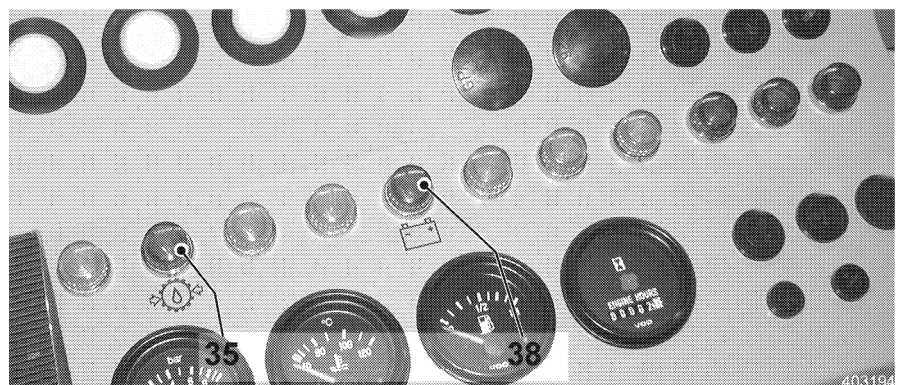

Indicator lights turn off

35 Indicator light - Replenishing oil pressure

38 Charge indicator light

Warning light - Operator's cab

Troubleshooting

The indicator lights do not turn off?

- Turn the engine off and fix the problem as outlined in "Operating problems".

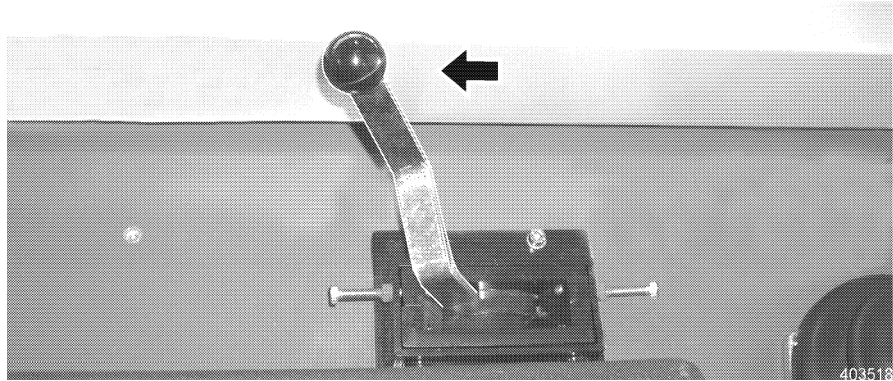

Throttle control lever - Low idle

- Regulate the engine RPMs with the throttle control lever.
 - Avoid full engine load until after a short warm up period.

Starting procedure at low temperatures

The following procedures improve the starting procedure at very low temperatures.

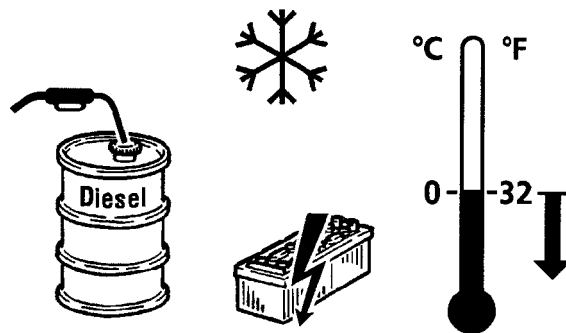

403046

Winter operation

Procedures:

- Check the battery charge, if necessary, recharge the battery.
- Use Winter fuel. See "Lubricants and service fluids" under cold season operation.

Danger

Danger of explosion of the Diesel engine!

Do not use ether cold start aids to start Diesel engines with preglow system, there is a danger of explosion!

! Do not use ether cold start aids.

- Carry out the noted procedures to start the engine at low ambient temperatures.

3.3.4 Travel operation

Preparations for travel

The preparations for travel should be carried out in the stated sequence. Make sure that the machine is in operating position. See paragraph "Operating position".

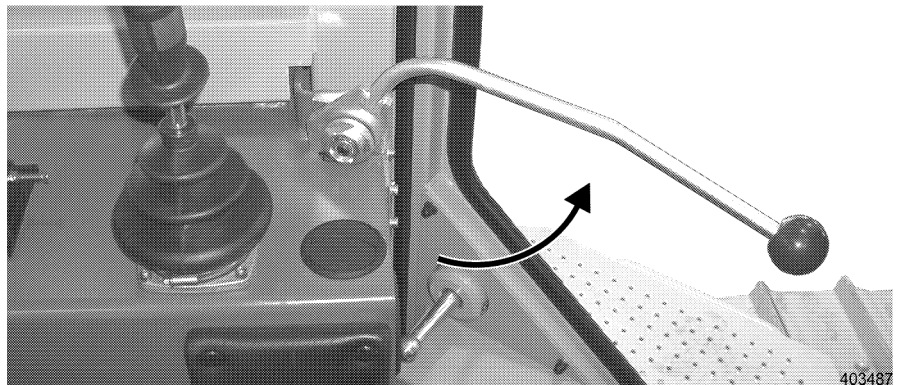

Safety lever up

- Raise the safety lever.
- Self-check - electronic system**
- After approx. 3 seconds, the indicator light - reduced travel speed lights up momentarily.
 - Do not deflect the travel joystick until after the indicator light - reduced travel speed. The electronic system runs through a self-check.
- The machine is now ready to travel.

Operating temperature

If the hydraulic oil is too cold, the machine reacts sluggish

- Actuate the working hydraulic cylinders repeatedly to stop to bring the hydraulic oil to operating temperature.

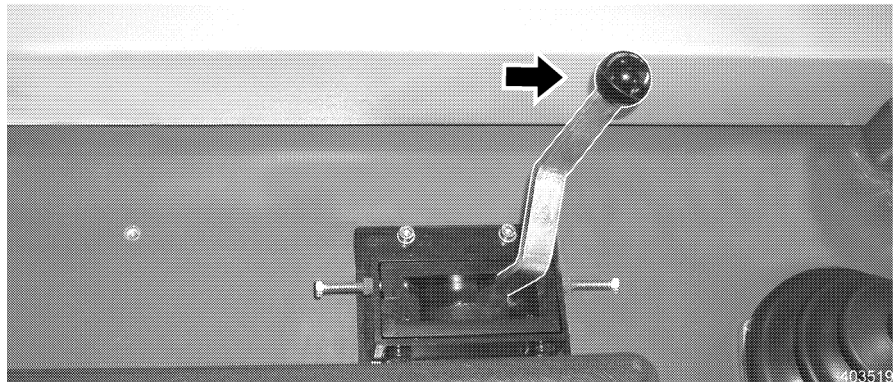

Throttle control lever - full load

- Move the throttle control lever to full load.
- When working, always run the engine at full load. Work at reduced engine RPM is only permitted in certain cases.

Preselect the speed ranges

The machine is equipped with a rocker switch to preselect the travel speed. The full travel speed can be reduced by switching to positions "II" or "I". The speed ranges can also be selected during travel. When switching back from full travel speed range, the machine is hydrostatically slowed down.



Low speed range

403648

Caution



When working constantly in heavy pushing application and when working on slopes, switch to the lower speed range "Position I".

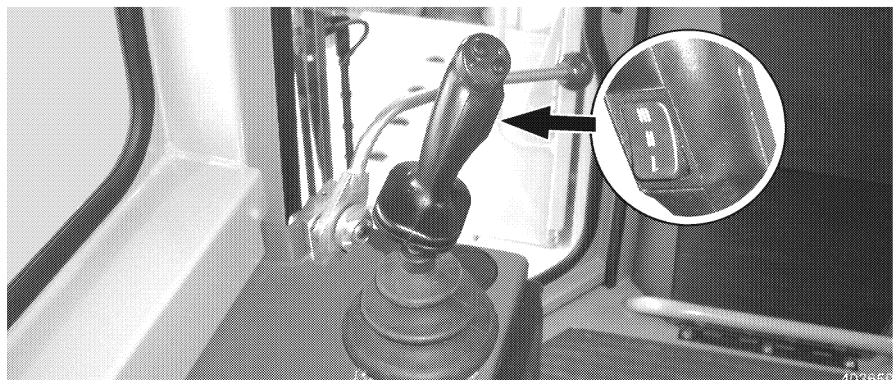

Rocker switch - speed ranges

Selectable speed ranges**Full speed range**

- Push rocker switch on top - Position "III".
- Speed 0 - 11 km/hr.

Medium speed range

- Rocker switch in center position - Position "II".
- Speed 0 - 6.5 km/hr.

Low speed range

- Push rocker switch on the bottom - Position "I".
- Speed 0 - 4 km/hr.



Indicator light - reduced speed ranges

The indicator light - reduced speed ranges 42 lights up in medium and low speed range.

3.3.5 Travel

Straight travel

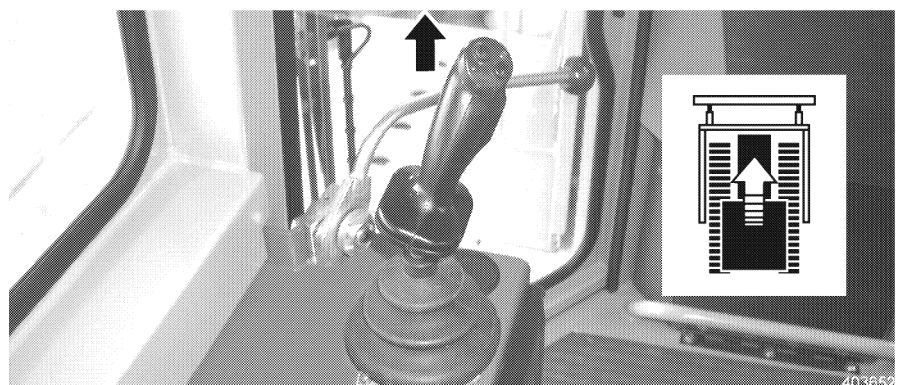

Forward travel

Forward travel

- Slowly push the travel joystick forward.
 - The machine drives forward.
- The further the travel joystick is pushed forward, the higher the travel speed.

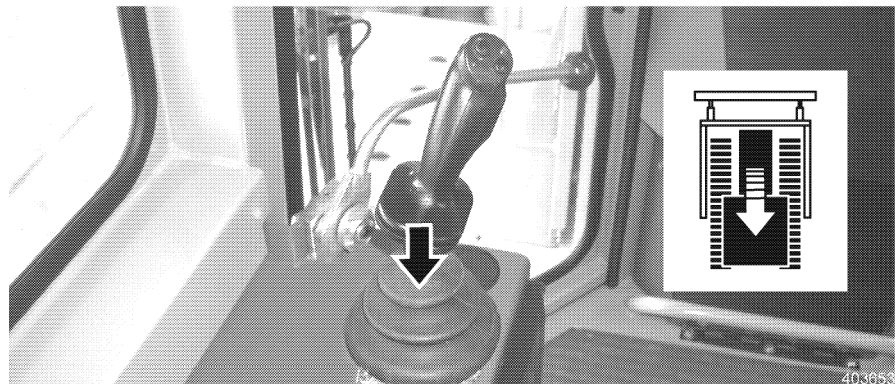

Reverse travel

Reverse travel

- Slowly pull the travel joystick backward.
 - The machine drives backwards.The further the travel joystick is pulled back, the higher the travel speed.

Various steering maneuvers

In addition to driving forward and reverse, any steering movement can be carried out at variable speeds.

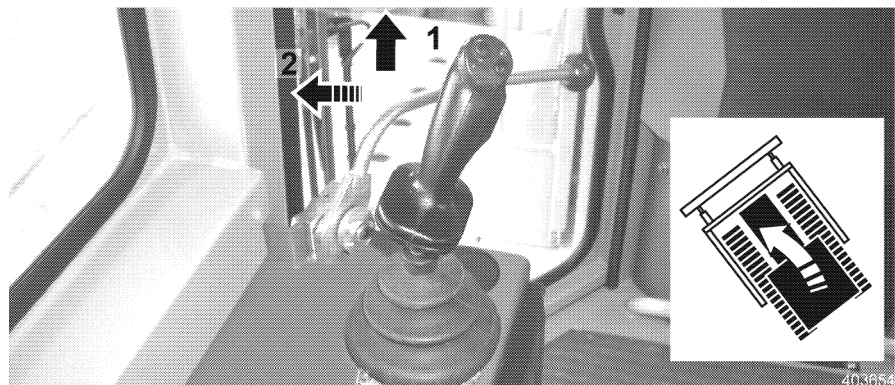

Left hand turn

Turn to the left

- Deflect the joystick to the front and push it to the left.
 - The machine drives forward at a slight left hand turn, both chains turn.The further the joystick is pushed to the left, the tighter the curve.



Right hand turn

Turn to the right

- Deflect the joystick to the front and push it to the right.

- The machine drives forward at a slight right hand turn, both chains turn.

The further the joystick is pushed to the right, the tighter the curve.

Counterrotation

During counterrotation, the two track chains turn in the opposite direction.

The counterrotation speed depends on the joystick deflection.

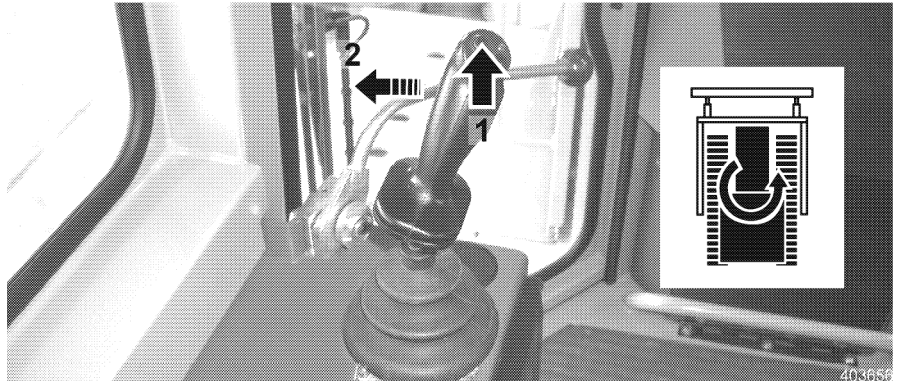

Left hand turn

Counterrotation to the left

- Push the push button on the joystick and push the joystick to the left at the same time.
- The machine turns to the left.

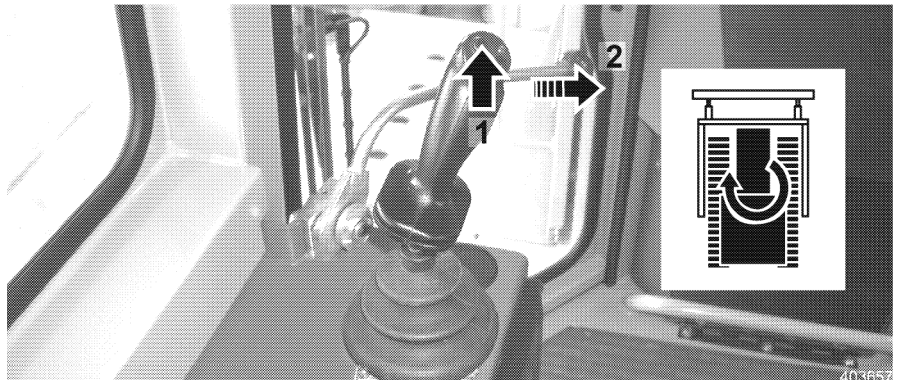

Right hand turn

Counterrotation to the right

- Push the push button on the joystick and push the joystick to the right at the same time.
- The machine turns to the right.

3.3.6 Brakes

Travel joystick

Braking with the travel joystick

The hydrostatic travel drive of the machine also serves as an operating or service brake.

As the travel joystick is moved into neutral direction, the travel speed is reduced in the same ratio.

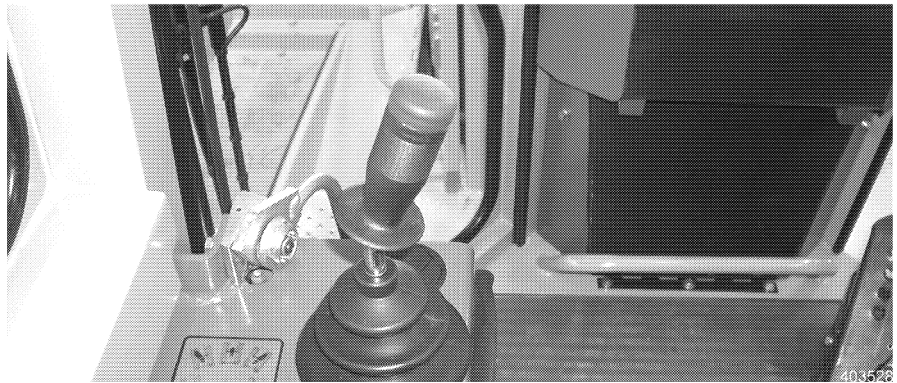

Travel joystick - Neutral position

- Move the travel joystick to neutral position.

By placing the travel joystick in neutral position, the hydrostatic drive will keep the machine from rolling off.

If the travel joystick remains in neutral position for more than 5 seconds, the parking brake is automatically applied. However, the attachment functions remain operational.

Caution



Danger of accidents due to careless breaking procedure!

Moving the travel joystick into neutral position too quickly causes the machine to stop suddenly and abruptly.

! Before operating the machine, make sure the seatbelt is fastened.

Parking brake

Apply the parking brake

The parking brake is applied as follows:

- by moving the safety lever in the down position,
- by leaving the travel joystick in neutral position for more than 5 seconds,
- or if the joystick is in neutral position and the chains continue to turn for approx. 2 cm.

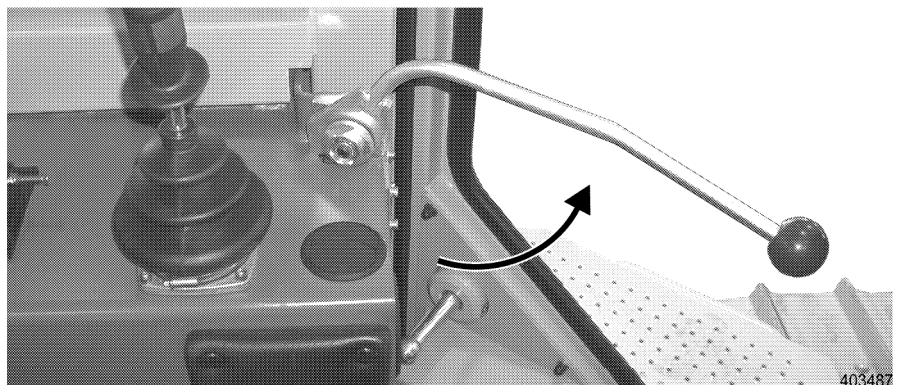

Safety lever up

Release the parking brake

With the Diesel engine running:

- Raise the safety lever.
- Deflect the travel joystick.

Turn the machine off.

The safety lever must always be in the full down position when the Diesel engine is not running.

- Indicator light - travel brake lights up.

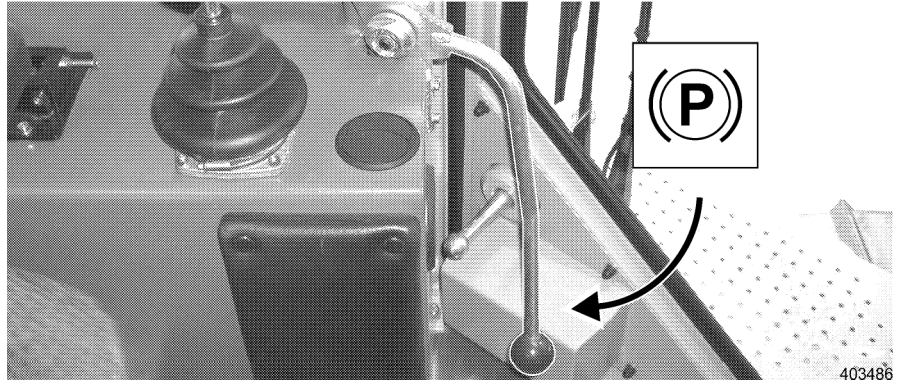

Safety lever down

- Move the safety lever down.

If the Diesel engine is turned off inadvertently, move the travel joystick to neutral position and bring the safety lever in the full down position. The parking brake is now applied.

3.3.7 Machine shut down

Before turning the engine off and leaving the machine, proceed as follows.

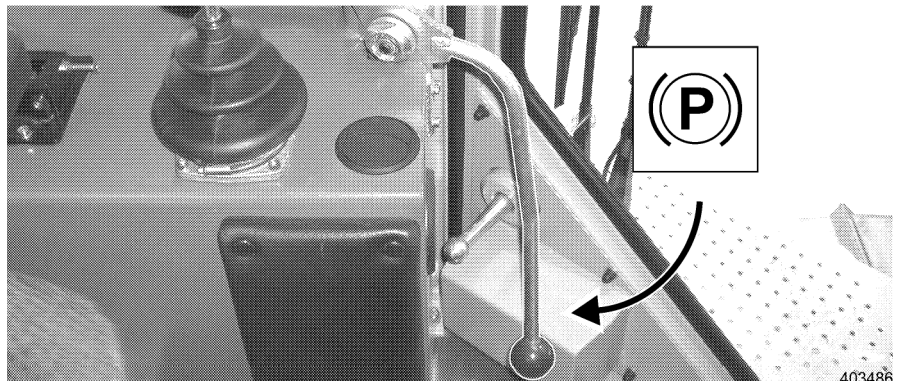

Safety lever down

- Move the safety lever down.
 - The indicator light - travel brake lights up.

Turn the Diesel engine off.

Do not turn the Diesel engine off suddenly from full load. This is especially important for turbocharged engines.

If the Diesel engine is turned off suddenly, the turbocharger continues to run for some time without oil supply.

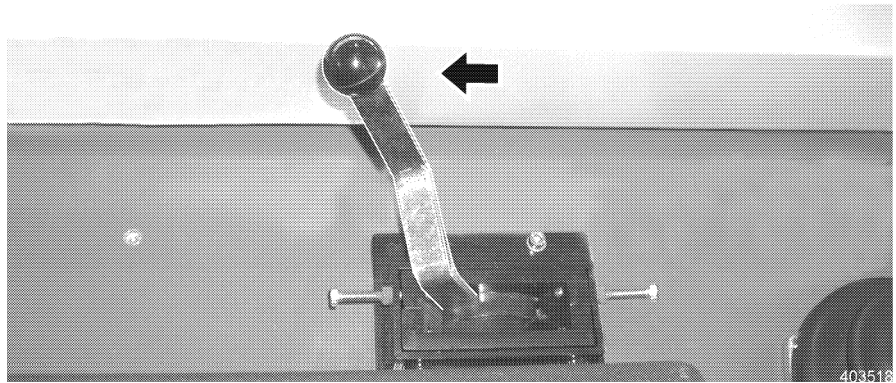

Diesel engine - low idle RPM

- Reduce the Diesel engine RPM to low idle.
- Continue to run the engine for a short time - approx. 10 to 15 seconds - at low idle.
- Turn off all electrical users (for example headlights, windshield wipers, ...) before turning off the ignition switch.

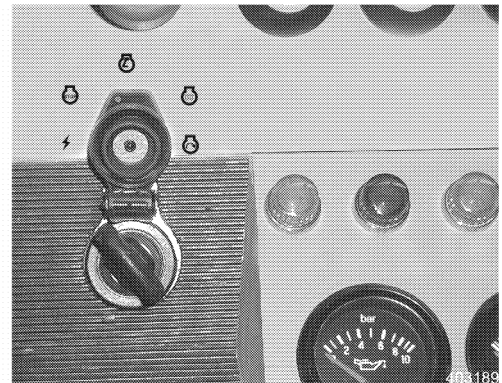
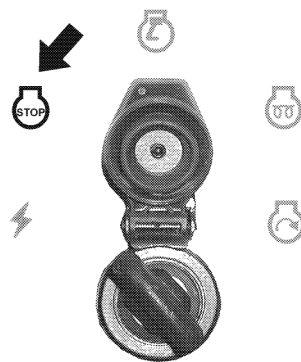

Ignition switch - Off position

- Turn the ignition switch to the "off" position and pull the key.
 - All indicator lights turn off.

Parking position

The ignition key cannot be pulled off in parking position.

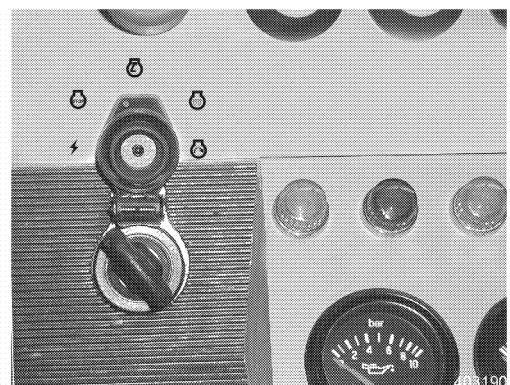
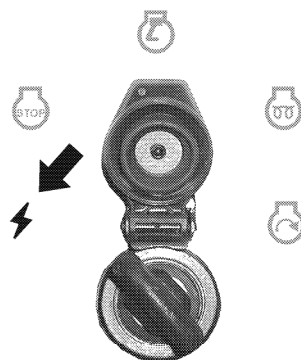

Ignition switch - Parking position

- Turn the key to parking position.
 - The following users are operational.
 - Interior illumination

- Electrical socket
- Radio

Danger

Unauthorized use of the machine by other persons causes severe danger of accidents for maintenance personnel!
! Secure the machine to prevent unauthorized access!

If you leave the machine:

- Turn the ignition switch to the "off" position and pull the key.

Emergency off button**Caution**

There is a danger of accidents as the machine stops suddenly. The machine stops suddenly.
! Always fasten the seatbelt before operating the machine.

Stop the travel drive

In dangerous or in emergencies, the travel drive can be stopped by pressing the emergency off button.

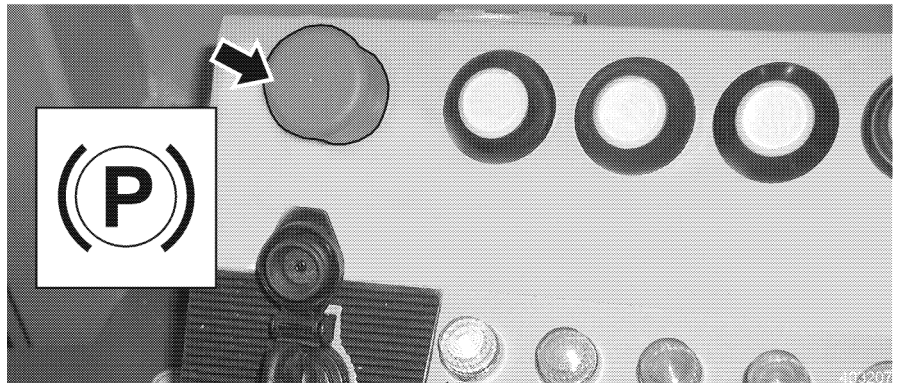

Emergency off button

- Press the emergency off button
- The travel drive is stopped abruptly, the Diesel engine continues to run. The attachment can still be operated.

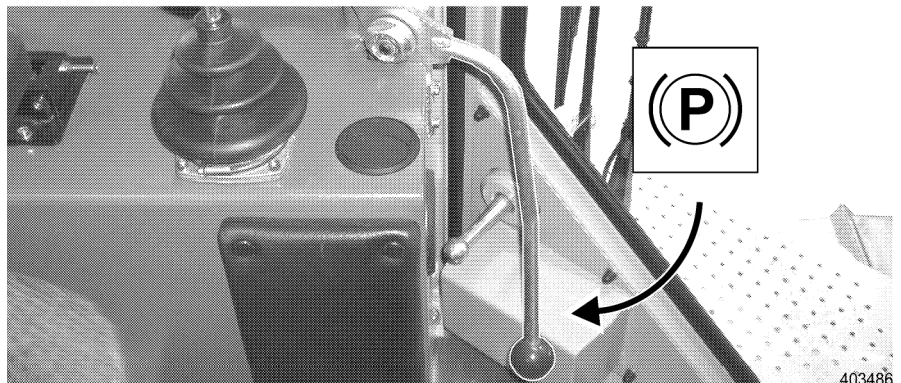

Safety lever down

Continue travel

- Move the travel joystick to neutral position.
- Move the safety lever in the full down position.

- Lift the emergency off button until it engages.
- Move the safety lever up.
- Deflect the travel joystick into the desired direction. See also "Travel".

3.3.8 Guidelines for working in water

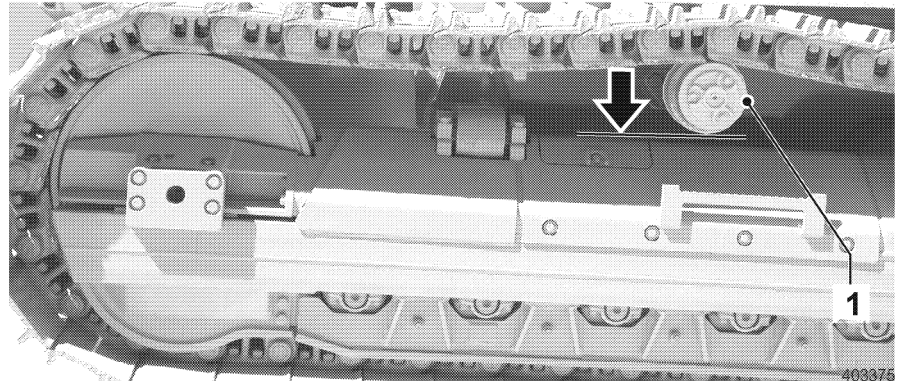

Lower edge - carrier roller

When driving through wet areas or when working in water, the maximum fording depth (lower edge of carrier roller 1) may not be exceeded.

- After working in water, lubricate all lube points.

Caution



! Danger of fan damage!

- If the maximum fording depth is being exceeded, the fan will be destroyed.

Never exceed the maximum fording depth (lower edge of carrier roller).

3.3.9 Transporting the machine

Transporting the machine by truck or rail.

Before driving onto the loading surface

Before driving onto the loading surface, proceed as follows.

- If necessary, remove part of the attachment for the duration of transport.
- Have suitable tension cables or chains ready for rigging.

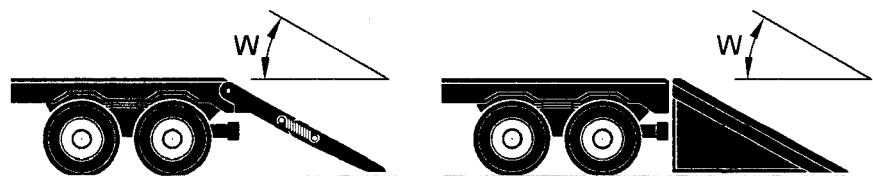

Ramp incline

403048

Have a suitable ramp ready to drive onto the loading surface. The ramp incline angle - **W** - may not exceed 30°.

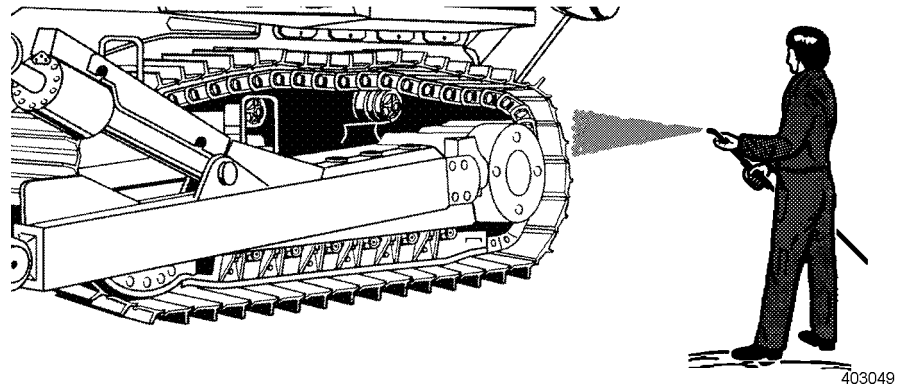

Cleaning

Before driving onto the ramp, clean the chains of the machine to remove ice and mud.

Driving onto the loading surface

For detailed description, see "Control, operation". When driving onto the loading surface, have a guide signal you! Make sure that a guide is available to signal the operator / driver of the machine.

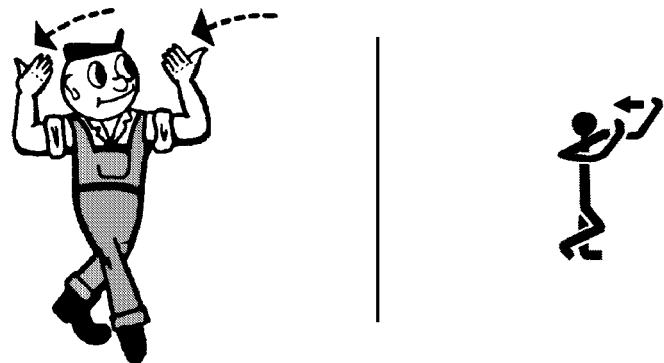

Guide

403050

Any person which functions as the guide must stand to the side of the machine!

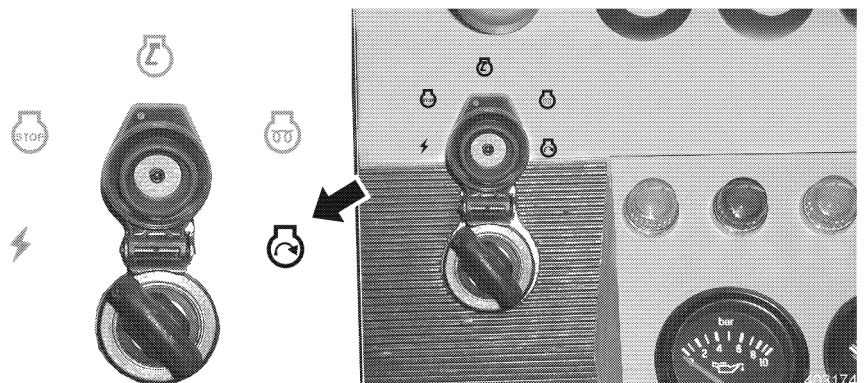

Starting procedure

- Start the Diesel engine.
- See also "Starting the Diesel engine" and "Travel operation".

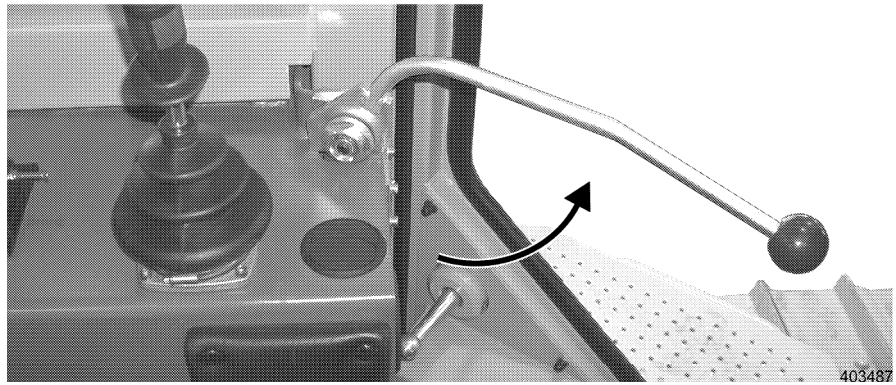

Safety lever up

- Move the safety lever up.

Danger



Danger of accidents due to careless driving!
Careless driving poses a danger of accidents for loading personnel, guide as well as for the driver / operator of the machine.
! Drive carefully when loading the machine!

Drive onto the ramp only in low speed range, position "I"!

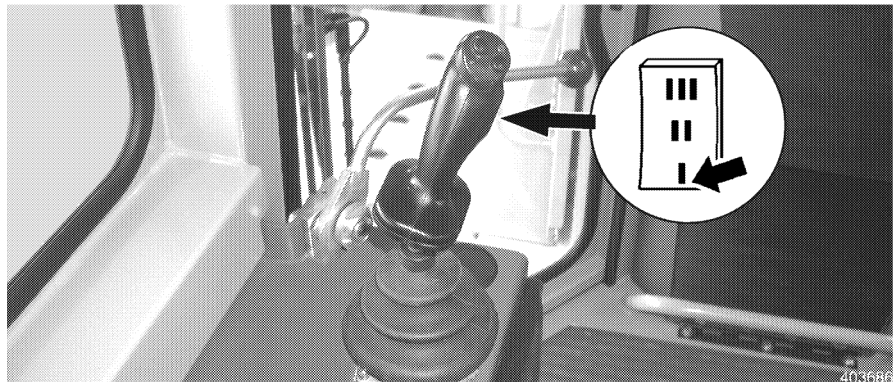

Low speed range

- Select the low speed range: move the rocker switch to position "I".
 - Start out the machine carefully.
- For detailed descriptions, see "Control, operation".

After driving on the loading surface

- Stop the machine.
- Lower the attachment and set down the attachment level onto the loading surface.

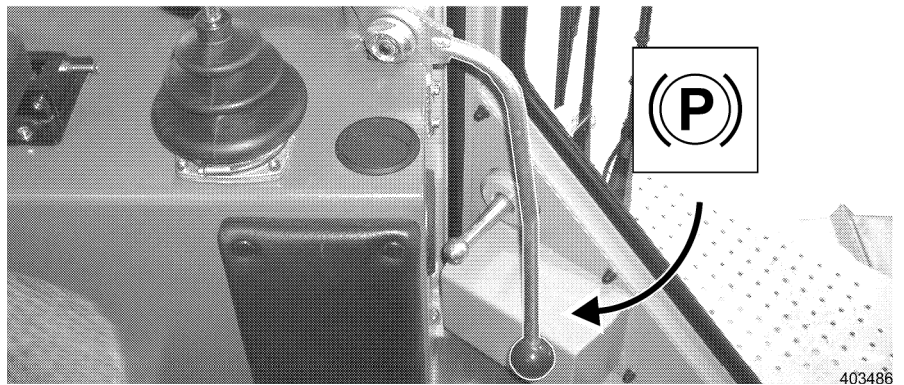

Safety lever down

- Move the safety lever down.
- Turn the Diesel engine off.
- Close and lock all doors and hoods on the machine.

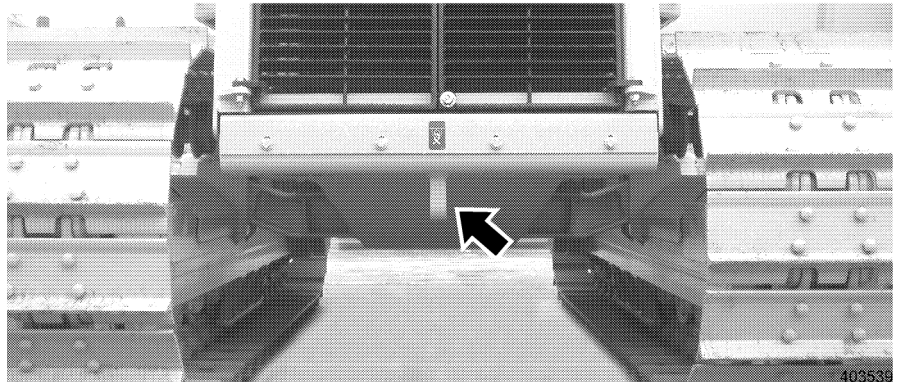

Front rigging point

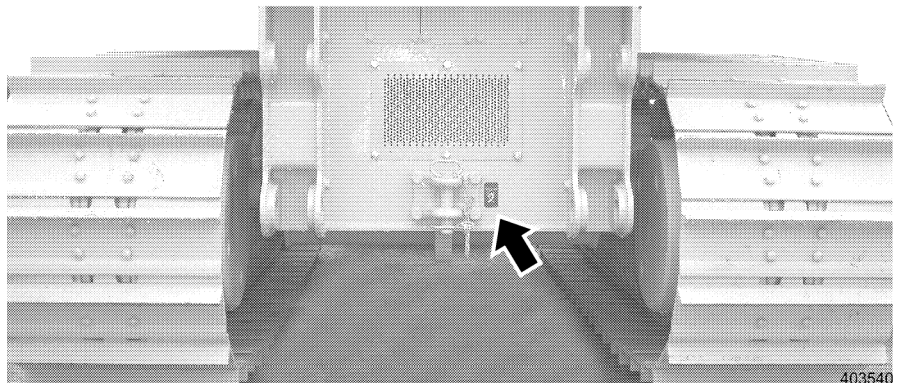

Rear rigging point

- Secure the machine to prevent it from slipping: use wedges as well as tension cables or chains.
- Attach the tension cables or chains to the Brand d rigging points on the machine.

If the machine is positioned against the transport direction, then the wind could enter into the exhaust opening.

The entering wind continues to drive the turbocharger of the Diesel engine.

To prevent damage to the turbocharger during transport, proceed as follows.

This is especially important during rail transport, because the travel direction is not known before!

Caution



Danger of damage to the turbocharger due to external influences! The entering wind through the exhaust opening can drive the turbocharger of the Diesel engine. If the engine is not running, the turbocharger is not lubricated. Without lubrication, the turbocharger will be damaged.
! Make sure that no wind enters into the exhaust!

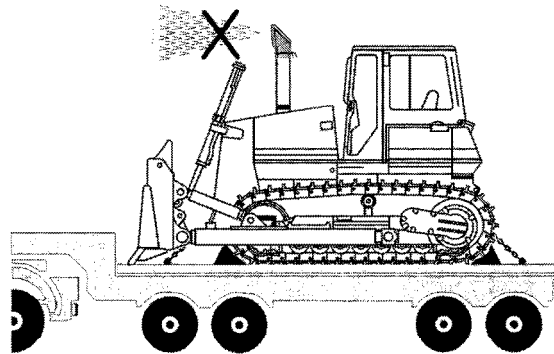

403541

Exhaust covering

- To close off the exhaust: step onto the machine only via the ladder and select a safe location to stand.
- Cover the exhaust opening with windproof material, make sure it doesn't slip off.

Reduce the transport height

Remove the operator's cab

The operator's cab can be removed for the duration of the transport.

Make sure that:

- a suitable lifting device is available,
- a ring screw from the toolbox is available.

Operator's cab with air conditioning system

If an air conditioner is installed the air conditioner hoses between the operator's cab and the operator's platform must also be disconnected. Shut off valves are installed in the air conditioner lines to prevent loss of refrigerant.

The air conditioner lines may only be disconnected on the quick couplings.

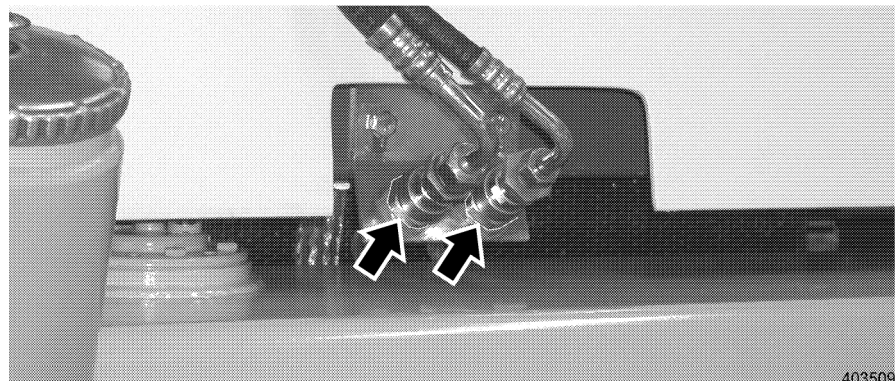

403509

Air conditioner lines - Operator's cab

- Disconnect the air conditioner lines on the quick couplings.

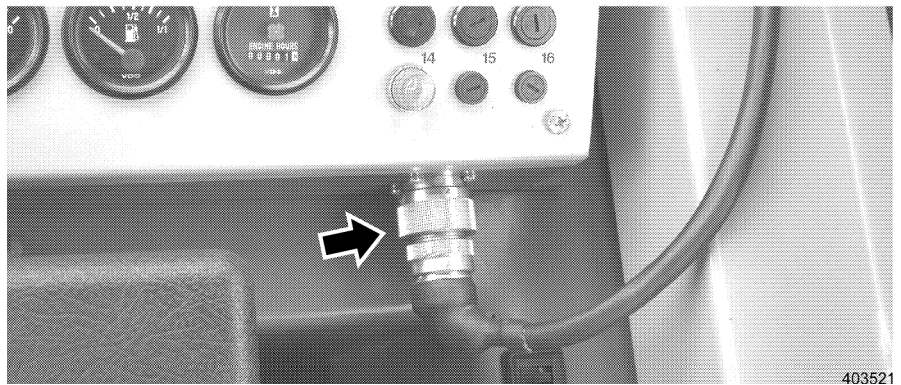

403521

Wiring harness - Operator's cab

- Disconnect the wiring harness for the operator's cab on the instrument panel by releasing the screw fitting.

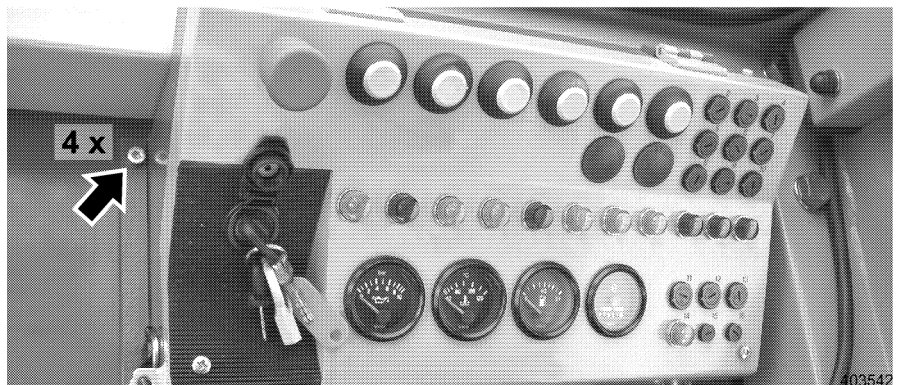

403542

Instrument panel

- Remove the mounting screws of the instrument panel.
- Push the instrument panel in direction of the operator's seat so that it will not be damaged when it is raised.

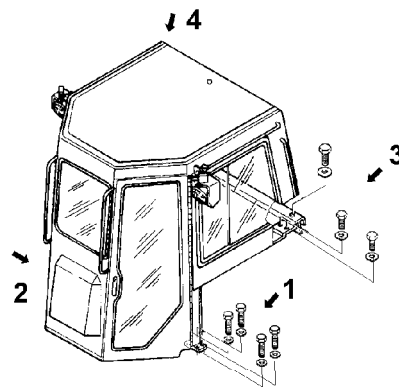

403510

Mounting screws - operator's cab

- Remove the mounting screws 1 and 2 for the operator's cab on the front left and right hand side.
- Remove the mounting screws 3 and 4 for the operator's cab on the inner and outer rear.

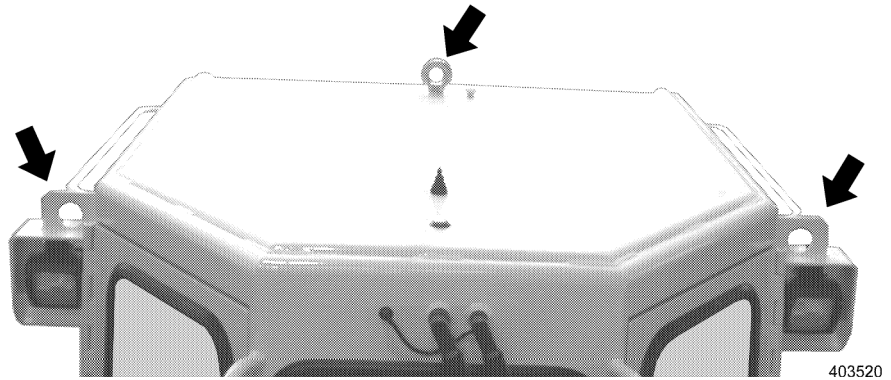

Tackle / lifting points - operator's cab

- Remove the screw plug from the roof of the cab.
- Remove the ring screw from the toolbox and install on the operator's cab roof.
- Carefully lift the operator's cab on the intended tackle points.
- Place the operator's cab down and secure it properly to prevent it from falling over.

Caution



Danger of damage to the electrical system of the machine.

- Cover the base to prevent damage due to environmental influences (rain, snow, ...).

After removal

- Cover the base with suitable covers to prevent damage due to environmental influences.
- Install in reverse order.

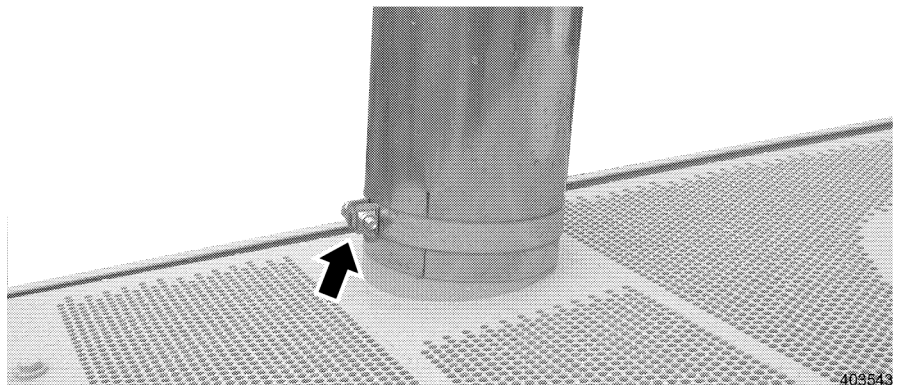

Smoke stack

Removal of smoke stack

- Loosen the lock screw on the smokestack and remove the smoke stack by turning it slightly to the left and right.
 - Close the exhaust opening off after removal.
- Step on the machine only via the ladder and choose a safe location to cover the opening.
- Cover the opening well with non-slip and wind resistant material.

3.3.10 Loading the machine with a crane

For any loading procedures, make sure to observe all applicable accident prevention guidelines!

See "Safety guidelines when loading the machine with the crane".
Before loading the machine with the crane, the following preparations must be made.

Preparations:

- Lower the attachment.
- Bring all control levers into neutral position.
- Move the safety lever down.
- Turn the Diesel engine off.
- Close and lock all doors and covers on the machine.

For detailed description, see "Control, operation".

Check the following:

- weight and dimensions of the machine: see "Technical Data",
- the required load carrying capacity and length of cables.

Danger



Danger of accidents due to suspended / falling load!

! It is not permitted for any person or persons to be under the raised machine.

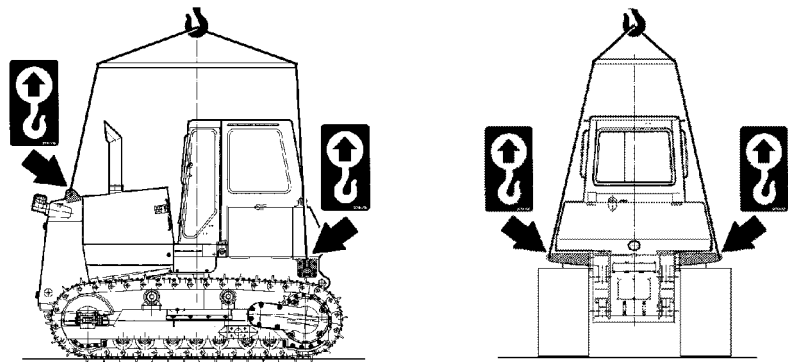

403501

Lifting points

Loading the machine for truck or rail transport

- Attach / hang the lifting devices to the intended tackle and lifting points on the machine.
- Carefully lift and load the machine.

3.4 Emergency operation

In case of a problem on the machine, it might become necessary to tow the machine from a danger zone.

The following towing instructions apply only for exceptional cases, to move the disabled machine to a location where it can be repaired or loaded for transport.

Towing speed and distance:

- The max. towing speed is no more than 2 km/hr. (step by step speed).
- Permissible only for a short distance to remove the machine from a danger zone.

Always haul the machine over long distances!

3.4.1 Towing the machine

Towing the machine is problematic, it is always the responsibility of the operator.

Damage or accidents, which occur when towing the machine are never covered by the manufacturer's warranty.

Towing safety

See also "Safe machine towing".

Danger



Danger of accidents due to improper towing procedure!

Improper towing of a disabled machine can cause severe injuries or death!

! Before releasing the brakes for towing, make sure the machine is secured to prevent it from rolling off!

- Observe all safety guidelines and the following recommendation when towing the machine.
 - Keep the angle of the towing cable in relation to the machine to a minimum. The angle should never exceed 30° from the machine length axle.
 - Start the machine out slowly and evenly. Do not jerk! Uneven movements of the machine can overload or snap the towing cable or the rod.
 - When towing the machine on a hill, the towing machine must be at least as large as the machine being towed. Power, weight and brakes must be adequate to keep both machines under control. If necessary, add machine of the same size to the rear for braking purposes.

Towing

The machine is equipped with a parking brake, which is vented with hydraulic pressure, the hydrostat acts as an operating brake. If the machine is disabled, the parking brake is applied and the machine cannot be moved.

Prepare the machine for towing

To be able to tow the machine, the hydrostatic drive must be short circuited and the parking brake must be released.

! The machine can only be towed if the electrical system is fully functioning.

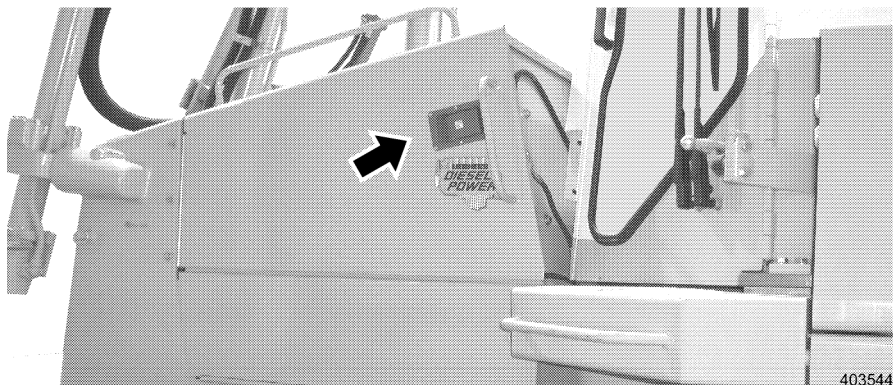

Open the left engine compartment door

- Open the left engine compartment door.

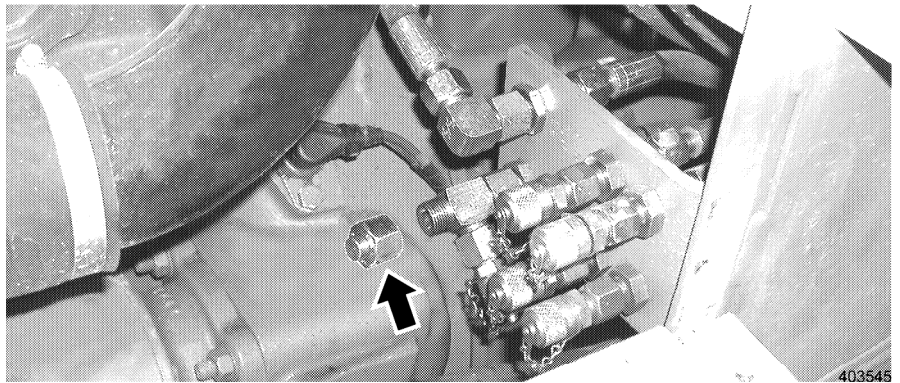

Connection "BS"

- On the test bracket on connection "BS", remove the union nut and the fitting.

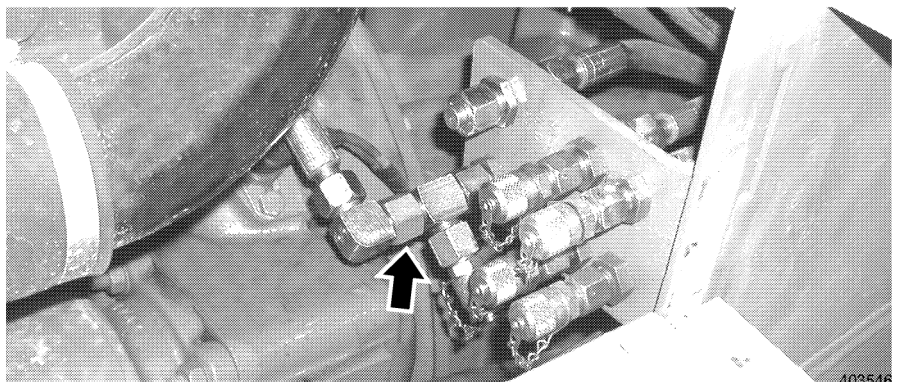

Connect the hose

- Remove the hose from connection "BB" and connect on connection "BS".
- Install the fitting and the union nut on connection "BB" of the removed hose.

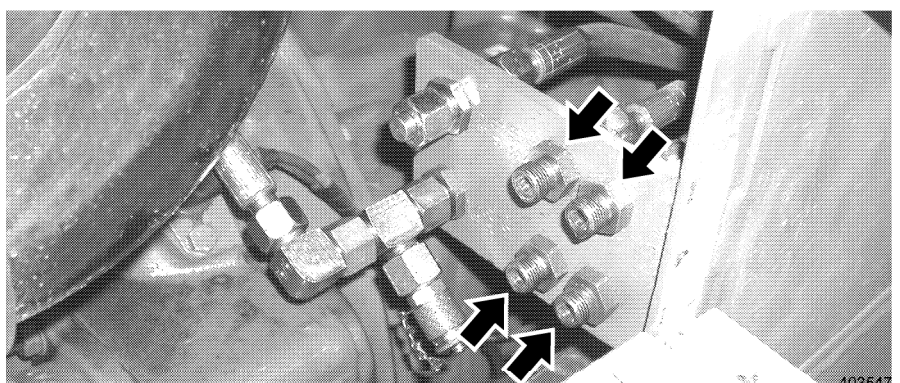

Remove the test fittings

- On the console, remove the four test fittings.
- Remove the hydraulic lines from the tool box to short circuit.

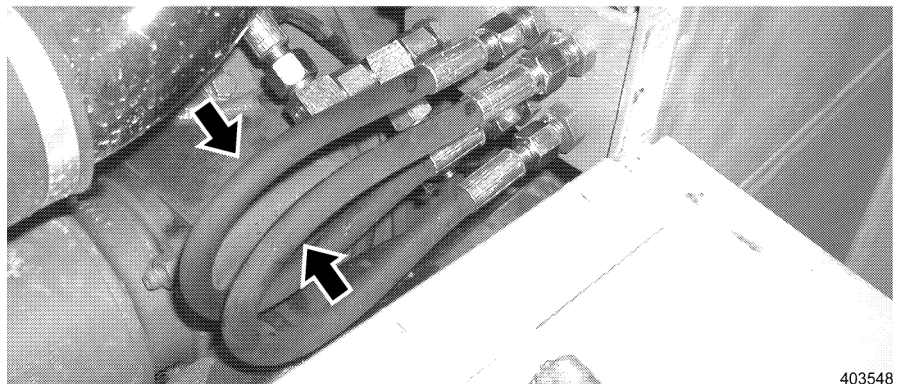

403548

Short circuit the connections.

- Short circuit the connections "M1L-M2L" and "M1R-M2R" with the hydraulic lines.
- Close the left engine compartment door.

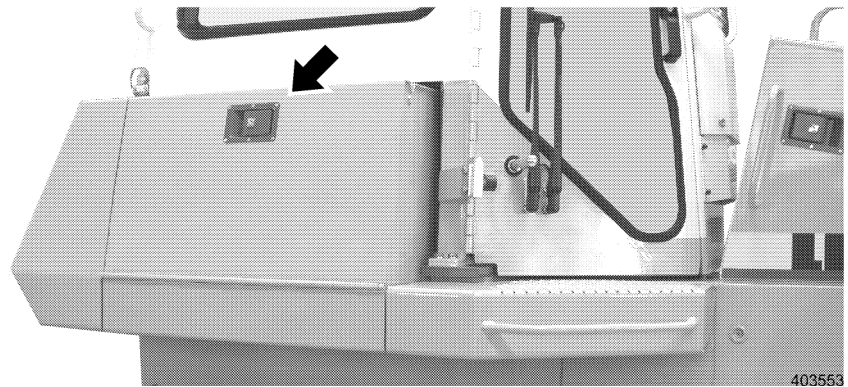

403553

Battery compartment door

- Open the battery compartment door.

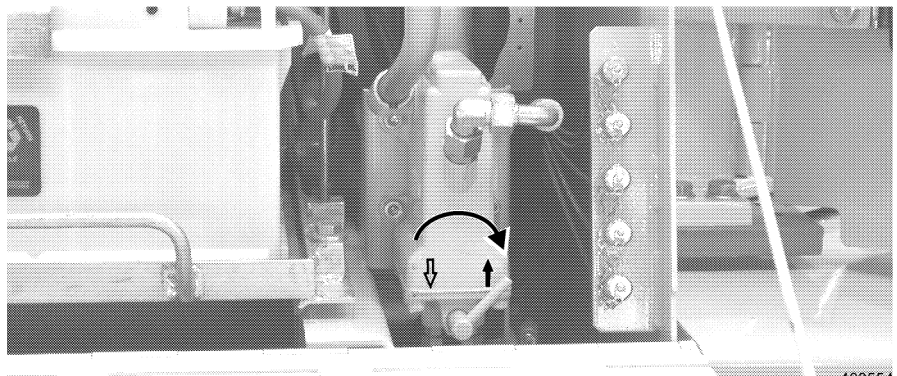

403554

Hand pump - Lever "UP"

- Set the lever on the hand pump to position "UP".

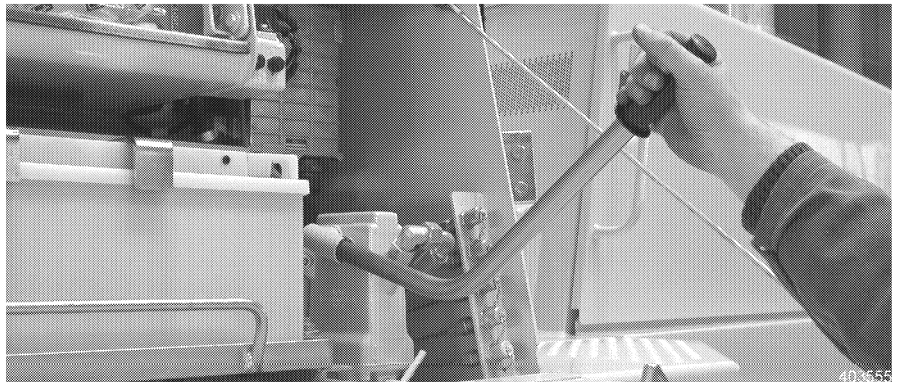

Actuate the hand pump

- Take the extension pipe from the tool box.
- Actuate the hand pump (approx. 20 times) until a noticeable increase in pressure can be felt and a noise can be heard (relief valve on the hand pump is actuated).
- Close the battery compartment door.

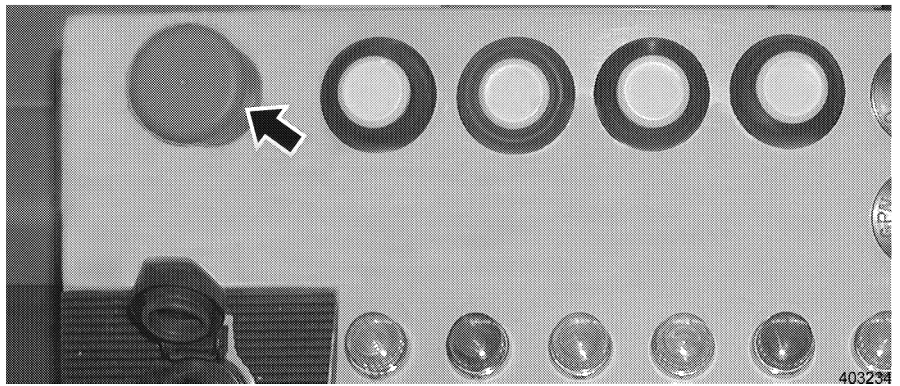

Emergency off button raised

- Check the position of the emergency off button.
 - For the towing procedure, the emergency off button must be in operating position (emergency off button raised).

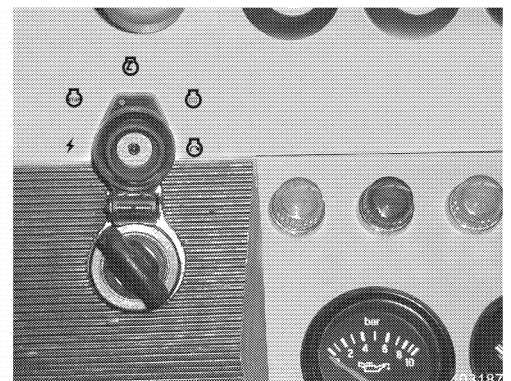
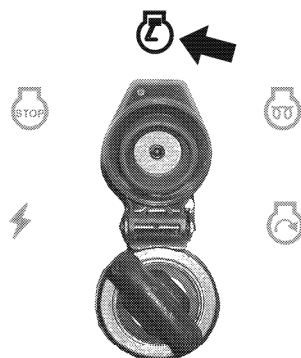

Starter switch - contact position

- Set the starter switch to contact position.
- The following indicator lights light up:
- Indicator light - Travel brake
 - Indicator light - Replenishing oil pressure
 - Charge indicator light
 - Indicator light - Low speed range

- Indicator light - Electronic

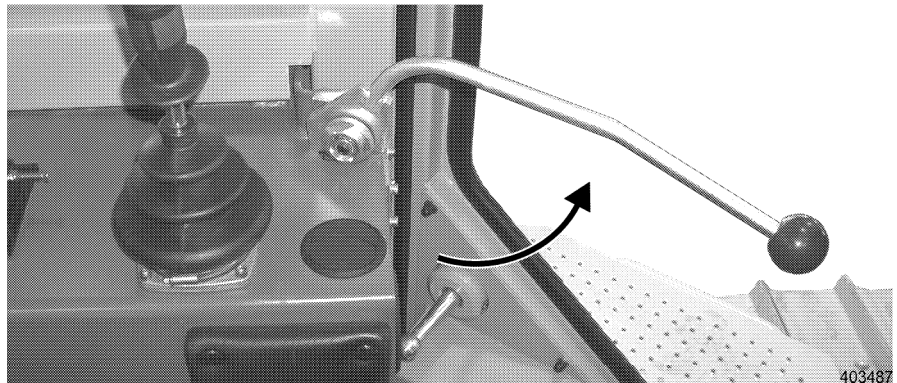

Safety lever up

The hydraulic pressure which was built up with the hand pump releases the parking brake by moving the safety lever to the up position.

- Move the safety lever to the up position.
- Indicator light - travel brake turns off.

Danger



The machine has no brakes.

- Carry out the towing procedure by observing all safety guidelines.

Stop the machine

Push the emergency off button or place the safety lever down to apply the parking brake.

Caution



The machine can be stopped in dangerous or unclear situations by pushing the emergency off button.

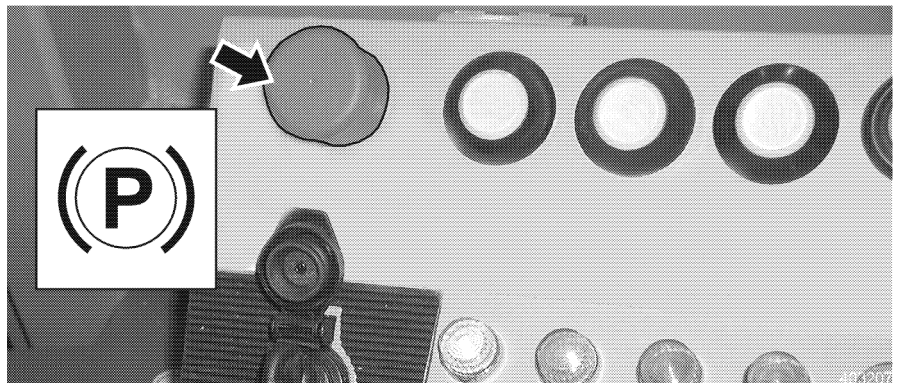

Push the emergency shut off button

- Push the emergency shut off button.
 - The parking brake is applied.
- To continue towing, repeat the towing procedure by actuating the hand pump.

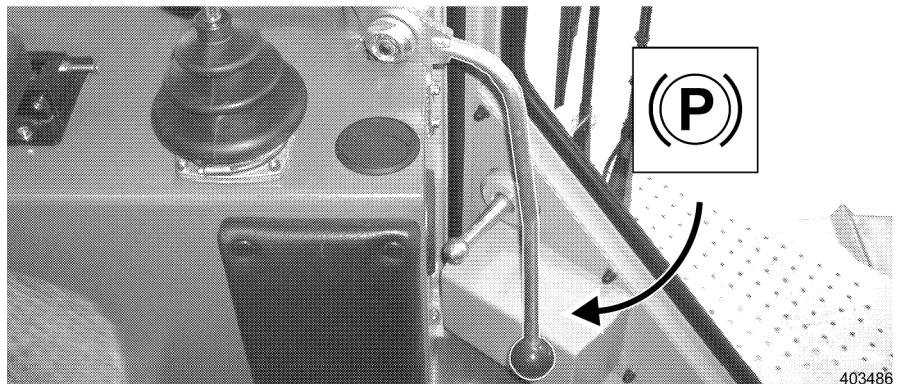

Safety lever down

After the towing procedure

- Push the emergency shut off button.
 - The parking brake is applied.
 - Indicator light - travel brake must light up.
- Move the safety lever down.
- Turn the ignition off.
- Open the battery compartment door.
- Set the lever on the hand pump to "DOWN".

Danger

Before operating the machine again, make sure that all parts which have been removed for towing have been reinstalled and that the machine is returned to its original series condition.

3.4.2 Auxiliary starting procedure

In case of starting problems due to old batteries, the machine can also be started with an external battery. Make sure that the following safety preparations have been made.

Attach the auxiliary battery**Danger**

Danger of accidents due to incorrect or unsafe procedure when starting the machine with auxiliary batteries!

When connecting the auxiliary batteries, increased gas formation on aging batteries can cause an "EXPLOSION"!

- ! Avoid open flames and sparks in the area of the batteries.
- ! Make sure to wear protective glasses and gloves when handling batteries.
- ! Use a sufficiently sized auxiliary starting cable.

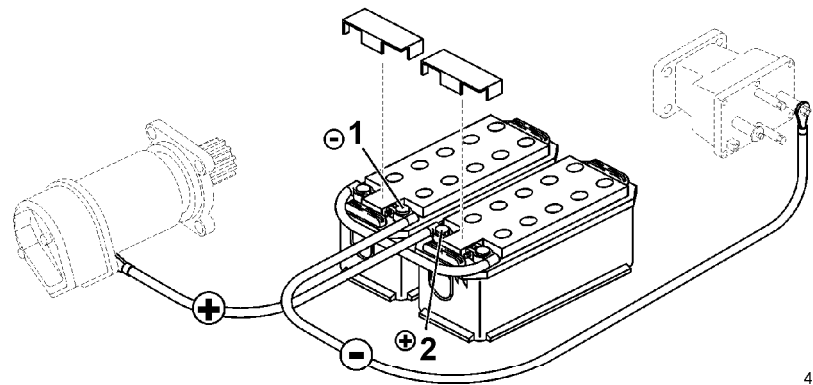

403235

External starting procedure

- 1 Ground point of discharged battery
- 2 Positive terminal of discharged battery

- Connect an auxiliary starting cable first to the positive terminal of the discharged battery 2 and then to the positive terminal of the external battery.
- Connect the second auxiliary starting cable first to the ground point for the auxiliary battery 1 and then to the negative terminal of the auxiliary battery.
- Start the Diesel engine. See paragraph "Start the Diesel engine".

Disconnect the auxiliary battery

Before removing the auxiliary starting cable, bring the Diesel engine to low idle speed.

If necessary, turn on a large power user, such as the headlights, to avoid over voltage.

- Remove the auxiliary starting cable first from the negative terminal of the auxiliary battery and then from the ground point of the discharged battery 1.
- Then remove the second auxiliary starting cable from the positive terminal of the auxiliary battery and then from the positive terminal of the discharged battery 2.

4. Operating problems

Warning and problem reports

- Diverse problems are shown optically via the corresponding indicator lights or indicators and gauges on the instrument panel.
See also "Control, operation", paragraph "Indicator unit".
- Warning functions are sometimes also acoustically supported.

Recognition and remedy of problems and errors

- Often problems are caused by improper machine operation or maintenance.

For that reason, always read the corresponding section in the Operating Manual if a problem occurs.

- Analyze the cause of the problem and fix it immediately!
- If you contact LIEBHERR Service, please describe the problem and all corresponding circumstances in detail.

Detailed information makes it possible to find and fix the cause of the problem quickly. Have the machine data and serial number of the machine available.

- Do not perform any work for which you are not trained.

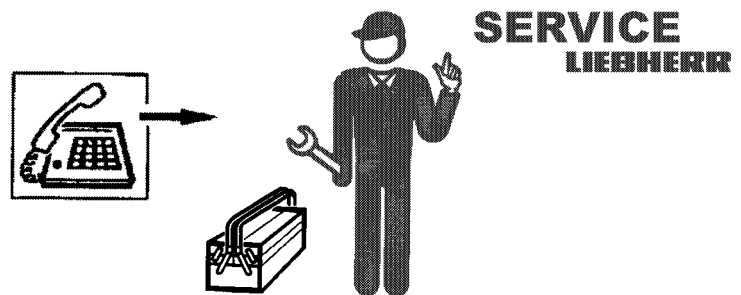



403052

LIEBHERR Service

If you cannot find the cause of the problem with the "Error code charts", or if you cannot fix the problem, contact LIEBHERR Service.

4.1 Problems and remedy

Diesel engine and fuel system

 Problem / error	 Cause	 Remedy
The engine does not start	The safety lever is in uppermost position	Place safety lever down
	Engine shut off control is not in operating position (PR732B/742B/LR632)	Bring engine shut off control into operating position
	Fuel tank is almost or completely empty	Add fuel and bleed the fuel system
	Shut off valve in fuel line is closed	Open shut off valve
	Fuel filter displaced	Clean or change filter and bleed the system, drain fuel / clean tank
	Ambient temperature below 0°C	Control and operation for special climatic conditions, see Operation and Maintenance Manual
	Starter does not operate	Check the line connections
	Starter does not operate	Overhaul the starter or change the starter ring (Inst)
	Battery capacity is low	Recharge / replace
Engine starts but stops again or runs unevenly	Fuel tank empty	Add fuel and bleed the system
	Fuel pre-cleaner is dirty	Clean and bleed the system
	Fuel filter is dirty	Clean the filter and bleed the system (tank)
	Especially in winter: engine oil is too viscous	Use engine oil recommended for the ambient temperature.
	Air filter is dirty	Clean or change the primary filter element
	Air in fuel system	Bleed the system
	Vent on fuel tank is plugged	Clean
	Fuel line is kinked	Check and fix line
Exhaust is gray or black	Air filter is dirty	Clean or replace filter

!	?	✓
Exhaust is white (vapor)	Water in combustion chamber	Call Service Dept.
Engine does not reach full RPM	The throttle control lever is not set to full load	Set the throttle control lever to full load
	Dry air filter is dirty	Clean or replace filter
	Bad fuel supply	Check fuel pre-cleaner, fuel filter, lines, drain tank
Engine is getting too hot	Not enough coolant	Add coolant, check for leaks
	Water pump is defective	Check for leaks / fix
	Thermostats are not working	Change thermostats
	Radiator is dirty	Clean radiator
Engine oil pressure is insufficient NOTE: Turn the engine off immediately!	Oil level too low	Correct oil level
	Oil pressure gauge is defective	Change oil pressure gauge
Engine uses too much oil	External leak on engine	Retighten screws, replace seals if necessary
Oil in coolant or coolant in oil		Call Service Dept.
Whistling noise on exhaust side	Exhaust system is not tight, leaks	Check / fix exhaust system

Hydraulic system

!	?	✓
Problem / error	Cause	Remedy
Indicator light for replenishing oil pressure does not turn off after starting the engine NOTE: Turn the engine off immediately!	Increased leakage	Call Service Dept.
Abnormal noise on hydraulic pumps NOTE: Turn the engine off immediately!	Shut off valve on hydraulic tank is closed	Open shut off valve
	Hydraulic pumps draw in air	Check the oil level in the hydraulic tank, check the suction lines for leaks
No reaction if travel lever is deflected	Safety lever in down position or emergency off switch is pressed	Raise the safety lever / pull the emergency off switch
No reaction when actuating the blade up function	Float position is turned on	Turn off float position

Tracks / travel gear

! Problem / error	? Cause	✓ Remedy
Oil emerges on track rollers, carrier rollers or idlers	Seal is defective	Replace seal
Deficient chain guidance on idler	Idler guide on track roller frame has too much play	Adjust the play of the idler guide
Chain jumps off or over	Chain tension too low / sprocket is worn	Adjust / replace chain tension
Correctly tensioned chain loses tension quickly during operation	Chain tension cylinder is defective	Check chain tension cylinder, change if necessary or reseal (only by authorized expert personnel)
Track roller or carrier roller is stuck	Track is extremely dirty	Clean

Electrical system

! Problem / error	? Cause	✓ Remedy
Charge indicator light does not turn off	V-belt for alternator is loose or broken	Tension or replace V-belt
	Alternator is defective	Change alternator
Batteries are not charging or insufficiently charged	Batteries are defective	Change the batteries
	Battery terminals are dirty / corroded	Clean battery terminals
	Cable is loose or defective	Connect or replace cable
No function or erroneous function of an indicator light or gauge	Bulb is burnt out, gauge is defective	Replace defective part
Failure of some or all instrument panel functions	Plug connector is unplugged or defective, ground is interrupted, short circuit - fuse is defective	Connect or change plug connector, fix short circuit, replace fuse

Heating system

! Problem / error	? Cause	✓ Remedy
Heater does not put out warm air	Shut off valves on coolant line on engine are closed	Open shut off valves
	Engine is not at operating temperature	Bring engine to operating temperature
Heater fan is not running	No power supply	Check fuse and check wires / fix if defective

!	?	✓
	Fan motor defective	Change fan motor
Insufficient fresh air in operator's cab	Fresh air filter is dirty	Clean air intake openings, replace fresh air filter

Working attachment

!	Problem / error	?	Cause	✓	Remedy
	Cylinder gives way under load		Piston seal in cylinder is defective		Overhaul cylinder
	PR- chain scrapes on push frame		Blade adjustment incorrect		Adjust correctly
	Increased bearing play on attachment		Bearing points worn		Replace bearing sections

4.2 Problem remedy

4.2.1 Change fuse

To prevent damage to the electrical system, always use fuses with the correct amperage. Before replacing the fuse, check the affected circuit!

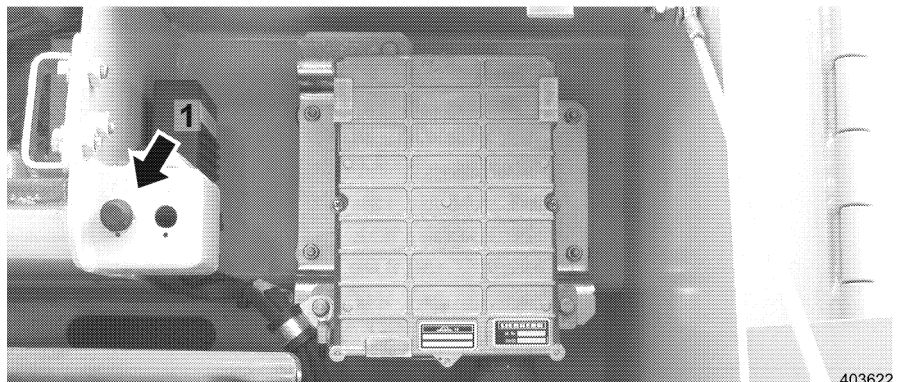

Main fuse 35 A

Main fuse

The main fuse 1 is installed on the right hand side of the machine in the battery compartment.

If the safety fuse is triggered, it is important to find the cause of the overload and remedy the problem before turning the safety fuse back on.

- The power supply of the machine is reestablished by pushing the push button on the safety fuse.

Additional fuses

The remaining fuses are located in the instrument panel as well as in the roof console of the operator's cab.

After opening and removing the screwed in cover, the individual fuses can be removed and checked.



Location of fuses F2 to F16

Fuses in the instrument panel.

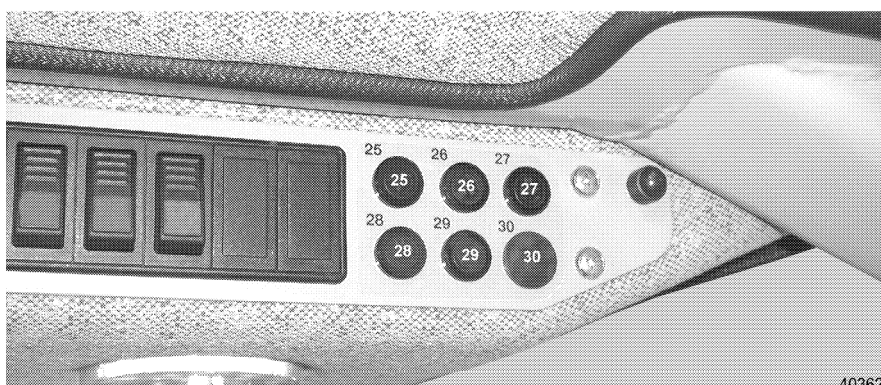

Location of fuses F25 to F30

Fuses in the roof console.

- Depending on the electrical problem, check the following chart for the description and fuse size.
- Pull the affected fuse and replace it with a new fuse (amperage according to location).

Fuse chart

Fuse	Value	Unit	Description / function
F 2	16	A	Preglow system
F 3	6,3	A	Charge indicator, cab illumination, radio, transformer
F 4	8	A	Electronic supply
F 5	10	A	Electrical outlet
F 6	5	A	Indicators / gauges, indicator lights, fan control
F 7	8	A	Auxiliary floodlight (optional equipment)
F 8	25	A	Power supply roof console
F 9			Not used (For optional equipment)
F 10	5	A	Hydraulic valves
F 11	10	A	Heater fan, air conditioning system, operator's seat with air suspension
F 12	16	A	Condenser fan, air conditioning system
F 13	20	A	Refueling pump
F 14			Not used (For optional equipment)
F 15	2	A	Shut off valve, button float position - quick drop

F 16			Not used (For optional equipment)
F 25	8	A	Windshield wiper and washer system, operator's cab doors
F 26	8	A	Windshield wiper and washer system, front and rear
F 27	8	A	Headlight, left front and right rear, instrument illumination
F 28	8	A	Headlight, right front and left rear
F 29	2	A	Warning light - Operator's cab
F 30			Not used (For optional equipment)

5. Maintenance

5.1 Maintenance and inspection schedule

Maintenance / In- spection at operating hours							Work to be carried out	Performance guidelines
At delivery	Every 8 - 10	Every 50	Every 250	Every 500	Every 1000	Every 2000		
							by maintenance personnel <input type="checkbox"/> First and only interval <input type="radio"/> Repeat interval OM - Operation and Maintenance Manual SM - Service Manual	by authorized personnel <input checked="" type="checkbox"/> First and only interval <input checked="" type="radio"/> Repeat interval Hrs. - Operating hours
Diesel engine								
<input checked="" type="radio"/>	<input type="radio"/>	<input type="radio"/>	<input type="radio"/>	<input checked="" type="radio"/>	<input checked="" type="radio"/>	<input checked="" type="radio"/>	Check oil level and oil pressure	OM
<input checked="" type="radio"/>	<input type="radio"/>	<input type="radio"/>	<input type="radio"/>	<input checked="" type="radio"/>	<input checked="" type="radio"/>	<input checked="" type="radio"/>	Check coolant level	OM
<input type="radio"/>	<input type="radio"/>	<input type="radio"/>	<input checked="" type="radio"/>	<input checked="" type="radio"/>	<input checked="" type="radio"/>	<input checked="" type="radio"/>	Check engine, coolant location and pan for contamination / clean as necessary	OM
<input type="radio"/>	<input type="radio"/>	<input type="radio"/>	<input checked="" type="radio"/>	<input checked="" type="radio"/>	<input checked="" type="radio"/>	<input checked="" type="radio"/>	Check fuel / water separator / empty as necessary	OM
<input type="radio"/>	<input type="radio"/>	<input type="radio"/>	<input checked="" type="radio"/>	<input checked="" type="radio"/>	<input checked="" type="radio"/>	<input checked="" type="radio"/>	Drain condensation and sediments from fuel tank - at least 1x per week	OM
<input type="radio"/>	<input type="radio"/>	<input type="radio"/>	<input type="radio"/>	<input checked="" type="radio"/>	<input checked="" type="radio"/>	<input checked="" type="radio"/>	Change engine oil ¹⁾ - at least 1 x a year	OM
<input type="radio"/>	<input type="radio"/>	<input type="radio"/>	<input type="radio"/>	<input checked="" type="radio"/>	<input checked="" type="radio"/>	<input checked="" type="radio"/>	Change lube oil filter ¹⁾ - at least 1 x a year	OM
<input type="radio"/>	<input type="radio"/>	<input type="radio"/>	<input type="radio"/>	<input checked="" type="radio"/>	<input checked="" type="radio"/>	<input checked="" type="radio"/>	Check radiator cap and fan	OM
<input type="radio"/>	<input type="radio"/>	<input type="radio"/>	<input type="radio"/>	<input checked="" type="radio"/>	<input checked="" type="radio"/>	<input checked="" type="radio"/>	Replace coolant filter, check antifreeze and DCA4 content in coolant	OM
<input type="radio"/>	<input type="radio"/>	<input type="radio"/>	<input type="radio"/>	<input checked="" type="radio"/>	<input checked="" type="radio"/>	<input checked="" type="radio"/>	Check V-belt - condition and tension	OM
<input checked="" type="radio"/>	<input type="radio"/>	<input type="radio"/>	<input type="radio"/>	<input checked="" type="radio"/>	<input checked="" type="radio"/>	<input checked="" type="radio"/>	Check oil, coolant and fuel system for leaks and condition	OM
<input checked="" type="radio"/>	<input type="radio"/>	<input type="radio"/>	<input type="radio"/>	<input checked="" type="radio"/>	<input checked="" type="radio"/>	<input checked="" type="radio"/>	Check intake and exhaust system for mounting and leaks	OM
<input type="radio"/>	<input type="radio"/>	<input type="radio"/>	<input type="radio"/>	<input checked="" type="radio"/>	<input checked="" type="radio"/>	<input checked="" type="radio"/>	Check mounting tightness of oil pan and engine brackets	OM
<input type="radio"/>	<input type="radio"/>	<input type="radio"/>	<input type="radio"/>	<input checked="" type="radio"/>	<input checked="" type="radio"/>	<input checked="" type="radio"/>	Check / adjust engine RPM	
<input type="radio"/>	<input type="radio"/>	<input type="radio"/>	<input type="radio"/>	<input checked="" type="radio"/>	<input checked="" type="radio"/>	<input checked="" type="radio"/>	Replace fuel prefilter - filter insert	OM
<input type="radio"/>	<input type="radio"/>	<input type="radio"/>	<input type="radio"/>	<input checked="" type="radio"/>	<input checked="" type="radio"/>	<input checked="" type="radio"/>	Check / adjust valve play - with cold engine	
<input type="radio"/>	<input type="radio"/>	<input type="radio"/>	<input type="radio"/>	<input checked="" type="radio"/>	<input checked="" type="radio"/>	<input checked="" type="radio"/>	Check and service mechanical control to injection pump and potentiometer	OM
<input type="radio"/>	<input type="radio"/>	<input type="radio"/>	<input type="radio"/>	<input checked="" type="radio"/>	<input checked="" type="radio"/>	<input checked="" type="radio"/>	Change fuel fine filter cartridges	OM
<input type="radio"/>	<input type="radio"/>	<input type="radio"/>	<input type="radio"/>	<input checked="" type="radio"/>	<input checked="" type="radio"/>	<input checked="" type="radio"/>	Grease gear ring on flywheel	
<input type="radio"/>	<input type="radio"/>	<input type="radio"/>	<input type="radio"/>	<input checked="" type="radio"/>	<input checked="" type="radio"/>	<input checked="" type="radio"/>	Check flame glow system - before start of cold season	
<input type="radio"/>	<input type="radio"/>	<input type="radio"/>	<input type="radio"/>	<input type="radio"/>	<input type="radio"/>	<input type="radio"/>	Replace air filter inserts - as necessary / once a year	OM
<input type="radio"/>	<input type="radio"/>	<input type="radio"/>	<input type="radio"/>	<input type="radio"/>	<input type="radio"/>	<input type="radio"/>	Replace oil separator - Every 2 years	OM
<input type="radio"/>	<input type="radio"/>	<input type="radio"/>	<input type="radio"/>	<input type="radio"/>	<input type="radio"/>	<input type="radio"/>	Replace coolant with antifreeze and DCA4 - Every 2 years	OM
<input type="radio"/>	<input type="radio"/>	<input type="radio"/>	<input type="radio"/>	<input type="radio"/>	<input type="radio"/>	<input type="radio"/>	Check / adjust injection valves - as necessary / every 3000 hrs.	

Maintenance / Inspection at operating hours							Work to be carried out		Performance guidelines
At delivery	Every 8 - 10	Every 50	Every 250	Every 500	Every 1000	Every 2000	by maintenance personnel <input type="checkbox"/> First and only interval <input type="radio"/> Repeat interval OM - Operating Manual SM - Service manual	by authorized personnel <input checked="" type="checkbox"/> First and only interval <input checked="" type="radio"/> Repeat interval Hrs. - Operating hours	
Hydraulic system									
<input checked="" type="radio"/>	<input type="radio"/>	<input type="radio"/>	<input type="radio"/>	<input checked="" type="radio"/>	<input checked="" type="radio"/>	<input checked="" type="radio"/>	Check the oil level in the hydraulic tank		OM
<input checked="" type="radio"/>	<input type="checkbox"/>	<input type="checkbox"/>	<input type="checkbox"/>	<input checked="" type="radio"/>	<input checked="" type="radio"/>	<input checked="" type="radio"/>	Clean the magnetic rod - up to 250 hrs. daily		OM
				<input checked="" type="radio"/>	<input checked="" type="radio"/>	<input checked="" type="radio"/>	Replace main hydraulic return filter insert, check all replenishing return filter inserts for deposits (only authorized personnel)		OM
				<input checked="" type="radio"/>	<input checked="" type="radio"/>	<input checked="" type="radio"/>	Replace hydraulic filter (inserts) - replenishing circuit		OM
<input checked="" type="radio"/>				<input checked="" type="radio"/>	<input checked="" type="radio"/>	<input checked="" type="radio"/>	Check working and travel hydraulic system for function and leaks, check hose routing for chafing.		OM
				<input checked="" type="radio"/>	<input checked="" type="radio"/>	<input checked="" type="radio"/>	Hydraulic tank - drain condensation and sediments - at least once every 6 months		OM
				<input checked="" type="radio"/>	<input checked="" type="radio"/>	<input checked="" type="radio"/>	Check / clean oil cooler for contamination + PR 752 check fan		OM
				<input checked="" type="radio"/>	<input checked="" type="radio"/>	<input checked="" type="radio"/>	Check / adjust all hydraulic pressures according to adjustment check list		
				<input checked="" type="radio"/>	<input checked="" type="radio"/>	<input checked="" type="radio"/>	Check mounting and fittings for tight seating		OM
						<input checked="" type="radio"/>	Replace oil in hydraulic system (add oil via filter) - at least one every 4 years - when using environmentally friendly hydraulic oils, request / observe special guidelines		OM
Splitterbox									
<input checked="" type="radio"/>			<input type="radio"/>	<input checked="" type="radio"/>	<input checked="" type="radio"/>	<input checked="" type="radio"/>	Check oil level		OM
				<input checked="" type="radio"/>	<input checked="" type="radio"/>	<input checked="" type="radio"/>	Replace gear oil - at least once every 2 years		OM
Electrical system									
<input checked="" type="radio"/>	<input type="radio"/>	<input type="radio"/>	<input type="radio"/>	<input checked="" type="radio"/>	<input checked="" type="radio"/>	<input checked="" type="radio"/>	Check system function, incl. indicators and gauges		OM
<input checked="" type="radio"/>				<input checked="" type="radio"/>	<input checked="" type="radio"/>	<input checked="" type="radio"/>	Check electrolyte level in battery		OM
				<input checked="" type="radio"/>	<input checked="" type="radio"/>	<input checked="" type="radio"/>	Clean / check / grease battery terminals		OM
				<input checked="" type="radio"/>	<input checked="" type="radio"/>	<input checked="" type="radio"/>	Check cable routing and connections		OM
						<input checked="" type="radio"/>	Check / adjust control system according to adjustment check list		
						<input checked="" type="radio"/>	Check battery charge - before start of cold season		

Maintenance / Inspection at operating hours							Work to be carried out		Performance guidelines
At delivery	Every 8 - 10	Every 50	Every 250	Every 500	Every 1000	Every 2000	by maintenance personnel <input type="checkbox"/> First and only interval <input type="radio"/> Repeat interval	by authorized personnel <input checked="" type="checkbox"/> First and only interval <input checked="" type="radio"/> Repeat interval	
							OM - Operation and Maintenance Manual SM - Service manual	Hrs. - Operating hours	
Heater / ventilation									
<input checked="" type="checkbox"/>				<input checked="" type="checkbox"/>	<input checked="" type="checkbox"/>	<input checked="" type="checkbox"/>	Check system for function and leaks		OM
							Replace fresh air filter - as necessary		OM
Travel gear									
<input checked="" type="checkbox"/>				<input checked="" type="checkbox"/>	<input checked="" type="checkbox"/>	<input checked="" type="checkbox"/>	Check oil level - clean magnetic plug		OM
				<input checked="" type="checkbox"/>	<input checked="" type="checkbox"/>	<input checked="" type="checkbox"/>	Check fittings for tight seating		OM
				<input checked="" type="checkbox"/>	<input checked="" type="checkbox"/>	<input checked="" type="checkbox"/>	Replace gear oil ¹⁾ - clean magnetic plug / rods - at least once every 4 years		OM
				<input checked="" type="checkbox"/>	<input checked="" type="checkbox"/>	<input checked="" type="checkbox"/>	Replace lube oil in sealing chamber - at least once every 4 years		OM
Track components									
		<input type="checkbox"/>	<input type="checkbox"/>	<input checked="" type="checkbox"/>	<input checked="" type="checkbox"/>	<input checked="" type="checkbox"/>	Check mounting screws and nuts on track components, specifically pad and chain gear segment screws for mounting tightness		OM
		<input type="checkbox"/>		<input checked="" type="checkbox"/>	<input checked="" type="checkbox"/>	<input checked="" type="checkbox"/>	Check carrier rollers, track rollers, idlers for leaks		OM
			<input type="checkbox"/>	<input checked="" type="checkbox"/>	<input checked="" type="checkbox"/>	<input checked="" type="checkbox"/>	PR 752 - lubricate outer oscillating axle bearing - Shorten interval as necessary		OM
				<input checked="" type="checkbox"/>	<input checked="" type="checkbox"/>	<input checked="" type="checkbox"/>	Check / adjust idler guides, replace parts as necessary		OM
				<input checked="" type="checkbox"/>		<input checked="" type="checkbox"/>	PR 752 - Check screws on front side of axle bearing mount for tightness		OM
							Adjust chain tension to suit application - as necessary		OM
							Clean travel gear / tracks - as necessary		OM
							Check track wear - as necessary		

Maintenance / Inspection at operating hours							Work to be carried out		Performance guidelines
At delivery	Every 8 - 10	Every 50	Every 250	Every 500	Every 1000	Every 2000	by maintenance personnel <input type="checkbox"/> First and only interval <input type="radio"/> Repeat interval OM - Operating Manual SM - Service manual	by authorized personnel <input checked="" type="checkbox"/> First and only interval <input checked="" type="radio"/> Repeat interval Hrs. - Operating hours	
Working attachment									
<input checked="" type="radio"/>	<input type="radio"/>	<input type="radio"/>	<input type="radio"/>	<input checked="" type="radio"/>	<input checked="" type="radio"/>	<input checked="" type="radio"/>	Check cutting edges, corners and ripper teeth for wear / make sure attachment is suited to application		OM
<input checked="" type="radio"/>		<input type="radio"/>	<input type="radio"/>	<input checked="" type="radio"/>	<input checked="" type="radio"/>	<input checked="" type="radio"/>	Lubricate all bearing points including lift cylinder forks according to the lubrication chart - Shorten interval as necessary		OM
				<input checked="" type="radio"/>	<input checked="" type="radio"/>	<input checked="" type="radio"/>	Check all bearing points for wear / check bearing play		OM
<input checked="" type="radio"/>		<input type="checkbox"/>		<input checked="" type="radio"/>	<input checked="" type="radio"/>	<input checked="" type="radio"/>	Check blade center position - and at every installation		OM
		<input type="checkbox"/>		<input checked="" type="radio"/>	<input checked="" type="radio"/>	<input checked="" type="radio"/>	Check screws, nuts and pin retainers for tight seating		OM
				<input checked="" type="radio"/>	<input checked="" type="radio"/>	<input checked="" type="radio"/>	Check attachment for intentional damage		OM
General									
<input checked="" type="radio"/>				<input checked="" type="radio"/>	<input checked="" type="radio"/>	<input checked="" type="radio"/>	Check the complete machine for proper maintenance and condition		OM
							PR 752 - Lubricate door hinges (Operator's cab, battery and oil cooler compartment doors) - as necessary		OM
<input checked="" type="radio"/>							Explain machine literature, special operating instructions / safety guidelines to operator		OM

1) For oil specification and viscosity, refer to "Lubricants and service fluids".

5.2 Lubrication chart

The lubrication chart is used as an overview for the location of the maintenance points on the machine and the maintenance intervals.

For detailed information, refer to "Maintenance and Inspection plan", as well as individual descriptions of maintenance procedures, see "Maintenance".

For detailed information about required lubricants and service fluids, as well as fill quantities, see "Lubricants and service fluids".

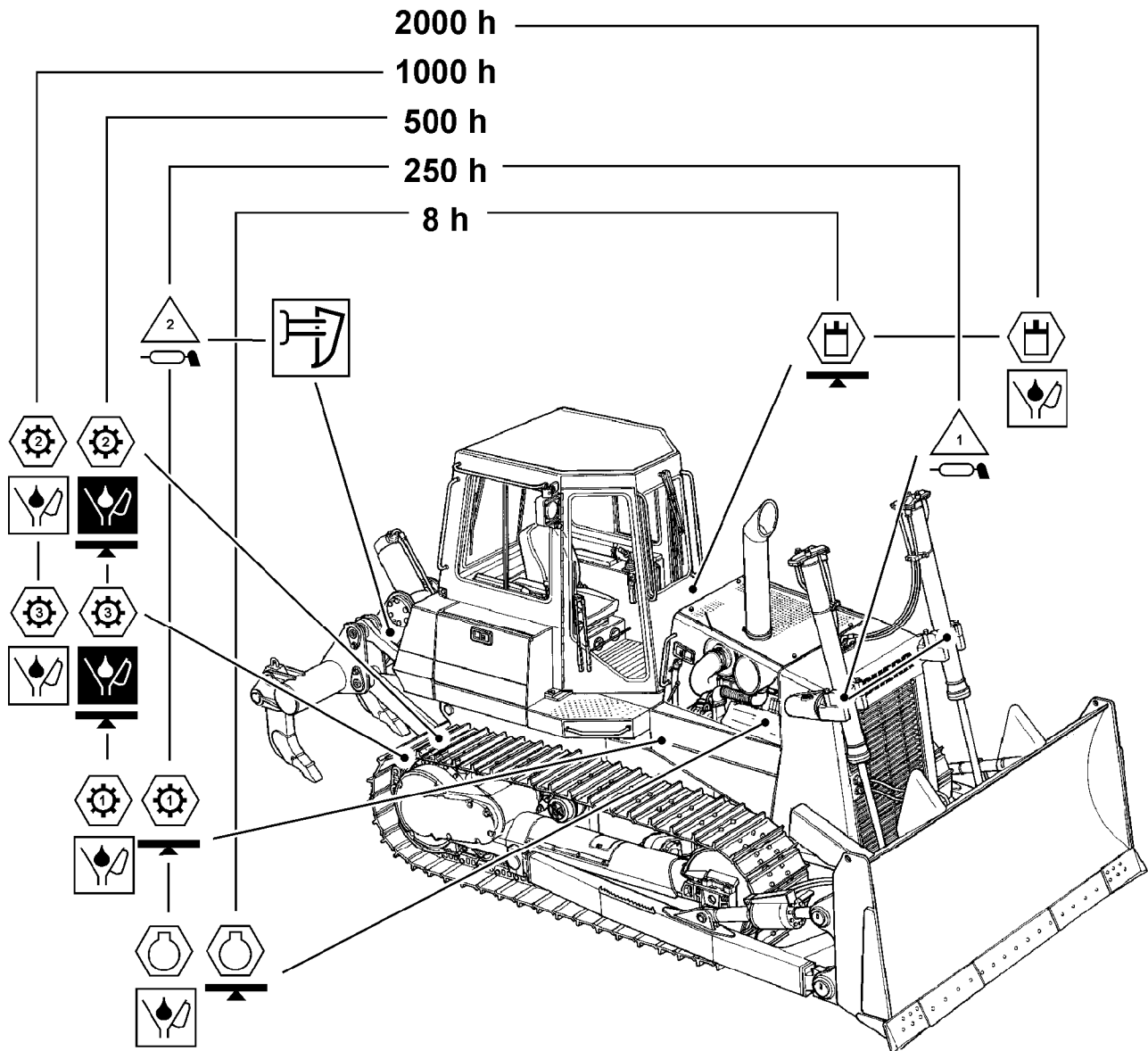

403558

Lubrication chart - illustration



Diesel engine



Hydraulic tank



Splitterbox



Travel gear



Travel gear - Lifetime seal



Lube points



Hinges

h

Interval in operating hours



Check oil level



Oil change - once



Oil change



Lubricate

5.3 Lubricants and service fluids

5.3.1 Handling lubricants and service fluids

Careful adherence to the handling instructions for lubricants and service fluids increases the reliability and life expectancy of your machine. It is especially important that the lubrication specifications are adhered to.

Cleanliness is of utmost importance when changing engine, gear and hydraulic oil. Always clean fittings, covers and the surrounding area before removing them.

For information regarding maintenance intervals, refer to "Maintenance and inspection schedule" and "Lubrication chart".

For information regarding procedure for lubrication, fluid level check and changing of service fluids, refer to "Maintenance", "Maintenance tasks...". When handling lubricants and service fluids, proceed as follows and observe environmental guidelines.

Environmental measures

- Always adhere to and observe environmental measures.
- Observe all regional and local regulations.
- Before draining service fluids, make sure you know the correct way to dispose of the fluids.

Disposition of used service fluids and materials

Affected are used service fluids and materials, such as:

- oils, lubricants, coolants, etc.,
- fuels,
- filters, oil filter elements, etc.,
- rubber, insulating panels, etc.,
- batteries.
- Please observe all environmental protection regulations and guidelines when disposing of used service fluids and material.
- Collect all used service fluids and materials in a suitable container, store and dispose of them only in an environmentally safe manner in officially designated locations.
- Observe all local and regional regulations.

5.3.2 Lubricants and service fluid specification, quantities

The quantities given in the lubrication and service fluid chart are only guidelines:

- In any case, the dipstick or the level marks are the deciding factors.

Check the oil level in the corresponding component after every lubrication or service fluid change or after adding fluids.

Specification Explanation:

API = American Petroleum Institute
 ACEA (CCMC) = Association des Constructeurs Européens de l'Automobile
 SAE = Society of Automotive Engineers



Diesel engine

Quantity	Service fluids	Specification
20 l (5.3 US gal.)	Engine oil, viscosity per SAE	API CF-4, CG-4, CH-4 ACEA E2, E3, E4, E5, (D4, D5)

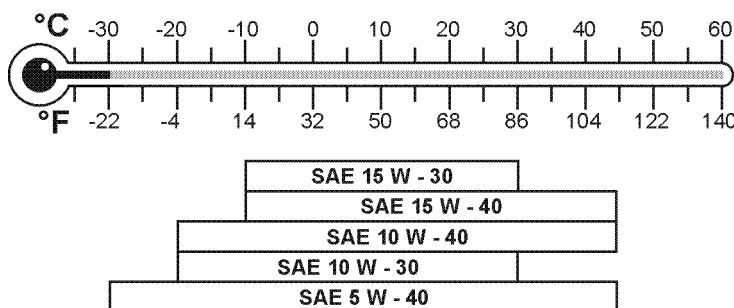

403058

Temperature dependent selection of SAE classification

Lube oil viscosity

The lube oil viscosity is selected according to the SAE - classification (Society of Automotive Engineers).
 The determining factor for the correct sections of the SAE - classification is the ambient temperature.
 The selection of the SAE - classification provides no information regarding the quality of the lube oil.
 If the viscosity is too high, the machine may be hard to start, if the viscosity is too low, it may provide insufficient lubrication.
 The temperature ranges noted in the chart are guidelines and may be exceeded in either direction for a short time period.

Lube oil maintenance interval

Maintenance interval
 – Change the oil depending on climate zone, sulfur content in the fuel and oil quality, according to the following chart.
 If the note operating hours are not reached, change the engine oil and filter once a year.

Aggravating circumstances

Various factors or difficult applications can change the maintenance intervals:
 Aggravating circumstances or difficult applications are:
 – repeated cold starts
 – Sulfur content in fuel of more than 0.5%
 – ambient temperature below -10°C
 If aggravating circumstances or difficult applications are present, then the oil change intervals noted in the "maintenance and inspection schedule" must be cut in half, according to the following chart.

Ambient temperature	Sulfur content in fuel	E2, D4, CG-4, CF-4, CH-4	E3, E4, E5, D5
to -10 °C	to 0.5 % Above 0.5 %	250 hrs. 125 hrs.	500 hrs. 250 hrs.
below -10 °C	to 0,5 % above 0.5 %	125 hrs. -	250 hrs. 125 hrs.



Fuel system

Quantity	Service fluids	Specification
310 l (82 US gal.)	Fuel	DIN EN 590, ASTM D 975-89a 1D and 2D

Specification

Diesel fuels must meet the minimum requirements of the above noted fuel specifications.

For additional fuel specifications contact Diesel engine design at LIEBHERR Machines Bulle S.A.

The sulfur content may not exceed 0.5 %. A higher sulfur content affects oil change intervals and the service life of the Diesel engine.

Viscosity

Lowering the sulfur content changes the viscosity of the Diesel fuel. Tests showed that Diesel fuels with 0.5 % sulfur content, as valid in Europe, can cause increased injection pump wear (especially on distributor type injection pumps).

"Brand fuels" (in Germany DIN EN 590) contain these additives. The fuel viscosity must be less than 400 µm, per HFRR (60°) test.

The additives should be added by the supplier as the responsible party for fuels. We do not recommend that our customers add secondary additives to fuels.

Diesel fuels in very low ambient temperatures

When working in ambient temperatures below 0°C, the flow capacity of the standard warm weather Diesel fuel might be insufficient due to paraffin excretion. The same applies for cold season Diesel fuels below -15°C .

Diesel fuels with additives for use in temperatures to -20°C are often available.

To prevent operating problems in colder temperatures, Diesel fuel must be mixed with regular gasoline or petroleum. Adding regular gasoline should be considered a temporary measure and may not exceed **30 % of the total volume** .

Do not use Super gasoline for mixing.

These cold season additives can influence engine output. For that reason, always add as little as possible, just enough for that particular ambient temperature range.

For safety reasons, always mix fuel additives only in the fuel tank. When refueling, fill the specifically lighter fuel before refueling the Diesel fuel. Then run the Diesel engine until the two types of fuel are spread throughout the fuel system.

Diesel fuels - mixing ratio (% of the total volume)

Ambient temperature in °C	Summer Diesel fuel %	Additive %	Winter Diesel fuel %	Additive %
0 to -10	70	30	100	--
-10 to -15	50 *	50	100	--
-15 to -20	--	--	70	30
-20 to -25	--	--	50 *	50

* If more than 50% are necessary, use only petroleum (no regular fuel).

Additives to Diesel fuel (flow improvers)

Commercially available flow additive can also help to improve the Diesel fuel for cold temperatures. Make sure to follow the manufacturing instructions regarding quantities and use.



Cooling system

Quantity	Service fluids	Specification
52 l (13.7 US gal.)	Corrosion inhibitor / antifreeze fluids	For corrosion inhibitor / antifreeze fluids, refer to chart

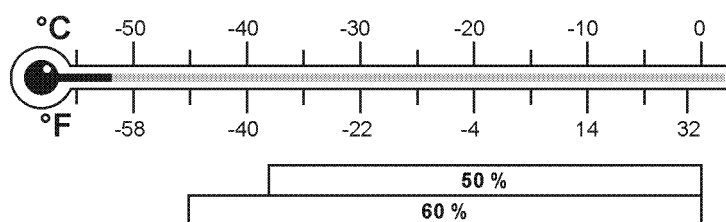

403059

Percentage (%) of corrosion inhibitor - antifreeze fluids

Coolant with DCA4 (DCA4 = Diesel Coolant Additives)

The cooling system must contain at least 50% corrosion inhibitor / antifreeze fluids year round. This corresponds to an antifreeze protection to approx. -37°C. In case any coolant is lost, check the ratio, do not fall below 50 % of the total volume.

Caution



Danger of damage to the Diesel engine!

- ! A higher percentage would actually reduce the cooling efficiency and the antifreeze protection, which in turn will damage the Diesel engine.
- Do not use more than 60% of corrosion inhibitor / antifreeze fluid.

Check and correct the ratio during maintenance checks.

The DCA4 concentration must be between 0.3 and 0.8 units per liter.

Use the test kit CC2602 M by Fleetguard for testing.

Change the coolant at least once every 2 years.

Refilling the cooling system

Before adding new coolant, check the cooling system for cleanliness and flush, if necessary.

When filling or refilling the cooling system after repairs, DCA4 in liquid form must be added to the corrosion inhibitor - antifreeze fluid (see chart), in addition to the DCA4 concentration in the water filter.

- Premix the coolant in a suitable container.

Mixing ratio

Machine type	Quantity	Part water	Part corrosion inhibitor - antifreeze fluids	Part DCA liquid
SR 712 B	approx. 52 l	25 l	25 l	2 l

Fresh water guidelines

When preparing the coolant, use water which is not too hard. Often, but not always, drinking water can be used. Sea water, brackish water, brine and industrial waste water are not suitable.

Fresh water quality

Sum of alkaline earths (water hardness): 0.6 to 2.7 mmol/l (3 to 15° d)

Ph-value at 20 °C: 6.5 to 8.0

Chloride ion content: max. 80 mg/l

Sulfate ion content: max. 80 mg/l

Use of DCA4 without corrosion inhibitor - antifreeze fluids

In **exceptional cases** and in constant ambient temperatures above the freezing point, for example in tropical regions, where no corrosion inhibitor - antifreeze fluids are available, water and DCA4 may be used as coolant.

To protect the cooling system from corrosion:

- Use approximately twice the amount of DCA4 as compared to the mixing ratio of corrosion inhibitor / antifreeze fluid noted above.

- Keep the DCA4 concentration between 0.6 - 1.06 units per liter.

Check the DCA 4 concentration during regular maintenance, correct as necessary.

The coolant must be changed once a year.

Caution

When using water and DCA4, do not use other coolant refiners (corrosion protective oils).

Approved corrosion inhibitors / antifreeze fluids

Brand	Manufacturer
Agip Antifreeze Plus	Agip Petroli S.p.A Rome, Italy
Agip- Auto Langzeit-Frostschutz	Agip Schmiertechnik GmbH., Würzburg
Antigel DB 486	Sotragal SA, St. Priest/France
Aral Antifreeze Extra	Aral AG, Bochum
Aral Antifreeze T	Aral AG, Bochum
Avia Antifreeze APN	Deutsche Avia - Mineralöl GmbH., München
BP anti-frost X 2270 A	Deutsche BP AG, Hamburg
BP Nappel C 2270/1	BP Chemicals Ltd., London/England
DEA Kühlerfrostschutz	DEA Mineral AG, Hamburg
Deutz Kühlschutzmittel 0101 1490	Deutz Service International GmbH., Cologne, Germany
DOW Kühlmittel D 542 / 1993	BOSS Chemie AG, Wittenbach / Switzerland
Frostschutz 600	Mobil Schmierstoffe GmbH., Hamburg
Glacelf SX	Elf Lubrifants Paris/France
Glyco Shell	Shell Chemie GmbH., Eschborn
Glysantin G 48-00	BASF AG, Ludwigshafen
Igol Antigel Type DB	Igol France, Paris/France
Motul Anti Freeze	Motul SA, Aubervilliers Cedex / France
OEMV - Kühlerfrostschutzmittel	OEMV-AG, Vienna /Austria
OZO Frostschutz S	Total Deutschland GmbH., Düsseldorf
Total Multipreduct	Total Deutschland GmbH., Düsseldorf



Hydraulic system

Quantity	Service fluids	Specification
178 l (47 US gal.)	Engine oil, viscosity according to SAE Only Diesel engine lube oils or special approved oils may be used in the hydraulic system.	API: CF-4, CF, CG-4, CH-4 ACEA: E2, E3, E4, E5

In addition to the quality, the oil must also meet a certain viscosity. The selection of the lube oil viscosity is made according to the SAE classification.

The determining factor for the correct selection of the SAE classification is the ambient temperature.

The temperature ranges shown in the chart are only guidelines. If a machine is operated within the black temperature range, then the following warm up procedure must be carried out.

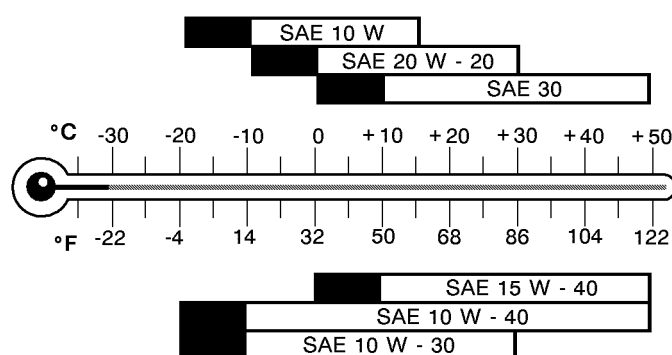

403060

Temperature dependent selection of SAE classification

Warm up procedure

- For temperatures to 10°C below the indicated limit: (black range)
 - After starting, run the Diesel engine ½ speed. Carefully actuate the working hydraulic. Actuate the hydraulic cylinders and move to stop for a short time. After approx. 5 minutes, carefully actuate the travel hydraulic too. The warm up procedure takes approx. 10 minutes.
- At even lower temperatures:
 - Preheat the hydraulic tank before starting the Diesel engine, then proceed with the warm up procedure, paragraph 1.



Splitter box

Quantity	Service fluids	Specification
2,5 l (2.6 quarts.)	Gear oil, viscosity according to SAE SAE 90 EP SAE 80 W 90 EP SAE 85 W 140 EP	API GL-5 and MIL-L-2105 B,C or D



Travel gear

Quantity	Service fluids	Specification
2 x 5,5 l (5.8 quarts.)	Gear oil, viscosity according to SAE SAE 85 W 140 EP	API GL-5 and MIL-L-2105 B,C or D



Lifetime seal - travel gear

Quantity	Service fluids	Specification
2 x 1,1 l (1.1 quarts.)	Hydraulic oil, viscosity according to SAE See Hydraulic system (use oil quality and viscosity as for the hydraulic system)	



Lube points on attachments, chain tensioner and door hinges

Quantity	Service fluids	Specification
	Grease, viscosity according to SAE The grease must be Lithium based, with a VKA value of at least 2300 N according to DIN 51350 or ASTM D 2596.	High pressure grease KP2k, consistency 2 of NLGI classification per DIN 51818 and DIN 51825 or EP 2 per NF-T-60 132



Door hinges and joints

Quantity	Service fluids	Specification
	Engine oil, viscosity according to SAE	



Windshield washer system

Quantity	Service fluids	Specification
8,5 l (9 quarts)	Commercially available windshield cleaning fluid	

Rubber seals on doors and covers

Quantity	Service fluids	Specification
	Silicon spray or Talcum powder	

Corrosion protection

Quantity	Service fluids	Specification
	Corrosion protective grease To conserve and protect exposed piston rods, apply a thick layer of acid free corrosion protective grease.	LIEBHERR - Anti-corrosion grease CTK Id. No. 861331301

5.3.3 Change from mineral oils to environmentally friendly hydraulic fluids

To operate the LIEBHERR crawler with "environmentally friendly hydraulic fluids", we recommend **Panolin HLP Synth 46**.

Caution

Danger of damage to the hydraulic system of the machine!
 Mixing "environmentally friendly hydraulic fluids" with "mineral oils" can cause a strong reaction, which can damage the hydraulic system.
 ! Avoid mixing "environmentally friendly hydraulic fluids" with "mineral oils".

Change over guidelines

- Contact LIEBHERR service before changing the machine to "environmentally friendly hydraulic fluids"!
- Request and follow the instructions in the "**Instruction sheet**" and the "**Change over guidelines**"!

5.3.4 Proper oil diagnostics analysis

Oil is subjected to various influences. Temperatures, pressures, non-oily fluids, most dust, friction particles, water and air contaminate the oil and its properties, which in turn can increase the risk of damage to the hydraulic system, Diesel engine and gear.

Unplanned repairs and downtime can be prevented by regularly taking oil samples, which show the condition of your machine.

Always take oil samples and oil analysis in certain intervals.

Advantages

- You will learn everything about the condition of your machine.
- Impending damage is discovered in time.
- Unplanned repairs and downtime are prevented.
- The oil can be changed at the correct point in time (only Hydraulic system).
- You relieve your environment because less used oil is disposed of (only hydraulic system).

Oil change interval

The oil change intervals may only be extended for the hydraulic system, if oil samples are taken!

Taking oil samples

Take the oil sample:

- Shortly after machine shut down - at that point in time, dirt, contaminants and wear particles are still suspended in the oil, and any water in the oil has not yet dropped to the bottom,
- at operating temperature - warm oil is easier to take,
- always in the same manner and at the same point,
- never from the filter,
- not right after an oil change or after larger amounts of oil have been added,
- only into a clean and dry sample container.

Sample points

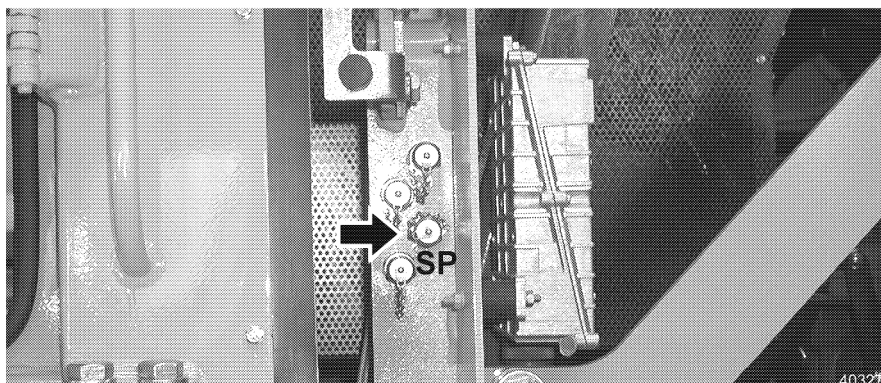

SP - connection

Hydraulic system

- a) On the SP- connection with a mini test hose (recommended method) or,

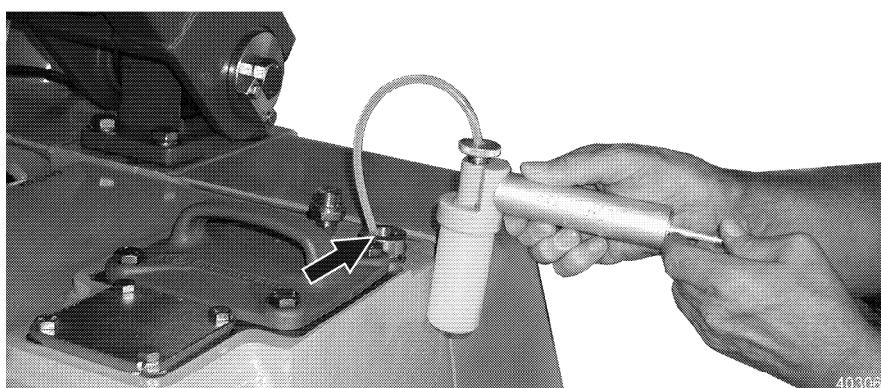

Bleeder screw

- b) remove the bleeder screw on the hydraulic tank and remove an oil sample with a suitable manual suction pump.

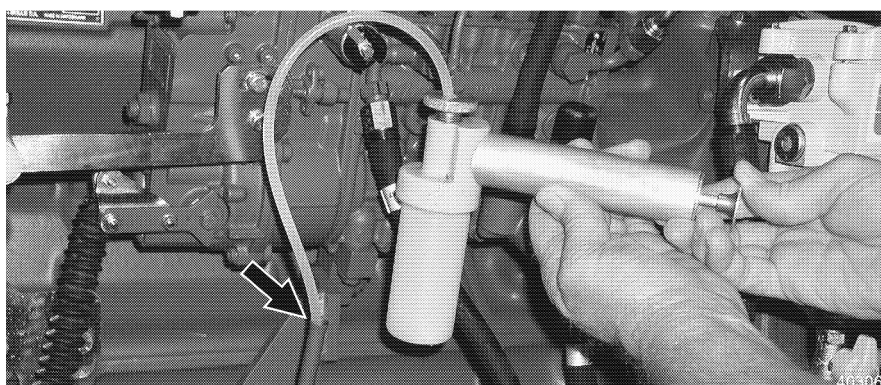

Dipstick

Diesel engine

- a) With the manual suction pump above the dipstick,
b) take oil sample when changing the oil from the discharging oil flow.



Dipstick

Distributor gear

- a) With a manual suction pump above dipstick or,
- b) take an oil sample when changing the oil from the discharging oil flow.

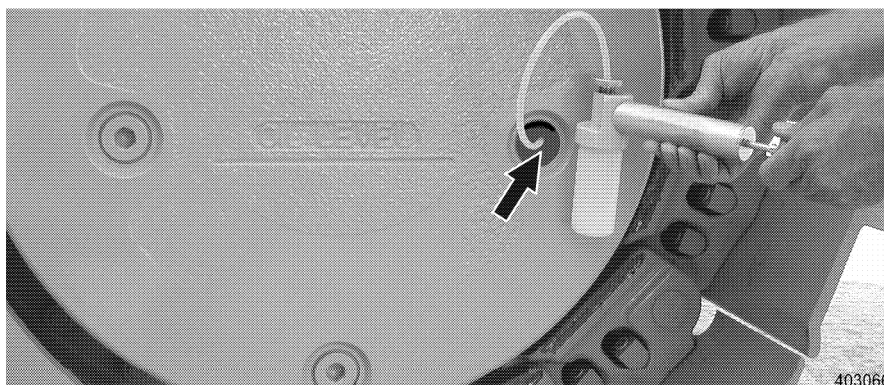

Oil filler port

Travel gear

With a manual suction pump above filler port.

Oil sample intervals

Component	Sample intervals
Hydraulic system	Every 500 hrs.
Diesel engine	At every oil change
Splitterbox	At every oil change
Travel gear	At every oil change

Oil analysis

An oil analysis should contain the minimum data:

Method	Determination of
Atom emissions spectroscopy (AES)	Wear metals, additives, contaminants iron, chromium, tin, aluminum, nickel, copper, lead, molybdenum, silver, silicium, callum, calcium, magnesium, borax, zinc, phosphorus, barium
FT-Infrared spectroscopy (FT-IR),	Oil condition and contaminants Oil oxidation, glycol, water, nitration, fuel, carbon
Viscosity	Viscosity test - viscosity at 40°C and 100°C, viscosity index Note about lubricating and mixing ability
Analex PQ-Index	Magnetic metallic particles Notation about quantity of total magnetic metal particles in the oil, which are larger than 5 micron

LIEBHERR recommends to send the oil to "Wear Check" for oil analysis. A set, which includes sample bottles, hose, sample documentation and mailing pouches is available from LIEBHERR under the following Id. No.:

Id. No.: 70 18 369 (12 units)
Id. No.: 70 18 368 (6 units)

A manual hand pump to take the samples is required and can be ordered separately (Id. No. 81 45 666).

5.4 Preparations for maintenance

Before carrying out diverse maintenance tasks on the machine, bring the machine into maintenance position, if not otherwise noted.

Diverse maintenance tasks are, for example:

- Lubrication of attachment,
- oil level check or oil change on engine, splitterbox, travel gear, hydraulic tank, etc.,
- filter change as well as maintenance tasks on the hydraulic system.

Safety preparations for maintenance

Always observe all accident prevention guidelines when carrying out maintenance tasks!

See "Measures for safe maintenance".

Make sure that the operator in the operator's cab is always in visual contact with the maintenance personnel.

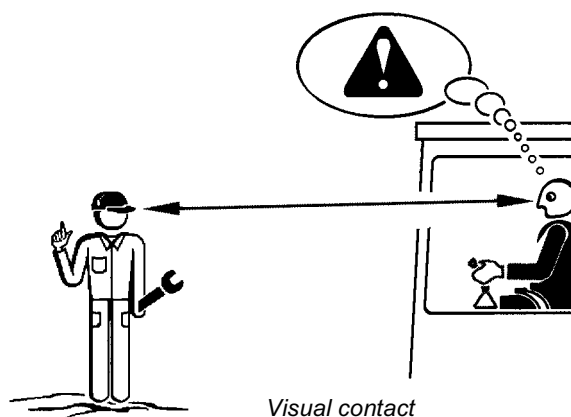

403061

Danger



Danger of accidents for maintenance personnel!

Never let other persons work on the machine, this would severely endanger the maintenance personnel!

! Never step unnoticed into the danger zone of the machine.

- Alert the operator before stepping into the danger zone of the machine!

5.4.1 Maintenance position

The basic maintenance position of the machine is described below. It allows access to the individual maintenance points.

Maintenance position

To bring the machine into maintenance position, proceed as follows. For detailed description of various procedures, see "Control, operation".

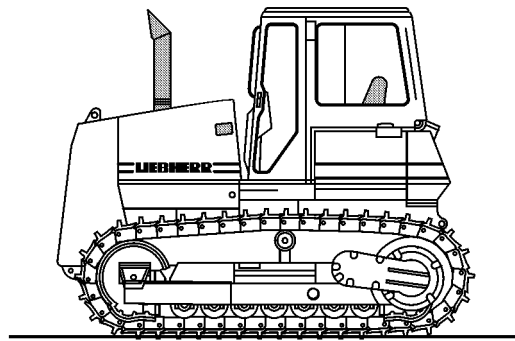

404174

Maintenance position

- Park the machine on level ground.

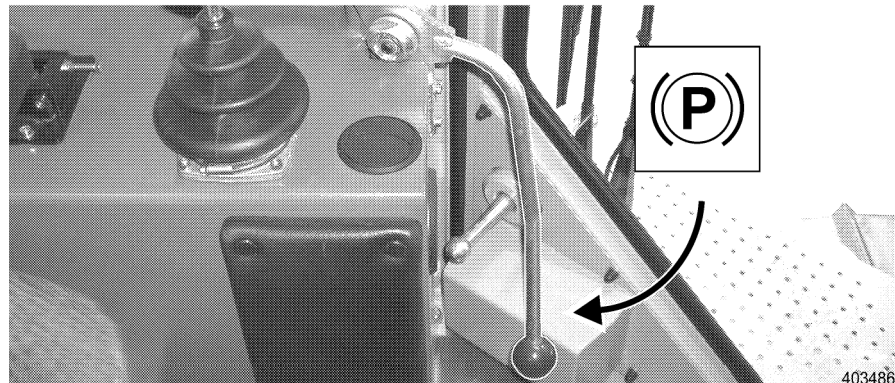

Safety lever down

- Place the safety lever down.
- Turn the Diesel engine off.
- Pull the starter key.

Open the engine compartment doors

Open the service doors and hoods

When the doors are open, the following components can be accessed:

- Diesel engine
- Cooling system
- Air filter
- Splitterbox

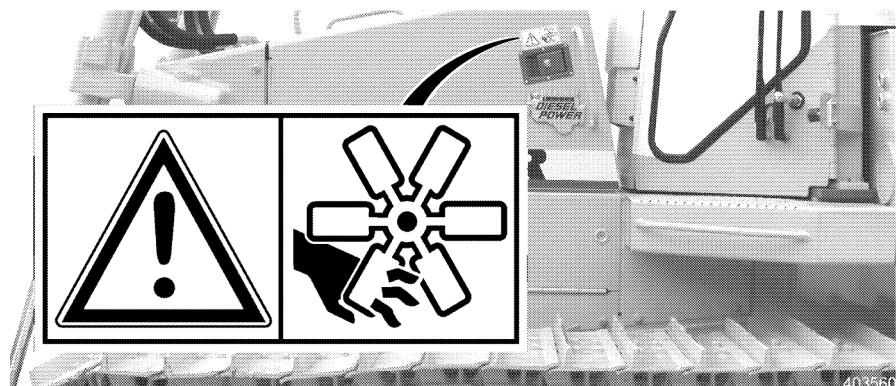

Open only if the engine is at a standstill!

Danger

Danger of injury due to turning engine parts!

Turning or moving engine parts, such as fan blades or V-belt can cause injuries!

! Open the engine compartment doors only if the engine is at a standstill.

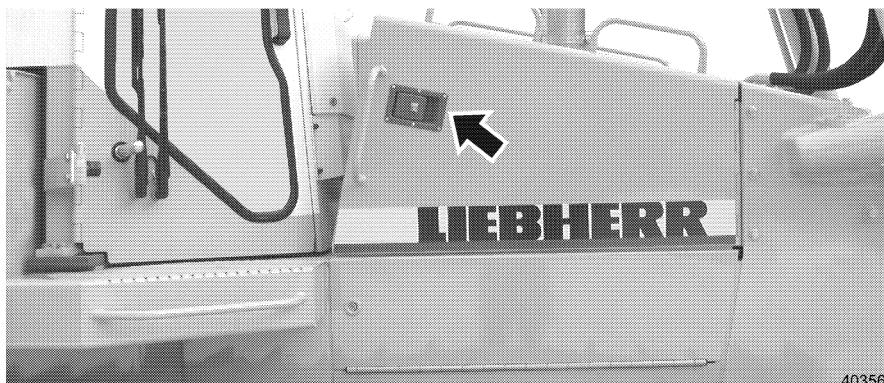

Open the engine compartment doors

- Open the lock with the key.
- Open the door with handle.
- Open the engine compartment door and secure it with the door latch to prevent it from closing inadvertently.

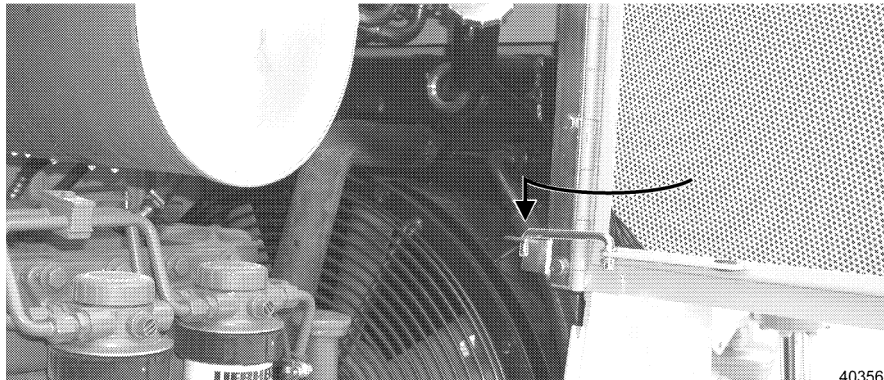

Door latch

Caution

Danger of injury if the engine compartment door closes!

! Check if the completely open door is held in open position by the door latch.

- If the function is not ensured, then the problem must be fixed.

5.4.2 Electrical system

When working on the electrical system of the machine and before any welding on the machine, always disconnect the battery.

- Disconnect the negative terminal (-) first and reconnect is last.

Disconnect the battery and remove the electronic box before any arc welding on the machine.

Remove the electronic box

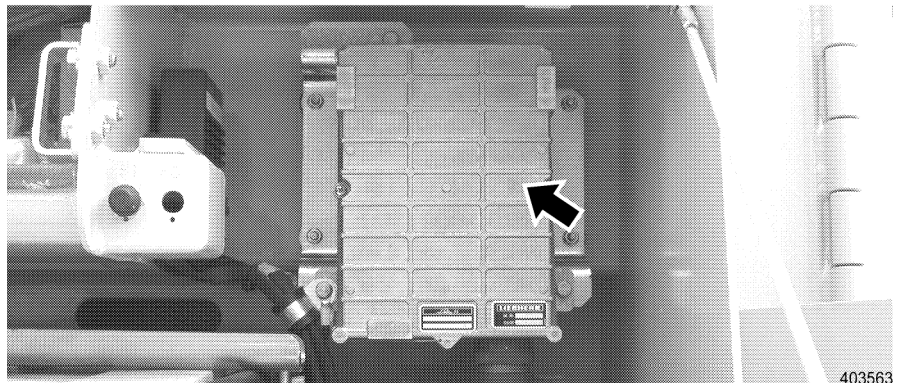

Electronic box

The electronic box is installed in the battery compartment.

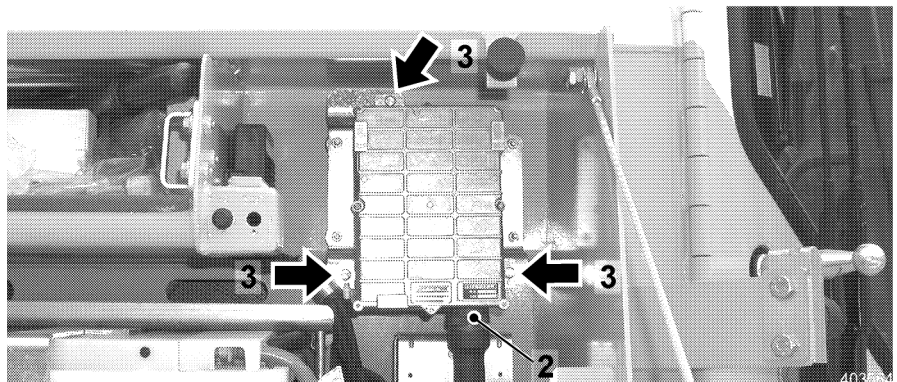

Remove the electronic box

- Disconnect the cable fitting 2 on the bottom of the electronic box.
- Remove the mounting screws 3.
- Remove the electronic box from the battery compartment.

5.5 Diesel engine

5.5.1 Check the engine oil level

Make sure that:

- the machine is in maintenance position,
- the right engine compartment door is open.

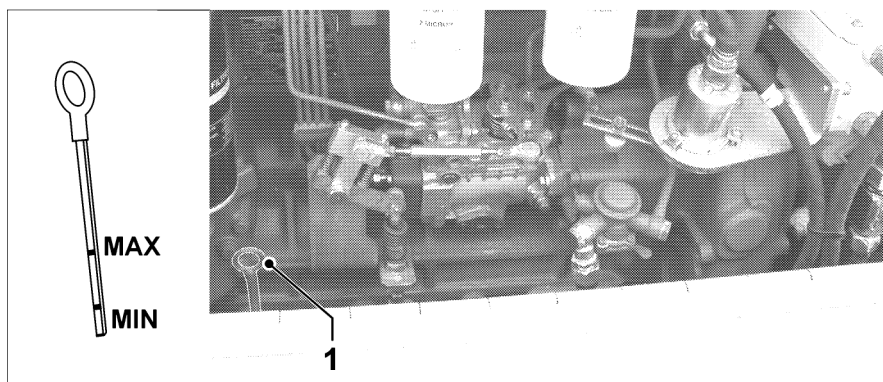
*Dipstick*

After engine shut down, wait for a few minutes for the oil to collect in the oil pan.

- Pull the dipstick 1, wipe it with a clean cloth. Reinsert it all the way.
- Pull the dipstick out again and check the oil level.

The oil level must be between the MIN and MAX mark on the dipstick.

*Add oil*

If the oil level is too low:

- Remove the cap 2 and add oil. For oil specification, see "Lubricants and service fluids".
- Add oil via the filler neck.
- Check the oil level again, do not fill the Diesel engine above the "MAX" mark.
- Clean the cap, reinstall it on the filler neck and tighten.

5.5.2 Check the engine oil pressure

- Start the Diesel engine.

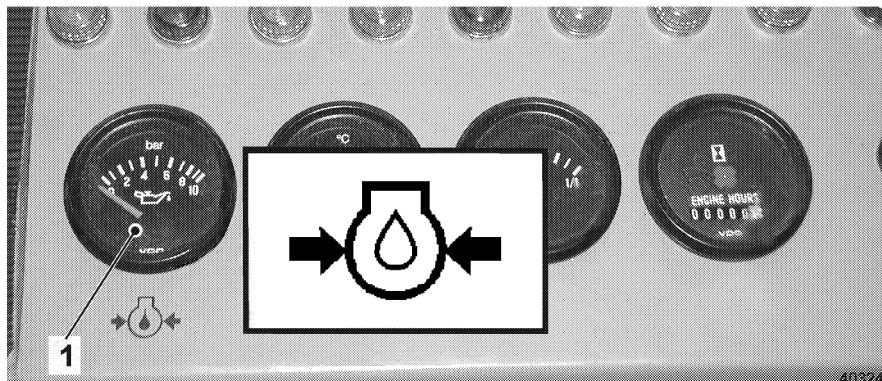

Engine oil pressure gauge

The oil pressure is shown on the oil pressure gauge 1.
The oil pressure may not fall below the following values:

- at low idle RPM 1 bar
- at full load 3.5 bar

Troubleshooting

If the engine oil pressure is below these values, turn the engine off immediately and find the problem (change the engine oil and filter, if necessary).

5.5.3 Engine compartment

Make sure that:

- the machine is in maintenance position, see "Maintenance position",
- the engine compartment doors are open.

Check the Diesel engine location and oil pans for contamination

- Check the complete engine compartment for damage and contamination.

If very soiled, clean the engine - cooler and oil pan area.

Clean the Diesel engine

When cleaning the engine with water or steam, make sure that the sending units, such as oil pressure switch are not subjected to a direct blast.

Caution



Danger of damage to the Diesel engine!

Infiltrating moisture can cause corrosion and failure of the measuring function.

! Do not subject electrical sending units, such as oil pressure switch to a direct water or steam blast.

- Carefully clean the engine with steam.

5.5.4 Change the engine oil

Make sure that:

- the engine oil is warm,
- the machine is in maintenance position,
- the left engine compartment door is open.
- a suitable container and a drain hose with valve connection is available,
- the correct oil quality and amount is available, according to the data in "Lubricants and service fluids" .

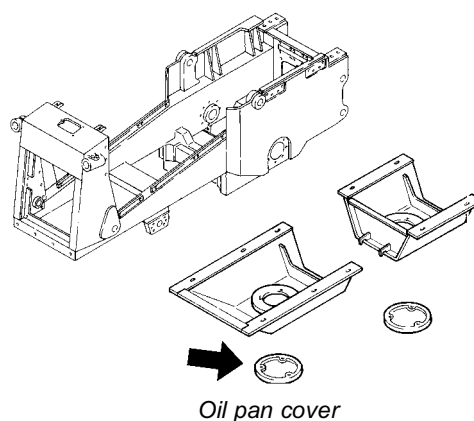

- Remove the oil pan cover.
- In case of heavy deposits in the oil pan area, the oil pans must be removed and cleaned.

Danger

! Danger of injury when removing the oil pans. Due to space restrictions and heavy weight of the oil pans, removal is very difficult. To remove the oil pans, use a suitable lifting device.

- Remove the cap on the oil drain valve on the oil pan.

Caution

! When draining hot engine oil, there is a danger of scalding. Avoid skin contact with engine oil. Always wear gloves when changing oil.

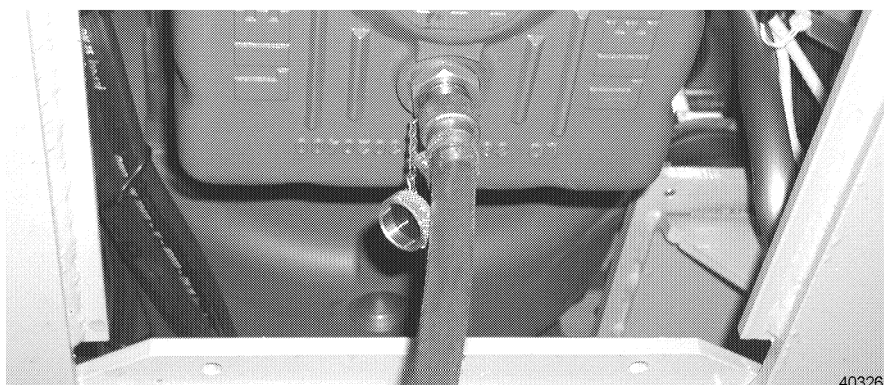
*Drain the oil*

- Attach the oil drain hose to the oil drain valve and drain the oil in a suitable container.
- Remove the oil drain hose and install the cap on the oil drain valve.
- Remove the oil pan cover.



Add oil

- Add clean oil via the filler neck 1 to the MAX mark on the dipstick.
- Clean the filler cap, install on the oil filler neck 1 and tighten.
- Start the Diesel engine and check the oil pressure.
- Turn the Diesel engine off and check the oil level on the dipstick after approx. 1 - 2 minutes. Correct the oil level as necessary.

5.5.5 Change the lube oil filter

Make sure that:

- the machine is in maintenance position,
- the right engine compartment door is open,
- two LIEBHERR oil filter elements are available.

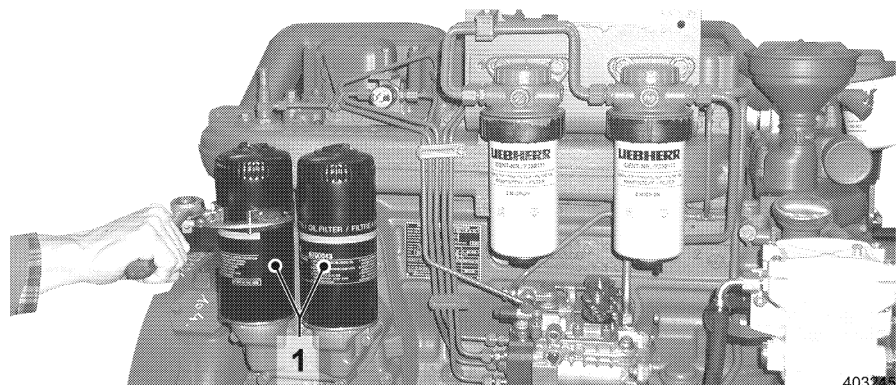

Filter elements

- Release filter elements 1 with a filter wrench and remove.
- Clean the sealing surfaces on the filter console.
- Apply a thin layer of engine oil to the rubber seal rings on the new filter elements.
- Install new filter elements on the filter console and tighten by hand.

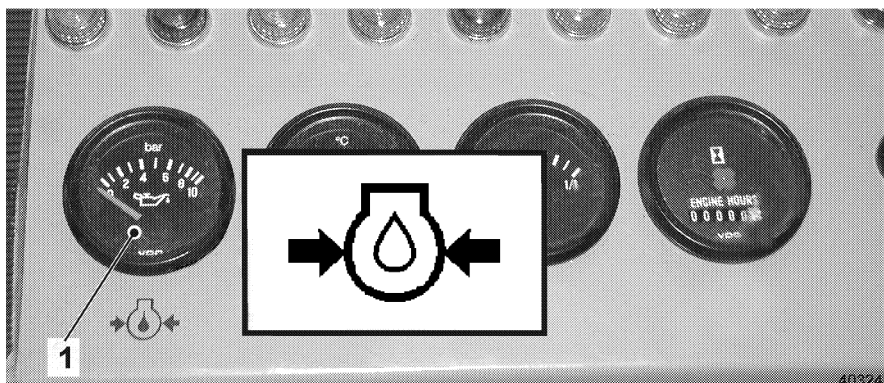

Engine oil pressure gauge

- Start the Diesel engine and check the oil pressure on the engine oil pressure gauge.
- Turn the engine off, check for leaks on the oil filters and check the oil level. Correct the oil level, as necessary.

5.5.6 Check / change the V-belt

The V-belt installation is self-tensioning and maintenance free. Only the V-belt and the tension pulleys need to be checked for damage or wear.

To check, access from the right side of the engine.

Always replace broken or damaged belts with new belts.

Make sure that:

- the machine is in maintenance position,
- the right engine compartment door is open.

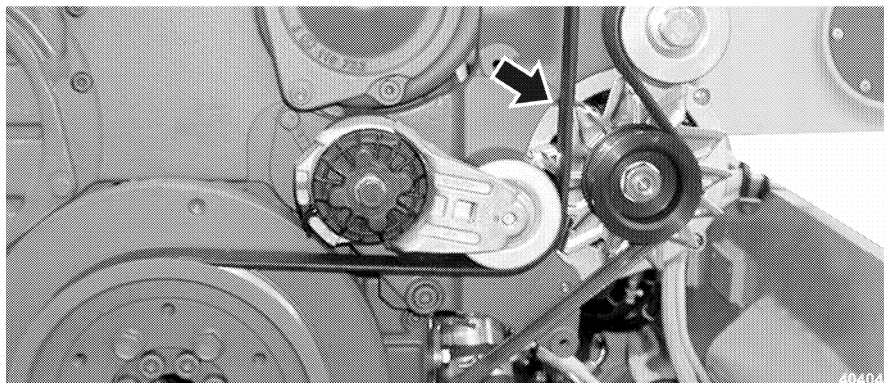

V-belt

Check the belt assembly

- Check the V-belt for cracks or damage.
- Check the pulleys and tension pulley for proper condition and play (such as worn belts, damaged tension pulley)
- If any parts are damaged, replace damaged parts immediately with new parts.

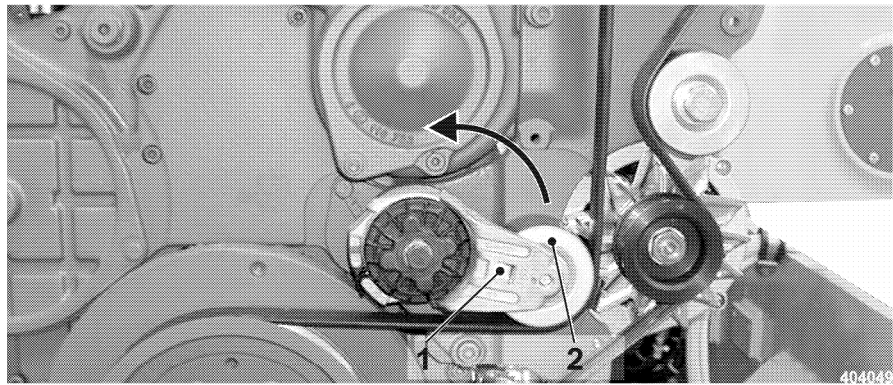

Change the V-belt

Change the V-belt

- Insert a ratchet per DIN 3122 D 12,5 (1/2") into the square hole 1 of the tension device 2.
- Swing back the tension device 2 against the spring force in counterclockwise direction to the stop and remove the V-belt.
- Check the pulleys and tension pulley for proper condition and play (such as worn belts, damaged tension pulley).
 - If any parts are damaged, replace damaged parts immediately with new parts.
- With the tension device 2 swung back, place the new V-belt on all pulleys and the tension pulley.
- Return the tension device 2 to tension position.

5.5.7 Check the Diesel engine area for leaks and condition

Make sure that:

- the machine is in maintenance position,
- the engine compartment doors are open.

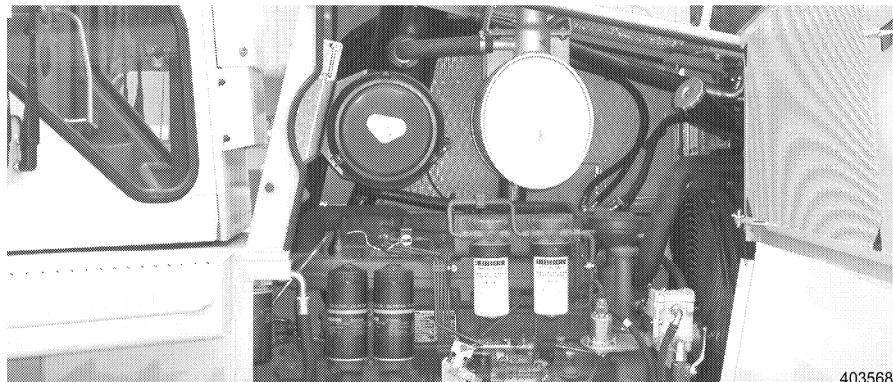

Diesel engine area

- Check the complete engine area for condition and leaks.
 - Check the fuel lines especially careful.
- Replace defective seals immediately.

5.5.8 Check the mounting of intake and exhaust lines

Make sure that:

- the machine is in maintenance position,
- the engine compartment doors are open.

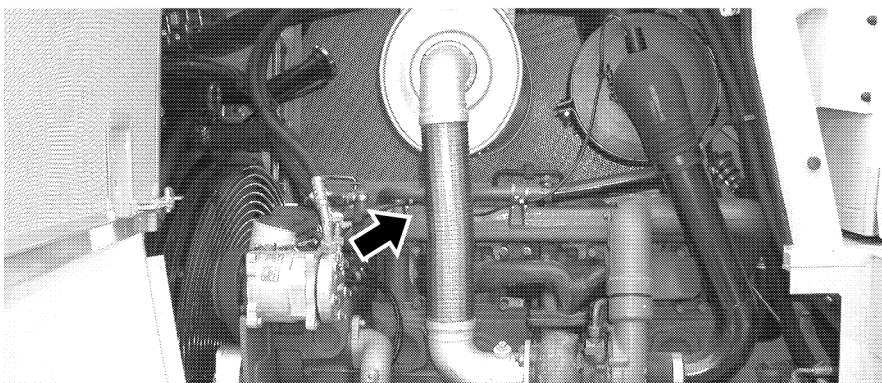

Intake / exhaust lines

- Check the intake lines between turbo charger, cooler and engine for leaks and mounting.
- Check the exhaust lines between engine and turbo charger, muffler and exhaust pipe for leaks and mounting tightness.

5.5.9 Oil separator

Change the oil separator

A damaged or pushed in oil separator can influence the function. The oil separator must be replaced. The oil separator must also be replaced if oil vapor emerges from the bleeder bore on the cover.

Make sure that:

- the machine is in maintenance position,
- the right engine compartment door is open.

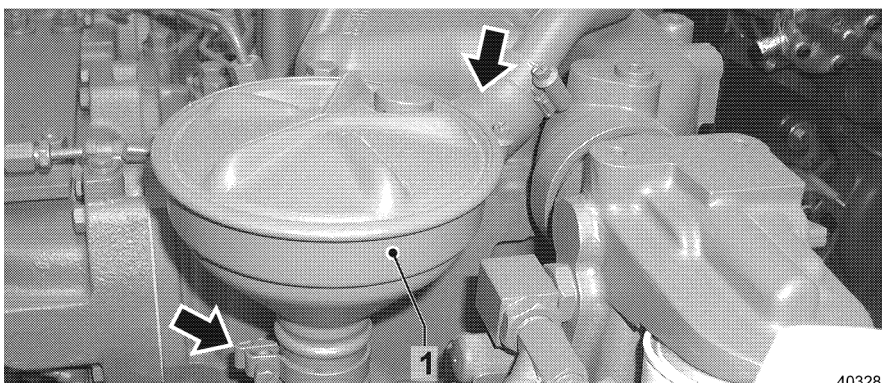

403288

Oil separator

- Loosen the mounting clamps on the oil separator 1 and on the hose and remove the oil separator.
- Insert a new O-Ring into the oil separator.
- Add the new oil separator and tighten the mounting clamp.
- Push on the hose and tighten the hose clamp.
- Prevent infiltration of cleaning fluid (when cleaning the engine).

5.6 Cooling system

5.6.1 Check the coolant level

The coolant expansion tank with filler fitting is on the upper side of the cooling unit. Access is provided via the right engine compartment door.

Make sure that:

- the machine is in maintenance position,
- the right engine compartment door is open.

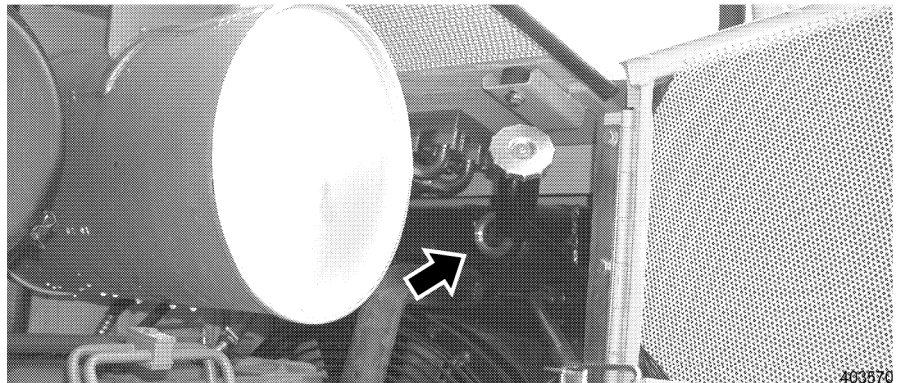

Inspection port - coolant

- The coolant must be visible in the inspection port when the Diesel engine is turned off.
- If the coolant is not visible in the inspection port, add more coolant.

Antifreeze concentration

The coolant must have the correct antifreeze and DCA-4 concentration. For details, see "Check antifreeze and DCA-4 concentration in coolant".



Danger of scalding

403276

Caution

There is a danger of scalding due to splashing coolant!

- ! At or near operating temperature, the engine cooling system is hot and under pressure.
- ! Open the cap on the filler neck of the expansion tank only after the engine has cooled off.
- ! Check the coolant level only after the cap on the expansion tank is cool enough to touch. Then turn the cover slowly to relieve the pressure.
- ! Never add coolant if the engine is hot.

Add coolant

- Open the right engine compartment door.
- Use a suitable ladder for access.
- Turn the cap on the filler neck a little in counterclockwise direction to relieve the pressure, then open.

Caution

- ! Avoid skin contact with the coolant!
- ! Observe manufacturer's instructions.
- When mixing coolant, always wear rubber gloves and safety glasses.
- In case of an accidental splash, flush eyes or skin immediately with plenty of water.

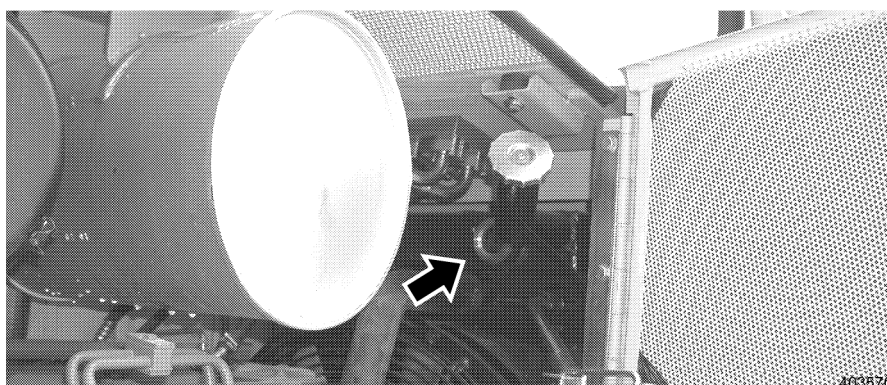

Sight gauge - coolant

- Add coolant to the center of the sight gauge.
- Install the cap on the filler neck and tighten.

5.6.2 Clean the cooling system

To ensure proper cooling function, it is necessary to clean the cooler. In dusty job applications, check the cooler daily and clean, if necessary. Dirty cooling units can cause overheating, which will trigger a visual warning.

Dust and other dirt can be removed from the cooling fins with water spray, steam or air pressure. We recommend the use of pressurized air.

Make sure that:

- the machine is in maintenance position,
- the engine compartment doors are open.

Caution

Be careful not to damage the cooling fins.

- ! Do not use hard objects or high water pressure for cleaning.

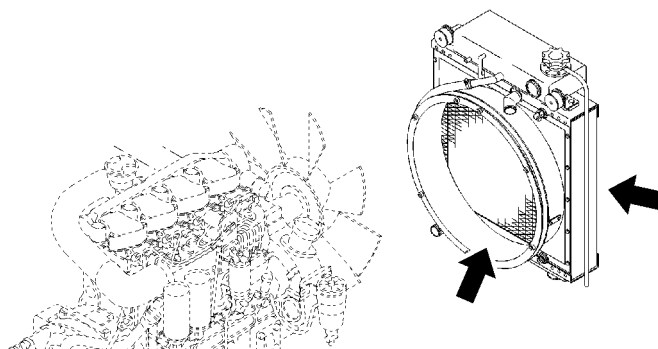

403270

Cooler

- Clean the cooler units with air pressure, steam or water.
- Close the engine compartment doors again.

5.6.3 Check the cooling system for leaks

Make sure that:

- the machine is in maintenance position,
- the right engine compartment door is open.

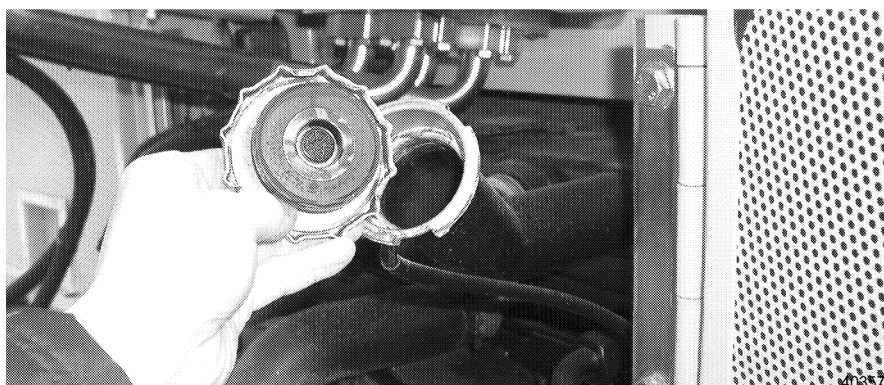

403571

Cap

- Check the cap for leaks.

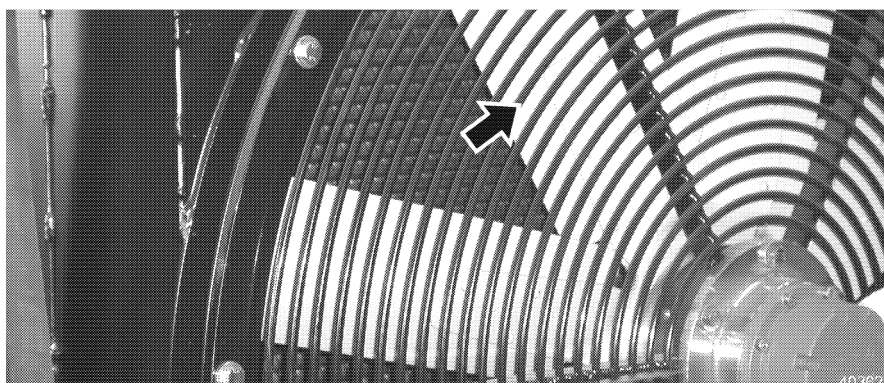

403625

Fan

- Check the fan**
- Check the fan for damage.

5.6.4 Change the coolant filter

Make sure that:

- the machine is in maintenance position,
- the right engine compartment door is open.

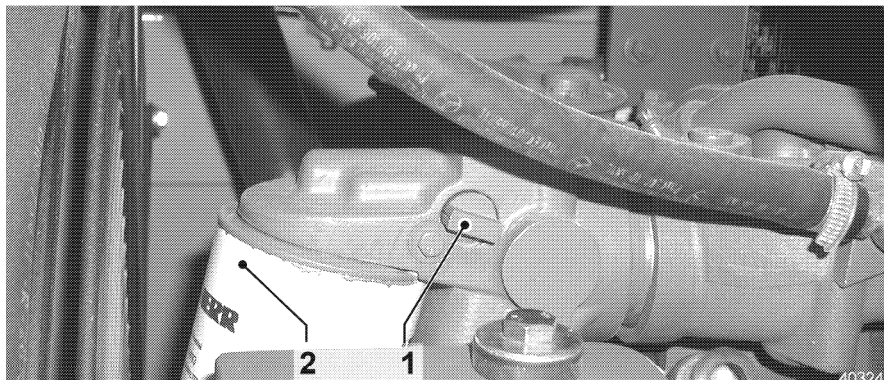

Coolant filter

- Close the shut off valve 1 on the filter housing.
(The handle on the shut off valve is in vertical position when closed).
- Loosen the water filter 2 with a filter wrench and remove.
- Clean the sealing surfaces of the filter console to remove any remains of the seal.
- Lightly lubricate the rubber seal ring on the new water filter with engine oil.
- Install the new water filter 2 on the filter console until it is seated all the way and tighten by hand.
- Open the shut off valve 1.
(The handle on the shut off valve is then in horizontal position).

5.6.5 Check the antifreeze and DCA-4 concentration in the coolant

The cooling system must contain at least 50% corrosion inhibitor / antifreeze fluids year round. This corresponds to an antifreeze protection to approx. -37°C . The coolant must contain the correct DCA-4 concentration. The correct DCA-4 concentration is between 0.3 - 0.8 units per liter.

Make sure that:

- The test kit CC 2602 M by Fleetguard for the DCA-4 concentration and the antifreeze concentration in the coolant is available.

Caution

Danger of scalding due to splashing coolant!

! Open the cap on the filler neck 1 only if the engine is cooled off - the coolant temperature gauge on the segment field of the indicator unit should be in the lower third of the segment field.

- Carefully open the cap on the filler neck.
- Check the antifreeze concentration and the DCA-4 concentration with test kit CC 2602 M by Fleetguard.
- If the concentration deviates from the correct value:
Add antifreeze and DCA-4 until the nominal value is obtained.
See "Lubricant and service fluid specification".

5.6.6 Change the coolant

Make sure that:

- the machine is in maintenance position,
- the engine compartment door is open,
- the heater valves are open,
- a suitable container is available,
- the required amount of coolant with DCA4 is available (for mixing ration, see "Lubricants and service fluids").



Danger of scalding

403276

Caution

Danger of scalding due to splashing coolant!

! At or near operating temperature the engine coolant is hot and under pressure.

! Open the cap on the filler neck of the expansion tank only after the engine has cooled down.

! Open the cap on the expansion tank only after it is cool enough to touch. Turn the cap carefully to relieve pressure.

! Never add coolant if the engine is hot.

Drain the coolant

- Turn the cap on the filler neck a little in counterclockwise direction to relieve pressure before opening it.

Caution

- ! Do not allow your skin to come into contact with coolant.
- ! Observe the manufacturer's guidelines.
- When mixing coolant, always wear rubber gloves and safety glasses.
- In case of an accidental splash, flush eyes or skin immediately with plenty of water.

- Place the container under the drain plug.

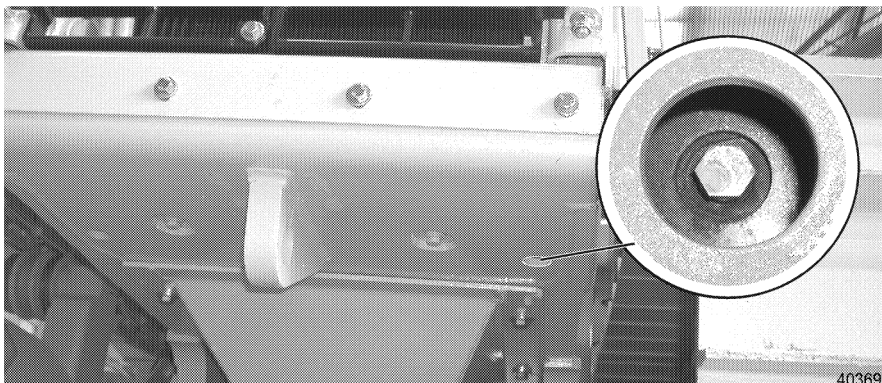

Drain plug - cooler

- Remove the drain plug on the underside of the cooler and drain the coolant into a suitable container.
- Reinstall the drain plug.

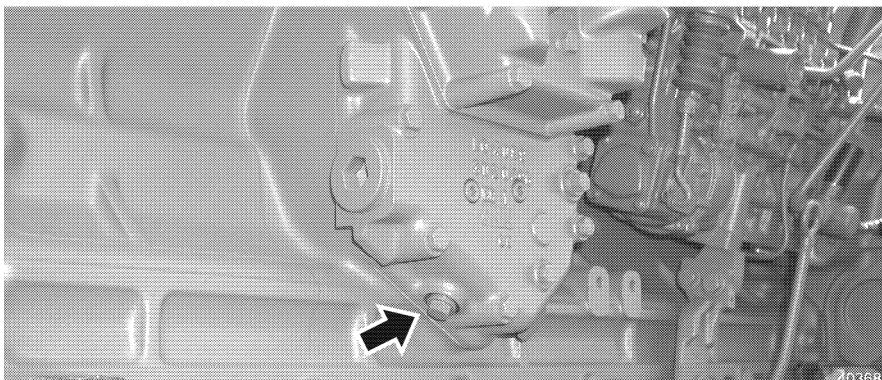

Oil cooler plate - drain plug

- Place a suitable container under the oil cooler plate and remove the drain plug.
- Reinstall the drain plug.

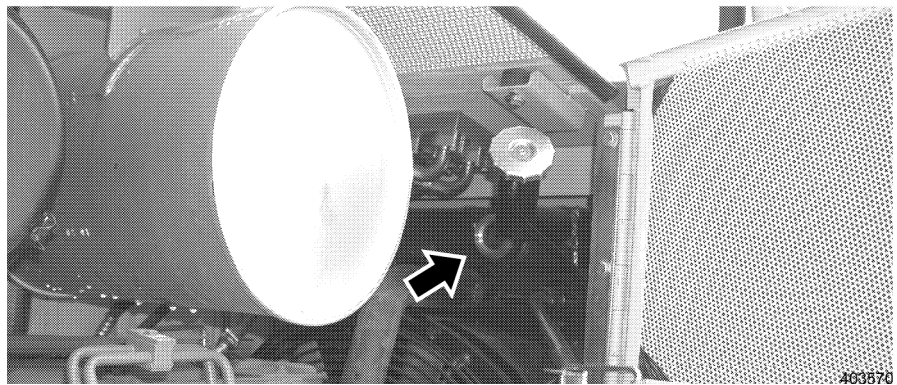

Sight gauge - coolant

Add coolant

- Add the premixed coolant via the filler neck according to the "Lubricants and service fluid chart" until it reaches the center of the sight gauge.
- Place the cap on the filler neck and close.
- Close the engine compartment doors.
- Set the heater knob to "warm". Start the Diesel engine to bring it to operating temperature.
- Recheck the coolant level and correct, as necessary.

5.7 Fuel system

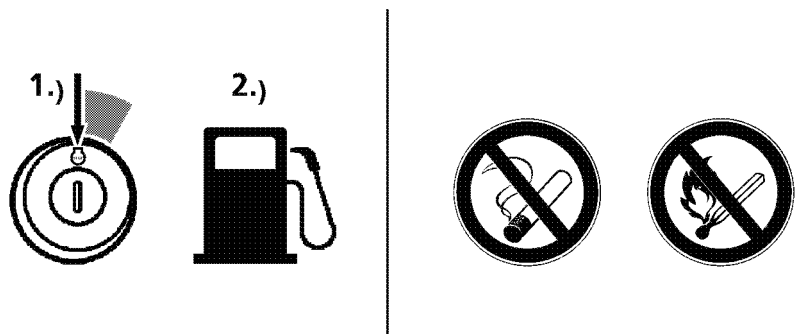

Danger of fire

403183

Caution

! Danger of fire!

- When working on the fuel system, never smoke or allow an open flame in refueling areas.

5.7.1 Drain the fuel separator condensation

Make sure that:

- the machine is in maintenance position,
- a suitable container, which is large enough, is available.

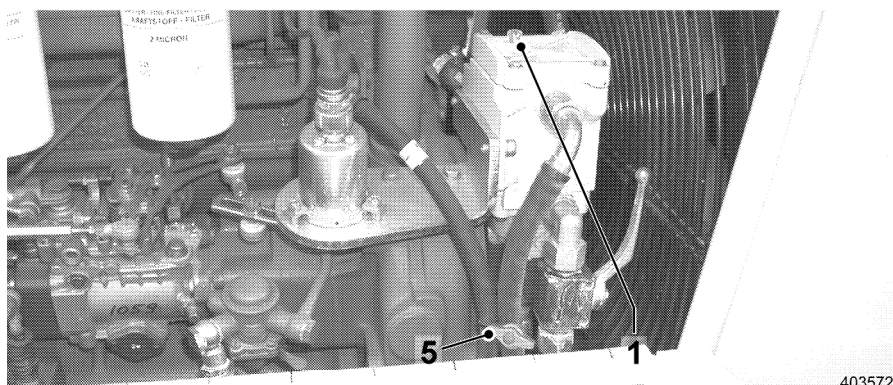

Fuel separator

- Open the bleeder screw 1 .
- Open the shut off valve 5 and drain the condensation into a suitable container until clean fuel emerges.
- Close the shut off valve 5 again and close the bleeder screw 1.

5.7.2 Drain water and contaminants in the fuel tank

Make sure that:

- the machine is in maintenance position,
- a suitable container, which is large enough, is available.

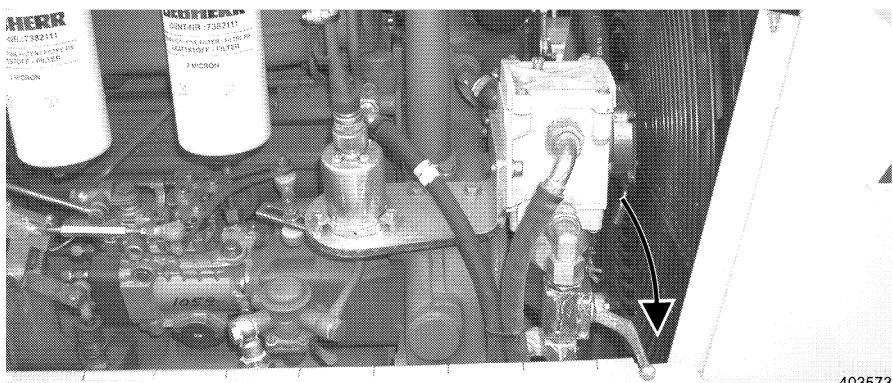

Fuel system shut off valve

- Close the fuel system shut off valve.
The shut off valve is accessible via the right engine compartment door.

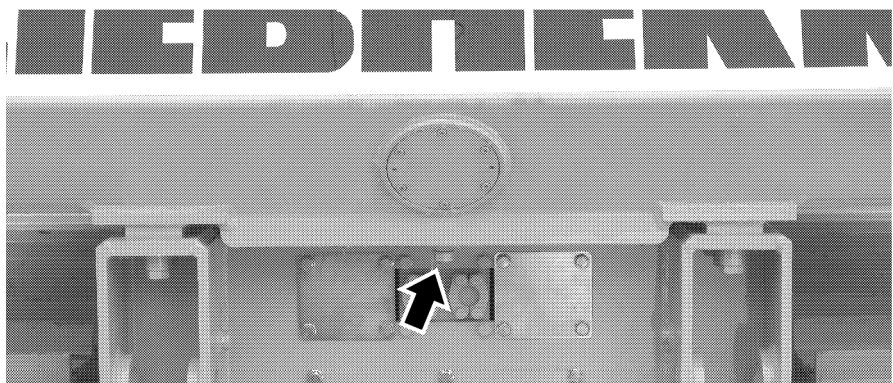

Shut off valve - fuel tank

- Remove the cap on the drain valve on the underside of the fuel tank.

- Install a drain hose to the drain valve.
- Drain condensation and sediments into a suitable container until clean fuel emerges.
- Remove the drain hose and install the cap on the drain valve and tighten.
- Open the shut off valve on the fuel tank.

5.7.3 Empty the fuel tank

If the filter becomes dirty often, empty the fuel tank and clean it.
Make sure that:

- the machine is in maintenance position,
- a suitable container, which is large enough, is available.

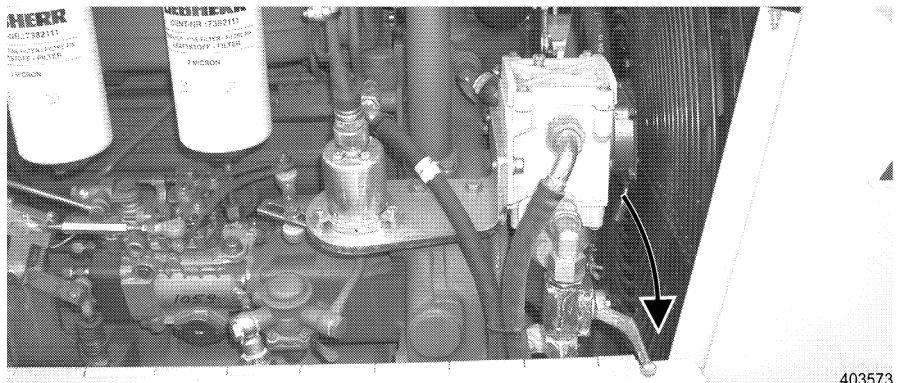

Fuel system - shut off valve

- Close the shut off valve for the fuel system.
- Set a suitable container, which is large enough, under the drain valve.
- Remove the tank cover.

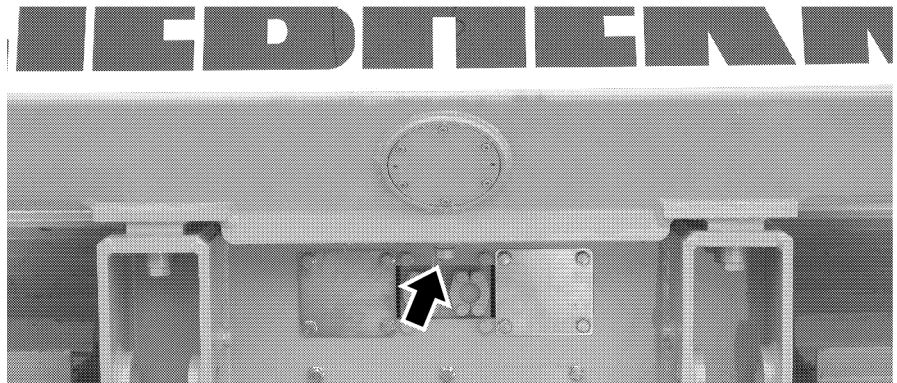

Shut off valve - fuel tank

- Remove the cap on the drain valve on the underside of the Diesel fuel tank.
- Install a drain hose on the drain valve.
- Drain the fuel into a suitable container.
- Remove the drain hose and install the cap on the drain valve and tighten.

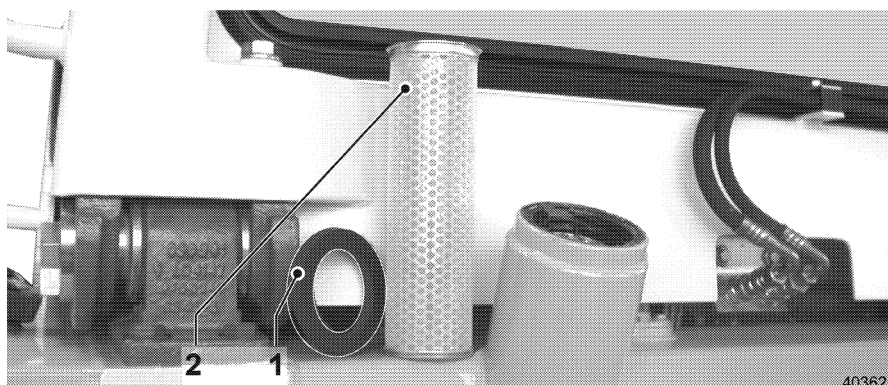

Fuel tank - filler neck

- On the fuel filler neck, remove the rubber ring 1.
- Remove the strainer 2, check the strainer and replace it, if necessary.
- Check the fuel tank.

Troubleshooting

If the fuel tank is dirty, it must be cleaned.

If cleaning is not necessary, reinstall the strainer and rubber ring.

Clean the fuel tank

- Empty the fuel tank completely.

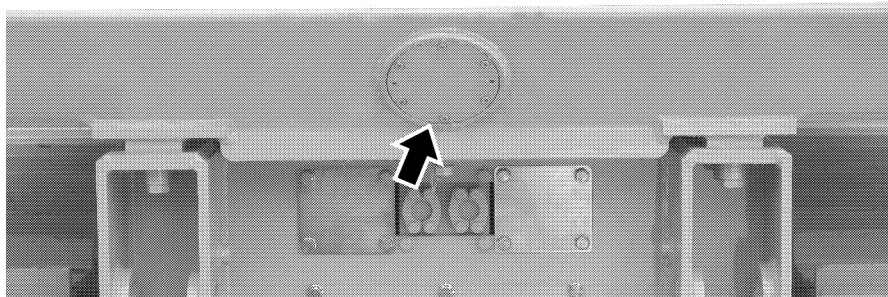

Covers - Fuel tank

- Remove cleaning cover.
 - Check the O - ring on the cleaning cover and replace, as necessary.
- Clean the fuel tank.
- Reinstall the cleaning cover with O - ring.
- Refuel the fuel tank.
- Open the shut off valve - fuel system.

5.7.4 Change the fuel filter elements

Make sure that:

- the machine is in maintenance position,
- the right engine compartment door is open.



Fuel fine filter

Fuel fine filter

- Close the shut off valve - fuel system.
- Drain the fuel: Open the drain valve on the fine filter.
- Push the retaining ring upward and turn it by 1/4 turn in counterclockwise direction.
- Pull away the filter insert with the retaining ring.
- Dispose of the old filter insert.
- Clean the filter base.
- Install the new filter insert on the filter base. Make sure that the slit of the filter base and the cams of the filter insert align.
- Turn the retaining ring by hand in clockwise direction by 1/4 turn.
 - The retaining ring clicks into the notch.
- Open the fuel shut off valve and bleed the fuel fine filter.

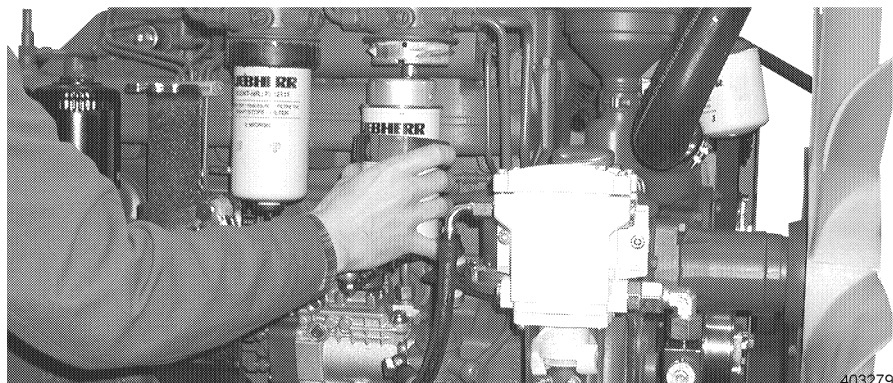

Fuel prefilter

Fuel prefilter

- Close the shut off valve - fuel system.
- Drain the fuel: Open the drain screw on the prefilter.
- Push the retaining ring up and turn by 1/4 turn in counterclockwise direction.
- Pull away the filter insert with the retaining ring.
- Dispose of the old filter insert.
- Clean the filter base.
- Install the new filter insert on the filter base. Make sure that the slits of the filter base align with the cams of the filter insert.

- Turn the retaining ring by hand in clockwise direction by 1/4 turn.
- The retaining ring clicks into the notch.
- Open the fuel shut off valve and bleed the fuel prefilter.

5.7.5 Bleed the fuel system

Make sure that:

- the machine is in maintenance position,
- the right engine compartment door is open.

The fuel system must be bled after:

- Changing the fuel filter.
- Cleaning the fuel tank.
- Repairs on the fuel system.
- Emptying the fuel tank.

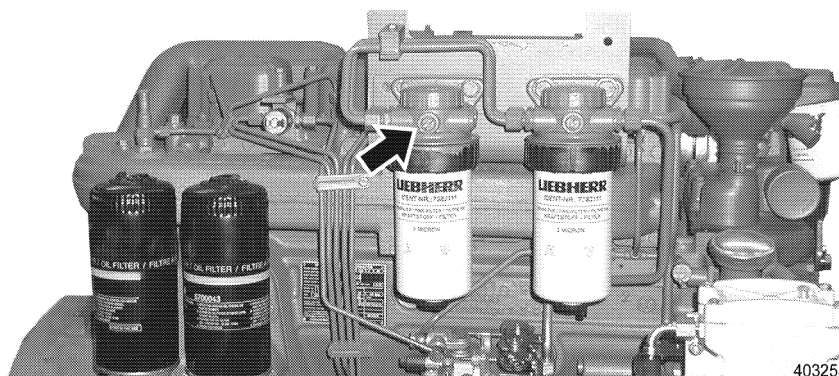

Bleeder screw - fuel fine filter

- Loosen the bleeder screw on the fuel fine filter and turn out by 2-3 threads.

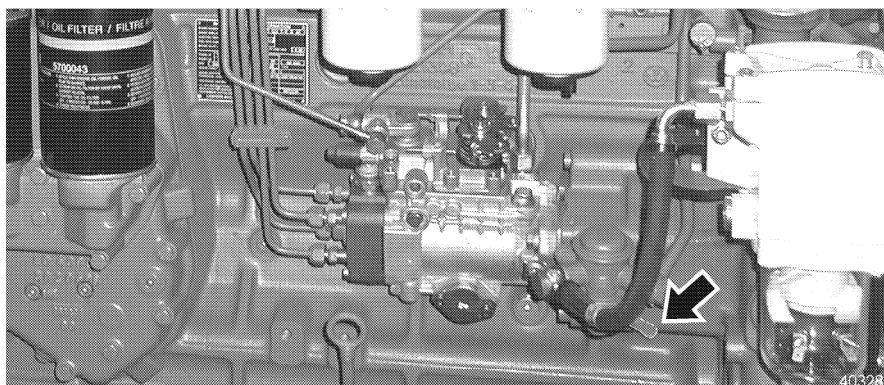

Hand pump

- Actuate the hand pump until fuel without air bubbles emerges on the bleeder screw.

The hand pump is only operating if a noticeable resistance of approx. 1 - 1.5 cm can be felt on the pump lever (= pump path).

Otherwise close the engine compartment doors and turn the starter for a short time to move the plunger into a different position

Caution

Start the Diesel engine only if the engine compartment doors are closed.

- Retighten the bleeder screw.

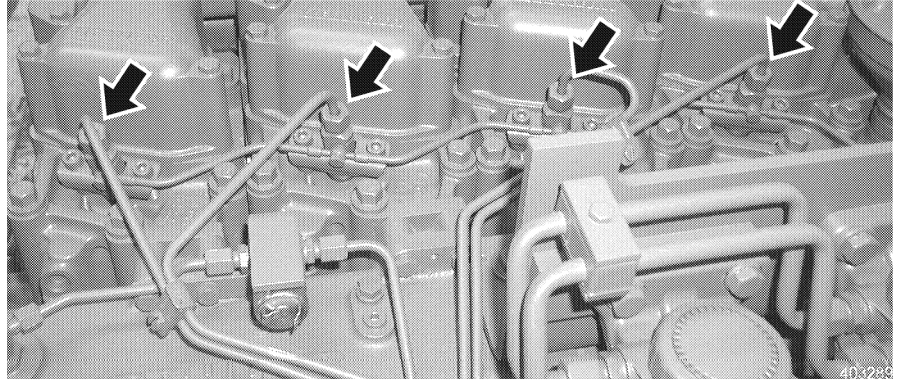

Union nuts

- Loosen the union nuts on the injector valves.
- Close the engine compartment doors.
- Actuate the starter switch until fuel without air bubbles emerges. Retighten the union nut.

Start the Diesel engine as described in "Control, operation". If the Diesel engine does not start, repeat the bleeding procedure.

5.8 Air filter system

5.8.1 Clean / change the air filter

Clean or change the main element if the indicator light - air filter contamination in the instrument panel lights up or according to the change interval in the maintenance and inspection schedule.

If the indicator light - air filter contamination continues to light up after servicing the main element, then the safety element must also be changed.

Make sure that:

- the machine is in maintenance position,
- the right engine compartment door is open.

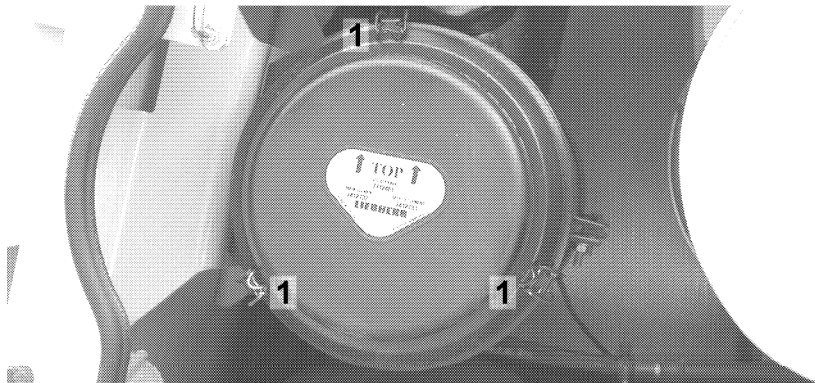

Mounting clamps

403576

- Open the mounting clamps 1 on the service cover and remove the cover.

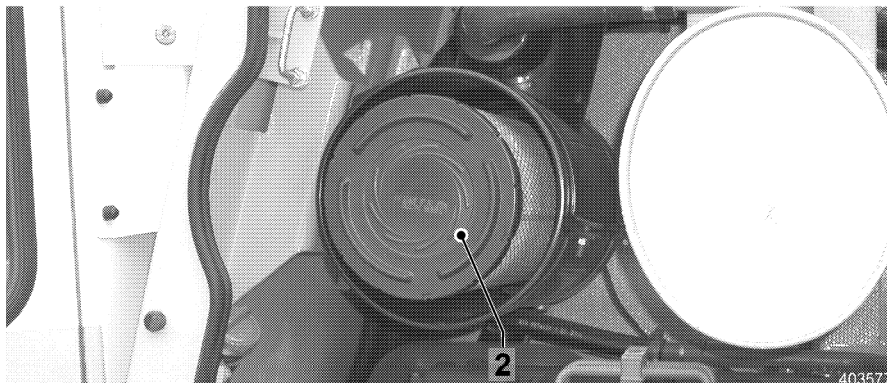

Primary filter element

Primary filter element

- Pull out the primary filter element 2, clean or change it.

Clean the primary filter element

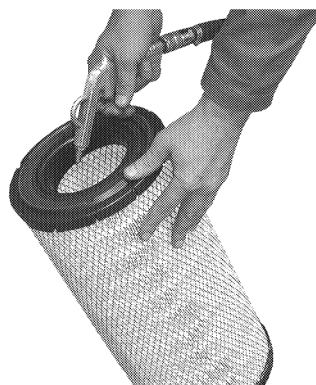

Blow out the primary filter element

403283

- Blow the primary filter element from the inside to the outside with dry air. Do not hit the filter, as this could damage the filter.

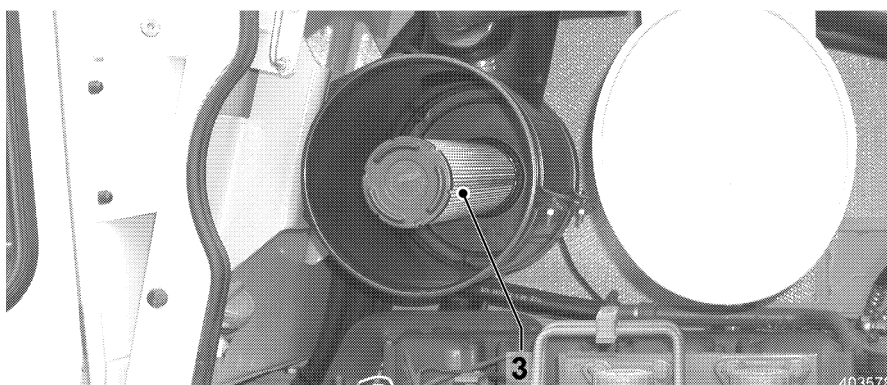

Safety element

Safety element

- The safety element 3 should be changed after the primary filter element 2 has been changed three times or whenever the primary filter element 2 is replaced.
 - The safety element may not be cleaned!

Caution



Danger of damage to the Diesel engine.
! NEVER operate the machine without air filter.

- Make sure that any dirt in the filter housing is removed before a new or cleaned filter element is reinserted.

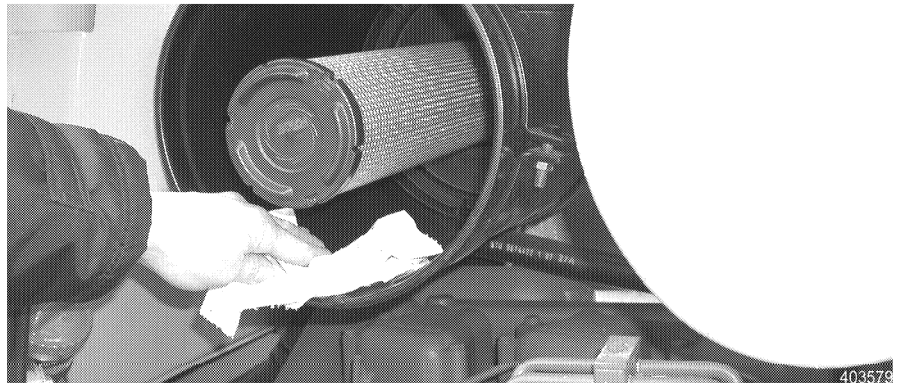

Clean the filter housing

- Wipe out the filter housing with a clean rag.
 - Never use pressurized air!
 - Make sure the area you work in is free of dust. Dust may not enter into the air intake line.
- Reinstall the filter element (3) and (2) and make sure it is seated properly.
- Clean the service cover and install the filter housing. The cover must be seated all the way on the filter housing before the mounting clamps (1) can be closed easily.
- Close the mounting clamps (1).

5.9 Hydraulic system



Hydraulic pressure

403281

Caution

! Do not remove any hydraulic lines, hoses, connectors as long as the hydraulic system is under pressure.

Turn the engine off and actuate all functions again to release pressure in all hydraulic lines.

5.9.1 Oil level in hydraulic tank

Make sure that:

- the hydraulic oil is cold,
- the machine is in maintenance position.

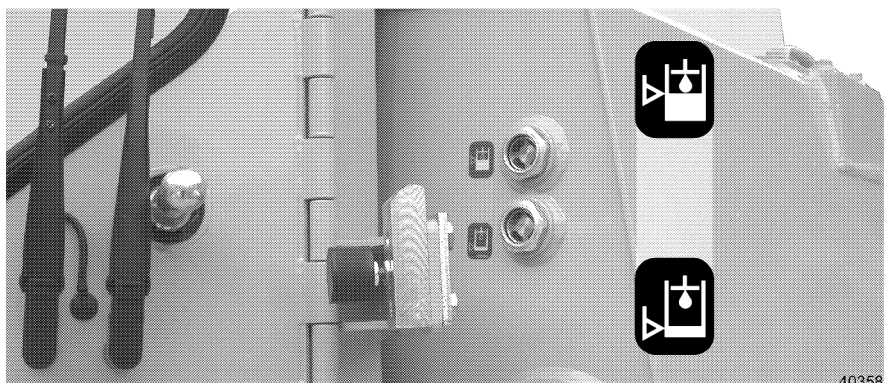

Sight gauges

Check oil level

- Check the oil level on the sight gauges.
 - With the hydraulic cylinders retracted, the oil level may not exceed the center of the upper sight gauge.
 - With the hydraulic cylinders extended, the oil level may not fall below the center of the lower sight gauge.
- If the oil level is under the nominal level: add hydraulic oil.

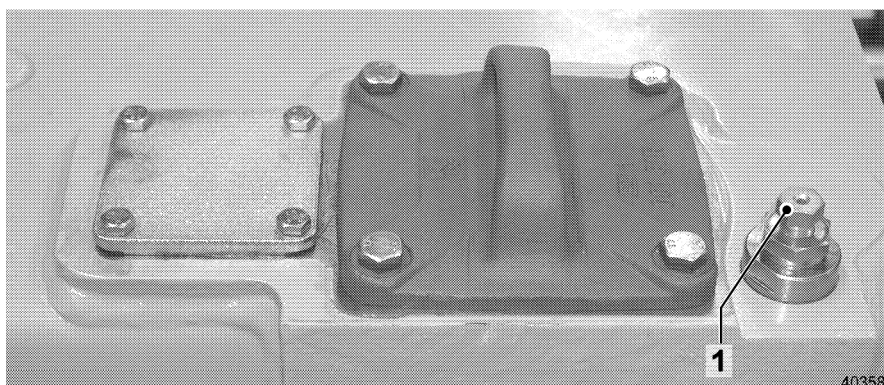

Hydraulic tank - bleeder screw

Add hydraulic oil

- Relieve tank pressure: turn out the bleeder screw 1 on the hydraulic tank by two turns.
- Add hydraulic oil only via the return filter.

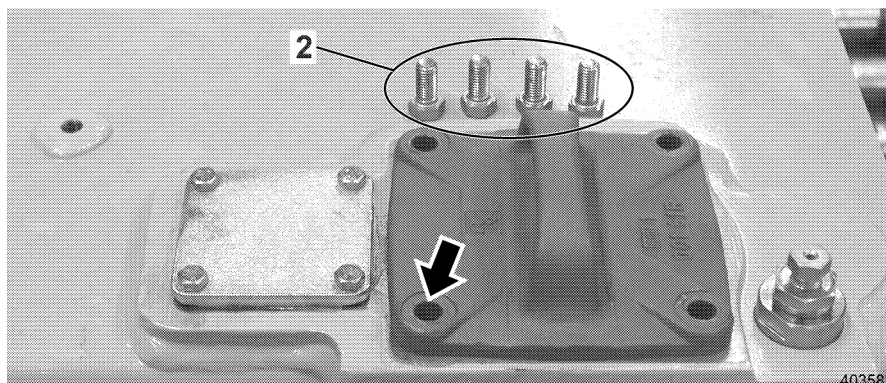

Filter cover

- Loosen and remove the screws 2 on the filter cover.
- Remove the filter cover with the magnetic rod.

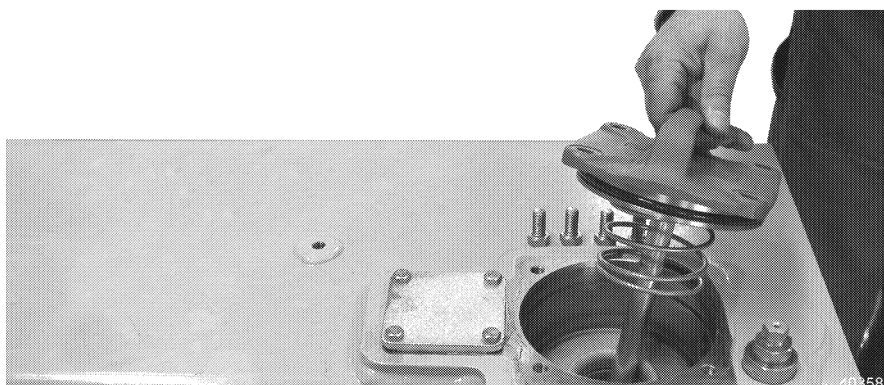

Magnetic rod

- Check the magnetic rod and clean, if necessary.

Troubleshooting

Heavy contamination or larger metallic particles on the magnetic rod or in the return filter can cause damage in the hydraulic system.

- In this case, find the cause and fix the problem in the hydraulic system.
-
- Add hydraulic oil via the return filter to the MAX mark.

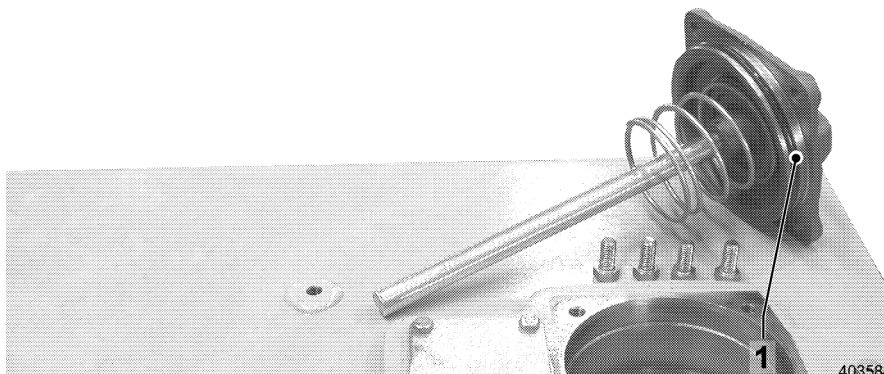

O - ring

- Check the O - ring 1 on the filter cover and replace it, if necessary.
- Insert filter cover with magnetic rod and fasten with screws.

- Close the bleeder screw on the hydraulic tank.

5.9.2 Clean the magnetic rod on the hydraulic tank.

Make sure that:

- the machine is in maintenance position.

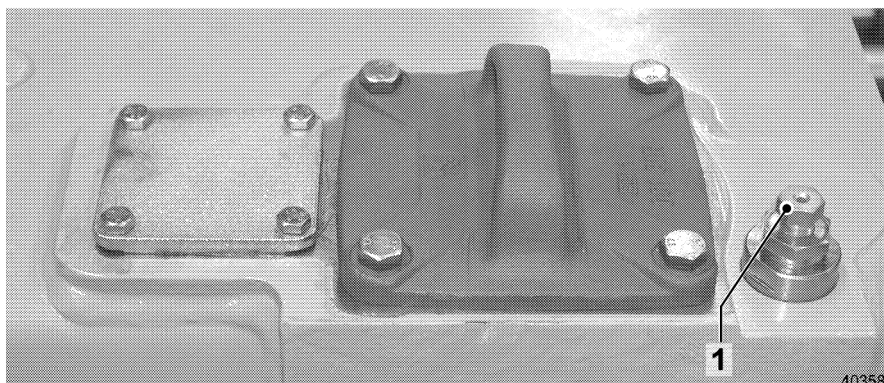

Bleeder screw

- Relieve the tank pressure: Back out the bleeder screw 1 on the hydraulic tank by two turns.

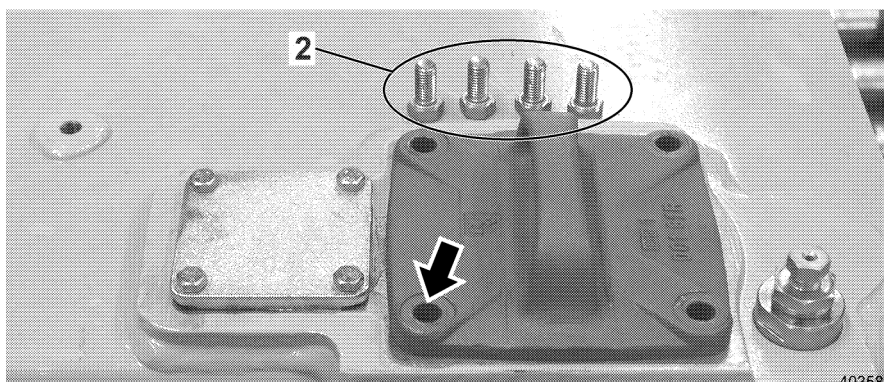

Filter cover

- Loosen the screws on the filter cover and slowly lift off the filter cover with the magnetic rod.

Troubleshooting

Heavy contamination or larger metallic particles on the magnetic rod or in the return filter can point to a problem in the hydraulic system.

- In this case, find the cause and fix the problem in the hydraulic system.

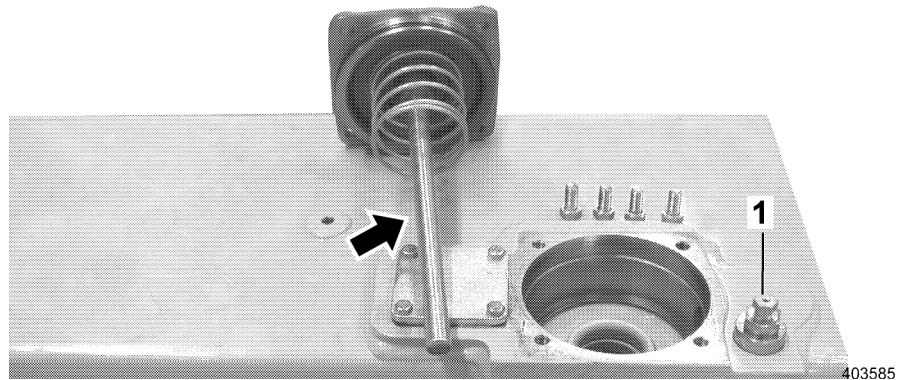

Magnetic rod

- Carefully clean the magnetic rod.
- Set the O - ring and filter cover with magnetic rod onto the housing.
- Tighten the screws on the filter cover.
- Tighten the bleeder screw 1.

5.9.3 Change the return filter insert

The return filter must be changed, in addition to the intervals given in the Maintenance and inspection schedule if the indicator light "Return filter" lights up when the hydraulic oil is at operating temperature. Use only Original LIEBHERR return filter insert. Make sure that the machine is in maintenance position. The return filter insert cannot be cleaned.

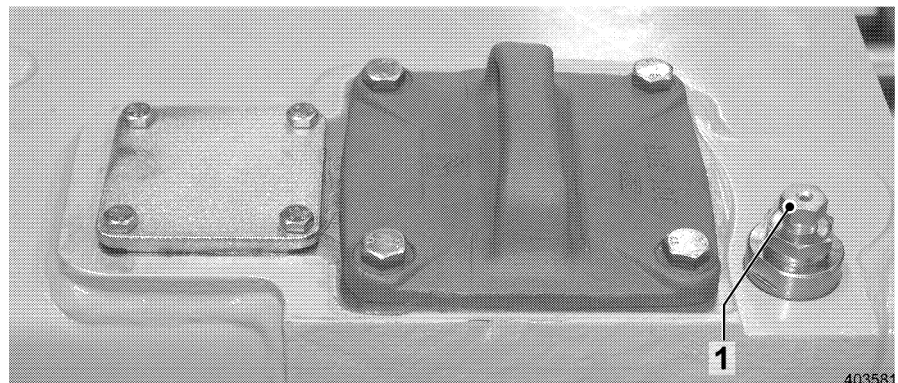

Bleeder screw

- Relieve the tank pressure: Back out the bleeder screw 1 on the hydraulic tank by two turns.

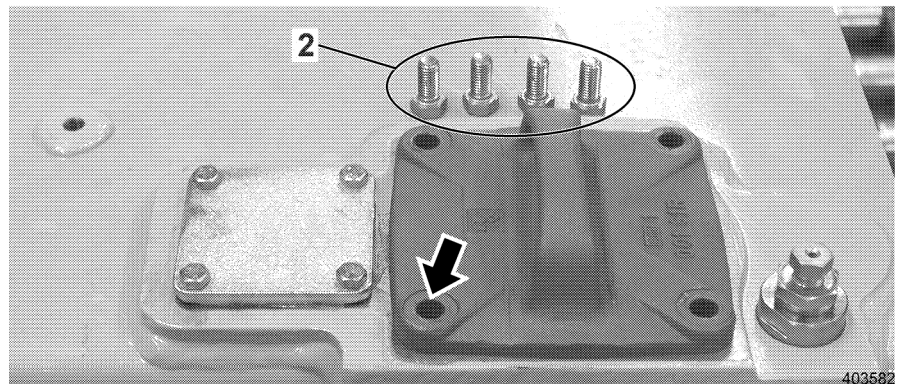
*Filter cover*

- Loosen the screws 2 on the filter cover and slowly lift off the filter cover with the magnetic rod.

Troubleshooting

Heavy contamination or larger metallic particles on the magnetic rod or in the return filter can point to a problem in the hydraulic system.

- In this case, find the cause and fix the problem in the hydraulic system.

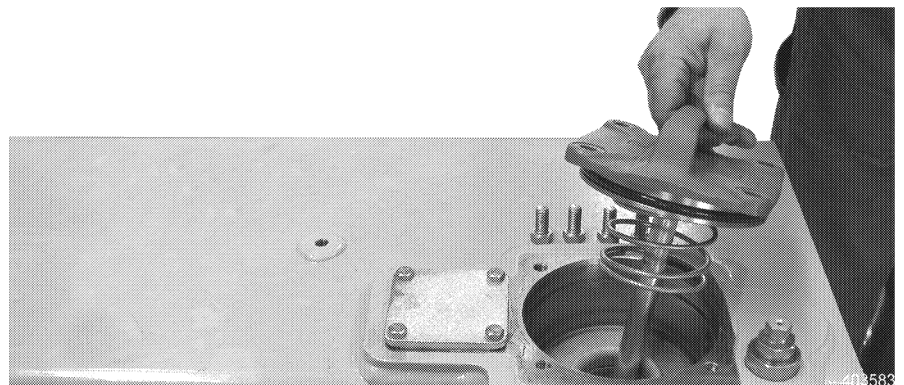
*Magnetic rod*

- Remove the filter cover with spring and magnetic rod.

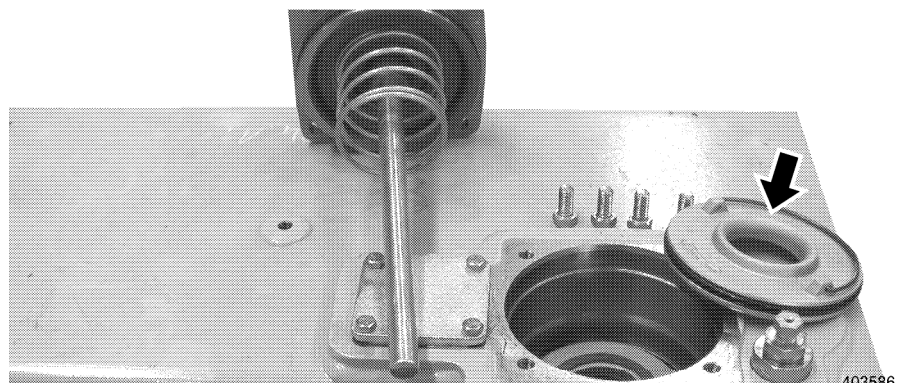
*Pressure plate*

- Remove the pressure plate.

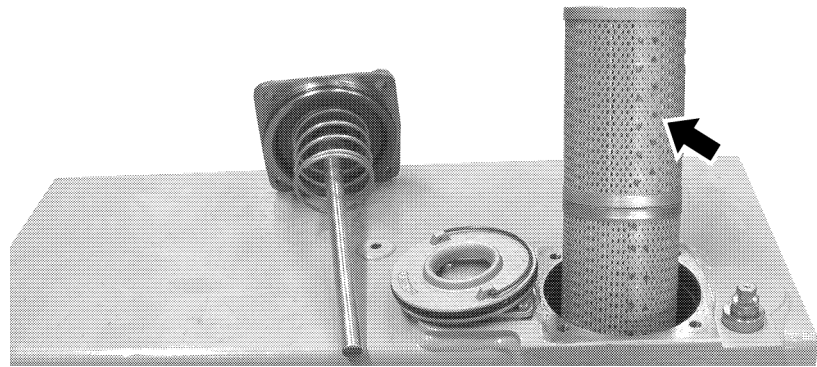

403587

Return filter

- Remove the filter insert and dispose of it properly.
- Carefully insert a new filter insert.
- Clean the magnetic rod carefully.
- Check the O - ring on the filter cover and replace, if necessary.
- Set the filter cover with magnetic rod onto the housing.
- Tighten the screws on the filter cover.
- Tighten the bleeder screw 1.

5.9.4 Change the replenishing oil filter

Make sure that:

- the machine is in maintenance position,
- the right engine compartment door is open,
- a LIEBHERR oil filter element is available.



Replenishing oil filter

- Remove the filter element 1 with a filter wrench.
- Clean the sealing surfaces on the filter console.
- Apply a thin layer of engine oil to the rubber seal ring on the new filter element.
- Install the new filter element on the filter console and tighten by hand.

5.9.5 Check the hydraulic system for function and leaks



Hydraulic pressure

403281

Caution

- ! Never check for leaks on the machine with your bare hands.
- Fluid escaping from a small hole can have enough force to penetrate the skin and cause severe injury.
 - Always wear protective gloves.

Make sure that:

- the machine is in maintenance position,
- the cab is raised, see "Maintenance", "Cab tilting device".
- See also "Safe maintenance of hydraulic hoses and lines".
- Check the complete hydraulic system for leaks.
- Replace defective hydraulic seals and hoses.
- Tighten loose hydraulic connections.

5.9.6 Clean the oil cooler

To ensure proper cooling function for all components, the cooler must be cleaned, as necessary. In dusty job applications, check the cooler daily and clean, as necessary.

Dirty cooler units cause overheating.

Dust and dirt can be removed from the cooling fins with water spray, steam or pressurized air. We recommend the use of pressurized air.

Make sure that:

- the machine is in maintenance position,
- the left and the right engine compartment door are open.

Caution

- Be careful not to damage the cooling fins.
- ! Do not use hard objects or high water pressure for cleaning.

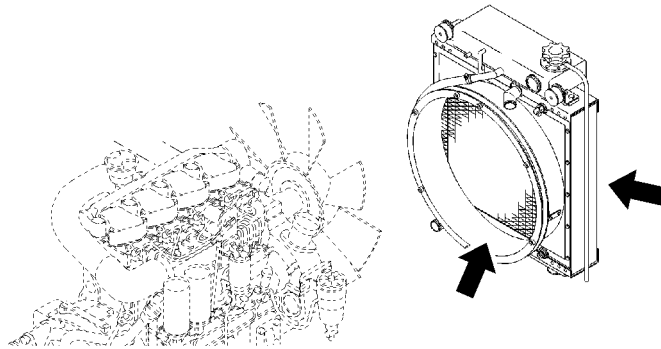

403270

Oil cooler

- Clean cooler units with pressurized air, steam or water.
- Close the left and right engine compartment doors again.

5.9.7 Change the hydraulic oil

Make sure that:

- the machine is at operating temperature,
- the machine is in maintenance position,
- a suitable container is available,
- oil with the correct oil specification and quantity according to the data in "Lubricants and Service fluids " is available.

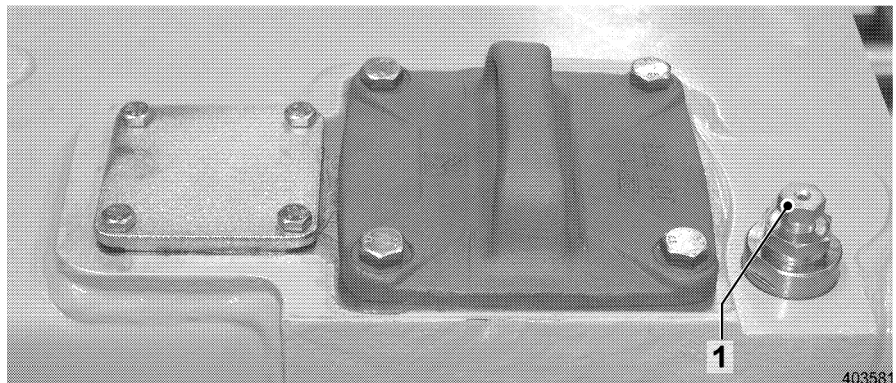

403584

Hydraulic tank bleeder screw

- Relieve the tank pressure: Back out the bleeder screw 1 by two turns.

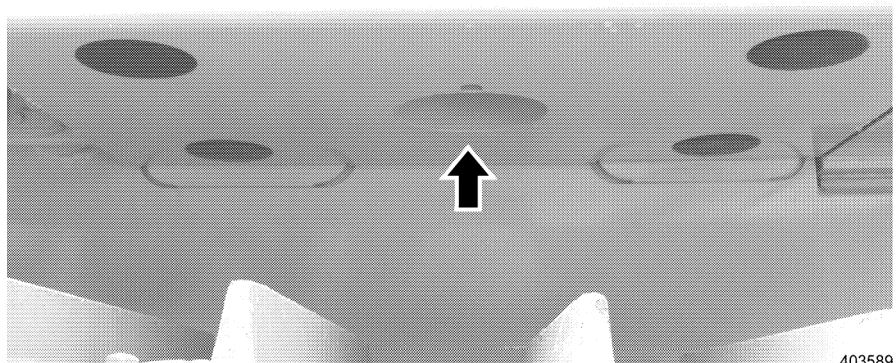

403589

Hydraulic tank oil drain valve

- Remove the cap on the drain valed on the underside of the hydraulic tank.

- Install a drain hose onto the drain valve.
- Drain the hydraulic oil into a suitable container.
- Remove the drain hose and install the cap on the drain valve and tighten.

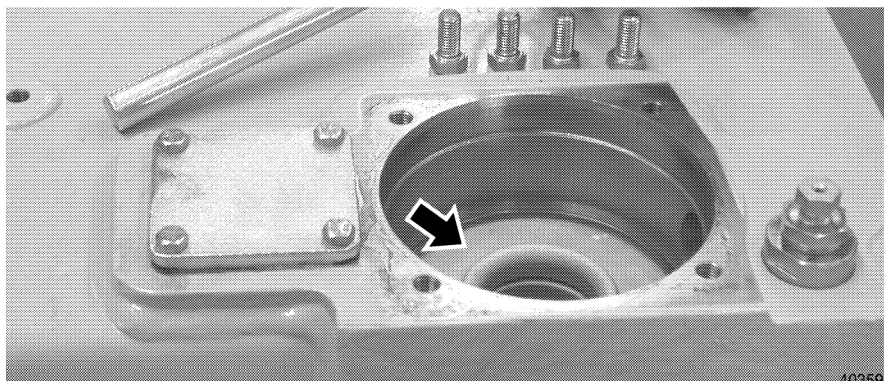

Add hydraulic oil

Add hydraulic oil only via the return filter.

- Loosen the screws on the filter cover and slowly lift the filter cover with the magnetic rod.

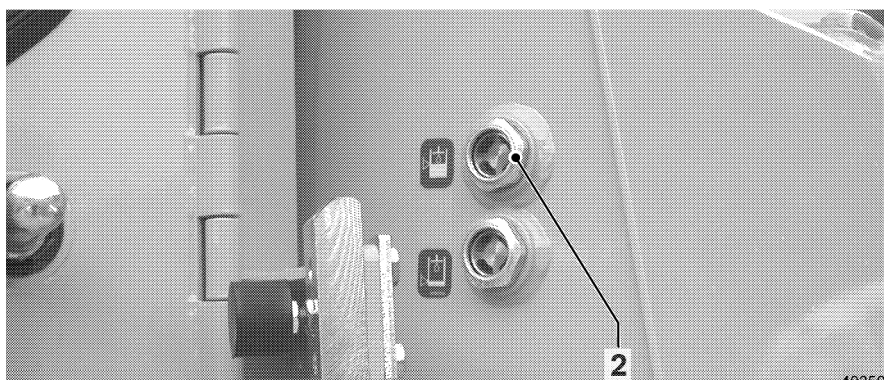

Oil level mark

- Add hydraulic oil to the oil level mark 2.
- Set the cover with spring onto the housing and tighten.
- Retighten the bleeder screw.

5.10 Splitterbox

5.10.1 Check oil level

The dipstick 3 and the oil filler tube 2 are in the engine compartment on the right hand side of the engine.

Make sure that:

- the machine is in maintenance position,
- the engine compartment door is open.

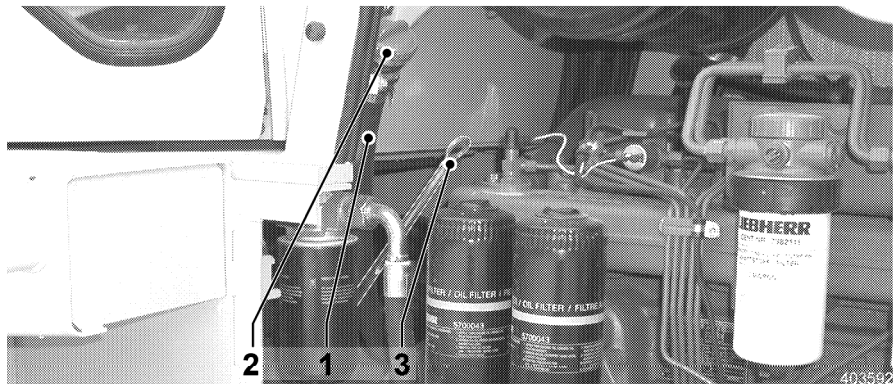

Oil filler neck - dipstick

- Pull out the dipstick 3, wipe it off and reinsert it.
- Pull the dipstick 3 out again and check the oil level. The oil level must be between the MIN and MAX mark.

If the oil level is too low:

- Remove the cover 2 from the oil filler tube 1 and add oil.

For oil quality, see "Lubricants and Service fluids ".

- Clean the cover on the oil filler tube and set it on the oil filler tube on the splitterbox and tighten.

5.10.2 Change the gear oil

Make sure that:

- the machine is in maintenance position,
- the engine compartment door is open,
- a suitable container and the drain hose with valve connection is available,
- oil with the correct oil specification and quantity according to the data in "Lubricants and Service fluids " is available.

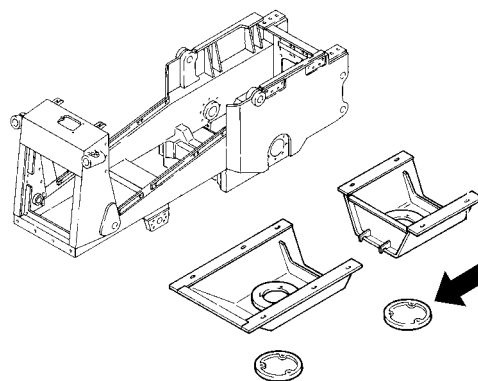

Oil pan cover

403593

- Remove the oil pan cover.
- In case of heavy deposits in the oil pan area, the oil pans must be removed and cleaned.

Danger

! Danger of injury when removing the oil pans.
Due to space restrictions and heavy weight of the oil pans, removal is very difficult.
To remove the oil pans, use a suitable lifting device.

- Remove the cap on the oil drain valve on the oil pan.

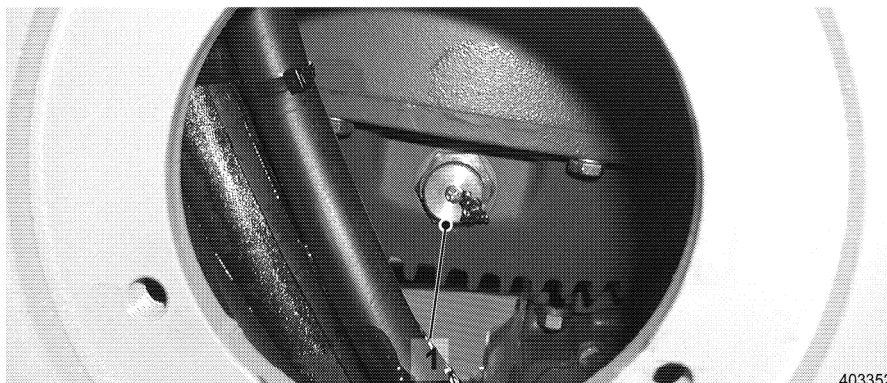

Oil drain valve

- Install the oil drain hose on the oil drain valve 1 and drain the oil into a suitable container.
- Remove the oil drain hose and install the cap on the oil drain valve.
- Install the oil pan cover.



Oil filler neck - dipstick

- Add new oil via the filler neck to the MAX mark on the dipstick.
- Clean the filler cap, set it on the filler neck and tighten.

5.11 Electrical system

When working on the electrical system of the machine and before any welding on the machine, always disconnect the battery.

- Disconnect the negative terminal (-) first and reconnect is last.
Disconnect the battery and remove the electronic box before any arc welding on the machine.

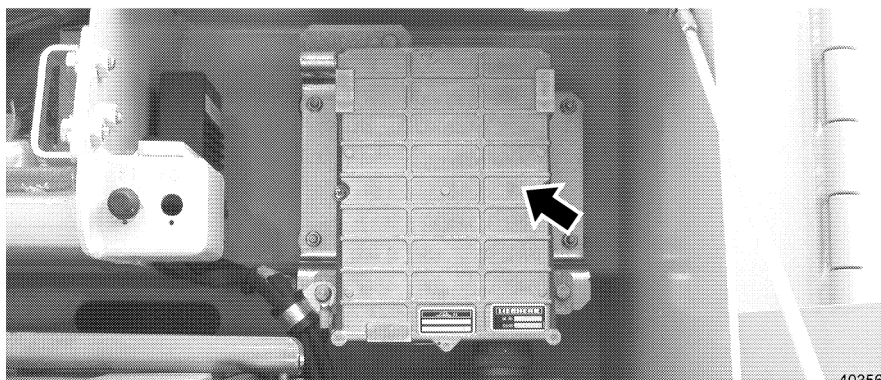

403563

Electronic box

The electronic box is installed in the battery compartment.

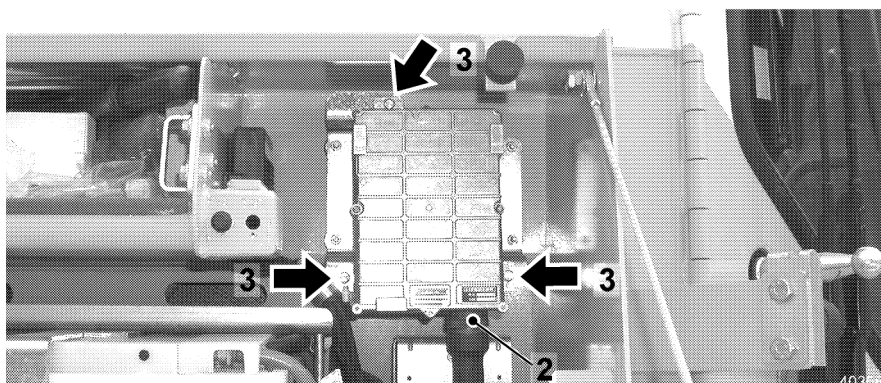

403564

Remove the electronic box

Remove the electronic box

- Remove the cable fitting 2 on the bottom of the electronic box by turning it.
- Remove the mounting nuts 3.
- Remove the electronic box from the battery compartment.

5.11.1 Check indicator lights and illumination

For the location of lights and indicator lights on the indicator unit, see "Operation".

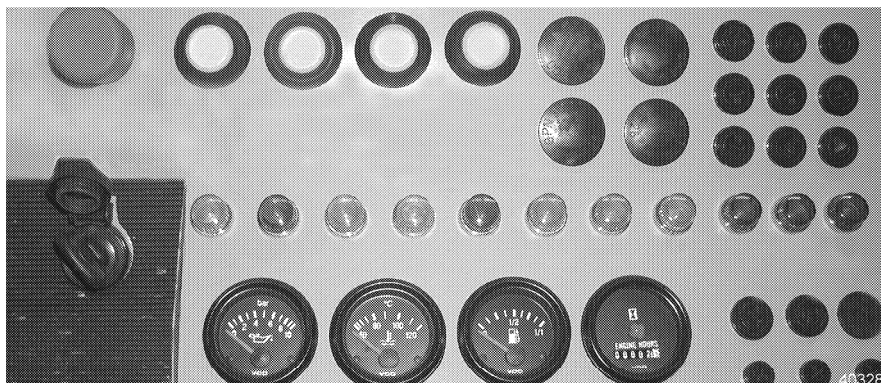

403284

Illumination

- Start the Diesel engine and check the lights and indicator lights.

5.11.2 Batteries

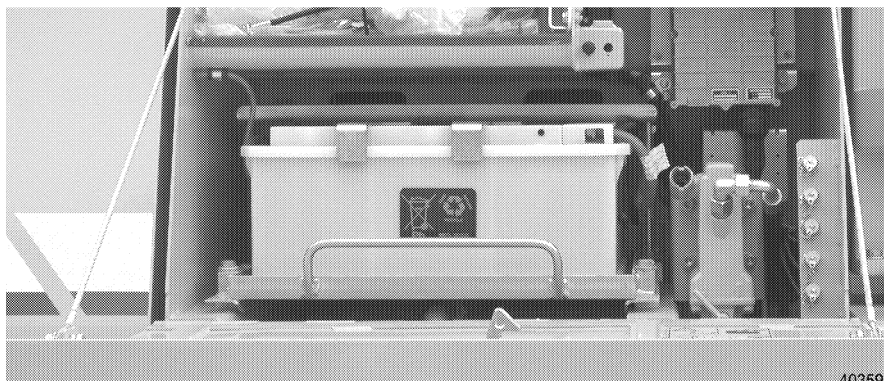

Batteries

Check the electrolyte level and terminals.

The batteries are located in the battery compartment and can be serviced after opening the battery compartment door. For better access, pull out the battery pan after removing the mounting screws.

To ensure trouble free operation of your machine, the electrical system and the batteries must always be in good condition.

Make sure that:

- the machine is in maintenance position,
- the battery compartment door is open.



Explosive gases

403285

Caution



Batteries discharge explosive vapors. Battery acid can cause serious injury.

! Never smoke, keep sparks and open flames away from the batteries when handling batteries, during maintenance and recharging.

- Wear protective gloves and safety glasses when handling batteries.

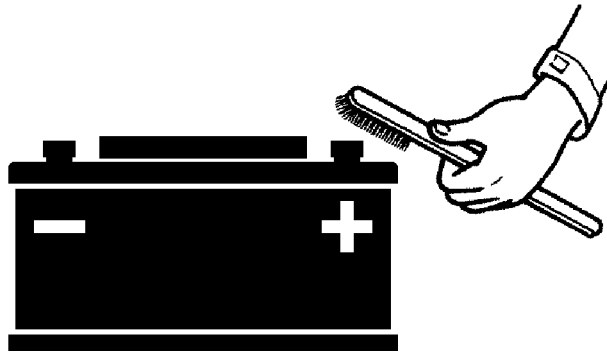

403286

Special brush for terminals

Caution

Danger of spark formation and explosion!

! Use special brush for terminals. Do not use a metal brush!

- Clean the battery surface with a clean rag.
- Tighten the battery mounts.
- Clean the terminals and cable clamps.
- To prevent loose contact, check the cable clamps to ensure they are seated tightly on the terminals and tighten, if necessary.
- Coat the battery terminals and cable clamps with acid resistant grease (such as Vaseline).

In extremely high temperatures, the acid level in the individual cells can drop, due to different gases.

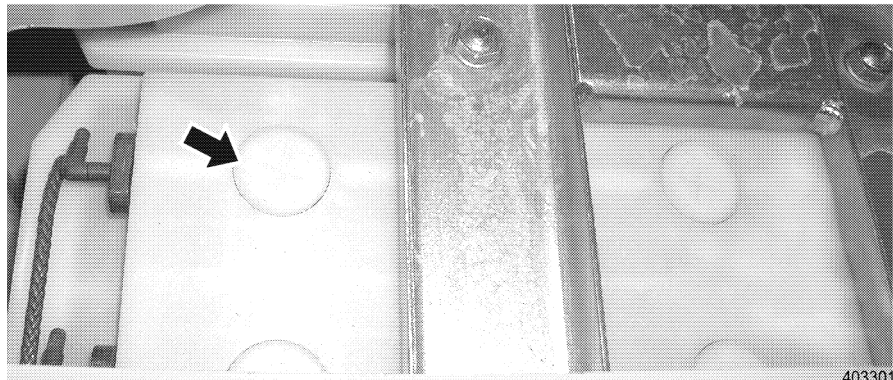

403301

Battery cells - plugs

- Open the plugs on the individual battery cells and check the electrolyte level.

Troubleshooting

If the electrolyte level is too low:

- Add distilled water to approx. 10 mm above the plates.

5.11.3 Change bulbs

Make sure that:

- the machine is in maintenance position.



403595

Halogen lights

Change the halogen bulbs in the halogen lights

- Remove the screws on the frame of the lights.
- Remove the frame with the glass cover.



403596

Lamp base

- Release the spring bar and pull out the lamp base.
- Remove the bulb from the base and replace with a new bulb.
- Do not touch the halogen bulb with bare fingers.

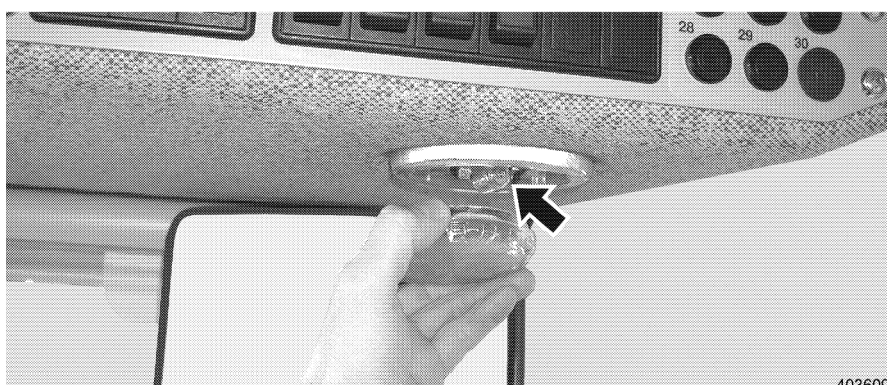

403609

Cab interior lighting

Change the bulb for the cab interior light

- Remove the diffuser.
- Remove the bulb from the contact brackets and replace with new bulb.
- Do not touch the new bulb with bare fingers.
- Insert the bulb.
- Insert the diffuser and push up.

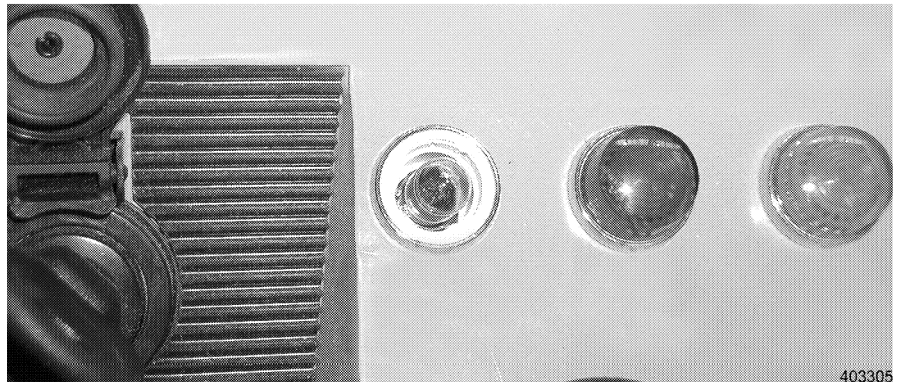

Indicator light

Change the bulbs in the indicator lights

- Unscrew and remove the cap of the affected indicator light.
- Turn the bulb slightly to the left, remove it from the base and change it.
 - If necessary, use a short piece of hose with an inside diameter of 6-8 mm.
 - Do not touch the new bulb with bare fingers.

5.12 Heating and fresh air system, air conditioning system

The following checks must be made regularly, but at least once a year before the start of the cold season.

5.12.1 Check the heater for function and for leaks

Check for leaks

- Check all water circuit connections for leaks.
- Check all clamps and tighten them, if necessary.
 - Replace damaged hoses.

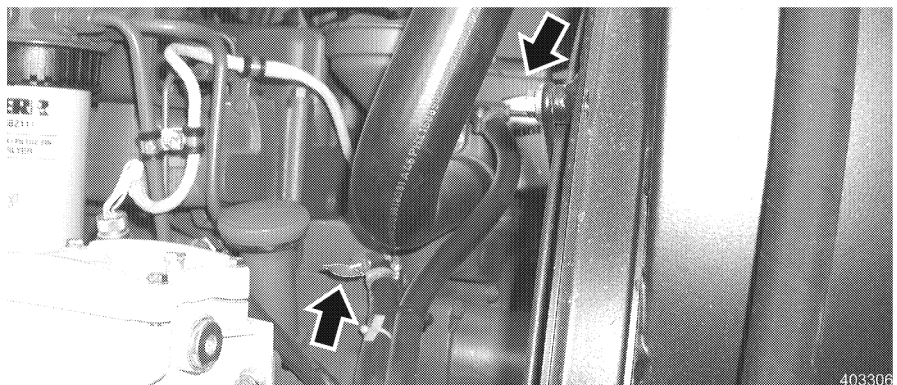

Shut off valves

During the summer months, when the heater is not used, or during maintenance or repairs, close off the shut off valves on the engine block.

- Close the shut off valve.

By closing of the shut off valves, the warm water flow to the heat exchanger is interrupted.

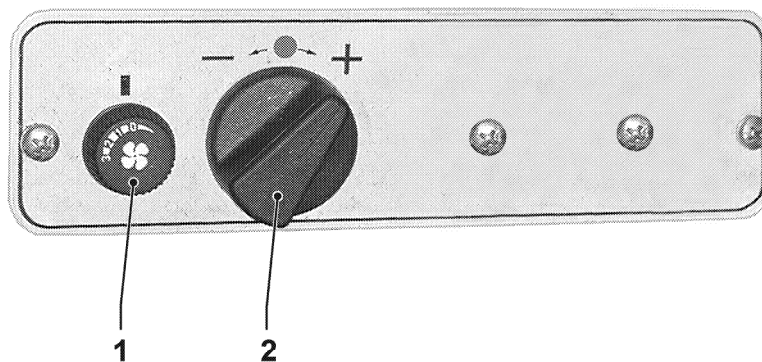

Heater operation

403136

Check function

- Turn the heater on and check the function.
- Operate the heater to ensure that the coolant fluid contains sufficient antifreeze fluid. See "Check antifreeze and DCA-4 concentration in coolant".

5.12.2 Heater - fresh air filter

Make sure that the machine is in maintenance position.

Clean / change the air filter

Access to the air filter is at the front in the operator's cab, below the compartment for the machine documentation.

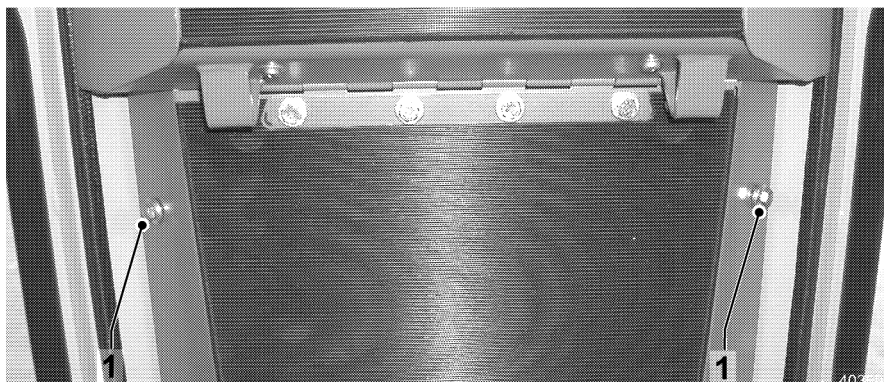

Hex head screws

403136

- Remove the hex head screws and open the lock.

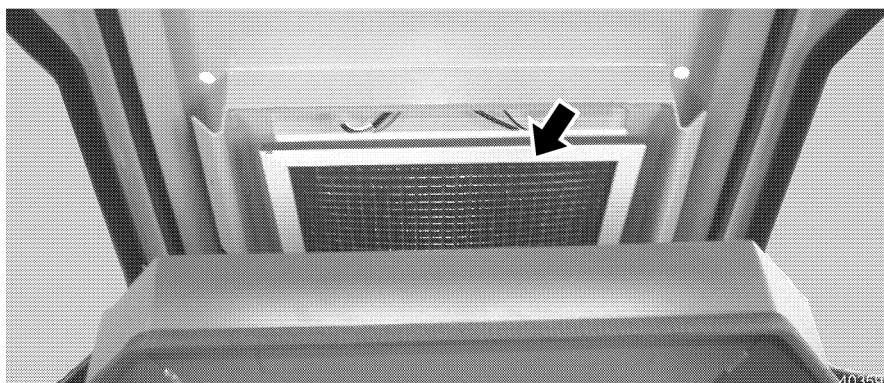

Location of fresh air filter

403136

- Fold the cover down.

- Pull the filter out and remove.
- Clean the filter (blow out) or change, if necessary.
- Reinsert the cleaned or new filter.
- Fold the cover up and reinstall with hex head screws.

5.12.3 Air conditioning system

Proper function of the complete air conditioning system is only ensured if the maintenance tasks are carried out fully, properly and by especially trained personnel.

Only trained air conditioning mechanics may access and repair the cooling circuit.

The air conditioning system must be serviced once a year, before the begin of the warm season, by an authorized service center, the service must be recorded for warranty purposes.

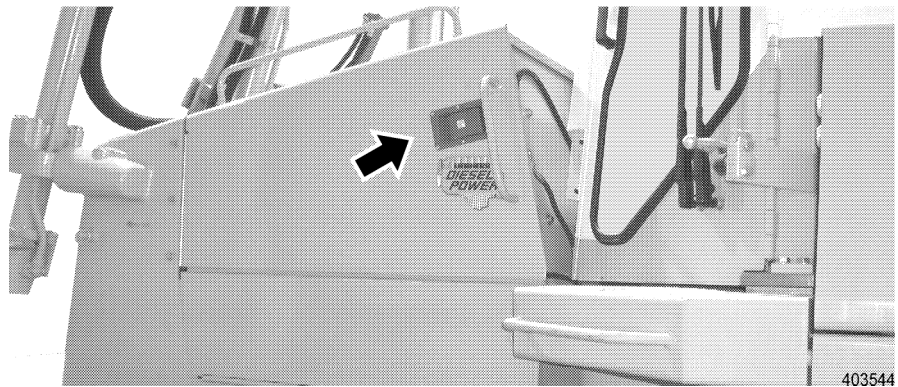

Open the engine compartment door

Compressor mounting

- Open the engine compartment door on the left hand side and secure it with the door latch to prevent it from closing inadvertently.

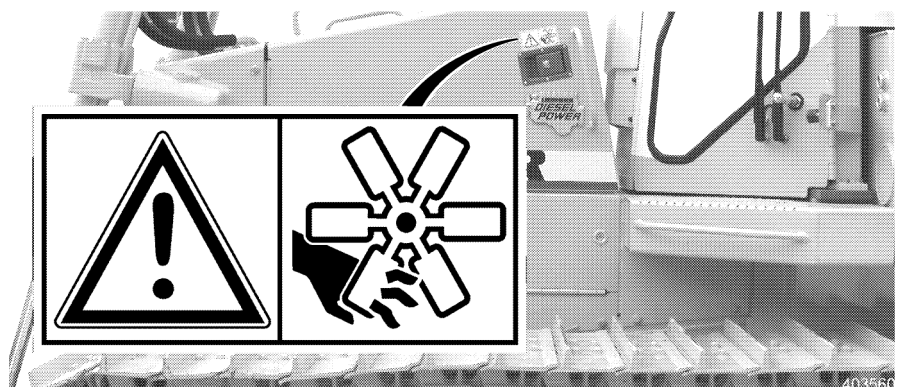

Open only if the engine is at a standstill!

Danger



Danger of injury due to rotating engine parts!

Turning and moving engine parts, such as fan blade or V-belt can cause serious injuries!

! Open the engine compartment doors only when the engine is at a standstill.

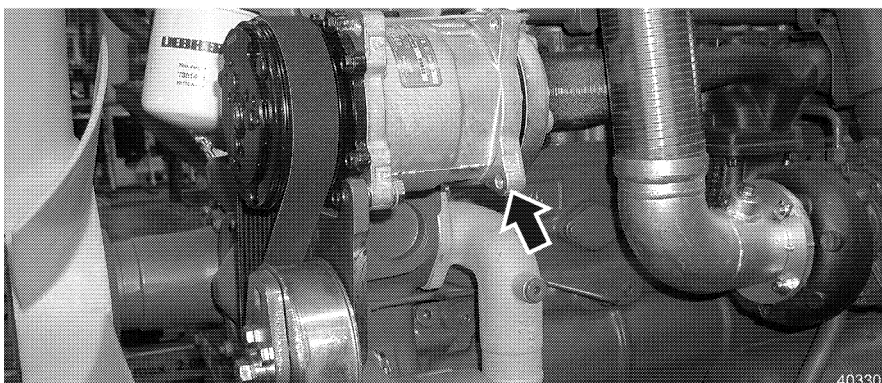

Compressor

- Check the compressor carrier and compressor supports for cracks and breaks, make sure they are all present and check the screws to ensure that they are seated tightly.
- Check the compressor for leaks.
- Check the hose lines for leaks and possible chafing.

Check / change the V-belt

See "Diesel engine" and "Check / change the V-belt".

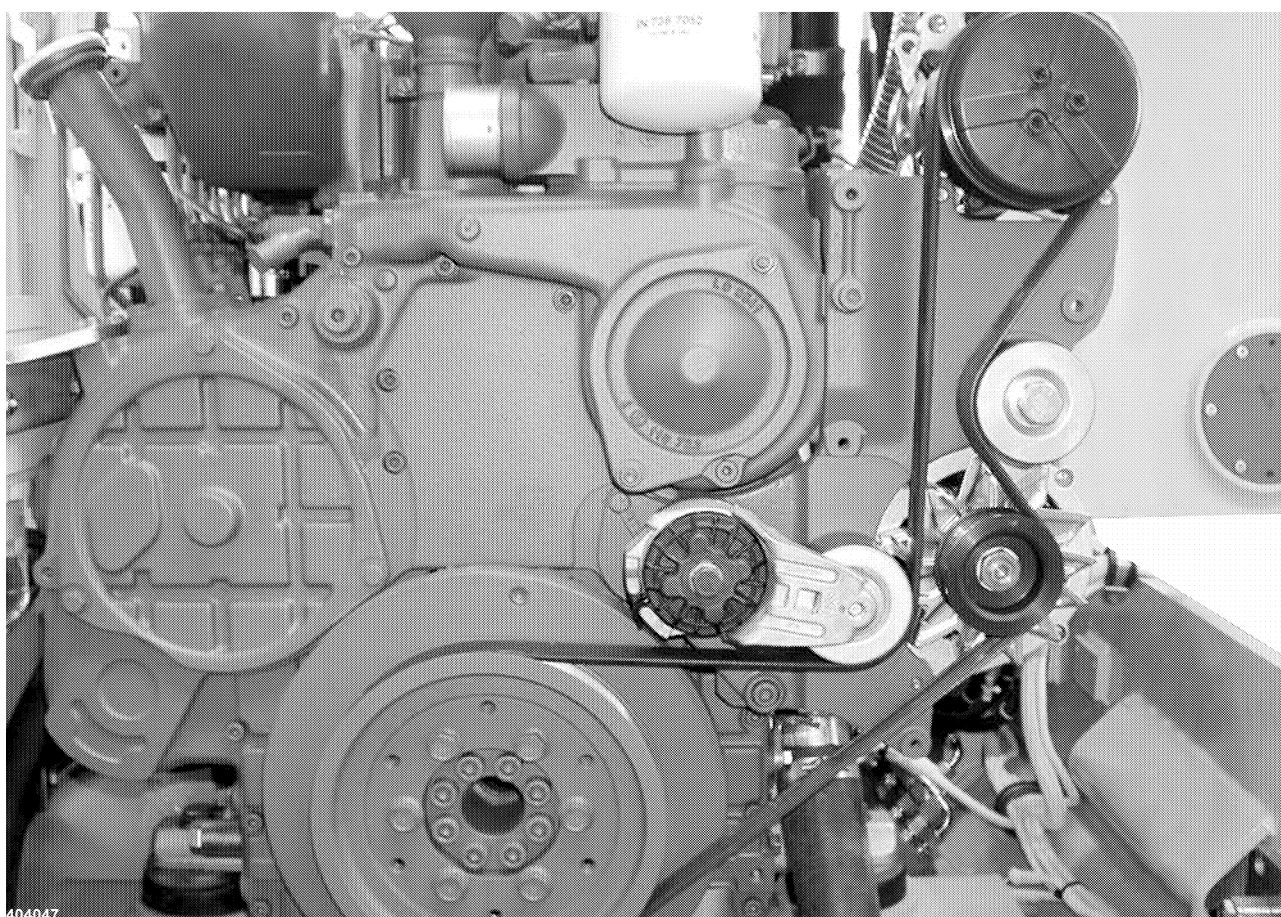

Air conditioning system - V-belt

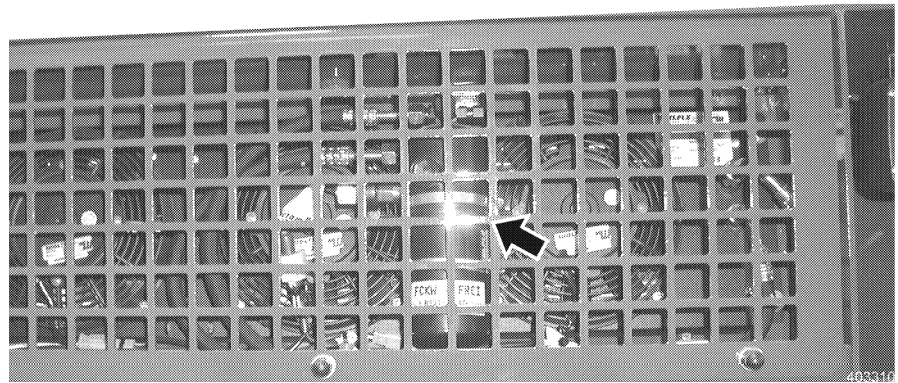

Dryer

Refrigerant and moisture content

The dryer is installed on the roof of the operator's cab in the evaporator unit and can be seen through the protective grill.

Caution



! Danger of falling!
To check, use a suitable ladder!

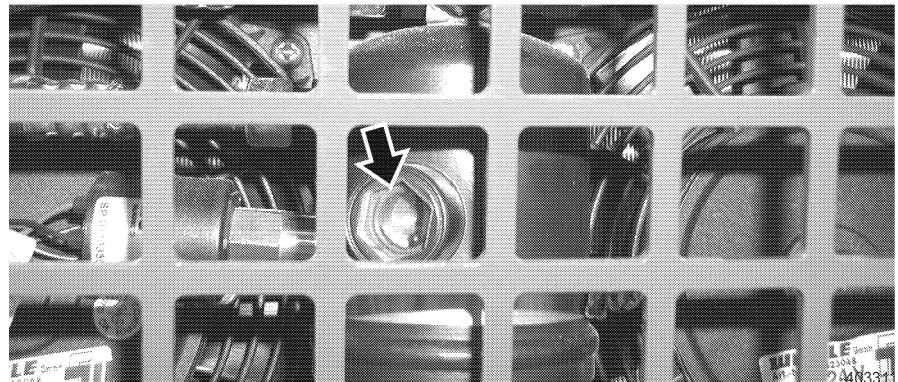

Indicator pearls

- Check the color of the indicator pearls.

Two indicator pearls are in the sight gauge.

A white floater ball and a blue moisture indicator.

When the Diesel engine is running, the refrigerant must flow through the sight gauge of the fluid reservoir (dryer) and lift the white floater ball.

After the engine is turned off, the fluid level must fall back into the reservoir to ensure that the system is not overfilled.

If the blue ball (moisture indicator) in the sight gauge changes to red or pink, then the dryer must be replaced.

The moisture content must be checked regularly, otherwise the air conditioning system can be destroyed due to acid formation.

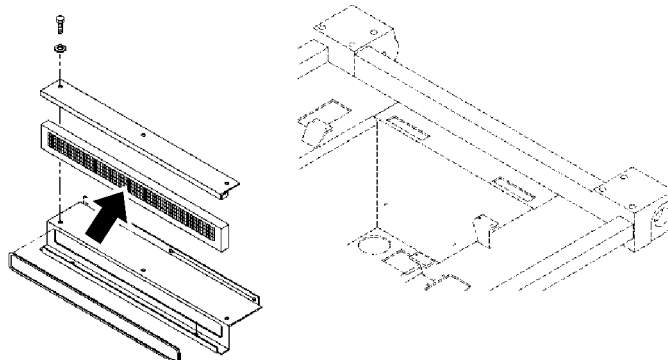

Air filter

403599

- Air filter** The air filter for the ventilation system is behind the operator's seat, on the floor of the cab.
The air in the cab is filtered via the air filter.

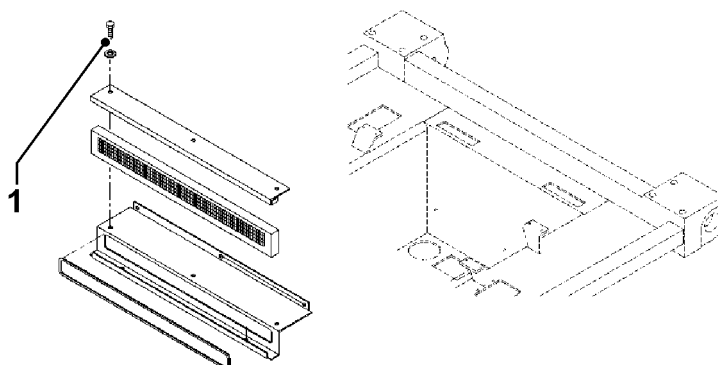

Change the air filter

403600

- Replace the air filter**
- Set the complete operator's seat to the front.
 - Remove the hex head screws 1 on the top of the filter housing.
 - Remove the retainer and remove the filter.
- When inserting a new filter, make sure to align the sealing profile to the rear.
- Add the retainer and install the hex head screws.

5.13 Travel gear

5.13.1 Check the condition of the travel gear

- Check the travel gear for leaks.
- Check the travel gear housing.
- Remove anything which have wound around the gear to prevent damage to the seals.

5.13.2 Check oil level

Make sure that:

- the machine is in maintenance position,
- the machine is parked in such a way that the oil drain plug 1 is at the lowest point on the gear,
- a torque wrench is available.

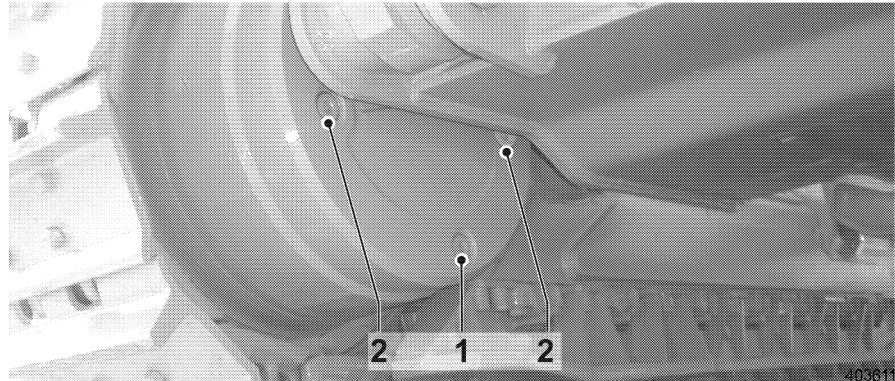

Travel gear

- Clean the area around the oil filler plug 2.
- Turn out the oil filler plug 2 with a socket wrench.
The oil level must be at the level of the oil filler port.
If the oil level is too low:
 - Add oil via the oil filler port 2.
 - For oil specification, see "Lubricants and Service fluids".
- Turn in the oil filler plug and torque to 160 Nm.

5.13.3 Change the gear oil

Make sure that:

- the machine is in maintenance position,
- the machine is parked in such a way that the oil drain plug is at the lowest point of the gear,
- a torque wrench is available,
- a suitable container is available,
- oil with the correct specification and quantity according to "Lubricants and Service fluids" is available.

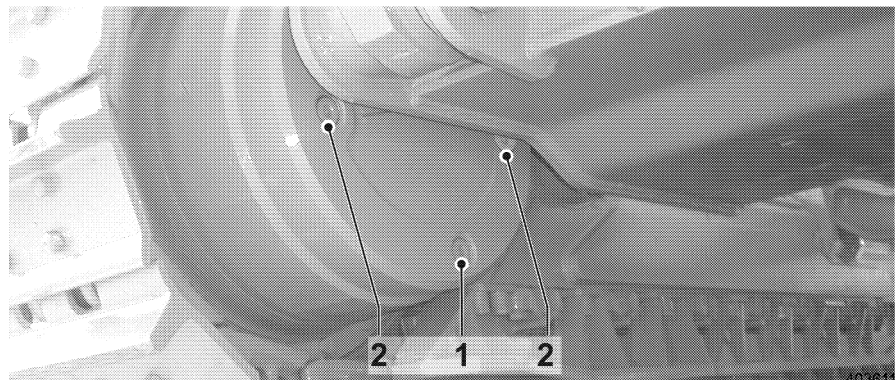

Travel gear

- Clean the area of the oil filler and drain plug.

- Place a container under the drain plug.
- Remove the oil filler plug 2.
- Remove the oil drain plug 1.
- Drain the oil into the container.
- Check the oil for mechanical contamination.
- Clean and reinsert the oil drain plug 1.
 - Note the tightening torque of 160 Nm.
- Add oil to the lower edge of the filler port via the oil filler plug 2.
- Clean the oil filler plug 2 and reinstall.
 - Note the tightening torque of 160 Nm.

5.13.4 Travel gear - lifetime seal area

Lifetime seal area oil level

If the oil level is too low, the indicator lights "travel gear - lifetime seal area" 46 / 47 light up in the instrument panel. .

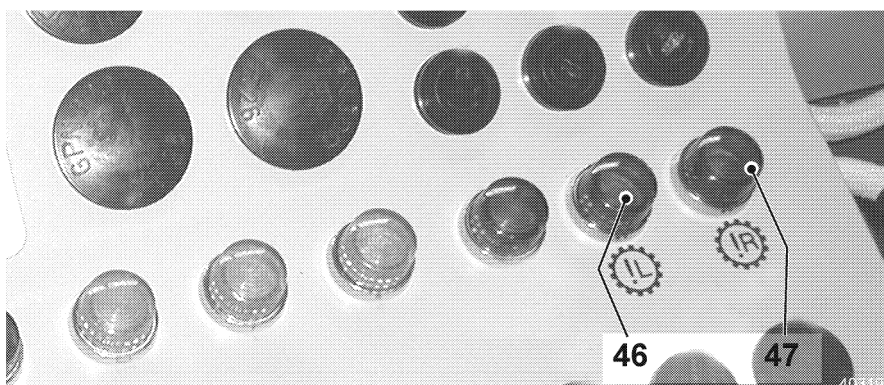

Indicator light - Travel gear - lifetime seal area

If the indicator light lights up, proceed as follows:

- Turn the machine off.
- Check the outside of the travel gear for leaks.
- Contact Liebherr Service.
- To continue operation in the meantime, bring the oil level to normal level.

Change the oil in the lifetime seal area

Make sure that:

- the machine is in maintenance position,
- a suitable container, the overflow hose and a filler line is available.

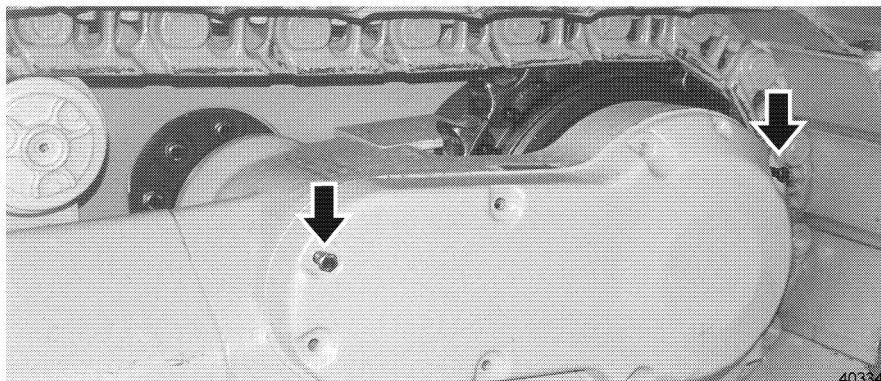

Gear cover

Remove the gear cover

- Loosen the 2 screws on the upper left and right hand side of the gear cover, then remove the remaining screws.

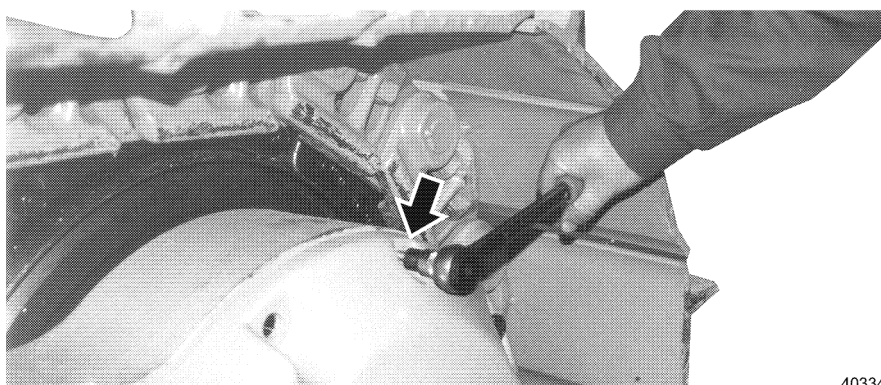

Push the gear cover off

- To remove the cover, install 2 hex head screws M 8 x 40 to push the cover off. Push the gear cover off until it is released from the sleeves.

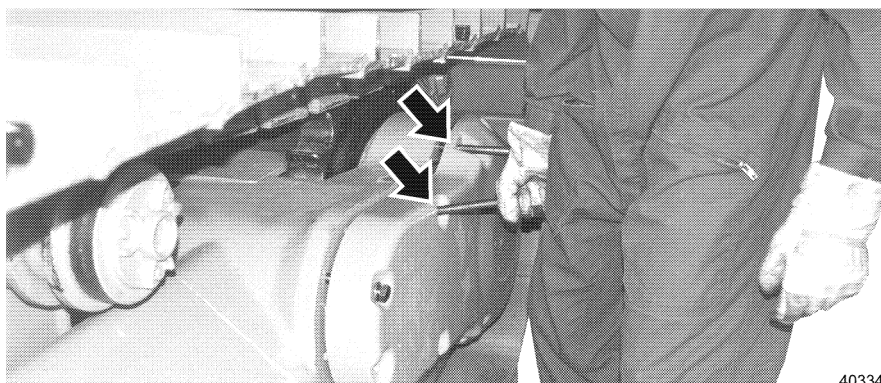

Remove the gear cover

- Insert suitable studs into the upper bore holes and remove the 2 remaining hex head screws. Place the gear cover on the ground.

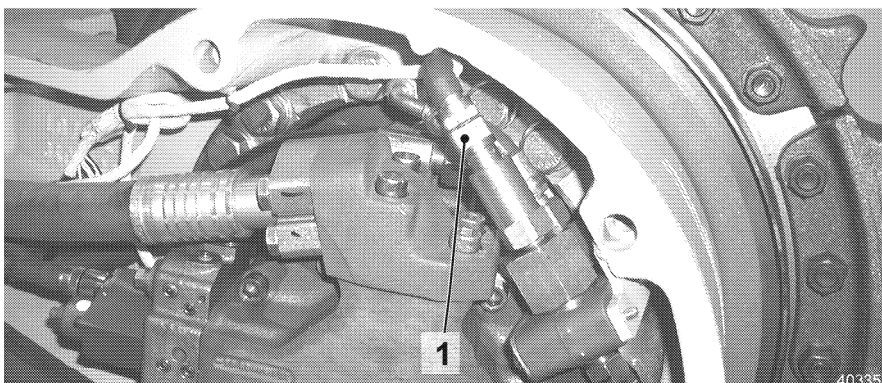

Sensor cable

Drain the oil in the lifetime seal area

- Remove the electrical cable 1 on the sensor by releasing the bayonet lock.

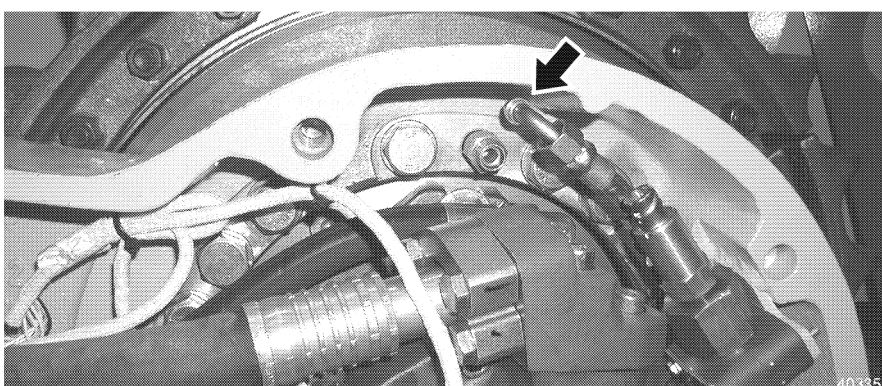

Connection - travel gear top

- Remove the ring line on the connection - travel gear top.

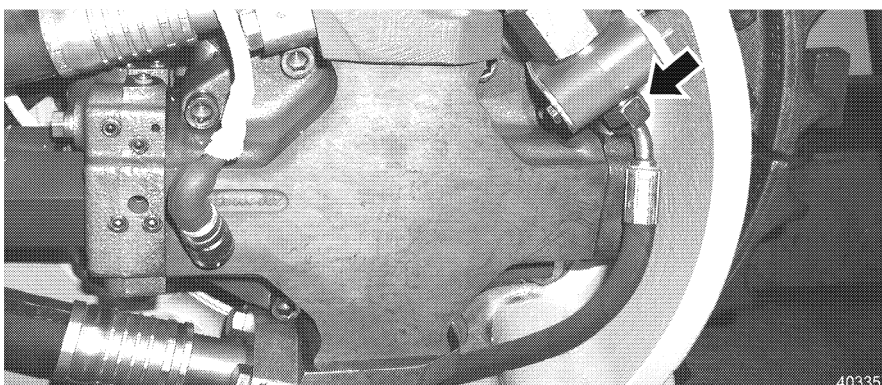

Sensor line bottom

- Remove the sensor line on the bottom. Catch emerging oil in a suitable container and dispose of it properly.

Flush the lifetime seal area

Before refilling, always flush the lifetime seal area sufficiently to remove any deposits in the area.

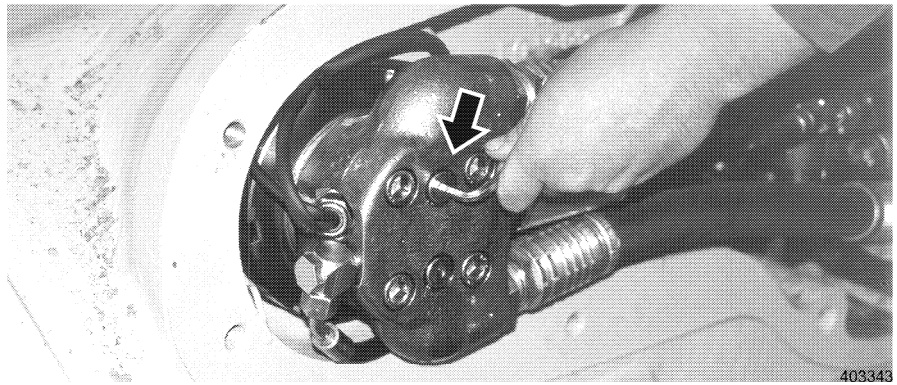

Test connection HD

- Open the plug on the test connection HD.

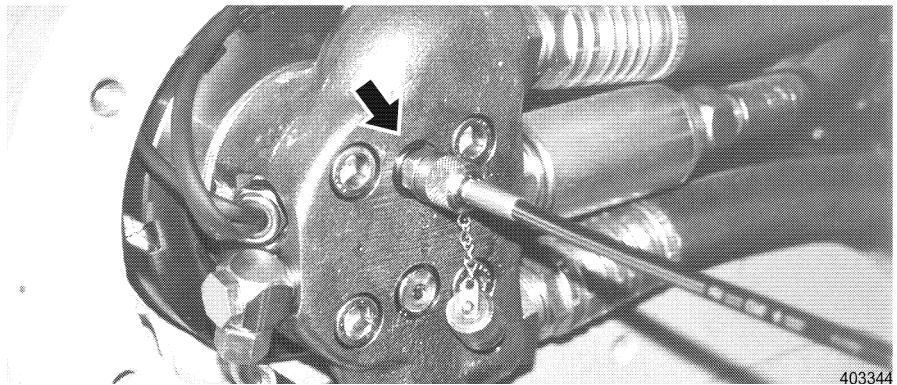

Filler line with fitting

- Install the filler line with fitting (supplied in the tool box).

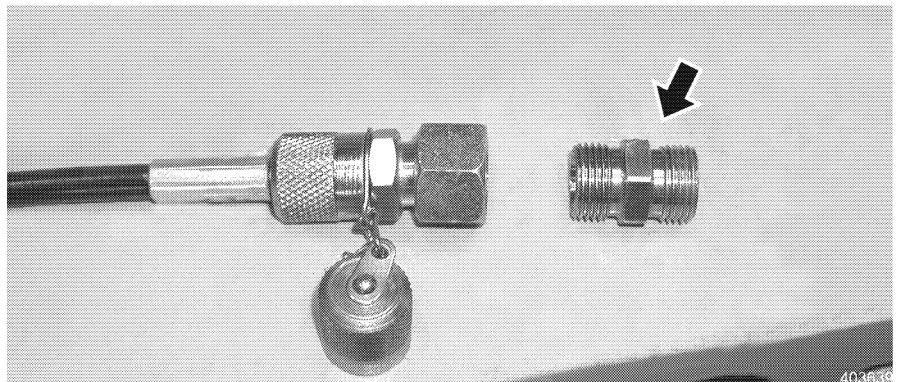

Filler line - screw fitting

- Remove the screw fitting on the filler line.

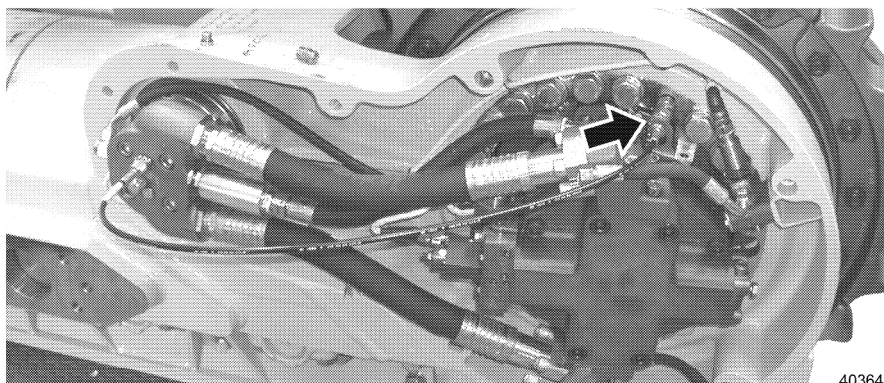

403640

Connection travel gear - top

- Install the filler line on the connection travel gear - top.

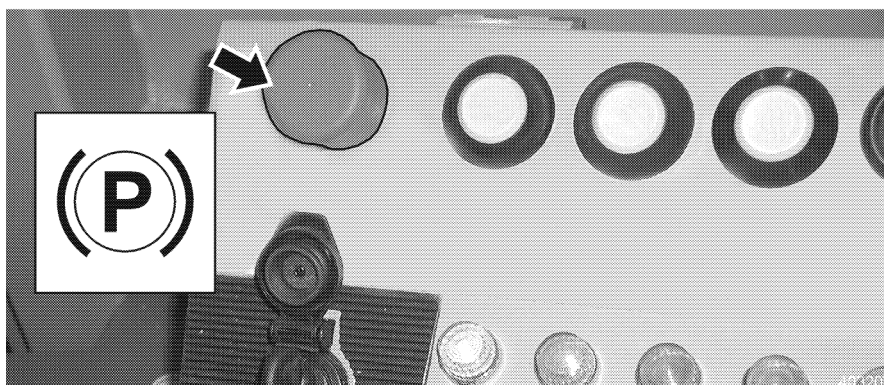

403640

Emergency off button

- Push the emergency off button in the instrument panel.

Caution

Danger of accidents!

! The emergency off button must be pushed during the oil change procedure, and the safety lever must remain in the down position!

- Start the Diesel engine in low idle RPM. See "Control, operation".
- Let the Diesel engine run until only clean oil emerges.
- Turn the Diesel engine off.
- Remove the filler line on the connection travel gear - top. Install the previously removed screw fitting on the filler.

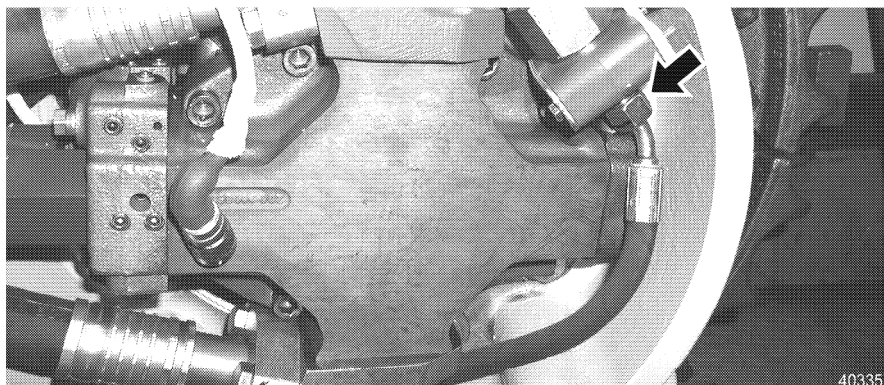

403657

Sensor line, bottom

- Install the bottom sensor line.

Fill the lifetime seal area with oil

Drain the oil as described above, and flush the lifetime seal area.

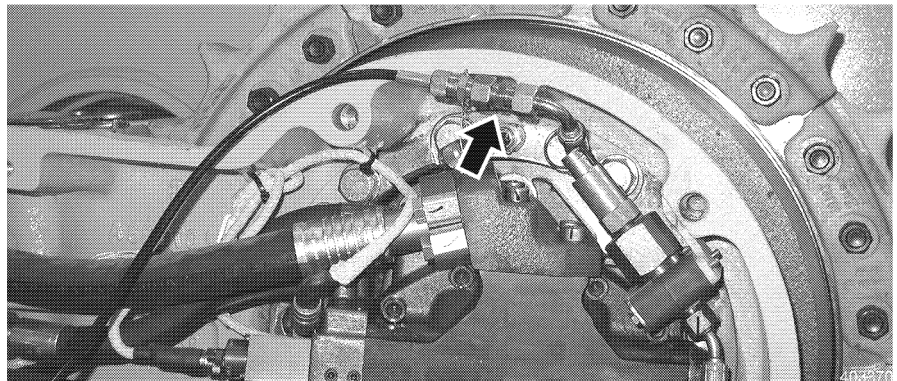

Filler line - ring line

- Connect the filler line with the upper ring line.

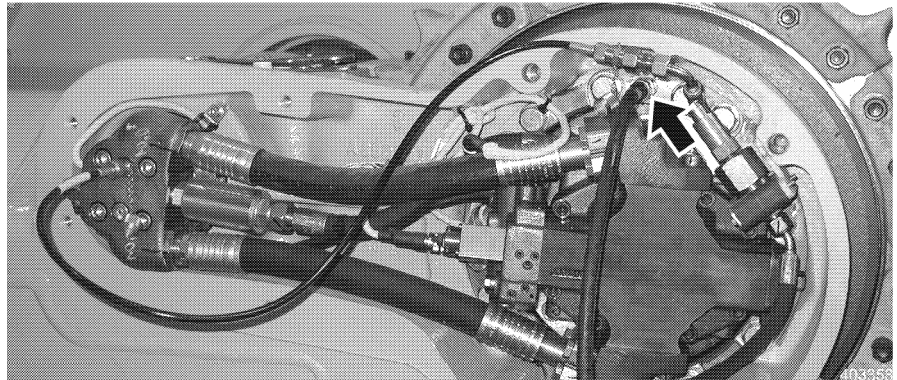

Connect the overflow hose

- Connect the overflow hose (in the tool box) on the open connection, travel gear - top.
- Place a suitable container under the overflow hose.

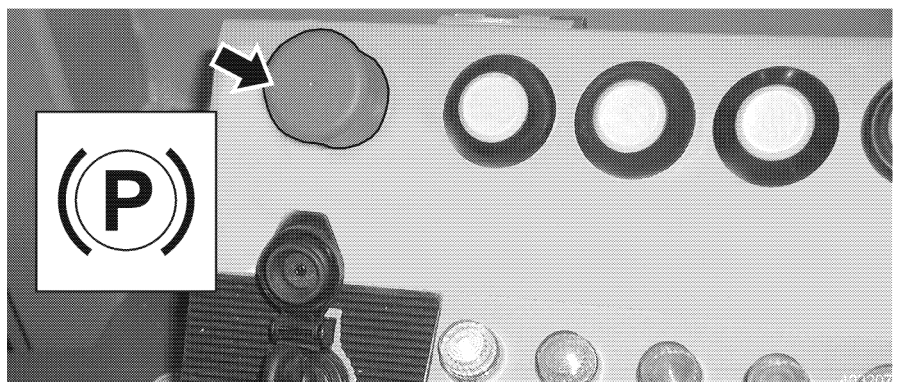

Emergency off button

- Push the emergency off button on the instrument panel.

Caution

Danger of accidents!

! The emergency off button must remain down and the safety lever must also remain in the full down position during the oil change!

- Start the Diesel engine in low idle RPM. See "Control, operation".

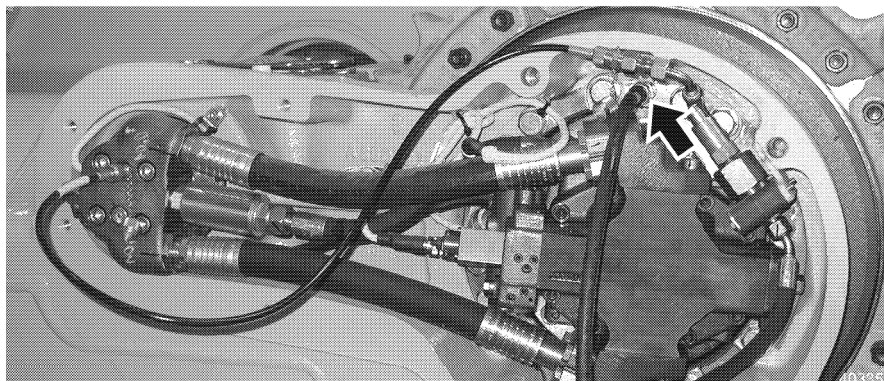

Overflow hose

- Let the Diesel engine run until approx. 1 l of oil has drained from the overflow hose.
- Turn the Diesel engine off.
 - Continue to let oil drain from the overflow hose, until no more oil emerges.
- Remove the overflow hose and the filler line.
- Connect the ring line travel gear - top.
- Connect the electrical cable to the sensor.
- Install the plug on the test connection HD.
- Install the gear cover.
 - Tighten the screws crosswise.

5.14 Track components

5.14.1 Check the screws on nuts on the track components for tight seating

Make sure that:

- the machine is in maintenance position,
- a torque wrench is available.
- Visually inspect the mounting screws on the track pads and sprocket segments to ensure they are tight.

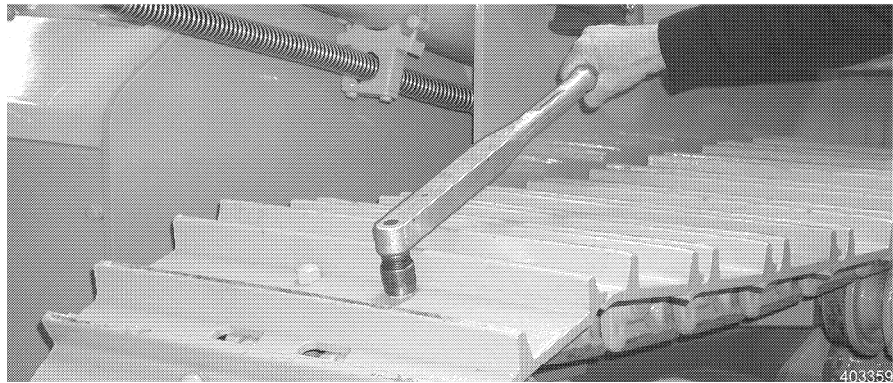

Tightening torque

- Check the tightening torques.
Tightening torques for track pads and sprocket segment bolts:
 - 5/8" UNF: 180 Nm + 120°
 - 3/4" UNF: 320 Nm + 120°
 - 7/8" UNF: 350 Nm + 120°

5.14.2 Check the seal on the carrier rollers, track rollers and idlers

- Check visually.

5.14.3 Idler guide

- Make sure that:
- the machine is in maintenance position.

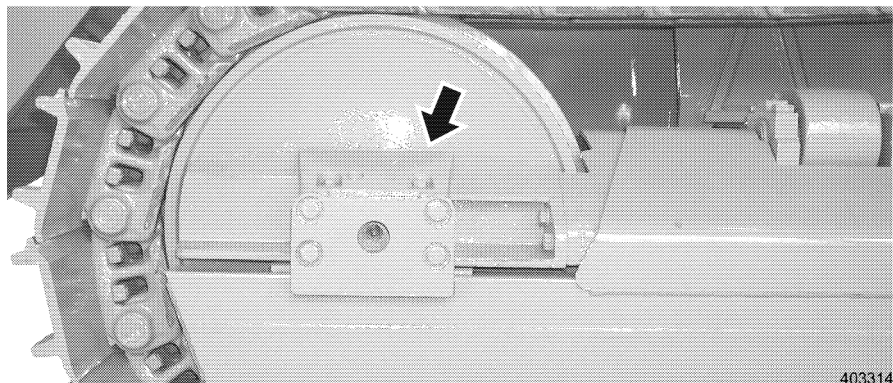

Idler guides

Check / adjust idler guides

The normal clearance between the track roller frame and the side guides is 1 - 2 mm, the height clearance of the rubber springs is approx. 3 mm. The clearance is increased due to wear of the wear bars, guide rails and plates.
When the maximum permissible value is reached, the clearance must be readjusted or the worn guide sections must be replaced.

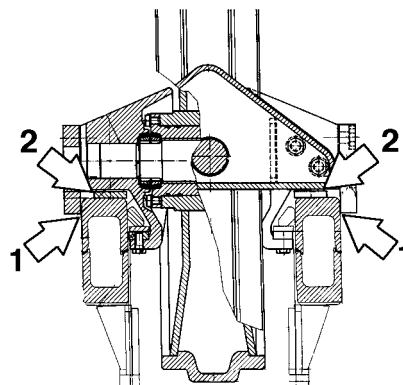

Side - height clearance

403363

New / repair measurement

- Side clearance 1 = min. 1 - 2 mm
- Height clearance 2 = min. 3 mm

Maximum permissible clearance

- Side clearance 1 = 5 mm
- Height clearance 2 = 6 mm

Check / adjust the side clearance

- Touch the inner guide plate to the track roller frame.
- For example via "counter rotation" see "Control", "Operation".

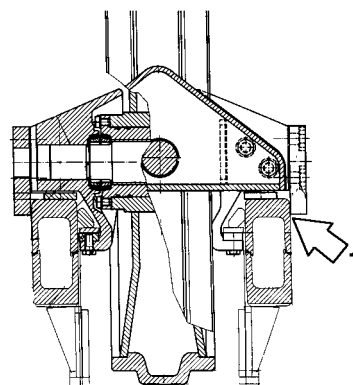

Check the side clearance

403364

- Measure the existing clearance between the track roller frame and the outer guide plate.

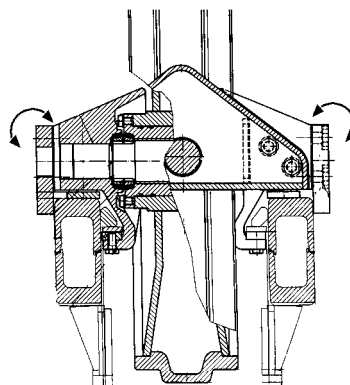

Correct the side clearance

403365

- If the maximum permissible value is being exceeded, remove the shims on the inside and / or the outside.

- The difference between the outside and the inside shims may not be more than one shim.
- If no shims are left, then replace the guide plates.

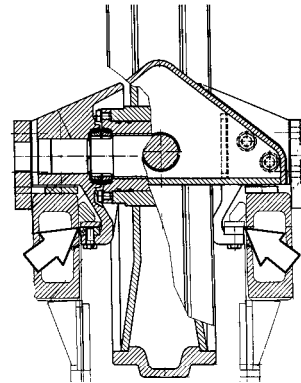

Raise the idler

403366

Check / adjust the height clearance

- Raise the idler by moving onto a piece of wood until the claws touch the guide rails.

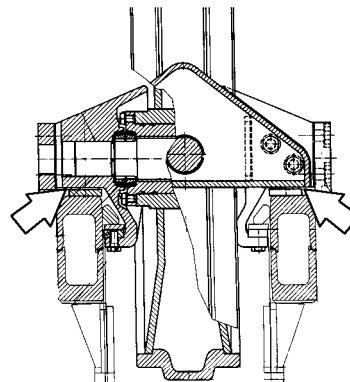

Check the height clearance

403367

- Measure the clearance between the wear strips and the bearing.

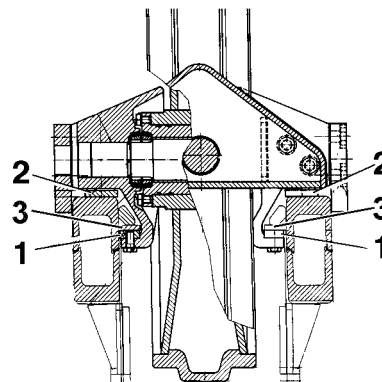

Adjust the height clearance

403368

- If the permissible play is being exceeded, replace the worn wear strips 1 and 2 in equal numbers.
- When replacing the wear strips, check the welded on guide rails 3 and replace them also, if they are worn significantly.

5.14.4 Chain tension

Danger



The chain tensioner may only be replaced or repaired by authorized expert personnel.

! Even though the chain is released, the chain tensioning spring is still pretensioned!

Due to wear of track components, it is necessary to check the chain tension regularly and to adjust the chain tension, as necessary.

Since the material deposits on rocky terrain are less than on muddy ground, the adjustment of the chain must be made to reflect the job application.

Do not remove any material, which has built up during working hours before checking the chain tension.

! The conditions must be identical as the working conditions!

Make sure that:

- the machine is in maintenance position,
- a measuring stick is available.

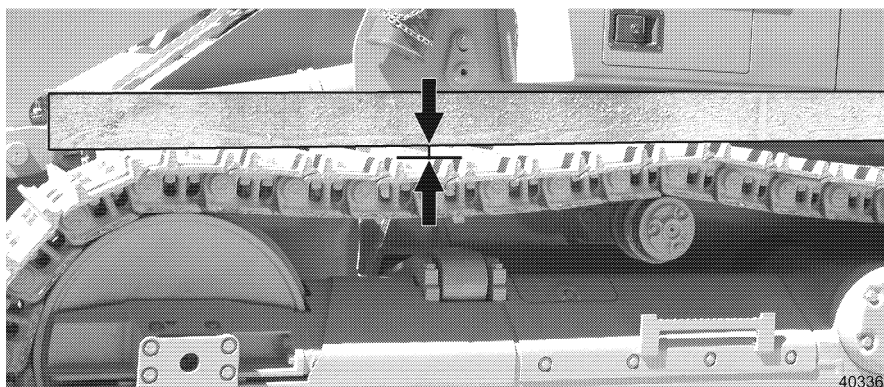

Check the chain tension

Check the chain tension

- Relieve the chain by moving the machine back and forth.
- Place the measuring stick on the area between the idler and the carrier roller.
- Measure the distance between the measuring stick - lower edge and chain bar.
 - The chain is tensioned correctly for the job application if the slack between the carrier roller and the idler or sprocket is between 30 - 60 mm.
- Correct the chain tension, as necessary.

To tighten the track tension

Make sure that:

- the machine is in maintenance position,
- a manual grease gun with adapter for the fitting of the chain tension cylinder is available.

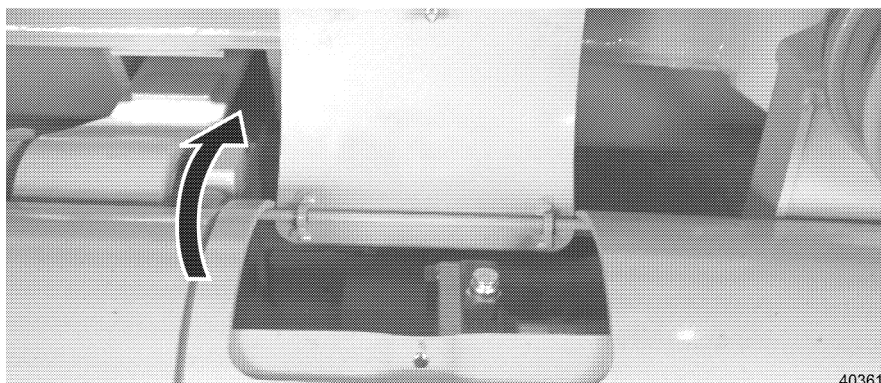

403612

Cover = track roller frame

- Clean the areas next to the cover on the track roller frame.
- Loosen the hex head screw on the cover and open the cover.

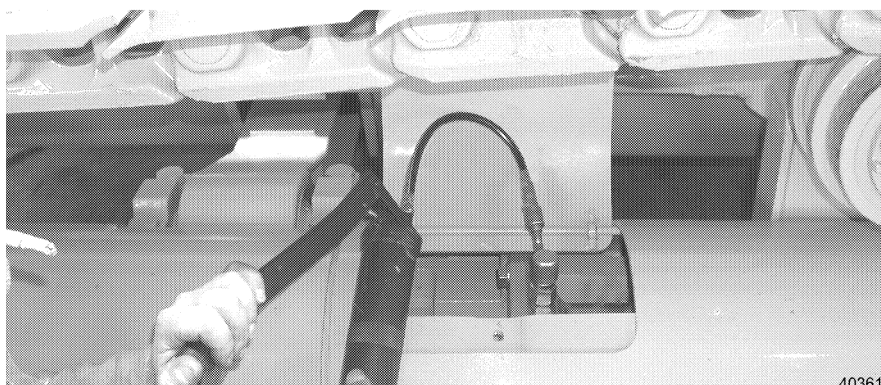

403613

Manual grease gun with adapter

- Connect the manual grease gun with the adapter to the grease fitting on the tension cylinder.
- Pump grease into the cylinder until the proper tension is reached (30-60 mm).
- Attach the cover with the hex head screw.

Release chain tension

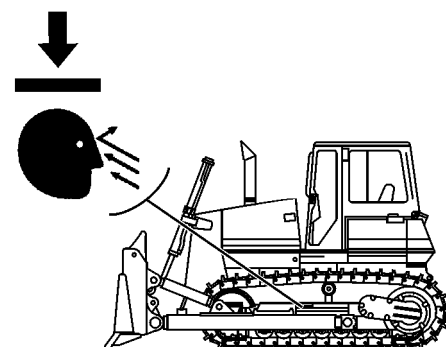

403601

Danger of injury

Danger

Danger of injury!

! The chain will sag and grease can squirt out.

- When adjusting the chain tension, keep your head clear of the access hole and track roller frame.

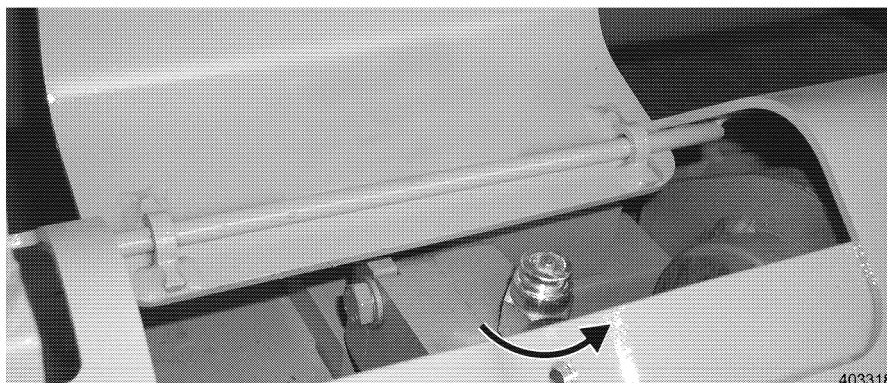

Grease fitting

- Carefully back out the grease fitting by a few turns until the grease emerges from the ring groove of the fitting.
- Tighten the grease fitting as soon as the correct chain tension is reached.
- After the adjustment procedure, move the machine back and forth and recheck the chain tension.

5.14.5 Changing the chain

Make sure that:

- a torque wrench is available,
- the necessary tools to change the chain are available.

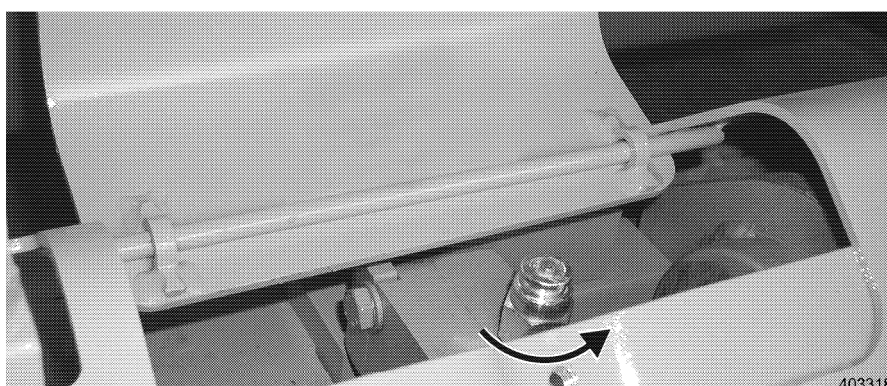

Grease fitting

Removal of sealed chain

- Release chain tension, see "Chain tension".
- Back out the grease fitting by a few turns.

- Slowly move the machine with the idler against a wooden block to push the idler completely closed.
- Park the machine on level ground in such a way that the master link pin is at the sprocket wheel about 1/3 between the horizontal and vertical center.
- The master link pin can be recognized by a chamfered edge or countersunk bore.

Caution



- ! Knocking the master pin in or out with a sledge hammer can be very dangerous due to material chipping off the pin which could cause serious injuries.
- Always wear safety glasses and protective clothing.
- If possible, use a hydraulic press to install and remove the pin.

Knurled master pins must be pressed in from the outside to the inside and pressed out from the inside to the outside. Knurled edge on the outside!

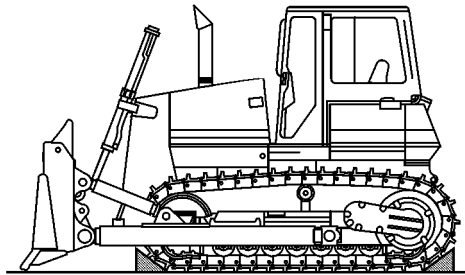

403602

Place a wooden block

- Secure the chain in front of the idler and behind the sprocket with a wooden block to prevent it from rolling off.

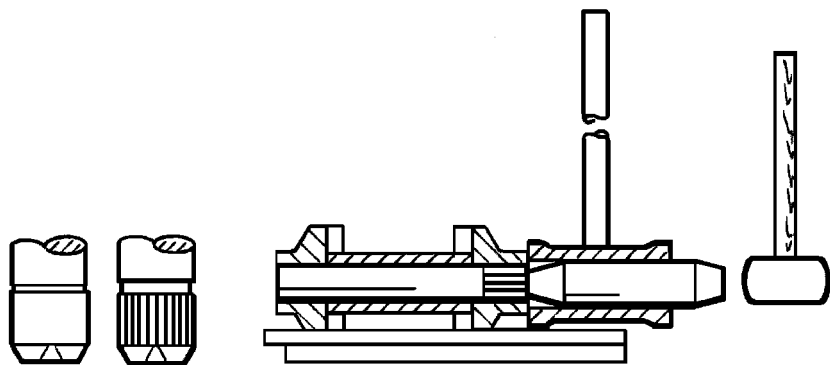

403339

Press out the chain link pins

- Press out the master pin with a pin press or with a suitable tool.
- When knocking out the master pins, support the chain link on the other side.
- Raise the attachment.
- Carefully drive the machine forward until the complete chain rests on the ground.
- Drive the machine backward on the old chain.

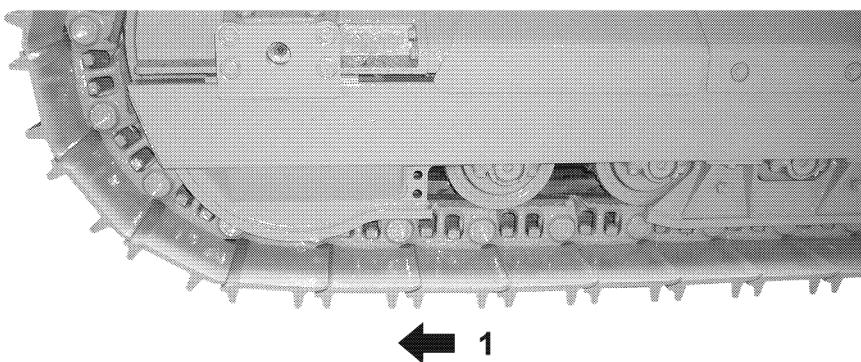

403369

Travel direction forward

Install a sealed chain

- Place the new chain in proper direction on the ground and connect it to the old track chain with the master link pin.
- Make sure the new chain and track pads are installed in the correct direction 1 = travel direction forward.
- Align the chain to the track frame and move the machine carefully onto the new chain until you get to the end of the new chain.
- Release the new chain from the old chain and attach the end of the new chain with a wire to the sprocket.
- Carefully drive the machine forward until the chain is on the sprocket on top.
- Release the wire from the chain and sprocket and continue to drive forward to bring the chain over the carrier roller and idler. Stop the machine when the idler approaches the last 2 track pads.

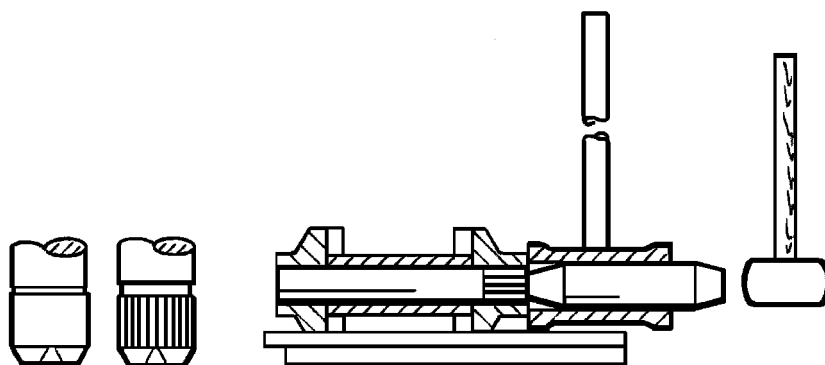

403339

Press in the master pin

- Raise the last track pads, reinsert the spacer rings and press in or knock in the master pin from the outside to the inside.
- Tension the chain. See "Adjust chain tension".

Remove a chain with split master link

- Park the machine on firm and level ground.

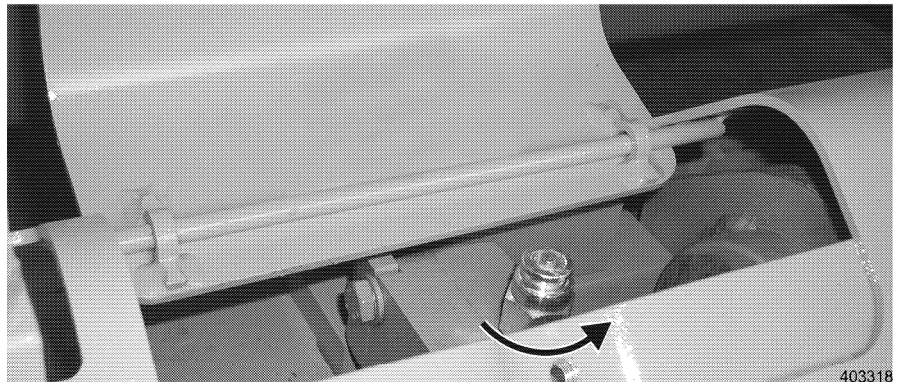

Grease fitting

- Release the chain tension. See "Adjust chain tension".
 - Back out the grease fitting by a few threads.
- Slowly move the machine with the idler against a wooden block, until the idler is pushed back all the way.

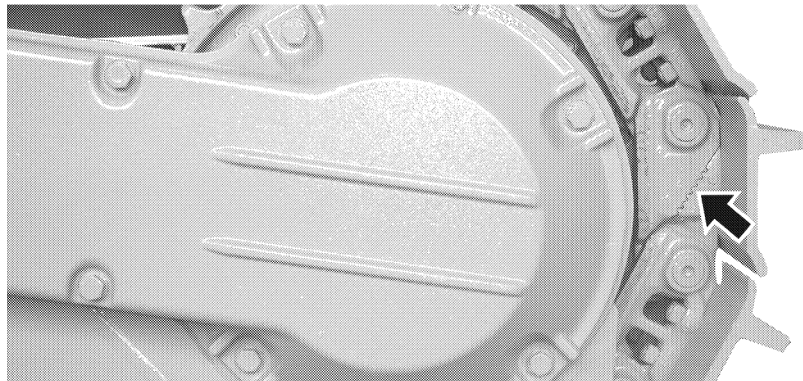

Master link

- Move and park the machine until the master link and the center of the sprocket are at the same level.

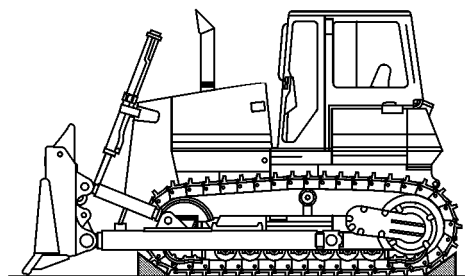

Place the wooden blocks

- Secure the chain in front of the idler and behind the sprocket with a wooden block to prevent it from rolling off.
- Spray the teeth and mating area of the master link with penetrating oil to help the oil penetrate by hitting the master link lightly with a hammer.

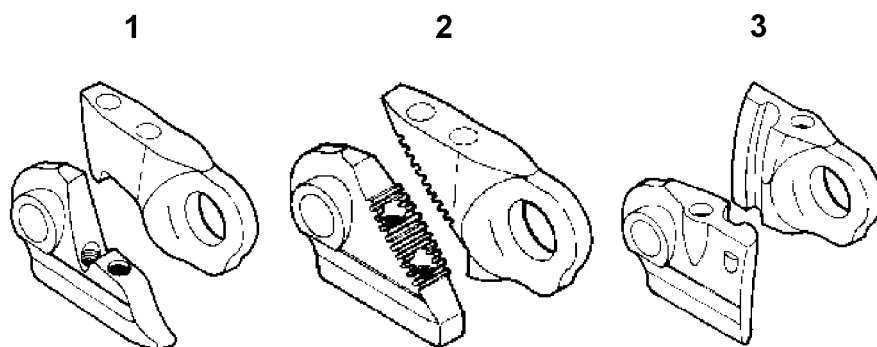

403345

Master link manufacturers

Various chains with split master links are used in LIEBHERR machines.

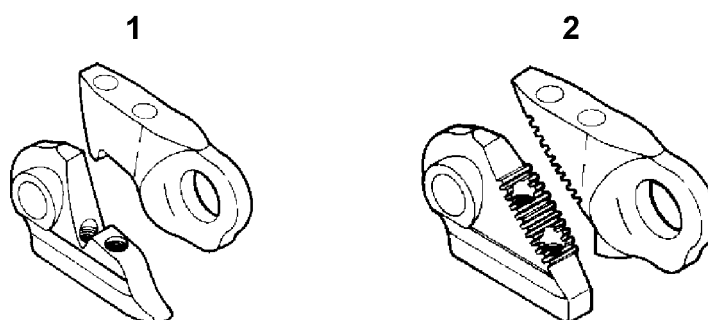

403346

*Version 1 + 2***Version 1 + 2**

- Unscrew the track pad bolts, remove the track pad and release and split the master link by hitting the master link lightly with a hammer.
- If necessary, apply more penetrating oil.

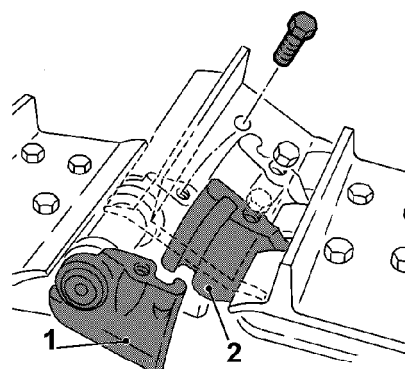

403347

*Version 3***Version 3****Marks:**

The pin section 1 is pressed to the pin, marked with the manufacturer's name and the track pad screws are spaced farther apart. The bushing section 2 is pressed to the bushing, appears shorter from the outside and the track pad screws are spaced closer together.

- Remove only the track pad screws from the pin section.

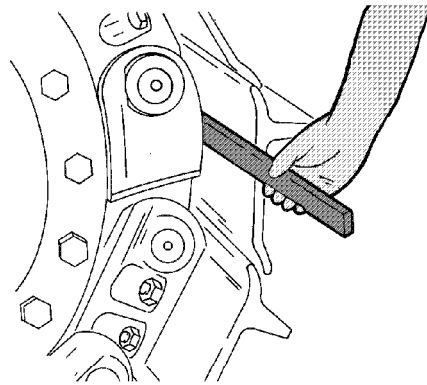

403348

Drive out the bushing section

- Use a steel wedge between the track pad and the pin section to drive out the bushing section.
- Support the drive action of the wedge by hitting the track pads lightly with a hammer.

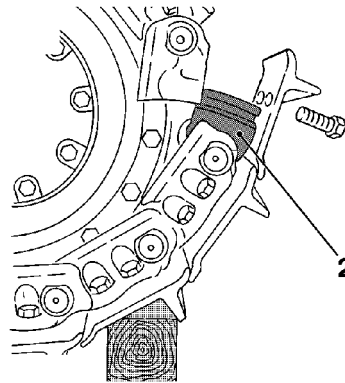

403349

Bushing section

- Only the bushing section 2 can be turned to the outside.
- Place down the chain by carefully driving forward.

Install a chain with split master link

Track chains with master links can be easily installed on the sprocket or idlers.

- Drive the machine back on the placed down chain.
- Make sure that the new chain is free of paint, protective grease or other material. Coat the mating surfaces lightly with grease.
- Clean the bore holes, apply Never Seize (special lubricant) or grease to the track pad bolts.
- The bolts must be inserted by hand.

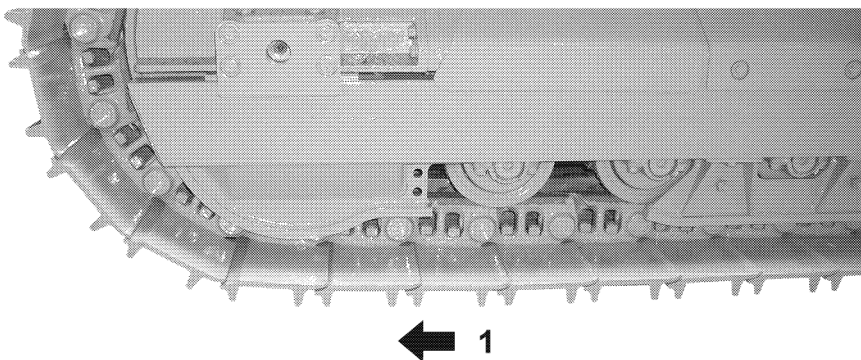

403369

Travel direction forward

Make certain that the chain is installed correctly with the track pads on the correct side (1 = travel direction forward).

On version 3, the chain bracket with the pin section must point to the sprocket, when the new chain is behind the sprocket.

- Place the new chain on the ground and connect it with the old chain with a wire.
- Align the chain to the track roller frame and carefully move the machine forward to the end of the new chain.
- Loosen the new chain from the old one and attach the new chain with the wire to the sprocket.
- Carefully move the machine forward until the chain is on top of the sprocket.
- Release the wire from the chain and the sprocket and continue to drive forward to bring the chain over the carrier rollers and the idler. Stop the machine when the master link is at the same height as the center of the idler.

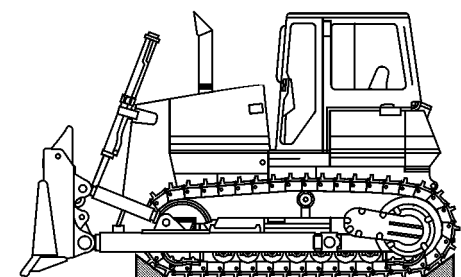

403602

Place a wooden block

- Secure the chain in front of the idler and behind the sprocket with a wooden block.
- Connect the chain links.

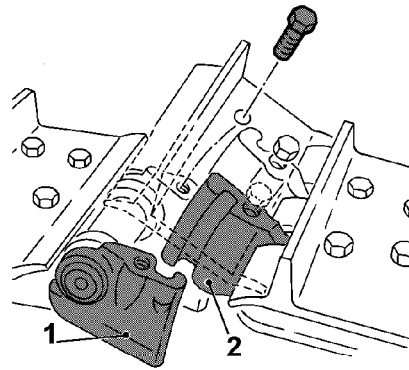

403347

Version 3

For chain version 3, the track pads must be installed with the bushing section before the master link is connected.

- Push the pin end toward the center of the idler, insert the bushing end and slide both parts together until the track pad makes contact. Only the bushing section can be inserted.

– DO NOT hit the mating surfaces with a hammer.

Place the track pad, insert the bolts and torque correctly.

5/8" UNF: 180 Nm + 120°

3/4" UNF: 320 Nm + 120°

7/8" UNF: 350 Nm + 120°

- Tension the chain. See "Chain tension".

5.14.6 Clean the tracks

Make sure that:

- the machine is in maintenance position.

DO NOT operate the machine, if rocks, wood or metal pieces, wires or cables are stuck in the tracks.

Dried or frozen mud as well as rocks or other foreign matter in the track sections can cause severe damage, if the machine is put in operation or if the operator tries to free the machine by force.

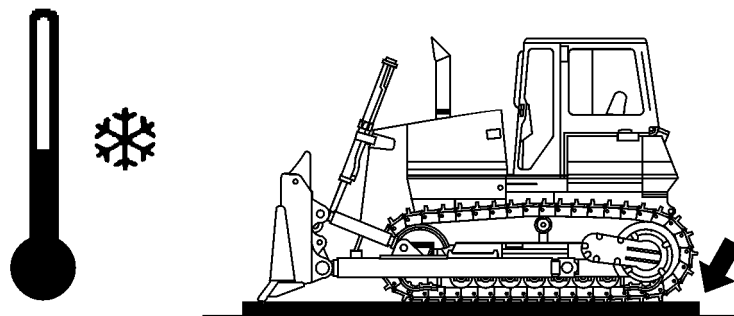

403603

Turning the machine off in freezing temperatures

If temperatures are below freezing, park the machine on wooden boards to prevent the chains from freezing to the ground.

If the machine is frozen to the ground, heat the track pads carefully to free the machine.

Never try to move a frozen machine by force, this can cause significant damage.

- Check the tracks, clean or repair as necessary.

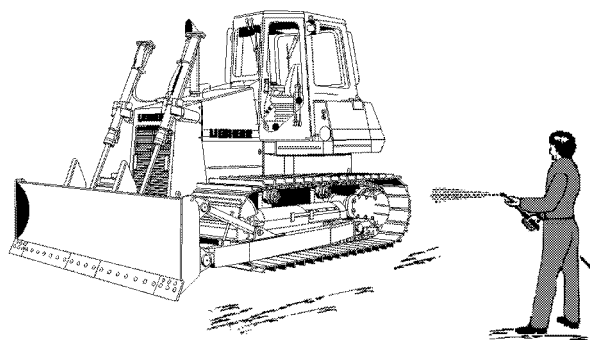

403604

Wet cleaning

After cleaning the machine with hot water or steam, all grease points on the machine must be re-lubricated!

- Clean the machine with steam.
- Grease all lube points on the machine.

5.14.7 Check track wear

The tracks are maintenance free, except for the wear of some parts. Track wear increases due to improper operation or if tolerances are not observed.

Visual inspections or wear checks must be made to recognize wear in time and to be able to overhaul and continue to use these parts.

Make sure that:

- the machine is in maintenance position.

Check track component wear

- Check chains, chain guides, track pads and sprockets for wear.

5.15 Total machine

5.15.1 Check the machine for external damage

Make sure that:

- the machine is in maintenance position.



403350

Visual inspection

- Before operating the machine, check the machine for external damage, which could affect operating safety.
- Fix any safety relevant damage immediately!

5.15.2 Windshield wiper

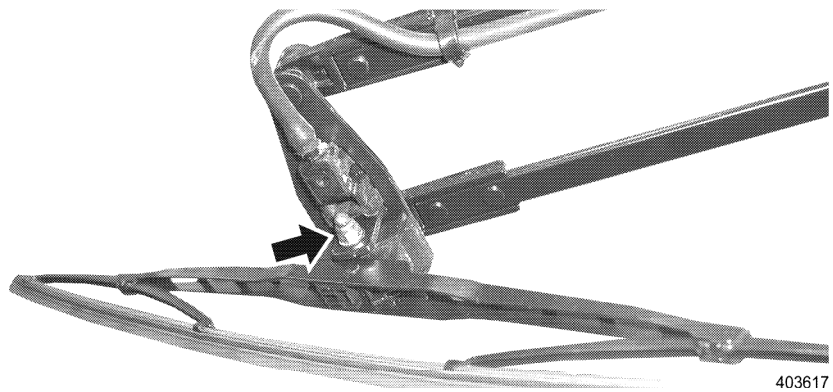

Windshield wiper

403617

Change the windshield wiper blade

- Fold the wiper arm up.
- Remove the nut of the mounting screw.
- Remove the spring ring and washer and pull out the mounting screw.
- Remove the wiper blade and change it.

Adjust the windshield wiper position

- Release the lock screw on the wiper arm and set the wiper blade vertically by changing the length of the guide arm.

5.15.3 Taking the machine out of service

If the machine is scheduled to be stored for an extended period of time, consult your LIEBHERR Service representative.

5.16 Cab - tilting device

To replace, clean or check components between the engine compartment and the reservoir, the cab can be tilted.

Danger



The cab may only be tilted if the machine is at a standstill!
 No persons may be in the tilting range when tilting the cab either way.
 No one may remain under the tilted cab unless the machine is at a standstill and the safety bar on the hydraulic cylinder is in place.
 ! The machine may NOT be started or driven when the cab is tilted.
 The safety lever must remain in the down position.

5.16.1 Raise the cab

Make sure that:

- the machine is in maintenance position,
- the extension pipe to operate the hand pump is available.

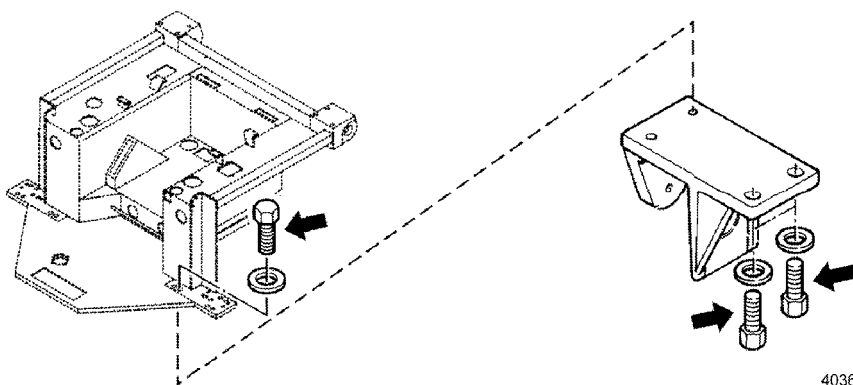

403620

Mounting screws - cab

- Back out 3 each hex head screws per side on the cab.
- Close both cab doors.

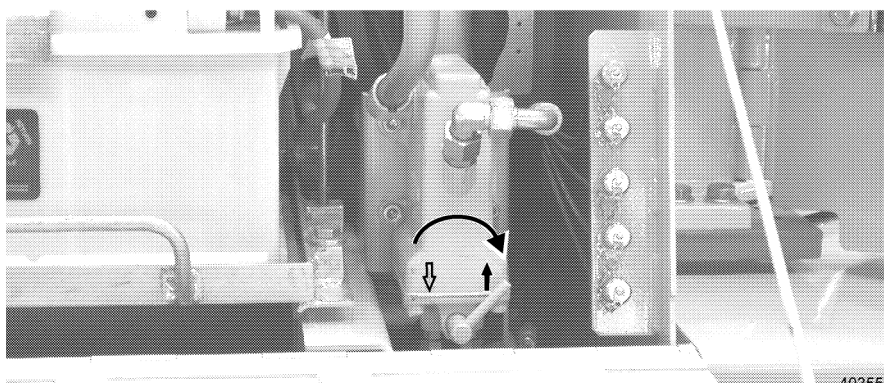

403554

Hand pump "up"

- Set the lever on the hand pump to "up".



403656

Actuate the hand pump

- Place the extension pipe for the hand pump.
- Actuate the hydraulic hand pump until the piston has reached the end position (intermediate positions are not allowed!).

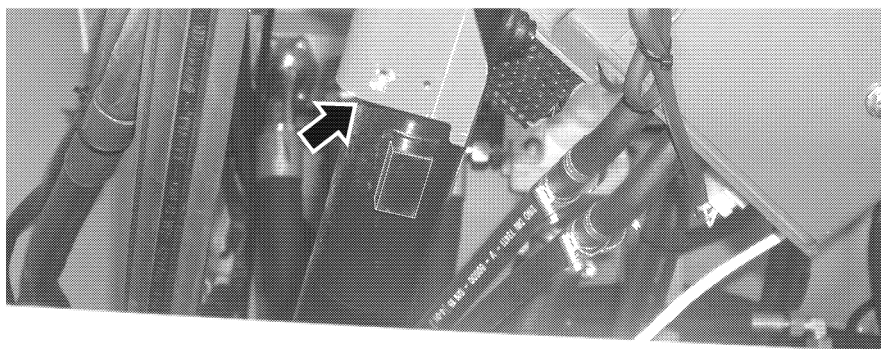

403618

Engage the safety support

- Engage the mechanical safety support on the hydraulic cylinder.

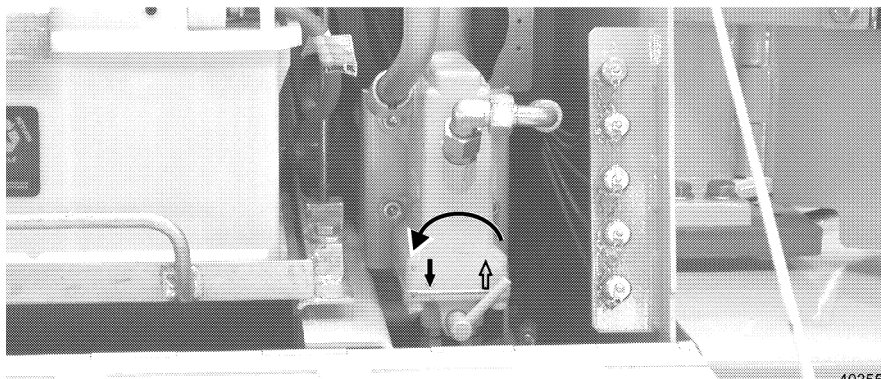

403557

Hand pump "down"

- The move the lever on the hand pump to the "down" position.

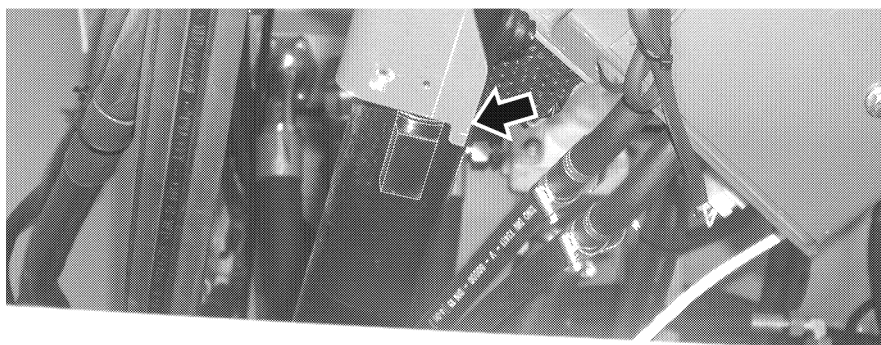

403619

Safety support

- Lower the cab by actuating the hydraulic hand pump until it is locked by the mechanical safety support.

5.16.2 Lower the cab

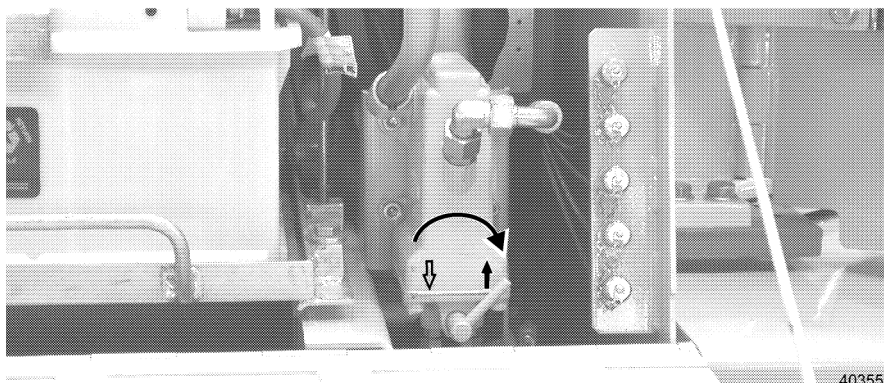

403554

Hand pump "up"

- Set the lever on the hand pump to "up".
- Raise the cab by actuating the hydraulic hand pump.
- Disengage the mechanical safety support.

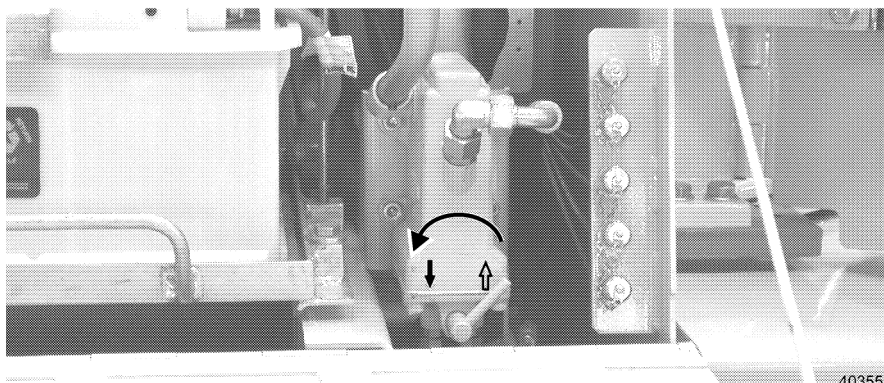

403557

Hand pump "down"

- Then move the lever to the "down" position. The cab is lowered by actuating the hydraulic hand pump.

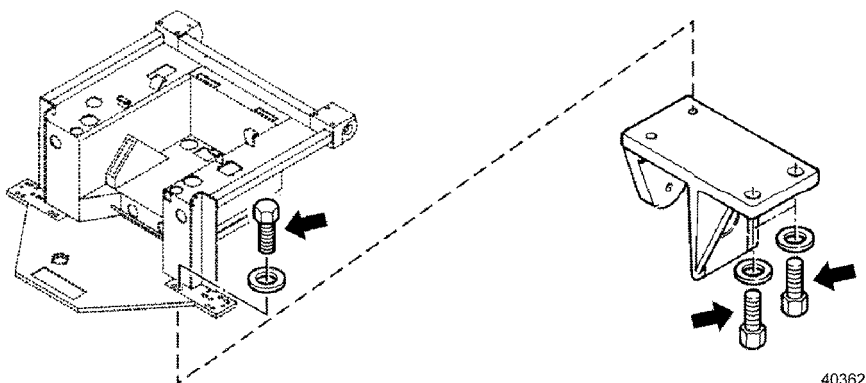

403620

Mounting screws - cab

Danger

It is strictly prohibited to start the Diesel engine before the cab is lowered again and reattached.

- Attach the cab with 3 hex head screws per side.

Liebherr-Hydraulikbagger GmbH

Hans-Liebherr-Straße 12
D-88457 Kirchdorf/Iller
☎ + 49 7354 80-0
Fax + 49 7354 80-72 94
www.liebherr.com
E-Mail: info@lhb.liebherr.com

Liebherr-France SAS

2, Avenue Joseph Rey, B.P. 287
F-68005 Colmar Cedex
☎ + 33 389 21 30 30
Fax + 33 389 21 37 93
www.liebherr.com
E-Mail: info@lfr.liebherr.com

Liebherr-Werk Telfs GmbH

Hans-Liebherr-Straße 35
A-6410 Telfs
☎ + 43 5262 6 00-0
Fax + 43 5262 6 00-72
www.liebherr.com
E-Mail: info@lwt.liebherr.com

Liebherr-Werk Bischofshofen GmbH

Postfach 49
A-5500 Bischofshofen
☎ + 43 6462 8 88-0
Fax + 43 6462 8 88-3 85
www.liebherr.com
E-Mail: info@lbh.liebherr.com