

# Operation & Maintenance Manual

SEAM017100

## EG125B-2 EG125BS-2

### DIESEL ENGINE GENERATOR

SERIAL NUMBERS EG125B-4001 and up  
EG125BS-5001

#### WARNING

Unsafe use of this machine may cause serious injury or death. Operators and maintenance personnel must read this manual before operating or maintaining this machine. This manual should be kept near the machine for reference and periodically reviewed by all personnel who will come into contact with it.

#### NOTICE

Komatsu has Operation & Maintenance Manuals written in some other languages. If a foreign language manual is necessary, contact your local distributor for availability.

# KOMATSU

# 1. FOREWORD

---

This manual provides rules and guidelines which will help you use this machine safely and effectively. Keep this manual handy and have all personnel read it periodically. If this manual has been lost or has become dirty and can not be read, request a replacement manual from Komatsu or your Komatsu distributor.

If you sell the machine, be sure to give this manual to the new owners.

Continuing improvements in the design of this machine can lead to changes in detail which may not be reflected in this manual. Consult Komatsu or your Komatsu distributor for the latest available information of your machine or for questions regarding information in this manual.

This manual may contain attachments and optional equipment that are not available in your area. Consult Komatsu or your Komatsu distributor for those items you may require.

## WARNING

- **Improper operation and maintenance of this machine can be hazardous and could result in serious injury or death.**
- **Operators and maintenance personnel should read this manual thoroughly before beginning operation or maintenance.**
- **Some actions involved in operation and maintenance of the machine can cause a serious accident, if they are not done in a manner described in this manual.**
- **The procedures and precautions given in this manual apply only to intended uses of the machine. If you use your machine for any unintended uses that are not specifically prohibited, you must be sure that it is safe for you and others. In no event should you or others engage in prohibited uses or actions as described in this manual.**
- **Komatsu delivers machines that comply with all applicable regulations and standards of the country to which it has been shipped. If this machine has been purchased in another country or purchased from someone in another country, it may lack certain safety devices and specifications that are necessary for use in your country. If there is any question about whether your product complies with the applicable standards and regulations of your country, consult Komatsu or your Komatsu distributor before operating the machine.**
- **The description of safety is given in SAFETY INFORMATION on page 0-2 and in SAFETY from page 1-1.**

## **CALIFORNIA**

### **Proposition 65 Warning**

**Diesel engine exhaust and some of its constituents are known to the State of California to cause cancer, birth defects, and other reproductive harm.**

## 2. SAFETY INFORMATION

---

Most accidents are caused by the failure to follow fundamental safety rules for the operation and maintenance of machines. To avoid accidents, read, understand and follow all precautions and warnings in this manual and on the machine before performing operation and maintenance.

To identify safety messages in this manual and on machine labels, the following signal words are used.

 **DANGER** – This word is used on safety messages and safety labels where there is a high probability of serious injury or death if the hazard is not avoided. These safety messages or labels usually describe precautions that must be taken to avoid the hazard. Failure to avoid this hazard may also result in serious damage to the machine.

 **WARNING** – This word is used on safety messages and safety labels where there is a potentially dangerous situation which could result in serious injury or death if the hazard is not avoided. These safety messages or labels usually describe precautions that must be taken to avoid the hazard. Failure to avoid this hazard may also result in serious damage to the machine.

 **CAUTION** – This word is used on safety messages and safety labels for hazards which could result in minor or moderate injury if the hazard is not avoided. This word might also be word for hazards where the only result could be damage to the machine.

**NOTICE** – This word is used for precautions that must be taken to avoid actions which could shorten the life of the machine.

Safety precautions are described in SAFETY from page 1-1.

Komatsu cannot predict every circumstance that might involve a potential hazard in operation and maintenance. Therefore the safety messages in this manual and on the machine may not include all possible safety precautions. If any procedures or actions not specifically recommended or allowed in this manual are used, you must be sure that you and others can do such procedures and actions safely and without damaging the machine. If you are unsure about the safety of some procedures, contact Komatsu distributor.

## **3. INTRODUCTION**

---

### **3.1 FEATURES**

This Komatsu DIESEL ENGINE GENERATOR is designed to be used mainly for the following work:

- Brushless type
- High power
- For both 50Hz and 60Hz
- Emphasis placed on safety (emergency stop device installed)

### **3.2 BREAKING IN THE MACHINE**

Your Komatsu machine has been thoroughly adjusted and tested before shipment. However, operating the machine under severe conditions at the beginning can adversely affect the performance and shorten the machine life.

Be sure to break in the machine for the initial 100 hours (as indicated by the service meter.)

During breaking in:

- Idle the engine for 5 minutes after starting it up.
- Avoid operation with heavy loads or at high speeds.

The precautions given in this manual for operating, maintenance, and safety procedures are only those that apply when this product is used for the specified purpose. If the machine is used for a purpose that is not listed in this manual, Komatsu cannot bear any responsibility for safety. All consideration of safety in such operations is the responsibility of the user.

Operations that are prohibited in this manual must never be carried out under any circumstances.

# 4. LOCATION OF PLATES, TABLE TO ENTER SERIAL NO. AND DISTRIBUTOR

## 4.1 MACHINE SERIAL NO. PLATE POSITION

On the bottom of the right of the control panel.

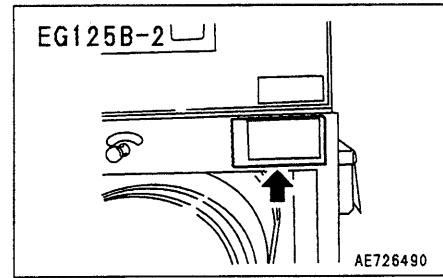

On the bottom of the left of the control panel.

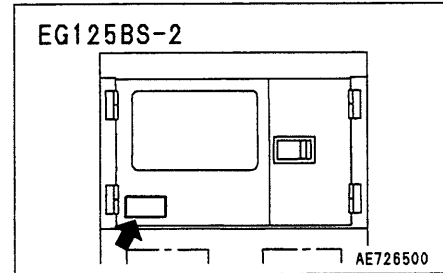

## 4.2 ENGINE SERIAL NO. PLATE POSITION

On the right of the cylinder block, when seen from the radiator fan.

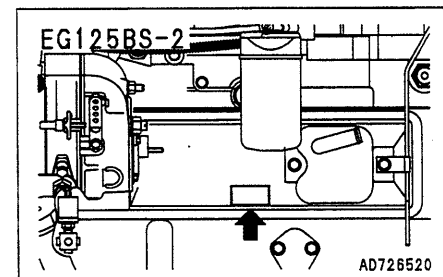
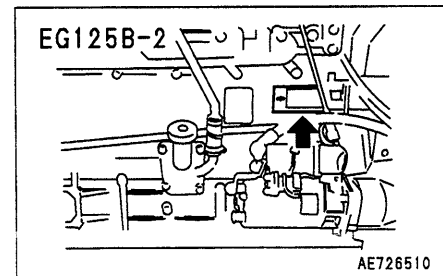

## 4.3 TABLE TO ENTER SERIAL NO. AND DISTRIBUTOR

Machine serial No.:	
Engine serial No.:	
Distributor name:	
Address:	Phone:
Service personnel for your machine:	

### REMARKS

# 5. CONTENTS

---

1. Foreword .....	0- 1
2. Safety information .....	0- 2
3. Introduction .....	0- 3
4. Location of plates, table to enter serial No. and distributor .....	0- 4

## SAFETY

6. General precautions .....	1- 2
7. Precautions during operation .....	1- 6
7.1 Before starting engine .....	1- 6
7.2 After starting engine .....	1- 8
7.3 Transportation .....	1- 9
7.4 Battery .....	1-10
8. Precautions for maintenance .....	1-11
8.1 Before carrying out maintenance .....	1-11
8.2 During maintenance .....	1-14
9. Position for attaching safety labels .....	1-18

## OPERATION

10. General view .....	2- 2
10.1 General view of machine .....	2- 2
10.2 General view of controls and gauges .....	2- 4
11. Explanation of components .....	2- 5
11.1 Meter and lamp .....	2- 5
11.2 Switch .....	2-10
11.3 Output terminal .....	2-16
12. Operation .....	2-19
12.1 Check before starting engine .....	2-21
12.2 Starting engine .....	2-29
12.3 Operations and checks after starting engine .....	2-33
12.4 Setting frequency and voltage .....	2-34
12.5 Changing voltage (EG125BS-2) .....	2-35
12.6 Parallel-arranged operation .....	2-36
12.7 Precautions for operating .....	2-39
12.8 Stopping engine .....	2-42
12.9 Precautions for stacking .....	2-44
13. Transportation .....	2-45
13.1 Loading, unloading work .....	2-45
13.2 Precautions for transportation .....	2-46
14. Cold weather operation .....	2-47
14.1 Precautions for low temperature .....	2-47
14.2 Precautions after completion of work .....	2-49
14.3 After cold weather .....	2-49

<b>15. Long-term storage</b> .....	2-50
15.1 Before storage .....	2-50
15.2 During storage .....	2-50
15.3 After storage .....	2-50
<b>16. Troubleshooting</b> .....	2-51
16.1 After running out of fuel .....	2-51
16.2 If battery is discharged .....	2-51
16.3 Other trouble .....	2-56

## **MAINTENANCE**

<b>17. Guides to maintenance</b> .....	3- 2
<b>18. Outlines of service</b> .....	3- 4
18.1 Outline of oil, fuel, coolant .....	3- 4
18.2 Outline of electric system .....	3- 7
<b>19. Wear parts list</b> .....	3- 8
<b>20. Use of fuel, coolant and lubricants according to ambient temperature</b> .....	3- 9
<b>21. Standard tightening torques for bolts and nuts</b> .....	3-14
21.1 Introduction of necessary tools .....	3-14
21.2 Torque list .....	3-15
<b>22. Periodic replacement of safety critical parts</b> .....	3-16
<b>23. Maintenance schedule chart</b> .....	3-18
23.1 Maintenance schedule chart .....	3-18
<b>24. Service Procedure</b> .....	3-20
24.1 Initial 250 hours service .....	3-20
24.2 When required .....	3-21
24.3 Check before starting .....	3-31
24.4 Every 50 hours service .....	3-35
24.5 Every 250 hours service .....	3-36
24.6 Every 500 hours service .....	3-40
24.7 Every 1000 hours service .....	3-43
24.8 Every 2000 hours service .....	3-44
24.9 Every 4000 hours service .....	3-45

## **SPECIFICATIONS**

<b>25. Specifications</b> .....	4- 2
---------------------------------	------

# SAFETY



## WARNING

**Read and follow all safety precautions. Failure to do so may result in serious injury or death.**

This safety section also contains precautions for optional equipment and attachments.



## 6. GENERAL PRECAUTIONS

**⚠ WARNING:** For reasons of safety, always follow these safety precautions.

### SAFETY RULES

- Follow all safety rules, precautions and instructions when operating or performing maintenance on the machine.
- Do not operate the machine if you are not feeling well, or if you are taking medicine which will make you sleepy, or if you have been drinking. Operating in such a condition will adversely affect your judgement and may lead to an accident.
- When working with another operator or with a person on worksite traffic duty, be sure that all personnel understand all hand signals that are to be used.

### SAFETY FEATURES

- Be sure that all guards and covers are in their proper position. Have guards and covers repaired if damaged.
- Always close the door during operation.
- If the door must be opened during operations, never put your hands or face inside.
- Never remove any safety features. Always keep them in good operating condition.
- Improper use of safety features could result in serious bodily injury or death.

### CLOTHING AND PERSONAL PROTECTIVE ITEMS

- Avoid loose clothing, jewelry, and loose long hair. They can catch on controls or in moving parts and cause serious injury or death.
- Also, do not wear oily clothes, because they are flammable.
- Wear a hard hat, safety glasses, safety shoes, mask or gloves when operating or maintaining the machine. Always wear safety goggles, hard hat and heavy gloves if your job involves scattering metal chips or minute materials particularly when driving pins with a hammer and when cleaning the air cleaner element with compressed air. Check also that there is no one near the machine.
- Check that all protective equipment functions properly before using.

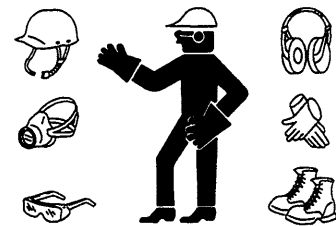

AE305770

### UNAUTHORIZED MODIFICATION

Any modification made without authorization from Komatsu can create hazards. Before making a modification, consult your Komatsu distributor. Komatsu will not be responsible for any injury or damage caused by any unauthorized modification.

**FIRE PREVENTION FOR FUEL AND OIL**

Fuel, oil, and antifreeze can be ignited by a flame. Fuel is particularly flammable and can be hazardous.

Always observe the following:

- Keep any flame or lighted cigarette away from flammable fluids.
- Stop the engine and do not smoke when refueling.
- Tighten all fuel and oil caps securely.
- Use well-ventilated areas for adding or storing oil and fuel.
- Keep oil and fuel in the determined place and do not allow unauthorized persons to enter.



A0055020

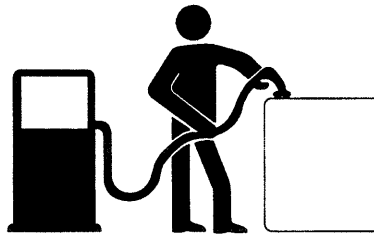

A0055030



A0055040

**PRECAUTIONS WHEN HANDLING AT HIGH TEMPERATURE**

- Immediately after operations are stopped, the engine oil and hydraulic oil are at high temperature and are still under pressure. Attempting to remove the cap, drain the oil or water, or replace the filters may lead to serious burns. Always wait for the temperature to go down, and follow the specified procedures when carrying out these operations.
- To prevent hot water from spurting out, stop the engine, wait for the water to cool, then loosen the cap slowly to relieve the pressure before removing the cap. (When checking if the water temperature has gone down, put your hand near the front face of the radiator and check the air temperature. Be careful not to touch the radiator.)

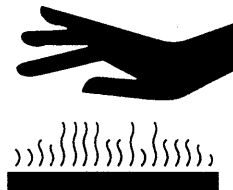

A0055050

**ASBESTOS DUST HAZARD PREVENTION**

Asbestos dust can be hazardous to your health if it is inhaled.

Komatsu does not use asbestos in its products, but if you handle materials containing asbestos fibers, follow the guidelines given below:

- Never use compressed air for cleaning.
- Use water to keep down the dust when cleaning.
- If there is danger that there may be asbestos dust in the air, operate the machine from an upwind position whenever possible.
- Use an approved respirator if necessary.

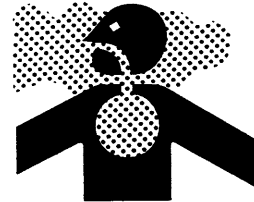

A0055060

**FIRE EXTINGUISHER AND FIRST AID KIT**

Always follow the precautions below to prepare for action if any injury or fire should occur.

- Be sure that fire extinguishers have been provided and read the labels to ensure that you know how to use them.
- Provide a first aid kit at the storage point. Carry out periodic checks and add to the contents if necessary.
- Know what to do in the event of a fire or injury.
- Decide the phone numbers of persons (doctor, ambulance, fire station, etc.) to contact in case of an emergency. Post these contact numbers in specified places and make sure that all personnel know the numbers and correct contact procedures.

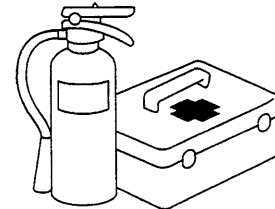

A0055070

**NOISE**

Always keep the door closed during operations. If this machine is operated with the door open, it will generate a lot of noise. Workers exposed to excessive noise for long periods may suffer from hearing problems.

If the door must be opened during operations, use ear plugs or other devices to protect your hearing.

**PRECAUTIONS FOR ATTACHMENTS**

- When installing and using an optional attachment, read the instruction manual for the attachment and the information related to attachments in this manual.
- Do not use attachments that are not authorized by Komatsu or your Komatsu distributor. Use of unauthorized attachments could create a safety problem and adversely affect the proper operation and useful life of the machine.
- Any injuries, accidents, product failures resulting from the use of unauthorized attachments will not be the responsibility of Komatsu.

**PRECAUTIONS FOR STACKING**

Improper stacking may cause the stack to collapse or the machine to fall. When stacking another machine on top of this machine, always do as follows.

- Check the machine for damage to the hood, and loose or missing bolts.
- Stop the machine on firm, horizontal ground that can withstand the load of stacked machines.
- A maximum of two machines can be put in one stack. The weight and dimensions of the machine stacked on top must be less than those of the machine at the bottom.
- Set wooden blocks in the places marked in the diagram, and make sure that the weight of the top machine is applied equally to the blocks.
- Never operate any machine that is stacked. This will cause the load to collapse or the machine to fall.

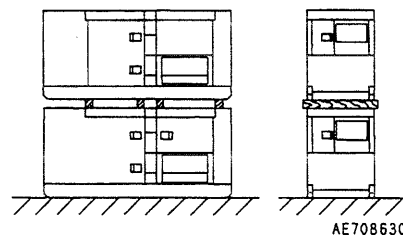

## 7. PRECAUTIONS DURING OPERATION

**⚠ WARNING:** For reasons of safety, always follow these safety precautions.

### 7.1 BEFORE STARTING ENGINE

#### SAFETY AT WORKSITE

- Before starting operations, thoroughly check the area for any unusual conditions that could be dangerous.
- Check the terrain and condition of the ground at the worksite, and determine the best and safest ground to set.
- If you need to operate on a road, protect pedestrians and cars by designating a person for worksite traffic duty or by installing fences and putting up No Entry signs around the worksite.
- If water lines, gas lines, or high-voltage electrical lines may be buried under the worksite, contact each utility and identify their locations. Be careful not to sever or damage any of these lines.
- Make sure that the exhaust gas is not directed at passing pedestrians or neighboring houses.

#### PREVENTION OF FIRE

- Thoroughly remove wood chips, leaves, paper and other flammable things accumulated on the engine compartment. They could cause a fire.
- Check fuel, lubrication, and hydraulic systems for leaks. Have any leaks repaired. Wipe up any excess oil, fuel or other flammable fluids.  
**Check point → See "12.1.1 WALK-AROUND CHECK".**
- Be sure that a fire extinguisher is present at the inspection and maintenance point.



A0055020

#### VENTILATION FOR ENCLOSED AREAS

Exhaust fumes from the engine can kill.

- If it is necessary to start the engine within an enclosed area, or you handle fuel, flushing oil, or paint, open the doors and windows to ensure that you provide adequate ventilation to prevent gas poisoning.
- If opening the doors and windows still does not provide adequate ventilation, set up fans.

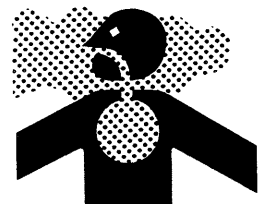

A0055060

#### **CHECKS BEFORE STARTING ENGINE**

Carry out the following checks before starting the engine at the beginning of the days work. Failure to carry out these checks may lead to serious injury or damage.

**Walk-around checks → See "12.1.1 WALK-AROUND CHECK".**

**Checks before starting → See "12.1.2 CHECK BEFORE STARTING".**

**Operations and checks before starting engine →**

**See "12.1.3 OPERATIONS AND CHECKS BEFORE STARTING ENGINE".**

During maintenace, attach warning tag to the instrument panel, and put up notice near the generator. Do not allow unauthorized persons to come near the generator.

#### **ELECTRIC SHOCK FROM ELECTRICAL LEAKAGE**

- If the method for grounding is not correct, the machine will not be effectively protected from electrical leakage, and this may lead to electric shock.  
Always carry out grounding individually for the electrical leakage relay contact terminals, outside box contact terminal, and outside box of load equipment.
- Check the action of the electrical leakage relay by pressing the test button when starting operations.

## 7.2 AFTER STARTING ENGINE

### PRECAUTIONS WHEN STARTING OFF

- Before starting engine, check again that there are no persons or obstacles in the surrounding area.
- Do not start the engine if any warning sign is attached to the control panel.
- When starting engine, perform a sign to warn people in the surrounding area.

### WORKING ON LOOSE GROUND

- Avoid operating your machine too close to the edge of cliffs, overhangs, and deep ditches. If these areas collapse under the mass or vibration of your machine, it could fall or tip over and this could result in serious injury or death. Remember that the soil after heavy rain, blasting, or earthquakes is weakened in these areas.
- Earth laid on the ground and the soil near ditches is loose. It can collapse under the mass or vibration of your machine and cause your machine to tip over.

### ELECTRIC SHOCK

- Never touch the output terminal during operations. There is danger of electric shock. It is particularly dangerous if your hands are wet.
- When connecting wiring, turn the breaker OFF and stop operations. When operating in parallel, shut off the power for the other machine also.
- Always keep the output terminal cover closed during operations.
- Even at low idling, some voltage is generated. Always stop the machine completely before touching the output terminal.
- There is danger of electric shock if you touch the internal electric circuit during operations.
- During operation, always close the control panel, tighten the panel screws, and close the side door.
- When opening the control panel to switch the voltage, turn the breaker OFF and stop operations. When operating in parallel, shut off the power for the other machine also.

### 7.3 TRANSPORTATION

#### PRECAUTIONS FOR TRANSPORTATION

- Loading and unloading the machine always involves potential hazards. **EXTREME CAUTION SHOULD BE USED.**
- Perform loading and unloading on firm, level ground only. Maintain a safe distance from the edge of a road.
- After loading, block the machine tracks and secure the machine with tie-downs.  
**Loading and unloading → See "13. TRANSPORTATION".**  
**Tie-downs → See "13. TRANSPORTATION".**

#### SHIPPING

- When shipping the machine on a hauling vehicle, obey all state and local laws governing the weight, width, and length of a load. Also obey all applicable traffic regulations.
- Determine the shipping route while taking into account the width, height and weight of the load.



## 7.4 BATTERY

### BATTERY HAZARD PREVENTION

- Battery electrolyte contains sulfuric acid and can quickly burn the skin and eat holes in clothing. If you spill acid on yourself, immediately flush the area with water.
- Battery acid could cause blindness if splashed into the eyes. If acid gets into the eyes, flush them immediately with large quantities of water and see a doctor at once.
- If you accidentally drink acid, drink a large quantity of water or milk, beaten egg or vegetable oil. Call a doctor or poison prevention center immediately.
- When working with batteries, ALWAYS wear safety glasses or goggles.
- Batteries generate hydrogen gas. Hydrogen gas is very EXPLOSIVE, and is easily ignited with a small spark or flame.
- Before working with batteries, stop the engine and turn the starting switch to the OFF position.
- Avoid short-circuiting the battery terminals through accidental contact with metallic objects, such as tools, across the terminals.
- When removing or installing, check which is the positive (+) terminal and negative (-) terminal.
- Tighten the battery cap securely.
- Tighten the battery terminals securely. Loosened terminals can generate sparks and lead to an explosion.

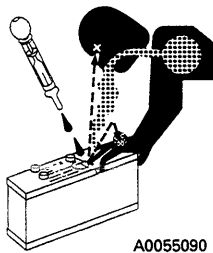

A0055090

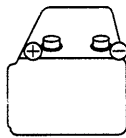

A0055100

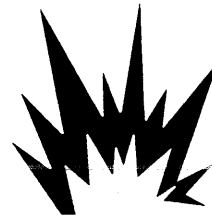

A0055110

### STARTING WITH BOOSTER CABLES

- ALWAYS wear safety glasses or goggles when starting the machine with booster cables.
- When starting from another machine, do not allow the two machines to touch.
- Be sure to connect the positive (+) cable first when installing the booster cables. Disconnect the ground or negative (-) cable first when removing them.
- If any tool touches between the positive (+) terminal and the chassis, it will cause sparks. This is dangerous, so be sure to work carefully.
- Connect the batteries in parallel: positive to positive and negative to negative.
- When connecting the ground cable to the frame of the machine to be started, be sure to connect it as far as possible from the battery.

Starting with booster cables → See "16. TROUBLESHOOTING".

**INCORRECT**

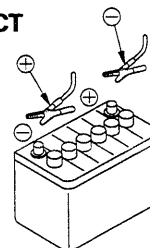

A0067320

## 8. PRECAUTIONS FOR MAINTENANCE

**⚠ WARNING:** Failure to follow these safety precautions may lead to a serious accident.

### 8.1 BEFORE CARRYING OUT MAINTENANCE

#### WARNING TAG

If others start the engine, or touch a switch while you are performing service or maintenance, you could suffer serious injury or death.  
Always attach the warning tag to the control panel to alert others that you are working on the machine.

#### PROPER TOOLS

Use only tools suited to the task. Using damaged, low quality, faulty, or makeshift tools could cause personal injury.

Broken pieces of chisels or hammers could fly into your eyes and blind you.

**Tools → See "21.1 INTRODUCTION OF NECESSARY TOOLS".**



A0055120

#### PERIODIC REPLACEMENT OF SAFETY CRITICAL PARTS

- Replace the following fire-related components periodically.  
Fuel system: Fuel hoses and spill hoses
- Replace these components periodically with new ones even if there is no abnormality. These components deteriorate over time.
- Even if they have not reached the specified replacement period, replace or repair them immediately if no abnormality is found.

**Replacement of safety critical parts →**

**See "22. PERIODIC REPLACEMENT OF SAFETY CRITICAL PARTS".**

#### STOP ENGINE BEFORE CARRYING OUT INSPECTION AND MAINTENANCE

When carrying out inspection and maintenance, always stop the machine on firm, level ground where there is no danger of falling rocks, landslides, or flooding.

If it is necessary to run the engine when carrying out maintenance, such as when cleaning the inside of the radiator, carry out the operation with two workers.

One worker should sit in the operator's seat so that he can stop the engine immediately if necessary. He should also be extremely careful not to touch any lever by mistake. Touch the levers only when they have to be operated.

The worker carrying out the maintenance should be extremely careful not to touch or get caught in the moving parts.

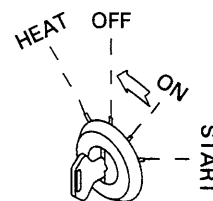

AM089160

**RULES TO FOLLOW WHEN ADDING FUEL OR OIL**

If any flame is brought close to fuel or oil, there is danger that it will catch fire, so always follow the precautions below.

- Stop the engine when adding fuel or oil.
- Do not smoke.
- Spilled fuel and oil may cause you to slip, so always wipe it up immediately.
- Always tighten the cap of the fuel and oil fillers securely.
- Always add fuel and oil in a well-ventilated place.



A0055020



A0055030



A0055040

**RADIATOR WATER LEVEL**

- When inspecting the radiator water level, stop the engine, and wait for the engine and radiator to cool down. Check the water level in the sub-tank. Under normal conditions, do not open the radiator cap.
- Release the internal pressure before removing the radiator cap, and remove the radiator cap slowly.

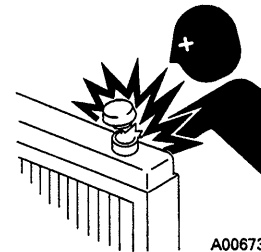

A0067380

**USE OF LIGHTING**

When checking fuel, oil, or battery electrolyte, always use lighting with anti-explosion specifications. If such lighting equipment is not used, there is danger of explosion.



A0055160

### PREVENTION OF FIRE

There is danger of the fuel and battery gas catching fire during maintenance, so always follow the precautions below when carrying out maintenance.

- Store fuel, oil, grease, and other flammable materials away from flame.
- Use non-flammable materials as the flushing oil for cleaning parts. Do not use diesel oil or gasoline. There is danger that they will catch fire.
- Never smoke when carrying out inspection or maintenance. Always smoke in the prescribed place.
- When checking fuel, oil, or battery electrolyte, always use lighting with anti-explosion specifications. Never use lighters or matches as lighting.
- When carrying out grinding or welding operations on the chassis, remove any flammable materials to a safe place.
- Be sure that a fire extinguisher is present at the inspection and maintenance point.



A0055020

## 8.2 DURING MAINTENANCE

### PERSONNEL

- Only authorized personnel can service and repair the machine. Extra precaution should be used when grinding, welding, and using a sledge-hammer.

### ATTACHMENTS

- Place attachments that have been removed from the machine in a safe place so that they do not fall. If they fall on you or others, serious injury could result.



A0055130

### WORK UNDER THE MACHINE

- Always lower all movable work equipment to the ground or to their lowest position before performing service or repairs under the machine.
- Always block the track shoes of the machine securely.
- Never work under the machine if the machine is poorly supported.



A0055140

### KEEP THE MACHINE CLEAN

- Spilled oil or grease, or scattered tools or broken pieces are dangerous because they may cause you to slip or trip. Always keep your machine clean and tidy.
- If water gets into the electrical system, there is danger that the machine may not move or may move unexpectedly. Do not use water or steam to clean the sensors, connectors, or the inside of the operator's compartment.

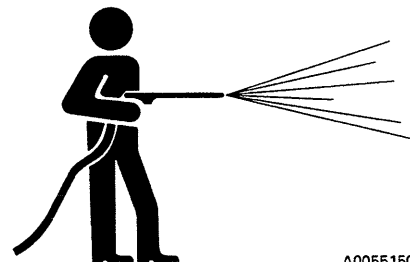

A0055150

**PRECAUTIONS WITH BATTERY**

- When repairing the electrical system or when carrying out electrical welding, remove the negative (-) terminal of the battery to stop the flow of current.



A0055170

**HANDLING HIGH-PRESSURE HOSES**

- Do not bend high-pressure hoses or hit them with hard objects. Do not use any bent or cracked piping, tubes or hoses. They may burst during use.
- Always repair any loose or broken fuel hoses or oil hoses. If fuel or oil leaks, it may cause a fire.

**PRECAUTIONS WITH HIGH PRESSURE OIL**

- Do not forget that the work equipment circuits are always under pressure.
- Do not add oil, drain oil, or carry out maintenance or inspection before completely releasing the internal pressure.
- If oil is leaking under high pressure from small holes, it is dangerous if the jet of high-pressure oil hits your skin or enters your eyes. Always wear safety glasses and thick gloves, and use a piece of cardboard or a sheet of wood to check for oil leakage.
- If you are hit by a jet of high-pressure oil, consult a doctor immediately for medical attention.

**INCORRECT**



A0055180

**CORRECT**

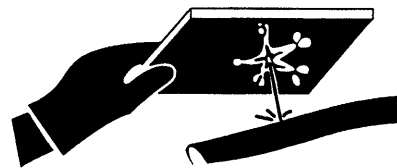

A0055190

**PRECAUTIONS WHEN CARRYING OUT MAINTENANCE AT HIGH TEMPERATURE OR HIGH PRESSURE**

- Immediately after stopping operations, the engine cooling water and oil at all parts is at high temperature and under high pressure. In this condition, if the cap is removed, or the oil or water are drained, or the filters are replaced, this may result in burns or other injury. Wait for the temperature to go down, then carry out the inspection and maintenance in accordance with the procedures given in this manual.

**Cleaning inside or cooling system → see “24.2 WHEN REQUIRED”.**

**Checking cooling water level, hydraulic oil level → see “24.3 CHECK BEFORE STARTING”.**

**Checking lubricating oil level, adding oil → see “24.3-7 PERIODIC MAINTENANCE”.**

**Changing oil, replacing filters → see “24.5 - 8 PERIODIC MAINTENANCE”.**

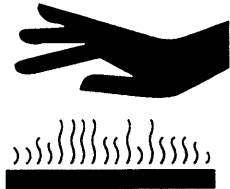

A0055050

**ROTATING FAN AND BELT**

- Keep away from rotating parts and be careful not to let anything get caught in them.
- If your body or tools touch the fan blades or fan belt, they may be cut off or sent flying, so never touch any rotating parts.



A0055210

**WASTE MATERIALS**

- Never dump waste oil in a sewer system, rivers, etc.
- Always put oil drained from your machine in containers. Never drain oil directly on the ground.
- Obey appropriate laws and regulations when disposing of harmful objects such as oil, fuel, coolant, solvent, filters, batteries, and others.

**INCORRECT**

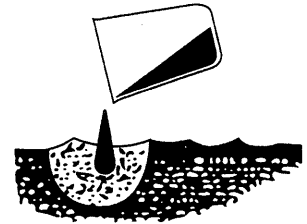

A0055220



# 9. POSITION FOR ATTACHING SAFETY LABELS

Always keep these labels clean. If they are lost or damaged, attach them again or replace them with a new label.

There are other labels in addition to the safety labels listed as follows, so handle them in the same way.

Safety labels may be available in languages other than English. To find out what labels are available, contact your Komatsu distributor.

## 9.1 POSITION FOR ATTACHING SAFETY LABELS

### 9.1.1 EG125B-2

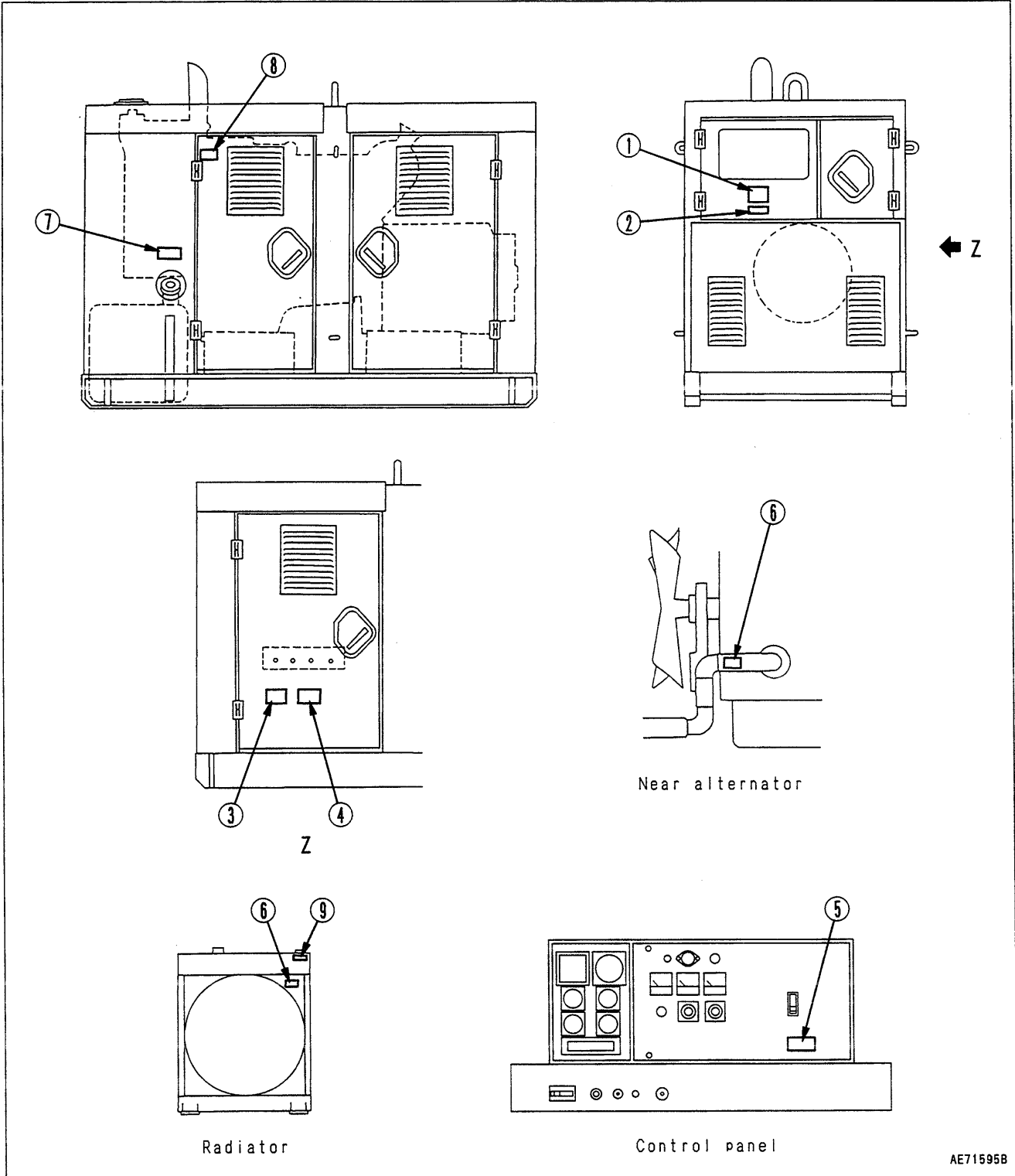

AE71595B

9.1.2 EG125BS-2

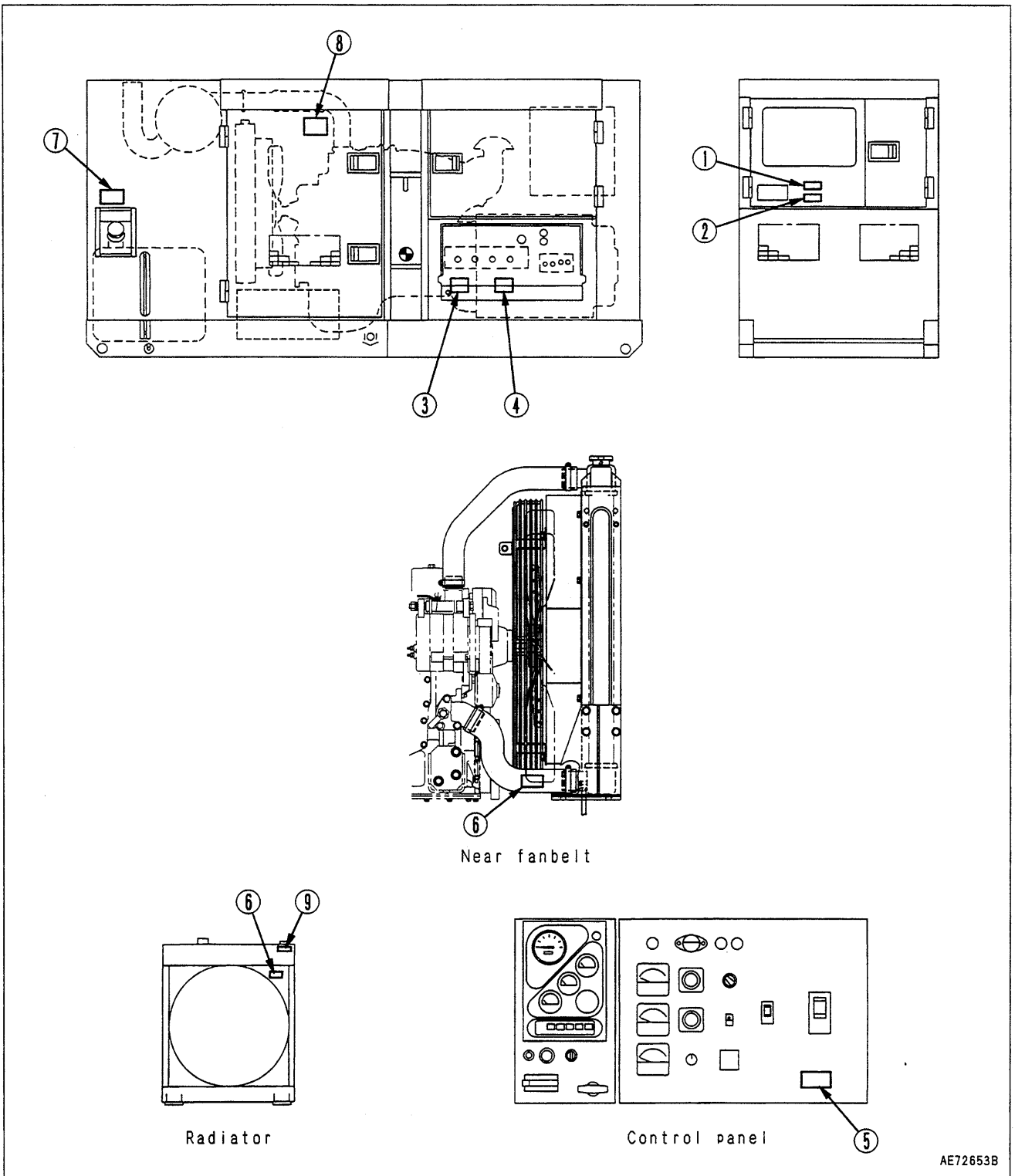

9. POSITION FOR ATTACHING SAFETY LABELS

1. Precautions for safety  
(B92110040)

<b>SAFETY INSTRUCTIONS</b>	
<p>Improper operation of this machine can cause severe injury or death.</p> <ul style="list-style-type: none"> <li>• Read the instruction manual carefully before operation or servicing.</li> </ul> <p>This machine should only be operated by a person with sufficient knowledge and skill to ensure safe operation.</p> <p>High voltage circuits are located inside the output terminal cover and control panel.</p> <ul style="list-style-type: none"> <li>• Close the cover and control panel before operating.</li> </ul> <p>Moving parts and hot surfaces are contained within the enclosure.</p> <ul style="list-style-type: none"> <li>• Close all doors and lock them before operating.</li> </ul>	
B92110040	

2. Danger of exhaust gas  
(B90420000)

	<b>⚠ WARNING</b>
	<p>ENGINE EXHAUST can cause severe injury or death.</p> <ul style="list-style-type: none"> <li>• Use only in open, well ventilated areas or vent exhaust outside.</li> </ul>
B90420000	

3. Danger from output terminals  
(B93110050)

	<b>⚠ WARNING</b>
	<p>ELECTRIC SHOCK HAZARD</p> <ul style="list-style-type: none"> <li>• Do not touch output terminals while this machine is operating.</li> <li>• Turn power off before servicing.</li> </ul>
B93110050	

4. Danger of electrical leakage  
(B91110040)

	<b>⚠ WARNING</b>
	<p>ELECTRIC SHOCK HAZARD</p> <ul style="list-style-type: none"> <li>• Always complete the grounding path from the ground terminal on this genset to an external grounding source. See instruction manual for details.</li> </ul>
B91110040	

5. Danger of electric shock  
(B93110060)

	<b>⚠ WARNING</b>
	<p>ELECTRIC SHOCK HAZARD</p> <ul style="list-style-type: none"> <li>• Do not touch internal wiring or connections while this machine is operating.</li> <li>• Turn power off before servicing.</li> </ul>
B93110060	

6. Danger from rotating parts  
(B90400040)

	<b>⚠ WARNING</b>
	<p>MOVING PARTS can cause severe injury.</p> <ul style="list-style-type: none"> <li>• Do not operate with doors open.</li> <li>• Stop engine before servicing.</li> </ul>
B90400040	

7. Precautions to prevent fire  
(B90450000)

	<b>⚠ WARNING</b>
	<p>DIESEL FUEL can cause fire or explosion.</p> <ul style="list-style-type: none"> <li>• Stop engine before fueling.</li> <li>• Keep cigarettes, sparks and flame away.</li> </ul>
B90450000	

8. Precautions for high temperature  
(B90400030)

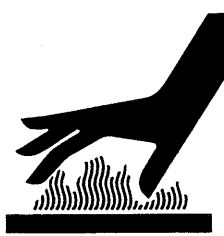
	<b>⚠ CAUTION</b>
	<p>HOT PARTS can burn skin.</p> <ul style="list-style-type: none"> <li>• Do not touch until the machine has sufficiently cooled.</li> </ul>
B90400030	

9. Precautions for radiator cap  
(B90410010)

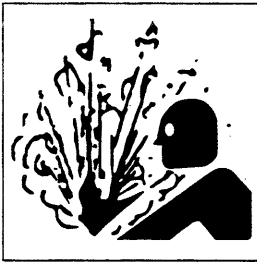
	<p><b>⚠ WARNING</b></p> <p><b>HOT COOLANT</b> can cause severe burns.</p> <ul style="list-style-type: none"><li>• Do not remove cap if radiator is hot.</li></ul> <p>B90410010</p>
---	--

# **OPERATION**

# 10. GENERAL VIEW

## 10.1 GENERAL VIEW OF MACHINE

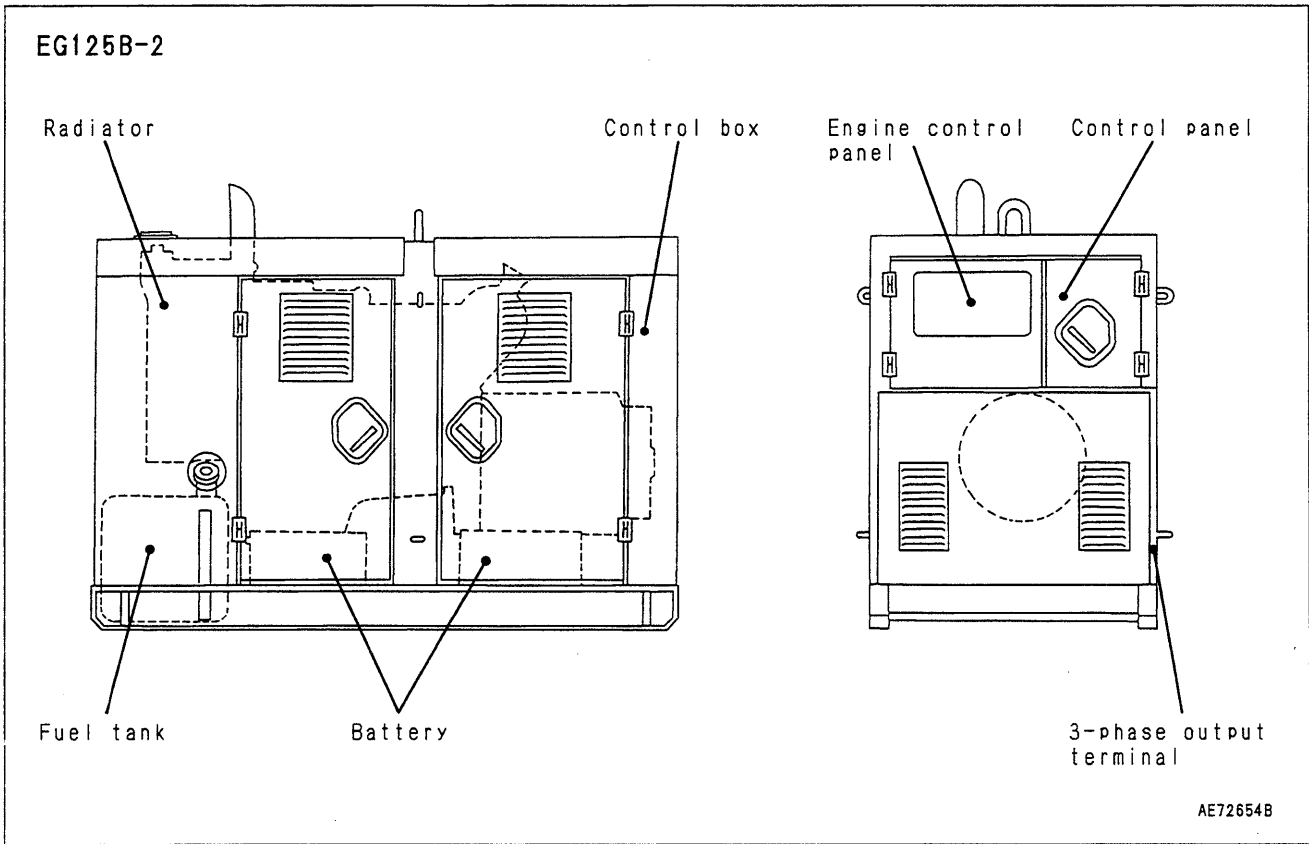

EG125BS-2

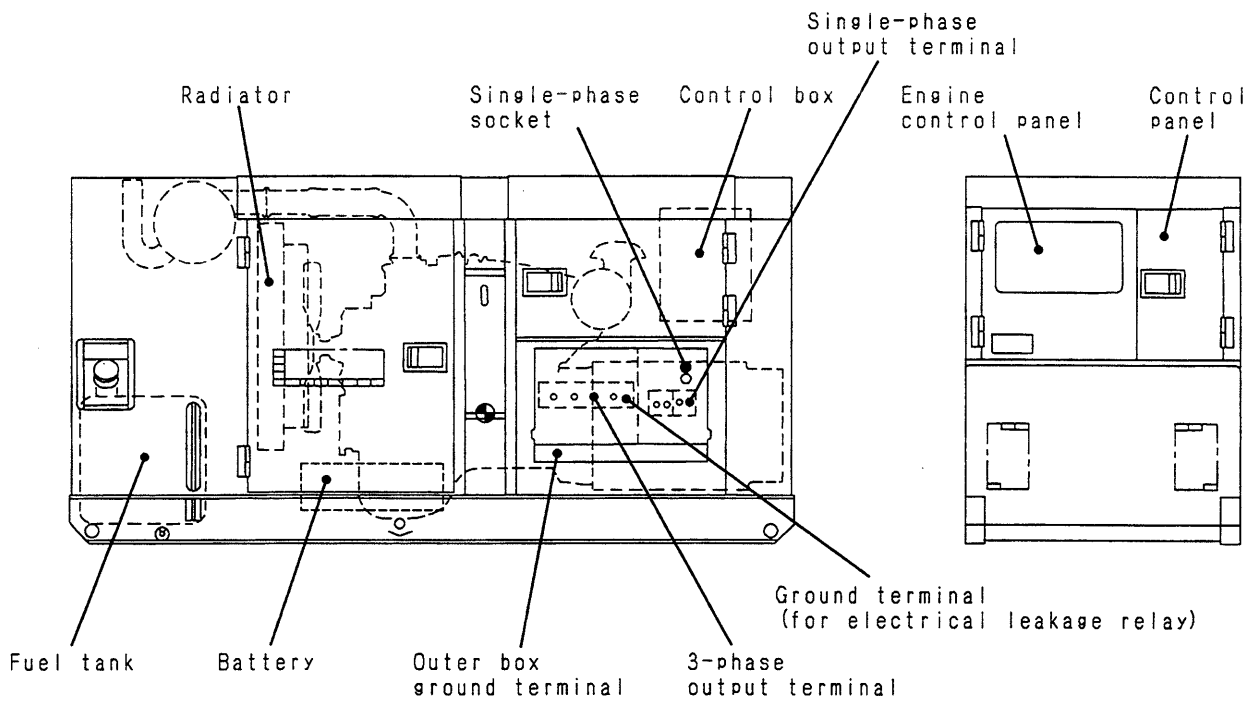
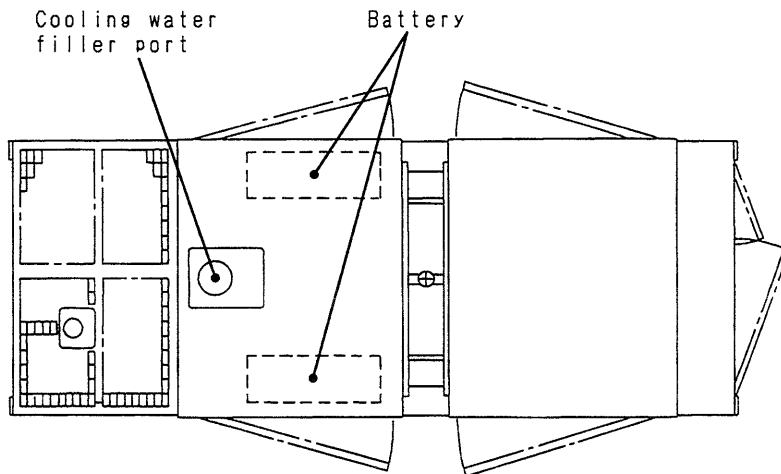

AE72604B

10.2 GENERAL VIEW OF CONTROLS AND GAUGES

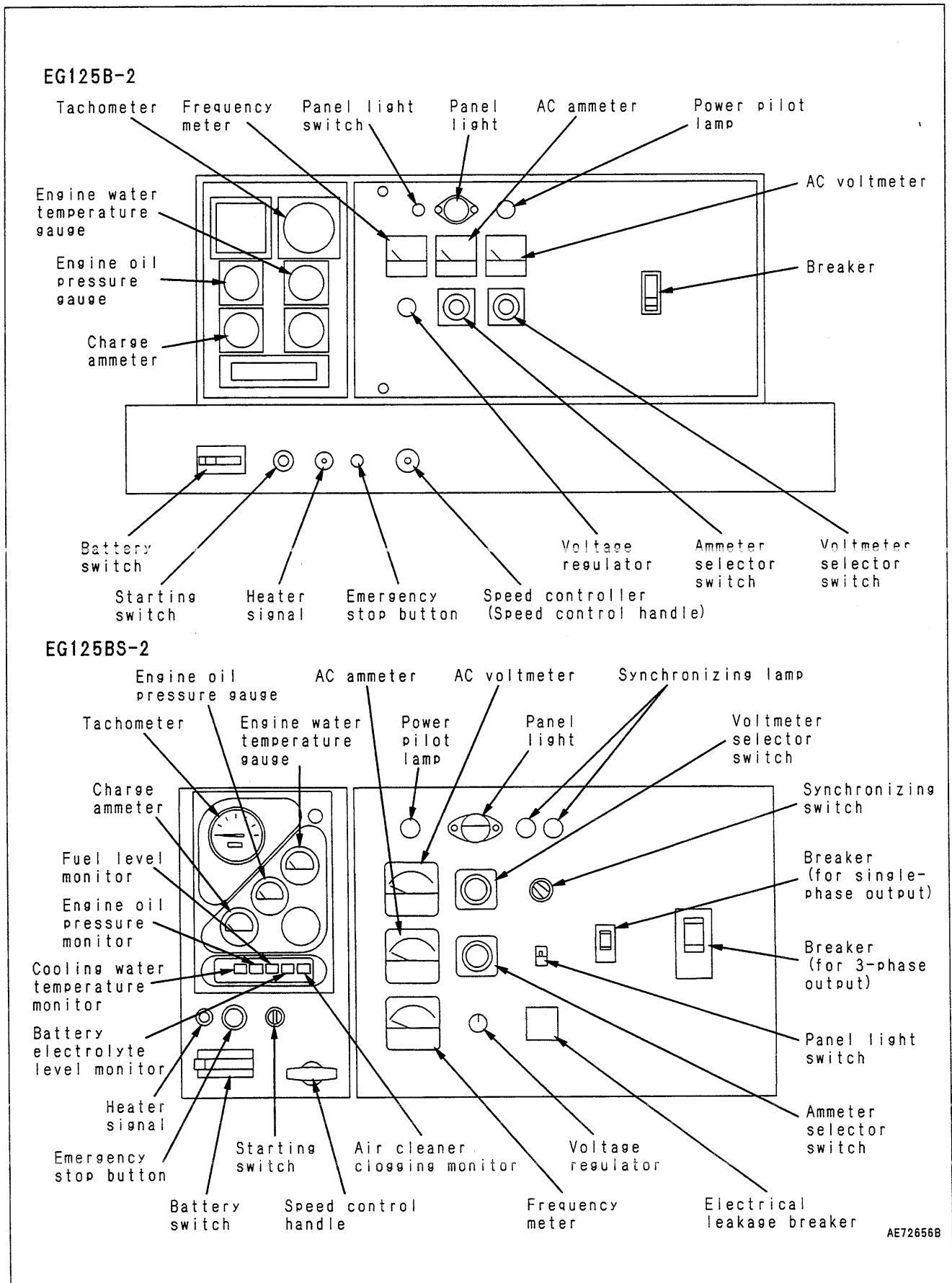

AE72656B



# 11. EXPLANATION OF COMPONENTS

The following is an explanation of the devices needed for operating the machine.

To carry out suitable operations correctly and safely, it is important to understand fully the methods of operating the equipment and the meanings of the displays.

## 11.1 METER AND LAMP

### 11.1.1 EG125B-2

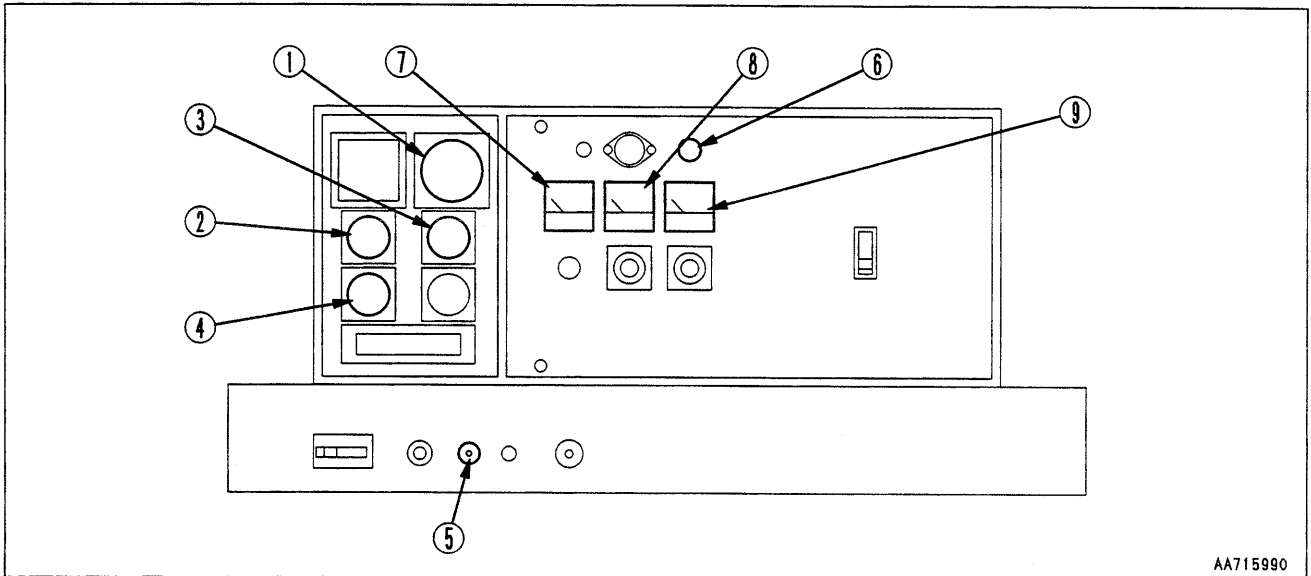

AA715990

#### 1. TACHOMETER

This displays the engine speed in rpm.  
A service meter is also assembled.

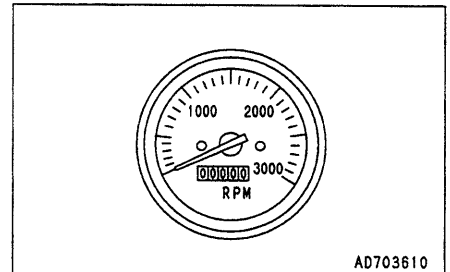

AD703610

#### 2. ENGINE OIL PRESSURE GAUGE

This shows the engine lubricating oil pressure.

During normal operations, it should indicate 0.25 – 0.49 MPa {2.5 – 5.0 kgf/cm<sup>2</sup>}.

If the oil pressure drop alarm is actuated during operations, dump the load, then stop the engine and carry out the necessary action.

For details, see "16. Troubleshooting".

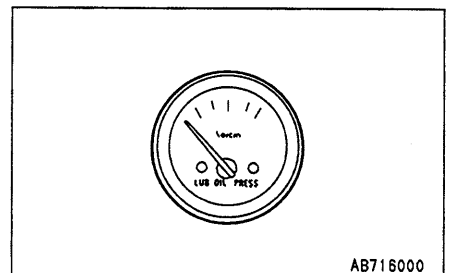

AB716000

#### 3. ENGINE WATER TEMPERATURE GAUGE

This indicates the engine cooling water temperature.

During normal operations, the gauge reading should be 60 – 95°C.

If the water temperature alarm is actuated during operations, dump the load, run the engine at low idling to lower the temperature, then stop the engine and carry out the necessary action.

For details, see "16. TROUBLESHOOTING".

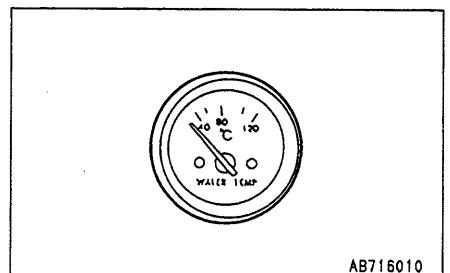

AB716010

## 11. EXPLANATION OF COMPONENTS

### 4. CHARGE AMMETER

This shows the charge current when the engine is running.

During normal operations, it should be in the range on the positive (+) side of 0.

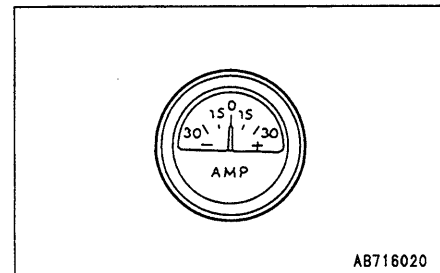

### 5. HEATER SIGNAL

This informs the operator of the red hot condition of the electric intake air heater.

When the starting switch is turned to the HEAT position, it will glow red after approx. 30 seconds.

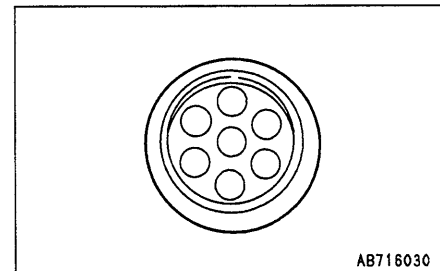

### 6. POWER PILOT LAMP

This lights up when the battery switch is turned ON.

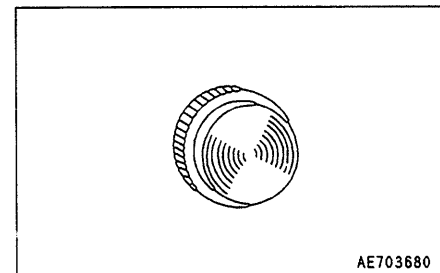

### 7. FREQUENCY METER

This indicates the frequency of the power source.

Check that it indicates 50 Hz or 60 Hz during operation.

The frequency of the diesel generator is proportional to the engine speed.

Rated frequency: 50 Hz/1500 rpm  
60 Hz/1800 rpm

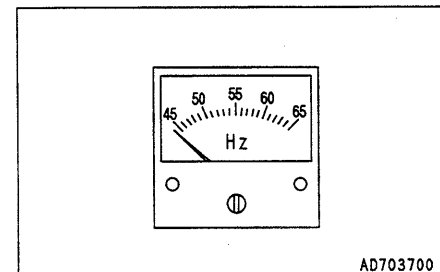

### 8. AC AMMETER

This indicates the output current (3-phase AC) during operations.

Check that the machine is being used at or below the rated current.

When the ammeter selector switch is operated, the current for U phase, V phase, and W phase are each shown.

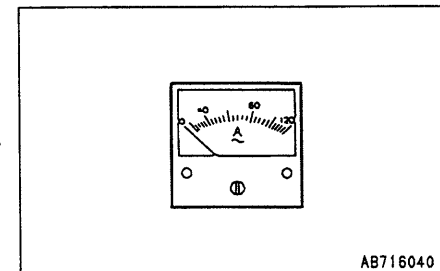

### 9. AC VOLTMETER

This indicates the output voltage during operation.

When the voltmeter selector switch is operated, the voltage between each wire is indicated.

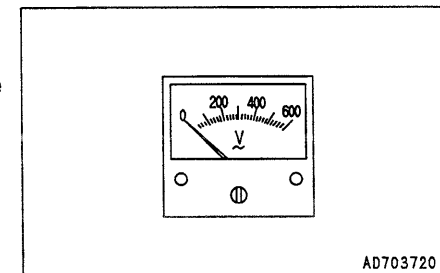

11.1.2 EG125BS-2

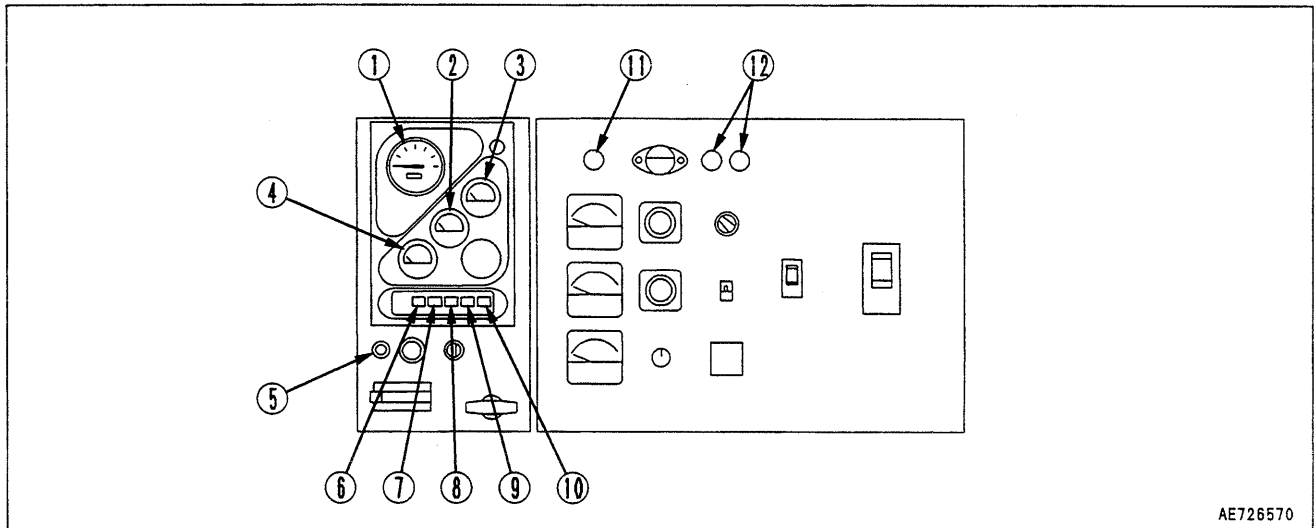

AE726570

**1. TACHOMETER**

This displays the engine speed in rpm.  
A service meter is also assembled.

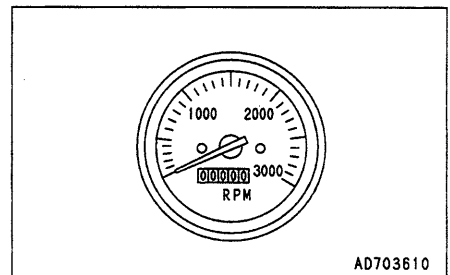

AD703610

**2. ENGINE OIL PRESSURE GAUGE**

This shows the engine lubricating oil pressure.

During normal operations, it should indicate 0.25 – 0.49 MPa {2.5 – 5.0 kgf/cm<sup>2</sup>}.

If the oil pressure drop alarm is actuated during operations, dump the load, then stop the engine and carry out the necessary action.

For details, see "16. TROUBLESHOOTING".

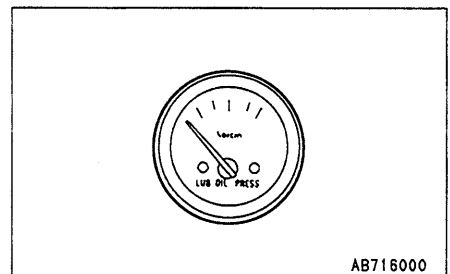

AB716000

**3. ENGINE WATER TEMPERATURE GAUGE**

This indicates the engine cooling water temperature.

During normal operations, the gauge reading should be 60 – 95°C.

If the water temperature alarm is actuated during operations, dump the load, run the engine at low idling to lower the temperature, then stop the engine and carry out the necessary action.

For details, see "16. TROUBLESHOOTING".

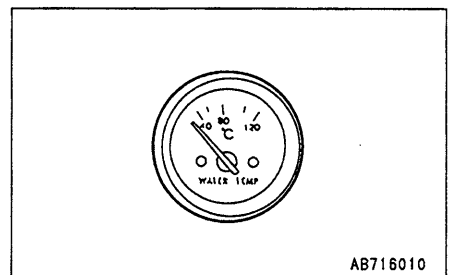

AB716010

**4. CHARGE AMMETER**

This shows the charge current when the engine is running.

During normal operations, it should be in the range on the positive (+) side of 0.

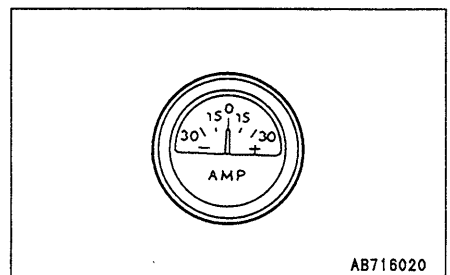

AB716020

## 11. EXPLANATION OF COMPONENTS

### 5. HEATER SIGNAL

This informs the operator of the red hot condition of the electric intake air heater.

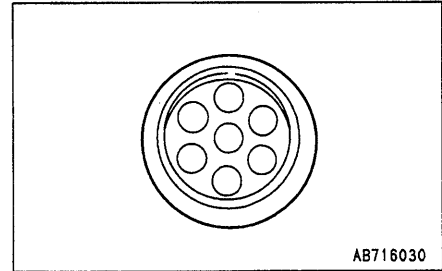

### 6. COOLING WATER TEMPERATURE MONITOR

This warns of a rise in the cooling water temperature.

If it lights up during operations, the emergency stop system will stop the engine.

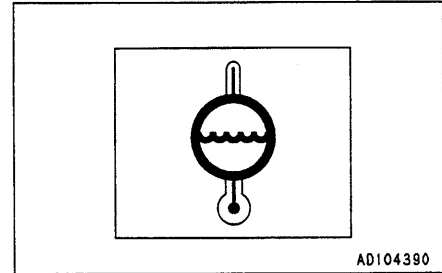

### 7. ENGINE OIL PRESSURE MONITOR

This warns the operator that there has been a drop in the engine lubricating oil pressure.

If it lights up during operations, the engine oil pressure has dropped, so stop the engine immediately and carry out inspection.

The light will stay on until the engine has been stopped and the starting switch has been turned OFF.

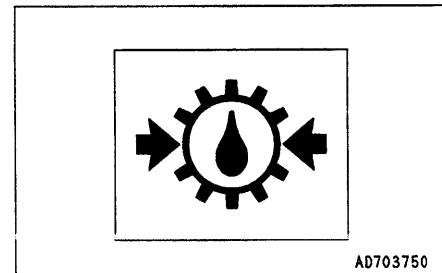

### 8. FUEL LEVEL MONITOR

This lights up when the fuel level in the fuel tank is low.

If it lights up, check the fuel level and add fuel.

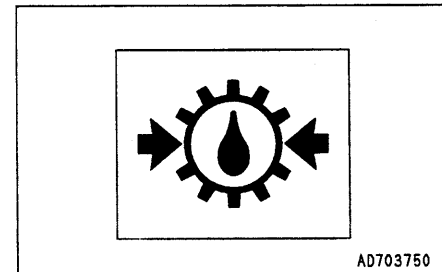

### 9. BATTERY ELECTROLYTE LEVEL MONITOR

This warns the operator that the battery electrolyte level is low.

If it lights up, check the battery electrolyte level and add distilled water.

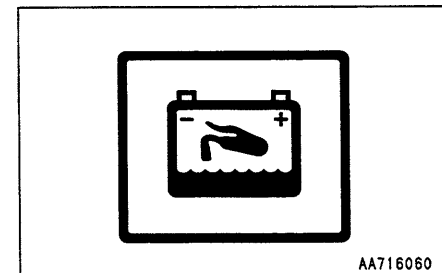

### 10. AIR CLEANER CLOGGING MONITOR

This warns the operator that the air cleaner element is clogged.

If it lights up, stop the engine immediately, then clean or replace the element.

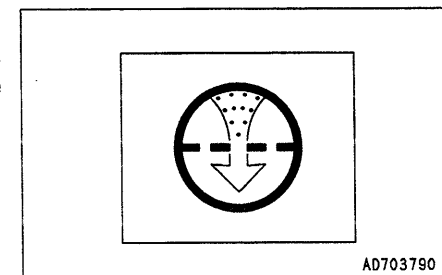

**11. POWER PILOT LAMP**

This lights up when the battery switch is turned ON.

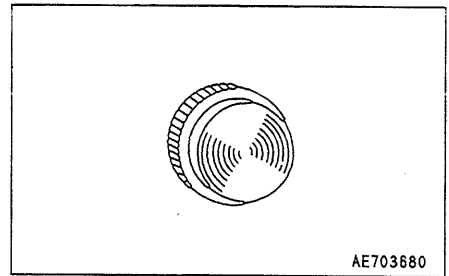

**12. SYNCHRONIZING LAMP**

Used for parallel-arranged operation.

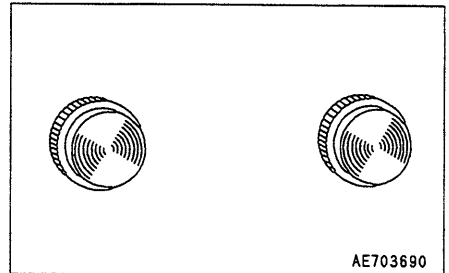

**13. FREQUENCY METER**

This indicates the frequency of the power source.

Check that it indicates 50 Hz or 60 Hz during operation.

The frequency of the diesel generator is proportional to the engine speed.

Rated frequency: 50 Hz/1500 rpm  
60 Hz/1800 rpm

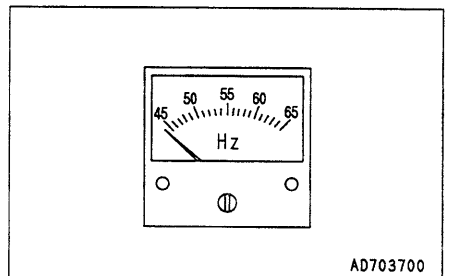

**14. AC AMMETER**

This indicates the output current (3-phase AC) during operations.

Check that the machine is being used at or below the rated current.

When the ammeter selector switch is operated, the current for U phase, V phase, and W phase are each shown.

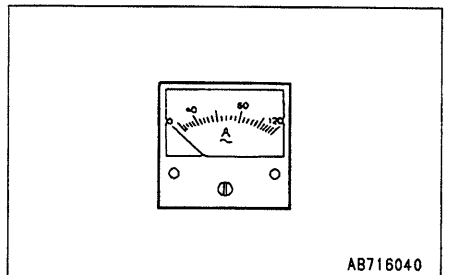

**15. AC VOLTMETER**

This indicates the output voltage during operation.

When the voltmeter selector switch is operated, the voltage between each wire is indicated.

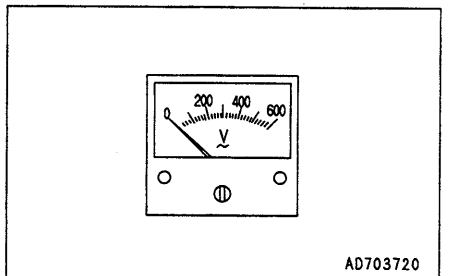

**11.2 SWITCH**  
**11.2.1 EG125B-2**

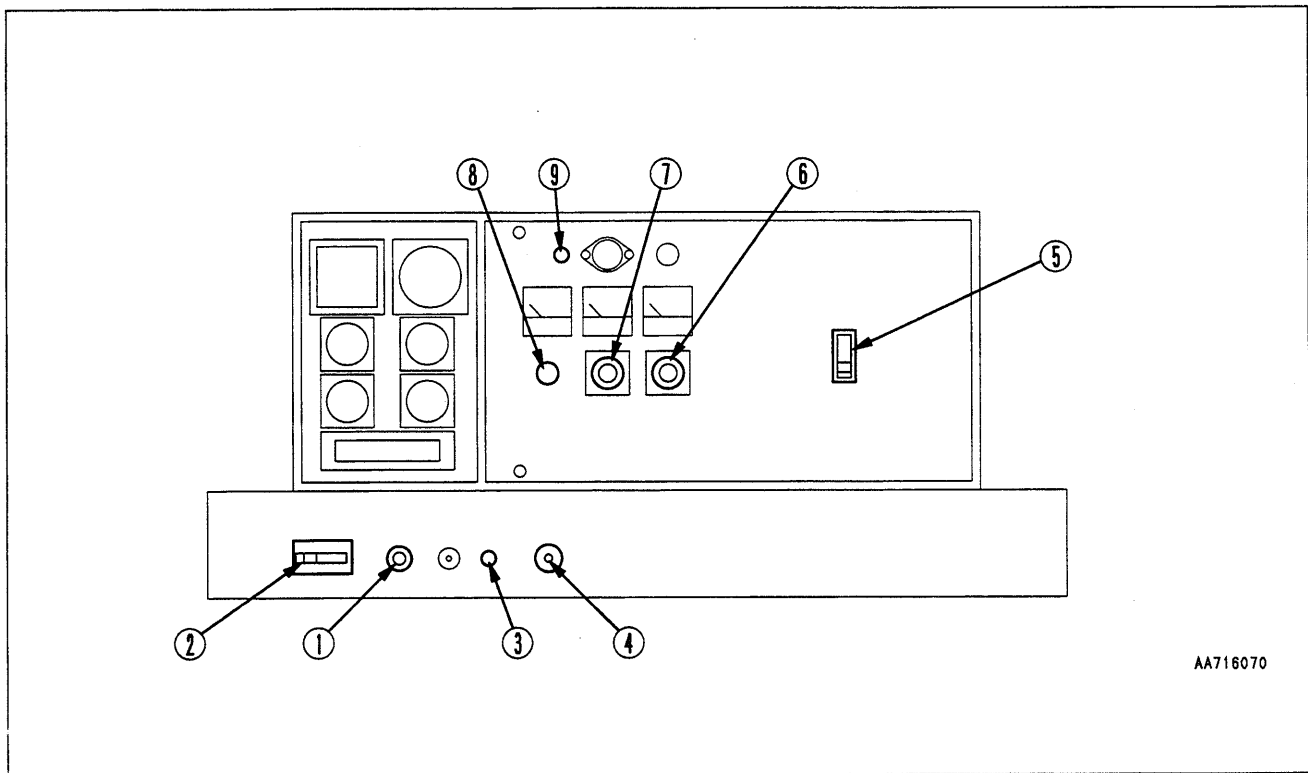

AA716070

**1. STARTING SWITCH**

This switch is used to start and stop the engine.

**OFF**

The starting key can be inserted and removed at this position. When the key is turned to this position, the switches of the electric circuit are turned off and the engine stops.

**ON**

Electricity flows to the charging circuit. After starting the engine, keep the key at this position. Do not turn it to OFF while the engine is running.

**START**

This is the position for starting the engine. Keep the key at this position while cranking the engine. When the engine starts, release the key.

**HEAT (preheat) position**

When starting the engine in cold weather, set the key to this position. When the key is set to the HEAT position, the engine intake air is heated to make it easier to start the engine. When the engine starts, release the key. The key automatically returns to the OFF position. Then start the engine by turning the key immediately to the START position.

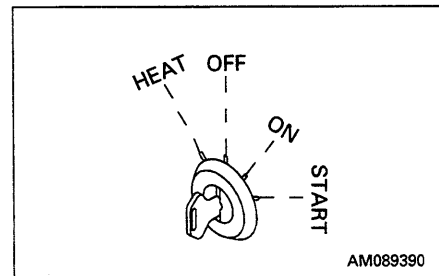

AM089390

**2. BATTERY SWITCH**

During operations, always keep this switch at the ON position. Never turn it to the OFF position during operations. After stopping the engine, always turn it to the OFF position.

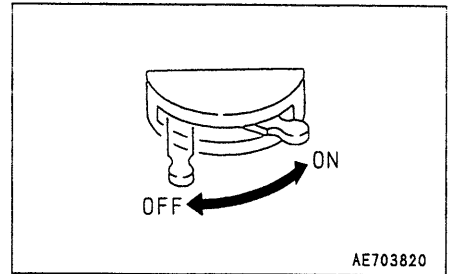

**3. EMERGENCY STOP BUTTON**

When this button is pressed, the engine will stop. Do not use this switch except during emergencies.

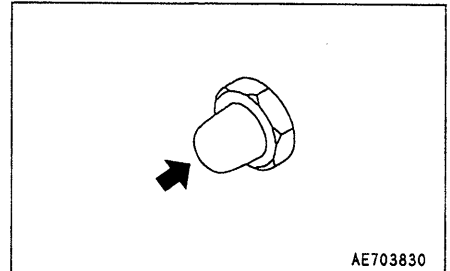

**4. SPEED CONTROLLER (SPEED CONTROL HANDLE)**

Used to adjust the speed and output of the engine. If knob ② is pulled with push-button ① pushed, the engine speed rises. For fine adjustment of the engine speed, turn knob ②. After setting the engine speed and frequency, fix knob ② with adjustment lock nut ③.

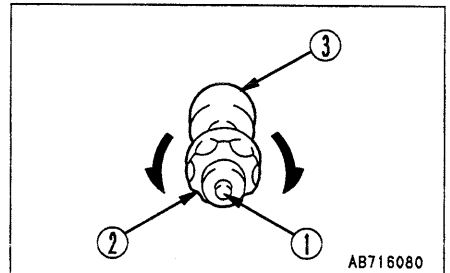

**5. BREAKER (FOR 3-PHASE OUTPUT)**

If the load is short circuited and excessive current flows, the electric circuit is automatically shut off. Do not use this breaker to switch the load ON/OFF.

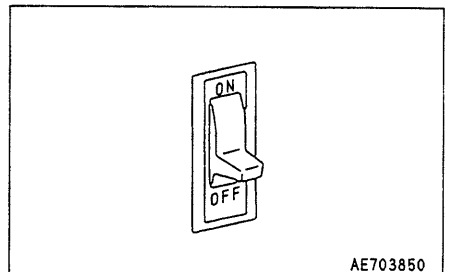

**6. VOLTMETER SELECTOR SWITCH**

Use this switch to display the output voltage between U and V, V and W, and W and U on the voltmeter.

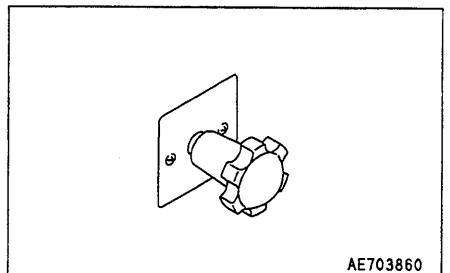

**7. AMMETER SELECTOR SWITCH**

Use this switch to select the output current U phase, V phase, or W phase on the ammeter.

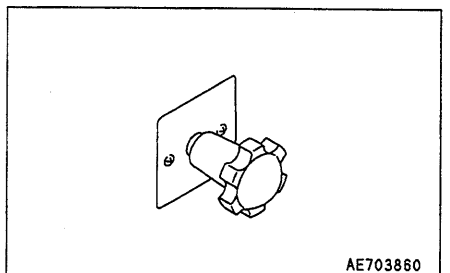

## 11. EXPLANATION OF COMPONENTS

---

### 8. VOLTAGE REGULATOR

This regulates the output voltage as follows.

To INCREASE voltage, turn CLOCKWISE

To DECREASE voltage, turn COUNTERCLOCKWISE

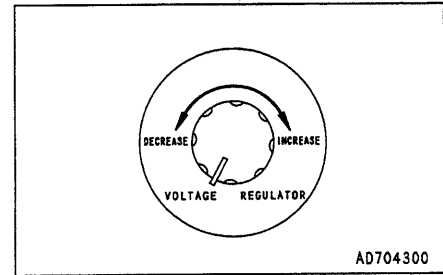

### 9. PANEL LIGHT SWITCH

This lights up the panel lighting.

ON position: Lamp lights up

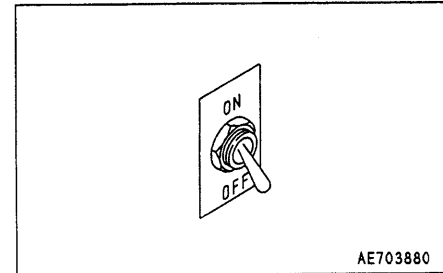



## 11.2.2 EG125BS-2

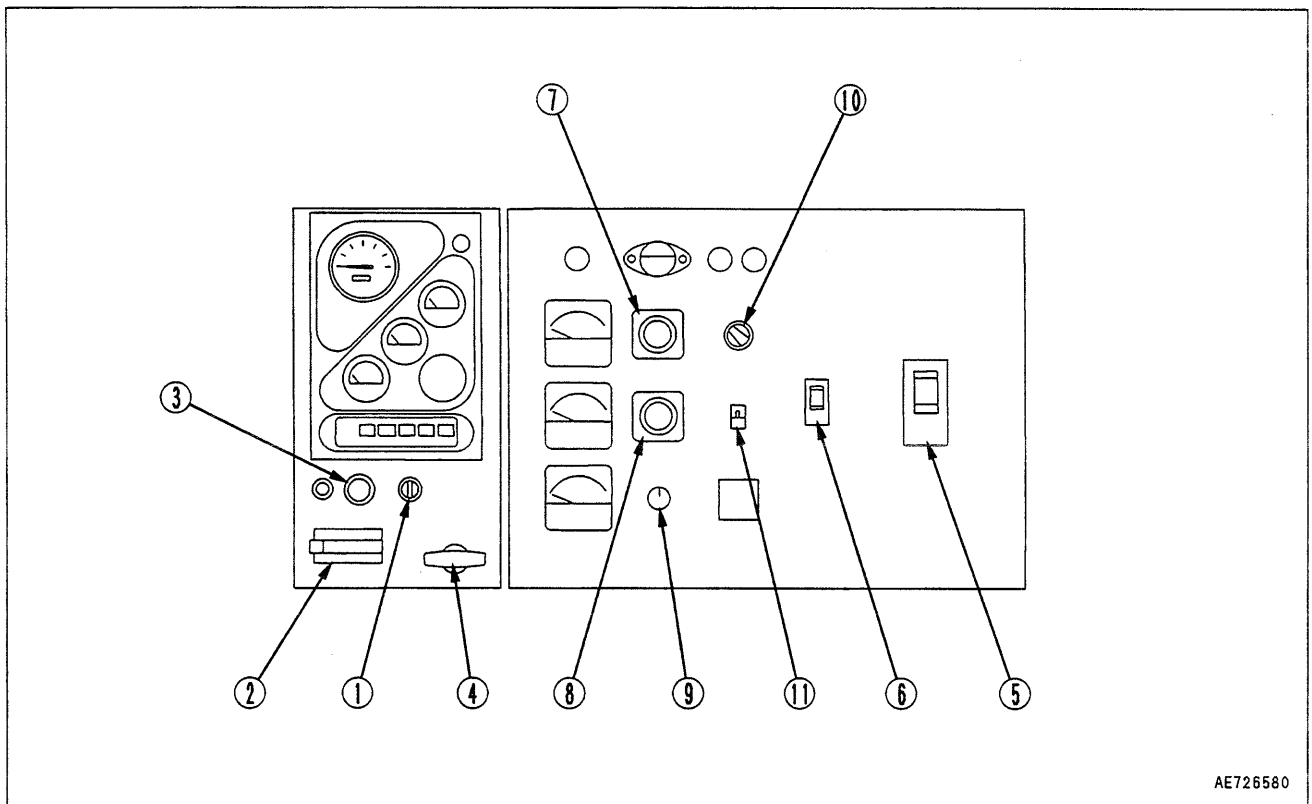

AE726580

**1. STARTING SWITCH**

This switch is used to start and stop the engine.

**OFF**

The starting key can be inserted and removed at this position. When the key is turned to this position, the switches of the electric circuit are turned off and the engine stops.

**ON**

Electricity flows to the charging circuit. After starting the engine, keep the key at this position. Do not turn it to OFF while the engine is running.

**START**

This is the position for starting the engine. Keep the key at this position while cranking the engine. When the engine starts, release the key.

**HEAT (preheat) position**

When starting the engine in cold weather, set the key to this position. When the key is set to the HEAT position, the engine intake air is heated to make it easier to start the engine. When the engine starts, release the key. The key automatically returns to the OFF position. Then start the engine by turning the key immediately to the START position.

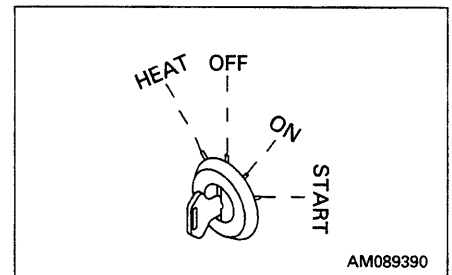

AM089390

## 11. EXPLANATION OF COMPONENTS

### 2. BATTERY SWITCH

During operations, always keep this switch at the ON position. Never turn it to the OFF position during operations. After stopping the engine, always turn it to the OFF position.

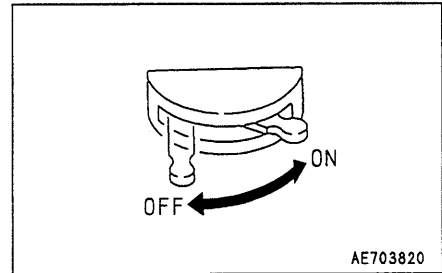

### 3. EMERGENCY STOP BUTTON

When this button is pressed, the engine will stop. Do not use this switch except during emergencies.

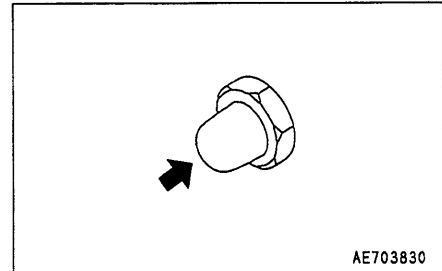

### 4. SPEED CONTROLLER (SPEED CONTROL HANDLE)

Turn the handle in the HIGH direction to increase the speed; turn the handle in the LOW direction to decrease the speed.

If the handle is turned fully in the LOW direction, the engine will stop.

After setting the engine speed and frequency, lock the handle in position with adjustment locknut ①.

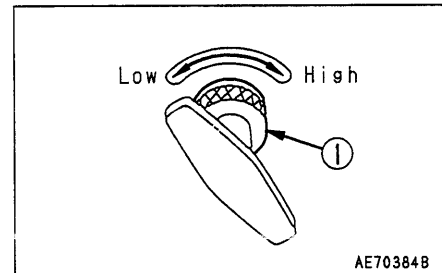

### 5. BREAKER (FOR 3-PHASE OUTPUT)

If the load is short circuited and excessive current flows, the electric circuit is automatically shut off.

Do not use this breaker to switch the load ON/OFF.

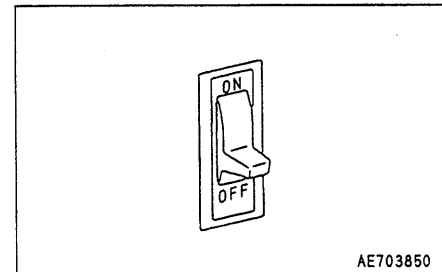

### 6. BREAKER (FOR OUTPUT)

If the load is short circuited and excessive current flows, the electric circuit is automatically shut off.

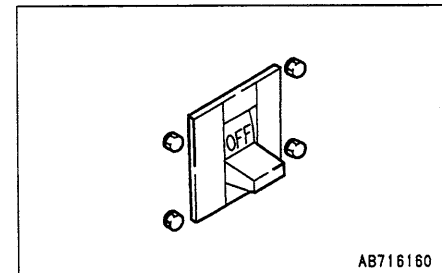

### 7. VOLTMETER SELECTOR SWITCH

Use this switch to display the output voltage between U and V, V and W, and W and U on the voltmeter.

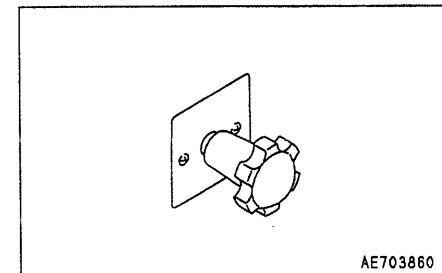

**8. AMMETER SELECTOR SWITCH**

Use this switch to select the output current U phase, V phase, or W phase on the ammeter.

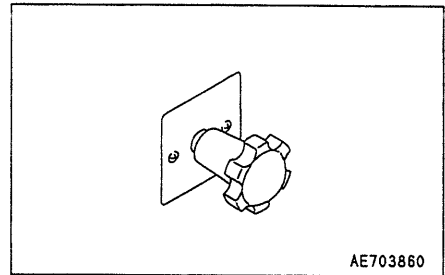

**9. VOLTAGE REGULATOR**

This regulates the output voltage as follows.  
 To INCREASE voltage, turn CLOCKWISE  
 To DECREASE voltage, turn COUNTERCLOCKWISE

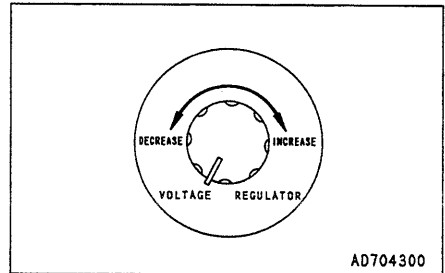

**10. SYNCHRONIZING SWITCH**

Turn the switch to select between single operation and parallel operation.

For single operation, turn the switch to the SINGLE side.

For parallel operation, turn the switch to the PARALLEL side.  
 (The synchro detector lamp and cross flows compensator circuit are actuated, and parallel operation becomes possible.)

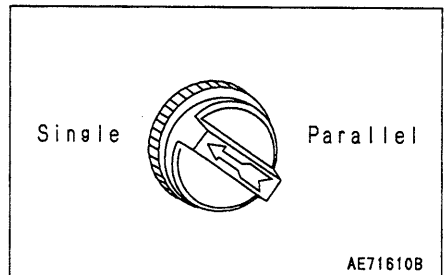

**11. PANEL LIGHT SWITCH**

This lights up the panel lighting.

ON position: Lamp lights up

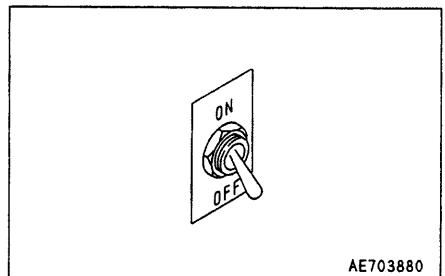

### 11.3 OUTPUT TERMINAL

#### 11.3.2 EG125B-2

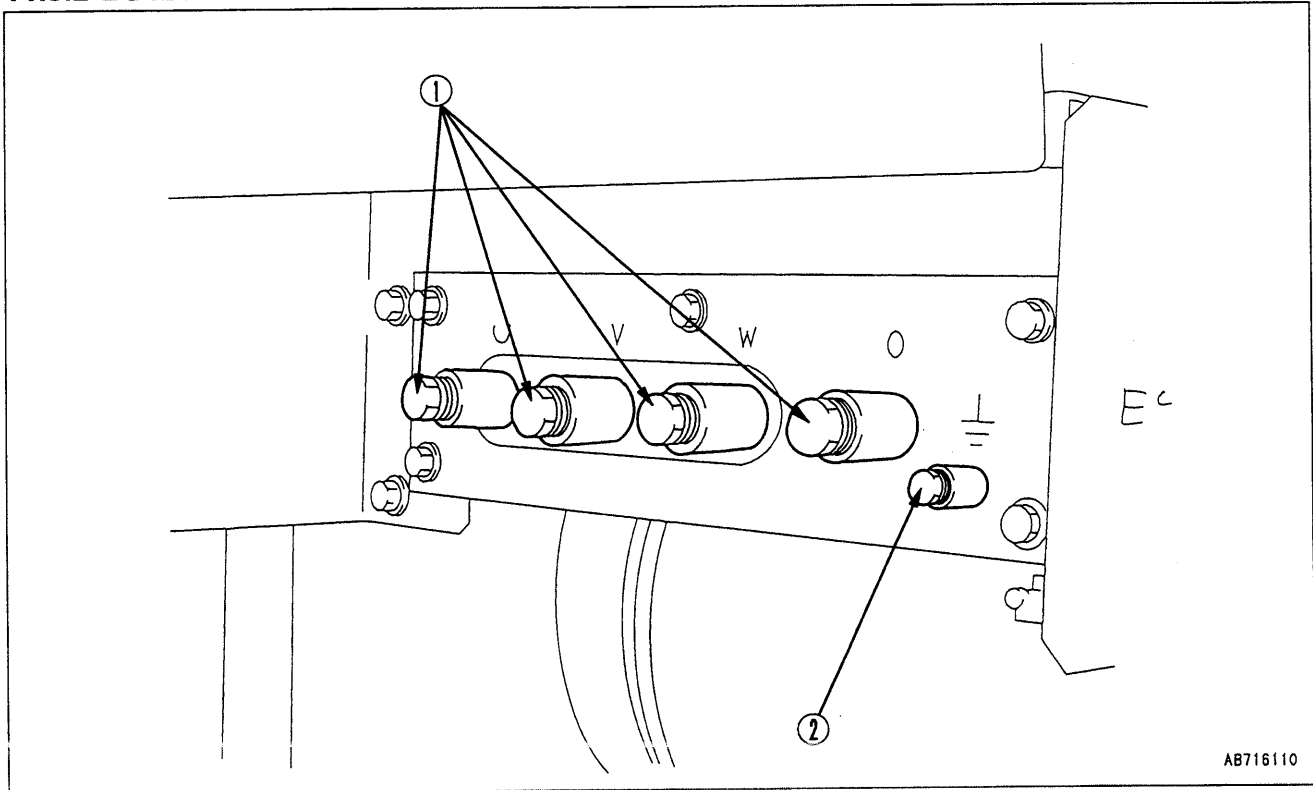

AB716110

#### 1. 3-PHASE OUTPUT TERMINAL

**⚠ WARNING**

**O terminal is not a ground, so never connect the ground cable to it.  
If O terminal is grounded, the danger of electric shock is increased.**

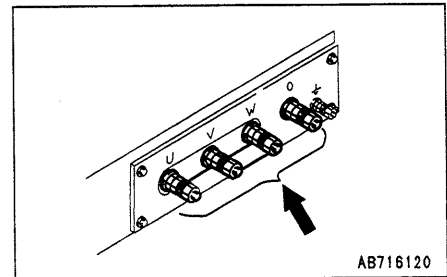

AB716120

The U terminal, V terminal, and W terminal are output terminals for the 3-phase output pick-up used on 3-phase induction motors, but they can also be used for single-phase.

#### 2. GROUNDING TERMINAL

This is the special terminal for grounding.

When the generator is installed to a wet place or to a steel plate, steel bar, etc. which is very conductive, be sure to bury the grounding cable deep under the ground.

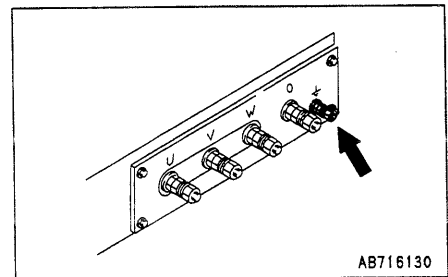

AB716130

11.3.2 EG125BS-2

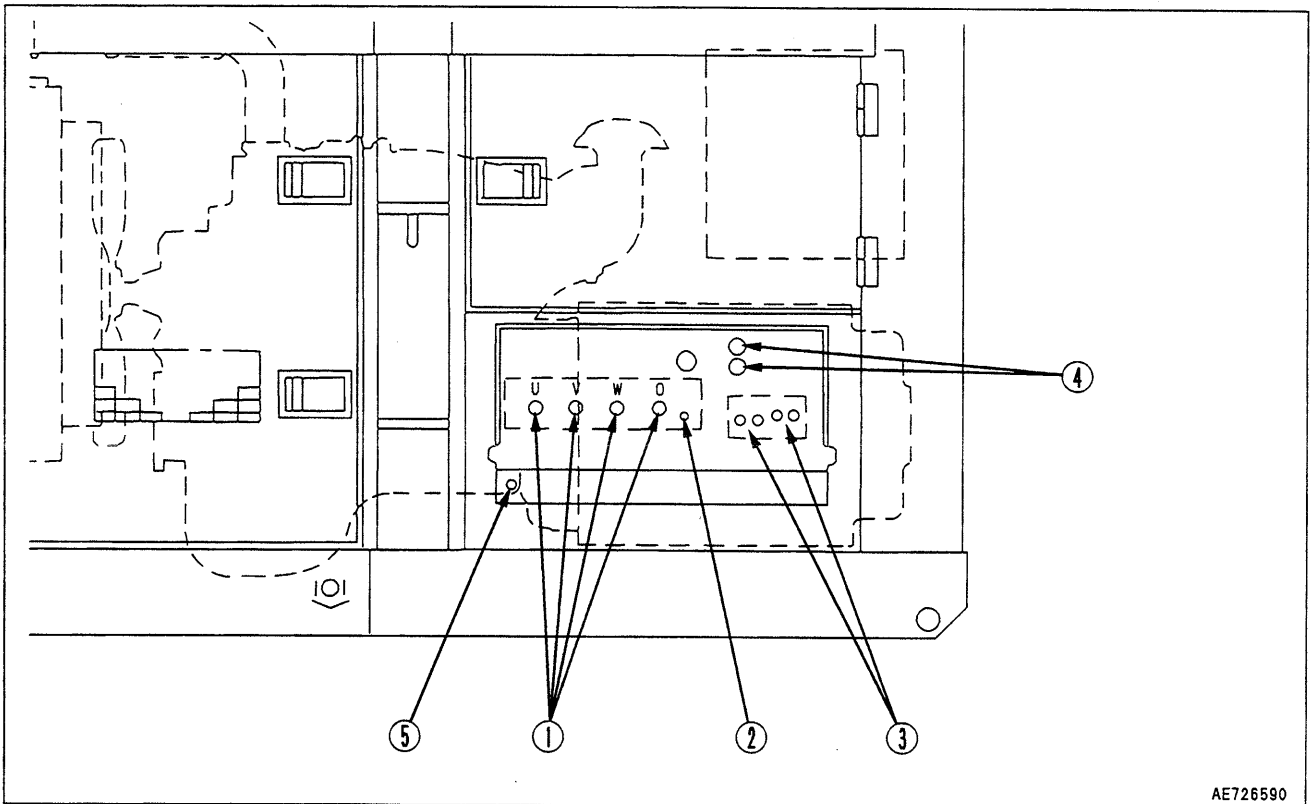

AE726590

1. 3-PHASE OUTPUT TERMINAL

**⚠ WARNING**

**O terminal is not a ground, so never connect the ground cable to it.  
If O terminal is grounded, the danger of electric shock is increased.**

The U terminal, V terminal, and W terminal are output terminals for the 3-phase output pick-up used on 3-phase induction motors, but they can also be used for single-phase.

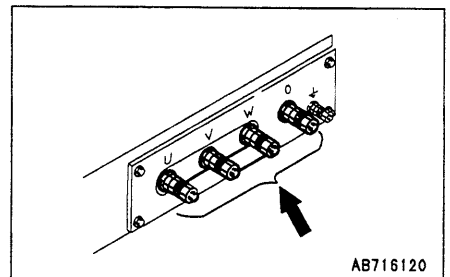

AB716120

2. GROUND TERMINAL (FOR ELECTRICAL LEAKAGE RELAY)

This terminal is used exclusively for the electrical leakage relay.

When operating in damp places, or in places with iron sheets or iron rods where there is high conductivity, always bury the ground cable securely deep in the ground.

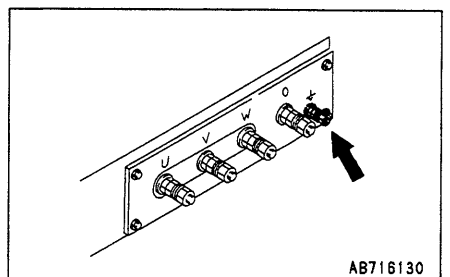

AB716130

## 11. EXPLANATION OF COMPONENTS

### 3. SINGLE-PHASE OUTPUT TERMINAL

This picks up the single-phase output. The single-phase (50/60 Hz, 100/110 V) output terminal gives 100/110 V single-phase output voltage when the AC ammeter shows 200/210 V.

When using 3-phase output, the single-phase output drops by this amount of output, so be extremely careful when using single-phase and 3-phase at the same time.

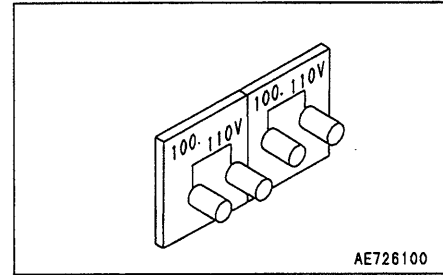

### 4. SINGLE-PHASE SOCKET

The single-phase socket is used for lighting. It takes the 100/110 V single-phase output.

It can also be used when 3-phase output is being used.

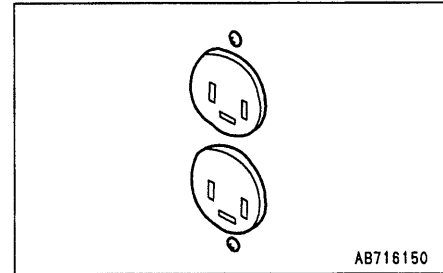

### 5. OUTER BOX GROUND TERMINAL

This terminal is used exclusively for the body ground.

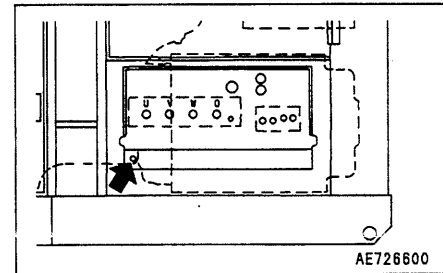

# 12. OPERATION

## 12.1 CHECK BEFORE STARTING ENGINE

### 12.1.1 WALK-AROUND CHECK

**⚠ WARNING**

Leakage of oil or fuel, or accumulation of flammable material around high temperature parts, such as the engine muffler may cause fire.

Check carefully, and if any abnormality is found, repair it or contact your Komatsu distributor.

Before starting the engine, look around the machine and under the machine to check for loose nut or bolts, or leakage of oil, fuel, or coolant. Check also for loose wiring, play, and collection of dust at places which reach high temperatures.

Always carry out the items in this section before starting the engine each day.

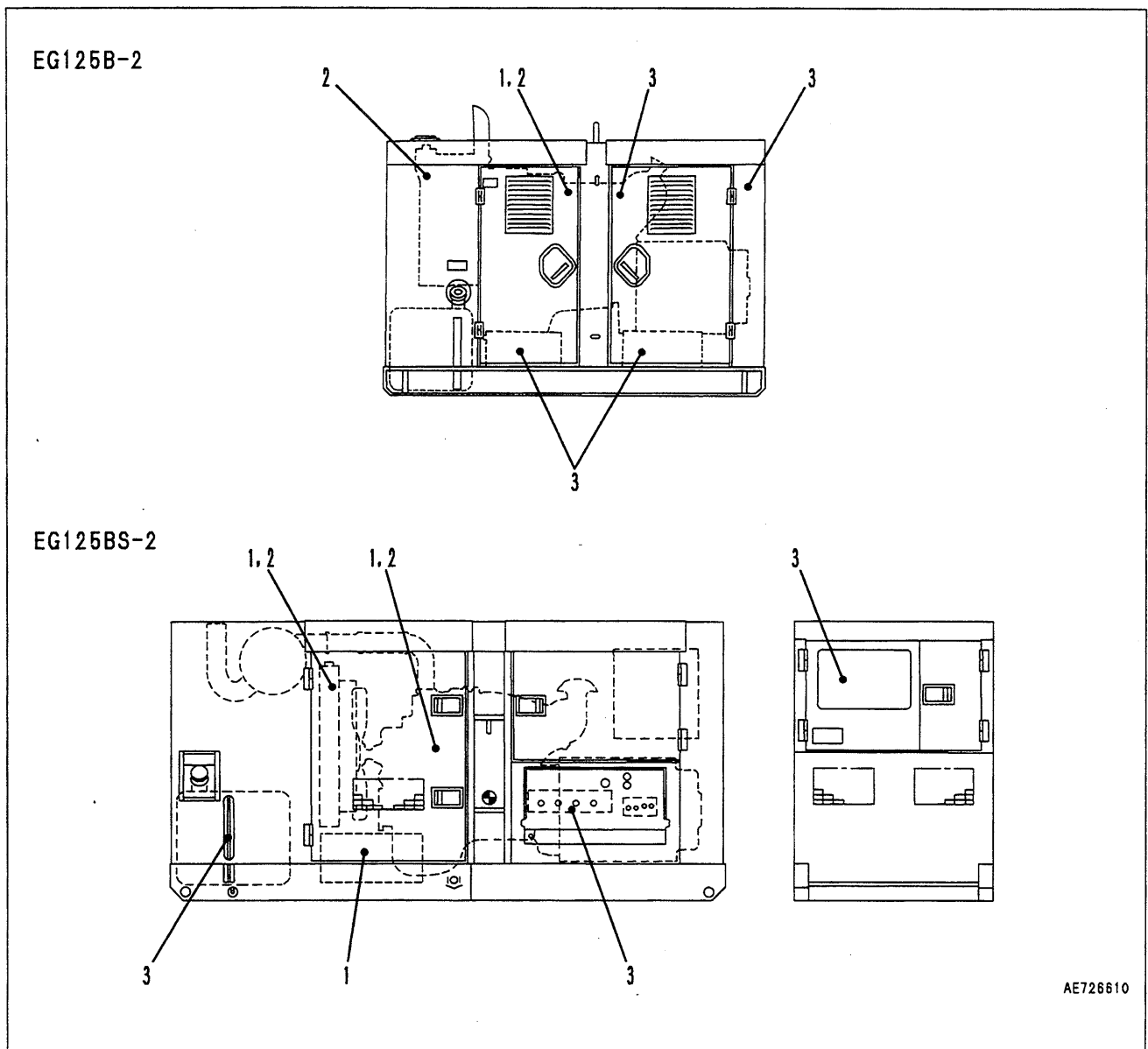

## 12. OPERATION

---

- 1. Remove dirt and dust from around engine, battery, radiator**  
Check if there is any dirt or dust accumulated around the engine or radiator. Check also if there is any flammable material (dead leaves, twigs, grass, etc.) accumulated around the battery or high temperature engine parts, such as the engine muffler or turbocharger. Remove all such dirt or flammable material.
- 2. Check for leakage of water or oil around engine**  
Check that there is no leakage of oil from the engine or leakage of water from the cooling system. If any abnormality is found, repair it.
- 3. Check for damage to gauges, monitor, loose bolts**  
Check that there is no damage to the gauges and monitor in the control panel. If any abnormality is found, replace the parts. Clean off any dirt on the surface.
- 4. Check for loose nuts of battery terminal**



### 12.1.2 CHECK BEFORE STARTING

Always carry out the items in this section before starting the engine each day.

#### CHECK COOLANT LEVEL, ADD WATER

**⚠ WARNING**

**Do not remove the cap when the radiator water temperature is high. Boiling water may spur out. When removing the cap, turn it slowly to release the internal pressure before removing it.**

● **EG125B-2**

1. Remove radiator cap ① and confirm that the cooling water is filled to the hatched level. Add water if necessary.
2. After adding water, tighten the cap securely.
3. If more water must be added than usual, check for water leakage.

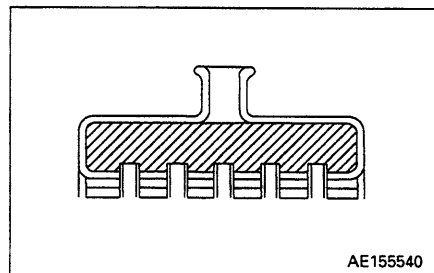
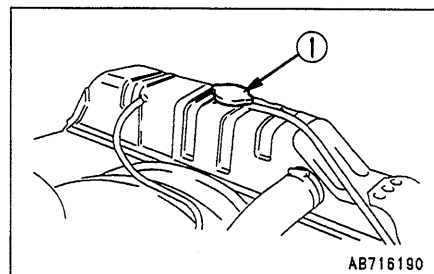

● **EG125BS-2**

1. Check that the cooling water is between the FULL and LOW marks on the reserve tank. If the level is low, remove cap ① and add water.
2. After adding water, tighten the cap securely.
3. If more water must be added than usual, check for water leakage.

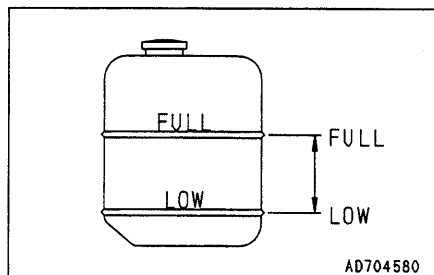
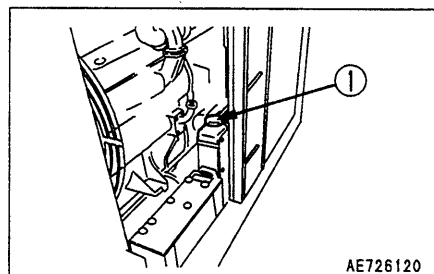

**CHECK FUEL LEVEL, ADD FUEL**

**⚠ WARNING**

**Spilled fuel will cause fire, so when adding fuel, be careful not to let the fuel overflow. Wipe up any spilled fuel completely.**

1. Check the fuel level with sight gauge ⑥.
2. If the fuel level is low, add fuel through fuel filler port ⑦.  
Always fill the tank after finishing operations.

**Fuel tank capacity:**

EG125B-2 260 l (68.6 US gal, 57.2 UK gal)  
EG125BS-2 250 l (66.0 US gal, 55.0 UK gal)

For details of the fuel to use, see "20. USE OF FUEL, COOLANT AND LUBRICANTS ACCORDING TO AMBIENT TEMPERATURE".

3. After filling with fuel, tighten the fuel filler securely.

**REMARK**

If the breather hole in the cap is clogged, the pressure inside the tank will go down and fuel will not be supplied properly, so clean the breather hole.

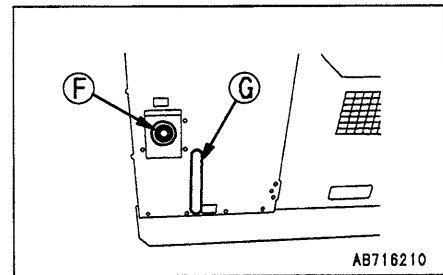

**CHECK OIL LEVEL IN ENGINE OIL PAN, ADD OIL**

1. Remove dipstick ③ and wipe it with a cloth.
2. Insert dipstick ③ fully in the dipstick guide, then pull it out again.
3. Check that the oil is between the H and L marks on dipstick ③. If it is not between the H and L marks, add engine oil through oil filler port ④.

For details of the oil to use, see "20. USE OF FUEL, COOLANT AND LUBRICANTS ACCORDING TO AMBIENT TEMPERATURE".

**REMARK**

When checking the oil level, wait for at least 15 minutes after stopping the engine.

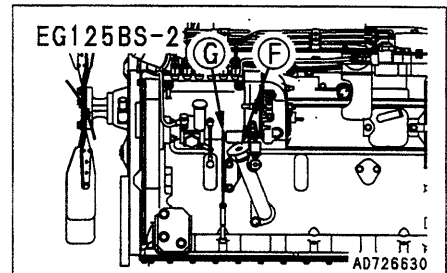
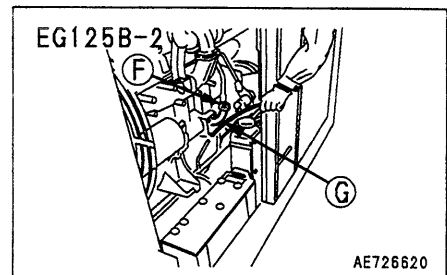
**CHECK DUST INDICATOR (EG125B-2)**

Check if the red piston of dust indicator ① has reached the service level.

If the red piston has appeared, clean or replace the element.

For the cleaning method of the element, see "24.2 WHEN REQUIRED".

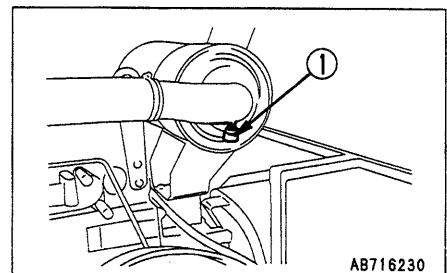
**CHECK AIR CLEANER FOR CLOGGING (EG125BS-2)**

Check that air cleaner clogging monitor ① is not lighted up. If it is lighted up, clean or replace the element.

For details of the method for cleaning the element, see "24.2 WHEN REQUIRED".

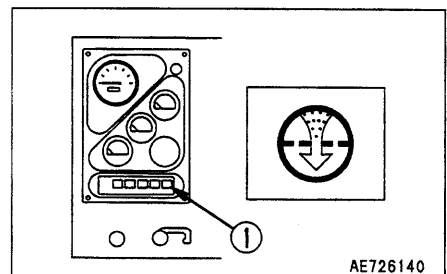
**CHECK ELECTRIC WIRING****⚠ WARNING**

- If fuses are frequently blown or if there are traces of short circuit on the electrical wiring, locate the cause and carry out repair.
- Accumulation of flammable material (dead leaves, twigs, grass, etc.) around the battery may cause fire, so always check and remove such material.
- Keep the top surface of the battery clean and check the breather hole in the battery cap. If it is clogged with dirt or dust, wash the battery cap to clean the breather hole.

Check for damage and wrong capacity of the fuse and any sign of disconnection or short circuit in the electric wiring. Check also for loose terminals and tighten any loose parts.

Check the wiring of the "battery", "starting motor" and "alternator" carefully, in particular.

When carrying out walk-around checks or checks before starting, always check if there is any accumulation of flammable material around the battery, and remove such flammable material.

### 12.1.3 OPERATIONS AND CHECKS BEFORE STARTING ENGINE

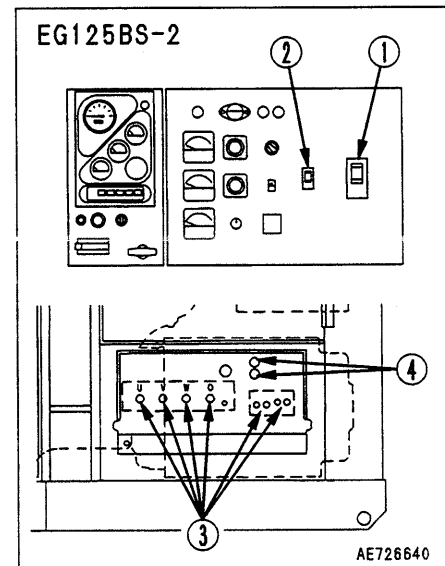
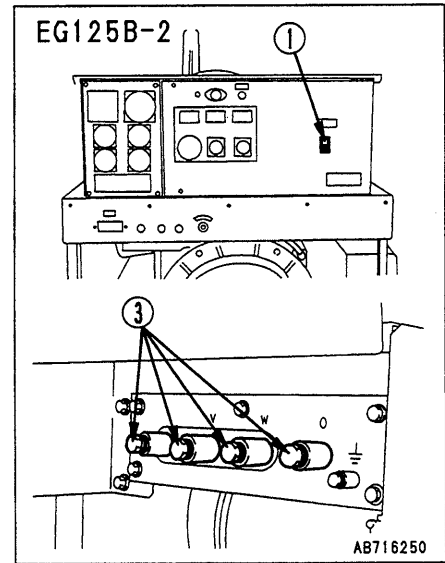

1. Check the position of the switches and knobs.
2. Check that the breakers (3-phase breaker ① and single-phase breaker ②) are at the OFF position.

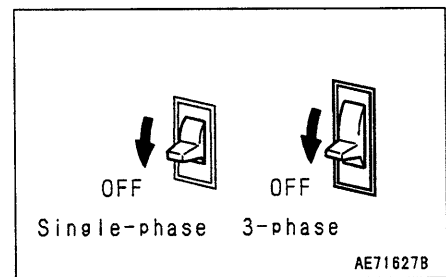

3. Check that the load cable is connected securely to output terminal ③ and single-phase socket ④.

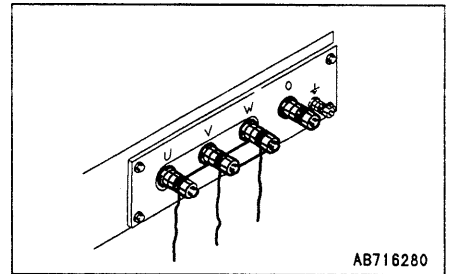

AB716280

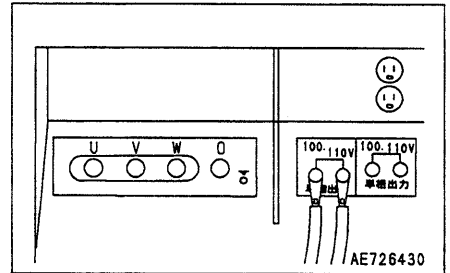

AE726430

12.1.4 LOAD CONNECTION

**WARNING**

- Stop the engine and turn the breaker OFF before connecting the load.
- Never connect bare cables directly. If bare cables are connected directly, they cannot be tightened sufficiently, and this will lead to abnormal generation of heat.
- Do not connect to the indoor wiring system (the wiring taking electricity from the normal power supply). If the load is connected to the indoor wiring, there is danger that excessive current will flow in the indoor wiring and the generator, and this will cause fire or electric shock.

Before starting, connect the load cable securely.

When connecting the load cable to output terminal ① and single-phase socket ②, do as follows.

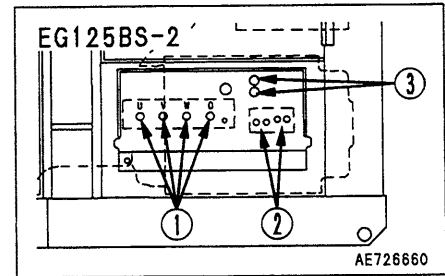
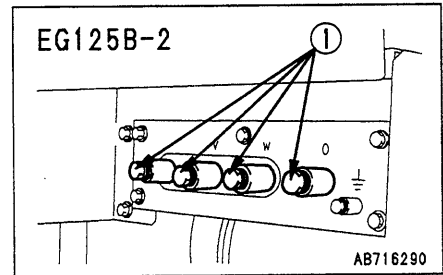

**CONNECTING SINGLE-PHASE LOAD**

When connecting the load for lights, single-phase induction motors, or welding equipment, which use single-phase, do as follows.

There are four output terminals: U, V, W, and O.

If the load is connected so that the load is balanced and each phase of current has an equal value, the equipment can be used up to the full rating.

- When connecting between O – U, O – V, and O – W

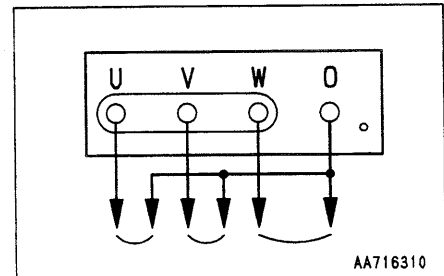

- When connecting between U – V, V – W, and W – U

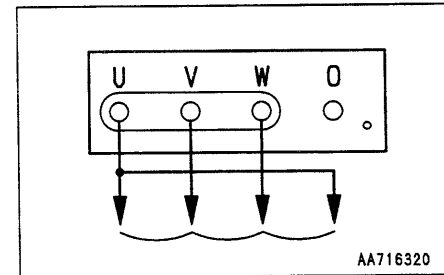

Terminal	Voltage
Between O – U, O – V, O – W	115/127 (V)
Between U – V, V – W, W – U	200/220 (V)
Outlet	100/110 (V)

- One outlet can be used up to the following capacity.

EG125BS ..... 10 KVA

**CONNECTING SINGLE-PHASE OUTPUT TERMINAL AND SOCKET**

Two sets of single-phase (50/60 Hz, 100/110 V) output terminals ② and two sockets ③, together with the breakers for them, are installed to the output terminal portion. When the AC voltmeter displays 200/220 V, the single-phase output voltage is 100/110 V.

**REMARK**

- When using 3-phase output, the single-phase output drops by this amount of output, so be extremely careful when using single-phase and 3-phase at the same time.  
Single-phase output terminal ① uses U phase and single-phase output terminal ② and the socket use W phase
- Each socket can be used up to 10 KVA.

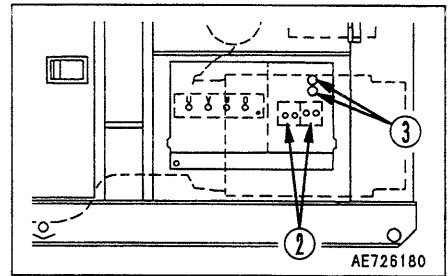

**CONNECTING 3-PHASE LOAD**

When connecting a load using 3-phase, such as 3-phase induction motors, do as follows.

The limit for use when connecting a load is that the value indicated on the ammeter must not exceed the rated current.

When connecting a 3-phase induction motor from U, V, and W, the motor may not turn even when the breaker is turned ON.

If this happens, change any two of the wires for U, V, or W.

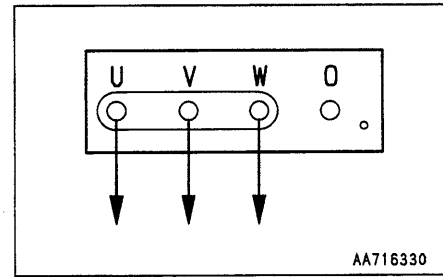

**METHOD OF CONNECTING LOAD CABLE FOR OUTPUT TERMINAL**

● **When using crimped terminal**

Lock the cable securely after connecting it to the output terminal.

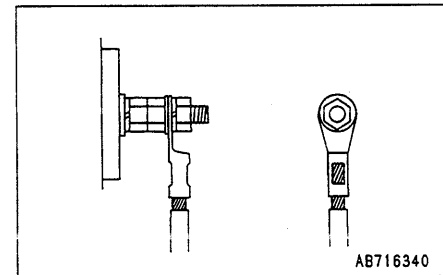

● **When not using crimped terminal**

If there is not a crimped terminal fitted to the cable, form the end of the cable in a shape to match the output, then connect it.

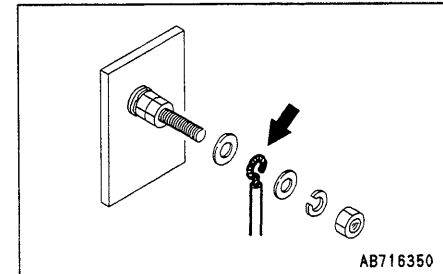



## 12.2 STARTING ENGINE

### 12.2.1 NORMAL STARTING

#### NOTICE

Do not keep the starting motor rotating continuously for more than 20 seconds.

After starting the engine, do not turn the starting switch to the OFF position.

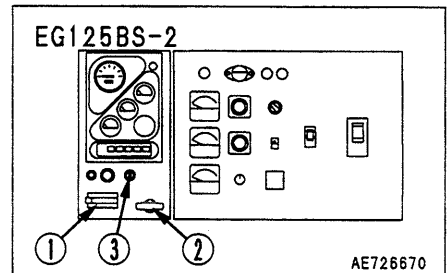
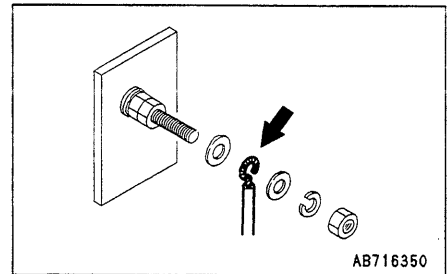

1. Turn battery switch ① ON.

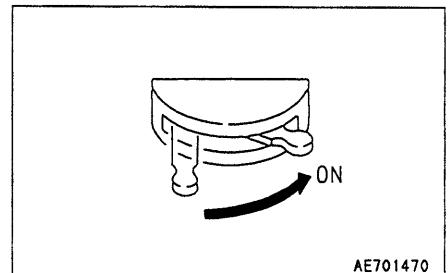

2. EG125B-2  
Set speed control handle ② to the "low idling" position (Push it in to the end, then pull it back about 1/3 of the stroke).

#### EG125BS-2

Turn speed control handle ② toward the high speed side by two - three turns.

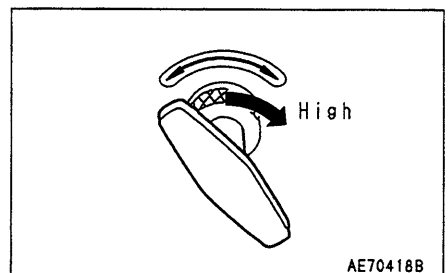
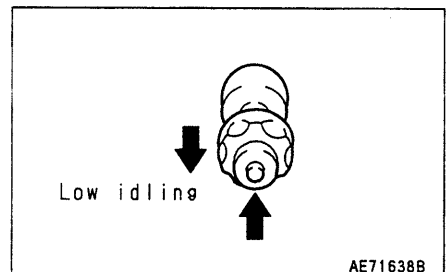

3. Turn the key in starting switch ③ to the START position and start the engine.

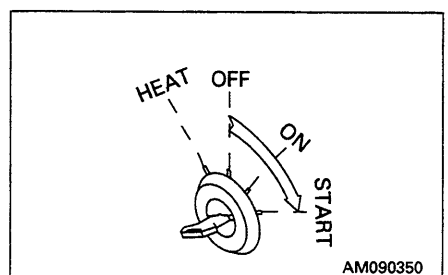

## 12. OPERATION

---

4. After starting the engine, release the key in starting switch ③.  
The key will return automatically to the ON position.

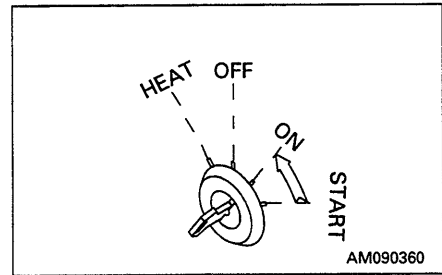

## 12.2.2 STARTING IN COLD WEATHER

**⚠ WARNING**

Never use starting aid fluids as they may cause explosions.

**NOTICE**

Do not keep the starting motor rotating continuously for more than 20 seconds.

If the engine fails to start, repeat steps from 3 and after waiting for about 2 minutes.

When starting in low temperatures, do as follows.

1. Turn battery switch ① ON.

2. EG125B-2

Set speed control handle ② to the "low idling" position (Push it in to the end, then pull it back about 1/3 of the stroke).

## EG125BS-2

Turn speed control handle ② toward the high speed side by two – three turns.

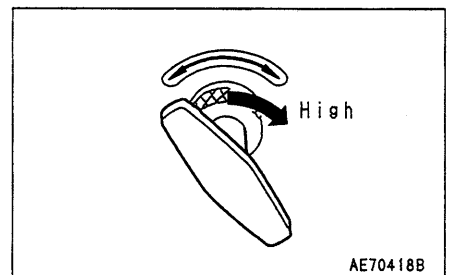
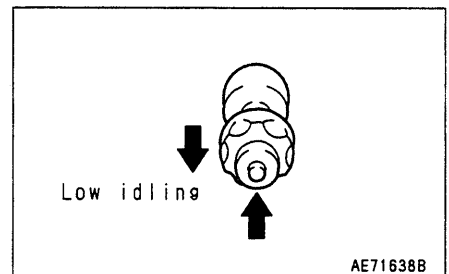
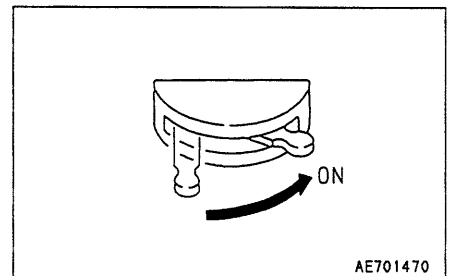
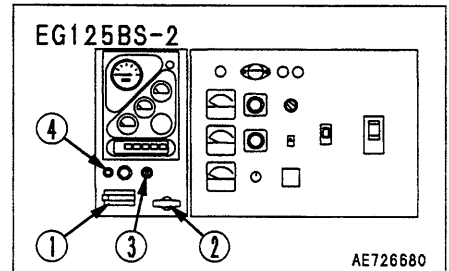
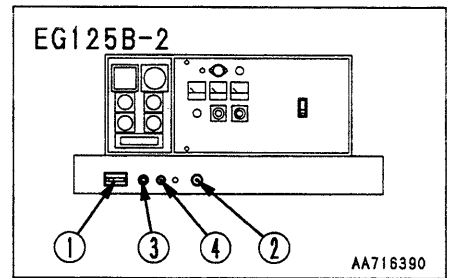

## 12. OPERATION

- Turn the key in starting switch ③ to the HEAT position and keep in this position until heater signal ④ glows red.

The preheating time is as follows.

Ambient emperature	Preheating time
0°C or above	—
0°C to -10°C	20 sec.
-10°C to -20°C	30 sec.

### REMARK

Starting will become difficult if the preheating time is either too short or too long. Always keep to the correct preheating time.

- When heater signal ④ glows red, turn the key in starting switch ③ to the START position and start the engine.

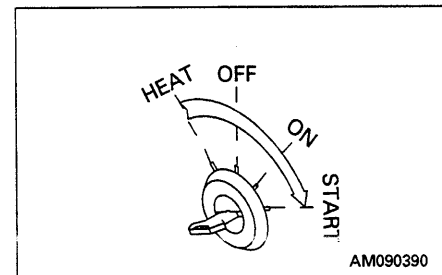
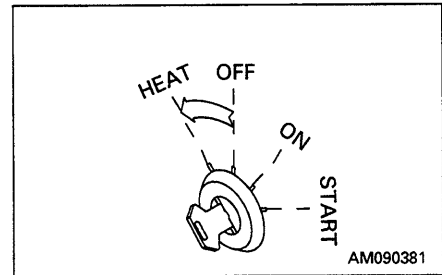

- After starting the engine, release the key in the starting switch. The key will return automatically to the ON position.

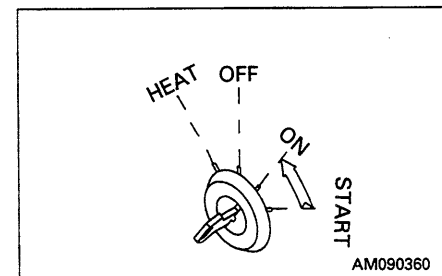

### 12.3 OPERATIONS AND CHECKS AFTER STARTING ENGINE

#### NOTICE

Do not suddenly accelerate the engine before the warming-up operation is completed.

Do not run the engine at low idling or high idling continuously for more than 20 minutes.

If it is necessary to run the engine at idling, apply a load from time to time or run the engine at a mid-range speed.

After starting the engine, do not immediately start operations. First, carry out the following operations and checks.

1. Run the engine at a mid-range speed, and run for approx. 5 minutes at low idling.
2. After warming up, check that the caution lamps are normal.
3. Run at a light load until engine water temperature gauge ① is in the operating range.
4. Check for any abnormal exhaust gas, noise, or vibration.

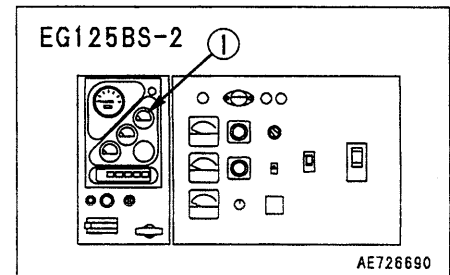
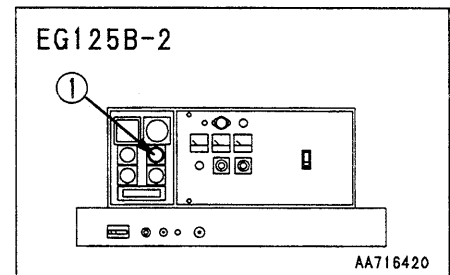

## 12.4 SETTING FREQUENCY AND VOLTAGE

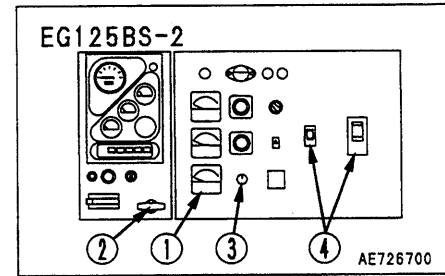
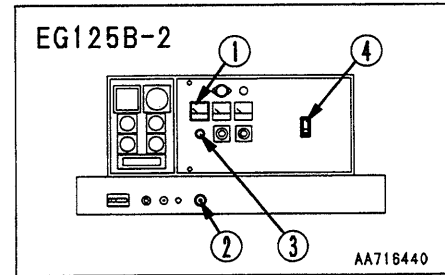

1. Check that frequency meter ① matches the low idling speed given below.

	Frequency gauge	Engine speed
Operating at 50 Hz	52.5 Hz	1,575 rpm
Operating at 60 Hz	62.5 Hz	1,875 rpm

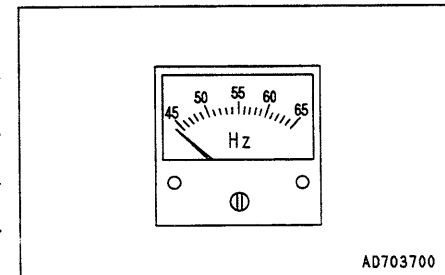

2. If the frequency is not normal or if it needs to be changed, adjust it with speed control handle ②.
3. After setting to the specified voltage with voltage regulator ④, turn breaker ⑤ ON.

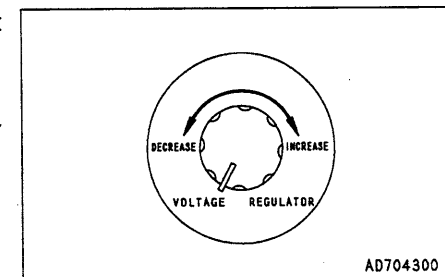

4. Adjust so that the gauges (tachometer, frequency gauge, AC voltmeter) are as shown in the diagram when running under load.

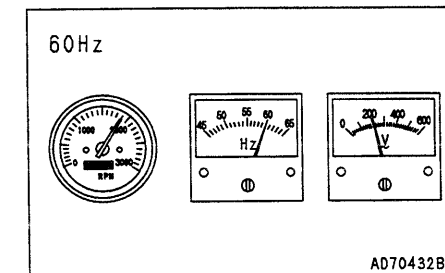
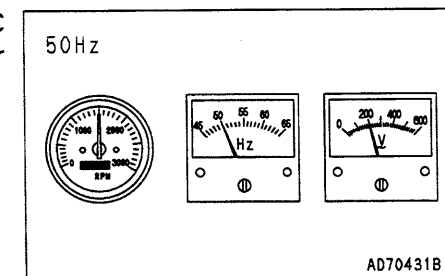

## 12.5 CHANGING VOLTAGE (EG125BS-2)

### ⚠ WARNING

- When opening the protective cover, be sure to stop the engine.
- If the shorting bar is connected wrongly, the generator may burn. Be careful.  
Clamp the shorting bar with the nuts securely. If it is loosened, it will heat up and cause a fire.

Set the rated voltage as follows according to the type of work and the district where the generator is used.

50 Hz	200 V, 400 V
60 Hz	220 V, 440 V

Select a desired output voltage according to the following procedure.

1. Remove the protective cover of the voltage changeover plate on the right side of the control box viewed from front.
2. Change the output voltage by changing the connection of the terminal of the voltage changeover plate and shorting bar ①.
3. After connecting shorting bar ①, change voltage changeover switch ② according to the connection of the shorting bar.

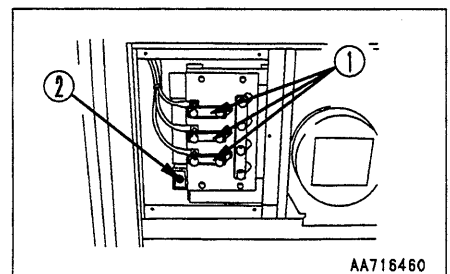

- 200V/220V connection diagram  
Turn the voltage changeover switch to the 200V position.

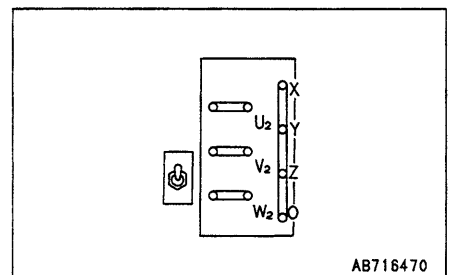

- 400V/440V connection diagram  
Turn the voltage changeover switch to the 400V position.

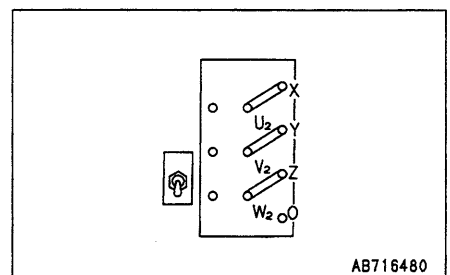

## 12.6 PARALLEL-ARRANGED OPERATION (EG125BS-2)

Since this machine is equipped with the following, two or more sets can be operated in parallel:

- Synchronizing switch (Single/Parallel change-over switch)
- Synchronizing lamp
- Crosscurrent compensation circuit

When operating two or more generators in parallel, their frequencies, voltages, and phases must be set to the same values. Operating the generators under this condition is called synchronized operation.

### NOTICE

Take care not to let the fuel run out while the generators are running.

### 12.6.1 CONNECTION METHODS

#### WARNING

- **Terminal O is not for grounding.**  
If it is connected to the ground, workers may suffer electric shocks and the machines may be damaged. Never connect terminal O to the ground.
- **Terminals of the same symbols (U – U, V – V, W – W)**  
If the terminals of different symbols are connected to each other, the generators and loads may be damaged and motors may rotate in reverse.

As shown in the diagram, connect the cables so that the terminals of the same symbols (U, V, W) on the terminal and load terminal boards are connected together.

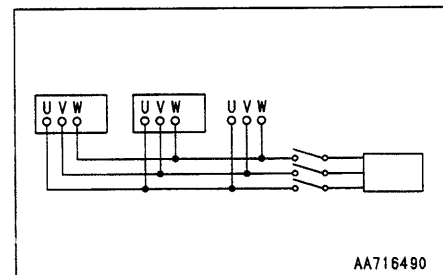



**12.6.2 OPERATION**

When operating in parallel-arranged operation under no load and switching to a load.

1. Turn synchronizing switch ① to the "PARALLEL" position.
2. Turn "off" circuit breaker ② of each generator and the switch on the load side.
3. Adjust the frequency and voltage of each generator to the rated values with speed control handle ③, then turn "on" circuit breaker ② of generator No. 1.
4. If the phase sequence of generator No. 1 is not matched to generator No. 2 (to be turned on), synchronizing lamps ④ light up alternately. In this case, stop the engine and change the connection of the generators, then confirm that the synchronizing lamps flashes simultaneously.
5. Turn speed control handle ③ so that the flashing period of the synchronizing lamp of generator No. 2 (to be turned on) becomes longer. After the flashing period exceeds 5 seconds, at the moment it goes off, turn "on" circuit breaker ② of generator No. 2.
6. Operate generators No. 3 and after according to Step 4 and Step 5.
7. If the ammeter reads more than "0", adjust the voltage regulator of each generator so that the ammeter will read "0".
8. Turn "on" the switch on the load side.
9. If the ammeters of all the generators do not read the same value, adjust them with speed control handle ③.

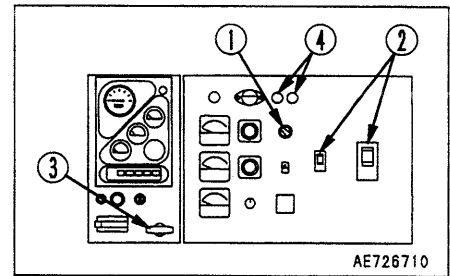

## 12. OPERATION

---

When running a second generator in parallel-arranged operator during operation under load.

1. Warm up the generator No. 2 (to be turned on).
2. Set the frequency and voltage of the generator No. 2 (to be turned on) slightly higher than the generator running under load.
3. Adjust with governor handle ② so that synchronizing lamp ① of the generator No. 2 (to be turned on) flashes slowly. When the flashing cycle is more than five seconds, switch on breaker ③ of generator No. 2 (to be turned on) at the moment synchronizing lamp ① stops flashing.
4. If the ammeter readings on each generator are not the same, adjust with speed control handle ②.

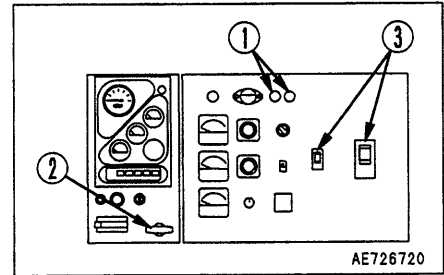

## 12.7 PRECAUTIONS FOR OPERATING

### 12.7.1 OPERATING

#### When operating outdoors

When operating on roads or outdoors, pay careful attention to the direction of the wind and the opening of the exhaust pipe to prevent exhaust gas from blowing into neighboring houses.

#### When operating indoors

- Operation and periodic maintenance are carried out around the machine, so a space of at least 1 m is needed.
- Use the exhaust pipe to take the exhaust gas outside when operating.
- When setting the machine up, connect it directly to a concrete foundation.

### 12.7.2 LOAD CONNECTION

- Always install a switch to turn the load ON/OFF between the output terminal board and load.  
If the generator breaker is used directly to switch the load ON/OFF, there is danger that it will cause failure of the breaker.
- When connecting directly to the load, always stop the engine and turn the control panel and output terminal board breaker OFF before starting.
- Be careful not to let the load connection cable touch the other output terminals at the output terminal portion.
- When the load connection is completed, close the output terminal cover and tighten with the lock bolts.

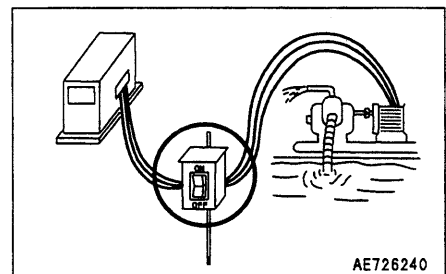

### 12.7.3 CABLE SELECTING

If the load current flowing through the cable exceeds the permitted current, it will cause burning out because of excess heat. If the cable is too thin for the length, the input voltage of the electrical equipment will drop, and this may reduce the production or prevent the machine from working.

The drop in the voltage from the current used and the thickness and length of the cable can be calculated by the following formula.

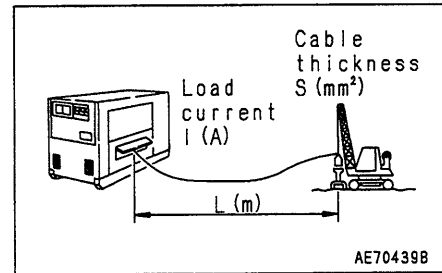

Drop in voltage e (V)

$$= \frac{1}{58} \times \frac{\text{length } L \text{ (m)}}{\text{thickness } S \text{ (mm}^2\text{)}} \times \text{current } I \text{ (A)} \times \sqrt{3}$$

Select the length and thickness of the cable so that the drop in the voltage is within 5%.

The relationship between the current used and the thickness, length, and permissible current in the insulated cable (single core and triple core) is as shown in the table below. (Note: The voltage used is taken as 200 V and drop in voltage as 10 V.)

Single core

(Unit: mm<sup>2</sup>)

Length(m) Current	Less than 50m	75m	100m	125m	150m	200m
50A	8	14	22	22	30	38
100A	22	30	38	50	50	60
200A	60	60	60	80	100	125
300A	100	100	100	125	150	200

Triple core

(Unit: mm<sup>2</sup>)

Length(m) Current	Less than 50m	75m	100m	125m	150m	200m
50A	14	14	22	22	30	38
100A	38	38	38	50	50	60
200A	38 x 2	38 x 2	38 x 2	50 x 2	50 x 2	60 x 2
300A	60 x 2	60 x 2	60 x 2	60 x 2	80 x 2	100 x 2

### 12.7.4 HANDLING ELECTRICAL LEAKAGE RELAY (EG125BS-2)

#### ⚠ WARNING

- Always connect the load end to the ground. If it is not grounded, there is danger that the electricity will flow through your body.  
This relay does not work for electrical leakage when the load is at the 100V/110V end, so always carry out grounding of the outer box (Type 3 grounding) of the load equipment.
- Always carry out individual grounding for the electrical leakage relay grounding terminal, outer box grounding terminal, and outer box of the load equipment. If the same ground is used, it may not prevent electric shock.
- If the method of grounding is not correct, the electrical leakage protection device may not work efficiently, and this may lead to death from electric shock.

The electrical leakage relay is installed to detect electrical leakage caused by defective insulation of the load used during operation and to shut off the circuit.

#### PRECAUTIONS FOR USE

- **Generator ground**
  - Carry out grounding with the supply (optional) ground bar from ground terminal ① of the output terminal board.  
Carry out grounding so that the grounding resistance is max. 500  $\Omega$  when the electrical leakage relay detection current is 30 mA.
  - Ground the outer box of the generator also from outer box ground terminal ②.
- **Grounding load equipment**
  - Carry out grounding work for the outer box of the load equipment in the same way as for the generator.

#### CHECKING ACTUATION

Check the actuation of the electrical leakage relay periodically as follows.

1. Start the generator and adjust to the rated voltage.
2. Turn the breaker ON.
3. Press the test button on the front face of the electrical leakage relay.

#### REMARK

When this is done, the electrical leakage display lamp (red) on the front face of the electrical leakage relay should light up and the breaker should break the circuit.

4. Press the reset button, switch the breaker OFF, then switch it ON to actuate the breaker again.

#### REMARK

Once the electrical leakage relay is actuated, it will remain actuated until the reset button is pressed or the generator is stopped.

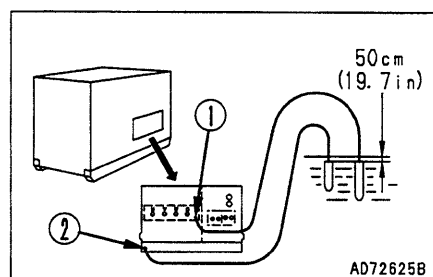
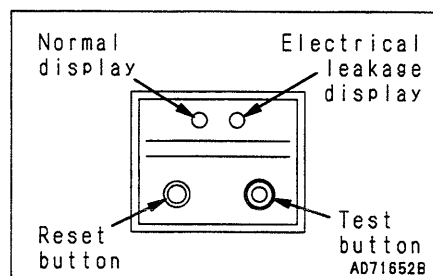

## 12.8 STOPPING ENGINE

### 12.8.1 NORMAL STOPPING

#### NOTICE

If the engine is abruptly stopped before it has cooled down, engine life may be greatly shortened. Consequently, do not abruptly stop the engine apart from an emergency.

In particular, if the engine has overheated, do not abruptly stop it but run it at medium speed to allow it to cool gradually, then stop it.

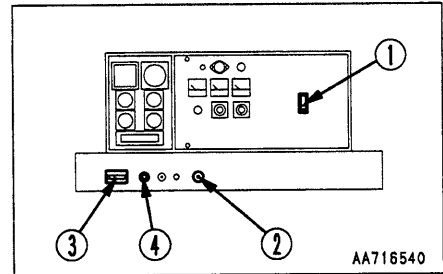

#### EG125B-2

1. Turn the breaker at the load end OFF.
2. Set breaker ① at the generator end to the OFF position.
3. Set speed control handle ② to the "low idling" position (Push it in to the end, then pull it back about 1/3 of the stroke), then run the engine idle at a low speed to cool it gradually.
4. Push in speed control handle ② toward "Low speed side" until the engine stops.
5. Turn starting switch ② to the OFF position, then turn battery switch ③ OFF.

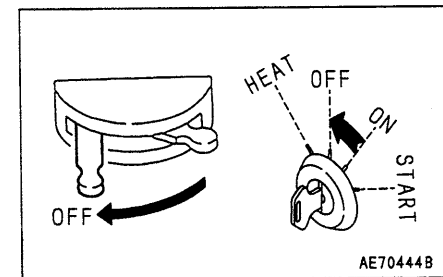
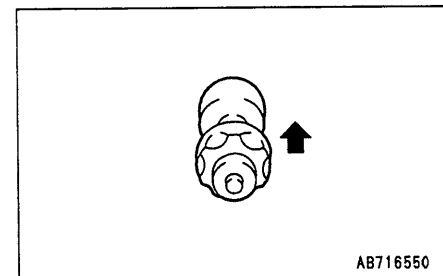
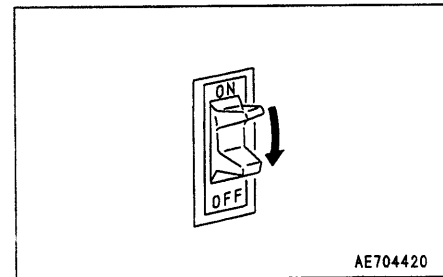

## EG125BS-2

## NOTICE

If the engine is abruptly stopped before it has cooled down, engine life may be greatly shortened. Consequently, do not abruptly stop the engine apart from an emergency.

In particular, if the engine has overheated, do not abruptly stop it but run it at medium speed to allow it to cool gradually, then stop it.

1. Turn the breaker at the load end OFF.
2. Set breaker ① at the generator end to the OFF position.
3. Set speed control handle ② to the "Low" position, then run the engine idle at a low speed to cool it gradually.
4. Push in speed control.
5. Turn starting switch ② to the OFF position, then turn battery switch ③ OFF.

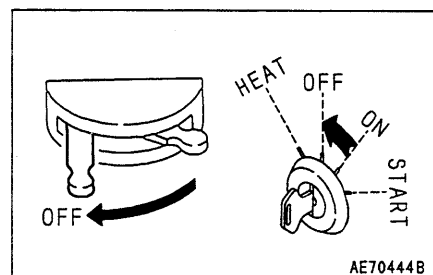
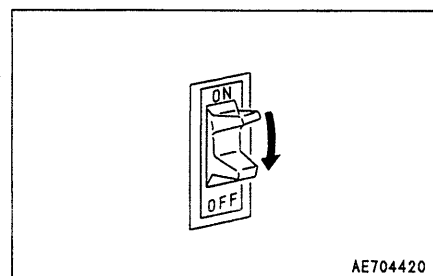
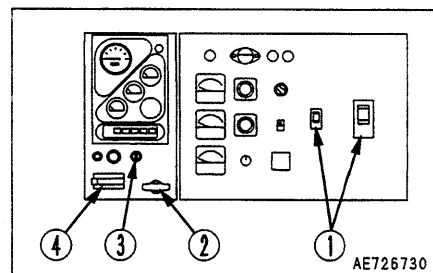

## 12.8.2 EMERGENCY STOPPING (EG125BS-2)

Keep emergency stop button ① pressed until the engine stops.

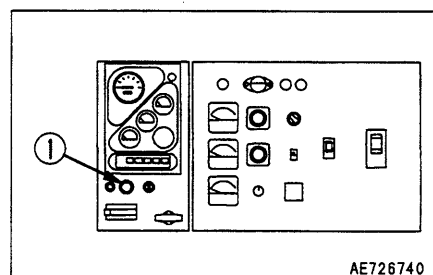
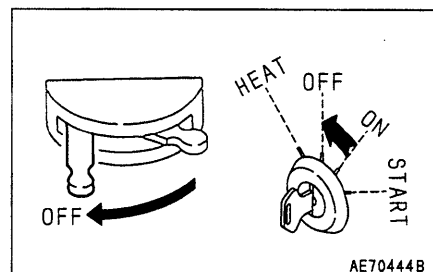

## 12.9 PRECAUTIONS FOR STACKING

**⚠ WARNING**

- Mistaken stacking can cause the stack to collapse or the machine to fall.
- Never operate the generator when the machines are stacked.

When stacking the generators for storage in confined spaces, do as follows.

### EG125B-2

- When operating the generators, do not pile them up.

### EG125BS-2

- Set the machine on firm horizontal ground.
- Never stack a machine of greater weight on top of this machine.
- When stacking, place wooden blocks at the places given on the name plate stuck to the machine.
- A maximum of two machines can be put in one stack. Never stack more than two machines in the same stack.
- When stacking, stack the top machine carefully to prevent any shock to the bottom machine.

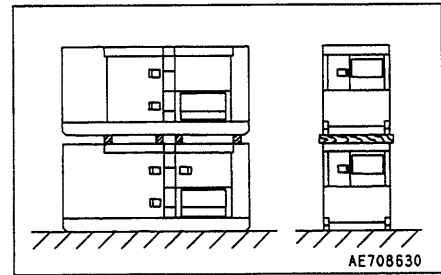



## 13. TRANSPORTATION

---

When transporting the machine, observe all related laws and regulations, and be careful to assure safety.

### 13.1 LOADING, UNLOADING WORK

**WARNING**

- When loading and unloading the machine, park the trailer on a flat firm roadbed. Keep a fairly long distance between the road shoulder and the machine.
- Do not lift the machine with a worker on it.
- When lifting the machine, use wire ropes sufficiently strong for the machine weight.
- Do not lift the machine in a different position from the position shown in the following procedure. If it is lifted in a different position, it may be unbalanced.
- When lifting the machine, balance it, being especially careful of the center of gravity.

1. Apply the brakes of the truck, and put blocks under the tires to prevent it from moving.
2. Stop the engine.
3. Set the lifting positions of the machine as shown in the diagram on the right.
4. Use a crane to load the machine at the specified position on the truck. Secure the machine with chains or wire rope to prevent it from moving during transportation. Be particularly careful to tie it down securely to prevent it from slipping to the side.

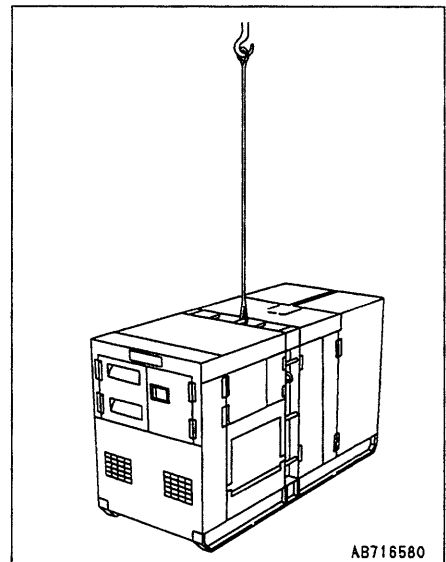

## 13.2 PRECAUTIONS FOR TRANSPORTATION

 **WARNING**

- **Determine the route for transporting the machine by taking into account the width, height and weight of the machine.**
- **Always check that the door is closed and locked before transporting the machine.**

Obey all state and local laws governing the weight, width and length of a load. Observe all regulations governing wide loads.

# 14. COLD WEATHER OPERATION

---

## 14.1 PRECAUTIONS FOR LOW TEMPERATURE

If the temperature becomes low, it becomes difficult to start the engine, and the coolant may freeze, so do as follows.

### 14.1.1 FUEL AND LUBRICANTS

Change to fuel and oil with low viscosity for all components. For details of the specified viscosity, see "20. USE OF FUEL, COOLANT AND LUBRICANTS ACCORDING TO AMBIENT TEMPERATURE".

### 14.1.2 COOLANT

 **WARNING**

**Keep antifreeze fluid away from an open flame. Never smoke when using antifreeze.**

#### NOTICE

- **Never use methanol, ethanol or propanol based antifreeze.**
- **Absolutely avoid using any water leak preventing agent irrespective of whether it is used independently or mixed with an antifreeze.**
- **Do not mix one antifreeze with a different brand.**

For details of the antifreeze mixture when changing the coolant, see "24.2 WHEN REQUIRED".

Use a Permanent Antifreeze (ethylene glycol mixed with corrosion inhibitor, antifoam agent, etc.) meeting the standard requirements as shown below. With permanent antifreeze, no change of coolant is required for a year. If it is doubtful that an available antifreeze meets the standard requirements, ask the supplier of that antifreeze for information.

Standard requirements for permanent antifreeze

- SAE ..... J1034
- FEDERAL STANDARD ..... O-A-548D

#### REMARK

Where no permanent antifreeze is available, an ethylene glycol antifreeze without corrosion inhibitor may be used only for the cold season. In this case, clean the cooling system twice a year (in spring and autumn). When refilling the cooling system, add antifreeze in autumn, but do not add any in spring.

### 14.1.3 BATTERY

**⚠ WARNING**

- To avoid gas explosions, do not bring fire or sparks near the battery.
- Battery electrolyte is dangerous. If it gets in your eyes or on your skin, wash it off with large amounts of water, and consult a doctor.

When the ambient temperature drops, the capacity of the battery will also drop. If the battery charge ratio is low, the battery electrolyte may freeze. Maintain the battery charge as close as possible to 100%, and insulate it against cold temperature so that the machine can be started easily the next morning.

**REMARK**

Measure the specific gravity and calculate the rate of charge from the following conversion table.

Temp. of fluid	20°C	0°C	-10°C	-20°C
Rate of charge				
100%	1.28	1.29	1.30	1.31
90%	1.26	1.27	1.28	1.29
80%	1.24	1.25	1.26	1.27
75%	1.23	1.24	1.25	1.26

## 14.2 PRECAUTIONS AFTER COMPLETION OF WORK

To prevent mud, water, or the undercarriage from freezing and making it impossible for the machine to move on the following morning, always observe the following precautions.

- Mud and water on the machine body should be completely removed. This is to prevent damage to the seal caused by mud or dirt getting inside the seal with frozen drops of water.
- Park the machine on hard, dry ground. If this is impossible, park the machine on wooden boards. The boards help protect the tracks from being freezed in soil and the machine can start next morning.
- Open the drain valve and drain any water collected in the fuel system to prevent it from freezing.
- As the battery capacity drops markedly in low temperatures, cover the battery or remove it from the machine, keep it in a warm place, and install it again the next morning.
- If electrolyte level is found low, add distilled water in the morning before beginning work. Do not add the water after the day's work so as to prevent fluid in the battery from freezing in the night.

## 14.3 AFTER COLD WEATHER

When season changes and the weather becomes warmer, do as follows.

- Replace the fuel and oil for all parts with oil of the viscosity specified.  
For details, see "20. USE OF FUEL, COOLANT AND LUBRICANTS ACCORDING TO AMBIENT TEMPERATURE".
- If for any reason permanent antifreeze cannot be used, and an ethyl glycol base antifreeze (winter, one season type) is used instead, or if no antifreeze is used, drain the cooling system completely, then clean out the inside of the cooling system thoroughly, and fill with fresh water.

## 15. LONG-TERM STORAGE

---

### 15.1 BEFORE STORAGE

When putting the machine in storage for a long time, do as follows.

- After every part is washed and dried, the machine shall be housed in a dry building. Never leave it outdoors.  
In case it is indispensable to leave it outdoors, park the machine on the well-drained concrete and cover it with canvas etc.
- Completely fill the fuel tank, lubricate and change the oil before storage.
- Disconnect the negative terminals of the battery and cover it, or remove it from the machine and store it separately.
- If the ambient temperature is expected to drop below 0°C, always add antifreeze to the cooling water.

### 15.2 DURING STORAGE

 **WARNING**

**If it is unavoidably necessary to carry out the rustpreventive operation while the machine is indoors, open the doors and windows to improve ventilation and prevent gas poisoning.**

Operate the engine and move the machine for a short distance once a month so that a new film of oil will be coated over movable parts and component surfaces. At the same time, also charge the battery.

### 15.3 AFTER STORAGE

#### NOTICE

**If the machine is stored without carrying out the monthly rust prevention operation, request your Komatsu distributor for service.**

Carry out the following procedure when taking the machine out of long-term storage.

- Wipe off all dirt, oil, and moisture from the inside and outside of the generator, then check the insulation resistance with a 500 V megger.  
If the insulation resistance is less than 1 MΩ, dry the generator.

## 16. TROUBLESHOOTING

### 16.1 AFTER RUNNING OUT OF FUEL

When starting after running out of fuel, fill with fuel, then fill the fuel filter cartridge with clean fuel and bleed the air from the fuel system before starting.

For details of bleeding the air, see "24.6 EVERY 500 HOURS SERVICE".

### 16.2 IF BATTERY IS DISCHARGED

#### WARNING

- When checking or handling the battery, stop the engine and turn the starting switch key to the OFF position before starting.
- Before starting the engine, wipe off the dust from the top of the battery with a wet cloth.
- The battery generates hydrogen gas, so there is danger of explosion. Do not bring lighted cigarettes near the battery, or do anything that will cause sparks.
- Battery electrolyte is dilute sulphuric acid, and it will attack your clothes and skin. If it gets on your clothes or on your skin, wash it immediately off with large amounts of water. If it gets in your eyes, wash it out with fresh water, and consult a doctor.
- When handling battery, always wear protective goggles.
- When removing the battery, first disconnect the cable from the ground (normally, from the negative  $\ominus$  terminal). When installing, install the positive  $\oplus$  terminal first. If a tool touches the cable connecting the positive terminal and the chassis, there is danger that it will cause sparks.
- If the terminals are loose, there is danger that the defective contact may generate sparks that will cause an explosion. When installing the terminals, install them tightly.
- When removing or installing, check which is the positive  $\oplus$  terminal and negative  $\ominus$  terminal.
- If the battery is replaced, secure it. If it is not secured, its terminals may be loosened and sparks will be made.

When removing, disconnect the cable from the ground terminal first.

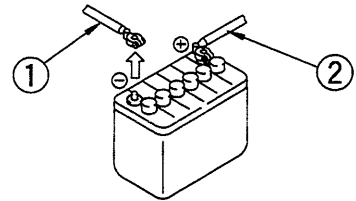

When installing, connect the cable to the positive  $\oplus$  terminal first.

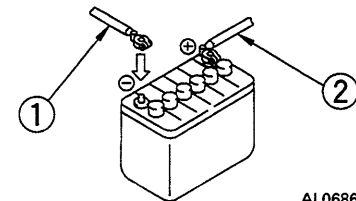

AL068670

### 16.2.1 REMOVING AND INSTALLING BATTERY

- When removing the battery, disconnect the grounded cable (from the negative  $\ominus$  terminal side, in general) first. If the terminal and the machine body is connected by a tool, etc., dangerous sparks will be made.
- When installing the battery, connect the grounded cable at last.
- After the battery is replaced, secure it with battery fitting.

Tightening torque of mounting nut

9.81 – 14.7 N·m (1 – 1.5 kgf·m, 7.2 – 10.8 lbft)

#### NOTICE

**Secure the battery, and confirm that it does not move. If it moves, secure it again.**

#### Charging battery while still mounted on machine

- There is danger that an abnormal voltage may be applied to the alternator and damage it, so remove the wires from the battery terminals when charging.
- Remove all the battery filler caps when charging to release the gas that is generated.
- If the battery overheats (the electrolyte exceeds 45°C), stop the charging temporarily.
- After completing charging, stop the charging immediately. If charging is continued after the charging is completed, the following problems will occur.
  - 1) Overheating of battery
  - 2) Reduction in battery electrolyte level
  - 3) Problems with battery
- When connecting the battery, be sure to connect the wires properly. Never connect ( $\oplus$  to  $\ominus$  or  $\ominus$  to  $\oplus$ ). Connecting the wires wrongly will cause damage to the alternator and other parts.
- Except when checking the battery electrolyte level or measuring the specific gravity, always remove the cables connected to the battery before handling the battery.



### 16.2.2 STARTING ENGINE WITH BOOSTER CABLE

When starting the engine with a booster cable, do as follows:

#### Precautions when connecting and disconnecting booster cable

#### WARNING

- When connecting the cables, never contact the positive  $\oplus$  and negative  $\ominus$  terminals.
- When starting the engine with a booster cable, always wear safety glasses.
- Be careful not to let the normal machine and problem machine contact each other. This prevents sparks from generating near the battery which could ignite the hydrogen gas given off by the battery. If hydrogen gas explodes, it could cause serious injury.
- Make sure that there is no mistake in the booster cable connections. The final connection is to the revolving frame, but sparks will be generated when this is done, so connect to a place as far as possible from the battery. (However, avoid connecting the cable to the work equipment, as conduction is poor.)
- Use care when removing the cables from the machine that has been started. Do not allow the cable ends to contact each other or the machine, to avoid hydrogen explosion.

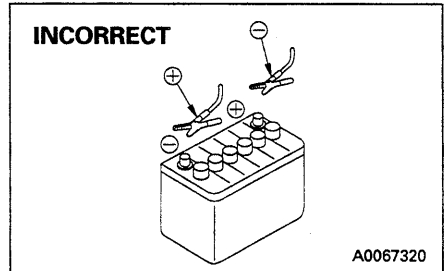

#### NOTICE

- The size of the booster cable and clip should be suitable for the battery size.
- The battery of the normal machine must be the same capacity as that of the engine to be started.
- Check the cables and clips for damage or corrosion.
- Make sure that the cables and clips are firmly connected.

**Connecting the booster cables**

Keep the starting switch at the OFF position.

Connect the booster cable as follows, in the order of the numbers marked in the diagram.

1. Make sure that the starting switches of the normal machine and problem machine are both at the OFF position.
2. Connect one clip of booster cable (A) to the positive (+) terminal of the problem machine.
3. Connect the other clip of booster cable (A) to the positive (+) terminal of the normal machine.
4. Connect one clip of booster cable (B) to the negative (-) terminal of the normal machine.
5. Connect the other clip of booster cable (B) to the engine block of the problem machine.

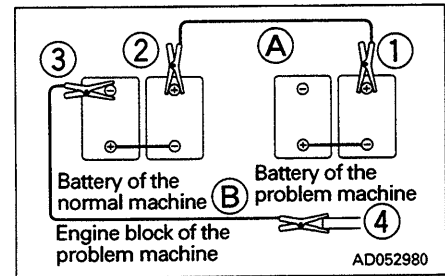
**Starting the engine**

1. Make sure the clips are firmly connected to the battery terminals.
2. Start the engine of the normal machine and keep it to run at high idling speed.
3. Turn the starting switch of the problem machine to the START position and start the engine. If the engine doesn't start at first, try again after 2 minutes or so.

**Disconnecting the booster cables**

After the engine has started, disconnect the booster cables in the reverse of the order in which they were connected.

1. Remove one clip of booster cable **(B)** from the engine block of the problem machine.
2. Remove the other clip of booster cable **(B)** from the negative  $\ominus$  terminal of the normal machine.
3. Remove one clip of booster cable **(A)** from the positive  $\oplus$  terminal of the normal machine.
4. Remove the other clip of booster cable **(A)** from the positive  $\oplus$  terminal of the problem machine.

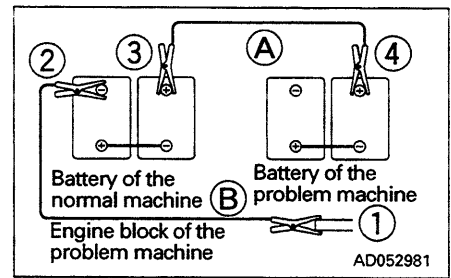

## 16.3 OTHER TROUBLE

### 16.3.1 ENGINE

- ( ): Always contact your Komatsu distributor when dealing with these items.
- In cases of abnormalities or causes which are not listed below, please contact your Komatsu distributor for repairs.

Problem	Main causes	Remedy
Engine oil pressure gauge is outside range of 0.25 – 0.49 MPa {2.5 – 5.0 kgf/cm <sup>2</sup> }	<ul style="list-style-type: none"> <li>● Lack of oil in oil pan (air sucked in)</li> <li>● Clogged oil filter cartridge</li> <li>● Oil leakage caused by damage, defective tightening of oil pipe, pipe joint</li> <li>● Defective oil pressure gauge</li> <li>● Viscosity of oil is too high</li> </ul>	<ul style="list-style-type: none"> <li>● Add oil to specified level</li> <li>● Replace cartridge</li> <li>● Inspect, repair</li> <li>● Replace oil pressure gauge</li> <li>● Change to specified oil</li> </ul>
Steam spurts out from top of radiator (pressure valve)	<ul style="list-style-type: none"> <li>● Lack of cooling water, water leakage</li> <li>● Loose fan belt</li> <li>● Dirt or scale accumulated in cooling system</li> <li>● Clogged radiator fin, damaged fin</li> <li>● Defective thermostat</li> <li>● Loose radiator filler cap (high altitude work)</li> <li>● Defective water temperature gauge</li> </ul>	<ul style="list-style-type: none"> <li>● Inspect, add cooling water, repair</li> <li>● Adjust tension</li> <li>● Change cooling water, clean inside of cooling system</li> <li>● Clean or repair (● Replace thermostat)</li> <li>● Tighten cap or replace packing</li> <li>● Replace water temperature gauge</li> </ul>
Water temperature gauge is outside range of 60 – 95°C	<ul style="list-style-type: none"> <li>● Lack of fuel</li> <li>● Air in fuel line</li> <li>● Defective fuel injection pump or nozzle</li> <li>● Starting motor cranks engine too slowly</li> <li>● Heater signal does not light up</li> <li>● Defective compression <ul style="list-style-type: none"> <li>○ Improper valve clearance</li> </ul> </li> </ul>	<ul style="list-style-type: none"> <li>● Add fuel</li> <li>● Repair location of air leakage (● Replace pump or nozzle)</li> <li>● See ELECTRICAL SYSTEM</li> <li>● See ELECTRICAL SYSTEM (○ Adjust valve clearance)</li> </ul>
Starting motor turns but engine does not start	<ul style="list-style-type: none"> <li>● Too much oil in oil pan</li> <li>● Improper fuel</li> </ul>	<ul style="list-style-type: none"> <li>● Reduce oil to specified level</li> <li>● Change to specified fuel</li> </ul>
Exhaust gas is white or bluish	<ul style="list-style-type: none"> <li>● Clogged air cleaner element</li> <li>● Defective nozzle</li> <li>● Defective compression</li> </ul>	<ul style="list-style-type: none"> <li>● Clean or replace (● Replace nozzle)</li> <li>● See defective compression above)</li> </ul>
Exhaust gas is sometimes black	<ul style="list-style-type: none"> <li>● Air entering from suction end of fuel line</li> </ul>	<ul style="list-style-type: none"> <li>● Repair location of air leakage</li> </ul>
There is hunting of engine	<ul style="list-style-type: none"> <li>● Low-class fuel being used</li> <li>● Overheating</li> <li>● Breakage inside muffler</li> <li>● Excessive valve clearance</li> </ul>	<ul style="list-style-type: none"> <li>● Change to specified fuel</li> <li>● See "Water temperature gauge is outside range of 60 – 95°C"</li> <li>● Replace muffler (● Adjust valve clearance)</li> </ul>
Abnormal noise is generated (combustion or mechanical system)		

### 16.3.2 ELECTRICAL SYSTEM

- ( ): Always contact your Komatsu distributor when dealing with these items.
- In cases of abnormalities or causes which are not listed below, please contact your Komatsu distributor for repairs.

Problem	Main causes	Remedy
Starting motor does not turn when starting switch is turned to START	<ul style="list-style-type: none"> <li>● Defective starting switch</li> <li>● Defective wiring</li> <li>● Insufficient battery charge</li> <li>● Defective battery relay switch</li> </ul>	<ul style="list-style-type: none"> <li>● Replace switch</li> <li>● Inspect or repair</li> <li>● Charge battery</li> <li>● Replace switch</li> </ul>
Starting motor cranks engine slowly	<ul style="list-style-type: none"> <li>● Insufficient battery charge</li> <li>● Defective starting motor</li> </ul>	<ul style="list-style-type: none"> <li>● Charge battery</li> <li>● Replace</li> </ul>
Starting motor disengages before engine starts	<ul style="list-style-type: none"> <li>● Defective wiring</li> <li>● Insufficient battery charge</li> </ul>	<ul style="list-style-type: none"> <li>● Inspect, repair</li> <li>● Charge battery</li> </ul>
Heater signal does not become red	<ul style="list-style-type: none"> <li>● Defective wiring</li> <li>● Disconnection in electric intake air heater</li> <li>● Defective actuation of heater relay switch</li> </ul>	<ul style="list-style-type: none"> <li>● Inspect, repair</li> <li>● Replace</li> <li>● Inspect, repair heater relay switch</li> </ul>
Heater signal becomes white hot	<ul style="list-style-type: none"> <li>● Preheating time is too long</li> <li>● Short circuit in electric intake air heater</li> </ul>	<ul style="list-style-type: none"> <li>● Do not repeat starting operation excessively</li> <li>● Replace</li> </ul>

**16.3.3 GENERATOR**

- ( ): Always contact your Komatsu distributor when dealing with these items.
- In cases of abnormalities or causes which are not listed below, please contact your Komatsu distributor for repairs.

Problem	Main causes	Remedy
Voltage is not generated (voltmeter does not move)	<ul style="list-style-type: none"> <li>● Defective voltmeter</li> <li>● Defective AVR</li> <li>● Defective speed regulator</li> </ul>	<ul style="list-style-type: none"> <li>(● Replace)</li> <li>(● Replace)</li> <li>(● Replace)</li> </ul>
Voltage is low (does not become rated voltage)	<ul style="list-style-type: none"> <li>● Defective voltmeter</li> <li>● Defective AVR</li> <li>● Defective speed regulator</li> <li>● Rotating speed is slow</li> </ul>	<ul style="list-style-type: none"> <li>(● Replace)</li> <li>(● Replace)</li> <li>(● Replace)</li> <li>● Increase speed</li> </ul>
Voltage is high (does not become rated voltage)	<ul style="list-style-type: none"> <li>● Defective voltmeter</li> <li>● Defective AVR</li> <li>● Defective speed regulator</li> <li>● Rotating speed is fast</li> </ul>	<ul style="list-style-type: none"> <li>(● Replace)</li> <li>(● Replace)</li> <li>(● Replace)</li> <li>● Decrease speed</li> </ul>
Voltage drops excessively when load is applied	<ul style="list-style-type: none"> <li>● Defective speed regulator</li> <li>● Imbalance of load</li> </ul>	<ul style="list-style-type: none"> <li>(● Replace)</li> <li>● Adjust balance</li> </ul>
Breaker cannot be switched ON	<ul style="list-style-type: none"> <li>● Defective breaker</li> <li>● Defective overcurrent relay</li> <li>● Short circuit in load circuit</li> </ul>	<ul style="list-style-type: none"> <li>(● Repair or replace)</li> <li>(● Replace)</li> <li>● Inspect</li> </ul>

# **MAINTENANCE**

## **17. GUIDES TO MAINTENANCE**

---

**Do not carry out any inspection and maintenance operation that is not given in this manual.**

**Perform maintenance work on hard, flat ground.**

**Check service meter:**

Check the service meter reading every day to see if the time has come for any necessary maintenance to be carried out.

**Komatsu genuine replacement parts:**

Use Komatsu genuine parts specified in the Parts Book as replacement parts.

**Komatsu genuine oils:**

Use Komatsu genuine oils and grease. Choose oils and grease with proper viscosities specified for ambient temperature.

**Always use clean oil and grease:**

Use clean oil and grease. Also, keep containers of the oil and grease clean. Keep foreign materials away from oil and grease.

**Keeping the machine clean:**

Always keep the machine clean. This makes it easier to find parts causing problems. Keep in particular grease fittings, breathers and oil level gauges clean and avoid foreign matters from getting in them.

**Be careful of hot water and oil:**

Draining hot oils and coolants and removing their filters immediately after the engine stops are hazardous. Allow the engine to cool.

If the oil has to be drained when it is cold, warm up the oil to a suitable temperature (approx. 20 – 40°C) before draining it.

**Checking foreign materials in drained oil and on filter:**

After oil is changed or filters are replaced, check the oil and filters for metallic particles and foreign materials. If large quantities of metallic particles or foreign materials are found, consult your Komatsu distributor.

**Fuel strainer:**

If your machine is equipped with a fuel strainer, do not remove it while fueling.

**Oil change:**

Check or change oils in the places where dust is scarce to keep foreign materials away from oils.

**Warning tag:**

Attach the warning tag to the starting switch or other appropriate control panel to avoid someone who is not aware of the circumstances from starting the engine.

**Obey precautions:**

During the operation, always obey the precautions on the safety label attached to the machine.



**Welding instructions:**

- Turn off the engine starting switch.
- Do not apply more than 200 V continuously.
- Connect grounding the cable within 1 m from the area to be welded.
- Avoid seals or bearings from being between the area to be welded and the position of grounding point.

**Fire prevention:**

Use nonflammable cleaner or light oil for cleaning parts. Keep flame or cigarette light away from light oil.

**Clamp faces:**

When O-rings or gaskets are removed, clean the clamp faces and replace the O-rings and gaskets with new ones. Be sure to fit O-rings and gaskets when assembling.

**Objects in your pockets:**

Keep your pockets free of loose objects which can fall out and drop into the machinery; especially when you work on the machinery while bending over it.

**Precautions when washing machine:**

- Never spray steam or water directly on the connectors and mechatronics parts.
- Do not allow water to get on control panel.
- Never spray steam or water directly at the radiator or oil cooler portions.

**Pre-and post-work checks:**

Before starting work in mud, rain, snow or at seashore, check plugs and valves for tightness. Wash the machine immediately after the work to protect components from rusting. Lubricate components more frequently than usual.

**Dusty worksites:**

When working at dusty worksites, do as follows:

- Inspect the dust indicator to see whether the air cleaner is blocked up. Clean the air cleaner at shorter intervals than specified.
- Clean the radiator core frequently to avoid clogging.
- Clean and replace the fuel filter frequently.
- Clean electrical components, especially the starting motor and alternator, to avoid accumulation of dust.

**Avoid mixing oils:**

Never mix oils of different brands. If you have only oil which is a different brand from the one that is used in the machine, do not add it but replace all the oil.

## 18. OUTLINES OF SERVICE

---

- Use Komatsu genuine parts for replacement.
- When changing or adding oil, do not use a different type of oil.
- Unless otherwise specified, the oil and coolant used at the time of shipment from the factory are as shown in the table below.

Item	Kind of fluid
Engine oil pan	SAE 10W-30 API classification CD
Fuel tank	ASTM D975 No. 2 (However, ASTM D975 No. 1 is used for the winter season (October to March))
Radiator	Komatsu Super Coolant (AF-ACL) 30% added to water

### 18.1 OUTLINE OF OIL, FUEL, COOLANT

#### 18.1.1 OIL

- Oil is used in the engine and work equipment under extremely severe conditions (high temperature, high pressure), and it deteriorates with use.  
Always use oil that matches the grade and temperature for use given in the Operation and Maintenance Manual. Even if the oil is not dirty, always replace the oil after the specified interval.
- Oil corresponds to blood in the human body, so always be careful when handling it to prevent any impurities (water, metal particles, dirt, etc.) from getting in.  
The majority of problems with machine are caused by the entry of such impurities.  
Take particular care not to let any impurities get in when storing or adding oil.
- Never mix oils of different grades or brands.
- Always add the specified amount of oil.  
Having too much oil or too little oil are both causes of problems.
- If the oil in the work equipment is not clear, there is probably water or air getting into the circuit.  
In such cases, please contact your Komatsu distributor.
- When changing the oil, always replace the related filters at the same time.
- We recommend you to have an analysis made of the oil periodically to check the condition of the machine. For those who wish to use this service, please contact your Komatsu distributor.

### 18.1.2 FUEL

- The fuel pump is a precision instrument, and if fuel containing water or dirt is used, it cannot work properly.
- Be extremely careful not to let impurities get in when storing or adding fuel.
- Always use the fuel specified in the Operation and Maintenance Manual.  
Fuel may congeal depending on the temperature when it is used (particularly in low temperature below  $-15^{\circ}\text{C}$ ), so it is necessary to change to a fuel that matches the temperature.
- To prevent the moisture in the air from condensing and forming water inside the fuel tank, always fill the fuel tank after completing the day's work.
- Before starting the engine, or when 10 minutes have passed after adding fuel, drain the sediment and water from the fuel tank.
- If the engine runs out of fuel, or if the filters have been replaced, it is necessary to bleed the air from the circuit.

### 18.1.3 COOLANT

- River water contains large amounts of calcium and other impurities, so if it is used, scale will stick to the engine and radiator, and this will cause defective heat exchange and overheating.  
Do not use water that is not suitable for drinking.
- When using anti-freeze, always observe the precautions given in the Operation and Maintenance Manual.
- Komatsu machines are supplied with Komatsu original anti-freeze in the coolant when the machine is shipped.  
This anti-freeze is effective in preventing corrosion of the cooling system.  
The anti-freeze can be used continuously for two years or 4000 hours. Therefore, it can be used as it is even in hot areas.
- Anti-freeze is inflammable, so be extremely careful not to expose it to flame or fire.
- The proportion of anti-freeze to water differs according to the ambient temperature.  
For details of the mixing proportions, see "24.2.2 CLEAN INSIDE OF COOLING SYSTEM."
- If the engine overheats, wait for the engine to cool before adding coolant.
- If the coolant level is low, it will cause overheating and will also cause problems with corrosion from the air in the coolant.

#### **18.1.4 GREASE**

- Grease is used to prevent twisting and noise at the joints.
- The nipples not included in the maintenance section are nipples for overhaul, so they do not need grease.  
If any part becomes stiff after being used for long time, add grease.
- Always wipe off all of the old grease that is pushed out when greasing. Be particularly careful to wipe off the old grease in places. Where sand or dirt sticking in the grease would cause wear of the rotating parts.

#### **18.1.5 STORING OIL AND FUEL**

- Keep indoors to prevent any water, dirt, or other impurities from getting in.
- When keeping drum cans for a long period, put the drum on its side so that the filler port of the drum can is at the side. (To prevent moisture from being sucked in)  
If drum cans have to be stored outside, cover them with a waterproof sheet or take other measures to protect them.
- To prevent any change in quality during long-term storage, be sure to use in the order of first in - first out (use the oldest oil or fuel first).

#### **18.1.6 FILTERS**

- Filters are extremely important safety parts. They prevent impurities in the fuel and air circuits from entering important equipment and causing problems.  
Replace all filters periodically. For details, see the Operation and Maintenance Manual.  
However, when working in severe conditions, it is necessary to consider replacing the filters at shorter intervals according to the oil and fuel (sulfur content) being used.
- Never try to clean the filters (cartridge type) and use them again. Always replace with new filters.
- When replacing oil filters, check if any metal particles are stuck to the old filter. If any metal particles are found, please contact your Komatsu distributor.
- Do not open packs of spare filters until just before they are to be used.
- Always use Komatsu genuine filters.

## 18.2 OUTLINE OF ELECTRIC SYSTEM

- If the wiring gets wet or the insulation is damaged, the electric system leaks and this could result in hazardous malfunction of the machine.
- Services relating to the electric system are (1) check of fan belt tension, (2) check of damage or wear in the fan belt and (3) check of battery fluid level.
- Never remove or disassemble any electric components installed in the machine.
- Never install any electric components other than these specified by Komatsu.
- Be careful to keep the electric system free of water when washing the machine or when it rains.
- Since the controller for the control system may cause malfunction due to external wave interference, before installing a radio receiver and a walkie-talkie or citizen band, consult your Komatsu distributor.
- When working on the seashore, carefully clean the electric system to prevent corrosion.
- When installing a car cooler or any other electrical equipment, connect it to an independent power source connector. The optional power source must never be connected to the fuse, starting switch, or battery relay.

## 19. WEAR PARTS LIST

Wear parts such as the filter element, air cleaner element, etc. are to be replaced at the time of periodic maintenance or before their abrasion limits.

The wear parts should be changed correctly in order to use the machine economically.

For part change, Komatsu genuine parts of excellent quality should be used.

When ordering parts, please check the part number in the parts book.

### EG125B-2

Item	Part No.	Part Name	Q'ty	Replacement interval
Engine oil filter	6136-51-5121	Cartridge	1	Every 250 hours service
Air cleaner	6131-82-7011	Element assembly	1	Every 250 hours service
Fuel filter	600-311-8293	Cartridge	1	Every 500 hours service
Electrical air-intake heater	6136-11-4850	Gasket	2	Every 500 hours service

### EG125BS-2

Item	Part No.	Part Name	Q'ty	Replacement interval
Engine oil filter	6735-51-5140	Cartridge	1	Every 250 hours service
Fuel filter	6732-71-6110	Cartridge	1	Every 500 hours service
Air cleaner	600-181-6540	Single element assembly	1	-
	600-181-6050	Double element assembly (option)	1	
Electrical air-intake heater	6732-11-4810	Gasket	2	-

# 20. USE OF FUEL, COOLANT AND LUBRICANTS ACCORDING TO AMBIENT TEMPERATURE

## PROPER SELECTION OF FUEL, COOLANT AND LUBRICANTS

RESERVOIR	KIND OF FLUID	AMBIENT TEMPERATURE										CAPACITY	
		-22 -30	-4 -20	14 -10	32 0	50 10	68 20	86 30	104 40	122 50	°F	°C	Specified
Engine oil pan (EG125B-2)	Engine oil	SAE 30										24ℓ 6.34 US gal 5.28 UK gal	22ℓ 5.81 US gal 4.84 UK gal
		SAE 10W											
		SAE 10W-30											
		SAE 15W-40											
Engine oil pan (EG125BS-2)	Engine oil	SAE 30										22ℓ 5.81 US gal 4.84 UK gal	21ℓ 5.54 US gal 4.62 UK gal
		SAE 10W											
		SAE 10W-30											
		SAE 15W-40											
Fuel tank	Diesel fuel	ASTM D975 No.2										260ℓ (EG125B-2) 68.6 US gal 57.2 UK gal	-
		※											
Cooling system	Water	Add antifreeze										30ℓ (EG125B-2) 7.92 US gal 6.6 UK gal	-
												21.5ℓ (EG125BS-2) 5.68 US gal 4.73 UK gal	-

※ ASTM D975 No. 1

**REMARK**

- When fuel sulphur content is less than 0.5%, change oil in the oil pan every periodic maintenance hours described in this manual.  
Change oil according to the following table if fuel sulphur content is above 0.5%.

Fuel sulphur content	Change interval of oil in engine oil pan
0.5 to 1.0%	1/2 of regular interval
Above 1.0%	1/4 of regular interval

- When starting the engine in an atmospheric temperature of lower than 0°C, be sure to use engine oil of SAE10W, SAE10W-30 and SAE15W-40, even though an atmospheric temperature goes up to 10°C more or less in the day time.
- Use API classification CD as engine oil and if API classification CC, reduce the engine oil change interval to half.
- There is no problem if single grade oil is mixed with multigrade oil (SAE10W-30, 15W-40), but be sure to add single grade oil that matches the temperature in the table.
- We recommend Komatsu genuine oil which has been specifically formulated and approved for use in engine and hydraulic work equipment applications.

Specified capacity: Total amount of oil including oil for components and oil in piping.

Refill capacity: Amount of oil needed to refill system during normal inspection and maintenance.

ASTM: American Society of Testing and Material

SAE: Society of Automotive Engineers

API: American Petroleum Institute



**METHOD OF HANDLING WHEN HEAVY OIL A IS USED AS FUEL**

● **Properties of heavy oil A**

When using heavy oil A as the fuel, use an oil that fulfills the following properties.

Specific gravity	Flash point	Dynamic viscosity	10% residual oil, residual carbon	Sulfur content	Setane value
15/4°C	°C	50°Ccst	%	%	-
0.82 – 0.86	Min. 60	2.0 – 3.5	Max. 1.0	Max. 0.8	Min. 45

● **Storage of heavy oil A**

- 1) The moisture, dirt, and sediment in heavy oil A will sink to the bottom because of the difference in specific gravity. Therefore, when taking the oil from a drum can or storage tank, take from the top, and drain the sediment.
- 2) Always keep the fuel tank full. This can prevent moisture from forming on the inside wall of the tank (condensation), which will prevent moisture from entering the oil.

If the sulfur content of the fuel exceeds 0.5%, always carry out analysis of the oil being used (new oil), and determine the oil change interval from the chart below.

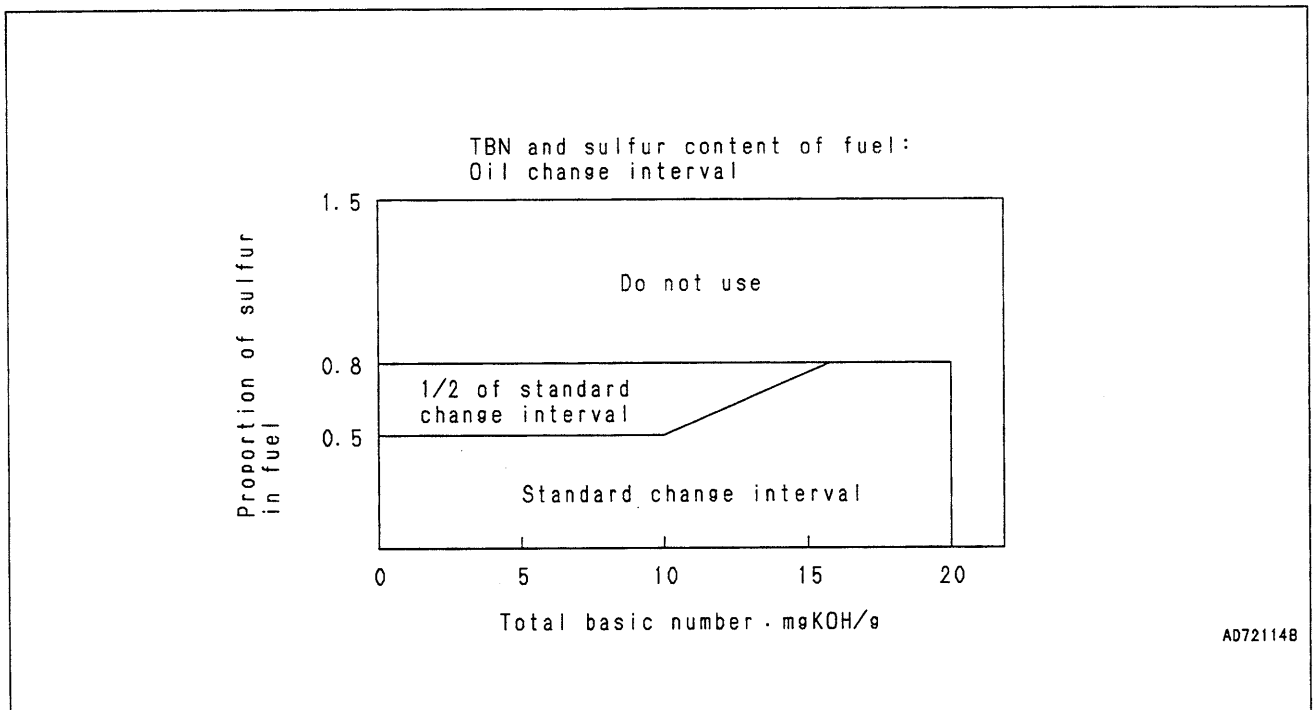

**Note:** The total basic number (TBN) of class CE and CF-4 oil is low, so it may be impossible to use it together with high sulfur content fuel.  
We recommend that you check the sulfur content of the fuel and the TBN of the new oil before starting and follow the chart above to determine the use.

20. USE OF FUEL, COOLANT AND LUBRICANTS ACCORDING TO AMBIENT TEMPERATURE

No.	Supplier	Engine Oil [CD or CE] SAE10W, 30, 40 10W30, 15W40 (The 15W40 oil marked * is CE.)	Gear Oil [GL-4 or GL-5] SAE80, 90, 140	Grease [Lithium-Base] NLGI No. 2	Anti-freeze Coolant [Ethylene Glycol Base] Permanent Type
1	KOMATSU	EO10-CD EO30-CD EO10-30CD EO15-40CD	GO90 GO140	G2-LI G2-LI-S	AF-ACL AF-PTL AF-PT (Winter, one season type)
2	AGIP	Diesel sigma S Super dieselmulti- grade *Sigma turbo	Rotra MP	GR MU/EP	-
3	AMOCO	*Amoco 300	Multi-purpose gear oil	RYKON premium grease	-
4	ARCO	*Arcofleet S3 plus	Arco HD gear oil	Litholine HEP 2 Arco EP moly D	-
5	BP	Vanellus C3	Gear oil EP Hypogear EP	Energrease LS-EP2	Antifreeze
6	CALTEX	*RPM delo 400 RPM delo 450	Universal thuban Universal thuban EP	Marfak all purpose 2 Ultra-duty grease 2	AF engine coolant
7	CASTROL	*Turbomax *RX super CRD	EP EPX Hypoy Hypoy B Hypoy C	MS3 Spheerol EPL2	Anti-freeze
8	CHEVRON	*Delo 400	Universal gear	Ultra-duty grease 2	-
9	CONOCO	*Fleet motor oil	Universal gear lubricant	Super-sta grease	-
10	ELF	Multiperformance 3C Performance 3C	-	Tranself EP Tranself EP type 2	Glacelf
11	EXXON (ESSO)	Essolube D3 *Essolube XD-3 *Essolube XD-3 Extra *Esso heavy duty Exxon heavy duty	Gear oil GP Gear oil GX	Beacon EP2	All season coolant
12	GULF	Super duty motor oil *Super duty plus	Multi-purpose gear lubricant	Gulfcrown EP2 Gulfcrown EP special	Antifreeze and coolant
13	MOBIL	Delvac 1300 *Delvac super 10W-30, 15W-40	Mobilube GX Mobilube HD	Mobilux EP2 Mobilgrease 77 Mobilgrease special	-

**20. USE OF FUEL, COOLANT AND LUBRICANTS ACCORDING TO AMBIENT TEMPERATURE**

No.	Supplier	<b>Engine Oil [CD or CE]</b> SAE10W, 30, 40 10W30, 15W40 (The 15W40 oil marked * is CE.)	<b>Gear Oil [GL-4 or GL-5]</b> SAE80, 90, 140	<b>Grease [Lithium-Base]</b> NLGI No. 2	<b>Anti-freeze Coolant [Ethylene Glycol Base] Permanent Type</b>
14	PENNZOIL	*Supreme duty fleet motor oil	Multi-purpose 4092 Multi-purpose 4140	Multi-purpose white grease 705 707L White – bearing grease	Anti-freeze and summer coolant
15	PETROFINA	FINA kappa TD	FINA potonic N FINA potonic NE	FINA marson EPL2	FINA tamidor
16	SHELL	Rimula X	Spirax EP Spirax heavy duty	Alvania EP grease	–
17	SUN	–	Sunoco GL5 gear oil	Sunoco ultra prestige 2EP Sun prestige 742	Sunoco antifreeze and summer coolant
18	TEXACO	*Ursa super plus Ursa premium	Multigear	Multifak EP2 Starplex 2	Code 2055 startex antifreeze coolant
19	TOTAL	Rubia S *Rubia X	Total EP Total transmission TM	Multis EP2	Antigel/antifreeze
20	UNION	*Guardol	MP gear lube LS	Unoba EP	–
21	VEEDOL	*Turbostar *Diesel star MDC	Multigear Multigear B Multigear C	–	Antifreeze

## 21. STANDARD TIGHTENING TORQUES FOR BOLTS AND NUTS

### 21.1 INTRODUCTION OF NECESSARY TOOLS

The following tools are needed when carrying out maintenance.

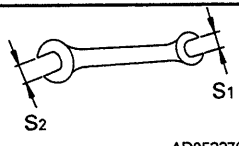
No.	Name of tool	Part No.	Remarks
1	Wrench set	09000-30006	Applicable width across flats ( $S_1 - S_2$ ) 8 mm - 10 mm, 12 mm - 14 mm 13 mm - 17 mm, 19 mm - 22 mm 24 mm - 27 mm, 30 mm - 32 mm  <small>AD053370</small>
2	Screw driver	09033-00190	Interchangeable flat-head and cross-head type
3	Filter wrench	09019-08035	
4	Plier	09036-00150	

If any of the above tools are broken, please order them from your Komatsu distributor.

**21.2 TORQUE LIST**

Unless otherwise specified, tighten the metric bolts and nuts to the torque shown in the table.

The tightening torque is determined by the width across the flats (b) of the nut and bolt.

If it is necessary to replace any nut or bolt, always use a Komatsu genuine part of the same size as the part that was replaced.

Nm (newton meter): 1 N·m ≅ 0.1 kgf·m  
 ≅ 0.74 lbft

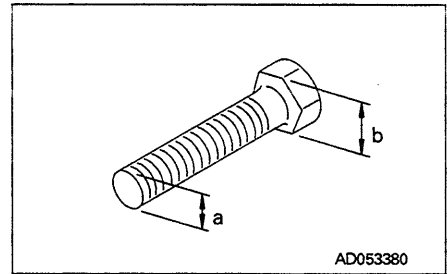

Thread diameter of bolt (mm) (a)	Width across flat (mm) (b)	AD054300		
		N·m	kgf·m	lbft
6	10	13.2 ± 1.4	1.35 ± 0.15	9.73 ± 1.03
8	13	31.4 ± 2.9	3.2 ± 0.3	23.2 ± 2.1
10	17	65.7 ± 6.8	6.7 ± 0.7	48.5 ± 5.0
12	19	112 ± 9.8	11.5 ± 1.0	82.6 ± 7.2
14	22	177 ± 19	18.0 ± 2.0	131 ± 14
16	24	279 ± 29	28.5 ± 3	206 ± 21
18	27	383 ± 39	39 ± 3	282 ± 29
20	30	549 ± 58	56 ± 6	405 ± 43
22	32	745 ± 78	76 ± 8	549 ± 58
24	36	927 ± 98	94.5 ± 10	684 ± 72
27	41	1320 ± 140	135 ± 15	973 ± 100
30	46	1720 ± 190	175 ± 20	1270 ± 140
33	50	2210 ± 240	225 ± 25	1630 ± 180
36	55	2750 ± 290	280 ± 30	2030 ± 210
39	60	3280 ± 340	335 ± 35	2420 ± 250

**NOTICE**

When tightening panels or other parts having tightening fixtures made of plastic, be careful not to use excessive tightening torque: doing so will damage the plastic parts.

## **22. PERIODIC REPLACEMENT OF SAFETY CRITICAL PARTS**

To ensure safety at all times when operating or driving the machine, the user of the machine must always carry out periodic maintenance. In addition, to further improve safety, the user should also carry out periodic replacement of the parts given in the table. These parts are particularly closely connected to safety and fire prevention.

With these parts, the material changes as time passed, or they easily wear or deteriorate. However, it is difficult to judge the condition of the parts simply by periodic maintenance, so they should always be replaced after a fixed time has passed, regardless of their condition. This is necessary to ensure that they always maintain their function completely.

However, if these parts show any abnormality before the replacement interval has passed, they should be repaired or replaced immediately.

If the hose clamps show any deterioration, such as deformation or cracking, replace the clamps at the same as the hoses.

When replacing the hoses, always replace the O-rings, gaskets, and other such parts at the same time.

Ask your Komatsu distributor to replace the safety critical parts.

**SAFETY CRITICAL PARTS**● **EG125B-2**

No.	Safety critical parts for periodic replacement	Q'ty	Replacement interval
1	Fuel hose (Fuel tank – Injection pump)	1	Every 2 years or 4000 hours, whichever comes sooner
2	Fuel hose (Injection pump – Fuel filter)	2	
3	Spill hose (Nozzle – Fuel tank)	1	

● **EG125BS-2**

No.	Safety critical parts for periodic replacement	Q'ty	Replacement interval
1	Fuel hose (Fuel tank – Injection pump)	1	Every 2 years or 4000 hours, whichever comes sooner
2	Fuel hose (Injection pump – Fuel tank)	1	
3	Spill hose (Nozzle – Fuel tank)	1	
4	Turbocharger lubrication hose	1	
5	Fuel hose (Fuel filter's head – Spill tube)	1	

## 23. MAINTENANCE SCHEDULE CHART

### 23.1 MAINTENANCE SCHEDULE CHART

SERVICE ITEM	PAGE
<b>INITIAL 250 HOURS SERVICE</b>	
Replace fuel filter cartridge	3-40
Check engine valve clearance, adjust	3-44
<b>WHEN REQUIRED</b>	
Check, clean and replace air cleaner element	3-21
Clean inside of cooling system	3-27
Check electrical air-intake heater	3-30
<b>CHECK BEFORE STARTING</b>	
Check coolant level, add water	3-31
Check fuel level, add fuel	3-32
Check oil level in engine oil pan, add oil	3-33
Check dust indicator (EG125B-2)	3-33
Check air cleaner for clogging (EG125BS-2)	3-33
Check electric wiring	3-34
<b>EVERY 50 HOURS SERVICE</b>	
Drain water and sediment from fuel tank	3-35
<b>EVERY 250 HOURS SERVICE</b>	
Check level of battery electrolyte	3-36
Check fan belt tension, adjust (EG125B-2)	3-37
Check insulation resistance	3-37
Check grease of shaft bearing	3-37
Change oil in engine oil pan, replace engine oil filter cartridge	3-38
<b>EVERY 500 HOURS SERVICE</b>	
Replace fuel filter cartridge	3-40
Check, clean radiator fins	3-42
<b>EVERY 1000 HOURS SERVICE</b>	
Check clamping parts of turbocharger	3-43
Check play of turbocharger rotor	3-43
Check fan belt tension, replace (EG125BS-2)	3-43



<b>SERVICE ITEM</b>	<b>PAGE</b>
<b>EVERY 2000 HOURS SERVICE</b>	
Clean engine breather element (EG125B-2)	3-44
Clean, check turbocharger	3-44
Check alternator and starting motor	3-44
Check engine valve clearance, adjust	3-44
Check vibration damper	3-44
<b>EVERY 4000 HOURS SERVICE</b>	
Check water pump	3-45

## **24. SERVICE PROCEDURE**

---

### **24.1 INITIAL 250 HOURS SERVICE**

Carry out the following maintenance only after the first 250 hours.

- **REPLACE FUEL FILTER CARTRIDGE**
- **CHECK ENGINE VALVE CLEARANCE, ADJUST**

For details of the method of replacing or maintaining, see the section on EVERY 500 HOURS and 2000 HOURS SERVICE.

## 24.2 WHEN REQUIRED

### 24.2.1 CHECK, CLEAN AND REPLACE AIR CLEANER ELEMENT

#### SINGLE ELEMENT

#### ⚠ WARNING

- Never clean or replace the air cleaner element with the engine running.
- When using pressure air to clean the element wear safety glasses or goggles to protect the eyes.

#### CHECKING

If air cleaner clogging monitor ① is red, clean the air cleaner element.

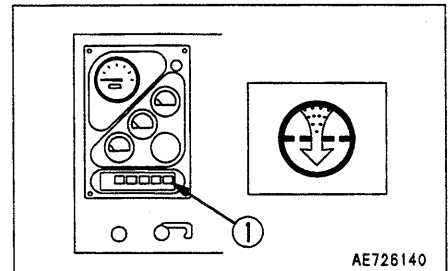

#### CLEANING AND REPLACEMENT OF OUTER CYLINDER ELEMENT

1. Loosen wing nut ②, take out the element, then cover the air connector inside the air cleaner with clean cloth or tape to prevent dirt or dust from entering.
2. Clean the inside of the body and cover.
3. Blow dry compressed air (0.69 MPa (7 kgf/cm<sup>2</sup>) maximum) against the side of the element along the pleats. Then, blow against outside along the pleats, then against inside gain.
  - 1) Remove one seal each time the element is cleaned.
  - 2) Replace the outer cylinder element after cleaning it 6 times or after one year. When replacing it, replace the inner cylinder element, too.
  - 3) Even if the outer cylinder element has not been cleaned 6 times yet, if the dust indicator indicates red just after cleaning it, replace both outer and inner cylinder elements.
  - 4) Remove evacuator valve ③ and clean it with compressed air. Then, install it again.

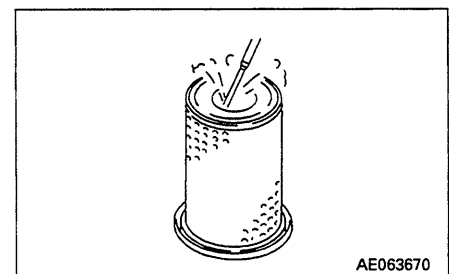
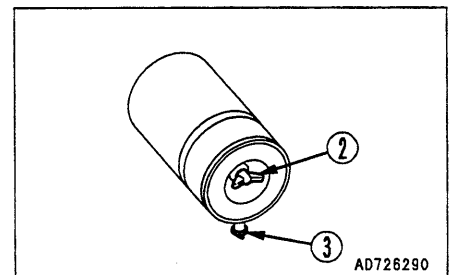

#### NOTICE

**Do not clean the element before the dust indicator indicates red.**

**If the element is cleaned frequently before the dust indicator indicates red, the true performance of the air cleaner is not used and the cleaning efficiency is lowered. In addition, when the element is cleaned, more of the dust sticking to it drops onto the inner element.**

#### NOTICE

**When cleaning the element, do not hit it or beat in against something.**

**Do not use an element whose folds or gasket or seal are damaged.**

**Wrap unused elements and store them in dry place.**

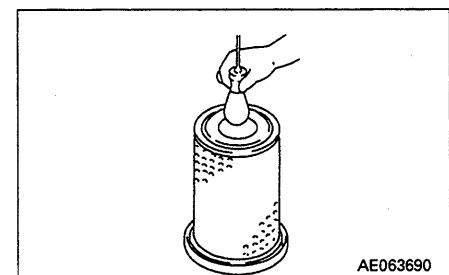

4. Remove the cloth or tape used as a cover in Step 1.
5. Set the cleaned element in position, and secure it with the wing nut ②.

**DOUBLE ELEMENT (EG125B-2) (EG125BS-2 (option))**

**⚠ WARNING**

- Never clean or replace the air cleaner element with the engine running.
- When using pressure air to clean the element wear safety glasses or goggles to protect the eyes.

**EG125B-2**

**CHECKING**

If dust indicator ① becomes red, clean the air cleaner element.

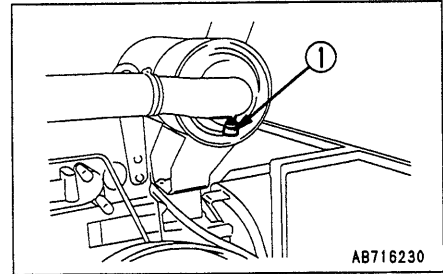

**CLEANING AND REPLACEMENT OF OUTER CYLINDER ELEMENT**

1. Loosen bolt ② and remove band ③, then remove cover ④.
2. Clean the inside of the body and cover.
3. Remove wing nut ⑤, and remove and clean the element.

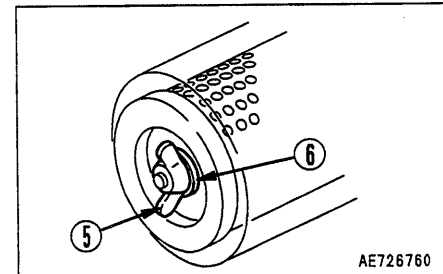
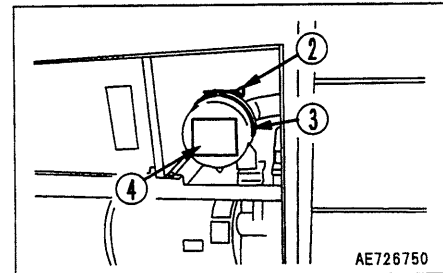

4. Blow dry compressed air (0.69 Mpa {7 kgf/cm<sup>2</sup>}) along the inside pleats, then along the outside pleats, then along the inside pleats again.

- (1) Each time the element is cleaned, remove one seal.
- (2) After the outer element is cleaned six times or used for one year, replace it.
- (3) If the dust indicator indicates red soon after the outer element is cleaned, replace the element even if it has not been cleaned six times.
- (4) Check the clamping nut of the inner element for looseness. If it is loosened, retighten it.

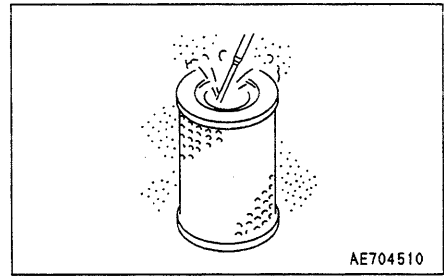

#### NOTICE

Irradiate the inside of the cleaned element with a bulb. If any hole or thin part is found, replace the element.

When replacing the element, do not hit, tap it, or hit it against anything.

If a pleat, gasket or seal of the element is damaged, do not use that element.

Keep the unused element wrapped and store it in a dry place.

5. Set the cleaned element and secure it with wing nut ⑤.
6. If seal washer ⑥ is broken or the threads of wing nut ⑤ are damaged, replace them.
7. Install cover ④ and band ③, then tighten bolt ②.
8. Remove evacuator valve ⑦ and clean it with compressed air.
9. Press the button of dust indicator ① to return the red piston.

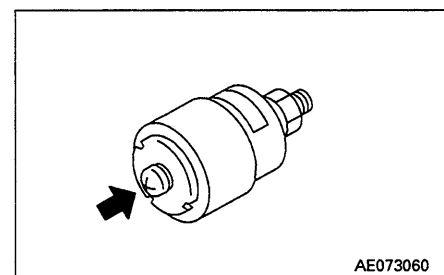
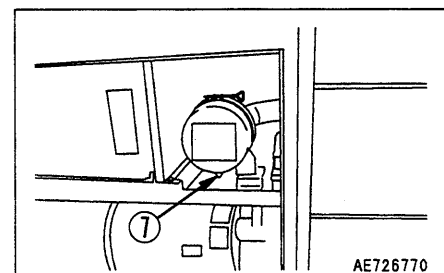
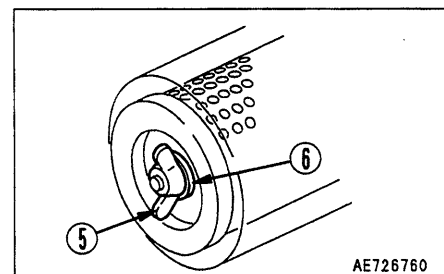
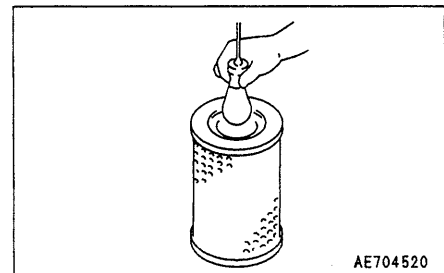

### REPLACEMENT OF INNER ELEMENT

1. Remove bolt ② and remove band ③, then remove cover ④ and outer element.
2. Remove the clamping nut of the inner element, and remove the inner element.
3. Cover the air connector with a clean cloth or cloth tape to prevent dust from entering it.
4. Clean the inside of the body, then remove the cover fitted in 3 above.
5. Install a new inner element to the connector, and tighten the inner element clamping nut.  
Do not clean and reuse the inner element.
6. Install a new outer element, then install cover ④ and band ③, and tighten bolt ②.

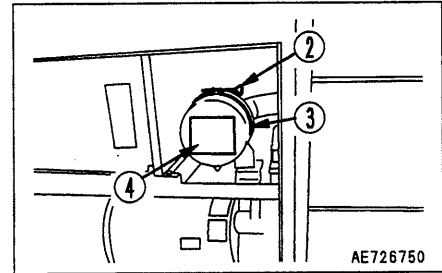

7. After replacing the element, return the red piston of dust indicator ①.

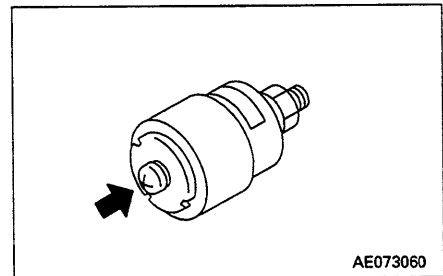

### EG125BS-2 (OPTION) INSPECTION

If air cleaner monitor lights up, clean the air cleaner element.

### CLEANING AND REPLACEMENT OF OUTER CYLINDER ELEMENT

1. Loosen wing nut ② and remove the outer element.
2. Clean the inside of the body.
3. Blow dry compressed air (0.69 Mpa {7 kgf/cm<sup>2</sup>}) along the inside pleats, then along the outside pleats, then along the inside pleats again.
  - (1) Each time the element is cleaned, remove one seal.
  - (2) After the outer element is cleaned six times or used for one year, replace it.
  - (3) If the dust indicator indicates red soon after the outer element is cleaned, replace the element even if it has not been cleaned six times.
  - (4) Check the clamping nut of the inner element for looseness. If it is loosened, retighten it.

### NOTICE

Irradiate the inside of the cleaned element with a bulb. If any hole or thin part is found, replace the element.

When replacing the element, do not hit, tap it, or hit it against something.

If a pleat, gasket or seal of the element is damaged, do not use that element.

Keep the unused element wrapped and stored in a dry place.

4. Set the cleaned element and secure it with wing nut ②.

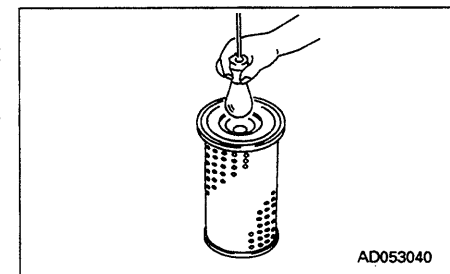
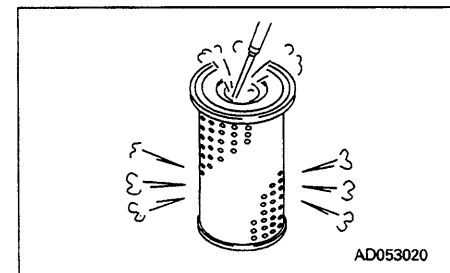
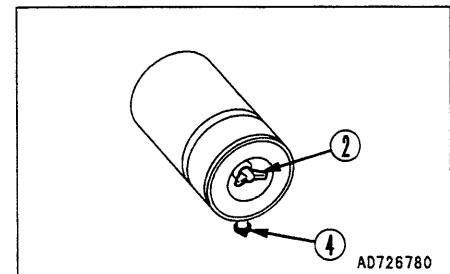
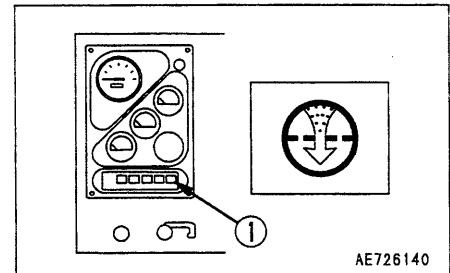

## 24. SERVICE PROCEDURE

---

5. If seal washer ③ is broken or the threads of wing nut are damaged, replace them.
6. Remove evacuator valve ④ and clean it with compressed air, then install it.

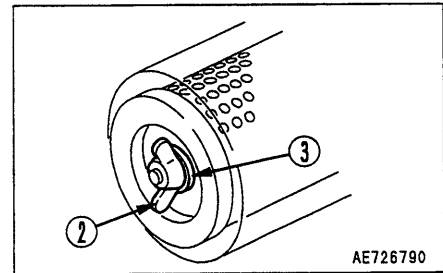

### REPLACEMENT OF INNER ELEMENT

1. Loosen wing nut ② and remove the outer element.
2. Remove the clamping nut of the inner element, and remove the inner element.
3. Cover the air connector (outlet side) with a clean cloth or cloth tape to prevent dust from entering it.
4. Clean the inside of the body, then remove the cover fitted in 3 above.
5. Install a new inner element to the connector, and tighten the inner element clamping nut.  
Do not clean and reuse the inner element.
6. Set a new outer element and secure it with wing nut ②.

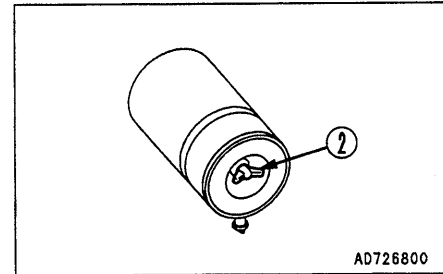



### 24.2.2 CLEAN INSIDE OF COOLING SYSTEM

**⚠ WARNING**

- **Soon after the engine has been stopped, the coolant is hot and can cause personal injury. Allow the engine to cool before draining water.**
  - **Since cleaning is performed while the engine is running, it is very dangerous to enter the rear side of the machine as the machine may suddenly start moving. There is also danger of touching the fan when the engine hood is open. While the engine is running, never enter the rear side of the machine.**
  - **Never remove the radiator cap when the engine is at operating temperature. At operating temperature, the coolant is under pressure. Steam blowing up from the radiator could cause personal injury. Allow the engine to cool until the radiator filler cap is cool enough to touch with your hand. Remove the filler cap slowly to allow pressure to be relieved.**
- Clean the inside of the cooling system, change the coolant and replace the corrosion resistor according to the table below.

Kind of coolant	Cleaning inside of cooling system and changing coolant	Adding corrosion resistor agent KI or replacing corrosion resistor cartridge
Permanent type antifreeze (All season type)	Every year (autumn) or every 2000 hours whichever comes first	Every 1000 hours and when cleaning the inside of the cooling system and when changing coolant.
Non permanent type antifreeze containing ethylene glycol (Winter, one season type)	Every 6 months (spring, autumn) (Drain antifreeze in spring, add antifreeze in autumn)	
When not using antifreeze	Every 6 months or every 1000 hours whichever comes first	

- Stop the machine on level ground when cleaning or changing the coolant.
- Use a permanent type of antifreeze.  
If, for some reason, it is impossible to use permanent type antifreeze, use an antifreeze containing ethylene glycol.

- When deciding the ratio of antifreeze to water, check the lowest temperature in the past, and decide from the mixing rate table given below.

It is actually better to estimate a temperature about 10°C lower when deciding the mixing rate.

**Mixing rate of water and antifreeze  
EG125B-2**

Min. atmospheric temperature	°C	-5	-10	-15	-20	-25	-30
	°F	23	14	5	-4	-13	-22
Amount of antifreeze	ℓ	6.9	9.0	11.0	12.5	14.0	15.0
	US gal	1.82	2.38	2.9	3.3	3.7	3.96
	UK gal	1.52	1.98	2.42	2.75	3.08	3.3
Amount of water	ℓ	23.1	21.0	19.0	17.5	16.0	15.0
	US gal	6.1	5.54	5.02	4.62	4.22	3.96
	UK gal	5.08	4.62	4.18	3.85	3.52	3.3

**EG125BS-2**

Min. atmospheric temperature	°C	-5	-10	-15	-20	-25	-30
	°F	23	14	5	-4	-13	-22
Amount of antifreeze	ℓ	4.9	6.5	8.0	9.0	10.0	11.0
	US gal	1.29	1.72	2.11	2.38	2.64	2.9
	UK gal	1.08	1.43	1.76	1.98	2.2	2.42
Amount of water	ℓ	16.6	15.0	13.5	12.5	11.5	10.5
	US gal	4.38	3.96	3.56	3.3	3.04	2.77
	UK gal	3.65	3.3	2.97	2.75	2.53	2.31

**⚠ WARNING**

**Antifreeze is flammable, so keep it away from any flame.**

- Use city water for the cooling water.  
If river water, well water or other such water supply must be used, contact your Komatsu distributor.
- We recommend use of an antifreeze density gauge to control the mixing proportions.

Prepare the following.

- Container for drained coolant
  - EG125B-2: at least 30 ℓ (7.92 US gal, 6.6 UK gal)
  - EG125BS-2: at least 21.5 ℓ (5.68 US gal, 4.73 UK gal)
- Hose for adding water.

1. Stop the engine and turn radiator cap ① slowly to remove it.
2. Set a container under drain valve ②, drain valve ③ and drain valve ④ to catch the drained coolant.
3. Open drain valve ② at the bottom of the radiator and drain valve ③ and drain valve ④ on the side face of the cylinder block, and drain the coolant.
4. After draining the coolant, close drain valve ②, drain valve ③ and drain valve ④, and fill the radiator with tap water.
5. When the radiator is full, run the engine at low idling, open drain valve ②, drain valve ③ and drain valve ④ and flush water through the system for 10 minutes.

Adjust the flow of the water flowing in and draining out to ensure that the radiator is always full during the flushing operation. While flushing water through the system, watch carefully that the water inlet hose does not come out of the radiator filler port.

6. After flushing, stop the engine, open drain valve ②, drain valve ③ and drain valve ④, drain the water, then close the valves again.
7. After draining the water, use a cleaning agent to carry out cleaning.

Follow the instructions on the cleaning agent container when carrying out the cleaning operation.

8. After cleaning, open drain valve ②, drain valve ③ and drain valve ④, drain out all the water, then close drain valve ②, drain valve ③ and drain valve ④, and fill with tap water to near the water filler port.
9. When the water comes to near the water filler port, run the engine at low idling, open drain valve ②, drain valve ③ and drain valve ④, and continue to run water through the system until clean water comes out.

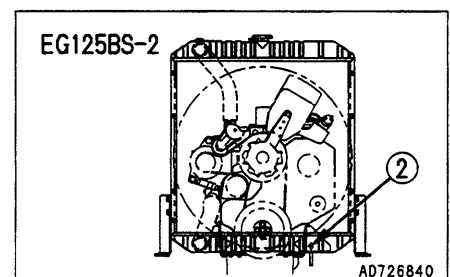
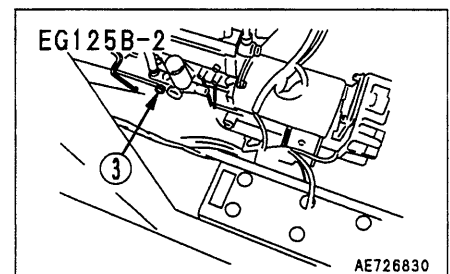
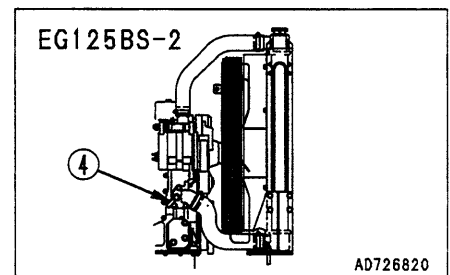
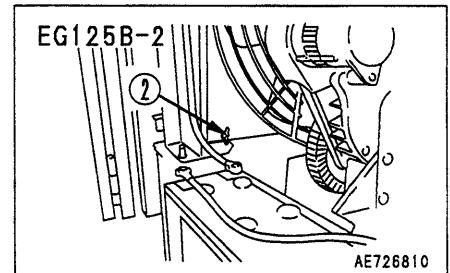
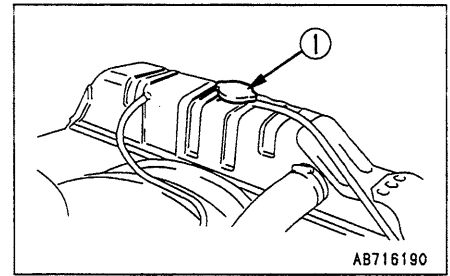

## 24. SERVICE PROCEDURE

Adjust the flow of the water flowing in and draining out to ensure that the radiator is always full during the flushing operation.

10. When clean water comes out, stop the engine, drain all the water, then close drain valve ②, drain valve ③ and drain valve ④.
11. Add coolant, then fill with tap water until the water flows out from the water filler port.  
For details of the amount of coolant, see the water and coolant proportion table.
12. To remove the air in the coolant, run the engine for 5 minutes at low idling, then run for a further 5 minutes at high idling. (When doing this, leave the water filler cap off.)
13. Drain the water inside reserve tank ⑤, clean the inside of the reserve tank, then fill with cooling water to between the FULL and LOW lines. (Only EG125BS-2)
14. Stop the engine, wait for 3 minutes, add tap water until the water level reaches near the water filler port, then tighten the cap.

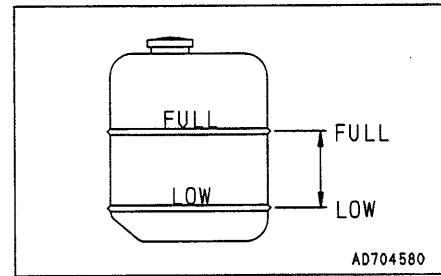
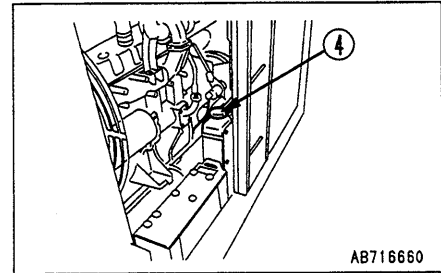

### 25.2.3 CHECK ELECTRICAL AIR-INTAKE HEATER

Carry out this check once a year before the cold weather starts.

Remove electrical air intake heater ① from the engine intake manifold, and check for disconnections and dirt.

When inspecting or installing the electrical intake air heater, replace the gasket with a new part.

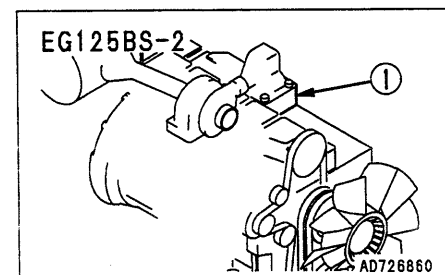
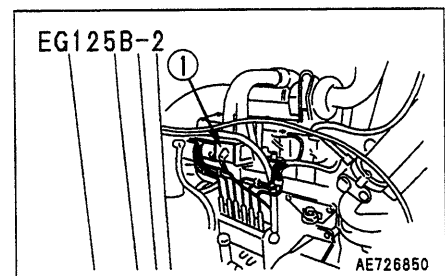

## 24.3 CHECK BEFORE STARTING

### 24.3.1 CHECK COOLANT LEVEL, ADD WATER

#### **⚠ WARNING**

Do not remove the cap when the radiator water temperature is high. Boiling water may spur out. When removing the cap, turn it slowly to release the internal pressure before removing it.

#### ● EG125B-2

1. Remove radiator cap ① and confirm that the cooling water is filled to the hatched level. Add water if necessary.
2. After adding water, tighten the cap securely.
3. If more water must be added than usual, check for water leakage.

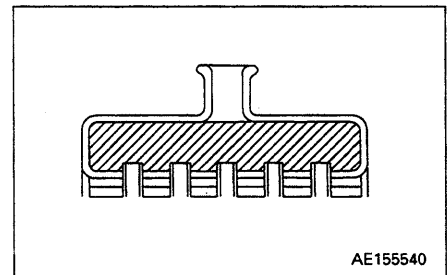
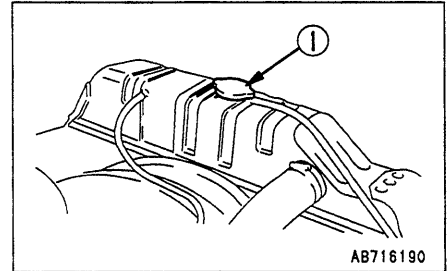

#### ● EG125BS-2

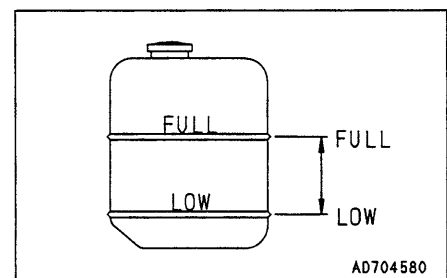
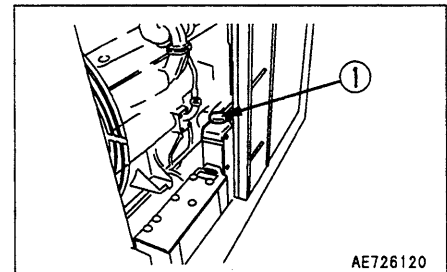

1. Check that the cooling water is between the FULL and LOW marks on the reserve tank. If the level is low, remove cap ① and add water.
2. After adding water, tighten the cap securely.
3. If more water must be added than usual, check for water leakage.



### 24.3.2 CHECK FUEL LEVEL, ADD FUEL

 **WARNING**

**Spilled fuel will cause fire, so when adding fuel, be careful not to let the fuel overflow. Wipe up any spilled fuel completely.**

1. Check the fuel level with sight gauge .
2. If the fuel level is low, add fuel through fuel filler port .  
Always fill the tank after finishing operations.

#### **REMARK**

Fuel tank capacity:

EG125B-2	260 l (68.6 US gal, 57.2 UK gal)
EG125BS-2	250 l (66.0 US gal, 55.0 UK gal)

For details of the fuel to use, see "20. USE OF FUEL, COOLANT AND LUBRICANTS ACCORDING TO AMBIENT TEMPERATURE".

3. After filling with fuel, tighten the fuel filler securely.

#### **REMARK**

If the breather hole in the cap is clogged, the pressure inside the tank will go down and fuel will not be supplied properly, so clean the breather hole.

**24.3.3 CHECK OIL LEVEL IN ENGINE OIL PAN, ADD OIL**

1. Remove dipstick ⑥ and wipe it with a cloth.
2. Insert dipstick ⑥ fully in the dipstick guide, then pull it out again.
3. Check that the oil is between the H and L marks on dipstick ⑥. If it is not between the H and L marks, add engine oil through oil filler port ⑦.

For details of the oil to use, see "20. USE OF FUEL, COOLANT AND LUBRICANTS ACCORDING TO AMBIENT TEMPERATURE".

**REMARK**

When checking the oil level, wait for at least 15 minutes after stopping the engine.

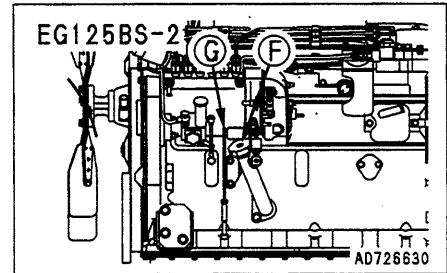
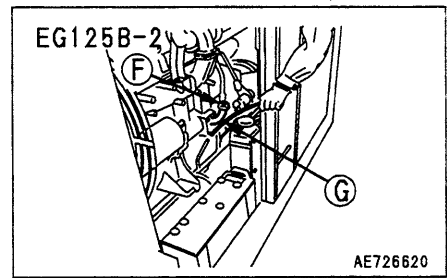

**24.3.4 CHECK DUST INDICATOR (EG125B-2)**

Check if the red piston of dust indicator ① has reached the service level.

If the red piston has appeared, clean or replace the element.

For the cleaning method of the element, see "24.2 MAINTENANCE WHEN REQUIRED".

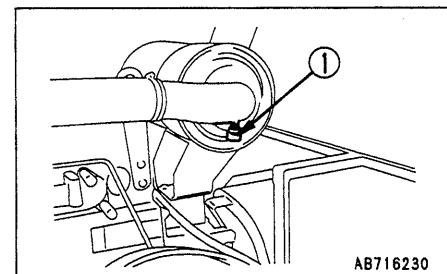

**24.3.5 CHECK AIR CLEANER FOR CLOGGING (EG125BS-2)**

Check that air cleaner clogging monitor ① is not lighted up. If it lighted up, clean or replace the element.

For details of the method for cleaning the element, see "24.2 MAINTENANCE WHEN REQUIRED".

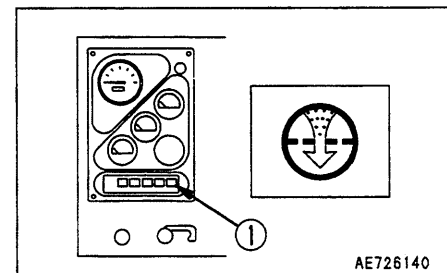

### 24.3.6 CHECK ELECTRIC WIRING

 **WARNING**

- **If fuses are frequently blown or if there are traces of short circuit on the electrical wiring, locate the cause and carry out repair.**
- **Accumulation of flammable material (dead leaves, twigs, grass, etc.) around the battery may cause fire, so always check and remove such material.**
- **Keep the top surface of the battery clean and check the breather hole in the battery cap. If it is clogged with dirt or dust, wash the battery cap to clean the breather hole.**

Check for damage and wrong capacity of the fuse and any sign of disconnection or short circuit in the electric wiring. Check also for loose terminals and tighten any loose parts.

Check the wiring of the "battery", "starting motor" and "alternator" carefully, in particular.

When carrying out walk-around checks or checks before starting, always check if there is any accumulation of flammable material around the battery, and remove such flammable material.



## 24.4 EVERY 50 HOURS SERVICE

### 24.4.1 DRAIN WATER AND SEDIMENT FROM FUEL TANK

1. Place a container under drain valve ① to catch the drained fuel.
2. Loosen drain valve ① and drain the sediment and water collected at the bottom together with the fuel.
3. When clean fuel comes out, close drain valve ①.

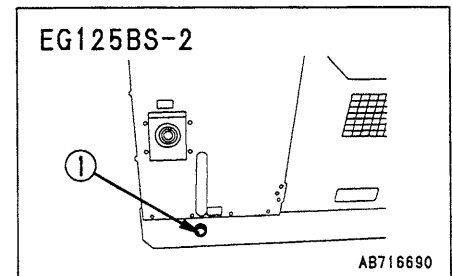
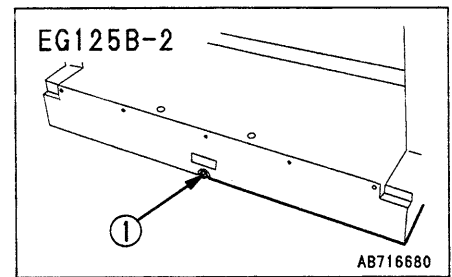

## 24.5 EVERY 250 HOURS SERVICE

Maintenance for every 50 hours service should be carried out at the same time.

### 24.5.1 CHECK LEVEL OF BATTERY ELECTROLYTE

**⚠ WARNING**

- Battery electrolyte is dangerous. If it gets in your eyes or on your skin, wash it off with large amounts of water, and consult a doctor.
- The battery generates flammable gas, so keep away from flame.

1. Remove cap ①, and check that the electrolyte is at the specified level (10 to 12 mm above the plate). If the electrolyte level is low, add distilled water to the specified level.

If the battery electrolyte is spilled, have dilute sulphuric acid added.

2. Clean the air hole in the battery cap, then tighten the cap securely.

When adding distilled water, add it before starting operations in the morning to prevent the electrolyte from freezing.

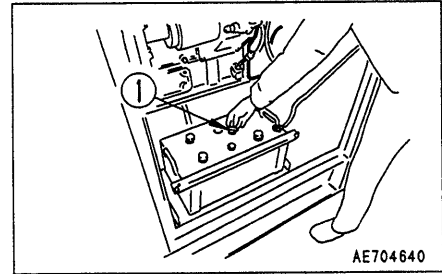

### 24.5.2 CHECK FAN BELT TENSION, ADJUST (EG125B-2) CHECK

Push the intermediate point between the alternator and fan pulley with the thumb (About 59 N (6 kgf, 13.2 lbft)). It should be deflected 10 mm (0.4 in).

#### ADJUSTMENT

1. To adjust the belt tension, loosen bolt ① and nut ② and shift alternator ③ slightly.

When adjusting the V-belt, do not attempt to push alternator ③ directly with a bar or the like, but use a wood pad to prevent damage to the core.

2. Check each pulley for damage and V-grooves and V-belt for wear. Particularly, check to see if the V-belt touches the bottom of any V-groove.
3. If the belt is lengthened eliminate the adjustment allowance or it has any cut or crack, replace it.

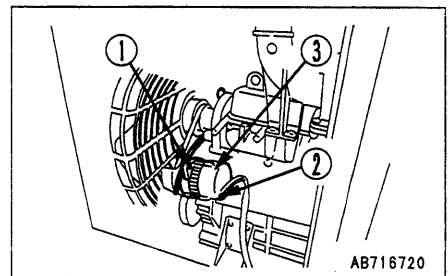
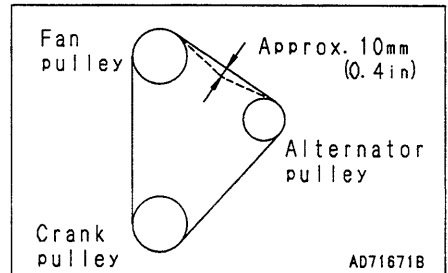
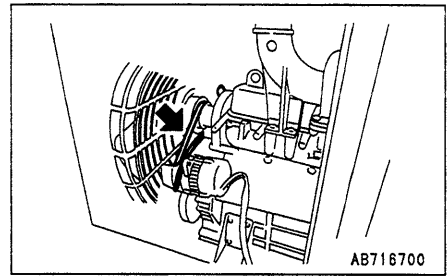

### 24.5.3 CHECK INSULATION RESISTANCE

Remove the electric wire at the load end of the output terminal board, turn the breaker ON, and measure the insulation resistance between the hood and the output terminal bolt.

If the measurement is less than 1 MΩ, there is danger of electric shock or fire, so carry out repairs.

### 24.5.4 CHECK GREASE OF SHAFT BEARING

1. Remove bearing cover, check for dirt, and check that the grease chamber is about 1/3 full.
2. If the grease level is low, add the same type of grease. If the grease is very dirty, change the grease.

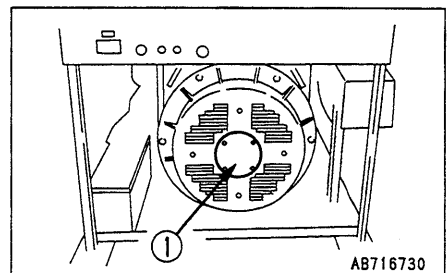

### 24.5.4 CHANGE OIL IN ENGINE OIL PAN, REPLACE ENGINE OIL FILTER CARTRIDGE

**⚠ WARNING**

The oil is at high temperature after the engine has been operated, so never change the oil immediately after finishing operations. Wait for the oil to cool down before changing it.

- Refill capacity:  
 EG125B 22 ℓ (5.81 US gal, 4.84 UK gal)  
 EG125BS 21 ℓ (5.54 US gal, 4.62 UK gal)
- Container to catch drained oil: Min. 21 ℓ
- Prepare a filter wrench.

1. Set a container under drain valve (P) to catch the oil.
2. Open drain valve (P), drain the oil, then tighten the drain valve again.
3. Using a filter wrench, turn filter cartridge (1) counterclockwise to remove it.
4. Clean the filter holder, fill the new filter cartridge with clean engine oil, then coat the seal and thread of the new filter cartridge with engine oil (or coat thinly with grease), and install it to the filter holder.
5. When installing the filter cartridge, tighten it about 3/4 – 1 turn for EG125B-2 and about 3/4 turns for EG125BS-2. Do not tighten it any more.

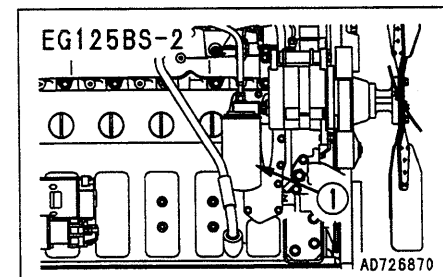
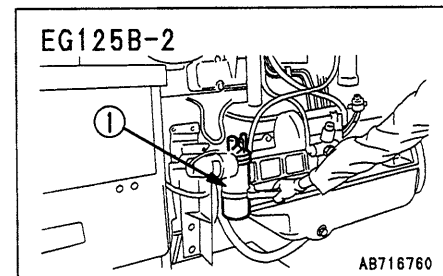
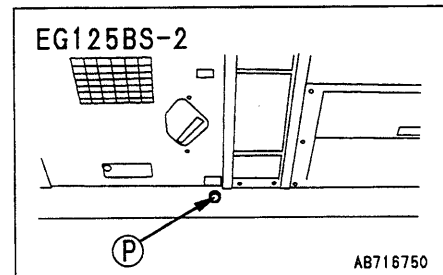
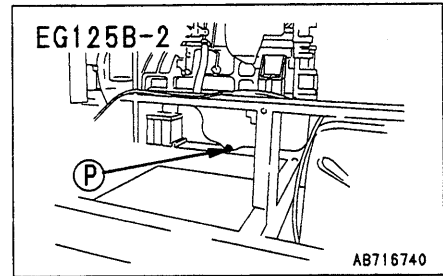

6. After replacing the filter cartridge, add engine oil through oil filler  $\text{\textcircled{F}}$  until the oil level is between the H and L marks on the dipstick.

For details of the oil to use, see "20. USE OF FUEL, COOLANT AND LUBRICANTS ACCORDING TO AMBIENT TEMPERATURE".

7. Run the engine at idling for a short time, then stop the engine, and check that the oil level is between the H and L marks on the dipstick.

For details, see "24.3 CHECKS BEFORE STARTING".

Change the engine oil and replace the filter once every 6 months even if the machine has not been operated for 250 hours (125 hours if heavy fuel A is used).

Carry out the replacement every 250 hours (125 hours if heavy oil A is used) even if 6 months have not passed.

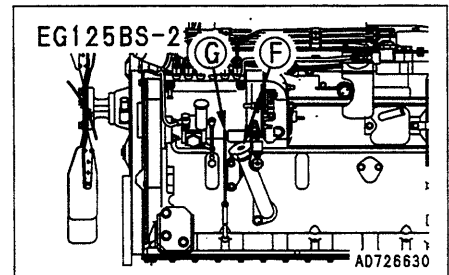
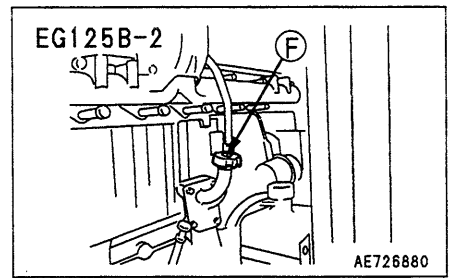

## 24.6 EVERY 500 HOURS SERVICE

Maintenance for every 50 and 250 hours service should be carried out at the same time.

### 24.6.1 REPLACE FUEL FILTER CARTRIDGE EG125B-2

**⚠ WARNING**

- The machine is at high temperature after the engine has been operated, so never replace the filter immediately after finishing operations. Wait for the machine to cool down before replacing the fuel filter cartridge.
- Never bring flames near the fuel filter cartridge.

Prepare the following:

- Filter wrench
- Oil container

1. Set the oil container under the filter cartridge.
2. Using the filter wrench, turn filter cartridge ① counterclockwise to remove.
3. Clean the filter holder, fill the new filter cartridge with clean fuel, then coat the packing surface with engine oil and install it to the filter holder.
4. When installing, to prevent overtightening, tighten until the packing surface contacts the seal surface of the filter holder, then tighten a further approx. 1/2 turns.  
If the filter cartridge is tightened too far, the packing will be damaged and this will cause leakage of fuel. If it is not tightened enough, there will be a gap at the packing, and this will also cause fuel leakage, so be sure to tighten exactly to the specified tightening angle.
5. After replacing filter cartridge ①, loosen joint bolt ②.
6. Loosen the knob of feed pump ③, pump it up and down, and continue until no more bubbles come out in the fuel flowing out from joint bolt ②.
7. Tighten air bleed plug ②.
8. Securing sleeve ⑤ of injection pump, loosen air bleed plug ④ to bleed air according to the same procedure for the fuel filter.
9. After bleeding air, tighten air bleed plug ④, securing sleeve ⑤, then push in and tighten knob of feed pump ③.
10. After replacing the filter cartridge, start the engine and check the filter seal for oil leakage.

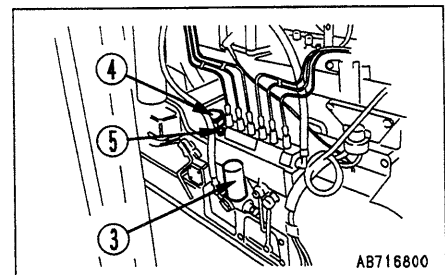
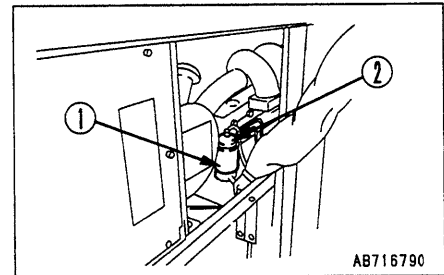

## EG125BS-2

**⚠ WARNING**

- The machine is at high temperature after the engine has been operated, so never replace the filter immediately after finishing operations. Wait for the machine to cool down before replacing the fuel filter cartridge.
- Never bring flames near the fuel filter cartridge.

Prepare the following:

- Filter wrench
- Oil container

1. Set the oil container under the filter cartridge.
2. Using the filter wrench, turn filter cartridge ① counterclockwise to remove.
3. Clean the filter holder, fill the new filter cartridge with clean fuel, then coat the packing surface with engine oil and install it to the filter holder.
4. When installing, to prevent overtightening, tighten until the packing surface contacts the seal surface of the filter holder, then tighten a further approx. 1/2 turns.  
If the filter cartridge is tightened too far, the packing will be damaged and this will cause leakage of fuel. If it is not tightened enough, there will be a gap at the packing, and this will also cause fuel leakage, so be sure to tighten exactly to the specified tightening angle.
5. After replacing filter cartridge ①, loosen joint bolt ②.
6. Loosen the knob of feed pump ③, pump it up and down, and continue until no more bubbles come out in the fuel flowing out from joint bolt ②.
7. After bleeding the air, tighten joint bolt ②, then push in the knob of feed pump ③, and tighten it.

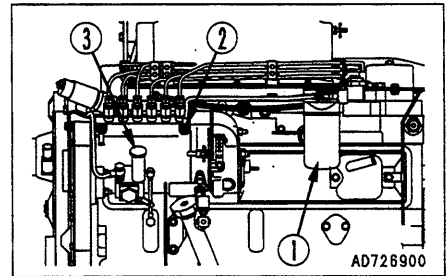

 **WARNING**

**The engine is started in this operation, so check carefully that the area around the engine is safe before cranking.**

8. After replacing the filter cartridge, if the key in the starting switch is turned to the START position, the air will be bled in a few seconds and the engine will start. When the engine starts, check for any leakage from the filter seal surface. If any leakage is found, check the tightening of the filter cartridge. If there is still fuel leakage, repeat Steps 1 and 2 to remove the filter cartridge, then check the packing surface for damage or foreign material caught in the surface.  
If any damage or foreign material is found in the packing, replace the filter cartridge with a new filter cartridge, then repeat Steps 3 to 8 to install the new filter cartridge.

#### 24.6.2 CHECK, CLEAN RADIATOR FINS

 **WARNING**

**If compressed air, steam, or water hit your body directly, there is danger of injury. Always wear protective glasses, mask, and safety shoes.**

Blow with compressed air to remove any mud, dirt, or leaves that are clogging the radiator fins.

Steam or water can be used instead of compressed air.

#### **NOTICE**

**Check the rubber hoses, and if any cracks or deterioration are found, replace the hose. Check also for loose hose clamps.**



## **24.7 EVERY 1000 HOURS SERVICE**

Maintenance for every 50, 250 and 500 hours service should be carried out at the same time.

### **24.7.1 CHECK CLAMPING PARTS OF TURBOCHARGER**

Ask your Komatsu distributor for check of clamping parts of the turbocharger.

### **24.7.2 CHECK PLAY OF TURBOCHARGER ROTOR**

Ask your Komatsu distributor for check of the turbocharger rotor for play.

### **24.7.3 CHECK FAN BELT TENSION, REPLACE (EG125BS-2)**

As special tool is required for inspection or replacement the parts, you shall request Komatsu distributor for service.

#### **REMARK**

The machine is equipped with an auto tensioner, so there is no need to adjust the tension.

## **24.8 EVERY 2000 HOURS SERVICE**

Maintenance for every 50, 250, 500 and 1000 hours service should be carried out at the same time.

### **24.8.1 CLEAN ENGINE BREATHER ELEMENT**

1. Loosen the clamp and disconnect the hose, then, remove the breather from the cylinder head cover.
2. Wash the whole breather in diesel fuel oil. Then, dry it with compressed air and install it.
3. Check the breather hose. If any deteriorated oil (sludge) is sticking to its insides, replace it.

### **24.8.2 CLEAN, CHECK TURBOCHARGER**

Ask your Komatsu distributor to clean and check the turbo-charger.

### **24.8.3 CHECK ALTERNATOR AND STARTING MOTOR**

Since the brushes of the alternator and starting motor may be worn and grease in their bearings may have been used up, ask your Komatsu distributor for check and repair.

If the engine is started frequently, have them checked every 1000 hours.

### **24.8.4 CHECK ENGINE VALVE CLEARANCE, ADJUST**

Since special tools are required for check and adjustment of the engine valve clearance, ask your Komatsu distributor.

### **24.8.5 CHECK VIBRATION DAMPER**

Check the outside surface of the rubber for cracks or peeling. If any cracks or peeling are found, please contact your Komatsu distributor for inspection or replacement.

## **24.9 EVERY 4000 HOURS SERVICE**

**Maintenance for every 50, 250, 500, 1000 and 2000 hours service should be carried out at the same time.**

### **24.9.1 CHECK WATER PUMP**

Check the water pump pulley for play. Check water leakage from the pump and clogging drain hole. If any defect is found, ask your Komatsu distributor for overhaul or replacement of the water pump.

# **SPECIFICATIONS**

## 25. SPECIFICATIONS

EG125B-2  
EG125BS-2

Item		Model	EG125B-2	EG125BS-2
GENERATOR RELATED	3-phase rated output	[kVA]	100/125	
	3-phase rated output (power factor = 0.8)	[kW]	80/100	
	Number of phases		3-phase, 4 wire	
	3-phase rated voltage	[V]	200/220	200/220, 400/440
	Single-phase rated voltage	[V]	100/110	
	Frequency	[Hz]	50/60	
	Engine speed	[rpm]	1500/1800	
	Number of poles		4	
	Type of rating		Continuous	
	Energizing method		Brushless	
	Single-phase socket		10 KVA x 2	
ENGINE RELATED	Name of engine		Komatsu S6D105-1 Diesel Engine	Komatsu SA6D102E-1 Diesel Engine
	Flywheel horsepower (1500/1800) rpm	[kW {HP}]	98/115 {133/155}	
	Starting motor		24 V 5.5 kW	24 V 4.5 kW
	Alternator		24 V 25A	
	Battery		12 V 200 Ah x 2	12 V 100 Ah x 2
Dry weight	[kg]	1880	2120	

EG125B-2

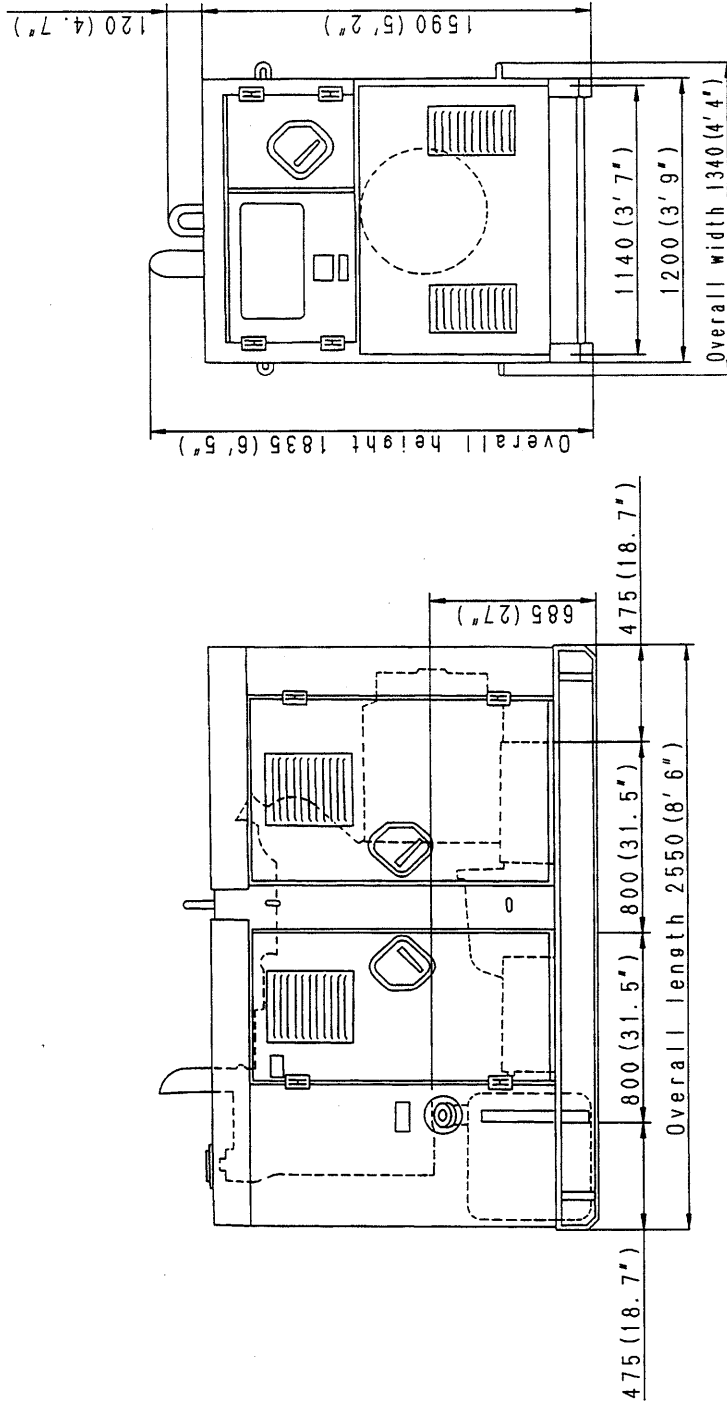

AE716818

EG125BS-2

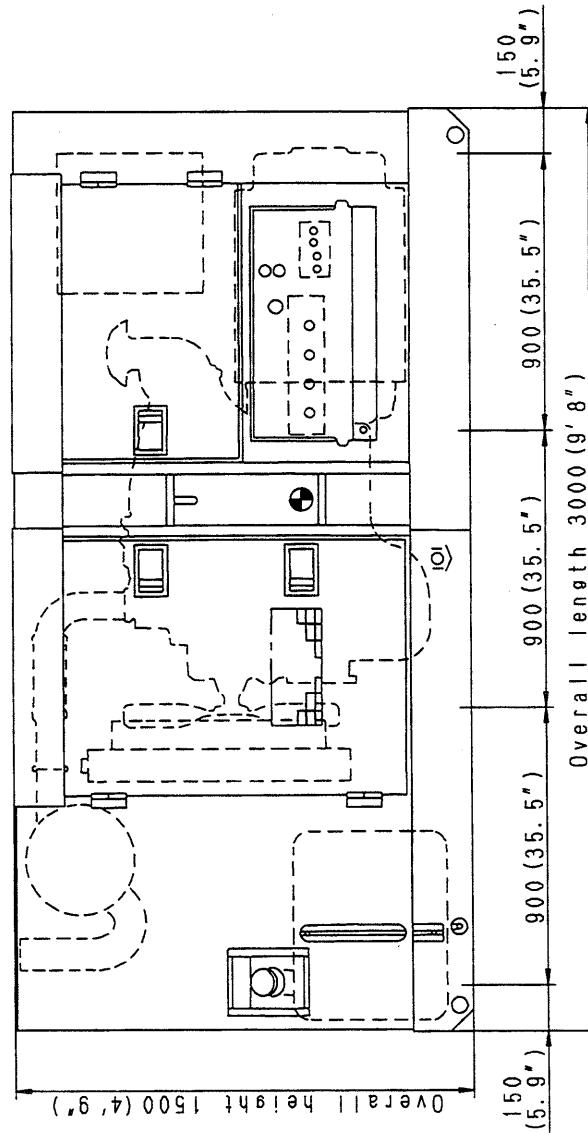
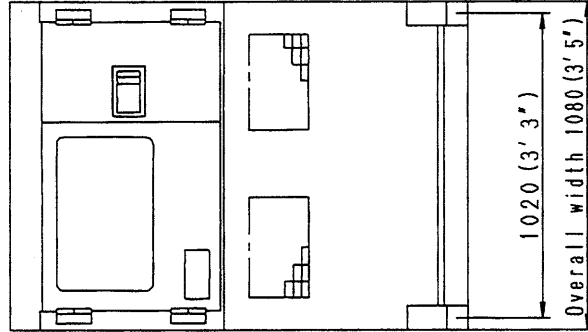

AE72691B

**EG125B-2, EG125BS-2 DIESEL ENGINE GENERATOR**

---

Form No. SEAM017100

©1997 **KOMATSU**  
All Rights Reserved  
Printed in Japan 04-97 (01-1)

---