

# Operation & Maintenance Manual

SEAM037200

## D41E-6 D41P-6 BULLDOZER

SERIAL NUMBERS D41E-50001 and up  
D41P-50001

### WARNING

Unsafe use of this machine may cause serious injury or death. Operators and maintenance personnel must read this manual before operating or maintaining this machine. This manual should be kept near the machine for reference and periodically reviewed by all personnel who will come into contact with it.

### NOTICE

Komatsu has Operation & Maintenance Manuals written in some other languages. If a foreign language manual is necessary, contact your local distributor for availability.

# KOMATSU

# 1. FOREWORD

---

This manual provides rules and guidelines which will help you use this machine safely and effectively. Keep this manual handy and have all personnel read it periodically. If this manual has been lost or has become dirty and can not be read, request a replacement manual from Komatsu or your Komatsu distributor.

If you sell the machine, be sure to give this manual to the new owners.

Continuing improvements in the design of this machine can lead to changes in detail which may not be reflected in this manual. Consult Komatsu or your Komatsu distributor for the latest available information of your machine or for questions regarding information in this manual.

This manual may contain attachments and optional equipment that are not available in your area. Consult Komatsu or your Komatsu distributor for those items you may require.

## WARNING

- **Improper operation and maintenance of this machine can be hazardous and could result in serious injury or death.**
- **Operators and maintenance personnel should read this manual thoroughly before beginning operation or maintenance.**  
**Keep this manual in a readily available place near the machine (on machines with cab, there is a door pocket to hold the manual), and have all personnel involved in working on the machine read the manual periodically.**
- **Some actions involved in operation and maintenance of the machine can cause a serious accident, if they are not done in a manner described in this manual.**
- **The procedures and precautions given in this manual apply only to intended uses of the machine. If you use your machine for any unintended uses that are not specifically prohibited, you must be sure that it is safe for you and others. In no event should you or others engage in prohibited uses or actions as described in this manual.**
- **Komatsu delivers machines that comply with all applicable regulations and standards of the country to which it has been shipped. If this machine has been purchased in another country or purchased from someone in another country, it may lack certain safety devices and specifications that are necessary for use in your country. If there is any question about whether your product complies with the applicable standards and regulations of your country, consult Komatsu or your Komatsu distributor before operating the machine.**
- **The description of safety is given in SAFETY INFORMATION on page 0-2 and in SAFETY from page 1-1.**

## **CALIFORNIA**

### **Proposition 65 Warning**



**Diesel engine exhaust and some of its constituents are known to the State of California to cause cancer, birth defects, and other reproductive harm.**

## 2. SAFETY INFORMATION

---

Most accidents are caused by the failure to follow fundamental safety rules for the operation and maintenance of machines. To avoid accidents, read, understand and follow all precautions and warnings in this manual and on the machine before performing operation and maintenance.

To identify safety messages in this manual and on machine labels, the following signal words are used.

-  **DANGER** – This word is used on safety messages and safety labels where there is a high probability of serious injury or death if the hazard is not avoided. These safety messages or labels usually describe precautions that must be taken to avoid the hazard. Failure to avoid this hazard may also result in serious damage to the machine.
  
-  **WARNING** – This word is used on safety messages and safety labels where there is a potentially dangerous situation which could result in serious injury or death if the hazard is not avoided. These safety messages or labels usually describe precautions that must be taken to avoid the hazard. Failure to avoid this hazard may also result in serious damage to the machine.
  
-  **CAUTION** – This word is used on safety messages and safety labels for hazards which could result in minor or moderate injury if the hazard is not avoided. This word might also be word for hazards where the only result could be damage to the machine.
  
- NOTICE** – This word is used for precautions that must be taken to avoid actions which could shorten the life of the machine.

Safety precautions are described in SAFETY from page 1-1.

Komatsu cannot predict every circumstance that might involve a potential hazard in operation and maintenance. Therefore the safety messages in this manual and on the machine may not include all possible safety precautions. If any procedures or actions not specifically recommended or allowed in this manual are used, you must be sure that you and others can do such procedures and actions safely and without damaging the machine. If you are unsure about the safety of some procedures, contact your Komatsu distributor.

## **3. INTRODUCTION**

---

### **3.1 INTENDED USE**

This Komatsu BULLDOZER is designed to be used mainly for the following work:

- Dozing
- Smoothing
- Cutting into hard or frozen ground or ditching.
- Felling trees, removing stumps

See the section "12.15 WORK POSSIBLE USING BULLDOZER" for further details.

### **3.2 FEATURES**

- Joystick for easy lever operations
- Pressurized, sealed cab with air conditioner for pleasant operations
- Simple check operations using monitor panel
- High power engine with turbocharger, combined with long track give high operating performance
- Large angle blade for ease of transportation
- Low noise and stylish form and coloring for operations without problem even in residential areas
- Engine can be stopped with starting switch key

### **3.3 BREAKING IN THE MACHINE**

Your Komatsu machine has been thoroughly adjusted and tested before shipment.

However, operating the machine under severe conditions at the beginning can adversely affect the performance and shorten the machine life.

Be sure to break in the machine for the initial 100 hours (as indicated by the service meter.)

During breaking in:

- Idle the engine for 5 minutes after starting it up.
- Avoid operation with heavy loads or at high speeds.
- Avoid sudden starts, sudden acceleration, sudden steering and sudden stops except in cases of emergency.

The precautions given in this manual for operating, maintenance, and safety procedures are only those that apply when this product is used for the specified purpose. If the machine is used for a purpose that is not listed in this manual, Komatsu cannot bear any responsibility for safety. All consideration of safety in such operations is the responsibility of the user.

Operations that are prohibited in this manual must never be carried out under any circumstances.



## 4. LOCATION OF PLATES, TABLE TO ENTER SERIAL NO. AND DISTRIBUTOR

### 4.1 MACHINE SERIAL NO. PLATE POSITION

This is at the front bottom right of the operator's seat.

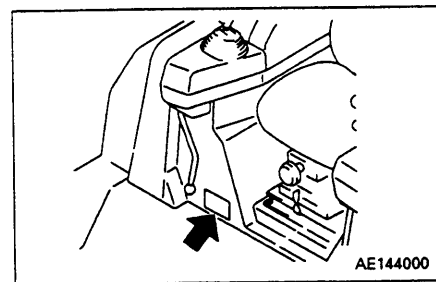

### 4.2 ENGINE SERIAL NO. PLATE POSITION

This is on the side of the front gear housing at the front of the engine on the left side of the machine.

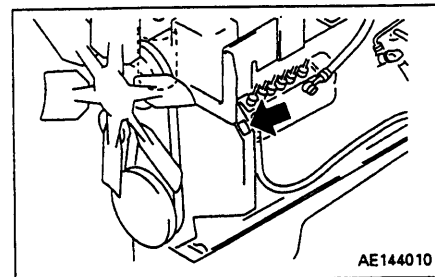

### 4.3 TABLE TO ENTER SERIAL NO. AND DISTRIBUTOR

Machine serial No.:	
Engine serial No.:	
Distributor name:	
Address:	Phone:
Service personnel for your machine:	

REMARKS

# 5. CONTENTS

---

1. Foreword .....	0- 1
2. Safety information .....	0- 2
3. Introduction .....	0- 3
4. Location of plates, table to enter serial No. and distributor .....	0- 4

## SAFETY

6. General precautions .....	1- 2
7. Precautions during operation .....	1- 7
7.1 Before starting engine .....	1- 7
7.2 After starting engine .....	1- 9
7.3 Transportation .....	1-15
7.4 Battery .....	1-16
7.5 Towing .....	1-18
8. Precautions for maintenance .....	1-19
8.1 Before carrying out maintenance .....	1-19
8.2 During maintenance .....	1-23
9. Position for attaching safety labels .....	1-28
9.1 Position for attaching safety labels .....	1-28

## OPERATION

10. General view .....	2- 2
10.1 General view of machine .....	2- 2
10.2 General view of controls and gauges .....	2- 3
11. Explanation of components .....	2- 5
11.1 Front panel (meters, lamps, switches) .....	2- 6
11.2 Switches .....	2-17
11.3 Control levers, pedals .....	2-20
11.4 Fuse box .....	2-26
11.5 Grease pump holder .....	2-27
11.6 Door-open lock (machines equipped with cab) .....	2-27
11.7 Opening and closing rear window (machines equipped with cab) .....	2-27
11.8 Cap with lock .....	2-28
11.9 Hot and cool box (machines equipped with cab) .....	2-28
11.10 Tool box .....	2-28
11.11 Using car radio (machines equipped with cab, car radio) .....	2-29
11.12 Using car stereo (machines equipped with cab) .....	2-33
11.13 Handling air conditioner (machines equipped with cab) .....	2-38
11.14 Handling heater (machines equipped with cab) .....	2-42
11.15 Power outlets .....	2-43

<b>12. Operation</b> .....	2-45
12.1 Check before starting engine .....	2-45
12.2 Starting engine .....	2-59
12.3 Operations and checks after starting engine .....	2-63
12.4 Moving machine .....	2-65
12.5 Shifting gear .....	2-66
12.6 Shifting between forward and reverse .....	2-67
12.7 Steering machine .....	2-68
12.8 Stopping machine .....	2-70
12.9 Precautions for operation .....	2-71
12.10 Parking machine .....	2-73
12.11 Check after finishing work .....	2-74
12.12 Stopping engine .....	2-75
12.13 Check after stopping engine .....	2-76
12.14 Locking .....	2-76
12.15 Work possible using bulldozer .....	2-77
12.16 Tips for longer undercarriage life .....	2-79
<b>13. Transportation</b> .....	2-82
13.1 Loading, unloading work .....	2-82
13.2 Precautions for loading .....	2-83
13.3 Precautions for transportation .....	2-84
13.4 Removing cab (machines equipped with cab) .....	2-85
13.5 Lifting machine .....	2-86
<b>14. Cold weather operation</b> .....	2-87
14.1 Precautions for low temperature .....	2-87
14.2 After completion of work .....	2-89
14.3 After cold weather .....	2-89
<b>15. Long-term storage</b> .....	2-90
15.1 Before storage .....	2-90
15.2 During storage .....	2-90
15.3 After storage .....	2-90
<b>16. Troubleshooting</b> .....	2-91
16.1 After running out of fuel .....	2-91
16.2 Towing machine .....	2-91
16.3 If battery is discharged .....	2-91
16.4 Other trouble .....	2-94

## MAINTENANCE

17. Guides to maintenance .....	3- 2
18. Outlines of service .....	3- 4
18.1 Outline of oil, fuel, coolant .....	3- 4
18.2 Relating to electric system .....	3- 6
19. Wear parts list .....	3- 7
20. Use of fuel, coolant and lubricants according to ambient temperature .....	3- 8
21. Standard tightening torques for bolts and nuts .....	3-12
21.1 Introduction of necessary tools .....	3-12
21.2 Torque list .....	3-13
22. Periodic replacement of safety critical parts .....	3-14
23. Maintenance schedule chart .....	3-16
24. Service Procedure .....	3-18
24.1 When required .....	3-18
24.2 Check before starting .....	3-32
24.3 Every 50 hours service .....	3-33
24.4 Every 250 hours service .....	3-34
24.5 Every 500 hours service .....	3-40
24.6 Every 1000 hours service .....	3-41
24.7 Every 2000 hours service .....	3-42
24.8 Every 4000 hours service .....	3-51

## SPECIFICATIONS

25. Specifications .....	4- 2
--------------------------	------

## OPTIONS, ATTACHMENTS

26. General precautions .....	5- 2
26.1 Precautions related to safety .....	5- 2
27. Handling deluxe seat .....	5- 3

# SAFETY



## WARNING

**Read and follow all safety precautions. Failure to do so may result in serious injury or death.**

This safety section also contains precautions for optional equipment and attachments.

## 6. GENERAL PRECAUTIONS

**⚠ WARNING:** For reasons of safety, always follow these safety precautions.

### SAFETY RULES

- Only trained and authorized personnel can operate and maintain the machine.
- Follow all safety rules, precautions and instructions when operating or performing maintenance on the machine.
- Do not operate the machine if you are not feeling well, or if you are taking medicine which will make you sleepy, or if you have been drinking. Operating in such a condition will adversely affect your judgement and may lead to an accident.
- When working with another operator or with a person on worksite traffic duty, be sure that all personnel understand all hand signals that are to be used.
- Always follow all rules related to safety.

### SAFETY FEATURES

- Be sure that all guards and covers are in their proper position. Have guards and covers repaired if damaged.
- Use safety features such as safety lock lever ① parking brake lever ② and the seat belt properly.
- Never remove any safety features. Always keep them in good operating condition.  
Safety lock lever, parking lever → See "12.10 PARKING MACHINE".  
Seat belt → See "12.1.4 USING SEAT BELT".
- Improper use of safety features could result in serious bodily injury or death.

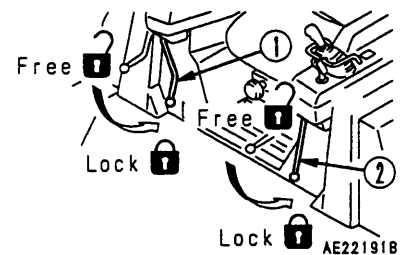

### CLOTHING AND PERSONAL PROTECTIVE ITEMS

- Avoid loose clothing, jewelry, and loose long hair. They can catch on controls or in moving parts and cause serious injury or death.
- Also, do not wear oily clothes, because they are flammable.
- Wear a hard hat, safety glasses, safety shoes, mask or gloves when operating or maintaining the machine. Always wear safety goggles, hard hat and heavy gloves if your job involves scattering metal chips or minute materials particularly when driving pins with a hammer and when cleaning the air cleaner element with compressed air. Check also that there is no one near the machine.
- Check that all protective equipment functions properly before using.

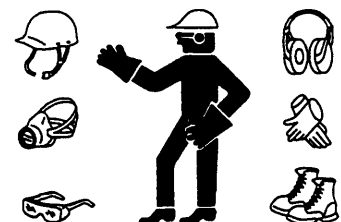

### UNAUTHORIZED MODIFICATION

Any modification made without authorization from Komatsu can create hazards. Before making a modification, consult your Komatsu distributor. Komatsu will not be responsible for any injury or damage caused by any unauthorized modification.

**⚠ WARNING:** Failure to follow these safety precautions may lead to a serious accident.

## 6. GENERAL PRECAUTIONS

### ALWAYS APPLY LOCK WHEN LEAVING OPERATOR'S SEAT

- When standing up from the operator's seat, always place the safety lock lever ① and parking brake lever ② securely in the LOCK position. If you accidentally touch the levers when they are not locked, the work equipment may suddenly move and cause serious injury or damage.
- When leaving the machine, lower the blade and ripper completely to the ground, set the safety lock levers and parking brake lever to the LOCK position, then stop the engine. Use the key to lock all the equipment. Always remove the key and take it with you.

**Work equipment posture → See "12.10 PARKING MACHINE".**

**Locking → See "12.14 LOCKING"**

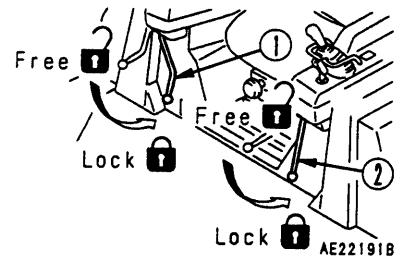

### MOUNTING AND DISMOUNTING

- Never jump on or off the machine. Never get on or off a moving machine.
- When getting on or off the machine, always face the machine and use the handrails and steps.
- Never hold any control levers or lock levers when getting on or off the machine.
- To ensure safety, always maintain three-point contact (both feet and one hand, or both hands and one foot) with the handrails and steps to ensure that you support yourself.
- If there is any oil, grease, or mud on the handrails or steps, wipe it off immediately. Always keep these parts clean. Repair any damage and tighten any loose bolts.
- Use the parts in the diagram below when setting on or off the machine.
- When getting on or off the machine, or when moving along the top of the track, if you hold the handrail inside the door when moving on top of the track shoe, and the door lock is not locked securely, the door may move and cause you to fall.

Always lock the door securely.

**Method of locking door → See "11.6 DOOR-OPEN LOCK".**

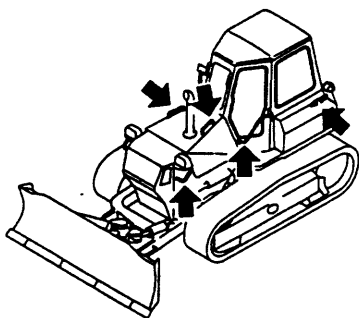

9JA02257

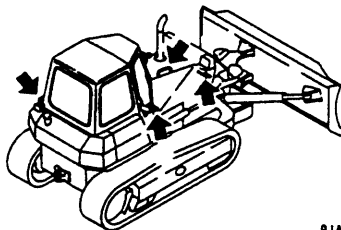

9JA02258



AL187320

### FIRE PREVENTION FOR FUEL AND OIL

Fuel, oil, and antifreeze can be ignited by a flame. Fuel is particularly flammable and can be hazardous.

Always observe the following:

- Keep any flame or lighted cigarette away from flammable fluids.
- Stop the engine and do not smoke when refueling.
- Tighten all fuel and oil caps securely.
- Use well-ventilated areas for adding or storing oil and fuel.
- Keep oil and fuel in the determined place and do not allow unauthorized persons to enter.



A0055020

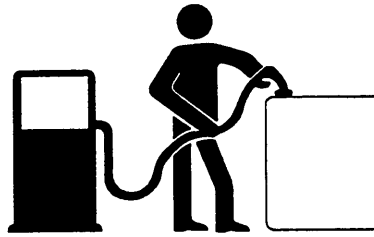

A0055030



A0055040

### PRECAUTIONS WHEN HANDLING AT HIGH TEMPERATURE

- Immediately after operations are stopped, the engine oil and hydraulic oil are at high temperature and are still under pressure. Attempting to remove the cap, drain the oil or water, or replace the filters may lead to serious burns. Always wait for the temperature to go down, and follow the specified procedures when carrying out these operations.
- To prevent hot water from spurting out, stop the engine, wait for the water to cool, then loosen the cap slowly to relieve the pressure before removing the cap.  
(When checking if the water temperature has gone down, put your hand near the front face of the radiator and check the air temperature. Be careful not to touch the radiator.)
- To prevent hot oil from spurting out, stop the engine, wait for the oil to cool, then loosen the cap slowly to relieve the pressure before removing the cap.  
(When checking if the oil temperature has gone down, put your hand near the front face of the hydraulic tank and check the air temperature. Be careful not to touch the hydraulic tank.)



A0055050



**▲ WARNING:** Failure to follow these safety precautions may lead to a serious accident.

### ASBESTOS DUST HAZARD PREVENTION

Asbestos dust can be hazardous to your health if it is inhaled.

Komatsu does not use asbestos in its products, but if you handle materials containing asbestos fibers, follow the guidelines given below:

- Never use compressed air for cleaning.
- Use water to keep down the dust when cleaning.
- If there is danger that there may be asbestos dust in the air, operate the machine from an upwind position whenever possible.
- Use an approved respirator if necessary.

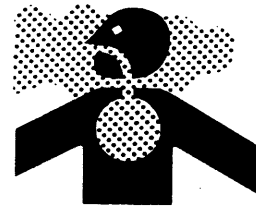

A0055060

### CRUSHING OR CUTTING PREVENTION

Do not enter, or put your hand or arm or any other part of your body between movable parts such as the work equipment and cylinders, or between the machine and work equipment.

If the work equipment is operated, the clearance will change and this may lead to serious damage or personal injury.

If it is necessary to go between movable parts, always lock the levers and be sure that the work equipment cannot move. For details, see "PRECAUTIONS DURING MAINTENANCE".



A0066090

### FIRE EXTINGUISHER AND FIRST AID KIT

Always follow the precautions below to prepare for action if any injury or fire should occur.

- Be sure that fire extinguishers have been provided and read the labels to ensure that you know how to use them.
- Provide a first aid kit at the storage point. Carry out periodic checks and add to the contents if necessary.
- Know what to do in the event of a fire or injury.
- Decide the phone numbers of persons (doctor, ambulance, fire station, etc.) to contact in case of an emergency. Post these contact numbers in specified places and make sure that all personnel know the numbers and correct contact procedures.

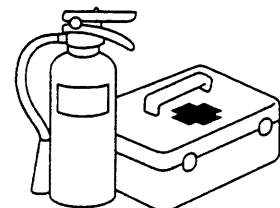

A0055070

## 6. GENERAL PRECAUTIONS

### ROPS

If ROPS is installed, do not operate the machine with the ROPS removed.

ROPS is installed to protect the operator if the machine should roll over. It supports the load when the machine rolls over and also absorbs impact energy. The Komatsu ROPS fulfills all worldwide regulations and standards, but it is damaged by falling objects or by rolling over, its strength will be reduced and it will not be able to provide its original capacity.

In such a case, please contact your Komatsu distributor for advice on the method of repair. Even if ROPS is installed, it can only protect you properly if you wear the seat belt.

Always fasten the seat belt when operating the machine.

**Seat belt → See "12.1.4. USING SEAT BELT".**

### PRECAUTIONS FOR ATTACHMENTS

- When installing and using an optional attachment, read the instruction manual for the attachment and the information related to attachments in this manual.
- Do not use optional parts or attachments that are not authorized by Komatsu or your Komatsu distributor. Use of unauthorized attachments could create a safety problem and adversely affect the proper operation and useful life of the machine.
- Any injury, accidents, product failures resulting from the use of unauthorized attachments will not be the responsibility of Komatsu.

### PRECAUTIONS WITH SEAT BELT

- To ensure safety during operations, always wear the seat belt.
- Before fastening the seat belt, check that there is no abnormality in the belt or belt mount bracket. If these are worn or damaged, replace the seat belt.
- Be sure that the seat belt is not twisted when fastening it.

**Seat belt → See "12.1.4 USING SEAT BELT".**

### VENTILATION FOR ENCLOSED AREAS

Exhaust fumes from the engine can kill.

- If it is necessary to start the engine within an enclosed area, or you handle fuel, flushing oil, or paint, open the doors and windows to ensure that you provide adequate ventilation to prevent gas poisoning.
- If opening the doors and windows still does not provide adequate ventilation, set up fans.



A0055060

## 7. PRECAUTIONS DURING OPERATION

**⚠ WARNING:** Failure to follow these safety precautions may lead to a serious accident.

### 7.1 BEFORE STARTING ENGINE

#### SAFETY AT WORKSITE

- Before starting operations, thoroughly check the area for any unusual conditions that could be dangerous.
- Check the terrain and condition of the ground at the worksite, and determine the best and safest method of operation.
- Make the ground surface as hard and horizontal as possible before carrying out operations. If the jobsite is dusty, spray water before starting operations.
- If you need to operate on a road, protect pedestrians and cars by designating a person for worksite traffic duty or by installing fences and putting up No Entry signs around the worksite.
- If water lines, gas lines, or high-voltage electrical lines may be buried under the worksite, contact each utility and identify their locations. Be careful not to sever or damage any of these lines.
- Check the ground condition and the depth and flow of water before operating in water or crossing a river. NEVER be in water which is in excess of the permissible water depth.  
**Permissible water depth → See "12.9 PRECAUTIONS FOR OPERATION".**

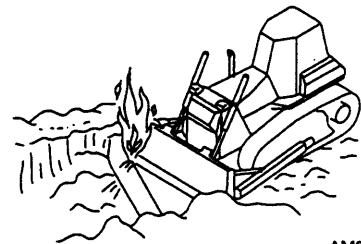

AM085860

#### CHECKS BEFORE STARTING ENGINE

Carry out the following checks before starting the engine at the beginning of the days work. Failure to carry out these checks may lead to serious injury or damage.

- Completely remove all flammable materials accumulated around the engine and battery, return all fuel containers to their proper place, remove all parts and tools from the operator's compartment, and remove any dirt from the mirrors, handrails, and steps.

**Walk-around checks → See "12.1.1 WALK-AROUND CHECK".**

- Check the coolant level, fuel level, and oil level in the hydraulic tank, check for clogging of the air cleaner, and check the electric wiring.

**Checks before starting → See "12.1.2 CHECK BEFORE STARTING".**

- Adjust the operator's seat to a position where it is easy to carry out operations, and check for wear or damage to the seat belt and seat belt mounting equipment.

**Adjusting operator's seat → See "12.1.3 ADJUST OPERATOR'S SEAT".**

- Check that the gauges work properly, and check that the control levers are all at the NEUTRAL position.

**Method of checking operation of gauges →**

**See "12.1.5 OPERATIONS AND CHECKS BEFORE STARTING ENGINE".**

If the above inspections show any abnormality, carry out repairs immediately.



A0055020

**WHEN STARTING ENGINE**

- Walk around your machine again just before mounting it, and check for people and objects that might be in the way.
- Never start the engine if a warning tag has been attached to the blade control lever.
- When starting the engine, sound the horn as an alert.
- Start and operate the machine only while seated.
- An additional worker may ride in the machine only when sitting in the passenger seat. Do not allow anyone to ride on the machine body.
- Do not short circuit the starting motor circuit to start the engine. It is not only dangerous, but will also cause damage to the equipment.



**⚠ WARNING:** Failure to follow these safety precautions may lead to a serious accident.

## 7.2 AFTER STARTING ENGINE

### CHECKS AFTER STARTING ENGINE

Failure to carry out the checks properly after starting the engine will lead to delays in discovery of abnormalities, and this may lead to serious injury or damage to the machine.

When carrying out the checks, use a wide area where there are no obstructions. Do not allow anyone near the machine.

- Check the operation of the gauges and equipment, and check the operation of the blade, ripper, brakes, travel system, and steering system.
  - Checks for any abnormality in the sound of the machine, vibration, heat, smell, or gauges; check also that there is no leakage of air, oil, or fuel.
  - If any abnormality is found, carry out repairs immediately.
- If the machine is used when it is not in proper condition, it may lead to serious injury or damage to the machine.

### PRECAUTIONS WHEN STARTING OFF

- Before starting off, check again that there is no one in the surrounding area and that there is no obstacles.
- When starting off, sound the horn as an alert.  
Always operate the machine only when seated.
- An additional worker may ride in the machine only when sitting in the passenger seat. Do not allow anyone to ride on the machine body.
- Check that the backup alarm works properly.
- Always close the door of the operator's compartment and check that the door is securely locked.

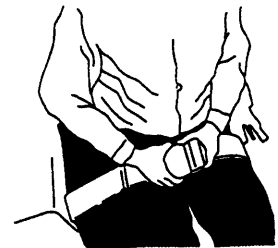

AE305800

### CHECK WHEN CHANGING DIRECTION

To prevent serious injury or death, always do the following before moving the machine or doing the leveling work.

- Before changing between forward and reverse, reduce speed and stop the machine.
- Before operating the machine, sound the horn to warn people in the area.
- Check that there is no one near the machine. Be particularly careful to check behind the machine.
- When operating in areas that may be hazardous or have poor visibility, designate a person to direct worksite traffic.
- Ensure that no unauthorized person can come within the direction of turning or direction of travel.  
Always be sure to carry out the above precautions even when the machine is equipped with a backup alarm and mirrors.

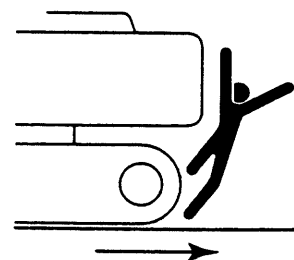

A0066100

### PRECAUTIONS WHEN TRAVELING

- Never turn the key in the starting switch to the OFF position when traveling. It is dangerous if the engine stops when the machine is traveling, because it becomes impossible to operate the steering.
- It is dangerous to look around you when operating. Always concentrate on your work.
- It is dangerous to drive too fast, or to start suddenly, stop suddenly, turn sharply, or zigzag.
- If you find any abnormality in the machine during operation (noise, vibration, smell, incorrect gauges, air leakage, oil leakage, etc.), move the machine immediately to a safe place and look for the cause.
- Set the work equipment to a height of 40 – 50 cm (16 – 20 in) from the ground level and travel on level ground.
- When traveling, do not operate the work equipment control levers. If the work equipment control levers have to be operated, never operate them suddenly.
- Do not operate the steering suddenly. The work equipment may hit the ground surface and cause the machine to lose its balance, or may damage the machine or structures in the area.
- When traveling on rough ground, travel at low speed, and avoid sudden changes in direction.
- Avoid traveling over obstacles as far as possible. If the machine has to travel over an obstacle, keep the work equipment as close to the ground as possible and travel at low speed. Never travel over obstacles which make the machine tilt strongly (10° or more).
- When traveling or carrying out operations, always keep your distance from other machines or structures to avoid coming into contact with them.
- NEVER be in water which is in excess of the permissible water depth.  
**Permissible water depth → See "12.9 PRECAUTIONS FOR OPERATION".**
- When passing over bridges or structures on private land, check first that the structure is strong enough to support the mass of the machine. When traveling on public roads, check first with the relevant authorities and follow their instructions.

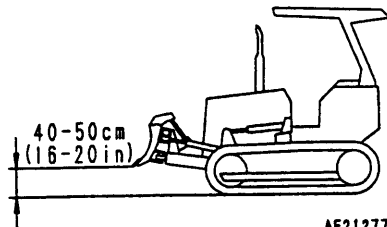

AE21277B

### TRAVELING ON SLOPES

- Traveling on slopes could result in the machine tipping over or slipping to the side.
- When traveling on slopes, keep the blade approximately 20 to 30 cm above the ground. In case of emergency, quickly lower the blade to the ground to help the machine to stop.
- Do not turn on slopes or travel across slopes. Always go down to a flat place to perform these operations.
- Do not travel on grass, fallen leaves, or wet steel plates. Even slight slopes may cause the machine to slip to the side, so travel at low speed and make sure that the machine is always traveling directly up or down the slope.
- When traveling downhill, use the braking force of the engine and travel slowly.
- Be careful when allowing the machine to travel downhill under its own weight. It may steer in the opposite direction.

Reverse steering when traveling downhill →

See "12.7.2 TURNING WHILE DESCENDING A SLOPE".

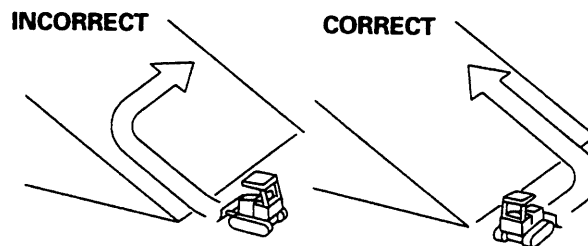

AD051690

### PROHIBITED OPERATIONS

To prevent the machine from turning over or the work equipment from being damaged because of overload, always keep within the safe angle and maximum load specified for the machine. Never use the machine in excess of its capacity.

### PRECAUTIONS WHEN OPERATING

- Be careful not to approach too close to the edge of cliffs.  
When making embankments or landfills, or when dropping soil over a cliff, dump one pile, then use the next pile of soil to push the first pile.
- The load suddenly becomes lighter when the soil is pushed over a cliff or when the machine reaches the top of a slope. When this happens, there is danger that the travel speed will suddenly increase, so be sure to reduce the speed.
- If the load is applied to only one side of the blade, the rear of the machine may swing.
- Carry out only work that is specified as the purpose of the machine. Carrying out other operations will cause breakdowns.

Specified operations → See "12.15 WORK POSSIBLE USING BULLDOZER".

- Do the following to ensure good visibility.
  - When operating in dark places, turn on the working lamps and front lamps, and install lighting at the jobsite if necessary.
  - Do not carry out operations in fog, mist, snow, or heavy rain, or other conditions where the visibility is poor. Wait for the weather to clear so that visibility is sufficient to carry out work.
- Always do the following to prevent the work equipment from hitting other objects.
  - When operating in tunnels, under bridges, under electric wires, or other places where the height is limited, be extremely careful not to let the blade hit anything.
  - To prevent accidents caused by hitting other objects, always operate the machine at a speed which is safe for operation, particularly in confined spaces, indoors, and in places where there are other machines.

**7. PRECAUTIONS DURING OPERATION**

**DO NOT GO CLOSE TO HIGH-VOLTAGE CABLES**

- Do not let the machine touch overhead electric cables. Even going close to high-voltage cables can cause electric shock. Always maintain the safe distance given below between the machine and the electric cable.
- To prevent accidents, always do as follows.
  - On jobsites where there is danger that the machine may touch the electric cables, consult the electricity company before starting operations to check that the actions determined by the relevant laws and regulations have been taken.
  - Wear rubber shoes and gloves. Lay a rubber sheet on top of the operator's seat, and be careful not to touch the chassis with any exposed part of your body.
  - Use a signalman to give warning if the machine approaches too close to the electric cables.
  - If the work equipment should touch the electric cable, the operator should not leave the operator's compartment.
  - When carrying out operations near high voltage cables, do not let anyone come close to the machine.
  - Check with the electricity company about the voltage of the cables before starting operations.

	Voltage	Min. safety distance
Low voltage	100 - 200 V	2 m
	6,600 V	2 m
Very high voltage	22,000 V	3 m
	66,000 V	4 m
	154,000 V	5 m
	187,000 V	6 m
	275,000 V	7 m
	500,000 V	11 m

**USING BRAKES**

- When the machine is traveling, do not rest your foot on the brake pedal. Put your foot on the pedal only when using the brakes.  
If you travel with your foot resting on the pedal, the brake will always be applied, and this will cause the brakes to overheat and fail.
- Do not depress the brake pedal lightly to apply partial braking to control the travel speed. This will cause the brake to overheat and it will be impossible to use the brakes effectively when they are needed.
- When traveling downhill, use the braking force of the engine, and always use the brake pedal.

**OPERATE CAREFULLY ON SNOW**

- When working on snow or icy roads, even a slight slope may cause the machine to slip to the side, so always travel at low speed and avoid sudden starting, stopping, or turning. There is danger of slipping particularly on uphill or downhill slopes.
- With frozen road surfaces, the ground becomes soft when the temperature rises, so the travel conditions become unstable. In such cases be extremely careful when traveling.
- When there has been heavy snow, the road shoulder and objects placed beside the road are buried in the snow and cannot be seen, so always carry out operations carefully.  
When traveling on snow-covered slopes, never apply the brakes suddenly. Reduce the speed and use the engine as a brake while applying the foot brake intermittently (depress the brake intermittently several times). If necessary, lower the blade to the ground to stop the machine.
- The load varies greatly according to the characteristics of the snow, so adjust the load accordingly and be careful not to let the machine slip.



**⚠ WARNING:** Failure to follow these safety precautions may lead to a serious accident.

## 7. PRECAUTIONS DURING OPERATION

### WORKING ON LOOSE GROUND

- Do not operate the machine on soft ground. It is difficult to get the machine out again.
- Avoid operating your machine too close to the edge of cliffs, overhangs, and deep ditches. If these areas collapse under the mass or vibration of your machine, it could fall or tip over and this could result in serious injury or death. Remember that the soil after heavy rain, blasting, or earthquakes is weakened in these areas.
- Earth laid on the ground and the soil near ditches is loose. It can collapse under the mass or vibration of your machine and cause your machine to tip over.
- Install the head guard (FOPS) when working in areas where there is danger of falling stones.
- Install the ROPS and wear the seat belt when working in areas where there is danger of falling rocks or of the machine turning over.

### PARKING MACHINE

- Park the machine on level ground where there is no danger of falling rocks or landslides, or of flooding if the land is low, and lower the work equipment to the ground.
- If it is necessary to park the machine on a slope, set blocks under the tracks to prevent the machine from moving, then dig the work equipment into the ground.
- After stopping the engine, operate the blade control lever several times to the RAISE and LOWER positions to release the remaining pressure in the hydraulic circuit.
- When parking on public roads, provide fences, signs, flags, or lights, and put up any other necessary signs to ensure that passing traffic can see the machine clearly, and park the machine so that the machine, flags, and fences do not obstruct traffic.

**Parking procedure → See "12.10 PARKING MACHINE".**

- When leaving the machine, lower the work equipment completely to the ground, place the joystick to the neutral position, and the blade and ripper control levers to the HOLD position. Then set the safety lock lever ① and parking brake lever ② to the LOCK position, stop the engine, and use the key to lock all the equipment. Always remove the key and take it with you.

**Work equipment posture → See "12.10 PARKING MACHINE".**

**Locks → See "12.14 LOCKING".**

- Always close the door of the operator's compartment.

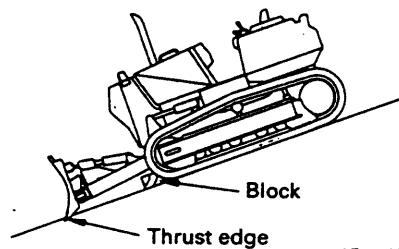

AE144050

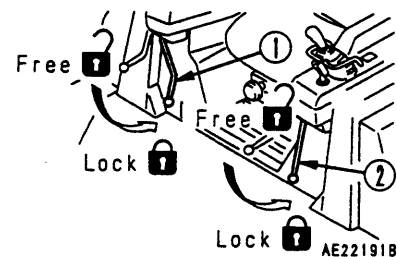

AE221918

**PRECAUTIONS IN COLD AREAS**

- After completing operations, remove all water, snow, or mud stuck to the wiring harness, connector ①, switches, or sensors, and cover these parts.  
If the water freezes, it will cause malfunctions of the machine when it is next used, which may lead to unexpected accidents.
- Carry out the warming-up operation thoroughly. If the machine is not thoroughly warmed up before the control levers are operated, the reaction of the machine will be slow, and this may lead to unexpected accidents.
- Operate the control levers to relieve the hydraulic pressure (raise to above the set pressure for the hydraulic circuit and release the oil to the hydraulic tank) to warm up the oil in the hydraulic circuit. This ensures good response from the machine and prevents malfunctions.
- If the battery electrolyte is frozen, do not charge the battery or start the engine with a different power source. There is danger that this will ignite the battery.  
When charging or starting the engine with a different power source, melt the battery electrolyte and check for leakage of battery electrolyte before starting.

**Battery charge rate → See "14. COLD WEATHER OPERATION".**

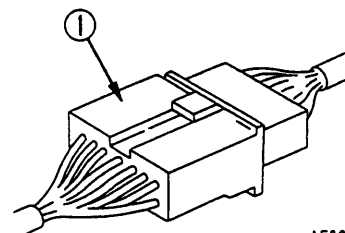

AE305820

## 7.3 TRANSPORTATION

### LOADING AND UNLOADING

- Loading and unloading the machine always involves potential hazards. **EXTREME CAUTION SHOULD BE USED.**
- When loading or unloading the machine, run the engine at low idling and travel at low speed.
- Perform loading and unloading on firm, level ground only. Maintain a safe distance from the edge of a road.
- **ALWAYS** use ramps of adequate strength. Be sure that the ramps are wide, long, and thick enough to provide a safe loading slope. Place blocks under both ramps to support them before loading and unloading.
- When unloading on to an embankment or temporary structure, make sure that it has ample width, strength, and grade.
- To prevent the machine from slipping, be sure that the ramp surface is clean and free of grease, oil, ice and loose materials. Remove mud from the machine tracks.
- **NEVER** correct your steering on the ramps. If necessary, drive away from the ramps and climb again.
- After loading, block the machine tracks and secure the machine with tie-downs.  
Loading and unloading → See "13. TRANSPORTATION".  
Tie-downs → See "13. TRANSPORTATION".

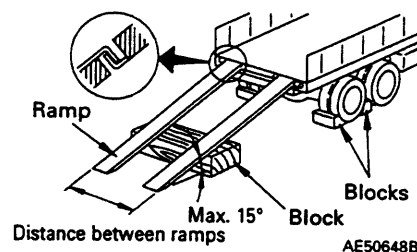

### SHIPPING

- When shipping the machine on a hauling vehicle, obey all state and local laws governing the weight, width, and length of a load. Also obey all applicable traffic regulations.
- Take into account the width, height and weight of the load when determining the shipping route.  
Height, width, load of machine → See "13.3 PRECAUTIONS FOR TRANSPORTATION".
- When passing over bridges or structures on private land, check first that the structure is strong enough to support the mass of the machine. When traveling on public roads, check first with the relevant authorities and follow their instructions.
- On machines equipped with a cab, always lock the door securely.

## 7. PRECAUTIONS DURING OPERATION

### PRECAUTIONS WHEN FIXING ROPE AND RAISING MACHINE

When raising the machine, if the rope is not fixed properly, the machine may slip and cause a serious accident or injury.

- (1) Always apply the parking brake before fitting a sling or wire rope.
- (2) Always use a sling or rope of suitable strength when raising the machine.
- (3) Use protectors at sharp corners or places where the wire or cable will bite in. Position the crane so that the machine is raised horizontally. Make the width of the speaker and bar wide enough so that it does not contact the machine.
- (4) Method of fitting rope

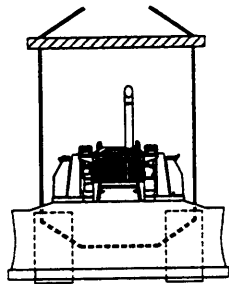

AD213250

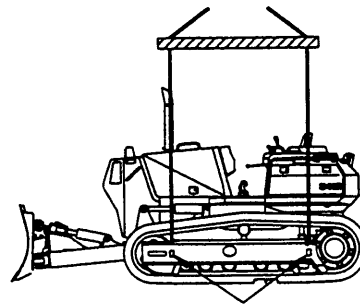

Lifting position

AD171520

Pass the cable under the undercover and steering case.

- (5) **Checking safety**  
After fitting the rope, raise 100 – 200 mm (3.9 – 7.9 in) and check that there is no slack in the wire cable and that the machine is being raised horizontally.
- (6) If any points are unclear, please contact your Komatsu distributor for advice.
- (7) For details of the weights, see "25. SPECIFICATIONS".

## 7.4 BATTERY

### BATTERY HAZARD PREVENTION

Battery electrolyte contains sulphuric acid, and batteries generate hydrogen gas, so mistaken handling can lead to serious injury or fire. For this reason, always observe the following precautions.

- Never bring any lighted cigarette or flame near the battery.
- When working with batteries, ALWAYS wear safety glasses and rubber gloves.
- If you spill acid on your clothes or skin, immediately flush the area with large amounts of water.
- Battery acid could cause blindness if splashed into the eyes. If acid gets into your eyes, flush them immediately with large quantities of water and see a doctor at once.
- If you accidentally drink electrolyte, drink a large quantity of water or milk, beaten egg or vegetable oil. Call a doctor or poison prevention center immediately.
- Before working with batteries, stop the engine and turn the starting switch to the OFF position.
- Avoid short-circuiting the battery terminals (between the positive ⊕ terminal and negative ⊖ terminal) through accidental contact with metal objects, such as tools.
- When installing the battery, connect the positive ⊕ terminal first, and when removing the battery, disconnect the negative ⊖ terminal (ground side) first.
- When removing or installing, check which is the positive ⊕ terminal and negative ⊖ terminal, and tighten the nuts securely.  
If the battery electrolyte is near the LOWER LEVEL, add distilled water. Do not add distilled water above the UPPER LEVEL.
- When cleaning the top surface of the battery, wipe it with a damp cloth. Never use gasoline, thinner, or any other organic solvent or cleaning agent.
- Tighten the battery caps securely.
- If the battery electrolyte is frozen, do not charge the battery or start the engine with a different power source. There is danger that this will ignite the battery.  
When charging or starting the engine with a different power source, melt the battery electrolyte and check for leakage of battery electrolyte before starting.
- Always remove the battery from the chassis before charging it.

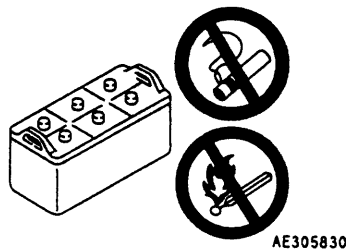
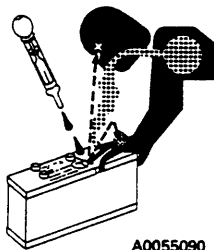

### STARTING WITH BOOSTER CABLES

If any mistake is made in the method of connecting the booster cables, it may cause a fire, so always do as follows.

- Carry out the starting operation with two workers (with one worker sitting in the operator's seat).
- When starting from another machine, do not allow the two machines to touch.
- When connecting the booster cables, turn the starting switch OFF for both the normal machine and problem machine.
- Be sure to connect the positive  $\oplus$  cable first when installing the booster cables. Disconnect the ground or negative  $\ominus$  cable first when removing them.
- The final ground connection is the connection of the ground to the engine block of the problem machine. However, this will cause sparks, so be sure to connect it as far as possible from the battery.

**Starting procedure when using booster cables → See "16.2 IF BATTERY IS DISCHARGED".**

- When removing the booster cables, be careful not to let the booster cable clips touch each other or to let the clips touch the machine.

INCORRECT

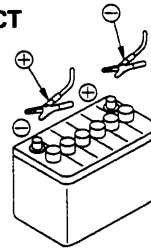

A0067320

### CHARGING BATTERY

If the battery is handled incorrectly when it is being charged, there is danger that the battery may explode, so follow the instructions in HANDLING BATTERY and in the instruction manual for the charger, and always observe the following precautions.

- Carry out the charging in a well-ventilated place, and remove the battery caps. This disperses the hydrogen gas and prevents explosion.
- Set the voltage on the charger to match the voltage on the battery to be charged. If the voltage setting is wrong, it will cause the charger to overheat and catch fire, and this may lead to an explosion.

Connect the positive  $\oplus$  charging clip of the charger to the positive  $\oplus$  terminal of the battery, then connect the negative  $\ominus$  charging clip to the negative  $\ominus$  terminal of the battery. Be sure to tighten both terminals securely.

- If the battery charge is less than 1/10 of the rated charge, and high speed charging is carried out, set to a value below the rated capacity of the battery.

If there is an excessive flow of charging current, it may cause leakage or evaporation of the electrolyte, which may catch fire and explode.

INCORRECT

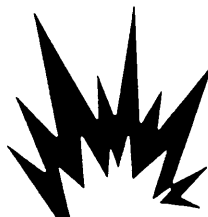

A0055110

**⚠ WARNING:** Failure to follow these safety precautions may lead to a serious accident.

## 7.5 TOWING

### WHEN TOWING

- Injury or death could result if a disabled machine is towed incorrectly or if there is a mistake in the selection of the wire rope, so always do as follows.
- Do not tow in a different way from the method given in the section METHOD OF TOWING.
- Always wear leather gloves when handling wire rope.
- When carrying out the preparation for towing with another worker, agree on signals before starting the operation.
- If the engine on the problem machine will not start or there is a failure in the brake system, please contact your Komatsu distributor for repairs.
- It is dangerous to tow a machine on a slope, so choose a place where there is a gradual slope. If there is no place with a gradual slope, carry out work to make the slope as small as possible.
- If a problem machine is towed by another machine, ALWAYS use a wire rope with a sufficient towing capacity for the weight of the problem machine.
- Do not use a wire rope which has cut strands (A), kinks (B), or reduced diameter (C).

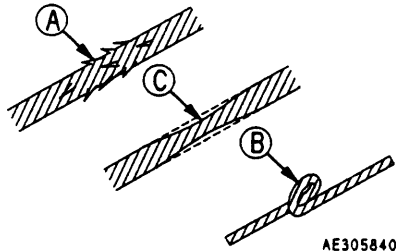

AE305840

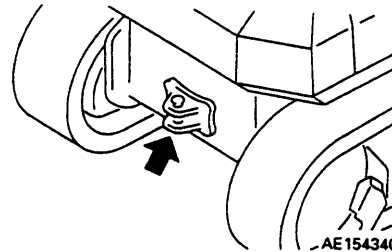

AE154340

## 8. PRECAUTIONS FOR MAINTENANCE

**⚠ WARNING:** For reasons of safety, always follow these safety precautions.

### 8.1 BEFORE CARRYING OUT MAINTENANCE

#### NOTIFICATION OF FAILURE

Carrying out maintenance not described in the Komatsu operation and maintenance manual may lead to unexpected failures.  
Please contact your Komatsu distributor for repairs.

#### WARNING TAG

- ALWAYS attach the "DO NOT OPERATE" warning tag to the blade control lever in the operator's cab to alert others that you are working on the machine. Attach additional warning tags around the machine if necessary.
- If others start the engine, or touch or operate the blade control lever while you are performing service or maintenance, you could suffer serious injury or death.

Warning tag Part No. 09963-03001

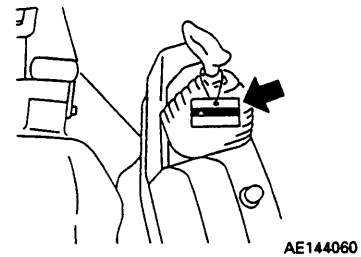
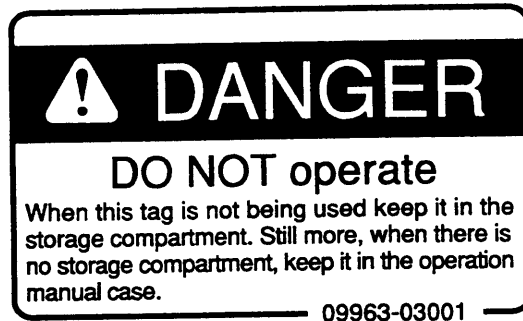

#### CLEAN BEFORE INSPECTION AND MAINTENANCE

- Clean the machine before carrying out inspection and maintenance. This will ensure that dirt does not get into the machine and will also ensure that maintenance can be carried out safely.
- If inspection and maintenance are carried out with the machine still dirty, it will be difficult to find the location of problems, and there is also the danger that you will get dirty or mud in your eyes, and that you will slip and injure yourself.
- When washing the machine, always do as follows.
  - Wear non-slip shoes to prevent yourself from slipping on the wet surface.
  - When using high-pressure steam to wash the machine, always wear protective clothing. This will protect you from being hit by high-pressure water, and cutting your skin or getting mud or dust into your eyes.
  - Do not spray water directly on to the electrical system (sensors, connectors) ①. If water gets into the electrical system, there is danger that it will cause defective operation and malfunction.

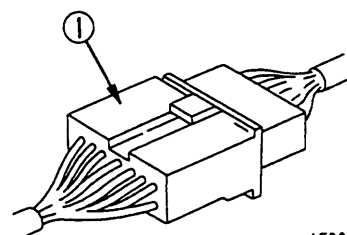
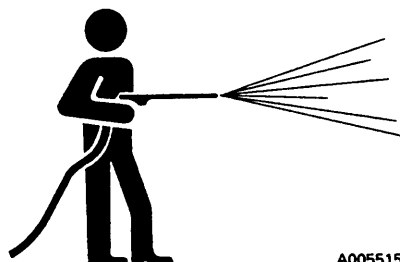



**⚠ WARNING:** Failure to follow these safety precautions may lead to a serious accident.

**KEEP WORK PLACE CLEAN AND TIDY**

Do not leave hammers or other tools lying around in the work place. Wipe up all grease, oil, or other substances that will cause you to slip. Always keep the work place clean and tidy to enable you to carry out operations safely.

If the work place is not kept clean and tidy, there is danger that you will trip, slip, or fall over and injure yourself.

**APPOINT LEADER WHEN WORKING WITH OTHERS**

When repairing the machine or when removing and installing the work equipment, appoint a leader and follow his instructions during the operation.

When working with others, misunderstandings between workers can lead to serious accidents.

**RADIATOR WATER LEVEL**

- When inspecting the radiator water level, stop the engine, and wait for the engine and radiator to cool down. Check the water level in the sub-tank. Under normal conditions, do not open the radiator cap.
- If there is no sub-tank, or the radiator cap must be removed, always do as follows.
- Wait for the radiator water temperature to go down before checking the water level. (When checking if the water temperature has gone down, put your hand near the engine or radiator and check the air temperature. Be careful not to touch the radiator or engine.)
- Release the internal pressure before removing the radiator cap, and remove the radiator cap slowly.

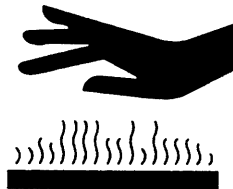

A0055050

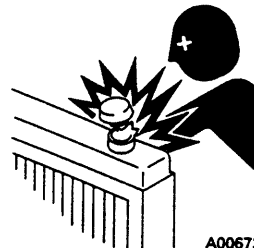

A0067380

**STOP ENGINE BEFORE CARRYING OUT INSPECTION AND MAINTENANCE**

- When carrying out inspection and maintenance, park the machine on level ground where there is no danger of falling rocks or land slides, or of flooding if the land is low, then lower the work equipment to the ground and stop the engine.
- Operate blade control lever ① several times to the RAISE and LOWER positions to release the remaining pressure in the hydraulic circuit, then set safety lock lever ② and parking brake lever ③ to the LOCK position.
- Put blocks under the track to prevent the machine from moving.
- The worker carrying out the maintenance should be extremely careful not to touch or get caught in the moving parts.

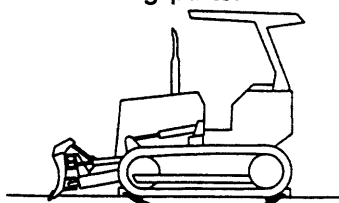

Block AE212798

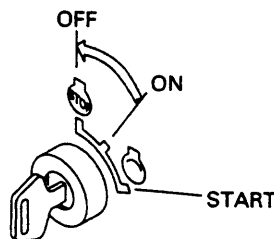

AD051781

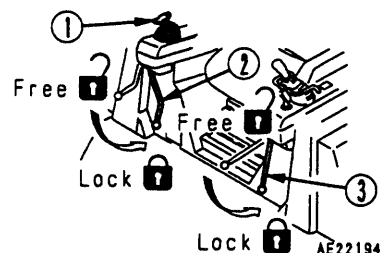

AE221948

**⚠ WARNING:** For reasons of safety, always follow these safety precautions.

## 8. PRECAUTIONS FOR MAINTENANCE

### SAFETY DEVICES FOR WORK EQUIPMENT

When carrying out inspection and maintenance with the blade raised, fit a stand securely under the blade to prevent the blade from coming down. Place the work equipment control levers at HOLD, and set the safety lock lever ① and parking brake lever ② to the LOCK position.



A0055140

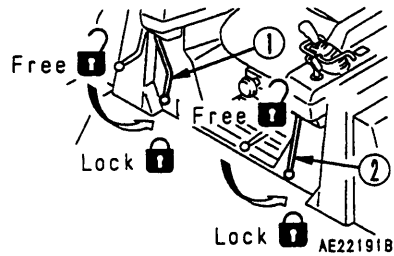

AE221918

### PROPER TOOLS

Use only tools suited to the task. Using damaged, low quality, faulty, or makeshift tools could cause personal injury.

Broken pieces of chisels or hammers could fly into your eyes and blind you.

Tools → See "21.1 INTRODUCTION OF NECESSARY TOOLS".



A0055120

### PERIODIC REPLACEMENT OF SAFETY CRITICAL PARTS

Hoses and other parts of the fuel, hydraulic, and brake system are critical parts for ensuring safety, so they must be replaced periodically.

Replacement of safety critical parts requires skill, so please ask your Komatsu distributor to carry out replacement.

- Replace these components periodically with new ones, regardless of whether or not they appear to be defective.  
These components deteriorate over time, and can cause fire because of oil leakage or failure in the work equipment system.
- Replace or repair any such components if any defect is found, even though they have not reached the time specified.

Replacement of safety critical parts →

See "22. PERIODIC REPLACEMENT OF SAFETY CRITICAL PARTS".

### USE OF LIGHTING

- When checking fuel, oil, or battery electrolyte, always use lighting with anti-explosion specifications. If such lighting equipment is not used, there is danger of explosion.
- If work is carried out in dark places without installing lighting, there is danger of injury, so always install proper lighting.
- Even if it is dark, do not use a lighter or flame instead of lighting. There is danger of starting a fire, and if the battery gas ignites, it may cause an explosion.
- When using the machine as the power supply for the lighting, follow the instructions in this Operation and Maintenance Manual.

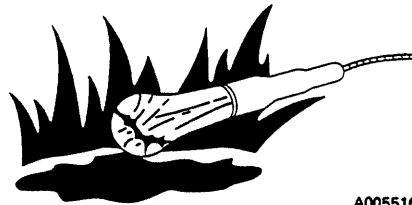

A0055160

### PREVENTION OF FIRE

There is danger of the fuel and battery gas catching fire during maintenance, so always follow the precautions below when carrying out maintenance.

- Store fuel, oil, grease, and other flammable materials away from flame.
- Use non-flammable materials as the flushing oil for cleaning parts. Do not use diesel oil or gasoline. There is danger that they will catch fire.
- Never smoke when carrying out inspection or maintenance. Always smoke in the prescribed place.
- When checking fuel, oil, or battery electrolyte, always use lighting with anti-explosion specifications. Never use lighters or matches as lighting.
- When carrying out grinding or welding operations on the chassis, remove any flammable materials to a safe place.
- Be sure that a fire extinguisher is present at the inspection and maintenance point.



A0055020

## 8.2 DURING MAINTENANCE

### PERSONNEL

Only authorized personnel can service and repair the machine. Do not allow unauthorized personnel into the area. If necessary, employ an observer. Extra precaution should be used when grinding, welding, and using a sledge-hammer.

### ATTACHMENTS

- Appoint a leader before starting removal or installation operations for attachments.
- Do not allow anyone other than the workers close to the machine or attachment.
- Place attachments that have been removed from the machine in a safe place so that they do not fall. Put a fence around the attachments, and set up No Entry signs to prevent unauthorized persons from coming close.



A0055130

### WORK UNDER THE MACHINE

- Stop the machine on firm, level ground, and always lower all work equipment to the ground before performing service or repairs under the machine.
- Always block the track shoes securely.
- It is extremely dangerous to work under the machine if the track shoes are off the ground and the machine is supported only by the work equipment. Never work under the machine if the machine is poorly supported.



A0055140

### WORK ON TOP OF MACHINE

- When carrying out maintenance on top of the machine, make sure that the footholds are clean and free of obstructions, and follow the precautions below to prevent yourself from falling.
  - Do not spill oil or grease.
  - Do not leave tools lying around.
  - Mind your step when you are walking.
- Never jump down from the machine. When getting on or off the machine, always use the steps and handrails, and maintain three-point contact (both feet and one hand or both hands and one foot) at all times.
- Use protective equipment if necessary.



A0305870

**⚠ WARNING:** Failure to follow these safety precautions may lead to a serious accident.

## 8. PRECAUTIONS FOR MAINTENANCE

### LOCKING INSPECTION COVERS

When carrying out maintenance with the inspection cover open, lock it securely with a lock bar. If maintenance is carried out with the inspection cover open and not locked in position, it may close suddenly if knocked or blown by the wind, and may cause injury to the operator.

### MAINTENANCE WITH ENGINE RUNNING

To prevent injury, do not carry out maintenance with the engine running. If maintenance must be carried out with the engine running, carry out the operation with at least two workers and do as follows.

- One worker must always sit in the operator's seat and be ready to stop the engine at any time. All workers must maintain contact with the other workers.
- When carrying out operations near rotating parts, there is danger of being caught in the parts, so be extremely careful.
- When cleaning inside the radiator, set safety lock lever ① and parking brake lever ② to the LOCK position to prevent the work equipment and body from moving.
- Do not touch any control levers. If any control lever must be operated, always give a signal to the other workers to warn them to move to a safe place.
- Never touch the fan blade or fan belt with any tool or any part of your body. There is danger of serious injury.



A0055210

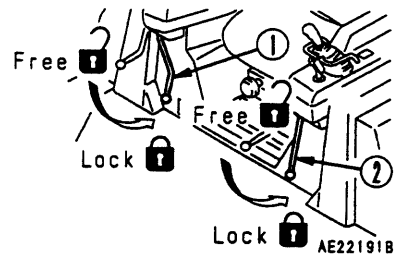

AE22191B

### DO NOT DROP TOOLS OR PARTS INSIDE MACHINE

- When opening the inspection window or tank oil filler to carry out inspection, be careful not to drop any nuts, bolts, or tools inside the machine. If such parts are dropped into the machine, it will cause breakage of the machine, mistaken operation, and other failures. If you drop any part into the machine, always be sure to remove it from the machine.
- When carrying out inspection, do not carry any unnecessary tools or parts in your pocket.

### PRECAUTIONS WHEN USING HAMMER

When using a hammer, always wear safety glasses, safety helmet, and other protective clothing, and put a brass bar between the hammer and the part being hammered.

If hard metal parts such as pins, edges, teeth, or bearings are hit with a hammer, there is danger that broken pieces might fly into your eyes and cause injury.

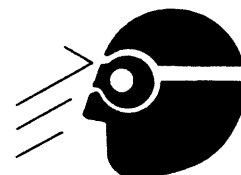

AE305880

**REPAIR WELDING**

Welding operations must always be carried out by a qualified welder and in a place equipped with a proper equipment. Gas is generated, and there is danger of fire or electrocution when carrying out welding, so never allow any unqualified personnel to carry out welding.

The qualified welder must follow the precautions given below.

- Disconnect the battery terminals to prevent explosion of the battery.
- Remove the paint from the place being welded to prevent gas from being generated.
- If hydraulic equipment or piping, or places close to these are heated, flammable vapor or spray will be generated, and there is danger of this catching fire, so avoid applying heat to such places.
- If heat is applied directly to rubber hoses or piping under pressure, they may suddenly burst, so cover them with fireproof sheeting.
- Always wear protective clothing.
- Ensure that there is good ventilation.
- Clear up any flammable materials, and make sure that there is a fire extinguisher at the workplace.

**PRECAUTIONS WITH BATTERY**

When repairing the electrical system or when carrying out electrical welding, remove the negative (-) terminal of the battery to stop the flow of current.

Handling battery → See "16.2 IF BATTERY IS DISCHARGED".

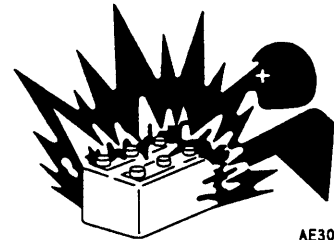

AE305890

**WHEN ABNORMALITY IS LOCATED**

- If any abnormality is found during inspection, always carry out repairs. In particular, if the machine is used when there is any abnormality in the brakes or work equipment systems, it may lead to serious accident.
- Depending on the type of failure, please contact your Komatsu distributor for repairs.

**RULES TO FOLLOW WHEN ADDING FUEL OR OIL**

If any flame is brought close to fuel or oil, there is danger that it will catch fire, so always follow the precautions below.

- Stop the engine when adding fuel or oil.
- Do not smoke.
- Spilled fuel and oil may cause you to slip, so always wipe it up immediately.
- Always tighten the cap of the fuel and oil fillers securely.
- Always add fuel and oil in a well-ventilated place.



A0055020



A0055030



A0055040

**PRECAUTIONS WHEN USING HIGH-PRESSURE GREASE TO ADJUST TRACK TENSION**

- Grease is pumped into the track tension adjustment system under high pressure. If the specified procedure for maintenance is not followed when making adjustment, valve ① may fly out and cause damage or personal injury.
- When loosening grease drain valve ①, never loosen it more than one turn.
- Never put your face, hands, feet, or any other part of your body directly in front of any grease drain valve.

Adjusting track tension → See "24.1 WHEN REQUIRED".

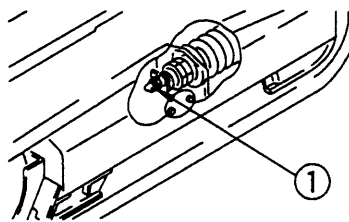

AE145060



A0055200

**HANDLING HIGH-PRESSURE HOSES**

- If oil or fuel leaks from high-pressure hoses, it may cause fire or defective operation, which may lead to personal injury or damage. If any damaged hoses or loose bolts are found, stop work and contact your Komatsu distributor for repairs.
- Replacing high-pressure hoses requires a high level of skill, and the torque is determined according to the type of hose and size, so please do not carry out replacement yourself. Ask your Komatsu distributor to carry out replacement.

**PRECAUTIONS WITH HIGH-PRESSURE OIL**

When inspecting or replacing high-pressure piping or hoses, always check that the pressure in the hydraulic circuit has been released. If the circuit is still under pressure, it will lead to serious injury or damage, so always do as follows.

- For details of the method of releasing the pressure, see 8.1 BEFORE MAINTENANCE, STOP ENGINE BEFORE CARRYING OUT INSPECTION AND MAINTENANCE. Never carry out inspection or replacement before releasing the pressure completely.
- Wear safety glasses and leather gloves.
- If there is any leakage from the piping or hoses, the piping, hoses, and the surrounding area will be wet, so check for cracks in the piping and hoses and for swelling in the hoses. If it is difficult to locate the leakage, always please contact your Komatsu distributor for repairs.
- If you are hit by a jet of high-pressure oil, consult a doctor immediately for medical attention.

**INCORRECT**



A0055180

**CORRECT**

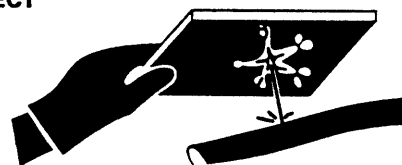

A0055190

### PRECAUTIONS WHEN CARRYING OUT MAINTENANCE AT HIGH TEMPERATURE

Immediately after stopping operations, the engine coolant, oil at all parts, the exhaust manifold, and the muffler are at high temperature.

In this condition, if the cap is removed, or the oil is drained, or the filters are replaced, this may result in burns or other injury. Wait for the temperature to go down, then carry out the inspection and maintenance in accordance with the procedures given in this manual.

**Cleaning inside of cooling system → See "24.1 WHEN REQUIRED".**

**Checking coolant level, oil level in hydraulic tank → see "24.2 CHECK BEFORE STARTING".**

**Checking lubricating oil level, adding oil → see "24.2 CHECK BEFORE STARTING".**

**Changing oil, replacing filters → see "24.4 PERIODIC MAINTENANCE".**



A0055050

### CHECKS AFTER INSPECTION AND MAINTENANCE

Failure to carry out inspection and maintenance fully, or failure to check the function of various maintenance locations may cause unexpected problems and may even lead to personal injury or damage, so always do as follows.

- Checks when engine is stopped
  - Have all the inspection and maintenance locations been checked?
  - Have all the inspection and maintenance items been carried out correctly?
  - Have any tools or parts dropped inside the machine? It is particularly dangerous if they get caught in the lever linkage.
  - Has water and oil leakage been repaired? Have bolts been tightened?
- Checks when engine is running
 

For details of checks when the engine is running, see "8.2 DURING MAINTENANCE, MAINTENANCE WITH ENGINE RUNNING", and be extremely careful to ensure safety.
- Do the inspection and maintenance locations work normally?
- Is there any oil leakage when the engine speed is raised and load is applied to the hydraulic system?

### WASTE MATERIALS

To prevent pollution, particularly in places where people or animals are living, always follow the procedures given below.

- Never dump waste oil in a sewer system, rivers, etc.
- Always put oil drained from your machine in containers. Never drain oil directly onto the ground.
- Obey appropriate laws and regulations when disposing of harmful objects such as oil, fuel, coolant, solvent, filters, and batteries.

**INCORRECT**

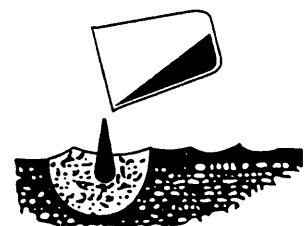

A0055220



## 9. POSITION FOR ATTACHING SAFETY LABELS

Always keep these labels clean. If they are lost or damaged, attaching them again or replace them with a new label.

There are other labels in addition to the safety labels listed as follows, so handle them in the same way.

Safety labels may be available in languages other than English.

To find out what labels are available, contact your Komatsu distributor.

### 9.1 POSITION FOR ATTACHING SAFETY LABELS

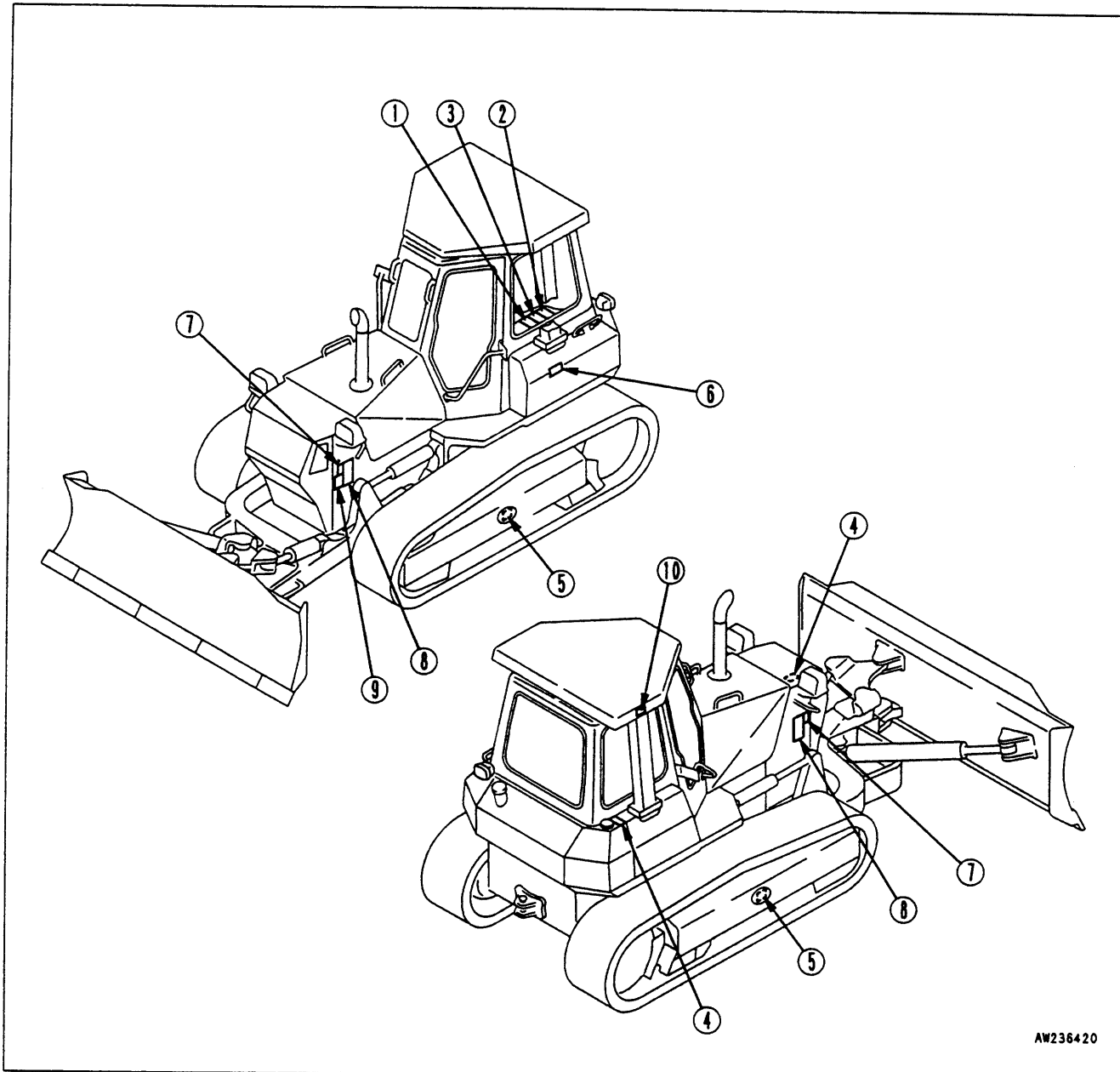

9. POSITION FOR ATTACHING SAFETY LABELS

1. Warnings before operating machine  
(09651-A0641)

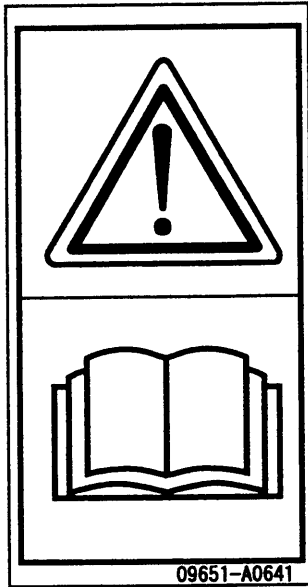

Warning sign.

Read the Operation and Maintenance Manual before operating, maintaining, carrying out disassembly, assembly or transportation of this machine.

2. Warnings before moving in reverse  
(09802-13000)

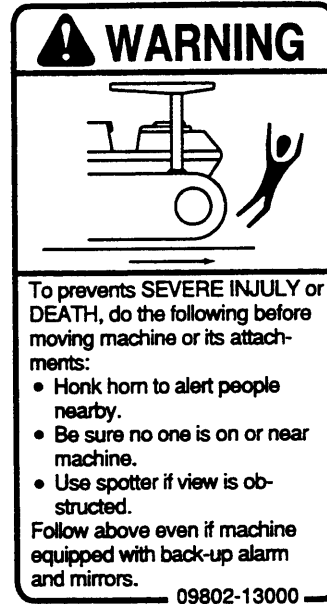

To prevent SEVERE INJURY or DEATH, do the following before moving machine or its attachments:

- Honk horn to alert people nearby.
- Be sure no one is on or near machine.
- Use spotter if view is obstructed.

Follow above even if machine equipped with back-up alarm and mirrors.

3. Warnings for leaving operator's seat  
(09654-B0641)

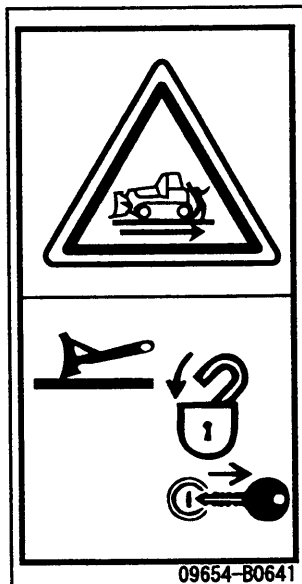

There is the hazard that machine may move suddenly and catch or run over someone near the machine causing injury.

When leaving the machine, always lower the work equipment completely to the ground, place the control levers in LOCK position, stop the engine and remove the key and take it with you.

4. Warnings for hot water hazard  
(09653-A0481)



Never remove the cap when the engine is at operating (high) temperature. Stream or high temperature oil blowing up from the radiator or hydraulic tank, will cause personal injury and/or burns.

Never remove the radiator cap or hydraulic tank oil filler when cooling water or hydraulic oil is at high temperatures.

5. Warning for adjusting track tension  
(09657-A0881)

Safety label is attached on the back side of the inspection cover of the track frame.

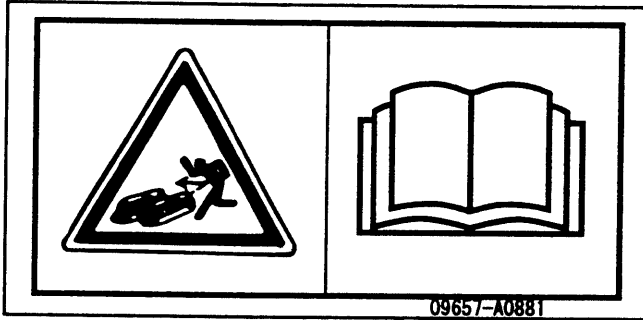

Plug coming from track shoe tension adjustment device causing injury.

Read the operation and maintenance manual and carrying out the correct method when loosening track tension.

6. Warning for battery cable  
(09808-A0881)

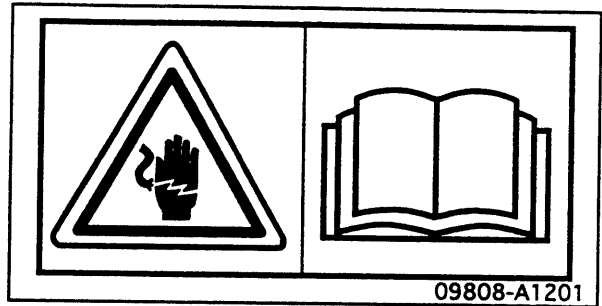

There is the hazard to electric shock when handling electric wires.

Read the operation and maintenance manual and carrying out the correct method when handling.

7. Caution for engine running  
(09667-A0481)

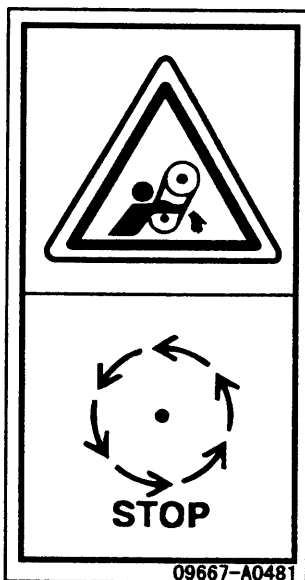

There is the hazard of being caught in the rotating parts of the machine causing injury.

Stop the rotating parts of the machine completely when carrying out inspection and maintenance.

8. Caution for approach when machine moving  
(09806-B1201)

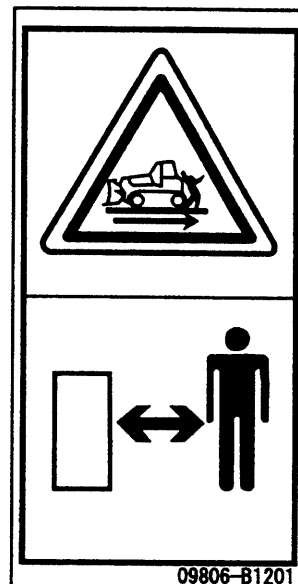

There is danger of getting hit and injured by approach when machine moving.

Do not go close to machine.

9. POSITION FOR ATTACHING SAFETY LABELS

9. Warnings for crush hazard by the blade  
(124-98-51260)

**⚠ DANGER**

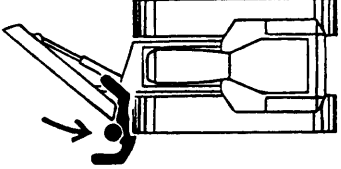

Crush Hazard. Can cause severe injury or death.  
When machine is being operated, never place yourself in angling area of the blade.

124-98-51260

10. Warnings for ROPS  
(09620-30200)

**ROLL-OVER PROTECTIVE STRUCTURE (ROPS)**  
THE ROLL-OVER PROTECTIVE STRUCTURE OF THIS MACHINE COMPLIES WITH THE FOLLOWING STANDARDS OR (RECOMMENDED PRACTICES)  
INTERNATIONAL STANDARD: ISO 3471 (ROPS) & ISO 3449 (FOPS)  
AMERICAN STANDARD: SAE J  & SAE J

**KOMATSU**

MODEL  MACHINE MODEL  SERIAL NO.  MAX MASS

---

**⚠ WARNING**

- Altering ROPS may weaken it. Consult Komatsu Distributor before altering.
- ROPS may provide less protection if it has been structurally damaged or involved in roll-over.
- Always wear seat belt when moving.

Komatsu Ltd. Japan    2-3-4 Akasaka, Minato-ku, Tokyo, Japan    09620-30200

# **OPERATION**



# 10. GENERAL VIEW

## 10.1 GENERAL VIEW OF MACHINE

If directions are indicated in this section, they refer to the directions shown by the arrows in the diagram below.

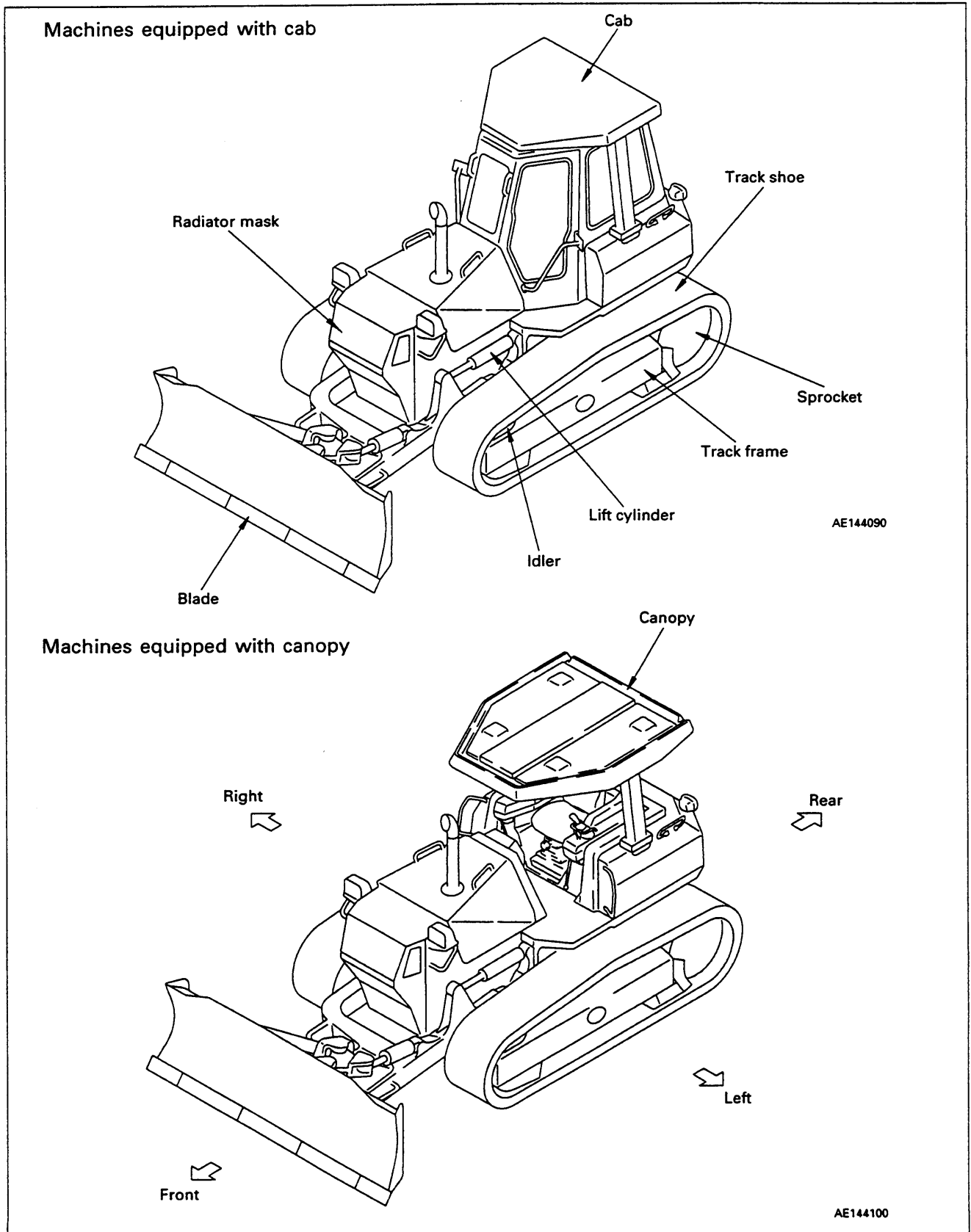

10.2 GENERAL VIEW OF CONTROLS AND GAUGES

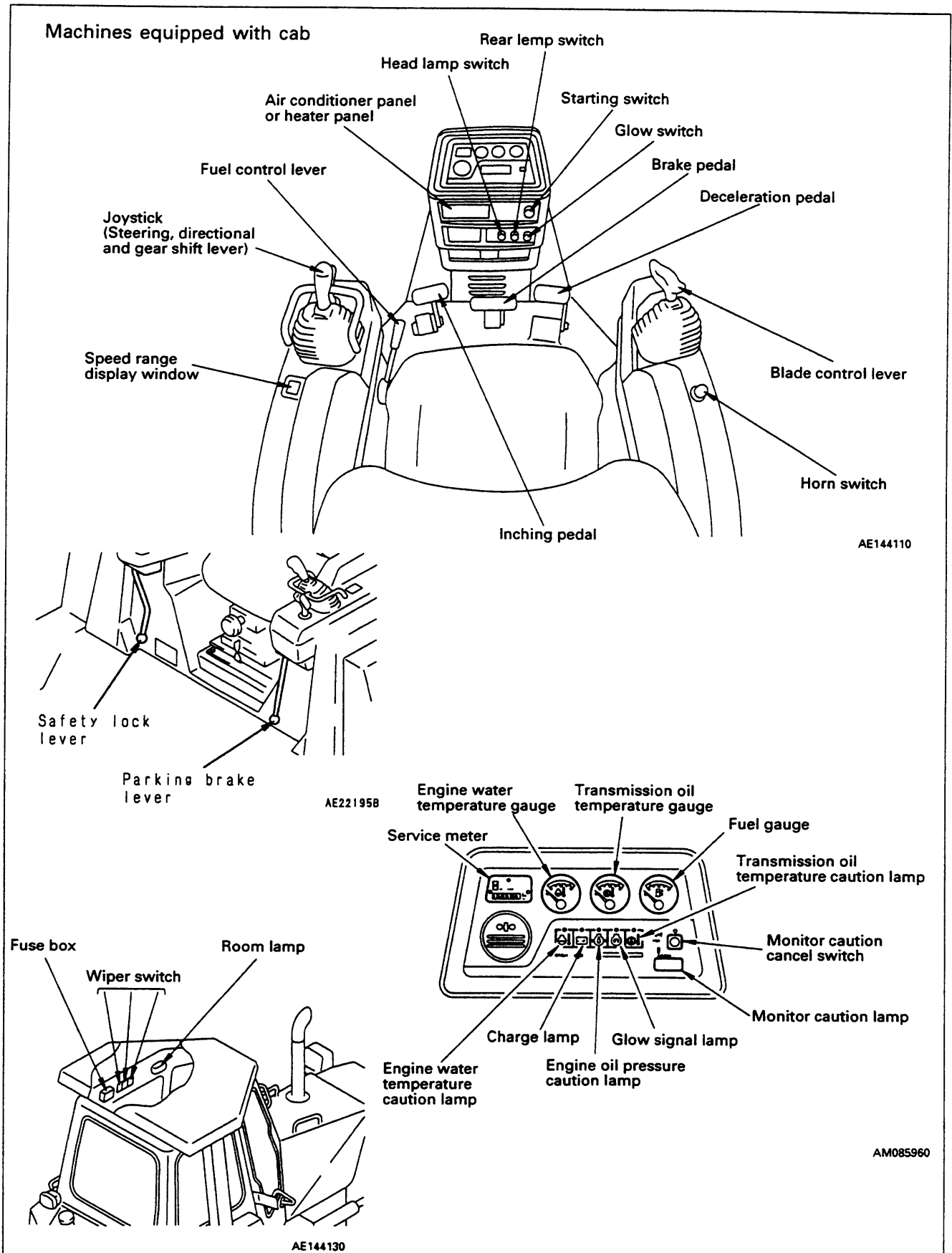

Machines equipped with canopy

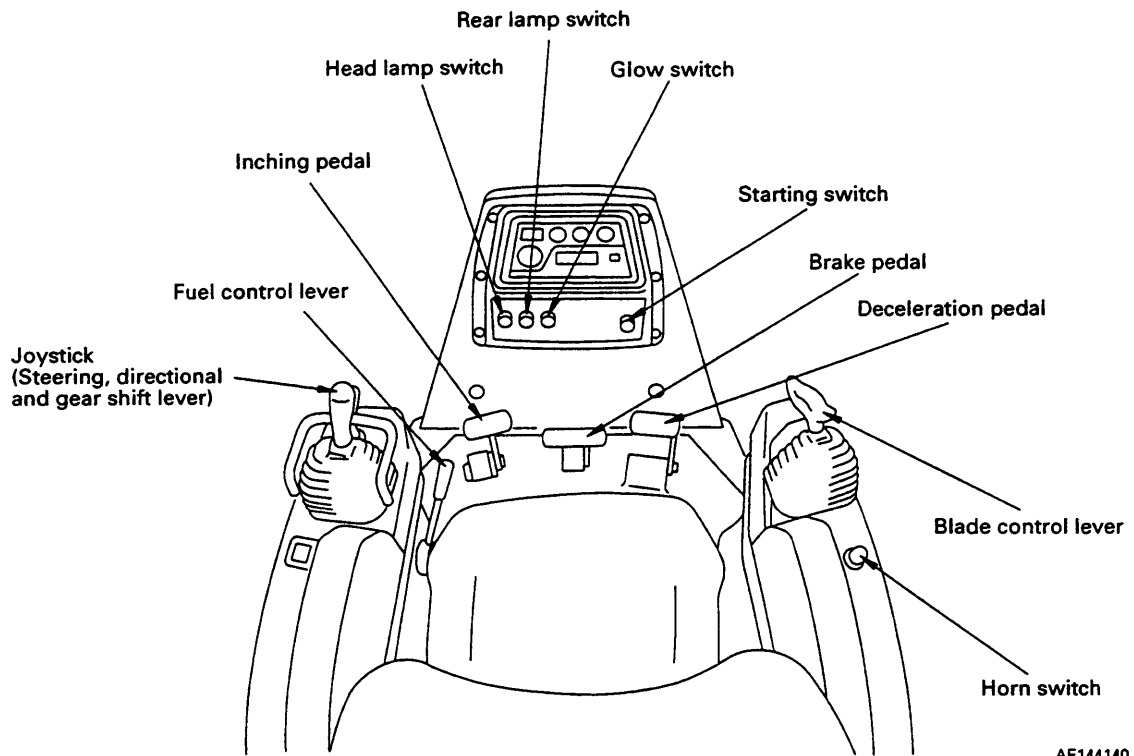

AE144140

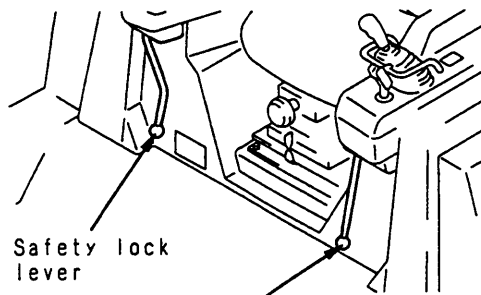

AE221958

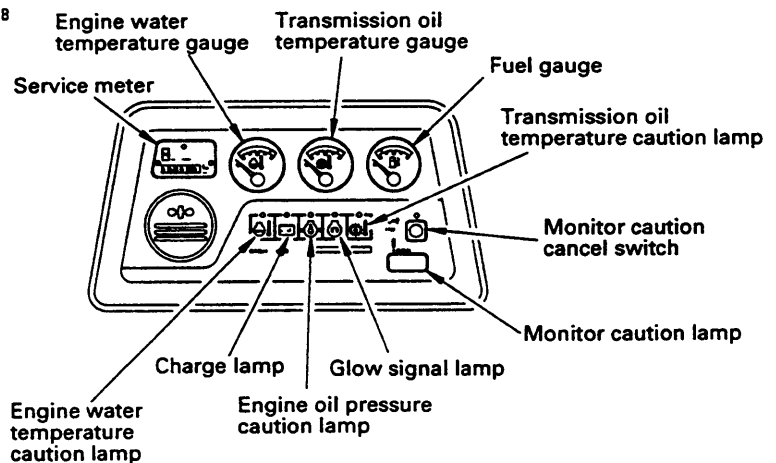

AM085960



# 11. EXPLANATION OF COMPONENTS

The following is an explanation of the devices needed for operating the machine.

To carry out suitable operations correctly and safely, it is important to understand fully the methods of operating the equipment and the meanings of the displays.

Before reading the explanation of components, please read the table below to check what equipment is installed to your machine.

Equipment	Section No.	D41E-6, D41P-6	
		Canopy	Cab
<b>Front panel</b>			
Monitor panel	11.1.1	○	○
Air conditioner panel	11.1.2	—	○
Heater panel	11.1.3	—	○
Switch panel (cab)	11.1.4	—	○
Switch panel (canopy)	11.1.5	○	—
<b>Switches</b>			
Horn switch	11.2 1	○	○
Room lamp switch	11.2 2	—	○
Wiper switch	11.2 3	—	○
Additional working lamp switch	11.2 4	—	○
<b>Control levers, pedals</b>			
Fuel control lever	11.3 1	○	○
Joystick (steering, directional and gear shift lever) (Speed range display window)	11.3 2	○	○
Brake pedal	11.3 3	○	○
Inching pedal	11.3 4	○	○
Decelerator pedal	11.3 5	○	○
Parking lever	11.3 6	○	○
Safety lever (for blade control lever)	11.3 7	○	○
Blade control lever	11.3 8		
Power angle, power tilt/dozer specification		○	○

## 11.1 FRONT PANEL (METERS, LAMPS, SWITCHES)

### 11.1.1 MONITOR PANEL

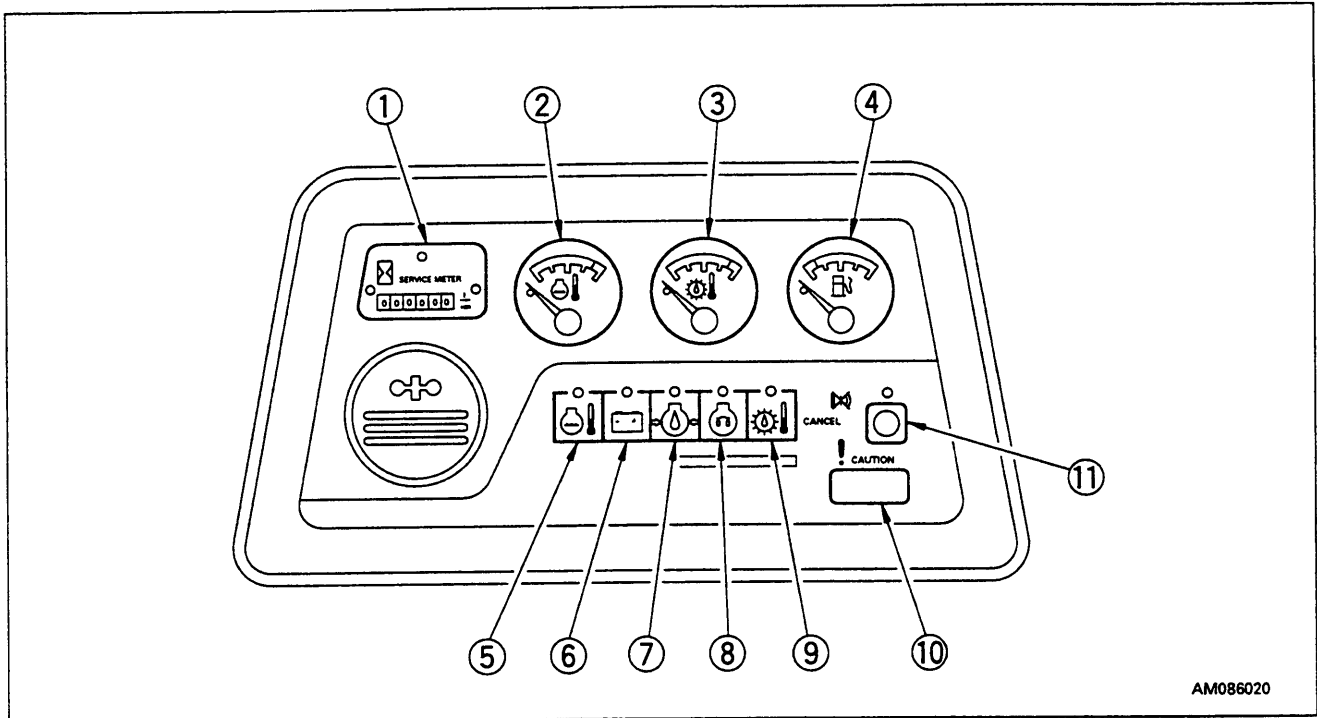

AM086020

#### 1. SERVICE METER

This meter shows the total operation hours of the machine. The service meter advances while the engine is running – even if the machine is not traveling.

Set the periodic maintenance intervals using this display.

When the engine is running, the green pilot lamp ① at the top of the meters flashes to indicate that the meter is advancing.

Meter ② will advance by 1 for each 1/10 hour of operation regardless of the engine speed.

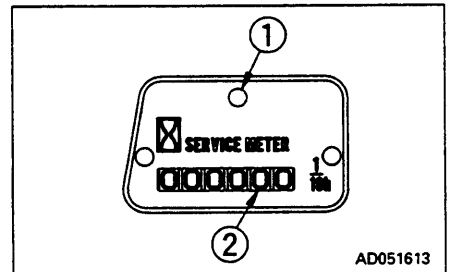

AD051613

#### 2. ENGINE WATER TEMPERATURE GAUGE

This gauge indicates the cooling water temperature.

When the indicator is in the white range during operation, the water temperature is normal.

If the indicator moves from the white range into the red range during operation, stop the machine immediately, run the engine under no load at a midrange speed, and wait for the indicator to go down to the white range.

After starting the engine, warm up it until the indicator moves into the white range.

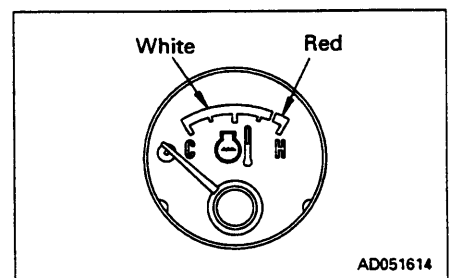

AD051614

**3. TRANSMISSION OIL TEMPERATURE GAUGE**

This indicates the temperature of the transmission lubricating oil.

When the indicator is in the white range during operation, the oil temperature is normal.

If the indicator moves from the white range into the red range during operation, stop the machine, run the engine under no load at a midrange speed, and wait for the indicator to go down to the white range.

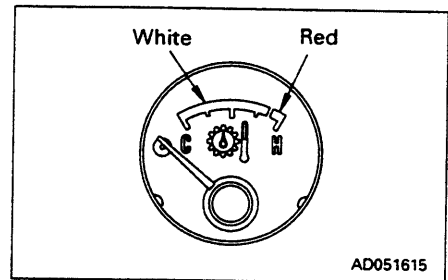
**4. FUEL GAUGE**

When the starting switch is turned ON, this displays the amount of fuel remaining in the fuel tank.

F indicates a full tank.

When the indicator points to E, it indicates that there is less than 20 l (5.28 US gal, 4.40 UK gal) remaining, so add fuel.

Always fill the tank after finishing operations.

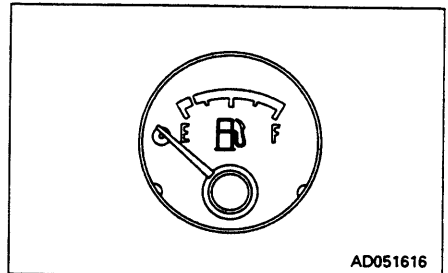
**5. ENGINE WATER TEMPERATURE CAUTION LAMP**

This warns of a rise in the temperature of the engine cooling water.

If the lamp lights up, stop the machine, run the engine under no load at a midrange speed, and wait for the indicator of the engine water temperature gauge to go down to the white range.

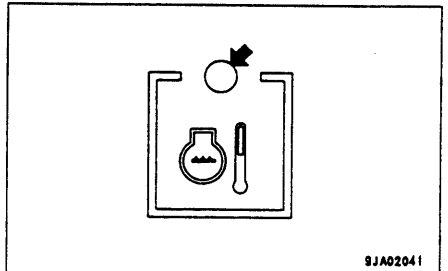
**6. CHARGE LAMP**

This lamp indicates malfunction of the alternator.

When the starting switch is turned ON, it will light up, but it should go out when the engine speed rises.

If the lamp lights up during operation, stop the engine and check the fan belt tension. If any abnormality is found, see "16. TROUBLESHOOTING".

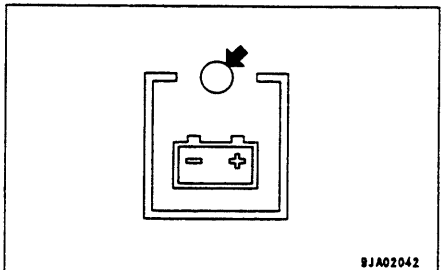
**7. ENGINE OIL PRESSURE CAUTION LAMP**

This lamp warns that the engine lubricating oil pressure has dropped. When the starting switch is turned ON, it will light up.

When the lamp goes off after the engine is started, the oil pressure is normal.

When the lamp lights up during operation, the oil pressure is lower.

Immediately stop the engine and look for the cause. For details, see "16. TROUBLESHOOTING".

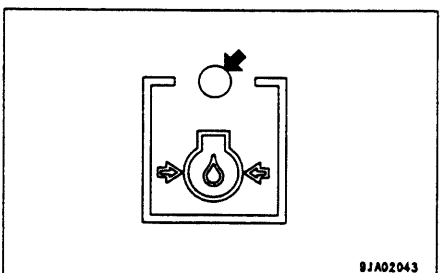
**8. GLOW SIGNAL LAMP**

This indicates the electrical intake air heater is red-heated.

While preheating is being carried out with the glow switch, the lamp lights up.

In the case of automatic preheating, the lamp goes out when the preheating is completed.

In the case of manual preheating, the lamp goes out when the glow switch is released.

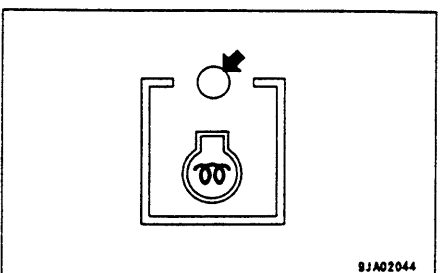

## 11. EXPLANATION OF COMPONENTS

---

### 9. TRANSMISSION OIL TEMPERATURE CAUTION LAMP

This warns the operator that the oil temperature at the transmission outlet port has risen.

If the lamp lights up, stop the machine, run the engine under no load at a midrange speed, and wait for the transmission oil temperature gauge to go down to the white range.

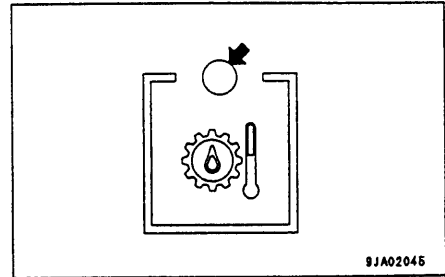

### 10. MONITOR CAUTION LAMP

If any of caution lamps 5, 6, 7 or 9 light up, the monitor caution lamp lights up. In addition, the alarm buzzer sounds at the same time.

- 5: Rise in engine water temperature
- 6: Drop in alternator charge
- 7: Drop in engine oil pressure
- 9: Rise in transmission oil temperature

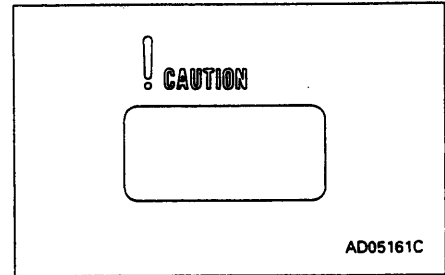

### 11. MONITOR CAUTION CANCEL SWITCH

This switch is used to cancel monitor caution lamp ⑩. Press the switch to turn the monitor caution lamp out and to stop the alarm buzzer.

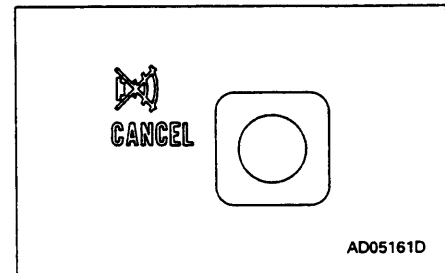

**11.1.2 AIR CONDITIONER PANEL  
(MACHINES EQUIPPED WITH CAB, AIR  
CONDITIONER)**

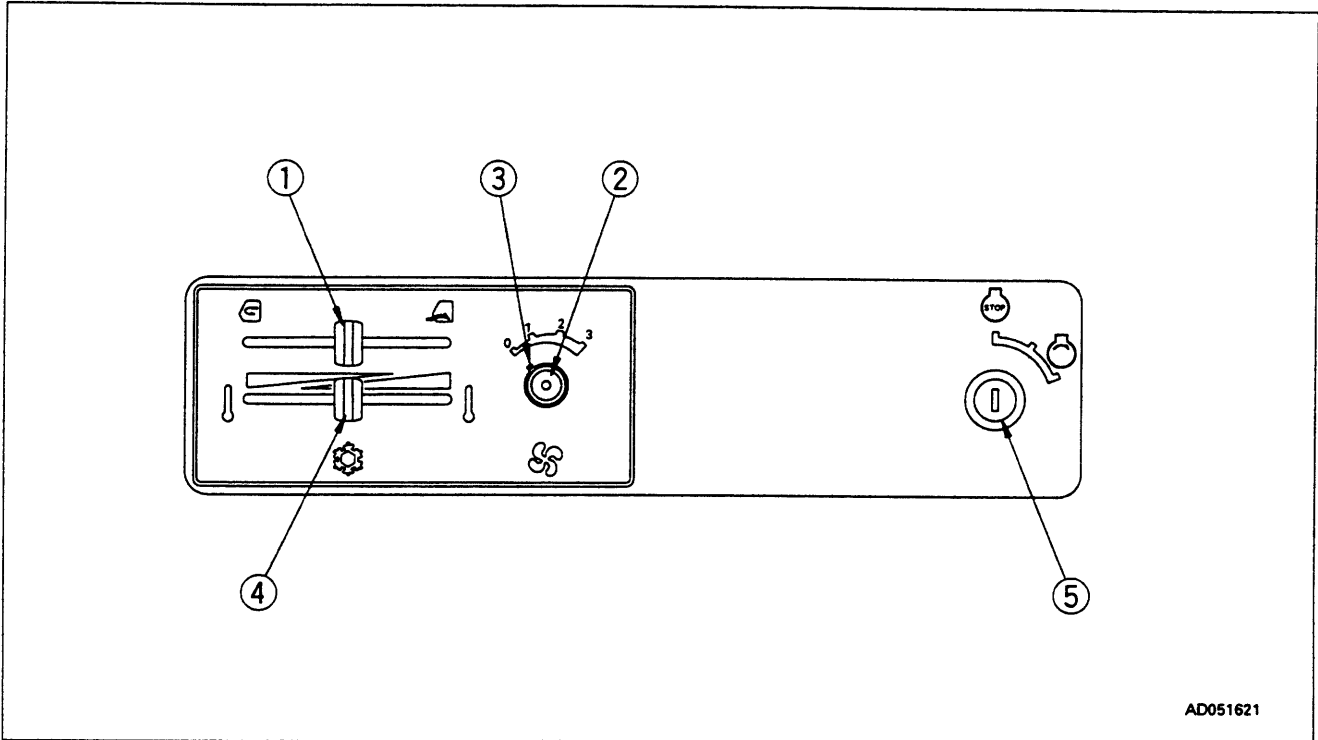



AD051621

For details of handling switches ① to ④ below, see "11.13 HANDLING AIR CONDITIONER".

**1. FRESH/RECIRC SELECTOR LEVER**

This changes the air intake port used when cooling or heating.

- RECIRC (  ) uses the air inside the cab.  
Turn the switch normally to this position when strong cooling is needed. In this position, no ventilation or pressurizing is carried out.
- FRESH (  ) takes in outside air.

This is the standard position for cooling and heating.

In this position, fresh air is brought in from outside to carry out ventilation. In addition, the inside of the cab is pressurized to prevent the entry of dust.

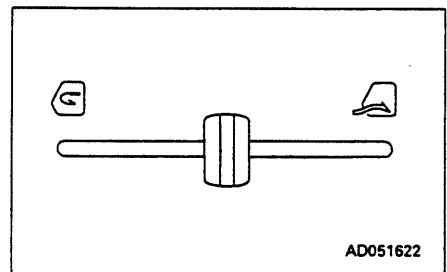

AD051622

**2. AIR CONDITION SWITCH**

When the switch is pressed and the blue lamp lights up, the cooling function is actuated. Use this switch for cooling or dehumidifying.

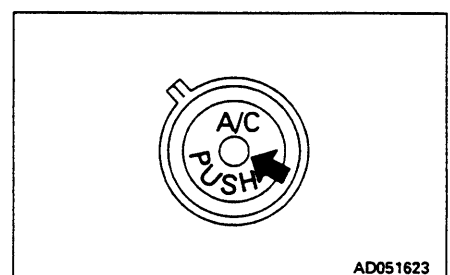

AD051623

## 11. EXPLANATION OF COMPONENTS

### 3. BLOWER SWITCH

This acts as the wind flow control switch and main switch when cooling or heating.

- The air flow can be set to three stages: 1 (LOW) → 2 (MEDIUM) → 3 (HIGH).
- If the switch is set to 0, the power is switched off and the air conditioner stops.

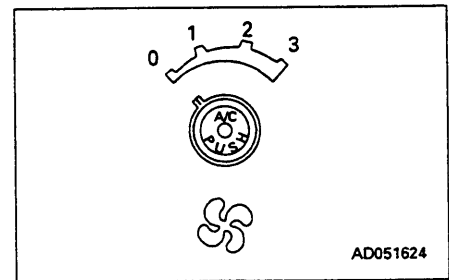

### 4. TEMPERATURE CONTROL LEVER

This is used to control the temperature for cooling or heating.

- When the temperature control lever is moved to the right, the temperature of the air coming from the vents becomes lower. (The water valve is closed and the heating function is stopped.)
- When the temperature control lever is moved to the left, the temperature of the air coming from the vents becomes higher. (The water valve is opened and the heating function is started.)

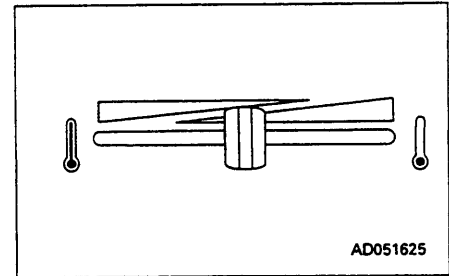

### 5. STARTING SWITCH

This switch is used to start or stop the engine.

OFF (  ) position:

The key can be inserted or withdrawn. The switches for the electric system are all turned off and the engine is stopped.

ON position:

In this position, electric current flows in the charging and lamp circuits.

Keep the starting switch key at the ON position while the engine is running.

START (  ) position:

This is the position to start the engine. Hold the key at this position while cranking. Release the key immediately after the engine has been started. The key will return to ON position when released.

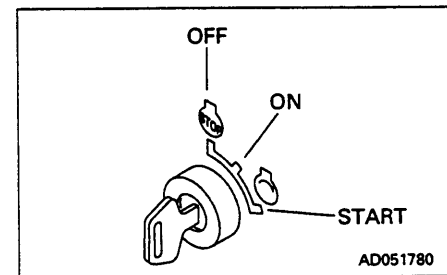

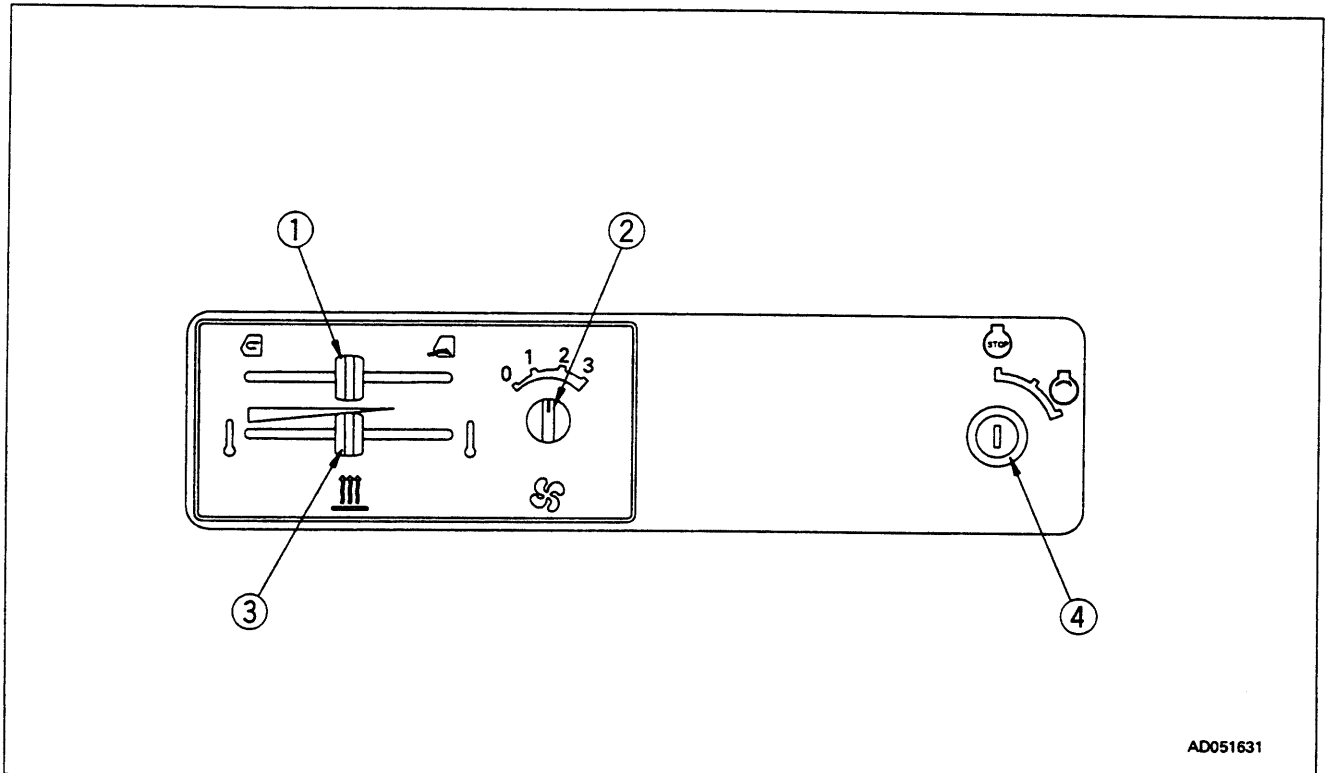

### 11.1.3 HEATER PANEL (MACHINES EQUIPPED WITH CAB, HEATER)



For details of handling switches ① to ③ below, see "11.14 HANDLING HEATER".

#### 1. FRESH/RECIRC SELECTOR LEVER

This changes the air intake port used when cooling or heating.

- RECIRC (  ) uses the air inside the cab.  
Turn the switch normally to this position when strong cooling is needed. In this position, no ventilation or pressurizing is carried out.
- FRESH (  ) takes in outside air.  
This is the standard position for cooling and heating. In this position, fresh air is brought in from outside to carry out ventilation. In addition, the inside of the cab is pressurized to prevent the entry of dust.

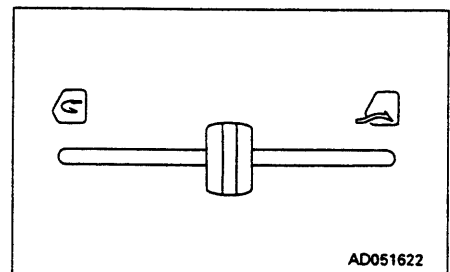

#### 2. BLOWER SWITCH

This acts as the wind flow control switch and main switch when cooling or heating.

- The air flow can be set to three stages: 1 (LOW) → 2 (MEDIUM) → 3 (HIGH).
- If the switch is set to 0, the power is switched off and the heater stops.

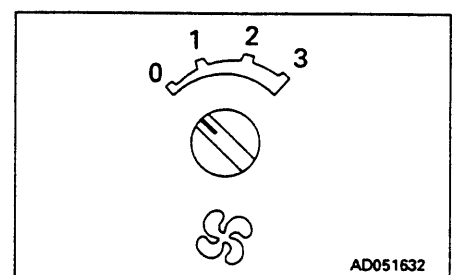

## 11. EXPLANATION OF COMPONENTS

### 3. TEMPERATURE CONTROL LEVER

This is used to control the temperature for heating.

- When the temperature control lever is moved to the right, the temperature of the air coming from the vents becomes lower.
- When the temperature control lever is moved to the left, the temperature of the air coming from the vents becomes higher.

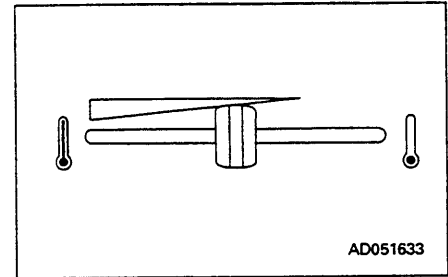

### 4. STARTING SWITCH

This switch is used to start or stop the engine.

OFF (⊖) position:

The key can be inserted or withdrawn. The switches for the electric system are all turned off and the engine is stopped.

ON position:

In this position, electric current flows in the charging and lamp circuits.

Keep the starting switch key at the ON position while the engine is running.

START (⊕) position:

This is the position to start the engine. Hold the key at this position while cranking. Release the key immediately after the engine has been started. The key will return to ON position when released.

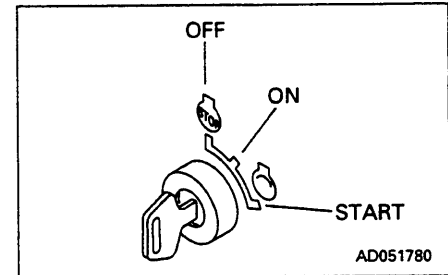



**11.1.4 SWITCH PANEL  
(MACHINES EQUIPPED WITH CAB)**

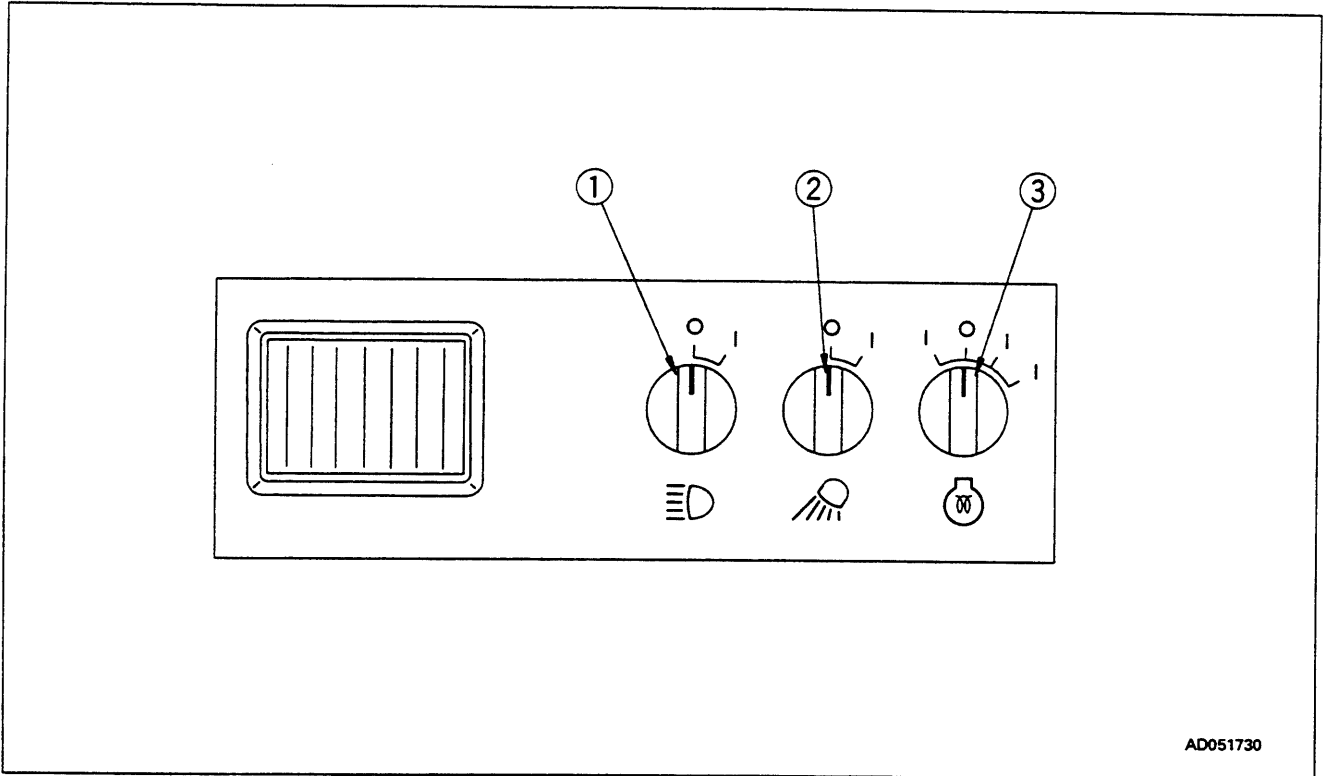

AD051730

**1. HEAD LAMP SWITCH**

This lights up the head lamps.

OFF position: Lamps are out

ON position: Lamps light up

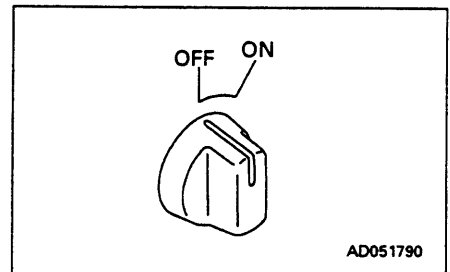

AD051790

**2. REAR LAMP SWITCH**

This lights up the rear lamps.

OFF position: Lamps are out

ON position: Lamps light up

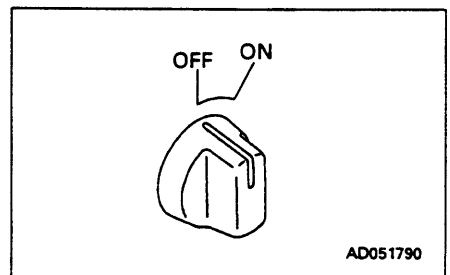

AD051790

## 11. EXPLANATION OF COMPONENTS

---

### 3. GLOW SWITCH

This actuates the electrical heater to warm up the engine intake air.

**OFF position:** The preheating is not actuated.

**AUTO position:** AUTO preheating is actuated. The length of the preheating time varies according to the ambient temperature when the ambient temperature is below approx.  $-5^{\circ}\text{C}$ .

**I position:** This is used when AUTO preheating is not enough to start the engine in cold weather simply with the glows witch at the AUTO position.

When the switch is released, it will return to the AUTO position.

**II position:** This is used when carrying out preheating manually without using AUTO preheating.

When the switch is released, it will return to the OFF position.

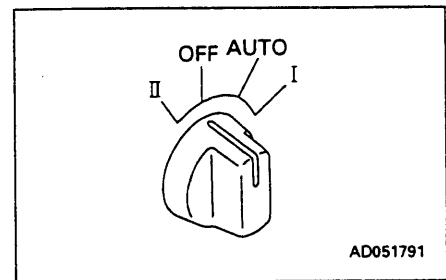

**11.1.5 SWITCH PANEL  
(MACHINES EQUIPPED WITH CANOPY)**

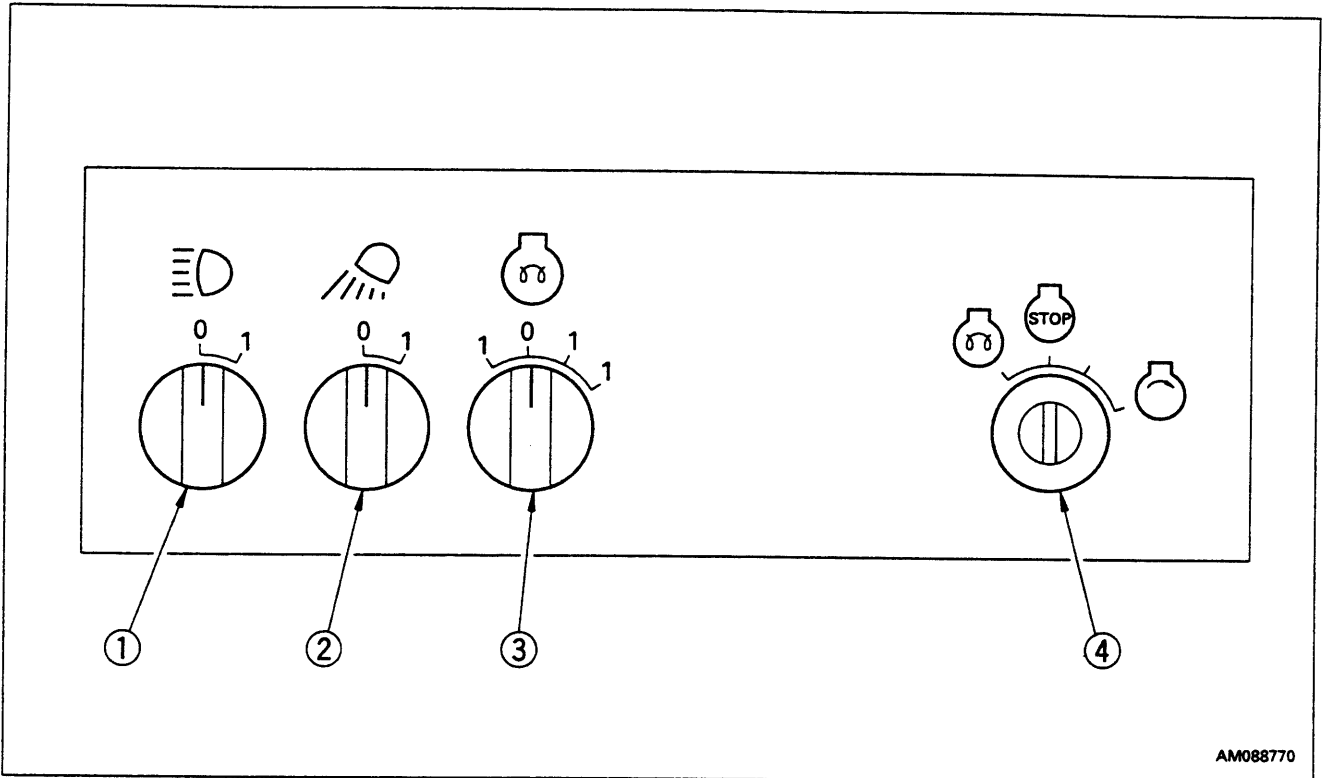

**1. HEAD LAMP SWITCH**

This lights up the head lamps.

OFF position: Lamps are out

ON position: Lamps light up

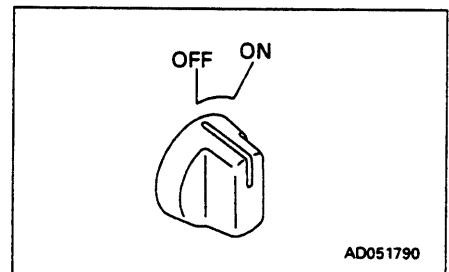

**2. REAR LAMP SWITCH**

This lights up the rear lamps.

OFF position: Lamps are out

ON position: Lamps light up

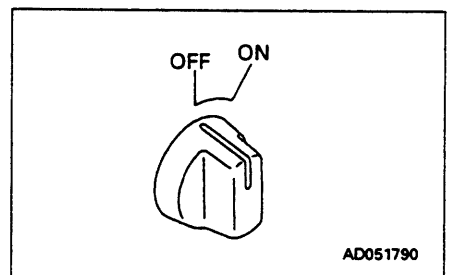

## 11. EXPLANATION OF COMPONENTS

### 3. GLOW SWITCH (MONITOR PANEL SPECIFICATION)

This actuates the electrical heater to warm up the engine intake air.

**OFF position:** The preheating is not actuated.

**AUTO position:** AUTO preheating is actuated. The length of the preheating time varies according to the ambient temperature when the ambient temperature is below approx.  $-5^{\circ}\text{C}$ .

**I position:** This is used when AUTO preheating is not enough to start the engine in cold weather simply with the glow switch at the AUTO position.

When the switch is released, it will return to the AUTO position.

**II position:** This is used when carrying out preheating manually without using AUTO preheating.

When the switch is released, it will return to the OFF position.

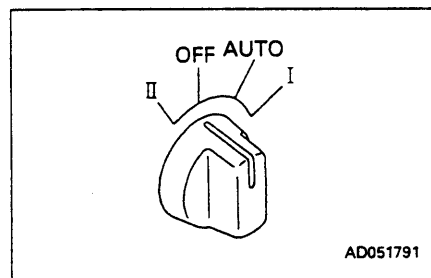

### 4. STARTING SWITCH

This switch is used to start or stop the engine.

**OFF (STOP) position:**

The key can be inserted or withdrawn. The switches for the electric system are all turned off and the engine is stopped.

Do not the starting switch key at the OFF position while the engine is running.

**ON position:**

In this position, electric current flows in the charging and lamp circuits.

Keep the starting switch key at the ON position while the engine is running.

**START ( ) position:**

This is the position to start the engine. Hold the key at this position while cranking. Release the key immediately after the engine has been started. The key will return to ON position when released.

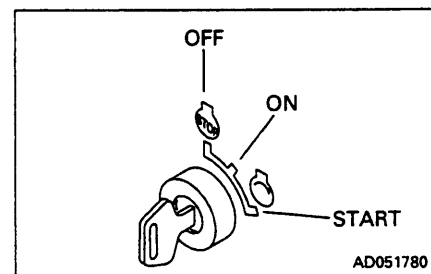

## 11.2 SWITCHES

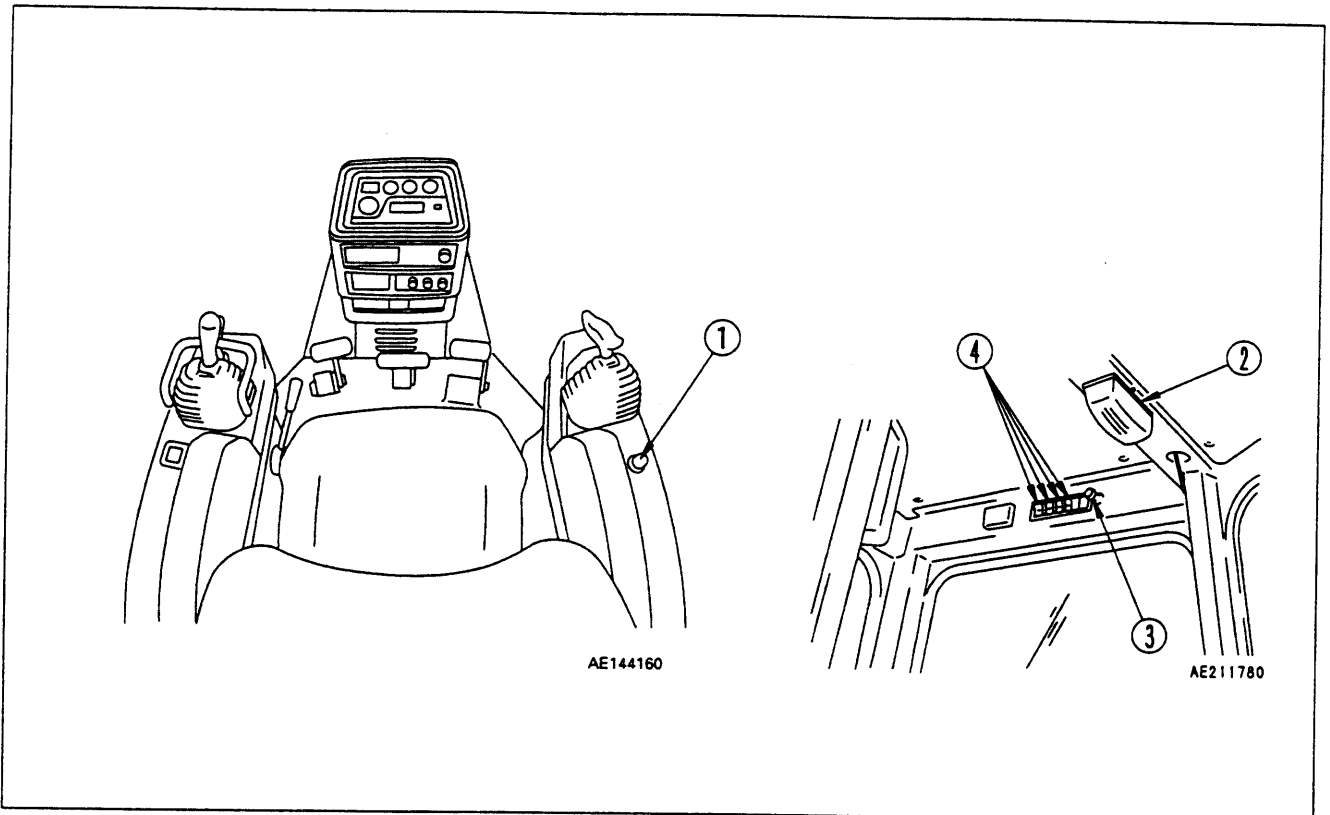

### 1. HORN SWITCH

The horn sounds when the button at the rear of the blade control lever at the right side of the operator's seat is pressed.

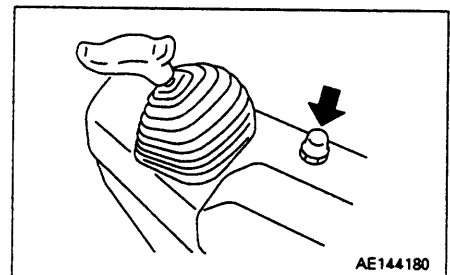

### 2. ROOM LAMP SWITCH (MACHINES EQUIPPED WITH CAB)

This lights up the room lamp.

ON position: Lamp lights up

OFF position: Lamp is out

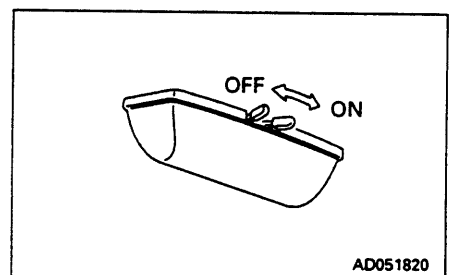

### 3. CIGARETTE LIGHTER (MACHINES EQUIPPED WITH CAB)

This is used to light cigarettes.

When the cigarette lighter is pushed in, it will return to its original position after a few seconds, so take it out to light your cigarette.

#### NOTICE

This cigarette lighter is 24V. Do not use it as the power source for 12 V equipment.

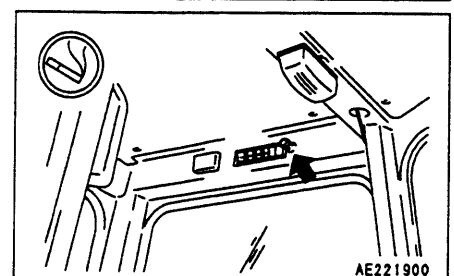

## 11. EXPLANATION OF COMPONENTS

### 4. WIPER SWITCH (MACHINES EQUIPPED WITH CAB)

This activates the wipers.

The wiper switches are as follows.

- ① Left door
- ② Front window
- ③ Right door
- ④ Rear window (rear window wiper is if equipped)

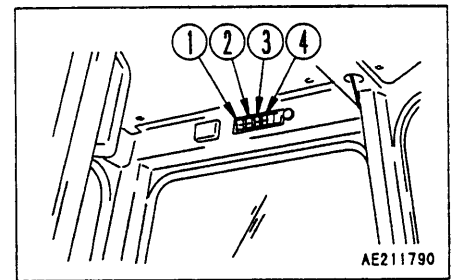

This is also used as the window washer switch.  
The switch is operated as follows.

- Window washer only  
Keep the switch pressed to the OFF position to spray out water.

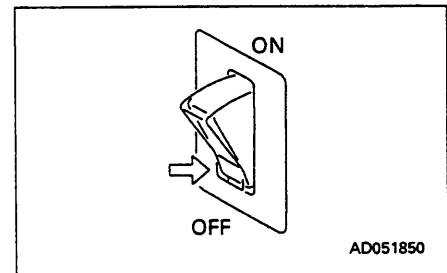

- Wiper only  
If this is switched on, the wiper will start.

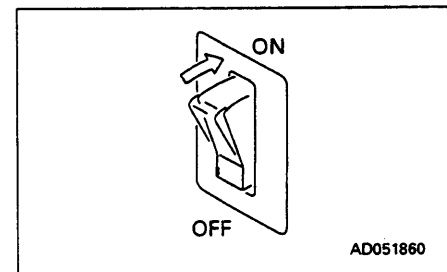

- Wiper and window washer  
If this is kept pressed to the ON position while the wiper is working, water will be sprayed out.

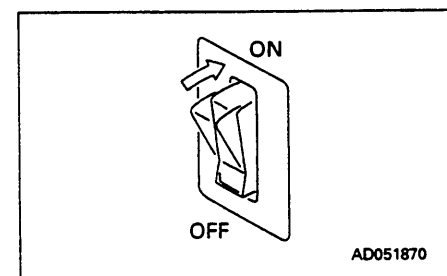

**5. ADDITIONAL WORKING LAMP SWITCH  
(MACHINES EQUIPPED WITH CAB)**

This is used to turn on the additional working lamp.

- ① Head lamp switch
- ② Rear lamp switch

Push in the direction of the arrow to turn on the lamps.

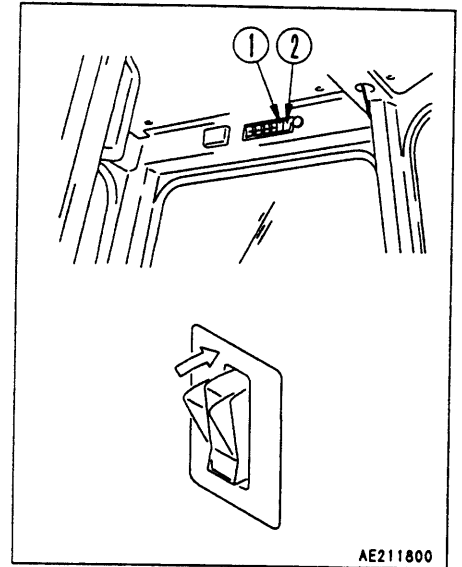

### 11.3 CONTROL LEVERS, PEDALS

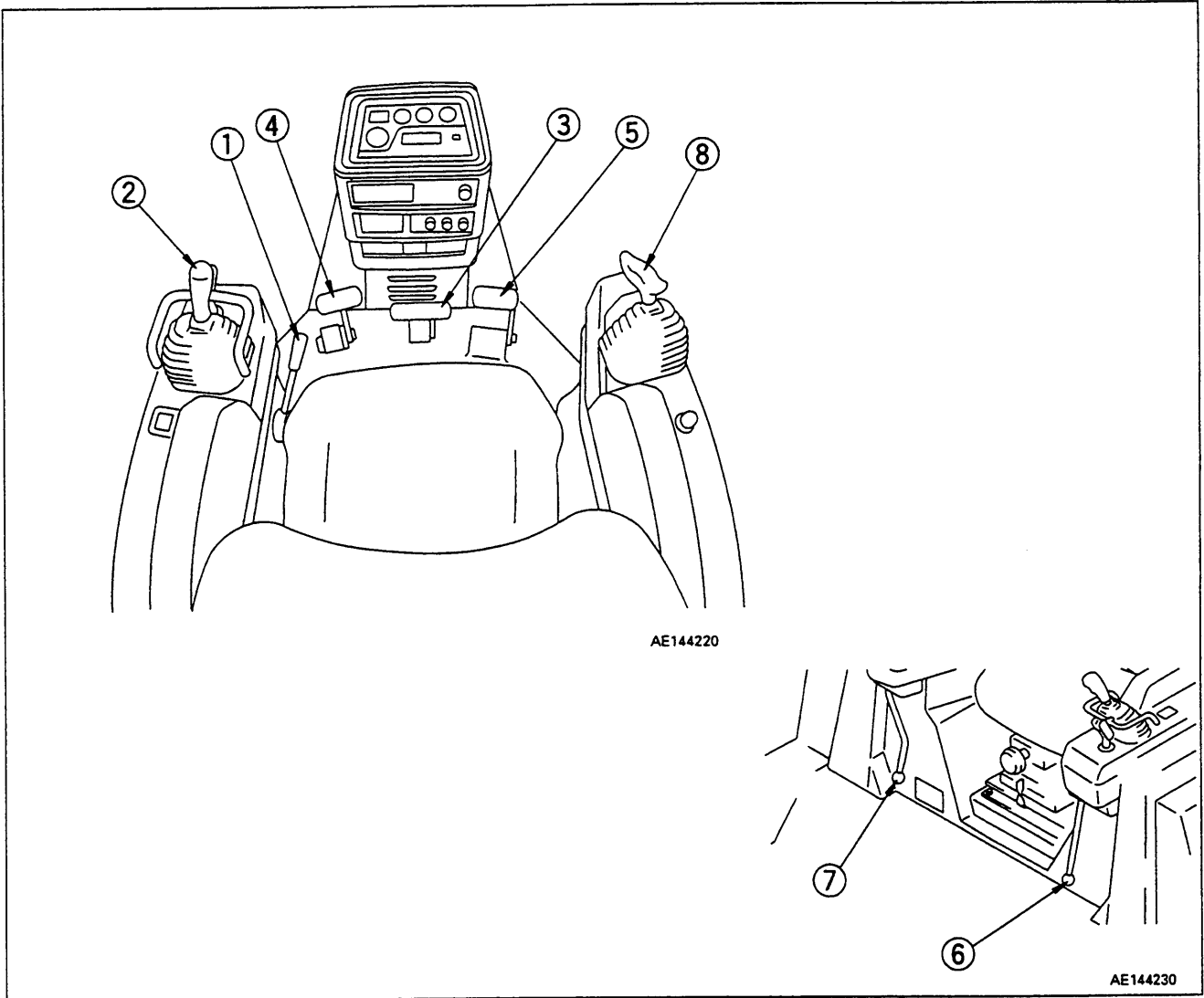

AE144220

AE144230

#### 1. FUEL CONTROL LEVER

This lever is used to control the engine speed and output.

- ① Low idling position: Push the lever forward fully
- ② High idling position: Pull the lever fully

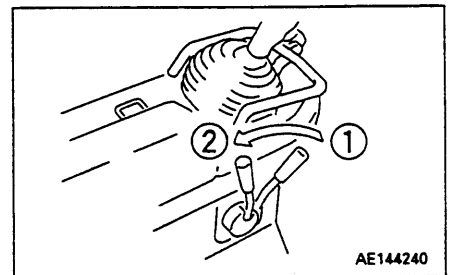

AE144240



**2. JOYSTICK (STEERING, DIRECTIONAL AND GEAR SHIFT LEVER)**

This is used to select the direction of travel, to select the speed range of transmission, and to carry out steering.

**Forward-reverse shifting**

- ①: FORWARD
- ②: REVERSE
- N: NEUTRAL

Push the lever forward, the machine will move off forward.

Pull the lever backward, the machine will move off in reverse.

**Steering**

- Ⓛ: LEFT TURN
- Ⓡ: RIGHT TURN

Move the joystick to the FRONT to travel FORWARD

Move the joystick to the REAR to travel in REVERSE

If the joystick is operated to travel forward or in reverse, and is then moved partially in the direction of turn, the machine will turn gradually.

If the joystick is moved further in the direction of turn, the machine will turn more sharply.

**REMARK**

If the lever is released when steering the machine, the lever will return to the ① position or the ② position and the machine will be returned to straight movement.

If you support the lever guide with your hand when steering, the turning operation will be easier.

**Gear shifting**

Rotate the joystick 30° to carry out gear shifting operation.

- Position Ⓐ : 1st
- Position Ⓑ : 2nd
- Position Ⓒ : 3rd

**REMARK**

When gear shifting operation is carried out, the display panel at the rear of the joystick will display the speed range.

1st: ① is displayed on the display panel

2nd: ② is displayed on the display panel

3rd: ③ is displayed on the display panel

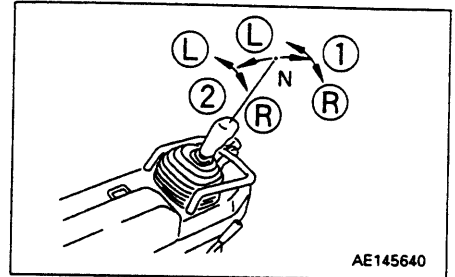

AE145640

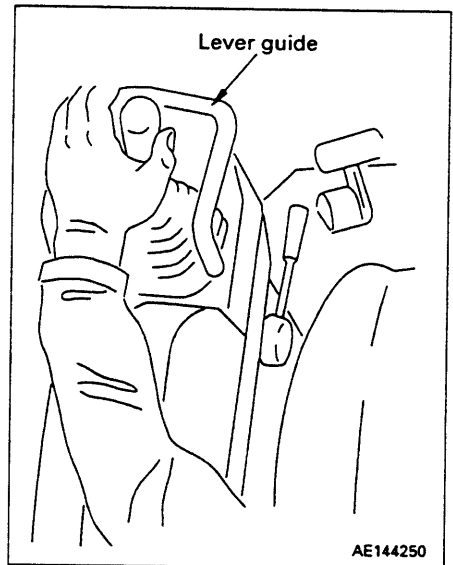

AE144250

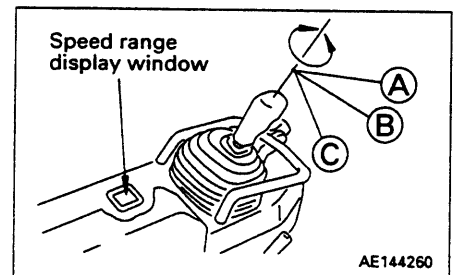

AE144260

**3. BRAKE PEDAL****⚠ WARNING**

Do not place your foot on this pedal unnecessarily.

Depress the pedal to apply the right and left brakes.

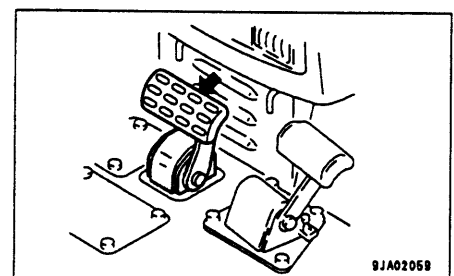

9JA02058

#### 4. INCHING PEDAL

**WARNING**

Do not place your foot on this pedal unnecessarily.

This pedal is used to engage or disengage the power from the engine. Use it for fine control of the travel. When the pedal is partially depressed, the power is cut off; if the pedal is depressed fully, the brake is applied and the machine will stop.

Use this pedal when approaching the target position.

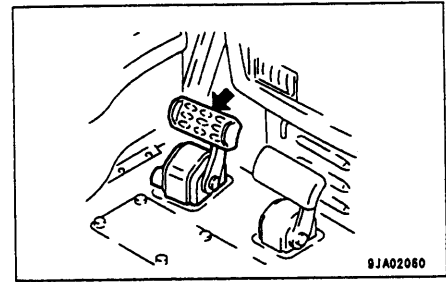

#### 5. DECELERATION PEDAL

**WARNING**

- Do not place your foot on this pedal unnecessarily.
- When passing over the top of a hill or when a load is dumped over a cliff, the load is suddenly reduced, so there is danger that the travel speed will also increase suddenly. To prevent this, depress the decelerator pedal to reduce the travel speed.

This pedal is used for reducing the engine speed or stopping the machine.

Depress this pedal to reduce the speed when shifting between forward and reverse or when stopping the machine.

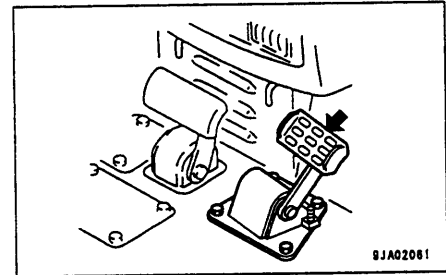

#### 6. PARKING BRAKE LEVER

**WARNING**

When the machine is parked, always set the parking brake lever to the LOCK position.

This lever is used to apply the parking brake.

#### NOTICE

The engine will not start if the parking brake lever is not at the LOCK position.

#### REMARK

When the steering and directional lever is at the FORWARD or REVERSE position, if the parking brake lever is operated to the LOCK position, the steering and directional lever will automatically return to the N position.

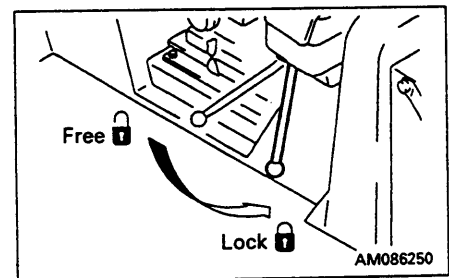

## 7. SAFETY LOCK LEVER (FOR BLADE CONTROL LEVER)

**⚠ WARNING**

- When standing up from the operator's seat, always set the safety lock lever securely to the LOCK position. If the blade control and ripper control levers are not locked and are touched by accident, it may lead to serious injury or damage.
- If the safety lock lever is not set securely to the LOCK position, the lock may not be applied. Check that it is in the position shown in the diagram.
- When parking the machine or when carrying out maintenance, always lower the blade to the ground, then set the safety lock lever to the LOCK position.

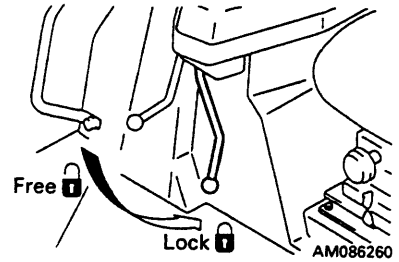

This lever is a device to lock the blade control levers.

When it is set to the LOCK position, the TILT, ANGLE, RAISE, LOWER, and FLOAT operations are locked.

When the blade control lever is at the FLOAT position it is impossible to operate the safety lever to the LOCK position.

Operate the blade control lever to release the float (return to the HOLD position), then apply the lock.

11. EXPLANATION OF COMPONENTS

8. BLADE CONTROL LEVER

This lever is used to raise, tilt and angle the blade.

**⚠ DANGER**

- During left side blade angling, this machine can reduce overall width to 2.5 m (8.2 ft) by angling the blade to 55°. At this time, the blade may touch the track. Be careful about this when angling the blade. In particular, when an operator is checking around the blade during angling operation, have him/her focus his/her attention on the blade.
- If the wide blade is installed, the overall width exceeds 2.5 m (8.2 ft). When angling the blade, be careful about the clearance between the left end of the blade and the track.

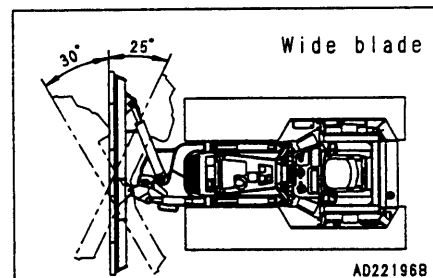
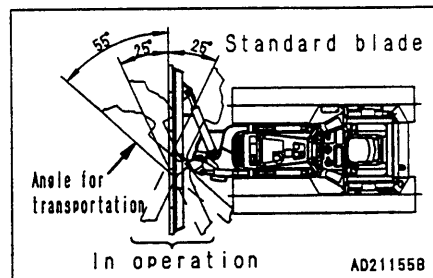

**Lifting control**

- ① RAISE : (▲)
- ② HOLD : (▲)
- Blade is stopped and held in this position.
- ③ LOWER : (▼)
- ④ FLOAT : (▲)
- Blade will move freely according to external force.

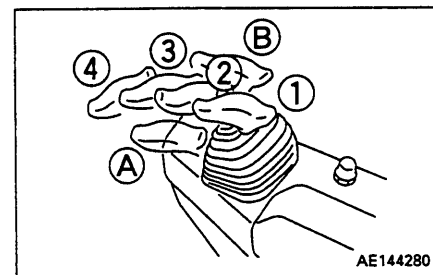

**REMARK**

- When released from FLOAT position, this lever will not return to HOLD position, so it must be moved back by hand.
- Before starting the engine, check that the blade control lever is at the HOLD position.

**Tilting control**

- Ⓐ LEFT TILT : (◀)
- Ⓑ RIGHT TILT : (▶)

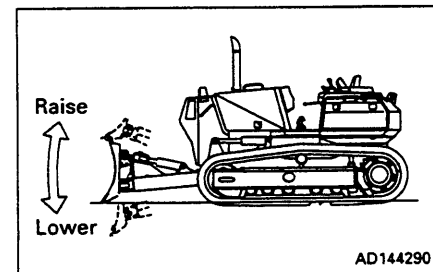

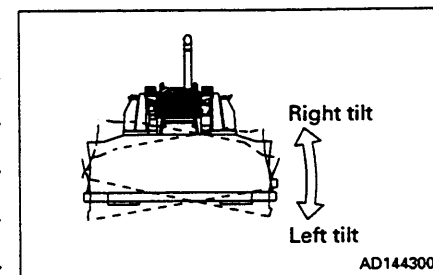

**Amount of tilt of power angle power tilt dozer**

Tilting direction	Amount of tilt	
	Standard blade	Wide blade
Right tilt	485 mm (19.1")	530 mm (20.9")
Left tilt	645 mm (25.4")	710 mm (28.0")



**Angling control**

- Ⓐ LEFT ANGLE : 
- Ⓑ HOLD : Blade is stopped and held in this position.
- Ⓒ RIGHT ANGLE : 

Turn the knob to the left or right to operate the blade angle.

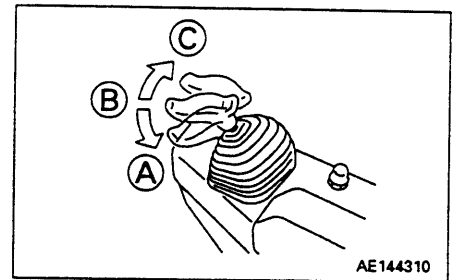
**REMARK**

- When operating only the angle, always keep the lever at the HOLD position and turn the knob to the left or right.
- If the lever is not at the HOLD position (if either the lift or tilt or both lift and tilt are being operated), and the angle is operated, it is possible to carry out both operations at the same time, but the blade speed will become slower. Decide the method of use according to the type of operation.
- The same applies if the lift or tilt are operated during angle operations.

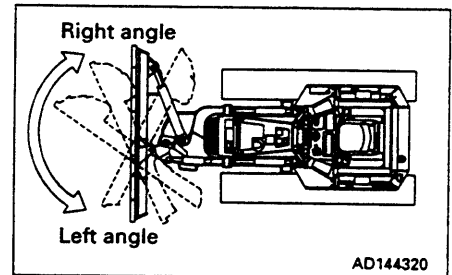

## 11.4 FUSE BOX

### NOTICE

- Before replacing a fuse, be sure to turn off the starting switch.
- If the fuse blows again immediately after it is replaced, please contact your Komatsu distributor to have the system inspected.

The fuses protect the electrical equipment and wiring from burning out.

If the fuse becomes corroded, or white powder can be seen, or the fuse is loose in the fuse holder, replace the fuse.

Replace a fuse with another of the same capacity.

- Chassis  
When the battery cover is opened, two fuse boxes can be found inside.
- Cab (machines equipped with cab)  
It is installed at the left side of the overhead panel.

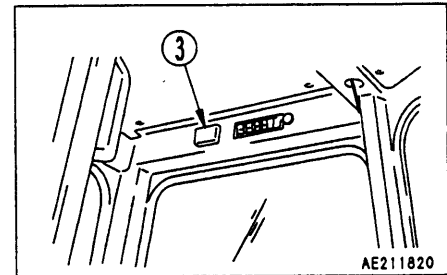
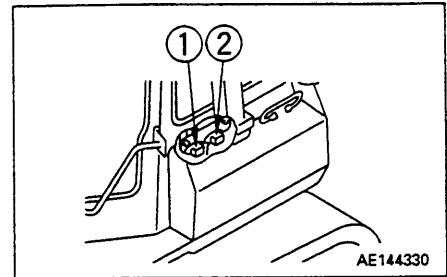

### 11.4.1 FUSE CAPACITY AND CIRCUIT NAME

#### Fuse box ①

No.	FUSE CAPACITY	CIRCUIT NAME
①	20 A	Head lamp, Rear lamp
②	10 A	Chassis power source
③	10 A	Engine control system
④	10 A	Horn
⑤	10 A	Back-up alarm

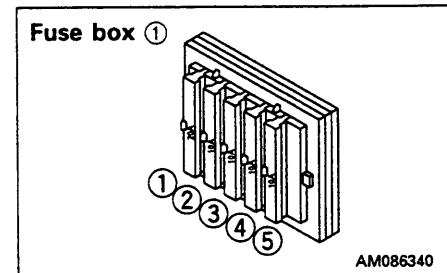

#### Fuse box ②

No.	FUSE CAPACITY	CIRCUIT NAME
①	10 A	Cab radio
②	-	-
③	20 A	Air conditioner
④	20 A	Auxiliary power source circuit
⑤	30 A	Chassis power source

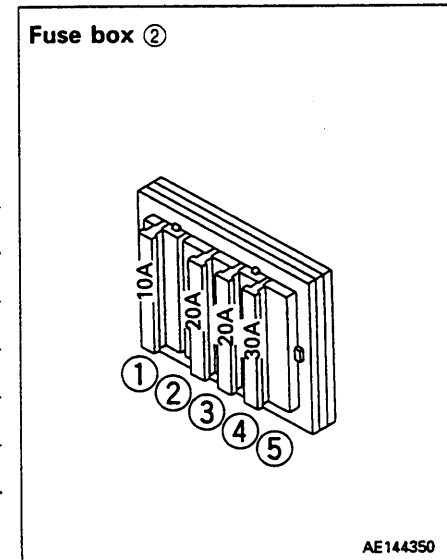

#### Fuse box ③ (machine equipped with cab)

No.	FUSE CAPACITY	CIRCUIT NAME
①	10 A	Radio memory
②	20 A	Radio, lamps, cigarette lighter
③	10 A	Rear wiper
④	10 A	Right door wiper
⑤	10 A	Front wiper
⑥	10 A	Left door wiper

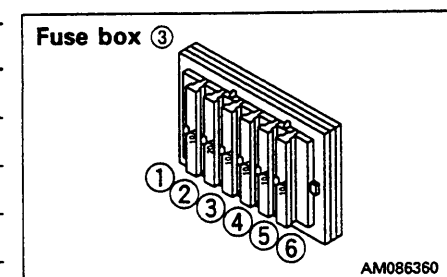

### 11.5 GREASE PUMP HOLDER (IF EQUIPPED)

This is inside the left engine side cover.  
Fit the grease pump to the holder when it is not being used.

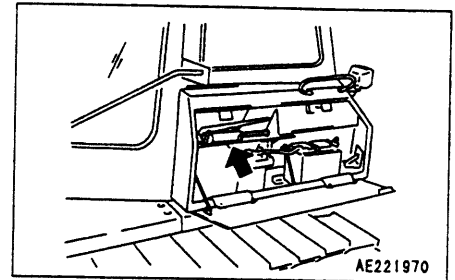

### 11.6 DOOR-OPEN LOCK (MACHINES EQUIPPED WITH CAB)

Use this when you want to keep the door held open.

1. Push the open door into door catch ①. The door will be held in position by the door catch.
2. To release the door, move lever ② inside the cab to the front of the cab. This will release the catch.

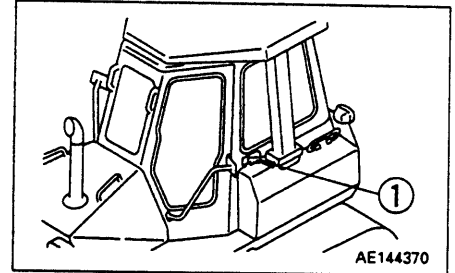

#### NOTICE

- When keeping the door open, fix it securely to the catch.
- Always close the door when traveling or carrying out operations. Leaving the door open will cause the door to break.
- Keep the door locked open securely.  
The door may swing closed because of the vibration.

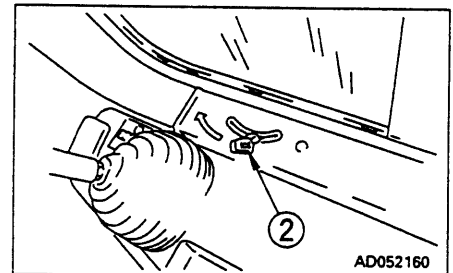

### 11.7 OPENING AND CLOSING REAR WINDOW (MACHINES EQUIPPED WITH CAB)

The rear glass can be opened or closed with a quarter lock.

If the left and right lock levers of the quarter lock are pulled up and pushed out at the same time, the glass moves to the open position.

If the left and right lock levers of the quarter lock are pulled up and pulled back in at the same time, the glass moves to the closed position.

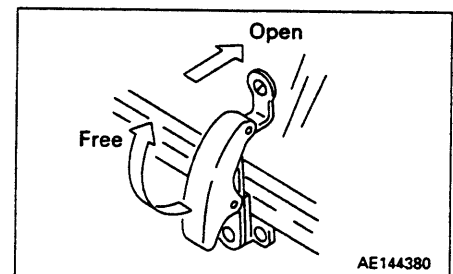

#### NOTICE

Keep the rear glass closed when traveling or during operations.  
Leaving it open will cause damage to the glass.

### 11.8 CAP, COVER WITH LOCK

Locks are fitted to the fuel tank filler port, operator's cab, and engine hood. Use the starting key to open and close the cap. Insert the key fully to the shoulder, then turn it. If the key is turned when it is not fully inserted, it may break.

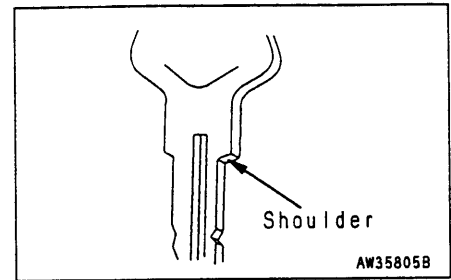

#### 11.8.1 OPENING AND CLOSING CAPS WITH LOCK

- **Opening the cap**

1. Insert the key into the key slot.
2. Turn the key clockwise, align the match marks on the cap with the groove in the rotor, then open the cap.

- **Locking the cap**

1. Turn the cap into place and insert the key into the key slot.
2. Turn the key counterclockwise and take the key out.

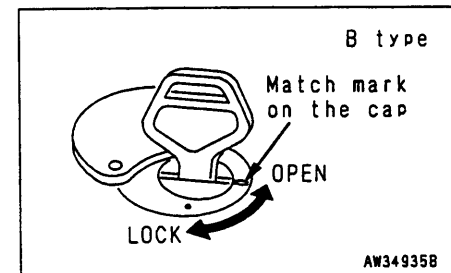
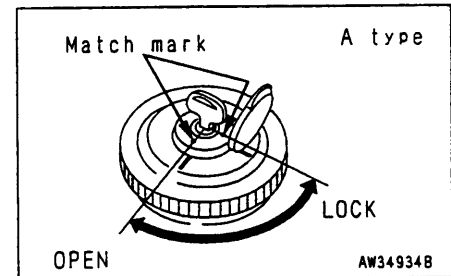

#### 11.8.2 OPENING AND CLOSING COVERS WITH LOCK

- **Opening the cover**

1. Insert the key into the key slot.
2. Turn the key counterclockwise and open the cover by pulling the cover grip.

- **Locking the cover**

1. Close the cover and insert the key into the key slot.
2. Turn the key counterclockwise and take the key out.

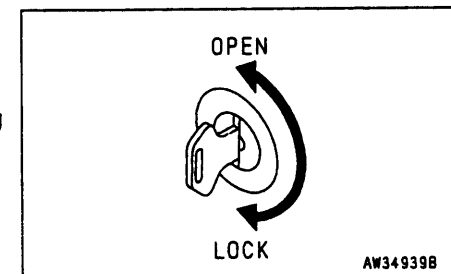

### 11.9 HOT AND COOL BOX (MACHINES EQUIPPED WITH CAB)

This is at the top of the front panel. It can be used to warm or cool three canned drinks.

This is interconnected with the air conditioner: During heating, it warms up the drinks; during cooling, it cools to the drinks.

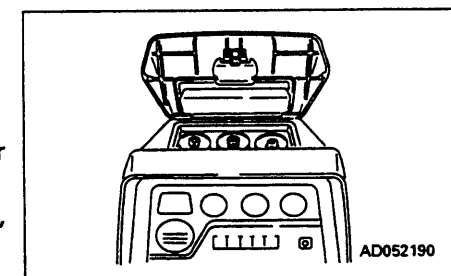

### 11.10 TOOL BOX

This is used for keeping the tools.

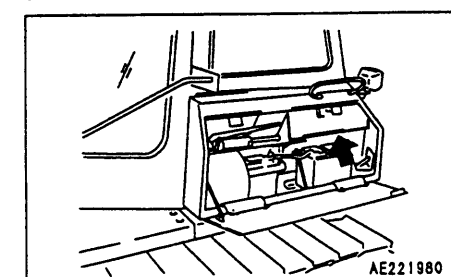



## 11.11 USING CAR RADIO (MACHINES EQUIPPED WITH CAB, CAR RADIO)

### 11.11.1 EXPLANATION OF PARTS

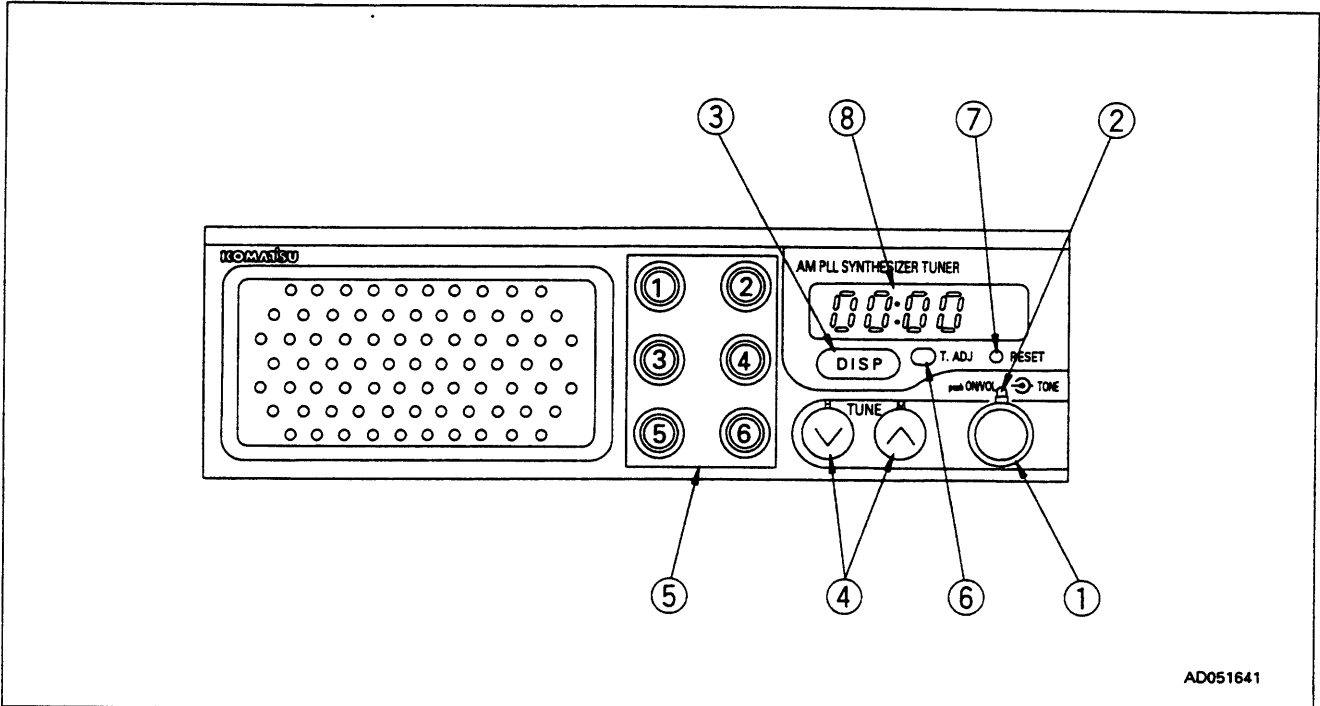

AD051641

#### 1. POWER SWITCH/VOLUME CONTROL KNOB (PUSH ON/VOL)

Push this knob to switch the radio on. The lighting in display area ① will light up and the frequency will be displayed. Press again to switch the power off.

Turn the knob clockwise to increase the sound, and counterclockwise to reduce it.

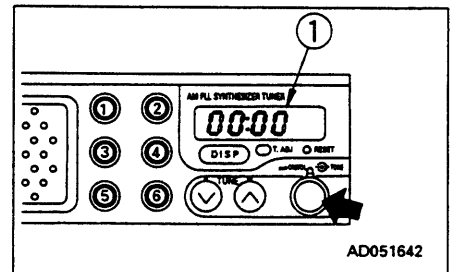

AD051642

#### 2. TONE CONTROL KNOB (TONE)

Turn this knob clockwise from the center position to emphasize the high sounds, and counterclockwise to emphasize the low sounds.

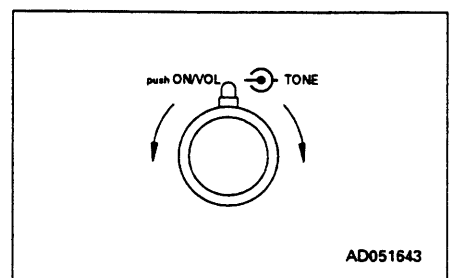

AD051643

#### 3. DISPLAY BUTTON (DISP)

If the display button is pressed when the radio is being used, the frequency of the station being listened to is displayed for 5 seconds.

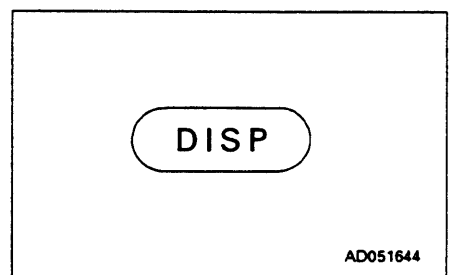

AD051644

## 11. EXPLANATION OF COMPONENTS

### 4. TUNING/HOUR, MIN ADJUSTMENT BUTTON (TUNE)

This is used to select the station or change the frequency.

If the station UP button  $\wedge$  is pressed, the frequency will go up by 9 kHz each time it is pressed; if the station DOWN button  $\vee$  is pressed, the frequency will go down 9 kHz each time it is pressed.

If these buttons are kept pressed for more than 2 seconds, the station will be selected automatically.

When adjusting the time, these change the hour display and minute display.

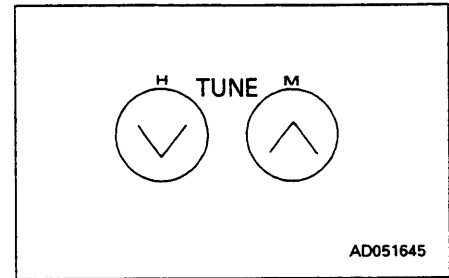

### 5. PRESET BUTTON (1, 2, 3, 4, 5, 6)

These buttons can be used to program the desired broadcasting stations. It is then possible to select the station at a touch.

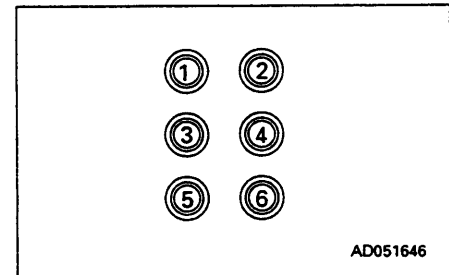

### 6. TIME ADJUSTMENT BUTTON (T.ADJ)

Press this button to adjust the time.

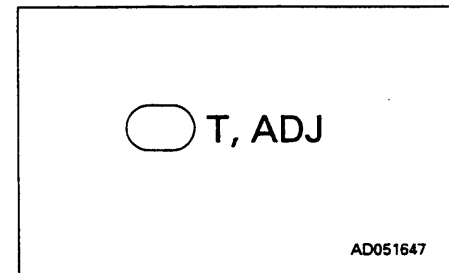

### 7. TIME RESET BUTTON (RESET)

Press this button to reset to the exact hour.

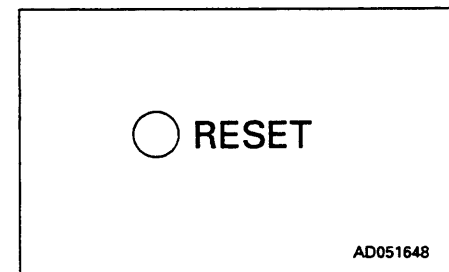

### 8. DISPLAY

This displays the frequency, time, and preset symbols.

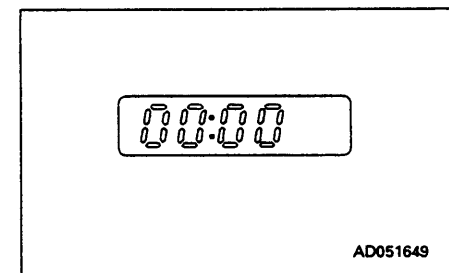

### 11.11.2 METHOD OF USE

#### Method of setting preset buttons

1. Press power switch ①. The frequency is displayed in display area ②.
2. Use selector button ③ (∧ or ∨) to adjust to the desired frequency.
3. Choose a preset button to use for this station, and keep it pressed for at least 2 seconds to program the button to that frequency.

When the sound suddenly disappears and appears again, the button is programmed, and the preset number is shown in display area ②.

After programming the button, press the preset button and release it within approx. 2 sec. The station programmed to that button will be selected for reception.

It is possible to program one station for each preset button.

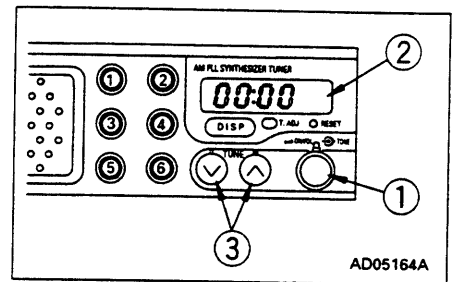

#### Method of manual tuning

Press the tuning button lightly to adjust to the desired frequency.

Each time the button is pressed, the frequency will change by 9 kHz.

∧ button: Select station at higher frequency

∨ button: Select station at lower frequency

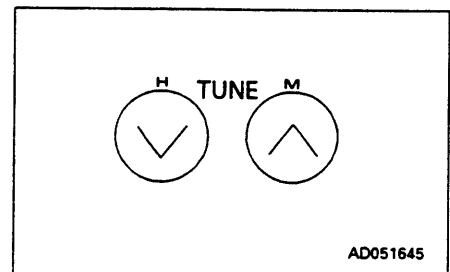

#### Method of automatic tuning

Keep the tuning button pressed for at least 2 seconds and then release it. When reception from a broadcasting station is picked up, the selector will automatically stop at that position.

When searching for the next station, keep the selector button pressed again for at least 2 seconds.

∧ button: Select station at higher frequency

∨ button: Select station at lower frequency

If the reception is weak, and stations are not found, adjust the frequency manually to select the desired station.

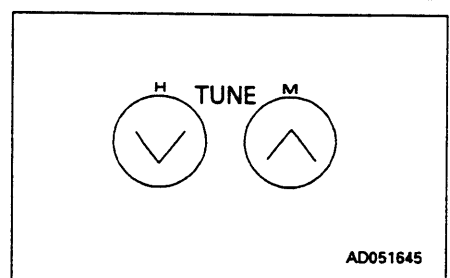

## 11. EXPLANATION OF COMPONENTS

### Adjusting time

1. Keep T.ADJ button ① pressed, and press H button ②.  
The hour display will change, so when it reaches the correct hour, release the button.
2. Keep T.ADJ button ① pressed and press M button ③.  
The minute display will change, so when it reaches the correct time, release the button.

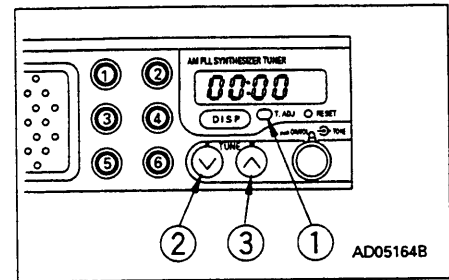

### Method of using RESET button

If RESET button ① is pressed at the same time as the time signal or standard time, the display will return immediately to the exact hour (o hour 00 min).

- If the display is 01 – 29 min, the display will go back to 0 min.
- If the display is 30 – 59 min, the display will advance to 0 min.

### [Example]

- 10:29 → 10:00 (return to exact hour)
- 10:30 → 11:00 (advances to exact hour)

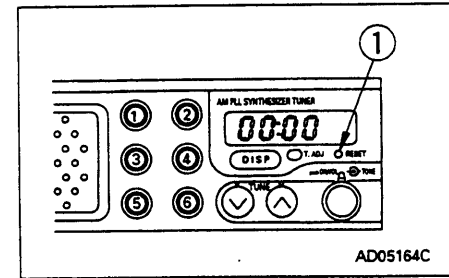

### 11.11.3 PRECAUTIONS WHEN USING



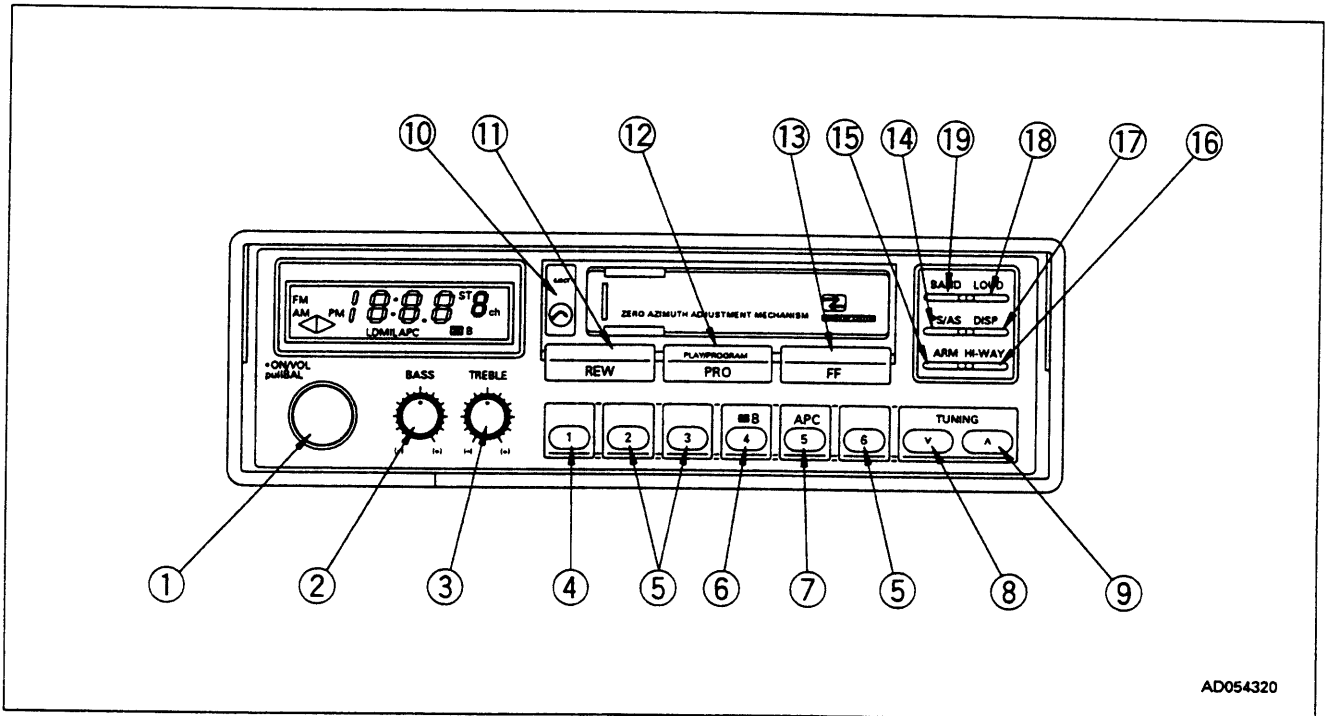

- For safety reasons, when operating keep the sound to a level where you can enjoy the sound but still hear the sound from outside vehicles.
- If water gets inside the speaker case or car radio (auto tuning), it may cause a serious problem, so do not let water get on these parts.
- Do not wipe the knobs or buttons or any other parts with any solvent such as benzene or thinner. Always wipe with a soft dry cloth (in cases of extreme dirt, use alcohol on the cloth).

### 11.12 USING CAR STEREO (MACHINES EQUIPPED WITH CAB AND CAR STEREO)



#### 11.12.1 EXPLANATION OF PARTS





AD054320

Symbol	Name	Control function	Control method	Explanation
①	ON/BAL/VOL	Radio power ON/OFF	PUSH	Each time the button is pressed, the radio is switched between ON and OFF. This switch does not work when the tape is being used.
		Volume balance	PULL  PULL 	Pull the knob and turn clockwise to emphasize the sound from the right speaker; turn counterclockwise to emphasize the sound from the left speaker. After adjusting, return the knob to its original position.
		Volume	Low  High	Turn to adjust the volume. This switch has no effect on the volume of the alarm.
	Sleep timer	Automatic power OFF	Radio power ON	If the radio power is turned ON when the switch is at ACC-OFF, the radio or tape starts and the power goes OFF after 1 hour.
②	BASS	Control of low sounds	Release push lock 	From the center: Turn CLOCKWISE to BOOST Turn COUNTERCLOCKWISE to CUT
③	TREBLE	Control of high sounds	 - +	





## 11. EXPLANATION OF COMPONENTS

Symbol	Name	Control function	Control method	Explanation
④	1	Recall Channel 1	Push the button for less than 2.0 seconds	Frequency set in Channel 1 is called up
		Save Channel 1 (memory)	Push the button for more than 2.0 seconds	The frequency in the display is set to Channel 1 (saved to memory)
⑤	2, 3, 6	See 1	See 1	See 1 (only channel is different)
⑥	4  B	When using radio: Channel 4	See 1	See 1
		When using tape: Dolby ON/OFF	PUSH	Each time button is pressed, it is switched between ON and OFF.
⑦	5APC	When using radio: Channel 5	See 1	See 1
		When using tape: APC ON/OFF	PUSH	Each time button is pressed, it is switched between ON and OFF. When it is ON, APC (finding beginning) is possible in FF/REW.
⑧		Manual down	Push the button for less than 0.5 seconds	Frequency goes down one step (AM 9 kHz, FM 100 kHz)
		Seek down	Push the button for more than 0.5 seconds	When button is being pressed, changes to fast forward. Seeks down from frequency where button is released.
⑨		Manual up	Push the button for less than 0.5 seconds	Frequency goes up one step (AM 9 kHz, FM 100 kHz)
		Seek up	Push the button for more than 0.5 seconds	When button is being pressed, changes to fast forward. Seeks up from frequency where button is released.
⑩	EJECT	EJECT	PUSH	When using tape (PLAY/FF/REW), press to eject cassette. This can also be used when switch is at ACC-OFF.
⑪	REW	Rewind	PUSH	Rewinds tape during tape PLAY or FF
⑫	PRO	Changes between A side and B side	Push the button during PLAY	Changes between A side and B side and changes the direction of the tape.
		PLAY from FF/REW	Push the button during FF/REW	Push this button to play tape during FF/REW
⑬	FF	Fast forward	PUSH	Push this button to fast forward tape during PLAY/REW
⑭	PS/AS	PS (Preset Scan)	Push the button for less than 0.5 seconds	Receives preset channels for 5 seconds each. However, it skips channels which do not yet have stop sensing. Display flashes during PS.
		AS (Auto Store)	Push the button for more than 0.5 seconds	When AS is turned ON, it searches from bottom of band and stores frequencies in memory (preset memory) starting from Channel 1. When doing this, it searches during the 1st cycle at LO and during the 2nd cycle at DX. However, it skips any frequencies that are already stored, so there is no case of the same frequency being stored twice. When the illumination is lighted up, the 2nd cycle is also carried out at LO.

11. EXPLANATION OF COMPONENTS

Symbol	Name	Control function	Control method	Explanation
⑮	ARM	Alarm ON/OFF	PUSH	Alarm can be turned ON/OFF by pushing button when time or frequency is being displayed.
		Alarm/wake-up selection	PUSH	If button is pushed when alarm time is being displayed, it switches between alarm and wake-up. When the alarm is being used, "A" is displayed on the LCD channel display. When the time set for the alarm is reached and the alarm is ON, the alarm sound from the PS on the right side. This also works when switch is at ACC-OFF. When the wake-up is being used, "U" is displayed on the LCD channel display. When the time set for the wake-up is the same as the actual time and the alarm is ON, the radio or tape starts to play. This also works when switch is at ACC-OFF.
		Stop alarm		The alarm sound stops after 3 minutes, but if you wish to stop the alarm, push any button or turn the tape to IN. With wake-up, the radio or tape stops after 1 hour, but if you wish to stop the tape or radio, push the radio power button (when using the radio) or push the EJECT button (when using the tape) to turn the power OFF.
⑯	 (HI WAY)	Highway traffic information (HW) ON/OFF	PUSH	<p>This key turns the highway traffic information ON/OFF. This system works when using tape or radio (AM/FM), but returns to original model when OFF. The frequencies are 1620 kHz and 1629 kHz; the default setting is 1620 kHz. If the key is pressed and released within 2 seconds, the present setting is displayed; if the key is pressed for more than 2 seconds, the other frequency is displayed. The  mark lights up during reception.</p> <p>Method of canceling</p> <ol style="list-style-type: none"> <li>1. Push HW (  ).</li> <li>2. Turn radio OFF.</li> <li>3. Insert cassette.</li> <li>4. If HW is selected when playing tape, push any of PRO/FF/REW/EJECT buttons to cancel HW.</li> </ol>

## 11. EXPLANATION OF COMPONENTS

Symbol	Name	Control function	Control method	Explanation
⑰	DISP	Display selection	PUSH	<p>Each time it is turned ON, display changes as follows.</p> <div style="text-align: center;"> <p>Frequency (When using radio)</p> <p>↙                      ↘</p> <p>Alarm time → Present time</p> </div> <p>If the key is released, the frequency is displayed for 5 seconds, then the alarm time is displayed for 15 seconds. If no other key is operated, the display then returns to the present time.</p> <p>To distinguish between the present time and the alarm time, the alarm mark (Ⓜ) flashes when the alarm time is being displayed.</p> <p>This key cannot be used during auto tuning.</p>
	Resetting time	Setting alarm time, present time	Use DISP key and  ,  keys	Use the DISP key to display the item to be set. (Alarm/present) Keep the DISP key pressed and use the  key to set the hour and the  key to set the minute.
		Resetting minute and second for present time	DISP key and ARM	Keep the DISP key pressed and turn ARM ON. The second display will return to 00 sec; with the minute display, if the displayed time is less than 30 min., the display will return to 00 min., and if the displayed time is 30 min. or more, the display will advance to the next hour.
⑱	LOUD	Loudness ON/OFF	PUSH	<p>Each time the button is pushed, it will switch the loudness between ON and OFF.</p> <p>When it is ON, "LD" is displayed on the LCD.</p> <p>When it is ON, the soft sounds are boosted.</p>
⑲	BAND	Changing reception band	Push the button for less than 2.0 seconds	<p>AM 1 switches to FM 1</p> <p>FM 1 switches to AM 1</p> <p>AM 2 switches to AM 1</p> <p>FM 2 switches to FM 1</p>
			Push the button for more than 2.0 seconds	<p>AM 1 switches to AM 2</p> <p>FM 1 switches to FM 2</p> <p>AM 2 switches to AM 1</p> <p>FM 2 switches to FM 1</p> <p>Only the memory for AM 1 and AM 2 and for FM 1 and FM 2 differs; the reception frequency is the same.</p> <p>1 and 2 are switched for both AM and FM at the same time.</p>



### 11.12.2 PRECAUTIONS WHEN USING

- If the head is dirty, clean it with a head cleaning tape.
- Never touch the head with a magnet, screwdriver, or any other hard object.
- Use a pencil to wind the tape to the outside to remove any slack.
- When not listening to the cassette tape, always remove it.
- Put the tape in its case. Do not keep the tape in any of the following places.
  - On top of the instrument panel
  - Any place where it is exposed to direct sunlight
  - Any place that is excessively humid
  - Any place that is excessively dusty
  - Any place where there is a strong magnetic field (near a speaker, etc.)
  - Any place where there is high temperature (near the car heater, etc.)
- Use a C-60 (60 minute) tape. Avoid using longer tapes as far as possible. In particular, do not use C-120 (120 minute) tapes. These tapes easily get caught up in the machine.
- When replacing the fuse, always use a 5A fuse.
- Do not put anything except a cassette tape in the tape insertion port.
- When cleaning, wipe off the dirt with a dry cloth. Never use any organic solvent such as thinner or benzene.

### 11.13 HANDLING AIR CONDITIONER (MACHINES EQUIPPED WITH CAB)

#### 11.13.1 COOLING OPERATION

When the cooling operation is carried out, the inside of the cab is cooled, and at the same time the drinks inside the hot and cool box can be cooled.

##### Cooling (RECIRC)

When the control switch and lever are operated as shown in the diagram, a cool breeze is sent out.

Use this position when strong cooling is needed.

- Press switch ②.
- Place levers ① and ④ in the position shown in the diagram.
- Set switch ③ to the desired position.

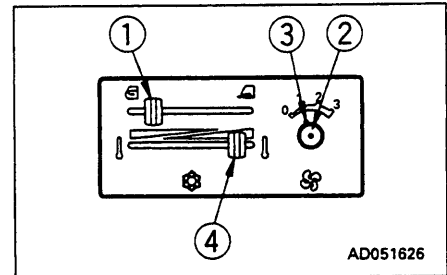

##### Cooling (FRESH)

If the air inside the cab is no longer fresh, set FRESH/RECIRC selector lever ① to FRESH to bring in fresh air. Keep the other switches at the same positions as for cooling (RECIRC).

In this position, the inside of the cab is pressurized to prevent the entry of dust.

##### REMARK

If the cooling effect is reduced, set FRESH/RECIRC selector lever ① to RECIRC again. This increases the cooling effect.

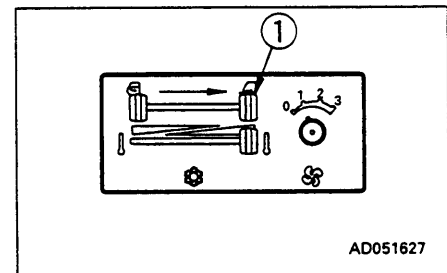

### 11.13.2 HEATING OPERATION

When the heating operation is carried out, the inside of the cab is heated, and at the same time the drinks inside the hot and cool box can be heated.

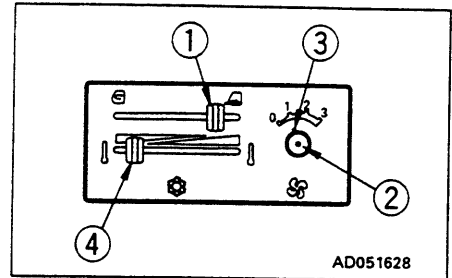

AD051628

#### Heating (RECIRC)

When the control switch and lever are operated as shown in the diagram, warm air is sent out. Use this position when strong cooling is needed.

- Place levers ① and ④ in the position shown in the diagram.
- Set switch ③ to the desired position.

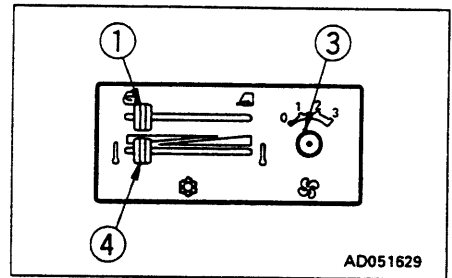

AD051629

#### Heating (FRESH)

If the air inside the cab is no longer fresh, set FRESH/RECIRC selector lever ① to FRESH to bring in fresh air. Keep the other switches at the same positions as for heating (RECIRC). In this position, the inside of the cab is pressurized to prevent the entry of dust.

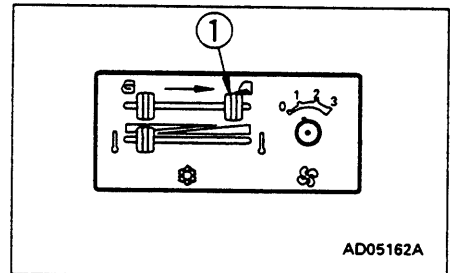

AD05162A

#### REMARK

If the cab is not heated up sufficiently, turn FRESH/RECIRC selector lever ① back to RECIRC. This increases the heating effect.

#### Dehumidifying and heating

Push switch ②. When temperature control lever ④ is placed at the central position, dry warm air blows out.

Keep the other switches at the same positions as for heating (FRESH).

#### REMARK

If this is used in spring and fall on rainy days when the air inside the cab is damp, there is no problem of the windows misting up, and the cab be warmed up to a comfortable temperature.

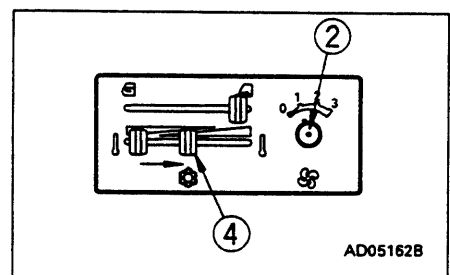

AD05162B

### 11.13.3 PREVENTION METHOD OF ENTRY OF DUST

Entry of dust into the cab can be prevented by starting the blower fan for the air conditioner to raise the pressure in the cab a little higher than outside.

When working in a dusty job site or when preventing dust from entering the cab, use this function.

- Close the windows and doors.
- Set FRESH/RECIRC selector lever ① to the FRESH position.
- Set blower switch ② to position 1, 2, or 3.
- Set air conditioner switch ③ and temperature control lever ④ to the desired position.

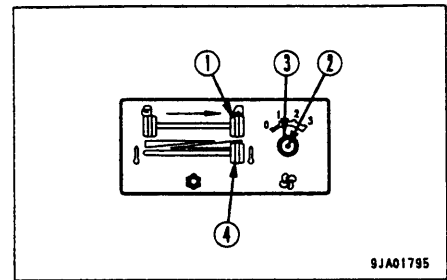

### 11.13.4 PRECAUTIONS WHEN USING AIR CONDITIONER

**Carry out ventilation from time to time when using the cooler.**

- If you smoke when the cooler is on, the smoke may start to hurt your eyes, so turn the lever to FRESH to remove the smoke while continuing the cooling.
- When running the air conditioner for a long time, turn the lever to the FRESH position once an hour to carry out ventilation and cooling.

**Be careful not to make the temperature in the cab too low.**

- When the cooler is on, set the temperature so that it feels slightly cool when entering the cab (5 – 6°C lower than the outside temperature). This temperature difference is considered to be the most suitable for your health, so always be careful to adjust the temperature properly.

**Direction of vents when cooling**

- If the vents (left and right) in the middle of the dashboard are turned so that cold air plays directly on the cab door glass, moisture may condense on the outside of the cab door glass and reduce the visibility. (This occurs particularly in high temperatures.)

If this happens, turn the vent fully to the rear and raise the air conditioner temperature setting slightly.

### 11.13.5 INSPECTION DURING OFF-SEASON

Even during the off-season, run the compressor at low speed for several minutes once a week to prevent the loss of the oil film at the lubricated parts of the compressor. (Run the engine at low speed and set the temperature control lever at the central position.)

#### REMARK

When the ambient temperature is low, if the compressor is suddenly run at high speed, it may cause failure of the compressor.

Note that the system is set so that the compressor will not run when the cooler switch is turned on if the ambient temperature is less than 2 – 6.5°C.

### 11.13.6 PROCEDURE FOR REPLACING RECEIVER

Replace the receiver once every two years.

After replacing the receiver, add compressor oil. Turn the receiver at an angle and measure the oil remaining inside the receiver, then add the same amount of oil (Denso Oil 8) to fill the receiver.

#### REMARK

Depending on the condition of use, the replacement interval may be shorter.

#### REMARK

If the receiver is used when the desiccant has exceeded the water absorption limit, the refrigerant circuit may become clogged and cause failure of the compressor.

#### Precautions when replacing receiver

- If the receiver is left for more than 15 minutes with the blind cover removed, the moisture in the air will be absorbed, and this will reduce the life of the desiccant. If you remove the blind cover, connect the piping quickly, evacuate the system and fill with refrigerant.
- When removing the refrigerant from the refrigerant circuit, release it gradually from the low pressure side to prevent oil from flowing out.

### 11.13.7 CLEANING AIR FILTER

If the air filter for the FRESH or RECIRC air intake becomes clogged, the cooling or heating capacity will drop. To prevent this, clean the air filter with compressed air once a week.

For details of the cleaning method, see "24.1 WHEN REQUIRED".

## 11.14 HANDLING HEATER (MACHINES EQUIPPED WITH CAB)

### 11.14.1 METHOD OF OPERATION

#### To heat quickly

Set the switches to the position shown in the diagram on the right to carry out heating quickly.

- Set FRESH/RECIRC selector lever ① and temperature control lever ③ to the position in the diagram on the right.
- Set blower switch ② to position 3 (HIGH).

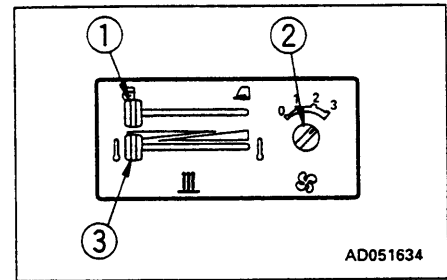

#### NOTICE

If heating is carried out continuously for a long period with the lever at the RECIRC position, the air inside the cab will become stale, so when the cab is warmed up, always set the FRESH/RECIRC selector lever ① to the FRESH position.

In this position, the inside of the cab is pressurized to prevent the entry of dust.

#### Normal use

Set each switch to the desired position.

### 11.14.2 PREVENTION METHOD OF ENTRY OF DUST

Entry of dust into the cab can be prevented by starting the blower fan for the heater to raise the pressure in the cab a little higher than outside.

When working in a dusty job site or when preventing dust from entering the cab, use this function.

- Close the windows and doors.
- Set FRESH/RECIRC selector lever ① to the FRESH position.
- Set blower switch ② to position 1, 2, or 3.
- Set temperature control lever ③ to the desired position.

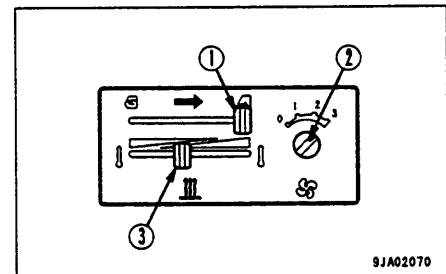

### 11.14.3 CLEANING AIR FILTER

If the air filter for the FRESH or RECIRC air intake becomes clogged, the heating capacity will drop. To prevent this, clean the air filter with compressed air once a week.

For details of the cleaning method, see "24.1 WHEN REQUIRED".

## 11.15 POWER OUTLETS

### CAB SPECIFICATION

1. Remove grommet ① from the overhead panel on the left side.

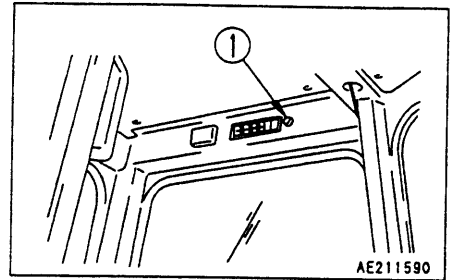

2. Power pick-up connector ② is inside the hole, so pull it out.

Connector No.	CN22
Applicable connector	08021-00400
Fuse capacity	20A

For machines equipped with a cigarette lighter, use the cigarette lighter socket as the power outlet.

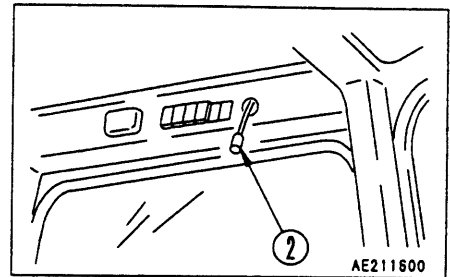

### CANOPY SPECIFICATION

1. Remove grommet ① from the front left side of the operator's seat.

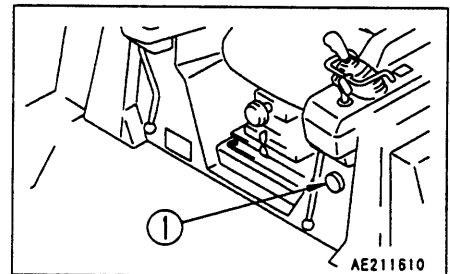

2. There is a power pick-up connector inside the hole, so pull it out.

Connector No.	CN25
Applicable connector	08021-04000
Fuse capacity	10A

## 11.16 OPERATION MANUAL STORAGE

### CAB SPECIFICATION

These are on the inside of the left and right doors, and can be used for keeping things or Operation & Maintenance manual.

However, do not put tools or other heavy objects in the pocket.

If the pocket becomes dirty, turn three clips ①, remove the pocket and wash it.

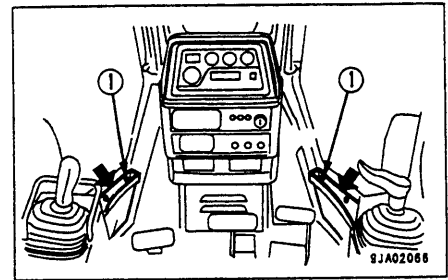

### CANOPY SPECIFICATION

There is a pocket on the back of the operator's seat.

Keep the operation manual in this pocket so that the operator can read it whenever necessary.

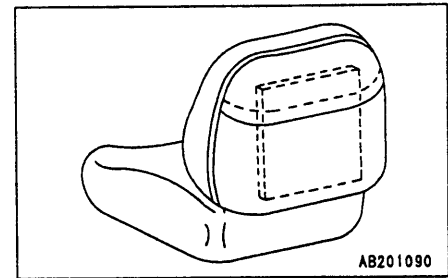



## 12. OPERATION

### 12.1 CHECK BEFORE STARTING ENGINE

#### 12.1.1 WALK-AROUND CHECK

**⚠ WARNING**

- Leakage of oil or fuel, or accumulation of flammable material around high temperature parts, such as the engine muffler or turbocharger, may cause fire. Check carefully, and if any abnormality is found, repair it or contact your Komatsu distributor.
- Do not get on or off the machine from the rear. Using this position is dangerous because it is easy to slip and you cannot be seen from the operator's compartment. Always use the handrail and step at the front when getting on or off the machine.

Before starting the engine, look around the machine and under the machine to check for loose nut or bolts, or leakage of oil, fuel, or coolant, and check the condition of the work equipment and hydraulic system. Check also for loose wiring, play, and collection of dust at places which reach high temperatures.

Always carry out the items in this section before starting the engine each day.

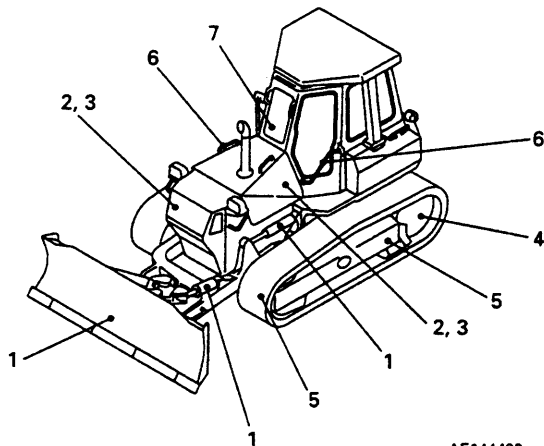

AE144400

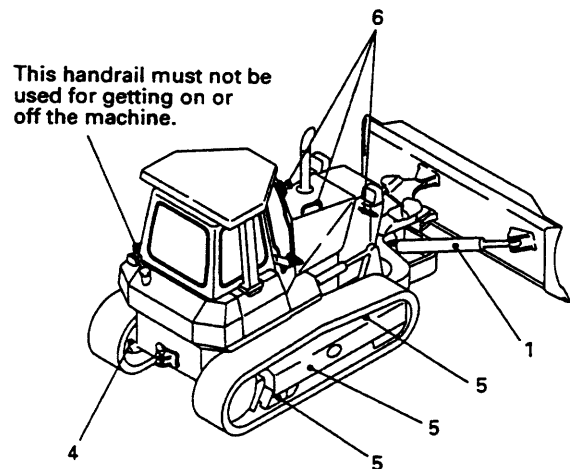

AE144410

- 1. Check for damage, wear, play in work equipment, cylinders, linkage, hoses**  
Check that there are no cracks, excessive wear, or play in the work equipment, cylinders, linkage, or hoses. If any abnormality is found, repair it.
- 2. Remove dirt and dust from around engine, battery radiator**  
Check if there is any dirt or dust accumulated around the engine or radiator. Check also if there is any flammable material (dead leaves, twigs, grass, etc.) accumulated around the battery or high temperature engine parts, such as the engine muffler or turbocharger. Remove all such dirt or flammable material.
- 3. Check for leakage of water or oil around engine**  
Check that there is no leakage of oil from the engine or leakage of water from the cooling system. If any abnormality is found, repair it.
- 4. Check for oil leakage of oil from power train case, final drive case, hydraulic tank, hose, joints**  
Check that there is no oil leakage. If any abnormality is found, repair the place where the oil is leaking.  
Check for leakage of oil from the undercover. Check the ground for traces of oil leakage.
- 5. Check the undercarriage (track, sprocket, idler, guard) for damage, wear, loose bolts, or leakage of oil from rollers**  
If any damage, wear, or oil leakage is found, repair the problem and tighten the bolts.
- 6. Check for damage to handrail, loose bolts**  
Repair any damage and tighten any loose.
- 7. Check for damage to gauges, lamps on instrument panel, loose bolts**  
Check that there is no damage to the panel, gauges and lamps. If any abnormality is found, replace the parts. Clean off any dirt on the surface.
- 8. Check for damage to seat belt and mounting clamps**  
Check that there is no abnormality in the seat belt or mounting clamps. If there is any damage, replace with new parts.

### 12.1.2 CHECK BEFORE STARTING

Always carry out the items in this section before starting the engine each day.

#### CHECK COOLANT LEVEL, ADD WATER

#### WARNING

Normally, do not open the radiator cap. When checking the cooling water level, check the sub-tank when the engine is cold.

1. Open the engine side cover on the left side of the chassis, and check that the cooling water is between the FULL and LOW marks on sub-tank ①. If the water level is low, add water to the FULL level through the water filler port in sub-tank ①.

#### REMARK

In summer, the coolant may overflow from the sub-tank drain hose. This is no problem. It occurs because too much coolant has been added.

2. After adding water, tighten the cap securely.
3. If the sub-tank is empty, check for leakage of water, then add water to the radiator and sub-tank.
4. After adding water, close the engine side cover.

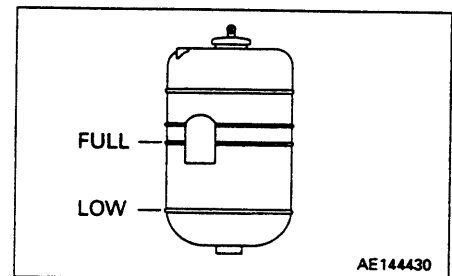
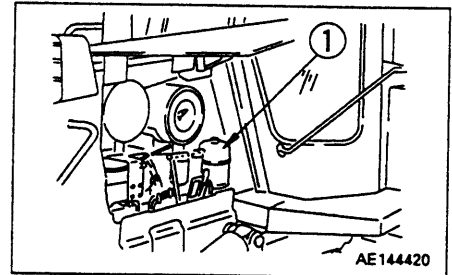

#### CHECKING WITH MACHINE MONITOR

1. Turn starting switch ① to the ON position.
2. Check that all monitor lamps light up for 3 seconds, the warning lamp lights up for 2 seconds, and the alarm buzzer sounds for 1 second.

#### REMARK

- If the lamps do not light up, there may be a failure or disconnection in the monitor, so please contact your Komatsu distributor.
- When carrying out the checks before starting, do not rely only on the monitor. Always carry out all the items listed for periodic maintenance.

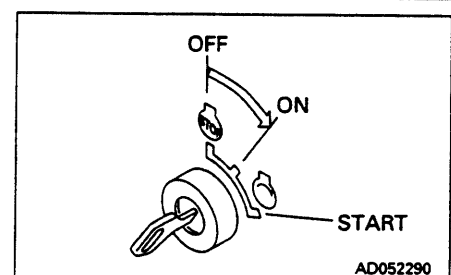
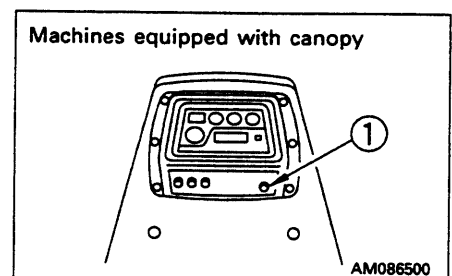
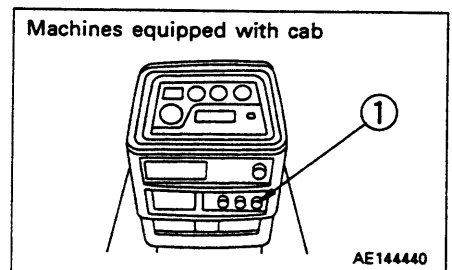

**CHECK FUEL LEVEL, ADD FUEL**

**⚠ WARNING**

**When adding fuel, never let the fuel overflow. This may cause a fire. If you spill fuel, thoroughly clean up any spillage.**

1. Turn the engine starting switch to the ON position and check the fuel level with fuel level gauge ③ on the monitor panel. After checking, turn the switch back to the OFF position.
2. After completing work, fill the fuel tank through oil filler port ④. For details of the method of opening and closing the cap, see "11.8 CAP WITH LOCK". For details of the fuel to use, see "20. USE OF FUEL, COOLANT AND LUBRICANTS ACCORDING TO AMBIENT TEMPERATURE".
3. After adding fuel, tighten the cap securely.  
Fuel capacity: 225 ℓ (59.4 US gal, 49.5 UK gal)

**REMARK**

If breather hole ① on the cap is clogged, the pressure in the tank will drop and fuel will not flow.  
Clean the hole from time to time.

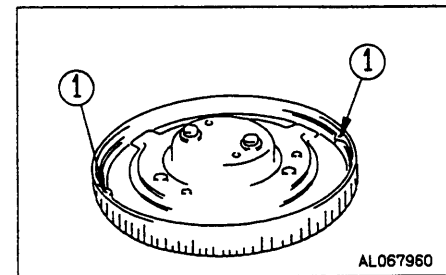
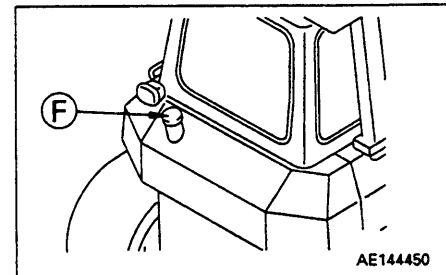
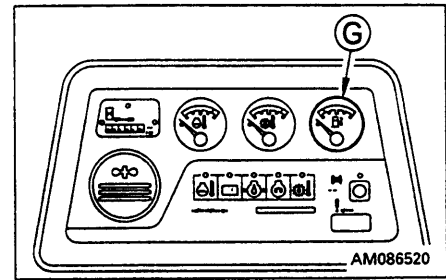

**CHECK OIL LEVEL IN ENGINE OIL PAN, ADD OIL**

1. Open the inspection cover on top of the engine hood.
2. Remove dipstick ⑤ and wipe the oil off with a cloth.
3. Insert dipstick ⑤ fully in the oil filler pipe, then take it out again.
4. The oil level should be between the H and L marks on dipstick ⑤.  
If the oil is below the L mark, open the inspection cover on top of the engine hood and add engine oil through oil filler ④. For details of the oil to use, see "20. USE OF FUEL, COOLANT AND LUBRICANTS ACCORDING TO AMBIENT TEMPERATURE".
5. If the oil is above the H mark, drain the excess engine oil from drain plug ⑥, and check the oil level again.
6. If the oil level is correct, tighten the oil filler cap securely and close the engine side cover.

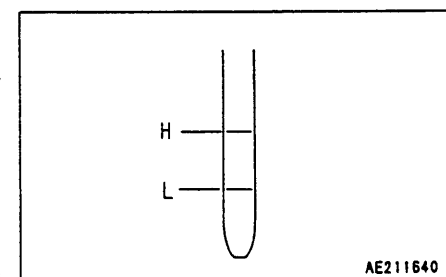
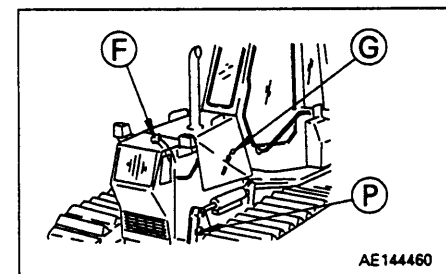

**REMARK**

When checking the oil level after the engine has been operated, wait for at least 15 minutes after stopping the engine before checking.

If the machine is at an angle, make it horizontal before checking. The oil level between the L and H marks is 7.5 ℓ (2.0 US gal, 1.7 UK gal).

**CHECK OIL LEVEL IN TRANSMISSION CASE, ADD OIL**

1. Remove dipstick **Ⓒ**, and wipe the oil off with a cloth.
2. Insert dipstick **Ⓒ** fully in the oil filler pipe, then take it out again.
3. The oil level should be between the H and L marks on dipstick **Ⓒ**.  
If the oil level is below the L mark, add engine oil through oil filler **Ⓕ**.  
For details of the oil to use, see "20. USE OF FUEL, COOLANT AND LUBRICANTS ACCORDING TO AMBIENT TEMPERATURE".
4. If the oil is above the H mark, drain the excess engine oil from drain plug **Ⓗ**, and check the oil level again.
5. If the oil level is correct, insert dipstick **Ⓒ** fully into the dipstick guide.

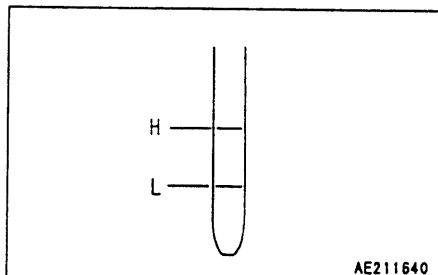
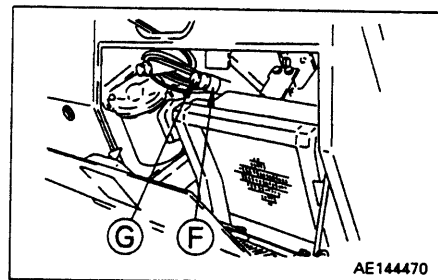
**REMARK**

- When stopping the engine, check the oil level.
  - When checking the oil level after the engine has been operated, wait for at least 15 minutes after stopping the engine before checking.
- If the machine is at an angle, make it horizontal before checking.

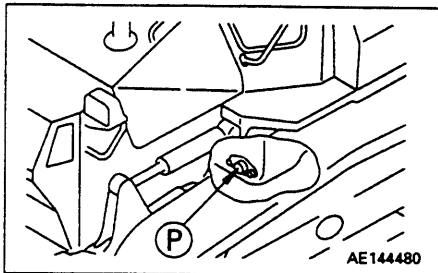
**CHECK OIL LEVEL IN STEERING CLUTCH CASE, ADD OIL**

1. Remove dipstick **Ⓒ**, and wipe the oil off with a cloth.
2. Insert dipstick **Ⓒ** fully in the oil filler pipe, then take it out again.
3. The oil level should be between the H and L marks on dipstick **Ⓒ**.  
If the oil level is below the L mark, add engine oil through oil filler **Ⓕ**.  
For details of the oil to use, see "20. USE OF FUEL, COOLANT AND LUBRICANTS ACCORDING TO AMBIENT TEMPERATURE".
4. If the oil is above the H mark, drain the excess engine oil from drain plug **Ⓗ**, and check the oil level again.
5. If the oil level is correct, insert dipstick **Ⓒ** fully into the dipstick guide.

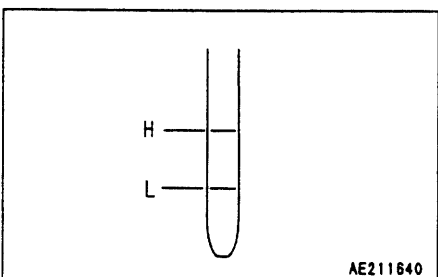
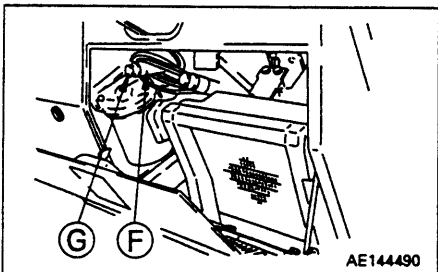
**REMARK**

- When stopping the engine, check the oil level.
  - When checking the oil level after the engine has been operated, wait for at least 15 minutes after stopping the engine before checking.
- If the machine is at an angle, make it horizontal before checking.

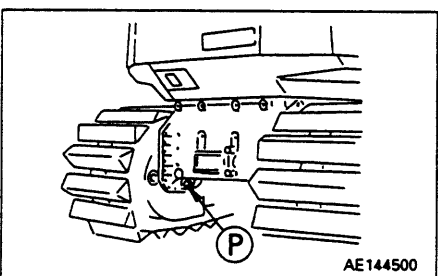

### CHECK ELECTRIC WIRING

 **WARNING**

- If fuses are frequently blown or if there are traces of short circuit on the electrical wiring, locate the cause and carry out repair.
- Accumulation of flammable material (dead leaves, twigs, grass, etc.) around the battery may cause fire, so always check and remove such material.
- Keep the top surface of the battery clean and check the breather hole in the battery cap. If it is clogged with dirt or dust, wash the battery cap to clean the breather hole.

Check the fuse for damage, and confirm that its capacity conforms to specifications. Check the wiring for breakage and short-circuits. Tighten any loosened terminals.

In particular, check the wiring of the "battery", "starting motor", "alternator", etc. carefully.

Be sure to remove any flammable materials from around the battery.

Please contact your Komatsu distributor for investigation and correction of the cause.

**CHECK BRAKE PEDAL TRAVEL**

1. Depress the brake pedal all the way until it stops.
2. The distance of travel at the center of the pedal (position in the diagram on the right) should be 70 – 90 mm (2.8 – 3.5 in).
3. When this value exceeds 90 mm (3.5 in), or the brake fails to work, please contact your Komatsu distributor for adjustment.

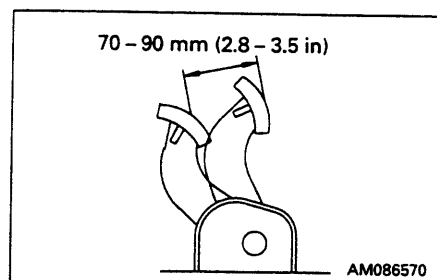
**CHECK INCHING PEDAL TRAVEL**

1. Depress the inching pedal.
2. The distance of travel at the center of the pedal (position in the diagram on the right) should be 95 – 115 mm (3.7 – 4.5 in).
3. When this value exceeds 115 mm (4.5 in), or the brake fails to work, please contact your Komatsu distributor for adjustment.

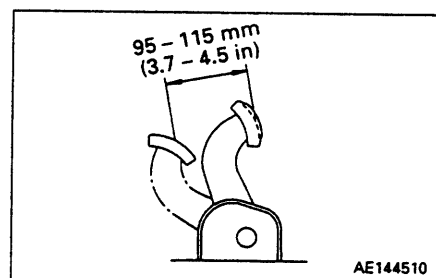
**CHECK DUST INDICATOR**

1. Open the engine side cover on the right side of the chassis, and check that the red piston has not appeared in the transparent portion of dust indicator ①.
2. If the red piston has appeared, clean or replace the element immediately.  
For details of the method of cleaning the element, see "24.1 WHEN REQUIRED".
3. After checking, cleaning, and replacing, press the knob of dust indicator ① to return the red piston to its original position.

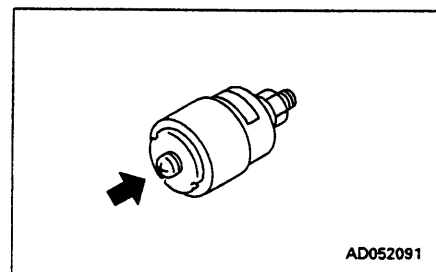
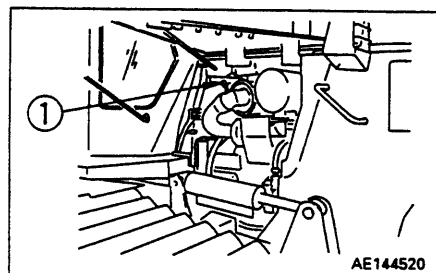

**CHECK THAT LAMPS LIGHT UP**

Check that the head lamp, rear lamp, additional working lamp (if equipped), and instrument lamp light up normally and they are free from stain and damage.

If the lamps do not light up, there is probably a broken bulb or disconnection in the wiring, so contact your Komatsu distributor for repairs.

1. Turn the key to the ON position.
2. Turn the head lamp switch and the rear lamp switch to the ON position and check that the head lamps and rear lamps light up.
3. Turn the additional working lamp switch to the ON position and check that the lamp light up.

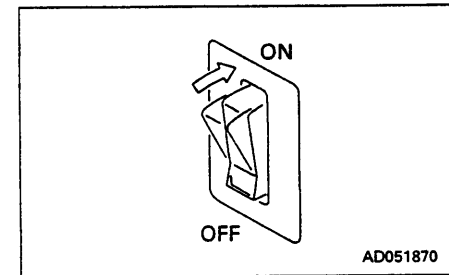
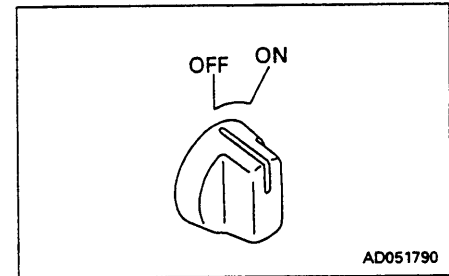
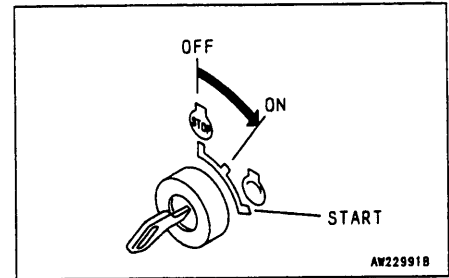

**CHECK HORN SOUND**

If the horn does not sound or the sound level is extremely low, there is probably a failure or disconnection in the horn, so please contact your Komatsu distributor for repairs.

1. Turn the key to the ON position.
2. Push the horn switch and check that the horn sounds.

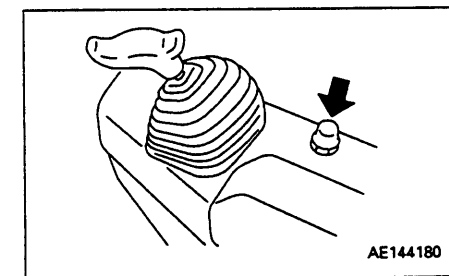
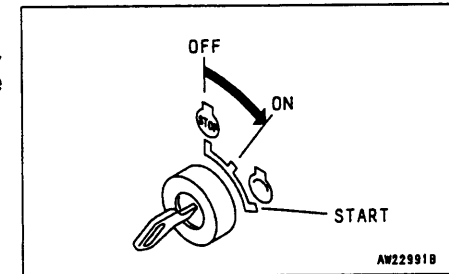



**CHECK BACKUP ALARM SOUND**

Confirm that the backup alarm operates normally. If it does not operate, it may be broken or a wire may be loose or broken. In such cases ask your Komatsu distributor for repairs.

1. Turn on the starting switch.
2. Set parking brake lever to the FREE position.
3. Set the steering, directional and speed lever to the reverse position, and confirm that the alarm operates.

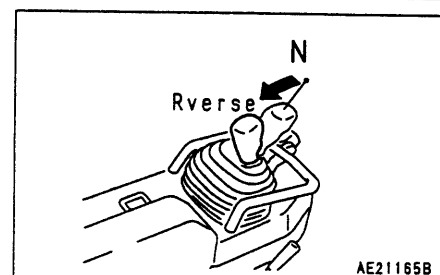
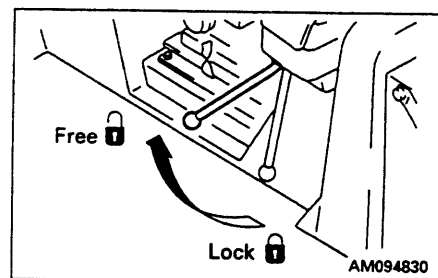
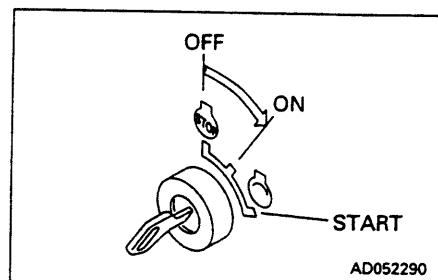
**CHECK SEAT BELT FOR WEAR OR DAMAGE**

Check the belt and mounting clamps, and if they are worn or damaged, replace the seat belt.

**CHECK FOR WATER AND SEDIMENT IN WATER SEPARATOR, DRAIN WATER**

The water separator separates water mixed in the fuel. If float ② is at or above red line ①, drain the water according to the following procedure:

1. Open the inspection cover at the bottom of the fuel tank.
2. Loosen drain plug ③ and drain the accumulated water until the float reaches the bottom.
3. Tighten drain plug ③.
4. If the air is sucked into fuel line when draining and water, be sure to bleed air in the same manner as for the fuel filter. See "24.5 EVERY 500 HOURS SERVICE".

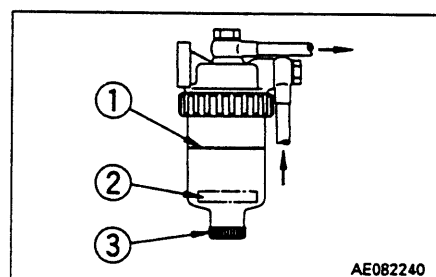
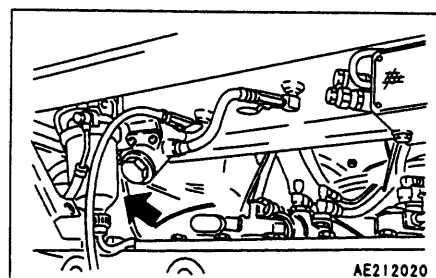

### 12.1.3 ADJUST OPERATOR'S SEAT

**⚠ WARNING**

- Adjust the seat position at the beginning of each shift or when operators change.
- Adjust the seat so that the brake pedal can be depressed all the way with the operator's back against the backrest.

#### Fore-aft adjustment of seat

Pull up lever ①, set the seat to a position where it is easy to operate, then release the lever.

Fore-aft adjustment: 160 mm (6.3 in) (17 stages)

#### Adjusting cushion

Turn knob ② to adjust the cushion to the desired strength.

#### Adjuster reclining angle

#### NOTICE

When reclining the seat back to the rear, check the space behind, and adjust to a suitable position.

Pull lever ③, set the seatback to a position where it is easy to operate, then release the lever.

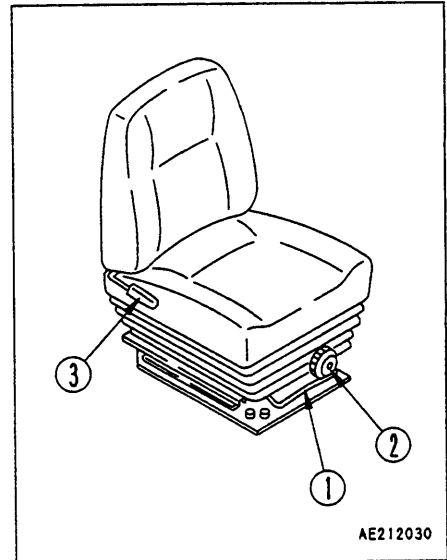

### 12.1.4 USING SEAT BELT

#### **⚠ WARNING**

- Before fastening the seat belt, inspect the securing brackets and belt for abnormal conditions.  
Replace any worn or damaged seat belt or the securing brackets.
- Even if there appears to be no abnormality with the seat belt, always replace it once every three years. The data manufacture is woven on the reverse side of the belt.
- Adjust and fasten the seat belt before operating the machine.
- Always use seat belt when operating the machine.
- Fit the seat belt across your lap without twisting.

- **Fasten the belt and remove it in the following manner**

1. Adjust the seat so that the brake pedal can be depressed all the way with the operator's back against the backrest.
2. After positioning the seat, adjust the tether belt ①. With the seat unoccupied, tense the belt slightly across the seat and install.
3. Sit in the set. Hold buckle ② with your left hand and tongue ③ with your right hand, put the tongue into the buckle. Check that the belt has locked by pulling it.
4. When removing the belt, raise the tip of the buckle lever to release it.

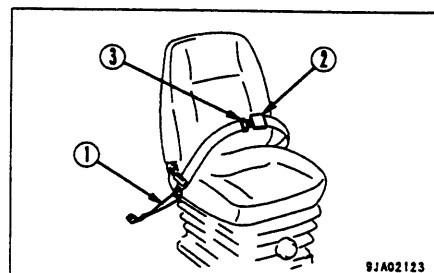

Fasten belt along your body without kinking it. Adjust the lengths of the belt on both the buckle and the tongue sides so that the buckle is located at the mid-point of your body front.

9JA02123

**ADJUST THE BELT LENGTH IN THE FOLLOWING MANNER**

**To shorten the belt**

Pull the free end of the belt on either the buckle body or tongue side.

**To lengthen the belt**

Pull the belt while holding it at a right angle to buckle or tongue.

Inspect bolts and fittings on the chassis for tightness. Retighten any loose bolts to  $25 \pm 5$  Nm ( $2.5 \pm 0.5$  kgm,  $18 \pm 3.6$  lbft) torque.

If the seat is scratched or frayed or if any of the fittings are broken or deformed from long service, replace the seat belt immediately.

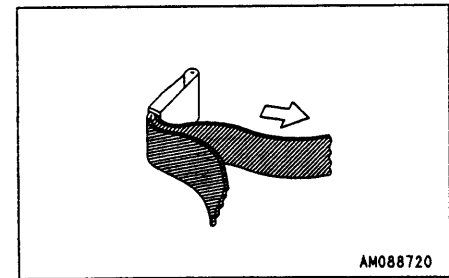
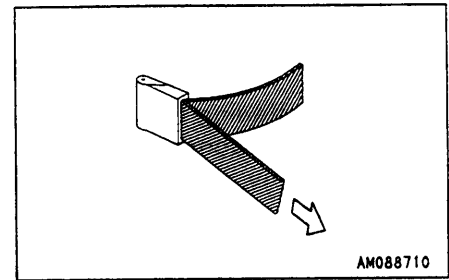

### 12.1.5 OPERATIONS AND CHECKS BEFORE STARTING ENGINE

#### **⚠ WARNING**

If the work equipment control levers are touched by accident, the work equipment may move suddenly. When leaving the operator's compartment, always set the safety lock lever securely to the LOCK position.

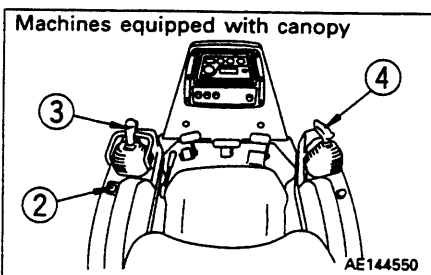
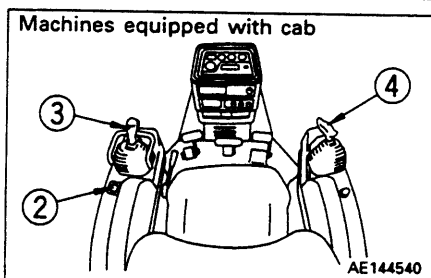
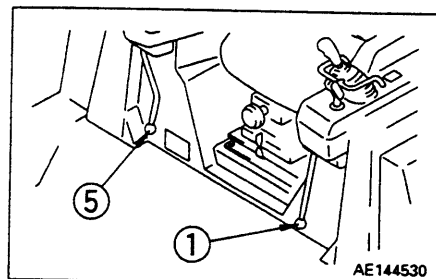

1. Check that the brake pedal is locked with parking brake lever ①. If this lever is not at the LOCK position, the engine will not start.

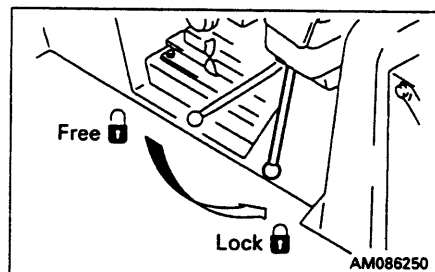

2. Check that speed range display window ② shows 1st.

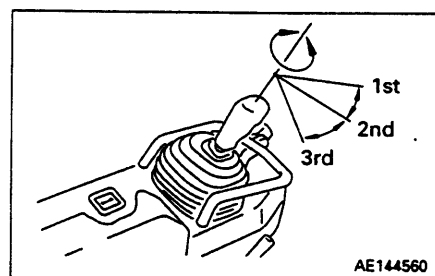

3. Check that joystick ③ is at the neutral position.

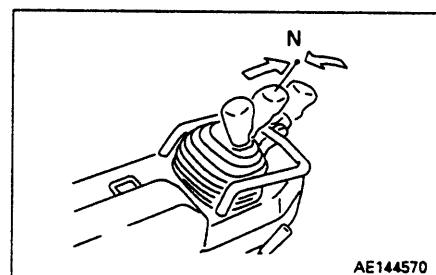

## 12. OPERATION

---

4. Check that the blade is lowered to the ground and that blade control lever ④ is at the HOLD position.

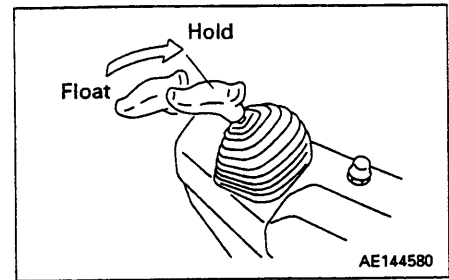

5. Check that the safety lock lever ⑤ is locked.

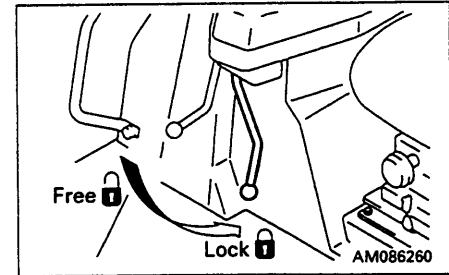

## 12.2 STARTING ENGINE

### 12.2.1 NORMAL STARTING

**⚠ WARNING**

Check that there are no persons or obstacles in the surrounding area, then sound the horn and start the engine.

**NOTICE**

Do not keep the starting motor rotating continuously for more than 20 seconds.

If the engine will not start, wait for at least 2 minutes before trying to start the engine again.

1. Pull fuel control lever ① to a position midway between the low idling and full speed positions.

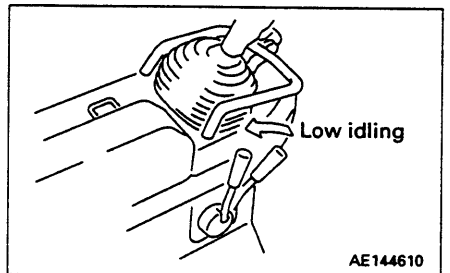
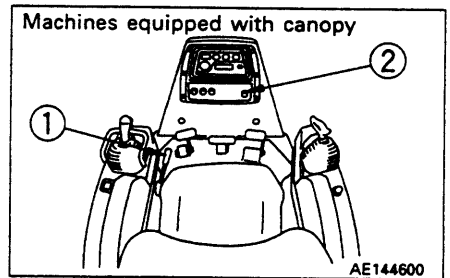
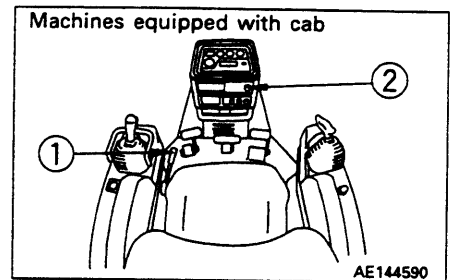

2. Insert the key into starting switch ② and turn the key to the START position. The engine will start.

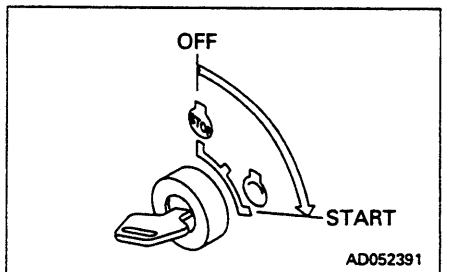

3. When the engine starts, release the key in starting switch ②. The key will return automatically to the ON position.

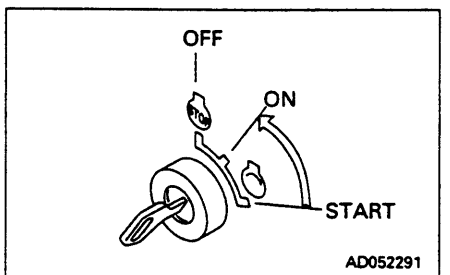

**12.2.2 STARTING IN COLD WEATHER**

When starting in low temperatures, do as follows.

**⚠ WARNING**

**Never use starting aid fluids as they may cause explosions.**

**NOTICE**

Do not keep the starting motor rotating continuously for more than 20 seconds.

If the engine fails to start, repeat steps 2 and 3 after waiting for about 2 minutes.

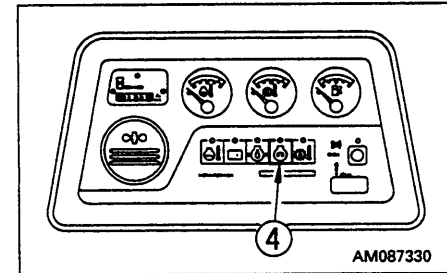
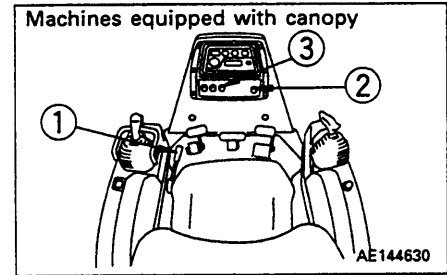
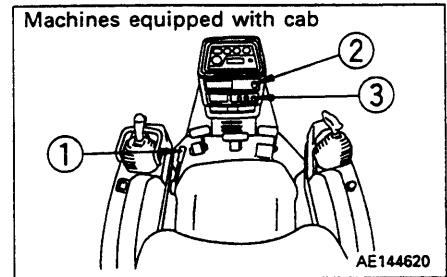

1. Pull fuel control lever ① to a position midway between the low idling and full speed positions.

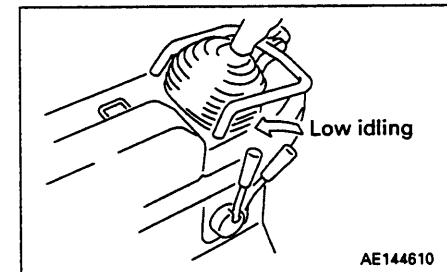

2. Insert the key into starting switch ② and turn the key to the ON position.

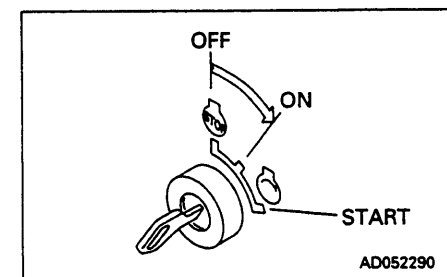

3. Carry out preheating.  
There are the following two ways of carrying out preheating.  
First use the convenient automatic preheating system.



- **Automatic preheating**

- (1) Turn glow switch ③ to the AUTO position.  
When it is turned to the AUTO position, preheating is automatically carried out according to the ambient temperature. Lamp ④ lights up during the preheating operation. When the preheating is completed, lamp ④ will go out.

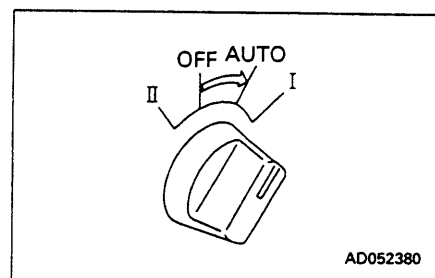

- (2) When the preheating is completed, turn the key in starting switch ② to the START position to start the engine.

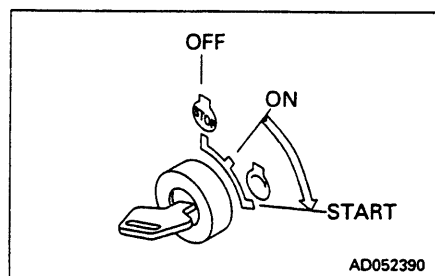

- (3) After starting the engine, return glow switch ③ to the OFF position.

- **REMARK**

If the engine can not start after automatic preheating, start it using manual preheating.

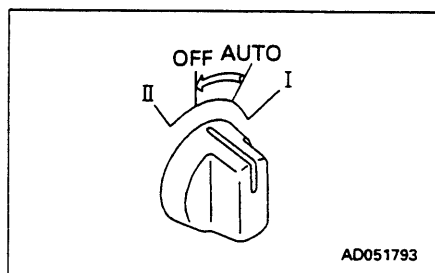

- **Manual preheating**

- (1) Turn glow switch ③ to position I or II.  
Lamp ④ lights up during the preheating operation.  
When the preheating is completed, release the switch. The key will then return automatically to the following position.  
From position I, it will return to AUTO  
From position II, it will return to OFF

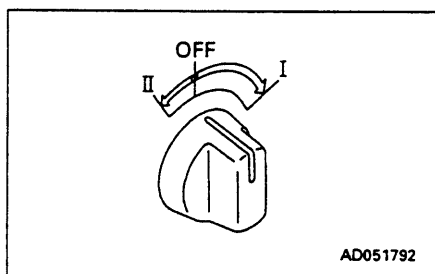

The preheating times are as shown below.

Ambient temperature	Preheat time
0°C to -5°C	-
-5°C to -10°C	15 seconds
-10°C to -20°C	30 seconds
-20°C to -30°C	45 seconds

If the preheating time is too long or too short, the engine will not start easily. Observe the correct preheating time.

- (2) When the preheating is completed, turn the key in starting switch ② to the START position to start the engine.

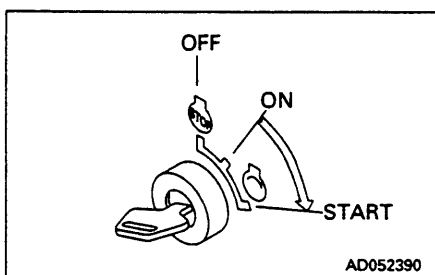

## 12. OPERATION

---

4. When the engine starts, release the key in starting switch ②. The key will return automatically to the ON position.

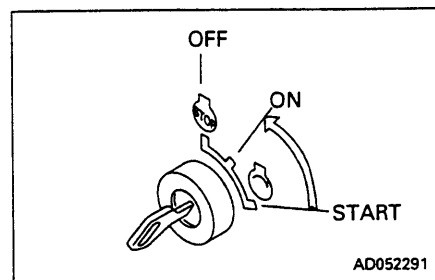

## 12.3 OPERATIONS AND CHECKS AFTER STARTING ENGINE

After starting the engine, do not immediately start operations. First, carry out the following operations and checks.

### NOTICE

**Avoid abrupt acceleration until warm-up run is completed.**

**Do not run the engine at low idling or high idling for more than 20 minutes. If it is necessary to run the engine at idling, apply a load or run at a medium speed from time to time.**

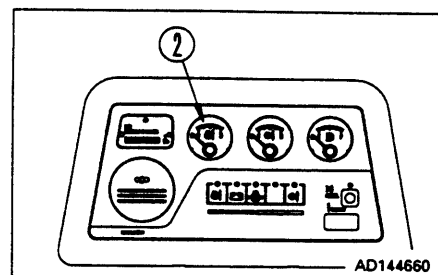
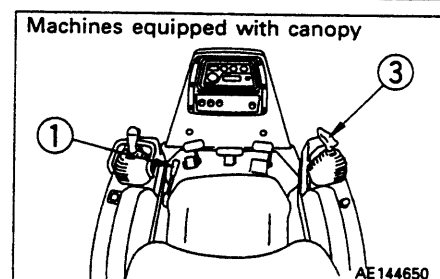
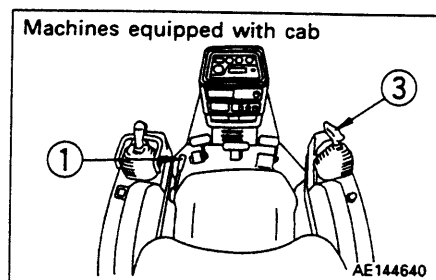

### 12.3.1 NORMAL OPERATION

1. Pull fuel control lever ① to the center position between LOW IDLING and HIGH IDLING and run the engine at medium speed for about 5 minutes with no load.
2. After warm-up run is completed, check gauges and caution lamps for proper operation. If any abnormality is found, repair it.  
Continue to run the engine at light load until engine water temperature gauge indicator ② falls within the white range.
3. Check that there is no abnormal exhaust gas color, noise, or vibration. If any abnormality is found, repair it.

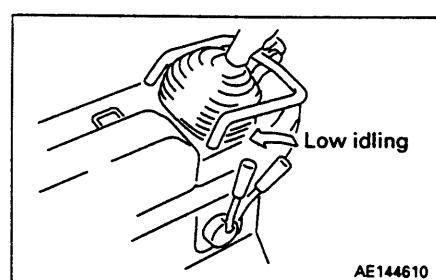

### 12.3.2 STARTING IN COLD WEATHER

1. Pull fuel control lever ① to a position midway between the low idling and full speed positions, run the engine at a mid-range speed, and continue to run under no load for approx. 10 minutes.

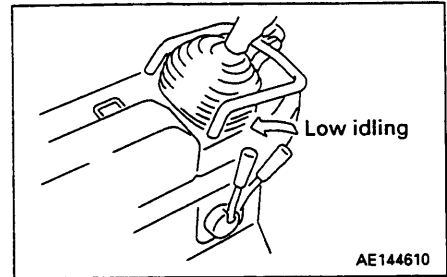

2. Operate blade control lever ③ for 5 minutes to relieve the tilt circuit intermittently, then operate lift + tilt for a further 5 minutes.

If the work equipment oil is not sufficiently warmed up, there will be a delay in the response of the work equipment and steering.

3. After warm-up run is completed, check gauges and caution lamps for proper operation. If any abnormality is found, repair it.

Continue to run the engine at light load until engine water temperature gauge indicator ② falls within the white range.

4. Check that there is no abnormal exhaust gas color, noise, or vibration. If any abnormality is found, repair it.

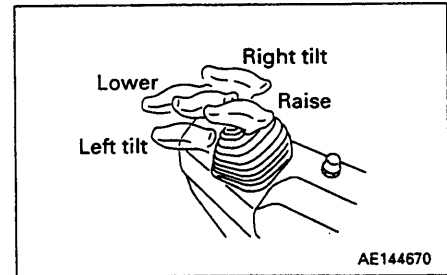

## 12.4 MOVING MACHINE

### WARNING

- When moving machine, check that the area around the machine is safe, and sound the horn before moving. Clear all personnel from the machine and the area. Clear all obstacles from the path of the machine. Use extreme care when reversing the machine. Note there is an blind spot behind the machine.
- When starting on slopes, always keep brake pedal ② depressed even after releasing parking brake lever ①.
- When starting on steep slopes, run the engine at full throttle, keep brake pedal ② fully depressed, and set joystick ④ to the F1 position. When the machine starts to move slowly (or the shoes slip), release brake pedal ② slowly and allow the machine to move off.

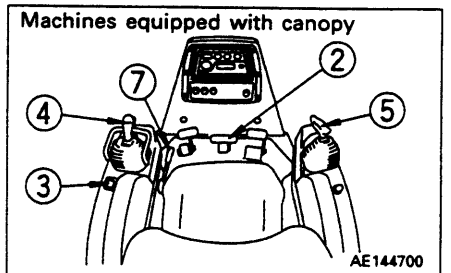
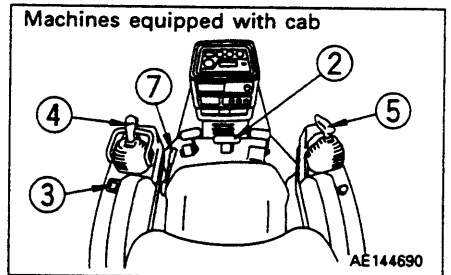
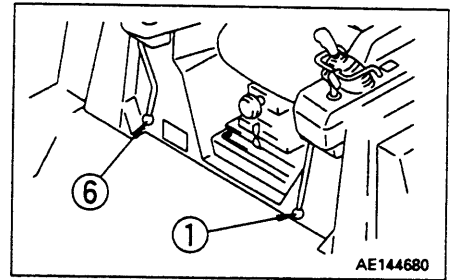

1. Set parking brake lever ① to the FREE position.

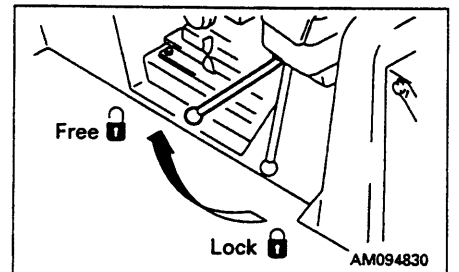

2. Operate joystick ④ to the desired position, and check that speed range display window ③ shows the correct position.

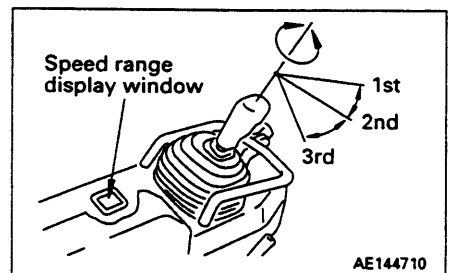

3. Set safety lock lever ⑥ for blade control lever ⑤ to the FREE position.

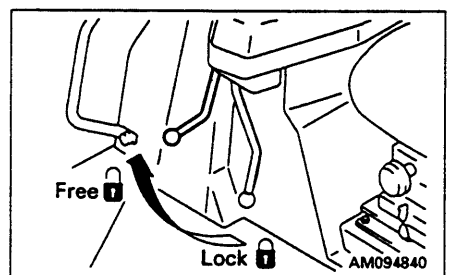

## 12. OPERATION

4. Put blade control lever ⑤ in the RAISE position to raise the blade 400 to 500 mm (15, 8 to 19.7 in) off the ground.

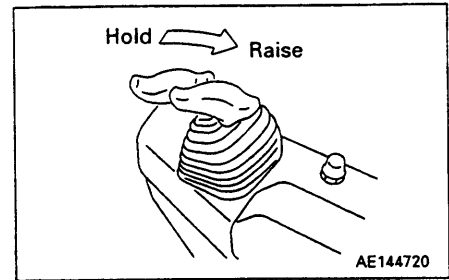

5. Move joystick ④ to the F (forward) or R (reverse) position to move the machine off.

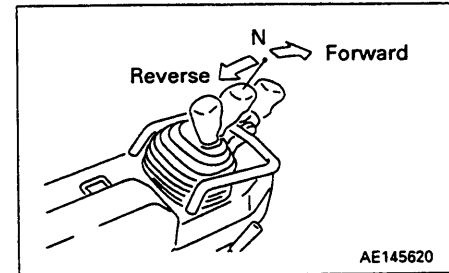

6. Pull fuel control lever ⑦ to increase engine speed.

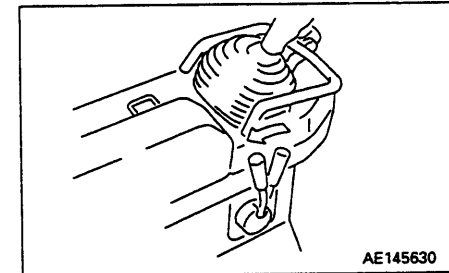

### 12.5 SHIFTING GEAR

There is no need to stop machine to shift gears.

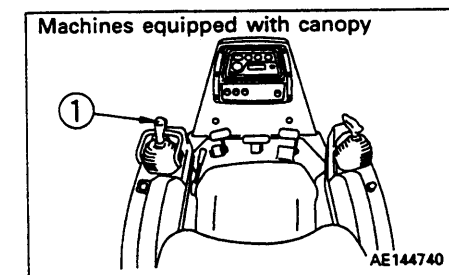
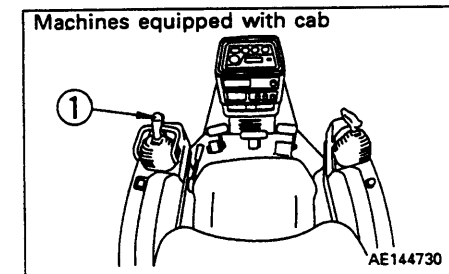

Turn the knob of joystick ① to select the desired speed range.

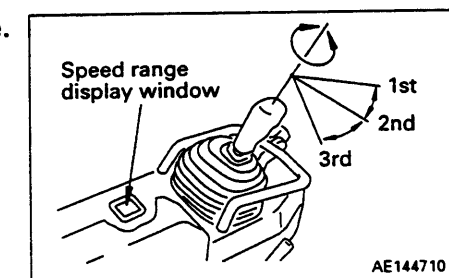

## 12.6 SHIFTING BETWEEN FORWARD AND REVERSE

### WARNING

When shifting between forward and reverse, for safety reasons and to reduce shock, stop the machine first, then change the direction of travel.

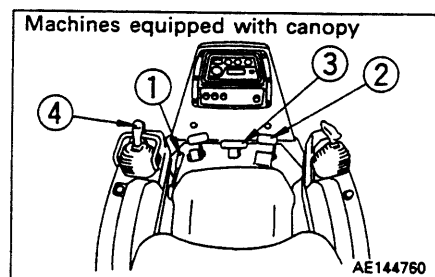
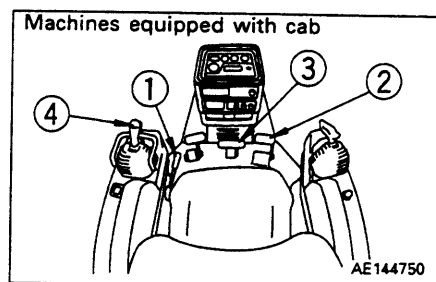

1. Set fuel control lever ① to the LOW IDLING position or depress decelerator pedal ② to reduce the engine speed.

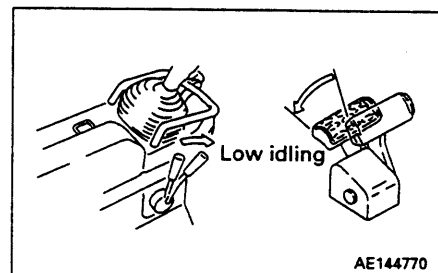

2. Depress brake pedal ③ to apply the brake.
3. Move joystick ④ to the N position, depress brake pedal ③ further, and stop the machine.

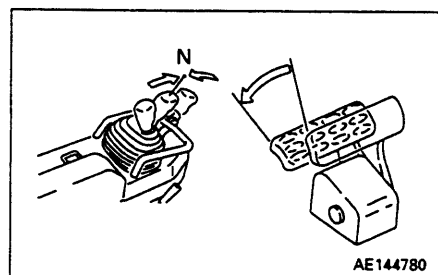

4. Shift joystick ④ to the desired position.

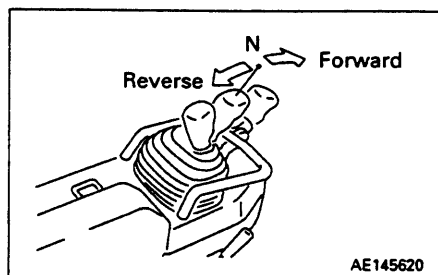

5. Pull fuel control lever ① or release decelerator pedal ② to raise the engine speed.

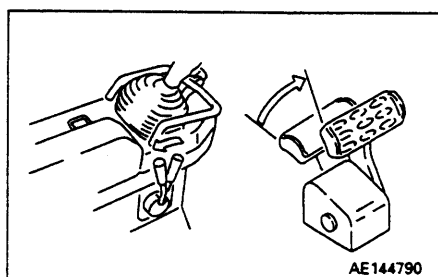

## 12.7 STEERING MACHINE

### ⚠ WARNING

- Avoid as much as possible turning the machine on a slope. The machine will tend to slip sideways. Particular care should be taken on soft or clay land.
- Never make a pivot turn at high speed.

### 12.7.1 NORMAL TURNING

To turn the machine while traveling, incline joystick ① in the direction to turn.

- Turning gradually to left while traveling forward  
If the joystick is pushed forward and moved partially to the left (L), the steering clutch is disengaged and the machine turns gradually to the left.

#### REMARK

When turning gradually to the right, push the joystick forward, and move it partially to the right.  
Do the same when traveling in reverse.

- Making sharp turns to left while traveling forward  
If the joystick is pushed forward and moved fully to the left (L), the steering clutch is disengaged, the brake is applied, and the machine turns sharply to the left.

#### REMARK

When making sharp turns to the right, push the joystick forward, and move it fully to the right.  
Do the same when traveling in reverse.

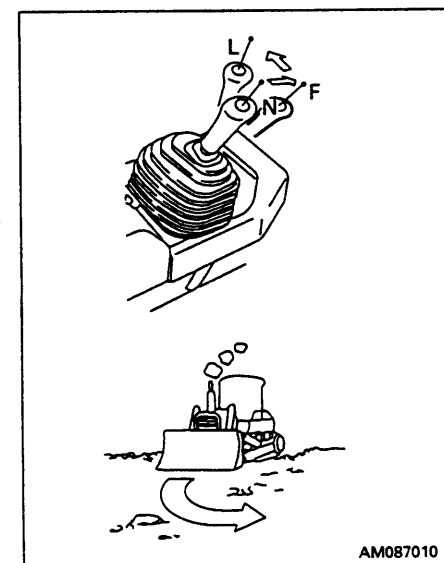
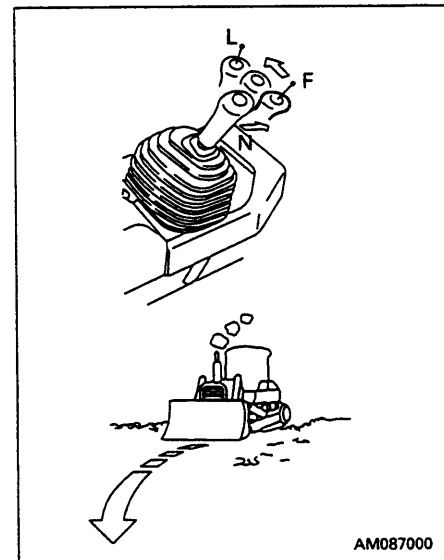
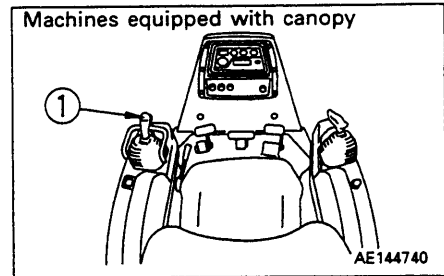
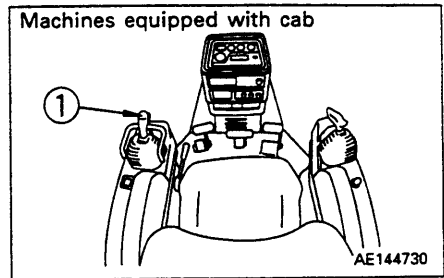



### 12.7.2 TURNING WHILE DESCENDING A SLOPE

On steep downhill slopes where the machine may travel under its own weight, or on downhill slopes where it is being pushed by a towed machine, the machine will steer in the opposite direction, so do as follows.

- Turning gradually to left while traveling forward  
If the joystick is pushed forward and moved partially to the right (R), the machine turns gradually to the left. (Becomes reverse steering)

#### REMARK

When turning gradually to the right, push the joystick forward, and move it partially to the left. (Becomes reverse steering)  
Do the same when traveling in reverse.

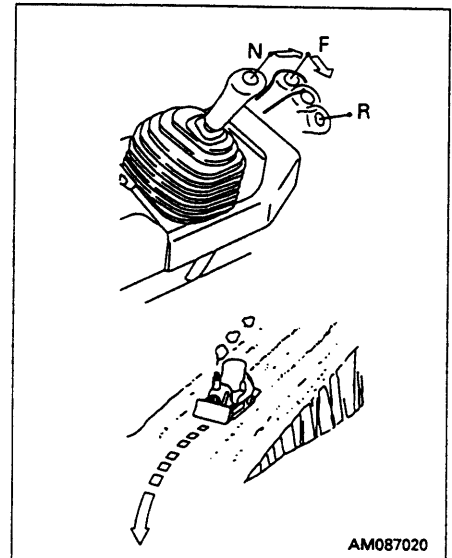

AM087020

- Making sharp turns to left while traveling forward  
If the joystick is pushed forward and moved fully to the left (L), the machine turns sharply to the left. (Does not become reverse steering)

#### REMARK

When making sharp turns to the right, push the joystick forward, and move it fully, to the right. (Does not become reverse steering)  
Do the same when traveling in reverse.

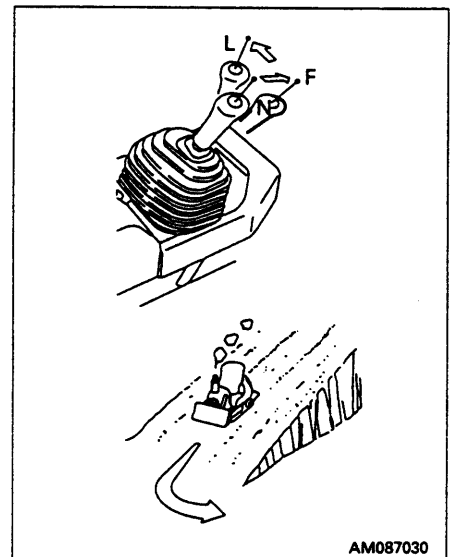

AM087030

## 12.8 STOPPING MACHINE

**⚠ WARNING**

- Avoid stopping suddenly. Give yourself ample room when stopping.
- When stopping the machine, select flat hard ground and avoid dangerous places. If it is unavoidably necessary to park the machine on a slope, place the parking brake lever in the LOCK position and insert blocks underneath the track shoes. As an additional safety measure, thrust the blade into the ground.
- If the work equipment control lever is touched by accident, the work equipment may move suddenly, and this may lead to a serious accident. Before leaving the operator's seat, always operate the safety lock lever to place it securely at the LOCK position.

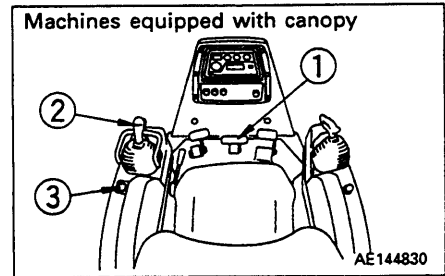
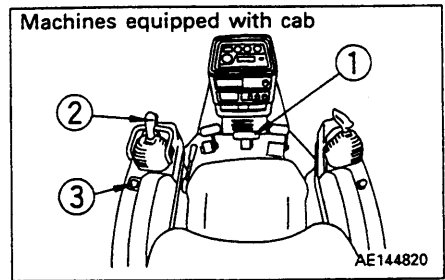

1. Depress brake pedal ① to stop the machine.

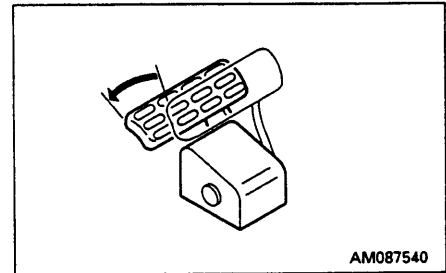

2. Place joystick ② in the N (neutral) position.

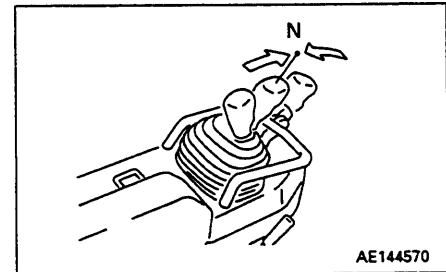

3. Operate joystick ② to 1st, and check that speed range display window ③ shows the correct position.

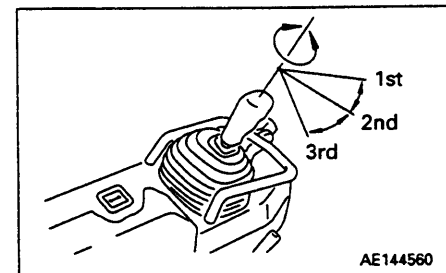

## 12.9 PRECAUTIONS FOR OPERATION

### 12.9.1 METHOD OF USING STEERING CLUTCH

If the steering clutch one side is used frequently or if many gradual turns are made with steering clutch half-engaged, the steering clutch will wear out in a short time. Design the travel road well and steer the machine properly.

### 12.9.2 PERMISSIBLE WATER DEPTH

When operating in water, always keep the bottom of carrier roller ① above the surface of the water.

Also, be careful that the engine cooling fan will not come in contact with water. The fan can be damaged.

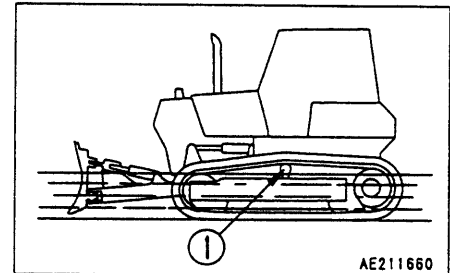

### 12.9.3 PRECAUTIONS WHEN TRAVELING UP OR DOWN HILLS

#### Use engine as a brake

When going downhill, shift gear shift lever into low speed to run engine at slow speed and travel down slope using the engine as a brake.

Never coast down slope with the steering and directional lever in the N (neutral) position.

#### REMARK

When using the inching pedal to reduce speed, the braking force of the engine cannot be used if the pedal is not fully depressed.

When traveling uphill or downhill, do not keep the inching pedal depressed continuously.

#### Braking when traveling downhill

While descending a slope using the engine as a brake, also apply the brakes.

Failure to brake may result in overrunning, causing engine trouble.

### 12.9.4 PRECAUTIONS ON SLOPES

#### Be careful of fuel level

If the fuel level in the fuel tank becomes low when working on slopes, the engine may suck in air because of the angle of the machine or the swaying of the machine. If this makes the engine stop, so be careful not to let the fuel level in the fuel tank become too low.

#### Precautions when engine stops on slopes

If the engine stops while working or traveling on a hill, depress the brake pedal to stop the machine, then move the parking brake lever to the LOCK position to apply the parking brake.

#### REMARK

- The engine cannot be started again if the parking brake lever is not at the LOCK position.
- The parking brake is applied when the parking brake lever is at the LOCK position.

### 12.9.5 IT IS PROHIBITED TO KEEP THE DOOR OPEN DURING OPERATIONS (MACHINES EQUIPPED WITH CAB)

Always keep the door closed when traveling or carrying out operations. If the door is left open, there is danger of damage from obstacles or strong vibration.

### 12.9.6 IT IS PROHIBITED TO MODIFY THE CAB GLASS IN ANY WAY THAT WILL OBSTRUCT THE VIEW (MACHINES EQUIPPED WITH CAB)

- For safety reasons, do not install anything to the cab glass that will obstruct the view.
- Always keep the glass clean to ensure safety during operations.

### 12.9.7 PRECAUTIONS FOR BLIND SPOTS CAUSED BY CAB STAY

**⚠ WARNING**

The cab stay cause blind spots.

When operating, always be sure to check carefully that there is no obstacle or worker in the surrounding area.

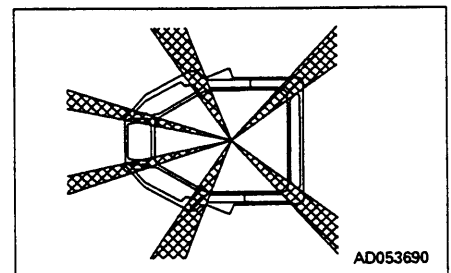

## 12.10 PARKING MACHINE

### WARNING

- Avoid stopping suddenly. Give yourself ample room when stopping.
- When stopping the machine, select flat hard ground and avoid dangerous places. If it is unavoidably necessary to park the machine on a slope, place the parking brake lever in the LOCK position and insert blocks underneath the track shoes. As an additional safety measure, thrust the blade into the ground.
- If the work equipment control lever is touched by accident, the work equipment may move suddenly, and this may lead to a serious accident. Before leaving the operator's seat, always operate the safety lock lever to place it securely at the LOCK position.

### NOTICE

The safety lock lever cannot be set to the LOCK position to lock the blade control lever if the control lever is at the FLOAT position. Always return the blade control lever to the HOLD position, then set the safety lock lever to the LOCK position.

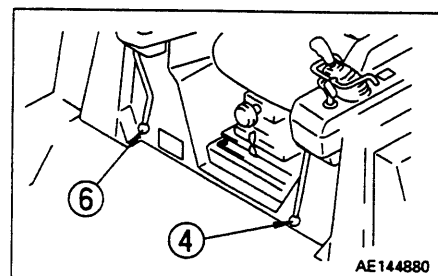
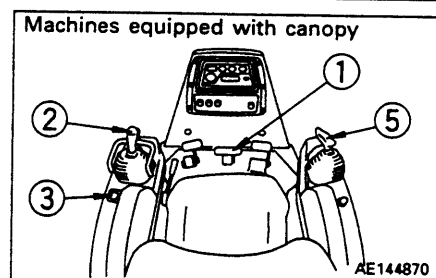
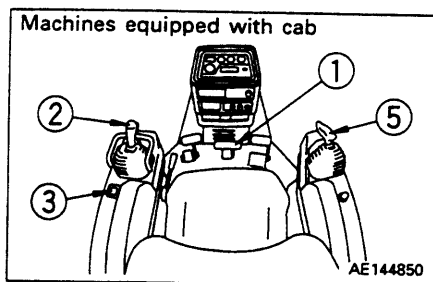

1. Depress brake pedal ① to stop the machine.

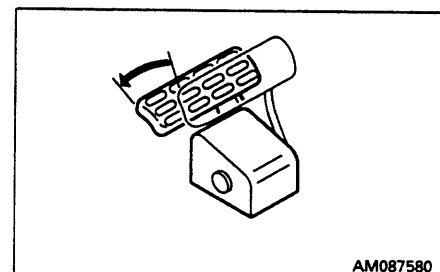

2. Place joystick ② in NEUTRAL position.

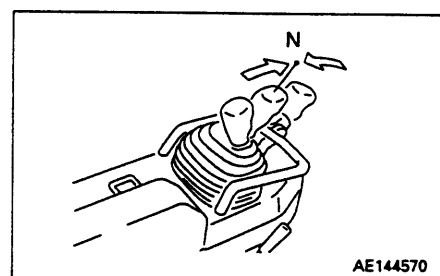

3. Operate joystick ② to 1st, and check that speed range display window ③ shows the correct position.

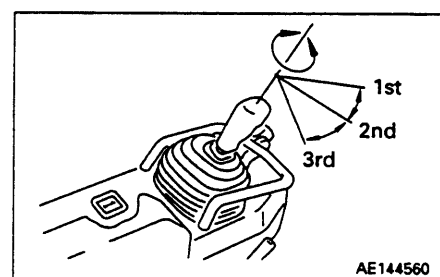

## 12. OPERATION

4. Operate parking brake lever ④ to lock the brakes.

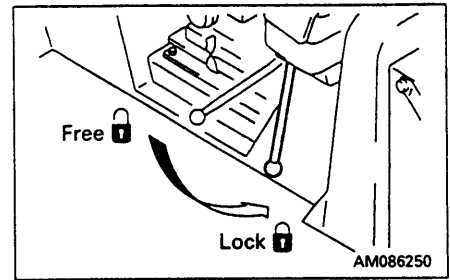

5. Operate blade control lever ⑤ to the LOWER position, and lower the blade to the ground.

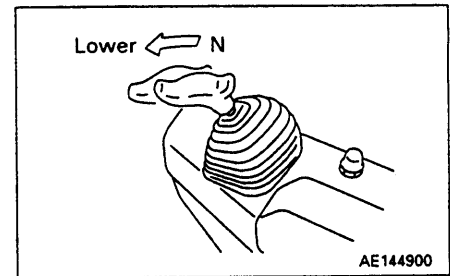

6. Lock blade control lever ⑤ with safety lock lever ⑥.

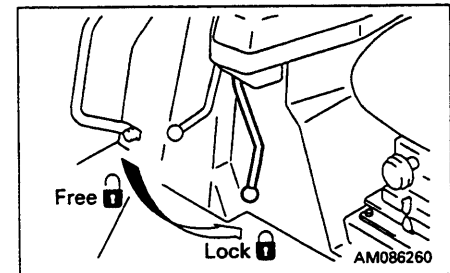

### 12.11 CHECK AFTER FINISHING WORK

1. Use the meters and caution lamps to check the engine water temperature, engine oil pressure, fuel level, and transmission oil temperature.

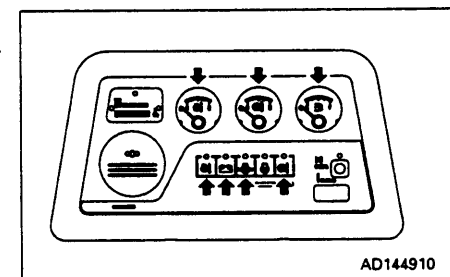

## 12.12 STOPPING ENGINE

### NOTICE

If the engine is abruptly stopped before it has cooled down, engine life may be greatly shortened. Consequently, do not abruptly stop the engine apart from an emergency.

In particular, if the engine has overheated, do not abruptly stop it but run it at medium speed to allow it to cool gradually, then stop it.

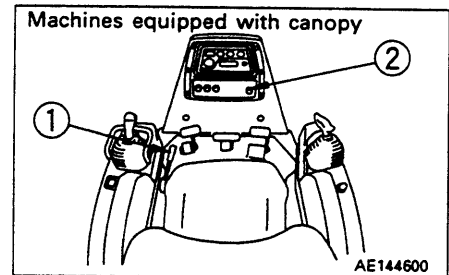
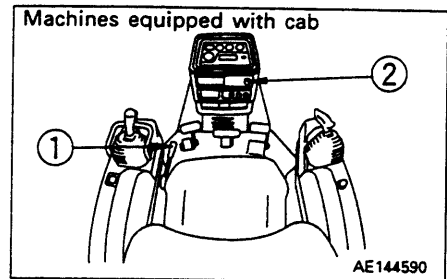

1. Place fuel control lever ① in the low idling position and run the engine at low idling speed for about 5 minutes to allow it to gradually cool down.

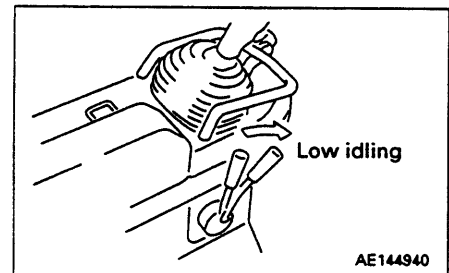

2. Turn the key in starting switch ② to the OFF position and stop the engine.

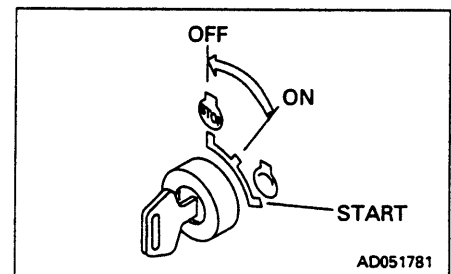

3. Remove the key from starting switch ②.

### 12.13 CHECK AFTER STOPPING ENGINE

1. Walk around the machine and check the work equipment, paint-work, and undercarriage, and check also for leakage of oil or water. If any abnormalities are found, repair them.
2. Fill the fuel tank.
3. Check the engine compartment for paper and debris. Clean out any paper and debris to avoid a fire hazard.
4. Remove any mud stuck to the undercarriage.

### 12.14 LOCKING

To prevent vandalism, there are locks at the following places.  
Places that can be locked with the starting switch key.

- Top cover at front of chassis ①
- Right and left engine side cover ②
- Battery inspection cover ③
- Hydraulic oil tank front cover ④
- Inspection cover for fuel tank drain valve ⑤
- Cab door opener ⑥ (machines equipped with cab)
- Cap with lock ⑦

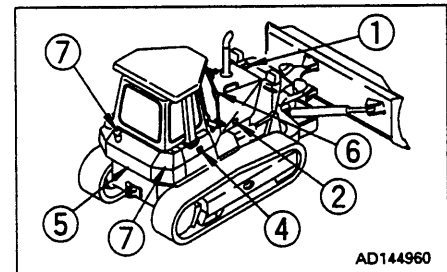
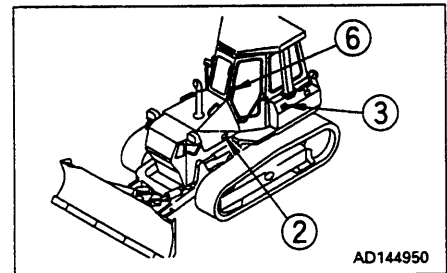



## 12.15 WORK POSSIBLE USING BULLDOZER

In addition to the following, it is possible to further increase the range of applications by using various attachments.

### 12.15.1 DOZING

A bulldozer digs and transports dirt in a forward direction.

Slope excavation can always be most effectively carried out by proceeding from the top downward.

When dozing toward one side only, operate with angled blade.

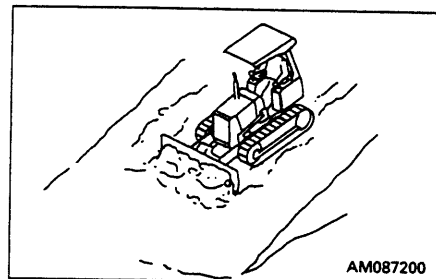

AM087200

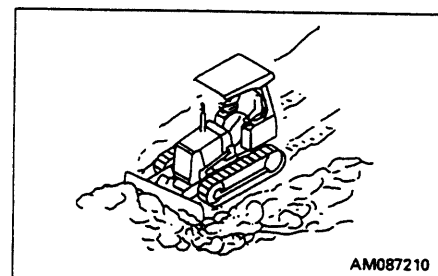

AM087210

### REMARK

To reduce the width when the machine is transported, it is equipped with a large angle mechanism. When carrying out angling operations, be careful of the following points.

- With this machine, when the blade is angled to the left, it can be angled to 55°, so the blade can be stored within an overall width of 2.5 m. In this condition, the left tip of the blade may contact the left tip (idler portion) of the left track.
- When using the angling for operations, an angle of 25° is normally enough, so carry out operations within this range. If angling operations are carried out to a greater angle than this, be extremely careful to maintain a clearance between the blade and the track.
- The normal angle of angling to the right is 25°. At this angle, the blade will not contact the track.

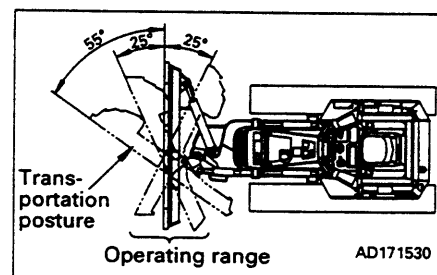

AD171530

### 12.15.2 SMOOTHING

#### NOTICE

Avoid smoothing on rocky or stony ground. It can damage the blade.

Uneven ground surfaces remaining after digging can be levelled off by fine operation of blade. The basic method is to operate the machine at low speeds with the blade fully loaded with soil and sand. A flat finished surface is also possible by slowly backing the machine with the blade "floating" so it is dragged across the surface. However, avoid this on rocky or stony ground, as it may damage the blade.

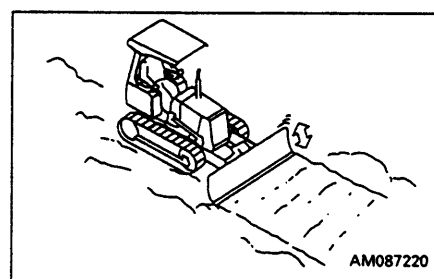

AM087220

### 12.15.3 CUTTING INTO HARD OR FROZEN GROUND OR DITCHING

For digging and ditch excavation of hard or frozen ground, tilt the blade. Even hard ground can be dug effectively by a tilted or angled blade.

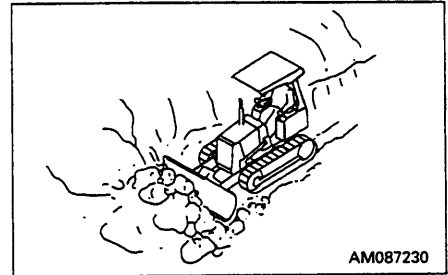

### 12.15.4 FELLING TREES, REMOVING STUMPS

**NOTICE**  
Do not up root trees or stumps or fell trees by angling or tilting the blade.

For trees with a diameter of 10 – 30 cm (3.9 – 11.8 in), raise the blade high and push 2 or 3 times to fell the tree. Next, travel in reverse, and dig the corner of the blade into the ground to cut and dig up the roots.

When doing this, never hit the tree at high speed or apply shock to fell the tree.

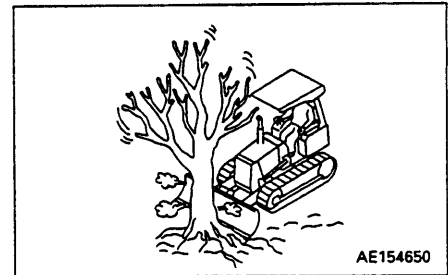

## 12.16 TIPS FOR LONGER UNDERCARRIAGE LIFE

Undercarriage life greatly varies depending on operation method, inspection and maintenance. For most efficient operation, keep the following point in mind.

### 12.16.1 OPERATION METHOD

- Select the track shoe that best suits the type of soil to be encountered in service.

Please consult your Komatsu distributor when selecting track shoes.

- Do not allow shoe slipping to occur during operation. If shoe slipping occurs, reduce load to the blade until slipping stops.
- Avoid sudden starts, acceleration or stops, unnecessarily high speeds and sharp turns.
- Always operate machine in a straight line whenever possible. When making turns, be careful not to allow the machine to stay to one side, so operation in both turning directions can be done properly. Make turns with the largest possible radius.
- Prior to operation, clear boulders and obstacles to prevent machine from riding over them while operating.
- On a slope, operate the machine parallel to the inclination of the slope. Do not operate across the slope. Also when stopping the machine on a slope, the machine should face toward the top of the slope.

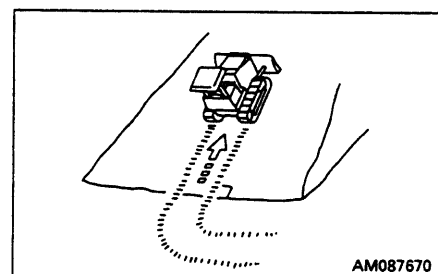

- When ground inclines to left or right during digging operation, do not continue to dig with machine inclined. Move machine back to level ground and start to dig again.
- Do not force the machine to carry out work that exceeds its working capability. Such work includes cases where the idler or sprocket come off the ground when the machine meets obstacles that resist the power of the machine during dozing or ripping operations.

**12.16.2 INSPECTION AND ADJUSTMENT**

- Properly adjust track tension.  
Tension should be measured at clearance **A** shown in the diagram – usually 20 to 30 mm (0.8 to 1.2 in) at this point. For rocky terrain, tighten tracks slightly. In clay or sandy areas, slightly loosen them. (For inspection and adjustment procedures, refer to “24.1 WHEN REQUIRED”).
- Check idler rollers for oil leakage as well as for loose bolts and nuts. If any trouble is detected, repair immediately.

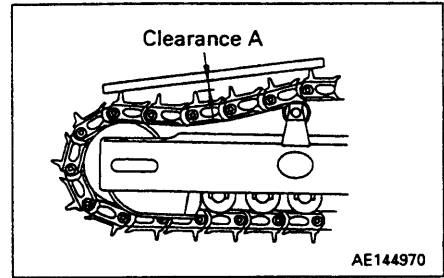

**12.16.3 INSPECTION AND REPAIR**

Frequent inspection and prompt repair will reduce repair costs. The following items for inspection will serve as a guide to maintenance service of each undercarriage part. Perform periodical inspection and contact the Komatsu distributor in your area when machine has approached repairable limits and reversing limits.

**MEASURING LINK PITCH**

1. Insert a wooden block between track shoe and sprocket to take up the slack in track shoes.
2. Measure pitch length of 4 links in stretched portion at more than 2 links away from master pin. Of length obtained, 1/4 is the link pitch.

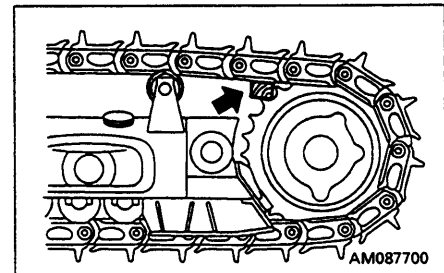

Basic link pitch (P): 171.5 mm (6.8 in)  
Link pitch limit for turning: 174.5 mm (6.9 in)

**REMARK**

There is no link window on the master link.

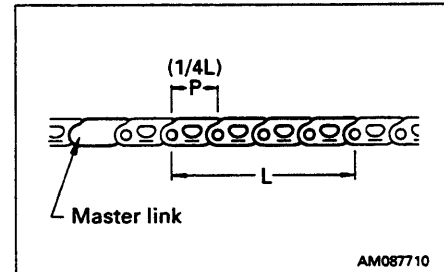

**MEASURING HEIGHT OF GROUSER (D41E)**

After taking up slack in track shoes, measure height at center of shoe as shown below.

Standard height (h): 53 mm (2.1 in)  
Repair limits: 25 mm (1 in)

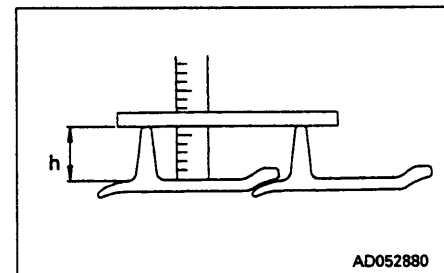

**MEASURING OUTSIDE DIAMETER OF TRACK ROLLER**

1. Measure height (size C) of link tread as shown.
2. Stop machine at position where link tread, whose size C has been measured completely, contacts roller tread. Then measure size B.
3. Calculate outside diameter of tread (size A):  
$$A = (B - C) \times 2$$

Standard size (A): 175 mm (6.9 in)  
Service limit: 150 mm (5.9 in)

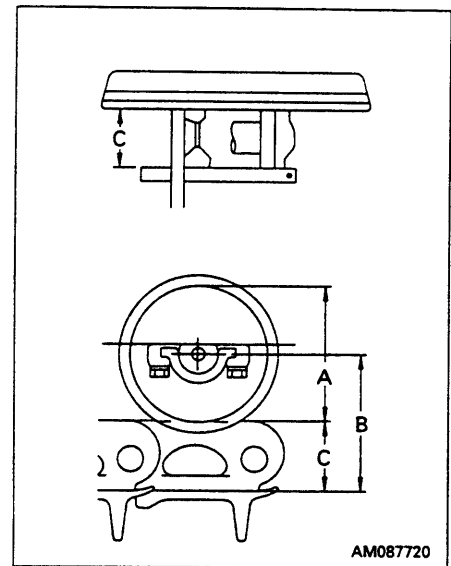

## 13. TRANSPORTATION

When transporting the machine, observe all related laws and regulations, and be careful to assure safety.

### 13.1 LOADING, UNLOADING WORK

#### ⚠ WARNING

- Make sure the ramp has sufficient width, length and thickness to enable the machine to be safely loaded and unloaded. If the ramp sags appreciably, reinforce it with blocks, etc.
- When loading and unloading the machine, park the trailer on a flat firm roadbed. Keep a fairly long distance between the road shoulder and the machine.
- Remove the mud from the undercarriage to prevent the machine from slipping to the side on slopes. Be sure the ramp surface is clean and free of grease, oil, ice and loose materials.
- Never change the direction of travel when on the ramps. If it is necessary to change direction, drive off the ramps and correct the direction, then drive on to the ramps again.

When loading or unloading, always use ramps or a platform and carry out the operations as follows.

1. Properly apply the brakes on the trailer and insert blocks beneath the tires to ensure that it does not move. Then fix the ramps in line with the centers of the trailer and the machine.
2. Determine the direction of the ramps, then slowly load or unload the machine.
3. When the machine is on ramps, stop it and check the parking brake.
  - (1) With the engine running, press brake pedal ② and set joystick ③ to neutral to stop the machine.
  - (2) Set parking brake lever ① to the LOCK position.
  - (3) Release brake pedal ②. If the machine does not move, the parking brake is working normally.
  - (4) If the machine moves, press brake pedal ②.
  - (5) Move the machine to a flat place and ask your Komatsu distributor to repair the brake.
4. Load the machine correctly in the specified position on the trailer.
5. Use the 1st speed range and run the engine at low idling. When moving only very small distances, use the inching pedal. When traveling on ramps or slopes, the brake has effect even when the inching pedal is being used, but always depress the brake with your right foot, and be careful not to let the machine fall.

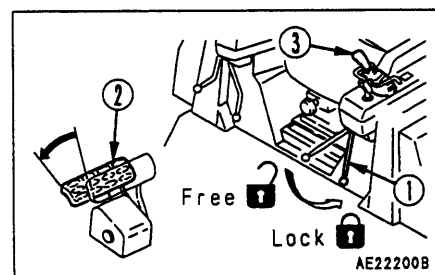
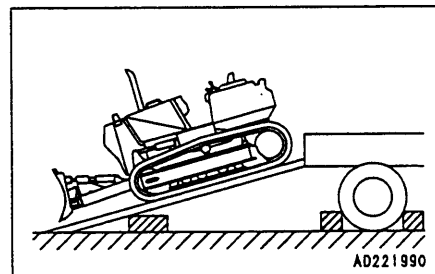
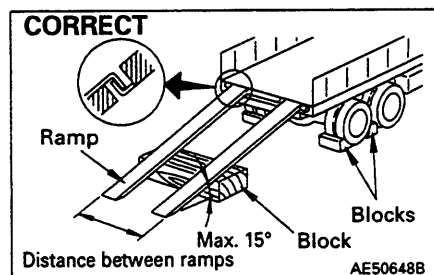

## 13.2 PRECAUTIONS FOR LOADING

 **WARNING**

**When the edge of the blade protrudes beyond the trailer, angle the blade.**

After loading to the specified position, secure the machine as follows.

1. LOWER the blade slowly.
2. Lock the blade control levers securely with the safety lock lever.
3. Set the parking brake lever to the LOCK position.
4. Set the fuel control lever to the ENGINE STOP position, then turn the starting switch to the OFF position to stop the engine, and remove the key.
5. When transporting the machine, place rectangular timber underneath the front and rear track shoes to prevent the machine from moving about. Also, hold it down with chains or rope. Be particularly careful to ensure that the machine does not slip sideways.

### 13.3 PRECAUTIONS FOR TRANSPORTATION

**⚠ WARNING**

Determine the route for transporting the machine by taking into account the width, height and weight of the machine.

Obey all state and local laws governing the weight, width and length of a load. Observe all regulations governing wide loads.

**REMARK**

- This machine is equipped with a large angle mechanism to prevent the blade from protruding during transportation. When transporting the machine on a trailer, angle the blade fully to the left. This makes it possible to keep the overall width within 2.5 m (8.2 ft).

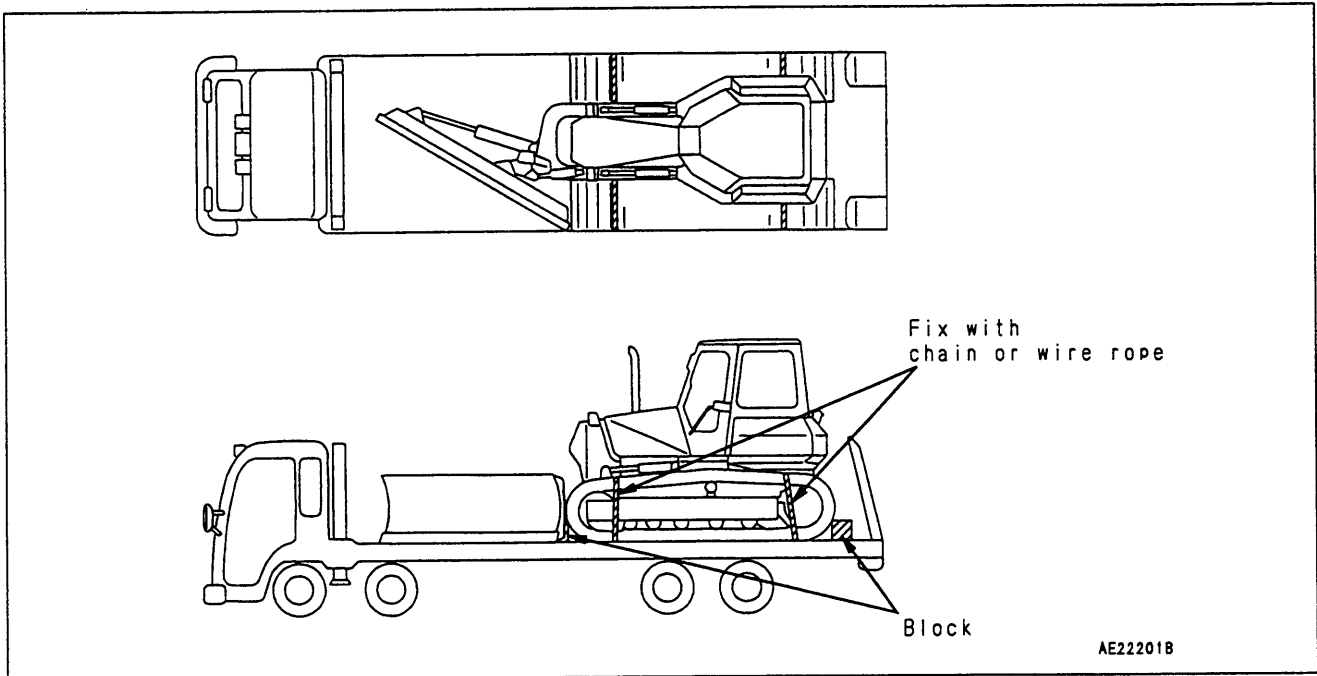

- When angling the blade fully to the left, the left tip of the blade may contact the left tip of the left track. Check the clearance carefully and do not move the machine if the blade is in contact with the track. If the blade is tilted when it is at the maximum angle, the clearance will become smaller, so do not operate the tilt at the maximum angle.



- **Precautions when wide blade is installed**

When a wide blade is installed, even when the blade is angled to the maximum, the width of the machine for transportation cannot be reduced to less than 2.5 m (8.2 ft).

Always remove the blade before transporting the machine.

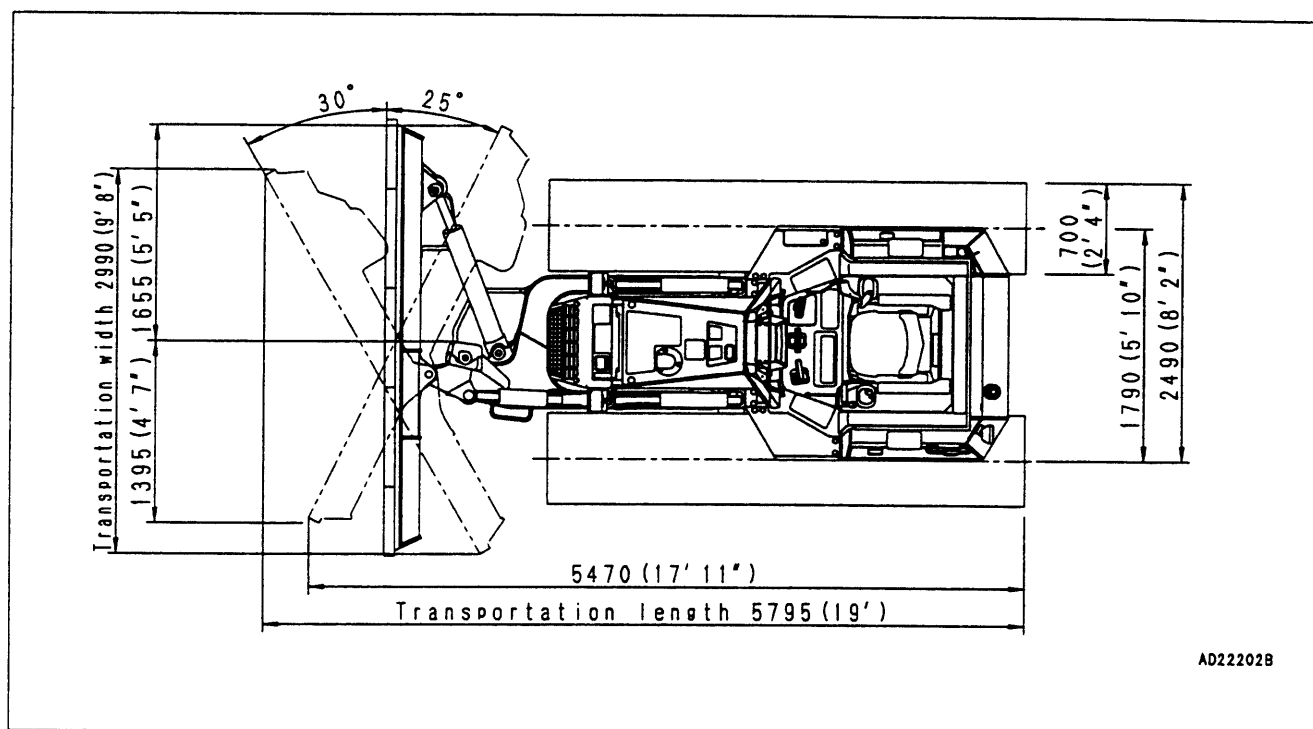

### 13.4 REMOVING CAB (MACHINES EQUIPPED WITH CAB)

If it is necessary to remove the cab for transportation, there is danger that the seal may be damaged when removing or installing the cab, so please contact your Komatsu distributor.

### 13.5 LIFTING MACHINE

**⚠ WARNING**

- Do not lift the machine with any worker on it.
- Use wire ropes having sufficient strength for the weight of this machine.
- Lift the machine in only the position shown below. If it is lifted in another position, it may be unbalanced.
- Lift the machine horizontally.

**NOTICE**

The lifting procedure applies to machines with standard specifications.

The method of lifting differs according to the attachments and options actually installed. In such cases, please contact your Komatsu distributor for information.

For details of the weight, see "25. SPECIFICATIONS".

#### PROCEDURE FOR LIFTING OPERATIONS

When lifting the machine, stop it on a level place, then observe the following procedure.

1. Stop the engine and set the parking lever to the LOCK position.
2. Use wire rope, slings, and other lifting equipment that match the weight of the machine and wind the wire rope under the under-cover and steering case at the lifting positions.

**NOTICE**

- To prevent damage to the wire rope, fit protectors at sharp corners or places where the wire rope may be caught.
  - Use sleds and bars of ample width so that they do not contact the machine.
3. Before lifting the machine, set the equipment in position, raise 100 – 200 mm from the ground, check that the wire rope is not loose and that the machine is horizontal, then raise the machine.

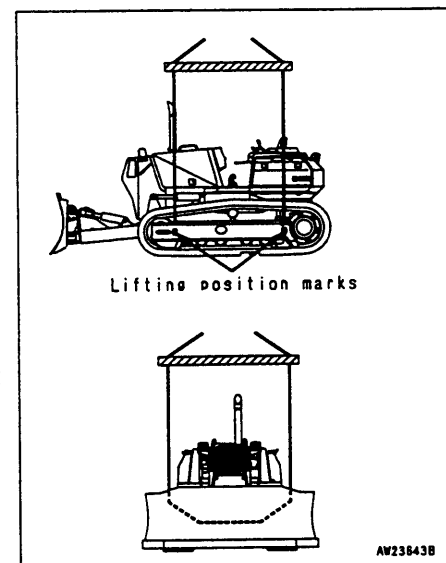
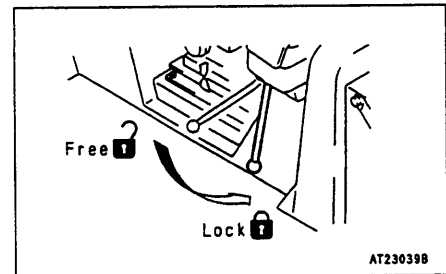

# 14. COLD WEATHER OPERATION

---

## 14.1 PRECAUTIONS FOR LOW TEMPERATURE

If the temperature becomes low, it becomes difficult to start the engine, and the coolant may freeze, so do as follows.

### 14.1.1 FUEL AND LUBRICANTS

Change to fuel and oil with low viscosity for all components.

For details of the specified viscosity, see "20. USE OF FUEL, COOLANT AND LUBRICANTS ACCORDING TO AMBIENT TEMPERATURE".

### 14.1.2 COOLANT

 **WARNING**

**Keep antifreeze fluid away from an open flame. Never smoke when using antifreeze.**

#### NOTICE

**Never use methanol, ethanol or propanol based antifreeze.**

Where no permanent antifreeze is available, an ethylene glycol antifreeze without corrosion inhibitor may be used only for the cold season. In this case, clean the cooling system twice a year (in spring and autumn). When refilling the cooling system, add antifreeze in autumn, but do not add any in spring.

Absolutely avoid using any water leak preventing agent irrespective of whether it is used independently or mixed with an antifreeze.

Do not mix one antifreeze with a different brand.

For details of the antifreeze mixture when changing the coolant, see "24.1 WHEN REQUIRED".

Use a Permanent Antifreeze (ethylene glycol mixed with corrosion inhibitor, antifoam agent, etc.) meeting the standard requirements as shown below. With permanent antifreeze, no change of coolant is required for a year. If it is doubtful that an available antifreeze meets the standard requirements, ask the supplier of that antifreeze for information.

Standard requirements for permanent antifreeze.

- SAE ..... J1034
- FEDERAL STANDARD ..... O-A-548D

**14.1.3 BATTERY**

**⚠ WARNING**

- To avoid gas explosions, do not bring fire or sparks near the battery.
- Battery electrolyte is dangerous. If it gets in your eyes or on your skin, wash it off with large amounts of water, and consult a doctor.

When the ambient temperature drops, the capacity of the battery will also drop. If the battery charge ratio is low, the battery electrolyte may freeze. Maintain the battery charge as close as possible to 100%, and insulate it against cold temperature so that the machine can be started easily the next morning.

Measure the specific gravity and calculate the rate of charge from the following conversion table.

Temp. of fluid Rate of charge	20°C	0°C	-10°C	-20°C
100%	1.28	1.29	1.30	1.31
90%	1.26	1.27	1.28	1.29
80%	1.24	1.25	1.26	1.27
75%	1.23	1.24	1.25	1.26

## 14.2 AFTER COMPLETION OF WORK

To prevent mud, water, or the undercarriage from freezing and making it impossible for the machine to move on the following morning, always observe the following precautions.

- Mud and water on the machine body should be completely removed. This is to prevent damage to the seal caused by mud or dirt getting inside the seal with frozen drops of water.
- Park the machine on concrete or hard ground. If this is impossible, park the machine on wooden boards.
- Open the drain valve and drain any water collected in the fuel system to prevent it from freezing.
- As the battery capacity drops markedly in low temperatures, cover the battery or remove it from the machine, keep it in a warm place, and install it again the next morning.

## 14.3 AFTER COLD WEATHER

When season changes and the weather becomes warmer, do as follows.

- Replace the fuel and oil for all parts with oil of the viscosity specified.  
For details, see "20. USE OF FUEL, COOLANT AND LUBRICANTS ACCORDING TO AMBIENT TEMPERATURE".
- If for any reason permanent antifreeze cannot be used, and an ethyl glycol base antifreeze (winter, one season type) is used instead, or if no antifreeze is used, drain the cooling system completely, then clean out the inside of the cooling system thoroughly, and fill with fresh water.

# 15. LONG-TERM STORAGE

---

## 15.1 BEFORE STORAGE

When putting the machine in storage for more than one month, do as follows.

- After every part is washed and dried, the machine shall be housed in a dry building. Never leave it outdoors.  
In case it is indispensable to leave it outdoors, park the machine on the flat ground and cover it with canvas etc.
- Completely fill the fuel tank, lubricate and change the oil before storage.
- Apply a thin coat of grease to metal surface of the hydraulic piston rods and the idler adjusting rods.
- Disconnect the negative terminals of the battery and cover it, or remove it from the machine and store it separately.
- If the ambient temperature is expected to drop below 0°C, always add antifreeze to the cooling water.
- Place all control levers at the neutral position, operate the safety lock lever and parking brake lever to the LOCK position, then move the fuel control lever to the low idling position.

## 15.2 DURING STORAGE

**⚠ WARNING**

**If it is unavoidably necessary to carry out the rustpreventive operation while the machine is indoors, open the doors and windows to improve ventilation and prevent gas poisoning.**

- Operate the engine and move the machine for a short distance once a month so that a new film of oil will be coated over movable parts and component surfaces. At the same time, also charge the battery.
- Before operating the work equipment, wipe off the grease on the hydraulic piston rod.

## 15.3 AFTER STORAGE

### NOTICE

**If the machine is stored without carrying out the monthly rust prevention operation, request your Komatsu distributor for service.**

Carry out the following procedure when taking the machine out of long-term storage.

- Wipe off the grease from the hydraulic cylinder rods.
- Add oil and grease to all places.

## 16. TROUBLESHOOTING

### 16.1 AFTER RUNNING OUT OF FUEL

When starting after running out of fuel, fill with fuel and bleed the air from the fuel system before starting.

For details of bleeding the air, see "24.5 EVERY 500 HOURS SERVICE"

### 16.2 TOWING MACHINE

#### ⚠ WARNING

- Be sure to use a wire rope sufficiently strong for the towing weight.
- When using the towing hook, be sure to use a shackle.
- Set the wire rope horizontally and align it with the track frame.
- Tow the machine slowly.

If the machine gets stuck in the mud or a heavy thing needs to be towed, install a towing wire rope to the draw bar pin.

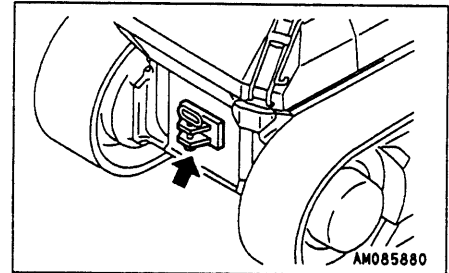

### 16.3 IF BATTERY IS DISCHARGED

#### ⚠ WARNING

- When checking or handling the battery, stop the engine and turn the starting key to the OFF position before starting.
- The battery generates hydrogen gas, so there is danger of explosion. Do not bring lighted cigarettes near the battery, or do anything that will cause sparks.
- Battery electrolyte is dilute sulphuric acid, and it will attack your clothes and skin. If it gets on your clothes or on your skin, wash it immediately off with large amounts of water. If it gets in your eyes, wash it out with fresh water, and consult a doctor.
- When removing the battery, first disconnect the cable from the ground (normally, from the negative  $\ominus$  terminal). When installing, install the positive  $\oplus$  terminal first. If a tool touches the cable connecting the positive terminal and the chassis, there is danger that it will cause sparks.
- If the terminals are loose, there is danger that the defective contact may generate sparks that will cause an explosion. When installing the terminals, install them tightly.

#### 16.3.1 STARTING ENGINE WITH BOOSTER CABLE

When starting the engine with a booster cable, do as follows:

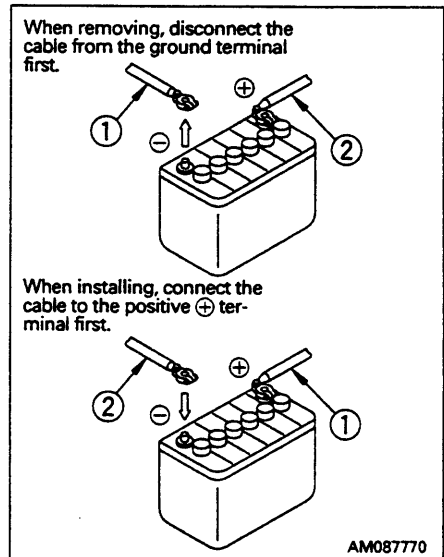

### REMOVAL, INSTALLATION OF BATTERY

1. Open battery cover ①, remove 4 bolts ② on the inside, then remove cover ①.
2. Before removing the battery, remove the ground cable (normally connected to the negative  $\ominus$  terminal). If any tool touches between the positive terminal and the chassis, there is danger of sparks being generated. Loosen the nut of the terminal and remove the wires from the battery.
3. When installing the battery, connect the ground cable last. Insert the hole of the terminal on the battery and tighten the nut. Tightening torque:
  - ③ Mounting bolt for battery holder bracket  
59 – 74 Nm (6.0 – 7.5 kgm, 43.4 – 54.2 lbft)
  - ④ Battery terminal nut  
5.9 – 9.8 Nm (0.6 – 1.0 kgm, 4.3 – 7.2 lbft)
4. Install battery cover ①.

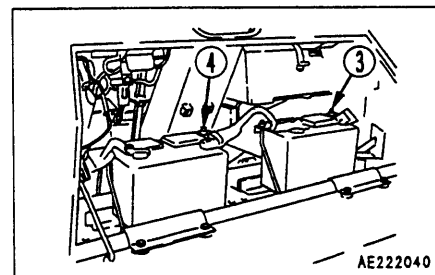
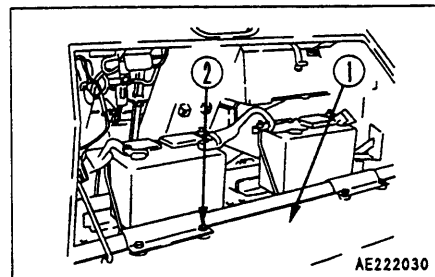

### PRECAUTIONS WHEN CONNECTING AND DISCONNECTING BOOSTER CABLE

#### ⚠ WARNING

- When starting the engine from another machine, connect the batteries in parallel.
- When connecting the cables, never contact the positive  $\oplus$  and negative  $\ominus$  terminals.
- When starting the engine with a booster cable, always wear safety glasses.
- Be careful not to let the normal machine and problem machine contact each other. This prevents sparks from generating near the battery which could ignite the hydrogen gas given off by the battery. If hydrogen gas explodes. It could cause serious injury.
- Make sure that there is no mistake in the booster cable connections. The final connection is to the engine block of the problem machine, but sparks will be generated when this is done, so connect to a place as far as possible from the battery.
- Use care when removing the cables from the machine that has been started. Do not allow the cable ends to contact each other or the machine, to avoid hydrogen explosion.

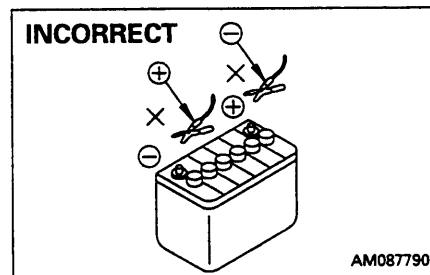

#### NOTICE

- The size of the booster cable and clip should be suitable for the battery size.
- The battery of the normal machine must be the same capacity as that of the engine to be started.
- Check the cables and clips for damage or corrosion.
- Make sure that the cables and clips are firmly connected.



**CONNECTING THE BOOSTER CABLES**

Keep the starting switch at the OFF position.

Connect the booster cable as follows, in the order of the numbers marked in the diagram.

1. Make sure that the starting switches of the normal machine and problem machine are both at the OFF position.
2. Connect one clip of booster cable (A) to the positive  $\oplus$  terminal of the problem machine.
3. Connect the other clip of booster cable (A) to the positive  $\oplus$  terminal of the normal machine.
4. Connect one clip of booster cable (B) to the negative  $\ominus$  terminal of the normal machine.
5. Connect the other clip of booster cable (B) to the engine block of the problem machine.

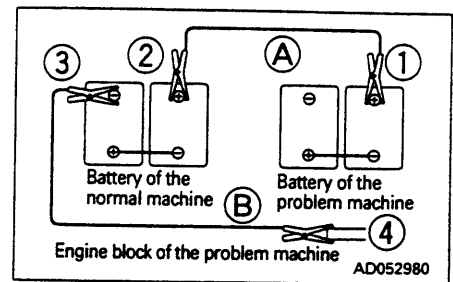
**STARTING THE ENGINE**

1. Make sure the clips are firmly connected to the battery terminals.
2. Start the engine of the normal machine and keep it to run at high idling speed.
3. Turn the starting switch of the problem machine to the START position and start the engine. Refer to "12.2 STARTING ENGINE".

**DISCONNECTING THE BOOSTER CABLES**

After the engine has started, disconnect the booster cables in the reverse of the order in which they were connected.

1. Remove one clip of booster cable (B) from the engine block of the problem machine.
2. Remove the other clip of booster cable (B) from the negative  $\ominus$  terminal of the normal machine.
3. Remove one clip of booster cable (A) from the positive  $\oplus$  terminal of the normal machine.
4. Remove the other clip of booster cable (A) from the positive  $\oplus$  terminal of the problem machine.

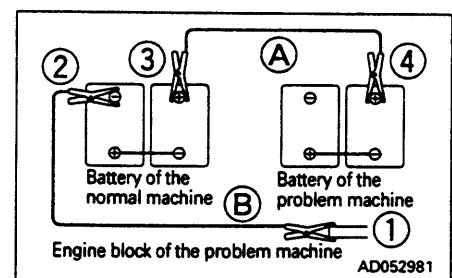

## 16.4 OTHER TROUBLE

- ( ): Always contact your Komatsu distributor when dealing with these items.
- In cases of abnormalities or causes which are not listed below, please contact your Komatsu distributor for repairs.

### 16.4.1 ELECTRICAL SYSTEM

Problem	Main causes	Remedy
Lamp does not glow brightly even when the engine runs at high speed	<ul style="list-style-type: none"> <li>● Defective wiring</li> <li>● Defective adjustment of fan belt tension</li> </ul>	<ul style="list-style-type: none"> <li>● Check, repair loose terminals, disconnections</li> <li>● Check fan belt tension For details, see EVERY 1000 HOURS SERVICE</li> </ul>
Lamp flickers while engine is running		
Charge lamp does not go out even when engine is running	<ul style="list-style-type: none"> <li>● Defective alternator</li> <li>● Defective wiring</li> </ul>	<ul style="list-style-type: none"> <li>● Replace</li> <li>● Check, repair</li> </ul>
Abnormal noise is generated from alternator	<ul style="list-style-type: none"> <li>● Defective alternator</li> </ul>	<ul style="list-style-type: none"> <li>● Replace</li> </ul>
Starting motor does not turn when starting switch is turned to ON	<ul style="list-style-type: none"> <li>● Defective wiring</li> <li>● Insufficient battery charge</li> <li>● Safety switch out of adjust</li> </ul>	<ul style="list-style-type: none"> <li>● Check, repair</li> <li>● Charge</li> <li>● Adjust safety switch</li> </ul>
Pinion of starting motor keeps going in and out	<ul style="list-style-type: none"> <li>● Insufficient battery charge</li> </ul>	<ul style="list-style-type: none"> <li>● Charge</li> </ul>
Starting motor turns engine sluggishly	<ul style="list-style-type: none"> <li>● Insufficient battery charge</li> <li>● Defective starting motor</li> </ul>	<ul style="list-style-type: none"> <li>● Charge</li> <li>● Replace</li> </ul>
Starting motor disengages before engine starts	<ul style="list-style-type: none"> <li>● Defective wiring</li> <li>● Insufficient battery charge</li> </ul>	<ul style="list-style-type: none"> <li>● (Check, repair)</li> <li>● Charge</li> </ul>
Automatic preheating is not actuated	<ul style="list-style-type: none"> <li>● Defective wiring</li> <li>● Defective glow heater</li> <li>● Defective timer</li> </ul>	<ul style="list-style-type: none"> <li>● Check, repair</li> <li>● Replace</li> <li>● Replace</li> </ul>
Glow signal lamp does not go out	<ul style="list-style-type: none"> <li>● Defective wiring</li> <li>● Defective heater relay</li> </ul>	<ul style="list-style-type: none"> <li>● Check, repair</li> <li>● Replace</li> </ul>
Oil pressure caution lamp does not light up when engine is stopped (starting switch at ON position)	<ul style="list-style-type: none"> <li>● Defective caution lamp</li> <li>● Defective caution lamp switch</li> <li>● Defective wiring</li> </ul>	<ul style="list-style-type: none"> <li>● Replace</li> <li>● Replace</li> <li>● Check, repair</li> </ul>
Charge lamp does not light up when engine is stopped (starting switch at ON position)	<ul style="list-style-type: none"> <li>● Defective charge lamp</li> <li>● Defective wiring</li> </ul>	<ul style="list-style-type: none"> <li>● Replace</li> <li>● Check, repair</li> </ul>
Outside of electrical intake air heater is not warm when touched by hand	<ul style="list-style-type: none"> <li>● Defective wiring</li> <li>● Disconnection in electrical intake air heater</li> <li>● Defective operation of heater relay switch</li> </ul>	<ul style="list-style-type: none"> <li>● Check, repair</li> <li>● Replace</li> <li>● Check, repair heater relay switch</li> </ul>
Air conditioner does not work properly	<ul style="list-style-type: none"> <li>● Blown fuse</li> <li>● Insufficient battery charge</li> <li>● Defective air conditioner switch</li> <li>● Defective blower switch</li> <li>● Defective compressor</li> </ul>	<ul style="list-style-type: none"> <li>● Check, repair</li> <li>● Charge</li> <li>● Replace air conditioner switch</li> <li>● Replace blower switch</li> <li>● Replace</li> </ul>

## 16.4.2 CHASSIS

Problem	Main causes	Remedy
When brake pedal is depressed, machine does not stop	<ul style="list-style-type: none"> <li>Brakes out of adjust, defective brake oil pressure</li> </ul>	<ul style="list-style-type: none"> <li>Check, adjust</li> </ul>
Track comes off	<ul style="list-style-type: none"> <li>Track too loose</li> </ul>	<ul style="list-style-type: none"> <li>Adjust track tension, see WHEN REQUIRED</li> </ul>
Abnormal wear of sprocket	<ul style="list-style-type: none"> <li>Track too loose or too tightened</li> </ul>	
Blade, rises slowly, does not rise	<ul style="list-style-type: none"> <li>Lack of hydraulic oil</li> </ul>	<ul style="list-style-type: none"> <li>Add oil to specified level, see EVERY 250 HOURS SERVICE.</li> </ul>
Does not steer even when steering is operated	<ul style="list-style-type: none"> <li>Defective hydraulic pressure at steering clutch</li> </ul>	<ul style="list-style-type: none"> <li>Check, repair</li> </ul>
Transmission oil pressure does not rise	<ul style="list-style-type: none"> <li>Wear, scuffing of gear pump</li> <li>Lack of oil in transmission case</li> <li>Clogged transmission case oil filter cartridge or strainer</li> </ul>	<ul style="list-style-type: none"> <li>Check, replace</li> <li>Add oil to specified level. For details, see CHECKS BEFORE STARTING.</li> <li>Clean. For details, see EVERY 1000 HOURS SERVICE.</li> </ul>
Lacks drawbar pull (cannot travel at full speed)	<ul style="list-style-type: none"> <li>Lack of drive power from engine</li> </ul>	<ul style="list-style-type: none"> <li>See ENGINE RELATED PARTS</li> </ul>
Machine does not move off when gear shift lever is placed in gear	<ul style="list-style-type: none"> <li>Lack of oil in transmission case</li> <li>Transmission oil pressure does not rise</li> <li>Steering clutch is slipping <ul style="list-style-type: none"> <li>Wear, scuffing of gear pump</li> </ul> </li> </ul>	<ul style="list-style-type: none"> <li>Add oil to specified level. For details, see CHECKS BEFORE STARTING.</li> <li>See "Transmission oil pressure does not rise" above</li> <li>Check, replace</li> </ul>
Transmission overheats (indicator enters red range)	<ul style="list-style-type: none"> <li>Lack of oil in transmission case</li> <li>Transmission oil pressure does not rise</li> <li>Steering clutch is slipping <ul style="list-style-type: none"> <li>Wear, scuffing of gear pump</li> </ul> </li> <li>Excessive load when operating</li> </ul>	<ul style="list-style-type: none"> <li>Add oil to specified level. For details, see CHECKS BEFORE STARTING.</li> <li>See "Transmission oil pressure does not rise" above</li> <li>Check, replace</li> <li>Shift down one position, or reduce the load and increase the speed when operating.</li> </ul>

## 16. TROUBLESHOOTING

### 16.4.3 ENGINE

Problem	Main causes	Remedy
Engine oil pressure caution lamp remains alight when engine speed is raised after completion of warm-up	<ul style="list-style-type: none"> <li>● Engine oil pan oil level is low (sucking in air)</li> <li>● Clogged oil filter cartridge</li> <li>● Defective tightening of oil pipe joint, oil leakage from damaged part</li> <li>● Defective caution lamp</li> </ul>	<ul style="list-style-type: none"> <li>● Add oil to specified level, see CHECK BEFORE STARTING</li> <li>● Replace cartridge, see EVERY 250 HOURS SERVICE</li> <li>(● Check, repair)</li> <li>(● Replace lamp)</li> </ul>
Steam is emitted from top part of radiator (pressure valve)	<ul style="list-style-type: none"> <li>● Cooling water level low, water leakage</li> <li>● Loose fan belt</li> <li>● Dirt or scale accumulated in cooling system</li> <li>● Clogged radiator fin or damaged fin</li> <li>● Defective thermostat</li> <li>● Loose radiator filler cap (high altitude operation)</li> <li>● Defective water temperature gauge</li> </ul>	<ul style="list-style-type: none"> <li>● Add cooling water, repair, see CHECK BEFORE STARTING</li> <li>● Check fan belt tension</li> <li>● Change cooling water, clean inside of cooling system, see WHEN REQUIRED</li> <li>● Clean or repair, see WHEN REQUIRED</li> <li>(● Replace thermostat)</li> <li>● Tighten cap or replace packing</li> <li>(● Replace water temperature gauge)</li> </ul>
Indicator of water temperature gauge is in red range on right side of gauge	<ul style="list-style-type: none"> <li>● Defective thermostat</li> <li>● Defective water temperature gauge</li> </ul>	<ul style="list-style-type: none"> <li>(● Replace thermostat)</li> <li>(● Replace water temperature gauge)</li> </ul>
Indicator of water temperature gauge is in white range on left side of gauge	<ul style="list-style-type: none"> <li>● Defective thermostat</li> <li>● Defective water temperature gauge</li> </ul>	<ul style="list-style-type: none"> <li>(● Replace thermostat)</li> <li>(● Replace water temperature gauge)</li> </ul>
Engine does not start when starting motor is turned	<ul style="list-style-type: none"> <li>● Lack of fuel</li> <li>● Air in fuel system</li> <li>● Defective fuel injection pump or nozzle</li> <li>● Starting motor cranks engine sluggishly</li> <li>● Defective compression                             <ul style="list-style-type: none"> <li>○ Defective valve clearance</li> </ul> </li> </ul>	<ul style="list-style-type: none"> <li>● Add fuel, see CHECK BEFORE STARTING</li> <li>● Repair place where air is sucked in</li> <li>(● Replace pump or nozzle)</li> <li>See ELECTRICAL SYSTEM</li> <li>(○ Adjust valve clearance)</li> </ul>
Exhaust gas is white or blue	<ul style="list-style-type: none"> <li>● Too much oil in oil pan</li> <li>● Improper fuel</li> </ul>	<ul style="list-style-type: none"> <li>● Add oil to specified level, see CHECK BEFORE STARTING</li> <li>● Change to specified fuel</li> </ul>
Exhaust gas occasionally turns black	<ul style="list-style-type: none"> <li>● Clogged air cleaner element</li> <li>● Defective nozzle</li> <li>● Defective compression</li> </ul>	<ul style="list-style-type: none"> <li>● Clean or replace, see WHEN REQUIRED</li> <li>(● Replace nozzle)</li> <li>(● Adjust valve clearance)</li> </ul>
Combustion noise occasionally makes breathing sound	<ul style="list-style-type: none"> <li>● Defective nozzle</li> </ul>	<ul style="list-style-type: none"> <li>(● Replace nozzle)</li> </ul>
Abnormal noise generated (combustion or mechanical)	<ul style="list-style-type: none"> <li>● Low grade fuel being used</li> <li>● Overheating</li> <li>● Damage inside muffler</li> <li>● Excessive valve clearance</li> </ul>	<ul style="list-style-type: none"> <li>● Change to specified fuel</li> <li>● See item "Indicator of water temperature gauge is in red range on right side of gauge".</li> <li>(● Replace muffler)</li> <li>(● Adjust valve clearance)</li> </ul>

# **MAINTENANCE**

## 17. GUIDES TO MAINTENANCE

---

Do not carry out any inspection and maintenance operation that is not given in this manual.

Perform maintenance work on hard, flat ground.

### **Check service meter**

Check the service meter reading every day to see if the time has come for any necessary maintenance to be carried out.

### **Komatsu genuine replacement parts:**

Use Komatsu genuine parts specified in the parts list as replacement parts.

### **Komatsu genuine oils:**

Use Komatsu genuine oils and grease. Choose oils and grease with proper viscosities specified for ambient temperature.

### **Always use clean washer fluid:**

Use automobile window washer fluid and be careful not to let any dirt get into it.

### **Clean oil and grease:**

Use clean oil and grease. Also, keep containers of the oil and grease clean. Keep foreign materials away from oil and grease.

### **Keeping the machine clean:**

Always keep the machine clean. This makes it easier to find parts causing problems. Keep in particular grease fittings, breathers and oil level gauges clean and avoid foreign matters from getting in them.

### **Be careful of hot water and oil:**

Draining hot oils and coolants and removing their filters immediately after the engine stops are hazardous. Allow the engine to cool.

If the oil has to be drained when it is cold, warm up the oil to a suitable temperature (approx. 20 – 40°C) before draining it.

### **Checking foreign materials in drained oil:**

After oil is changed or filters are replaced, check the oil and filters for metallic particles and foreign materials. If large quantities of metallic particles or foreign materials are found, consult your Komatsu distributor.

### **Fuel strainer:**

If your machine is equipped with a fuel strainer, do not remove it while fueling.

### **Oil change:**

Check or change oils in the places where dust is scarce to keep foreign materials away from oils.

### **Warning tag:**

Attach the warning tag to the starting switch or other appropriate control lever to avoid someone who is not aware of the circumstances from starting the engine.

### **Obey precautions:**

During the operation, always obey the precautions on the safety label stuck to the machine.

### **Welding instructions:**

- Turn off the engine starting switch.
- Do not apply more than 200 V continuously.
- Connect grounding the cable within 1 m from the area to be welded.
- Avoid seals or bearings from being between the area to be welded and the position of grounding point.

**Fire prevention:**

Use nonflammable cleaner or light oil for cleaning parts. Keep flame or cigarette light away from light oil.

**Clamp faces:**

When O-rings or gaskets are removed, clean the clamp faces and replace the O-rings and gaskets with new ones. Be sure to fit O-rings and gaskets when assembling.

**Objects in your pockets:**

Keep your pockets free of loose objects which can fall out and drop into the machinery; especially when you work on the machinery while bending over it.

**Checking undercarriage:**

When working in rocky areas, check for damage to the undercarriage and for looseness, flaws, wear and damage in bolts and nuts. Loosen the track tension a little when working in such areas.

**Cleaning machine:**

- Do not direct a high-pressure jet directly at the radiator.
- Do not splash water over the electrical equipment.

**Pre- and post-work checks:**

Before starting work in mud, rain, snow or at seashore, check plugs and valves for tightness. Wash the machine immediately after the work to protect components from rusting.

Lubricate components more frequently than usual. Be sure to lubricate work equipment pins daily if they are submerged in water.

**Dusty worksites:**

When working at dusty worksites, do as follows:

- Check the air cleaner for clogging more frequently. Clean the air cleaner at shorter intervals than specified.
- Clean the radiator core frequently to avoid clogging.
- Clean and replace the fuel filter frequently.
- Clean electrical components, especially the starting motor and alternator, to avoid accumulation of dust.

**Avoid mixing oils:**

Never mix oils of different brands. If you have only oil which is a different brand from the one that is used in the machine, do not add it but replace all the oil.

**Precautions when opening and closing engine side cover:**

- When standing on the track to open the engine side cover, adopt a standing position.
- When the engine side cover is open, do not open or close the cab.  
Before opening or closing the cab, always close the engine side cover first.



AE222058

INCORRECT



AM087810

CORRECT

## 18. OUTLINES OF SERVICE

---

- Use Komatsu genuine parts for replacement.
- When changing or adding oil, do not use a different type of oil.
- Unless otherwise specified, the oil and coolant used at the time of shipment from the factory are as shown in the table below.

Item	Kind of fluid
Engine oil pan	SAE 15W-40 API classification
Damper case Transmission case Steering clutch case Final drive case	SAE 30 API classification
Hydraulic tank	SAE 10W API classification
Fuel tank	ASTM D975 No. 2 (However, ASTM D975 No. 1 is used for the winter season (October to March))
Radiator	Komatsu Super Coolant (AF-ACL) 41% added to water

### 18.1 OUTLINE OF OIL, FUEL, COOLANT

#### 18.1.1 OIL

- Oil is used in the engine and work equipment under extremely severe conditions (high temperature, high pressure), and it deteriorates with use.  
Always use oil that matches the grade and temperature for use given in the Operation and Maintenance Manual. Even if the oil is not dirty, always replace the oil after the specified interval.
- Oil corresponds to blood in the human body, so always be careful when handling it to prevent any impurities (water, metal particles, dirt, etc.) from getting in.  
The majority of problems with machine are caused by the entry of such impurities.  
Take particular care not to let any impurities get in when storing or adding oil.
- Never mix oils of different grades or brands.
- Always add the specified amount of oil.  
Having too much oil or too little oil are both causes of problems.
- If the oil in the work equipment is not clear, there is probably water or air getting into the circuit.  
In such cases, please contact your Komatsu distributor.
- When changing the oil, always replace the related filters at the same time.
- We recommend you to have an analysis made of the oil periodically to check the condition of the machine. For those who wish to use this service, please contact your Komatsu distributor.



### 18.1.2 FUEL

- The fuel pump is a precision instrument, and if fuel containing water or dirt is used, it cannot work properly.
- Be extremely careful not to let impurities get in when storing or adding fuel.
- Always use the fuel specified in the Operation and Maintenance Manual.  
Fuel may congeal depending on the temperature when it is used (particularly in low temperature below  $-15^{\circ}\text{C}$ ), so it is necessary to change to a fuel that matches the temperature.
- To prevent the moisture in the air from condensing and forming water inside the fuel tank, always fill the fuel tank after completing the day's work.
- Before starting the engine, or when 10 minutes have passed after adding fuel, drain the sediment and water from the fuel tank.
- If the engine runs out of fuel, or if the filters have been replaced, it is necessary to bleed the air from the circuit.

### 18.1.3 COOLANT

- River water contains large amounts of calcium and other impurities, so if it is used, scale will stick to the engine and radiator, and this will cause defective heat exchange and overheating.  
Do not use water that is not suitable for drinking.
- When using anti-freeze, always observe the precautions given in the Operation and Maintenance Manual.
- Komatsu machines are supplied with Komatsu original anti-freeze in the coolant when the machine is shipped.  
This anti-freeze is effective in preventing corrosion of the cooling system.  
The anti-freeze can be used continuously for two years or 4000 hours. Therefore, it can be used as it is even in hot areas.
- Anti-freeze is inflammable, so be extremely careful not to expose it to flame or fire.
- The proportion of anti-freeze to water differs according to the ambient temperature.  
For details of the mixing proportions, see "24.1.1 CLEAN INSIDE OF COOLING SYSTEM".
- If the engine overheats, wait for the engine to cool before adding coolant.
- If the coolant level is low, it will cause overheating and will also cause problems with corrosion from the air in the coolant.

### 18.1.4 GREASE

- Grease is used to prevent twisting and noise at the joints.
- The nipples not included in the maintenance section are nipples for overhaul, so they do not need grease.  
If any part becomes stiff after being used for a long time, add grease.
- Always wipe off all of the old grease that is pushed out when greasing. Be particularly careful to wipe off the old grease in places where sand or dirt sticking in the grease would cause wear of the rotating parts.

### 18.1.5 STORING OIL AND FUEL

- Keep indoors to prevent any water, dirt, or other impurities from getting in.
- When keeping drum cans for a long period, put the drum on its side so that the filler port of the drum can is at the side. (To prevent moisture from being sucked in)  
If drum cans have to be stored outside, cover them with a waterproof sheet or take other measures to protect them.
- To prevent any change in quality during long-term storage, be sure to use in the order of first in – first out (use the oldest oil or fuel first).

### 18.1.6 FILTERS

- Filters are extremely important safety parts. They prevent impurities in the fuel and air circuits from entering important equipment and causing problems.  
Replace all filters periodically. For details, see the Operation and Maintenance Manual.  
However, when working in severe conditions, it is necessary to consider replacing the filters at shorter intervals according to the oil and fuel (sulfur content) being used.
- Never try to clean the filters (cartridge type) and use them again. Always replace with new filters.
- When replacing oil filters, check if any metal particles are stuck to the old filter. If any metal particles are found, please contact your Komatsu distributor.
- Do not open packs of spare filters until just before they are to be used.
- Always use Komatsu genuine filters.

## 18.2 RELATING TO ELECTRIC SYSTEM

- If the wiring gets wet or the insulation is damaged, the electric system leaks and this could result in hazardous malfunction of the machine.
- Services relating to the electric system are (1) check of fan belt tension, (2) check of damage or wear in the fan belt and (3) check of battery fluid level.
- Never remove or disassemble any electric components installed in the machine.
- Never install any electric components other than these specified by Komatsu.
- Be careful to keep the electric system free of water when washing the machine or when it rains.
- When working on the seashore, carefully clean the electric system to prevent corrosion.
- Never connect any optional power source to the fuse, starting switch, battery relay, etc.

## 19. WEAR PARTS LIST

Wear parts such as the filter element, cutting edge, etc. are to be replaced at the time of periodic maintenance or before their abrasion limits.

The wear parts should be changed correctly in order to use the machine economically.  
For part change, Komatsu genuine parts of excellent quality should be used.

The parts in parentheses are to be replaced at the same time.

Item	Part No.	Part Name	Weight/each (kg)	Q'ty	Replacement frequency
Engine oil filter	6735-51-5140	Cartridge	-	1	Every 250 hours service
Fuel filter	6732-71-6110	Cartridge	-	1	Every 500 hours service
Power train filter	23S-49-13122	Cartridge (Including O-ring)	-	1 (1)	Every 1000 hours service
Hydraulic oil filter	113-60-43321	Element	-	1	Every 2000 hours service
Air cleaner	600-181-6050	Element ass'y	-	1	-
	600-181-6540	Outer element ass'y	-	1	
Blade (STD) (Power angle-tilt dozer)	12F-70-31251	Cutting edge	13.3	3	-
	11G-71-31170	End bit (right and left)	6.9	2	
	(02090-11055)	(Bolt)	-	(23)	
	(02290-11016)	(Nut)	-	(23)	
Blade (Wide) (Power angle-power tilt dozer)	12F-70-31251	Cutting edge	13.3	1	-
	12F-70-31261	Cutting edge	21.1	2	
	11G-71-31170	End bit (right and left)	6.9	2	
	(02090-11055)	(Bolt)	-	(25)	
	(02290-11016)	(Nut)	-	(25)	

### NOTICE

When handling parts that weight more than 25 kg, remember that they are heavy objects, and take the necessary care.

## 20. USE OF FUEL, COOLANT AND LUBRICANTS ACCORDING TO AMBIENT TEMPERATURE

### PROPER SELECTION OF FUEL, COOLANT AND LUBRICANTS

RESERVOIR	KIND OF FLUID	AMBIENT TEMPERATURE								CAPACITY	
		-22 -30	-4 -20	14 -10	32 0	50 10	68 20	86 30	104°F 40°C	Specified	Refill
Engine oil pan	Engine oil								<b>SAE 30CE, CF-4</b>	26.8 ℓ 7.1 US gal 5.9 UK gal	22.8 ℓ 6.0 US gal 5.0 UK gal
									<b>SAE 10W CE, CF-4</b>		
									<b>SAE 10W-30CE, CF-4</b>		
									<b>SAE 15W-40CE, CF-4</b>		
Damper case	Engine oil								1.1 ℓ 0.29 US gal 0.24 UK gal	1.1 ℓ 0.29 US gal 0.24 UK gal	
Transmission case								<b>SAE 30</b>	22 ℓ 5.8 US gal 4.9 UK gal	19 ℓ 5.0 US gal 4.2 UK gal	
Steering clutch case								<b>SAE 10W</b>	74 ℓ 19.5 US gal 16.3 UK gal	74 ℓ 19.5 US gal 16.3 UK gal	
Final drive case (each)									13 ℓ 3.4 US gal 2.9 UK gal	13 ℓ 3.4 US gal 2.9 UK gal	
Hydraulic system	Engine oil								<b>SAE 10W</b>	73 ℓ 19.3 US gal 16.1 UK gal	37 ℓ 9.8 US gal 8.1 UK gal
									<b>SAE 10W-30</b>		
									<b>SAE 15W-40</b>		
Fuel tank	Diesel fuel								<b>ASTM D975 No.2</b>	225 ℓ 59.4 US gal 49.5 UK gal	-
									*		
Cooling system (incl. sub-tank)	Water	<b>Add antifreeze</b>							30 ℓ 7.9 US gal 6.6 UK gal	-	

\* ASTM D975 No. 1

**REMARK**

- When fuel sulphur content is less than 0.5%, change oil in the oil pan every periodic maintenance hours described in this manual.

Change oil according to the following table if fuel sulphur content is above 0.5%.

Fuel sulphur content	Change interval of oil in engine oil pan
0.5 to 1.0%	1/2 of regular interval
1.0 to 1.5%	1/4 of regular interval

- When starting the engine in an atmospheric temperature of lower than 0°C, be sure to use engine oil of SAE10W, SAE10W-30 and SAE15W-40, even though an atmospheric temperature goes up to 10°C more or less in the day time.
- Use API classification CD as engine oil and if API classification CC, reduce the engine oil change interval to half.
- There is no problem if single grade oil is mixed with multigrade oil (SAE10W-30, 15W-40), but be sure to add single grade oil that matches the temperature in the table.
- We recommend Komatsu genuine oil which has been specifically formulated and approved for use in engine and hydraulic work equipment applications.

Specified capacity: Total amount of oil including oil for components and oil in piping.

Refill capacity: Amount of oil needed to refill system during normal inspection and maintenance.

ASTM: American Society of Testing and Material

SAE: Society of Automotive Engineers

API: American Petroleum Institute

20. USE OF FUEL, COOLANT AND LUBRICANTS ACCORDING TO AMBIENT TEMPERATURE

No.	Supplier	Engine Oil [CD or CE] SAE10W, 30, 40 10W30, 15W40 (The 15W40 oil marked * is CE.)	Gear Oil [GL-4 or GL-5] SAE80, 90, 140	Grease [Lithium-Base] NLGI No. 2	Anti-freeze Coolant [Ethylene Glycol Base] Permanent Type
1	KOMATSU	EO10-CD EO30-CD EO10-30CD EO15-40CD	GO90 GO140	G2-LI G2-LI-S	AF-ACL AF-PTL AF-PT (Winter, one season type)
2	AGIP	Diesel sigma S Super dieselmulti- grade *Sigma turbo	Rotra MP	GR MU/EP	-
3	AMOCO	*Amoco 300	Multi-purpose gear oil	RYKON premium grease	-
4	ARCO	*Arcofleet S3 plus	Arco HD gear oil	Litholine HEP 2 Arco EP moly D	-
5	BP	Vanellus C3	Gear oil EP Hypogear EP	Energrease LS-EP2	Antifreeze
6	CALTEX	*RPM delo 400 RPM delo 450	Universal thuban Universal thuban EP	Marfak all purpose 2 Ultra-duty grease 2	AF engine coolant
7	CASTROL	*Turbomax *RX super CRD	EP EPX Hypoy Hypoy B Hypoy C	MS3 Spheerol EPL2	Anti-freeze
8	CHEVRON	*Delo 400	Universal gear	Ultra-duty grease 2	-
9	CONOCO	*Fleet motor oil	Universal gear lubricant	Super-sta grease	-
10	ELF	Multiperformance 3C Performance 3C	-	Tranself EP Tranself EP type 2	Glacelf
11	EXXON (ESSO)	Essolube D3 *Essolube XD-3 *Essolube XD-3 Extra *Esso heavy duty Exxon heavy duty	Gear oil GP Gear oil GX	Beacon EP2	All season coolant
12	GULF	Super duty motor oil *Super duty plus	Multi-purpose gear lubricant	Gulfcrown EP2 Gulfcrown EP special	Antifreeze and coolant
13	MOBIL	Delvac 1300 *Delvac super 10W-30, 15W-40	Mobilube GX Mobilube HD	Mobilux EP2 Mobilgrease 77 Mobilgrease special	-

20. USE OF FUEL, COOLANT AND LUBRICANTS ACCORDING TO AMBIENT TEMPERATURE

No.	Supplier	Engine Oil [CD or CE] SAE10W, 30, 40 10W30, 15W40 (The 15W40 oil marked * is CE.)	Gear Oil [GL-4 or GL-5] SAE80, 90, 140	Grease [Lithium-Base] NLGI No. 2	Anti-freeze Coolant [Ethylene Glycol Base] Permanent Type
14	PENNZOIL	*Supreme duty fleet motor oil	Multi-purpose 4092 Multi-purpose 4140	Multi-purpose white grease 705 707L White – bearing grease	Anti-freeze and summer coolant
15	PETROFINA	FINA kappa TD	FINA potonic N FINA potonic NE	FINA marson EPL2	FINA tamidor
16	SHELL	Rimula X	Spirax EP Spirax heavy duty	Alvania EP grease	-
17	SUN	-	Sunoco GL5 gear oil	Sunoco ultra prestige 2EP Sun prestige 742	Sunoco antifreeze and summer coolant
18	TEXACO	*Ursa super plus Ursa premium	Multigear	Multifak EP2 Starplex 2	Code 2055 startex antifreeze coolant
19	TOTAL	Rubia S *Rubia X	Total EP Total transmission TM	Multis EP2	Antigel/antifreeze
20	UNION	*Guardol	MP gear lube LS	Unoba EP	-
21	VEEDOL	*Turbostar *Diesel star MDC	Multigear Multigear B Multigear C	-	Antifreeze

## 21. STANDARD TIGHTENING TORQUES FOR BOLTS AND NUTS

### 21.1 INTRODUCTION OF NECESSARY TOOLS

The following tools are needed when carrying out maintenance.

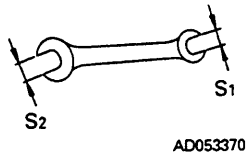
No.	Name of tool	Part No.	Remarks
1	Wrench set	09000-30006	Applicable width across flats ( $S_1 - S_2$ ) 8 mm - 10 mm, 12 mm - 14 mm 13 mm - 17 mm, 19 mm - 22 mm 24 mm - 27 mm, 30 mm - 32 mm
			 AD053370
2	Screwdriver	09033-00190	Interchangeable flat-head and cross-head type
3	Socket	09021-01725	Applicable width across flats 17 mm
4	Socket	09021-02436	Applicable width across flats 24 mm for power train filter
5	Extension	09022-00150	
6	Handle	09023-00300	
7	Handle	09024-00300	For drain plug of steering clutch case and final drive case
8	Filter wrench	09019-08035	For filter cartridges
9	Grease pump	07952-70002	For greasing work
10	Grease cartridge	07950-90403	(Lithium base grease, 400 g)

If any of the above tools are broken, please order them from your Komatsu distributor.

When not using the tools, always put them in the tool box on the inside of the battery inspection cover on the left side of the machine.



## 21.2 TORQUE LIST

Unless otherwise specified, tighten the metric bolts and nuts to the torque shown in the table.

The tightening torque is determined by the width across the flats (b) of the nut and bolt.

If it is necessary to replace any nut or bolt, always use a Komatsu genuine part of the same size as the part that was replaced.

Nm (newton meter): 1Nm  $\approx$  0.1 kgm  
 $\approx$  0.74 lbft

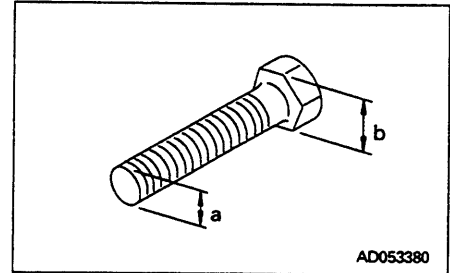

Thread diameter of bolt (mm) (a)	Width across flat (mm) (b)	AD054300		
		Nm	kgm	lbft
6	10	13.2 ± 1.4	1.35 ± 0.15	9.73 ± 1.03
8	13	31.4 ± 2.9	3.2 ± 0.3	23.2 ± 2.1
10	17	65.7 ± 6.8	6.7 ± 0.7	48.5 ± 5.0
12	19	112 ± 9.8	11.5 ± 1.0	82.6 ± 7.2
14	22	177 ± 19	18.0 ± 2.0	131 ± 14
16	24	279 ± 29	28.5 ± 3	206 ± 21
18	27	383 ± 39	39 ± 3	282 ± 29
20	30	549 ± 58	56 ± 6	405 ± 43
22	32	745 ± 78	76 ± 8	549 ± 58
24	36	927 ± 98	94.5 ± 10	684 ± 72
27	41	1320 ± 140	135 ± 15	973 ± 100
30	46	1720 ± 190	175 ± 20	1270 ± 140
33	50	2210 ± 240	225 ± 25	1630 ± 180
36	55	2750 ± 290	280 ± 30	2030 ± 210
39	60	3280 ± 340	335 ± 35	2420 ± 250

### NOTICE

When tightening panels or other parts having tightening fixtures made of plastic, be careful not to use excessive tightening torque: doing so will damage the plastic parts.

Apply the following table for Hydraulic Hose.

Thread diameter (mm) (a)	Width across flat (mm) (b)	Tightening torque (N·m{kgf·m})	
		Target valve	Service limit
14	19	44.1 {4.5}	34.3 – 63.7 {3.5 – 6.5}
18	24	78.5 {8.0}	58.8 – 98.1 {6.0 – 10.0}
22	27	117.7 {12.0}	88.3 – 137.3 {9.0 – 14.0}
24	32	147.1 {15.0}	117.7 – 176.5 {12.0 – 18.0}
30	36	215.7 {22.0}	176.5 – 245.2 {18.0 – 25.0}
33	41	255.0 {26.0}	215.7 – 284.4 {22.0 – 29.0}

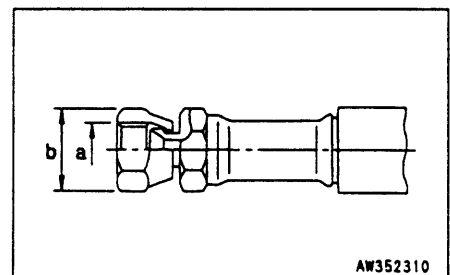

## 22. PERIODIC REPLACEMENT OF SAFETY CRITICAL PARTS

To ensure safety at all times when operating or driving the machine, the user of the machine must always carry out periodic maintenance. In addition, to further improve safety, the user should also carry out periodic replacement of the parts given in the table. These parts are particularly closely connected to safety and fire prevention.

With these parts, the material changes as time passed, or they easily wear or deteriorate. However, it is difficult to judge the condition of the parts simply by periodic maintenance, so they should always be replaced after a fixed time has passed, regardless of their condition. This is necessary to ensure that they always maintain their function completely.

However, if these parts show any abnormality before the replacement interval has passed, they should be repaired or replaced immediately.

If the hose clamps show any deterioration, such as deformation or cracking, replace the clamps at the same as the hoses.

When replacing the hoses, always replace the O-rings, gaskets, and other such parts at the same time.

Ask your Komatsu distributor to replace the critical parts.

No.	Safety critical parts for periodic replacement	Q'ty	Replacement interval
1	Fuel hose (fuel tank – feed pump)	1	Every 2 years or 4000 hours, whichever comes sooner
2	Fuel hose (feed pump – fuel filter)	1	
3	Fuel hose (fuel filter – injection pump)	1	
4	Fuel hose (injection pump – fuel tank)	1	
5	Fuel hose (injection nozzle – fuel tank)	1	
6	Turbocharger lubrication hose	1	
7	Hose (power train strainer – power train pump)	1	
8	Hose (power train pump – power train filter)	1	
9	Hose (power train filter – priority valve)	1	
10	Hose (priority valve – transmission case)	1	
11	Hose (transmission case – oil cooler)	1	
12	Hose (oil cooler – transmission case)	1	
13	Hose (priority valve – PPC valve)	1	
14	Hose (PPC valve – brake valve)	2	
15	Hose (PPC valve – clutch piston)	2	
16	Hose (PPC valve – transmission case)	1	
17	Hose (priority valve – brake valve)	2	
18	Hose (brake valve – brake piston)	2	

**22. PERIODIC REPLACEMENT OF SAFETY CRITICAL PARTS**

No.	Safety critical parts for periodic replacement	Q'ty	Replacement interval
19	Hose (brake valve – brake cylinder)	1	Every 2 years or 4000 hours, whichever comes sooner
20	Hose (brake valve – transmission case)	1	
21	Brake piston pressure detection hose	2	
22	Clutch piston pressure detection hose	2	
23	Transmission inching pressure detection hose	1	
24	Transmission modulating pressure detection hose	1	
25	Hose (control valve – oil cooler)	1	
26	Hose (oil cooler – control valve)	1	
27	Seat belt		Replace every 3 years

## 23. MAINTENANCE SCHEDULE CHART

### 23.1 MAINTENANCE SCHEDULE CHART

SERVICE ITEM	PAGE
WHEN REQUIRED	
Clean inside of cooling system	3-18
Check, clean and replace air cleaner element	3-21
Check track tension	3-23
Check and tighten track shoe bolts	3-25
Check electrical intake air heater	3-25
Reverse and replace the end bits and cutting edges	3-26
Clean, check radiator fins	3-27
Adjust play of center ball	3-27
Check, Adjust air conditioner (Machines equipped with cab)	3-28
Grease door hinge (Machines equipped with cab)	3-28
Check door lock striker (Machines equipped with cab)	3-28
Replace door damper (Machines equipped with cab)	3-29
Check window washer fluid level, add fluid (Machines equipped with cab)	3-29
Replace wiper blade (Machines equipped with cab)	3-29
Check idler oil level, add oil	3-30
Check oil level in damper case, add oil	3-31
<b>CHECK BEFORE STARTING</b>	
See "12.1.2 CHECK BEFORE STARTING" in the OPERATION section.	
<b>EVERY 50 HOURS SERVICE</b>	
Drain water, sediment from fuel tank	3-33
<b>EVERY 250 HOURS SERVICE</b>	
Lubricating	3-34
● Angle-tilt frame center pin (1 place)	3-34
● Tilt link lift rod (2 places)	3-34
● Lift cylinder bottom pin (2 places)	3-34
● Lift cylinder head pin (2 places)	3-34
● Tilt link (2 places)	3-34
● Tilt cylinder head pin (1 place)	3-34
● Tilt cylinder bottom pin (1 place)	3-34
● Angle cylinder head pin (1 place)	3-34
● Angle cylinder bottom pin (1 place)	3-34

## 23. MAINTENANCE SCHEDULE CHART

SERVICE ITEM	PAGE
<b>EVERY 250 HOURS SERVICE (continued)</b>	
Check oil level in final drive case, add oil	3-35
Check oil level in hydraulic tank, add oil	3-35
Check level of battery electrolyte	3-36
Check, clean fuel strainer	3-36
Change oil in engine oil pan, replace engine oil filter cartridge	3-37
Check brake performance	3-38
Clean air conditioner air filter (FRESH/RECIRC filter) (Machines equipped with cab)	3-39
<b>EVERY 500 HOURS SERVICE</b>	
Replace fuel filter cartridge	3-40
<b>EVERY 1000 HOURS SERVICE</b>	
Change oil in transmission case, clean strainer in power train	3-41
Replace transmission oil filter cartridge	3-43
Transmission case breather (1 place)	3-44
Steering clutch case breather (1 place)	3-44
Grease universal joint (2 places)	3-44
Change oil in steering clutch case	3-45
Check fan belt tension, replace	3-46
Check engine valve clearance, adjust	3-46
Check all tightening parts of turbocharger	3-46
Check play of turbocharger rotor	3-46
Check for loose ROPS mount bolts	3-46
<b>EVERY 2000 HOURS SERVICE</b>	
Change oil in hydraulic tank, replace hydraulic oil filter cartridge	3-47
Change oil in final drive case	3-48
Check alternator, starting motor	3-48
Check vibration damper	3-48
Check engine valve clearance, adjust	3-48
Add anti-corrosive agent to cooling system	3-49
<b>EVERY 4000 HOURS SERVICE</b>	
Check water pump	3-51

## 24. SERVICE PROCEDURE

---

### 24.1 WHEN REQUIRED

#### 24.1.1 CLEAN INSIDE OF COOLING SYSTEM

**⚠ WARNING**

- Soon after the engine has been stopped, the coolant is hot and can cause personal injury. Allow the engine to cool before draining water.
  - Never be under the machine with the engine running. To avoid serious injury, always stop the engine before being under the machine to open the drain valve.
  - Never remove the radiator cap when the engine is at operating temperature. At operating temperature, the coolant is under pressure. Steam blowing up from the radiator could cause personal injury. Allow the engine to cool until the radiator filler cap is cool enough to touch with your hand. Remove the filler cap slowly to relieve pressure.
  - When removing drain plug, avoid pouring coolant on yourself.
  - Antifreeze is flammable, so keep it away from any flame.
- Clean the inside of the cooling system, change the coolant according to the table below.

Kind of coolant	Cleaning inside of cooling system and changing coolant
Permanent type antifreeze (All season type)	Every year (autumn) or every 2000 hours whichever comes first
Non permanent type antifreeze containing ethylene glycol (Winter, one season type)	Every 6 months (spring, autumn) (Drain antifreeze in spring, add antifreeze in autumn)
When not using antifreeze	Every 6 months or every 1000 hours whichever comes first

- Use a permanent type of antifreeze.  
If, for some reason, it is impossible to use permanent type antifreeze, use an antifreeze containing ethylene glycol.
- Stop the machine on level ground when cleaning or changing the coolant.
- When deciding the ratio of antifreeze to water, check the lowest temperature in the past, and decide from the mixing rate table given below.  
It is actually better to estimate a temperature about 10°C (50°F) lower when deciding the mixing rate.

#### Mixing rate of water and antifreeze

Min. atmospheric temperature	°C	-5	-10	-15	-20	-25	-30
	°F	23	14	5	-4	-13	-22
Amount of antifreeze	ℓ	6.9	9.0	10.8	12.3	13.8	15.0
	US gal	1.8	2.4	2.9	3.2	3.6	3.95
	UK gal	1.5	2.0	2.4	2.7	3.0	3.3
Amount of water	ℓ	23.1	21.0	19.2	17.7	16.2	15.0
	US gal	6.1	5.5	5.0	4.7	4.3	3.95
	UK gal	5.1	4.6	4.2	3.9	3.6	3.3

- We recommend use of an antifreeze density gauge to control the mixing proportions.
- Use city water for the cooling water.  
If river water, well water or other such water supply must be used, contact your Komatsu distributor.

## 24. SERVICE PROCEDURE

1. Turn radiator cap ① slowly to remove it.
2. Set a container to catch the coolant under drain valve ② and drain plug ③. Open drain valve ② at the bottom of the radiator to drain the water.
3. After draining the water, close drain valve ② and drain plug ③, and fill with city water.
4. After draining the coolant, close drain valve ② and drain plug ③, and fill with city water. When the radiator is full, start the engine and run at low idling to raise the temperature to at least 90°C, then continue to run for approx. 10 minutes.
5. Stop the engine, open drain valve ② and drain plug ③, and drain the water.
6. After draining the water, clean the radiator with detergent. For the cleaning method, follow the instruction of detergent.
7. Close drain valve ②, then wrap drain plug ③ with sealing tape and close it.
8. Add city water until the water overflows from the water filler port.
9. To remove the air in the cooling water, run for five minutes at low idling, then for another five minutes at high idling. (When doing this, leave the radiator cap off.)

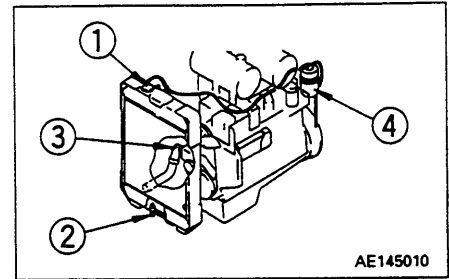

10. Drain the cooling water inside sub-tank ④, clean the inside of the sub-tank, then fill again with cooling water to a point midway between the FULL and LOW marks.
11. Stop the engine, wait for 3 minutes, and city water until the water level reaches near the water filler port, then tighten the cap.
12. Add anti-corrosive-agent as described in "24.7.6 ADD ANTI-CORROSIVE-AGENT TO COOLING SYSTEM".

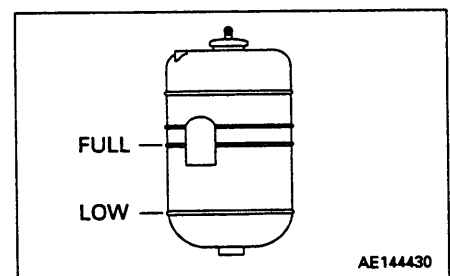



### 24.1.2 CHECK, CLEAN AND REPLACE AIR CLEANER ELEMENT

#### ⚠ WARNING

- Never clean or replace the air cleaner element with the engine running.
- When using pressure air to clean the element wear safety glasses or goggles to protect the eyes.

#### Checking

Whenever the red piston in dust indicator ① appears, clean the air cleaner element.

#### NOTICE

Do not clean the air cleaner element before the red piston in dust indicator ① appears.

If the air cleaner element is cleaned frequently before the red piston in the dust indicator appears, the air cleaner cannot provide the proper performance and the cleaning efficiency is lowered.

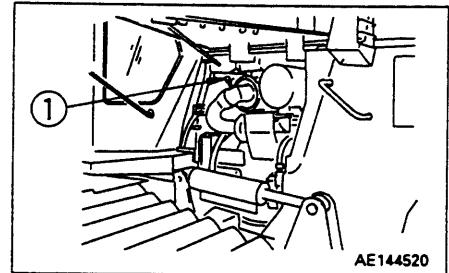

#### Cleaning or replacing outer element

- Loosen wing nut ②, remove seal washer ③ and take out element ④.
- Clean interior of the air cleaner body.
- Direct dry compressed air (less than 0.69 MPa (7 kgf/cm<sup>2</sup>, 99.4 PSI)) to element ④ from inside along its folds, then direct it from outside along its folds and again from inside.
  - Remove one seal from the element whenever the element has been cleaned.
  - Replace the outer element if it has been cleaned 6 times repeatedly or used throughout a year. Replace the inner element at the same time.
  - Replace both inner and outer elements when the dust indicator red piston appears soon after installing the cleaned outer element even though it has not been cleaned 6 times.
  - Check inner element mounting nuts for looseness and, if necessary, retighten.  
Tightening torque: 3.92 to 5.88 N·m  
(0.4 to 0.6 kgf·m, 2.9 to 4.3 lbf·ft)
- If small holes or thinner parts are found on the element when it is checked by shining a light through it after cleaning, replace the element.

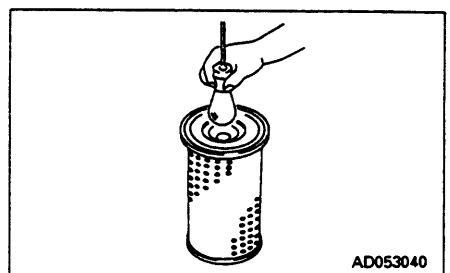
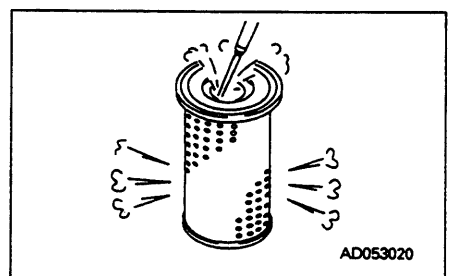
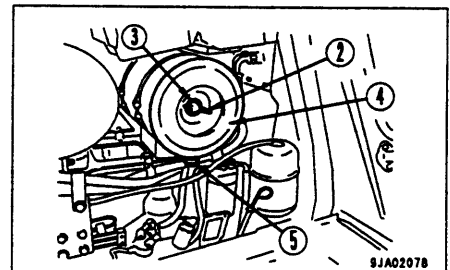

#### NOTICE

When cleaning the element, do not hit it or beat it against something.

Do not use an element whose folds or gasket or seal are damaged.

Wrap unused element and store them in a dry place.

## 24. SERVICE PROCEDURE

5. Install the cleaned element and fix it with the wing nut ② and seal washer ③.  
Tightening torque of wing nut: 5.88 to 7.85 N·m  
(0.6 to 0.8 kgf·m, 4.3 to 5.8 lbft)
6. Replace seal washer ③ or wing nut ② with new parts if they are broken.
7. Remove evacuator valve ⑤ and clean with compressed air.  
After cleaning, install it.
8. Press the button of dust indicator ① to return the red piston to its original position.

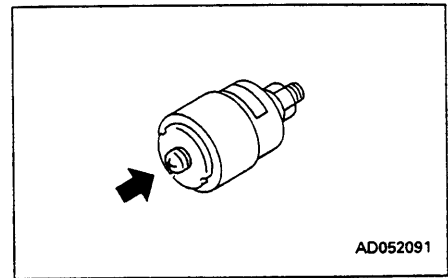

### Replacing inner element

1. Remove wing nut ②, seal washer ③ and take out of outer element ④.
2. Remove nut ⑥, washer ⑦ and take out of inner element ⑧.
3. To prevent dust from getting in, use a clean cloth or tape to cover the air connector (outlet side).
4. Clean the air cleaner body interior, then remove the cover installed in Step 2.
5. Fit a new inner element ⑧ to the connector and tighten it with nut ⑥ and washer ⑦.  
Tightening torque of nut ⑥: 3.92 to 5.88 N·m  
(0.4 to 0.6 kgf·m, 2.9 to 4.3 lbft)

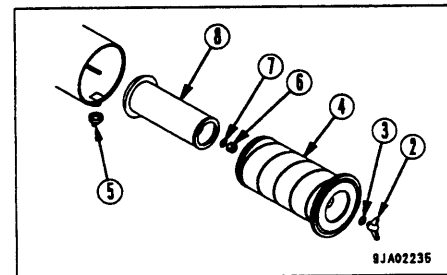

### NOTICE

- Do not clean and reinstall a inner element ⑧. When replacing the outer element, replace the inner element at the same time.
  - Use a new nut ⑥, washer ⑦, wing nut ② and seal washer ③.
6. Install new outer element ④ and fix it with wing nut ② and seal washer ③.
  7. Remove vacuator valve ⑤ and clean with compressed air.  
After cleaning, install it.
  8. Press button of dust indicator ① to return the red piston to its original position.

### 24.1.3 CHECK TRACK TENSION

The wear of pins and bushings on the undercarriage will vary with the working conditions and soil properties. It is thus necessary to continually inspect the track tension so as to maintain the standard tension.

Carry out the check and adjustment under the same conditions as when operating (on jobsites where the track becomes clogged with mud, measure with the track clogged with mud).

#### INSPECTION

Stop the machine on level ground (stop with the transmission in FORWARD without applying the brake). Then place a straight bar on the track shoes between the carrier roller and the idler as shown in the figure, and measure the clearance between the bar and the grouser at the midpoint. If the clearance is 20 – 30 mm (0.79 – 1.18 in), the tension is standard.

If the track tension is not at the standard value, adjust it in the following manner.

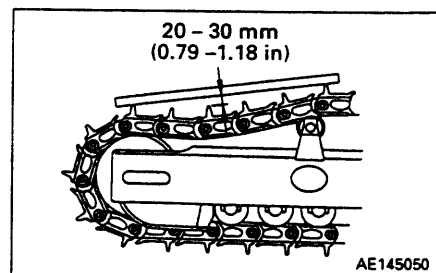

#### ADJUSTMENT

#### ⚠ WARNING

Grease inside the adjusting mechanism is under high pressure. Grease coming from lubricator ① under pressure can penetrate the body causing injury or death. For this reason, do not loosen lubricator ① more than one turn. Do not loosen any part other than lubricator ①. Furthermore, do not bring your face in front of the grease fitting.

If the track tension is not relieved by this procedure, please contact your Komatsu distributor.

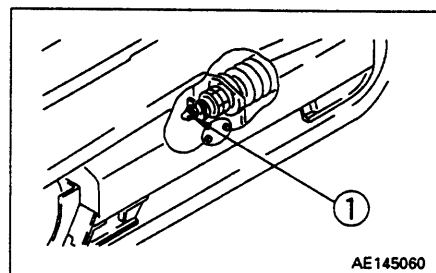

#### ● When increasing tension

1. Pump in grease through the grease fitting with a grease pump.
2. To check that the correct tension has been achieved, move the machine backwards and forwards.
3. Check the track tension again, and if the tension is not correct, adjust it again.
4. Grease can be pumped in until front idler support ③ can be seen from tip ② of the track frame. If the tension is still loose, the pin and bushing are excessively worn, so they must be either turned or replaced.  
Please contact your Komatsu distributor.

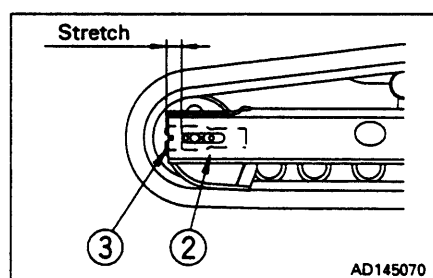

● When loosening tension

**⚠ WARNING**

It is extremely dangerous to release the grease by any method except the procedure given below. If the track tension is not relieved by this procedure, please contact your Komatsu distributor.

1. Loosen lubricator ① gradually to release the grease.
2. Turn lubricator ① a maximum of one turn.
3. If the grease does not come out smoothly, move the machine backwards and forwards a short distance.
4. Tighten lubricator ①.
5. To check that the correct tension has been achieved, move the machine backwards and forwards.
6. Check the track tension again, and if the tension is not correct, adjust it again.

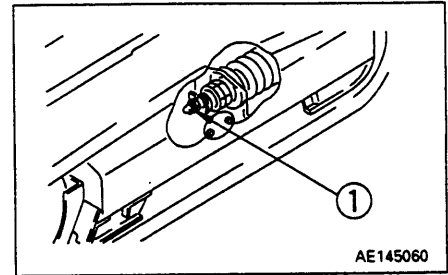

### 24.1.4 CHECK AND TIGHTEN TRACK SHOE BOLTS

If the machine is used with track shoe bolts ① loose, they will break, so tighten any loose bolts immediately.

- **Method for tightening (shoe bolt)**

1. First tighten to a tightening torque of  $196 \pm 20$  Nm ( $20 \pm 2$  kgm,  $145 \pm 14$  lbft) then check that the nut and shoe are in close contact with the link contact surface.
2. After checking, tighten a further  $120 \pm 10^\circ$ .

- **Method for tightening (master link connecting bolt)**

1. First tighten to a tightening torque of  $196 \pm 20$  Nm ( $20 \pm 2$  kgm,  $145 \pm 14$  lbft) then check that the link contact surfaces are in close contact.
2. After checking, tighten a further  $180 \pm 10^\circ$ .

#### Order for tightening

Tighten the bolts in the order shown in the diagram on the right.

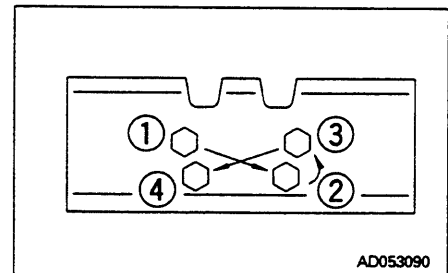
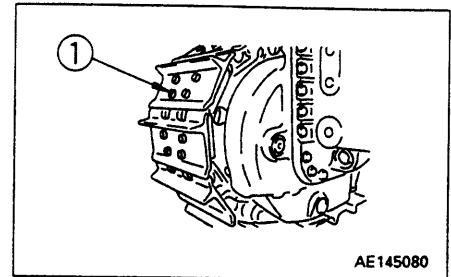

### 24.1.5 CHECK ELECTRICAL INTAKE AIR HEATER

Before the start of the cold season (once a year), contact your Komatsu distributor to have the electrical intake air heater repaired or checked for dirt or disconnections.

**24.1.6 REVERSE AND REPLACE THE END BITS AND CUTTING EDGES**

**⚠ WARNING**

It is dangerous if the work equipment moves by mistake when the cutting edges and end bits are being reversed or replaced. Set the work equipment in a stable condition, then stop the engine and lock the blade control lever securely with the safety lock lever.

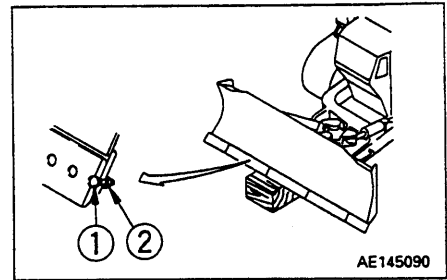

**NOTICE**

The safety lever cannot be set to the LOCK position to lock the blade control lever if the control lever is at the FLOAT position. Always return the blade control lever to the HOLD position, then set the safety lock lever to the LOCK position.

Reverse or replace the end bits and cutting edges before it is worn out to the blade end.

1. Raise the blade to a proper height and apply a block to the frame so as to prevent fall of the blade.
2. Operate the safety lock lever to the LOCK position.
3. Measure the wear of the end bit and cutting edge in accordance with the wear standards given below.

**Wear standards**

Unit: mm (in)

Item		Judgement standard	
No.	Measurement point	Standard dimension	Repair limit
1	Height of end bit	160 (6.3)	110 (4.3)
2	Width of end bit	380 (15.0)	-
3	Height of cutting edge (from center of bolt mounting hole to end face)	80 (3.2)	55 (2.2)

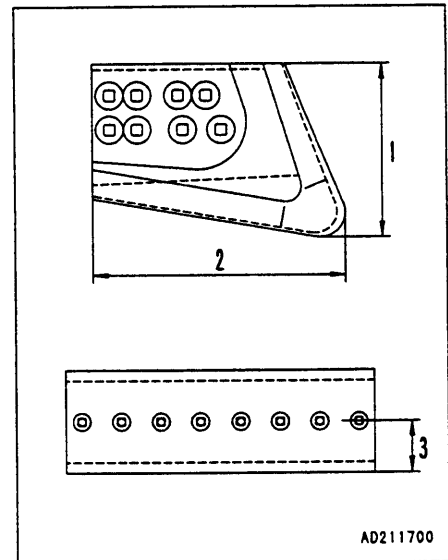

If the cutting edge and the end bit on both sides are worn out, replace with new one.

If it has been worn out up to the fitting surface, repair the fitting surface and then reverse or replace.

4. Remove the cutting edge and the end bit and clean the mounting surface.
5. Reverse or replace the cutting edge and the end bit when worn out.

Nut tightening torque:

255 ± 34 Nm  
(26 ± 3.5 kgm, 188 ± 25 lbf)

If bolt ① and nut ② are damaged, replace them with new ones at the same time.

6. After several hours of running, retighten the nuts.

### 24.1.7 CLEAN, CHECK RADIATOR FINS

#### **⚠ WARNING**

If compressed air, steam, or water hit your body directly, there is danger of injury. Always wear protective glasses, mask, and safety shoes.

If the radiator fins are clogged or dirty, clean and inspect them.

1. Remove 4 bolts ①, and remove covers ②.
2. Clean the radiator fins clogged with mud, dust and leaves with compressed air. Steam or water may be used instead of compressed air.

#### **REMARK**

Check the rubber hose. If the hose is found to have cracks to be hardened by ageing, replace such hose with new one. Further, loosen hose clamp should also be checked.

3. Install covers ②.

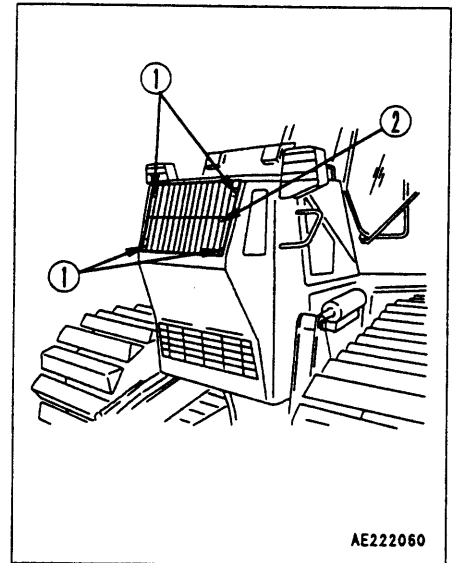

### 24.1.8 ADJUST PLAY IN CENTER BALL

When transporting the machine, the blade must be removed. When the blade is assembled again, the center ball play must be adjusted. If it is not adjusted, dirt will get in, and this will lead to premature wear and damage, and to shaking of the blade during operations.

Adjust as follows.

#### **⚠ WARNING**

Always apply the safety lock to the blade control lever securely. Release the safety lock only when operating the blade during the adjustment operation.

#### **NOTICE**

The safety lock cannot be applied when the blade control lever is at the FLOAT position. Always return the blade to the HOLD position, then move the safety lever to the LOCK position.

1. Remove bolt ① and cap ④, then remove shim ②.
2. Without installing the shim, install cap ④ and tighten bolt ①.
3. Measure clearance A, then add 0.2 – 0.7 mm to calculate the shim thickness. Assemble this shim thickness.  
Shim thickness: 0.5 mm x 4  
1.0 mm x 6

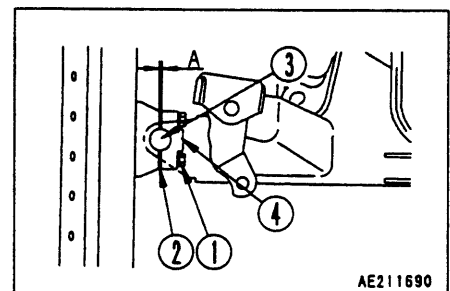

### 24.1.9 CHECK, ADJUST AIR CONDITIONER (MACHINES EQUIPPED WITH CAB)

#### CHECKING TENSION OF COMPRESSOR BELT

If the belt is loose, it will slip and the cooling effect will be reduced. From time to time, press a point midway between the drive pulley and compressor pulley with your finger (approx. 10 kg (22.05 lb)) and check that the tension is 15 – 18 mm (0.59 – 0.71 in).

When the belt is new, there will be initial elongation, so always adjust again after 2 or 3 days.

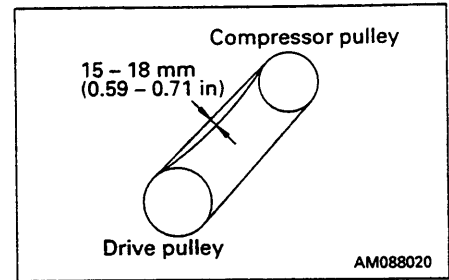

#### CHECK LEVEL OF REFRIGERANT (GAS)

#### ⚠ WARNING

The refrigerant used in the cooler is colorless and odorless and does not harm the atmosphere, but if the liquid gets into your eyes or on your hands, it may cause loss of sight or frostbite, so never loosen any part of the refrigerant circuit.

If the level of the refrigerant (gas) is low, the cooling effect will be reduced. Run the engine at high idling, and check the flow of the refrigerant in the refrigerant circuit through the sight glass of the receiver when the cooler is running at high speed.

- No bubbles in refrigerant flow: Correct
- Bubbles in refrigerant flow (bubbles continuously pass through): Refrigerant level low
- Colorless, transparent: No refrigerant

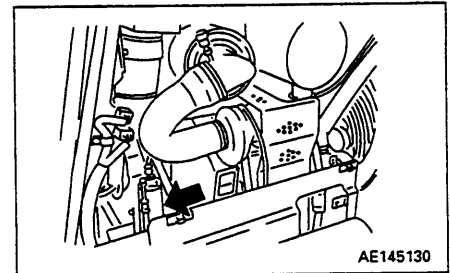

#### REMARK

When there are bubbles, the refrigerant gas level is low, so contact your refrigerant dealer to have refrigerant added. If the air conditioner is run with the refrigerant gas level low, it will cause damage to the compressor.

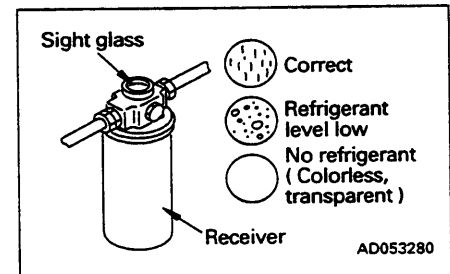

### 24.1.10 GREASE DOOR HINGE (MACHINES EQUIPPED WITH CAB)

If the door makes a squeaking noise when it is opened or closed, spray lubricant in through the split in the hinge bushing.

If the bushing is worn, replace the hinge.

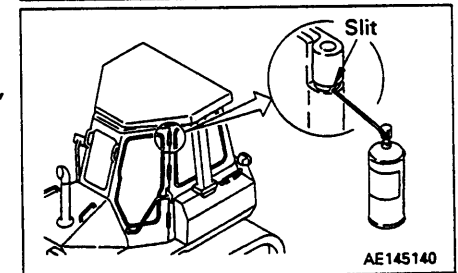

### 24.1.11 CHECK DOOR LOCK STRIKER (MACHINES EQUIPPED WITH CAB)

If the wear of the doors lock striker exceeds 0.5 mm (0.02 in), replace the striker. If it is used at it is, the play will increase and this may result in breakage of the hinge or door lock.

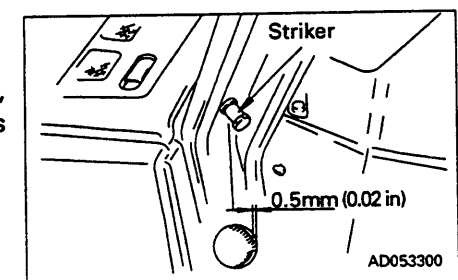



**24.1.12 REPLACE DOOR DAMPER  
(MACHINES EQUIPPED WITH CAB)**

If the depth of the door damper rubber groove is less than 2 mm (0.08 in), replace the damper.

There are two dampers each at the top and bottom on the left and right doors.

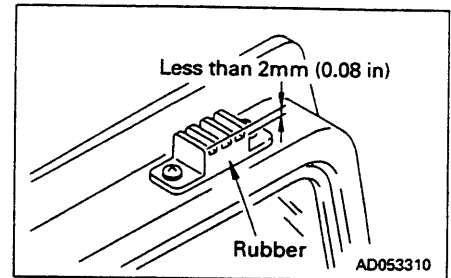

**24.1.13 CHECK WINDOW WASHER FLUID LEVEL, ADD FLUID (MACHINES EQUIPPED WITH CAB)**

If there is air in the window washer fluid, check the level and add fluid.

Open the engine side cover on the right side, check the level of the fluid in window washer tank ①, and if it is low, add automobile window washer fluid.

When adding fluid, be careful not to let dirt or dust get in.

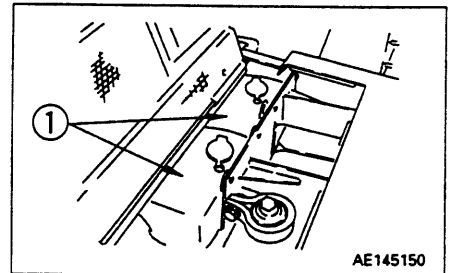

**24.1.14 REPLACE WIPER BLADE  
(MACHINES EQUIPPED WITH CAB)**

If the blade is damaged, it will not wipe the window clean, so replace the blade.

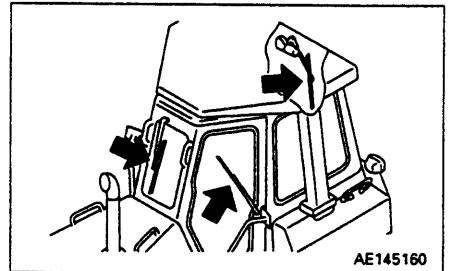

**Method of replacement**

● Front, rear wiper

1. Remove screw ①, then remove the blade.
2. Install a new blade, then tighten screw ① securely.

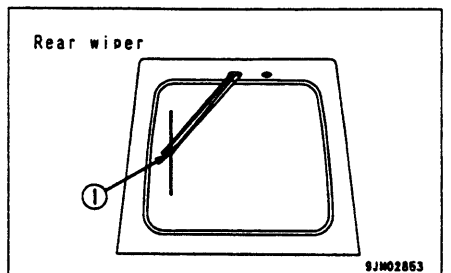
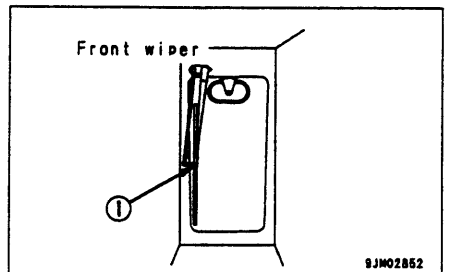

● Door wiper

1. It is hooked at portion ①, so move the blade in the direction of the arrow to remove it.
2. Install the new blade and hook it securely.

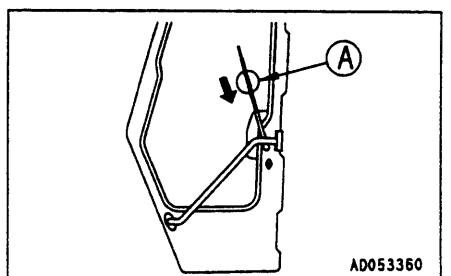

### 24.1.15 CHECK IDLER OIL LEVEL, ADD OIL

If the oil level in the idler is low, noise will be generated and there will be seizure, so check the oil level as follows.

#### Checking

1. Stop the machine on level ground.
2. Loosen seal bolt ① slowly and check if oil oozes out from the thread. If oil oozes out, the oil level is normal, so tighten the bolt again immediately.

#### REMARK

If oil does not come out even if seal bolt ① is removed, the oil level is low, so please contact your Komatsu distributor for repairs.

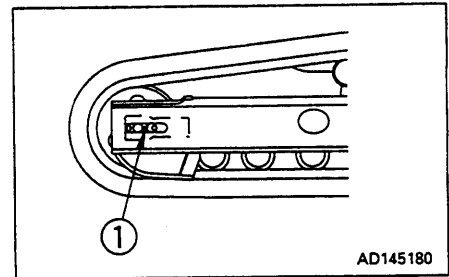

AD145180

## 24.1.16 CHECK OIL LEVEL IN DAMPER CASE, ADD OIL

**⚠ WARNING**

- The oil is very hot just after the operation. Wait until the oil temperature drops, then start the work.
- The undercover is heavy. Do not open or close it just under it. When removing bolt ②, stand after the cover so that you can escape at any moment.
- When removing drain plug ⑤ of the damper case, take care not to get soaked with oil.

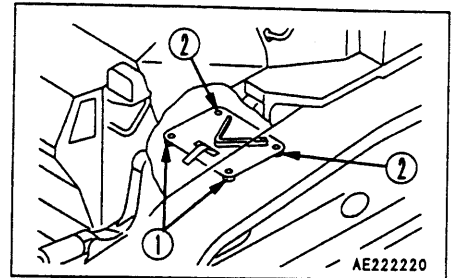

If the quantity of the oil in the damper is insufficient, the damper may be seized. Accordingly, check, and add or replace the oil according to the following procedure.

- At the time of "24.6.1 CHANGE OIL IN TRANSMISSION CASE, CLEAN STRAINER IN POWER TRAIN", check the oil in the damper case and add new oil.
1. Remove the undercover from the rear bottom of the machine body according to the following procedure.
    - 1) Remove two bolts ① from the front side of the machine body.
    - 2) Holding the cover, remove two bolts ② from the rear side of the machine body.
    - 3) Lower and open the cover gradually.  
Weight of undercover: 25 kg (55 lb)
  2. Remove oil level plug ③ and check the oil level. The proper oil level is the bottom edge of the plug hole. Tighten plug ③.

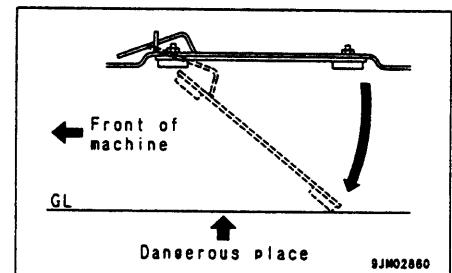
**REMARK**

- Check the oil level while the engine is stopped.
  - If the machine is inclined, set it in a level position before checking the oil level.
3. If the oil level is below the bottom edge of the plug hole, remove oil filler plug ④ and add new oil. Add new engine oil until the oil level reaches the bottom edge of oil level plug ③.
  4. After adding the oil, tighten plug ③ and ④.

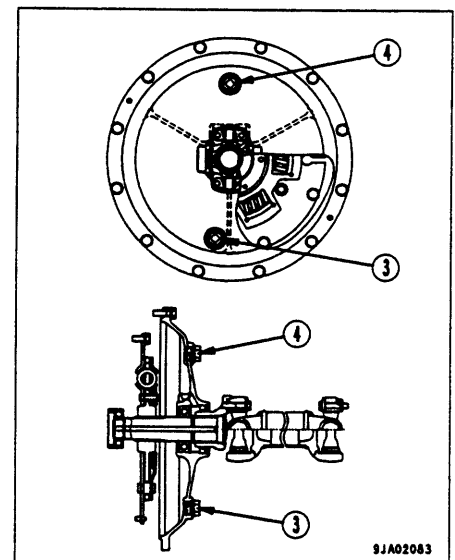

## **24.2 CHECK BEFORE STARTING**

For details of the following items, see "12.1.2 CHECK BEFORE STARTING" in the OPERATION section.

- CHECK COOLANT LEVEL, ADD WATER
- CHECKING WITH MACHINE MONITOR
- CHECK FUEL LEVEL, ADD FUEL
- CHECK OIL LEVEL IN ENGINE OIL PAN, ADD OIL
- CHECK OIL LEVEL IN TRANSMISSION CASE, ADD OIL
- CHECK OIL LEVEL IN STEERING CLUTCH CASE, ADD OIL
- CHECK ELECTRIC WIRING
- CHECK BRAKE PEDAL TRAVEL
- CHECK INCHING PEDAL TRAVEL
- CHECK DUST INDICATOR
- CHECK THAT LAMPS LIGHT UP
- CHECK HORN SOUND
- CHECK BACK UP ALARM SOUND
- CHECK SEAT BELT FOR WEAR OR DAMAGE
- CHECK FOR WATER AND SEDIMENT IN WATER SEPARATOR, DRAIN WATER

## 24.3 EVERY 50 HOURS SERVICE

### 24.3.1 DRAIN WATER, SEDIMENT FROM FUEL TANK

Open the inspection cover at the bottom of the fuel tank, loosen valve ①, and drain the fuel together with the water and sediment accumulated at the bottom of the tank.

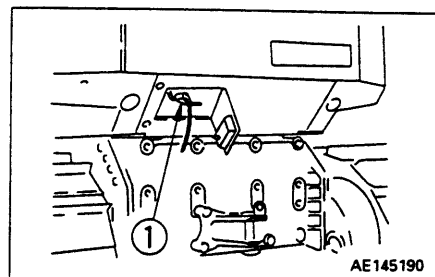

## 24.4 EVERY 250 HOURS SERVICE

Maintenance for every 50 hours service should be carried out at the same time.

### 24.4.1 LUBRICATING

1. Lower the work equipment to the ground, then stop the engine.
2. Using a grease pump, pump in grease through the grease fittings shown by arrows.
3. After greasing, wipe off any old grease that was pushed out.

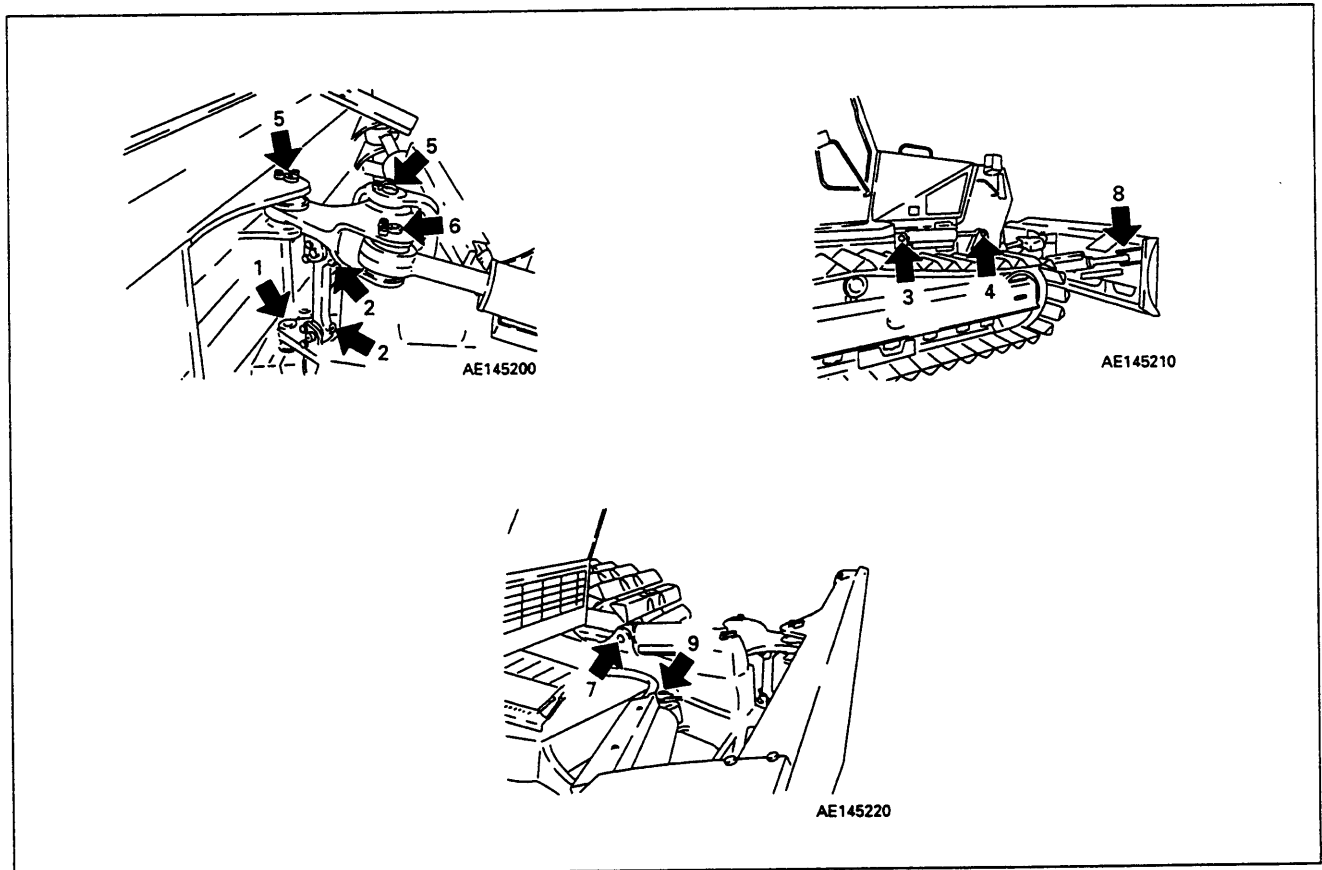

1. Angle-tilt frame center pin (1 place)
2. Tilt link lift rod (2 places)
3. Lift cylinder bottom pin (2 places)
4. Lift cylinder head pin (2 places)
5. Tilt link (2 places)
6. Tilt cylinder head pin (1 place)
7. Tilt cylinder bottom pin (1 place)
8. Angle cylinder head pin (1 place)
9. Angle cylinder bottom pin (1 place)

## 24.4.2 CHECK OIL LEVEL IN FINAL DRIVE CASE, ADD OIL

**⚠ WARNING**

The oil is at high temperature immediately after the machine has been operated. Wait for the oil to cool down before starting the operation.

1. Remove oil level plug ① and check whether the final drive case is filled with oil to lower edge of the plug hole.
2. If the oil level is still too low, add engine oil through the level plug hole until the oil overflows.

For details of the oil to use, see "20. USE OF FUEL, COOLANT AND LUBRICANTS ACCORDING TO AMBIENT TEMPERATURE".

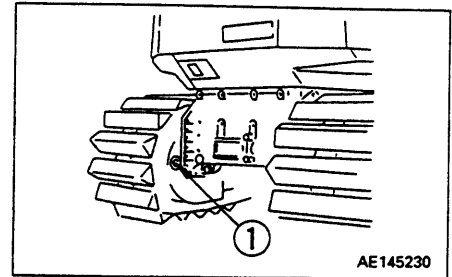

## 24.4.3 CHECK OIL LEVEL IN HYDRAULIC TANK, ADD OIL

**⚠ WARNING**

When removing the oil filler cap, oil may spurt out, so stop the engine and wait for the oil temperature to go down, then turn the cap slowly to release the internal pressure before removing the cap.

**NOTICE**

Do not add oil if the level is above the H line. This will damage the hydraulic equipment and cause the oil to spurt out.

Always lock the cap with the key.

1. Lower the blade to the ground, stop the engine and wait for about 5 minutes before checking oil level. If oil level is between H and L in sight gauge ㉔.
2. If the level is below the L mark, add engine oil through oil filler ㉕.

For details of the oil to use, see "20. USE OF FUEL, COOLANT AND LUBRICANTS ACCORDING TO AMBIENT TEMPERATURE".

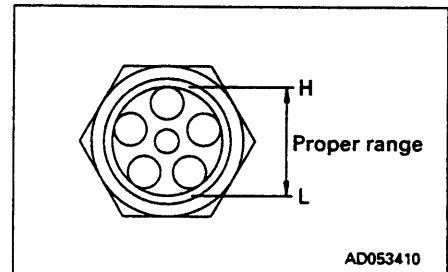
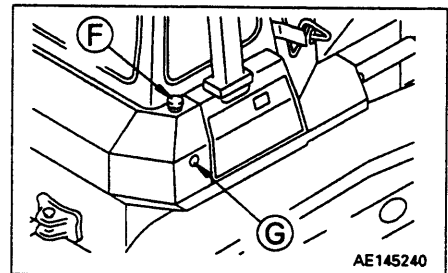
**⚠ WARNING**

If oil has been added to above the H mark, stop the engine and wait for the hydraulic oil to cool down, then drain the excess oil from the drain plug.

3. After adding oil, tighten the cap securely and lock with the key.

### 24.4.4 CHECK LEVEL OF BATTERY ELECTROLYTE

**⚠ WARNING**

- Since the battery produces combustible gas and can explode, do not bring fire near it.
- The battery fluid is a dangerous object. Take care that it will not stick to your eyes or skins. If it sticks, wash it away with a large quantity of water, then see a doctor.
- Do not use or change the battery when its fluid level is below the LOWER LEVEL. If it is used or charged as it is, it may explode.  
Be sure to check the battery fluid level periodically and add distilled water to the UPPER LEVEL, if necessary.

Carry out this check before operating the machine.

1. Open the battery cover ①.
2. Check the battery electrolyte level from the side of the battery case. If it is not up to the UPPER LEVEL line, remove cap ② and add distilled water to the UPPER LEVEL line.  
Do not add water above the UPPER LEVEL line. This may cause leakage of the electrolyte, which may cause fire.
3. Clean the air hole in the battery cap ②, then tighten the cap securely.  
Wipe the top surface of the battery with a damp cloth to keep it clean.

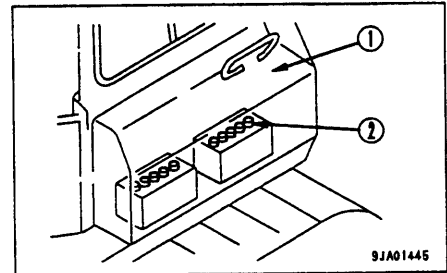

**NOTICE**

When adding distilled water in cold weather, add it before starting operations in the morning to prevent the electrolyte from freezing.

### 24.4.5 CHECK, CLEAN FUEL STRAINER

1. Open the inspection cover at the bottom of the fuel tank.
2. Tighten the fuel supply valve, then remove the cap, and clean the strainer and strainer case.  
The strainer forms one unit with the cap.
3. Set the strainer in the case, then tighten the cap.
4. After installing, open the fuel supply valve.

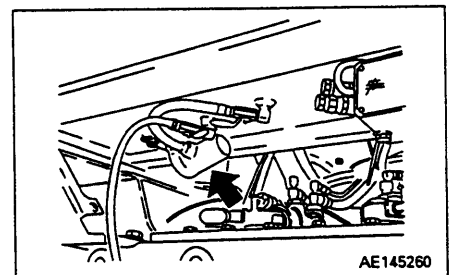



### 24.4.6 CHANGE OIL IN ENGINE OIL PAN, REPLACE ENGINE OIL FILTER CARTRIDGE

#### **⚠ WARNING**

The oil is at high temperature after the engine has been operated, so never change the oil immediately after finishing operations. Wait for the oil to cool down before changing it.

Prepare the following.

- Container to catch drained oil: Min 22.8 ℓ capacity
- Refill capacity: 22.8 ℓ (6.02 US gal, 5.02 UK gal)
- Socket wrench, filter wrench.

1. Remove the cover at the bottom of the machine and set a container to catch the oil under the drain plug.
2. Remove drain plug **Ⓟ** slowly to avoid getting oil on yourself, and drain the oil.
3. Check the drained oil, and if there are excessive metal particles or foreign material, please contact your Komatsu distributor.
4. Install drain plug **Ⓟ**.

5. Using a filter wrench, turn filter cartridge **①** counterclockwise to remove it. When doing this, to prevent getting oil on yourself, do not carry out this operation from immediately under the cartridge.

In particular, if this operation is carried out immediately after stopping the engine, a large amount of oil will come out, so wait for 10 minutes before starting the operation.

6. Clean the filter holder, fill the new filter cartridge with engine oil, coat the packing surface and thread with engine oil (or coat it thinly with grease).
7. When installing the filter cartridge, bring the packing surface into contact with the filter holder, then tighten a further 3/4-1 turn. There is a mark on the outside of the cartridge, so use this as a guideline.
8. After replacing the filter cartridge, add engine oil through oil filler **ⓕ** until the oil level is between the H and L marks on dipstick **Ⓢ**.  
For details of the oil to use, see "20. USE OF FUEL, COOLANT AND LUBRICANTS ACCORDING TO AMBIENT TEMPERATURE".
9. Run the engine at idling for a short time, then stop the engine, and check that the oil level is between the H and L marks on dipstick **Ⓢ**. For details, see "24.2 CHECK BEFORE STARTING".

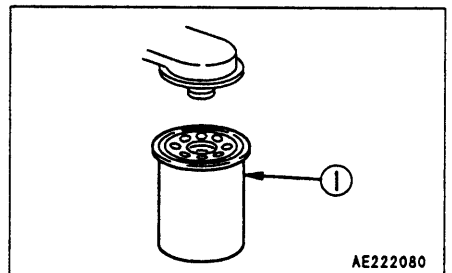
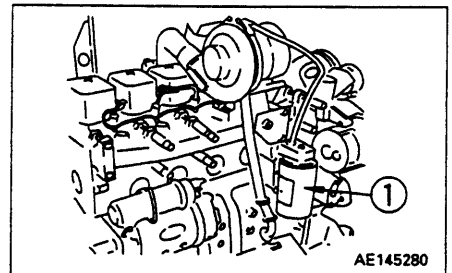
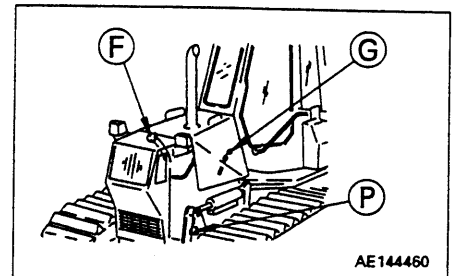

### 24.4.7 CHECK BRAKE PERFORMANCE

**⚠ WARNING**

If the machine moves during the following operation, please contact your Komatsu distributor for repairs immediately.

**NOTICE**

Do not place the gear shift lever in 1st under any circumstances. The machine will be damaged.

Before starting the engine, check that the area around the machine is safe, then do as follows.

1. Depress inching pedal ⑦ fully.
2. Start the engine.
3. Set safety lever ① to the FREE position then operate blade control lever ② to raise the blade. Leave the safety lever to the FREE position.
4. Set parking lever ③ to the FREE position.
5. Operate fuel control lever ⑥ and pull to the low idling positions.
6. Depress brake pedal ④, set joystick ⑤ to 2nd, check that the display on speed range display window ⑧ shows 2nd, then move joystick ⑤ to the FORWARD position.
7. Keep brake pedal ④ depressed and slowly release inching pedal ⑦.
8. If the machine does not move with the above operation when the engine is stopped, the service brake is normal.

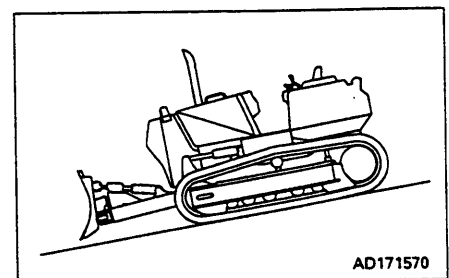
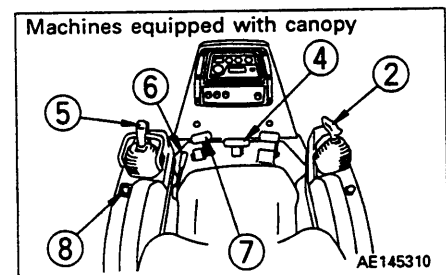
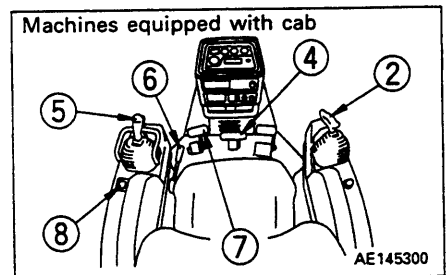
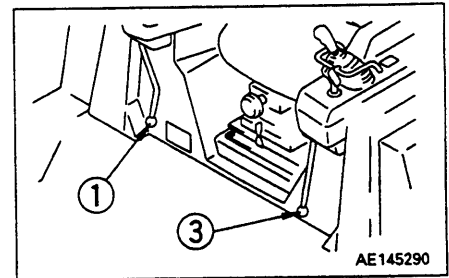

**REMARK**

If the decelerator pedal is released suddenly, the machine may move momentarily, but if it does not move when the decelerator pedal is released slowly, the situation is normal.

9. Next, check the parking brake. Move the machine to a slope and stop it with the front facing downhill.
10. With the engine running and the machine on a slope, press brake pedal ④ and set joystick ⑤ to the neutral position to stop the machine.
11. Set parking brake lever ③ to the LOCK position. Release brake pedal ④. If the machine does not move, the parking brake is working normally.
12. If the machine moves, press brake pedal ④.

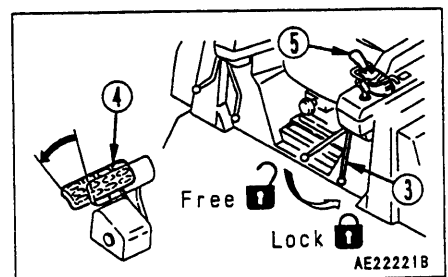

### 24.4.8 CLEAN AIR CONDITIONER AIR FILTER (FRESH/RECIRC FILTER) (MACHINES EQUIPPED WITH CAB)

If the air conditioner air filter is clogged or there is dirt or dust in it, clean the filter.

1. Open inspection cover ①, remove cover ②, then remove FRESH filter ③.
2. Open inspection cover ④ under the front panel, pull up RECIRC filter ⑤, and remove it.
3. Clean filters ③ and ⑤ with compressed air. If there is oil stuck to the filter, or it is extremely dirty, wash it in a neutral agent. After washing it, dry it completely before installing it again. If the clogging of the filter cannot be removed by washing or using compressed air, replace the filter with a new part.

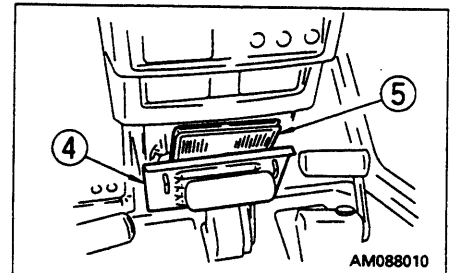
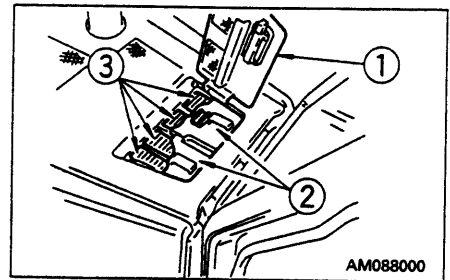

## 24.5 EVERY 500 HOURS SERVICE

Maintenance for every 50 and 250 hours service should be carried out at the same time.

### 24.5.1 REPLACE FUEL FILTER CARTRIDGE

**⚠ WARNING**

- Engine is at high temperature immediately after the machine has been operated. Wait for engine to cool down before replacing the filter.
- Do not bring fire or sparks near the fuel.

Prepare a filter wrench and a container to catch the fuel.

1. Set the container to catch the fuel under the filter cartridge.
2. Using a filter wrench, turn filter cartridge ① counterclockwise to remove it.
3. Clean the filter holder, fill a new filter cartridge with clean fuel, coat the packing surface with engine oil, then install it to the filter holder.

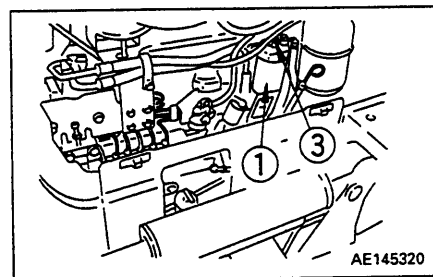

4. When installing, tighten until the packing surface contacts the seal surface of the filter holder, then tighten it up 1/2 of a turn. There is a mark on the outside of the cartridge, so use this as a guideline.  
If the filter cartridge is tightened too far, the packing will be damaged and this will lead to leakage of fuel. If the filter cartridge is too loose, fuel will also leak from the packing, so always tighten to the correct amount.

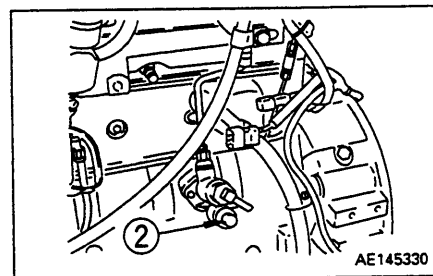

5. After replacing the filter cartridge, loosen air bleed plug ③.
6. Press the button of feed pump ② repeatedly until no more bubbles come out with the fuel from plug ③.
7. Tighten air bleed plug ③.
8. After replacing the filter cartridge, start the engine and check that there is no leakage of fuel from the filter seal surface. If there is any leakage of fuel, check the tightening of the filter cartridge. Whenever there is leakage of fuel, follow Steps 1 and 2 to remove the filter cartridge, then check the packing surface for damage or foreign material. If any damage or foreign material is found in the packing, replace the packing with a new part, then repeat Steps 3 – 7 to install the filter cartridge.

## 24.6 EVERY 1000 HOURS SERVICE

Maintenance for every 50, 250 and 500 hours should be carried out at the same time.

### 24.6.1 CHANGE OIL IN TRANSMISSION CASE, CLEAN STRAINER IN POWER TRAIN

#### ⚠ WARNING

- The oil is at high temperature immediately after the machine has been operated. Wait for the oil to cool down before starting the operation.
- The undercover is heavy.  
Never try to open or close the cover when directly beneath it. When removing bolts ②, carry out the work from the rear below the cover so that you can easily get out of the way.

Prepare the following.

- Container to catch drained oil: Min 22.5 ℓ capacity
  - Refill capacity: 22.5 ℓ (5.9 US gal, 5.0 UK gal)
1. Loosen drain plug ① (with a slit), drain the oil, then tighten drain plug ① again.  
Do not remove drain plug ①.
  2. Remove the undercover at the bottom rear of the machine as follows.
    - (1) Remove 2 bolts ① at the front of the machine.
    - (2) Support the cover with your elbow while gradually removing 2 bolts ② at the rear of the machine.
    - (3) Lower the cover gradually to open it.
  3. Loosen mounting bolt ③ of the power train strainer, then remove cover ④.
  4. Take out spring ⑤, then take out strainer ⑥.
  5. Remove all dirt from strainer ⑥, then wash in clean diesel oil or flushing oil.  
Clean the case interior and the removed parts.

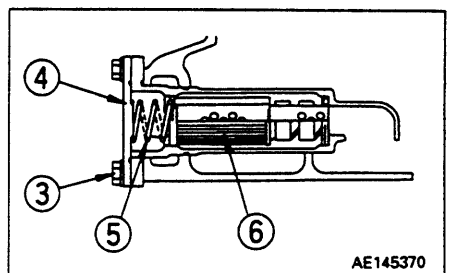
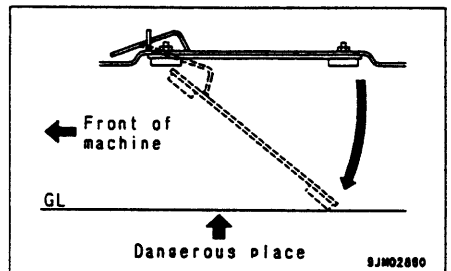
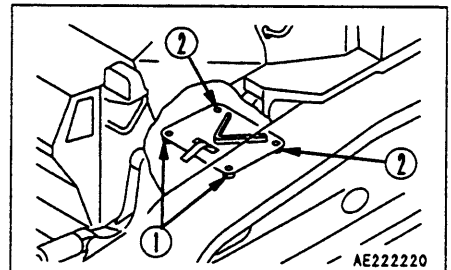
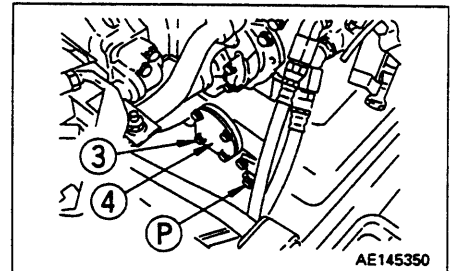

## 24. SERVICE PROCEDURE

---

6. Install the strainers to their original position.
7. After installing, replace the cartridge in the power train oil filter.  
For details, see "24.6.2 REPLACE TRANSMISSION OIL FILTER CARTRIDGE".
8. Refill the specified quantity of engine oil through oil filler  $\text{Ⓕ}$ .  
For details of the oil to use, see "20. USE OF FUEL, COOLANT AND LUBRICANTS ACCORDING TO AMBIENT TEMPERATURE".
9. Check that the oil is at the specified level.  
For details, see "24.2 CHECK BEFORE STARTING".

If the spring or strainer are damaged, replace them.

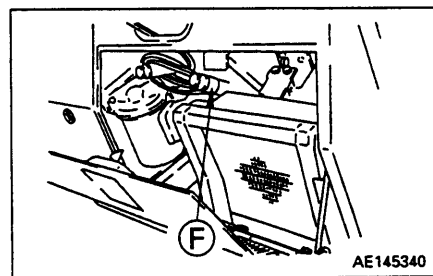

## 24.6.2 REPLACE TRANSMISSION OIL FILTER CARTRIDGE

**⚠ WARNING**

The oil is at high temperature immediately after the machine has been operated. Wait for the oil to cool down before starting the operation.

Prepare the following.

- Socket 24 mm (0.95 in)
- Handle
- Extension

1. Open cover ①.
2. Remove blind plug (rubber cap) ④ on the fender surface under the filter.
3. Use the prepared tools on the bolt head of the 24 mm (0.95 in) bolt at the bottom of the filter, then turn cartridge ② counterclockwise to remove it.
4. Replace the packing on cartridge head ③ with a new part.
5. Coat the packing surface of the new cartridge with engine oil, then install the filter cartridge.
6. When installing, tighten until the packing surface contacts the seal surface of the filter holder, then tighten to a torque of 49 – 59 Nm (5 – 6 kgm, 36 – 43 lbft).
7. Install the blind plug ④.
8. Close cover ①.

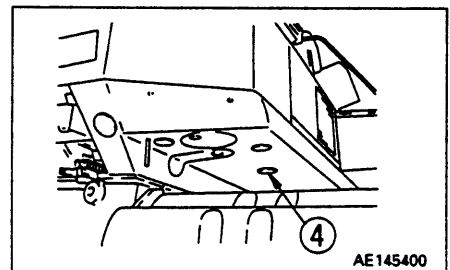
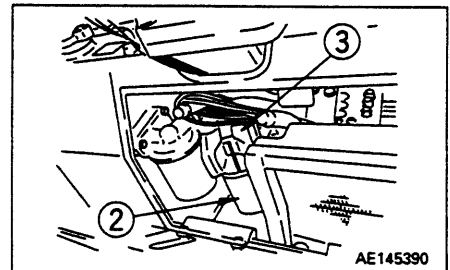
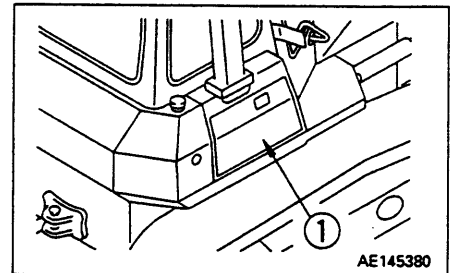
**NOTICE**

Tighten the filter to the specified tightening torque. If the torque is too low, there will be oil leakage.

### 24.6.3 CLEAN BREATHER

Remove the breather and wash out dust remaining inside with diesel oil and flushing oil.

1. Transmission case breather (1 place)

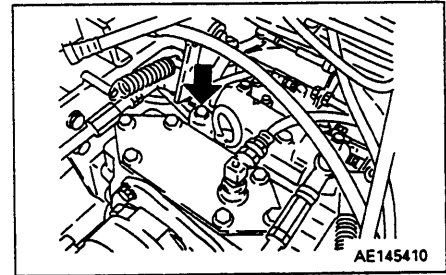

2. Steering clutch case breather (1 place)

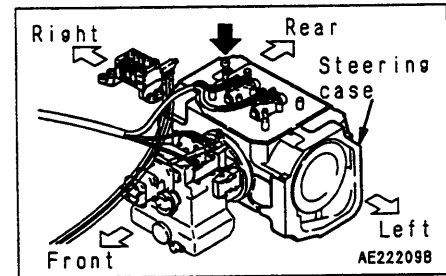

### 24.6.4 GREASE UNIVERSAL JOINT

Apply grease to the grease fittings (2 places) shown by arrows.

**WARNING**

The undercover is heavy.  
 Never try to open or close the cover when directly beneath it.  
 When removing bolts ②, carry out the work from the rear below the cover so that you can easily get out of the way.

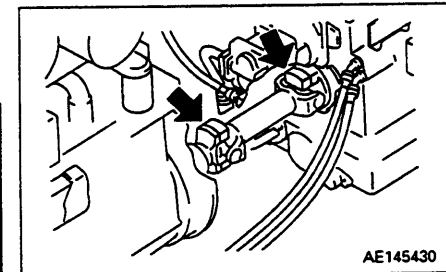

Remove the undercover at the rear bottom of the chassis as follows.

- (1) Remove 2 bolts ① at the front of the machine.
- (2) Support the cover with your elbow while gradually removing 2 bolts ② at the rear of the machine.
- (3) Lower the cover gradually to open it.

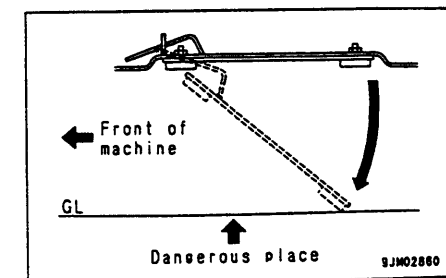
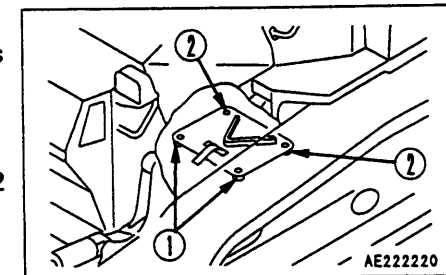



### 24.6.5 CHANGE OIL IN STEERING CLUTCH CASE

**⚠ WARNING**

The oil is at high temperature immediately after the machine has been operated. Wait for the oil to cool down before starting the operation.

Prepare the followings.

- Container to catch drained oil: Min. 74 ℓ capacity
  - Refill capacity: 74 ℓ (19.5 US gal, 16.3 UK gal)
  - Socket wrench
1. Set a container to catch the oil under drain plug **(P)** at the bottom of the machine.
  2. Remove drain plug **(P)** slowly to avoid getting oil on yourself, and drain the oil.  
After draining the oil, tighten drain plug **(P)**.
  3. Refill the specified quantity of engine oil through oil filler **(F)**.  
For details of the oil to use, see "20. USE OF FUEL, COOLANT AND LUBRICANTS ACCORDING TO AMBIENT TEMPERATURE".
  4. Check that the oil is at the specified level.  
For details, see "24.2 CHECK BEFORE STARTING".

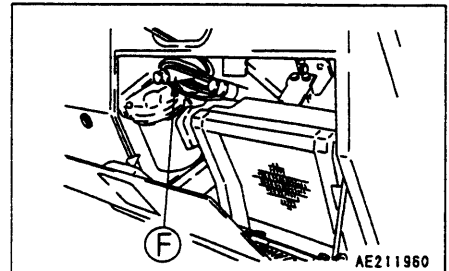
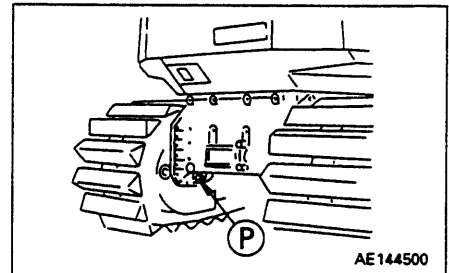

**24.6.6 CHECK FAN BELT TENSION, REPLACE**

As special tool is required for inspection or replacement the parts, you shall request Komatsu distributor for service.

The machine is equipped with an auto tensioner, so there is no need to adjust the tension.

**24.6.7 CHECK ENGINE VALVE CLEARANCE, ADJUST  
(Only after the first 1000 hours)**

Contact your Komatsu distributor for inspection or adjustment.

**24.6.8 CHECK ALL TIGHTENING PARTS OF  
TURBOCHARGER**

Contact your Komatsu distributor to have the tightening portions checked.

**24.6.9 CHECK PLAY OF TURBOCHARGER ROTOR**

Contact your Komatsu distributor to have the play checked.

**24.6.10 CHECK FOR LOOSE ROPS MOUNT BOLTS**

Check for loose and damaged bolts. If any loose bolt is found, tighten to a torque of 490 to 608 N·m (50 to 62 kgf·m, 362 to 448 lbft).

If any damaged bolt is found, replace the bolt with a genuine Komatsu bolt.

## 24.7 EVERY 2000 HOURS SERVICE

Maintenance for every 50, 250, 500 and 1000 hours service should be carried out at the same time.

### 24.7.1 CHANGE OIL IN HYDRAULIC TANK, REPLACE HYDRAULIC OIL FILTER CARTRIDGE

#### WARNING

The oil is at high temperature immediately after the machine has been operated. Wait for the oil to cool down before changing the oil. When removing the oil filler cap, turn it slowly to release the internal pressure, then remove it carefully.

Prepare the following.

- Container to catch drained oil: Min. 37 ℓ capacity
- Refill capacity: 37 ℓ (9.77 US gal, 8.14 UK gal)

1. Lower the blade on the ground securely, stop the engine and slowly turn the cap of oil filler **F** to release the internal pressure. Then, remove the cap.
2. Remove drain cover **①** at the bottom of the hydraulic tank.
3. Loosen drain valve **②** to drain the oil, then tighten valve **②** again. After tightening, install drain cover **①**.  
When loosening drain valve **②**, be careful not to get the oil on you.

#### REMARK

When draining the oil, connect a drain hose (07286-02660) to the drain tube to make the direction of drainage easier.

4. Open cover **③**.
5. Using a filter wrench, turn filter cartridge **④** to the left to remove.
6. Clean the filter holder, coat the seal surface of the new filter cartridge with engine oil (or coat thinly with grease), then install.
7. When installing, bring the packing surface into contact with the seal surface of the filter holder, then tighten approx. 2/3 turns. Always use a genuine Komatsu cartridge.
8. Add the specified amount of engine oil through the oil filler **F**. For details of the oil to use, see "20. USE OF FUEL, COOLANT AND LUBRICANTS ACCORDING TO AMBIENT TEMPERATURE".
9. Check that the oil is at the specified level. For details, see "24.4 EVERY 250 HOURS SERVICE".
10. Close cover **③**.

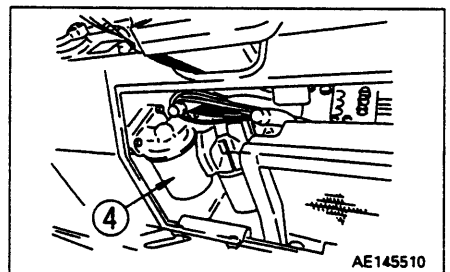
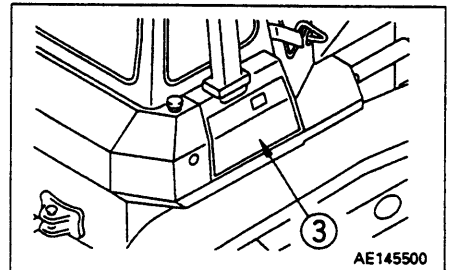
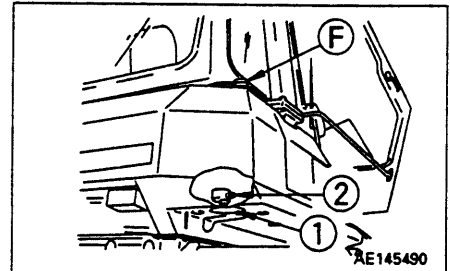

### 24.7.2 CHANGE OIL IN FINAL DRIVE CASE

**⚠ WARNING**

The oil is at high temperature immediately after the machine has been operated. Wait for the oil to cool down before starting the operation.

Prepare the following.

- Container to catch drained oil: Min. 13 ℓ capacity
- Refill capacity: 13 ℓ (3.4 US gal, 2.9 UK gal)

1. Stop the machine so that drain plug ① is directly at the bottom.
2. Remove oil level plug ②, then remove drain plug ③, and drain the oil. After draining the oil, tighten the plugs.
3. Add engine oil through the hole in oil level plug ② to the specified level (oil overflows from the plug hole).  
For details of the oil to use, see "20. USE OF FUEL, COOLANT AND LUBRICANTS ACCORDING TO AMBIENT TEMPERATURE".
4. Check that the oil is at the specified level.  
For details, see "24.4 EVERY 250 HOURS SERVICE".
5. Install oil level plug ②.

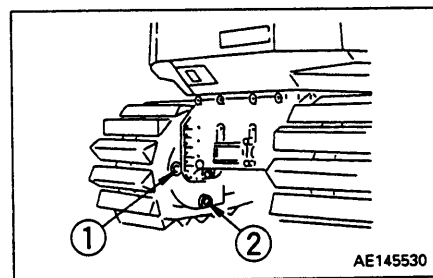

### 24.7.3 CHECK ALTERNATOR, STARTING MOTOR

The brush may be worn, or the bearing may have run out of grease, so contact your Komatsu distributor for inspection or repair.

If the engine is started frequently, carry out inspection every 1000 hours.

### 24.7.4 CHECK VIBRATION DAMPER

Check for any cracks or peeling on the outside surface of the rubber.

If there are any cracks or peeling, please contact your Komatsu distributor to have the parts replaced.

### 24.7.5 CHECK ENGINE VALVE CLEARANCE, ADJUST

Contact your Komatsu distributor for inspection or adjustment.

### 24.7.6 ADD ANTI-CORROSIVE AGENT TO COOLING SYSTEM (Applicable only in hard water areas)

#### WARNING

- Do not remove the radiator cap when the water is hot. Boiling water may spurt out. Wait for the temperature to go down, then turn the cap slowly to release the pressure before removing the cap.
- The anti-corrosive agent KI-2 is a strong alkali, so be careful not to get it on your skin. If it gets on your skin, wash it off with ample water.
- Do not use the empty anti-corrosive KI-2 packet for keeping food.

#### NOTICE

To restrict the formation of rust and scale in hard water areas, add Komatsu genuine anti-corrosive agent KI-2 (powder) to the cooling system. Never use commercially available anti-corrosive agents made by (Fleetguard, etc.).

Select the amount of anti-corrosive agent KI-2 to match the quality of cooling water.

Quality of cooling water	Amount of anti-corrosive agent
Class 1	2 packets
Class 2	4 packets

If it is unclear what the quality of the water is, please contact your Komatsu distributor.

#### Method of adding

1. Stop the engine.
2. Slowly remove radiator water filler cap ①.

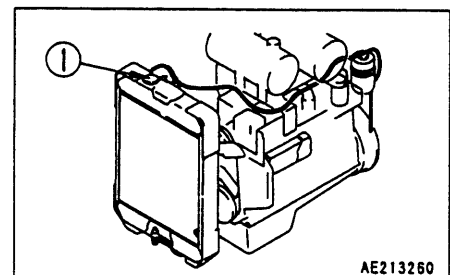

## 24. SERVICE PROCEDURE

---

3. Using a clean container, dissolve the specified number of packets of anti-corrosive agent KI-2 in fresh water.  
(At room temperature, one packet will dissolve in approx. 3 liters of water.)
4. Pour the solution made in Step 3 into the radiator through the radiator water filler.  
To prevent the radiator water from overflowing when doing this, first drain enough water from the radiator to leave room for the added solution. After adding the anti-corrosive agent solution, add fresh water to the specified level.
5. If anti-corrosive agent KI-2 is added directly through the radiator water filler, run the engine for 30 – 60 minutes to make sure that the solution is thoroughly mixed.

### REMARK

Anti-corrosive agent KI-2 can be used together with almost any brand of antifreeze, but do not use it together with DOW-THERM 209.

When using anti-corrosive agent KI-2 for the first time in the engine of a machine that is in operation, first flush the cooling system.

## **24.8 EVERY 4000 HOURS SERVICE**

**Maintenance for every 50, 250, 500, 1000 and 2000 hours service should be carried out at the same time.**

### **24.8.1 CHECK WATER PUMP**

Check that there is oil leakage, water leakage, or clogging of the drain hole. If any abnormality is found, contact your Komatsu distributor for disassembly and repair or replacement.

# **SPECIFICATIONS**



## 25. SPECIFICATIONS

	D41E-6		D41P-6	
<b>OPERATING WEIGHT (without operator)</b>	<b>Standard blade</b>	<b>Wide blade</b>	<b>Standard blade</b>	<b>Wide blade</b>
With power angle – tilt dozer and steel cab	10400 kg (22932 lb)	10470 kg (23086 lb)	10890 kg (24012 lb)	10960 kg (24167 lb)
<b>PERFORMANCE</b>				
● Travel speed	Forward	2.4 km/h (1.5 MPH)		
	1st	4.4 km/h (2.7 MPH)		
	2nd	7.6 km/h (4.7 MPH)		
	3rd	3.0 km/h (1.9 MPH)		
	Reverse	5.5 km/h (3.4 MPH)		
	1st	9.4 km/h (5.8 MPH)		
2nd				
3rd				
● Maximum drawbar pull	14540 kg (32061 lb)		14490 kg (31950 lb)	
<b>ENGINE</b>				
● Model	Komatsu S6D102E-1 diesel engine			
● Flywheel horsepower	105 HP			
● Max. torque	461 Nm (47 kgm)/1300 rpm			
● Starting motor	24 V 5.5 kW			
● Alternator	24 V 40 A			
● Battery	12 V 70 Ah x 2 pieces (65D26R)			

D41E-6  
STD blade

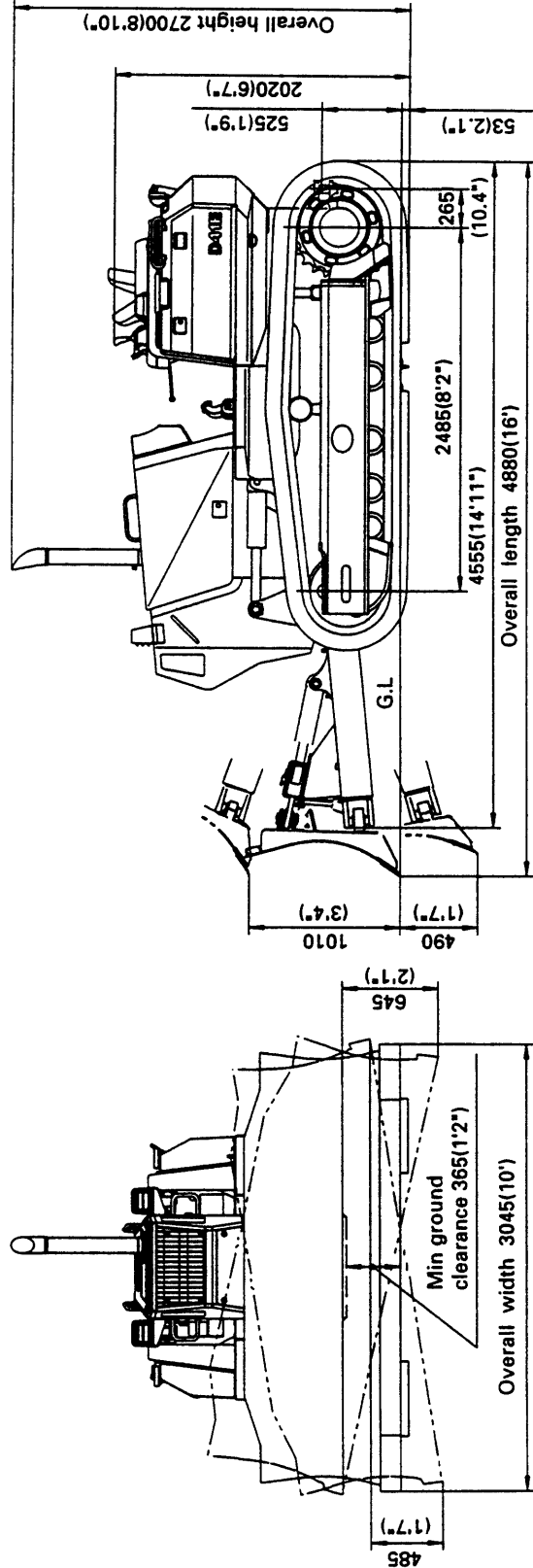
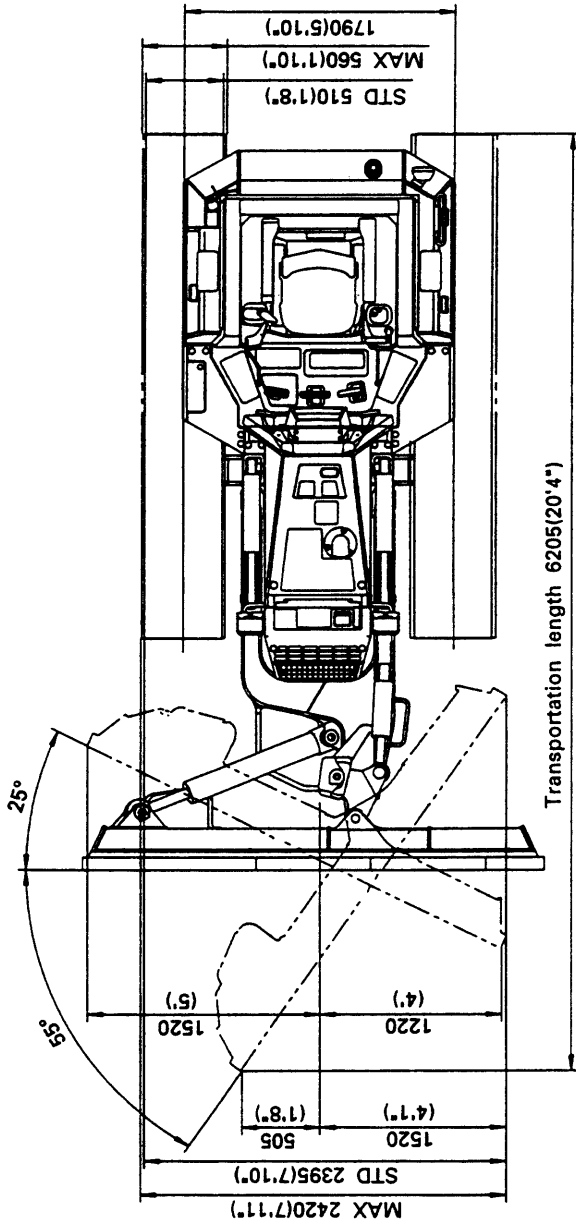

AD145540

25. SPECIFICATIONS

D41E-6  
Wide blade

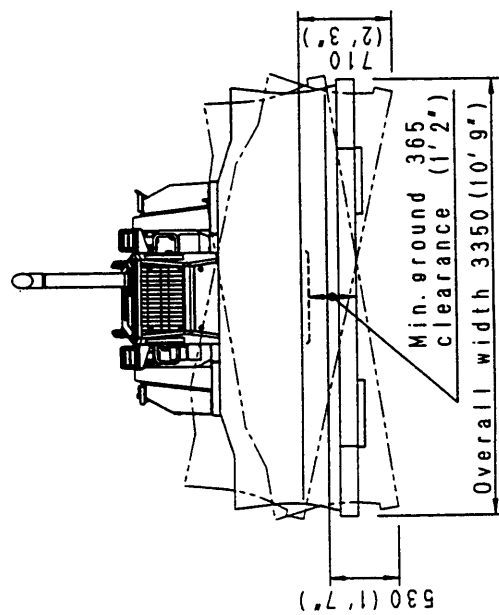
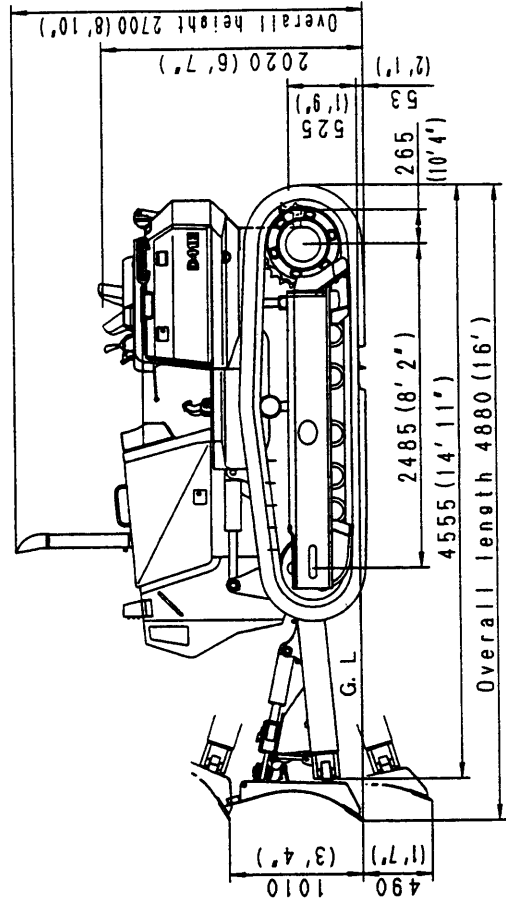
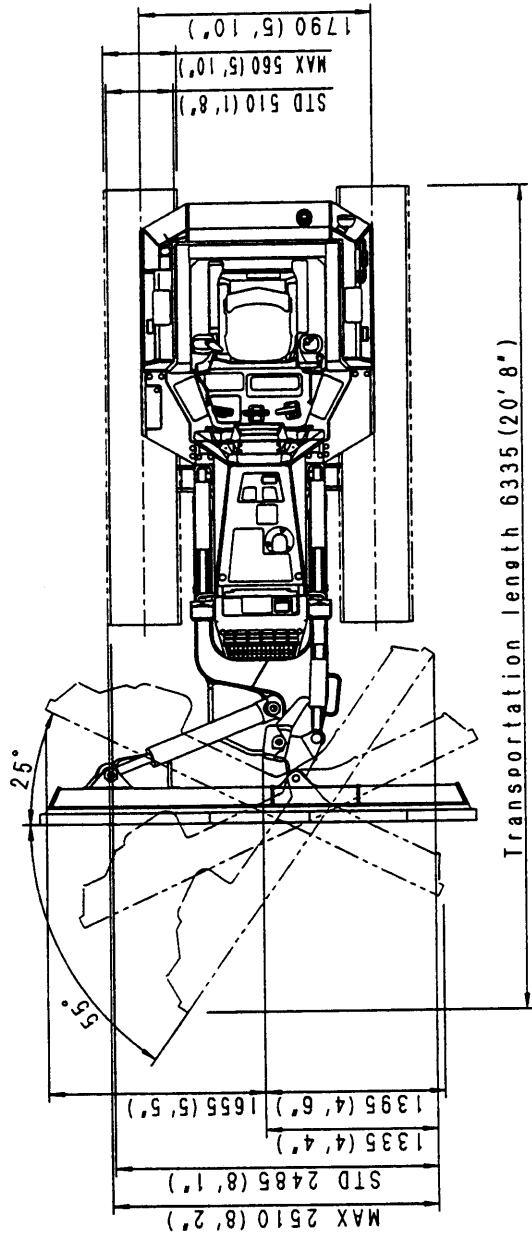

A0222238

● With cab + ROPS canopy

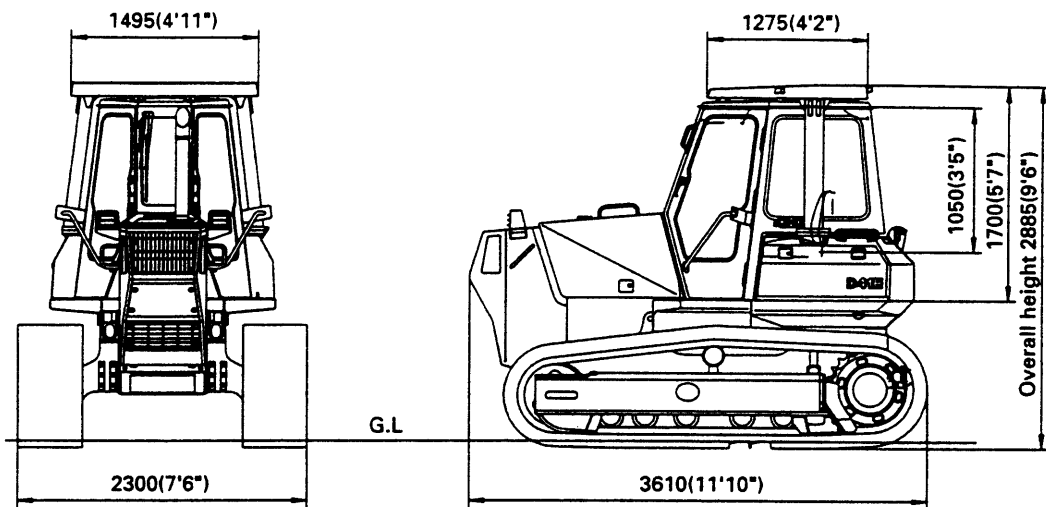

AD145550

● With canopy

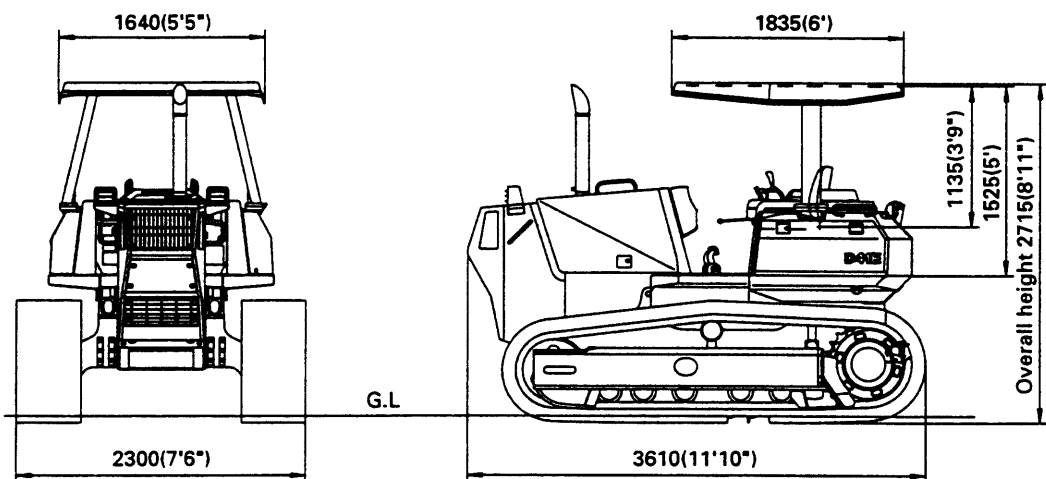

AD145560

● With ROPS canopy

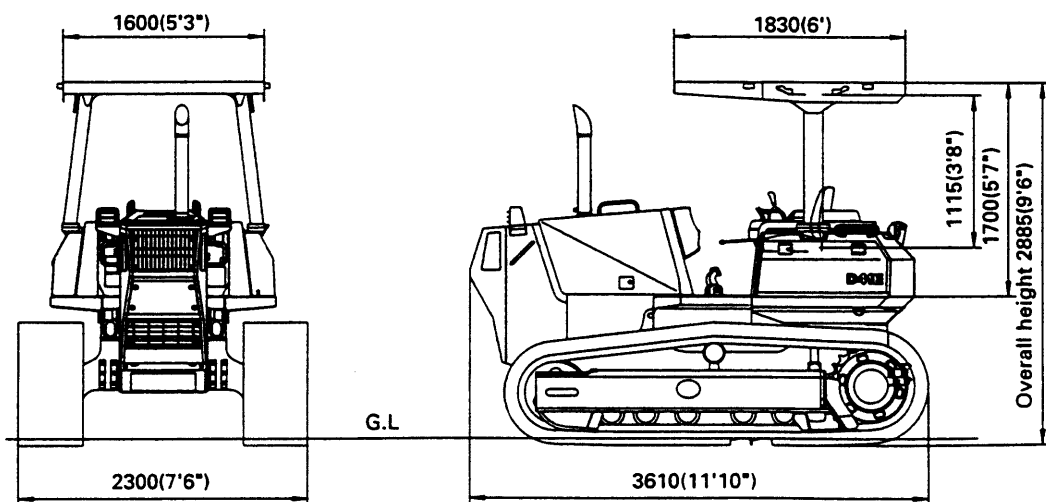

AD145570

25. SPECIFICATIONS

- With cab

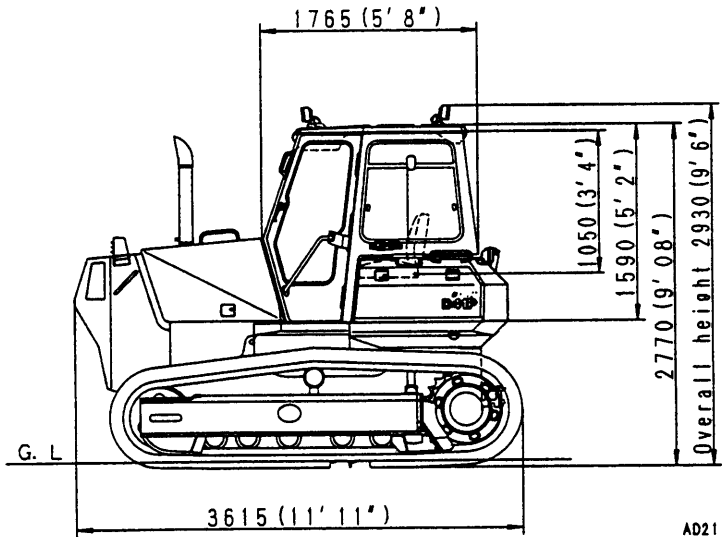
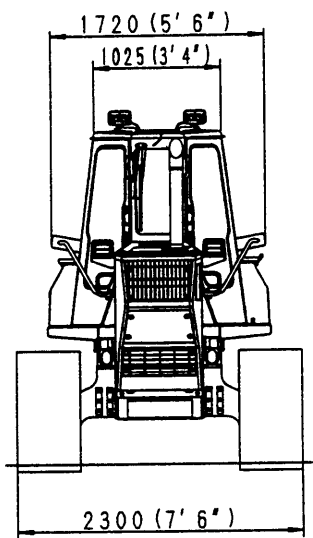

A021192B

D41P-6  
STD blade

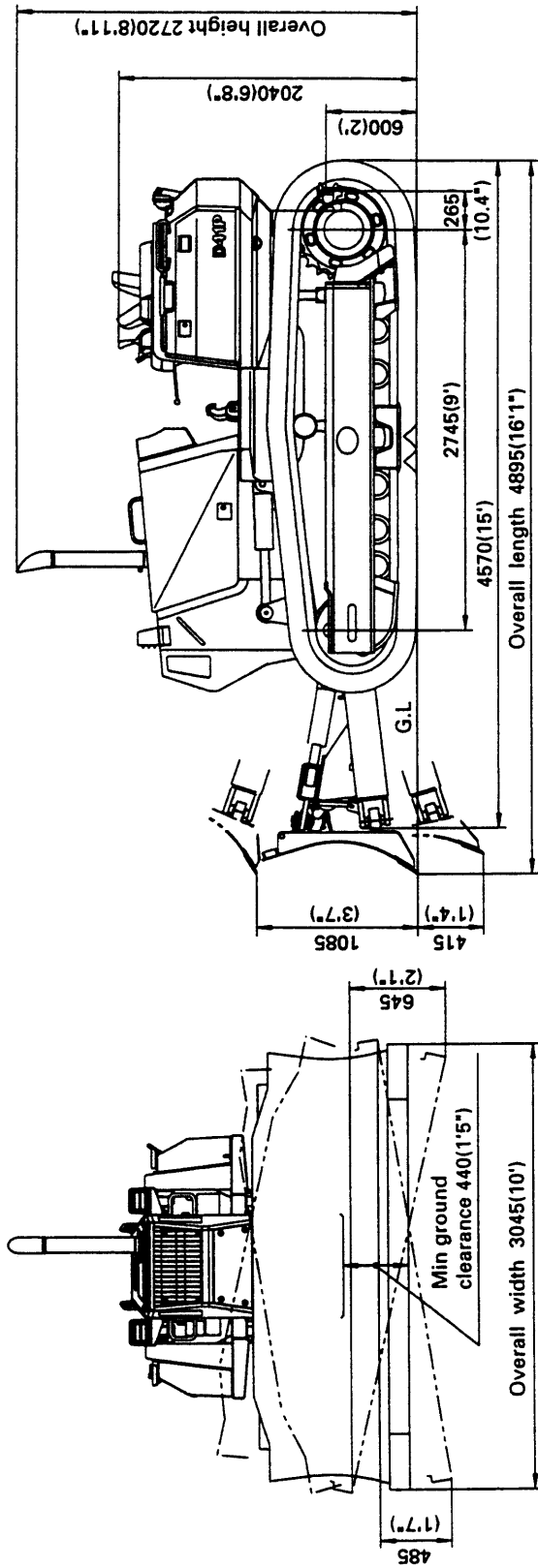
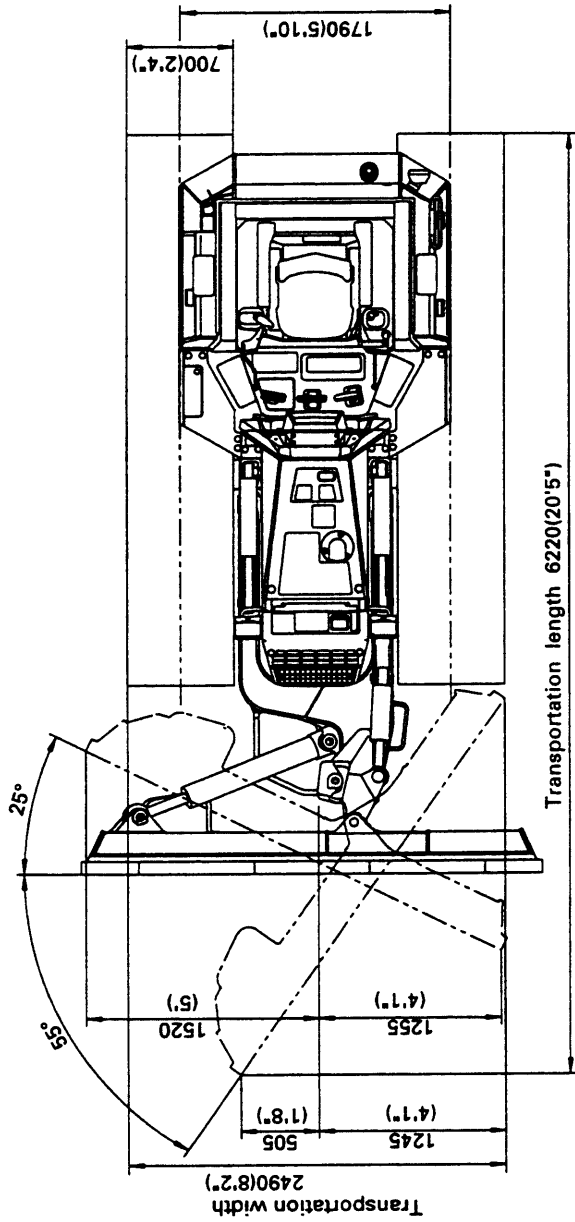

AD145580

25. SPECIFICATIONS

D41P-6  
Wide blade

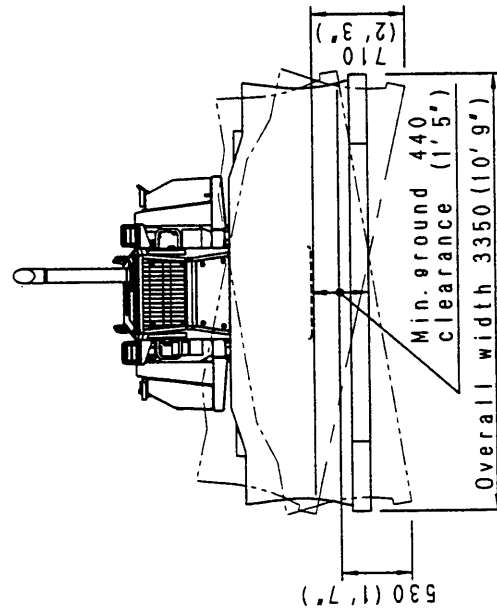
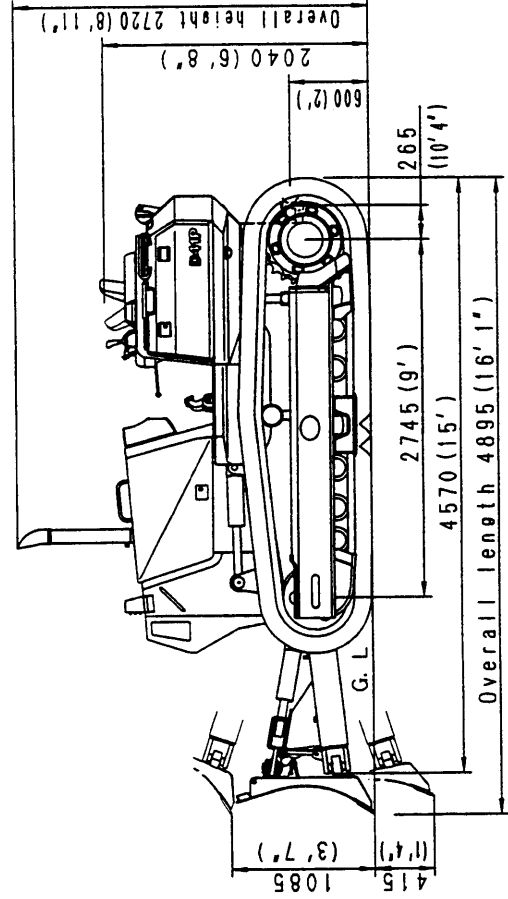
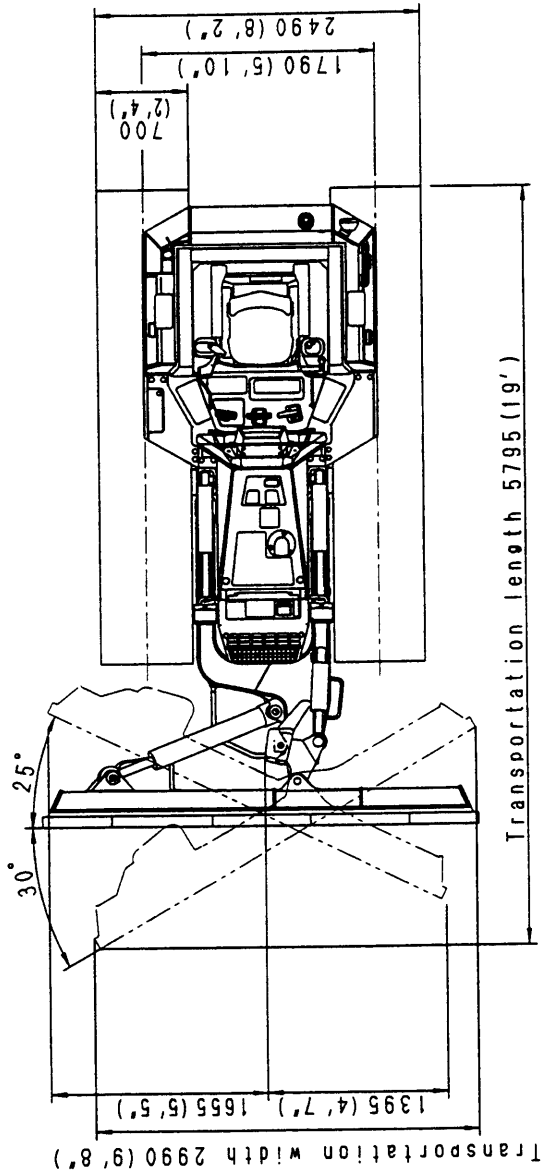

A022224B

● With cab + ROPS canopy

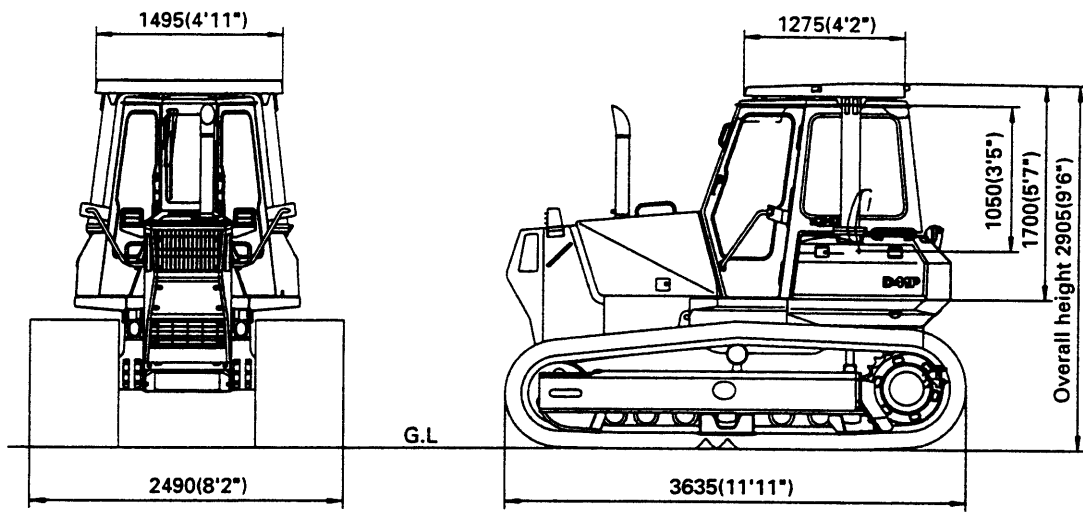

AD145590

● With canopy

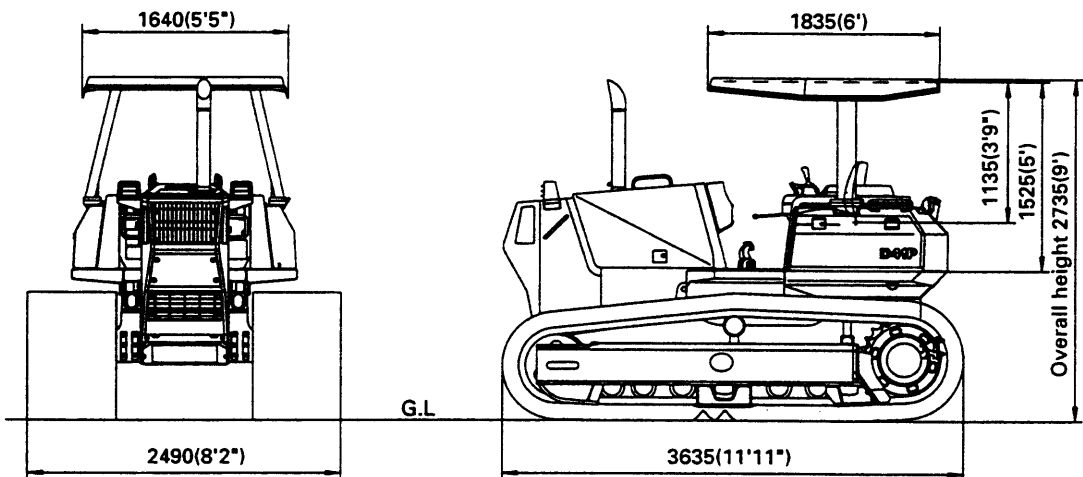

AD145600

● With ROPS canopy

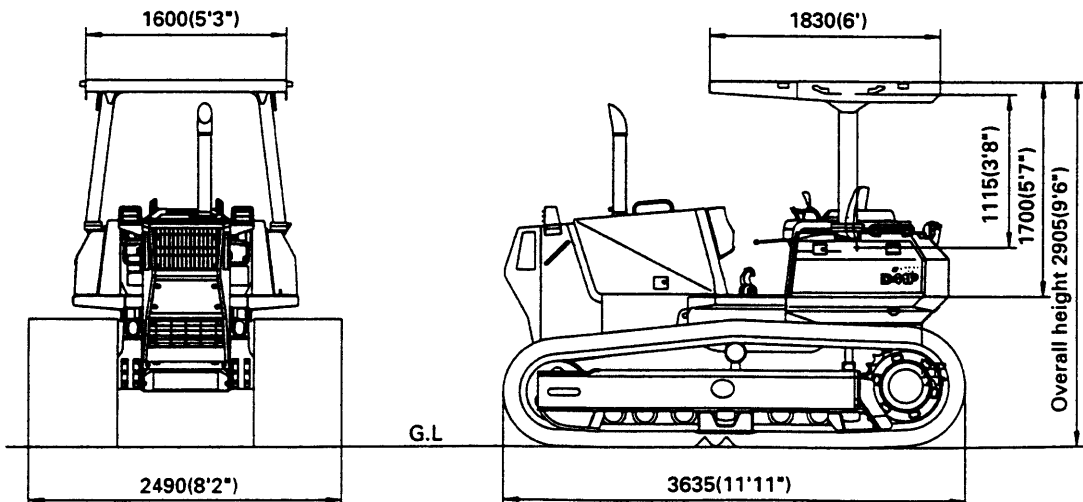

AD145610



25. SPECIFICATIONS

- With cab

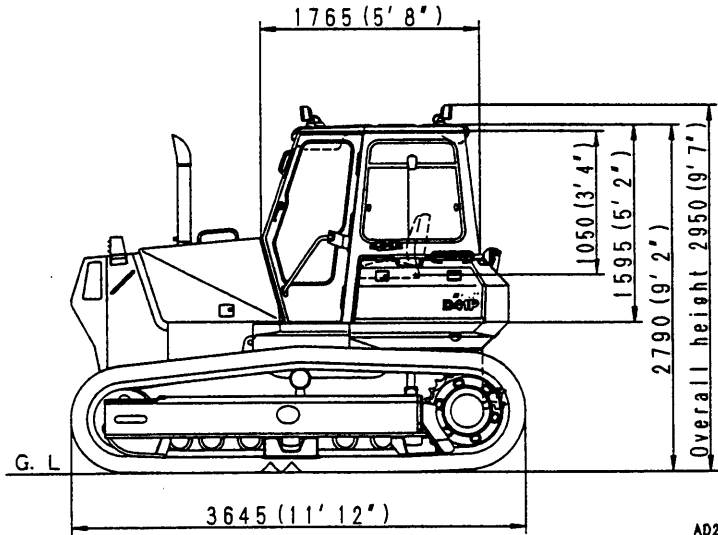
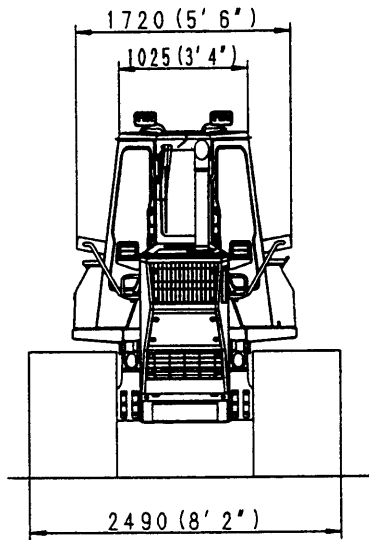

AD21193B

# **OPTIONS, ATTACHMENTS**

## 26. GENERAL PRECAUTIONS

---

### 26.1 PRECAUTIONS RELATED TO SAFETY

If attachments or options other than those authorized by Komatsu are installed, this will not only affect the life of the machine, but will also cause problems with safety. When installing attachments not listed in this Operation and Maintenance Manual, please contact your Komatsu distributor first.

If you do not contact Komatsu, we cannot accept any responsibility for any accident or failure.

#### WARNING

##### Precautions for removal and installation operations

- When removing or installing attachments, obey the following precautions and take care to ensure safety during the operation.
- Carry out the removal and installation operations on a flat, firm ground surface.
- When the operation is carried out by two or more workers, determine signals and follow these during the operation.
- When carrying heavy objects (more than 25 kg (55 lb)), use a crane.
- When removing heavy parts, always support the part before removing it.  
When lifting such heavy parts with a crane, always pay careful attention to the position of the center of gravity.
- It is dangerous to carry out operations with the load kept suspended. Always set the load on a stand, and check that it is safe.
- When removing or installing attachments, make sure that they are in a stable condition and will not fall over.
- Never go under a load suspended from a crane.  
Always stand in a position that is safe even if the load should fall.

#### NOTICE

Qualifications are required to operate a crane. Never allow the crane to be operated by an unqualified person.

For details of the removal and installation operations, please contact your Komatsu distributor.

## 27. HANDLING DELUXE SEAT

### WARNING

- Adjust the seat position at the beginning of each shift or when operators change.
- Adjust the seat so that the brake pedal can be depressed all the way with the operator's back against the backrest.

#### A Fore-aft adjustment of seat

Pull up lever ①, the seat to a position where it is easy to operate, then release the lever.

Fore-aft adjustment: 160 mm (6.3 in) (17 stages)

#### B Weight adjustment of seat

Turn knob ② under the seat to match the weight adjustment scale with your own weight.

The weight can be adjusted within a range of 50 – 120 kg (110 – 265 lb)

#### REMARK

If you want to make the seat softer, turn the weight adjustment to a lower weight; if you want to make the seat harder, adjust to a higher weight.

When operating on uneven surfaces, adjust the seat to a harder setting.

#### C Adjusting reclining angle

#### NOTICE

When reclining the seat back to the rear, check the space behind, and adjust to a suitable position.

Pull lever ③, set the seatback to a position where it is easy to operate, then release the lever.

#### D Adjusting seat tilt

Pull up lever ④ to remove the lock, set the seat to the desired position, then release the lever to lock the seat in position.

Tilt adjustment: 13° up and down.

#### E Height adjustment of seat

Pull levers ④ and ⑤ up at the same time to remove the lock, set the seat to the desired position, then release the lever to lock the seat in position.

Height adjustment: 65 mm (2.6 in)

#### F Adjusting direction of seat

When lever ⑥ is moved to the left, it is possible to turn the seat manually to the right to change the position by 15°.

After changing the direction of the seat, move the lever back securely and lock it.

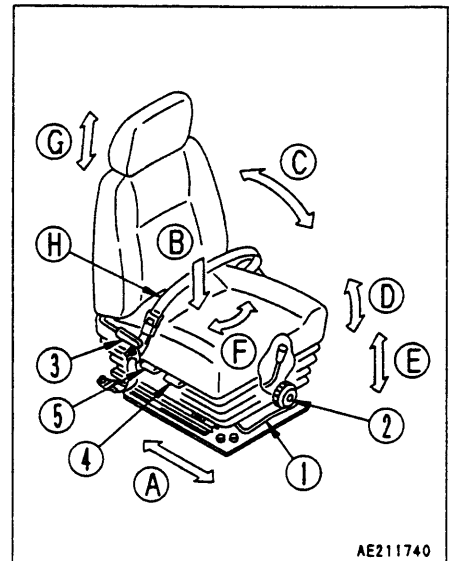

## 27. HANDLING DELUXE SEAT

### Ⓒ Adjusting height of headrest

- To make it higher  
Hold the headrest and pull it up.

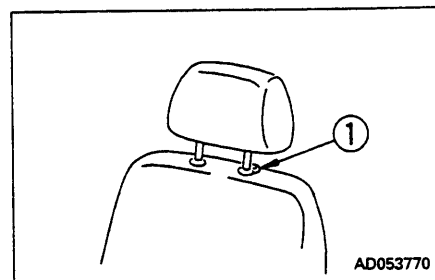

- To make it lower  
Keep knob ⑦ pushed down, and push the headrest down to the desired position.  
Height adjustment: 60 mm (2.6 in) (2 stages)

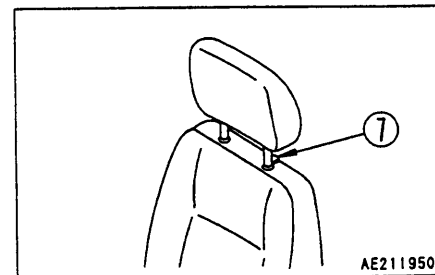

### Ⓓ Using seat belt

When operating a machine equipped with ROPS, be sure to use the seat belt.

#### WARNING

- Before fastening the seat belt, inspect the securing brackets and belt for abnormal conditions. Replace any worn or damaged seat belt or the securing brackets.
- Even if there appears to be no abnormality with the seat belt, always replace it once every three years. The data manufacture is woven on the reverse side of the belt.
- Adjust and fasten the seat belt before operating the machine.
- Always use seat belt when operating the machine.
- Fit the seat belt across your lap without twisting.

#### ● Fasten the belt and remove it in the following manner

1. Adjust the seat so that the brake pedal can be depressed all the way with the operator's back against the backrest.
2. After positioning the seat, adjust the tether belt ①. With the seat unoccupied, tense the belt slightly across the seat and install.
3. Sit in the seat, hold the tongue of reel ②, and pull the belt out slowly to a length which fully covers your lap.
4. Insert the tongue into buckle ③ and push until there is a click. Pull back reel ② until the belt fits securely across your lap. In this condition, the lock is applied to prevent the belt from extending any further.  
Fit the seat belt across your lap without twisting.

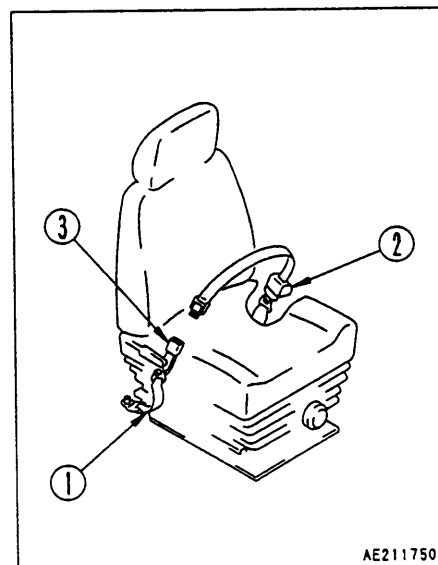

#### REMARK

If the lock is applied before the tongue is installed into the buckle, return the belt to the reel, then carry out the operation again from the beginning.

**D41E,P-6 BULLDOZER**

---

Form No. SEAM037200

©2000 **KOMATSU**  
All Rights Reserved  
Printed in Japan 01-00 (01-1)

---