

Operation & Maintenance Manual

PEN00007-03

GALEO BR380JG-1

MOBILE CRUSHER

SERIAL NUMBERS 1201 and up

WARNING

Unsafe use of this machine may cause serious injury or death. Operators and maintenance personnel must read this manual before operating or maintaining this machine. This manual should be kept near the machine for reference and periodically reviewed by all personnel who will come into contact with it.

NOTICE

Komatsu has Operation & Maintenance Manuals written in some other languages. If a foreign language manual is necessary, contact your local distributor for availability.

KOMATSU

FOREWORD

CALIFORNIA

Proposition 65 Warning

Diesel engine exhaust and some of its constituents are known to the State of California to cause cancer, birth defects, and other reproductive harm.

CALIFORNIA

Proposition 65 Warning

Battery posts, terminals and related accessories contain lead and lead compounds, chemicals known to the State of California to cause cancer and birth defects or other reproductive harm.

Wash hands after handling.

FOREWORD

This manual provides rules and guidelines which will help you use this machine safely and effectively. The precautions in this manual must be followed at all times when performing operation and maintenance. Most accidents are caused by the failure to follow fundamental safety rules for the operation and maintenance of machines. Accidents can be prevented by knowing beforehand conditions that may cause a hazard when performing operation and maintenance.



WARNING

Operators and maintenance personnel must always do as follows before beginning operation or maintenance.

- Always be sure to read and understand this manual thoroughly before performing operation and maintenance.
- Read the safety messages given in this manual and the safety labels affixed to the machine thoroughly and be sure that you understand them fully.

Keep this manual in the storage location for the operation and maintenance manual given below, and have all personnel read it periodically.

If this manual has been lost or has become dirty and cannot be read, request a replacement manual immediately from Komatsu or your Komatsu distributor.

If you sell the machine, be sure to give this manual to the new owners together with the machine.

Komatsu delivers machines that comply with all applicable regulations and standards of the country to which it has been shipped. If this machine has been purchased in another country or purchased from someone in another country, it may lack certain safety devices and specifications that are necessary for use in your country. If there is any question about whether your product complies with the applicable standards and regulations of your country, consult Komatsu or your Komatsu distributor before operating the machine.

Storage location for the Operation and Maintenance Manual:
Main Control Box

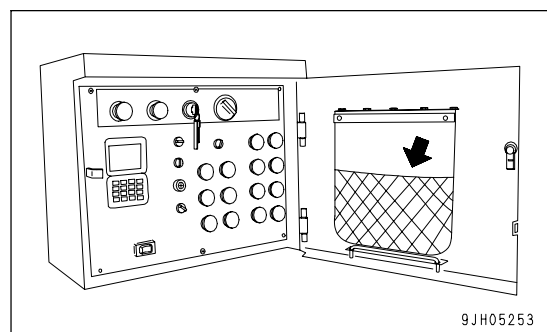

EMISSION CONTROL WARRANTY**EMISSION CONTROL WARRANTY STATEMENT (APPLIES TO CANADA ONLY)****1. Products Warranted**

Komatsu America International Company, Komatsu Mining Systems Inc. and Komatsu Utility Corporation (collectively "Komatsu") produce and/or market products under brand names of Komatsu, Dresser, Dressta, Haulpak and Galion. This emissions warranty applies to new engines bearing the Komatsu name installed in these products and used in Canada in machines designed for industrial off-highway use. This warranty applies only to these engines produced on or after January 1, 2000. This warranty will be administered by Komatsu distribution in Canada.

2. Coverage

Komatsu warrants to the ultimate purchaser and each subsequent purchaser that the engine is designed, built and equipped so as to conform, at the time of sale by Komatsu, with all U.S. Federal emission regulations applicable at the time of manufacture and that it is free from defects in workmanship or material which would cause it not to meet these regulations within five years or 3,000 hours of operation, whichever occurs first, as measured from the date of delivery of the engine to the ultimate purchaser.

3. Limitations

Failures, other than those resulting from defects in materials or workmanship, are not covered by this warranty. Komatsu is not responsible for failures or damage resulting from what Komatsu determines to be abuse or neglect, including, but not limited to: operation without adequate coolant or lubricants; over fueling; over speeding; lack of maintenance of lubricating, cooling or intake systems; improper storage, starting, warm-up, run-in or shutdown practices; unauthorized modifications of the engine. Komatsu is also not responsible for failures caused by incorrect fuel or by water, dirt or other contaminants in the fuel. Komatsu is not responsible for non-engine repairs, "downtime" expense, related damage, fines, all business costs or other losses resulting from a warrantable failure.

KOMATSU IS NOT RESPONSIBLE FOR INCIDENTAL OR CONSEQUENTIAL DAMAGES.

This warranty, together with the express commercial warranties, are the sole warranties of Komatsu. **THERE ARE NO OTHER WARRANTIES, EXPRESS OR IMPLIED, OR OF MERCHANTABILITY OR FITNESS FOR A PARTICULAR PURPOSE.**

GARANTIE SUR LE CONTRÔLE DES ÉMISSIONS**ÉNONCÉ DE GARANTIE SUR LE CONTRÔLE DES ÉMISSIONS (APPLICABLE AU CANADA SEULEMENT):****1. Produits garantis:**

Komatsu America International Company, Komatsu Mining Systems Inc. et Komatsu Utility Corporation (collectivement Komatsu) produisent et/ou font la mise en marché de produits portant les noms de marque Komatsu, Dresser, Dressta, Haulpak et Galion. Cette garantie sur les émissions s'applique à tous les nouveaux moteurs portant le nom Komatsu, installés dans ces produits et utilisés au Canada dans des machines conçues pour utilisation industrielle non-routière. Cette garantie s'applique seulement sur les moteurs produits à partir du 1er Janvier 2000. Cette garantie sera administrée par la distribution de Komatsu au Canada.

2. Couverture:

Komatsu garantit à l'acheteur ultime et chaque acheteur subséquent que le moteur est conçu, construit et équipé en toute conformité, au moment de la vente par Komatsu, avec toutes les Réglementations fédérales américaines sur les émissions applicables au moment de la fabrication et qu'il est exempt de défauts de construction ou de matériaux qui auraient pour effet de contrevenir à ces réglementations en dedans de 5 ans ou 3000 heures d'opération, mesuré à partir de la date de livraison du moteur au client ultime.

3. Limitations:

Les bris, autres que ceux résultant de défauts de matériaux ou de construction, ne sont pas couverts par cette Garantie. Komatsu n'est pas responsable pour bris ou dommages résultant de ce que Komatsu détermine comme étant de l'abus ou négligence, incluant mais ne se limitant pas à: l'opération sans lubrifiants ou agent refroidissants adéquats; la suralimentation d'essence; la survitesse; le manque d'entretien des systèmes de lubrification, de refroidissement ou d'entrée; de pratiques non-propices d'entreposage, de mise en marche, de réchauffement, de conditionnement ou d'arrêt; les modifications non-autorisées du moteur. De plus, Komatsu n'est pas responsable de bris causés par de l'essence inadéquate ou de l'eau, des saletés ou autres contaminants dans l'essence. Komatsu n'est pas responsable des réparations non-relées au moteur, des dépenses encourues suite aux temps d'arrêts, des dommages relatifs, amendes, et de tout autre coût d'affaires ou autres pertes résultant d'un bris couvert par la garantie.

KOMATSU N'EST PAS RESPONSABLE DES INCIDENTS OU DOMMAGES CONSÉQUENTS.

Cette garantie, ainsi que les garanties expresses commerciales, sont les seules garanties de Komatsu. **IL N'Y A AUCUNE AUTRE GARANTIE, EXPRESSE OU SOUS-ENTENDUE, MARCHANDABLE OU PROPICE A UNE UTILISATION PARTICULIÈRE.**

INFORMATION IMPORTANTE SUR LE MOTEUR
 CE MOTEUR EST CONFORME AUX NORMES AMÉRICAINES DE L'EPA (ANNÉE DU MODÈLE) ET DE LA CALIFORNIE POUR LES MOTEURS LARGES NON-ROUTIERS À IGNITION PAR COMPRESSION. CE MOTEUR EST CERTIFIÉ POUR OPÉRER À ESSENCE DIESEL.

AVERTISSEMENT
 DES BLESSURES PEUVENT RESULTER ET LA GARANTIE S'ANNULER SI LES RPM DU TAUX D'ESSENCE OU L'AUTITUDE EXCÈDENT LES VALEURS MAXIMALES PUBLIÉES POUR CE MODÈLE ET SON APPLICATION.

IMPORTANT ENGINE INFORMATION
 THIS ENGINE CONFORMS TO YYYY MODEL YEAR U.S. EPA REGULATION AND THE CALIFORNIA REGULATIONS LARGE NON ROAD COMPRESSION IGNITION ENGINES. THIS ENGINE IS CERTIFIED TO OPERATE ON DIESEL FUEL.

WARNING
 INJURY MAY RESULT AND WARRANTY IS VOIDED IF FUEL RATE RPM OR ALTITUDES EXCEED PUBLISHED MAXIMUM VALUES FOR THIS MODEL AND APPLICATION.

| | | | |
|---------------------------------|------------|-----------------------|-------------------------|
| ENGINE MODEL | SERIAL NO. | DISPLACEMENT | LITERS |
| ENGINE FAMILY | | | |
| EXHAUST EMISSION CONTROL SYSTEM | | FIRING ORDER | 1 - 5 - 3 - 6 - 2 - 4 |
| ADV. LOAD OUTPUT | Kw (HP) | RPM | |
| VALVE LASH COLD (mm) | IN. EX. | FUEL RATE AT ADV. | mm ³ /STROKE |
| IDLE SPEED | RPM | FAMILY EMISSION LIMIT | |
| INITIAL INJECTION TIMING | DEG. BTDC | DATE OF MANUFACTURE | |
| KOMATSU LTD. MADE IN JAPAN | | | |

MODÈLE DU MOTEUR

FAMILLE DU MOTEUR

SYSTÈME DE CONTRÔLE DES ÉMISSIONS D'ÉCHAPPEMENT

CHARGE DE SORTIE ADV

PORTÉE DE VALVE À FROID (mm)

VITESSE STATIQUE

RÉGLAGE DE L'ALLUMAGE - INJECTION INITIALE

DEG. BTDC

NO. SÉRIE

DÉPLACEMENT

LITRES

SÉQUENCE DE MISE À FEU

mm³/BAITTEMENT

TAUX D'ESSENCE À ADV.

LIMITE D'ÉMISSION DE LA FAMILLE

DATE DE FABRICATION

KOMATSU LTDÉ
FABRIQUÉ AU JAPON

ENGINE DATAPLATE - ENGLISH / FRENCH



SAFETY INFORMATION

To enable you to use this machine safely, safety precautions and labels are given in this manual and affixed to the machine to give explanations of situations involving potential hazards and of the methods of avoiding such situations.

Signal words

The following signal words are used to inform you that there is a potential hazardous situation that may lead to personal injury or damage.

In this manual and on machine labels, the following signal words are used to express the potential level of hazard.

- | | |
|--------------------------------------------------------------------------------------------------|-----------------------------------------------------------------------------------------------------------------------------------------------------------------------------------------------------|
|  DANGER | Indicates an imminently hazardous situation which, if not avoided, will result in death or serious injury. |
|  WARNING | Indicates a potentially hazardous situation which, if not avoided, could result in death or serious injury. |
|  CAUTION | Indicates a potentially hazardous situation which, if not avoided, may result in minor or moderate injury. This word is used also to alert against unsafe practices that may cause property damage. |

Example of safety message using signal word



When standing up from the operator's seat, always place the lock lever in the LOCK position.

If you accidentally touch the control levers when they are not locked, this may cause a serious injury or death.

Other signal words

In addition to the above, the following signal words are used to indicate precautions that should be followed to protect the machine or to give information that is useful to know.

NOTICE This word is used for precautions that must be taken to avoid actions which could shorten the life of the machine.

REMARKS This word is used for information that is useful to know.

• Safety labels

Safety labels are affixed to the machine to inform the operator or maintenance worker on the spot when carrying out operation or maintenance of the machine that may involve hazard.

This machine uses "Safety labels using words" and "Safety labels using pictograms" to indicate safety procedures.

Example of safety label using words

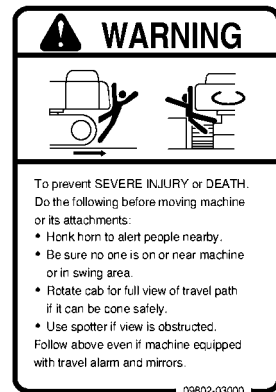

Part No

Safety labels using pictogram

Safety pictograms use a picture to express a level of hazardous condition equivalent to the signal word. These safety pictograms use pictures in order to let the operator or maintenance worker understand the level and type of hazardous condition at all times. Safety pictograms show the type of hazardous condition at the top or left side, and the method of avoiding the hazardous condition at the bottom or right side. In addition, the type of hazardous condition is displayed inside a triangle and the method of avoiding the hazardous condition is shown inside a circle.



Part No

Komatsu cannot predict every circumstance that might involve a potential hazard in operation and maintenance. Therefore, the safety messages in this manual and on the machine may not include all possible safety precautions. If any procedures or actions not specifically recommended or allowed in this manual are used, it is your responsibility to take the necessary steps to ensure safety.

In no event should you engage in prohibited uses or actions described in this manual.

The explanations, values, and illustrations in this manual were prepared based on the latest information available at that time. Continuing improvements in the design of this machine can lead to changes in detail which may not be reflected in this manual. Consult Komatsu or your Komatsu distributor for the latest available information of your machine or for questions regarding information in this manual.

The numbers in circles in the illustrations correspond to the numbers in () in the text. (For example: ① -> (1))

INTRODUCTION

This Komatsu machine is designed to be used mainly for the following work:

- Crushing Operation

For details on operations, please refer to the section "SCOPE OF WORKS USING MOBILE CRUSHER (PAGE 3-111)".

FRONT/REAR, LEFT/RIGHT DIRECTIONS OF MACHINE

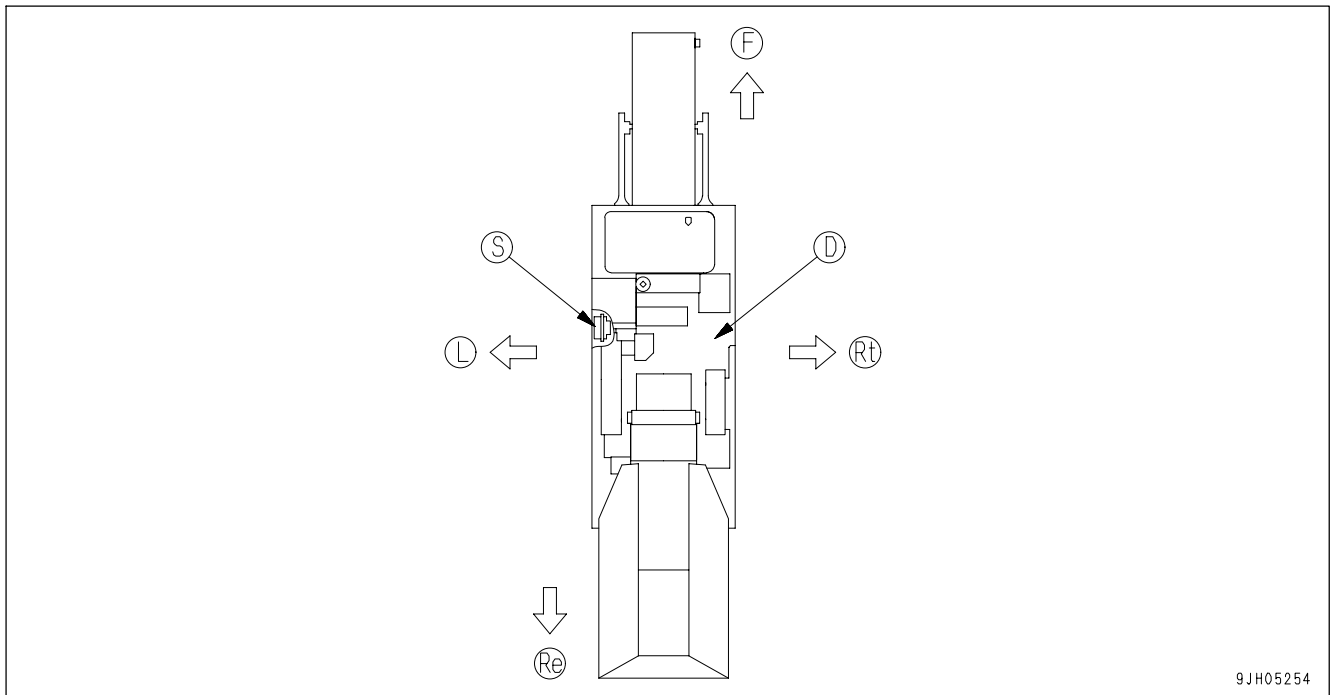

This manual indicates the right and left as well as the fore and aft sides of the machine, as viewed from the operator's platform in the foreword traveling direction and with the sprockets turned to the front side.

(F) Front

(L) Left

(S) Sprocket

(Re) Rear

(Rt) Right

(D) Places for operation

BREAKING IN THE NEW MACHINE

NOTICE

Your Komatsu machine has been thoroughly adjusted and tested before shipment from the factory. However, operating the machine under full load before breaking the machine in can adversely affect the performance and shorten the machine life.

Be sure to break in the machine for the initial 100 hours (as indicated on the service meter).

- Idle the engine for 5 minutes after starting it up.
- Avoid operation with heavy loads or at high speeds.
- Immediately after starting the engine, avoid sudden starts, sudden acceleration, unnecessary sudden stops, and sudden changes in direction.

NECESSARY INFORMATION

When requesting service or ordering replacement parts, please inform your Komatsu distributor of the following items.

PRODUCT IDENTIFICATION NUMBER (PIN)/MACHINE SERIAL NO. PLATE

Provided at the rear on the right side of the frame.

The design of the nameplate differs according to the territory.

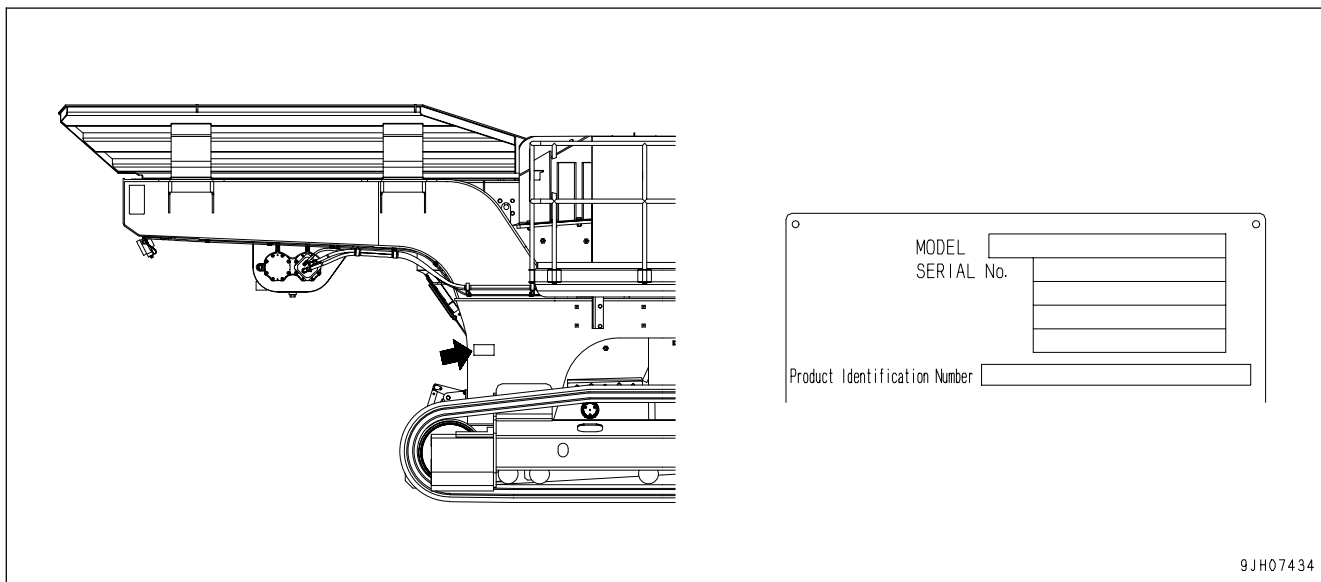

ENGINE SERIAL NO. PLATE AND POSITION

Provided at the side of the engine cylinder head cover (under the suction manifold).

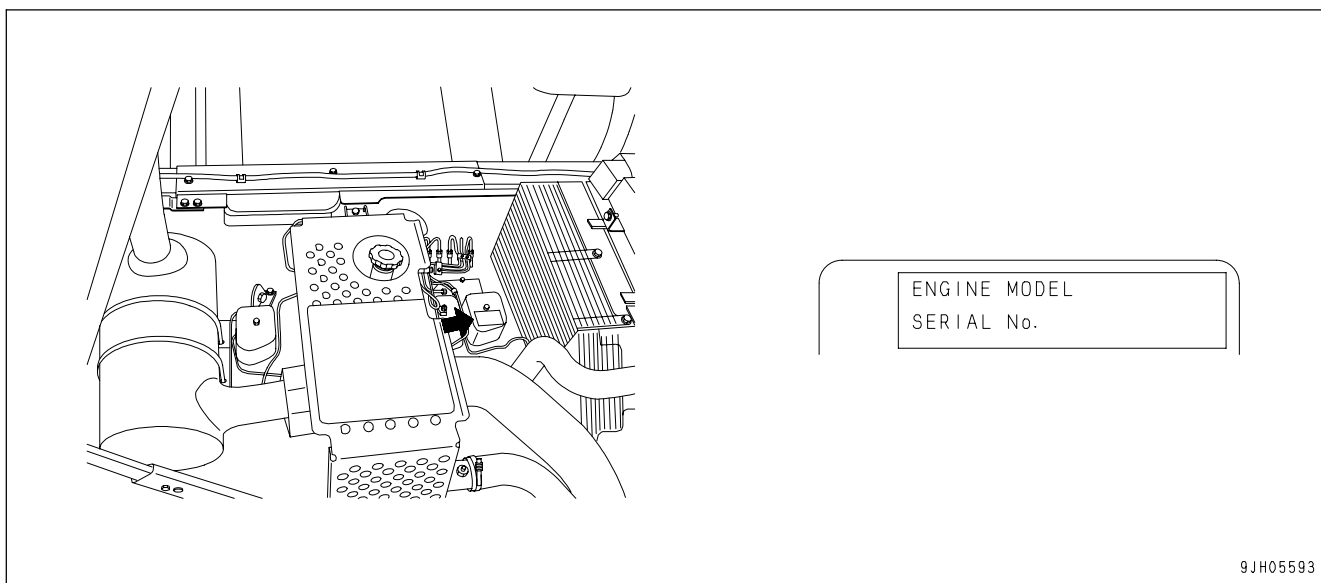

POSITION OF SERVICE METER

Provided above the machine monitors on the control panel.

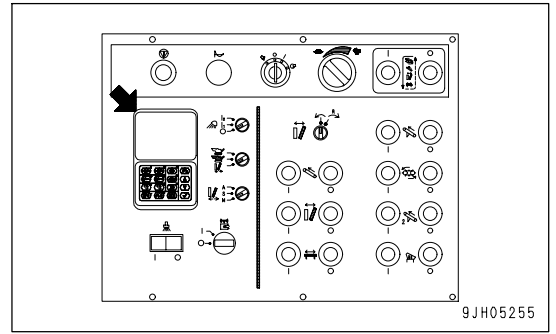

TABLE OF ENTER SERIAL NO. AND DISTRIBUTOR

| | |
|-------------------------------------|-------|
| Machine serial No. | |
| Engine serial No. | |
| Product identification number (PIN) | |
| Distributor name | |
| Address | ----- |
| | ----- |
| | ----- |
| Service Personnel | ----- |
| Phone/Fax | |

CONTENTS

| | |
|--------------------------------------------------------------------|-------|
| FOREWORD | 1- 1 |
| FOREWORD | 1- 2 |
| SAFETY INFORMATION | 1- 5 |
| INTRODUCTION | 1- 7 |
| FRONT/REAR, LEFT/RIGHT DIRECTIONS OF MACHINE | 1- 7 |
| BREAKING IN THE NEW MACHINE | 1- 7 |
| NECESSARY INFORMATION | 1- 8 |
| PRODUCT IDENTIFICATION NUMBER (PIN)/MACHINE SERIAL NO. PLATE | 1- 8 |
| ENGINE SERIAL NO. PLATE AND POSITION | 1- 8 |
| POSITION OF SERVICE METER | 1- 9 |
| TABLE OF ENTER SERIAL NO. AND DISTRIBUTOR | 1- 9 |
| SAFETY | 2- 1 |
| SAFETY | 2- 2 |
| SAFETY LABELS | 2- 5 |
| POSITIONS OF SAFETY PICTOGRAMS | 2- 6 |
| SAFETY LABELS | 2- 7 |
| GENERAL PRECAUTIONS | 2- 15 |
| PRECAUTIONS FOR OPERATION | 2- 23 |
| STARTING ENGINE | 2- 23 |
| OPERATION | 2- 25 |
| CRUSHING OPERATION | 2- 28 |
| TRANSPORTATION | 2- 31 |
| BATTERY | 2- 32 |
| TOWING | 2- 34 |
| PRECAUTIONS FOR MAINTENANCE | 2- 35 |
| OPERATION | 3- 1 |
| GENERAL VIEW | 3- 2 |
| GENERAL VIEW OF MACHINE | 3- 2 |
| GENERAL VIEW OF CONTROLS AND GAUGES | 3- 3 |
| EXPLANATION OF COMPONENTS | 3- 7 |
| MACHINE MONITOR | 3- 7 |
| SWITCHES | 3- 32 |
| CONTROL LEVERS | 3- 41 |
| OPTION-RELATED SWITCHES | 3- 42 |
| CAP, COVER WITH LOCK | 3- 44 |
| REVOLVING WARNING LAMP | 3- 46 |
| ELECTRIC POWER TAKEOFF | 3- 47 |
| FUSIBLE LINK | 3- 49 |
| CONTROLLERS | 3- 49 |
| FUSE | 3- 49 |
| TOOL BOX | 3- 50 |
| OPERATION | 3- 51 |
| CHECK BEFORE STARTING ENGINE | 3- 51 |
| STARTING ENGINE | 3- 70 |
| OPERATIONS AND CHECKS AFTER STARTING ENGINE | 3- 74 |
| STOPPING ENGINE | 3- 79 |
| CHECK AFTER STOPPING ENGINE | 3- 79 |
| MACHINE OPERATION | 3- 80 |
| STEERING MACHINE | 3- 86 |

| | |
|----------------------------------------------------------------------------------------------|-------|
| OPERATION OF WORK EQUIPMENT | 3- 88 |
| CHECK AND CONFIRMATION OF JAW CRUSHER AFTER WORK | 3- 97 |
| CHECK AFTER FINISHING WORK | 3- 97 |
| LOCKING | 3- 98 |
| RUN-IN OPERATION OF JAW CRUSHER | 3- 99 |
| PRECAUTIONS WHEN OPERATING JAW CRUSHER | 3-101 |
| EFFICIENT USE OF JAW CRUSHER | 3-105 |
| SCOPE OF WORKS USING MOBILE CRUSHER | 3-111 |
| PROHIBITIONS FOR OPERATION | 3-119 |
| PRECAUTIONS WHEN TRAVELING UP OR DOWNHILLS | 3-121 |
| TRANSPORTATION | 3-122 |
| TRANSPORTATION PROCEDURE | 3-122 |
| LOADING, UNLOADING WORK | 3-122 |
| LIFTING MACHINE | 3-128 |
| COLD WEATHER OPERATION | 3-129 |
| PRECAUTIONS FOR LOW TEMPERATURE | 3-129 |
| AFTER COMPLETION OF WORK | 3-131 |
| AFTER COLD WEATHER | 3-131 |
| LONG-TERM STORAGE | 3-132 |
| BEFORE STORAGE | 3-132 |
| DURING STORAGE | 3-132 |
| AFTER STORAGE | 3-132 |
| STARTING MACHINE AFTER LONG-TERM STORAGE | 3-132 |
| TROUBLESHOOTING | 3-133 |
| AFTER RUNNING OUT OF FUEL | 3-133 |
| PHENOMENA THAT ARE NOT FAILURES | 3-133 |
| METHOD OF TOWING MACHINE | 3-134 |
| IF BATTERY IS DISCHARGED | 3-135 |
| OTHER TROUBLE | 3-138 |
| MAINTENANCE | 4- 1 |
| GUIDE TO MAINTENANCE | 4- 2 |
| OUTLINE OF SERVICE | 4- 4 |
| HANDLING AND PERFORMANCE OF OIL CLINIC FOR OIL, FUEL, COOLANT | 4- 4 |
| RELATING TO ELECTRIC SYSTEM | 4- 7 |
| OUTLINE OF HYDRAULIC EQUIPMENT | 4- 7 |
| AIR-BLEEDING FROM HYDRAULIC CIRCUIT | 4- 8 |
| WEAR PARTS | 4- 9 |
| WEAR PARTS LIST | 4- 9 |
| JAW CRUSHER RELATED PARTS | 4- 10 |
| PRIMARY CONVEYOR RELATED PARTS | 4- 12 |
| RECOMMENDED FUEL, COOLANT AND LUBRICANTS | 4- 13 |
| RECOMMENDED BRANDS, RECOMMENDED QUALITY FOR PRODUCTS OTHER THAN KOMATSU GENUINE OIL | 4- 15 |
| STANDARD TIGHTENING TORQUES FOR BOLTS AND NUTS | 4- 16 |
| CRUSHER ACCESSORY TOOLS | 4- 16 |
| TORQUE LIST | 4- 18 |
| PERIODIC REPLACEMENT OF SAFETY CRITICAL PARTS | 4- 19 |
| SAFETY CRITICAL PARTS | 4- 19 |
| MAINTENANCE SCHEDULE CHART | 4- 20 |
| MAINTENANCE SCHEDULE CHART | 4- 20 |

| | |
|---------------------------------------------------------------------------|-------|
| SERVICE PROCEDURE | 4- 22 |
| INITIAL 250 HOURS SERVICE (FIRST MAINTENANCE FOR NEW MACHINE ONLY) | 4- 22 |
| INITIAL 1000 HOURS SERVICE (FIRST MAINTENANCE FOR NEW MACHINE ONLY) | 4- 22 |
| WHEN REQUIRED | 4- 23 |
| CHECK BEFORE STARTING | 4- 66 |
| EVERY 10 HOURS SERVICE | 4- 67 |
| EVERY 100 HOURS SERVICE | 4- 68 |
| EVERY 250 HOURS SERVICE | 4- 70 |
| EVERY 500 HOURS SERVICE | 4- 74 |
| EVERY 1000 HOURS SERVICE | 4- 79 |
| EVERY 2000 HOURS SERVICE | 4- 83 |
| EVERY 4000 HOURS SERVICE | 4- 85 |
| EVERY 5000 HOURS SERVICE | 4- 86 |
| SPECIFICATIONS | 5- 1 |
| SPECIFICATIONS | 5- 2 |
| ATTACHMENTS, OPTIONS | 6- 1 |
| GENERAL PRECAUTIONS | 6- 2 |
| PRECAUTIONS RELATED TO SAFETY | 6- 2 |
| ATTACHMENTS, OPTIONS | 6- 3 |
| ATTACHMENTS, OPTIONS CHART | 6- 3 |
| METHOD FOR CONNECTING HYDRAULIC HOSES FOR OPTIONS | 6- 3 |
| RADIO CONTROL UNIT | 6- 4 |
| ON USE OF RADIO CONTROL UNIT | 6- 4 |
| DIRECTIONS FOR USE | 6- 7 |
| REMOTE CONTROL OPERATION | 6- 11 |
| MUCK DISCHARGE CONVEYOR | 6- 19 |
| PROCEDURE FOR RAISING (BENDING) MUCK DISCHARGE CONVEYOR | 6- 19 |
| PROCEDURE FOR LOWERING MUCK DISCHARGE CONVEYOR | 6- 20 |
| GREASING MUCK DISCHARGE CONVEYOR | 6- 23 |
| CHECK AND ADJUSTMENT OF MUCK DISCHARGE CONVEYOR | 6- 24 |
| FAILURES AND CORRECTIVE ACTIONS | 6- 26 |
| WEARING PARTS | 6- 28 |
| SPECIFICATIONS | 6- 29 |
| M-TYPE CHUTE | 6- 30 |
| METHOD OF OPERATION | 6- 30 |
| BELT CONVEYOR PROTECTIVE PLATE | 6- 31 |
| GRIZZLY BAR OPENING | 6- 33 |
| HANDLING MACHINES EQUIPPED WITH KOMTRAX | 6- 34 |
| BASIC PRECAUTIONS | 6- 34 |
| MACHINES THAT CAN INSTALL ATTACHMENTS | 6- 35 |
| NAMES OF CONTROL PANEL SWITCHES | 6- 35 |
| HYDRAULIC POWER TAKEOFF PORT | 6- 35 |
| ATTACHMENT PORT | 6- 36 |
| PROCEDURE FOR CONNECTING OPTIONS | 6- 37 |
| HYDRAULIC VIBRATORY SIEVE | 6- 39 |
| SPECIFICATION | 6- 39 |
| GENERAL VIEW | 6- 39 |
| CAUTIONS TO BE NOTED FOR SAFETY | 6- 40 |
| CONNECTING METHOD TO MACHINE BODY | 6- 40 |
| PRECAUTIONS DURING OPERATION | 6- 40 |

| | |
|--------------------------------------------------------|-------|
| HYDRAULIC SECONDARY CONVEYOR ----- | 6- 41 |
| SPECIFICATIONS ----- | 6- 41 |
| GENERAL VIEW ----- | 6- 41 |
| INCLINED LEG CONNECTING METHOD ----- | 6- 43 |
| LIFTING METHOD ----- | 6- 44 |
| CONNECTING METHOD TO MACHINE BODY ----- | 6- 44 |
| PRECAUTIONS ON OPERATION ----- | 6- 44 |
| INSPECTION, MAINTENANCE AND ADJUSTMENT ----- | 6- 45 |
| TROUBLES AND CORRECTIVE ACTIONS ----- | 6- 47 |
| CONSUMABLE PARTS OF HYDRAULIC SECONDARY CONVEYOR ----- | 6- 49 |
| SPRINKLER ----- | 6- 51 |
| EXPLANATIONS FOR COMPONENT PARTS ----- | 6- 51 |
| HOW TO USE SPRINKLER ----- | 6- 52 |
| INSPECTION AND MAINTENANCE ----- | 6- 55 |
| INDEX ----- | 7- 1 |

SAFETY

WARNING

Please read and make sure that you fully understand the precautions described in this manual and the safety labels on the machine. When operating or servicing the machine, always follow these precautions strictly.

SAFETY

| | |
|-----------------------------------------------------------|-------|
| SAFETY LABELS | 2- 5 |
| POSITIONS OF SAFETY PICTOGRAMS | 2- 6 |
| SAFETY LABELS | 2- 7 |
| | |
| GENERAL PRECAUTIONS | 2- 15 |
| SAFETY RULES | 2- 15 |
| IF ABNORMALITIES ARE FOUND | 2- 15 |
| CLOTHING AND PERSONAL PROTECTIVE ITEMS | 2- 15 |
| FIRE EXTINGUISHER AND FIRST AID KIT | 2- 15 |
| SAFETY FEATURES | 2- 15 |
| KEEP MACHINE CLEAN | 2- 16 |
| ON OPERATOR'S PLATFORM | 2- 16 |
| ALWAYS APPLY LOCK WHEN LEAVING UPPER OPERATION DECK | 2- 16 |
| HANDRAILS AND STEPS | 2- 17 |
| PRECAUTIONS WHEN WORKING IN HIGH PLACES | 2- 17 |
| MOUNTING AND DISMOUNTING | 2- 17 |
| NO PEOPLE ON ATTACHMENTS | 2- 17 |
| CRUSHING OR CUTTING PREVENTION | 2- 17 |
| PREVENTION OF BURNS | 2- 18 |
| FIRE PREVENTION | 2- 18 |
| ACTION IF FIRE OCCURS | 2- 19 |
| PRECAUTIONS FOR ATTACHMENTS | 2- 19 |
| UNAUTHORIZED MODIFICATION | 2- 19 |
| SAFETY AT WORKSITE | 2- 19 |
| WORKING ON LOOSE GROUND | 2- 20 |
| DO NOT GO CLOSE TO HIGH-VOLTAGE CABLES | 2- 20 |
| ENSURE GOOD VISIBILITY | 2- 20 |
| VENTILATION FOR ENCLOSED AREAS | 2- 21 |
| CHECKING SIGNALMAN'S SIGNALS AND SIGNS | 2- 21 |
| BE CAREFUL ABOUT ASBESTOS DUST | 2- 21 |
| MAGNETIC SEPARATOR | 2- 22 |

| | |
|------------------------------------------------------------------------|-------|
| PRECAUTIONS FOR OPERATION | 2- 23 |
| STARTING ENGINE | 2- 23 |
| CHECKS BEFORE STARTING ENGINE | 2- 23 |
| PRECAUTIONS WHEN STARTING | 2- 23 |
| PRECAUTIONS IN COLD AREAS | 2- 26 |
| OPERATION | 2- 25 |
| CHECK BEFORE OPERATION | 2- 25 |
| PRECAUTIONS WHEN CHANGING DIRECTION | 2- 25 |
| PRECAUTIONS WHEN TRAVELING | 2- 25 |
| TRAVELING ON SLOPES | 2- 26 |
| OPERATIONS ON SLOPES | 2- 26 |
| PRECAUTIONS WHILE IN OPERATION | 2- 26 |
| OPERATE CAREFULLY ON SNOW | 2- 26 |
| PARKING MACHINE | 2- 27 |
| CRUSHING OPERATION | 2- 28 |
| CHECKS AROUND MACHINE | 2- 28 |
| TURN MODE SELECTOR SWITCH TO WORK POSITION | 2- 28 |
| ENSURE SAFETY WHILE OPERATING IN TANDEM WITH HYDRAULIC EXCAVATOR | 2- 29 |
| CHECKS OF CRUSHER BEFORE STARTING OPERATION | 2- 29 |
| PRECAUTIONS FOR CRUSHING WORK | 2- 29 |
| EMERGENCY STOP TO WARD OFF DANGERS WHILE IN CRUSHING WORK | 2- 30 |
| REMOVE FOREIGN MATERIAL FROM INSIDE CRUSHER | 2- 30 |
| TRANSPORTATION | 2- 31 |
| LOADING AND UNLOADING | 2- 31 |
| SHIPPING | 2- 31 |
| BATTERY | 2- 32 |
| BATTERY HAZARD PREVENTION | 2- 32 |
| STARTING WITH BOOSTER CABLE | 2- 33 |
| TOWING | 2- 34 |
| WHEN TOWING | 2- 34 |

| | |
|---------------------------------------------------------------------------|-------|
| PRECAUTIONS FOR MAINTENANCE | 2- 35 |
| WARNING TAG | 2- 35 |
| KEEP WORK PLACE CLEAN AND TIDY | 2- 35 |
| APPOINT LEADER WHEN WORKING WITH OTHERS | 2- 35 |
| STOP ENGINE BEFORE CARRYING OUT INSPECTION AND MAINTENANCE | 2- 35 |
| TWO WORKERS FOR MAINTENANCE WHEN ENGINE IS RUNNING | 2- 36 |
| PRECAUTIONS FOR CONVEYOR MAINTENANCE | 2- 36 |
| PRECAUTIONS WHEN CARRYING OUT MAINTENANCE OF FEEDER, CRUSHER | 2- 37 |
| PROPER TOOLS | 2- 37 |
| PERSONNEL | 2- 37 |
| PRECAUTIONS WHEN MOUNTING, DISMANTLING AND STORING ATTACHMENTS | 2- 37 |
| PRECAUTIONS FOR WORK UNDER MACHINE | 2- 37 |
| NOISE | 2- 38 |
| PRECAUTIONS WHEN USING HAMMER | 2- 38 |
| REPAIR WELDING | 2- 38 |
| REMOVING BATTERY TERMINAL | 2- 38 |
| PRECAUTIONS WHEN USING HIGH-PRESSURE GREASE TO ADJUST TRACK TENSION | 2- 38 |
| DO NOT DISASSEMBLE RECOIL SPRING | 2- 39 |
| PRECAUTIONS WITH HIGH-PRESSURE OIL | 2- 40 |
| HANDLING HIGH-PRESSURE HOSES | 2- 40 |
| WASTE MATERIAL | 2- 40 |
| COMPRESSED AIR | 2- 40 |
| PERIODIC REPLACEMENT OF SAFETY CRITICAL PARTS | 2- 41 |

SAFETY LABELS

The following warning signs and safety labels are used on this machine.

- Be sure that you fully understand the correct position and content of labels.
- To ensure that the content of labels can be read properly, be sure that they are in the correct place and always keep them clean. When cleaning them, do not use organic solvents or gasoline. These may cause the labels to peel off.
- There are also other labels in addition to the warning signs and safety labels. Handle those labels in the same way.
- If the labels are damaged, lost, or cannot be read properly, replace them with new ones. For details of the part numbers for the labels, see this manual or the actual label, and place an order with Komatsu distributor.

POSITIONS OF SAFETY PICTOGRAMS

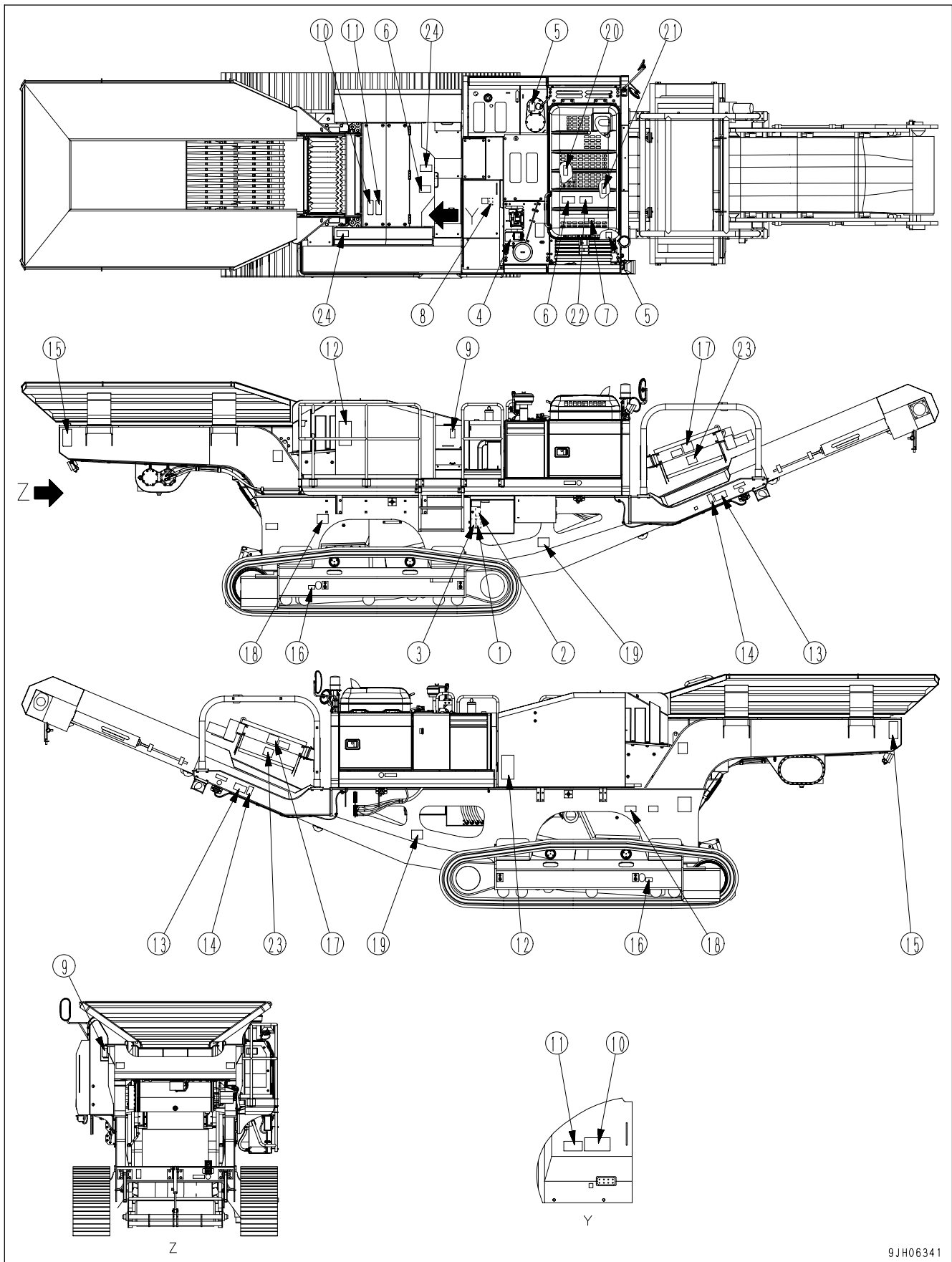

9JH06341

SAFETY LABELS

(1) Caution when leaving top operating place (8295-93-1371)



There is the hazard that the machine may move suddenly and catch on or run over someone near the machine, causing an injury.

Be sure to put the travel control lever in the LOCK position, whenever leaving the operator's platform.

(2) Caution for electrical wires (8295-93-1580)



If the machine goes close to high-voltage wires, it will result in an electric shock to the operator.

Maintain a safe distance between the machine and the electric wires. (See SAFETY section, in this manual)

(3) Caution when operating and performing inspection or maintenance (09651-A0641)

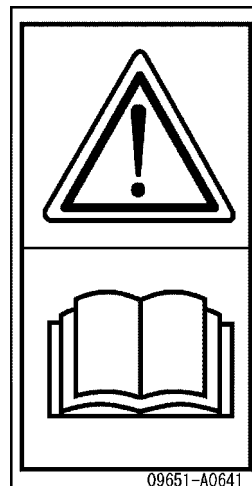

Warning !

Read manual before operation, maintenance, disassembly, assembly and transportation.

(4) Warning when operating (8221-93-1611)

⚠ WARNING

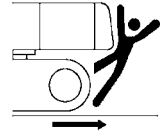

To prevent SEVERE INJURY or DEATH, do the following before moving this machine.

- Sound horn to alert people nearby.
- Be sure no one is on or near this machine.
- Set watchman to guide this machine if view is obstructed.

Follow matters noted above, even if this machine equipped with travel alarm and mirrors.

8221-93-1611

(5) Caution for high-temperature coolant, hydraulic oil (09653-A0481)





09653-A0481

Never remove the cap when the engine is at operating (high) temperature. Steam or high temperature oil blowing up from the radiator or hydraulic tank, will cause personal injury and/or burns.

Never remove the radiator cap or hydraulic tank oil filler when cooling water or hydraulic oil is at high temperatures.

(6) Warning to prevent operator from falling (09805-C0881)





09805-C0881

Sign indicates a hazard of falling.

Do not stand on this place here.

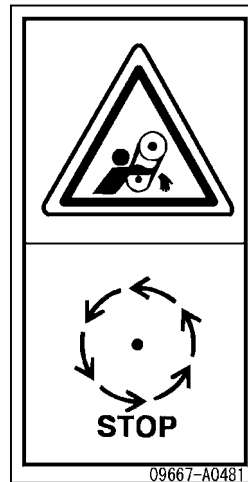
(7) Caution when engine is running (09667-A0481)



Sign indicates a hazard of rotating parts, such as belt.

Turn off before inspection and maintenance.

09667-A0481

(8) Caution when handling cable (09808-A0881)

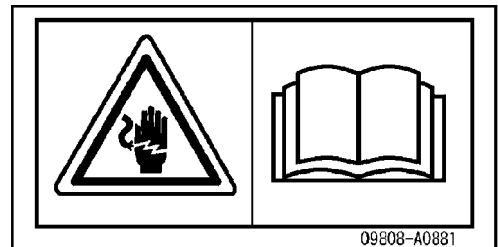

09808-A0881

Sign indicates an electric hazard from handling the cable.

Read manual for safe and proper handling.

(9) Warning when inspecting crusher pulley (09667-A0641)

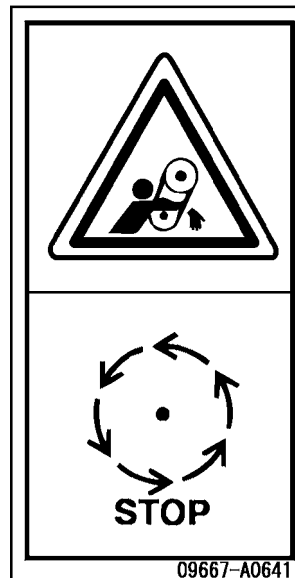

09667-A0641

Sign indicates a hazard of rotating parts, such as belt.

Turn off before inspection and maintenance.

(10) Caution when inspecting crusher (09838-H1201)



Sign indicates a crush hazard between the jaws of the jaw crusher.

Keep away from hopper during operation.

(11) Warning about flying rubble (09826-A0881)



Crushed debris pieces may fly off from within the crusher, causing an injury to those in the vicinity.

Do not get close to the crusher, while in operation.

(12) Prohibition of entry inside operating range (09829-H1681)



Sign indicates a hazard of falling rock and objects.

Keep away from conveyor during operation.

(13) Danger around conveyor (09828-H2321)

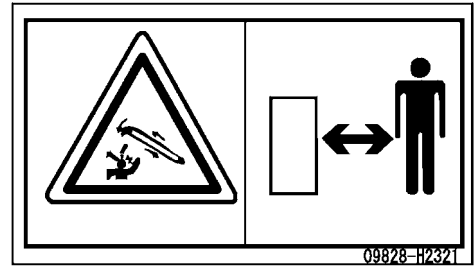

Sign indicates a hazard of falling rock and objects. Keep away from conveyor during operation.

(14) Warning when inspecting conveyor (09667-A0641)

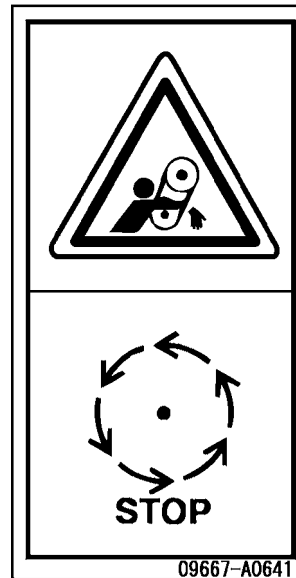

Sign indicates a hazard of rotating parts, such as belt. Turn off before inspection and maintenance.

(15) Caution when approaching when grizzly feeder is operating (09834-H1201)

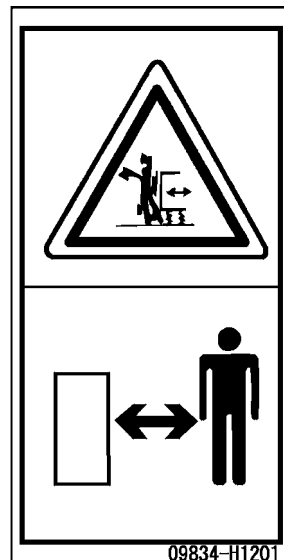

Sign indicates a hazard of being hit by vibrating feeder or sieve. Keep away from hopper during operation.

(16) Caution when adjusting track tension (09657-A0881)

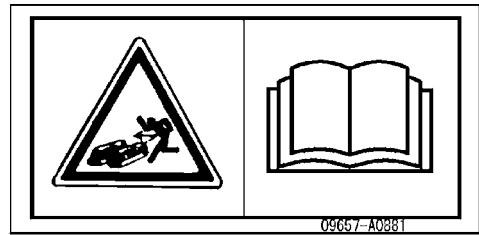

Sign indicates a hazard of flying plug from track adjuster that could cause injury.

Read manual and adjusting track for safe and proper handling.

(17) Caution when approaching when magnetic separator is operating (8248-93-1630)

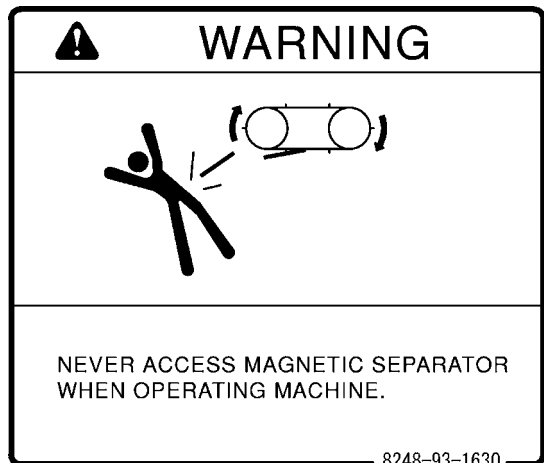

(18) Caution when removing steel rods (8240-93-1280)

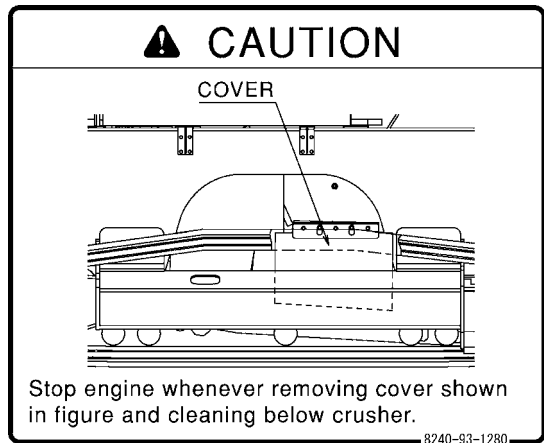

(19) Caution when removing steel rods (8240-93-1290)

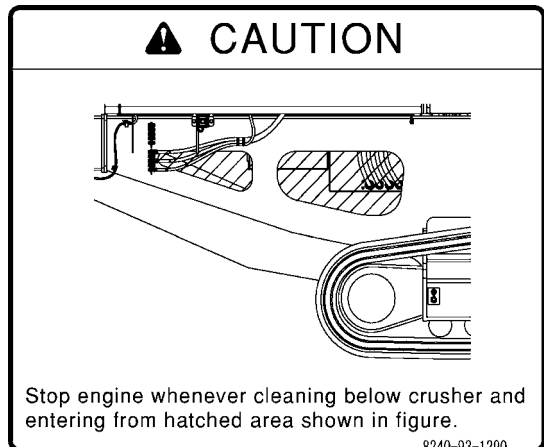

(20) Prohibition of jump start (09842-A0481)



Start the engine only after sitting down in the operator's seat.

Do not attempt to start the engine by short-circuiting the engine starting circuit. Such an act may cause a serious bodily injury or fire.

(21) Caution with high temperatures (09817-A0753)



Sign indicates a burn hazard from touching heated parts, such as engine, motor, or muffler during or right after operation.

Never touch when hot.

(22) Caution to prevent falling (09805-A0881)



There is the hazard of falling down.

Do not go close to the edge of the machine by mistake.

(23) Caution with high magnetic force (09831-H3281)

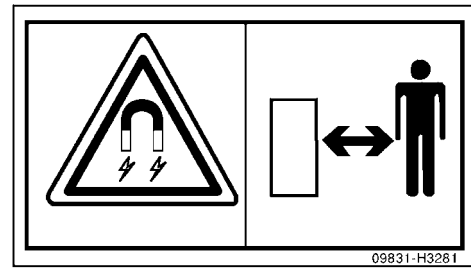

(24) Caution when removing foreign material (8295-93-2840)



GENERAL PRECAUTIONS

SAFETY RULES

- Only trained and authorized personnel can operate and maintain the machine.
- Follow all safety rules, precautions and instructions when operating or performing maintenance on the machine.
- If you are under the influence of alcohol or medication, your ability to safely operate or repair your machine may be severely impaired putting yourself and everyone else on your jobsite in danger.
- When working with another operator or with a person on worksite traffic duty, be sure that all personnel understand all hand signals that are to be used.

IF ABNORMALITIES ARE FOUND

If you find any problems in the machine during operation or maintenance (noise, vibration, smell, incorrect gauges, smoke, oil leakage, etc., or any abnormal display on the warning devices or monitor), report to the person in charge and have the necessary action taken. Do not operate the machine until the problem has been corrected.

CLOTHING AND PERSONAL PROTECTIVE ITEMS

- Do not wear loose clothing and accessories. There is a hazard that they may catch on control levers or other protruding parts.
- If you have long hair and it hangs out from your hard hat, there is a hazard that it may get caught up in the machine, so tie your hair up and be careful not to let it get caught.
- Always wear a hard hat and safety shoes. If the nature of the work requires it, wear safety glasses, mask, gloves, ear plugs, and safety belt when operating or maintaining the machine.
- Check that all protective equipment functions properly before using it.

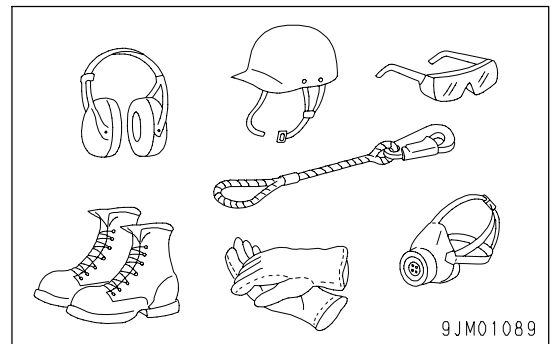

FIRE EXTINGUISHER AND FIRST AID KIT

Always follow the precautions below to prepare for action if any injury or fire should occur.

- Be sure that fire extinguishers have been provided and read the labels to ensure that you know how to use them in
- Carry out periodic inspection and maintenance to ensure that the fire extinguisher can always be used.
- Provide a first aid kit in the storage point. Carry out periodic checks and add to the contents if necessary.

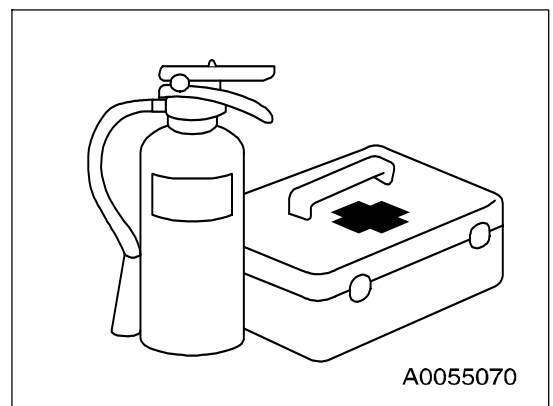

SAFETY FEATURES

- Be sure that all guards and covers are in their proper position. Have guards and covers repaired immediately if they are damaged.
- Understand the method of use of safety features and use them properly.
- Never remove any safety features. Always keep them in good operating condition.

KEEP MACHINE CLEAN

- If water gets into the electrical system, there is a hazard that it will cause malfunctions or misoperation. Do not use water or steam to wash the electrical system (sensors, connectors).
- If inspection and maintenance is carried out when the machine is still dirty with mud or oil, there is a hazard that you will slip and fall, or that dirt or mud will get into your eyes. Always keep the machine clean.

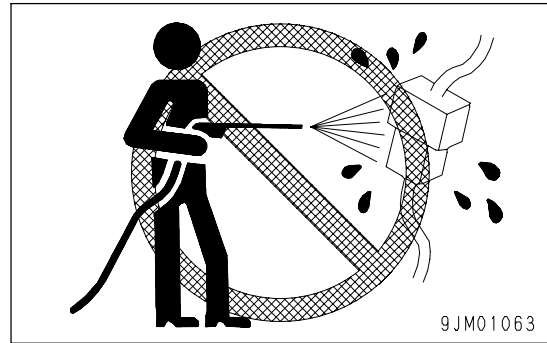

ON OPERATOR'S PLATFORM

- Wipe out oil, grease and mud stuck to shoe soles before getting on the machine. If you get on the machine without them being wiped out, you will likely slip off and suffer a serious accident.
- Make sure that no parts or tools are left around the operator's platform.
- Never use a cellular phone on the operator's platform, while operating the machine.
- Never place any dangerous material like inflammables or explosives around the operator's platform.

ALWAYS APPLY LOCK WHEN LEAVING UPPER OPERATOR'S PLATFORM

- When leaving the top operating position to start operations after traveling and setting in position, always apply travel lever lock (1). If the travel lever is touched by accident, there is danger that the machine may suddenly move and cause serious personal injury or damage.

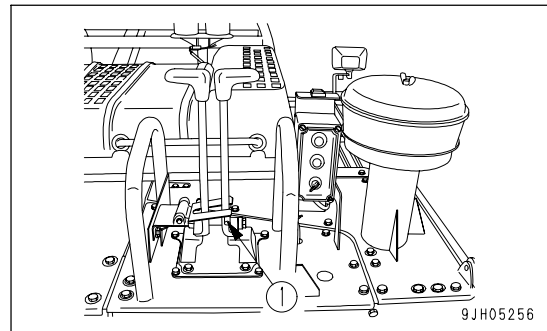

- When completing operations, set mode selector switch (A) to operating mode (b) and stop the engine. Lock all the equipment with the key, take it with you, and keep it in the specified place.

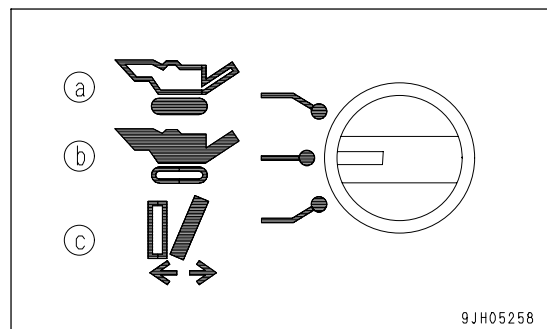
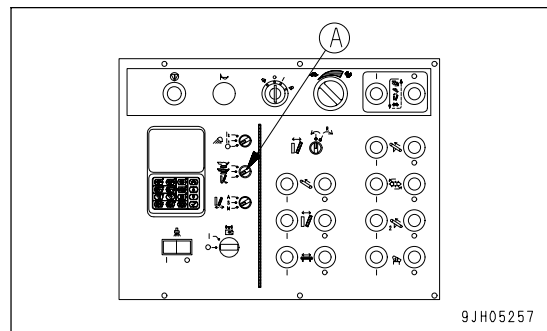

HANDRAILS AND STEPS

To prevent personal injury caused by slipping or falling off the machine, always do as follows.

- Use the handrails and steps marked by arrows in the diagram on the right when getting on or off the machine.

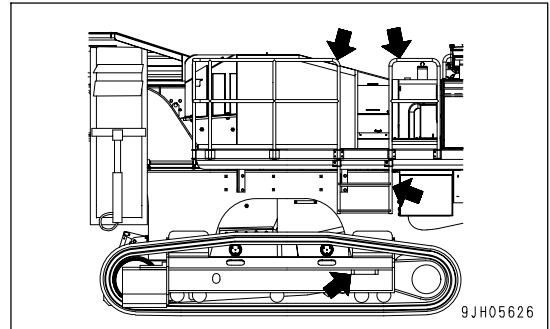

- To ensure safety, always face the machine and maintain three-point contact (both feet and one hand, or both hands and one foot) with the handrails and steps (including the track shoe) to ensure that you support yourself.
- Never climb on the engine hood or covers where there are no non-slip pads.
- Before getting on or off the machine, check the handrails and steps (including the track shoe). If there is any oil, grease, or mud on the handrails or steps (including the track shoe), wipe it off immediately. Always keep these parts clean. Repair any damage and tighten any loose bolts.
- Do not get on or off the machine while holding tools in your hand.

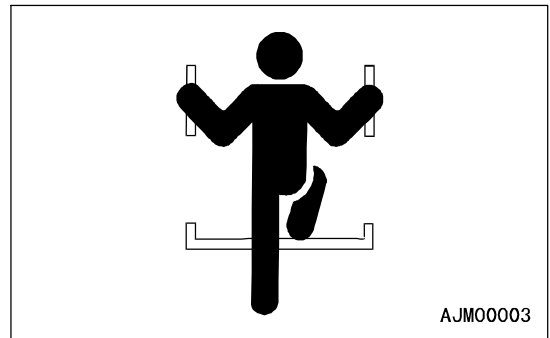

PRECAUTIONS WHEN WORKING IN HIGH PLACES

When working at high places, use a step ladder or other stand to ensure that the work can be carried out safely.

MOUNTING AND DISMOUNTING

- Never jump on or off the machine. Never get on or off a moving machine.
- If the machine starts to move when there is no operator on the machine, do not jump on to the machine and try to stop it.
- Always use a stand or step when going inside the hopper.

NO PEOPLE ON ATTACHMENTS

Never let anyone ride on the work equipment, or other attachments. There is a hazard of falling and suffering serious injury.

CRUSHING OR CUTTING PREVENTION

If anyone is caught between parts around the crusher and conveyor, there is danger of serious personal injury. Do not allow anyone to approach any rotating or extending/retracting parts.

PREVENTION OF BURNS

Hot coolant

- To prevent burns from hot water or steam spurting out when checking or draining the coolant, wait for the water to cool to a temperature where it is possible to touch the radiator cap by hand before starting the operation. Even when the coolant has cooled down, loosen the cap slowly to relieve the pressure inside the radiator before removing the cap.

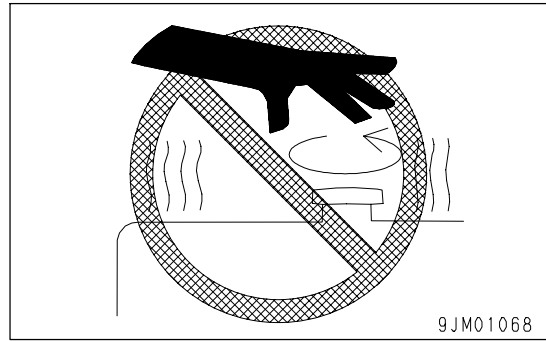

Hot oil

- To prevent burns from hot oil spurting out when checking or draining the oil, wait for the oil to cool to a temperature where it is possible to touch the cap or plug by hand before starting the operation. Even when the oil has cooled down, loosen the cap or plug slowly to relieve the internal pressure before removing the cap or plug.

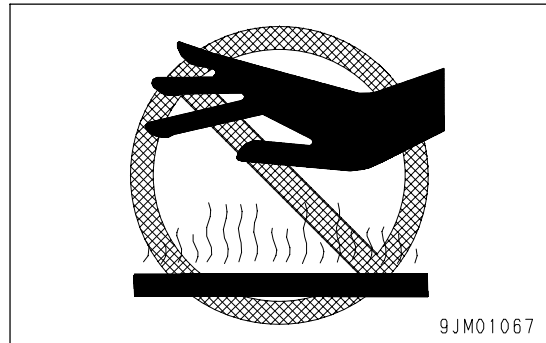

FIRE PREVENTION

• Fire Prevention for Fuel and Oil

Fuel, oil and antifreeze can be ignited by a flame. Be sure to follow the instructions given below without fail.

- Never smoke nor use fire near any of them.
- Stop the engine for refuelling and oiling.
- Never leave the machine, while refueling or oiling.
- Tighten all the fuel and oil caps securely.
- Do not spill fuel on the heated engine parts or electrical parts.
- Keep fuel and oil in a well ventilated place.
- Keep fuel and oil in the determined place and do not allow unauthorized persons to enter.
- Wipe out the spillage after fuel, oil and grease are added.
- When machining or welding any machine parts, move away inflammables and keep them in a safe place beforehand.
- When cleaning parts, do not use inflammable oil such as light oil and gasoline for cleaning, but use nonflammable oil.
- Inflammables like cloth wet with oil should be placed in a safe container and kept in a safe place.
- Do not try to weld or gas-cut piping or tubes containing



• Fire caused by accumulation of flammable material.

Remove any dry leaves, chips, pieces of paper, dust, or any other flammable materials accumulated or affixed around the engine, exhaust manifold, muffler, or battery, or inside the undercovers.

- **Fire coming from electric wiring**

Short circuits in the electrical system can cause fire.

- Always keep electric wiring connections clean and securely tightened.
- Check the wiring every day for looseness or damage. Tighten any loose connectors or wiring clamps. Repair or replace any damaged wiring.

- **Fire coming from hydraulic line**

Check that all the hose and tube clamps, guards, and cushions are securely fixed in position.

If they are loose, they may vibrate during operation and rub against other parts. This may lead to damage to the hoses, and cause high-pressure oil to spurt out, leading to fire damage or serious injury.

- **Use of Anti-explosion Type Lighting**

- When checking the fuel, oil, coolant and battery electrolyte levels, use a lighting apparatus of anti-explosion specification. If a lighting apparatus without anti-explosion specification is used, there will be a danger that they catch fire and explode, causing a serious injury or death.

ACTION IF FIRE OCCURS

If a fire occurs, escape from the machine as follows.

- Turn the start switch OFF to stop the engine.
- Use the handrails and steps to get off the machine.

PRECAUTIONS FOR ATTACHMENTS

- When installing optional parts or attachments, there may be problems with safety or legal restrictions. Therefore contact your Komatsu distributor for advice.
- Any injuries, accidents, or product failures resulting from the use of unauthorized attachments or parts will not be the responsibility of Komatsu.
- When installing and using optional attachments, read the instruction manual for the attachment, and the general information related to attachments in this manual.

UNAUTHORIZED MODIFICATION

Any modification made without authorization from Komatsu can create hazards. Before making a modification, consult your Komatsu distributor.

- Komatsu will not be responsible for any injuries, accidents, product failures or other property damages resulting from modifications made without authorization from Komatsu.

SAFETY AT WORKSITE

Before starting operations, thoroughly check the area for any unusual conditions that could be dangerous.

- When carrying out operations near combustible materials such as thatched roofs, dry leaves or dry grass, there is a hazard of fire, so be careful when operating.
- Check the terrain and condition of the ground at the worksite, and determine the safest method of operation. Do not operate where there is a hazard of landslides or falling rocks.
- If water lines, gas lines, or high-voltage electrical lines may be buried under the worksite, contact each utility and identify their locations. Be careful not to sever or damage any of these lines.
- Take action to prevent unauthorized people from approaching the jobsite.
When working on public roads, position flagmen and erect barriers to ensure the safety of passing traffic and pedestrians.
- When traveling or operating in shallow water or on soft ground, check the shape and condition of the bedrock, and the depth and speed of flow of the water before starting operations.

WORKING ON LOOSE GROUND

- Avoid traveling or operating your machine too close to the edge of cliffs, overhangs, and deep ditches. The ground may be weak in such areas. If the ground should collapse under the weight or vibration of the machine, there is a hazard that the machine may fall or tip over. Remember that the soil after heavy rain or blasting or after earthquakes is weak in these areas.
- When working on embankments or near excavated ditches, there is a hazard that the weight and vibration of the machine will cause the soil to collapse. Before starting operations, take steps to ensure that the ground is safe and to prevent the machine from rolling over or falling.

DO NOT GO CLOSE TO HIGH-VOLTAGE CABLES

Do not travel or operate the machine near electric cables. There is a hazard of electric shock, which may cause serious injury or property damage. On jobsites where the machine may go close to electric cables, always do as follows.

- Before starting work near electric cables, inform the local power company of the work to be performed, and ask them to take the necessary action.

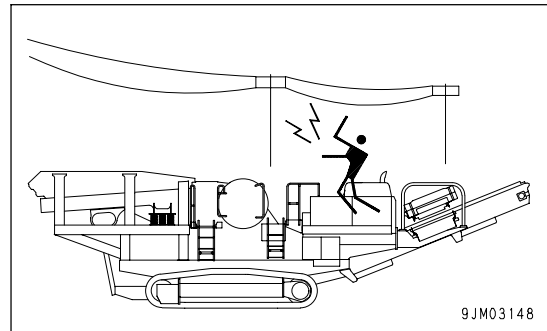

- Even going close to high-voltage cables can cause electric shock, which may cause serious burns or even death. Always maintain a safe distance (see the table on the right) between the machine and the electric cable. Check with the local power company about safe operating procedure before starting operations.
- Wear rubber-soled shoes and rubber gloves for fear of an electric shock and be careful that any unprotected body part will never touch the machine.
- Use a signalman to give warning if the machine approaches too close to the electric cables.
- When carrying out operations near high voltage cables, do not let anyone near the machine.
- Should the machine have got too close to an electric wire or come to contact with it, the operator must not leave the machine, but stay in the operator's platform, in order to avoid a risk of electric shock, until the electricity is switched off. Likewise do not allow anyone to come close to the machine.

| Voltage of Cables | Safety Distance |
|-------------------|-------------------|
| 100 V - 200 V | Over 2 m (7 ft) |
| 6,600 V | Over 2 m (7 ft) |
| 22,000 V | Over 3 m (10 ft) |
| 66,000 V | Over 4 m (14 ft) |
| 154,000 V | Over 5 m (17 ft) |
| 187,000 V | Over 6 m (20 ft) |
| 275,000 V | Over 7 m (23 ft) |
| 500,000 V | Over 11 m (36 ft) |

ENSURE GOOD VISIBILITY

- Check for any persons or obstacles in the area around the machine and check the conditions of the jobsite to ensure that operations and travel can be carried out safely. Always do as follows.
 - When working in dark places, turn on the working lamp and front lamps installed to the machine, and set up additional lighting in the work area if necessary.
 - Stop operations if the visibility is poor, such as in mist, snow, rain, or dust.

VENTILATION FOR ENCLOSED AREAS

Exhaust fumes from the engine can kill.

- If it is necessary to start the engine within an enclosed area, or when handling fuel, flushing oil, or paint, open the doors and windows to ensure that adequate ventilation is provided to prevent gas poisoning.

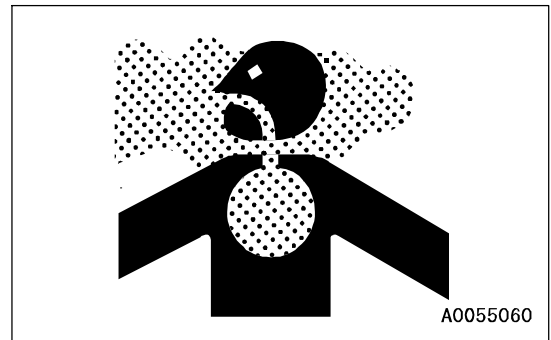
**CHECKING SIGNALMAN'S SIGNALS AND SIGNS**

- Set up signs to inform of road shoulders and soft ground. If the visibility is not good, position a signalman if necessary. Operators should pay careful attention to the signs and follow the instructions from the signalman.
- Only one signalman should give signals.
- Make sure that all workers understand the meaning of all signals and signs before starting work.

BE CAREFUL ABOUT ASBESTOS DUST

Asbestos dust in the air can cause lung cancer if it is inhaled. There is danger of inhaling asbestos when working on jobsites handling demolition work or work handling industrial waste. Always observe the following.

- Spray water to keep down the dust when cleaning. Do not use compressed air for cleaning.
- If there is danger that there may be asbestos dust in the air, always operate the machine from an upwind position. All workers should use an approved respirator.
- Do not allow other persons to approach during the operation.
- Always observe the rules and regulations for the work site and environmental standards.

This machine does not use asbestos, but there is a danger that imitation parts may contain asbestos, so always use genuine Komatsu parts.

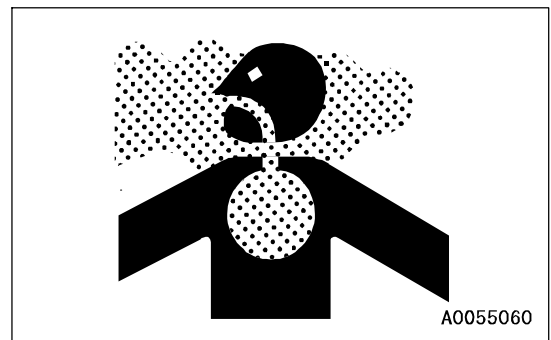

MAGNETIC SEPARATOR (HANGING TYPE)

There is a strong magnetic force around the magnetic separator, and this may cause malfunction of pacemakers or other serious injury, so always do as follows when operating this machine (driving, operating, carrying out maintenance, transporting, storing, etc.).

- There is danger that the magnetic field may cause malfunction of pacemakers, so persons wearing pacemakers should not approach within a range of 5 m (16 ft 5 in) from the magnetic separator.
- The magnetic force will attract metal tools and pieces of steel, and there is danger of getting your fingers or hands caught between such objects and the attracting surface, so do not approach the magnetic separator when carrying metal tools or pieces of steel.
- Use a steel object removal belt to remove any pieces of steel attracted to the magnetic separator. There is danger of injury, so do not approach the magnetic separator while it is being operated.
- When storing this machine or removing the magnetic separator, set up cones and do not allow any person wearing a pacemaker to approach within a range of 5 m (16 ft 5 in) from the magnetic separator.
- There is danger of the magnetic field causing damage, so do not bring watches, cellular phones, or other precision instruments close to the magnetic separator.
- There is danger of the stored data being damaged by the magnetic field, so do not carry bank cards, credit cards, or other cards with magnetic strips when approaching the magnetic separator.

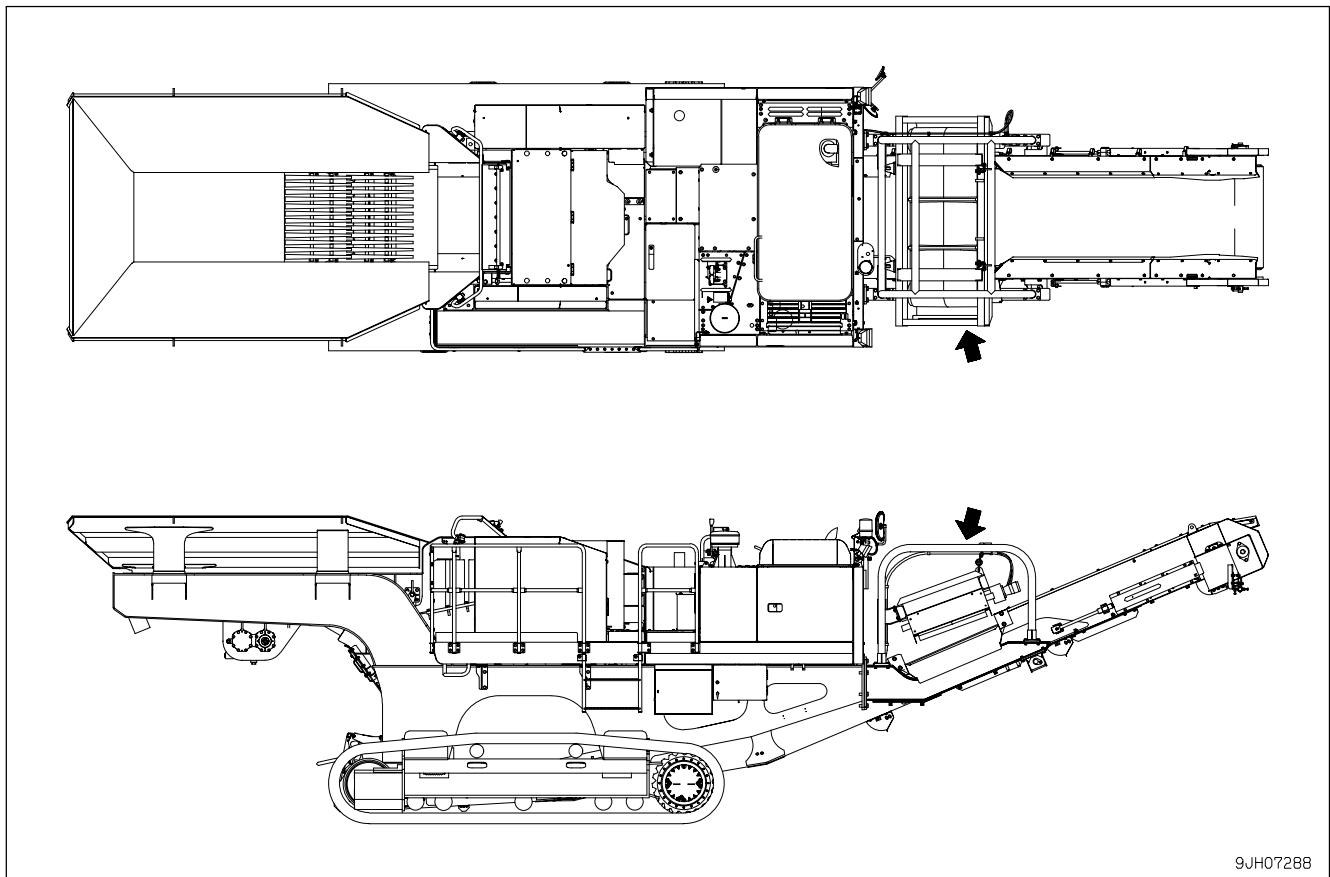

PRECAUTIONS FOR OPERATION

STARTING ENGINE

If there is a warning tag on the starting switch, do not start the engine or touch any switch.

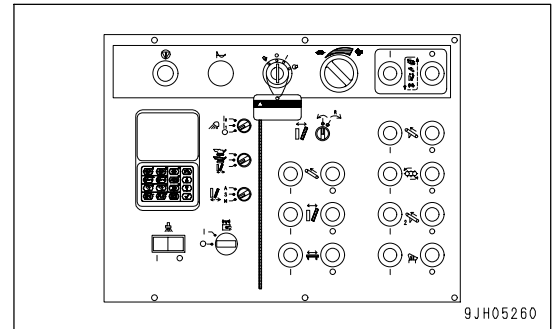

CHECKS BEFORE STARTING ENGINE

Carry out the following checks before starting the engine at the beginning of the day's work.

- Remove all dirt from the surface of the lens of the front lamps and working lamps, and check that they light up correctly.
- Check the coolant level, fuel level, and oil level in engine oil pan, check for clogging of the air cleaner, and check for damage to the electric wiring.
- Check that the gauges work properly, check the angle of the lights and working lamps, and check that the control levers are all at the neutral position.
- Before starting the engine, make sure that the lock lever is in the LOCK position.
- Adjust the position of the rear view mirror so that both sides and the rear part of the machine can be clearly seen from the operator's platform.

Refer to "ADJUSTMENT OF REAR VIEW MIRROR (PAGE 3-58)" for the position adjustment.

- Check that there are no persons or obstacles above, below, or in the area around the machine.

PRECAUTIONS WHEN STARTING

- When starting the engine, always stand in front of the control panel at the operating point.
- Never short circuit the starting circuit to start the engine. There is danger that the machine may run out of control and cause an accident or fire.
- When starting the engine, sound the horn as a warning.
- Do not allow anyone apart from the operator to ride on the machine.

PRECAUTIONS IN COLD AREAS

- Always carry out the warming-up operation thoroughly. If the machine is not thoroughly warmed up, and the travel lever or switches are operated, the reaction of the machine may be slow or it may change suddenly and cause an accident.

- If the battery electrolyte is frozen, do not charge the battery or start the engine with a different power source. There is a hazard that this will ignite the battery and cause the battery to explode. Before charging or starting the engine with a different power source, melt the battery electrolyte and check that there is no leakage of electrolyte before starting.

OPERATION

CHECK BEFORE OPERATION

When carrying out the checks, move the machine to a wide area where there are no obstructions, and operate slowly. Do not allow anyone near the machine.

- Check that the work equipment, traveling device, etc. work properly.
- Check for any problem in the sound of the machine, vibration, heat, smell, or gauges; check also that there is no leakage of oil or fuel.
- If any problem is found, carry out repairs immediately.

PRECAUTIONS WHEN CHANGING DIRECTION

- Before travelling, check again that there is no one in the surrounding area, and that there are no obstacles.
- Before travelling, sound the horn to warn people in the area.
- Do not allow anyone apart from the operator to ride on the machine.
- Make sure that the travel alarm works properly.
- Post a signal person at the worksite, if there is a blind spot at the rear of the machine where the operator's view is blocked.

Always be sure to carry out the above precautions even when the machine is equipped with mirrors.

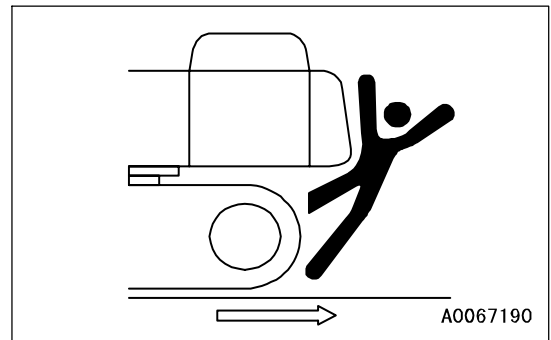

PRECAUTIONS WHEN TRAVELING

- On the uneven ground, operate the machine at a low speed, avoiding jerky operation, so that the machine will not roll over. Otherwise the machine might inflict a damage on the surrounding structures.
- Operate the machine with the hopper, crusher and belt conveyor empty.
- Try to avoid having the machine climb over obstacles. If that is unavoidable, let the machine do that at a low speed. Nonetheless avoid a big obstacle that greatly tilts the machine to the right or left, because in such a case the machine can easily overturn sideways.
- When traveling or carrying out operations, always keep a safe distance from people, structures, or other machines to avoid coming into contact with them.
- When passing over bridges or structures, check first that the structure is strong enough to support the weight of the machine. When traveling on public roads, check first with the relevant authorities and follow their instructions.
- When operating in tunnels, under bridges, under electric wires, or other places where the height is limited, operate slowly and be extremely careful not to let the work equipment hit anything.

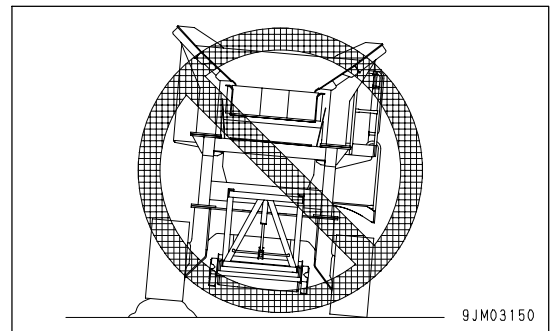

TRAVELING ON SLOPES

- When traveling downhill, lower the engine speed, keep the travel lever close to the neutral position, and travel at low speed.
- Always travel straight up or down a slope. Traveling at an angle or across the slope is extremely dangerous.
- Do not turn on slopes or travel across slopes. Always go down to a flat place to change the position of the machine, then travel on to the slope again.
- Travel on grass, fallen leaves, or wet steel plates with low speed. Even with slight slopes there is a hazard that the machine may slip.
- If the engine stops when the machine is traveling on a slope, move the control levers immediately to the neutral position and start the engine again.

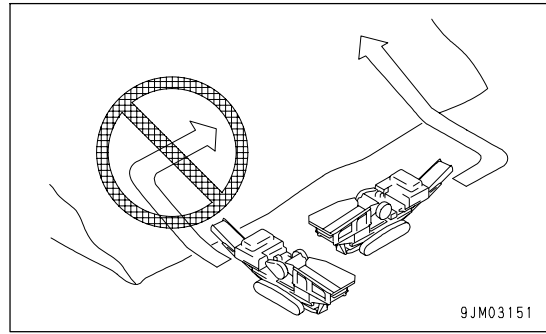

9JM03151

OPERATIONS ON SLOPES

- When working on slopes, there is a hazard that the machine may lose its balance and turn over when the swing or work equipment are operated. This may lead to serious injury or property damage, so always provide a stable place when carrying out these operations, and operate carefully.
- If the machine has to be used on a slope, pile the soil to make a platform that will keep the machine as horizontal as possible.

PRECAUTIONS WHILE IN OPERATION

- Park the machine on the even and solid ground for starting the work.
- When operating in tunnels, under bridges, under electric wires, or other places where the height is limited, be extremely careful not to let the work equipment hit anything.
- To prevent accidents caused by hitting other objects, always operate the machine at a speed which is safe for operation, particular in confined spaces, indoors, and in places where there are other machines.

OPERATE CAREFULLY ON SNOW

- Snow-covered or frozen surfaces are slippery, so be extremely careful when traveling or operating the machine, and do not operate the levers suddenly. Even a slight slope may cause the machine to slip, so be particularly careful when working on slopes.
- With frozen ground surfaces, the ground becomes soft when the temperature rises, and this may cause the machine to tip over.
- If the machine enters deep snow, there is a hazard that it may tip over or become buried in the snow. Be careful not to leave the road shoulder or to get trapped in a snow drift.

PARKING MACHINE

- Park the machine on firm, level ground.
- Select a place where there is no hazard of falling rocks or landslides, or of flooding if the land is low.
- When the machine is parked on a public road, put up a warning flag, a fence or any other caution sign as well as install an illumination system to the extent that they do not hinder the traffic, so that other ongoing vehicles can readily spot the machine.
- When parking the machine, always set travel lever lock (1) to the LOCK position, set mode selector switch (A) to OPERATION position (b), then stop the engine.
- Shut all the locks on the machine and pull off the key so that an unauthorized person may not operate the machine without permission, and safe-keep it in the determined place.

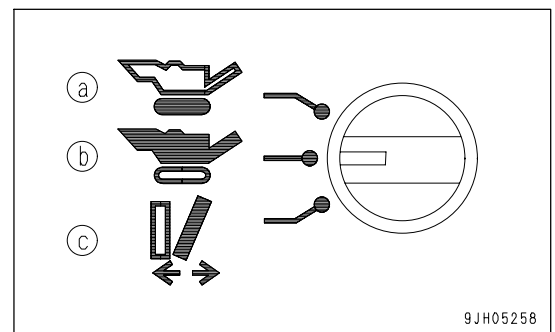
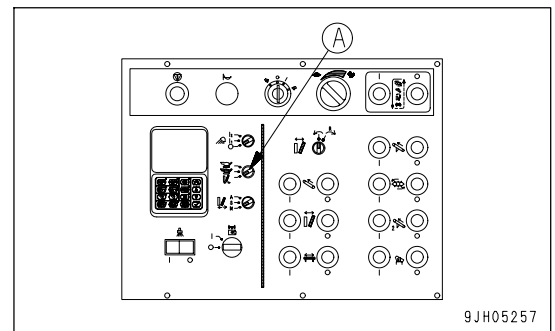
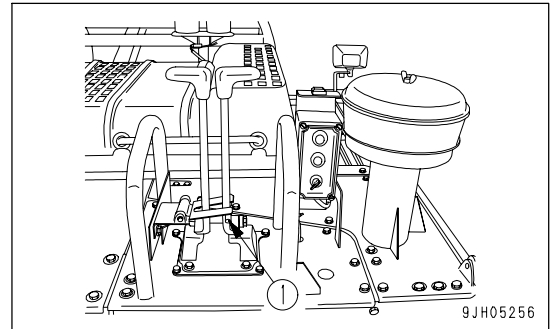

- When it becomes unavoidable to park the machine on a slope, follow the instructions below.
 - Place blocks at the end of the track shoes so that the machine will not slithers down.

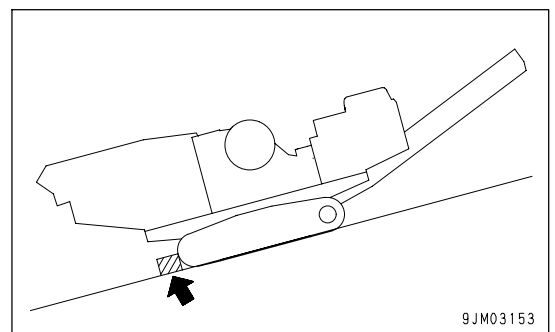

CRUSHING OPERATION

When inspecting or cleaning the conveyor or crusher, there is danger of getting caught in the rotating parts. Always stop the conveyor and crusher before starting the operation.

CHECKS AROUND MACHINE

- In consideration of the safety to the neighbourhood, put up a protective screen all around the machine.
- Crusher workers should wear protective glasses and a dust-proof respirator not to mention a hard hat.

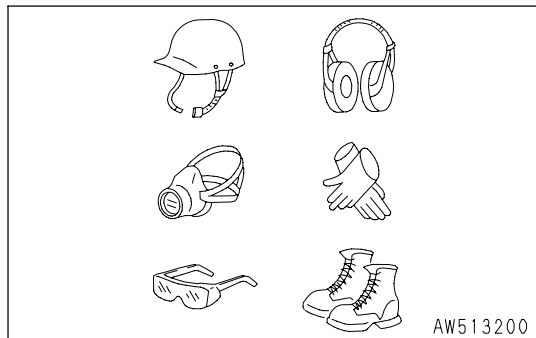

TURN MODE SELECTOR SWITCH TO WORK POSITION

- Set travel lever lock (1) to the LOCK position.

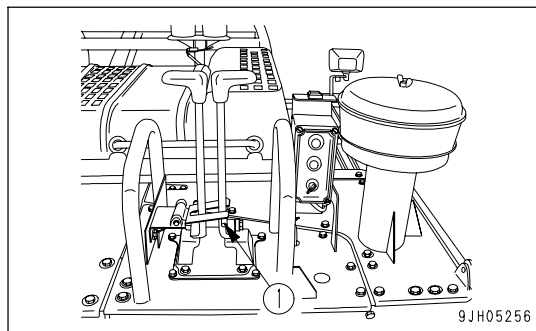

- Set mode selector switch (A) to OPERATION position (b), then follow the instructions in the OPERATION section (operating work equipment, starting operation of jaw crusher) to operate the machine.

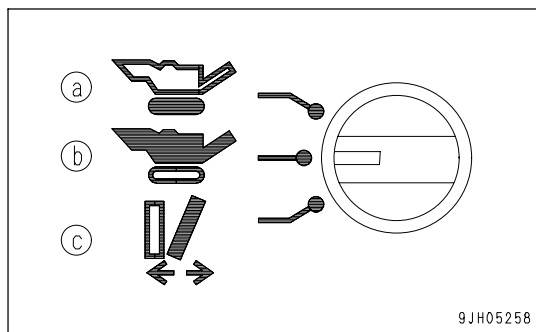
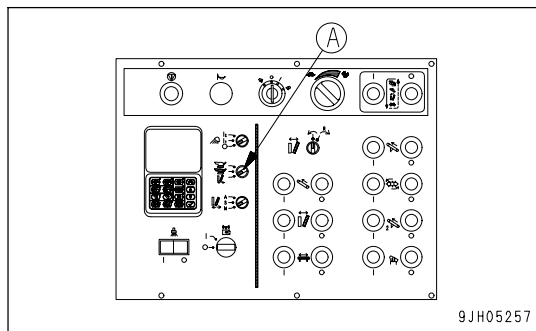

ENSURE SAFETY WHILE OPERATING IN TANDEM WITH HYDRAULIC EXCAVATOR

- The operator of this machine is supposed to work in cooperation with the operator of a loading machine like a hydraulic excavator or wheel loader. Hence, for the sake of mutual safety, it is recommended for them to determine common signals beforehand and to follow the advice below in particular.
 - Always position the machine so that the operator of the loading equipment can see inside the hopper and the operator of the machine itself can also see.
 - The operator of this machine is advised to take his/her stand from where the bucket and the operator of the loading machine can clearly be seen.
- The next loading work should only be begun at a signal from the operator of this machine.

CHECKS OF CRUSHER BEFORE STARTING OPERATION

Before starting with crushing work, inspect the following to confirm that there is nothing abnormal with the machine.

- Check that there is no foreign material left inside the hopper and crusher.
- Check that each bolt is securely tightened.
In this case, pay special attention to the crusher mounting bolts, wedge bolts securing jaw plates and cheek plate securing bolts in particular.
- Check the machine main frame whether there is no deformation or crack developed on it.

PRECAUTIONS FOR CRUSHING WORK

- Do not allow anyone close to the machine during operations.
Do not climb on top of the machine. There is danger of injury from flying pieces of crushed rock.
- During crusher operations, never go near the hopper, crusher, or chassis.
- Even if the hopper or crusher becomes clogged with crushed material, never use a rod or breaker to poke the material.
There is danger that the rod or breaker may be pulled in by the crusher together with the crushed material. When carrying out operations around the hopper or crusher, stop the crusher, then stop the engine.

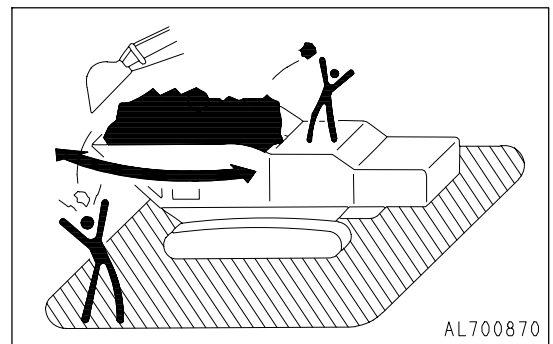

EMERGENCY STOP TO WARD OFF DANGERS WHILE IN CRUSHING WORK

- If the operator of the machine feels that there is any abnormality in the machine, or if he feels that there is some danger, he should press the emergency stop switch immediately and stop all operations.

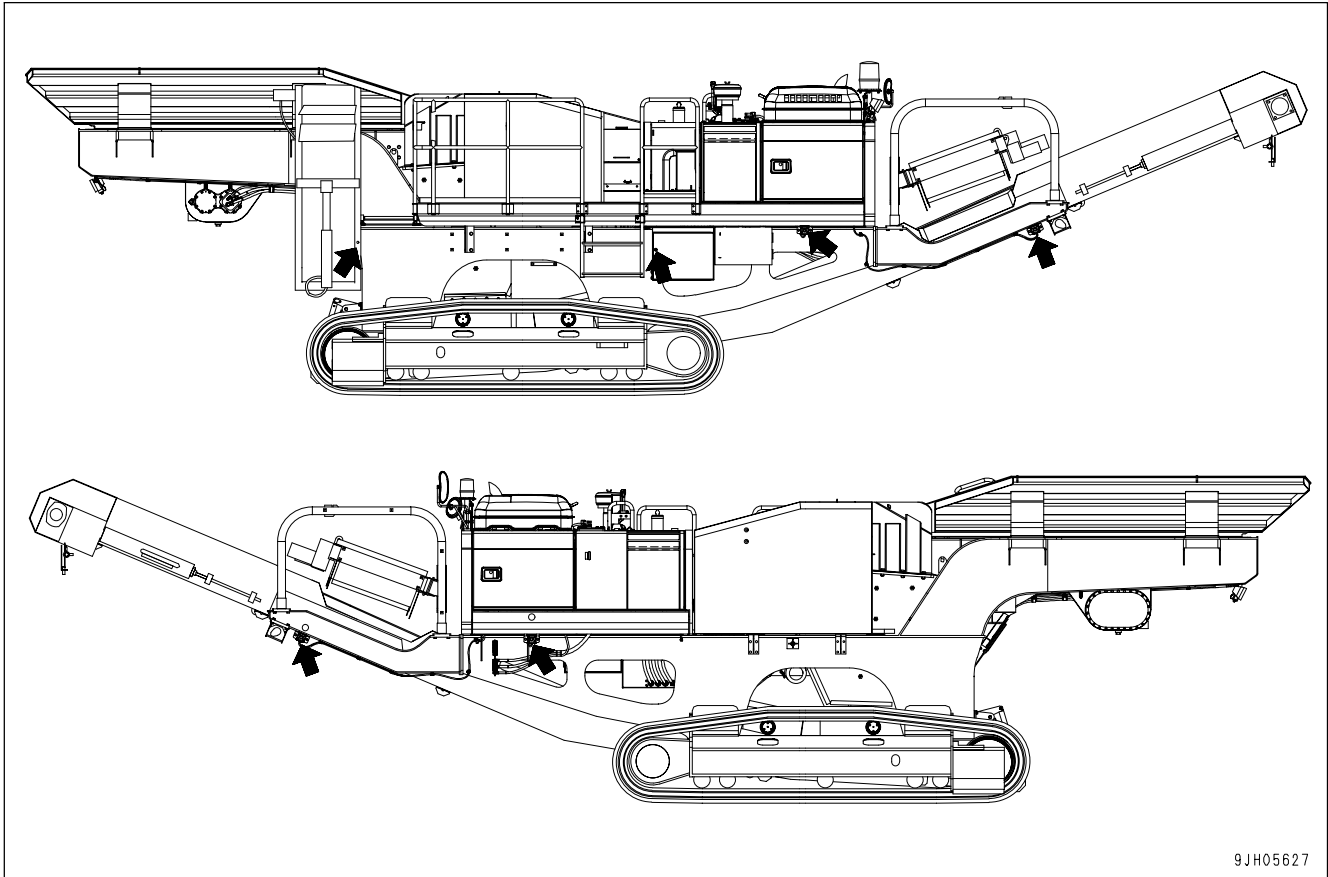
**REMOVE FOREIGN MATERIAL FROM INSIDE CRUSHER**

If any lumps of steel or other foreign material are caught inside the crusher, always use the following procedure to carry out operations.

1. When entering crusher chamber
 - 1) Turn the engine OFF, then remove the key from the starting switch.
 - 2) Always hang a warning sign on the starting switch of the main control box.
 - 3) Press the lock switch.

2. Procedure for removing foreign material

When carrying out this operation, follow the procedure given in "PRECAUTIONS WHEN OPERATING JAW CRUSHER (PAGE 3-101)".

TRANSPORTATION

The machine can be divided into parts for transportation, so when transporting the machine, please contact your Komatsu distributor to have the work carried out.

LOADING AND UNLOADING

When loading or unloading the machine, mistaken operation may bring the hazard of the machine tipping over or falling, so particular care is necessary. Always do as follows.

- Perform loading and unloading on firm, level ground only. Maintain a safe distance from the edge of the road or cliff.
- Always use ramps of adequate strength. Be sure that the ramps are wide, long, and thick enough to provide a safe loading slope. Take suitable steps to prevent the ramps from moving out of position or coming off.

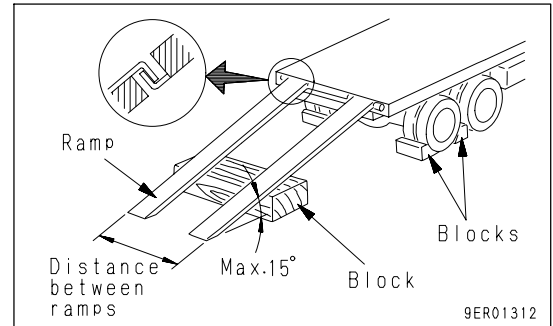

- Be sure the ramp surface is clean and free of grease, oil, ice and loose materials. Remove dirt from machine-tracks. On a rainy day, in particular, be extremely careful since the ramp surface is slippery.
- Run the engine at low idle, set to low speed, and operate the machine slowly when loading or unloading.
- Never correct your steering on the ramps. If necessary, drive off the ramps, correct the direction, then enter the ramps again.
- While the machine is still on the ramps, do not attempt to operate the machine other than travel it forward or backward.
- The center of gravity of the machine will change suddenly at the joint between the ramps and the track or trailer, and there is danger of the machine losing its balance. Travel slowly over this point.
- When loading or unloading to an embankment or platform, make sure that it has suitable width, strength, and grade.
- After the loading, fasten the machine securely with a wire rope and wooden blocks to prevent the machine from moving.

SHIPPING

When shipping the machine on a trailer, do as follows.

- The weight, transportation height, and overall length of the machine differ according to the work equipment, so be sure to confirm the dimensions.
- When passing over bridges or structures on private land, check first that the structure is strong enough to support the weight of the machine. When traveling on public roads, check first with the relevant authorities and follow their instructions.
- For details of the shipping procedure, see "TRANSPORTATION (PAGE 3-122)" in the OPERATION section.

BATTERY

BATTERY HAZARD PREVENTION

Battery electrolyte contains sulphuric acid, and batteries generate flammable hydrogen gas, which may explode. Mistaken handling can lead to serious injury or fire. For this reason, always observe the following precautions.

- When working with batteries, always wear safety glasses and rubber gloves.
- Never smoke or use any flame near the battery.

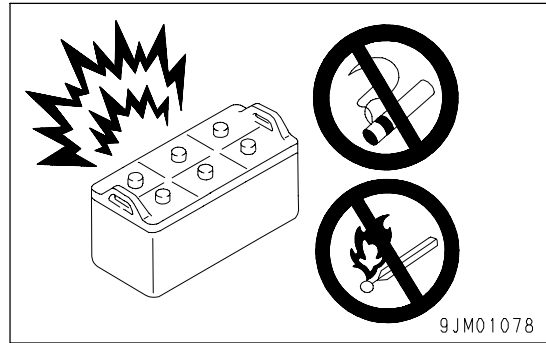

- If you spill acid on your clothes or skin, immediately flush the area with large amount of water.
- If acid gets into your eyes, flush them immediately with large amount of water and seek medical attention.

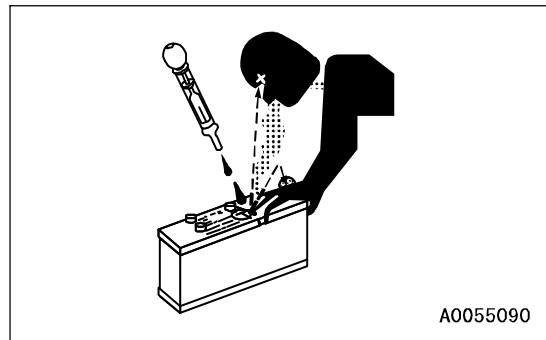

- Before working with batteries, turn the starting switch to the OFF position.

As there is a hazard that sparks will be generated, always do as follows.

- Do not let tools or other metal objects make any contact between the battery terminals. Do not leave tools or other metal objects lying around near the battery.
- Always disconnect the negative (-) terminal (ground side) first when removing the battery; when installing the battery, connect the positive (+) terminal first, and connect the ground last. Tighten the battery terminals
- Flammable hydrogen gas is generated when the battery is charged, so remove the battery from the chassis, take it to a well-ventilated place, and remove the battery caps before charging it.
- Tighten the battery caps securely.
- Install the battery securely to the determined place.

STARTING WITH BOOSTER CABLE

If any mistake is made in the method of connecting the booster cables, it may cause the battery to explode, so always do as follows.

- Starting the engine using a booster cable has to be conducted by a team of two persons with one taking a position at the operator's platform and the other at the battery.
- When starting from another machine, do not allow the two machines to touch.
- When connecting the booster cables, turn the starting switch OFF position for both the normal machine and problem machine. There is a hazard that the machine will move when the power is connected.
- Be sure to connect the positive (+) cable first when installing the booster cables. Disconnect the negative (-) cable (ground side) first when removing them.
- When removing the booster cables, be careful not to let the booster cable clips touch each other or to let the clips touch the machine.
- Always wear safety glasses and rubber gloves when starting the engine with booster cables.
- When connecting a normal machine to a problem machine with booster cables, always use a normal machine with the same battery voltage as the problem machine.
- For details of the starting procedure when using booster cables, see "STARTING ENGINE WITH BOOSTER CABLE (PAGE 3-136)" in the OPERATION section.

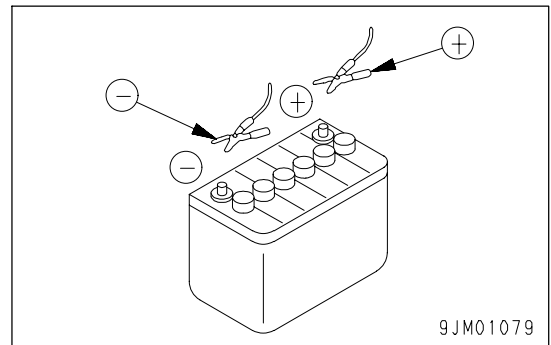
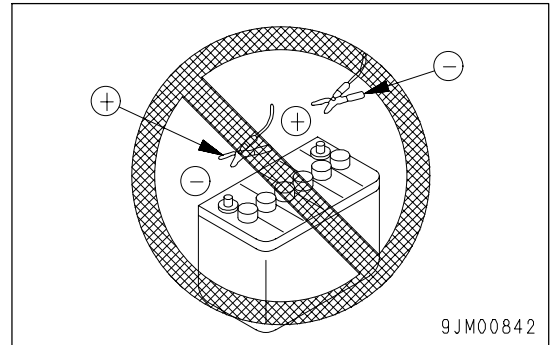

TOWING

WHEN TOWING

Serious injury or death could result if a disabled machine is towed incorrectly or if there is a mistake in the selection or inspection of the wire rope.

For towing method, see "METHOD OF TOWING MACHINE (PAGE 3-134)".

- Always check that the wire rope used for towing has ample strength for the weight of the machine being towed.
- Never use a wire rope which has cut strands (A), reduced diameter (B), or kinks (C). There is danger that the rope may break during the towing operation.

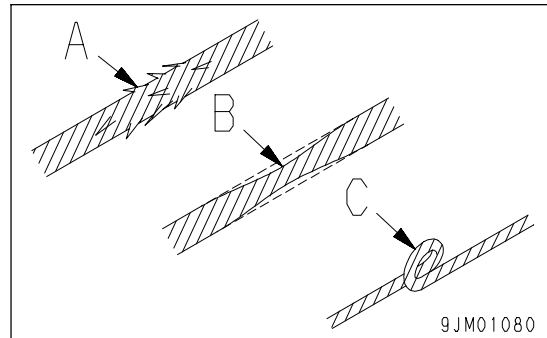

- Always wear leather gloves when handling wire rope.
- Never tow a machine on a slope.
- During the towing operation, never stand between the towing machine and the machine being towed.
- Operate the machine slowly and be careful not to apply any sudden load to the wire rope.

PRECAUTIONS FOR MAINTENANCE

WARNING TAG

- Always attach the "DO NOT OPERATE" warning tag to the work equipment control lever in the operator's cab to alert others that you are performing service or maintenance on the machine.

Attach additional warning tags around the machine if Keep this warning tag in the tool box while it is not used. If there is not the tool box, keep the tag in the operation manual pocket.

- Should an irrelevant person start the engine, while the machine is under inspection or maintenance, that would cause a serious accident like bodily injury.

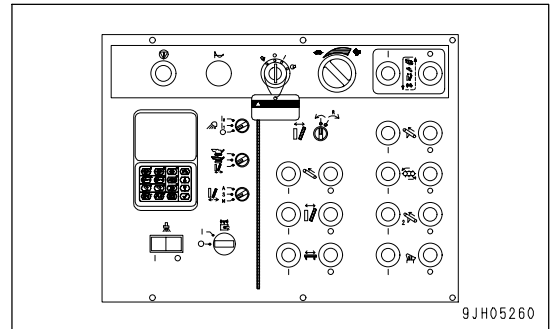

KEEP WORK PLACE CLEAN AND TIDY

- Do not leave hammers or other tools lying around in the work place. Wipe up all grease, oil, or other substances that will cause you to slip. Always keep the work place clean and tidy to enable you to carry out operations safely. If the work place is not kept clean and tidy, there is the danger that you will trip, slip, or fall over and injure yourself.

APPOINT LEADER WHEN WORKING WITH OTHERS

- When repairing the machine or when removing and installing the work equipment, appoint a leader and follow his instructions during the operation.

STOP ENGINE BEFORE CARRYING OUT INSPECTION AND MAINTENANCE

- Stop the machine on firm, level ground.
- Select a place where there is no hazard of falling rocks or landslides, or of flooding if the land is low.
- Stop the engine.

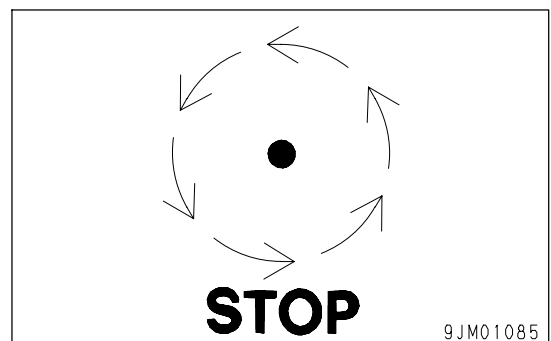

- Put blocks under the track to prevent the machine from moving.

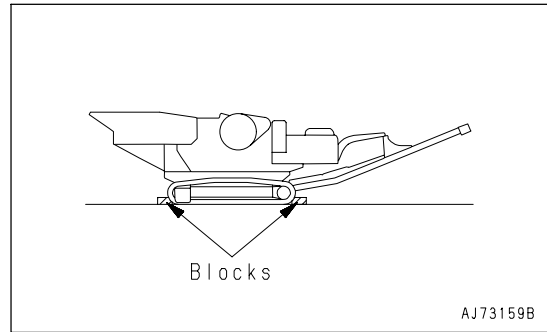

TWO WORKERS FOR MAINTENANCE WHEN ENGINE IS RUNNING

To prevent injury, do not carry out maintenance with the engine running. If maintenance must be carried out with the engine running, carry out the operation with at least two workers and do as follows.

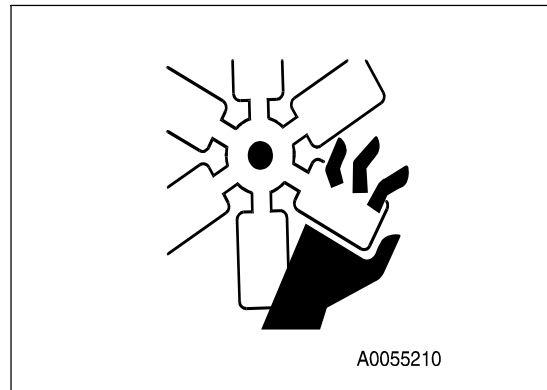

- One of the two should take his/her stand before the control panel, all ready to stop the engine any moment.
- When working near any revolving parts of the machine, exercise the special care, since there is always the danger of getting caught in the revolving parts.
- If it becomes necessary to clean the interior of the radiator with the engine running, turn the mode selector switch (A) to the "Work" position. Moreover make sure that the work will be carried out by two workers in combination.
- Do not touch the control levers. If it becomes unavoidable to do so, signal the partner to evacuate to a safe place.
- If part of your body or tools touch the fan blades or the fan belt, they may be cut off, so never touch any of them.

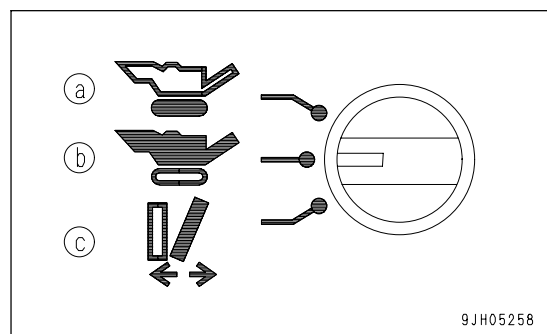
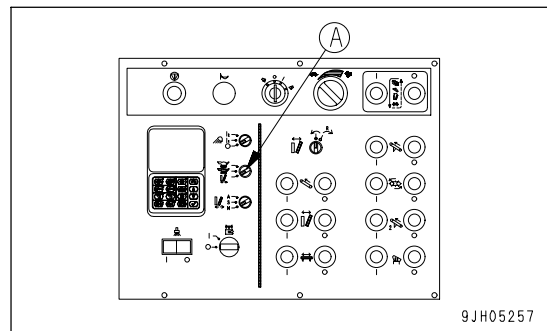

PRECAUTIONS FOR CONVEYOR MAINTENANCE

Since you may get caught in the moving belt conveyor or the rollers, observe the following strictly.

- When maintaining the belt conveyor and the rollers, be sure to stop the belt conveyor and the engine, and then start the work.
- When adjusting snaking, stop the conveyor, then stop the engine.

PRECAUTIONS WHEN CARRYING OUT MAINTENANCE OF FEEDER, CRUSHER

There is danger of getting caught in the crusher or the drive parts of the feeder, so always do as follows.

- When carrying out maintenance of the feeder or crusher, always stop the feeder or crusher, then stop the engine.
- When carrying out checks with the feeder or crusher rotating, check that there is no person inside, on top, or

PROPER TOOLS

Use only tools suited to the task and be sure to use the tools correctly. Using damaged, low quality, faulty, makeshift tools or improper use of the tools could cause serious personal injury.

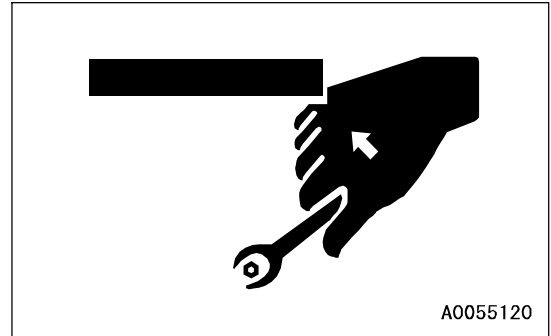
**PERSONNEL**

Only authorized personnel can service and repair the machine. Do not allow unauthorized personnel into the area. If necessary, employ an observer.

PRECAUTIONS WHEN MOUNTING, DISMANTLING AND STORING ATTACHMENTS

- Appoint a leader before starting removal or installation operations for attachments.
- Place attachments that have been removed from the machine in a stable condition so that they do not fall. And take steps to prevent unauthorized persons from entering the storage area.

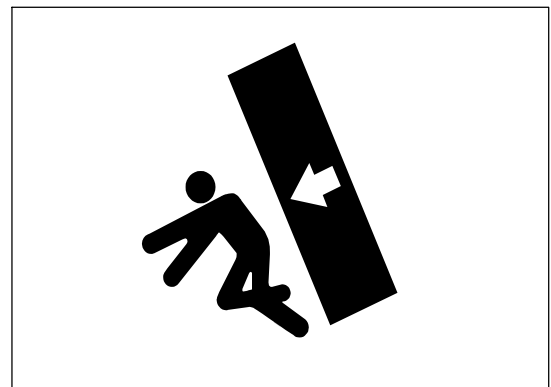
**PRECAUTIONS FOR WORK UNDER MACHINE**

- If it is necessary to go under the work equipment or the machine to carry out service and maintenance, support the work equipment and machine securely with blocks and stands strong enough to support the weight of the work equipment and machine.

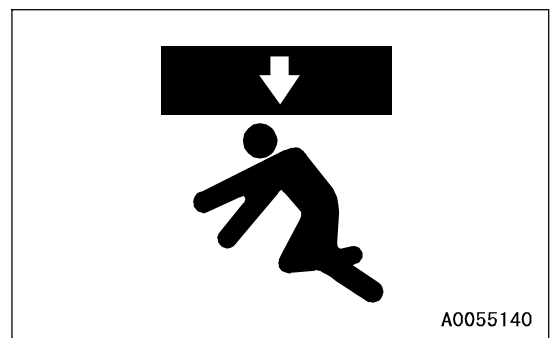

NOISE

When carrying out maintenance of the engine and you are exposed to noise for long periods of time, wear ear covers or ear plugs while working.

If the noise from the machine is too loud, it may cause temporary or permanent hearing problems.

PRECAUTIONS WHEN USING HAMMER

When using a hammer, pins may fly out or metal particles may be scattered. This may lead to serious injury. Always do as follows.

- When hitting hard metal parts, such as pins, tooth plates, cheek plates, or bearings, there is danger of pieces flying and causing serious personal injury. Always wear protective glasses, gloves, and other protective equipment.
- When hitting pins, tooth plates, or cheek plates, there is danger of broken pieces or other parts flying and causing injury to persons in the surrounding area. Always check that there is no one in the surrounding area before starting the operation.
- There is a hazard that the pin hit with strong force may fly out and injure people in the surrounding area.

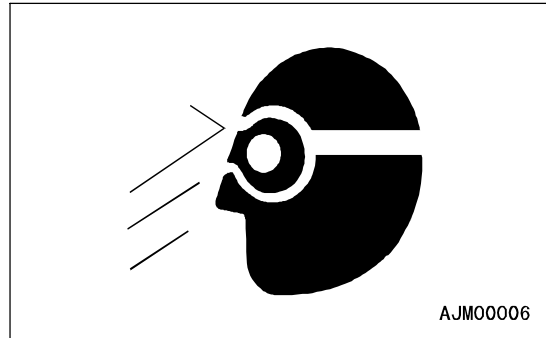

REPAIR WELDING

Welding operations must always be carried out by a qualified welder and in a place equipped with proper equipment. There is a hazard of gas, fire, or electrocution when carrying out welding, so never allow any unqualified personnel to carry out welding.

REMOVING BATTERY TERMINAL

When repairing the electrical system or when carrying out electrical welding, remove the negative (-) terminal of the battery to prevent the flow of current.

PRECAUTIONS WHEN USING HIGH-PRESSURE GREASE TO ADJUST TRACK TENSION

- Grease is pumped into the track tension adjustment system under high pressure. If the specified procedure for maintenance is not followed when making adjustment, grease drain plug (1) may fly out and cause serious injury or property damage.
- When loosening grease drain plug (1) to loosen the track tension, never loosen it more than one turn. Loosen the grease drain plug slowly.
- Never put your face, hands, feet, or any other part of your body close to grease drain plug (1).

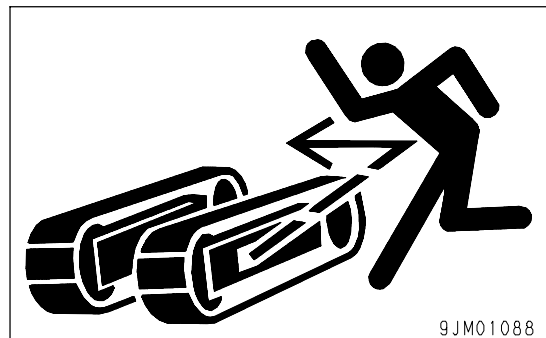
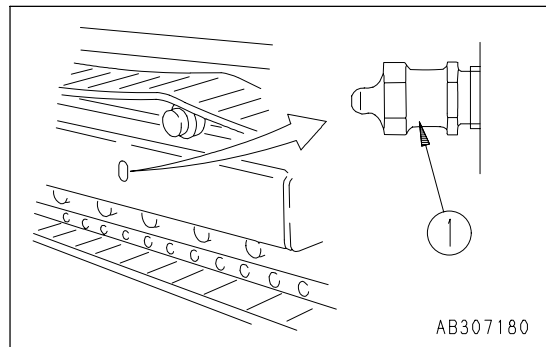

DO NOT DISASSEMBLE RECOIL SPRING

Never attempt to disassemble the recoils spring assembly. It contains a spring under high pressure which serves as a shock absorber for the idler. If it is disassembled by mistake, the spring will fly out and cause serious injury. When it becomes necessary to disassemble it, ask your Komatsu distributor to do the work.

PRECAUTIONS WITH HIGH-PRESSURE OIL

The hydraulic system is always under internal pressure. When inspecting or replacing piping or hoses, always check that the pressure in the hydraulic circuit has been released. If the circuit is still under pressure, it will lead to serious injury, so always do as follows.

- Do not start with the inspection and replacement works, while pressure is still present in the hydraulic circuit.
- If there is any leakage from the piping or hoses, the surrounding area will be wet, so check for cracks in the piping and hoses and for swelling in the hoses.

When carry out inspection, wear safety glasses and leather gloves.

- There is a hazard that high-pressure oil leaking from small holes may penetrate your skin or cause blindness if it contacts your eyes directly. If you are hit by a jet of high-pressure oil and suffer injury to your skin or eyes, wash the place with clean water, and consult a doctor immediately for medical attention.

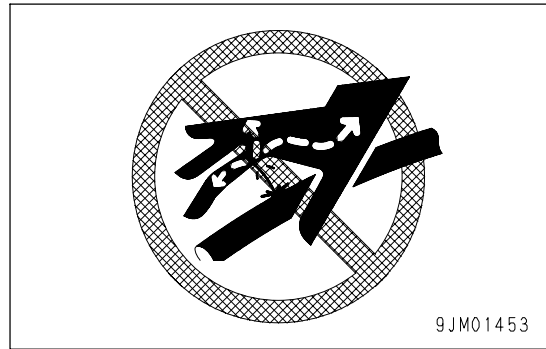

HANDLING HIGH-PRESSURE HOSES

- If oil or fuel leaks from high-pressure hoses, it may cause fire or defective operation, which may lead to serious injury. If any loose bolts are found, stop work and tighten to the specified torque. If any damaged hoses are found, stop operations immediately and contact your Komatsu distributor.

Replace the hose if any of the following problems are found.

- Damaged or leaking hydraulic fitting.
- Frayed or cut covering or exposed reinforcement wire layer.
- Covering swollen in places.
- Twisted or crushed movable portion.
- Foreign material embedded in covering.

WASTE MATERIAL

To prevent pollution, pay careful attention to the method of disposing of waste materials.

- Always put oil drained from your machine in containers. Never drain oil directly onto the ground or dump into the sewage system, rivers, the sea, or lakes.
- Obey appropriate laws and regulations when disposing of harmful objects such as oil, fuel, coolant, solvent, filters, and batteries.

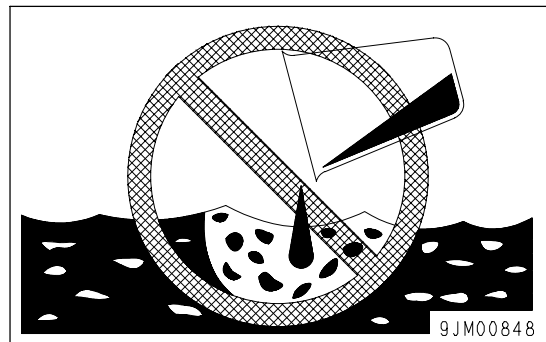

COMPRESSED AIR

- When carrying out cleaning with compressed air, there is a hazard of serious injury caused by flying particles.
- When using compressed air to clean elements or the radiator, always wear safety glasses, dust mask, gloves, and other protective equipment.

PERIODIC REPLACEMENT OF SAFETY CRITICAL PARTS

- It is recommended to carry out machine refueling, inspection and maintenance works without fail and on a periodic basis so that the machine may be used safely for an extended period of time. Be sure to periodically replace the hoses in particular, which are safety critical parts of the machine.

Replacement of safety critical parts: See "PERIODIC REPLACEMENT OF SAFETY CRITICAL PARTS (PAGE 4-19)".

- The material of these components naturally changes over time, and repeated use causes deterioration, wear, and fatigue. As a result, there is a hazard that these components may fail and cause serious injury or death. It is difficult to judge the remaining life of these components from external inspection or the feeling when operating, so always replace them at the specified interval.
- Replace or repair safety-critical parts if any defect is found, even when they have not reached the time specified interval.

OPERATION

 **WARNING**

Please read and make sure that you understand the SAFETY section before reading this section.

GENERAL VIEW

GENERAL VIEW OF MACHINE

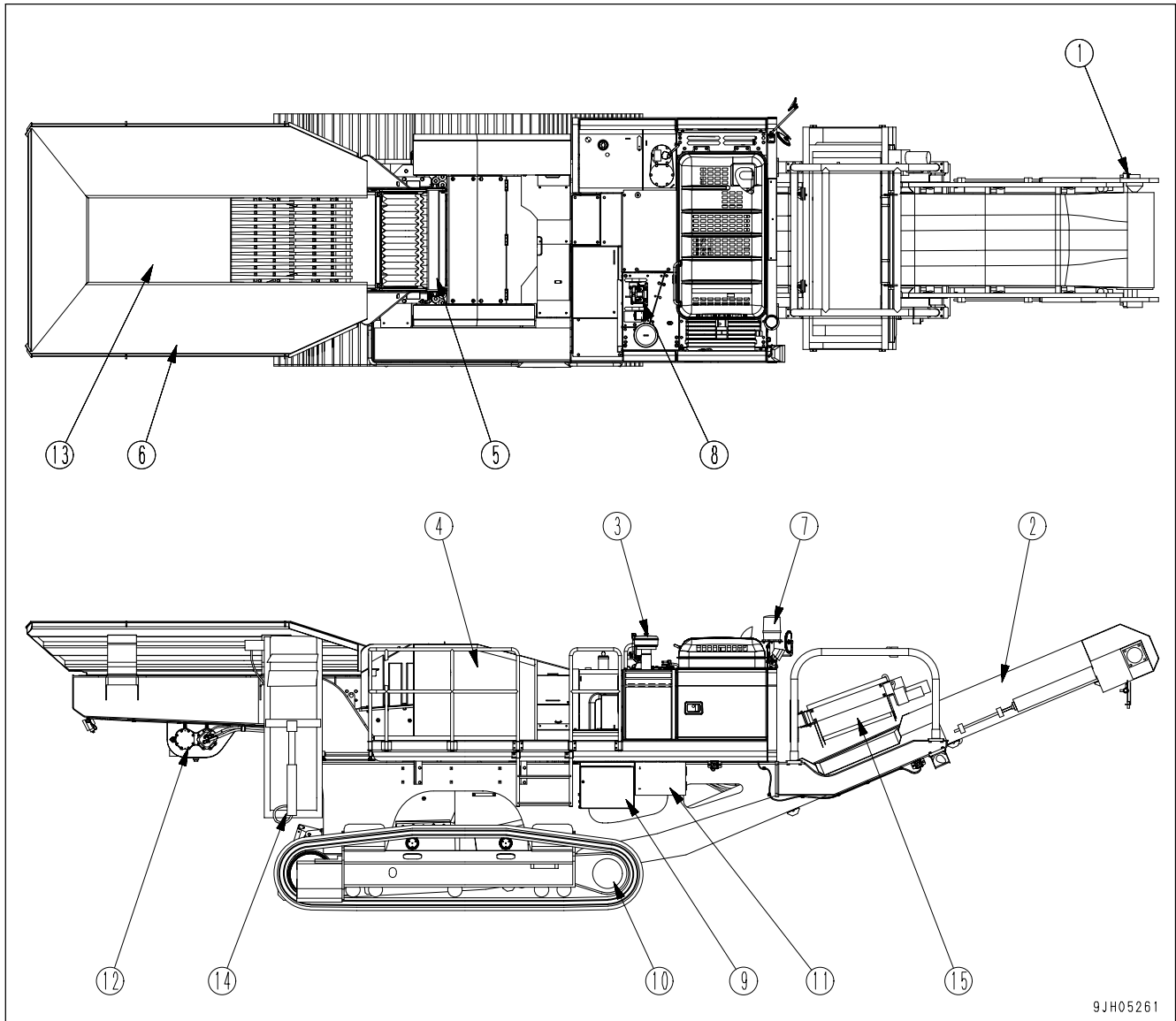

9JH05261

- | | |
|-----------------------------|--------------------------------------------|
| (1) Belt conveyor motor | (9) Control box |
| (2) Primary conveyor | (10) Sprocket |
| (3) Pre-cleaner | (11) Tool box |
| (4) Jaw crusher | (12) Grizzly feeder vibrator case |
| (5) Sprinkler (if equipped) | (13) Grizzly feeder |
| (6) Hopper | (14) Muck discharge conveyor (if equipped) |
| (7) Revolving caution lamp | (15) Magnetic separator |
| (8) Upper control box | |

GENERAL VIEW OF CONTROLS AND GAUGES

Switches (Main control box and Upper control box)

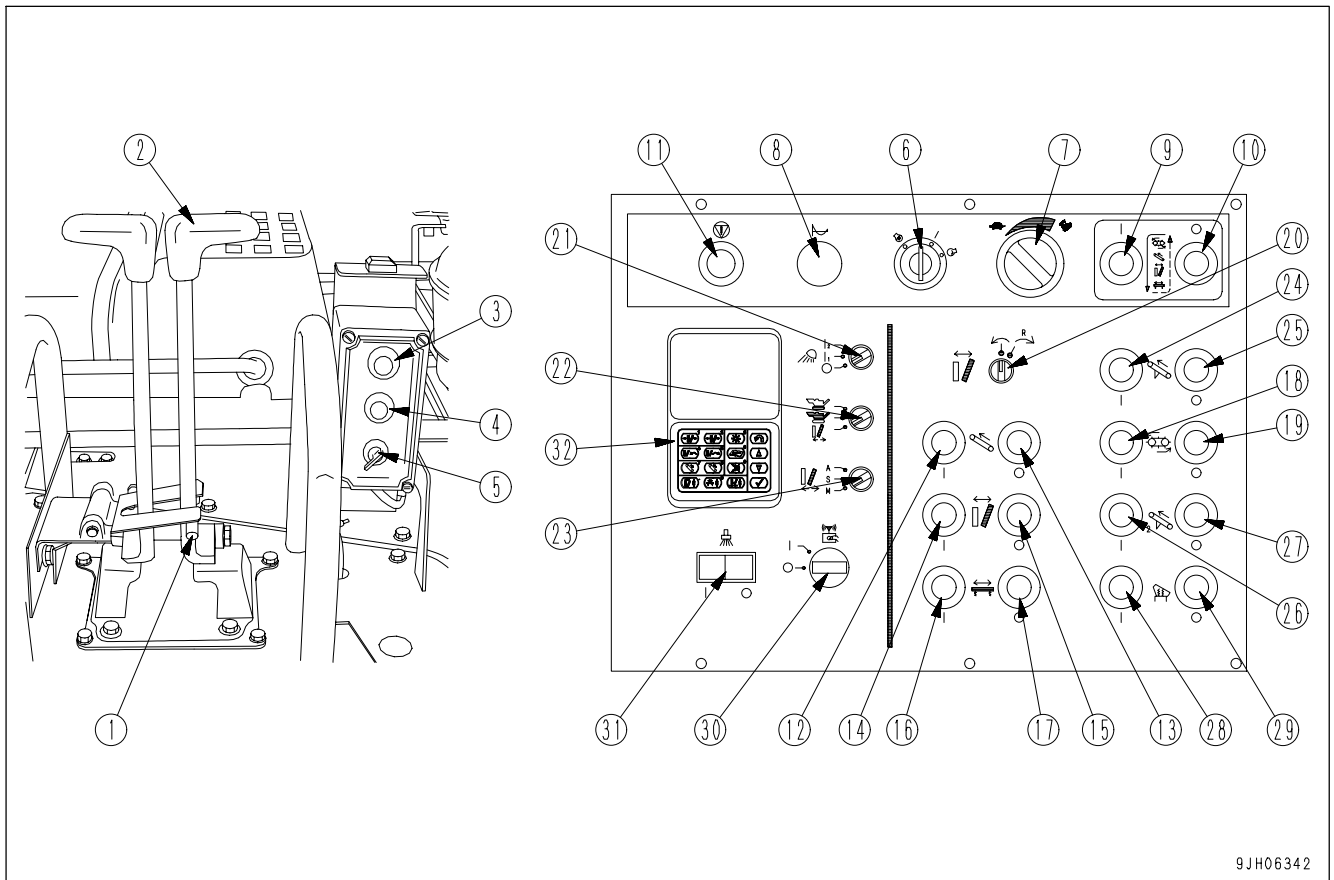

9JH06342

- | | |
|-----------------------------------------------------------|------------------------------------------------------------|
| (1) Travel lever lock | (17) Grizzly feeder stop switch |
| (2) Travel lever | (18) Magnetic separator start switch |
| (3) Horn button | (19) Magnetic separator stop switch |
| (4) Engine stop switch | (20) Crusher rotation direction selector switch |
| (5) Travel speed selector switch | (21) Lamp switch |
| (6) Starting switch | (22) Mode selector switch |
| (7) Fuel control dial | (23) Clearance adjustment selector switch |
| (8) Horn button | (24) Muck discharge conveyor start switch (if equipped) |
| (9) Work equipment start switch (1-touch start switch) | (25) Muck discharge conveyor stop switch (if equipped) |
| (10) Work equipment stop switch (1-touch stop switch) | (26) Secondary conveyor start switch (if equipped) |
| (11) Emergency stop switch | (27) Secondary conveyor stop switch (if equipped) |
| (12) Primary conveyor start switch | (28) Vibratory sieve start switch (if equipped) |
| (13) Primary conveyor stop switch | (29) Vibratory sieve stop switch (if equipped) |
| (14) Jaw crusher start switch | (30) Radio controller selector switch (if equipped) |
| (15) Jaw crusher stop switch | (31) Water spray start switch (if equipped) |
| (16) Grizzly feeder start switch | (32) Machine monitor |

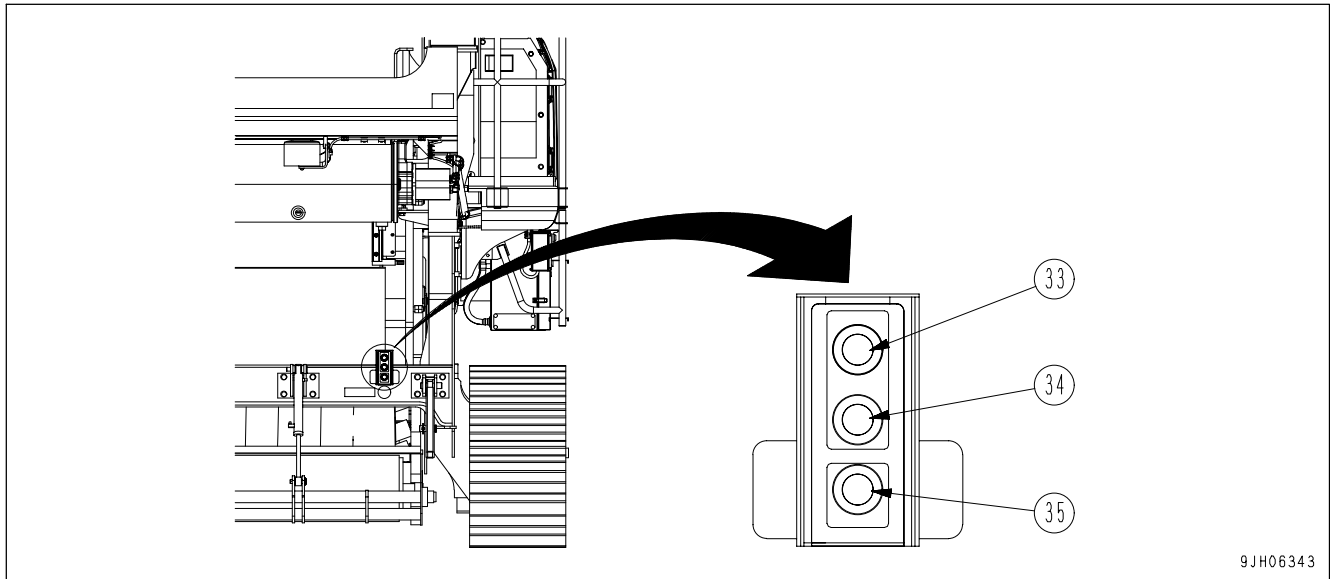

(33) Primary conveyor UP switch/muck discharge conveyor UP switch (if equipped)

(34) Primary conveyor DOWN switch/muck discharge conveyor DOWN switch (if equipped)

(35) Emergency stop switch/actuation selector switch (if equipped)

All lighted up screen (in travel mode)

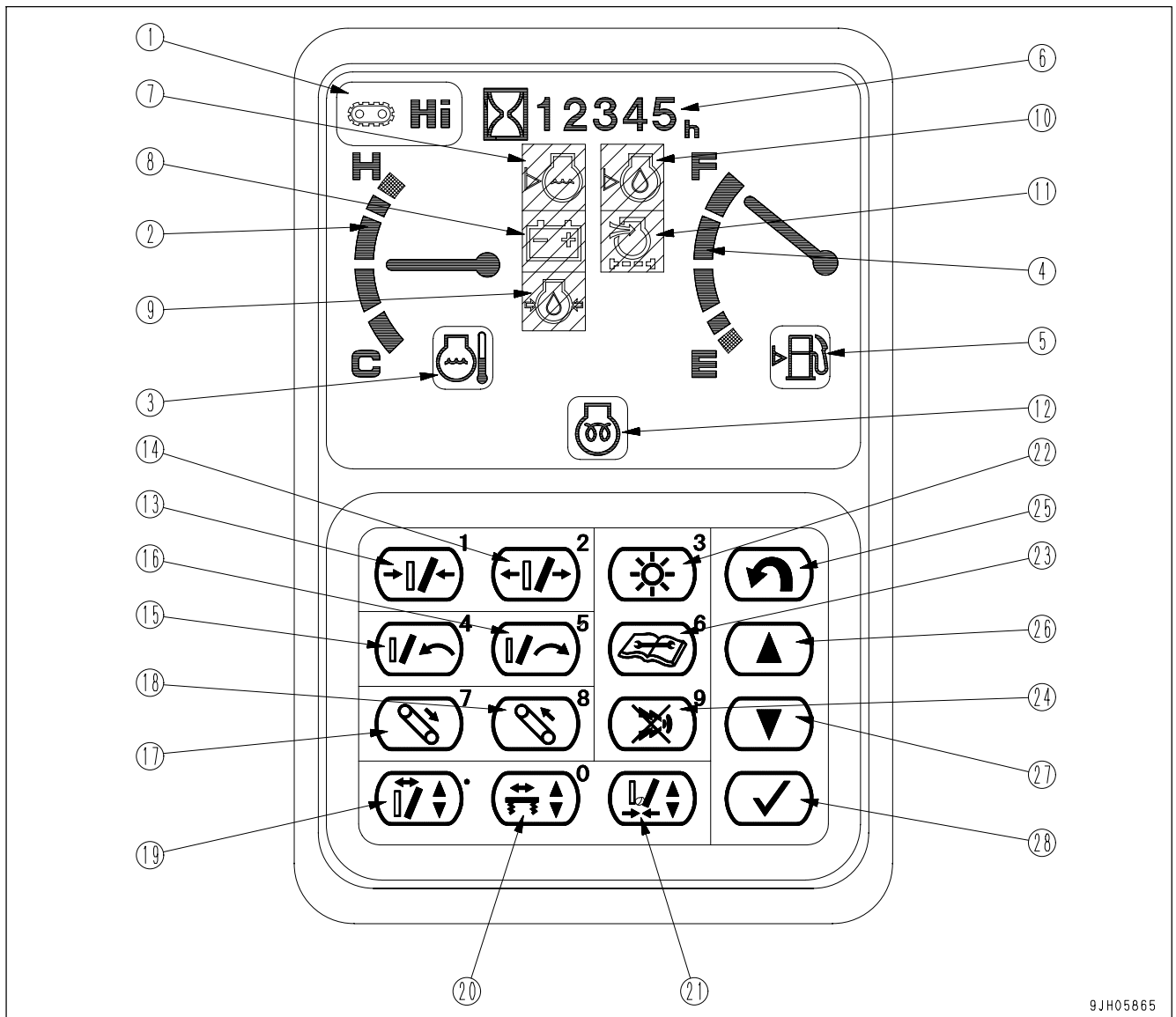

9JH05865

- | | |
|----------------------------------------|---------------------------------------------------|
| (1) Mode monitor | (15) Crusher manual normal rotation switch |
| (2) Engine coolant temperature gauge | (16) Crusher manual reverse rotation switch |
| (3) Engine coolant temperature monitor | (17) Conveyor manual reverse rotation switch |
| (4) Fuel gauge | (18) Conveyor manual normal rotation switch |
| (5) Fuel level monitor | (19) Crusher speed setting screen selector switch |
| (6) Service meter | (20) Feeder speed setting screen selector switch |
| (7) Radiator coolant level monitor | (21) Crusher load setting screen selector switch |
| (8) Battery charge monitor | (22) Liquid-crystal monitor adjustment switch |
| (9) Engine oil pressure monitor | (23) Maintenance switch |
| (10) Engine oil level monitor | (24) Buzzer cancel switch |
| (11) Air cleaner clogging monitor | (25) Return switch |
| (12) Engine pre-heating monitor | (26) UP and numeral input (+) switch |
| (13) Crusher clearance decrease switch | (27) DOWN and numeral input (-) switch |
| (14) Crusher clearance increase switch | (28) Input confirmation switch |

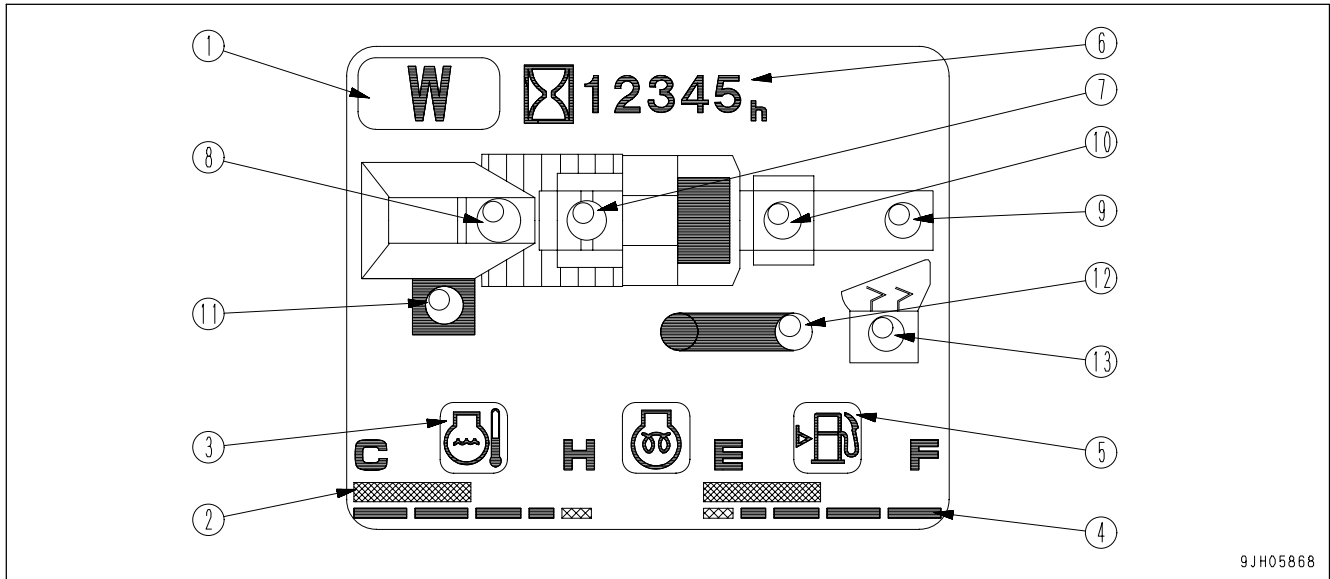

9JH05868

- (1) Mode monitor
- (2) Engine coolant temperature gauge
- (3) Engine coolant temperature monitor
- (4) Fuel gauge
- (5) Fuel level monitor
- (6) Service meter
- (7) Crusher status confirmation lamp
- (8) Grizzly feeder status lamp
- (9) Conveyor status lamp
- (10) Magnetic separator status lamp
- (11) Muck discharge conveyor status lamp
- (12) Secondary conveyor status lamp
- (13) Vibratory sieve status lamp

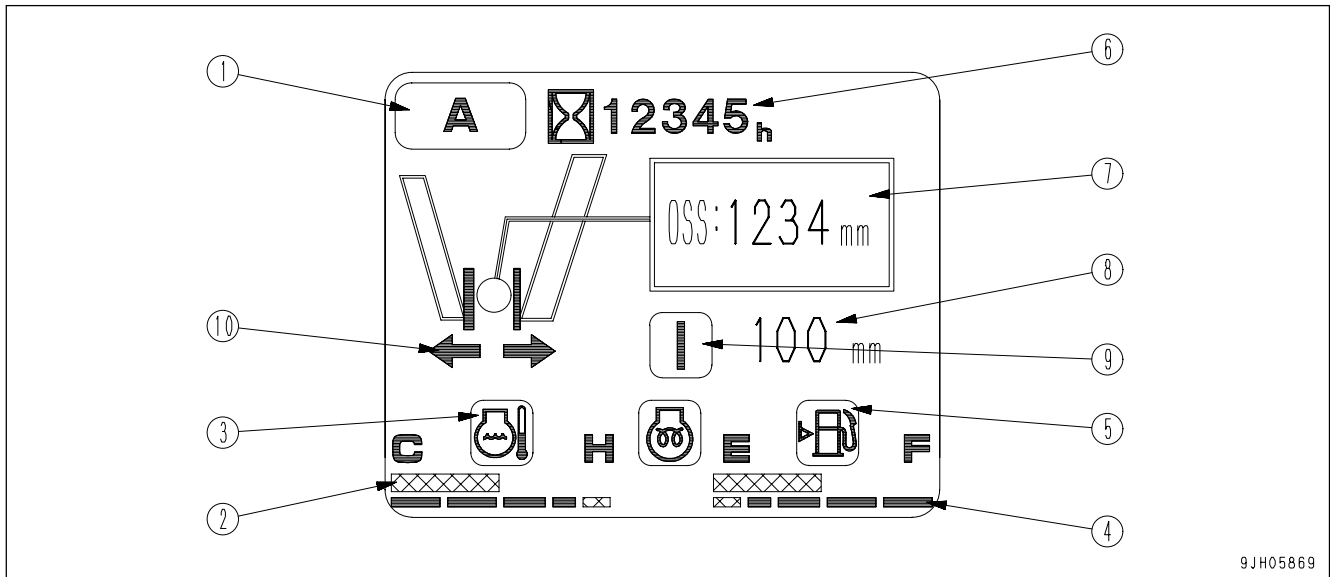

9JH05869

- (1) Mode monitor
- (2) Engine coolant temperature gauge
- (3) Engine coolant temperature monitor
- (4) Fuel gauge
- (5) Fuel level monitor
- (6) Service meter
- (7) Crusher actual clearance monitor
- (8) Crusher set clearance monitor
- (9) Adjusting crusher clearance
- (10) Crusher clearance open/close operation monitor

EXPLANATION OF COMPONENTS

The following is an explanation of devices needed for operating the machine.

To perform suitable operations correctly and safely, it is important to completely understand methods of operating the equipment, and the meanings of the displays.

MACHINE MONITOR

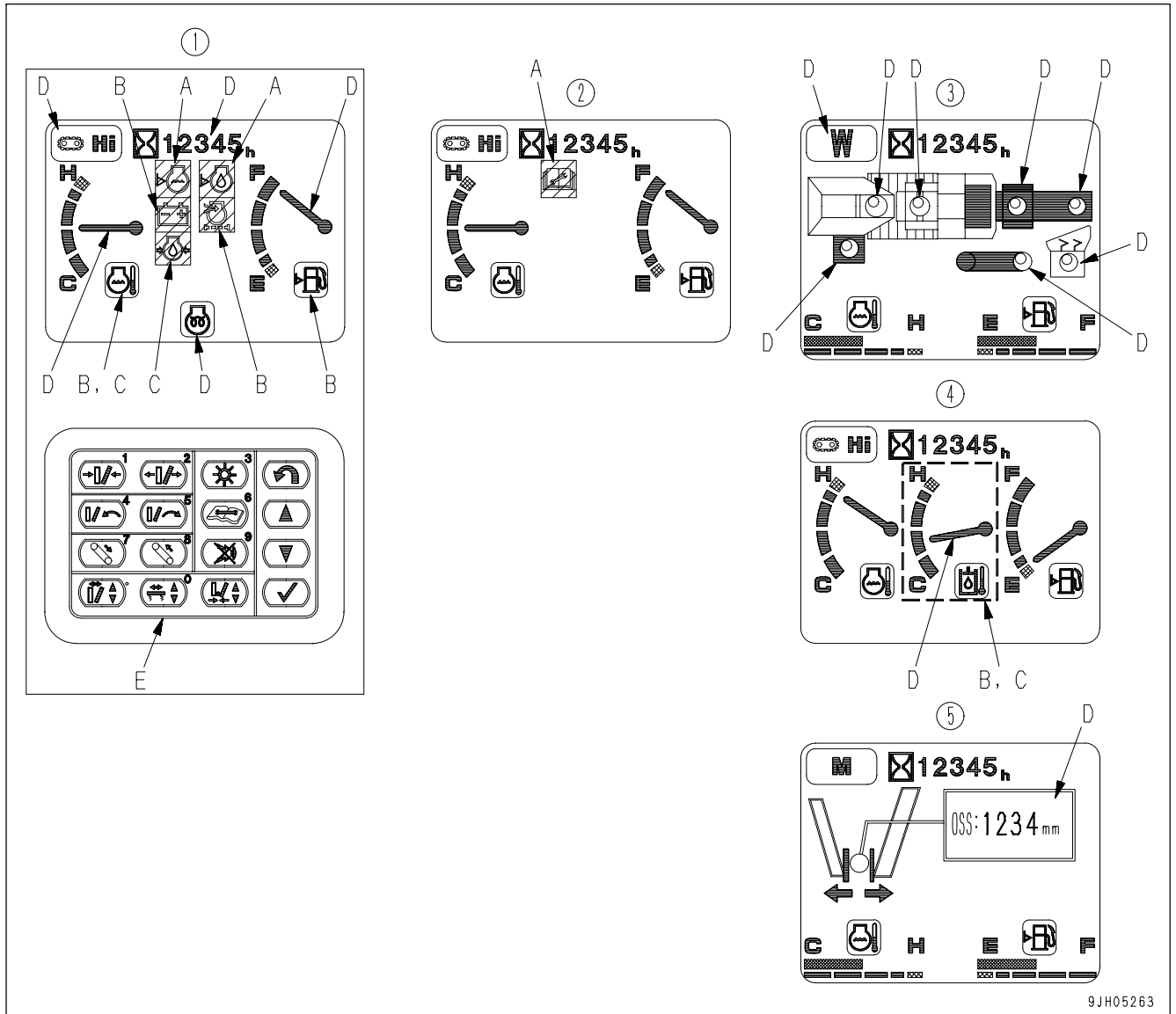

9JH05263

- (1) Check before starting screen
- (2) Maintenance warning screen
- (3) Normal operation screen

- (4) Normal travel screen
- (5) Normal inspection screen

- A Basic check items
- B Caution items
- C Emergency stop items

- D Meter display portion
- E Monitor switch

BASIC ACTUATION OF MACHINE MONITOR

WHEN THERE IS AN ABNORMALITY WHEN STARTING THE ENGINE

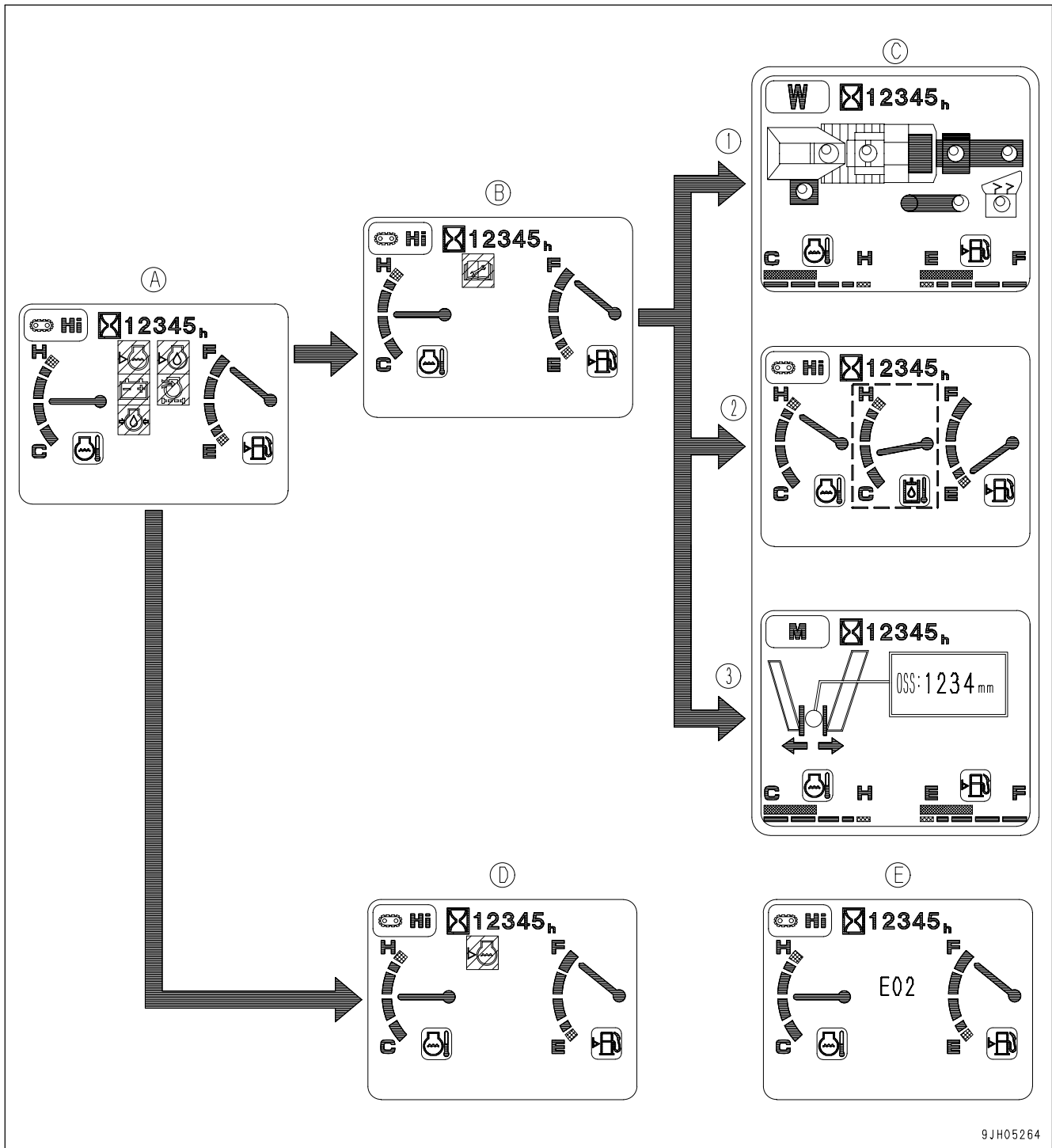

- (1) When in operation mode
- (2) When in travel mode
- (3) When in inspection mode

• If there is any abnormality when starting the engine, the check before starting screen (A) changes to the maintenance interval warning screen (B), warning screen (D), or error screen (E).

BASIC CHECK ITEMS

CAUTION

These monitors are not provided for the purpose of guaranteeing the conditions of the machine. Do not solely rely on the monitors for the daily inspection, but conduct each specified item of the daily inspection without fail.

This displays the basic items that should be checked before starting the engine. If there is any problem, the appropriate monitor lamp will flash.

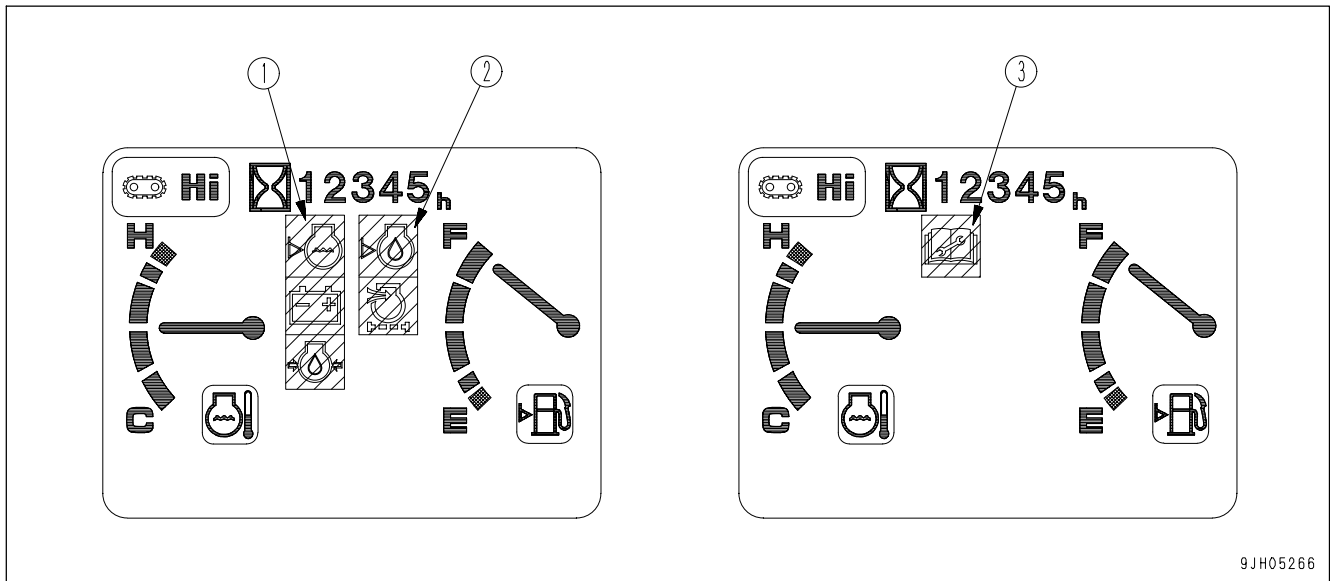

9JH05266

A(1) Radiator coolant level monitor
A(2) Engine oil level monitor

A(3) Maintenance time monitor

RADIATOR COOLANT LEVEL MONITOR

Monitor (1) warns the operator that there has been a drop in the radiator coolant level.

If the radiator coolant is low, the lamp lights up red, so check coolant level in the radiator and subtank, and add coolant.

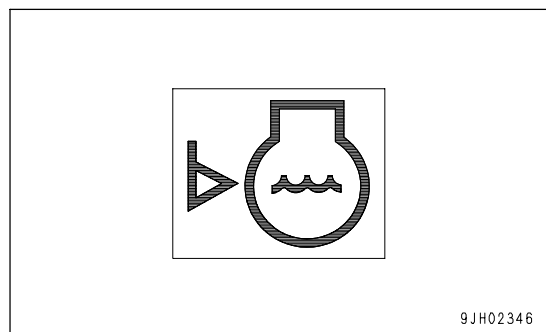

9JH02346

ENGINE OIL LEVEL MONITOR

Monitor (2) warns the operator that the oil level in the engine oil pan has dropped.

If oil level in the engine oil pan is low, the lamp lights up red, so check the oil level, and add oil.

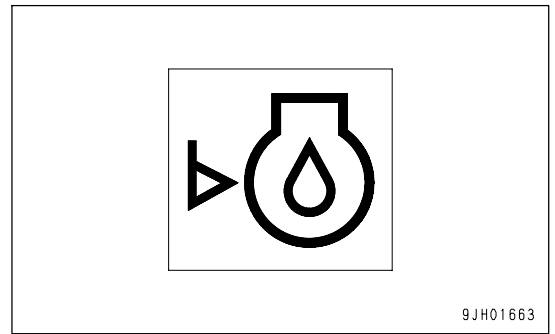
**MAINTENANCE TIME MONITOR**

This monitor (3) lights up red to warn the operator when the set time has passed from the time of the previous maintenance.

This monitor screen goes out after 30 seconds and switches to the normal screen.

- For details of the method of checking the maintenance time, see "MAINTENANCE SCREEN SELECTOR SWITCH (PAGE 3-25)".

If it is desired to change the maintenance interval settings, have your Komatsu distributor change the interval settings.

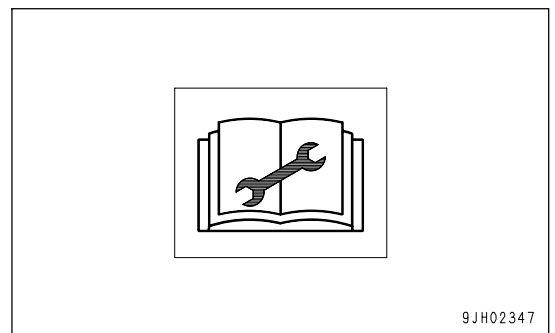

CAUTION ITEMS

CAUTION

When the warning monitor lamp begins to flash or the revolving warning lamp lights up, check and identify the cause in no time. If left unattended for some time, it will lead to a failure.

These are items which need to be observed while the engine is running. If any problem occurs, items which need to be repaired as soon as possible are displayed.

If there is any problem, the appropriate monitor lamp will flash to indicate the location of the problem.

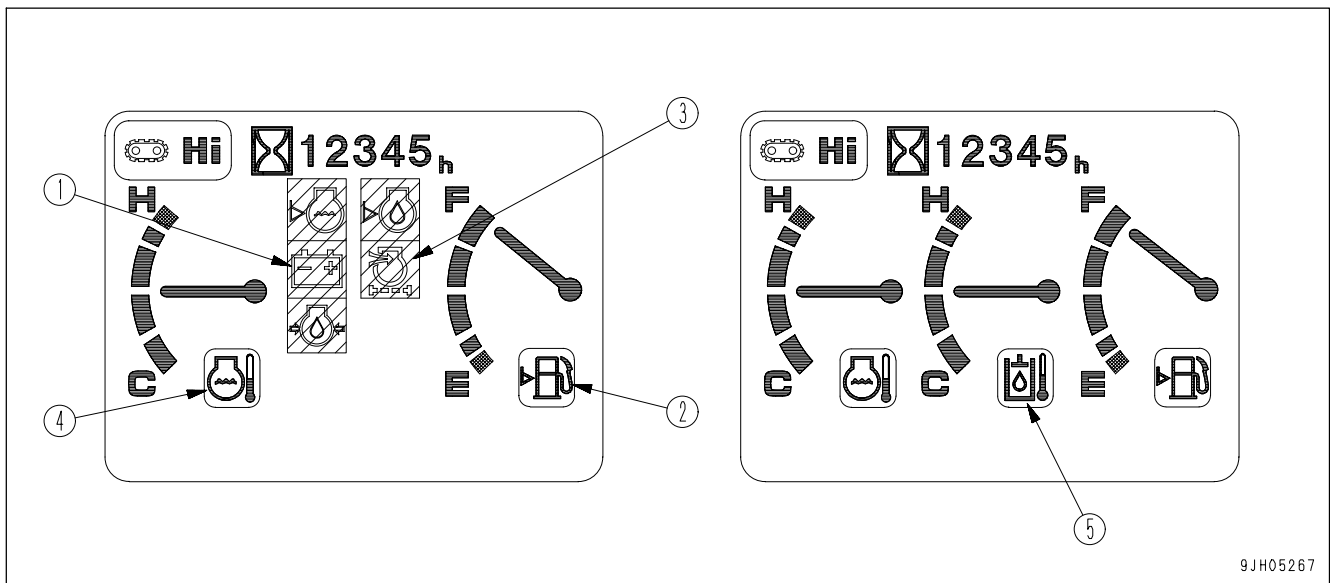

9JH05267

B(1) Charge level monitor

B(2) Fuel level monitor

B(3) Air cleaner clogging monitor

B(4) Engine coolant temperature monitor

B(5) Hydraulic oil temperature monitor

CHARGE LEVEL MONITOR

Monitor (1) warns the operator of an abnormality in the charging system while the engine is running.

If charging is not being carried out correctly when the engine is running, the red lamp lights up, and at the same time, all work equipment stops and the horn sounds.

If the red lamp lights up, check for looseness of the V-belt, and if there is any abnormality, see "OTHER TROUBLE (PAGE 3-138)".

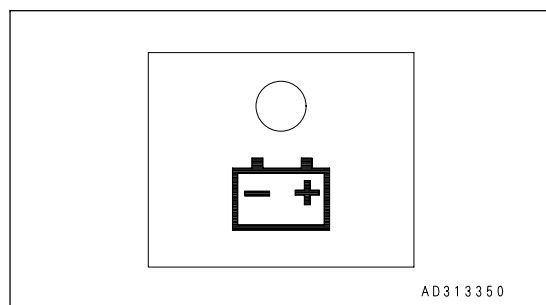

AD313350

REMARK

- When the starting switch is at the ON position, the lamp is always lighted up, and after the engine started, it goes out.
- When the starting switch is at the ON position, the lamp may light up and the buzzer and horn may sound for a moment when the engine is started or stopped, but this is not an abnormality.
- If the horn sounds, set the fuel control dial to low idling. The horn will stop.

FUEL LEVEL MONITOR

Monitor (2) lights up to warn the operator the fuel level in the tank is low.

If the remaining amount of fuel goes down to 41 liters (10.83 US gal), the light changes from green to red, so add fuel as soon as possible.

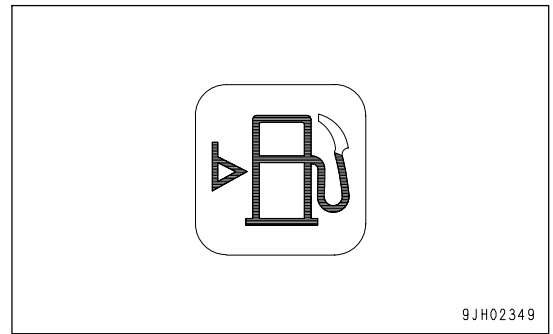
**AIR CLEANER CLOGGING MONITOR**

Monitor (3) warns the operator of a clogged air cleaner.

If the monitor lights up red, stop the engine, inspect and clean the air cleaner.

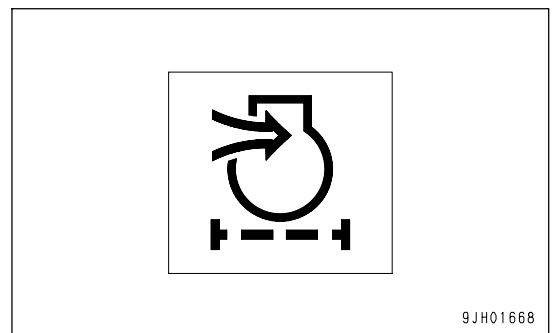
**ENGINE COOLANT TEMPERATURE MONITOR**

If monitor (4) lights up white in low temperatures, perform warming-up operation. For details, see "WARMING-UP OPERATION IN COLD WEATHER (PAGE 3-76)".

Continue warming-up operation until monitor (4) changes to

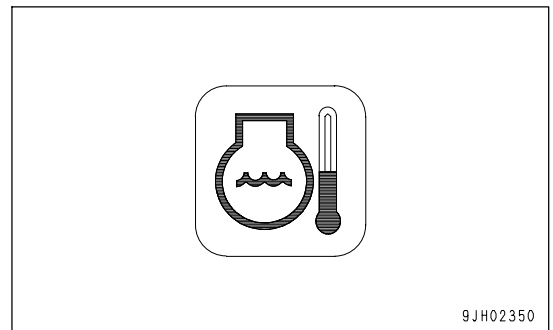
**HYDRAULIC OIL TEMPERATURE MONITOR**

If monitor (5) lights up white in low temperatures, perform warming-up operation. For details, see "WARMING-UP OPERATION IN COLD WEATHER (PAGE 3-76)".

Continue warming-up operation until monitor (5) changes to

REMARK

This monitor is displayed only in the travel mode. In the working mode, it is not displayed.

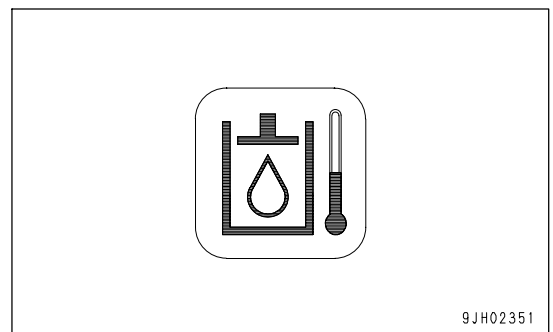

EMERGENCY STOP ITEMS

CAUTION

When this monitor begins to flash or the revolving warning lamp lights up, either stop the engine or reduce the engine speed to low idling immediately, and then check for the trouble spot and take appropriate actions, if necessary.

These items must be observed when the engine is running. If there is any abnormality, the monitor for the problem location lights up and the buzzer and horn sound.

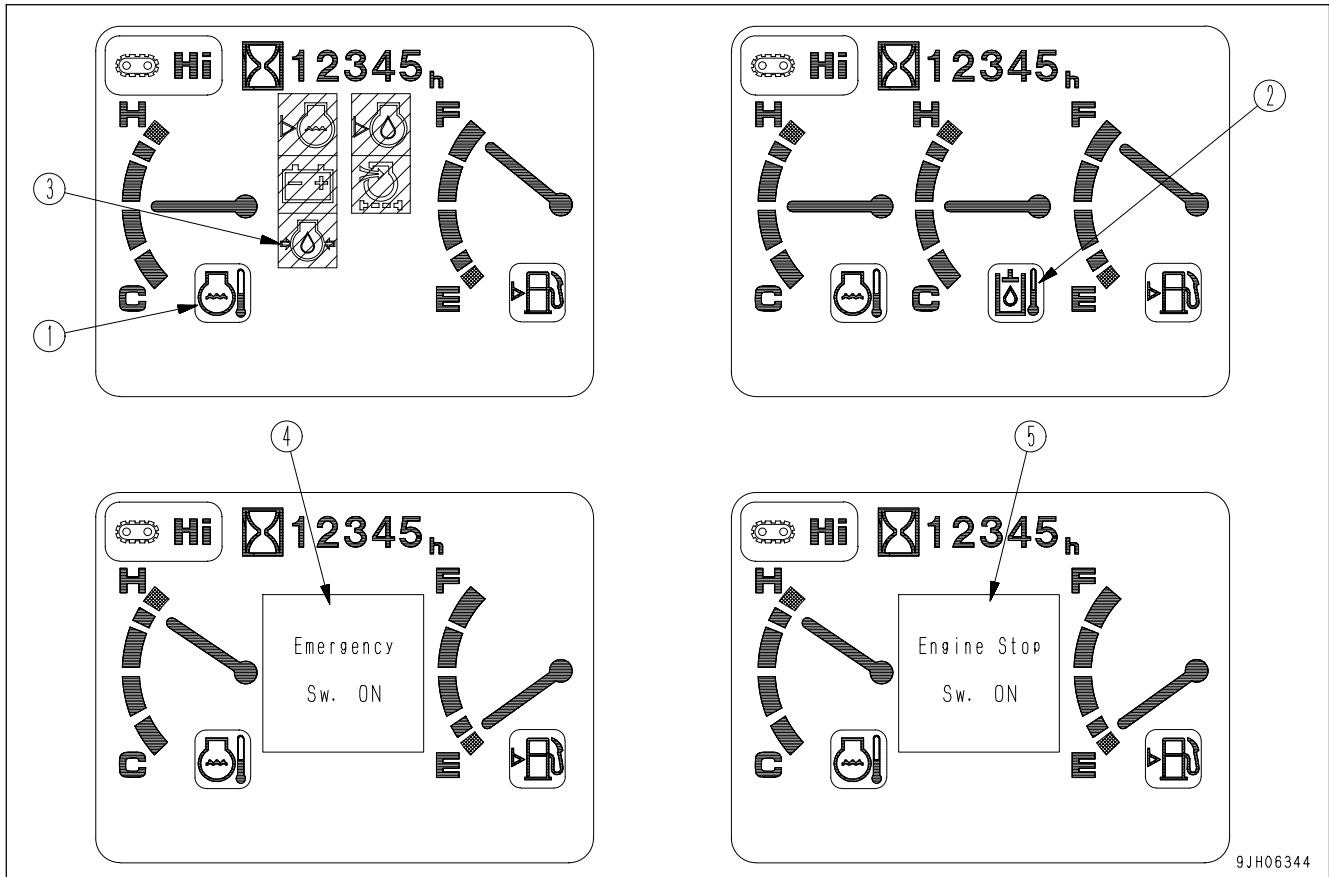

- C(1) Engine coolant temperature monitor
- C(2) Hydraulic oil temperature monitor
- C(3) Engine oil pressure monitor

- C(4) Emergency stop monitor
- C(5) Engine stop monitor

9JH06344

ENGINE COOLANT TEMPERATURE MONITOR

Monitor (1) warns operator that the engine coolant temperature has risen.

If engine coolant temperature becomes abnormally high, monitor lights up red, overheat prevention system is automatically actuated, and the engine speed goes down.

Stop operations and run engine at low idle until monitor (1) changes to green.

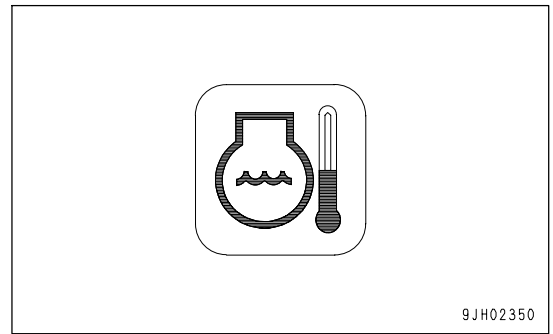
**HYDRAULIC OIL TEMPERATURE MONITOR**

Monitor (2) warns operator that the hydraulic oil temperature has risen.

If monitor lights up red during operations, run engine at low idle or stop the engine and wait until the oil temperature goes down and monitor (2) changes to green.

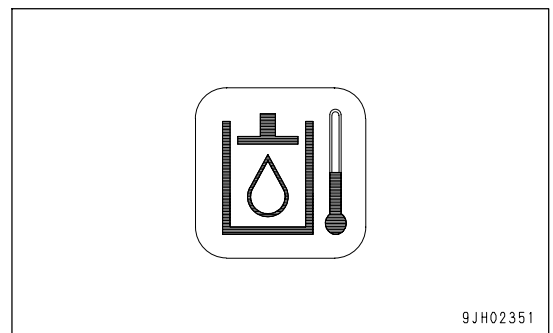
**ENGINE OIL PRESSURE MONITOR**

This monitor (3) lights up red when the engine lubricating oil pressure goes below the correct value. At the same time, all the work equipment stops and the horn sounds. If the monitor lights up red, stop the engine, and check the lubricating system and oil level in the oil pan.

REMARK

- When the starting switch is at the ON position, the lamp is always lighted up, and after the engine started, it goes out. When the engine is started, the buzzer may sound for a moment, but this is not an abnormality.
- When the horn sounds, turn the fuel control dial to the low idling position. The horn will stop.

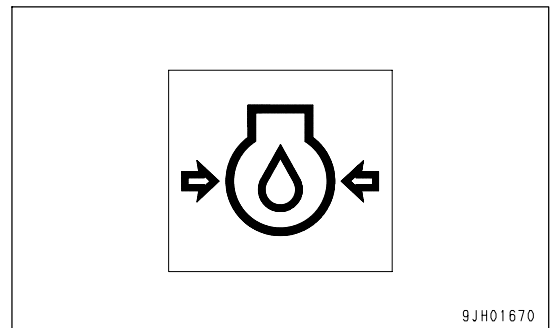

REMARK

Color when the monitor lights up for basic check items, caution items, and emergency stop items are as follows.

| Type of monitor | Color when monitor lights up | | |
|------------------------------------|------------------------------|---------------|--------------------|
| | When normal | When abnormal | At low temperature |
| Radiator coolant level monitor | OFF | Red | - |
| Engine oil level monitor | OFF | Red | - |
| Maintenance interval monitor | OFF | Red | - |
| Charge monitor | OFF | Red | - |
| Fuel level monitor | Green | Red | - |
| Air cleaner clogging monitor | OFF | Red | - |
| Engine coolant temperature monitor | Green | Red | White |
| Hydraulic oil temperature monitor | Green | Red | White |
| Engine oil pressure monitor | OFF | Red | - |

EMERGENCY STOP MONITOR

This monitor (4) shows that the emergency stop switch located around the machine has been pressed and the work equipment has all stopped. Check that there is no abnormality on the machine and that the surrounding area is safe, then cancel the

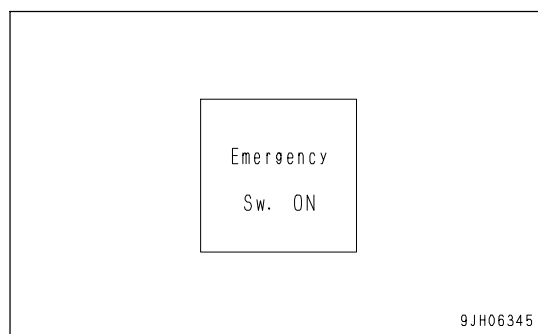

ENGINE STOP MONITOR

This monitor (5) shows that the engine stop switch located on the control box has been pressed and the engine has been stopped. Turn the starting switch to the OFF position, check that there is no abnormality on the machine and that the surrounding area is safe, then start the machine again.

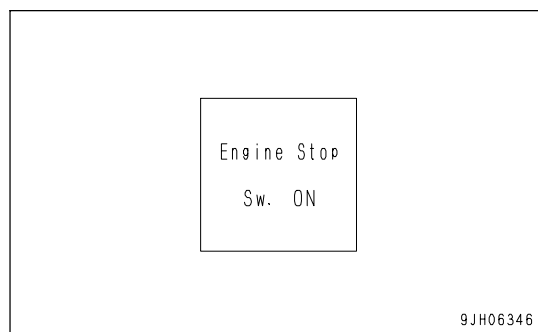

METER DISPLAY PORTION

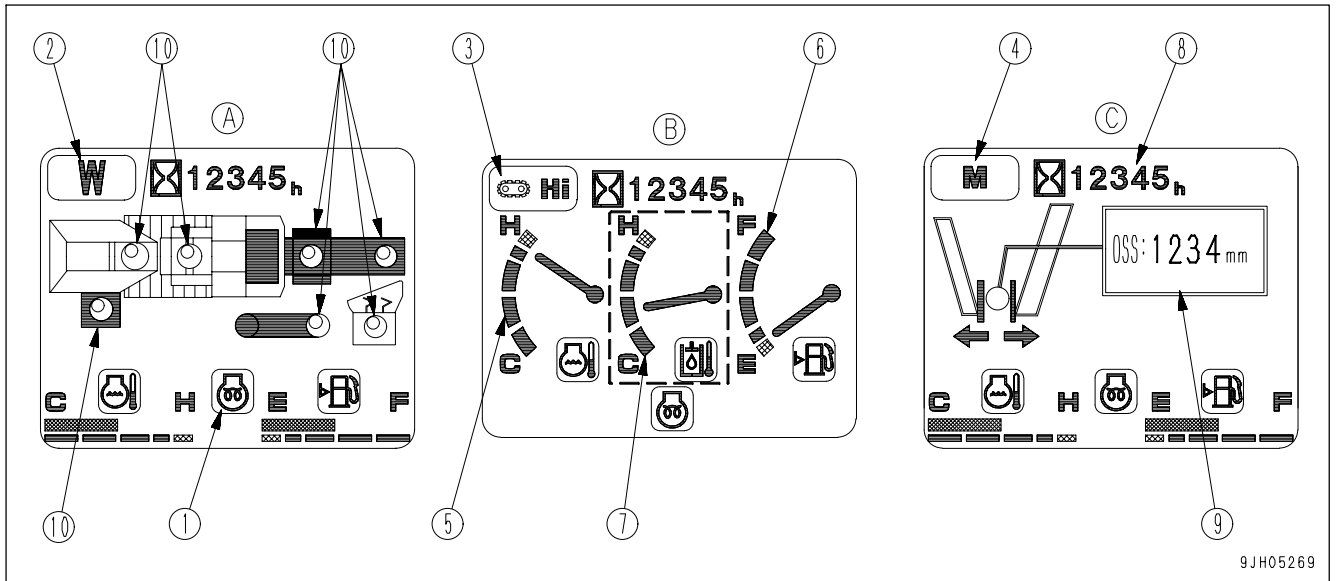

(A) Normal operation screen
 (B) Normal travel screen

(C) Normal inspection screen

- | | |
|--------------------------------------|--------------------------------------|
| (1) Engine pre-heating monitor | (6) Fuel gauge |
| (2) Operating mode monitor | (7) Hydraulic oil temperature gauge |
| (3) Travel mode monitor | (8) Service meter |
| (4) Inspection mode monitor | (9) Crusher actual clearance monitor |
| (5) Engine coolant temperature gauge | (10) Operating status display lamp |

PILOT DISPLAY PORTION

When starting switch is ON, the pilot display lights up when display items are functioning.

ENGINE PRE-HEATING MONITOR

This monitor (1) indicates the pre-heating time required when starting the engine at an ambient temperature below 0°C (32°F). The monitor lamp lights up when the engine starting switch is turned to the HEAT position and begins to flash after about 30 seconds to show that the pre-heating is completed. (The monitor lamp will go off after about 10 seconds)

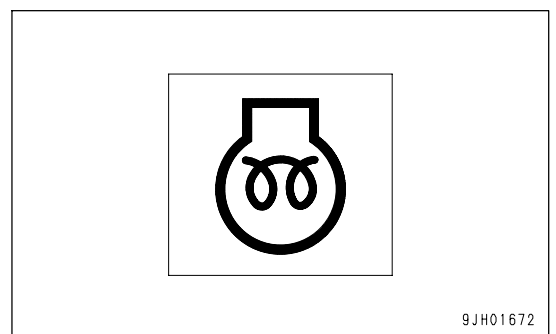

OPERATING MODE MONITOR

This monitor (2) shows that the mode selector switch is at working mode.

It is possible to check the operating condition of each piece of work equipment and to identify the work equipment that has suffered excessive load or abnormal load.

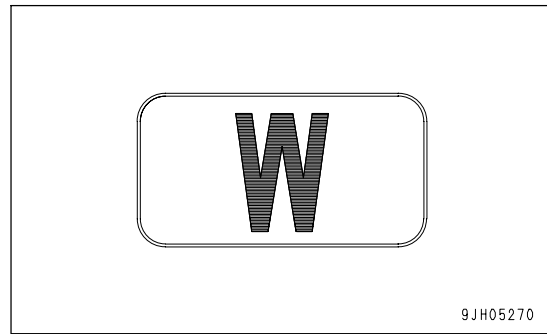
**TRAVEL MODE MONITOR**

This monitor (3) shows that the mode selector switch is at travel mode.

The monitor display shows the operation of the travel speed selector switch as follows.

Lo: Low travel speed

Hi: High travel speed

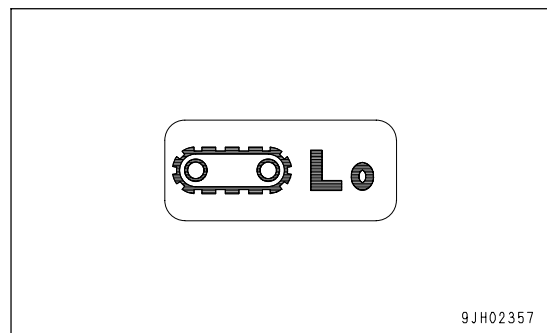
**INSPECTION MODE MONITOR**

This monitor (4) shows that the mode selector switch is at inspection mode.

The monitor display changes as follows according to the operation of the crusher selector switch on the control panel.

(a) A: Automatic mode

(b) S: Semi-automatic mode

(c) M: Manual mode

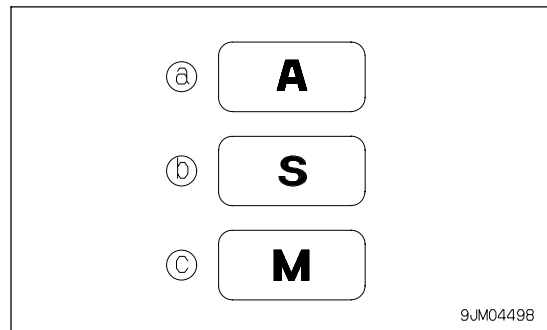

For details of the method of adjusting the clearance for each mode, see "CHECK AND ADJUSTMENT OF OUTLET CLEARANCE (PAGE 4-35)".

METER PORTION

ENGINE COOLANT TEMPERATURE GAUGE

This meter (5) shows the engine coolant temperature.

During operation, the indicator should be in black range (A) to (C). If the indicator enters red range (A) to (B) during operation, the overheat prevention system is actuated.

The overheat prevention system acts as follows.

Red range (A) position: Engine coolant temperature monitor (1) lights up red.

Red range (B) position: Engine speed is set to low idling, engine coolant monitor lamp (C) lights up red, and at the same time, the alarm buzzer and horn sound, and all work equipment stops. To stop the horn, turn the fuel control dial to the low idling position.

The overheat prevention system works until the temperature enters the black range (A) to (C).

When the engine is started, if the indicator is at position (C), engine coolant temperature monitor (1) lights up white. In this case, carry out the warming-up operation. For details, see "WARMING-UP OPERATION IN COLD WEATHER (PAGE 3-76)".

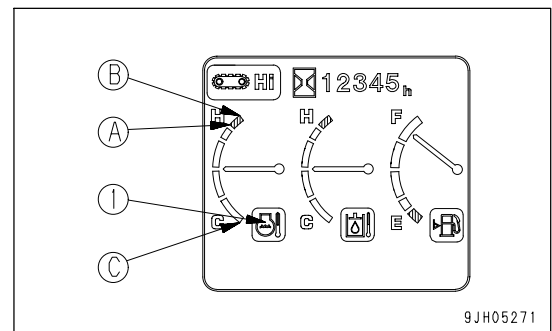

FUEL GAUGE

This meter (6) shows the amount of fuel remaining in the fuel tank.

The indicator should be in the black range during operation.

If the indicator enters red range (A) during operation, the remaining amount of fuel is less than 60 liters (15.85 US gal), so check and add fuel.

REMARK

If the indicator enters red range (B), the remaining amount of fuel is less than 41 liters (10.83 US gal).

When the indicator is in red range (A) to (B), fuel level monitor (1) lights up red.

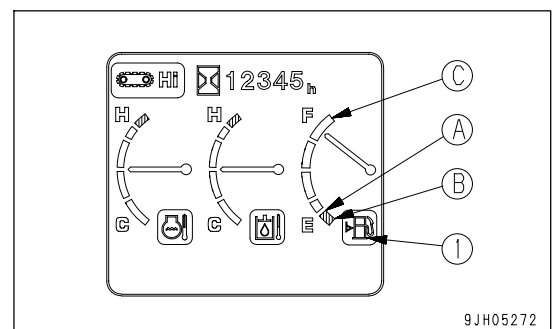

If the indicator enters the red range (A) to (B), do not carry out operations on steep slopes. There is danger of the engine stalling.

The correct fuel level may not be displayed for a short time when the starting switch is turned ON, but this is not an abnormality.

HYDRAULIC OIL TEMPERATURE GAUGE

This meter (7) shows the hydraulic oil temperature. During operation, the indicator should be in black range (A) to (C). If the indicator enters red range (A) during operation, the hydraulic oil temperature is more than 102 °C (215.6 °F). Run the engine at low idling or stop it and wait until the hydraulic oil temperature goes down.

REMARK

The hydraulic oil temperature when the indicator enters red range (A) is as follows.

- Red range (A) position: More than 102 °C (215.6 °F)
The hydraulic oil temperature monitor lights up red.
- Red range (B) position: More than 105 °C (221 °F)
The hydraulic oil temperature monitor lights up red and the alarm buzzer sounds at the same time.

If the indicator is at position (C) when the engine is started, the hydraulic oil temperature is less than 25 °C (77 °F) and hydraulic oil temperature monitor (1) lights up white. When this happens, see "WARMING-UP OPERATION IN COLD WEATHER (PAGE 3-76)" and carry out the warming-up operation.

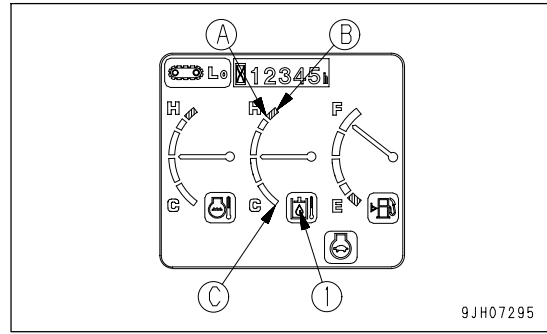

SERVICE METER

This monitor (8) shows the total hours of operation of the machine. Use the time display to set the periodic maintenance intervals. When the starting switch is at the ON position, the service meter advances even if the machine is not moving. The reading of the meter advances by 1 for every hour of operation, regardless of the engine speed.

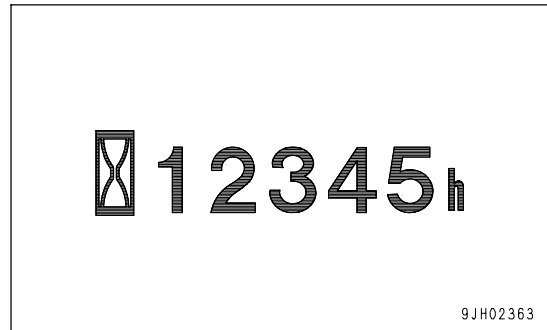

CRUSHER ACTUAL CLEARANCE MONITOR

This monitor (9) displays the clearance at the discharge port when the crusher jaw and fixed teeth are fully opened (OSS clearance).

REMARK

- This clearance display is shown in black between 50 mm and 150 mm (2 in and 5.9 in), and when it goes outside this range, it is displayed in red. Carry out actual crushing operations with the OSS clearance between 50 mm and 150 mm (2 in and 5.9 in) (black display).
- The display value for the clearance may not match the actual measured value.

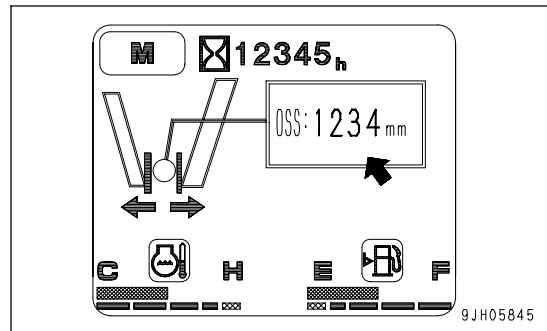

OPERATING STATUS DISPLAY LAMP

This lamp (10) display is as shown in the diagram on the right when the working mode is selected with the mode selector switch on the control panel. It is possible to confirm the operating status of each piece of work equipment and to identify the work equipment that has suffered excessive load or abnormal load.

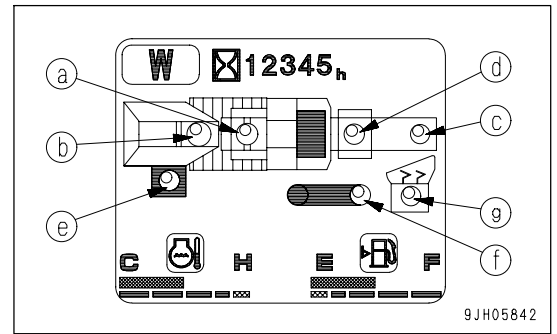

- (a) Crusher status confirmation lamp
- (b) Grizzly feeder status lamp
- (c) Conveyor status lamp
- (d) Magnetic separator status lamp
- (e) Muck discharge conveyor status lamp
- (f) Secondary conveyor status lamp
- (g) Vibratory sieve status lamp

The status display by the lamps is as shown in the table below.

| | Conveyor | Crusher | Feeder | Magnetic separator | Muck discharge conveyor (if equipped) | Secondary conveyor (if equipped) | Vibratory sieve (if equipped) |
|------------------------|----------------------|----------------------|----------------------|--------------------|---------------------------------------|----------------------------------|-------------------------------|
| Stop | White lamp lights up | White lamp lights up | White lamp lights up | Transparent | Transparent | Transparent | Transparent |
| Normal rotation drive | White lamp lights up | White lamp lights up | White lamp lights up | Transparent | Transparent | Transparent | Transparent |
| Reverse rotation drive | - | White lamp lights up | - | - | - | - | - |
| Overload | - | Red lamp flashes | - | - | - | - | - |
| Abnormal load | Red lamp lights up | Red lamp lights up | - | Red lamp lights up | Red lamp lights up | Red lamp lights up | Red lamp lights up |
| Reducing overload | - | - | Green lamp flashes | - | - | - | - |

MONITOR SWITCH UNIT

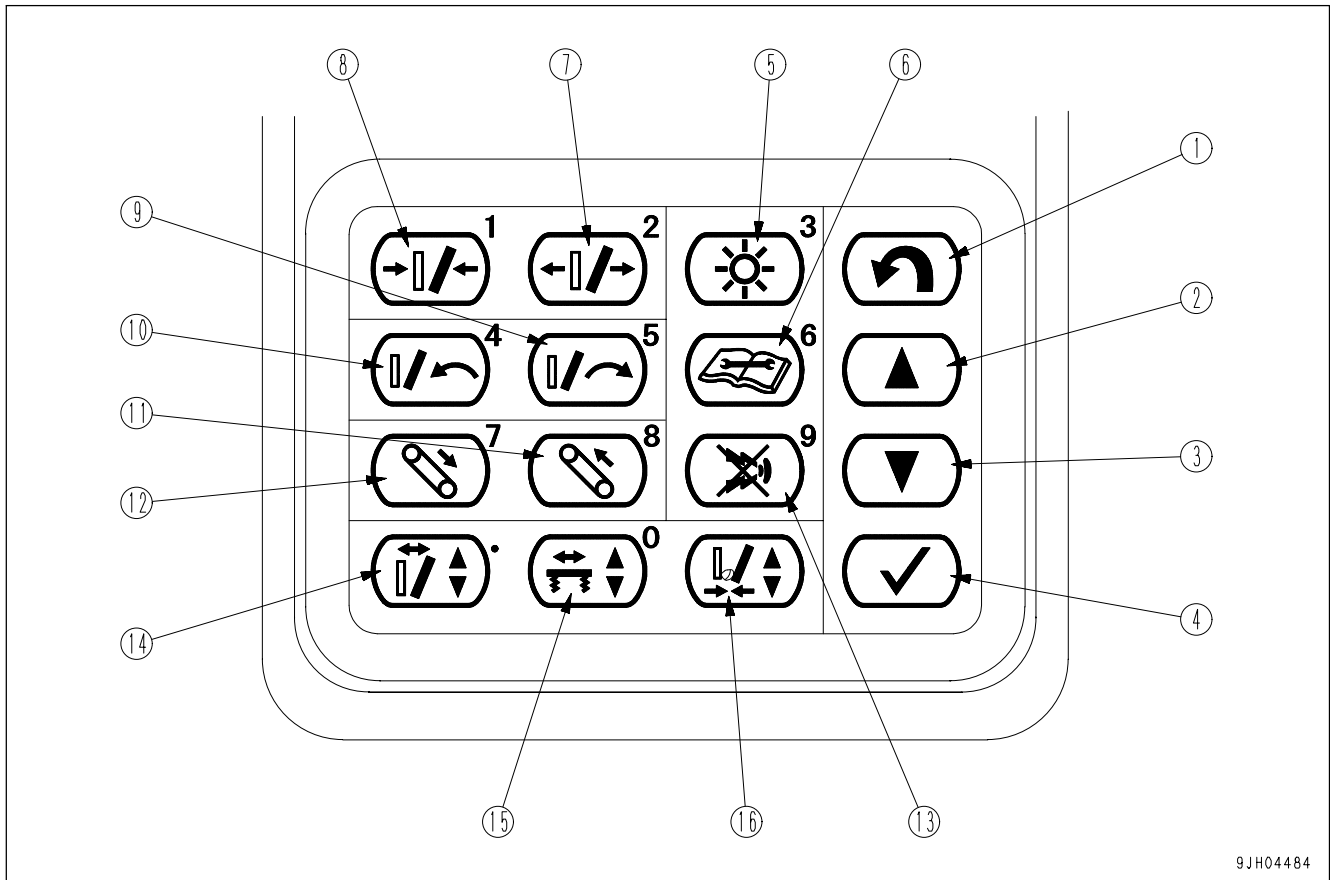

9JH04484

- | | |
|----------------------------------------------|---------------------------------------------------|
| (1) Return switch | (9) Crusher manual reverse rotation switch |
| (2) UP and numeral input (+) switch | (10) Crusher manual normal rotation switch |
| (3) DOWN and numeral input (-) switch | (11) Conveyor manual normal rotation switch |
| (4) Input confirmation switch | (12) Conveyor manual reverse rotation switch |
| (5) Liquid-crystal monitor adjustment switch | (13) Buzzer cancel switch |
| (6) Maintenance screen selector switch | (14) Crusher speed setting screen selector switch |
| (7) Crusher clearance increase switch | (15) Feeder speed setting screen selector switch |
| (8) Crusher clearance decrease switch | (16) Crusher load setting screen selector switch |

RETURN SWITCH

This switch (1) has a function to return the current display to the immediately foregoing one. It works in displays of the maintenance mode as well as brightness and contrast adjusting mode. Every time the switch is pressed in those modes, a display in the screen continuously returns to the immediately foregoing

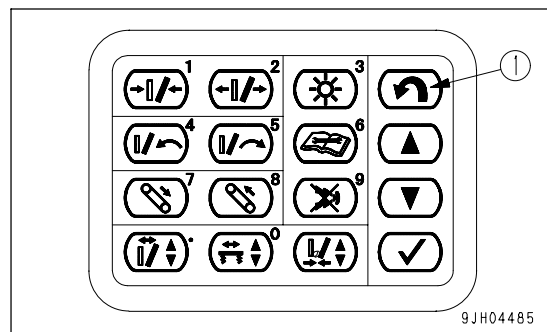

9JH04485

UP/DOWN SWITCH AND NUMERAL INPUT (+/-) SWITCH

1. These switches (2) and (3) function to move the cursor on the screen display up and down.

- (2) UP
- (3) DOWN

Each time this switch is pressed, the cursor moves. The screen display is highlighted to match this.

2. This switch is used to input the values when adjusting the crusher clearance (all automatic/automatic).

- (2) Increase input
- (3) Decrease input

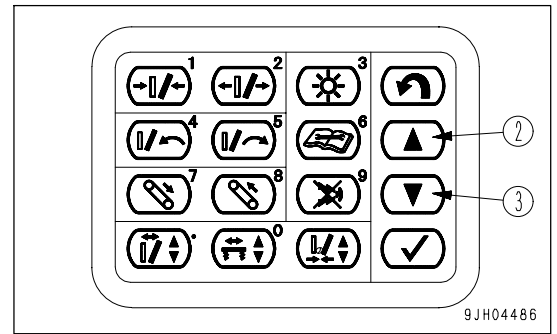

INPUT CONFIRMING SWITCH

This switch (4) has a function to determine selected contents in the display. It works in the maintenance mode as well as in the brightness and contrast mode. Press the switch in those modes and the selected contents are determined.

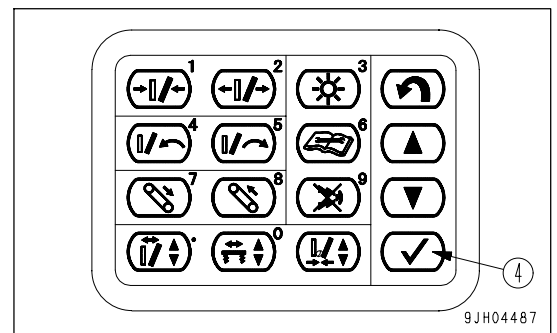

LIQUID-CRYSTAL MONITOR ADJUSTMENT SWITCH

This switch (5) is used when adjusting brightness and contrast of the display in the screen.

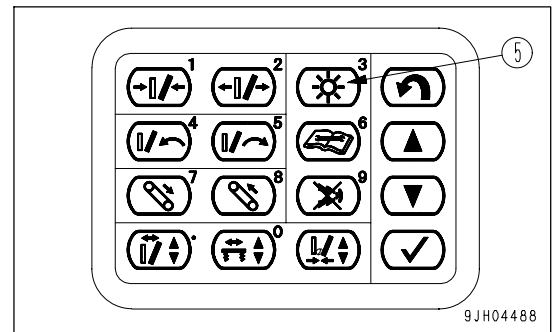

When this switch is pressed, the display in the screen changes to the selective display for brightness and contrast adjustment as shown at right.

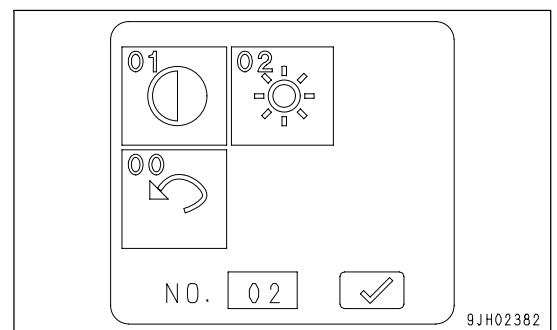

BRIGHTNESS ADJUSTMENT

1. Press either UP switch (2) or DOWN switch (3) to call the brightness adjusting monitor.

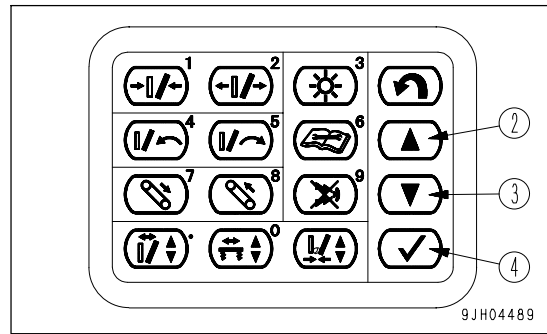

- 2. When the display in the screen is changed to brightness adjusting monitor, press either UP switch (2) or DOWN switch (3) for desired brightness.
- 3. When selecting the desired brightness is finished, press input confirmation switch (4).

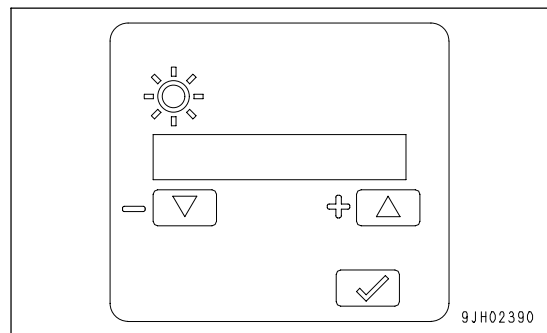

CONTRAST ADJUSTMENT

1. Press either UP switch (2) or DOWN switch (3) to call the contrast monitor.

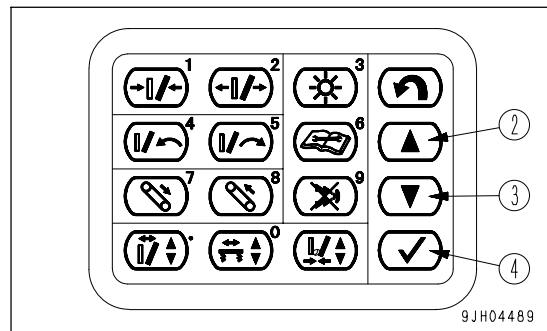

- 2. When the display is changed to the contrast monitor, press either UP switch (2) or DOWN switch (3) for desired contrast.
- 3. When selecting the desired contrast is finished, press input confirmation switch (4).

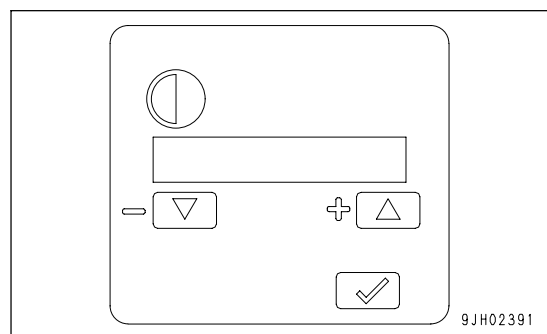

MAINTENANCE SCREEN SELECTOR SWITCH

- Switch (6) is used to check the time remaining until maintenance.

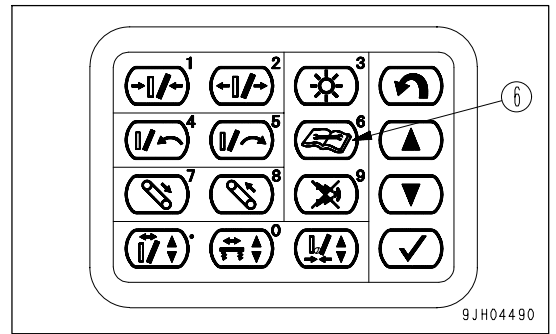

- When switch (6) is pressed, screen on the monitor display changes to the maintenance screen, as shown in diagram on the right.

The time remaining until maintenance is indicated by the color of each monitor display. After confirming the maintenance time, perform the maintenance.

White display: More than 30 hours remaining until maintenance
 Yellow display: Less than 30 hours remaining until maintenance

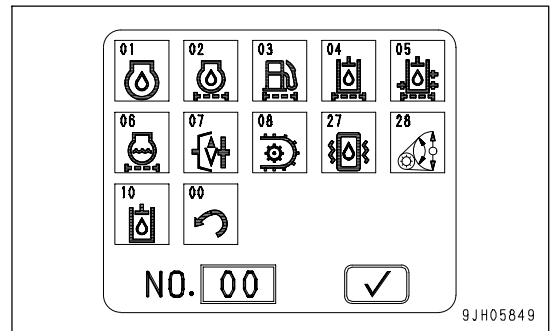

NOTICE

1. If the monitor display changes to the maintenance warning screen when the engine is started or when the machine is being operated, stop operations immediately. When this happens, the monitor corresponding to the maintenance warning screen will light up red.
2. Press switch (6) to display the maintenance screen and check that there is no abnormality in any other monitor.
3. If another monitor is lighted up red on the maintenance screen, carry out maintenance for that item also.

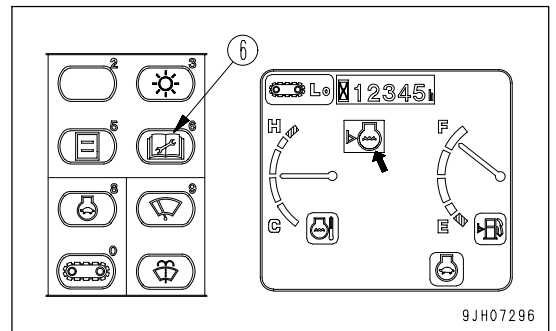

• Maintenance display items are as follows:

| Monitor No. | Maintenance items | Initial setting screen(H) |
|-------------|------------------------------------------|---------------------------|
| 01 | Change engine oil | 500 |
| 02 | Replace engine oil filter | 500 |
| 03 | Replace fuel filter | 500 |
| 04 | Replace hydraulic oil filter | 1000 |
| 05 | Replace hydraulic tank breather | 500 |
| 06 | Replace corrosion resister (if equipped) | - |
| 07 | Check damper case oil, add oil | 1000 |
| 08 | Cange final drive case oil | 2000 |
| 10 | Change hydraulic oil | 5000 |
| 27 | Change feeder excitation machine oil | 1000 |
| 28 | Change crusher motor case oil | 1000 |

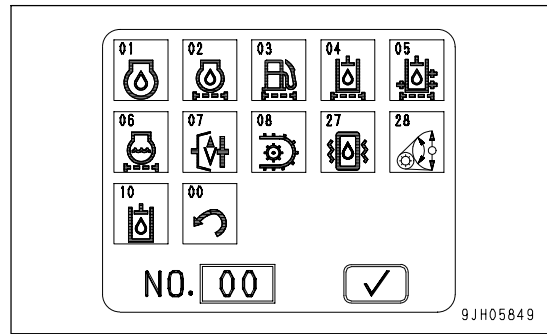

If it is desired to change settings for the maintenance interval, have your Komatsu distributor change the settings.

• The method of checking time remaining until maintenance is as follows:

1. Look at the maintenance screen and press the UP switch (2) or DOWN switch (3) on the monitor switches to select the item. (The selector monitor is highlighted in black.)

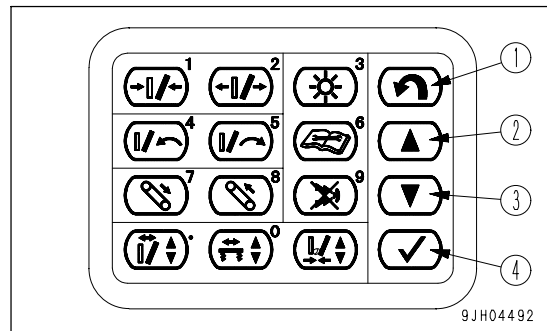

2. After selecting the monitor item, press input confirmation switch (4). The display changes to the time remaining to maintenance. (If return switch (1) is pressed, the screen returns to the previous screen.)

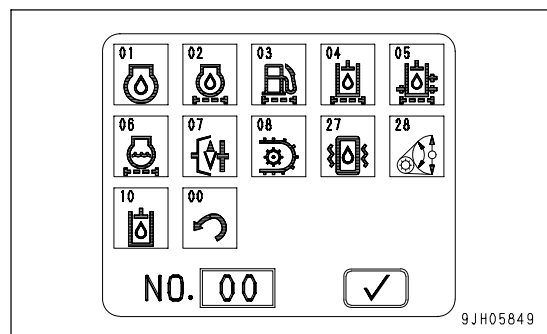

3. Confirm the time remaining to maintenance.

- (a): Time remaining to maintenance
- (b): Initial set time for maintenance

When checking only the time remaining to maintenance, press return switch (1) twice.

The screen returns to the monitor screen for normal operations.

To cancel the time remaining to maintenance and return to the initial set time, press input confirmation switch (4). The screen switches to the initial set screen.

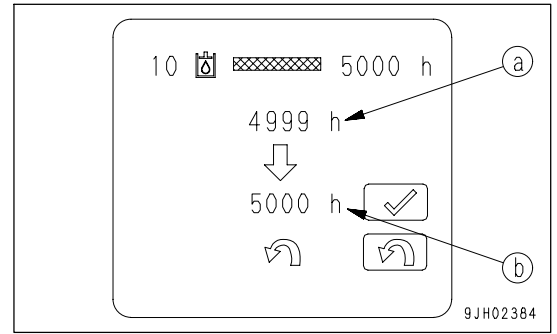

4. After checking the time on the initial set time screen, press input confirmation switch (4).

The screen returns to the maintenance screen.

(If return switch (1) is pressed, the screen returns to the previous screen.)

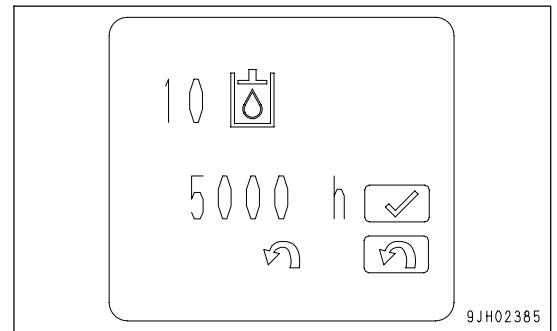

CRUSHER CLEARANCE DECREASE SWITCH

If this switch (7) is kept pressed, the discharge port clearance of the jaw crusher becomes larger.

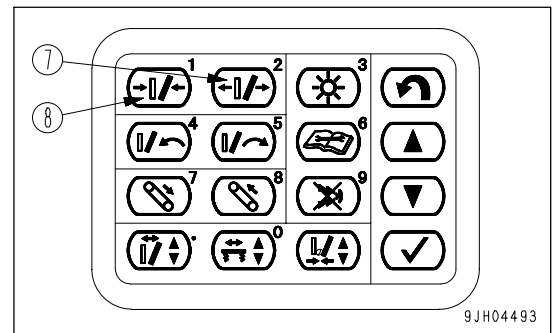

CRUSHER CLEARANCE INCREASE SWITCH

NOTICE

Operate this switch only after confirming that no debris or earth remains inside the crusher chamber.

If this switch (8) is kept pressed, the discharge port clearance of the jaw crusher becomes smaller.

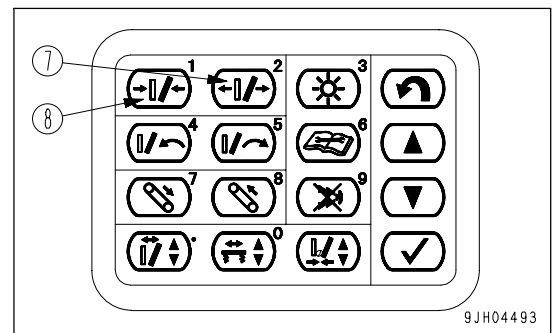

REMARK

Switches (7) and (8) are effective only when the mode selector switch on the control panel is at inspection mode and the crusher clearance adjustment mode is at manual mode.

CRUSHER MANUAL REVERSE ROTATION SWITCH

This switch (9) is used during maintenance and inspection of the jaw crusher or to escape from the bridging or blocking condition.

It is used when adjusting the discharge port clearance of the jaw crusher, or when carrying out operations to position the flywheel (inching operation).

It can also be used together with the starting switch for manual operation of the jaw crusher (normal rotation) (10) to make it easier to remove foreign material from the discharge port of the jaw crusher.

When using this switch, set the engine speed at low idling.

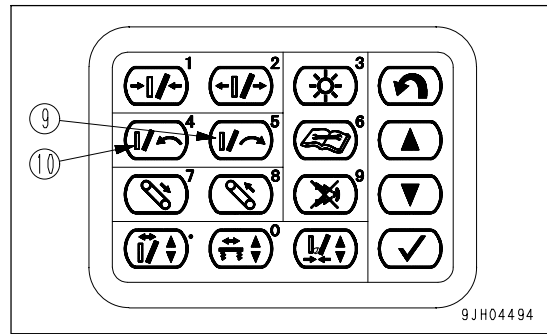

CRUSHER MANUAL NORMAL ROTATION SWITCH

This switch (10) is used during maintenance and inspection of the jaw crusher or to escape from the bridging or blocking condition. The function is the same as the manual reverse rotation switch (9), but when the discharge port of the jaw crusher is clogged with foreign material, this switch can be pressed after stopping the jaw crusher to make it easier to remove the foreign material.

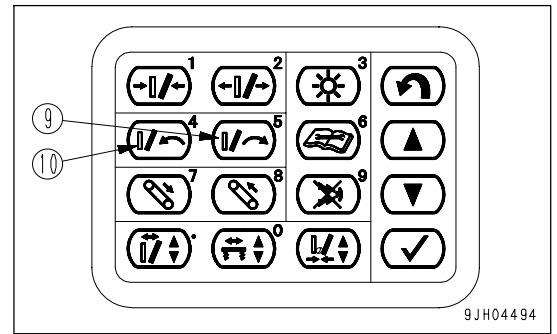

REMARK

- While these switches are kept pressed, the jaw crusher rotates in the normal direction or reverse direction.
- Switches (9) and (10) are effective only when the mode selector switch on the control panel is at working mode or inspection mode.

CONVEYOR MANUAL NORMAL ROTATION SWITCH



Use the conveyor manual switch for operations only when an abnormality has occurred in the conveyor or when carrying out inspection, maintenance, or repair, and use it only for inching operations. When carrying out this operation, check that the area around the conveyor is safe.

While this switch (11) is kept pressed, the conveyor rotates in the normal direction.

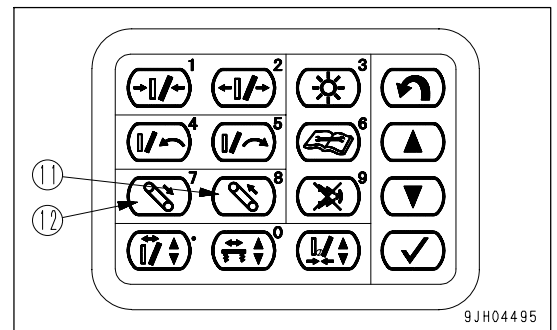

CONVEYOR MANUAL REVERSE ROTATION SWITCH

While this switch (12) is kept pressed, the conveyor rotates in the reverse direction.

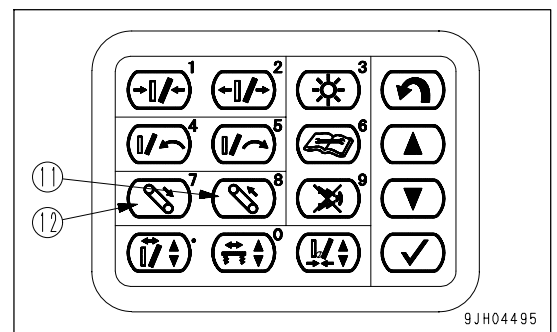

REMARK

Switches (11) and (12) are effective only when the mode selector switch on the control panel is at inspection mode.

BUZZER CANCEL SWITCH

NOTICE

If the engine starting switch is turned OFF because some abnormality has been noticed in the machine, and turned ON again, the buzzer sounds, unless that abnormality has not been removed.

This switch (13) is used to stop the alarm buzzer when an abnormality has occurred in a warning item during operation of the engine.

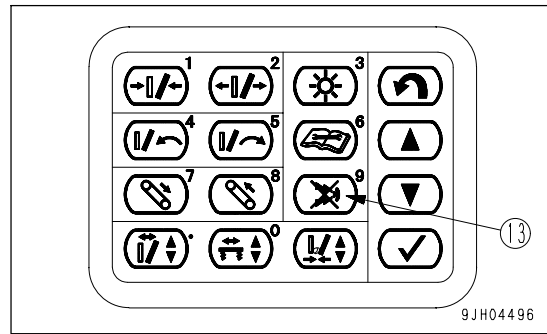

CRUSHER SPEED SETTING SCREEN SELECTOR SWITCH

This switch (14) is used to adjust the rotating speed of the crusher. When numeral input switch (3) is pressed, the scale goes down in direction (A).

When numeral input switch (2) is pressed, the scale goes up in direction (B).

(A) Rotating speed at minimum (MIN): Whole scale is reduced in direction (A)

(B) Rotating speed at maximum (MAX): Whole scale is increased in direction (B)

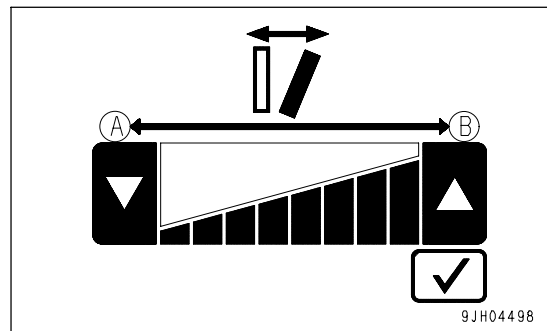
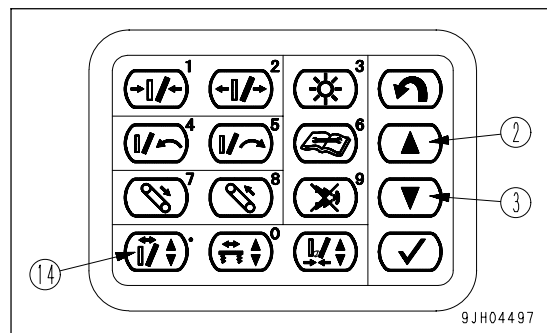

FEEDER SPEED SETTING SCREEN SELECTOR SWITCH

This switch (15) is used to change the vibration speed of the grizzly feeder and to adjust the feed speed for rubble and rock.

When numeral input switch (3) is pressed, the scale goes down in direction (A).

When numeral input switch (2) is pressed, the scale goes up in direction (B).

(A) Feed speed at minimum (MIN): Whole scale is reduced in direction (A)

(B) Feed speed at maximum (MAX): Whole scale is increased in direction (B)

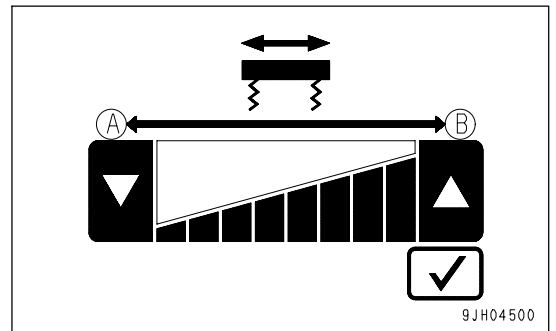
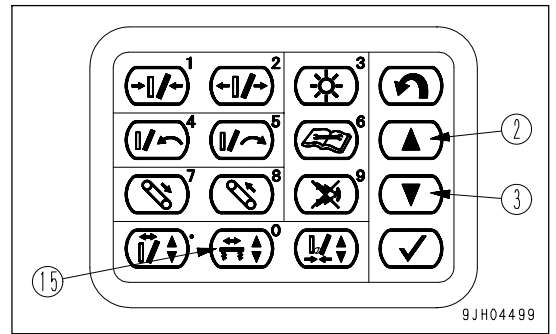

CRUSHER LOAD SETTING SCREEN SELECTOR SWITCH

This switch (16) is designed to maintain the charge ratio inside the crusher chamber to around 60% under any working conditions and to enable the crusher to display the maximum operating capacity.

With the scale, it is possible to adjust the feed speed from the grizzly feeder to the crusher.

When numeral input switch (3) is pressed, the scale goes down in direction (A).

When numeral input switch (2) is pressed, the scale goes up in direction (B). After starting operations, check the charge ratio of the crusher for around one hour and adjust the crusher load setting to the optimum position.

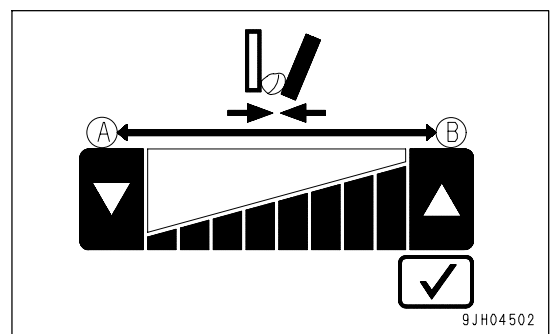
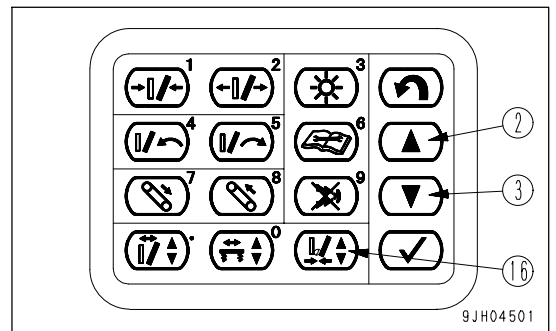

Guideline for adjusting scale

SOFT<----->HARD

SWITCHES

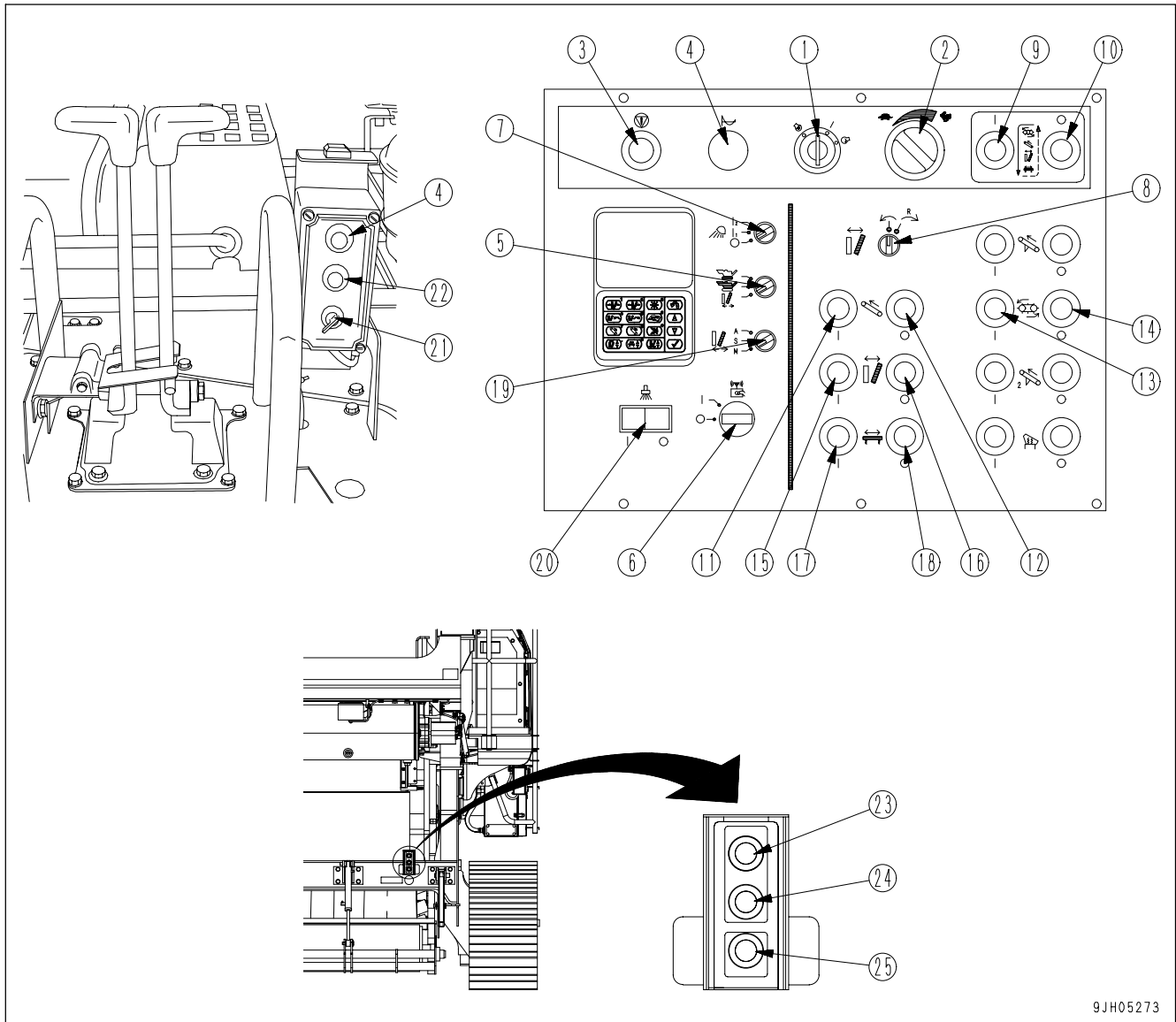

9JH05273

- (1) Starting switch
- (2) Fuel control dial
- (3) Emergency stop switch
- (4) Horn button
- (5) Mode selector switch
- (6) Radio controller selector switch
- (7) Lamp switch
- (8) Crusher rotation direction selector switch
- (9) Work equipment start switch
(1-touch start switch)
- (10) Work equipment stop switch
(1-touch stop switch)
- (11) Primary conveyor start switch
- (12) Primary conveyor stop switch
- (13) Magnetic separator start switch
- (14) Magnetic separator stop switch
- (15) Jaw crusher start switch
- (16) Jaw crusher stop switch
- (17) Grizzly feeder start switch
- (18) Grizzly feeder stop switch
- (19) Clearance adjustment selector switch
- (20) Water spray start switch
- (21) Travel speed selector switch
- (22) Engine stop switch
- (23) Primary conveyor UP switch
- (24) Primary conveyor DOWN switch
- (25) Emergency stop switch

STARTING SWITCH

Starting switch (1) is used to start or stop the engine.

(A): OFF position

The starting switch key can be removed, the flow of electricity to the electrical system is cut, and the engine stops.

(B): ON position

Electricity flows to the charging circuit and lamp circuit. Keep the key at this position when the engine is running.

(C): START position

This is the position for starting the engine. Keep the key in this position when cranking the engine, and when the engine starts, release the key immediately. The key will return to the ON position

(D): HEAT (pre-heating) position

Turn the key to this position when starting the engine in cold weather.

When the key is turned to the HEAT (pre-heating) position, the engine pre-heating monitor lights up. Keep the key at this position until the engine pre-heating monitor goes out. When the engine pre-heating monitor goes out, release the key immediately. When it is released, it will return to the OFF position, so turn it immediately to the START position to start the engine.

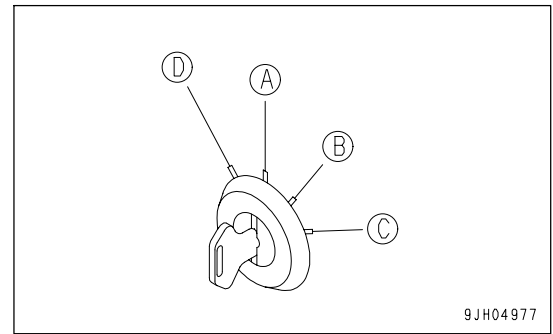

FUEL CONTROL DIAL

NOTICE

- Set the engine starting switch key to ON position after confirming the fuel control dial is at the low idling (MIN) position.
- When starting the work, set the fuel control dial to the MAX position.

This dial (2) adjusts the engine speed and output.

(a) Low idling (MIN): Dial turned fully to left

(b) Engine at full speed (MAX): Dial turned fully to right

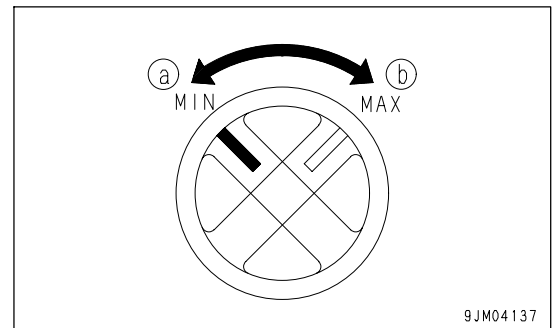

EMERGENCY STOP SWITCH

When this switch (3) is pressed, the horn sounds and all the work equipment stops.

The engine does not stop.

When starting again, first stop the engine, return the emergency stop switch to the OFF position, then start again. When the switch is pressed again, it returns to the OFF position.

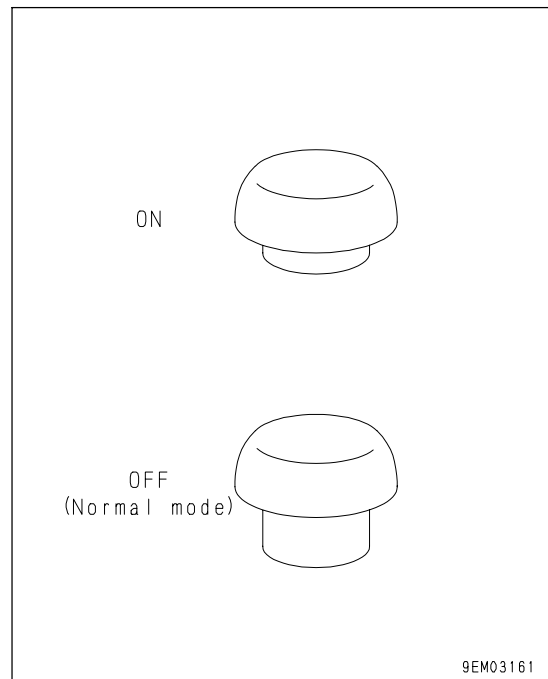

HORN BUTTON

This switch (4) sounds the horn, when depressed.

Be sure to honk it before starting the engine for the purpose of giving warning to those in the surrounding.

The horn also sounds under the following conditions.

If abnormalities occur at the same time, the horn sounds in the order of priority (1), (2), (3), (4), (5).

| No. | Abnormality items | Method of sounding horn |
|-----|------------------------------------------------------------------------------------------------------------------------------------|------------------------------------------------------------------------------------------|
| (1) | • When emergency stop switch is pressed | Horn continues to sound until starting switch is turned OFF. Sounds while being pressed. |
| | • When engine stop switch on top control box is being pressed | |
| (2) | | Horn continues to sound until fuel control dial is set to low idling position. |
| | | |
| (3) | • When failure is detected by controller (when error code is displayed) | Sounds 1 second ON, 1 second OFF 3 times in a row. |
| (4) | • When foreign material is caught inside crusher, and lock cylinder slips and discharge port clearance expands because of abnormal | Continues to sound for 5 sec. |
| (5) | • When all work equipment stops because of abnormal load on | Continues to sound for 5 sec. |
| | • When all work equipment stops because of abnormal load on | |
| | • When all work equipment stops because of abnormal load on muck | |
| | • When all work equipment stops because of abnormal load on | |
| | • When all equipment stops because of abnormal load on vibratory | |

MODE SELECTOR SWITCH



Stop all the working equipment before operating the mode selector switch. If the mode selector switch is operated while the work equipment is moving, the work equipment makes an emergency stop.

This switch (5) is used to switch between travel, work, and inspection.

- (a) Travel: Select this when traveling.
- (b) Work: Select this when carrying out crushing operations.
- (c) Inspection: Select this when carrying out inspection operations.

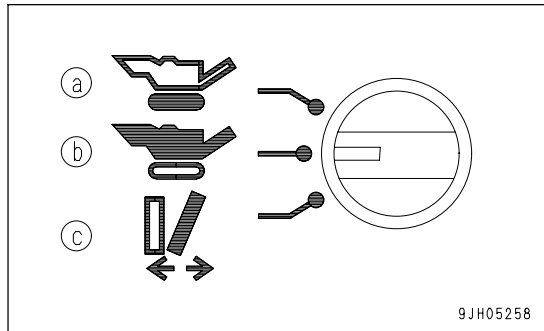

The table below shows a list of equipment that can be operated in

| No. | Device (Motion) | Mode | | |
|------|-----------------------------------------------|--------|------|------------|
| | | Travel | Work | Inspection |
| (1) | Crusher continuous operation | × | ○ | × |
| (2) | Crusher inching operation | × | ○ | ○ |
| (3) | Grizzly feeder operation | × | ○ | × |
| (4) | Primary conveyor operation | × | ○ | × |
| (5) | Magnetic separator operation | × | ○ | × |
| (6) | Muck discharge conveyor (if equipped) | × | ○ | × |
| (7) | Crusher outlet clearance adjustment | × | × | ○ |
| (8) | Primary conveyor UP/DOWN | ○ | ○ | ○ |
| (9) | Muck discharge conveyor UP/DOWN (if equipped) | ○ | ○ | ○ |
| (10) | Travel | ○ | × | × |
| (11) | Manual rotation of primary conveyor | × | × | ○ |

REMARK

When the mode selector switch is at the "Travel" position, the work equipment (jaw crusher, belt conveyor, grizzly feeder and any other options) may not be set in motion, even if their respective starting switches are depressed.

RADIO CONTROLLER SELECTOR SWITCH

This switch (6) is used to select whether to operate the machine by remote control or to operate it using the main panel and travel levers.

- (a) Radio control: Select this when operating the machine by radio control.
- (b) Panel: Select this when operating the machine using the main panel and travel levers.

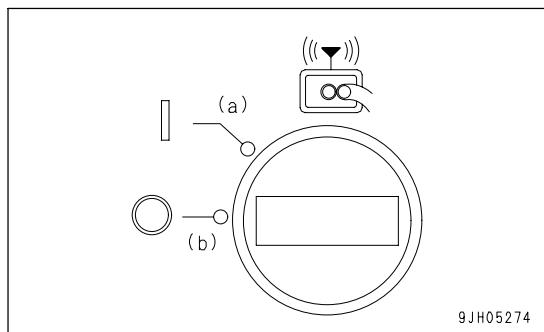

LAMP SWITCH

This switch (7) is used to light up the lamps.
The panel lamp and working lamp light up.

- (a) Position 2: Panel lamp and working lamp light up
- (b) Position 1: Panel lamp lights up
- (c) OFF position: Lamps are off

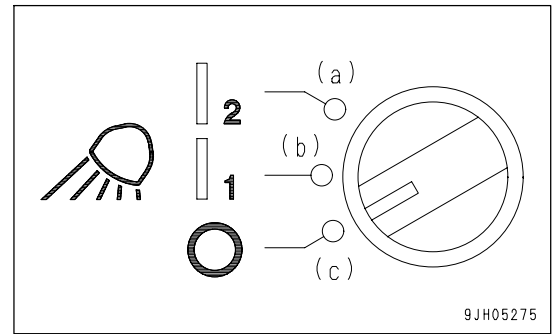

CRUSHER ROTATION DIRECTION SELECTOR SWITCH

This switch (8) is used to select the direction of rotation of the crusher.

- (a) Normal rotation: This selects normal rotation of crusher
- (b) Reverse rotation: This selects reverse rotation of crusher

Normally, carry out operations with (a) Normal rotation.

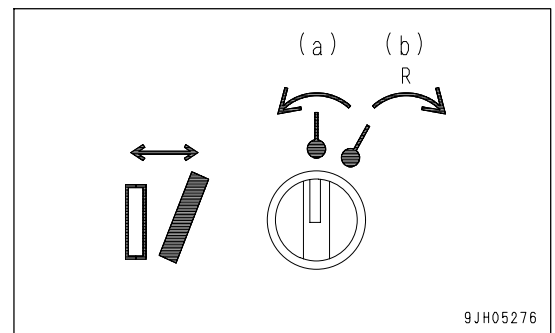

WORK EQUIPMENT START SWITCH

(1-touch starting switch)

CAUTION

- This switch cannot be operated when starting or stopping optional equipment (muck discharge conveyor, secondary conveyor, vibratory sieve). For details of the switches to choose, see "OPTION-RELATED SWITCHES (PAGE 3-42)".
- When operating in cold weather, the method of operating the work equipment is different. For details of the switches to use, see "PROCEDURE FOR OPERATING WORK EQUIPMENT IN COLD WEATHER (PAGE 3-77)".

For normal operations, use this switch.

When this switch (9) is pressed, it is possible to start the work equipment in turn.

The order for starting is as follows.

Conveyor, magnetic separator -> crusher -> feeder

The work equipment starts and the concrete rubble and rocks (material for crushing) loaded inside the hopper can be crushed and discharged.

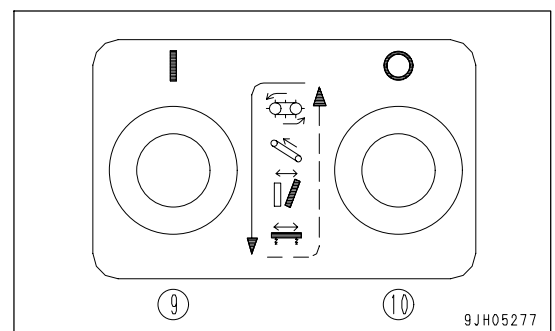

WORK EQUIPMENT STOP SWITCH

(1-touch stop switch)

For normal operations, use this switch.

When this switch (10) is pressed, it is possible to stop the work equipment in turn.

The order for starting is as follows.

Feeder -> crusher, conveyor, magnetic separator

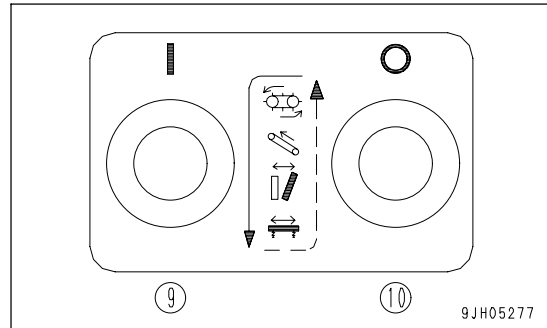

When it is desired to start and stop each piece of work equipment (primary conveyor, magnetic separator, crusher, feeder) individually, operate the following switches.

PRIMARY CONVEYOR START SWITCH

When this switch (11) is pressed, the primary conveyor is operated and the rubble and rocks (material for crushing) crushed by the crusher are discharged.

PRIMARY CONVEYOR STOP SWITCH

When this switch (12) is pressed, the primary conveyor stops.

MAGNETIC SEPARATOR START SWITCH

When this switch (13) is pressed, the magnetic separator is operated and the steel rods included with the crushed rubble arm of the primary conveyor are removed.

MAGNETIC SEPARATOR STOP SWITCH

When this switch (14) is pressed, the magnetic separator stops.

JAW CRUSHER START SWITCH

When this switch (15) is pressed, the jaw crusher is operated and carries out the crushing operation.

JAW CRUSHER STOP SWITCH

When this switch (16) is pressed, the jaw crusher stops.

GRIZZLY FEEDER START SWITCH

When this switch (17) is pressed, the grizzly feeder is operated and separates the soil from the rubble contained in the hopper while feeding the rubble and rocks to the crusher.

GRIZZLY FEEDER STOP SWITCH

When this switch (18) is pressed, the grizzly feeder stops.

CLEARANCE ADJUSTMENT SELECTOR SWITCH

When this switch (19) is operated, it is possible to select the method for adjusting the crusher clearance.

- (a) A Automatic: The clearance is automatically adjusted according to the set value input on the clearance set monitor.
- (b) S Semi-automatic: The clearance is automatically made larger or smaller by inputting the desired value on the clearance set monitor.
- (c) M Manual: It is possible to adjust the clearance manually by using the panel switch.

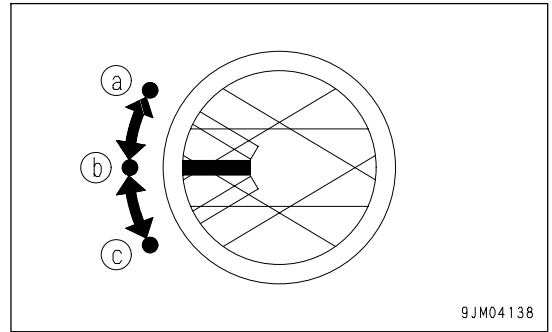

SPRINKLER START SWITCH

(if equipped)

When this switch (20) is pressed, the water spray pump starts and sprays water.

- Position (a): ON
- Position (b): OFF

If the level of water in the water spray tank becomes low, the pump protection circuit is actuated to prevent the pump from operating even when it is turned ON.

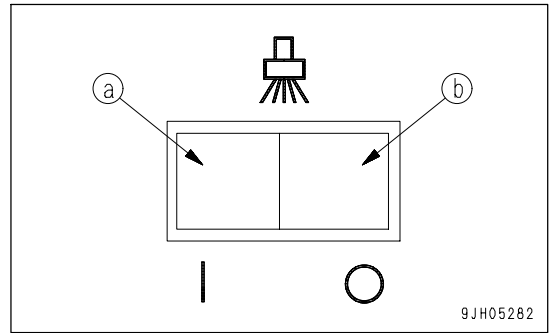

TRAVEL SPEED SELECTOR SWITCH

This switch (21) switches between the two travel speeds.

- Position (a): Low-speed travel
- Position (b): High-speed travel

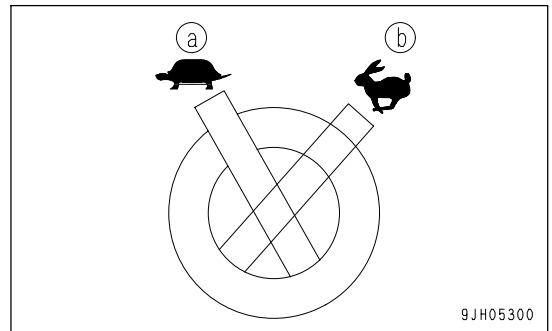

ENGINE STOP SWITCH

When this switch (22) is pressed, the horn sounds and the engine stops.

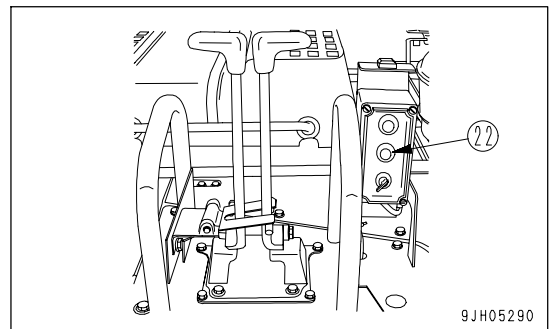

CONVEYOR UP/DOWN SWITCH

Use these switches to raise or lower the primary conveyor.

- Switch (23): Raises the conveyor
- Switch (24): Lowers the conveyor

The conveyor raise or lower cylinder is operated only while the switch is being pressed.

Switch (25): Emergency stop switch

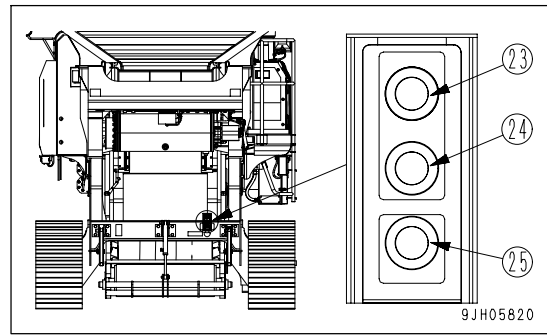

CONVEYOR UP/DOWN SELECTOR SWITCH

(Only machines equipped with muck discharge conveyor (if equipped))

Use this switch (26) to select either the primary conveyor or muck discharge conveyor to raise or lower.

- Position (a): Primary conveyor
- Position (b): Muck discharge conveyor

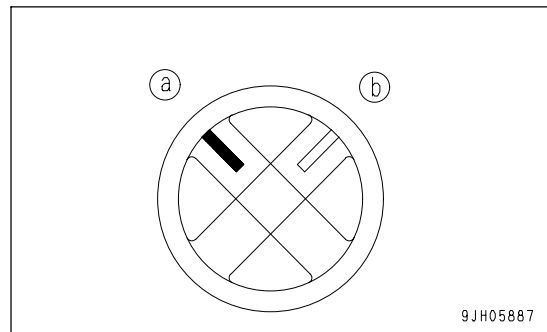
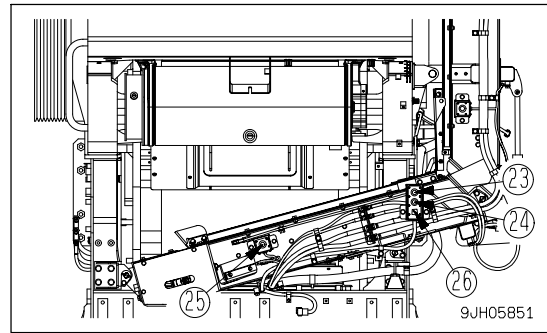

CONVEYOR/MUCK DISCHARGE CONVEYOR UP/DOWN SWITCH

Use this switch to raise or lower the primary conveyor or muck discharge conveyor.

- Switch (23): Raises the primary conveyor or muck discharge conveyor
- Switch (24): Lowers the primary conveyor or muck discharge conveyor

The conveyor UP/DOWN cylinder is operated only while the switch is being pressed.

Switch (25): Emergency stop switch

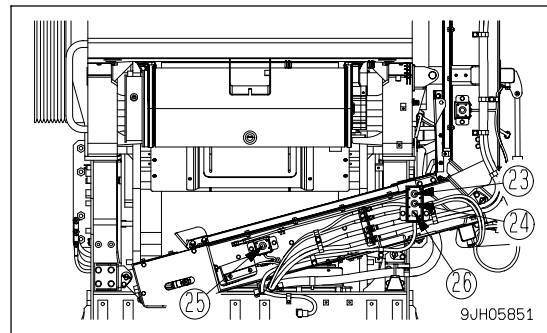

CONTROL LEVERS

TRAVEL LEVERS

This control lever is used to run the machine.

(1) Foreward: Push the control lever forward.

(2) Reverse: Pull the lever toward yourself.

N Neutral: The machine comes to a halt.

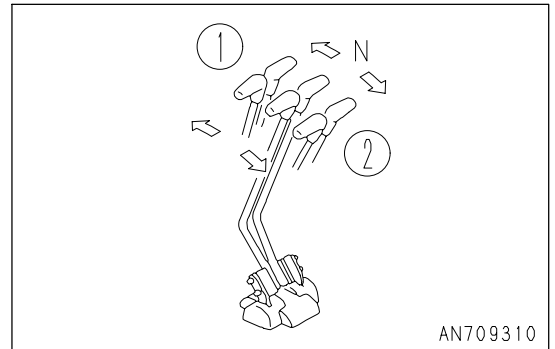

When you shift the travel control lever from Neutral to Forward, or from Neutral to Reverse, an alarm begins to sound to caution the people around the machine that it is about to move.

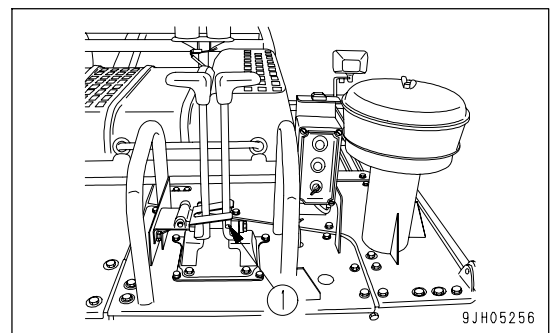

OPTION-RELATED SWITCHES

CAUTION

The name and panel display for option switches (1) to (6) may differ according to the number and type of options that are connected. In such cases, check the display at the hydraulic pressure pickup port and the panel display to check which switch corresponds to the option before operating.

If the wrong starting switch is pressed for the optional equipment, abnormal load will be generated and the horn will sound, so be sure not to press the wrong switch.

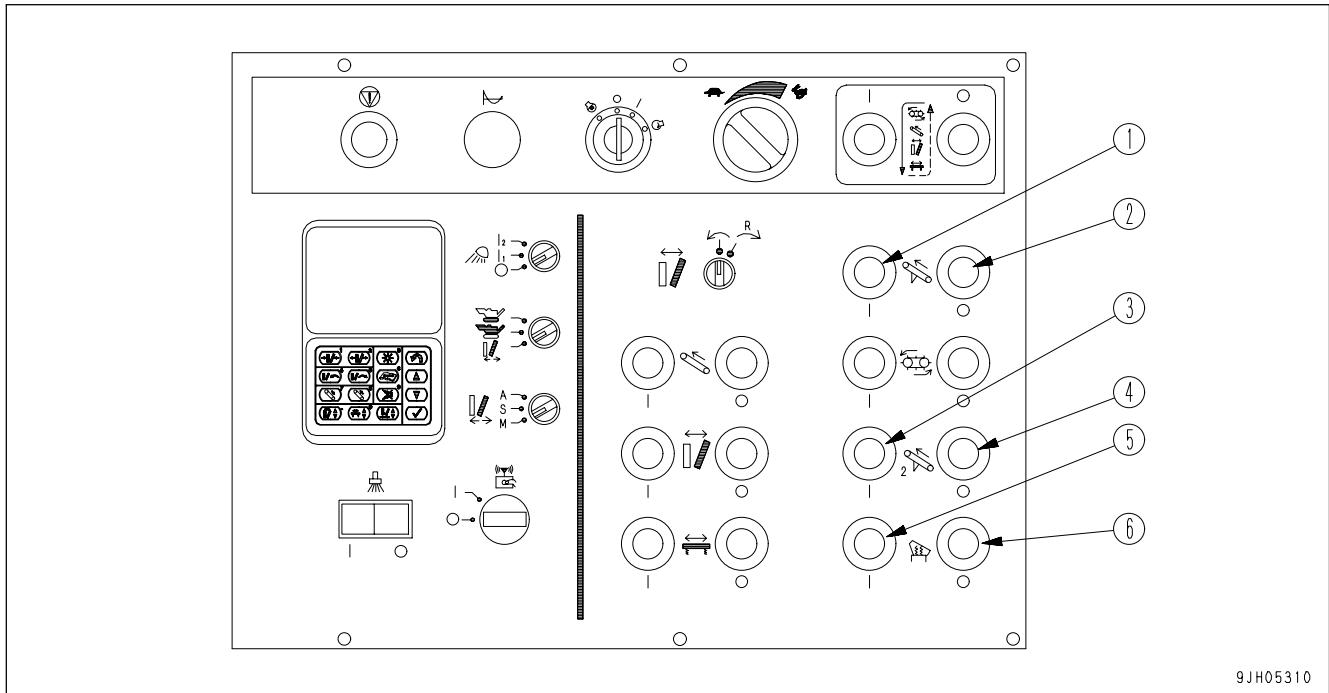

9JH05310

- (1) Muck discharge conveyor start switch
- (2) Muck discharge conveyor stop switch
- (3) Secondary conveyor start switch
- (4) Secondary conveyor stop switch
- (5) Vibratory sieve start switch
- (6) Vibratory sieve stop switch

MUCK DISCHARGE CONVEYOR START SWITCH

When this switch (1) is pressed, the muck discharge conveyor is operated and the soil separated in the grizzly feeder is discharged from the machine.

MUCK DISCHARGE CONVEYOR STOP SWITCH

When this switch (2) is pressed, the muck discharge conveyor stops.

SECONDARY CONVEYOR START SWITCH

When this switch (3) is pressed, the secondary conveyor is operated and the rubble separated by the vibratory sieve is discharged.

SECONDARY CONVEYOR STOP SWITCH

When this switch (4) is pressed, the secondary conveyor stops.

VIBRATORY SIEVE START SWITCH

When this switch (5) is pressed, the vibratory sieve is operated and the product discharged from the primary conveyor is sifted and separated.

VIBRATORY SIEVE STOP SWITCH

When this switch (6) is pressed, the vibratory sieve stops.

CAP, COVER WITH LOCK

A lock is provided at the following locations of the machine; the oil filler of the fuel tank, the oil filler of the hydraulic oil tank, the main control box cover, the tool box, the engine hood, the battery box cover and the left and right side doors.

Use the engine starting switch key when opening and closing the caps.

Insert the key as far as it will go to the shoulder (A). If the key is turned before it is inserted all the way, it may break.

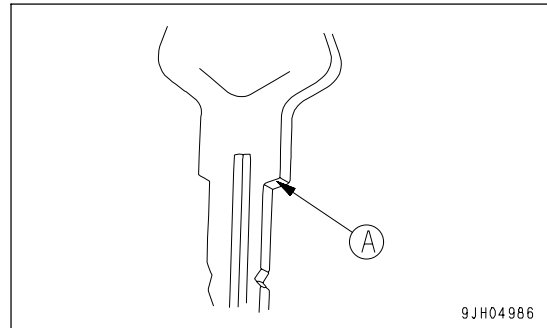

METHOD OF OPENING AND CLOSING CAP WITH LOCK

TO OPEN THE CAP

1. Insert the key into the key slot.
2. Turn the starting switch key counterclockwise, align the key slot with the match mark (3) on the cap, then open the cap.
 - (1): Open
 - (2): Lock

REMARK

- A type is used for the fuel tank cap. B type is used for the hydraulic tank.
- With this type, if the cap rotates freely, it is locked. In this condition, the cap cannot be removed from the tank.

Turn the starting switch key counterclockwise, align counter mark (3) on the cap with the groove of the rotor, then turn the cap slowly until a click is heard. This releases the lock and the cap can be opened.

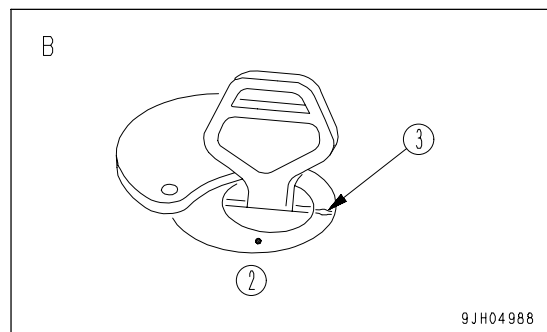
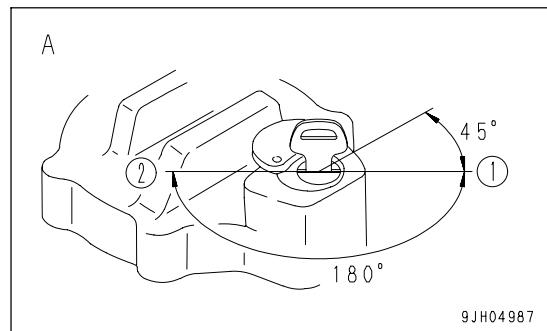

TO LOCK THE CAP

1. Turn the cap until tight, then insert the key into the key slot.
2. Turn the key counterclockwise (but, for the B type, turn clockwise) and take the key out.

METHOD OF OPENING AND CLOSING COVER WITH LOCK**TO OPEN THE COVER**

1. Insert the key into the key slot.
2. Turn the key counterclockwise and open the cover by pulling the cover grip.
(A): Open
(B): Lock

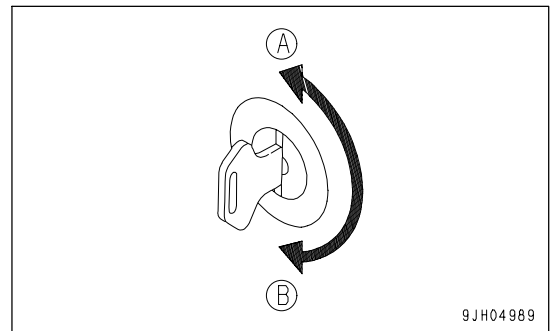
**TO LOCK THE COVER**

1. Close the cover and insert the key into the key slot.
2. Turn the key clockwise and take the key out.

REVOLVING WARNING LAMP

(Red)

- The revolving warning lamps light on and off on the following occasions.

If abnormalities occur at the same time, the rotating lamp lights up or flashes in the order of priority (1), (2), (3), (4), (5).

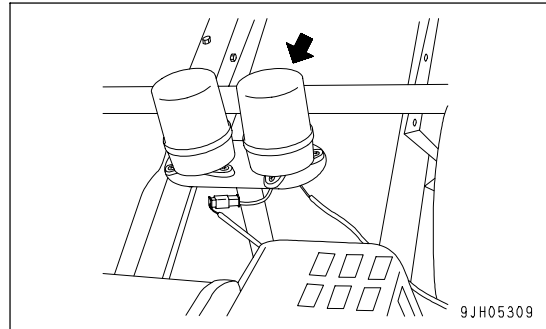

| No. | Abnormality items | Rotating lamp displaying |
|-----|-------------------------------------------------|-----------------------------------------------------------------------------------------------------------------------------|
| (1) | • When there is abnormality in engine coolant | Continues to flash when any one of conditions on left has occurred (goes out when condition is restored to normal range) |
| | • When there is abnormality in engine oil | |
| | • When there is abnormality in remaining fuel | |
| | • When there is abnormality in radiator coolant | |
| | | |

When the following condition has been detected during operation of the grizzly feeder

| | | |
|-----|---------------------------------------------------------------------------------------|--------------------------------------------------------------------------------------------------------|
| (2) | • Excessive load on crusher | Lights up when condition on left has occurred (goes out when condition is restored to normal range) |
| (3) | • When crusher wear limit has been detected | Lights up when condition on left has occurred (goes out when condition is restored to normal range) |
| (4) | • During prohibited operation of crusher (30 seconds from completion of clearance) | Lights up when condition on left has occurred (goes out when condition is restored to normal range) |
| (5) | • When key switch is at ON position | Lights up (3 seconds) when condition on left has occurred |

ELECTRIC POWER TAKEOFF

24 V POWER SOURCE

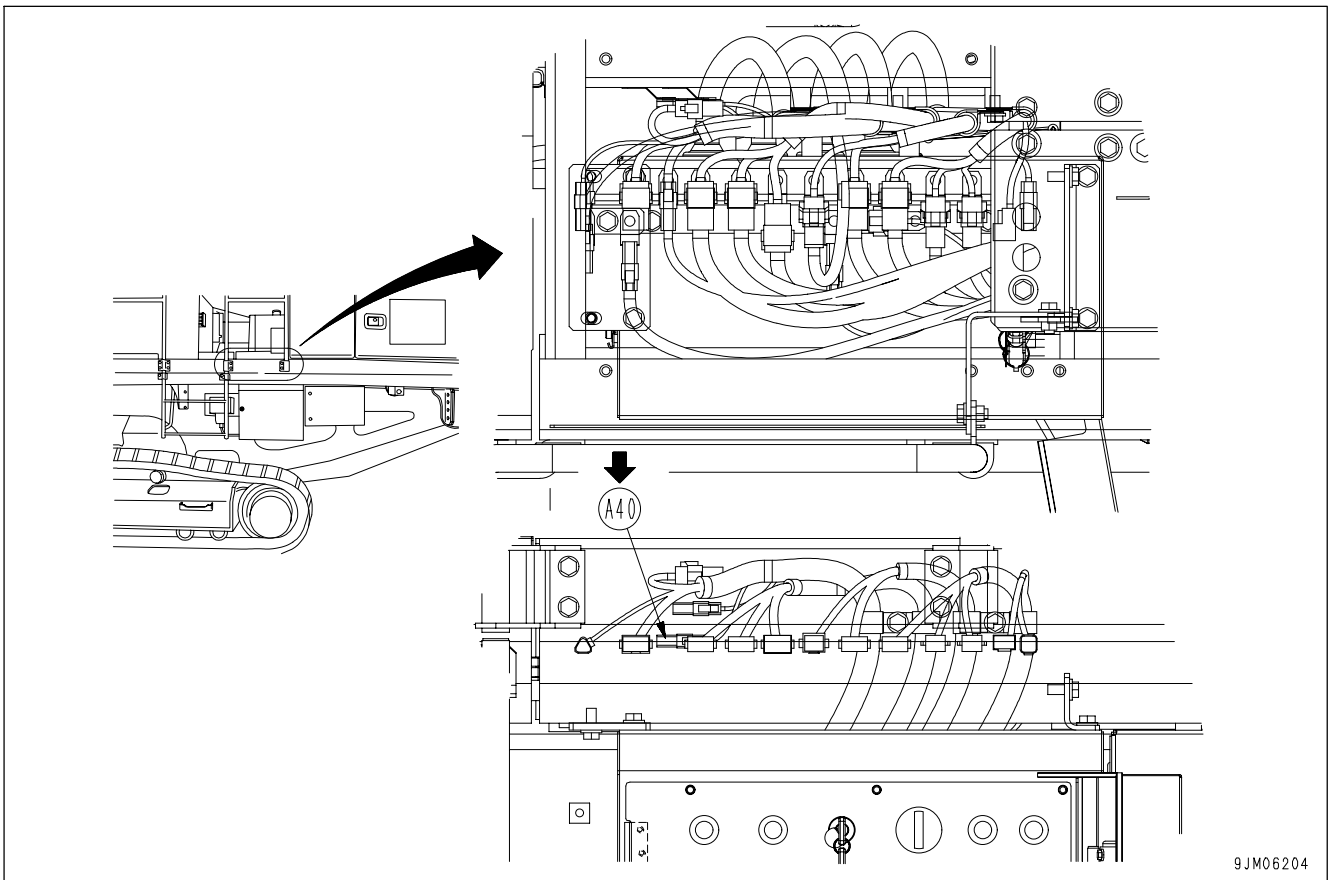

NOTICE

Do not use this as the power source for 12 V equipment.

It is possible to use the electric power connector (A40) inside the cover at the top of the control box.
Capacity: 85 W (24 V x 3.5 A)

WHEN REMOTE CONTROL IS INSTALLED

(If equipped)

It is possible to use the power supply socket (1) inside the toolbox on the machine.

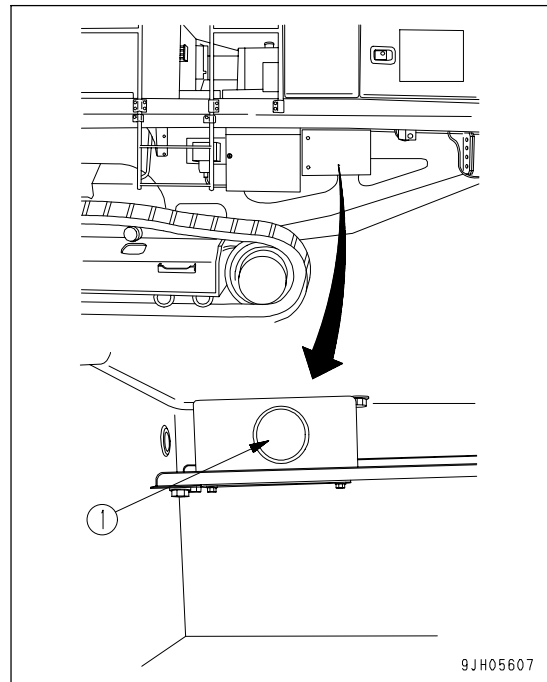

FUSIBLE LINK

When the starter motor does not function, after turning the engine starting switch ON, the fusible link on the wiring may be broken. In that case open the cover of the batter box located on the right side of the machine, and check and replace it.

REMARK

A fusible link refers to the large-sized fuse wiring installed in the high current flow portion of the circuit to protect electrical components and wiring from burning, in the same way as an ordinary fuse.

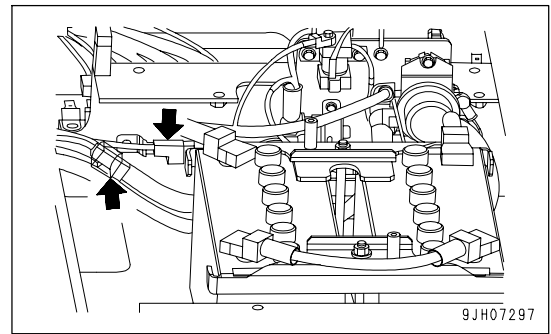

CONTROLLERS

Governor and pump controller is installed.

NOTICE

- Take care so that these controllers do not get wet with water or mud. It may cause a failure.
- If anything unusual has developed on any of the controllers, do not attempt to overhaul it by yourself, but call your Komatsu distributor for check and repair.
- Do not open the door inside the main control box in a wet weather condition. If it has to be opened by all means for some reason or other, take care so that dust or rainwater will not get in the box.

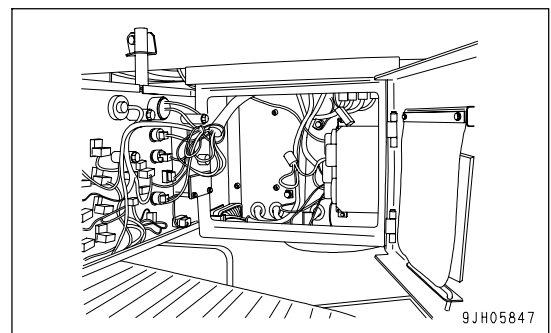

FUSE

FUSE BOX

NOTICE

Before replacing a fuse, be sure to turn off the starting switch.

The fuses protect the electrical equipment and wiring from burning out.

If the fuse becomes corroded, or white powder can be seen, or the fuse is loose in the fuse holder, replace the fuse.

- When replacing the fuses, use ones with the same capacity.

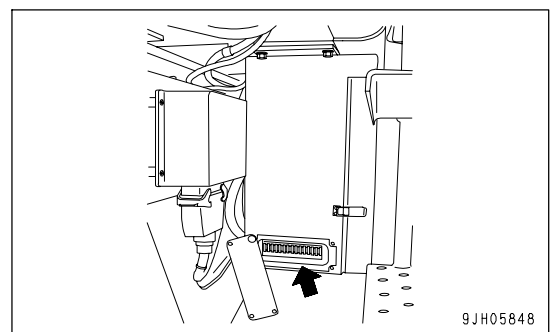

FUSE CAPACITY AND NAME OF CIRCUIT

| No. | Fuse capacity | Name of circuit |
|------|---------------|----------------------------------------------------|
| (1) | 10A | Key switch |
| (2) | 10A | Monitor (permanent power source) |
| (3) | 10A | Spare |
| (4) | 20A | Spare |
| (5) | 10A | Controller |
| (6) | 10A | Solenoid |
| (7) | 20A | Working lamp |
| (8) | 10A | Traveling in straight line, 2-stage relief |
| (9) | 10A | Rotating lamp |
| (10) | 10A | Electromagnetic valve for attachment, travel alarm |
| (11) | 10A | Monitor |
| (12) | 10A | Horn spare |
| (13) | 10A | Remote control (if equipped) |
| (14) | 20A | Power source for option (water spray) |
| (15) | 10A | Additional power source |

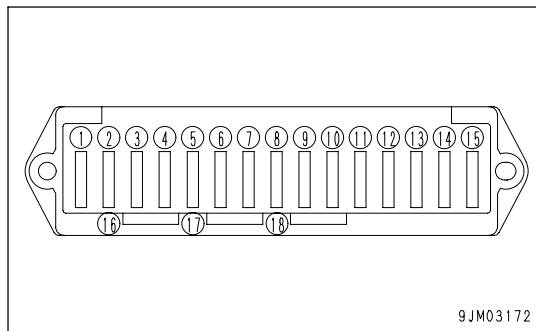

TOOL BOX

The tools and remote control are stored in the place marked by an arrow in the illustration on the right.

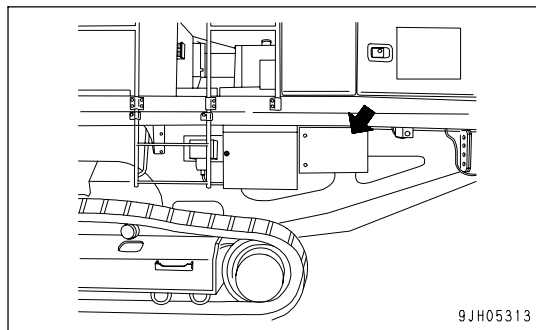

OPERATION

CHECK BEFORE STARTING ENGINE



WARNING

Ensuring the safety at the job site

- Before starting the work, confirm that there is no danger in the job site.
- Before starting the job, level the ground as evenly as possible.
- When working on a public road, ensure the safety for both pedestrians and passing vehicles by manning a guide and putting up a fence around to turn the area off-limit.

WALK-AROUND CHECK



WARNING

Inflammables piled on the intensely heated engine parts like an exhaust muffler and on the battery or fuel and oil leakage can cause a fire on the machine.

Make a thorough check, and if something unusual is found, be sure to fix it or inform it to the komatsu distributor in your territory.

Before starting the engine, walk around the machine and look at the underside of chassis for anything unusual like loose bolts and nuts, leakage of fuel, oil and coolant. Also check the condition of the work equipment and the hydraulic system.

Also check for loose wiring, play, and collection of dust at places that reach high temperature.

Be sure to check the items listed here before starting the engine for the day's work.

1. Check for damage, wear and play of the work equipment, hydraulic cylinders and hoses
Check the work equipment, the hydraulic cylinders and hoses for any damage, wear and play. If any of them is found, fix it.
2. Removing dust from the engine parts and the radiator
Walk around the engine and the radiator to check if dust is piled up on any of them. Remove it, if any.
3. Check for coolant and oil leakage around the engine
Check for oil leakage from the engine and coolant leaks from the cooling system. If any problem is found, repair it.
4. Inspection of the operator's platform
Check around the operator's platform to see if there is any parts or tool left, and put it back or move to the specified place.
Furthermore inspect the platform floor, control levers, handrails, step, etc. for mud, oil, snow stuck to them, and remove them, if any.
5. Inspection of the lamps for smudge
Inspect the surface of the lamps for any smudges, and wipe them out, if any.
6. Inspection of the head lamps and the working lamp
Inspect the head lamps and the working lamp to determine that they are suited to the work, and if not, replace them.
7. Check for oil leakage from hydraulic equipment, hydraulic tank, hoses, and joints
Check for oil leakage. If any problem is found, repair the area where oil is leaking.
8. Check of the undercarriage parts
Check track shoe, sprocket, idler, guard for damage, wear, loose bolts, or leakage of oil from rollers, etc.
Repair them if any trouble is found.

9. Check of the handrails and steps

Check the handrails and steps for any damage or loosened bolts, and repair the damaged part and tighten the loosened bolts, if any.

10. Inspection of damage on the gauges and monitors and looseness of the bolts

Inspect if no damage has occurred on the gauges and monitors, and if any abnormality is found, replace it. At the same time wipe out the smudges on their surface.

11. Check and cleaning of the rear view mirrors

Check the rear view mirrors for breakage, and replace any broken one. Clean the surface of each mirror and adjust the angle so that the rear view can be seen clearly from the operator's platform.

12. Check of outer cover mounting bolts

Check the outer cover mounting bolts for looseness, and tighten any loosened bolt.

CHECK BEFORE STARTING

CHECK COOLANT LEVEL, ADD COOLANT



WARNING

- Do not open the radiator cap unless necessary. Wait for the engine to cool down before checking the coolant in the sub-tank.
- Immediately after the engine is stopped, the coolant is at a high temperature and the radiator is under high internal pressure. If the cap is removed to check the coolant level in this condition, there is a hazard of burns. Wait for the temperature to go down, then turn the cap slowly to release the pressure before removing it.

1. Open the door under the precleaner and check that the coolant is in the range between the FULL and LOW marks in sub tank (1). If the level is low, add water to the FULL level through the water filler of sub tank (1).
2. After adding coolant, tighten the cap securely.
3. If the sub-tank (1) is empty, there is probably leakage of coolant. After inspecting, repair any problem immediately. If there is no problem, check the coolant level in the radiator. If the coolant level is low, add coolant to the radiator, then fill the sub-tank (1).

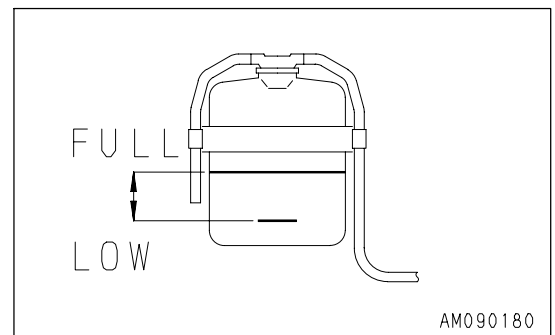
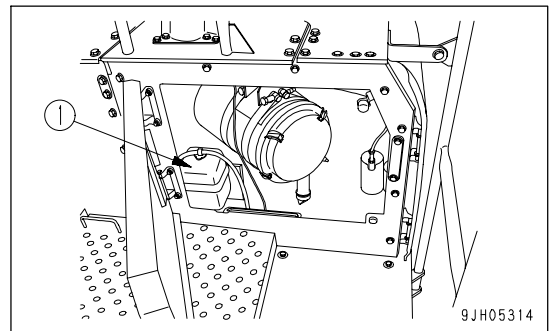

CHECK AFTERCOOLER FINS

1. Check through the duct at the top of the machine that the aftercooler fins are not clogged with dust or leaves.
2. If there is any abnormality, carry out cleaning. For details, see "CLEAN, INSPECT RADIATOR FINS, OIL COOLER FINS, AFTERCOOLER FINS (PAGE 4-76)".

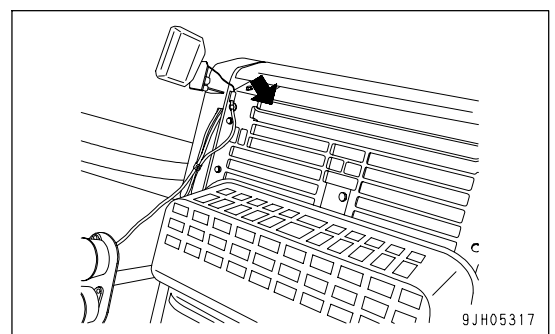

CHECK OIL LEVEL IN ENGINE OIL PAN, ADD OIL

**WARNING**

Parts and oil are at high temperature immediately after the engine is stopped and may cause serious burns. Wait for the oil temperature to go down before performing this operation.

1. Open the engine hood.
2. Remove dipstick (G), and wipe the oil off with a cloth.
3. Fully insert dipstick (G) into filler pipe (F), then remove it.
4. The oil level should be between the H and L marks on dipstick (G).
If the oil level is below the L mark, add oil through oil filler (F).

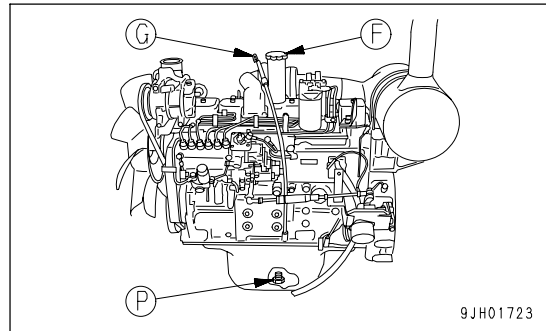

5. If the oil is above the H line, open drain valve (P) at the bottom of the engine oil pan, drain the excess engine oil, then check the oil level again.
6. If oil level is correct, securely tighten the oil filler cap and close the engine hood.

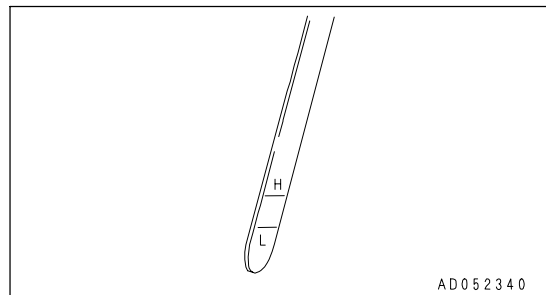
**REMARK**

When checking the oil level after the engine has been operated, wait for at least 15 minutes after stopping the engine before checking.

If the machine is at an angle, make it to a horizontal position before checking.

CHECK FUEL LEVEL, ADD FUEL

**WARNING**

When adding fuel, never let the fuel overflow. This may cause a fire. If any fuel is spilled, wipe it up completely. Never bring flames near fuel because it is highly flammable and dangerous.

1. Open fuel filler cap (F) of the fuel tank.
2. If fuel filler cap (F) is opened, float gauge (G) rises to the fuel level. Check that the fuel tank is full. Check the fuel level visually and with float gauge (G).
3. If the fuel tank is not full, add fuel through the fuel filler until float gauge (G) rises to the maximum position.
 - Fuel tank capacity: 400 liters (105.68 US gal)
 - Position of tip of float gauge (G) when tank is full: Approx. 50 mm (2 in) from top surface of fuel tank
4. After adding fuel, push float gauge (G) straight down with fuel filler cap (F). Be careful not to get float gauge (G) caught in the tab of fuel filler cap (F), and tighten fuel filler cap (F) securely.

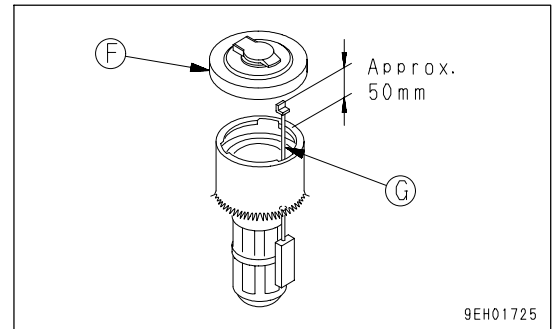
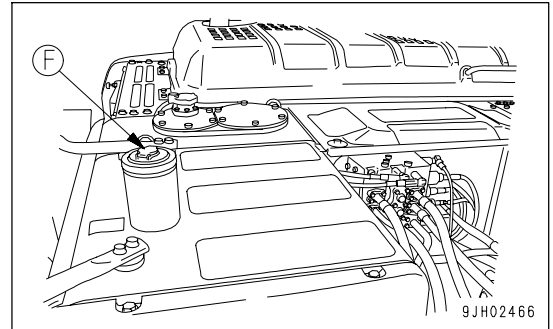
**REMARK**

If breather hole (1) in the cap is clogged, the pressure in the tank will drop and fuel will not flow. Clean the hole from time to time.

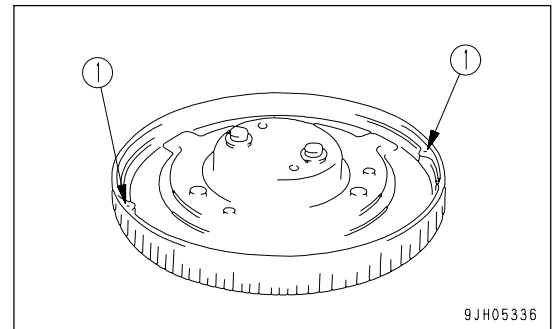
**DRAIN WATER, SEDIMENT FROM FUEL TANK**

1. Set a container under drain hose (1) to catch the drained fuel.
2. Open drain valve (2) at the rear of the fuel tank and drain the water and sediment accumulated at the bottom of the tank together with the fuel.
3. When only clean fuel comes out, close drain valve (2).

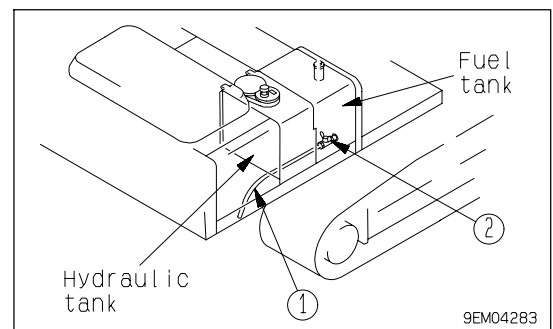

CHECK WATER SEPARATOR, DRAIN WATER AND SEDIMENT

1. Open the inspection window in the bottom face of the pump chamber.
2. Inspect the water separator, and check if the ring inside has risen to the marked line.
3. If the ring has risen to the marked line, carry out the procedure from Step 4.

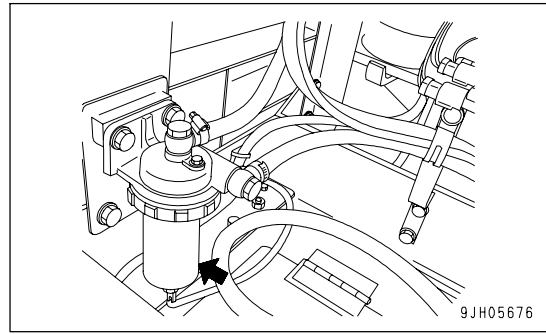

4. Prepare a container to catch the drained fuel and set it under the water separator.
5. Close fuel valve (6) at the bottom of the fuel tank.
6. Remove air bleed plug (5) at the top of the water separator.
7. Loosen drain valve (1) at the bottom of the water separator, and drain the water and sediment into the container.
8. Loosen ring nut (2), then remove filter case (3).
9. Remove element (4) from the separator base.
10. Wash element (4) and filter case (3) in clean diesel oil.
11. Check element (4) and replace it if it is damaged.
12. When installing element (4), perform Steps 5 and 9 in the opposite order.

Tightening torque of ring nut (2):

$40 \pm 3 \text{ N}\cdot\text{m}$ ($4.1 \pm 0.3 \text{ kgf}\cdot\text{m}$, $29.7 \pm 2.2 \text{ lbf}\cdot\text{ft}$)

13. Loosen air bleed plug (5) then Fill filter case (3) with fuel. When the fuel comes out from air bleed plug (5), tighten air bleed plug (5).

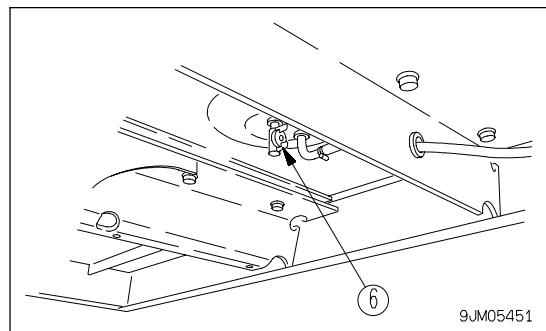
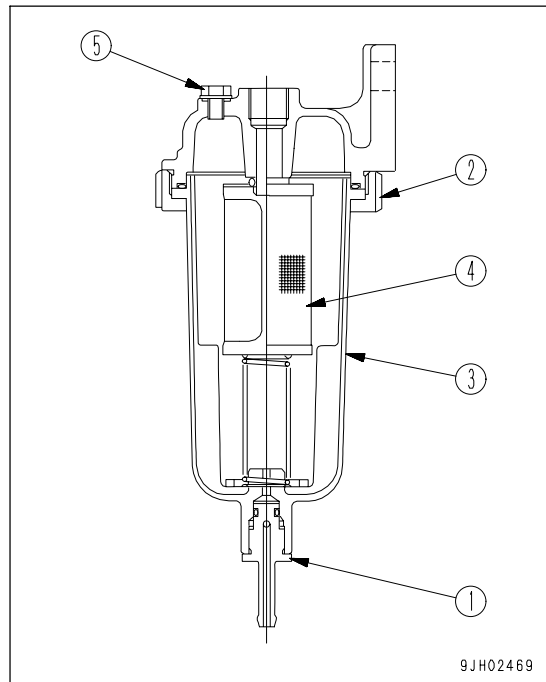

CHECK OIL LEVEL IN HYDRAULIC TANK, ADD OIL

**WARNING**

When removing the oil filler cap, oil may spurt out, so turn the cap slowly to release the internal pressure before removing the cap.

1. Check sight gauge (G) on the left side of the machine. The oil level should be between the H and L lines.

NOTICE

Do not add oil above the H line. This will damage the hydraulic circuit or cause the oil to spurt out. If oil has been added to above the H level, stop the engine and wait for the hydraulic oil to cool down, then drain the excess oil from drain plug (P).

2. If the oil level is below the L line, add oil through oil filler (F) at the top of the hydraulic tank.

REMARK

The oil level will vary depending upon the oil temperature. Accordingly, use the following as a guide:

- Before starting operation: Between H and L levels (Oil temperature 10 to 30°C (50 to 86°F))
- Normal operation: Around H level (Oil temperature 50 to 80°C (122 to 176°F))

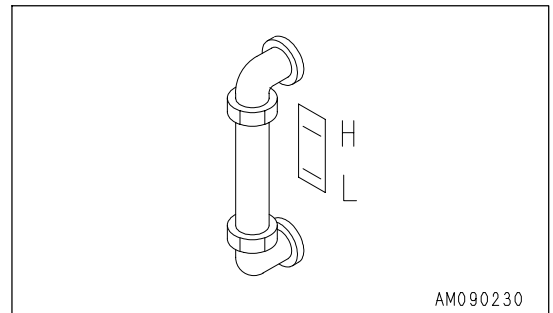
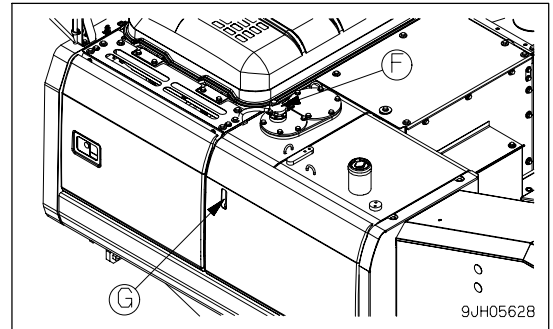

CHECK ELECTRIC WIRING

**WARNING**

- If the fuses frequently blow or if there are traces of short circuits on the electrical wiring, locate the cause immediately and carry out repairs, or contact your Komatsu distributor for repairs.
- If flammable materials (dead leaves, twigs, dry grass, etc.) accumulate around the battery, they will cause fire, so always remove such material immediately.
- Keep the top surface of the battery clean and check the breather hole in the battery cap. If it is clogged with dirt or dust, wash the battery cap to clean the breather hole.

Check for damage and improper capacity of the fuses, and any sign of disconnection or short circuit in the electric wiring. Check also for loose terminals and tighten any loosened ones.

Pay special attention to the wiring of the battery, starter and alternator, when checking.

Be sure to check that there are no piles of inflammables on and around the battery and remove them, if any.

For the checkup and repairs of troubles in the battery, consult the Komatsu distributor in your territory.

CHECK FUNCTION OF HORN

1. Turn the starting switch to the ON position.
2. Confirm that the horn sounds immediately when the horn button is pressed.
If the horn does not sound, contact your Komatsu distributor for repair.

ADJUSTMENT OF REAR VIEW MIRROR

Loosen the bolts securing the square rear view mirror (1) and those securing the round rear view mirror (2), and then adjust the mirror positions so that there will be no blind spot at the rear and left side of the machine and a better view will be available.

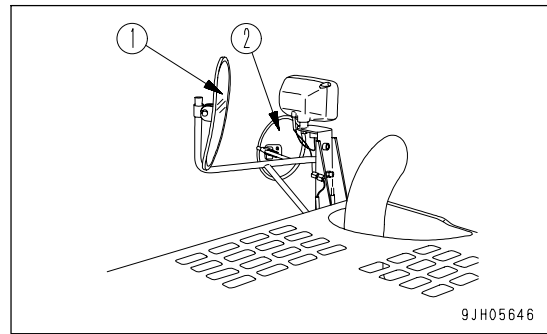

CHECK OF JAW CRUSHER

| No. | Check Item | Check Interval | | | Method | Standard Value | Corrective Measure |
|-----|-------------------------------|-------------------|--------|---------|-----------------------|-----------------------------------------------------|-------------------------------------------------------------------------------------------------------------------------------|
| | | Daily | Weekly | Monthly | | | |
| 1 | Abnormal vibration of machine | ○ | | | Visual check, Spanner | - | Stop and check. Check crusher for loosened securing bolts. |
| 2 | Abnormal noise from machine | ○ | | | Hearing check | - | Stop and check. |
| 3 | Flow of crushed debris | ○ | | | Visual check | - | Check for excessive feeding. Limit feeding amount. Adjust grizzly feeder setting amount dial and crusher charge setting dial. |
| 4 | Abnormal heating of bearings | ○ | | | Feeling check | Less than 120°C (248°F) (converted to 45°C (113°F)) | Stop and check, if temperature is abnormally high. Check greasing amount is proper. |
| 5 | Abnormal noise from bearings | ○ | | | Hearing check | None | If any abnormality is noticed, stop and check. Repair or replace. |
| 6 | Loosening of bolts | ○ | | | Spanner | No looseness | Retighten. |
| 7 | Wear of fixed jaw plate | ○ | | | Visual check | - | Reverse or replace. |
| 8 | Wear of swing jaw plate | ○ | | | Visual check | - | Reverse or replace. |
| 9 | Wear of cheek plate | ○ | | | Visual check | - | Replace. |
| 10 | Wear of protector | ○ | | | Visual check | - | Replace. |
| 11 | V-belt | Degree of tension | ○ | | Try to press by hand | - | Check tension. |
| | | Slip | ○ | | Visual check | - | Pay attention to insufficient tension and misalignment. |
| | | Wear and damage | ○ | | Visual check | - | Replace. |
| 12 | Adding grease | ○ | | | Grease pump | - | Add. |

CHECK OF PRIMARY CONVEYOR

 **WARNING**

When correcting zigzag movement of the primary conveyor, carry that out with the adjust bolts.

1. Foreign materials such as stones, gravel, wire chips, iron and steel bar chips, etc. are likely caught in various parts of the primary conveyor. Check for them inside the conveyor, between the rollers and the belt, inside the hopper rubber and the belt as well as inside the return roller guides. If found, remove them.

2. Snaking of belt

- If there is any snaking of the belt, use the procedure in diagrams (a) and (b) on the right and turn left and right adjustment bolts (1) to adjust the belt .
- If the snaking of the belt cannot be corrected simply by adjusting with the adjustment bolts (1) at the head pulley portion, the structure makes it also possible to adjust the alignment with the carrier roller bracket and return roller bracket mounting bolts, so carry out adjustment with these bolts also.

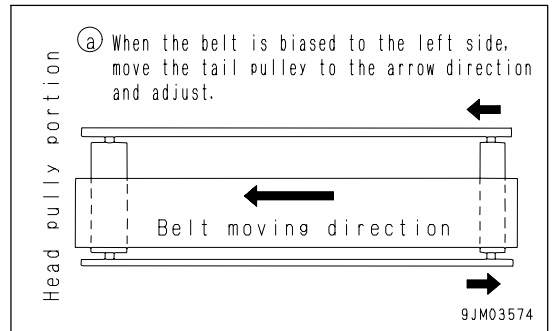

3. Check that there is no damage nor cut on the belt rubber.

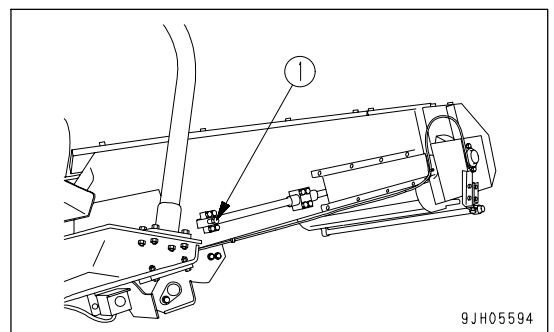
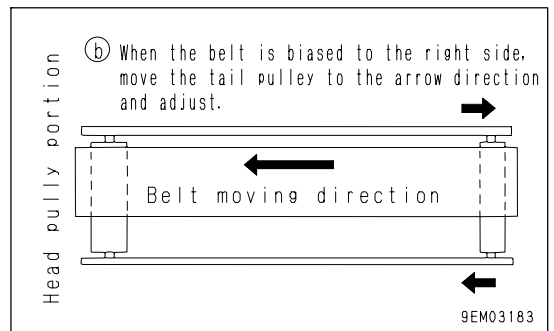

CHECK MAGNETIC SEPARATOR

**WARNING**

- There is danger that the magnetic field may cause malfunction of pacemakers, so persons wearing pacemakers should not approach within a range of 5 m (16 ft 5 in) from the magnetic separator.
- The magnetic force will attract metal tools and pieces of steel, and there is danger of getting your fingers or hands caught between such objects and the attracting surface, so do not approach the magnetic separator when carrying metal tools or pieces of steel.
- Use a steel object removal belt to remove any pieces of steel attracted to the magnetic separator. There is danger of injury, so do not approach the magnetic separator while it is being operated.
- When storing this machine or removing the magnetic separator, set up cones and make a no entry area. Do not allow any person wearing a pacemaker to approach within a range of 5 m (16 ft 5 in) from the magnetic separator.
- Before starting operations, check that there is no misalignment or snaking of the belt.
If there is any misalignment or snaking of the belt, there is danger that the belt will be damaged or cut.
- There is danger of the magnetic field causing damage, so do not bring watches, cellular phones, or other precision instruments close to the magnetic separator.
- There is danger of the stored data being damaged by the magnetic field, so do not carry bank cards, credit cards, or other cards with magnetic strips when approaching the magnetic separator.

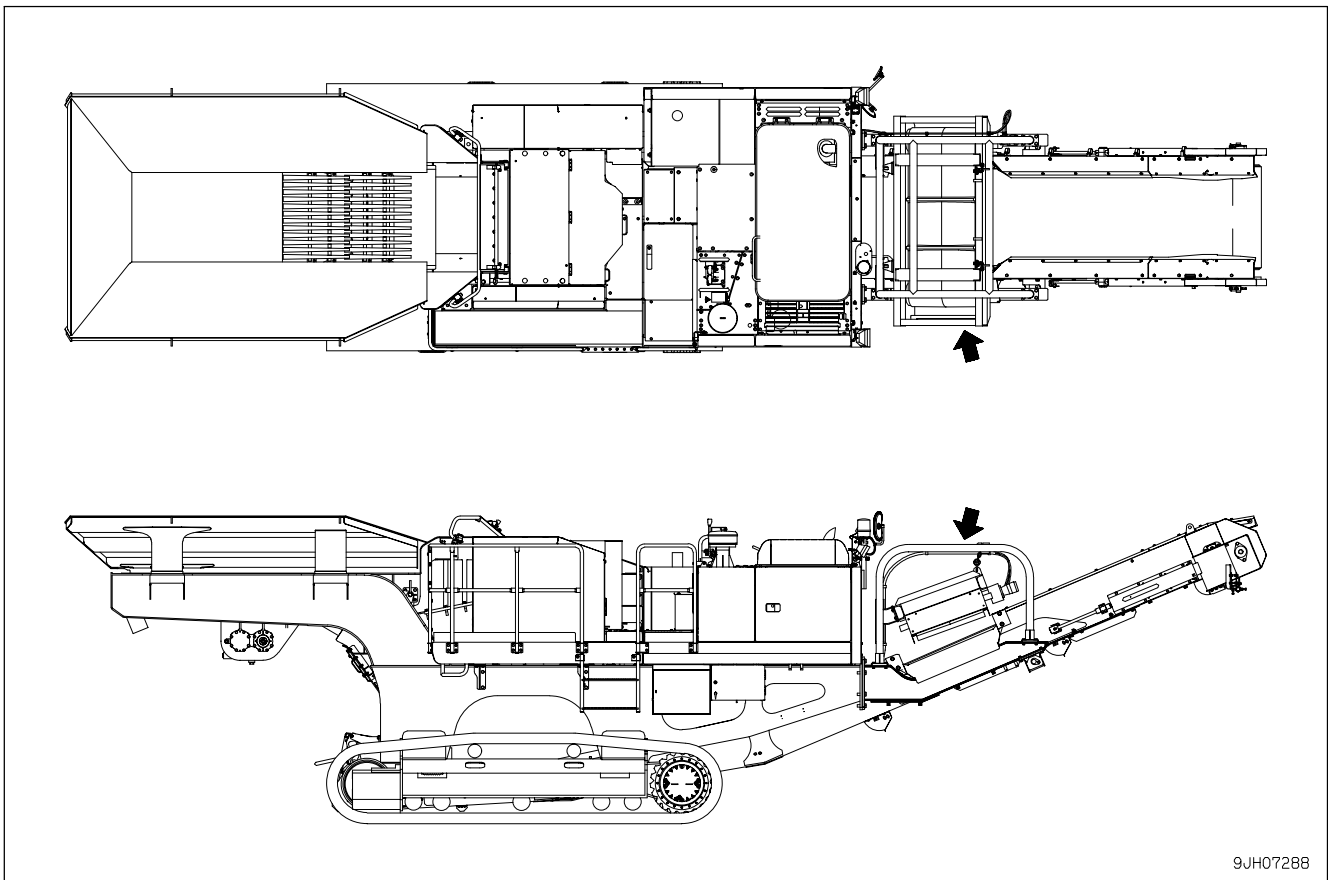

9JH07288

! CAUTION

- When conducting a trial run of the machine, be sure to run the motor at low speed and check that the conveyor belt does not make a snaky movement.
- If metal pieces are drawn by the magnetic separator, they will be ejected, accelerated by the metal piece discharging belt. As that poses a big danger, provide a safety cover at the discharging outlet to prevent the metal pieces from flying off.

The discharging belt for this machine has the same structure as that for the conventional belt conveyor. Pay attention to the following points, when starting the day's work or daily inspection.

- Has the belt been biased or does it make a snaky movement?
- Is the belt tension appropriate?
- Are debris stuck to the backside of the belt?
- Has the belt surface been scratched or peeled off?
- Has the belt scraper not been damaged?
- Have metal parts or bolts at the connection of the belt end not been damaged or fallen off?

If anything unusual is found, take the following actions.

- 1) In case the belt is deflected or makes a snaky movement; Adjust the position of the take-up unit, referring to the figure at right. The take-up unit consists of a base plate, a pillow block and a tap bolt. Loosen the lock bolt on the base plate and adjust the position of the take-up unit with the tap bolt. After the adjustment, tighten the lock bolt again. When there is a clearance more than 10 mm (0.4 in) at both ends from the inner surface of the flange at the end of the pulley, the belt is at a proper position.
- 2) In case the belt tension is not appropriate; Adjust the belt tension in the same way as mentioned above. At that time, adjust the belt so that it will have a clearance of 30 to 40 mm (1.2 to 1.6 in) from the lower surface of the magnet on the main body.
- 3) In case debris are stuck at the backside of the belt; Remove them as soon as found, since they can cause a damage on the belt or the pulley.
- 4) If the belt or any related part is broken, replace it immediately.

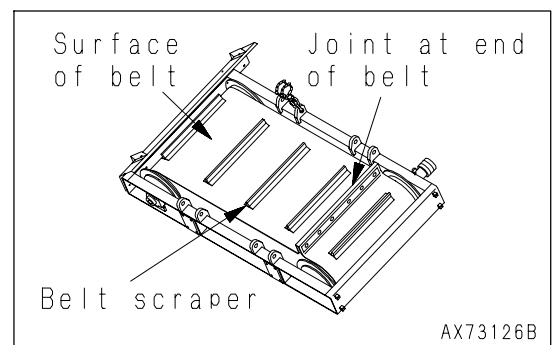
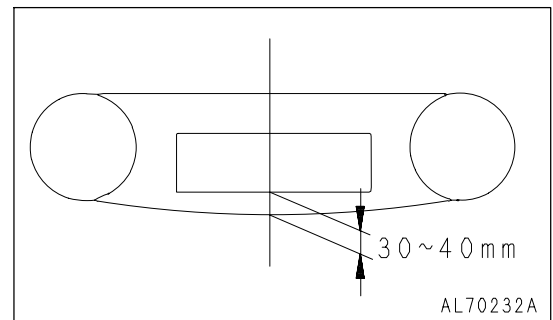
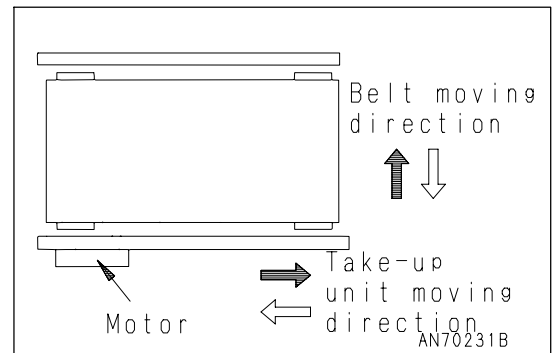

ADJUST CLEARANCE FROM CONVEYOR

- The standard clearance between V-belt surface of the belt conveyor and the magnet is (A), (B) = 350 mm (13.8 in). Change this as necessary according to the condition of the crusher discharge port clearance.

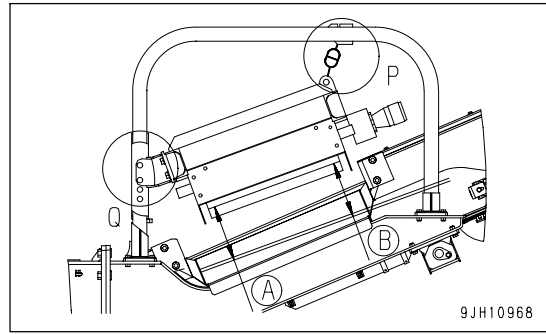

- Front (P): Change position of magnetic separator chain (1) to adjust, and fit on magnetic separator frame hook (2).
- Rear (Q): Change position of magnetic separator bracket hole (5) and magnetic separator frame hole (4) to adjust, then secure with pin (3).

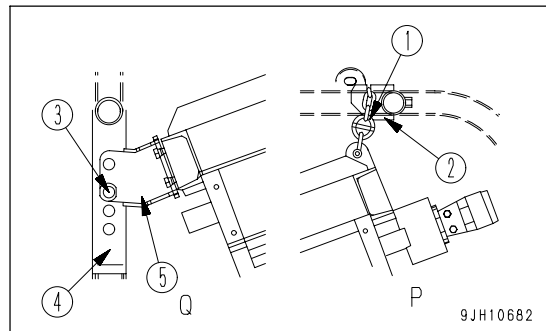
**CHECK OF GRIZZLY FEEDER****NOTICE**

Park the machine on the level and solid ground, then carry out this check.

1. Check the drive motor for oil leakage.
2. Check the grizzly bars for clogging.
3. Check that the oil level in the vibrator case is in the middle of the oil level gauge.

CHECK OF JAW CRUSHER AND RELATED ACCESSORIES

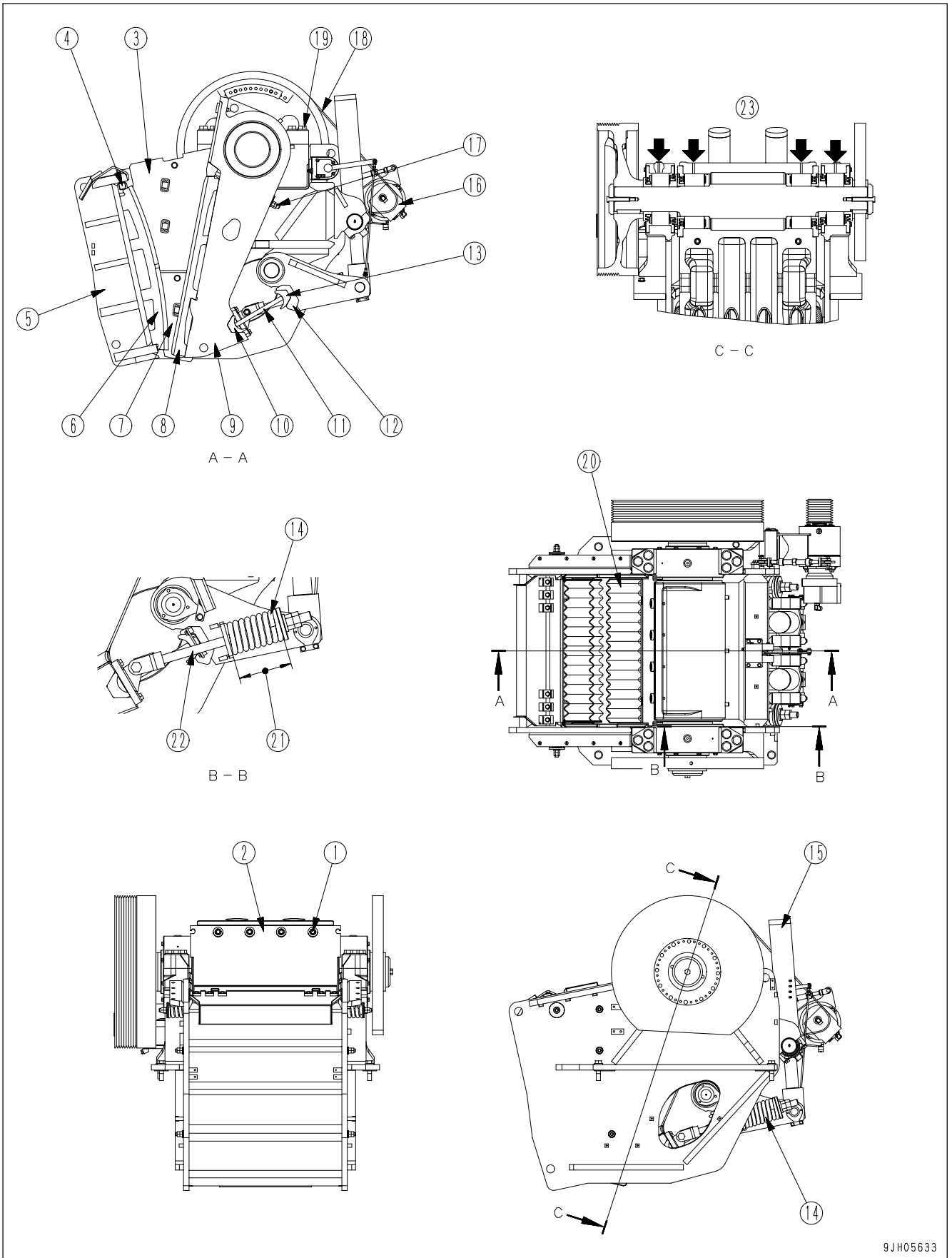

9JH05633

- (1) Protector bolt
- (2) Protector
- (3) Cheek plate
- (4) Fixed jaw plate wedge bolt
- (5) Front frame
- (6) Fixed jaw plate
- (7) Crushing chamber
- (8) Swing jaw plate
- (9) Swing jaw
- (10) Toggle seat
- (11) Toggle plate
- (12) Fixed link
- (13) Toggle seat
- (14) Tension spring
- (15) Lock cylinder
- (16) Crusher motor
- (17) Movable tooth wedge bolt
- (18) V-belt
- (19) Bearing cap tightening bolt
- (20) Swing jaw
- (21) Tension spring set length
- (22) Tension rod
- (23) Remote greasing point

- Check whether there are any foreign materials in the crusher chamber.
- Check that each bolt is tightened sufficiently.
Particularly check the main body securing bolts, toggle tension bolts of the toggle block, and wedge bolts of the fixed jaw and swing jaw with an extra care.
- Check that the crusher rotates in the right direction.
- Check that the spring set length is proper.
The right spring set length is as indicated below.

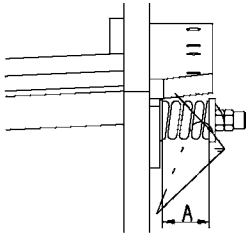
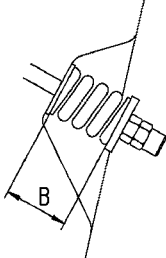
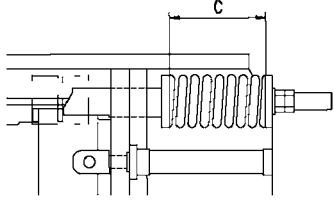
| Spring No. | A | B | C |
|-----------------|-------------------------------------------------------------------------------------|-------------------------------------------------------------------------------------|---------------------------------------------------------------------------------------|
| Part name | Fixed jaw pleate wedge bolt spring | Swing jaw plate wedge bolt spring | Tension spring (at the minimum length of lock cylinder) |
| Set length | 110 ⁰ / ₂ mm | 110 ⁰ / ₂ mm | 260 ⁰ / ₂ mm |
| Free length | 130mm | 130mm | 350mm |
| Diameter | φ 22mm | φ 22mm | φ 25mm |
| Shape of spring |  |  |  |

When measuring the tension spring set length, make sure that measurement is made at four points 90° apart from each other on the periphery and that the spring is upright.
If the actual spring set length is longer than the specified dimension by more than 3 mm (0.118 in), turn the spring to change the spring seat and tighten it again.

**CAUTION**

After receiving delivery of a new machine or after turning or replacing the teeth or other wear parts, for the first 50 hours (displayed on the service meter), the settling of mating parts may cause changes in the spring set length and the tightening torque of the nuts and bolts. Be particularly careful to carry out inspection and maintenance of these items fully.

If the tension spring set length is longer than the above dimension:

- There will be hitting between the toggle plate and toggle seat, and this will reduce the service life of the toggle plate and toggle seat.
- The toggle plate may fall out.

If the tension spring set length is shorter than the above dimension:

- There may be failures, such as breakage of the tension rod or breakage of the tension spring.

-
- Is the V-belt tension correct?

**CAUTION**

- If the belt tension is not correct, there will be slipping of the V-belt when starting and stopping the crusher, and this will cause extreme reduction in the service life of the V-belt.

Guideline for V-belt tension when carrying out check before starting

The deflection should be approx. 15 mm when 1 V-belt is pressed with a finger force of approx. 5-6 kg.

If the V-belt tension is not correct, carry out the following procedure to adjust to the specified tension.

V belt tension adjusting method

The V belt tension may be changed by adjusting the turnbuckle located behind the crusher motor. After the adjustment, be sure to tighten the lock nut.

1. Open the V-belt inspection window.
2. Adjust the turnbuckle so that tension load F for one V-belt is 63.6 to 73.6 N {6.5 to 7.5 kgf}. (When this is done, deflection δ is 15 mm (0.59 in).)
Tension load F is the average value of the measurement for the tension load for nine V-belts.
3. Start and stop the crusher 2-5 times.
4. Measure tension load F again for each V-belt, and check that the measurement is within the specified value of 48.9 to 58.9 N {5 to 6 kgf}. (When this is done, deflection δ is 15 mm.)
5. Close the V-belt inspection window.
6. Start the engine and turn the fuel control dial to the MAX position.

Next, start and stop the crusher and check that there is no slipping sound from the V-belt. If the V-belt slips, it emits a loud noise.

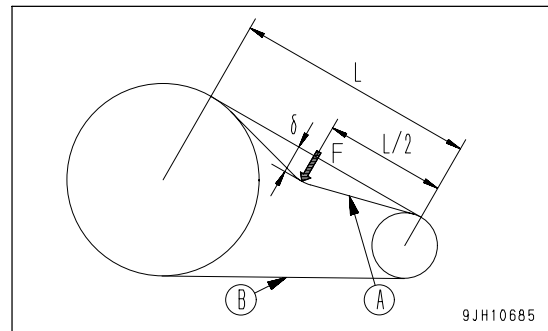

REMARK

There may be a difference in the V-belt tension between the top (A) and bottom (B). Repeat Steps 2 and 3 to adjust the belt tension, and start and stop the crusher 2 to 5 times to remove the difference in tension between the top and bottom, then carry out Step 4 to check the tension.

CAUTION

A feature of the V-belt is that the V-belt tension may drop greatly in the first 4 to 8 hours of operation, so after the first 4 to 8 hours of operation, repeat the procedure in "METHOD FOR ADJUSTING V-BELT TENSION" to adjust the V-belt tension.

OPERATION AND CHECK BEFORE STARTING ENGINE

WARNING

A careless touch on the travel control lever may start the machine all of sudden.

Before leaving the operator's platform, be sure to set the operation mode selector switch to the "OPERATION" position.

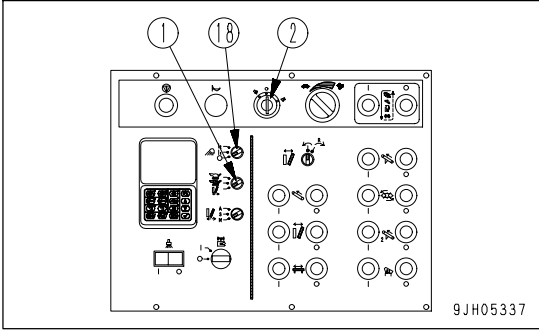

1. Check that mode selector switch (1) is at work position (b).
2. Check that the main control box, top control box, and the emergency stop switches on the left and right of the machine (total: 6 places) have been canceled.

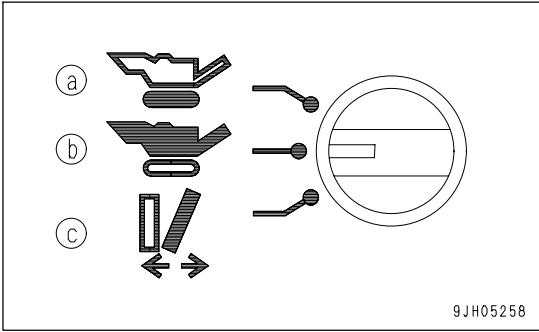

3. Turn lamp switch (18) and check that the headlamps, working lamps, and panel lamps light up. If they do not light up, there is probably a blown bulb or disconnection, so ask your Komatsu distributor to carry out repairs.

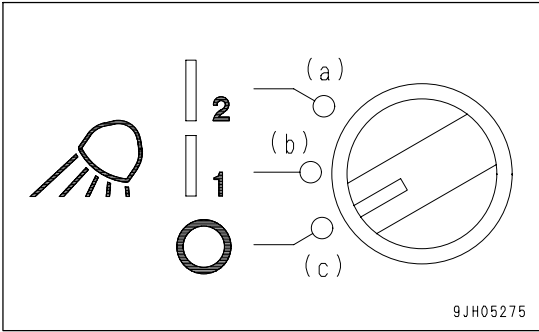

4. Insert key into starting switch (2), turn the key to ON position (B), then perform the following checks.

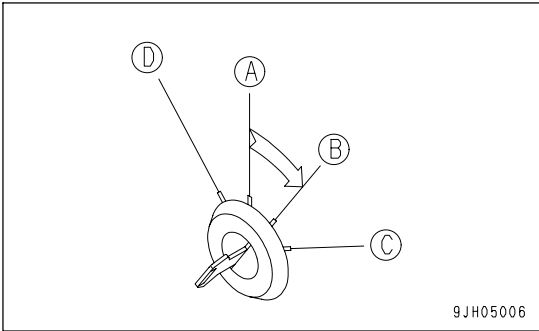

- If a password has been set, the input display screen is shown on the monitor screen.
After inputting the password, press input confirmation switch

REMARK

For details of the method of setting, changing, or canceling the password, see separate "PROCEDURE FOR SETTING, CHANGING, OR CANCELING PASSWORD".

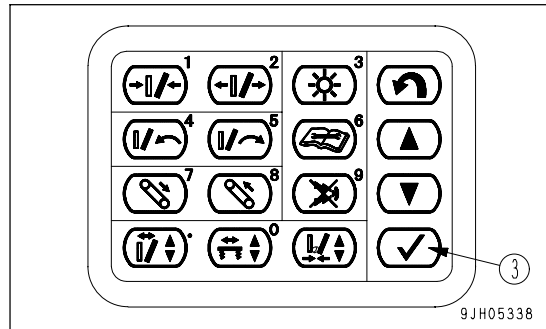
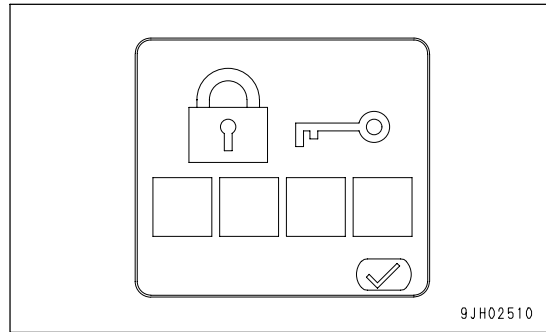

1) The buzzer sounds for approx. 1 second, then the monitors and meters light up for approx. 3 seconds. Rotating display lamp (19) also lights up for 2 seconds.

- Radiator coolant level monitor (4)
- Engine oil level monitor (5)
- Battery charge monitor (6)
- Fuel level monitor (7)
- Engine coolant temperature monitor (8)
- Engine oil pressure monitor (9)
- Engine coolant temperature gauge (10)
- Fuel gauge (11)
- Air cleaner clogging monitor (12)

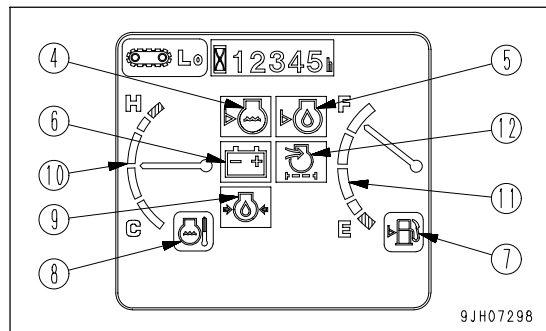

If the monitor does not light up or the buzzer does not sound, the monitor is probably broken, so ask your Komatsu distributor to carry out repairs.

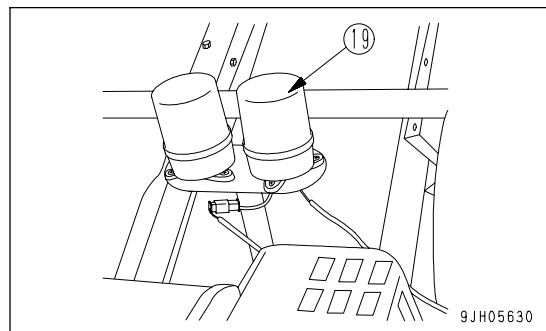

2) After approx. 3 seconds, the screen switches to the normal screen.

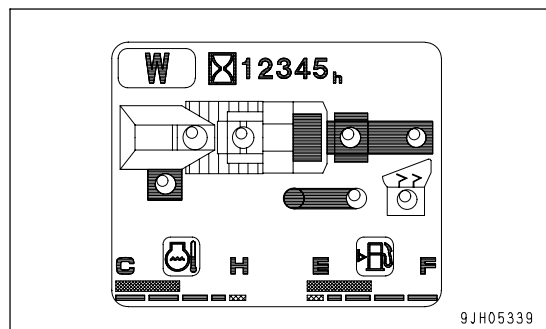

- 3) If the normal screen switches and caution lamp (15) stays lighted up red, carry out inspection immediately of the item where the red lamp is lighted up.

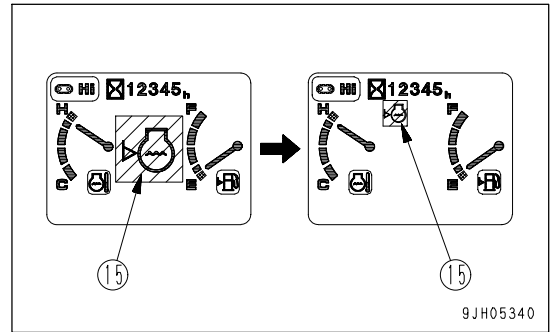

- 4) If there are any items where the maintenance time has passed, maintenance interval monitor (16) lights up for 30 seconds. Press maintenance switch (17), check the item, then perform maintenance immediately.

For details of the method of checking the maintenance time, see the explanation for each component in "MAINTENANCE SCREEN SELECTOR SWITCH (PAGE 3-25)".

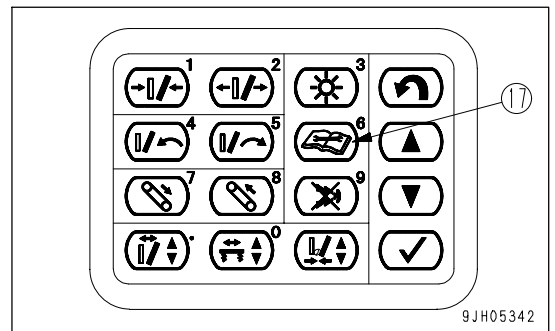
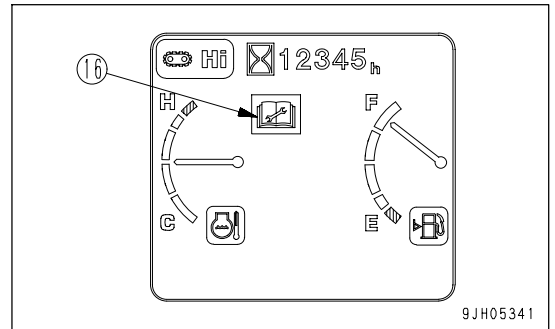

STARTING ENGINE

NORMAL STARTING

WARNING

- Do not short circuit the starting circuit to start the engine. This may cause serious personal injury or fire.
- Check that there is no person or obstacle in the surrounding area, then sound the horn and start the engine.
- Exhaust gas is toxic. When starting the engine in confined places, be careful to ensure ample ventilation.
- There is danger of explosion if a starting aid fluid is used when starting the engine. Never use any starting aid fluid.

NOTICE

- Before starting the engine, check that the fuel control dial is at the low idling (MIN) position.
- Do not crank the starting motor continuously for more than 20 seconds. If the engine does not start, wait for at least 2 minutes before trying again.

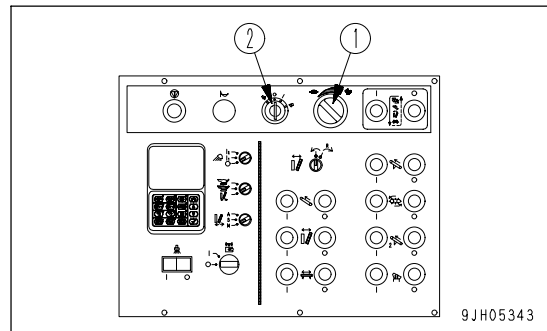

1. Turn fuel control dial (1) to the left to the low idling position (a).

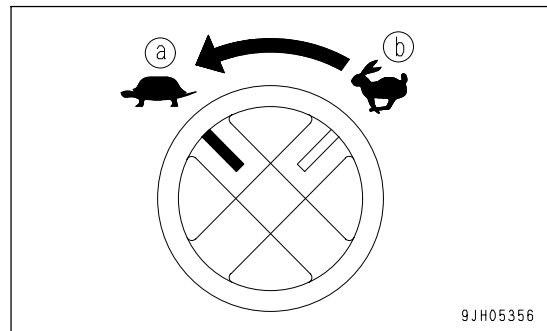

2. Turn starting switch (2) to START position (C) to start the engine.

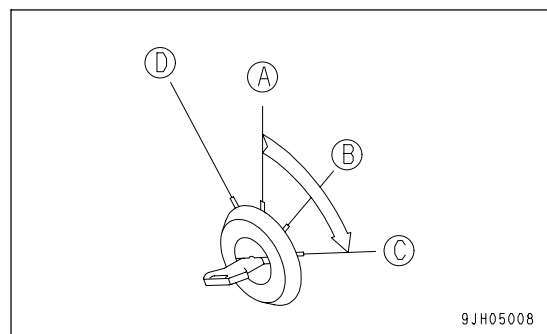

3. After starting the engine, release the key in starting switch (2).
The key will automatically return to ON position (B).

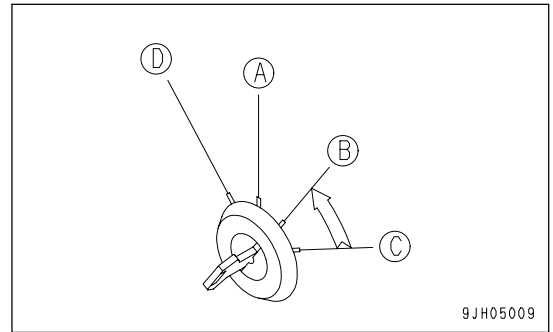

4. If the engine oil pressure monitor stays lighted up even after the engine has started, do not touch the work equipment starting switch or travel levers.

NOTICE

If the engine oil pressure monitor does not go out even after 4 to 5 seconds have passed, stop the engine immediately. Check the oil level, check for leakage of oil, and take the necessary action.

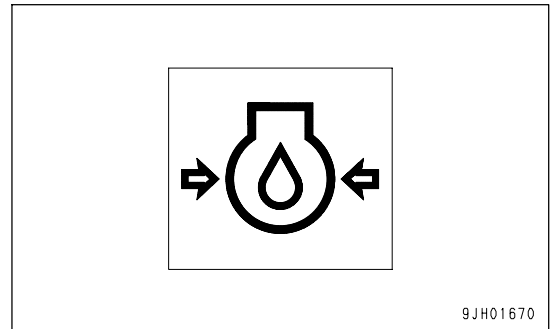

STARTING IN COLD WEATHER

WARNING

- Do not short circuit the starting circuit to start the engine. This may cause serious personal injury or fire.
- Check that there is no person or obstacle in the surrounding area, then sound the horn and start the engine.
- Exhaust gas is toxic. When starting the engine in confined places, be careful to ensure ample ventilation.
- There is danger of explosion if a starting aid fluid is used when starting the engine. Never use any starting aid fluid.

NOTICE

Before starting the engine, check that the fuel control dial is at the low idling (MIN) position.

Do not crank the starting motor continuously for more than 20 seconds.

If the engine does not start, wait for at least 2 minutes, then repeat the operation from Step 2 again.

When starting the engine in cold temperatures, do as follows.

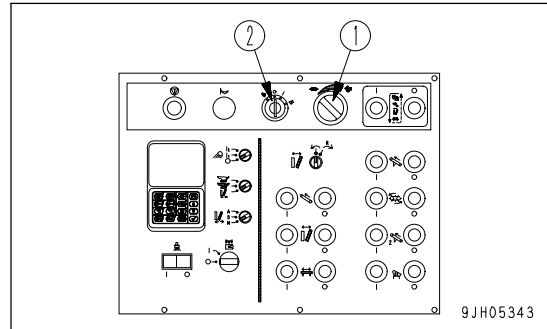

1. Turn fuel control dial (1) to the left to the low idling position (a).

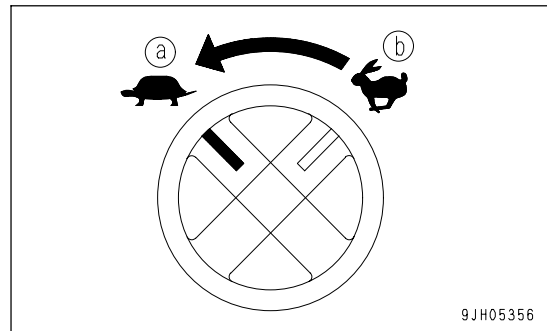

2. Hold the key in starting switch (2) at the HEAT (pre-heating) (D) position and check that engine pre-heating monitor (3) is lighted up. After approx. 18 seconds, engine pre-heating monitor (3) will flash to inform the operator that pre-heating has been completed.

REMARK

- The monitors and gauges will light up also when the key is turned to the HEAT position, but this is not a problem.
- If the temperature is low, the monitor screen may become dark or it may take time for the display to appear, but this is not a problem.

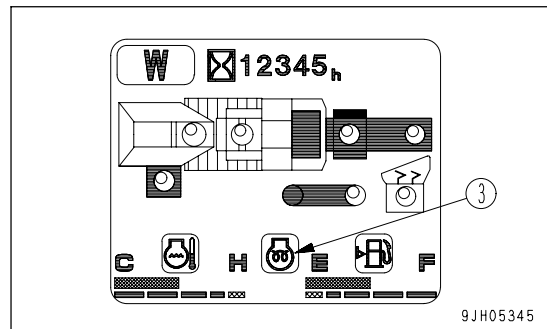
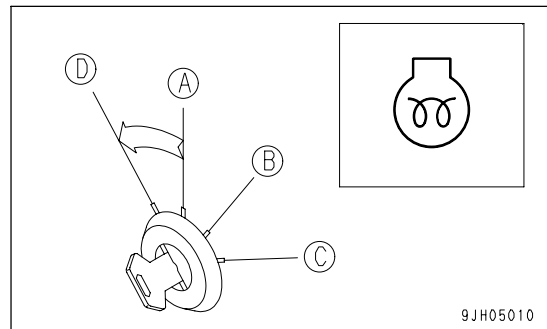

3. When engine pre-heating monitor (3) flashes, turn the key in starting switch (2) to START position (C) to start the engine.

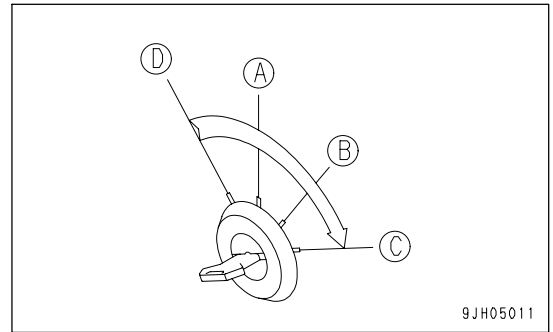

4. After starting the engine, release the key in starting switch (2). The key will automatically return to ON position (B).

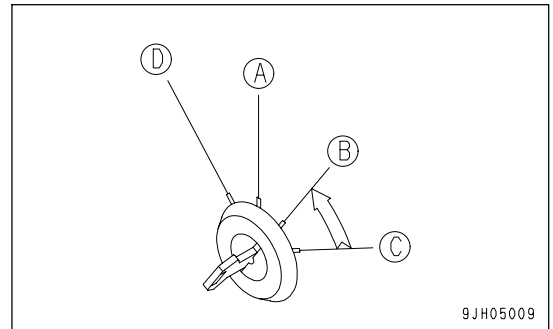

5. If the engine oil pressure monitor stays lighted up even after the engine has started, do not start the work equipment.

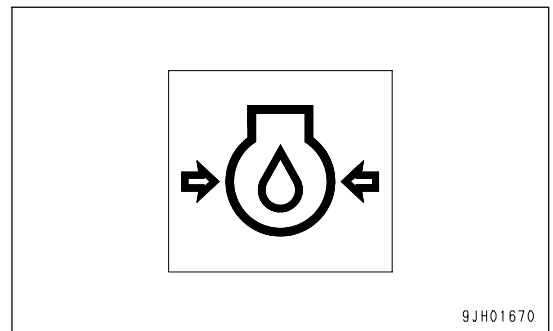

OPERATIONS AND CHECKS AFTER STARTING ENGINE

WARMING UP OPERATIONS



WARNING

- **Emergency stop**
When a failure or something unusual takes place on the machine, turn the starting switch key to the OFF position, and the electrical system ceases to function and the engine stops. Then ask the Komatsu distributor in your territory for the inspection.
- If you try to operate the work equipment without sufficient machine warming-up, the work equipment may respond to an activated control lever or switch only slowly, or move against the operator's intention, or an automated operation does not function properly. Hence be sure to warm up the machine prior to starting the work. This particularly applies to the cold start, which requires sufficient machine warming-up.

NOTICE

- The hydraulic oil temperature is normal at 50 to 80°C (122 to 176°F). Even if it becomes unavoidable to operate the machine with low hydraulic oil temperature, wait until the hydraulic oil temperature rises up to approx. 20°C (68°F) before starting with work. That practice helps extend the machine life.
- Avoid a jerky operation of control levers and work equipment with the hydraulic oil temperature lower than 20°C (68°F).
- Do not accelerate the engine suddenly until the warming-up run is finished. Moreover, do not run the engine at low idling (low running speed) or at high idling (high running speed) for more than 20 minutes. Such practice not only affects the environment adversely, but also can cause trouble to the internal mechanism of turbocharger and engine. In case that idling the engine is required, run the engine at medium speed from time to time, which applies load to the engine.

REMARK

- If the engine coolant temperature is above 30°C (86°F), to protect the turbocharger, the engine speed does not rise for 2 seconds after starting, even if the fuel control dial is turned.
- If the hydraulic oil temperature is low, the hydraulic oil temperature monitor display will be white.

After starting the engine, do not immediately start operations. First, perform the following operations and checks.

1. Turn fuel control dial (1) to position (c) midway between the low idling and full positions, set the engine to a mid-range speed, and run under no load for approx. 5 minutes.

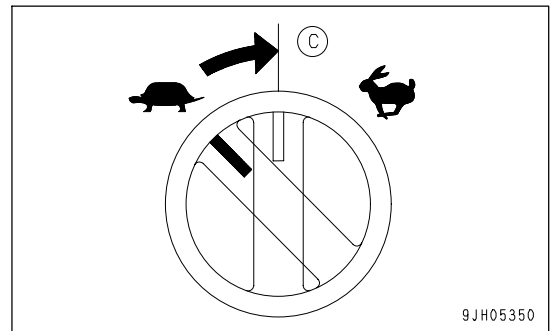
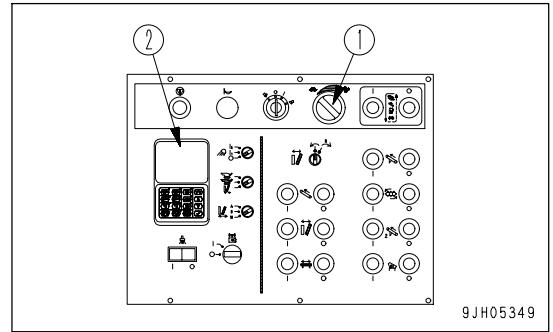

2. After completing the warming-up operation, check that the caution lamps and gauges on machine monitor (2) are in the following condition.

- Radiator coolant level monitor (3): Is monitor out?
- Engine oil level monitor (4): Is monitor out?
- Battery charge monitor (5): Is monitor out?
- Fuel level monitor (6): Is green color displayed?
- Engine coolant temperature monitor (7): Is green color displayed?
- Engine oil pressure monitor (8): Is monitor out?
- Engine coolant temperature gauge (9): Is indicator in black range?
- Fuel gauge (10): Is indicator in black range?
- Engine pre-heating monitor (11): Is monitor out?
- Air cleaner clogging monitor (12): OFF

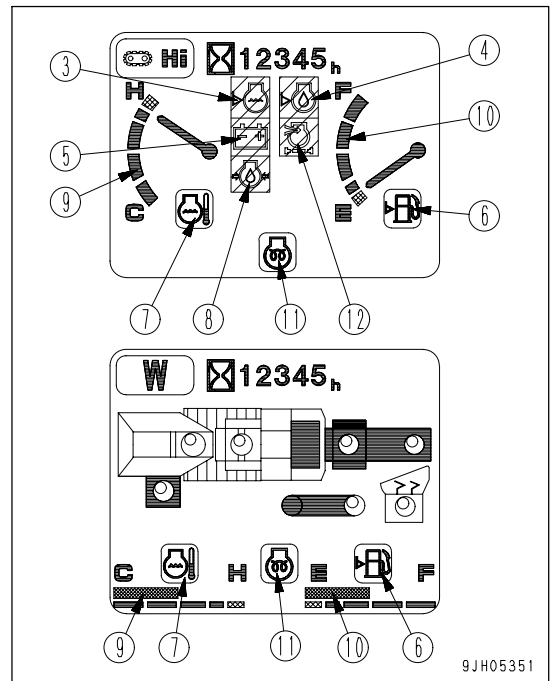

3. Check for abnormal exhaust gas color, noise, or vibration. If any problem is found, contact your Komatsu distributor.

4. If air cleaner clogging monitor (12) is lighted up, clean or replace the element immediately.

For details of the method of cleaning the element, see "CHECK, CLEAN AND REPLACE AIR CLEANER ELEMENT (PAGE 4-23)".

WARMING-UP OPERATION IN COLD WEATHER

(AUTOMATIC WARMING-UP OPERATION)

This machine is equipped with an automatic warming-up device.

When the engine is started, if the engine coolant temperature is low (below 30 °C (86 °F)), the warming-up operation is carried out automatically.

The automatic warming-up operation is canceled if the engine coolant temperature reaches the specified temperature (30 °C (86 °F)) or if the warming-up operation is continued for 10 minutes. If the engine coolant temperature or hydraulic oil temperature are low after the automatic warming-up operation, warm the engine up further as follows.

NOTICE

- Do not accelerate the engine suddenly before the warming-up operation is completed.
Do not run the engine at low idling or high idling for more than 20 minutes. This may cause oil leakage from the turbocharger oil supply pipe. If it is necessary to run the engine at idling for more than 20 minutes, apply a load or run at a mid-range speed from time to time.
- Do not carry out operations while the hydraulic oil is still at low temperature. Always continue the warming-up operation until the hydraulic oil temperature monitor display is green.

1. After the warming-up operation is completed, check that each gauge and monitor lamp is in the following condition:

- Radiator coolant level monitor (1): Is monitor out?
- Engine oil level monitor (2): Is monitor out?
- Battery charge monitor (3): Is monitor out?
- Fuel level monitor (4): Is green color displayed?
- Engine coolant temperature monitor (5): Is green color displayed?
- Engine oil pressure monitor (6): Is monitor out?
- Engine coolant temperature gauge (7): Is indicator in black range?
- Fuel gauge (8): Is indicator in black range?
- Engine pre-heating monitor (9): Is monitor out?
- Air cleaner clogging monitor (10): Is monitor out?

2. Check for abnormal exhaust gas color, noise, or vibration. If any problem is found, contact your Komatsu distributor.

3. If air cleaner clogging monitor (10) is lighted up, clean or replace the element immediately.

For details of the method of cleaning the element, see "CHECK, CLEAN AND REPLACE AIR CLEANER ELEMENT (PAGE 4-23)".

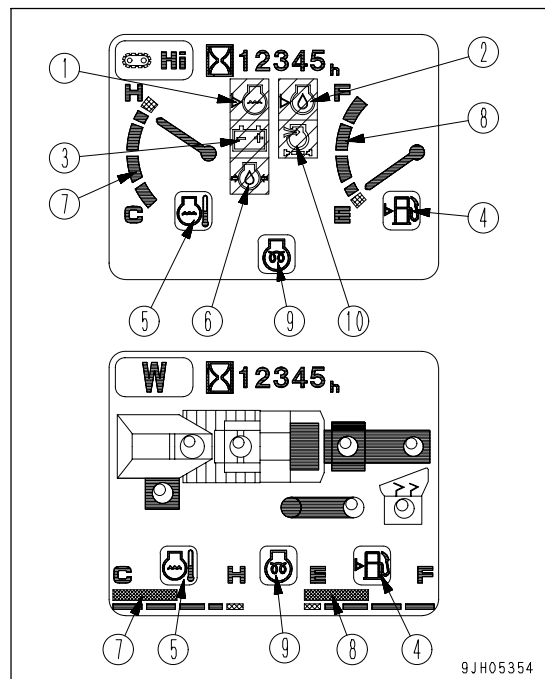

NOTICE

Canceling automatic warm-up operation

If it becomes necessary in an emergency to cancel the automatic warm-up operation or to lower the engine speed to low idle, do as follows.

- 1] Set the fuel control dial to FULL position (b) and hold for 3 seconds.

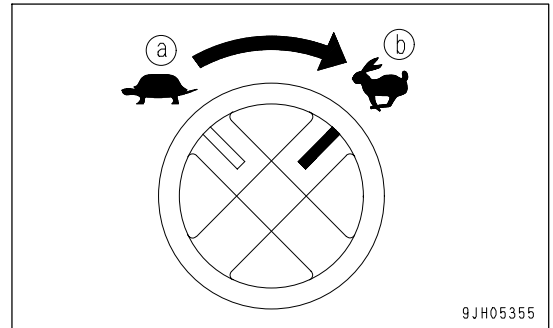

- 2] When the fuel control dial is set to low idling position (a), the engine speed drops.

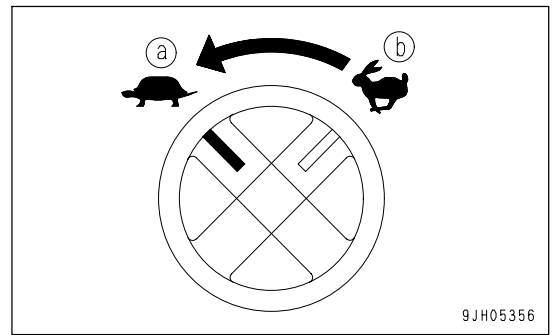
**PROCEDURE FOR OPERATING WORK EQUIPMENT IN COLD WEATHER**

NOTICE

Do not carry out operations when the engine coolant temperature and hydraulic oil temperature are low. Always switch the machine monitor to the travel motor monitor and carry out the warming-up operation until the engine coolant temperature monitor and hydraulic oil temperature monitor light up green.

1. In cold weather, always run the engine under no load at a mid-range speed for at least 15 minutes.
2. After warming up the engine, warm up the work equipment as follows.
 - 1) Set the crusher speed to the maximum rotation speed and run under no load for 1 minute.
 - 2) With the crusher running under no load, press the starting switch of the primary conveyor (magnetic separator) and run the primary conveyor (magnetic separator) under no load for 1 minute.
 - 3) With the crusher and primary conveyor (magnetic separator) running under no load, press the starting switch of the grizzly feeder and operate the crusher, primary conveyor, magnetic separator, and grizzly feeder under no load for at least 30 minutes.
3. After warming up the engine and work equipment, start the crusher operations.

NOTICE

If the movement of the cylinder is slow when adjusting the crusher clearance, retract the cylinder fully and keep crusher clearance expansion switch (7) pressed for at least 30 seconds.

After carrying out the above operation, carry out adjustments related to the crusher discharge clearance.

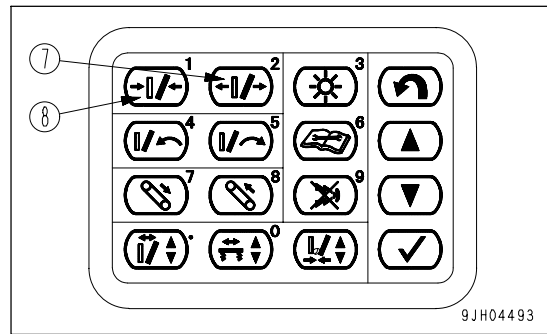

STOPPING ENGINE



WARNING

Do not stop the engine suddenly except in case of emergency, before it cools down. Otherwise durability of the engine components may be shortened. Sudden stop of the engine should be limited only to a case emergency.

Let the engine cool down gradually after the work and stop it thereafter.

1. Set the fuel control dial to low idling position (a).
2. Run the engine at low idle for about 5 minutes to cool down gradually.

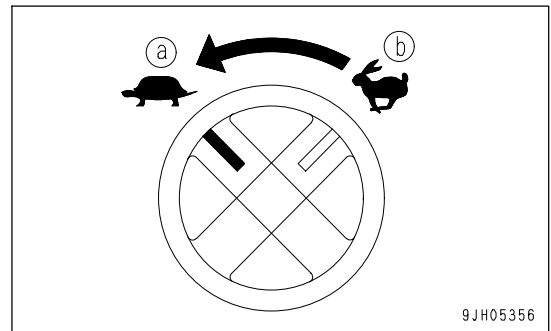

3. Turn the key in starting switch (1) to the OFF position (A) and stop the engine.
4. Remove the key from starting switch (1).

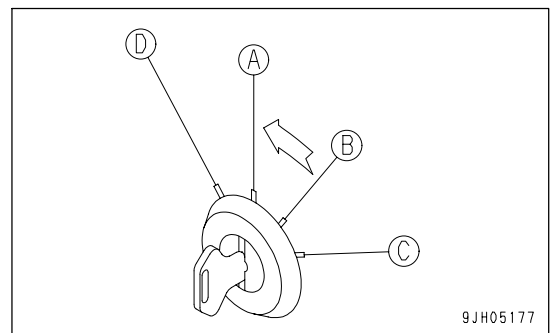

REMARK

- When the engine is overheated, do not stop it on the spot, but allow it to cool down gradually while running at a medium speed, and then stop it.
- If it is required to start the engine again, start it after approx. 30 seconds.

CHECK AFTER STOPPING ENGINE

1. Walk around the undercarriage, crusher, belt conveyor and machine covers to check for oil and water leakage. If any leakage or abnormality is found, fix it.
2. Fill the fuel tank.
3. Check the engine compartment for paper and debris. Clean out any paper and debris to avoid a fire hazard.
4. Remove any mud affixed to the undercarriage.

REMARK

If the switch is turned to ON or START within approx. 10 seconds after stopping the engine, the monitor display is not reset and the previous screen is displayed.

MACHINE OPERATION

**WARNING**

- When moving the machine, confirm the safety around and sound a horn.
- Do not allow people to come near the machine.
- Remove obstacles from the machine's traveling course.
- Support and steady yourself by holding to the travel control lever with one hand and the handrail with the other. If you push the travel control lever forward or pull it back toward yourself abruptly, the machine makes a jerky movement, giving a shock to you. Since that is dangerous, operate the travel control lever slowly and with good time allowance.

TRAVEL PREPARATIONS FOR PRIMARY CONVEYOR

Raise the primary conveyor as follows.

1. Start the engine.
2. Set conveyor selector switch (1) on the conveyor up/down control panel to CONVEYOR (a).

(Only for machines equipped with muck discharge conveyor.)

3. Press conveyor UP switch (2) and remove the conveyor from the mount hook.

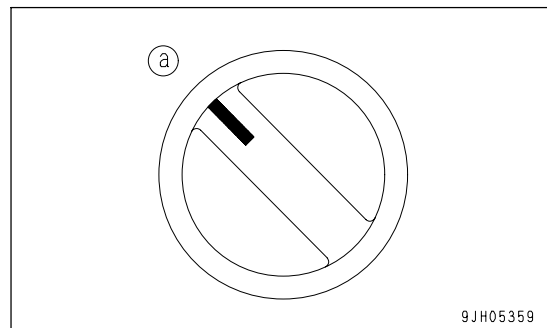
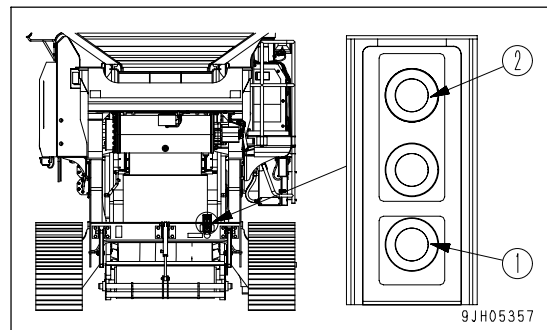

4. Using the conveyor up/down control switch, set the mount hook to fixed position (3) for travel.

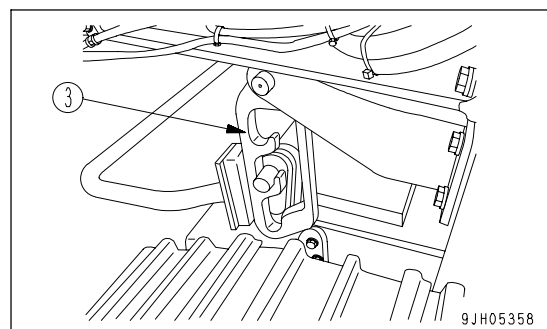

TRAVEL PREPARATIONS FOR MUCK DISCHARGE CONVEYOR

Bend the muck discharge conveyor (if equipped) as follows.

1. Remove lock bolt (1) for the conveyor center side cover, then raise (bend) the side cover.
(M12 x 2)

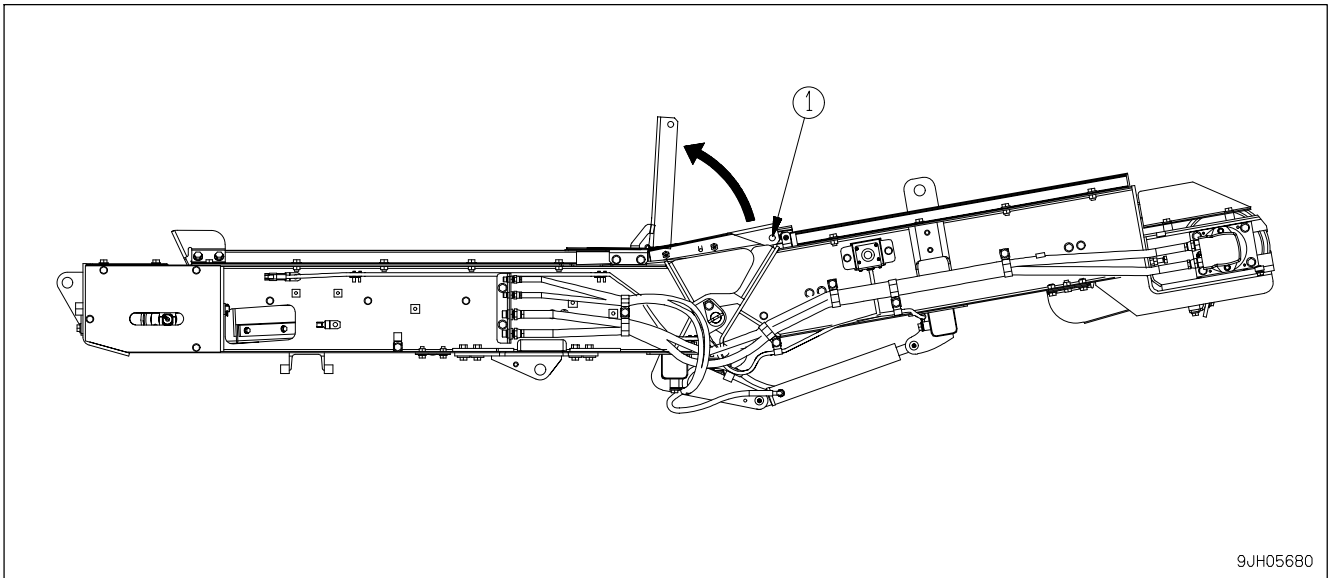

2. Start the engine.
3. Set conveyor selector switch (1) on the conveyor up/down control panel to MUCK DISCHARGE CONVEYOR (b).
4. Press muck discharge conveyor UP switch (3) and fold the conveyor.

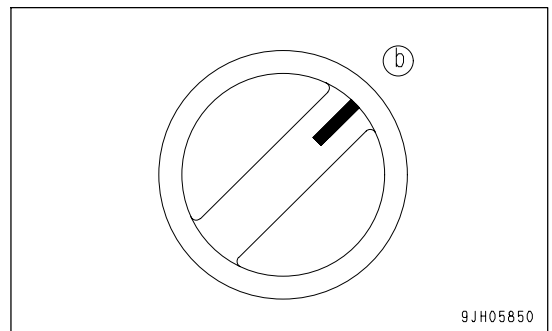
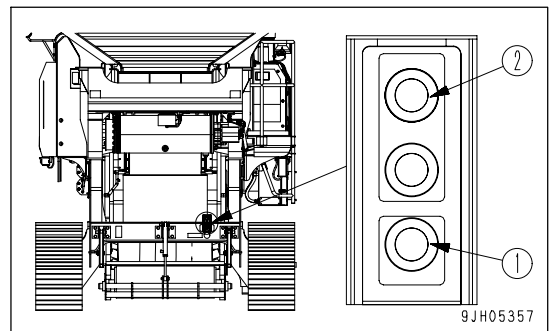

5. Insert pin (4) in the travel lock bracket to fix the conveyor in position.

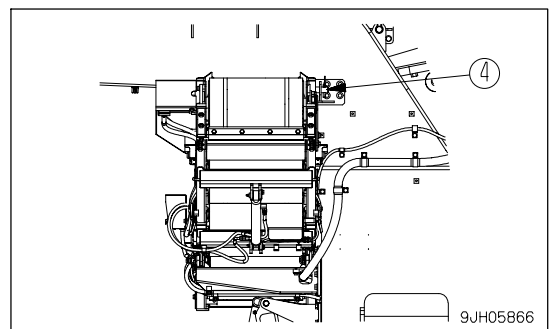

MOVING MACHINE

1. Set mode selector switch (1) to the TRAVEL position (a).

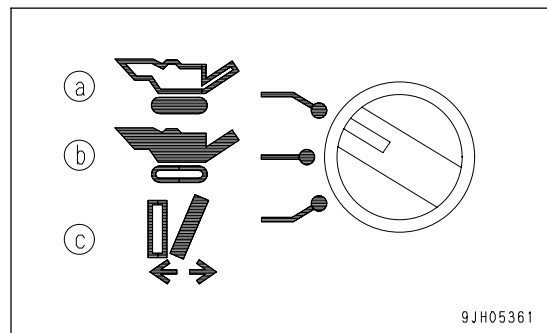
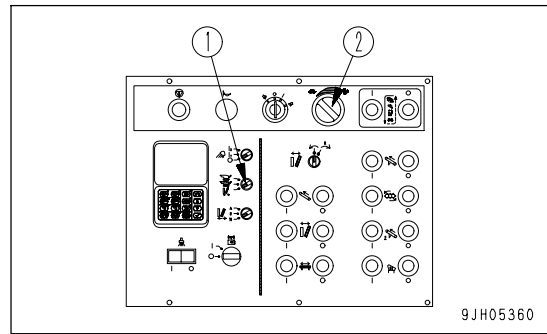

2. Turn fuel control dial (2) in the FULL direction (b) and raise the engine speed.

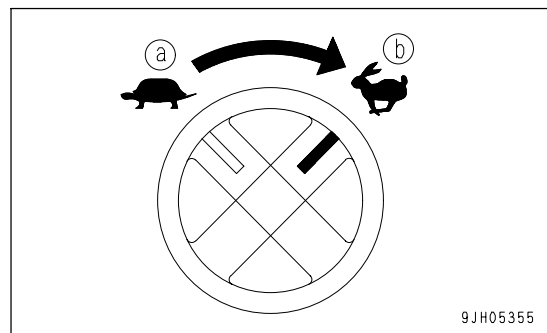

3. Set travel speed selector switch (3) to the desired position.

Position (a): Low-speed travel

Position (b): High-speed travel

4. Release travel lever lock (4).

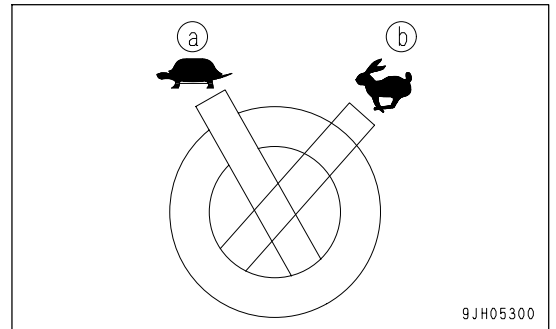
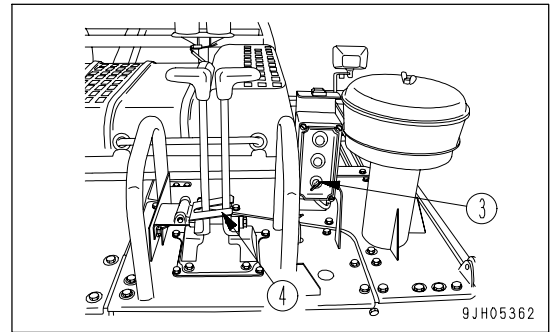

MOVING MACHINE FORWARD

1. Operate the left and the right travel levers as follows.
 - Tilt the lever slowly forward to move the machine off.

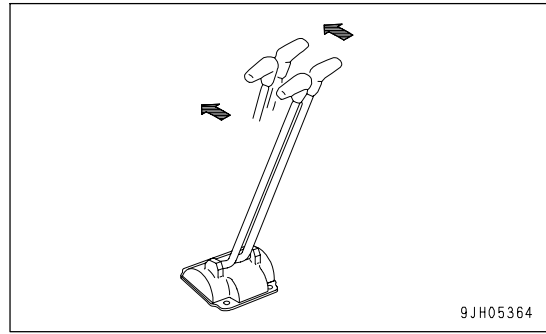

MOVING MACHINE BACKWARD

1. Operate the left and right travel levers as follows.
 - Tilt the lever slowly back to move the machine off.

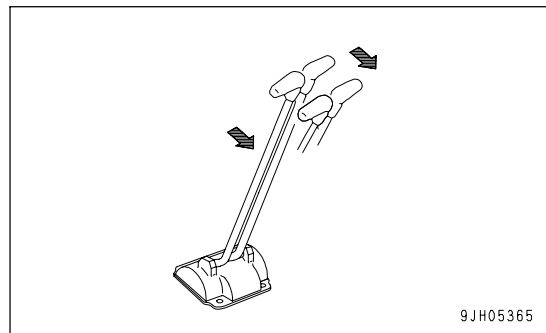

REMARK

- In cold temperatures, if the travel speed is not normal, carry out the warming-up operation thoroughly. In addition, if the undercarriage is clogged with soil or mud and the travel speed is not normal, clean off the soil and mud.
- Check that the travel alarm sounds.

STOPPING MACHINE

 **WARNING**

- If the travel levers are touched by accident, the machine may suddenly move and cause a serious accident. When leaving the machine, always set the mode selector switch to the WORK or INSPECTION position.
- Avoid stopping the machine suddenly: always leave as much room as possible when stopping.
- When parking the machine, always apply the safety lock to the travel levers and turn the lock switch ON.

1. Put the left and right travel levers (1) in the neutral position, then stop the machine.
2. Set the travel lever lock securely to the LOCK position.

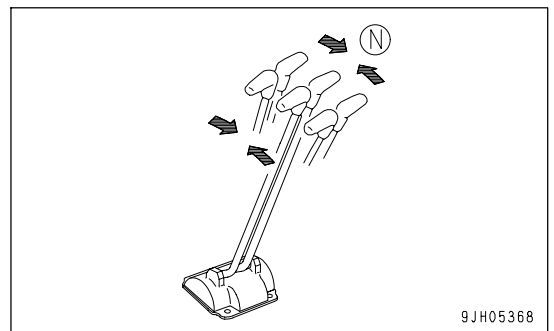
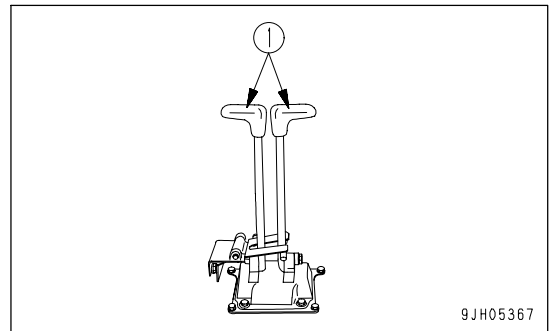

3. Set mode selector switch (2) to the WORK position (b) or INSPECTION position (c).

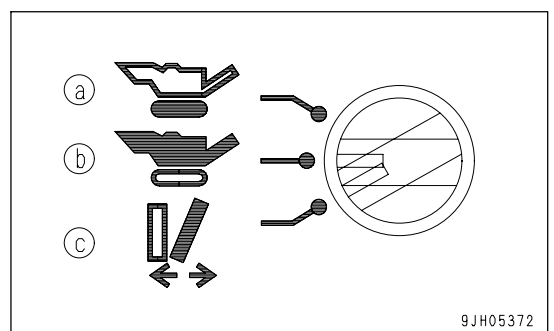
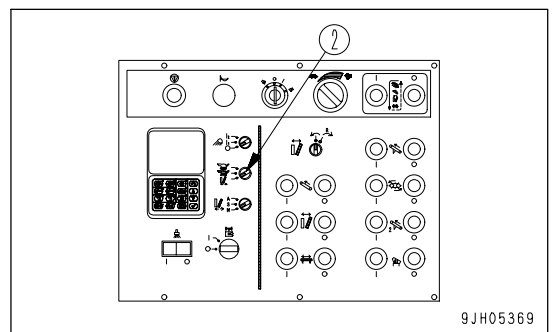

STEERING MACHINE

STEERING (CHANGING DIRECTION)



WARNING

When the machine makes a turn, while traveling, you will be swayed to the right or left, so hold to the handrail with one hand to steady yourself and make a turn.

Use the travel levers to change direction.

Avoid sudden changes of direction as much as possible. Especially when performing counter-rotation (spin turn), stop the machine before turning.

Operate two travel levers (1) as follows.

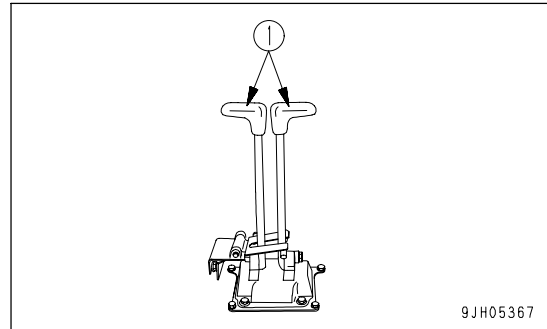

9JH05367

CHANGING DIRECTION OF MACHINE WHEN STOPPED

When turning to the left:

Push the right travel lever forward to turn to the left when traveling forward; and pull it back to turn left when traveling in reverse.

(A): Forward left turn

(B): Reverse left turn

REMARK

When turning to the right, operate the left travel lever in the same way.

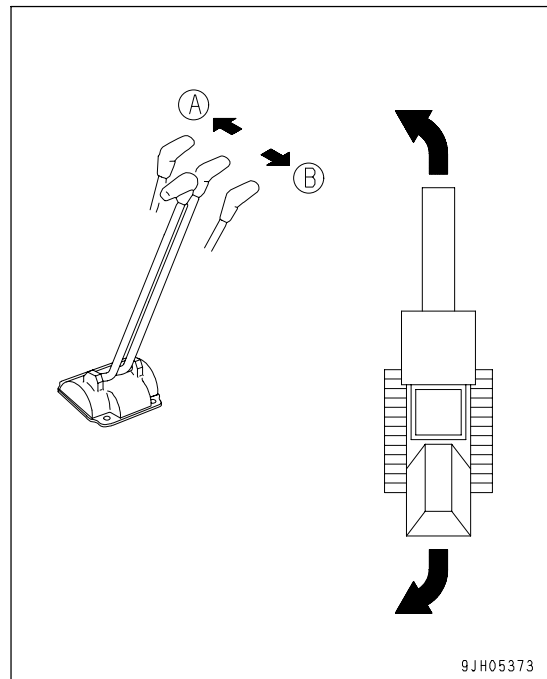

9JH05373

STEERING WHEN TRAVELING (BOTH LEFT AND RIGHT TRAVEL LEVERS OPERATED IN SAME DIRECTION)

When turning to the left:

If the left travel lever is returned to the neutral position, the machine will turn to the left.

(A): Forward left turn

(B): Reverse left turn

REMARK

When turning to the right, operate the right travel lever in the same way.

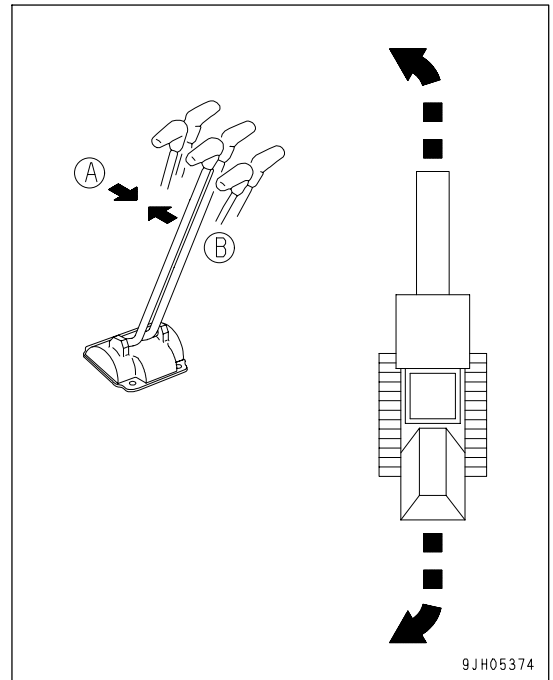

WHEN MAKING COUNTER-ROTATION TURN (SPIN TURN)

When using counter-rotation (spin turn) to turn left, pull the left travel lever back and push the right travel lever forward.

REMARK

When using counter-rotation to turn right, pull the right travel lever back and push the left travel lever forward.

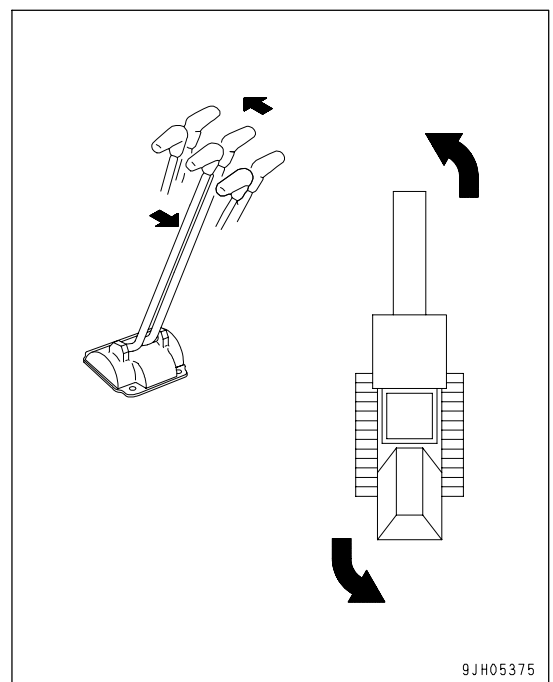

OPERATION OF WORK EQUIPMENT

WARNING

- When starting operations, set the machine on horizontal ground and carry out operations.
- To prevent abnormal vibration during operations, check that the outermost lower wheels (4 places) are firmly in contact with the ground.
- If any abnormality occurs, press the emergency stop switch.
The buzzer will sound, and the crusher, grizzly feeder, conveyor, magnetic separator, and other options (muck discharge conveyor, secondary conveyor, vibratory sieve) will stop.

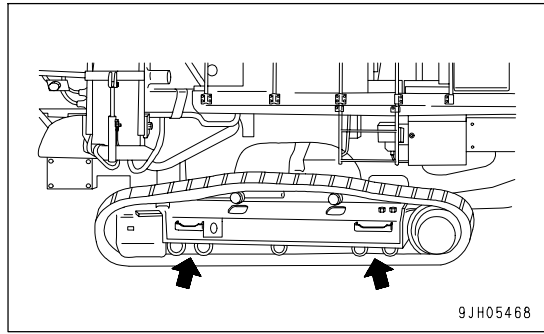

PREPARATIONS FOR PRIMARY CONVEYOR

When lowering the primary conveyor, use the opposite procedure from the operation to raise the primary conveyor.

1. Start the engine.
2. Set conveyor selector switch (1) on the conveyor up/down control panel to CONVEYOR (a).

(Only for machines equipped with muck discharge conveyor.)

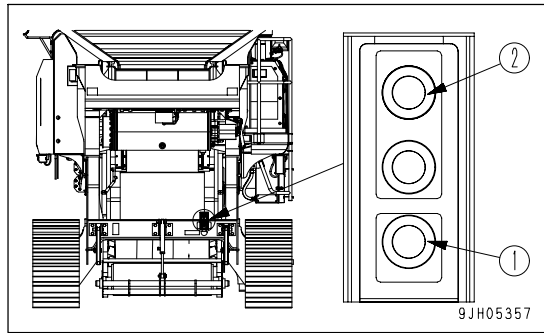

3. Press conveyor UP switch (2) and remove the conveyor from the mount hook.

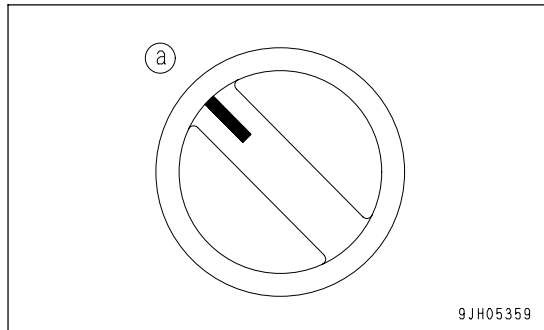

4. Using the up/down control switch, set the mount hook to the position to match the conditions of use, then set each fixed position switch.

- (3) Fixed position when traveling
- (4) Fixed position for normal crushing
- (5) Fixed position when crushing reinforced concrete

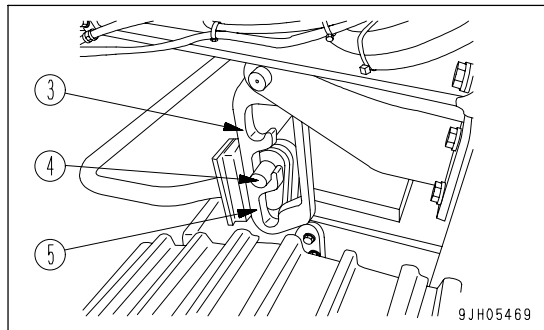

PREPARATIONS FOR MUCK DISCHARGE CONVEYOR

(When used)

Extend the muck discharge conveyor (if equipped) as follows.

1. Remove travel lock pin (1).
2. Start the engine.

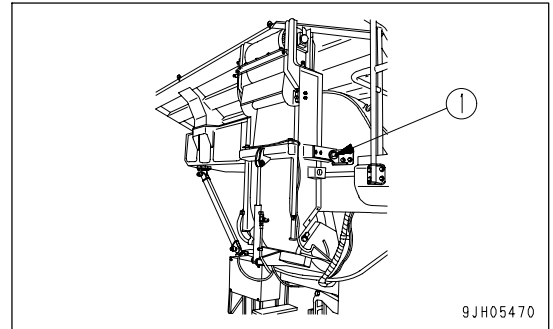

3. Set conveyor selector switch (2) on the conveyor up/down control panel to MUCK DISCHARGE CONVEYOR (b).
4. Press muck discharge conveyor DOWN switch (3) and extend the conveyor.
5. Stop the engine.

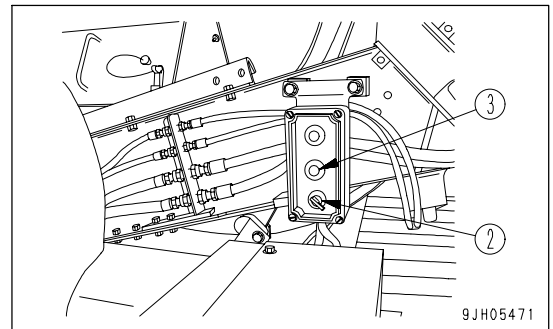

6. Remove side cover lock bolt (4).

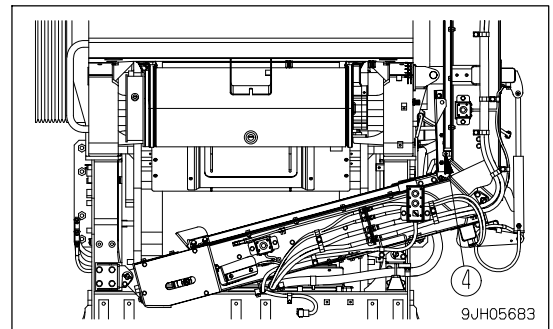

7. Install lock bolt (5) at the conveyor center side.

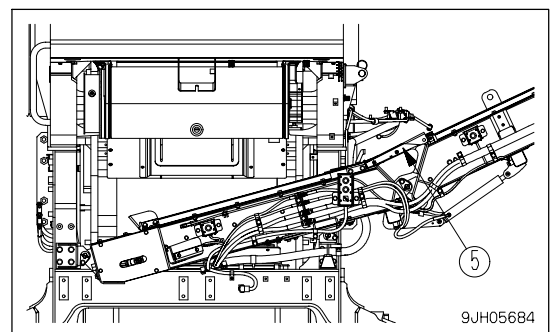

8. Set muck chute selector lever (6) at position (A) in the diagram on the right. Muck is discharged from the muck discharge conveyor.

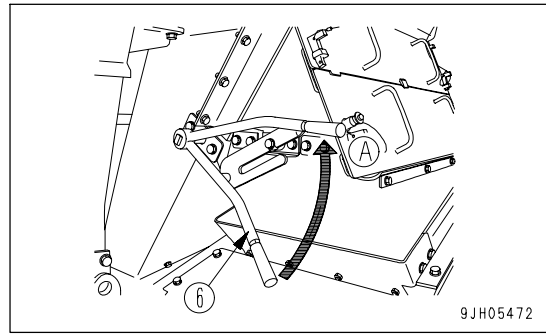

(When not used)

Set muck chute selector lever (6) at position (B). Muck is discharged from the primary conveyor.

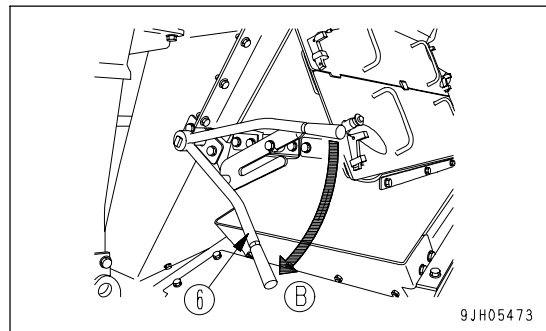

CAUTION

When operating the machine without using the muck discharge conveyor, always set muck chute selector lever (6) at position (B) (discharge to the primary conveyor side). If the machine is operated with the lever set at position (A), the muck discharge conveyor and chute may be damaged.

PREPARATIONS FOR GRIZZLY FEEDER

When the transportation lock pin is installed, remove pins (1) installed to the side face of the grizzly feeder (left and right, 2 places) in the order (A), (B).

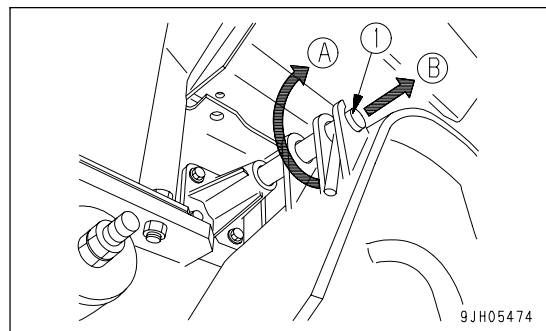

STARTING JAW CRUSHER OPERATION

! WARNING

- When that the work equipment starting switch is turned ON, the work equipment starting in turn, so check that the surrounding area is safe before starting operation.
- Optional work equipment is not actuated with this switch. First, use the starting switch for each piece of work equipment, then start operations.

1. After starting the engine, set the mode selector switch to WORK position (b).

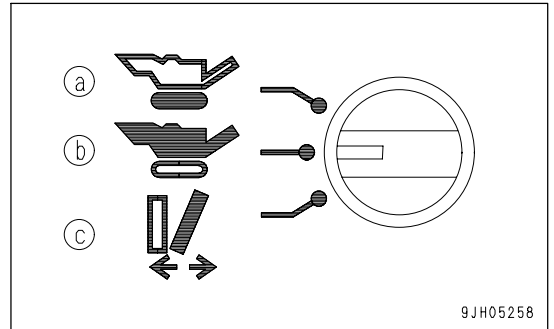

2. Set the crusher rotation direction selector switch to the normal rotation position (a).

For normal operations, choose normal rotation (a). Reverse rotation (b) may be effective according to the crushing conditions. Consider the conditions and judge which direction of rotation to use.

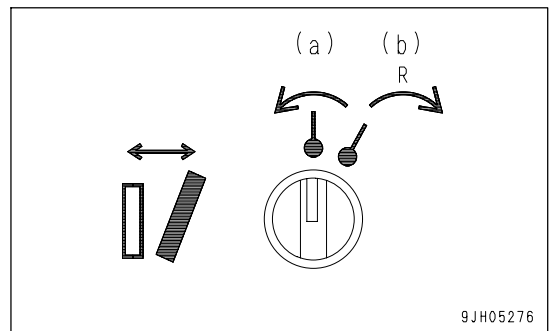

3. When optional equipment (muck discharge conveyor, secondary conveyor, vibratory sieve) is installed, press the starting switch in the following order when starting.

- (1) Muck discharge conveyor start switch
- (2) Secondary conveyor start switch
- (3) Vibratory screen start switch

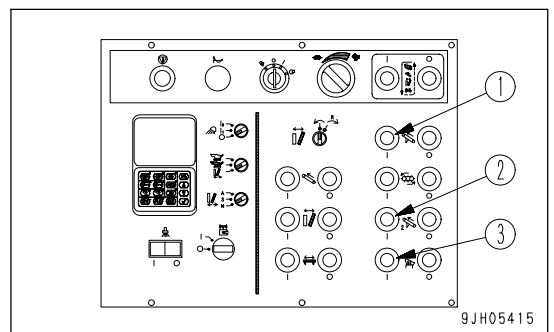

4. Turn the work equipment start switch (4) ON, then check that the work equipment starts in the following order.

Conveyor, magnetic separator -> crusher -> feeder

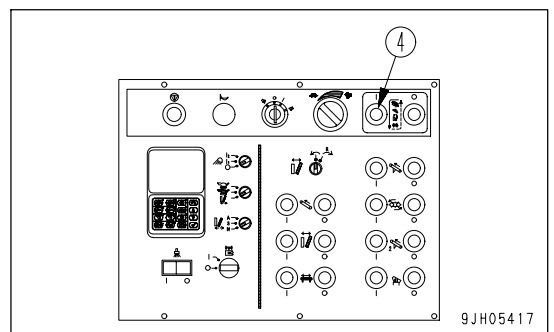

NOTICE

Run the engine at a low idling speed (low revolution) without any load for about five minutes.

5. After the machine warming-up, check if there is no bearing of abnormally high temperature or abnormal vibration.

Refrain from accelerating the engine suddenly until after the engine is sufficiently warmed up.

6. Turn the fuel control dial to the full speed (MAX) to raise the crusher revolution.
7. When the crusher revolution has risen sufficiently and becomes constant after turning the fuel control dial to the full speed, begin to feed debris to the crusher.

When starting again after an emergency stop, cancel the emergency stop switch (press it again), then follow the procedure for operating the crusher and start again from the beginning.

SETTING GRIZZLY FEEDER SPEED

Control the flow of debris to be crushed by adjusting the below mentioned grizzly feeder speed dial to the optimum condition according to the size of debris and the crusher revolution speed.

This switch (15) is used to change the vibration speed of the grizzly feeder and to adjust the feed speed for rubble and rock.

When numeral input switch (3) is pressed, the scale goes down in direction (A).

When numeral input switch (2) is pressed, the scale goes up in direction (B).

(A) Feed speed at minimum (MIN): Whole scale is reduced in direction (A)

(B) Feed speed at maximum (MAX): Whole scale is increased in direction (B)

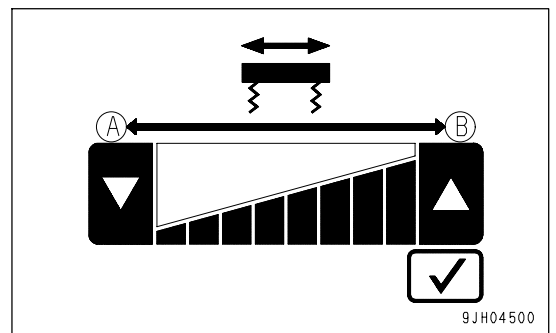
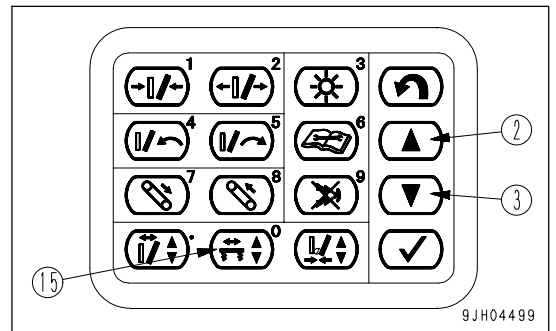

SETTING JAW CRUSHER SPEED

This switch (14) is used to adjust the rotating speed of the crusher.

When numeral input switch (3) is pressed, the scale goes down in direction (A).

When numeral input switch (2) is pressed, the scale goes up in direction (B).

(A) Rotating speed at minimum (MIN): Whole scale is reduced in direction (A)

(B) Rotating speed at maximum (MAX): Whole scale is increased in direction (B)

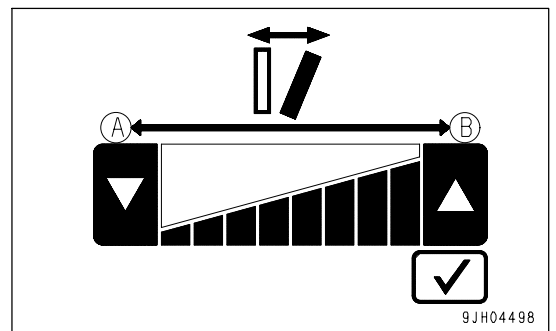
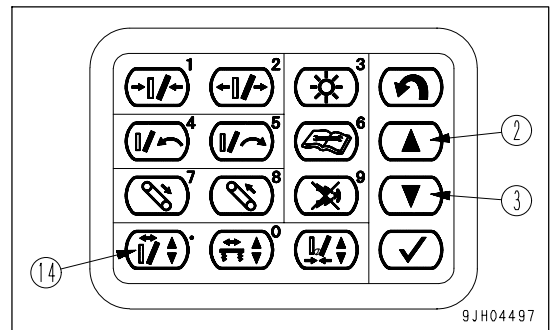

REGULATING CHARGING AMOUNT IN CRUSHER CHAMBER

(Crusher load set dial)

When numeral input switch (3) is pressed, the scale goes down in direction (A).

When numeral input switch (2) is pressed, the scale goes up in direction (B).

(A) Charging ratio at minimum (MIN): Whole scale is reduced in direction (A)

(B) Charging ratio at maximum (MAX): Whole scale is increased in direction (B)

The optimum charging rate for the crusher chamber is approx. 60%, considering the allowable work amount and wear on the consumable parts in the crusher chamber.

This machine is equipped with an automatic grizzly feeder stop function (excess charge preventive function). However the timing that the automatic feeder stops feeding is likely to vary according to the size and hardness of debris to be crushed and their muck content, resulting in the change in the actual charged amount in the crushing chamber.

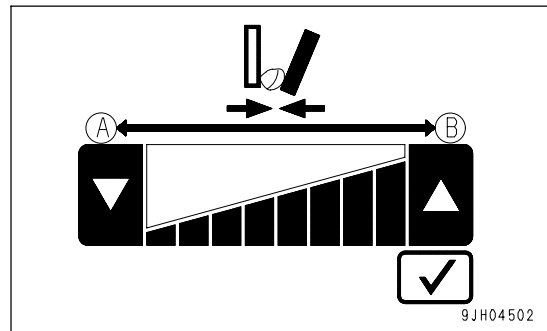
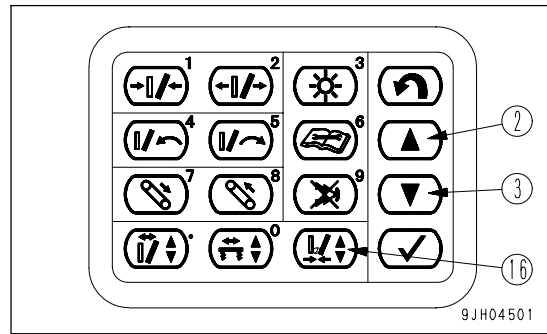

Keep watching the charging rate in the crushing chamber for about an hour after starting the work, and adjust the crusher charge setting dial to the optimum condition.

Guideline for adjusting scale

SOFT<----->HARD

- Adjusting method for grizzly feeder speed, crusher speed and crusher chamber charging amount
 1. Basically, the jaw crusher speed is set to the maximum (MAX).
 2. Visually inspect the charge amount in the crushing chamber, and if it is found more or less than 60%, adjust it by the crusher load setting dial.
 3. When crushing boulders or many big lumps contained in the debris, reduce the grizzly feeder speed as well as the jaw crusher speed for attaining higher work efficiency.
 4. Feed debris into the hopper, aiming at 50% charging of the hopper capacity, and good hopper efficiency is assured and debris screening efficiency can be also heightened.

REMARK

The grizzly feeder speed and the jaw crusher speed will also vary with the engine rpm.

LOAD ON CRUSHER

EXCESSIVE LOAD PREVENTIVE DEVICE



WARNING

When the charging ratio inside the crusher is reduced, the feeder automatically changes from low- speed operation to high-speed operation, so never go close to the grizzly feeder during operations.

After the grizzly feeder starting switch is pressed, if the jaw crusher load is checked and found to be excessive, the grizzly feeder speed is automatically reduced and the supply of material for crushing (rubble) is stopped. When this happens, the rotating red lamp at the front of the machine and the green machine status lamp on the panel flash. After this, if the jaw crusher returns to the normal load, the grizzly feeder is automatically restarted and supplies rubble. In this case, the rotating lamp goes out and the status lamp lights up white.

DEVICE FOR STOPPING ALL WORKS WHEN ABNORMAL LOAD IS APPLIED

If an abnormal load (for example, the material for crushing gets caught in the conveyor) is generated in the conveyor or optional equipment (muck discharge conveyor, secondary conveyor, vibratory sieve), all the work equipment is automatically stopped.

The horn sounds for 5 seconds after the work equipment is stopped. Stop the engine, remove the rubble that is caught in the conveyor and causing the abnormal load, then start again.

When this happens, the machine status lamp for the location of the abnormality on the panel lights up red, so it is possible to identify the location of the abnormality.

MONITOR WARNING DEVICE (REVOLVING WARNING LAMP LIGHTS UP)

When something unusual occurs in the engine coolant temperature, engine hydraulic oil pressure, battery charging amount, etc., each corresponding monitor lamp on the monitor panel lights up and the revolving warning lamp repeats coming on and off.

For further details, refer to the section "REVOLVING WARNING LAMP (PAGE 3-46)".

ERROR CODE DISPLAY DEVICE

When error screen (A) is shown on the monitor, the screen will switch as follows after a fixed interval when input switch (1) is pressed:

Screen B -> screen C -> screen D -> screen B

When input switch (1) is pressed again, the screen will switch to error screen (A).

Check the contact telephone number on screen D.

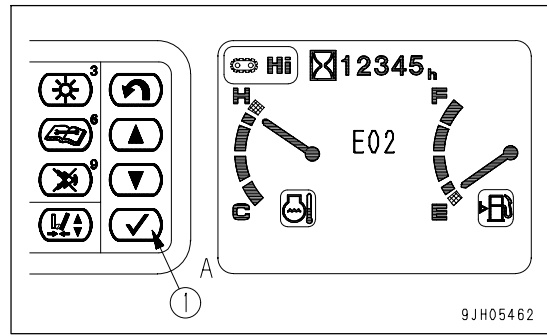

9JH05462

REMARK

If the point of contact telephone number has not been registered, screen B is not displayed.

If it is necessary to register the point of contact telephone number, ask your Komatsu distributor to register it.

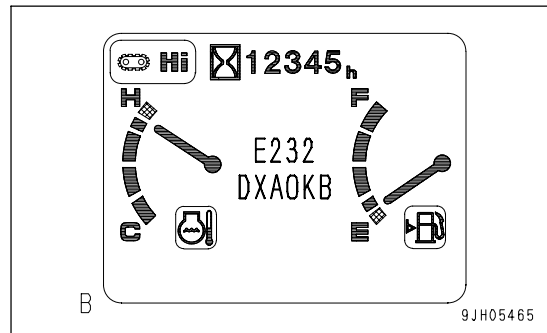

9JH05465

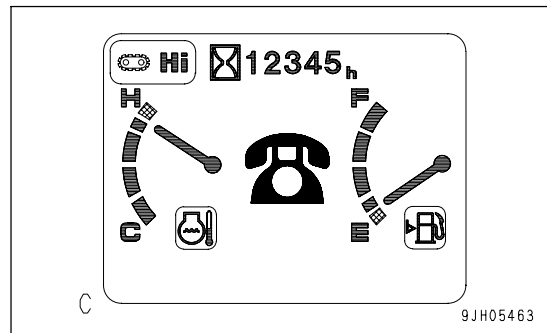

9JH05463

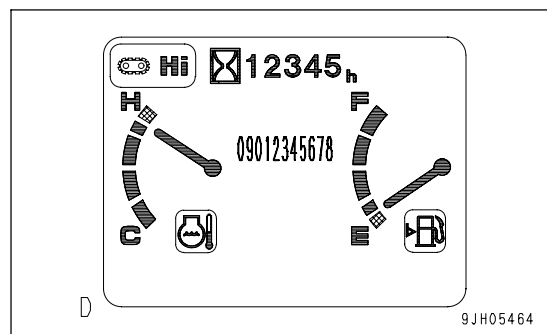

9JH05464

STOP FUNCTION WHEN FOREIGN MATERIAL IS CAUGHT



This machine is designed so that the lock cylinder slips and opens the clearance if any foreign material is loaded inside the crusher. This design prevents breakage of the crusher bearings, shaft, or frame.

However, this does not mean that it is permitted to load the crusher with such foreign material.

There is a limit to the number of times that the lock cylinder can slip. If the crusher is used in a way that makes the lock cylinder slip frequently, it will become necessary to make early replacement of the cylinder and replacement of other structural parts.

(Suitable frequency of slipping: less than once a week)

If any foreign material (excessively large lumps of iron, etc.) has been loaded into the crusher or there is an abnormal load on the crusher, the lock cylinder may slip and the crusher clearance may become larger. If this happens, the crusher and feeder stop and the horn sounds for 5 seconds.

Stop the engine, remove the foreign material caught in the crusher, and check that there is no abnormality at any part.

In addition, the actual crusher clearance may be larger than the value displayed on the monitor clearance display, so bring the fixed plate and jaw plate into contact, then adjust the crusher clearance. For details, see "CHECK AND ADJUSTMENT OF JAW CRUSHER (PAGE 4-35)". After adjusting, start operations again.

CHECK AND CONFIRMATION OF JAW CRUSHER AFTER WORK

1. After feeding of the material for crushing on the grizzly feeder stops, press work equipment stop switch (1) to stop the work equipment. The work equipment stops in the following order.

Feeder -> crusher, conveyor, magnetic separator

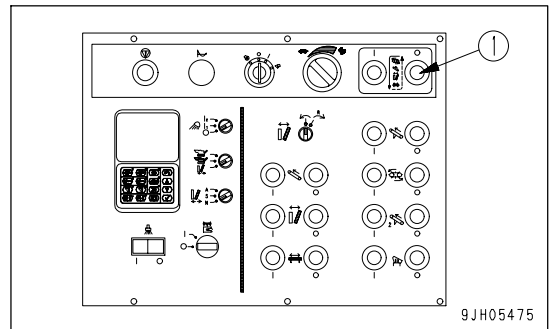

2. With the work equipment stop switch, optional equipment does not stop, so press the switches in the following order to stop the optional equipment.

- (1) Vibratory sieve start switch
- (2) Secondary conveyor start switch
- (3) Muck discharge conveyor start switch

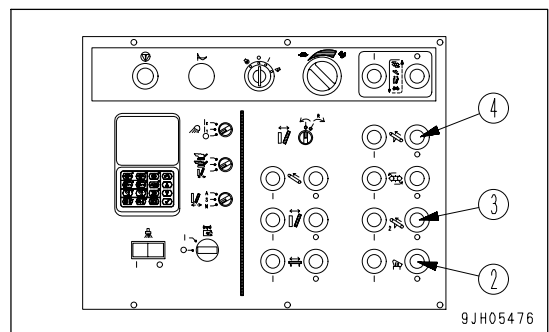

CHECK AFTER FINISHING WORK

For normal stop of the engine, see the section of "STOPPING ENGINE (PAGE 3-79)".

LOCKING

Always lock the following places.

- (1) Fuel tank filler port
- (2) Engine hood
- (3) Battery box cover
- (4) Machine left side door
- (5) Machine right side door
- (6) Tool box
- (7) Main control box
- (8) Hydraulic oil tank filler port

REMARK

Use the starting switch key to lock and unlock all these places.

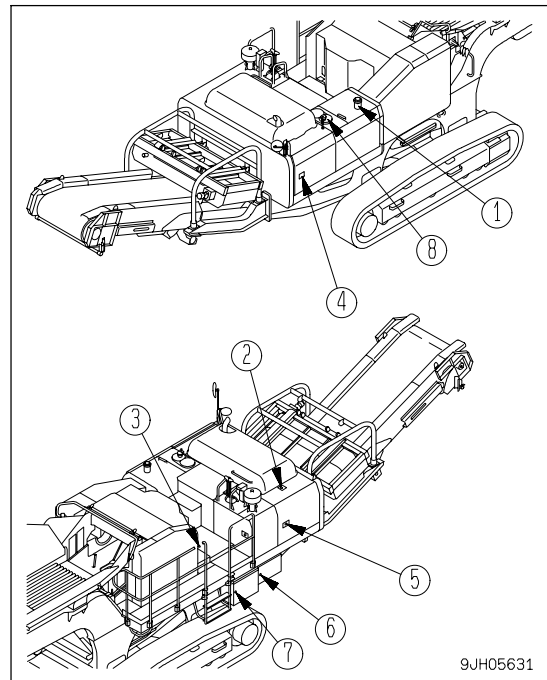

RUN-IN OPERATION OF JAW CRUSHER

After confirming by inspection that there is nothing unusual with the jaw crusher, carry out both no load operation and loaded operation by way of running-in in the following manner, but this should be conducted only at the time of the initial delivery.

OPERATING TIME UNDER NO LOAD, 30 MINUTES OR MORE

NOTICE

Carry out a running-in also when replacing a crusher wearing parts or reversing a jaw plate. If load is increased fast, partial friction may be caused to various inner parts, leading to their shortened service life.

Check if the bearings have generated abnormal heat.

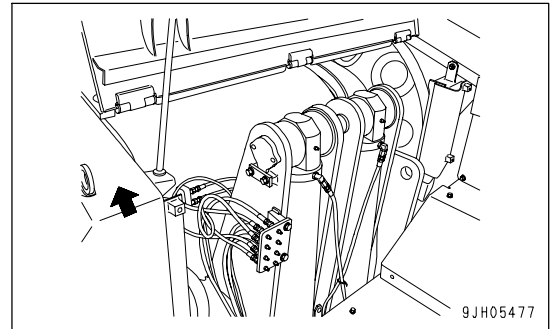

LOADER OPERATION

Start to feed fresh debris to the jaw crusher after confirming that the crusher revolution stays steady and constant. If the debris are found directly hitting the swing jaw protector, after starting the feeding, try to change the feeding mode so that they will not hit the protector.

The feeding amount at a time should not be up to the full capacity, but follow the values shown in the table below. Loaded operation (after no-load operation)

| Load Ratio (Charging Amount) % | No. of Days |
|--------------------------------|----------------------|
| 30 | Two days |
| 60 | Two days |
| 60 - (100) | After the days above |

FEEDING AMOUNT OF DEBRIS AS RAW MATERIAL

Continue with the ordinary operation after the running-in, keeping the debris feeding amount less than 60% of the crusher chamber capacity.

STOP OF WORKS

After terminating to feed fresh debris, stop the motor, confirming that crushing work has been completed finished.

RETIGHTENING OF BOLTS AFTER WORKS

Each part securing bolt is likely to loosen at the initial stage of machine operation. Check and tighten the part securing bolts based on the following table, after the loaded operation is commenced.

| The 1st time | The 2nd time | The 3rd time | Thereafter |
|---------------|---------------|----------------|-----------------|
| After 4 hours | After 8 hours | After 50 hours | Every 100 hours |

Tightening torque for bolts used in jaw crusher Unit: N·m (kgf·m, lbft)

| Bolt Size | Target Value N·m (kgf·m, lbft) | Tolerance N·m (kgf·m, lbft) | Major Applicable Points |
|-----------|--------------------------------------|-----------------------------------------------------|----------------------------------------------------------------------------|
| M10 | 65.7 (6.7, 48.5) | 58.8 - 73.5 (6.0 - 7.5, 43.4 - 54.2) | |
| M12 | 112.8 (11.5, 83.2) | 98.1 - 122.6 (10.0 - 12.5, 72.3 - 90.4) | |
| M16 | 279.5 (28.5, 206.1) | 230.5 - 289.3 (23.5 - 29.5, 170.0 - 213.4) | Toggle seat holding BKT |
| M20 | 549.2 (56.0, 405.0) | 456.0 - 568.8 (46.5 - 58.0, 336.3 - 419.5) | Protector securing bolt, toggle block holding BKT |
| M24 | 926.7 (94.5, 683.5) | 784.5 - 980.7 (80.0 - 100.0, 578.6 - 723.3) | Cheek plate securing bolt, (fixed jaw plate & swing jaw plate wedge bolts) |
| (M30) | 1716.2 (175.0, 1265.8) | 1520.0 - 1912.3 (155.0 - 195.0, 1121.1 - 1410.4) | (Slotted head nut of tension spring rod) |
| M36 | 2745.9 (280.0, 2025.2) | 2451.7 - 3040.1 (250.0 - 310.0, 1808.3 - 2242.2) | Crusher securing anchor bolt |
| M42 | 5325.0 (543.0, 3927.5) | 4256.1 - 6393.9 (434.0 - 652.0, 3139.1 - 4715.9) | Tension spring rod tip, (spring side of tension spring rod) |
| M64 | 6825.4 (696.0, 5034.2) | 5462.3 - 8188.6 (557.0 - 835.0, 4028.8 - 6039.6) | Bearing cap bolt |

BACK LASH ON FIXED JAW PLATE

An amount of backlash at the fixed jaw plate may increase at the initial stage of machine operation or right after replacement or reversal of the fixed jaw plate (within 30 hours). This is largely due to deformation of the fixed jaw plate at the securing portion. If this happens, check again if the spring set length of the wedge bolts securing the fixed jaw plate is within the specified limit. If not, tighten the wedge bolts again.

If backlash at the fixed jaw plate cannot be corrected, detach the plate, then completely remove dirt and sand stuck to the backside of the plate and the frame and install it again.

PRECAUTIONS WHEN OPERATING JAW CRUSHER



CAUTION

When using the mobile crusher, always observe the following precautions.

1. Always make sure that lock cylinder cover (1), unbalanced weight cover (2), and flywheel cover (3) are installed before starting operations.

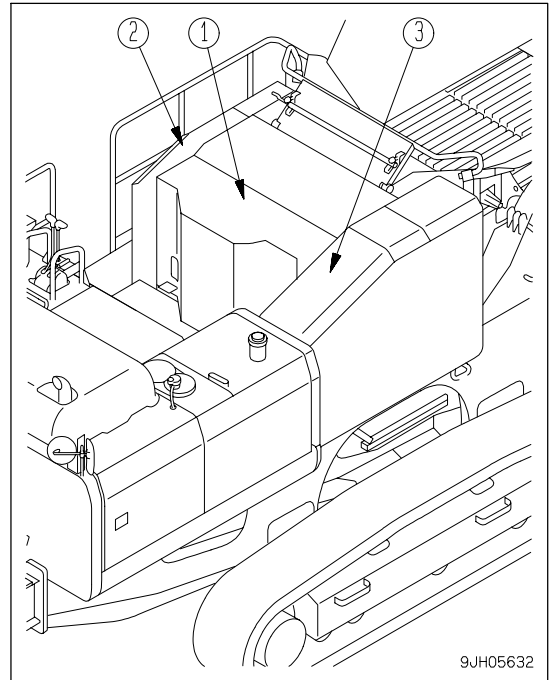

2. Start the jaw crusher without any debris left in the crusher chamber.
3. When feeding crush stuff, do not hit the bar directly, but dump them on the flat surface.

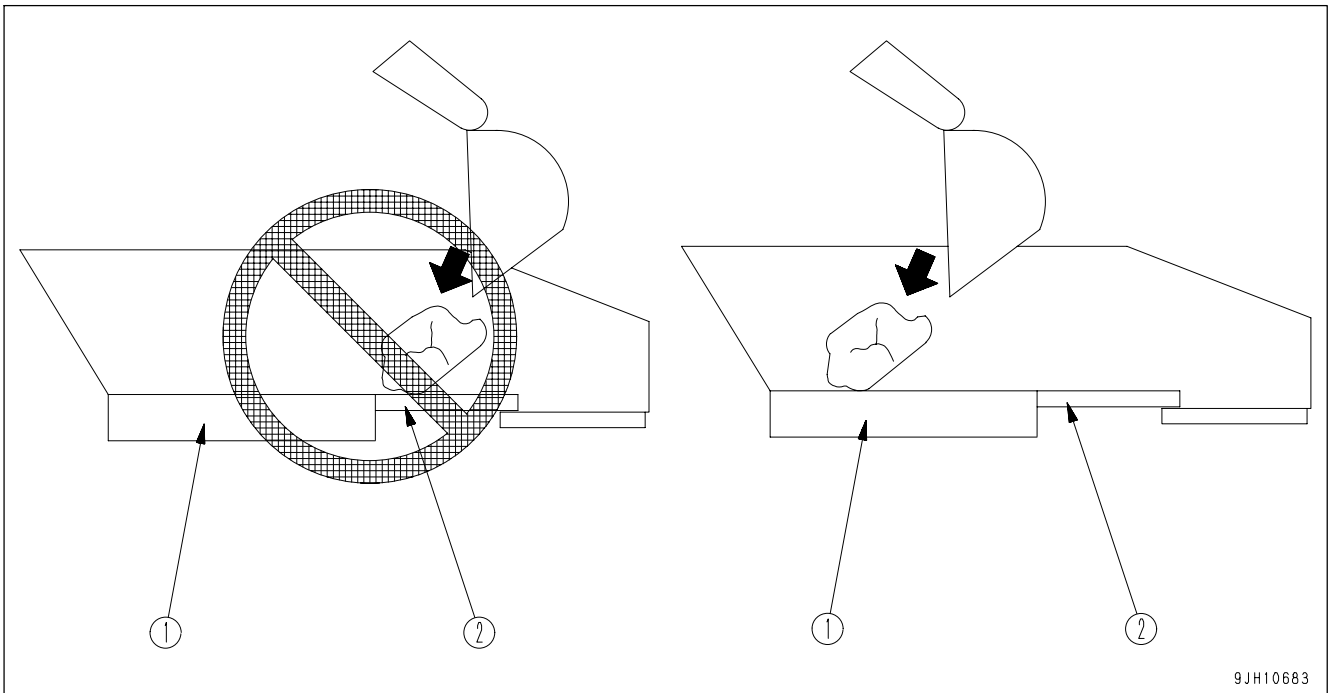

4. In a continuous work, keep the debris feeding amount less than 50% of the hopper capacity. Avoid charging the hopper fully, since not only the work efficiency is lowered, but also debris may clog the inlet, causing a failure.

5. Do not try to look into the crushing chamber while in operation. That is very dangerous, because crushed debris may fly off and hit you.
6. To stop the jaw crusher, stop feeding debris first, next check that there is nothing to be crushed any more in the crusher chamber and then stop it.
7. Do not blast debris in the crusher chamber.
8. If it becomes necessary to hang a parts at the time of replacing wear parts, do not go under the hung parts.
9. Retighten each bolt sufficiently.
10. When adjusting the clearance at the outlet of the crusher, do so only after the crusher has been completely stopped. For details, see "CHECK AND ADJUSTMENT OF OUTLET CLEARANCE (PAGE 4-35)".
11. Do not feed a reinforcing bar exceeding 600 mm (23.6 in) in length and 13 mm (0.5 in) in diameter, because it can cause a trouble to the jaw crusher and the primary conveyor.
12. If the teeth of the swing jaw plate and the fixed jaw plate are worn out beyond the specified limit, either reverse or replace the jaw plate.
-> If used beyond the specified limit, the worn jaw plate will cause a serious damage to the jaw crusher main body.

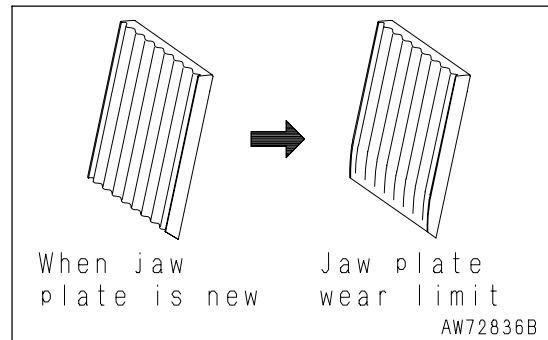

13. Procedure and caution for removing foreign objects inside crusher
Should foreign objects such as iron lumps and wooden blocks other than crushable materials (rock and concrete block) have been fed, mixed with debris, and clogged the jaw crusher, remove them following the instructions given below.
14. Do not feed debris of the maximum of feed dimension into the crusher. The crushing ability of the crusher will be reduced and the productivity will go down. In addition, an excessive crushing force will become necessary, so this may result in damage to the crusher itself.
15. Adjust the grizzly feeder so that the amount of debris in the crusher is a maximum of approx. 80% (average 60%). Never fill the crusher. This will cause abnormal wear of the top of the jaw plate and an excessive crushing force will become necessary, so this may result in damage to the crusher itself.

! WARNING

If the crusher becomes clogged with foreign material, never carry out the inspection operation from the top of the crusher. The crusher remains under load and a dangerous condition continues, and this may lead to serious personal injury.

1. Remove the foreign material as follows.

1) Start the engine.

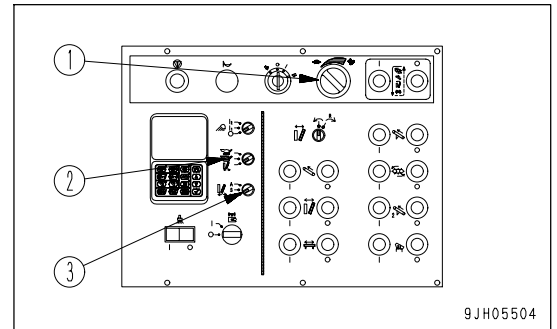

2) Set fuel control dial (1) to the low idling (MIN) position.

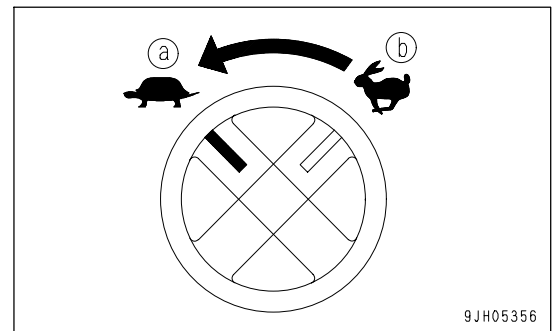

3) Set mode selector switch (2) to the INSPECTION position (c). The machine monitor will switch to the normal inspection screen.

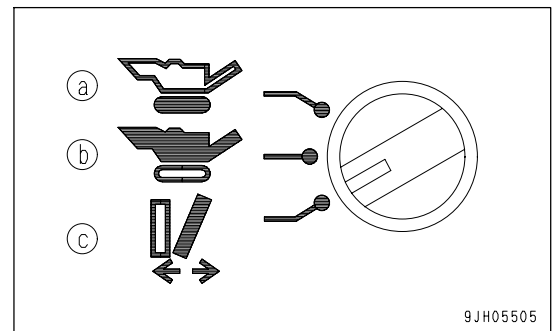

4) Set clearance adjustment selector switch (3) to the M (manual) position.

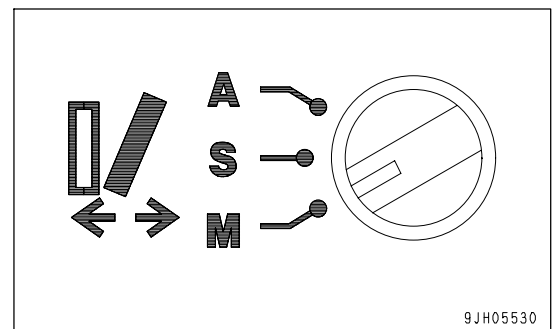

- 5) Check that mode monitor (D) of the machine monitor is in the M (manual) mode.
- 6) Using crusher clearance decrease switch (4) and crusher clearance increase switch (5), increase the crusher clearance.

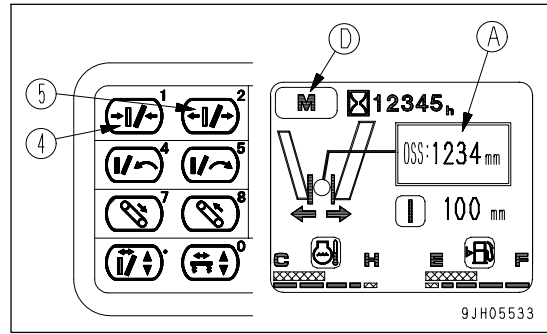

- 7) Set fuel control dial (1) to the high idling (MAX) position.
- 8) Using crusher manual normal rotation switch (7) and crusher manual reverse rotation switch (6), repeatedly change direction between normal rotation and reverse rotation, and check that all the foreign material has been removed.
- 9) When all the foreign material has been removed, use crusher clearance decrease switch (4) to set the crusher clearance to the original clearance.

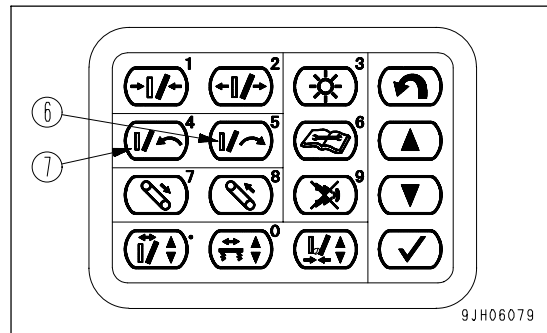

2. If any foreign material cannot be removed by expanding the clearance and repeatedly changing direction between normal rotation and reverse rotation, please contact your Komatsu distributor.
 Always follow the procedure exactly. If the wrong procedure is used when removing foreign material, excessive force will be released inside the crusher, and this may lead to serious personal injury or damage.

EFFICIENT USE OF JAW CRUSHER

PRINCIPLE OF CRUSHER OPERATION

The swing jaw makes a circular motion at contact point (1), but it makes a long and thin elliptical motion at points closer to contact point (3) owing to the eccentric crankshaft and a swing motion of the toggle plate.

The swing jaw plate fixed to the swing jaw repeats the above mentioned motion against the fixed jaw plate. Hence the debris fed into the crusher chamber are subjected to the more compression force, as they go down, and eventually crushed.

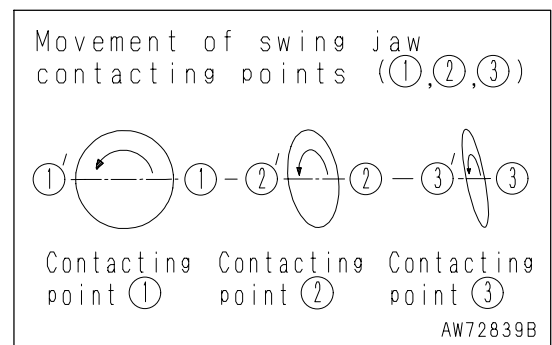
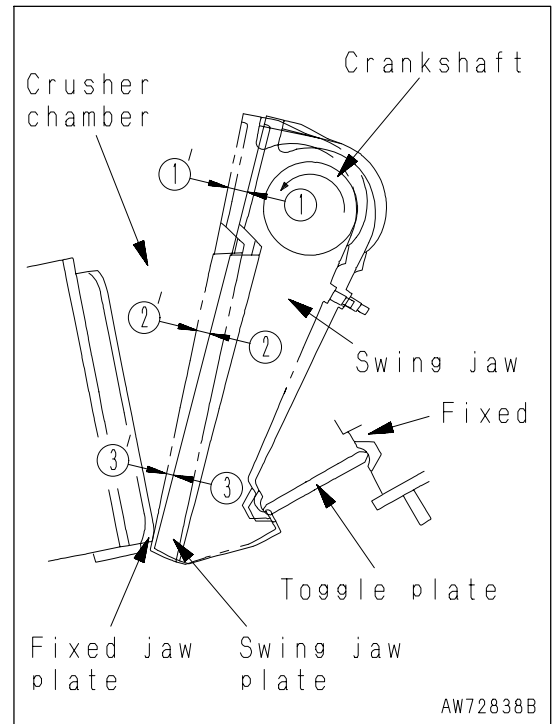

The wear life of fixed jaw plate (1) and swing jaw plate (2) differs greatly according to the conditions and the material being crushed, but generally speaking, the life become shorter when crushing material that includes large amounts of sand and water. In addition, the wear life is reduced if the discharge port clearance is small.

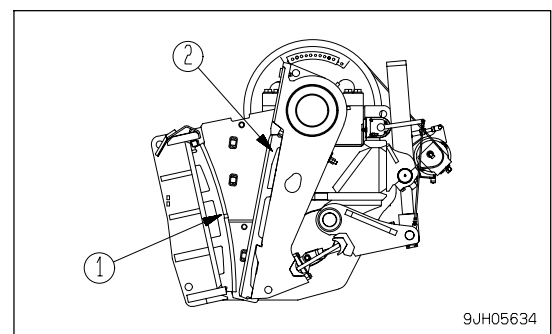

USAGE OF JAW CRUSHER

GRAIN DISTRIBUTION, ADJUSTMENT OF CRUSHER OUTLET CLEARANCE AND CRUSHABLE AMOUNT

DEFINITION OF "UNDER 40"

The grain size of 0 to 40 mm (0 to 1.6 in) shown in the catalog indicates a grain size distribution in which the maximum size of the crushed concrete block is 50 mm (2.0 in) in diameter and concrete blocks smaller than 40 mm (1.6 in) account for approx. 95% of all.

ADJUSTMENT OF CRUSHER OUTLET CLEARANCE

Clearance xx mm (xx in) means the dimension when the discharge port clearance is opened to the maximum. In the case of 50 mm (2.0 in) clearance, if the size of the discharged crushed material is concrete, with a new tooth plate, muck bar opening of 50 mm (2.0 in), and muck content approx. 30%, it is more or less possible to obtain 40 and under.

The dimension of the particle distribution is generally described as follows.

Dimension of particle distribution = discharge port clearance - 10 mm (0.4 in)

GRAIN DISTRIBUTION

The shape of the discharge port of the jaw crusher is as shown in the diagram on the right. It is possible to adjust in direction a (amplitude stroke of crusher), but it is impossible to adjust in the vertical direction and in direction b (width of crusher itself).

Therefore, square-shaped materials such as concrete can be crushed to give a product of 0 to 40 mm (0 to 1.6 in) with a ratio of nearly 95% when the setting is 50 (OSS). However, with natural rock with close grain, when crushing with the jaw crusher, the rock cracks along the grain, so large amounts of flat pieces are discharged from the crusher discharge port and the proportion of oversize material increases. The proportion changes according to the strength of the grain in natural rock. In such cases, if 0 to 40 mm (0 to 1.6 in) is necessary, use the optional vibratory sieve.

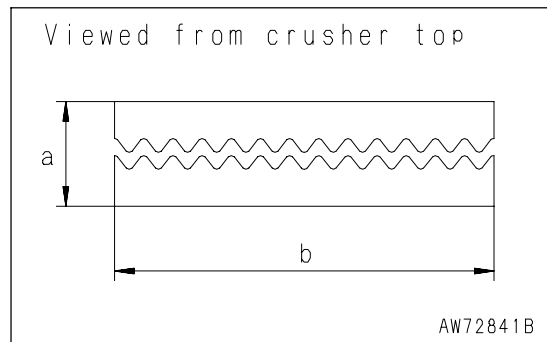

NOTICE

If many large pieces can be seen in the piled material after crushing, this is because the coarser the pieces are, the smaller the density becomes and these appear on the surface. Normally, there are more smaller pieces than it appears by looking at the surface.

CRUSHABLE AMOUNT

The crushable amount shown in the catalog is a value measured under the condition of the best adjustment. In order to gain the practical value in the ordinary crushing work, therefore, it is recommended to multiply the catalog value by work coefficient of 0.6 to 0.75.

DETECTING WEAR ON JAW PLATES

CAUSE FOR PREMATURE WEAR

| | Advanced | Delayed |
|------------------------|----------|---------|
| Outlet clearance | Narrow | Wide |
| Water content | Plenty | Scarce |
| Muck mixing ratio | Plenty | Scarce |
| Sio2 content in silica | Plenty | Scarce |
| Rock hardness | Hard | Soft |

The outlet clearance and silica content particularly exercise a big influence among several factors listed above.

PREVENTION OF PREMATURE WEAR

Considering the efficiency, the best method is not to make the discharge port clearance extremely small but to adjust it to a larger dimension and to use a sieve. This is the ideal method because it increases the service life of the fixed jaw plate and movable teeth.

For concrete rubble, keep to 50 mm (2.0 in) as the minimum clearance of the jaw crusher.

PRECAUTIONS WHEN OPERATING JAW CRUSHER

PRECAUTIONS IN OPERATION

1. Adjust the grizzly feeder so that the crusher chamber will not be filled more than 80% at the most (approx. 60% on average). Never fill up the crusher chamber.
If the feeding rate is too high, abnormal wear develops on the center to upper part of the fixed and swing crusher plates. In addition, an excessive crushing force will become necessary, so this may result in damage to the crusher itself.
2. Try to feed a large chunk of debris or a concrete block containing many reinforcing bars toward the end of the day's operation, because they are highly likely to disrupt the work by stopping the machine.

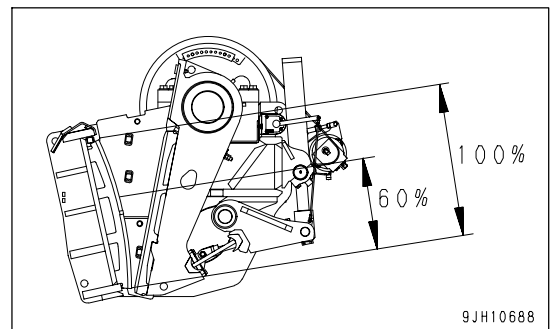

PREPARATION FOR DEBRIS AS RAW MATERIALS

1. Break up the rubble to a size of less than 1000 x 900 x 475 mm (39.4 x 35.5 x 18.7 in) before feeding it into the hopper.
If there are large amounts of rubble at the maximum size, the productivity will drop. (In the case of natural rock, break up into sizes of 425 mm (16.7 in) square.)
2. Debris should not contain so much water that it becomes muddy.
3. Preferably reinforcing bars should not be included in the debris to be crushed for better working efficiency. (They tend to narrow the clearance at the outlet, thereby reducing the discharging efficiency)
4. For good work efficiency, debris may well be mixed in the debris to be crushed at the rate of 20 to 30%.
(If this ratio is higher than that, debris serves as a cushion in the crusher chamber, lowering the work efficiency. Moreover it causes premature wear on the fixed and swing jaw crusher plates)
5. Do not allow impurities (wood, paper, etc.) to get mixed in the debris to be crushed. Otherwise they can clog the outlet, and lowered debris discharge may lead to a damage on the crusher and toggle plate.

LOADING WITH MATERIAL

1. Always set so that the top of the feeder can be seen by the operator of the loader.
2. When loading with material, load the machine from the side or rear. However, when loading with a wheel loader, carry out the loading operation only from the rear.
3. Load the material at the position of the fixed bottom at the rear end of the feeder (1), and avoid loading directly onto the muck bar portion (2).

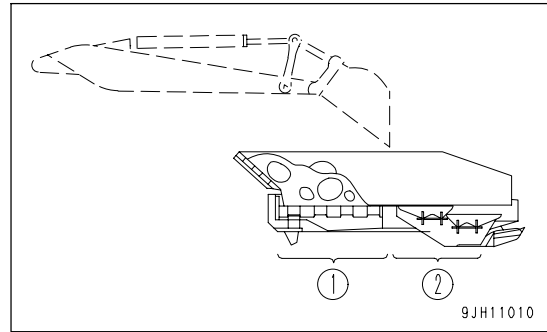
**PILE OF MATERIAL**

Always maintain distance (h) between the top of the pile and of the conveyor to at least 200 mm to prevent the height of the pile of material discharged from the conveyor from becoming higher than the conveyor.

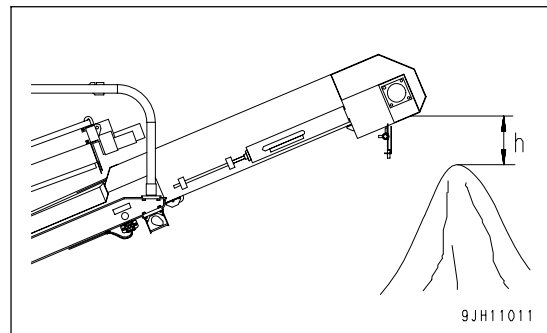

BASIC USAGE OF GRIZZLY FEEDER (EFFECTIVE METHOD FOR REMOVING MUCK)

A grizzly feeder is provided to separate sand and earth from natural stones or concrete debris. Pay attention to the separation condition of the feeder.

UNDESIRABLE USAGE

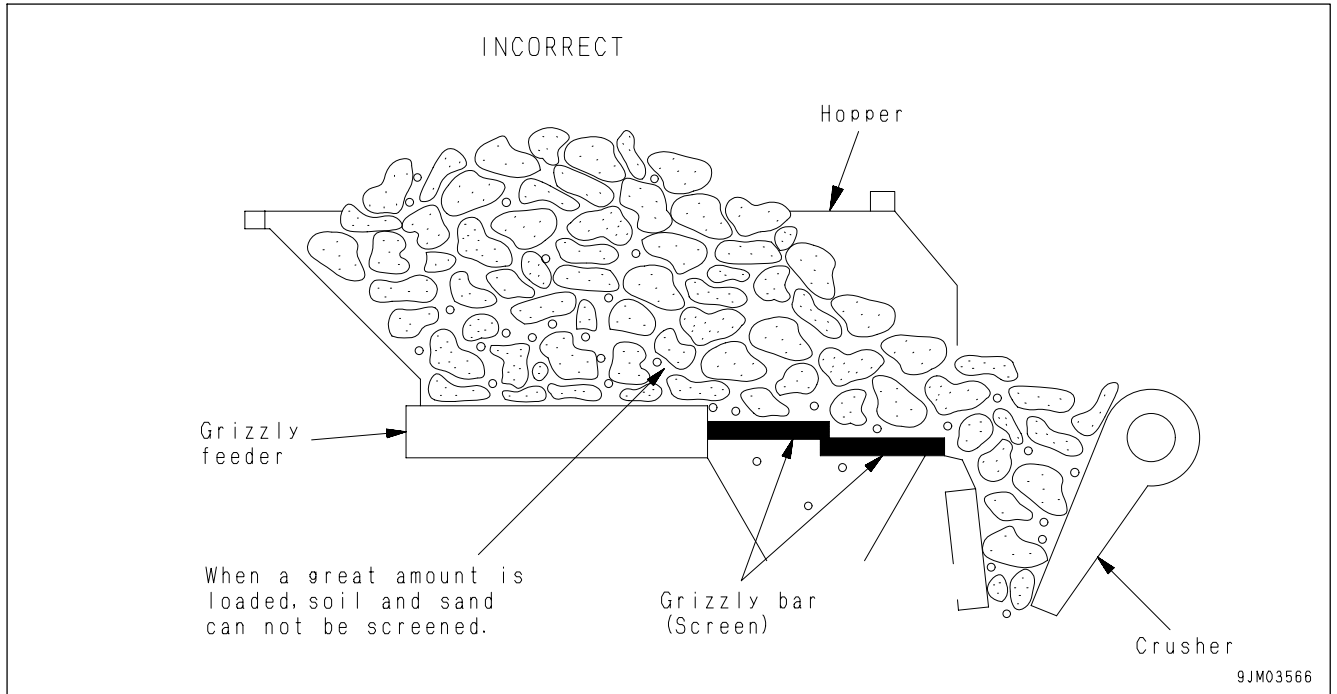

DESIRABLE USAGE

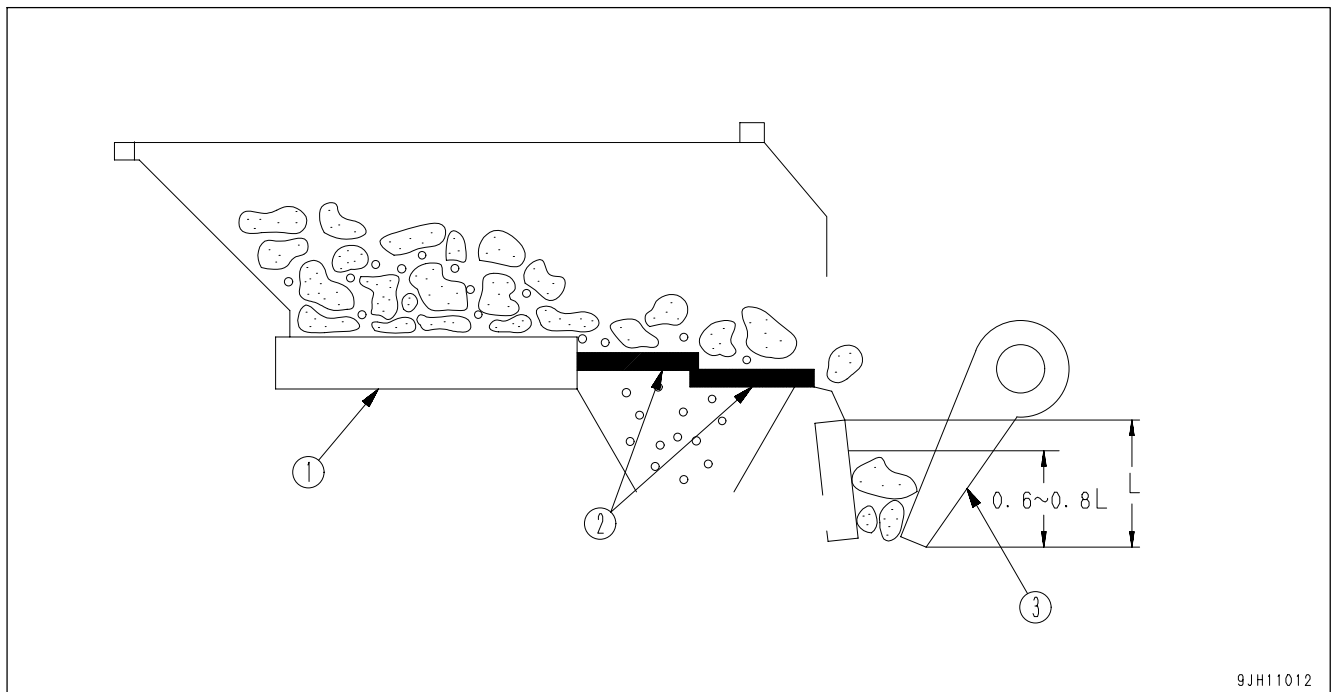

- (1) Grizzly feeder
- (2) Grizzly bar (screen)

- (3) Crusher

EXAMPLE FOR DESIRABLE OPERATION

STEP 1

The optimum amount of rubble to feed in the hopper at one time is 0.5 to 0.7 m³ (0.65 to 0.92 cu.yd). Use 50% of the capacity (top surface of trough) as a guideline. However, check the condition on the feeder and adjust the amount that is fed into the hopper.

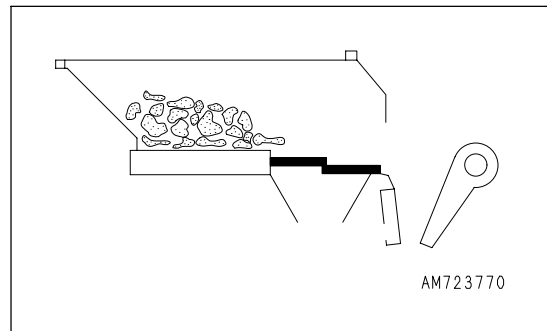

STEP 2

Feeding the optimum amount assures that the screen separates soils and sand from concrete debris completely.

Note: Do not feed the next lot of debris immediately.

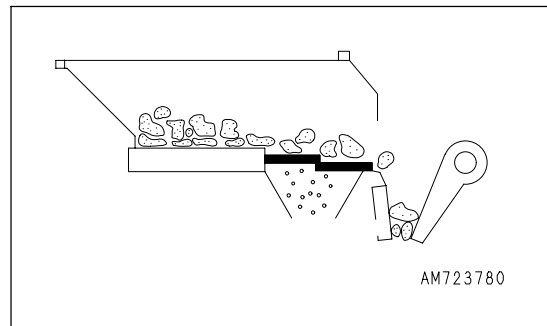

STEP 3

When the remaining debris decreased almost to the half, feed the next lot.

Repeat the same practice thereafter.

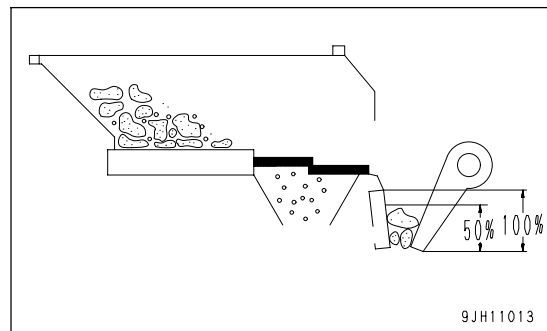

SCOPE OF WORKS USING MOBILE CRUSHER



WARNING

When crushing natural rock, do not feed the crusher with pieces of rock that are larger than the maximum feed dimension. This will not only reduce the crushing capacity and lower the production, but may also cause pieces of rock to fly out. In addition, it will create overload in the crushing operation, and there is danger that this will damage the crusher.

The mobile crusher can crush concrete debris and natural rocks.

SIZE THAT CAN BE CRUSHED

CONCRETE RUBBLE

- Optimum dimension for rubble feed:
475 (A) x 325 (B) x 325 (C) mm
(18.7 x 12.8 x 12.8 in)

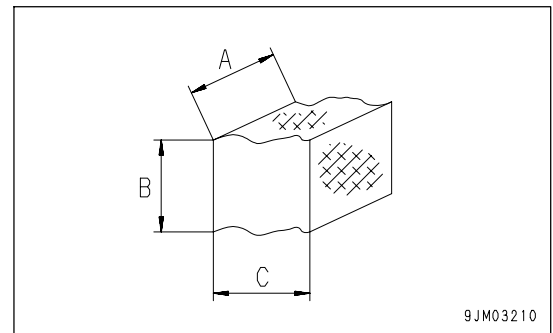

- Maximum dimension for rubble feed:
1000 (A) x 475 (B) x 900 (C) mm
(39.4 x 18.7 x 35.5 in)

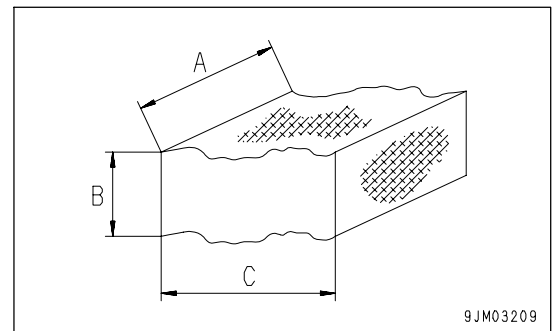

The optimum dimension for concrete rubble means the optimum dimension that can be crushed when no attention is paid to the direction of the rubble when it is fed in.

The maximum dimension for concrete rubble means the maximum dimension that can be crushed when the rubble is fed in facing the correct direction.

NATURAL ROCK

- Optimum dimension for rubble feed: 350 mm (13.8 in) for any side
- Maximum dimension for rubble feed: 425 mm (16.7 in) (maximum length of any side)

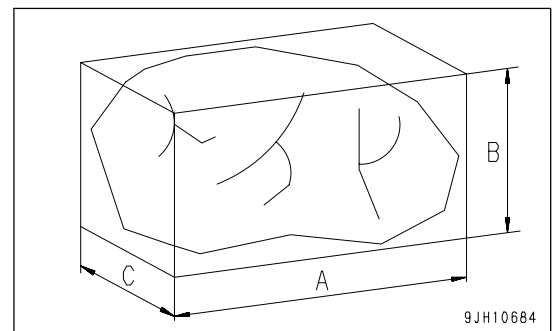

The optimum dimension for natural rock means the dimension that can be crushed efficiently.

The maximum dimension for natural rock means the maximum dimension that can be fed into the crusher.

! CAUTION

When crushing natural rock, do not feed the crusher with lumps of rock larger than the maximum dimension for rubble feed.

- The crusher will not be able to grip the lumps easily and this will lead to a drop in production. In addition, there is danger that the rock will fly up and out.
- Excessive crushing force is also required, so this will damage the crusher itself.

NOTICE

If rubble larger than the optimum dimension is fed into the crusher, set the selector switch on the crusher load setting screen to SOFT when carrying out operations. This will reduce the occurrence of bridging or blocking, and will improve the overall operating efficiency.

CRUSHING CONCRETE DEBRIS

NOTICE

Do not feed concrete debris containing reinforcing bars larger than 13 mm (0.5 in) in diameter and longer than 600 mm (23.6 in), since they can damage the machine.

It is possible to crush the concrete rubble (including reinforced concrete) generated at building demolition sites.

The size after crushing can be adjusted to 50 to 150 mm (2.0 to 5.9 in) by adjusting the discharge clearance of the jaw crusher.

When crushing rubble consisting of reinforced concrete, installing a magnetic separator and optional conveyor protector plate can enable the work to be carried out efficiently. (See "BELT CONVEYOR PROTECTIVE PLATE (PAGE 6-31)".)

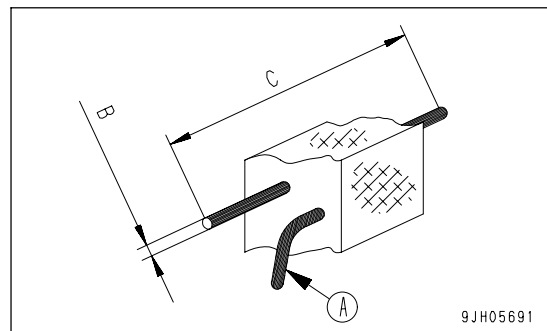

(A) Steel rods

(B) Max. $\phi 13$

(C) Max. 600

KEEPING SOME HEIGHT UNDER CRUSHER

When crushing reinforced concrete debris, it is advisable to increase the clearance between the crusher underside and the belt conveyor top to ensure good discharge of the debris.

If many long reinforcing bars are contained in the reinforced concrete debris to be crushed, adjust the posture of the primary belt conveyor in the following manner prior to the start of work.

NOTICE

A reinforced concrete debris block larger than 13 mm (0.5 in) in diameter and longer than 600 mm (23.6 in) must not be crushed, since it may damage the crusher.

1. Start the engine.
2. Set selector switch (1) for the conveyor up/down control panel to CONVEYOR.
(Only for machines equipped with muck discharge conveyor.)
3. Press conveyor UP switch (2) and remove the conveyor from the mount hook.

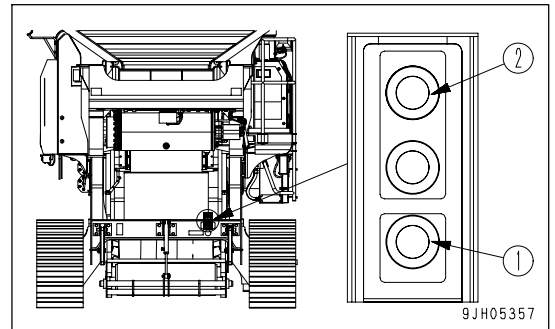

4. Using the conveyor up/down control switch, set the mount hook to fixed position (3) for crushing reinforced concrete.

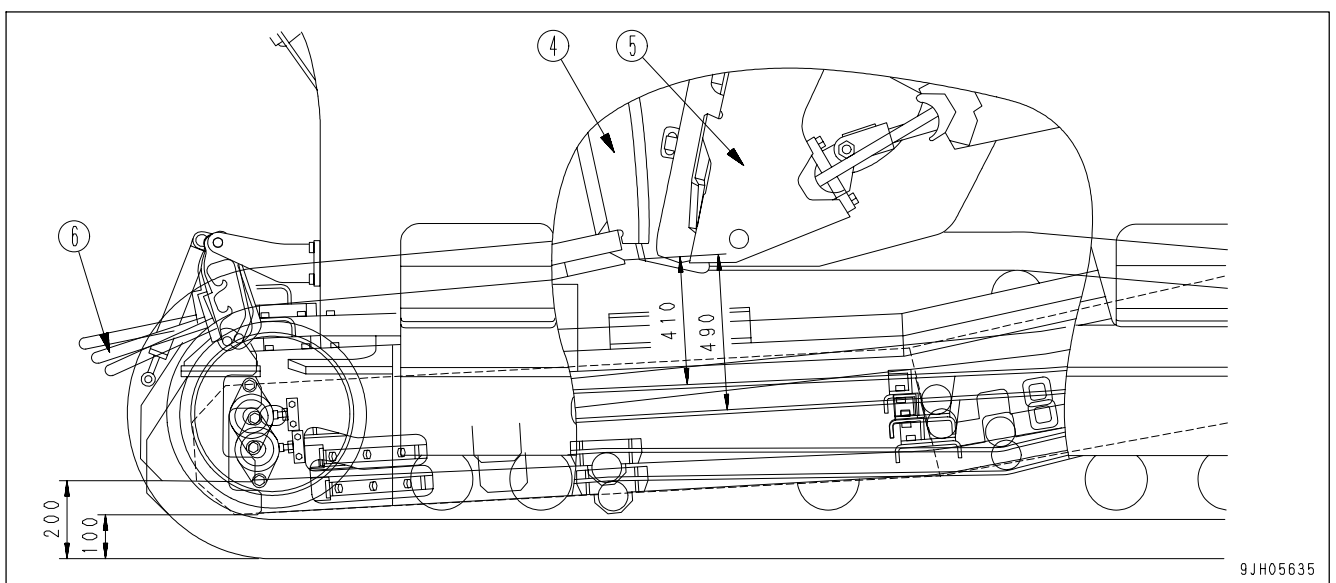
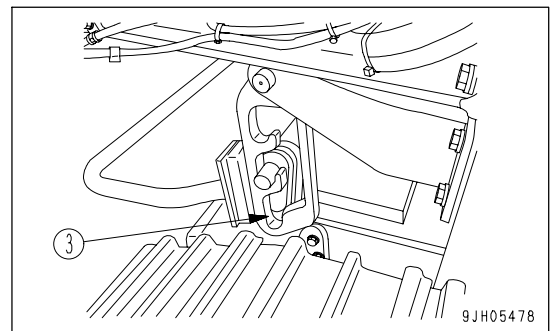

REMOVING REINFORCING BARS FROM CONCRETE BLOCKS

**WARNING**

When you have to get in the crusher chamber for removing reinforcing bars, be sure to stop the engine first, then hang a warning tag to the starting switch in the main control box and start the work.

NOTICE

- When crushing reinforced concrete debris, they may remain around the jaw crusher outlet or on the belt conveyor.
 - When crushing them, check that there are no reinforcing bars left around those spots every two to three hours.
 - Remove the remaining reinforcing bars in the following manner to prevent a damage on the machine.
1. In order to secure working space for removing reinforcing bars, set the primary conveyor to a recycling posture, or remove the conveyor frame stopper bar off the conveyor stopper hook, and extend the primary conveyor two-way cylinder to the maximum.
 2. Detach the earth spillage preventive plates provided on both sides of the machine.
(Bolts used: M12 x 2 bolts/plate)
(Weight of earth spillage preventive plate :17.2 kg (37.93 lb)/plate)

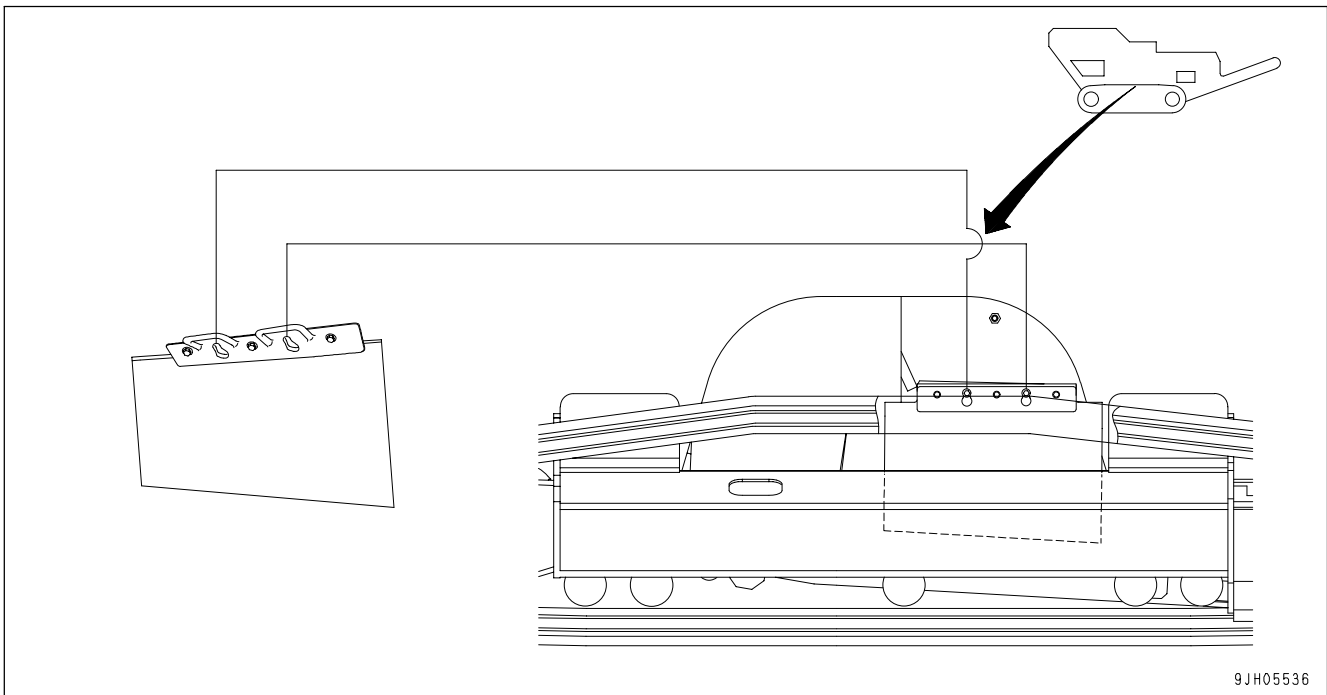

3. Enter the machine from the side of the engine frame and remove the accumulated steel rods.

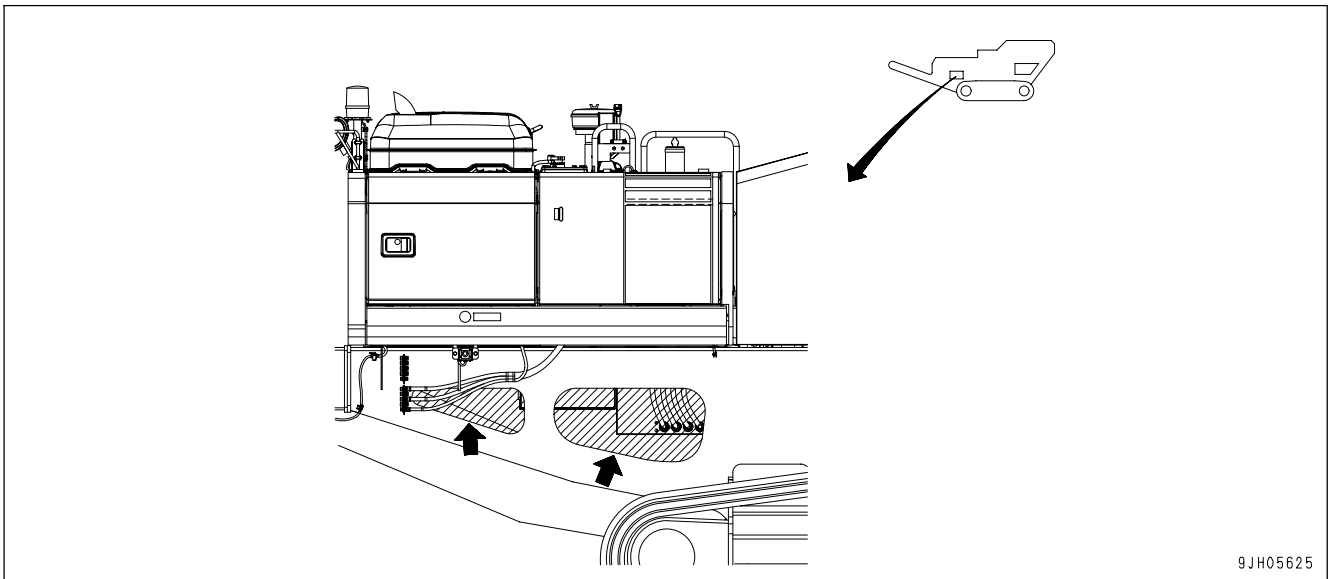

4. After all the reinforcing bars have been removed, attach the earth spillage preventive rubber plates that were detached in Item 2 above.

NOTICE

Be sure to push in the rubber part of the earth spillage preventive plates on to the primary conveyor frame surface after attaching them to the machine.

5. Following the instructions set forth in the section "STARTING JAW CRUSHER OPERATION (PAGE 3-91)", start the work again.

REMARK

If the steel rods are caught inside the conveyor and cannot be removed, run the conveyor in the reverse direction to reduce the pressure and make them easier to remove.

CAUTION

If inching is used continuously in the reverse operation, the soil on top of the conveyor will be carried back and accumulate, and this may damage the equipment. Watch the condition while using the inching operation.

- 1) Set the mode selector switch to inspection mode.
 - 2) Start the engine.
 - 3) Press the conveyor switch and run it in the normal direction and reverse direction. (It is actuated while the switch is kept pressed.)
- (1) Conveyor manual normal rotation switch
 (2) Conveyor manual reverse rotation switch

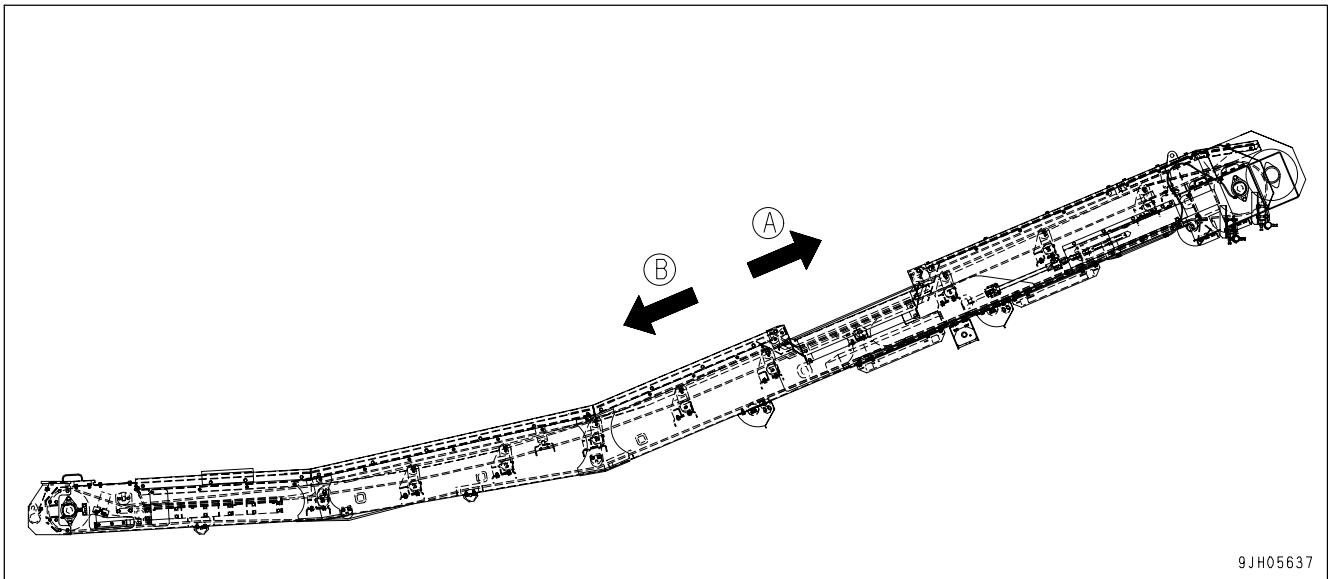
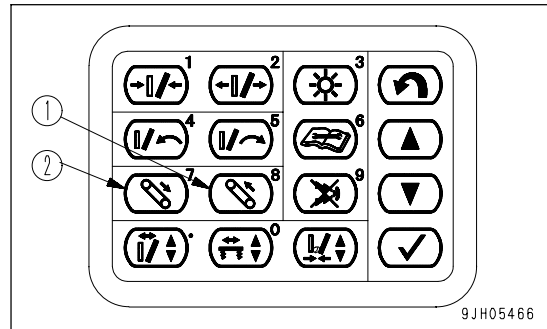

(A) Normal rotation

(B) Reverse rotation

CRUSHING NATURAL ROCKS

NOTICE

- If natural rock with large amounts of moisture (soil, mud, etc.) stuck to it is crushed, it may cause clogging of the grizzly feeder and premature wear of the fixed jaw plate, movable teeth, and packing at the discharge port of the crushing chamber of the jaw crusher, so use a skeleton bucket for the loading operation.
- When crushing boulders on river beds, set the selector switch on the crusher speed adjustment screen to the MIN position to carry out the work. This makes it possible to reduce the slip-up of boulders (flying out, floating to the top) and improve the production efficiency.

It is possible to crush boulders on river bed sites and rock that is dug up on rock crushing and tunnel project job sites.

The size after crushing can be adjusted to 50 to 150 mm (2.0 to 5.9 in) by adjusting the discharge clearance of the jaw crusher.

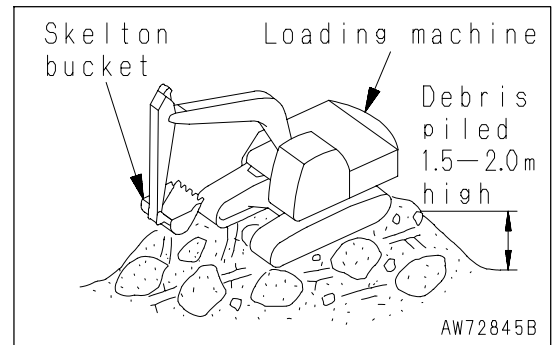

CRUSHING ASPHALT CONCRETE DEBRIS

The mobile crusher can crush asphalt concrete debris produced in a road construction site.

NOTICE

Asphalt concrete rubble has high viscosity, so be careful of the following points when carrying out the operation.

- If discharge port clearance (A) is set to less than 80 mm (3.2 in) (OSS), packing will occur more easily at discharge port (B) of the crushing chamber of the jaw crusher, so use with the discharge port clearance (A) of the jaw crusher within a range of 80 to 150 mm (3.2 to 5.9 in) (OSS).
- If the crushing effect drops because of the viscosity, press selector switch (14) on the crusher speed setting screen to display the setting screen, then use selector switches (2) and (3) to throttle the jaw crusher rotating speed and switch to low-speed crushing. This makes it possible to prevent softening of the asphalt caused by friction heat, and makes the operation more efficient.

Asphalt concrete is a mixture of asphalt, emulsion, and aggregate, and when it is crushed many times by the jaw crusher during compression crushing, it generates heat and changes to tar. As a result, if it stays for a long time inside the crusher, it clogs the discharge port (creates packing), and finally makes the crusher stop.

REMARK

O.S.S (Open Set Side) is the width when the outlet clearance of the jaw crusher is fully opened.

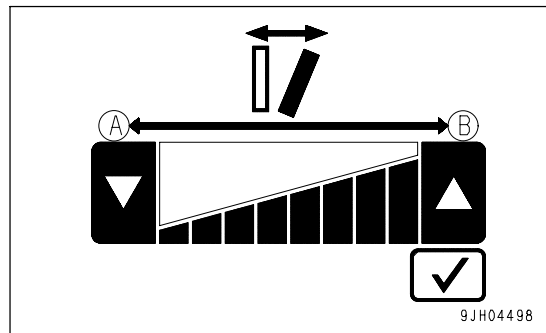
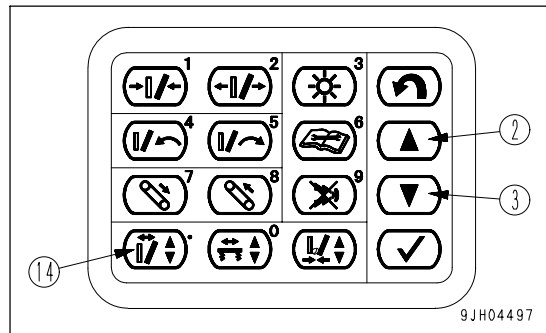
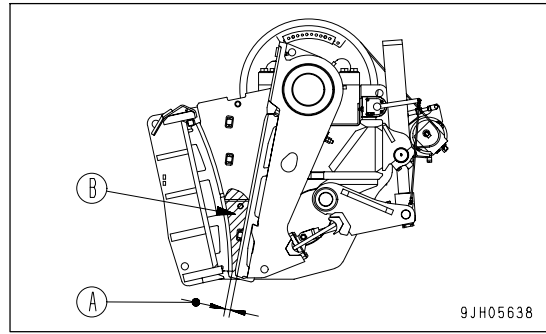

PRODUCTION OF PRODUCTS UNDER DESIRED SIZE

NOTICE

When creating products of under 40, adjust the clearance of the discharge port of the jaw crusher to a larger setting (for example: 60 to 80 mm (2.4 to 3.2 in) (OSS)), and use a vibratory sieve to adjust the particle size. This will have a great effect both on extending the service life of the machine and on production.

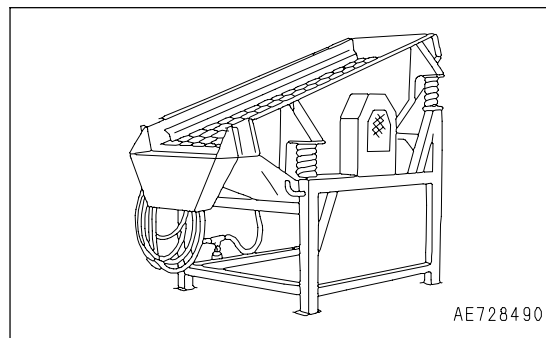

The jaw crusher carries out rolling compression and crushing, so particularly for natural rock, the influence of the grain peculiar to rocks may cause the generation of flat products.

When generating products with a desired particle size, such as under 40 or under 30, install the optional vibratory sieve when carrying out the crushing operation.

PROHIBITIONS FOR OPERATION

PROHIBITION OF SETTING OUTLET CLEARANCE NARROWER THAN 50 mm

NOTICE

When carrying out crushing operations for reinforced concrete at the 50 mm (2.0 in) setting, do not feed in steel rods with a circumference of more than $\phi 13$ under any circumstances.

The teeth plates will hit each other and may cause damage to the machine.

If discharge port clearance (1) is set to smaller than 50 mm (2.0 in), the following problems will occur.

- The load on the jaw crusher itself will become larger and this will reduce the service life of the jaw crusher.
- The service life of the tooth plate of fixed jaw plate (2) and swing jaw plate (3) will be reduced.
- The tooth plates of fixed jaw plate (2) and swing jaw plate (3) may hit each other.

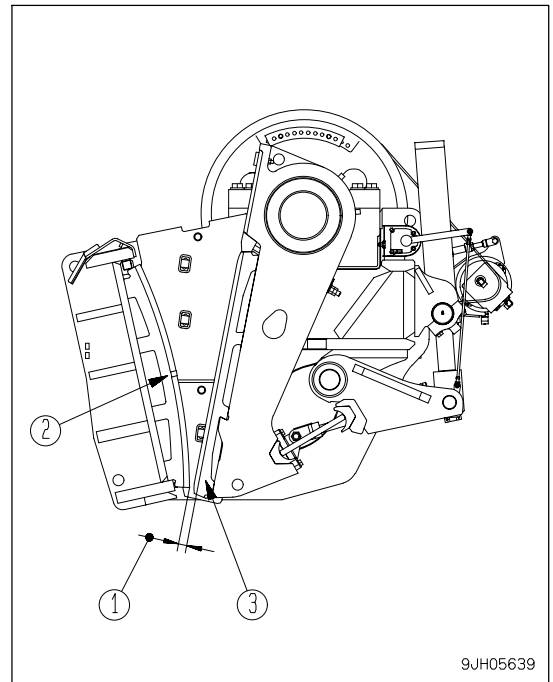

PROHIBITION OF WORK ON SLOPE

NOTICE

- Use spirit level (1) on the side of the control box to check that the machine is horizontal to the front, rear, left, and right before starting crushing operations.
Check also that the outermost lower wheels (4 places) are firmly in contact with the ground.
- If rock is protruding at the center portion (bottom of primary conveyor) between the tracks of the machine, there is danger that the conveyor frame and conveyor belt may be damaged when the primary conveyor is set in the operating posture.
Before bringing the machine in, level the ground and make it flat.

A crushing work on a slop will result in the following problems.

- Since the debris are huddled on one side of the crusher chamber, partial wear develops on the jaw plates.
- The debris crushed in the crusher chamber will not fall down on the center of the primary conveyor belt (partial loading), causing the conveyor to make a snaky movement.
- The machine may start to vibrate abnormally.

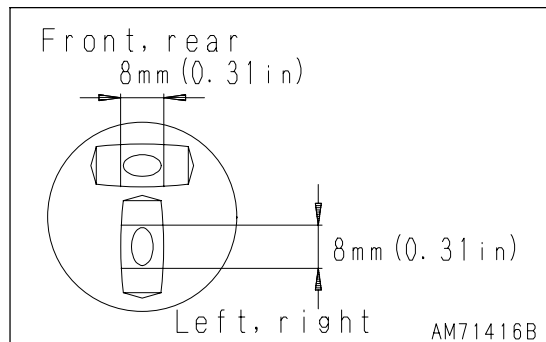
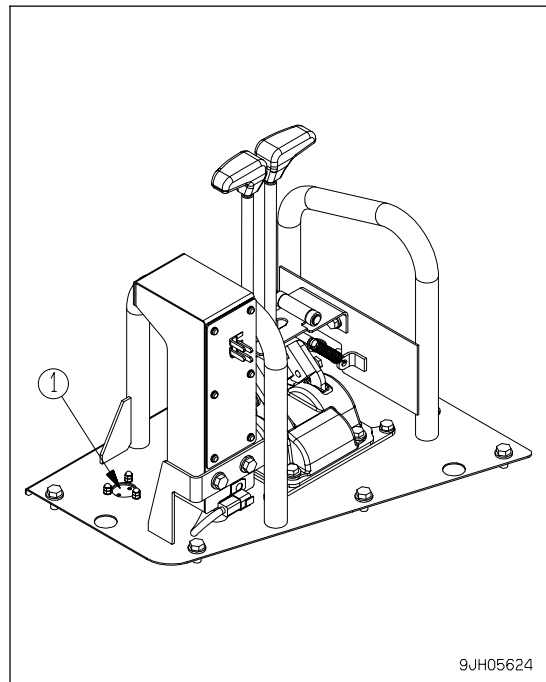
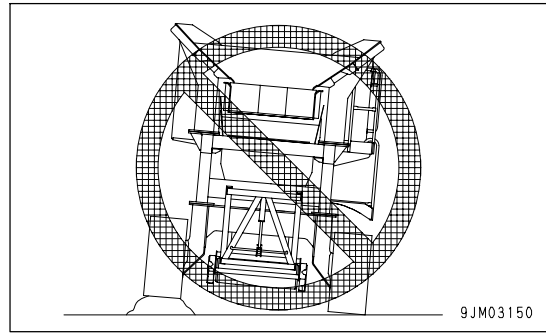

PRECAUTIONS WHEN TRAVELING UP OR DOWNHILLS



DANGER

- Keep the primary conveyor raised, while traveling the machine.
- If the machine has to climb over an obstacle on an unpaved road, lower the travel speed.
- Never try to change the traveling direction on a slope, nor traverse it. Climb down to a flat ground once and make a detour for safety.
- Never try to carry out a work, parking the machine on a slope.
- Do not travel the machine on a slope of more than 25° for fear of machine roll over.

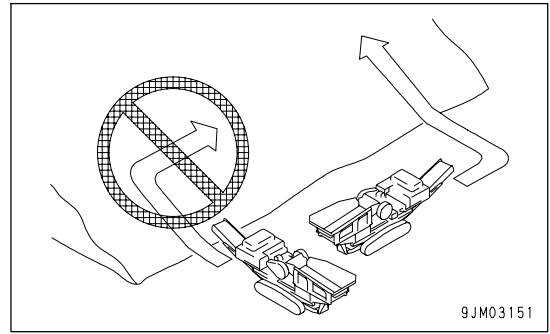

1. When climbing down a steep slope, lower the travel speed with the travel lever and fuel control dial. If a slope exceeds 10°, when climbing down, maintain the machine posture shown in the figure at right, while keeping a low engine rpm.
2. When climbing up a slope exceeding 10°, maintain the machine posture as shown in the figure at right, wherever possible.

REMARK

As far as possible, set with sprocket (S) at the downhill end when traveling up or down slopes. If the machine travels up or down slopes with sprocket (S) at the uphill end, it is easier for the track shoe assembly to become loose and to cause pitch jumping.

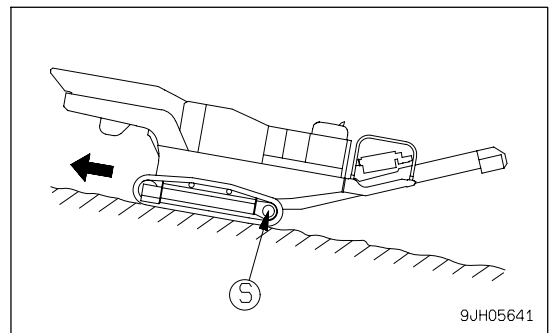
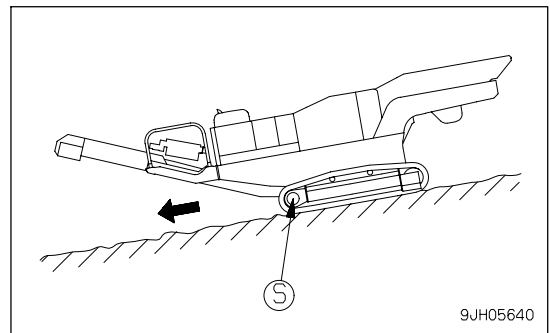

BRAKING AT DOWNHILL TRAVEL

In climbing down a slope, set the travel control lever to the neutral position for activating automatic braking.

IF ENGINE STOPS

If the engine stops while the machine is climbing on a slope, set the travel control lever to the neutral position, stop the machine once, and the start the engine again.

TRANSPORTATION

TRANSPORTATION PROCEDURE

Select the method of transportation to match the weight and dimensions given in "SPECIFICATIONS (PAGE 5-2)". Note that the weight and dimensions given in SPECIFICATIONS may differ according to other attachments.

LOADING, UNLOADING WORK



WARNING

- When loading or unloading the machine, run the engine at low idling and travel at low speed.
- When loading or unloading the machine, park a trailer on a level and solid roadbed. Moreover keep a good distance between the road shoulder and the machine.
- Make sure that ramps have sufficient width, length and thickness, and securely fix them, inclined at less than 15°. If an earth mound is employed, firmly compact it so that the slopes will not collapse.
- Remove mud or oil on the undercarriage beforehand so that the machine will not slip off sideways on the ramps. Furthermore remove water, snow, ice, grease, oil, etc. from the ramps, too.
- Never try to change the travel direction on the ramps. Otherwise the machine will slip off them. Return to the ground or the trailer bed once, and then change the direction.
- Do not operate any other lever than the travel control lever on the ramps.
- The center of gravity of the machine suddenly shifts forward at the connecting point of the ramps and trailer bed, throwing the machine off the balance. Pass it slowly for safety.
- Be sure to install after unloading the rear view mirror, handrails, step, etc. that were removed when the machine was loaded. Don not start a work without them, because it is dangerous, leading to an accident.

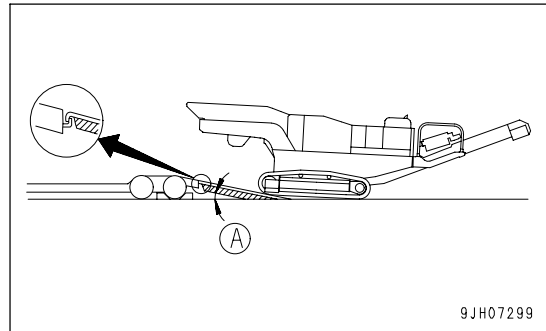

When loading or unloading, always use ramps or a platform. Proceed as follows.

LOADING

1. Load and unload on firm level ground only.
 Maintain a safe distance from the edge of a road.
2. Properly apply the brakes on the trailer and put blocks under the tires to ensure that the trailer does not move.
 Make the slope of the ramps a maximum of 15°.
3. Turn fuel control dial (2) fully to the left and run the engine at low idling.

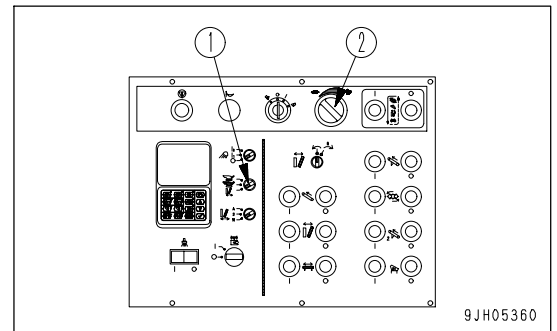
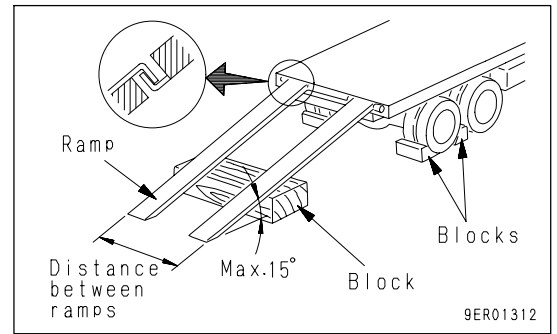

4. Set mode selector switch (1) to the TRAVEL (a) position, and check that the screen changes to the travel mode screen.

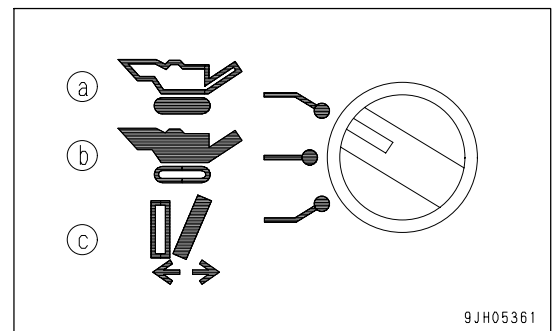

5. Set conveyor selector switch (1) on the conveyor up/down control panel to CONVEYOR (a).

(Only for machines equipped with muck discharge conveyor.)

6. Press conveyor UP switch (2) and remove the conveyor from the mount hook.

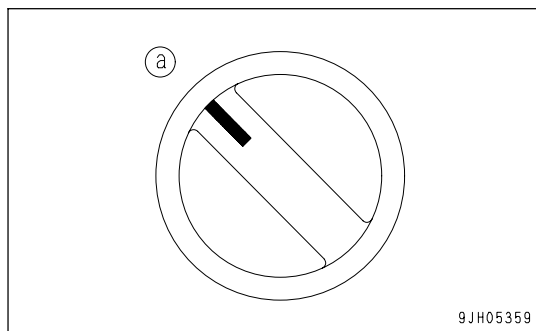
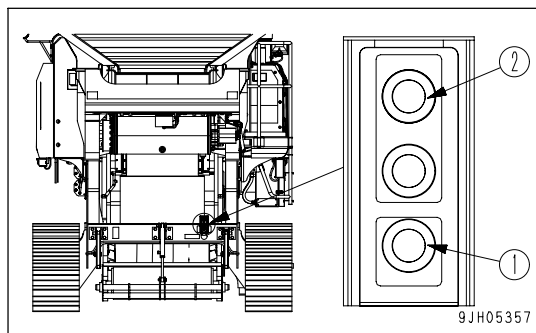

7. Using the conveyor up/down control switch, set the mount hook to fixed position (3) for travel.

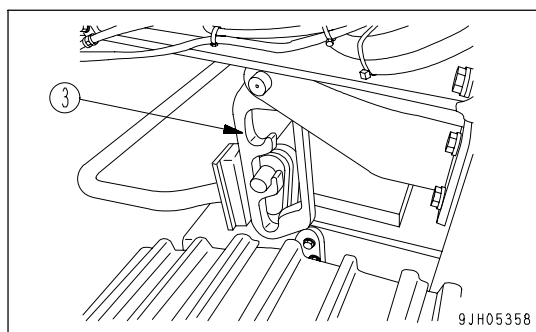

Install the grizzly feeder transportation lock pins.
Install pins (1) (left and right, two places) in the order (B) -> (A).

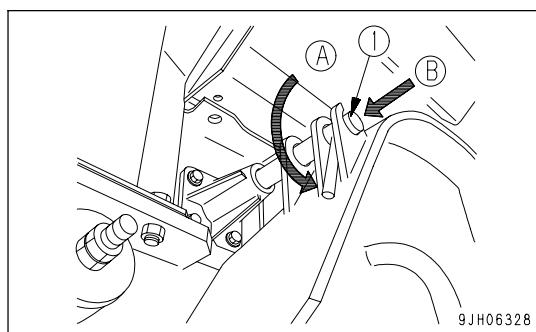

8. Remove travel lever lock (A).

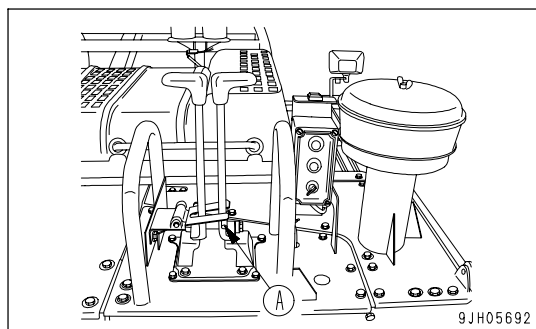

9. Push travel control levers (4) forward slowly for starting the machine.

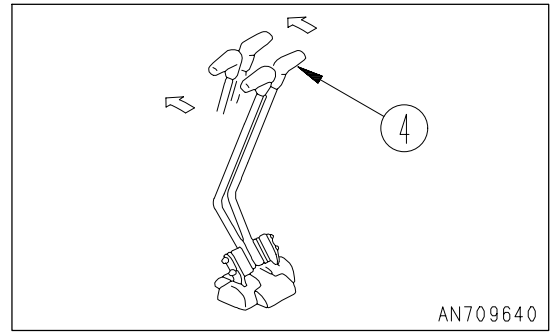

SECURING MACHINE

Load the machine onto a trailer as follows:

1. Stop the machine, when it takes a level posture right above the rear wheels on the trailer bed.
2. Move the machine forward slowly on the trailer.
3. Stop the machine at the specified position on the trailer.

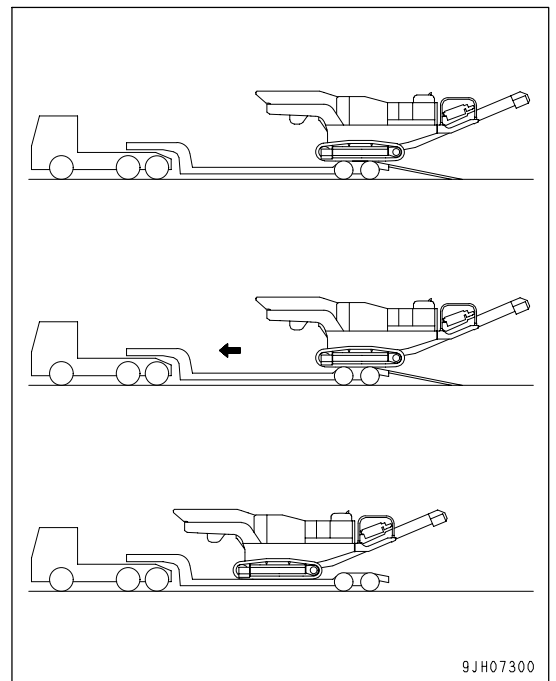

4. Stop the engine, then remove the key from the starting switch.
5. Apply travel lever lock (A) securely to lock the travel lever.

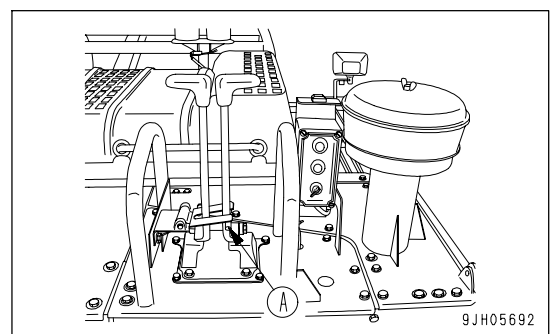

- When transporting the machine, place a rectangular block under the front and rear track shoes to prevent the machine from moving. Furthermore fasten the machine with chains or wire ropes of sufficient strength. Make sure particularly that the machine will not slip sideways.

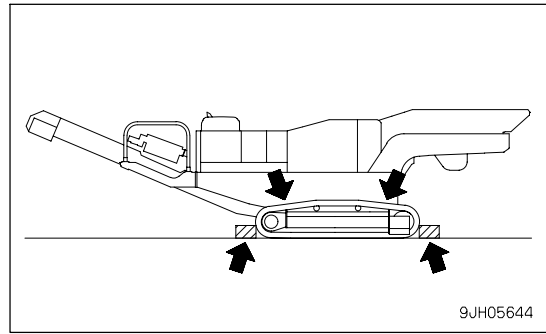

UNLOADING

- Load and unload on firm level ground only. Maintain a safe distance from the edge of a road.
- Properly apply the brakes on the trailer and put blocks under the tires to ensure that the trailer does not move. Make the slope of the ramps a maximum of 15°.

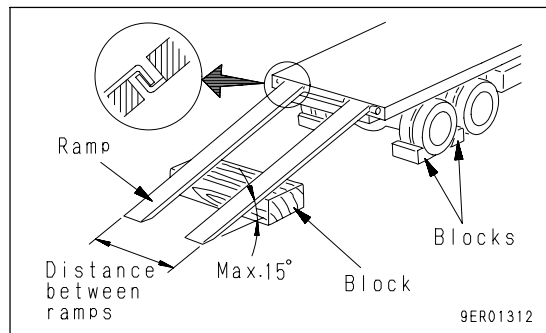

- Remove the chains and wire ropes fastening the machine.
- Start the engine.
Warm the engine up fully.
- Turn fuel control dial (2) fully to the left and run the engine at low idling.
- Set mode selector switch (1) to the TRAVEL position, and check that the travel (a) lock monitor goes out.

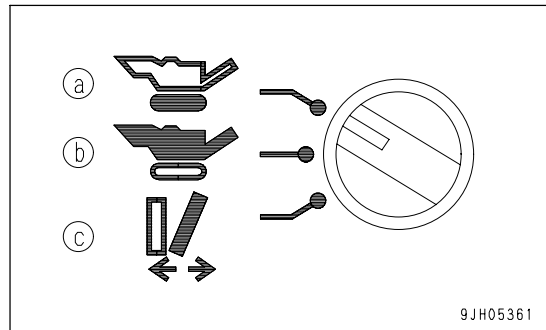
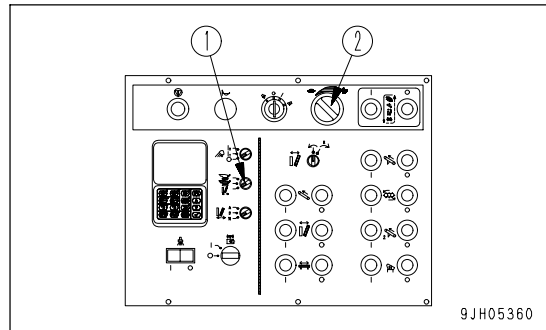

7. Remove travel lever lock (A).

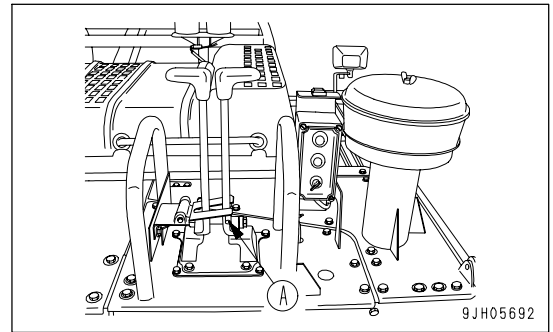

8. Pull travel control lever (4) backward slowly for starting the machine.
 9. Turn the machine toward the ramps and travel to them slowly. Never operate any other lever than the travel control levers on the ramps.

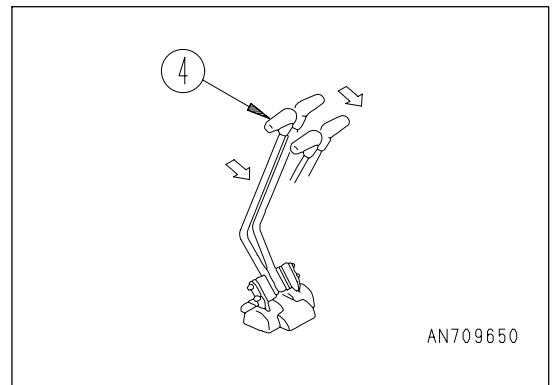

10. Stop the machine, when it takes a level posture right above the rear wheels on the trailer.

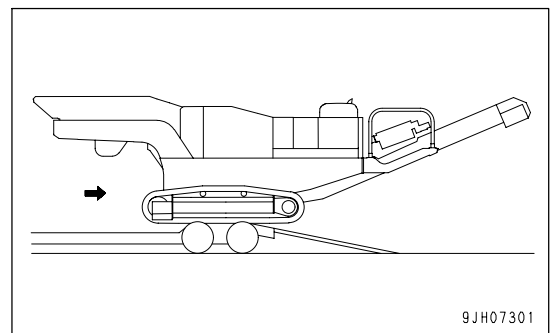

11. When climbing down the ramps, travel slowly, operating the travel control lever gently, until after the machine gets clear of the ramps completely.

12. After unloading and reaching the jobsite, remove grizzly feeder transportation lock pins (1) securely to the side of the grizzly feeder (left and right, 2 places) in the order (A) -> (B).

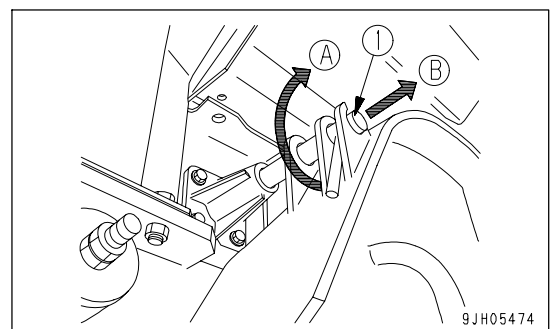

LIFTING MACHINE

**WARNING**

- The operator carrying out the lifting operation using a crane must be a properly qualified crane operator.
- Never raise the machine with any worker on it.
- Always make sure that the wire rope is of ample strength for the weight of this machine.
- When lifting, keep the machine horizontal.
- When carrying out lifting operations, set the travel lock lever to the LOCK position to prevent the machine from moving unexpectedly.
- Never enter the area under or around a raised machine.

Never try to lift the machine in any posture other than the posture given in the procedure below or using lifting equipment other than in the procedure below.

There is a hazard that the machine may lose its balance.

NOTICE

The lifting procedure applies to machines with standard specifications.

The method of lifting differs according to attachments and options actually installed on the machine. For the proper lifting procedures, contact your Komatsu distributor.

For details of the weight, see "SPECIFICATIONS (PAGE 5-2)".

When lifting the machine, perform the operation on flat ground as follows:

1. Set to the transportation posture when lifting the whole machine.
2. Set travel lever lock to the LOCK position.
3. Pass the lifting wire between the 1st and 2nd track rollers at both the front and rear.
4. Set the lifting angle (A) of the wire rope to 30° to 40°, then lift the machine slowly.
5. After the machine comes off the ground, check the hook condition and the lifting posture, and then lift slowly.

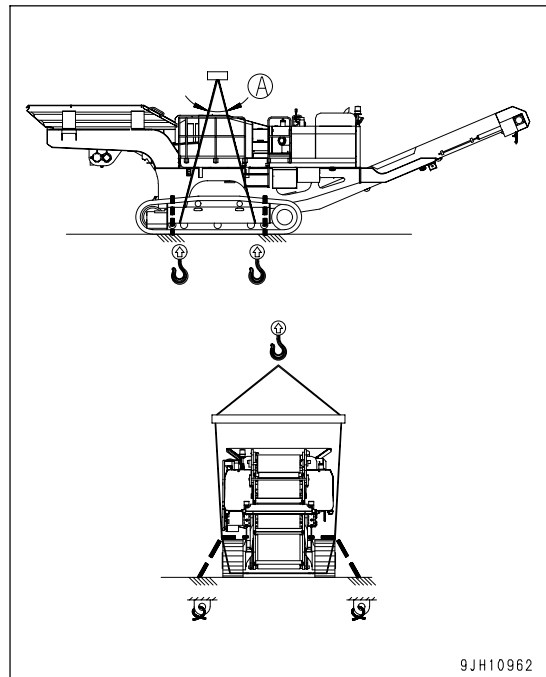

9JH10962

COLD WEATHER OPERATION

PRECAUTIONS FOR LOW TEMPERATURE

If the temperature becomes low, it becomes difficult to start the engine, and the coolant may freeze, so do as

FUEL AND LUBRICANTS

Change to fuel and oil with low viscosity for all components. For details of the specified viscosity, see "RECOMMENDED FUEL, COOLANT AND LUBRICANTS (PAGE 4-13)".

COOLANT



WARNING

- Antifreeze is toxic. Be careful not to get it into your eyes or on your skin. If it should get into your eyes or on your skin, wash it off with large amounts of fresh water and see a doctor at once.
- When changing the coolant or when handling coolant containing antifreeze that has been drained when repairing the radiator, please contact your Komatsu distributor or request a specialist company to carry out the operation. Antifreeze is toxic. Do not let it flow into drainage ditches or spray it onto the ground surface.
- Antifreeze is flammable. Do not bring any flame close. Do not smoke when handling antifreeze.

NOTICE

- Use Komatsu Supercoolant wherever available, or use permanent type antifreeze coolant.
- Never use methanol, ethanol, or propanol-based antifreeze.
- Do not use any water leakage prevention agent, either alone, or in combination with antifreeze.
- Do not mix one brand of antifreeze with a different brand.

For details of the antifreeze mixture when changing the coolant, see "CLEAN INSIDE OF COOLING SYSTEM (PAGE 4-28)".

MONITOR

A feature of the liquid-crystal monitor is that the screen becomes dark and is difficult to read in cold weather (particularly with the starting switch ON).

In this case, adjust the brightness and contrast of the screen.

For details, see "BRIGHTNESS ADJUSTMENT (PAGE 3-24)" and "CONTRAST ADJUSTMENT (PAGE 3-24)".

If the screen is dark, increase the brightness and contrast (extend the scale in the + E direction) to make the screen brighter and easier to read.

Brightness

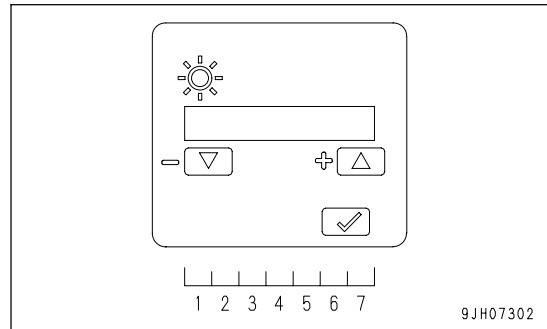

Contrast

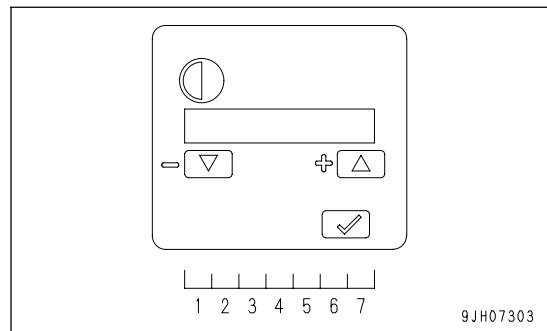

Guideline for bar display for brightness and contrast in cold weather

| Ambient temperature | Brightness | Contrast |
|---------------------|------------|----------|
| -10°C (14°F) | 7 (max) | 5 - 4 |
| -20°C (-4°F) | 7 | 7 - 6 |

BATTERY

**WARNING**

- To avoid gas explosions, do not bring fire or sparks near the battery.
- Battery electrolyte is dangerous. If it gets in your eyes or on your skin, wash it off with large amounts of water, and consult a doctor.

When the ambient temperature drops, the capacity of the battery will also drop. If the battery charge ratio is low, the battery electrolyte may freeze. Maintain the battery charge as close as possible to 100%. Insulate it against cold temperature to ensure the machine can be started easily the next morning.

REMARK

Measure the specific gravity and calculate the charging rate from the following conversion table.

| Charging Rate (%) | Electrolyte Temperature (°C) | 20 | 0 | -10 | -20 |
|-------------------|------------------------------|------|------|------|------|
| | 100 | | 1.28 | 1.29 | 1.30 |
| 90 | | 1.26 | 1.27 | 1.28 | 1.29 |
| 80 | | 1.24 | 1.25 | 1.26 | 1.27 |
| 75 | | 1.23 | 1.24 | 1.25 | 1.26 |

AFTER COMPLETION OF WORK

The undercarriage, belt conveyor and feeder may be frozen due to mud and water on them, hindering the engine from starting up the next morning. To prevent such a trouble, observe the following.

- Remove the mud and water on the machine.
- Park the machine on the hard and dry ground.
If a ground of such conditions is not available, place wooden boards on the ground and park the machine on them.
That practice will prevent the undercarriage from being frozen, keeping it off the ground, and the machine can
- Open the drain valve and drain any water collected in the fuel system to prevent it from freezing.
- As the battery capacity drastically drops in low temperatures, cover or remove the battery from the machine, store the battery in a warm place, and install it again the next morning.
- If the electrolyte level is low, add distilled water in the morning before beginning work. Do not add water after the day's work to prevent diluted electrolyte in the battery from freezing during the night.
- The machine can be protected from fast cooling down during the night time either by parking it in a garage or covering it with tarpaulin.
- Disconnect the hose from the water sprinkler nozzle or drain all water in it.

AFTER COLD WEATHER

When the season changes and the weather becomes warmer, do as follows.

- Replace the fuel and oil for all parts with oil of the viscosity specified.
For details, see "RECOMMENDED FUEL, COOLANT AND LUBRICANTS (PAGE 4-13)".

LONG-TERM STORAGE

BEFORE STORAGE

When putting the machine in storage for a long time, do as follows.

- Clean and wash all parts, then store the machine indoors. If the machine has to be stored outdoors, select level ground and cover the machine with canvas.
- Fill the fuel tank. This prevents moisture from collecting.
- Lubricate and change the oil before storage.
- Disconnect the negative terminals of the battery and cover it or remove it from the machine and store it
- Set the travel lock to the LOCK position.
- Coat the exposed portion of the piston rod of the hydraulic cylinder (primary conveyor up/down cylinder, muck discharge conveyor stowing cylinder (if equipped), lock cylinder) with grease.
- To prevent corrosion, be sure to fill the cooling system with Supercoolant (AF-NAC) or permanent type antifreeze (density between 30% and 68%).

DURING STORAGE



WARNING

If it is necessary to perform the rust-prevention operation while the machine is indoors, open the doors and windows to improve ventilation and prevent gas poisoning.

Operate the engine and move the machine for a short distance once a month so that a new film of oil will be coated over movable parts and component surfaces. At the same time, also charge the battery.

AFTER STORAGE

NOTICE

If the machine has been stored without carrying out the monthly rust-prevention operation, consult your Komatsu distributor before using it.

When using the machine after long-term storage, do as follows before using it.

- Wipe off the grease from the hydraulic cylinder rods.
- Be sure to apply oil and grease to all the parts requiring lubrication.
- When the machine is stored for a long period, moisture in the air will mix with the oil. Check the oil before and after starting the engine. If there is water in the oil, change all the oil.

STARTING MACHINE AFTER LONG-TERM STORAGE

- When starting the engine for the first time after a long storage period, observe the following procedures.
 1. Turn the starting switch key to the ON position.
 2. Turn the fuel control dial from the low idling (MIN) position to the full speed (MAX) position, and hold on at that position for three seconds. Then return the dial to the low idling position and start the engine.

TROUBLESHOOTING

AFTER RUNNING OUT OF FUEL

When starting the engine after it has run out of fuel, fill the tank with fuel, bleed the air from the fuel system, then start the engine.

For details of the method of bleeding the air, see "REPLACE FUEL FILTER CARTRIDGE (PAGE 4-74)".

PHENOMENA THAT ARE NOT FAILURES

Note that the following phenomena are not failures:

- When the machine travels down a slope at low speed, the travel motor generates noises.

METHOD OF TOWING MACHINE



WARNING

Serious injury or death could result if a disabled machine is towed incorrectly or if there is a mistake in the selection or inspection of the wire rope.

- Always check that the wire rope used for towing has ample strength for the weight of the machine being towed.
- Never use a wire rope which has cut strands (A), reduced diameter (B), or kinks (C). There is danger that the rope may break during the towing operation.
- Always wear leather gloves when handling wire rope.
- Never tow a machine on a slope.
- During the towing operation, never stand between the towing machine and the machine being towed.
- Operate the machine slowly and be careful not to apply any sudden load to the wire rope.

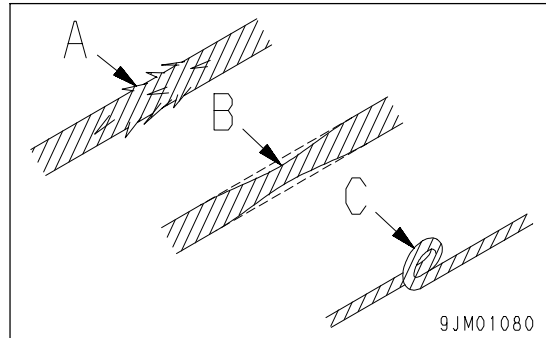

NOTICE

The max, allowable pull of this machine is 176,000N(18,000kg).

Do not attempt to pull anything beyond this limit.

- If the machine sinks in mud and cannot get out under its own power, or if the drawbar pull of the excavator is being used to tow a heavy object, use a wire rope as shown in the diagram on the right.
- Adjust putting angle of the wire rope to 15° or less so that the wire rope should not come in contact with the conveyer frame and pull it.
- Put a wooden block between the wire rope and the machine to prevent possible damages on the machine and the rope.
- Hold the wire rope level and direct it straight to the track frame.
- When towing a machine, travel at a speed of less than 1 km/h for a distance of only a few meters to a place that is suitable for carrying out repairs.

This is for use only in emergencies.

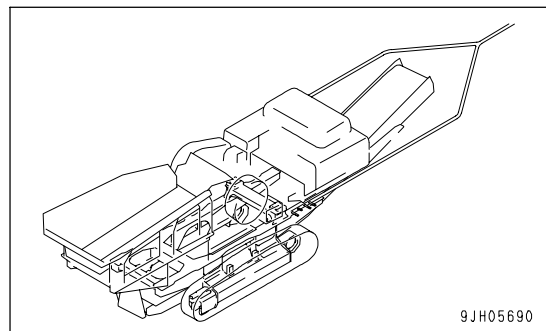

IF BATTERY IS DISCHARGED



WARNING

- Do not charge the battery when the battery is installed on the machine. This is dangerous.
- Before inspecting or handling the battery, stop the engine and turn the key in the starting switch to the OFF position.
- Batteries generate hydrogen gas, so there is danger of explosion. Never smoke or bring any flame close to the battery. Also be careful not to cause any spark.
- The battery electrolyte is dilute sulphuric acid, and it will attack your clothes or skin. If you get any battery electrolyte on your clothes or skin, wash it off immediately with large amounts of fresh water. If it gets into your eyes, wash immediately with fresh water, then consult a doctor for treatment.
- When handling the battery, wear protective glasses and rubber gloves.
- When removing the battery, remove the ground side (normally the negative (-) terminal) first. When installing the battery, install the positive (+) terminal first.
If any tool touches between the positive terminal and the chassis, it will cause a spark. This is dangerous, so be careful not to allow this to happen.
- If the terminal is loose, there is danger that defective contact may generate a spark and cause an explosion.
When connecting the terminal, be sure to tighten it securely.
- When removing or installing the battery, be sure to confirm the positive (+) terminal and negative (-) terminal.

When removing, disconnect the cable from the ground terminal first

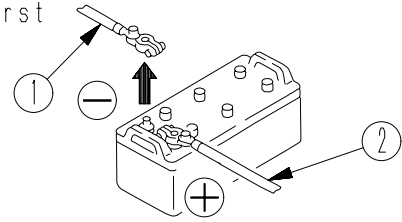

AE42128B

When installing, connect the cable to the positive (+) terminal first.

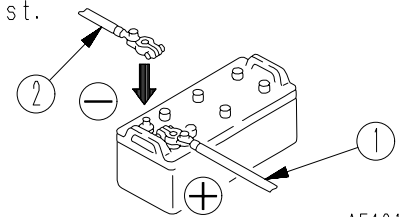

AE42129B

REMOVE AND INSTALL BATTERY

- Before removing the battery, remove the ground cable (normally connected to the negative (-) terminal).
If any tool touches between the positive terminal and the chassis, there is a hazard of sparks being generated.
- When installing the battery, connect the ground cable last.
- When replacing the battery, secure it with battery hold-down.
Tightening torque: Tightening battery terminal: 9.8 to 14.7 N·m (1 to 1.5 kgf·m, 7.2 to 10.8 lbf·ft)

PRECAUTIONS FOR CHARGING BATTERY

If the battery is charged improperly, it may explode. Accordingly, charge it according to "IF BATTERY IS DISCHARGED (PAGE 3-135)" and the instruction manual attached to the charger, and observe the following items.

- Set the voltage of the charger to match the voltage of the battery to be charged. If the correct voltage is not selected, the charger may overheat and cause an explosion.
- Connect the positive (+) charger clip of the charger to the positive (+) terminal of the battery, then connect the negative (-) charger clip of the charger to the negative (-) terminal of the battery. Be sure to attach the clips securely.

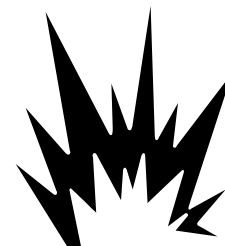

A0055110

- Set the charging current to 1/10 of the value of the rated battery capacity; when carrying out rapid charging, set it to less than the rated battery capacity.
If the charger current is too high, the electrolyte will leak or dry up, and this may cause the battery to catch fire and explode.
- If the battery electrolyte is frozen, do not charge the battery or start the engine with a different power source. There is a danger that this will ignite the battery electrolyte and cause the battery to explode.
- Do not use or charge the battery if the battery electrolyte level is below the LOWER LEVEL line. This may cause an explosion. Check the battery electrolyte level periodically and add distilled water to bring the electrolyte level to the UPPER LEVEL line.

STARTING ENGINE WITH BOOSTER CABLE

When starting the engine with a booster cable, do as follows:

PRECAUTIONS WHEN CONNECTING AND DISCONNECTING BOOSTER CABLE



WARNING

- When connecting the cables, never contact the positive (+) and negative (-) terminals.
- When starting the engine with a booster cable, always wear safety glasses.
- Be careful not to let the normal machine and problem machine contact each other. This prevents sparks from generating near the battery which could ignite the hydrogen gas given off by the battery. If hydrogen gas explodes, it could cause serious injury.
- Make sure you do not make a mistake in connecting the booster cables. Make the final connection to the engine block, be aware that sparks might be generated when this is done, so connect to a place as far as possible from the battery. (However, avoid connecting the cable to the work equipment, as conduction is poor.)
- Use care when removing the cables from the machine that has been started. To avoid hydrogen explosion, do not allow the cable ends to contact each other or the machine.

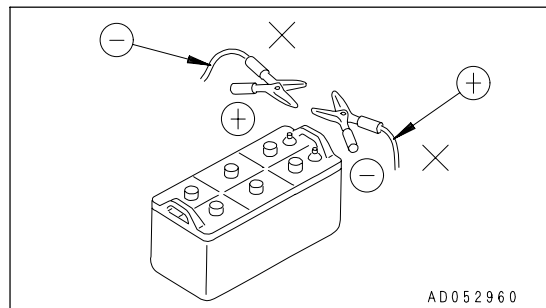

NOTICE

- The starting system on this machine is 24 V. Always use a 24 V machine for the normal machine also.
- Always use a booster cable or clip of a thickness that is suitable for the size of the battery.
- For the battery on the normal machine, use a battery with the same capacity as the problem machine.
- Check that the cable and clips are not damaged or corroded.
- Connect the clips securely.
- Check that the lock levers of both machines are at the LOCK position.
- Check that all levers are at the neutral position.

CONNECTING THE BOOSTER CABLE

Keep the starting switch of the normal machine and problem machine in the OFF position.

Connect the booster cable as follows, in the order of the numbers marked in the diagram.

1. Connect one clip of booster cable (A) to the positive (+) terminal of the problem machine.
2. Connect the other clip of booster cable (A) to the positive (+) terminal of the normal machine.
3. Connect one clip of booster cable (B) to the negative (-) terminal of the normal machine.
4. Connect the other clip of booster cable (B) to the engine block of the problem machine.

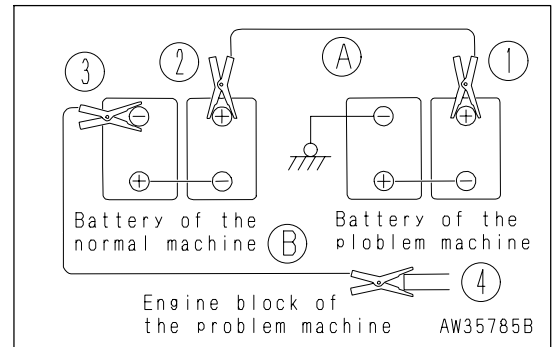
**STARTING ENGINE****CAUTION**

Check that the lock lever and the travel lever lock and work equipment lock switch is set at the LOCK position, irrespective of whether the machine is in a normal condition or broken down.

1. Make sure the clips are firmly connected to the battery terminals.
2. Start engine of the normal machine and run it at high idle speed.
3. Turn the starting switch of the problem machine to the START position and start the engine.
If the engine doesn't start at first, try again after 2 minutes or so.

DISCONNECTING THE BOOSTER CABLE

After the engine has started, disconnect booster cables in the reverse order in which they were connected.

1. Remove one clip of booster cable (B) from the engine block of the problem machine.
2. Remove the other clip of booster cable (B) from the negative (-) terminal of the normal machine.
3. Remove one clip of booster cable (A) from the positive (+) terminal of the normal machine.
4. Remove the other clip of booster cable (A) from the positive (+) terminal of the problem machine.

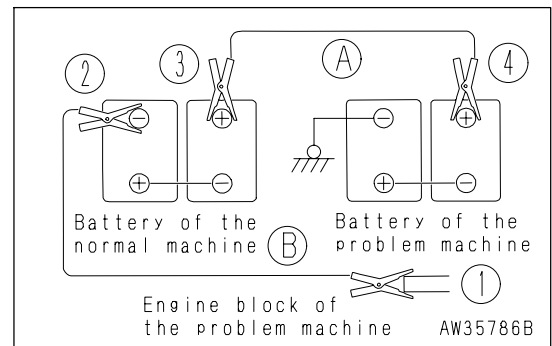

OTHER TROUBLE

CRUSHER AND RELATED ACCESSORIES

- (): Always contact your Komatsu distributor when dealing with these items.
- In cases of problems or causes which are not listed below, contact your Komatsu distributor for repairs.

| Problem | Main causes | Remedy |
|----------------------------------------|---------------------------------------|----------------------------------------------|
| Abnormal noise is generated | | |
| | | |
| | • Loosened main body securing | • Retighten |
| | • Backlash at fixed jaw plate | • Retighten fixed jaw plate wedge |
| | | |
| | • Wear on toggle plate and toggle | • Replace |
| | | |
| | • Backlash at swing jaw plate | • Retighten swing jaw plate |
| Vibration is big | • Machine in insufficient contact | • Level the ground |
| Abnormal heat is generated at bearings | | |
| | | |
| | • Machine in poor contact with ground | • Park machine on flat ground, using a level |

ELECTRICAL SYSTEM

- (): Always contact your Komatsu distributor when dealing with these items.
- In cases of problems or causes which are not listed below, contact your Komatsu distributor for repairs.

| Problem | Main causes | Remedy |
|--------------------------------------------------------------------------------------------------------------------------------------------------|-------------------------------------------------------------------------------------------------------------------------------------------------------|---------------------------------------------------------------------------------------------------------------------------------------------------------------------------------------------------------------------------|
| The lamps are dimly lit even with the maximum engine speed | <ul style="list-style-type: none"> • Defective wiring, deteriorated battery | (<ul style="list-style-type: none"> • Loose terminal, check for disconnection, repair, replace |
| The lamps flickers while the engine is running | <ul style="list-style-type: none"> • Loose fan belt | <ul style="list-style-type: none"> • Replace fan belt, |
| The charging level monitor flickers while the engine is running | <ul style="list-style-type: none"> • Alternator fault | (<ul style="list-style-type: none"> • Replace) |
| Abnormal noise is generated in the alternator | <ul style="list-style-type: none"> • Alternator fault | (<ul style="list-style-type: none"> • Replace) |
| The starting motor does not rotate with the engine starting switch turned on | <ul style="list-style-type: none"> • Wiring fault • Starting motor fault | (<ul style="list-style-type: none"> • Check and repair) (<ul style="list-style-type: none"> • Replace) |
| The starting motor alternates engagement and disengagement | <ul style="list-style-type: none"> • Battery charging amount shortage | <ul style="list-style-type: none"> • Charge battery (<ul style="list-style-type: none"> • Replace) |
| The starting motor turns the engine slowly | <ul style="list-style-type: none"> • Battery charging amount | <ul style="list-style-type: none"> • Charge battery |
| The starting motor is disengaged before the engine is started | <ul style="list-style-type: none"> • Defective wiring, defective ring gear, pinion | (<ul style="list-style-type: none"> • Check and repair) |
| Engine pre-heating monitor does not lights up | <ul style="list-style-type: none"> • Wiring fault • Heater relay fault | (<ul style="list-style-type: none"> • Check and repair) (<ul style="list-style-type: none"> • Replace) |
| Engine hydraulic oil pressure monitor remains lit up for more than three seconds, even after the engine is stopped (with the starting switch ON) | <ul style="list-style-type: none"> • Monitor fault • Defective caution lamp switch | (<ul style="list-style-type: none"> • Replace) (<ul style="list-style-type: none"> • Replace) |
| When outside of electric heater is touched by hand, it is not warm | <ul style="list-style-type: none"> • Wiring fault • Disconnection in electric heater • Defective actuation of heater | (<ul style="list-style-type: none"> • Check and repair) (<ul style="list-style-type: none"> • Replace) (<ul style="list-style-type: none"> • Replace) |

ENGINE

- (): Always contact your Komatsu distributor when dealing with these items.
- In cases of problems or causes which are not listed below, contact your Komatsu distributor for repairs.

| Problem | Main causes | Remedy |
|--------------------------------------------------------|-------------------------------------------------------------------------------------------------------------------------------------------------------------------------------------------------------------------------------------------------------------------------------|----------------------------------------------------------------------------------------------------------------------------------------------------------------------------------------------------------------------------------------------------------------------------|
| Engine oil pressure monitor lights up | <ul style="list-style-type: none"> • Engine oil pan oil level is low (sucking in air) • Clogged oil filter cartridge • Defective tightening of oil pipe, pipe joint, oil leakage from damaged point • Defective engine oil pressure | <ul style="list-style-type: none"> • Add oil to specified level, see CHECK BEFORE STARTING • Replace cartridge, see EVERY 500 HOURS SERVICE (• Check, repair) (• Replace sensor) |
| Steam spurts out from top of radiator (pressure valve) | <ul style="list-style-type: none"> • Coolant level low, leakage of water • Loose fan belt • Dirt or scale accumulated in cooling system | <ul style="list-style-type: none"> • Check, add coolant, repair, see CHECK BEFORE STARTING • Check fan belt tension, adjust, replace • Change coolant, flush inside of cooling system, see WHEN REQUIRED |
| Radiator coolant level monitor lights up | <ul style="list-style-type: none"> • Clogged radiator fins or damaged fins • Defective thermostat • Loose radiator filler cap (high-altitude operations) | <ul style="list-style-type: none"> • Clean or repair, see EVERY 500 HOURS SERVICE (• Replace thermostat) • Tighten cap or replace packing |
| Engine does not start when starting motor is turned | <ul style="list-style-type: none"> • Lack of fuel • Air in fuel system • Defective fuel injection pump or defective nozzle • Starting motor cranks engine sluggishly • Engine pre-heating monitor does not light up | <ul style="list-style-type: none"> • Add fuel, see CHECK BEFORE STARTING • Repair place where air is sucked in, see EVERY 500 HOURS SERVICE (• Replace pump or nozzle) • See ELECTRICAL SYSTEM • See ELECTRICAL SYSTEM |
| Exhaust gas is white or blue | <ul style="list-style-type: none"> • Too much oil in oil pan | <ul style="list-style-type: none"> • Set oil to specified level, see CHECK BEFORE STARTING |
| Exhaust gas occasionally turns black | <ul style="list-style-type: none"> • Clogged air cleaner element • Defective nozzle • Defective compression | <ul style="list-style-type: none"> • Clean or replace, see WHEN REQUIRED (• Replace nozzle) (• See defective compression above) |
| Combustion noise occasionally make breathing sound | <ul style="list-style-type: none"> • Defective nozzle | <ul style="list-style-type: none"> (• Replace nozzle) |

| Problem | Main causes | Remedy |
|--------------------------------------------------------|-----------------------------------------------------------------------------------------------------------------------------------|--------------------------------------------------------------------------------------------------------------------------------------------------------------------------------|
| Abnormal noise generated (combustion or mechanical) | <ul style="list-style-type: none">• Low-grade fuel being used• Overheating• Damage inside muffler | <ul style="list-style-type: none">• Change to specified fuel• Refer to "Radiator coolant level monitor lights up" as above(• Replace muffler) |

ELECTRONIC CONTROL SYSTEM AND RELATED ACCESSORIES

When the user code is shown on the display portion of the machine monitor, take the respective measures shown in the self-diagnosis chart below.

| Monitor Display | Failure Mode | Corrective Action |
|----------------------------------------------------------------------|--------------------------------|------------------------------------------------------------------------------------------------------------------------------------------------------------------------------------------------------------------------------------------------------|
| E02 | Error in pump control system | Ask for inspection promptly. |
| E05 | Error in speed governor system | Governor controller is incapacitated. Operate governor manually. For fixing at full speed, fixing bolt hole is provided on the bracket. In this case, have governor inspected promptly. Set machine in safe posture and receive inspection promptly. |
| When work equipment cannot be operated but no user code is displayed | | Ask for inspection promptly. |

POINT OF CONTACT TO TELEPHONE WHEN ERROR OCCURS

When error screen (A) is shown on the monitor, the screen will switch as follows after a fixed interval when input switch (1) is pressed:

Screen B -> screen C -> screen D -> screen B

When input switch (1) is pressed again, the screen will switch to error screen (A).

Check the contact telephone number on screen D.

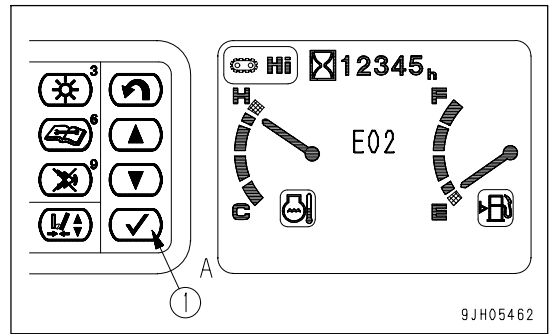

REMARK

If the point of contact telephone number has not been registered, screen B is not displayed.

If it is necessary to register the point of contact telephone number, ask your Komatsu distributor to register it.

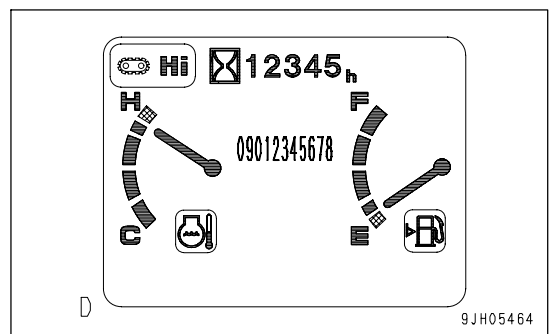
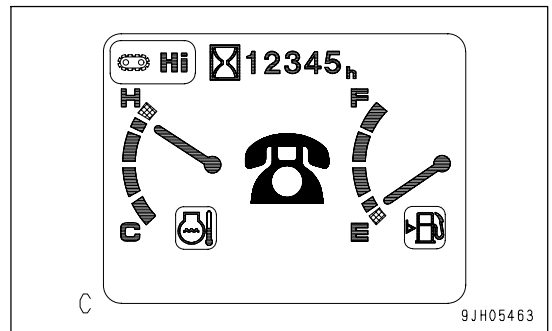
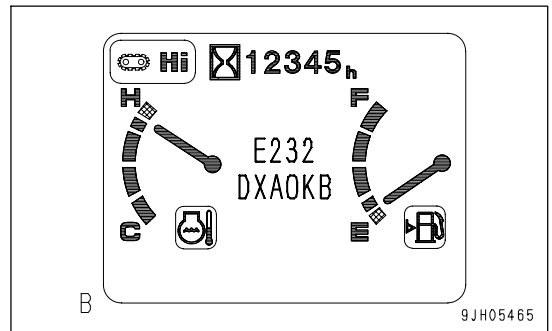

CHASSIS

- In cases of problems or causes which are not listed below, contact your Komatsu distributor for repairs.

| Problem | Main causes | Remedy |
|-------------------------------------------------------------------|--------------------------------------------------------------------------------------------------------------------------------------------------------|---------------------------------------------------------------------------------------------------------------------------------------------------------------------------------------------------------------------|
| Traveling speed, and crusher and conveyor rotating speed are slow | <ul style="list-style-type: none"> • Insufficient hydraulic oil | <ul style="list-style-type: none"> • Set to specified oil level. For details, see Check before |
| Abnormal noise generated from pump (air being sucked in) | <ul style="list-style-type: none"> • Clogged strainer element in | <ul style="list-style-type: none"> • Wash. For details, see EVERY |
| Hydraulic oil temperature rises too high | <ul style="list-style-type: none"> • Loosened cooling fan belt • Contaminated oil cooler • Insufficient hydraulic oil | <ul style="list-style-type: none"> • Replace fan belt. Check tension • Wash. For details, see EVERY 2000 HOURS SERVICE • Set to specified oil level. For details, see Check before |
| Track shoes go off Sprocket wears abnormally | <ul style="list-style-type: none"> • Track shoes loosened beyond specified limit | <ul style="list-style-type: none"> • Adjust tension. For details, see WHEN REQUIRED |

BELT CONVEYOR AND RELATED ACCESSORIES

| Problem | Main causes | Remedy |
|----------------|---------------------------------------------------------------------------------------------------------------------------------------------------------------------------------------------------------------------------------------------------------------------------------------------------------------------------------------------------------------------------------------------------------------------------------------------------------------------|--------------------------------------------------------------------------------------------------------------------------------------------------------------------------------------------------------------------------------------------------------------------------------------------------------------------------------------------------------------------------------------------------------------------------------------------------------------------------------------------------------------------------------------------|
| Conveyor belt | | |
| Not operable | <ul style="list-style-type: none"> • Electric circuit fault: Electric failure in section from switch to solenoid valve | <ul style="list-style-type: none"> • Correct wiring or relay connections |
| Snaky movement | <ul style="list-style-type: none"> • Misalignment of rollers and improper mounting • Debris transport direction • Debris stuck to rollers (Likewise wire or string winding about rollers) • Belt elongation • Belt bending, or not installed properly in endless processing • Frame twisting and bending • Frame not poised evenly (Belt is deflected to lower side) • Belt too rigid | <ul style="list-style-type: none"> • Adjust roller mounting angle • Load debris evenly in the middle of the belt, after making sure that the machine is kept level on the ground • Clean roller periphery • Adjust belt tension with take-up • Retry endless processing, or replace belt with new one • Correct twisting and eccentricity at time of assembly or machine installation • Correct twisting and eccentricity at time of assembly or machine installation |

| Problem | Main causes | Remedy |
|----------------------------------------|------------------------------------------------------------------------------------------------------------------------------------------------------------------------------------------------------------------------------------------------------------------------------------------------------------------------------------------------------|--------------------------------------------------------------------------------------------------------------------------------------------------------------------------------------------------------------------------------------------------------|
| Abnormal wear on backside | <ul style="list-style-type: none"> Slip on motor pulley (or driving pulley) surface Debris or foreign object stuck in between belt and pulley (Foreign objects stuck on pulley surface) | <ul style="list-style-type: none"> Correct belt elongation with take-up a. Remove foreign objects (Remove sticking) b. Improve loading conditions at loading part |
| Damage (fissure in vertical direction) | <ul style="list-style-type: none"> Debris or foreign objects caught where belt contacts hopper, scraper, etc Rollers falling off from bracket and bracket coming to direct contact belt Rollers of faulty rotation worn out and perforated Shock due to drop of large and heavy mass Edged debris | <ul style="list-style-type: none"> Remove foreign objects Insert rollers into bracket correctly Replace faulty rollers Devise to alleviate shock, or ensure right load Do not let such materials be |
| Abnormal elongation | <ul style="list-style-type: none"> Too strong take-up Transport of hot materials Abnormal load | <ul style="list-style-type: none"> Return to normal tension Replace with heat-resistant belt Ensure proper load |
| Warping | <ul style="list-style-type: none"> Oily debris (Warping to lower cover side) Transport of hot materials Acid content or alkali content | <ul style="list-style-type: none"> Remove cause for oil to mix with debris, or use oil-resistant belt Use heat-resistant belt Use acid-resistant or |
| Scraper | | |
| Wear and damage | <ul style="list-style-type: none"> Debris caught | <ul style="list-style-type: none"> a. Remove caught-in debris and correct scraper mounting so as to evenly contact belt b. Replace with new one |
| Rollers | | |
| Abnormal sound Breakage | <ul style="list-style-type: none"> Faulty rotation of rollers Wire or string winding about shafts Shock due to fall of large and | <ul style="list-style-type: none"> Replace with new one Remove foreign objects Take measures to ensure proper |
| Motor | | |
| Faulty operation | <ul style="list-style-type: none"> Insufficient hydraulic oil | <ul style="list-style-type: none"> a. Add oil up to specified level |

MAGNETIC SEPARATOR

- In cases of problems or causes which are not listed below, contact your Komatsu distributor for repairs.

| Problem | Main causes | Remedy |
|---------------------------------|-----------------------------------------------------------------------------------------------------------------------|------------------------------------------------------------------------------------------------------------------------------------|
| Abnormal sound from bearings | <ul style="list-style-type: none"> • Seizure of bearing | <ul style="list-style-type: none"> • Replace bearing |
| Snaky movement of belt | <ul style="list-style-type: none"> • Improper adjustment of pulley | <ul style="list-style-type: none"> • Adjust pulley position with take-up bolt |
| Breakage of belt Perforation | <ul style="list-style-type: none"> • Wear, fatigue or attraction of metal pieces on attractive surface | <ul style="list-style-type: none"> • Remove metal pieces DReplace belt with new one, depending on hole size and |
| Damage on scraper | - | |

MAINTENANCE

WARNING

Please read and make sure that you understand the SAFETY section before reading this section.

GUIDE TO MAINTENANCE

Do not perform any inspection and maintenance operation that is not found in this manual.
Stop the machine on flat hard ground when performing inspections and maintenance.

CHECK SERVICE METER:

Check the service meter reading every day to see if the time has come for any necessary maintenance to be performed.

KOMATSU GENUINE REPLACEMENT PARTS:

Use Komatsu genuine parts specified in the Parts Book as replacement parts.

KOMATSU GENUINE LUBRICANTS:

For lubrication of the machine, use the Komatsu genuine lubricants. Moreover use oil of the specified viscosity according to the ambient temperature.

CLEAN OIL AND GREASE:

Use clean oil and grease. Also, keep the containers of the oil and grease clean. Keep foreign materials away from oil and grease.

CHECKING FOREIGN MATERIALS IN DRAINED OIL:

After oil is changed or filters are replaced, check the old oil and filters for metal particles and foreign materials. If large quantity of metal particles or foreign materials are found, always report to the person in charge, and carry out suitable action.

FUEL STRAINER:

If an oil filler port is equipped with a strainer, do not remove it, when adding oil.

WELDING INSTRUCTIONS:

- Turn off the engine starting switch.
- Do not apply more than 200 V continuously.
- Connect grounding cable within 1 m (3.3 ft) of the area to be welded. If grounding cable is connected near instruments, connectors, etc., the instruments may malfunction.
- If a seal or bearing happens to come between the part being welded and grounding point, change the grounding point to avoid such parts.
- Do not use the area around the work equipment pins or the hydraulic cylinders as the grounding point.

DO NOT DROP THINGS INSIDE MACHINE:

- When opening inspection windows or the oil filler port of the tank to carry out inspection, be careful not to drop nuts, bolts, or tools inside the machine.
If such things are dropped inside the machine, it may cause damage and/or malfunction of the machine, and will lead to failure. If you drop anything inside the machine, always remove it immediately.
- Do not put unnecessary things in your pockets. Carry only things which are necessary for inspection.

DUSTY WORKSITES:

When working at dusty worksites, do as follows:

- Inspect the air cleaner clogging monitor frequently to see if the air cleaner is clogged.
Clean the air cleaner element at a shorter interval than specified.
- Clean the radiator core frequently to avoid clogging.
- Clean and replace the fuel filter frequently.
- Clean electrical components, especially the starting motor and alternator, to avoid accumulation of dust.

- When inspecting or changing the oil, move the machine to a place that is free of dust to prevent dirt from getting into the oil.

AVOID MIXING OILS:

If a different brand or grade of oil has to be added, drain the old oil and replace all the oil with the new brand or grade of oil. Never mix different brand or grade of oil.

LOCKING THE INSPECTION COVER:

Lock inspection cover securely into position with the lock bar. If inspection or maintenance is performed with inspection cover not locked in position, there is a danger that it may be suddenly blow shut by the wind and cause injury to the worker.

HYDRAULIC SYSTEM - AIR BLEEDING:

After repairing or replacing hydraulic equipment or removing hydraulic piping, it is necessary to bleed the air from inside the circuit. For details of the procedure for bleeding air, see "METHOD FOR RELEASING INTERNAL PRESSURE IN HYDRAULIC CIRCUIT (PAGE 4-64)".

HYDRAULIC HOSE INSTALLATION:

- When removing places fitted with O-rings, gaskets, or other seals, clean the mounting surface and replace with a new part.
When doing this, do not forget to install the O-rings and gaskets.
- When installing the hoses, do not twist them or bend them sharply. If they are installed so, their service life will be shortened extremely and they may be damaged.

CHECK AFTER INSPECTION AND MAINTENANCE WORKS:

If you forget to perform the checks after inspection and maintenance, unexpected problems may occur, and this may lead to serious injury or property damage. Always do the following:

- Checks after operation (with engine stopped)
 - Have any inspection and maintenance points been forgotten?
 - Have all inspection and maintenance items been performed correctly?
 - Have any tools or parts been dropped inside the machine? It is particularly dangerous if parts are dropped inside the machine and get caught in the lever linkage mechanism.
 - Are there any leakage of coolant or oil? Have all nuts and bolts been tightened?
- Checks when operating engine
 - For details of the checks when operating the engine, see "PROPER TOOLS (PAGE 2-37)" and pay careful attention to safety.
 - Are the inspection and maintenance items working properly?
 - Is there any leakage of fuel or oil when the engine speed is raised?

SELECTING FUEL AND LUBRICANTS TO MATCH AMBIENT TEMPERATURE:

It is necessary to use fuel and lubricants that match the ambient temperature.

For details, see "RECOMMENDED FUEL, COOLANT AND LUBRICANTS (PAGE 4-13)".

OUTLINE OF SERVICE

- Always use Komatsu genuine parts for replacement parts, grease or oil.
- When changing the oil or adding oil, do not mix different types of oil. When changing the type of oil, drain all the old oil and fill completely with the new oil. Always replace the filter at the same time. (There is no problem if the small amount of oil remaining in the piping mixes with the new oil.)
- Unless otherwise specified, when the machine is shipped from the factory, it is filled with the oil and coolant listed in the table below.

| Item | Type |
|--------------------------------|---------------------------------------------------------------------|
| Engine oil pan | Engine oil EO15W40DH (Komatsu genuine parts) |
| Damper case | Power train oil TO30 (Komatsu genuine parts) |
| Jaw crusher motor bearing case | |
| Final drive case | |
| Grizzly feeder vibrator case | |
| Hydraulic oil system | Power train oil TO10 (Komatsu genuine parts) |
| Radiator | Supercoolant AF-NAC (density: 30% or above) (Komatsu genuine parts) |

HANDLING AND PERFORMANCE OF OIL CLINIC FOR OIL, FUEL, COOLANT

OIL

- The engine and hydraulic equipment are used under extremely severe conditions (high temperature, high-pressure), so the oil deteriorates as time passes.
Always use the recommended oil in the list given in the Operation and Maintenance Manual that matches the grade, maximum temperature, and minimum temperature.
Even if the oil is not dirty, always change the oil at the specified interval.
- Oil corresponds to blood in the human body, always be careful when handling it to prevent any impurities (water, metal particles, dirt, etc.) from getting in.
The majority of problems with the machine are caused by the entry of such impurities.
Take particular care not to let any impurities get in when storing or adding oil.
- Never mix oils of different grades or brands.
- Always add the specified amount of oil.
Having too much oil or too little oil are both causes of problems.
- If the oil in the hydraulic equipment becomes cloudy, there is probably water or air inside the circuit. Please consult your Komatsu distributor.
- When changing the oil, always replace the related filters at the same time.
- We recommend you to have an analysis made of the oil periodically to check the condition of the machine. For those who wish to use this service, please contact your Komatsu distributor.

FUEL

- The fuel pump is a precision instrument, and if fuel containing water or dirt is used, it cannot work properly.
- Be extremely careful not to let impurities get in when storing or adding fuel.
- Always use the fuel specified in the Operation and Maintenance Manual.
Fuel may congeal depending on the temperature when it is used (particularly in low temperature below -15°C (5°F)). It is necessary to use the fuel that is suitable for the temperature.
- To prevent the moisture in the air from condensing and forming water inside the fuel tank, always fill the fuel tank after completing the day's work.
- Before starting the engine, or when 10 minutes have passed after adding fuel, drain the sediment and water from the fuel tank.
- If the engine runs out of fuel, or if the filters have been replaced, it is necessary to bleed the air from the circuit.

COOLANT AND DISTILLED WATER

- Coolant is diluted for use, but always use distilled water or city water (soft water) when diluting it. River water and well water (hard water) contain minerals (calcium and magnesium) in large quantities, and this will cause scale to form inside the engine or radiator. Once scale has formed, it is difficult to remove it, resulting in defective heat exchange, which will lead to overheating. To avoid this, we recommend using water with a hardness of less than 100 PPM/liters when diluting the coolant.
- This machine is filled with Komatsu genuine super coolant (AF-NAC) at the factory. This super coolant has the important function of preventing corrosion in the cooling system as well as preventing freezing.
As a general rule, we do not recommend use of any coolant other than the Komatsu super coolant (AF-NAC). If any other coolant is used, it may cause serious problems with the engine and cooling system.
- Komatsu genuine super coolant can be used continuously for two years or 4000 hours.
- The undiluted coolant is flammable, so be particularly careful to keep it away from flame.
- The mixing ratio for the super coolant differs according to the ambient temperature.
For details of the mixing ratio, see "CLEAN INSIDE OF COOLING SYSTEM (PAGE 4-28)".
- If the engine overheats, wait for the engine to cool before adding coolant.
- If the coolant level is low, it will cause overheating, and will also cause problems with corrosion due to air entering the coolant.

GREASE

- Grease is used to prevent seizure and noises at the joints.
- This construction equipment is used under heavy-duty conditions. Always use the recommended grease and follow the change intervals and recommended ambient temperatures given in this Operation and Maintenance Manual.
- The nipples not included in the MAINTENANCE section are nipples used when overhauling, so they do not need grease.
If any part becomes stiff or generates noise after being used for a long time, grease it.
- Always wipe off all of the old grease that is pushed out when greasing.
Be particularly careful to wipe off the old grease in places where sand or dirt sticking in the grease would cause wear of the rotating parts.

PERFORMANCE OF OIL CLINIC

The Komatsu oil clinic samples the oil periodically and analyzes it. This is a preventive maintenance service, which provides early discovery of abnormal parts and wear of the drive parts of the machine. This then makes it possible to ensure prevention of failures and reduction in downtime.

Komatsu's long years of experience and rich supply of accumulated data make it possible to accurately determine the condition of your machine. This enables us to locate the problems and to recommend suitable and timely repair methods.

The oil clinic charges the customer only the actual costs, and provides an immediate report of the results of the analysis and recommendations for action to take, so we strongly recommend you to avail yourself of this service.

ANALYSIS ITEMS

- Measurement of density of metal wear particles
This uses an ICP (Inductively Coupled Plasma) analyzer to measure the density of iron, copper, and other metal wear particles in the oil.

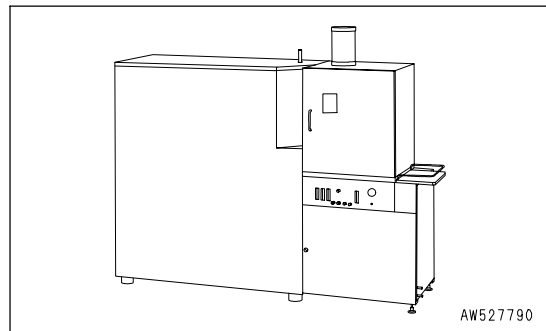

- Measurement of quantity of particles
This uses a particle quantifier index measurement machine to measure the quantity of iron particles of 5µ or more, enabling early detection of failures.

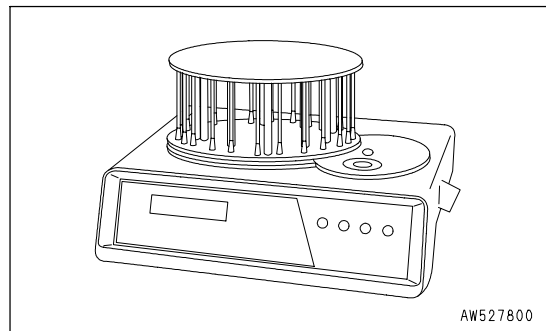

- Others
Measurements are made of items such as the ratio of water in the oil, density of the antifreeze coolant, ratio of fuel in the oil, and dynamic viscosity, enabling a highly precise diagnosis of the machine's health.

SAMPLING OIL

- Sampling interval
250 hours: Engine
500 hours: Other components
- Precautions when sampling
 - Make sure that the oil is well mixed before sampling.
 - Perform sampling at regular fixed intervals.
 - Do not perform sampling on rainy or windy days when water or dust can get into the oil.

For further details of KOWA, please contact your Komatsu distributor.

KEEPING AND STORING OIL, FUEL

- Keep indoors to prevent any water, dirt, or other impurities from getting in.
- When keeping drum cans for a long period, put the drum on its side so that the filler port of the drums is at the side to prevent moisture from being sucked in.
If drums have to be stored outside, cover them with a waterproof sheet or take other measures to protect them.
- To prevent any change in quality during long-term storage, be sure to use in the order of first in - first out (use the oldest oil or fuel first).

FILTERS

- Filters are extremely important safety parts. They prevent impurities in the fuel and air circuits from entering important equipment and causing problems.
Replace all filters periodically. For details, see the Operation and Maintenance Manual.
However, when working in severe conditions, replace the filters at shorter intervals according to the oil and fuel (sulfur content) being used.
- Never try to clean the filters (cartridge type) and use them again. Always replace with new filters.
- When replacing oil filters, check if any metal particles are attached to the old filter. If any metal particles are found, contact your Komatsu distributor.
- Do not open packs of spare filters until just before they are to be used.
- Use of Komatsu genuine filter elements is strongly recommended.

RELATING TO ELECTRIC SYSTEM

- If the wiring gets wet or the insulation is damaged, there may likely be short circuit. That is very dangerous, since a defective electric parts often results in an erratic motion of the machine. Hence avoid to splash water on the electric accessories and repair damaged insulation.
- Inspection and maintenance works include checking the fan belt for tension and damage as well as the battery for electrolyte level.
- Never try to dismantle the electrical accessories installed on the machine or disassemble them.
- Never install any electric components other than those specified by Komatsu.
- When washing the machine, or when it rains, take care so that the electric accessories do not get splashed with water.
- External electro-magnetic interference may cause malfunction of the control system controller, before installing a radio receiver or other wireless equipment, contact your Komatsu distributor.
- When the machine is operated on a seaside, take a good care of the electric accessories so that they do not get corroded.

OUTLINE OF HYDRAULIC EQUIPMENT

- The hydraulic components are hot during and right after operation. Moreover they are under high pressure while in operation. Take a good care when carrying out inspection or maintenance work for them under such circumstances.
- Inspection and maintenance include checking the hydraulic system for oil level, replacement of filter elements and replacement of hydraulic oil.
- When disconnecting the high pressure hoses, check that there is no flaw on the O rings. Replace it with new one, if any.
- When the hydraulic oil filter elements or strainers are cleaned or replaced, or when any hydraulic component has been repaired or replaced, or when a hydraulic piping has been disconnected, bleeding air from the hydraulic system is required.

AIR-BLEEDING FROM HYDRAULIC CIRCUIT

When the hydraulic oil filter elements or strainers are cleaned or replaced, or when any hydraulic component has been repaired or replaced, or when a hydraulic piping has been disconnected, bleed air from the hydraulic oil

JOB CONTENTS AND AIR-BLEEDING PROCESS

| Item Contents of work | Air bleeding procedure | | | | | | |
|-----------------------------------------------------------------------------------|--------------------------|-----------------|------------------------------------------|---------------------------------------|----------------------------------|-----------------------------------------|--------------------|
| | 1 | 2 | 3 | 4 | 5 | 6 | 7 |
| | Air bleeding in the pump | Starting engine | Air bleeding in the grizzly feeder motor | Air bleeding in the jaw crusher motor | Air bleeding in the travel motor | Air bleeding in the belt conveyor motor | Starting operation |
| • Replacement of hydraulic tank • Cleaning of strainer | ○ → | ○ → | ○ → | ○ → | ○ → | | ○ |
| • Replacement of return filter element | | ○ → | | | | | ○ |
| • Replacement and repair of pump • Removal of suction piping | ○ → | ○ → | ○ → | ○ → | ○ → | | ○ |
| • Replacement and repair of control valve | | ○ → | ○ → | ○ → | ○ → | | ○ |
| • Replacement of grizzly feeder motor • Removal of grizzly feeder motor piping | | ○ → | ○ → | | | | ○ |
| • Replacement of jaw crusher motor • Removal of jaw crusher motor piping | | ○ → | | ○ → | | | ○ |
| • Replacement of travel motor • Removal of travel motor piping | | ○ → | | | ○ → | | ○ |
| • Replacement of belt conveyor motor • Removal of belt conveyor motor piping | | ○ → | | | | ○ → | ○ |

WEAR PARTS

Replace wear parts such as the filter element or air cleaner element at the time of periodic maintenance or before they reach the wear limit. The wear parts should be replaced correctly in order to ensure more economic use of the machine. When replacing parts, always use Komatsu genuine parts.

As a result of our continuous efforts to improve product quality, the part number may change, so inform your Komatsu distributor of the machine serial number and check for the latest part number when ordering parts.

WEAR PARTS LIST

The parts in parentheses are to be replaced at the same time.

| Item of Filter | Part No. | Part Name | Q'ty | Replacement Interval |
|-----------------------------|-------------------------------|---------------------|----------|--------------------------|
| Engine oil filter | 6736-51-5142 | Cartridge | 1 | Every 500 hours service |
| Hydraulic oil filter | 20Y-60-31121 (07000-15160) | Element (O-ring) | 1 (1) | Every 1000 hours service |
| Fuel filter | 6732-71-6111 | Cartridge | 1 | Every 500 hours service |
| Hydraulic oil tank breather | 20Y-60-21470 | Element | 1 | Every 500 hours service |
| Air cleaner | 600-185-4100 | Element assembly | 1 | - |

JAW CRUSHER RELATED PARTS

| No. | Part Name | Part No. | Q'ty | Unit Weight [kg (lb)] |
|-----|--------------------------------------------|--------------|------|-----------------------|
| 1 | Protector | 8240-70-5091 | 1 | 72.0 |
| 2 | Protector bolt | 01010-81680 | 4 | - |
| 3 | Protector washer | 01643-31645 | 4 | - |
| 4 | Wedge (for fixed jaw plate) | 8240-70-5791 | 2 | 2.7 |
| 5 | Wedge bolt (for fixed jaw plate) | 8240-70-5491 | 2 | 1.4 |
| 6 | Wedge nut (for fixed jaw plate) | 01580-12419 | 2 | - |
| 7 | Wedge rod cover (for fixed jaw plate) | 8240-70-6120 | 2 | 0.3 |
| 8 | Wedge washer (small) | 01643-32460 | 2 | - |
| 9 | Wedge washer (large) (for fixed jaw plate) | 8293-70-1580 | 2 | 1.2 |
| 10 | Wedge spring (for fixed jaw plate) | 8240-70-5710 | 2 | 3.6 |
| 11 | Dust cover | 8240-70-5910 | 1 | 0.9 |
| 12 | Fixed jaw plate | 8240-70-5051 | 1 | 890.4 |
| 13 | Swing jaw plate | 8240-70-5071 | 1 | 726.5 |
| 14 | Cheek plate (upper right) | 8240-70-5112 | 1 | 74.3 |
| 15 | Cheek plate (lower right) | 8240-70-5142 | 1 | 36.2 |
| 16 | Cheek plate (upper left) | 8240-70-5122 | 1 | 74.3 |
| 17 | Cheek plate (lower left) | 8240-71-5132 | 1 | 36.2 |
| 18 | Cheek plate bolt | 8240-70-5691 | 6 | 0.6 |
| 19 | Cheek plate nut | 01580-12419 | 12 | - |
| 20 | Cheek plate washer | 01644-12408 | 6 | - |
| 21 | Wedge (for swing jaw plate) | 8240-70-5083 | 1 | 36.2 |
| 22 | Wedge bolt (for swing jaw plate) | 8240-70-5482 | 2 | 2.3 |
| 23 | Wedge nut (for swing jaw plate) | 01580-12419 | 4 | - |
| 24 | Wedge washer (small) (for swing jaw plate) | 01643-32460 | 4 | - |
| 25 | Wedge washer (large) (for swing jaw plate) | 8293-70-1580 | 2 | 1.2 |
| 26 | Wedge spring (for swing jaw plate) | 8240-70-5710 | 2 | 3.6 |
| 27 | Toggle seat (for swing jaw side) | 8240-70-5190 | 1 | 44.3 |
| 28 | Toggle seat holder (right) | 8240-70-5641 | 1 | 10.0 |
| 29 | Toggle seat holder (left) | 8240-70-5741 | 1 | 10.0 |
| 30 | Toggle seat holder bolt | 01010-82065 | 8 | - |
| 31 | Toggle seat holder washer | 01643-32060 | 8 | - |
| 32 | Toggle seat (toggle link end) | 8240-70-5180 | 1 | 40.0 |
| 33 | Toggle seat holder (toggle link end) | 209-62-14430 | 2 | - |
| 34 | Toggle seat holder bolt (toggle link end) | 01024-81230 | 4 | - |
| 35 | Toggle plate | 8240-70-5172 | 1 | 101.3 |
| 36 | V-belt (5V-1700 x 9 pcs) | 8240-70-5730 | 1 | 7.8 |

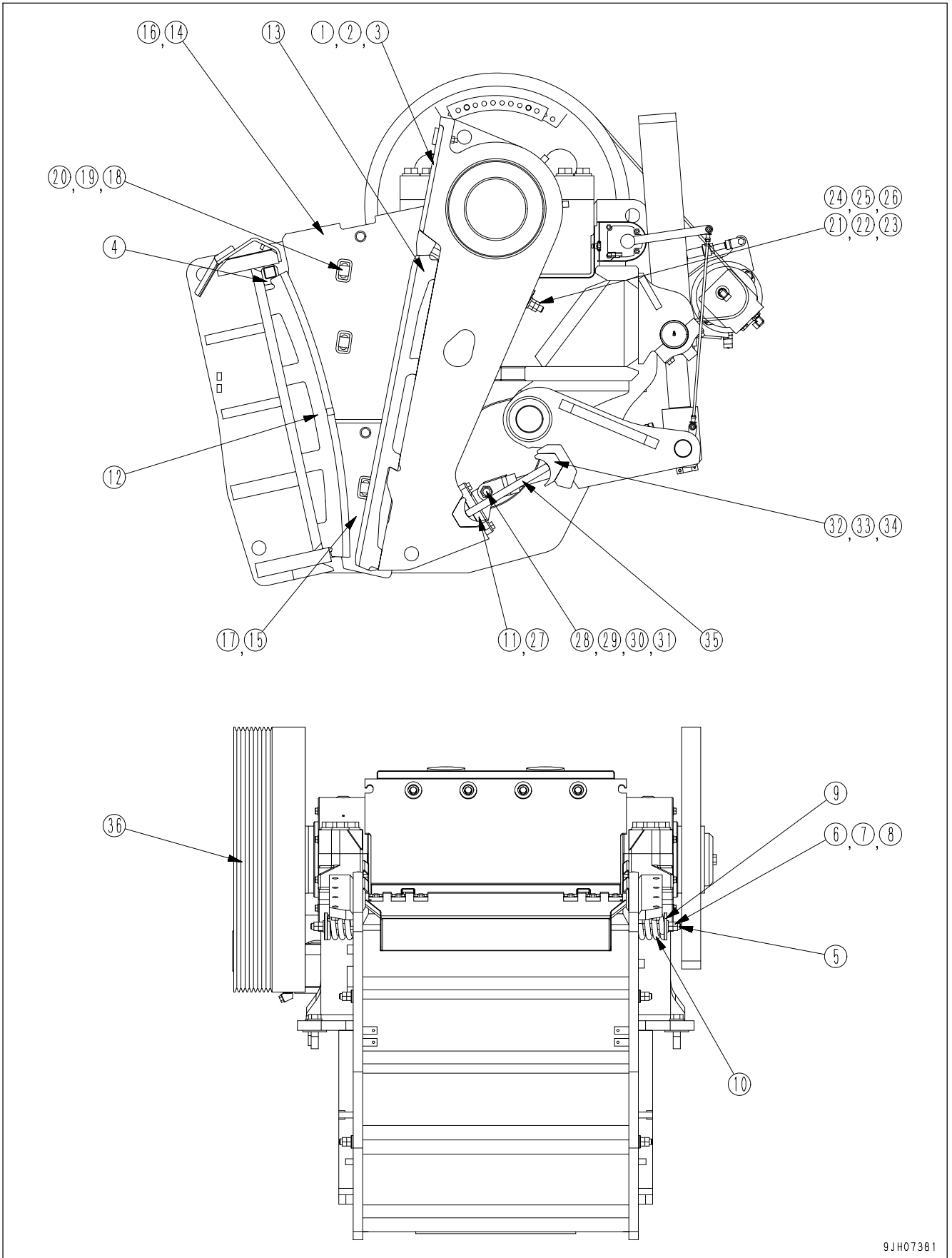

9JH07381

PRIMARY CONVEYOR RELATED PARTS

| No. | Part Name | Part No. | Q'ty | Unit Weight [kg (lb)] | |
|-----|-----------------------|-------------------------------------------------------------------|--------------|-----------------------|-----------|
| 1 | Conveyor belt | Not to be supplied as single parts. See following specifications. | | | |
| 2 | Bearing unit | 8248-75-4290 | 3 | 3.80 (8.38) | |
| 3 | Belt cleaner | Assembly | 8240-75-1090 | 1 | 19.1 (42) |
| 3-1 | | Cushion | 8294-75-2160 | 10 | - |
| 3-2 | | Tip | 8294-75-2180 | 10 | - |
| 4 | Carrier roller | 8240-75-1910 | 27 | 4.50 (9.92) | |
| 5 | Guide roller | 8248-75-3180 | 8 | 1.50 (3.31) | |
| 6 | Return roller (outer) | 8240-75-1920 | 7 | 11.0 (24.26) | |
| 7 | Scraper rubber | 8295-75-2780 | 1 | 0.75 (1.65) | |
| 8 | Impact bar plate | 8240-75-1311 | 9 | 1.00 (2.21) | |
| 9 | Rubber | 8240-75-2360 | 2 | 2.20 (4.85) | |
| 10 | Rubber | 8240-75-2851 | 2 | 3.05 (6.73) | |
| 11 | Rubber | 8240-75-2571 | 2 | 3.15 (6.95) | |
| 12 | Rubber | 8240-75-2550 | 2 | 3.15 (6.95) | |
| 13 | Rubber | 8240-75-1792 | 2 | 3.81 (8.40) | |

Conveyor belt specification

| | | | | | |
|----------------------------------------|----------------------|----------------------------------|----------------------------------|----------------------------------|----------------------------------|
| Condition | Head pulley diameter | φ400 | φ400 | φ400 | φ350 |
| | Tail pulley diameter | φ320 | φ340 | φ300 | φ280 |
| Size | Width | 1050 mm (3 ft 5 in) | | | |
| | Length of endless | 20400 mm (66 ft 11 in) | | | |
| Belt strength | | 500 kg/cm | | | |
| No. of ply | | 2 | 2 | 2 | 2 |
| Core material | | Polyester | Nylon | Highly elastic polyester | Nylon |
| Cover rubber thickness (front x rear) | | 6.0 x 3.0 mm (0.24 x 0.12 in) | 6.0 x 3.0 mm (0.24 x 0.12 in) | 6.0 x 3.0 mm (0.24 x 0.12 in) | 6.0 x 3.0 mm (0.24 x 0.12 in) |
| Overall thickness (for reference only) | | 11.8 mm (0.465 in) | 11.9 mm (0.469 in) | 12.1 mm (0.477 in) | 12.0 mm (0.473 in) |

RECOMMENDED FUEL, COOLANT AND LUBRICANTS

- Komatsu genuine oils are adjusted to maintain the reliability and durability of Komatsu construction equipment and components.

In order to keep your machine in the best conditioner for long periods of time, it is essential to follow the instructions in this Operation and Maintenance Manual.

- Failure to follow these recommendations may result in shortened life or excess wear of the engine, power train, cooling system, and/or other components.
- Commercially available lubricant additives may be good for the machine, but they may also cause harm. Komatsu does not recommend any commercially available lubricant additive.
- Use the oil recommended according to the ambient temperature in the chart below.
- Specified capacity means the total amount of oil including the oil in the tank and the piping. Refill capacity means the amount of oil needed to refill the system during inspection and maintenance.
- When starting the engine in temperatures below 0°C (32°F), be sure to use the recommended multi-grade oil, even if the ambient temperature may become higher during the course of the day.
- If the machine is operated at a temperature below -20°C (-4°F), a separate device is needed, so consult your Komatsu distributor.
- When the fuel sulfur content is less than 0.5%, change the engine oil according to the period inspection table given in this Operation and Maintenance Manual.

If the fuel sulfur content is more than 0.5%, change the oil according to the following table.

| Fuel sulfur content | Engine oil change interval |
|---------------------|----------------------------|
| 0.5 to 1.0% | 1/2 of regular interval |
| Above 1.0% | 1/4 of regular interval |

| Reservoir | Fluid Type | Ambient Temperature, degrees Celsius | | | | | | | | | Recommended Komatsu Fluids |
|---------------------------------------------------------------------------------------------------|-----------------------------|--------------------------------------|-----------|-----------|---------|----------|----------|----------|-----------|---------------|-------------------------------|
| | | -22 -30 | -4 -20 | 14 -10 | 32 0 | 50 10 | 68 20 | 86 30 | 104 40 | 122°F 50°C | |
| Engine Oil Pan | Engine Oil | [Temperature Range: 10°C to 40°C] | | | | | | | | | Komatsu EO10W30DH |
| | | [Temperature Range: 0°C to 30°C] | | | | | | | | | Komatsu EO15W40DH |
| | | [Temperature Range: 10°C to 30°C] | | | | | | | | | Komatsu EO30DH |
| Jaw crusher motor bearing Case Final Drive Case Grizzly feeder vibrator Case Damper Case | Power train Oil (Note.1) | [Temperature Range: 0°C to 30°C] | | | | | | | | | TO30 |
| Hydraulic System | Power train Oil | [Temperature Range: 0°C to 30°C] | | | | | | | | | TO10 |
| | Hydraulic Oil | [Temperature Range: 0°C to 30°C] | | | | | | | | | HO46-HM |
| | Engine Oil | [Temperature Range: 10°C to 40°C] | | | | | | | | | Komatsu EO10W30DH |
| | | [Temperature Range: 0°C to 30°C] | | | | | | | | | Komatsu EO15W40DH |
| Grease Fitting | Hyperwhite Grease (Note.2) | [Temperature Range: 0°C to 30°C] | | | | | | | | | G2-T |
| | Lithium EP Grease | [Temperature Range: 0°C to 30°C] | | | | | | | | | G2-LI |
| Cooling System | Supercoolant AF-NAC(Note.3) | [Temperature Range: 0°C to 30°C] | | | | | | | | | AF-NAC |
| Fuel Tank | Diesel Fuel | [Temperature Range: 10°C to 30°C] | | | | | | | | | ASTM No.2-D |
| | | [Temperature Range: 0°C to 30°C] | | | | | | | | | ASTM No.1-D |

| | | Engine oil pan | Dumper case | Jaw crusher motor bearing case | Final drive case (each on right and left) | Grizzly feeder vibrator case |
|----------------------|--------|----------------|-------------|--------------------------------|-------------------------------------------|------------------------------|
| Specified oil amount | Liters | 26.3 | 0.75 | 4.7 | 3.5 | 15 |
| | US gal | 6.95 | 0.20 | 1.24 | 0.92 | 3.96 |
| Refill oil amount | Liter | 24 | - | 4.7 | 3.5 | 15 |
| | US gal | 6.34 | - | 1.24 | 0.92 | 3.96 |

| | | Hydraulic oil system | Cooling system | Fuel tank |
|----------------------|--------|----------------------|----------------|-----------|
| Specified oil amount | Liters | 209 | 43.9 | 400 |
| | US gal | 55.22 | 11.60 | 105.68 |
| Refill oil amount | Liters | 112 | - | - |
| | US gal | 29.59 | - | - |

Note .1: Power train of oil has different properties from engine oil. Be sure to use the recommended oil.

Note .2: Hyper white grease (G2-T) has a high performance.

When it is necessary to improve the lubricating ability of the grease in order to prevent squeaking of pins and bushings, the use of G2-T is recommended.

Note .3: Supercoolant (AF-NAC)

1) The coolant has the important function of preventing corrosion as well as preventing freezing.

Even in the areas where freezing is not an issue, the use of antifreeze coolant is essential.

Komatsu machines are supplied with Komatsu Supercoolant (AF-NAC). Komatsu Supercoolant (AF-NAC) has excellent anticorrosion, antifreeze and cooling properties and can be used continuously for 2 years or 4000 hours.

Komatsu Supercoolant (AF-NAC) is strongly recommended wherever available.

2) For details of the ratio when diluting super coolant with water, see "CLEAN INSIDE OF COOLING SYSTEM (PAGE 4-28)".

When the machine is shipped from the factory, it may be filled with coolant containing 30% or more Supercoolant (AF-NAC). In this case, no adjustment is needed for temperatures down to -10 °C (14 °F). (never dilute with water)

3) To maintain the anticorrosion properties of Supercoolant (AF-NAC), always keep the density of Supercoolant

RECOMMENDED BRANDS, RECOMMENDED QUALITY FOR PRODUCTS OTHER THAN KOMATSU GENUINE OIL

When using commercially available oils other than Komatsu genuine oil, consult your Komatsu distributor.

STANDARD TIGHTENING TORQUES FOR BOLTS AND NUTS

REMARK

For tightening torque of the bolts used for the jaw crusher, see the section of "OPERATION (PAGE 3-51)".

CRUSHER ACCESSORY TOOLS

| No. | Name of tool | Part No. | Q'ty | Reference |
|-----|-------------------------------------|--------------|------|-----------------|
| 1 | Wrench for tooth plate, cheek plate | 09001-03600 | 1 | 36 mm (for M24) |
| 2 | Wrench for tension spring | 09001-06500 | 2 | 65 mm (for M42) |
| 3 | Handle for tooth plate, cheek plate | 09026-00500 | 1 | 500L |
| 4 | Extension | 09022-00250 | 1 | 200L |
| 5 | Socket for tooth plate, cheek plate | 8240-98-1140 | 1 | M24 x 100L |
| 6 | Hook for swing jaw plate | 8240-98-1180 | 2 | |
| 7 | Wrench for swing jaw plate | 8240-98-1170 | 1 | M24 x 410L |
| 8 | Pipe | 8242-70-5E50 | 1 | φ42.7 x 900L |
| 9 | Eyebolt for cheek plate | 04530-11628 | 2 | |
| 10 | Lifting tool for cheek plate | 8240-98-1191 | 1 | |

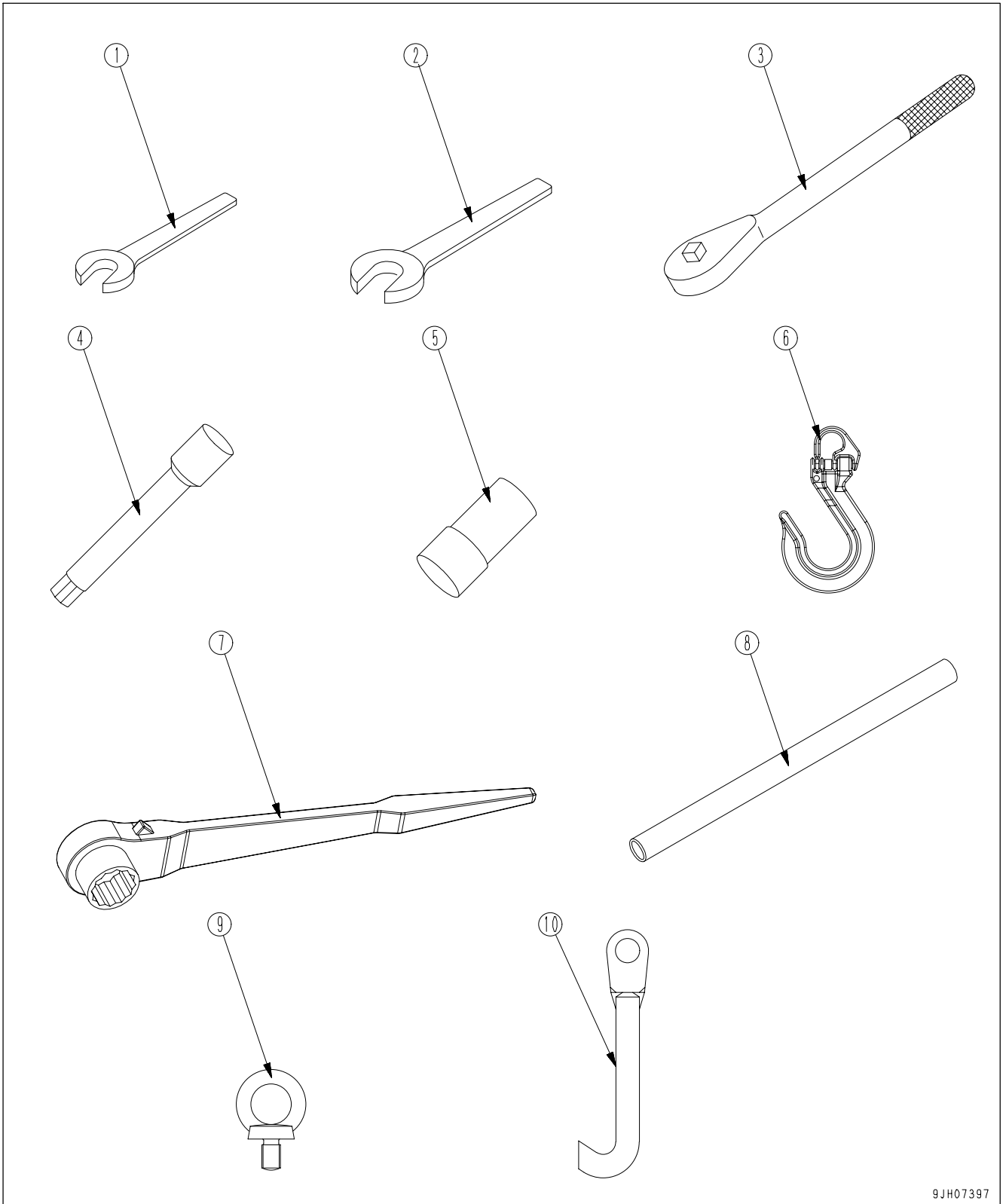

9JH07397

TORQUE LIST

NOTICE

When tightening a bolt through panels made of resin, they will be broken at the base, if an excessive tightening torque is applied to the bolt. Be careful not to exceed the right tightening torque.

Unless otherwise specified, tighten the metric nuts and bolts to the torque shown in the table below.

The tightening torque is determined by the width across the flats (b) of the nut and bolt.

If it is necessary to replace any nut or bolt, always use a Komatsu genuine part of the same size as the part that was replaced.

| Thread diameter of bolt (a)(mm) | Width across flats (b)(mm) | Tightening torque | | | | | |
|---------------------------------|----------------------------|-------------------|-------|--------|---------------|-------------|---------------|
| | | Target value | | | Service limit | | |
| | | N-m | kgf-m | lbft | N-m | kgf-m | lbft |
| 6 | 10 | 13.2 | 1.35 | 9.8 | 11.8-14.7 | 1.2-1.5 | 8.7-10.8 |
| 8 | 13 | 31 | 3.2 | 23.1 | 27-34 | 2.8-3.5 | 20.3-25.3 |
| 10 | 17 | 66 | 6.7 | 48.5 | 59-74 | 6.0-7.5 | 43.4-54.2 |
| 12 | 19 | 113 | 11.5 | 83.2 | 98-123 | 10.0-12.5 | 72.3-90.4 |
| 14 | 22 | 177 | 18 | 130.2 | 157-196 | 16.0-20.0 | 115.7-144.7 |
| 16 | 24 | 279 | 28.5 | 206.1 | 231-289 | 23.5-29.5 | 170.0-213.4 |
| 18 | 27 | 382 | 39 | 282.1 | 343-425 | 35.0-43.5 | 253.2-314.6 |
| 20 | 30 | 549 | 56 | 405.0 | 456-569 | 46.5-58.0 | 336.3-419.5 |
| 22 | 32 | 745 | 76 | 549.7 | 662-829 | 67.5-84.5 | 488.2-611.2 |
| 24 | 36 | 927 | 94.5 | 683.5 | 785-981 | 80.0-100.0 | 578.6-723.3 |
| 27 | 41 | 1320 | 135.0 | 976.5 | 1180-1470 | 120.0-150.0 | 868.0-1085.0 |
| 30 | 46 | 1720 | 175.0 | 1265.8 | 1520-1910 | 155.0-195.0 | 1121.1-1410.4 |
| 33 | 50 | 2210 | 225.0 | 1627.4 | 1960-2450 | 200.0-250.0 | 1446.6-1808.3 |
| 36 | 55 | 2750 | 280.0 | 2025.2 | 2450-3040 | 250.0-310.0 | 1808.3-2242.2 |
| 39 | 60 | 3280 | 335.0 | 2423.1 | 2890-3630 | 295.0-370.0 | 2133.7-2676.2 |

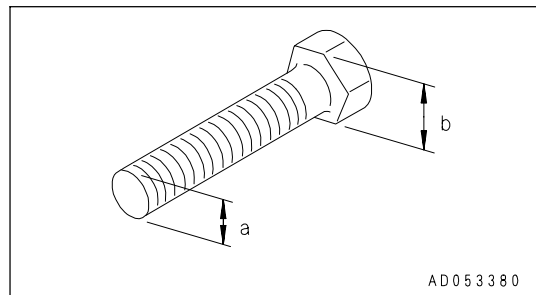

Apply the following table for Hydraulic Hose.

| Thread diameter a (mm) | Width across flat b(mm) | Tightening torque [N·m (kgf·m)] | |
|------------------------|-------------------------|---------------------------------|-------------------------|
| | | Target value | Permissible range |
| 9/16 -18UNF | 19 | 44 (4.5) | 35 - 54 (3.5 - 5.5) |
| 11/16 -16UN | 22 | 74 (7.5) | 54 - 93 (5.5 - 9.5) |
| 13/16 -16UN | 27 | 103 (10.5) | 84 - 132 (8.5 - 13.5) |
| 1 -14UNS | 32 | 157 (16.0) | 128 - 186 (13.0 - 19.0) |
| 1-3/16 -12UN | 36 | 216 (22.0) | 177 - 245 (18.0 - 25.0) |
| *1-7/16-12UN -2B | 41 | 215 (22) | 176 - 234 (18 - 24) |

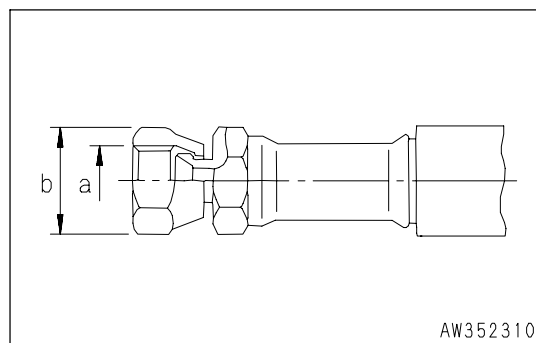

- The torques marked * indicate the tightening torques for the hoses at the top of the swivel joint.

PERIODIC REPLACEMENT OF SAFETY CRITICAL PARTS

To ensure safety at all times when operating or driving the machine, the user of the machine must always carry out periodic maintenance. In addition, to further improve safety, the parts in the safety-critical parts list on the next page must also be replaced at the specified interval. These parts are particularly closely connected to safety and fire prevention, so please contact your Komatsu distributor to have them replaced.

Material quality of these parts can change as time passes and they are likely to wear out or deteriorate. However, it is difficult to determine the extent of wear or deterioration at the time of periodic maintenance. Hence, it is required to replace them with new ones regardless of their condition after a certain period of usage. This is important to ensure that these parts maintain their full performance at all times.

Furthermore, should anything abnormal be found on any of these parts, replace it with a new one even if the periodic replacement time for the part has not yet arrived.

If any of the hose clamps show deterioration like deformation or cracking, replace the clamps at the same time as the hoses.

Also perform the following checks with hydraulic hoses which need to be replaced periodically. Tighten all loose clamps and replace defective hoses, as required.

When replacing hoses, always replace O-rings, gaskets, and other such parts at the same time.

SAFETY CRITICAL PARTS

| No | Periodic Replacement Part | Q'ty | Replacement Interval |
|----|--------------------------------------------------------|------|-------------------------------------------------------|
| 1 | Fuel hose (fuel tank - connector) | 2 | Every 2 years or every 4000 hours, whichever earlier. |
| 2 | Spill hose (nozzle - fuel tank) | 1 | |
| 3 | Spill hose (between nozzles) | 2 | |
| 4 | Fuel hose (fuel filter - fuel injection pump) | 2 | |
| 5 | fuel pump outlet hose (fuel pump - control valve) | 2 | |
| 6 | Work equipment hose (at crusher motor gate) | 4 | |
| 7 | Work equipment hose (feeder motor gate) | 2 | |
| 8 | Work equipment hose (primary conveyor belt motor gate) | 2 | |
| 9 | Main suction hose | 1 | |
| 10 | Gear pump suction hose | 1 | |

MAINTENANCE SCHEDULE CHART

MAINTENANCE SCHEDULE CHART

INITIAL 250 HOURS MAINTENANCE (ONLY AFTER THE FIRST 250 HOURS)

| | |
|-----------------------------------------------------|-------|
| Replace fuel filter cartridge | 4- 74 |
| Change of oil in grizzly feeder vibrator case | 4- 80 |

INITIAL 1000 HOURS SERVICE (FIRST MAINTENANCE FOR NEW MACHINE ONLY)

| | |
|--------------------------------------------|-------|
| Check engine valve clearance, adjust | 4- 84 |
|--------------------------------------------|-------|

WHEN REQUIRED

| | |
|-------------------------------------------------------------------|-------|
| Check, clean and replace air cleaner element | 4- 23 |
| Clean inside of cooling system | 4- 28 |
| Check and tighten track shoe bolt | 4- 31 |
| Check and adjust track tension | 4- 32 |
| Inspection of electric heater | 4- 34 |
| Check and adjustment of jaw crusher | 4- 35 |
| Check and adjustment of primary conveyor | 4- 57 |
| Inspection and maintenance of magnetic separator | 4- 61 |
| Method for releasing internal pressure in hydraulic circuit | 4- 64 |

CHECK BEFORE STARTING

EVERY 10 HOURS SERVICE

| | |
|-------------------------------------|-------|
| Greasing crusher bearing seat | 4- 67 |
| Greasing crusher link | 4- 67 |

EVERY 100 HOURS SERVICE

| | |
|-----------------------------------------------------|-------|
| Greasing crusher lock cylinder securing point | 4- 68 |
| Greasing primary conveyor | 4- 69 |

EVERY 250 HOURS SERVICE

| | |
|-----------------------------------------------------------------------|-------|
| Check level of battery electrolyte | 4- 70 |
| Check and adjustment of jaw crusher V-belt | 4- 73 |
| Check of oil level in crusher motor bearing case and adding oil | 4- 73 |

EVERY 500 HOURS SERVICE

| | |
|-------------------------------------------------------------------------|-------|
| Replace fuel filter cartridge | 4- 74 |
| Check oil level in final drive case, add oil | 4- 75 |
| Clean, inspect radiator fins, oil cooler fins, aftercooler fins | 4- 76 |
| Change oil in engine oil pan, replace engine oil filter cartridge | 4- 77 |
| Replace hydraulic tank breather element | 4- 78 |

EVERY 1000 HOURS SERVICE

| | |
|-----------------------------------------------------|-------|
| Change of oil in crusher motor bearing case ----- | 4- 79 |
| Change of oil in grizzly feeder vibrator case ----- | 4- 80 |
| Change oil in damper case ----- | 4- 81 |
| Check all tightening parts of turbocharger ----- | 4- 81 |
| Check play of turbocharger rotor ----- | 4- 81 |
| Check and replace of fan belt tension ----- | 4- 81 |
| Replace hydraulic filter element ----- | 4- 82 |

EVERY 2000 HOURS SERVICE

| | |
|--------------------------------------------|-------|
| Change oil in final drive case ----- | 4- 83 |
| Clean hydraulic tank strainer ----- | 4- 84 |
| Clean, check turbocharger ----- | 4- 84 |
| Check alternator, starting motor ----- | 4- 84 |
| Check engine valve clearance, adjust ----- | 4- 84 |
| Check vibration damper ----- | 4- 84 |

EVERY 4000 HOURS SERVICE

| | |
|------------------------|-------|
| Check water pump ----- | 4- 85 |
|------------------------|-------|

EVERY 5000 HOURS SERVICE

| | |
|-------------------------------------------------------|-------|
| Change oil in hydraulic tank and clean strainer ----- | 4- 86 |
|-------------------------------------------------------|-------|

SERVICE PROCEDURE

INITIAL 250 HOURS SERVICE (FIRST MAINTENANCE FOR NEW MACHINE ONLY)

Carry out the following maintenance only for once after the initial 250 hours of operation.

- Replace fuel filter cartridge
- Change of oil in grizzly feeder vibrator case

Special tools are needed for the inspection and maintenance, have your Komatsu distributor perform this work. For details of the method of replacing or maintaining, see the section on EVERY 500 HOURS AND 1000 HOURS SERVICE.

INITIAL 1000 HOURS SERVICE (FIRST MAINTENANCE FOR NEW MACHINE ONLY)

Carry out the following maintenance only after the first 1000 hours of operation on new machines.

- Check engine valve clearance, adjust

Special tools are needed for the inspection and maintenance, have your Komatsu distributor perform this work. For details of the method of replacing or maintaining, see the section on EVERY 2000 HOURS SERVICE.

WHEN REQUIRED

CHECK, CLEAN AND REPLACE AIR CLEANER ELEMENT

WARNING

- When using compressed air, there is danger of dirt flying and causing personal injury. Always wear protective glasses, dust mask, or other protective equipment.
- When removing the outer element from the air cleaner body, it is dangerous to pull it out by force. When working in high places or where the foothold is poor, be careful not to fall because of the reaction when pulling out the outer element.

CHECKING

If air cleaner clogging monitor (1) of the monitor panel flashes, clean the air cleaner element.

Replacing

- Replacing element, O-ring
 - If one year has passed since installing the element or if air cleaner clogging monitor (1) on the monitor panel flashes immediately after the element is cleaned, replace the outer element, inner element, and O-ring.
- Replacing evacuator valve
 - Replace it if it is damaged or the rubber is markedly deformed.

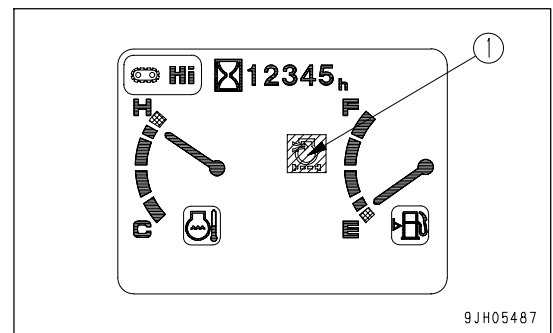

NOTICE

Do not clean the air cleaner element until the air cleaner clogging monitor on the monitor panel flashes. If the element is cleaned frequently before the clogging monitor flashes, the air cleaner will not be able to display its performance fully, and the cleaning efficiency will also go down.

In addition, during the cleaning operation, more dirt stuck to the element will fall inside the inner element.

METHOD OF CLEANING OUTER ELEMENT

1. Open the door at the rear left of the machine, remove 4 hooks (2), then remove cover (3).

NOTICE

Before and after cleaning the element, do not leave or keep it in direct sunlight.

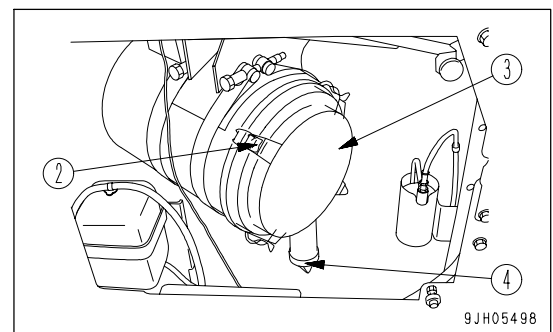

2. Hold the outer element (6), rock it lightly up and down and to the left and right, and rotate the element to the left and right to pull it out.

NOTICE

- Never remove the inner element (5). It will allow dirt to enter and cause failure of the engine.
- Do not use a screwdriver or other tool.

3. After removing the outer element (6), cover the air connector inside the air cleaner body with a clean cloth or tape to prevent dirt or dust from entering.

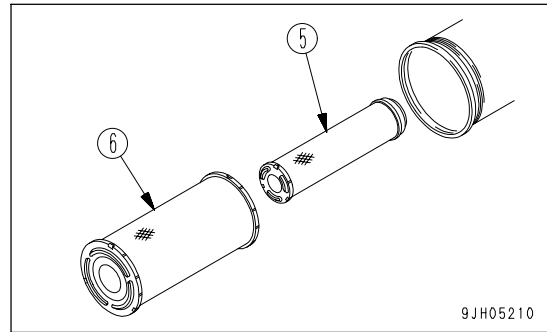

4. Wipe off or brush off the dirt stuck to cover (3) and the inside of the air cleaner body (7).

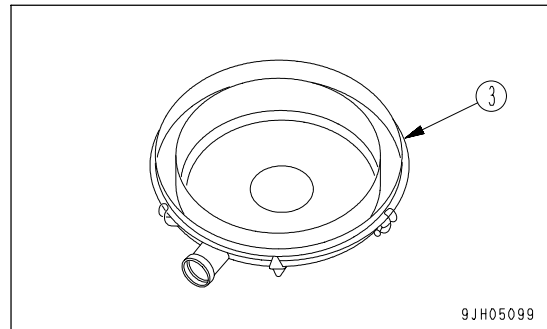
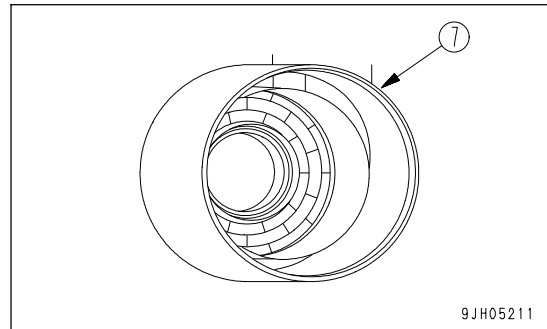

5. Remove any dirt or dust that is accumulated to evacuator valve (4) installed to cover (3).

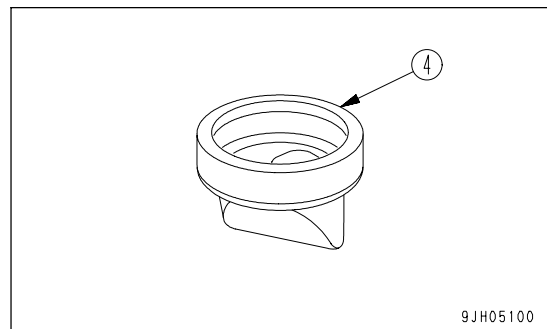

6. Direct dry compressed air (less than 0.69 MPa (7 kgf/cm², 99.4 PSI)) to the outer element from inside along its folds, then direct it from outside along its folds and again from inside.

- 1) Remove one seal from the element whenever the element has been cleaned.
- 2) Replace the outer element which has been cleaned 6 times repeatedly or used throughout a year. Replace the inner element at the same time.

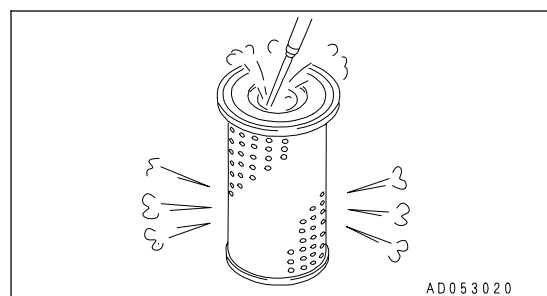

- 3) Replace both inner and outer elements when the air cleaner clogging monitor (1) lights up soon after installing the cleaned outer element even though it has not been cleaned 6 times.
- 4) When replacing the element, stick on seal (A) packed in the same box as the element. Stick the seal in the position shown in the diagram on the right.

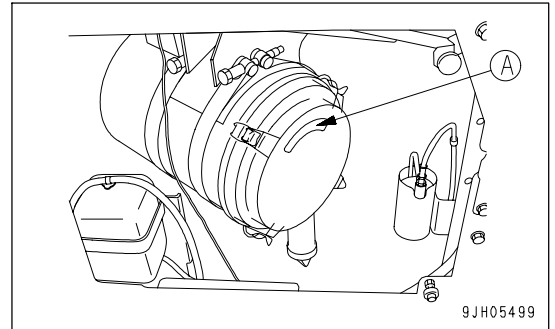

7. Remove the cloth or tape cover installed in Step 3.
8. If small holes or thinner parts are found on the element when it is checked by shining a light through it after cleaning, replace the element.

NOTICE

- When cleaning the element, do not hit or beat it against anything.
- Do not use an element whose folds or gasket or seal are damaged.

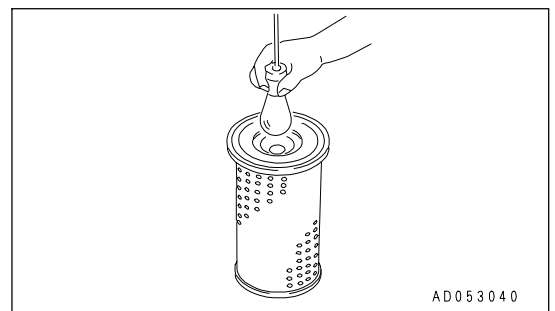

INSTALLING ELEMENT

NOTICE

- Do not use any damaged gasket or seal or element with damaged pleats.
- Cleaning the element or O-ring after one year has passed and using them again will cause problems. Always replace them with new parts.
- The seal portion on imitation parts lacks precision, and allows the entry of dust, which leads to damage of the engine. Do not use such imitation parts.
- Do not run the engine with the inner element removed. It will cause damage to the engine.

1. Check that there is no dirt or oil stuck to the seal portion of the new element or cleaned element. Wipe off any dirt or oil.
2. When the outer element has been removed, check that the inner element has not come out of position and is not at an angle. If inner element is at an angle, insert your hand and push it in straight.
3. Push the outer element in straight with your hand when installing it to the air cleaner body.
If the outer element is held and rocked lightly up and down and to the left and right while pushing it in, the outer element can be inserted easily.

NOTICE

When inserting the element, if the rubber at the tip is swollen or the outer element is not pushed in straight, and cover (3) is assembled by force to hook (2), there is danger that the hook and air cleaner body may be damaged, so be careful when assembling.

4. Install cover (3) as follows.
 - 1) Align cover (3) with the element.
 - 2) Hook the tip of hook (2) to the protruding part of the air cleaner body and lock it in position.
 - 3) When locking hooks (2) in position, apply the hooks in turn on opposite sides (top, bottom, left, right) in the same way as when tightening bolts.
 - 4) Always install cover (3) so that the evacuator (5) is facing the ground (A).
 - 5) When cover (3) is installed, check that the clearance between the air cleaner body and cover (3) is not too large. If it is too large, install again.

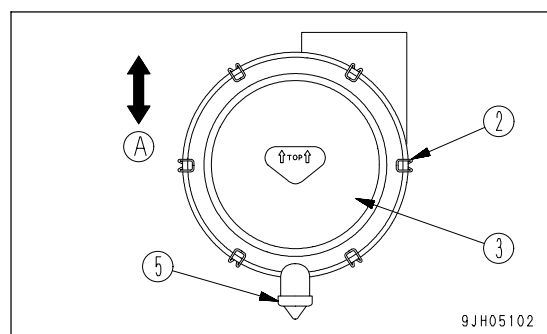
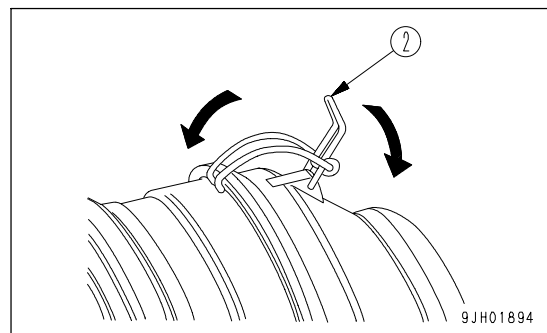

REPLACING INNER ELEMENT

1. First remove the outer element, and then remove the inner element.
2. Cover the air connector side (outlet side) with a clean cloth or tape.
3. Clean the air cleaner body interior, then remove the cover from the air intake port in Step 2.
4. Install the new inner element to the body, then tighten the nut.
Do not clean the inner element and use it again.

NOTICE

The inner element must not be used again even after cleaning. When replacing the outer element, replace the inner element at the same time.

5. Set the outer element in position, then lock cover (3) with hooks (2).

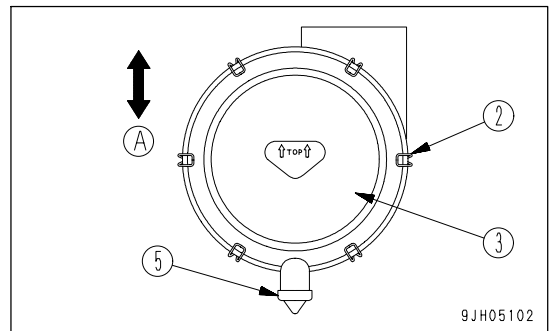
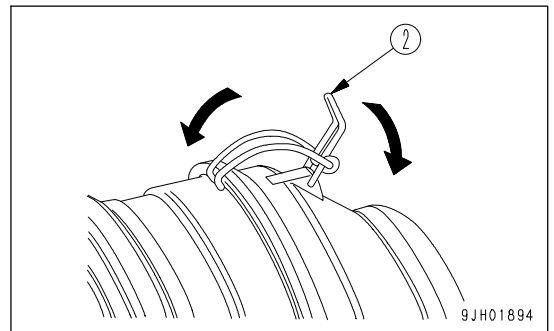

CLEAN INSIDE OF COOLING SYSTEM



WARNING

- The engine coolant is still at high temperature right after the engine is stopped and the radiator interior is pressurized. If the radiator cap is loosened under such conditions, the hot water spurts out, causing a serious burn. Wait until the temperature cools down and turn the cap slowly to release the internal pressure.
- Start the engine for cleaning. When leaving the machine, while the engine is running, set the travel lever safety lock to the LOCK position.
- For starting the engine, see the sections of "CHECK BEFORE STARTING ENGINE (PAGE 3-51)" and "STARTING ENGINE (PAGE 3-70)" in OPERATION of Operation in this manual.
- If the engine is run without the undercover, there is the danger that you may touch the rotating fan. When the engine is running, never get close to the rear of the machine.

Wash the inside of the cooling system and change the coolant (antifreeze) according to the table below.

| Antifreeze coolant | Interval of cleaning inside of cooling system and changing antifreeze coolant |
|------------------------------------------------|-------------------------------------------------------------------------------|
| Komatsu supercoolant AF-NAC | Every two years or every 4000 hours whichever comes first. |
| Permanent type antifreeze (All season type, *) | Every year (autumn) or every 2000 hours whichever comes first. |

*: Permanent type antifreeze shall meet the requirements of ASTM D3306-03.

Stop the machine on level ground when cleaning or changing the coolant.

The coolant has the important function of preventing corrosion as well as preventing freezing.

Even in the areas where freezing is not an issue, the use of antifreeze coolant is essential.

Komatsu machines are supplied with Komatsu Supercoolant (AF-NAC). Komatsu Supercoolant (AF-NAC) has excellent anticorrosion, antifreeze and cooling properties and can be used continuously for 2 years or 4000 hours. Komatsu Supercoolant (AF-NAC) is strongly recommended wherever available.

To maintain the anticorrosion properties of Supercoolant (AF-NAC), always keep the density of Supercoolant between 30% and 68%.

When deciding the ratio of antifreeze to water, check the lowest temperature in the past, and decide from the mixing table given below.

It is actually better to estimate and temperature about 10°C (18°F) lower when deciding the mixing ratio.

The mixing ratio depends on the ambient temperature, but it should always be a minimum of 30% by volume (antifreeze/total amount of coolant x 100).

The freezing temperature of undiluted antifreeze is -15°C (5°F). Do not store undiluted antifreeze at a temperature of below -15°C (5°F).

Stop the machine on level ground when cleaning or changing the coolant.

Super coolant provides corrosion resistance effect in addition to preventing freezing.

The mixing ratio differs according to the ambient temperature, but a minimum of 30% by volume is needed.

When deciding the proportions for mixing the coolant with water, investigate the minimum temperature in the past and use the table below to decide the mixing ratio.

In fact, set a temperature that is 10 °C (18 °F) lower than the minimum temperature.

The freezing temperature of 100% undiluted super coolant is -15 °C (5°F). Be careful not to keep undiluted super coolant at temperatures below -15 °C (5°F).

Mixing rate of water and antifreeze

| | | | | | | |
|------------------------------|--------|-----------|------|------|------|------|
| Min. atmospheric temperature | °C | Above -10 | -15 | -20 | -25 | -30 |
| | °F | Above 14 | 5 | -4 | -13 | -22 |
| Amount of antifreeze | Liters | 13.2 | 15.8 | 18.0 | 20.2 | 21.9 |
| | US gal | 3.49 | 4.18 | 4.76 | 5.34 | 5.80 |
| Amount of water | Liters | 30.7 | 28.1 | 25.9 | 23.7 | 21.9 |
| | US gal | 8.11 | 7.42 | 6.84 | 6.26 | 5.80 |
| Volume ratio | % | 30 | 36 | 41 | 46 | 50 |

**WARNING**

Super coolant is flammable, so be particularly careful to keep it away from flame.

Super coolant is toxic. When removing the drain plug, be careful not to get coolant on yourself.

If it gets into your eyes, wash your eyes immediately with ample water, then consult a doctor for treatment.

Use city water for the coolant.

If river water, well water or other such water supply must be used, contact your Komatsu distributor.

We recommend the use of a super coolant density meter to control the mixing ratio.

- Prepare a container of at least 44 liters (11.62 US gal) to hold the coolant mix.

1. Turn radiator cap (1) slowly and remove it.
2. Remove the undercover, then set the container under drain valve (2) to catch the coolant mixture.
Open drain valve (2) at the bottom of the radiator and drain the coolant.
3. After draining the coolant, close drain valve (2), and fill with city water. When the radiator is full, start the engine and run at low idling to raise the temperature to at least 90°C (194°F), then continue to run for approx. 10 minutes.
4. Stop the engine, open drain valve (2), and drain the water.
5. After draining the water, clean the radiator with detergent.
For the cleaning method, follow the instruction of detergent.
6. Close drain valve (2).
7. Install the undercover.
8. Add water through the water filler up to the filler port.
9. Run the engine idle at a low speed for 5 minutes, then at a high speed for 5 minutes to bleed air mixed in the cooling water. (At this time, keep the water filler cap removed.)
10. After draining off the coolant of sub tank (3), clean the inside of the sub tank and refill the water between FULL and LOW
11. Stop the engine and tighten the cap. Check the coolant level, and add water if the level is low.

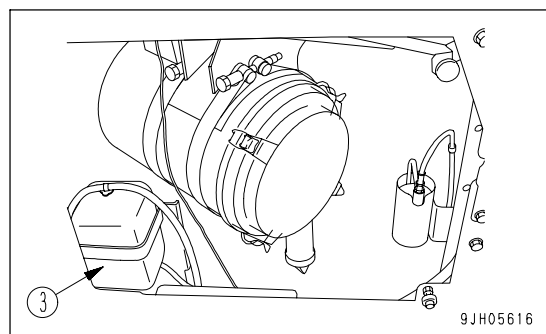
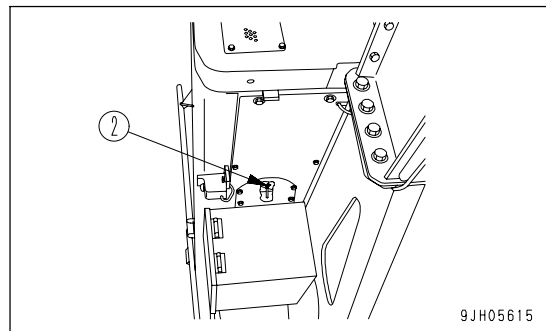
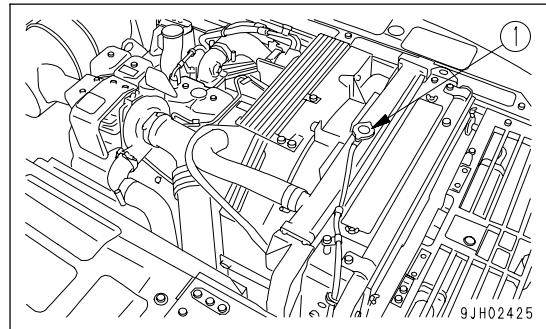

CHECK AND TIGHTEN TRACK SHOE BOLT

Track shoes may be broken, if they are used with loosened shoe bolts (1). Hence whenever a loosened bolt is found, be sure to retighten it.

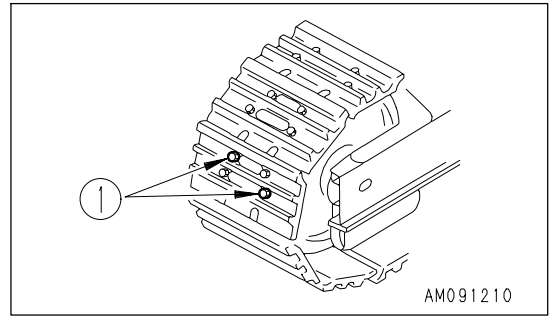

METHOD OF TIGHTENING

1. Tighten first to a tightening torque of $490 \pm 49 \text{ N}\cdot\text{m}$ ($50 \pm 5 \text{ kgf}\cdot\text{m}$, $361.7 \pm 36.2 \text{ lbf}\cdot\text{ft}$), then check that nut (A) and shoe (B) are in tight contact with mating surface (a) of link (C).
2. After checking, further tighten to the tightening torque of $120^\circ \pm 10^\circ$.

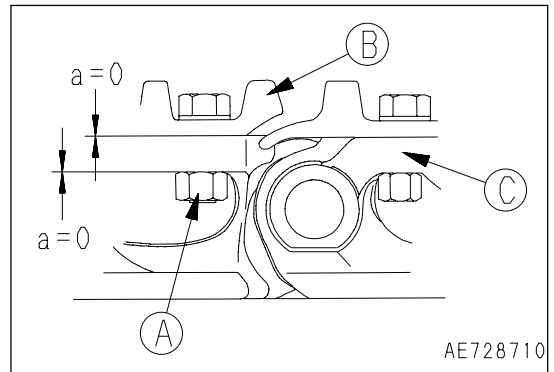

ORDER FOR TIGHTENING

- Tighten the bolts in the order as illustrated in the figure at right. After tightening, confirm that nut (A) and shoe plate (B) are in close contact with contact surface (a) of track link (C).

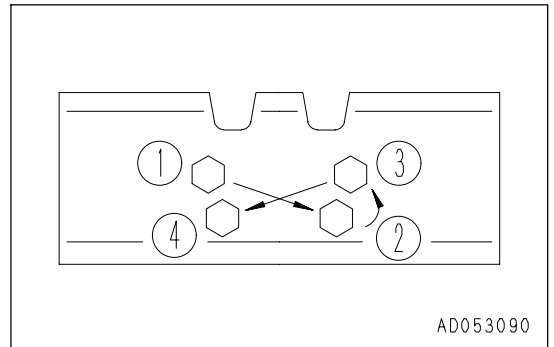

CHECK AND ADJUST TRACK TENSION

**WARNING**

For details of starting the engine and operating the work equipment, see "CHECK BEFORE STARTING ENGINE (PAGE 3-51)", "STARTING ENGINE (PAGE 3-70)", "OPERATIONS AND CHECKS AFTER STARTING ENGINE (PAGE 3-74)", and "PRECAUTIONS WHEN TRAVELING UP OR DOWNHILLS (PAGE 3-121)" in the OPERATION section.

Wear on pins and bushings of the undercarriage will vary with working conditions and type of soil, so inspect the track tension every now and then in order to maintain the standard tension.

For carrying out inspection and adjustment of track shoes, park the machine on the flat and solid ground.

CHECKING

1. Run the engine at low idle, then move the machine forward for a distance equal to the track length on ground, and slowly stop the machine.
2. Put on the track shoe straight wooden bar (3) which stretches from idler (1) to upper carrier roller (2).
3. Measure the maximum deflection between bottom surface of the wooden bar and top surface of the track shoe. Deflection "a" should be 10 - 30 mm (0.4 - 1.2 in).

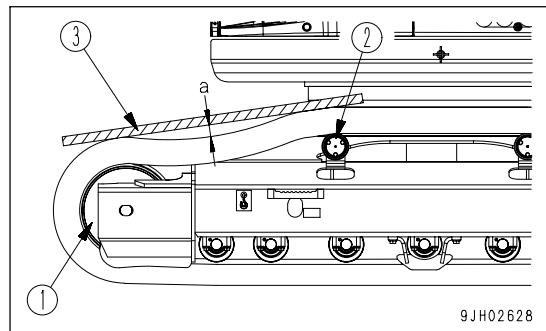

9JH02628

If the track tension is not at the standard value, adjust it in the following manner.

ADJUSTMENT

! WARNING

Since grease may spurt out due to the internal high pressure, do not loosen plug (1) by more than one turn.
 Do not loosen any other parts than plug (1) at that time. Furthermore do not turn your face and body toward plug (1).
 If the track shoe assembly may not be loosened following the procedures shown here, consult the Komatsu distributor in your territory.

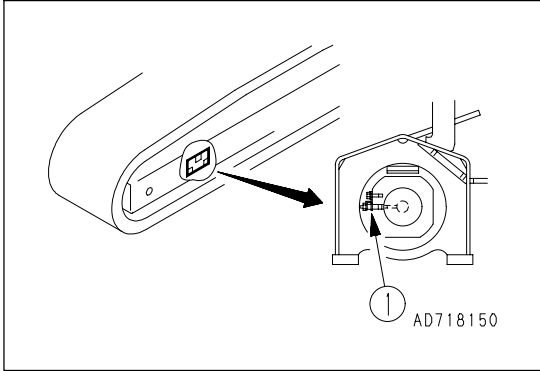

WHEN INCREASING TENSION

! WARNING

Prepare a grease pump.

1. Inject grease through grease fitting (2), using a grease gun.
2. Move the machine back and forth a few times for a distance of 5 m (16 ft 5 in) in order to confirm that the track shoe tension is correct, and then stop the engine.
3. Check the track tension again, and if the tension is not correct, adjust it again.

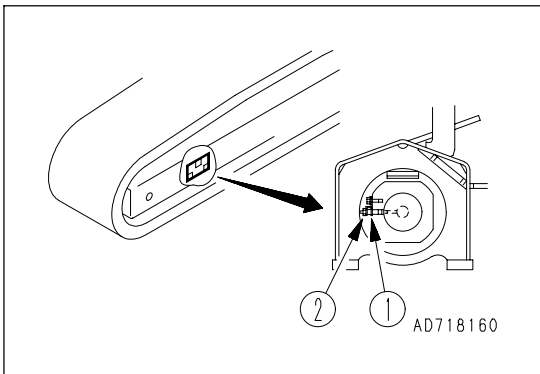

4. Continue to pump in grease until dimension (S) becomes zero (0). If the tension is still loose, the pin and bushing are excessively worn, so they must be either turned or replaced. Please contact your Komatsu distributor for repairs.

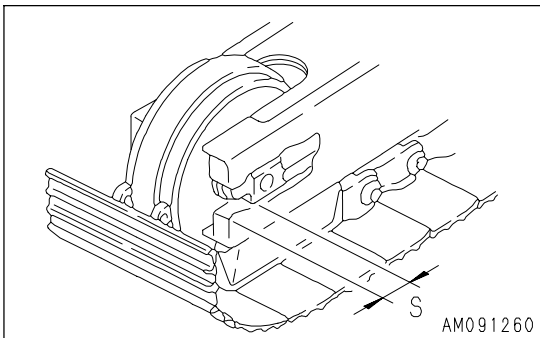

WHEN LOOSENING TENSION

**WARNING**

It is extremely dangerous to release the grease by any method except the procedure given below.
If track tension is not relieved by this procedure, contact your Komatsu distributor for repairs.

1. Loosen plug (1) gradually to release the grease.
2. When loosening plug (1), turn it a maximum of one turn.
3. If the grease does not come out smoothly, move the machine forwards and backwards a short distance.
4. Tighten plug (1).
5. Move the machine back and forth to confirm the track shoe tension is correct.
6. Check the track tension again, and if the tension is not correct, adjust it again.

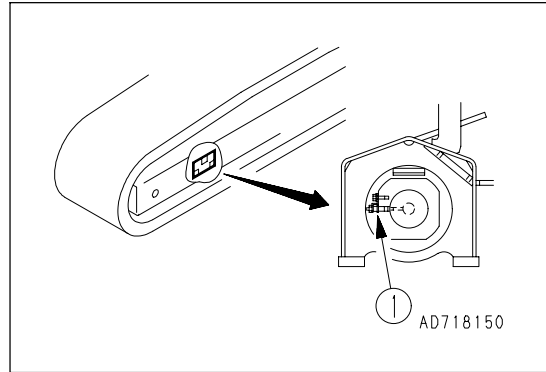
**INSPECTION OF ELECTRIC HEATER**

Before the start of the cold season (once a year), contact your Komatsu distributor to have the electrical intake air heater checked for dirt or disconnections.

CHECK AND ADJUSTMENT OF JAW CRUSHER

CHECK AND ADJUSTMENT OF OUTLET CLEARANCE

CHECK OF OUTLET CLEARANCE

Discharge port clearance (A) (opening end) means the distance from the tip of the fixed jaw plate to the bottom of the movable tooth when the crusher discharge port is fully open.

Measure at three places (both ends and the center) and take the value for the smallest clearance as the representative value.

REMARK

When measuring discharge port clearance (A), it is convenient to use a jig as shown in the example below.

(Example) Length = approx. 1500 mm (4 ft 11 in), diameter of rod = $\phi 6$ to 10 mm at both ends. Weld a rod of the commonly used discharge port clearance dimension (for example: 50 mm (2.0 in)) to an H-shape.

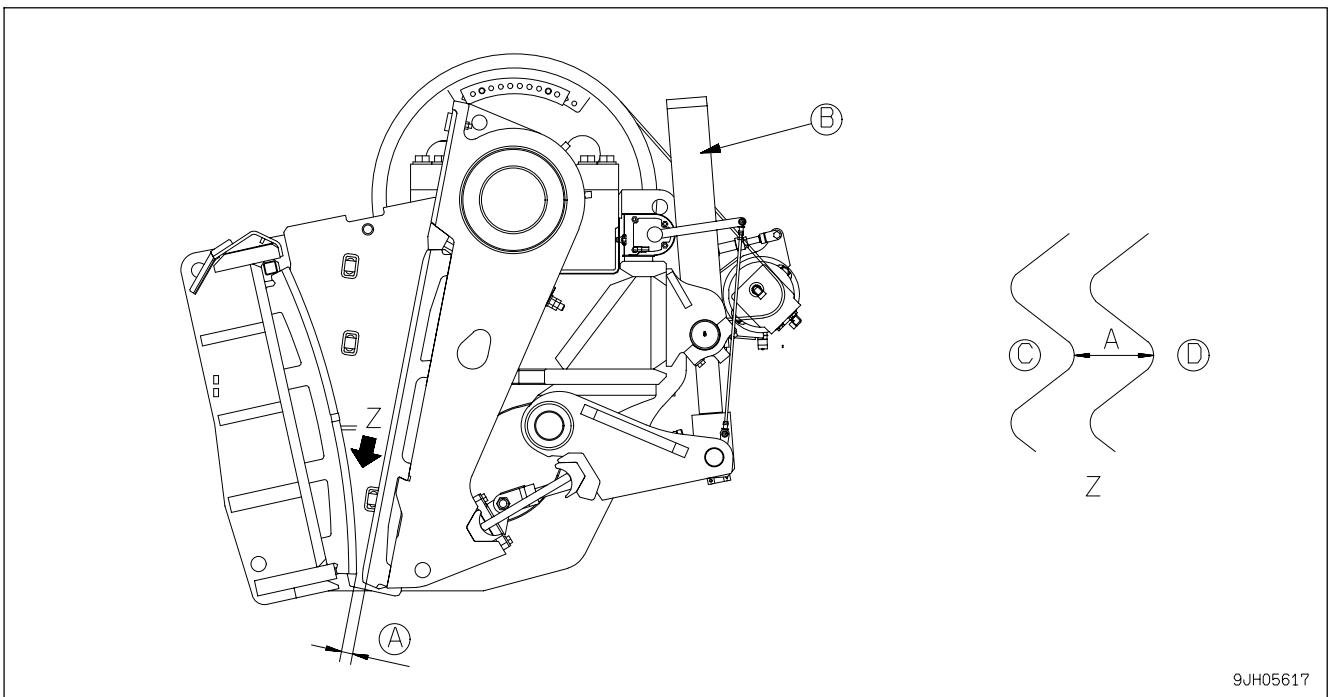
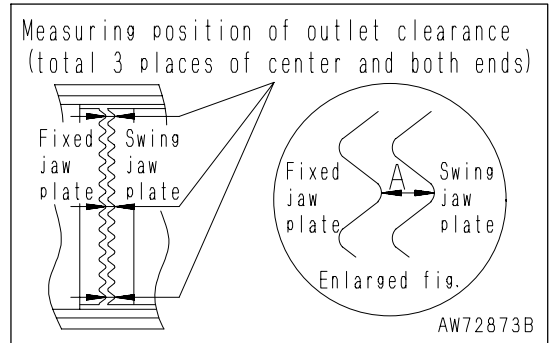

- (A) Crusher discharge port clearance
- (B) Lock cylinder

- (C) Fixed jaw plate
- (D) Swing jaw plate

OUTLET CLEARANCE ADJUSTING METHOD

When the machine is used continuously, wear of the tooth tip will cause the crusher discharge port clearance to become larger, and the size of the particle will become coarser. If the crushed particles are remarkably worse than when the clearance was last adjusted, adjust the clearance as follows.

The crusher discharge port clearance is adjusted by extending or retracting the lock cylinder.

On this machine, there are three types of clearance adjustment function.

A (Automatic): The clearance is automatically adjusted according to the set value input on the clearance set monitor.

S (Semi-automatic): The clearance is automatically adjusted by inputting the desired value for change on the clearance set monitor. (If the input value is +, the clearance becomes larger; if the input value is -, the clearance becomes smaller.)

M (Manual): It is possible to adjust the clearance manually by using the panel switch.

**WARNING**

- Start the engine. For adjusting the outlet clearance, set the travel lever lock to the LOCK position without fail.
- Be sure to attach a warning tag to the starting switch in the control box.
- For starting the engine, see the sections of "CHECK BEFORE STARTING ENGINE (PAGE 3-51)" and "STARTING ENGINE (PAGE 3-70)" in Operation of OPERATION in this manual.

When adjusting the discharge port clearance, use the inching operation to bring the position of the flywheel to the center of the adjustment range on the right to position it before adjusting the discharge port clearance.

(A): Adjustment range

(B): Flywheel marking (red painted part)

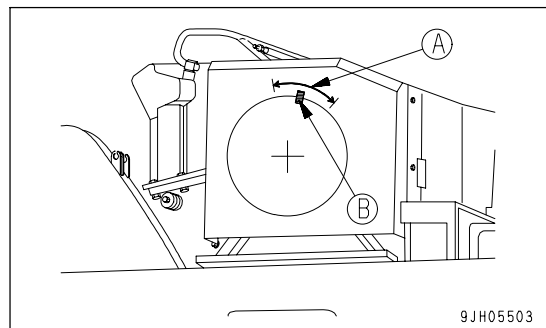

⚠ CAUTION

- Before starting operations, check that there is no one inside the crusher or in the surrounding area.
- When the machine is shipped from the factory, the clearance is set to 50 mm (2.0 in) (O. S. S.), so adjust the discharge clearance to the desired size or size suitable for the material being crushed.
- O. S. S. means the condition when the crusher discharge clearance is fully opened.
- Always be sure to check that the crusher chamber is empty and that there is no mud, sand, or soil stuck to the teeth.

ADJUSTING CLEARANCE IN A (AUTOMATIC) MODE

1. Start the engine.

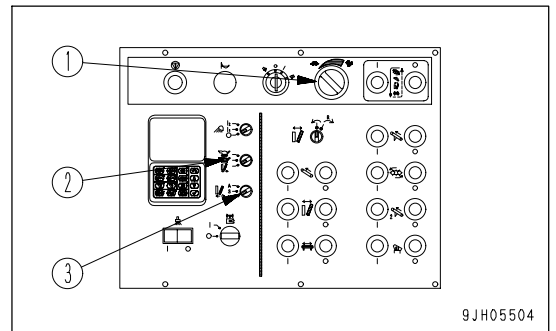

2. Set fuel control dial (1) to the low idling (MIN) position.

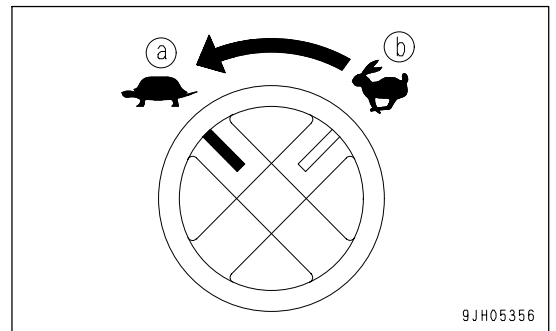

3. Set mode selector switch (2) to INSPECTION (c) position.
The machine monitor switches to the normal inspection

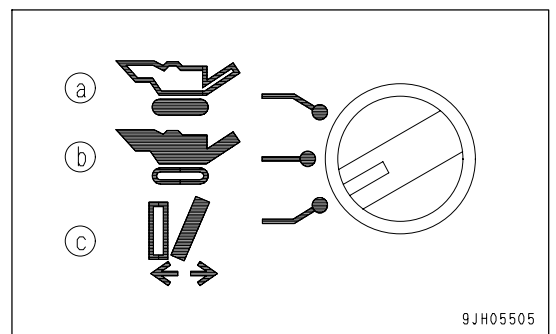

- Set clearance adjustment selector switch (3) to position A (automatic).

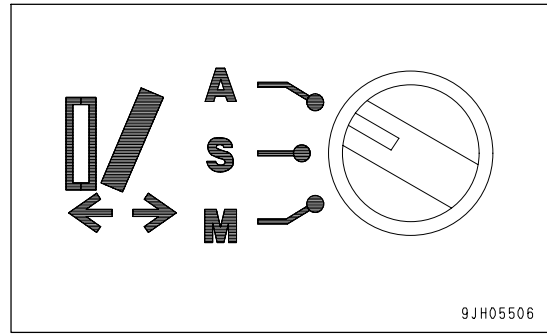

- Check that clearance adjustment monitor (D) of the machine monitor is set to A (automatic) mode, then input the OSS clearance (A) to be adjusted to the machine monitor in the following order.
 - Use UP switch (4) or DOWN switch (5) to move the cursor on the screen display to position (A).

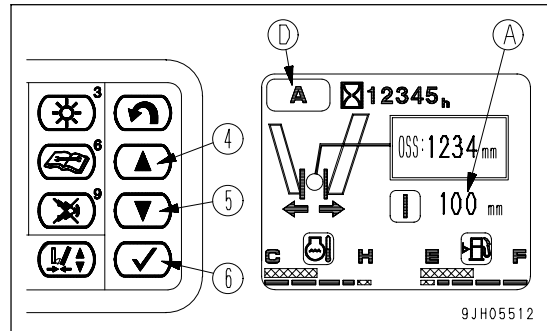

- Press input confirmation switch (6). (A) starts flashing and numeral input window (B) is displayed at the top left of the screen.

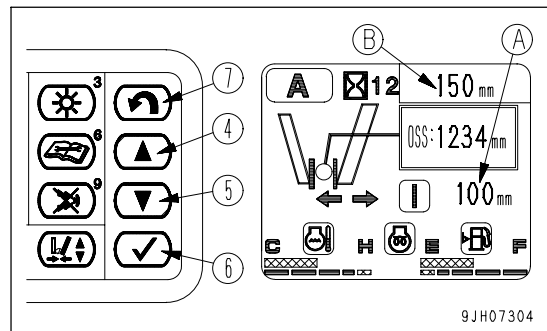

- Use UP switch (4) or DOWN switch (5) to increase or decrease the value on the display and adjust to give the desired set value.

The numerical value can be set in units of 1 mm (0.039 in) in a range of 50 to 150 mm (2.0 to 5.9 in).

If the UP switch (4) or DOWN switch (5) is kept pressed continuously, the set value will increase or decrease in units of 10 mm (0.4 in).

- After inputting the desired OSS clearance, press input confirmation switch (6) to set the input value.

REMARK

- The set value is saved and is displayed when the next adjustment is made to the clearance. If that value is to be used as it is, there is no need to input the set value again.
- If it is desired to abort the setting of the OSS clearance, press return switch (7). This will return the set value to the original setting.

- Adjust the clearance.
 - Use UP switch (4) or DOWN switch (5) to move the cursor on the screen display to position (C).

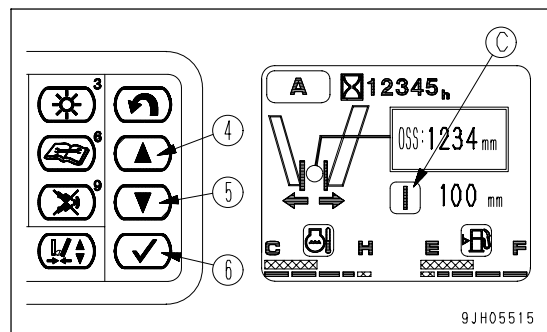

- Press input confirmation switch (6) to complete the preparations.

"|" lamp (C) flashes.

- Press input confirmation switch (6) again to carry out the adjustment.

"|" lamp (C) lights up and the automatic adjustment is carried out.

7. "I" lamp (C) goes out to show that the clearance adjustment is completed.

• Automatic adjustment is carried out with the following procedure.

1) The movable swing jaw plate to the fixed tooth side and the crusher clearance closes. When this happens, portion (E) on the machine monitor flashes.

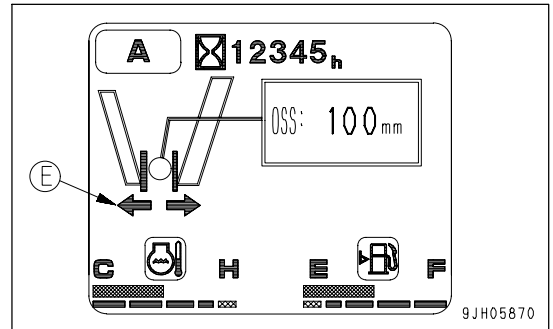

2) When the swing jaw plate contacts the fixed tooth, the buzzer inside the machine monitor sounds, and crusher actual clearance monitor display value (F) is as shown as 0.

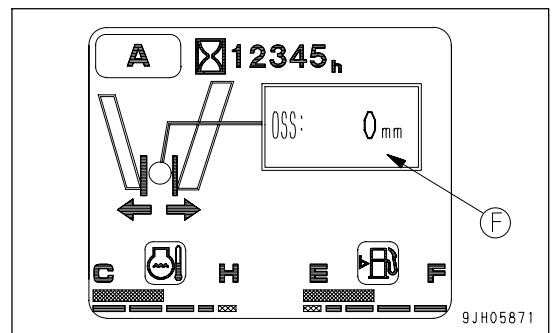

3) The swing jaw plate acts in the direction to open the crusher clearance. While the clearance is opening, machine monitor portion (G) flashes.

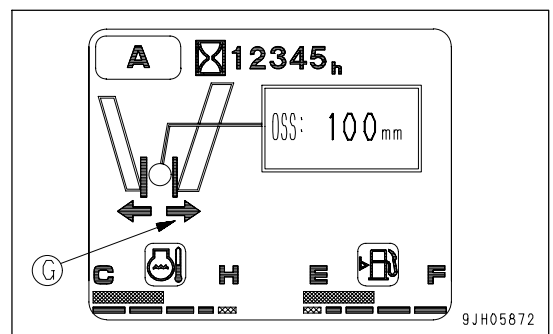

4) When the crusher clearance reaches the desired OSS clearance set value (H), the automatic clearance adjustment is completed.

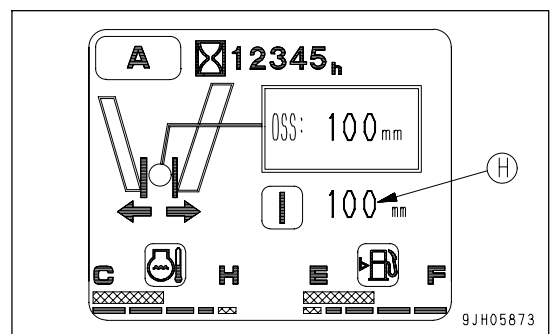

CAUTION

The value for the discharge port clearance displayed on the monitor panel and selector and the discharge port clearance adjusted in the A (automatic) mode may be different because of the wear of the tooth plate and the condition of installation. In such cases, measure the clearance and adjust with S (semi-automatic) mode or M (manual) mode.

ADJUSTING CLEARANCE IN S (SEMI-AUTOMATIC) MODE

1. Measure the present crusher discharge port clearance to understand how much to increase or decrease the value to reach the target value for the clearance.

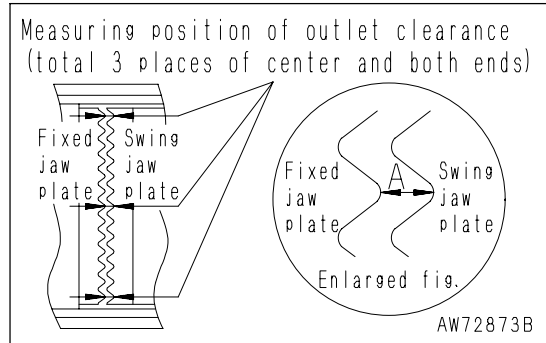

2. Start the engine.

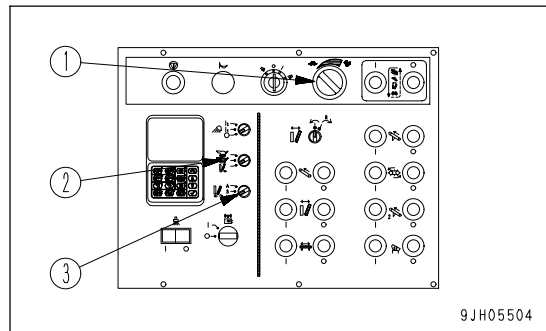

3. Set fuel control dial (1) to the low idling (MIN) position.

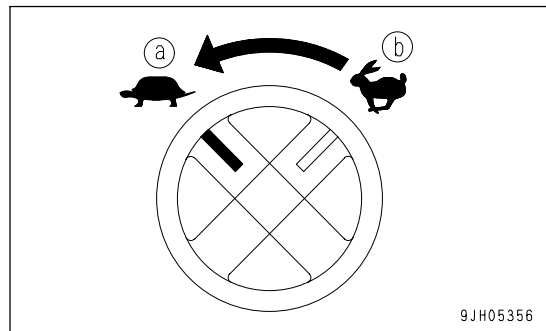

4. Set mode selector switch (2) to INSPECTION (c) position.
The machine monitor switches to the normal inspection

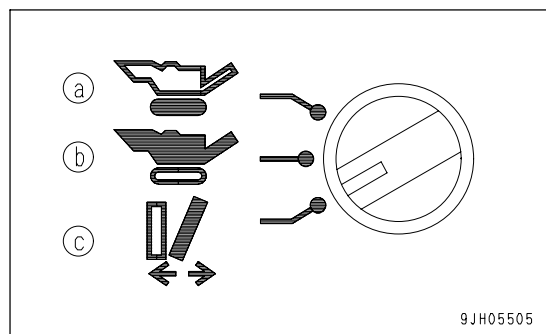

- Set clearance adjustment selector switch (3) to the S (semi-automatic) position.

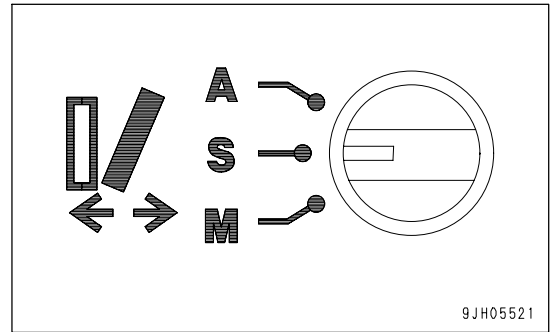

- Check that mode monitor (D) of the machine monitor has changed to S (semi-automatic) mode, then input clearance value (A) for the amount to change the present clearance on the machine monitor as follows.

- Use UP switch (4) or DOWN switch (5) to move the cursor on the screen display to position (A).

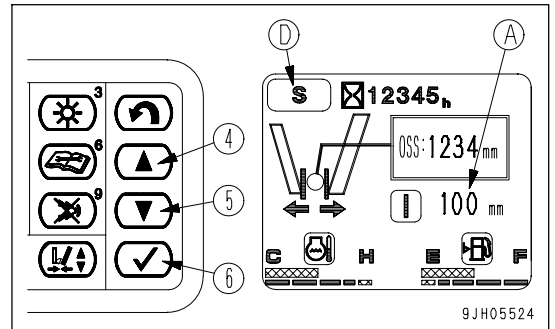

- Press input confirmation switch (6). (A) starts flashing and numeral input window (B) is displayed at the top left of the screen.
- Use UP switch (4) or DOWN switch (5) to increase or decrease the value on the display and adjust to give the desired set value.
The numerical value can be set in units of 1 mm (0.039 in) in a range of 50 to 150 mm (2.0 to 5.9 in).

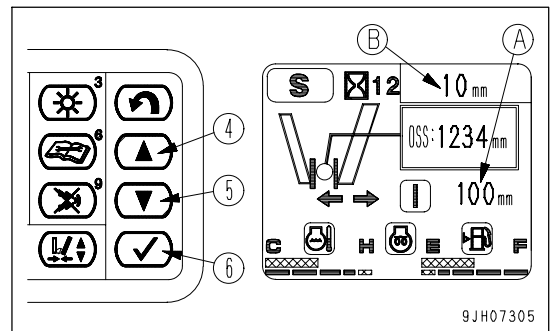

+ display: Adjustment to open clearance
- display: Adjustment to close clearance

If the UP switch (4) or DOWN switch (5) is kept pressed continuously, the set value will increase or decrease in units of 10 mm (0.4 in).

- After inputting the set value for the adjustment, press input confirmation switch (6) to set the input value.

- Adjust the clearance.

- Use UP switch (4) or DOWN switch (5) to move the cursor on the screen display to position (C).
- Press input confirmation switch (6) to complete the preparations.
"|" lamp (C) flashes.
- Press input confirmation switch (6) again to carry out the adjustment.
"|" lamp (C) lights up.

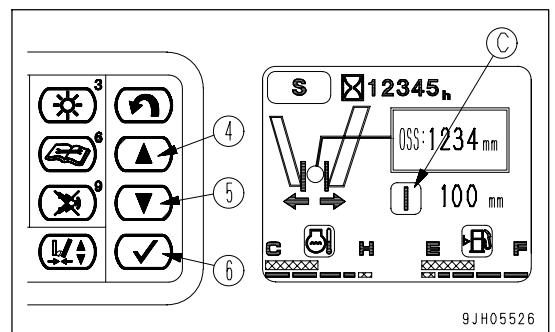

- "|" lamp (C) goes out to show that the clearance adjustment is completed.

ADJUSTING CLEARANCE IN M (MANUAL) MODE

1. Measure the present crusher discharge port clearance to understand how much to increase or decrease the value to reach the target value for the clearance.

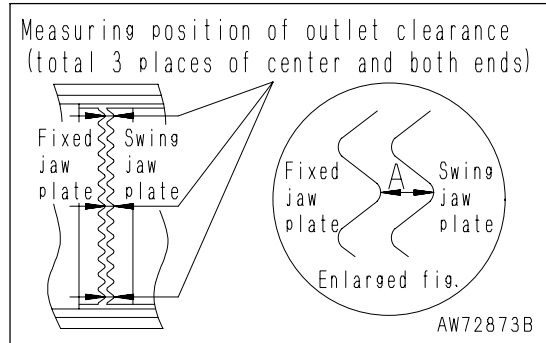

2. Start the engine.

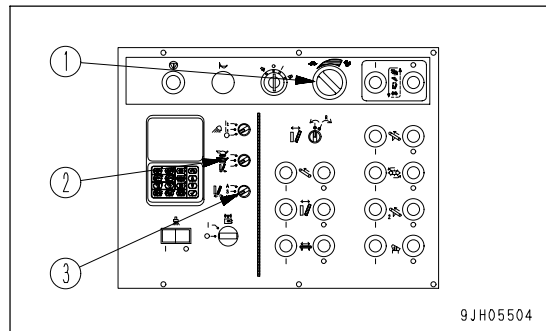

3. Set fuel control dial (1) to the low idling (MIN) position.

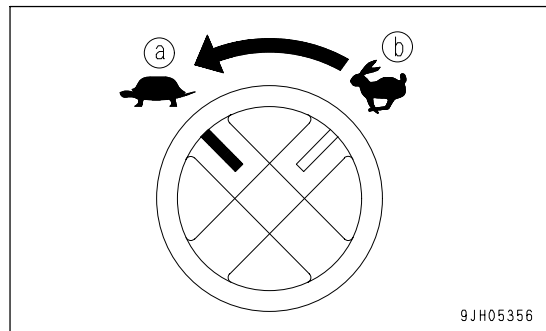

4. Set mode selector switch (2) to INSPECTION (c) position.
The machine monitor switches to the normal inspection

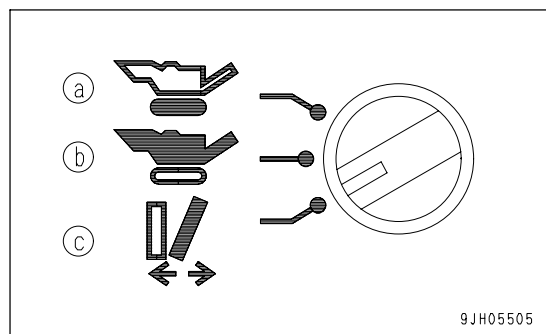

- Set clearance adjustment selector switch (3) to the M (manual) position.

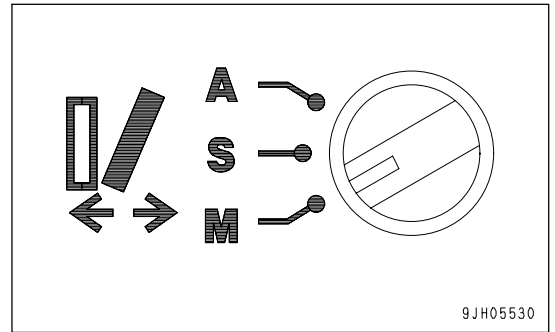

- Check that mode monitor (D) of the machine monitor has changed to M (manual) mode.
- Using crusher clearance decrease switch (4) and crusher clearance increase switch (5), adjust so that crusher actual clearance monitor (A) for the amount to change the present clearance reaches the target value.

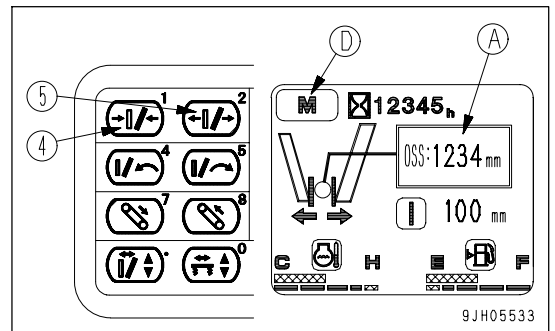

- (4) Crusher clearance decrease switch
Action to close crusher clearance continues while switch is being pressed.
- (5) Crusher clearance increase switch
Action to open crusher clearance continues while switch is being pressed.

REMARK

As the crusher is operated, the teeth become worn, so the value displayed on clearance display monitor (A) gradually becomes different from the actual clearance. When this happens, it is possible to compensate for the value by keeping crusher clearance decrease switch (4) pressed to bring the teeth into contact with the fixed jaw plate.

- Keep crusher clearance decrease switch (4) pressed to bring the movable teeth and fixed jaw plate into contact. When the value (A) shows no more change, the movable teeth and fixed jaw plate are in contact.
- After bringing the movable teeth and fixed jaw plate into contact, keep crusher clearance decrease switch (4) pressed for approx. 10 seconds.
- The buzzer sounds and the compensation is completed. When this happens, the value on crusher actual clearance monitor (A) changes to 0.

REMARK

Depending on the wear of the teeth, the value after compensation may not become exactly 0, but this does not indicate any abnormality.

- Press crusher clearance increase switch (5) and adjust so that the value on crusher actual clearance monitor (A) becomes the target value.

CHECK OF WEAR ON MAJOR WEARING PARTS

JAW PLATE

WARNING

When checking the wear, stop the crusher, then stop the engine and check the wear.

CAUTION

- If the machine is used continuously with the crusher chamber excessively charged, premature partial wear will develop on the tips of jaw plates.
- If a work is continued with the partially worn jaw plates, rocks may not be discharged smoothly, eventually resulting in damages on the jaw plates on account of the worsened partial wear.
Replace the partially worn jaw plates with new ones.
- If jaw plates are used beyond their wear limit, a serious damage will be inflicted on the jaw crusher main body itself.

Hatched portion (1): Virtual wear range

If the bottom tips of fixed and swing jaw plates have been worn off and reached the wear limit as illustrated in the figure at right, either reverse or replace them, as the case may be.

- (A) Wear limit for fixed jaw plate: 55 mm (2.2 in) (thickness from mounting surface to root of tooth)
(new part: 74 mm (2.9 in))
- (B) Wear limit for swing jaw plate: 60 mm (2.4 in)(thickness from mounting surface to root of

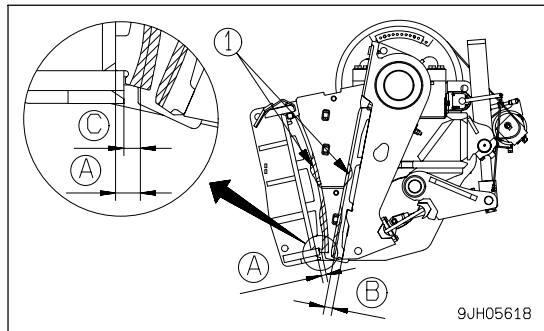

REMARK

The bottom part of the frame at the fixed jaw plate mounting surface protrudes 25 mm (1.0 in).
(A) - (C) = 25 mm (1.0 in))

CHEEK PLATE

Carry out replacement when the remaining dimension reaches approx. 15 mm (0.6 in) (wear amount: 10 mm (0.4 in)) at the top, and approx. 10 mm (0.4 in) (wear amount: 15 mm (0.6 in)) at the bottom.

NOTICE

When replacing the cheek plate, replace the cheek plate mounting bolts also at the same time.

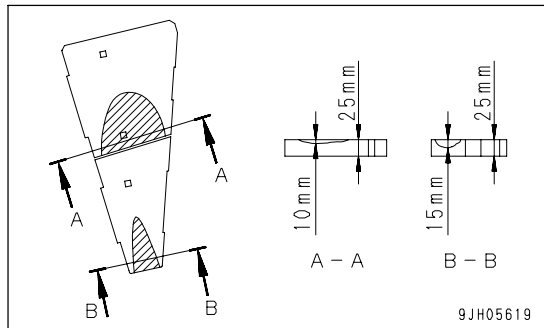

PROTECTOR

Replace when the remaining dimension is approx. 10 mm (0.4 in) (wear amount: 10 mm (0.4 in)).

Replace also if part of the protector is worn unevenly.

(A) Wear amount: 10 mm (0.4 in)

(B) Protector thickness: 19t

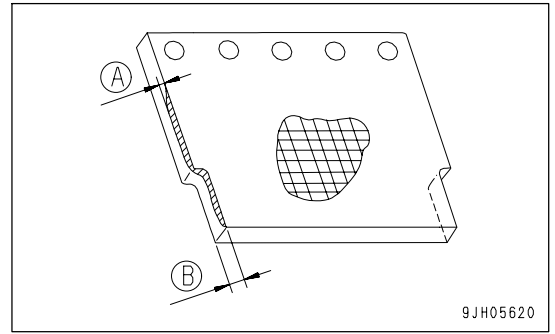

SWING JAW PLATE WEDGE

Replace when remaining dimension (A) at the bottom of the wedge is approx. 79 mm (3.1 in) (wear amount (B): 10 mm (0.4 in)).

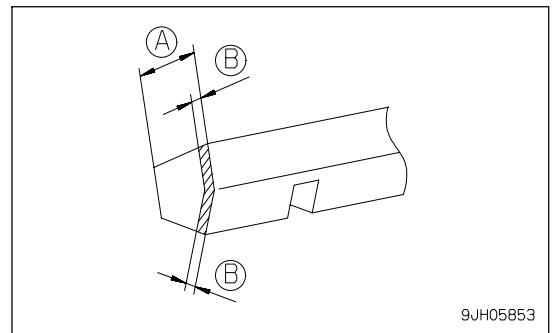

TOGGLE SEAT

If the wear dimension reaches approx. 5 mm (0.197 in), proceed with the replacement.

(A) Wear amount: 5 mm (0.197 in)

(B) 50 mm (2.0 in)

(C) 30 mm (1.2 in)

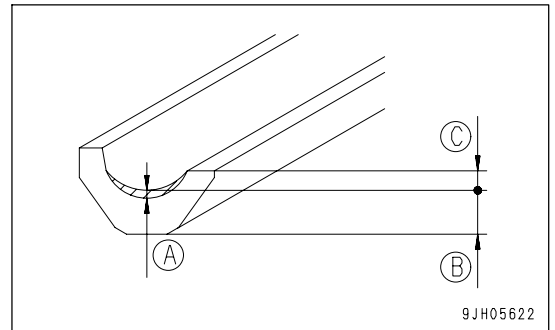

TOGGLE PLATE

Replace if wear dimension (A) is approx. 5 mm (0.197 in) on one side.

Replace also if the wear is on one side as shown in the diagram.

REMARK

- Use the wear tolerance of toggle sheet (2) and toggle plate (1) as a guideline for the above dimension.
- When replacing toggle plate (1) replace the toggle plate dust cover also at the same time.
- If noise is generated between toggle sheet (2) and toggle plate (1), the noise made when toggle plate (1) rolls on the surface of the toggle sheet has no effect on the machine itself. If a knocking noise is generated, check if tension spring set length (B) is the specified value.

(For details of the tension spring set length, see "CHECK OF JAW CRUSHER AND RELATED ACCESSORIES (PAGE 3-63)".)

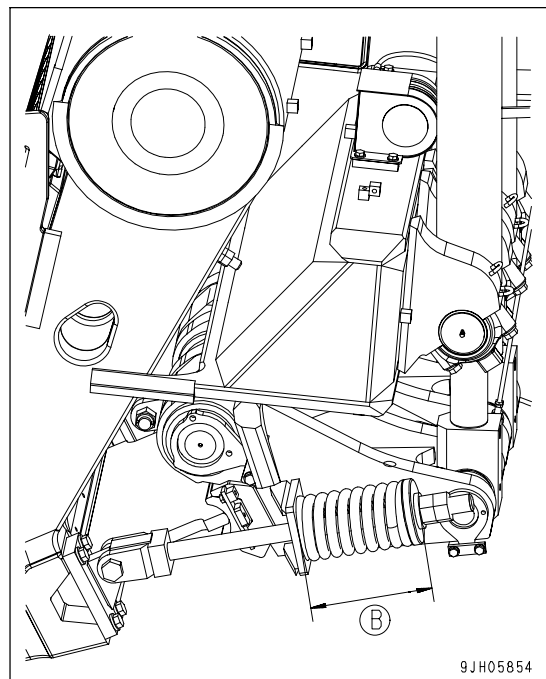
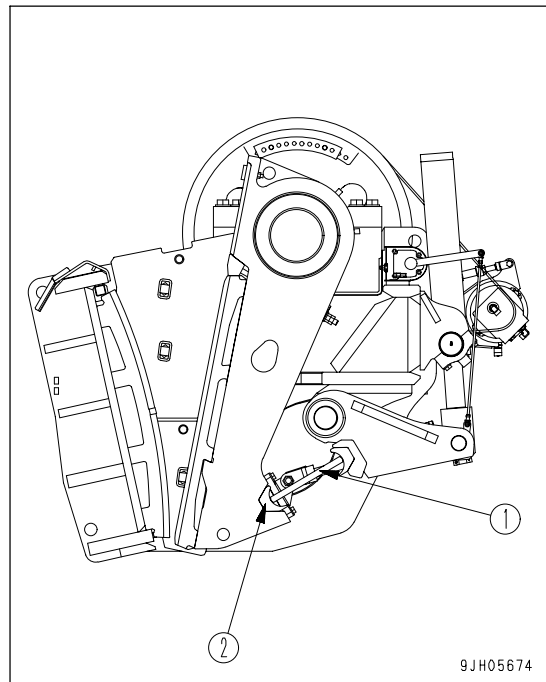
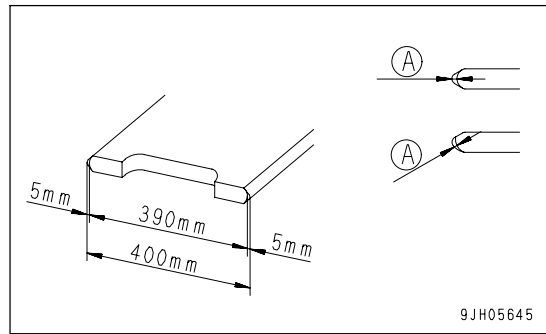

REPLACEMENT OF CHEEK PLATE

1. Use an air gun or wire brush to remove the sand or soil clogging lifting hole (3) of top cheek plate (1).
2. Loosen cheek plate mounting bolt (4). Next, with the bolt loosened, tighten locknut (5) again.

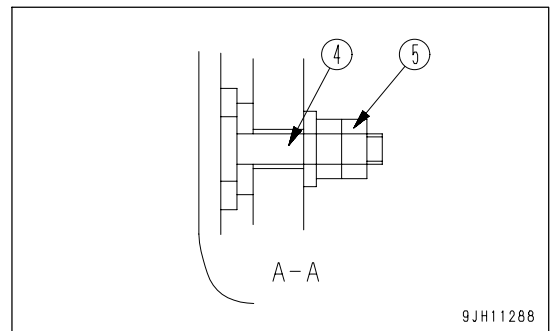
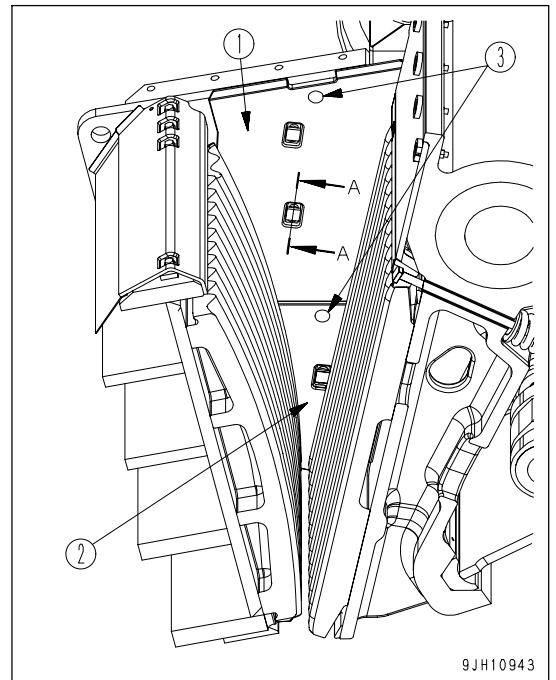

3. Fit the tool supplied with the machine to the lifting hole, then lift up vertically. If the load is at an angle, it may be difficult to remove.

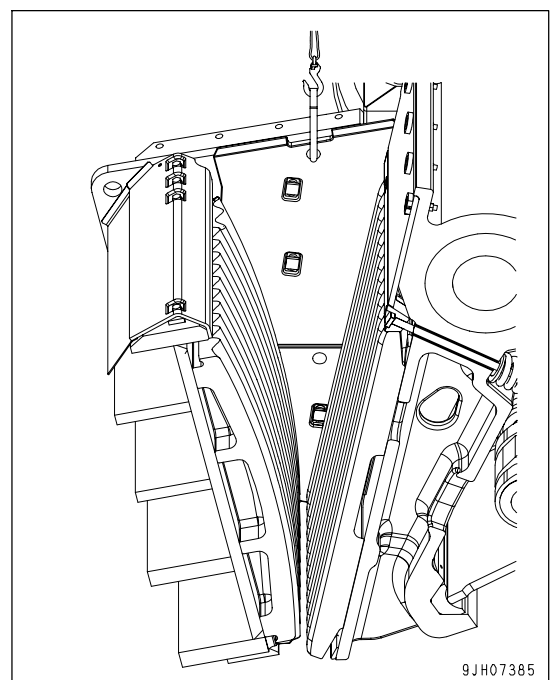

4. While lifting, hit the area around the cheek plate with a medium-sized hammer.
5. When cheek plate (1) comes free, remove the mounting bolts and lift up.
(Weight of top cheek plate (1): 74.0 kg(163 lb))
6. Repeat the same procedure to lift up bottom cheek plate (2).
(Weight of the bottom cheek plate (2): 36.0 kg(76 lb))
7. After removing all the cheek plates, completely remove the soil and sand from the cheek plate fitting surfaces (front, rear, right and left).
In particular, remove the soil and sand clogging both sides of the fixed jaw.

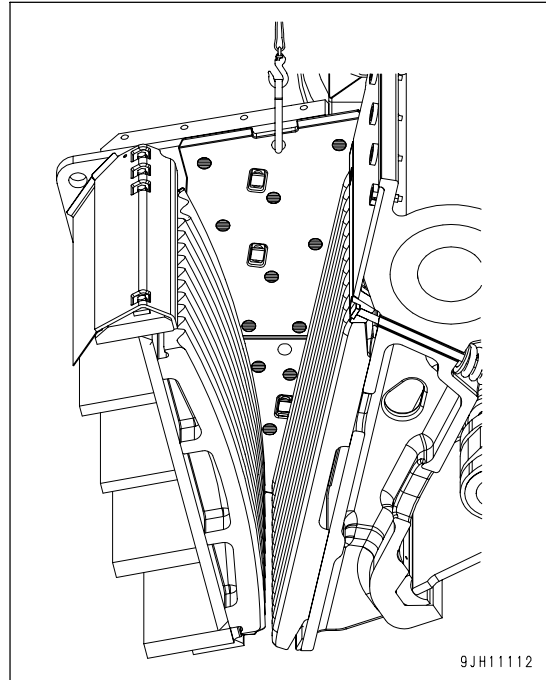

8. Insert new cheek plates in order from the underside along the fixed jaw and a guide of the side frame.
9. Tighten the cheek plate lock bolts.
Top cheek plate (1): M24 x 2 (each side)
Bottom cheek plate (2): M24 x 1 (each side)

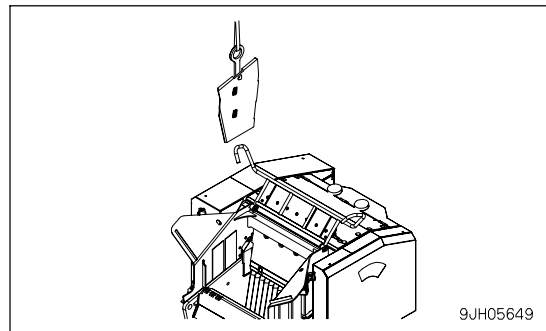

REVERSAL OR REPLACEMENT OF FIXED JAW PLATE



CAUTION

After dismantling the fixed jaw plate, completely remove soils, sand, etc. from the fixed jaw fitting surfaces (front frame and mount stopper upper surface). Unless removed completely, they may cause a backlash on the fixed jaw plate.

If the clearance is not even on the right and left sides, there will be a slippage from the swing jaw plate tip, which likely leads to premature wear or partial wear on the jaw plates.

1. Dismantle the cheek plates, referring to the section dealing with the cheek plate replacement.
2. Remove the fixed jaw plate wedge bolt and fixed jaw plate wedge lock.

Tools to use

- (1) Extension socket: Supplied tool No. 5
- (2) Ratchet handle: Supplied tool No. 3
- (3) Extension pipe: Supplied tool No. 8

3. Lift up the fixed jaw plate with a wire rope.
 - When reversing the fixed jaw plate, lower it on to a block once. Then hook a wire rope on the other side to lift it up and insert it into the crusher frame.
 - When replacing the worn fixed jaw plate, lower it on to a block once. Then lift up a new fixed jaw plate with a wire rope and insert it into the crusher frame.

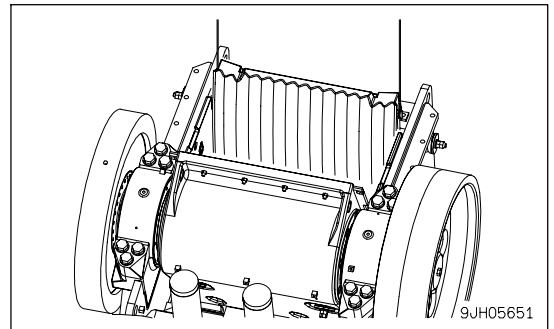
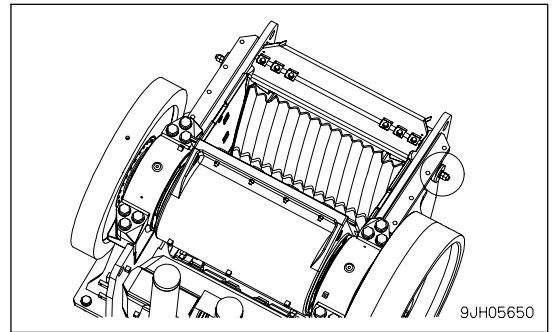

4. Take measurements of the clearance on both sides of fixed jaw plate, and position the fixed jaw plate and the crusher frame so that both centers are aligned.

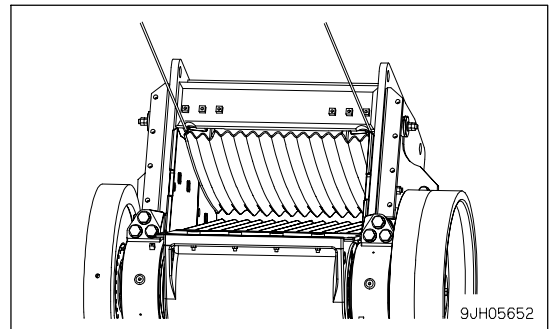

5. If the fixed jaw plate (3) is not in tight contact with the frame, insert wooden block (or equivalent part) (1) between fixed jaw plate (3) and swing jaw plate (2).
6. Push out the swing jaw plate (swing jaw) (2) and push fixed jaw plate (3) against the front frame.
For details, see Method for adjusting discharge port

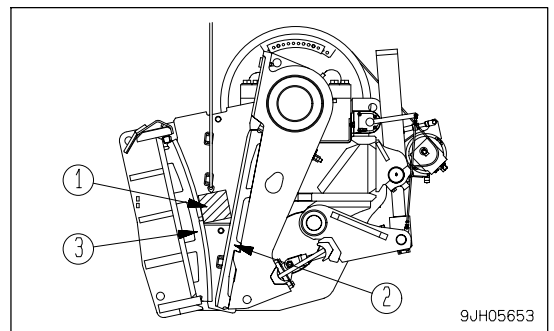

7. Install the fixed jaw plate wedge bolt and fixed jaw plate wedge lock.
Set fixed jaw plate wedge bolt spring (A) to 108 to 110 mm (4.26 to 4.33 in).

8. Install the cheek plates.

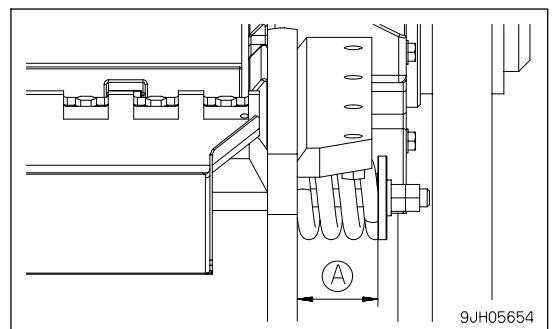

REVERSAL OR REPLACEMENT OF SWING JAW PLATE

1. Loosen the bolts of the crusher inspection hatch and fix it with a hook at the open position.

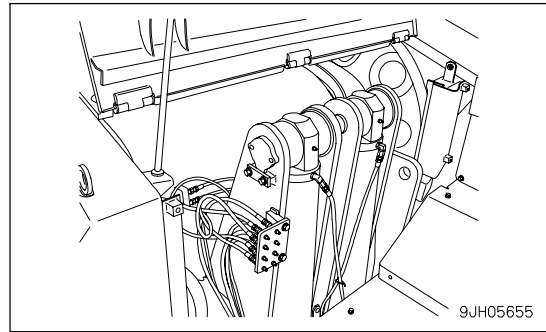
**CAUTION**

When pushing out the swing jaw plate wedge from the rear of the swing jaw, to prevent the movable wedge from falling, always leave one of the swing jaw plate wedge bolts inserted.

2. Loosen 2 swing jaw plate wedge bolts (1) then remove one bolt on one side. Install a nut on the remaining bolt after removing swing jaw plate wedge spring (2), and leave it

Tools to use

- (1) Ratchet handle: Supplied tool No. 7
- (2) Extension pipe: Supplied tool No. 8
- (3) Hook for wedge maintenance: Supplied tool No. 6

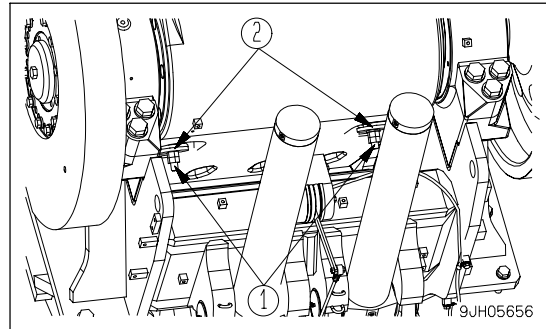
**NOTICE**

To make it easier to fit lifting wire (A) to the swing jaw plate wedge, push the swing jaw plate wedge out approximately 30 mm (1.2 in).

3. Check that the swing jaw plate wedge is completely loosened, fit lifting wire (A) to the center portion, remove the temporarily installed bolt, then lift off the wedge.

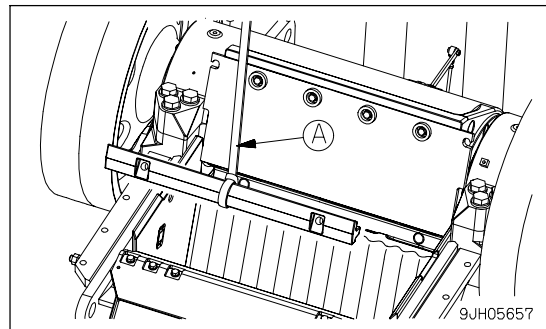

4. Fit movable lifting bolt (A) to the hook on the top surface of the swing jaw plate, then raise.
(Weight of swing jaw plate: 735 kg (1621 lb))

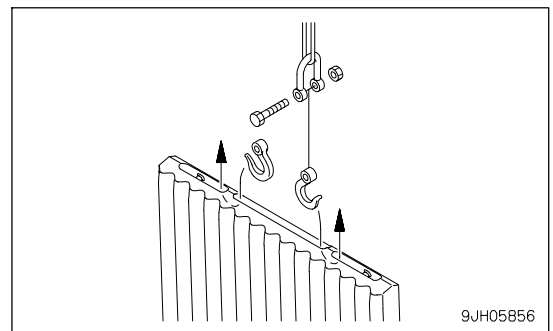
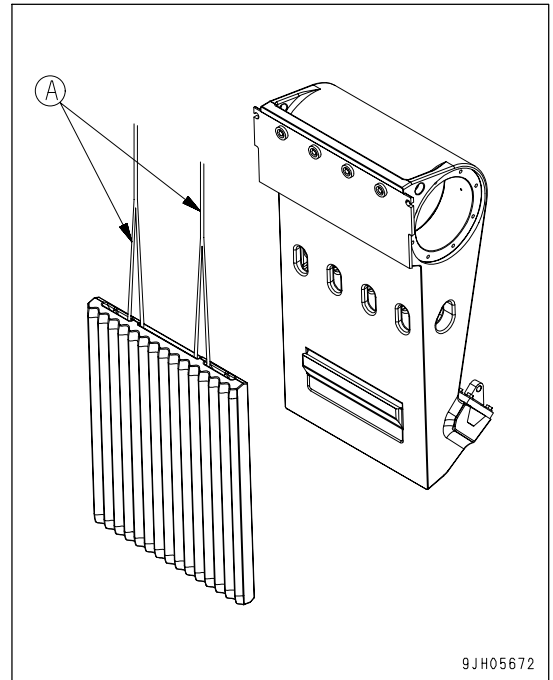

CAUTION

After detaching the swing jaw plate, completely remove soils, sand, etc. from the swing jaw plate fitting surfaces (swing jaw, each upper surface of swing jaw plate mount stopper and transverse stopper piece)
If not removed completely, they may cause a backlash on the swing jaw plate.

- When turning over, lower the swing jaw plate on top of a stand, then fit the wire to the hook on the opposite side, and insert again in the crusher frame.
- When replacing the swing jaw plate, lower the worn plate on to a block once. Lift up a new swing jaw plate with a wire rope and insert it into the crusher frame.

5. Install the swing jaw plate wedge and swing jaw plate wedge bolt.
Set fixed jaw plate wedge bolt spring (B) to 108 to 110 mm (4.23 to 4.33 in).

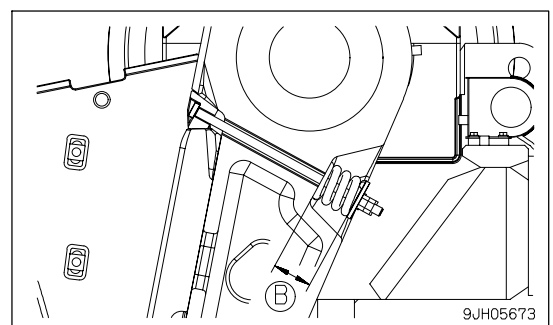

REPLACEMENT OF TOGGLE PLATE

1. Loosen the bolts of the crusher inspection hatch and fix it with a hook at the open position.
2. Remove the dust prevention rubber palte at the side of the crusher. (left and right)

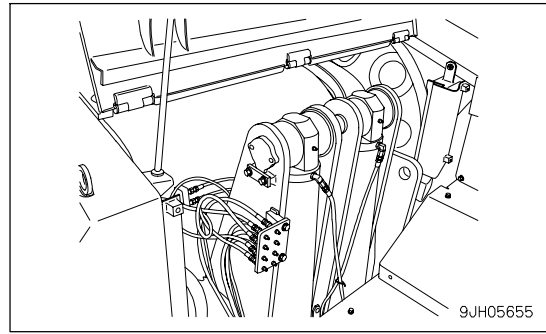

3. Wrap a nylon sling around toggle plate (1) and sling it.

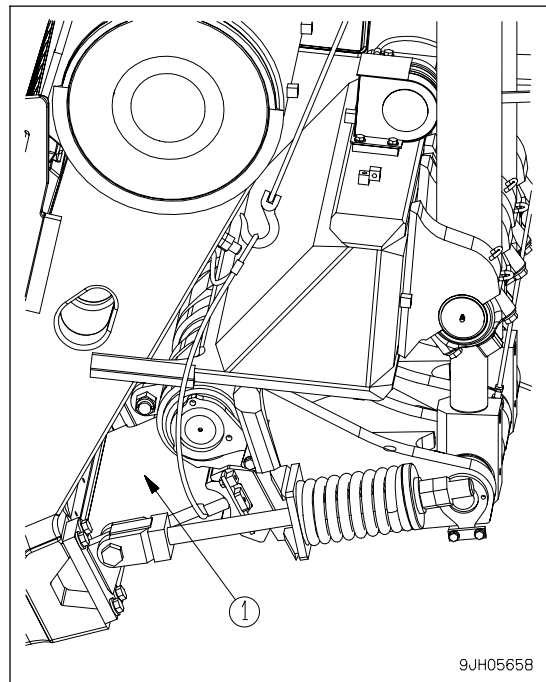

4. Start the engine.
5. Set mode selector switch (3) to the inspection position.
6. Attach a warning tag to announce to those concerned that the machine is now worked on.
7. Press crusher clearance decrease switch (4) on the control box, and move the fixed link forward until the fixed jaw plate contacts the fixed jaw plate.
8. If the tooth plates come into contact with each other, stop the engine.

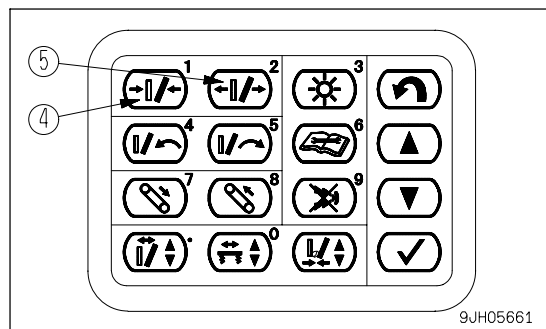
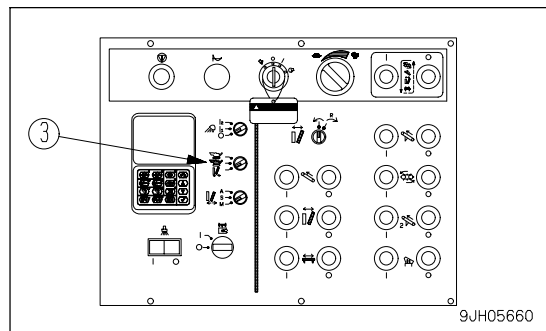

! WARNING

It is extremely dangerous if you go on to the next work without completely loosening tension spring (2), so remove tension spring nut (M42) from the rod.

9. Loosen tension spring (2) (both ends: M42) completely.
 - (1) Single-ended wrench: Supplied tool No. 2
 - (2) Extension pipe: Supplied tool No. 8
10. Pass the wire through the hole in the bottom of the swing jaw, then use a chain block to pull the crusher case and the track frame and fix them in position.
11. Start the engine.
12. Press crusher clearance increase switch (5) on the control box, and pull back the fixed link slowly.
13. Stop the engine.

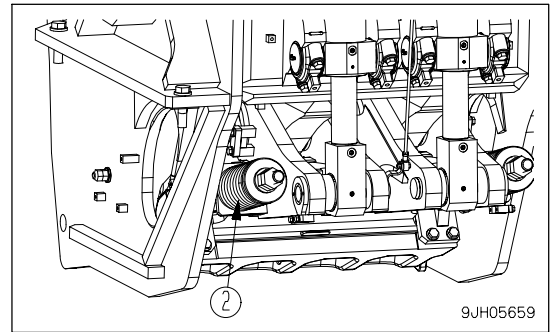

14. Take out the toggle plate.

(Weight of toggle plate: 101 kg (223 lb))

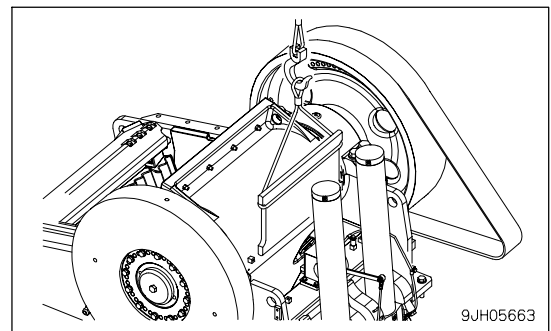
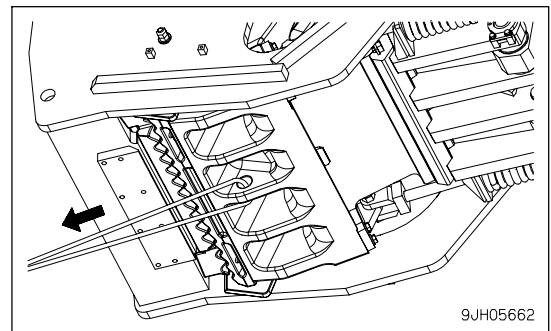

15. Wrap a nylon sling around the new toggle plate.

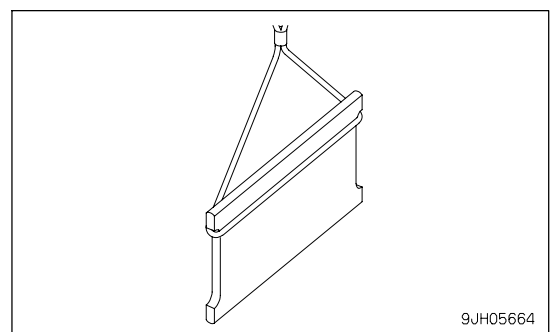

16. Lower the toggle plate and align it with the center of the seat at the fixed link end.
17. Start the engine.
18. Set the operation mode selector switch to the INSPECTION position.
19. Attach a warning tag to the engine starting switch to announce to those concerned that the machine is now worked on.
20. Push the crusher clearance decrease switch on the control box, push out the fixed link, and adjust the lifting weight of the wire at the same time, then set in position so that the center of the contact surface at the front of the toggle plate is aligned with the center of the contact surface of the swing jaw seat.
21. Stop the engine.
22. Remove the nylon sling fitted to the toggle plate.

23. Install the tension spring and tighten it to the specified tightening length.

Set so that the tightening length (C) of the tension spring is 258 to 260 mm (10.17 to 10.24 in) when the lock cylinder length is the minimum.

24. Install the rubber cover (x 1) on top of the toggle plate.
(M12 bolts x 4)
25. Loosen the chain block installed to the bottom of the swing jaw and remove the wire.
26. Close the crusher inspection hatch and secure with bolts.
27. Install the dustproof rubber plate to the side of the crusher.
28. Check crusher outlet clearance (A) and adjust it to a desired clearance.

For adjusting the crusher outlet clearance, see the section of "CHECK AND ADJUSTMENT OF OUTLET CLEARANCE (PAGE 4-35)".

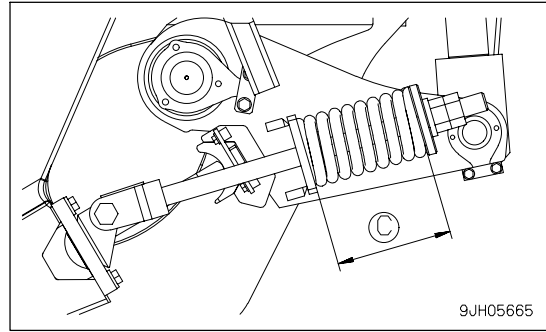

REPLACEMENT OF TOGGLE SEAT



WARNING

Before replacing the toggle seat, follow the items below without fail.

- After long use, the toggle seat becomes deformed, so it may get stuck to the fixed link or swing jaw. In this case, weld a hook to the center of the toggle seat and pull out the worn toggle seat.
In addition, if necessary, take action with the gasket or other part as necessary.
(Toggle seat material: Carbon steel)



CAUTION

- The toggle seat has no interchangeability, so be careful not to mistake the combination when installing.
Toggle seat at swing jaw end: Amount of protrusion and protruding parts: 32.5 mm (1.3 in) (center part), protruding part is at bottom.
Toggle seat at fixed link end: Amount of protrusion and protruding parts: 47 mm (1.9 in), protruding part is at bottom.
- To prevent the toggle seat at the fixed link end from falling, extend the lock cylinder fully when carrying out the work.

1. Start with removing the toggle plate beforehand, referring to the section dealing with replacement of the toggle plate in this manual.
2. Remove toggle seat holder plates (1) of the swing jaw at both ends.
(Bolts to use: M20 x 8)

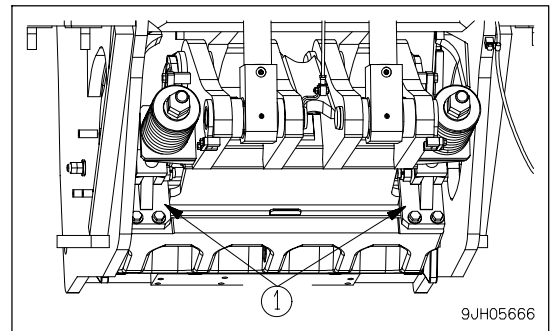

3. Screw in eyebolts (M12) into tap hole (2) at both ends of the toggle seat and fit the wire.

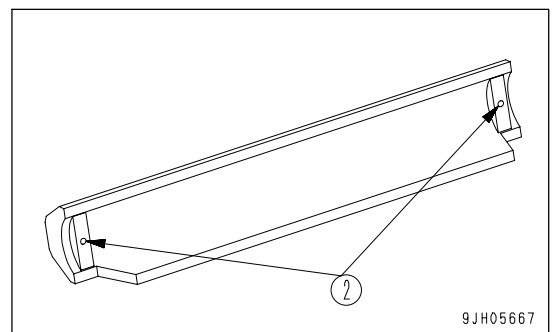

4. Raise the toggle seat.
(Weight of toggle seat at swing jaw end: 44.3 kg (98 lb))

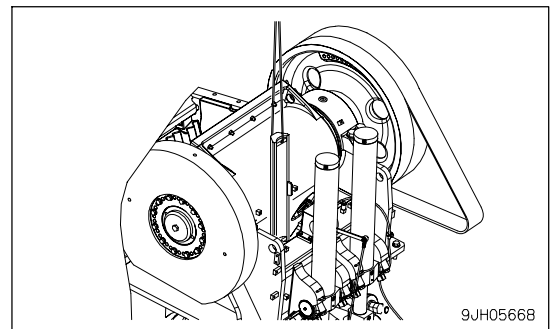

5. Remove only one toggle seat holder plate (3) at the fixed link end.
6. Screw in an eyebolt (M12) on the side from which a holding plate has been removed and lift up the toggle seat provisionally, taking care not to let it fall.
7. When the work of lifting up the toggle seat provisionally has been completed, proceed to remove a toggle seat holding plate on the opposite side.
8. Insert eyebolts into both ends of the toggle seat at the toggle block end, then raise the toggle seat.
(Weight of torque seat at toggle block end: 40.0 kg (88 lb))
9. Insert new toggle seats in the reverse order of the works explained above.

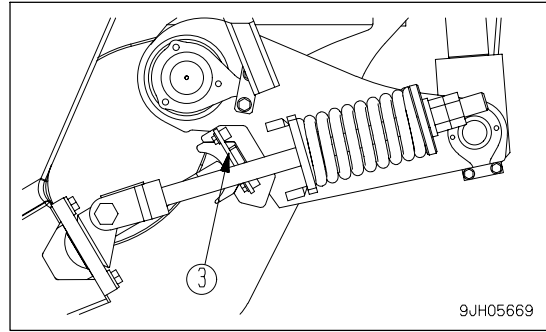

REPLACEMENT OF CRUSHER DRIVING V-BELT

1. Loosen the bolts of flywheel cover (1) at the side of the top step to release it, and at the same time, remove motor cover (2).

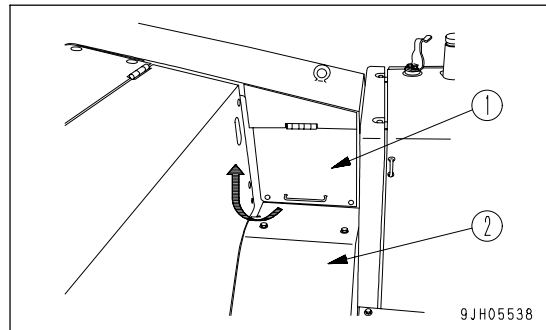

2. Reduce the length of turnbuckle (3) of the crusher motor bracket.

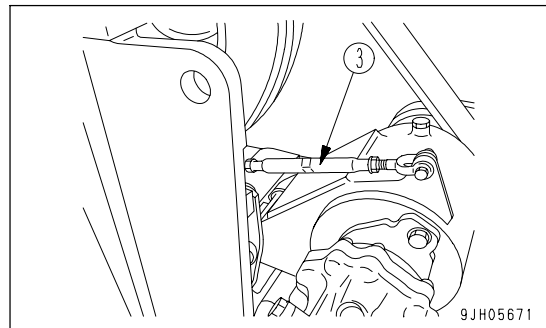

3. Loosen the bolts of cover (4) at the rear and under the left flywheel cover, and open it.
Remove the V-belts in turn from the outside the belt, then remove from the top opening of the crusher motor.

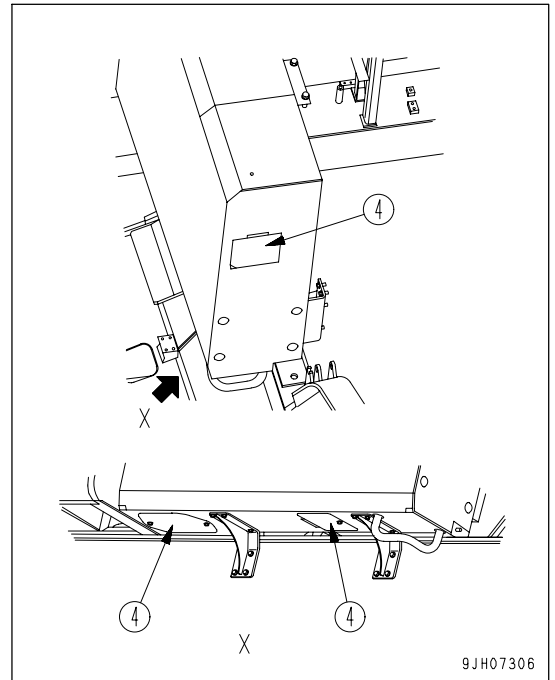

4. Install the new belts to the flywheel in the opposite order, and use the turnbuckle to adjust the tension to the specified value.
5. Return the cover to its original position.

CHECK AND ADJUSTMENT OF PRIMARY CONVEYOR

 **WARNING**

When inspecting and cleaning the primary conveyor and its surrounding, there is always the danger that you are caught in a revolving parts. Be sure to start the work only after stopping the belt conveyor.

CHECK AND ADJUSTMENT OF SNAKY MOVEMENT OF CONVEYOR BELT

 **CAUTION**

If it becomes necessary to work on the adjust bolts, start with the work only after stopping the engine.

If the belt starts snaking, turn adjustment bolt (1) to adjust the left and right tension.

When turning the adjustment bolt, remove the stopper plate to adjust, and after adjustment, install it to its original position without fail.

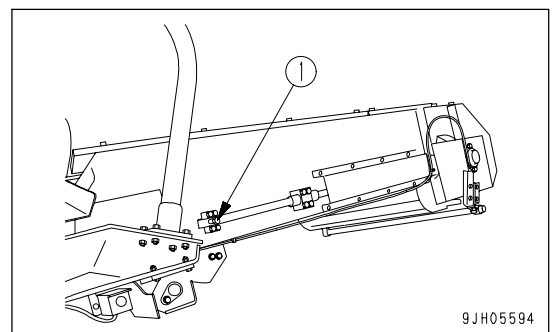

CHECK TENSION OF CONVEYOR BELT

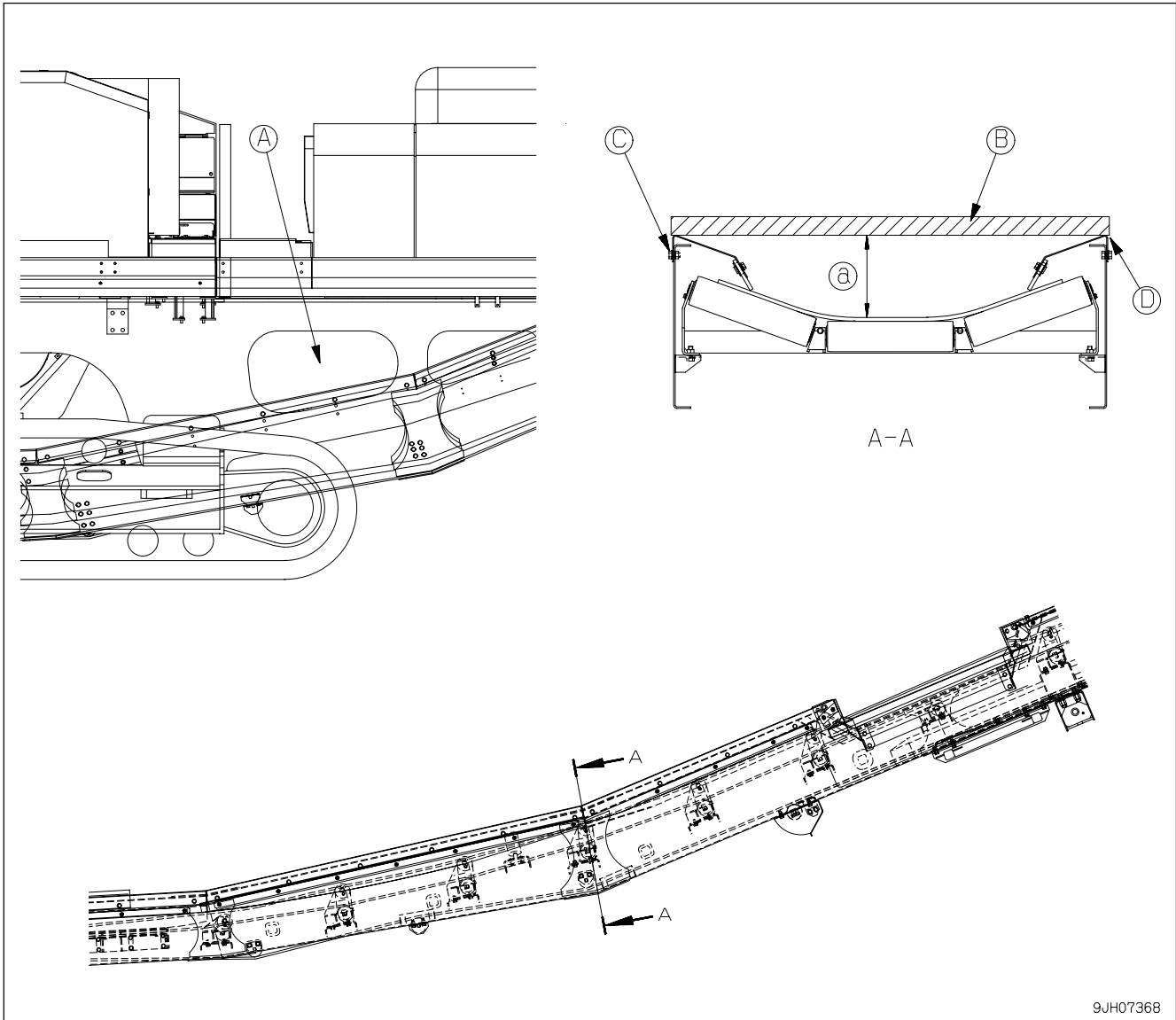

9JH07368

1. Remove rubber cover (A) at the side of the machine.
2. Place wooden block (B) on top of the conveyor between both sides (C) - (D) of the conveyor frame at cross-section A - A where the conveyor frame bends.
3. Measure the maximum deflection of the conveyor belt top surface from the bottom surface of the wooden block.

Standard value for deflection

Deflection (a) should be 170 to 175 mm (6.7 to 6.9 in).

ADJUSTMENT OF CONVEYOR SIDE RUBBER

If the conveyor side rubber has been worn out, creating a clearance between the rubber and belt, loosen the adjustment bolt.

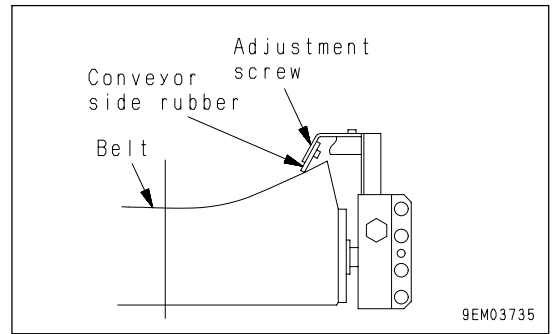

ADJUSTMENT OF SCRAPER

DRIVING PULLEY SIDE

1. The default condition is as shown in the diagram on the right.

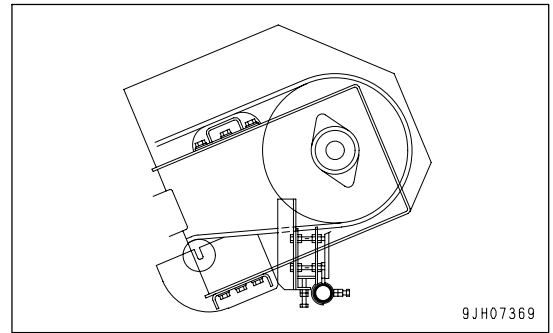

2. Loosen nuts (1) and bolts (2), then set cleaner plate (4) so that it is at right angles to belt (3).

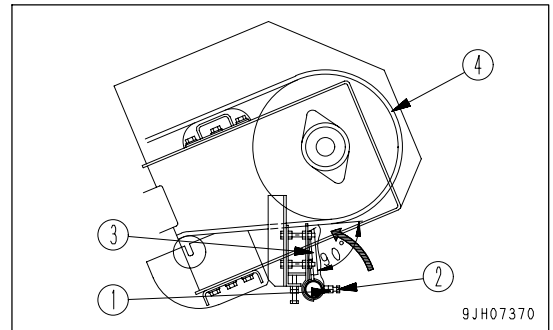

3. Loosen nuts (5) and (6), then move the cleaner up so that the tip of the cleaner contacts the belt.

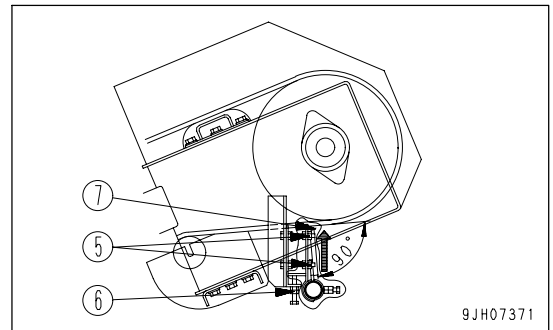

4. Loosen bolts (2), then rotate the cleaner plate as shown in the diagram on the right.

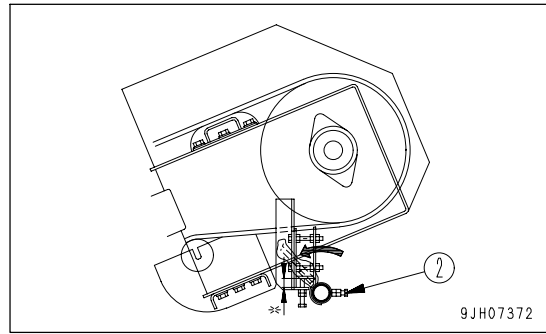

5. Raise the cleaner 5 mm (0.2 in).

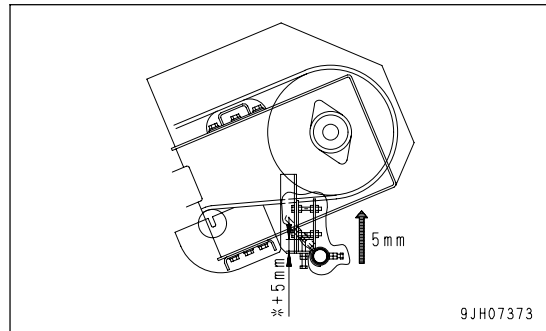

6. Tighten nuts (5) and (6).

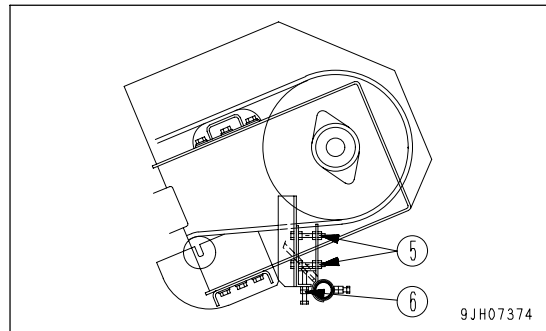

7. Rotate cleaner shaft (8) so that cleaner plate (4) is at right angles.

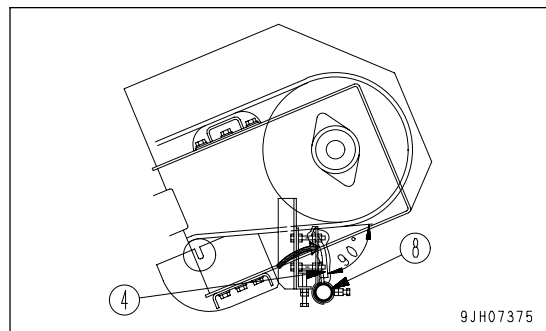

8. Check that cleaner tip (7) and the belt are at the 60° position, then tighten bolt (2) and nut (1).
If the angle of the tip of the cleaner and the belt is less than 60°, move the cleaner up.

Tightening torque of bolt: M12 (34.3 N·m (3.5 kgf·m, 25.3 lbf·ft))

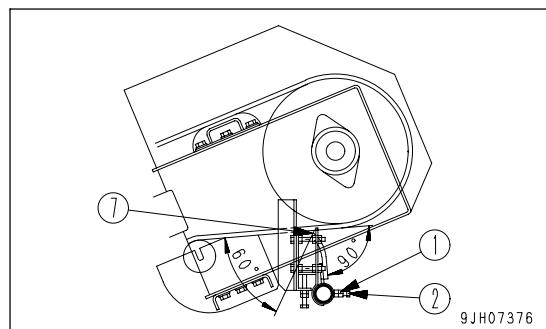

DRIVEN PULLEY SIDE

If the scraper rubber has been worn out, replace it by loosening the securing bolts.

(It is in even contact with the belt across the width)

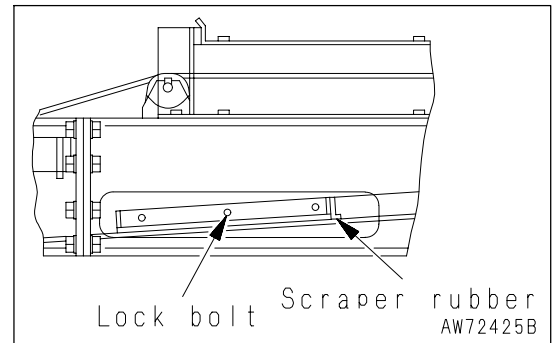

INSPECTION AND MAINTENANCE OF MAGNETIC SEPARATOR

! WARNING

- There is danger that the magnetic field may cause malfunction of pacemakers, so persons wearing pacemakers should not approach within a range of 5 m (16 ft 5 in) from the magnetic separator.
- The magnetic force will attract metal tools and pieces of steel, and there is danger of getting your fingers or hands caught between such objects and the attracting surface, so do not approach the magnetic separator when carrying metal tools or pieces of steel.
- Use a steel object removal belt to remove any pieces of steel attracted to the magnetic separator. There is danger of injury, so do not approach the magnetic separator while it is being operated.
- When storing this machine or removing the magnetic separator, set up cones and make a no entry area. Do not allow any person wearing a pacemaker to approach within a range of 5 m (16 ft 5 in) from the magnetic separator.
- Before starting operations, check that there is no misalignment or snaking of the belt.
If there is any misalignment or snaking of the belt, there is danger that the belt will be damaged or cut.
- There is danger of the magnetic field causing damage, so do not bring watches, cellular phones, or other precision instruments close to the magnetic separator.
- There is danger of the stored data being damaged by the magnetic field, so do not carry bank cards, credit cards, or other cards with magnetic strips when approaching the magnetic separator.

! CAUTION

- When conduction a trial run of the machine, be sure to run the motor at low speed and check that the conveyor belt does not make a snaky movement.
- If metal pieces are drawn by the magnetic separator, they will be ejected, accelerated by the metal piece discharging belt. As that poses a big danger, provide a safety cover at the discharging outlet to prevent the metal pieces from flying off.
- Do not feed concrete debris containing reinforcing bars larger than 13 mm (0.5 in) in diameter and longer than 600 mm (23.6 in), since they can damage the conveyor belt.

The discharging belt for this machine has the same structure as that for the conventional belt conveyor. Pay attention to the following points, when starting the day's work or daily inspection.

- Has the belt been biased or does it make a snaky movement?
- Is the belt tension appropriate?
- Are debris stuck to the backside of the belt?
- Has the belt surface been scratched or peeled off?
- Has the belt scraper not been damaged?

- Have metal parts or bolts at the connection of the belt end not been damaged or fallen off?

If anything unusual is found, take the following actions.

- 1) In case the belt is deflected or makes a snaky movement;
Adjust the position of the take-up unit, referring to the figure at right. The take-up unit consists of a base plate, a pillow block and a tap bolt. Loosen the lock bolt on the base plate and adjust the position of the take-up unit with the tap bolt. After the adjustment, tighten the lock bolt again. When there is a clearance more than 10 mm (0.4 in) at both ends from the inner surface of the flange at the end of the pulley, the belt is at a proper position.
- 2) In case the belt tension is not appropriate;
Adjust the belt tension in the same way as mentioned above. At that time, adjust the belt so that it will have a clearance of 30 to 40 mm (1.2 to 1.6 in) from the lower surface of the magnet on the main body.
- 3) In case debris are stuck at the backside of the belt;
Remove them as soon as found, since they can cause a damage on the belt or the pulley.

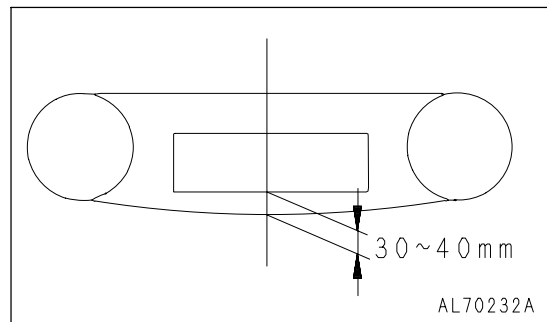
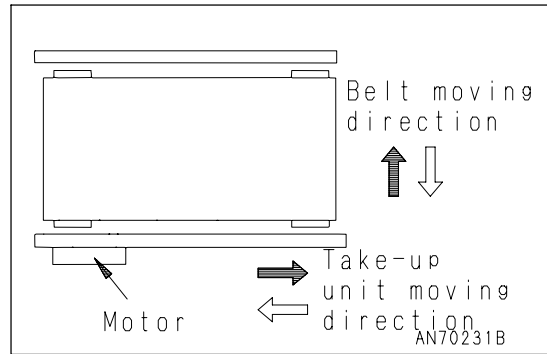

- 4) If the belt or any related part is broken, replace it immediately.

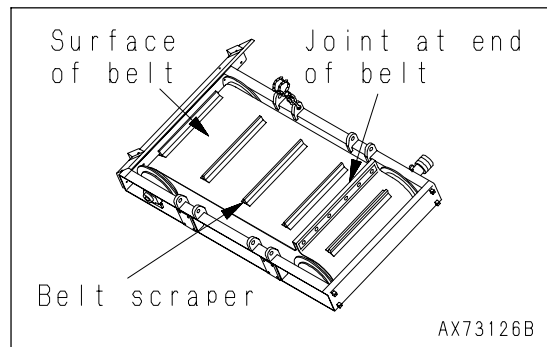

ADJUSTING CLEARANCE FROM CONVEYOR

- The standard clearance between V-belt surface of the belt conveyor and the magnet is (A), (B) = 350 mm (13.8 in). Change this as necessary according to the condition of the crusher discharge port clearance.

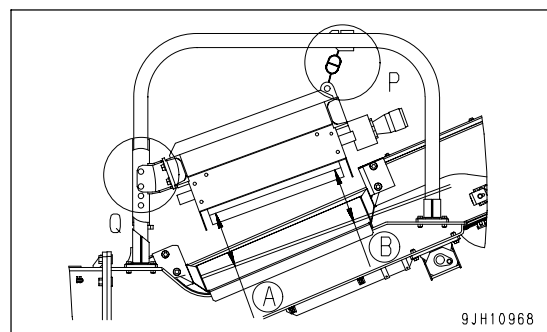

- Front (P): Change position of magnetic separator chain (1) to adjust, and fit on magnetic separator frame hook (2).
- Rear (Q): Change position of magnetic separator bracket hole (5) and magnetic separator frame hole (4) to adjust, then secure with pin (3).

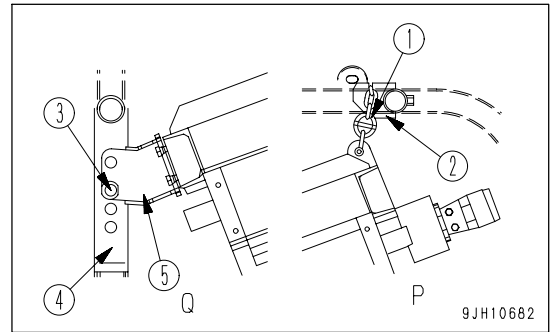

METHOD FOR RELEASING INTERNAL PRESSURE IN HYDRAULIC CIRCUIT

For details, see "STARTING ENGINE (PAGE 3-70)". If it is necessary to refer to the items for starting the engine, moving the machine off, steering, or stopping, see the OPERATION section.

1. Bleeding air from pump

- 1) Loosen air bleeder (1) and check that oil oozes out from the air bleeder.
- 2) If the oil does not ooze out, remove the drain hose from the hydraulic pump case and fill the pump case completely with hydraulic oil through drain port (2).
Hold the removed hose firmly, keeping the mouthpiece higher than the oil level in the hydraulic tank so that oil will not spill out of the hose.
- 3) After completing the air bleed operation, tighten air bleeder (1) and install the drain hose.

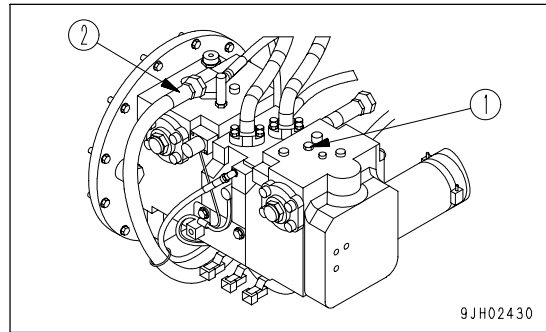
**NOTICE**

If the drain hose is installed first, oil will spurt out from bleeder hole (1).

If the pump is operated without filling the pump case with hydraulic oil, abnormal heat will be generated and this may cause an unexpected damage to the pump.

2. Starting engine

Start the engine, referring to "STARTING ENGINE (PAGE 3-70)".

Run the engine at low idle for 10 minutes after starting, then start operations.

3. Bleed air from crusher motor

- 1) Run the engine at low idling, loosen drain hose (1), and check that oil oozes out.
- 2) If no oil oozes out, stop the engine, remove drain hose (1), and fill the inside of the motor case with hydraulic oil.
- 3) After completing the air bleeding operation, tighten drain hose (1).
- 4) Run the engine at low idling to rotate slowly.

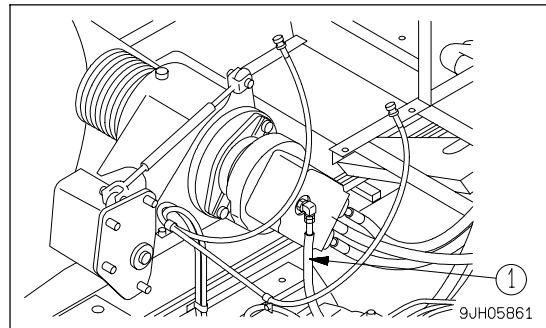
**4. Bleed air from grizzly feeder motor**

- 1) Run the engine at low idling, loosen drain hose (1), and check that oil oozes out from drain hose (1).
- 2) If no oil oozes out, stop the engine, remove drain hose (1), and fill the inside of the motor case with hydraulic oil.
- 3) After completing the air bleeding operation, tighten drain hose (1).
- 4) Run the engine at low idling to rotate slowly.

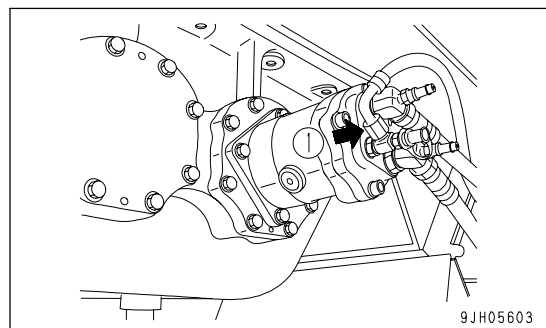

5. Bleed air from conveyor motor

NOTICE

When bleeding the air from the conveyor motor, prepare a suitable stand (ladder, etc.) to use when carrying out the operation.

(Height of conveyor motor from ground: 3.0 m (9 ft 10 in))

- 1) Run the engine at low idling, loosen drain hose (1) at the connection port, and check that oil oozes out from drain hose (1).
- 2) If no oil oozes out, stop the engine, remove drain hose (1), and fill the inside of the motor case with hydraulic oil.
- 3) After completing the air bleeding operation, tighten drain hose (1).
- 4) Run the engine at low idling to rotate slowly.

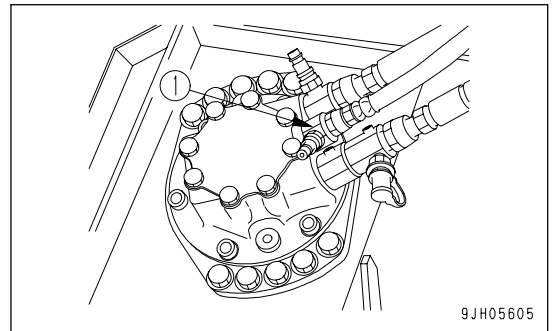
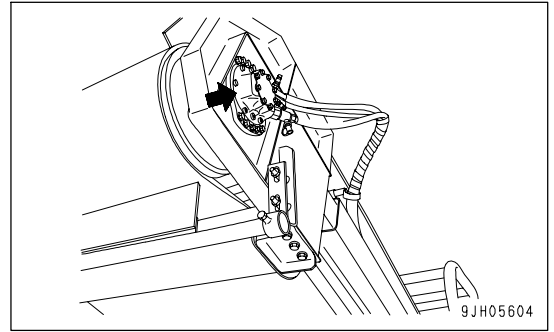

6. Bleeding air from travel motor

(Bleed the air only when the oil inside the travel motor case has been drained.)

- 1) Run the engine at low idling, loosen air bleeder (1), and tighten it when oil flows out.

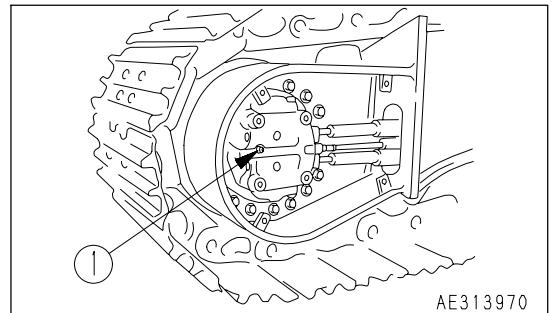

NOTICE

- After completing the air bleeding operation, stop the engine, wait for at least 5 minutes before starting operations. This releases the bubbles in the oil in the tank.
- Check that there is no oil leakage and wipe off any spilled oil.
- After completing the air bleeding operation, check the oil level, and add oil if necessary.

CHECK BEFORE STARTING

For the following items, see "CHECK BEFORE STARTING (PAGE 3-53)".

- Check coolant level, add coolant
- Check oil level in engine oil pan, add oil
- Check fuel level, add fuel
- Drain water, sediment from fuel tank
- Check water separator, drain water and sediment
- Check oil level in hydraulic tank, add oil
- Check electric wiring
- Check function of horn
- Adjustment of rear view mirror
- Check of jaw crusher
- Check of primary conveyor
- Check of grizzly feeder

EVERY 10 HOURS SERVICE

GREASING CRUSHER BEARING SEAT

Pump in grease through the grease fittings marked by arrows.
(15g x 4 place)

REMARK

A guideline for "15g" is pumping 8 times or more using the grease gun supplied with the machine.

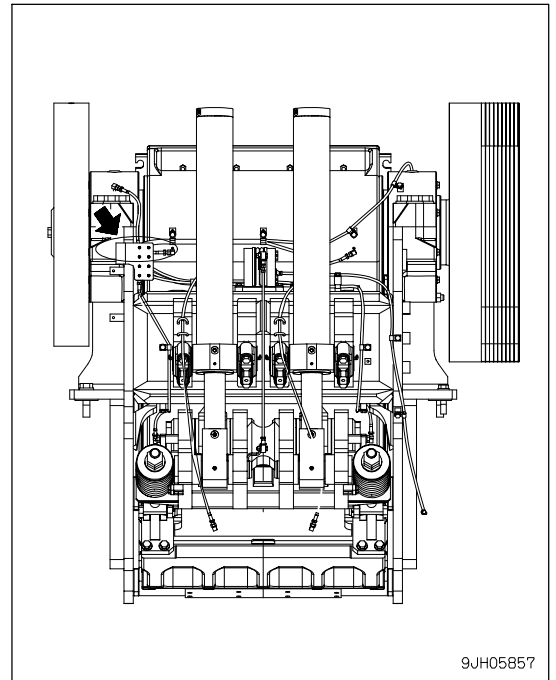

GREASING CRUSHER LINK

Provide grease to the grease fittings indicated with an arrow in the figure at right.
(10g x 4 places)

REMARK

A guideline for "10g" is pumping 8 times or more using the grease gun supplied with the machine.

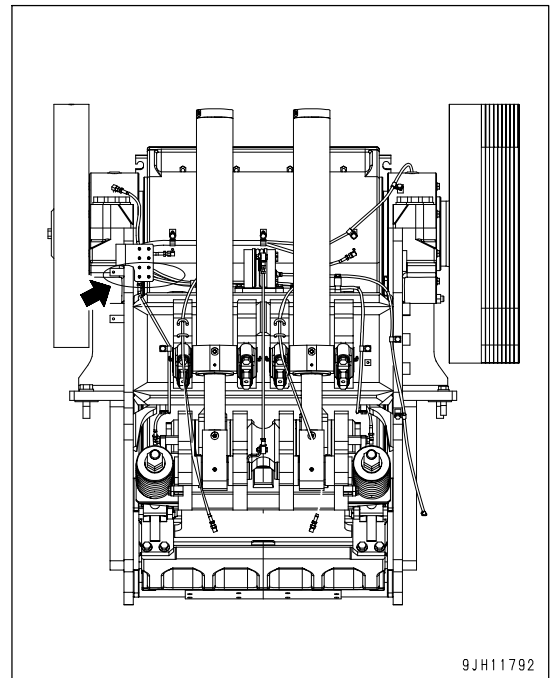

EVERY 100 HOURS SERVICE

GREASING CRUSHER LOCK CYLINDER SECURING POINT

Open cover (1) and apply grease to the grease fittings (greasing ports) marked by the arrows. (10g x 4 places)

REMARK

A guideline for "10g" is pumping 8 times or more using the grease gun supplied with the machine.

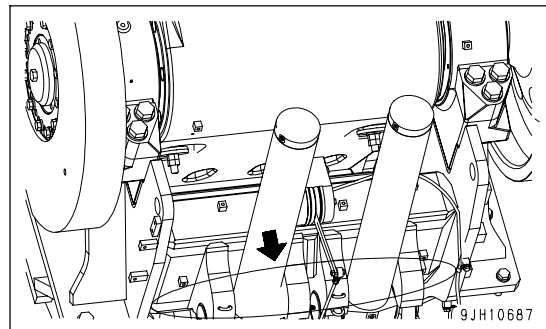
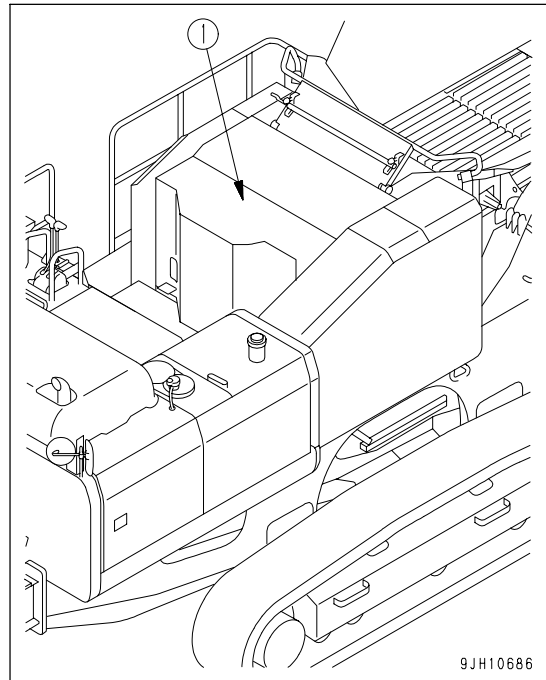

GREASING PRIMARY CONVEYOR

1. Grease the pillow block of the head pulley. (1 place)

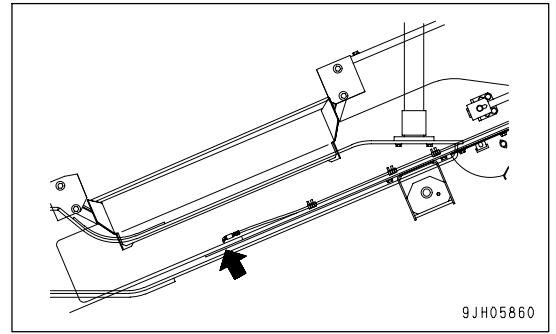

2. Greasing tail pulley bearings (2 places on both sides)

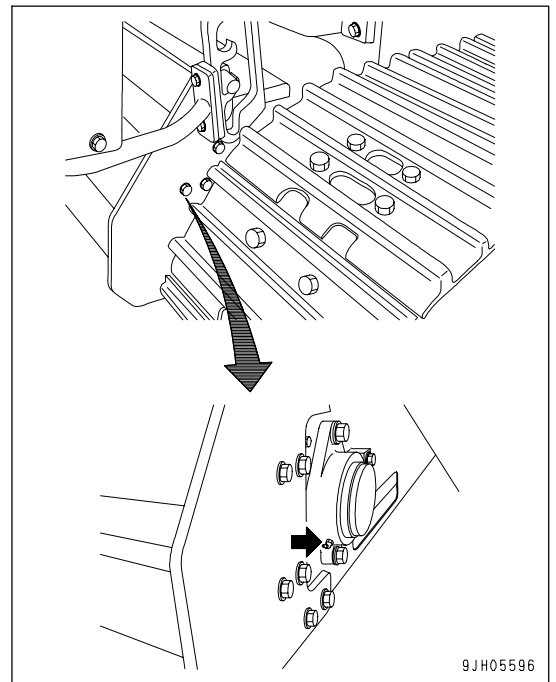

EVERY 250 HOURS SERVICE

CHECK LEVEL OF BATTERY ELECTROLYTE

Perform this check before operating the machine.



WARNING

- Do not use the battery if the battery electrolyte level is below the LOWER LEVEL line. This will accelerate deterioration of the inside of the battery and reduce the service life of the battery. In addition, it may cause an explosion.
- The battery generates flammable gas and there is danger of explosion, do not bring fire or sparks near the battery.
- Battery electrolyte is dangerous. If it gets in your eyes or on your skin, wash it off with a large amount of water and consult a doctor.
- When adding distilled water to the battery, do not allow the battery electrolyte to go above the UPPER LEVEL line. If the electrolyte level is too high, it may leak and cause damage to the paint surface or corrode other parts.

NOTICE

When adding distilled water in cold weather, add it before starting operations in the morning to prevent the electrolyte from freezing.

Inspect the battery electrolyte level at least once a month and follow the basic safety procedures given below. Open the cover at the rear of the crusher. The battery is installed at position (A).

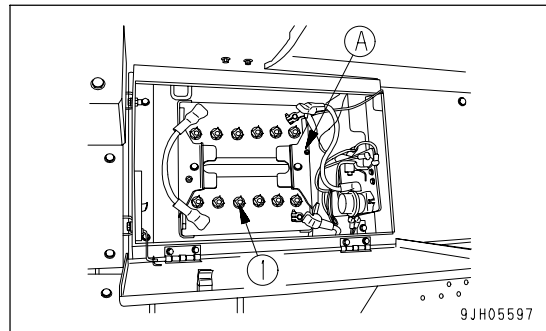

WHEN CHECKING ELECTROLYTE LEVEL FROM BATTERY SIDE

If it is possible to check the electrolyte level from the side of the battery, check as follows.

1. Use a wet cloth to clean the area around the electrolyte level lines and check that the electrolyte level is between the UPPER LEVEL (U.L.) and LOWER LEVEL (L.L.) lines. If the battery is wiped with a dry cloth, static electricity may cause a fire or explosion.

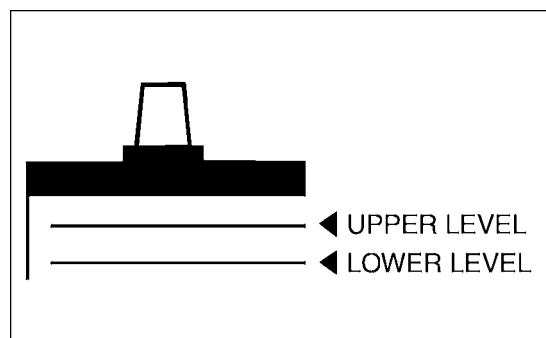

2. If the electrolyte level is below the midway point between the U.L. and L.L. lines, remove cap (1) and add distilled water to the U.L. line.
3. After adding distilled water, tighten cap (1) securely.

REMARK

If distilled water is added to above the U.L. line, use a syringe to lower the level to the U.L. line. Neutralize the removed fluid with baking soda (sodium bicarbonate), then flush it away with a large amount of water or consult your Komatsu distributor or battery maker.

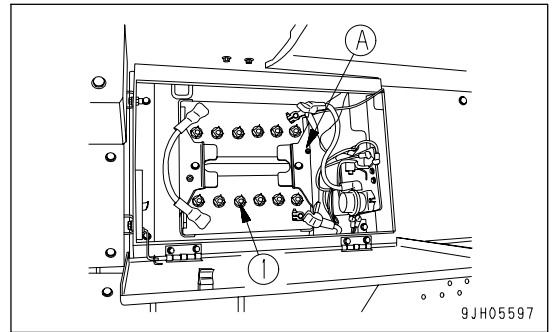

WHEN CHECK FROM BATTERY SIDE IS NOT FEASIBLE

If it is impossible to check the electrolyte level from the side of the battery, or there is no display of the UPPER LEVEL line on the side of the battery, check as follows.

1. Remove cap (1) at the top of the battery, look through the water filler port, and check the electrolyte surface. If the electrolyte does not reach the sleeve, add distilled water so that the level reaches the bottom of the sleeve (UPPER LEVEL line) without fail.

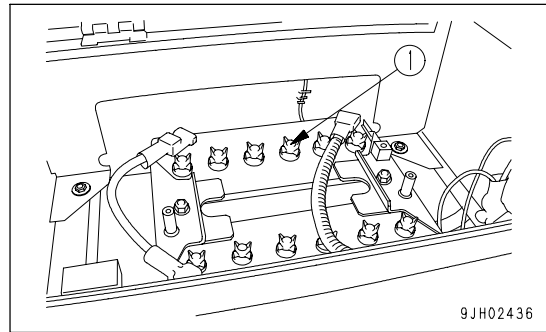

Use the diagram below for reference, and check if the electrolyte reaches the bottom of the sleeve.

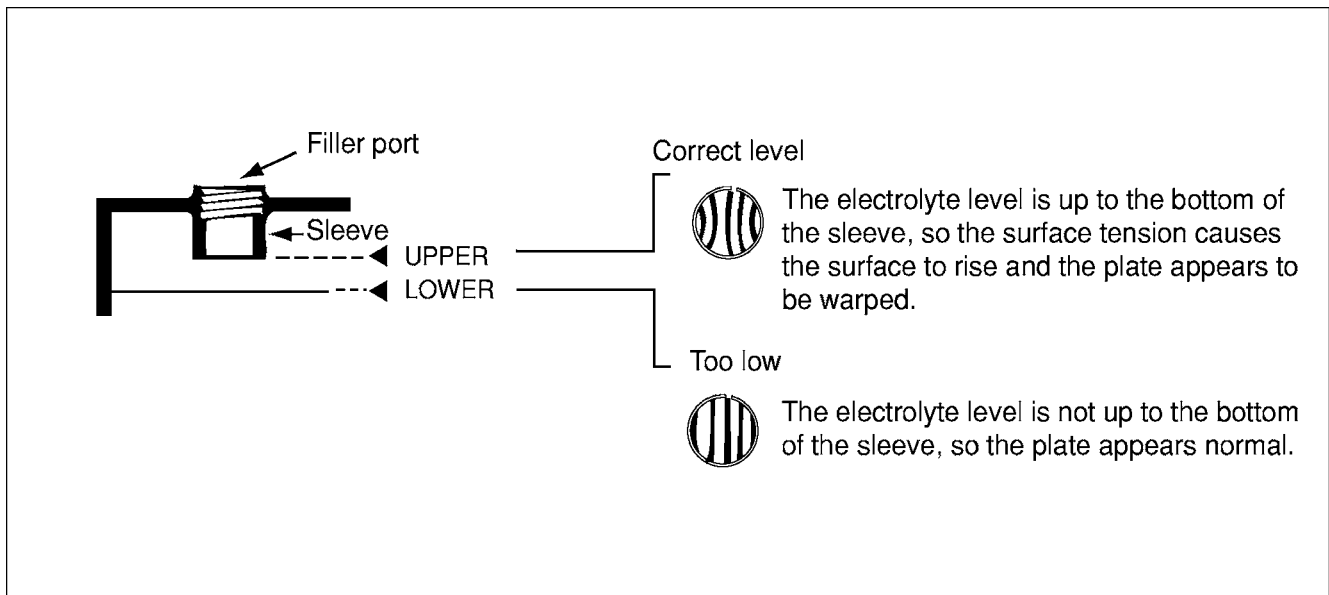

2. After adding distilled water, tighten cap (1) securely.

REMARK

If distilled water is added to above the bottom of the sleeve, use a syringe to lower the level to the bottom of the sleeve. Neutralize the removed fluid with baking soda (sodium bicarbonate), then flush it away with a large amount of water or consult your Komatsu distributor or battery maker.

WHEN IT IS POSSIBLE TO USE INDICATOR TO CHECK ELECTROLYTE LEVEL

If it is possible to use an indicator to check the electrolyte level, follow the instructions given.

CHECK AND ADJUSTMENT OF JAW CRUSHER V-BELT

Check the tension of the V-belt. For details, see "CHECK OF JAW CRUSHER AND RELATED ACCESSORIES (PAGE 3-63)".

CHECK OF OIL LEVEL IN CRUSHER MOTOR BEARING CASE AND ADDING OIL

1. Unscrew oil filler plug (F) and loosen oil check port (A). If oil seeps out, the oil level is normal.
2. If oil is short, add it through oil filler plug (F) until oil overflows from oil check port (A).

NOTICE

When checking the oil level inside the crusher motor bearing case and adding oil, carry out the operation with turnbuckle length (B) (distance between pins) within a range of 500 to 512.5 mm (19.7 to 20.2 in).

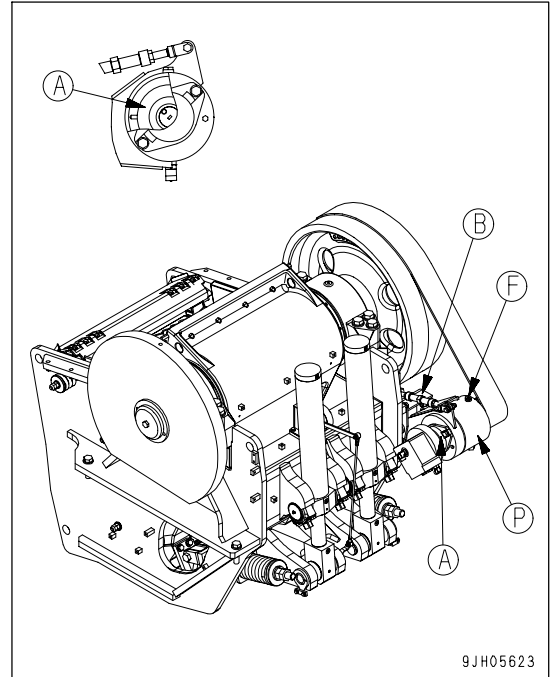

EVERY 500 HOURS SERVICE

Carry out periodic maintenance work of every 100 and 250 hours of operation at the same time.

REPLACE FUEL FILTER CARTRIDGE



WARNING

- The engine is at high temperature immediately after the machine has been operated. Wait for the engine to cool down before replacing the filter.
- Do not bring fire or sparks near the fuel.

Prepare a filter wrench and a container to catch the fuel.

1. Set the container to catch the fuel under the filter cartridge.
2. Using a filter wrench, turn filter cartridge (1) counterclockwise on remove it.
3. Clean the filter holder. Fill a new filter cartridge with clean fuel. Coat the packing surface with engine oil. Then install the new cartridge into the filter holder.
4. When installing, screw in cartridge until seal comes in contact with sealing surface, then tighten approx. 2/3 turn. If the filter cartridge is tightened too far, the packing will be damaged and this will lead to leakage of fuel. If the filter cartridge is too loose, fuel will also leak from the packing, always tighten to the correct amount.
5. After replacing the fuel filter cartridge, bleed the air from the system. Bleed the air as follows.
 6. Fill the fuel tank with fuel (to the position where the float is at the highest position).
 7. After replacing filter cartridge (1), loosen air bleed plug (2).
 8. Loosen the knob of feed pump (3), operate it up and down, and continue until no more bubbles come out with the fuel from air bleed plug (2).
 9. Tighten air bleeding plug (2).

A genuine Komatsu filter cartridge is recommended for use.

After finishing the replacement of the filter cartridge, start the engine and check that there is no oil leakage from the filter seal surface.

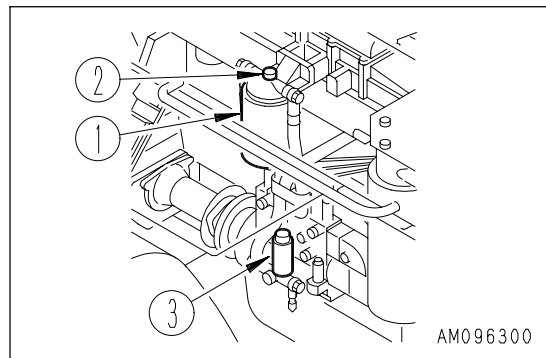

CHECK OIL LEVEL IN FINAL DRIVE CASE, ADD OIL

! WARNING

- The oil still remains at high temperature just after an operation is finished. Start the job after the oil temperature cools down.
- If pressure is left in the final drive case, oil may spurt out or the plug may fly off. Loosen the plug slowly to relieve the internal pressure.

- Prepare a handle.

1. Set the TOP mark at the top, with the UP mark and plug (P) perpendicular to the ground surface.
2. Remove plug (F) using the handle. When the oil level reaches a point 10 mm (0.4 in) below the bottom of the plug hole, the correct amount of oil has been added.
3. If the oil level is too low, install plug (F), operate the travel levers, and drive forward or in reverse to rotate the sprocket one turn. Then repeat Step 2 to check again.
4. If the oil level is low, add engine oil through plug hole (F) until the oil overflows from plug hole (F).
5. After checking, install plug (F).

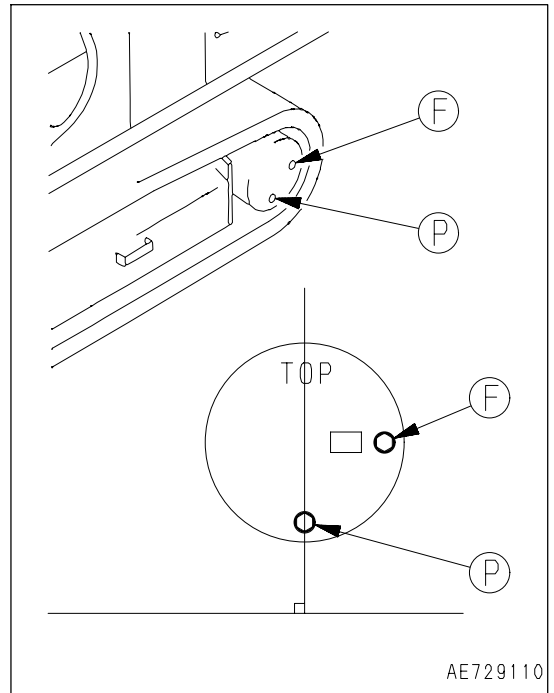

CLEAN, INSPECT RADIATOR FINS, OIL COOLER FINS, AFTERCOOLER FINS

**WARNING**

If compressed air, high-pressure water, or steam hit your body directly, or they cause dirt or dust to be blown up, there is a hazard of serious injury. Always use safety glasses, dust mask, or other protective equipment.

NOTICE

When using compressed air for cleaning, blow it keeping some distance to avoid damaging the fins. Damage on the fins can cause water leakage and overheating. In a dusty job site, check the fins every day, regardless of the maintenance interval.

1. Open the engine hood.
2. Loosen screw (3) and pull up net (2).
3. Clean net (2). (it is to be installed again, as instructed in the step 8.)
4. Loosen screw (5) and detach net (6) between the radiator and the oil cooler.
5. Check the front face and rear face of oil cooler fins (4), radiator fins (7), and aftercooler fins (8). If any mud, dirt, or leaves are found, blow them off with compressed air.
It is also possible to use steam or water in place of compressed air.
6. Check the rubber hose. Replace with a new one if the hose is found to have cracks or to be hardened by aging. In addition, check the hose clamps for looseness.

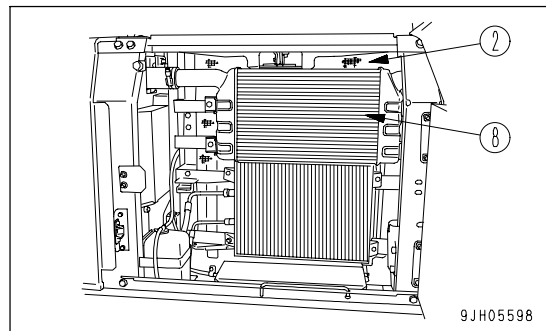
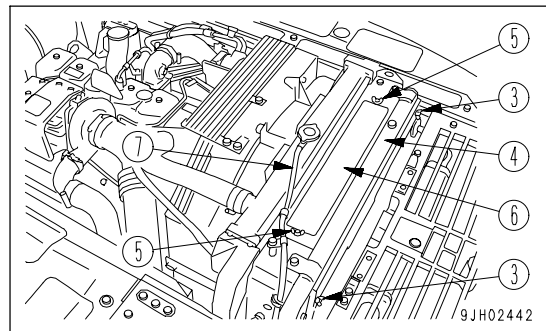

7. Remove undercover (9) and blow the mud, dirt, and leaves that have been cleaned off to the outside.
8. Push in cleaned net (2) back to the original place and secure it with screw (3).
9. Secure net (6) with screw (5).

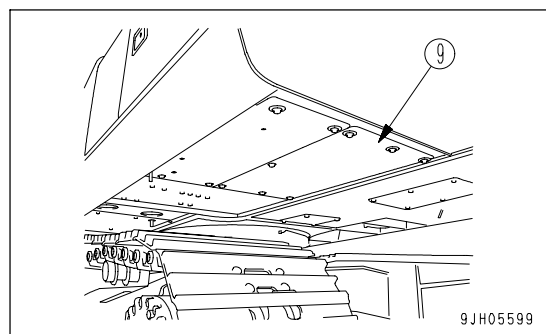

CHANGE OIL IN ENGINE OIL PAN, REPLACE ENGINE OIL FILTER CARTRIDGE

 **WARNING**

Parts and oil are at high temperature immediately after the engine is stopped and may cause serious burns. Wait for the oil temperature to go down before performing this operation.

- Refill capacity of oil pan: 24 liters (6.34 US gal)
- Prepare a filter wrench
 1. Remove the undercover directly under pump on the left side of the machine and put a container to catch the oil under it.
 2. Taking care not to get oil over yourself, loosen the drain plug (P) slowly and drain the oil. After draining the oil, close the plug.

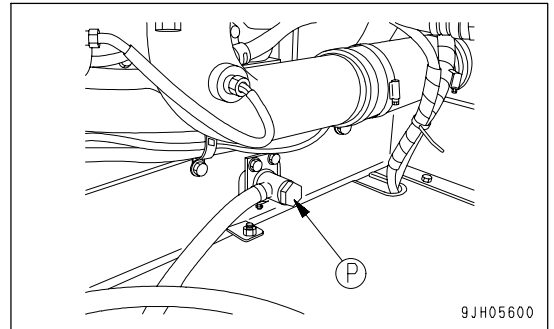

3. Using a filter wrench, turn the filter cartridge (1) to the left and remove it.

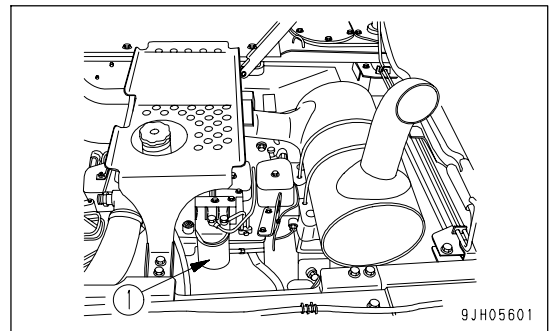

4. Clean the filter holder, fill the new filter cartridge with clean oil, coat the thread and packing surface of the new filter cartridge with clean oil (or coat it thinly with grease), then install it to the filter holder.

REMARK

Check that there is no old packing stuck to the filter holder. If there is any old packing stuck to the filter, it will cause leakage of oil.

5. When installing, tighten until the packing surface contacts the seal surface of the filter holder, then tighten it a further 3/4 to 1 turn.
6. After replacing the filter cartridge, open the engine hood and add engine oil through oil filler (F) to between the H and L marks on dipstick (G).
7. Run the engine for a short time at idling, then stop the engine and check that the oil level is between the H - L marks on the level gauge. For details, see "CHECK OIL LEVEL IN ENGINE OIL PAN, ADD OIL (PAGE 3-54)".
8. Install the undercover.

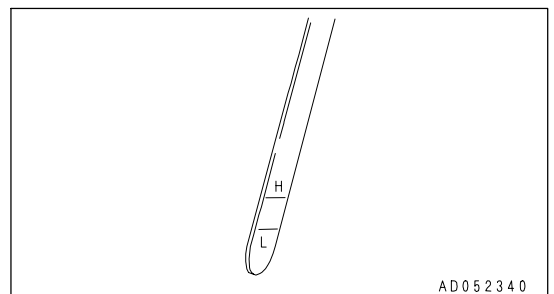

REPLACE HYDRAULIC TANK BREATHER ELEMENT

**WARNING**

- The parts and oil are at high temperature immediately after the engine is stopped, and may cause burns. Wait for the temperature to go down before starting the work.
- When removing the oil filler cap, turn it slowly to release the internal pressure, then remove it.

1. Remove the cap of oil filler (F) at the top of the hydraulic tank.

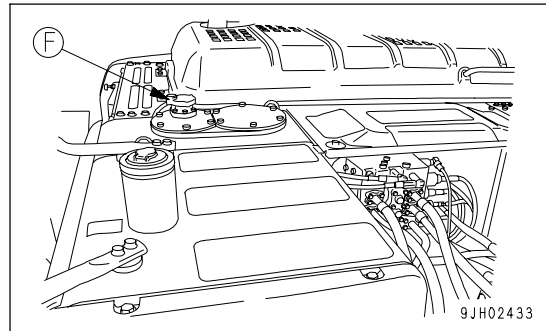

2. Replace element (1) inside the cap.

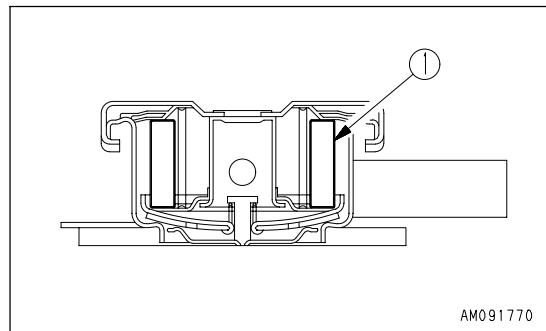

EVERY 1000 HOURS SERVICE

Carry out the periodic maintenance work of every 100, 250 and 500 hours of operation at the same time.

CHANGE OF OIL IN CRUSHER MOTOR BEARING CASE

1. Remove drain plug (P) to drain oil and screw it in after the drainage.
2. Add engine oil through oil filler port (F) to the specified level.
Oil replacement amount: 4.7 liters (1.24 US gal)
3. When oil begins to flow out from plug hole (A), stop adding oil and tighten plug hole (A) and the plug of oil filler port (F).

NOTICE

When checking the oil level inside the crusher motor bearing case and adding oil, carry out the operation with turnbuckle length (B) (distance between pins) within a range of 500 to 512.5 mm (19.7 to 20.2 in).

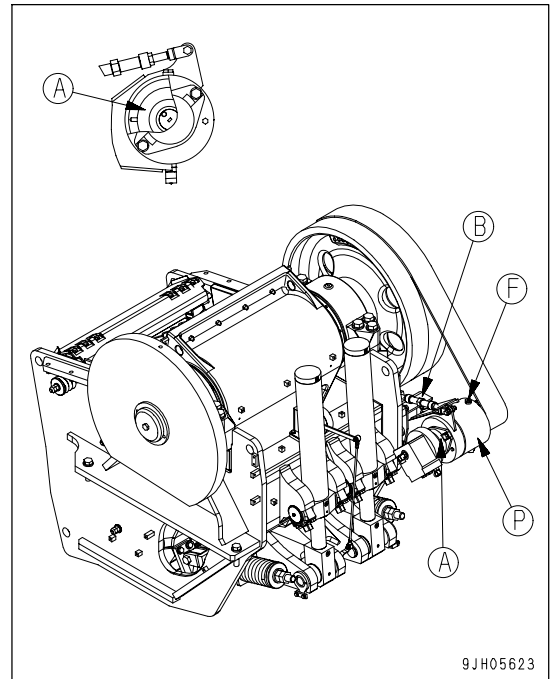

9JH05623

CHANGE OF OIL IN GRIZZLY FEEDER VIBRATOR CASE**OIL LEVEL**

The correct oil level is up to the center of the level gauge (15 liters (3.96 US gal)). To drain the oil, remove drain plug (P). To fill with oil, remove filler plug (F) and add oil until the oil level is at the center of level gauge (G). Having the oil level too high or too low will cause problems, so always maintain the correct oil level.

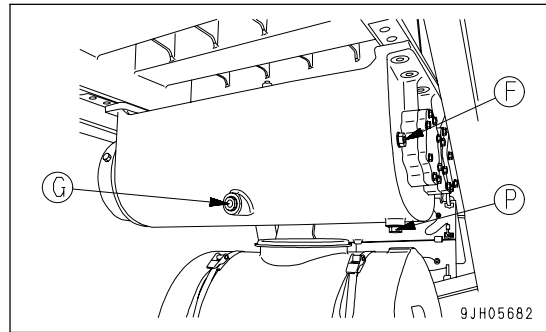
**CHANGE OF OIL**

Replace all the oil at the initial 250 hours of operation. Thereafter replace it completely roughly every 1000 hours of operation. Should the oil amount decrease even before each periodic replacement time, add oil properly. When using oil of different brand anew, replace all the oil so that two different brands of oil are not blended in the vibrator case.

CHANGE OIL IN DAMPER CASE

**WARNING**

The oil is at high temperature immediately after the machine has been operated. Wait for the oil to cool down before starting the operation.

NOTICE

For checking the oil level, park the machine on the flat ground, and start checking 30 minutes after the engine has stopped.

1. Open the cover located on the right side of the machine.
2. Remove plug (G) and check the oil level. If the oil level is near the bottom of the plug hole, the oil amount is at a proper level. If found short, remove plug (F) and replenish oil through plug (F) filler port up to the bottom of plug (G) hole.

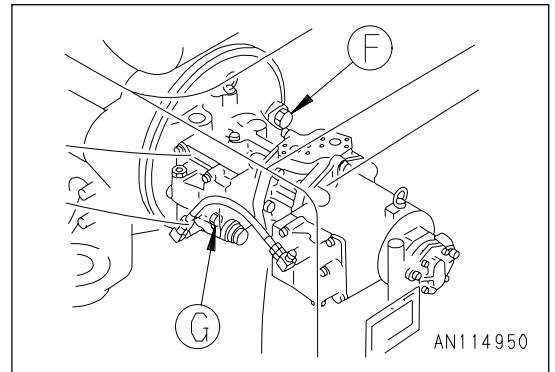
**NOTICE**

If excess oil is supplied, drain it to the specified amount to avoid overheating.

3. Install plugs (G) and (F).
4. Shut the door.

CHECK ALL TIGHTENING PARTS OF TURBOCHARGER

Contact your Komatsu distributor to have the tightening portions checked.

CHECK PLAY OF TURBOCHARGER ROTOR

Contact your Komatsu distributor to have the tightening portions checked.

CHECK AND REPLACE OF FAN BELT TENSION

Special tools are required for inspection and replacement of the fan belt. Contact your Komatsu distributors for inspection and replacement.

REMARK

An installed auto fan belt tension adjuster, "Auto Tensional Fan Belt", dispenses with the belt deflection adjustment.

REPLACE HYDRAULIC FILTER ELEMENT

**WARNING**

- The parts and oil are at high temperature immediately after the engine is stopped, and may cause burns. Wait for the temperature to go down before starting the work.
- When removing the oil filler cap, turn it slowly to release the internal pressure, then remove it.

1. Move the machine to flat, firm ground and stop the engine.
2. Remove the cap from oil filler (F), and release the internal pressure.
3. Loosen 6 bolts, then remove cover (1). When doing this, the cover may fly out under the force of spring (2), so hold the cover down when removing the bolts.
4. After removing spring (2), valve (3) and strainer (4), take out element (5).
 - Inspect the bottom of the filter case for dirt, and remove it, if any. Take good care then not to let fall the dirt into the hydraulic tank.
5. Clean the removed parts in diesel oil.
6. Install the new element in the place where old element (5) was installed.
7. Set valve (3), strainer (4) and spring (2) on top of the element.
8. Set cover (1) in position, push it down by hand, and install the cover with the mouning bolts.
9. Screw in the oil filler cap and install the cover.
10. To bleed the air, start the engine according to "STARTING ENGINE (PAGE 3-70)" and run the engine at low idle for 10 minutes.
11. Stop the engine.

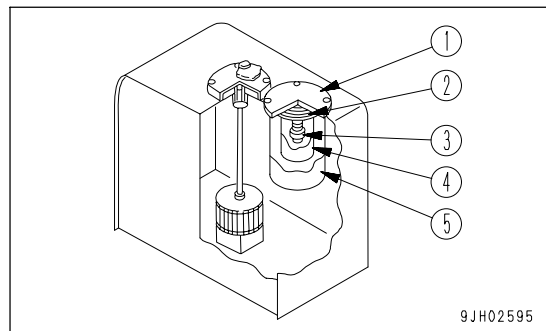
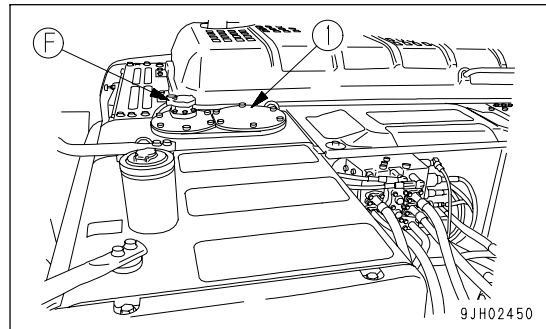

EVERY 2000 HOURS SERVICE

Maintenance for every 100, 250, 500 and 1000 hours should be carried out at the same time.

CHANGE OIL IN FINAL DRIVE CASE



WARNING

- The component parts and oil are warmed up to high temperature just after an operation. A casual touch will cause a burn. Hence start the replacement job after the temperature cools down.
- If pressure is still left in the case, oil may spurt out, or the plug may fly off. Release the internal residual pressure by turning the plug slowly.

- Oil replacement amount: 305 liters (0.92 US gal)(both let and right)
- Prepare a handle.
- 1. Set the TOP mark at the top, with the TOP mark and plug (P) perpendicular to the ground surface.
- 2. Place an oil receiving container under plug (P).
- 3. Remove plugs (P) and (F), using a handle, to drain oil.

REMARK

Check an O-ring fitted to the plug for any damage, and replace it with new one, if judged necessary.

4. Tighten plug (P).
5. Add oil through the hole of plug (F).
6. When oil begins to overflow from the plug (F) hole, install plug (F).

Tightening torque of plugs (P) and (F):
 $68.6 \pm 9.8 \text{ N}\cdot\text{m}$ ($7 \pm 1 \text{ kgf}\cdot\text{m}$, $50.6 \pm 7.2 \text{ lbft}$)

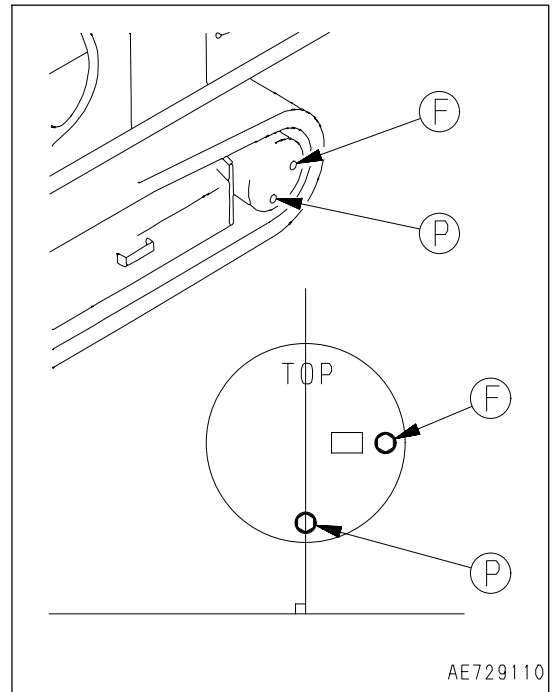

CLEAN HYDRAULIC TANK STRAINER**WARNING**

- The parts and oil are at high temperature immediately after the engine is stopped, and may cause burns. Wait for the temperature to go down before starting the work.
- When removing the oil filler cap, turn it slowly to release the internal pressure, then remove it.

1. Remove 4 bolts, then remove cover (1). When doing this, cover (1) may fly off because of the force of spring (2), keep the cover pushed down when removing the bolts.
2. Hold the top of rod (3) and pull up to remove spring (2) and strainer (4).
3. Remove any dirt stuck to strainer (4), then wash it in flushing oil. If strainer (4) is damaged, replace it with a new part.
4. When installing, insert strainer (4) into protruding part (5) of the tank, and assemble.
5. Install cover (1) with bolts.

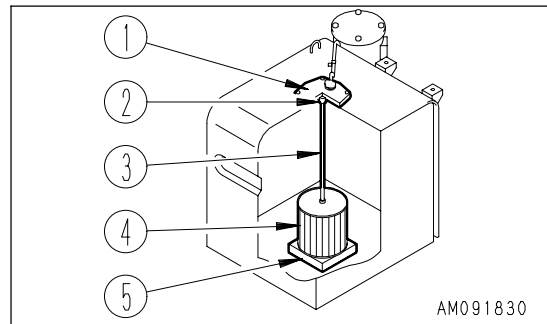
**CLEAN, CHECK TURBOCHARGER**

Contact your Komatsu distributor for cleaning and inspection.

CHECK ALTERNATOR, STARTING MOTOR

Wear on the brush and the bearings short of grease are suspected, so ask the Komatsu distributor in your territory for the repairs.

NOTICE

If the engine is started frequently, shorten the periodic check interval to every 1000 hours of operation.

CHECK ENGINE VALVE CLEARANCE, ADJUST

As special tools is required for removing and adjusting the parts, you should request service from your Komatsu distributor.

CHECK VIBRATION DAMPER

As special tool is required for removing and adjusting the parts, you shall request Komatsu distributor for service.

EVERY 4000 HOURS SERVICE

Carry out the periodic maintenance work of every 100,250, 500, 1000 and 2000 hours of operation at the same

CHECK WATER PUMP

Since the pulley may have play, oil may leak, water may leak and the drain hole (A) may be clogged, contact your Komatsu distributor for inspection, overhaul or replacement.

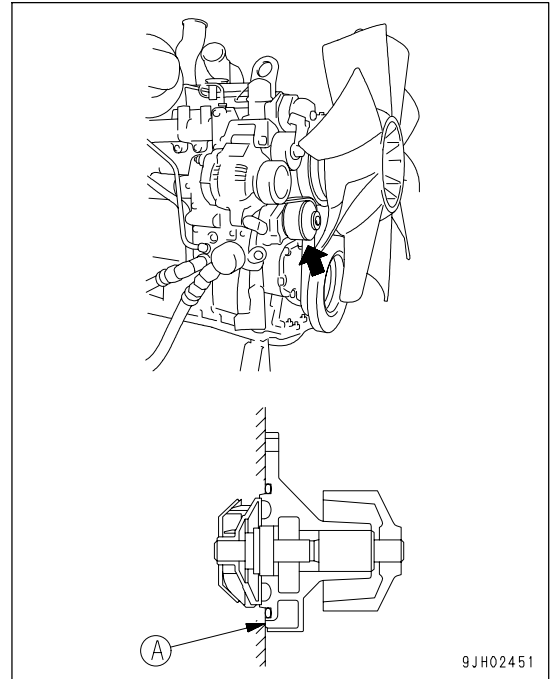

EVERY 5000 HOURS SERVICE

Carry out the periodic maintenance work of every 100, 250, 500 and 1000 hours of operation at the same time.

CHANGE OIL IN HYDRAULIC TANK AND CLEAN STRAINER



WARNING

- The parts and oil are at high temperature immediately after the engine is stopped, and may cause burns. Wait for the temperature to go down before starting the work.
- When removing the oil filler cap, turn it slowly to release the internal pressure, then remove it.

- Oil replacement amount: 112 liters (29.59 US gal)
- Prepare a handle (for the socket wrench).

1. Remove the cap of oil filler port (F) at the top of the hydraulic tank.

2. Set a container direct under the drain plug located on the machine's underside to catch oil that is drained. Remove drain plug (P) and drain the oil. Check an O-ring installed to Plug (P), and if it has a scratch or damage, replace it with new one. After draining the oil, tighten drain plug (P).

- The specified tightening torque is 68.6 ± 9.81 N·m (7 ± 1 kgf·m, 50.6 ± 7.2 lbft)
- Take care not to get oil on yourself when you remove drain plug (P).

3. Add the specified amount of new and clean oil through oil filler port (F). Check that the oil level is between H and L on the sight gauge.

For an oil level checking method, refer to the section of "CHECK OIL LEVEL IN HYDRAULIC TANK, ADD OIL (PAGE 3-57)".

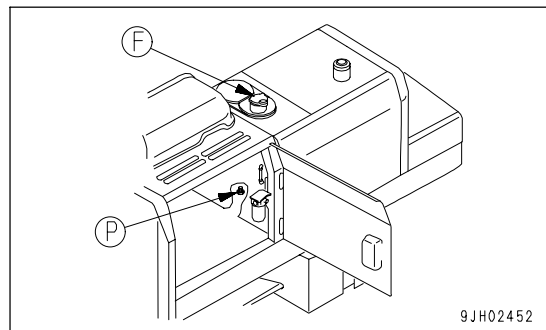

SPECIFICATIONS

SPECIFICATIONS

| Items | Unit | BR380JG-1 |
|------------------------------------------------------------------------|------------------------|------------------------------------------------------------|
| Weight | | |
| Overall machine weight(including magnetic separator, fuel and coolant) | kg (lb) | 33,000 (72,765) |
| Dimensions | | |
| A Overall length | mm (ft in) | 12,500 (41') |
| B Overall height | mm (ft in) | 3,200 (10' 6") |
| C Overall width | mm (ft in) | 2,815 (9' 3") |
| D Track shoe width | mm (ft in) | 500 (1' 8") |
| E Track gauge | mm (ft in) | 2,280 (7' 6") |
| F Track length on ground | mm (ft in) | 3,275 (10' 9") |
| Engine | | |
| Name | - | SAA6D102E-2C |
| Type | - | Direct injection + turbocharger + aftercooler |
| Rated horsepower | kW(HP/rpm) | 132/2,050 (182/2,050) |
| Feeding device | | |
| Method | - | Grizzly feeder with vibration controller |
| Trough dimensions (width x length excluding grizzly bar) | mm (ft in) | 1,000 (3' 3") x 3,070 (10' 1") (1,625 (5' 4")) |
| Crusher | | |
| Jaw crusher (Type) | - | 42 x 22 |
| Weight | kg (lb) | 13,000 (28,665) |
| Primary conveyor | | |
| Belt (width x length) | mm (ft in) | 1,050 (3' 5") x 20,400 (66' 11") |
| Belt rotating speed | m/min | 120 |
| Magnetic separator | | |
| Type | - | HPK105A |
| Belt speed | m/min | 70 |
| Conveyor belt (width) | mm (ft in) | 750 (2' 6") |
| Drive type | - | Hydraulic type |
| Weight | kg (lb) | 1,200 (2,646) |
| Hopper | | |
| Capacity | m ³ (cu.yd) | 3.5 (4.6) |
| Type | - | Fixed type |
| Performance | | |
| Dimensions of max. crushable debris | mm (ft in) | 1000 (3' 3") x 900 (2' 11") x 475 (1' 7")(concrete debris) |
| Travel speed | km/h (MPH) | 3.0 (1.9) |
| Gradeability | Degree | 25 |
| Drive | | |
| Travel drive method | - | Hydraulic type |
| Crusher drive method | - | Hydraulic type |
| Capacity | | |

| | | |
|--------------------|----------------|--------------|
| Fuel tank | Liters(US gal) | 400 (105.68) |
| Hydraulic oil tank | Liters(US gal) | 209 (55.22) |

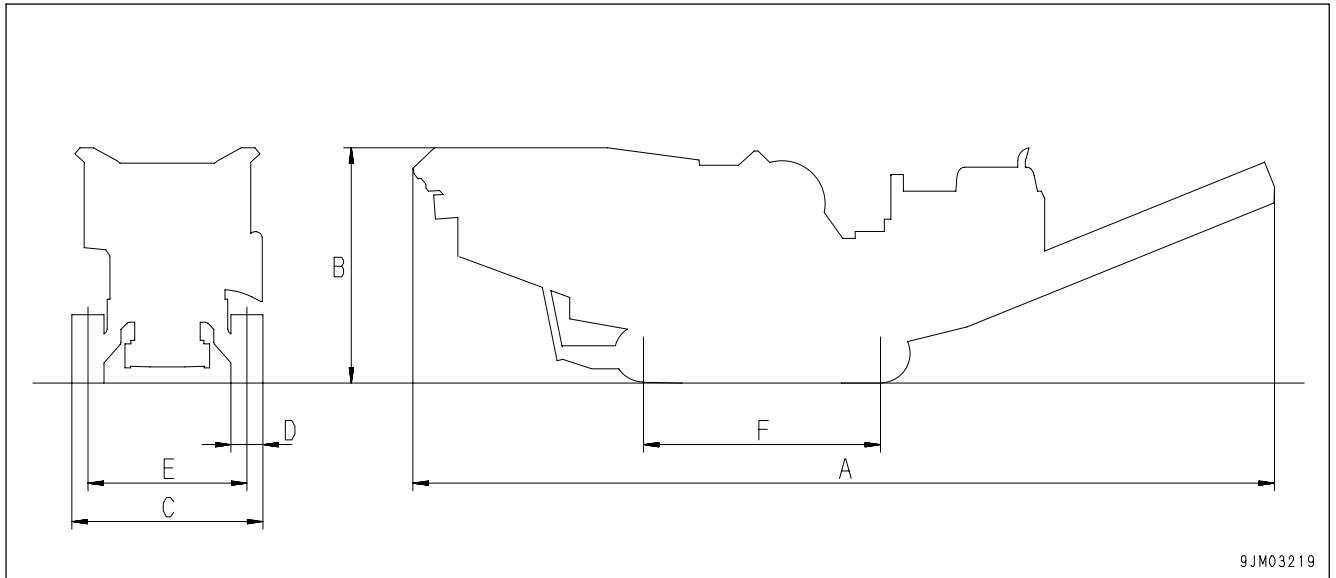

ATTACHMENTS, OPTIONS

 **WARNING**

Please read and make sure that you understand the SAFETY section before reading this section.

GENERAL PRECAUTIONS

PRECAUTIONS RELATED TO SAFETY



WARNING

A crane ought to be operated only by a licensed operator. Do not allow an operator without such license.

NOTICE

For detail on the works of installing and dismantling attachments, consult the Komatsu distributor in your territory.

If attachments or options other than those authorized by Komatsu are installed, this will not only affect the life of the machine, but will also cause problems with safety.

When installing attachments not listed in this Operation and Maintenance Manual, contact your Komatsu distributor first.

If you do not contact Komatsu, we cannot accept any responsibility for any accidents or failures.



WARNING

Precautions for dismantling and installation

When dismantling or installing attachments, observe the following precautions for safety work.

- Carry out dismantling and installation works on the flat and solid ground.
- When a work is carried out by two workers or more, decide signals and let them obey the signals while working.
- Use a crane for removing a heavy item (over 25 kg (55 lb)).
- When detaching a heavy parts, be sure to prepare for a support beforehand.
Furthermore, when lifting up a heavy item with a crane, pay a special attention to the position of the center of gravity.
- It is dangerous to proceed with the work with a heavy item hung up in the air with a crane. Be sure to provide a stand and lower the heavy item on it to ensure safety during the work.
- When leaving any attachment as detached or installing it, let it stand or hold it securely.
- Do not go under a heavy item that is hung up in the air with a crane.
Keep well clear of a hung item and stay in a safe position to avoid an injury, should it fall off.

ATTACHMENTS, OPTIONS

ATTACHMENTS, OPTIONS CHART

| No. | Name | Page |
|-----|---------------------------------------------------------------------|----------------------------------------------------|
| 1 | Remote control device | RADIO CONTROL UNIT(6-4 PAGE) |
| 2 | Muck discharge conveyor(4 m (13 ft 1 in) x 500 (1 ft 8 in) width) | MUCK DISCHARGE CONVEYOR(6-19 PAGE) |
| 3 | M-type chute | M-TYPE CHUTE(6-30 PAGE) |
| 4 | Conveyor protector plate | BELT CONVEYOR PROTECTIVE PLATE(6-31 PAGE) |
| 5 | Grizzly bar opening (15 mm (0.6 in) - 40 mm (1.6 in)) | GRIZZLY BAR OPENING(6-33 PAGE) |
| 6 | HANDLING MACHINES EQUIPPED WITH KOMTRAX | HANDLING MACHINES EQUIPPED WITH KOMTRAX(6-34 PAGE) |
| 7 | Machine that can install attachment | MACHINES THAT CAN INSTALL ATTACHMENTS(6-35 PAGE) |
| 8 | Hydraulic type vibratory sieve | HYDRAULIC VIBRATORY SIEVE(6-39 PAGE) |
| 9 | Secondary conveyor (7 m (22 ft 12 in) x 600 (1 ft 12 in) width) | HYDRAULIC SECONDARY CONVEYOR(6-41 PAGE) |
| 10 | Secondary conveyor (10 m (32 ft 10 in) x 600 (1 ft 12 in) width) | HYDRAULIC SECONDARY CONVEYOR(6-41 PAGE) |
| 11 | Sprinkler | SPRINKLER(6-51 PAGE) |

METHOD FOR CONNECTING HYDRAULIC HOSES FOR OPTIONS

For details, see "PROCEDURE FOR CONNECTING OPTIONS (PAGE 6-37)".

RADIO CONTROL UNIT

ON USE OF RADIO CONTROL UNIT



WARNING

When operating by remote control, follow the operation method given in this manual. Mistaken operation may lead to serious personal injury or damage.

SAFETY PRECAUTIONS WHEN USING RADIO CONTROL UNIT

Several electronic and mechanical safety devices are provided in this radio control unit. One of them is that, once a transmission code is set, it will not accept any signal for work from the other transmitter.

Please be reminded that depending on a wrong operation or use of the unit, there are always the following dangers.

- A machine operator or workers in the surrounding may be critically injured.
- Damages may be inflicted on the machine, its apparatus and materials fed into the machine.

When operating this equipment, you must follow the operating method given in the instruction manual.

FACTORS OF HAZARD

The machine can be remote-controlled using a wave in this system. A work instruction can be conveyed to the opposite side of an obstacle, or to a place where an operator cannot see. Hence observe the following.

- If the transmitter is located at a distance from the operator, turn transmitter power switch (1) OFF and disconnect the power.
- When installing the unit somewhere, or when carrying out maintenance and repair works on the machine, be sure to turn the POWER switch of the unit to the OFF position.
- Never try to remove any of the safety devices in this unit nor modify any of them.

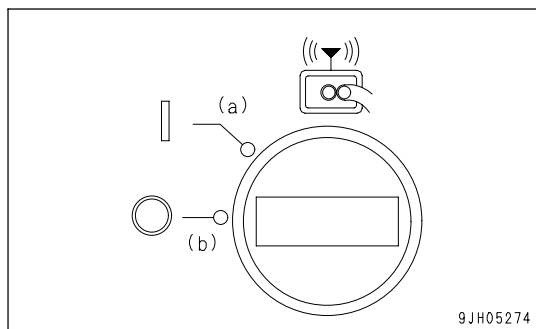
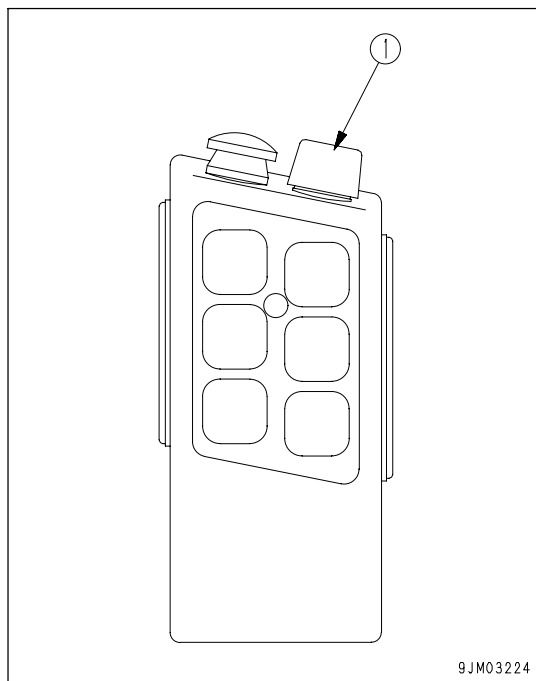

QUALIFICATIONS FOR UNIT OPERATOR

An operator of this unit is required to carefully read both operation manuals for the machine and the unit and thoroughly understand both operation methods. If the transmitter is left away from an operator, do not forget to remove the key. This practice is necessary to prevent someone from operating the transmitter carelessly.

The supervisor of operations using the unit, the machine owner and administrator have a responsibility to ensure that a unit operator has an easy access to the operation manuals, and to confirm that he/she reads them and understands all the contents.

ESTABLISHING SAFETY MEASURES AT WORKSITE

An operator is required to ensure safety at the work site where he/she uses the radio control unit. Make sure that there is no danger of slipping or tripping over something.

DEVICES PROVIDED FOR SAFETY PROTECTION

**WARNING**

Never remove any of the safety devices in the unit nor modify any for whatsoever reason.

**CAUTION**

When transmission of electric waves is stopped, it is impossible to stop or start the work equipment. When stopping the work equipment, turn transmitter power switch (1) to the right, pull transmitter stop switch (2), then press the stop switch for each work equipment or ALL STOP switch (3). It then becomes possible to transmit electric waves.

With the transmitter, it is possible to stop transmission of electrical waves by one of the following methods. If the transmission of electrical waves is stopped, the rotating lamp (yellow) on the chassis will go out.

- Depress TRANSMISSION STOP switch (2) located on top of the transmitter control panel.
- Turn transmitter power switch (1) on the transmitter to the OFF position. (The transmission of electrical waves will stop approx. 450 ms after the switch is turned OFF.)

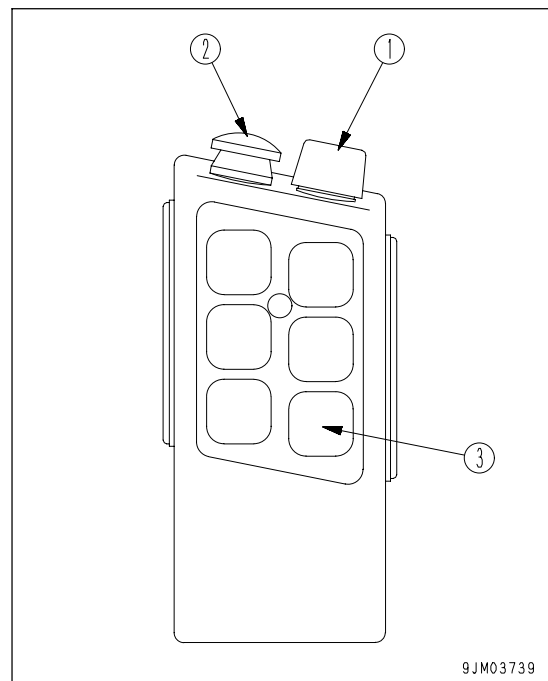
**ACTIONS IN CASE OF EMERGENCY**

Should any emergency take place, depress STOP switch (3).

Then take necessary actions, as the case may be, following the instructions set forth in the operation manual for the machine.

DIRECTIONS FOR USE

(1) Remote control selector switch

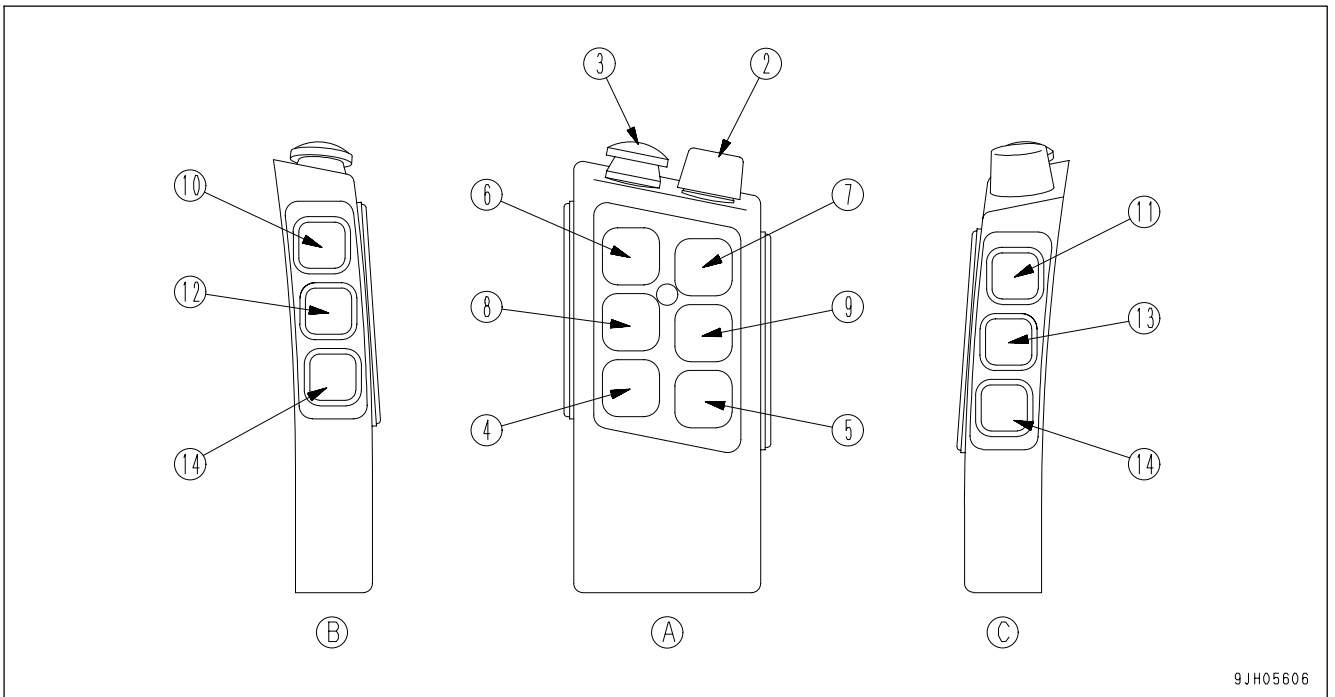
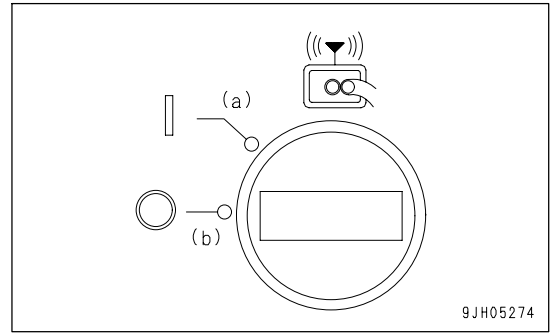

(A) Front face
 (B) Left side face

(C) Right side face

- (2) Transmitter power switch (key)
- (3) Transmitter stop switch
- (4) Horn switch
- (5) ALL STOP switch
- (6) Left travel FORWARD switch
- (7) Right travel FORWARD switch
- (8) Left travel REVERSE switch

- (9) Right travel REVERSE switch
- (10) Grizzly feeder start switch
- (11) Grizzly feeder stop switch
- (12) Crusher start switch
- (13) Crusher stop switch
- (14) No function

NOTICE

If the radio control selector switch is at the RADIO CONTROL position, the crusher and feeder cannot be started from the main panel.

The relationship between the position of the radio control selector switch and the components that can be operated is as shown in the table below.

| Component (operation) | Radio control selector switch | | | |
|-------------------------------------|-------------------------------|---------------------------|------------------|---------------------------|
| | Radio control | | Panel | |
| | Main panel | Radio control transmitter | Main panel | Radio control transmitter |
| Start crusher (continuous rotation) | × | ○ | ○ | × |
| Stop crusher (continuous rotation) | ○ | ○ | ○ | × |
| Manual rotation of crusher | × | - | ○ | - |
| Start feeder | × | ○ | ○ | × |
| Stop feeder | ○ | ○ | ○ | × |
| 1-touch start | × | - | ○ | - |
| 1-touch stop | ○ | - | ○ | - |
| Travel | ○ (Travel lever) | ○ | ○ (Travel lever) | × |

REMARK

Even when the radio control selector switch is at the RADIO CONTROL position, if the mode selector switch on the main panel is not set to the TRAVEL position, the travel will not be actuated even when the travel switch on the radio control transmitter is pressed. In the same way, if the mode selector switch is not set to the OPERATION position, the crusher and feeder will not be actuated even when the crusher and feeder switch on the radio control transmitter is pressed.

SWITCH

(1) Remote control selector switch

This switch (1) is used to select operation of the machine by remote control or operation of the machine by the main panel and travel levers.

- (a) Remote control: This selects operation of machine by remote control
- (b) Panel: This selects operation of machine by main panel and travel levers

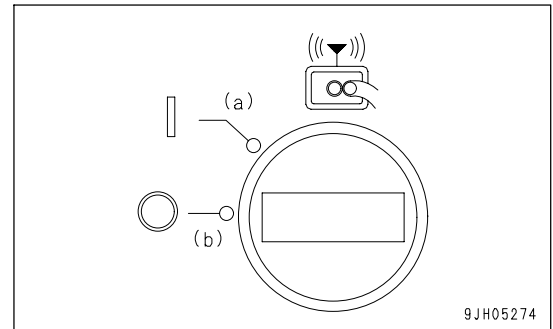

(2) Transmitter power switch

! WARNING

When the remote control is not being used, always turn it OFF and remove the key. This will prevent accidents caused by mistaken operation.

This switch (2) turns on the power for the transmitter. Set the remote control selector switch on the machine to Remote Control, then turn the transmitter power ON. The yellow rotating lamp on the machine will light up to show that preparations for remote control operation have been completed.

- (a) Power ON
- (b) Power OFF

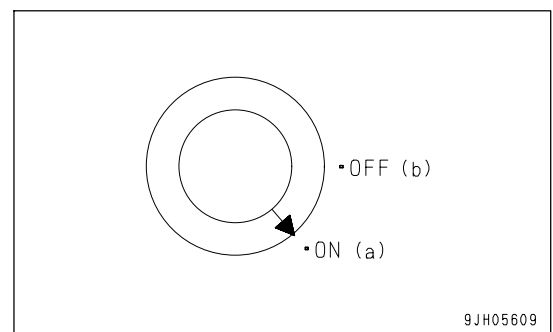

(3) Transmission stop switch

When this switch is pressed, no radio signal is sent from the remote control transmitter even when the remote control switches are operated.

Note: In this condition, it is impossible to start or stop the work equipment.

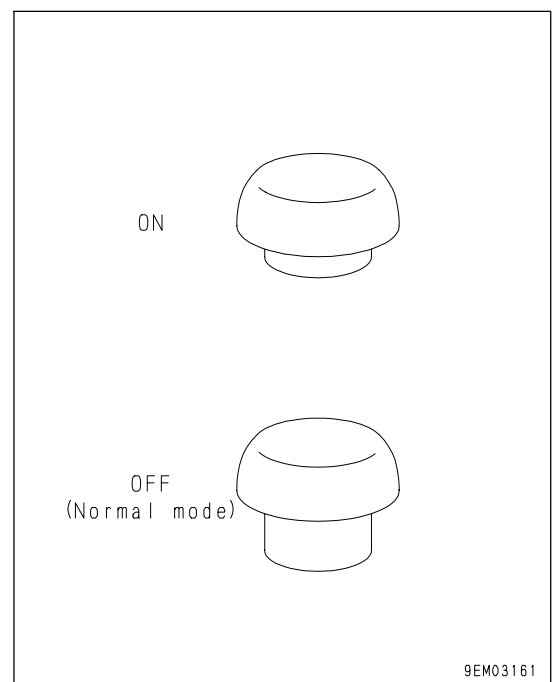

(4) Horn switch

Press this switch to sound the horn.

(5) ALL STOP switch

Press this switch to stop all the work equipment and the engine.

TRAVELING



CAUTION

When the machine is traveling under remote control, travel at low speed to ensure safety.

NOTICE

The following switches may be operated by setting the operation mode selector switch to the TRAVEL position.

(6) Left travel FORWARD switch

Press this switch to operate the left FORWARD travel.

(7) Right travel FORWARD switch

Press this switch to operate the right FORWARD travel.

(8) Left travel REVERSE switch

Press this switch to operate the left REVERSE travel.

(9) Right travel REVERSE switch

Press this switch to operate the right REVERSE travel.

CRUSHING WORK

NOTICE

The following switches may be operated by setting the operation mode selector switch in the main control box to the WORK position.

(10) Grizzly feeder starting switch

Press this switch to start the grizzly feeder.

(11) Grizzly feeder stop switch

Press this switch to stop the grizzly feeder.

(12) Crusher starting switch

Press this switch to start the crusher.

(13) Crusher stop switch

Press this switch to stop the crusher.

REMOTE CONTROL OPERATION

CHECK BEFORE STARTING OPERATION



WARNING

To prevent mistaken transmission, carry out this check carefully before starting operations.

Before starting operations, check the following items.

1. Check that there is no problem with the safety functions on the transmitter.
Check that none of the switches or any other parts are broken. If any broken part is found, do not carry out operations until it has been repaired.
2. Check that the transmitter power switch on the transmitter is at the OFF position.
3. Check that a charged battery is installed in the battery compartment at the bottom of the transmitter.
4. Turn the transmitter power switch key to set the transmitter switch to the ON position.
5. The transmitter lamp will start to flash red.
6. Approx. 2 seconds after the lamp flashes red, the transmitter lamp will start to flash green.
If the lamp continues to flash red, the battery charge is low, so take the action given in "REPLACE, CHARGE BATTERY (PAGE 6-11)".
7. Check that the transmitter stop switch is OFF.

NOTICE

If the transmitter stop switch is kept pressed, the work equipment will not start or stop. Cancel the stop switch, then turn the engine starting switch OFF and wait for at least 10 seconds.

8. Turn the engine starting switch ON again and start operation of the work equipment.
(This is to check, so do not start the engine.)
9. Set the remote control selector switch on the machine control box to the REMOTE CONTROL position.
10. Check that the yellow rotating lamp at the front of the machine is lighted up.
11. Press the transmitter horn switch and check that the machine horn sounds.
12. After completing the checks, turn the transmitter power switch ON and set the remote control selector switch to the PANEL position.
Start the operation as follows.

REPLACE, CHARGE BATTERY



WARNING

If the remaining charge in the battery on the transmitter becomes low, the red lamp will start to flash. If this happens, do as follows immediately.

- Operate the transmitter to set the machine in a safe place or in a safe condition within 30 seconds.
- After 30 seconds, the transmitter will switch to emergency stop status.
- Turn the transmitter power switch key on the transmitter to the OFF position to turn the transmitter OFF.

If the transmitter lamp flashes red, replace the battery as follows.

1. Push battery (1) slightly to the front and lift it up to remove it from the battery compartment.
2. Use the reverse procedure to install a charged battery in the battery compartment.

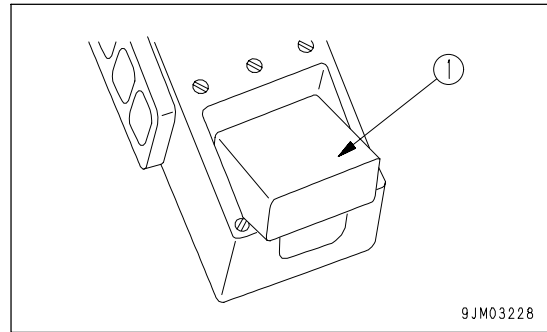

WARNING

If the battery is used mistakenly, there is danger of explosion. Always use genuine parts for the charger and battery.

3. Charge the battery as follows.
 - 1) Connect the charger to the special power socket (1) inside the toolbox on the machine.

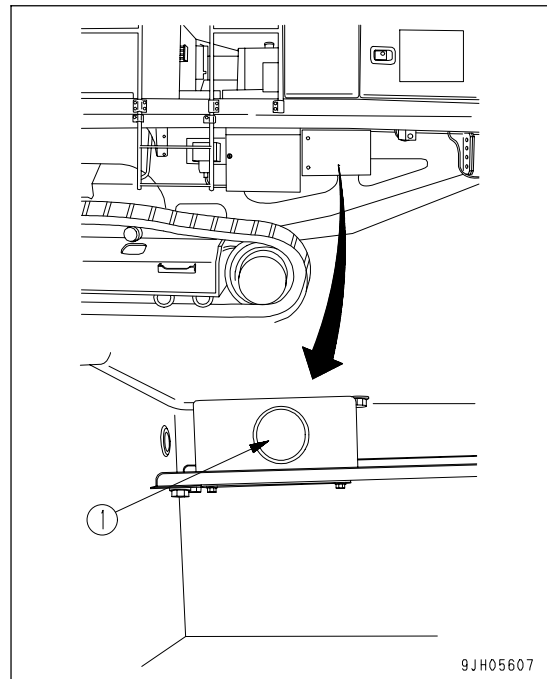

- 2) Insert the contact surface of the battery into the charger first. Push the whole unit lightly and check that it is installed.
- 3) The green lamp on the charger lights up continuously during charging. When the battery is completely charged, the green lamp flashes.

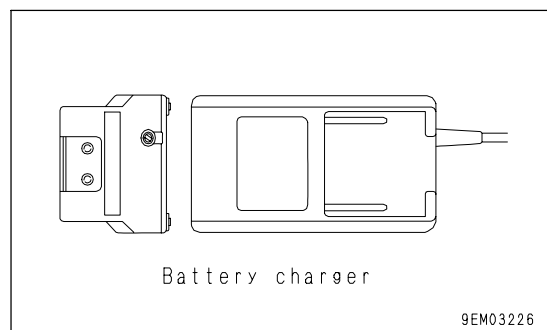

NOTICE

A battery charger judges automatically that the batteries have been fully charged. When batteries are fully charged, the battery charger switches a charging mode to "light charging". Then the battery charger automatically begins to charge the batteries again, when they are fully or slightly discharged.

OPERATING WITH REMOTE CONTROL

 **WARNING**

Check that there is no person or obstacle in the surrounding area, sound the horn, then start the machine. In particular, when carrying out remote control travel, check the area around the machine extremely carefully and start to operate the remote control travel only if it is judged that there is no problem with safety.

As shown in the diagram, it is possible for the operator to use the transmitter to carry out remote control operation from the ground or from the loading machine, but the operations possible by remote control differ from the mode on the machine itself as follows.

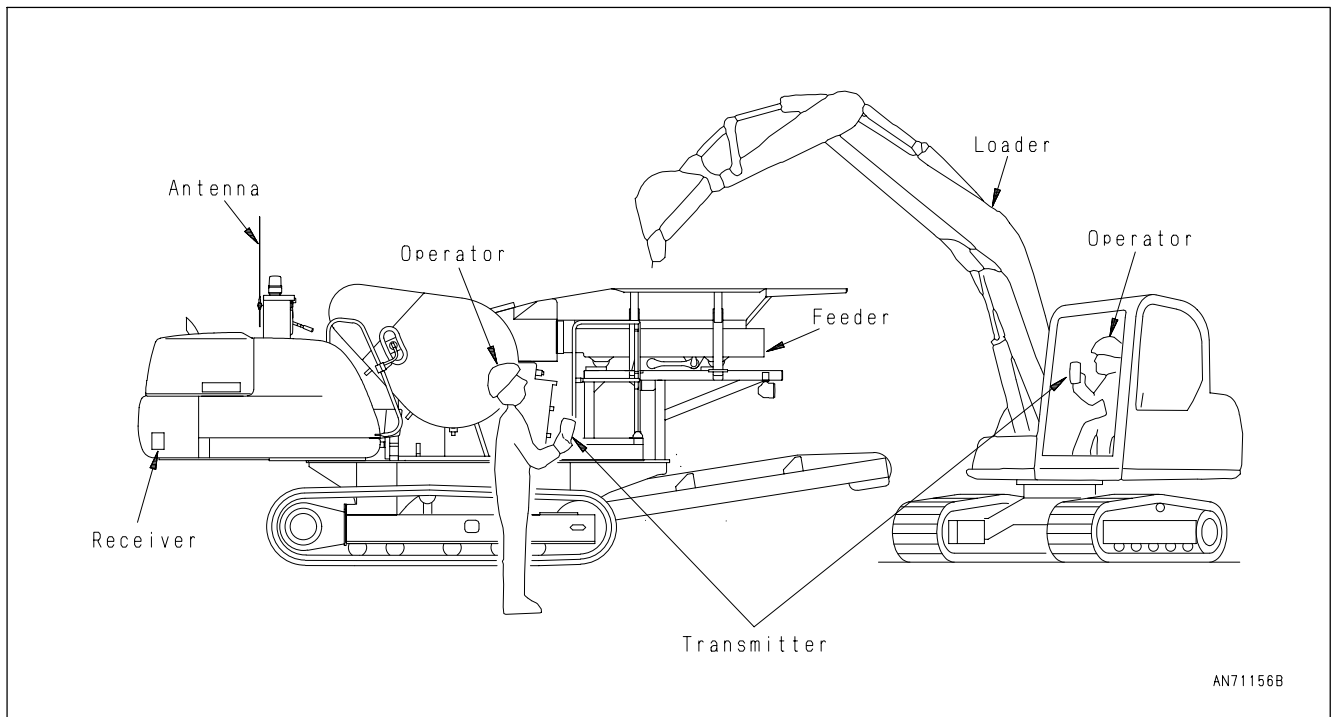

(a) When travel mode is selected

It is possible to carry out travel operations using the transmitter, but the work equipment on the machine cannot be

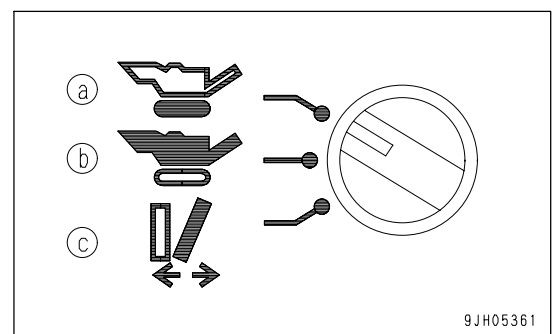

(b) When operating mode is selected

It is possible to operate the work equipment using the transmitter, but travel operations cannot be carried out.

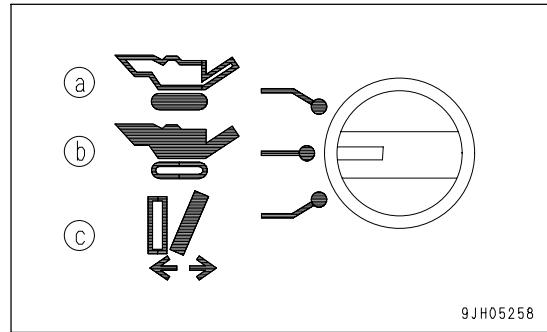

9JH05258

(c) When carrying out maintenance in inspection mode

Operations cannot be carried out with the remote control.

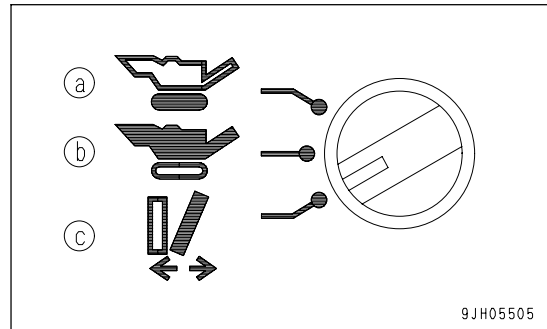

9JH05505

TRAVEL OPERATION WITH REMOTE CONTROL



WARNING

When using the remote control to carry out travel operations, always carry out the following safety checks.

- If the travel lever on the machine itself is touched by mistake, the machine will move and may cause serious personal injury or damage. When using the remote control to carry out operations, contact the people in the area and always set travel lever lock (1) to the LOCK position.
- When starting the machine off, confirm that the area around the machine is safe, and sound the horn before moving.

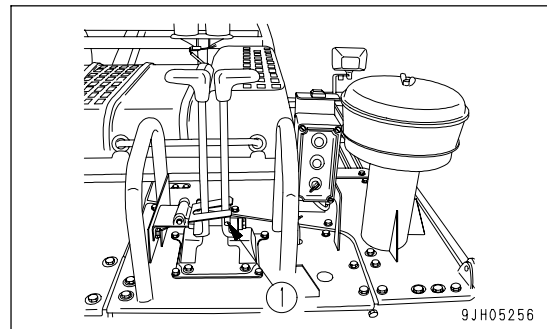

9JH05256

1. After starting the engine, set the mode selector switch to the travel position (a).

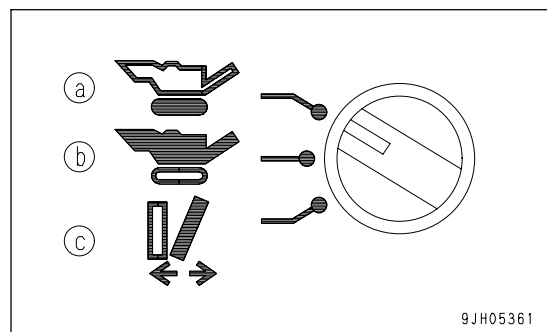

9JH05361



WARNING

When the remote control selector switch on the machine is set to the REMOTE CONTROL position (a), it becomes possible to carry out operations with the remote control. Always check first that the switches on the transmitter are not being pressed by mistake.

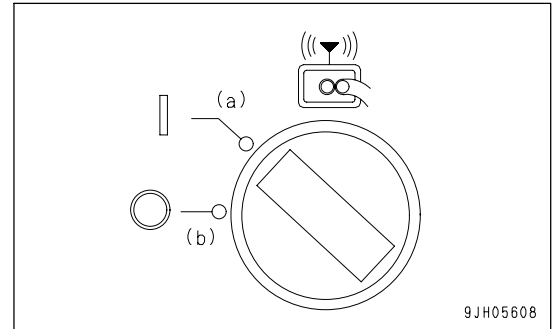
2. Set the remote control selector switch on the machine to the REMOTE CONTROL position (a).

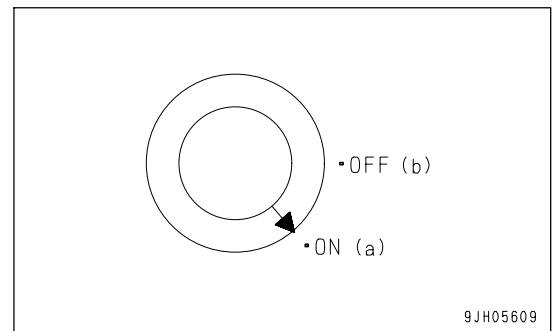

3. Insert the key in the transmitter power switch and turn it to ON position (a).



4. Check that yellow rotating lamp (2) on the machine lights up and that it is possible to operate with the remote control.

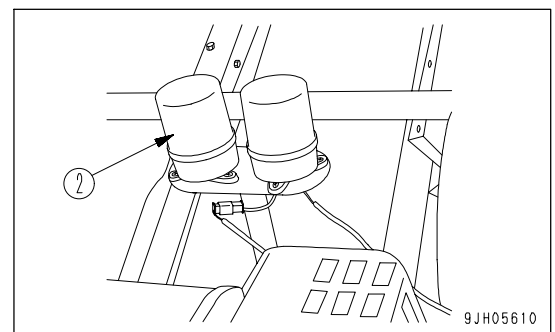

5. Check that the conveyor is at fixed position (3) for travel. If it is at any other position, change the position. For details, see "TRAVEL PREPARATIONS FOR PRIMARY CONVEYOR (PAGE 3-80)".

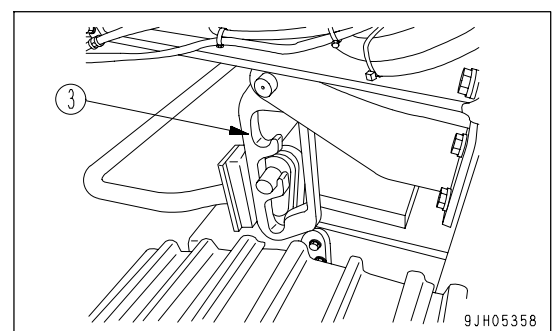

**WARNING**

- Before carrying out operations with the remote control, contact the surrounding area to inform everyone that you are about to start operations. Always confirm contact with the other operators to make sure that they do not operate the machine.
- When moving the machine off, confirm that the area surrounding the machine is safe, and sound the horn before moving.
- Do not allow anybody to climb onto the machine.
- Do not allow anybody to approach the area around the machine.
- Remove all obstacles from the travel path.

6. Turn the fuel control dial in the full speed direction to raise the engine speed.

7. Operate the transmitter travel control switch as follows.

The machine works while the switch is being pressed, and stops when the switch is released.

FORWARD: Press switches (4) and (5) at the same time

REVERSE: Press switches (6) and (7) at the same time

Right turn FORWARD: Press switch (4)

Right turn REVERSE: Press switch (6)

Left turn FORWARD: Press switch (5)

Left turn REVERSE: Press switch (7)

Counterrotation turn to right: Press switches (4) and (7) at the same time

Counterrotation turn to left: Press switches (5) and (6) at the same time

ALL STOP (in emergencies): Press switch (8) to stop the engine

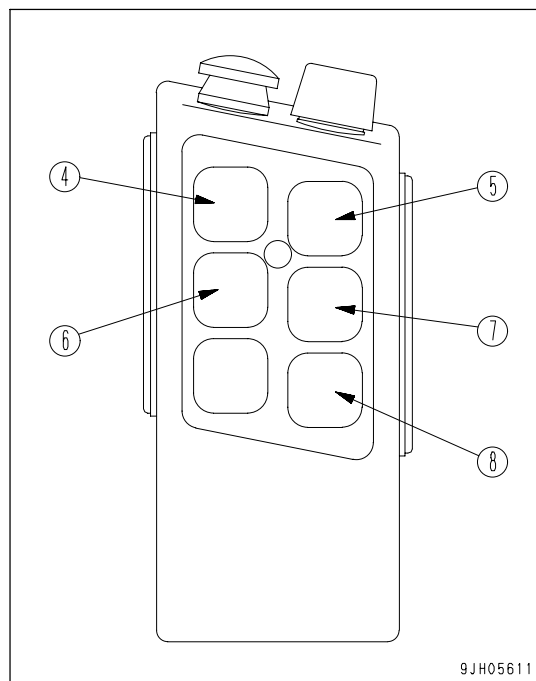

8. When finishing remote control operations, turn the transmitter power switch OFF, then set the remote control selector switch on the machine panel to the PANEL position.

WORK EQUIPMENT OPERATION WITH REMOTE CONTROL**WARNING**

When the remote control selector switch on the machine is set to the REMOTE CONTROL position (a), it becomes possible to carry out operations with the remote control. Always check first that the switches on the transmitter are not being pressed by mistake.

Is possible to start and stop the feeder and crusher with the remote control.

Use the monitor panel for the start and stop operations of the conveyor, magnetic separator, and other optional attachments. The feeder and crusher can also be stopped from the monitor panel.

1. After starting the engine, set the mode selector switch to the OPERATION position (b).

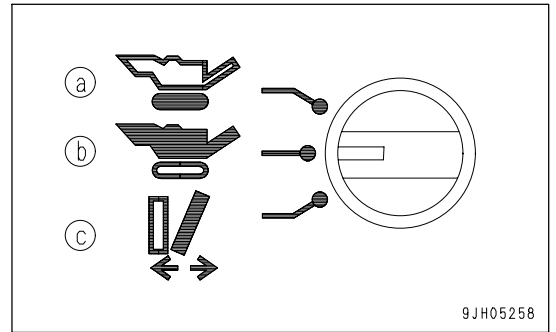

9JH05258

2. Set the remote control selector switch on the machine to the REMOTE CONTROL position (a).

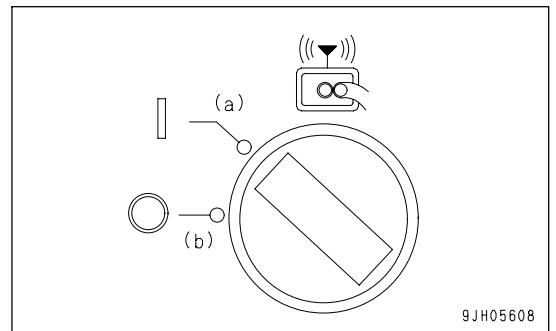

9JH05608

3. Insert the key in the transmitter power switch and turn it to ON position (a).

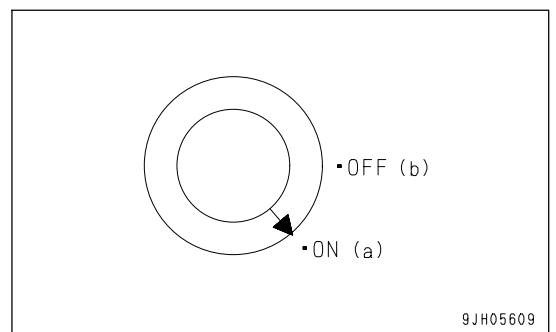

9JH05609

4. Check that yellow rotating lamp (2) on the machine lights up and that it is possible to operate with the remote control.

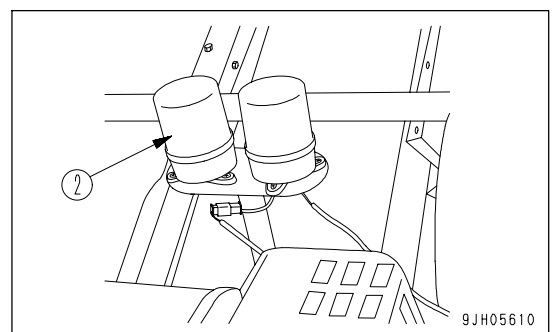

9JH05610

! WARNING

- Before carrying out operations with the remote control, contact the surrounding area to inform everyone that you are about to start operations. Always confirm contact with the other operators to make sure that they do not operate the machine.
- Do not allow anybody to approach the area around the machine.

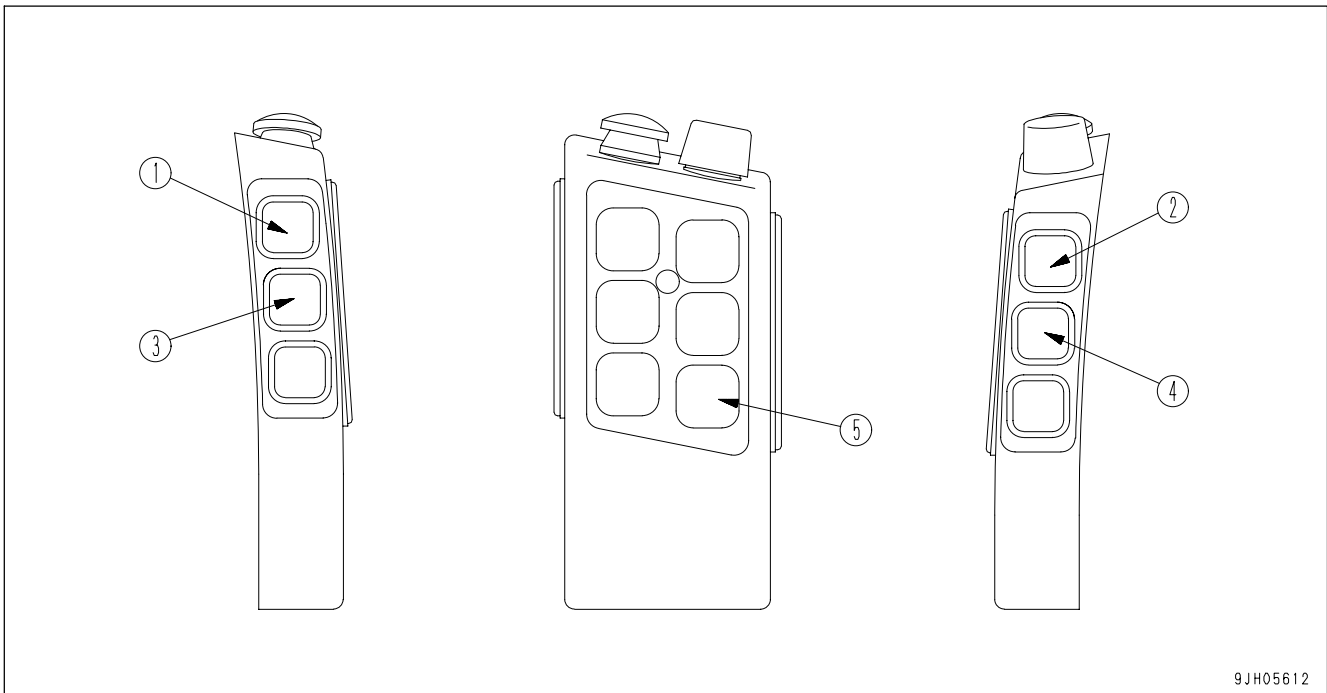

9JH05612

5. Operate the transmitter control switches as follows.

Starting, stopping feeder

Use this when observing the amount charged to the crusher and setting limits.

Feeder start: Press switch (1)

Feeder stop: Press switch (2)

! CAUTION

When stopping the crusher, always check that the feeder is stopped. Failure to stop the feeder will cause the material for crushing to accumulate inside the crusher and cause clogging.

Starting, stopping crusher

Crusher start: Press switch (3)

Crusher stop: Press switch (4)

6. In emergencies, press ALL STOP switch (5).

7. When finishing remote control operations, turn the transmitter power switch OFF, then set the remote control selector switch on the machine panel to the PANEL position.

MUCK DISCHARGE CONVEYOR

Of the raw material loaded into the hopper, it is possible to discharge only the muck portion selected by the grizzly feeder. The muck discharge conveyor can discharge to the left or right, and it can also be bent. This makes it unnecessary to remove it for transportation.

PROCEDURE FOR RAISING (BENDING) MUCK DISCHARGE CONVEYOR

Bend the muck discharge conveyor (if equipped) as follows.

1. Remove side cover lock bolt (1) at the center of the conveyor.
(M12 x 2)

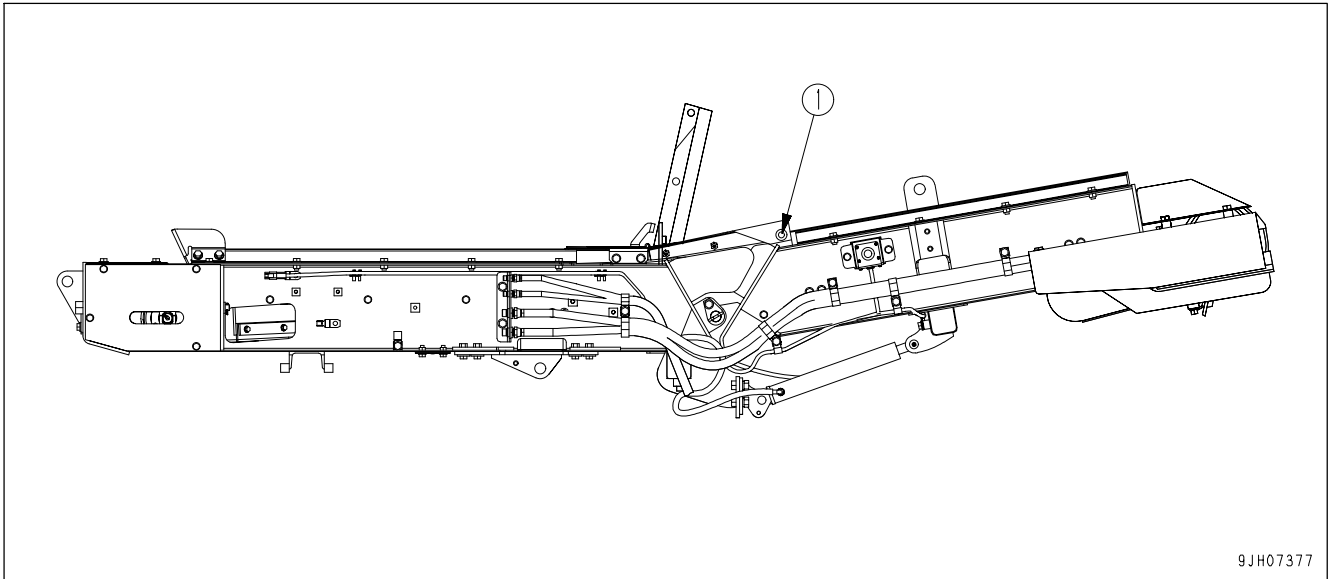

2. When discharging to the right, rotate side cover lock plate (6) and keep the conveyor center side cover (front of machine) in the raised posture.
When discharging to the left, lower the conveyor center side covers (both sides) to the rear.

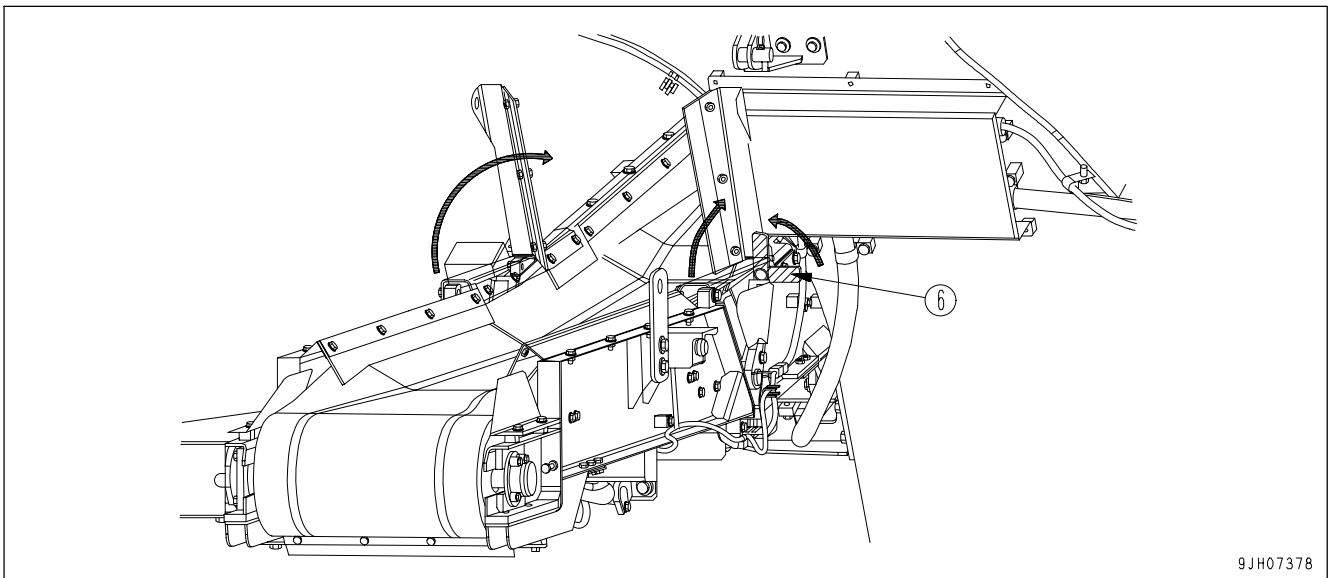

3. Start the engine.
4. Press muck discharge conveyor UP switch (2) and fold the conveyor.
5. Set conveyor up/down selector switch (5) to the muck discharge conveyor position (b).

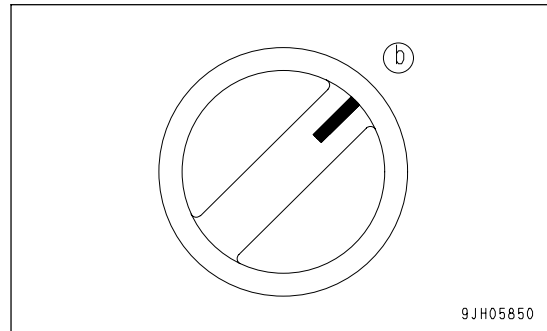
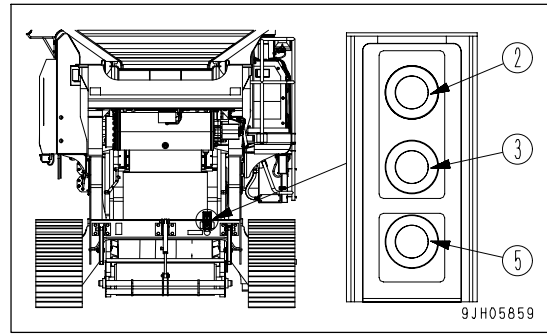

6. Insert pin (4) in the travel lock bracket to fix the conveyor in position.

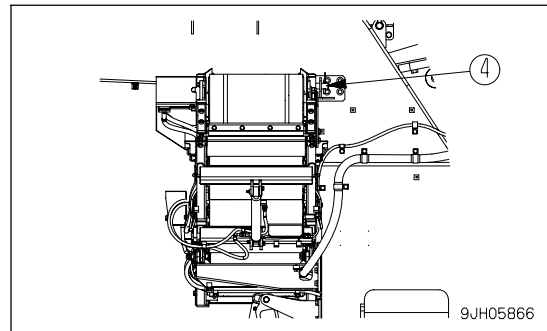

PROCEDURE FOR LOWERING MUCK DISCHARGE CONVEYOR

Lower the muck discharge conveyor (if equipped) as follows.

1. Remove pin (4) from the transportation lock bracket. Keep the removed pin in the toolbox.

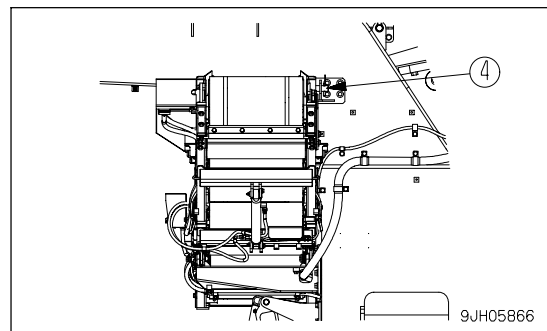

2. Start the engine.
3. Set conveyor up/down selector switch (5) to the muck discharge conveyor position (b).
4. Press the DOWN switch (3) of the muck discharge conveyor up/down switch to lower the conveyor.

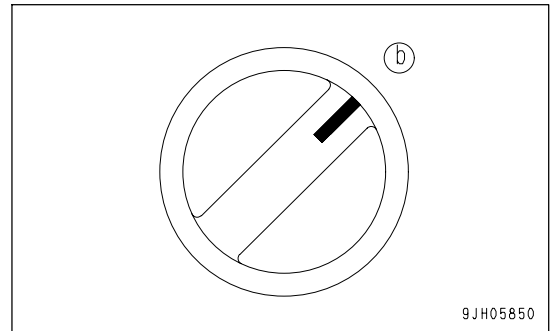
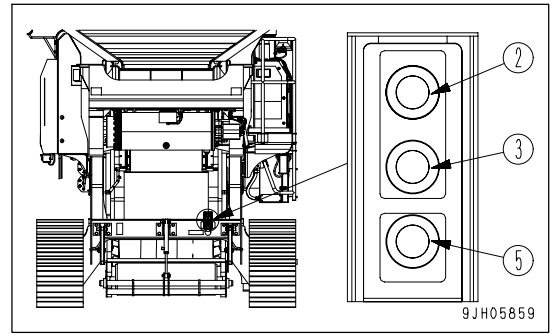

5. Lower side cover lock plate (6) and return the conveyor center side covers (both sides) to the operating

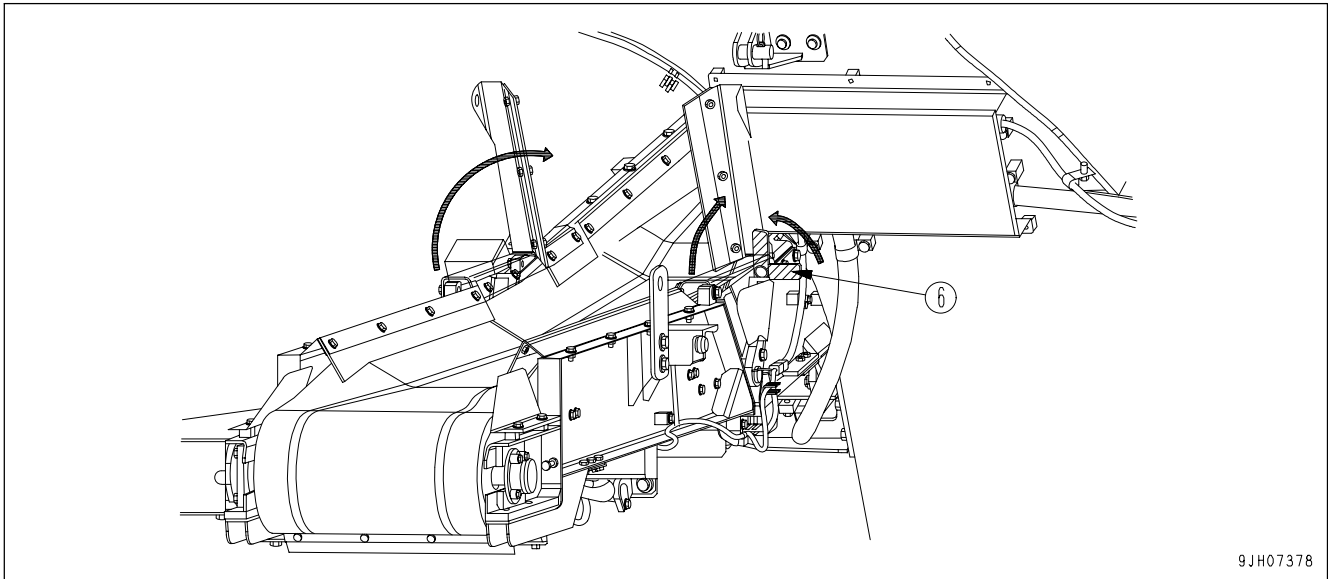

6. Install lock bolt (1) of the conveyor center side cover and install the side cover.
(M12 x 2)

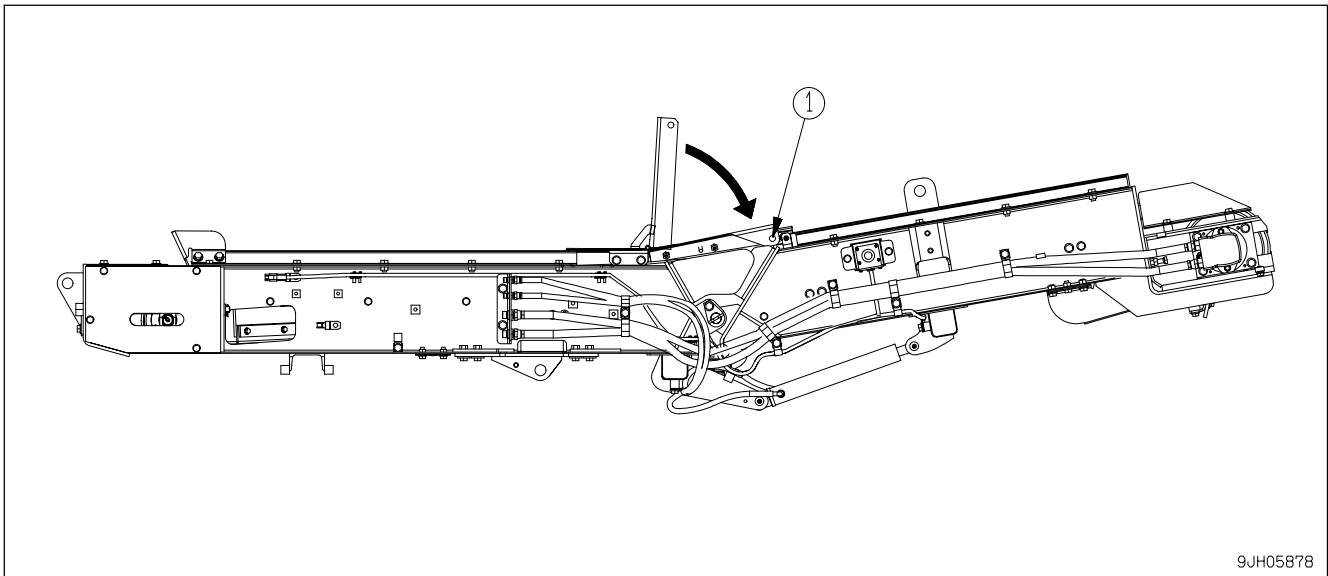

GREASING MUCK DISCHARGE CONVEYOR

NOTICE

Grease the muck discharge conveyor every 100 hours of operation.

1. Head pulley bearings (2 places)

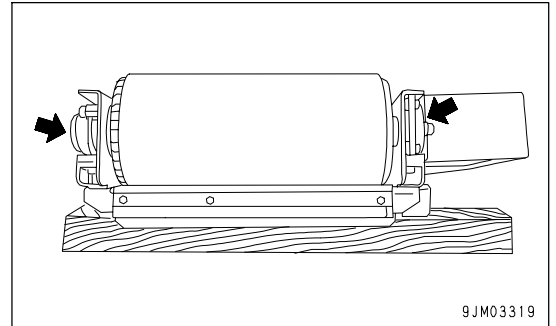

2. Tail pulley bearings (2 places)

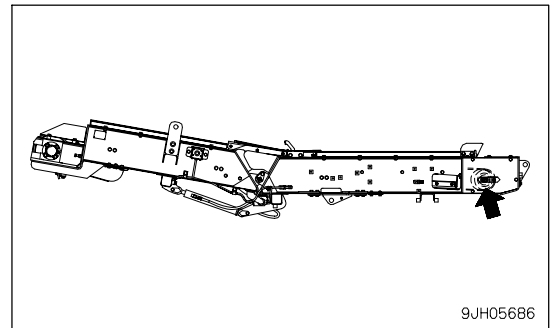

CHECK AND ADJUSTMENT OF MUCK DISCHARGE CONVEYOR

WARNING

There is always the danger that you get caught in the revolving parts of the conveyor, while inspecting or cleaning it. Be sure to stop the engine before starting the work.

IS THE BELT NOT SLACKENED?

CAUTION

Stop the engine first and start to work on the adjusting bolt (1).

If the conveyor belt is slackened, it tends to slip off and does not perform properly. Adjust the belt tension by turning the adjusting bolts (1) on the right and left sides of the belt.

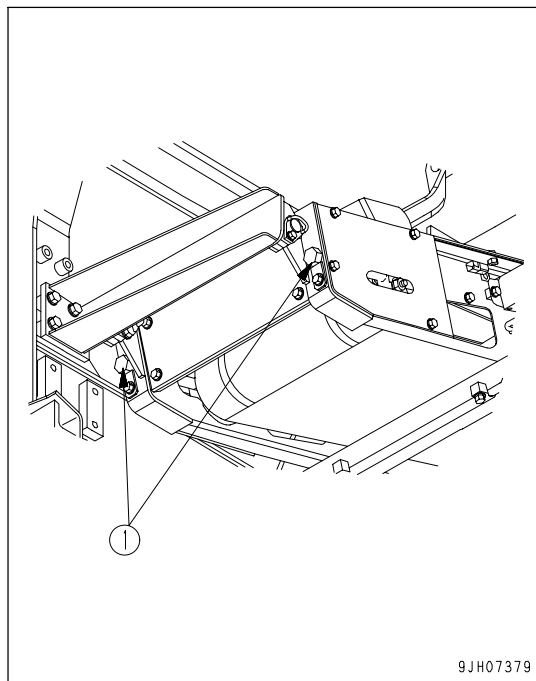

IS THE BELT NOT DEFLECTED?

1. When the belt is deflected to the left, move the belt in the direction indicated with an arrow.

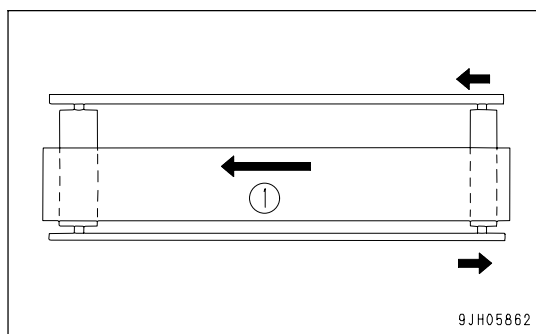

2. When the belt is deflected to the right, move the belt in the direction indicated with an arrow.

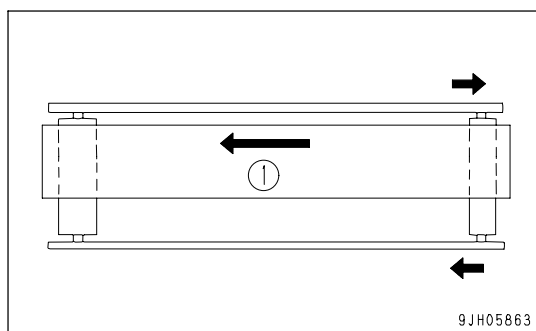

CHECK OF EACH PART IN BELT CONVEYOR FOR ANY STUCK FOREIGN OBJECT

Remove a stone, wire shred, gravel, etc. that are stuck at the backside of the belt conveyor, or in between the rollers and belt, or inside the hopper rubber and belt.

DO THE TAIL PULLEY AND ROLLERS TURN SMOOTHLY? OR IS THERE ANY PART IN THE BELT THAT IS ABOUT TO BREAK?

The conveyor belt may be damaged or broken while in operation. In that case, replace the defective belt with new one promptly.

1. Keep a close watch on the head scraper constantly.

Unless the scraper is in firm contact with the belt, earth stuck to the rollers will likely cause the rollers to wear prematurely.

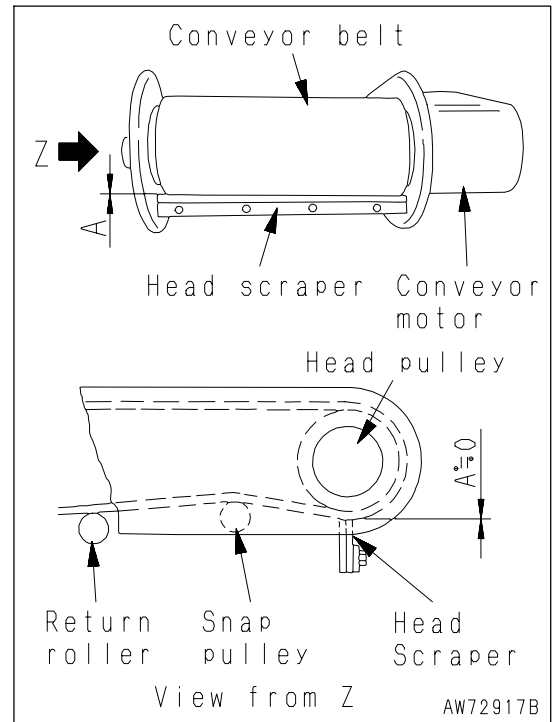

FAILURES AND CORRECTIVE ACTIONS

| Problem | Main causes | Remedy |
|----------------------------------------|-------------------------------------------------------------------------------------------------------------------------------------------------------------------------------------------------------------------------------------------------------------------------------------------------------------------------------------------------------------------------------------------------------------------------------------------|--------------------------------------------------------------------------------------------------------------------------------------------------------------------------------------------------------------------------------------------------------------------------------------------------------------------------------------------------------------------------------------------------------------------------------------------------------------------------------------------------------------------------------------------|
| Conveyor belt | | |
| Not operable | <ul style="list-style-type: none"> • Electric circuit fault | <ul style="list-style-type: none"> • Correct wiring |
| Snaky movement | <ul style="list-style-type: none"> • Misalignment of rollers and improper mounting • Debris transport direction • Debris stuck to rollers (Likewise wire or string winding about rollers) • Belt elongation • Belt bending, or not installed properly in endless processing • Frame twisting and bending • Frame not poised evenly (Belt is deflected to lower side) | <ul style="list-style-type: none"> • Adjust roller mounting angle • Load debris evenly in the middle of fan belt, after making sure that the machine is kept level on the ground • Clean roller periphery • Adjust belt tension with take-up • Retry endless processing, or replace belt with new one • Correct twisting and eccentricity at time of assembly or machine installation • Correct twisting and eccentricity at time of assembly or machine installation |
| Abnormal wear on backside | <ul style="list-style-type: none"> • Slip on motor pulley (or drive pulley) surface • Debris or foreign object stuck in between belt and pulley (Foreign objects stuck on pulley surface) | <ul style="list-style-type: none"> • Correct belt elongation with take-up • a. Remove foreign objects (Remove sticking) • b. Improve loading conditions at loading part |
| Damage (fissure in vertical direction) | <ul style="list-style-type: none"> • Debris or foreign objects caught where belt contacts hopper, scraper, etc. • Rollers falling off from bracket and bracket coming to direct contact belt • Rollers or faulty rotation worn out and perforated • Shock due to drop of large and heavy mass • Edged debris | <ul style="list-style-type: none"> • Remove foreign objects • Insert rollers into bracket correctly • Replace faulty rollers • Device to alleviate shock, or ensure right load • Do not let such materials be |
| Abnormal elongation | <ul style="list-style-type: none"> • Too strong take-up • Transport of hot materials • Abnormal load | <ul style="list-style-type: none"> • Return to normal tension • Replace with heat-resistant belt • Ensure proper load |
| Warpage | <ul style="list-style-type: none"> • Oily debris (Warpage to lower cover side) • Transport of hot materials • Acid content or alkali content | <ul style="list-style-type: none"> • Remove cause for oil to mix with debris, or use oil-resistant belt • Use heat-resistant belt • Use acid-resistant or |

| Problem | Main causes | Remedy |
|------------------------------|-------------------------------------------------------------------------------------------------------------------------------------------------------------------------|---------------------------------------------------------------------------------------------------------------------------------------------------------------|
| Belt cleaner, Scraper rubber | | |
| Wear and damage | <ul style="list-style-type: none"> • Debris caught | <ul style="list-style-type: none"> • a. Remove caught-in debris and correct belt cleaner, scraper rubber mounting so as to evenly contact belt |
| Rollers | | |
| Abnormal sound Breakage | <ul style="list-style-type: none"> • Faulty rotation of rollers • Wire or string winding about shafts • Shock due to fall of large and | <ul style="list-style-type: none"> • Replace with new one • Remove foreign objects • Take measures to ensure proper |
| Motor | | |
| Faulty operation | <ul style="list-style-type: none"> • Insufficient hydraulic oil | <ul style="list-style-type: none"> • a. Add oil up to specified level |

WEARING PARTS

| No. | Part Name | Part No. | Q'ty | Unit Weight [kg (lb)] |
|-----|----------------|-------------------------------------------------------------------|------|-----------------------|
| 1 | Conveyor belt | Not to be supplied as single parts. See following specifications. | | |
| 2 | Bearing unit | 8298-75-1260 | 1 | 1.50 (3.31) |
| 3 | Bearing | 8248-75-4250 | 1 | 0.55 (1.21) |
| 4 | Belt cleaner | 8240-75-5270 | 1 | 0.27 (0.60) |
| 5 | Carrier roller | 8240-75-5151 | 9 | 1.80 (3.97) |
| 6 | Rubber | 8295-75-5161 | 2 | 0.70 (1.54) |
| 7 | Return roller | 8240-75-5161 | 3 | 4.40 (9.70) |
| 8 | Rubber | 8295-75-5211 | 2 | 0.31 (0.68) |
| 9 | Rubber | 8240-75-5421 | 2 | 0.10 (0.22) |
| 10 | Slide plate | 8240-75-5141 | 1 | 19.76 (43.57) |
| 11 | Rubber | 8240-75-5240 | 1 | 0.50 (1.10) |
| 12 | Bearing | 06300-06207 | 2 | - |
| 13 | Scraper rubber | 8240-75-5340 | 1 | 0.26 (0.57) |

Conveyor belt specification

| | | | | |
|-------------------------------------------|-------------------|---------------------------------------|---------------------|-------|
| Size | Width | 500 mm (1 ft 8 in) | | |
| | Length of endless | 6750 mm (22 ft 2 in) | | |
| Belt strength | | 160 kg/cm | | |
| No. of ply | | 2 | 1 | |
| Core material | | Polyester | Nylon, Polyester | Nylon |
| Cover rubber thickness (front x rear) | | 3.0 mm (0.118 in) x 1.5 mm (0.059 in) | | |
| Overall thickness (for reference only) | | 6.3mm (0.248 in) | | |

SPECIFICATIONS

| | | |
|-----------------------------|---------|---------------------------------------|
| Komatsu Part No. | | 8240-75-5101 |
| Belt width x machine length | | 500 mm x 3 m (1 ft 8 in x 9 ft 10 in) |
| Max. gradeability | degree | 24 |
| Motor rotation | rpm | 153 |
| Belt travel speed | m/min | 120 |
| Weight | kg (lb) | 350 (772) |

M-TYPE CHUTE

It is possible to switch the muck discharge simply between a merged flow and a divided flow on the jobsite.

METHOD OF OPERATION



WARNING

During inspection and maintenance, when opening the inspection cover and operating the selector panel, be extremely careful. There is danger of catching your fingers.



CAUTION

When are not using the muck discharge conveyor, set the handle to position (a) (merge) when carrying out operations. If operations are carried out with the handle at position (b), debris will accumulate inside the chute, and this will cause damage to the muck discharge conveyor and chute.

1. Install handle (1) (kept in the tool box) to the handle mount on the opposite side from the direction of discharge of the muck.
2. It is possible to switch to merged flow or divided flow of the muck by operating handle (1).

Position (a): Muck flow is marged

Position (b): Muck flow is divided

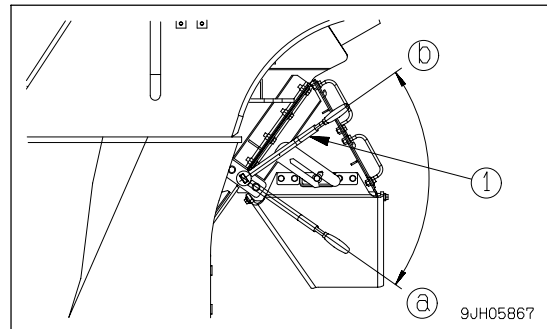

BELT CONVEYOR PROTECTIVE PLATE

CONVEYOR PROTECTIVE BELT

When crushing mainly reinforced concrete debris, a conveyor protection plate is effective at preventing the conveyor belt from breakage.

NOTICE

This conveyor protector plate is designed for general discharge clearance 50 mm (2.0 in) (OSS) [production of RC40] when crushing concrete. When using with a discharge port clearance of greater than that, the range of the cover for the conveyor belt becomes smaller, so it is necessary to be extremely careful when charging the crusher.

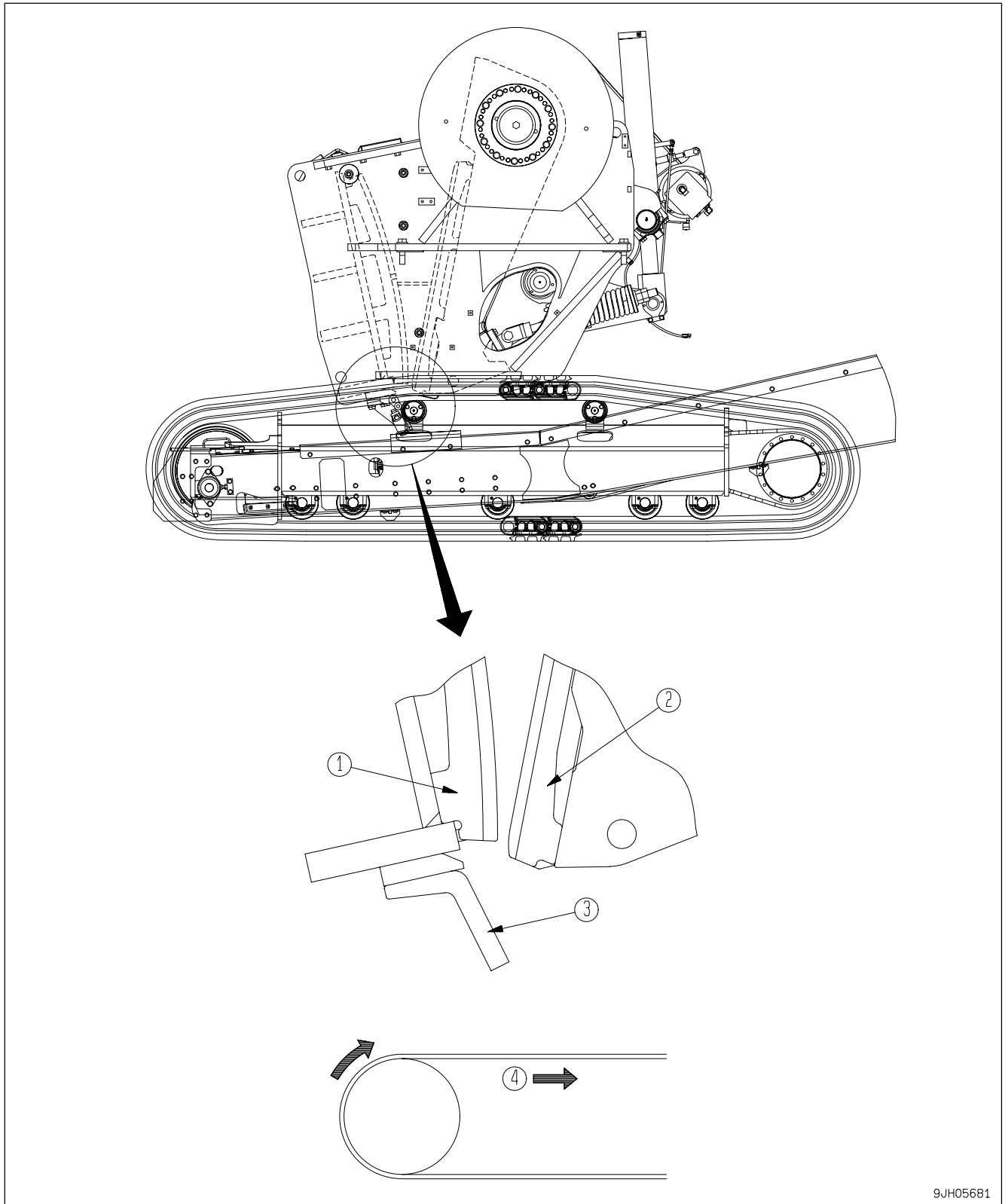

9JH05681

- (1) Fixed jaw plate
- (2) Swing jaw plate

- (3) Conveyor protector plate
- (4) Direction of travel of conveyor belt

GRIZZLY BAR OPENING

GRIZZLY BAR OPENING

Grizzly bar opening (15 mm to 40 mm (0.6 to 1.6 in))

In addition to the standard grizzly bar (25 to 50 mm (1.0 to 2.0 in)) the grizzly bar shown below is also available.

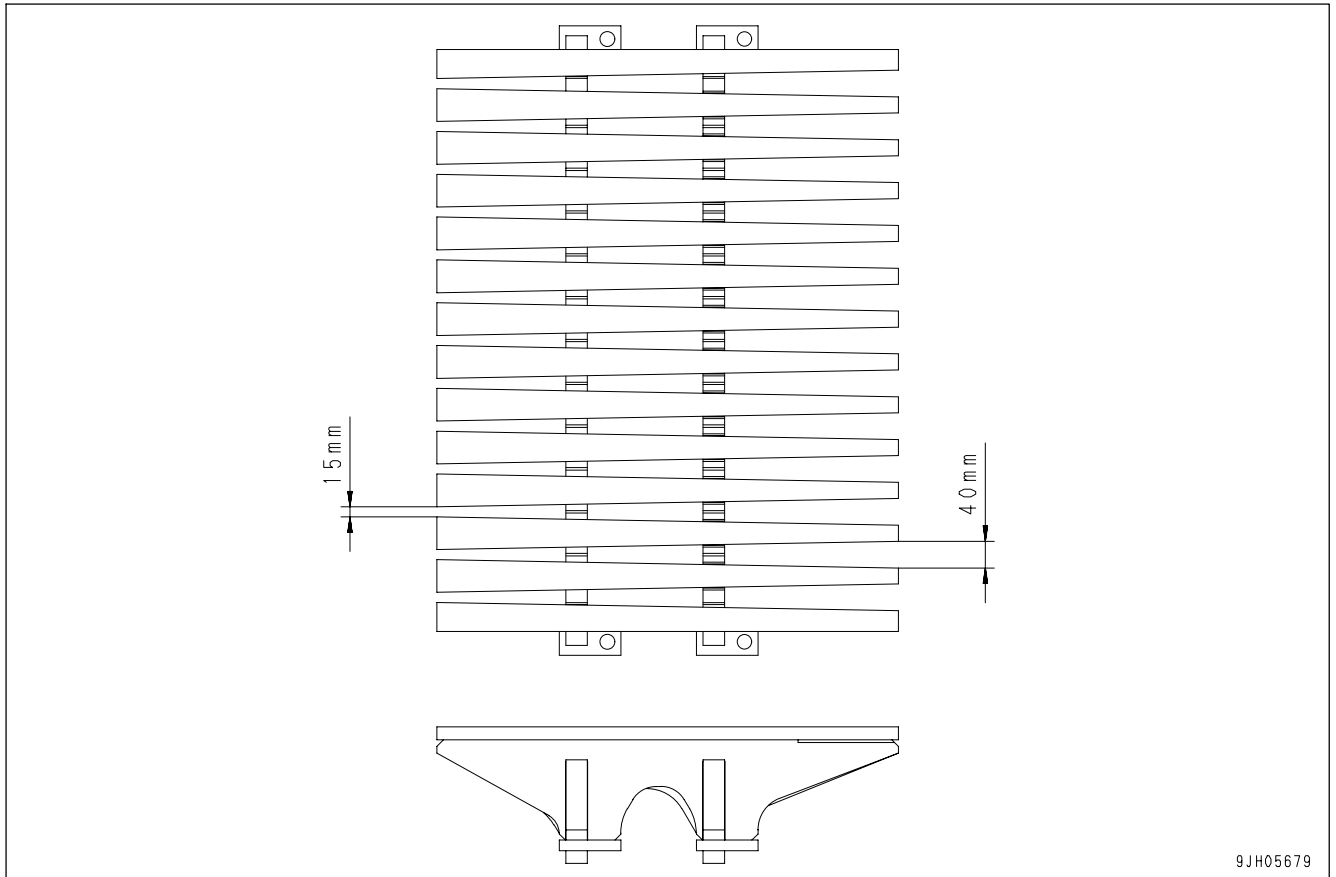

9JH05679

HANDLING MACHINES EQUIPPED WITH KOMTRAX

- KOMTRAX is a machine management system that uses wireless communications.
- A contract with your Komatsu distributor is necessary before the KOMTRAX system can be used. Any customers desiring to use the KOMTRAX system should consult their Komatsu distributor.
- The KOMTRAX equipment is a wireless device using radio waves, so it is necessary to obtain authorization and conform to the laws of the country or territory where the machine equipped with KOMTRAX is being used. Always contact your Komatsu distributor before selling or exporting any machine equipped with KOMTRAX.
- When selling or exporting the machine or at other times when your Komatsu distributor considers it necessary, it may be necessary for your Komatsu distributor to remove the KOMTRAX equipment or to carry out action to stop communications.
- If you do not obey the above precautions, neither Komatsu nor your Komatsu distributor can take any responsibility for any problem that is caused or for any loss that results.

BASIC PRECAUTIONS



WARNING

- Never disassemble, repair, modify, or move the communications terminal, antenna, or cables. This may cause failure or fire on the KOMTRAX equipment or the machine itself. (Your Komatsu distributor will carry out removal and installation of KOMTRAX.)
- Do not allow cables or cords to become caught; do not damage or pull cables or cords by force. Short circuits or disconnected wires may cause failure or fire on the KOMTRAX equipment or the machine itself.
- For anyone wearing a pacemaker, make sure that the communications antenna is at least 22 cm (8.7 in) from the pacemaker. The radio waves may have an adverse effect on the operation of the pacemaker.

NOTICE

- Even when the key in the starting switch of the KOMTRAX system is at the OFF position, a small amount of electric power is consumed. When putting the machine into long-term storage, take the action given in "LONG-TERM STORAGE (PAGE 3-132)".
- Please contact your Komatsu distributor before installing a top guard or other attachment that covers the cab roof.
- Be careful not to get water on the communications terminal or wiring.

REMARK

- The KOMTRAX system uses wireless communications, so it cannot be used inside tunnels, underground, inside buildings, or in mountain areas where radio waves cannot be received. Even when the machine is outside, it cannot be used in areas where the radio signal is weak or in areas outside the wireless communication service area.
- There is absolutely no need to inspect or operate the KOMTRAX communications terminal, but if any abnormality is found, please consult your Komatsu distributor.

MACHINES THAT CAN INSTALL ATTACHMENTS

(if equipped)

For machines that can install attachments (if equipped), a hydraulic power source (valve, hydraulic pressure pickup port) and start-stop switch is provided to drive the vibratory sieve and secondary conveyor (x 2).

NAMES OF CONTROL PANEL SWITCHES

- (1) Vibratory sieve start switch
- (2) Vibratory sieve stop switch
- (3) Secondary conveyor start switch
- (4) Secondary conveyor stop switch

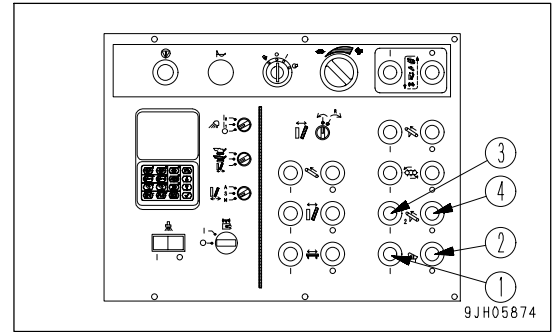

HYDRAULIC POWER TAKEOFF PORT

| | Name of ports |
|-----|--------------------------------------------------|
| (1) | Vibratory sieve |
| (2) | Vibratory sieve (return) |
| (3) | Secondary conveyor |
| (4) | Secondary conveyor (return) |
| (5) | Drain |
| (6) | Magnetic separator (+ tertiary conveyor) |
| (7) | Magnetic separator (+ tertiary conveyor)(return) |

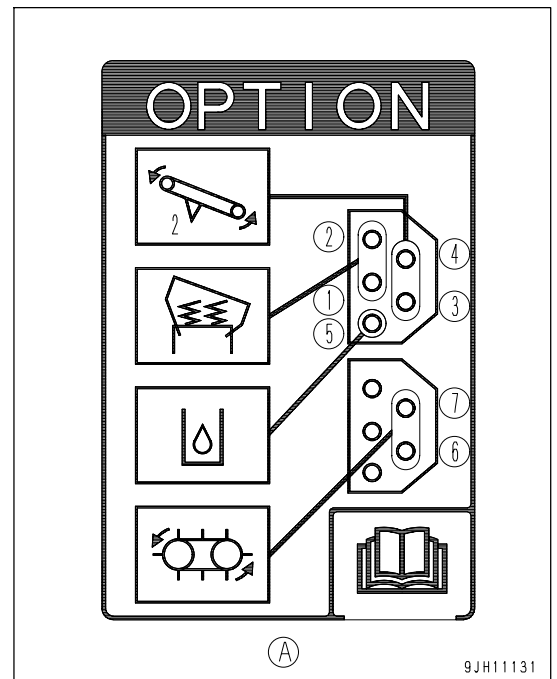
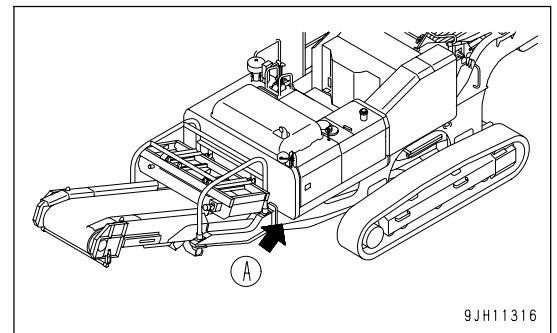

ATTACHMENT PORT

| Name | Flow (l/min) | Relief set pressure MPa(kg/cm ²) | Overload pressure switch set pressure MPa(kg/cm ²) | Action when actuating pressure rises and remedy to restart machine (*1) | Remarks |
|--------------------------------------------------|--------------|----------------------------------------------|----------------------------------------------------------------|----------------------------------------------------------------------------------------------------------------------------|----------------------------------------------------------------------------------------|
| Vibratory sieve port | 28 | 20.6(210) | 19.6(200) | When pressure switch has been ON for more than 10 seconds, all work equipment stops Turn each switch ON to start again | - |
| Secondary conveyor port | 28 | 13.7(140) | 12.3(125) | When pressure switch has been ON for more than 1.5 seconds, all work equipment stops Turn each switch ON to start again | - |
| Magnetic separator port (tertiary conveyor port) | 28 | 13.7(140) (*2) | 12.3(125) (*2) | When pressure switch has been ON for more than 1.5 seconds, all work equipment stops Turn each switch ON to start again | Tertiary conveyor return hose is connected to magnetic separator motor inlet port (*3) |
| Drain port | - | - | - | - | Connected directly to hydraulic tank |

*1: There is a function to stop the work equipment in order to protect the machine if the hydraulic pressure of the connected equipment rises.

*2: The tertiary conveyor is connected to the upstream side of the magnetic separator motor, so the specification is the total including the magnetic separator load. The actuating pressure of the magnetic separator motor is added to the return pressure of the tertiary conveyor. Check the specifications of the tertiary conveyor carefully. The actuation pressure of the magnetic separator motor is 3 - 4 MPa (30-40 kg/cm²).

*3: A 4HP size coupler (Part No.: 8248-62-1210) is supplied at the tip of the hose at the selector motor inlet port. Install a 4HS size coupler (Part No.: 8248-62-1220) to the return hose of the tertiary conveyor.

When using a one-touch coupler, install the matching Part No. in the table below for the machine to be connected.

| Name | One-touch coupler size (machine) | Machine coupler Part No. | Matching coupler Part No. (reference) |
|--------------------------------------------------|----------------------------------|--------------------------|---------------------------------------|
| Vibratory sieve port | Discharge: 4HS Return: 4HP | 8248-62-1210 | 8248-62-1220 |
| | | 8248-62-1220 | 8248-62-1210 |
| Secondary conveyor port | Discharge: 4HS Return: 4HP | 8248-62-1210 | 8248-62-1220 |
| | | 8248-62-1220 | 8248-62-1210 |
| Magnetic separator port (tertiary conveyor port) | Discharge: 4HS Return: | 8248-62-1210 | 8248-62-1220 |
| | | - | - |
| Drain port | Return: 3S | 8242-76-2531 | 8242-76-2520 |

PROCEDURE FOR CONNECTING OPTIONS

(Example of connection of vibratory sieve, secondary conveyor, tertiary conveyor, magnetic separator)

The diagram below is an example of when a vibratory sieve and 2 conveyors are additionally connected. When actually carrying out the connection, also refer to the Operation and Maintenance Manual of the equipment to be connected.

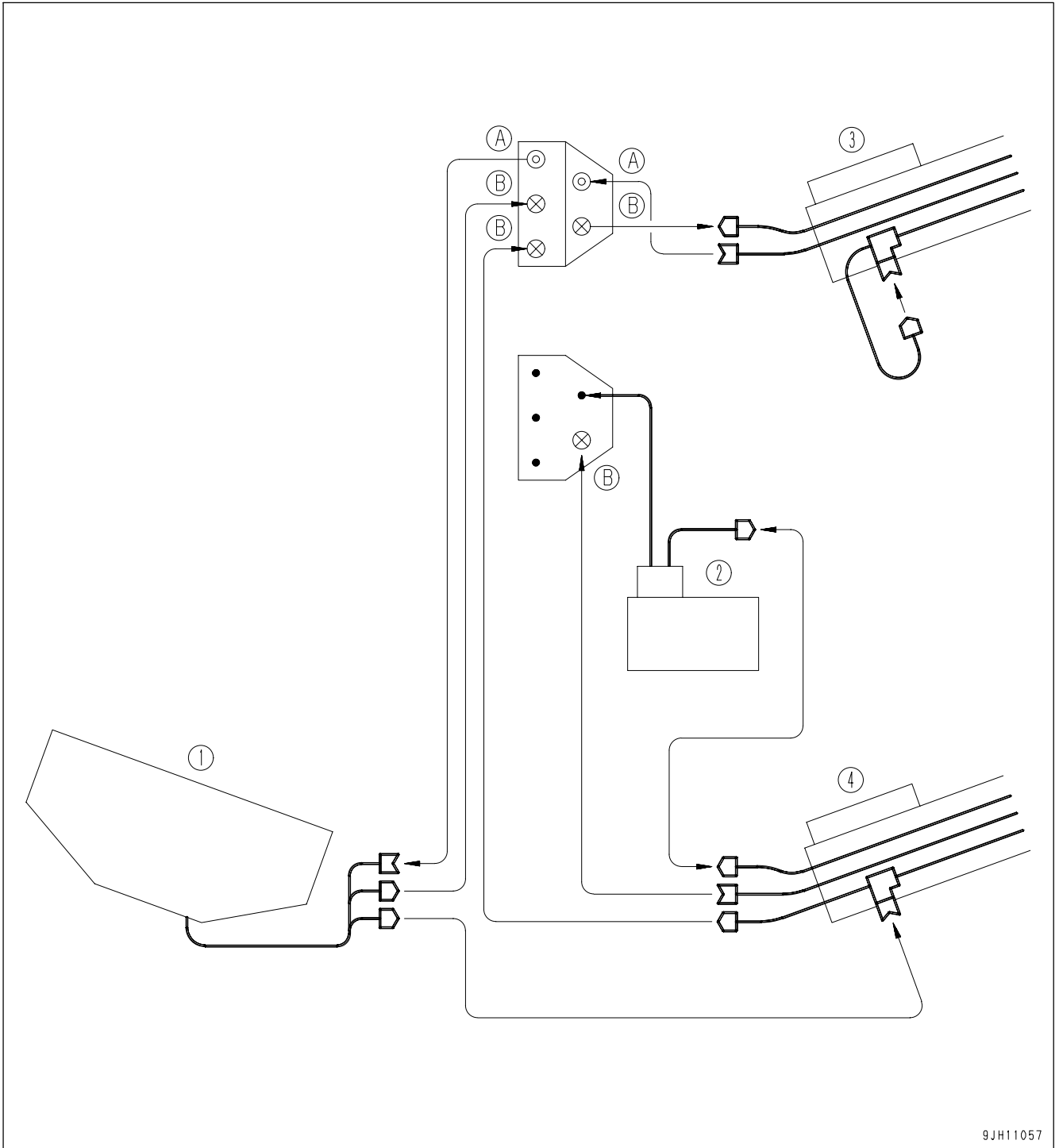

9JH11057

(A) Male

(B) Female

- (1) Vibratory sieve
- (2) Magnetic separator

- (3) Secondary conveyor
- (4) Tertiary conveyor

← : Path of the oil

HYDRAULIC VIBRATORY SIEVE

(Installed only on machines that can install attachments)

SPECIFICATION

Model: 1200 width 2-floor type vibratory sieve

Amplification (speed): 10 mm (0.4 in) (800 rpm)

Driving method: Hydraulic gear motor

Angle of inclination: 17°

Dimension of crusher feed: Max. 80 mm (3.2 in) crushed rock, concrete rubble

Processing capacity: 144 t/h (screen mesh 40 mm)

May change according to conditions of feeder material.

Weight: 1110 kg (2448 lb)

GENERAL VIEW

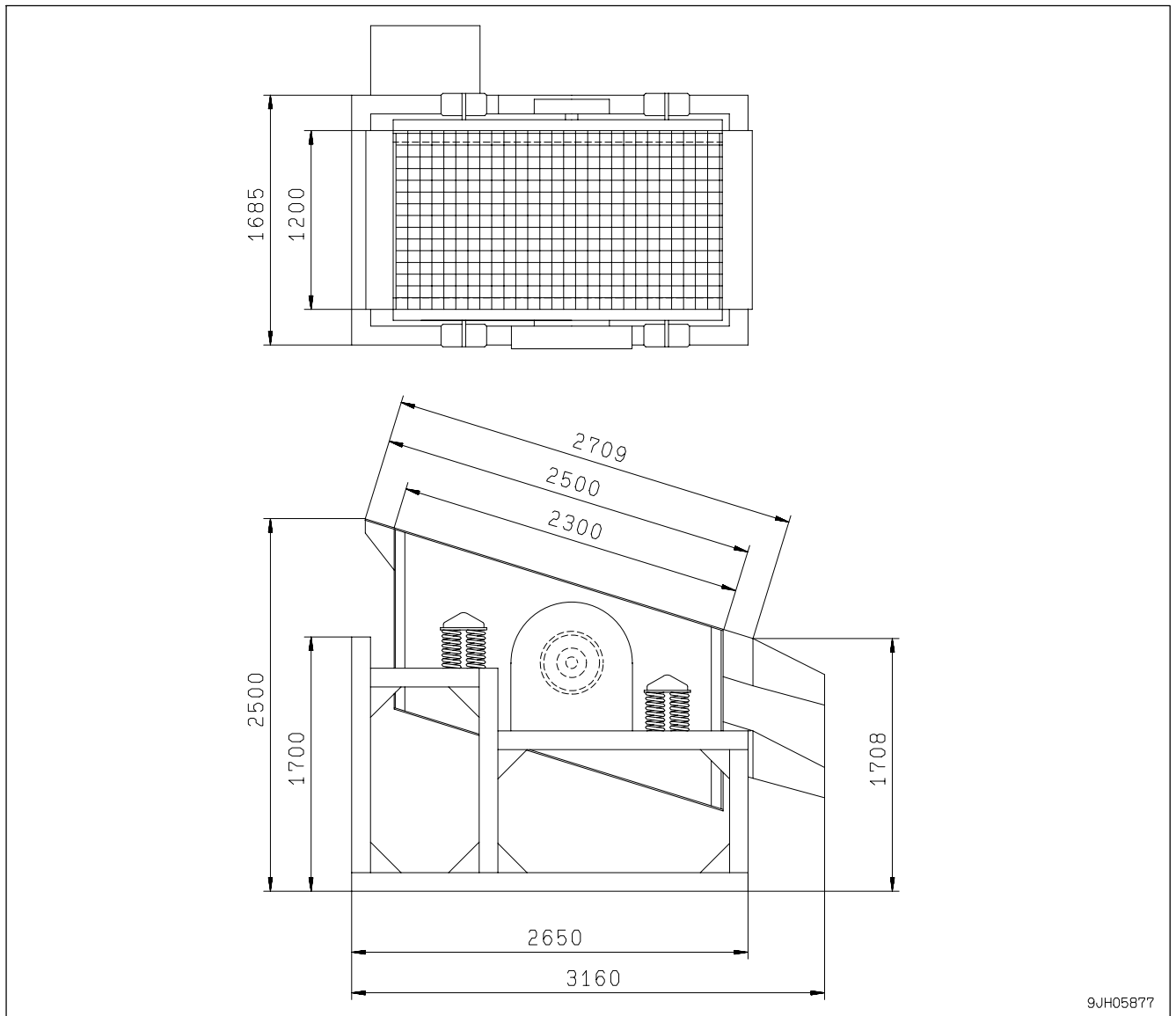

CAUTIONS TO BE NOTED FOR SAFETY

- When starting and stopping the conveyor, it vibrates with large amplitude. So, do not access it.
- Feed debris when the amplitude is reduced and become stable.
- Install the conveyor so that the four large legs set on the ground.
Since the conveyor screens debris by vibration, it is very dangerous that the four legs are not firmly set on the ground, because it increases the amplitude.
- When the conveyor is laid on concrete floor or iron plate, place wood or rubber under each leg. Otherwise, vibration may move the conveyor.

CONNECTING METHOD TO MACHINE BODY

For details, see "PROCEDURE FOR CONNECTING OPTIONS (PAGE 6-37)".

PRECAUTIONS DURING OPERATION

- Select a screen suitable for grain size of product.
- Place the screen right below the primary conveyor, and align the centers. When debris approach, the sieve comes to vibrate with large amplitude.
- Since fine muck fall right below the sieve, place the secondary conveyor right in the center of the sieve.
- Coarse muck are discharged from the tip of the sieve. Place the Tertiary conveyor at right angle to the sieve.

HYDRAULIC SECONDARY CONVEYOR

(Installed only on machines that can install attachments)

This is a belt conveyor to be used for extending the hauling distance of crushed muck or in combination with a vibration sieve.

SPECIFICATIONS

| | | | |
|-----------------------------|---------|----------------------------------------|-----------------------------------------|
| Belt width x machine length | | 60 cm x 7 m (1 ft 12 in x 22 ft 12 in) | 60 cm x 10 m (1 ft 12 in x 32 ft 10 in) |
| Max. gradeability | degree | 23 | 23 |
| Motor rotation | rpm | 107 | 107 |
| Belt travel speed | m/min | 87 | 107 |
| Weight | kg (lb) | 640 (1411) | 884 (1949) |

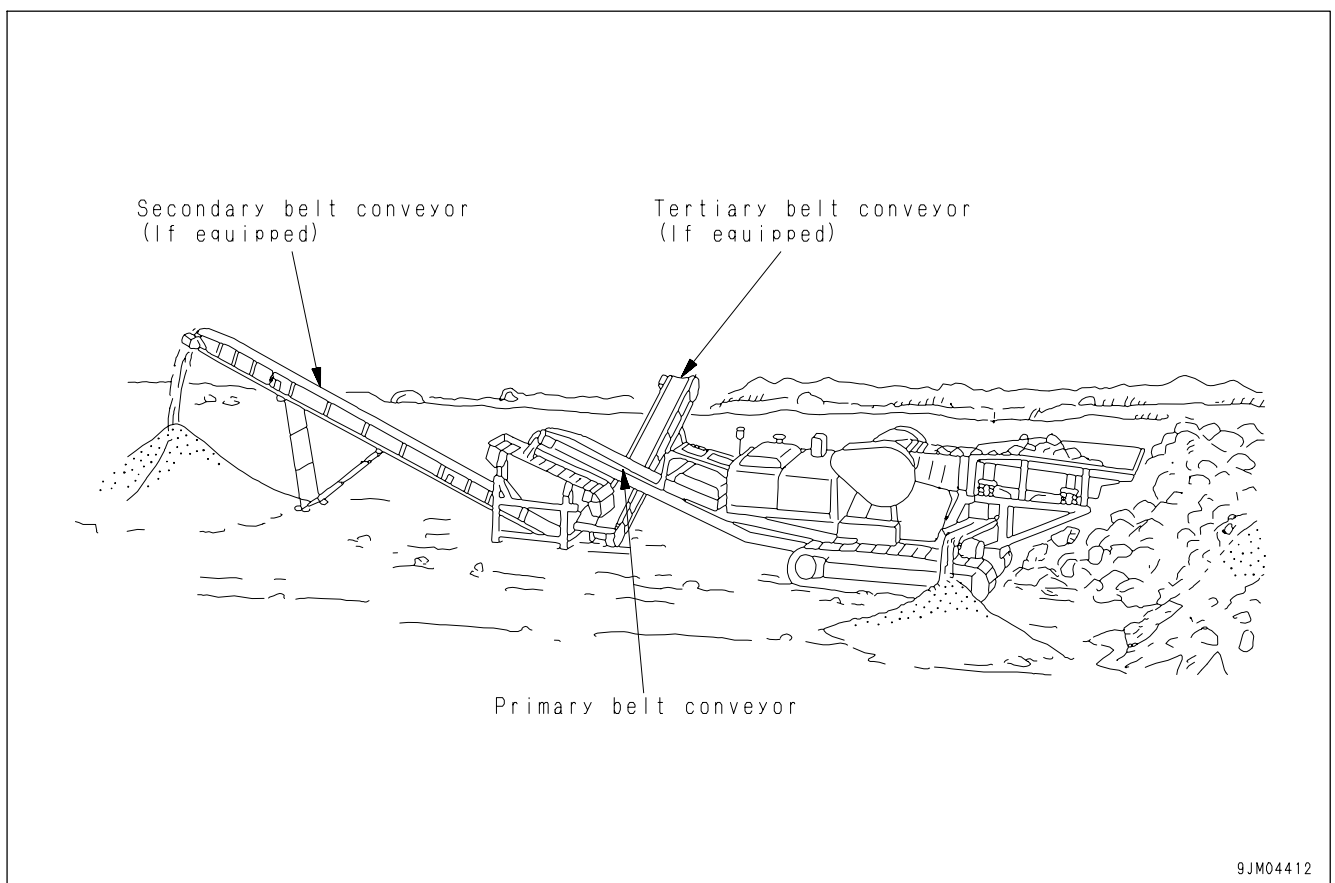

GENERAL VIEW



CAUTION

- It is dangerous to mount the belt conveyor and climb to the top of the belt conveyor. When greasing or adjusting zigzagging, prepare steps or a stand to provide a stable foothold to carry out the work.
- Insert the single-touch coupler securely until a click is heard. If it is not inserted securely, it will cause failure of the equipment.

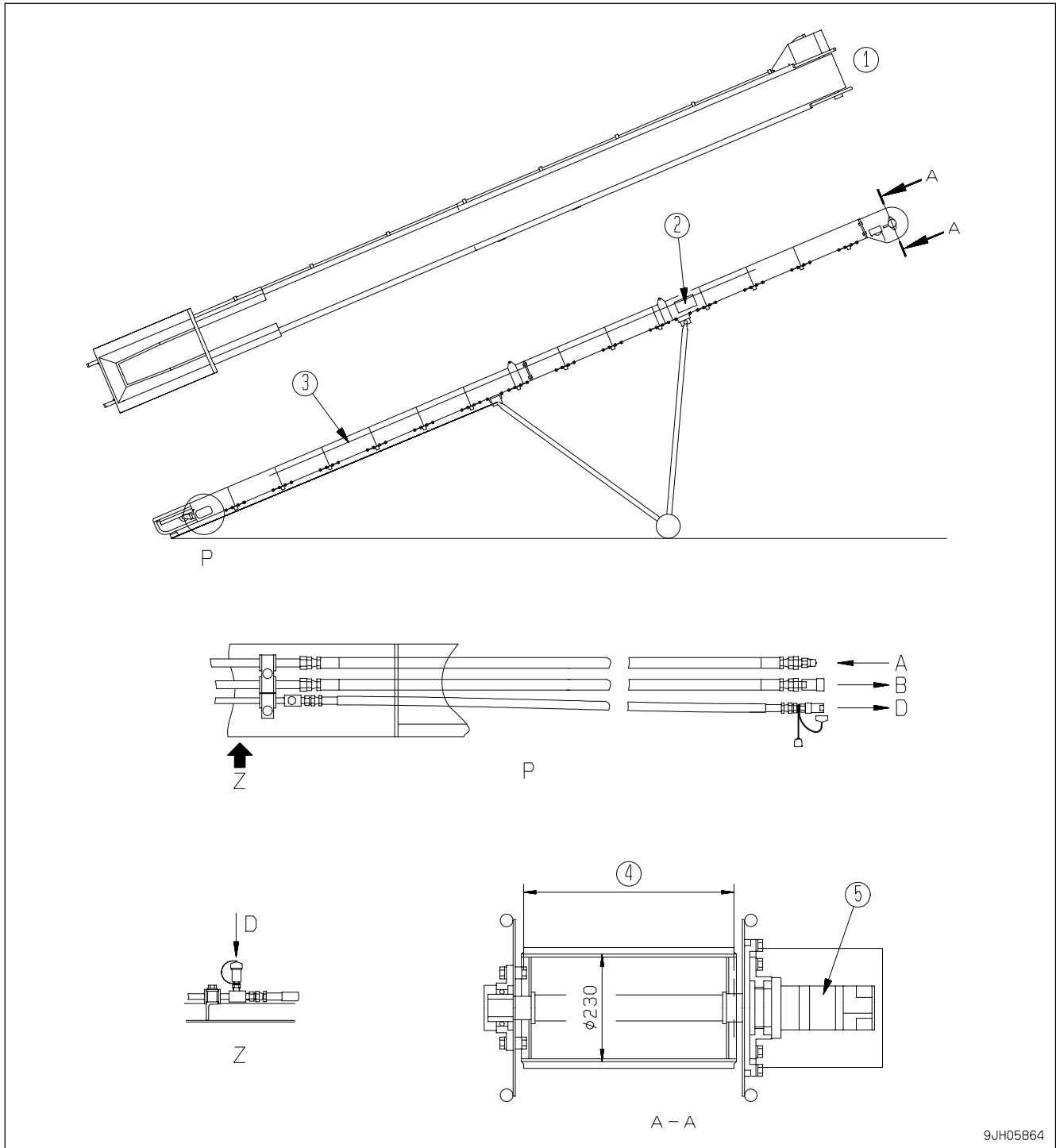

- (1) Head portion
- (2) Nameplate
- (3) Emergency stop switch (wire rope)

- (4) Belt width
- (5) Hydraulic motor

INCLINED LEG CONNECTING METHOD

- Keep the head raised and fix the leg to the conveyor body with bolts.

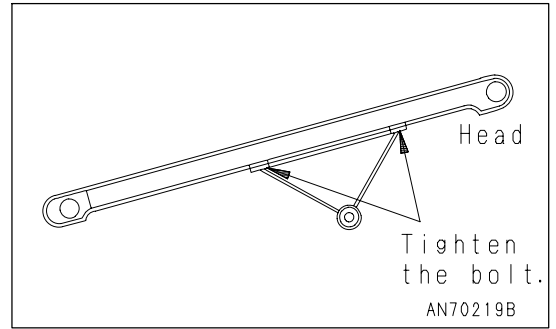

- After having fitted the leg, reduce the angle of inclination to the minimum when moving the belt conveyor.

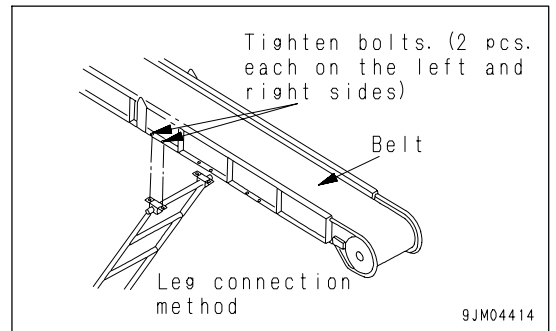

- Leg Fitting Sizes

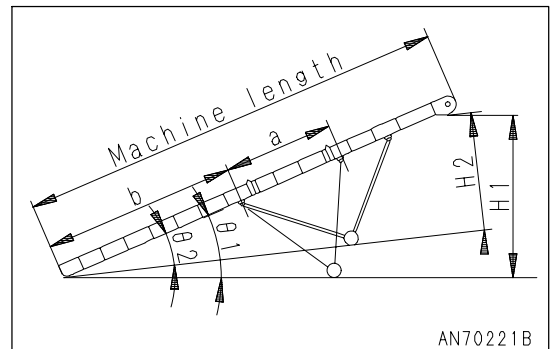

| Belt width x machine length | | 60 cm x 7 m (1 ft 12 in x 22 ft 12 in) | 60 cm x 10 m (1 ft 12 in x 32 ft 10 in) |
|-----------------------------|------------|----------------------------------------|-----------------------------------------|
| a | mm (ft in) | 1340 (4' 5") | 2520 (8' 3") |
| b | mm (ft in) | 3490 (11' 5") | 4464 (14' 8") |
| H1 (θ1) | mm (ft in) | 2460 (8' 8", 23°) | 3640 (11' 11", 23°) |
| H2 (θ2) | mm (ft in) | 1815 (5' 11", 17°) | 2700 (8' 10", 17°) |

The maximum height H1 (maximum angle θ1) can be increased and decreased. When the maximum angle θ1 is more than 20°, use care that debris do not slip.

LIFTING METHOD

- Clamp a wire rope firmly to the four lifting brackets by using shackle.

At the time, keep the lifting angle of the wire rope below 90°. *1

- When the belt conveyor is hung up in the air, move it as slowly as possible.

In addition, never go under the hung belt conveyor.

*1: The inclined leg can be fitted at three places, but the center of gravity hardly changes with these places. So, the conveyor can be lifted with the same lifting brackets.

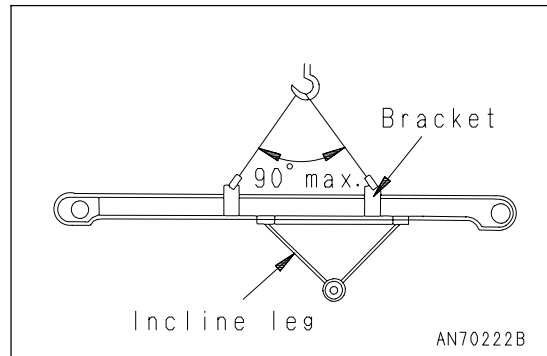

CONNECTING METHOD TO MACHINE BODY

For details, see "PROCEDURE FOR CONNECTING OPTIONS (PAGE 6-37)".

PRECAUTIONS ON OPERATION

1. When operating the secondary conveyor together with the primary conveyor, arrange them so that muck are loaded on the centers of the both belt conveyors. If muck are not loaded on the centers, the belts will zigzag or earth and sand will fall from the belt conveyors, and they will be caught in the tail pulley. Consequently, the belt conveyors may stop.
2. Keep a close watch on the head scraper constantly. Unless the scraper is in firm contact with the belt, earth stuck to the rollers will likely cause the rollers to wear prematurely.

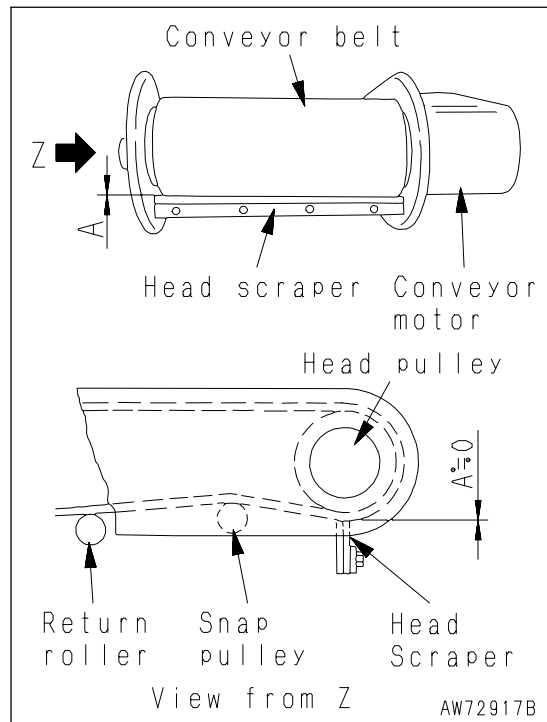

INSPECTION, MAINTENANCE AND ADJUSTMENT



CAUTION

- During operation of belt conveyor, do not remove sediment inside and outside the belt conveyor, but an accident or a trouble will occur.
- Soil and dust entering through hose joint couplers will damage the hydraulic motor. So, handle it carefully.



CAUTION

Entry of soil and the dirt from the hose connection coupler is a cause of damage to the hydraulic motor.
Be extremely careful when handling.

- During operation, do not touch the belts and other rotating parts.
- Do not get in the area under the belt conveyor.
During operation, it is very dangerous to trespass the area under the belt conveyor and to stride over the belt conveyor. Take a detour though troublesome.
- At the time of adjustment, cleaning or movement, turn off the hydraulic circuit.
When moving the belt conveyor or when adjusting angle of the inclined leg, be sure to turn off the hydraulic circuit. Also, when moving a belt conveyor fitted with an inclined leg, minimum the angle of inclination (θ) during the movement.
- Do not strike some thing against the belt conveyor and do not handle it roughly.
- Simple inspections can extend the life of belt conveyor, and the belt conveyors can operate very efficiently.

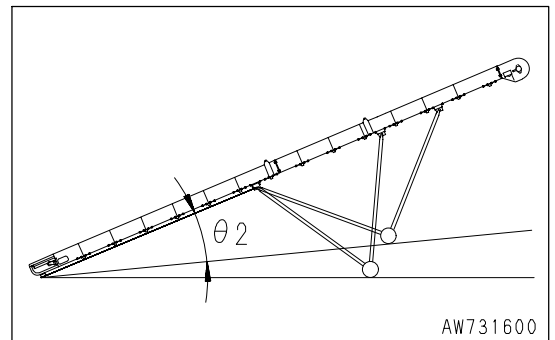

INSTALLATION OF BELT CONVEYOR

Install the belt conveyor so that the frame is not twisted or curved, but the belt will be biased or unexpected accidents may occur.

ADHESION OF MUD AND FOREIGN MATERIALS TO MOTOR PULLEY, TAIL PULLEY, CARRIER ROLLER, ETC.

Remove foreign materials in advance to prevent incorrect rotation and bias of belt.

ROTATION OF TAIL PULLEY AND ROLLERS, AND CONDITION OF BELT

Improper rotation will damage the belt, and damaged belt will be broken during operation. Replace defectives with non-defectives.

LOOSE BELT

The belt will slip and the conveyor cannot operate efficiently. Adjust tension of the conveyor belt by turning the left and right takeup screw bar.

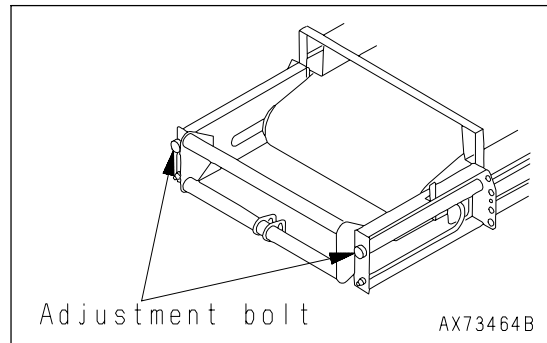

BIAS OF BELT

1. When the belt biased to the left, move the belt in the arrow direction for adjustment.

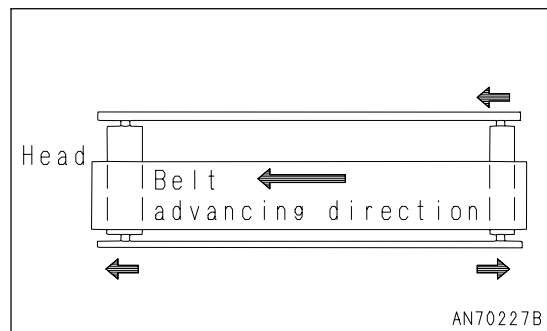

2. When the belt biased to the right, move the belt in the arrow direction for adjustment.

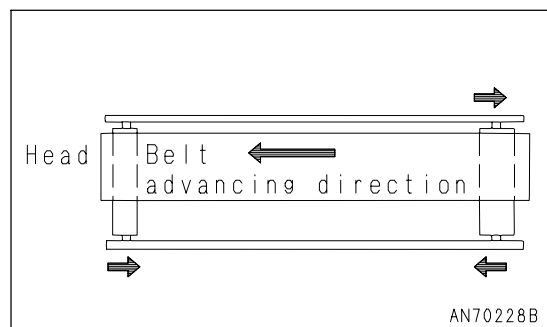

TROUBLES AND CORRECTIVE ACTIONS

| Problem | Main causes | Remedy |
|---------------------------|-----------------------------------------------------------------------------------------------------------------------------------------------------------------------------------------------------------------------------------------------------------------------------------------------------------------------------------------------------------------------------------------------------------------------------------------------------------------------------------------|----------------------------------------------------------------------------------------------------------------------------------------------------------------------------------------------------------------------------------------------------------------------------------------------------------------------------------------------------------------------------------------------------------------------------------------------------------------------------------------------------------------------------------------------------------------------------------------------------------------------------|
| Conveyor belt | | |
| Not operable | <ul style="list-style-type: none"> • Electric circuit fault: Electric failure in section from switch to solenoid valve • Relief valve fault • Defective coupler connection • Emergency stop switch is ON | <ul style="list-style-type: none"> • Correct wiring or relay connections • Measure hydraulic oil pressure • Fit correctly in connecting portion • Turn emergency stop switch OFF |
| Snaky movement | <ul style="list-style-type: none"> • Misalignment of rollers and improper mounting • Debris transport direction • Debris stuck to rollers (Likewise wire or string winding about rollers) • Belt elongation • Belt bending, or not installed properly in endless processing • Frame twisting and bending • Frame not poised evenly (Belt is deflected to lower side) • Belt too rigid (Wrong belt chosen) | <ul style="list-style-type: none"> • Adjust roller mounting angle • Load debris evenly in the middle of the belt, after making sure that the machine is kept level on the ground • Clean roller periphery • Adjust belt tension with take-up • Retry endless processing, or replace belt with new one • Correct twisting and eccentricity at time of assembly or machine installation • Correct twisting and eccentricity at time of assembly or machine installation • a. Run in belt without load b. replace with softer (proper) belt |
| Abnormal wear on backside | <ul style="list-style-type: none"> • Slip on motor pulley (or driving pulley) surface • Debris or foreign object stuck in between belt and pulley (Foreign objects stuck on pulley surface) • Faulty rotation of rollers | <ul style="list-style-type: none"> • Correct belt elongation with take-up • a. Remove foreign objects (Remove sticking) b. Improve loading conditions at loading part • Replace faulty rollers |

| Problem | Main causes | Remedy |
|-------------------------------------------|-----------------------------------------------------------------------------------------------------------------------------------------------------------------------------------------------------------------------------------------------------------------------------------------------------------------------------------------------------------------|------------------------------------------------------------------------------------------------------------------------------------------------------------------------------------------------------------------------------------------------------------------------------|
| Damage (fissure in vertical direction) | <ul style="list-style-type: none"> • Debris or foreign objects caught where belt contacts hopper, scraper, etc. • Rollers falling off from bracket and bracket coming to direct contact belt • Rollers of faulty rotation worn out and perforated • Shock due to drop of large and heavy mass • Edged debris | <ul style="list-style-type: none"> • Remove foreign objects • Insert rollers into bracket correctly • Replace faulty rollers • Devise to alleviate shock, or ensure right load • Do not let such materials be transported |
| Abnormal elongation | <ul style="list-style-type: none"> • Too strong take-up • Transport of hot materials • Abnormal load • End of service life | <ul style="list-style-type: none"> • Return to normal tension • Replace with heat-resistant belt • Ensure proper load • Replace with new belt |
| Warpage | <ul style="list-style-type: none"> • Oily debris (Warpage to lower cover side) • Transport of hot materials • Acid content or alkali content included in debris | <ul style="list-style-type: none"> • Remove cause for oil to mix with debris, or use oil-resistant belt • Use heat-resistant belt • Use acid-resistant or alkali-resistant belt |
| Scraper belt | | |
| Wear and damage | <ul style="list-style-type: none"> • Debris caught | <ul style="list-style-type: none"> • a. Remove caught-in debris and correct scraper rubber mounting so as to evenly contact belt • b. Replace with new one |
| Rollers | | |
| Abnormal sound Breakage | <ul style="list-style-type: none"> • Faulty rotation of rollers • Wire or string winding about shafts • Shock due to fall of large and heavy mass | <ul style="list-style-type: none"> • Replace with new one • Remove foreign objects Take measures to ensure proper lump size and weight to alleviate shock |
| Motor | | |
| Faulty operation | <ul style="list-style-type: none"> • Insufficient hydraulic oil | <ul style="list-style-type: none"> • a. Add oil up to specified level • b. Replace or repair |

CONSUMABLE PARTS OF HYDRAULIC SECONDARY CONVEYOR

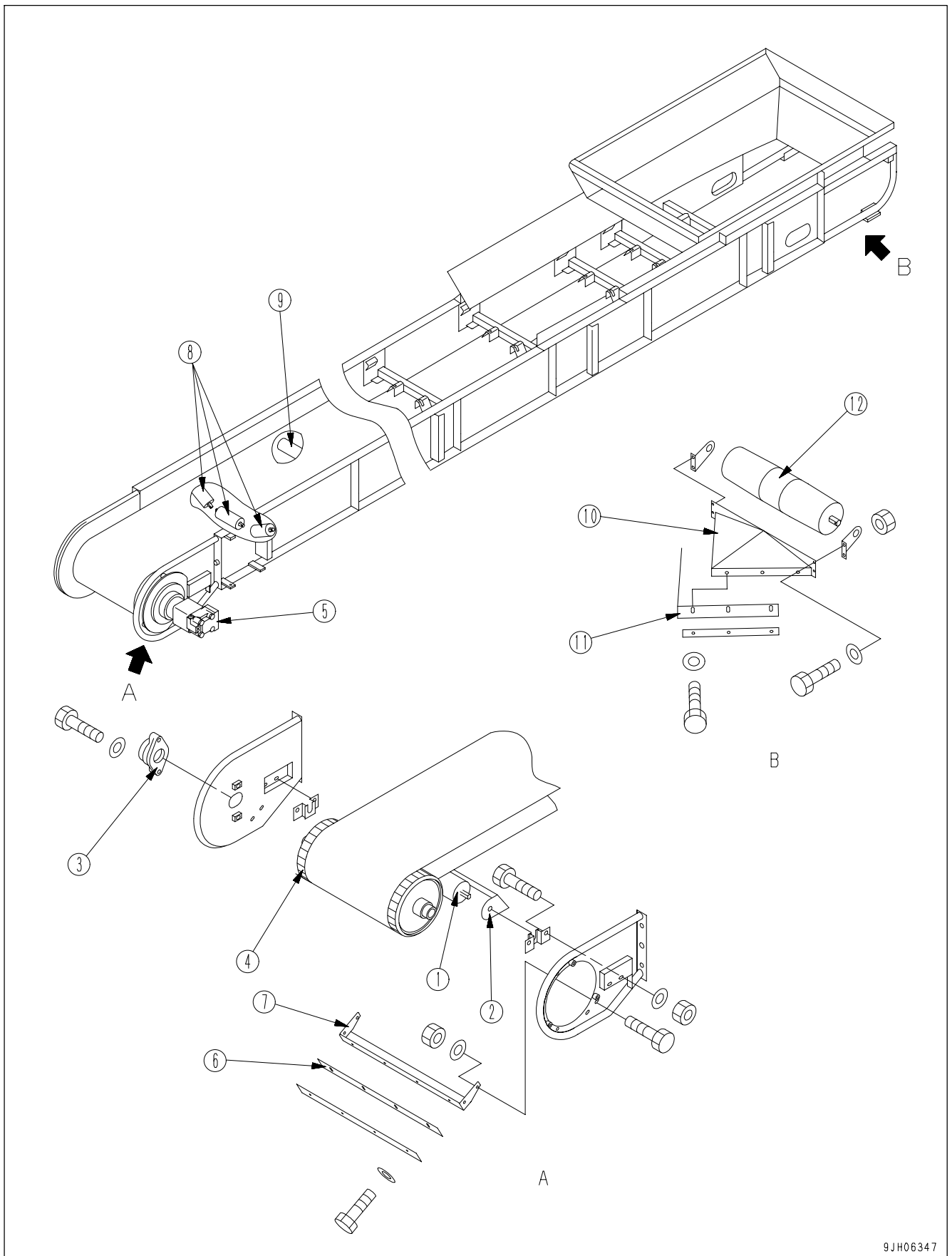

9JH06347

| No. | Komatsu Part No. | KWKKS-75-56004 (60 cm x, 10 m) (1 ft 12 in x 22 ft 12 in) | Q'ty | KWKKS-75-57004 (60 cm x 10 m) (1 ft 12 in x 32 ft 10 in) | Q'ty |
|-----|------------------|-----------------------------------------------------------------|------|----------------------------------------------------------------|------|
| | Name | | | | |
| 1 | Pulley, snap | KWKKS-75-57191 | 1 | KWKKS-75-57191 | 1 |
| 2 | Scraper, snap | 8242-75-1160 | 1 | 8242-75-1160 | 1 |
| 3 | Bearing | KWKKS-75-51290 | 1 | KWKKS-75-51290 | 1 |
| 4 | Head pulley | KWKKS-75-57131 | 1 | KWKKS-75-57131 | 1 |
| 5 | Motor | KWKKS-75-71373 | 1 | KWKKS-75-71373 | 1 |
| 6 | Rubber, scraper | KWKKS-75-57220 | 1 | KWKKS-75-57220 | 1 |
| 7 | Scraper | KWKKS-75-57210 | 1 | KWKKS-75-57210 | 1 |
| 8 | Carrier roller | KKS-75-51631 | 27 | KKS-75-51631 | 45 |
| 9 | Return roller | KKS-75-57261 | 2 | KKS-75-57261 | 3 |
| 10 | Scraper | 8242-75-1990 | 1 | 8242-75-1990 | 1 |
| 11 | Rubber, plate | 8221-75-2550 | 2 | 8221-75-2550 | 1 |
| 12 | Tail pulley | KWKKS-75-57421 | 1 | KWKKS-75-57421 | 1 |

Specification of belt (Maker: Bando Chemical Industries, Ltd.)

| | | | |
|------------------------------------------|-------------|------------------------------|------------------------------|
| Belt width x machine length | | 600 mm x 7 m | 600 mm x 10 m |
| Width | mm (ft in) | 600 (1' 12") | 600 (1' 12") |
| Endless length | mm (ft in) | 13,600 (44' 7") | 17,600 (57' 9") |
| Belt strength | kg/cm width | 160 | 160 |
| Ply number | - | 2 | 2 |
| Cover rubber thickness (front x back) | mm (in) | 3.0 x 1.5 (0.118 x 0.059) | 3.0 x 1.5 (0.118 x 0.059) |
| Total thickness (reference value) | mm (in) | 6.3 (0.248) | 6.3 (0.248) |

SPRINKLER

EXPLANATIONS FOR COMPONENT PARTS

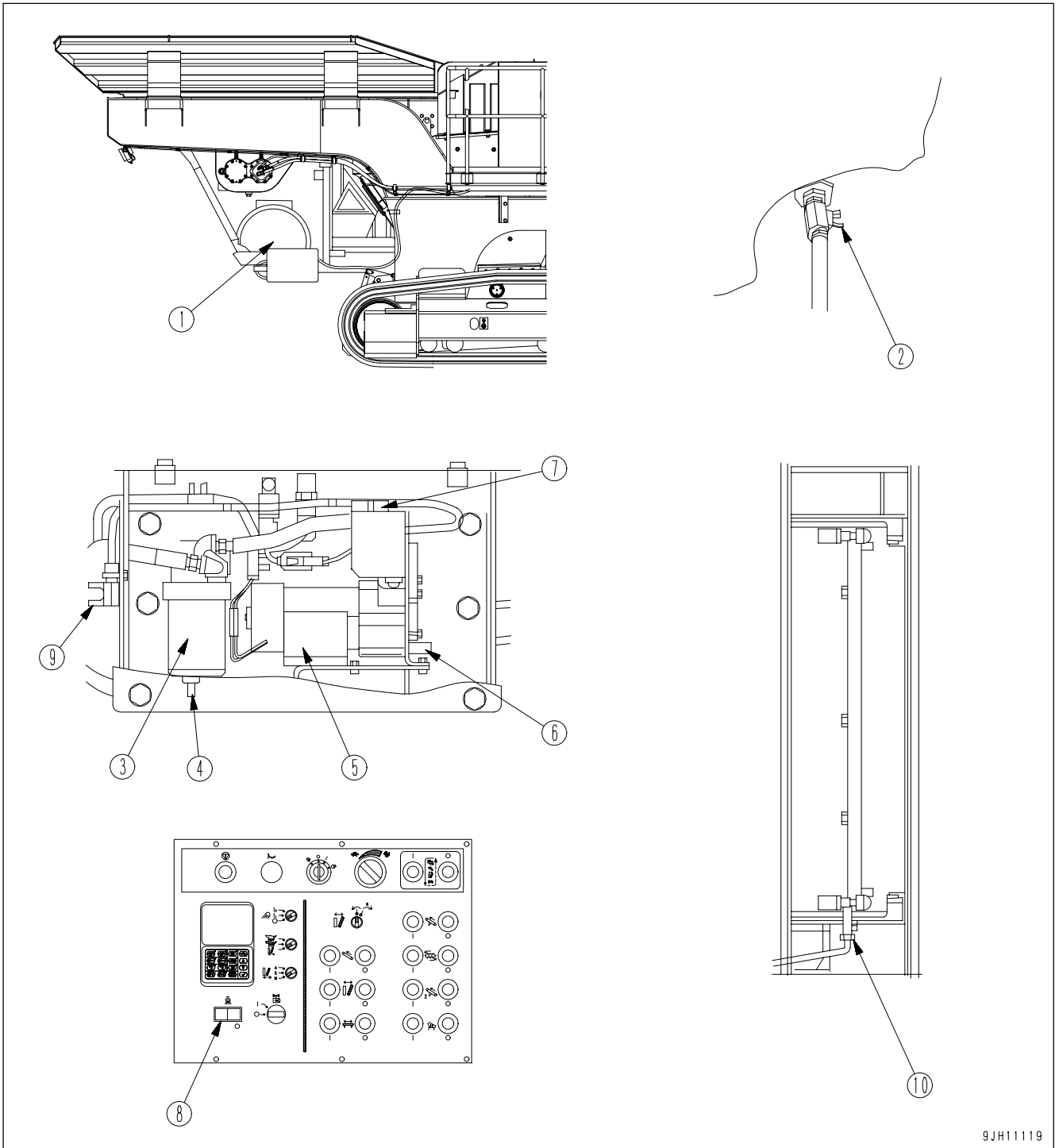

9JH11119

- | | |
|--------------------------|------------------------------|
| (1) Tank | (6) Pump drain valve |
| (2) Tank valve | (7) Float sensor |
| (3) Strainer | (8) Pump start-stop switch |
| (4) Strainer drain valve | (9) Air bleeding valve |
| (5) Pump | (10) Crusher sprinkler valve |

HOW TO USE SPRINKLER

STARTING SPRINKLING WATER

1. Fill tank (1) with water.

Water tank capacity: 350 liters (92.47 US gal)

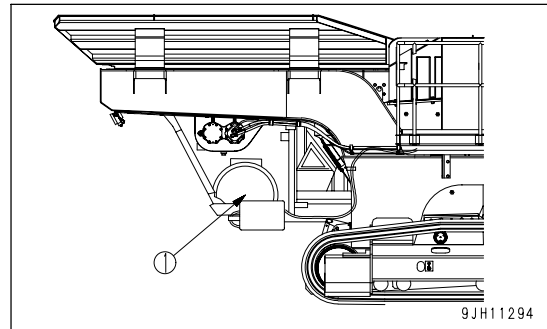

2. Turn water tank valve (2) to the OPEN position.

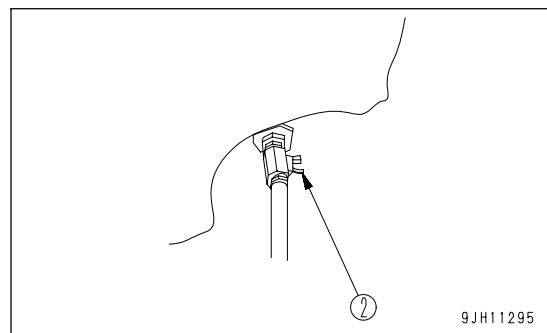

3. Open air bleeder valve (3) and feed water pump (4) with water.
Close air bleeder valve (3), after checking that water begins to flow out.

REMARK

If water is not in the water pump, it does not work even if the pump switch is turned on.

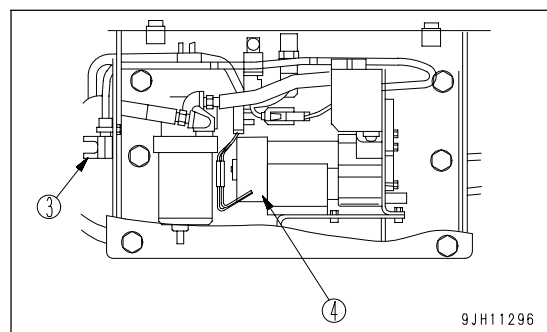

4. Open crusher spray valve (5) at the top of the crusher.

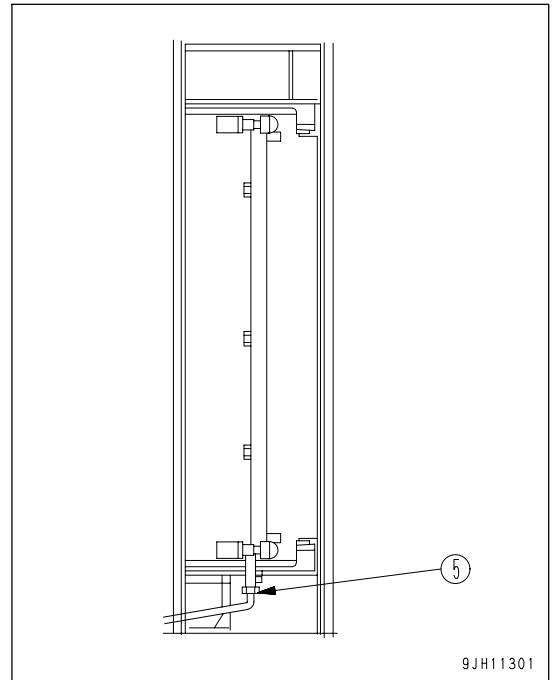

5. Turn water pump switch (6) ON.

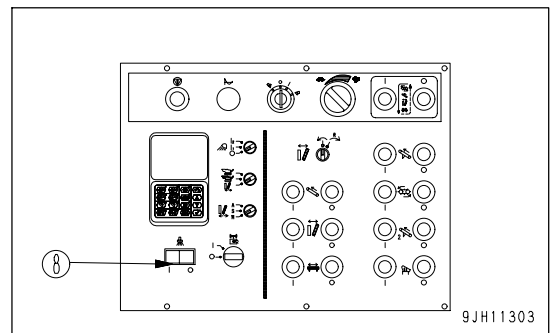

FINISHING SPRINKLING WATER

1. Turn water pump switch (1) OFF.

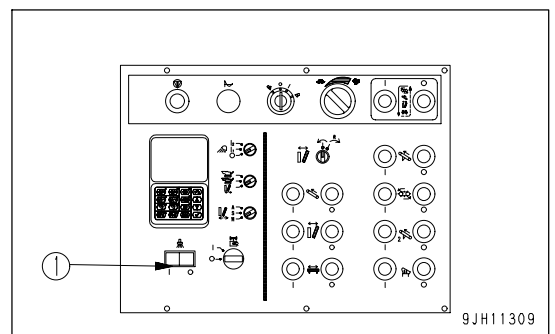

2. Turn water tank valve (2) to the CLOSE position.

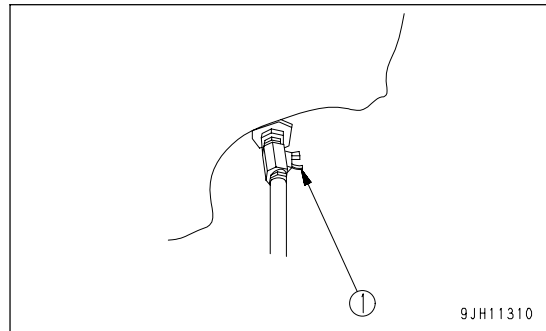
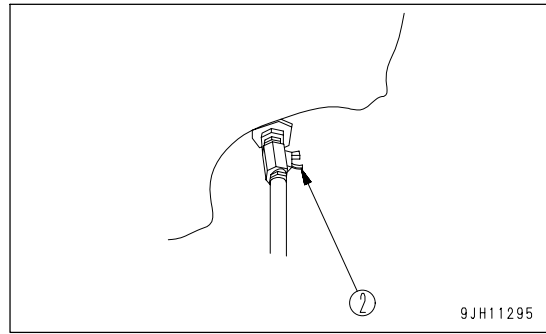

REMARK
When draining water in cold weather, open water pump drain valve (3) and strainer drain plug (4).

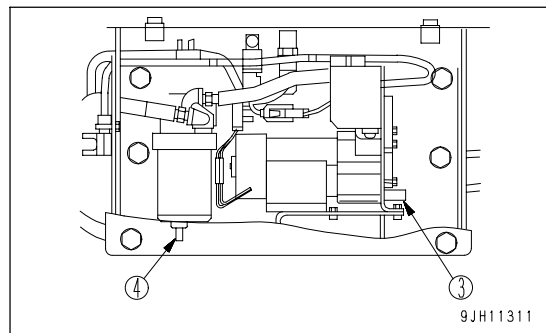

INSPECTION AND MAINTENANCE

WHEN-REQUIRED MAINTENANCE

CLEANING SPRINKLER STRAINER

1. Turn the water tank valve (1) to the CLOSE position.

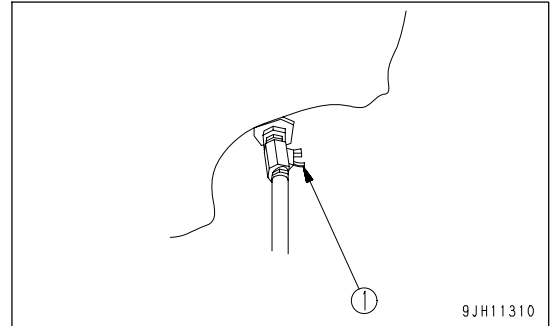

2. Open drain plug (2) to drain water remaining in the strainer.

3. Turn strainer ring (3) to the left and remove case (4).

4. Wash the interior of case (4) and filter element.

5. After washing them, fix case (4) securely by hand, while paying attention to the O-ring.

6. Close drain plug (2).

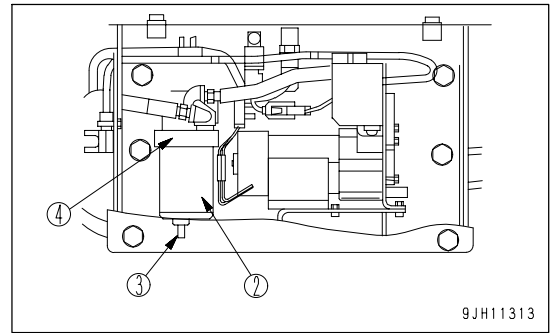

CLEANING FLOAT SENSOR

Remove sensor (1) and plug (2), then remove the dirt stuck to these parts and block (3).

Wash the inside of block (3).

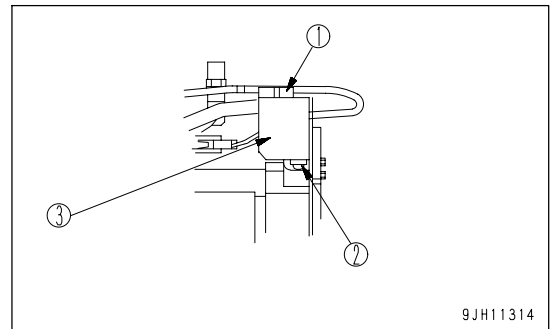

EVERY 250 HOURS SERVICE

CLEANING SPRINKLER WATER TANK

1. Drain water in the water tank completely.
2. Clean the interior of the water tank, removing all the

| Abnormal Phenomenon | Major Cause | Corrective Action |
|-------------------------------------------------------------|------------------------------|---------------------------------------------------------------------------------|
| The pump stopped working while sprinkling water. | Water in the tank ran short. | Refill with water. |
| There is no water sprinkling, though the pump works. | Strainer clogged | Clean strainer. |
| The pump does not start to work when the switch is pressed. | Float sensor in malfunction | Clean float sensor. |
| | No water in the tank | Fill tank with water. |
| | Tank valve closed | Open tank valve. |
| | Air bleeding insufficient | Open air bleeding valve, and check that only water flows out. Then close valve. |

INDEX

| | | | |
|------------------------------------|-------|---------------------------------|-------|
| <A> | | PRECAUTIONS RELATED TO | |
| AIR-BLEEDING FROM HYDRAULIC | | SAFETY----- | 6- 2 |
| CIRCUIT ----- | 4- 8 | GENERAL VIEW ----- | 3- 2 |
| ATTACHMENTS, OPTIONS ----- | 6- 3 | GENERAL VIEW OF CONTROLS AND | |
| ATTACHMENTS, OPTIONS CHART ---- | 6- 3 | GAUGES ----- | 3- 3 |
| METHOD FOR CONNECTING | | GENERAL VIEW OF MACHINE ----- | 3- 2 |
| HYDRAULIC HOSES FOR OPTIONS --- | 6- 3 | GRIZZLY BAR OPENING ----- | 6- 33 |
| | | GUIDE TO MAINTENANCE ----- | 4- 2 |
| | | <H> | |
| BELT CONVEYOR PROTECTIVE | | HANDLING MACHINES EQUIPPED | |
| PLATE ----- | 6- 31 | WITH KOMTRAX ----- | 6- 34 |
| BREAKING IN THE NEW MACHINE ----- | 1- 7 | BASIC PRECAUTIONS ----- | 6- 34 |
| | | HYDRAULIC SECONDARY | |
| <C> | | CONVEYOR ----- | 6- 41 |
| CAP, COVER WITH LOCK ----- | 3- 44 | CONNECTING METHOD TO | |
| CHECK AFTER FINISHING WORK ----- | 3- 97 | MACHINE BODY ----- | 6- 44 |
| CHECK AFTER STOPPING ENGINE ----- | 3- 79 | CONSUMABLE PARTS OF | |
| CHECK AND CONFIRMATION OF JAW | | HYDRAULIC SECONDARY | |
| CRUSHER AFTER WORK ----- | 3- 97 | CONVEYOR ----- | 6- 49 |
| CHECK BEFORE STARTING ENGINE ---- | 3- 51 | GENERAL VIEW ----- | 6- 41 |
| COLD WEATHER OPERATION ----- | 3-129 | INCLINED LEG CONNECTING | |
| AFTER COLD WEATHER ----- | 3-131 | METHOD ----- | 6- 43 |
| AFTER COMPLETION OF WORK ----- | 3-131 | INSPECTION, MAINTENANCE AND | |
| PRECAUTIONS FOR LOW | | ADJUSTMENT ----- | 6- 45 |
| TEMPERATURE ----- | 3-129 | LIFTING METHOD ----- | 6- 44 |
| CONTROL LEVERS ----- | 3- 41 | PRECAUTIONS ON OPERATION ----- | 6- 44 |
| CONTROLLERS ----- | 3- 49 | SPECIFICATIONS ----- | 6- 41 |
| CRUSHER ACCESSORY TOOLS ----- | 4- 16 | TROUBLES AND CORRECTIVE | |
| | | ACTIONS ----- | 6- 47 |
| <E> | | HYDRAULIC VIBRATORY SIEVE ----- | 6- 39 |
| EFFICIENT USE OF JAW CRUSHER ----- | 3-105 | CAUTIONS TO BE NOTED FOR | |
| ELECTRIC POWER TAKEOFF ----- | 3- 47 | SAFETY----- | 6- 40 |
| ENGINE SERIAL NO. PLATE | | CONNECTING METHOD TO | |
| AND POSITION ----- | 1- 8 | MACHINE BODY ----- | 6- 40 |
| EXPLANATION OF COMPONENTS ----- | 3- 7 | GENERAL VIEW ----- | 6- 39 |
| | | PRECAUTIONS DURING | |
| <F> | | OPERATION----- | 6- 40 |
| FOREWORD ----- | 1- 2 | SPECIFICATION ----- | 6- 39 |
| FRONT/REAR, LEFT/RIGHT | | <I> | |
| DIRECTIONS OF MACHINE ----- | 1- 7 | INTRODUCTION ----- | 1- 7 |
| FUSE ----- | 3- 49 | | |
| FUSIBLE LINK ----- | 3- 49 | <J> | |
| | | JAW CRUSHER RELATED PARTS ----- | 4- 10 |
| <G> | | | |
| GENERAL PRECAUTIONS ----- | 2- 15 | | |
| GENERAL PRECAUTIONS ----- | 6- 2 | | |

| | | | |
|-----------------------------------|-------|--------------------------------------|-------|
| <L> | | CRUSHING OPERATION ----- | 2- 28 |
| LIFTING MACHINE ----- | 3-128 | OPERATION----- | 2- 25 |
| LOADING, UNLOADING WORK ----- | 3-122 | TOWING ----- | 2- 34 |
| LOCKING----- | 3- 98 | TRANSPORTATION ----- | 2- 31 |
| LONG-TERM STORAGE ----- | 3-132 | PRECAUTIONS WHEN OPERATING | |
| AFTER STORAGE ----- | 3-132 | JAW CRUSHER ----- | 3-101 |
| BEFORE STORAGE ----- | 3-132 | PRECAUTIONS WHEN TRAVELING UP | |
| DURING STORAGE ----- | 3-132 | OR DOWNHILLS ----- | 3-121 |
| STARTING MACHINE AFTER | | PRIMARY CONVEYOR RELATED | |
| LONG-TERM STORAGE ----- | 3-132 | PARTS----- | 4- 12 |
| <M> | | PRODUCT IDENTIFICATION NUMBER | |
| M-TYPE CHUTE ----- | 6- 30 | (PIN)/MACHINE SERIAL NO. PLATE ----- | 1- 8 |
| METHOD OF OPERATION ----- | 6- 30 | PROHIBITIONS FOR OPERATION ----- | 3-119 |
| MACHINE MONITOR ----- | 3- 7 | <R> | |
| MACHINE OPERATION ----- | 3- 80 | RADIO CONTROL UNIT ----- | 6- 4 |
| MACHINES THAT CAN INSTALL | | DIRECTIONS FOR USE ----- | 6- 7 |
| ATTACHMENTS ----- | 6- 35 | ON USE OF RADIO CONTROL UNIT --- | 6- 4 |
| MAINTENANCE SCHEDULE CHART ----- | 4- 20 | REMOTE CONTROL OPERATION ----- | 6- 11 |
| MAINTENANCE SCHEDULE CHART --- | 4- 20 | RECOMMENDED FUEL, COOLANT | |
| MUCK DISCHARGE CONVEYOR ----- | 6- 19 | AND LUBRICANTS ----- | 4- 13 |
| CHECK AND ADJUSTMENT OF | | RECOMMENDED BRANDS, | |
| MUCK DISCHARGE CONVEYOR ----- | 6- 24 | RECOMMENDED QUALITY FOR | |
| FAILURES AND CORRECTIVE | | PRODUCTS OTHER THAN | |
| ACTIONS ----- | 6- 26 | KOMATSU GENUINE OIL ----- | 4- 15 |
| GREASING MUCK DISCHARGE | | RELATING TO ELECTRIC SYSTEM ----- | 4- 7 |
| CONVEYOR ----- | 6- 23 | REVOLVING WARNING LAMP ----- | 3- 46 |
| SPECIFICATIONS ----- | 6- 29 | RUN-IN OPERATION OF JAW | |
| WEARING PARTS ----- | 6- 28 | CRUSHER ----- | 3- 99 |
| <N> | | <S> | |
| NECESSARY INFORMATION ----- | 1- 8 | SAFETY ----- | 2- 2 |
| <O> | | SAFETY CRITICAL PARTS ----- | 4- 19 |
| OPERATION ----- | 3- 51 | SAFETY INFORMATION ----- | 1- 5 |
| OPERATION OF WORK EQUIPMENT ----- | 3- 88 | SAFETY LABELS ----- | 2- 5 |
| OPERATIONS AND CHECKS AFTER | | SCOPE OF WORKS USING MOBILE | |
| STARTING ENGINE ----- | 3- 74 | CRUSHER ----- | 3-111 |
| OPTION-RELATED SWITCHES ----- | 3- 42 | SERVICE PROCEDURE ----- | 4- 22 |
| OUTLINE OF HYDRAULIC | | CHECK BEFORE STARTING ----- | 4- 66 |
| EQUIPMENT ----- | 4- 7 | EVERY 10 HOURS SERVICE ----- | 4- 67 |
| OUTLINE OF SERVICE ----- | 4- 4 | EVERY 100 HOURS SERVICE ----- | 4- 68 |
| <P> | | EVERY 1000 HOURS SERVICE ----- | 4- 79 |
| PERIODIC REPLACEMENT OF SAFETY | | EVERY 2000 HOURS SERVICE ----- | 4- 83 |
| CRITICAL PARTS----- | 4- 19 | EVERY 250 HOURS SERVICE ----- | 4- 70 |
| POSITION OF SERVICE METER ----- | 1- 9 | EVERY 4000 HOURS SERVICE ----- | 4- 85 |
| PRECAUTIONS FOR MAINTENANCE ----- | 2- 35 | EVERY 500 HOURS SERVICE ----- | 4- 74 |
| PRECAUTIONS FOR OPERATION ----- | 2- 23 | EVERY 5000 HOURS SERVICE ----- | 4- 86 |
| BATTERY ----- | 2- 32 | INITIAL 1000 HOURS SERVICE | |
| | | (FIRST MAINTENANCE FOR NEW | |
| | | MACHINE ONLY) ----- | 4- 22 |

INDEX

| | |
|--------------------------------------------------------------------------------|-------|
| INITIAL 250 HOURS SERVICE (FIRST MAINTENANCE FOR NEW MACHINE ONLY) ----- | 4- 22 |
| WHEN REQUIRED ----- | 4- 23 |
| SPECIFICATIONS ----- | 5- 2 |
| SPRINKLER ----- | 6- 51 |
| EXPLANATIONS FOR COMPONENT PARTS ----- | 6- 51 |
| HOW TO USE SPRINKLER ----- | 6- 52 |
| INSPECTION AND MAINTENANCE ----- | 6- 55 |
| STANDARD TIGHTENING TORQUES FOR BOLTS AND NUTS ----- | 4- 16 |
| STARTING ENGINE ----- | 3- 70 |
| STEERING MACHINE ----- | 3- 86 |
| STOPPING ENGINE ----- | 3- 79 |
| SWITCHES ----- | 3- 32 |
| <T> | |
| TABLE OF ENTER SERIAL NO. AND DISTRIBUTOR ----- | 1- 9 |
| TOOL BOX ----- | 3- 50 |
| TORQUE LIST ----- | 4- 18 |
| TRANSPORTATION ----- | 3-122 |
| TRANSPORTATION PROCEDURE ----- | 3-122 |
| TROUBLESHOOTING ----- | 3-133 |
| AFTER RUNNING OUT OF FUEL ----- | 3-133 |
| IF BATTERY IS DISCHARGED ----- | 3-135 |
| METHOD OF TOWING MACHINE ----- | 3-134 |
| OTHER TROUBLE ----- | 3-138 |
| PHENOMENA THAT ARE NOT FAILURES ----- | 3-133 |
| <W> | |
| WEAR PARTS ----- | 4- 9 |
| WEAR PARTS LIST ----- | 4- 9 |

BR380JG-1 GALEO MOBILE CRUSHER

Form No. PEN00007-03

©2006 KOMATSU
All Rights Reserved
Printed in Japan 06-06
