

Operation & Maintenance Manual

SEAM04280102

WA800-1

WHEEL LOADER

SERIAL NUMBERS **WA800-10001** and up

KOMATSU

FOREWORD

This manual describes procedures for operation, handling, lubrication, maintenance, checking, and adjustment. It will help the operator or anyone realize peak performance through effective, economical and safe machine operation and maintenance.

- Please read this manual carefully **BEFORE** operating the machine.
- Please continue studying this manual until proper operation is completely reinforced into personal habit.
- This manual describes the basic techniques. Skill is performed as the operator or anyone get the correct knowledge and performance of the machine.
- Operation, inspection, and maintenance should be carefully carried out, and the safety must be given the first priority. Safety precautions are indicated with  marks and technical precautions with ★ marks in this manual. The safety information contained in this manual is intended only to supplement safety codes, insurance requirements, local laws, rules and regulations.
- Some photographs and illustration pictures are different from your machine as technical improvement is continuously reflected on it. Revision to up-to-date manual's content is performed in later editions.
- This operation & maintenance manual may contain attachments and optional equipment that are not available in your area. Please consult your local Komatsu distributor for those items you may require. Materials and specifications are subject to change without notice.

BREAKING IN YOUR NEW MACHINE

Each machine is carefully adjusted and tested before shipment. However, a new machine requires careful operation during the first 100 hours to break in the various parts.

If a machine is subjected to unreasonably hard use at the initial operation stage, the potential of performance will prematurely deteriorate and the service life will be reduced. A new machine must be operated with care, particularly with regard to the following items.

- After starting, let the engine idle for 5 minutes to allow proper engine warm-up prior to actual operation.
- Avoid operation with heavy loads or at high speeds.
- Sudden starting or acceleration, unnecessarily abrupt braking and sharp turning should be avoided.
- At the first 250 hours of operation, the machine should be maintained in the following manner in addition to usual 250 hours service:
 - 1) Replacement of fuel filter cartridge and transmission oil filter element
 - 2) Checking and adjustment of engine valve clearance
- ★ When replacing oil filter elements (cartridges), check their interiors for dirt and dust. If heavily collected, check for possible cause before starting operation.
- ★ Hours of operation are indicated by the service meter.

For replacement procedure and details, see maintenance table in the maintenance section.

CONTENTS

OPERATION		MAINTENANCE	
GENERAL LOCATIONS AND SPECIFICATIONS ..	4	PERIODIC MAINTENANCE	69
INSTRUMENTS AND CONTROLS	5	BLEEDING AIR FROM CIRCUIT	70
REMOVAL AND INSTALLATION OF BUCKET	34	PERIODICAL REPLACEMENT OF	
USING ACCUMULATORS	38	SAFETY PARTS	73
CHECK BEFORE STARTING	39	MAINTENANCE TABLE	74
OPERATING YOUR MACHINE	45	OIL FILLER AND LEVEL GAUGE POSITIONS ..	78
ADJUSTMENT OF WORK EQUIPMENT	54	EVERY 50 HOURS SERVICE	79
HANDLING THE TIRES	56	EVERY 100 HOURS SERVICE	80
TOWING	59	INITIAL 250 HOURS SERVICE	83
TRANSPORTATION	61	EVERY 250 HOURS SERVICE	83
COLD WEATHER OPERATION	62	EVERY 500 HOURS SERVICE	87
		EVERY 1000 HOURS SERVICE	90
		EVERY 2000 HOURS SERVICE	96
		EVERY 4000 HOURS SERVICE	104
		WHEN REQUIRED	105
		ADJUSTMENT	118
		TROUBLE SHOOTING GUIDE	120
		SERVICE METER	124
		MACHINE AND ENGINE SERIAL NUMBERS	125
		FUEL, COOLANT AND LUBRICANTS	126

GENERAL LOCATIONS AND SPECIFICATIONS

GENERAL LOCATIONS AND SPECIFICATIONS

- | | |
|---------------------|------------------|
| 1. Bucket | 6. Front wheel |
| 2. Lift arm | 7. Lift cylinder |
| 3. Head lamp | 8. Dump cylinder |
| 4. Turn signal lamp | 9. Tilt lever |
| 5. Rear wheel | |

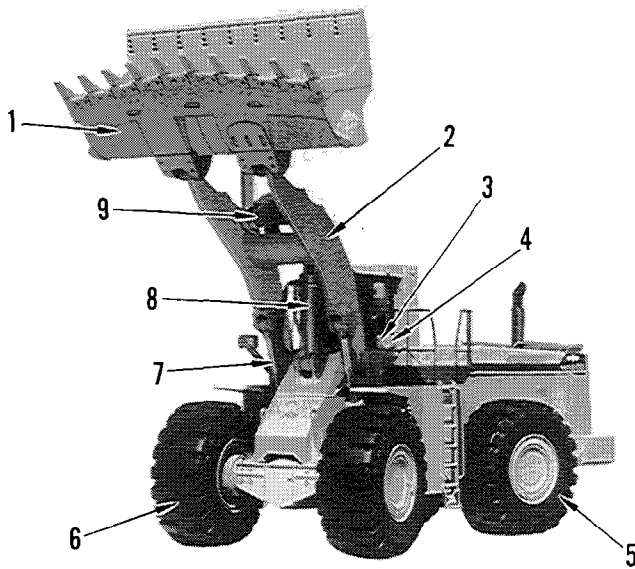

With cab and ROPS canopy

PERFORMANCE

- | | |
|-----------------------------|---------------------|
| 1. Bucket capacity (Heaped) | 10.5 m ³ |
| 2. Travel speeds | |
| Forward | Max. 28.0 km/h |
| Reverse | Max. 28.3 km/h |

OPERATING WEIGHT

86800 kg

ENGINE

- | | |
|--------------------------------------|----------------------------------|
| 1. Model | Komatsu SA8V170-1C diesel engine |
| 2. Flywheel horsepower (at 2000 rpm) | 789 HP |

NOTE:

Specifications are subject to change without notice.

INSTRUMENTS AND CONTROLS

MONITOR PANEL

This monitor system consists of monitor lamp groups (A)(B)(C), meter group (D) and warning lamp (E).

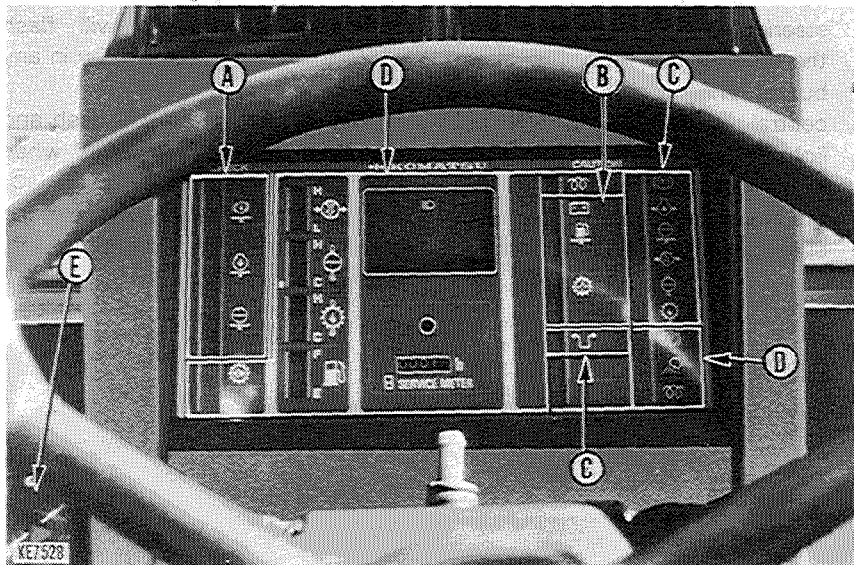

- To check the monitor system, turn the starting switch to ON before starting the engine. Then all the monitor lamps, the gauges and the warning lamp light up for about 3 seconds and the alarm buzzer sounds for about 2 seconds. Three figures, 188, are displayed on the speedometer while the monitor system is being checked. After that all lamps go off and the buzzer stops. If any monitor lamp does not light up, ask your Komatsu distributor to inspect that monitor lamp.

- ★ When the starting switch is turned to ON, if the directional lever is not at neutral, the warning lamp will flash and the alarm buzzer will continue to sound. If this happens, return the lever to neutral. The lamp will go out and the buzzer will stop.

INSTRUMENTS AND CONTROLS

- ★ To check the monitor immediately when the engine is stopped, wait for at least 30 seconds after the engine is stopped.

Ⓐ CHECK MONITOR GROUP **(Check items before starting)**

If there is any abnormality, the appropriate monitor lamp will flash.

- ★ When the engine is started, these monitor lamps will go off even if there are abnormalities.

Ⓑ CAUTION MONITOR GROUP **(Caution items)**

If any abnormality occurs while the engine is running, the appropriate monitor lamp will flash to indicate the abnormality.

- ★ Even if any monitor lamp flashes, the machine can operate, but it should be repaired as soon as possible.

Ⓒ CAUTION MONITOR GROUP **(Emergency stop items)**

If any abnormality occurs while the engine is running, the appropriate monitor lamp will flash and the alarm buzzer will sound intermittently at the same time.

- ★ However, when the emergency steering is being operated, only the monitor will flash. The alarm buzzer will not sound, and the central warning lamp will not light up.
- ★ If any monitor lamp flashes, stop the engine or run it at a low idling speed, and repair it immediately.

Ⓓ METER GROUP

This group consists of air pressure gauge, engine water temperature gauge, torque converter oil temperature gauge, fuel gauge, speedometer, service meter and pilot display.

Ⓔ WARNING LAMP

The warning lamp will flash when there is an abnormality in any Ⓑ group item.

The warning lamp will flash and the alarm buzzer will sound when there is an abnormality in any Ⓒ group item or when the parking brake is applied, but the directional lever is not at neutral.

**A: CHECK MONITOR GROUP
(Check items before starting)**

- ★ Do not rely on the "CHECK MONITOR GROUP (Check before starting)" only for the check before starting. Always make the check by referring to the section on CHECK BEFORE STARTING.

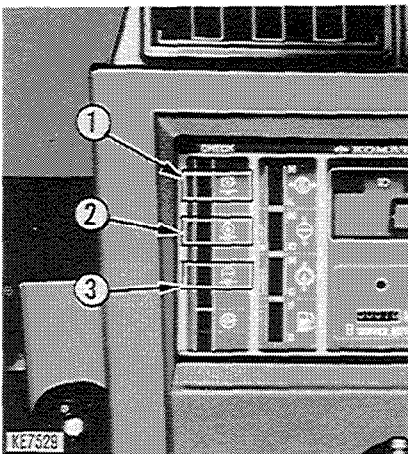

1. BRAKE OIL LEVEL MONITOR



This monitor indicates a low brake oil level.

If the monitor lamp flashes, check the oil level and add brake oil as required.

2. ENGINE OIL LEVEL MONITOR



This monitor indicates a low oil level in the engine oil pan.

If the monitor lamp flashes, check the oil level in the engine oil pan and add oil as required.

3. RADIATOR COOLANT LEVEL MONITOR



This monitor indicates a low radiator coolant level.

If the monitor lamp flashes, check the coolant level and add water as required.

- ★ Park the machine on level ground and check the monitor lamps.
- ★ Confirm that these monitor lamps light for about 3 seconds after turning the starting switch to **ON**. If any monitor lamp does not light, ask your Komatsu distributor to inspect that monitor lamp.

INSTRUMENTS AND CONTROLS

B: CAUTION MONITOR GROUP
(Caution items)

If any abnormality occurs while the engine is running, the appropriate monitor lamp and the warning lamp will flash to indicate the abnormality at the same time.

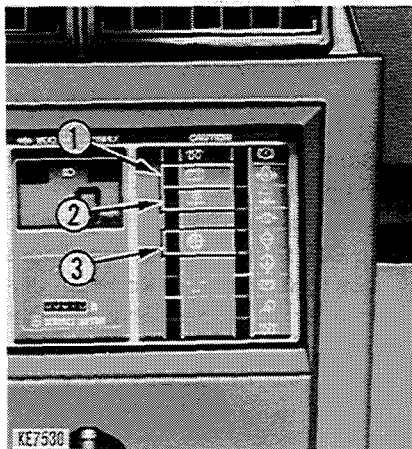

1. CHARGE MONITOR

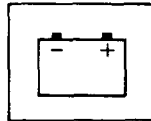

This monitor indicates an abnormality in the charging system while the engine is running.

If the monitor lamp flashes, check the charging circuit.

★ This monitor lamp flashes and the alarm buzzer sounds, when the starting switch is turned to ON immediately after the engine is started or immediately before the engine is stopped. It does not indicate an abnormality.

2. FUEL LEVEL MONITOR



This monitor indicates there is less than 155 liters of fuel in the tank.

If the monitor lamp flashes, add fuel.

3. TRANSMISSION OIL FILTER MONITOR



This monitor indicates clogging of the transmission oil filter.

If the monitor lamp flashes, replace the filter element.

- ★ Park the machine on level ground and check the monitor lamps.
- ★ Confirm that these monitor lamps light for about 3 seconds after turning the starting switch to **ON**. If any monitor lamp does not light, ask your Komatsu distributor to inspect that monitor lamp.

C: CAUTION MONITOR GROUP (Emergency stop items)

If any abnormality occurs while the engine is running, the appropriate monitor lamp and the warning lamp will flash and the alarm buzzer will sound intermittently at the same time.

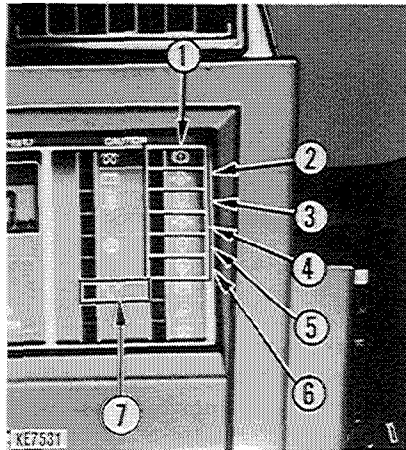

1. BRAKE LINE FAILURE MONITOR



This monitor indicates a drop in the brake oil pressure when the brakes are operated.

If the lamp flashes, stop the machine immediately and check the brake system.

- ★ After checking and repair of brake system, push in over-stroke sensor rod. If this operation is not done, a buzzer and lamp will continue to warn of brake line trouble.

INSTRUMENTS AND CONTROLS

2. ENGINE OIL PRESSURE MONITOR

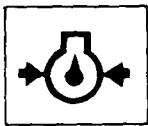

This monitor indicates a low engine oil pressure.

If the lamp flashes, the engine oil pressure is below the lower limit. Immediately stop the engine.

- ★ This monitor lamp flashes and the alarm buzzer sounds, when the starting switch is turned to ON immediately after the engine is started or immediately before the engine is stopped. It does not indicate an abnormality.

3. COOLANT LEVEL MONITOR

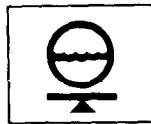

This monitor indicates a low radiator coolant level.

Check the coolant level when the monitor lamp flashes, stop engine and add water as required.

4. AIR PRESSURE MONITOR

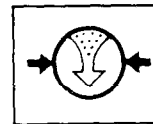

This monitor indicates a drop in the air pressure in the air tank.

If the lamp flashes, increase the engine speed and wait until the lamp goes out.

- ★ Park the machine on level ground and check the monitor lamps.
- ★ Confirm that these monitor lamps light for about 3 seconds after turning the starting switch to **ON**. If any monitor lamp does not light, ask your Komatsu distributor to inspect that monitor lamp.

5. COOLANT TEMPERATURE MONITOR

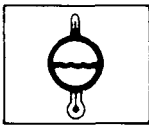

This monitor indicates a rise in the cooling water temperature.

When the monitor lamp flashes, run the engine with no load at midrange speed until the green range of the engine water temperature gauge lights.

6. TORQUE CONVERTER OIL TEMPERATURE MONITOR

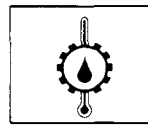

This monitor indicates a rise in the torque converter oil temperature.

When the monitor lamp flashes, stop the machine and run the engine with no load at midrange speed until the green range of the temperature gauge lights.

7. EMERGENCY STEERING OPERATION MONITOR

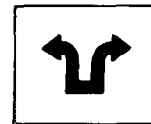

If the engine stops while the machine is traveling or an abnormality occurs in the pump circuit, the operator will be warned that the emergency steering is in operation. When flashing begins, stop the machine immediately.

- ★ Park the machine on level ground and check the monitor lamps.
- ★ Confirm that these monitor lamps light for about 3 seconds after turning the starting switch to **ON**. If any monitor lamp does not light, ask your Komatsu distributor to inspect that monitor lamp.

INSTRUMENTS AND CONTROLS

**D: METER GROUP
PILOT DISPLAY**

When the starting switch is turned to ON, this lights up to indicate that the display items are working.

1. PARKING BRAKE PILOT LAMP



This lamp lights up when the parking brake is applied.

2. PILOT LAMP FOR WORKING LAMP



This lamp lights up when the working lamps are switched on.

3. ENGINE PRE-HEATING MONITOR

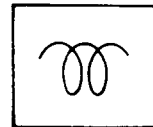

When using APS (automatic priming system) and when starting, switch on lamp and you will be informed that pre-heating has started.

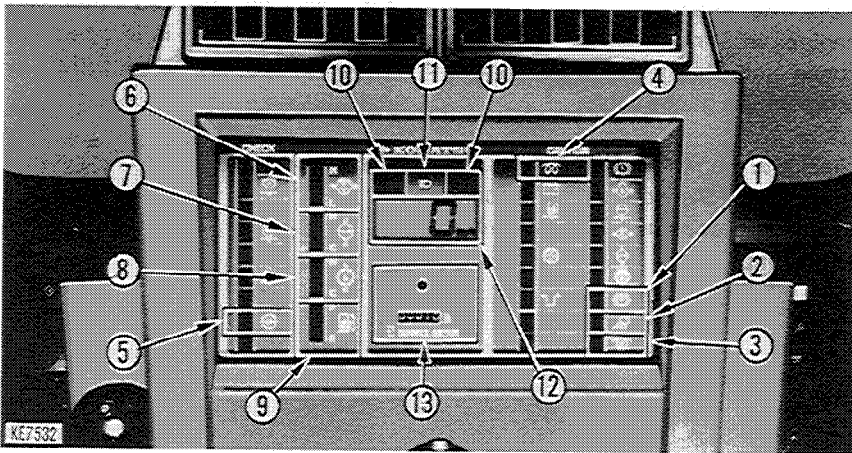

4. AFTERHEATING MONITOR

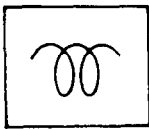

When using APS (automatic priming system) in cold weather, and when starting, after the engine starts, the lamp will flash until the water temperature reaches 20°C, informing you that afterheating has started.

5. TRANSMISSION CUT-OFF SELECTOR PILOT LAMP

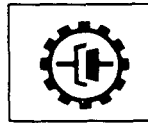

This lamp lights up when the transmission cut-off selector switch is turned to ON.

★ If the monitor lamp is ON and the left brake pedal is depressed, the transmission will be returned to neutral.

6. AIR PRESSURE GAUGE

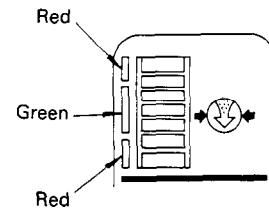

This gauge indicates the air pressure in the air tank. The green range should be lighted during normal operation.

If the red range lights up during operations, the alarm buzzer will sound, the warning lamp will flash, and the air pressure monitor lamp will flash.

If this happens, stop the machine, increase the engine speed and wait until the green range lights up.

★ If the air pressure drops even lower, the parking brake will be automatically applied.

INSTRUMENTS AND CONTROLS

7. ENGINE COOLING WATER TEMPERATURE GAUGE

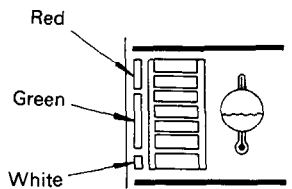

This gauge indicates the temperature of the cooling water. If the temperature is normal during operation, the green range will light. If the red range lights during operation, the alarm buzzer will sound, the warning lamp will flash and the coolant temperature monitor lamp will flash at the same time. If this occurs, stop the machine and run the engine with no load at midrange speed until the green range lights.

8. TORQUE CONVERTER OIL TEMPERATURE GAUGE

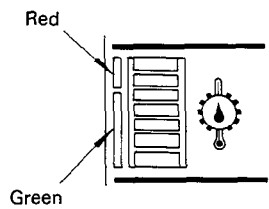

This gauge indicates the temperature of the torque converter oil. If the temperature is normal during operation, the green range will light. If the red range lights during operation, the alarm buzzer will sound, the warning lamp will flash and the torque converter oil temperature monitor lamp will flash at the same time. If this occurs, stop the machine and run the engine with no load at midrange speed until the green range lights.

9. FUEL GAUGE

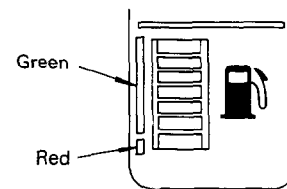

This gauge indicates the amount of fuel in the fuel tank. If there is enough fuel in the tank while the engine is running, the green range lights. If the red range lights, there is less than 155 liters of fuel in the tank.

When the red range lights, add fuel.

10. TURN SIGNAL PILOT LAMP

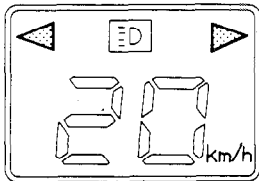

When the turn signal lamp flashes, the pilot lamp also flashes.
 ★ If the wiring of the turn signal lamp is disconnected, the pilot lamp will flash faster.

11. HIGH BEAM PILOT LAMP

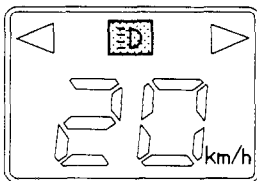

This lamp lights up when the head lamp is at high beam.

12. SPEEDOMETER

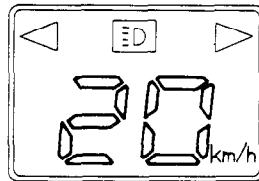

This meter indicates the running speed of the machine.
 ★ A speedometer for MPH is also available.

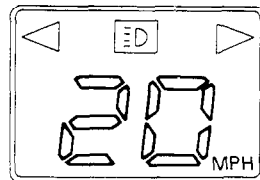

13. SERVICE METER

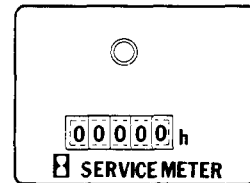

This meter shows the total operation hours of the machine. The service meter advances while the engine is running - even if the machine is not traveling.

Refer to the section "SERVICE METER".

★ While engine is running, green pilot lamp on the service meter flashes to show the service meter advances.

SWITCHES

1. TRANSMISSION CUT-OFF SELECTOR SWITCH

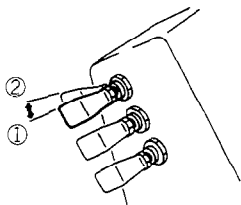

This switch selects the operation of the left brake pedal. Normally, put this switch in ON position.

① OFF:

Acts as normal brake (like right brake pedal).

② ON:

Acts as normal brake, but also switches transmission to NEUTRAL.

★ If the switch is at ON, the transmission cut-off selector pilot lamp will light up.

⚠ If the machine has to be started on a slope, always turn the transmission cut-off selector switch to OFF and depress the left brake pedal. Then depress the accelerator pedal while releasing the left brake pedal to start the machine off slowly.

★ Put the switch to the desired position according to working condition to make operation easy.



2. FUEL CUT-OFF SWITCH

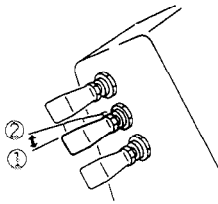

Engine fuel consumption will be cut.

When using APS (automatic priming system) in cold weather, use when starting.

- ① OFF:
Fuel is not supplied to the engine.
- ② ON:
Fuel is supplied to the engine.
- ★ When hand is removed from OFF position, switch returns to ON position.
- ★ For detailed method of usage, refer to "starting in cold weather".

3. ENGINE LOW IDLING SELECTOR SWITCH

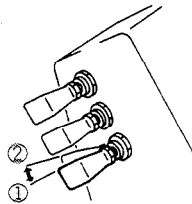

The engine low idling speed can be switched between two levels.

- ① ON:
The engine low idling speed is set to approx. 850 rpm. This is used on busy jobsites where it is necessary to reduce the cycle time.
- ② OFF:
This sets the engine low idling speed to approx. 650 rpm. This is used for normal operations at low idling, such as when waiting for dump trucks.

4. HAZARD LAMP SWITCH

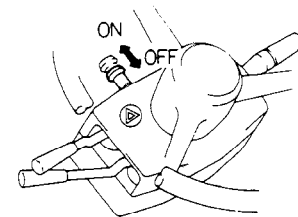

This switch is used in emergencies, such as when the machine breaks down.

ON: All turn signal lamps flash.

- ★ All turn signal lamps and pilot lamp on the steering column flash.

⚠ Do not use this switch unless abnormality is occurred.

INSTRUMENTS AND CONTROLS

5. PARKING BRAKE SWITCH

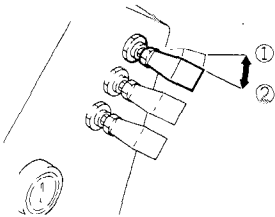

This switch operates the parking brake.

① ON position:

The parking brake is applied, and the parking brake pilot lamp lights up.

② OFF position:

The parking brake is released.

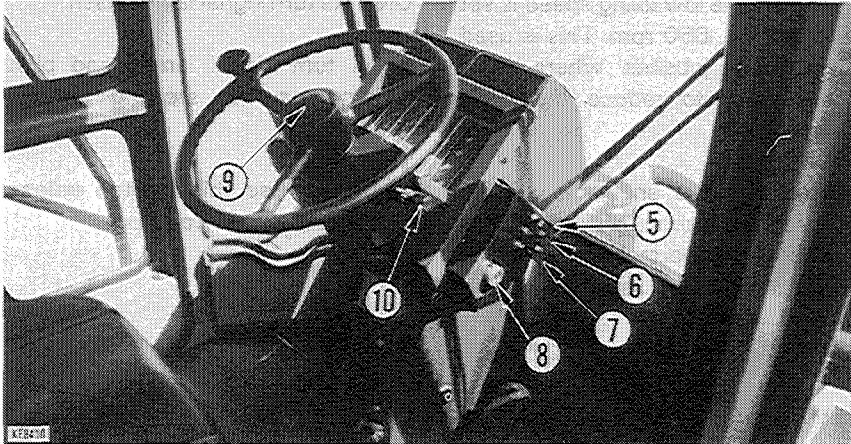

⚠ Always apply the parking brake when leaving the machine or parking it.

★ If the directional lever is placed in F (FORWARD) or R (REVERSE) with the parking brake applied, the warning lamp will flash and the alarm buzzer will sound.

★ When the starting switch is turned to OFF, the parking brake is automatically applied.

Before starting the engine, turn the parking brake switch to ON, then turn it to OFF.

★ The machine does not start when the directional lever is operated with parking brake applied.

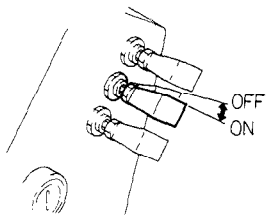
6. WORKING LAMP SWITCH

When the front and rear working lamps are turned ON, the pilot lamp and illumination lamp for monitor panel will also light up.

ON: Working lamps are ON.

⚠ When travelling on public roads, turn the working lamps OFF.

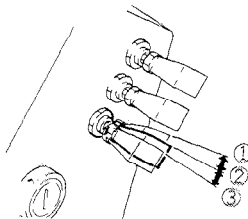
7. PREHEATER SWITCH (APS (automatic priming system) switch)

When using APS, engine intake air is heated. Usually, the switch is in the OFF position.

① OFF position:

The pre-heat function is not working.

② AUTO position:

When engine water temperature is below 13°C, APS starts.

After starting, maintain this position until the lamp of the after-heating monitor goes out.

★ Before starting APS, put the switch to ON and then put it to this position.

③ ON position:

If the switch is moved again from AUTO position and upward to ON, APS operation will begin.

★ If the switch is released when at the ON position, it will automatically return to AUTO.

★ Method of using preheater switch, refer to the section "starting in cold weather".

★ When the engine settle down after starting, put the preheater switch in OFF position.

INSTRUMENTS AND CONTROLS

8. STARTING SWITCH

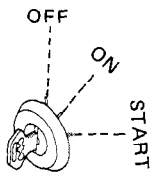

This switch is used to start or stop the engine.

OFF

Key insertion-withdrawal position. None of electrical circuits activate.

The hazard lamp, parking lamp and the room lamp will remain on, however, when the switch is turned OFF.

To stop the engine, turn the switch to OFF.

ON

Charging, lamp and accessory circuits activate. Keep key at ON after starting.

START

At this key position, the starting motor will crank the engine. Release the key immediately after starting, and the key will return automatically to ON.

9. HORN BUTTON

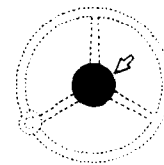

When the button in the center of the steering wheel is pressed, the horn will sound.

10. LAMP SWITCHES
(for lamps, turn signal lamps,
dimmer switch)

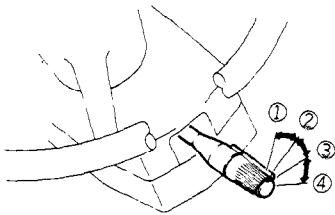

Lamp switch

Position ① $\cdot P \equiv$:

Parking lamp lights up.

Position OFF ② $- \cdot \bullet$:

Lamps go off.

Position ③ $\ni \triangleright \cdot \triangleleft \ni$:

Clearance lamps, tail lamps and machine monitor lighting light up.

Position ④ $\ni \triangleright \cdot$:

Head lamps light up in addition to the lamps in position ③ $\ni \triangleright \cdot \triangleleft \ni$.

★ The lamp switch can be operated regardless of the position of the lever.

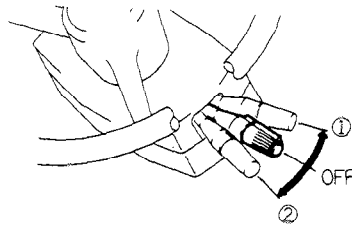

Turn signal lever

This lever operates the turn signal lamps.

① LEFT TURN:

Push lever FORWARD.

② RIGHT TURN:

Pull lever BACK.

★ When the lever is operated, the turn signal pilot lamp will also light up.

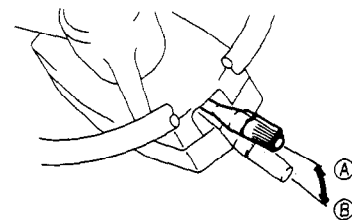

★ When the steering wheel is turned to the neutral position, the turn signal lever will return automatically to OFF. If not, return the lever to OFF manually.

Dimmer switch

This switches the head lamp between high beam and low beam.

Ⓐ Low beam

Ⓑ High beam

INSTRUMENTS AND CONTROLS

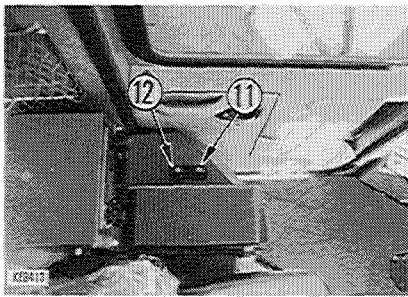

11. FRONT WIPER SWITCH

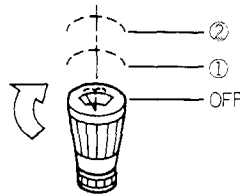

- ① The wiper is actuated at low speed.
- ② The wiper works at high speed.

When this switch is turned clockwise, solvent will be sprayed on glass.

12. REAR WIPER SWITCH

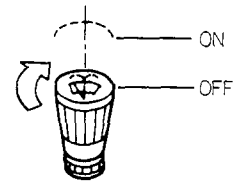

When this switch is pulled to ON position, wiper operates on rear glass.

When this switch is turned clockwise, solvent will be sprayed on glass.

13. CIGARETTE LIGHTER

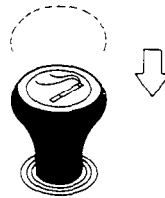
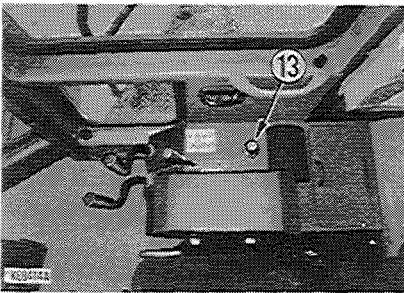

This is used to light cigarettes. To use, push the lighter in. After the few seconds it will spring back. At that time, remove the lighter and light your cigarette.

14. ROOM LAMP SWITCH

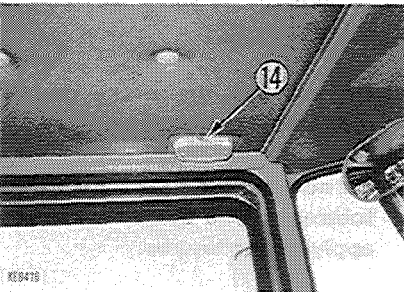

When this switch is moved to ON position, room lamp will light.

PEDALS AND LEVERS

1. ACCELERATOR PEDAL

This pedal controls the engine speed and output. The engine speed can be freely controlled between low idling and full speed.

2. BRAKE PEDALS

Right brake pedal

The right brake pedal operates the wheel brakes, and is used for normal braking.

⚠ On hills, use the right brake pedal or use the left pedal with the transmission cut-off selector switch put in OFF.

Left brake pedal

The left brake pedal operates the wheel brakes, and if the transmission cut-off selector switch is at ON, it also returns the transmission to neutral.

If the transmission cut-off selector switch is at OFF, the left brake pedal acts in the same way as the right brake pedal.

⚠ Do not use the brake pedals repeatedly unless necessary.

⚠ Do not use the brake pedals as footrests. Use them only when applying the brakes.

★ When the accelerator is being used for operating the work equipment, always use the left brake pedal to slow or stop the machine after putting the transmission cut-off selector switch in ON.

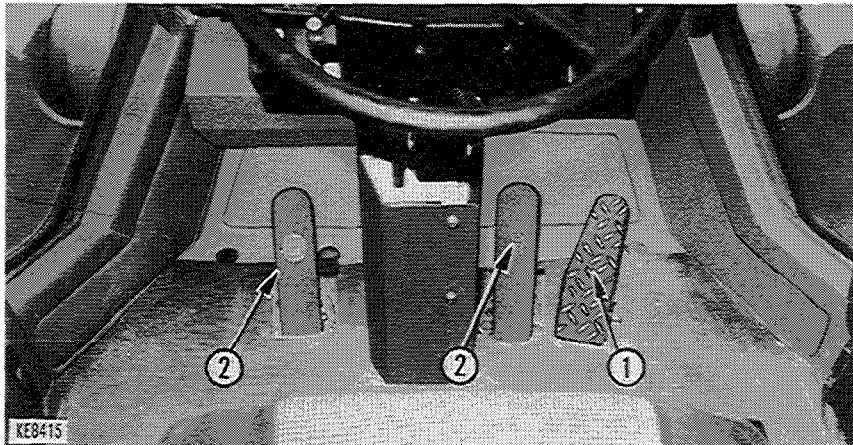

3. DIRECTIONAL LEVER

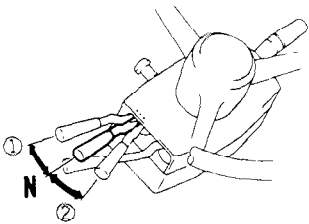

- ① Forward
- ② Reverse
- Ⓝ Neutral

- ★ The engine cannot be started if the directional lever is not at N (neutral).
- ★ When operating the directional lever, place your hand on a steering wheel and operate it by your fingers.

This lever is used to change the direction of travel of the machine.

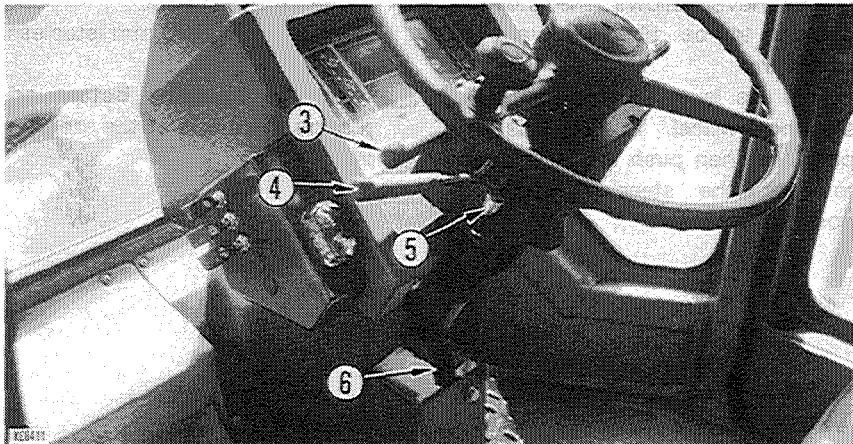

4. SPEED CONTROL LEVER

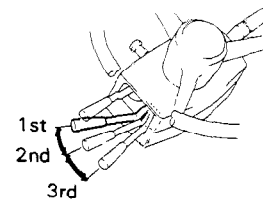

This lever controls the travel speed of machine.

This machine has a 3-FORWARD, 3-REVERSE speed transmission. Place the speed control lever in a suitable position to obtain the desired speed range.

1st and 2nd speeds are used for working.

3rd speed are used for traveling.

INSTRUMENTS AND CONTROLS

5. SPEED CONTROL LEVER STOPPER

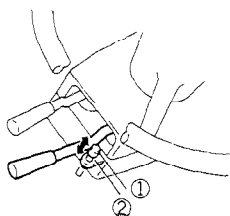

This stopper prevents the speed control lever from entering the 3rd position, when working.

Position ①

Stopper actuated.

Position ②

Stopper released.

6. STEERING COLUMN TILT LEVER

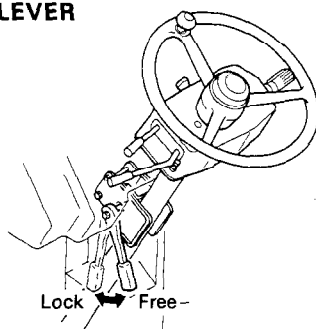

This lever allows the steering column to be tilted forward or backward.

Pull the lever up and move the steering wheel to the desired position. Then push the lever down to lock the steering wheel in position.

★ Range of adjustment:
100 mm (stepless)

⚠ Stop the machine before adjusting the angle of the steering wheel.

7. LIFT ARM CONTROL LEVER

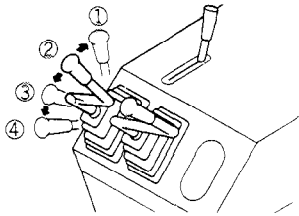

This lever is used to operate the lift arm.

- ① Raise ()
- ② Hold ():
The lift arm is kept in the same position.
- ③ Lower ()
- ④ Float ():
The lift arm moves freely under external force.

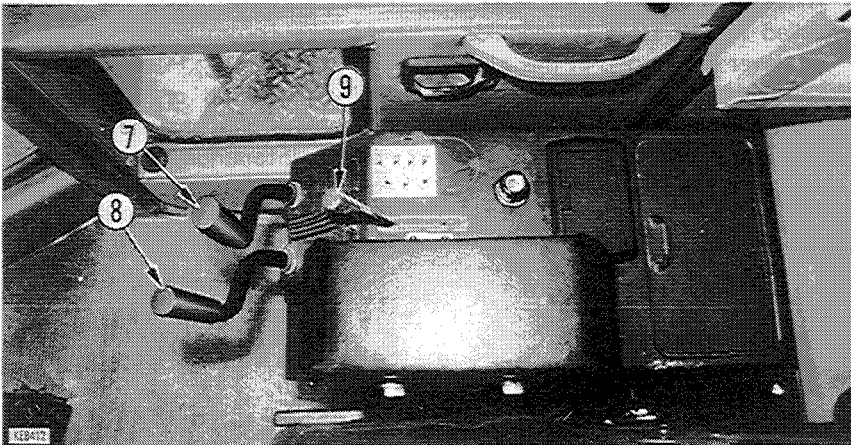
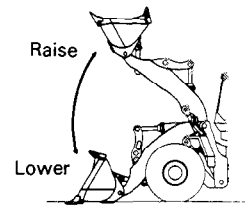

★ When the lift arm control lever is pulled further from ① position, the lever is stopped in this position until lift arm reaches the preset position of kick-out, and the lever is backed to hold position.

INSTRUMENTS AND CONTROLS

8. BUCKET CONTROL LEVER

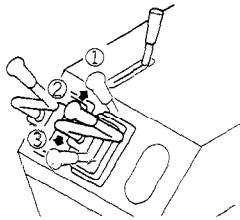

This lever operates the bucket.

① Tilt ()

② Hold ():

The bucket is kept in the same position.

③ Dump ()

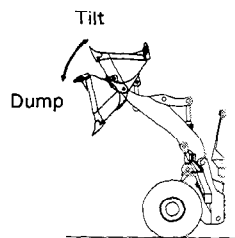

★ When the bucket control lever is pulled further from ① position, the lever is stopped in this position until bucket reaches the preset position of bucket positioner, and the lever is backed to hold position.

9. SAFETY LOCK

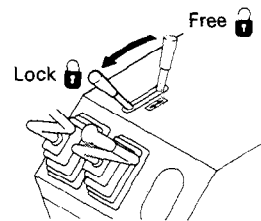

This is used to lock the lift arm and bucket control levers.

⚠ When parking or leaving the machine, or when the performing maintenance, always lower the bucket to the ground, put the work equipment levers in hold position and check that safety lock lever is locked.

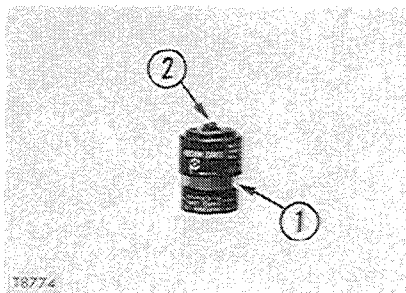
DUST INDICATOR

This device indicates clogging of the air cleaner element. When red piston (1) appears in the transparent part of this indicator, the element is clogged. Immediately clean element.

After cleaning, push indicator button (2) to return red piston to original position.

There are two dust indicators on the front of the engine hood behind the cab.

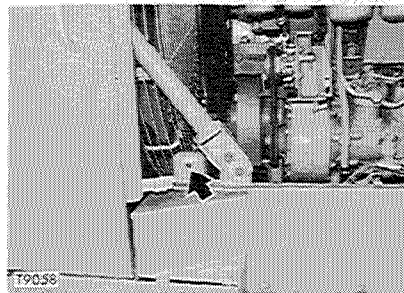
CIRCUIT BREAKER (MAIN)

This prevents damage to the electrical components and electric wiring.

When the breaker has been actuated, press the reset button to reset the system. However, if the circuit breaker is frequently actuated after the button is pressed, or the circuit breaker is frequently actuated, there may be a short circuit in the electrical system. In such cases, contact your Komatsu distributor for repairs.

★ The main breaker is not reset for 45 seconds after the breaker is actuated.

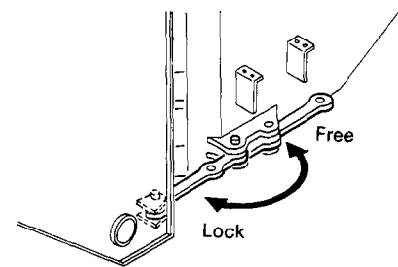
SAFETY BAR

The safety bar is used during maintenance or when transporting the machine. It locks the front frame and rear frame, and prevents the front and rear frames from bending.

⚠ Always use the safety bar for maintenance or when transporting the machine.

⚠ Always remove the safety bar during normal travel operations.

CIRCUIT BREAKER

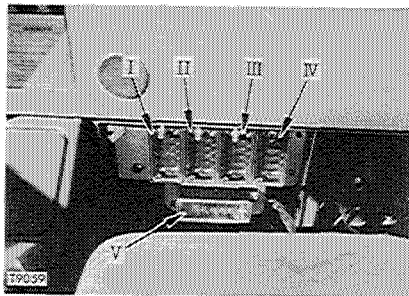

Circuit breaker is in cover behind the operator's seat.

When breaker has been actuated, press the reset button to reset the system.

Pressing the reset button will reset all six breakers in the breaker box at the same time.

⚠ When resetting the breaker, always turn off the electrical current before starting (turn starting switch OFF).

Breaker arrangement and circuit

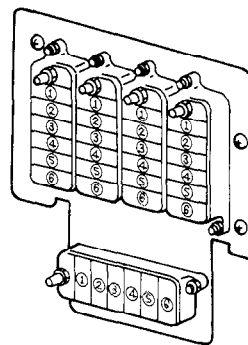

Circuit breaker I

No.	Breaker capacity	Circuit
①	20A	Starting switch
②	10A	Hazard lamp
③	10A	Left head lamp
④	10A	Right head lamp
⑤	20A	Left side clearance lamp
⑥	10A	Right side clearance lamp

Circuit breaker II

No.	Breaker capacity	Circuit
①	20A	Head lamp, parking lamp Clearance lamp, Tail lamp
②	10A	Turn signal lamp
③	10A	Brake lamp, Back up lamp
④	10A	Transmission control valve
⑤	10A	Horn, Parking brake
⑥	10A	—

Circuit breaker III

No.	Breaker capacity	Circuit
①	20A	APS (automatic priming system)
②	10A	APS (automatic priming system)
③	10A	Monitor panel
④	10A	Bucket positioner Boom kick-out
⑤	10A	Rear working lamp
⑥	10A	Front working lamp

Circuit breaker IV

No.	Breaker capacity	Circuit
①	20A	Air conditioner (Fan outside room)
②	10A	Air conditioner (Fan inside room)
③	10A	Radio, Room lamp
④	10A	Cigarette lighter
⑤	10A	Rear wiper Rear washer
⑥	10A	Front wiper Front washer

Circuit breaker V

No.	Breaker capacity	Circuit
①	20A	Engine stop
②	10A	Front working lamp
③	10A	Rear working lamp
④	10A	Side working lamp
⑤	10A	—
⑥	10A	—

INSTRUMENTS AND CONTROLS

OPERATOR'S SEAT

The seat adjustment should be checked at the beginning of each shift and when operators change.

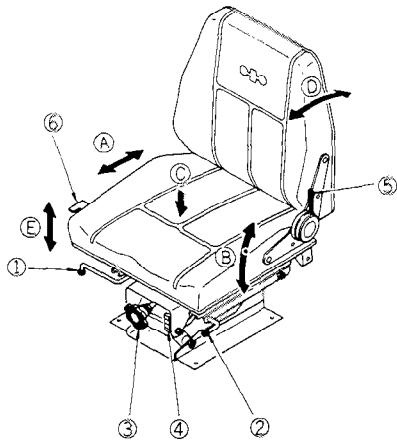

A: Forward-backward adjustment

Move lever (1) to the right, move the seat to the best position and release the lever. The seat can be moved forward or backward within a range of 140 mm in 7 stages.

B: Seat angle adjustment

Move lever (2) up, set the seat to the desired angle, and release the lever.

The seat can be tilted up or down about 3°.

C: Seat cushion adjustment

Rotate grip (3) under the seat to adjust scale (4) on the cushion adjustment to your own weight. (50 to 120 kg)

D: Backrest adjustment

Pull lever (5), move the backrest to the best position and release the lever. The backrest can be set to 11 steps.

E: Seat height adjustment

Move lever (6) upward, set the seat to the desired height and release the lever.

The seat can be set within 50 mm.

RIGHT SIDE ARMREST

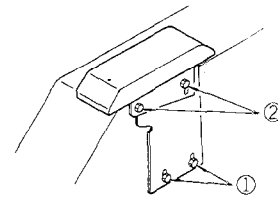

Height adjustment

Loosen bolts (1) to move the arm rest to the desired position, and tighten the bolts.

Angle adjustment

Loosen bolts (2) to move the armrest to the desired angle and tighten the bolts.

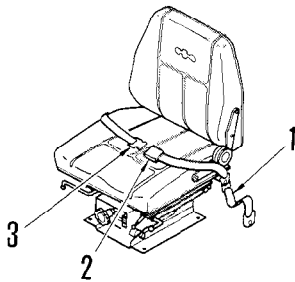
SEAT BELT

⚠ Before fastening the seat belt, inspect the securing brackets and belt for abnormal conditions.

Fasten the belt and remove it in the following manner.

1. Adjust the seat so that the brake pedal can be depressed all the way with the operator's back against the backrest.
2. After positioning the seat, install the tether belt (1). With the seat unoccupied, tense the belt slightly across the seat and install.

⚠ Check that there are no kinks in the belt.

3. Sit in the seat. Hold buckle (2) and insert (3) into the buckle (2). Check that the belt has locked by pulling it.
4. When removing the belt, raise the tip of the buckle lever to release it.

★ When leaving the operator's seat, release the seat belt and hang it over the arm rest.

★ Fasten belt along your body without kinking it. Adjust the lengths of the belt on both the buckle and the insert sides so that the buckle is located at the mid-point of your body front.

Adjust the belt length in the following manner.

- i) To shorten the belt, pull the free end of the belt on either the buckle body or insert side.

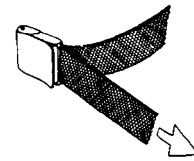

- ii) To lengthen, pull the belt while holding it at a right angle to buckle or insert.

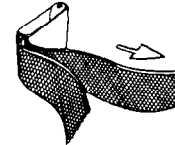

5. When operating a machine equipped with ROPS, be sure to use the seat belt.

★ Inspect bolts and fittings on the chassis for tightness. Retighten any loose bolts to 2 to 3 kgm torque.

★ If the seat is scratched or frayed or if any of the fittings are broken or deformed from long service, replace the seat belt immediately.

REMOVAL AND INSTALLATION OF BUCKET

REMOVAL AND INSTALLATION OF BUCKET

When removing or installing bucket for transporting, use the following steps:

⚠ Park the machine on level ground, set the safety bar on the frame, ground the bucket, shut down the engine, apply the parking brake and place blocks under the tires.

Removing the bucket

1. Loosen retainer mounting bolts on the bucket link pin part and the bucket pin part, then remove retainer (1) and shim (2).

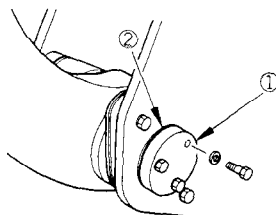
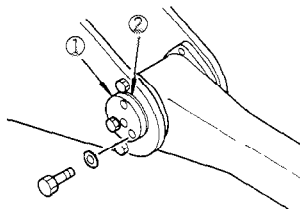

2. Loosen lock bolt (3) and remove cam (4).

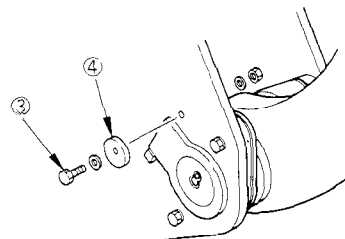
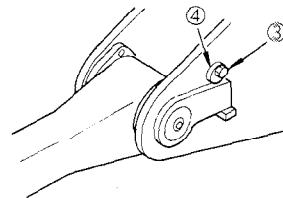

REMOVAL AND INSTALLATION OF BUCKET

3. Remove mounting bolt (5) of flange.

★ Before pulling pin, be sure to remove mounting bolt of flange. Otherwise the seal will be damaged.

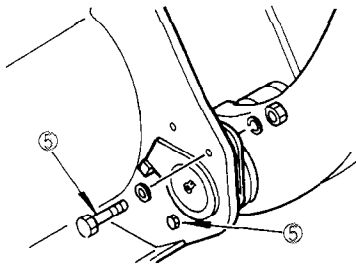
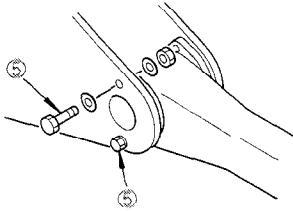

4. Sling the bucket link, then pull out the bucket link pin.

★ Secure the bucket link to the tilt lever with wire.

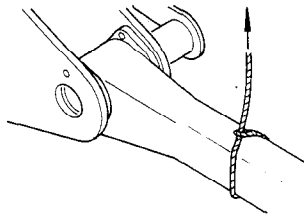

5. Pull out and remove pin (6) on both sides of bucket.

6. Disconnect lift arm and bucket.

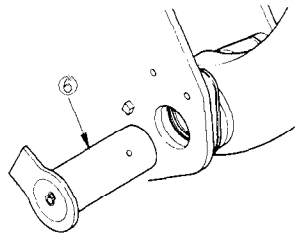

Installing the bucket

1. Assemble O-ring (2) on flange (1) of bucket pin.

★ Assemble O-ring after coating with grease.

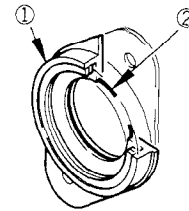

2. Check that there is nothing wrong with the oil seal (2) and dust seal (3) that are assembled on flange (1), and that dust seal is assembled 0 to 0.5 mm from edge of flange (1), or that there is no clearance between dust seal (3) and oil seal (2).

REMOVAL AND INSTALLATION OF BUCKET

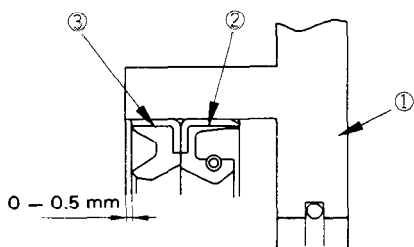

3. Fill the space between oil seal (2) and dust seal (3) with grease.

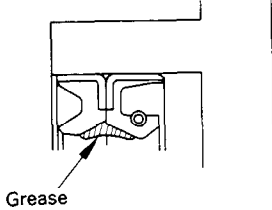

4. Coat the tip of the outer circumference of the lift arm bushing with grease.
5. Insert flange (1) in lift arm. Do not tap with a hammer. Be sure to insert by hand.

- ★ After inserting, rotate flange 1 to 2 times with the hand until the flange settles in with the seal.
- ★ Insert the flange until there is no clearance between the inner face of the flange and the edge face of the bushing.

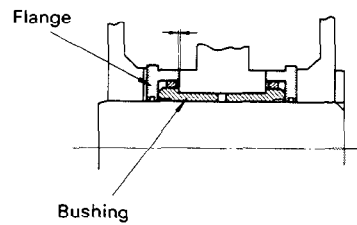

6. Assemble mounting side of the flange the same way.
 7. Assemble lift arm to bucket and insert hinge pin.
- ★ When attaching bucket to lift arm, do not hit flange (1) with the bucket. If the bucket hits the flange, the oil seal (2) and dust seal (3) will be damaged.

- ★ When inserting pin, do not damage O-ring, and coat with engine oil or grease.
8. Adjust number of shims so there is less than 0.2 mm clearance between flange (1) and bucket hinge plate, then install the mounting bolts of flange.

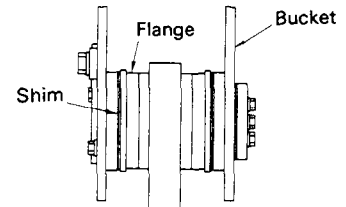

- ★ When selecting the shim, measure the clearance for each separable shim mount at the top and bottom, and assemble the optimum shim at each location. Be careful that the flange is not at an angle.

REMOVAL AND INSTALLATION OF BUCKET

9. Attach the lock plate for bucket pin (5) to the block on the hinge plate and then secure the lock plate with cam (4).

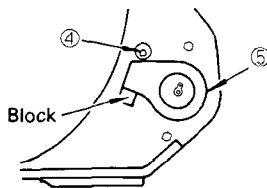

10. Install retainer (1) and shim (2) (Standard thickness: 2.5 mm) to bucket pin (5).

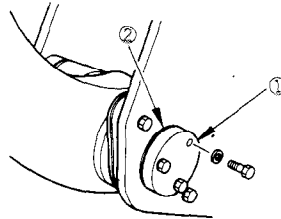

★ Adjust the thickness of the shim so that the clearance between the end surface of the retainer and the hinge plate is reduced to less than 0.2 mm.

11. Install bucket link pin according to the procedure 1 to 10.

12. Lubricate the bucket pin and bucket link pin by referring to the section EVERY 2000 HOURS SERVICE.

USING ACCUMULATORS

PRECAUTIONS FOR MAINTENANCE

The accumulators are on the right inside of the rear frame under the center platform.

⚠ The accumulators are filled with highly pressurized nitrogen. To avoid explosions, observe the following precautions.

- If accumulators breakdown or have trouble, immediately ask your Komatsu distributor to make the repairs.
- Only Komatsu personnel and those licensed to service high pressure equipment may recharge an accumulator with nitrogen.

- Never strike a charged accumulator or expose it to flames.
- Never weld piping to or cut opening in an accumulator.
- Never overhaul or dispose of an accumulator without first bleeding out all the nitrogen through the air bleeder valve.

- ★ Always handle an accumulator with the utmost care!
- ★ Have your Komatsu distributor check the gas pressure once a year!

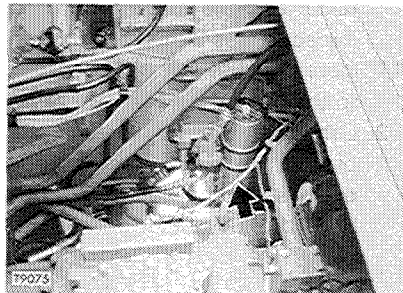

CHECK BEFORE STARTING

Pre-operation checks forestall machine trouble. Never neglect them.

a. WALK-AROUND CHECK

1. Check bucket for wear.
2. Check transmission case joints for oil leak.
3. Check brake system for air leak and oil leak.
4. Check tightness of air cleaner mounting bolt.
5. Check tightness of battery terminal.
6. Check radiator for water leak.
7. Check around the engine for water and oil leaks.
8. Check axle for oil leak.
9. Check hydraulic tank joint for oil leak.
10. Check for oil leak at high pressure hose and high pressure hose joints.

b. CHECK MONITOR PANEL

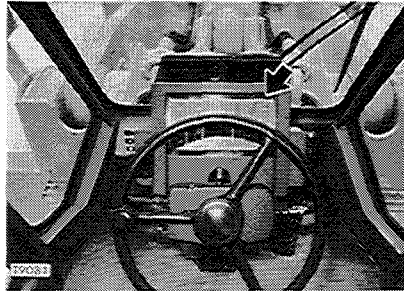

1. Turn the starting switch to ON.
 2. Check that all the monitor lamps, the gauges and the warning lamp light up for about 3 seconds and the alarm buzzer sounds for about 2 seconds.
- ★ If any monitor lamp does not light up, ask your Komatsu distributor to inspect that monitor lamp.
 - ★ Always make the check by referring to this section on CHECK BEFORE STARTING.

c. CHECK AND REFILL COOLANT

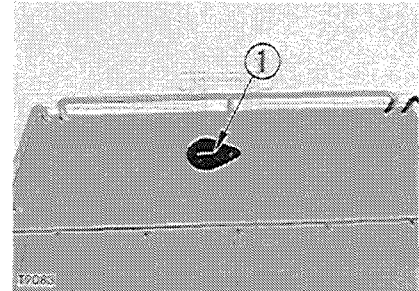

Remove radiator cap (1) on rear machine body, and check that cooling water is filled up to depth indicated by shadowed portion. If not, add water.

- ★ If the volume of coolant added is more than usual, check for possible water leakage.
- ★ Confirm that any oil is not in coolant.

CHECK BEFORE STARTING

**d. CHECK OIL LEVEL AND REFILL
IN ENGINE OIL PAN**

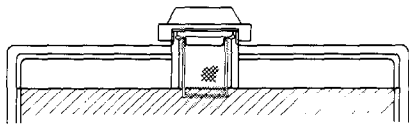

⚠ Do not remove the cap while cooling water is hot. Hot water may spout out. Before removing radiator cap, turn cap slowly to relieve inner pressure.

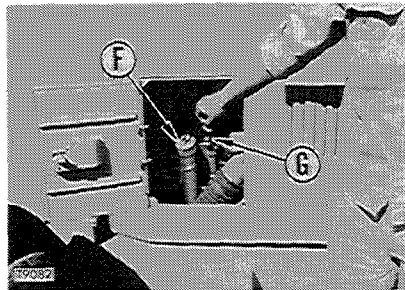

1. Open the inspection window at the rear left side of the machine.
 2. Use dipstick (G) to check the oil level.
 3. The oil level should be between mark L and H, if necessary, add oil at oil filler (F).
- ★ The type of lubricant used depends on the ambient temperature. Select according to the table "FUEL, COOLANT AND LUBRICANTS".
 - ★ After checking, be sure to tighten the handle of (G) and (F).

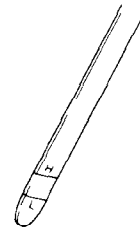

- ★ When checking the oil level, park the machine on a level surface, stop the engine and wait for 15 minutes before checking.

e. CHECK FUEL LEVEL AND REFILL FUEL

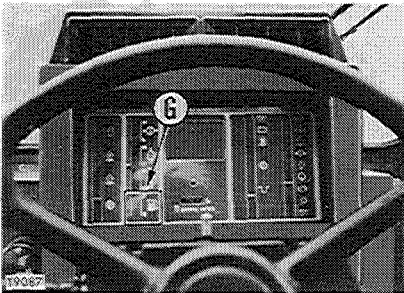

1. Check the fuel level using fuel gauge (G) on the monitor panel.
2. Upon completion of work, pour in additional fuel from filler (F) until the fuel tank is full.

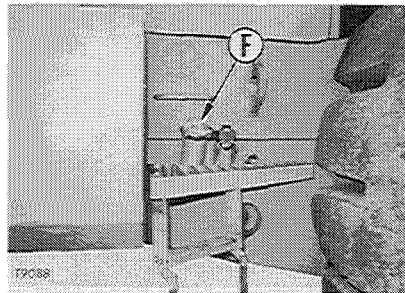

- ★ Fuel capacity: 1200 ℓ
- ★ When adding fuel, never let the fuel overflow. This may cause a fire.

f. CHECK ELECTROLYTE LEVEL IN BATTERY

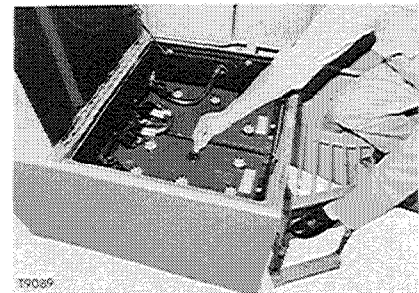

1. Open the battery box covers.
 2. If the electrolyte level is lower than the prescribed level (10 to 12 mm above the plate), supply distilled water.
- ★ Should any of the acid be spilt, have it replenished by the nearest battery shop with acid of the correct specific gravity.
 - ★ When inspecting electrolyte level, clean the air hole of the battery cap.

CHECK BEFORE STARTING

g. CHECK DUST INDICATOR

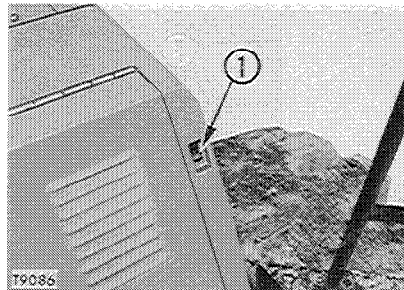

⚠ If the electrolyte gets on your skin or clothes, immediately wash with plenty of clean water.

⚠ To avoid gas explosions, do not bring fire or sparks near the battery.

When air cleaner element is clogged, the red piston of dust indicator (1) (2 points) reaches service level and gets locked.

In that case, clean element referring to the section "WHEN REQUIRED".

After cleaning element, push button to return red piston.

h. DRAIN WATER FROM AIR TANK

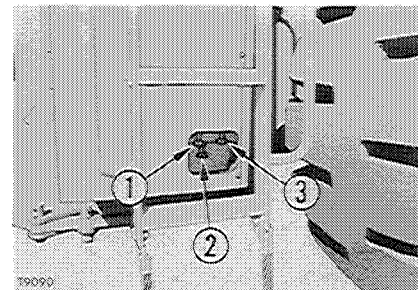

Upon completion of work, open drain valves (1), (2), (3) and drain water out of the tank.

i. CHECK AND REFILL OF OIL IN BRAKE OIL TANK

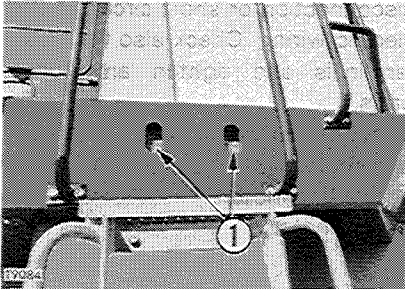

1. Check using sight gauge (1) of the brake oil tank on the left side of the machine to check that the oil level is between the MAX and MIN marks.
2. If the oil level is low, open the cover at the top of the platform, then open cap (2) and add engine oil.

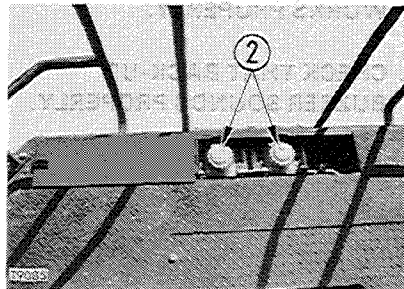

★ The type of lubricant used depends on the ambient temperature. Select according to the table "FUEL, COOLANT AND LUBRICANTS".

⚠ Never use the vegetable oil.

j. CHECK FOR SEDIMENT AND WATER IN THE WATER SEPARATOR

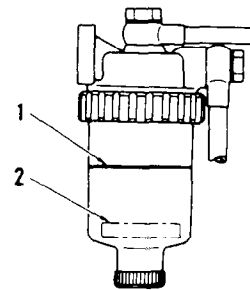

The water separator separates water mixed in the fuel. If float (2) is at or above red line (1), drain the water. For the draining procedure, see section "WHEN REQUIRED".

★ Even if a water separator is installed, be sure to check the fuel tank to remove water and sediment in the fuel.

CHECK BEFORE STARTING

k. CHECK THAT PARKING BRAKE WORKS PROPERLY.

l. CHECK THAT BRAKES WORK PROPERLY.

m. CHECK THAT HORN SOUNDS PROPERLY.

n. CHECK THAT LAMPS FLASH PROPERLY; CHECK FOR DIRT OR DAMAGE.

o. CHECK DIRECTION OF REAR VIEW MIRROR; CHECK FOR DIRT OR DAMAGE.

p. CHECK THAT ENGINE EXHAUST GAS COLOR AND SOUND ARE NORMAL.

q. CHECK THAT GAUGES AND INSTRUMENTS WORK PROPERLY.

r. CHECK STEERING PLAY; CHECK THAT STEERING WORKS PROPERLY.

s. CHECK THAT BACK-UP BUZZER SOUNDS PROPERLY.

t. CHECK ELECTRICAL WIRING

Check for any sign of disconnection or short circuit in the electric wiring. Check also for loose terminals and tighten any loose parts.

Check the following points carefully.

- Battery
- Starting motor
- Alternator

OPERATING YOUR MACHINE

BEFORE STARTING THE ENGINE

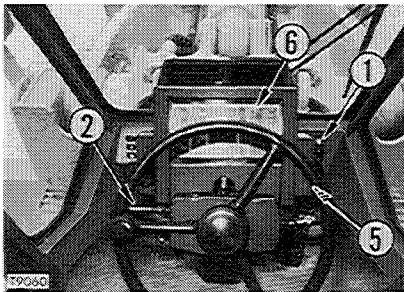

1. Carry out an initial inspection. (For details of the inspection, see CHECK BEFORE STARTING.)

2. With your back against the back rest of the operator's seat, adjust the seat position so that the brake pedals can be easily depressed.

3. Is the parking brake switch (1) in ON position?

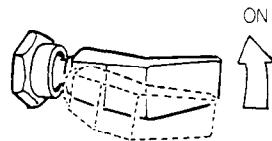

4. Is the directional lever (2) in N (neutral) position?

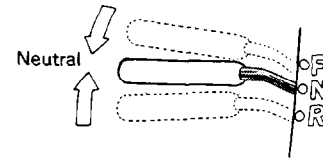

★ The engine will not start while the directional lever (2) is in any position other than N (neutral).

5. Are work equipment control levers (3) locked by safety lock (4)?

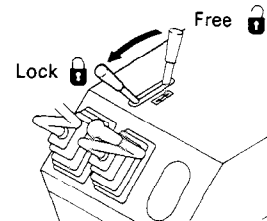

OPERATING YOUR MACHINE

6. Turn the key of starting switch (5) to the ON position.

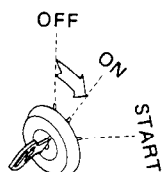

7. In (6) of machine monitor, confirm that there is no warning indication of following:
- brake oil amount
 - engine oil amount
 - radiator water level.

When there is a warning indicator in the monitor, refer to item, "A check group" explanation of each device.

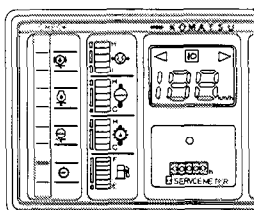

TO START THE ENGINE

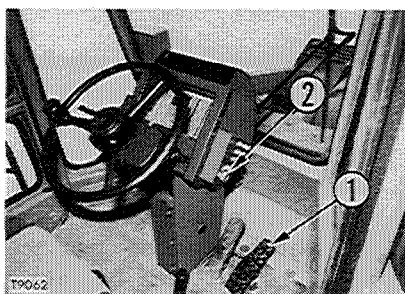

1. Depress accelerator pedal (1) lightly.
2. Turn the key of starting switch (2) to the START position to start engine.

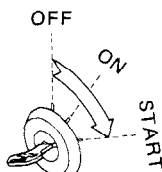

3. When engine is started, release the key of starting switch (2) and the key will return automatically to ON.

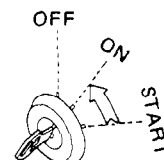

- ★ If engine will not start, repeat the starting procedure after about 2 minutes.

- ★ Do not leave the key in START for more than 20 seconds.
- ★ To start engine in cold weather, refer to COLD WEATHER OPERATION.
- ★ When using fuel with a low cetane value, starting the engine is usually difficult in normal temperatures. In such cases, use the procedure for starting in cold weather to make it easier to start the engine.

Special starting

When starting after running out of fuel, fill with fuel, then fill the fuel filter cartridge with fuel and bleed the air from the fuel system before starting.

Refer to FUEL FILTER in every 500 hours services.

CHECKS AFTER STARTING

After starting make the following checks.

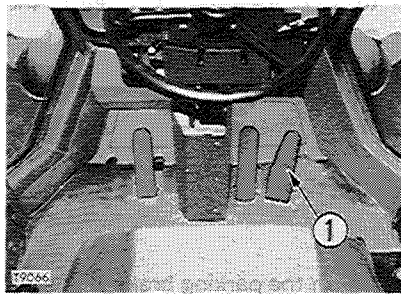

1. Depress accelerator pedal (1) lightly and run the engine with no load at midrange speed for about 5 minutes.
 2. After warm-up run is completed, check monitor lamps for proper operation.
- ★ Continue to run the engine at light load until the green ranges of the engine water temperature gauge and torque converter oil gauge light.

3. Check if the exhaust color is normal or whether there is any abnormal noise or vibration.
- ★ Avoid abruptly accelerating the engine until the completion of warm-up.
 - ★ Do not run the engine for more than 20 minutes at low idling or at high idling.
 - ★ When warming up the engine for at least 20 minutes, load it from time to time, or if this is not possible run the engine at medium speed.
 - ★ For machines where the air dryer is installed as an option, in cold temperatures below -10°C , when operating the machine after it has been stopped for several hours, run the engine for at least 10 minutes after starting before moving the machine.

OPERATING YOUR MACHINE

TO MOVE THE MACHINE OFF

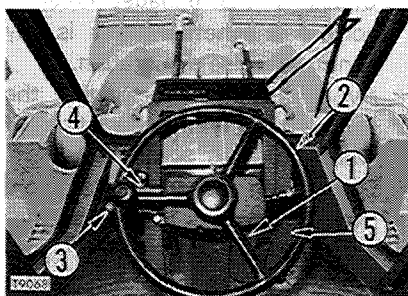

1. Check that the warning item is not displayed on the monitor panel.
2. Free the safety lock for work equipment control lever. Bring the work equipment in the traveling posture.

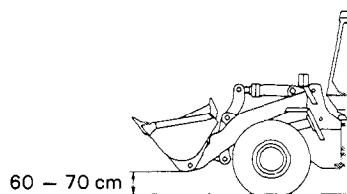

3. Depress right brake pedal (1), and turn parking brake switch (2) to OFF (release) to release the parking brake.

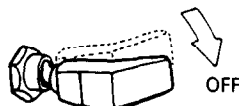

- ★ When the parking brake is applied with parking brake switch (2) put in OFF, put switch (2) to ON and return it to OFF again.

4. Set speed control lever (3) and directional lever (4) to the desired position.

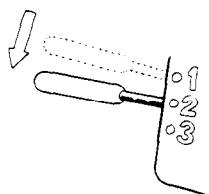

5. Release right brake pedal (1), then depress accelerator pedal (5) to move the machine off.

! If the machine has to be started on a slope, always turn the transmission cut-off selector switch to OFF and depress the left brake pedal. Then depress the accelerator pedal while releasing the left brake pedal to start the machine off slowly.

CHANGING GEAR SPEED

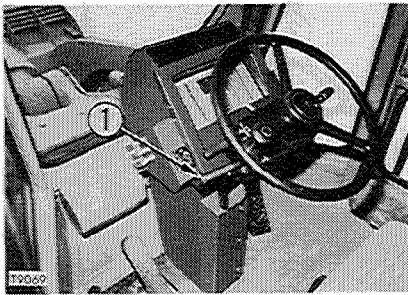

Move speed control lever (1) to the desired position.

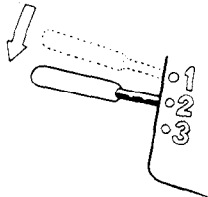

★ To use 1st or 2nd speeds for digging and loading operations, actuate speed control lever stopper.

CHANGING DIRECTION

There is no need to stop the machine even when switching between FORWARD and REVERSE.

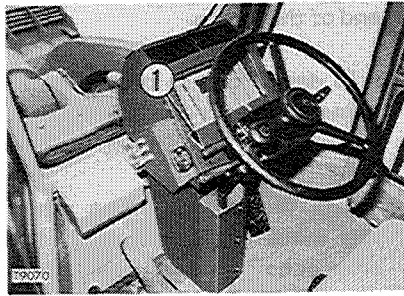

Place directional lever (1) in the desired position.

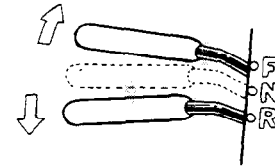

⚠ Before changing direction, check that it is safe.

⚠ Never change between FORWARD and REVERSE at high speed.

OPERATING YOUR MACHINE

TURNING

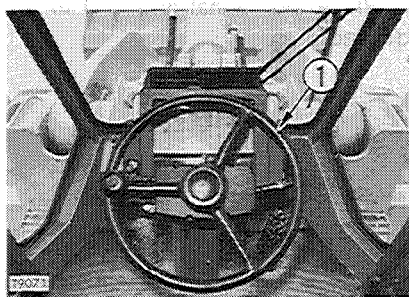

When traveling, use steering wheel (1) to turn the machine.

★ With this machine, the front frame is joined to the rear frame at the center of the machine by the center pin. The front and rear frames bend at this point, and the rear wheels follow in the same track as the front wheels when turning.

★ Turn the steering wheel lightly to follow the machine as it turns. When turning the steering wheel fully, do not turn it beyond the end of the stroke.

⚠ It is dangerous to turn the machine suddenly at high speed, or to turn on steep hills.

⚠ When the engine stops while the machine is traveling, the emergency steering will operate. But, since this device is an emergency steering device, never stop the engine while the machine is traveling. It is especially dangerous on a hill (For machines equipped with emergency steering).

TO STOP THE MACHINE

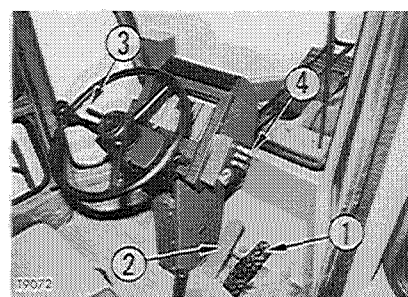

1. Release accelerator pedal (1), and depress brake pedal (2) to stop the machine.

2. Place directional lever (3) in N (neutral).

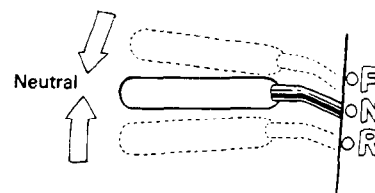

3. Turn parking brake switch (4) to ON to apply the parking brake.

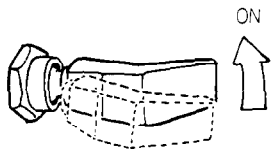

★ When the parking brake is applied, the transmission is automatically returned to neutral.

4. Operate the work equipment lever and lower the bucket to the ground, then lock the safety lock lever for work equipment lever.

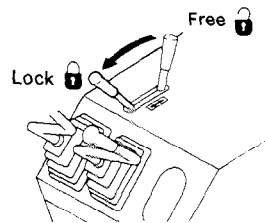

⚠ Stop the machine in a safe place on firm level ground. If the machine has to be stopped on a slope, put blocks under the wheels. In addition, dig the bucket into the ground to increase safety.

TO STOP THE ENGINE

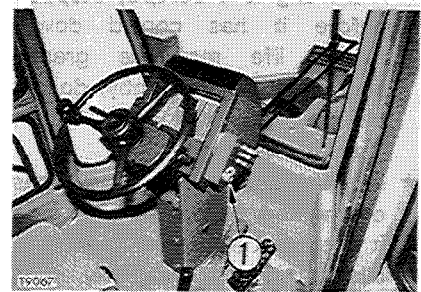

1. Run the engine at low idling speed for about 5 minutes to allow it to gradually cool down.
2. Return starting switch (1) to the OFF position and remove the key.

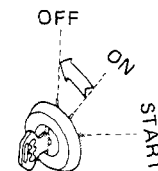

OPERATING YOUR MACHINE

- ★ If the engine is abruptly stopped before it has cooled down, engine life may be greatly shortened. Consequently, do not abruptly stop the engine apart from an emergency.
- ★ In particular, if the engine has overheated, do not abruptly stop it but run it at medium speed to allow it to cool gradually, then stop it.

MAXIMUM DEPTH OF WATER

When working in water or on swampy ground, do not let the water come above the bottom of the axle housing.

- ★ After finishing the operation, wash and check the lubricating points.

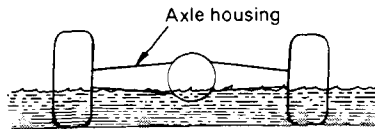

IF WHEEL BRAKE DOES NOT WORK

If the machine is not stopped by depressing brake pedal, use the parking brake to stop the machine.

PRECAUTIONS WHEN DRIVING UP OR DOWN SLOPES

Lower the center of gravity when turning.

When turning on slopes, lower the work equipment to lower the center of gravity before turning. It is dangerous to turn the machine with the work equipment raised.

Braking on downhill slopes

When driving down a slope, put the speed control lever in a low speed position and fully apply the engine brake. Run the engine at medium speed, and to apply the service brake, depress the right brake pedal.

If the speed control lever is not placed in a proper speed position, the torque converter oil may overheat. If it overheats, place the speed control lever in the next lower gear speed to lower the oil temperature.

If the temperature gauge does not indicate the green range of the scale even with the lever in the 1st speed position, stop the machine, place the lever in neutral, and run the engine at medium speed until the gauge indicates the green range.

If engine stops

If the engine stops on a slope, depress the right brake pedal fully. Next, lower the work equipment to the ground and apply the parking brake. Then put the directional and speed control levers in neutral, and start the engine again. (If the directional lever is not in neutral, the engine will not start.)

ADJUSTMENT OF WORK EQUIPMENT

The boom kickout makes it possible to set the bucket so that it automatically stops at the desired lifting height (lift arm higher than horizontal) and the bucket positioner makes it possible to set the bucket so that it automatically stops at the desired digging angle. The setting can be adjusted to match the working conditions.

ADJUSTING BOOM KICKOUT

1. Raise the bucket to the desired height, set the lift arm control lever at HOLD and lock the lever in position. Then stop the engine and adjust as follows.
2. Loosen two bolts (1), and adjust plate (2) so that the bottom edge is in line with the center of the sensing surface of proximity switch (3). Then tighten the bolts to hold the plate in position.

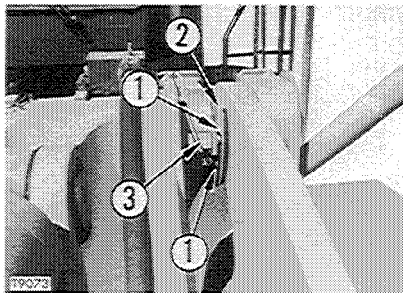

3. Loosen two nuts (4) to make a clearance of 3 to 5 mm between plate (2) and the sensing surface of proximity switch (3). Then tighten the nuts to hold in position.

★ Tightening torque:

$1.75 \pm 0.25 \text{ kgm}$

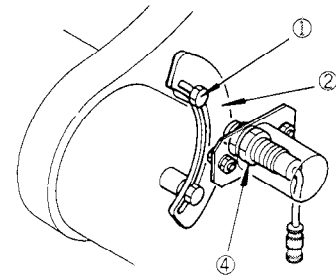

4. After adjusting, start the engine and operate the lift arm control lever. Check that the lever is automatically returned to HOLD when the bucket reaches the desired height.

ADJUSTING BUCKET POSITIONER

1. Lower the bucket to the ground and adjust the bucket to the desired digging angle. Set the bucket control lever at HOLD, stop the engine and adjust as follows.
2. Loosen two bolts (1) and adjust the mounting bracket (4) of the proximity switch so that the rear tip of angle (2) is in line with the center of the sensing surface of proximity switch (3). Then tighten the bolts to hold the bracket in position.

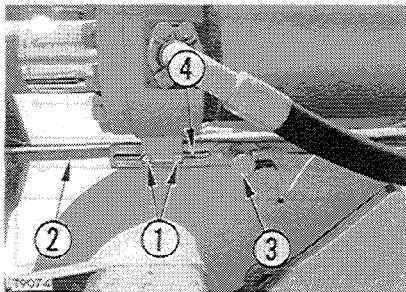

3. Loosen two nuts (5) and to make a clearance of 3 to 5 mm between angle (2) and the sensing surface of proximity switch (3). Then tighten the nuts to hold in position.

★ Tightening torque:
 $1.75 \pm 0.25 \text{ kgm}$

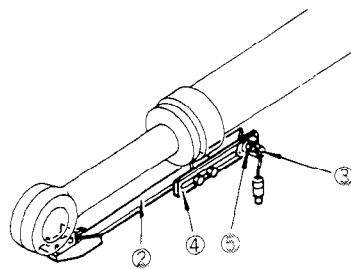

4. After adjusting, start the engine and raise the lift arm. Operate the bucket control lever to the DUMP position, then operate it to the TILT position and check that the bucket control lever is automatically returned to HOLD when the bucket reaches the desired angle.

BUCKET LEVEL INDICATOR

(A) and (B) at the top rear of the bucket are the level indicators, so the bucket angle can be checked during operations.

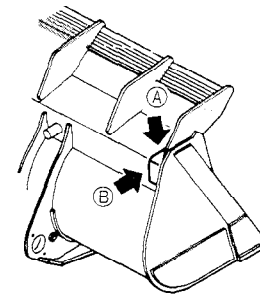

A: Parallel with cutting edge
 B: 90° to cutting edge

HANDLING THE TIRES

HANDLING THE TIRES

PRECAUTIONS WHEN HANDLING TIRES

If the following defects are found in tires, for safety reasons the tire should be replaced with a new tire.

- Bead wire is broken or bent, or the tire is greatly deformed.
- Wear is excessive and the carcass ply (excluding breaker) is exposed for more than 1/4 of the circumference.
- Damage to the carcass exceeds 1/3 of the tire width.
- Tire layers are separated.
- Radial cracks reach the carcass.
- Deformation or damage which makes the tire unsuitable for use.

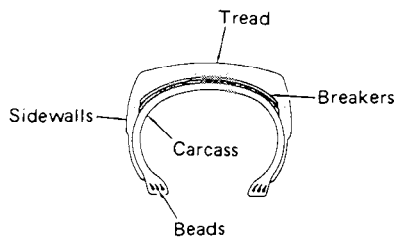

PRECAUTIONS WHEN DRIVING MACHINE

When the machine travels at high speed for a long distance, the tires become extremely hot. This causes early wear of the tires, so it should be avoided as far as possible. If the machine must be driven for a long distance, take the following precautions.

- Follow the regulations related to this machine, and drive carefully.
- The most suitable tire pressure, travel speed, or tire type differ according to the condition of the travel surface. Contact your Komatsu distributor or tire dealer for information.

Ambient temperature (°C)	Max. travel speed (km/h)	Traveling time and breaking time
50	20	Travel → Break (3H) → Repeat → 13 km or 40'
	25	Travel → Break (3H) → Repeat → 13 km or 35'
	28	Travel → Break (3H) → Repeat → 13 km or 25'
30	25	Travel → Break (3H) → Repeat → 15 km or 35'
	28	Travel → Break (3H) → Repeat → 15 km or 30'
0	28	Travel → Break (3H) → Repeat → 18 km or 40'

(Air pressure: 5.25 kg/cm²)

- When traveling with standard tires L-5 on a paved road surface, use the table as a guide.
- L-4 tires are suitable as tires for driving on roads, so contact your Komatsu distributor or tire dealer.
- Check the tire pressure before starting, when the tire is cool.
- When the machine is stopped, check the tires and all other parts for abnormalities, and check the oil and coolant levels.
- Always travel with the bucket empty.
- Never put calcium chloride or dry ballast in the tires when traveling.

TIRE PRESSURE

Measure the tire pressure before starting operations, when the tires are cool.

If the inflation pressure is too low, it causes overload on the tires; if the inflation pressure is too high, the tire may be cut or may burst under shock. Therefore adjust the inflation pressure to the values in the following table.

Inflating tires

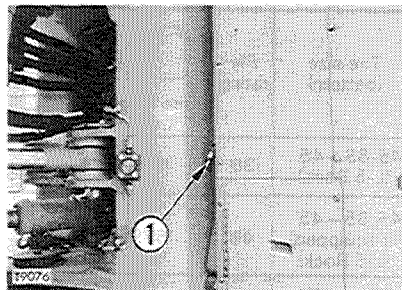

Connect the air charge hose to air pickup (1) to inflate the tires.

- ★ Stockpile operations mean the loading of sand and other loose materials.

★ Deflection ratio = $\frac{H - h}{H} \times 100$

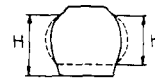

As a guide for visual checks, the deflection ratio (deflection/free height) of the front tire should be as follows.

Normal loading and carrying operations: approx. 10 – 15%
 Digging operations (rear wheels off ground):
 approx. 20 – 25%

HANDLING THE TIRES

- ★ When checking the tire pressure, check also for small cracks and damage, and for wire or small pieces of metal which may cause punctures. Check also for abnormal wear.
- ★ Operating costs can be reduced and tire life increased by keeping the operating area in good condition and free from fallen rocks.

- For operations on normal road surfaces, rock digging operations: High end of range in air pressure chart
- Stockpile operations on soft ground: Average pressure in air pressure chart
- Operations on sand (operations not using much digging force) Low end of range in air pressure chart

If the deflection of the tire is excessive, raise the inflation pressure within the limits given in the table to give a suitable deflection (see deflection ratio).

Tire size (pattern)	Ply rating	 Free height (mm)	Inflation pressure (kg/cm ²)				When shipped from factory
			Soft ground (sandy ground)		Normal road		
			Stockpile	Digging	Stockpile	Digging	
45/65-45 (L-5 Rock)	38	679	4.25 - 4.75	4.75 - 5.25	4.75 - 5.25	4.75 - 5.25	
45/65-45 (If equipped) (L-5 Rock)	46	679	4.25 - 4.75	4.75 - 5.25	4.75 - 5.25	4.75 - 5.25	Front tire: 5.25 Rear tire: 5.25
45/65-45 (L-5 Rock)	50	679	4.25 - 4.75	4.74 - 5.25	4.75 - 5.25	4.75 - 5.25	

TOWING

TOWING THE MACHINE

This machine must not be towed except in emergencies. When towing the machine, take the following precautions.

 **If there is a failure in the brake line, the brakes cannot be used, so be extremely careful when towing.**

When engine can be used.

- Always keep the engine running when towing the machine, so that the steering and braking can be used.

When engine cannot be used.

- No lubrication oil flows in the transmission, so disconnect the front and rear drive shafts before moving the machine.
- The steering cannot be used, so disconnect the steering cylinder and steering linkage.
- ★ The machine should be towed only to the nearest place for inspection and maintenance. Do not tow the machine for long distances.
- ★ If leakage in the air circuit has caused the pressure inside the air tank to drop, the parking brake will be applied. When towing the machine, release the parking brake.

TOWING

RELEASING PARKING BRAKE

(When no air is in air tank.)

1. Remove air charge socket (1) installed on the front left of the rear frame.

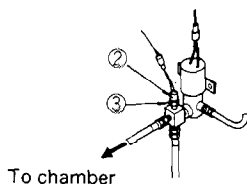
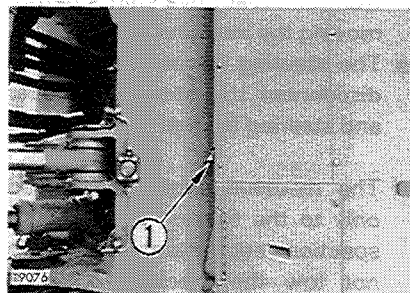

2. Remove parking brake switch (2) and adapter (3) installed to the outlet side of the parking brake solenoid valve, and install the socket removed in Step 1 in their place.
3. Install the air charge hose for the tire to the air charge socket.

⚠ If there is a failure in the air circuit, the brakes cannot be used. This is dangerous, so always tow the machine at low speed. Keep the engine running so that the steering can be used.

4. Push the end of the hose on the tire valve, and air will be supplied to the brake chamber to release the brake.
5. When the parking brake is released, remove the air charge hose. Tow the machine immediately to a safe place.

⚠ Stop the machine on a flat surface when releasing the parking brake, and check that the surroundings are safe. In emergencies or when the parking brake must be released on a hill, block the tires carefully before releasing the brake.

★ Contact your Komatsu distributor for details.

TRANSPORTATION

When transporting this machine, it is necessary to disassemble it for transportation.

Contact your Komatsu distributor for details of disassembly, transportation and assembly after transportation.

COLD WEATHER OPERATION

PREPARATION FOR LOW TEMPERATURE

- Change lubrication oil by that with prescribed viscosity.
- Fuel of low pour point shall be used. ASTM D975 No. 1 diesel fuel should be used at atmospheric temperature lower than -10°C .

- Add antifreeze in the cooling water
When deciding the ratio of antifreeze to water, check the lowest temperature in the past, and decide from the mixing rate table given below.
It is actually better to estimate a temperature about 10°C lower when deciding the mixing rate.

Mixing rate of water and antifreeze

Min. atmospheric temperature ($^{\circ}\text{C}$)	-5	-10	-15	-20	-25	-30
Amount of antifreeze (ℓ)	73	95	114	130	146	158.5
Amount of water (ℓ)	244	222	203	187	171	158.5

Coolant capacity: 317 ℓ

★ Cautions for using antifreeze

- 1) Permanent type antifreeze shall be used.
- 2) Soft water (ex: city water) shall be used as mixing water.
- 3) Cooling systems must be thoroughly flushed before filling with antifreeze mixture.
- 4) When the climate becomes warmer so that antifreeze (without corrosion inhibitor) is not needed, replace by clean water (ex: city water) after perfectly cleaning the cooling system.

 **Take care for fire as antifreeze is inflammable.**

- ★ When operating the machine at temperatures below -20°C , special equipment is needed. Contact your Komatsu distributor for details.

Care in using antifreeze

Use a Permanent Antifreeze (ethylene glycol mixed with corrosion inhibitor, antifoam agent, etc.) meeting the standard requirements as shown below. With permanent antifreeze, no change of coolant is required for a year. If it is doubtful that an available antifreeze meets the standard requirements, ask the supplier of that antifreeze for information.

Standard requirements for permanent antifreeze

- SAE J1034
- FEDERAL STANDARD
..... O-A-548D

★ Never use any antifreeze made from alcohol which may be a cause of engine trouble.

★ Where no permanent antifreeze is available, an ethylene glycol antifreeze without corrosion inhibitor may be used only for the cold season. In this case, coolant must be changed two times a year (at the beginning and at the end of the cold season).

★ Do not mix an antifreeze with one of different brand.

★ Absolutely avoid using any water leak preventing agent irrespective of whether it is used independently or mixed with an antifreeze.

● Battery

As ambient temperature drops, battery capacity will drop, and electrolyte may sometimes freeze if battery charge is low. Maintain battery at a charge level of approx. 100% and insulate it against cold temperature so that machine can be readily started the next morning.

★ Measure specific gravity of fluid and obtain rate of charge from the following conversion table:

Temp. of fluid Rate of charge	20°C	0°C	-10°C	-20°C	-30°C
100%	1.28	1.29	1.30	1.31	1.32
90%	1.26	1.27	1.28	1.29	1.30
80%	1.24	1.25	1.26	1.27	1.28
75%	1.23	1.24	1.25	1.26	1.27

★ When electrolyte level is low, add distilled water in the morning before work instead of after the day's work. This is to prevent fluid from freezing at night.

⚠ To avoid gas explosions, do not bring fire or sparks near the battery.

⚠ If the electrolyte gets on your skin or clothes, immediately wash with plenty of clean water.

COLD WEATHER OPERATION

STARTING IN COLD WEATHER STARTING BY AUTOMATIC PRIMING SYSTEM (APS)

When the ambient temperature drops and it is difficult to start the engine normally, use the following starting procedure.

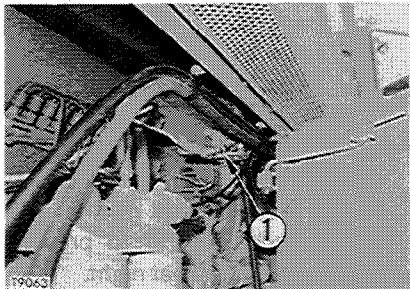

1. Open fuel valve (1) of the automatic priming system.
★ Keep fuel valve (1) open when the temperature drops during the season the APS is used.

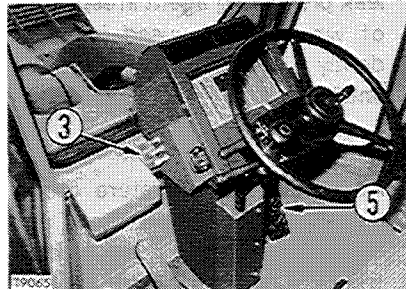
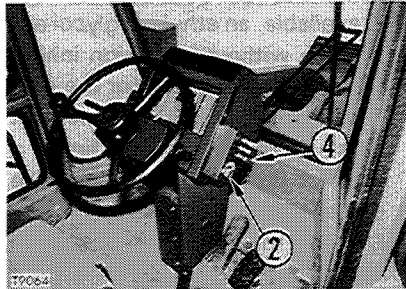

2. Turn starting switch key (2) to ON position.

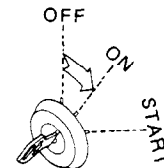

3. Keep fuel cut-off switch (3) in OFF position (pull forward). Put starting switch (2) in START position and engine will start in about 10 seconds.

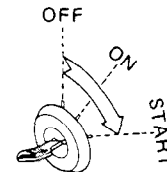

COLD WEATHER OPERATION

4. Put fuel cut-off switch (3) in ON position.
(When releasing the switch, it will return to ON position.)
5. When preheater switch (4) is put in the ON position, the pre-heat monitor will light and automatic pre-heating will start.
 - ★ If the pre-heating monitor lights, return the preheater switch to AUTO position. (When releasing the switch, it will return to AUTO position.)
6. Depress the accelerator pedal (5) about half way.
7. Pre-heating finishes in about 80 seconds. The pre-heating monitor lamp will stop illuminating so turn starting switch key (2) to START position to start.
 - ★ When the engine cooling water temperature is over 13°C, if the preheat switch is returned to AUTO, the preheating monitor will go out and automatic pre-heating cannot be carried out. If normal starting is difficult, use the procedure given in "Starting using manual preheating" to start the engine.
 - ★ When the pre-heat monitor is still illuminated and the starting switch is put in START position, the glow plug will get wet, and there will be no ignition, so be careful of starting problems.
 - ★ When starting, and the starting motor is rotating, the monitor will start to flash. If the flashing stops after the engine starts, there is nothing wrong.
 - ★ Do not continue cranking the engine for more than 20 seconds.

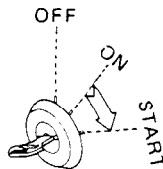

COLD WEATHER OPERATION

8. If starting, return key of starting switch (1) to ON position. (When releasing the key, it will automatically return to ON.)

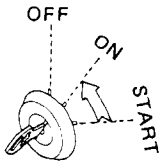

- ★ If the engine does not start through the steps specified above, turn key of the starting switch to OFF position and repeat Steps 2 to 8 at an interval of approx. 2 minutes.
9. After starting the engine, when the after-heating monitor lamp goes out, turn preheating switch (4) to the OFF position.

- ★ After starting the engine, when the water temperature reaches about 20°C, the after-heating is automatically cancelled and the after-heating monitor lamp goes out. The time taken for the after-heating lamp to go out depends on the ambient temperature.

Ambient temperature	Time taken after starting engine until after-heating monitor goes out
15 – 0°C	1 – 2 minutes
Below 0°C	3 – 5 minutes

- ★ If a work operation starts with forgetting to turn preheater switch to OFF position, the exhaust color will become bad, the horsepower will drop, and the life of the glow plug will be shortened, therefore, always be sure to put preheater switch in OFF position.
- ★ Do not run engine rpm higher than middle speed rpm.

- ★ The standard specification machine is designed to work in ambient temperature from –20°C to 40°C.

**STARTING USING MANUAL
PREHEATING**

When the engine water temperature is above 13°C, automatic preheating cannot be carried out. (When the preheat switch is turned to AUTO, the preheating monitor lamp goes out.) If it is difficult to start the engine, use the following procedure.

- 1) Put starting switch key to ON position.
- 2) Keep the preheater switch in ON position with hand until the preheating monitor goes off.
- 3) As soon as light goes off, quickly return starting switch to START position, and start engine.
- 4) After starting, put preheater switch in OFF position.

 **There is a danger of explosion when using a starting aid liquid for starting the engine, therefore, never use it.**

**CAUTIONS AFTER
COMPLETION OF WORK**

1. Mud and water on the machine body should be completely removed.

Park the machine on concrete or hard ground. If this is impossible, park the machine on wooden boards. This will prevent the accessories from freezing to the ground thereby preventing machine movement the next morning. Particular attention should be given to water drops collected on the surface of the hydraulic cylinder piston rods. Such droplets must be fully wiped off because if water is frozen to the rod when the cylinder is utilized, the cylinder oil seals may be damaged.

2. Drain water collected in air tank and fuel system so that such water may be frozen at night.
3. As battery capacity drops at low ambient temperature, cover the battery or remove it from the machine to be kept warm at night.

COLD WEATHER OPERATION

AFTER COLD WEATHER

When weather becomes warm, perform the following without fail:

- Replace lubricating oils for various units with the ones specified for warm-weather use.
- Drain antifreeze coolant (except permanent type), flush the inside of cooling system completely, and fill with clean soft water (such as city water).
- As the APS (Automatic Priming System) becomes useless (at 15°C or above), be sure to close the fuel valve for the APS.

PERIODIC MAINTENANCE

Proper lubrication and maintenance assure trouble-free operation and long machine life. Time and money spent for scheduled periodic maintenance will be amply compensated by prolonged machine operation and reduced operating cost.

All hourly figures given in the following descriptions are based on service meter readings. In practice, however, it is recommended to rearrange all of them into units of days, weeks and months to make the maintenance schedule more convenient. Under rough job site or operating conditions, it is necessary to somewhat shorten the maintenance intervals stated in this manual.

BLEEDING AIR FROM CIRCUIT

BLEEDING AIR FROM CIRCUIT

BLEEDING AIR FROM POC CIRCUIT

Remove piping of POC circuit, or when removing strainer, after assembling, bleed air from inside of the circuit as follows:

- 1) Put bucket control lever in TILT position and boom control lever in FLOAT position, and after cylinder reaches stroke end, keep in that position for one minute.
- 2) Put bucket control lever in DUMP position and boom control lever in RAISE position, and after cylinder reaches stroke end, keep in that position for one minute.

★ For details, contact your Komatsu Distributor.

BLEEDING AIR FROM BRAKE HYDRAULIC CIRCUIT

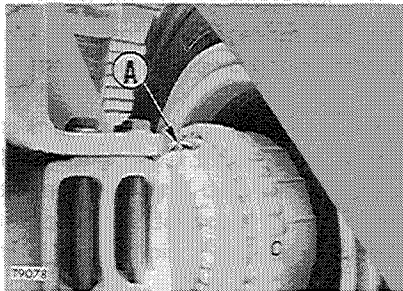

After removing piping of brake hydraulic circuit, bleed air from inside of the circuit as follows:

- ★ After assembling the piping, be sure to check that the connectors are not loose.
1. Remove the cap of air bleeder plug (A).
 2. Depress brake pedal, loosen air bleeder plug (A) about 3/4 of a turn and after closing plug, release pedal.

3. Repeat until air bubbles stop coming out of air bleeder plug (A). After bleeding air, close plug and fit cap.

- ★ Bleed air at 4 locations.
- ★ After bleeding air, check the oil level in the brake oil tank. If it is insufficient, add engine oil.

⚠ Never use the vegetable oil.

BLEEDING AIR FROM PISTON PUMP

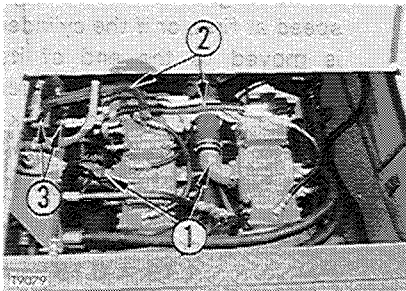

When changing the oil in the hydraulic tank, or removing the piston pump, or removing the piping of the piston pump, bleed the air from the piston pump in the following way after assembling.

★ Before bleeding the air from the piston pump, check that the hydraulic oil in the hydraulic tank is filled to the specified level.

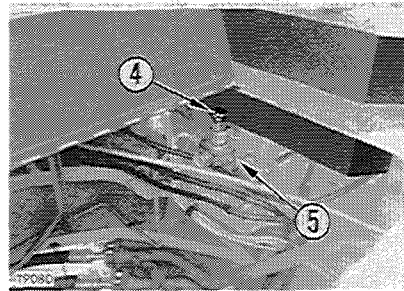

1. Loosen plug (1) on top of the tube at the suction side of the piston pump. There is one plug for each pump, so loosen all plugs (3 places).
2. Loosen the connector at block (3) side of case drain hose (2) of the piston pump.

★ The case drain hoses (x 3) for each pump are connected to block (3), but loosen only the connector of case drain hose (2) connected to the top of the block. There is no need to loosen the connectors of the other two case drain hoses.

3. Turn knob (4) of the hydraulic tank pressurizing valve to the left, and adjust so that the gauge indicator reads approx. 0.01 kg/cm².

⚠ If the pressure of the pressurizing valve is too high, oil may spurt out from plug (1) and hose (2), so adjust the pressure carefully.

4. Turn valve (5) to the right to open it, and pressurize the oil inside the hydraulic tank.

BLEEDING AIR FROM CIRCUIT

5. Continue until oil flows out from plug (1) (3 places) and the connector of hose (2). When the air has been completely bled, tighten plug (1) (3 places) and the connector of hose (2).
6. Close valve (5), and set the reading of the gauge of the pressurizing valve to "0".
7. Check the oil level and add oil if necessary.

! If the air is not bled completely, the piston pump may be damaged, so always carry out the air bleeding operation correctly.

- ★ When pressurizing the tank, the tank cannot be pressurized if the oil filler cap of the hydraulic tank is not tightened.
- ★ For details, contact your Komatsu distributor.

BLEEDING AIR FROM HYDRAULIC CIRCUIT

- After bleeding air from piston pump, bleed air from hydraulic circuit.
- After replacing oil, filter element or strainer, bleed the air from the circuit.
- To bleed the air from the hydraulic cylinders or hydraulic piping, run the engine at low idling and do as follows.
 1. Operate each hydraulic cylinders (of steering, bucket and lift arm) 4 to 5 times, stopping 100 mm from stroke end.
 2. Next, operate each cylinder 3 to 4 times to the end of its stroke, then stop the engine and loosen air bleeding plug (1) of the hydraulic tank to bleed the air.
 3. Increase the engine speed, and repeat step 2 to bleed the air until no more bubbles come out from plug (1).

- ★ If the engine is run at high speed at first, or if the cylinder is moved to the end of its stroke, the air in the cylinder may damage the piston packing, etc.
4. After bleeding the air, tighten air bleeding plug (1).
- ★ Tightening torque of the plug (1): $1.15 \pm 0.15 \text{ kgm}$

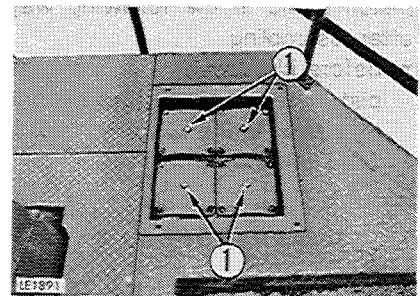

PERIODICAL REPLACEMENT OF SAFETY PARTS

The users of our machine should carry out periodical maintenance in order to ensure the working and operation safety. Those parts, as listed on the right, which are closely connected with safety, must be replaced periodically so that the highest safety standard can be maintained.

These parts with the passage of time have a great tendency to deteriorate in quality, and to wear rather soar. Furthermore, their defective condition is difficult to detect during periodical maintenance. These parts must, therefore, be replaced with new ones after a predetermined service period even though there is no apparent abnormality.

It goes without saying that if any abnormality should be found, these parts must be replaced or repaired even before the predetermined period expires.

The periodical replacement is completely different from the replacement due to the claim against the guarantee by the manufacturer, so they must be treated separately.

	Safety parts for periodic replacement	Replacement interval	Remarks
1	Brake hose	Every year	
2	Rubber parts for power cluster	Every year	Replace with repair kit
3	Packings, seals, O-rings of steering cylinder	Every 2 years	
4	Rubber hose for steering cylinder	Every 2 years	
5	Fuel hose	Every 2 years	
6	Rubber parts for treadle valve	Every year	Replace with repair kit
7	Rubber parts for parking brake spring cylinder	Every year	Replace with repair kit
8	Rubber parts for slack adjuster	Every year	Replace with repair kit

MAINTENANCE TABLE

MAINTENANCE TABLE

No.	ITEM	SERVICE	PAGE
CHECK BEFORE STARTING			
a	Walk-around check		39
b	Monitor panel	Check	39
c	Coolant	Check and supply	39
d	Engine oil pan	Check and supply	40
e	Fuel tank	Check and supply	41
f	Battery electrolyte	Check fluid level	41
g	Dust indicator	Check	42
h	Air tank	Drain water and sediment	42
i	Brake oil tank	Check and supply	43
j	Water separator	Check	43
k	Parking brake	Check function	44
l	Foot brake	Check function	44
m	Horn	Check function	44
n	Lamps	Check function	44

No.	ITEM	SERVICE	PAGE
o	Rear view mirror	Check	44
p	Exhaust gas and color	Check	44
q	Instrument	Check function	44
r	Steering wheel	Check play	44
s	Back-up buzzer	Check function	44
t	Electrical wiring	Check	44
EVERY 50 HOURS SERVICE			
a	Fuel tank	Drain water and sediment	79
b	Tires	Check air pressure and damage	79
EVERY 100 HOURS SERVICE			
a	Hydraulic tank	Check and supply	80
b	Air conditioner filter	Clean	80
c	Lubricating		81
-1	Lift arm pivot pin	Lubricate 2 points	81

MAINTENANCE TABLE

No.	ITEM	SERVICE	PAGE
-2	Dump cylinder pin	Lubricate 2 points	81
-3	Tilt lever pin	Lubricate 1 point	81
-4	Bucket link pin	Lubricate 1 point	81
-5	Lift cylinder pin	Lubricate 4 points	82
-6	Steering cylinder pin	Lubricate 4 points	82
-7	Rear axle pivot pin	Lubricate 3 points	82
INITIAL 250 HOURS SERVICE			
a	Fuel filter	Replace cartridge	83
b	Transmission oil filter	Replace element	83
c	Engine valve clearance	Check and adjust	83
EVERY 250 HOURS SERVICE			
a	Wheel hub nuts	Check and retighten	83
b	Engine oil pan and filter	Change oil and replace cartridge	83
c	Air conditioner compressor belt	Check tension	85
d	Alternator belt	Check tension	86

No.	ITEM	SERVICE	PAGE
EVERY 500 HOURS SERVICE			
a	Fuel filter	Replace cartridge	87
b	Transmission oil filter	Replace element	88
c	Fan belt	Check	88
d	Lubricating		89
-1	Center drive shaft	Lubricate 3 points	89
-2	Fan pulley bearing	Lubricate 1 point	89
-3	Tension pulley bearing	Lubricate 1 point	89
e	Air dryer	Check	89
EVERY 1000 HOURS SERVICE			
a	Transmission case	Change oil and clean strainer	90
b	Transmission case breather	Clean	91
c	Lubricating		92
-1	Center hinge pin	Lubricate 2 points	92
-2	Drive shaft center support	Lubricate 1 point	92
-3	Front drive shaft	Lubricate 3 points	92

MAINTENANCE TABLE

No.	ITEM	SERVICE	PAGE
(EVERY 1000 HOURS SERVICE)			
-4	Rear drive shaft	Lubricate 3 points	92
-5	Upper drive shaft	Lubricate 2 points	93
-6	Parking brake linkage	Lubricate 6 points	93
-7	Damper	Lubricate 1 point	93
-8	Torque converter mount trunnion	Lubricate 1 point	93
d	Turbocharger various fasteners	Check and retighten	93
e	ROPS canopy	Check and retighten	94
f	Corrosion resistor	Replace cartridge	94
EVERY 2000 HOURS SERVICE			
a	Hydraulic tank and filter	Change oil and replace element	96
b	Axle (Front and rear)	Change oil	97
c	Air conditioner filter	Replace element	99
d	Hydraulic tank breather	Replace element	99
e	POC (Pilot Operated Control) circuit strainer	Clean	100
f	Engine breather	Clean element	100
g	Turbocharger rotor	Check play	101

No.	ITEM	SERVICE	PAGE
h	Turbocharger	Check and clean	101
i	Alternator and starting motor	Check	102
j	Engine valve clearance	Check and adjust	102
k	Brake disc	Check and repair	102
l	Bucket hinge pin and bucket link pin	Change oil	102
m	Hydraulic tank strainer	Clean	102
n	Air dryer	Replace internal parts	103
EVERY 4000 HOURS SERVICE			
a	Water pump	Check	104
b	Air compressor	Check and adjust	104
c	Fan pulley and tension pulley	Check	104
d	Engine vibration damper	Check	104
WHEN REQUIRED			
a	Cooling system	Clean	105
b	Air cleaner element	Check, clean or replace when required	107
c	Transmission	Check and supply	110

MAINTENANCE TABLE

No.	ITEM	SERVICE	PAGE
d	Radiator fins	Clean	111
e	Axle oil	Check and supply	111
f	Lubricating		112
-1	Work equipment control valve linkage	Lubricate 2 points	112
-2	Accelerator pedal linkage	Lubricate 2 points	112
-3	Steering column	Lubricate 1 point	113
g	Bucket teeth	Replace	113
h	Air conditioner	Check	114
i	Condenser of air conditioner	Check and clean	115
j	Window washer	Check and supply	115
k	Axle case breather	Clean	116
l	Glow plug of APS	Check	116
m	APS fuel filter	Replace cartridge	117
n	Water separator	Drain water	117

OIL FILLER AND LEVEL GAUGE POSITIONS

OIL FILLER AND LEVEL GAUGE POSITIONS

- | | | |
|--|-----------------------------------|--------------------------------|
| 1. Engine oil pan level gauge and oil filler | 6. Cooling water inlet | 10. Hydraulic tank drain valve |
| 2. Cooling water drain plug | 7. Hydraulic tank oil filler | 11. Rear axle drain plug |
| 3. Engine oil pan drain plug | 8. Hydraulic tank oil level gauge | 12. Fuel tank drain valve |
| 4. Final drive case drain plug | 9. Front axle drain plug | 13. Fuel tank oil filler |
| 5. Final drive case level plug | | |

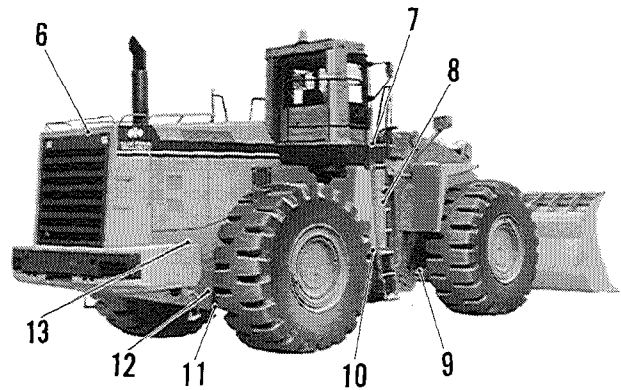
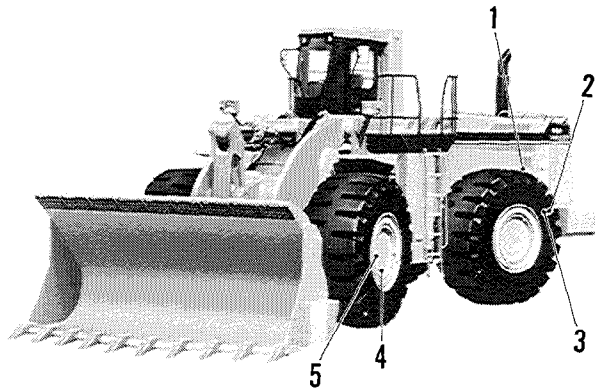

CHECK BEFORE STARTING

See the section on **CHECK BEFORE STARTING** aforementioned.

EVERY 50 HOURS SERVICE

a. FUEL TANK

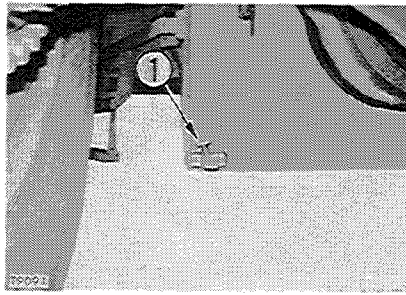

Loosen valve (1) on the right side of the tank so that the precipitation and mixed water will be drained in accompaniment with fuel.

CHECK BEFORE STARTING EVERY 50 HOURS SERVICE

b. TIRE

Measure the inflation pressure before operations when the tires are cool. (Refer to **HANDLING THE TIRES.**)

EVERY 100 HOURS SERVICE

EVERY 100 HOURS SERVICE

★ Maintenance for every 50 hours should be carried out at the same time.

a. HYDRAULIC TANK

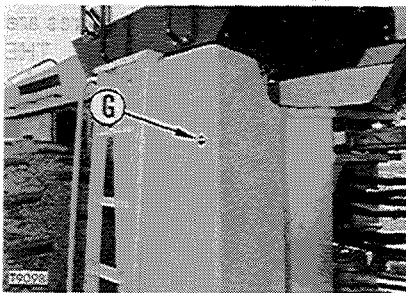

1. Lower the bucket horizontally to the ground and stop the engine. Wait for 5 minutes, then check sight gauge (G). The oil should be visible in sight gauge (G).
2. Add engine oil from oil filler (F), if necessary.

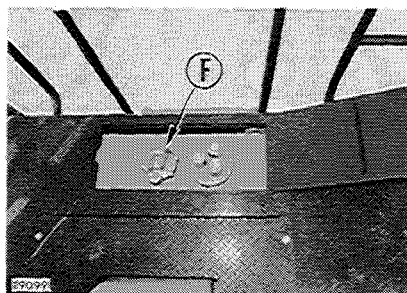

★ The type of lubricant used depends on the ambient temperature. Select according to the table "FUEL, COOLANT AND LUBRICANTS".

⚠ When removing the cap, turn it slowly to relieve inner pressure.

b. AIR CONDITIONER FILTER

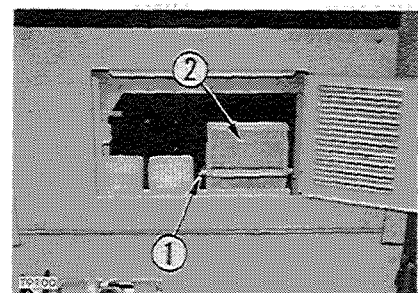

If the air conditioner has been used, the air filter should be cleaned.

★ Stop the air conditioner before cleaning the element.

1. Open the cover located on the behind of the operator's seat.
2. Loosen screw (1) of holder holding the filter element, pull out element (2) and clean it.

c. LUBRICATING

Apply grease to the grease fittings shown by arrows.

- 1. Lift arm pivot pin (2 points)
- 2. Dump cylinder pin (2 points)
- 3. Tilt lever pin (1 point)

- 4. Bucket link pin (1 point)

3. Align the direction of the arrows and assemble.

★ Direct dry compressed air (less than 7 kg/cm²) to element from inside along its folds, then direct it from outside along its folds and again from inside, and check element.

⚠ When using compressed air, wear safety glasses and other things required to maintain safety.

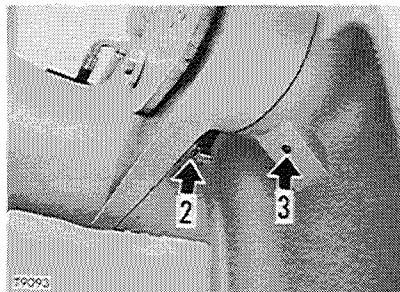
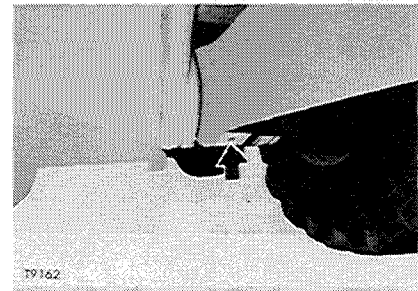
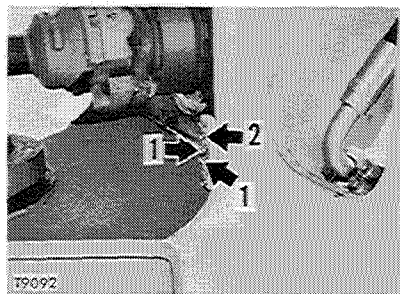

EVERY 100 HOURS SERVICE

5. Lift cylinder pin (4 points)



6. Steering cylinder pin (4 points)

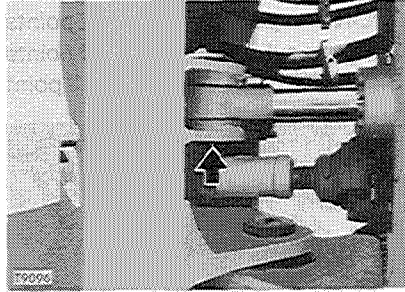

7. Rear axle pivot pin (3 points)

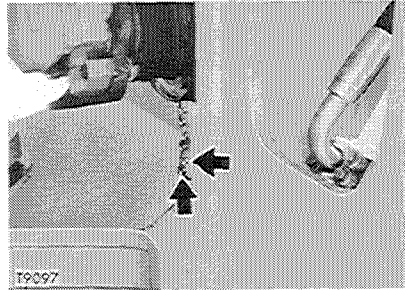
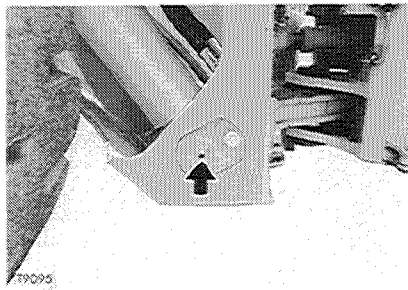
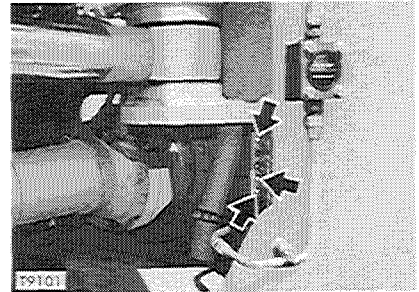

INITIAL 250 HOURS SERVICE

Perform the following maintenance after running the machine for the first 250 hours.

- a. FUEL FILTER
- b. TRANSMISSION OIL FILTER
- c. ENGINE VALVE CLEARANCE

For details of the method of replacing or maintaining, see the section on EVERY 500 HOURS AND 2000 HOURS SERVICE.

EVERY 250 HOURS SERVICE

a. WHEEL HUB NUTS

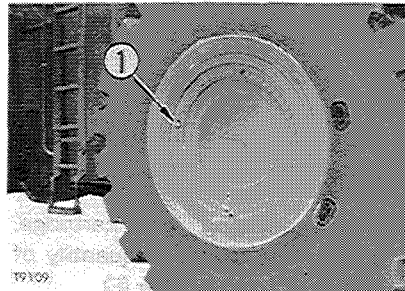

If wheel hub nuts (1) are loose, tire wear will be increased and accidents may be caused. If any hub nuts are loose, tighten them to the specified tightening torque.

★ Tightening torque:

$$94.5 \pm 10.5 \text{ kgm}$$

- ★ If any wheel nut is broken, replace all nuts for that wheel.
- ★ Always rotate in the direction of tightening when checking for loose nuts.

b. ENGINE OIL PAN AND FILTER

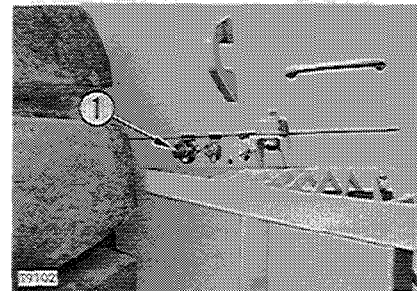

1. Open the engine side cover on the left side of the machine, and apply open lock.
 2. Loosen drain plug (1) on the left side of the machine to drain the oil, and tighten the drain plug again after draining the oil.
- ★ When draining the oil, fit the supplied vinyl tube to the drain ports of the drain plug to prevent the oil from spraying out.

EVERY 250 HOURS SERVICE

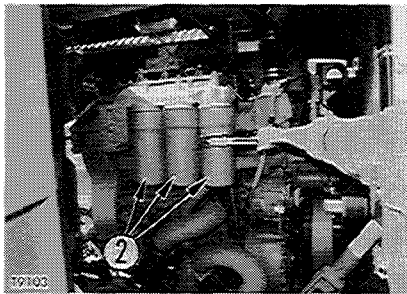

3. Using a filter wrench, remove cartridges (2) (3 pieces) of the engine oil filter by turning it counterclockwise.
 4. Apply a dab of oil to the gasket of the new cartridge.
- ★ After the gasket contacts the seal face, tighten it up by hand 2/3 of a turn.

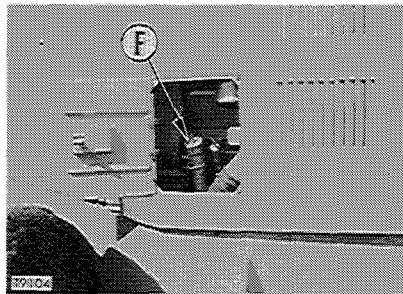

5. After replacing the cartridge, pour in the specified quantity of engine oil from oil filler (F).
6. After pouring in oil, run the engine for several minutes, then once again check the oil level and ensure that it is correct.
7. Close the engine side cover.

- ★ Refill capacity: 64 ℓ
- ★ The type of lubricant used depends on the ambient temperature. Select according to the table "FUEL, COOLANT AND LUBRICANTS".
- ★ Be sure to fit a genuine Komatsu cartridge.
- ★ Replace once every 6 months, regardless of the number of hours operated.
- ★ If filter cartridges (2) are removed immediately after stopping the engine, oil will spill. Wait at least 10 minutes after stopping the engine before replacing the filter cartridge.
- ★ Use API category CD class oil. If CC class oil must be used, change the oil and replace the oil filter at half the usual interval (125 hours).

**c. AIR CONDITIONER
COMPRESSOR BELT**

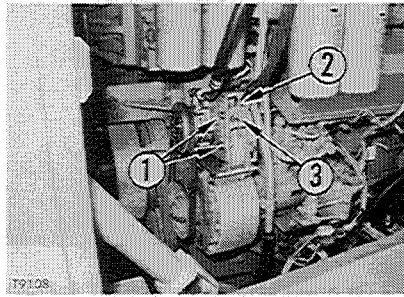
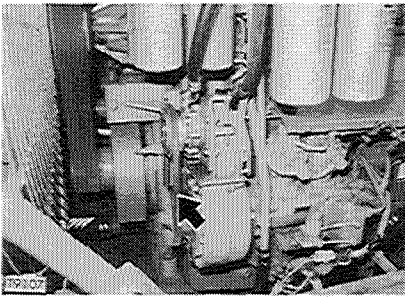

1. The belt tension should normally deflect by about 10 mm when pressed with the finger at a point midway between the air conditioner compressor pulley and the drive pulley (approx. 6 kg).

2. To adjust the belt tension, loosen bolts (1) and lock nut (3), and rotate adjusting bolt (2).

3. After adjustment, tighten bolts (1) and lock nut (3) securely.

★ After operating the machine for one hour with a newly exchanged V-belt, test and adjust the V-belt again.

★ When adjusting the V-belt, do not attempt to push the compressor directly with a bar or the like, but use a wood pad to prevent damage to the core.

★ Check each pulley for damage, and V-grooves and V-belt for wear. Particularly, check whether V-belt is in contact with bottom of V-groove through wear.

★ Replace belt if it has stretched, leaving no allowance for adjustment, or if there is a cut or crack on belt.

EVERY 250 HOURS SERVICE

d. ALTERNATOR BELT

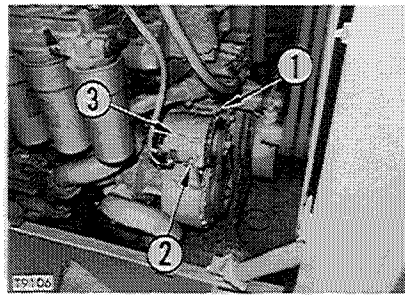
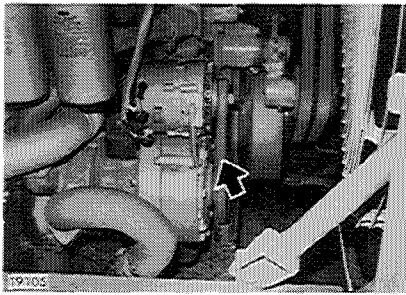

1. The belt tension should normally deflect by about 9 mm when pressed with the finger at a point midway between the alternator pulley and the drive pulley (approx. 6 kg).

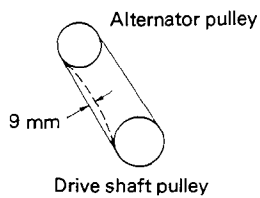

2. To adjust the belt tension, loosen bolt (1) and nut (2) and shift alternator (3) slightly.
3. After adjustment, tighten bolt (1) and nut (2) securely.

★ After operating the machine for one hour with a newly exchanged V-belt, test and adjust the V-belt again.

- ★ When adjusting the V-belt, do not attempt to push alternator (3) directly with a bar or the like, but use a wood pad to prevent damage to the core.
- ★ Check each pulley for damage, and V-grooves and V-belt for wear. Particularly, check whether V-belt is in contact with bottom of V-groove through wear.
- ★ Replace belt if it has stretched, leaving no allowance for adjustment, or if there is a cut or crack on belt.

EVERY 500 HOURS SERVICE

b. TRANSMISSION OIL FILTER

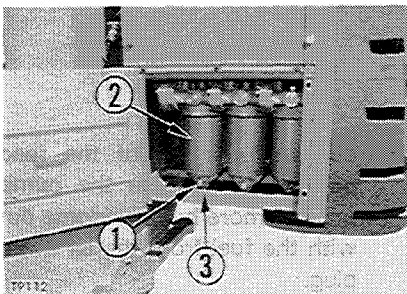

1. Loosen the bolt and open the side panel.
2. Remove drain plugs (1) (6 pieces) at the bottom of the filter case, and drain the oil. After draining the oil, tighten the plug.
3. Hold case (2) and loosen center bolt (3), then remove case (2).
4. Remove the element, and clean the inside of the case. Assemble a new element, then install the case.

- ★ Be careful not to apply excessive torque to center bolt (3).

Tightening torque:

15.5 ± 1.5 kgm

5. Run the engine for a short time at idling speed, then stop the engine. Check that the oil is at the specified level (for details, see WHEN REQUIRED).
- ★ Use a genuine Komatsu element.
 - ★ Replace the filter gasket and O-rings with new parts. Coat the gasket and O-rings with clean engine oil before installing.

c. FAN BELT

Check the V-belt and when the following conditions exist, exchange the V-belt:

- When the V-belt makes contact with the bottom of the groove in each pulley.
- When cracking and peeling of the V-belt occurs.
- ★ For details of the replacement procedure, refer to ADJUSTMENT (replacement of fan belt and adjustment of auto tensioner).
- ★ An auto tensioner is installed, so it is unnecessary to adjust the fan belt.

d. LUBRICATING

Apply grease to the grease fitting shown by arrow.

1. Center drive shaft (3 points)

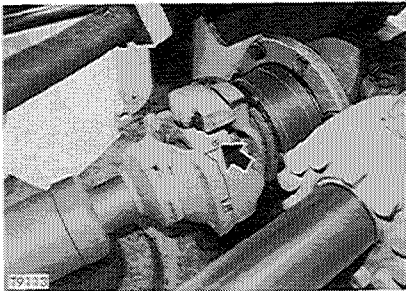

2. Fan pulley bearing (1 point)

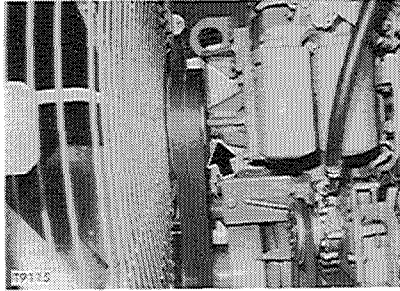

3. Tension pulley bearing (1 point)

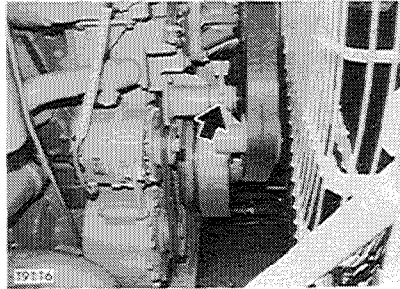
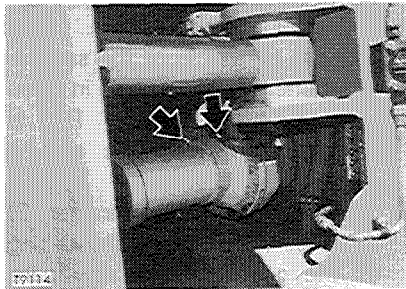

e. AIR DRYER

If the air dryer is installed as an option, carry out the following inspection, and if there is any abnormality, contact your Komatsu distributor.

- Open the air tank drain valve and check that nothing is drained. Note that if the temperature around the tank is lower than 16°C, a small amount of water may be collected in the drain.
- Check that there is no abnormal inclusion of oil in the water drain from the exhaust port of the air dryer.

EVERY 1000 HOURS SERVICE

EVERY 1000 HOURS SERVICE

★ Maintenance for every 50, 100, 250 and 500 hours should be carried out at the same time.

a. TRANSMISSION CASE AND STRAINER

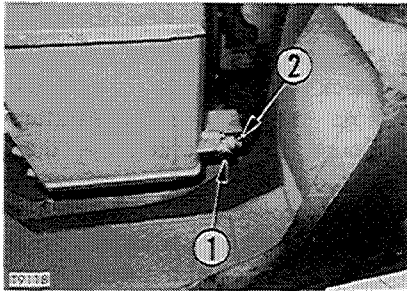

1. Remove drain plug (1) and loosen plug (2) to drain oil. After draining off the oil, tighten up drain plugs.
- ★ After loosening drain plug (2), pull out the plug slowly to prevent the oil spouting out.

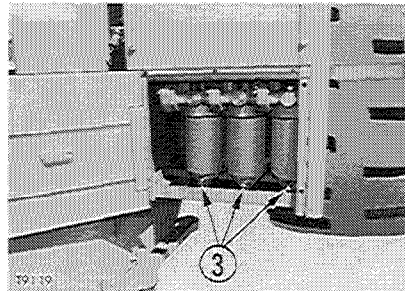

2. Loosen drain plugs (3) (6 pieces) of transmission oil filter to drain oil. After draining off the oil, tighten up drain plugs (3).

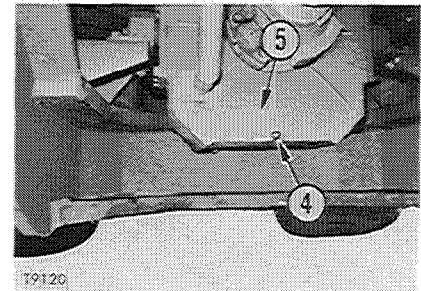

3. Remove bolt (4) and cover (5), then remove spring (6) together with strainer (7).
4. Remove all dirt from the surface of strainer (7), then wash in clean light oil. If strainer (7) is damaged, replace with a new part.
5. Install spring (6) and strainer (7) in cover (5). Replace the O-ring of the cover with a new part, then install the cover.

EVERY 1000 HOURS SERVICE

b. TRANSMISSION CASE BREATHER

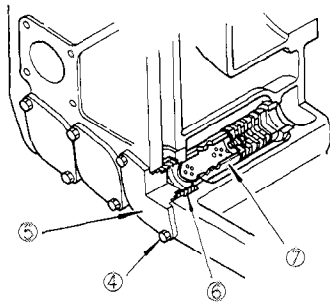

6. Pour in the specified amount of engine oil from oil filler (F).
7. After refilling, check the oil level and ensure that it is correct. (Refer to WHEN REQUIRED.)

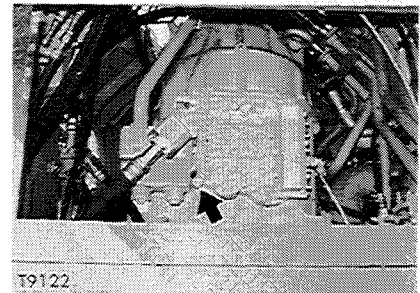
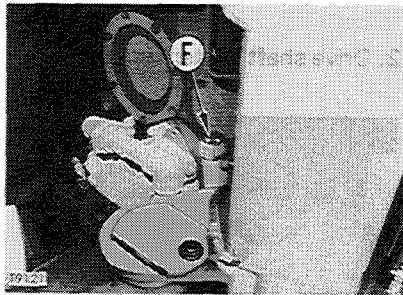

- ★ Refill capacity: 140 l
- ★ The type of lubricant used depends on the ambient temperature. Select according to the table "FUEL, COOLANT AND LUBRICANTS".
- ★ Check for oil leak at transmission case and filter.
- ★ Make an oil level check before starting engine or 60 minutes or more after the engine is stopped. If oil remains at various portions, the correct oil level cannot be measured.

Remove all mud and dirt from around the breather, then remove the breather. Put in cleaning fluid and clean the breather.

EVERY 1000 HOURS SERVICE

c. LUBRICATING

Apply grease to the grease fittings shown by arrows.

1. Center hinge pin (2 points)

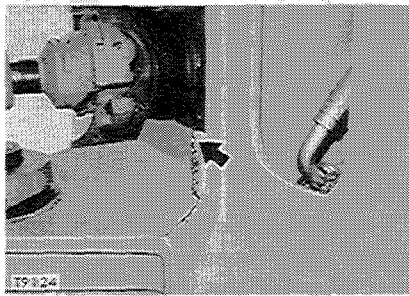

2. Drive shaft center support (1 point)

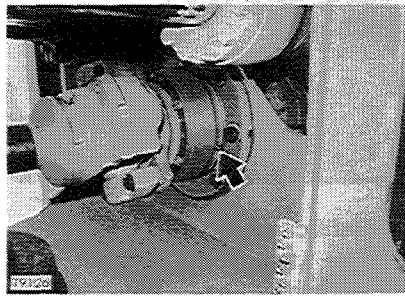

4. Rear drive shaft (3 points)

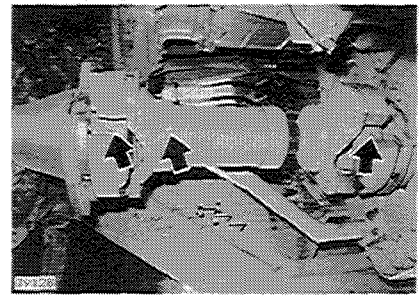

3. Front drive shaft (3 points)

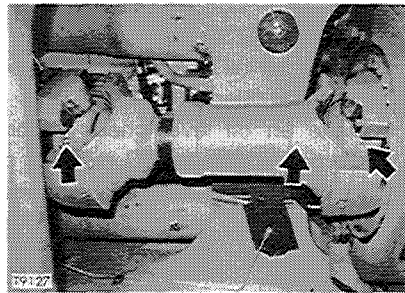
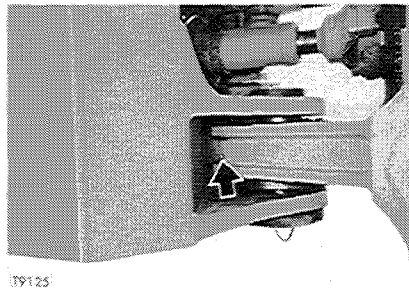

EVERY 1000 HOURS SERVICE

5. Upper drive shaft (2 points)

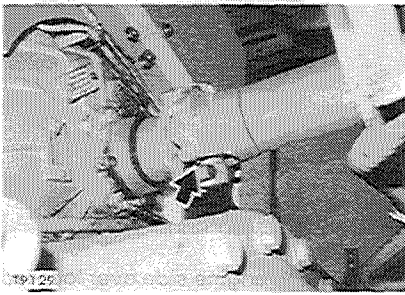

6. Parking brake linkage (6 points)

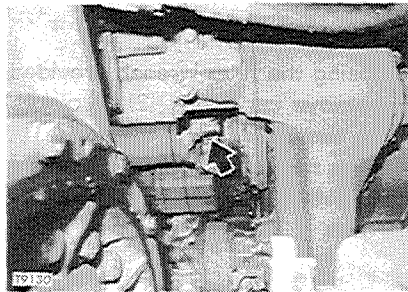
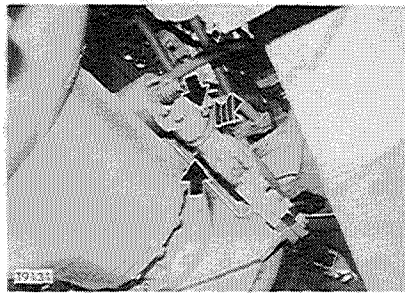

7. Damper (1 point)

8. Torque converter mount trunnion (1 point)

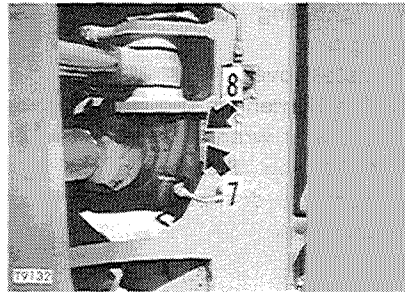

d. TURBOCHARGER VARIOUS FASTENERS

Any leaky joint connecting to the engine exhaust pipe will cause a lowering of oil pressure, resulting in seizing of bearings.

Connect your Komatsu distributor for repairs, or check as follows. Tighten if necessary.

- Turbine housing mounting bolt
Tightening torque: 6.0 – 7.5 kgm
- Blower housing clamping bolt
Tightening torque: 0.9 – 1.0 kgm
- Turbocharger mounting bolt (for securing the exhaust manifold and turbine housing together)
Tightening torque: 10.0 – 11.5 kgm

EVERY 1000 HOURS SERVICE

- Turbocharger oil feed pipe (inlet line)
Tightening torque:
2.8 – 3.5 kgm
- Turbocharger oil feed pipe (out line)
Tightening torque:
6.0 – 7.5 kgm

e. ROPS CANOPY

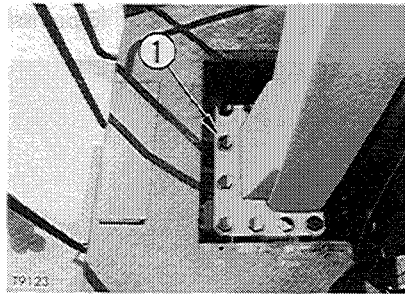

1. Loosen bolt, then remove cover.
2. Check that there is no looseness in mounting bolts (1) of the ROPS canopy. If any bolt is loose, tighten it.
★ Tightening torque: 280 ± 30 kgm
3. Install cover.
★ The tightening torque is large, so a power wrench is needed when tightening. Please request your Komatsu distributor to carry out this work.

f. CORROSION RESISTOR

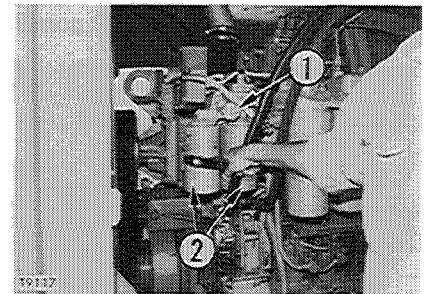

1. Open the engine side over located at the right of the body and lock open lock.
2. Close valve (1).
3. Using the filter wrench provided, remove cartridges (2) (2 pieces) by turning it counterclockwise.
4. Fit a new cartridge after applying a dab of engine oil to the seal face.

EVERY 1000 HOURS SERVICE

- ★ To fit the cartridge, put the seal face in contact with head, then screw it up by hand about 1/2 to 3/4 of a turn. (Be careful not to apply excessive torque.)
- 5. After replacement, open valve (1).
- ★ Be sure to use a genuine Komatsu cartridge.
- ★ After replacing the cartridge, start up the engine and check the filter seal face for possible oil leakage.

EVERY 2000 HOURS SERVICE

EVERY 2000 HOURS SERVICE

★ Maintenance for every 50, 100, 250, 500 and 1000 hours should be carried out at the same time.

a. HYDRAULIC TANK AND FILTER

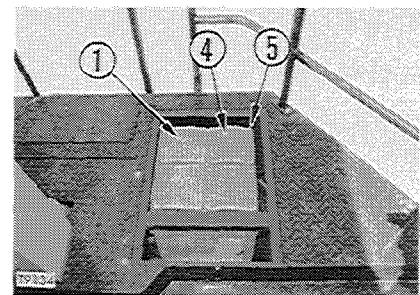
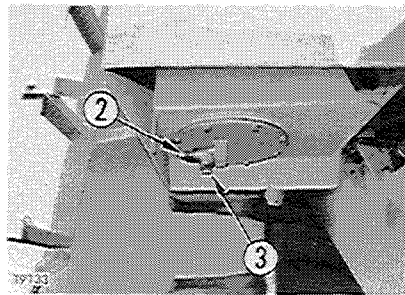
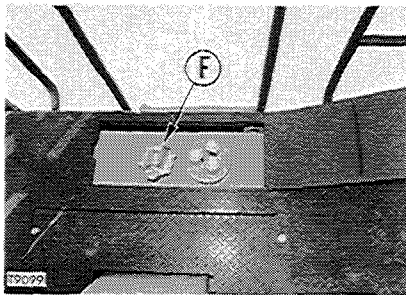

1. Lower the bucket horizontally to the ground and apply the parking brake, then stop the engine.

2. Remove the cap of oil filler (F) and air vent plug (1) on filter case.

⚠ When removing the cap, turn it slowly to relieve inner pressure.

3. Remove drain plug (3) and loosen drain valve (2) to drain oil. After draining off the oil tighten up them.

★ After loosening drain valve (2), pull it out slowly to drain oil.

4. Remove mounting bolt (5) of the filter cover (4), then remove cover (4).

⚠ The cover is pushed by a spring, so hold the cover when removing the bolts.

5. Remove spring (6) and bypass valve (7), then remove element (8).

★ Check that there is no foreign matter inside the tank before cleaning it.

6. Install a new element, then install bypass valve (7), spring (6), and cover (4).

★ If the O-ring of the cover is damaged or deteriorated, replace it with a new part.

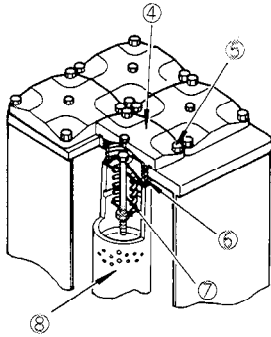

- ★ When installing the cover bolts, push down the cover and tighten the bolts evenly.
- 7. Pour in the specified quantity of engine oil from filler (F).
- 8. Bleed the air from the piston pump.
For details of bleeding the air, refer to BLEEDING AIR FROM CIRCUIT (bleeding air from piston pump).

⚠ Never start the engine before the air has been completely bled from the piston pump. If the engine is started without the air being bled from the piston pump, the piston pump may be broken.

9. Bleed the air of hydraulic circuit, refer to BLEEDING AIR FROM HYDRAULIC CIRCUIT. Then lower the bucket horizontally to the ground and stop the engine.
10. Check the oil level and ensure that is correct. (Refer to EVERY 100 HOURS SERVICE.)

- ★ The type of lubricant used depends on the ambient temperature. Select according to the table "FUEL, COOLANT AND LUBRICANTS".
- ★ Refill capacity: 550 ℓ
- ★ Check that there is no oil leaking from the filter cover mount.

b. AXLE

Front

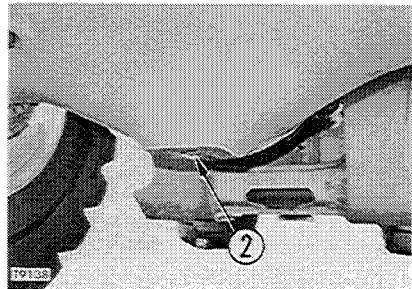
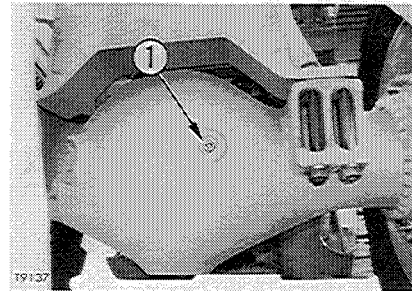

EVERY 2000 HOURS SERVICE

Rear

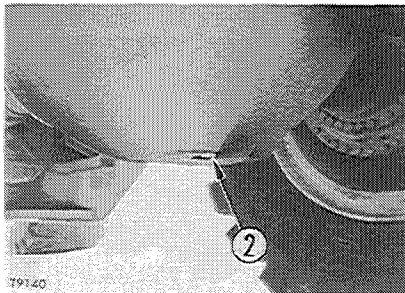
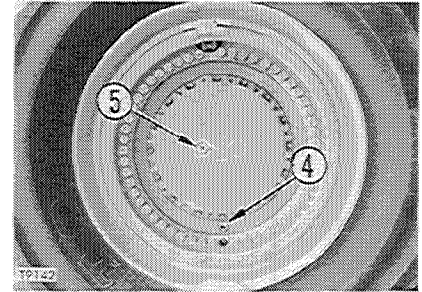
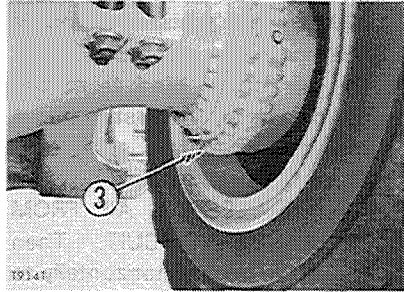
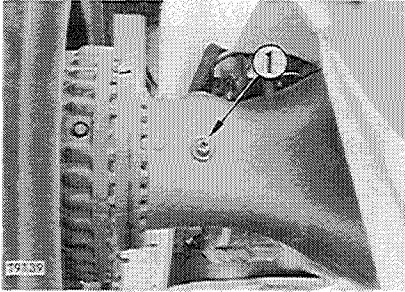

1. Remove front and rear oil filler plugs (1), then remove drain plugs (2) to drain the oil.
2. Remove drain plug (3) to drain the oil. After draining, tighten up it.
3. Stop the machine so that drain plug (4) of the final drive is at the bottom. Remove oil filler plug (5) and drain plug (4), and fit the tube of attached tool in hole of plug (4) and drain the oil.

4. After draining the oil, clean drain plugs (2), (3) and (4), then install them.
5. Add oil to the specified level through the oil filler ports (1) and (5) of the axle housing and left and right final drives.
6. Check the oil level and ensure that is correct. (Refer to WHEN REQUIRED.)

EVERY 2000 HOURS SERVICE

c. AIR CONDITIONER FILTER

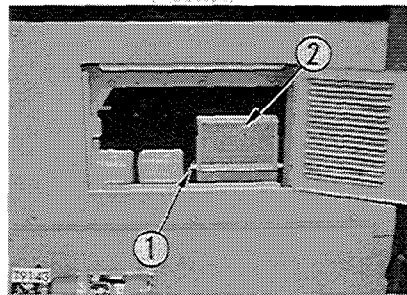

1. Open the cover located on the behind of the operator's seat.
2. Loosen nut (1) holding the filter element, pull out element (2).
3. Install a new element and close the cover.

d. HYDRAULIC TANK BREATHER

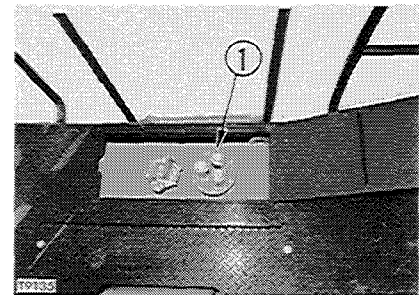

1. Remove cap of oil filler.

⚠ When removing the cap, turn it slowly to relieve inner pressure.

2. Remove snap ring on breather (1), then remove breather cap.

- ★ Use the same procedure to change the oil for the front and rear axles.
- ★ Refill capacity: 360 ℓ (each axle)
- ★ The type of lubricant used depends on the ambient temperature. Select according to the table "FUEL, COOLANT AND LUBRICANTS".

EVERY 2000 HOURS SERVICE

**e. POC (Pilot Operated Control)
CIRCUIT STRAINER**

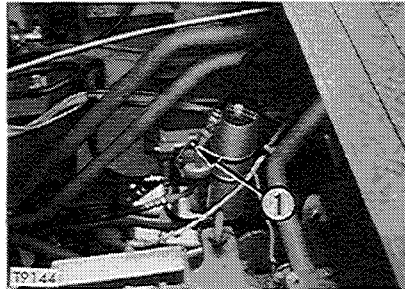

3. Replace filter element with a new part, then install cap and snap ring.

★ It is possible to replace the element with the breather installed in the tank. However, if the breather is removed, do not wrap the taper thread of the breather with seal tape when assembling again, and be careful not to tighten too much.

1. Loosen bolts (1) (3 pieces).
2. Remove strainer case and pull out the strainer, then wash strainer with clean diesel fuel.
3. Install the strainer in the strainer case, and mount with bolts (1).
4. Bleed the air from the hydraulic oil circuit. (See Section on "BLEEDING AIR FROM CIRCUIT".)

f. ENGINE BREATHER

1. Remove the breather pipes from the cylinder blocks of the left and right banks.
 2. Check that there is no sludge inside the pipes.
- ★ If there is any sludge, replace the pipe with a new part.

g. TURBOCHARGER ROTOR PLAY

Contact your Komatsu distributor for checking, or proceed as follows:

Remove air intake pipe from turbocharger.

1. Axial play

Check axial play by moving rotor in axial direction.

Play:

Standard 0.08 – 0.18 mm

2. Radial play

Measure radial play by moving rotor holding both ends by hands in radial direction in parallel.

Play:

Standard 0.25 – 0.60 mm

★ If the rotor is excessively soiled with dust or carbon or if any oil leakage caused by turbocharger trouble is noted, have the turbocharger repaired by your Komatsu distributor.

h. TURBOCHARGER

Excessive carbon or oil sludge adhering to turbocharger blower impeller may lead to deterioration of normal charger performance, and possible damage. Have turbocharger cleaned by Komatsu distributor.

1. Remove the turbocharger oil filler pipe and drain pipe, then remove the intake air pipe connector and blower housing so that the blower impeller can be seen.

2. Using light oil as a cleaning agent, remove the carbon, sludge and other dirt from the blower impeller. Do not use a wire brush or other tool which may damage the impeller.

3. Pour in light oil through the turbocharger oil filler and rotate the blower impeller several times to wash out the sludge.

4. Rotate the impeller by hand at least one turn at speed to check that there is contact noise or catching inside.

If the impeller does not turn smoothly, contact your Komatsu distributor for repair or replacement.

5. If there is no abnormality, dry off the light oil with compressed air after inspection, then add engine oil.

EVERY 2000 HOURS SERVICE

i. ALTERNATOR AND STARTING MOTOR

As the hours of engine employment indicate that the brushes are already worn out, you should request repair from a Komatsu distributor.

- ★ They should be repaired every 1000 hours, if the machine is frequently operated at night.

j. ENGINE VALVE CLEARANCE

Ask Komatsu distributor to check engine valve clearance because special tools should be used.

k. BRAKE DISC

Ask Komatsu distributor to check and repair brake disc.

l. BUCKET HINGE PIN AND BUCKET LINK PIN

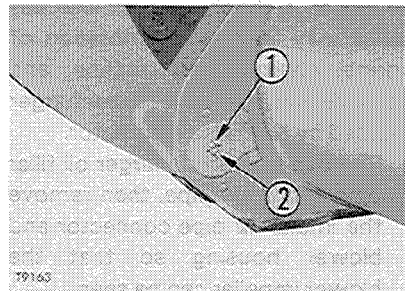

1. After removing plugs (1) and (2), refill gear oil (SAE140 GL-5) from hole of plug (1) until new oil comes out from grease fitting inside.

- ★ Amount of refill oil:
Approx. 0.27ℓ

2. Install plugs (1) and (2).
- ★ After removing bucket pin, be sure to refill with oil.
 - ★ Never use grease in place of gear oil.

m. HYDRAULIC TANK STRAINER

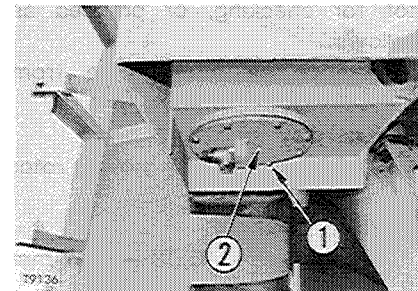

When changing the oil in the hydraulic tank, drain the oil from the tank and clean the strainer.

1. Loosen bolts (1) and (3), then remove covers (2) and (4).
 2. Loosen bolt (5), remove strainer cover (6), then remove strainer (8) together with spring (7).
 3. Remove any dirt from strainer (8), then wash in clean light oil or flushing oil.
- If strainer (8) is broken, replace it with a new part.

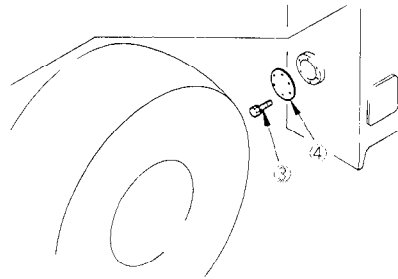
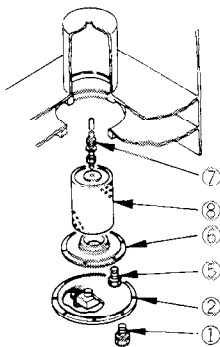

n. INTERNAL PART OF AIR DRYER

If the air dryer is installed as an option, replace the following internal parts of the air dryer:

Desiccant, oil filter, filter, and all rubber parts.

Contact your Komatsu distributor to have these parts replaced.

4. Install spring (7), strainer (8), and cover (6). When doing this, look through the mounting hole of cover (4) to check that the strainer guide pin is fitted in the guide hole.

★ When installing cover (6), coat the thread of bolt (5) with thread tightener (LT-2) to prevent it from coming loose. If bolt (5) becomes loose and drops out, it will be sucked into the piston pump and will damage the pump.

Tightening torque of bolt (5):

9 ± 3.5 kgm

5. Install covers (2) and (4).

★ Replace the O-rings of the covers with new parts.

EVERY 4000 HOURS SERVICE

EVERY 4000 HOURS SERVICE

★ Maintenance for every 50, 100, 250, 500, 1000 and 2000 hours should be carried out at the same time.

a. WATER PUMP

Inspect the water pump for play in the pulley, grease leakage and water leakage.

If any fault is detected, ask Komatsu distributor to disassemble and repair or replace.

b. AIR COMPRESSOR

Special tools are needed for testing and adjusting, so ask your Komatsu distributor to disassemble and repair or replace.

c. FAN PULLEY AND TENSION PULLEY

Check the pulley to see if there is any leaking grease. If any abnormality is found, ask your Komatsu distributor to repair or replace it.

d. ENGINE VIBRATION DAMPER

Check decrease of damper fluid, dent or out-of-flat. If there is any abnormality, contact your Komatsu distributor for repair.

WHEN REQUIRED

WHEN REQUIRED

a. CLEAN INSIDE OF COOLING SYSTEM

- Clean the inside of the cooling system, replace the antifreeze, and replace the corrosion resistor, according to the table.
- Change water after first parking the machine on a level surface.

Type of antifreeze solution	Cleaning inside of cooling system and replacing antifreeze	Replacing corrosion resistor
Permanent type antifreeze	Every year (autumn) or every 2000 hours whichever comes first	Every 1000 hours and when cleaning the inside of the cooling system and when replacing antifreeze
Other permanent type antifreeze of ethylene glycol base	Every 6 months (spring, autumn) Change antifreeze only in autumn	Every 1000 hours and when cleaning the inside of the cooling system and when replacing antifreeze
When not using antifreeze	Every year (autumn) or every 2000 hours whichever comes first	Every 1000 hours and when cleaning the inside of the cooling system

Corrosion resistor

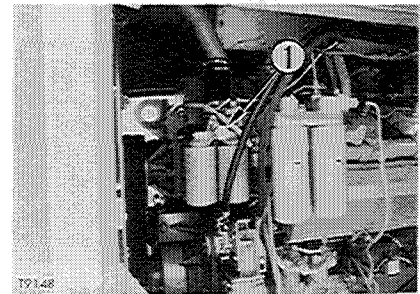

1. Stop the engine, tighten up corrosion resistor valve (1), and turn cap (2) slowly until it comes off.
2. Open drain valve (3) of the radiator, valve (4) of the oil cooler and valve (5) on the side of cylinder block to drain off the cooling water.
3. After draining the cooling water, close up drain valves (3), (4) and (5), and pour in soft water (ex: city water) up to the vicinity of the water filler.

WHEN REQUIRED

Water filler

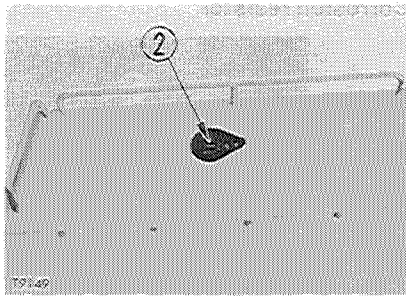

4. When the water reaches the vicinity of the water filler, put the engine at low idling, open drain valves (3), (4) and (5), then pass water for 10 minutes through the cooling system until clean water comes out from drain valves (3), (4) and (5).

★ When doing this, adjust the speed of filling and draining the water so that the radiator is always full.

Drain valves (radiator, oil cooler)

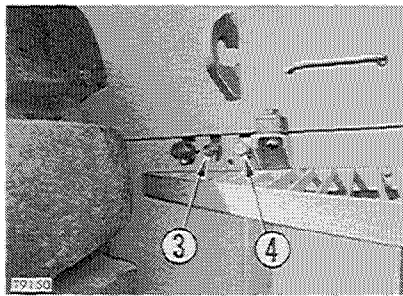

5. When the water becomes completely clean, stop the engine, draining off the cooling water, and close drain valves (3), (4) and (5).

6. After draining the water, clean with a cleaning agent.

★ We recommend use of a Komatsu genuine cleaning agent. For details of the cleaning method, see the instructions given with the cleaning agent.

Drain valve (cylinder block)

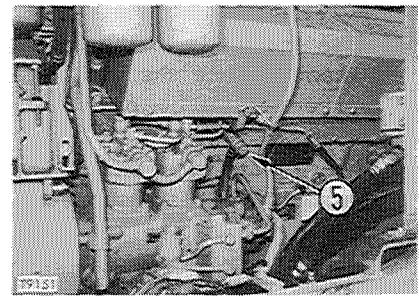

7. After cleaning, drain all the cooling water, then close the drain valves (3), (4) and (5), and fill slowly with soft water.

8. When the soft water comes up to near the radiator water filler port, start the engine, and run at low idling. Add soft water, open drain valves (3), (4) and (5), and continue to run water until clean colorless water comes out from the drain valves (3), (4) and (5).

★ When doing this, adjust the speed of filling and draining the water so that the radiator is always full.

WHEN REQUIRED

9. When the water is completely clean, stop the engine and close drain valves (3), (4) and (5).
10. Replace the corrosion resistor cartridge with a new part, and open the corrosion resistor valve (1).
 - ★ For details of replacement of the corrosion resistor, see EVERY 1000 HOURS SERVICE.
11. Add soft water until it overflows from the water filler.
12. To remove the air in the cooling water, run for 5 minutes at low idling, then for another 5 minutes at high idling.
When doing this, leave radiator cap (2) off.
13. Stop the engine, wait for about 3 minutes, add soft water to the specified level, then tighten cap (2).

- ★ Use city water for the cooling water.
If river water, well water or other such water supply must be used, contact your Komatsu distributor.
- ★ Do not use any alcohol base antifreeze.
- ★ Be sure to replace the corrosion resistor cartridge.

⚠ Do not remove the cap while cooling water is hot. Hot water may spout out.
When removing radiator cap, lift the lever to relieve inner pressure.

b. CHECK, CLEAN AND REPLACE AIR CLEANER ELEMENT

Checking

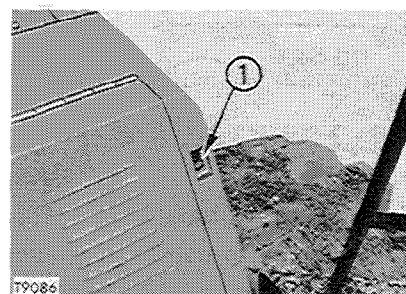

Whenever the red piston in dust indicator (1) appears, clean the air cleaner outer element. Stop the engine when cleaning the element.

WHEN REQUIRED

Cleaning or replacing outer element

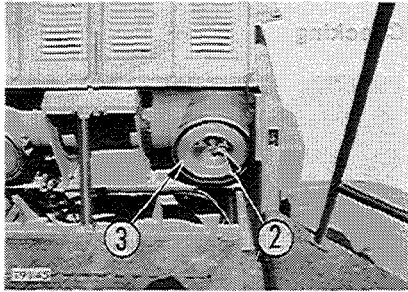

1. Remove wing nut (2) and outer element (3).
2. Clean the air cleaner body interior and the removed cover.
3. Clean and inspect the element. (See the item "Cleaning outer element" for cleaning procedure.)
4. Install the cleaned element.
5. Push the dust indicator reset button to return the red piston to the original position.

- ★ Replace the outer element which has been cleaned 6 times repeatedly or used throughout a year. Replace the inner element at the same time.
- ★ Replace both inner and outer elements when the dust indicator red piston appears soon after installing the cleaned outer element even though it has not been cleaned 6 times.

- ★ Remove one seal from the outer element. The number of times the outer element has been cleaned can be seen by the number of removed seals.
- ★ Check inner element mounting nuts for looseness and, if necessary, retighten.
- ★ Replace seal washer (4) or wing nut (2) if they are broken.

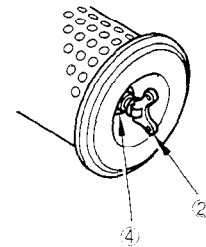

WHEN REQUIRED

Replacing inner element

1. First remove the outer element.
2. Remove the inner element.
3. Place the cover over the air intake part to prevent dust entering.
4. Clean the air cleaner body interior, then remove the cover from the air intake port.
5. Fit a new inner element and tighten it with nuts.
6. Install the outer element and the cover. Push the dust indicator reset button.

- ★ Do not attempt to reinstall a cleaned inner element.

⚠ Do not clean or replace the air cleaner element with the engine running.

Cleaning outer element

With compressed air

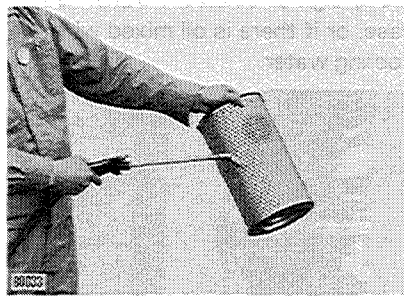

Direct dry compressed air (less than 7 kg/cm²) to element from inside along its folds, then direct it from outside along its folds and again from inside, and check element.

⚠ When using compressed air, wear safety glasses and other things required to maintain safety.

The following methods require spare parts.

With water

Dash city water (less than 3 kg/cm²) on element from inside along folds, then from outside and again from inside. Dry and check it.

With cleaning agent

For removing oils and fats as well as carbon etc. attached on the element, the element may be cleaned in lukewarm solution of mild detergent, then rinsed in clean water and left to drip dry.

- ★ Drying can be speeded up by blowing dried compressed air (less than 7 kg/cm²) from the inside to the outside of the element.

Never attempt to heat the element.

- ★ Using warm water (about 40°C) instead of soapy water may also be effective.

WHEN REQUIRED

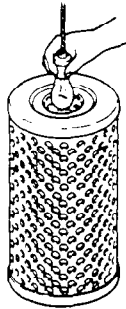

- ★ If small holes or thinner parts are found on element when it is checked with an electric bulb after cleaning and drying, replace the element.
- ★ Do not use element whose folds or gasket or seal are damaged.
- ★ When cleaning element, do not hit it or beat it against something.

c. CHECK AND REFILL TRANSMISSION OIL

Carry out this procedure if there is any sign of oil on the transmission case, or if there is oil mixed with the cooling water.

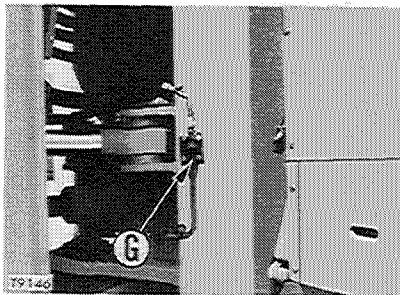

1. Use sight gauge (G) to check the oil level.
2. If the oil level is not between the top and bottom marks on the sight gauge, add engine oil through oil filler (F).

- ★ The type of lubricant used depends on the ambient temperature. Select according to the table "FUEL, COOLANT AND LUBRICANTS".

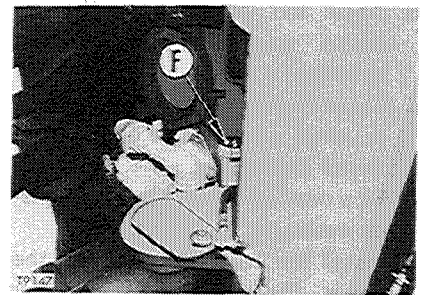

- ★ Stop the engine when checking the oil level.
- ★ Make an oil level check before starting engine or 60 minutes or more after the engine is stopped. If oil remains at various portions, the correct oil level cannot be measured.

! When checking the oil level, apply the parking brake, and lock the front and rear frames with the safety bar and pin.

WHEN REQUIRED

d. CLEAN RADIATOR FINS

Carry out this procedure if there is any mud or dirt seen stuck to the radiator.

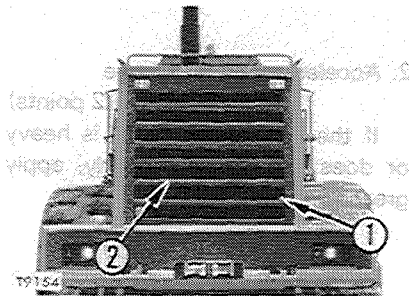

1. Loosen bolt (1) and remove radiator grille (2).
2. Clean the radiator fins and oil cooler fins clogged with mud, dust and leaves with compressed air. Steam or water may be used instead of compressed air.

★ The rubber hose should be checked at the same time. If the hose is found to have cracks or to be hardened by ageing, such hose should be replaced by new one. Further, loosened hose clamp should also be checked.

e. CHECK AND REFILL AXLE OIL

Carry out this procedure if there is any sign of oil on the axle case.

Front

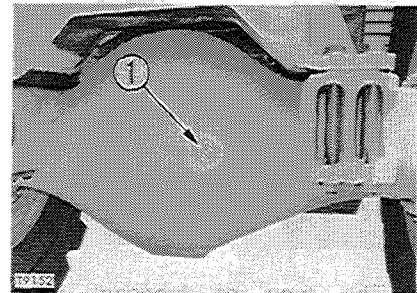

Remove oil level plug (1), and check that the oil level reaches the bottom of the plug hole. If necessary, add oil through the hole of plug (1).

WHEN REQUIRED

Rear

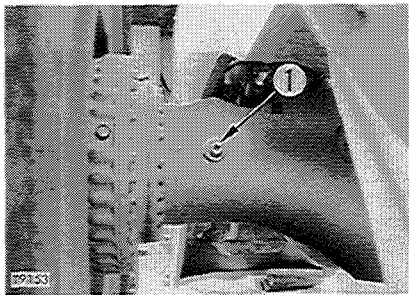

★ The type of lubricant used depends on the ambient temperature. Select according to the table "FUEL, COOLANT AND LUBRICANTS".

f. LUBRICATING

Apply grease to the grease fittings shown by arrows.

1. Work equipment control valve linkage (2 points)

If the work equipment control lever is heavy or does not move smoothly, apply grease.

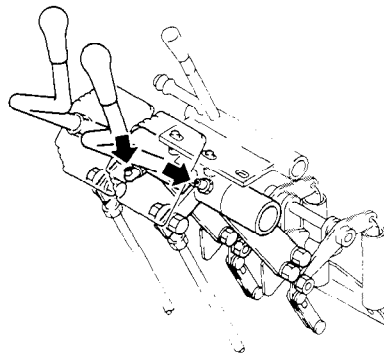

2. Accelerator pedal linkage (2 points)

If the accelerator pedal is heavy or does not return properly, apply grease.

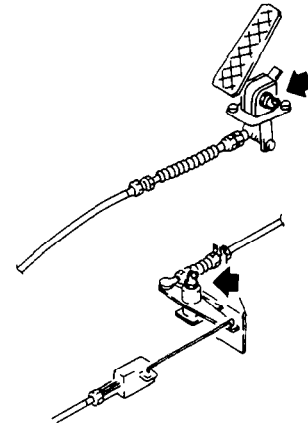

WHEN REQUIRED

3. Steering column (1 point)
If the play of the steering column is heavy or does not return properly, apply grease.

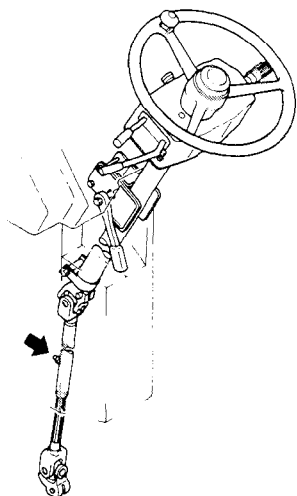

g. REPLACING BUCKET TEETH

If the bucket equipped with tip tooth.

Replace the teeth before they wear down as far as the adaptor.

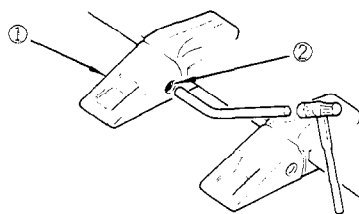

1. Extract pin (2) fitted to the bucket and then remove tooth (1).

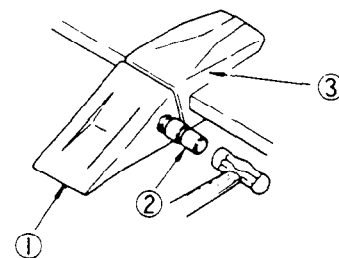

- ★ When extracting pin (2), strike the part (either the left or right part) with a sharp object. This will enable the pin to be extracted from the opposite side.
2. Insert the new tooth (1) into the adaptor (3), and insert pin (2) partway as shown in the diagram. Then drive it home by means of a hammer.

WHEN REQUIRED

h. CHECK AIR CONDITIONER

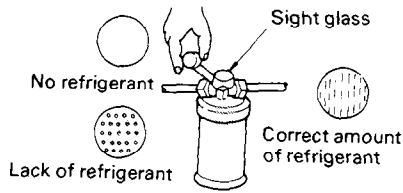

Check refrigerant (gas) level

If the refrigerant level is too low, the cooling effect is reduced. When the cooler is being operated at high speed, air bubbles cannot usually be seen in the sight glass (inspection window) installed on the receiver on the right side of the air cleaner.

If air bubbles are formed, the refrigerant level is too low, so have your dealer add refrigerant immediately.

Cooler condition	Normal	Abnormal	
Temp. of high, and low pressure pipes	High pressure pipe is hot. Low pressure pipe is cold. Clear difference in temperature	High pressure pipe is warm. Low pressure pipe is cold. Little difference in temperature	Almost no difference in temperature between high and low pressure pipes.
Sight glass	Almost transparent. Any bubbles disappear if the engine speed is raised or lowered.	Bubbles are always flowing. Sometimes becomes transparent, or white bubbles appear.	Misty substance is flowing.
Connections of pipes	Properly connected	Some parts dirty with oil	Some parts very dirty with oil
General condition of cooler	Coolant level correct, no abnormalities. Ready for use	May be a leak somewhere. Call service repair shop for inspection.	Almost all coolant has leaked out. Contact service repair shop immediately.

WHEN REQUIRED

i. CLEAN CONDENSER OF AIR CONDITIONER

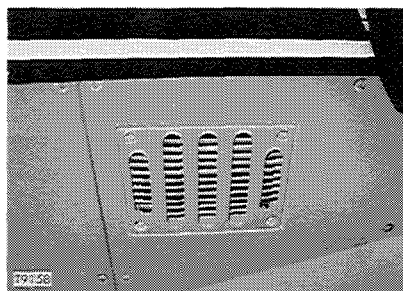

⚠ The cooler refrigerant is colorless and odorless and does not cause pollution of the atmosphere. However it may cause injury if it gets in the eyes or on the hands, so never loosen any parts of the refrigerant circuit.

If there is mud or dust on the air conditioner condenser, clean it with water.

★ If the water pressure is too high, the fins may get deformed. When washing with a high pressure washing machine, apply the water from a reasonable distance.

⚠ Do not wash the condenser with a steam cleaner. Otherwise, the condenser will get hot and may break down.

j. CHECK AND REFILL WINDOW WASHING FLUID

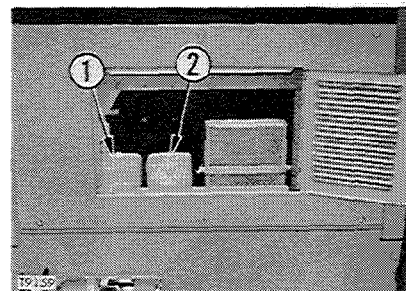

Check the washing fluid levels in washer tanks (1) and (2). When the fluid has run short, add automotive window washing fluid.

(1): Front window washing fluid tank
(2): Rear window washing fluid tank

★ To prevent the nozzles from clogging, be careful not to let dust get into the fluid.

WHEN REQUIRED

k. CLEAN AXLE CASE BREATHER

Carry out this procedure if there is any mud or dirt stuck around the breather.

Front

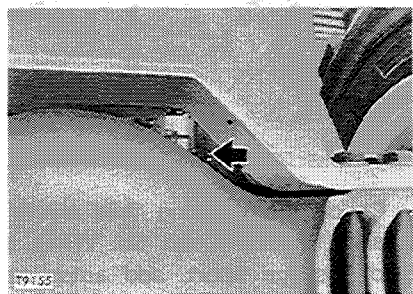

Remove all mud and dirt from around the breather with brush.

Then, remove breather, immerse in cleaning fluid and clean.

Rear

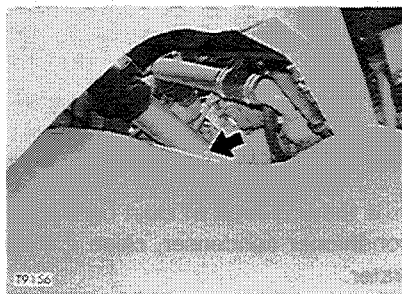

- ★ Clean the breathers of the front and rear axles in the same way.
- ★ Do not let dirt get into the port while breather is removed.
- ★ If dust sticks to area around breather, clean with a brush.

l. CHECKING OF GLOW PLUG OF APS

(Automatic priming system)

Checking is performed in autumn (when the ambient temperature is below 15°C).

1. Remove the two glow plugs from the engine intake manifold, and clean them.
2. Check for any disconnection in the wiring.
3. Replace the gasket with a new part, then install the glow plug.

WHEN REQUIRED

m. REPLACE APS FUEL FILTER

Before using APS in cold weather, replace the cartridge (once a year).

1. Close the valve (1) at the front of the APS fuel filter cartridge.

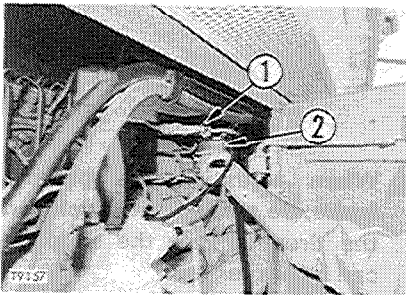

2. Using a filter wrench, turn the filter cartridge (2) to the left to remove.

- ★ Clean the filter base, and check that the filter gasket is not stuck to the filter base.

If the old gasket is stuck to the filter base, oil will leak between the new gasket and old gasket.

3. Fill the new filter cartridge with fuel, coat the packing surface with engine oil, and install.

- ★ When installing, be careful not to overtighten. When the cartridge comes in contact with the packing face, tighten 1/2 to 3/4 of a turn by hand.

n. DRAIN WATER FROM WATER SEPARATOR

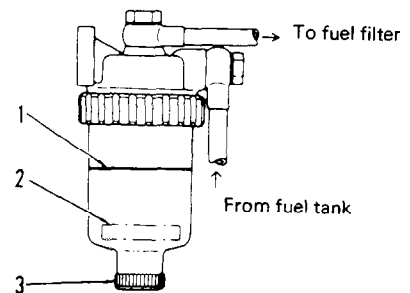

When float (2) is at or above red line (1), drain the water according to the following procedure:

1. Loosen drain plug (3) and drain the accumulated water until the float reaches the bottom.
2. Tighten drain plug (3).
3. If the air is sucked into fuel line when drain the water, be sure to bleed air in the same manner as for the fuel filter.

(See Fuel Filter Cartridge in EVERY 500 HOURS SERVICE section.)

ADJUSTMENT

PARKING BRAKE

If the parking brake fails to work properly, adjust it in the following manner.

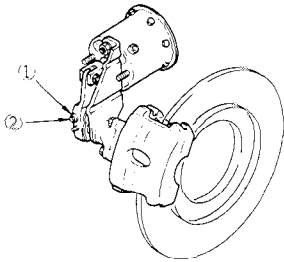

1. Confirm that the indication of the air pressure gauge is in the green range and then release the parking brake.
2. Turn bolt (2) clockwise while pressing bolt retainer (1) and let pads (3) on both sides come into close contact with disc (4).
3. Back off bolt (2) a half turn counter-clockwise while pressing bolt retainer (1).

ADJUSTMENT

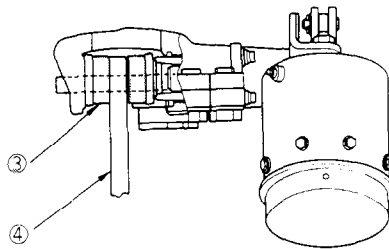

4. Restore bolt retainer (1) to the original position and confirm that the retainer is in locking position to bolt (2).
5. There are two calipers in the parking brake, so adjust the other caliper in the same way.

⚠ When adjusting the parking brake, be sure to put chocks on the tires so that the slippage can be prevented.

⚠ Maintain the air pressure at a sufficiently high pressure to prevent the parking brake from operating automatically while adjusting the brake.

To prevent a third person from operating the parking brake by mistake, be sure to attach a caution tag to the parking brake switch.

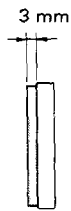

Check the lining for wear and replace the pad, if the thickness of the lining is reduced to less than 3 mm.

★ Ask your Komatsu distributor for replacement of the pad.

⚠ Take care not to stain the brake pad and the disc surface with oil or grease.

FAN BELT AND TENSIONER

Method of replacement

Loosen lock nut (2), then loosen bolt (3).

Push the tension pulley (1) in the direction of arrow to a position where the belt can be removed, then replace the belt.

★ When changing belts, do not only change one belt. Always change as a set.

Adjustment procedure

If noise comes from the belt, tighten adjustment bolt (3) to make A dimension 80 mm, and lock in position with lock nut (2).

★ Tightening torque: 38 kgm

★ When the belt is new, A dimension is about 100 mm.

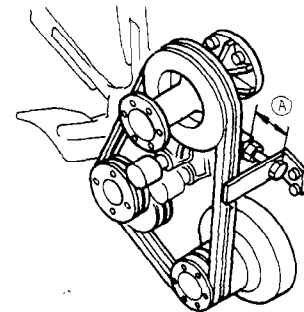
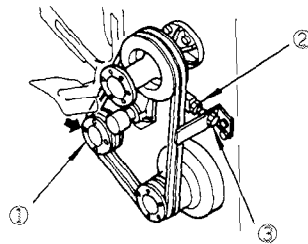

TROUBLE SHOOTING GUIDE

This guide is not intended to cover every conditions, however many of the more common possibilities are listed.

ELECTRICAL SYSTEM

Lamp does not glow brightly even when engine runs at high speed.

Lamp flickers while engine runs.

- Check for loose terminals and open-circuit wiring.
- Replace fan belt.

Charge monitor does not go out even when engine runs at high speed.

- Replace the alternator.
- Inspect and repair wiring.

Unusual noise is emitted from the alternator.

- Replace the alternator.

Starting motor does not turn when starting switch is turned on.

- Inspect and repair the wiring.
- Charge the battery.

The pinion of the starting motor keeps going in and out.

- Charge the battery.

Starting motor turns the engine sluggishly.

- Charge the battery.
- Replace the starting motor.

The starting motor disengages before the engine starts up.

- Check and repair the wiring.
- Charge the battery.

The engine pre-heating monitor does not flash.

- Check and repair wiring.
- Replace the heater relay.
- Replace the monitor.

The engine oil pressure monitor does not light up when engine is stationary (when the starting switch is in ON position.)

- Replace the monitor.
- Repair or replace the sensor.
- Check wiring.

Charge monitor does not light up when the engine is stationary. (When the starting switch is in ON position.)

- Replace the monitor.
- Inspect and repair the wiring.

Outside the glow plug is not warm when touched with the hand.

- Check and repair wiring.
- Replace the glow plug.
- Check and repair the pre-heater switch.

ENGINE

The engine oil pressure monitor flashes.

- Add the oil to the specified level.
- Replace the oil element.
- Check oil leakage from the pipe or the joint.
- Replace the monitor.

Steam is emitted from the front part of the radiator (the pressure valve).

Engine oil temperature monitor flashes.

- Supply the cooling water and check leakage.
- Replace fan belt.
- Wash out inside of cooling system.
- Clean or repair the radiator fin.
- Replace the thermostat.
- Tighten the radiator cap firmly or replace the gasket of it.
- Replace the monitor.

The engine does not start when the starting motor is turned over.

- Add fuel.
- Repair where air is leaking into fuel system.
- Replace the injection pump or the nozzle.
- Check the valve clearance.
- Check engine compression pressure.
- Refer to the section of electrical system.

Exhaust gas is white or blue.

- Adjust to specified oil quantity.
- Replace with specified fuel.

Exhaust gas occasionally turns black.

- Clean or replace the air cleaner element.
- Replace the nozzle.
- Check engine compression pressure.
- Clean or replace the turbocharger.

Combustion noise occasionally changes to breathing sound.

- Replace the nozzle.

Unusual combustion noise or mechanical noise.

- Replace with specified fuel.
- Check over-heating.
- Replace the muffler.
- Adjust valve clearance.

TROUBLE SHOOTING GUIDE

CHASSIS

Transmission

Engine is running but machine will not move.

- Release parking brake.
- Put directional lever in position properly.
- Add oil to transmission case to the specified level.

Even at full throttle, machine moves slowly and lacks power.

- Add oil to transmission case to the specified level.
- Disassemble transmission strainer and clean.

Oil overheats

- Add oil to transmission case to the specified level or drain oil.
- Use a suitable gear speed.
- Reduce time using torque converter at stall speed.
- Check engine.

Abnormal noise is produced.

- Add oil to transmission case to the specified level.

Axle

Abnormal noise is produced.

- Add oil to axle case to the specified level.

Disc brake

Brake does not work when pedal is depressed.

- Raise air pressure to specified level.
- Replace disc.
- Add brake oil.
- Bleed air from brake system.

Brake drags or stays applied

- Clean exhaust hole of treadle valve.
- Clean breather of power cluster.
- Check and repair slack adjuster.

Brake slips.

- Replace disc.

Parking brake

Brake does not work properly.

- Adjust linkage.
- Clean brake pad.
- Replace spring in air cylinder.
- Adjust or replace brake pad.

Steering

Steering wheel is heavy.

- Adjust steering gear.
- Check linkage, replace parts.

Hydraulic system

Bucket lacks lifting power.

Bucket lifting speed is slow.

- Add oil.
- Replace filter in hydraulic tank.

Many bubbles from in oil.

- Replace with specified oil.
- Add oil.
- Bleed air from oil line.

Oil pressure is too low.

- Add oil and bleed air.

Cylinder vibrates when operating.

- Add oil.

SERVICE METER

This meter indicates the integrated work hours. So, use it according to the following instructions.

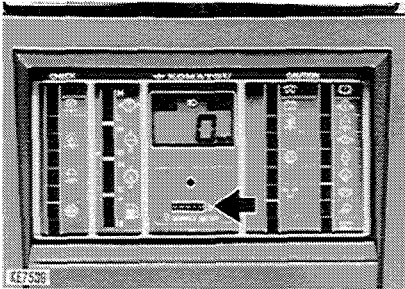

SERVICE METER

- Record the readings at the start and the end of work, this is the work record of the machine.
- This record will indicate, when periodical maintenance is due.
- It also indicates the integrated working hours when machine problems are encountered.
- ★ **How the meter progresses**

The service meter progresses by 1 when the engine is operated for one hour, regardless of the engine speed.

Consequently, if the engine is running, the service meter will advance even if the machine does not move.

- While engine is running, green pilot lamp on the service meter flashes to show the service meter advances.

MACHINE AND ENGINE SERIAL NUMBERS

When calling for a service of mechanic or when making replacement-parts order, be sure to give Komatsu distributor the machine and engine serial numbers as well as the service meter reading before mentioned. These numbers are found on the plates shown in the photos below.

- Location of the machine serial number mark

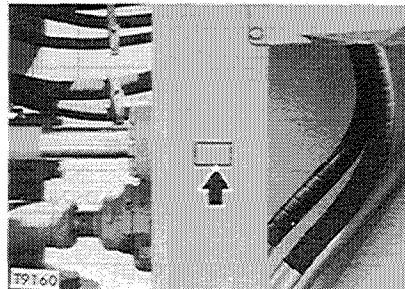

This is seen on the center right of the front frame.

- Location of the engine serial number mark

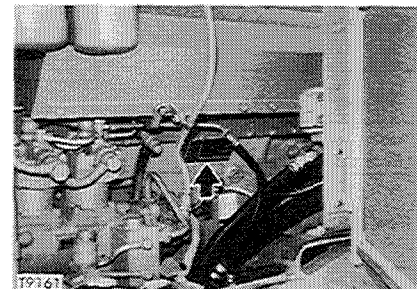

This is seen on the right of the cylinder block, when seen from the fan side.

FUEL, COOLANT AND LUBRICANTS

FUEL, COOLANT AND LUBRICANTS

PROPER SELECTION OF FUEL, COOLANT AND LUBRICANTS

RESERVOIR	KIND OF FLUID	AMBIENT TEMPERATURE									CAPACITY (ℓ)	
		-22 -30	-4 -20	14 -10	32 0	50 10	68 20	86 30	104 40	122° F 50° C	Specified	Refill
Engine oil pan	Engine oil	SAE 30							82	64		
		SAE 10W				SAE 10W-30						
		SAE 15W-40										
Brake	Engine oil	SAE 10W									10.3	10.3
Transmission case	Engine oil	SAE 30							164	140		
		SAE 10W										
Hydraulic system	Engine oil	SAE 10W									946	550
Axle (Front and rear)		See NOTE (4)									each 360	each 360
Fuel tank	Diesel fuel	ASTM D975 No. 2									1200	-
		ASTM D975 No. 1										
Cooling system	Water	Add antifreeze									317	-

NOTE:

(1) When fuel sulphur content is less than 0.5%, change oil in the oil pan every periodic maintenance hours described in this manual. Change oil according to the following table if fuel sulphur content is above 0.5%.

Fuel sulphur content	Change interval of oil in engine oil pan
0.5 to 1.0%	1/2 of regular interval
Above 1.0%	1/4 of regular interval

- (2) When starting the engine in an atmospheric temperature of lower than 0°C, be sure to use engine oil of SAE10W, SAE10W-30 and SAE15W-40, even though an atmospheric temperature goes up to 10°C more or less in the day time.
- (3) Use API classification CD as engine oil and if API classification CC, reduce the engine oil change interval to half.
- (4) For axle oil, use only recommended oil as follows.
 SHELL: DONAX TT or TD
 CALTEX: RPM TRACTOR HYDRAULIC FLUID
 CHEVRON: TRACTOR HYDRAULIC FLUID
 TEXACO: TDH OIL
 MOBIL: MOBILAND SUPER UNIVERSAL
- ★ It is possible to substitute engine oil CLASS-CD SAE30 for axle oil.

ASTM: American Society of Testing and Material
 SAE: Society of Automotive Engineers

Specified capacity: Total amount of oil including oil for components and oil in piping.

Refill capacity: Amount of oil needed to refill system during normal inspection and maintenance.

SAFETY AND OPERATION



CONTENTS

SAFETY HINTS . . . 	2
PRECAUTIONS FOR MAINTENANCE	8
BUCKET OPERATION	12
OPERATING THE AIR CONDITIONER	18
OPERATING THE CAR HEATER	21
LOCKING CAP	23
RADIO	24
HANDLING OF BATTERY	26
STORAGE	29
COOLANT AND LUBRICANTS	31

SAFETY HINTS . . .

Protect yourself and others. Safety is always first.

OPERATION

GENERAL

- Wear well-fitting helmet, safety shoes and working clothes. If the nature of the work requires safety, wear protective goggles or mask, thick gloves, ear plugs or other protection.
- Take care of your health. Do not operate when tired, or after drinking.
- When there is a leader, fix standard signals and always follow these signals when operating.
- Learn the prohibitions, cautions and rules about work procedures in the work site.
- Read the Operation and Maintenance Manual carefully. Learn how to use the control devices, gauges and warning devices. Be sure you understand the meaning of the caution plates.
- Confirm that all gauges and warning devices are functioning correctly, and that the gauge readings are within the prescribed range.
- Learn about the safety devices on your own machine and about how to use them.
- Never allow another person to operate the machine.
- If there should be an accident or fire or any other such unexpected mishap, deal with it quickly, using the nearest apparatus. Learn beforehand the locations of the first aid boxes and fire extinguishers and how to use them. It is also important to know the emergency contact system.
- Fuel or oil are dangerous substances. Never handle fuel, oil, grease or oily cloth in places where there is any fire of flame.

CHECKING JOBSITE CONDITIONS

- Examine the lay of the land and the kind of soil at the work site to determine the dangerous points and the best method of operation.

Proceed with the work only after making safety arrangements about the dangerous points.

- Do not work when visibility is reduced by smoke, fog or dust. If the jobsite is dark, install lighting if necessary.
- Keep work site flat!
By continually grading the work site, work efficiency will be improved and machines will be able to drive smoothly over the site. If the work site is very sandy or dusty, sprinkle water over the ground before working on the site.

- Check the load limits of bridges before crossing.
- When operating a machine in water or fording streams, survey the water depth, ground condition and velocity of the water in advance. Do not take the machine in water exceeding the allowable depth (up to the underside of the axle housing).
- The overall height of the machine is restricted by tunnels, roof height or overhead electric wires, so check first whether the jobsite is safe. Be particularly careful when working near power lines as electric shock can be caused if the machine touches the electric cables.

BEFORE STARTING OPERATION

CHECK BEFORE STARTING

- Carry out checks before starting the machine. If any problem is found, do not start the engine, but inform the foreman immediately. Always keep the machine in good condition.
- Before operating the machine, be sure to check the bar and pins for setting in storage position. The machine can not be steered with frames locked. (In articulate frame model)
- Always stop the engine when adding fuel. After adding fuel, tighten the fuel cap properly.
- Inspect the inside of the engine room and remove any dead leaves or papers. Dead leaves or papers are highly inflammable and can cause fires.

- Do not leave parts or tools lying around in the vicinity of or on the floor of the operator's compartment. Keep everything in its proper place.
Wipe off thoroughly any grease, oil or mud on the handrail, floor or control levers. Failure to do this may cause you to slip.

PRECAUTIONS WHEN GETTING ON THE MACHINE

- If the machine is fitted with a cab, make sure the windows are clean and check the visibility. Always lock the door before starting operations.
- When getting on or off the machine, use the handrail and step provided. Do not jump up onto or down from the machine.
- If a seat belt is provided, always use it. If the belt is damaged or worn, replace it with a new one.

PRECAUTIONS WHEN STARTING THE ENGINE

- Before starting the engine, confirm that all control levers are in neutral position.
- Exhaust gas is dangerous. When working inside, be particularly careful to have good ventilation.
- To ensure the safety of workers near the machine, always sound the horn to warn them before starting the engine and moving the machine. Be particularly careful to check that the rear is clear before backing the machine.

CHECKS AFTER STARTING THE ENGINE

- Before starting work, test drive the machine in a safe place and check that the transmission, brakes, accelerator, and steering are working properly. At the same time, check that there is not abnormal noise or vibration, or any abnormality in the instruments and gauges.

DURING OPERATION

- Always sit in the operator's seat when operating the machine.
- Do not allow anyone except the operator on the machine.
- Always be aware of the operating capacity of the machine. Using the machine to do work beyond its capacity will not only damage the machine, but may even cause unexpected accidents.
- The machine condition can be judged from many factors. Changes in the gauges, sound, vibration, exhaust gas color or response of the control levers can indicate the occurrence of some disorder. If any disorder occurs, park the machine immediately in a safe place and take appropriate action.

ATTENTION TO SURROUNDINGS

- To ensure the safety of workers near the machine, always sound the horn to warn them before starting the engine and moving the machine. Be particularly careful to check that the rear is clear before backing the machine.
- Do not allow unauthorized persons into the work area.
- Always concentrate. It is extremely dangerous to allow yourself to be distracted or to think of other things when operating a machine.
- When loading trucks or hoppers, be careful not to hit the truck or hopper with the bucket. Do not bring the bucket over people's heads or over the cab of the truck.

- In dangerous places or in places where the visibility is poor, get down from the machine and check that it is safe before continuing the operation.
- Always operate slowly in crowded places. On haul roads or in narrow places, give way to loaded machines.
- When traveling, keep the work equipment close to the ground to maintain the stability of the machine. Pay particular careful attention to the stability of the machine when traveling with a load.
- If the machine has to travel on rough ground, be careful to avoid obstacles as far as possible.
- Always travel at a slow speed, and do not suddenly change direction.

- Do not use the bucket as a brake except in emergencies.
- If the engine stops when the machine is traveling, it is impossible to use the steering. This is dangerous, so apply the brake immediately to stop the machine.
- When traveling on hills with a loaded bucket, travel forward up the hill and in reverse down the hill.
- The machine should always be operated at a speed where it can be correctly controlled. Never do the following:
 - ★ Speeding
 - ★ Sudden starting, sudden braking, sudden turning
 - ★ Snaking
 - ★ Coasting

RESTRICTIONS CREATED BY JOBSITE

- Do not approach the edge of the cliff or road shoulder.
- In dangerous places, always work in teams of two; one man to operate the machine, and the other to give instructions.
- On windy days, always load downwind.
- When continuing operations after rain, remember that conditions will have changed from those before the rain started, so proceed with caution. Be careful when working on the place made of piled soil, after earthquakes or after blasting.
- Always travel directly up or down slopes. When traveling down a slope, use the same gear speed as when going up the slope. When traveling down a slope, never put the transmission in neutral.

PARKING

- If the engine stops on a slope, apply the brake quickly and carefully. Next, lower the work equipment to the ground and apply the parking brake. Then put the directional and speed control levers in neutral, and start the engine again.
- Be careful when traveling on planks or steel plates, as these can cause slippage.
- When operating at night, remember the following points:
 - Be sure to arrange an adequate lighting system.
 - At night it is very easy to make mistakes in assuming the distance and height of objects and land.
- Before towing operations, always check the wire rope.
- Before starting towing operations, make sure that no one is near the machine. Start the machine slowly to take up the slack in the wire rope. Then start towing carefully. Do not tow any machine whose brakes or steering have broken down.
- When parking the machine, park it in a safe place outside the working area, or in the specified place. The following factors should be considered when choosing a parking place: it should be on flat, firm ground where there is no danger of rock-falls, landslides or floods.
- If the machine has to be parked on a slope, it should be parked facing directly up or down the slope, and chocks should be placed under the tires.
- When leaving the machine, always lower the work equipment completely to the ground, and put all control levers in neutral. Next, apply the parking brake and lock all levers. Then put blocks under the tires.
- After stopping the engine, always remove the starting key.

PRECAUTIONS FOR MAINTENANCE

PRECAUTIONS FOR MAINTENANCE

GENERAL

- Wear well-fitting helmet, safety shoes and working clothes. When drilling, grinding or hammering, always wear protective goggles.
- When working with others, choose a group leader and work according to his instructions. Do not perform any maintenance beyond the agreed work.
- Hand a caution sign in the operator's compartment (for example "Do not start" or "Maintenance in progress"). This will prevent anyone from starting or moving the machine by mistake.
- Smoke only in designated places. Never smoke while working.
- Always keep the work shop in good condition. Make sure there is no mud or oil on the floor.
- Keep oily cloths and other combustible things in a safe place away from fire. In addition, learn the location and method of operation of fire extinguishers.
- Always stop the engine before cleaning the machine or adding fuel.
- Flame should never be used instead of lamps. Never use a naked flame to check leaks or the level of oil, fuel, anti-freeze or electrolyte.
- Always use non-inflammable cleaning agents when cleaning parts.

BEFORE MAINTENANCE

- Before starting work, stop the machine on a firm, level surface, and use blocks to keep the machine from moving during operations.
- Lower the bucket to the ground. If this is impossible, use the safety pin and blocks to hold the work equipment securely in position. In addition, apply the locks to all control levers.
- Always lock the front and rear frames before inspecting and servicing the machine.
(In articulate frame model)
- Remove all oil and mud from the machine. In particular, be sure that the steps, hand grips, and the floor of the operator's compartment are clean.
- Always use the standard ROPS equipment. Do not modify the ROPS equipment.

DURING MAINTENANCE

- When getting on or off the machine, use the steps, hand grips and ladders. Never jump on or off the machine. If the steps, hand grips, or ladder cannot be used, use a stand to give firm footing.
- If necessary, remove the cables from the battery terminals. When charging the battery, make sure the area is well ventilated.
- Exhaust gas is dangerous. When working inside, be particularly careful to have good ventilation.
- When opening inspection covers, stop the engine. If the hood or other covers are fitted with a lock, always apply the locks securely when opening or closing the hood or cover.
- Always stop the engine before adjusting belt tension or before checking or servicing the water pump.
- Be particularly careful when removing the radiator cap or the hydraulic oil tank filler cap. If this is done immediately after using the machine, there is a danger that boiling water or oil may spurt out.
- Always release the pressure in the circuit before checking or servicing the oil, water or air circuits.
- When the engine stops, the water and oil in the circuit is hot, so be careful not to get burned. Wait for the water and oil to cool before starting any work on the machine.

MISCELLANEOUS

- Thoroughly wash the machine, particularly the oiling and greasing parts and the vicinity, thereof, in order to prevent the ingress of dust.
- Use genuine Komatsu replacement parts specified in the parts list.
- Use Komatsu specified oil and grease. Use oil and grease having the recommended viscosity for the particular ambient temperature.
- Use clean oil and grease and keep them in clean containers to avoid the ingress of dust.
- Inspect or replace oil in a dust-free location to prevent the ingress of dirt.
- Drain off used oil after heating it to a suitable temperature (about 20 to 40°C).

PRECAUTIONS FOR MAINTENANCE

- When the strainer is located in the oil filler, the strainer must not be removed while adding oil.
- When adding oil or checking the oil level, check that the oil is at the correct level.
- After greasing up, always wipe off the old grease that was forced out.
- When changing the oil or filter, check the drained oil and filter for any signs of excessive metal particles or other foreign materials.
- When removing parts containing O-rings, gaskets or seals, clean the mounting surface and replace with new sealing parts.
- When washing the machine, ensure that water does not get onto the alternator.
- Special measuring apparatus is needed for testing hydraulic pressure.
- Thoroughly wash the machine. In particular, be careful to clean the filler caps, grease fittings and the area around the dipsticks. Be careful not to let any dirt or dust into the system.
- When check an open cover there is a risk of dropping things in. Before removing the covers to inspect cover, empty everything from your pockets. Be particularly careful to remove wrenches and nuts.
- When working on the sea shore, carefully clean all electrical equipment to ensure that it does not corrode.
- Before working in muddy water, rain or snow, check that the various plugs, valves, are properly screwed up. Upon completion of work, wash the machine, then check the various parts of the machine for cracking, scratching, loose or missing nuts and bolts. Also, oil and grease the various parts of the machine.
- When working on rocky ground, be careful of damage to the undercarriage, loose nuts and bolts, cracks, wear and other damage.

PRECAUTIONS FOR MAINTENANCE

- When working in a dusty location, be careful of the following:
 - 1) Inspect the dust indicator to see whether the air cleaner is blocked up. Clean the air cleaner as soon as it becomes dirty.
 - 2) Clean the radiator core so that it does not become blocked up.
 - 3) Clean or replace the fuel filter as soon as it becomes dirty.
 - 4) Clean the electrical equipment, particularly the starting motor and alternator, to prevent accumulation of dust.
- When installing car radio and a walkie-talkie or citizen band, contact your Komatsu distributor.
- When washing the machine, take care not to splash water over the electrical equipment. If it is soaked with water, it may not operate normally.
- After disconnecting the connector, cover it with a vinyl bag to prevent oil or dust from sticking to its contact section.
- When welding, be careful of the following:
 - 1) Turn OFF the power (starting switch).
 - 2) Do not continuously apply more than 200 V.
 - 3) Install the ground cable at least 1 m from the range to be welded.
 - 4) Take care not to install the seals between the grounded point and the range to be welded.
- ★ Use ordinary automobile washer fluid. Be careful not to let dirt or dust get in.

BUCKET OPERATION

Various types of attachments are available to extend the range of application beyond the applications described below.

EXCAVATION

- When loading piled soil or blasted rock, drive the machine forward as follows to load. To prevent cutting of the tires caused by the tires slipping, be careful of the following points during the operation.
- ★ Always keep the operating jobsite flat, and remove any fallen rocks.
- ★ When working with stockpiles, operate the machine in 1st or 2nd, operate the machine in 1st when loading blasted rock.

1. When driving the machine forward and lowering the bucket, stop the bucket about 30 cm from the ground, then lower it slowly.
- ★ If the bucket hits the ground, the front tires will come off the ground, and the tires will slip.

2. Shift down immediately in front of the material to be loaded. When completing the shift down, depress the accelerator pedal at the same time and thrust the bucket into the load.

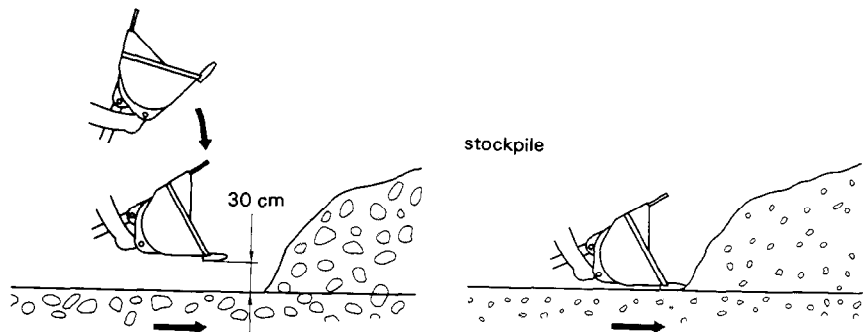

BUCKET OPERATION

3. When the material is in a stockpile, keep the cutting edge of the bucket horizontal; when loading blasted rock, have the bucket tilting slightly down.

★ Be careful not to get blasted rock under the bucket. This will make the front tires come off the ground and slip.

★ Try to keep the load in the center of the bucket; if the load is on one side of the bucket, the load will be unbalanced.

4. At the same time as thrusting the bucket into the material, raise the lift arm to prevent the bucket from going in too far. By raising the lift arm, ample traction will be produced by the front tires.

5. Check that there is enough material loaded into the bucket, then operate the bucket control lever to tilt the bucket and load the bucket fully.

★ If the bucket edge is moved up and down while pushing in the bucket and digging, the front tires will come off the ground and this will cause the tires to slip.

Blasted rock

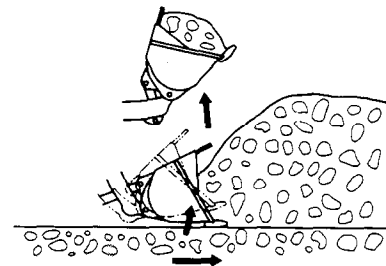
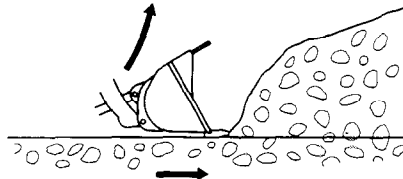
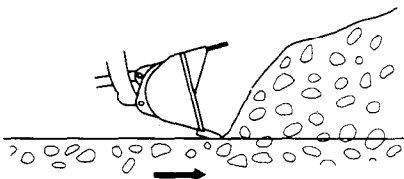

BUCKET OPERATION

6. If there is too much material loaded in the bucket, dump and tilt the bucket quickly to remove the excessive load. This prevents spillage of the load during hauling.

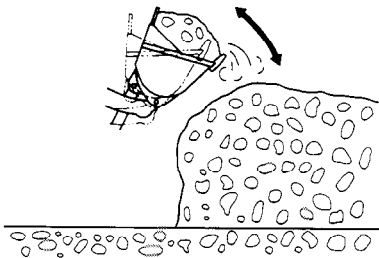

- When digging and loading on level ground, set the bucket edge facing down slightly as follows and drive the machine forward. Always be careful not to load the bucket on one side and cause an unbalanced load.

★ This operation should be carried out in 1st gear.

1. Set the edge of the bucket facing slightly down.

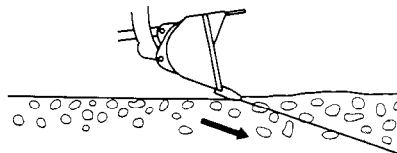

2. Drive the machine forward and operate the lift arm control lever forward to cut a thin layer of the surface each time when excavating the soil.

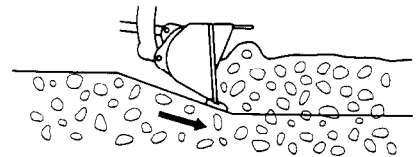

3. Operate the lift arm control lever slightly up and down to reduce the resistance when driving the machine forward.

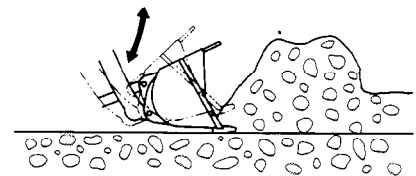

- ★ When digging with the bucket, avoid imposing the digging force onto only one side of the bucket.

⚠ Never dig or scoop when the machine body is articulated.

Precautions when scooping up materials.

When scooping up materials, be careful not to let the counterweight at the rear touch the ground.

- ★ Do not allow tires slipping to occur during operation. Tires slipping shortens tire's life.

LEVELING

1. Scoop soil into the bucket. Move the machine backward while spreading soil from the bucket little by little.
2. Go over the spread soil with the bucket teeth touching the ground and level the ground by back-dragging.
3. Scoop some more soil into the bucket, put the lift arm in float, level the bucket at ground level, and smooth the ground by moving backward.

- ★ Always move the machine backward during leveling operations.

⚠ If leveling by forward travel can not be avoided, do not dump the bucket beyond 20°. This will prevent quick wear and damage of the work equipment and frame.

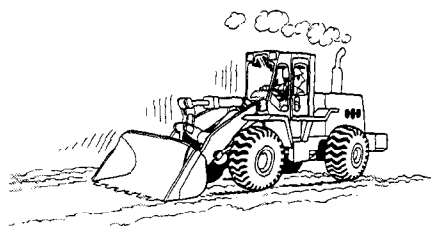

BUCKET OPERATION

LOAD AND CARRY OPERATIONS

Load and carry operation is a series of processes (scooping → carrying → loading to a hopper or glory hole) carried out by the wheel loader.

★ Always maintain the road in good condition.

⚠ Lower the bucket to bring down the center of gravity when carrying material.

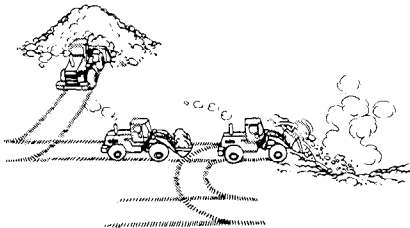

LOADING

Select and proceed effective operation which avails less turning and the shortest hauling distance according to ground conditions.

CROSS DRIVE LOADING

When a wheel loader is operated, the digging should be made at a right angle toward accumulated soil. When the scooping is completed, the machine should be traveled backwards as it is. Then, bring the truck between the accumulated soil and the wheel loader for the purpose of loading upon the dump truck.

⚠ Provide a flat road free of rocks and hollows. When the boom is raised with the bucket loaded, do not make quick turns or quick braking because it is very dangerous.

⚠ Do not load the bucket by thrusting into a pile of soil or gravel at high speed because it is dangerous.

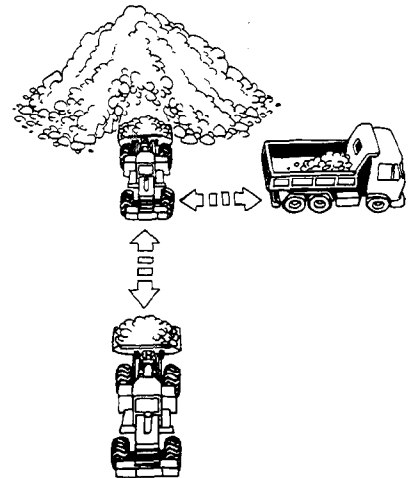

V-SHAPE LOADING

Stop the truck with the angle of about 60° toward the scooping direction of the wheel loader. After scooping the soil, back the wheel loader in such a way that it makes a right angle to the truck. The loading on the truck is made by the wheel loader going forward.

The smaller the turning angle, the higher the efficiency. However, turning of 90° can be made if necessary.

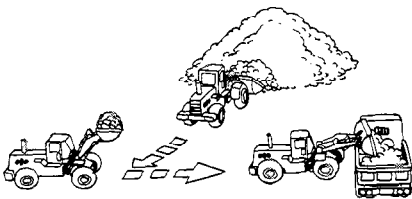

OPERATING THE AIR CONDITIONER

It is possible to use the air conditioner to good effect in dusty job-sites. The outside air is passed through the filter and is sent to the operator's cab to increase the pressure inside the cab. In this way, dust is prevented from entering, so comfortable operating conditions are always maintained for the operator.

EQUIPMENT ON CONTROL PANEL

① Fan switch

- This controls the air flow when the air conditioner is used for cooling or heating.
 - There are 3 levels: L (Low), M (Medium), and H (High).

② Air conditioner switch

- This is the control switch for cooling.

ON:

When this button is pressed, the dehumidifying and cooling systems are switched ON.

The green lamp inside the button lights up to indicate that cooling is in operation.

OFF:

If the button is pressed when the cooling is ON, the cooling is switched OFF.

- ★ Turn the fan switch on before turning the air conditioner switch on.

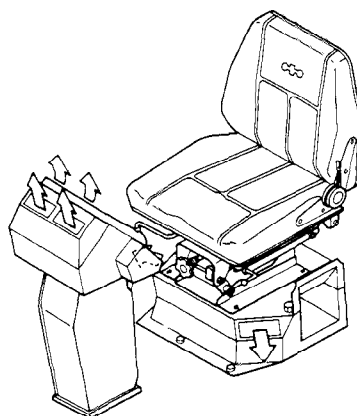
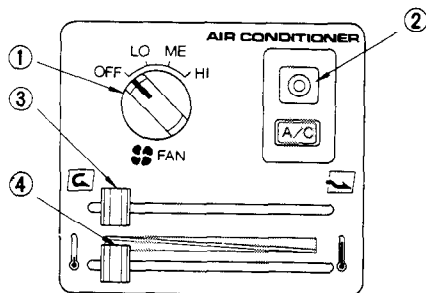

③ Air selector lever

- This lever switches the source for the cooling air or heating air.
 - FRE (fresh air)
Fresh air is brought into the cooling system from outside. (This position is used for normal cooling and heating, and when increasing the pressure inside the cab.)
 - REC (recirculate)
The air conditioning system uses only the air inside the cab. (This position is mainly used for cooling or heating the air inside the cab quickly.)

④ Temperature control lever

- This lever regulates the temperature when cooling.
 - The closer the lever is to COOL, the lower the temperature of the air becomes.
 - The closer the lever is to WARM, the higher the temperature of the air becomes.

Precautions for using air conditioner

When cooling, change the air occasionally.

- Smoking in the air-conditioned cab will cause your eyes to get sore. While smoking, open the window to let the smoke out of the cab.
- While using the air conditioner, open the window once every hour.

Be careful not to overcool the cab.

The cab should feel cool when entering there from outside (5°C or 6°C lower than the outside temperature). It is not good for the health to have the temperature in the cab too low. Always give careful consideration to temperature regulation.

Handling the air conditioner in season

To use the air conditioner comfortably during its season, ask your Komatsu distributor to check the air conditioner and add the refrigerant if necessary.

Handling the air conditioner in off-seasons

To lubricate each part of the compressor during the off-seasons, operate the air conditioner for a few minutes two or three times a month.

OPERATING THE AIR CONDITIONER

METHOD OF OPERATION

SELECTING AIR VENT

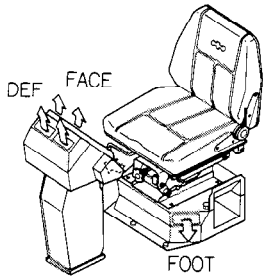

Purpose \ Vent	FACE	FOOT	DEF
Cooling	Open	Open or closed	Closed
Heating	Open or closed	Open	Open or closed
Defrosting	Closed	Open or closed	Open
Ventilation	Open	Open	Open

- ★ The effectiveness of the air conditioning system can be increased by selecting the most suitable vent.
- ★ Do not turn the fan switch on when all the vents are closed.

OPERATION OF CONTROL PANEL

Lever, switch Purpose		Fan switch	Air conditioner switch	Temperature control lever	Air selector lever
Cooling	Quick	H	ON	COOL (moved fully to COOL side)	REC
	Normal	H – L	ON	COOL – Middle	FRE
Dehumidifying, heating		H – L	ON	Middle – WARM	FRE
Heating	Quick	H	OFF	WARM (moved fully to WARM side)	REC
	Normal	H – L	OFF	Middle – WARM	FRE
Defrosting		H	ON	Middle – WARM (to remove frost quickly or to prevent the window from misting up, move the lever to the top)	FRE
Ventilation or pressurizing		H – L	OFF	COOL (move fully to COOL side)	FRE

- ★ If the outside air is extremely dusty, set the fan switch to the H position. This will pressurize the cab and prevent the dust from entering.

OPERATING THE CAR HEATER

It is possible to use the car heater to good effect in dusty jobsites. The outside air is passed through the filter and is sent to the operator's cab to increase the pressure inside the cab. In this way, dust is prevented from entering, so comfortable operating conditions are always maintained for the operator.

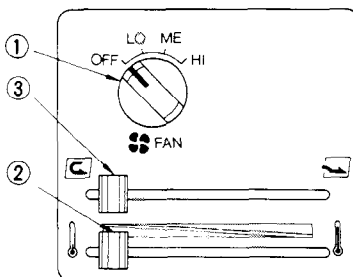

EQUIPMENT ON CONTROL PANEL

① Fan switch

- This controls the air flow when the car heater is used for heating.
 - There are 3 levels:
 - L (Low), M (Medium) and H (High)

② Temperature control lever

- This lever regulates the temperature when heating.
 - The closer the lever is to WARM, the higher the temperature of the air becomes.

③ Air selector lever

- This lever switches the source for the heating air.
 - FRE (fresh air)
 - Fresh air is brought into the heating system from outside. (This position is used for normal heating, and when increasing the pressure inside the cab.)
 - REC (recirculate)
 - The heating system uses only the air inside the cab. (This position is mainly used for heating the air inside the cab quickly.)

OPERATING THE CAR HEATER

**METHOD OF OPERATION
SELECTING AIR VENT**

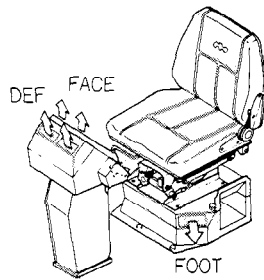

Purpose \ Vent	FACE	FOOT	DEF
Heating	Open or closed	Open	Open or closed
Defrosting	Closed	Open or closed	Open
Ventilation	Open	Open	Open

- ★ The effectiveness of the heating system can be increased by selecting the most suitable vent.
- ★ Do not turn the fan switch on when all the vents are closed.

OPERATION OF CONTROL PANEL

Purpose	Lever, switch	Fan switch	Temperature control lever	Air selector lever
Heating	Quick	H	WARM (moved fully to WARM side)	REC
	Normal	H – L	Middle – WARM	FRE
Defrosting		H	Middle – WARM (to remove frost quickly or to prevent the window from misting up, move the lever to the top)	FRE
Ventilation or pressurizing		H – L	COOL (move fully to COOL side)	FRE

- ★ If the outside air is extremely dusty, set the fan switch to the H position. This will pressurize the cab and prevent the dust from entering.

LOCKING CAP

A locking cap is available as an optional radiator cap, fuel tank cap or hydraulic tank cap. Open and close locking caps as follows:

1. To open the cap

1) Insert the key into the cap.

★ Insert the key as far as it will go. If the key is turned before it is inserted all the way, it may break.

2) Turn the key counterclockwise and bring the rotor groove in line with the aligning mark on the cap. Turn the cap slowly until a "clicking" sound is made. This releases the lock and allows the cap to be opened.

2. To lock the cap

1) Turn the cap into place.

2) Turn the key clockwise and take the key out.

★ When the cap is locked (against vandalism), it rotates freely.

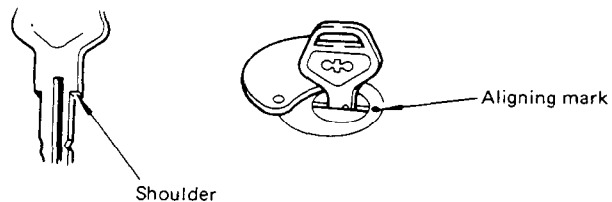
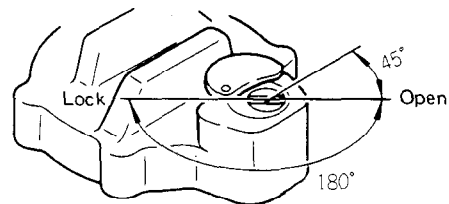

RADIO

RADIO

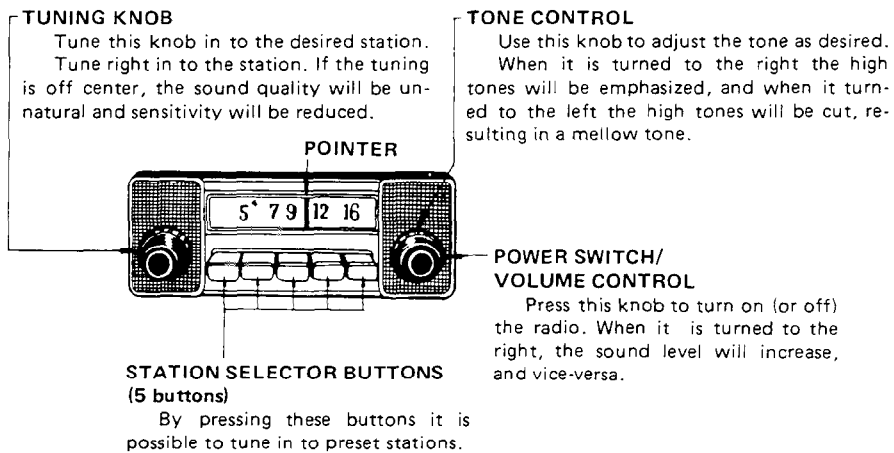

How to set station selector buttons

Set the station selector buttons to the desired stations as shown in the following figure.



1. Pull back the button corresponding to the station to be preselected.

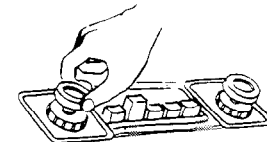

2. Turn the station selector knob until the pointer is in front of the desired station. (Carefully tune in so that noise disappears and the broadcast is heard plainly.)



3. Carefully push back the button with the fingertip until it clicks into place.

- ★ When setting the turning selector to a strong station, shorten the antenna to reduce the input as far as possible before carrying out alignment.

Precautions when using radio

- To prevent possible breakdown, keep water well away from the speaker case and interior of the radio. In particular, close the window during rain or when washing the machine.
- Do not wipe the dial plate or knobs with benzine or paint thinners, etc. Always use a dry, soft cloth (if the radio is particularly dirty, soak the cloth in alcohol).
- Do not disassemble the radio.

Trouble shooting guide

No sound

- Turn the SW/VOL knob to the right and press it two or three times.

Sound quality is poor.

Reception is noisy.

- Return using the station selector knob. If the problem disappears, reset the tuning button.
- Try lengthening the antenna to its fullest extent.

HANDLING OF BATTERY

PRECAUTIONS FOR CHARGING BATTERY

1. Before charging, disconnect the cable from the negative (–) terminal of the battery. Otherwise, an unusually high voltage will damage the alternator.
2. While charging the battery, remove all battery plugs for satisfactory ventilation.
To avoid gas explosions, do not bring fire or sparks near the battery.
3. If the electrolyte temperature exceeds 45°C, stop charging for a while.
4. Turn off the charger as soon as the battery is charged.
Overcharging the battery may cause followings:
 - 1) Overheating the battery
 - 2) Decreasing the quantity of electrolyte.
 - 3) Damaging the electrode plate.
5. If the electrolyte gets on your skin or clothes, immediately wash with plenty of clean water.
6. Do not mix up cables (positive (+) to negative (–) or negative (–) to positive (+)), as it will damage the alternator.
7. When inspecting or servicing a battery, be sure to stop the engine and turn the starting switch key to “OFF” position.
8. When performing any service to battery besides checking the electrolyte level or measuring the specific gravity, disconnect cables from the battery.

REMOVAL AND INSTALLATION OF BATTERY

⚠ When removing battery, first disconnect the cable with the black tube from the ground (normally, from the negative (-) terminal). If a tool touches a cable connecting the positive terminal and the chassis, there is danger of sparks being emitted.

● When installing battery, the ground cable should be connected to the ground terminal as the last step.

★ There is a total of four batteries (two on each side) at the rear of the machine, and a total of two batteries at the ground end (one on each side of the machine).

When removing or installing the batteries, always follow the above procedure for the batteries on both sides.

STARTING ENGINE WITH A BOOSTER CABLE

When starting up the engine with a booster cable, do as follows:

1. Before connecting the booster cable
 - 1) Size of booster cable and clip should be suitable for the battery size.
 - 2) Check cables and clips for breaks, corroded surfaces, etc.
 - 3) Make sure cables and clips are firmly secured.
 - 4) Keep the starting switch in "OFF" position.
 - 5) The battery of the running engine must be the same capacity as that of engine to be started.

2. Connect the booster cables in the following manner.

- 1) Connect one clip of booster cable A to the positive (+) terminal of the engine to be started.
- 2) Connect the other clip to the positive (+) terminal to the engine which is running.
- 3) Connect one clip of booster cable B to the negative (-) terminal of the engine which is running.
- 4) Connect the other clip to the engine block to be started.

★ Make sure the clips are firmly connected to battery terminals. Then, start the engine.

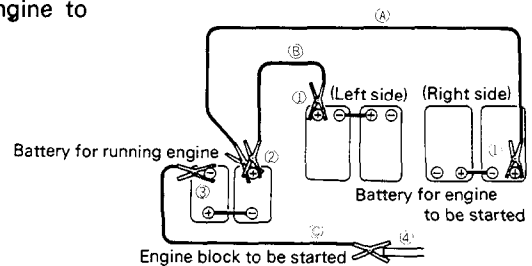

HANDLING OF BATTERY

★ If the battery capacity of the normal machine is smaller than the battery capacity of the failed machine, use two normal machines. Connect the booster cable from one machine to the battery on the right side of the failed machine; connect the booster cable from the other machine to the battery on the left side of the failed machine using the same procedure.

⚠ When connecting the cables, never contact the positive (+) and negative (–) terminals.

⚠ Make sure that the booster cable connections are correct. Connect the booster cable to the engine block as far as possible from the battery.

3. Starting engine

- 1) Turn the starting switch to START position and start up the engine.
- 2) If the engine doesn't start at first, try again after 2 minutes or so.

After the engine has started, the booster cables should be disconnected in the reverse order in which they were connected.

1. Disconnecting the booster cables
 - 1) Disconnect the clip of booster cable B from the engine block which was started.
 - 2) Disconnect the other clip from the negative (–) terminal of the running engine.

- 3) Disconnect the clip of booster cable A from the positive (+) terminal of the running engine.
- 4) Disconnect the other clip from the positive (+) terminal of the engine which was started.

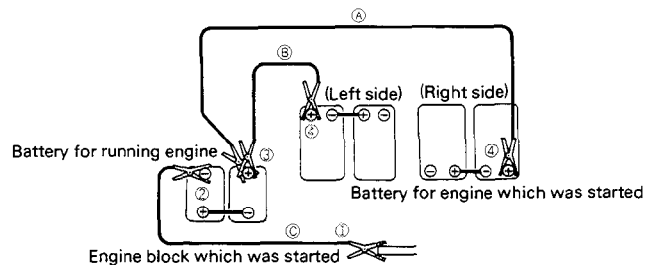

STORAGE

BEFORE STORAGE

To place the machine in storage for an extended period of time, the following measures must be taken to insure that it can be returned to operation with minimum of service.

- After every part is washed and dried, the machine shall be housed in a dry building. Never leave it outdoors.

In case it is indispensable to leave it outdoors, lay wood plates on the ground, and park the machine on the wood plates and cover it with canvas etc.

- Completely fill fuel tank, lubricate and change oil before storage.

- Apply a thin coat of grease to metal surface (hydraulic piston rods and splined shaft).
- As to batteries, remove the terminals and cover them, or remove them from the machine and store separately.

- When the ambient temperature is anticipated to drop below 0°C, always add antifreeze in the cooling water.
- Set each control levers to neutral or hold position, lock them and apply the parking brake.
- Open the drain valve of the air tank to drain condensation. Close after completely drained.

STORAGE

DURING STORAGE

- Operate the engine and move the machine for a short distance once a month so that new oil film will be coated over movable parts and component surfaces.
- Before operating the work equipment, wipe off the grease on the hydraulic piston rod.

⚠ If it is unavoidably necessary to carry out rust-preventive operation while the machine is indoors, open up doors and windows to improve ventilation and prevent the gas poisoning.

AFTER STORAGE

After storage (when it is kept without cover or the rust-preventive operation once a month is not made), you shall apply the following treatment before operation.

- Wipe off the grease on the hydraulic piston rod.
- Loosen the drain plugs on oil pan and other cases and drain mixed water.

- You should request Komatsu distributor for following service.
 - Remove the cylinder head cover and lubricate sufficiently valves and rocker arms. And inspect the valve operation.
 - Remove the oil pipe flange on the turbocharger oil inlet, fill with 0.5 to 1 ℓ engine oil, and leave the flange lightly loosened. Then, rotate the engine by the starting motor without fuel injection and decompression so that the discharge of oil is confirmed. Then, tighten the flange and start the engine.
- After the engine is started, operate it until it is warmed up completely.

COOLANT AND LUBRICANTS

No.	Supplier Name	Engine Oil [CD] SAE10W, SAE30, SAE10W/30, SAE15W/40	Gear Oil [GL-4, GL-5] SAE90, SAE140,	Grease [Lithium-Base] NLGI-2	Anti-Freeze Coolant [Ethylene Glycol Base] [Permanent Type]
1	AGIP	Diesel Sigma S Superdiesel Multigrade	ROTRA MP	GR M	—
2	AMOCO	Amoco 300	Multi-Purpose Gear	Super Permalube Grease	—
3	ARCO	Arco Fleet S-3 Plus	HD Gear Oil	Litholine H-EP	—
4	BP	Vanellus C-3	Hypoidgear EP Gear Oil EP	Energrease L2 Energrease LS2	Antifreeze
5	CALTEX	RPM Delo 300 RPM Delo 400	Multipurpose Thuban EP Universal Thuban	Marfak Multipurpose Marfak All Purpose	AF Engine Coolant
6	CASTROL	RX Super CRD	Hypoy, Hipress Hypoy B, Hypoy C	LM Grease	Antifreeze
7	CHEVRON	Delo 300 Delo 400	Universal Gear	Multi-Motive Grease Ultra-Duty Grease 2	—
8	ELF	Multiperformance 3C Performance 3C	Tranself EP Tranself EP Type B	Multi EPEXA 2	Glacelf
9	EXXON (ESSO)	Essolube D-3 Essolube XD-3 Essolube XD-3 Extra	Gear Oil GP Gear Oil GX	Multi Purpose Grease Beacon 2 Beacon EP2	—

COOLANT AND LUBRICANTS

No.	Supplier Name	Engine Oil [CD] SAE10W, SAE30, SAE10W/30, SAE15W/40	Gear Oil [GL-4, GL-5] SAE90, SAE140,	Grease [Lithium-Base] NLGI-2	Anti-Freeze Coolant [Ethylene Glycol Base] [Permanent Type]
10	GULF	Super Duty	Multi-Purpose Gear Hypoid Gear All Purpose Type	Gulfcrown Grease No. 2 Gulfcrown EP Special Grease No. 2	Cruisemaster Antifreeze and Summer Coolant
11	MOBIL	Delvac 1300 Delvac 1400 Delvac 1400 Super	Mobilube HD Mobilube GX	Mobilgrease MP Mobilgrease 77 Mobilgrease 532 Mobilux EP2	Permazone
12	PENNZOIL	Supreme Duty Fleet Multi-Duty	Multi-Purpose Gear No.4092 No.4096 No.4140	Multi-Purpose No. 705 Wheel Bearing No.707L	Anti Freeze & Summer Coolant
13	SHELL	Rimula Rimula X	Spirax EP Spirax Heavy Duty	Alvania Grease EP	—
14	SUN	Sunfleet Dieselube XL Sunfleet Super C	Sunfleet GL-5	Sunfleet HP Sun Prestige 742 EP	Sunoco Multi-Season Anti-Freeze
15	TEXACO	Ursa Super Plus Ursa Oil LA Ursa Super LA	Multigear Lubricant EP Thuban	Marfak All Purpose Marfak Multi Purpose 2	Startex AF & Summer Coolant
16	TOTAL	Rubia S Rubia x	TOTAL EP Transmission TM	Multis EP2	Antifreeze
17	UNION	Guardol	MP Gear Lube LS	Unoba EP	—

EVERY 500 HOURS SERVICE

★ Maintenance for every 50, 100 and 250 hours should be carried out at the same time.

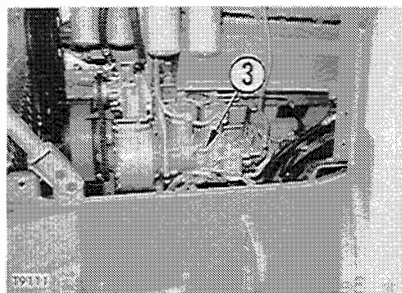
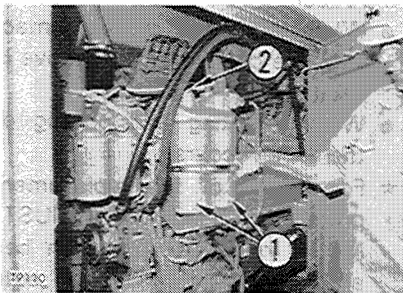
a. FUEL FILTER

1. Open the engine side panel located at the right of the body and lock open lock.
2. Using a filter wrench, remove cartridges (1) (2 pieces) by turning it counterclockwise.
3. Fill the new cartridge with fuel and refit it after applying a dab of oil to the gasket face.

- ★ To refit the cartridge, place the gasket face in contact with the seal face of the filter stand, then screw up the cartridge 1/2 to 3/4 of a turn (be careful not to tighten it up excessively).
4. After replacing the filter cartridge, loosen air bleed plug (2) of the fuel filter.

5. Loosen knob (3) of the feed pump, and operate the pump until no more bubbles come out with the fuel from the air bleed plug.
 6. Tighten air bleed plug (2).
 7. Loosen the fuel injection pump air bleed plug or overflow valve.
 8. Operate the feed pump until no more bubbles come out with the fuel.
 9. After bleeding the air, tighten the overflow valve.
 10. Push in feed pump knob (3) and tighten it.
- ★ After replacing the cartridge, start up the engine and check the filter seal face for possible oil leakage.
- ★ Be sure to use a genuine Komatsu cartridge.

Komatsu America International Company
 440 North Fairway Drive
 Vernon Hills, IL 60061-8112 U.S.A.
 Attn: Technical Publications
 Fax No. (847) 970-4186

PROPOSAL FOR MANUAL REVISION

FOR INTERNAL USE ONLY -- No. PMR

P R O P O S E R	NAME OF COMPANY:		LOCATION:	
			PHONE NO:	
	DEPARTMENT:		DATE:	
	NAME:			
MANUAL NAME:				
MANUAL NO:				
MACHINE MODEL: S/N IF APPLICABLE:				
PAGE NO:				
PROBLEM:				
Attach photo or sketch. If more space is needed, use another sheet.				
FOR INTERNAL USE ONLY				
CORRECTIVE ACTION:				
