

Operation & Maintenance Manual

SEAM031401P

avance
LOADER

WA420-3

WHEEL LOADER

SERIAL NUMBERS WA420-54001 and up

⚠ WARNING

Unsafe use of this machine may cause serious injury or death. Operators and maintenance personnel must read this manual before operating or maintaining this machine. This manual should be kept near the machine for reference and periodically reviewed by all personnel who will come into contact with it.

NOTICE

Komatsu has Operation & Maintenance Manuals written in some other languages. If a foreign language manual is necessary, contact your local distributor for availability.

KOMATSU

1. FOREWORD

This manual provides rules and guidelines which will help you use this machine safely and effectively. Keep this manual handy and have all personnel read it periodically. If this manual has been lost or has become dirty and can not be read, request a replacement manual from Komatsu or your Komatsu distributor.

If you sell the machine, be sure to give this manual to the new owners.

Continuing improvements in the design of this machine can lead to changes in detail which may not be reflected in this manual. Consult Komatsu or your Komatsu distributor for the latest available information of your machine or for questions regarding information in this manual.

This manual may contain attachments and optional equipment that are not available in your area. Consult Komatsu or your Komatsu distributor for those items you may require.

WARNING

- **Improper operation and maintenance of this machine can be hazardous and could result in serious injury or death.**
- **Operators and maintenance personnel should read this manual thoroughly before beginning operation or maintenance.**
- **Some actions involved in operation and maintenance of the machine can cause a serious accident, if they are not done in a manner described in this manual.**
- **The procedures and precautions given in this manual apply only to intended uses of the machine. If you use your machine for any unintended uses that are not specifically prohibited, you must be sure that it is safe for you and others. In no event should you or others engage in prohibited uses or actions as described in this manual.**
- **Komatsu delivers machines that comply with all applicable regulations and standards of the country to which it has been shipped. If this machine has been purchased in another country or purchased from someone in another country, it may lack certain safety devices and specifications that are necessary for use in your country. If there is any question about whether your product complies with the applicable standards and regulations of your country, consult Komatsu or your Komatsu distributor before operating the machine.**
- **The description of safety is given in SAFETY INFORMATION on page 0-2 and in SAFETY from page 1-1.**

CALIFORNIA



Proposition 65 Warning

Diesel engine exhaust and some of its constituents are known to the State of California to cause cancer, birth defects, and other reproductive harm.

2. SAFETY INFORMATION

Most accidents are caused by the failure to follow fundamental safety rules for the operation and maintenance of machines. To avoid accidents, read, understand and follow all precautions and warnings in this manual and on the machine before performing operation and maintenance.

To identify safety messages in this manual and on machine labels, the following signal words are used.

-  **DANGER** – This word is used on safety messages and safety labels where there is a high probability of serious injury or death if the hazard is not avoided. These safety messages or labels usually describe precautions that must be taken to avoid the hazard. Failure to avoid this hazard may also result in serious damage to the machine.
-  **WARNING** – This word is used on safety messages and safety labels where there is a potentially dangerous situation which could result in serious injury or death if the hazard is not avoided. These safety messages or labels usually describe precautions that must be taken to avoid the hazard. Failure to avoid this hazard may also result in serious damage to the machine.
-  **CAUTION** – This word is used on safety messages and safety labels for hazards which could result in minor or moderate injury if the hazard is not avoided. This word might also be word for hazards where the only result could be damage to the machine.
- NOTICE** – This word is used for precautions that must be taken to avoid actions which could shorten the life of the machine.

Safety precautions are described in SAFETY from page 1-1.

Komatsu cannot predict every circumstance that might involve a potential hazard in operation and maintenance. Therefore the safety messages in this manual and on the machine may not include all possible safety precautions. If any procedures or actions not specifically recommended or allowed in this manual are used, you must be sure that you and others can do such procedures and actions safely and without damaging the machine. If you are unsure about the safety of some procedures, contact your Komatsu distributor.

3. INTRODUCTION

3.1 INTENDED USE

This machine is intended mainly for the following operations.

- Digging operations
- Leveling operations
- Pushing operations
- Loading operations

For details of the operating procedure, see "12.10 WORK POSSIBLE USING WHEEL LOADER".

3.2 FEATURES

- Curved glass and improved sealing for reduced noise, low vibration cab, viscous mount
- Console and steering post with neat foot area and no protrusions, giving the same comfortable feeling as on an automobile
- Fully hydraulic sharp, effective brake control with no need to drain water or any need to worry about freezing or rust
- Maintenance-free, wet-type disc parking brake (acts also as emergency brake)
- Big reduction in maintenance operations with use of auto-greasing system
- Remote boom positioner which allows the position for stopping the bucket to be set to the desired position from the operator's seat
- Large capacity pump and 2-stage hydraulic system for reduced cycle time and increased productivity
- One-touch panel control and air conditioner with new refrigerant installed
- Full fender system installed to prevent mud or water from splashing on or around the machine

3.3 BREAKING IN THE MACHINE

Your Komatsu machine has been thoroughly adjusted and tested before shipment. However, operating the machine under severe conditions at the beginning can adversely affect the performance and shorten the machine life.

Be sure to break in the machine for the initial 100 hours (as indicated by the service meter.)

During breaking in:

- Idle the engine for 5 minutes after starting it up.
- Avoid operation with heavy loads or at high speeds.
- Avoid sudden starts, sudden acceleration, sudden steering and sudden stops except in cases of emergency.

The precautions given in this manual for operating, maintenance, and safety procedures are only those that apply when this product is used for the specified purpose. If the machine is used for a purpose that is not listed in this manual, Komatsu cannot bear any responsibility for safety. All consideration of safety in such operations is the responsibility of the user.

Operations that are prohibited in this manual must never be carried out under any circumstances.

4. LOCATION OF PLATES, TABLE TO ENTER SERIAL NO. AND DISTRIBUTOR

4.1 MACHINE SERIAL NO. PLATE POSITION

Position of plate

On the center right of the front frame.

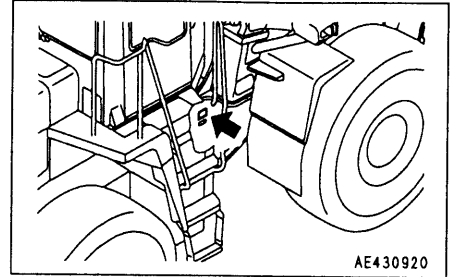

Position of stamp

This is stamped on the center of the front frame on the right side of the machine.

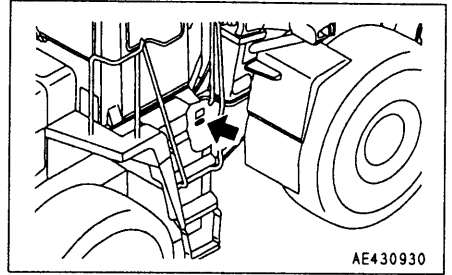

4.2 ENGINE SERIAL NO. PLATE POSITION

Position of plate

On the upper right of the cylinder block, when seen from the fan side.

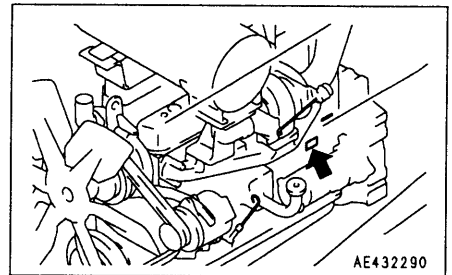

Position of stamp

This is stamped on the right side of the engine cylinder block as seen from the fan.

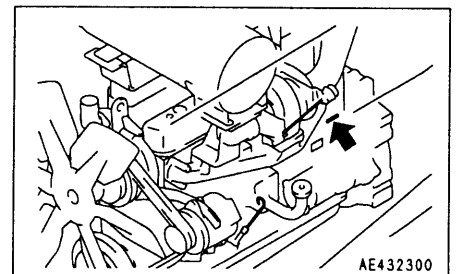

4.3 TABLE TO ENTER SERIAL NO. AND DISTRIBUTOR

Machine serial No.:	
Engine serial No.:	
Distributor name:	
Address:	Phone:
Service personnel for your machine:	

REMARKS

5. CONTENTS

1. Foreword	0- 1
2. Safety information	0- 2
3. Introduction	0- 3
4. Location of plates, table to enter serial No. and distributor	0- 4

SAFETY

6. General precautions	1- 2
7. Precautions during operation	1-11
7.1 Before starting engine	1-11
7.2 After starting engine	1-12
7.3 Transportation	1-17
7.4 Battery	1-18
7.5 Towing	1-20
8. Precautions for maintenance	1-21
8.1 Before carrying out maintenance	1-21
8.2 During maintenance	1-23
8.3 Tires	1-27
9. Position for attaching safety labels	1-28

OPERATION

10. General view	2- 2
10.1 General view of machine	2- 2
10.2 General view of controls and gauges	2- 3
11. Explanation of components	2- 4
11.1 Machine monitor	2- 4
11.2 Switches	2-14
11.3 Control levers, pedals	2-20
11.4 Steering column tilt lever	2-24
11.5 Cap with lock	2-25
11.6 Safety bar	2-26
11.7 Towing pin	2-26
11.8 Grease pump	2-27
11.9 Backup alarm	2-27
11.10 Fuse	2-28
11.11 Slow-blow fuse	2-29
11.12 Storing place of this manual	2-30
11.13 Taking off power	2-30
11.14 Taking off power (with out ROPS cab)	2-30

5. CONTENTS

12. Operation	2-31
12.1 Check before starting engine	2-31
12.2 Starting engine	2-45
12.3 Operations and checks after starting engine	2-47
12.4 Moving machine off	2-48
12.5 Changing gear speed	2-49
12.6 Changing direction	2-50
12.7 Turning	2-50
12.8 Stopping machine	2-51
12.9 Operation of work equipment	2-52
12.10 Work possible using wheel loader	2-53
12.11 Precautions for operation	2-58
12.12 Adjusting work equipment posture	2-60
12.13 Parking machine	2-62
12.14 Checks after completion of operation	2-63
12.15 Stopping engine	2-63
12.16 Check after stopping engine	2-64
12.17 Locking	2-64
12.18 Handling the tires	2-65
13. Transportation	2-67
13.1 Loading, unloading work	2-67
13.2 Precautions for loading	2-68
13.3 Lifting machine	2-68
13.4 Precautions for transportation	2-70
14. Cold weather operation	2-71
14.1 Precautions for low temperature	2-71
14.2 Precautions after completion of work	2-73
14.3 After cold weather	2-73
15. Long-term storage	2-74
15.1 Before storage	2-74
15.2 During storage	2-74
15.3 After storage	2-74
16. Troubleshooting	2-75
16.1 When machine runs out of fuel	2-75
16.2 Towing the machine	2-76
16.3 If battery is discharged	2-81
16.4 Other trouble	2-85

MAINTENANCE

17. Guides to maintenance	3- 2
18. Outlines of service	3- 5
18.1 Outline of oil, fuel, coolant	3- 5
18.2 Outline of electric system	3- 8
19. Wear parts list	3- 9
20. Use of fuel, coolant and lubricants according to ambient temperature	3-10
21. Standard tightening torques for bolts and nuts	3-14
21.1 Introduction of necessary tools	3-14
21.2 Torque list	3-15
22. Periodic replacement of safety critical parts	3-16
23. Maintenance schedule chart	3-20
23.1 Maintenance schedule chart	3-20
24. Service Procedure	3-24
24.1 Initial 250 hours service	3-24
24.2 When required	3-25
24.3 Check before starting	3-40
24.4 Every 50 hours service	3-45
24.5 Every 100 hours service	3-46
24.6 Every 250 hours service	3-48
24.7 Every 500 hours service	3-55
24.8 Every 1000 hours service	3-58
24.9 Every 2000 hours service	3-63
24.10 Every 4000 hours service	3-69

SPECIFICATIONS

25. Specifications	4- 2
---------------------------------	------

OPTIONS, ATTACHMENTS

26. Optional parts and attachments	5- 2
27. Selecting buckets and tires	5- 3
28. Car radio	5- 4
28.1 Explanation of components	5- 4
28.2 Method of use	5- 6
28.3 Precautions when using radio	5- 7
29. Air conditioner	5- 8
29.1 General locations and function of control panel	5- 8
29.2 Method of operation	5-10
29.3 Cool box	5-10
30. Handling E.C.S.S. (Electronic controlled suspension system)	5-11
30.1 Method of operating E.C.S.S.	5-11
30.2 Precautions when operating E.C.S.S. switch	5-11
31. Handling auto-greasing system	5-12
31.1 Method of operating auto-greasing system	5-12
31.2 Precautions when handling auto-greasing system	5-20
31.3 Troubleshooting	5-21
31.4 Specifications	5-21
32. Option display	5-22
33. Handling auto-leveling, remote positioner	5-23
33.1 Structure and function of auto-leveling, remote positioner	5-23
33.2 General locations.....	5-24
33.3 Method of operating auto-leveling, remote positioner	5-25
33.4 Adjusting auto-leveling, remote positioner.....	5-27

SAFETY

 **WARNING**

Please be sure that you fully understand this manual and the precautions related to safety for the machine. When operating or servicing the machine, always follow these precautions strictly.

6. GENERAL PRECAUTIONS

⚠ WARNING: For reasons of safety, always follow these safety precautions.

SAFETY RULES

- Only trained and authorized personnel can operate and maintain the machine.
- Follow all safety rules, precautions and instructions when operating or performing maintenance on the machine.
- If you are under the influence of alcohol or medication, your ability to safely operate or repair your machine may be severely impaired putting yourself and everyone else on your jobsite in danger.
- When working with another operator or with a person on worksite traffic duty, be sure that all personnel understand all hand signals that are to be used.

IF ABNORMALITIES ARE FOUND

If you find any abnormality in the machine during operation or maintenance (noise, vibration, smell, incorrect gauges, smoke, oil leakage, etc., or any abnormal display on the warning devices or monitor), report to the person in charge and have the necessary action taken. Do not operate the machine until the abnormality has been corrected.

CLOTHING AND PERSONAL PROTECTIVE ITEMS

- Do not wear loose clothing and accessories. There is a hazard that they may catch on control levers or other protruding parts.
- If you have long hair and it hangs out from your hard hat, there is a hazard that it may get caught up in the machine, so tie your hair up and be careful not to let it get caught.
- Always wear a hard hat and safety shoes. If the nature of the work requires it, wear safety glasses, mask, gloves, ear plugs, and safety belt when operating or maintaining the machine.
- Check that all protective equipment functions properly before using it.

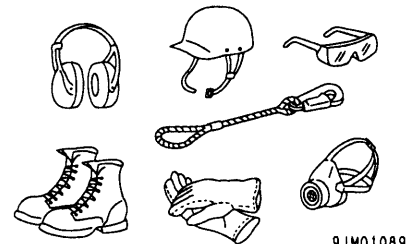

FIRE EXTINGUISHER AND FIRST AID KIT

Always follow the precautions below to prepare for action if any injury or fire should occur.

- Be sure that fire extinguishers have been provided and read the labels to ensure that you know how to use them in emergencies.
- Carry out periodic inspection and maintenance to ensure that the fire extinguisher can always be used.
- Provide a first aid kit at the storage point. Carry out periodic checks and add to the contents if necessary.

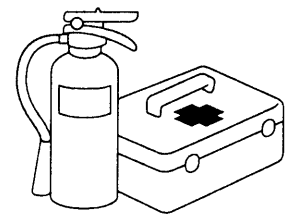

SAFETY FEATURES

- Be sure that all guards and covers are in their proper position. Have guards and covers repaired immediately if they are damaged.
- Understand the method of use of safety features and use them properly.
- Never remove any safety features. Always keep them in good operating condition.

KEEP MACHINE CLEAN

- If water gets into the electrical system, there is a hazard that it will cause malfunctions or misoperation. Do not use water or steam to wash the electrical system (sensors, connectors).
- If inspection and maintenance is carried out when the machine is still dirty with mud or oil, there is a hazard that you will slip and fall, or that dirt or mud will get into your eyes. Always keep the machine clean.

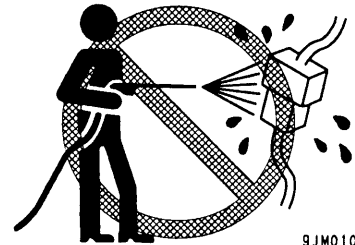

INSIDE OPERATOR'S COMPARTMENT

- When entering the operator's compartment, always remove all mud and oil from the soles of your shoes. If you operate the pedal with mud or oil affixed to your shoes, your foot may slip and this may cause a serious accident.
- Do not leave parts or tools lying around the operator's compartment.
- Do not fix any suction pad to the window glass. The suction pad will act as a lens and may cause a fire.
- Do not use cellular telephones inside the operator's compartment when driving or operating the machine.
- Never bring any dangerous objects such as flammable or explosive items into the operator's cab.

ALWAYS APPLY LOCK WHEN LEAVING OPERATOR'S SEAT

- Before standing up from the operator's seat to adjust the operator's seat, always lower the work equipment, set safety lock lever ① to the LOCK position and parking brake switch ② to the ON position, then stop the engine. If you accidentally touch the travel or swing lever when they are not locked, the work equipment may suddenly move and cause serious injury or damage.
- When leaving the machine, always lower the work equipment to the ground, set safety lock lever ① to the LOCK position and parking brake switch ② to the ON position, then stop the engine. Lock all places and always take the key with you and leave it in the specified location.

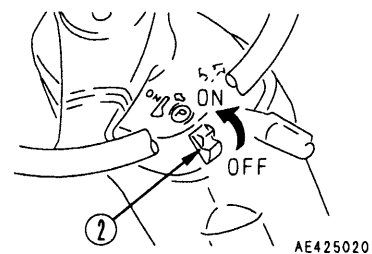
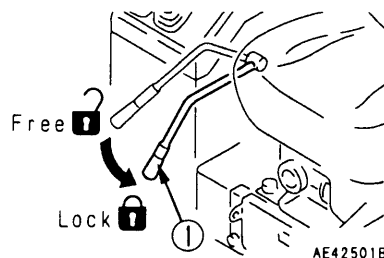

HANDRAILS AND STEPS

To prevent personal injury caused by slipping or falling off the machine, always do as follows.

- Use the handrails and steps marked by arrows in the diagram on the right when getting on or off the machine.
- To ensure safety, always face the machine and maintain three-point contact (both feet and one hand, or both hands and one foot) with the handrails and steps to ensure that you support yourself.
- When entering the cab, stand on the top step before opening the door.
- Do not grip the control levers when getting on or off the machine.
- Use only the inspection path fitted with non-slip pads when climbing on top of the machine. Never climb on the engine hood or covers where there are no non-slip pads.
- Never step down on to the tire from the step at the rear of the machine or the step at the side of the cab.
- If there is any oil, grease, or mud on the handrails or steps, wipe it off immediately. Always keep these parts clean. Repair any damage and tighten any loose bolts.
- Do not get on or off the machine while holding tools in your hand.

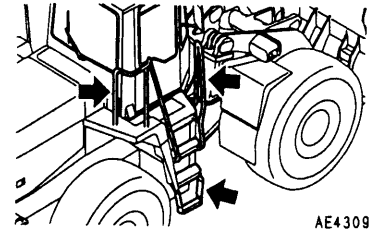

AE430970

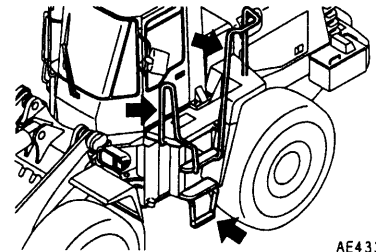

AE433500



AL187320

MOUNTING AND DISMOUNTING

- Never jump on or off the machine. Never get on or off a moving machine.
- If the machine starts to move when there is no operator on the machine, do not jump on to the machine and try to stop it.

NO PEOPLE ON ATTACHMENTS

Never let anyone ride on the bucket or attachments. There is a hazard of falling and suffering serious injury.

DO NOT GET CAUGHT IN ARTICULATED PORTION

If the clearance at the articulated portion changes, it may lead to serious personal injury.

Do not let anyone stand in the area of articulation.

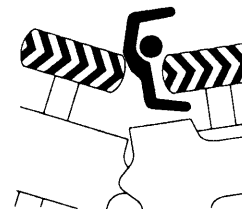

A0060760

PREVENTION OF BURNS

Hot coolant

- To prevent burns from hot water or steam spurting out when checking or draining the coolant, wait for the water to cool to a temperature where it is possible to touch the radiator cap by hand before starting the operation. Even when the coolant has cooled down, loosen the cap slowly to relieve the pressure inside the radiator before removing the cap.

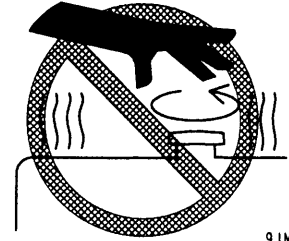

9JM01068

Hot oil

- To prevent burns when checking or draining the oil, wait for the oil to cool to a temperature where it is possible to touch the plug by hand before starting the operation. Even when the oil has cooled down, loosen the plug slowly to relieve the internal pressure before removing the plug.



9JM01067

FIRE PREVENTION

- Fire caused by fuel or oil
Fuel, oil, antifreeze, and window washer liquid are particularly flammable and can be hazardous. To prevent fire, always observe the following:
 - Do not smoke or use any flame near fuel or oil.
 - Stop the engine before refueling.
 - Do not leave the machine while adding fuel or oil.
 - Tighten all fuel and oil caps securely.
 - Do not spill fuel on overheated surfaces or on parts of the electrical system.
 - Use well-ventilated areas for adding or storing oil and fuel.
 - Keep oil and fuel in the determined place and do not allow unauthorized persons to enter.
 - After adding fuel or oil, wipe up any spilled fuel or oil.
 - When carrying out grinding or welding work on the chassis, move any flammable materials to a safe place before starting.
 - When washing parts with oil, use a non-flammable oil. Diesel oil and gasoline may catch fire, so do not use them.
 - Put greasy rags and other flammable materials into a safe container to maintain safety at the work place.
 - Do not weld or use a cutting torch to cut any pipes or tubes that contain flammable liquids.



A0055020



A0055040

- Fire caused by accumulation of flammable material.
Remove any dry leaves, chips, pieces of paper, dust, or any other flammable materials accumulated or affixed around the engine, exhaust manifold, muffler, or battery, or inside the undercovers.
- Fire coming from electric wiring
Short circuits in the electrical system can cause fire.
 - Always keep electric wiring connections clean and securely tightened.
 - Check the wiring every day for looseness or damage. Tighten any loose connectors or wiring clamps. Repair or replace any damaged wiring.
- Fire coming from hydraulic line
Check that all the hose and tube clamps, guards, and cushions are securely fixed in position. If they are loose, they may vibrate during operation and rub against other parts. This may lead to damage to the hoses, and cause high-pressure oil to spurt out, leading to fire damage or serious injury.
- Explosion caused by lighting equipment
 - When checking fuel, oil, battery electrolyte, window washer fluid, or coolant, use explosion-proof lighting. If you do not use explosion-proof lighting, there is a hazard of serious injury or damage caused by explosion.
 - When taking the electrical power for the lighting from the machine, follow the instructions in this manual.

⚠ WARNING: Failure to follow these safety precautions may lead to a serious accident.

ACTION IF FIRE OCCURS

If a fire occurs, escape from the machine as follows.

- Turn the starting switch OFF and stop the engine.
- Use the handrails and steps to get off the machine.

WINDOW WASHER LIQUID

Use an ethyl alcohol base washer liquid. Methyl alcohol base washer liquid may irritate your eyes, so do not use it.

PRECAUTIONS WHEN USING ROPS (Roll Over Protective Structure)

Install ROPS when working in places where there is danger of falling rocks, such as in mines and quarries, or in places where there is danger of rolling over.

- If ROPS is installed, do not remove ROPS when operating the machine.
- The ROPS is installed to protect the operator if the machine should roll over. It is designed not only to support the load if the machine should roll over, but also to absorb the impact energy.
- If ROPS is modified, its strength may drop. Consult your Komatsu distributor before carrying out any modification.
- If ROPS is damaged or deformed by falling objects or by rolling over, its strength will be reduced and it will not be able to fulfill its function properly. In such cases, always Komatsu contact your distributor for advice of the method of repair.

Even if ROPS is installed, always fasten your seat belt properly when operating the machine. If you do not use your fasten your seat belt properly, it cannot display its effect.



A0055200



A0084311

PRECAUTIONS FOR ATTACHMENTS

- When installing optional parts or attachments, there may be problems with safety or legal restrictions, so contact your Komatsu distributor for advice.
- Any injuries, accidents, or product failures resulting from the use of unauthorized attachments or parts will not be the responsibility of Komatsu.
- When installing and using optional attachments, read the instruction manual for the attachment, and the general information related to attachments in this manual.

UNAUTHORIZED MODIFICATION

Any modification made without authorization from Komatsu can create hazards. Before making a modification, consult your Komatsu distributor.

- Komatsu will not be responsible for any injuries, accidents, or product failures resulting from modifications made without authorization from Komatsu.

SAFETY AT WORKSITE

Before starting operations, thoroughly check the area for any unusual conditions that could be dangerous.

- When carrying out operations near combustible materials such as thatched roofs, dry leaves or dry grass, there is a hazard of fire, so be careful when operating.
- Check the terrain and condition of the ground at the worksite, and determine the safest method of operation. Do not carry out operations at places where there is a hazard of landslides or falling rocks.
- If water lines, gas lines, or high-voltage electrical lines may be buried under the worksite, contact each utility and identify their locations. Be careful not to sever or damage any of these lines.
- Take necessary measures to prevent any unauthorized person from entering the operating area.
- When traveling or operating in shallow water or on soft ground, check the shape and condition of the bedrock, and the depth and speed of flow of the water before starting operations.
- Set and maintain the haul load on the jobsites so that the machine can always travel safely.

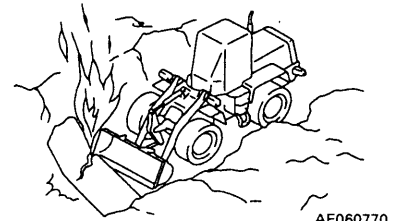
**WORKING ON LOOSE GROUND**

- Avoid traveling or operating your machine too close to the edge of cliffs, overhangs, and deep ditches. The ground may be weak in such areas. If the ground should collapse under the weight or vibration of the machine, there is a hazard that the machine may fall or tip over. Remember that the soil after heavy rain or blasting or after earthquakes is weak in these areas.
- When working on embankments or near excavated ditches, there is a hazard that the weight and vibration of the machine will cause the soil to collapse. Before starting operations, take steps to ensure that the ground is safe and to prevent the machine from rolling over or falling.

DO NOT GO CLOSE TO HIGH-VOLTAGE CABLES

Do not travel or operate the machine near electric cables. These is a hazard of electric shock, which may cause serious injury or property damage. On jobsites where the machine may go close to electric cables, always do as follows.

- Before starting work near electric cables, inform the local power company of the work to be performed, and ask them to take the necessary action.
- Even going close to high-voltage cables can cause electric shock, which may cause serious burns or even death. Always maintain a safe distance (see the table on the right) between the machine and the electric cable. Check with the local power company about safe operating procedure before starting operations.
- To prepare for any possible emergencies, wear rubber shoes and gloves. Lay a rubber sheet on top of the seat, and be careful not to touch the chassis with any exposed part of your body.
- Use a signalman to give warning if the machine approaches too close to the electric cables.
- When carrying out operations near high voltage cables, do not let anyone come close to the machine.
- If the machine should come too close or touch the electric cable, to prevent electric shock, the operator should not leave the operator's compartment until it has been confirmed that the electricity has been shut off.
Also, do not let anyone come close to the machine.

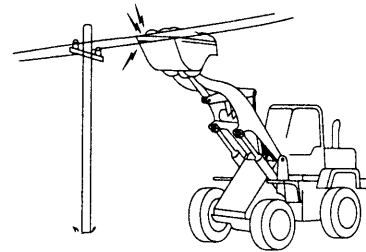

A0060820

	Voltage	Min. safety distance
Low voltage	100 • 200 V	2 m
	6,600 V	2 m
Very high voltage	22,000 V	3 m
	66,000 V	4 m
	154,000 V	5 m
	187,000 V	6 m
	275,000 V	7 m
	500,000 V	11 m

ENSURE GOOD VISIBILITY

- Check for any persons or obstacles in the area around the machine and check the conditions of the jobsite to ensure that operations and travel can be carried out safely. Always do as follows.
 - Position a signalman if there are areas at the rear of the machine where the visibility is not good.
 - When working in dark places, turn on the working lamp and front lamps installed to the machine, and set up additional lighting in the work area if necessary.
 - Stop operations if the visibility is poor, such as in mist, snow, rain, or dust.

VENTILATION FOR ENCLOSED AREAS

Exhaust fumes from the engine can kill.

- If it is necessary to start the engine within an enclosed area, or when handling fuel, flushing oil, or paint, open the doors and windows to ensure that you provide adequate ventilation is provided to prevent gas poisoning.



A0055060

CHECKING SIGNALMAN'S SIGNALS AND SIGNS

- Set up signs to inform of road shoulders and soft ground. If the visibility is not good, position a signalman if necessary. Operators should pay careful attention to the signs and follow the instructions from the signalman.
- Only one signalman should give signals.
- Make sure that all workers understand the meaning of all signals and signs before starting work.

EMERGENCY EXIT FROM OPERATOR'S CAB

Machines equipped with a cab have doors on the left and right sides. If the door on one side does not open, escape from the door on the opposite side.

ASBESTOS DUST HAZARD PREVENTION

Asbestos dust in the air can cause lung cancer if it is inhaled. There is danger of inhaling asbestos when working on jobsites handling demolition work or work handling industrial waste. Always observe the following.

- Spray water to keep down the dust when cleaning.
- Do not use compressed air for cleaning.
- If there is danger that there may be asbestos dust in the air, always operate the machine from an upwind position.
- All workers should use an approved respirator.
- Do not allow other persons to approach during the operation.
- Always observe the rules and regulations for the work site and environmental standards.

This machine does not use asbestos, but there is a danger that imitation parts may contain asbestos, so always use genuine Komatsu parts.

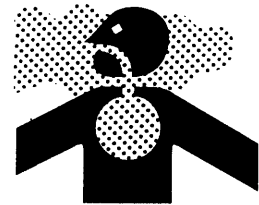

A0055060

7. PRECAUTIONS DURING OPERATION

⚠ WARNING: For reasons of safety, always follow these safety precautions.

7.1 BEFORE STARTING ENGINE

If there is a warning tag hanging from work equipment control lever ①, do not start the engine or touch the levers.

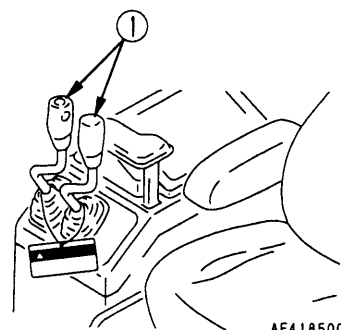

AE418500

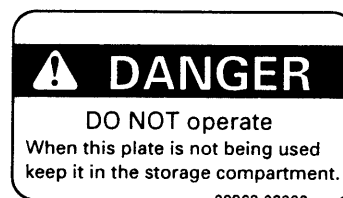

CHECKS BEFORE STARTING ENGINE, ADJUST

Carry out the following checks before starting the engine at the beginning of the day's work.

- Remove all dirt from the surface of the lens of the front lamps, working lamps, and rear combination lamp, and check that they light up correctly.
- Check the coolant level, fuel level, and oil level in engine oil pan, check for clogging of the air cleaner, and check for damage to the electric wiring.
- Check that there is no mud or dust accumulated around the movable parts of the accelerator pedal or brake pedal, and check that the pedals work properly.
- Adjust the operator's seat to a position where it is easy to carry out operations, and check that there is no damage or wear to the seat belt or mounting clamps.
- Check that the gauges work properly, and check that the control levers are all at the neutral position.
- Before starting the engine, check that the safety lock lever is at the LOCK position.
- Adjust the mirrors so that the rear of the machine can be seen clearly from the operator's seat.
- Check that there are no persons or obstacles above, below, or in the area around the machine.

PRECAUTIONS WHEN STARTING

- When starting the engine, sound the horn as a warning.
- Start and operate the machine only while seated.
- Do not allow anyone apart from the operator to ride on the machine.
- Do not short circuit the starting motor circuit to start the engine. It is not only dangerous, but will also cause damage to the equipment.
- For machines equipped with a back-up alarm, check that the alarm works properly.

PRECAUTIONS IN COLD AREAS

- Carry out the warming-up operation thoroughly. If the machine is not thoroughly warmed up before the control levers are operated, the reaction of the machine will be slow, and this may lead to unexpected accidents.
- If the battery electrolyte is frozen, do not charge the battery or start the engine with a different power source. There is a hazard that this will ignite the battery. Before charging or starting the engine with a different power source, melt the battery electrolyte and check for frost and leakage of battery electrolyte before starting.

7.2 AFTER STARTING ENGINE

CHECKS AFTER STARTING ENGINE

When carrying out the checks, move the machine to a wide area where there are no obstructions, and operate slowly. Do not allow anyone near the machine.

- Always fasten your seat belt.
- Check the actuating condition of the work equipment, travel, and brake systems.
- Check for any abnormality in the sound of the machine, vibration, heat, smell, or gauges; check also that there is no leakage of oil or fuel.
- If any abnormality is found, carry out repairs immediately.
- Before driving the machine or starting operations, check that safety lever ① is securely fixed at the FREE position.

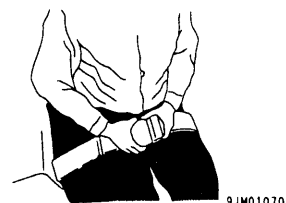

9JM01070

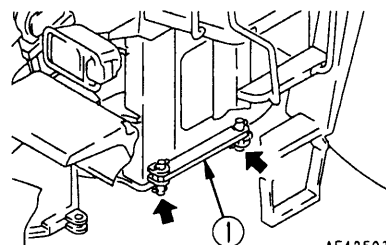

AE425030

CHECK WHEN CHANGING DIRECTION

- Before traveling, check again that there is no one in the surrounding area, and that there are no obstacles.
- Before traveling, sound the horn to warn people in the area.
- Always operate the machine only when seated.
- Do not allow anyone apart from the operator to ride on the machine.
- Check that the back-up alarm (alarm buzzer when machine travels in reverse) works properly.
- Fix the operator's compartment doors and windows in position securely (both when they are open and when they are closed). On job sites where there is danger of flying objects or objects entering the operator's compartment, always close the doors and windows.
- If there is any blind spot to the rear of the machine, position a signalman.

Always be sure to carry out the above precautions even when the machine is equipped with mirrors.

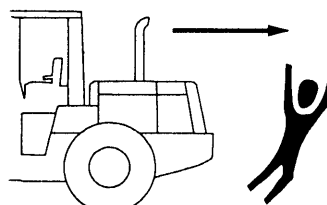

AE414590

⚠ WARNING: Failure to follow these safety precautions may lead to a serious accident.

7. PRECAUTIONS DURING OPERATION

PRECAUTIONS WHEN TRAVELING

- Never turn the key in the starting switch to the OFF position. It is dangerous if the engine stops when the machine is traveling, because the steering becomes heavy. If the engine stops, depress the brake pedal immediately to stop the machine.
 - Set the work equipment to a height of 40 – 50 cm (16 – 20 in) from the ground level and travel on level ground.
When traveling, do not operate the work equipment control levers. If the work equipment control levers have to be operated, stop the machine first, then operate the levers.
 - When traveling on rough ground, to avoid turning over, travel at low speed, and avoid sudden changes in direction. There is also danger of the work equipment touching the ground and making the machine lose its balance, or of hitting other machines or structures in the surrounding area.
 - Avoid traveling over obstacles as far as possible. If the machine has to travel over an obstacle, keep the work equipment as close to the ground as possible and travel at low speed. The machine will also tend to turn over to the left or right sides, so do not travel over obstacles that make the machine tilt excessively to one side.
 - When traveling or carrying out operations, always keep your distance from other persons, machines, or structures to avoid coming into contact with them.
 - When passing over bridges or structures, check first that the structure is strong enough to support the mass of the machine.
When traveling on public roads, check first with the relevant authorities and follow their instructions.
 - When operating in tunnels, inside buildings, under bridges, under electric wires, or other places where the height is limited, operate slowly and be extremely careful not to let the machine or work equipment hit anything.
 - Always obey the traffic regulations when traveling on public roads. This machine travels at a lower speed than normal automobiles, so keep to the side of the road and be careful to leave the center of the road free for other vehicles.
 - If you drive the machine at high speed continuously for a long time, the tires will overheat and the internal pressure will become abnormally high. This may cause the tires to burst. If a tire bursts, it produces an extremely large destructive force, and this may cause serious injury or accident.
- If you are going to travel continuously, please consult your Komatsu distributor.

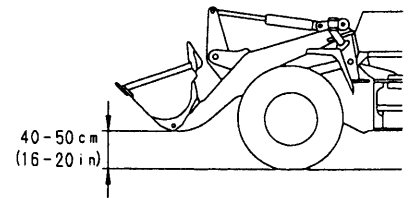

AE41532B

PRECAUTIONS WHEN TRAVELING ON SLOPES

To prevent the machine for tipping over or slipping to the side, always do as follows.

- When traveling on slopes, keep the bucket approximately 40 – 50 cm (16 – 20 in) above the ground. In case of emergency, quickly lower the bucket to the ground to help the machine to stop.
- Always travel straight up or down a slope. Traveling at an angle or across the slope is extremely dangerous.
- Do not turn on slopes or travel across slopes. Always go down to a flat place to change the position of the machine, then travel on to the slope again.
- Travel on grass, fallen leaves, or wet steel plates with low speed. Even with slight slopes there is a hazard that the machine may slip.
- If the engine stops, depress the brake pedal immediately, lower the bucket to the ground, and apply the parking brake to stop the machine.
- When traveling downhill, never shift gear or place the transmission at neutral. It is dangerous not to use the braking force of the engine. Always place the transmission in a low gear before starting to travel downhill.
- When traveling downhill, travel slowly. If necessary, use the braking force of the engine together with the brake pedal to control the travel speed.
- When traveling up or down hills with a loaded bucket, always travel with the bucket facing uphill. If the machine travels with the bucket facing downhill, there is danger that the machine may tip over.

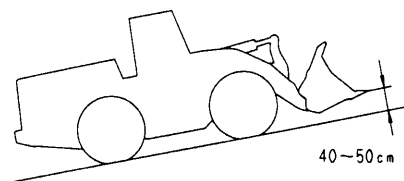

9JW01430

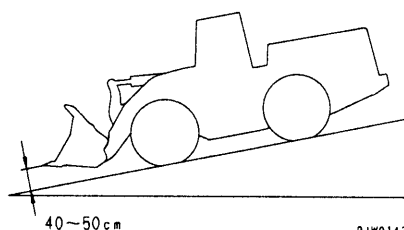

9JW01431

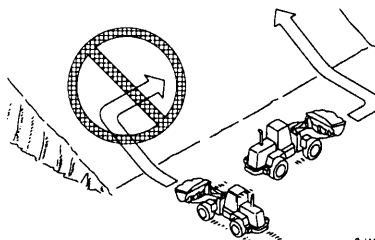

9JM02053

PROHIBITED OPERATIONS

- It is dangerous to excavate the bottom of a rock face. Never do this.
- It is dangerous to use the bucket or lift arm for crane operations, so do not carry out such operations.
- Do not pass the bucket over the head of other workers or over the operator's seat of dump trucks or other hauling equipment. The load may spill or the bucket may hit the dump truck or worker and cause serious personal injury or damage.

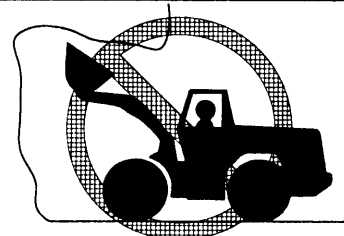

AW36000



9JM02055

⚠ WARNING: Failure to follow these safety precautions may lead to a serious accident.

7. PRECAUTIONS DURING OPERATION

PRECAUTIONS WHEN OPERATING

- To prevent overloading from causing the machine to turn over or from damaging the work equipment when the machine is used, be sure that you do not exceed the maximum payload or other machine capacities determined by the structure of the machine.
- If the engine cannot be started again after it has stopped, immediately operate the work equipment control levers to lower the work equipment to the ground. (After the engine stops, the accumulator allows the work equipment to be operated for a limited time.)
- Be careful not to approach too close to the edge of cliffs. When making embankments or landfills, or when dropping soil over a cliff, dump one pile, then use the next pile of soil to push the first pile.
- The load suddenly becomes lighter when the soil is pushed over a cliff or when the machine reaches the top of a slope. When this happens, there is danger that the travel speed will suddenly increase, so be sure to reduce the speed.
- When the bucket is fully loaded, never start, turn, or stop the machine suddenly. There is danger of the machine turning over.
- When handling unstable loads, such as round or cylindrical objects, or piled sheets, if the work equipment is raised high, there is danger that the load may fall on top of the operator's compartment and cause serious injury or damage.
- When handling unstable loads, be careful not to raise the work equipment too high or tip the bucket back too much.
- If the work equipment is suddenly lowered or suddenly stopped, the reaction may cause the machine to tip over. Particularly when carrying a load, be sure to operate the work equipment carefully.
- When operating in tunnels, under bridges, under electric wires, or other places where the height is limited, be extremely careful not to let the work equipment hit anything.
- To prevent accidents caused by hitting other objects, always operate the machine at a speed which is safe for operation, particularly in confined spaces, indoors, and in places where there are other machines.

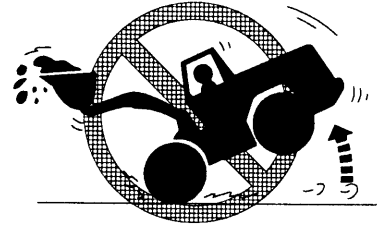

9JM02056

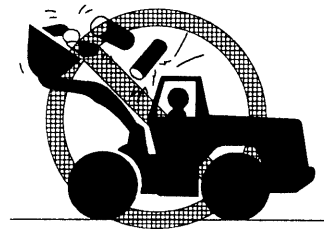

9JM02057

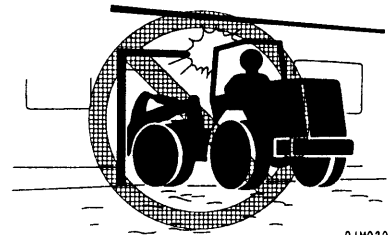

9JM02058

METHODS OF USING BRAKE

- Do not rest your foot on the brake pedal if you are not using the brake. If you travel with your foot on the pedal, the brake will always be applied. This will cause abnormal heating of the brake and the brake will not work.
- Do not depress the brake pedal repeatedly if not necessary.
- When traveling downhill, use the braking force of the engine, and always use the right brake pedal at the same time.

OPERATE CAREFULLY ON SNOW

- Snow-covered or frozen surfaces are slippery, so be extremely careful when traveling or operating the machine, and do not operate the levers suddenly. Even a slight slope may cause the machine to slip, so be particularly careful when working on slopes.
- With frozen ground surfaces, the ground becomes soft when the temperature rises, and this may cause the machine to tip over.
- If the machine enters deep snow, there is a hazard that it may tip over or become buried in the snow. Be careful not to leave the road shoulder or to get trapped in a snow drift.
- When clearing snow, the road shoulder and objects placed beside the road are buried in the snow and cannot be seen. There is a hazard of the machine tipping over or hitting covered objects, so always carry out operations carefully.
- When traveling on snow-covered roads, always fit tire chains.
- When traveling on snow-covered slopes, never apply the brakes suddenly. Reduce the speed and use the engine as a brake while applying the foot brake intermittently (depress the brake intermittently several times). If necessary, lower the bucket to the ground to stop the machine.

PARKING MACHINE

- Park the machine on firm, level ground.
 - Select a place where there is no hazard of falling rocks or landslides, or of flooding if the land is low.
 - Lower the work equipment completely to the ground.
-
- When leaving the machine, set safety lock lever ① to the LOCK position and parking brake switch ② to the ON position, and stop the engine.
 - Always close the door of the operator's cab, lock all the equipment to prevent any unauthorized person from moving the machine, then remove the key and leave it in the specified location.
-
- If it is necessary to park the machine on a slope, set blocks under the wheels to prevent the machine from moving.

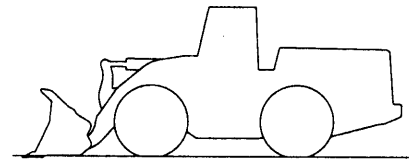

9JM01203

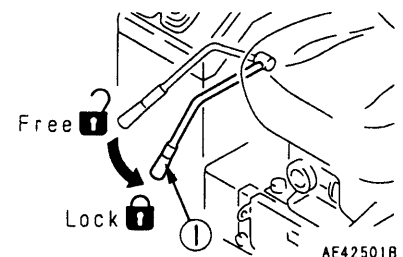

AE42501B

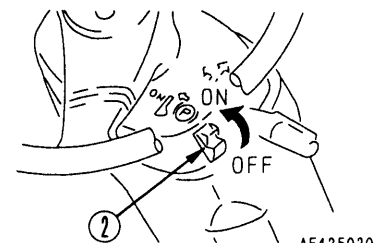

AE425020

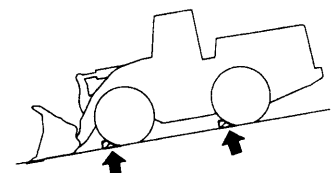

9JM01204

7.3 TRANSPORTATION

The machine can be divided into parts for transportation, so when transporting the machine, please contact your Komatsu distributor to have the work carried out.

LOADING AND UNLOADING

When loading or unloading the machine, mistaken operation may bring the hazard of the machine tipping over or falling, so particular care is necessary. Always do as follows.

- Perform loading and unloading on firm, level ground only. Maintain a safe distance from the edge of the road or cliff.
- Always use ramps of adequate strength. Be sure that the ramps are wide, long, and thick enough to provide a safe loading slope. Take suitable steps to prevent the ramps from moving out of position or coming off.
- Be sure the ramp surface is clean and free of grease, oil, ice and loose materials. Remove dirt from machine-tracks. On a rainy day, in particular, take extremely careful since the ramp surface is slippery.
- Run the engine at low idling and operate slowly at low speed.
- Never correct your steering on the ramps. There is danger that the machine may turn over. If necessary, drive off the ramps, correct the direction, then enter the ramps again.
- When loading or unloading to an embankment or platform, make sure that it has suitable width, strength, and grade.
- For machines equipped with a cab, always lock the door after loading the machine. If this is not done, the door may suddenly open during transportation.
See 13. TRANSPORTATION.

CORRECT

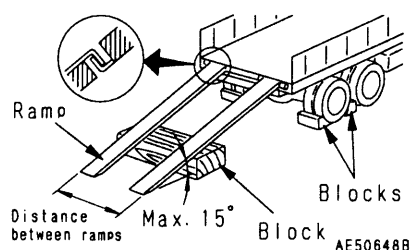

SHIPPING

When shipping the machine on a trailer, do as follows.

- Investigate all state and local laws governing the weight, width, and length of a load. If necessary, disassemble the work equipment. The width, height and weight of the load differ according to the work equipment, so take this into account when determining the shipping route.
- When passing over bridges or structures on private land, check first that the structure is strong enough to support the weight of the machine. When traveling on public roads, check first with the relevant authorities and follow their instructions.
- Lock the frame with the safety bar to prevent the machine from articulating.
- For details of the shipping procedure, see 13. TRANSPORTATION in the OPERATION section.

7.4 BATTERY

BATTERY HAZARD PREVENTION

Battery electrolyte contains sulphuric acid, and batteries generate flammable hydrogen gas, which may explode. Mistaken handling can lead to serious injury or fire. For this reason, always observe the following precautions.

- Do not use or charge the battery if the battery electrolyte level is below the LOWER LEVEL line. This may cause an explosion. Always check the battery electrolyte level periodically and add distilled water to bring the electrolyte level to the UPPER LEVEL line.
- When working with batteries, always wear safety glasses and rubber gloves.
- Never smoke or use any flame near the battery.
- If you spill acid on your clothes or skin, immediately flush the area with large amounts of water.
- If acid gets into your eyes, flush them immediately with large quantities of water and seek medical attention.
- Before working with batteries, turn the starting switch to the OFF position.

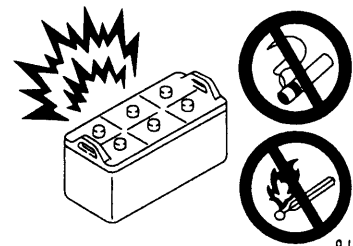

9JM01078

As there is a hazard that sparks will be generated, always do as follows.

- Do not let tools or other metal objects make any contact between the battery terminals. Do not leave tools or other metal objects lying around near the battery.
- Always disconnect the negative \ominus terminal (ground side) first when removing the battery; when installing the battery, connect the positive \oplus terminal first, and connect the ground last. Tighten the battery terminals securely.
- Flammable hydrogen gas is generated when the battery is charged, so remove the battery from the chassis, take it to a well-ventilated place, and remove the battery caps before charging it.
- Tighten the battery caps securely.
- Install the battery securely to the determined place.

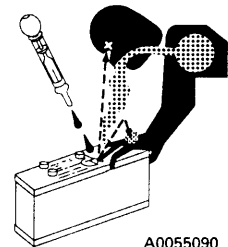

A0055090

STARTING WITH BOOSTER CABLES

If any mistake is made in the method of connecting the booster cables, it may cause the battery to explode, so always do as follows.

- When starting with a booster cable, carry out the starting operation with two workers (one worker sitting in the operator's seat and the other working with the battery).
- When starting from another machine, do not allow the two machines to touch.
- When connecting the booster cables, turn the starting switch OFF for both the normal machine and problem machine. There is a hazard that the machine will move when the power is connected.
- Be sure to connect the positive \oplus cable first when installing the booster cables. Disconnect the ground or negative \ominus cable (ground side) first when removing them.
- When removing the booster cables, be careful not to let the booster cable clips touch each other or to let the clips touch the machine.
- Always wear safety goggles and rubber gloves when starting the engine with booster cables.
- When connecting a normal machine to a problem machine with booster cables, always use a normal machine with the same battery voltage as the problem machine.
- For details of the starting procedure when using booster cables, see 16.3.3 STARTING ENGINE WITH BOOSTER CABLE in the OPERATION section.

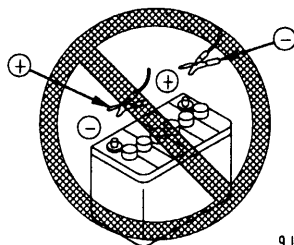

9JM00842

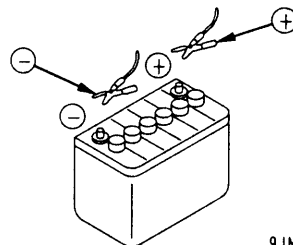

9JM01079

7.5 TOWING

WHEN TOWING

Serious injury or death could result if a disabled machine is towed incorrectly or if there is a mistake in the selection or inspection of the wire rope.

When towing, always use the method given in 16.2 TOWING THE MACHINE in the OPERATION section.

- Always wear leather gloves when handling wire rope.
- During the towing operation, never stand between the towing machine and the machine being towed.
- Never tow a machine on a slope.
- Never use a wire rope which has cut strands **Ⓐ**, reduced diameter **Ⓑ**, or kinks **Ⓒ**. There is a hazard that the rope may break during the towing operation.

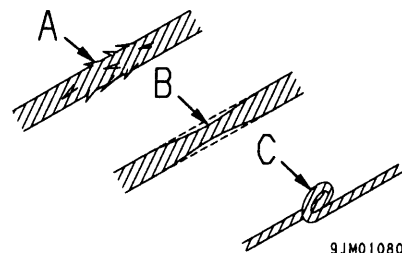
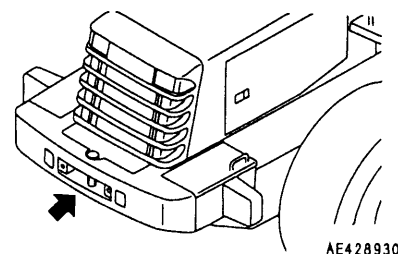

8. PRECAUTIONS FOR MAINTENANCE

⚠ WARNING: For reasons of safety, always follow these safety precautions.

8.1 BEFORE CARRYING OUT MAINTENANCE

WARNING TAG

- Always attach the "DO NOT OPERATE" warning tag to work equipment control lever ① in the operator's cab to alert others that you are performing service or maintenance on the machine. Attach additional warning tags around the machine if necessary.

Warning tag Part No.09963-03000

Keep this warning tag in the tool box while it is not used. If there is not the tool box, keep the tag in the operation manual pocket.

- If others start the engine, or touch or operate the work equipment control lever while you are performing service or maintenance, you could suffer serious injury or property damage.

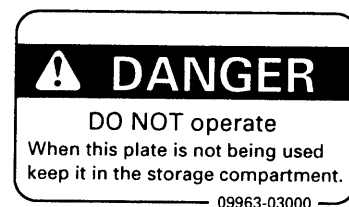
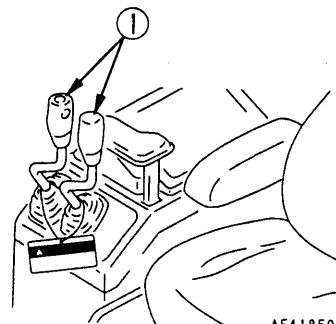

KEEP WORK PLACE CLEAN AND TIDY

Do not leave hammers or other tools lying around in the work place. Wipe up all grease, oil, or other substances that will cause you to slip. Always keep the work place clean and tidy to enable you to carry out operations safely.

If the work place is not kept clean and tidy, there is the danger that you will trip, slip, or fall over and injure yourself.

APPOINT LEADER WHEN WORKING WITH OTHERS

When repairing the machine or when removing and installing the work equipment, appoint a leader and follow his instructions during the operation.

When working with others, misunderstandings between workers can lead to serious accidents.

STOP ENGINE BEFORE CARRYING OUT INSPECTION AND MAINTENANCE

- Stop the machine on firm, level ground.
- Select a place where there is no hazard of falling rocks, landslides, or flooding.
- Lower the work equipment to the ground and stop the engine.

- After stopping the engine, operate work equipment control lever ① 2 – 3 times fully to the RAISE and LOWER positions to release the pressure inside the hydraulic circuit, then set safety lock lever ② to the LOCK position.

- Turn parking brake switch ③ to the ON position and apply the parking brake, then put blocks under the front and rear of the tires.

- Lock the front and rear frames with safety bar ④.

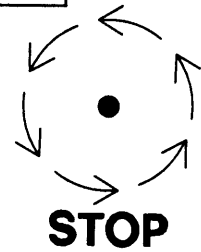

9JM01085

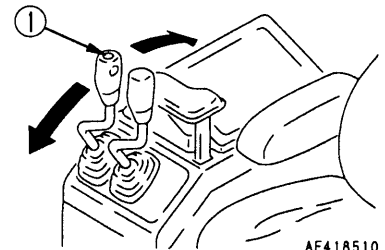

AE418510

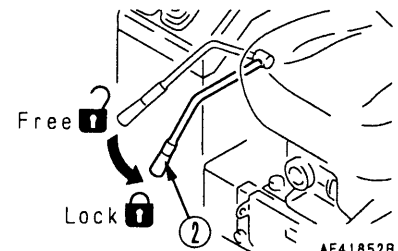

AE41852B

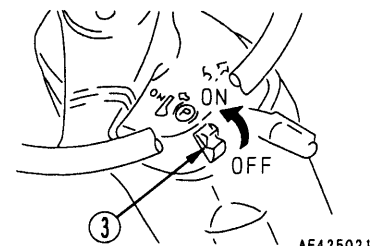

AE425021

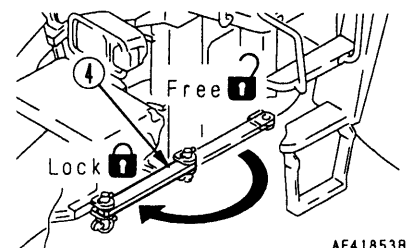

AE41853B

8.2 DURING MAINTENANCE

TWO WORKERS FOR MAINTENANCE WHEN ENGINE IS RUNNING

To prevent injury, do not carry out maintenance with the engine running. If maintenance must be carried out with the engine running, carry out the operation with at least two workers and do as follows.

- One worker must always sit in the operator's seat and be ready to stop the engine at any time. All workers must maintain contact with the other workers.
- When carrying out operations near the fan, fan belt, or other rotating parts, there is a hazard of being caught in the parts, so be extremely careful.
- Never drop or insert tools or other objects into the fan or fan belt. Parts may break or be sent flying.
- Set safety lock lever ① to the LOCK position to prevent the work equipment from moving. Turn parking brake switch ② to the ON position and apply the parking brake.
- Do not touch any control levers. If any control lever must be operated, always give a signal to the other workers to warn them to move to a safe place.

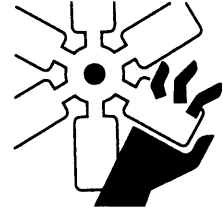

A0055210

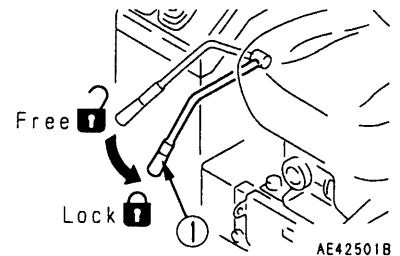

AE42501B

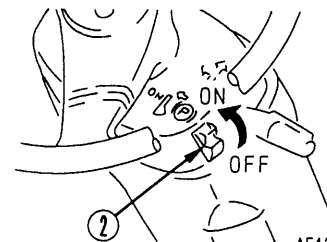

AE425020

PROPER TOOLS

Use only tools suited to the task and be sure to use the tools correctly. Using damaged, low quality, faulty, makeshift tools or improper use of the tools could cause serious personal injury.



A0055120

WORK EQUIPMENT SUPPORT

- When carrying out inspection and maintenance with the work equipment raised, or if it is necessary to go under the machine, use strong supports that can fully withstand the weight of the machine or work equipment, and be sure to fix the stands in position securely.



A0055140

ACCUMULATOR

The accumulator is charged with high-pressure nitrogen gas. When handling the accumulator, careless procedure may cause an explosion which could lead to serious injury or property damage. For this reason, always observe the following precautions.

- Do not disassemble the accumulator.
- Do not bring it near flame or dispose of it in fire.
- Do not make holes in it, weld it, or use a cutting torch.
- Do not hit or roll the accumulator, or subject it to any impact.
- When disposing of the accumulator, the gas must be released. Please contact your Komatsu distributor to have this work performed.

**PERSONNEL**

Only authorized personnel can service and repair the machine. Do not allow unauthorized personnel into the area. If necessary, employ an observer.

ATTACHMENTS

- Appoint a leader before starting removal or installation operations for attachments.
- Place attachments that have been removed from the machine in a stable condition so that they do not fall. And take steps to prevent unauthorized persons from entering the storage area.

**NOISE**

If the noise from the machine is too loud, it may cause temporary or permanent hearing problems. When carrying out maintenance of the engine and you are exposed to noise for long periods of time, wear ear covers or ear plugs while working.

⚠ WARNING: Failure to follow these safety precautions may lead to a serious accident.

PRECAUTIONS WHEN USING HAMMER

When using a hammer, pins may fly out or metal particles may be scattered. This may lead to serious injury. Always do as follows.

- If hard metal parts such as pins or bearings are hit with a hammer, there is danger that pieces might be scattered and cause serious injury. Always wear safety goggles, gloves and other protective clothing.
- When hitting pins or other parts, there is danger that broken pieces might be sent flying and injure people in the surrounding area. Always check that there is no one in the surrounding area.
- If pins are hit with strong force, there is a hazard that the pin may fly out and injure people in the surrounding area.

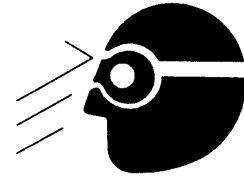

AE305880

REPAIR WELDING

Welding operations must always be carried out by a qualified welder and in a place equipped with a proper equipment. There is a hazard of fire or electrocution when carrying out welding, so never allow any unqualified personnel to carry out welding.

REMOVING BATTERY TERMINAL

When repairing the electrical system or when carrying out electrical welding, remove the negative ⊖ terminal of the battery to prevent the flow of current.

PRECAUTIONS WITH HIGH-PRESSURE OIL

The hydraulic system is always under internal pressure. When inspecting or replacing piping or hoses, always check that the pressure in the hydraulic circuit has been released. If the circuit is still under pressure, it will lead to serious injury or property damage, so always do as follows.

- When carrying out inspection and maintenance of the pressure, release the pressure before starting. For details, see "STOP ENGINE BEFORE CARRYING OUT INSPECTION AND MAINTENANCE". Do not carry out inspection or replacement work with the circuit under pressure.
- If there is any leakage from the piping or hoses, the surrounding area will be wet, so check for cracks in the piping and hoses and for swelling in the hoses.
When carry out inspection, wear safety glasses and leather gloves.
- There is a hazard that high-pressure oil leaking from small holes may penetrate your skin or cause blindness if it contacts your eyes directly. If you are hit by a jet of high-pressure oil and suffer injury to your skin or eyes, wash the place with clean water, and consult a doctor immediately for medical attention.



9JM01453

HANDLING HIGH-PRESSURE HOSES

- If oil or fuel leaks from high-pressure hoses, it may cause fire or defective operation, which may lead to serious injury or property damage. If any loose bolts are found, stop work and tighten to the specified torque. If any damaged hoses are found, stop operations immediately and contact your Komatsu distributor.

Replace the hose if any of the following problems are found.

- Damaged or leaking hydraulic fitting.
- Frayed or cut covering or exposed reinforcement layer of wire.
- Covering swollen in places.
- Twisted or crushed movable portion.
- Foreign material embedded in covering.

WASTE MATERIALS

To prevent pollution, pay careful attention to the method of disposing of waste materials.

- Always put oil drained from your machine in containers. Never drain oil directly onto the ground or dump into the sewage system, rivers, the sea, or lakes.
- Obey appropriate laws and regulations when disposing of harmful objects such as oil, fuel, coolant, solvent, filters, and batteries.

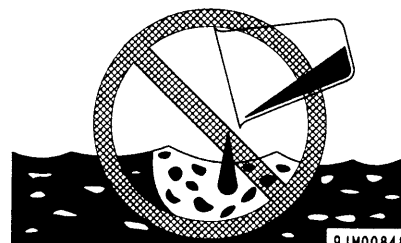

MAINTENANCE OF AIR CONDITIONER

If air conditioner refrigerant gets into your eyes, it may cause blindness; if it touches your skin, it may cause frostbite.

Never touch refrigerant.

COMPRESSED AIR

- When carrying out cleaning with compressed air, there is a hazard of serious injury or property damage caused by flying particles.
- When using compressed air to clean elements or the radiator, always wear safety goggles, dust mask, gloves, and other protective equipment.

PERIODIC REPLACEMENT OF SAFETY CRITICAL PARTS

- In order for the machine to be operated safely for a long time, it is necessary to add oil and to carry out service and maintenance at periodic intervals. In order to further increase safety, components with a strong relationship to safety, such as hoses and seat belts, must be replaced at periodic intervals.
Replacement of safety critical parts: See 22. PERIODIC REPLACEMENT OF SAFETY CRITICAL PARTS.
- The material of these components naturally changes over time, and repeated use causes deterioration, wear, and fatigue. As a result, there is a hazard that these components may fail and cause serious injury or property damage. It is difficult to judge the remaining life of these components from external inspection or the feeling when operating, so always replace them at the specified interval.
- Replace or repair safety critical parts if any defect is found, even when they have not reached the time specified interval.

8.3 PRECAUTIONS WITH TIRES

HANDLING TIRES

If tires or rims are handled mistakenly, there is danger that the tire may explode or be damaged, or that the rim may fly off and cause serious injury or death.

To maintain safety, always do as follows.

- Maintenance, disassembly, repair, and assembly of the tires and rims requires special equipment and special technology, so always ask your Komatsu distributor to carry out these operations.
- Always use the tires specified by Komatsu and maintain the specified inflation pressure.
Suitable tire inflation pressure: see "12.18 HANDLING THE TIRES".
- When pumping up the tires, check that no other person is standing near the tire, and install an air chuck with a clip that can be secured to the air valve.

To prevent the tire inflation pressure from becoming too high, measure the pressure from time to time with an air gauge while pumping up the tire.

- If the tire pressure goes down abnormally or the rim parts do not fit the tire, there is a problem with the tire or rim parts. Always contact your Komatsu distributor for repairs.
- If the rim parts are not fitted properly when the tire is being pumped up, there is danger that the rim parts may fly off, so set up a protective fence around the tire, and do not stand directly in front of the rim. Stand beside the tread when pumping up the tire.
- Do not adjust the tire inflation pressure immediately after traveling at high speed or carrying out operations under heavy load.
- Never carry out welding or light a fire near the tire.

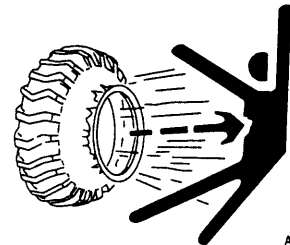

AW636370



AW636380

PRECAUTIONS WHEN STORING TIRE

Tires for construction equipment are extremely heavy, so they may cause serious personal injury.

- As a basic rule, store the tires in a warehouse which unauthorized persons cannot enter.
If the tires must be stored outside, always erect a fence and put up "No Entry" signs.
- Stand the tire on level ground, and block it securely so that it cannot roll or fall over if any person should touch it.
Do not lay the tire on its side. This will deform the tire and cause it to deteriorate.
- If the tire should fall over, do not attempt to stop it. Get out of the way quickly.

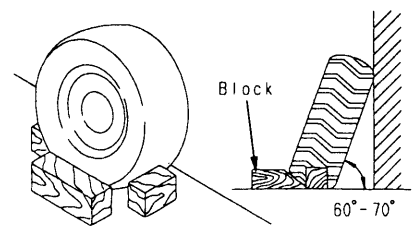

AW637488

9. POSITION FOR ATTACHING SAFETY LABELS

Always keep these labels clean. If they are lost or damaged, attach them again or replace them with a new label.

There are other labels in addition to the safety labels listed as follows, so handle them in the same way.

Safety labels may be available in languages other than English. To find out what labels are available, contact your Komatsu distributor.

9.1 POSITION FOR ATTACHING SAFETY LABELS

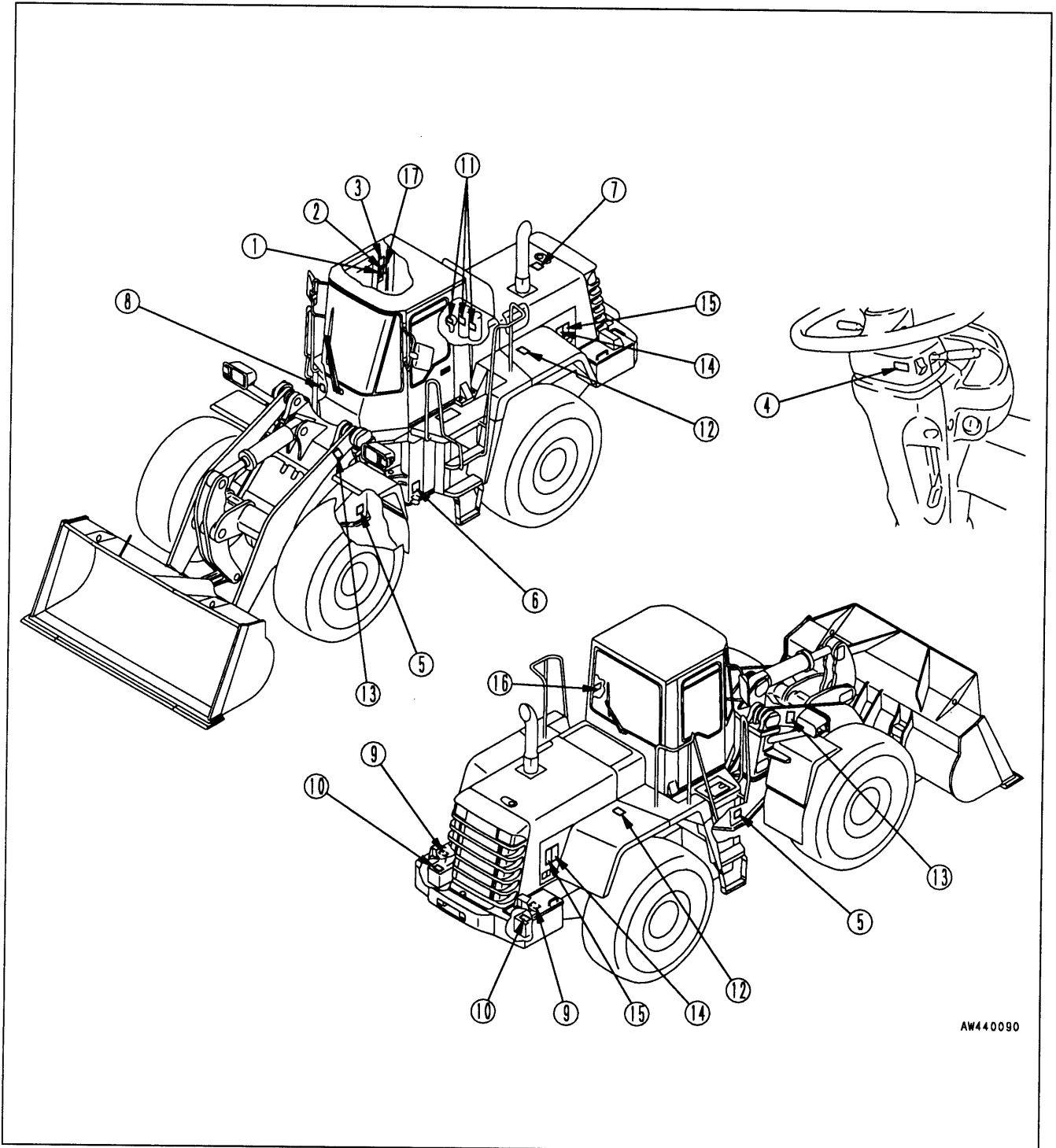

AW440090

1. Precautions before starting
(09651-A0481)

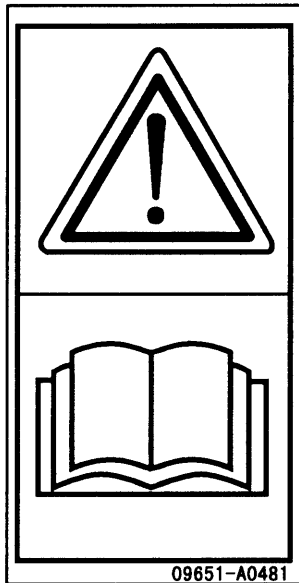

Warning!

Read the **Operation and Maintenance Manual** before operating, maintaining, carrying out disassembly, assembly or transportation of this machine.

2. Precautions for safety lock lever
(09654-C0481)

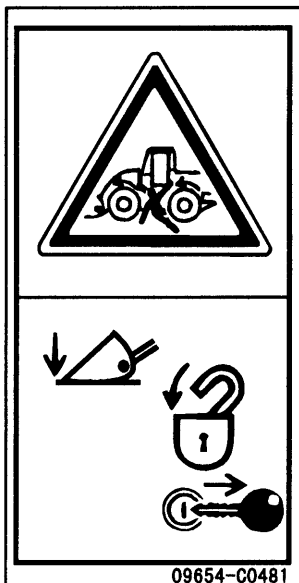

There is the hazard that the machine may move suddenly and catch or run over someone near the machine causing injury.

When leaving the machine, always lower the work equipment completely to the ground, place the control levers in the LOCK position, stop the engine and remove the key.

3. Precautions when traveling in reverse

WARNING

To prevent **SEVERE INJURY** or **DEATH**, do the following before moving machine or its attachments:

- Honk horn to alert people nearby.
- Be sure no one is on or near machine.
- Use spotter if view is obstructed.

Follow above even if machine equipped with back-up alarm and mirrors.

4. Precautions for parking brake

WARNING

If the switch is set to **RELEASE**, a serious accident could result, as this operation releases the parking brake and the machine may move off suddenly. Never set the switch to **RELEASE** except when towing a disabled machine. Before towing such machine, read its manual carefully and be sure to follow the instructions given therein.

9. POSITION FOR ATTACHING SAFETY LABELS

5. Do not enter
(09162-C0641)

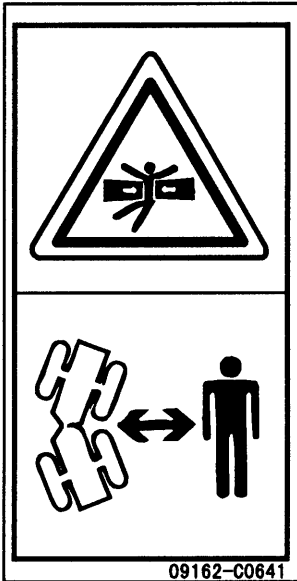

There is danger of getting caught in the articulating portion of the machine.

Do not go close to machine.

6. Precautions for safety bar
(09161-C0641)

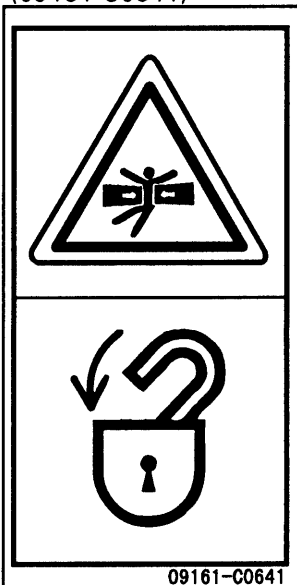

There is danger of getting caught in the articulating portion of the machine.

Lock with the lock bar to prevent the machine from articulating during maintenance or transportation.

7. Precautions when coolant is at high temperature (09653-A0481)



Never remove the cap when the engine is at operating (high) temperature. Stream or high temperature oil blowing up from the radiator or hydraulic tank, will cause personal injury and/or burns.

Never remove the radiator cap or hydraulic tank oil filler when cooling water or hydraulic oil is at high temperatures.

8. Precautions when oil is at high temperature (09653-A0481)



Never remove the cap when the engine is at operating (high) temperature. Stream or high temperature oil blowing up from the radiator or hydraulic tank, will cause personal injury and/or burns.

Never remove the radiator cap or hydraulic tank oil filler when cooling water or hydraulic oil is at high temperatures.

9. Precautions when handling battery cable (09808-A1201)

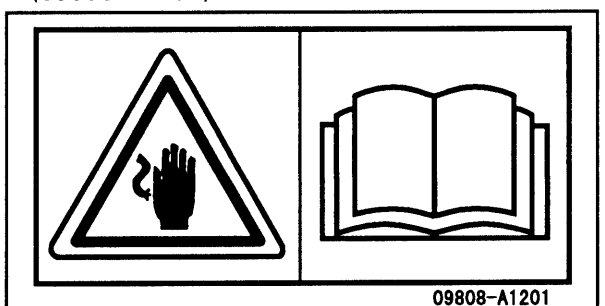

There is the hazard to electric shock when handling electric wires.

Read the operation and maintenance manual and carrying out the correct method when handling.

Please request part number 421-93-21810 for safety labels (1 - 4, 17).

Please request part number 426-93-21570 for safety labels (5 - 9, 14).

10. Precautions when handling battery



(This plate is stick on the machine by the battery maker.)

11. High pressure warning (09659-A057B)

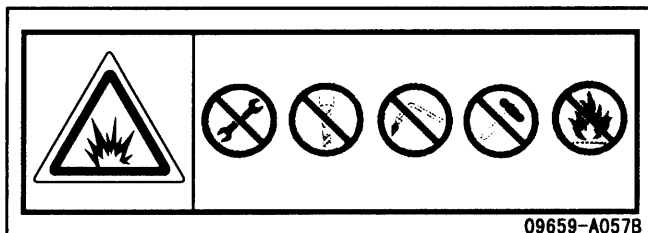

There is the hazard of explosion causing injury. Do not disassemble the accumulator, make holes in it, weld it, cut it, hit it, roll it or bring it near flame.

12. Do not climb on fender (Machine equipped with rear full fender) (09805-C0881)

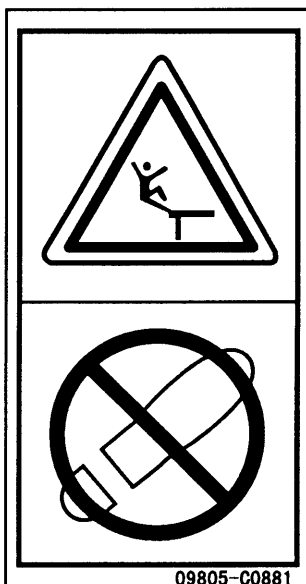

There is the hazard of falling.

Do not step here.

13. "Do not go under work equipment" sign (09807-C0883)



There is danger of work equipment coming down.

Do not go close when work equipment is raised.

14. "Do not open when engine is running" sign. (09667-A0880)

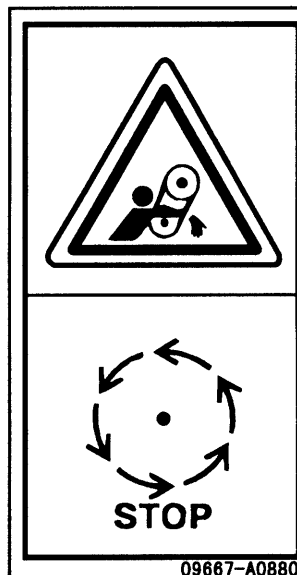

There is the hazard of being caught in the rotating parts of the machine causing injury.

Stop the rotating parts of the machine completely when carrying out inspection and maintenance.

9. POSITION FOR ATTACHING SAFETY LABELS

15. "Do not come near machine" sign
(09806-C0883)

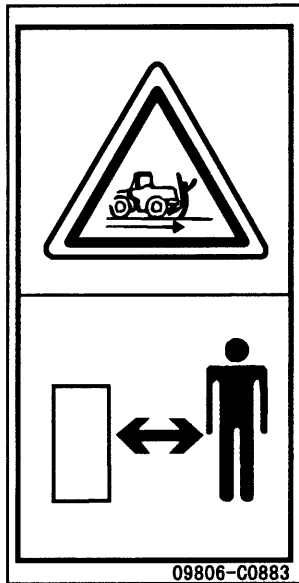

There is danger of being run over by machine .

Do not go close to machine.

16. "Do not modify ROPS" sign

KOMATSU			
ROLL-OVER PROTECTIVE STRUCTURE (ROPS) THE ROLL-OVER PROTECTIVE STRUCTURE OF THIS MACHINE COMPLIES WITH THE FOLLOWING STANDARDS OR RECOMMENDED PRACTICES)			
INTERNATIONAL STANDARD: ISO J471 (ROPS)			
AMERICAN STANDARD : SAE J <input type="text"/> g SAE J <input type="text"/>			
MODEL <input type="text"/>	MACHINE MODEL <input type="text"/>	SERIAL NO. <input type="text"/>	MAX. MASS <input type="text"/> kg
⚠ WARNING	<ul style="list-style-type: none"> ● Altering ROPS may weaken it. Consult Komatsu Distributor before altering. ● ROPS may provide less protection if it has been structurally damaged or involved in roll-over. ● Always wear seat belt when moving. 		
	Komatsu Ltd. Japan 2-3-6 Akasaka, Minato-ku, Tokyo, Japan 09620-30200		

17. Precautions for going close to electric cables
(09801-C0481)

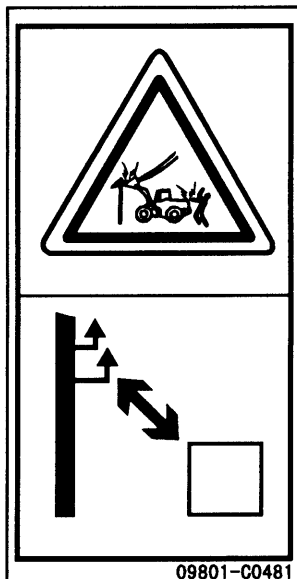

If machine goes close to high-voltage cables, it will result in electric shock to the operator.

Maintain a safe distance between the machine and the electric cables.

OPERATION

10. GENERAL VIEW

10.1 GENERAL VIEW OF MACHINE

If directions are indicated in this section, they refer to the directions shown by the arrows in the diagram below.

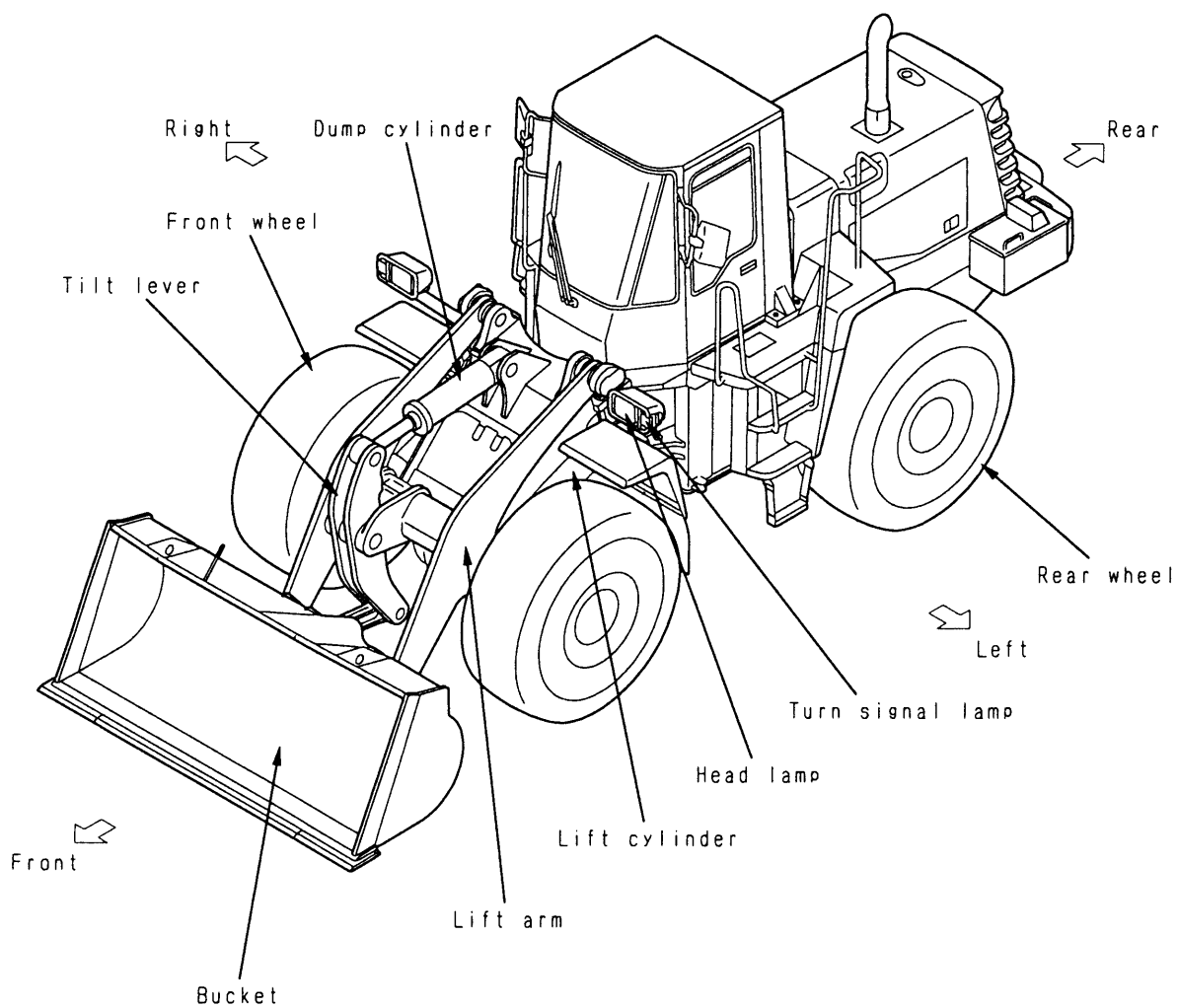

AE433548

10.2 GENERAL VIEW OF CONTROLS AND GAUGES

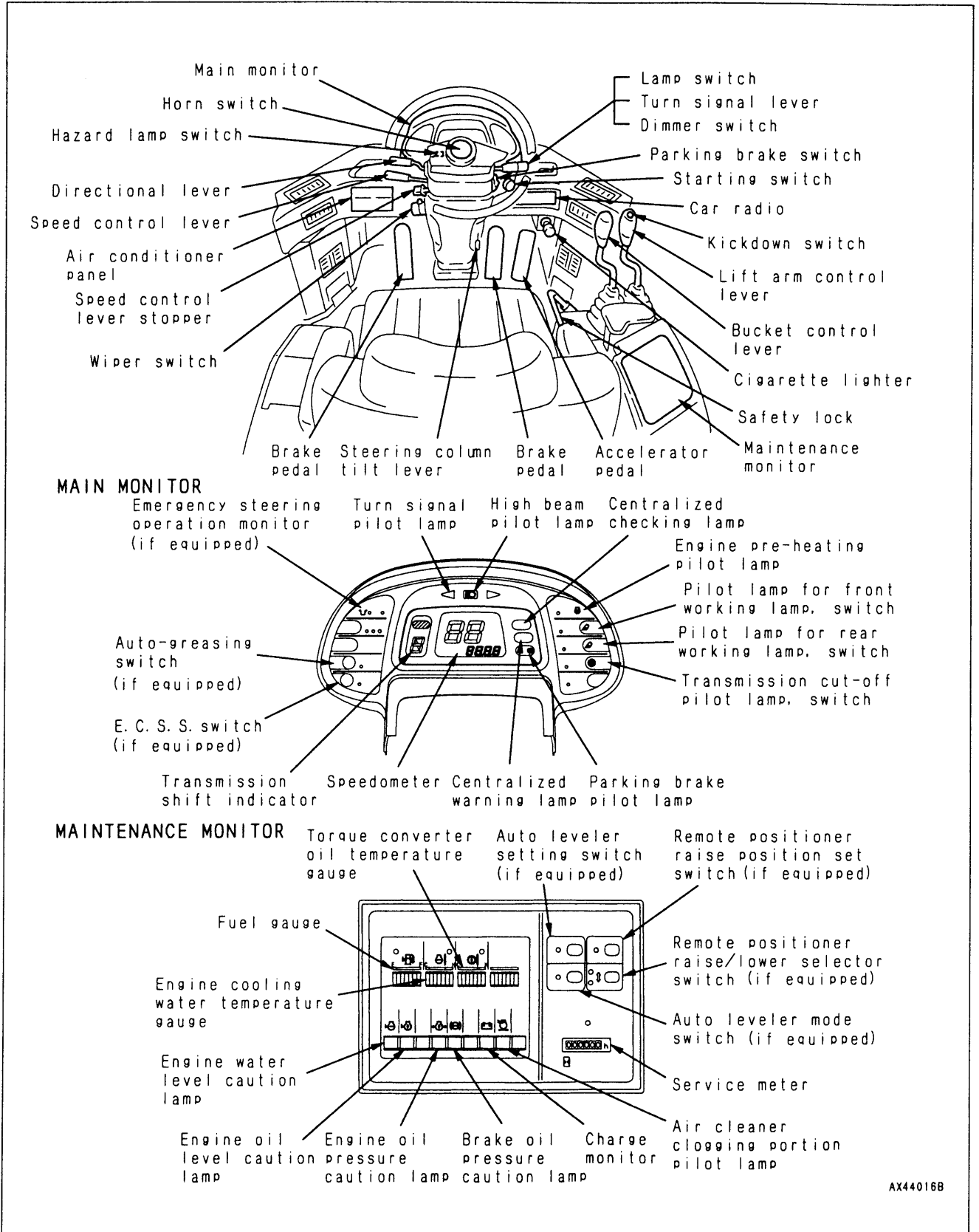

11. EXPLANATION OF COMPONENTS

The following is an explanation of the devices needed for operating the machine.

To carry out suitable operations correctly and safely, it is important to understand fully the methods of operating the equipment and the meanings of the displays.

11.1 MACHINE MONITOR

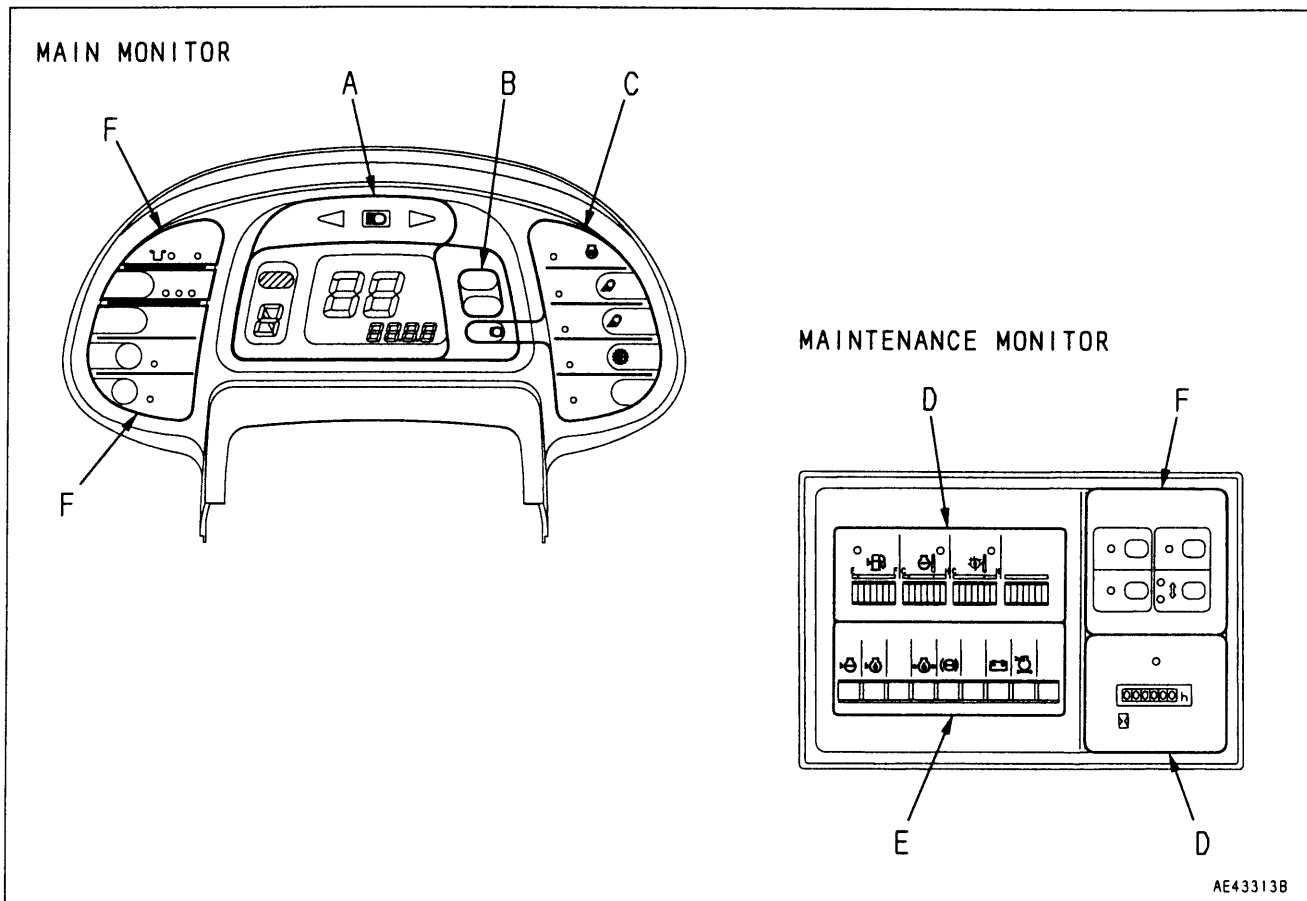

The machine monitor system consists of the main monitor (in front of the operator's seat) and the maintenance monitor (on the right side of the operator's seat).

The monitor system can be divided functionally into the alarm display portions (B, E) and the meter display portions (A, C, D), and option display portion (F).

ALARM DISPLAY PORTIONS (B, E) (11.1.1)

These consist of the centralized check lamp (CHECK), central warning lamp (CAUTION), and warning pilot lamps (engine water level, engine oil level, brake oil pressure, engine oil pressure, battery charge, and air cleaner clogging).

METER DISPLAY PORTION (A, C, D) (11.1.2)

These consist of the meters (speedometer, fuel gauge, engine water temperature gauge, torque converter oil temperature gauge, service meter, transmission shift indicator) and the pilot lamps (turn signal indicator, head lamp Hi beam, preheating, front working lamp, rear working lamp, transmission cut-off, parking brake).

OPTION DISPLAY PORTION (F)

This consists of the monitor lamps and switches for the emergency steering system, auto-greasing system, E.C.S.S., auto leveler, and remote positioner.

For details of each system or component, see OPTIONS, ATTACHMENTS.

TESTING ACTUATION OF MACHINE MONITOR SYSTEM

When the starting switch is turned to the ON position before starting the engine, all monitor lamps, gauges, and centralized warning lamps will light up for approx. 3 seconds, and the alarm buzzer will sound for approx. 1 second.

When this happens, 88 is displayed on the speedometer, and 8 is displayed on the transmission shift indicator.

Finally, there will be two beeps to indicate that the monitor check has been completed.

If the monitor lamps do not light up, there is probably a failure or disconnection, so please contact your Komatsu distributor for inspection.

When the starting switch is turned to the ON position, if the directional lever is not at the neutral position, the central warning lamp (CAUTION) will flash and the alarm buzzer will sound intermittently. If this happens, return the lever to the neutral position, and the lamps will go out and the buzzer will stop.

The monitor check cannot be carried out for at least 30 seconds after the engine has been stopped.

11.1.1 WARNING DISPLAYS

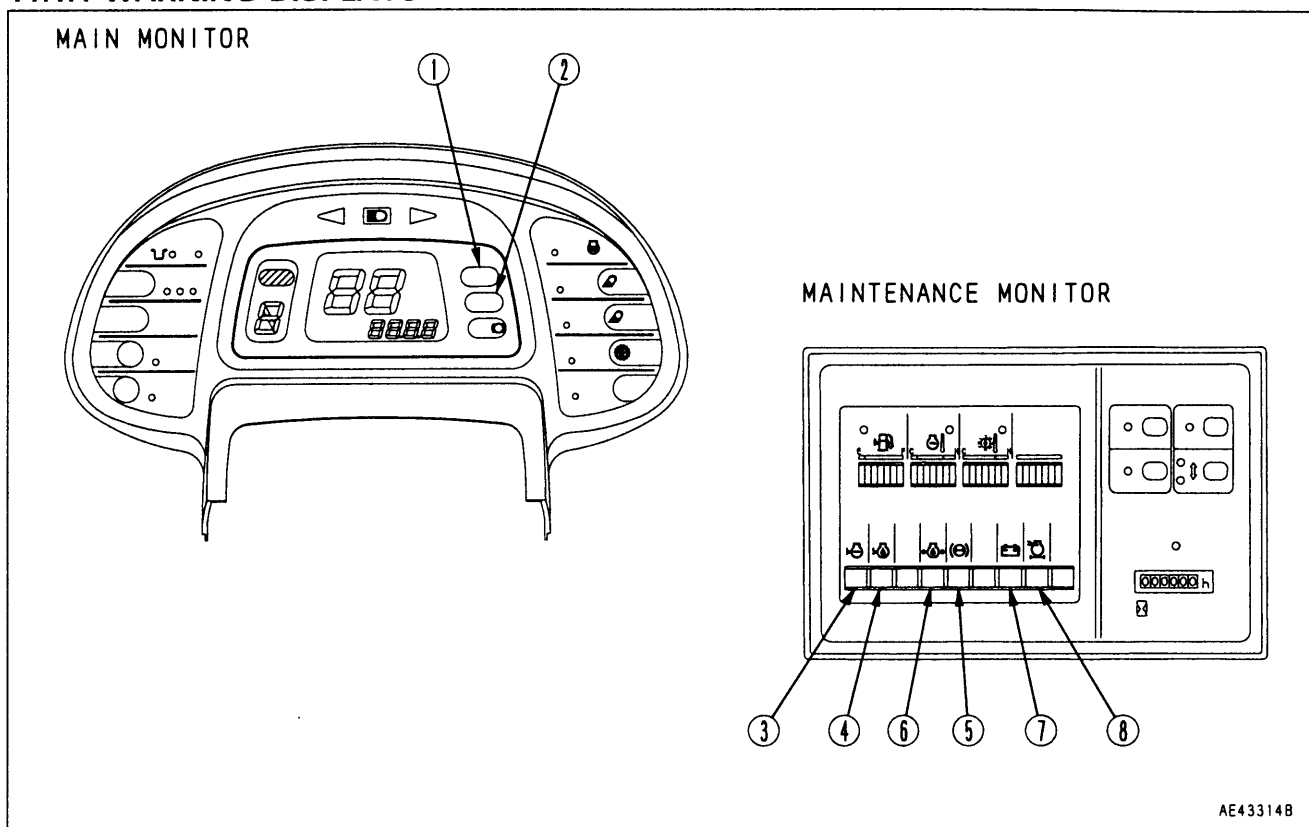

AE43314B

1. CENTRAL CHECK LAMP (CHECK)

WARNING

If this monitor flashes, carry out inspection and maintenance of the appropriate location as soon as possible.

- If any abnormality is found in the CHECK items before starting the engine (engine oil level, engine water level), the monitor lamp for the abnormal location will flash and the central CHECK lamp will also flash.
Check the location where the monitor lamp is flashing and carry out the check before starting.
When carrying out the checks before starting, do not rely simply on the monitor. Always carry out the specified maintenance items.
When carrying out checks before starting, if the engine oil level is abnormal, the engine oil level will change when the engine is started, so even if there is any abnormality, the central CHECK lamp and monitor lamp will stop flashing.
If there is any abnormality in the engine water level, the central CHECK lamp will go out when the engine is started, but instead of this, the central CAUTION lamp will flash and the alarm buzzer will sound intermittently.

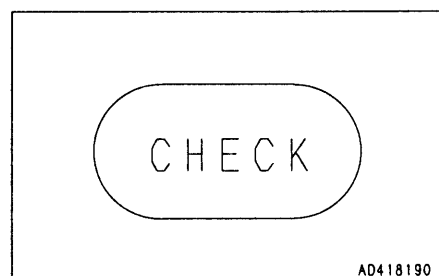

AD418190

- If there is any abnormality in the battery charging system when the engine is running, the battery charge caution pilot lamp will flash and the central CHECK lamp will also flash at the same time. If the lamps flash, check the charging circuit.

2. CENTRAL CAUTION LAMP (CAUTION)

WARNING

If these monitor lamps flash, stop the engine immediately or run it at low idling and do as follows.

- If there is an abnormality in any CAUTION item when the engine is running (engine water temperature, torque converter oil temperature, engine water level, brake oil pressure, engine oil pressure), the alarm buzzer will sound intermittently and the monitor lamp for the location of the abnormality will flash and the central CAUTION lamp will also flash.
- If the fuel gauge enters the red range when the engine is running, the fuel gauge will flash and the central CAUTION lamp will also flash. If they flash, check the fuel level and add fuel.

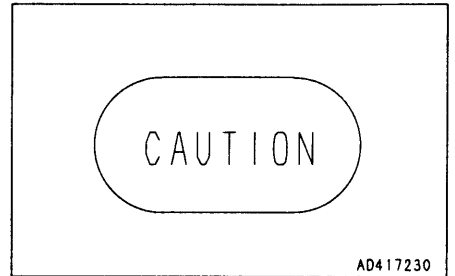

3. ENGINE WATER LEVEL CAUTION LAMP

This warns the operator that the coolant level in the radiator has dropped.

When carrying out the checks before starting (main switch ON, engine stopped):

If the level of the coolant in the radiator is low, the caution pilot lamp and central CHECK lamp will flash.

If the monitor lamps flash, check the coolant level in the radiator sub-tank and add water.

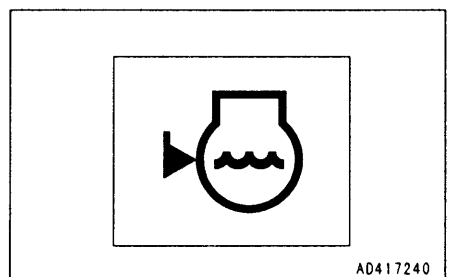

When operating (engine running):

If the condition is normal, the caution pilot lamp should be off.

If the level of the coolant in the radiator is too low, the warning pilot lamp and central CAUTION lamp will flash, and the alarm buzzer will sound intermittently.

If the monitor lamps flash, stop the engine, check the level of the coolant in the radiator and sub-tank, and add water.

Stop the machine on level ground before carrying out this check.

4. ENGINE OIL LEVEL CAUTION PILOT LAMP

This warns the operator that the level of the oil in the engine oil pan has dropped.

When carrying out checks before starting:

If the oil level in the engine oil pan is low, the caution pilot lamp and central CHECK lamp will flash.

If the monitor lamps flash, check the oil level in the engine oil pan and add oil.

When operating:

Even if the engine oil level caution pilot lamp is flashing during check before starting, it will go out when the engine is started.

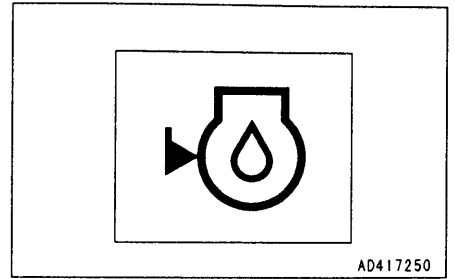

5. BRAKE OIL PRESSURE CAUTION PILOT LAMP

This warns the operator that the brake oil pressure has dropped.

When carrying out checks before starting:

When the engine is stopped, the brake oil pressure circuit is not actuated, so the caution pilot lamp and central CHECK lamp are also off.

When operating:

If the brake oil pressure goes down, the caution pilot lamp and central CAUTION lamp will flash, and the alarm buzzer will sound intermittently. If the monitor lamps flash, stop the engine immediately and check the brake oil pressure circuit.

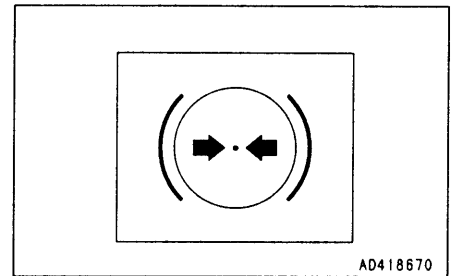

REMARK

The monitor lamp may flash and go out after approx. 10 seconds immediately after the engine is started. This is because pressure is being stored in the brake accumulator. It does not indicate any abnormality.

6. ENGINE OIL PRESSURE CAUTION PILOT LAMP

This warns the operator that the engine lubricating oil pressure has dropped.

If it flashes, stop the engine and check.

Check before starting: Lights up

Engine started or running: When the engine is started, the lubrication pressure is formed and the lamps go out. If the engine lubrication pressure drops, the warning pilot lamp and central CAUTION lamp will flash, and the buzzer will sound intermittently.

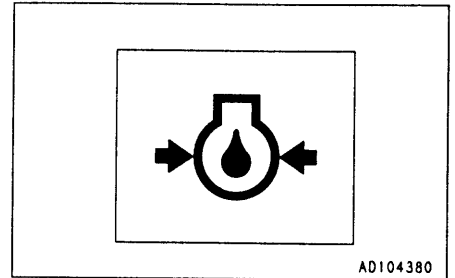
**7. BATTERY CHARGE CAUTION PILOT LAMP**

This warns the operator that there is an abnormality in the charging system when the engine is running.

Check before starting: Lights up

Engine started or running: When the engine is started, the alternator generates electricity and the lamp goes out.

If any abnormality occurs in the charging system, the caution pilot lamp and central CHECK lamp will flash. If they flash, check the charging circuit.

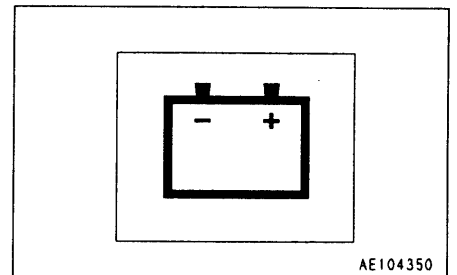
**8. AIR CLEANER CLOGGING PORTION PILOT LAMP**

When the engine is running, this warns the operator that the air cleaner element is clogged.

Check before starting: OFF

When operating: If the air cleaner becomes clogged, the caution pilot lamp and central CHECK lamp will flash.

If they flash, clean or replace the element.

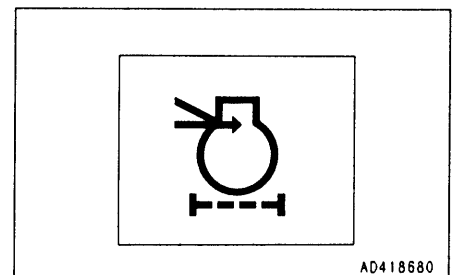

11. EXPLANATION OF COMPONENTS

11.1.2 METER DISPLAY PORTION

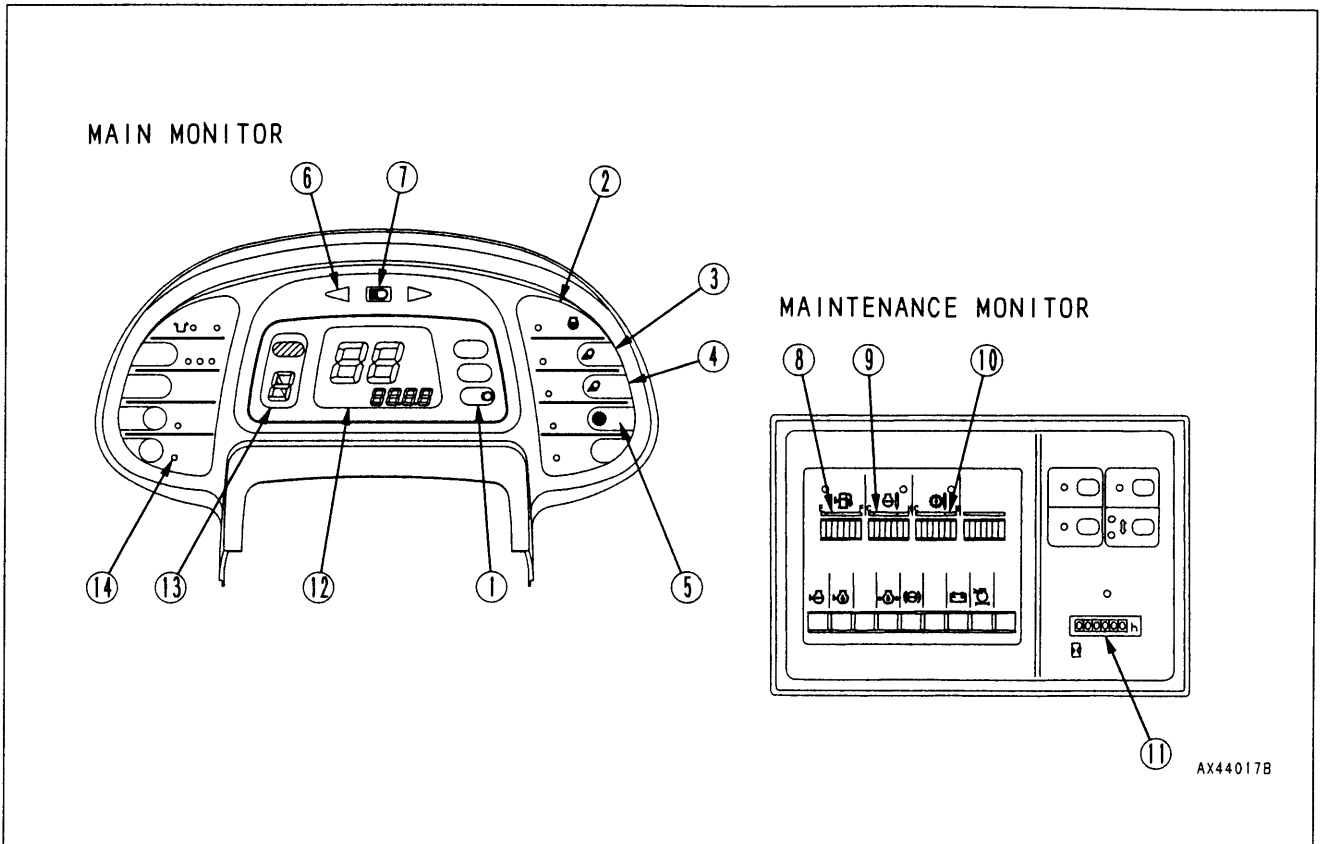

PILOT DISPLAY

When the starting switch is ON, the pilot display lights up when the display items are functioning.

1. PARKING BRAKE PILOT LAMP

This lamp lights up when the parking brake is applied.

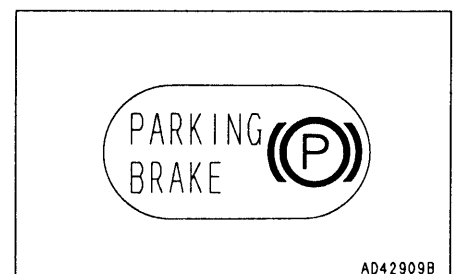

2. PREHEATING PILOT LAMP

This informs the operator that the glow plug is heated.

This lamp lights up when the starting switch is turned to the ON position, and goes out when the preheating is completed.

The time that it remains lighted up differs according to the water temperature when the engine is started.



3. FRONT WORKING LAMP PILOT LAMP

This lamp lights up when the front working lamp is switched on.

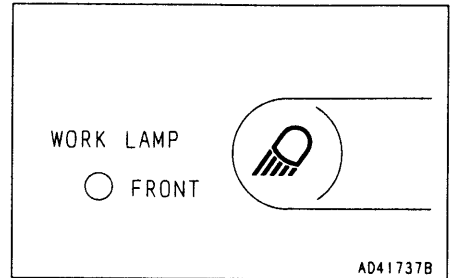

4. REAR WORKING LAMP PILOT LAMP

This lamp lights up when the rear working lamp is switched on.

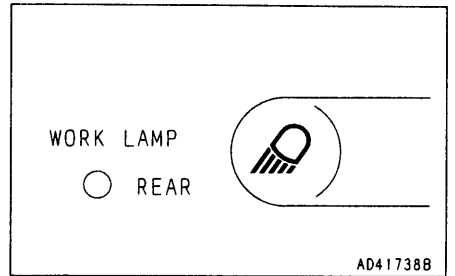

5. TRANSMISSION CUT-OFF PILOT LAMP

This lamp lights up when the transmission cut-off switch is turned to ON.

If the monitor lamp is ON and the left brake pedal is depressed, the transmission will be returned to neutral.

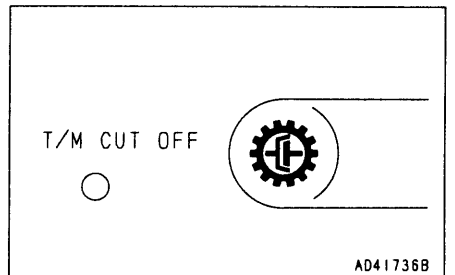

6. TURN SIGNAL PILOT LAMP

When the turn signal lamp flashes, the pilot lamp also flashes.

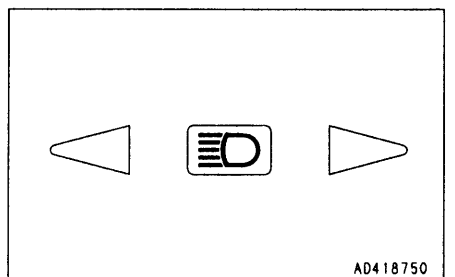

7. HIGH BEAM PILOT LAMP

This lamp lights up when the head lamp is at high beam.

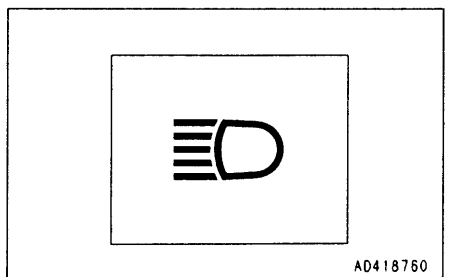

11. EXPLANATION OF COMPONENTS

METERS

8. FUEL GAUGE

This gauge indicates the amount of fuel in the fuel tank.

E: Tank is EMPTY

F: Tank is FULL

The lamp should light up in the green range during operation.

If it enters the red range during operation, the fuel gauge lamp and central CAUTION lamp will flash.

If only the red range lights up during operation, it means that there is less than 40 liters (10.56 US gal, 8.80 UK gal) of fuel left, so check and add fuel.

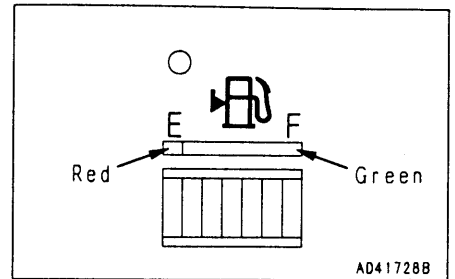

9. ENGINE COOLING WATER TEMPERATURE GAUGE

This gauge indicates the temperature of the cooling water.

If the temperature is normal during operation, the green range will light.

If the red range lights during operation, stop the machine and run the engine with no load at midrange speed until the green range lights.

If the lamps light up to the 1st red level, the engine water temperature gauge lamp and central CAUTION lamp will flash; when the lamps light up to the 2nd red level, the alarm buzzer will also sound intermittently.

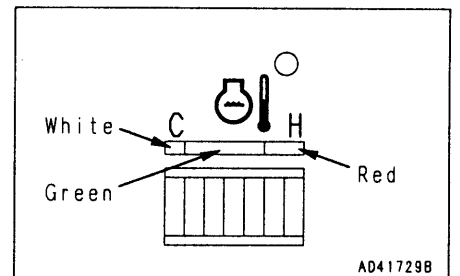

10. TORQUE CONVERTER OIL TEMPERATURE GAUGE

This gauge indicates the temperature of the torque converter oil. If the temperature is normal during operation, the green range will light.

If the red range lights during operation, stop the machine and run the engine with no load at midrange speed until the green range lights.

If the lamps light up to the 1st red level, the torque converter oil temperature gauge lamp and central CAUTION lamp will flash; when the lamp lights up to the 2nd red level, the alarm buzzer will also sound intermittently.

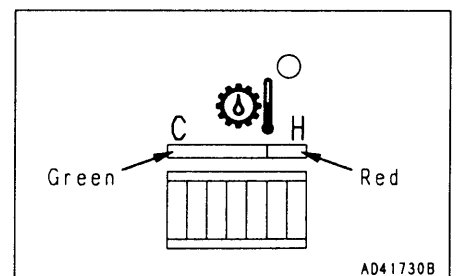

11. SERVICE METER

This meter shows the total operation hours of the machine.

The service meter advances while the engine is running - even if the machine is not traveling.

While the engine is running, green pilot lamp on the service meter flashes to show the service meter advances.

The service meter progresses by 1 when the engine is operated for one hour, regardless of the engine speed.

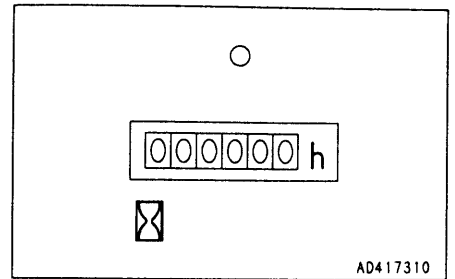

12. SPEEDOMETER

This meter indicates the travel speed of the machine.

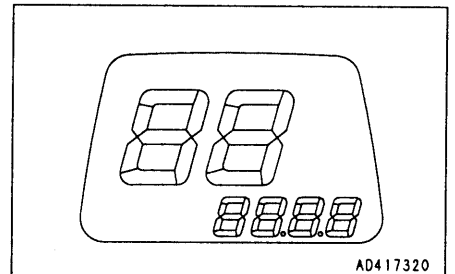

13. TRANSMISSION SHIFT INDICATOR

This indicates the present speed range of the transmission.

When the directional lever is at the N position, N is displayed on the indicator.

When the directional lever is at the F or R position, the shift position of the speed lever is displayed as a numeral.

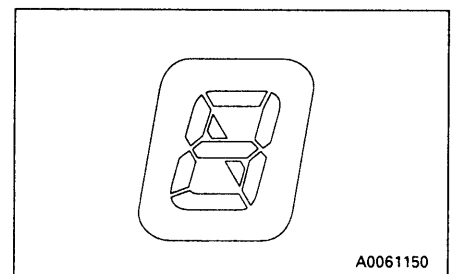

14. E.C.S.S. INDICATOR (if equipped)

This lamp lights up when the E.C.S.S. switch ON.

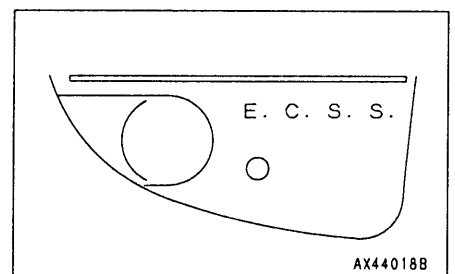

11.2 SWITCHES

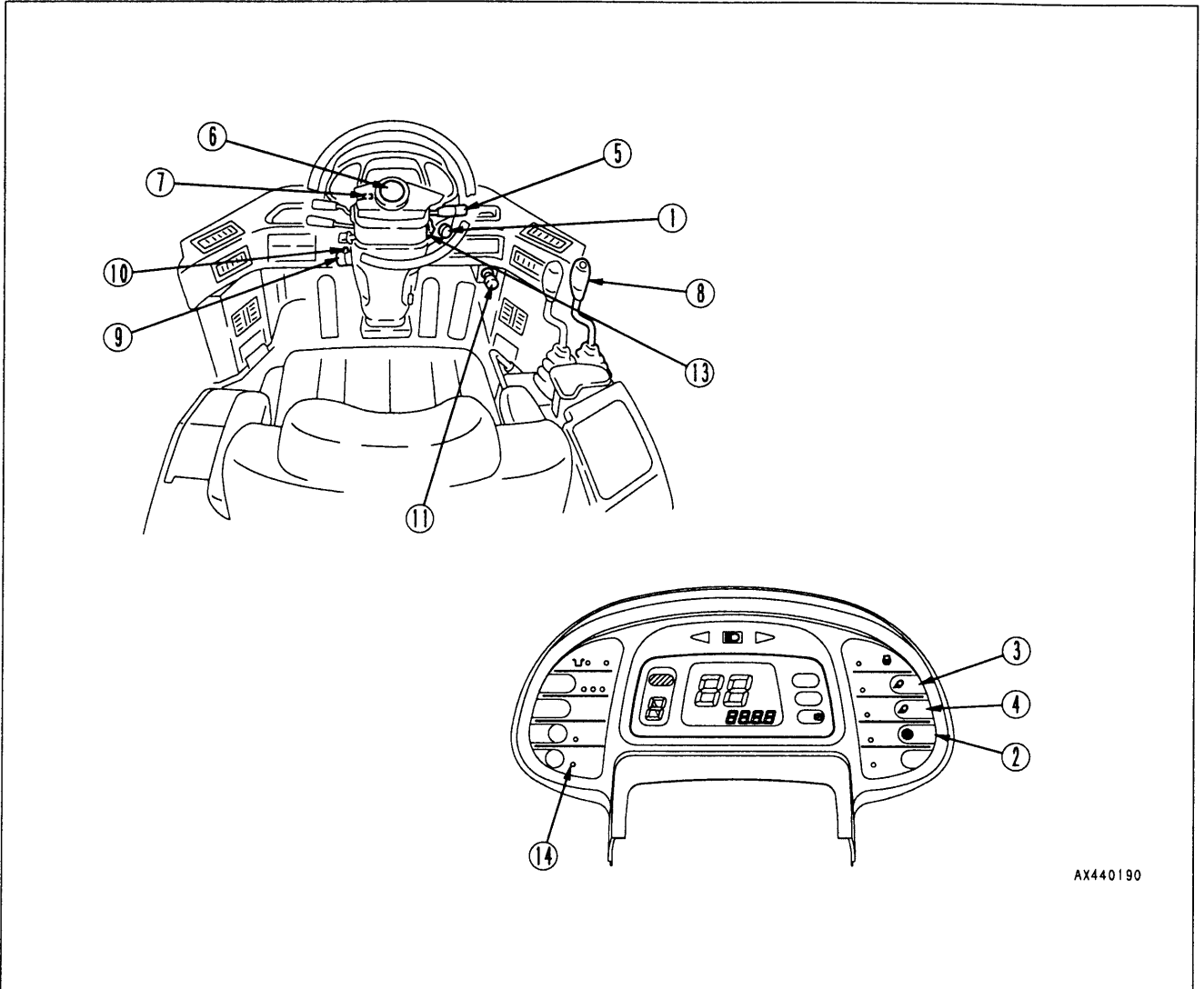

AX440190

1. STARTING SWITCH

This switch is used to start or stop the engine.

OFF position

The key can be inserted and removed at this position. When the key is turned to this position, the electric circuit is turned off and the engine stops.

ON position

Electric current flows in the charging, lamp and accessory circuits. Keep the starting switch key at the ON position while the engine is running.

START position

This is the engine-start position. Keep the key at this position during cranking. Immediately after starting the engine, release the key which will automatically return to the ON position.

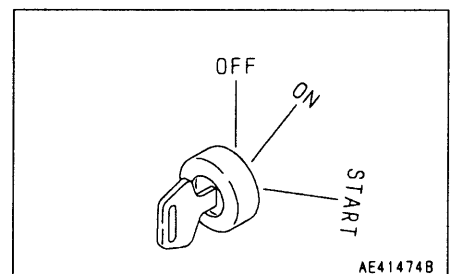

AE41474B

2. TRANSMISSION CUT-OFF SWITCH

WARNING

If the machine has to be started on a slope, always turn the transmission cut-off switch to OFF and depress the left brake pedal. Then depress the accelerator pedal while releasing the left brake pedal to start the machine off slowly.

Press the push button to switch ON and OFF.

When the pilot lamp is pressed, it will light up and come ON; if it pressed again, the pilot lamp will go out and the transmission cut-off will be turned OFF.

Normally, put this switch in the ON position.

- ① OFF: Acts as normal brake (like right brake pedal).
- ② ON: Acts as normal brake, but also switches transmission to NEUTRAL.

If the switch is at ON, the transmission cut-off pilot lamp will light up.

REMARK

General loading work can be carried out more smoothly if the transmission cut-off function is not used.

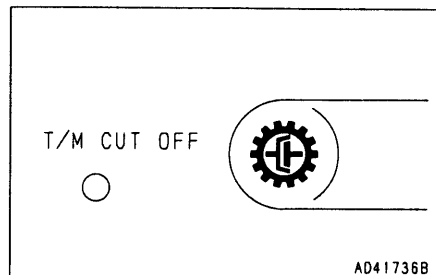

3. FRONT WORKING LAMP SWITCH

WARNING

Always turn the working lamp off before traveling on public roads.

When turning on the front working lamp, turn the lamp switch to the ON position for the side clearance lamp or ON position for the head lamp, then operate the switch.

When the pilot lamp is pressed, it will light up and come ON; if it pressed again, the pilot lamp will go out and the working lamp will be turned OFF.

The working lamp will not light up if the lamp switch is not at the ON position for the side clearance lamp or ON position for the head lamp.

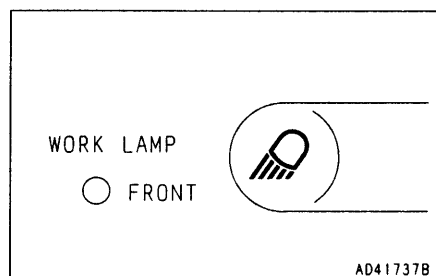

4. REAR WORKING LAMP SWITCH

WARNING

Always turn the working lamp off before traveling on public roads.

When turning on the rear working lamp, turn the lamp switch to the ON position for the side clearance lamp or ON position for the head lamp, then operate the switch.

When the pilot lamp is pressed, it will light up and come ON; if it pressed again, the pilot lamp will go out and the working lamp will be turned OFF.

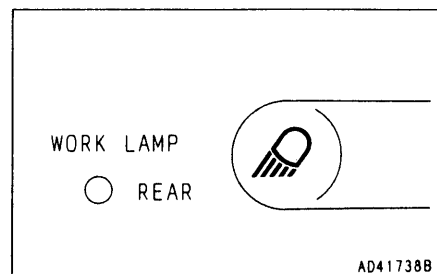

The working lamp will not light up if the lamp switch is not at the ON position for the side clearance lamp or ON position for the head lamp.



11. EXPLANATION OF COMPONENTS

5. LAMP SWITCH

This is used to light up the head lamps, side clearance lamps, tail lamps, and instrument panel lighting.

- ① OFF
- ②  position: Side clearance lamp, tail lamps, and gauge lighting light up
- ③  position: Head lamps light up in addition to lamps at  position

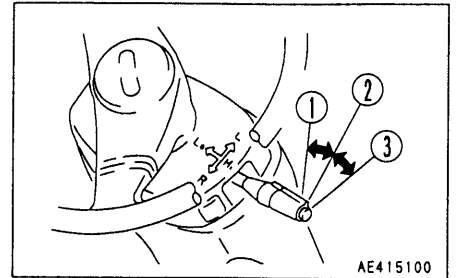

REMARK

The lamp switch can be operated regardless of the position of the lever.

5. TURN SIGNAL LEVER

This lever operates the turn signal lamps.

- ① LEFT TURN: Push lever FORWARD.
- ② RIGHT TURN: Pull lever BACK.

REMARK

- When the lever is operated, the turn signal pilot lamp will also light up.
- When the steering wheel is turned to the neutral position, the turn signal lever will return automatically to OFF. If not, return the lever to OFF manually.

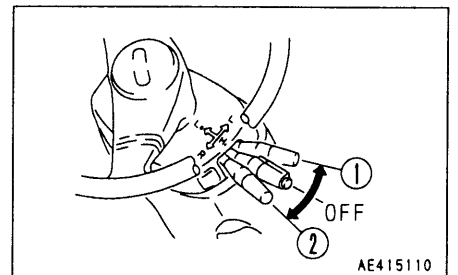

5. DIMMER SWITCH

This switches the head lamp between high beam and low beam.

- Ⓐ Low beam
- Ⓑ High beam

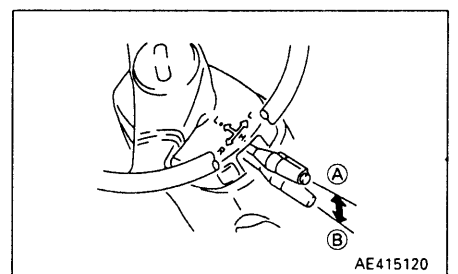

6. HORN BUTTON

When the button in the center of the steering wheel is pressed, the horn will sound.

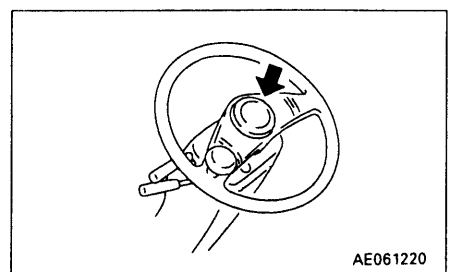

7. HAZARD LAMP SWITCH

⚠ WARNING
Use the hazard lamps only in emergencies. Using the hazard lamps when traveling will cause problems for other machines.

This switch is used in emergencies, such as when the machine breaks down.

ON: All turn signal lamps flash.

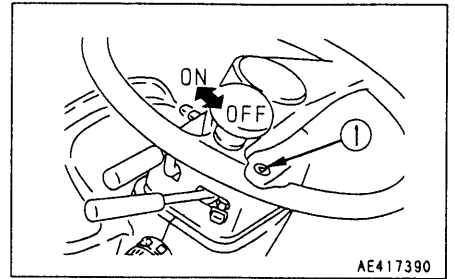

REMARK

When this switch is turned to the ON position, the turn direction indicator lamps and turn indicator pilot lamp flash, and display lamp ① lights up at the same time.

8. KICKDOWN SWITCH

When the speed control lever is in 2nd, and the switch at the top of the knob of the lift arm control lever is pressed, the gear will shift down to 1st.

This switch is used to increase the drawbar pull in digging operations.

REMARK

To cancel the kickdown switch, move the directional lever to REVERSE or NEUTRAL, or move the speed control lever to any position except 2nd. It is also possible to cancel the kickdown switch by operating the parking brake switch or by turning the starting switch OFF.

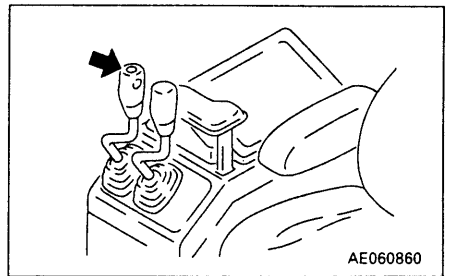

9. FRONT WIPER SWITCH

- Turn switch ① to operate the front wiper.

Switch position	Window display	Operation
1	OFF	OFF
2	INT	Intermittent wiper
3	1	Low-speed wiper
4	2	High-speed wiper

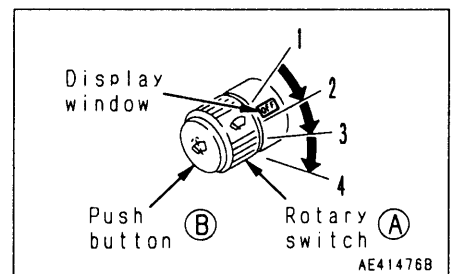



- If button ② is kept pressed, washer fluid will be sprayed out on to the front glass.

11. EXPLANATION OF COMPONENTS

10. REAR WIPER SWITCH

- Turn lever © to operate the rear wiper.

Position of switch	Display	Operation
1		Washer fluid sprayed
2	OFF	OFF
3		Wiper actuated
4		Washer fluid sprayed, wiper actuated

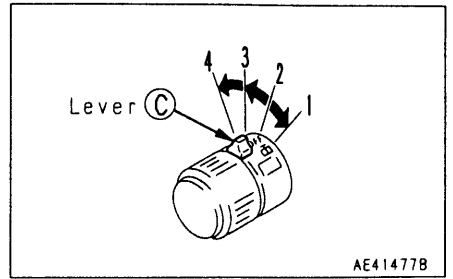

11. CIGARETTE LIGHTER

This is used to light cigarettes.

To use, push the lighter in. After the few seconds it will spring back. At that time, remove the lighter and light your cigarette.

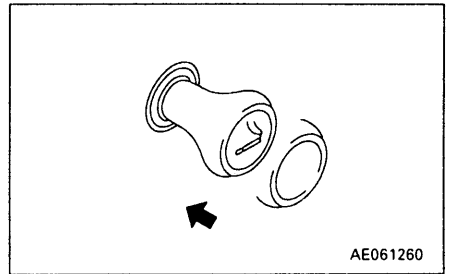

12. ROOM LAMP SWITCH

This lights up the room lamp.

On position: Lights up

Position 1: OFF

Position 2: Lights up when cab door is opened

Position 3: Lights up

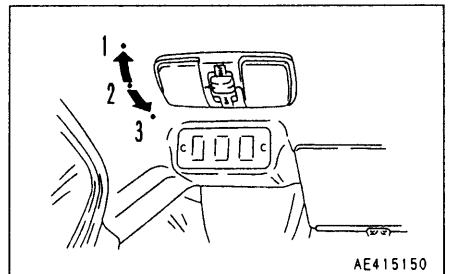

REMARK

- The room lamp lights up even when the main switch is OFF, so when leaving the operator's compartment, turn the switch to position 1 or 2.
- When operating with the cab door fully open, set the switch to position 1 (OFF).

13. PARKING BRAKE SWITCH

WARNING

Always apply the parking brake when leaving the machine or parking it.

Even if the parking brake switch is turned ON, there is danger until the parking brake pilot lamp lights up, so keep the brake pedal depressed.

This switch operates the parking brake.

- ① ON position: The parking brake is applied, and the parking brake pilot lamp lights up.
- ② OFF position: The parking brake is released.

REMARK

- If the directional lever is placed in F (FORWARD) or R (REVERSE) with the parking brake applied, the warning lamp will flash and the alarm buzzer will sound.
- When the starting switch is turned to OFF, the parking brake is automatically applied.
Before starting the engine, turn the parking brake switch to ON, then turn it to OFF.
- The machine does not start when the directional lever is operated with the parking brake applied.

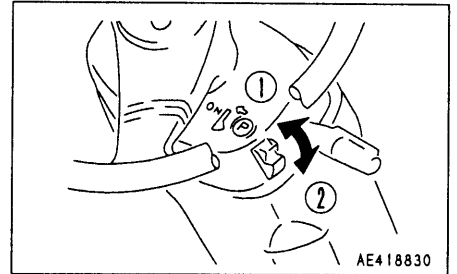

NOTICE

- **Never use the parking brake switch to apply the brakes when traveling, except in an emergency. Apply the parking brake only after the machine has stopped.**
- **If the parking brake has been used as an emergency brake when traveling at high speed (near the maximum speed), contact your Komatsu distributor to have the parking brake checked for any abnormality.**

14. E.C.S.S. SWITCH (if equipped)

This switch turns the E.C.S.S. ON/OFF.

When the switch is pressed, the E.C.S.S. is turned ON, the pilot lamp lights up, and the E.C.S.S. is actuated.

When the switch is pressed again, it is turned OFF, the pilot lamp goes out, and the E.C.S.S. is canceled.

NOTICE

- **Before operating the E.C.S.S. switch, always stop the machine and lower the work equipment to the ground first.**
- **When carrying out inspection and maintenance, first lower the work equipment to the ground, then turn the E.C.S.S. switch OFF and carry out inspection and maintenance.**
- **For leveling operations, turn the E.C.S.S. switch OFF.**

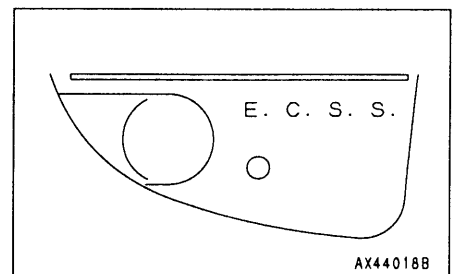

11.3 CONTROL LEVERS, PEDALS

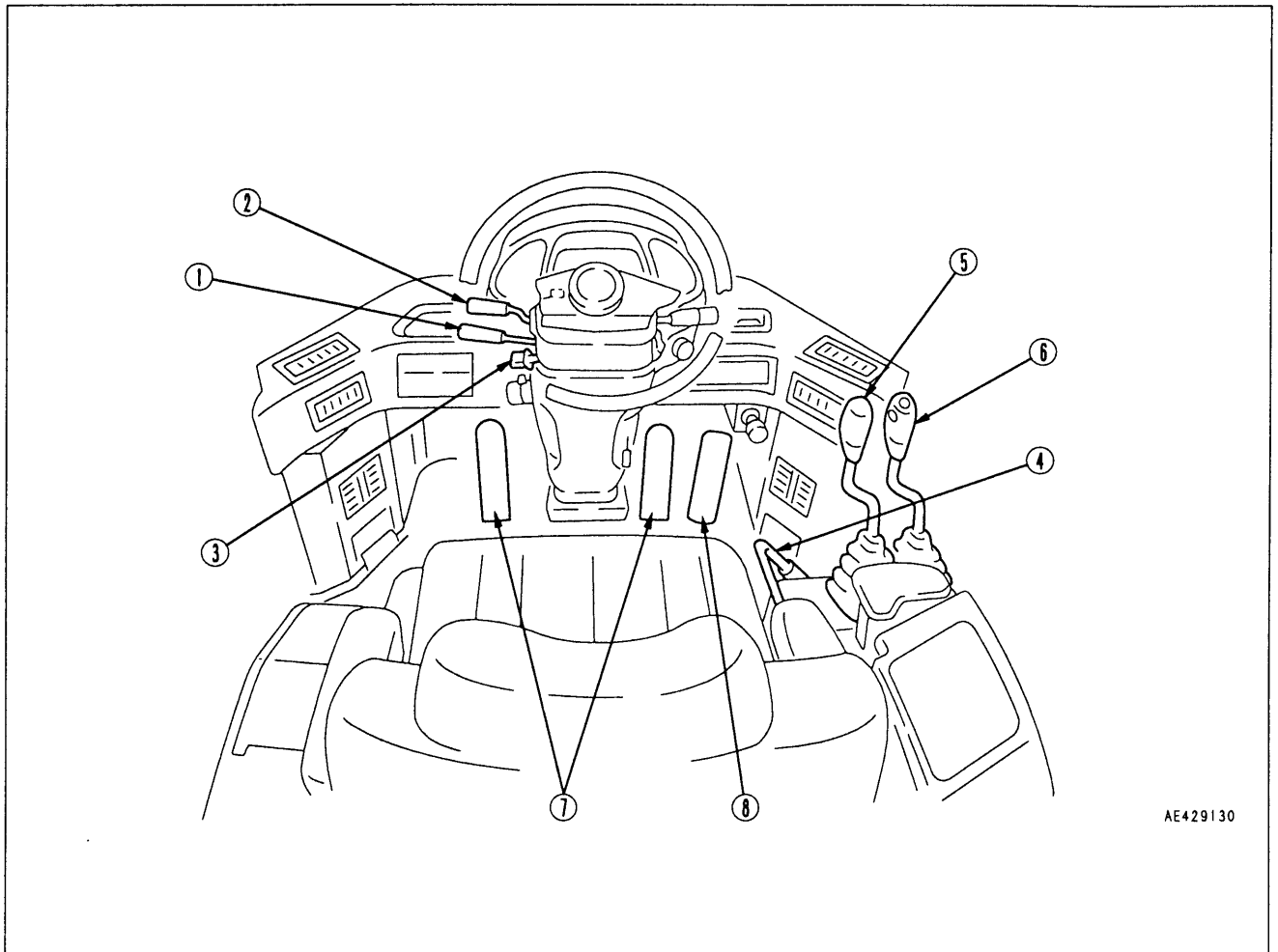

AE429130

1. SPEED CONTROL LEVER

This lever controls the travel speed of machine.

This machine has a 4-FORWARD, 4-REVERSE speed transmission.

Place the speed control lever in a suitable position to obtain the desired speed range.

1st and 2nd speeds are used for working.

3rd and 4th speeds are used for traveling.

However, when the speed control lever stopper is being used, it is impossible to shift to 3rd or 4th. Disengage the speed control lever stopper before trying to shift gear.

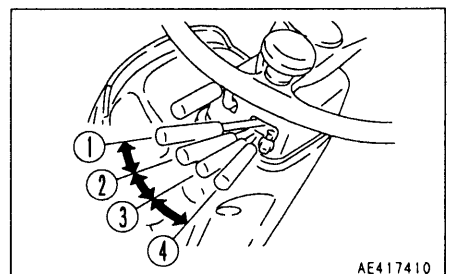

AE417410

Position ①: 1st

Position ②: 2nd

Position ③: 3rd

Position ④: 4th

REMARK

The length of the lever can be adjusted to 3 stages (positions A, B, C). To adjust the length, remove the screw at the bottom of the lever knob, slide the knob to the desired position, then tighten the screw again.

(The lever is installed to position B when it is shipped from the factory.)

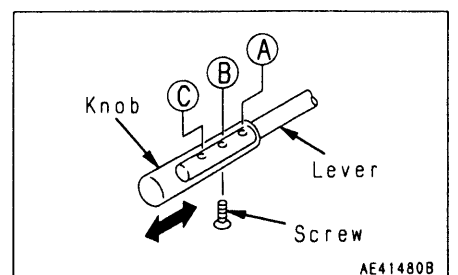

AE414808

2. DIRECTIONAL LEVER

This lever is used to change the direction of travel of the machine.

The engine cannot be started if the directional lever is not at N (neutral).

Position ① : Forward

Position N : Neutral

Position ② : Reverse

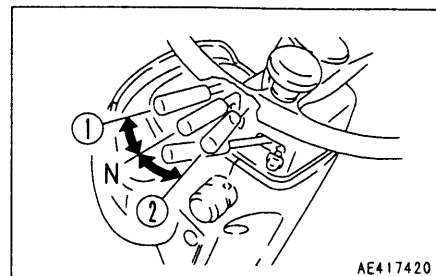

AE417420

REMARK

The length of the lever can be adjusted to 3 stages (positions ①, ②, ③). To adjust the length, remove the screw at the bottom of the lever knob, slide the knob to the desired position, then tighten the screw again.

(The lever is installed to position ② when it is shipped from the factory.)

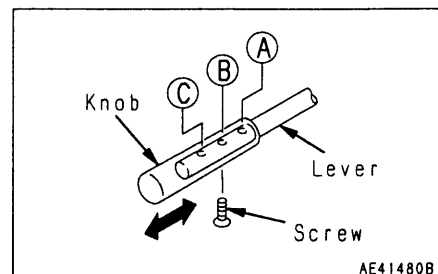

AE41480B

3. SPEED CONTROL LEVER STOPPER

This stopper prevents the speed control lever from entering the 3rd positions when working.

Position ①: Stopper actuated.

Position ②: Stopper released.

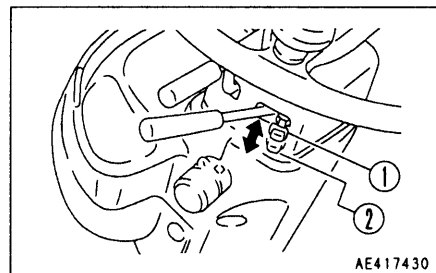

AE417430

4. SAFETY LOCK LEVER

⚠ WARNING

- When leaving the operator's compartment, set the safety lock lever securely to the LOCK position. If the control levers are not locked, and they are touched by mistake, this may lead to a serious accident.
- If the safety lock lever is not placed securely in the LOCK position, the control levers may not be properly locked. Check that the situation is as shown in the diagram.
- When parking the machine or carrying out maintenance, always lower the bucket to the ground and apply the lock.

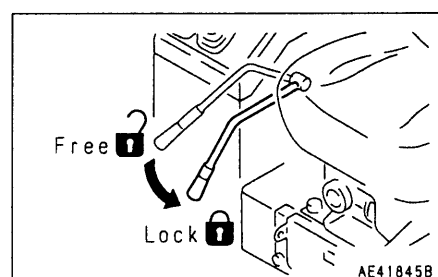



AE41845B

This is used to lock the work equipment levers.
Push the lever down to apply the lock.

11. EXPLANATION OF COMPONENTS

5. BUCKET CONTROL LEVER



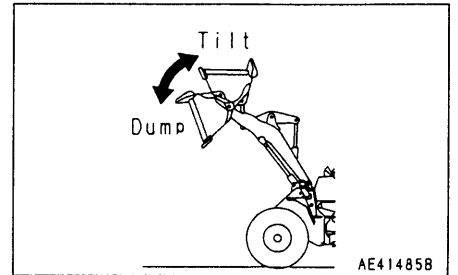
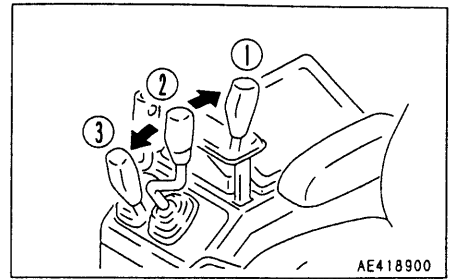

This lever operates the bucket.

- ① TILT (): When the bucket control lever is pulled further from the TILT position, the lever is stopped in this position until the bucket reaches the preset position of the positioner, and the lever is returned to the HOLD position.
- ② HOLD (): The bucket is kept in the same position.
- ③ DUMP ()



6. LIFT ARM CONTROL LEVER

This lever is used to operate the lift arm.

- ① RAISE (): When the lift arm control lever is pulled further from the RAISE position, the lever is stopped in this position until the lift arm reaches the preset position of the kick-out, and the lever is returned to the HOLD position.
- ② HOLD (): The lift arm is kept in the same position.
- ③ LOWER ()
- ④ FLOAT (): The lift arm moves freely under external force.

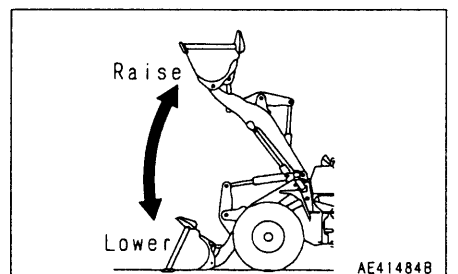
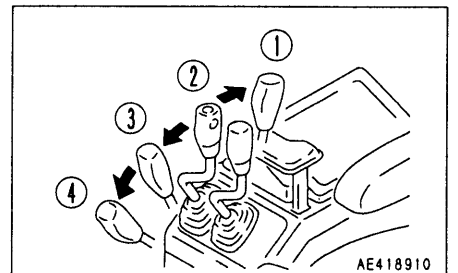

7. BRAKE PEDALS

⚠ WARNING

- When traveling downhill, use the engine as a brake, and always use the right brake pedal.
- Do not use the brake pedals repeatedly unless necessary.
- Do not put your foot on this pedal unless necessary.

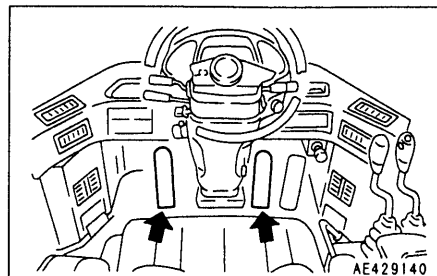

Right brake pedal

The right brake pedal operates the wheel brakes, and is used for normal braking.

Left brake pedal

The left brake pedal operates the wheel brakes, and if the transmission cut-off switch is at ON, it also returns the transmission to neutral.

If the transmission cut-off switch is at OFF, the left brake pedal acts in the same way as the right brake pedal.

REMARK

When the accelerator is being used for operating the work equipment, always use the left brake pedal to slow or stop the machine after putting the transmission cut-off switch to the ON position.

8. ACCELERATOR PEDAL

This pedal controls the engine speed and output.

The engine speed can be freely controlled between low idling and full speed.

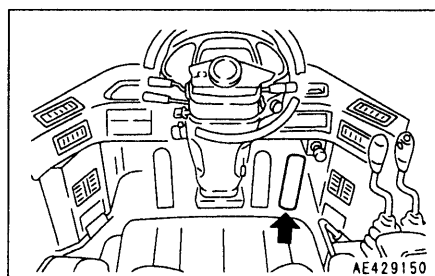

11.4 STEERING COLUMN TILT LEVER

⚠ WARNING

Stop the machine before adjusting the angle of the steering wheel.

This lever allows the steering column to be tilted forward or backward.

Pull the lever up and move the steering wheel to the desired position. Then push the lever down to lock the steering wheel in position.

Range of adjustment: 125 mm (4.9 in) (stepless)

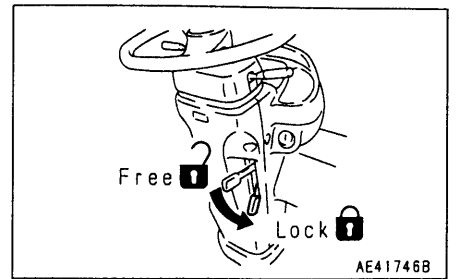

11.5 CAP WITH LOCK

The fuel tank filler port and the hydraulic tank filler port (if equipped) are equipped with locks.

Open and close the cap lock as follows.

Use the starting key to open and close the cap.

11.5.1 METHOD OF OPENING AND CLOSING CAP WITH LOCK

TO OPEN THE CAP (For the fuel tank filler port)

1. Insert the key into the cap.
Insert the key as far as it will go. If the key is turned before it is inserted all the way, it may break.
2. Turn the key clockwise, align the match mark on the cap with the rotor groove, then remove the cap.

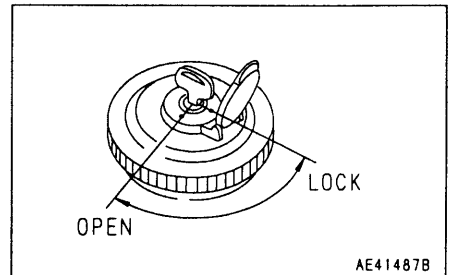

TO LOCK THE CAP

1. Turn the cap into place.
2. Turn the key counterclockwise and take the key out.

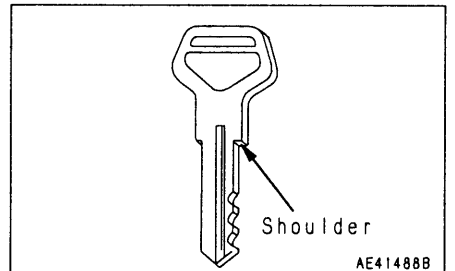

TO OPEN THE CAP (For the hydraulic tank filler port)

1. Insert the key into the cap.
Insert the key as far as it will go. If the key is turned before it is inserted all the way, it may break.
2. Turn the key counterclockwise and bring the rotor groove in line with the aligning mark on the cap. Turn the cap slowly until a "clicking" sound is made. This releases the lock and allows the cap to be opened.

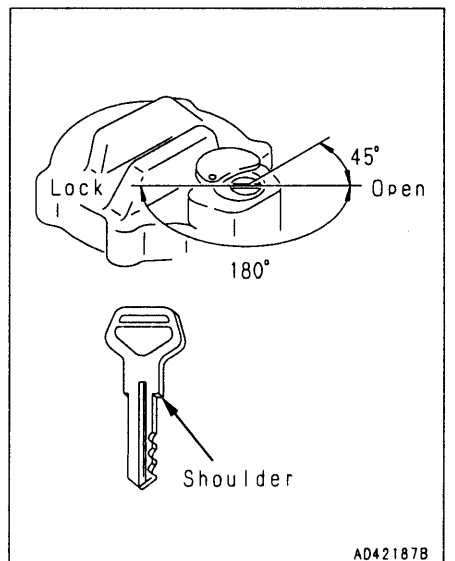

TO LOCK THE CAP

1. Turn the cap into place.
2. Turn the key clockwise and take the key out.

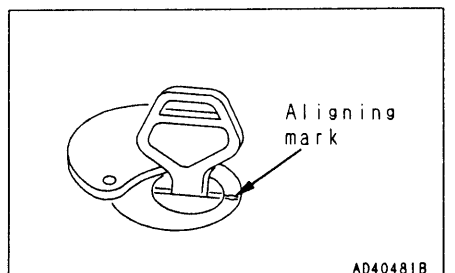

11.6 SAFETY BAR

⚠ WARNING

- Always use the safety bar for maintenance or when transporting the machine.
- Always remove the safety bar during normal travel operations.

The safety bar is used during maintenance or when transporting the machine. It locks the front frame and rear frame, and prevents the front and rear frames from bending.

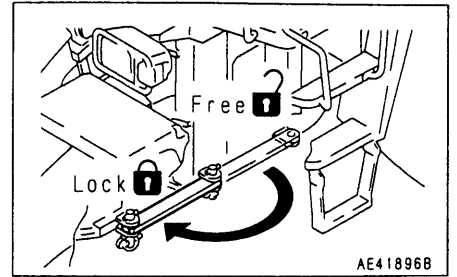

11.7 TOWING PIN

1. Insert towing pin ① into hole ② in the counterweight.

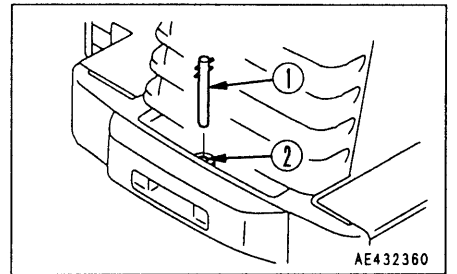

2. Use linch pin ③ to set so that the towing pin does not come out.

Carry out this operation in reverse to remove the pin.

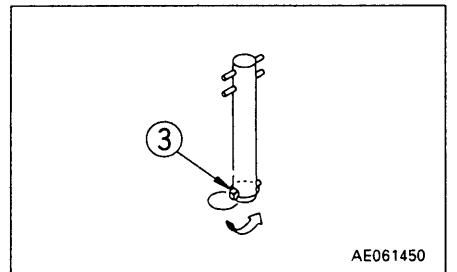

11.8 GREASE PUMP

The grease pump is stored inside the battery box at the rear of the machine. After using it, wipe off all grease stuck to the outside of the pump and then store it in the box.

It can be stored in either the left or right battery box.

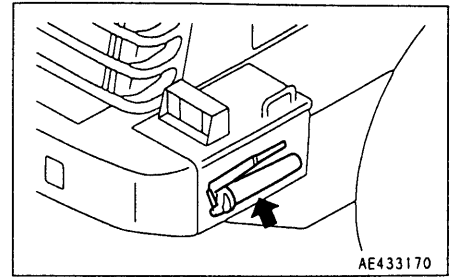

11.9 BACKUP ALARM

This sounds an alarm when the directional lever is set to the R position. It is used to warn people behind the machine that the machine will travel in reverse.

If the alarm cannot be heard clearly or is too loud, adjust the volume as follows.

The volume can be adjusted to three levels.

REMARK

The alarm is set to the highest level when the machine is shipped from the factory.

METHOD OF CHANGING

Operate the sound pressure selector switch at the rear face of the backup alarm to adjust the volume.

High: 112 dB

Medium: 107 dB

Low: 97 dB

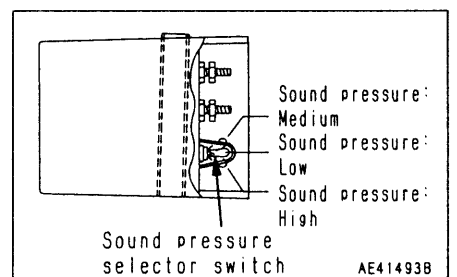

11. EXPLANATION OF COMPONENTS

11.10 FUSE

NOTICE

Before replacing a fuse, be sure to turn off the starting switch.

The fuses protect the electrical equipment and wiring from burning out.

If the fuse becomes corroded, or white powder can be seen, or the fuse is loose in the fuse holder, replace the fuse.

Replace a fuse with another of the same capacity.

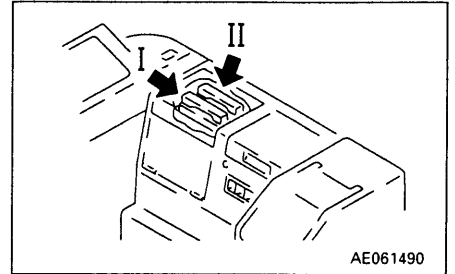

11.10.1 FUSE CAPACITY AND NAME OF CIRCUIT

Fuse box I

No.	Fuse capacity	Name of circuit
①	20A	Main lamp circuit
②	20A	Backup lamp, brake lamp
③	10A	Turn signal indicator lamp
④	10A	R.H. head lamp
⑤	10A	L.H. head lamp
⑥	10A	R.H. side clearance lamp
⑦	10A	L.H. side clearance lamp
⑧	10A	Parking brake
⑨	10A	Transmission control
⑩	10A	Instrument panel
⑪	10A	Work equipment positioner
⑫	10A	Starting switch
⑬	20A	Hazard lamp
⑭	10A	Engine stop motor
⑮	10A	Auto-greasing (if equipped)

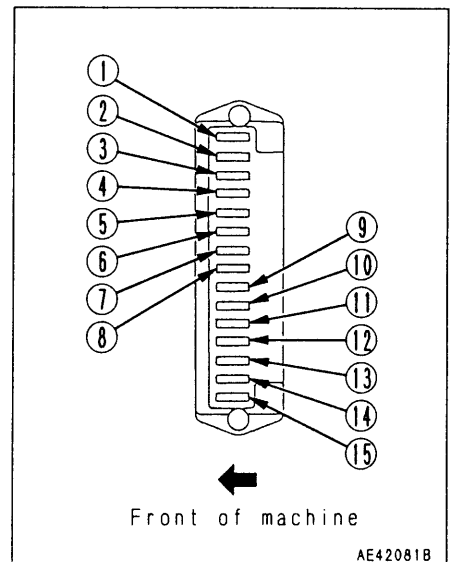

Fuse box II

No.	Fuse capacity	Name of circuit
①	20A	Front working lamp
②	20A	Rear working lamp
③	20A	Air conditioner
④	20A	Air conditioner
⑤	20A	Wiper, washer
⑥	10A	Auto shift (if equipped)
⑦	10A	Cigarette lighter, radio
⑧	10A	Rotating lamp (if equipped)
⑨	-	-
⑩	10A	Auto-greasing (if equipped)
⑪	10A	Spare
⑫	10A	Spare
⑬	10A	Spare
⑭	10A	Spare
⑮	10A	Spare

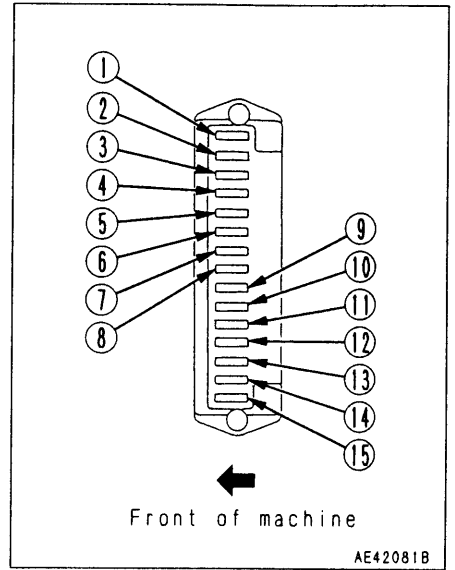

11.11 SLOW-BLOW FUSE

If the power does not come on when the starting switch is turned ON, the slow-blow fuse may be blown, so check and replace it.

The slow blow fuse is beside the engine on the right side of the machine.

SLOW-BLOW FUSE

- ① 50A: Heater relay (glow plug)
- ② 80A: Main power
- ③ 30A: Battery power (starting switch, hazard)

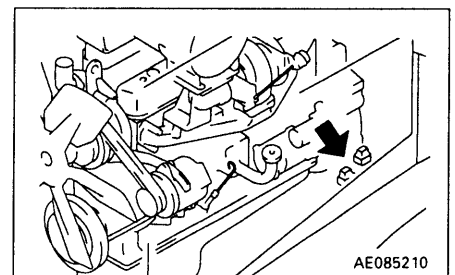

11. EXPLANATION OF COMPONENTS

11.12 STORAGING PLACE OF THIS MANUAL

Keep this manual into the operator's seat rear pocket ① so as to take it out immediately needed.

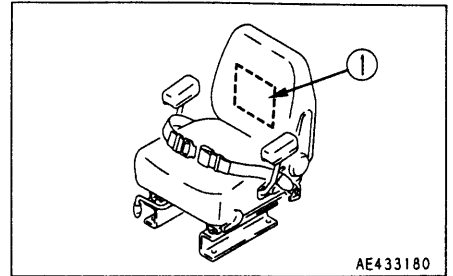

11.13 TAKING OFF POWER

The fuse terminal ① in the right consol box allows to use it power.

The maximum electric current is 10 A (240 W).

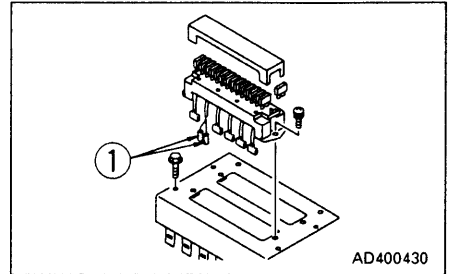

11.14 TAKING OFF POWER (with ROPS CAB)

Removing the cigarette lighter ① allows to use it power. The maximum electric current is 7 A (168 W).

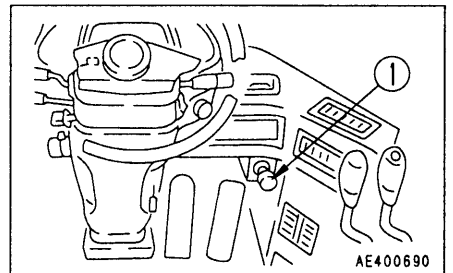

12. OPERATION

12.1 CHECK BEFORE STARTING ENGINE

12.1.1 WALK-AROUND CHECK

⚠ WARNING

- Always attach the warning tag to control lever in the operator's cab to alert others that you are working on the machine.
 - Leakage of oil or fuel, or accumulation of flammable material around high temperature parts, such as the engine muffler or turbocharger, may cause fire.
- Check carefully, and if any abnormality is found, repair it or contact your Komatsu distributor.

Before starting the engine, look around the machine and under the machine to check for loose nuts or bolts, or leakage of oil, fuel, or coolant, and check the condition of the work equipment and hydraulic system.

Check also for loose wiring, play, and collection of dust at places which reach high temperatures.

Always carry out the items in this section before starting the engine each day.

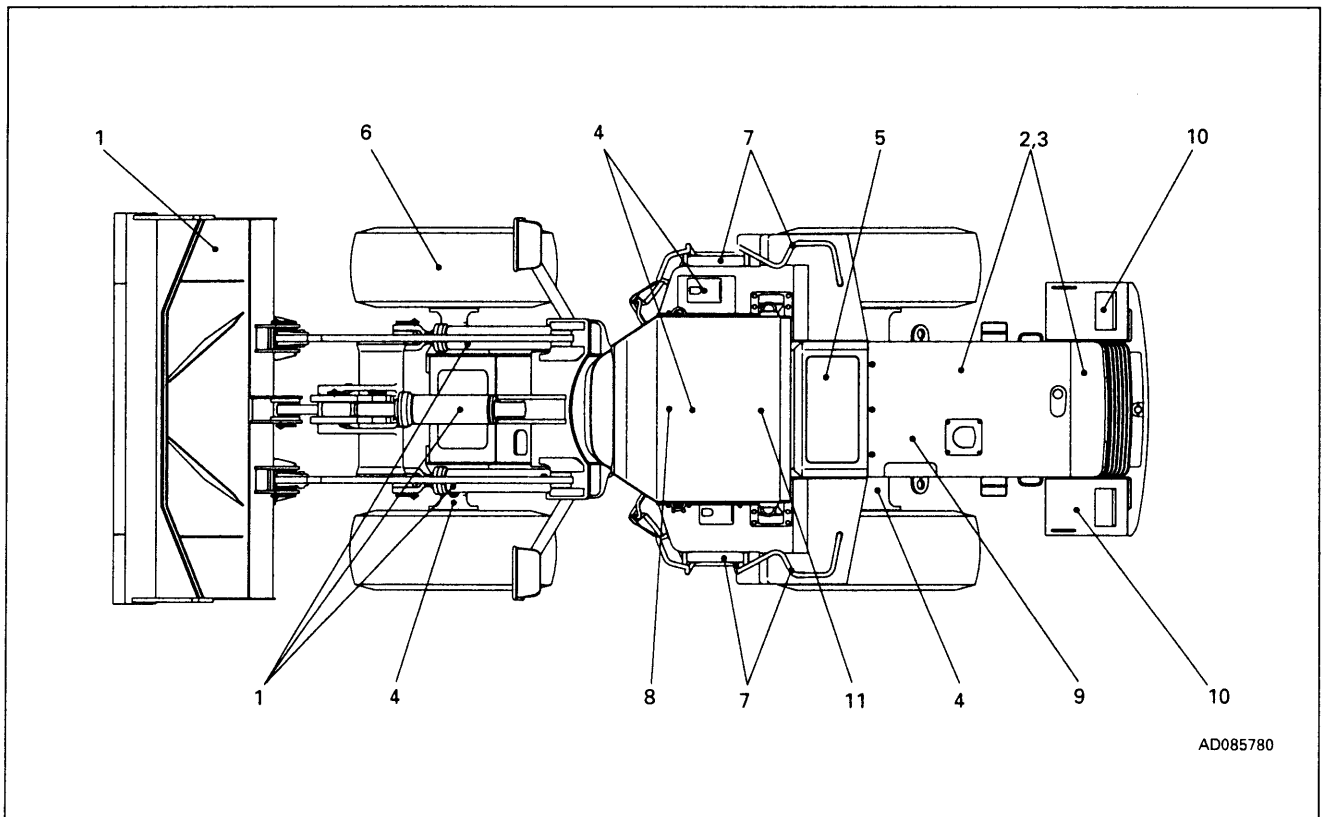

12. OPERATION

- 1. Check for damage, wear, play in work equipment, cylinders, linkage, hoses**
Check that there are no cracks, excessive wear, or play in the work equipment, cylinders, linkage, or hoses. If any abnormality is found, repair it.
- 2. Remove dirt and dust from around engine, battery, radiator**
Check if there is any dirt or dust accumulated around the engine or radiator. Check also if there is any flammable material (dead leaves, twigs, grass, etc.) accumulated around the battery or high temperature engine parts, such as the engine muffler or turbocharger. Remove all such dirt or flammable material.
- 3. Check for leakage of water or oil around engine**
Check that there is no leakage of oil from the engine or leakage of water from the cooling system. If any abnormality is found, repair it.
- 4. Check for leakage of oil from transmission case, axle, hydraulic tank, hoses, joints**
Check that there is no leakage of oil. If any abnormality is found, repair it.
- 5. Check for leakage of oil from brake line**
Check that there is no leakage of oil. If any abnormality is found, repair it.
- 6. Check for damage or wear to tires, loose mounting bolts**
Check for cracks or peeling of the tires and for cracks or wear to the wheels (side rim, rim base, lock ring). Tighten any loose wheel nuts. If any abnormality is found, repair or replace the part.
If any valve caps are missing, install new caps.
- 7. Check for damage to handrail and steps, loose bolts**
Repair any damage and tighten any loose bolts.
- 8. Check for damage to gauges, monitor, loose bolts**
Check that there is no damage to the gauges and monitor in the operator's cab. If any abnormality is found, replace the parts. Clean off any dirt on the surface.
- 9. Check for loose air cleaner mounting bolts**
Check for any loose mounting bolts, and tighten if necessary.
- 10. Check for loose battery terminals**
Tighten any loose terminal.

11. Check seat belt and equipment

⚠ WARNING

Even if there appears to be no abnormality with the seat belt, always replace it once every three years.

REMARK

The date of manufacture of the seat belt is marked on the belt at the place indicated by the arrow in the diagram on the right.

Check that there are no loose bolts on the equipment mounting the seat belt to the machine, and tighten if necessary.

Tightening torque: $24.5 \pm 4.9 \text{ N}\cdot\text{m}$ ($2.5 \pm 0.5 \text{ kgf}\cdot\text{m}$, $18.1 \pm 3.6 \text{ lbft}$)

If the belt is damaged or fluff is starting to form, or if there is any damage or deformation of the seat belt holders, replace the seat belt with a new part.

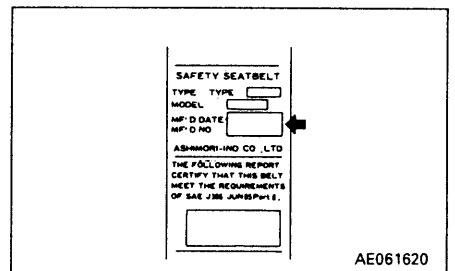
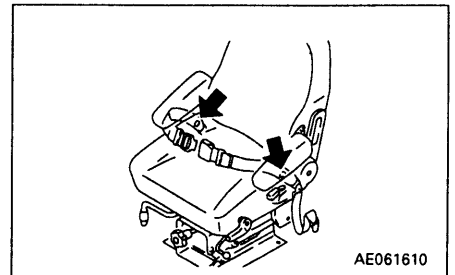

12. Check for loose bolts on ROPS

Check for any loose or damaged bolts. If any loose bolts are found tighten them to $785 - 892 \text{ N}\cdot\text{m}$ ($80 - 91 \text{ kgf}\cdot\text{m}$, $579 - 658 \text{ lbft}$).

If any bolts are damaged, replace them with genuine Komatsu bolts.

13. Clean cab window

Clean the cab window to ensure good visibility when operating the machine.

14. Inspection of tires

⚠ WARNING

If worn or damaged tires are used, they may burst and cause serious injury or death.

To ensure safety, do not use the following tires.

Wear:

- Tires with a tread groove of less than 15% of that of a new tire
- Tires with extreme uneven wear or with stepped-type wear

Damage:

- Tires with damage which has reached the cords, or with cracks in the rubber
- Tires with cut or pulled cords
- Tires with peeled (separated) surface
- Tires with damaged bead
- Leaking or improperly repaired tubeless tires
- Deteriorated, deformed or abnormally damaged tires which do not seem usable

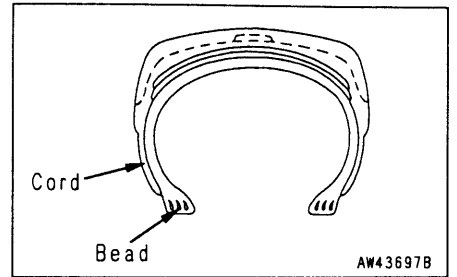

15. Inspection of rims

⚠ WARNING

Check the rims (wheels) and rings for deformation, corrosion and cracks.

In particular, check the side rings, lock rings and rim flanges thoroughly.

12.1.2 CHECK BEFORE STARTING

Always carry out the items in this section before starting the engine each day.

CHECK MONITOR PANEL

1. Turn the starting switch to ON.
2. Check that all the monitor lamps, the gauges and the warning lamp light up for about 3 seconds and the alarm buzzer sounds for about 1 second.

If any monitor lamp does not light up, ask your Komatsu distributor to inspect that monitor lamp.

Do not carry out the checks before starting using only the monitor; always carry out also the items specified for the periodic maintenance.

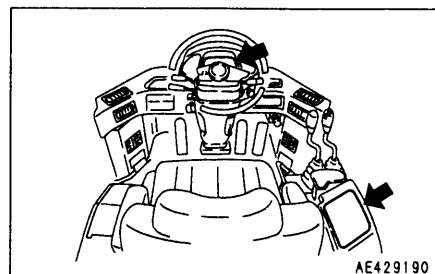

CHECK COOLANT LEVEL, ADD WATER

⚠ WARNING

Normally, do not open the radiator cap. Always wait for the engine to cool down before checking the water level, and check using the sub-tank.

1. Open the top cover at the front of the engine hood in the middle of the machine, and check that the coolant level is between the FULL and LOW marks on sub-tank ①. If the coolant level is low, add water to the FULL level through the water filler in sub-tank ①.
2. After adding water, tighten the cap securely.
3. If sub-tank ① is empty, check for water leakage, then add water to the radiator and sub-tank.

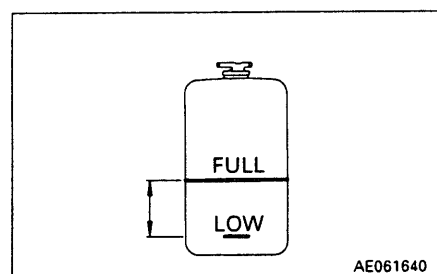
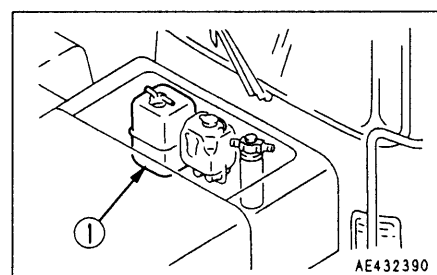

CHECK FUEL LEVEL, ADD FUEL

⚠ WARNING

When adding fuel, never let the fuel overflow. This may cause a fire. If you spill fuel, thoroughly clean up any spillage.

1. Turn the engine starting switch to the ON position, then check the fuel level with fuel gauge Ⓒ.
After checking, return the starting switch to the OFF position.

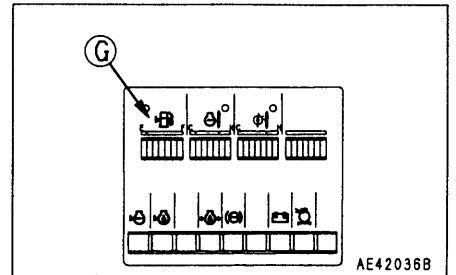

2. Upon completion of work, add fuel through filler Ⓕ until the fuel tank is full.

For details of the method for opening and closing the cap, see "11.5 CAP WITH LOCK".

For details of the fuel to use, see "20. USE OF FUEL, COOLANT AND LUBRICANTS ACCORDING TO AMBIENT TEMPERATURE".

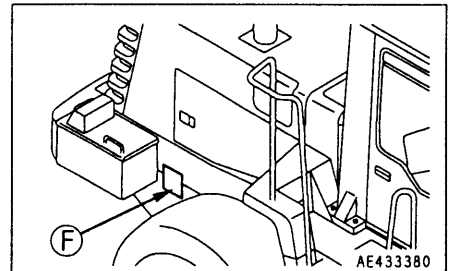

3. After adding fuel, tighten the cap securely.

Fuel capacity: 340 ℓ (89.76 US gal, 74.80 UK gal)

CHECK OIL LEVEL IN ENGINE OIL PAN, ADD OIL**⚠ WARNING**

The parts and oil are at high temperature after the engine is stopped, and may cause serious burns. Wait for the temperature to go down before starting the operation.

1. Open the engine side cover at the rear right side of the machine.
2. Remove dipstick ③ and wipe the oil off with a cloth.
3. Insert dipstick ③ fully in the oil filler pipe, then take it out again.
4. The oil level should be between the H and L marks on dipstick ③.
If the oil level is below the L mark, add engine oil through oil filler ④.

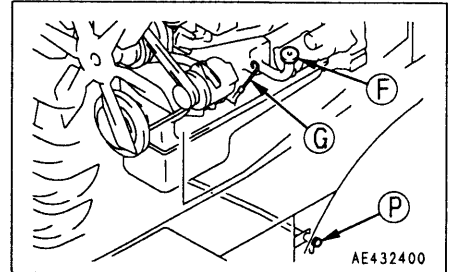

For details of the oil to use, see "20. USE OF FUEL, COOLANT AND LUBRICANTS ACCORDING TO AMBIENT TEMPERATURE".

5. If the oil is above the H mark, drain the excess engine oil from drain plug ④, and check the oil level again.
6. If the oil level is correct, tighten the oil filler cap securely, then tighten the engine side cover.

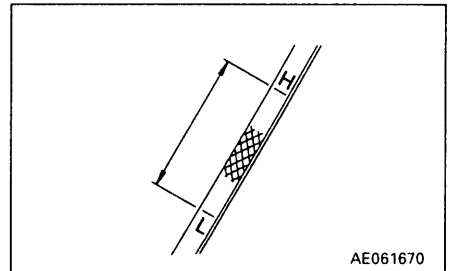
**REMARK**

When checking the oil level after the engine has been operated, wait for at least 15 minutes after stopping the engine before checking.

If the machine is at an angle, make it horizontal before checking.

CHECK ELECTRIC WIRING

⚠ WARNING

- If fuses are frequently blown or if there are traces of short circuit on the electrical wiring, locate the cause and carry out repair it or contact your Komatsu distributor.
- Accumulation of flammable material (dead leaves, twigs, grass, etc.) around the battery may cause fire, so always check and remove such material.
- Keep the top surface of the battery clean and check the breather hole in the battery cap. If it is clogged with dirt or dust, wash the battery cap to clear the breather hole.

Check for damage and wrong capacity of the fuse and any sign of disconnection or short circuit in the electric wiring. Check also for loose terminals and tighten any loose parts.

Check the wiring of the "battery", "starting motor" and "alternator" carefully, in particular.

When carrying out walk-around checks or checks before starting, always check if there is any accumulation of flammable material around the battery, and remove such flammable material.

Please contact your Komatsu distributor for investigation and correction of the cause.

CHECK FOR WATER AND SEDIMENT IN WATER SEPARATOR

The water separator separates water mixed in the fuel. If float ② is at or above red line ①, drain the water.

For the draining procedure, see section "24.2 WHEN REQUIRED".

Even if a water separator is installed, be sure to check the fuel tank to remove water and sediment in the fuel.

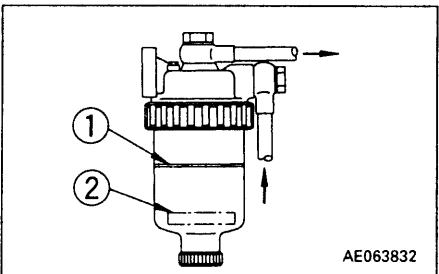

DRAIN WATER FROM AIR TANK (if equipped)

Upon completion of work, stop the engine, open drain valve ① and drain the water from the tank.

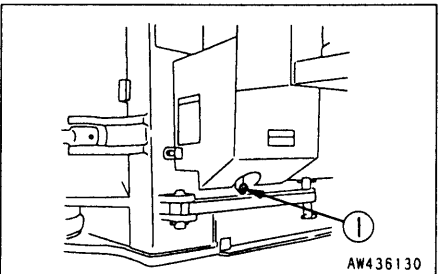

CHECK EFFECT OF PARKING BRAKE**⚠ WARNING**

Even if the parking brake switch is turned ON, there is danger until the parking brake pilot lamp lights up, so keep the brake pedal depressed.

Measurement conditions

- Tire inflation pressure: Specified pressure
- Road surface: Dry paved surface with 1/5 (11°20') grade
- Machine: Operating condition

Method of measurement

1. Start the engine, set the machine facing straight to the front, then drive the machine up a 1/5 grade with the bucket empty.
2. Depress the brake, stop the machine, return the directional lever to the neutral position, then stop the engine.
3. Press the parking brake switch to the ON position, release the brake pedal slowly, and check that the machine is held in position.

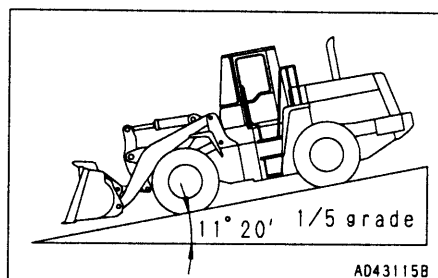
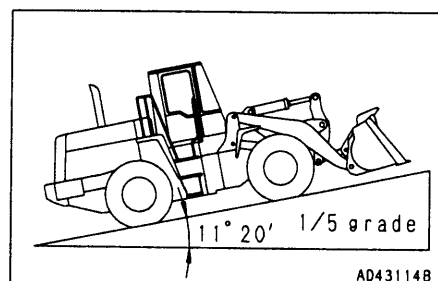
**CHECK EFFECT OF BRAKE**

Drive the machine at a speed of 20 km/h (12.4 MPH) on a dry flat concrete road surface, and check that the stopping distance is less than 5 m (16 ft 5 in).

CHECK SOUND OF HORN AND BACKUP ALARM**CHECK FLASHING OF LAMPS, CHECK FOR DIRT AND DAMAGE****CHECK ENGINE EXHAUST COLOR AND SOUND****CHECK OPERATION OF GAUGES****CHECK PLAY OF STEERING WHEEL, CHECK OPERATION OF STEERING****CHECK DIRECTION OF REAR VIEW MIRROR, CHECK FOR DIRT OR DAMAGE****CHECK INFLATION PRESSURE OF TIRES**

Measure the inflation pressure with a tire pressure gauge while the tires are cool before starting work.

Check for damage or wear to the tires and the rims.

Check for loose wheel hub nuts (bolts). The proper inflation pressure is shown below.

Tire size	Inflation pressure
23.5-25-16PR (L3 Rock) (standard)	Front tire: 0.34 MPa (3.5 kgf/cm ² , 49.7 PSI) Rear tire: 0.30 MPa (3.1 kgf/cm ² , 44.02 PSI)
26.5-25-16PR (L3 Rock) (if equipped)	Front tire: 0.32 MPa (3.3 kgf/cm ² , 46.86 PSI) Rear tire: 0.27 MPa (2.8 kgf/cm ² , 39.76 PSI)

NOTICE

The appropriate tire inflation pressure differs according to the type of work, so see "12.18 HANDLING THE TIRES".

**12.1.3 ADJUSTMENT BEFORE OPERATION
OPERATOR'S SEAT**

⚠ WARNING

- Park the machine in a safe place and stop the engine when carrying out adjustment of the operator's seat.
- Adjust the seat before starting operations or when changing operators.
- Check that you can depress the brake pedal fully with your back against the seat backrest.

A: Forward-backward adjustment

Move lever ① to the right, move the seat to the desired position and release the lever.

Fore-and-aft adjustment: 160 mm (6.3 in)
(16 mm (0.6 in) x 10 stages)

B: Adjusting seat angle

Pull lever ② up and push down on the rear of the seat to tilt it backward.

Push lever ② down and push down on the front of the seat to tilt it forward.

Range of adjustment: 13° (front tilt, rear tilt: 4 stages each)

C: Adjusting seat weight

Turn grip ③ to adjust the strength of the suspension.

Adjustment range: (Target) 50 kg – 120 kg (110 – 265 lb)

D: Adjusting backrest angle

Move lever ④ up and move the backrest to the front or rear.

Adjustment range: Front 66° (3° x 22 stages)
Rear 72° (3° x 24 stages)

NOTICE

If the seat back is reclined too far, the seat back may hit the rear glass, so use it in a position where it does not contact the glass.

When reclining the seat fully to take a rest, set the seat in the following position.

- Fore-and-aft adjustment: Max. front position
- Up-down adjustment: Max. height
- Seat angle adjustment: Horizontal or fully tilted
- Reclining adjustment: Fully tilted backward 36° (12 stages)

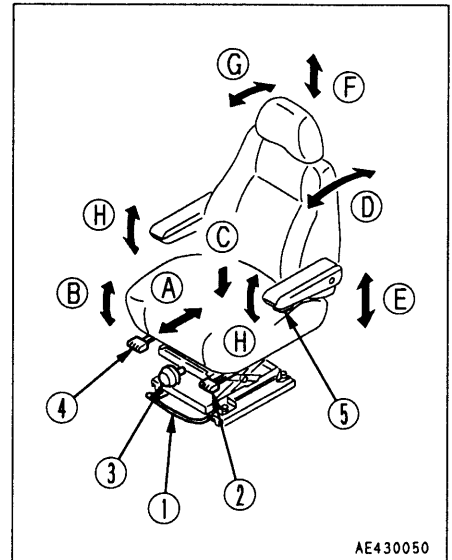

E: Seat height adjustment

Move lever ② up/down, then move the seat up or down as desired. Since lever ② is also used for adjusting seat angle, set the seat to the desired height while adjusting the angle.

Adjustment range: 60 mm (2.4 in)

F: Adjusting height of headrest

Move the headrest up and down to the desired height.

Adjustment range: 25 mm (1.0 in)

G: Adjusting headrest angle

Rotate the headrest to the front or rear.

H: Angle of armrest

Adjust angle of armrest by rotating knob ⑤ (left side only).

Adjustment range: 30° (forward tilt: 25°, backward tilt: 5°)

Also, when armrest is turned, it will spring up.

ADJUST SEAT BELT

Always install a seat belt on machines equipped with ROPS.

⚠ WARNING

- Before fitting the seat belt, check that there is no abnormality in the mounting bracket and mounting belt of the belt. If the belt is worn or damaged, replace it.
- Always fasten the seat belt before starting operations.
- Always use the seat belt during operations.
- Do not twist the left or right side of the seat belt when fastening it.

Fastening and removing belt

Fasten the belt so that it is tight without being too tight.

1. Sit on the seat, depress the brake pedal fully, and adjust the seat so that your back is pressed against the backrest.
2. After adjusting the seat position, adjust teaser belt ①. Tense the teaser belt and install it when there is no one sitting on the seat.
3. Sit on the seat, take buckle ② and tongue ③ in your left and right hands, insert tongue ③ into buckle ②, and pull the belt to check that it is securely locked.
4. When removing the belt, raise the lever of buckle ② to free the belt.

Adjust the length of the buckle and tongue so that the belt follows your body without twisting, and adjust so that the buckle is in the middle at the front of your body.

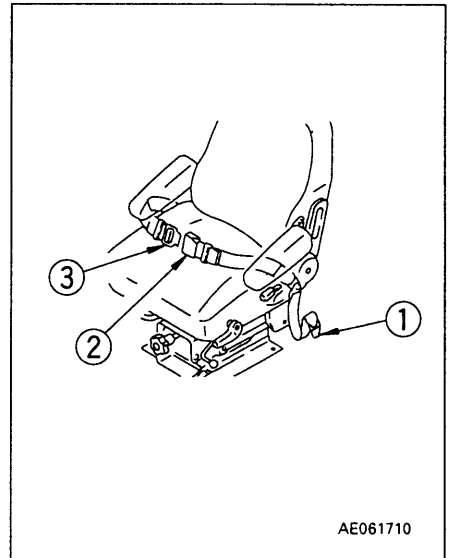

Adjust belt length

To make belt shorter: Pull the free end of the belt at the buckle end or tongue end.

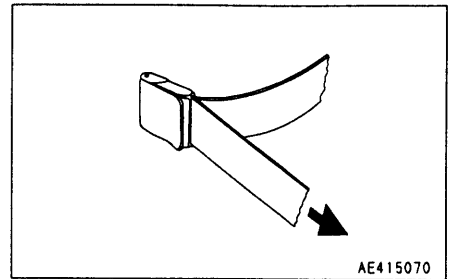

To make belt longer: Set the belt holding the buckle or tongue end at right angles to the buckle or tongue, and pull.

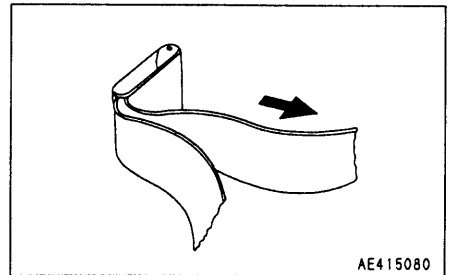
**LIFT REST HEIGHT ADJUSTMENT LEVER**

The height of lift rest ① can be adjusted easily with adjustment lever ②. Turn adjustment lever ② in the loosening direction and adjust the height of lift rest ① properly, then turn adjustment lever ② to the fixing direction.

Position ①: Loosening direction

Position ②: Fixing direction

REMARK

If adjustment lever ② is pulled towards the seat, the lever becomes free and faces directly down.

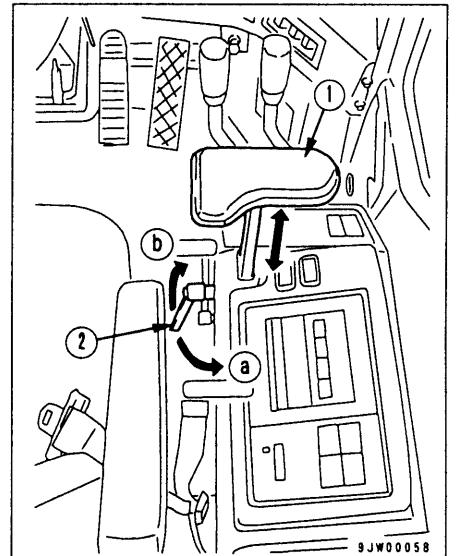
**ADJUST REAR VIEW MIRROR**

Sit in the operator's seat and adjust the rear view mirror so that you can see properly to the rear.

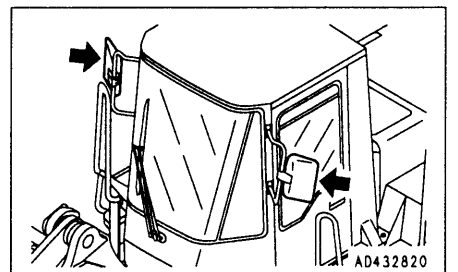

12.1.4 OPERATIONS AND CHECKS BEFORE STARTING ENGINE

⚠ WARNING

- If the control levers are touched by accident, the work equipment may move suddenly. When leaving the operator's compartment, always set the safety lever securely to the LOCK position.
- Before starting the engine, use a damp cloth to wipe off the dust accumulated on the top surface of the battery or on the starting motor and the alternator.

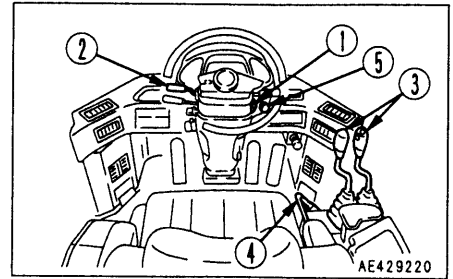

1. Check that parking brake switch ① is at the ON position.

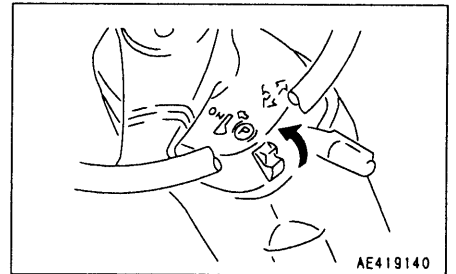

2. Check that directional lever ② is at the N position. When starting the engine, if directional lever ② is not at the N position, the engine will not start.

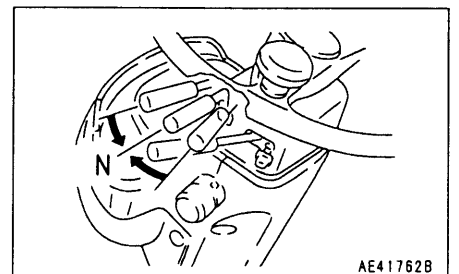

3. Lower the bucket to the ground, then check that work equipment control lever ③ is locked by safety lock ④.

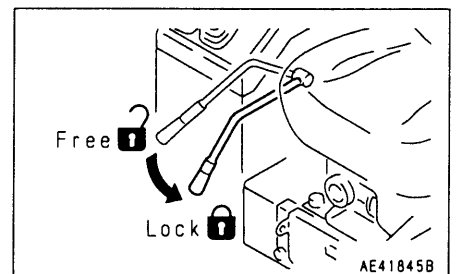

4. Insert the key in starting switch ⑤, turn the key to the ON position, and check that the pilot lamp lights up.

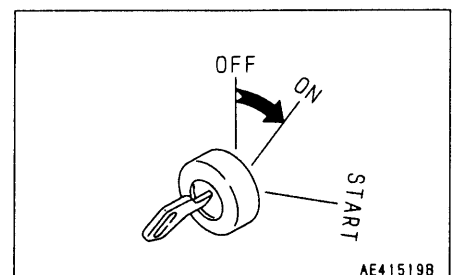

12.2 STARTING ENGINE

⚠ WARNING

Check that there are no persons or obstacles in the surrounding area, then sound the horn and start the engine.

NOTICE

Do not keep the starting motor rotating continuously for more than 20 seconds.

If the engine will not start, wait for at least 2 minutes before trying to start the engine again.

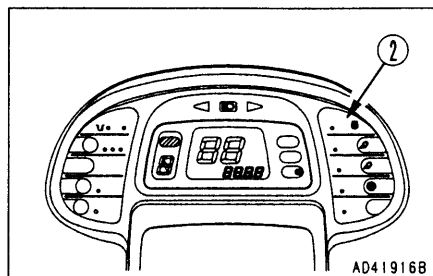
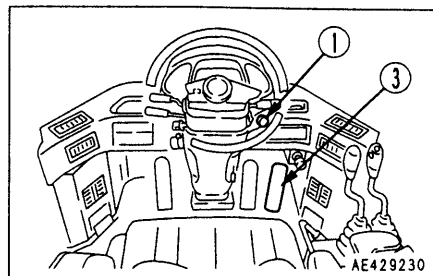

1. Turn the key in starting switch ① to the ON position. Preheating will automatically start and preheating pilot lamp ② will light up.

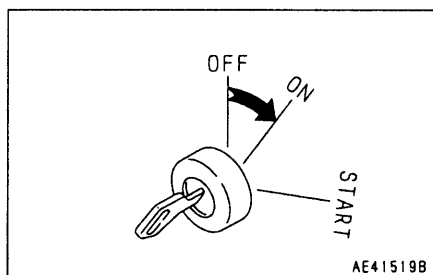

The table on the right gives a guideline for the preheating time.

The preheating time in cold areas changes according to the water temperature when starting the engine.

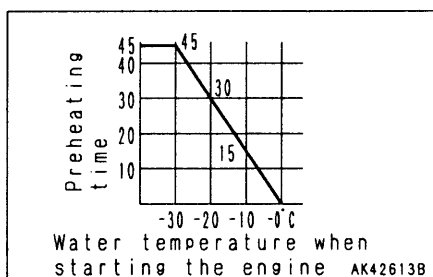

2. Depress accelerator pedal ③ lightly.

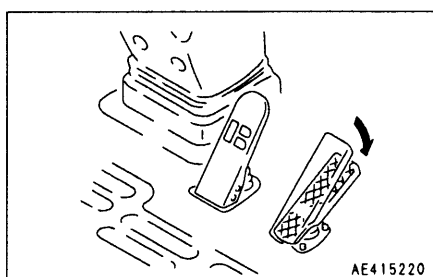

3. Check that preheat pilot lamp ② is out, then turn the key of starting switch ① to the START position to start the engine.

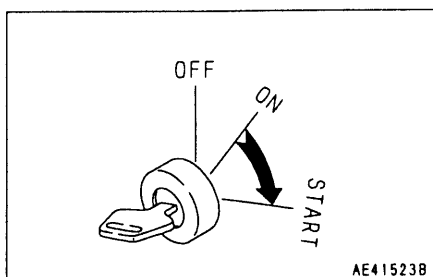

12. OPERATION

4. When engine is started, release the key of starting switch ① and the key will return automatically to ON.

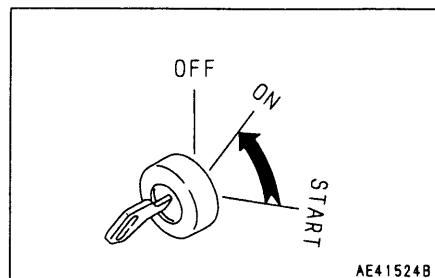

12.3 OPERATIONS AND CHECKS AFTER STARTING ENGINE

After starting the engine, do not immediately start operations. First, carry out the following operations and checks.

NOTICE

Do not suddenly accelerate the engine before the warming-up operation is completed.

Do not run the engine at low idling or high idling continuously for more than 20 minutes.

If it is necessary to run the engine at idling, apply a load from time to time or run the engine at a mid-range speed.

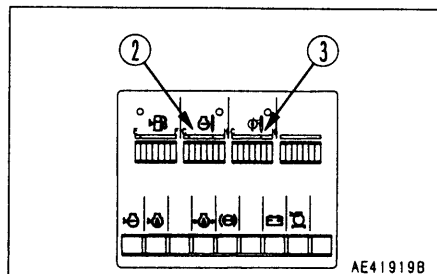
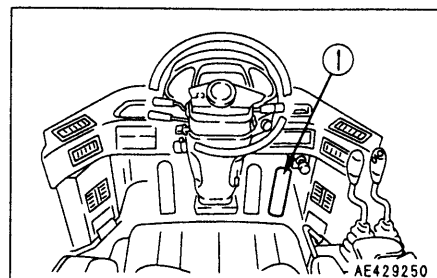

1. Depress accelerator pedal ① lightly and run the engine with no load at midrange speed for about 5 minutes.

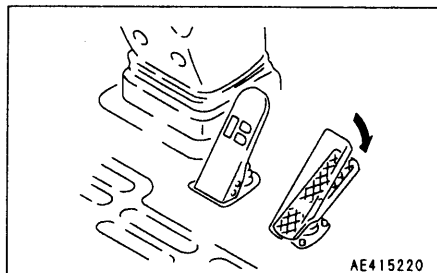

2. To warm up the hydraulic oil only in cold areas, do as follows. During the warming-up operation, check that the engine rotation is smooth, then set the safety lock of the work equipment control lever to the FREE position and move the bucket control lever in and out of the TILT position to warm up the hydraulic oil. The relief time at the tilt position should be a maximum of 10 seconds. With this operation, the oil will reach the relief pressure and this will warm up the hydraulic oil more quickly.

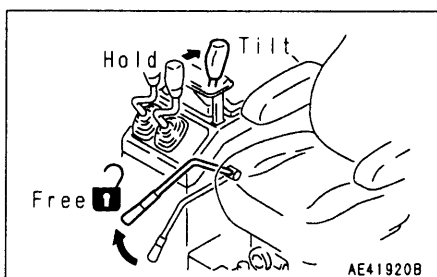

3. After carrying out the warming-up operation, check that the gauges and caution lamps are normal. If there is any abnormality, carry out maintenance or repair. Run the engine under a light load until engine water temperature gauge ② and torque converter oil gauge ③ are in the green range.
4. Check that there is no abnormality in the exhaust color, sound, or vibration. If there is any abnormality, carry out repairs.

12.4 MOVING MACHINE OFF

⚠ WARNING

- When moving the machine off, check that the area around the machine is safe, then sound the horn before starting. Do not allow people near the machine. There is a blind spot behind the machine, so be particularly careful when traveling in reverse.
- When starting the machine on slopes, set transmission cut-off switch ① to the OFF position, depress left brake pedal ② while depressing accelerator pedal ③, then gradually release left brake pedal ② to allow the machine to start.

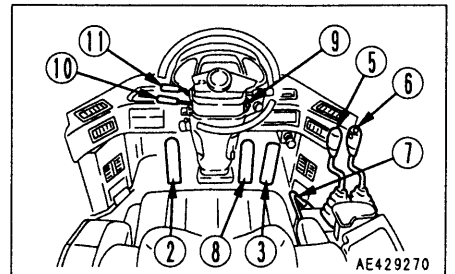
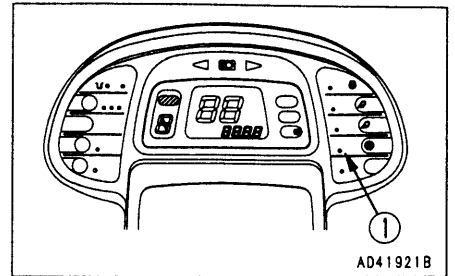

1. Check that caution pilot lamp ④ is not lighted up.

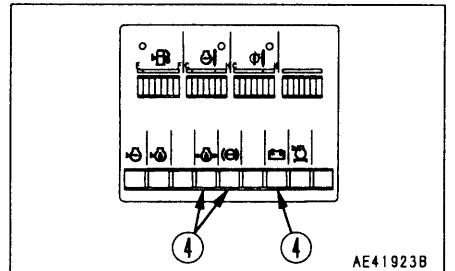

2. Set safety lock ⑦ of bucket control lever ⑤ and lift arm control lever ⑥ to the FREE position.

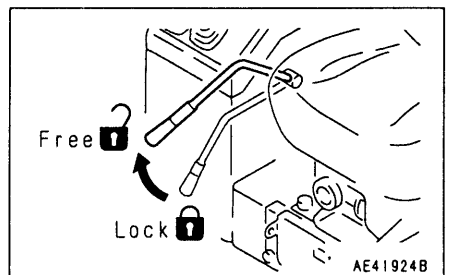

3. Operate lift arm control lever ⑥ to set the work equipment to the travel posture shown in the diagram on the right.

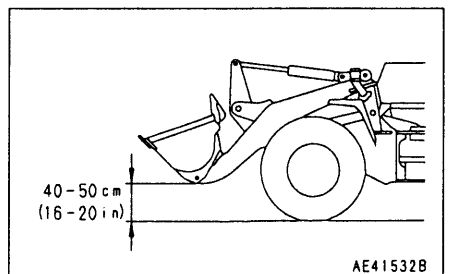

4. Depress right brake pedal ⑧ and turn parking brake switch ⑨ to the OFF (RELEASE) position to release the parking brake. Keep right brake pedal ⑧ depressed.

REMARK

If the parking brake is still actuated when parking brake switch ⑨ is at the OFF (RELEASE) position, turn the parking brake switch ON, then turn it OFF again.

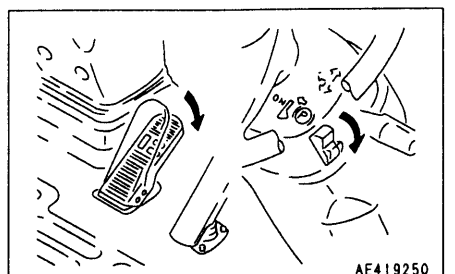

5. Set speed control lever ⑩ to the desired position.

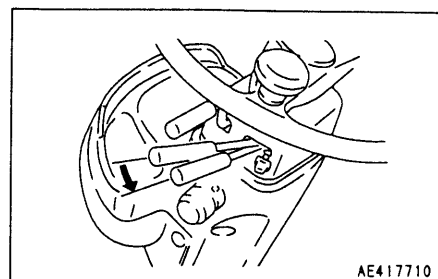

6. Set directional lever ⑪ to the desired position.

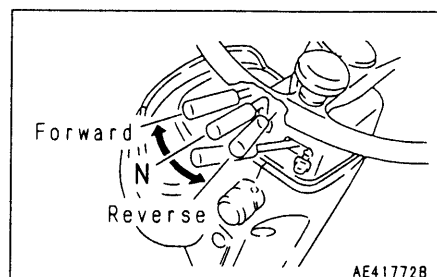

7. Release right brake pedal ⑧, then depress accelerator pedal ③ to move the machine off.

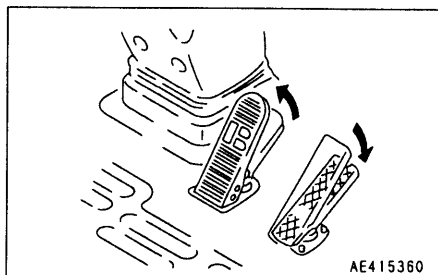

12.5 CHANGING GEAR SPEED

⚠ WARNING

When traveling at high speed, do not change the gear speed suddenly. When shifting gear, use the brakes to reduce the travel speed, then shift gear.

Shift the gear as follows.

Move speed control lever ① to the desired position.

Only 1st or 2nd speeds are used for digging and loading operations, so actuate speed control lever stopper.

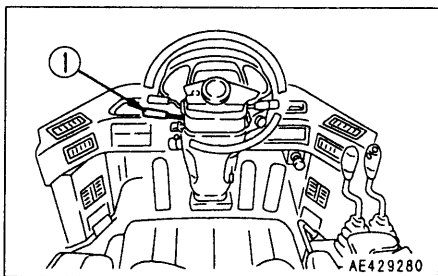

REMARK

- This machine is equipped with a kickdown switch that shifts the gear down to 1st if the button at the tip of the lift arm control lever is pushed when the machine is traveling in 2nd gear. We recommend the use of the kickdown switch when carrying out digging or loading operations in 1st or 2nd gear. For details of use, see "11. EXPLANATION OF COMPONENTS".
- If the gear shift lever is operated slowly or it is stopped between speed ranges, error code "CALL" may be displayed. This is not a failure: the gear shift lever must be operated to complete the gear shifting within 2 seconds.

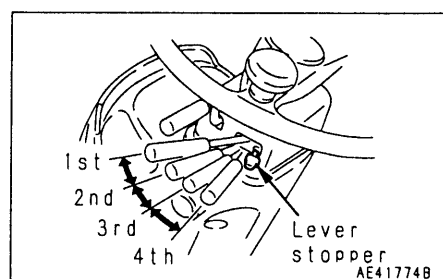

12.6 CHANGING DIRECTION

⚠ WARNING

- When changing direction between FORWARD and REVERSE, check that the new direction of travel is safe. There is a blind spot behind the machine, so be particularly careful when changing direction to travel in reverse.
- Do not switch between FORWARD and REVERSE when traveling at high speed.
When switching between FORWARD and REVERSE, depress the brake to reduce the travel speed sufficiently, then change the direction of travel. (Max. speed for changing direction: 12 km/h (7.5 MPH))

There is no need to stop the machine even when switching between FORWARD and REVERSE.

Place directional lever ① in the desired position.

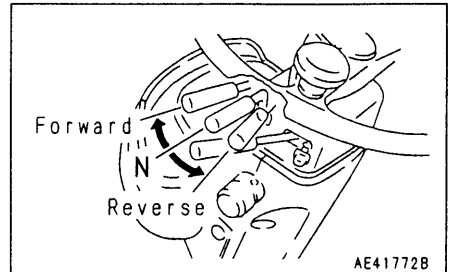
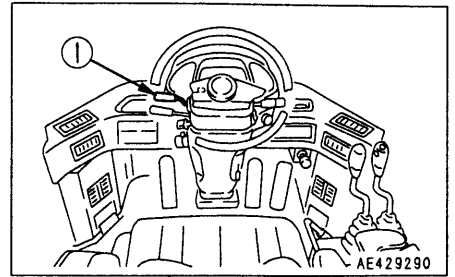

REMARK

If the directional lever is operated slowly or it is stopped between speed ranges, error code "CALL" may be displayed. This is not a failure: the directional lever must be operated to complete the directional shifting within 2 seconds.

12.7 TURNING

⚠ WARNING

- It is dangerous to turn the machine suddenly at high speed, or to turn on steep hills.
- If the engine stops when the machine is traveling, the steering cannot be used.
This is particularly dangerous on hills, so never stop the engine when the machine is traveling.
If the engine stops, stop the machine immediately at a safe place.

When traveling, use steering wheel ① to turn the machine.

With this machine, the front frame is joined to the rear frame at the center of the machine by the center pin. The front and rear frames bend at this point, and the rear wheels follow in the same track as the front wheels when turning.

Turn the steering wheel lightly to follow the machine as it turns. When turning the steering wheel fully, do not turn it beyond the end of the stroke.

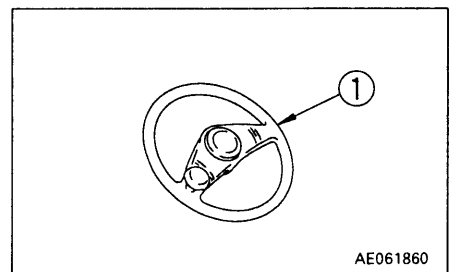

NOTICE

When the steering wheel is turned fully, if it reaches the end of its stroke, do not try to turn it further.

Check that there is a play of 50 – 100 mm (2.0 – 3.9 in) in the steering wheel. Check also that the steering works properly. If any abnormality is found, please contact your Komatsu distributor for inspection.

12.8 STOPPING MACHINE

⚠ WARNING

- Avoid stopping suddenly. Give yourself ample room when stopping.
- Do not park the machine on slopes.
If the machine has to be parked on a slope, set it facing directly down the slope, then dig the bucket into the ground and put blocks under the tires to prevent the machine from moving.
- If the control lever is touched by accident, the work equipment or the machine may move suddenly, and this may lead to a serious accident. Before leaving the operator's compartment, always set the safety lock lever securely to the LOCK position.
- Even if the parking brake switch is turned ON, there is danger until the parking brake pilot lamp lights up, so keep the brake pedal depressed.

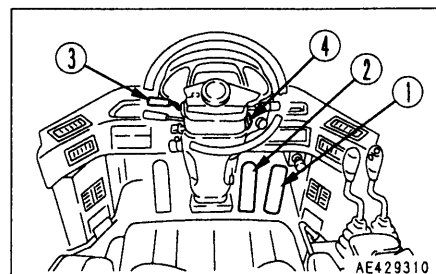
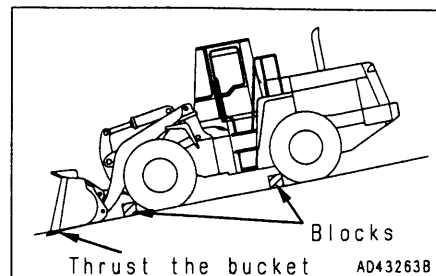

NOTICE

Never use the parking brake switch to brake the machine when traveling except in an emergency. Apply the parking brake only after the machine has stopped.

1. Release accelerator pedal ①, and depress brake pedal ② to stop the machine.

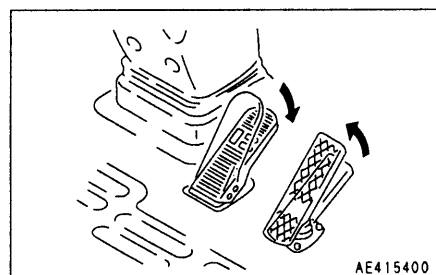

2. Place directional lever ③ in N (neutral).

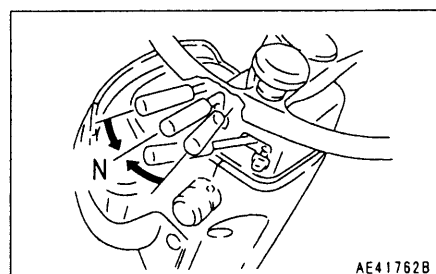

3. Turn parking brake switch ④ to ON to apply the parking brake.

REMARK

When the parking brake is applied, the transmission is automatically returned to neutral.

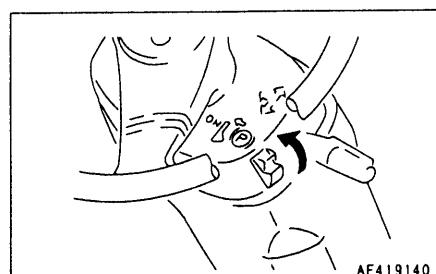



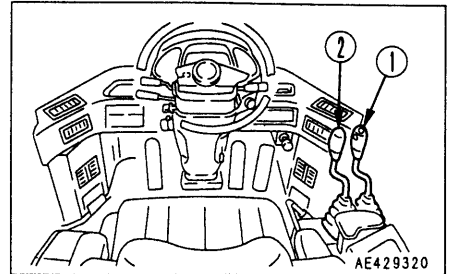

12.9 OPERATION OF WORK EQUIPMENT

Lift arm control lever ① and bucket control lever ② can be used to operate the lift arm and bucket as follows.



LIFT ARM OPERATION (LEVER ①)

- ① Raise ()
- ② Hold (): The lift arm is kept in the same position.
- ③ Lower ()
- ④ Float (): The lift arm moves freely under external force.

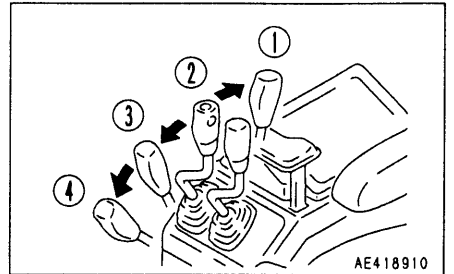



When the lift arm control lever is pulled further from the raise position, the lever is stopped in this position until the lift arm reaches the preset kick-out position, and the lever is return to the hold position.

NOTICE

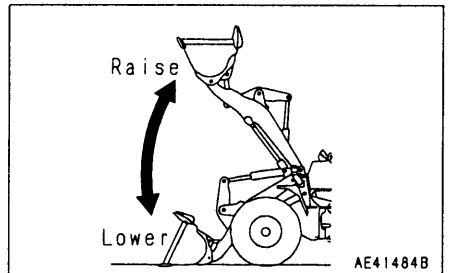
Do not use the FLOAT position when lowering the bucket.



BUCKET OPERATION (LEVER ②)

- ① Tilt ()
- ② Hold (): The bucket is kept in the same position.
- ③ Dump ()

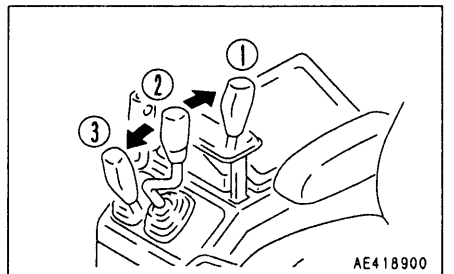

When the bucket control lever is pulled further from the tilt position, the lever is stopped in this position until the bucket reaches the preset position of the positioner, and the lever is return to the hold position.

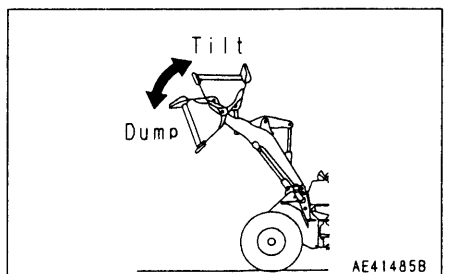

12.10 WORK POSSIBLE USING WHEEL LOADER

In addition to the following, it is possible to further increase the range of applications by using various attachments.

12.10.1 DIGGING OPERATIONS

⚠ WARNING

Always set the machine facing directly to the front when carrying out digging or scooping operations. Never carry out these operations with the machine articulated.

NOTICE

If the tires slip, the tire life will be reduced, so do not allow the tires to slip during operation.

- When loading piled soil or blasted rock, drive the machine forward as follows to load. To prevent cutting of the tires caused by the tires slipping, be careful of the following points during the operation.
 - Always keep the operating jobsite flat, and remove any fallen rocks.
 - When working with stockpiles, operate the machine in 1st or 2nd; when loading blasted rock operate the machine in 1st.

1. When driving the machine forward and lowering the bucket, stop the bucket about 30 cm (12 in) from the ground, then lower it slowly.

REMARK

If the bucket hits the ground, the front tires will come off the ground, and the tires will slip.

2. Shift down immediately in front of the material to be loaded. When completing the shift down, depress the accelerator pedal at the same time and thrust the bucket into the load.
3. When the material is in a stockpile, keep the cutting edge of the bucket horizontal; when loading blasted rock, have the bucket tilting slightly down.

Be careful not to get blasted rock under the bucket. This will make the front tires come off the ground and slip.

Try to keep the load in the center of the bucket; if the load is on one side of the bucket, the load will be unbalanced.

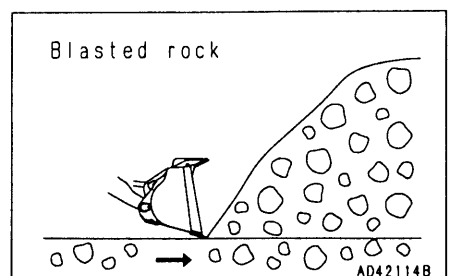
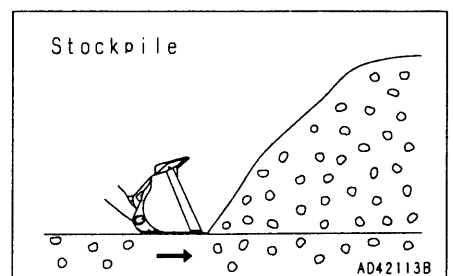
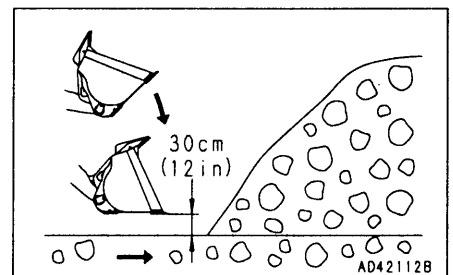

12. OPERATION

- At the same time as thrusting the bucket into the material, raise the lift arm to prevent the bucket from going in too far. By raising the lift arm, ample traction will be produced by the front tires.

REMARK

If the bucket is thrust too much and the lift arm stops rising or the machine stops moving forward, release the accelerator pedal a little. Proper operation of the accelerator pedal for each type of the soil is effective for saving of fuel and prevention of wear of the tires.

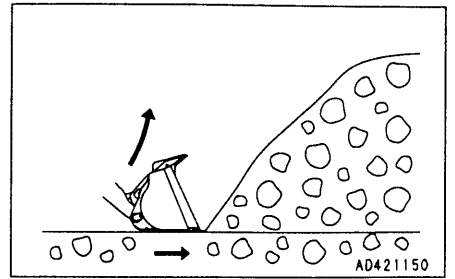

- Check that there is enough material loaded into the bucket, then operate the bucket control lever to tilt the bucket and load the bucket fully.

REMARK

If the bucket edge is moved up and down while pushing in the bucket and digging, the front tires will come off the ground and this will cause the tires to slip.

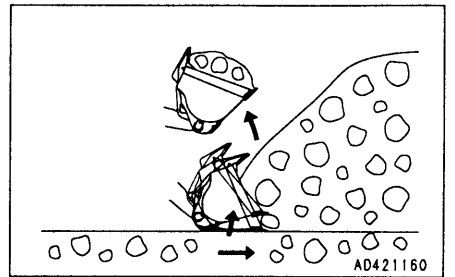

- If there is too much material loaded in the bucket, dump and tilt the bucket quickly to remove the excessive load. This prevents spillage of the load during hauling.

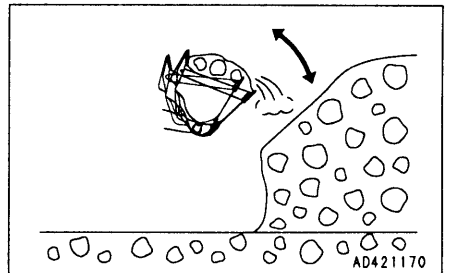

- When digging and loading on level ground, set the bucket edge facing down slightly as follows and drive the machine forward. Always be careful not to load the bucket on one side and cause an unbalanced load. This operation should be carried out in 1st gear.

⚠ WARNING

Do not set the bucket facing down more than 20°.

- Set the edge of the bucket facing slightly down.

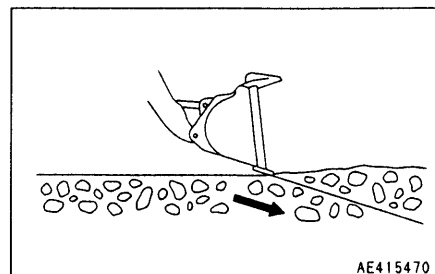

- Drive the machine forward and operate the lift arm control lever forward to cut a thin layer of the surface each time when excavating the soil.

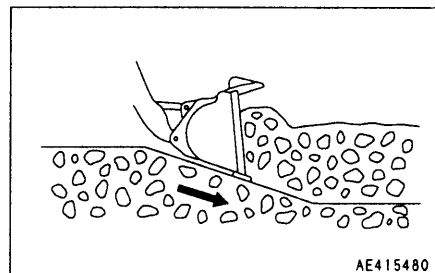

- Operate the lift arm control lever slightly up and down to reduce the resistance when driving the machine forward.

When digging with the bucket, avoid imposing the digging force onto only one side of the bucket.

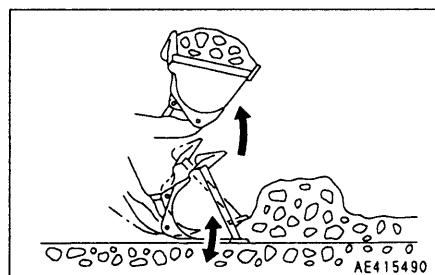

12.10.2 LEVELING OPERATIONS

NOTICE

Always operate the machine in reverse when carrying out leveling operations.

If it is necessary to carry out leveling operations when traveling forward, do not set the bucket dumping angle to more than 20°.

1. Scoop soil into the bucket. Move the machine backward while spreading soil from the bucket little by little.
2. Go over the spread soil with the bucket teeth touching the ground and level the ground by back-dragging.
3. Scoop some more soil into the bucket, put the lift arm in float, level the bucket at ground level, and smooth the ground by moving backward.

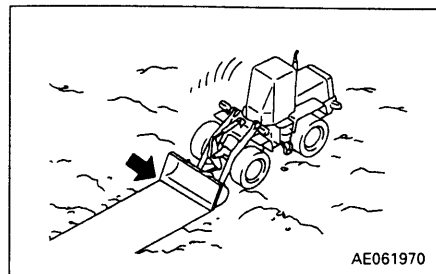

12.10.3 PUSHING OPERATION

WARNING

Never set the bucket to the DUMP position when carrying out pushing operation.

1. When carrying out pushing operations, set the bottom of the bucket parallel to the ground surface.

12.10.4 LOAD AND CARRY OPERATIONS

WARNING

When carrying a load, lower the bucket to lower the center of gravity when traveling.

The load and carry method for wheel loaders consists of a cycle of scooping → hauling → loading (into a hopper, glory hole, etc.)

Always keep the travel path properly maintained.

When using the load and carry method, see "12.18 HANDLING THE TIRES".

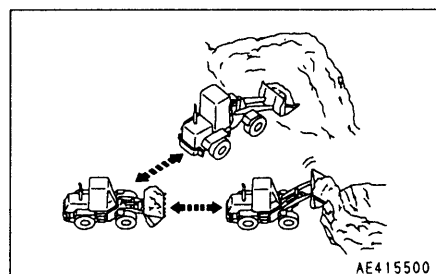

12.10.5 LOADING OPERATIONS

Select the method of operation which will give the minimum amount of turning and travel in order to provide the most efficient method for the jobsite.

⚠ WARNING

- Always keep the working area flat. Do not turn suddenly or apply the brake suddenly when traveling with a raised load. These actions are dangerous.
- It is also dangerous to drive the bucket at high speed into a stockpile or pile of rocks.

NOTICE

- If the tires slip, the tire life will be reduced, so do not allow the tires to slip during operation.
- Avoid excessive shaking of the bucket.

CROSS DRIVE LOADING

Always set the wheel loader facing at a right angle to the stockpile. After digging in and scooping up the load, drive the machine straight back in reverse, then bring the dump truck in between the stock pile and the wheel loader.

This method requires the least time for loading, and is extremely effective in reducing the cycle time.

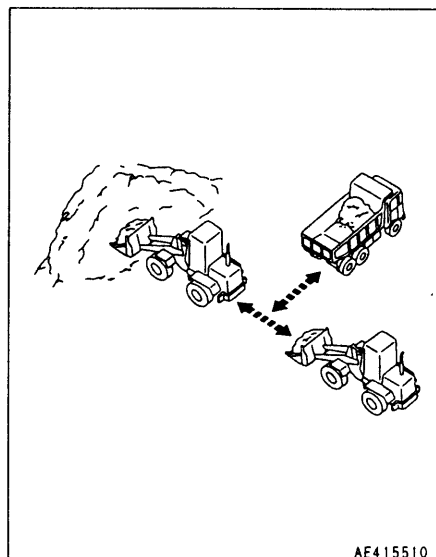

V-SHAPE LOADING

Position the dump truck so that the direction of approach of the wheel loader is approx. 60° from the direction of approach to the stockpile. After loading the bucket, drive the wheel loader in reverse, then turn it to face the dump truck and travel forward to load the dump truck.

The smaller the turning angle of the wheel loader is, the more efficient the operation becomes.

When loading a full bucket and raising it to the maximum height, first shake the bucket to stabilize the load before raising the bucket. This will prevent the load from spilling to the rear.

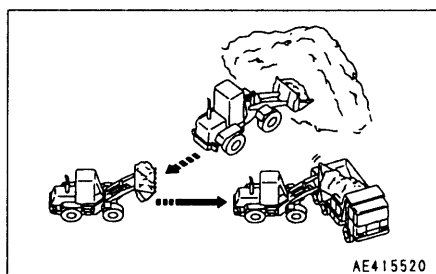

Precautions when piling up loads

When forming products into a pile, be careful not to let the rear counterweight come into contact with the ground.

Do not set the bucket to the DUMP position when carrying out piling-up operations.

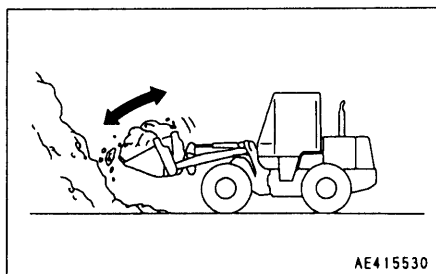

REMARK

Avoid using the transmission cut-off function during scooping up operations. It prevents the machine from traveling in reverse.

12.11 PRECAUTIONS FOR OPERATION

12.11.1 PERMISSIBLE WATER DEPTH

When working in water or on swampy ground, do not let the water come above the bottom of the axle housing.

After finishing the operation, wash and check the lubricating points.

12.11.2 IF WHEEL BRAKE DOES NOT WORK

If the machine is not stopped by depressing the brake pedal, use the parking brake to stop the machine.

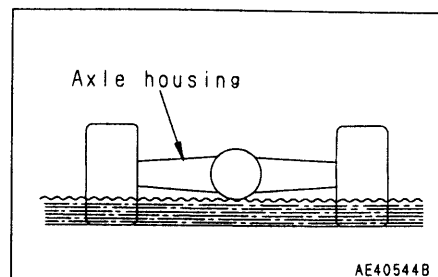

NOTICE

If the parking brake has been used as an emergency brake, contact your Komatsu distributor to have the parking brake checked for any abnormality.

12.11.3 PRECAUTIONS WHEN DRIVING UP OR DOWN SLOPES

LOWER THE CENTER OF GRAVITY WHEN TURNING.

When turning on slopes, lower the work equipment to lower the center of gravity before turning. It is dangerous to turn the machine with the work equipment raised.

BRAKING ON DOWNHILL SLOPES

If the service brake is used too frequently when traveling downhill, the brake may overheat and be damaged. To avoid this problem, shift down to a low range and make full use of the braking force of the engine.

When braking, use the right brake pedal.

If the speed control lever is not placed in a proper speed position, the torque converter oil may overheat. If it overheats, place the speed control lever in the next lower gear speed to lower the oil temperature.

If the temperature gauge does not indicate the green range of the scale even with the lever in the 1st speed position, stop the machine, place the lever in neutral, and run the engine at medium speed until the gauge indicates the green range.

IF ENGINE STOPS

If the engine stops on a slope, depress the right brake pedal fully. Next, lower the work equipment to the ground and apply the parking brake. Then put the directional and speed control levers in neutral, and start the engine again. (If the directional lever is not in neutral, the engine will not start.)

12.11.4 PRECAUTIONS WHEN DRIVING MACHINE

When the machine travels at high speed for a long distance, the tires become extremely hot. This causes early wear of the tires, so it should be avoided as far as possible. If the machine must be driven for a long distance, take the following precautions.

- Follow the regulations related to this machine, and drive carefully.
- Before driving the machine, carry out the checks before starting.
- The most suitable tire pressure, travel speed, or tire type differ according to the condition of the travel surface. Contact your Komatsu distributor or tire dealer for information.
- The following is a guide to suitable tire pressures and speeds when traveling on a paved surface with standard tires.
Tire pressure: front 0.34 MPa (3.5 kgf/cm², 49.7 PSI)
 rear 0.30 MPa (3.1 kgf/cm², 44.02 PSI)
Speed: 14 km/h (8.7 MPH)
- Check the tire pressure before starting, when the tire is cool.
- After traveling for 1 hour, stop for 30 minutes. Check the tires and other parts for damage; also check the oil and coolant levels.
- Always travel with the bucket empty.
- Never put dry ballast in the tires when traveling.

12.12 ADJUSTING WORK EQUIPMENT POSTURE

⚠ WARNING

- Stop the machine on flat ground and put blocks in front and behind the wheels.
- Apply the parking brake.
- Secure the front and rear frames with the safety bar.
- Do not go under the work equipment when the arm is raised.

The boom kickout makes it possible to set the bucket so that it automatically stops at the desired lifting height (lift arm higher than horizontal) and the bucket positioner makes it possible to set the bucket so that it automatically stops at the desired digging angle. The setting can be adjusted to match the working conditions.

12.12.1 ADJUSTING BOOM KICKOUT

1. Raise the bucket to the desired height, set the lift arm control lever at HOLD and lock the lever in position. Then stop the engine and adjust as follows.
2. Loosen two bolts ①, and adjust plate ② so that the bottom edge is in line with the center of the sensing surface of proximity switch ③. Then tighten the bolts to hold the plate in position.
3. Loosen two nuts ④ to make a clearance of 3 – 5 mm (0.118 – 0.197 in) between plate ② and the sensing surface of proximity switch ③. Then tighten the nuts to hold in position.

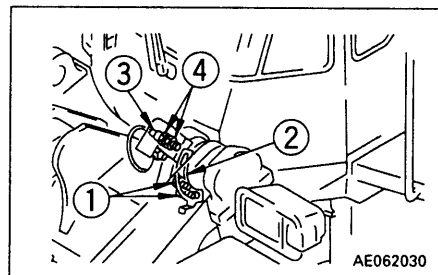

AE062030

Tightening torque: $17.2 \pm 2.5 \text{ N}\cdot\text{m}$ ($1.75 \pm 0.25 \text{ kgf}\cdot\text{m}$, $12.7 \pm 1.8 \text{ lbft}$)

4. After adjusting, start the engine and operate the lift arm control lever. Check that the lever is automatically returned to HOLD when the bucket reaches the desired height.

12.12.2 ADJUSTING BUCKET POSITIONER

1. Lower the bucket to the ground, set to the desired digging angle, return the bucket control lever to the HOLD position, then lock the work equipment control lever with the safety lock lever and stop the engine.
2. Loosen 2 bolts ①, adjust the position of mounting bracket ④ of the proximity switch so that the rear tip of bar ② is in line with the center of the sensing surface of proximity switch ③, then tighten bolts to hold the bracket in position.
3. Loosen 2 bolts ⑤, adjust so that the clearance between bar ② and support ⑥ is 0.5 – 2 mm (0.020 – 0.079 in), then tighten bolts ⑤ to hold in position.
4. Loosen 2 nuts ⑦, adjust so that the clearance between bar ② and the sensing surface of proximity switch ③ is 3 – 5 mm (0.118 – 0.197 in), then tighten the nuts to hold in position.
Tightening torque: $17.2 \pm 2.5 \text{ N}\cdot\text{m}$ ($1.75 \pm 0.25 \text{ kgf}\cdot\text{m}$, $12.7 \pm 1.8 \text{ lbft}$)
5. After adjusting, start the engine and raise the lift arm. Operate the bucket control lever to the DUMP position, then operate it to the TILT BACK position and check that the lever is automatically returned to the HOLD position when the bucket reaches the desired digging angle.

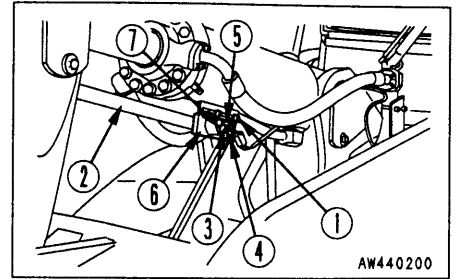

12.12.3 BUCKET LEVEL INDICATOR

Ⓐ and Ⓑ at the top rear of the bucket are the level indicators, so the bucket angle can be checked during operations.

- Ⓐ: Parallel with cutting edge
- Ⓑ: 90° to cutting edge

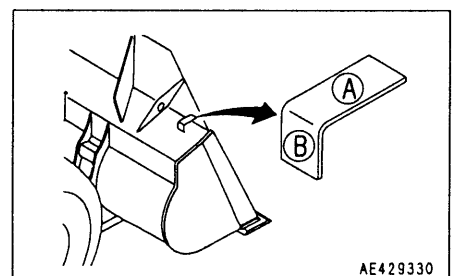

12.13 PARKING MACHINE

⚠ WARNING

- Avoid stopping suddenly. Give yourself ample room when stopping.
- Do not park the machine on slopes.
If the machine has to be parked on a slope, set it facing directly down the slope, then dig the bucket into the ground and put blocks under the tires to prevent the machine from moving.
- If the control lever is touched by accident, the work equipment or the machine may move suddenly, and this may lead to a serious accident. Before leaving the operator's compartment, always set the safety lock lever securely to the LOCK position.
- Even if the parking brake switch is turned ON, there is danger until the parking brake pilot lamp lights up, so keep the brake pedal depressed.

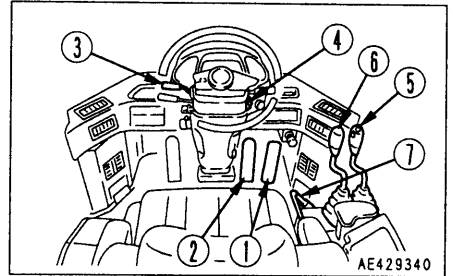
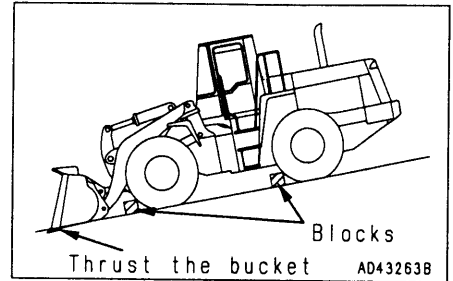

NOTICE

Never use the parking brake switch to brake the machine when traveling except in an emergency. Apply the parking brake only after the machine has stopped.

1. Release accelerator pedal ①, and depress brake pedal ② to stop the machine.

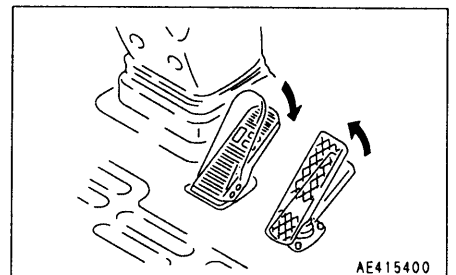

2. Place directional lever ③ in N (neutral).

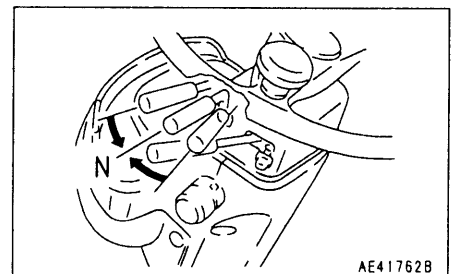

3. Turn parking brake switch ④ to ON to apply the parking brake.

REMARK

When the parking brake is applied, the transmission is automatically returned to neutral.

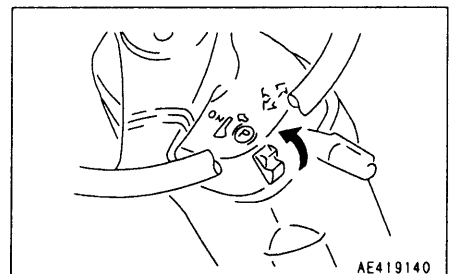

- Operate lift arm control lever ⑤ to lower the bucket to the ground.

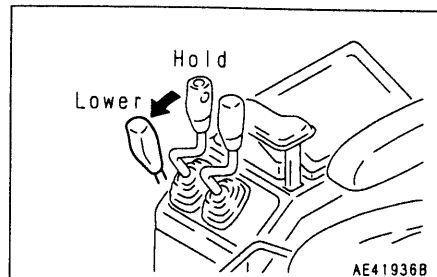

- Lock lift arm control lever ⑤ and bucket control lever ⑥ with safety lock ⑦.

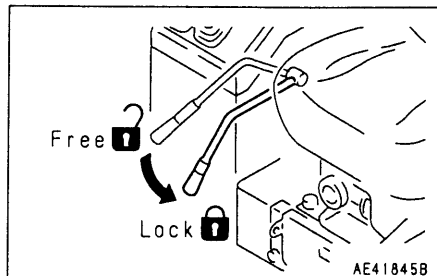

12.14 CHECKS AFTER COMPLETION OF OPERATION

Check the engine water temperature, engine oil pressure, torque converter oil temperature, and fuel level with the meter and lamps. If the engine has overheated, do not stop it suddenly. Run the engine at a midrange speed to allow the engine to cool down before stopping it.

12.15 STOPPING ENGINE

NOTICE

If the engine is abruptly stopped before it has cooled down, engine life may be greatly shortened. Consequently, do not abruptly stop the engine apart from an emergency.

In particular, if the engine has overheated, do not abruptly stop it but run it at medium speed to allow it to cool gradually, then stop it.

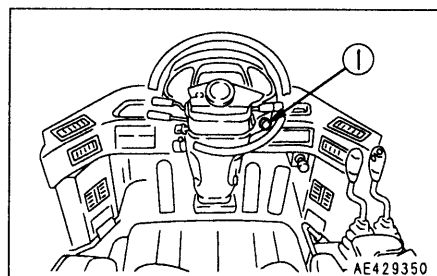

- Run the engine at low idling speed for about 5 minutes to allow it to gradually cool down.

- Turn the key in starting switch ① to the OFF position and stop the engine.
- Remove the key from starting switch ①.

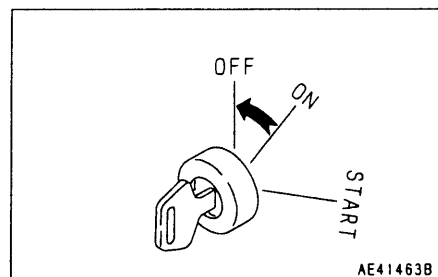

12.16 CHECK AFTER STOPPING ENGINE

1. Walk around the machine and check the work equipment, body work, and undercarriage, and check also for leakage of oil and water. If any leakage or abnormality is found, carry out repairs.
2. Fill the fuel tank.
3. Remove any waste paper or dead leaves from inside the engine room. These may cause a fire.
4. Remove any mud stuck to the undercarriage.

12.17 LOCKING

Always lock the following places.

- ① Fuel tank filler cap
- ② Engine side panel (left, right)
- ③ Cab door

REMARK

The starting switch key is used also for locks ①, ②, and ③.

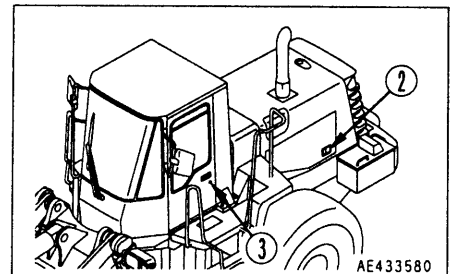
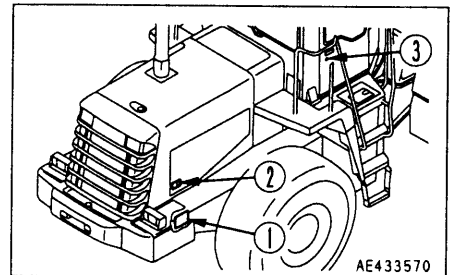

12.18 HANDLING THE TIRES

12.18.1 PRECAUTIONS WHEN HANDLING TIRES

CAUTION

If a tire has reached any of the following service limits, there is danger that the tire may burst or cause an accident, so to ensure safety, replace it with a new tire.

- **Service limits for wear**
 - When the remaining depth of the groove on construction equipment tires (at a point approx. 1/4 of the tread width) is 15% of the groove depth on a new tire.
 - When the tire shows marked uneven wear, stepped wear or other abnormal wear, or when the cord layer is exposed.
- **Service limits for damage**
 - When there is external damage extending to the cord or when the cord is broken
 - When the cord is cut or there is dragging
 - When the tire is peeling (there is separation)
 - When the bead is damaged
 - For tubeless tires, when there is air leakage or improper repair

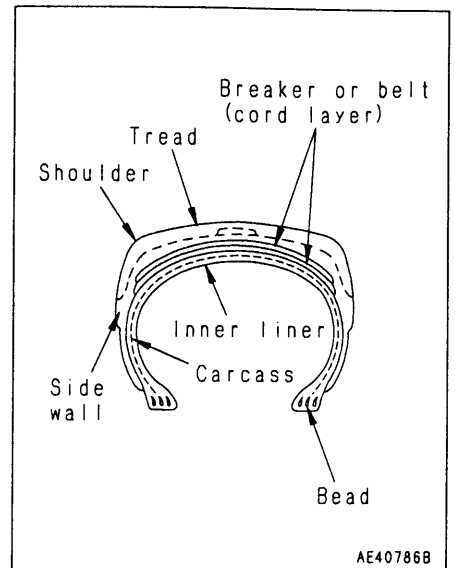

Please contact your Komatsu distributor when replacing the tires. It is dangerous to jack up the machine without taking due care.

12.18.2 TIRE PRESSURE

Measure the tire pressure before starting operations, when the tires are cool.

If the tire inflation pressure is too low, there will be overload; if it is too high, it will cause tire cuts and shock burst. To prevent these problems, adjust the tire inflation pressure according to the table on the next page.

$$\text{Deflection ratio} = \frac{H - h}{H} \times 100$$

As a guideline that can be checked visibly, the deflection ratio of the front tire (deflection/free height) is as follows.

When carrying normal load (lift arm horizontal): Approx. 15 – 25%

When digging (rear wheels off ground): Approx. 25 – 35%

When checking the tire inflation pressure, check also for small scratches or peeling of the tire, for nails or pieces of metal which may cause punctures, and for any abnormal wear.

Clearing fallen stones and rocks from the operating area and maintaining the surface will extend the tire life and give improved economy.

- For operations on normal road surfaces, rock digging operations:
..... High end of range in air pressure chart
- Stockpile operations on soft ground:
..... Average pressure in air pressure chart
- Operations on sand (operations not using much digging force)
..... Low end of range in air pressure chart

12. OPERATION

If the deflection of the tire is excessive, raise the inflation pressure within the limits given in the table to give a suitable deflection (see deflection ratio).

Tire size (Pattern)	Ply rating	Inflation pressure			
		Soft ground (sandy ground)	Normal road		When shipped from factory
			Stockpile	Digging	
23.5 – 25 (L3 Rock)	20	0.24 – 0.35MPa (2.4 – 3.6kgf/cm ² , 34.08 – 51.12PSI)	0.26 – 0.35MPa (2.6 – 3.6kgf/cm ² , 36.92 – 51.12PSI)	0.26 – 0.35MPa (2.6 – 3.6kgf/cm ² , 36.92 – 51.12PSI)	Front tire: 0.34MPa (3.5kgf/cm ² , 49.7PSI)
23.5 – 25 (L3 Rock)	16	0.24 – 0.35MPa (2.4 – 3.6kgf/cm ² , 34.08 – 51.12PSI)	0.26 – 0.35MPa (2.6 – 3.6kgf/cm ² , 36.92 – 51.12PSI)	0.26 – 0.35MPa (2.6 – 3.6kgf/cm ² , 36.92 – 51.12PSI)	Rear tire: 0.30MPa (3.1kgf/cm ² , 44.02PSI)
26.5 – 25 (L3 Rock)	16	0.24 – 0.35MPa (2.4 – 3.6kgf/cm ² , 34.08 – 51.12PSI)	0.26 – 0.35MPa (2.6 – 3.6kgf/cm ² , 36.92 – 51.12PSI)	0.26 – 0.35MPa (2.6 – 3.6kgf/cm ² , 36.92 – 51.12PSI)	Front tire: 0.32MPa (3.3kgf/cm ² , 46.86PSI) Rear tire: 0.27MPa (2.8 kgf/cm ² , 39.76PSI)

Stockpile operations mean the loading of sand and other loose materials.

PRECAUTIONS WITH LOAD AND CARRY METHOD

When traveling continuously with load and carry operations, choose the correct tires to match the operating conditions, or choose the operating conditions to match the tires. If this is not done, the tires will be damaged, so contact your Komatsu distributor or tire dealer when selecting tires.

METHOD OF CHARGING TIRES WITH AIR (if equipped)

Connect the supplied air charge hose to air pickup port ① to pump up the tires.

NOTICE

When using the compressor (to charge the tires with air), run the engine at low idling.

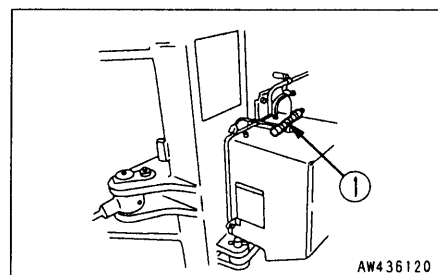

AW436120

13. TRANSPORTATION

When transporting the machine, observe all related laws and regulations, and be careful to assure safety.

13.1 LOADING, UNLOADING WORK

⚠ WARNING

- Make sure the ramp has sufficient width, length and thickness to enable the machine to be safely loaded and unloaded.
- When loading and unloading the machine, park the trailer on a flat firm roadbed. Keep a fairly long distance between the road shoulder and the machine.
- Remove the mud from the undercarriage to prevent the machine from slipping to the side on slopes.
Be sure the ramp surface is clean and free of grease, oil, ice and loose materials.
- Never change the direction of travel when on the ramps. If it is necessary to change direction, drive off the ramps and correct the direction, then drive on to the ramps again.

When loading or unloading, always use ramps or a platform and carry out the operations as follows.

1. Properly apply the brakes on the trailer and insert blocks beneath the tires to ensure that it does not move. Then fix the ramps in line with the centers of the trailer and the machine. Be sure that the two sides are at the same level as one another. If the ramp sags appreciably, reinforce it with blocks, etc.

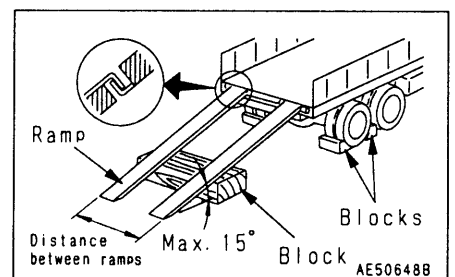

2. Determine the direction of the ramp, then slowly load or unload the machine.

REMARK

When transmission cut-off switch is set to OFF, the left brake pedal and accelerator pedal are operated at the same time.

3. Correctly load the machine onto the specified part of the trailer.

13.2 PRECAUTIONS FOR LOADING

After loading the machine in the specified position, secure it in place as follows.

1. Lower the work equipment slowly.
2. Apply the safety lock to lock all the control levers securely.
3. Turn the starting switch to the OFF position and stop the engine. Remove the key from the starting switch.
4. Lock front frame and rear frame with safety bar.
5. Put blocks in front and behind the wheels, and secure the machine with chains or wire ropeto prevent the machine from moving during transportation.
6. Always retract the car radio antenna fully.

13.3 LIFTING MACHINE

 **DANGER**

- When lifting the machine, if the wire rope is not fitted correctly the machine may fall and cause serious injury or even death. Raise the machine 100 – 200 mm (3.9 – 7.9 in) from the ground, check that the machine is horizontal and that there is no slack in the wire rope, then continue to lift the machine.
- Before lifting the machine, always stop the engine and lock the brakes.

 **WARNING**

- Lifting operations using a crane must be carried out by a qualified operator.
- Never raise the machine with any worker on it.
- Always make sure that the wire rope used for lifting the machine is of ample strength for the weight of the machine.
- Never try to lift the machine at any position or in any posture other than the posture given in the procedure next page.

13.3.1 POSITION FOR STICKING LIFTING POSITION MARK

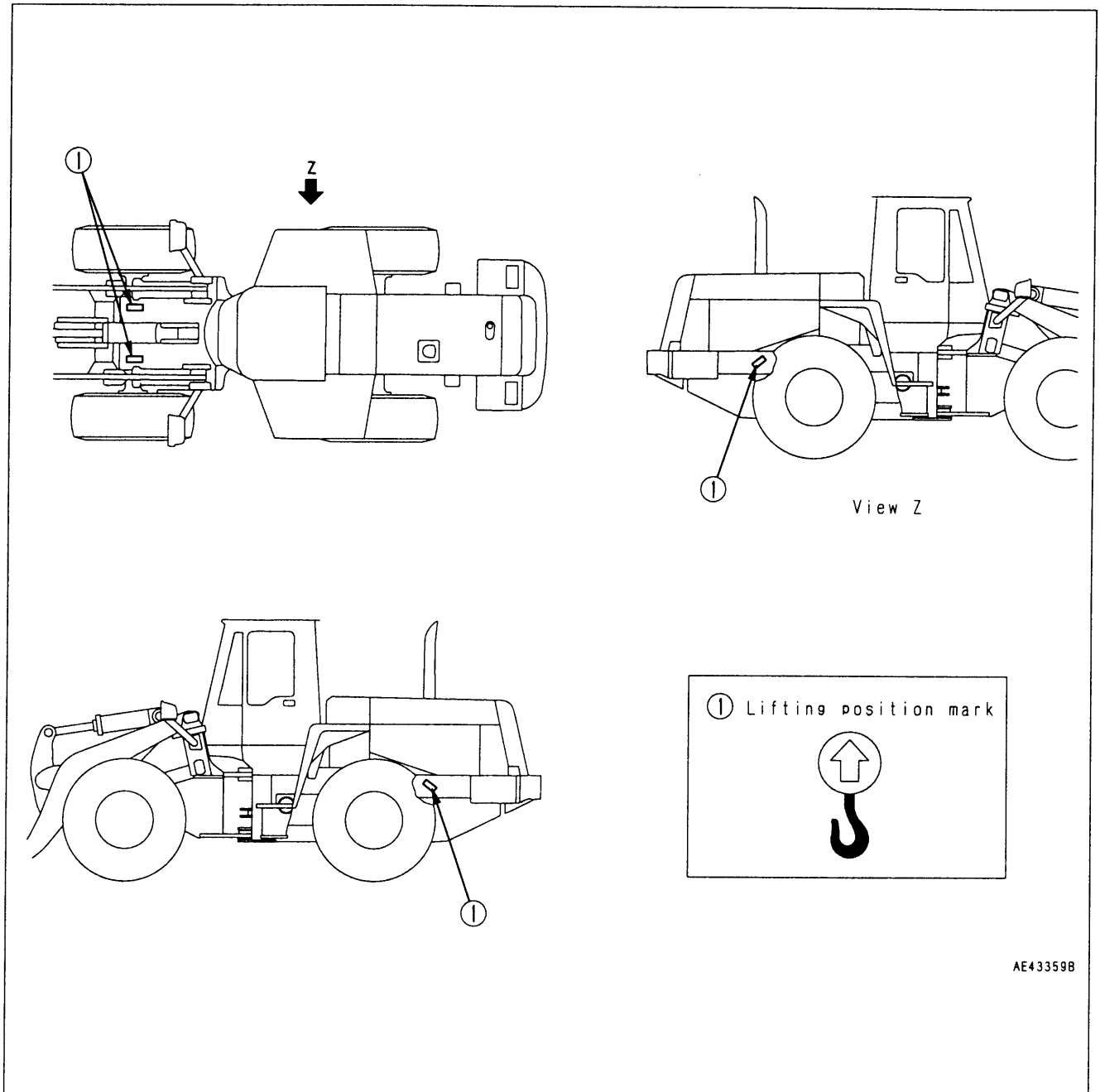

AE43359B

13.3.2 WEIGHT TABLE

	Operating weight	Front wheel load	Rear wheel load	Center of gravity (from front axle)
WA420-3	18550 kg (40903 lb)	9455 kg (20848 lb)	9095 kg (20054 lb)	1618 mm (5 ft 4 in)

13. TRANSPORTATION

13.3.3 LIFTING PROCEDURE

CAUTION

When lifting the machine, check that there is no leakage of oil from the hydraulic circuit or any other part.

Lifting work can be carried out only for machines with lifting marks. Before starting the lifting operation, stop the machine in a horizontal place and do as follows.

1. Start the engine, make sure that the machine is horizontal, then set the work equipment to the travel posture. For details, see "12.4 MOVING MACHINE OFF".

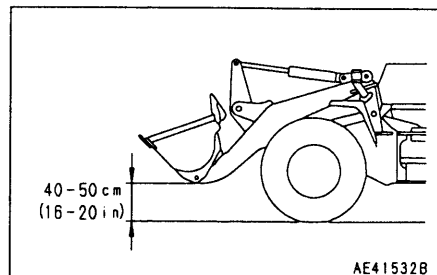

2. Move the work equipment safety lock lever to the LOCK position.

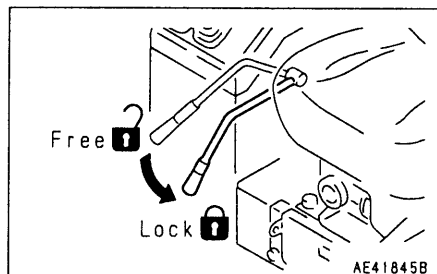

3. Stop the engine, check that the area around the operator's compartment is safe, then lock with the safety bar so that the front frame and rear frame will not articulate.

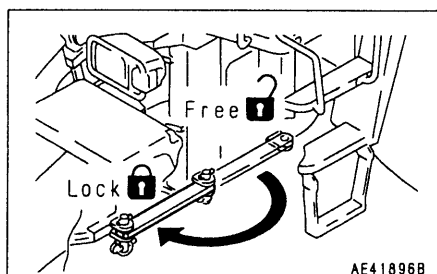

4. Fit the lifting equipment to the lifting hooks (marked by the lifting mark) at the front of the front frame and the rear of the rear frame.
5. When the machine leaves the ground, stop for a moment and wait for the machine to stabilize, then continue the lifting operation slowly.

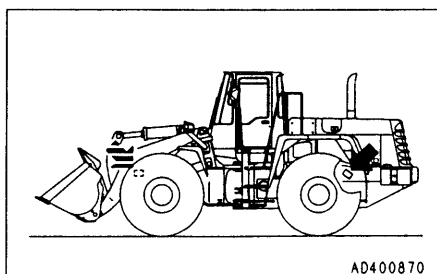

13.4 PRECAUTIONS FOR TRANSPORTATION

WARNING

Determine the route for transporting the machine by taking into account the width, height and weight of the machine.

Obey all state and local laws governing the weight, width and length of a load. Observe all regulations governing wide loads.

14. COLD WEATHER OPERATION

14.1 PRECAUTIONS FOR LOW TEMPERATURE

If the temperature becomes low, it becomes difficult to start the engine, and the coolant may freeze, so do as follows.

14.1.1 FUEL AND LUBRICANTS

Change to fuel and oil with low viscosity for all components. For details of the specified viscosity, see "20. USE OF FUEL, COOLANT AND LUBRICANTS ACCORDING TO AMBIENT TEMPERATURE".

14.1.2 COOLANT

 **WARNING**

Keep antifreeze fluid away from an open flame. Never smoke when using antifreeze.

NOTICE

- Never use methanol, ethanol or propanol based antifreeze.
- Absolutely avoid using any water leak preventing agent irrespective of whether it is used independently or mixed with an antifreeze.
- Do not mix one antifreeze with a different brand.

For details of the antifreeze mixture when changing the coolant, see "24.2 WHEN REQUIRED".

Use a Permanent Antifreeze (ethylene glycol mixed with corrosion inhibitor, antifoam agent, etc.) meeting the standard requirements as shown below. With permanent antifreeze, no change of coolant is required for a year. If it is doubtful that an available antifreeze meets the standard requirements, ask the supplier of that antifreeze for information.

Standard requirements for permanent antifreeze

- SAE J1034
- FEDERAL STANDARD O-A-548D

REMARK

Where no permanent antifreeze is available, an ethylene glycol antifreeze without corrosion inhibitor may be used only for the cold season. In this case, clean the cooling system twice a year (in spring and autumn). When refilling the cooling system, add antifreeze in autumn, but do not add any in spring.

14.1.3 BATTERY

⚠ WARNING

- To avoid gas explosions, do not bring fire or sparks near the battery.
- Battery electrolyte is dangerous. If it gets in your eyes or on your skin, wash it off with large amounts of water, and consult a doctor.

When the ambient temperature drops, the capacity of the battery will also drop. If the battery charge ratio is low, the battery electrolyte may freeze. Maintain the battery charge as close as possible to 100%, and insulate it against cold temperature so that the machine can be started easily the next morning.

REMARK

Measure the specific gravity and calculate the rate of charge from the following conversion table.

Temp. of fluid	20°C	0°C	-10°C	-20°C	-30°C
Rate of charge					
100%	1.28	1.29	1.30	1.31	1.32
90%	1.26	1.27	1.28	1.29	1.30
80%	1.24	1.25	1.26	1.27	1.28
75%	1.23	1.24	1.25	1.26	1.27

14.2 PRECAUTIONS AFTER COMPLETION OF WORK

To prevent mud, water, or the undercarriage from freezing and making it impossible for the machine to move on the following morning, always observe the following precautions.

- Mud and water on the machine body should be completely removed.
This is to prevent damage to the seal caused by water in mud or dirt getting inside the seal and freezing.
- Park the machine on hard, dry ground.
If this is impossible, park the machine on wooden boards.
The boards help protect the tracks from being frozen in the soil and the machine can start next morning.
- Open the drain valve and drain any water collected in the fuel system to prevent it from freezing.
- As the battery capacity drops markedly in low temperatures, cover the battery or remove it from the machine, keep it in a warm place, and install it again the next morning.

14.3 AFTER COLD WEATHER

When season changes and the weather becomes warmer, do as follows.

- Replace the fuel and oil for all parts with oil of the viscosity specified.
For details, see "20. USE OF FUEL, COOLANT AND LUBRICANTS ACCORDING TO AMBIENT TEMPERATURE".
- If for any reason permanent antifreeze cannot be used, and an ethyl glycol base antifreeze (winter, one season type) is used instead, or if no antifreeze is used, drain the cooling system completely, then clean out the inside of the cooling system thoroughly, and fill with fresh water.

15. LONG-TERM STORAGE

15.1 BEFORE STORAGE

When putting the machine in storage for a long time, do as follows.

- After every part is washed and dried, house the machine in a dry building. Never leave it outdoors.
If the machine must be left outdoors, park it on well-drained concrete and cover it with canvas, etc.
- Completely fill the fuel tank, lubricate, and change the oil before storage.
- Apply a thin coat of grease to the metal surface of the hydraulic piston rods.
- Disconnect the negative terminals of the battery and cover it, or remove it from the machine and store it separately.
- If the ambient temperature is expected to drop below 0°C, always add antifreeze to the cooling water.
- Apply the safety locks to the bucket control lever, lift arm control lever, and directional lever, then apply the parking brake.

15.2 DURING STORAGE

 **WARNING**

If it is unavoidably necessary to carry out the rust-prevention operation while the machine is indoors, open the doors and windows to improve ventilation and prevent gas poisoning.

Operate the engine and move the machine for a short distance once a month so that a new film of oil will be coated over movable parts and component surfaces. At the same time, also charge the battery.

Before operating the work equipment, wipe off the grease on the hydraulic piston rod.

If the machine is equipped with an airconditioner, operate it for 3–5 minutes once a month to lubricate each portion of its compressor. Be sure to idle the engine at low speed for this purpose. Also, check the quantity of refrigerant twice a year.

15.3 AFTER STORAGE

NOTICE

If the machine is stored without carrying out the monthly rust prevention operation, request your Komatsu distributor for service.

Carry out the following procedure when taking the machine out of long-term storage.

- Wipe off the grease from the hydraulic cylinder rods.
- Add oil and grease to all places.

16. TROUBLESHOOTING

16.1 WHEN MACHINE RUNS OUT OF FUEL

 **WARNING**

The engine will start, so check carefully that the area around the engine is safe before cranking the engine.

If the machine has run out of fuel, add fuel and then bleed the air from the fuel system before starting the engine.

PROCEDURE FOR BLEEDING AIR

Turn the key in the starting switch to the START position and crank the engine for 15 – 20 seconds. Repeat this procedure 2 – 3 times to bleed the air.

Do not turn the starting motor continuously for more than 20 seconds. Wait for 2 minutes before turning the starting motor again.

The air can be bled more quickly if the fuel tank is completely filled with fuel.

16.2 TOWING THE MACHINE

 **WARNING**

- If the machine that has broken down is towed in the wrong way, it may lead to serious injury or damage.
- If there is a failure in the brake line, the brakes cannot be used, so be extremely careful when towing.

NOTICE

- Towing is for moving the machine to a place where inspection and maintenance can be carried out, and not for moving it long distances.
The machine must not be towed for long distances.
- For details of the procedure for towing a machine when it has broken down, please contact your Komatsu distributor.

This machine must not be towed except in emergencies. When towing the machine, take the following precautions.

- When releasing the brakes, put blocks under the wheels to prevent the machine from moving. If the wheels are not blocked, the machine may suddenly move.
- When towing a machine, tow it at a low speed of less than 2 km/h (1.2 MPH), and for a distance of a few meters to a place where repairs can be carried out. The machine should be towed only in emergencies.
If the machine must be moved long distances, use a transporter.
- Fit a guard plate to the machine being towed to protect the operator if the tow rope or bar should break.
- If the steering and brake of the machine being towed cannot be operated, do not let anyone sit on the machine.
- Check that the tow rope or bar is of ample strength for the weight of the machine being towed. If the machine being towed must travel through mud or up hills, use a tow rope or bar of a strength of at least 1.5 times the weight of the machine being towed.

- Keep the angle of the tow rope as small as possible. Keep the angle between the center lines of the two machines to within 30°.
- If the machine is moved suddenly, an excessive load will be applied to the tow rope or bar, and it may break. Always move the machine slowly at a fixed speed.
- The towing machine should normally be of the same class as the machine being towed. Check that the towing machine has ample braking power, weight, and rimpull to allow it to control both machine on slopes or on the tow road.
- When towing a machine downhill, use a larger machine for towing to provide ample rimpull and braking power, or connect another machine to the rear of the machine being towed. In this way it is possible to prevent the machine from losing control and turning over.
- Towing may be carried out under various differing conditions, so it is impossible to determine beforehand the requirements for towing. Towing on flat horizontal roads will require the minimum rimpull, while towing on slopes or on uneven road surfaces will require the maximum rimpull.

16.2.1 WHEN ENGINE CAN BE USED

- If the transmission and steering wheel can be operated, and the engine is running, it is possible to tow the machine out of mud or to move it for a short distance to the edge of the road.
- The operator should sit on the machine being towed and operate the steering in the direction that the machine is towed.

16.2.2 WHEN ENGINE CANNOT BE USED

When towing a machine with the engine stopped, use the following procedure.

1. The transmission oil does not lubricate the system, so remove the front and rear drive shafts. If necessary, block the tires to prevent the machine from moving.
2. The steering cannot be operated, so remove the steering cylinder. Even if the brakes are in good condition, the brakes can only be used a limited number of times. There is no change in the operating force for the brake pedal, but the braking force is reduced each time the pedal is depressed.
3. Connect the towing equipment securely. When carrying out towing operations, use two machines of at least the same class as the machine being towed. Connect one machine each to the front and rear of the machine being towed, then remove the blocks from the tires and tow the machine.

16.2.3 RELEASING PARKING BRAKE

WARNING

- Stop the machine on a flat surface when releasing the parking brake, and check that the surroundings are safe. In emergencies or when the parking brake must be released on a hill, block the tires carefully before releasing the brake.
- When the parking brake is released, no braking force can be applied, so check carefully that the situation is safe when moving the machine.

If the engine will not run for some reason, use the following method to release the parking brake and tow the machine.

1. METHOD OF RELEASING BRAKE BY USING EMERGENCY PARKING BRAKE CANCEL SWITCH

If the pressure in the brake accumulator is high, do as follows.

1. Turn the starting switch to the ON position.
2. Turn the emergency parking brake switch to the CANCEL position. When doing this, check that the parking brake caution lamp goes out. When the switch is set to the CANCEL position, the alarm buzzer will sound continuously.

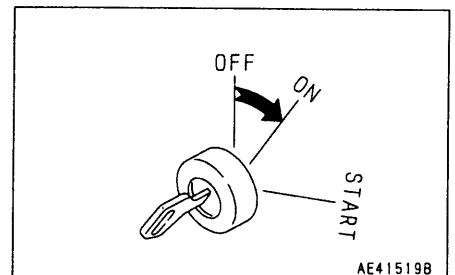

REMARK

- Normally, keep the switch at the NORMAL position to actuate it.
- If the pressure in the brake accumulator is low, the parking brake caution lamp will not go out, or the alarm buzzer will sound with a continuous beep. If this happens, follow the instructions in METHOD FOR CANCELING WITH ADJUSTMENT SCREW to release the brake.

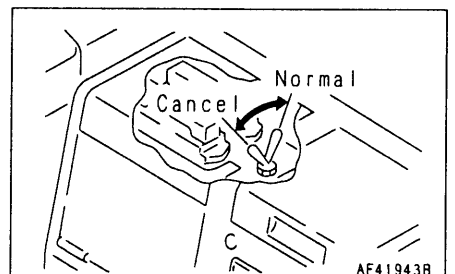

2. METHOD FOR CANCELING WITH ADJUSTMENT SCREW

If the pressure in the brake accumulator is low, do as follows.

1. Loosen adjustment screws ① and bolts ② at A, B, C (3 places) at the front of the transmission case.
2. Rotate lock plate ③ to release the lock, then tighten adjustment screw ① until it stops.
3. If this is done simultaneously for all three places (A, B, C), the parking brake can be released.

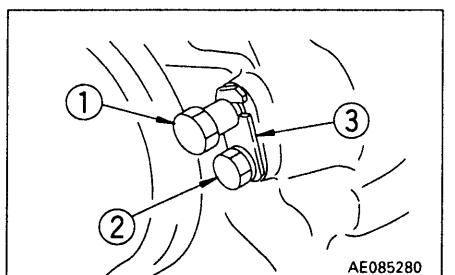
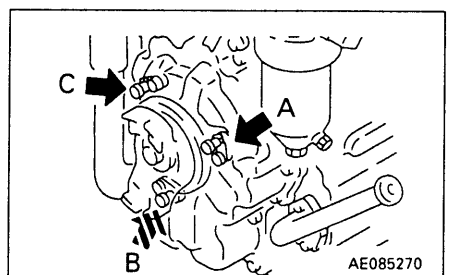

16.2.4 EMERGENCY TRAVEL OPERATION

The normal gear shifting operation is carried out by electric signals. If there should be a failure in the electrical system and the machine does not move, it is possible to move the machine by using the following procedure.

⚠ WARNING

- When carrying out this operation, always keep the engine stopped except when starting the machine.
- When starting the engine, always depress the brake pedal and check that the surrounding area is safe.
- This operation is to enable the machine to drive under its own power to the nearest repair shop when there is a failure in the electrical system. This operation must not be used for any other purpose.
- Always keep the speed lever at the neutral position.
- Install plate ② securely. There is danger that the spool may come out when the machine is traveling.

NOTICE

Always request your Komatsu distributor to carry out the emergency travel operation, or consult your Komatsu distributor before carrying it out yourself.

1. Set the parking brake switch to the ON position and set the speed lever to the neutral position.
2. Loosen bolt ①, then remove plate ②.
3. Pull out spool ③ to the F position or push it into the R position. The transmission range for this operation is 2nd.
4. After resetting, set the spool to the neutral position, then install plate ② and bolt ① to hold it in position.
5. Depress the brake pedal, start the engine, then release the parking brake and let the brake pedal out slowly to allow the machine to start.

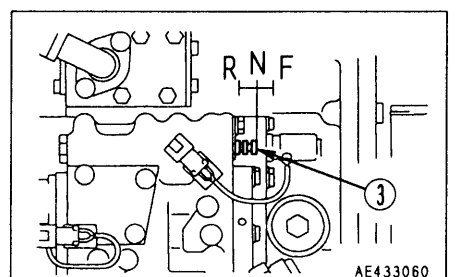
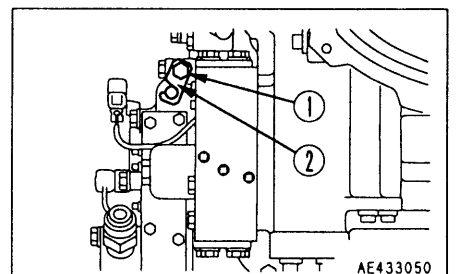

16.3 IF BATTERY IS DISCHARGED

WARNING

- When checking or handling the battery, stop the engine and turn the starting switch key to the OFF position before starting.
- Before starting the engine, use a damp cloth to wipe off the dust accumulated on the top surface of the battery.
- The battery generates hydrogen gas, so there is danger of explosion. Do not bring lighted cigarettes near the battery, or do anything that will cause sparks.
- Battery electrolyte is dilute sulphuric acid, and it will attack your clothes and skin. If it gets on your clothes or on your skin, wash it immediately off with large amounts of water. If it gets in your eyes, wash it out with fresh water, and consult a doctor.
- When handling battery, always wear protective goggles and rubber gloves.
- When removing the battery, first disconnect the cable from the ground (normally, from the negative \ominus terminal). When installing, install the positive \oplus terminal first. If a tool touches the cable connecting the positive terminal and the chassis, there is danger that it will cause sparks.
- If the terminals are loose, there is danger that the defective contact may generate sparks that will cause an explosion. When installing the terminals, install them tightly.
- When removing or installing, check which is the positive \oplus terminal and negative \ominus terminal.

When removing, disconnect the cable from the ground terminal first

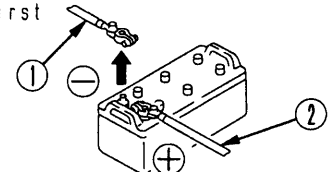

AE42128B

When installing, connect the cable to the positive \oplus terminal first.

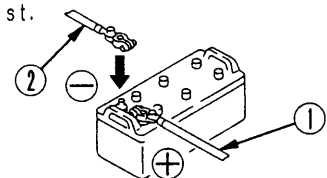

AE42129B

16.3.1 REMOVAL AND INSTALLATION OF BATTERY

When starting the engine with a booster cable, do as follows:

- When removing battery, first disconnect the cable from the ground (normally, from the negative \ominus terminal). If a tool touches a cable connecting the positive terminal and the chassis, there is danger of sparks being emitted.
- When installing battery, the ground cable should be connected to the ground terminal as the last step.

REMARK

The batteries are on both sides at the rear of the machine. The battery used for the ground is on the left side of the machine.

16.3.2 PRECAUTIONS FOR CHARGING BATTERY CHARGING BATTERY WHEN MOUNTED ON MACHINE

- Before charging, disconnect the cable from the negative \ominus terminal of the battery. Otherwise, an unusually high voltage will damage the alternator.
- While charging the battery, remove all battery plugs for satisfactory ventilation.
To avoid gas explosions, do not bring fire or sparks near the battery.
- Do not use or charge the battery if the battery electrolyte level is below the LOWER LEVEL line. This may cause an explosion. Always check the battery electrolyte level periodically and add distilled water to bring the electrolyte level to the UPPER LEVEL line.
- If the electrolyte temperature exceeds 45°C, stop charging for a while.
- Turn off the charger as soon as the battery is charged.
Overcharging the battery may cause the following:
 - 1) Overheating the battery
 - 2) Decreasing the quantity of electrolyte.
 - 3) Damaging the electrode plate.
- Do not mix the cables (positive \oplus to negative \ominus or negative \ominus to positive \oplus), as it will damage the alternator.
- When performing any service to the battery besides checking the electrolyte level or measuring the specific gravity, disconnect cables from the battery.

REMARK

The batteries are on both sides at the rear of the machine. The battery used for the ground is on the left side of the machine.

16.3.3 STARTING ENGINE WITH BOOSTER CABLE

When starting the engine with a booster cable, do as follows:

PRECAUTIONS WHEN CONNECTING AND DISCONNECTING BOOSTER CABLE

WARNING

- When connecting the cables, never contact the positive \oplus and negative \ominus terminals.
- When starting the engine with a booster cable, always wear safety glasses and rubber gloves.
- Be careful not to let the normal machine and problem machine contact each other. This prevents sparks from generating near the battery which could ignite the hydrogen gas given off by the battery. If hydrogen gas explodes, it could cause serious injury.
- Make sure that there is no mistake in the booster cable connections. The final connection is to the engine block of the problem machine, but sparks will be generated when this is done, so connect to a place as far as possible from the battery.
- Use care when removing the cables from the machine that has been started. Do not allow the cable ends to contact each other or the machine, to avoid hydrogen explosion.

INCORRECT

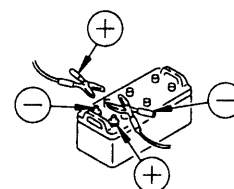

AE063650

NOTICE

- The size of the booster cable and clip should be suitable for the battery size.
- The battery of the normal machine must be the same capacity as that of the engine to be started.
- Check the cables and clips for damage or corrosion.
- Make sure that the cables and clips are firmly connected.

The batteries are on both sides at the rear of the machine. The battery used for the ground is on the left side of the machine.

CONNECTING THE BOOSTER CABLES

Keep the starting switch at the OFF position.

Connect the booster cable as follows, in the order of the numbers marked in the diagram.

1. Make sure that the starting switches of the normal machine and problem machine are both at the OFF position.
2. Connect one clip of booster cable (A) to the positive (+) terminal of the problem machine.
3. Connect the other clip of booster cable (A) to the positive (+) terminal of the normal machine.
4. Connect one clip of booster cable (B) to the negative (-) terminal of the normal machine.
5. Connect the other clip of booster cable (B) to the engine block of the problem machine.

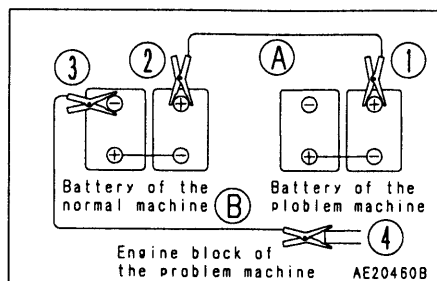
**STARTING THE ENGINE**

1. Make sure the clips are firmly connected to the battery terminals.
2. Turn the starting switch of the problem machine to the START position and start the engine. If the engine doesn't start at first, wait for at least 2 minutes before trying again.

DISCONNECTING THE BOOSTER CABLES

After the engine has started, disconnect the booster cables in the reverse of the order in which they were connected.

1. Remove one clip of booster cable (B) from the engine block of the problem machine.
2. Remove the other clip of booster cable (B) from the negative (-) terminal of the normal machine.
3. Remove one clip of booster cable (A) from the positive (+) terminal of the normal machine.
4. Remove the other clip of booster cable (A) from the positive (+) terminal of the problem machine.

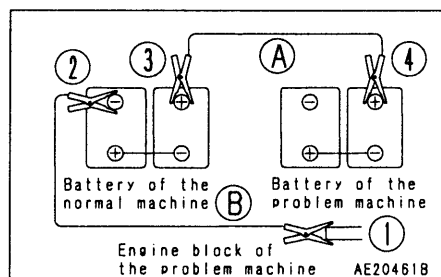

16.4 OTHER TROUBLE

16.4.1 ELECTRICAL SYSTEM

- (): Always contact your Komatsu distributor when dealing with these items.
- In cases of abnormalities or causes which are not listed below, please contact your Komatsu distributor for repairs.

Problem	Main causes	Remedy
Lamp does not glow brightly even when the engine runs at high speed	<ul style="list-style-type: none"> ● Defective wiring ● Defective adjustment of fan belt tension 	<ul style="list-style-type: none"> ● Check, repair loose terminals, disconnections ● Adjust fan belt tension For details, see EVERY 250 HOURS SERVICE
Lamp flickers while engine is running		
Even when the engine is rotating, the charge caution pilot lamp does not go out	<ul style="list-style-type: none"> ● Defective alternator ● Defective wiring ● Defective adjustment of belt tension 	<ul style="list-style-type: none"> ● Replace ● Check, repair ● Adjust fan belt tension. See EVERY 250 HOURS SERVICE
Abnormal noise is generated from alternator	<ul style="list-style-type: none"> ● Defective alternator 	<ul style="list-style-type: none"> ● Replace
Starting motor does not turn when starting switch is turned to ON	<ul style="list-style-type: none"> ● Defective wiring ● Insufficient battery charge 	<ul style="list-style-type: none"> ● Check, repair ● Charge
Pinion of starting motor keeps going in and out	<ul style="list-style-type: none"> ● Insufficient battery charge 	<ul style="list-style-type: none"> ● Charge
Starting motor turns engine sluggishly	<ul style="list-style-type: none"> ● Insufficient battery charge ● Defective starting motor 	<ul style="list-style-type: none"> ● Charge ● Replace
Starting motor disengages before engine starts	<ul style="list-style-type: none"> ● Defective wiring ● Insufficient battery charge 	<ul style="list-style-type: none"> ● Check, repair ● Charge
Preheating pilot lamp does not light up	<ul style="list-style-type: none"> ● Defective wiring ● Defective glow relay, glow controller, water temperature sensor ● Defective preheating pilot lamp 	<ul style="list-style-type: none"> ● Check, repair ● Replace ● Replace
Even when engine is stopped, charge caution pilot lamp does not light up (starting switch at ON position)	<ul style="list-style-type: none"> ● Defective wiring ● Defective monitor 	<ul style="list-style-type: none"> ● Check, repair ● Replace

16.4.2 CHASSIS

- (): Always contact your Komatsu distributor when dealing with these items.
- In cases of abnormalities or causes which are not listed below, please contact your Komatsu distributor for repairs.

Problem	Main causes	Remedy
Transmission		
Engine is running but machine does not move	<ul style="list-style-type: none"> ● Parking brake is applied ● Directional lever is not shifted properly ● Lack of oil in transmission case 	<ul style="list-style-type: none"> ● Release parking brake ● Shift lever properly ● Add oil to specified level. See WHEN REQUIRED
Even when engine is run at full throttle, machine only move slowly and lacks power	<ul style="list-style-type: none"> ● Lack of oil in transmission case ● Screen is clogged 	<ul style="list-style-type: none"> ● Add oil to specified level. See WHEN REQUIRED (● Disassemble, clean)
Oil overheats	<ul style="list-style-type: none"> ● Too much oil or too little oil ● Machine is not traveling in correct speed range ● Torque converter is stalled for long periods ● Engine is overheating 	<ul style="list-style-type: none"> ● Add or drain oil to specified level. See WHEN REQUIRED ● Place in correct speed range ● Reduce stall time (● Check engine)
Noise generated	<ul style="list-style-type: none"> ● Lack of oil 	<ul style="list-style-type: none"> ● Add oil to specified level. See WHEN REQUIRED
Axle		
Noise generated	<ul style="list-style-type: none"> ● Lack of oil 	<ul style="list-style-type: none"> ● Add oil to specified level. See WHEN REQUIRED

CHASSIS continued (16.4.2)

Problem	Main causes	Remedy
Brake		
Brake is not applied when pedal is depressed	<ul style="list-style-type: none"> ● Disc has reached wear limit ● Defective hydraulic system <ul style="list-style-type: none"> ○ Lack of oil ● Air in brake line 	<ul style="list-style-type: none"> (● Replace disc) ○ Add oil to specified level. See EVERY 100 HOURS SERVICE ● Bleed air See WHEN REQUIRED
Brake drags or remains applied	<ul style="list-style-type: none"> ● Vent hole of brake valve is clogged 	<ul style="list-style-type: none"> ● Clean
Brakes squeal	<ul style="list-style-type: none"> ● Disc is worn ● Large amount of water in axle oil ● Deteriorated axle oil due to overuse of brake 	<ul style="list-style-type: none"> (● Replace disc) ● Change axle oil ● Change axle oil
Parking brake		
Braking effect is poor	<ul style="list-style-type: none"> ● Disc is worn 	<ul style="list-style-type: none"> (● Replace disc)
Brake drags or remains applied	<ul style="list-style-type: none"> ● Lack of oil in transmission case ● Screen is clogged 	<ul style="list-style-type: none"> ● Add oil to specified level. See WHEN REQUIRED (● Disassemble and clean)
Steering		
Steering wheel is heavy	<ul style="list-style-type: none"> ● Defective hydraulic system <ul style="list-style-type: none"> ○ Lack of oil 	<ul style="list-style-type: none"> ○ Add oil to specified level. See EVERY 100 HOURS SERVICE
Steering wheel is loose	<ul style="list-style-type: none"> ● Play in steering cylinder pin ● Defective hydraulic system <ul style="list-style-type: none"> ○ Lack of oil 	<ul style="list-style-type: none"> ● Grease bearing or replace pin and bushing where there is play ○ Add oil to specified level. See EVERY 100 HOURS SERVICE

CHASSIS continued (16.4.2)

Problem	Main causes	Remedy
Hydraulic system		
Lack of lifting power for bucket Bucket takes time to rise	<ul style="list-style-type: none"> ● Lack of oil ● Clogged hydraulic tank filter 	<ul style="list-style-type: none"> ● Add oil to specified level. See EVERY 100 HOURS SERVICE ● Replace filter. See EVERY 2000 HOURS SERVICE
Excessive bubbles in oil	<ul style="list-style-type: none"> ● Low quality oil being used ● Oil level is low ● Air in oil line 	<ul style="list-style-type: none"> ● Replace with good quality oil ● Add oil to specified level. See EVERY 100 HOURS SERVICE ● Bleed air. See EVERY 2000 HOURS SERVICE
Hydraulic pressure is low	<ul style="list-style-type: none"> ● Oil level is low and pump is sucking in air 	<ul style="list-style-type: none"> ● Add oil to specified level. See EVERY 100 HOURS SERVICE Then bleed air. See EVERY 2000 HOURS SERVICE
Movement of cylinder is irregular	<ul style="list-style-type: none"> ● Oil level is low 	<ul style="list-style-type: none"> ● Add oil to specified level. See EVERY 100 HOURS SERVICE

16.4.3 ENGINE

- (): Always contact your Komatsu distributor when dealing with these items.
- In cases of abnormalities or causes which are not listed below, please contact your Komatsu distributor for repairs.

Problem	Main causes	Remedy
Engine oil pressure caution pilot lamp lights up	<ul style="list-style-type: none"> ● Engine oil pan oil level is low (sucking in air) ● Clogged oil filter cartridge ● Defective tightening of oil pipe joint, oil leakage from damaged part ● Defective engine oil pressure sensor 	<ul style="list-style-type: none"> ● Add oil to specified level, see CHECK BEFORE STARTING ● Replace cartridge, see EVERY 250 HOURS SERVICE (● Check, repair) (● Replace sensor)
Steam is emitted from top part of radiator (pressure valve) Water temperature gauge is in red range Coolant temperature monitor lights up	<ul style="list-style-type: none"> ● Cooling water level low, water leakage ● Loosen fan belt ● Dirt or scale accumulated in cooling system ● Clogged radiator fin or damaged fin ● Defective thermostat ● Loose radiator filler cap (high altitude operation) ● Defective water level sensor 	<ul style="list-style-type: none"> ● Add cooling water, repair, see CHECK BEFORE STARTING ● Adjust fan belt tension, see EVERY 250 HOURS SERVICE ● Change cooling water, clean inside of cooling system, see WHEN REQUIRED ● Clean or repair, see WHEN REQUIRED (● Replace thermostat) ● Tighten cap or replace packing (● Replace sensor)
Water temperature gauge is in white range on left	<ul style="list-style-type: none"> ● Defective thermostat ● Defective monitor 	<ul style="list-style-type: none"> (● Replace thermostat) (● Replace)
Engine does not start when starting motor is turned	<ul style="list-style-type: none"> ● Lack of fuel ● Air in fuel system ● Defective fuel injection pump or nozzle ● Starting motor cranks engine sluggishly ● Preheating pilot lamp does not light up ● Defective compression <ul style="list-style-type: none"> ○ Defective valve clearance 	<ul style="list-style-type: none"> ● Add fuel, see CHECK BEFORE STARTING ● Repair place where air is sucked in, see EVERY 500 HOURS SERVICE (● Replace pump or nozzle) — See ELECTRICAL SYSTEM (○ Adjust valve clearance)
Exhaust gas is white or blue	<ul style="list-style-type: none"> ● Too much oil in oil pan ● Improper fuel 	<ul style="list-style-type: none"> ● Add oil to specified level, see CHECK BEFORE STARTING ● Change to specified fuel

ENGINE continued (16.4.3)

Problem	Main causes	Remedy
Exhaust gas occasionally turns black	<ul style="list-style-type: none"> ● Clogged air cleaner element black ● Defective nozzle ● Defective compression ● Defective turbocharger 	<ul style="list-style-type: none"> ● Clean or replace, see WHEN REQUIRED (● Replace nozzle) (● See defective compression above) (● Clean or replace turbocharger)
Combustion noise occasionally makes breathing sound	<ul style="list-style-type: none"> ● Defective nozzle 	<ul style="list-style-type: none"> (● Replace nozzle)
Abnormal noise generated (combustion or mechanical)	<ul style="list-style-type: none"> ● Low grade fuel being used ● Overheating ● Damage inside muffler ● Excessive valve clearance 	<ul style="list-style-type: none"> ● Change to specified fuel ● Refer to "Water temperature gauge is in red range" as above (● Replace muffler) (● Adjust valve clearance)

16.4.4 RELATIONSHIP OF ELECTRONIC CONTROL SYSTEM

If an error code is displayed on the main monitor portion (normally the speedometer display) of the machine monitor, follow the corresponding table when carrying out the selfdiagnostic troubleshooting below.

MAIN MONITOR FAILURE DISPLAY

Error code	Trouble mode	Action by operator
------------	--------------	--------------------

Transmission control system (if equipped)

E00	Error of travel speed sensor	Auto shifting cannot be used but manual shifting is possible. Although normal work is possible, have machine inspected immediately.	
E01 + CALL	Error of HL solenoid and speed solenoid	Gear speed is fixed to 1st or 3rd and alarm buzzer sounds. Since machine can travel by itself, however, park it in a safe place, then have it inspected immediately.	
E03 + CALL	Error of gear shift lever	Since outputs of F and R solenoids are turned OFF, alarm buzzer sounds and transmission is set to neutral position.	Machine can travel by itself if emergency spool is operated and modulation solenoid is operated by hand. Park machine in a safe place, then have it inspected immediately.
	Error of F and R solenoids	Since outputs of F, R and modulation solenoids are turned OFF, alarm buzzer sounds and transmission is set to neutral position.	
	Error of modulation solenoid		
CALL	Short circuit of return harness of modulation solenoid	Since outputs of F, R and modulation solenoids are turned OFF, alarm buzzer sounds and transmission is set to neutral position. Since controller may have burnt, stop machine immediately and turn off power, then have it inspected without delay.	

Work equipment control system (if equipped)

E01 + CALL	Short circuit of damping solenoid (+) power source 24V	Boom movement becomes slow, alarm buzzer sounds, but it is still possible to travel under own power, so move machine to safe place, then have it inspected without delay.	
CALL	Short circuit in power source of damping solenoid return wiring harness	Remote positioner function stops and alarm buzzer sounds. Since controller may have burnt out, stop machine immediately and turn off power, then have it inspected without delay.	
	Short circuit in power source of bucket (tilt, dump) solenoid return wiring harness	Auto leveling function stops and alarm buzzer sounds. Bucket moves, but since controller may have burnt out, stop machine immediately and turn off power, then have it inspected without delay.	

MAINTENANCE

17. GUIDES TO MAINTENANCE

Do not carry out any inspection and maintenance operation that is not given in this manual.

Perform maintenance work on hard, flat ground.

Set to the inspection and maintenance posture.

Always carry out operations with the machine in the following posture unless otherwise specified.

- Lower the work equipment to the ground and set in the posture shown in the diagram on the right.
- Set all control levers to the neutral or HOLD position.
- Set the safety lever to the LOCK position.
- Press the parking brake switch to apply the parking brake.
- Put blocks in front and behind the tires.
- Lock the front and rear frames with the safety bar.

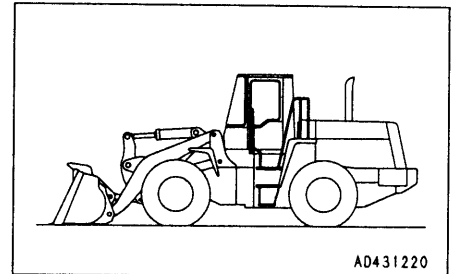

Check service meter:

Check the service meter reading every day to see if the time has come for any necessary maintenance to be carried out.

Komatsu genuine replacement parts:

Use Komatsu genuine parts specified in the Parts Book as replacement parts.

Komatsu genuine oils:

Use Komatsu genuine oils and grease. Choose oils and grease with proper viscosities specified for ambient temperature.

Always use clean washer fluid:

Use automobile window washer fluid and be careful not to let any dirt get into it.

Always use clean oil and grease:

Use clean oil and grease. Also, keep containers of the oil and grease clean. Keep foreign materials away from oil and grease.

Keeping the machine clean:

Always keep the machine clean. This makes it easier to find parts causing problems. In particular, keep grease fittings, breathers and oil level gauges clean and avoid foreign materials from getting in them.

Be careful of hot water and oil:

Draining hot oils and coolants and removing their filters immediately after the engine stops are hazardous. Allow the engine to cool.

If the oil has to be drained when it is cold, warm up the oil to a suitable temperature (approx. 20 – 40°C) before draining it.

Checking foreign materials in drained oil and on filters:

After oil is changed or filters are replaced, check the oil and filters for metallic particles and foreign materials. If large quantities of metallic particles or foreign materials are found, consult your Komatsu distributor.

Fuel strainer:

If your machine is equipped with a fuel strainer, do not remove it while fueling.

Oil change:

Check or change oils in the places where dust is scarce to keep foreign materials away from oils.

Warning tag:

Attach the warning tag to the starting switch or other appropriate control lever to prevent anyone from starting the engine during maintenance.

The warning tag is supplied together with the tools.

Obey precautions:

During the operation, always obey the precautions on the safety label attached to the machine.

Welding instructions:

- Turn off the engine starting switch.
- Do not apply more than 200 V continuously.
- Connect grounding the cable within 1 m (3 ft 3 in) from the area to be welded.
- Avoid seals or bearings from being between the area to be welded and the position of the grounding point.
- Never weld any pipe or tube containing fuel or oil.

Fire prevention:

Use nonflammable cleaner or light oil for cleaning parts. Keep flame or cigarette light away from light oil.

Clamp faces:

When O-rings or gaskets are removed, clean the clamp faces and replace the O-rings and gaskets with new ones. Be sure to fit O-rings and gaskets when assembling.

Objects in your pockets:

Keep your pockets free of loose objects which can fall out and drop into the machinery; especially when you work on the machinery while bending over it.

Checking undercarriage:

When working in rocky areas, check for damage to the undercarriage and for looseness, flaws, wear and damage in bolts and nuts.

Precautions when washing machine:

- Never spray steam or water directly at the radiator.
- Do not allow water to get on any electrical component.

Pre-and post-work checks:

Before starting work in mud, rain, snow or at the seashore, check plugs and valves for tightness.

Wash the machine immediately after the work to protect components from rusting.

Lubricate components more frequently than usual. Be sure to lubricate work equipment pins daily if they are submerged in water.

On jobsites where heavy-duty operations are common, reduce the maintenance intervals and carry out greasing more frequently.

Dusty worksites:

When working at dusty worksites, do as follows:

- Inspect the air cleaner clogging portion pilot lamp to see whether the air cleaner is blocked up. Clean the air cleaner at shorter intervals than specified.
- Clean the radiator core frequently to avoid clogging.
- Clean and replace the fuel filter frequently.
- Clean electrical components, especially the starting motor and alternator, to avoid accumulation of dust.

Avoid mixing oils:

Never mix oils of different brands. If you have only oil which is a different brand from the one that is used in the machine, do not add it but replace all the oil.

18. OUTLINES OF SERVICE

- Use Komatsu genuine parts for replacement.
- When changing or adding oil, do not use a different type of oil.
- Unless otherwise specified, the oil and coolant used at the time of shipment from the factory are as shown in the table below.

Item	Kind of fluid
Engine oil pan	SAE 10W-30, 15W-40 API classification CD
Transmission case	SAE 10W API classification CD
Axle (Front and rear)	AXO75
Hydraulic tank	SAE 10W API classification CD
Pins	Lithium base grease No. 2
Fuel	ASTM D975 No. 2 (However, ASTM D975 No. 1 is used for the winter season (October to March))
Radiator	Komatsu Super Coolant (AF-ACL) above 30% added to water

18.1 OUTLINE OF OIL, FUEL, COOLANT

18.1.1 OIL

- Oil is used in the engine and work equipment under extremely severe conditions (high temperature, high pressure), and it deteriorates with use.
Always use oil that matches the grade and temperature for use given in the Operation and Maintenance Manual. Even if the oil is not dirty, always replace the oil after the specified interval.
- Oil corresponds to blood in the human body, so always be careful when handling it to prevent any impurities (water, metal particles, dirt, etc.) from getting in.
The majority of problems with machine are caused by the entry of such impurities.
Take particular care not to let any impurities get in when storing or adding oil.
- Never mix oils of different grades or brands.
- Always add the specified amount of oil.
Having too much oil or too little oil are both causes of problems.
- If the oil in the work equipment is not clear, there is probably water or air getting into the circuit.
In such cases, please contact your Komatsu distributor.
- When changing the oil, always replace the related filters at the same time.
- We recommend you to have an analysis made of the oil periodically to check the condition of the machine. For those who wish to use this service, please contact your Komatsu distributor.

18.1.2 FUEL

- The fuel pump is a precision instrument, and if fuel containing water or dirt is used, it cannot work properly.
- Be extremely careful not to let impurities get in when storing or adding fuel.
- Always use the fuel specified in the Operation and Maintenance Manual.
Fuel may congeal depending on the temperature when it is used (particularly in low temperature below -15°C), so it is necessary to change to a fuel that matches the temperature.
- To prevent the moisture in the air from condensing and forming water inside the fuel tank, always fill the fuel tank after completing the day's work.
- Before starting the engine, or when 10 minutes have passed after adding fuel, drain the sediment and water from the fuel tank.
- If the engine runs out of fuel, or if the filters have been replaced, it is necessary to bleed the air from the circuit.

18.1.3 COOLANT

- River water contains large amounts of calcium and other impurities, so if it is used, scale will stick to the engine and radiator, and this will cause defective heat exchange and overheating.
Do not use water that is not suitable for drinking.
- When using anti-freeze, always observe the precautions given in the Operation and Maintenance Manual.
- Komatsu machines are supplied with Komatsu original anti-freeze in the coolant when the machine is shipped.
This anti-freeze is effective in preventing corrosion of the cooling system.
The anti-freeze can be used continuously for two years or 4000 hours. Therefore, it can be used as it is even in hot areas.
- Anti-freeze is flammable, so be extremely careful not to expose it to flame or fire.
- The proportion of anti-freeze to water differs according to the ambient temperature.
For details of the mixing proportions, see "24.2.2 CLEAN INSIDE OF COOLING SYSTEM".
- If the engine overheats, wait for the engine to cool before adding coolant.
- If the coolant level is low, it will cause overheating and will also cause problems with corrosion from the air in the coolant.

18.1.4 GREASE

- Grease is used to prevent twisting and noise at the joints.
- The nipples not included in the maintenance section are nipples for overhaul, so they do not need grease.
If any part becomes stiff after being used for long time, add grease.
- Always wipe off all of the old grease that is pushed out when greasing. Be particularly careful to wipe off the old grease in places where sand or dirt sticking in the grease would cause wear of the rotating parts.

18.1.5 STORING OIL AND FUEL

- Keep indoors to prevent any water, dirt, or other impurities from getting in.
- When keeping drum cans for a long period, put the drum on its side so that the filler port of the drum can is at the side. (To prevent moisture from being sucked in)
If drum cans have to be stored outside, cover them with a waterproof sheet or take other measures to protect them.
- To prevent any change in quality during long-term storage, be sure to use in the order of first in - first out (use the oldest oil or fuel first).

18.1.6 FILTERS

- Filters are extremely important safety parts. They prevent impurities in the fuel and air circuits from entering important equipment and causing problems.
Replace all filters periodically. For details, see the Operation and Maintenance Manual.
However, when working in severe conditions, it is necessary to consider replacing the filters at shorter intervals according to the oil and fuel (sulfur content) being used.
- Never try to clean the filters (cartridge type) and use them again. Always replace with new filters.
- When replacing oil filters, check if any metal particles are stuck to the old filter. If any metal particles are found, please contact your Komatsu distributor.
- Do not open packs of spare filters until just before they are to be used.
- Always use Komatsu genuine filters.

18.2 OUTLINE OF ELECTRIC SYSTEM

- If the wiring gets wet or the insulation is damaged, the electric system leaks and this could result in hazardous malfunction of the machine.
- Services relating to the electric system are (1) check of fan belt tension, (2) check of damage or wear in the fan belt and (3) check of battery fluid level.
- Never remove or disassemble any electric components installed in the machine.
- Never install any electric components other than those specified by Komatsu.
- Be careful to keep the electric system free of water when washing the machine or when it rains.
- When working on the seashore, carefully clean the electric system to prevent corrosion.
- The optional power source must never be connected to the fuse, starting switch, or battery relay.

19. WEAR PARTS LIST

Wear parts such as the filter element, air cleaner element, bolt on edge, etc. are to be replaced at the time of periodic maintenance or before their abrasion limits.

The wear parts should be changed correctly in order to use the machine economically.

For part change, Komatsu genuine parts of excellent quality should be used.

When ordering parts, please check the part number in the parts book.

The parts in parentheses are to be replaced at the same time.

Item	Part No.	Part Name	Q'ty	Replacement frequency
Engine oil filter	6136-51-5121	Cartridge	1	EVERY 250 HOURS
Fuel filter	600-311-8292	Cartridge	1	EVERY 500 HOURS
Transmission oil filter	714-07-28710	Cartridge	1	EVERY 1000 HOURS
Transmission strainer	07000-15085	O-ring	1	EVERY 1000 HOURS
Corrosion resistor	600-411-1190	Cartridge	1	EVERY 1000 HOURS
Hydraulic filter	07063-01142 (07000-15175)	Element (O-ring)	2 (2)	EVERY 2000 HOURS
Hydraulic tank breather	285-62-17320	Element	1	EVERY 2000 HOURS
Air cleaner	600-182-3300 600-181-1660	Element ass'y Outer element ass'y	1 1	-
Air conditioner air filter	421-07-12312	Element	2	-
Bolt on edge	424-815-1111 421-815-1121 (02090-11485) (02290-11422) (01643-32260)	Center edge Side edge (Bolt) (Nut) (Washer)	1 2 (16) (16) (16)	-

20.USE OF FUEL, COOLANT AND LUBRICANTS ACCORDING TO AMBIENT TEMPERATURE

PROPER SELECTION OF FUEL, COOLANT AND LUBRICANTS

RESERVOIR	KIND OF FLUID	AMBIENT TEMPERATURE										CAPACITY	
		-22 -30	-4 -20	14 -10	32 0	50 10	68 20	86 30	104 40	122°F 50°C	Specified	Refill	
Engine oil pan		SAE 30										31 ℓ 8.18 US gal 6.82 UK gal	28 ℓ 7.39 US gal 6.16 UK gal
		SAE 10W											
		SAE 10W-30											
		SAE 15W-40											
Transmission case	Engine oil	SAE 10W										65 ℓ 17.16 US gal 14.30 UK gal	60 ℓ 15.84 US gal 13.20 UK gal
Hydraulic system		SAE 10W										210 ℓ 55.44 US gal 46.2 UK gal	138 ℓ 36.43 US gal 30.36 UK gal
Axle (with standard differential) (Front and rear) (Each)		See Note 1										60 ℓ 15.84 US gal 13.20 UK gal	60 ℓ 15.84 US gal 13.20 UK gal
Pins	Grease	NLGI No. 2										-	-
Pins (with auto-greasing system)		★	NLGI No. 2										-
Fuel tank	Diesel fuel	ASTM D975 No.2										340 ℓ 89.76 US gal 74.80 UK gal	-
		※											
Cooling system	Water	Add antifreeze										53 ℓ 13.99 US gal 11.66 UK gal	-

※ ASTM D975 No. 1

When operating the machine at temperatures below -20°C, other equipment is needed, so please consult your Komatsu distributor.

★: NLGI No. 0

When operating a machine with the auto-greasing system at temperatures below -20°C, set the greasing time to 20 minutes. See "31.1.3 METHOD OF SETTING."

Note 1:

For axle oil, use only recommended oil as follows.

SHELL: DONAX TT or TD

CALTEX: RPM TRACTOR HYDRAULIC FLUID

CHEVRON: TRACTOR HYDRAULIC FLUID

TEXACO: TDH OIL

MOBIL: MOBILAND SUPER UNIVERSAL

It is possible to substitute engine oil CLASS-CD SAE30 for axle oil.

If noise comes from the brake, it is no problem of durability.

REMARK

- When fuel sulphur content is less than 0.5%, change oil in the oil pan every periodic maintenance hours described in this manual.
Change oil according to the following table if fuel sulphur content is above 0.5%.

Fuel sulphur content	Change interval of oil in engine oil pan
0.5 to 1.0%	1/2 of regular interval
Above 1.0%	1/4 of regular interval

- When starting the engine in an atmospheric temperature of lower than 0°C, be sure to use engine oil of SAE10W, SAE10W-30 and SAE15W-40, even though an atmospheric temperature goes up to 10°C more or less in the day time.
- Use API classification CD as engine oil and if API classification CC, reduce the engine oil change interval to half.
- There is no problem if single grade oil is mixed with multigrade oil (SAE10W-30, 15W-40), but be sure to add single grade oil that matches the temperature in the table.
- We recommend Komatsu genuine oil which has been specifically formulated and approved for use in engine and hydraulic work equipment applications.

Specified capacity: Total amount of oil including oil for components and oil in piping.

Refill capacity: Amount of oil needed to refill system during normal inspection and maintenance.

ASTM: American Society of Testing and Material

SAE: Society of Automotive Engineers

API: American Petroleum Institute

20. USE OF FUEL, COOLANT AND LUBRICANTS ACCORDING TO AMBIENT TEMPERATURE

No.	Supplier	Engine Oil [CD or CE] SAE10W, 30, 40 10W30, 15W40 (The 15W40 oil marked * is CE.)	Gear Oil [GL-4 or GL-5] SAE80, 90, 140	Grease [Lithium-Base] NLGI No. 2	Anti-freeze Coolant [Ethylene Glycol Base] Permanent Type
1	KOMATSU	EO10-CD EO30-CD EO10-30CD EO15-40CD	GO90 GO140	G2-LI G2-LI-S	AF-ACL AF-PTL AF-PT (Winter, one season type)
2	AGIP	Diesel sigma S Super dieselmulti- grade *Sigma turbo	Rotra MP	GR MU/EP	-
3	AMOCO	*Amoco 300	Multi-purpose gear oil	RYKON premium grease	-
4	ARCO	*Arcofleet S3 plus	Arco HD gear oil	Litholine HEP 2 Arco EP moly D	-
5	BP	Vanellus C3	Gear oil EP Hypogear EP	Energrease LS-EP2	Antifreeze
6	CALTEX	*RPM delo 400 RPM delo 450	Universal thuban Universal thuban EP	Marfak all purpose 2 Ultra-duty grease 2	AF engine coolant
7	CASTROL	*Turbomax *RX super CRD	EP EPX Hypoy Hypoy B Hypoy C	MS3 Spheerol EPL2	Anti-freeze
8	CHEVRON	*Delo 400	Universal gear	Ultra-duty grease 2	-
9	CONOCO	*Fleet motor oil	Universal gear lubricant	Super-sta grease	-
10	ELF	Multiperformance 3C Performance 3C	-	Tranself EP Tranself EP type 2	Glacelf
11	EXXON (ESSO)	Essolube D3 *Essolube XD-3 *Essolube XD-3 Extra *Esso heavy duty Exxon heavy duty	Gear oil GP Gear oil GX	Beacon EP2	All season coolant
12	GULF	Super duty motor oil *Super duty plus	Multi-purpose gear lubricant	Gulfcrown EP2 Gulfcrown EP special	Antifreeze and coolant
13	MOBIL	Delvac 1300 *Delvac super 10W-30, 15W-40	Mobilube GX Mobilube HD	Mobilux EP2 Mobilgrease 77 Mobilgrease special	-

20. USE OF FUEL, COOLANT AND LUBRICANTS ACCORDING TO AMBIENT TEMPERATURE

No.	Supplier	Engine Oil [CD or CE] SAE10W, 30, 40 10W30, 15W40 (The 15W40 oil marked * is CE.)	Gear Oil [GL-4 or GL-5] SAE80, 90, 140	Grease [Lithium-Base] NLGI No. 2	Anti-freeze Coolant [Ethylene Glycol Base] Permanent Type
14	PENNZOIL	*Supreme duty fleet motor oil	Multi-purpose 4092 Multi-purpose 4140	Multi-purpose white grease 705 707L White – bearing grease	Anti-freeze and summer coolant
15	PETROFINA	FINA kappa TD	FINA potonic N FINA potonic NE	FINA marson EPL2	FINA tamidor
16	SHELL	Rimula X	Spirax EP Spirax heavy duty	Alvania EP grease	-
17	SUN	-	Sunoco GL5 gear oil	Sunoco ultra prestige 2EP Sun prestige 742	Sunoco antifreeze and summer coolant
18	TEXACO	*Ursa super plus Ursa premium	Multigear	Multifak EP2 Starplex 2	Code 2055 startex antifreeze coolant
19	TOTAL	Rubia S *Rubia X	Total EP Total transmission TM	Multis EP2	Antigel/antifreeze
20	UNION	*Guardol	MP gear lube LS	Unoba EP	-
21	VEEDOL	*Turbostar *Diesel star MDC	Multigear Multigear B Multigear C	-	Antifreeze

21. STANDARD TIGHTENING TORQUES FOR BOLTS AND NUTS

21.1 INTRODUCTION OF NECESSARY TOOLS

The following tools are provided with the machine.

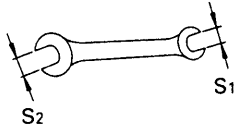
No.	Name of tool	Part No.	Remarks
1	Wrench set	09000-30006	Applicable width across flats (S_1 - S_2) 8mm – 10mm, 12mm – 14mm 13mm – 17mm 19mm – 22mm 24mm – 27mm 30mm – 32mm
			 <small>AD053370</small>
2	Socket wrench set	09020-10284	
3	Screwdriver	09033-00190	Crosshead/flat head interchangeable type
4	Wrench	09014-10200	
5	Pliers	09036-00150	
6	Wrench	09001-03600	36 jaw
7	Filter wrench	09019-08035	For filter cartridge
8	Bar	424-98-11130	
9	Tire gauge	09289-00000	
10	Grease pump	07952-70004	For greasing work
11	Nozzle	07951-31400	Hose nozzle for grease pump
12	Grease cartridge	07950-90403	(Lithium base grease: 400 g)
13	Gauge, thickness	09054-00009	
14	Hammer	09039-00150	
15	Plate	09963-03000	Warning tag

If any of the above tools are broken, please order them from your Komatsu distributor.

21.2 TORQUE LIST

Unless otherwise specified, tighten the metric bolts and nuts to the torque shown in the table.

The tightening torque is determined by the width across the flats ⓑ of the nut and bolt.

If it is necessary to replace any nut or bolt, always use a Komatsu genuine part of the same size as the part that was replaced.

Nm (newton meter): $1\text{N}\cdot\text{m} \approx 0.1 \text{ kgf}\cdot\text{m}$
 $\approx 0.74 \text{ lbft}$

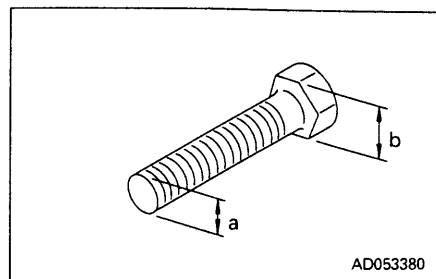

Thread diameter of bolt (mm) (a)	Width across flat (mm) (b)	AD054300		
		N·m	kgf·m	lbft
6	10	13.2 ± 1.4	1.35 ± 0.15	9.73 ± 1.03
8	13	31.4 ± 2.9	3.2 ± 0.3	23.2 ± 2.1
10	17	65.7 ± 6.8	6.7 ± 0.7	48.5 ± 5.0
12	19	112 ± 9.8	11.5 ± 1.0	82.6 ± 7.2
14	22	177 ± 19	18.0 ± 2.0	131 ± 14
16	24	279 ± 29	28.5 ± 3	206 ± 21
18	27	383 ± 39	39 ± 3	282 ± 29
20	30	549 ± 58	56 ± 6	405 ± 43
22	32	745 ± 78	76 ± 8	549 ± 58
24	36	927 ± 98	94.5 ± 10	684 ± 72
27	41	1320 ± 140	135 ± 15	973 ± 100
30	46	1720 ± 190	175 ± 20	1270 ± 140
33	50	2210 ± 240	225 ± 25	1630 ± 180
36	55	2750 ± 290	280 ± 30	2030 ± 210
39	60	3280 ± 340	335 ± 35	2420 ± 250

NOTICE

When tightening panels or other parts having tightening fixtures made of plastic, be careful not to use excessive tightening torque: doing so will damage the plastic parts.

22. PERIODIC REPLACEMENT OF SAFETY CRITICAL PARTS

To ensure safety at all times when operating or driving the machine, the user of the machine must always carry out periodic maintenance. In addition, to further improve safety, the user should also carry out periodic replacement of the parts given in the table. These parts are particularly closely connected to safety and fire prevention.

With these parts, the material changes as time passed, or they easily wear or deteriorate. However, it is difficult to judge the condition of the parts simply by periodic maintenance, so they should always be replaced after a fixed time has passed, regardless of their condition. This is necessary to ensure that they always maintain their function completely.

However, if these parts show any abnormality before the replacement interval has passed, they should be repaired or replaced immediately.

If the hose clamps show any deterioration, such as deformation or cracking, replace the clamps at the same as the hoses.

When replacing the hoses, always replace the O-rings, gaskets, and other such parts at the same time.

Ask your Komatsu distributor to replace the safety critical parts.

SAFETY CRITICAL PARTS

No.	Safety critical parts for periodic replacement	Q'ty	Replacement interval
1	Fuel hose (fuel tank - injection pump)	1	Every 2 years or every 4000 hours, whichever comes first
2	Fuel return hose (injection pump - fuel tank)	1	
3	Fuel return hose (injection nozzle - fuel tank)	1	
4	Fuel hose (injection pump - fuel filter)	1	
5	Fuel hose (fuel filter - injection pump)	1	
6	Fuel spill hose (between nozzle)	5	
7	Fuel spill hose cap	1	
8	Steering hose (pump - steering valve)	1	
9	Steering hose (steering valve - steering cylinder)	4	
10	Steering hose (steering valve - stop valve)	2	
11	Steering hose (orbitrol valve - stop valve)	2	
12	Steering hose (orbitrol valve - pump)	1	
13	Steering hose (orbitrol valve - joint to tank)	1	
14	Brake hose (pump - accumulator charge valve)	2	
15	Brake hose (accumulator charge valve - check valve)	1	
16	Brake hose (check valve - tandem valve)	2	
17	Brake hose (check valve - single valve)	1	
18	Brake hose (check valve - accumulator P.P port)	1	
19	Brake hose (tandem valve - front brake)	2	
20	Brake hose (tandem valve - rear brake)	2	
21	Brake hose (single valve - tandem valve)	1	
22	Brake hose (tandem valve - drain block)	1	
23	Brake hose (single valve - drain block)	1	
24	Brake hose (drain block - hydraulic tank)	1	
25	Brake hose (brake accumulator - reduction valve for emergency parking brake cancel)	1	
26	Brake hose (transmission valve - reduction valve)	1	
27	Brake hose (reduction valve - parking brake chamber)	1	
28	Brake hose (parking brake - reduction valve)	1	
29	Brake hose (reduction valve - charge valve drain)	1	
30	Brake hose (charge valve drain - hydraulic tank)	1	
31	Seat belt	1	Every 3 years

22. PERIODIC REPLACEMENT OF SAFETY CRITICAL PARTS

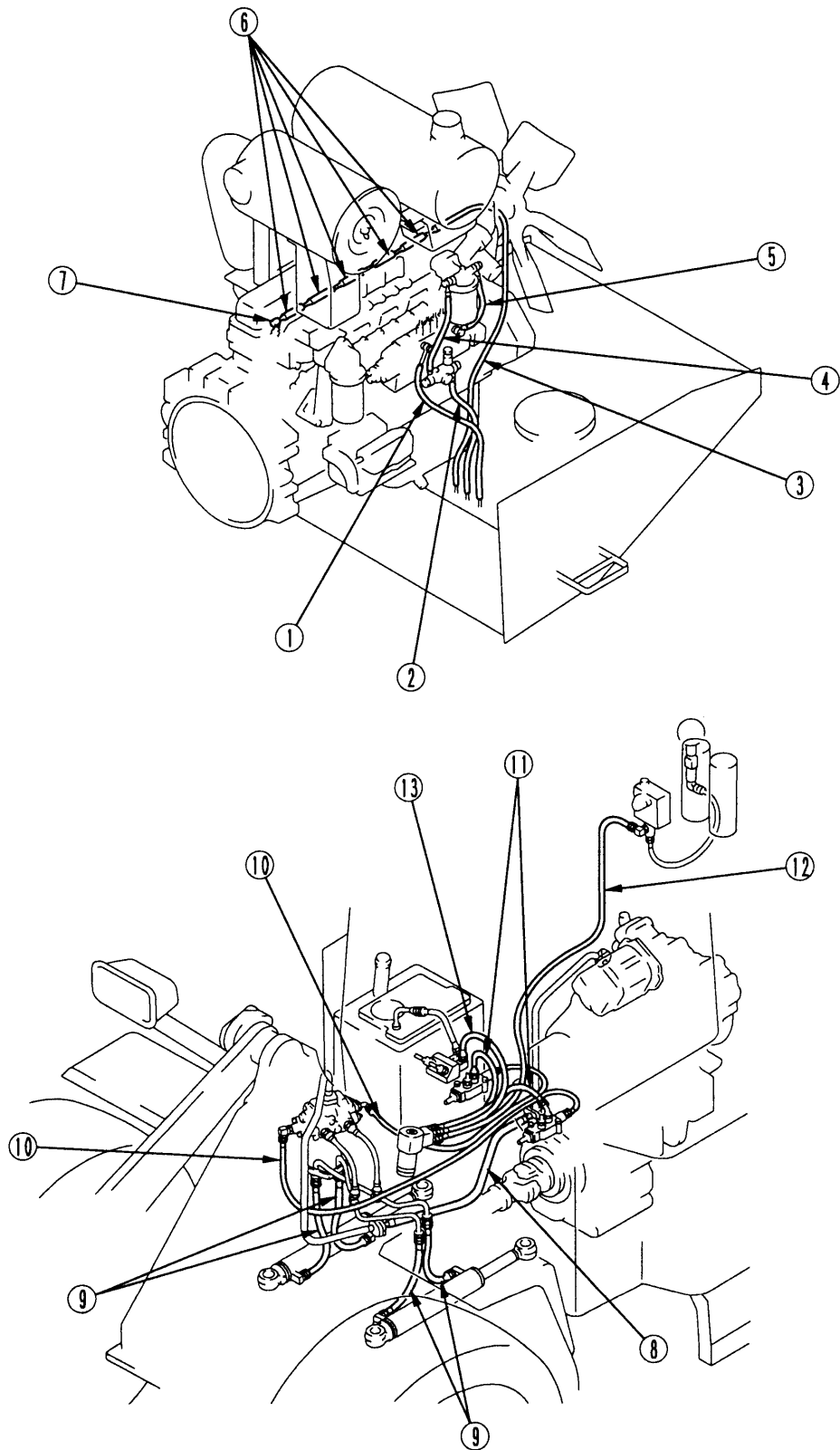

AE433600

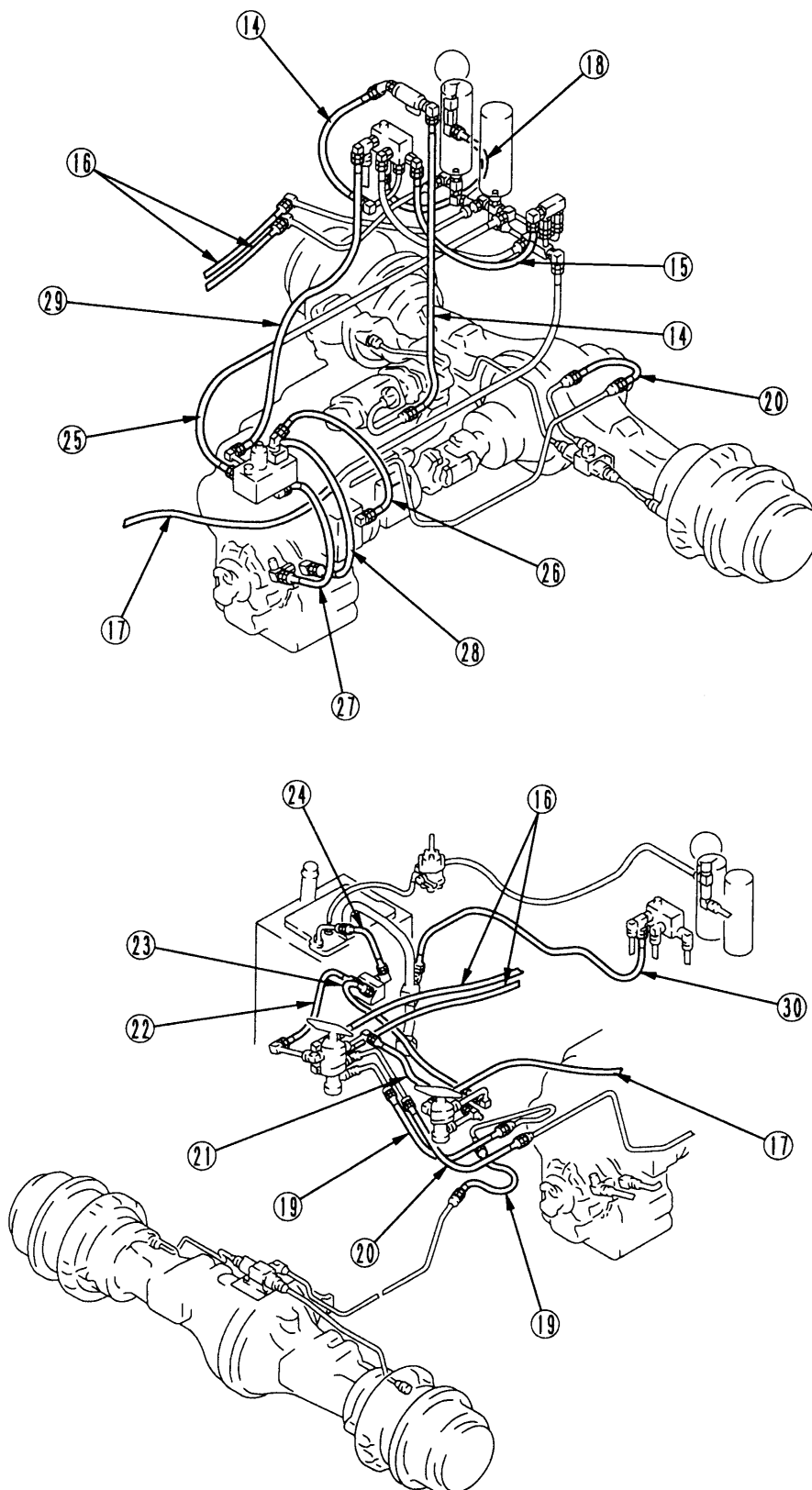

AE433610

23. MAINTENANCE SCHEDULE CHART

23.1 MAINTENANCE SCHEDULE CHART

SERVICE ITEM	PAGE
INITIAL 250 HOURS SERVICE (only after the first 250 hours)	
Replace fuel filter cartridge	3-24
Replace transmission oil filter cartridge	3-24
Replace hydraulic tank filter element	3-24
Check engine valve clearance, adjust	3-24
WHEN REQUIRED	
Check, clean, or replace air cleaner element	3-25
Clean inside of cooling system	3-27
Check transmission oil level, add oil	3-31
Check axle oil level, add oil	3-32
Clean axle case breather	3-32
Clean radiator fins	3-33
Replace bolt-on cutting edge	3-33
Replace bucket teeth	3-34
Check air conditioner	3-35
Clean condenser of air conditioner	3-36
Check window washing fluid level, add fluid	3-36
Lubricate work equipment control valve linkage (2 points)	3-36
Replace slow blow-fuse	3-37
Drain water from water separator	3-37
Selection and inspection of tires	3-38
CHECK BEFORE STARTING	
Check monitor panel	3-40
Check coolant level, add water	3-40
Check fuel level, add fuel	3-41
Check oil level in engine oil pan, add oil	3-42
Check electric wiring	3-43

SERVICE ITEM	PAGE
Check for water and sediment in water separator	3-43
Drain water from air tank (if equipped)	3-43
Check effect of parking brake	3-44
Check effect of brake	3-44
Check sound of horn and backup alarm	3-44
Check flashing of lamps, check for dirt or damage	3-44
Check engine exhaust color and sound	3-44
Check operation of gauges	3-44
Check play of steering wheel, check operation of steering	3-44
Check direction of rear view mirror, check for dirt or damage	3-44
Check of inflation pressure of tires	3-44
EVERY 50 HOURS SERVICE	
Drain water, sediment from fuel tank	3-45
EVERY 100 HOURS SERVICE	
Check oil level in hydraulic tank, add oil	3-46
Clean element in air conditioner fresh air filter	3-47
Lubricate rear axle pivot pin (3 points)	3-47
EVERY 250 HOURS SERVICE	
Change oil in engine oil pan, replace engine oil filter cartridge	3-48
Check tension of fan belt, alternator belt, adjust	3-50
Check for loose wheel hub nuts, tighten	3-51
Clean element in air conditioner recirculation filter	3-51
Check air conditioner compressor belt tension, adjust	3-52
Check battery electrolyte level	3-53
Check parking brake	3-53
Lubricating	3-54
● Bucket pin (2 points)	3-54
● Bucket link pin (2 points)	3-54

23. MAINTENANCE SCHEDULE CHART

SERVICE ITEM	PAGE
EVERY 250 HOURS SERVICE (continued)	
● Dump cylinder pin (2 points)	3-54
● Lift cylinder pin (4 points)	3-54
● Lift arm pivot pin (2 points)	3-54
● Tilt lever pin (1 point)	3-54
● Steering cylinder pin (4 points)	3-54
EVERY 500 HOURS SERVICE	
Replace fuel filter cartridge	3-55
Lubricate center drive shaft spline (1 point)	3-57
Check fan belt for wear	3-57
EVERY 1000 HOURS SERVICE	
Change oil in transmission case and transmission oil filter cartridge, clean strainer	3-58
Clean transmission case breather	3-59
Lubricating	3-60
● Center hinge pin (2 points)	3-60
● Front drive shaft (2 points)	3-60
● Drive shaft center support (1 point)	3-60
● Center drive shaft (2 points)	3-60
● Rear drive shaft (2 points)	3-61
● Engine stop motor linkage (1 point)	3-61
Check tightening parts of turbocharger	3-62
Check play of turbocharger rotor	3-62
Replace corrosion resistor cartridge	3-62
EVERY 2000 HOURS SERVICE	
Change oil in hydraulic tank, replace hydraulic filter element	3-63
Replace hydraulic tank breather element	3-65

SERVICE ITEM	PAGE
Change axle oil ★	3-66
Check brake disc wear	3-67
Check alternator, starting motor	3-67
Check engine valve clearance, adjust	3-67
Check vibration damper	3-67
Replace element in air conditioner recirculation air filter, fresh air filter	3-67
Clean and check turbocharger	3-67
Clean PPC circuit strainer	3-68
Check accumulator gas pressure	3-68
Clean engine breather element	3-68
EVERY 4000 HOURS SERVICE	
Check water pump	3-69
Check and adjust of the air conditioner	3-69

- ★ The interval of 2000 hours for changing the axle oil is for standard operations. If the brake is used frequently or the brakes make a sound, change the oil after a shorter interval.

24. SERVICE PROCEDURE

24.1 INITIAL 250 HOURS SERVICE

Carry out the following maintenance only after the first 250 hours.

- **REPLACE FUEL FILTER CARTRIDGE**
- **REPLACE TRANSMISSION OIL FILTER CARTRIDGE**
- **REPLACE HYDRAULIC TANK FILTER ELEMENT**
- **CHECK ENGINE VALVE CLEARANCE, ADJUST**

For details of the method of replacing or maintaining, see the section on EVERY 500 HOURS and 2000 HOURS SERVICE.

24.2 WHEN REQUIRED

24.2.1 CHECK, CLEAN, OR REPLACE AIR CLEANER ELEMENT

WARNING

- Never clean or replace the air cleaner element with the engine running.
- When using pressure air to clean the element wear safety glasses or goggles to protect the eyes.

CHECKING

If air cleaner clogging caution lamp  on the maintenance monitor flashes, clean the air cleaner element.

NOTICE



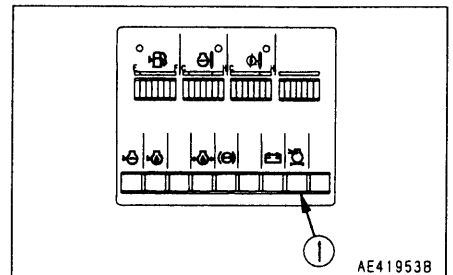

Do not clean the air cleaner element before the air cleaner clogging caution lamp flashes.

If the air cleaner element is cleaned frequently before the air cleaner clogging caution lamp flashes, the proper performance of the air cleaner is not provided and the cleaning efficiency is lowered.

In addition, dust sticking to the cleaner element falls on the inner element side while cleaning the element.



CLEANING OR REPLACING OUTER ELEMENT

1. Remove wing nut  and cover , take out outer element.
2. Clean the inside of the air cleaner body.
3. Direct dry compressed air (less than 0.69 MPa (7 kgf/cm², 99.4 PSI)), to the element from inside along its folds, then direct it from outside along its folds and again from inside.
 - 1) Remove one seal from the outer element whenever the outer element has been cleaned.
 - 2) Replace the outer element which has been cleaned 6 times repeatedly or used throughout a year. Replace the inner element at the same time.
 - 3) If the dust indicator displays red immediately after the outer element has been cleaned, replace both the inner and outer elements, even if the outer element has not been cleaned 6 times.
 - 4) Check inner element mounting nuts for looseness and, if necessary, retighten.
 - 5) Replace seal washer  or wing nut  with new parts if they are broken.

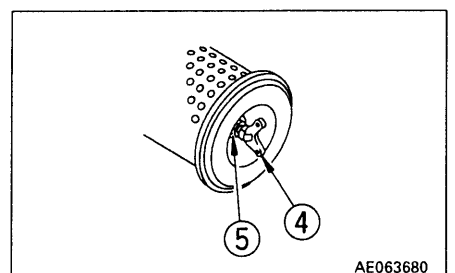
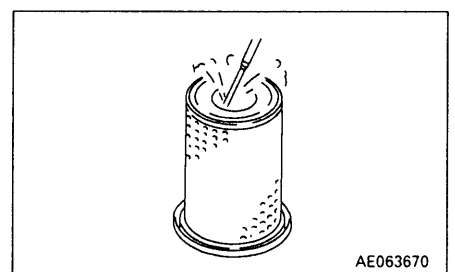
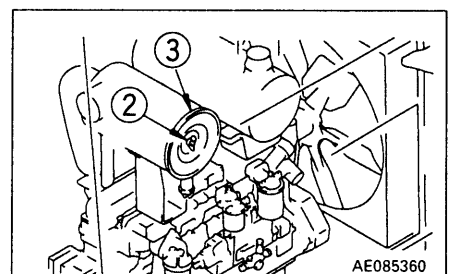

24. SERVICE PROCEDURE

NOTICE

If small holes or thinner parts are found on element when it is checked with an electric bulb after cleaning and drying, replace the element.

When cleaning the element, do not hit it or beat it against anything.

Do not use element whose folds or gasket or seal are damaged.

4. Install the cleaned element.

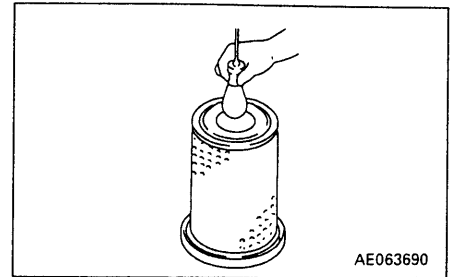

REPLACING INNER ELEMENT

1. First remove the outer element, and then remove the inner element.
2. To prevent dust from getting in, use a clean cloth or tape to cover the air connector (outlet side).
3. Clean the air cleaner body interior, then remove the cover installed in Step 2.
4. Fit a new inner element to the connector and tighten it with nuts. Do not clean and reinstall an inner element.

NOTICE

Do not clean the inner element and use it again.

When replacing the outer element, replace the inner element at the same time.

5. Install the outer element.

REMARK

When installing the inner element and outer element, turn the element lightly so that the seal rubber at the tip of the element fits tightly inside the body, then tighten the nut.

24.2.2 CLEAN INSIDE OF COOLING SYSTEM

WARNING

- Soon after the engine has been stopped, the coolant is hot and can cause personal injury. Allow the engine to cool before draining water.
 - Since cleaning is performed while the engine is running, it is very dangerous to go under the machine as the machine may suddenly start moving. While the engine is running, never go under the machine.
 - Never remove the radiator cap when the engine is at operating temperature. At operating temperature, the coolant is under pressure. Boiling water and steam spurting out from the radiator could cause personal injury. Allow the engine to cool until the radiator filler cap is cool enough to touch with your hand. Remove the filler cap slowly to allow pressure to be relieved.
- Stop the machine on level ground when cleaning or changing the coolant.
 - Use a permanent type of antifreeze.
If, for some reason, it is impossible to use permanent type antifreeze, use an antifreeze containing ethylene glycol.
 - Be sure to replace the corrosion resistor cartridge.
 - Clean the inside of the cooling system change the coolant and replace the corrosion resistor according to the table below.

Kind of coolant	Cleaning inside of cooling system and changing coolant	Replacing corrosion resistor
Permanent type antifreeze (All season type)	Every year (autumn) or every 2000 hours, whichever comes first	Every 1000 hours and when cleaning the inside of the cooling system and when changing coolant.
Non-permanent type antifreeze containing ethylene glycol (Winter, one season type)	Every 6 months (spring, autumn) (Drain antifreeze in spring, add antifreeze in autumn)	
When not using antifreeze	Every 6 months or every 1000 hours, whichever comes first	

24. SERVICE PROCEDURE

- When deciding the ratio of antifreeze to water, check the lowest temperature in the past, and decide from the mixing rate table given below.

It is actually better to estimate a temperature about 10°C lower when deciding the mixing rate.

Mixing rate of water and antifreeze

Min. atmospheric temperature	°C	-5	-10	-15	-20	-25	-30
	°F	23	14	5	-4	-13	-22
Amount of antifreeze	ℓ	12.2	15.9	18.6	21.2	23.9	26.5
	US gal	3.22	4.20	4.91	5.60	6.31	7.00
	UK gal	2.68	3.50	4.09	4.66	5.26	5.83
Amount of water	ℓ	40.8	37.1	34.4	31.8	29.1	26.5
	US gal	10.77	9.79	9.08	8.39	7.68	6.99
	UK gal	8.98	8.16	7.57	7.00	6.40	5.83

⚠ WARNING

Antifreeze is flammable, so keep it away from any flame.

- Use city water for the cooling water.
If river water, well water or other such water supply must be used, contact your Komatsu distributor.
- We recommend use of an antifreeze density gauge to control the mixing proportions.

1. Stop the engine and tighten corrosion resistor valves ①.

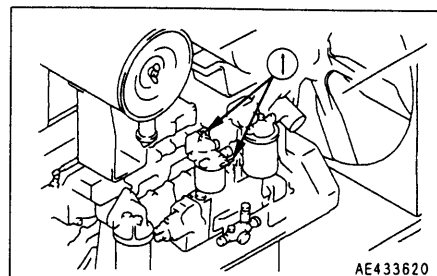

2. Turn radiator cap ② slowly to remove it.

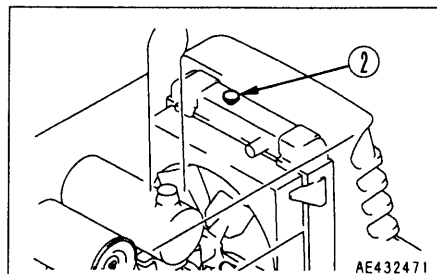

3. Prepare a container to catch the coolant, then open drain valve ③ at the radiator left lower portion and drain plug ④ at the side of the cylinder block to drain the coolant.

4. After draining the water, close drain valve ③ and plug ④, and fill with city water.

5. When the radiator is full of water, start the engine and run it at low idling.

Open drain valve ③ and plug ④, run the engine at low idling, and flush water through the system for 10 minutes.

When doing this, adjust the speed of filling and draining the water so that the radiator is always full.

While flushing water through the system, watch carefully that the water inlet hose does not come out of the radiator water filler.

6. After flushing, stop the engine, open drain valve ③ and plug ④, then close it again after all the water has drained out.

7. After draining the water, clean with a flushing agent.
For details of the cleaning method, see the instructions given with the cleaning agent.

8. After cleaning, open drain valve ③ and plug ④ to drain all the cooling water, then close them and fill slowly with clean water.

9. When the water comes up to near the water filler port, open drain valve ③ and plug ④, run the engine at low idling, and continue to run water through the system until clean colorless water comes out.

When doing this, adjust the speed of filling and draining the water so that the radiator is always full.

10. When the water is completely clean, stop the engine, close drain valve ③ and plug ④.

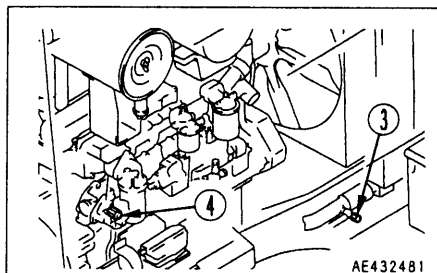

AE432481

24. SERVICE PROCEDURE

11. Replace the corrosion resistor cartridge and open the valves.
For details of replacement of the corrosion resistor, see "24.8 EVERY 1000 HOURS SERVICE".
12. Add cooling water until it overflows from the water filler.
13. To remove the air in the cooling water, run for five minutes at low idling, then for another five minutes at high idling.
When doing this, leave radiator cap ② off.
14. Drain the coolant from sub-tank ⑤, clean the inside of the sub-tank, then add water until the coolant level is between the FULL and LOW marks.
15. Stop the engine, wait for about three minutes, add cooling water up to near the radiator water filler port, then tighten the cap.

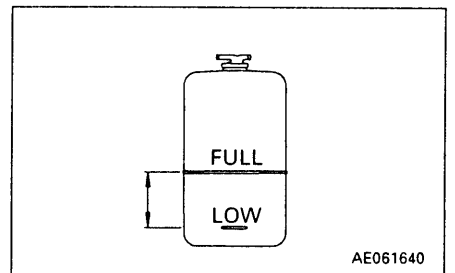
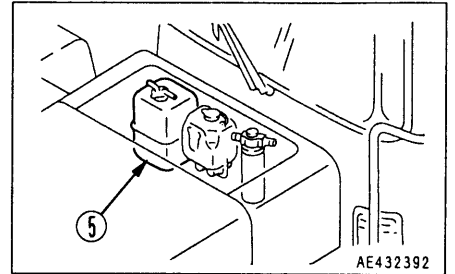

24.2.3 CHECK TRANSMISSION OIL LEVEL, ADD OIL

⚠ WARNING

- When checking the oil level, apply the parking brake, and lock the front and rear frames with the safety bar and pin.
- The oil is at high temperature after the machine has been operated. Always wait for the temperature to go down before starting this operation.

Carry out this procedure if there is any sign of oil on the transmission case, or if there is oil mixed with the cooling water.

1. Start the engine and run it for at least 5 minutes.
2. Open the cap of oil filler port (F), remove dipstick (G), and wipe the oil off with a cloth.
3. Insert dipstick (G) fully in the oil filler pipe, then take it out again.
4. The oil level should be between the H and L marks on dipstick (G).
If the oil level is below the L mark, add engine oil through oil filler (F).

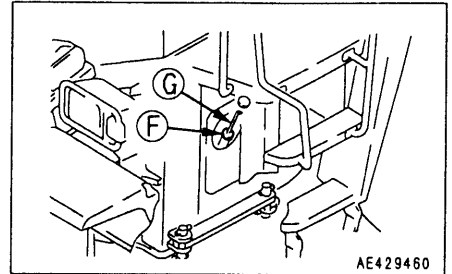

For details of the oil to use, see "20. USE OF FUEL, COOLANT AND LUBRICANTS ACCORDING TO AMBIENT TEMPERATURE."

5. If the oil is above the H mark, drain the excessive engine oil from drain plug (P), then check the oil level again.
6. If the oil level is correct, insert dipstick (G) into the oil filler pipe, then tighten the cap.

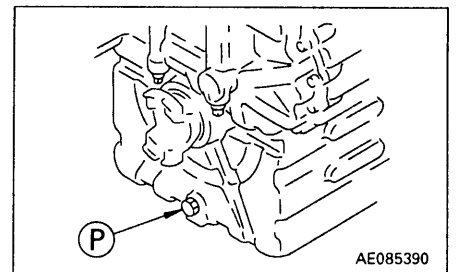

24.2.4 CHECK AXLE OIL LEVEL, ADD OIL

⚠ WARNING

- When checking the oil level, apply the parking brake, and lock the front and rear frames with the safety bar and pin.
- The oil is at high temperature after the machine has been operated. Always wait for the temperature to go down before starting this operation.

Carry out this procedure if there is any sign of oil on the axle case.

Carry out the inspection with the machine on a horizontal road surface. (If the road surface is at an angle, the oil level cannot be checked correctly.)

1. Stop the engine and remove oil level plug ①.
2. Check that the oil level reaches the bottom of the plug hole.
3. If the oil is not close to the bottom edge, add axle oil through filler port ②.

For details of the oil to use, see "20. USE OF FUEL, COOLANT AND LUBRICANTS ACCORDING TO AMBIENT TEMPERATURE."

4. If the oil level is correct, install plug ①.

Tightening torque: $152 \pm 24.5 \text{ N}\cdot\text{m}$
 $(15.5 \pm 2.5 \text{ kgf}\cdot\text{m}, 112.1 \pm 18.1 \text{ lbft})$

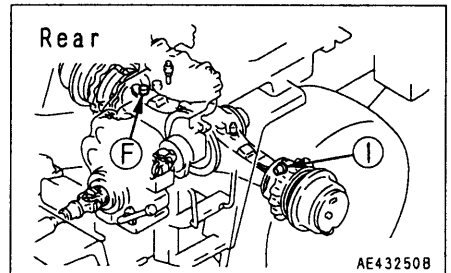
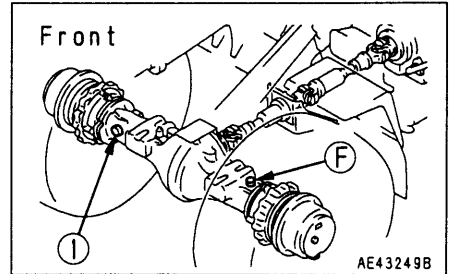

24.2.5 CLEAN AXLE CASE BREATHER

⚠ WARNING

When cleaning, apply the parking brake, and lock the front and rear frames with the safety bar and pin.

Remove all mud and dirt from around the breather with a brush.

When cleaning the breather, clean the breathers at two places (front and rear).

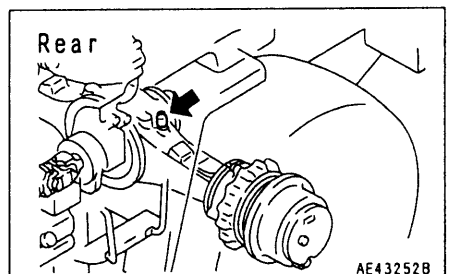
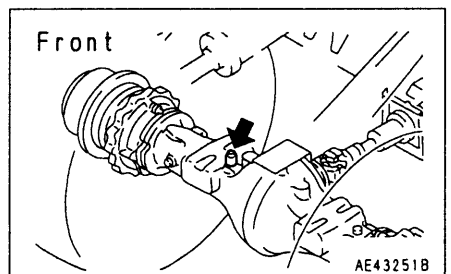

24.2.6 CLEAN RADIATOR FINS

Carry out this procedure if there is any mud or dirt seen stuck to the radiator.

1. Remove bolts ①, then open the rear grill from the rear of the machine. Remove the connector of the rear working lamp at the same time.
2. Use compressed air to clean the mud dust, and leaves from the radiator fins. Steam or water may be used instead of compressed air.
3. The rubber hose should be checked at the same time. If the hose is found to have cracks or to be hardened by ageing, it should be replaced with a new one. Further, loosen hose clamps should also be tightened.

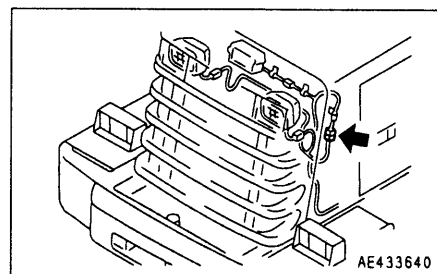
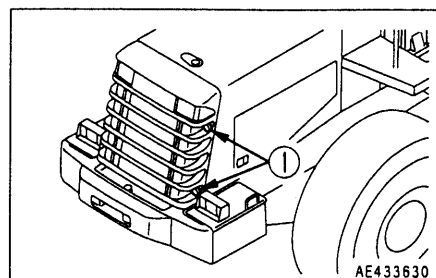

24.2.7 REPLACE BOLT-ON CUTTING EDGE

⚠ WARNING

It is extremely dangerous if the work equipment moves when carrying out the turning or replacement operation. Set the work equipment in a stable position, stop the engine, then set the safety lock for the work equipment control lever securely to the LOCK position.

Turn or replace the cutting edge before the wear reaches the edge of the bucket.

1. Raise the bucket to a suitable height, then put blocks under the bucket to prevent the bucket from coming down. Raise the bucket so that the bottom surface of the bucket is horizontal.
2. Remove nuts and bolts ①, then remove cutting edge ②.
3. Clean the mounting surface of cutting edge ②.
4. Turn cutting edge ② and install it to the bucket. When turning the edge, install it to the opposite side (left edge to right side, right edge to left side).

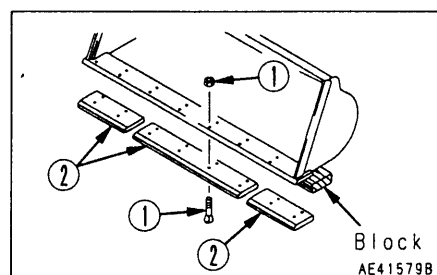

If both sides of the cutting edge are worn, replace with a new part.

If the wear extends to the mounting surface, repair the mounting surface before installing the cutting edge.

5. Tighten nuts and bolts ① uniformly so that there is no gap between the bucket and cutting edge.

Tightening torque for mounting bolt:

$745 \pm 108 \text{ N}\cdot\text{m}$ ($76 \pm 11 \text{ kgf}\cdot\text{m}$, $549.7 \pm 79.6 \text{ lbft}$)

6. Tighten the mounting bolts again after operating for several hours.

24.2.8 REPLACE BUCKET TEETH

⚠ WARNING

It is dangerous if the work equipment moves by mistake when the teeth are being replaced. Set the work equipment in a stable condition, then stop the engine and apply the locks securely to the work equipment control levers.

When the bucket teeth are worn, replace them as follows.

1. Raise the bucket to a convenient height, and put blocks under the bucket to prevent it from coming down.
Raise the bucket so that the bottom is horizontal.

2. Remove the bolt and nuts ① and ②, then remove bucket tooth ③.
3. Clean the installation surface of bucket tooth ③.
4. Install new teeth to the bucket. When doing this, insert shims so that there is no clearance between the teeth and the top surface of the bucket.

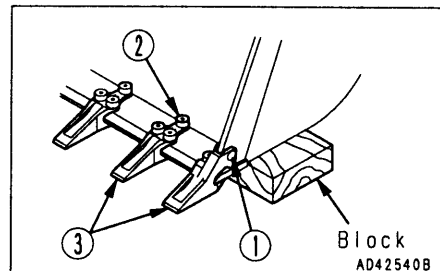

Continue to add shims until it becomes impossible to add a 0.5 mm (0.02 in) shim.

If the mounting surface is worn, correct the mounting surface before installing the teeth.

5. To prevent any gap from forming between the teeth and tip of the bucket, tighten bolts and nuts ① and ② temporarily, then hit the tip of the teeth with a hammer.

Tightening torque of mounting bolt ①:

$902 \pm 39.2 \text{ N}\cdot\text{m}$ ($92 \pm 4 \text{ kgf}\cdot\text{m}$, $665.4 \pm 28.9 \text{ lbft}$)

Tightening torque of mounting bolt ②:

$902 \pm 39.2 \text{ N}\cdot\text{m}$ ($92 \pm 4 \text{ kgf}\cdot\text{m}$, $665.4 \pm 28.9 \text{ lbft}$)

6. After operating the machine for a few hours, tighten the mounting bolts again.

24.2.9 CHECK AIR CONDITIONER

CHECK LEVELS OF REFRIGERANT (GAS)

Check twice a year, in spring and autumn.

⚠ WARNING

If the liquid gets into your eyes or on your hands, it may cause loss of sight or frostbite, so never loosen any part of the refrigerant circuit.

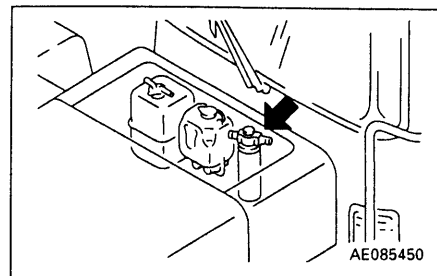

Operate the cooler of the air conditioner for 5 – 10 minutes, then touch the high pressure portion and low pressure portion of the compressor (or high pressure hose and low pressure hose joint) by hand. At the same time, inspect the flow of refrigerant gas (R134a) through the sight glass to check the gas level.

Please contact your Komatsu distributor for this inspection.

The sight glass is installed to the receiver at the side of the condenser.

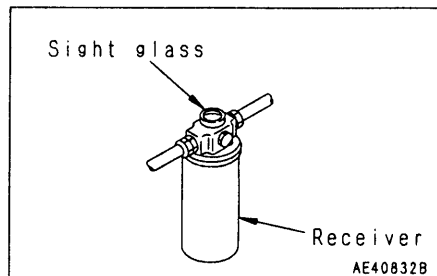

Cooler condition	Normal	Abnormal	
Temp. of high and low pressure pipes.	High pressure pipe is hot. Low pressure pipe is cold. Clear difference in temperature	High pressure pipe is warm. Low pressure pipe is cold. Little difference in temperature	Almost no difference in temperature between high and low pressure pipes.
Sight glass	Almost transparent. Any bubbles disappear if the engine speed is raised or lowered.	Bubbles are always flowing. Sometimes becomes transparent, or white bubbles appear.	Misty substance is flowing.
Connections of pipes	Properly connected	Some parts dirty with oil.	Some parts very dirty with oil.
General condition of cooler	Coolant level correct, no abnormalities. Ready for use.	May be a leak somewhere. Call service repair shop for inspection.	Almost all coolant has leaked out. Contact service repair shop immediately.

OPERATING THE AIR CONDITIONER OFF SEASON

To lubricate each portion of the compressor of the air conditioner during the off-season, operate the air conditioner for 3 – 5 minutes once a month. Be sure to idle the engine at low speed for this purpose.

24.2.10 CLEAN CONDENSER OF AIR CONDITIONER

⚠ WARNING

Do not wash the condenser with a steam cleaner. Otherwise, the condenser will get hot and may break down.

If there is mud or dust on the air conditioner condenser, clean it with water.

If the water pressure is too high, the fins may get deformed. When washing with a high pressure washing machine, apply the water from a reasonable distance.

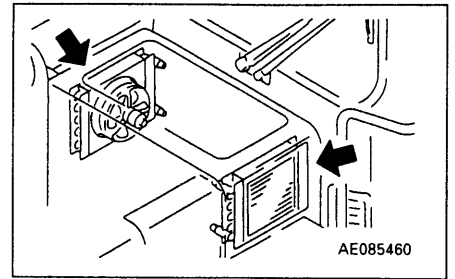

24.2.11 CHECK WINDOW WASHING FLUID LEVEL, ADD FLUID

Check the washing fluid levels in washer tank ①. When the fluid has run short, add automotive window washing fluid.

To prevent the nozzles from clogging, be careful not to let dust get into the fluid.

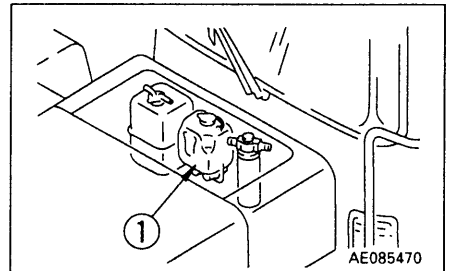

24.2.12 LUBRICATE WORK EQUIPMENT CONTROL VALVE LINKAGE (2 POINTS)

If the work equipment control lever is heavy or does not move smoothly, apply grease.

1. Using a grease pump, pump in grease through the grease fittings shown by arrows.
2. After greasing, wipe off any old grease that was pushed out.

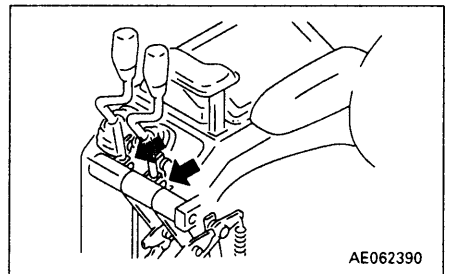

24.2.13 REPLACE SLOW BLOW FUSE

NOTICE

- Always turn the power OFF when replacing the slow blow fuse (turn the starting switch to the OFF position).
- Always replace the slow blow fuse with a fuse of the same capacity.

1. Turn the starting switch to the OFF position.
2. Remove the slow blow fuse box from the chassis.
3. Open covers ①, ②, and ③ of the slow blow fuse box. Covers ② and ③ can be removed easily by using protrusion A on the body as a fulcrum and levering the catch of the cover with a flat-headed screwdriver to release it.
4. Loosen screws ④ and ⑤, and remove. When screws ④ and ⑤ are removed, slow blow fuse ⑥ will also come off together with electric wiring ⑦ and ⑧.
5. Using screws ④ and ⑤, install a new slow blow fuse together with electric wiring ⑦ and ⑧ to the slow blow fuse box, then close covers ①, ②, and ③.
6. Install the slow blow fuse box to the chassis.

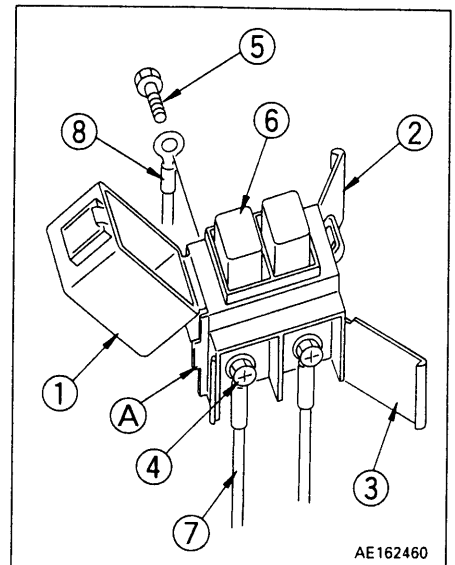

AE162460

24.2.14 DRAIN WATER FROM WATER SEPARATOR

When float ② is at or above red line ①, drain the water according to the following procedure:

1. Loosen drain plug ③ and air bleed plug ④ (if equipped), drain the accumulated water until the float reaches the bottom.
2. Tighten air bleed plug ④ (if equipped), and drain plug ③.
3. If the air is sucked into fuel line when drain the water, be sure to bleed air in the same manner as for the fuel filter.

See Fuel Filter Cartridge in "24.7 EVERY 500 HOURS SERVICE" section.

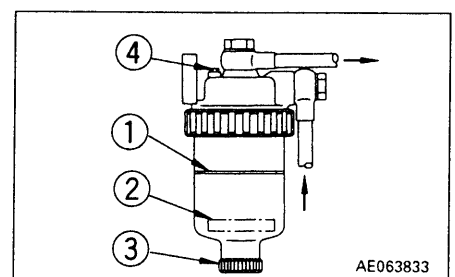

AE063833

24.2.15 SELECTION AND INSPECTION OF TIRES

⚠ WARNING

If a tire or a rim is handled wrongly, the tire may burst or may be damaged and the rim may be broken and scattered, and that can cause serious injury and death.

- Since maintenance, disassembly, repair and assembly of the tires and rims require special equipment and skill, be sure to ask a tire repair shop to carry out the work.
- Do not heat or weld the rim to which the tire is installed. Do not make a fire near the tire.

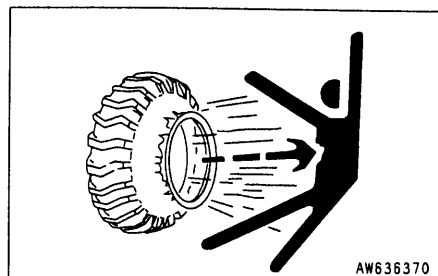

SELECTION OF TIRES

⚠ WARNING

Select the tires according to the conditions of use and attachments on the machine. Use only specified tires and inflate them to the specified pressure.

Select the tires according to the conditions of use and attachments of the machine. Use the following table. Since the indicated speed varies with the tire size, consult your Komatsu distributor when using optional tires.

	Maximum load	Tire size	Remarks
Front wheel	9530 kg (21014 lb)	23.5-25-16PR (L3 Rock)	Type 3 for construction equipment
Rear wheel	9530 kg (21014 lb)	23.5-25-16PR (L3 Rock)	

CHECK OF INFLATION PRESSURE OF TIRES AND INFLATION OF THEM

⚠ WARNING

- When inflating a tire, check that no one will enter the working area and use an air chuck which has a clip and which can be fixed to the air valve.
While inflating the tire, check the inflation pressure occasionally so that it will not rise too high.
If the rim is not fitted normally, it may be broken and scattered while the tire is inflated. To ensure safety, place a guard around the tire and do not work in front of the rim but work on the tread side of the tire.
- Abnormal drop of inflation pressure and abnormal fitting of the rim indicate a trouble in the tire or rim. In this case, be sure to ask a tire repair shop to carry out repairs.
- Be sure to observe the specified inflation pressure.
- Do not adjust the inflation pressure of the tires just after high-speed travel or heavy-duty work.

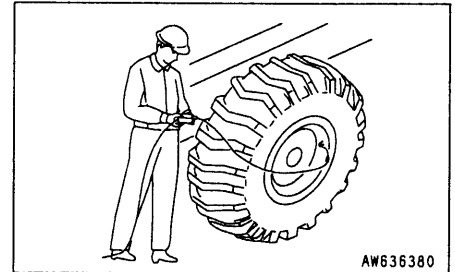

Check

Measure the inflation pressure with a tire pressure gauge while the tires are cool before starting work.

Inflation of tires

Adjust the inflation pressure properly.

When inflating a tire, use an air chuck which can be fixed to the air valve of the tire as shown in the figure. Do not work in front of the rim but work on the tread side of the tire.

The proper inflation pressure is shown below.

Standard tire inflation pressure (front and rear wheels)

Tire size	Inflation pressure
23.5-25-16PR (L3 Rock) (standard)	Front tire: 0.34 MPa (3.5 kgf/cm ² , 49.7 PSI) Rear tire: 0.30 MPa (3.1 kgf/cm ² , 44.02 PSI)
26.5-25-16PR (L3 Rock) (if equipped)	Front tire: 0.32 MPa (3.3 kgf/cm ² , 46.86 PSI) Rear tire: 0.27 MPa (2.8 kgf/cm ² , 39.76 PSI)

NOTICE

The appropriate tire inflation pressure differs according to the type of work, so see "12.18 HANDLING THE TIRES".

24.3 CHECK BEFORE STARTING

24.3.1 CHECK MONITOR PANEL

1. Turn the starting switch to ON.
2. Check that all the monitor lamps, the gauges and the warning lamp light up for about 3 seconds and the alarm buzzer sounds for about 1 second.

If any monitor lamp does not light up, ask your Komatsu distributor to inspect that monitor lamp.

Do not carry out the checks before starting using only the monitor; always carry out also the items specified for the periodic maintenance.

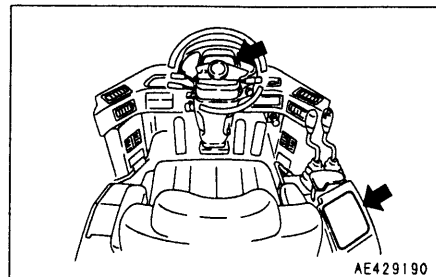

24.3.2 CHECK COOLANT LEVEL, ADD WATER

⚠ WARNING
Normally, do not open the radiator cap. Always wait for the engine to cool down before checking the water level, and check using the sub-tank.

1. Open the top cover at the front of the engine hood in the middle of the machine, and check that the coolant level is between the FULL and LOW marks on sub-tank ①. If the coolant level is low, add water to the FULL level through the water filler in sub-tank ①.
2. After adding water, tighten the cap securely.
3. If sub-tank ① is empty, check for water leakage, then add water to the radiator and sub-tank.

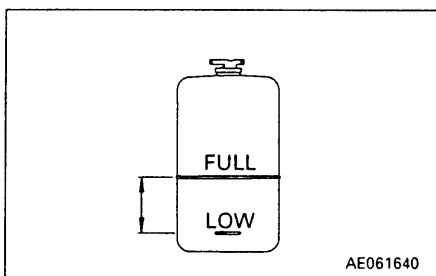
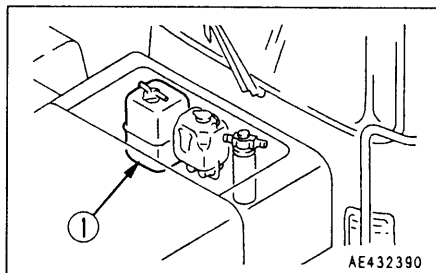

24.3.3 CHECK FUEL LEVEL, ADD FUEL

⚠ WARNING

When adding fuel, never let the fuel overflow. This may cause a fire. If you spill fuel, thoroughly clean up any spillage.

1. Turn the engine starting switch to the ON position, then check the fuel level with fuel gauge **Ⓒ**.
After checking, return the starting switch to the OFF position.

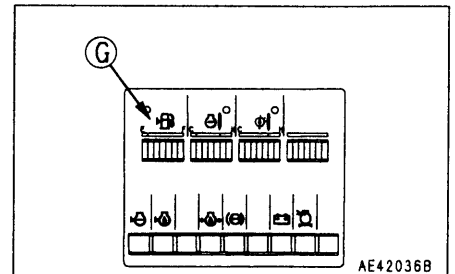

2. Upon completion of work, add fuel through filler **Ⓕ** until the fuel tank is full.

For details of the method for opening and closing the cap, see "11.5 CAP WITH LOCK".

For details of the fuel to use, see "20. USE OF FUEL, COOLANT AND LUBRICANTS ACCORDING TO AMBIENT TEMPERATURE".

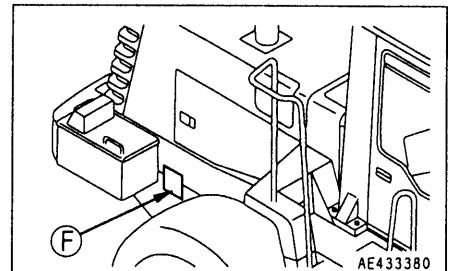

3. After adding fuel, tighten the cap securely.

Fuel capacity: 340 l (89.76 US gal, 74.80 UK gal)

24.3.4 CHECK OIL LEVEL IN ENGINE OIL PAN, ADD OIL

⚠ WARNING

The parts and oil are at high temperature after the engine is stopped, and may cause serious burns. Wait for the temperature to go down before starting the operation.

1. Open the engine side cover at the rear right side of the machine.
2. Remove dipstick ⑥ and wipe the oil off with a cloth.
3. Insert dipstick ⑥ fully in the oil filler pipe, then take it out again.
4. The oil level should be between the H and L marks on dipstick ⑥.
If the oil level is below the L mark, add engine oil through oil filler ⑦.

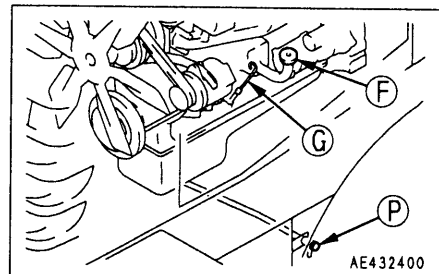

For details of the oil to use, see "20. USE OF FUEL, COOLANT AND LUBRICANTS ACCORDING TO AMBIENT TEMPERATURE".

5. If the oil is above the H mark, drain the excess engine oil from drain plug ①, and check the oil level again.
6. If oil level is correct, tighten the oil filler cap securely, then tighten the engine side cover.

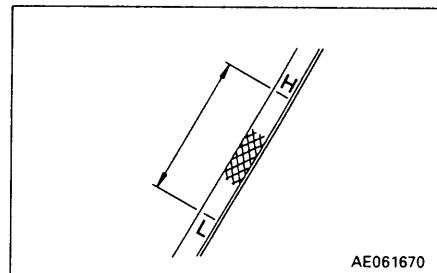

REMARK

When checking the oil level after the engine has been operated, wait for at least 15 minutes after stopping the engine before checking.

If the machine is at an angle, make it horizontal before checking.

24.3.5 CHECK ELECTRIC WIRING

⚠ WARNING

- If fuses are frequently blown or if there are traces of short circuit on the electrical wiring, locate the cause and carry out repair it or contact your Komatsu distributor.
- Accumulation of flammable material (dead leaves, twigs, grass, etc.) around the battery may cause fire, so always check and remove such material.
- Keep the top surface of the battery clean and check the breather hole in the battery cap. If it is clogged with dirt or dust, wash the battery cap to clear the breather hole.

Check for damage and wrong capacity of the fuse and any sign of disconnection or short circuit in the electric wiring. Check also for loose terminals and tighten any loose parts.

Check the wiring of the "battery", "starting motor" and "alternator" carefully, in particular.

When carrying out walk-around checks or checks before starting, always check if there is any accumulation of flammable material around the battery, and remove such flammable material.

Please contact your Komatsu distributor for investigation and correction of the cause.

24.3.6 CHECK FOR WATER AND SEDIMENT IN WATER SEPARATOR

The water separator separates water mixed in the fuel. If float ② is at or above red line ①, drain the water.

For the draining procedure, see section "24.2 WHEN REQUIRED".

Even if a water separator is installed, be sure to check the fuel tank to remove water and sediment in the fuel.

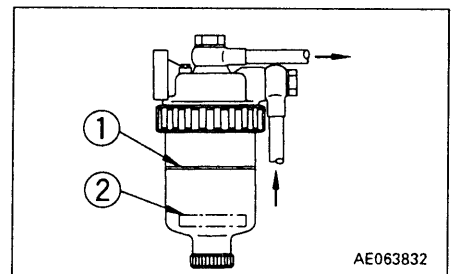

24.3.7 DRAIN WATER FROM AIR TANK (if equipped)

Upon completion of work, stop the engine, open drain valve ① and drain the water from the tank.

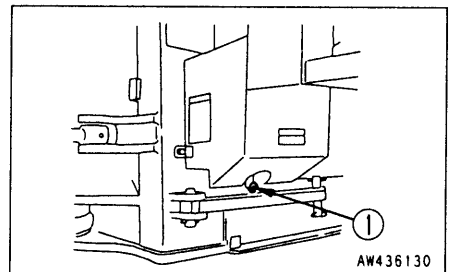

24.3.8 CHECK EFFECT OF PARKING BRAKE

⚠ WARNING

Even if the parking brake switch is turned ON, there is danger until the parking brake pilot lamp lights up, so keep the brake pedal depressed.

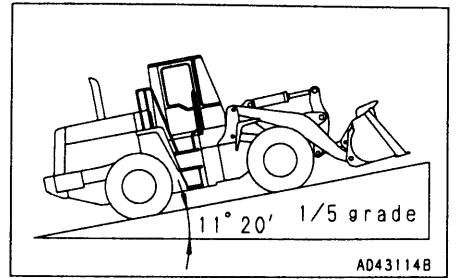

Measurement conditions

- Tire inflation pressure: Specified pressure
- Road surface: Dry paved surface with 1/5 (11°20') grade
- Machine: Operating condition

Method of measurement

1. Start the engine, set the machine facing straight to the front, then drive the machine up a 1/5 grade with the bucket empty.
2. Depress the brake, stop the machine, return the directional lever to the neutral position, then stop the engine.
3. Press the parking brake switch to the ON position, release the brake pedal slowly, and check that the machine is held in position.

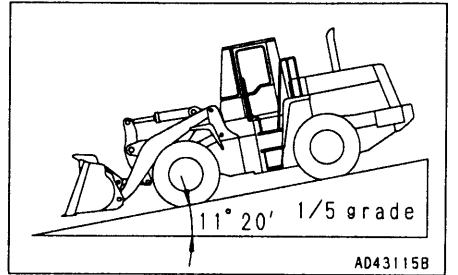

24.3.9 CHECK EFFECT OF BRAKE

Drive the machine at a speed of 20 km/h (12.4 MPH) on a dry flat concrete road surface, and check that the stopping distance is less than 5 m (16 ft 5 in).

24.3.10 CHECK SOUND OF HORN AND BACKUP ALARM

24.3.11 CHECK FLASHING OF LAMPS, CHECK FOR DIRT OR DAMAGE

24.3.12 CHECK ENGINE EXHAUST COLOR AND SOUND

24.3.13 CHECK OPERATION OF GAUGES

24.3.14 CHECK PLAY OF STEERING WHEEL, CHECK OPERATION OF STEERING

24.3.15 CHECK DIRECTION OF REAR VIEW MIRROR, CHECK FOR DIRT OR DAMAGE

24.3.16 CHECK INFLATION PRESSURE OF TIRES

Measure the inflation pressure with a tire pressure gauge while the tires are cool before starting work.

Check for damage or wear to the tires and the rims.

Check for loose wheel hub nuts (bolts). The proper inflation pressure is shown below.

Tire size	Inflation pressure
23.5-25-16PR (L3 Rock) (standard)	Front tire: 0.34 MPa (3.5 kgf/cm ² , 49.7 PSI) Rear tire: 0.30 MPa (3.1 kgf/cm ² , 44.02 PSI)
26.5-25-16PR (L3 Rock) (if equipped)	Front tire: 0.32 MPa (3.3 kgf/cm ² , 46.86 PSI) Rear tire: 0.27 MPa (2.8 kgf/cm ² , 39.76 PSI)

NOTICE

The appropriate tire inflation pressure differs according to the type of work, so see "12.18 HANDLING THE TIRES".

24.4 EVERY 50 HOURS SERVICE

24.4.1 DRAIN WATER, SEDIMENT FROM FUEL TANK

Loosen valve ① on the right side of the tank so that the sediment and water will be drained together with fuel.

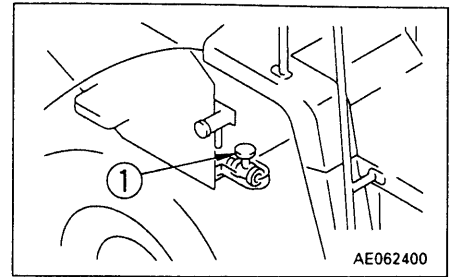

24.5 EVERY 100 HOURS SERVICE

Maintenance for every 50 hours should be carried out at the same time.

24.5.1 CHECK OIL LEVEL IN HYDRAULIC TANK, ADD OIL

⚠ WARNING

- When the oil filler cap is removed, oil may spurt out, so stop the engine and wait for the oil temperature to go down, then turn the cap slowly to release the internal pressure before removing the cap.
- If oil has been added to above the H mark, stop the engine and wait for the hydraulic oil to cool down, then drain the excess oil from the drain plug.

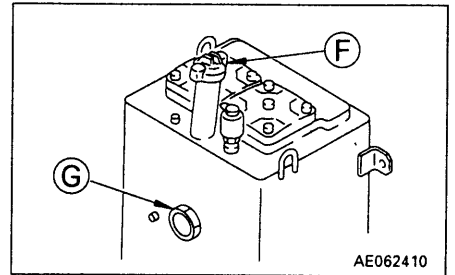

1. Lower the bucket horizontally to the ground and stop the engine. Wait for 5 minutes, then check sight gauge Ⓒ. The oil level should be between the H and L marks.

NOTICE

Do not add oil if the level is above the H line. This will damage the hydraulic equipment and cause the oil to spurt out.

2. If the oil is below the L level, open the inspection cover above the step and add oil through oil filler port Ⓕ.

For details of the oil to use, see "20. USE OF FUEL, COOLANT AND LUBRICANTS ACCORDING TO AMBIENT TEMPERATURE".

24.5.2 CLEAN ELEMENT IN AIR CONDITIONER FRESH AIR FILTER

⚠ WARNING

When using compressed air, wear safety glasses and other things required to maintain safety.

If the air conditioner has been used, the air filter should be cleaned.

Stop the air conditioner before cleaning the element.

1. Loosen bolt ① and remove cover ②.

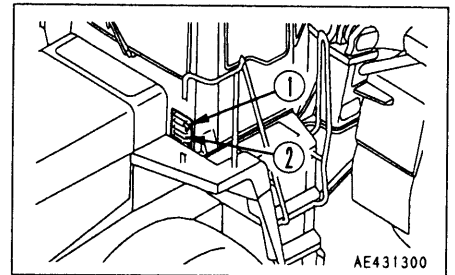

2. Loosen screw ③, then take out element ④ and clean it.

3. Blow dry compressed air (max. 0.69 MPa (7 kgf/cm², 99.4 PSI)) along the folds from the inside of the element. Next, blow air along the folds from the outside, then blow from the inside again.

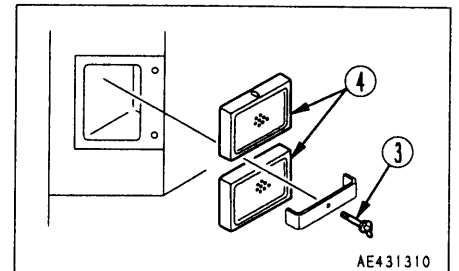

REMARK

When assembling the element again, install so that the arrow on top of the element is facing the inside of the cab.

24.5.3 LUBRICATE REAR AXLE PIVOT PIN (3 points)

⚠ WARNING

- Apply the parking brake, and lock the front and rear frames with the safety bar and pin.
- Set the work equipment in a stable condition, then stop the engine and apply the locks securely to the work equipment control levers.

1. Using a grease pump, pump in grease through the grease fittings marked by the arrows.

2. After greasing, wipe off any old grease that is pushed out.

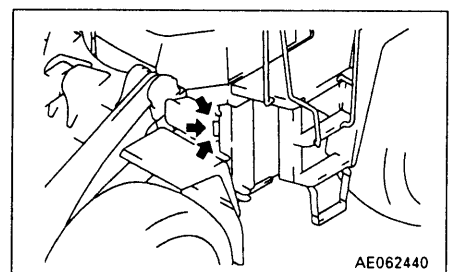

24.6 EVERY 250 HOURS SERVICE

Maintenance for every 50 and 100 hours should be carried out at the same time.

24.6.1 CHANGE OIL IN ENGINE OIL PAN, REPLACE ENGINE OIL FILTER CARTRIDGE

⚠ WARNING

The oil is at high temperature after the engine has been operated, so never change the oil immediately after finishing operations. Wait for the oil to cool down before changing it.

Prepare the following

- Container to catch drained oil: Min 28 ℓ capacity
- Refill capacity: 28 ℓ (7.39 US gal, 6.16 UK gal)
- Filter wrench

1. Open the engine side cover located on the right of machine.
2. Open oil filler (F).
3. Place a container to catch the oil under drain plug (P).
4. Loosen drain plug (P), and drain the oil.
5. Check the drained oil, and if there are excessive metal particles or foreign material, please contact your Komatsu distributor.
6. Install drain plug (P).
7. Open the engine side cover located on the left of machine.
8. Using the filter wrench, turn filter cartridge (1) counterclockwise to remove it.
In particular, if this operation is carried out immediately after stopping the engine, a large amount of oil will come out, so wait for 10 minutes before starting the operation.

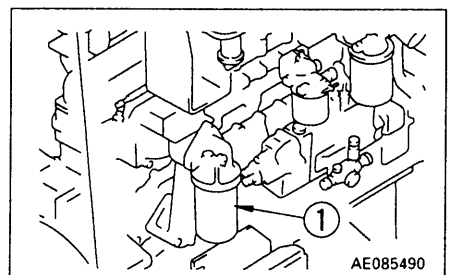
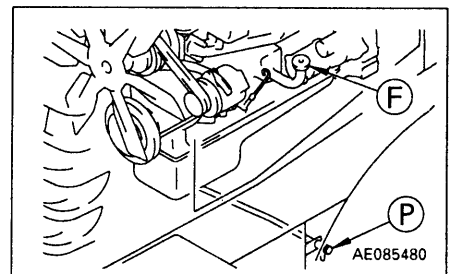

9. Clean the filter holder, fill the new filter cartridge with engine oil, then coat the seal and thread of the filter cartridge with engine oil (or coat thinly with grease) and install.
10. When installing, bring the seal surface into contact with the filter holder, then tighten a further 3/4 – 1 turns.
11. After replacing the filter cartridge, add engine oil through oil filler \oplus until the oil level is between the H and L marks on the dipstick.

For details of the oil to use, see "20. USE OF FUEL, COOLANT AND LUBRICANTS ACCORDING TO AMBIENT TEMPERATURE".

12. Run the engine at idling for a short time, then stop the engine, and check that the oil level is between the H and L marks on the dipstick. For details, see "24.3 CHECK BEFORE STARTING".

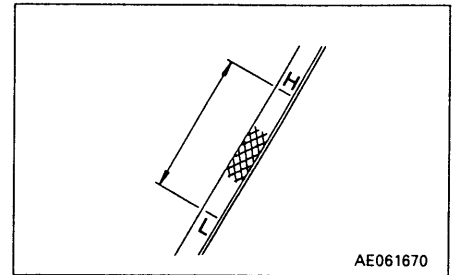

Even if the machine has not been operated for 250 hours, the oil and filter cartridge must be replaced when the machine has been operated for 6 months.

In the same way, even if the machine has not been operated for 6 months, the oil and filter cartridge must be replaced when the machine has been operated for 250 hours.

Use API category CD class oil. If CC class oil must be used, change the oil and replace the oil filter at half the usual interval (125 hours).

24.6.2 CHECK TENSION OF FAN BELT, ALTERNATOR BELT, ADJUST

CHECKING

The deflection of the belt should be approx. 7.5 mm (0.3 in) when pressed with a finger force of approx. 58.8 N (6 kgf) at a point midway between the fan pulley and the alternator pulley.

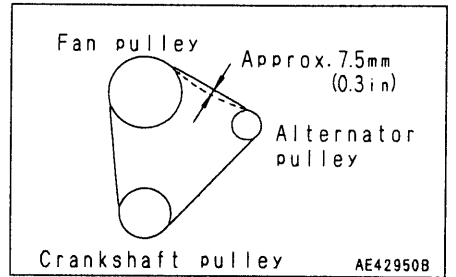
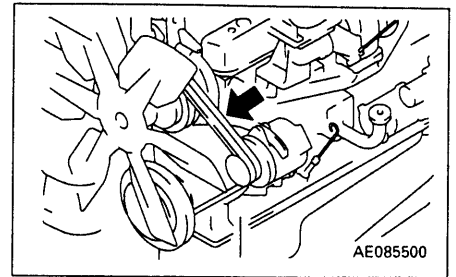

ADJUSTING

1. Fix alternator ① by inserting bar between it and the exhaust manifold. When fixing, insert a piece of wood between the bar and alternator ① to prevent damage to the alternator.
2. Loosen bolt ② and nut ③.
3. Move alternator ① using the bar so that the belt deflection is 7.5 mm (0.3 in) when pressed with a force of approx. 58.8 N (6 kgf).
4. Tighten nuts and bolts ②, and ③ to hold alternator ① in position.
5. Check each pulley for damage, wear of the groove, and wear of the belt. In particular, be sure to check that the belt is not touching the bottom of the groove.
6. Replace the belt if it has stretched, leaving no allowance for adjustment, or if there is any cut or crack on belt.
7. When replacing the V-belt, adjust the tension again after operating for one hour.

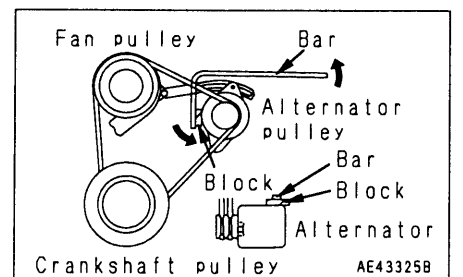
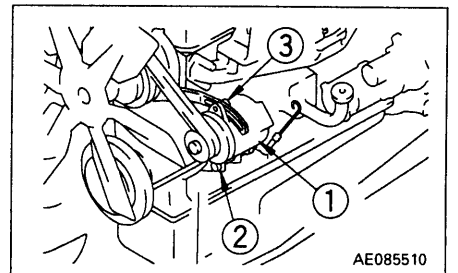

24.6.3 CHECK FOR LOOSE WHEEL HUB NUTS, TIGHTEN

If wheel hub nuts ① are loose, tire wear will be increased and accidents may be caused.

1. Check for loose nuts, and tighten if necessary.
When checking for loose nuts, always turn the nuts in the direction of tightening to check.

Tightening torque: $476 \pm 49 \text{ N}\cdot\text{m}$ ($48.5 \pm 5 \text{ kgf}\cdot\text{m}$, $350.8 \pm 36.2 \text{ lbft}$)

2. If any stud bolt is broken, replace all the stud bolts for that wheel.

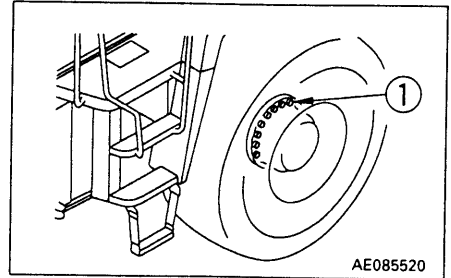
**24.6.4 CLEAN ELEMENT IN AIR CONDITIONER RECIRCULATION FILTER**

1. Open the filter inspection cover, remove the filter cover, then remove the filter in the direction of the arrow.
When removing the filter to the side, put your weight on the seat, and push down.
2. Clean with compressed air in the same way as for the fresh air filter.
If the filter is extremely dirty, rinse it in water. After rinsing the filter, dry it completely before installing it again.

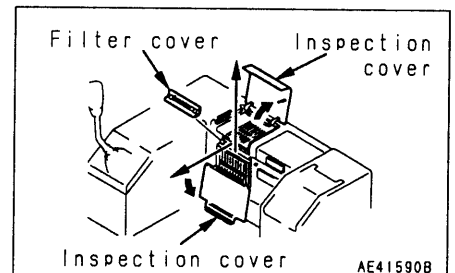

24.6.5 CHECK AIR CONDITIONER COMPRESSOR BELT TENSION, ADJUST

CHECKING

The deflection of the belt should be approx. 11 – 15 mm (0.4 – 0.6 in) when pressed with the thumb force of approx. 98.1 N (10 kgf) at a point midway between the air conditioner compressor pulley and fan pulley.

When belt tension gauge is used, it is considered normal for tension to remain in the range of 353 – 530 N (36 – 54 kgf).

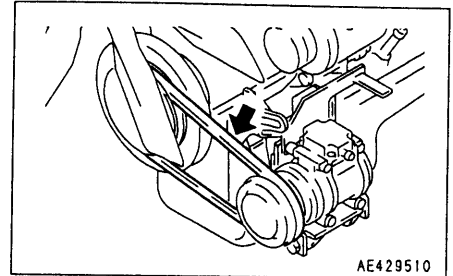

Check when changing the V-belt

The deflection of the belt should be approx. 8 – 11.5 mm (0.315 – 0.45 in) when pressed with the thumb force of approx. 98.1 N (10 kgf) at a point midway between the air conditioner compressor pulley and fan pulley.

When belt tension gauge is used, it is considered normal for tension to remain in the range of 530 – 745 N (54 – 76 kgf).

ADJUSTING

Loosen bolt ① and move compressor ② to adjust the belt tension.

Check each pulley for damage, wear of the V-groove, and wear of the V-belt. In particular, be sure to check that the V-belt is not touching the bottom of the V-groove.

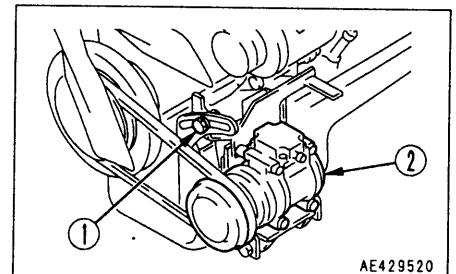

Replace the V-belt if it has stretched, leaving no allowance for adjustment, or if there is any cut or crack on belt.

When adjusting the V-belt, do not push the compressor directly with a bar. Use a wrench.

24.6.6 CHECK BATTERY ELECTROLYTE LEVEL

⚠ WARNING

- To avoid gas explosions, do not bring fire or sparks near the battery.
- Battery electrolyte is dangerous. If it gets in your eyes or on your skin, wash it off with large amounts of water, and consult a doctor.
- Do not use or charge the battery if the battery electrolyte level is below the LOWER LEVEL line. This may cause an explosion. Always check the battery electrolyte level periodically and add distilled water to bring the electrolyte level to the UPPER LEVEL line.

Carry out this check before operating the machine.

1. Open the cover of the battery box.
There are two battery boxes: One on each side at the rear of the machine.
2. Remove cap ①, and check that the battery electrolyte is up to the UPPER LEVEL line. If the level is low, add distilled water. Do not add water above the UPPER LEVEL line. This may cause leakage of the electrolyte, which may cause fire.

If the battery electrolyte is spilled, have dilute sulphuric acid added.

3. If distilled water has been added to any cell of cap ①, add distilled water also to the other cells.
4. Clean the air hole in battery cap ①, then tighten the cap securely. Keep the upper face of the battery clean.

NOTICE

When adding distilled water in cold weather, add it before starting operations in the morning to prevent the electrolyte from freezing.

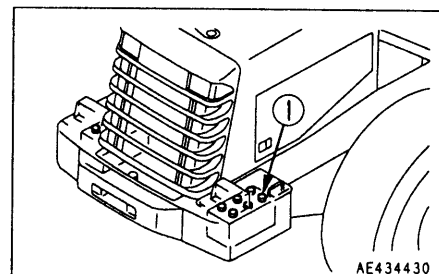

24.6.7 CHECK PARKING BRAKE

1. Stop the machine on a downhill road, turn the parking brake switch ON, and check that the machine is held in position.
2. If there is any abnormality, please contact your Komatsu distributor for adjustment.

24.6.8 LUBRICATING

⚠ WARNING

- Apply the parking brake, and lock the front and rear frames with the safety bar and pin.
- Set the work equipment in a stable condition, then stop the engine and apply the locks securely to the work equipment control levers.

1. Using a grease pump, pump in grease through the grease fittings marked by the arrows.
 2. After greasing, wipe off any old grease that is pushed out.
1. Bucket pin (2 points)
 2. Bucket link pin (2 points)
 3. Dump cylinder pin (2 points)
 4. Lift cylinder pin (4 points)
 5. Lift arm pivot pin (2 points)
 6. Tilt lever pin (1 point)
 7. Steering cylinder pin (4 points)

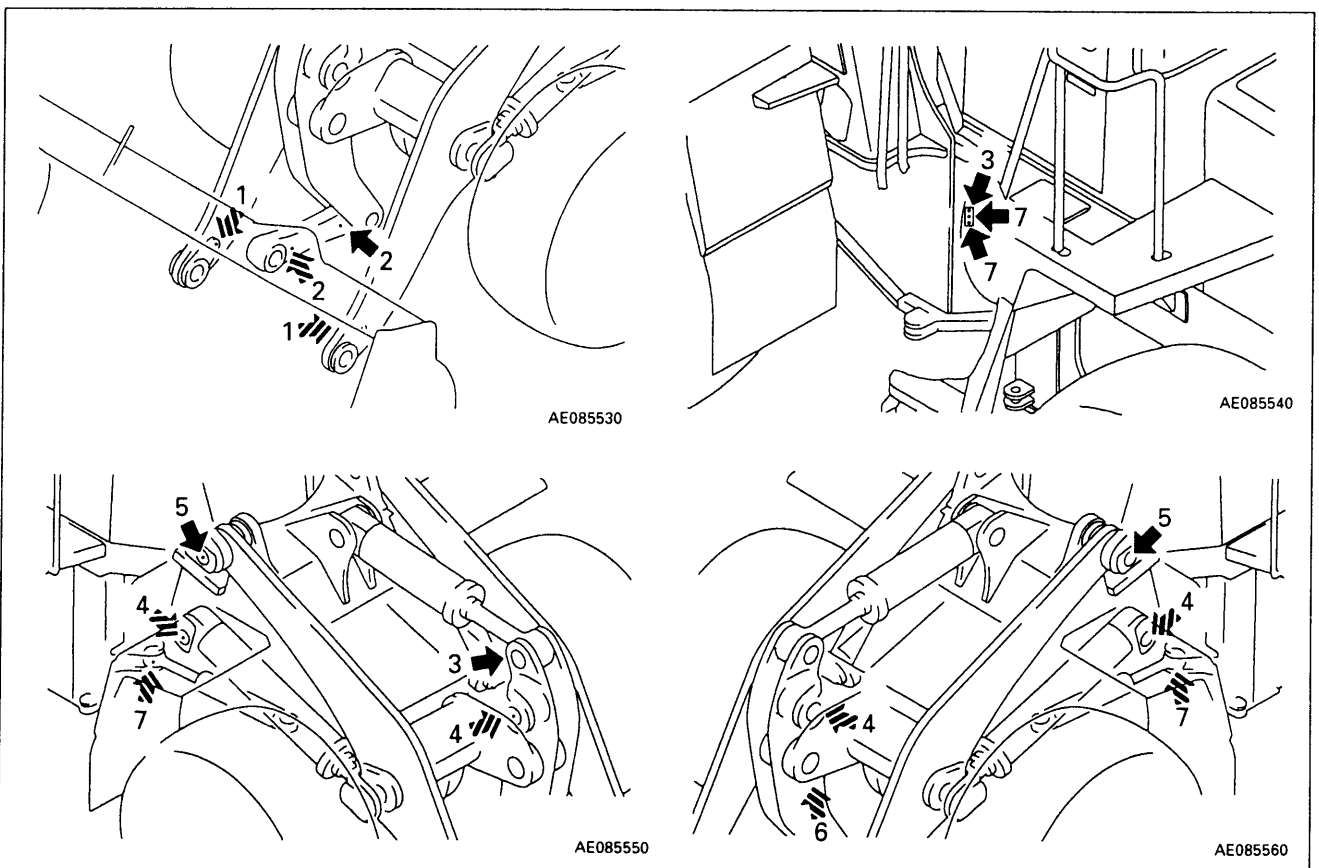

24.7 EVERY 500 HOURS SERVICE

Maintenance for every 50, 100 and 250 hours should be carried out at the same time.

24.7.1 REPLACE FUEL FILTER CARTRIDGE

WARNING

- Engine is at high temperature immediately after the machine has been operated. Wait for engine to cool down before replacing the filter.
- Do not bring fire or sparks near the fuel.

Prepare a filter wrench and a container to catch the fuel.

1. Open the side cover located on the left of the machine.
2. Set the container to catch the fuel under the filter cartridge.
3. Using a filter wrench, turn filter cartridge ① counterclockwise to remove it.
4. Clean the filter holder, fill a new filter cartridge with clean fuel, coat the packing surface with engine oil, then install it to the filter holder.
5. When installing, tighten until the packing surface contacts the seal surface of the filter holder, then tighten approx. 2/3 of a turn. If the filter cartridge is tightened too far, the packing will be damaged and this will lead to leakage of fuel. If the filter cartridge is too loose, fuel will also leak from the packing, so always tighten to the correct amount.
6. After replacing filter cartridge ①, loosen air bleed plug ②.
7. Loosen feed pump knob ③ and move the pump up and down to draw off fuel until air ceases to come out of air bleed plug ②.
8. After bleeding the air, tighten air bleed plug ②, then push in the knob of feed pump ③ and tighten it.

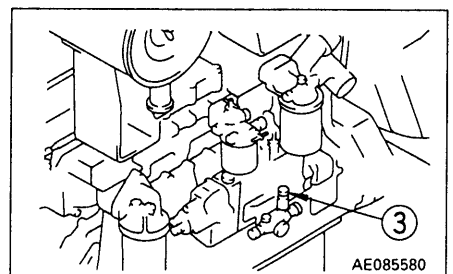
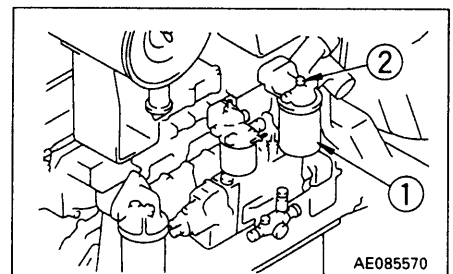

 **WARNING**

When cranking the engine, confirm the safety around the engine, as the engine may start.

9. After replacing the filter cartridge, turn the key in the starting switch to the START position. The air will be bled within a few seconds and the engine will start. When the engine starts, check for any leakage from the filter seal surface. If there is any leakage, check the tightening of the filter cartridge. If there is still any leakage, follow the procedure in Steps 2 and 3 to remove the filter cartridge, and check the packing surface. If there is any damage or any dirt or dust caught in the surface, replace the packing with a new part, then repeat Steps 4 to 9 to install again.

24.7.2 LUBRICATE CENTER DRIVE SHAFT SPLINE (1 point)

⚠ WARNING

- Apply the parking brake, and lock the front and rear frames with the safety bar and pin.
- Set the work equipment in a stable condition, then stop the engine and apply the locks securely to the work equipment control levers.

1. Using a grease pump, pump in grease through the grease fittings marked by the arrows.
2. After greasing, wipe off any old grease that is pushed out.

REMARK

Carry out the same procedure also for machines equipped with the auto-greasing system.

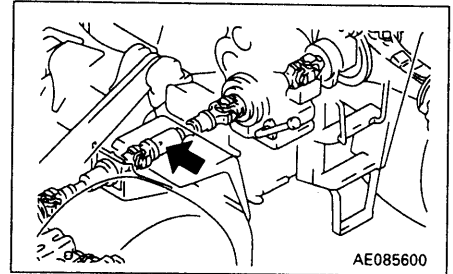

24.7.3 CHECK FAN BELT FOR WEAR

Check the V-belt and when the following conditions exist, replace or adjust the V-belt.

- When there is a clearance between the tension pulley lever and tip of the adjustment screw.
- When the V-belt makes contact with the bottom of the groove in each pulley.
- When the V-belt is worn, and its surface is lower than the outer diameter of the pulley.
- When the V-belt is cracked or flaked.
- When the V-belt makes an abnormal noise.

24.8 EVERY 1000 HOURS SERVICE

Maintenance for every 50, 100, 250 and 500 hours should be carried out at the same time.

24.8.1 CHANGE OIL IN TRANSMISSION CASE AND TRANSMISSION OIL FILTER CARTRIDGE, CLEAN STRAINER

WARNING

The oil is at high temperature immediately after the machine has been operated. Wait for the oil to cool down before carrying out maintenance.

- Container to catch drained oil: Min. 60 ℓ capacity
- Refill capacity: 60 ℓ (15.84 US gal, 13.20 UK gal)

1. Set a container to catch the oil under drain plug **(P)**, then remove drain plug **(P)** and drain the oil.
To prevent the oil from pouring out suddenly, loosen drain plug **(P)** and remove it gradually.

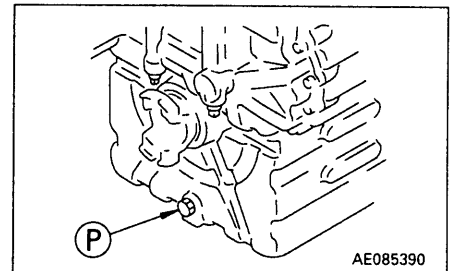

2. After draining the oil, install drain plug **(P)**.

Tightening torque: $68.6 \pm 9.81 \text{ N}\cdot\text{m}$ ($7.0 \pm 1.0 \text{ kgf}\cdot\text{m}$, $50.6 \pm 7.2 \text{ lbft}$)

3. Set a container to catch the oil under the transmission filter.
4. Using a filter wrench, turn filter cartridge **(1)** counterclockwise to remove it.
5. Clean the filter holder, coat the thread and seal surface of the new filter cartridge with clean engine oil, then install it to the filter holder.

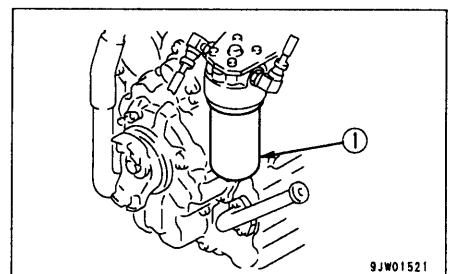

6. When installing, tighten until the seal surface contacts the filter holder, then tighten a further 2/5 turns with a filter wrench.
7. Remove bolt **(2)**, then remove cover **(3)** and take out strainer **(4)**, which is screwed into cover **(3)**.
8. Remove any dirt stuck to strainer **(4)**, then wash it in clean diesel oil or flushing oil. If strainer 4 is damaged, replace it with a new part.

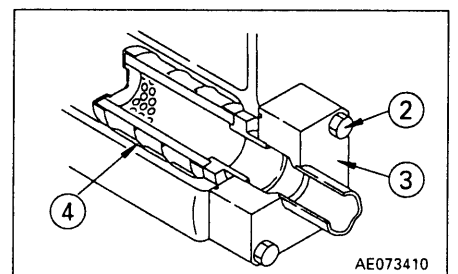

9. Install strainer **(4)** to cover **(3)**.

Strainer tightening torque: $107.9 \pm 14.7 \text{ N}\cdot\text{m}$
($11 \pm 1.5 \text{ kgf}\cdot\text{m}$, $79.6 \pm 10.8 \text{ lbft}$)

Replace the O-ring on the cover with a new part, then install the cover.

10. Pour in the specified amount of engine oil from oil filler ⑥.

For details of the oil to use, see "20. USE OF FUEL, COOLANT AND LUBRICANTS ACCORDING TO AMBIENT TEMPERATURE".

11. After filling with oil, check that the oil is at the specified level. For details, see "24.2 WHEN REQUIRED".
12. Check for oil leakage from the transmission case and filter.

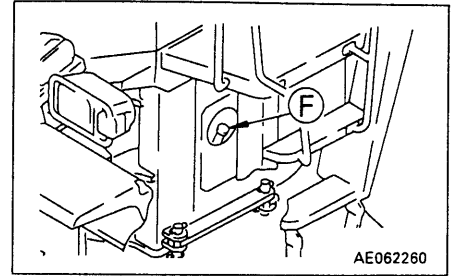

24.8.2 CLEAN TRANSMISSION CASE BREATHER

Remove all mud and dirt from around the breather, then remove the breather. Put in cleaning fluid and clean the breather.

Take care not to allow dust and dirt to enter the transmission case through the port while the breather is removed.

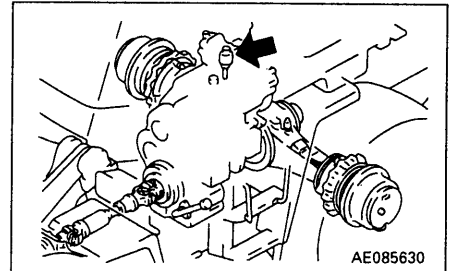

24.8.3 LUBRICATING

⚠ WARNING

- Apply the parking brake, and lock the front and rear frames with the safety bar and pin.
- Set the work equipment in a stable condition, then stop the engine and apply the locks securely to the work equipment control levers.

1. Using a grease pump, pump in grease through the grease fittings marked by the arrows.
2. After greasing, wipe off any old grease that is pushed out.

1. Center hinge pin (2 points)

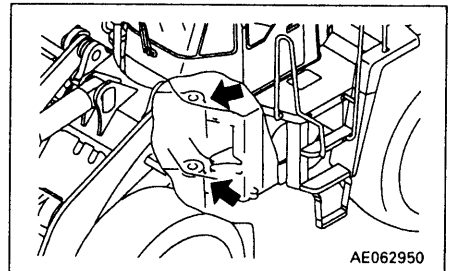

2. Front drive shaft (2 points)

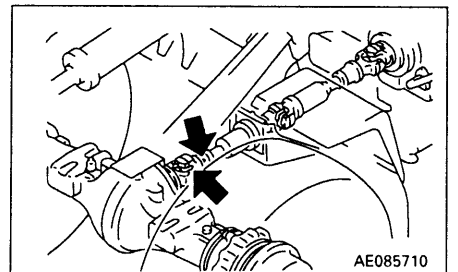

3. Drive shaft center support (1 point)

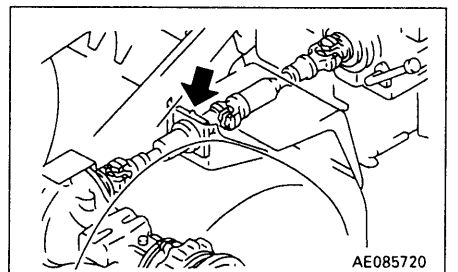

4. Center drive shaft (2 points)

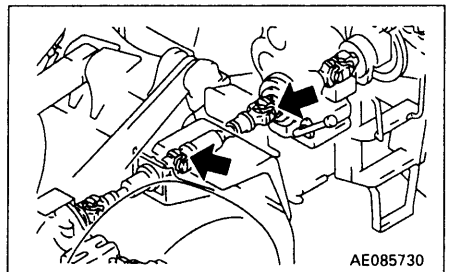

5. Rear drive shaft (2 points)

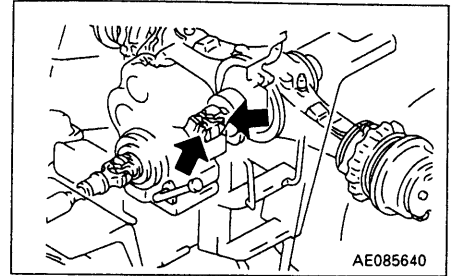

6. Engine stop motor linkage (1 point)

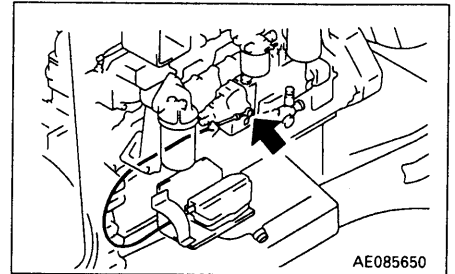

24.8.4 CHECK TIGHTENING PARTS OF TURBOCHARGER

Contact your Komatsu distributor to have the tightening portions checked.

24.8.5 CHECK PLAY OF TURBOCHARGER ROTOR

Ask your Komatsu distributor to check the play of the turbocharger rotor.

24.8.6 REPLACE CORROSION RESISTOR CARTRIDGE

1. Screw in valves ① at the corrosion resistor.
2. Using the filter wrench provided, remove cartridge ② by turning it counterclockwise.
3. Coat the seal surface of the new cartridge with engine oil, and install it to the filter holder.
4. When installing, bring the gasket into contact with the seal surface of the filter holder, then tighten approx. 2/3 turns.
5. After replacement, open valves ①.

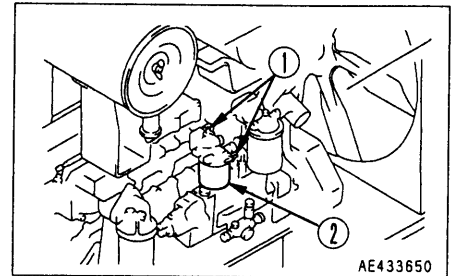

After replacing the cartridge, start the engine and check that there is no leakage of water from the filter seal surface.

24.9 EVERY 2000 HOURS SERVICE

Maintenance for every 50, 100, 250, 500 and 1000 hours should be carried out at the same time.

24.9.1 CHANGE OIL IN HYDRAULIC TANK, REPLACE HYDRAULIC FILTER ELEMENT

⚠ WARNING

The oil is at high temperature immediately after the machine has been operated. Wait for the oil to cool down before changing the oil. When removing the oil filler cap, turn it slowly to release the internal pressure, then remove it carefully.

Prepare the following.

- Container to catch drained oil: min. 138 ℓ capacity
- Refill capacity: 138 ℓ (36.43 US gal, 30.36 UK gal)

1. Lower the bucket horizontally to the ground and apply the parking brake, then stop the engine.
2. Remove the bolt, then remove the cover.
3. Remove the cap of oil filler (F).
4. Set a container to catch the oil under drain plug (1).
5. Remove drain plug (1).
6. Open drain valve (2) gradually to drain the oil.
7. After draining the oil, close drain valve (2), then tighten drain plug (1).

Tightening torque

Drain plug (1): $68.6 \pm 9.81 \text{ N}\cdot\text{m}$ ($7.0 \pm 1.0 \text{ kgf}\cdot\text{m}$, $50.6 \pm 7.2 \text{ lbft}$)

Drain valve (2): $63.7 \pm 14.7 \text{ N}\cdot\text{m}$ ($6.5 \pm 1.5 \text{ kgf}\cdot\text{m}$, $47.0 \pm 10.8 \text{ lbft}$)

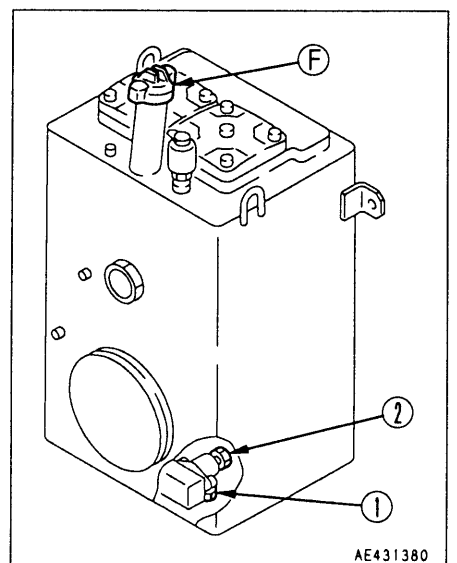
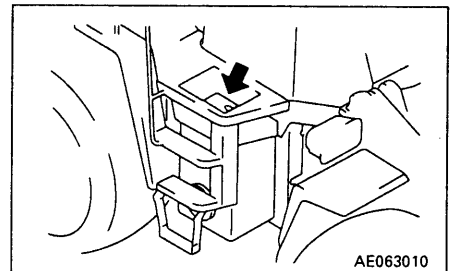

24. SERVICE PROCEDURE

- Remove mounting bolts ④ of the 2 filter covers ③ at the top of the tank, then remove the covers.

When doing this, the cover may fly off because of the force of spring ⑤, so keep the cover pushed down while removing the bolts.

- Remove spring ⑤ and bypass valve ⑥, then remove element ⑦.

- Check that there is no foreign matter inside the tank before cleaning it.

- Install a new element, then install bypass valve ⑥, spring ⑤, and cover ③.

If the O-ring of the cover is damaged or deteriorated, replace it with a new part.

- When installing the cover bolts, push down the cover and tighten the bolts evenly.

- Add engine oil through oil filler port ① to the specified level, then install cap ②.

For details of the oil to use, see "20. USE OF FUEL, COOLANT AND LUBRICANTS ACCORDING TO AMBIENT TEMPERATURE".

- Check that the hydraulic oil is at the standard level. For details, see "24.5 EVERY 100 HOUR SERVICE".

- Run the engine at low idling, and extend and retract the steering, bucket, and lift arm cylinders 4 – 5 times. Be careful not to operate the cylinder to the end of its stroke (stop approx. 100 mm (3.9 in) before the end of stroke).

NOTICE

If the engine is run immediately at high speed or the cylinder is operated to the end of its stroke, the air inside the cylinder will cause damage to the piston packing.

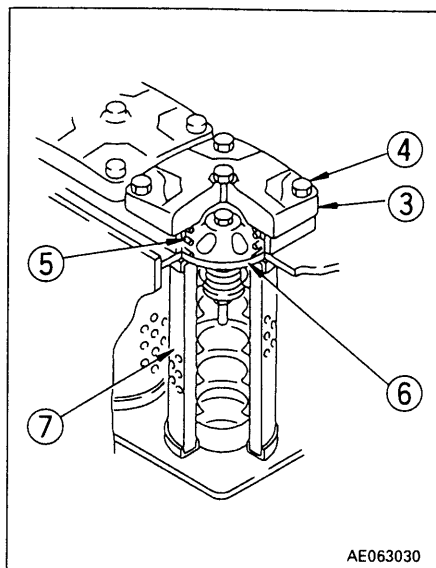

16. Next, operate the steering, bucket, and lift arm cylinders to the end of their stroke 3 – 4 times, then stop the engine and loosen bleed plug ⑧ to bleed the air from the hydraulic tank. After bleeding the air, tighten plug ⑧ again.
Run the engine at low idling when bleeding the air.

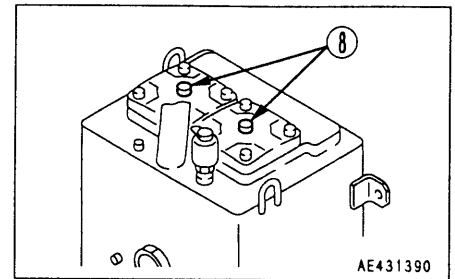

17. Check the hydraulic oil level and add oil to the specified level. For details, see "24.5 EVERY 100 HOURS SERVICE".
18. Next, increase the engine speed and repeat the procedure in Step 16 to bleed the air. Continue this operation until no more air comes out from plug ⑧.
19. After completing the air bleed operation, tighten plug ⑧.

Tightening torque: $11.3 \pm 1.47 \text{ N}\cdot\text{m}$ ($1.15 \pm 0.15 \text{ kgf}\cdot\text{m}$, $8.3 \pm 1.1 \text{ lbft}$)

20. Check that the hydraulic oil is at the standard level. For details, see "24.5 EVERY 100 HOUR SERVICE".
21. Check that there is no leakage of oil from the filter cover mount.

24.9.2 REPLACE HYDRAULIC TANK BREATHER ELEMENT

⚠ WARNING

The oil is at high temperature immediately after the machine has been operated. Wait for the oil to cool down before changing the oil. When removing the oil filler cap, turn it slowly to release the internal pressure, then remove it carefully.

1. Remove the cap of oil filler ⑥.
2. Remove the snap ring on breather ①, then remove the breather cap.
3. Replace the filter element with a new part, then the install cap and snap ring.
4. Tighten the cap of oil filler ⑥.

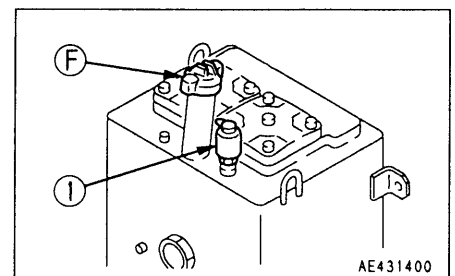

REMARK

It is possible to replace the element with the breather installed in the tank. However, if the breather is removed, do not wrap the taper thread of the breather with seal tape when assembling again, and be careful not to tighten too much.

24.9.3 CHANGE AXLE OIL

⚠ WARNING

The oil is at high temperature after the machine has been operated. Always wait for the temperature to go down before starting this operation.

Prepare the following.

- Container to catch drained oil: min. 120 ℓ capacity
- Refill, capacity (front and rear, each):
60 ℓ (15.84 US gal, 13.20 UK gal)

1. Set a container to catch the oil under drain plug (P).
2. Remove front and rear oil filler plugs (F), then remove drain plug (P) to drain the oil.
3. After draining the oil, clean drain plug (P), then install it.
4. Remove level plug (I) and add axle oil until it is near the bottom edge of the plug hole.

For details of the oil to use, see "20. USE OF FUEL, COOLANT AND LUBRICANTS ACCORDING TO AMBIENT TEMPERATURE".

5. After adding oil, check that the oil is at the specified level. For details, see "24.2 WHEN REQUIRED".

REMARK

For operations where the brake is used frequently, change the axle oil at shorter intervals.

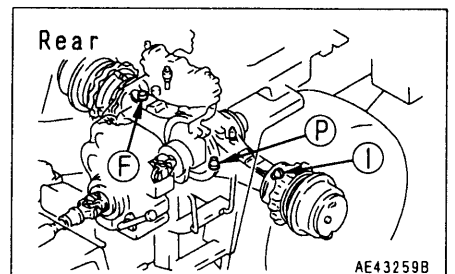
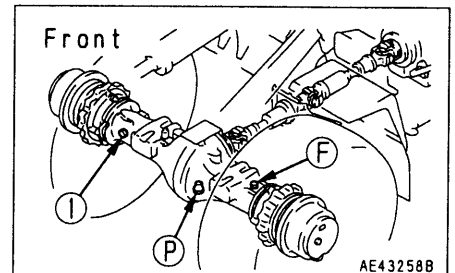

24.9.4 CHECK BRAKE DISC WEAR

Ask Komatsu distributor to check and repair brake disc.

24.9.5 CHECK ALTERNATOR, STARTING MOTOR

The brush may be worn, or the bearing may have run out of grease, so contact your Komatsu distributor for inspection or repair.

If the engine is started frequently, carry out inspection every 1000 hours.

24.9.6 CHECK ENGINE VALVE CLEARANCE, ADJUST

As special tool is required for removing and adjusting the parts, request your Komatsu distributor for service.

24.9.7 CHECK VIBRATION DAMPER

Check that there are no cracks or peeling in the outside surface of the rubber.

If any cracks or peeling are found, contact your Komatsu distributor to have the parts replaced.

24.9.8 REPLACE ELEMENT IN AIR CONDITIONER RECIRCULATION AIR FILTER, FRESH AIR FILTER

Remove both the recirculation air filter and fresh air filter in the same way as when cleaning, and replace them with new parts.

For details of cleaning the recirculation air filter, see "24.6.4 CLEAN ELEMENT IN AIR CONDITIONER RECIRCULATION FILTER".

For details of cleaning the fresh air filter, see "24.5.2 CLEAN ELEMENT IN AIR CONDITIONER FRESH AIR FILTER".

24.9.9 CLEAN AND CHECK TURBOCHARGER

If there is carbon or oil sludge stuck to the blower impeller, it will lower the performance of the turbocharger or cause it to break, so ask your Komatsu distributor to carry out the cleaning.

24.9.10 CLEAN PPC CIRCUIT STRAINER

1. Remove flange ①.
2. Remove strainer case ②, take out the strainer, wash it in clean diesel oil.
3. Assemble the strainer to strainer case ②, then install with flange ①.

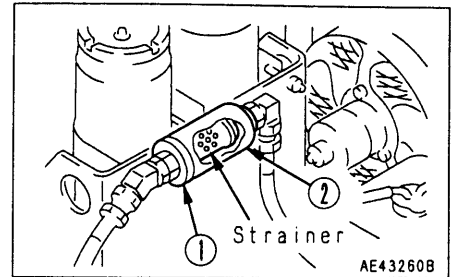

24.9.11 CHECK ACCUMULATOR GAS PRESSURE

When carrying out the EVERY 2000 HOURS SERVICE or EVERY YEAR SERVICE or when making periodic replacement of the critical safety parts, please ask your Komatsu distributor to check the accumulator gas pressure.

24.9.12 CLEAN ENGINE BREATHER ELEMENT

⚠ WARNING

The parts and oil are at high temperature immediately after the engine has been stopped, and there is danger of burns, so wait for the temperature to go down before starting the operation. When using compressed air, there is danger that dust may fly and cause personal injury. Always wear protective glasses, dust mask, or other protective clothing.

1. Wipe off the dirt from around the breather.
2. Loosen the clamp, remove the hose, then remove breather ① from the cylinder head cover.
3. Wash the breather in diesel oil or flushing oil, then dry it with compressed air and install it again.
4. Replace the breather O-ring with a new part, coat with engine oil when installing, then install breather ①.
5. Check the breather hose and pipe, and if any deteriorated oil (sludge) is stuck to the inside, replace with a new hose and pipe.

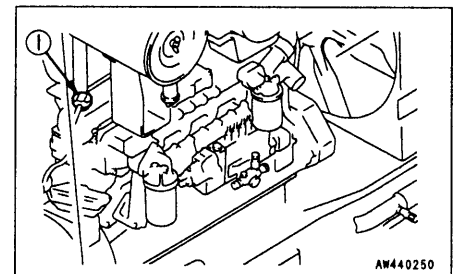

24.10 EVERY 4000 HOURS SERVICE

Maintenance for every 50, 100, 250, 500, 1000 and 2000 hours should be carried out at the same time.

24.10.1 CHECK WATER PUMP

Check that there is no play in the pulley, grease leakage, water leakage, or clogging of the drain hole. If any abnormality is found, please contact your Komatsu distributor for disassembly and repair or replacement.

24.10.2 CHECK AND ADJUST OF THE AIR CONDITIONER (if equipped)

Ask your Komatsu distributor to check and adjust of the air conditioner.

SPECIFICATIONS

25. SPECIFICATIONS

WA420-3

PERFORMANCE

● Bucket capacity		3.7 m ³ (4.8 cu.yd)	
● Normal load		5920 kg (13054 lb)	
● Travel speed	Forward	1st	6.3 km/h (3.9 MPH)
		2nd	11.7 km/h (7.3 MPH)
		3rd	20.5 km/h (12.7 MPH)
		4th	32.8 km/h (20.4 MPH)
	Reverse	1st	6.6 km/h (4.1 MPH)
		2nd	12.2 km/h (7.6 MPH)
		3rd	21.2 km/h (13.2 MPH)
		4th	33.9 km/h (21.1 MPH)
● Max. rimpull		175540 N (17900 kgf)	
● Min. turning radius	Outside of chassis	6635 mm (21 ft 9 in)	
	Center of outside tire	5650 mm (18 ft 6 in)	

WEIGHT

● Operating weight (including 1 operator: 80 kg (176 lb.) (with bolt on cutting edge)	18630 kg (41079 lb)
--	---------------------

ENGINE

● Model	Komatsu SA6D108 diesel engine
● Flywheel horsepower	162 kW (217 HP)/2200 rpm
● Max. torque	847 N•m (86.4 kgf•m)/1500 rpm
● Starting motor	24 V 7.5 kW
● Alternator	24 V 35 A
● Battery	12 V 150 Ah x 2 pieces (145G51)

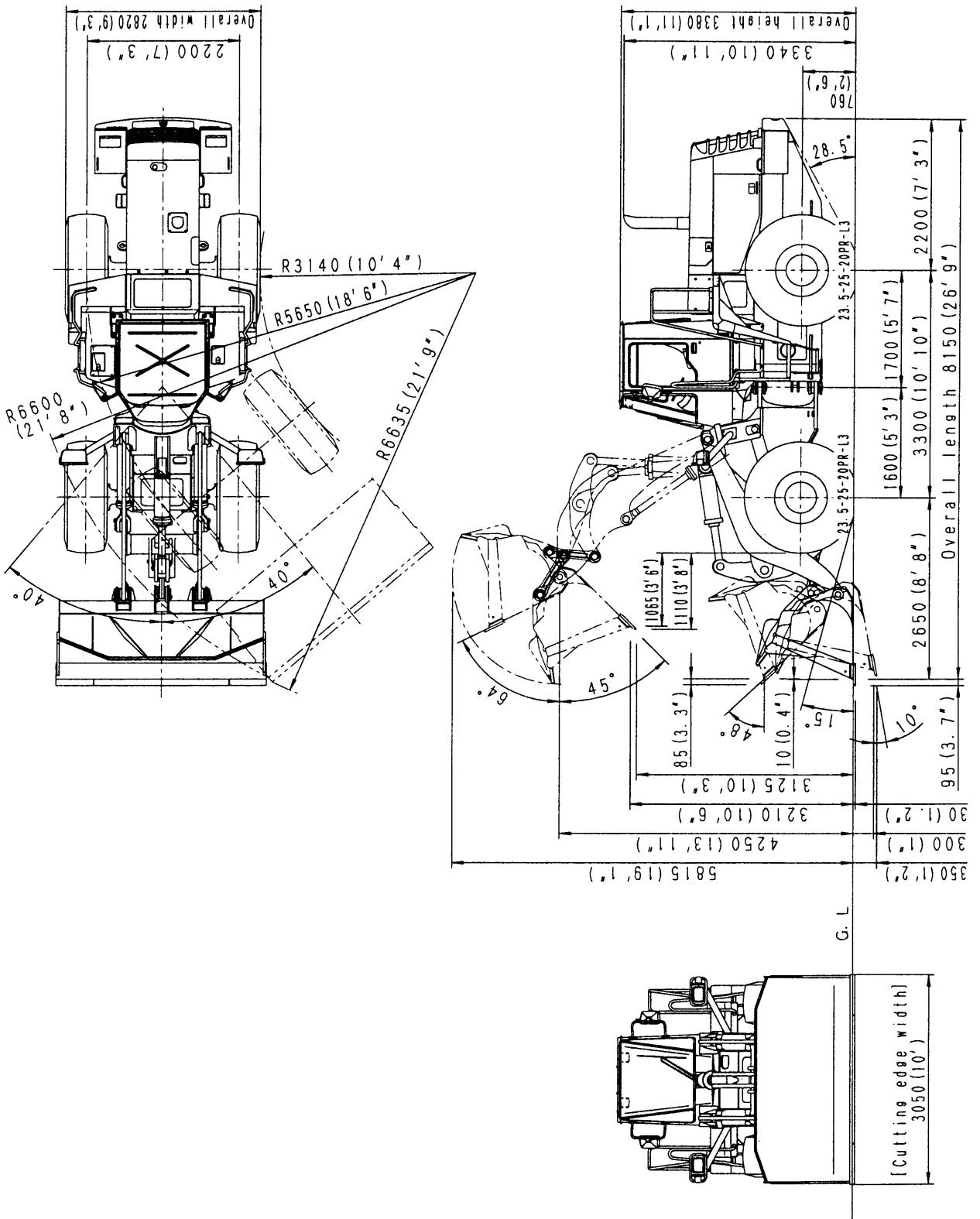

A043366B

OPTIONS, ATTACHMENTS

26. OPTIONAL PARTS AND ATTACHMENTS

Name	Specifications, use
Bucket	Capacity (spade nose, for rock) 2.8 m ³ (3.6 cu.yd)
Excavating bucket	Capacity (with teeth) 2.8 m ³ (3.6 cu.yd)
Light material bucket	Capacity (for light duty work with BOC) 4.6 m ³ (6.0 cu.yd)
Bucket tooth	<ul style="list-style-type: none">● Bolt-on tooth● Tip tooth
Cutting edge	Bolt-on edge
Log grapple	Loading and carrying large logs

The following attachments are also available, so please contact your Komatsu distributor.

- Steel cab (with overhead guard)
- ROPS canopy
- Canopy
- E.C.S.S. (Electronic controlled suspension system)
- Auto-greasing kit
- Emergency steering
- Auto-leveling, remote positioner
- Rear full fender
- Tires

27. SELECTING BUCKETS AND TIRES

Select the most suitable bucket and tires for the type of work and jobsite conditions.

Type of work	Bucket	Ground conditions	Tire	
			Standard	Large size
<ul style="list-style-type: none"> ● Loading products ● Loading and carrying products 	Stockpile bucket (with bolt-on edge) (3.7 m ³ (4.8 cu.yd))	General ground conditions	23.5-25-16PR (Rock)	26.5-25-16PR (Rock)
		Leveled ground	23.5-25-16PR (Traction)	26.5-25-16PR (Traction)
		Hard ground	23.5-25-20PR (Rock)	26.5-25-20PR (Rock)
<ul style="list-style-type: none"> ● Loading products and crushed rock 	Stockpile bucket (with teeth) (3.5 m ³ (4.5 cu.yd))	General ground conditions	23.5-25-20PR (Rock)	26.5-25-20PR (Rock)
		Hard ground	23.5-25-20PR (Rock)	26.5-25-20PR (Rock)
<ul style="list-style-type: none"> ● Loading crushed rock 	Excavating bucket (2.8 m ³ (3.6 cu.yd))	General ground conditions	23.5-25-20PR (Rock)	26.5-25-20PR (Rock)
		Hard ground	23.5-25-20PR (Rock)	26.5-25-20PR (Rock)
	Spade nose bucket (2.8 m ³ (3.6 cu.yd))	Ground with many light rocks	23.5-25-20PR (Rock, side steel breaker)	26.5-25-20PR (Rock, side steel breaker)
		Soft ground with many light rocks	23.5-25-16PR (Rock, side steel breaker)	26.5-25-20PR (Rock, side steel breaker)
<ul style="list-style-type: none"> ● Loading and carrying crushed rock 	Spade nose bucket (2.8 m ³ (3.6 cu.yd))	General ground conditions	23.5-25-20PR (Rock)	26.5-25-20PR (Rock)
		Soft ground	23.5-25-20PR (Rock)	26.5-25-20PR (Rock)
		Ground with many rocks and stones	23.5-25-20PR (Rock, steel breaker)	26.5-25-20PR (Rock, steel breaker)
		Soft ground with many rocks and stones	23.5-25-16PR (Rock, steel breaker)	26.5-25-16PR (Rock, steel breaker)

The speed display differs according to the tire size, so when using optional tires, please contact your Komatsu distributor.

28. CAR RADIO

28.1 EXPLANATION OF COMPONENTS

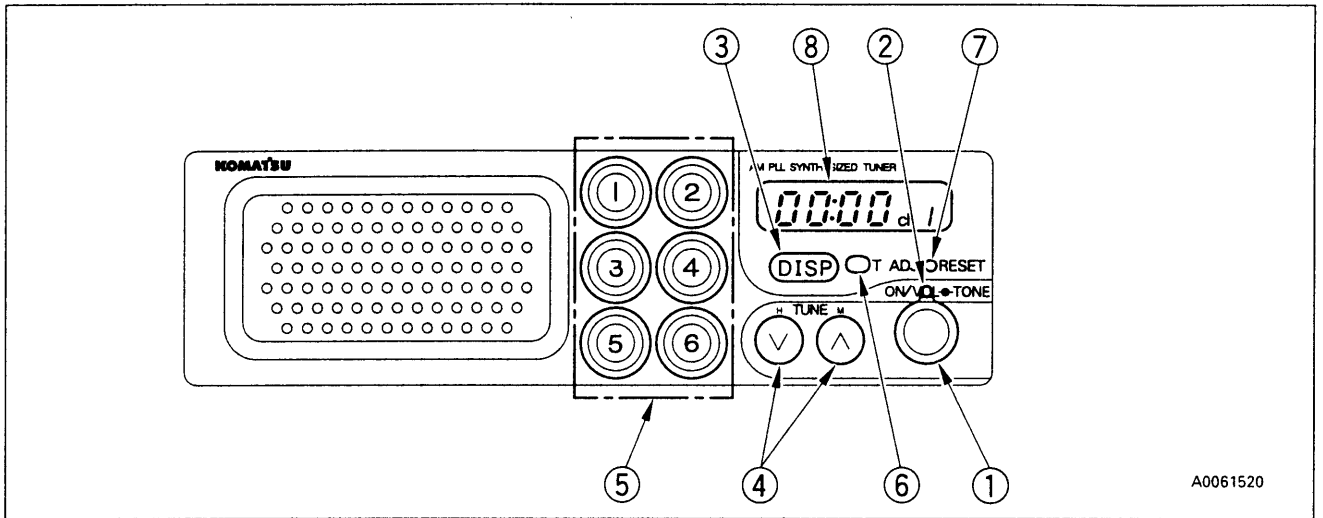

1. POWER SWITCH/VOLUME CONTROL KNOB (PUSH/VOL)

Push this knob to switch the radio on. The lighting in display area ① will light up and the frequency will be displayed. Press again to switch the power off.

Turn the knob clockwise to increase the sound, and counterclockwise to reduce it.

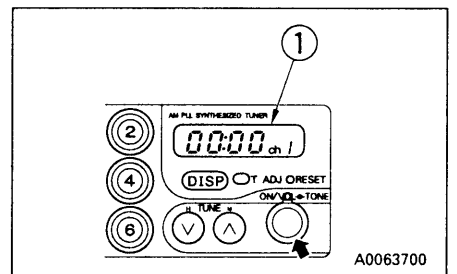

2. TONE CONTROL KNOB (TONE)

Turn this knob clockwise from the center position to emphasize the high sounds, and counterclockwise to emphasize the low sounds.

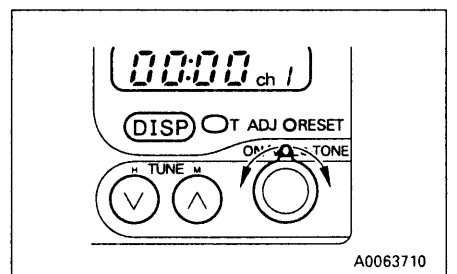

3. DISPLAY BUTTON (DISP)

If the display button is pressed when the radio is being used, the frequency of the station being listened to is displayed for 5 seconds.

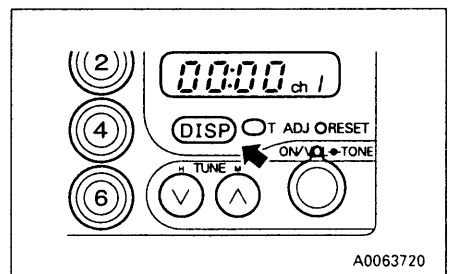

4. TUNING/HOUR, MIN ADJUSTMENT BUTTON (TUNE)

This is used to select the station or change the frequency.

If the station UP button \wedge is pressed, the frequency will go up by 9 kHz each time it is pressed; if the station DOWN button \vee is pressed, the frequency will go down 9 kHz each time it is pressed.

If these buttons are kept pressed for more than 2 seconds, the station will be selected automatically.

When adjusting the time, these change the hour display and minute display.

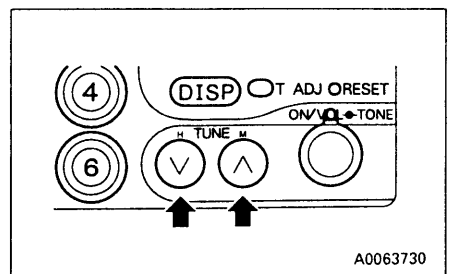

5. PRESET BUTTON (1, 2, 3, 4, 5, 6)

These buttons can be used to program the desired broadcasting stations. It is then possible to select the station at a touch.

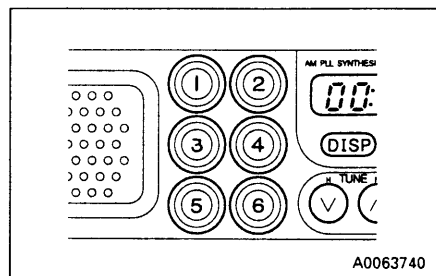

6. TIME ADJUSTMENT BUTTON (T.ADJ)

Press this button to adjust the time.

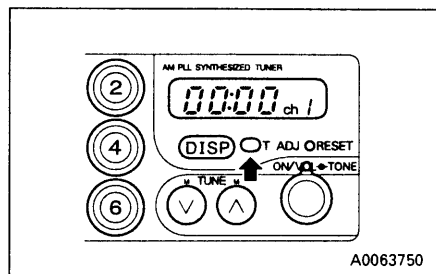

7. TIME RESET BUTTON (RESET)

Press this button to reset to the exact hour.

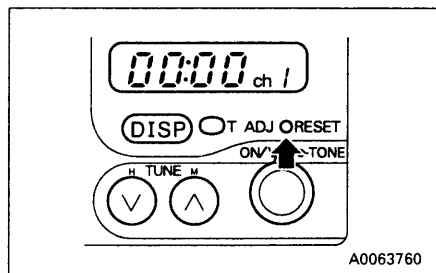

8. DISPLAY

This displays the frequency, time, and preset symbols.

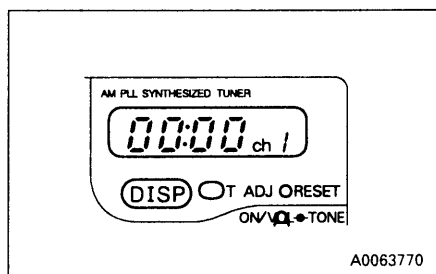

28.2 METHOD OF USE
METHOD OF SETTING PRESET BUTTONS

1. Press power switch ①. The frequency is displayed in display area ②.
2. Use selector button ③ (∧ or ∨) to adjust to the desired frequency.
3. Choose a preset button to use for this station, and keep it pressed for at least 2 seconds to program the button to that frequency.
 When the sound suddenly disappears and appears again, the button is programmed, and the preset number is shown in display area ②.

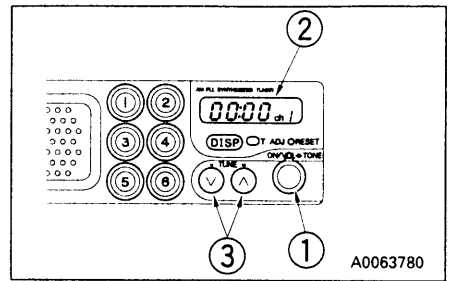

After programming the button, press the preset button and release it within approx. 2 sec. The station programmed to that button will be selected for reception.

It is possible to program one station for each preset button.

METHOD OF MANUAL TUNING

Press the tuning button lightly to adjust to the desired frequency. Each time the button is pressed, the frequency will change by 9 kHz.

- ∧ button: Select station at higher frequency
- ∨ button: Select station at lower frequency

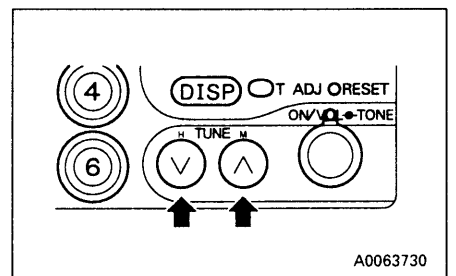

METHOD OF AUTOMATIC TUNING

Keep the tuning button pressed for at least 2 seconds and then release it. When reception from a broadcasting station is picked up, the selector will automatically stop at that position.

When searching for the next station, keep the selector button pressed again for at least 2 seconds.

- ∧ button: Select station at higher frequency
- ∨ button: Select station at lower frequency

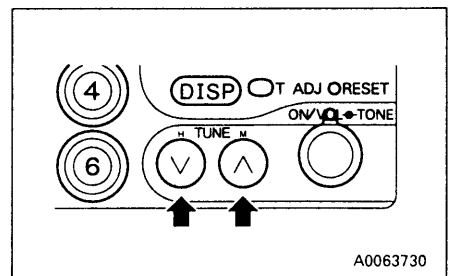

If the reception is weak, and stations are not found, adjust the frequency manually to select the desired station.

ADJUSTING TIME

1. Keep T.ADJ button ① pressed, and press H button ②.
The hour display will change, so when it reaches the correct hour, release the button.
2. Keep T.ADJ button ① pressed and press M button ③.
The minute display will change, so when it reaches the correct time, release the button.

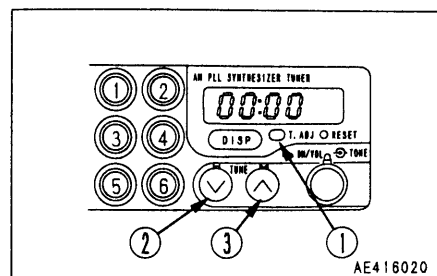
**METHOD OF USING PRESET BUTTON**

If RESET button ① is pressed at the same time as the time signal or standard time, the display will return immediately to the exact hour (○ hour 00 min).

If the display is 01 – 29 min, the display will go back to 0 min.

If the display is 30 – 59 min, the display will advance to 0 min.

[Example]

10:29 → 10:00 (return to exact hour)

10:30 → 11:00 (advance to exact hour)

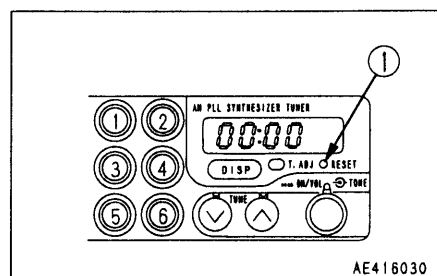
**28.3 PRECAUTIONS WHEN USING RADIO**

- Retract the antenna when traveling in places with low overhead clearance.
- For safety reasons, when operating keep the sound to a level where you can enjoy the sound but still hear the sound from outside vehicles.
- If water gets inside the speaker case or car radio (auto tuning), it may cause a serious problem, so do not let water get on these parts.
- Do not wipe the knobs or buttons or any other parts with any solvent such as benzene or thinner. Always wipe with a soft dry cloth (in cases of extreme dirt, use alcohol on the cloth).

29. AIR CONDITIONER

29.1 GENERAL LOCATIONS AND FUNCTION OF CONTROL PANEL

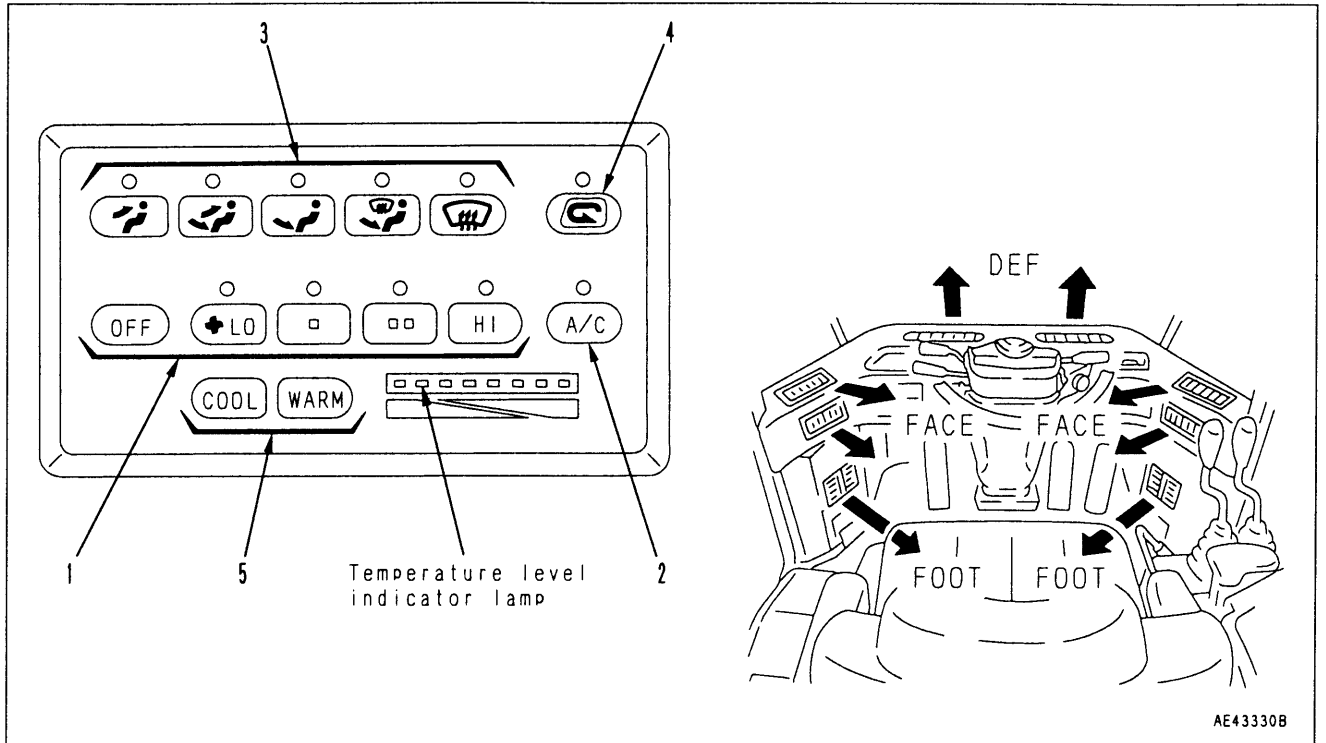

1. FAN SWITCH

This can be used to adjust the air flow to 4 stages.

This switch also acts as the main switch for the air conditioner.

When the switch is pressed, the indicator lamp above the switch lights up to indicate the air flow.

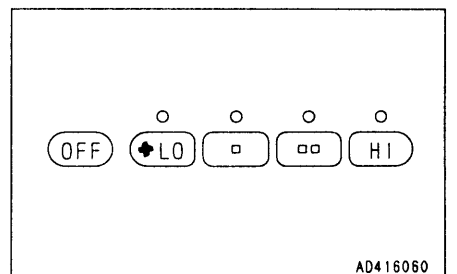

2. AIR CONDITIONER SWITCH

This is used to start or stop the cooling or dehumidifying function.

When the fan switch is turned ON and the air conditioner switch is pressed, the indicator lamp above the switch lights up.

When the switch is pressed again, the switch is turned OFF and the indicator lamp goes out.

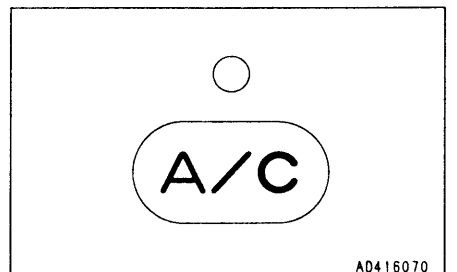

3. MODE SELECTOR SWITCH

This is used to select the vents.

The following five vent modes are available: FACE, FACE/FOOT, FOOT, FOOT/DEF, DEF.

When the switch is pressed, the indicator lamp above the switch lights up to display the vent mode.

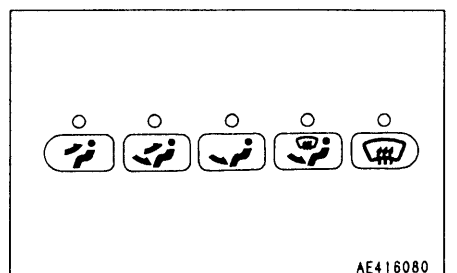

4. FRESH/RECIRC SELECTOR SWITCH

This switch is used to select between recirculating the air inside the cab or taking in fresh air from outside.

When the RECIRC position is selected, the indicator lamp above the switch lights up.

When the switch is pressed again, the indicator lamp goes out, and fresh air is taken in.

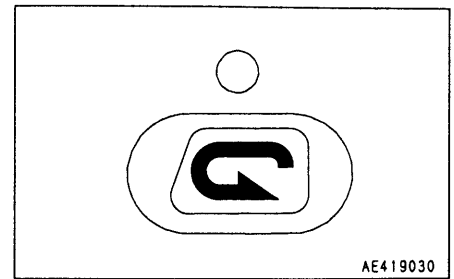

5. TEMPERATURE CONTROL SWITCH

The temperature can be adjusted steplessly from low temperature to high temperature.

The temperature level indicator lamps light up to display the temperature of the air coming from the vents.

The more the blue lamps light up, the lower the temperature is.

The color of the indicator lamp changes while the switch is being pressed.

When the temperature reaches the desired level, release the switch to set the temperature.

The settings for each mode are retained in memory even when the starting switch is turned OFF.

However, in the following cases, the settings must be made again.

- When the machine has been out of use for more than 7 days
- When the battery voltage is extremely low
- When there has been abnormal interference from outside
- When the fan switch is turned OFF (the setting is not kept in memory with only the air conditioner switch)

If the air conditioner is used at the FRESH position, the inside of the cab will be pressurized and this will prevent the entry of dust.

The higher the position of the fan switch, the more effective the pressurizing becomes.

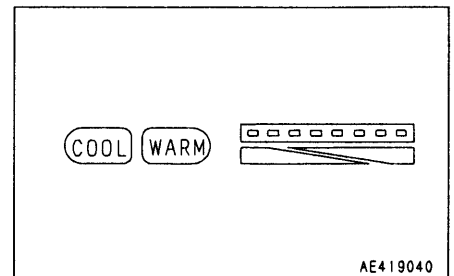

29.2 METHOD OF OPERATION

Condition of use		Switch	Fan switch	Air conditioner switch	Temperature control switch	FRESH/RECIRC switch	Vent mode selector switch
Cooling	Rapid		HI	ON	All blue	RECIRC	FACE
	Normal		HI-LO	ON	More than half are blue	FRESH	FACE
Dehumidifying, heating			HI-LO	ON	More than half are red	FRESH	FOOT
Heating	Rapid		HI	OFF	All red	RECIRC	FOOT
	Normal		HI-LO	OFF	More than half are red	FRESH	FOOT
Defroster			HI	ON	More than half are red	FRESH	DEF
Ventilation or pressurizing			HI-LO	OFF	All blue	FRESH	FACE

When carrying out the defrosting, if the temperature control switch is set so that all lamps are red, this will improve the performance for defrosting and demisting.

Set the vent mode selector switch to the intermediate position to give the desired condition.

With the FACE vents, it is possible to adjust the direction of the air flow and to turn it on or off.

However, do not set to the FACE mode with the vents closed.

WHEN NOT USING THE AIR CONDITIONER REGULARLY

To lubricate each part of the compressor, occasionally operate cooling, dehumidifying and heating for a few minutes.

REMARK

When temperature in the cab is low, the air conditioner may not operate. In such cases, warm the air inside the cab by recirculating, and then turn on the air conditioner.

29.3 COOL BOX

When the cooling is being used, this can be used for keeping drinks and other things cool.

When the heating is being used, it can be used to keep things warm.

When using the box, open the vent grill. When not using the box, close the grill.

Do not use the cool box for things which smell or leak water or break easily.

Do not use it as a holder for tools or other small objects.

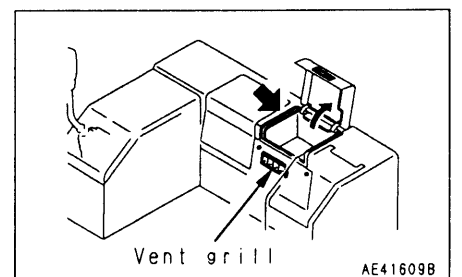

30. HANDLING E.C.S.S. (Electronic controlled suspension system)

Always read this section before using the E.C.S.S. in order to enable you to use it safely and effectively.

30.1 METHOD OF OPERATING E.C.S.S.

The E.C.S.S. switch is on the left side of the main panel. When the E.C.S.S. switch is pressed, it is turned on, the pilot lamp (orange) lights up, and the E.C.S.S. is actuated. If the switch is pressed again, it is turned off, the pilot lamp goes out, and the E.C.S.S. is canceled.

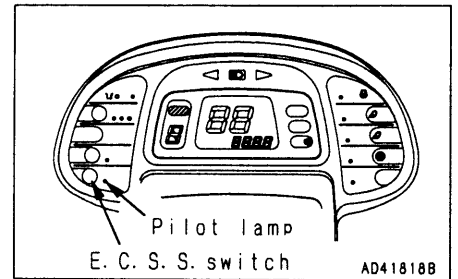

30.2 PRECAUTIONS WHEN OPERATING E.C.S.S. SWITCH

WARNING

- If the E.C.S.S. switch is turned ON when the machine is traveling or when the work equipment is raised, the work equipment may suddenly move.
- If operations are carried out with the E.C.S.S. switch ON, the work equipment may suddenly move when the E.C.S.S. is actuated.
- Never turn the E.C.S.S. switch ON during inspection or maintenance of the machine. This is extremely dangerous, as the work equipment may move.

NOTICE

- Before operating the E.C.S.S. switch, always stop the machine and lower the work equipment to the ground first.
- When carrying out inspection and maintenance, first lower the work equipment to the ground, then turn the E.C.S.S. switch OFF and carry out inspection and maintenance.
- For leveling operations, turn the E.C.S.S. switch OFF.

This switch turns the E.C.S.S. ON/OFF.

When the switch is pressed, the E.C.S.S. is turned ON, the pilot lamp lights up, and the E.C.S.S. is actuated.

When the switch is pressed again, it is turned OFF, the pilot lamp goes out, and the E.C.S.S. is canceled.

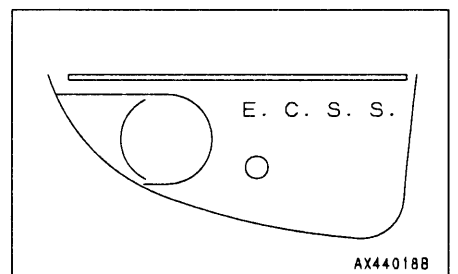

REMARK

- The E.C.S.S. uses the hydraulic spring effect of the accumulator to absorb the vibration of the chassis when the machine is traveling. This enables the machine to travel smoothly at high speed.
- If the starting switch is at the OFF position, the E.C.S.S. will not be actuated even if the E.C.S.S. switch is at the ON position. However, if the starting switch is at the ON position it is possible for the E.C.S.S. to be actuated, so it will switch to the actuation condition if the E.C.S.S. switch is turned ON.
- The E.C.S.S. is not actuated if the transmission is in 1st.
- When the transmission is in 2nd to 4th and the travel speed goes above 4 km/h (2.5 MPH), the E.C.S.S. is automatically actuated; when the travel speed goes below 4 km/h (2.5 MPH), it is automatically canceled.

31. HANDLING AUTO-GREASING SYSTEM

With this system, the electric pump is connected to the divider valve, and a lubricating controller with built-in micro computer controls the electric pump and automatically supplies the grease.

31.1 METHOD OF OPERATING AUTO-GREASING SYSTEM

1. Turn the starting switch ON and start the electric pump.

REMARK

Immediately after the power is turned on, all the display lamps on the lubrication controller inside the box under the step on the left side of the machine light up for several seconds.

This is a self check for the lamps, and does not indicate any abnormality.

The display portion for starting the calculation of the greasing interval will flash, but all other displays will go out after a few seconds.

However, even if the greasing interval has not been reached, if the switch is turned ON/OFF repeatedly, greasing will automatically start due to the function of the supplemental circuit, immediately after the starting switch is turned ON. After display of the 7-segment LED and greasing-in-progress LED, as shown in the LUBRICATION CONTROLLER DISPLAY TABLE, the above condition will be returned.

2. When the starting switch is turned ON, centralized greasing is carried out in accordance with the set time and frequency limit for greasing.

LUBRICATION CONTROLLER DISPLAY TABLE

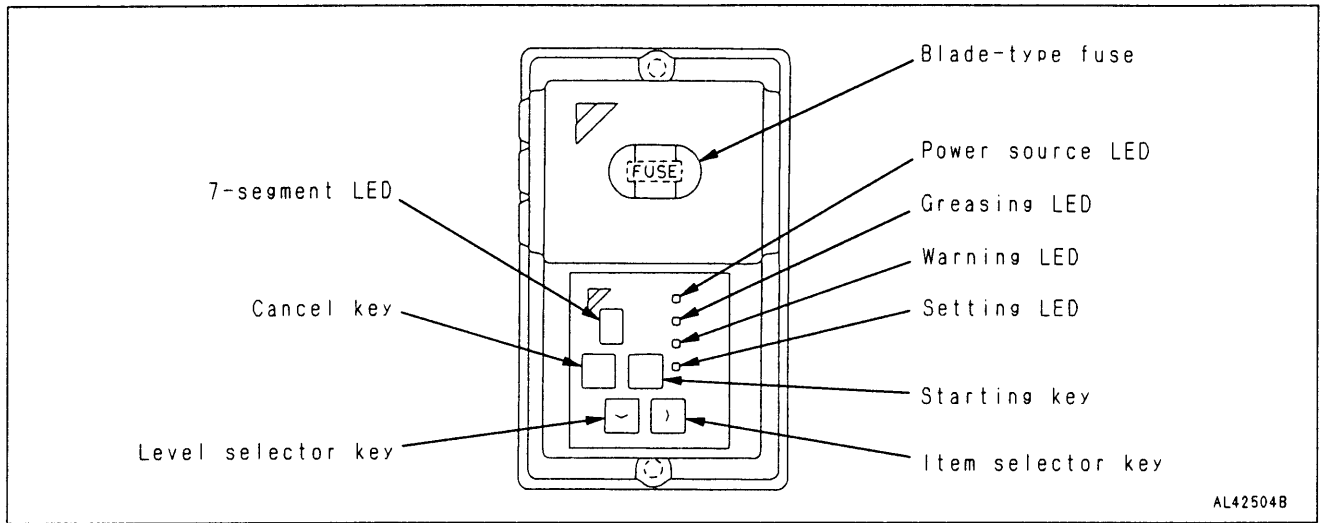

The condition of the lubricating system can be seen from the 7-segment LED and the LED display on the controller panel.

Type	Item	Symptom	LED display	7-segment display
When normal	Counting	When normal	Power source LED lights up	flashes or numeral flashes ※
	Greasing	I Pump operating	Greasing LED lights up	Rotating display
		II Maintaining pressure	Greasing LED flashes slowly (1 time/sec)	Stop display
		III Releasing pressure	Greasing LED flashes rapidly (2 times/sec)	Reverse rotation display
Setting	Set mode	Set LED flashes	Depends on each set mode	
When abnormal	Abnormality in pump pressure	Pressure does not rise within greasing time	Warning LED flashes	(E) (a) Flash alternately
	Abnormality in release of pressure	Pressure still remains after pressure is released (reverse rotation)		(E) (b) Flash alternately
	Abnormality in pressure detection	Limit switch for pressure detection is already actuated before system is started		(E) (c) Flash alternately
	Tank empty	No. of times of greasing has reached greasing frequency limit		(E) (0) Flash alternately

※ If the remaining number of times of greasing is less than 10, a numeral (0 – 9) will flash.

31.1.1 ACTUATION OF AUTO-GREASING

When engine starting switch ① is turned one stage, the auto-greasing system is automatically set to the actuation condition. (Do not press the auto-greasing switch.)

Pilot lamp on main monitor

Lighted up: Normal actuation

Flashes at 1-second interval: Grease cartridge empty

Flashes at 0.5-second interval: Improper release of pressure, pump pressurized, pressure detection, fuse blown

REMARK

Operating when desired

It is possible to start the system and carry out one cycle of greasing regardless of the time count. To do this, press the auto-greasing switch on the main monitor or the starting button for the lubrication controller inside the box containing the grease pump and grease tank located under the step on the left side of the machine. The count for the greasing time is canceled, and the electric pump starts the count again automatically after it is stopped.

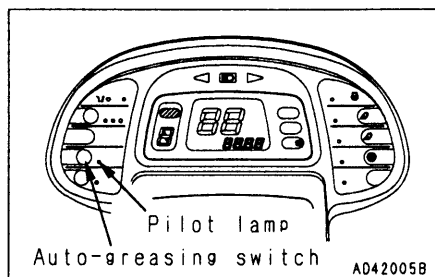
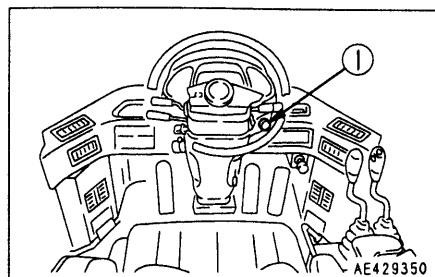

31.1.2 SETTING GREASING TIME

The set time and greasing frequency limit differs according to the operating condition and greasing plan for the machine, so set the following items to carry out suitable centralized greasing.

- Greasing interval (Hr): Greasing interval for automatic operation
- Greasing time (min): Length of time pump is operated for each greasing operation
- Greasing frequency limit (times): No. of times for operating pump before the 1000 cc grease cartridge becomes empty

The settings when shipping from the factory are as follows.

Greasing interval: 3 hours

Greasing time: 7 minutes

Greasing frequency limit: 100 times

The grease level alarm is set to sound after 300 hours on the hourmeter (when normal operation).

Setting greasing time in cold areas

In cold temperatures, the viscosity of the grease increases and the resistance inside the piping becomes greater, so it is necessary to extend the length of the greasing operations in order to ensure that the greasing is carried out properly.

If the machine is used in ambient temperatures below -20°C , set the greasing time to 20 minutes (code No. 7). In addition, use lithium-based grease No. 0.

For details of setting the time, see "31.1.3 METHOD OF SETTING".

When changing the set value, please contact your Komatsu distributor.

31.1.3 METHOD OF SETTING

When setting the various items, the value is not input directly. Select the code number from the set code table below, and set as follows.

Setting code table

Code no.	0	1	2	3	4	5	6	7	8	9
Greasing interval (Hr) (a)	/	1	1.5	2	3	4	5	6	8	/
Greasing time (min) (b)	/	2	3	5	7	10	15	20	25	/
Greasing frequency limit (c)	/	25	50	75	100	150	200	250	/	/

When delivered from the factory, all of (a), (b) and (c) are set to code No. 4.

NOTICE

When using the machine at ambient temperatures of below -20°C , set to greasing time (b) at code No. 7.

Procedure for setting

Turn the starting switch ON and start the engine.

1. Press the LEVEL and ITEM keys at the same time to set to the setting mode.
2. Press the ITEM key one or more times to select the item to be set.

REMARK

Each time the ITEM key is pressed, the setting item is changed:
a → b → c → a.

3. When the item to be set flashes, press the LEVEL key.
The set item and numeral are displayed alternately (a →→ 0 →→ a →→ 0).
4. Refer to the setting code table and press the ITEM key one or more times to select the code number to be set.

REMARK

Each time the ITEM key is pressed, the code number (numeric portion) goes up by 1.

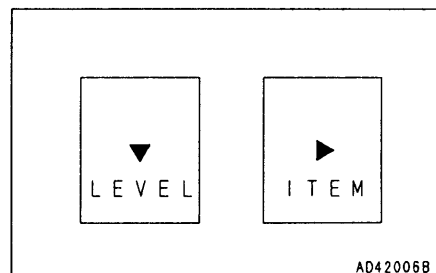

AD42006B

5. When the code number that is to be set flashes, press the SET key to carry out the setting.

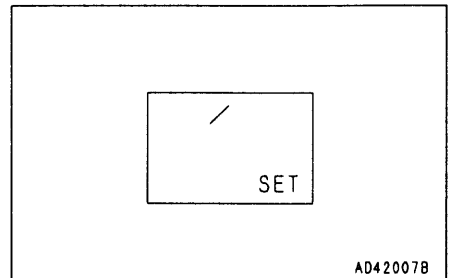

6. Repeat Steps 3 to 5 to set all of the items a, b, and c. After completing the setting, press the ESC key to leave the setting mode.

REMARK

Even if it is desired to change only one item, always carry out the setting according to Steps 1 to 5. After completing the setting, always press the ESC key to leave the setting mode.

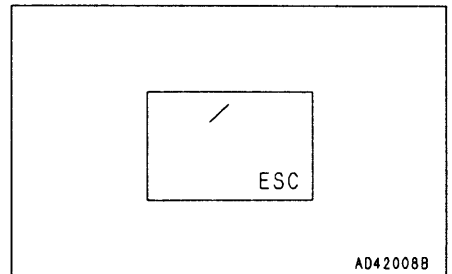

If the power is then turned ON, the count for the greasing interval will start immediately after the ESC key is pressed. Part of the display segment flashes to indicate that the system is counting. After setting, the set value is retained in memory even if the power is turned OFF.

31.1.4 REPLACEMENT OF GREASE CARTRIDGE

NOTICE

After replacing cartridge, make sure to reset number counter on controller. (Refer to "31.3 Troubleshooting")

Replace grease cartridge according to procedure described below.

1. Remove cover by turning cartridge cover ① approx. 60° to the left. Be careful of the force applied by spring ② installed inside the cover.

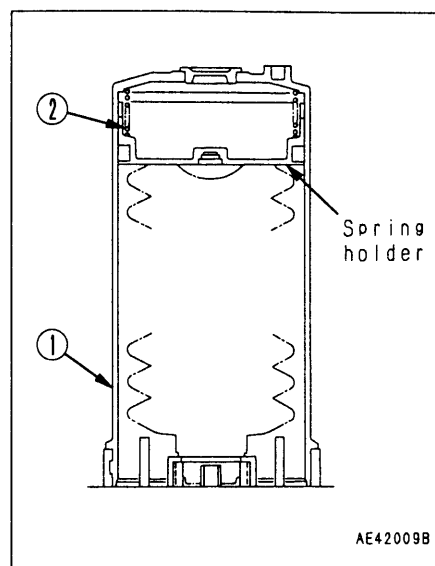

2. Remove grease cartridge ③ by turning it to the left. Do not detach seal cap ④ at this time.

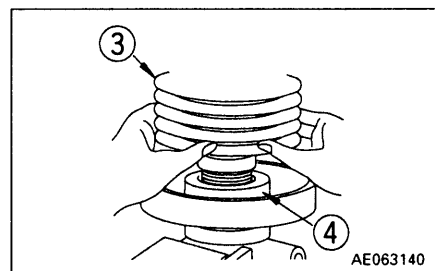

3. Detach cap ⑤ and middle plug ⑥ from new grease cartridge and tightly screw it in. Screw in tightly to ensure that no air enters.

4. When fixing, if grease cartridge is pressed slightly and grease comes out and deposits in a heaped shape, and if grease cartridge is screwed into suction port connector under above conditions, no air will enter. (Max. No. of turns is approx. 5)

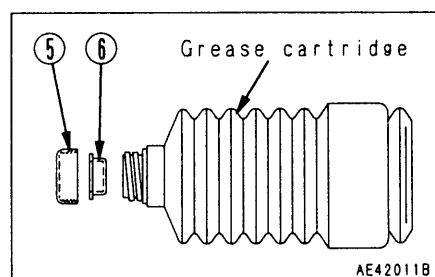

5. Turn cartridge cover ① to right and tighten it until securely fixed. If not tightened well, there is a possibility that it will work loose due to machine vibration.

31.1.5 METHOD FOR BLEEDING AIR

1. When there is air in piston portion of pump
 - 1) Remove the air bleed screw (hexagon head socket plug 1/8) from the side of the pump.
 - 2) Turn the power on, press the SET/START key, and run the pump.
 - 3) Continue to run the pump until no more bubbles come out with the grease from the pump.
 - 4) After checking that clean grease comes out continuously, turn off the power and stop the pump.
 - 5) Install the air bleed screw to its original position in the pump.

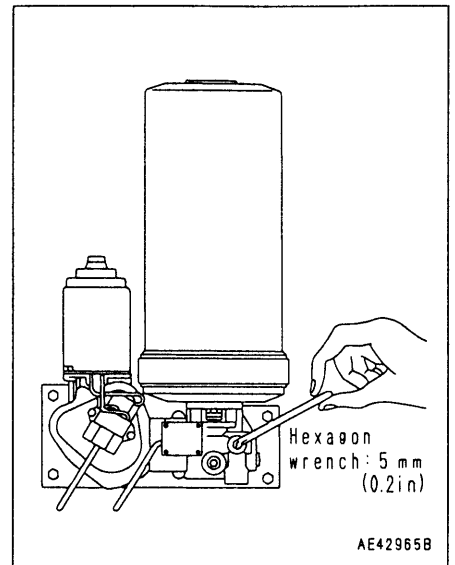

2. When there is air in piping
 - 1) After installing the divider valve, remove the plug from the greasing port of the divider valve at the end.
 - 2) Run the grease pump until no more bubble come out with the grease from the pump.
 - 3) Connect the grease piping to the discharge port of the divider valve, rotate the pump several times, and check that grease comes out, then connect the bearing end also.

Method of checking operation in cold areas

If the temperature suddenly drops, grease may not come out if the pump is operated only once.

If the grease comes out after the pump is operated 2 or 3 times, this does not indicate any abnormality in the system.

Greasing with grease gun

If the auto-greasing system does not work properly and does not supply grease, it is possible to carry out greasing by pumping in grease manually with a grease gun through the grease fittings installed to each divider valve.

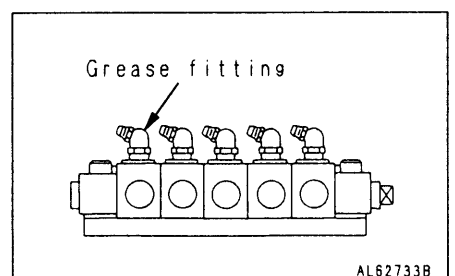

31.2 PRECAUTIONS WHEN HANDLING AUTO-GREASING SYSTEM

- Basically, the power source input to the lubrication controller should be DC24V, but use a maximum limit of 30V.
- The grease nipple installed to the service port used for initial charging of the divider valve has a ball check structure, so it may leak if dirt gets stuck in it.
Check it from time to time, and replace the grease nipple immediately if any grease is leaking.
- When carrying out initial operation or when the grease tank is empty, air may get into the piston portion of the pump. If the pressure does not rise within the specified time when running the pump, and an error is displayed for the controller, bleed the air.
- If the divider valve or grease piping are removed when replacing the attachment on the machine, handle carefully to prevent any damage. When storing or installing again, be extremely careful to prevent the entry of air, and particularly dirt. If there is any air in the system, bleed the air immediately.

31.3 TROUBLESHOOTING

If any abnormality occurs in the greasing system, the error codes will flash alternately to display the type of abnormality.

Error code	Item	Cause	Remedy
E → a	Defective pressurizing of pump	Air in main piping Air inside pump Grease tank is empty Grease leaking from main piping	Run pump as necessary and release grease from end of piping to bleed air Release grease from air bleed in pump to bleed air Add grease Check, tighten connections of main piping (including hoses)
E → b	Abnormality in release of pressure	Abnormality in pressure-releasing structure built into pump Abnormality in pressure-detection equipment built into pump	Disassemble pressure-releasing portion carefully, then check and clean Check limit switch at pressure-detection portion
E → c	Abnormality in pressure detection	Abnormality in pressure-releasing structure built into pump Abnormality in pressure-detection equipment built into pump	Check limit switch Check limit switch at pressure-detection portion
E → 0	Empty tank	Greasing frequency limit has been reached Grease added during frequency count	Add grease Confirm that 0 flashes three times on 7-segment LED by pressing reset button on controller for more than 5 seconds.

31.4 SPECIFICATIONS

Electric pump

Model: LD10C

Delivery pressure: 24.03 MPa (245 kgf/cm², 3479 PSI) (MAX)

Tank specification: 1000 cc cartridge type

Available temperature range: -20 to 60°C

Applicable grease: NLGI No. 2 to No. 0 lithium-based grease

Rated voltage: DC24V

Rated current: 3A (Note: 6.5A when temperature is -20°C)

Divider valve

Model: LL1

Discharge amount adjustment method: Fixed type

Available pressure: 24.03 MPa (245 kgf/cm², 3479 PSI) (MAX)

Discharge amount: 0.6 – 0.1 cc/st

No. of valves (discharge ports): 1 – 5

Available temperature range: -20 to 60°C

Applicable grease: NLGI No. 2 to No. 0 lithium-based grease

32. OPTION DISPLAY

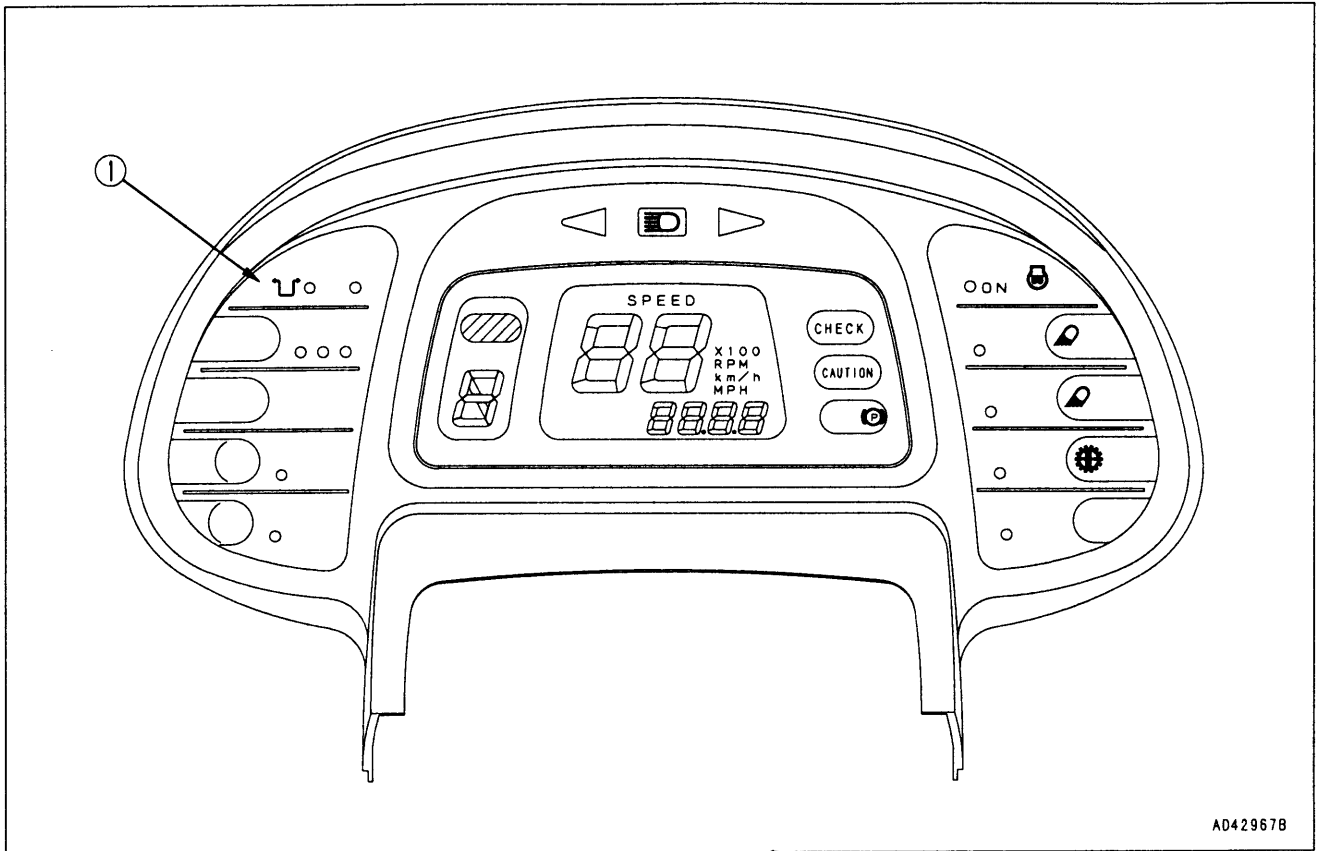

AD42967B

This is on the left side of the main panel and indicates the condition of actuation of the options.

1. EMERGENCY STEERING PILOT LAMP

This indicates that the main pump is operating normally when the machine is traveling.

If the engine stops when the machine is traveling, or if there is any abnormality in the pump circuit, the monitor flashes to indicate that the emergency steering system has been actuated. If the monitor flashes, stop the engine immediately.

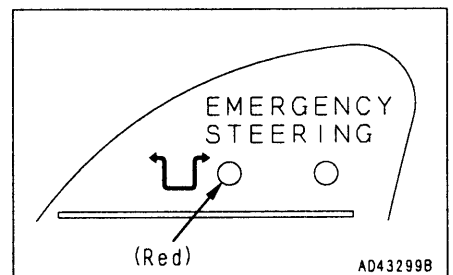

AD43299B

33. HANDLING AUTO-LEVELING, REMOTE POSITIONER

Always read this section before using the auto-leveling or remote positioner to enable it to be used effectively and safely.

33.1 STRUCTURE AND FUNCTION OF AUTO-LEVELING, REMOTE POSITIONER

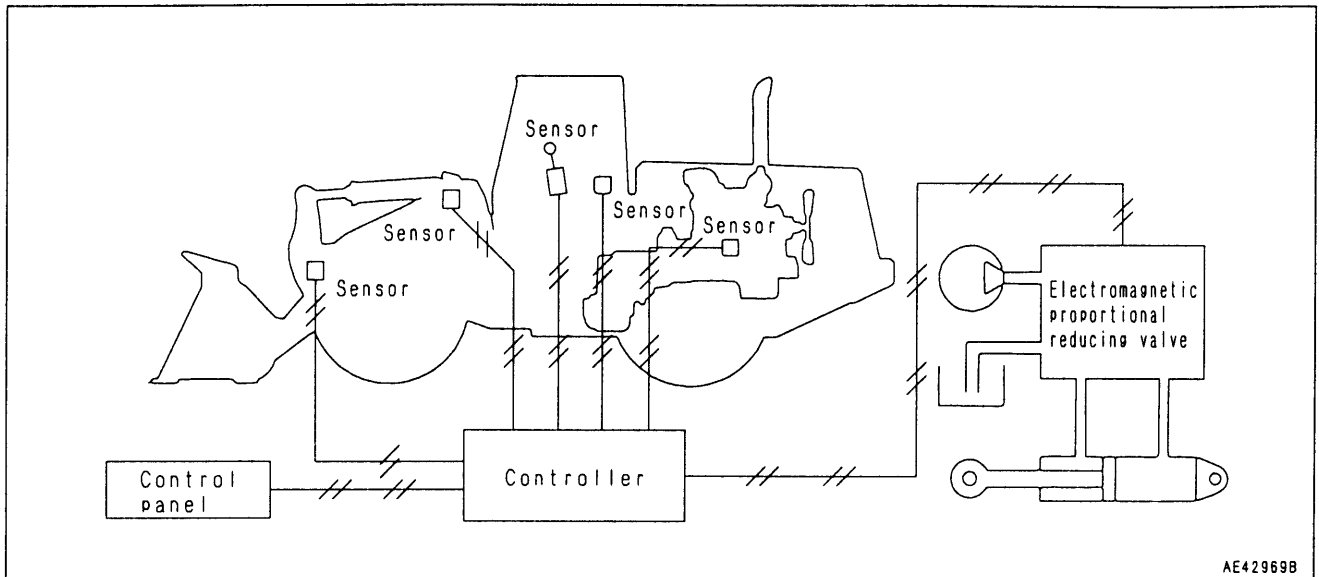

- The auto-leveling and remote positioner system is a system to increase operating efficiency and to reduce operator fatigue. It consists of two functions: the bucket auto-leveler and the lift arm remote positioner. The bucket auto-leveler system makes it easy to keep the bucket at a horizontal position when using the bucket to shake the load out during loading operations. The remote positioner system makes it possible to set the stop position for the lift arm at the desired position from the operator's seat, and it is also provided with a modulation function to reduce the shock when stopping the lift arm.
- The auto-leveling and remote positioner system consists of the auto-leveling and remote positioner switches, controller, sensors, and electromagnetic proportional reducing valve. The auto-leveling system has a controller which stores the settings so that the dumping angle (horizontal +15° – 30°) can be set with the lift arm above horizontal by operating the auto mode switch and level set switch. The electromagnetic proportional reducing valve controls the flow according to the electric signal from the controller. The remote positioner has a controller which stores the settings made when the RAISE/LOWER selection switch and RAISE position set switch are operated to set the stopping position for the lift arm during raising or lowering operations. The system also makes it possible to reduce the speed and stop when the boom reaches the stop position. The electromagnetic proportional reducing valve controls the flow according to the electric signal from the controller.

33.2 GENERAL LOCATIONS

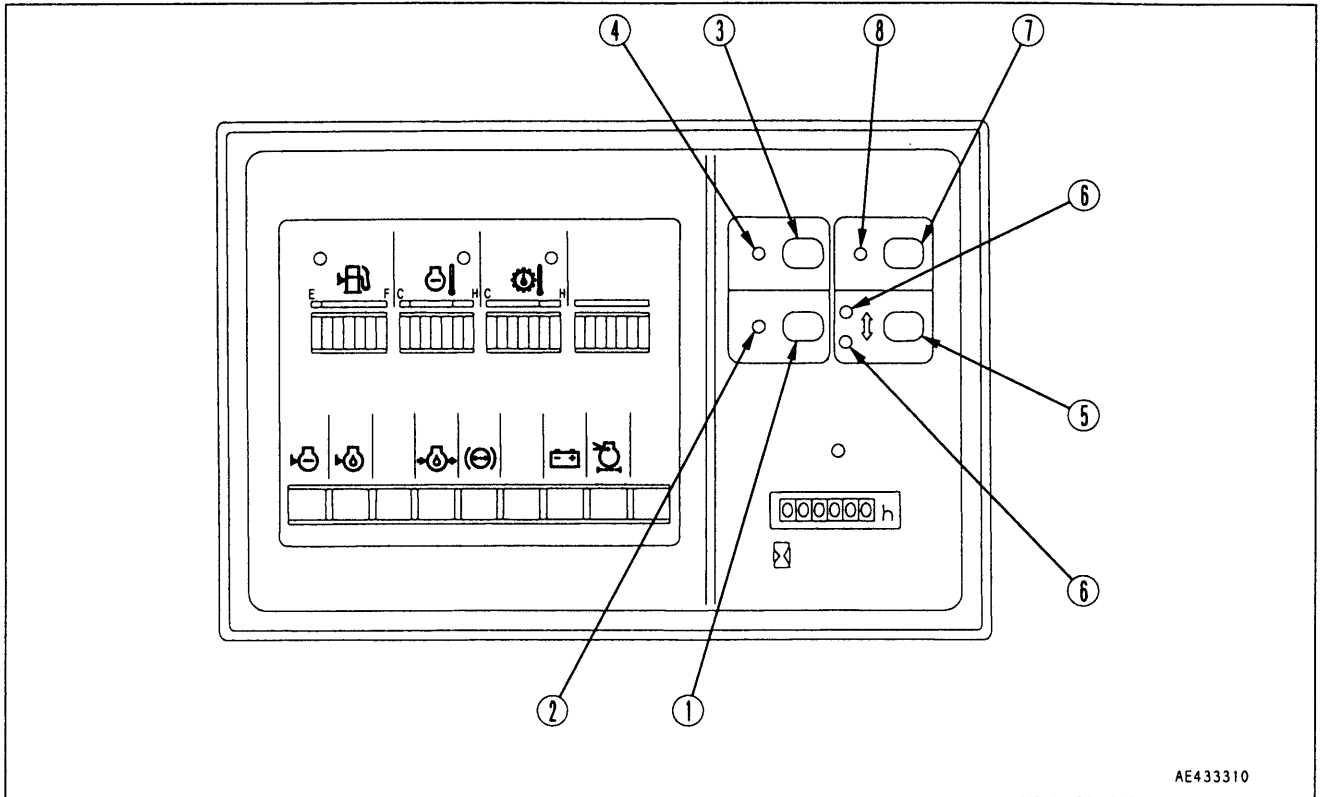

AE43310

1. Auto mode switch
2. Auto mode pilot lamp
3. Level set switch
4. Level set pilot lamp
5. RAISE/LOWER selector switch
6. RAISE/LOWER pilot lamp
7. RAISE position set switch
8. RAISE position set pilot lamp

33.3 METHOD OF OPERATING AUTO-LEVELING, REMOTE POSITIONER

33.3.1 METHOD OF OPERATING AUTO-LEVELING

1. When auto mode switch ① is pressed, the system is turned ON, pilot lamp ② lights up, and the auto-leveling system is actuated.
2. Operate the bucket to the desired dumping angle, then stop and press level set switch ③.
Pilot lamp ④ will flash for 2.5 seconds to complete the setting.

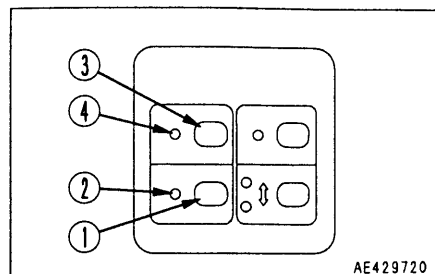

REMARK

- Dumping angle θ can be set within a range of $+15^\circ$ and -30° from the horizontal position of the bucket.
 - If the pilot lamp does not flash, the setting is outside the above angle, so operate to the desired angle again.
 - Once the angle is set, it is kept in memory until it is set again.
3. When the level set switch is pressed, the system is turned OFF and the pilot lamp goes out.
 4. When the auto mode switch is pressed, the system is turned OFF, the pilot lamp goes out, and the system changes to the normal leveler condition.

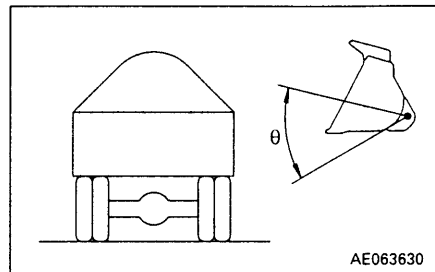

33.3.2 METHOD OF OPERATING REMOTE POSITIONER

When RAISE/LOWER selector switch ① is pressed, the system is turned ON, pilot lamp ② lights up, and the remote positioner is actuated.

REMARK

Each time the RAISE/LOWER selector switch is pressed, the lighting of the RAISE and LOWER lamp changes. (RAISE lighted up → LOWER lighted up → RAISE/LOWER both lighted up → go out)

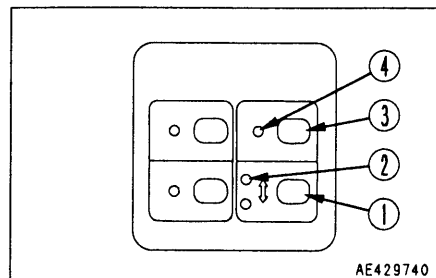

2. Raise the lift arm to the desired height (above horizontal), then stop it and keep RAISE position set switch ③ pressed. Pilot lamp ④ will flash for 2.5 seconds and the setting is completed.

REMARK

Actuate the remote positioner, raise the lift arm to the desired height, and set the position with the RAISE set switch. Once the RAISE position is set, it is kept in memory until it is set again. However, the LOWER position is fixed as the carrying position.

3. When the RAISE/LOWER selector set switch is pressed, the system is turned OFF and the pilot lamp goes out.
4. When the RAISE/LOWER selector switch is pressed, the system is turned OFF, the pilot lamp goes out, and the system changes to the normal positioner condition.

33.3.3 BUCKET OPERATIONS AND OPERATION OF LEVER

Boom position	Bucket operation	Necessary angle for bucket	Remote bucket positioner	Bucket auto-leveler	Lever operation by operator
Max. height dump position	Loading	Dump	Set	<p>The diagram shows a vertical line representing the boom. A dashed arc indicates the bucket's path from 0° to 30°. A 'Control portion' is marked on the boom. Arrows indicate height adjustments: up for 'Dump' and 'Horizontal' operations, and down for 'Digging standard' and 'Digging scooping' operations. A note at the bottom right says 'When auto-leveler is not actuated'.</p>	<ul style="list-style-type: none"> ● Dump operation with bucket lever (not necessary to adjust boom height)
	Dumping load	Horizontal			<ul style="list-style-type: none"> ● Adjusting height with boom lever (not necessary to adjust bucket angle)
Horizontal					<p>Boom lever at FLOAT position (not necessary to hold at boom LOWER)</p>
Carrying position	Digging standard		Set		<ul style="list-style-type: none"> ● Automatic boom stop, boom lower operation (not necessary to adjust bucket angle)
Ground level	Digging scooping, maintaining ground	Horizontal		<p>0° 30° Bucket angle</p>	

33.4 ADJUSTING AUTO-LEVELING, REMOTE POSITIONER

When the lift arm or tilt lever has been removed or the setting does not work efficiently, please contact your Komatsu distributor for adjustment.

WA420-3 WHEEL LOADER

Form No. SEAM031401P