

SHOP MANUAL

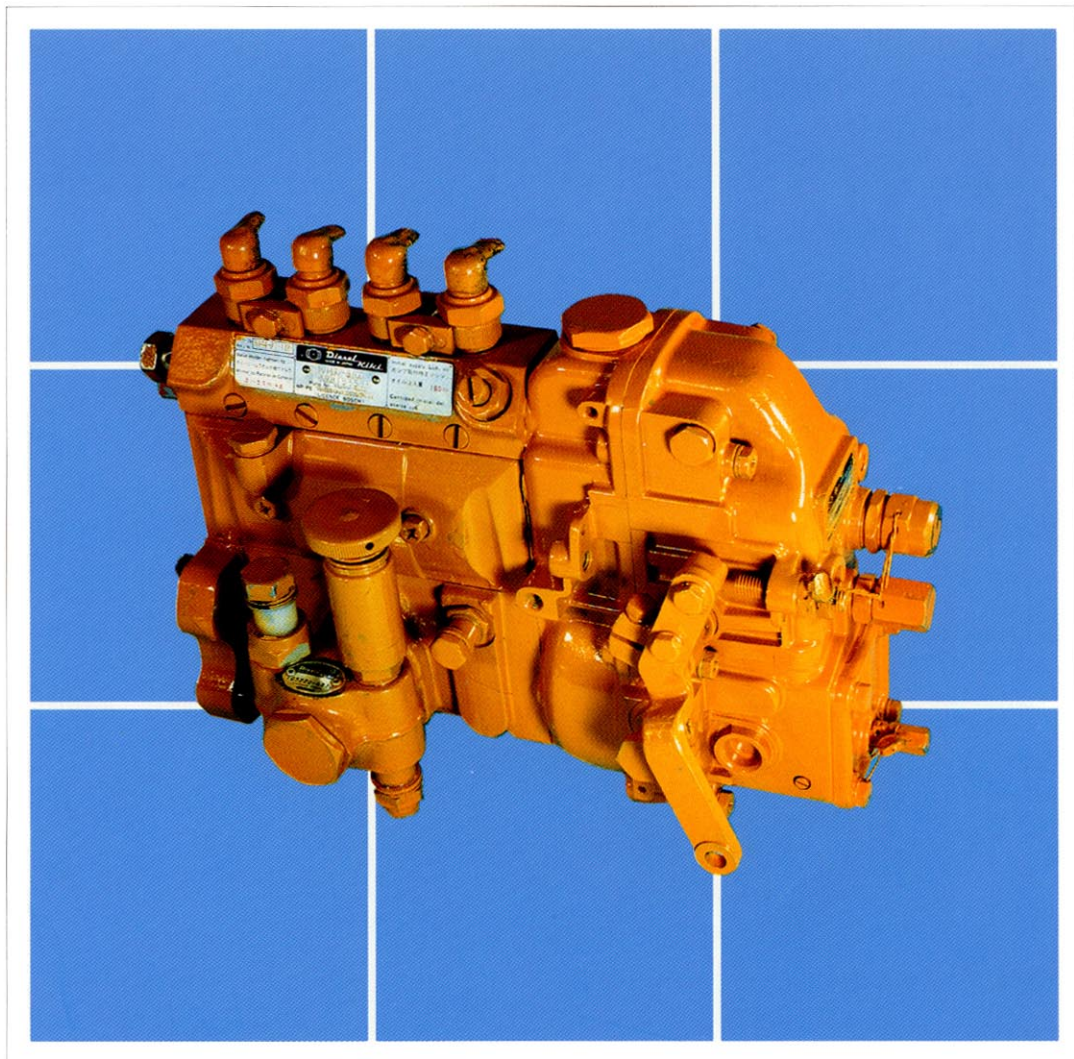

GUIDANCE FOR REUSABLE PARTS

FUEL INJECTION PUMP



GUIDANCE FOR REUSABLE PARTS
KOMATSU

INDEX

INTRODUCTION	1
FAILURE SIGNS AND DIAGNOSIS FOR REUSE	2
• Inspection Points for Parts Reuse Diagnosis	
• Standards for Failure Determination	
• Standard for Reuse of Injection Pumps Parts	
EXAMPLES OF FAILURES	6
CONSTRUCTION & FUNCTION OF FUEL INJECTION PUMPS	19
• Types of Injection Pumps	
• Construction of Injection Pumps	
• Types of Governors	
• Construction of Governors	
FAILURES AND THEIR CAUSES	31
• Fuel	
• Dust and Water	
• Adjustments	
PREVENTIVE MAINTENANCE	32

INTRODUCTION

Diesel engines used in construction machines must have a wide range of characteristics so that they can operate in severe conditions. They require not only higher performance and horsepower but also high durability and reliability and easier preventive maintenance.

The fuel injection pump can be called the heart of a diesel engine because it controls the quantity, timing and pressure of fuel injected into the engine— factors that directly affect the engine performance.

For this reason, the component parts of fuel injection pumps are machined to high accuracy under a strict control of quality and performance. These parts should be serviced, inspected, disassembled, and repaired with the utmost care.

This GUIDANCE FOR REUSABLE PARTS contains the basic information necessary to disassemble and repair "FUEL INJECTION PUMPS", a description of causes of parts failures, and photos which show the criteria for determining the reusability of disassembled parts.

We hope that this GUIDANCE FOR REUSABLE PARTS will be helpful in troubleshooting and repair. All parties concerned should pay extra attention to preventive maintenance and early detection of failures. Based on the correct diagnosis of failures, *proper actions can be taken to prevent their recurrence. The repair costs can also be reduced by the proper reuse, replacement, or repair of parts.*



Note: This publication is intended for guidance only and KOMATSU LTD. hereby expressly denies and excludes any representation, warranty or implied for the reuse of injection pumps.

FAILURE SIGNS AND DIAGNOSIS FOR REUSE

The slightest wear, scores or seizure of parts of a fuel injection pump will affect the engine performance. The fuel injection pump is an important which is closely related to most engine troubles which occur in the field. Consequently, extra care should be taken to correctly diagnose parts in order to determine their reusability.

When determining the reusability of parts, take into consideration the daily maintenance and operating conditions and look for the true cause of the failures. Base your final judgement on your experience and accumulated know-how and by referring to the photos which classify faulty parts into three categories: "Use again," "Use after reconditioning" and "Do not use again."

Inspection Points for Parts Reuse Diagnosis

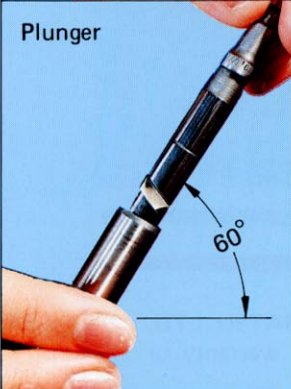

Before diagnosing faulty parts, clean them. Then, inspect them, paying attention to the following points.

Part	Inspection points
	<ul style="list-style-type: none"> ● Inspect its piston and seat portions for flaws, scores, wear, etc.
	<ul style="list-style-type: none"> ● Inspect its lead for flaws, seizure, "hitching," etc.

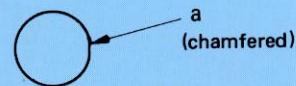
- Wash the delivery valve and insert it into place by closing the underside of the valve seat. Then, give a light push on the valve top. If the valve springs back to its original position, it indicates that the valve can be reused.
- The above inspection procedure does not apply to a delivery valve whose neck (a) is chamfered.

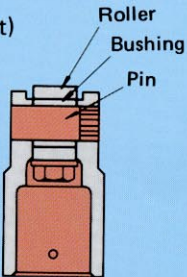
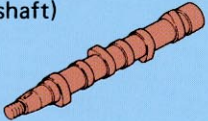

- Wash the plunger and tilt it approx. 60°. Then, draw it out halfway and release it. If it falls into the plunger barrel without a hitch, the plunger can be reused. (*This inspection procedure cannot be applied to a worn plunger.*)

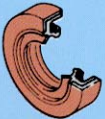
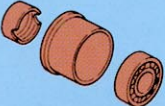
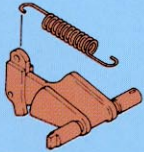
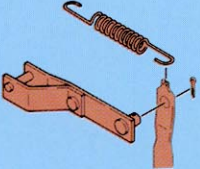
Part	Inspection points
<p>(Tappet)</p> 	<ul style="list-style-type: none"> ● Inspect tappet roller, bushing and pin for wear and scuffing.
<p>(Camshaft)</p> 	<ul style="list-style-type: none"> ● Inspect tapered cam surface for flaws and wear.
<p>(Bearing)</p> 	<ul style="list-style-type: none"> ● Inspect the surface for peeling.
<p>(Plunger spring)</p> 	<ul style="list-style-type: none"> ● Inspect for flaws, rust, uneven wear.
<p>(Oil seal)</p> 	<ul style="list-style-type: none"> ● Inspect the lip face for flaws, turning up, wear.
<p>(Shifter and bearing)</p> 	<ul style="list-style-type: none"> ● Inspect for wear.
<p>(Swivel lever & governor spring)</p> 	<ul style="list-style-type: none"> ● Inspect for looseness due to wear.
<p>(Link start spring)</p> 	<ul style="list-style-type: none"> ● Inspect for change in the free length and deformation.

Standards for Failure Determination

Rank	Failure degree
Use again	The failure will not cause any other problems and the pump can function properly.
Use after reconditioning	The pump can function properly for some time. However, if the pump is used continuously without reconditioning the faulty part, the failure will become worse and cause other troubles.
Do not use again	The failure causes the pump to malfunction. If the faulty part continues to be used, it will cause serious trouble.

Standards for Reuse of Injection Pump Parts

Part Name	Type of failure	Failure degree		
		Use again	Use after reconditioning	Do not use again
Plunger	1 Discolored, seized, or corroded sliding surface.	Slight degree of discoloration or corrosion. 1 & 2	—	Discoloration, corrosion, or seizure. 4, 5, 6, 7 & 9
	2 Worn or scratched sliding surface.	Slight degree of scratch. 10	—	Serious flaws or wear. 5 & 6
	3 Pitted notch.	Slight degree of pitting.	—	Serious pitting.
Camshaft	1 Worn or scratched cam surface.	Small scratches that do not catch on your finger nail, or slight degree of wear.	Scratch that can be easily removed with sand paper.	Scratches, uneven wear or flaking. 12, 14, 16 & 18
	2 Pitted cam surface.	Slight degree of pitting.	Pitting than can be smoothly reconditioned with sandpaper.	Pitting.
	3 Oil seal surface.	Small scratches that do not catch on your finger nail.	Scratches that can be easily removed with sandpaper.	Scratches.

Note: Bold numbers refer to photos in the text.

Part Name	Type of failure		Failure degree		
			Use again	Use after reconditioning	Do not use again
Tappet	1	Scratched or worn external surface of tappet.	Small scratches that do not catch on your finger nail. 19	Scratches that can be easily removed with sandpaper.	Scratches and uneven wear. 20, 21 & 22
	2	Flawed or worn tappet roller.	Scuffing without wear.	Slight degree of pitting, rust.	Flaws other than in B, and wear.
	3	Flawed or worn roller pin and pin bushing.	Uneven wear without discoloration.	Slight wear.	Flaws and wear. 24
Delivery valve	1	Rough or rusted seat surface.	Rough surface without rusting.	—	Rough and rusted seat surface. 25 & 26
	2	Scratched sliding surface.	Scratched without rusting (lustrous)	—	Scratched without rusting (not lustrous)
Bearing	1	Rotation	Bearing rotates smoothly without dragging.	—	Bearing rotates heavily and is dragged.
	2	Rust	No rust on balls or races.	Some rust on the external surface that can be easily removed with sandpaper.	Rust.
Pump housing	1	Housing thread area.	No broken or crushed threads.	Small scores or flaws in threaded area (excluding the delivery valve holder thread area).	Flaws and threads
	2	Flawed or cracked housing.	No cracks.	Small flaws or scores that can be easily removed with an oil stone.	Flaws and oil leakage.
Governor housing	1	Flawed or cracked housing.	No cracks.	Small flaws or scores than can be easily removed with an oil stone.	Flaws and oil leakage.
	2	Levers.	No deformation.	—	Deformed lever; lever which drags when in motion.

Note: Bold numbers refer to photos in the text.

EXAMPLES OF FAILURES

Plunger

1

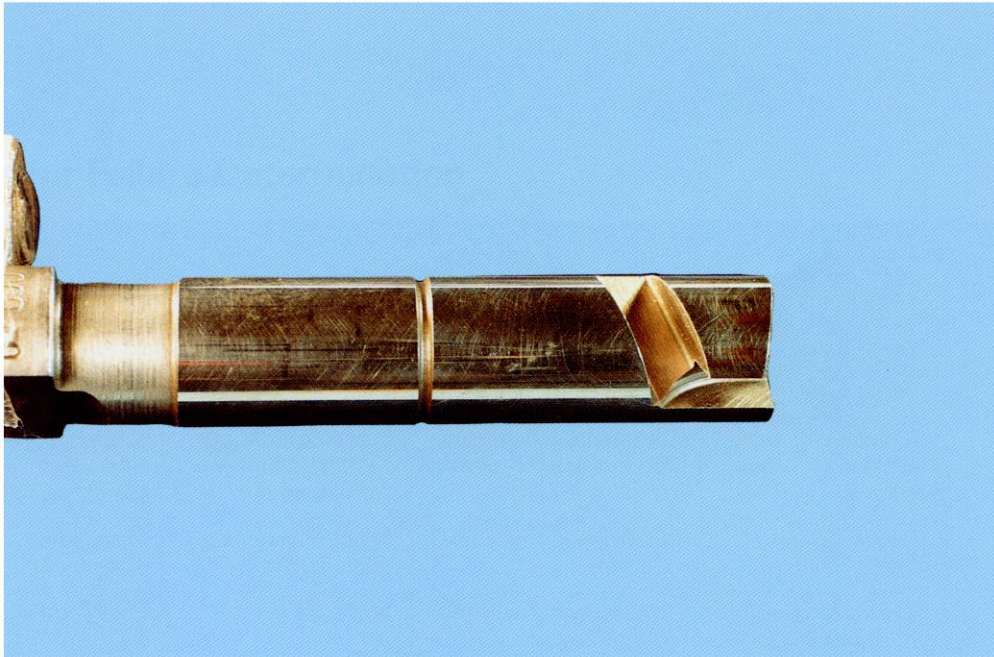

USE AGAIN

Failure Sign

- Discolored surface.

Cause

- Broken oil film.

2

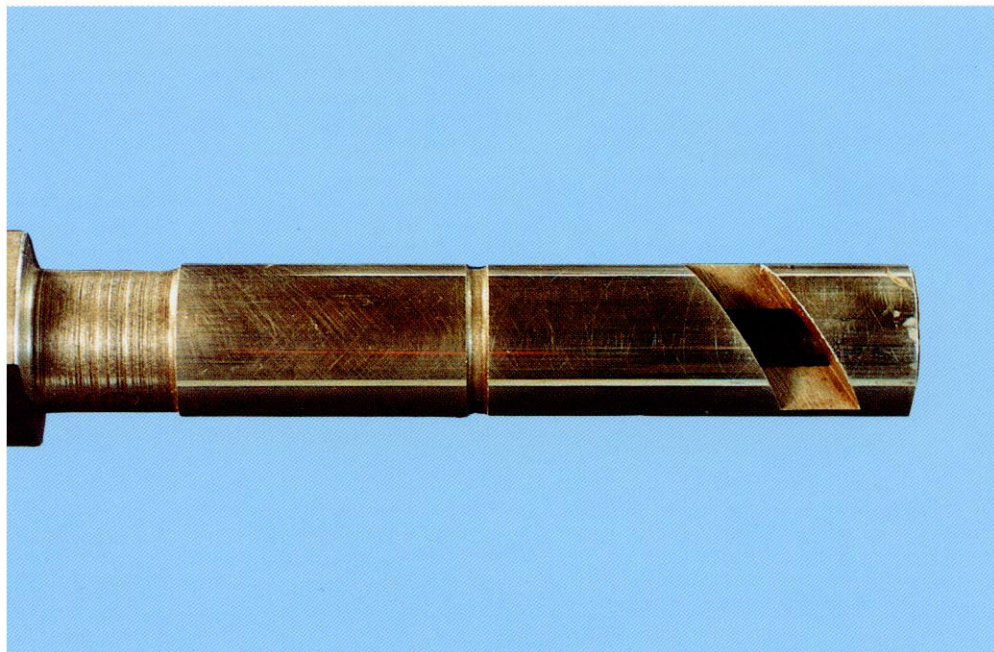

USE AGAIN

Failure Sign

- Slightly corroded tip

Cause

- Water in the fuel.

3

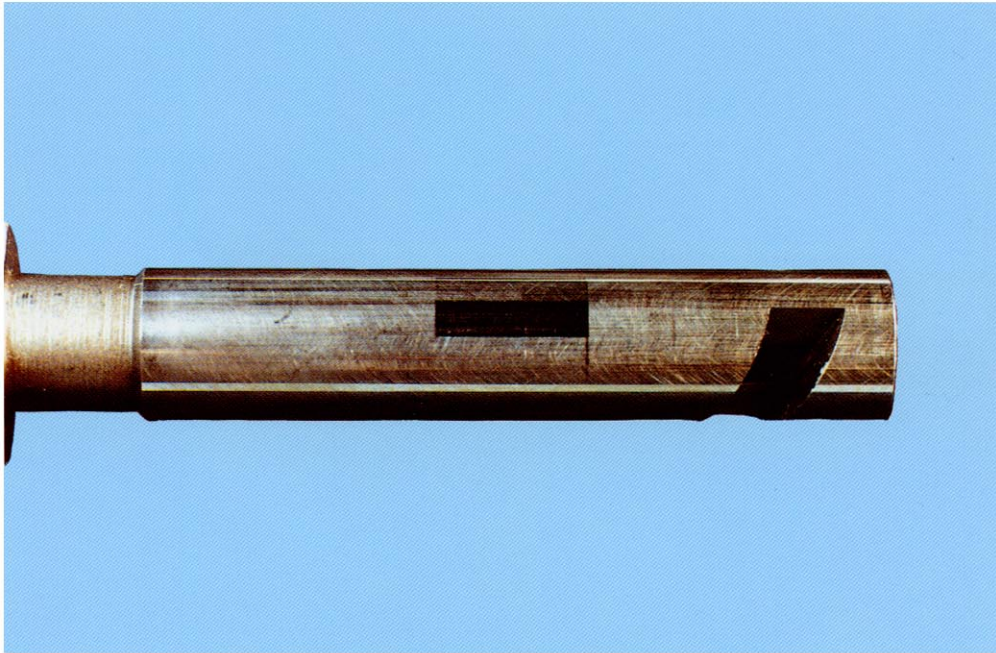

USE AFTER RECONDITIONING

Failure Sign

- Wear scratch due to metallic contact.

Cause

- Foreign matter lodged in plunger area.

4

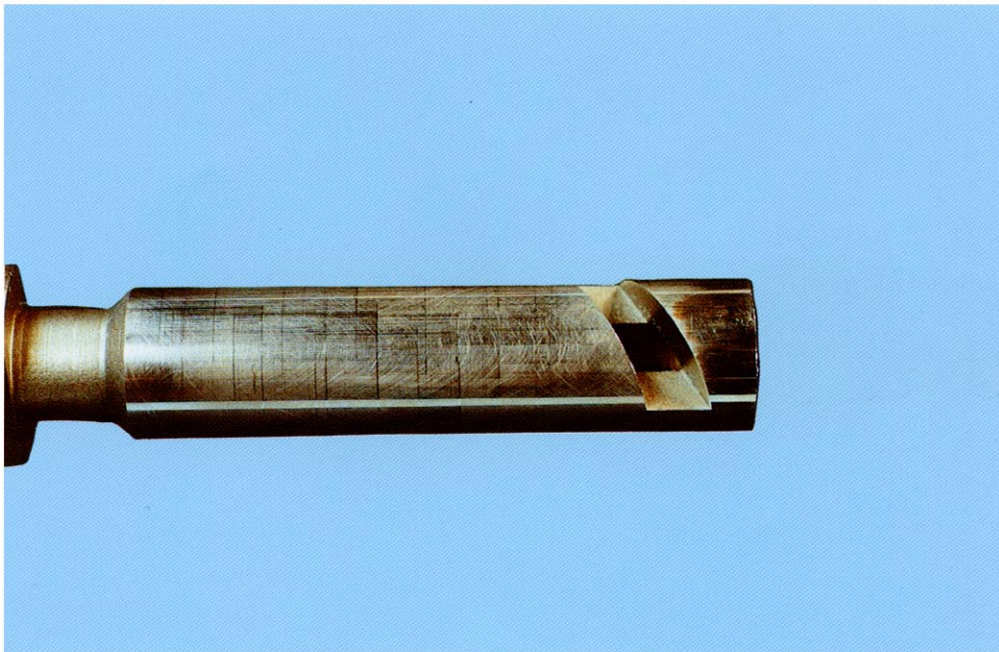

DO NOT USE AGAIN

Failure Sign

- Seizure.

Cause

- Improper viscosity and lubrication due to the use of poor quality fuel.

5

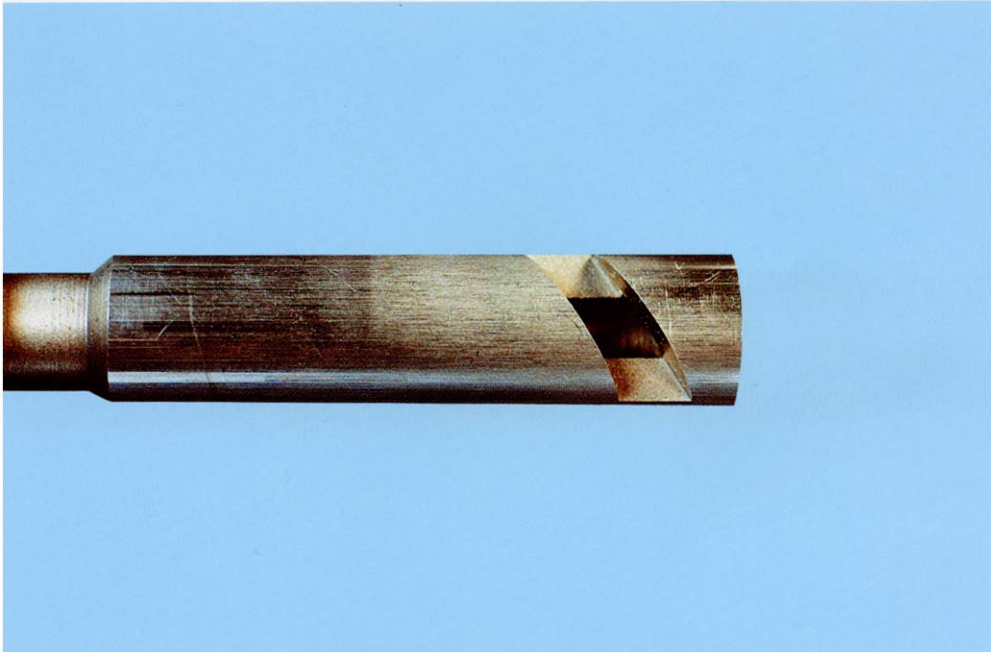

DO NOT USE AGAIN

Failure Signs

- Discolored and worn plunger (not lustrous).

Cause

- Unsatisfactory lubrication due to contamination with water, dust, etc.

6

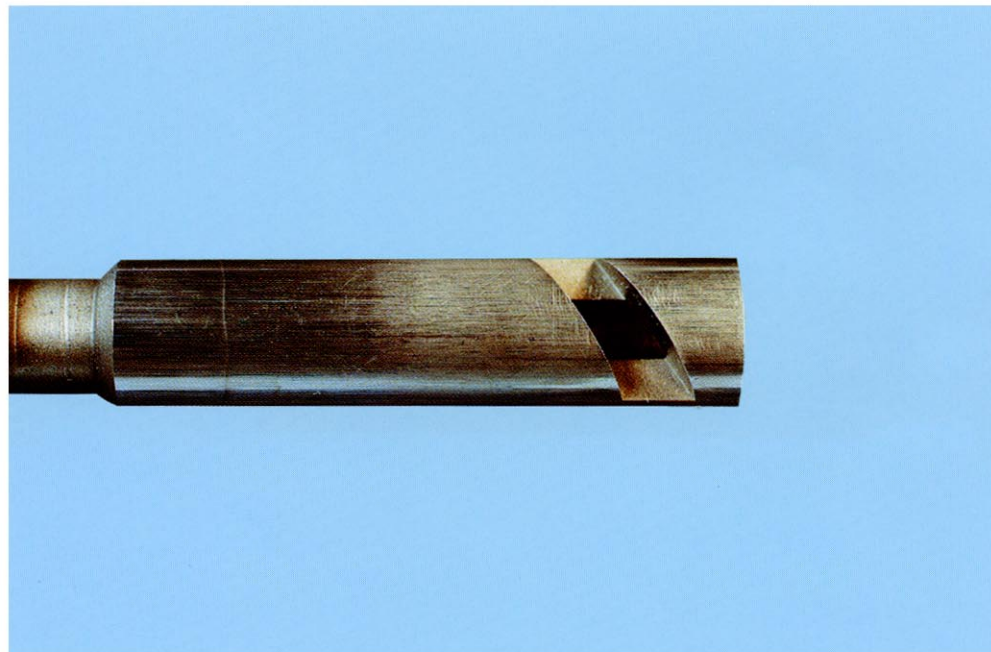

DO NOT USE AGAIN

Failure Signs

- Discolored and worn plunger (not lustrous).

Cause

- Unsatisfactory lubrication due to contamination with water, dust, etc.

7

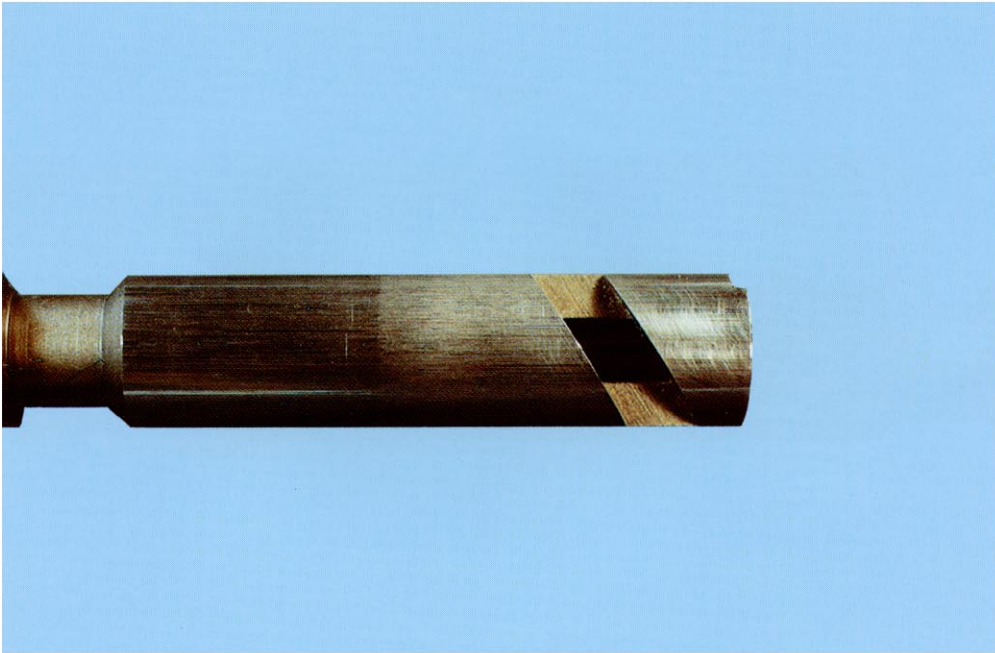

DO NOT USE AGAIN

Failure Sign

- Seizure

Cause

- Unsatisfactory lubrication due to contamination with water.

8

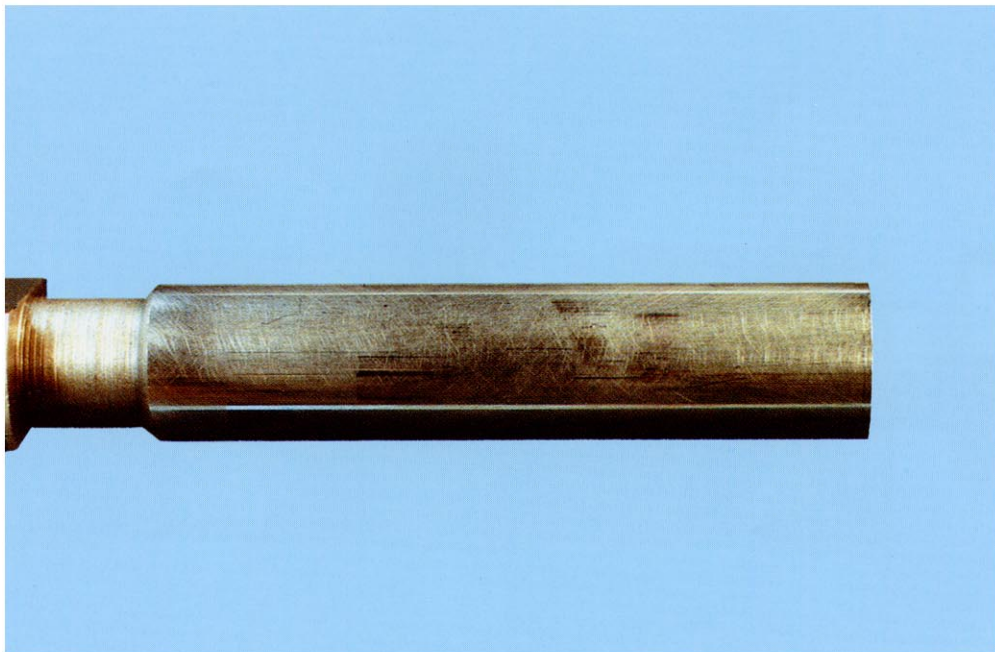

DO NOT USE AGAIN

Failure Sign

- Traces of dust lodged in plunger.

Cause

- Foreign matter lodged in plunger area.

9

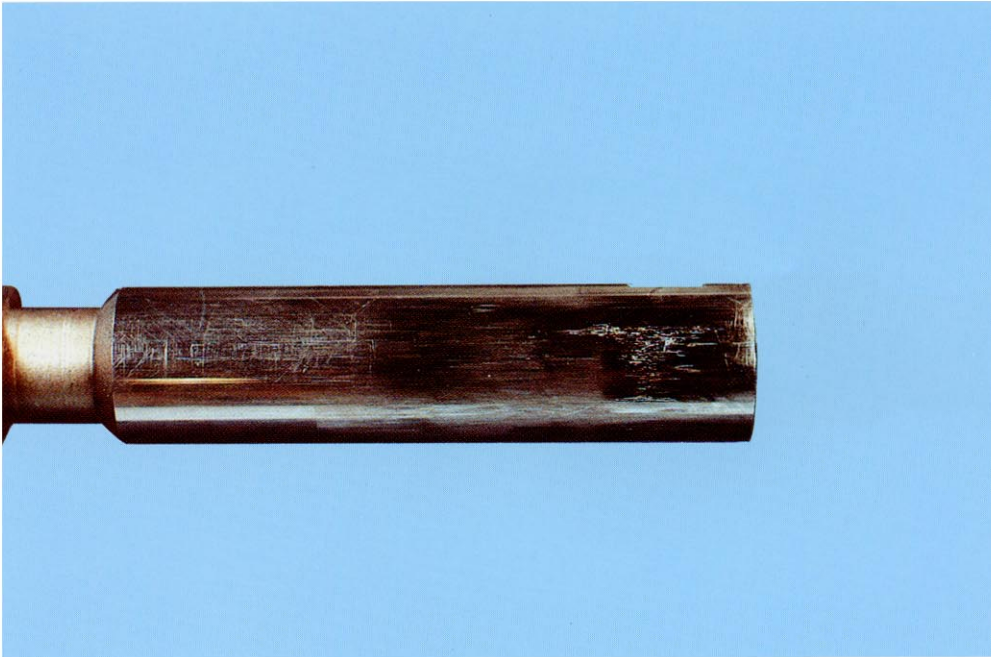

DO NOT USE AGAIN

Failure Sign

- Seizure

Cause

- Unsatisfactory lubrication due to poor quality of fuel.

10

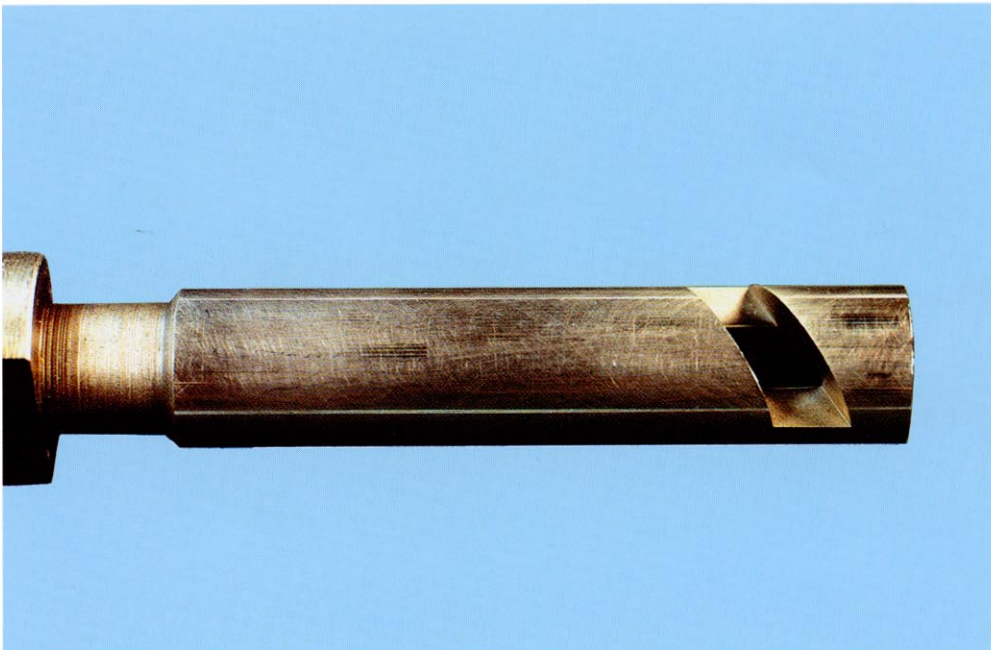

USE AGAIN

Failure Sign

- Small scratches.

Cause

- Foreign matter lodged in.

Camshaft

11

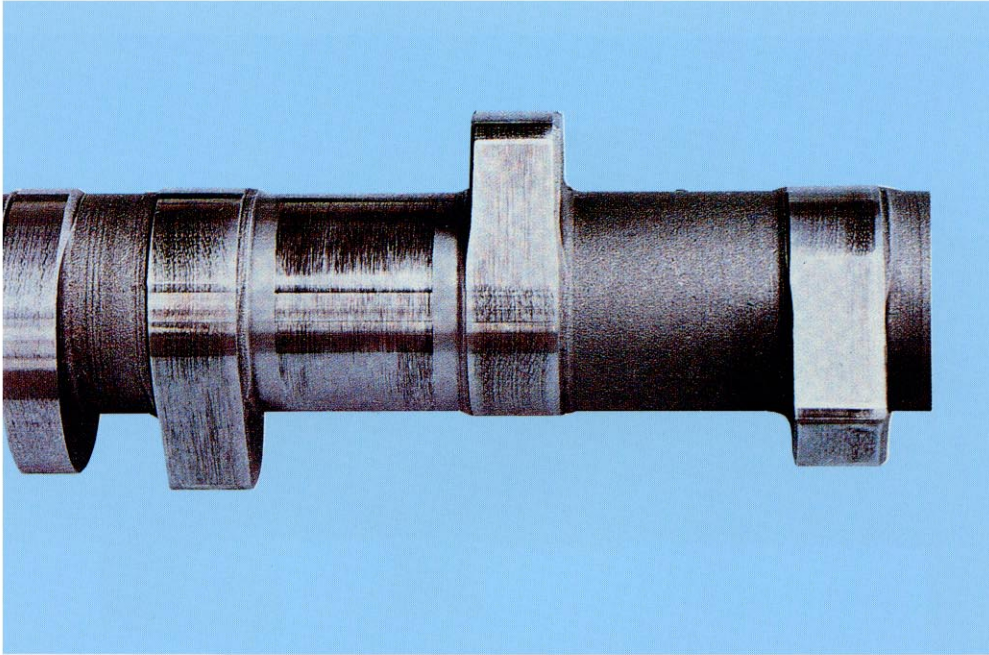

USE AGAIN

Failure Sign

- Metallic contact with roller.

Cause

- Bad lubricating oil.

12

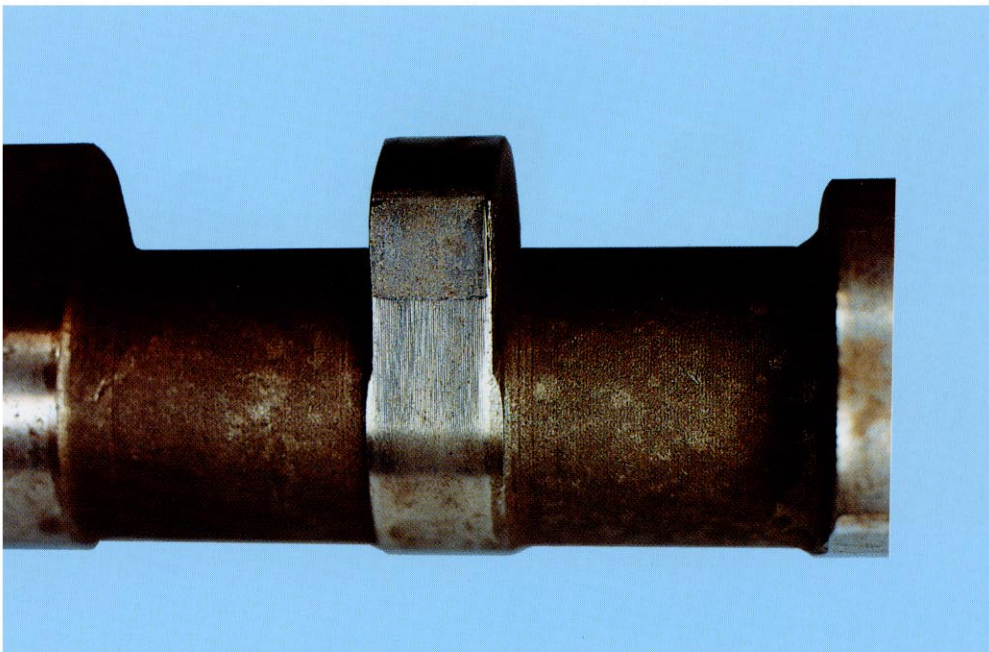

DO NOT USE AGAIN

Failure Signs

- Flaking and stepped, uneven wear.

Cause

- Broken oil film.

13

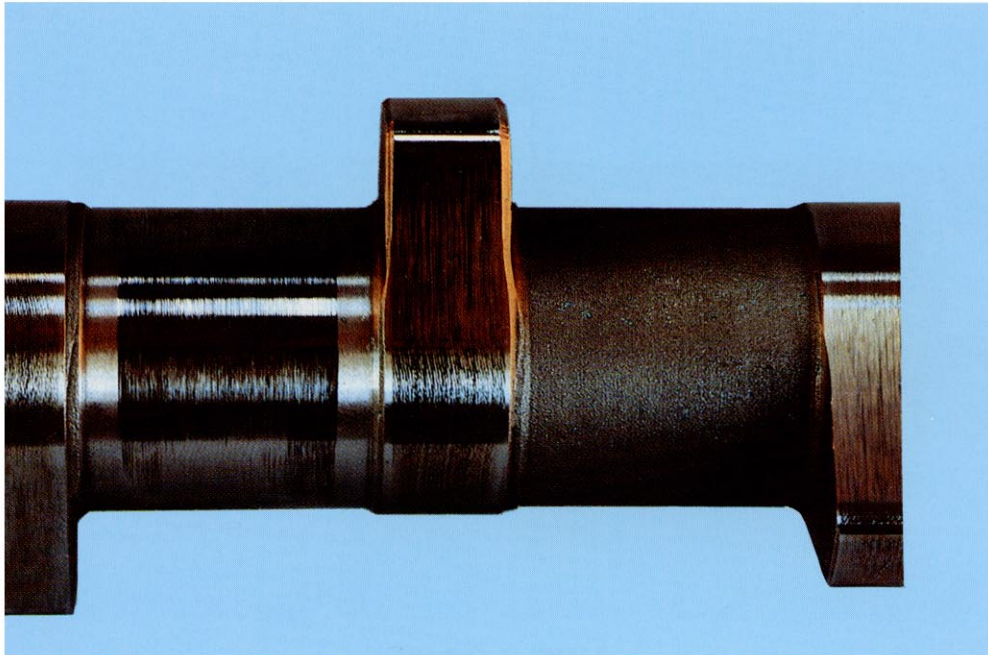

USE AGAIN

Failure Sign

- Metallic contact with roller.

Cause

- Lack of lubricating oil.

14

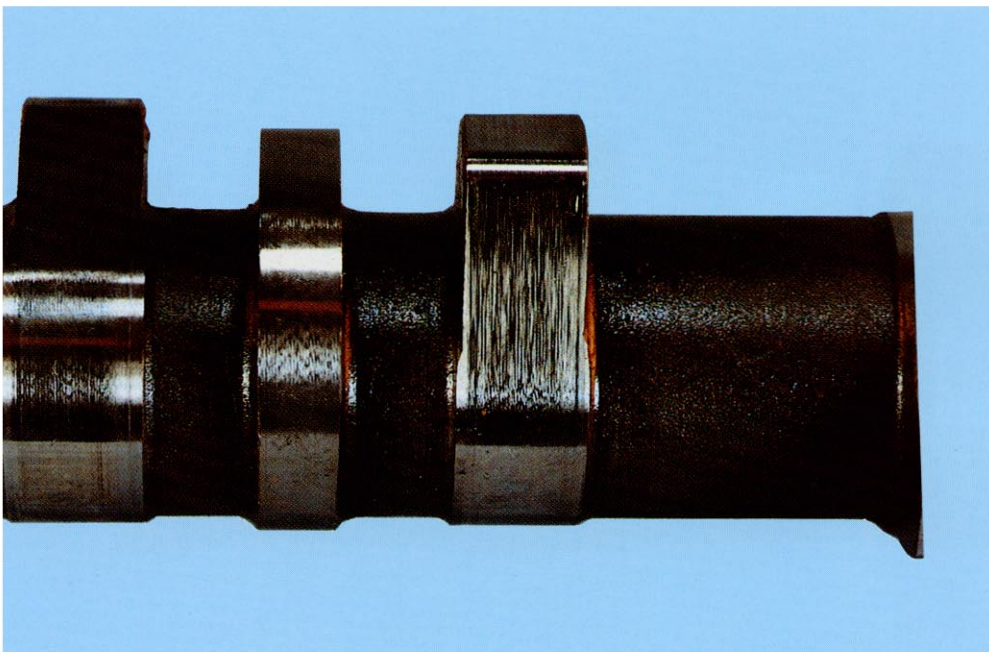

DO NOT USE AGAIN

Failure Sign

- Excessively worn surface.

Cause

- Bad lubricating oil
(contaminated with foreign matter)

15

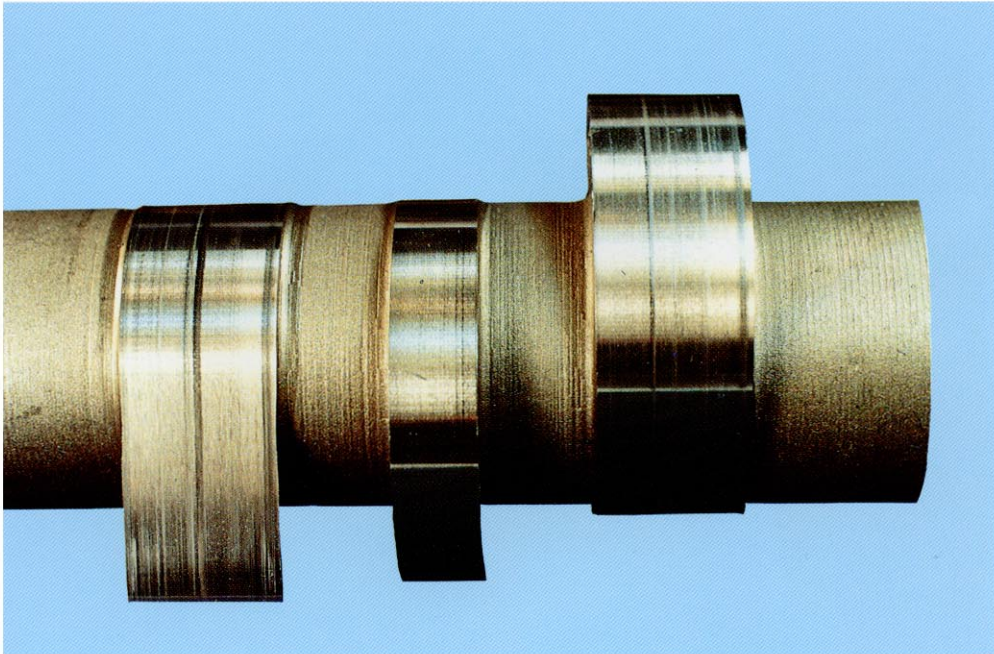

USE AFTER RECONDITIONING

Failure Sign

- Scuffed

Cause

- Foreign matter lodged in the camshaft area.

16

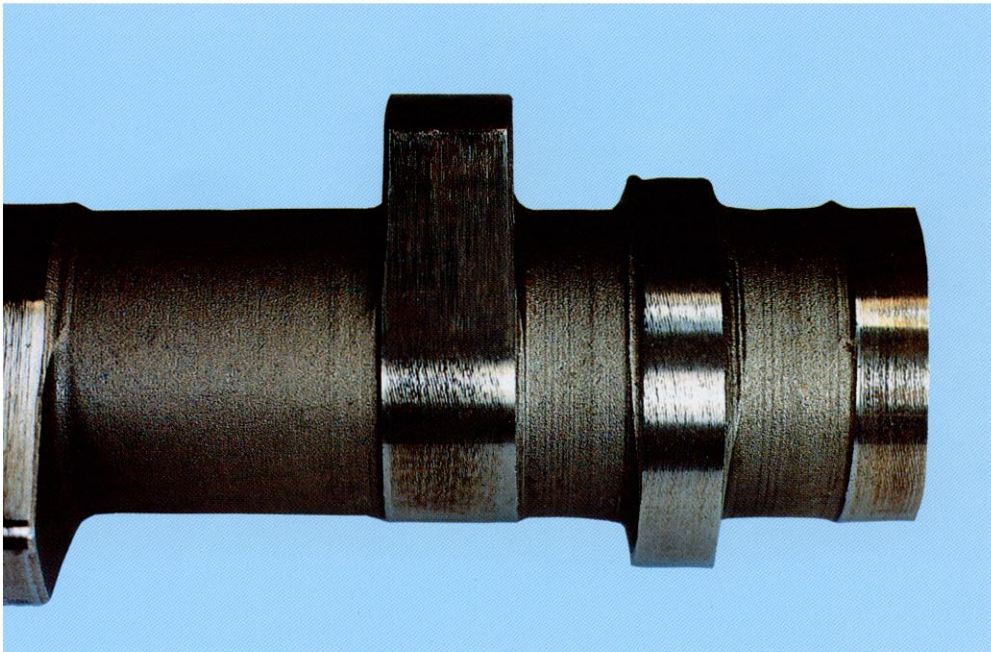

DO NOT USE AGAIN

Failure Sign

- Excessively worn.

Cause

- Lack of lubricating oil.

17

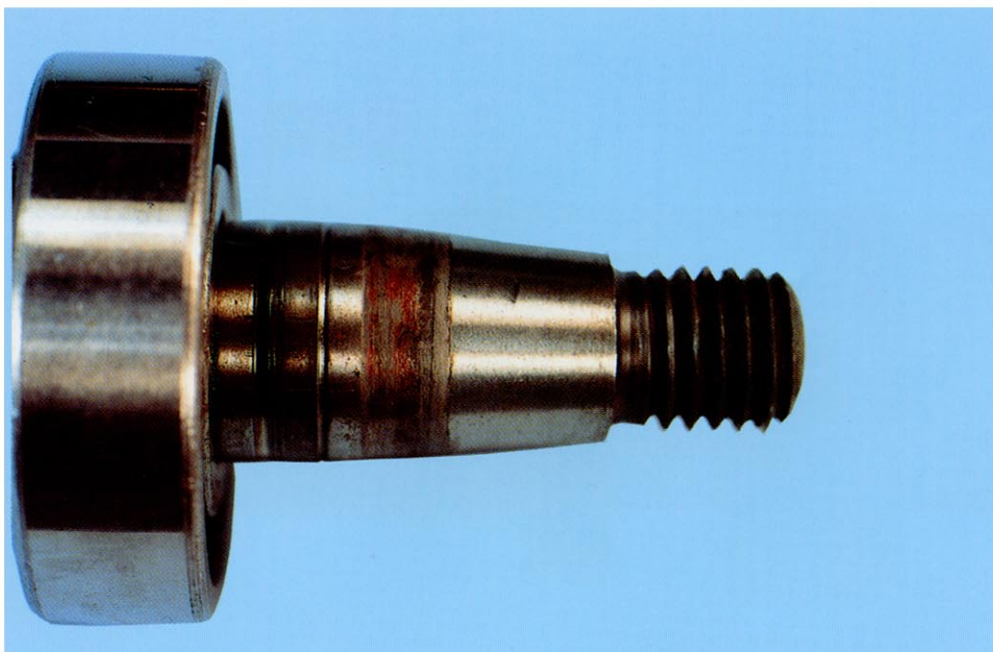

DO NOT USE AGAIN

Failure Sign

- Fretting

Causes

- Improperly attached coupling or extreme eccentricity of coupling.

18

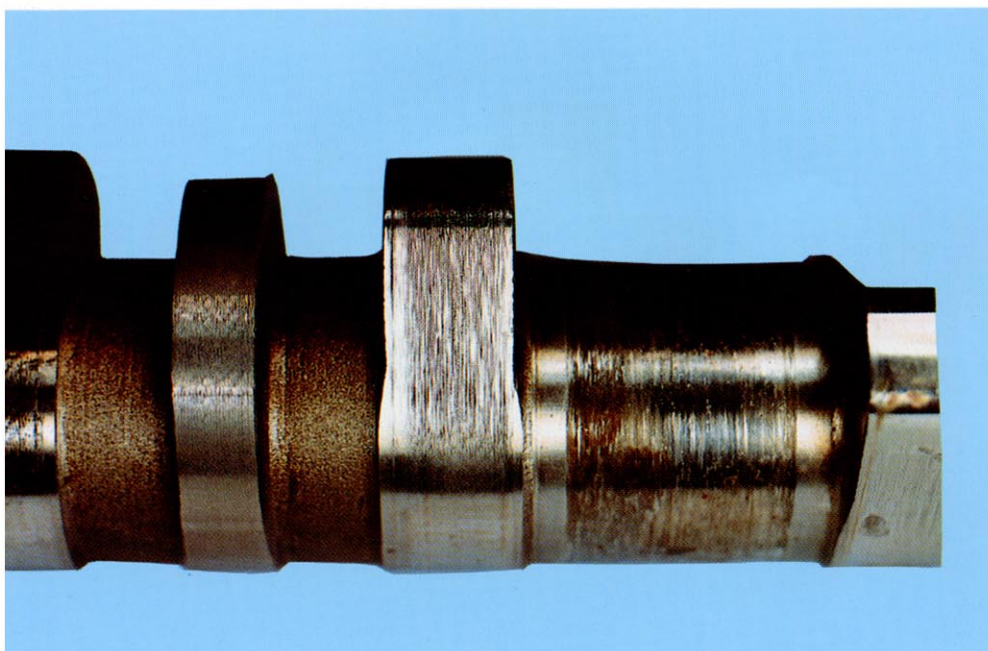

DO NOT USE AGAIN

Failure Sign

- Excessively worn.

Cause

- Bad lubricating oil.

Tappet

19

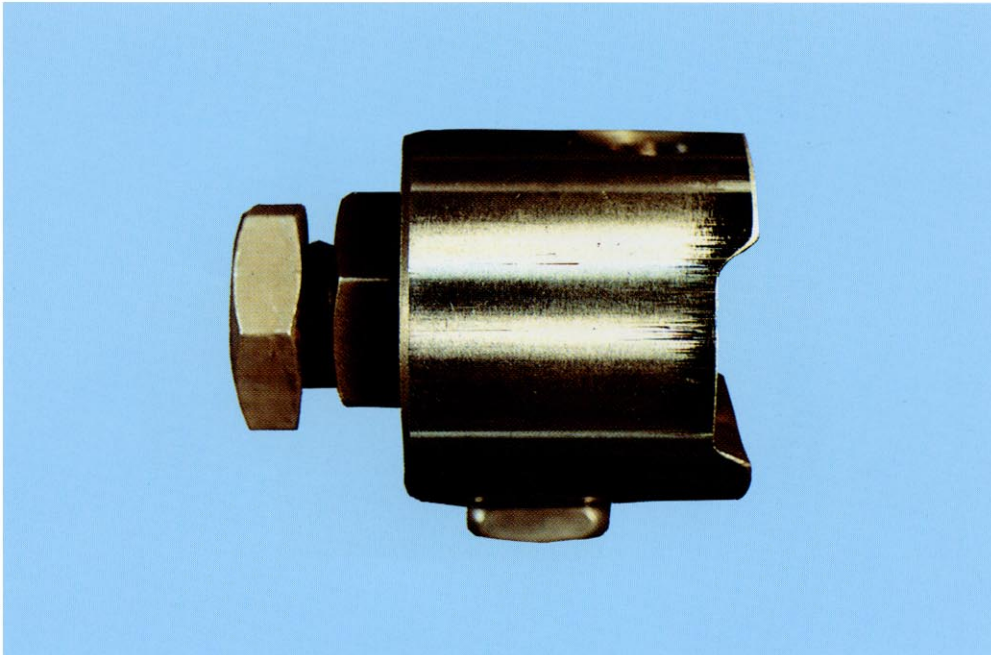

USE AGAIN

Failure Sign

- Slightly worn

Cause

- Lubricating oil a little low.

20

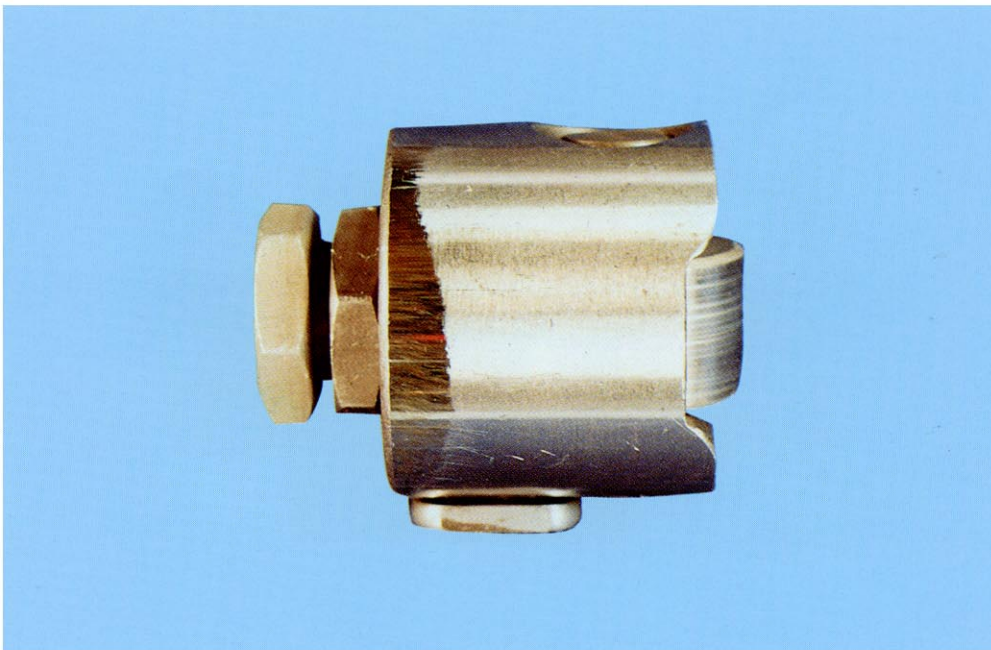

DO NOT USE AGAIN

Failure Sign

- Excessively worn.

Cause

- Broken oil film.

21

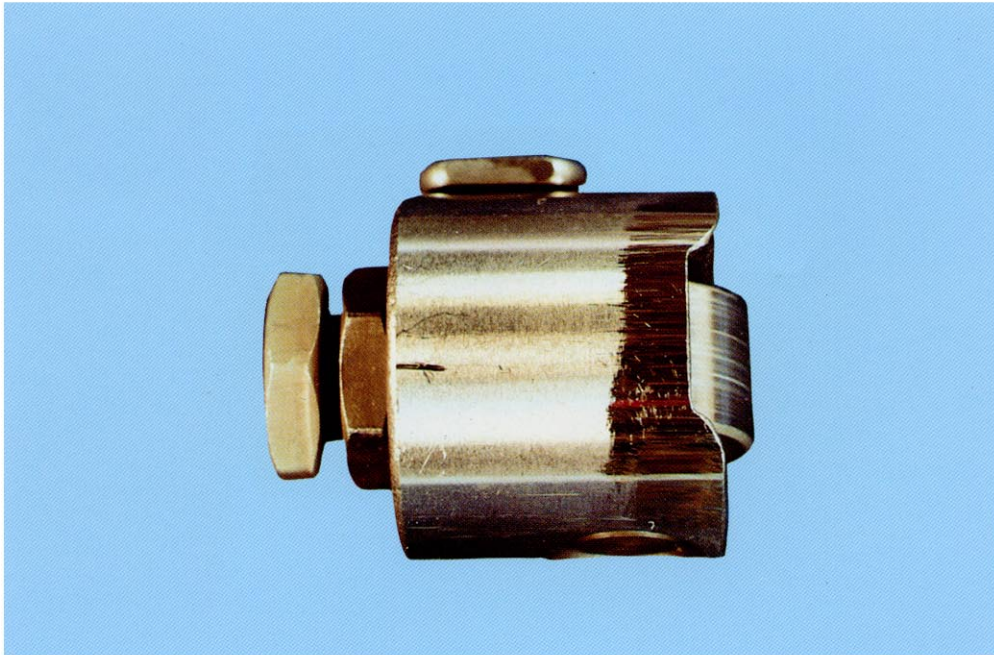

DO NOT USE AGAIN

Failure Sign

- Scuffing.

Causes

- Broken oil film, oil contaminated with foreign matter.

22

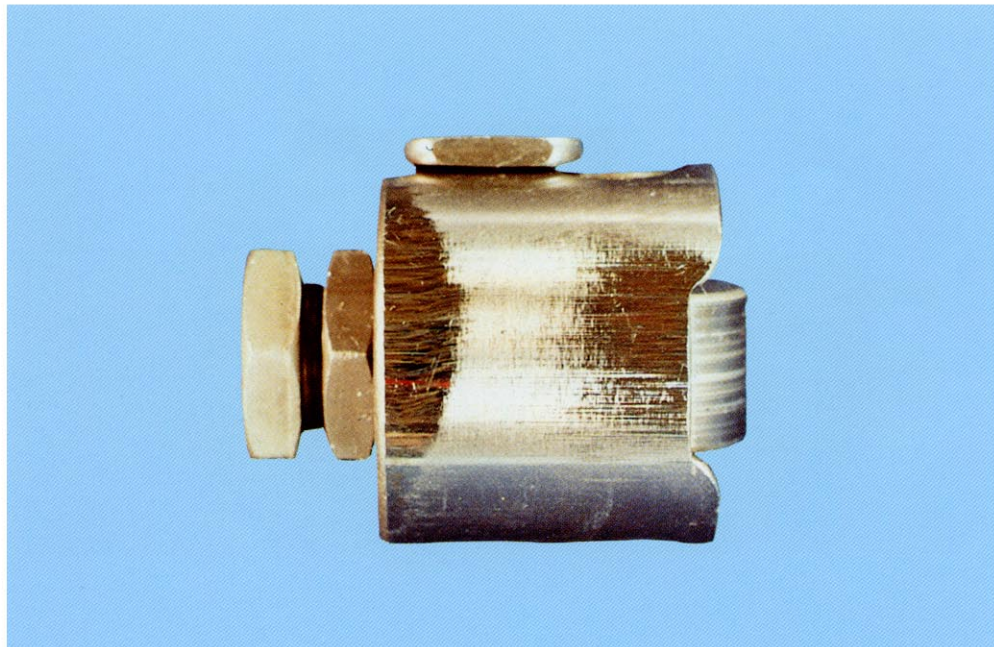

DO NOT USE AGAIN

Failure Sign

- Scuffing.

Causes

- Broken oil film & oil contaminated with foreign matter.

Tappet roller pin

23

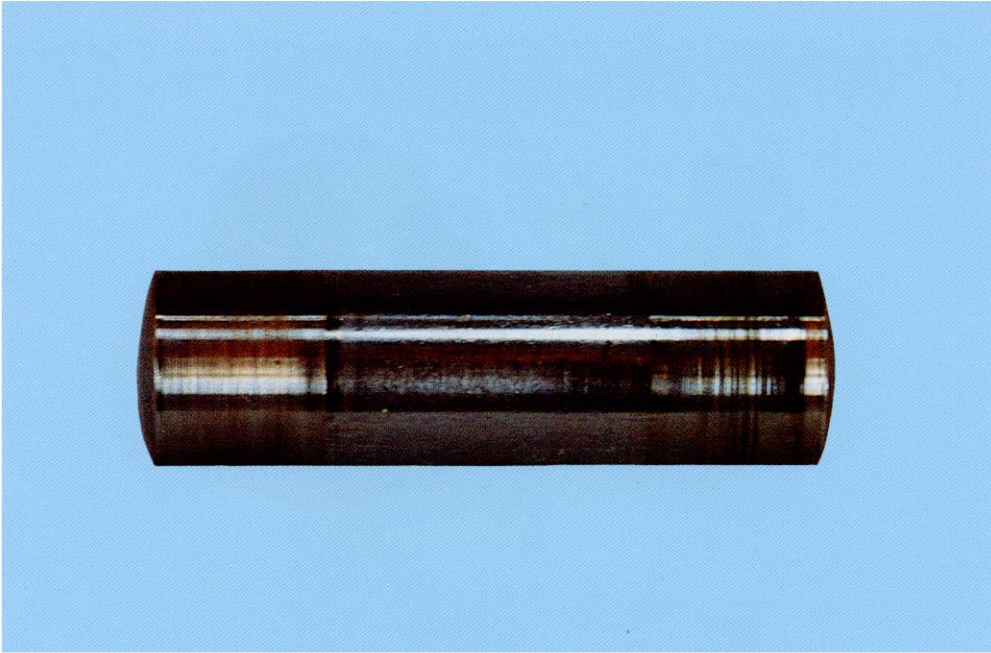

USE AGAIN

Failure Sign

- Slightly worn and discolored surface.

Cause

- Unsatisfactory lubrication.

24

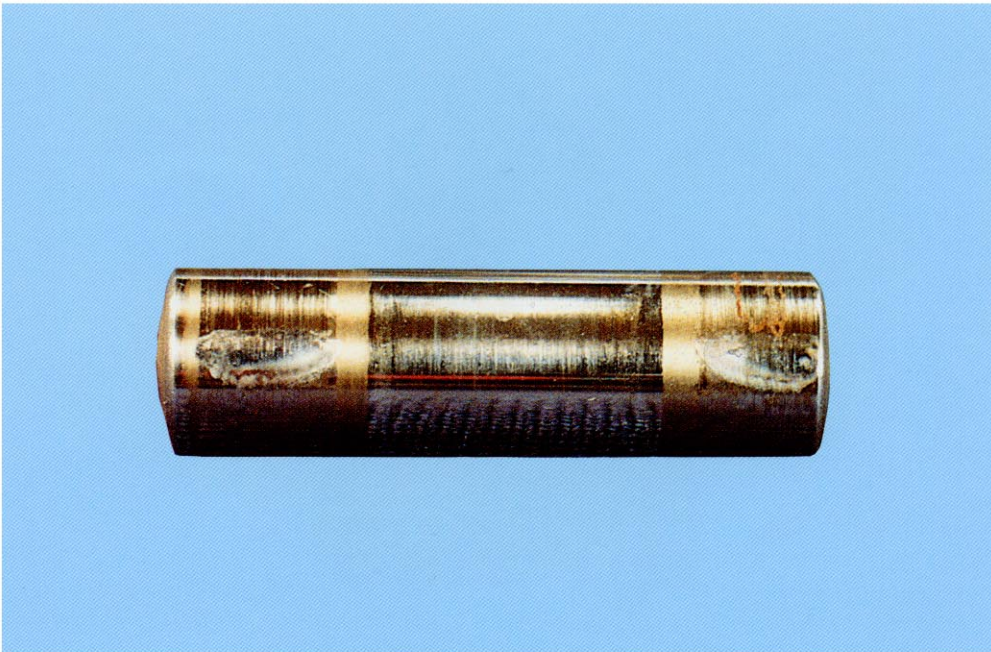

DO NOT USE AGAIN

Failure Sign

- Uneven wear.

Cause

- Unsatisfactory lubrication.

Delivery valve

25

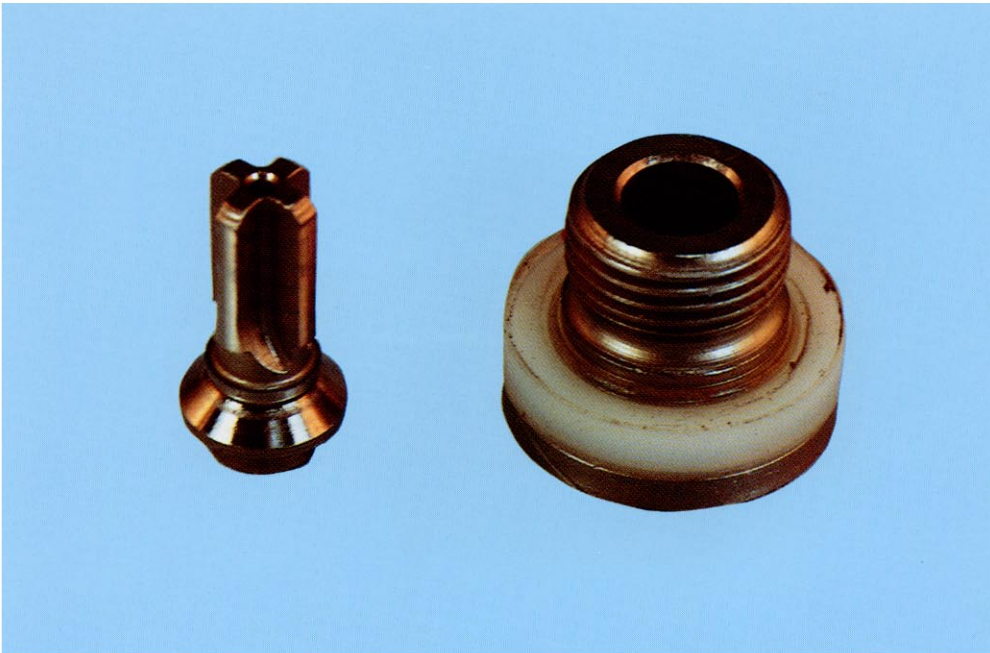

DO NOT USE AGAIN

Failure Sign

- Rough valve seat surface.

Causes

- Poor quality fuel and foreign matter lodged in the seat.

26



DO NOT USE AGAIN

Failure Sign

- Rough valve seat surface.

Cause

- Poor quality fuel and foreign matter lodged in the seat.

CONSTRUCTION AND FUNCTION OF FUEL INJECTION PUMPS

PE-A Type (RSV) Fuel Injection Pump

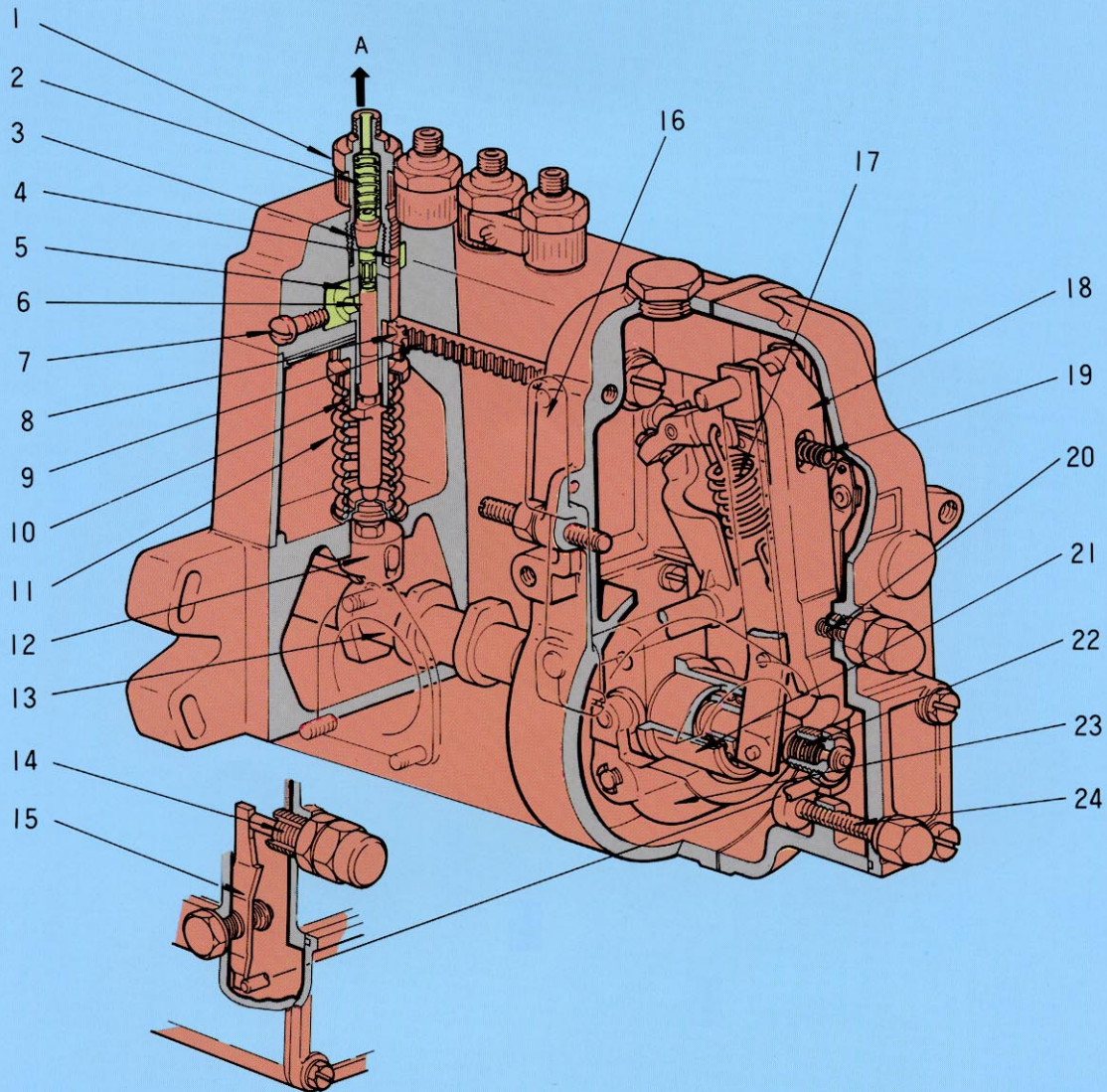

- | | | | |
|--------------------------|--------------------|---------------------|-----------------------|
| 1. Delivery valve holder | 8. Control pinion | 15. Lever | 22. Angleich spring |
| 2. Delivery valve spring | 9. Control rack | 16. Control lever | 23. Flyweight |
| 3. Delivery spring | 10. Control sleeve | 17. Governor spring | 24. Full load stopper |
| 4. Oil reservoir | 11. Plunger spring | 18. Tension lever | |
| 5. Plunger barrel | 12. Tappet | 19. Start spring | |
| 6. Plunger | 13. Camshaft | 20. Idle sub-spring | |
| 7. Deflector | 14. Torque spring | 21. Sleeve | |
- A. to injection nozzle

PE-PD Type (RSUV) Fuel Injection Pump

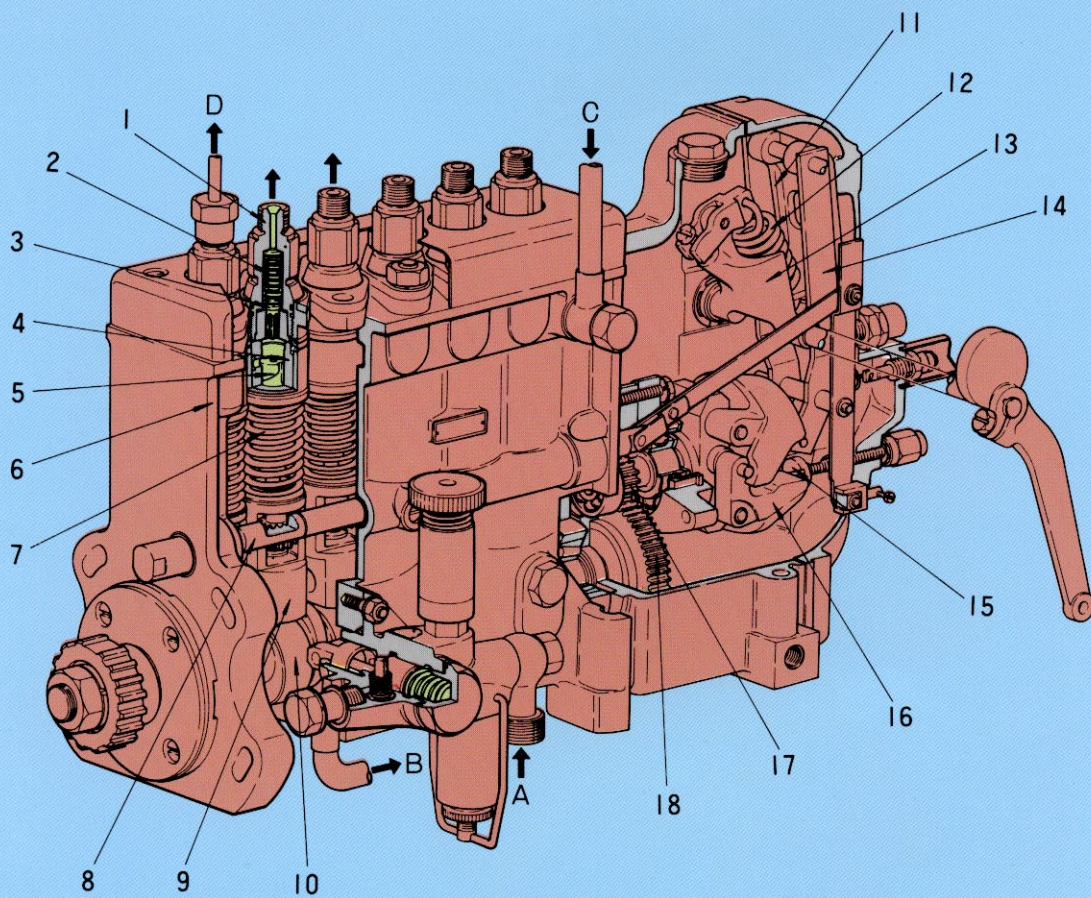

- | | | | |
|--------------------------|---------------------|-----------------------|------------------------|
| 1. Delivery valve holder | 7. Plunger spring | 13. Swivel lever | A. from fuel tank |
| 2. Delivery valve spring | 8. Control rack | 14. Guide lever | B. to fuel filter |
| 3. Delivery valve | 9. Tappet | 15. Full load stopper | C. from fuel filter |
| 4. Plunger barrel | 10. Camshaft | 16. Flyweight | D. to injection nozzle |
| 5. Plunger | 11. Tension lever | 17. Driven gear | |
| 6. Pump housing | 12. Governor spring | 18. Drive gear | |

Types of Injection Pumps

Bosch type injection pumps have various configurations depending on the structure. However, they all have the same basic structure and are classified by application as follows:

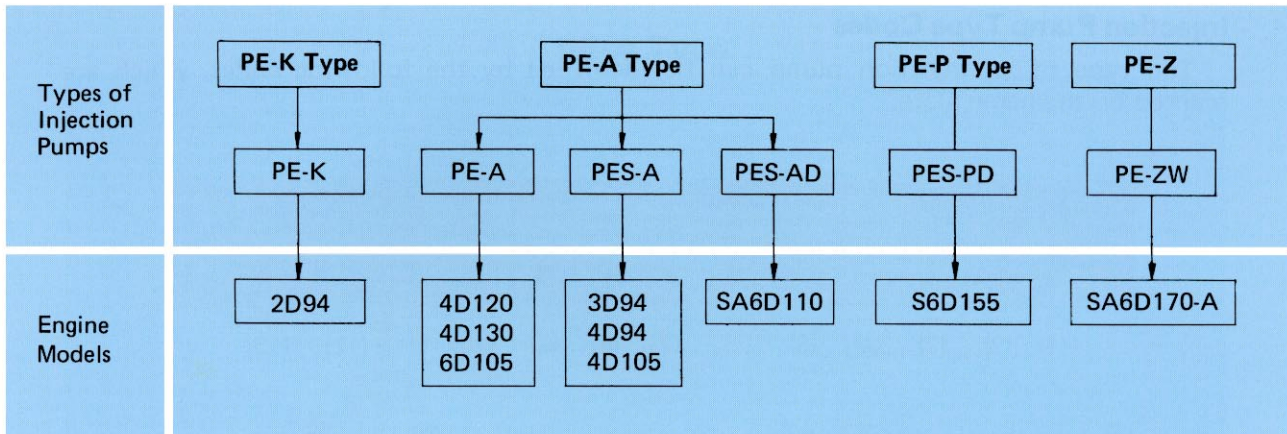

Note: Pump Types S & D have the following meaning (e.g. PES-PD)

S: Flanged type (without S: Coupling type)

D: Increased injection quantity and reinforced type

PE-K Type: Small-sized, lightweight. The injection pump body and governor are made as one unit.

PE-A Type: Most extensively used. The pump body, governor mechanism and feed pump are integrated into one unit.

PE-P Type: Large-sized, high-speed pump. The pump housing is totally enclosed. Plunger, delivery valves, etc. can be removed or installed as one unit.

PE-Z Type: This is a PE-P type with increased capacity.

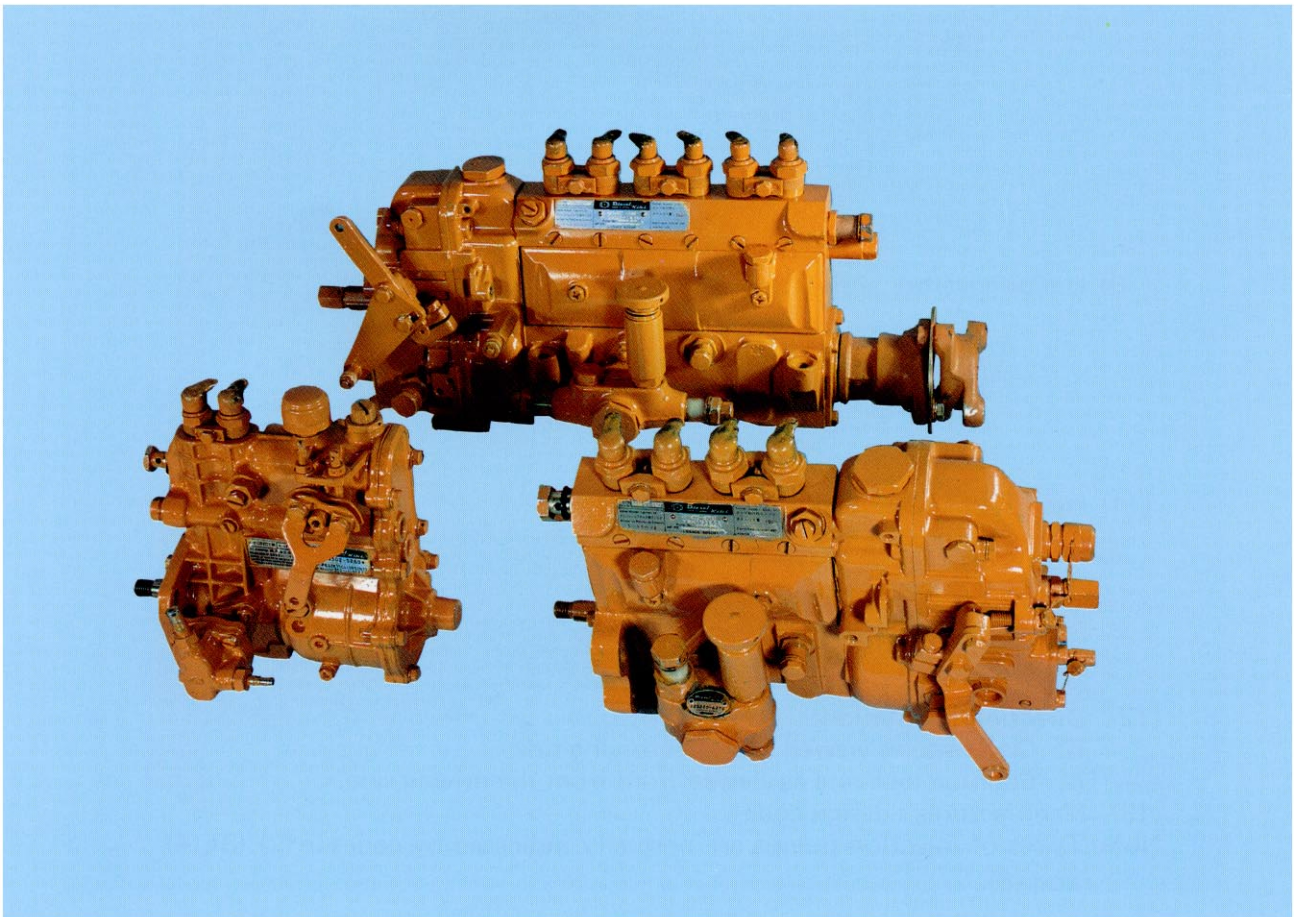

Injection Pump Type Codes

The type of an injection pump can be identified by the following codes, which are marked on the name plate.

NP	P	E	S	6	A	80	C	4	2	1	R	N229
ND	P	E	S	4	A	50	C	4	2	0	R	S256
(1)	(2)	(3)	(4)	(5)	(6)	(7)	(8)	(9)	(10)	(11)	(12)	(13)

- (1) Injection pump manufacturer's codes.
NP : DIESEL KIKI CO., LTD.
ND : NIPPON DENSO CO., LTD.
- (2) P denotes an injection pump.
- (3) E indicates that the injection pump has a camshaft.
- (4) S indicates that the injection pump has mounting flanges. An injection pump without this "S" code is connected by couplings to the other engine parts.
- (5) Number of plungers (Number of cylinders)
- (6) Pump basic types: A, B, K, P, Z, AD, PD, etc.
- (7) Plunger O.D. (mm) x 10
- (8) Design code by Robert Bosch G.m.b.H
- (9) Use of feed pump and setting direction of camshaft.

No.	Use of feed pump	Setting direction of camshaft
1	No pumps used	on left side
2	No pumps used	on right side
3	One pump used	on left side
4	One pump used	on right side
5	Two pumps used	on left side
6	Two pumps used	on right side

- (10) Use of governor and its position

No.	Governor position
0	No governor
1	On left side
2	On right side

- (11) Use of timer and its position

No.	Use of timer and its position
0	No timer used
1	Timer used on left side
2	Timer used on right side

- (12) Direction of rotation

R: Clockwise as viewed from the driving side.

L: Counterclockwise as viewed from from the driving side.

- (13) Manufacturer's design code

Note: Types of injection pumps are normally indicated by codes in (2),(3),(4) and (6).

Construction of Injection Pumps

PE-A Type

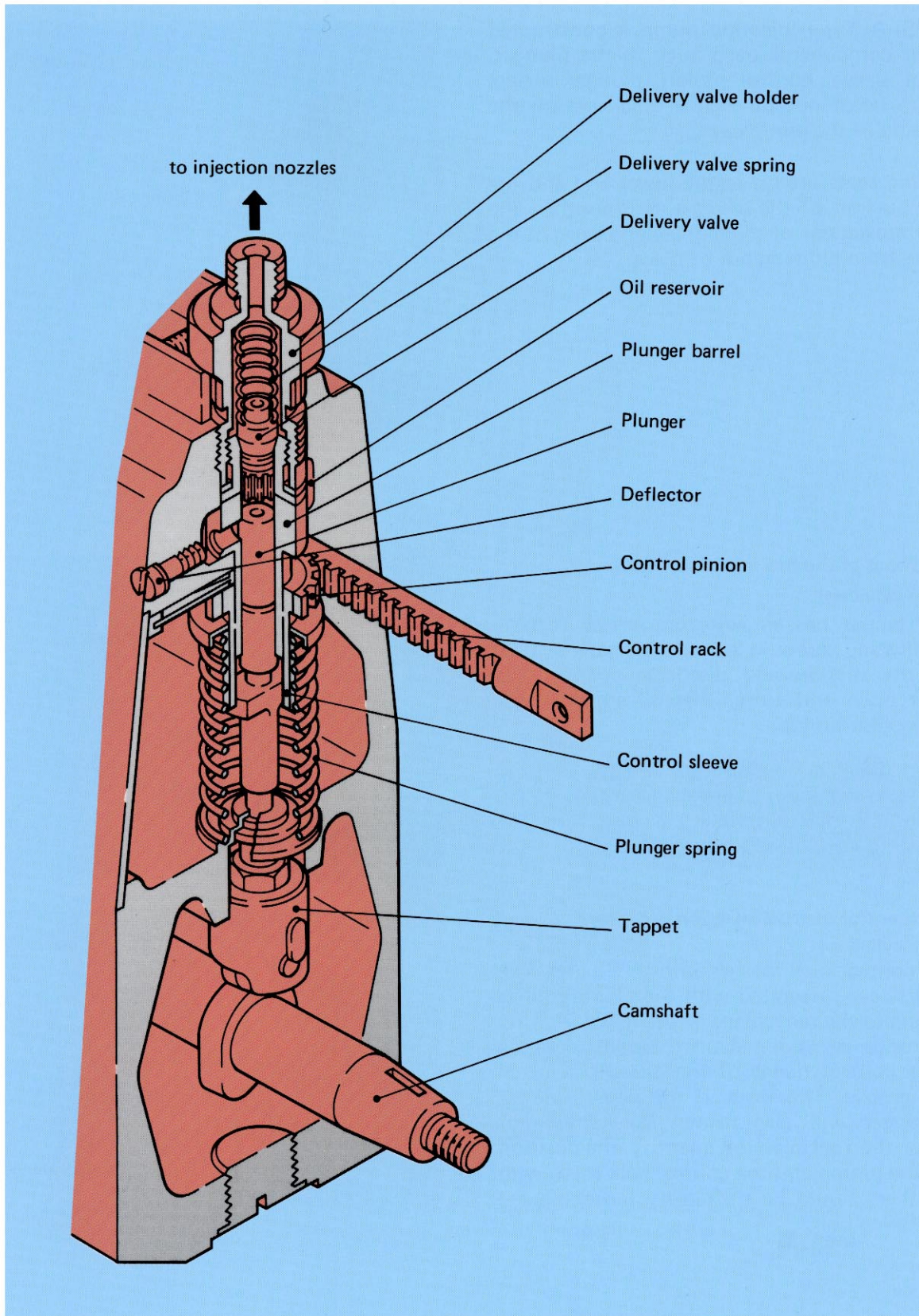

PE(S)-A Type injection pump is constructed so that components parts such as the plunger, control sleeve, control pinion, plunger spring, etc. are taken out through a plug hole on the underside of the pump case.

Spring seats are set at the lower end and the upper portion of the plunger to smoothen the return movement of the plunger and prevent the plunger from jumping out of place.

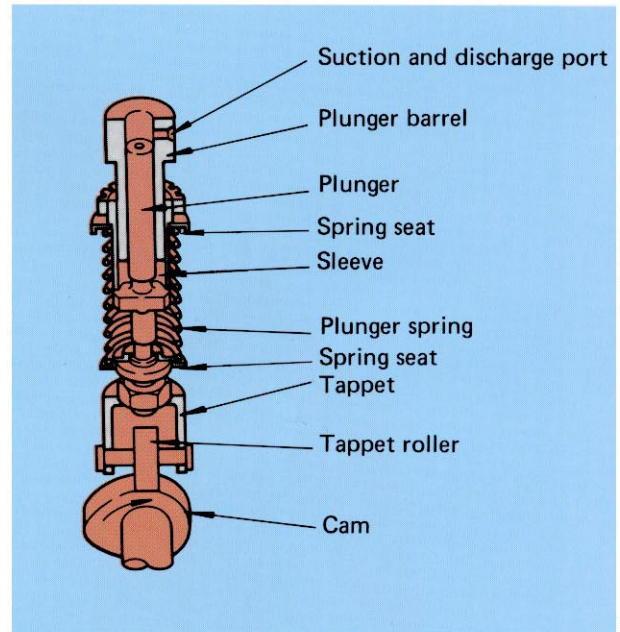

Adjustment of the fuel injection timing

(between cylinders)

The tappet has an adjusting screw. Turning this adjusting screw in or out changes the time when the suction and discharge ports in the plunger open and close, thereby adjusting the fuel injection timing.

- * When the injection timing is delay, turn the adjusting screw out to advance the timing.
- * When the injection timing is fast, turn the adjusting screw in to delay the timing.

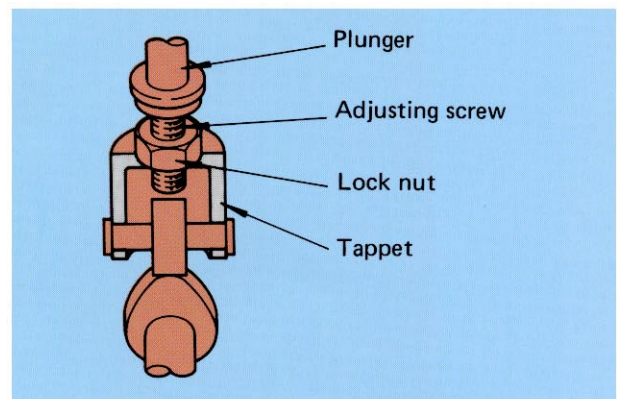

Adjustment of the fuel injection quantity

(between cylinders)

The control rack meshes with the pinion. The control sleeve integrated with the pinion rotates according to the movement of the rack.

A groove is machined on the control sleeve and the control flange of the plunger is fitted in this groove. Therefore, if the sleeve rotates, the plunger will also rotate. To increase or decrease the fuel injection quantity, the position where the pinion and the control rack mesh with each other should be shifted by loosening the pinion fixing bolt.

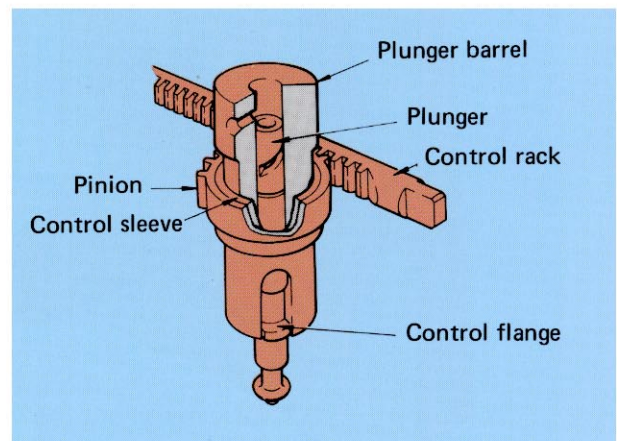

PES-PD Type

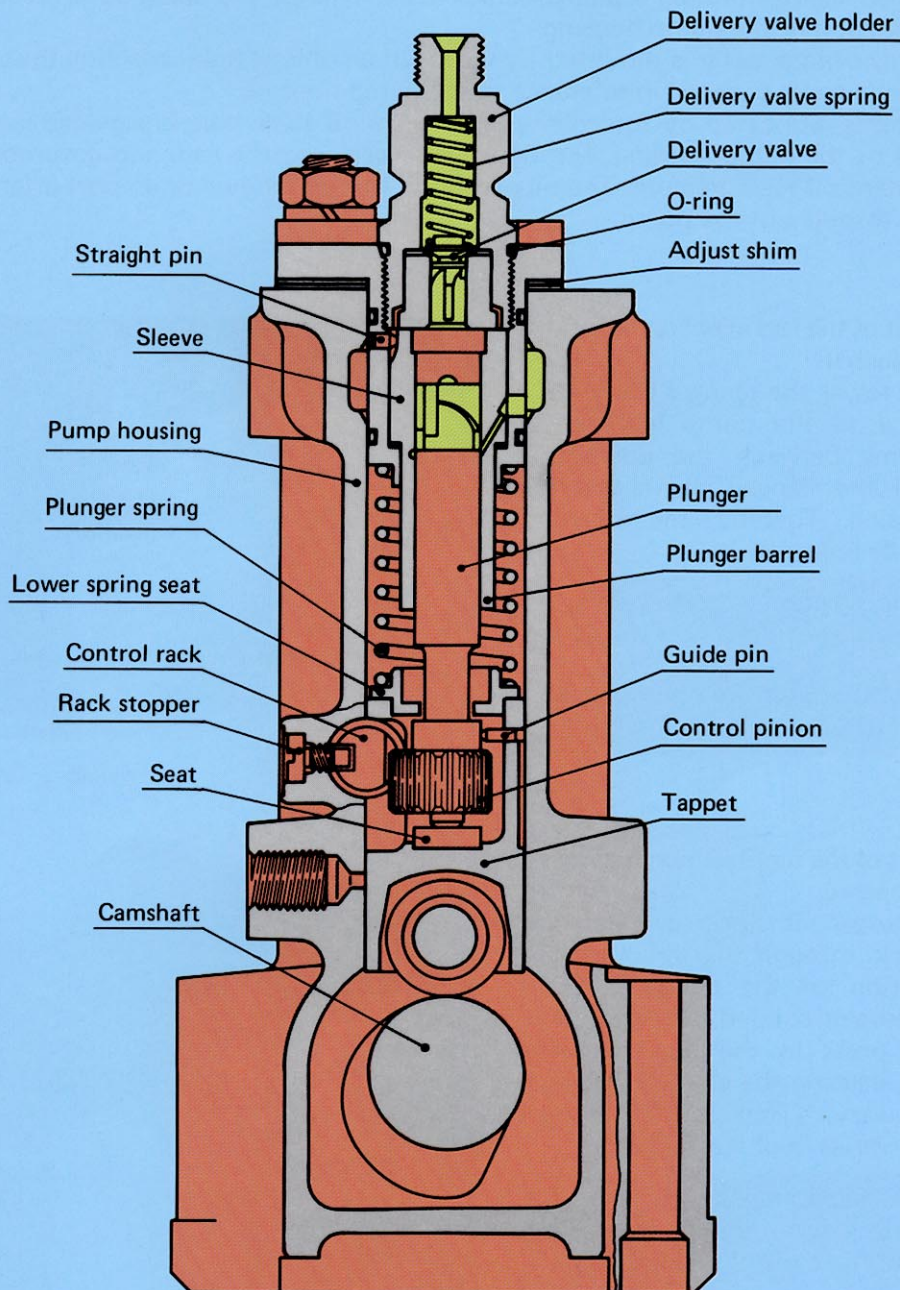

In fuel injection pumps, the quantity of fuel required for combustion in the engine is delivered to fuel injection nozzles at the proper time under the specified pressure.

PES-PD type injection pump is completely enclosed, which differs from the PE(S)-A type. The plunger barrel is located by a straight pin provided at the mid-point of the outer circumference of the sleeve. The plunger, delivery valve, and delivery valve spring are fixed in the flanged sleeve, forming a plunger block ass'y. This ass'y is taken out of place through the upper portion of the pump housing.

The plunger block ass'y is mounted by means of an oblong hole, enabling the position of the block ass'y to be changed in reference to the pump housing.

The pump is lubricated by forced circulation. An oil guide hole is provided in the tappet sliding area of the pump housing. Engine oil is forced into the cam and governor housings under constant oil feed pressure. The oil overflows through the oil drain port after providing lubrication throughout the pump.

Adjustment of the fuel injection timing (between cylinders)

Raise or lower the plunger block ass'y in reference to the pump housing by adding shims between the contacting surfaces of the flanged sleeve and the pump housing. Thereby, the injection timing can be adjusted.

- * When the injection timing is slow, remove a shim (or shims) to advance the timing.
- * When the injection timing is fast, add a shim (or shims) to delay the timing.

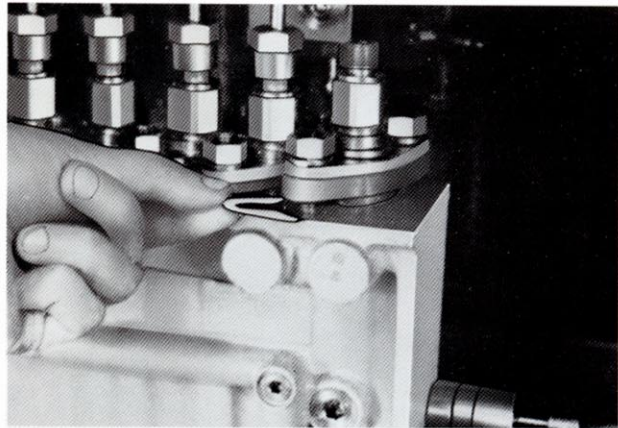

Adjustment of the fuel injection quantity (between cylinders)

The plunger is located near the control rack through the pinion at the lower portion of the plunger. As the plunger sleeve is rotated, the suction and drain ports in the plunger barrel also move, causing the effective plunger stroke to vary. (That is, the plunger block ass'y varies in phase.)

- * The adjustable range, 10° , of the flanged sleeve corresponds to approx. 1.8 mm in the control rack position.

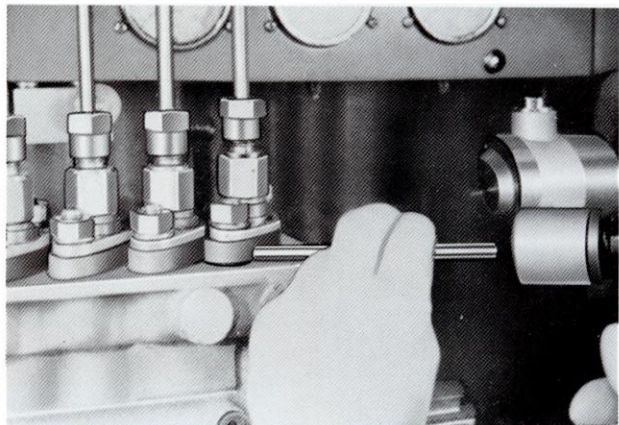

PE-ZW Type

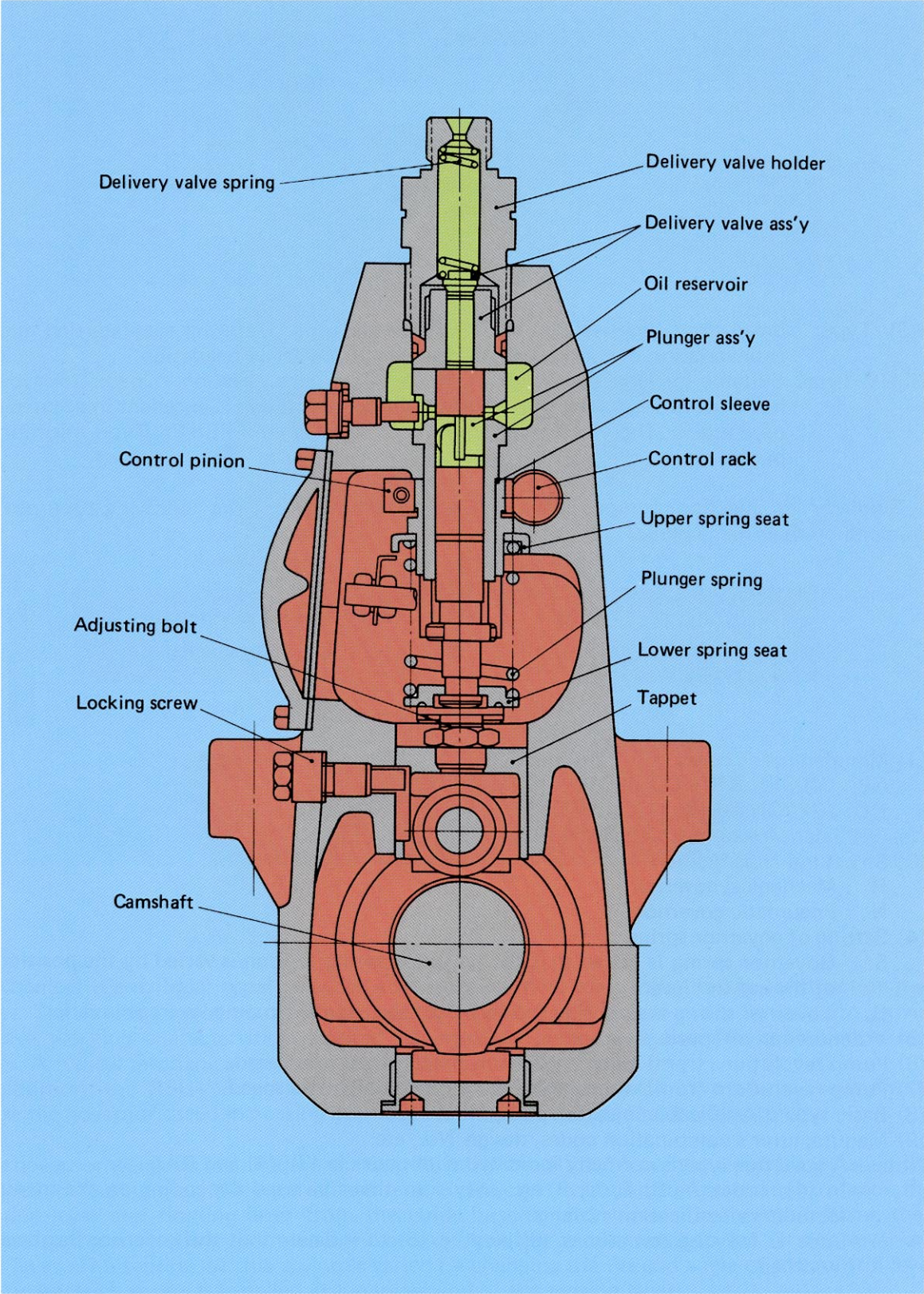

Types of Governors

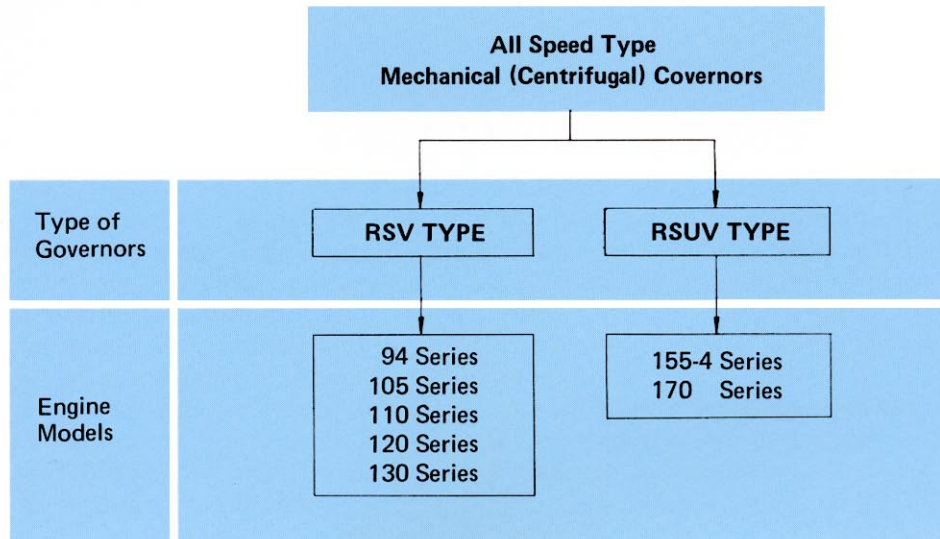

RSV Type: Small-sized, lightweight. Most extensively used, featuring easy starting and easy variation of the rotational speed range and speed regulation.

RSUV Type: Suitable for large-sized engines which have a large variation in load. This type has a speed increasing gear aided by the flyweight and is excellent in accuracy of control. Therefore, this governor is used in the PES-PS Type injection pump.

Similarly to injection pumps, governors can be identified by the following type nos. stamped on their name plates.

NP	EP	/	R	S	V	200 ~ 1450	A	Q2A11NP2139
ND	EP	/	R	Q		200 ~ 1302	A	1302ND62
(1)	(2)	(3)	(4)	(5)	(6)	(7)	(8)	(9)

- (1) Manufacturer's codes
NP : DIESEL KIKI CO., LTD.
ND: NIPPON DENSO CO., LTD.
- (2) "EP" denotes an injection pump part.
- (3) Structural classification
R : Mechanical governor
N : Pneumatic governor
- (4) Setting of governor spring
S: Governor spring is set so that the governor spring tension is varied by the position of the control lever.
Q: Governor spring is set inside the flyweight so that the floating leverage is varied.
- (5) V denotes an all-speed governor.
- (6) Pump revolutions (rpm) when engine is running at low idle speed.
- (7) Pump revolutions (rpm) when engine is running at high idle speed.
- (8) Basic type of applicable injection pump.
- (9) Manufacturer's combination codes, design No., etc.

Notes: ●A governor type is normally indicated with codes in (3), (4) and (5).

- In (4), codes A, B, F, U, P, etc. may sometimes be used depending on the manufacturer's classification systems.
- Code D may be sometimes suffixed to (5) to indicate that the governor has been modified.

Construction of Governors

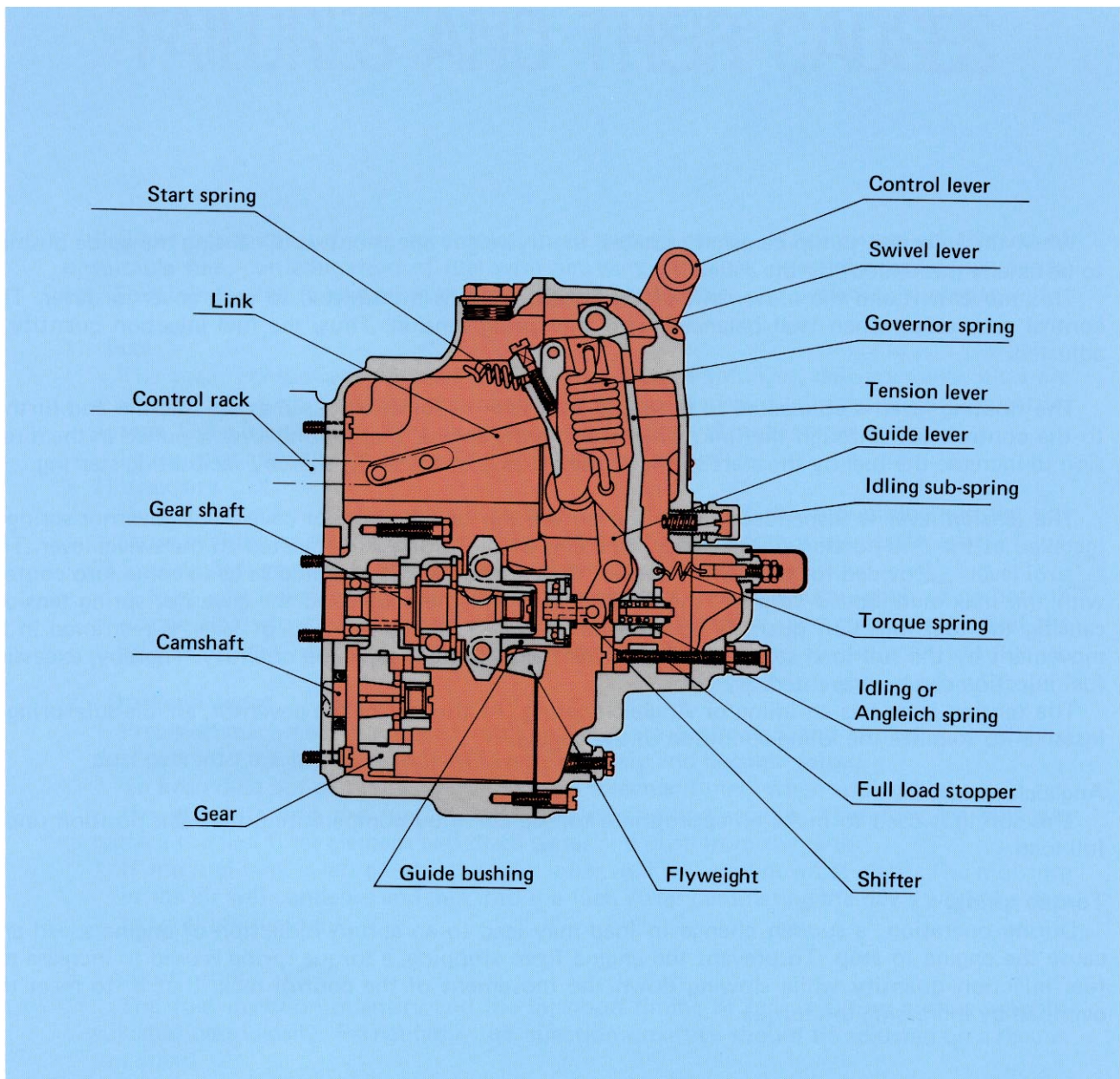

Mechanical (Centrifugal type) all speed governors are most frequently used in construction machine engines. The rotating speed control range and the speed regulation can easily be varied to provide the extensive working characteristics required of injection pump governors for construction machine engines. A typical mechanical governor is the RSV Type.

In addition, the RSUV Type is used for large-sized engines which have a large variation in load, because the governor speed increasing gear is set to improve the speed control accuracy.

The governor weight is installed on the camshaft. (In the RSUV type, the weight is installed through the speed increasing gear). The movement of this flyweight is transmitted to the control rack through the guide lever and floating lever from the guide bushing and shifter. On the other hand, the main governor spring controlling the movement of the flyweight is connected to the tension lever and the swivel lever. The tension of this spring is varied by changing the tilt and angle of the control lever. An idling or Angleich spring is installed at the lower end of the tension lever.

When the injection pump camshaft rotates, the flyweight opens outward, causing the guide bushing to be axially pushed out by the roller.

This movement and the movement of the control lever is transmitted to each governor lever. The control rack stops when well balanced with the spring tension. Thus, the fuel injection quantity is adjusted.

The floating lever is connected to the guide lever with its lower end used as the fulcrum and further to the control rack through the link. When starting the engine, the floating lever is pulled in the direction to increase the fuel by the start spring at the top end of the lever, thereby facilitating starting.

The tension lever is suspended from a pin on the top of the governor cover. The governor spring is installed at the mid-portion of the cover. One end of the spring is connected to the swivel lever. The control lever is provided for this swivel lever. If the control lever is operated so as to come into contact with the maximum speed stopper, the tension lever will be subject to the governor spring tension, causing the fuel injection quantity to increase. However, the lower end of lever is restricted in its movement by the full load stopper which limits the maximum injection quantity. Thereby, excessive fuel injection can be prevented.

The tension lever has an idling or Angleich spring. At the rear of the governor, an idle sub-spring is installed to stabilize the idling condition of the engine.

Angleich spring:

This spring is used to make an appropriate torque curve by compensating the rack position under full load.

Torque spring:

During operation, a sudden change in load may lead to an abrupt reduction of engine speed and cause the engine to stop. To prevent the engine from stopping, a torque spring is used to increase the fuel injection quantity while slowing down the movement of the control rack, that is, to meet the overload by increasing the torque.

FAILURES AND THEIR CAUSES

Failures occur through the accumulation of various causes. Major causes are the use of unsuitable fuel, contamination of fuel with air, water, or dust, unsatisfactory adjustments, etc. To minimize the failure of parts, strictly observe the daily and periodic maintenance.

1. Fuel

The main component parts of fuel injection pumps (plunger, delivery valve, etc.) are machined to a high degree of accuracy. Fuel is also used as a lubricating oil in injection pumps. Use a high quality light oil appropriate for the ambient temperature.

Pay special attention to the following properties of fuel:

1) Viscosity

Fuel must be viscous enough to circulate throughout the fuel piping and yet not cause sticking or seizure of the plunger and other parts, and not accelerate wear.

2) Fuel with a very low content of residual carbon and sludge

Fuel which has a high residual carbon content causes accumulation of carbon on nozzle tips, clogging of nozzle injection ports with carbon, and contamination of the oil with sludge, resulting in prematurely worn engine parts.

2. Dust and water

Precision-machined high-speed running parts are lubricated and cooled with fuel. If dust gets into the fuel, the parts will wear maturely and become seized.

To keep dust out of the tank, always use a screened funnel when adding fuel.

If water gets into the fuel, it will cause resting and seizure. Therefore, periodically replace the fuel filter element and drain water and dust from the tank.

* If the fuel tank is left empty, the tank inner wall will cool down at night. The moisture in the air will condense and mix into the fuel. After completing the day's work, be sure to refill the fuel tank.

3. Adjustments

The fuel injection quantity and the injection timing of fuel injection pumps must be adjusted periodically. Particularly, the injection quantity should be adjusted on a regular test stand.

Adjustment of the injection timing can be classified into that of the injection pump itself and that to be made when installing an injection pump to an engine.

1) When installing an injection pump which has not been reconditioned:

“Adjust by means of aligning marks”

2) When installing an injection pump which has been reconditioned:

“Adjust with delivery valve”

For the adjustment methods, refer to “GENERAL PRECAUTIONS” in the Shop Manual.

Note: A poorly adjusted fuel injection pump will not cause seizure or excessive wear to the pump itself, but it will have ill-effects on engine performance, causing such problems as lack of power, bad exhaust smoke color, etc.

PREVENTIVE MAINTENANCE

In order to prevent breakdowns and operate machines at full efficiency, it is necessary to give full attention to the machine at all times.

A faulty injection pump may lead to the following troubles: lack of power, instability of power, bad color of exhaust smoke, failure of the engine to start, and hunting.

Most machine troubles can be avoided if the maintenance is carried out in accordance with the Operation and Maintenance Manual. Please call your customers' attention to the following items:

1. Use fuel of high quality with a viscosity suitable for the ambient temperature.
2. Use the lubricating oils recommended by KOMATSU and change them periodically as scheduled. Always add fresh oil to the specified level.
3. Drain water from the fuel tank and filter to keep water out of the fuel system.
4. Use soft water as the cooling water. Do not operate the engine if dirty water is in the radiator or if the cooling system is short of cooling water.

Note: Whenever an abnormality is suspected, examine the cause with the following measuring and testing apparatus.

Measuring instrument	P/N	Item of measurement
Blow-by checker	799-201-1502	Measuring the blow-by pressure
Hydraulic tester	790-301-1103	Measuring the oil pressure
Thermistor checker	790-500-1300	Measuring the water and oil temperatures
Engine oil checker	799-201-6000	Checking engine oil for contamination with water and fuel
Water tester	799-202-7001	Checking the cooling water for suitability
Handy smoke checker	799-201-9000	Measuring the exhaust smoke color

Refer to the SECTION on "Testing and adjusting" in the Shop Manual.

