

DD Platform EuroIV Operators Manual



13400 Outer Drive, West, Detroit, Michigan 48239-4001
Telephone: 313-592-5000
www.demanddetroit.com

Specifications are subject to change without notice. Detroit Diesel Corporation is registered to ISO 9001:2001.

Copyright © Detroit Diesel Corporation. All rights reserved. Detroit Diesel Corporation is a Daimler company.

Printed in U.S.A.

Table of Contents

Forward	4
Introduction.....	4
Non-Genuine and Rebuilt Component Quality Alert.....	4
Personnel Requirements.....	4
Engine Conversions and Modifications.....	5
To the Operator	6
Caution Summary	8
Engine Identification	15
Engine Components - DD Platform.....	15
Engine Model and Serial Number Designation.....	16
Operating Instructions for Starting the Engine	20
First Time Start Preparations.....	20
Detroit Diesel Electronic Controls (DDEC) System	38
DDEC VI System.....	38
Detroit Diesel Electronic Control System Operation.....	40
Detroit Diesel Electronic Control System Features.....	44
Accelerating the Vehicle.....	46
Cruise Control.....	47
Engine Brake and Cruise Control.....	49
DD Platform Shifting.....	50
Idling.....	50
Engine Brake System	51
Driver Control Switches.....	51
Clutch Pedal and Throttle Position Controls.....	51
Engine Brake Activation Conditions.....	51
Engine Brake Operation.....	51
Anti-Lock Braking Systems.....	52
Operating on Flat, Dry Pavement.....	53
Operating Down a Long, Steep Grade.....	53
Operating on Wet or Slippery Pavement.....	54
Engine Systems	56
Preventive Maintenance Intervals	58
Preventive Maintenance Intervals.....	58
Preventive Maintenance Tables.....	62
Routine Preventive Maintenance	64
Monitoring the Lubricating Oil.....	64
Monitoring the Lubricating Oil Filter.....	65
Monitoring the Cooling System.....	66
Inspection of the Radiator.....	67
Monitoring the Cooling System Filter.....	68
Monitoring the Fuel Filters.....	68
Adjusting the Valve Lash.....	68
Monitoring the Belt Tensioner.....	69

Monitoring the Serpentine Belts.....	69
Inspection of the Air Intake System.....	70
Monitoring the Air Cleaner.....	70
Monitoring the Exhaust System.....	71
Inspection of the Air Compressor.....	71
Monitoring the Fuel and Fuel Tank.....	71
Inspection of Hoses and Fittings for Fuel Leaks.....	72
Inspection of the Turbocharger and Charge Air Cooler.....	73
Inspection of the Battery.....	73
Steam Cleaning the Engine.....	74
Inspection of the Battery-Charging Alternator.....	74
Lubricating the Fan Hub.....	75
Checking the Vibration Damper.....	75
How to Procedures.....	77
How to Select Lubricating Oil.....	77
When to Change Oil.....	78
How to Replace the Lubricating Oil and Oil Filter.....	79
How to Select Diesel Fuel.....	81
How to Replace the Fuel Filters.....	83
Engine Out of Fuel – How to Restart.....	89
How to Clean an Engine.....	90
How to Clean the Cooling System.....	91
Degreasing the Cooling System.....	92
How to Select Coolant.....	92
How to Replace the Coolant Filter.....	100
Checking the Hoses.....	101
How to Service the Dry Type Air Cleaner.....	101
Troubleshooting.....	103
Abnormal Coolant Temperature.....	103
Hard Starting.....	103
Abnormal Engine Operation.....	104
Abnormal Operating Conditions.....	105
Engine Storage.....	107
Preparing Engine for Storage.....	107
Procedure for Restoring to Service an Engine that Has Been in Extended Storage.....	110
Customer Assistance.....	112
Customer Assistance.....	112
Detroit Genuine Coolant Engine Products.....	114
Engine Oil Capacities.....	116

Forward

Introduction

This manual is intended for use by the operator of a Detroit™ engine used in On-Highway Vehicle applications.

Non-Genuine and Rebuilt Component Quality Alert

Electronic engine controls have been instrumental in aiding engine manufacturers in meeting the stringent emission requirements of the U.S. Environmental Protection Agency (EPA) and the California Air Resources Board (CARB) and also in meeting the ever-increasing performance demands of the customer.

Maintenance procedures must be followed in order to continue satisfactory performance and durability and to ensure coverage of the engine under the manufacturer's warranty. Many of these maintenance procedures also ensure that the engine continues to comply with applicable emissions standards. Proper maintenance procedures, using specific components engineered to comply with emissions regulations, may be performed by an authorized Detroit™ distributor or dealer, an independent outlet or the operator or owner. The owner is responsible for determining the suitability of components to maintain emissions compliance during the engine's useful emission life.

Detroit™ cautions that the indiscriminate rebuilding of precision components, without the benefit of specifications, specialized equipment, and knowledge of the electronic operating system, will jeopardize performance or lead to more serious problems, and can take the engine outside of compliance with U.S. EPA or CARB emissions standards.

There are several other components in an engine, such as turbocharger, camshaft, piston, which are specifically designed and manufactured to exacting standards for emissions compliance. It is important that these components, if replaced, modified or substituted, can be verified to ensure that the engine remains in compliance with emissions standards. The use of inadequately engineered, manufactured or tested components in repair or rebuild of the engine may be in violation of the federal Clean Air Act and applicable U.S. EPA or CARB regulations.

Furthermore, modern engines exhibit operating parameters which require the use of proper fluids, such as fuel, coolant and lubricating oil, to maintain long engine life. The use of fluids that do not meet Detroit™ specifications may result in premature wear or engine failure.

Personnel Requirements

Work on the engine should be carried out only by skilled technicians who have been instructed in the specific skills necessary for the type of work being performed.

Engine Conversions and Modifications

The function and safety of the engine could be affected if unauthorized modifications are made to it. Detroit™ will not accept responsibility for any resulting damage.

Tampering with the fuel injection system and engine electronics could also affect engine power output or exhaust emission levels. Compliance with the manufacturer's settings and with statutory environmental protection regulations cannot then be guaranteed.

To the Operator

This manual contains instructions on the safe operation and preventive maintenance of your Detroit™ engine used in vehicle applications. Maintenance instructions cover routine engine services such as lubricating oil and filter changes in enough detail to permit self-servicing, if desired.

The operator should become familiar with the contents of this manual before operating the engine or carrying out maintenance procedures.

Power-driven equipment is only as safe as the person operating the controls. You are urged, as the operator of this diesel engine, to keep fingers and clothing away from the revolving belts, drive shafts, pulleys, etc. on the engine installation.

Throughout this manual **CAUTIONS** and **WARNINGS** regarding personal safety and **NOTICES** regarding engine performance or service life will appear. To avoid personal injury and ensure long engine service life, always heed these instructions.

Whenever possible, it will benefit you to rely on an *authorized* Detroit™ service outlet for all your service needs from maintenance to major parts replacement. Authorized service outlets worldwide stock factory-original parts.

The information and specifications in this publication are based on the information in effect at the time of approval for printing. Contact an authorized Detroit™ service outlet for information on the latest revision. The right is reserved to make changes at any time without obligation.

Detroit™ engines are built in accordance with sound technological principles and based on state-of-the-art technology.

Despite this, the engine may constitute a risk of damage to property or injury to persons if it is not used for its intended purpose.

The engine should not be modified or converted in an incorrect manner or the safety instructions included in this manual disregarded.

Keep this Operator Manual with the engine installation at all times. It contains important operating, maintenance, and safety instructions.

NOTICE: Coolant must be inhibited with the recommended Supplemental Coolant Additives (SCA) listed in the “**How-To Procedures**” section of this engine Operator Manual. In addition, the engine can be equipped with a coolant filter as an installed option or as an after-sale item. **Failure to check and maintain SCA levels at required concentrations will result in severe damage (corrosion) to the engine cooling system and related components.**

Table 1.

WARRANTY
The applicable engine warranty is contained in the booklet "Warranty Information for Detroit™ Engines," available from authorized Detroit™ service outlets.

Trademark Information

DDC®, Detroit™, DDEC®, Optimized Idle®, Diagnostic Link®, POWER Trac®, POWER COOL®, and POWER GUARD® are registered trademarks of Detroit Diesel Corporation. All other trademarks used are the property of their respective owners.

Caution Summary

The following cautions must be observed by the operator of the vehicle or equipment in which this engine is installed and/or by those performing basic engine preventive maintenance. Failure to read and heed these cautions and exercise reasonable care for personal safety and the safety of others when operating the vehicle/equipment or performing basic engine preventive maintenance may result in personal injury and engine and/or vehicle/equipment damage.

Engine Operation

Observe the following cautions when operating the engine.



WARNING: PERSONAL INJURY

To avoid injury from loss of vehicle/vessel control, the operator of a DDEC equipped engine must not use or read any diagnostic tool while the vehicle/vessel is moving.



CAUTION: LOSS OF VEHICLE CONTROL

To avoid injury from the loss of vehicle control, do not use cruise control under these conditions:

- When it is not possible to keep the vehicle at a constant speed (on winding roads, in heavy traffic, in traffic that varies in speed, etc.).
- On slippery roads (wet pavement, ice-or snow-covered roads, loose gravel, etc.).



WARNING: PERSONAL INJURY

Diesel engine exhaust and some of its constituents are known to the State of California to cause cancer, birth defects, and other reproductive harm.

- Always start and operate an engine in a well ventilated area.
- If operating an engine in an enclosed area, vent the exhaust to the outside.
- Do not modify or tamper with the exhaust system or emission control system.



WARNING: PERSONAL INJURY

To avoid injury from engine shutdown in an unsafe situation, ensure the operator knows how to override the stop engine condition on a DDEC-equipped unit.

**CAUTION: LOSS OF VEHICLE CONTROL**

To avoid injury from loss of vehicle control, do not activate the Engine Brake system under the following conditions:

- On wet or slippery pavement, unless the vehicle is equipped with ABS (anti-lock braking system) and you have had prior experience driving under these conditions.
- When driving without a trailer (bobtailing) or pulling an empty trailer.
- If the tractor drive wheels begin to lock or there is fishtail motion after the Engine Brake is activated, deactivate the brake system immediately if this occurs.

**WARNING: BODILY INJURY**

To avoid injury from an explosion, do not use ether or starting fluid on engines equipped with a manifold (grid) heater.

Preventive Maintenance

Observe the following cautions when performing preventive maintenance.

**WARNING: PERSONAL INJURY**

To avoid injury when working near or on an operating engine, remove loose items of clothing and jewelry. Tie back or contain long hair that could be caught in any moving part causing injury.

**WARNING: PERSONAL INJURY**

To avoid injury when working on or near an operating engine, wear protective clothing, eye protection, and hearing protection.

**WARNING: HOT OIL**

To avoid injury from hot oil, do not operate the engine with the rocker cover(s) removed.

**WARNING: FIRE**

To avoid injury from fire, contain and eliminate leaks of flammable fluids as they occur. Failure to eliminate leaks could result in fire.



CAUTION: USED ENGINE OIL

To avoid injury to skin from contact with the contaminants in used engine oil, wear protective gloves and apron.



WARNING: PERSONAL INJURY

To avoid injury when using caustic cleaning agents, follow the chemical manufacturers usage, disposal, and safety instructions.



WARNING: PERSONAL INJURY

To avoid injury from hot surfaces, wear protective gloves, or allow engine to cool before removing any component.



WARNING: PERSONAL INJURY

To avoid injury, use care when working around moving belts and rotating parts on the engine.



WARNING: FIRE

To avoid injury from combustion of heated lubricating-oil vapors, stop the engine immediately if an oil leak is detected.



WARNING: PERSONAL INJURY

To avoid injury from contact with rotating parts when an engine is operating with the air inlet piping removed, install an air inlet screen shield over the turbocharger air inlet. The shield prevents contact with rotating parts.



WARNING: HOT COOLANT

To avoid scalding from the expulsion of hot coolant, never remove the cooling system pressure cap while the engine is at operating temperature. Wear adequate protective clothing (face shield, rubber gloves, apron, and boots). Remove the cap slowly to relieve pressure.



WARNING: FIRE

To avoid injury from fire, do not smoke or allow open flames when working on an operating engine.

**WARNING: FIRE**

To avoid injury from fire from a buildup of volatile vapors, keep the engine area well ventilated during operation.

**WARNING: PERSONAL INJURY**

To avoid injury from rotating belts and fans, do not remove and discard safety guards.

**WARNING: PERSONAL INJURY**

To avoid injury from slipping and falling, immediately clean up any spilled liquids.

Compressed Air

Observe the following cautions when using compressed air.

**WARNING: EYE INJURY**

To avoid injury from flying debris when using compressed air, wear adequate eye protection (face shield or safety goggles) and do not exceed 276 kPa (40 psi) air pressure.

Cooling System

Observe the following cautions when servicing the cooling system.

**WARNING: HOT COOLANT**

To avoid scalding from the expulsion of hot coolant, never remove the cooling system pressure cap while the engine is at operating temperature. Wear adequate protective clothing (face shield, rubber gloves, apron, and boots). Remove the cap slowly to relieve pressure.

**WARNING: PERSONAL INJURY**

To avoid injury from slipping and falling, immediately clean up any spilled liquids.

Electrical System

Observe the following cautions when jump starting an engine, charging a battery, or working with the vehicle/application electrical system.



WARNING: ELECTRICAL SHOCK

To avoid injury from electrical shock, do not touch battery terminals, alternator terminals, or wiring cables while the engine is operating.



WARNING: Battery Explosion and Acid Burn

To avoid injury from battery explosion or contact with battery acid, work in a well ventilated area, wear protective clothing, and avoid sparks or flames near the battery. If you come in contact with battery acid:

- Flush your skin with water.
- Apply baking soda or lime to help neutralize the acid.
- Flush your eyes with water.
- Get medical attention immediately.



WARNING: PERSONAL INJURY

To avoid injury from accidental engine startup while servicing the engine, disconnect/disable the starting system.

Air Intake System

Observe the following cautions when working on the air intake system.



WARNING: PERSONAL INJURY

To avoid injury from hot surfaces, wear protective gloves, or allow engine to cool before removing any component.



WARNING: PERSONAL INJURY

To avoid injury from contact with rotating parts when an engine is operating with the air inlet piping removed, install an air inlet screen shield over the turbocharger air inlet. The shield prevents contact with rotating parts.

Lubricating Oil and Filters

Observe the following cautions when replacing the engine lubricating oil and filter.



WARNING: PERSONAL INJURY

To avoid injury from slipping and falling, immediately clean up any spilled liquids.

**WARNING: FIRE**

To avoid injury from combustion of heated lubricating-oil vapors, stop the engine immediately if an oil leak is detected.

**WARNING: FIRE**

To avoid injury from fire, do not smoke or allow open flames when working on an operating engine.

**WARNING: FIRE**

To avoid injury from fire from a buildup of volatile vapors, keep the engine area well ventilated during operation.

Fuel System

Observe the following cautions when fueling the vehicle or working with the fuel system.

**WARNING: FIRE**

To avoid injury from fire, keep all potential ignition sources away from diesel fuel, including open flames, sparks, and electrical resistance heating elements. Do not smoke when refueling.

**WARNING: PERSONAL INJURY**

To prevent the escape of high pressure fuel that can penetrate skin, ensure the engine has been shut down for a minimum of 10 minutes before servicing any component within the high pressure circuit. Residual high fuel pressure may be present within the circuit.

**WARNING: FIRE**

To avoid increased risk of a fuel fire, do not mix gasoline and diesel fuel.



WARNING: FIRE

To avoid injury from fire caused by heated diesel-fuel vapors:

- Keep those people who are not directly involved in servicing away from the engine.
- Stop the engine immediately if a fuel leak is detected.
- Do not smoke or allow open flames when working on an operating engine.
- Wear adequate protective clothing (face shield, insulated gloves and apron, etc.).
- To prevent a buildup of potentially volatile vapors, keep the engine area well ventilated during operation.

Engine Identification

Engine Components - DD Platform

All DD Platform engine components are shown below:

DD15 Engine Components

For a general view of the Detroit™ engines and major components, see the following:

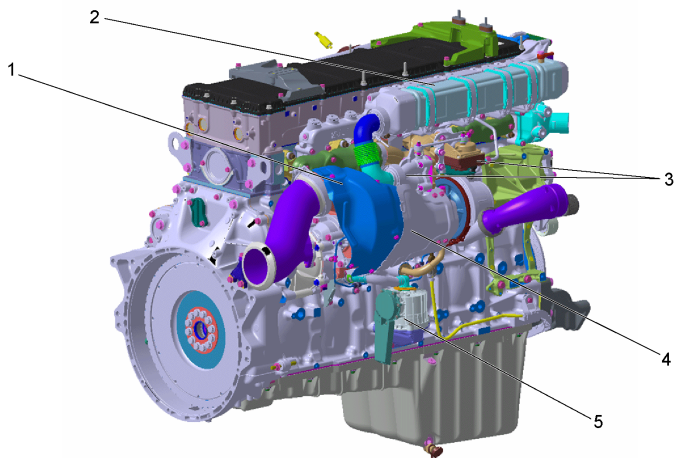

d010127

- | | |
|---|-----------------------|
| 1. Axial Power Turbine | 4. Turbocharger |
| 2. Exhaust Gas Recirculation (EGR) Cooler | 5. Crankcase Breather |
| 3. Exhaust Gas Recirculation (EGR) Valve / Actuator | 6. Fuel Doser Valve |

Figure 1. DD15 Left Side View

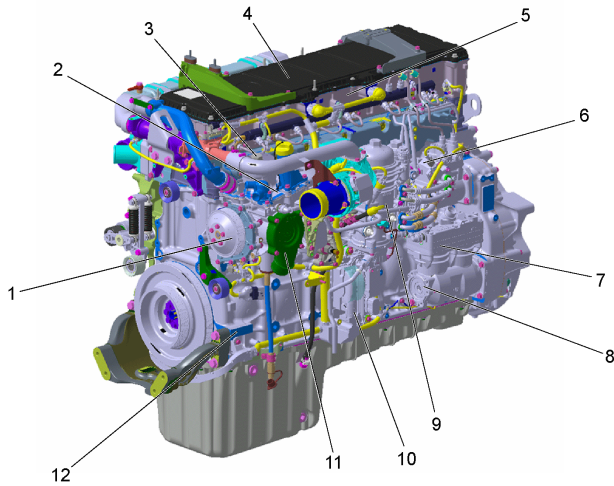

d010128

- | | |
|----------------------------|-----------------------------------|
| 1. Water Pump | 7. Dual Stage Air Compressor |
| 2. Oil/Coolant Module | 8. Power Steering Pump Location |
| 3. Oil Filter | 9. Fuel Filter Module |
| 4. Fuel Rail (under cover) | 10. Motor Control Module (MCM) |
| 5. Air Intake Manifold | 11. Thermostat |
| 6. High Pressure Fuel Pump | 12. Engine Serial Number Location |

Figure 2. DD15 Right Side View

Engine Model and Serial Number Designation

The following information covers engine model number, serial number and certification label.

Engine Model and Serial Number

The fourteen-digit engine model and manufacturing serial number is etched on a pad located on the left front of the engine cylinder block, above the date and time of manufacture. Using 472908S0005703 as an example:

- 472 = engine model (DD15 EuroIV)
- 908 = vehicle application (Freightliner EuroIV)
- S = assembly plant (Detroit™)
- 0005703 = serial number

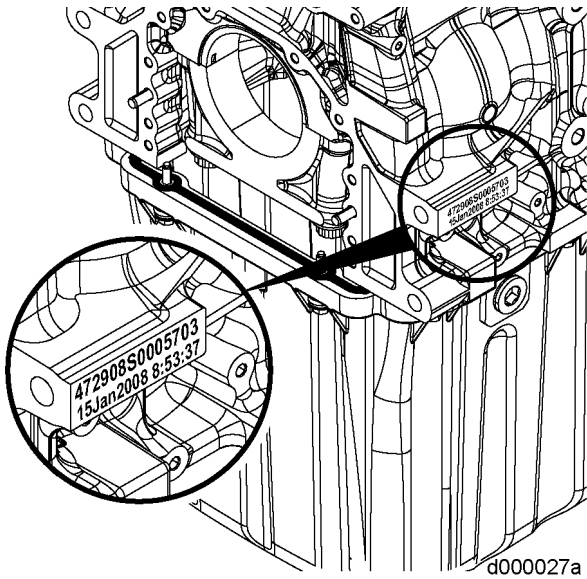

Figure 3. Engine Model and Serial Number Location

Engine Model Breakdown

- 472 - DD15

Motor Control Module and Engine Serial Number

The Motor Control Module (MCM) part number and Engine Serial Number (ESN) are located on the MCM label.

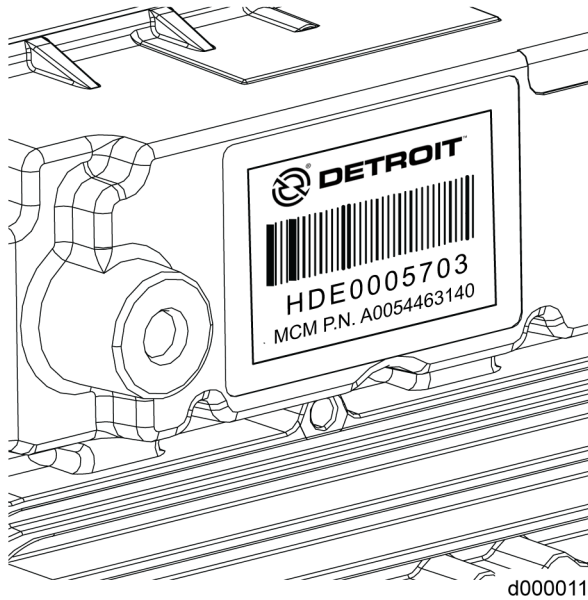

d000011

Figure 4. Motor Control Module Label
Engine Certification Exemption Label

An engine certification exemption label is attached to the engine rocker cover. This label certifies the engine conforms to federal and state emissions regulations for its application. It gives the operating conditions under which certification was made. The following illustration is an EPA07 engine certification exemption label.

 <p>CUSTOMER SERVICE / ATENCION AL CLIENTE AUSTRALIA: 1 - 800 - 023 236 EUROPE / MIDDLE EAST / AFRICA: 44 - 162 - 355 - 0550 USA / CANADA : 1 - 800 - 445 - 1980 MEXICO: 01 - 800 - 90271 - 00</p>	
<p style="text-align: center;">  </p> <p>IMPORTANT ENGINE INFORMATION / INFORMACION IMPORTANTE SOBRE EL MOTOR</p> <p>MODEL / MODELO: B DISP / DISP: C MFG DATE / FECHA DE MANUFACTURACION: MM/YYYY MES/AÑO</p> <p>THIS ENGINE IS FOR EXPORT ONLY. THIS ENGINE IS NOT CERTIFIED FOR SALE OR USE IN THE UNITED STATES OR CANADA. THIS ENGINE COMPLIES WITH EURO IV EMISSION STANDARDS FOR HEAVY DUTY DIESEL ENGINES. THIS ENGINE IS CERTIFIED TO OPERATE ON LOW SULFUR DIESEL FUEL.</p> <p>ESTE MOTOR ES EXCLUSIVO PARA EXPORTACION. ESTE MOTOR NO ESTA CERTIFICADO PARA SU VENTA U USO EN LOS ESTADOS UNIDOS DE AMERICA O EN CANADA. ESTE MOTOR CUMPLE CON LAS NORMATIVAS DE EURO IV PARA MOTORES DIESEL DE RANGO PESADO. ESTE MOTOR ESTA CERTIFICADO PARA OPERAR CON DIESEL DE BAJA CONTENIDO DE SULFURO UNIT/UNIDAD.</p> <p>UNIT / UNIDAD: XXXXXXXX</p>	

d000053

Figure 5. EuroIV Engine Certification Exemption Label

Operating Instructions for Starting the Engine

First Time Start Preparations

When preparing to start a new (or newly overhauled) engine, which has been in storage, perform all of the operations listed below. Failure to follow these instructions may result in serious engine damage.

Be sure you are familiar with all of the instruments, gauges and controls which are needed to operate the engine.

Note especially the location and function of the following:

- Oil pressure gauge
- Low oil pressure warning light
- Coolant temperature gauge
- High coolant temperature warning light
- Water-in-Fuel warning light in the side of the fuel filter module
- Air restriction indicator

Watch for any signs of engine problems when starting or driving. If the engine overheats, uses excessive fuel or lubricating oil, vibrates, misfires, makes unusual noises or shows an unusual loss of power, turn the engine off as soon as possible and determine the cause of the problem. Engine damage may be avoided by a quick response to early indications of problems.

When starting the engine in cold weather, Refer to section "Cold Weather Operation"

System Checks

Perform the following system checks before starting for the first time.

Checking the Cooling System

Check the cooling system as follows:

1. Make sure all drain cocks in the cooling system are installed (drain cocks are often removed for shipping) and are closed tightly.
2. Fill the coolant overflow surge tank with Detroit™ Genuine Coolant until coolant level stays between the low and full coolant marks on the tank.
3. Entrapped air must be purged after filling the cooling system. To do this, allow the engine to warm up with the pressure cap removed. With the transmission in neutral, increase engine speed to 1000 rpm and add coolant to the surge tank as required.
4. Check to make sure the front of the radiator and charge air cooler (if equipped) are unblocked and free of debris.

Lubrication System Checks

The lubricating oil film on the rotating parts and bearings of a new or newly overhauled engine, or one which has been in storage for six months or more, may be insufficient when the engine is started for the first time.

Pre-Lubricating the Engine

To ensure an immediate flow of oil to all bearing surfaces at initial engine startup, prepare the engines as follows:

NOTICE:

- Insufficient lubrication at startup can cause serious damage to engine components.
 - Do not add oil if the oil reading falls on the crosshatch area of the dipstick. There are approximately 5.0 L (5.2 qt) from the fill mark to the full mark. Overfilling the oil pan can cause engine damage.
1. Charge the engine lubrication system with lubricating oil using a commercially-available pressure pre-lubricator.
 2. Charge the engine lubrication system with lubricating oil using a commercially-available pressure pre-lubricator. Use only the heavy-duty oils recommended in the "How to Replace the Lubricating Oil and Oil Filter" section in this manual.
 3. After pre-lubricating, check the engine oil level. If necessary, top off by filling engine oil no more than 5.0 L (5.2 qt) at a time through the oil fill cap to the satisfactory fill range on the oil dipstick. Do not overfill.

Checking and Monitoring the Oil Level

Check the oil level as follows:



WARNING: PERSONAL INJURY

To avoid injury from slipping and falling, immediately clean up any spilled liquids.

NOTICE: Do not add oil if the oil reading is in the crosshatch area on the dipstick. There are approximately 5.0 L (5.2 qt) from the fill mark to the full mark. Overfilling the oil pan can cause engine damage.

NOTE: If the engine operating temperature is below 60°C (140°F), the engine must be on a level surface and then shut down for 60 minutes for an accurate oil level reading. Otherwise, the engine must be brought up to an operating temperature of 60°C (140°F), parked on a level surface and then shut down for five minutes for an accurate oil level reading.

1. Check the oil level daily with the engine stopped and on a level surface. If the engine has just been stopped and is warm, wait approximately 20 minutes to allow the oil to drain back into the oil pan before checking.
2. Add oil to maintain the correct level on the dipstick. Use only the heavy-duty oils recommended in the "How to Replace the Lubricating Oil and Oil Filter" section in this manual.

NOTE: The dipstick has a positive locking device such as a lever or twist-lock design that must be disengaged before pulling the dipstick out of the guide tube.

3. Remove the dipstick from the guide tube. Use a shop rag to wipe off the end of the dipstick.
4. Wait 15 seconds to allow any crankcase pressure to dissipate through the guide tube and let the oil level settle in the oil pan.
5. Reinstall the dipstick and make sure it is fully inserted into the guide tube.
6. Remove the dipstick and read the oil level dipstick.
7. The figure shows a comparison between the bends on the dipstick and a crosshatch pattern on a conventional dipstick. Note the exact area noted on the bends. For example, the 'maximum' oil level will be at the **BOTTOM** of that bend. For the 'minimum' oil level, it is noted at the **TOP** of the bend. If the oil level is below the 'minimum' bend, add oil to bring it up the 'maximum' level. Do **NOT** fill beyond the maximum fill level on the dipstick, since overfilling may result in high oil consumption and possible severe engine damage.

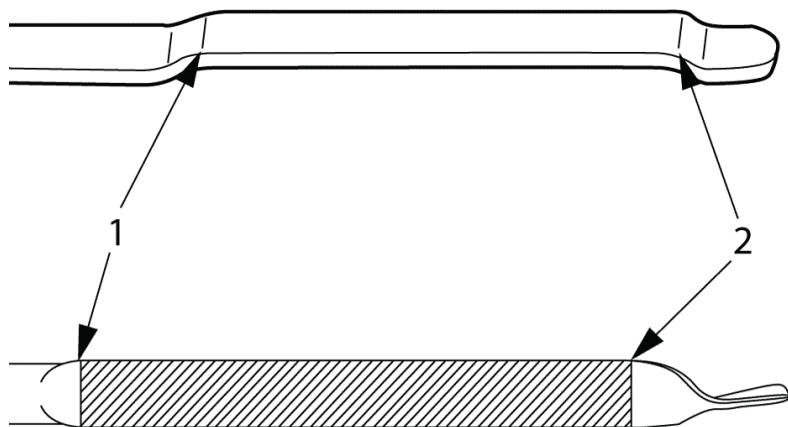

42141

After an Extended Storage

NOTICE: Failure to eliminate water-diluted lubricating oil may lead to serious engine damage at startup.

An engine in storage for an extended period of time (over winter, for example) may accumulate water in the oil pan through normal condensation of moisture (always present in the air) on the cold, internal surfaces of the engine.

Lubrication oil diluted by water cannot provide adequate bearing protection at engine startup. For this reason, Detroit™ recommends replacing the engine lubricating oil and filters after extended storage.

Fuel System Checks

Make sure the fuel shutoff valve (if used) is open. Fill the tanks with the recommended fuel. Keeping tanks full reduces water condensation and helps keep fuel cool, which is important to engine performance. Full tanks also reduce the chance for microbe (black slime) growth. For fuel recommendations, Refer to section "How to Select Diesel Fuel".

NOTICE: Prolonged use of the starting motor and engine fuel pumps to prime the fuel system can result in damage to the starter, fuel pumps, and injectors.

If the shutoff valve is even partially closed, it may cause erratic engine operation due to an inadequate supply of fuel to the fuel pump.

NOTICE: NEVER use ether as a starting aid to run the engine. Doing so will result in injector damage.

If an external starting aid is used, such as a starting fluid, the heat generated by the external fuel source will cause the injector tips to be damaged when the fuel cools them. The injector piston and bushing can be scored from running without lubrication.

To ensure prompt starting and even running, the fuel system must be primed if air has entered the fuel system. Priming is done by operating the manual hand priming pump located on the fuel filter module or connecting an external priming pump to the priming port on the fuel filter module.

Authorized Detroit™ service outlets are properly equipped for this type of service. Priming is required if the fuel system has been serviced.

Drain off any water that has accumulated. Water in fuel can seriously affect engine performance and may cause engine damage.

Adding Fuel

When adding fuel, pay attention to the following:

- Add winter or summer grade fuel according to the season of the year.
- Work in the cleanest conditions possible.
- Prevent water from entering the fuel tank.

For further information, Refer to section "How to Select Diesel Fuel".

Priming the Fuel System

Prime the fuel system as follows:

1. Operate the hand primer on module for three minutes or 250 strokes, or use an external priming source such as tool J-47912 or ESOC 350.
2. Crank the engine for 20 seconds.
3. Wait 60 seconds for the starter to cool down.
4. If the engine does not start, repeat step 2 and step 3. The starting cycle can be repeated up to three times.
5. If the engine still fails to start, continue as follows:
 - a. Use DDDL to check for fault codes, repair as necessary.
 - b. Repeat step 2 and step 3.

**WARNING: ENGINE EXHAUST**

To avoid injury from inhaling engine exhaust, always operate the engine in a well-ventilated area. Engine exhaust is toxic.

**WARNING: PERSONAL INJURY**

To avoid injury before starting and running the engine, ensure the vehicle is parked on a level surface, parking brake is set, and the wheels are blocked.

NOTICE: If no oil pressure is shown after approximately 10 seconds, stop the engine and determine the cause. Running the engine with no oil pressure could result in engine damage.

6. Start the engine with the accelerator pedal in the idle position. Monitor the oil pressure gauge or indicator lamp. **Keep the engine running at idling speed** until the oil pressure reading is 14 psi (97 kPa) or more.
7. Allow engine to reach operating temperature 60°C (140°F).

NOTICE: Increasing engine speed above idle before oil pressure has stabilized may cause severe engine damage.

8. Increase engine speed to 1800 rpm for three minutes.
9. Return the engine to idle and allow to idle for approximately one minute, then shut down the engine.
10. Check for leaks. Repair if necessary.

Checking Other Engine Parts

Check the engine compartment as follows:

- Make sure the transmission is filled to the proper level with the fluid recommended by the gear manufacturer. Do not overfill.
- Make sure cable connections to the storage batteries are clean and tight.
- Check for cracks in the battery cases (1), for tightness of the cable clamps (2) at the terminals, and for corrosion of the terminals (3). Service or replace as needed.
- To provide corrosion protection, apply dielectric grease liberally to the terminal pads.

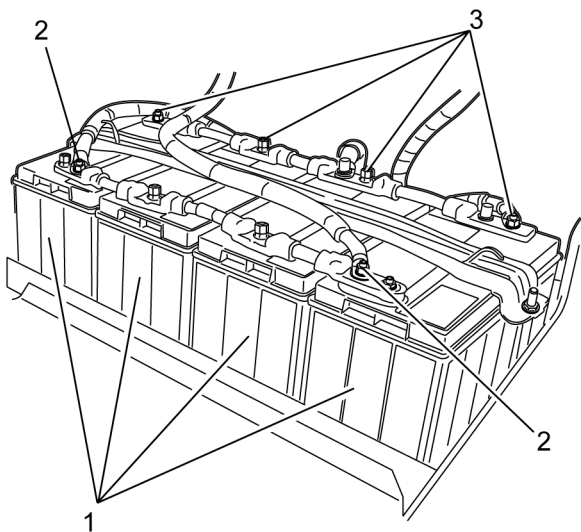

d540077

Starting the Engine for the First Time



WARNING: EXPLOSION

To avoid injury from explosion, never use ether with an engine's electrical cold starting system.

Before starting the engine the first time, perform an inspection of the engine systems.

To start the engine, the transmission should be in neutral and the ignition key turned to ON.



WARNING: ENGINE EXHAUST

To avoid injury from inhaling engine exhaust, always operate the engine in a well-ventilated area. Engine exhaust is toxic.



WARNING: PERSONAL INJURY

To avoid injury when working near or on an operating engine equipped with a hydraulic clutch fan, remove loose items of clothing and jewelry. Tie back or contain long hair that could be caught in any moving part causing injury. The hydraulic fan may start without warning.

You will notice that the Amber Warning Lamp (AWL), Red Stop Lamp (RSL), Malfunction Indicator Lamp (MIL) will come on. This is the result of the DDEC computer diagnosing the system to ensure everything is functional, including the light bulbs for the warning lights. If everything is OK, all lights will go out in approximately five seconds.

The lights must go out before starting the engine. If starting a vehicle, the operators foot must be *OFF* the accelerator pedal before starting the engine.

NOTICE: If the warning lights stay on, or do not come on momentarily after turning on the ignition, contact the Detroit™ Support Center. Operating the engine under these circumstances may result in engine damage.

Starting the Engine

1. Place the transmission in neutral, and set the parking brake.

NOTICE: To prevent serious starter motor damage, release the ignition switch immediately after the engine has started.

2. Turn on the ignition switch.
3. Wait for the engine system indicator lights on the instrument panel to go out.
4. With foot off the accelerator pedal, start the engine.
5. If the engine does not start after 20 seconds, stop. Try again after waiting about 60 seconds.

NOTICE: Do not increase engine speed if the oil pressure gauge indicates no oil pressure. Shut down the engine within approximately ten seconds to avoid engine damage. Check to determine the cause of the problem.

NOTE: Do not place the engine under full load until it reaches operating temperature. Colder engine temperatures will cause the engine to preset idle up to 900 rpm. Even at a high idle condition, you do not have to wait for engine warm up and return to normal 600 rpm idle to drive the truck.

6. Monitor the oil pressure gauge immediately after starting the engine.

Running the Engine

While the engine is operating, monitor the battery charge indicator light, the oil pressure, and avoid excessive idling.

Checking the Oil Pressure

Monitor the oil pressure as follows:



WARNING: HOT OIL

To avoid injury from hot oil, do not operate the engine with the rocker cover(s) removed.

1. Observe the oil pressure gauge immediately after starting the engine. An oil pressure gauge that registers pressure 14 psi (96 kPa) at idle speed and normal operating temperature is a good indicator that all moving parts are getting lubrication.
2. If no pressure is indicated within 10 to 15 seconds, stop the engine and check the lubrication system at normal operating temperature.
3. The oil pressure should not drop below 55 psi (380 kPa) at 1800 rpm, at normal operating temperature. If oil pressure does not fall within these guidelines, check it with a manual gauge.

Warming Up the Engine

Run the engine at part throttle for about five minutes to allow it to warm up before applying a load.

Inspection During Idling

While the engine is idling, inspect the transmission and crankcase for fluid leaks. On DD15 engines, check the Axial Power Turbine (APT) for oil leaks.

Checking the Transmission

While the engine is idling, check the automatic transmission (if equipped) for proper oil level and add oil as required.

Checking for Fluid Leaks

Check for fluid leaks as follows:

1. Look for coolant, fuel, or lubricating oil leaks.
2. If any leaks are found, shut down the engine immediately and have the leaks repaired after the engine has cooled.

Checking the Crankcase

Check the crankcase as follows:

1. If the engine oil was replaced, stop the engine after normal operating temperature has been reached. Allow the oil to drain back into the crankcase for about 60 minutes, then check the oil level.

NOTICE: Do not add oil if the oil reading is in the crosshatch area. There are approximately 5.0 L (5.2 qt) from the fill mark to the full mark. Overfilling the oil pan can cause engine damage.

2. If necessary, add no more oil than 5.0 L (5.2 qt) at a time to bring the level to the proper mark on the dipstick. Use only the heavy-duty oils recommended in the "How to Replace the Lubricating Oil and Oil Filter" section in this manual.

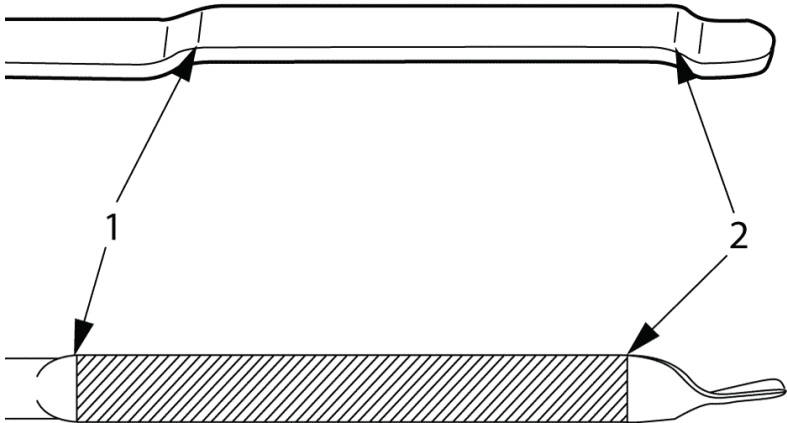

42141

Checking the Turbocharger

Check the turbocharger as follows:

1. Make a visual inspection of the turbocharger for oil leaks, exhaust leaks, excessive noise, or vibration.
2. If a leak, unusual noise, or vibration is noted, stop the engine immediately.
Do not restart the engine until the cause of the concern has been investigated and corrected.

Checking the Axial Power Turbine

Check the axial power turbine for excessive noise or vibration. Stop the engine immediately if unusual noise or vibration is noted. **Do not restart the engine until the cause of the concern has been investigated and corrected.**

Avoid Unnecessary Idling

Whenever possible, unnecessary idling should be avoided. During long engine idling periods with the transmission in neutral, the engine coolant temperature may fall below the normal operating range. The incomplete combustion of fuel in a cold engine will cause crankcase oil dilution, formation of lacquer or gummy deposits on the valves, pistons, and rings, and rapid accumulation of sludge in the engine. When prolonged idling is necessary, maintain at least 900 rpm.

Stopping the Engine

Stop an engine under normal operating conditions as follows:

NOTICE: Do not stop a turbocharged engine immediately after a high-speed operation. Allow a sufficient cool-down period of about five minutes to prevent the turbocharger from continuing to turn without an oil supply to the bearings or damage can result.

1. Reduce engine speed to idle and put all shift levers in the neutral position.

NOTE: Cool-down idling needs to take place after pulling off an interstate. When finding a parking spot or backing into a dock, immediate shutdown should be avoided. Shutting the engine off immediately retains more block heat than if the engine runs at idle for five minutes.

2. Allow the engine to run between idle and 1000 rpm with no load for five minutes. This allows the engine to cool and permits the turbocharger to slow down. After five minutes, shut down the engine.

Emergency Jump Starting

The engine's electronic system operates on 12 volts DC. If a DD Platform engine with an electric starting motor requires emergency jump starting, **DO NOT EXCEED 16 VOLTS DC.**



WARNING: BATTERY EXPLOSION

To avoid injury from battery explosion when jump starting the engine, do not attach the cable end to the negative terminal of the disabled battery.

**WARNING: Battery Explosion and Acid Burn**

To avoid injury from battery explosion or contact with battery acid, work in a well ventilated area, wear protective clothing, and avoid sparks or flames near the battery. If you come in contact with battery acid:

- Flush your skin with water.
- Apply baking soda or lime to help neutralize the acid.
- Flush your eyes with water.
- Get medical attention immediately.

NOTICE: Jump starting with voltages greater than those indicated or reversing battery polarity may damage the MCM.

NOTICE: Failure to connect jumper cables in the proper sequence can result in alternator and/or equipment damage.

Before attempting to jump start the engine, the jumper cables **must be** connected properly; positive-to-positive, and negative-to-chassis or suitable ground. The proper sequence is to connect negative to negative ground last.

Routine Engine Start

The following are procedures for a routine engine start.

**WARNING: ENGINE EXHAUST**

To avoid injury from inhaling engine exhaust, always operate the engine in a well-ventilated area. Engine exhaust is toxic.

**WARNING: PERSONAL INJURY**

To avoid injury when working near or on an operating engine equipped with an hydraulic clutch fan, remove loose items of clothing and jewelry. Tie back or contain long hair that could be caught in any moving part causing injury. The hydraulic fan may start without warning.

Routinely Starting the Engine

Before a routine start, see the daily checks for your engine in the Maintenance section of this manual.

NOTICE: Before starting the engine, carefully read all operating instructions in this manual and do all the recommended pre-trip inspections and daily maintenance. Check the coolant, engine oil, and fuel levels, and drain contaminants from the water separator/coalescer.

Start the engine as follows:

NOTE: If you drain water from the water separator/coalescer, you have to prime the fuel system with the built-in hand primer (about 50 strokes).

NOTE: As a safety function, the electronic engine control system may be wired to start the engine only if the transmission is in neutral. This feature is vehicle application specific.

1. Turn on the ignition switch.
2. Wait for the engine system indicator lights on the instrument panel to go out.
3. With the accelerator pedal in the idle position, start the engine.
4. Check the engine for leaks.
 - a. Check all hoses, hose clamps, and pipe unions on the engine for tightness. Shut down the engine and tighten them if necessary.
 - b. Check the oil feed and return lines at the turbocharger for leaks. Shut down the engine and tighten them if necessary.
5. Shut down the engine.

NOTE: If the engine operating temperature is below 60°C (140°F), the engine must be on a level surface and then shut down for 60 minutes for an accurate oil level reading. Otherwise, the engine must be brought up to an operating temperature of 60°C (140°F), parked on a level surface and then shut down for five minutes for an accurate oil level reading.

6. Check the oil level using the oil dipstick. The oil level is measured using the crosshatch area on the dipstick. If the oil reading within the crosshatch area, then the oil is at the proper level for engine operation.

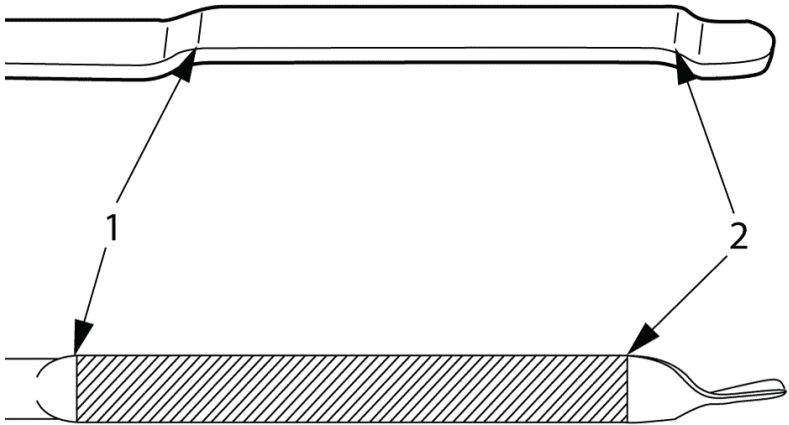

42141

7. Check all the mounting fasteners on the engine for tightness.

Checking the Coolant Level (Cold Check)

Check coolant level as follows:

1. Ensure that all coolant plugs in the bottom of the radiator and on the radiator outlet pipe are secure and tight.
2. Check the coolant level. The cooling system is correctly filled when the coolant is between the full and low marks on the surge tank.

Checking the Coolant Level (Hot Check)

Check the coolant levels as follows:

1. Allow the engine to run for approximately five minutes at a moderate speed.
2. After the coolant temperature reaches 50°C (122°F), recheck the coolant level in the surge tank.



WARNING: HOT COOLANT

To avoid scalding from the expulsion of hot coolant, never remove the cooling system pressure cap while the engine is at operating temperature. Wear adequate protective clothing (face shield, rubber gloves, apron, and boots). Remove the cap slowly to relieve pressure.

3. Add more coolant if necessary. Open the heater valves before adding coolant.
4. Do not close the heater valves until the engine has been running briefly and the coolant level is again checked and corrected as necessary.

Monitoring the Engine Operation

While the engine is operating, monitor the battery charge indicator light and the oil pressure. Excessive idling should be avoided.

Monitoring the Battery Charging System

The battery charge indicator light must go out once the engine starts. If the indicator light comes on while the engine is running, do the following:

1. Shut down the engine.
2. Test the charging system, per OEM guidelines.



WARNING: BATTERY EXPLOSION

To avoid injury from battery explosion when jump starting the engine, do not attach the cable end to the negative terminal of the disabled battery.

3. If necessary, visit the nearest authorized dealer to have the alternator voltage and output checked.
4. Do a load test on the batteries.
5. Replace components as needed.

Monitoring the Oil Pressure

When the engine has reached its normal operating temperature, the engine oil pressure must not drop below the following values:

- 55 psi (380 kPa) at rated speed
- 14 psi (97 kPa) at idling speed

If oil pressure drops below these values, stop the engine and determine the cause.

Excessive Idling

Never allow the engine to idle for more than 30 minutes. Excessive idling can cause oil to leak from the turbocharger.

Changing the Idle Speed

The idle speed range of the DD Platform engine is 600 to 900 rpm if the parameters in the CPC are set to the default range. Change the idle speed as follows:

1. Turn the cruise control switch to the ON position.
2. To increase the idle speed, push the RSM/ACC switch until the idle reaches the desired rpm.
3. To decrease the idle speed, push the SET/CST switch until the idle reaches the desired rpm.

Shutting Down the Engine after High Load Operation

If the engine has been running at full output or the coolant temperature has been high, idle the engine for five minutes without load. If any of the following conditions occur, shut down the engine immediately:

NOTICE: A engine running at full output or with high coolant temperature after a high load operation should idle for five minutes without load. Shutting down without idling may cause damage to the turbocharger.

- The oil pressure swings back and forth or falls sharply.
- Engine power and rpm fall, even though the accelerator pedal remains steady.
- The exhaust pipe gives off heavy smoke.
- The coolant and/or oil temperature climb abnormally.
- Abnormal sounds suddenly occur in the engine or turbocharger.

Emergency Running Mode

The engine is equipped with an electronic motor control system which monitors the engine as it is running.

NOTICE: To prevent possible serious engine damage, have any faults corrected without delay by an authorized service location.

As soon as an engine fault is detected, it is evaluated and one of the following measures is initiated.

- In conjunction with any dashboard or instrument panel display, the code for the electronic control unit reporting the fault can be read immediately on the display.
- If the fault is serious enough to impair normal operation, the electronic control unit switches over to a "limp home" mode. The limp home speed is dependent on engine control parameters and could be as low as 1000 rpm. This allows you to safely move the vehicle to a service location or a safe stopping area.

Stop Engine Override Option

The Stop Engine Override Option is used for a momentary override. The electronic engine control system will record the number of times the override is activated after an engine fault occurs.

Momentary Override

A Stop Engine Override Switch is used to override the shutdown sequence. This override resets the 60 second (30 second for oil pressure) shutdown timer, restoring power to the level when the RSL/Stop Engine was illuminated. The switch must be recycled after five seconds to obtain a subsequent override.

NOTE: The operator has the responsibility to take action to avoid engine damage.

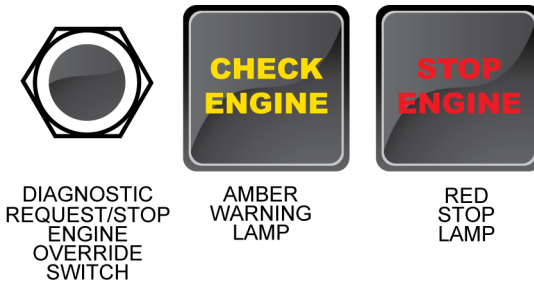

47471

Cold Weather Operation

Special precautions must be taken during cold weather. To protect your engine, special cold weather handling is required for fuel, engine oil, coolant, and batteries.

Winter Fronts

A winter front may be used to improve cab heating while idling. At least 25% of the grill opening should remain open in sectioned stripes that run perpendicular to the charge air cooler tube flow direction. This assures even cooling across each tube and reduces header to tube stress and possible failure. Winter fronts should only be used when the ambient temperature remains below -12°C (10°F).

Detroit Diesel Electronic Controls (DDEC) System

DDEC VI System

The engine is equipped with a fully electronic control system, which regulates the fuel injection quantity and timing using solenoid valves, allowing extremely low-emission operation. Besides the engine and its related sensors, the system is composed of the following:

- The Motor Control Module (MCM)
- The Common Powertrain Controller (CPC) located under the right-hand dash panel.

The two control units are connected by a proprietary datalink through which all necessary data and information can be exchanged.

The CPC then broadcasts all information on the J1587 and J1939 datalinks, where it can be read by the diagnostic tool.

The engine control system monitors both the engine and the datalink. When a malfunction or other problem is detected, the system selects an appropriate response; for example, the emergency running mode may be activated.

The Accelerator Pedal Assembly (AP) eliminates the need for any throttle linkage.

Motor Control Module Description

The Motor Control Module (MCM) is typically located on the left-hand side of the engine.

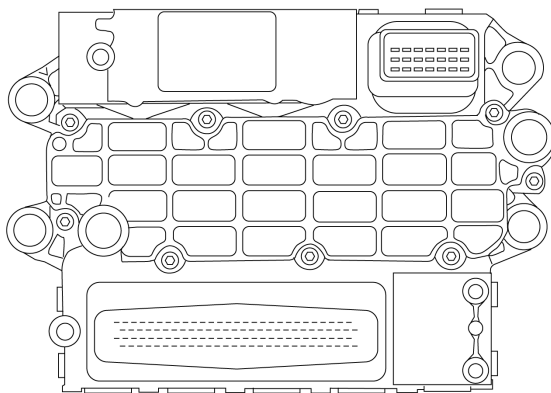

d540003a

Figure 6. Motor Control Module

The MCM processes the data received from the Common Powertrain Controller (CPC), for example the position of the Accelerator Pedal (AP), engine brake, etc.

These data are evaluated together with the data from the sensors on the engine, such as coolant and fuel temperature and oil and charge pressure. The data is then compared to the characteristic maps or lines stored in the MCM. From these data, quantity and timing of injection are calculated.

NOTE: To obtain a replacement MCM, all the data given on the MCM label are required.

The MCM data label has the 10 digit engine serial number.

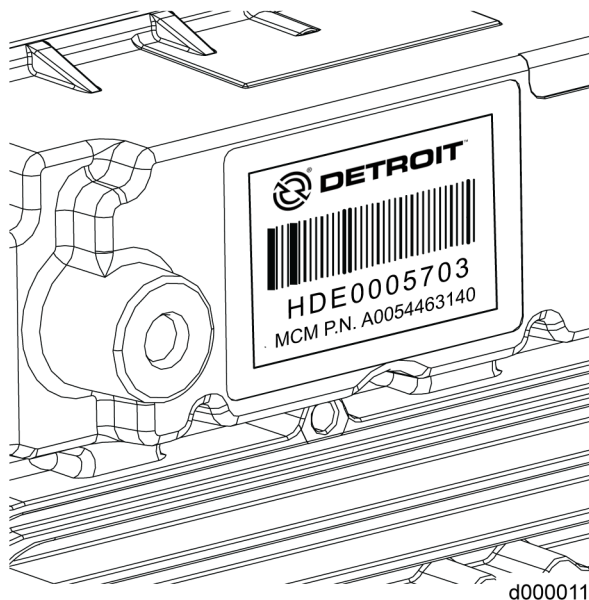

d000011

Figure 7. Motor Control Module Label

Common Powertrain Controller

The Common Powertrain Controller (CPC) communicates with any other Motor Control Module (MCM) unit installed on the vehicle over the J1939 data link.

Data for specific applications is stored in the CPC. These include idle speed, maximum running speed, and speed limitation. From these data, instructions are computed for controlling the engine and transmitted to the CPC via the proprietary datalink.

The CPC receives data from the following sources:

- The operator (accelerator pedal position, engine brake switch)
- Other electronic control units (for example, the anti-lock brake system)
- The MCM (oil pressure and coolant temperature)

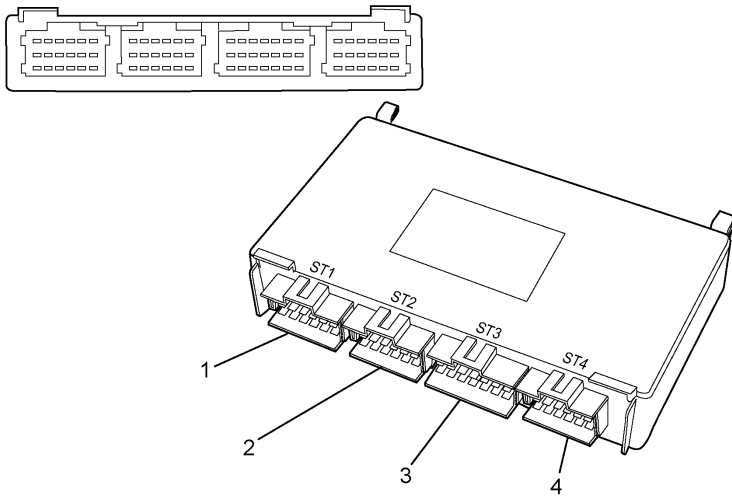

d150034

- 1. Connector 1
- 2. Connector 2
- 3. Connector 3
- 4. Connector 4

Figure 8. Common Powertrain Controller

Detroit Diesel Electronic Control System Operation

NOTE: This engine is equipped with DDEC software. This software generally assures optimal engine performance. The installation of software upgrades may cause minor changes in features and engine performance.

Since the DDEC system is electronic, a battery is required to operate the computer. The system operates at 12 volts. However, in the event of a power supply malfunction, the system will continue to operate at reduced voltage. When this occurs, the AWL (Check Engine) will come on.

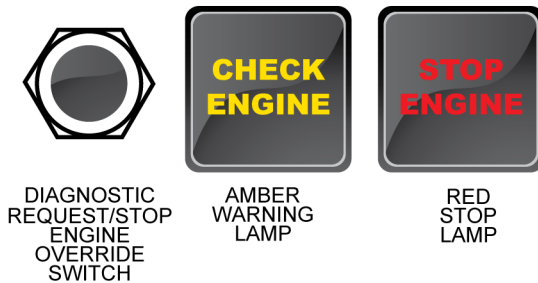

47471

The engine will only operate at reduced rpm until the battery voltage reaches a point where the MCM will no longer function and the engine shuts down.

Should the AWL (Check Engine) come on for any reason, the vehicle can still be operated and the driver can proceed to the required destination. *This condition should be reported to an authorized Detroit™ distributor or dealer.*

NOTICE: When the RSL (Stop Engine) comes on, the system has detected a major malfunction in the engine that requires immediate attention. **It is the operator's responsibility to shut down the engine to avoid serious damage.**

The engine can be configured to give a warning only, to ramp down (reduce power) or to shut down. Ramp down will reduce engine rpm to a predetermined speed, but will not shut down the engine. With the 30-second shutdown option, the engine will begin a 30-second, stepped power down sequence until it shuts down completely.

The "Stop Engine Override" feature can be activated in the case where the vehicle is operating in a critical location.

Stop Engine Override Switch

This feature allows the operator to override the automatic stop engine sequence.

This is done by pressing the Stop Engine Override Switch every 15 to 20 seconds to prevent engine shutdown from occurring.

NOTE: The Stop Engine Override Switch and the Diagnostic Request Switch are the same.

NOTE: Holding down the Stop Engine Override Switch will not prevent the engine shutdown sequence. You must continue to reset the automatic shutdown system by pressing the Stop Engine Override Switch at intervals of approximately 15 to 20 seconds.

It takes 30 seconds from the time the automatic shutdown sequence begins until engine shutdown. Therefore, the operator **must** press the override switch just prior to engine shutdown and continue to do so until the vehicle can be brought to a stop in a safe location.

Immediate Speed Reduction

The immediate speed reduction option will bring engine rpm back to a predetermined speed, but will not shut down the engine.

The engine should not be restarted after it has been shut down by the engine protection system, unless the problem has been located and corrected.

Red Stop Lamp

The conditions that will cause the RSL (Stop Engine) to come on are:

- High coolant temperature
- Loss of coolant
- High oil temperature
- Low oil pressure
- Auxiliary shutdown

If the malfunction is intermittent, the lights will come on and go off as the computer senses the changing engine condition.

Diagnostic Tool

The diagnostic tool for Detroit Diesel Electronic Control is the Detroit Diesel Diagnostic Link (DDDL 7.X). DDDL 7.X requirements are listed earlier in the manual under Data Recording Capability.

The temperature of air in the intake system is increased with the addition of EGR. DDEC is programmed to reduce fueling (power) for a short time to reduce air and coolant temperatures when necessary.

DDEC will store an information code that this event occurred, but no corrective action is required as this action is designed to maintain operation without a noticeable affect on vehicle performance.

Flashing Malfunction Codes

All malfunction codes are four digits. The malfunction code recorded in the computer memory will remain until it is erased by a technician.

The flashing malfunction code can also be obtained by the operator. To support flashing codes, a Stop Engine Override/Diagnostic Request Switch must be configured and the AWL (Check Engine) and RSL (Stop Engine) must be hard-wired. The CPC cannot flash these lamps if they are not hard-wired.

The flashing code feature may be activated by satisfying one of the following conditions:

- Engine speed is <100 rpm and the Stop Engine Override Switch is put in the ON position.
- Idle Governor is active and the Stop Engine Override Switch is put in the ON position.
- Vehicle speed is <3 mph and Parking Brake is activated and the Stop Engine Override Switch is put in the ON position.

The flashing code feature is deactivated once the Stop Engine Override Switch is returned to the OFF position or the listed conditions are no longer satisfied.

Only one light will be flashing codes at any time. All codes will be flashed twice. The inter-digit pause is 1.5 seconds. The pause between codes is 3.5 seconds. The same 3.5-second pause occurs as the switch is made from RSL (Stop Engine) to AWL (Check Engine).

When code flashing is initiated, the active codes will be flashed on the RSL (Stop Engine). Then the inactive codes will be flashed on the AWL (Check Engine). When all the inactive codes have been flashed, the process of flashing all the active codes followed by all the inactive codes will repeat until the conditions for code flashing are no longer satisfied.

If there are no active or inactive faults, the number 3 is flashed once followed by a gap of 3 seconds.

RED - RSL

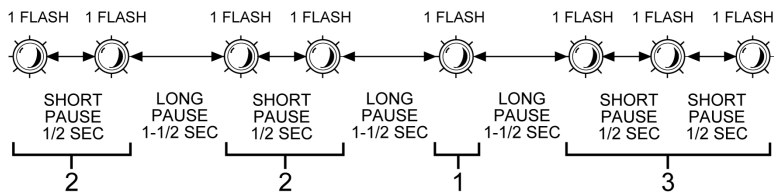

CODE 2213
ACTIVE

47709

Reading Fault Codes

To read the fault codes, press and hold the Stop Engine Override / Diagnostic Request Switch.

Active codes will be flashed on the RSL (Stop Engine) first, followed by inactive codes being flashed on the AWL (Check Engine). The codes will continue to flash and repeat as long as the Diagnostic Request Switch is held in the ON position. Both CPC and MCM faults are included.

Active Codes

The active codes will be flashed on the RSL (Stop Engine) in the order of most recent to least recent occurrence based on engine hours.

Inactive Codes

The inactive codes will be flashed on the AWL (Check Engine) in the order of most recent to least recent occurrence based on engine hours.

Detroit Diesel Electronic Control System Features

The electronic engine control system offers a variety of features and options designed to warn the operator of any engine or Aftertreatment System (ATS) malfunction. Options can range from warning panel lights to automatic reduction in engine power followed by automatic engine shutdown. **The electronic engine control system has the ability to perform diagnostics for self-checks and continuous monitoring of other system components.**

Depending on the application, the electronic engine control system can monitor oil temperature, coolant temperature, oil pressure, fuel pressure, coolant level and remote sensors (if used).

The electronic engine control system activates the Amber Warning Lamp (AWL) / Check Engine and the Red Stop Lamp (RSL) / Stop Engine to provide a visual warning of a system malfunction.

Data Recording Capability

The electronic engine control system contains the ability to extract detailed data on engine use and performance using DDEC Reports software. This detailed data (or DDEC Data) is stored in the CPC and contains information on engine performance such as fuel economy, idle time, and time in top gear. Critical incidents such as detailed diagnostic data records and hard braking events are also stored. DDEC Data can be downloaded using DDEC Reports software to produce reports.

NOTE: As the diagnostic and reprogramming software applications have evolved, the requirements for additional computer storage capacity and memory has increased. Please review these computer specifications carefully and take any necessary steps to update your hardware as needed.

Table 2.

DDDL 7.X System Requirements	
Minimum Hardware	Recommended Hardware
Windows XP, Windows Vista or Windows 7 (32 & 64 bit)	Windows XP, Windows Vista or Windows 7 (32 & 64 bit)
	Intel® Core™ 2 Duo, AMD Athlon™ 64X2, or equivalent
1.8 Ghz processor	2.0+ GHz Dual-Core processor
1.0 GB RAM	2 GB RAM or more
40 Gigabyte Hard drive with 20 Gigabyte free	100 GB hard drive with 20 GB free space
32x CD ROM Drive	DVD ROM drive
Monitor and graphics card supporting 1024 x 768 resolution and 16-bit color	Monitor and graphics card supporting 1280 x 1024 resolution and 32-bit color
1 free USB port	Parallel port, three free USB ports
Internet or Mainframe Connection to DDC Server (for updates)	High Speed Internet – Broadband Internet
Hardware	
Adapter device (One of the following) › Nexiq MagiKey device with parallel cable › Nexiq USB-Link with USB cable (Required for Cascadia diagnostics) Bluetooth functionality NOT approved at this time	

Engine Brake

The engine brake is enabled by a dash-mounted ON/OFF Switch with a separate intensity switch to select low, medium, or high braking power.



CAUTION: LOSS OF VEHICLE CONTROL

To avoid injury from loss of vehicle control, do not activate the Engine Brake system under the following conditions:

- On wet or slippery pavement, unless the vehicle is equipped with ABS (anti-lock braking system) and you have had prior experience driving under these conditions.
- When driving without a trailer (bobtailing) or pulling an empty trailer.
- If the tractor drive wheels begin to lock or there is fishtail motion after the Engine Brake is activated, deactivate the brake system immediately if this occurs.

The engine brake will only operate when the Accelerator Pedal is fully released. Disengaging the clutch will prevent the engine brake from operating.

The engine brake will supply braking power even when in Cruise Control. The Motor Control Module will control the amount of engine braking with respect to the Cruise Control set speed. The maximum amount of braking (low, medium, high) is selected with the dash or steering wheel switches.

Engine Protection

The electronic engine control protection system monitors all engine sensors, electronic components, and recognizes system malfunctions. If a critical fault is detected, the AWL (Check Engine) and RSL (Stop Engine) illuminate. The malfunction codes are logged into the MCM's memory.

The standard parameters which are monitored for engine protection are low coolant level, high coolant temperature, low oil pressure, and high oil temperature.



WARNING: PERSONAL INJURY

To avoid injury from engine shutdown in an unsafe situation, ensure the operator knows how to override the stop engine condition on a DDEC-equipped unit.

NOTICE: Engines equipped with the power down/shutdown option have a system override button or switch to allow engine operation for a short period of time. Using the override button so the engine does not shut down in 30 seconds but operates for an extended period may result in engine damage.

This system features a 30-second, stepped-power shutdown sequence, or an immediate speed reduction without shutdown in the event a major engine malfunction occurs, such as low oil pressure, high oil or coolant temperature, or low coolant level.

Idle Shutdown Timer

This feature is an optional 1-80 minute idle shutdown system. Its purpose is to conserve fuel by eliminating excessive idling and allowing a turbocharger cool-down period. To activate the shutdown, the transmission must be in neutral with the vehicle parking brakes set and the engine in idle or fast-idle mode.

Accelerating the Vehicle

Engine response versus pedal movement may feel different from the mechanical-governed engine you were driving. The Accelerator Pedal (AP) was designed to communicate 'percentage' foot pedal travel to the engine's Motor Control Module (MCM). The engine will respond accordingly to the driver's demand.

Another throttle or governor characteristic you may need time to get used to is the DDEC Limiting Speed Governor. This allows the driver to command total engine response between idle and rated speed, such as accelerating at half throttle - an advantage when driving under slippery conditions.

If you require wide-open throttle engine response, either accelerating or just plain pulling hard, the throttle AP will have to be held to the floor. To obtain 100% fueling at any speed, the AP will have to be maintained at the fully pressed position.

Cruise Control

For added driver convenience and comfort, DDEC also features a Cruise Control option that works just like the system in your car. It can be operated in any gear above 1100 rpm or road speed faster than 20 mph (32 kph), up to the rated engine speed. It also can be programmed to hold your road speed at or below the maximum vehicle speed. The switch to energize Cruise Control is usually mounted on the instrument panel or steering wheel.

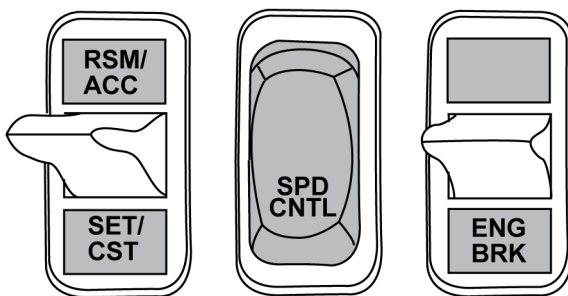

47521

Engine speed and power are varied under Cruise Control to maintain the set vehicle speed. The vehicle speed must be above Min Cruise Set Speed and below Max Cruise Set Speed. It is recommended that Max Cruise Set Speed be set to the default to allow proper operation of other features such as Fuel Economy Incentive and PasSmart. The Vehicle Speed Limit should be used to limit vehicle throttle speed.

Turn the switch ON to energize the system. Remember as a check after each engine start, DDEC looks for a one-time activation of the clutch (if equipped) and service brake before DDEC allows Cruise Control to be enabled.

DDEC must also see or recognize that the Cruise Enable Switch has changed. If the Cruise Enable Switch is OFF it needs to be turned ON. If the Cruise Enable Switch is left in the ON position at key OFF, the switch must be cycled OFF then ON for DDEC to see a status change to allow Cruise Control activation. The status of DDEC inputs to activate Cruise Control at key ON is listed in the following table.

Table 3.

Input Status to Activate Cruise Control		
Input	Input Status at Key ON	Input Status Before Cruise Control Activates
Service Brake Switch	ON	OFF
Clutch Release Switch (Manual Trans. only)	ON	OFF
Cruise Control Enable Switch	OFF	ON

Once Cruise Control is enabled and you reach your road speed, press the SET Switch to activate Cruise Control. The cruise light will come on. To increase road speed toggling the switch will result in a one mile-per-hour (1.6 kph) increase or decrease in vehicle speed. If Cruise Control has been disabled, toggling the RSM/ACC Switch restores the vehicle to the previously set cruise speed. , press the RSM/ACC Switch. To reduce road speed, press and hold the SET/CST Switch until the lower speed is reached.

Cruise Control can be overridden at any time with the throttle pedal if the vehicle is operating at less than the programmed Max Road Speed.

Cruise Control is deactivated by slightly pressing the service brakes, clutch pedal, or trailer brake. The ON/OFF Switch will also deactivate Cruise Control.

Cruise Control will maintain vehicle speed even on upgrades, unless power requirements demand a downshift. If the Cruise Control/Engine Brake function is turned ON, the Cruise Control will limit your speed on downgrades. Most likely, Cruise Control will feel stronger than driving with the accelerator pedal because of the instantaneous and wide-open throttle response. That's why Cruise Control use is not suggested during slippery driving conditions.

Use Cruise Control after downshifting on a hill to pull the hill. Hitting the RSM/ACC Switch (not the SET Switch) will keep the truck accelerating in the lower gears up to the rated engine speed.



CAUTION: LOSS OF VEHICLE CONTROL

To avoid injury from the loss of vehicle control, do not use cruise control under these conditions:

- When it is not possible to keep the vehicle at a constant speed (on winding roads, in heavy traffic, in traffic that varies in speed, etc.).
- On slippery roads (wet pavement, ice-or snow-covered roads, loose gravel, etc.).

Cruise Control will maintain the set speed under normal road and load conditions. It cannot limit vehicle speeds on down grades if available engine braking effort is exceeded, nor can it maintain speed on upgrades if power requirements exceed engine power capability.

Cruise Control will disengage below 1000 rpm or 20 mph (32 kph) road speed. When using Cruise Control, if you want to pull the engine below 1000 rpm, remember to hold the accelerator pedal to the floor to keep the engine pulling at wide-open throttle. The engine will pull down to about 1050 rpm.

Remember: The electronic data programmed into the DDEC system will not allow you to hurt or over fuel the engine at low or lug engine speeds. There is enough oil pressure to withstand hard pulls at low engine speeds.

Cruise Control may also be programmed to permit fast idle using the Cruise Control switches.

With the engine at normal idle, transmission in neutral and service brakes on, press the SPD CNTL Switch, and use the RSM/ACC Switch. The engine rpm should increase to a pre-defined speed. The engine rpm can be raised or lowered from this point using the SET/CST and RSM/ACC switches.

Engine Brake and Cruise Control

Your engine is equipped with both Cruise Control and an engine brake; the engine brake can operate automatically while you are in Cruise Control. If the Cruise Control/Engine Brake function is turned ON in the DDEC 10 system programming, the engine brake will come on low when your set road speed increases a few mph (kph) above your cruise set speed. If your speed continues to increase, the DDEC 10 system will increase the engine brake's braking power progressively. When the vehicle returns to the set cruise speed the engine brake will turn off until you need them.

For safety reasons, don't use Cruise Control when it is not possible to keep the vehicle at constant speed due to:

- Winding roads
- Heavy traffic
- Slippery pavement
- Descending grades calling for engine brake assistance

For an explanation of the engine brake system and recommendations for proper operation, "Engine Brake System" in this manual.

DD Platform Shifting

Depending on your transmission model, the gear split may vary from 400 to 500 rpm. The electronic governor provides almost no overrun capability; and, if the transmission is downshifted too early, you will experience a temporary loss of pulling power until the engine speed falls below rated speed.

In general, when using a 7- or 9-speed transmission, you should always downshift between 1000 and 1100 rpm for the DD15. This is true even on steep grades with heavy loads. When using an 18-, 15-, or 13-speed transmission, you will need to downshift at an rpm that allows "less than rated" rpm before throttle application in the next gear down. You may want to limit engine speed to 1900 rpm in all gears. DD Platform engines provide horsepower through 2100 rpm, but fuel economy is not as efficient above 1800 rpm.

If you decide to drive at a lower rpm for improved fuel economy, don't let different engine noises throw you off guard. The engine sounds quiet at 1400 rpm, almost as if it had quit pulling. Depending on the air intake arrangement, you may also experience a "chuffing" sound as the engine starts to pull hard at lower rpm. This is normal and caused by the velocity changes of the air flow within the air intake plumbing. Electronic engines can actually deliver more fuel at lower engine speeds than at rated speed.

The engine has been designed for a very quiet operation, but the air flow may be noticeable to the tuned, attentive ear. The turbocharger operates at higher boost pressure forcing EGR gas flow through the EGR plumbing. In some situations the driver may believe he/she has experienced a charge air cooler system leak. Even connecting trailer light and air hoses, the driver may hear a different tone (exhaust and under hood with the engine idling.) If equipped with a turbo boost gauge, the driver may occasionally note intake manifold pressure exceeds 35 psi (6.89 kPa).

Idling

The common belief that idling a diesel engine causes no engine damage is wrong. Idling produces sulfuric acid, which is absorbed by the lubricating oil and eats into bearings, rings, valve stems and engine surfaces. If you must idle the engine for cab heat or cooling, the high idle function of the Cruise Control switches should be used. An idle speed of 900 rpm should be enough to provide cab heat in above 0°C (32°F) temperatures.

Engine Brake System

The engine is equipped with an engine brake. Before operating the vehicle, you must familiarize yourself with the engine brake system to obtain optimum benefit from it. Engine brake control systems may vary slightly, depending on the engine brake configuration and cab design. However, basic operator controls are similar for all models.

Driver Control Switches

Vehicles with manual transmissions allow the driver to turn the engine brake on and off and select a Low, Medium, or High level of braking.

- The "Low" setting on this switch activates braking on two cylinders, yielding about one-third engine braking horsepower.
- The "Medium" setting on this switch activates four cylinders, supplying about two-thirds engine braking horsepower.
- The "High" setting on this switch activates all six cylinders, providing full engine brake horsepower.

NOTE: There is very little difference in the exhaust sound when the engine brakes are activated in either the medium or high position.

Clutch Pedal and Throttle Position Controls

Engine brakes have two additional controls, one activated by the position of the clutch pedal and the other activated by the position of the throttle. These controls permit fully automatic operation of the engine braking system.

Engine Brake Activation Conditions

The engine braking system only permits fully automatic operation when the following conditions are met:

- Engine Brake switch is on.
- An Engine Brake level (Low/Med/High) is selected.
- Vehicle meets the programmed minimum speed.
- The Clutch Pedal is out.
- The Accelerator Pedal is at zero percent activation.

Engine Brake Operation

NOTICE: Always allow the engine to reach full normal operating temperature before activating the engine brake system to ensure positive engine brake engagement.

The engine brake system depends on a full-pressure flow of warm engine lubricating oil for proper lubrication of moving parts and optimum performance.

The minimum operating speed for the engine brake is 900 rpm. A check engine lamp will be illuminated when the operating speed exceeds 2200 to 2300 rpm depending on engine configuration.

NOTICE: Never exceed 2500 rpm or extensive engine damage can occur.



CAUTION: LOSS OF VEHICLE CONTROL

To avoid injury from loss of vehicle control, do not activate the Engine Brake system under the following conditions:

- On wet or slippery pavement, unless the vehicle is equipped with ABS (anti-lock braking system) and you have had prior experience driving under these conditions.
- When driving without a trailer (bobtailing) or pulling an empty trailer.
- If the tractor drive wheels begin to lock or there is fishtail motion after the Engine Brake is activated, deactivate the brake system immediately if this occurs.

Under normal driving conditions the engine brake system is left in the ON position. However, this should change if roads become wet or slippery.

NOTICE: Do not attempt to “double clutch” the transmission while the engine brake system is turned on. Shifting gears without pressing the clutch or using the engine brake to reduce engine rpm may result in serious powertrain damage.

After it is switched on, the engine brake system is automatically activated each time you remove your feet completely from the clutch pedal and accelerator pedal. The engine brake automatically deactivates itself when you press the clutch pedal while shifting gears.

NOTE: Some systems may be programmed to activate themselves only when the brake pedal is pressed, so read your vehicle owner's manual thoroughly to find out if you have this option.

Anti-Lock Braking Systems

Vehicles equipped with ABS have the ability to turn the engine brake OFF if a wheel-slip condition is detected. The engine brake will automatically turn itself ON once the wheel slip is no longer detected.

The DDEC system will deactivate the engine brake system when the engine speed falls below a preset rpm or when the vehicle slows down to a preset speed, depending on DDEC programming. This prevents stalling the engine. The engine brake can also be used with vehicle Cruise Control turned ON.

Operating on Flat, Dry Pavement

Use the following guidelines when driving on flat, dry pavement:

- If driving on flat, dry, open stretches with a light load and greater slowing power is not required, place the progressive braking switch in the LOW position.
- If you find you are still using the service brakes, move the progressive braking switch to a higher position until you do not need to use the service brakes to slow the vehicle down.
- If you are carrying a heavier load and road traction is good, move the progressive braking switch to the HIGH position.
- Check your progressive braking switch often for proper position, since road conditions can change quickly. *Never skip a step when operating the progressive braking switch.* Always go from OFF to LOW, and then to a higher position.

Operating Down a Long, Steep Grade

An explanation of speed; may be helpful in understanding how to use the engine brake system while descending a grade. *Control Speed* is the constant speed at which the forces pushing the vehicle forward on a grade are equal to the forces holding it back, without using the vehicle service brakes. In other words, *this is the speed the vehicle will maintain without using the service brakes or fueling.*

NOTICE: Failure to keep the vehicle within safe control speed limits while descending a grade may result in vehicle or property damage or both.

Use the following guidelines when descending a long, steep grade:

1. Before beginning the descent, determine if your engine brake system is operating properly by lifting your foot briefly off the accelerator pedal. You should feel the system activate.



CAUTION: BRAKE FADE

To avoid injury, do not over apply the vehicle service brakes when descending a long, steep grade. Excessive use of the vehicle brakes will cause them to heat up, reducing their stopping ability. This condition, referred to as “brake fade”, may result in loss of braking, which could lead to personal injury or vehicle/property damage or both.

2. Ensure the progressive braking switch is in the appropriate power position (LOW/MED/HIGH).



WARNING: PERSONAL INJURY

Failure to keep the vehicle within safe control speed limits while descending a grade may result in loss of vehicle control, which could cause personal injury.

3. Do not exceed the safe control speed of your vehicle. Example: You could descend a 6% grade, under control only at 10 mph (16 kph) without an engine brake, but at 25 mph (40 kph) with an engine brake. You could not descend that same hill at 50 mph (80 kph) and still expect to remain under control. Get to know how much slowing power your engine brake can provide. So get to know your engine brake system before climbing hills and do not exceed a safe control speed.
4. Check your progressive braking switch often for proper position (LOW/MED/HIGH), since road conditions can change quickly. Never skip a step when operating the progressive braking switch. Always go from OFF to LOW and then to a higher position when on slippery roads.

Operating on Wet or Slippery Pavement

Operate the engine brake system as follows:

NOTE: Experience with the engine brake system on dry pavement is recommended before attempting to use it on wet or slippery roads.

1. On wet or slippery pavement, start with the master switch in the OFF position and use the gear you would normally use under these conditions.

**CAUTION: LOSS OF VEHICLE CONTROL**

To avoid injury from loss of vehicle control, do not activate the Engine Brake system under the following conditions:

- On wet or slippery pavement, unless the vehicle is equipped with ABS (anti-lock braking system) and you have had prior experience driving under these conditions.
- When driving without a trailer (bobtailing) or pulling an empty trailer.
- If the tractor drive wheels begin to lock or there is fishtail motion after the Engine Brake is activated, deactivate the brake system immediately if this occurs.

NOTE: On single trailers or combinations, a light air application of the trailer brakes may be desirable to help keep the trailer stretched out. Follow the manufacturer's recommended operating procedure when using your trailer brakes.

2. If the tractor drive wheels begin to lock or there is fishtail motion after the Engine Brake is activated, deactivate the brake system immediately if this occurs.
3. However, if the tractor drive wheels begin to lock or there is a fishtail motion, turn the engine brake system OFF immediately and do not activate it until road conditions improve.
4. Check your progressive braking switch often for proper position (LOW/MED/HIGH), since road conditions can change quickly. Never skip a step when operating the progressive braking system. Always go from OFF to LOW and then to a higher position.

Engine Systems

The engine systems are as follows:

Fuel System

The fuel system consists of DDEC control system, fuel injectors, low and high pressure pumps, fuel filter module, prefilter, coalescer/final filter, and the necessary connecting fuel lines. The common rail system with injectors provides amplification for better fuel atomization.

Lubrication System

The lubrication system consists of an oil pump, oil cooler, cartridge-style oil filter, pressure regulator valve, and oil pressure sensor. Clean, pressurized oil is fed to all components via passages in the engine block and cylinder head.

Air System

Outside air enters the engine through the air filter and is drawn to the turbocharger and then is compressed, and forced through the air-to-air charge cooler (heat exchanger) and is cooled. Next, it flows to the intake manifold and into the cylinders, where it mixes with atomized fuel from the injectors.

For optimum engine protection from dust and other airborne contaminants, service the dry-type air cleaners used when the maximum allowable air restriction has been reached.

Cooling System

A radiator/thermo-modulated fan cooling system is used on the engine. This system has a centrifugal-type coolant pump to circulate coolant within the engine. One full-blocking type thermostat located in the coolant module attached to the left side of the cylinder block controls the flow of coolant. The coolant module incorporates the oil cooler, oil filter, coolant filter, and coolant pump.

Electrical System

The electrical system consists of a starting motor, starting switch, battery-charging alternator, storage batteries, and necessary wiring.

Exhaust System

Hot exhaust gas from the exhaust manifolds is used to drive the turbocharger.

Exhaust Gas Recirculation System

The Exhaust Gas Recirculation (EGR) system consists of an EGR cooler, EGR valve and actuator. The EGR actuator opens and closes the EGR valve to allow hot exhaust gas to enter the EGR cooler. Heat is extracted from the exhaust gas,

resulting in cooler exhaust gas to the cylinders. EGR lowers the temperature of the exhaust from the engine, therefore, reducing exhaust gas emissions to acceptable levels.

The purpose of the Exhaust Gas Recirculation System (EGR) is to reduce engine exhaust gas emissions in accordance with EPA regulations.

The EGR system has been optimized to dramatically cut NO_x formation by routing a measured amount of exhaust flow to the cylinders to lower combustion temperatures. Lower temperatures result in lower NO_x levels without the negative effects of retarding engine timing. The EGR valve has been moved to the top of the engine for improved serviceability.

Preventive Maintenance Intervals

Preventive Maintenance Intervals

The following guide establishes preventive maintenance intervals. These recommendations should be followed as closely as possible to obtain long life and optimum performance from your engine. When performed on a regular basis, changing the engine oil, coolant, and filters is the least costly way of obtaining safe and reliable vehicle operation. Added benefits and savings occur when you check that the valves, fuel injectors, oil and cooling circuits are in good working order during oil changes.

The intervals shown apply only to the maintenance functions described. These functions should be coordinated with other regularly scheduled maintenance.

Schedule Use

Complete each maintenance operation at the required interval. The intervals are based on a collaboration of field and fleet data. For a more accurate analysis of when fluids should be changed, such as engine oil, refer to publication Engine Requirements; Lubricating Oil, Fuel and Filters and publication Coolant Selections for Detroit™ Engines, available from authorized Detroit™ distributors.

Each maintenance table shows which maintenance operation must be performed at the recommended interval (in miles, kilometers, and hours).

NOTE: Failure to check and maintain Supplemental Coolant Additive levels at required concentrations will result in severe damage (corrosion) to the engine cooling system and related components. Coolant must be inhibited with the recommended Supplemental Coolant Additives listed in this manual.

Cooling System Flush and Fill

Coolant Flush and Fill - Proper maintenance of the cooling system is vital to its performance and longevity. The cooling system must, on a constant basis, deal with cavitation, temperature / pressure swings, and continuous threats on the additive package. Once the additives have been depleted from the coolant, it will only be a matter of time until the engine components suffer. Refer to section "Cooling System Fill Procedure"

Cooling System Inspection - Inspect the cooling system as follows:



WARNING: HOT COOLANT

To avoid scalding from the expulsion of hot coolant, never remove the cooling system pressure cap while the engine is at operating temperature. Wear adequate protective clothing (face shield, rubber gloves, apron, and boots). Remove the cap slowly to relieve pressure.

1. Inspect the radiator, condenser, coolant pump, engine oil cooler, freeze plugs, and heat exchanger for damage and leaks.
2. Check all cooling system pipes and hoses for damage and leaks; ensure they are positioned to avoid chafing, and are securely fastened.
3. Check the outside of the radiator and condenser for blockage. Check fins for damage; straighten them if necessary.

Valve Lash Checking and Adjustment

Valve lash checking and adjustment should be performed per the maintenance intervals prescribed under the proper service category for the engine. All three service categories (Severe, Short Haul, and Long Haul) require a 'first time' valve lash adjustment at a shorter interval. After the initial adjustment, all others are based on the same mileage intervals. Proper valve lash clearance allows the engine to produce the best possible performance with the lowest emissions. Valve lash adjustments should be performed by an authorized Detroit™ maintenance or repair facility.

Drive Belt

Belts should be neither too tight nor too loose. Belts that are too tight impose extra loads on the crankshaft, fan and/or alternator bearings, shortening both belt and bearing life. Excessively overtightened belts can result in crankshaft breakage. A loose belt will slip and generate excessive heat that may cause damage to the belt and accessory drive components.



WARNING: PERSONAL INJURY

To avoid injury from rotating belts and fans, do not remove and discard safety guards.

Belt Replacement - Drive belts (V and poly-V) should be replaced every 2,000 hours or 100,000 miles (160,000 km).

After an extended time in service, minor rib cracks may appear, usually one or two cracks per inch is considered normal. A concern occurs when the belt ribs exhibit severe multiple cracking or 'chunking'. At this point, the belt should be replaced.

Poly-V Belt

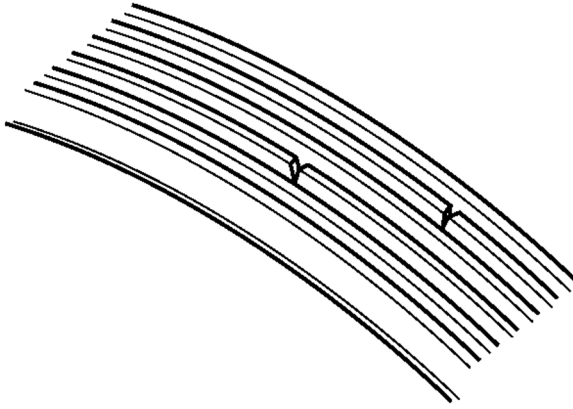

47676

Auto Tensioner - Auto tensioners are usually maintenance free for the life of the engine. However, routine inspections should be performed. Uneven belt wear can indicate a loose, wore out, or bad bearing on the auto tensioner. A build up of dirt or grime around the front bearing surface of the wheel can indicate a future bearing failure due to inadequate lubrication.

Fuel / Water Separator

Incorporated into the fuel filter module is a fuel/water separator. The separator removes emulsified water as well as droplets and is located in the lower compartment of the fuel filter module. A water-in-fuel (WIF) sensor indicates when trapped water needs to be drained.

NOTICE: Do not over-tighten the water drain valve. Failure to properly tighten the water drain valve may cause damage to the water drain valve and housing.

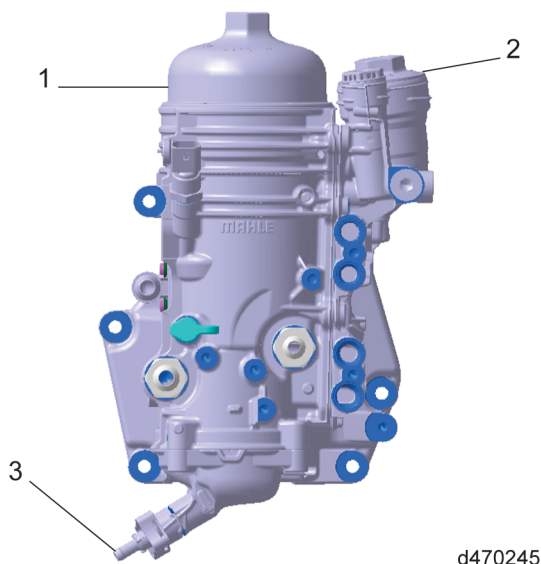

- | | |
|--|----------------------|
| 1. Water in Fuel Separator(Coalescer/
Final Filter) Cap | 3. Water Drain Valve |
| 2. Pre Filter Cap | |

Figure 9. Fuel Filter Module

Fuel Filters

The prefilter is housed within the fuel filter module. The prefilter element filters particles down to 100 microns and is snapped into the prefilter cap. The coalescer/final filter is housed within the fuel filter module. The coalescer/final filter has the task of separating out the water contained in the fuel and also filtering out particles down to 3 to 5 microns. The coalescer/final filter snaps into the coalescer/final filter cap.

Air System

Air Cleaner - The air cleaner element should be inspected per the maintenance intervals or more often if the engine is operated under severe dust conditions.

Replace the element, if necessary. Check the gaskets for deterioration and replace, if necessary. If the dry type air cleaner is equipped with an aspirator, check for aspirator damage or clogging. Clean, repair or replace, as necessary.

NOTICE: Do not allow the air inlet restriction to exceed 5.5 kPa (22 in. H₂O) under any engine operating conditions. A clogged air cleaner element will cause excessive intake restriction and reduced air supply to the engine resulting in increased fuel consumption, inefficient engine operation and reduced engine life.

Inspect the entire air system for leaks daily. Look especially for torn air inlet piping or boots and loose or damaged clamps. Have worn or damaged parts repaired or replaced, as required. Retighten loose connections

Air Cleaner Replacement - Dry type air cleaner elements should be replaced after one year of service or when the maximum allowable air intake restriction has been reached, whichever comes first.

Air-to-Air Charge Cooler - Periodically inspect the air-to-air charge cooler for buildup of dirt, mud, etc. and wash off using a mild soap solution. Check the charge cooler, ductwork, and flexible connections for leaks and have repaired or replaced, as required.

Exhaust System

The exhaust manifold retaining bolts and other connections should be inspected for leaks. The exhaust pipe rain cap should be checked for proper operation, if so equipped.

Air Compressor

The air compressor incorporates three of the major systems of a diesel engine (air, lubrication, and coolant). Proper inspection of air compressor would include inspecting for air, oil, and coolant leaks. Due to inadequate internal sealing air compressors, when failed, can produce excessive crankcase pressure or allow an engine to ingest oil.

Vibration Damper

The viscous vibration damper should be inspected periodically and replaced if dented or leaking. Heat from normal engine operation may, over a period of time, cause the fluid within the damper to break down and lose its dampening properties. For this reason the viscous vibration damper must be replaced at time of normal major engine overhaul, regardless of apparent condition.

Preventive Maintenance Tables

NOTE: Actual fuel filter life will vary based on fuel quality.

Table 4.

Service Maintenance Intervals						
Miles X 1000/	25/	50/	75/	100/	125/	150/
Km X 1000/	40/	80/	120/	160/	200/	240/
Hours*	640	1280	1925	2565	3205	3850
Lubricating Oil	R	R	R	R	R	R
Lubricating Oil Filter	R	R	R	R	R	R

Service Maintenance Intervals						
Coolant	Refer to section "How to Select Coolant" for the listing of required intervals using the recommended coolants.					
Cooling System Filter (if equipped)	-	-	-	R	-	-
Fuel Filters without Frame-mounted Filter						
Fuel Filters	R	R	R	R	R	R
Fuel Filters with Frame-mounted Filter						
Frame-mounted Filter	R	R	R	R	R	R
Fuel Filters	-	-	R	-	-	R
Valve Lash Adjustment	Adjust at 100,000 miles (160,000 km), at 500,000 miles (800,000 km), and then every 500,000 miles (800,000 km) thereafter.					
Belts	I	I	I	I	R	I
Air System	I	I	I	I	I	I
Air Cleaner	I	I	I	I	I	I
Exhaust System	I	I	I	I	I	I
Air Compressor	I	I	I	I	I	I
<ul style="list-style-type: none"> • *Whichever comes first. • Currently, Davco 482 is the only frame-mounted filtration system compatible for Detroit™ Engines. • Refer to "Routine Preventive Maintenance" for a description of all items. • R = Replace • I = Inspect 						

Routine Preventive Maintenance

This section describes the items listed in the maintenance interval tables. The Daily instructions apply to routine or daily starting of the engine. They do not apply to a new engine or one that has been operated for a considerable period of time.

Monitoring the Lubricating Oil

Perform the following maintenance on the lubricating oil:

1. Check the oil level daily with the engine stopped and on a level surface. If the engine has just been stopped and is warm, wait approximately 20 minutes to allow the oil to drain back into the oil pan before checking.

NOTE: the dipstick has a positive locking device such as a lever or twist-lock design that must be disengaged before pulling the dipstick out of the guide tube. Use a shop rag to wipe off the end of the dipstick. Wait 15 seconds to allow any crankcase pressure to dissipate through the guide tube and let the oil level settle in the oil pan.

2. Add the proper grade of oil to maintain the correct level on the dipstick. Remove the dipstick from the guide tube. Before adding lubricating oil, refer to "How to Select Lubricating Oil."

NOTICE: Do NOT fill beyond the maximum fill level on the dipstick, since overfilling may result in high oil consumption and possible severe engine damage.

NOTE: If the engine operating temperature is below 60° C (140° F), the engine must be on a level surface and then shut down for 60 minutes for an accurate oil level reading. Otherwise, the engine must be brought up to an operating temperature of 60° C (140° F), parked on a level surface and then shut down for five minutes for an accurate oil level reading.

3. Reinstall the dipstick and make sure it is fully inserted into the guide tube. Remove the dipstick and read the oil level dipstick.

NOTICE: Do not add oil if the oil reading is in the crosshatch area on the dipstick. There are approximately 5.0 L (5.2 qts) from the minimum mark to the maximum mark on the dipstick. Overfilling the oil pan can cause engine damage.

NOTICE: If the oil level is constantly above normal and excess oil has not been added to the crankcase, consult with an authorized Detroit service outlet for the cause. Fuel or coolant dilution of lubricating oil can result in serious engine damage.

4. Check the oil level daily. With the engine stopped, use the oil dipstick and measure the oil level on crosshatch area on the dipstick. Figure below shows Maximum oil level (1) and Minimum oil level (2). If the oil reading is in the crosshatch area or between the bends of the dipstick, then the oil is at the proper level for engine operation.

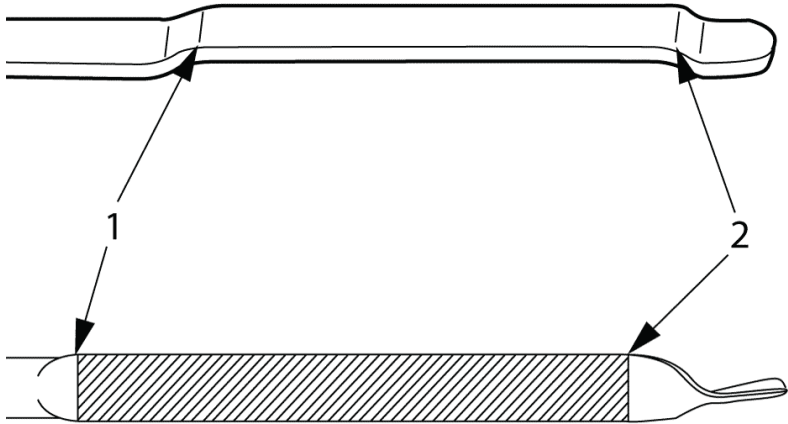

42141

5. Add the proper grade of oil to maintain the satisfactory range on the dipstick. All diesel engines are designed to use some oil, so the periodic addition of oil is normal. Before adding lubricating oil, refer to "How to Select Lubricating Oil."

Monitoring the Lubricating Oil Filter

The engines are equipped with a single cartridge-style oil filter (1) that is part of the oil/coolant module. Incorporated into the housing is a drain back port which allows residual oil to be returned to the oil pan when the filter is removed. This design, including the cartridge style element, allows for a more environmentally-safe oil change.

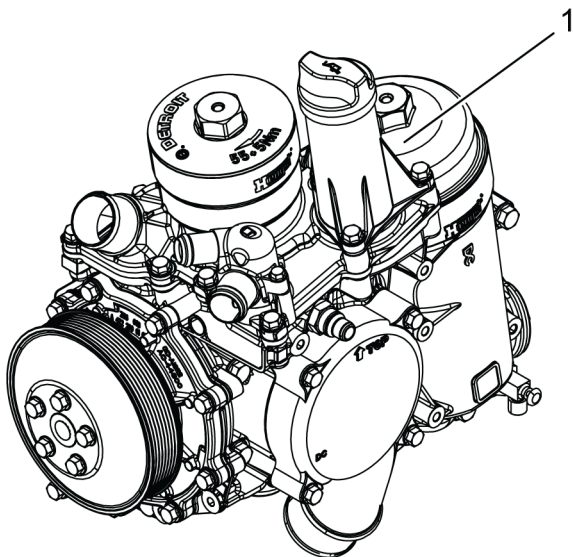

d200005

Perform the following maintenance on the Lubricating Oil Filter:

1. Replace the oil filters when recommended by the appropriate maintenance table.
Refer to section "Preventive Maintenance Tables"
2. Make a visual check of all lubricating oil lines for wear and/or chafing. If any indication of wear is evident, replace the oil lines and correct the cause.
3. Check for oil leaks after starting the engine.

Monitoring the Cooling System

The cooling system must be *full* for proper operation of the engine.



WARNING: HOT COOLANT

To avoid scalding from the expulsion of hot coolant, never remove the cooling system pressure cap while the engine is at operating temperature. Wear adequate protective clothing (face shield, rubber gloves, apron, and boots). Remove the cap slowly to relieve pressure.

1. Check the coolant level daily and maintain it between the full and low marks on the surge tank.
2. Add coolant as required, but do not overfill. Before adding coolant, refer to "How to Select Coolant" for the listing of required intervals using the recommended coolants

Checking for Coolant Leaks

Perform daily visual checks for cooling system leaks. Look for an accumulation of coolant when the engine is running and when it is stopped.

NOTE: Coolant leaks may be more apparent on a engine when it is cold.



WARNING: PERSONAL INJURY

To avoid injury before starting and running the engine, ensure the vehicle is parked on a level surface, parking brake is set, and the wheels are blocked.

Coolant Inhibitors

The inhibitors in antifreeze solutions must be replenished with an approved corrosion inhibitor supplement when indicated by testing the coolant. Refer to section "How to Select Coolant" for the listing of required intervals using the recommended coolants for required test intervals, inhibitor levels, and approved inhibitors.

NOTICE: Coolant must be inhibited with the recommended Supplemental Coolant Additives listed in this manual. Failure to check and maintain Supplemental Coolant Additive levels at required concentrations will result in severe damage (corrosion) to the engine cooling system and related components.

The cooling system is protected by a Supplemental Coolant Additive element. In addition, the engine can be equipped with a coolant filter/inhibitor system as an installed option or as an after-sale item.

Coolant Drain Interval

A coolant system properly maintained and protected with supplemental coolant inhibitors can be operated up to the intervals listed. At these intervals the coolant must be drained and disposed of in an environmentally responsible manner according to state and/or federal Environmental Protection Agency (EPA) recommendations.

Inspection of the Radiator

Inspect the radiator as follows:

1. Inspect the exterior of the radiator core every 30,000 miles (50,000 km) or 12 months.



WARNING: EYE INJURY

To avoid injury from flying debris when using compressed air, wear adequate eye protection (face shield or safety goggles) and do not exceed 276 kPa (40 psi) air pressure.

NOTE: It may be necessary to clean the exterior of the radiator more frequently if the engine is being operated in extremely dusty or dirty areas.

2. If necessary, clean the exterior using a quality grease solvent, such as mineral spirits, and dry with compressed air. Do not use fuel oil, kerosene, or gasoline.
3. If the low coolant level sensor is installed in the top tank of the radiator, test for proper operation every 100,000 miles (160,000 km) or 12 months, whichever comes first. Authorized Detroit™ distributors are properly equipped to perform this service.

Monitoring the Cooling System Filter

Install a new cooling system filter at the distance intervals indicated by each specific Maintenance Interval chart.

- Refer to section "Preventive Maintenance Tables".

Monitoring the Fuel Filters

Monitoring the Fuel System Filters

The engine is equipped with a prefilter that filters down to 100 microns, a coalescer/final filter that separates water, and filters down to 3 to 5 microns. When servicing these elements, all two filters should be changed at the same time. All two elements are located within the fuel filter module located on the left side of the engine.

NOTICE: Do not over-tighten the water drain valve. Failure to properly tighten the water drain valve may cause damage to the water drain valve and housing.

NOTE: Filter change intervals may be shortened to conform with established preventive maintenance schedules, but should never be extended.

1. Replace the fuel filters using the Preventative Maintenance Tables.

Adjusting the Valve Lash

NOTE: Proper valve lash clearance allows the engine to produce the best possible performance with the lowest emissions. Valve lash adjustments should be performed by an authorized Detroit™ maintenance or repair facility.

Perform a valve lash adjustment as scheduled for the appropriate engine duty cycle.

Monitoring the Belt Tensioner

The engine is equipped with two engine belt tensioners to ensure the belts are neither too tight nor too loose. Belts that are too tight impose extra loads on the crankshaft, fan, and alternator bearings shortening both belt and bearing life. A loose belt will slip and generate excessive heat that may cause damage to the belt and accessory drive components.



WARNING: PERSONAL INJURY

To avoid injury from rotating belts and fans, do not remove and discard safety guards.

1. Inspect the belt tensioner for wear or damage.
2. If damage is found it may need to be replaced by an authorized Detroit™ maintenance or repair facility.

Monitoring the Serpentine Belts

Two poly-V-belts (8 and 9) are used on the engine for On-Highway Vehicle applications. One belt drives the fan hub and the other belt drives the remaining accessories. To provide proper running tension, the current engine uses an automatic fan hub belt tensioner (6) and an accessory belt tensioner (2). Automatic belt tensioners require no adjustment.

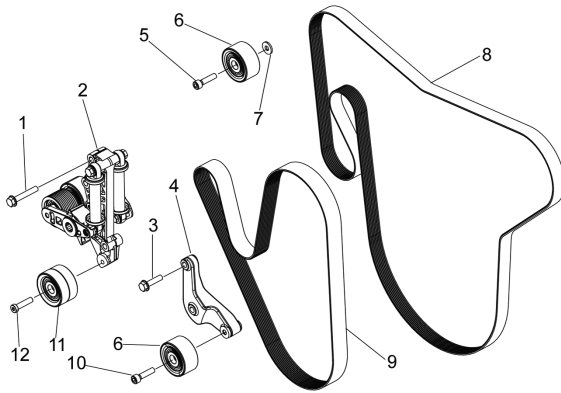

d200007

Replacement of Belts

Replace the drive belts every 2,000 hours or 300,000 miles (480,000 km).

Inspection of the Air Intake System

Perform the following maintenance on the Air Intake System:

1. Inspect all the connections in the air system to make sure they are tight and leak-free.
2. Check all hoses and ducting for punctures, deterioration, or other damage and replace, if necessary.

Monitoring the Air Cleaner

The engine is equipped with an engine-mounted air cleaner that is flat in design to accommodate various vehicle packages. Replace dry type air cleaner elements when the maximum allowable air intake restriction has been reached.

1. Inspect the air cleaner element every 50,000 miles (80,000 km) or more often if the engine is operating under severe dust conditions. Replace the element, if necessary.
2. Check the gaskets for deterioration and replace, if necessary.
3. If the dry type air cleaner is equipped with an aspirator, check for aspirator damage or clogging. Clean, repair or replace, as necessary.

NOTICE: Do not allow the air inlet restriction to exceed 20 in. H₂O (5.0 kPa) under any engine operating conditions. A clogged air cleaner element will cause excessive intake restriction and reduced air supply to the engine resulting in increased fuel consumption, inefficient engine operation, and reduced engine life.

4. Inspect the entire air system for leaks daily.

- a. Look especially for torn air inlet piping or boots and loose or damaged clamps. Have worn or damaged parts repaired or replaced, as required.
- b. Re-tighten loose connections.

Monitoring the Exhaust System

Inspect the Exhaust System as follows:

1. Check the exhaust manifold retaining bolts and other connections for tightness.
2. Check the exhaust pipe rain cap for proper operation, if so equipped.

Inspection of the Air Compressor

NOTE: Because the air compressor facilitates air, lubricating oil, and coolant flow, a failed air compressor could result in contamination between these three fluids. When failed, an air compressor can produce excessive crankcase pressure or allow an engine to ingest lubricating oil.

The air compressor incorporates three of the major systems of a diesel engine (air, lubrication, and cooling). Inspect the air compressor looking for air, oil, and coolant leaks.

Monitoring the Fuel and Fuel Tank

To prevent fuel and fuel tank problems, the following measures are recommended:

1. Keep the fuel tank filled to reduce condensation.
2. Before adding fuel, Refer to section "How to Select Diesel Fuel"
3. Refill the tank at the end of each day's operation to prevent condensation from contaminating the fuel. Condensation formed in a partially filled tank promotes the growth of microorganisms that can clog fuel filters and restrict fuel flow.
4. To prevent microbe growth, add a biocide to the fuel tank or primary fuel supply only as needed.
5. Open the drain at the bottom of the fuel tank every 30,000 miles (50,000 kilometers) to drain off any water and/or sediment.



WARNING: PERSONAL INJURY

To avoid injury from improper use of chemicals, follow the chemical manufacturer's usage, handling, and disposal instructions. Observe all manufacturer's cautions.

NOTICE: Never use galvanized steel fuel tanks, fittings, pipes, or supply lines. The fuel reacts chemically with the zinc coating to form powdery flakes that can quickly clog the fuel filters and damage the fuel pumps and injectors.

6. Every 120,000 miles (200,000 kilometers) or 12 months, tighten all fuel tank mountings and brackets. At the same time, check the seal in the fuel tank cap, the breather hole in the cap, and the condition of the flexible fuel lines. Repair or replace the parts, as necessary.

Inspection of Hoses and Fittings for Fuel Leaks

A pre-start inspection of hoses and fuel lines is recommended. Make a visual check for fuel leaks at all engine-mounted fuel lines and connections, and at the fuel tank suction and return lines. Since fuel tanks are susceptible to road hazards, leaks in this area may best be detected by checking for an accumulation of fuel under the tank.



WARNING: HOT OIL

To avoid injury from hot oil, do not operate the engine with the rocker cover(s) removed.

NOTE: Leaks are not only detrimental to machine operation, but they can also result in added expense caused by the need to replace lost fluids

Inspection of Hoses and Fittings

Check hoses daily as part of the pre-start inspection.

- Examine hoses for leaks, and check all fittings, clamps and ties carefully.
- Make sure hoses are not resting on or touching shafts, couplings, heated surfaces including exhaust manifolds, sharp edges, or other obvious hazardous areas.
- Since all machinery vibrates and moves to a certain extent, clamps and ties can fatigue with age. To ensure continued proper support, inspect fasteners frequently and tighten or replace them as necessary.
- If fittings have loosened or cracked, or if hoses have ruptured or worn through, take corrective action immediately.

Inspection of Hoses with Extended Service Life

A hose has a finite service life. With this in mind, inspect hoses as follows:

NOTE: Fire-resistant fuel and lubricating oil hose assemblies do not require automatic replacement after five years of service or at major overhaul, but should be inspected carefully before being put back into service.

1. Thoroughly inspect all hoses at least every 500 operating hours (1,000 hours for fire-resistant fuel and lubricating oil hoses) and/or annually. Look for cover damage and/or indications of twisted, worn, crimped, brittle, cracked or leaking lines. Hoses with their outer cover worn through or with damaged metal reinforcements should be considered unfit for further service.
2. Replace all hoses in and out of machinery during major overhaul and/or after a maximum of five (5) years of service.

Inspection of the Turbocharger and Charge Air Cooler

Inspect turbocharger and charge air cooler as follows:

1. Visually inspect the turbocharger mountings, intake and exhaust ducting, and connections for leaks daily.
2. Check the lubricating oil inlet and outlet lines for leaks or restrictions to oil flow.



WARNING: PERSONAL INJURY

To avoid injury from hot surfaces, wear protective gloves, or allow engine to cool before removing any component.

3. Check the turbocharger for unusual noise or vibration and, if excessive, stop the engine and do not operate until the cause is determined.
4. Periodically inspect the air-to-air charge air cooler for buildup of dirt, mud, or other debris. Clean as necessary.
5. Check the charge air cooler, duct work, and flexible connections for leaks and repair or replace as required.

Inspection of the Battery

Inspect the battery as follows:



WARNING: PERSONAL INJURY

To avoid injury from accidental engine startup while servicing the engine, disconnect/disable the starting system.

1. Check for cracks in the battery cases (1), for tightness of the cable clamps (2) at the terminals, and for corrosion of the terminals (3). Service or replace as needed.

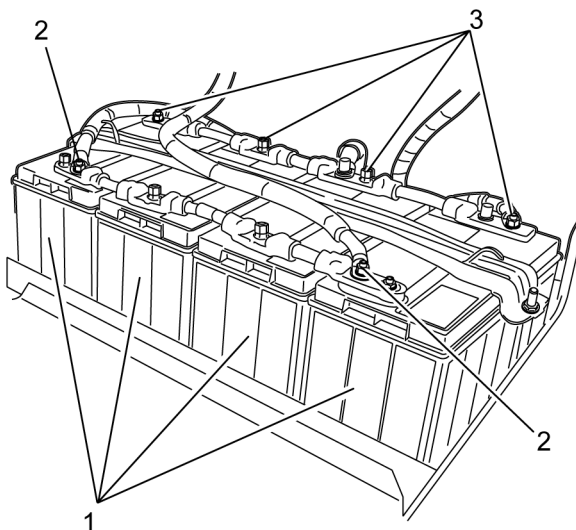

d540077

2. Keep the terminal surface clean.
3. Inspect the cables, clamps and hold-down brackets regularly. Clean and reapply a light coating of petroleum jelly when needed. Have corroded or damaged parts replaced.
4. If the engine is to be out of service for more than 30 days, remove the batteries and store in a cool, dry place.
 - a. Keep batteries fully charged, if possible.
 - b. Replace any battery that fails to hold a charge.
5. Periodically check battery connections for corrosion and tightness.
 - a. If necessary, remove connections and wire brush any corrosion from terminals and cable ends.
 - b. Replace damaged wiring.

Steam Cleaning the Engine

NOTICE: Do not apply steam or solvent directly to the battery-charging alternator, starting motor, DDEC components, sensors or other electrical components, as damage may result.

The engine and engine compartment should be steam cleaned every 60,000 miles (100,000 km) or 2,000 hours, whichever comes first.

Inspection of the Battery-Charging Alternator

Precautions must be taken when working on or around the alternator. The diodes and transistors in the alternator circuit are very sensitive and can be easily destroyed. To avoid equipment damage, the following conditions must be met:



WARNING: Battery Explosion and Acid Burn

To avoid injury from battery explosion or contact with battery acid, work in a well ventilated area, wear protective clothing, and avoid sparks or flames near the battery. If you come in contact with battery acid:

- Flush your skin with water.
 - Apply baking soda or lime to help neutralize the acid.
 - Flush your eyes with water.
 - Get medical attention immediately.
- Avoid grounding the output terminal. Grounding an alternator output wire or terminal (which is always hot, regardless of whether or not the engine is running) and accidentally reversing the battery polarity will result in equipment damage.
 - Do not reverse battery connections.
 - Never disconnect the battery while the alternator is operating. Disconnecting the battery can result in damage to the battery diodes. In applications which have two sets of batteries, switching from one set to the other while the engine is running will momentarily disconnect the batteries.
 - If a booster battery is to be used, batteries must be connected correctly (negative to negative, positive to positive).
 - Never use a fast charger with the batteries connected or as a booster for battery output.

For information on the alternator assembly, contact an authorized distributor, depending on manufacturer.

Check the alternator as follows:

1. Inspect the terminals for corrosion and loose connections and wiring for damage and frayed insulation. Have wiring repaired or replaced, as required.
2. Check torque on alternator mounting bolts and bracketing every 30,000 miles (50,000 km). Re-tighten if necessary.

Lubricating the Fan Hub

If the fan bearing hub assembly has a grease fitting, use a hand grease gun to lubricate the bearings with one shot of quality lithium-based, multipurpose grease every 120,000 miles (200,000 km). Care should be taken not to overfill the bearing housing.

Checking the Vibration Damper

Check the vibration damper as follows:

1. Inspect the viscous vibration damper (1) periodically and replace if dented or leaking.

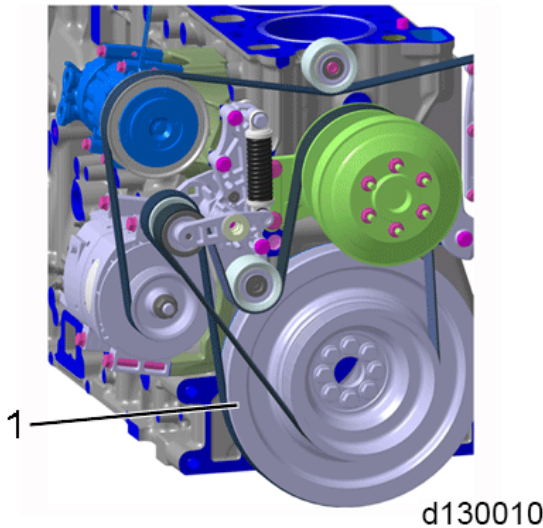

2. Heat from normal engine operation may, over a period of time, cause the fluid within the damper to break down and lose its dampening properties. For this reason, replace the viscous vibration damper at time of normal major engine overhaul, regardless of apparent condition.

How to Procedures

This section covers the Detroit™ recommendations on how to select lubricating oil, diesel fuel, and coolant. Also included are basic engine maintenance procedures which can be performed by the operator.

NOTICE: The manufacturer's warranty applicable to the engine provides in part that the provisions of such warranty shall not apply to any engine unit that has been subject to misuse, negligence or accident. Accordingly, malfunctions attributable to neglect or failure to follow the manufacturer's fuel or lubricating recommendations may not be within the coverage of the warranty.

How to Select Lubricating Oil

NOTICE: Detroit™ POWER GUARD® Oil Specification 93K214 is recommended for all EuroIV cooled EGR-equipped engines without aftertreatment devices or any engine operating on Low Sulfur fuel < 500 ppm. These engines meet 2002 to 2006 model year emission requirements. These oils are similar to API CI-4 PLUS.

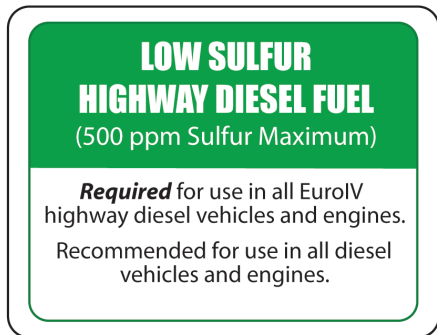
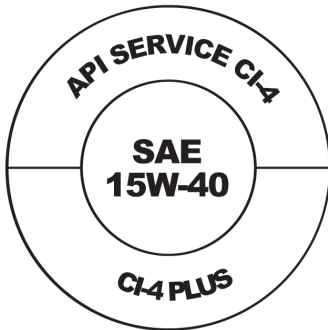

d470246a

Figure 10. Example SAE Viscosity Grade: 15W-40 API Classification: CI-4 PLUS

Cold Weather Starting

NOTICE: Monograde oils should not be used in the engine, regardless of API service classification. Monograde oils gel at lower ambient temperatures, reducing lubricant flow, and do not provide adequate lubricity at higher engine operating temperatures resulting in severe engine damage.

At ambient temperatures below -10° C (14° F), SAE 5W-30, 5W-40, or 10W-40 oils may be used, provided they are API CI-4 PLUS and have demonstrated field performance in Detroit™ engines. These oils must possess a High Temperature / High Shear Viscosity of 3.7 cP minimum.

Use of Synthetic Oils

NOTE: Synthetic oil does not permit extension of recommended oil drain intervals.

Synthetic oils may be used in Detroit™ engines provided they are approved by a POWER GUARD® Oil Specification (PGOS) 93K214. The use of synthetic oils does not necessarily ensure the extension of the recommended oil drain intervals beyond the limits. Synthetic oils offer improved low-temperature flow properties, high-temperature oxidation resistance, and improved fuel mileage. However, they are generally more costly than non-synthetic oils.

Product information about synthetic oils should be reviewed carefully. Performance additive systems often respond differently in synthetic oils.

Use of Supplemental Additives

Lubricants meeting the Detroit™ specifications outlined in this publication already contain a balanced additive treatment. Supplemental additives are generally not necessary and can even be harmful. These additives may be marketed as either oil treatments or engine treatments and are discouraged from use in Detroit™ engines.

Engine damage resulting from the use of such materials is not covered by your Detroit™ warranty. Detroit™ will not provide statements beyond this publication relative to their use.

When to Change Oil

Refer to DDC-SVC-BRO-0001 for more information.

The length of time an engine may operate before an oil change depends upon the lubricant and fuel used, engine oil consumption, and the operating cycle.



CAUTION: USED ENGINE OIL

To avoid injury to skin from contact with the contaminants in used engine oil, wear protective gloves and apron.

Oil analysis may be used to determine whether this interval should be shortened, but it should not be used to lengthen the interval.

The use of fuels with sulfur content above 0.05 mass percent will require a shortening of drain intervals and/or the use of a higher TBN oil.

Disposal of Waste Oil

Used lubricating oil and filters require disposal in an environmentally responsible manner, according to federal (EPA) and/or state recommendations. The disposal of waste oil may be best addressed by the engine oil supplier, who may accept responsibility for proper disposal of this material as part of the business of providing lubricant.

How to Replace the Lubricating Oil and Oil Filter

The oil filter is an integral part of the lubrication system. Proper filter selection and maintenance are important to satisfactory engine performance and service life. The filter should be used to maintain a clean system, not to clean up a contaminated system. The maintenance intervals for the appropriate duty cycle are listed in tables in this manual.

Change the oil and replace the lubricating oil filter as follows:

NOTE: If the used oil was contaminated by fuel or coolant, it may be necessary to take the vehicle to a certified Detroit Service Center. The Service Center may drain the oil and then remove the oil pan, oil pump, and oil pump intake manifold to drain the remaining oil held back by the backflow valve. It is important to remove all contaminated oil from the engine.

NOTE: Change the engine oil only when the engine oil temperature is approximately 60°C (140°F). Changing cold oil will result in extended drain times.



WARNING: PERSONAL INJURY

To avoid injury, never remove any engine component while the engine is running.

1. Place the transmission in neutral, and set the parking brake.

NOTICE: Use care to prevent foreign objects from entering the filter housing.

2. Clean outside of the oil filter housing.
3. Using a 36-mm socket, unscrew the oil filter cap and filter and allow the oil to drain into the housing. After draining is complete, remove the assembly from the housing.

4. Remove the filter element by pressing and twisting the side and detaching it from the cap.
5. Remove the oil filter O-ring and discard. Lightly coat a new O-ring with clean engine oil and install it on the filter cap.
6. Check the filter housing for any debris and remove if necessary.
7. Insert a new filter element into the oil filter cap.
8. Insert the filter element and cap assembly into the housing. Torque the cap to 40 to 50 N·m (30 to 37 lb·ft).
9. Drain oil from the oil pan as follows:
 - a. Place a suitable receptacle, 55 L (58 qt) or more, beneath the oil drain plug on the underside of the oil pan.
 - b. Carefully unscrew the oil drain plug, and allow the oil to drain out.
 - c. Discard the plug seal ring.
10. Install the oil pan drain plug with a new O-ring and torque the plug:
 - a. On a plastic oil pan, torque plug to 45 N·m +/- 7 N·m (33 lb·ft +/- 5 lb·ft).
 - b. On an aluminum oil pan, torque plug to 60 N·m +/- 9 N·m (44 lb·ft +/- 6 lb·ft).

NOTICE: Do not add oil if the oil reading is between the crosshatch area on the dipstick. There are approximately 5.0 L (5.2 qt) from the fill mark to the full mark. Overfilling the oil pan can cause engine damage.

11. Add new engine oil through the oil fill tube in the following amount; Refer to section "Engine Oil Capacities". Verify the oil level reading is between the full and fill marks on the dipstick.



WARNING: PERSONAL INJURY

To avoid injury before starting and running the engine, ensure the vehicle is parked on a level surface, parking brake is set, and the wheels are blocked.



WARNING: ENGINE EXHAUST

To avoid injury from inhaling engine exhaust, always operate the engine in a well-ventilated area. Engine exhaust is toxic.

NOTICE: If no oil pressure is shown after approximately 10 seconds, stop the engine and determine the cause. Running the engine with no oil pressure could result in engine damage.

12. Start the engine with the accelerator pedal in the idle position (600 rpm). Monitor the oil pressure gauge or indicator lamp. Keep the engine running at idling speed (600 rpm) until the oil pressure reading is 10.2 psi (70 kPa) or more for the DD15.

NOTICE: Do not add oil if the oil reading is between the crosshatch area on the dipstick. There are approximately 5.0 L (5.2 qt) from the fill mark to the full mark. Overfilling the oil pan can cause engine damage.

NOTE: If the engine operating temperature is below 60°C (140°F), the engine must be on a level surface and then shut down for 60 minutes for an accurate oil level reading. Otherwise, the engine must be brought up to an operating temperature of 60°C (140°F), parked on a level surface and then shut down for five minutes for an accurate oil level reading.

13. Check the filter housing for signs of leakage.
14. Stop the engine. Check the oil level again per the following guidelines. If necessary, add oil no more than 5.0 L (5.2 qt) at a time up to the maximum fill level on the oil dipstick.

How to Select Diesel Fuel

All EuroIV DD engines are designed to operate on Low Sulfur Diesel fuel.

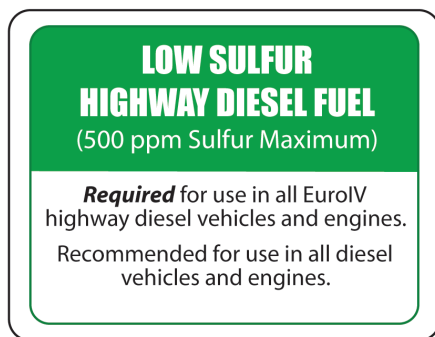

d470270

Quality

NOTICE: Use only Low Sulfur Diesel (LSD) fuel (500 PPM sulfur content maximum), based on ASTM Standard D 2622 test procedure.

Fuel quality is an important factor in obtaining satisfactory engine performance, long engine life, and acceptable exhaust emission levels. In general, fuels meeting the properties of ASTM Standard D 975 (grades 1-D and 2-D) have provided satisfactory performance. See "Diesel Fuel Specification" table in DDC-SVC-BRO-0001.

The fuels used must be clean, stable, and non-corrosive. For more information regarding the significance of these properties and selection of the proper fuel, refer to DDC-SVC-BRO-0001, "Diesel Fuel Properties."

Fuel Contamination

Generally, fuel contamination occurs as the result of improper fuel handling. The most common types of contamination are water, dirt, and microbial growth "black slime". The formation of varnishes and gums resulting from poor stability or extended storage "stale fuel" also affects fuel quality. The best treatment for contamination is prevention by maintaining a clean storage system and choosing a reputable fuel supplier.

Supplemental additives are not recommended due to potential injector system or engine damage. Our experience has been that such additives increase operating costs without providing benefit.

The use of supplemental fuel additives does not necessarily void the engine warranty. However, repair expenses which result from fuel system or engine component malfunctions or damage attributed to their use will not be covered.

Biodiesel ¹ General recommendations and guidelines

Detroit™ supports biodiesel as a renewable fuel. Biodiesel fuels are mono alkali esters of long chain fatty acids commonly referred to as Fatty Acid Methyl Esters (FAME) and are derived from renewable resources through a chemical process called transesterification.

Detroit™ approves the use of biodiesel fuel blends as follows:

- DD Family of Engines - Biodiesel blends up to 5% are allowed
- MBE900/4000 Engines - Biodiesel blends up to 5% are allowed
- S60 Engines - Biodiesel blends up to 20% are allowed*

*Engines built prior to MY 2004 may contain materials that are not compatible with biodiesel blends. Biodiesel blends above 5% are not recommended ².

Prohibited Additives

The following fuel additives are not allowed and MUST NOT be mixed with diesel fuel:

NOTICE: Do not burn used lubricating oil in fuel. It will cause the diesel particulate filter to prematurely plug with ash.

- **Used Lubricating Oil** Do not use fuel blended with used lubricating oil. Detroit™ specifically prohibits the use of used lubricating oil in diesel fuel. Used lubricating oil contains combustion acids and particulate materials which can severely erode fuel injector components, resulting in loss of power and increased exhaust emissions. In addition, the use of drained lubricating oil will increase maintenance requirements due to filter plugging and combustion deposits.



WARNING: FIRE

To avoid increased risk of a fuel fire, do not mix gasoline and diesel fuel.

NOTICE: Detroit™ will not be responsible for any detrimental effects resulting from adding drained lubricating oil or gasoline to the diesel fuel.

- **Gasoline** The addition of gasoline to diesel fuel will create a serious fire hazard. The presence of gasoline in diesel fuel will reduce fuel cetane number and increase combustion temperatures. Drain and clean tanks which contain a mixture of gasoline and diesel fuel as soon as possible.
- **Fuel Additives with Sulfur or Sulfated Ash** Do not use non-approved fuel additives containing sulfur or sulfated ash.

How to Replace the Fuel Filters

NOTICE: If you have just changed the engine oil and filter, you **MUST** start the engine and confirm proper oil pressure before changing the fuel filters. If no oil pressure is shown after approximately 10 seconds, stop the engine and determine the cause. Running the engine with no oil pressure could result in engine damage. Start the engine with the accelerator pedal in the idle position. Monitor the oil pressure gauge or indicator lamp. Keep the engine running at idling speed until the oil pressure reading is 97 kPa (14 PSI) or more.

NOTE: If you are replacing all fuel filters, it is not necessary to run the engine and test for leaks after installing each individual fuel filter. However, if repairing a leak at one filter, complete that repair and test the system for leaks after priming the fuel system.

Filters are an integral part of the fuel system. Proper filter selection and maintenance are important to satisfactory engine operation and service life. Filters should be used to maintain a clean system, not to clean up a contaminated system. The scheduled maintenance intervals for the appropriate duty cycles are listed in this manual.



WARNING: PERSONAL INJURY

To prevent the escape of high pressure fuel that can penetrate skin, ensure the engine has been shut down for a minimum of 10 minutes before servicing any component within the high pressure circuit. Residual high fuel pressure may be present within the circuit.

NOTICE: At cold temperatures (-40° C or -40° F), DO NOT remove the filter elements from the caps unless the intent is to replace the filter elements. Repeated removals at cold temperatures may break the filter element tabs.

Removal of the Fuel Prefilter

Remove the prefilter as follows:

1. Using a 36 mm socket, unscrew the prefilter cap.
2. Pull the cap and prefilter straight up and out of the fuel filter housing.
3. Remove the prefilter (1) from the prefilter cap (2) by placing the filter on a solid surface and apply pressure on prefilter cap (2) at an angle.



d470163

4. Discard the prefilter cap seal ring.

Installation of the Fuel Prefilter

Install the fuel prefilter as follows:

NOTE: If a filter service is being performed, replace all other filters before priming.

1. Install a new prefilter cap seal ring on to the prefilter cap.
2. Snap new prefilter into the prefilter cap.
3. Apply a thin coat of petroleum-based lithium grease to the prefilter cap seal ring and the prefilter seals (1).



d470162

4. Install the prefilter into the fuel filter module.
5. Turn the cap counterclockwise until a click sound is made, then turn clockwise and hand tighten.
6. Torque prefilter cap to 55-60 N·m (41-44 ft·lb).
7. Once all required filters have been changed, prime the fuel system using the ESOC 350, J-47912 or the engine mounted hand primer.



WARNING: ENGINE EXHAUST

To avoid injury from inhaling engine exhaust, always operate the engine in a well-ventilated area. Engine exhaust is toxic.



WARNING: PERSONAL INJURY

To avoid injury before starting and running the engine, ensure the vehicle is parked on a level surface, parking brake is set, and the wheels are blocked.

8. Start the engine with the accelerator pedal in the idle position. Monitor the oil pressure gauge or indicator lamp. Maintain the engine running at idle until a stable oil pressure reading of 97 kPa (14 psi) or more is maintained for one minute.
9. Check for leaks.

NOTICE: Increasing engine speed above idle before oil pressure has stabilized may cause severe engine damage.

10. Allow the engine to reach operating temperature of 60°C (140°F).
11. Increase engine speed to 1800 rpm for three minutes.
12. Return the engine to idle and allow to idle for approximately one minute, then shut down the engine.
13. Check for leaks.

Removal of the Water Coalescer/Final Filter

Remove the water coalescer/final filter as follows:

NOTICE: Do not tilt the water coalescer/final filter when removing it from the housing. Possible damage to the water coalescer/final filter or stand pipe may occur.

1. Using a 36mm socket, unscrew the water coalescer/final filter cap.
2. Pull the cap and water coalescer/final filter straight up and allow the fuel to drain back.
3. Remove the water coalescer/final filter (2) from the water coalescer/final filter cap (1) by placing the filter on a solid surface with the drain back plug location at 12 o'clock (3) and apply pressure on the water coalescer/final filter cap at an angle.



d470164

4. Discard the water coalescer/final filter.
5. Inspect inside the housing for any large debris, clean housing as needed.
6. Discard water coalescer/final filter cap seal ring.

Installation of the Coalescer/Final Filter - Two Filter System

Install the water coalescer/final filter as follows:

NOTE: If a fuel filter service is being performed, replace all other fuel filters before priming the fuel system.

1. Install a new seal ring on to water coalescer/final filter cap.
2. Snap a new water coalescer/final filter into the water coalescer/final filter cap.
3. Apply a light coat of Parker super O-lube or petroleum-based lithium grease to the water coalescer/final filter cap seal ring and drain back plug seal ring (C). Apply a heavy coat of Parker super O-lube or petroleum-based lithium grease to the upper (A) and lower seals (B) on the water coalescer/final filter.

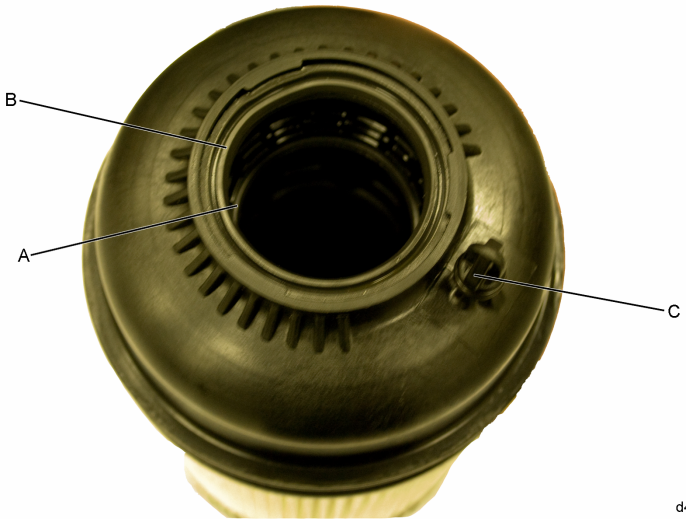

d470165a

The illustration below shows the proper amount of lubricant to use on the upper and lower seals.



d470301

4. Install the water coalescer/final filter into the fuel filter module.

NOTE: Viewing the fuel filter module from the top, the drain back port is located at 10 o'clock.

5. **Turn the water coalescer/final filter cap counterclockwise until the drain back plug has located the drain back port.** Apply light pressure to the top of the water coalescer/final filter cap to seat the drain back plug into the drain back port, hand tighten the filter cap by turning the cap clockwise.
6. Torque water coalescer/final filter cap to 55 to 60 N·m (41 to 44 lb·ft).
7. Once all required filters have been changed, prime the fuel system using the ESOC 350, J-47912 or the engine-mounted hand primer.



WARNING: ENGINE EXHAUST

To avoid injury from inhaling engine exhaust, always operate the engine in a well-ventilated area. Engine exhaust is toxic.



WARNING: PERSONAL INJURY

To avoid injury before starting and running the engine, ensure the vehicle is parked on a level surface, parking brake is set, and the wheels are blocked.

8. Start the engine with the accelerator pedal in the idle position. Monitor the oil pressure gauge or indicator lamp. Keep the engine running at an idling speed until a stable oil pressure reading of 97 kPa (14 psi) or more is maintained for one minute.
9. Check for leaks.
10. Allow the engine to reach operating temperature of 60°C (140°F).

NOTICE: Increasing engine speed above idle before oil pressure has stabilized may cause severe engine damage.

11. Increase engine speed to 1800 rpm for three minutes.
12. Return the engine to idle and allow to idle for approximately one minute, and then shut down the engine.
13. Check for leaks.

Engine Out of Fuel – How to Restart

When an engine has run out of fuel, there is a definite procedure to follow when restarting it.

NOTICE: Never use the starting motor and fuel pump to prime the fuel filters. Prolonged use of the starting motor and fuel pump to prime the fuel system can result in damage to the starter, fuel pump, and injectors.

Use the following procedure to prime the fuel system:

NOTE: If a vehicle is on uneven ground, more fuel may be required.

1. Fill the fuel tank with the recommended grade of fuel. If only partial filling is possible, add a minimum of 10% of the total tank volume of fuel to the tank. For example, a 150-gallon tank would require a minimum of 15 gallons of fuel.
2. Connect ESOC 350 (J-47912) or operate the engine mounted hand primer for three minutes or 250 strokes.
3. Turn on the ignition switch.
4. Wait for the engine system indicator lights on the instrument panel to go out.
5. With the accelerator pedal in the idle position, start the engine.
6. Crank engine for 20 seconds.

NOTE: The starting cycle can be repeated up to three times.

7. If engine does not start, allow for a 60-second cool down and repeat previous step.
8. Monitor the oil pressure gauge or indicator lamp. Keep the engine running at an idling speed until a stable oil pressure reading of 97 kPa (14 psi) or more is maintained for one minute.
9. Check for leaks.
10. Allow the engine to reach operating temperature of 60° C (140° F).

NOTICE: Increasing engine speed above idle before oil pressure has stabilized may cause severe engine damage.

11. Increase engine speed to 1800 RPM for three minutes.
12. Return the engine to idle and allow to idle for approximately one minute, then shut down the engine.
13. Check for leaks.
14. If engine still fails to start, contact an authorized Detroit™ repair facility.

How to Clean an Engine

Observance of all environmental protection regulations is required. Use high-pressure equipment as follows:



CAUTION: EYE INJURY

To avoid injury from flying debris, wear a face shield or goggles.

NOTICE: To prevent damage to engine components, keep the water moving at all times while cleaning. Never direct water onto electrical components, plug connectors, seals or flexible hoses.

Information on suitable cleaning and protective products is available from any authorized dealer. Note the equipment manufacturer's operating instructions.

Use the following minimum working distance between the high-pressure nozzle and the surface being cleaned:

- Approximately 28 in. (700 mm) for circular pattern jets
- Approximately 12 in. (300 mm) for 25-degree flat jets and dirt cutters

Power clean the engine as follows:

1. Allow engine to cool down to room temperature before spraying the engine.

NOTICE: Avoid all of the electrical connections with direct water or steam spray or damage can result.

2. Thoroughly clean the entire engine using a steam cleaner or high pressure washer with mild soap and warm water.



WARNING: EYE INJURY

To avoid injury from flying debris when using compressed air, wear adequate eye protection (face shield or safety goggles) and do not exceed 276 kPa (40 psi) air pressure.

NOTE: Do not use compressed air or pressurized water to clean or dry the engine if any part of the engine is disassembled.

3. Once the engine is clean, blow the electrical connectors dry with compressed air to remove most of the standing water.
4. Allow the engine to dry completely before making any kind of repair.
5. When reassembling, ensure that there is no standing water in any electrical connectors before seating the plug.

How to Clean the Cooling System

Collect the used coolant, cleaning solutions, and washing liquids and dispose of them in an environmentally responsible manner.

Clean as follows:

1. First remove debris (such as dust, insects) from the fins of the radiator grille.



WARNING: EYE INJURY

To avoid injury from flying debris when using compressed air, wear adequate eye protection (face shield or safety goggles) and do not exceed 276 kPa (40 psi) air pressure.

NOTICE: Clean at moderate air pressures only to avoid damaging the radiator grille fins.

2. Remove the debris by blowing them through with compressed air or spraying them out with water. Work from the rear of the radiator (in the opposite direction of the normal cooling air flow).
3. Drain the coolant when the engine is cold. Refer to section "Cooling System Drain Procedure". For detailed procedures, see the vehicle/chassis maintenance manual. For types of coolant, refer to the How to Select Coolant section for the listing of required intervals using the recommended coolants.
4. If the HVAC unit is connected to the cooling system, open the regulating valves all the way.

Degreasing the Cooling System

Degrease as follows:



WARNING: HOT COOLANT

To avoid scalding from the expulsion of hot coolant, never remove the cooling system pressure cap while the engine is at operating temperature. Wear adequate protective clothing (face shield, rubber gloves, apron, and boots). Remove the cap slowly to relieve pressure.

1. Fill the cooling system with a 5% solution (1.6 ounces per quart [50 grams per liter] of water) of a mildly alkaline cleaning agent, such as sodium carbonate.
2. Run the engine at moderate speed until the thermostat starts to open, at an operating temperature of approximately 60° C (140° F). Then run it for about five minutes longer. Shut down the engine and allow it to cool to approximately 50° C (112° F).
3. Drain all the cleaning solution.
4. Flush the cleaning solution from the cooling system.
 - a. Immediately after draining the cleaning solution, flush the system with clean water.
 - b. Once the clean water has drained, fill the system again with clean water.
 - c. Run the engine. Allow the engine to warm up to approximately 60° C (140° F), and then run it about five minutes longer.
 - d. Drain the hot water.
5. Fill the cooling system with new coolant. For detailed procedures, see the vehicle/chassis maintenance manual. For types of coolant, refer to the How to Select Coolant section for the listing of required intervals using the recommended coolants.

How to Select Coolant

This section covers selection of the required coolant for the engine.

Coolant Definitions

To help ensure complete understanding of the information, the definitions of the following terms are listed in the following Table.

Table 5.

Coolant Terms	
Term	Definition
Antifreeze	Ethylene Glycol containing a corrosion inhibitor package and which meets an appropriate heavy-duty specification (i.e., TMC RP-329 Type A or ASTM Standard D6210 Type A for ethylene glycol).
Coolant	The fluid mixture circulating in the engine cooling system, typically a mixture of 50% water and 50% antifreeze.
Drop-Out	Precipitated sludge or deposit formation on cooling system components.
Fully Formulated Antifreeze	Contains all the necessary inhibitors to protect a diesel engine, and does not, therefore, require a pre-charge of Supplemental Coolant Additive before its first use.
Initial-Fill Coolant	The coolant that is used in a new or rebuilt engine, or any time the cooling system is emptied and then refilled with coolant.
OAT	Organic Acid Technology. An inhibitor system based on organic acid inhibitors instead of traditional North American inhibitor formulations.
SCA	Supplemental Coolant Additive. Supplemental Coolant Additives are used in a preventive maintenance program to prevent corrosion, cavitation, and the formation of deposits.

Approved Coolants

Required specifications for water and ethylene glycol inhibitor packages and inhibitor concentration are included in this section.

NOTICE: To avoid engine damage from inadequate or over concentrated coolant, the required specifications must be adhered to before the coolant is replaced.

The approved and preferred coolants for the engine are listed in the following table.

Table 6.

Initial Fill Coolant Options	
Coolant Fill Option	Product
Ethylene Glycol & Water + Corrosion Inhibitors (Required Coolant)	Detroit Genuine Coolant
Ethylene Glycol & Water + Nitrated Organic Acid Technology Inhibitors	—

Once installed, this coolant should be maintained according to the recommended procedures.

Ethylene Glycol and Water Plus Supplemental Coolant Additive Inhibitor

These products are available as fully formulated, phosphate-free, Extended Service Interval coolants. They are commercially available from Detroit™ (recommended) and other manufacturers as either a concentrated antifreeze or as a premixed antifreeze. The premixed antifreeze is ready for use, while the concentrated coolant must be mixed with water prior to use.

Detroit Genuine Coolant (P/N: 23512138) is the preferred ethylene glycol coolant. If other commercial brands of ethylene glycol are used, they must be equivalent to the Detroit Genuine Coolant.

Fully formulated antifreeze does not require a dosage of Supplemental Coolant Additive prior to initial use.

Mixing and Using Ethylene Glycol Antifreeze

Use ethylene glycol antifreeze as follows:

- If a concentrated ethylene glycol antifreeze is purchased, mix the antifreeze with water meeting the required quality standards and fill the cooling system.
- If a pre-diluted, fully-formulated coolant is purchased, fill the cooling system without dilution.

NOTE: For best overall performance, a coolant consisting of 50% concentration of antifreeze (50% antifreeze, 50% water) is recommended. An antifreeze concentration over 67% (67% antifreeze, 33% water) is not recommended due to poor heat transfer, reduced freeze protection (Inhibited Ethylene Glycol [IEG] only), and possible silicate dropout. Also, an antifreeze concentration below 33% (33% antifreeze, 67% water) offers too little freeze and/or corrosion protection and is not recommended.

- Always verify that the freeze point and nitrite concentration of the antifreeze/water mixture are correct by using Detroit Genuine Fluid Analysis 3-Way Coolant Test Strip. If chemical analysis is used, elements in the coolant must fall within the following limits.

Table 7.

Fully Formulated Glycol Coolant Concentration Limits with TMC RP-329 Chemistry Type A (50/50 Coolant/Water Mixture)	
Boron	125 – 500 PPM
Nitrite	900 – 3200 PPM
Nitrate	200 – 1000 PPM
Silicon	50 – 150 PPM
Phosphorous	0 PPM
pH	8.0 – 11.0

Water Requirements

Distilled, reverse osmosis-purified, or de-ionized water which eliminates the adverse effects of minerals in tap water is preferred.

High levels of dissolved chlorides, sulfates, magnesium, and calcium in some tap water causes scale deposits and/or corrosion resulting in water pump failures and poor heat transfer, leading to overheating. If tap water is used, the mineral content in the water must be below the following maximum allowable limits.

Table 8.

Satisfactory Water Limits – Make-Up Water Only		
	Maximum Allowable	
	Parts per Million	Grains per Gallon
Chlorides	40	2.5
Sulfates	100	5.8
Total Dissolved Solids	340	20
Total Hardness – Magnesium and Calcium	170	10

NOTICE: Do not add additional supplemental coolant additives to new, fully formulated antifreeze or coolant. This can result in dropout and/or the formation of deposits.

Coolant Maintenance Intervals

Check the nitrite concentration at the regular intervals listed in the following table with a Detroit Genuine Fluid Analysis 3-Way Test Strip.

Table 9.

Coolant	Interval	Action
Ethylene Glycol* / Water + Conventional Corrosion Inhibitor	20,000 miles (32,000 km) or 3 months	Test nitrite concentration with test strip. Add SCA or dilute coolant as needed.
	300,000 miles (480,000 km)	Drain and clean system. Refill with new coolant.
Ethylene Glycol* / Water + OAT Inhibitor	300,000 miles (48,000 km) or 10,000 hours	Add POWERCOOL Plus extender.
	600,000 miles (960,000 km), 4–years, or Engine Overhaul	Drain and clean system. Refill with new coolant.
Ethylene Glycol* / Water + NOAT Inhibitor	300,000 miles (48,000 km) or 10,000 hours	Add NOAT extender.
	600,000 miles (960,000 km), 4–years, or Engine Overhaul	Drain and clean system. Refill with new coolant.
Water Only + Conventional Corrosion Inhibitor	20,000 miles (32,000 km), 3–months, or 500 hours	Test nitrite concentration with test strip. Add SCA or dilute coolant as needed.
	Engine Overhaul	Drain and clean system. Refill with new coolant.
Water Only + OAT Inhibitor	300,000 miles (480,000 km), 2–years, or 10,000 hours	Add POWERCOOL Plus extender.
	600,000 miles (960,000 km), 4–years, or Engine Overhaul	Drain and clean system. Refill with new coolant.
Water Only + NOAT Inhibitor	300,000 miles (480,000 km), 2–years, or 10,000 hours	Add NOAT extender.
	600,000 miles (960,000 km), 4–years, or Engine Overhaul	Drain and clean system. Refill with new coolant.
*Propylene glycol is an acceptable substitute for ethylene glycol.		

Coolants Not Recommended

The following coolants are not recommended for use in Detroit™ engines.

- **Antifreezes and Coolants Containing Phosphate** – Coolants containing phosphate are not recommended. Drop out, overheating, and water pump seal failures can result from the use of coolant or inhibitor packages based on phosphate.
- **Automotive Type Coolants** – These coolants generally contain high levels of phosphate and silicate, offer no liner pitting protection, and are not suitable for use in Detroit™ engines.
- **Methyl Alcohol-Based Antifreeze** – Methyl Alcohol-Based Antifreeze must not be used because of its effect on the non-metallic components of the cooling system and its low boiling point.
- **Glycol-Based Coolants Formulated for HVAC** – These coolants formulated for Heating/Ventilation/Air Conditioning (HVAC) should not be used. These coolants generally contain high levels of phosphates, which can deposit on hot internal engine surfaces and reduce heat transfer.

Additives Not Recommended

The following additives are not recommended for use in Detroit™ engines.

- **Soluble Oil Additives** – These additives are not approved for use in Detroit™ engine cooling systems. A small amount of oil adversely affects heat transfer. For example, a 1.25% concentration of soluble oil increases fire deck temperature 6%. A 2.50% concentration increases fire deck temperature 15%. The use of soluble oil additives may result in engine overheating and/or failure.
- **Chromate Additives** – These additives are not approved for use in Detroit™ engine cooling systems. Chromate additives can form chromium hydroxide, commonly called "green slime." This, in turn, can result in engine damage due to poor heat transfer. Cooling systems operated with chromium-inhibited coolant must be chemically cleaned with a recommended cooling system cleaner/conditioner (or equivalent sulphuric acid/sodium carbonate cleaner) and flushed.

Testing for Supplemental Coolant Additives

Detroit Genuine Fluid Analysis 3-Way Coolant Test Strips should be used to measure nitrite and glycol concentrations. Cavitation/corrosion is indicated on the strip by the level of nitrite concentration. Freeze/boil over protection is determined by glycol concentration.



WARNING: HOT COOLANT

To avoid scalding from the expulsion of hot coolant, never remove the cooling system pressure cap while the engine is at operating temperature. Wear adequate protective clothing (face shield, rubber gloves, apron, and boots). Remove the cap slowly to relieve pressure.

For best results, take the test while the coolant is between 10.0–60° C (50–140° F). Wait at least 60, but not longer than 75 seconds, before reading the nitrite level.

NOTE: A factory coolant analysis program is available through authorized Detroit™ service outlets.

Use the test strips as follows:

NOTE: Color change of the additive indicator (middle pad) indicates the presence of inhibitor that is not approved by Detroit™.

1. Dip the strip into coolant for one second. Remove and shake briskly to eliminate excess fluid.
2. Immediately compare the pad end (% glycol) to the color chart on the container.
3. Sixty seconds (one minute) after dipping, compare the nitrite pad to the color chart.
4. Promptly replace and tighten the test strip container cap after each use. Discard unused strips if they have turned light pink or tan.

Removal of Dropout

Excessive amounts of some inhibitors in the coolant can cause a gel or crystalline deposit that reduces heat transfer and coolant flow. The deposit, called "dropout," takes the color of the coolant when wet, but appears as a white or gray powder when dry. It can pick up solid particles in the coolant and become gritty, causing excessive wear of water pump seals and other cooling system components.



WARNING: PERSONAL INJURY

To avoid injury when using caustic cleaning agents, follow the chemical manufacturers usage, disposal, and safety instructions.

NOTE: If the gel is allowed to dry, it is necessary to disassemble the engine and clean it with a caustic solution or physically clean individual components.

Remove the wet gel using a non-acid (alkali) type heavy-duty cleaner, such as Detroit Genuine Cooling System On-Line Cleaner (sodium nitrite/sodium tetra borate).

Chronic Coolant System Problems

The most commonly seen coolant system problems result from maintenance and formulation factors such as:

- Hard water
- Dilution of the coolant by the addition of untreated water
- Over dosage or under dosage of corrosion inhibitors
- Improper corrosion inhibitor (most often phosphate)
- Mixing Supplemental Coolant Additives

- Improper testing

Detroit Cooling System Maintenance Products

Detroit Genuine Coolant Supplemental Coolant Additives are water-soluble chemical compounds. These products are available in coolant filter elements, liquid packages, and in fully formulated Detroit Genuine Coolant antifreeze and are available to do maintenance on the cooling system.

Summary of Coolant Recommendations

The Detroit™ coolant recommendations for the engine are:



WARNING: HOT COOLANT

To avoid scalding from the expulsion of hot coolant, never remove the cooling system pressure cap while the engine is at operating temperature. Wear adequate protective clothing (face shield, rubber gloves, apron, and boots). Remove the cap slowly to relieve pressure.

- Always maintain the engine coolant to meet Detroit™ specifications.
- Only use water that meets the specifications listed in this manual. Distilled, demineralized (reverse osmosis) or de-ionized water is preferred.
- The proper dosage of inhibitors be included in the coolant at initial fill for all Detroit™ engines. This dosage is usually included in the fully formulated antifreeze used, or it may need to be added if water alone or if less than 50% antifreeze is used. The user is urged to use the full text of this section to determine the proper dosage. Mixing of different manufacturers technologies (brands) could cause cooling system problems.
- Maintain the inhibitor at the prescribed concentration. Test the nitrite concentration by using a titration kit or Detroit Genuine Fluid Analysis 3-Way Coolant Test Strips. Add Supplemental Coolant Additives only if the nitrite concentration is below 900 PPM.

NOTE: If the nitrite concentration exceeds 3,200 PPM, the coolant must be drained and replaced with new coolant. A thorough cleaning of the cooling system may be required.

- Do not use another manufacturer's test kit to measure the Supplemental Coolant Additive concentration of Detroit™ maintenance products.
- Premix coolant makeup solutions to the proper concentration before adding to the cooling system.
- Do not mix Organic Acid Technology and other coolants in the same engine.
- Do not use automotive coolants.
- Where antifreeze/boil over protection is required, use only antifreeze that meets TMC RP-329 Type A specification or ASTM Standard D 6210 Type A for Ethylene Glycol. Always maintain coolant at the proper level.

Do not use the following in Detroit™ engine cooling systems:

- Soluble Oil
- High Silicate, Automotive-Type Antifreeze
- Chromate Supplemental Coolant Additives
- Methoxy Propenyl-Based Coolant
- Methyl Alcohol-Based Coolant
- Sealer Additives or Coolant Containing Sealer Additives
- HVAC Coolant
- Phosphate-Inhibited Coolant
- Nitrated Organic Acid Technology Coolant

Coolant Life of Glycol Coolant

A properly maintained cooling system, filled with phosphate-free coolant consisting of a 50/50 mix of antifreeze and water per TMC RP-329; Type A; (EG) specifications can be operated to the limits recommended. The proper maintenance involves periodic evaluation using Detroit Genuine Fluid Analysis 3-Way Coolant Test Strips and the addition of Supplemental Coolant Additive as needed, indicated by the strip test. To verify coolant acceptability, submit a sample for laboratory analysis once a year. Submit the sample in a Detroit Genuine Fluid Analysis Coolant Test Bottle.

How to Replace the Coolant Filter

The engine is equipped with a coolant filter. The coolant filter contains supplemental corrosion inhibitors. Refer to the EPA07 or EPA10 Preventative Maintenance Tables for the interval in which to replace the coolant filter.

- Refer to section "EPA07 DD Series Preventive Maintenance Tables"
- Refer to section "EPA10/GHG14 DD Series Preventive Maintenance Tables"

NOTE: In addition to the cleaning procedure, other components of the cooling system should be checked periodically to keep the engine operating at peak efficiency.

Service the cooling system as follows:



WARNING: HOT COOLANT

To avoid scalding from the expulsion of hot coolant, never remove the cooling system pressure cap while the engine is at operating temperature. Wear adequate protective clothing (face shield, rubber gloves, apron, and boots). Remove the cap slowly to relieve pressure.

NOTE: Change the coolant filter only after the vehicle has cooled and no residual pressure is present.

NOTE: Use care to prevent foreign objects from entering the filter housing.

1. Place the transmission in neutral, and set the parking brake.
2. Clean outside of the coolant filter housing.
3. Using a 36-mm socket, unscrew cap and filter and allow the coolant to drain into the housing. After draining, remove the assembly from the housing.
4. Remove the filter from the plastic cap by placing the filter on a solid surface and apply pressure on the plastic cap at an angle.
5. Remove coolant filter O-ring and discard it. Lightly lubricate a new O-ring with clean engine oil and install it on the filter cap.
6. Check filter housing for any debris and remove if necessary.
7. Insert a new filter element into the cap.
8. Insert element and cap assembly into the housing. Torque the cap to 55-60 N·m (41-44 lb·ft).
9. Check coolant level and adjust if necessary.



WARNING: ENGINE EXHAUST

To avoid injury from inhaling engine exhaust, always operate the engine in a well-ventilated area. Engine exhaust is toxic.



WARNING: PERSONAL INJURY

To avoid injury before starting and running the engine, ensure the vehicle is parked on a level surface, parking brake is set, and the wheels are blocked.

10. Start engine with the accelerator pedal in the idle position. Monitor all gauges or indicator lamps.
11. Check the filter housings for signs of leakage.

Checking the Hoses

Check the hoses as follows:

1. Inspect the cooling system hoses and replace any hose that shows obvious signs of damage or feels abnormally soft or hard.
2. Replace damaged clamps.
3. Correct all external leaks as soon as detected.

NOTE: If Detroit Genuine antifreeze/coolant (or equivalent fully formulated, pre-charged antifreeze is used, a pre-charged element is not required.

4. Check coolant inhibitor levels at the intervals listed in this manual.
Refer to section "EPA07 DD Series Preventive Maintenance Tables"
Refer to section "EPA10/GHG14 DD Series Preventive Maintenance Tables"

How to Service the Dry Type Air Cleaner

Maintain the air cleaner as follows:

1. Replace dry type air cleaner elements when the maximum allowable air cleaner restriction [20 in. H₂O (5.0 kPa)] has been reached. Some air cleaners are equipped with a restriction indicator which aids in determining the servicing interval.
2. Do not clean and/or reuse dry paper-type air cleaner elements unless the cleaning method used removes clogging without damaging the element.
3. Inspect and clean the elements in accordance with the air cleaner manufacturer's recommendations, if any.

Troubleshooting

This section covers basic troubleshooting of engine operation or performance malfunctions and their probable causes. In addition to operating the engine carefully and maintaining it properly, make sure to correct any malfunction promptly.

Abnormal Coolant Temperature

This section explains Abnormal Coolant Temperature Symptoms and Probable Causes.

Table 10.

Abnormal Coolant Temperature Symptoms and Probable Causes		
Probable Causes	Above Normal	Below Normal
Restricted cooling system passages	X	—
Restricted radiator core passages	X	—
Slipping fan drive belts	X	—
Faulty temperature-controlled fan	X	—
Obstruction in front of radiator or intercooler	X	—
Low coolant level	X	—
Damaged hoses	X	—
Faulty thermostat	X	—
Faulty water pump	X	—
Faulty radiator pressure cap	X	—
Air in coolant	X	—
Thermostat not fully closed	—	X
Leakage around thermostat seal	—	X
Faulty temperature-controlled fan	—	X

Hard Starting

This section explains hard starting.

Table 11.

Hard Starting Symptoms and Probable Causes			
Probable Causes	Engine Will Not Rotate	Low Cranking Speed	Engine Cranks But Will Not Start
Low Battery Voltage	X	X	—
Loose cranking motor connections	X	—	—
Faulty cranking motor	X	X	—
Faulty cranking motor switch	X	X	X
Internal seizure	X	—	—
Improper lubricating oil	—	X	—
Circuit breaker/electronic control malfunction	—	—	X
Fuse blown or missing	—	—	X
Insufficient Fuel Supply			
Air in fuel	—	—	X
Out of fuel	—	—	X
Loose fuel connections	—	—	X
Cracked fuel lines	—	—	X
Obstructed fuel filters/lines	—	—	X
Faulty fuel pumps	—	—	X
Faulty injector operation	—	—	X
Restricted fuel fitting missing	—	—	X
DDEC Malfunction	—	—	X
Installation/operation of fuel check valve or shutoff valve	—	—	X
Low Compression			
Worn intake and exhaust valves	—	—	X
Worn piston rings/liners	—	—	X
Leaking cylinder head gasket	—	—	X
Improper intake or exhaust valve adjustments	—	—	X

Abnormal Engine Operation

This section explains Abnormal Engine Operation Symptoms and Probable Causes

Table 12.

Abnormal Engine Operation Symptoms and Probable Causes			
Probable Causes	Rough Running or Frequent Stalling	Low Power	Detonation
Misfiring cylinder	X	X	—
Insufficient fuel	X	X	—
High return fuel temperature	X	X	—
Low compression	X	X	—
DDEC malfunction	X	X	—
High air inlet restriction/ exhaust back pressure	—	X	—
Engine application	—	X	—
High air inlet temperature	—	X	—
High altitude operation	—	X	—
Incorrect engine gear train timing	—	X	—
Low coolant temperature	—	—	X
Oil picked up by inlet airstream	—	—	X
Faulty injector operation	—	—	X
Incorrect injector height setting	—	X	X

Abnormal Operating Conditions

This section explains Abnormal Operating Condition Symptoms and Probable Causes

Table 13.

Abnormal Operating Condition Symptoms and Probable Causes		
Probable Causes	High Lubrication Oil Consumption	Low Oil Pressure
Loose connections	X	—
Cracked lines	X	—
Damaged gaskets or seal rings	X	—
* Lubrication oil loss at breather tube	X	—
* Lubrication oil loss at dipstick tube	X	—
Leaking oil cooler	X	—
Leaking valve stem seals	X	—

Abnormal Operating Condition Symptoms and Probable Causes		
Worn/broken oil control rings	X	—
Scored liner and/or piston	X	—
Excessive engine installation angle	X	—
Crankcase overfilled	X	—
Oil in air tanks (air compressor malfunction)	X	—
Plugged crankcase breather	X	—
Oil level low	—	X
Improper engine oil viscosity (fuel in the oil)	—	X
Faulty oil pressure regulator valve	—	X
Worn crankshaft, camshaft or connecting rod bearings	—	X
Faulty oil pressure relief valve	—	X
Air leaks in oil pump (suction side)	—	X
Worn or damaged oil pump	—	X
Faulty oil pressure gauge	—	X
Faulty electrical components (for gauge)	—	X
Plugged oil line or orifice	—	X
* Indicates high crankcase pressure		

Engine Storage

When an engine is to be stored or removed from operation for a period of time, special precautions should be taken to protect the interior and exterior of the engine, transmission and other parts from rust accumulation and corrosion. The parts requiring attention and the recommended preparations are given below.

Preparing Engine for Storage

It will be necessary to remove all rust or corrosion completely from any exposed part before applying rust preventive compound. Therefore, it is recommended that the engine be processed for storage as soon as possible after removal from operation.

The engine should be stored in a building that is dry and can be heated during the winter months. Moisture-absorbing chemicals are available commercially for use when excessive dampness prevails in the storage area.

Temporary Storage (30 Days or Less)

An engine prepared in this manner can be returned to service in a short time by removing the seals at the engine openings and by checking the engine coolant, fuel oil, lubricating oil and transmission oil levels.

To protect the engine for a temporary period of time (30 days or less), follow this procedure:

1. With the engine at ambient temperature and cool to the touch, drain engine crankcase oil into a suitable container. Dispose of the oil in an environmentally friendly manner, according to state and/or federal (EPA) recommendations.
2. Fill the crankcase to the proper level with the recommended viscosity and grade of oil.
3. Fill the fuel tank with the recommended grade of fuel oil. Operate the engine for two (2) minutes at 1200 rpm and no load. Do not drain the fuel system or the crankcase after this run.
4. Check the air cleaner and service it, if necessary.

NOTE: If an antifreeze solution is not required during storage, flush the cooling system with a good soluble oil (3% – 5% by volume) rust inhibitor to prevent rusting of the outside diameter of the cylinder liners.

5. If freezing weather is expected during the storage period, check the antifreeze/coolant for required freeze and inhibitor protection. Add antifreeze solution to the cooling system in accordance with Detroit's recommendations. Refer to section "How to Select Coolant"



WARNING: EYE INJURY

To avoid injury from flying debris when using compressed air, wear adequate eye protection (face shield or safety goggles) and do not exceed 276 kPa (40 psi) air pressure.

6. Clean the exterior of the engine (except electrical parts) with fuel oil and dry with compressed air.
7. Seal all engine openings. The material used must be waterproof, vapor-proof and possess sufficient physical strength to resist puncture and damage from the expansion of entrapped air.

Extended Storage (More than 30 Days)

Outdoor storage of the engine is not recommended. If units must be kept out of doors, follow the preparation and storage instructions already given. Protect units with quality, weather-resistant tarpaulins (or other suitable covers) arranged to provide for air circulation.

NOTICE: Do not use plastic sheeting for outdoor storage. Enough moisture can condense on the inside of the plastic to rust ferrous metal surfaces and pit aluminum surfaces. If a unit is stored outside for any extended period of time, severe corrosion damage can result.

NOTE: Plastic is fine for indoor storage.

The stored engine should be inspected periodically. If there are any indications of rust or corrosion, corrective steps must be taken to prevent damage to the engine parts. Perform a complete inspection at the end of one year and apply additional treatment as required.

To prepare an engine for extended storage (more than 30 days), follow this procedure:

1. Drain the cooling system. Refer to section "Cooling System Drain Procedure", and flush with clean, soft water. Refill with clean, soft water and add a rust inhibitor to the cooling system.
2. Circulate the coolant by operating the engine until normal operating temperature is reached. Refer to section "Cooling System Fill Procedure".
3. Stop the engine.
4. With the engine at ambient temperature and cool to the touch, drain the engine crankcase oil into a suitable container. Remove the oil filters. Dispose of the oil and filters in an environmentally friendly manner, according to state and/or federal (EPA) recommendations. Replace the drain plug and torque to 45-50 N·m (33-77 lb·ft).

5. Install new lubricating oil filters. Fill the crankcase to the proper level with Tectyl® 930A preservative lubricating oil or an equivalent 30-weight preservative lubricating oil meeting Mil-L-21260C, Grade 2 Specification.

NOTE: If engines are stored where condensation of water in the fuel tank may be a problem, additives containing methyl carbitol or butyl cellusolve may be added to the fuel. Follow manufacturer's instructions for treatment. Where biological contamination of fuel may be a problem, add a biocide such as Biobor® JF (or equivalent) to the fuel. When using a biocide, follow the manufacturer's concentration recommendations and observe all cautions and warnings.

6. Drain the fuel tank. Refill with enough clean No. 1 diesel fuel to permit the engine to operate for about ten (10) minutes. If draining the fuel tank is not convenient, use a separate, portable supply of recommended fuel.
7. Drain the fuel system and remove the fuel filters. Dispose of used filters in an environmentally responsible manner, according to state and/or federal (EPA) recommendations. Fill the new filters with No. 1 diesel fuel or pure kerosene and install on the engine.
8. Operate the engine for five (5) minutes to circulate the clean fuel throughout the engine. Be sure the engine fuel system is full.
9. Stop the engine and allow to cool. Then disconnect the fuel return line and the inlet line at the primary filter and securely plug both to retain the fuel in the engine.
10. Transmission: Follow the manufacturer's recommendations for prolonged storage.
11. Power Take-Off: If equipped, follow manufacturer's recommendations for prolonged storage.

NOTE: Failure to properly seal off the turbocharger air inlet and exhaust outlet openings before engine storage may permit air drafts to circulate through the turbocharger and rotate the turbine/compressor shaft without an adequate flow of lubricating oil to the center housing bearings resulting in severe bearing damage.

12. Turbocharger: Since turbocharger bearings are pressure lubricated through the external oil line leading from the oil filter adaptor while the engine is operating, no further attention is required. However, the turbocharger air inlet and turbine exhaust outlet connection should be sealed off with moisture-resistant tape.

NOTE: Do not apply oil, grease or any wax-base compound to the flywheel. The cast iron will absorb these substances, which can sweat out during operation and cause the clutch to slip.

13. Apply a non-friction rust preventive compound to all exposed engine parts. If convenient, apply the rust preventive compound to the engine flywheel. If not, disengage the clutch mechanism to prevent the clutch disc from sticking to the flywheel.
14. Drain the engine cooling system. If the engine will be exposed to freezing temperatures, install genuine Detroit Power Cool antifreeze or an equivalent ethylene glycol-base or propylene glycol-base antifreeze solution that provides the required freeze, boil over and inhibitor protection. Refer to section "Coolant Requirements"
15. Drain the preservative oil from the engine crankcase. Reinstall and torque the 3/4" – 14 square, magnetic drain plug to 45-50 N·m (33-77 lb·ft).
16. Remove and clean the battery and battery cables with a baking soda-water solution and rinse with fresh water. Do not allow the soda solution to enter the battery. Add distilled water to the electrolyte (if necessary) and fully charge the battery. Store the battery in a cool (never below 0° C or 32° F) dry place. Keep the battery fully charged and check the level and specific gravity of the electrolyte regularly.
17. Insert heavy paper strips between the pulleys and drive belts to prevent sticking.
18. Seal all engine openings, including the exhaust outlet, with moisture-resistant tape. Use cardboard, plywood or metal covers where practical.
19. Clean and dry the exterior painted surfaces of the engine and spray with a suitable liquid automobile body wax, a synthetic resin varnish, or a rust preventive compound.
20. Protect the engine with a good weather-resistant tarpaulin and store it under cover, preferably in a dry building which can be heated during the winter months.

Procedure for Restoring to Service an Engine that Has Been in Extended Storage

If an engine has been in extended storage, prepare it for service as follows:

1. Remove the covers and tape from all the openings of the engine, fuel tank and electrical equipment. Do not overlook the exhaust outlet.
2. Remove the plugs from the inlet and outlet fuel lines and reconnect the lines to their proper positions.
3. Wash the exterior of the engine with fuel oil to remove the rust preventive. Do not wash electrical components.
4. Remove the rust preventive from the flywheel. Flush any soluble oil rust inhibitor (if used) in the cooling system.
5. Remove the paper strips from between the pulleys and drive belts.
6. Fill the crankcase to the proper level with the required grade of lubricating oil. Use a pressure lubricator to insure all bearings and rocker shafts are lubricated.

7. Fill the fuel tank with the required fuel.
8. Close all drain cocks and fill the engine cooling system with clean, soft water and required inhibitors. If the engine is to be exposed to freezing temperatures, install genuine Detroit Power Cool antifreeze or an equivalent ethylene glycol-base or propylene glycol-base antifreeze solution which provides required freeze, boil over, and inhibitor protection. Refer to section "How to Select Coolant"
9. Install and connect the battery. Make sure the average specific gravity of the battery is 1.260 or higher. Charge the battery, if necessary.
10. Service the air cleaner, if required.
11. Transmission: Follow the manufacturer's recommendations covering the return of the transmission to service.
12. Power Take-Off: If equipped, follow the manufacturer's recommendations covering the return of the power take-off to service.
13. Turbocharger: Remove the covers from the turbocharger air inlet and turbine outlet connections. Reconnect piping as required. Pre-lube the turbocharger center bearing housing. Refer to section "Lubrication System Checks"
14. Fill the cooling system. Refer to section "Cooling System Fill Procedure"

**WARNING: ENGINE EXHAUST**

To avoid injury from inhaling engine exhaust, always operate the engine in a well-ventilated area. Engine exhaust is toxic.

15. After all preparations are completed, start the engine.

NOTE: The small amount of rust preventive which remains in the fuel system will cause smoky exhaust for a few minutes.

NOTE: Before subjecting the engine to a load or high speed, allow it to reach normal operating temperature.

16. Check for trouble codes.
 - a. If there are no codes, perform a parked regeneration.
 - b. If there are codes, repair what is necessary then perform a parked regeneration.

Customer Assistance

Customer Assistance

The satisfaction and goodwill of the owners of Detroit™ engines are of primary concern to Detroit™ and its distributor/dealer organizations. Contact the Regional Support Center.

Using Road Service

If you require road service for any reason in Latin America, you may call the Regional Support Center phone number. An operator will assist you in determining what type of service is required. Not all problems are engine related and not all problems are covered by engine or vehicle warranties. **YOU MAY BE RESPONSIBLE FOR REPAIR EXPENSES.**

Before calling Customer Assistance, please do the following:

- Check the coolant level.
- Check the fuel level.
- Check the DDEC fuses.
- Check for fuel leaks.
- Make sure manual shutoff valve (if installed) on the fuel filter adaptor or fuel supply line is open.
- Check the oil level on the dipstick.
- Check the diagnostic codes.

If you call, have the following information available:

- Engine serial number
- Vehicle make, model, and VIN
- Odometer mileage (kilometers) or hour meter hours
- Vehicle owner/company name

Availability of Detroit™ Service Outlets

As the owner of a Detroit™ product, you have a complete network of Detroit™ service outlets in Latin America, plus many outlets worldwide that are prepared to meet your parts and service needs:

- Service by trained personnel
- Sales team to help determine your specific power requirements
- In many areas, emergency service 24 hours a day
- Complete parts support
- Product information and literature

We recognize however, that despite the best intentions of everyone concerned, misunderstandings may occur. Normally, any situation that arises in connection with the sale, operation or service of your product will be handled by the authorized service outlet in your area (in Latin America, check the service locator at www.demanddetroit.com for Detroit™ service outlet nearest you).

Detroit Genuine Coolant Engine Products

Maintenance of the cooling system requires the chemical makeup of the system to be balanced.

Detroit Genuine Fully Formulated Inhibited Ethylene Glycol Coolants

The part numbers and sizes of concentrated and pre-blended 50:50 Detroit Genuine Coolants are listed in the following Tables.

Table 14.

Detroit Genuine Fully Formulated Inhibited Ethylene Glycol Coolants		
Coolant Type	Part Number	Description
Concentrated	23512138	One Gallon Jug – 6 Per Case
	23512139	55 Gallon Drum
	23529295	330 Gallon Tote
	23512140	Bulk Delivery – 1,000 Gallon Min.
Pre-blended 50:50	23528203	One Gallon Jug – 6 Per Case
	23518918	55 Gallon Drum
	23528544	330 Gallon Tote
	23513503	Bulk Delivery – 1,000 Gallon Min.

Detroit Genuine Supplemental Coolant Additive Need Release Filters

Detroit Genuine Supplemental Coolant Additive Need Release Filters are shown below.

Table 15.

Detroit Genuine Supplemental Coolant Additive Need Release Filters		
Coolant Type	Part Number	Description
Detroit Genuine Inhibited Ethylene Glycol Coolant	NF2091	For 0 – 8 Gallon Systems
	23516489	For 8 – 20 Gallon Systems

Detroit Genuine Cooling System Cleaners

Detroit Genuine Cooling System Cleaners are shown below.

Table 16.

Detroit Genuine Cooling System Cleaners		
Coolant Type	Part Number	Description
On-Line Cleaner	200164	One-Half Gallon Jug – 6 Per Case
	200105	5 Gallon Pail
	200155	55 Gallon Drum
Twin Pack	201549	Twin Pack – 2 Per Case

Detroit Genuine Fluid Analysis Products

Detroit Genuine Fluid Analysis Products are shown below.

Table 17.

Detroit Genuine Fluid Testing and Analysis Products		
Application	Part Number	Description
Indicates Nitrite, Molybdate & Glycol Levels	23519401	3-Way Coolant Test Strips (Single Foil Packs)
Indicates Nitrite, Molybdate & Glycol Levels	23519402	3-Way Coolant Test Strips (Bottle of 50)
Indicates Nitrite, Molybdate & Glycol Levels	23522774	3-Way Coolant Test Strips (Bottle of 10)
Complete Inhibited Ethylene Glycol Coolant Analysis	23516921	Coolant Analysis Bottle (Carton of 6)
Organic Coolant Analysis	23539088	Laboratory Coolant Analysis

Engine Oil Capacities

Consult with a Detroit distributor to obtain the proper engine oil filters.

The engine oil capacities for the DD Platform Engine On-Highway Vehicle application are listed in the following tables. Contact your local Detroit service center if you need more specific information.

NOTE: There are approximately 5.0 L (5.2 qts) of oil represented from the fill mark to the full mark.

NOTICE: Overfilling the oil pan can cause engine damage.

Table 18.

Engine Oil Capacities			
Truck	DD13	DD15	DD16
Total Dry Engine Oil Volume	44.0 L (46.5 qt)	49.0 L (51.8 qt)	49.0 L (51.8 qt)
Oil and Filter Change	38.0 L (40.1 qt)	43.0 L (45.4 qt)	43.0 L (45.4 qt)
Remaining in Engine after Oil Drain (Includes Filter Removal)	6.0 L (6.3 qt)	6.0 L (6.3 qt)	6.0 L (6.3 qt)
Dip Stick Min. to Max. Range	5.0 L (5.2 qt)	5.0 L (5.2 qt)	5.0 L (5.2 qt)
Sump Oil Volume	35.0 L (37.0 qt)	40.0 L (42.3 qt)	40.0 L (42.3 qt)

Table 19.

Coach	EPA10 DD13	GHG14 DD13
Total Dry Engine Oil Volume	51.0 L (53.8 qt)	47.0 L (49.7 qt)
Oil and Filter Change	45.0 L (47.6 qt)	40.0 L (42.3 qt)
Remaining in Engine after Oil Drain (Includes Filter Removal)	6.0 L (6.3 qt)	6.0 L (6.3 qt)
Dip Stick Min. to Max. Range	5.0 L (5.2 qt)	5.0 L (5.2 qt)
Sump Oil Volume	42.0 L (44.4 qt)	37.0 L (39.1 qt)