



Run SmartSM



CASCADIA[®]

Maintenance Manual



Run Smart™

CASCADIA MAINTENANCE MANUAL

**Models: CA113DC
CA113SLP
CA125DC
CA125SLP**

Foreword

Scheduled maintenance provides a key element for the safe operation of your vehicle. A proper maintenance program also helps to minimize downtime and to safeguard warranties. This maintenance manual provides information necessary for years of safe, reliable, and cost-efficient vehicle operation.

IMPORTANT: The maintenance operations in this manual are **not all-inclusive**. Also refer to other component and body manufacturers' instructions for specific inspection and maintenance instructions.

Perform the operations in this maintenance manual at scheduled intervals. Perform the pretrip inspection and daily/weekly/monthly maintenance, as outlined in the vehicle driver's manual. Major components, such as engines, transmissions, and rear axles, are covered in their own maintenance and operation manuals, that are provided with the vehicle. Perform any maintenance operations listed at the intervals scheduled in those manuals. Your Freightliner Dealership has the qualified technicians and equipment to perform this maintenance for you. They can also set up a scheduled maintenance program tailored specifically to your needs. Optionally, they can assist you in learning how to perform these maintenance procedures.

IMPORTANT: Descriptions and specifications in this manual were in effect at the time of printing. Freightliner Trucks reserves the right to discontinue models and to change specifications or design at any time without notice and without incurring obligation. Descriptions and specifications contained in this publication provide no warranty, expressed or implied, and are subject to revision and editions without notice.

Refer to www.Daimler-TrucksNorthAmerica.com and www.FreightlinerTrucks.com for more information, or contact Daimler Trucks North America LLC at the address below.

Environmental and Safety Concerns and Recommendations

Whenever you see instructions in this manual to discard materials, you should attempt to reclaim and recycle them. To preserve our environment, follow appropriate environmental rules and regulations when disposing of materials. Servicing vehicles may result in contact with items known to the state of California to cause harm.



Breathing diesel engine exhaust exposes you to chemicals known to the State of California to cause cancer and birth defects or other reproductive harm.

Always start and operate the engine in a well-ventilated area. If in an enclosed are, vent the exhaust to the outside. Do not modify or tamper with the exhaust system. Do not idle the engine except as necessary.

For more information go to www.P65warnings.ca.gov/diesel.



Cancer and Reproductive Harm www.P65warnings.ca.gov/diesel.

NOTICE: Parts Replacement Considerations

Do not replace suspension, axle, or steering parts (such as springs, wheels, hubs, and steering gears) with used parts. Used parts may have been subjected to collisions or improper use and have undetected structural damage.

© 2007–2021 Daimler Trucks North America LLC

All rights reserved. No part of this publication, in whole or in part, may be translated, reproduced, stored in a retrieval system, or transmitted in any form by any means, electronic, mechanical, photocopying, recording, or otherwise, without the prior written permission of Daimler Trucks North America LLC. Daimler Trucks North America is a Daimler company.

Daimler Trucks North America LLC
Service Systems and Documentation (CVI-SSD)
P.O. Box 3849
Portland, OR 97208–3849

Descriptions of Service Publications

Daimler Trucks North America LLC distributes the following major service publications in paper and electronic formats. Refer to www.DTNACconnect.com.

Workshop/Service Manual	Workshop/service manuals contain service and repair information for all vehicle systems and components, except for major components such as engines, transmissions, and rear axles. Each workshop/service manual section is divided into subjects that can include general information, principles of operation, removal, disassembly, assembly, installation, and specifications.
Maintenance Manual	Maintenance manuals contain routine maintenance procedures and intervals for vehicle components and systems. They have information such as lubrication procedures and tables, fluid replacement procedures, fluid capacities, specifications, and procedures for adjustments and for checking the tightness of fasteners. Maintenance manuals do not contain detailed repair or service information.
Troubleshooting Manual	Troubleshooting manuals contain diagnostic procedures for determining causes of problems in vehicle components and systems. Information on multiplexing diagnosis is included. These manuals are organized by functional systems, such as cab, chassis, and powertrain. Troubleshooting manuals do not contain repair or service information.
Driver's/Operator's Manual	Driver's/operator's manuals contain information needed to enhance the driver's understanding of how to operate and care for the vehicle and its components. Each manual contains a chapter that covers pre-trip and post-trip inspections, and daily, weekly, and monthly maintenance of vehicle components. Driver's/operator's manuals do not contain detailed repair or service information.
Service Bulletins	Service bulletins provide the latest service tips, field repairs, product improvements, and related information. Some service bulletins are updates to information in the workshop/service manual. These bulletins take precedence over workshop/service manual information, until the latter is updated; at that time, the bulletin is usually canceled. The service bulletins manual is available only to dealers. When doing service work on a vehicle system or part, check for a valid service bulletin for the latest information on the subject. IMPORTANT: Before using a particular service bulletin, check the current service bulletin validity list to be sure the bulletin is valid.
Parts Technical Bulletins	Parts technical bulletins provide information on parts. These bulletins contain lists of parts and BOMs needed to do replacement and upgrade procedures.
Web-based repair, service, and parts documentation can be accessed using the following applications on the www.DTNACconnect.com website.	
DTNACconnect	DTNACconnect provides Web-based access to the most up-to-date versions of the publications listed above. In addition, the Service Solutions feature provides diagnostic assistance with Symptoms Search, by connecting to a large knowledge base gathered from technicians and service personnel. Search results for both documents and service solutions can be narrowed by initially entering vehicle identification data.
PartsPro	PartsPro® is an electronic parts catalog system, showing the specified vehicle's build record.

Descriptions of Service Publications

EZWiring

EZWiring™ makes Freightliner, Sterling, Western Star, Thomas Built Buses, and Freightliner Custom Chassis Corporation products' wiring drawings and floating pin lists available online for viewing and printing. EZWiring can also be accessed from within PartsPro.

Warranty-related service information available on the www.DTNACconnect.com website includes the following documentation.

Recall Campaigns

Recall campaigns cover situations that involve service work or replacement of parts in connection with a recall notice. These campaigns pertain to matters of vehicle safety. All recall campaigns are distributed to dealers; customers receive notices that apply to their vehicles.

Field Service Campaigns

Field service campaigns are concerned with non-safety-related service work or replacement of parts. All field service campaigns are distributed to dealers; customers receive notices that apply to their vehicles.

Page Description

For an example of a Maintenance Manual page, see Fig. 1.

A
B
C

Driveline 41

41-01 Driveline Inspection

- Park the vehicle on a level surface, apply the parking brakes, and chock the tires.

CAUTION

Due to the extreme load occurring at high-speed rotation, a loose or broken capscrew at any point in the driveline will weaken the driveline connection, which could eventually result in serious vehicle damage. Tighten bearing-cap capscrews or yoke-strap capscrews to specified torque, being careful not to overtighten.

- For U-joints with bearing caps, tighten bearing-cap capscrews 43 lbf-ft (49 N-m). See Fig. 1.
For Arvin Meritor RPL series U-joints, tighten bearing-cap capscrews 125 lbf-ft (169 N-m). See Fig. 2.
For U-joints with yoke straps, tighten yoke-strap capscrews 125 lbf-ft (169 N-m). See Fig. 3.

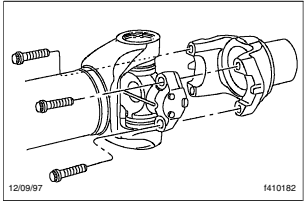

12/09/97 1410182

Fig. 2, Arvin Meritor RPL Series U-Joint

If any end-yoke can be moved in or out on its shaft, or can be rocked on its shaft, disconnect the driveshaft and U-joint from the yoke, then check the drive component's shaft seal for leakage or other visible damage that may have been caused by the loose yoke. Replace the seal if needed, then tighten the yoke nut. Refer to **Group 41** of the *Cascadia™ Workshop Manual for torque specifications*. If the yoke is still loose after tightening the yoke nut, replace the end-yoke and yoke nut.

Replace the prevailing torque locknut (end-yoke nut) if it was removed for yoke replacement, seal replacement, or any other reason.

- Check U-joint assemblies for wear by moving the driveshaft up and down, and from side to side. If any movement of the U-joint cross in the bearings can be felt or seen, replace the U-joint assembly.
- Check if the midship bearing and mounting are loose or have deteriorated, by attempting to move the driveshaft up and down, and from side to side. If the bearing is loose on its shaft, or rattles, replace it. If the bearing mount is loose on the frame, tighten the mounting fasteners to the proper torque value. See **Group 41** of the *Cascadia™ Workshop Manual for torque specifications*. Replace the midship bearing assembly if the rubber cushion is deteriorated or oil-soaked.
- Check slip joints for spline wear by moving the sleeve-yoke and splined shaft back and forth. See **Fig. 4** if the slip joint can be twisted in a clockwise, or counterclockwise movement

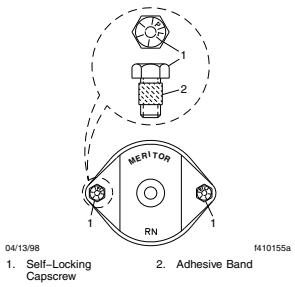

04/13/98 1410155a

Fig. 1, Arvin Meritor U-Joint Fasteners for Bearing Caps

- Self-Locking Capscrew
- Adhesive Band

- Check the driveline yokes for cracks, and check end-yokes for looseness. See **Fig. 3**. Replace cracked yokes.

D
E
F

Cascadia™ Maintenance Manual, July 2007 41/1

06/11/2007 f020166

A. Maintenance Operation Number consists of the Group Number followed by the Sequence Number
 B. Group Title
 C. Group Number
 D. Vehicle Name
 E. Release Date
 F. Group Number/Page Number

Fig. 1, Example of a Maintenance Manual Page

Group No.	Group Title
00	General Information
09	Air Intake
13	Air Compressor
15	Alternators and Starters
20	Engine Cooling/Radiator
25	Clutch
26	Transmission
31	Frame and Frame Components
32	Suspension
33	Front Axle
35	Rear Axle
40	Wheels and Tires
41	Driveline
42	Brakes
46	Steering
47	Fuel
49	Exhaust
54	Electrical, Instruments, and Controls
60	Cab
83	Heater and Air Conditioner
88	Hood, Grille, and Cab Fenders

Title of Maintenance Operation (MOP)	MOP Number
Determining Scheduled Maintenance Intervals.	00-01
Initial Maintenance (IM) Operations.	00-04
M1 Maintenance Interval Operations.	00-05
M2 Maintenance Interval Operations.	00-06
M3 Maintenance Interval Operations.	00-07
Maintenance Operation Sets Table	00-08
Noise Emission Controls Maintenance.	00-09
Service Schedule Table	00-02
Vehicle Maintenance Schedule Table	00-03
Verification of Inspections Log.	00-10

Determining Scheduled Maintenance Intervals

Performing regular maintenance on your Freightliner vehicle will help ensure that your vehicle delivers safe reliable service and optimum performance for years to come. Failure to follow a regular maintenance program can result in inefficient operation and unscheduled down time.

To determine the correct maintenance intervals for your vehicle you must first determine the type of service or conditions the vehicle will be operating in. Generally, over-the-road vehicles operate under conditions that fall within one of the two types of service described. Before placing your new vehicle in service, determine the type of service (Service Schedule I or II) that applies to the intended use of the vehicle. After determining the vehicle's type of service, refer to the service schedule table or the vehicle maintenance schedule table, to determine how often maintenance should be performed.

When the vehicle reaches the distance given for a maintenance interval, see the Maintenance Interval Operation Table for a list of the maintenance operations to be performed at that maintenance interval. Use the maintenance operation reference numbers to find detailed instructions in the manual on each operation.

Types of Service

Service Schedule I (short-haul transport) applies to vehicles that annually travel less than 60,000 miles (100 000 kilometers) and operate under normal conditions. Examples of Schedule I usage are: operation primarily in cities and densely populated areas; local transport with infrequent freeway travel; or high percentage of stop-and-go travel.

Service Schedule II (long-haul transport) is for vehicles that annually travel *more than* 60,000 miles (100 000 kilometers) with minimal city or stop-and-go operation. Examples of Schedule II usage are: regional delivery that is mostly freeway miles; interstate transport; or any road operation with high annual mileage.

NOTE: Maintenance instructions in this manual are based on average vehicle use and normal

operating conditions. Unusual vehicle operating conditions may require service at more frequent intervals.

Service Schedule Table: 00–02

Service Schedule	Maintenance Interval Operation	Maintenance Interval		
		Frequency	Miles	km
Schedule I (Short-Haul Transport) vehicles that annually travel less than 60,000 miles (100 000 km)	Initial Maintenance (IM)	first	10,000	16 000
	Maintenance 1 (M1)	every	10,000	16 000
	Maintenance 2 (M2)	every	50,000	80 000
	Maintenance 3 (M3)	every	150,000	240 000
Schedule II (Long-Haul Transport) vehicles that annually travel over 60,000 miles (100 000 km)	Initial Maintenance (IM)	first	25,000	40 000
	Maintenance 1 (M1)	every	25,000	40 000
	Maintenance 2 (M2)	every	100,000	161 000
	Maintenance 3 (M3)	every	300,000	483 000

Table 1, Service Schedule

Vehicle Maintenance Schedule Table: 00–03

Maintenance for Service Schedule I				
Maint. No.	Maintenance Interval	Service Date	Service Schedule I	
			Miles	km
1st	IM, M1		10,000	16 000
2nd	M1		20,000	32 000
3rd	M1		30,000	48 000
4th	M1		40,000	64 000
5th	M1, M2		50,000	80 000
6th	M1		60,000	96 000
7th	M1		70,000	112 000
8th	M1		80,000	128 000
9th	M1		90,000	144 000
10th	M1, M2		100,000	160 000
11th	M1		110,000	176 000
12th	M1		120,000	192 000
13th	M1		130,000	208 000
14th	M1		140,000	224 000
15th	M1, M2, M3		150,000	240 000
16th	M1		160,000	256 000
17th	M1		170,000	272 000
18th	M1		180,000	288 000
19th	M1		190,000	304 000
20th	M1, M2		200,000	320 000
21st	M1		210,000	336 000
22nd	M1		220,000	352 000
23rd	M1		230,000	368 000
24th	M1		240,000	384 000
25th	M1, M2		250,000	400 000
26th	M1		260,000	416 000
27th	M1		270,000	432 000
28th	M1		280,000	448 000
29th	M1		290,000	464 000
30th	M1, M2, M3		300,000	480 000
31st	M1		310,000	496 000
32nd	M1		320,000	512 000
33rd	M1		330,000	528 000
34th	M1		340,000	544 000
35th	M1, M2		350,000	560 000

Vehicle Maintenance Schedule Table: 00–03

Maintenance for Service Schedule I				
Maint. No.	Maintenance Interval	Service Date	Service Schedule I	
			Miles	km
36th	M1		360,000	576 000
37th	M1		370,000	592 000
38th	M1		380,000	608 000
39th	M1		390,000	624 000
40th	M1, M2		400,000	640 000
41st	M1		410,000	656 000
42nd	M1		420,000	672 000
43rd	M1		430,000	688 000
44th	M1		440,000	704 000
45th	M1, M2, M3		450,000	720 000
46th	M1		460,000	736 000
47th	M1		470,000	752 000
48th	M1		480,000	768 000
49th	M1		490,000	784 000
50th	M1, M2		500,000	800 000
51st	M1		510,000	820 000
52nd	M1		520,000	837 000
53rd	M1		530,000	853 000
54th	M1		540,000	869 000
55th	M1, M2		550,000	885 000
56th	M1		560,000	901 000
57th	M1		570,000	917 000
58th	M1		580,000	933 000
59th	M1		590,000	949 000
60th	M1, M2, M3		600,000	965 000
61st	M1		610,000	982 000
62nd	M1		620,000	998 000
63rd	M1		630,000	1 014 000
64th	M1		640,000	1 030 000
65th	M1, M2		650,000	1 046 000
66th	M1		660,000	1 062 000
67th	M1		670,000	1 078 000
68th	M1		680,000	1 094 000
69th	M1		690,000	1 110 000
70th	M1, M2		700,000	1 127 000

Vehicle Maintenance Schedule Table: 00–03

Maintenance for Service Schedule I				
Maint. No.	Maintenance Interval	Service Date	Service Schedule I	
			Miles	km
71st	M1		710,000	1 143 000
72nd	M1		720,000	1 159 000
73rd	M1		730,000	1 175 000
74th	M1		740,000	1 191 000
75th	M1, M2, M3		750,000	1 207 000
76th	M1		760,000	1 223 000
77th	M1		770,000	1 239 000
78th	M1		780,000	1 255 000
79th	M1		790,000	1 271 000
80th	M1, M2		800,000	1 287 000
81st	M1		810,000	1 304 000
82nd	M1		820,000	1 320 000
83rd	M1		830,000	1 340 000
84th	M1		840,000	1 352 000
85th	M1, M2		850,000	1 370 000
86th	M1		860,000	1 384 000
87th	M1		870,000	1 400 000
88th	M1		880,000	1 416 000
89th	M1		890,000	1 432 000
90th	M1, M2, M3		900,000	1 448 000
91st	M1		910,000	1 465 000
92nd	M1		920,000	1 481 000
93rd	M1		930,000	1 500 000
94th	M1		940,000	1 513 000
95th	M1, M2		950,000	1 530 000
96th	M1		960,000	1 550 000
97th	M1		970,000	1 561 000
98th	M1		980,000	1 577 000
99th	M1		990,000	1 593 000
100th	M1, M2		1,000,000	1 609 000

Table 2, Maintenance for Service Schedule I

Vehicle Maintenance Schedule Table: 00–03

Maintenance for Service Schedule II				
Maint. No.	Maintenance Interval	Service Date	Service Schedules II	km
			Miles	
1	IM, M1		25,000	40 000
2	M1		50,000	80 000
3	M1		75,000	121 000
4	M1, M2		100,000	161 000
5	M1		125,000	201 000
6	M1		150,000	241 000
7	M1		175,000	281 000
8	M1, M2		200,000	322 000
9	M1		225,000	362 000
10	M1		250,000	402 000
11	M1		275,000	443 000
12	M1, M2, M3		300,000	483 000
13	M1		325,000	523 000
14	M1		350,000	563 000
15	M1		375,000	604 000
16	M1, M2		400,000	644 000
17	M1		425,000	684 000
18	M1		450,000	724 000
19	M1		475,000	764 000
20	M1, M2		500,000	805 000
21	M1		525,000	845 000
22	M1		550,000	885 000
23	M1		575,000	925 000
24	M1, M2, M3		600,000	966 000
25	M1		625,000	1 005 800
26	M1		650,000	1 046 000
27	M1		675,000	1 086 000
28	M1, M2		700,000	1 127 000
29	M1		725,000	1 167 000
30	M1		750,000	1 207 000
31	M1		775,000	1 248 000
32	M1, M2		800,000	1 287 000
33	M1		825,000	1 328 000
34	M1		850,000	1 368 000

Vehicle Maintenance Schedule Table: 00–03

Maintenance for Service Schedule II				
Maint. No.	Maintenance Interval	Service Date	Service Schedules II	km
			Miles	
35	M1		875,000	1 408 000
36	M1, M2, M3		900,000	1 448 000
37	M1		925,000	1 490 000
38	M1		950,000	1 529 000
39	M1		975,000	1 569 000
40	M1, M2		1,000,000	1 609 000

Table 3, Maintenance for Service Schedule II

Initial Maintenance (IM) Operations: 00–04

The Initial Maintenance table lists all maintenance operations that are to be performed at the initial maintenance (IM) interval. Maintenance operation numbers are reference numbers used to help you find detailed instructions in this manual on the main-

tenance operations to be performed. All operations listed in the table, along with the operations listed in the applicable M1 maintenance interval table, must be performed to complete the initial maintenance (IM).

Maintenance Operation Number	Initial Maintenance (IM) Operations for Service Schedules I and II	Check
00–05	Perform all M1 Operations	
31–03	Frame Fastener Torque Check	
32–02	Suspension U-Bolt Torque Check	
33–04	All-Axle Alignment Check	
42–12	Bendix Automatic Drain Valve Operating and Leakage Tests*	
47–03	Fuel Tank Band-Nut Tightening	

* The automatic drain valve should be inspected every 6 months or 1500 operating hours, whichever comes first.

Table 4, Initial Maintenance (IM) Operations for Service Schedules I and II

M1 Maintenance Interval Operations: 00–05

The M1 Maintenance Interval Operations tables list all maintenance operations that are to be performed at the M1 maintenance interval. Maintenance operation numbers are reference numbers used to help you find detailed instructions in this manual on the maintenance operations to be performed.

IMPORTANT: After performing all operations listed in this table, perform all daily, weekly, and monthly maintenance operations listed in the "Pretrip and Post-Trip Inspections and Maintenance" chapter of the *Cascadia™ Driver's Manual*.

Maintenance Operation Number	M1 Maintenance Interval Operations for Service Schedules I and II	Check
13–01	Air Compressor Inspection	
25–01	Clutch Release Bearing Lubrication *	
31–01	Fifth Wheel Inspection	
31–02	Fifth Wheel Lubrication	
32–03	Lubrication of Front Suspensions with Grease Fittings	
33–05	Steer Axle Hub Cap Vent Plug Inspection	
40–01	Wheel Nut Check	
40–02	Tire Check	
41–01	Driveline Inspection	
41–02	Driveline Lubrication	
42–02	Bendix Air Dryer Desiccant Replacement (with an oil-coalescing desiccant cartridge)†	
42–05	Brake Inspection	
42–06	Dana Spicer, Haldex, and Gunitite Slack Adjuster Lubrication	
42–07	Meritor Camshaft Bracket Lubrication	
42–10	WABCO System Saver Air Dryer Desiccant Cartridge Replacement	
42–11	Versajust Slack Adjuster Inspection and Lubrication‡	
42–12	Bendix Automatic Drain Valve Operating and Leakage Tests§	
47–04	LNG Fuel System Inspecting	
47–06	CNG Fuel System Inspecting	
47–07	CNG High-Pressure Fuel Filter Element Replacing¶	
49–01	Exhaust System Inspection (noise emission control)	
60–02	Cab Shock Absorber Bracket Torque Check	
60–03	Aerodynamic Component Inspection	
83–03	ParkSmart™ Inspection	
88–01	Hood Rear Support Lubrication	

* On vehicles equipped with Detroit transmissions, the release bearing does not need to be lubricated. On vehicles equipped with Eaton Fuller UltraShift PLUS transmissions, lubricate the release bearing every 50,000 miles (80 000 km) or 3 months.

† If equipped with an oil-coalescing desiccant cartridge, replace the cartridge once a year, regardless of mileage. Otherwise use the M3 maintenance interval.

‡ Complete this procedure every 25,000 miles (40 225 km), 3 months, or 500 operating hours, whichever comes first.

§ The automatic drain valve should be inspected every 6 months or 1500 operating hours, whichever comes first.

¶ M1 maintenance interval should be used as a general guideline; the actual frequency of filter element replacement will vary depending on cleanliness of the fuel station system.

Table 5, M1 Maintenance Interval Operations for Service Schedules I and II

M2 Maintenance Interval Operations: 00–06

The M2 Maintenance Interval Operations tables list all maintenance operations that are to be performed at the M2 maintenance interval. Maintenance operation numbers are reference numbers used to help

you find detailed instructions in this manual on the maintenance operations to be performed. Perform all M1 maintenance interval operations at the M2 maintenance interval.

Maintenance Operation Number	M2 Maintenance Interval Operations for Service Schedules I and II	Check
00–05	Perform All M1 Operations	
15–01	Alternator, Battery, and Starter Check	
20–01	Pressure Relief Cap Check	
20–03	Fan Clutch Check (noise emission control)	
25–02	Fluid Level Check, Hydraulic Clutch Control	
26–01	Detroit™ Automated Transmission Fluid Change and Magnetic Plug Cleaning	
26–02	Detroit™ Automated Transmission Fluid Level Inspection	
26–03	Detroit™ Automated Transmission Air Filter Replacement	
26–05	Eaton Fuller Transmission Fluid Level Inspection	
26–06	Eaton Fuller Manual Transmission Air Filter/Regulator Check, Cleaning, or Replacement	
31–04	Fairing Bumper Wear Check	
32–01	Suspension Inspection	
32–02	Suspension U-Bolt Torque Check	
33–01	Knuckle Pin Lubrication *	
33–02	Tie Rod Inspection	
33–03	Tie Rod Lubrication *	
35–02	Axle Breather and Axle Lubricant Level Inspection	
42–01	Air Brake System Valve Inspection	
42–03	Air Dryer Inspection	
42–04	Alcohol Evaporator Cleaning and Inspection	
42–08	Meritor Slack Adjuster Lubrication	
46–01	Drag Link Inspection	
46–03	Power Steering Fluid Level Inspection	
46–04	Power Steering Gear Lubrication	
46–05	Drag Link Lubrication	
46–06	Rack and Pinion Steering Gear Inspection	
47–01	Fuel Filter Replacement	
47–02	Fuel/Water Separator Element Checking and Replacement	
47–08	CNG Fuel Cylinder Inspecting †	
54–01	Trailer Cable Inspection and Cleaning	
60–01	Mirror Folding Check	
60–04	Baggage Door and Sleeper Access Door Release Cable and Latch Lubrication	

M2 Maintenance Interval Operations: 00–06

Maintenance Operation Number	M2 Maintenance Interval Operations for Service Schedules I and II	Check
83-01	Air Conditioner Inspection	
83-02	Air Filter Replacement	

* For Schedule I vehicles with Detroit axles, complete this procedure once a year or every 25,000 miles (40 000 km), whichever comes first.

† The fuel cylinder should be inspected every year or 100,000 miles (160 900 km), whichever comes first.

Table 6, M2 Maintenance Interval Operations for Service Schedules I and II

M3 Maintenance Interval Operations: 00–07

The M3 Maintenance Interval Operations table lists all maintenance operations that are to be performed at the M3 maintenance interval. Maintenance operation numbers are reference numbers used to help

you find detailed instructions in this manual on the maintenance operations to be performed. Perform all M1 and M2 maintenance interval operations at the M3 maintenance interval.

Maintenance Operation Number	M3 Maintenance Interval Operations for Service Schedules I and II	Check
00–05	Perform All M1 Operations	
00–06	Perform All M2 Operations	
09–01	Air Cleaner Inspection	
20–02	Radiator Pressure-Flushing and Coolant Change	
25–03	Fluid Change, Hydraulic Clutch Control	
26–04	Eaton Fuller Transmission Fluid Change and Magnetic Plug Cleaning *	
35–01	Axle Lubricant and Filter Change, and Magnetic Strainer Cleaning	
42–02	Bendix Air Dryer Desiccant Replacement	
42–09	Bendix E–6 Foot Control Valve Inspection and Lubrication	
42–10	WABCO System Saver Air Dryer Desiccant Cartridge Replacement	
46–02	Power Steering Fluid and Filter Change	
46–07	Bellows Replacement, Rack and Pinion Steering Gear	
47–05	LNG Vacuum Integrity Testing	
49–02	CAT CGI Bellows Replacement	

* For Eaton Fuller transmissions, fluid change intervals are extended to 500,000 miles (800 000 km) on vehicles filled with synthetic transmission fluid.

Table 7, M3 Maintenance Interval Operations for Service Schedules I and II

Maintenance Operation Sets Table: 00–08

Maintenance Operation Sets					
Maint. No.	Operation Description	Service Schedules I and II			
		IM	M1	M2	M3
09–01	Air Cleaner Inspection				•
13–01	Air Compressor Inspection	•	•	•	•
15–01	Alternator, Battery, and Starter Check			•	•
20–01	Pressure Relief Cap Check			•	•
20–02	Radiator Pressure-Flushing and Coolant Change				•
20–03	Fan Clutch Check (noise emission control)			•	•
25–01	Clutch Release Bearing Lubrication*	•	•	•	•
25–02	Fluid Level Check, Hydraulic Clutch Control			•	•
25–03	Fluid Change, Hydraulic Clutch Control				•
26–01	Detroit™ Automated Transmission Fluid Change and Magnetic Plug Cleaning			•	
26–02	Detroit™ Automated Transmission Transmission Fluid Level Inspection			•	•
26–03	Detroit™ Automated Transmission Air Filter Replacement			•	•
26–04	Eaton Fuller Transmission Fluid Change and Magnetic Plug Cleaning†				•
26–05	Eaton Fuller Transmission Transmission Fluid Level Inspection			•	•
26–06	Eaton Fuller Manual Transmission Air Filter/Regulator Check, Cleaning, or Replacement			•	•
31–01	Fifth Wheel Inspection	•	•	•	•
31–02	Fifth Wheel Lubrication	•	•	•	•
31–03	Frame Fastener Torque Check	•			
31–04	Fairing Bumper Wear Check			•	•
32–01	Suspension Inspection			•	•
32–02	Suspension U-Bolt Torque Check	•		•	•
32–03	Lubrication of Front Suspensions with Grease Fittings	•	•	•	•
33–01	Knuckle Pin Lubrication‡			•	•
33–02	Tie Rod Inspection			•	•
33–03	Tie Rod Lubrication‡			•	•
33–04	All-Axle Alignment Check	•			
33–05	Steer Axle Hub Cap Vent Plug Inspection		•	•	•
35–01	Axle Lubricant and Filter Change, and Magnetic Strainer Cleaning				•
35–02	Axle Breather and Axle Lubricant Level Inspection			•	•
40–01	Wheel Nut Check	•	•	•	•
40–02	Tire Check	•	•	•	•
41–01	Driveline Inspection	•	•	•	•
41–02	Driveline Lubrication	•	•	•	•
42–01	Air Brake System Valve Inspection			•	•

Maintenance Operation Sets Table: 00–08

Maintenance Operation Sets					
Maint. No.	Operation Description	Service Schedules I and II			
		IM	M1	M2	M3
42–02	Bendix Air Dryer Desiccant Replacement [§]	•	•	•	•
42–03	Air Dryer Inspection			•	•
42–04	Alcohol Evaporator Cleaning and Inspection			•	•
42–05	Brake Inspection	•	•	•	•
42–06	Dana Spicer, Haldex, and Gunitex Slack Adjuster Lubrication	•	•	•	•
42–07	Meritor Camshaft Bracket Lubrication	•	•	•	•
42–08	Meritor Slack Adjuster Lubrication			•	•
42–09	Bendix E–6 Foot Control Valve Inspection and Lubrication				•
42–10	WABCO System Saver Air Dryer Desiccant Cartridge Replacement [§]	•	•	•	•
42–11	Versajust Slack Adjuster Inspection and Lubrication [¶]		•	•	•
42–12	Bendix Automatic Drain Valve Operating and Leakage Tests**	•	•		
46–01	Drag Link Inspection			•	•
46–02	Power Steering Fluid and Filter Change				•
46–03	Power Steering Fluid Level Inspection			•	•
46–04	Power Steering Gear Lubrication			•	•
46–05	Drag Link Lubrication			•	•
46–06	Rack and Pinion Steering Gear Inspection			•	•
46–07	Bellows Replacement, Rack and Pinion Steering Gear				•
47–01	Fuel Filter Replacement			•	•
47–02	Fuel/Water Separator Element Checking and Replacement			•	•
47–03	Fuel Tank Band-Nut Tightening	•			
47–04	LNG Fuel System Inspecting		•	•	•
47–05	LNG Vacuum Integrity Testing				•
47–06	CNG Fuel System Inspecting		•	•	•
47–07	CNG High-Pressure Fuel Filter Element Replacing		•	•	•
47–08	CNG Fuel Cylinder Inspecting				•
49–01	Exhaust System Inspection (noise emission control)	•	•	•	•
49–02	CAT CGI Bellows Replacement				•
54–01	Trailer Cable Inspection and Cleaning			•	•
60–01	Mirror Folding Check			•	•
60–02	Cab Shock Absorber Bracket Torque Check	•	•	•	•
60–03	Aerodynamic Component Inspection	•	•	•	•
60–04	Baggage Door and Sleeper Access Door Release Cable and Latch Lubrication			•	•
83–01	Air Conditioner Inspection			•	•

Maintenance Operation Sets Table: 00–08

Maintenance Operation Sets					
Maint. No.	Operation Description	Service Schedules I and II			
		IM	M1	M2	M3
83–02	Air Filter Replacement			•	•
83–03	ParkSmart™ Inspection	•	•	•	•
88–01	Hood Rear Support Lubrication	•	•	•	•

* On vehicles equipped with Detroit transmissions, the release bearing does not need to be lubricated. On vehicles equipped with Eaton Fuller UltraShift PLUS transmissions, lubricate the release bearing every 50,000 miles (80 000 km) or 3 months.

† For Eaton Fuller transmissions, fluid change intervals are extended to 500,000 miles (800 000 km) on vehicles filled with synthetic transmission fluid.

‡ For Schedule I vehicles with Detroit axles, complete this procedure once a year or every 25,000 miles (40 000 km), whichever comes first.

§ If equipped with an oil-coalescing desiccant cartridge, replace the cartridge once a year, regardless of mileage. Otherwise use the M3 maintenance interval.

¶ Complete this procedure every 25,000 miles (40 225 km), 3 months, or 500 operating hours, whichever comes first.

** The automatic drain valve should be inspected every 6 months or 1500 operating hours, whichever comes first.

Table 8, Maintenance Operation Sets

Noise Emission Controls Maintenance: 00–09

Noise Emission Control Maintenance

Federal Law, Part 205: Transportation Equipment Noise Emission Controls

Part 205, Transportation Equipment Noise Emission Controls, requires the vehicle manufacturer to furnish, with each new vehicle, such written instructions for the proper maintenance, use, and repair of the vehicle by the ultimate purchaser to provide reasonable assurance of the elimination or minimization of noise-emission-control degradation throughout the life of the vehicle. In compliance with the law, the noise emission controls maintenance information in each applicable group of this manual, in conjunction with the vehicle workshop manual, provides these instructions to owners.

Recommendations for Replacement Parts

Replacement parts used for maintenance or repair of noise emission controls should be genuine Freightliner parts. If other than genuine Freightliner parts are used for replacement or repair of components affecting noise emission control, the owner should be sure that such parts are warranted by their manufacturer to be equivalent to genuine Freightliner parts in performance and durability.

Freightliner Noise Emission Controls Warranty

Refer to the vehicle owner's warranty information book for warranty information concerning noise emission controls.

Tampering with Noise Controls is Prohibited

Federal law prohibits the following acts or the causing thereof:

1. The removal or rendering inoperative by any person (other than for purposes of maintenance, repair, or replacement) of any device or element of design incorporated into any new vehicle for

the purpose of noise control, prior to its sale or delivery to the ultimate purchaser, or while it is in use.

2. The use of the vehicle after such device or element of design has been removed or rendered inoperative by any person.

Among those acts presumed to constitute tampering are the acts listed below:

- A. Removal of engine noise-deadening panels.
- B. Removal of cab-tunnel or hood noise-deadening panels.
- C. Removal of, or rendering inoperative, the engine speed governor so as to allow engine speed to exceed manufacturer's specifications.
- D. Removal of, or rendering inoperative, the fan clutch, including bypassing the control on any thermostatic fan drive to cause it to operate continuously.
- E. Removal of the fan shroud.
- F. Removal of, or rendering inoperative, exhaust components, including exhaust pipe clamping.
- G. Removal of air intake components.

Maintenance Instructions

Scheduled intervals are in the maintenance tables in this group. A "Verification of Inspections Log" for Groups 20 and 49 follows, and should be filled in each time noise emission controls on the vehicle are maintained or repaired.

Verification of Inspections Log

Verification of Inspections Log, Group 20

Verification of Inspections Log — Group 20 — Fan Clutch				
Date	Mileage	Item	Cost	Maintenance Facility

Verification of Inspections Log, Group 49

Verification of Inspections Log — Group 49 — Exhaust System Components				
Date	Mileage	Item	Cost	Maintenance Facility

Title of Maintenance Operation (MOP)

MOP Number

Air Cleaner Inspection 09-01

09–01 Air Cleaner Inspection

Restriction of air flow through the air cleaner element is measured at the tap in the air cleaner outlet. Check the restriction indicator at the air cleaner or in the cab if the vehicle is equipped with a dash-mounted restriction gauge.

Vehicles may be equipped with either a manual-reset restriction indicator with graduations (**Fig. 1**), or a go/no-go restriction indicator without graduations (**Fig. 2**).

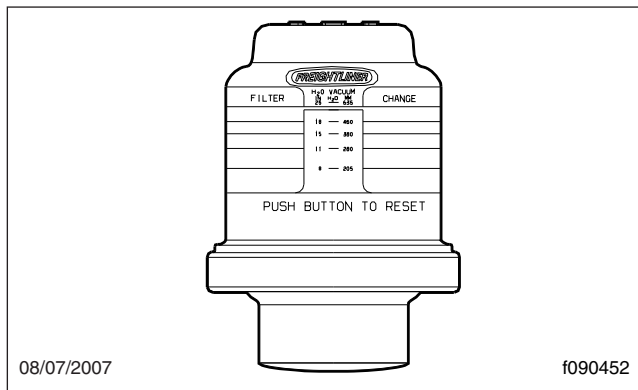

Fig. 1, Manual-Reset Air Restriction Indicator, Graduated

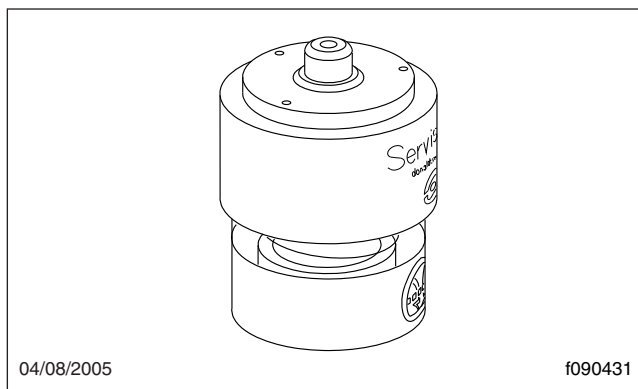

Fig. 2, Manual-Reset Air Restriction Indicator, Go/No-Go

1. Inspect the air restriction indicator to see if air restriction equals or exceeds the maximum allowable restriction. For instructions, see **Group 09** of the *Cascadia Workshop Manual*.

NOTICE

Do not use aftermarket air-cleaner elements. Aftermarket air-cleaner elements may not seal the housing correctly, which can lead to engine damage and potentially the loss of warranty. When replacing an air-cleaner element, use only the part listed in PartsPro for the serial number of the vehicle.

2. If necessary, replace the air cleaner element. For air cleaner element replacement instructions, see **Group 09** of the *Cascadia Workshop Manual*.
3. Inspect the air cleaner housing for cracks, leaks, or any other damage. If the air cleaner housing or element is damaged, replace it.
4. Inspect the forward and rear mounting isolators for damage. See **Fig. 3**. Ensure the bonds between the rubber and the steel plates are completely intact. See **Fig. 4**.
If a mounting isolator is damaged, replace it. For isolator replacement instructions, see **Section 09.01** of the *Cascadia Workshop Manual*.
5. Remove the pre-cleaners (if so equipped) from the hood plenum, then clean them with compressed air.
6. Reset the air restriction indicator.
7. Each time the air cleaner housing is replaced, perform the procedures in **MOP 13–01**.

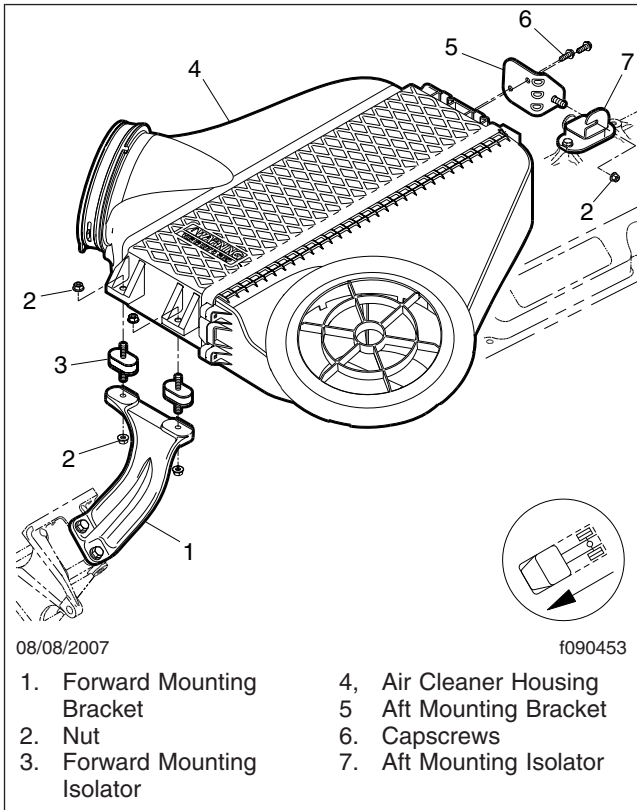

Fig. 3, Air Cleaner Assembly

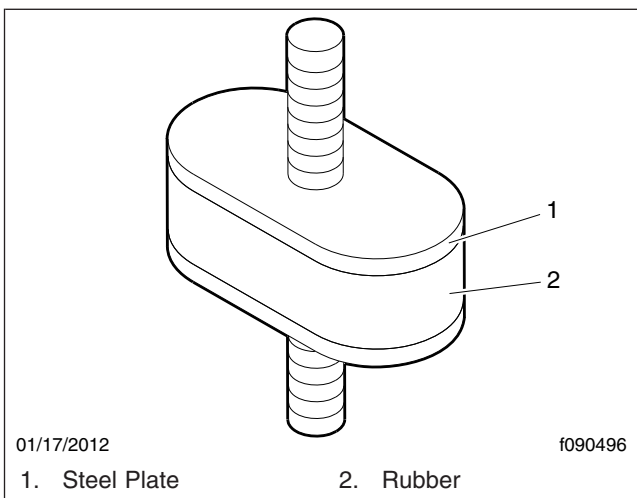

Fig. 4, Mounting Isolator

Title of Maintenance Operation (MOP)	MOP Number
Air Compressor Inspection	13-01
Safety Precautions	13-00

13–00 Safety Precautions

Safety Precautions in this section apply to all procedures within this group.



When working on the vehicle, shut down the engine or motor, set the parking brake, and chock the tires. Before working under the vehicle, always place jack stands under the frame rails to ensure the vehicle cannot drop. Failure to follow these steps could result in serious personal injury or death.

13–01 Air Compressor Inspection

1. Inspect the air compressor intake hoses and connections at the air intake and air compressor for physical damage. If needed, change the hoses, and/or tighten or replace the connections.
2. Inspect the coolant supply and return lines for tight connections. Tighten the connections and replace the lines and fasteners if needed.
3. For the air governor, inspect the piping and connections for leaks. Replace gaskets and faulty components as needed.

Title of Maintenance Operation (MOP)	MOP Number
Alternator, Battery, and Starter Connections Check	15-01
Safety Precautions	15-00

15–00 Safety Precautions

Safety Precautions in this section apply to all procedures within this group.

DANGER

When working on the vehicle, shut down the engine or motor, set the parking brake, and chock the tires. Before working under the vehicle, always place jack stands under the frame rails to ensure the vehicle cannot drop. Failure to follow these steps could result in serious personal injury or death.

15–01 Alternator, Battery, and Starter Connections Check

WARNING

Batteries generate explosive gas as a by-product of their chemical process. Do not smoke when working around batteries. Put out all flames and remove any source of sparks or intense heat in the vicinity of the battery compartment. Make sure the battery compartment has been completely vented before disconnecting or connecting the battery cables.

Battery acid is extremely harmful if splashed in the eyes or on the skin. Always wear a face shield and protective clothing when working around batteries.

1. Disconnect the batteries.
2. Check the tightness of the alternator bracket fasteners; tighten the fasteners as needed. For torque values, see **Group 15** of the *Cascadia™ Workshop Manual*.
3. Check that all electrical connections at the alternator and starter are clean. Clean and tighten all charging system electrical connections, including the connections at the starter B terminal and ground terminal, and where the alternator charging cable terminates.
4. Inspect the battery cables for wear, and replace them if they are damaged. Clean the cable connector terminals with a wire brush. See **Group**

54 of the *Cascadia™ Workshop Manual* for adjustment, repair, or replacement instructions.

- 4.1 Clean and tighten the battery ground cable, terminal, and clamps.
- 4.2 Inspect the retainer assembly or battery hold-downs, and the battery box. Replace worn or damaged parts. Remove any corrosion with a wire brush, and wash with a weak solution of baking soda and water. Flush with clean water, and dry. Paint the retainer assembly if needed, to prevent rusting.
- 4.3 Check that foreign objects, such as stones, bolts, and nuts, are removed from the battery box.
- 4.4 After cleaning, connect the cables to the batteries and tighten them to the torque specifications listed on the battery, generally 10 to 15 lbf-ft (14 to 20 N-m).
- 4.5 Coat the battery terminals with dielectric grease.
5. Check the alternator wiring for missing insulation, kinks, and heat damage. Replace or repair as needed.
6. Check the terminals on the battery shut-off switch and the magnetic switch. Make sure the terminal connections are clean and tight. Coat the terminal connections with dielectric red enamel after cleaning.

Title of Maintenance Operation (MOP)	MOP Number
Fan Clutch Check (Noise Emission Control)	20-03
Pressure Relief Cap Check.	20-01
Radiator Pressure-Flushing and Coolant Change.	20-02
Safety Precautions.	20-00

20–00 Safety Precautions

Safety Precautions in this section apply to all procedures within this group.

DANGER

When working on the vehicle, shut down the engine or motor, set the parking brake, and chock the tires. Before working under the vehicle, always place jack stands under the frame rails to ensure the vehicle cannot drop. Failure to follow these steps could result in serious personal injury or death.

20–01 Pressure Relief Cap Check

WARNING

Do not remove or loosen the surge tank cap until the engine and cooling system have completely cooled. Use extreme care when removing the cap. A sudden release of pressure from removing the cap prior to the system cooling can result in a surge of scalding coolant that could cause serious personal injury.

1. Remove the fill cap first, to relieve the cooling system pressure, then remove the SAE cap; see Fig. 1.
2. Using a radiator-cap tester, check the pressure cap to see if it maintains pressure to within 10% of the pressure rating marked on the cap. If it does not, replace the cap. Make sure that the replacement radiator cap is correctly rated for the cooling system of the vehicle.
3. There is a second valve in the radiator cap that opens under vacuum. This prevents the collapse of hoses and other parts that are not internally supported when the system cools. Inspect the vacuum-relief valve to be sure it is not stuck.
4. Make sure that the cap seals properly on the coolant filler neck seat, and that the radiator cap gasket is not damaged. On vehicles with screw-on caps with O-rings, make sure that the O-ring is not cracked or deteriorated. Replace the cap if the gasket shows deterioration or damage.

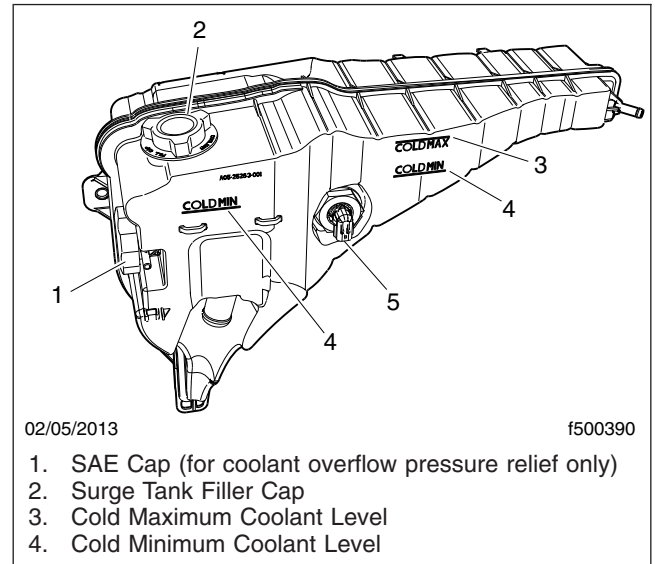

Fig. 1, Surge Tank

20–02 Radiator Pressure-Flushing and Coolant Change

NOTE: For additional instructions on cleaning and flushing the engine cooling system, see the applicable engine manufacturer’s maintenance and operation manual.

1. Apply the vehicle parking brakes, then chock the tires. Tilt the hood.
2. Place a suitable container under the elbow of the radiator outlet pipe and the radiator. The container should hold at least 60 quarts (59 liters) of fluid.

WARNING

Do not remove or loosen the surge tank cap until the engine and cooling system have completely cooled. Use extreme care when removing the cap. A sudden release of pressure from removing the cap prior to the system cooling can result in a surge of scalding coolant that could cause serious personal injury.

3. Remove the surge tank cap.

- Remove the drain plugs at the radiator side tank and at the lower radiator outlet pipe elbow, if equipped. See Fig. 2. Allow the coolant to drain.

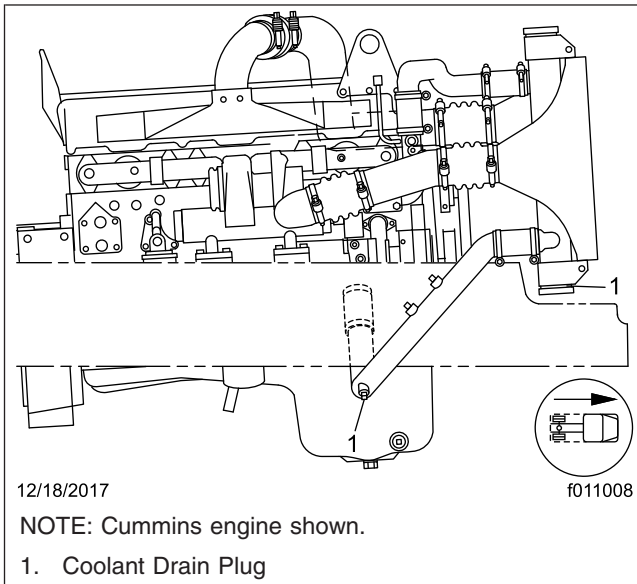

Fig. 2, Coolant Drain Plug Location

- Disconnect the radiator upper and lower hoses, and install the surge tank cap and the radiator side-tank drain plug. Attach the flushing gun nozzle to the radiator at the lower radiator hose opening. Run the water until the radiator is full.

CAUTION

When flushing the radiator, do not apply more than 15 psi (100 kPa) air pressure. Excessive pressure can damage the radiator.

- Gradually, apply up to 15 psi (100 kPa) air pressure to help dislodge sediment that has built up in the radiator core.
- Shut off the air at the pressure gun nozzle and allow the radiator to refill with water.
- Repeat the previous two steps until clean water flows from the radiator.
- Remove the radiator side-tank drain plug and allow the radiator to drain. Install and tighten the side-tank drain plug and the radiator outlet pipe drain plug after the radiator has been drained. Do not overtighten the plugs.

- Connect the hoses. Your hose clamps can be either T-bolt clamps (see Fig. 3) or Breeze Constant-Torque clamps (see Fig. 4).

When working with T-bolt hose clamps, tighten the clamps 55 lbf-in (620 N-cm). These clamps are now standard on hoses with an inside diameter greater than 2 inches (51 mm).

When installing Breeze Constant-Torque hose clamps, the clamps must be tightened to the correct torque. The screw tip of the clamp must extend about 1/4 inch (6 mm) from the clamp housing, and the Belleville washer stacks must be collapsed almost flat. Use a torque wrench to install these clamps correctly. The correct installation torque is as follows:

For Breeze Constant-Torque clamps with a 5/16-inch tightening screw hex: 55 lbf-in (620 N-cm).

For Breeze Constant-Torque clamps with a 3/8-inch tightening screw hex: 90 lbf-in (1020 N-cm).

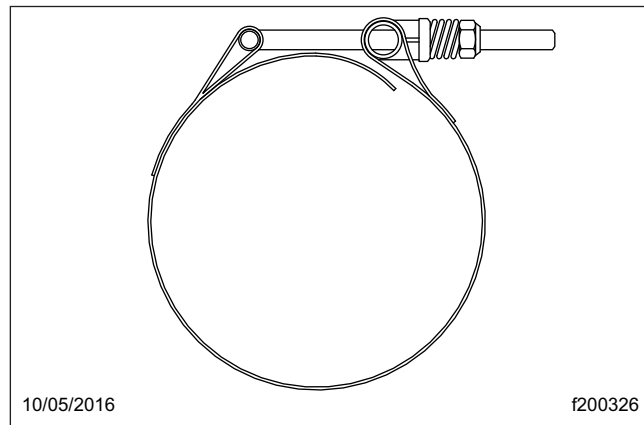

Fig. 3, T-Bolt Type Hose Clamp

NOTE: All hose clamps will lose torque after installation due to "compression set." However, when correctly installed, Breeze Constant-Torque clamps will hold enough torque to automatically adjust and keep consistent sealing pressure. During vehicle operation and shutdown, the screw tip may adjust according to temperature and pressure changes. The torque may need to be adjusted for individual applications.

- Place a pan under the coolant filter to catch engine coolant.

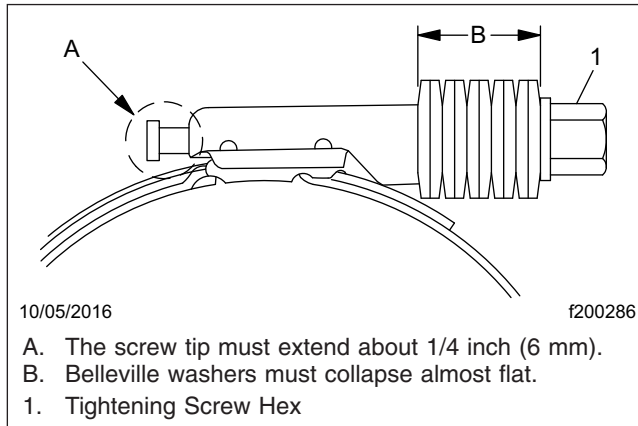

Fig. 4, Breeze Constant-Torque Hose Clamp Installation

12. Remove the coolant filter with a strap or chain wrench. Install a new coolant filter and tighten.
13. Fill the cooling system with new coolant. The cooling system is filled when the coolant level reaches the MAX line on the surge tank. Refer to the engine manufacturer's service literature for specific coolant information.
14. Replace the surge tank cap(s).
15. Return the hood to the operating position.
16. Start the engine and turn on the cab heater. Allow the engine to warm up to normal operating temperature. Check the radiator and hoses for leaks. Repair as needed.
17. Shut off the engine, then check the coolant level in the surge tank. Add coolant if the level isn't at the MAX line on the surge tank.

20-03 Fan Clutch Check (Noise Emission Control)

Borg Warner (Kysor) K26RA Fan Clutch

1. Disconnect the batteries at the negative terminals. Drain all air from the air system.
2. Measure the distance from the back surface of the fan clutch retaining plate to the forward-most edge of the fan belt pulley. See **Fig. 5**, Ref. A.
3. Disconnect the line from the air inlet of the air cylinder. Connect a shop air hose to the inlet.

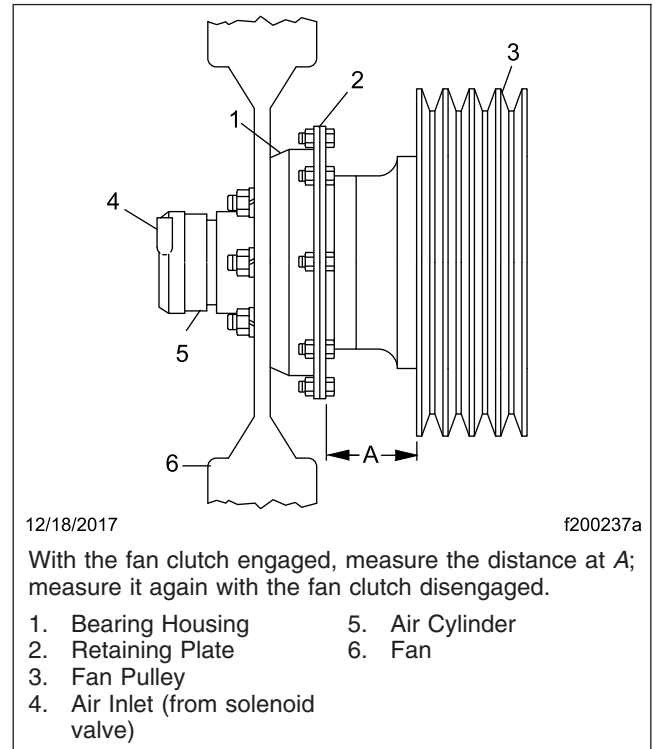

Fig. 5, Kysor K26RA Fan Clutch Lining Wear Check

4. Apply a minimum of 100 psi (690 kPa) air pressure to the air cylinder—the bearing housing will move backwards, disengaging the clutch. Again, measure the distance from the back surface of the retaining plate to the forward-most edge of the fan belt pulley.
5. Compare the two measurements; if the difference between the two measurements exceeds 0.150 inches (3.8 mm), the clutch lining is worn and must be replaced. See **Group 20** of the vehicle Workshop Manual for clutch lining replacement instructions.
6. Release the air pressure, then disconnect the shop hose from the air inlet of the air cylinder. Connect the vehicle air hose to the inlet.
7. Connect the battery cables. Start the engine.

Horton DriveMaster® Fan Clutch

NOTE: If any part of the fan clutch needs to be repaired or replaced after performing the checks below, see **Group 20** of the vehicle Workshop Manual.

1. Disconnect the batteries at the negative terminals.
2. Inspect the electrical connections and wires to the fan clutch solenoid; see **Fig. 6**. Secure the connection if loose; replace wires and connectors if damaged.
3. Clean the fan clutch air solenoid valve filter, if equipped, as follows.
 - 3.1 Unscrew the fan clutch solenoid valve air filter assembly and remove the filter element; see **Fig. 7**.
 - 3.2 Clean the filter element with cleaning solvent.
 - 3.3 Using a clean, lint-free cloth, wipe off any excess solvent.
 - 3.4 Reassemble the clutch valve solenoid air filter, then install it on the vehicle.

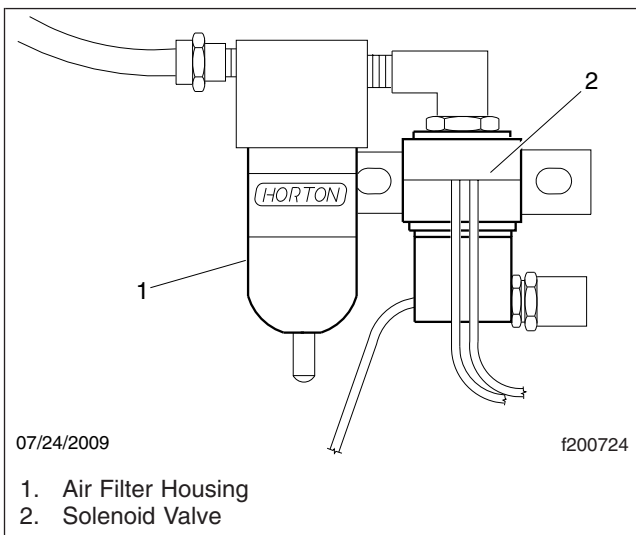

Fig. 6, Horton DriveMaster Air Solenoid Valve

4. Check the fan for bent, cracked, or damaged blades. Replace if damaged. Check for adequate clearance between the fan and other components.
5. Check the fan belt for wear, tension, and alignment. Correct if necessary.
6. Check for wear on the friction facing. Replace the friction facing if it is worn to a 3/16-inch (4.8-mm) thickness or less. Also check the facing for signs of oil contamination or burn marks. If evi-

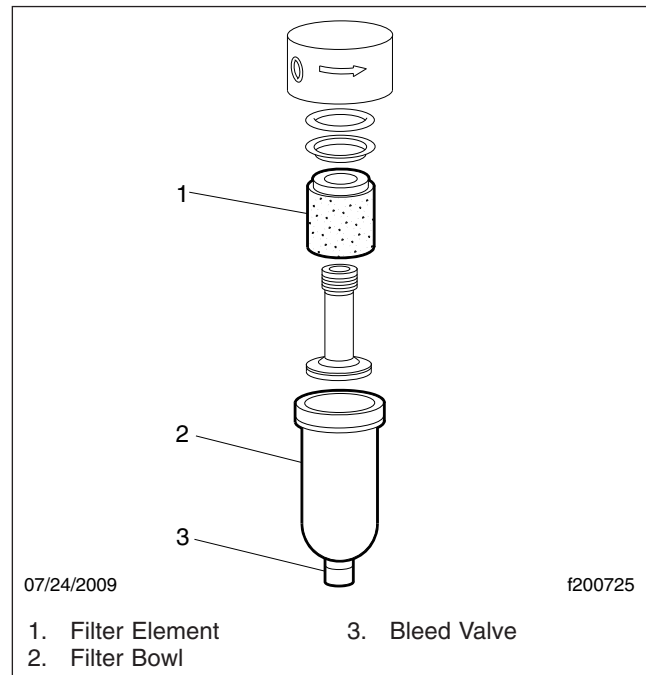

Fig. 7, Horton DriveMaster Solenoid Valve Air Filter

dence of oil or burn marks are found, replace the friction facing.

7. Connect the battery cables. Start the engine, and charge the air system to 120 psi (827 kPa). Manually engage and disengage the fan clutch. Check the fan and fan clutch from a distance. Look for vibration, fan blade contact, fan clutch slippage, and overall fan clutch operation. If the fan clutch does not operate correctly, see **Group 20** of the vehicle Workshop Manual for troubleshooting and repair procedures.
8. With the air system charged to 120 psi (827 kPa), check the fan clutch for audible air leaks, using a suitable listening device. Check at the solenoid valve, the air filter assembly, and the air hoses and fittings. See **Fig. 8**. Using a wet finger or a soapy water solution, check for a leak in the same areas.
9. If a leak is detected, remove the fan blade. Install a new seal kit. See **Group 20** of the vehicle Workshop Manual for repair procedures.
10. Check the fan drive for discoloration or any other signs of slipping or overheating.

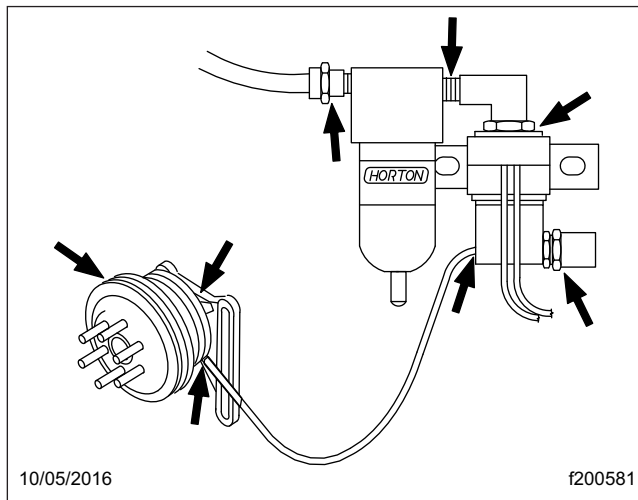

Fig. 8, Checking for Air Leaks (Horton DriveMaster)

NOTE: The fan clutch may slip if the air supply pressure is below 70 psi (483 kPa) or if there is a leak inside the fan clutch. Any leak must be remedied.

11. Check the fan clutch bearings as follows.
 - 11.1 Turn the fan in both directions and feel for worn hub bearings.
 - 11.2 If possible, remove the drive belt and check for worn sheave bearings by turning the sheave in both directions.
 - 11.3 If either the hub or sheave bearings are worn, replace them, using a Horton DriveMaster Super Kit; see **Group 20** of the vehicle Workshop Manual.

Title of Maintenance Operation (MOP)	MOP Number
Clutch Release Bearing Lubrication.	25-01
Fluid Change, Hydraulic Clutch Control.	25-03
Fluid Level Check, Hydraulic Clutch Control	25-02
Safety Precautions.	25-00

25–00 Safety Precautions

Safety Precautions in this section apply to all procedures within this group.

DANGER

When working on the vehicle, shut down the engine or motor, set the parking brake, and chock the tires. Before working under the vehicle, always place jack stands under the frame rails to ensure the vehicle cannot drop. Failure to follow these steps could result in serious personal injury or death.

25–01 Clutch Release Bearing Lubrication

The standard clutch release bearing is not sealed, and requires lubrication. Lubricate the bearing, as follows.

NOTE: On vehicles equipped with Detroit transmissions, the release bearing does not need to be lubricated. On vehicles equipped with Eaton Fuller UltraShift PLUS transmissions, lubricate the release bearing every 50,000 miles (80 000 km) or 3 months.

1. Park the vehicle on a level surface, shut down the engine, and set the parking brake. Chock the tires.
2. Remove the clutch inspection plate to see the release bearing while lubricating it. See [Fig. 1](#).
3. Clean the grease fitting. On some vehicles a lube tube will be used, and the fitting may be at the 9-o'clock position on the left side of the bellhousing (see [Fig. 2](#)).

NOTICE

Do not over-lubricate the clutch release bearing. Over-lubrication could contaminate the clutch internally, causing clutch slippage and premature failure. Do not use chassis grease or multipurpose lubricants.

4. Using a pressure-type grease gun, lubricate the release bearing with NLGI Grade 3 grease until

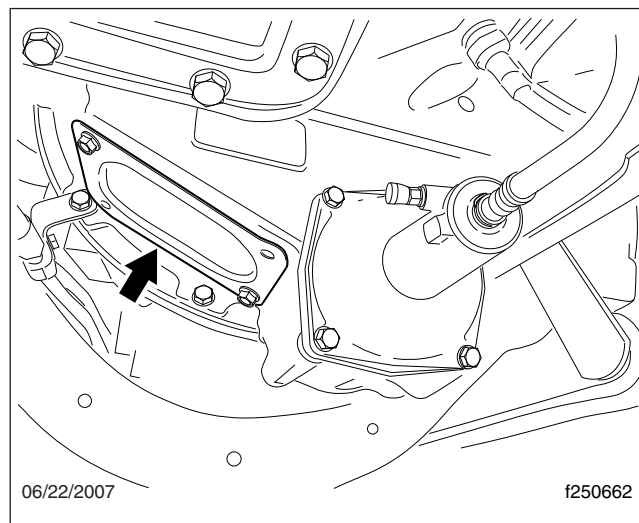

Fig. 1, Typical Clutch Inspection Plate

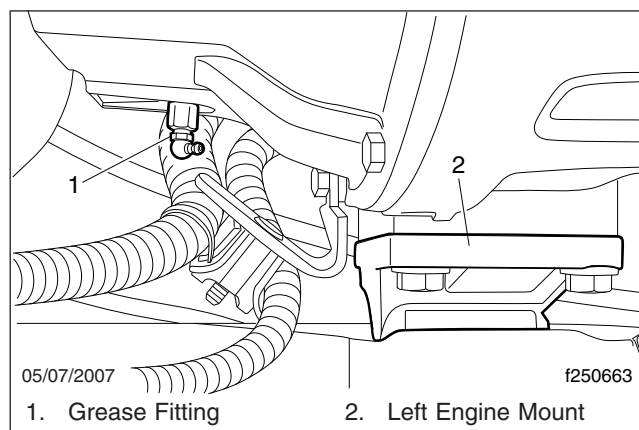

Fig. 2, Typical Release Bearing Grease Fitting

excess grease purges from the rear of the release bearing (toward the transmission).

5. Install the clutch inspection plate.

25–02 Fluid Level Check, Hydraulic Clutch Control

WARNING

Use only approved fluid (DOT 4 brake fluid) in the hydraulic clutch control system. Do not mix different types of brake fluid. The wrong fluid will dam-

age the rubber parts of the system, causing loss of clutch function and the risk of serious personal injury.

Hydraulic clutch control fluid is hazardous. It may be a skin irritant and can cause blindness if it gets in your eyes. Always wear safety glasses when handling it or bleeding hydraulic lines. If you get it on your skin, wash it off as soon as possible.

NOTICE

Do not spill hydraulic clutch control fluid on the cab paint. Clean it off immediately if any is spilled. Brake fluid can damage paint.

Do not allow the fluid level in the reservoir to go below the MIN line. If air enters the system, the hydraulic system will not operate correctly, and the clutch could be damaged.

If the fluid level is below the MIN line, fill the reservoir with new DOT 4 brake fluid from a tightly sealed container until the level reaches the MAX line. See Fig. 3.

25-03 Fluid Change, Hydraulic Clutch Control

Replace the hydraulic clutch control fluid to ensure clutch function is reliable and correct. It can be changed by pressure bleeding or manual bleeding. Pressure bleeding can be done by one person and manual bleeding requires two.

WARNING

Hydraulic clutch control fluid (DOT 4 brake fluid) is hazardous. It may be a skin irritant and can cause blindness if it gets in your eyes. Always wear safety glasses when handling it or bleeding hydraulic lines. If you get it on your skin, wash it off as soon as possible.

NOTICE

Do not spill hydraulic clutch control fluid on the cab paint. Clean it off immediately if any is spilled. Brake fluid can damage paint.

IMPORTANT: The pressure line must slope continuously downward between the master and

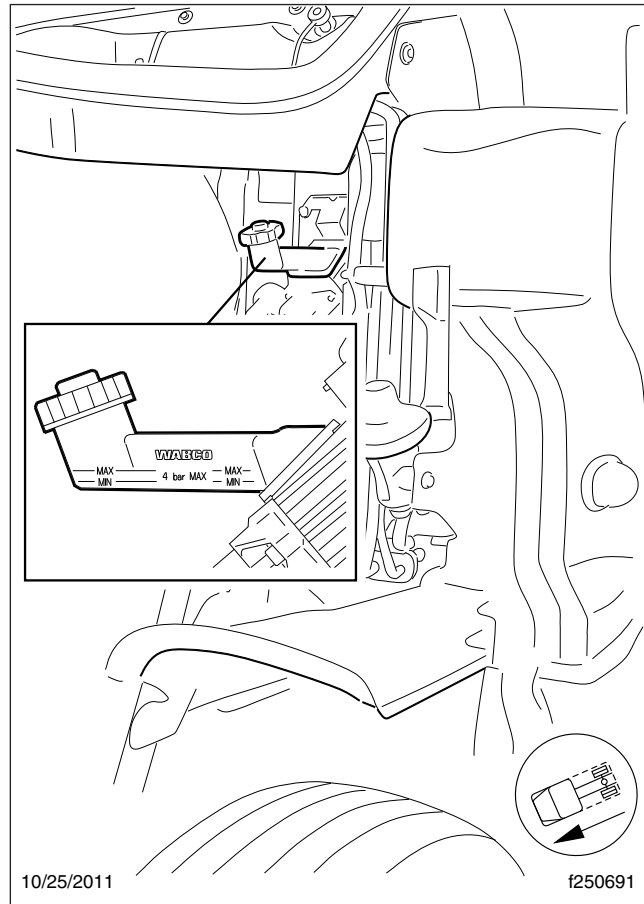

Fig. 3, Reservoir, Hydraulic Clutch Control

slave cylinders. On some vehicles, the securing clamps may need to be removed to achieve this and allow the air to be purged.

Pressure Bleeding

NOTE: A bleeder system (J-29532) and a bleed adaptor (J-35798) for the fluid reservoir are available through SPX Kent-Moore Tools and may be used to complete the following procedure. To order these parts, call Kent-Moore at 1-800-328-6657.

1. Park the vehicle on a level surface, shut down the engine, and set the parking brake. Chock the tires and raise the hood.
2. Prepare the pressure bleeding equipment according to the manufacturer's instructions. Use new DOT 4 brake fluid from a tightly sealed con-

tainer. Pressurize the bleeder system to 15 psi (103 kPa).

3. Remove the reservoir lid (see [Fig. 3](#)) and install the pressure bleed adaptor on the reservoir.
4. Bleed the hydraulic system as follows.
 - 4.1 Open the bleed valve on the bleed tank to pressurize the reservoir.
 - 4.2 Remove the cap from the bleed valve of the slave cylinder. See [Fig. 4](#). On the valve, install a transparent drain hose connected to a catch bottle. The hose needs to fit the bleed valve tight enough so it does not fall off when fluid is pumped out.
 - 4.3 Open the bleed valve on the slave cylinder.
 - 4.4 When the draining fluid is clear and free of air bubbles, close the bleed valve.

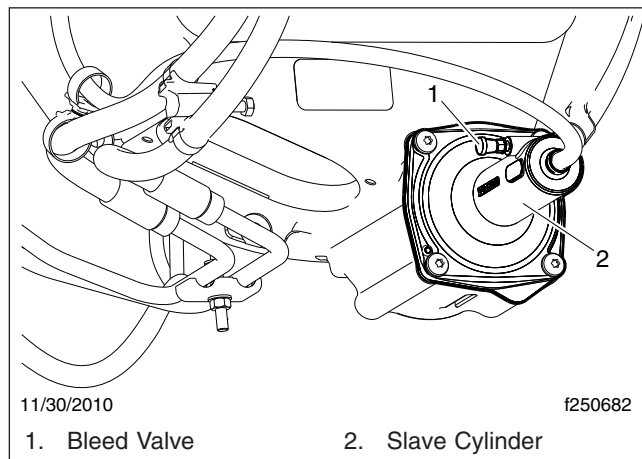

Fig. 4, Slave Cylinder, Hydraulic Clutch Control

5. Check the fluid level in the reservoir. If necessary, add or drain fluid to bring the fluid level to between the MIN and MAX lines marked on the side of the reservoir.
6. Install the reservoir lid.
7. Disconnect the transparent hose. Tighten the bleed screw 88 lbf-in (1000 N-cm) and install the cap on the slave cylinder bleed valve.
8. Depress the clutch pedal a few times. There should be resistance over the full pedal stroke.

Manual Bleeding

1. Park the vehicle on a level surface, shut down the engine, and set the parking brake. Chock the tires and open the hood.

NOTE: The hydraulic system holds approximately 0.5 quart (0.5 liter) of fluid. It may need to be refilled during the bleeding process to prevent air from re-entering the system.

2. Remove the reservoir lid and fill the reservoir (see [Fig. 3](#)) with new DOT 4 brake fluid from a tightly sealed container.
3. Remove the cap from the bleed valve of the slave cylinder. See [Fig. 4](#). On the valve, install a transparent drain hose connected to a catch bottle. The hose needs to fit the bleed valve tight enough so it does not fall off when fluid is pumped out.

NOTE: The following steps require two people—one in the cab to work the clutch pedal, and one to open and close the bleed valve and watch the fluid.

4. Bleed the system, as follows.
 - 4.1 Open the bleed valve.
 - 4.2 Depress the clutch pedal until it stops.
 - 4.3 Close the bleed valve.
 - 4.4 Return the pedal to the upper position.
 - 4.5 Repeat the previous steps until the fluid is clear and free of air bubbles.
 - 4.6 Depress the clutch pedal. There should be resistance over the full pedal stroke.
5. Check the fluid level in the reservoir. If necessary, add or drain fluid to bring the fluid level to between the MIN and MAX lines marked on the side of the reservoir. Install the reservoir lid.
6. Disconnect the transparent hose. Tighten the bleed valve 88 lbf-in (1000 N-cm) and install the cap on the slave cylinder bleed valve.

Title of Maintenance Operation (MOP)	MOP Number
Detroit™ Automated Transmission Air Filter Replacement	26-03
Detroit™ Automated Transmission Fluid Change and Magnetic Plug Cleaning	26-01
Detroit™ Automated Transmission Fluid Level Inspection	26-02
Eaton Fuller Manual Transmission Air Filter/Regulator Check, Cleaning, or Replacement	26-06
Eaton Fuller Transmission Fluid Change and Magnetic Plug Cleaning	26-04
Eaton Fuller Transmission Fluid Level Inspection	26-05
Safety Precautions	26-00

26–00 Safety Precautions

Safety Precautions in this section apply to all procedures within this group.

DANGER

When working on the vehicle, shut down the engine or motor, set the parking brake, and chock the tires. Before working under the vehicle, always place jack stands under the frame rails to ensure the vehicle cannot drop. Failure to follow these steps could result in serious personal injury or death.

26–01 Detroit™ Automated Transmission Fluid Change and Magnetic Plug Cleaning

NOTICE

Operating a transmission with the fluid level higher or lower than recommended can result in transmission damage. Do not overfill the transmission. Overfilling will force fluid out of the case through the main shaft openings.

Do not mix types or brands of fluid, because of possible incompatibility. Do not use fluid additives, friction modifiers, or extreme-pressure gear fluids.

IMPORTANT: Drain the transmission when the fluid is warm. If not already warm, run the engine until the transmission fluid reaches operating temperature. Shift the transmission to neutral (N) and shut down the engine.

1. Apply the parking brakes, and chock the rear tires. Place a large drain pan under the transmission.
2. Clean the area around the fill plug, then remove it from the side of the gear case. Remove the drain plug from the bottom of the case. See [Fig. 1](#).
3. Clean the fill plug and the drain plug.

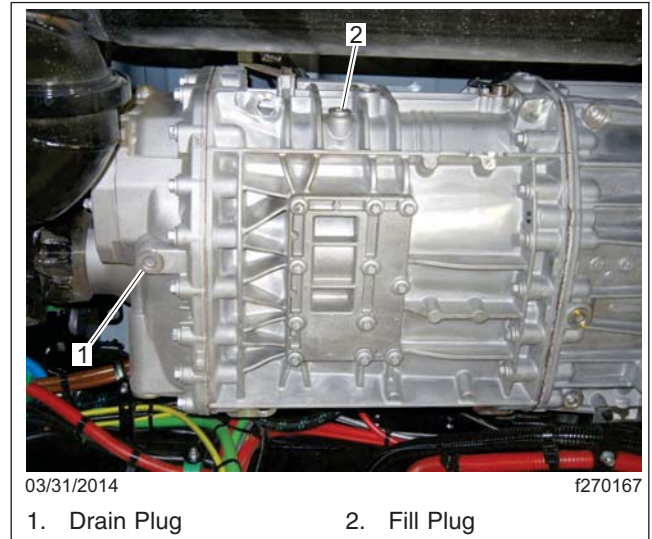

Fig. 1, Drain and Fill Plugs, Detroit Automated Transmissions

4. Install a new seal on the drain plug, then install the plug and tighten it 45 lbf·ft (60 N·m).

NOTICE

Detroit transmissions use synthetic lubricant that meets specific requirements. To see a list of approved lubricants and information to identify which transmissions they can be used with, see the **Transmission Fluid Service Information brochure** at <http://dtna.info/DT12FluidsManual>.

5. Add fluid until it is level with the lower edge of the fill opening; see [Fig. 2](#). See the Detroit Transmission Fluid Service Information brochure at <http://dtna.info/DT12FluidsManual>, for identifying the transmission type, estimated transmission fluid capacities, and applicable fluid specifications.

NOTE: In all cases, the correct fluid level is established by checking at the fill opening.

6. Operate the engine for five minutes after filling the transmission, then check the fluid level again.
7. Install a new seal on the fill plug, then install the plug and tighten it 45 lbf·ft (60 N·m).
8. Operate the vehicle to check for correct operation.

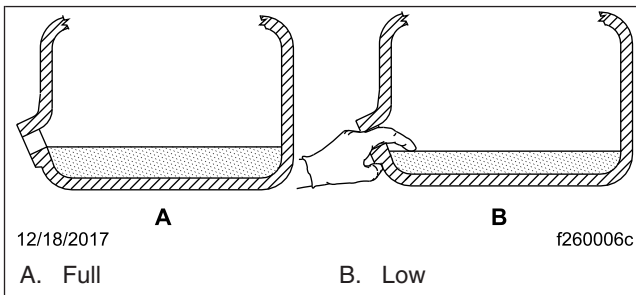

Fig. 2, Checking Transmission Fluid Level



Fig. 3, CO2 DT12



Fig. 4, Classic DT12

26–02 Detroit™ Automated Transmission Fluid Level Inspection

NOTICE

Operating a transmission with the fluid level higher or lower than recommended can result in transmission damage. Do not overfill the transmission. Overfilling will force fluid out of the case through the main shaft openings.

Do not mix types or brands of fluid, because of possible incompatibility. Do not use fluid additives, friction modifiers, or extreme-pressure gear fluids.

With the transmission at operating temperature, and the vehicle on a level surface, check the fluid level in the transmission.

1. Clean the area around the fill plug, then remove it from the side of the gear case.
2. Using your finger or a bent pipe cleaner, see if the fluid is level with the fill opening. See Fig. 2.
3. If the fluid level is low, check the transmission for leaks, and correct as needed.

NOTICE

Detroit transmissions use synthetic lubricant that meets specific requirements. To see a list of approved lubricants and information to identify which transmissions they can be used with, see the Transmission Fluid Service Information brochure at <http://dtna.info/DT12FluidsManual>.

4. If needed, add the recommended fluid until it is level with the lower edge of the fill opening. See the Transmission Fluid Service Information brochure at <http://dtna.info/DT12FluidsManual> for approved transmission lubricants.
5. Clean the fill plug and install a new seal on it. Install the plug in the side of the gear case, then tighten it 45 lbf·ft (60 N·m).

26–03 Detroit™ Automated Transmission Air Filter Replacement

NOTE: The information in this MOP only applies if the vehicle is equipped with a transmission air filter.

1. Park the vehicle on a level surface, shut down the engine, and set the parking brake. Chock the tires.
2. Drain the main air system and the isolated transmission reserve air tank. See Fig. 5.
3. Remove the air filter canister, located between the main air system and the transmission reserve air tank. See Fig. 6.
4. Remove and discard the air filter.
5. Install a new air filter.
6. Install the air filter canister.

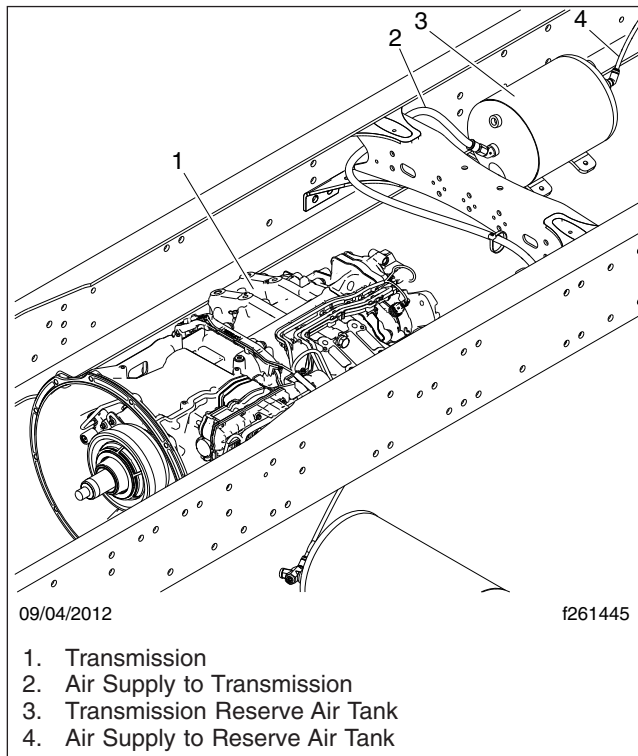

Fig. 5, Isolated Transmission Reserve Air Tank (typical installation)

7. Start the engine and charge the air system.

26-04 Eaton Fuller Transmission Fluid Change and Magnetic Plug Cleaning

NOTE: Information in this MOP applies to Eaton Fuller manual and automated transmissions. Fluid change intervals are extended to 500,000 miles (800 000 km) on any vehicles filled with synthetic transmission fluid.

NOTICE

Operating a transmission with the fluid level higher or lower than recommended can result in transmission damage. Do not overfill the transmission. Overfilling will force fluid out of the case through the main shaft openings.

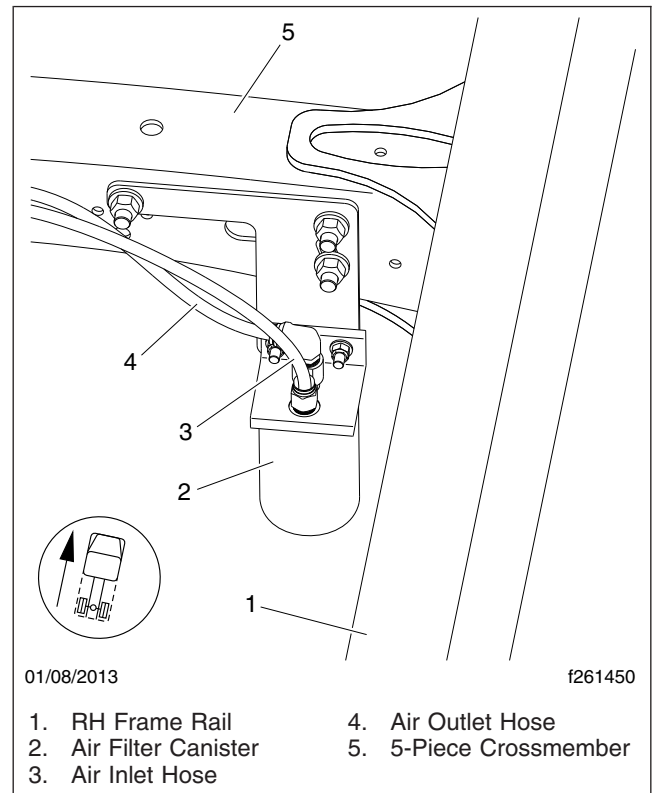

Fig. 6, Detroit Transmission Air Filter (typical installation)

Do not mix types or brands of fluid, because of possible incompatibility. Do not use fluid additives, friction modifiers, extreme-pressure gear fluids, or multiviscosity lubricants.

IMPORTANT: Drain the transmission when the fluid is warm. If not already warm, run the engine until the transmission fluid reaches operating temperature. Shift the transmission to neutral (N) and shut down the engine.

1. Apply the parking brakes, and chock the rear tires. Place a large drain pan under the transmission.
2. Clean the area around the fill plug, and remove it from the side of the gear case. Remove each drain plug from the bottom of the case.
3. Clean the fill and drain plugs. For magnetic plugs, use a piece of key stock or any other convenient steel slug to short the two magnetic poles and divert the magnetic field.

4. Install each drain plug and tighten them 50 lbf-ft (68 N·m).

NOTE: For an Eaton Fuller transmission, the optional transmission fluid filter is a remote-mount, spin-on type, and is located between the transmission and the fluid cooler. The filter bracket is attached to the frame rail or some other nearby location. The filter is mounted in a vertical position, and should be filled with fluid before installation to assure the proper fluid level. For optimum transmission performance, change the filter each time that the fluid is changed.

5. For an Eaton Fuller transmission equipped with a transmission fluid filter(s), replace the fluid filter(s) as follows:
 - 5.1 Place a drain pan under the transmission fluid filter.

⚠ CAUTION

To prevent skin burns from hot transmission fluid, wear protective gloves when removing the filter.

- 5.2 Place a strap or chain wrench around the filter canister, and rotate it in a counter-clockwise motion to separate the filter from the mounting. Carefully spin the filter off the mount and remove it from the vehicle.
- 5.3 Apply a light coat of transmission fluid to the O-ring gasket on the new filter. Fill the filter with specified transmission fluid, and spin the filter onto the mount.

NOTE: The filter fills slowly, so be patient to ensure the proper fluid level has been set.

- 5.4 Once the filter makes contact with the mount, use a strap wrench to rotate the canister an additional 180 to 270 degrees to firmly tighten the filter. Wipe the filter clean of any fluid after it is tightened.
6. Add fluid until it is level with the lower edge of the fill opening. See **Fig. 2**. If the transmission has two fill openings, add fluid to the level of both openings. See **Table 1** for approved transmission lubricants, and **Table 2** for transmission lubricant capacities.

For more information and a complete listing of approved lubricants, refer to the Eaton website, www.roadranger.com.

Eaton Approved Manual and Automated Transmission Lubricants		
Lubricant Type*	Temperature	SAE Viscosity
Synthetic transmission lubricant meeting Eaton PS-386 lubricant specification	All	—

* Do not mix types or brands of lubricant.

Table 1, Eaton Approved Manual and Automated Transmission Lubricants

Eaton Fuller Transmission Lubricant Capacities	
Transmission Model	Refill Capacity: qt (L)
<i>7-Speed T Series</i>	
All Models	18.0 (17.0)
<i>All 9-Speed Series</i>	
All Models	13.5 (12.8)
<i>All 10-Speed Manual (except deep reduction)</i>	
FR and FRO Series	11.75 (11.0)
RT and RTX Series	13.0 (12.3)
RTLO Series	14.0 (13.2)
<i>10-Speed Deep Reduction</i>	
RTO-14908LL	14.0 (13.2)
RTO-16908LL	
<i>10-Speed Advantage</i>	
FA Series	8.0 (7.5)
<i>10-Speed Automated</i>	
Lightning Top 2 (all)	13.5 (12.8)
10-Speed Autoshift AS2 (all)	13.0 (12.3)
<i>13-Speed RTLO Series</i>	
All Models	14.0 (13.2)
<i>15-Speed RTO Series</i>	
All Models	14.0 (13.2)
<i>All 18-Speed Series</i>	
RTLO Series	14.0 (13.2)
18-Speed Autoshift AS2 (all)	
<i>UltraShift PLUS</i>	

Eaton Fuller Transmission Lubricant Capacities	
Transmission Model	Refill Capacity: qt (L)
LAS	13.0 (12.0)
MHP and MXP	14.0 (13.0)

Table 2, Eaton Fuller Transmission Lubricant Capacities

NOTE: In all cases, the correct fluid level is established by checking at the fill opening.

7. Operate the engine for five minutes after filling the transmission, then check the fluid level again.
8. Clean the fill plug, then install it in the transmission. Tighten the plug as follows:
 - For an Eaton Fuller transmission with a plug with 3/4-inch pipe threads, tighten the plug 25 to 35 lbf-ft (34 to 48 N-m).
 - For an Eaton Fuller transmission with a plug with 1-1/4-inch pipe threads, tighten the plug 60 to 75 lbf-ft (81 to 102 N-m).
9. Operate the vehicle to check for correct operation.

26–05 Eaton Fuller Transmission Fluid Level Inspection

NOTICE

Operating a transmission with the fluid level higher or lower than recommended can result in transmission damage. Do not overfill the transmission. Overfilling will force fluid out of the case through the main shaft openings.

Do not mix types or brands of fluid, because of possible incompatibility. Do not use fluid additives, friction modifiers, extreme-pressure gear fluids, or multiviscosity lubricants.

With the transmission at operating temperature, and the vehicle on a level surface, check the fluid level in the transmission.

Some transmissions are equipped with a sight glass for checking the fluid level. For transmissions not so equipped, check the fluid level at the fill plug.

Checking at the Fill Plug

1. Clean the area around the fill plug, and remove it from the side of the gear case.
2. Using your finger or a bent pipe cleaner, see if the fluid is level with the fill opening. See [Fig. 2](#).
3. If the fluid level is low, check the transmission for leaks, and correct as needed.
4. If needed, add the recommended fluid, until it is level with the lower edge of the fill opening. See [Table 1](#) for approved transmission lubricants.
5. Clean the fill plug, then install it. Tighten the plug as follows:
 - For an Eaton Fuller transmission with a plug with 3/4-inch pipe threads, tighten the plug 25 to 35 lbf-ft (34 to 48 N-m).
 - For an Eaton Fuller transmission with a plug with 1-1/4-inch pipe threads, tighten the plug 60 to 75 lbf-ft (81 to 102 N-m).

Checking With the Sight Glass

If the transmission is equipped with a sight glass, check the fluid level as follows:

1. Clean the oil level sight glass. See [Fig. 7](#).
2. Check the fluid level in the sight glass. When the fluid level is at or above 3/4 of the sight glass, then it is at or above the minimum fill level. See [Fig. 8](#).
3. If the fluid level is low, check the transmission for leaks, and correct as needed.
4. If needed, add the recommended fluid, until it is at or above 3/4 of the sight glass. See [Table 1](#) for approved transmission lubricants.

For more information and a complete listing of approved lubricants, refer to the Eaton website, www.roadranger.com.

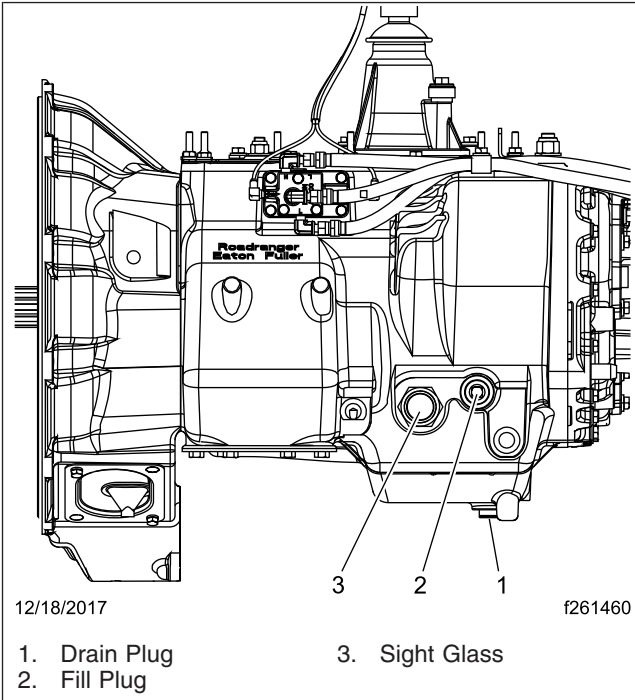

Fig. 7, Eaton Fuller Transmission With a Sight Glass

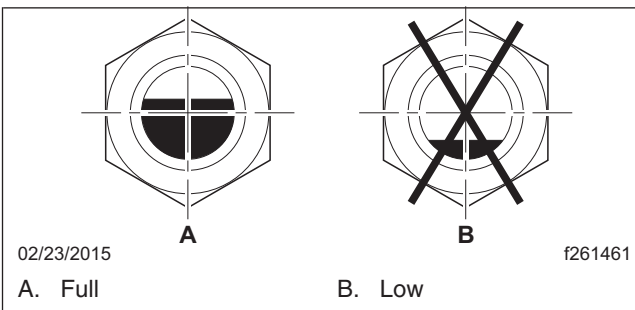

Fig. 8, Transmission Fluid Level Sight Glass

26-06 Eaton Fuller Manual Transmission Air Filter/Regulator Check, Cleaning, or Replacement

1. Apply the parking brakes, and chock the rear tires. Drain the air reservoirs.

WARNING

Drain the air supply; if the air supply is not drained before the air filter/regulator is serviced, serious injury and component damage could result.

2. Clean the outside of the air filter/regulator with cleaning solvent. See Fig. 9.

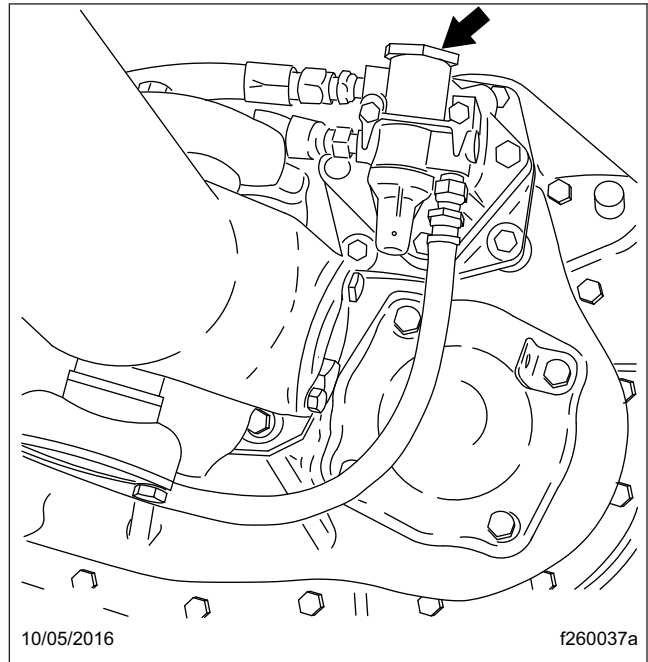

Fig. 9, Air Filter/Regulator Location

3. Remove the end cap, large O-ring, and filter element from the filter housing. See Fig. 10. Remove the small O-ring from the end cap.

NOTE: Do not remove, disassemble, or adjust the air regulator. If the air regulator is not keeping air pressure between 58 and 63 psi (400 and 435 kPa), replace the air filter/regulator. It cannot be repaired.

WARNING

Wear safety goggles when using compressed air to clean parts, as permanent harm to eyes could result from flying debris.

4. Clean the filter element by dipping it in alcohol or other cleaning solvent. Blow compressed air

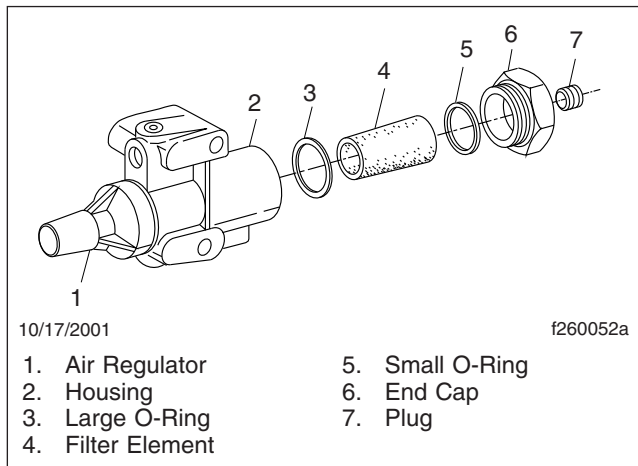

Fig. 10, Eaton Fuller Transmission Air Filter/Regulator Components

through the element (inside to outside) to loosen surface dirt and to dry the element. If it is not damaged, the sintered metallic filter element will last the life of the vehicle.

Wipe out the filter housing with a clean, dry, lint-free rag. Clean and inspect the O-rings and end cap. Replace any parts that are damaged.

5. Install the large O-ring, then the filter element (small end first) into the filter housing.
6. Install the small O-ring in the end cap, then install the end cap and tighten it until firm.

CAUTION

A leaking air filter or air lines can cause slow or hard shifting of the transmission, and eventual transmission damage.

7. Start the engine, and build pressure in the air system. Check for air leaks at the filter housing and air line connections; repair any leaks.

Title of Maintenance Operation (MOP)	MOP Number
Fairing Bumper Wear Check	31-04
Fifth Wheel Inspection	31-01
Fifth Wheel Lubrication	31-02
Frame Fastener Torque Check	31-03
Safety Precautions	31-00

31-00 Safety Precautions

Safety Precautions in this section apply to all procedures within this group.

DANGER

When working on the vehicle, shut down the engine or motor, set the parking brake, and chock the tires. Before working under the vehicle, always place jack stands under the frame rails to ensure the vehicle cannot drop. Failure to follow these steps could result in serious personal injury or death.

31-01 Fifth Wheel Inspection

WARNING

All fifth wheel maintenance, adjustment, and rebuilding must be done only by a qualified mechanic. Improper or incomplete procedures could result in a possible disengagement of the trailer from the tractor, which could result in personal injury or property damage.

Parts are under spring compression. Wear safety goggles while servicing the fifth wheel. Failure to do so can result in personal injury, due to parts ejecting with force.

WARNING

All fifth wheel maintenance, adjustment, and rebuilding must be done only by a qualified mechanic. Improper or incomplete procedures could result in a possible disengagement of the trailer from the tractor, which could result in personal injury or property damage.

Parts are under spring compression. Wear safety goggles while servicing the fifth wheel. Failure to do so can result in personal injury, due to parts ejecting with force.

Holland FWS1

1. Disconnect the tractor from the trailer. For instructions, see the vehicle Driver's/Operator's Manual.
2. Thoroughly steam clean the fifth wheel.

3. Check the fifth wheel plate for cracks. Check for sharp edges on top; the chamfer should be 1/8 to 1/4 inch (3 to 6 mm).
4. When the wheel is locked, the safety latch must swing free and fall freely into position. See [Fig. 1](#).

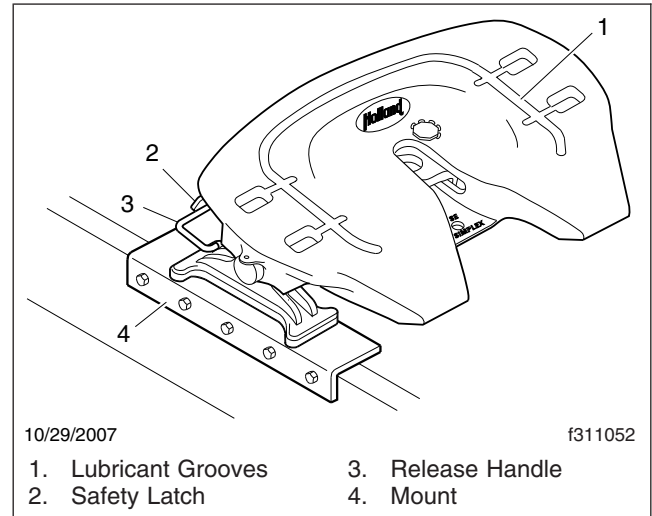

Fig. 1, Holland FWS1 Fifth Wheel

5. The lever bar and release handle must be in proper alignment. See [Fig. 2](#). Compare the lever bar and release handle alignment to a new, or a properly operating lever bar and release handle. Replace any bent or misaligned lever bar or release handle.

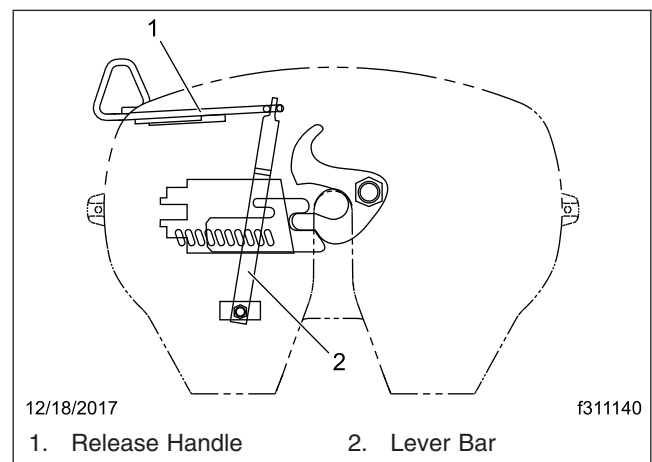

Fig. 2, Lever Bar and Release Handle Alignment

6. Check all cotter pins for cracking or damage. Replace any cotter pin that shows any signs of damage.
7. Check all mounting bolts for signs of fatigue, and tighten them to the proper torque. For torque specifications, see **Group 00** of the vehicle Workshop Manual. Inspect all angles, plates, and brackets for cracks or other damage.
8. Replace cracked, worn, or damaged parts with new parts. Replace all loose mounting bolts with 5/8–11 SAE grade 8 bolts, grade C locknuts, and hardened washers. *Do not* re-use bolts, nuts, and washers on fifth wheel mountings.
9. After inspecting the fifth wheel, lubricate all moving parts with a chassis or multipurpose grease. See **MOP 31–02** for lubrication instructions.

Holland FW35

1. Disconnect the tractor from the trailer. For instructions, see the vehicle Driver's/Operator's Manual.
2. Thoroughly steam clean all fifth wheel components before inspection.
3. Check for cracks in the fifth wheel assembly, mounting brackets, and mounting parts.
4. Check the fastener torques on the fifth wheel assembly and fifth wheel mounting. Tighten bolts and nuts as needed. Replace missing or damaged bolts.
5. Inspect the fifth wheel for bent, worn, damaged, and missing parts; replace them as needed with genuine Holland parts.
6. Using a Holland Kingpin Lock Tester (Holland tool number TF-TLN-5001, available through the PDCs as HLD TFTLN5001), check the operation of the locking mechanism by opening and closing the locks. See **Fig. 3**.
7. After inspecting the fifth wheel, lubricate all moving parts with a chassis or multipurpose grease. See **MOP 31–02** in this manual for lubrication instructions.

Fontaine

1. Disconnect the tractor from the trailer. For instructions, see the vehicle Driver's/Operator's Manual.

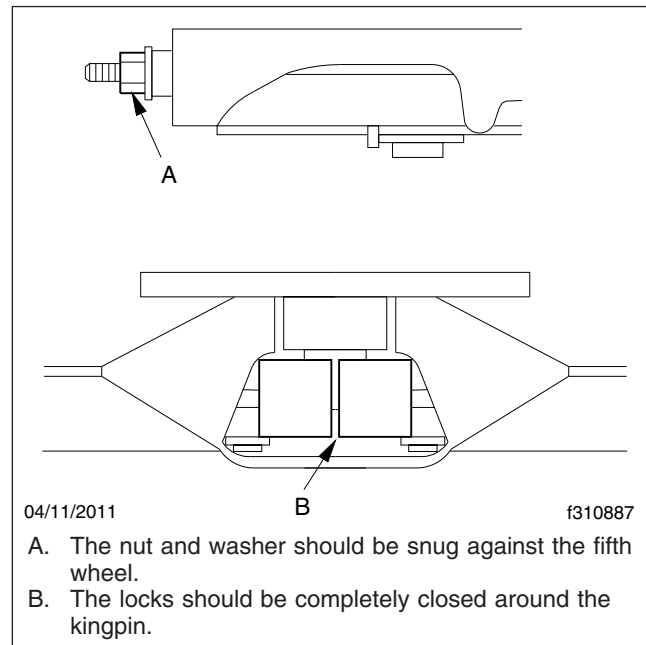

Fig. 3, Holland Fifth Wheel Properly Closed

2. Thoroughly steam clean the fifth wheel.
3. Check for cracks in the fifth wheel assembly, mounting brackets, and mounting parts.
4. Ensure that both bracket pins are in place and secured by retainer pins and cotter pins. See **Fig. 4**.
5. For fifth wheels equipped with bracket liners, rock the fifth wheel. If it does not rock freely, remove the top plate and inspect the bracket liners. Replace liners that are broken or less than 0.125 inch (3 mm) thick at the top of the liners. For the liner replacement procedure, see the Fontaine website, www.fifthwheel.com.
6. Check the jaw and stationary jaw for mushrooming, and check that the serrations at the jaw and wedge are in good condition.
7. Test the secondary safety lock latch for ease of operation.
8. Check for loose nuts or bolts on the fifth wheel and the mounting. Set a torque wrench to the maximum torque value for the bolt being checked, and confirm that the torque is to specification. Do not loosen the bolt to check the torque. For torque specifications, see **Group 00** of the vehicle Workshop Manual.

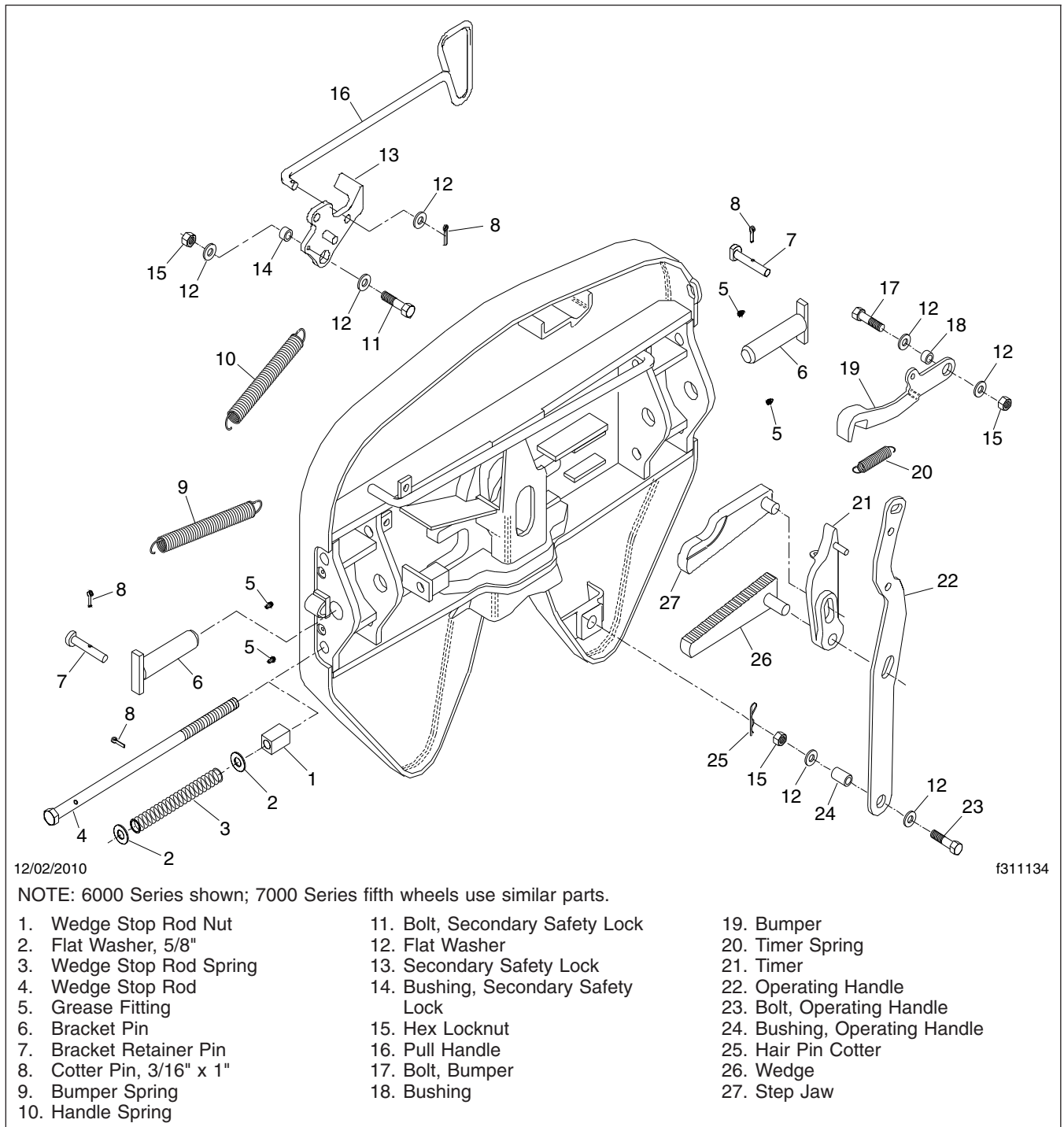

Fig. 4, Fontaine Fifth Wheel

9. Check all springs to see if they are securely fastened, and are not deformed.

⚠ WARNING

Do not disassemble the fifth wheel to inspect the springs. The springs are under extreme pressure, and could cause serious injury.

10. Check the wedge adjustment.
 - 10.1 Close the fifth wheel on a standard 2-inch (50-mm) kingpin or similar 2-inch (50-mm) diameter shaft so that it locks.
 - 10.2 Push on the wedge stop rod with hand pressure. It should move in 1/4 inch (6 mm) and spring back out on release.

If the free travel is not 1/4 inch (6 mm), adjust the distance to 1/4 inch (6 mm) by turning the wedge stop rod, on the right side of the top plate, clockwise to reduce the gap and counter-clockwise to increase it.
11. Replace cracked, worn, or damaged parts with new parts. Replace all loose mounting bolts with 5/8–11 SAE grade 8 bolts, grade C locknuts, and hardened washers. *Do not* re-use bolts, nuts, and washers on fifth wheel mountings.
12. After inspecting the fifth wheel, lubricate all moving parts with a chassis or multipurpose grease. Apply a generous coating of grease to the top plate to fill the grooves, or depressions, on the top plate. See **MOP 31–02** in this manual for lubrication instructions.

Jost

1. Disconnect the tractor from the trailer. For instructions, see the vehicle Driver's/Operator's Manual.
2. Thoroughly steam clean the fifth wheel.
3. Check the mounting for missing or damaged fasteners, and broken components. Replace or repair as needed.
4. Inspect the bracket pin bolts. Make sure the locking tabs are properly securing the bolts in place. See **Fig. 5**.
5. Check the fifth wheel for bent, worn, or broken parts. Replace as needed.

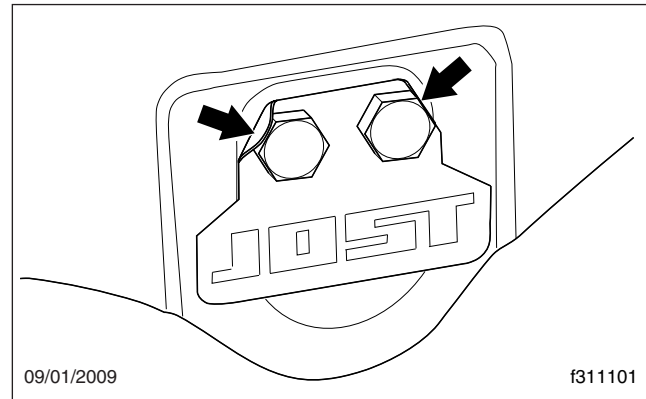

Fig. 5, Bracket Pin Bolt Locking Tabs

6. If the fifth wheel is equipped with low-lube plates, check the plates and replace if damaged or worn down to the securing bolts. It is normal for outside edges of the plate to pucker slightly; this does not affect performance.
7. Check the fifth wheel adjustment. Using a lock tester, lock and unlock the fifth wheel several times. Make sure that the locking mechanism works properly.

The lock is properly adjusted if: the wheel locks and unlocks easily each time and the lock tester rotates freely.

The lock is too loose if: you feel fore-aft play when pulling and pushing on the lock tester handle. See **Fig. 6**, Ref. A.

The lock is too tight if: the lock tester does not rotate freely in the lock. See **Fig. 6**, Ref. B.
8. If the lock is improperly adjusted, correct as follows.

If the lock is too tight, loosen the jam nut, turn the adjustment bolt *clockwise* one full turn, then reset the jam nut. Lock and unlock the mechanism several times to test. Repeat if necessary. See **Fig. 7**.

If the lock is too loose, loosen the jam nut, turn the adjustment bolt *counterclockwise* one full turn, then reset the jam nut. Lock and unlock the mechanism several times to test. Repeat if necessary. See **Fig. 7**.
9. If the fifth wheel is equipped with a sliding mechanism, inspect and adjust it as follows.

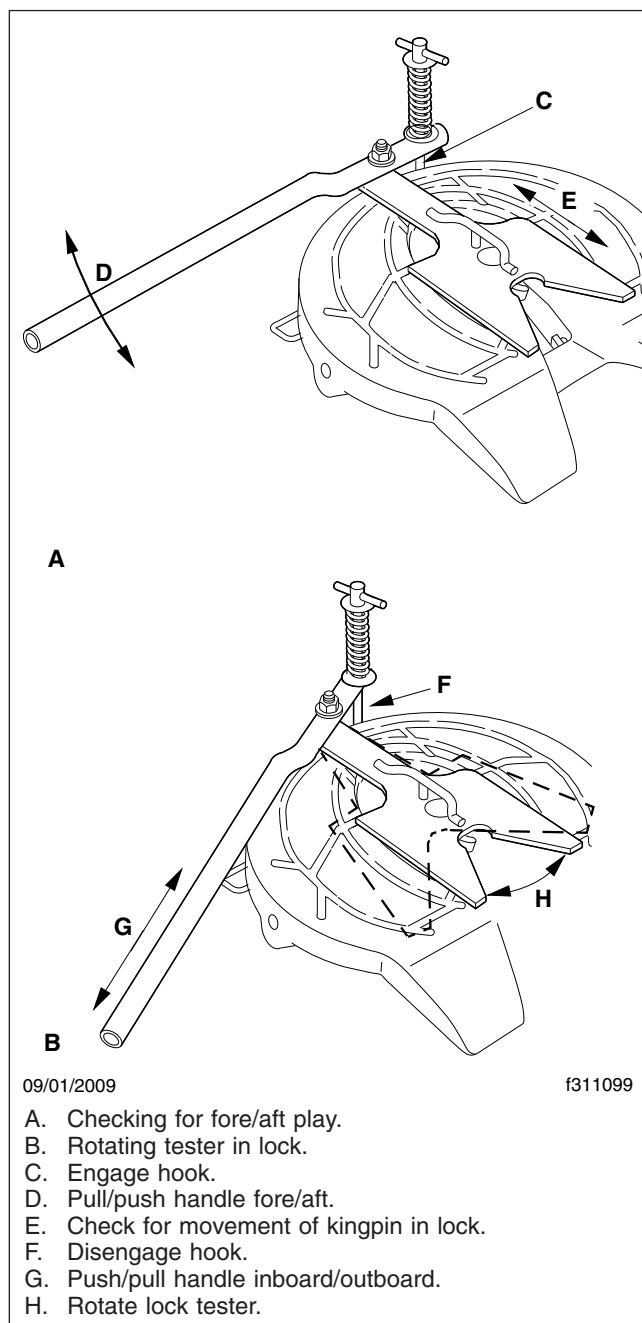

Fig. 6, Jost Fifth Wheel Adjustment

- 9.1 Check the bracket for any cracks or missing and damaged parts.
- 9.2 Inspect the locking plungers for full engagement.

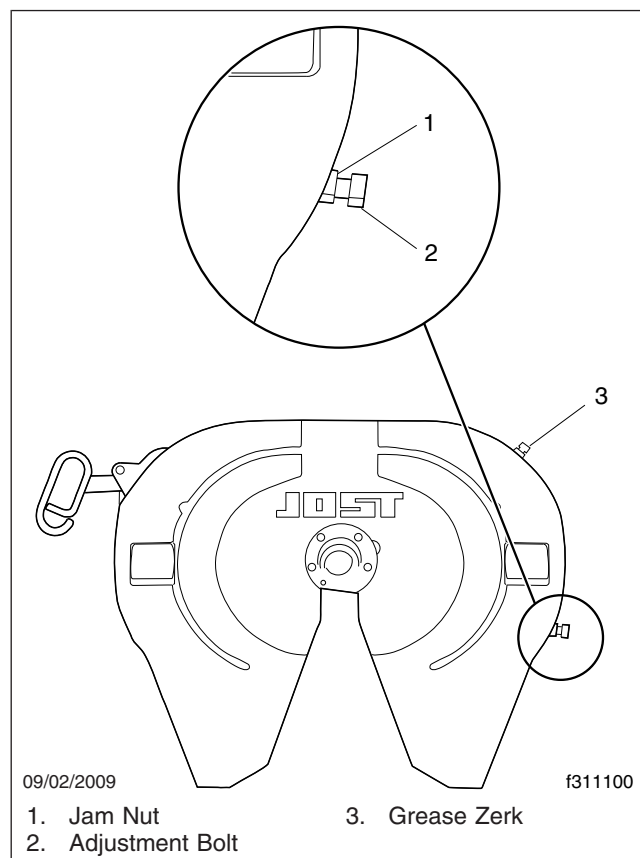

Fig. 7, Jost Fifth Wheel

- 9.3 Check the locking mechanism for proper operation.
If the plungers will not release, check the air cylinder or plunger adjustment.
If the plungers are loose, check the plunger adjustment and the plunger springs for proper compression. Replace if needed.
- 9.4 The outboard slider assembly requires no adjustment. If the plungers are loose, inspect and replace locking mechanism parts as needed.
- 9.5 The inboard slider is adjustable for frame width and plunger engagement. For adjustment, refer to the fifth wheel installation instructions.
- 10. Replace cracked, worn, or damaged parts with new parts. Replace all loose mounting bolts with 5/8–11 SAE grade 8 bolts, grade C locknuts, and

hardened washers. *Do not* re-use bolts, nuts, and washers on fifth wheel mountings.

11. After inspecting the fifth wheel, lubricate all moving parts with a chassis or multipurpose grease. Apply a generous coating of grease to the top plate to fill the grooves, or depressions, on the top plate. See **MOP 31–02** in this manual for lubrication instructions.

31–02 Fifth Wheel Lubrication

To maintain proper fifth wheel operation, always lubricate the fifth wheel after an inspection has been performed.

IMPORTANT: Lubricate the fifth wheel:

- After power washing, or steam cleaning.
- If the vehicle operates in harsh conditions such as salt spray from road surfaces, or in extremely dusty environments.
- After any service that requires removal of lubricant from the fifth wheel head or components.

WARNING

Failure to properly lubricate the fifth wheel could result in a possible disengagement of the trailer from the tractor, which could result in personal injury or property damage.

Fontaine

1. Tilt the top plate forward (the front of the fifth wheel is down) and apply grease to each bearing area through the zerk fittings located on each side of the top plate just to the front of the bracket pins. Continue to apply grease until it is coming out of the back of the bearing. It may be necessary to raise the rear of the fifth wheel with a pry bar to open up the pocket slightly and allow the grease to flow through. A substantial amount of grease may be required initially to fill the reservoir.

Tilt the fifth wheel ramps down (the rear of the fifth wheel is down) and repeat the greasing procedure. Rock the top plate back and forth several times to spread the grease over the bearing surface.

2. Inspect the trailer kingpin plate and top surface of the fifth wheel to make sure each is properly greased. A liberal coating of grease should be applied to the complete surfaces of both the trailer kingpin plate and the top surface of the fifth wheel.

NOTE: Do not use a lube plate (high density polyethylene) on top of the fifth wheel or on the kingpin instead of grease without prior approval by Fontaine Fifth Wheel. The additional thickness of this material can prevent the proper operation of the fifth wheel and may cause a dangerous condition.

NOTE: Fontaine suggests the use of a Moly based lubricant such as Mobilgrease XHP 320 or equivalent when applying lubricant to the locking jaw and wedge.

3. Lubricate the fifth wheel prior to opening and closing it. Separate the jaw and wedge with a screwdriver, and grease the full length of their mating surfaces. Lubricate the top and bottom contact surfaces of the jaw and wedge. See **Fig. 8**. Open and close the fifth wheel several times to further distribute the grease.

Lightly oil other moving parts in the fifth wheel.

4. Apply grease to the top plate. Spread grease all over the mating surface of the top plate. Be sure the grease pockets built into the top plates are full of grease.

Holland FWS1

Apply a heavy coat of grease to the top plate, either through the grease fittings located on the underside of the top plate, or by direct application.

Holland FW35

1. Using a water-resistant lithium-base grease, grease the top plate.
2. Using a light oil (such as SAE 10W or 20W motor oil), lubricate the cam track and pivot. See **Fig. 9**.
3. Grease the yoke tips, locks, and the release handle and spring; see **Fig. 10**. Grease the mounting bracket supports through the grease fittings. A “low temp” grade grease rated for -30°F (-34°C) or lower such as Cato Oil and

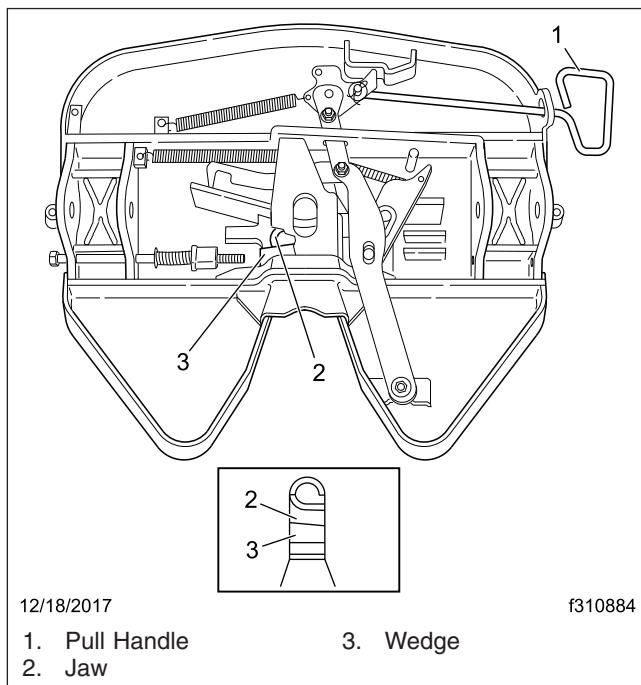

Fig. 8, Fontaine Fifth Wheel

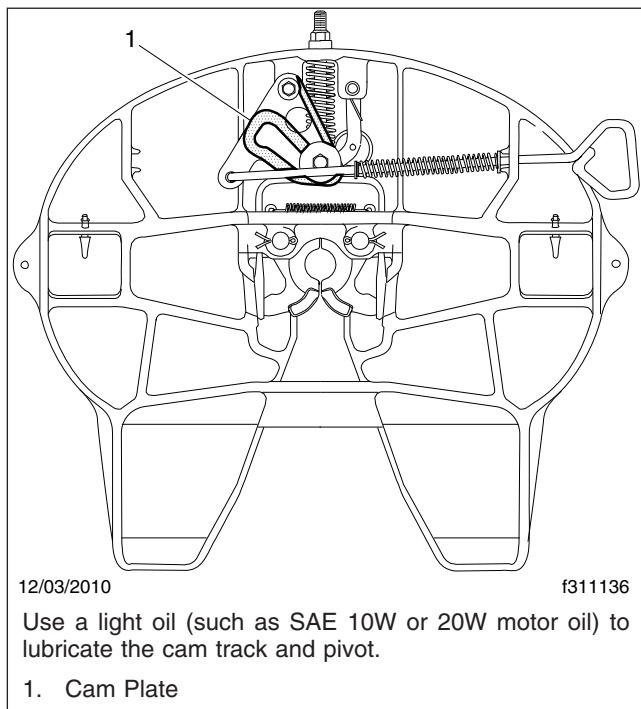

Fig. 9, Holland FW35 Fifth Wheel, Oil Lubrication

Grease #5213, Craftsman Chemical Co. #LTF 2, Mystic LP-200, or equivalent is recommended.

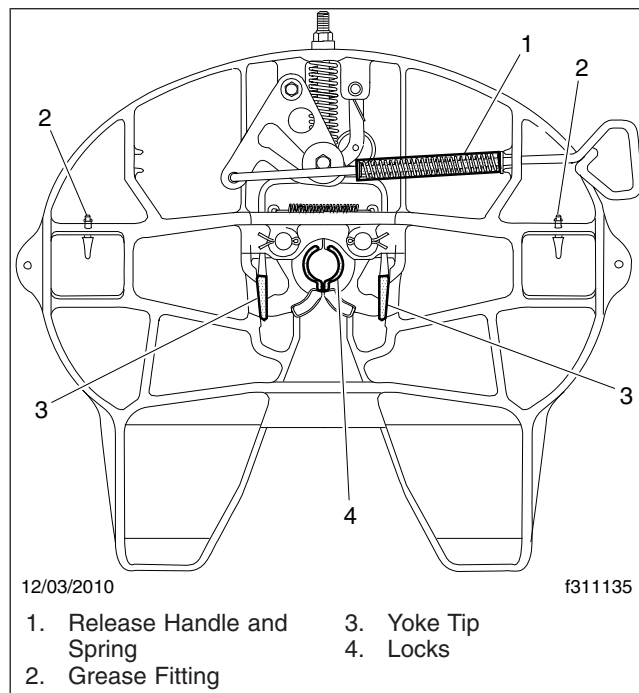

Fig. 10, Holland FW35 Fifth Wheel, Grease Lubrication

Just

Lubricate the kingpin lock using a hand pump grease gun through the grease zerk on the skirt of the fifth wheel; see Fig. 7. Apply a light oil to all moving parts. For sliding fifth wheels spray diesel fuel on the slide path of the base plate.

NOTICE

Do not use a power grease gun. The pressure will damage the lube line.

If the fifth wheel is not equipped with low-lube plates, apply a lithium-based grease with extreme pressure (EP) additive to the trailer contact surface of the fifth wheel.

NOTE: If the fifth wheel is equipped with low-lube plates, the top plate only requires lubrication at the new product break-in stage. The low-lube plates require no further lubrication.

31–03 Frame Fastener Torque Check

Frame brackets and components secured with Huck-bolt® fasteners do not require a torque check, however, they should be inspected for damage. Frame brackets and components secured with conventional bolts and nuts are to be checked at Initial Maintenance (IM). Check the torque of frame fasteners to offset the effects of "bedding in" (or seating). When checking torque, torque the nut, not the bolt head whenever possible. This will give a true torque reading by eliminating bolt-body friction. When checking the torque of frame fasteners, inspect the frame for cracks and other damage. Set a click-type torque wrench to the maximum torque of the fastener you are checking. Apply pressure until the torque wrench clicks. Do not loosen the bolt to check the torque. See **Group 00** in the vehicle workshop manual for torque specifications.

NOTICE

Make sure frame fasteners are properly tightened. Continued vehicle operation with loose fasteners could result in bracket or frame damage.

Check the fasteners at the following locations:

- axle stops
- deck plates
- equalizer brackets
- exhaust brackets
- fifth wheel legs
- fifth wheel mountings
- frame crossmembers and gussets
- front frame brackets
- front suspension spring brackets
- fuel tank brackets
- radius rods
- rear suspension spring brackets
- shock absorbers
- all other suspension fasteners
- all other axle fasteners
- all other frame fasteners

Any component that shows signs of cracking or other damage must be repaired or replaced. Refer to the vehicle workshop manual for repair or replacement information.

31–04 Fairing Bumper Wear Check

Vehicles equipped with chassis side fairings, and forward mounted battery boxes, have latched front panels. The bumpers on these fairings provide the tension for the latch mechanism. These bumpers will wear over time, and will not properly hold the fairings in place.

1. Open the latched section of the fairing panel.
2. Inspect the rubber bumpers for wear. See [Fig. 11](#) for the bumper wear area, and [Fig. 12](#) for the bumper location.

If the bumper rubber is worn down even with the top of the metal cup, or if there are signs of the metal cup coming in contact with the surface of the brace that the bumper makes contact with, replace the bumper.

3. Tighten the fastener 10 to 13 lbf·ft (14 to 18 N·m).
4. Close and latch the fairing.

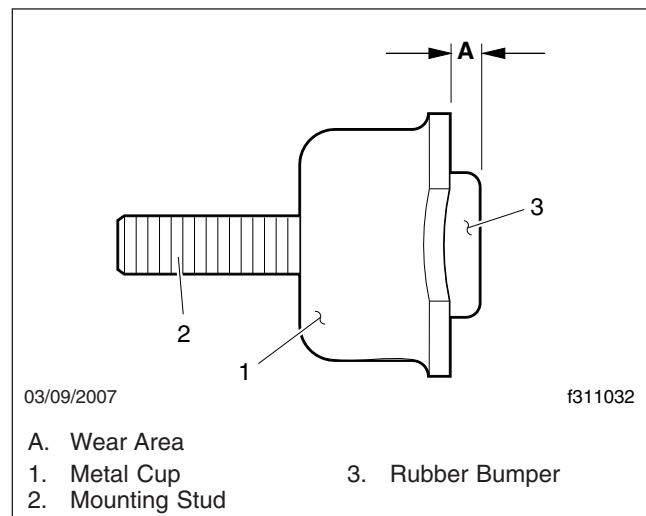

Fig. 11, Fairing Bumper

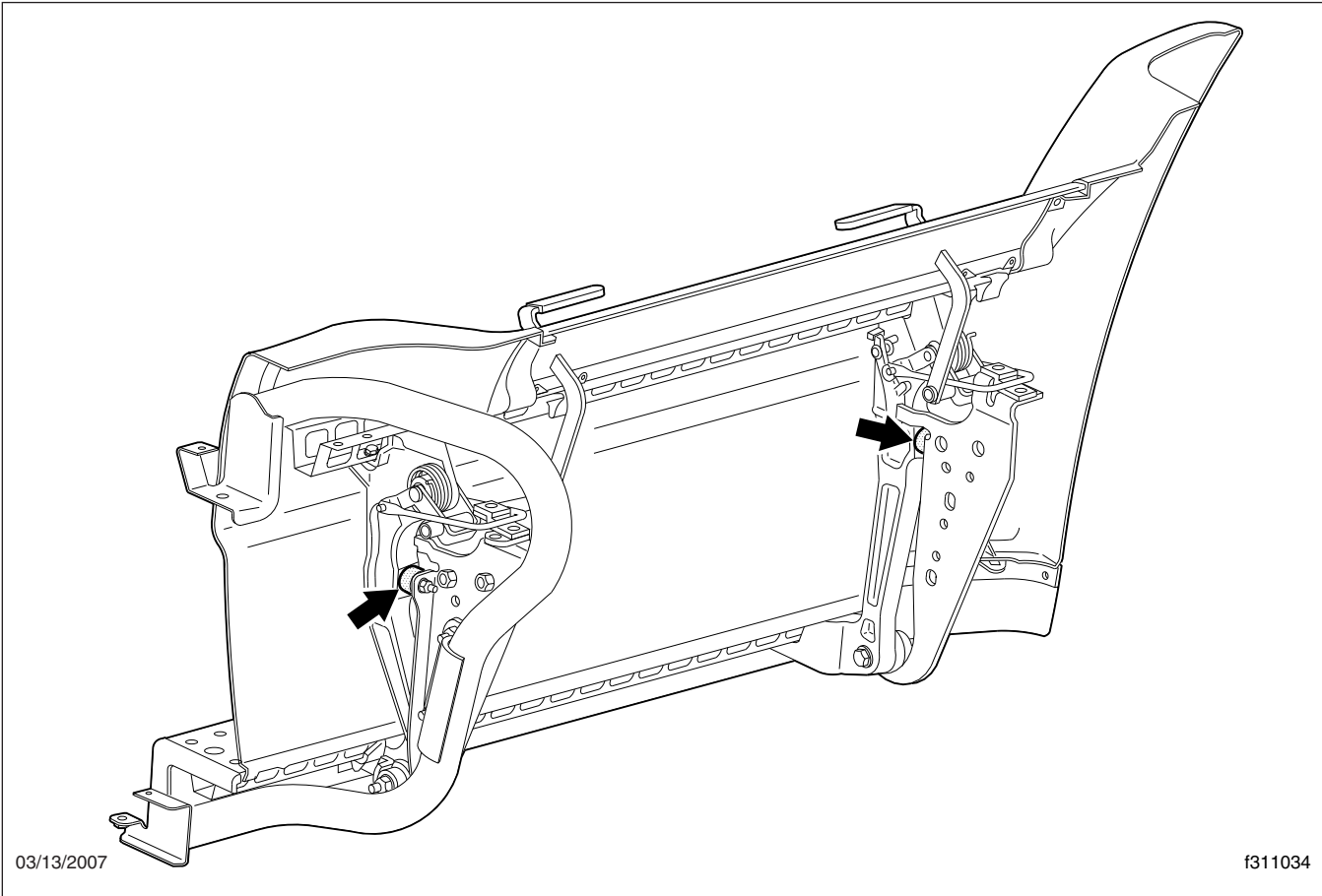

Fig. 12, Bumper Location

Title of Maintenance Operation (MOP)	MOP Number
Lubrication of Front Suspensions with Grease Fittings	32-03
Safety Precautions	32-00
Suspension Inspection	32-01
Suspension U-Bolt Torque Check	32-02

32-00 Safety Precautions

Safety Precautions in this section apply to all procedures within this group.

DANGER

When working on the vehicle, shut down the engine or motor, set the parking brake, and chock the tires. Before working under the vehicle, always place jack stands under the frame rails to ensure the vehicle cannot drop. Failure to follow these steps could result in serious personal injury or death.

32-01 Suspension Inspection

WARNING

Do not replace individual leaves of a damaged leaf spring assembly; replace the complete spring assembly. Visible damage (cracks or breaks) to one leaf causes hidden damage to other leaves. Replacement of only the visibly damaged part(s) is no assurance that the spring is safe. On front spring assemblies, if cracks or breaks exist in the two top leaves, a loss of vehicle control could occur. Failure to replace a damaged spring assembly could cause an accident resulting in property damage, serious personal injury, or death.

Front Suspension Check

Inspect the front spring assemblies for cracked, broken, or abnormally bent leaves. If any of these conditions exist, replace the spring assembly; see **Group 32** of the *Cascadia™ Workshop Manual*.

Front and Rear Suspension Shock Absorber Check

Make sure the shock absorber brackets are tight, and the shock absorber is not striking or rubbing the frame or some other part of the chassis. Striking or rubbing the frame is characterized by chafe marks on the shock absorber body and the frame rail; see **Fig. 1**. Check the rubber mounting bushings for cracks, cuts, swelling, dry rot, or missing pieces. If the shock absorber bushings are no longer serviceable, replace the shock absorber with a new one.

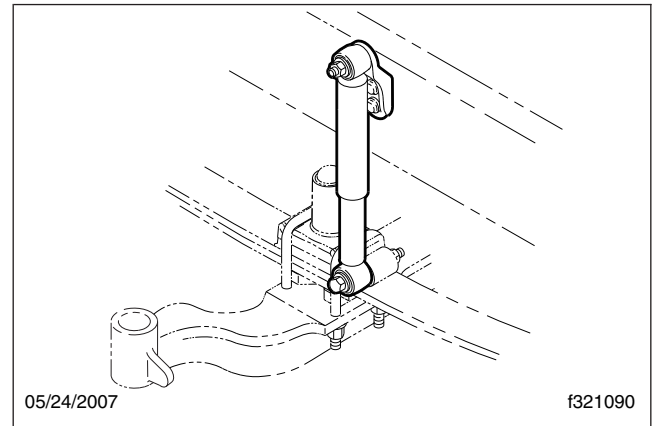

Fig. 1, Direct-Acting Shock Absorber (front suspension shown)

Inspect the shock absorber for oil leakage. Some misting of the oil is normal, and does not mean the shock is leaking. If the shock absorber is damaged or leaking, replace it with a new one; see **Group 32** of the *Cascadia™ Workshop Manual*.

Freightliner AirLiner Rear Suspension Check

Components Checking

Inspect the forward spring brackets for wear, cracks, and other damage. If any of these conditions exist, replace the damaged bracket(s); see **Group 32** of the *Cascadia™ Workshop Manual*.

Inspect the spring bushings for wear or other damage. If any of these conditions exist, replace the damaged bushings.

WARNING

Replace worn, cracked, or damaged spring brackets. Failure to do so could result in bracket breakage, possibly leading to loss of vehicle control and resulting in personal injury or property damage.

Inspect the crossmember(s) and gussets for wear, cracks, and other damage. If any of these conditions exist, replace the damaged parts; see **Group 32** of the *Cascadia™ Workshop Manual*.

Visually check the air spring piston for cracks, chips, and broken areas. Check the air bag for rips, tears, and holes. Verify that the air spring assembly does

not leak. If any of these conditions exist, replace the damaged parts; see **Group 32** of the *Cascadia™ Workshop Manual*.

Suspension Height Checking

IMPORTANT: Before checking the AirLiner suspension height, make sure there is no load on the chassis, and the trailer is unhitched.

IMPORTANT: To prevent voiding the warranty on Barksdale height-control valves, note the following:

- Do not overtighten the bolts in the Barksdale height-control valve housing. The bolts should not be loose, and should not require tightening. Only if necessary, tighten the valve housing bolts 45 lbf-in (500 N-cm). Any damage to the valve housing will void the warranty.
- Do not attempt to disassemble the Barksdale valve body or the control lever. There are no serviceable parts in the valve, and any disassembly will void the warranty.

NOTICE

When removing or loosening a Barksdale height-control valve from a mounting bracket, always hold the valve-side mounting studs in place with an Allen wrench while loosening or tightening the nuts that attach the valve to the bracket. Because the mounting studs are threaded into the valve body, loosening the nuts without holding the studs can tighten the studs, which can crush the valve body and damage the valve. Conversely, tightening the nuts without holding the studs can back the studs out, causing a separation of the two halves of the valve body, and possibly a leak.

1. Park the vehicle on a level surface, using a light application of the brakes. Do not apply the parking brakes. Shift the transmission into neutral, and build the secondary air pressure to at least 100 psi (690 kPa). Shut down the engine. Have an assistant chock the tires on one axle only.
2. Mark the location of the front and rear tires on the floor.

NOTE: The stud bolt that fastens the valve's height-control lever to the vertical linkage is oriented correctly when the linkage rod is vertical,

as viewed from the side of the vehicle; see **Fig. 2**. The rod may be on the forward or aft side of the lever to get it to be vertical.

3. Measure the distance between the left forward-most axle stop and the suspension as indicated; see **Table 1**, **Table 2**, **Table 3**, **Table 4**, and **Table 5** for an acceptable range of heights for each suspension.

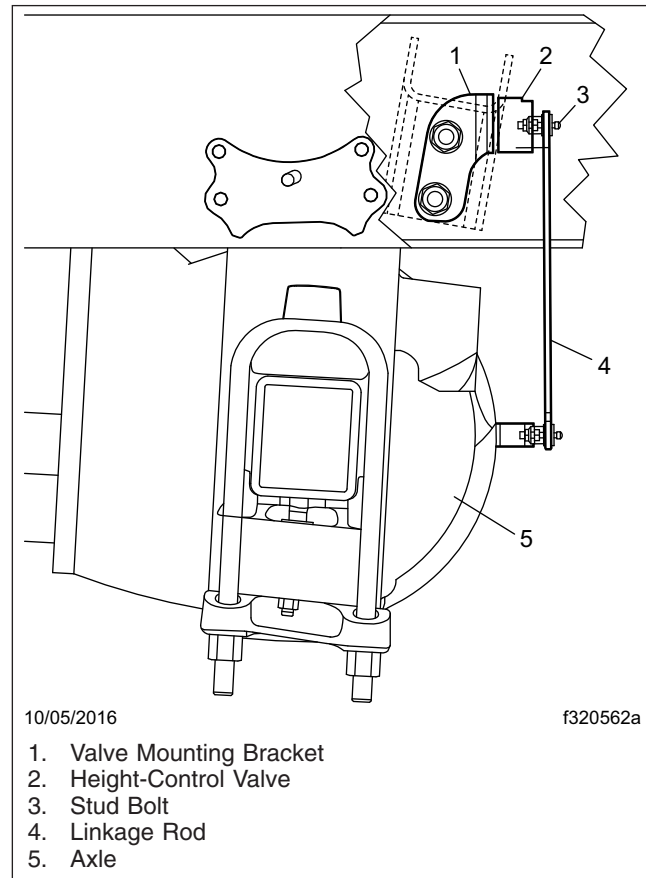

Fig. 2, Barksdale Height-Control Valve Installation (side view) (typical)

IMPORTANT: Suspensions with Dual-Leaf Springs: Measure between the top of the U-bolt and the bottom of the axle stop.

Suspensions with Single-Leaf Springs: Measure between the top of the U-bolt pad and the bottom of the axle stop.

4. If the measurement is not within the acceptable range, refer to the *Cascadia™ Workshop Manual*

for adjustment instructions. If the distance is within the acceptable range, apply the parking brakes.

32-02 Suspension U-Bolt Torque Check

CAUTION

Failure to retorque the U-bolt nuts could result in spring breakage and abnormal tire wear.

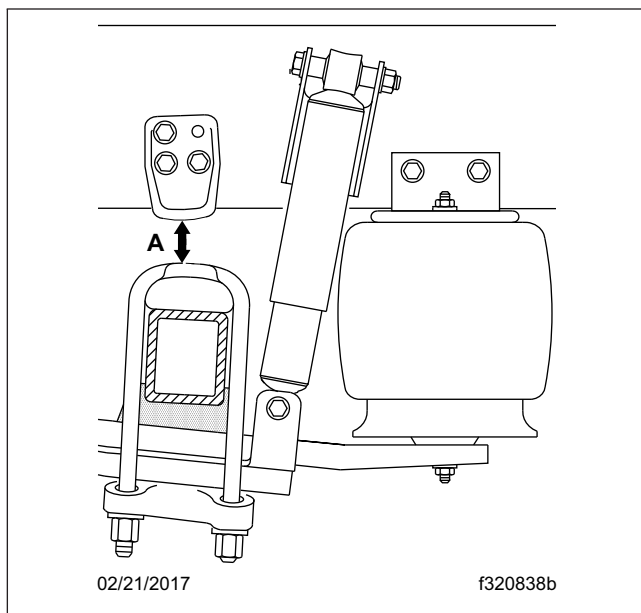

Measure Point	Suspension Height Measurement		
	Min	Target	Max
A = Measure Here	2-3/8 inch (60 mm)	2-5/8 inch (67 mm)	2-7/8 inch (73 mm)

Table 1, Suspension Ride-Height Measurement, Dual-Leaf Spring, 20k/40k High Ride

1. Park the vehicle on a level surface and apply the parking brakes. Chock the tires.
2. Check the U-bolt torque. See **Table 6** for U-bolt torque specifications. Tighten in a diagonal pattern as shown in **Fig. 3**. Set a click-type torque wrench to the mid-point torque value for the fastener being checked. Turn the wrench in a clockwise motion (looking up) until the torque wrench

clicks, then release pressure on the torque wrench, and turn the wrench again until it clicks. If the nut turns on the second application, the bolt is stretching and must be replaced. See **Group 32** of the *Cascadia™ Workshop Manual* for bolt replacement procedures.

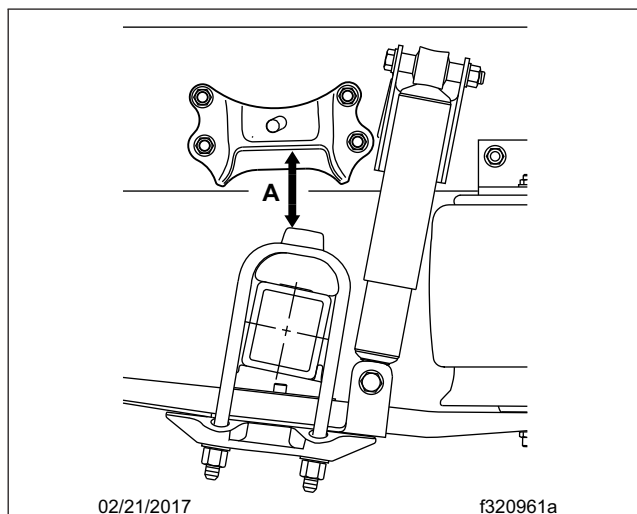

Measure Point	Suspension Height Measurement		
	Min	Target	Max
A = Measure Here	2-3/8 inch (60 mm)	2-5/8 inch (67 mm)	2-7/8 inch (73 mm)

Table 2, Suspension Ride-Height Measurement, Single-Leaf Spring, 20k/40k, High Ride

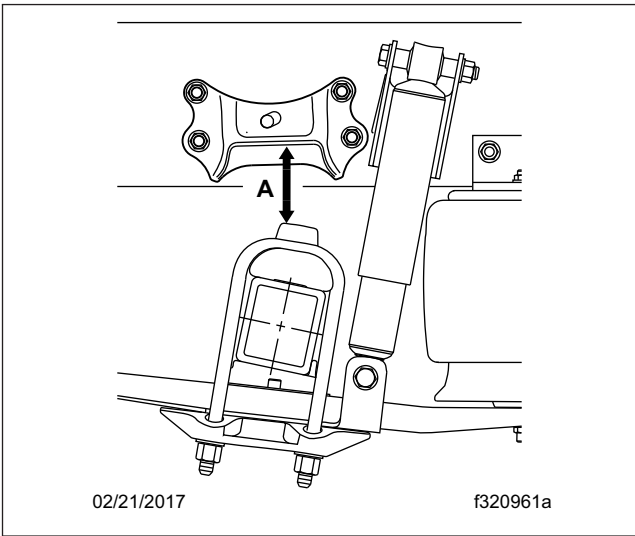

Measure Point	Suspension Height Measurement		
	Min	Target	Max
A = Measure Here	2-3/8 inch (60 mm)	2-1/2 inch (64 mm)	2-7/8 inch (73 mm)

Table 3, Suspension Ride-Height Measurement, Single-Leaf Spring, 10k/12k/15k/18k Mid Ride and 40k Low and Mid Ride

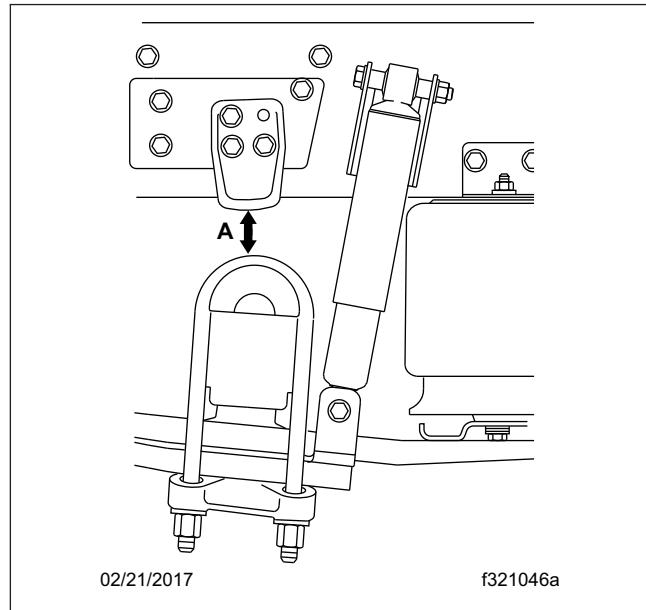

Measure Point	Suspension Height Measurement		
	Min	Target	Max
A = Measure Here	2-3/4 inch (70 mm)	3 inch (76 mm)	3-1/4 inch (83 mm)

Table 4, Suspension Ride-Height Measurement, Dual-Leaf Spring, 23k/46k/69k High Ride

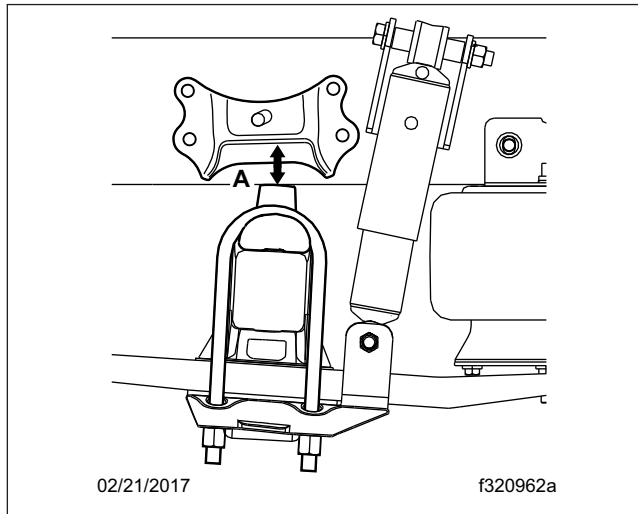

32-03 Lubrication of Front Suspensions with Grease Fittings

Wipe all dirt away from the grease fittings (if equipped) on the spring-eye bushings. Apply multi-purpose chassis grease with a pressurized grease gun until the old grease is forced out.

Measure Point	Suspension Height Measurement		
	Min	Target	Max
A = Measure Here	2-1/8 inch (54 mm)	2-9/32 inch (58 mm)	2-5/8 inch (67 mm)

Table 5, Suspension Ride-Height Measurement, Single-Leaf Spring, 10k/12k/15k Low and Extra-Low Ride

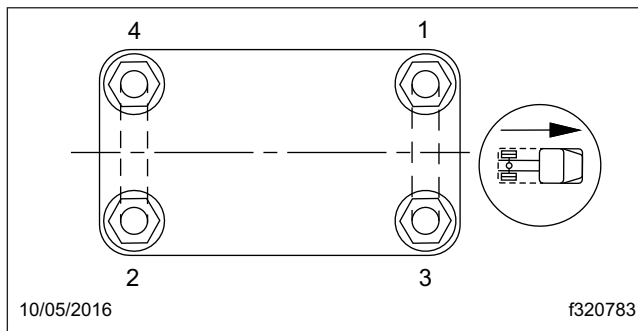

Fig. 3, Tightening Pattern for U-Bolt High Nuts

Spring U-Bolt High Nut Torque Values	
Size	Torque: lbf-ft (N·m)
5/8-18	180-230 (245-313)
3/4-16	270-330 (367-449)
7/8-14	420-500 (571-680)
1-14	520-600 (707-816)

Table 6, Spring U-Bolt High Nut Torque Values

Title of Maintenance Operation (MOP)	MOP Number
All-Axle Alignment Check	33-04
Knuckle Pin Lubrication	33-01
Safety Precautions	33-00
Steer Axle Hub Cap Vent Plug Inspection	33-05
Tie Rod Inspection	33-02
Tie Rod Lubrication	33-03

33-00 Safety Precautions

Safety Precautions in this section apply to all procedures within this group.

DANGER

When working on the vehicle, shut down the engine or motor, set the parking brake, and chock the tires. Before working under the vehicle, always place jack stands under the frame rails to ensure the vehicle cannot drop. Failure to follow these steps could result in serious personal injury or death.

33-01 Knuckle Pin Lubrication

NOTICE

Use regulated pressure when lubricating the knuckle assemblies, otherwise damage could result to the knuckle caps.

Detroit™ Axles

1. Park the vehicle on a level surface, shut down the engine, and set the parking brake. Chock the tires. When lubricating upper and lower knuckle assemblies, do not raise the front axle.
2. Wipe the fittings clean.
3. Apply multipurpose chassis grease, NLGI Grade 1 (6% 12-hydroxy lithium stearate grease) or NLGI Grade 2 (8% 12-hydroxy lithium stearate grease), until new grease is seen at the junctions of the axle beam and knuckles. For locations of grease fittings, see [Fig. 1](#); for grease exit points, see [Fig. 2](#).

Meritor Axles

When lubricating knuckle pin bushings, do not raise the front axle. Wipe the lube fittings clean, and apply multipurpose chassis grease, NLGI Grade 1 (6% 12-hydroxy lithium stearate grease) or NLGI Grade 2 (8% 12-hydroxy lithium stearate grease) until new grease is seen at the bushing grease seal opposite the fittings. The grease seal will accept grease pressure without damage, and is designed to have grease pumped out through it during lubrication. Even if grease leaks out around the top, or bottom-

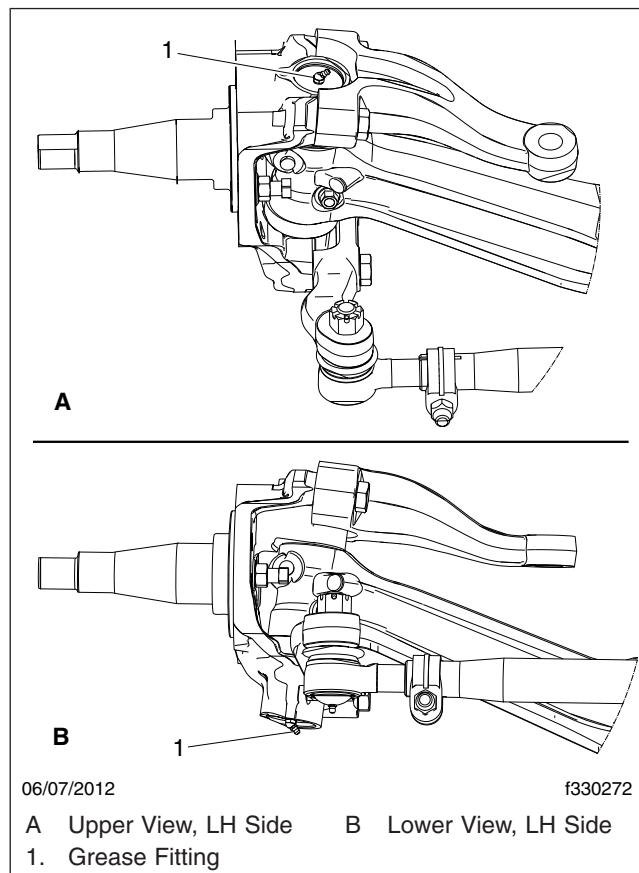

Fig. 1, Grease Fittings, Detroit Axles

plate gasket, continue pumping until new grease is seen at the bushing seal opposite the grease fitting. See [Fig. 2](#).

33-02 Tie Rod Inspection

Inspect the tie-rod ends as follows:

1. Shake the cross-tube. A loose fit, or movement between the tapered shaft of the ball and the cross-tube socket members indicates that the tie-rod end assembly must be replaced.
2. The threaded portion of the tie-rod end assembly must be inserted all the way into the cross-tube split for adequate clamping. See [Fig. 3](#). Replace the components if this cannot be done. For instructions, refer to **Group 33** of the *Cascadia™ Workshop Manual*.

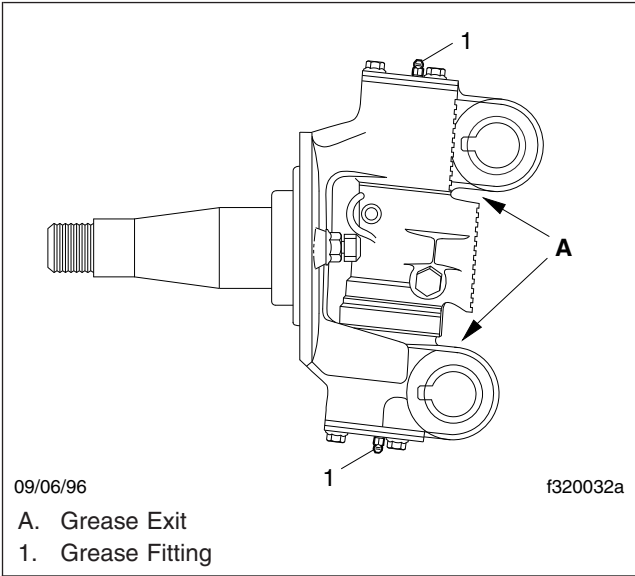

Fig. 2, Knuckle Pin Lubrication

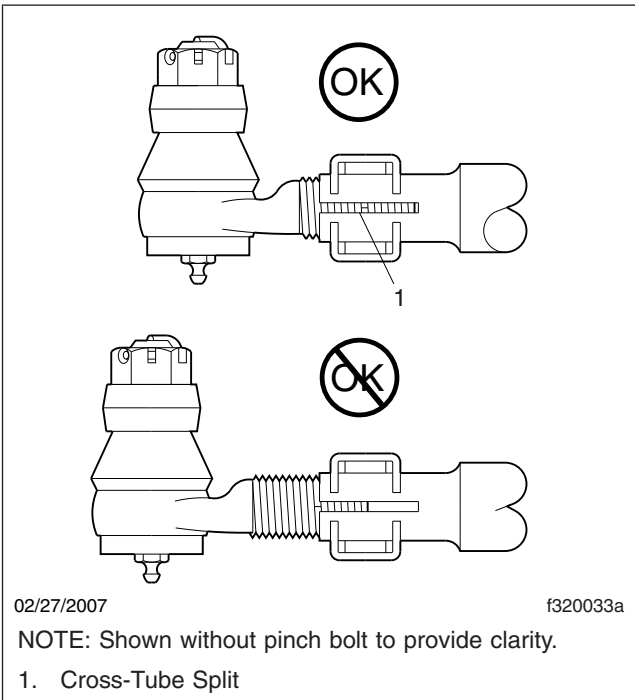

Fig. 3, Tie-Rod End Adjustment

33-03 Tie Rod Lubrication

Detroit and Meritor Axles

For any Detroit or Meritor axle that requires lubrication of the tie-rod ends, wipe the grease fittings clean, then pump multipurpose chassis grease, NLGI Grade 1 (6% 12-hydroxy lithium stearate grease) or NLGI Grade 2 (8% 12-hydroxy lithium stearate grease), into the tie-rod ends until all used grease is forced out and fresh grease is seen at the ball stud neck. See Fig. 4.

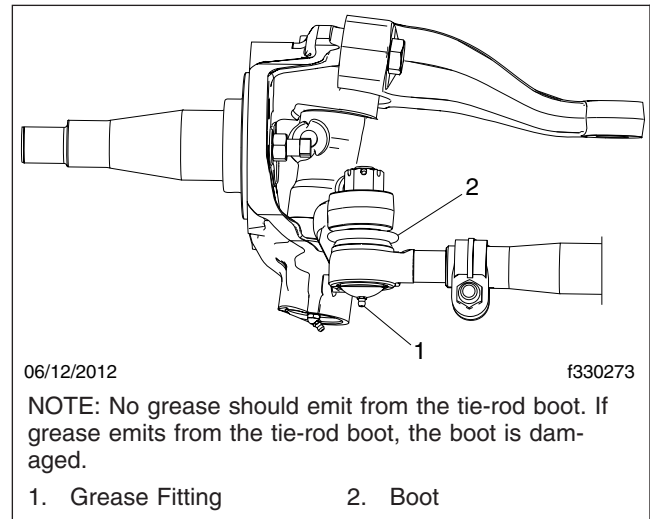

Fig. 4, Grease Fitting and Boot (Detroit axle shown)

33-04 All-Axle Alignment Check

Drive Axle Alignment Checking

Check the axle alignment, parallelism, and thrust angle measurements for the rear drive axles. Use the applicable procedure and specifications in **Group 35** of the *Cascadia™ Workshop Manual*.

Toe-In Inspection

For vehicle alignment to be accurate, the shop floor must be level in every direction. The turn plates for the front wheels must rotate freely without friction, and the alignment equipment must be calibrated every three months by a qualified technician from the

equipment manufacturer. Freightliner dealers must have proof of this calibration history.

1. Apply the parking brakes and chock the rear tires.
2. Raise the front of the vehicle until the tires clear the ground. Place safety stands under the axle.
3. Using spray paint or a piece of chalk, mark the entire center rib of each front tire.
4. Place a scribe or pointed instrument against the marked center rib of each tire, and turn the tires. The scribe must be held firmly in place so that a single straight line is scribed all the way around each front tire.
5. Place a turn-plate or turntable under both front tires. Remove the safety stands and lower the vehicle. Remove the lock-pins from the gauges; make sure the tires are exactly straight ahead. On vehicles with rack and pinion steering, center the rack using the pointers on the front of the input shaft housing. See **Fig. 5**.

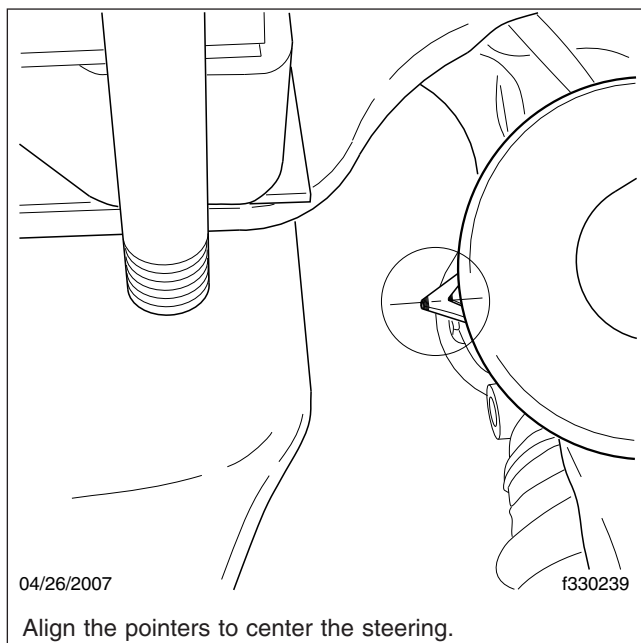

Fig. 5, Centering the Rack and Pinion Steering Gear

NOTE: If turn-plates or turntables are not available, lower the vehicle. Remove the chocks from the rear tires and release the parking brakes. Move the vehicle backward, then forward about six feet (two meters).

6. Place a trammel bar at the rear of the front tires; locate the trammel pointers at spindle height, and adjust the pointers to line up with the scribe lines on the center ribs of the front tires. See **Fig. 6**. Lock in place. Check that the scale is set on zero.

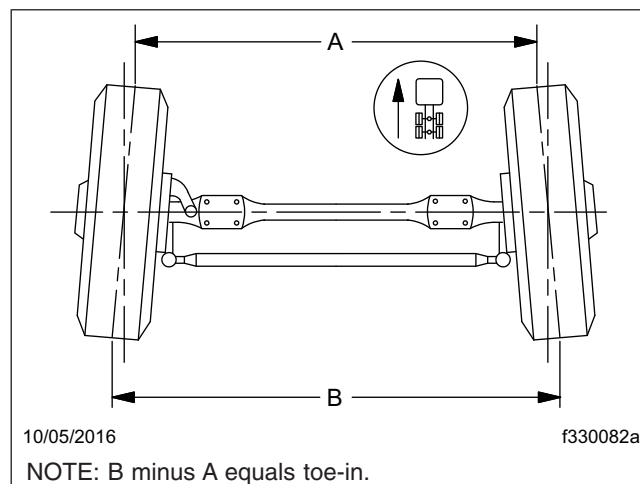

Fig. 6, Wheel Toe-In (overhead view)

7. Place the trammel bar at the front of the tires (see **Fig. 7**) and adjust the scale end so that the pointers line up with the scribe lines. See **Fig. 8**.

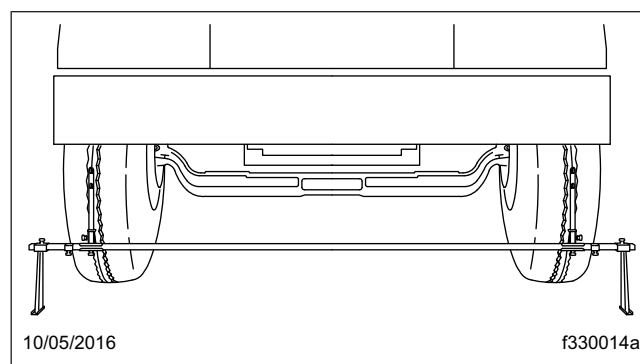

Fig. 7, Trammel Bar Positioning

8. Read the toe-in from the scale, and compare it to the toe-in specification in **Group 33** of the *Cascadia™ Workshop Manual*. If corrections are needed, refer to **Group 33** of the *Cascadia™ Workshop Manual* for instructions on adjusting the toe-in.

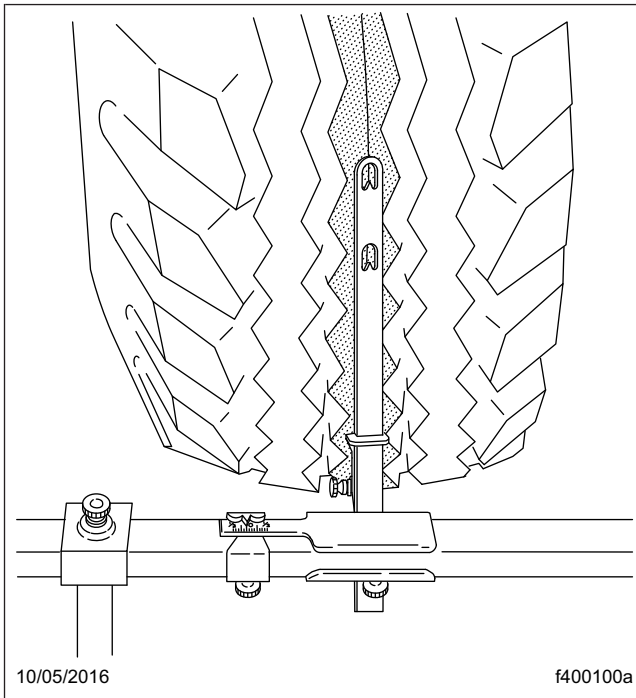

Fig. 8, Setting Trammel Bar Pointers

33-05 Steer Axle Hub Cap Vent Plug Inspection

General Information

As a function of their design, hubcap vent plugs will on occasion exhibit signs of hub oil on their exterior surface. Depending on environmental conditions and/or age of the plug, the amount of oil present can vary. This is a normal result of the venting process due to pressure increase within the hub cavity. For an example of normal vent plug appearance, see [Fig. 9](#).

A vent plug can wear or be damaged and cause excessive leakage, or allow water to enter the hub and contaminate the oil. For examples of a leaking vent plug, see [Fig. 10](#) and [Fig. 11](#). Evidence of a leaking vent plug may appear as;

- Oil splatter around the wheel
- Goey/gummy oil around the vent plug purge point
- Hub/plug area is dirty, and water contaminated oil in the hub.



Fig. 9, Normal Oil Venting

- Hub/plug area is clean, but there is water contaminated oil in the hub. (pressure washing is the most likely cause)

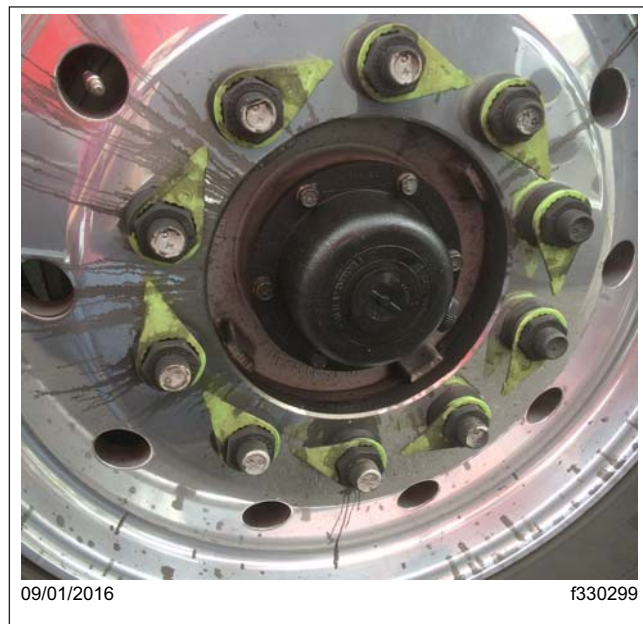

Fig. 10, Excessive Leakage



Fig. 11, Water in Oil

5. Check the oil level in the hub, and fill the hub with new approved oil as needed.

Inspection

NOTICE

Only remove vent plugs by hand. They can be damaged if a tool is used. Wipe the hub/plug area clean before checking the oil. Do not use a pressure washer to clean the hub/plug area. The plug has a vent and this can contaminate the oil with water.

1. Park the vehicle on a level surface, shut down the engine and set the parking brakes. Chock the tires.
2. Inspect the axle hub cap and vent plug for evidence of excessive leakage.
3. Wipe the hub cap and vent plug clean with a rag.
4. Remove the vent plug and check the oil for evidence of water contamination.

If there is evidence of water contaminated oil in the hub, disassemble the effected axle end, clean, inspect, and reassemble the axle end. For instructions, refer to **Group 33** of the vehicle's Workshop Manual.

If there is evidence of excessive leakage, remove the damaged part and replace it with a new part.

Title of Maintenance Operation (MOP)	MOP Number
Axle Breather and Axle Lubricant Level Inspection.	35-02
Axle Lubricant and Filter Change, and Magnetic Strainer Cleaning.	35-01
Safety Precautions.	35-00

35–00 Safety Precautions

Safety Precautions in this section apply to all procedures within this group.

DANGER

When working on the vehicle, shut down the engine or motor, set the parking brake, and chock the tires. Before working under the vehicle, always place jack stands under the frame rails to ensure the vehicle cannot drop. Failure to follow these steps could result in serious personal injury or death.

35–01 Axle Lubricant and Filter Change, and Magnetic Strainer Cleaning

NOTICE

When operating under adverse conditions, it may be necessary to change the axle lubricant at more frequent intervals than listed in the scheduled maintenance tables. Failure to do so could result in axle damage.

For all axles, including tandem drive axles and two-speed axles, perform the applicable procedures under the heading, "All Axle Models." For a two-speed axle with a shift unit, also change the shift unit lubricant; see under the heading, "Two-Speed Axles With Shift Unit."

All Axle Models

Detroit™

IMPORTANT: On Detroit axles, the oil change interval for long haul vehicles can be extended to 500,000 miles (800 000 km) for axles with weight ratings of 34,000 to 40,000 lb (15 000 to 18 000 kg) using synthetic lubricant if a lubricant analysis shows adequate quality. Oil must be changed at least every four years, and more often if the axle is exposed to high temperatures and steep grades.

1. Park the vehicle on a level surface, shut down the engine, and set the parking brake. Chock the tires.
2. Clean the fill plug and the area around it. In the axle housing rear cover, remove the plug from the oil fill hole. See [Fig. 1](#).

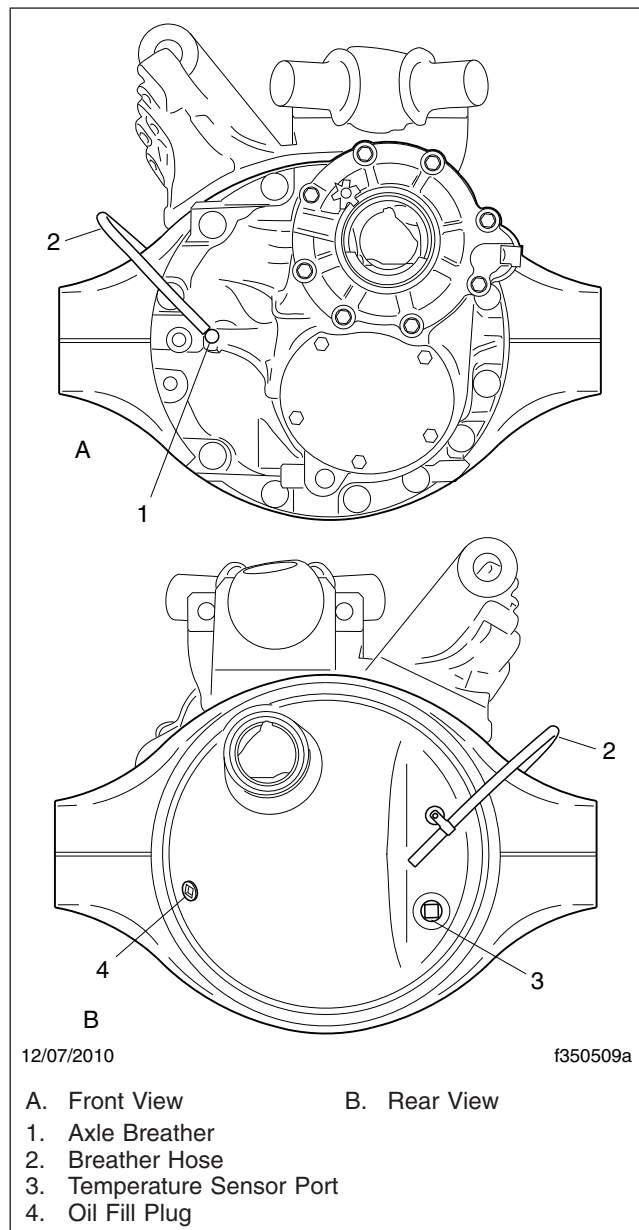

Fig. 1, Detroit Tandem Axle (forward axle shown)

CAUTION

Be careful when draining the axle oil. It may be very hot, and could cause personal injury if it contacts the skin.

3. Place a drain pan under the rear axle drain plug. Drain the oil when it is warm. At this temperature, the oil will run more freely and ensure that the axle is flushed.
4. Clean the fill and drain plugs. Change them if necessary.
 - 4.1 For magnetic plugs, use a piece of key stock or any other convenient steel slug to short the two magnetic poles and divert the magnetic field.
 - 4.2 Clean away the collected material deposited on each pole. Magnets will rapidly lose their effectiveness as collected material bridges the gap between the two poles.
 - 4.3 After the first oil is changed, inspect the drain plug each time for large quantities of metal particles.
 - 4.4 After cleaning, install the drain plug(s) and tighten to 30 lbf-ft (41 N·m).
5. Fill the axle with the recommended lubricant. See **Table 1** for recommended drive axle lubricants and **Table 2** for lubricant capacities.

NOTE: Some Detroit axles have a small tapped and plugged hole near and below the housing oil fill hole. This smaller hole is for a lubricant temperature indicator only, and should not be used as a fill or level hole.

- 5.1 Fill the axle through the oil fill hole. Lubricant should be level with the bottom of the oil fill hole. To check fluid level, see **Fig. 2**.
- 5.2 Install and tighten the fill plug 30 lbf-ft (41 N·m).

Detroit Drive Axle Lubricants*		
IMPORTANT: Lubricant used in Detroit rear axles must meet Mercedes-Benz specification 235.20 (mineral) or 235.8 (synthetic). Mobil Delvac™ Gear Oil A 80W-90 and Mobilube™ HD-A Plus 80W-90 meet specification 235.20. Mobil Delvac 1 Gear Oil 75W-90 and Mobilube 1 SHC 75W-90 meet specification 235.8. For more product information, see http://bevo.mercedes-benz.com .		
Type	Ambient Temperature	SAE Viscosity Grade
Mineral Oil	-15°F (-26.1°C) and up†	80W-90
Synthetic Oil	-40°F (-40°C) and up†	75W-90

* Detroit rear axles do not require the use of friction modifiers.

† There is no upper limit on the ambient temperature, but axle sump temperature must never exceed 250°F (121°C).

Table 1, Detroit Drive Axle Lubricants

Detroit Rear Axle Lubricant Capacity (Hubs Full)	
Axle	Oil Capacity: Quarts (liters)
Forward-Rear, Model 4	14.3 (13.5)*
Single and Rearmost Tandem, Model 4	10.6 (10.0)*
Single, Model 2	5.8 (5.5)*

* These values assume the wheel ends are properly lubricated. Actual oil capacity might vary slightly depending on gear ratio.

Table 2, Detroit Rear Axle Lubricant Capacity

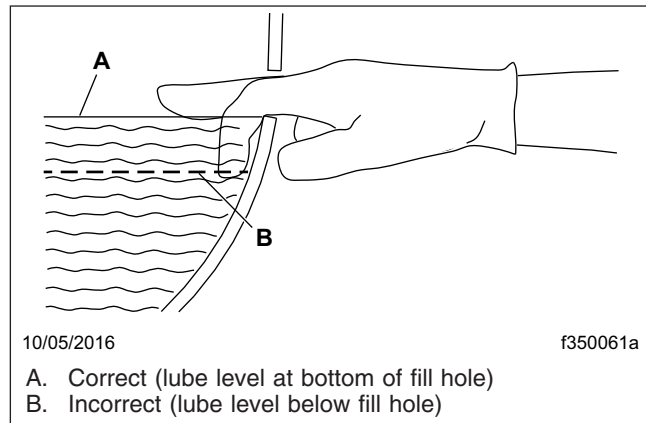

Fig. 2, Axle Lubricant Level Inspection

Meritor®

IMPORTANT: On Meritor axles, the oil change interval for Schedule III vehicles is extended to 500,000 miles (800 000 km) for axles using synthetic lubricant with a pump and filter system.

On single drive axles so equipped, the traction equalizer may slip or stick. When this happens, the driver will hear intervals of shrill noises when the vehicle is driven at low speed or makes sharp turns. Use a "limited-slip friction modifier" to correct this slip/stick condition. Add 1.6 ounces (35 mL) of additive for each pint (0.5 L) of lube capacity.

For all GL-5 oils, add one of the following limited-slip friction modifiers:

- Lubrizol No. 6178 (Lubrizol Corporation)
- DSL-178 (Guardzman Products)
- Equa-Torque No. 2411 (Sta-Lube Corporation)
- Equa-Torque No. 2414 (Sta-Lube Corporation)

IMPORTANT: These friction modifiers generally deteriorate faster than conventional extreme-pressure additives, so the lubricant change schedule must be shortened when using these additives. The traction equalizer additive (and recommended drive axle lubricant) must be changed at the Maintenance 2 (M2) interval, instead of the Maintenance 3 (M3) interval recommended in the Maintenance Operation Chart for axles that require only those lubricants recommended in [Table 3](#).

1. Park the vehicle on a level surface, shut down the engine, and set the parking brake. Chock the tires.
2. Remove the axle carrier fill plug. Then remove the drain plug from the bottom of the housing.

Completely drain the lubricant while the unit is warm, to allow the lubricant to drain faster.

On tandem drive axles, it is also necessary to remove the plug at the bottom of the interaxle differential housing to drain that lubricant.

3. If equipped with an oil pump, use a suitable filter strap wrench to remove the axle oil filter. See [Fig. 3](#). Discard the old filter.

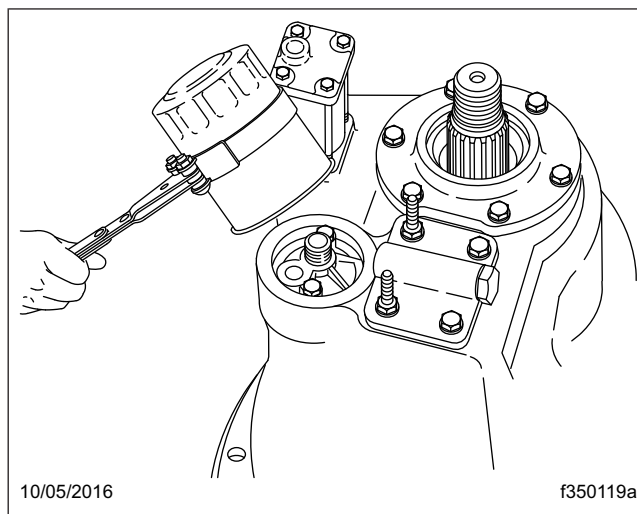

Fig. 3, Meritor Axle Oil Filter Removal

NOTE: There may be about one pint (0.5 L) of lubricant remaining in the filter. Be careful not to spill it when removing the filter.

4. Using the recommended drive axle lubricant, coat the face of the gasket on the new oil filter, if it was replaced. Install the filter over the adapter, and tighten the filter one full turn after the gasket contacts the base; do not overtighten. See [Table 3](#) for recommended lubricants.

Meritor Drive Axle Recommended Lubricant			
Recommended Lubricant Type	Ambient Temperature	Lubricant SAE Viscosity Grade	Meritor Specification
Synthetic Gear Oil	-40°F (-40°C) and Up*	75W-90	0-76-N
	-40°F (-40°C) and Up*	75W-140	0-76-M

* There is no upper limit on these outside temperatures, but axle sump temperature must never exceed 250°F (121°C).

Table 3, Meritor Drive Axle Recommended Lubricant

5. Clean the fill and drain plugs. Change them if necessary.
 - 5.1 For magnetic plugs, use a piece of key stock or any other convenient steel slug to short the two magnetic poles and divert the magnetic field.
 - 5.2 Check the drain plug for metal particles every 100,000 miles (160 000 km). Clean away the collected material deposited on each pole. Magnets will rapidly lose their effectiveness as collected material bridges the gap between the two poles.
 - 5.3 Each time the oil is changed, replace any magnetic drain plug that does not meet the minimum pickup capacity.

NOTE: Meritor recommends plugs with elements having a minimum pickup capacity of 1.5 pounds (0.7 kg) of low-carbon steel.

- 5.4 After cleaning, install the drain plug(s) and tighten to 35 lbf·ft (47 N·m).
6. Fill the axle with recommended lubricant. See **Table 4** for drive axle lubricant capacities.

NOTE: Some Meritor axles have a small tapped and plugged hole near and below the housing lubricant fill hole. This smaller hole is for a lubricant temperature indicator only, and should not be used as a fill or level hole.

- 6.1 With the vehicle on a level surface, fill the axle through the oil fill hole. Lubricant should be level with the bottom of the oil fill hole. To check fluid level, see **Fig. 2**.

Meritor Drive Axle Lubricant Capacities		
Axle Model	Capacity:* pt (L)	
<i>Single Drive, Single Reduction†</i>		
RS-21-160	39.5 (18.7)	
RS-23-160	39.5 (18.7)	
RS-23-161	37.2 (17.6)	
RS-23-185	47.3 (22.4)	
RS-25-160	37.2 (17.6)	
<i>Tandem Drive, Single Reduction</i>		
RT-40-145, RT-40-145A, RT-40-145P	Forward	30.2 (14.3)
	Rear	25.8 (12.2)

Meritor Drive Axle Lubricant Capacities		
Axle Model	Capacity:* pt (L)	
RT-44-145, RT-44-145P	Forward	29.3 (13.9)
	Rear	25.1 (11.9)
RT-46-160, RT-46-160P	Forward	39.1 (18.5)
	Rear	34.4 (16.3)

* Quantities listed are approximate. Fill axle until lubricant is level with bottom of fill hole with vehicle on level ground.

† See "Traction Equalizer Additives" in the text.

Table 4, Meritor Drive Axle Lubricant Capacities

- 6.2 Install and tighten the fill plug 35 lbf·ft (47 N·m).
7. Whenever the interaxle differential housing has been drained, add an additional 2 pints (0.9 L) of the recommended lubricant directly into the inter-axle differential housing.
8. Remove the chocks, then drive the vehicle, unloaded, for 1 or 2 miles (2 or 3 km) at speeds not to exceed 25 mph (40 km/h), to thoroughly circulate lubricant throughout the carrier and housing assemblies.

Dana® Spicer®

IMPORTANT: The use of friction modifiers is not approved in Dana drive axles.

1. Park the vehicle on a level surface, shut down the engine, and set the parking brake. Chock the tires.
2. Clean the fill plug and the area around it. In the axle housing rear cover, remove the plug from the oil fill hole (or standpipe, if installed in the oil fill hole). See **Fig. 4**.
3. Place a drain pan under the rear axle drain plug. See **Fig. 4**. Drain the oil at normal operating temperature, 150 to 200°F (65 to 93°C). At this temperature, the oil will run more freely and ensure that the axle is flushed.

NOTE: Some tandem drive axles are equipped with a cylindrical magnetic strainer, located below the lube pump on the front of the power divider cover. All rear axles are fitted with magnetic drain and fill plugs.

4. At each axle oil change, remove and clean the magnetic strainer, if equipped. See **Fig. 5**.

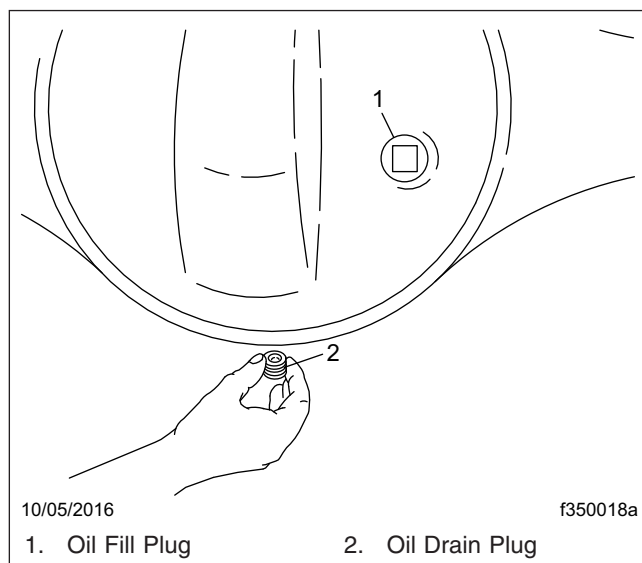

Fig. 4, Axle Housing Drain and Fill Plugs

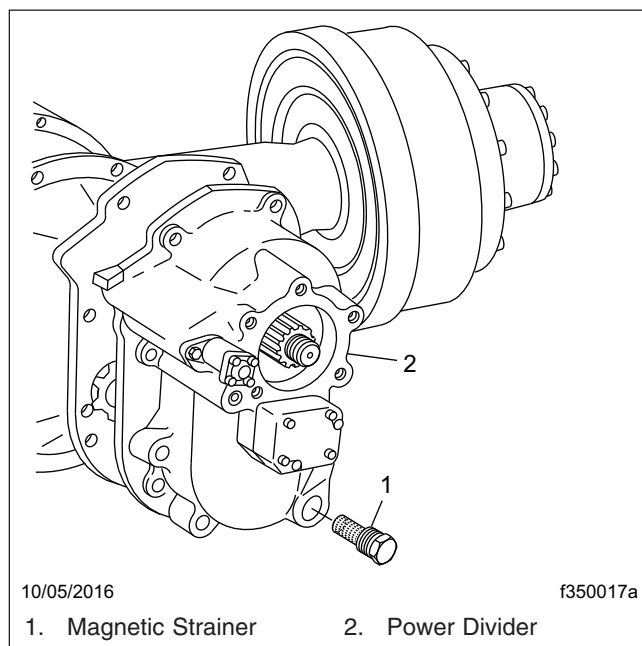

Fig. 5, Dana Spicer Tandem Drive Axle Magnetic Strainer

- 4.1 Remove the magnetic strainer from the power divider cover.

WARNING

Always wear eye protection when using compressed air to clean parts, as flying debris could cause permanent damage to unprotected eyes. Do not point the air stream in the direction of other persons.

- 4.2 Wash the strainer in solvent, and blow it dry with compressed air to remove oil and metal particles.
- 4.3 Install and tighten the magnetic strainer 40 to 60 lbf·ft (54 to 81 N·m).
- 5. Clean the fill and drain plugs. Change them if necessary.
 - 5.1 For magnetic plugs, use a piece of key stock or any other convenient steel slug to short the two magnetic poles and divert the magnetic field.
 - 5.2 Clean away the collected material deposited on each pole. Magnets will rapidly lose their effectiveness as collected material bridges the gap between the two poles.
 - 5.3 After the first oil is changed, inspect the drain plug each time for large quantities of metal particles.
 - 5.4 After cleaning, install the drain plug(s) and tighten to 40 to 60 lbf·ft (54 to 81 N·m).
- 6. Fill the axle with the recommended lubricant. See [Table 5](#) for recommended drive axle lubricants, and [Table 6](#) for drive axle lubricant capacities.

Dana Spicer Drive Axle Recommended Lubricant		
Lubricant Type	Condition	Lubricant SAE Viscosity Grade
Dana Spicer Roadranger® Synthetic Drive Axle Lubricants, or Equivalent with Military Specification MIL-L-2105D	Over-the-Road Service	75W-90
	Off-Highway Equipment, or Under Extra Heavy Loads	80W-140

Table 5, Dana Spicer Drive Axle Recommended Lubricant

Dana Spicer Drive Axle Lubricant Capacities		
Axle Type	Axle Model	Capacity:* Pints (liters)
<i>Single Drive Axle Installation</i>		
Single Reduction	23080S, 23080D	40 (18.9)
	23105S, 23105D	48 (22.7)
<i>Tandem Drive Axle Installation</i>		
Single Reduction	DD404, DD404-P	31 (14.7)†
	DS404, DS404-P	39 (18.5)†
	DS461-P	43 (20.3)†
2-Speed (dual-range)	DT402, 402-P	34 (16.1)†
	DT451-P	39 (18.5)†
	DT461-P	43 (20.3)†
Double Reduction	DP451-P	34 (16.1)†
	DP461-P	43 (20.3)†

* Quantities listed are approximate. Fill axle until lubricant is level with bottom of fill hole with vehicle on level ground.

† Add 2 pints (1 L) of additional lubricant to the power divider.

Table 6, Dana Spicer Drive Axle Lubricant Capacities

NOTE: Some Dana Spicer axles have a small tapped and plugged hole near and below the housing oil fill hole. This smaller hole is for a lubricant temperature indicator only, and should not be used as a fill or level hole.

- 6.1 Fill the axle through the oil fill hole or standpipe opening. Lubricant should be level with the bottom of the oil fill hole, or the top of the standpipe opening. To check fluid level, see [Fig. 2](#).
- 6.2 Install and tighten the fill plug 40 to 60 lbf-ft (54 to 81 N-m).

Two-Speed Axles With Shift Unit Dana Spicer and Meritor

1. Remove the shift unit housing cover. See [Fig. 6](#). Drain and discard the old lubricant. Discard the housing cover gasket.
2. Thoroughly wash the axle shift parts and housing cover, and allow them to air dry.
3. Install the housing cover and a new cover gasket. Tighten the housing cover capscrews 90 to

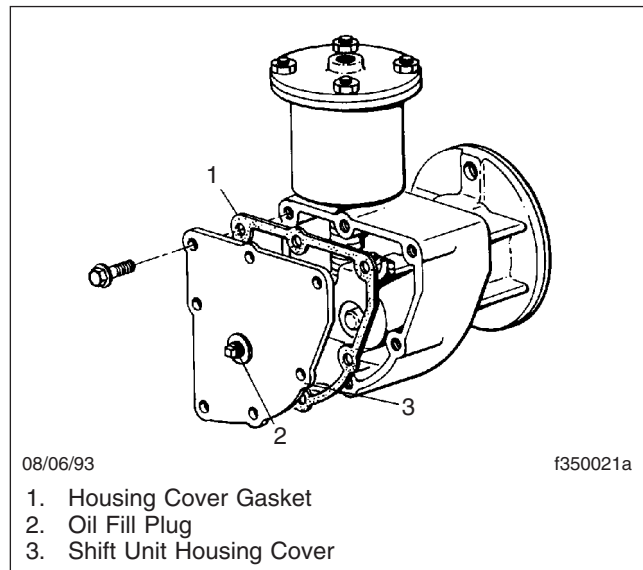

Fig. 6, Two-Speed-Axle Shift Unit

110 lbf-in (1020 to 1240 N-cm), then remove the oil fill plug from the cover.

IMPORTANT: When the ambient temperature is above 0°F (-18°C), use SAE 10 heavy-duty engine oil, API service classification SD (sulfated ash content must not exceed 1.85%). When the ambient temperature is below 0°F (-18°C), use one part kerosene to three parts SAE 10 heavy-duty engine oil, API service classification SD (sulfated ash content must not exceed 1.85%). This cold-weather mixture can be safely used up to 32°F (0°C).

Commercially available automatic transmission fluid may be used in place of SAE 10 engine oil. Automatic transmission fluid can be used for all temperatures; do not mix it with kerosene. To prevent component damage, do not mix engine oil and automatic transmission fluid.

4. Using the recommended lubricant, fill the shift unit housing through the oil fill hole until the lubricant is level with the bottom of the opening.
5. Coat the threads of the fill plug with a small amount of Loctite® 242, or equivalent sealant. Install the fill plug finger-tight in the rear axle shift unit housing. Using a wrench, tighten it an additional 1-1/2 turns.

35–02 Axle Breather and Axle Lubricant Level Inspection

For all axles, including tandem drive axles and two-speed axles, perform the applicable procedures under the heading, "All Axle Models." For a two-speed axle with a shift unit, also check the shift unit lubricant; see under the heading, "Two-Speed Axles With Shift Unit."

All Axle Models Detroit™

NOTICE

Failure to keep the rear axle filled to the proper level with the recommended lubricant can result in rear axle damage.

1. Park the vehicle on a level surface, shut down the engine, and set the parking brake. Chock the tires.
2. If the vehicle has just been driven, allow a few minutes for the lubricant to settle.

IMPORTANT: On Detroit axles, the oil change interval for long haul vehicles can be extended to 500,000 miles (800 000 km) for axles with weight ratings of 34,000 to 40,000 lb (15 000 to 18 000 kg) using synthetic lubricant if a lubricant analysis shows adequate quality. Oil must be changed at least every four years, and more often if the axle is exposed to high temperatures and steep grades.

3. Clean the fill plug and the area surrounding the fill plug on the side of the axle carrier. Remove the plug. Check lubricant level when the axle is cold, or near room temperature.

NOTE: Some Detroit axles have a small tapped and plugged hole near and below the housing oil fill hole. This smaller hole is for a lubricant temperature indicator only, and should not be used as a fill or level hole.

4. Check that the lubricant is level with the bottom of the fill hole. See [Fig. 2](#). If low, check for oil leaks, and correct as needed. Add oil to the level

of the fill plug, using the lubricant recommended in [Table 2](#).

IMPORTANT: A lubricant level close enough to be seen or touched is not sufficient. It must be level with the bottom of the fill hole.

5. Install and tighten the fill plug 30 lbf-ft (41 N·m).

IMPORTANT: Always check the axle breather whenever checking the lubricant level. Check the breather more frequently under adverse operating conditions.

6. Check the axle housing breather (see [Fig. 1](#)). Make sure that it is open and unclogged. If the breather is plugged or damaged, clean or replace it as needed.

Meritor®

NOTICE

Failure to keep the rear axle filled to the proper level with the recommended lubricant can result in rear axle damage.

NOTICE

When operating under adverse conditions, it may be necessary to change the axle lubricant at more frequent intervals than listed in the scheduled maintenance tables. Failure to do so could result in axle damage.

1. Park the vehicle on a level surface, shut down the engine, and set the parking brake. Chock the tires.

IMPORTANT: Oil level must be checked at each M1 interval on Meritor axles.

2. Clean the fill plug and the area surrounding the fill plug on the side of the axle carrier. Remove the plug. Check the lubricant level when the axle is cold, or near room temperature.

NOTE: Some Meritor axles have a small tapped and plugged hole near and below the housing oil fill hole. This smaller hole is for a lubricant temperature indicator only, and should not be used as a fill or level hole.

3. Check that the lubricant is level with the bottom of the fill hole. See [Fig. 2](#). If low, check for oil

leaks, and correct as needed. Add oil to the level of the fill plug, using the lubricant recommended in **Table 3**.

4. Install and tighten the fill plug 35 lbf-ft (47 N-m).

IMPORTANT: Always check the axle breather whenever checking the lubricant level. Check the breather more frequently under adverse operating conditions.

5. Check the axle housing breather. Make sure that it is open and unclogged. See **Fig. 7**. If the breather is plugged or damaged, clean or replace it as needed.

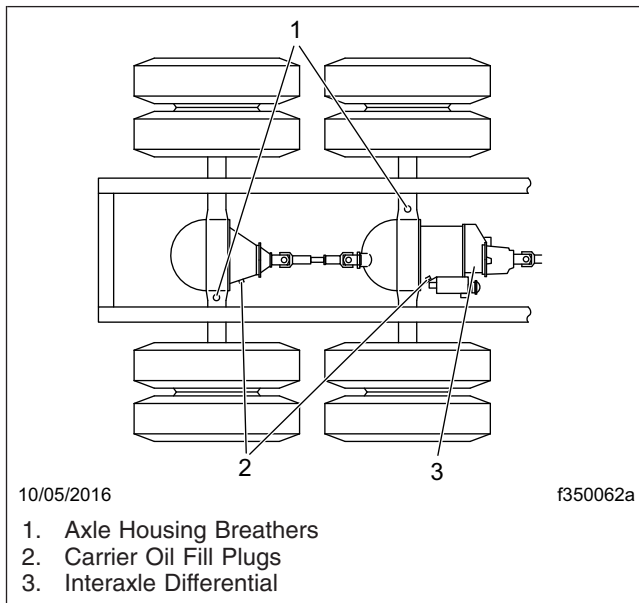

Fig. 7, Meritor Axle Housing Breathers

6. On non-drive axles using oil-lubricated wheel bearings, check the oil level at the wheels, and add oil if low. Use the same lubricant recommended for the drive axle.

NOTE: When adding to or checking the oil level, make certain the hub cap and plug are clean before removing the plug; this will minimize the possibility of dirt and road grime entering the assembly.

Dana® Spicer®

NOTICE

Failure to keep the rear axle filled to the proper level with the recommended lubricant can result in rear axle damage.

1. Park the vehicle on a level surface, shut down the engine, and set the parking brake. Chock the tires.
2. If the vehicle has just been driven, allow a few minutes for the lubricant to settle.
3. Clean the oil fill plug and the area surrounding it; see **Fig. 8**. Remove the plug from the fill hole (or standpipe, if installed in the oil fill hole).

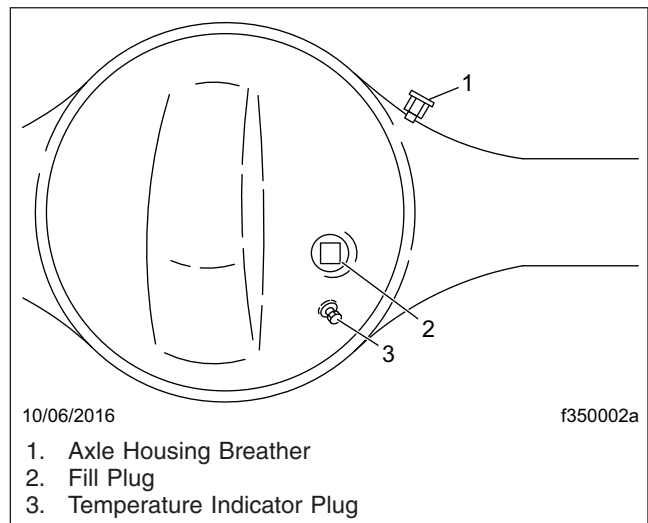

Fig. 8, Dana Spicer Axle Housing Breather

IMPORTANT: A lubricant level close enough to be seen or touched is not sufficient. It must be level with the bottom of the fill hole, or the top of the standpipe opening.

4. Check that the lubricant is level with the bottom of the fill hole, or with the top of the standpipe opening. See **Fig. 2**. If low, check for oil leaks, and correct as needed. Add oil to the level of the fill plug, using the lubricant recommended in **Table 5**.
5. Install and tighten the fill plug 40 to 60 lbf-ft (54 to 81 N-m).

IMPORTANT: Always check the axle breather whenever checking the lubricant level. Check the breather more frequently under adverse operating conditions.

6. Check the axle housing breather. Make sure that it is unclogged and free from corrosion. See **Fig. 8**. If the breather is plugged or damaged, clean or replace it as needed.

3. Coat the threads of the fill plug with a small amount of Loctite® 242, or equivalent sealant. Install the fill plug finger-tight in the rear axle shift unit housing. Using a wrench, tighten it an additional 1-1/2 turns.

Two-Speed Axles With Shift Unit Dana Spicer and Meritor

IMPORTANT: Also do the appropriate procedure under the heading "All Axle Models."

NOTICE

Failure to keep lubricant at the specified level could cause damage to the axle shift unit.

1. Clean the shift unit oil fill plug, and the area surrounding the plug. See **Fig. 6**. Turn the fill plug counterclockwise to remove it.
2. Insert a finger or pipe cleaner into the fill plug hole and check the fluid level. The lubricant should be level with the bottom of the fill hole. If low, add the recommended lubricant.

NOTICE

Before adding additional lubricant, make sure of the type currently in the shift unit. To prevent component damage, do not mix engine oil with automatic transmission fluid.

IMPORTANT: When the ambient temperature is above 0°F (-18°C), use SAE 10 heavy-duty engine oil, API service classification SD (sulfated ash content must not exceed 1.85%). When the ambient temperature is below 0°F (-18°C), use one part kerosene to three parts SAE 10 heavy-duty engine oil, API service classification SD (sulfated ash content must not exceed 1.85%). This cold-weather mixture can be safely used up to 32°F (0°C).

Commercially available automatic transmission fluid may be used in place of SAE 10 engine oil. Automatic transmission fluid can be used for all temperatures; do not mix it with kerosene.

Title of Maintenance Operation (MOP)	MOP Number
Tire Check	40-02
Wheel Nut Check	40-01

40-01 Wheel Nut Check

IMPORTANT: After a wheel has been installed, the wheel nut torque must be rechecked after 50 to 100 miles (80 to 160 km) of operation.

Check the torque on all wheel nuts. See **Table 1** for torque specifications, and see **Fig. 1** for the wheel nut tightening sequence.

NOTE: Torque values are given for lubricated threads. Apply 2 drops of SAE 30W oil to a point between the nuts and flanges.

CAUTION

Insufficient wheel nut torque can cause wheel shimmy, resulting in wheel damage, stud breakage, and extreme tire tread wear. Excessive wheel nut torque can break studs, damage threads, and crack discs in the stud hole area. Use the recommended torque values, and follow the tightening sequence shown in Fig. 1.

Disc Wheel Fastener Torque	
Nut Size	Torque: lbf·ft (N·m) Oiled
M22 x 1.5	450-500 (610-678)

NOTE: If using specialty fasteners, consult the manufacturer for recommended torque levels.

Table 1, Disc Wheel Fastener Torque

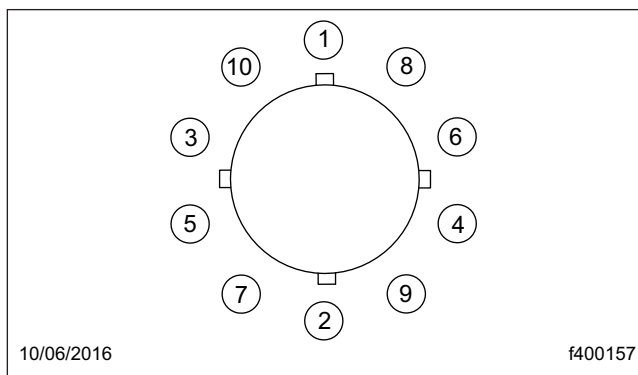

Fig. 1, Wheel Nut Tightening Sequence

40-02 Tire Check

Tires should be inspected closely during the first 3000 to 10,000 miles (5000 to 16 000 km) for abnormal wear.

Maintain the proper pressures for carried loads, per the tire manufacturers' recommendations, or the tire pressure label on the driver's door.

Have the wheel alignment checked after the first 10,000 miles (16 000 km), then every 40,000 miles (60 000 km) thereafter.

Do not continue to drive the vehicle if tires develop any of the following:

- blisters;
- cuts or punctures that reach to the cord;
- a nail, screw, rock, or other puncturing object;
- flat spots or irregular wear;
- tread worn to a minimum depth;
- inability to maintain proper tire pressure.

Title of Maintenance Operation (MOP)	MOP Number
Driveline Inspection	41-01
Driveline Lubrication	41-02
Safety Precautions	41-00

41–00 Safety Precautions

Safety Precautions in this section apply to all procedures within this group.

DANGER

When working on the vehicle, shut down the engine or motor, set the parking brake, and chock the tires. Before working under the vehicle, always place jack stands under the frame rails to ensure the vehicle cannot drop. Failure to follow these steps could result in serious personal injury or death.

41–01 Driveline Inspection

1. Park the vehicle on a level surface, apply the parking brakes, and chock the tires.

CAUTION

Due to the extreme load occurring at high-speed rotation, a loose or broken capscrew at any point in the driveline will weaken the driveline connection, which could eventually result in serious vehicle damage. Tighten bearing-cap capscrews or yoke-strap capscrews to specified torque, being careful to not overtighten.

2. For U-joints with bearing caps, tighten bearing-cap capscrews 43 lbf-ft (49 N·m). See [Fig. 1](#).

For Arvin Meritor RPL series U-joints, tighten bearing-cap capscrews 125 lbf-ft (169 N·m). See [Fig. 2](#).

For U-joints with yoke straps, tighten yoke-strap capscrews 125 lbf-ft (169 N·m). See [Fig. 3](#).

3. Check the driveline yokes for cracks, and check end-yokes for looseness. See [Fig. 3](#).

Replace cracked yokes.

If any end-yoke can be moved in or out on its shaft, or can be rocked on its shaft, disconnect the driveshaft and U-joint from the yoke, then check the drive component's shaft seal for leakage or other visible damage that may have been caused by the loose yoke. Replace the seal if needed, then tighten the yoke nut. Refer to **Group 41** of the *Cascadia™ Workshop Manual* for torque specifications. If the yoke is still loose

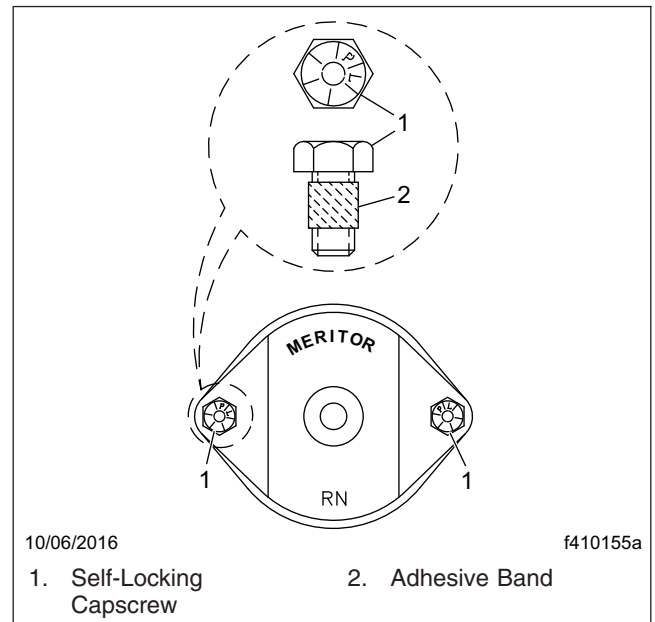

Fig. 1, Arvin Meritor U-Joint Fasteners for Bearing Caps

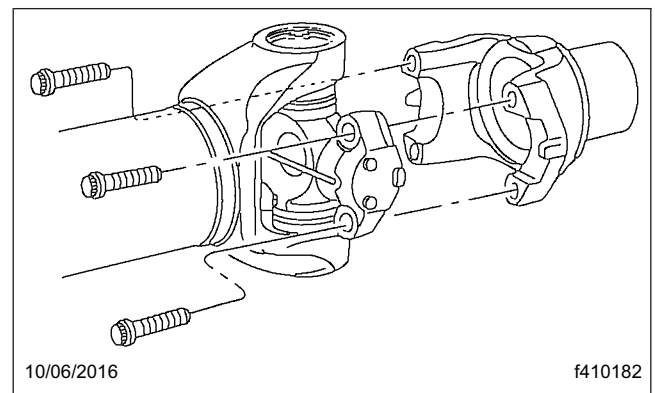

Fig. 2, Arvin Meritor RPL Series U-Joint

after tightening the yoke nut, replace the end-yoke and yoke nut.

Replace the prevailing torque locknut (end-yoke nut) if it was removed for yoke replacement, seal replacement, or any other reason.

4. Check U-joint assemblies for wear by moving the driveshaft up and down, and from side to side. If any movement of the U-joint cross in the bearings can be felt or seen, replace the U-joint assembly.

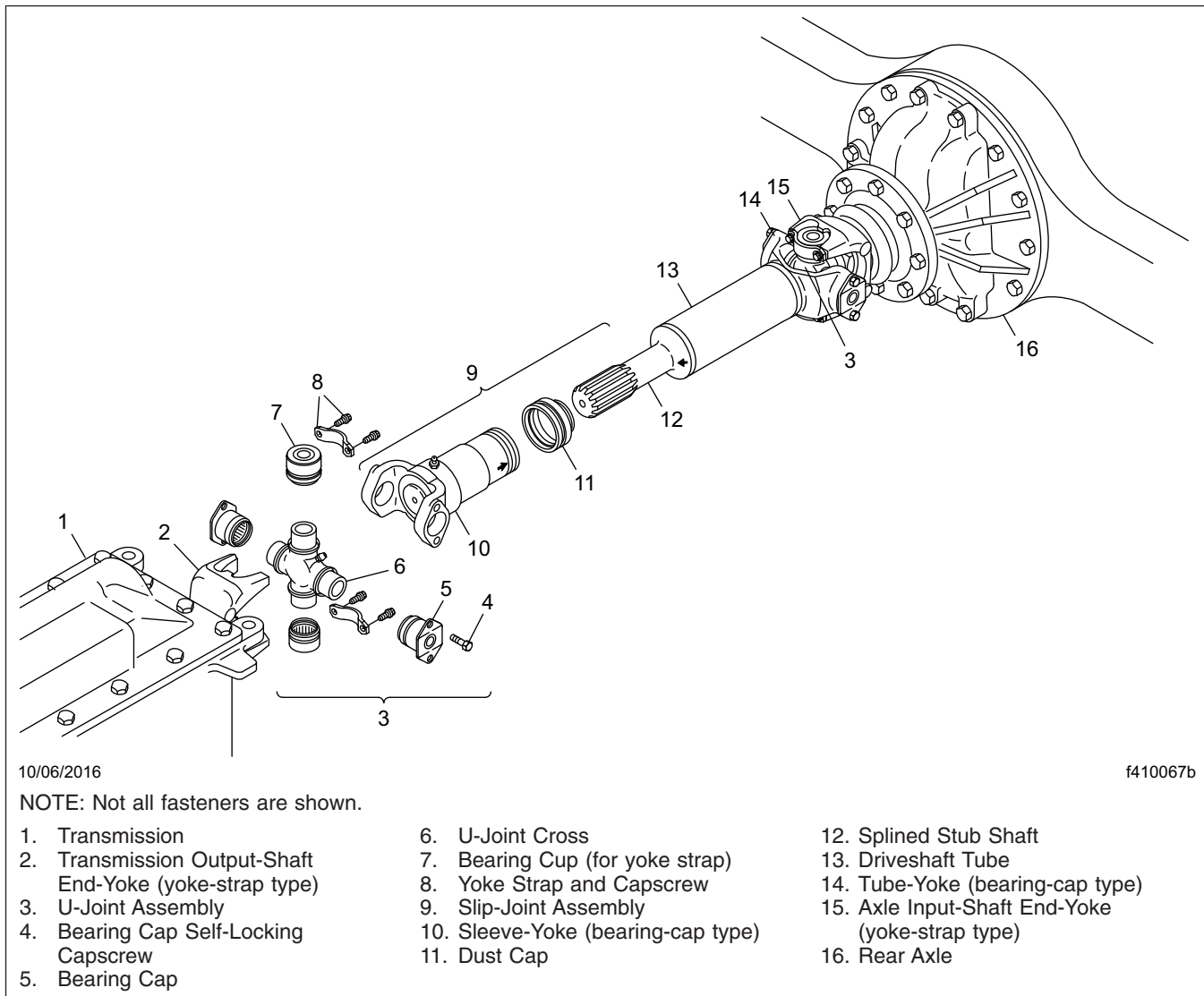

Fig. 3, Components of a Basic Driveline

5. Check if the midship bearing and mounting are loose or have deteriorated, by attempting to move the driveshaft up and down, and from side to side. If the bearing is loose on its shaft, or rattles, replace it. If the bearing mount is loose on the frame, tighten the mounting fasteners to the proper torque value. See **Group 41** of the *Cascadia™ Workshop Manual* for torque specifications. Replace the midship bearing assembly if the rubber cushion is deteriorated or oil-soaked.
6. Check slip joints for spline wear by moving the sleeve-yoke and splined shaft back and forth. See **Fig. 4**. If the slip joint can be twisted in a clockwise, or counterclockwise movement greater than 0.007 inch (0.18 mm), replace both the sleeve-yoke and the splined shaft.
7. Visually examine the driveshaft tubes for dents, bends, twists, or other damage. If any tube appears to be damaged, refer to **Group 41** of the *Cascadia™ Workshop Manual* for repair and replacement instructions.
8. Examine the driveshaft for evidence of missing balance weights, and for buildup of foreign mate-

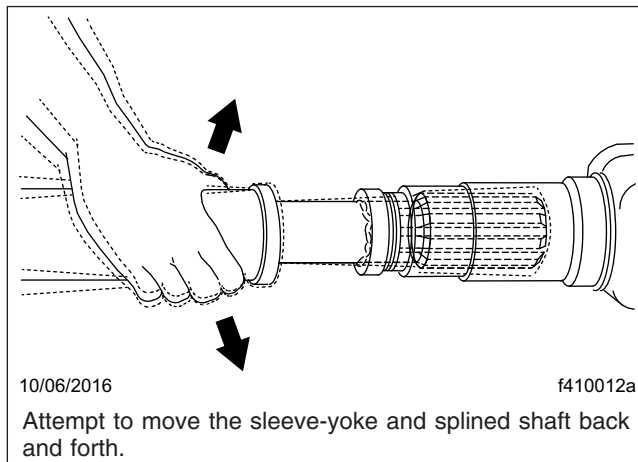

Fig. 4, Slip Joint Spline Wear Checking

rial. Remove any foreign material. If there is any evidence that balance weights are missing, remove the driveshaft and have it balanced.

9. For driveshafts with slip joints, check to be sure the yoke plug is not loose or missing. See **Fig. 5**. Repair or replace the yoke plug as needed. If the yoke plug is missing, the splined shaft may be hitting the plug and knocking it out; contact your Regional Service Office for assistance in determining the correct driveshaft length.

41-02 Driveline Lubrication

Universal Joint Lubrication

NOTE: Vehicles equipped with Meritor RPL Series drivelines do not require periodic lubrication.

1. Park the vehicle on a level surface, apply the parking brakes, and chock the tires.
2. Wipe all old grease and dirt from each U-joint grease fitting. See **Fig. 5**.
3. Use a hand-type grease gun, or a high-pressure gun with a low-pressure adapter, to lubricate U-joints. If a low-pressure adapter is not used, U-joints may not receive enough grease.

Using lithium 12-Hydroxy stearate grease (NLGI Grade 2, with EP additives), lubricate until *new* grease can be seen at *all four* U-joint seals. Fresh grease must be seen escaping from *all four* bearing-cap seals of each U-joint. On full-round yokes equipped with a bearing cup, if most

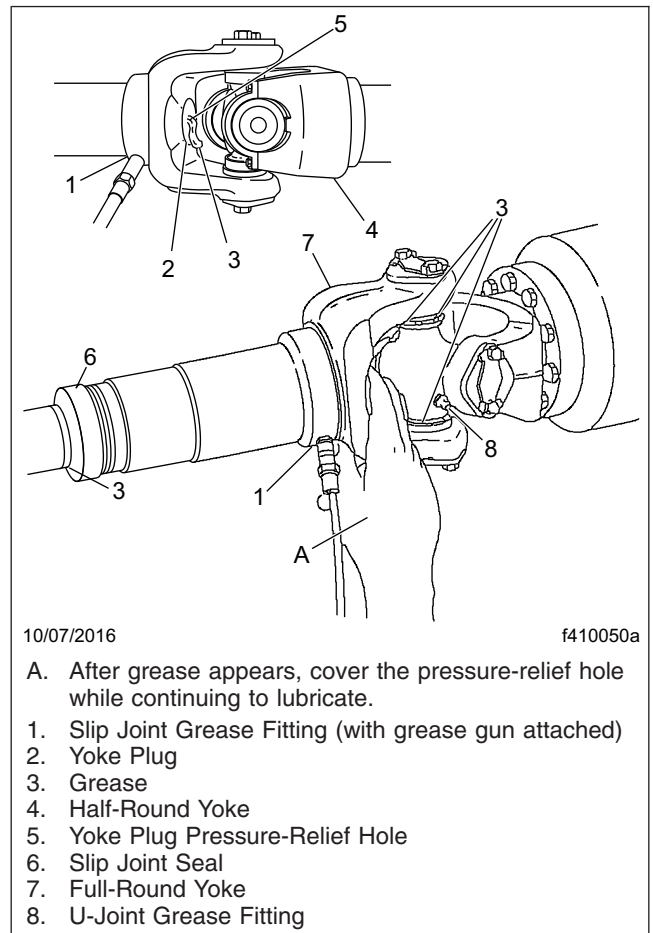

Fig. 5, Slip Joint and U-Joint Lubrication

- of the grease being added to a U-joint can be seen escaping from just one of the U-joint seals, check the torque on the capscrews at that seal.
4. Tighten the bearing-cup capscrews 43 lbf-ft (58 N-m). If the capscrews were already tight, or all of the U-joint seals still do not purge, remove the bearing cup at that seal, and examine the seal for damage. If the seal is damaged, replace the complete U-joint.
5. If grease does not appear at one seal, use a prying tool to pry the U-joint trunnion away from the non-purging seal, or tap the driveshaft or yoke with a plastic or rawhide mallet on the side opposite the dry seal, while continuing to lubricate. If grease still does not appear, loosen the capscrews at the bearing with the dry seal, to relieve seal tension. Lubricate the U-joint until new

grease is seen at the seal, then tighten the cap-screws to the correct torque specifications. If the bearing will not take grease, replace the U-joint. Refer to **Group 41** of the vehicle Workshop Manual for replacement instructions.

6. Check the purged grease. If it appears rusty, gritty, or burned, replace the U-joint.
7. Wipe the purged grease from the seals, and any excess grease from the grease fitting.

Slip Joint Spline Lubrication

NOTE: Vehicles equipped with Meritor RPL Series drivelines do not require periodic lubrication.

1. If equipped with a grease fitting, wipe all old grease and dirt from the slip joint grease fitting. See **Fig. 5**.
2. Use a hand-type grease gun or a high-pressure gun with a low-pressure adapter, to lubricate the slip joint. Add multipurpose chassis grease (lithium 12-hydroxy stearate, NLGI Grade 2, with EP additives) until it appears at the pressure-relief hole in the yoke plug. Then cover the relief hole with your finger, while continuing to apply gun pressure until new grease appears at the slip joint seal. See **Fig. 5**. This ensures complete lubrication of the splines.
3. Wipe the purged grease from the pressure-relief hole and slip joint seal, and any excess grease from the grease fitting.

Title of Maintenance Operation (MOP)	MOP Number
Air Brake System Valve Inspection	42-01
Air Dryer Inspection	42-03
Alcohol Evaporator Cleaning and Inspection	42-04
Bendix Air Dryer Desiccant Replacement	42-02
Bendix Automatic Drain Valve Operating and Leakage Tests	42-12
Bendix E-6 Foot Control Valve Inspection and Lubrication	42-09
Brake Inspection	42-05
Haldex Slack Adjuster Lubrication	42-06
Meritor Camshaft Bracket Lubrication	42-07
Meritor Slack Adjuster Lubrication	42-08
Safety Precautions	42-00
Versajust Slack Adjuster Inspection and Lubrication	42-11
WABCO System Saver Air Dryer Desiccant Cartridge Replacement	42-10

42–00 Safety Precautions

Safety Precautions in this section apply to all procedures within this group.

DANGER

When working on the vehicle, shut down the engine or motor, set the parking brake, and chock the tires. Before working under the vehicle, always place jack stands under the frame rails to ensure the vehicle cannot drop. Failure to follow these steps could result in serious personal injury or death.

42–01 Air Brake System Valve Inspection

NOTE: There is no scheduled air valve maintenance on vehicles equipped with Bendix air valves and a Bendix air dryer if the air dryer desiccant is replaced at 350,000 miles (563 000 km). If the desiccant is not changed at 350,000 miles (563 000 km), or if the vehicle is equipped with another air dryer, maintenance will have to be performed to the air brake valves. See **Group 42** of the vehicle Workshop Manual for procedures.

IMPORTANT: For vehicles equipped with an oil-coalescing air dryer desiccant cartridge, replace the cartridge once a year, regardless of mileage.

42–02 Bendix Air Dryer Desiccant Replacement

IMPORTANT: For vehicles equipped with an oil-coalescing air dryer desiccant cartridge, replace the cartridge once a year, regardless of mileage.

AD–9

1. Park the vehicle on a level surface, apply the parking brakes, and chock the tires.
2. Completely drain all air reservoirs. Air pressure gauges should read 0 psi (0 kPa).

NOTE: The compressor discharge line may still contain residual air pressure, open the line slowly.

3. Identify, tag, and disconnect the three air lines from the end cover.
4. Disconnect the harness connector from the heater and thermostat assembly.
5. Loosen the bolt that secures the upper mounting bracket strap.
6. Remove the two bolts and Nylok® nuts that secure the air dryer to the lower mounting bracket. Mark the position of the mounting bracket to the end cover and mark the bolts to ease installation.
7. Remove the upper mounting bracket strap fasteners, then remove the strap and the air dryer.
8. Place the air dryer on a bench and remove the remaining 6 bolts, 12 washers, 6 Nylok nuts, and the air dryer housing. See **Fig. 1**. Discard the Nylok nuts. Remove the end-cover-to-housing O-ring.
9. Clamp the desiccant cartridge in a vise.

WARNING

Clamping the end cover or housing in a vise could seriously compromise the air dryer's ability to hold air pressure, which could cause a failure in the brake system, resulting in property damage, personal injury, or death.

10. Twist the end cover counterclockwise to release the cartridge from the end cover. Rotate the end cover until it completely separates from the desiccant cartridge.

NOTE: A substantial torque, up to 50 lbf·ft (68 N·m), may be necessary to remove the desiccant cartridge.

NOTICE

Dirt or obstructions in the O-ring grooves can cause an O-ring failure that will result in an air leak.

11. Inspect the condition of the O-ring seals. If they are cracked, crimped, or otherwise damaged, replace them to ensure an airtight seal. Clean the O-ring grooves of any dirt or obstruction.

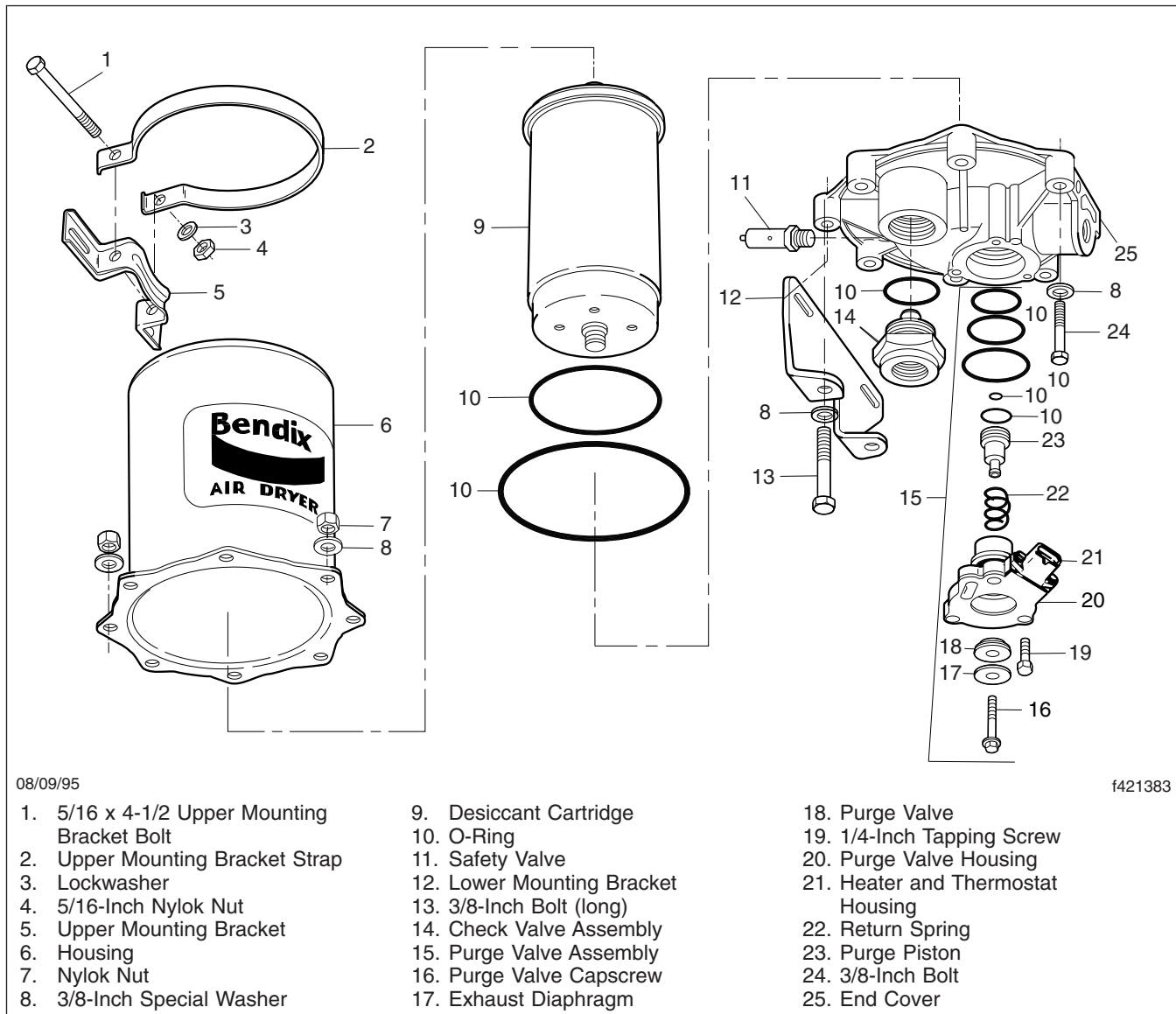

Fig. 1, AD-9 Air Dryer (exploded view)

12. Lubricate the O-rings with silicone or lithium grease and install them in the end cover.
13. Install the desiccant cartridge on the end cover. Turn the cartridge clockwise until the desiccant cartridge makes contact with the end cover.
14. Place the desiccant cartridge in a vise, and turn the end cover clockwise an additional 180 to 225 degrees to fully tighten the desiccant cartridge to the end cover.

NOTE: Desiccant cartridge torque should not exceed 50 lbf·ft (68 N·m).

15. Place the housing over the desiccant cartridge and align the mounting holes with the end cover.

IMPORTANT: Replace, do not reuse the Nylok nuts on the air dryer cover.

16. Install the 6 bolts, 12 washers, and 6 new Nylok nuts. Torque the Nylok nuts in a star pattern 17 to 24 lbf·ft (23 to 33 N·m). See [Fig. 2](#).

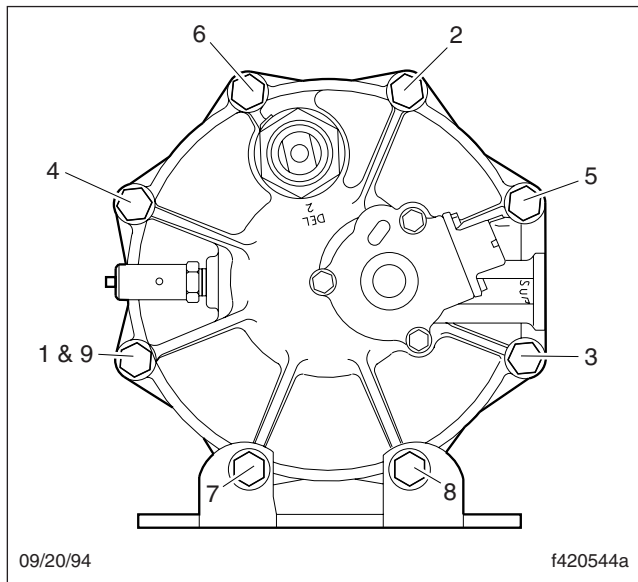

Fig. 2, AD-9 End Cover to Housing Torque Pattern

17. Install the air dryer on the lower mounting bracket. Install the two previously marked bolts, four washers, and two new Nylok nuts. Torque the two remaining Nylok nuts 17 to 24 lbf-ft (23 to 33 N·m). Install the bolt, two washers, and a new Nylok nut in the upper mounting bracket strap. Torque the upper mounting bracket strap Nylok nut 80 to 120 lbf-in (900 to 1360 N·cm).
18. Connect and tighten the three air lines. Connect the harness connector to the heater and thermostat assembly until the lock tab snaps in place.
19. Start the engine, build the air pressure, and check the air brake system for leaks. If any air leaks are present, see **Group 42** of the vehicle Workshop Manual for diagnosis and repair information.

AD-IP

1. Park the vehicle on a level surface, apply the parking brakes, and chock the tires.
2. Using a wrench or a socket, loosen the desiccant cartridge bolt. Then separate the desiccant cartridge from the end cover.
3. Pull the cartridge bolt out of the cover and remove the cartridge.

⚠ WARNING

Do not attempt to disassemble the desiccant cartridge assembly. Parts for the assembly are not available and the cartridge contains a 150 lb spring that cannot be mechanically caged. Disassembly could release the spring, resulting in personal injury.

4. Remove and discard both O-rings from the cartridge bolt.
5. Using a clean rag, wipe clean the inside of the end cover. Clean the cartridge bolt bore in the end cover, and the sealing surfaces for the large- and small-diameter desiccant cartridge sealing rings.
6. Inspect the end cover for physical damage, then inspect all air line fittings for corrosion; replace as necessary.
7. Clean and inspect the bolt, paying attention to the threads and O-ring grooves.

IMPORTANT: Use only the grease supplied with Bendix replacement kits.

8. Lubricate the O-rings, bolt O-ring grooves, sealing rings, and cartridge grooves. Lubricate the end cover bore for the bolt.
9. Install both O-rings on the cartridge bolt, then, using a twisting motion, insert the assembled desiccant cartridge bolt in the end cover.
10. Install the desiccant cartridge on the end cover, making sure the cartridge is properly seated and flush on the end cover.

NOTE: It may be necessary to rotate the cartridge slightly until the anti-rotation lugs are properly aligned and allow the cartridge to rest flush against the end cover.

11. Using a wrench or socket, tighten the desiccant cartridge bolt 70 lbf-ft (95 N·m). **Do not** over-torque.
12. Before placing the vehicle in service, perform the test below.
 - 12.1 Close all reservoir drain cocks.
 - 12.2 Build system pressure to governor cut-out, and note that the AD-IP air dryer purges with an audible escape of air.

- 12.3 Fan the service brakes to reduce system air pressure to governor cut-in. Note that the system once again builds to full pressure and is followed by a purge at the AD-IP air dryer exhaust.
- 12.4 Check for excessive leakage around the head of the desiccant cartridge where it contacts the end cover. With the compressor in loaded mode (compressing air), apply a soapy solution to these areas, and observe that any leakage does not exceed a 1-inch bubble in 1 second. If leakage exceeds this measure, remove and re-install the desiccant cartridge.

AD-9si and AD-IS

1. Park the vehicle on a level surface, apply the parking brakes, and chock the tires.
2. Drain the air reservoirs.
3. Using a strap wrench or equivalent, loosen the desiccant cartridge. Spin the cartridge off by hand and discard it. See [Fig. 3](#).

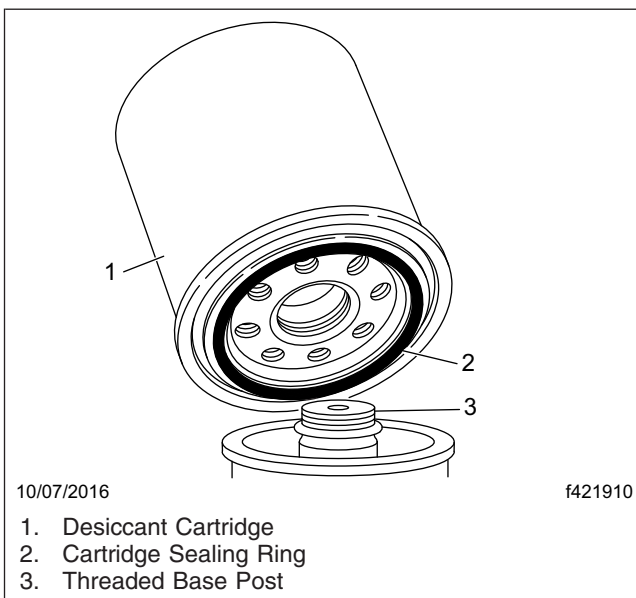

Fig. 3, Desiccant Cartridge Replacement

4. On the new desiccant cartridge, lubricate the sealing rings with silicone grease.

IMPORTANT: Only use the silicone grease supplied with Bendix replacement kits.

5. Screw the desiccant cartridge onto the body by hand until the seal makes contact with the body. Rotate the cartridge clockwise about one full turn. Tighten the cartridge firmly.

42-03 Air Dryer Inspection

1. Park the vehicle on a level surface and apply the parking brakes. Shut down the engine. Chock the tires.
2. Check for moisture in the air brake system by opening the reservoir drain cocks. Examine the discharge. Some trace of water in the discharge is normal. A discharge of a milky gray liquid indicates excessive moisture is present in the air system and the desiccant cartridge needs to be replaced. See **Group 42** of the vehicle Workshop Manual for troubleshooting procedures. The following conditions could cause small amounts of moisture to be found in the air system:
 - An outside air source has been used to charge the air brake system. This air did not pass through the drying bed.
 - Air usage is unusually high and not normal. This may be due to accessory air demands or some unusual air requirement that does not allow the compressor to load and unload in a normal fashion. Check for air system leaks.
 - The air dryer has been installed on a system that had previously been operated without an air dryer. This type of system will be saturated with moisture, and several weeks of operation may be needed to fully dry the system.
 - The temperature range in your area fluctuates more than 30 degrees in one day. Small amounts of water can accumulate in the air brake system due to condensation. Under these conditions, the presence of moisture is normal and should not be considered an indication of poor air dryer performance.
3. Inspect the air dryer for external damage, and check that the unit is tightly mounted on the frame. If the air dryer mounting is loose, See

Group 42 of the vehicle Workshop Manual for mounting instructions.

4. Turn on the ignition switch, but do not start the engine.
5. Disconnect the harness connector from the air dryer.
6. Connect a voltmeter to circuit 94 on the air dryer's harness connector and to a body ground point. Check for battery voltage. If voltage is not found, check and repair the open or short to ground in wire 94.
7. Connect a voltmeter between the two terminals on the air dryer's harness connector. If voltage is not found, repair the open in the ground circuit wiring.
8. Use an ohmmeter to check resistance between the terminals on the end cover. See **Fig. 4**. The end cover contains the heater/thermostat. If the heater/thermostat is between 40 and 90°F (5 and 32°C), the heater/thermostat measured resistance will be infinite ohms. If the measured resistance is less than infinity, replace the heater/thermostat.
9. Remove the heater/thermostat assembly and place it in a freezer for about five minutes to cool it below 40°F (5°C). Remove the cold heater/thermostat assembly and check resistance between the heater/thermostat terminals. Resistance should be 1.5 to 3.0 ohms. As the temperature of the heater/thermostat assembly increases, the ohm reading will increase. When the temperature goes above 45°F (7°C) measured resistance should be infinite ohms. If the heater/thermostat does not operate as outlined, replace it. If it does operate as outlined, install it.

42-04 Alcohol Evaporator Cleaning and Inspection

Maintenance is required during both the freeze season and the off season to keep the alcohol evaporator in good working order.

Off Season

During the off season, drain the unit of alcohol. At regular engine service intervals, open the drain cock to remove moisture from the alcohol evaporator. Before reactivating the evaporator for the next freeze season, drain, disassemble, inspect, and steam-clean the unit of any sludge that may have accumulated. It is advisable to replace any rubber parts when assembling the alcohol evaporator. Perform this service just before the freeze season.

Freeze Season Reactivation

1. Park the vehicle on a level surface and apply the parking brakes. Shut down the engine. Chock the tires.
2. Remove the filler cap, and check the cap tetraseal.
3. Remove the capscrews and reservoir from the cover.
4. Remove the cover tetraseal.
5. Drain the air tank, and disconnect the line from the evaporator outlet. Remove the check-valve retainer, spring, and disc.
6. Install the disc, spring, and check-valve retainer, and connect the line to the evaporator outlet.
7. Install the cover tetraseal.

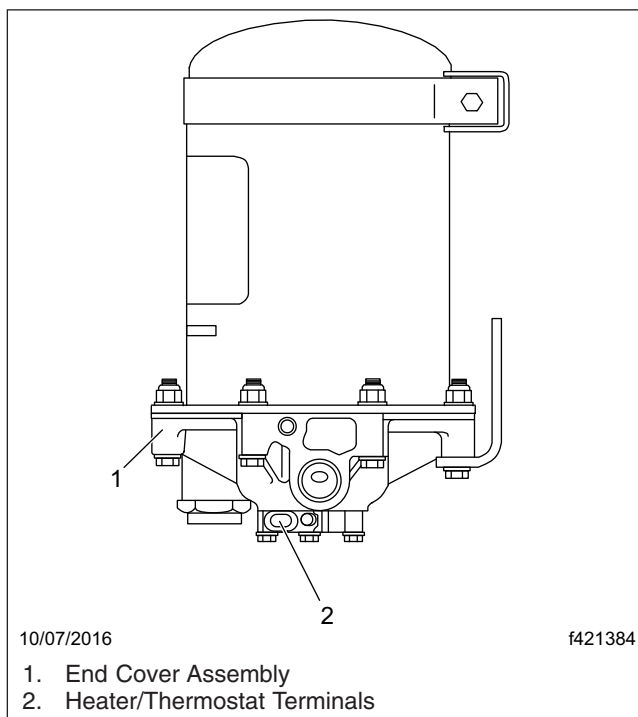

Fig. 4, End Cover Terminals Location

8. Install the reservoir on the cover and tighten the capscrews.
9. Fill the reservoir with 40 ounces (1183 mL) of methyl alcohol, then install the filler cap.

42–05 Brake Inspection

Parking Brake Operational Check

IMPORTANT: This procedure should be performed prior to lubrication of the brake components.

CAUTION

Perform the following check in a clear safe area. If the parking brakes fail to hold the vehicle, personal injury or property damage may result.

1. With the engine running, and air pressure at cut-out pressure, set the parking brake.
2. Put the vehicle in the lowest gear and gently attempt to move it forward. The vehicle should not move. If the vehicle moves, the parking brakes are not operating correctly and must be repaired before the vehicle is returned to service. See **Group 42** of the vehicle Workshop Manual for repair procedures.

Brake Component Inspection

Air Disc Brakes

IMPORTANT: The following step to inspect the caliper mounting bolts should only be performed at the initial maintenance (IM) interval.

Vehicles may have both **axial and radial** mounted calipers. Follow the instructions based on the type of calipers installed on the vehicle.

Axial Mounted Brakes

IMPORTANT: The following information applies to all types of axial mounted brake applications.

1. Park the vehicle on a level surface, shut down the engine, and set the parking brake. Chock the tires.

2. Raise the vehicle and support it on jack stands.
3. Remove all of the wheel assemblies. For instructions, see **Group 40** of the vehicle workshop manual for repair procedures.

NOTE: In all steps that require a torque wrench, use a Snap On torque wrench ATECH4RS600, or an equivalent, with a center to handle length of 47 inches (119 cm).

4. Set a torque wrench to 350 lbf-ft (475 N·m) and tighten the caliper mounting bolts following the tightening pattern shown in **Fig. 5**. If they do not turn, no further work is needed. If they turn, take the vehicle to an authorized Freightliner dealer to have all of the caliper bolts on that wheel end replaced. Due to limited caliper bolt access, it may be necessary to use tool DDC DSN-CHA018005 referenced in tool letter 18TL18. If the tool is needed, use tool DDC DSN-CHA018005 only and no other tools. See **Fig. 6**. If the tool is needed, see **Table 3** for torque specifications for a 47 in (119 cm) long wrench.



Fig. 5, Axial Bolt Tightening Pattern



Fig. 6, DDC DSNCHA018005 30mm Air Disc Brake Caliper Brake Bolt Torque Adaptor







Torque Check with 47 Inch (119 cm) Torque Wrench and Tool DDC DSNCHA018005			
Angle View	Extension Angle (degrees)	Target Torque [lbf-ft (N·m)]	Tool Setting [lbf-ft (N·m)]
 <p>0° 11/28/2016 f422613</p>	0	350 (475)	296 (401)
 <p>45° 11/28/2016 f422614</p>	45		310 (420)
 <p>60° 11/06/2018 f422668</p>	60		320 (434)
 <p>90° 11/28/2016 f422615</p>	90		350 (475)
 <p>120° 11/06/2018 f422669</p>	120		386 (523)
 <p>135° 11/28/2016 f422616</p>	135		402 (545)

Table 1, Torque Check with 47 Inch (119 cm) Torque Wrench and Tool DDC DSNCHA018005

5. Install the wheel assemblies. For instructions, see **Group 40** of the vehicle workshop manual for repair procedures.
6. Remove the jack stands and lower the vehicle.

Radial Mounted Brakes

Bendix Calipers

1. Park the vehicle on a level surface, shut down the engine, and set the parking brake. Chock the tires.

2. Raise the vehicle and support it on jack stands.
3. Remove all of the wheel assemblies. For instructions, see **Group 40** of the vehicle workshop manual for repair procedures.
4. Set a torque wrench to 200 lbf-ft (271 N·m) and tighten the caliper mounting bolts following the tightening pattern shown in **Fig. 7**. If they do not turn, no further work is needed. If they turn, take the vehicle to an authorized Freightliner dealer to have all of the caliper bolts on that wheel end replaced.

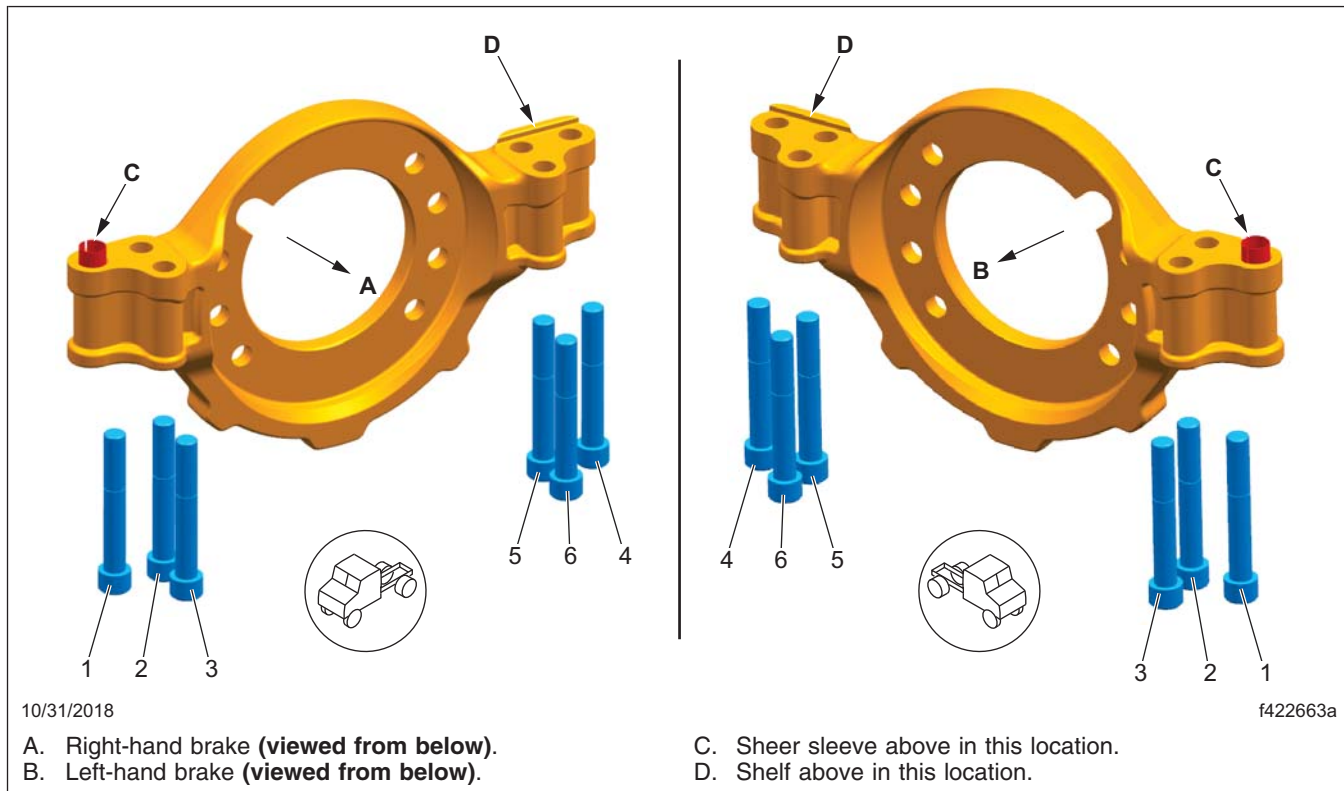

Fig. 7, Bendix Radial Mounted Caliper Tightening Pattern (viewed from below)

5. Install the wheel assemblies. For instructions, see **Group 40** of the vehicle workshop manual for repair procedures.
6. Remove the jack stands and lower the vehicle.

Meritor Calipers

1. Park the vehicle on a level surface, shut down the engine, and set the parking brake. Chock the tires.
2. Raise the vehicle and support it on jack stands.
3. Remove all of the wheel assemblies. For instructions, see **Group 40** of the vehicle workshop manual for repair procedures.
4. Set a torque wrench to 350 lbf-ft (475 N-m) and tighten the caliper mounting bolts following the tightening pattern shown in **Fig. 8**. If they do not turn, no further work is needed. If they turn, take the vehicle to an authorized Freightliner dealer to have all of the caliper bolts on that wheel end replaced.

5. Install the wheel assemblies. For instructions, see **Group 40** of the vehicle workshop manual for repair procedures.
6. Remove the jack stands and lower the vehicle.

WABCO Maxxus Calipers

1. Park the vehicle on a level surface, shut down the engine, and set the parking brake. Chock the tires.
2. Raise the vehicle and support it on jack stands.
3. Remove all of the wheel assemblies. For instructions, see **Group 40** of the vehicle workshop manual for repair procedures.
4. Set a torque wrench to 273 lbf-ft (370 N-m) and tighten the caliper mounting bolts following the tightening pattern shown in **Fig. 9**. If they do not turn, no further work is needed. If they turn, take the vehicle to an authorized Freightliner dealer to have all of the caliper bolts on that wheel end replaced.

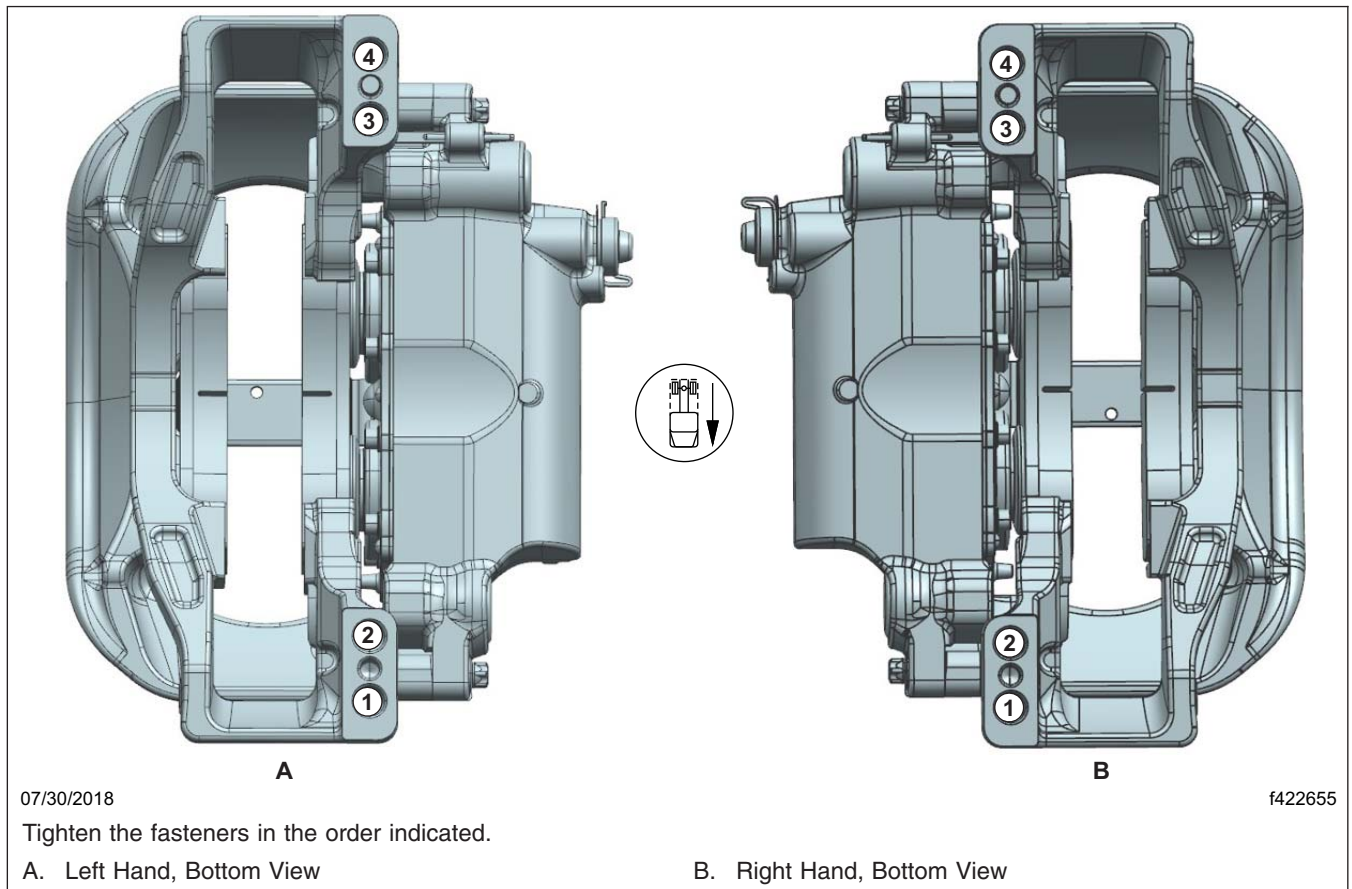

Fig. 8, Meritor Radial Mounted Caliper Tightening Pattern

5. Install the wheel assemblies. For instructions, see **Group 40** of the vehicle workshop manual for repair procedures.
6. Remove the jack stands and lower the vehicle.

Drum Brakes

1. Park the vehicle on a level surface, shut down the engine, and set the parking brake. Chock the tires. Once the tires are chocked, release the parking brake.

WARNING

Manually adjusting an automatic slack adjuster to bring the pushrod stroke within legal limits is likely masking a mechanical problem. Adjustment is not repairing. Before adjusting an automatic slack adjuster, troubleshoot the foundation brake system and inspect it for worn or damaged com-

ponents. Improperly maintaining the vehicle braking system may lead to brake failure, resulting in property damage, personal injury, or death.

2. With the engine off, and 100 psi (690 kPa) of air tank pressure, have an assistant apply and hold an 80 to 90 psi (552 to 621 kPa) brake application.
3. Check to see if the colored over-stroke band on each brake chamber pushrod is exposed.
If a band shows, the stroke is too long. Check the foundation brake components for wear or damage, and repair as needed. See **Group 42** of the vehicle workshop manual for inspection, troubleshooting, and repair procedures.
4. Measure the applied chamber stroke. See **Table 4** for the proper stroke for the type of chamber being used. If the stroke is too short, the brakes may drag or will not fully apply. Check

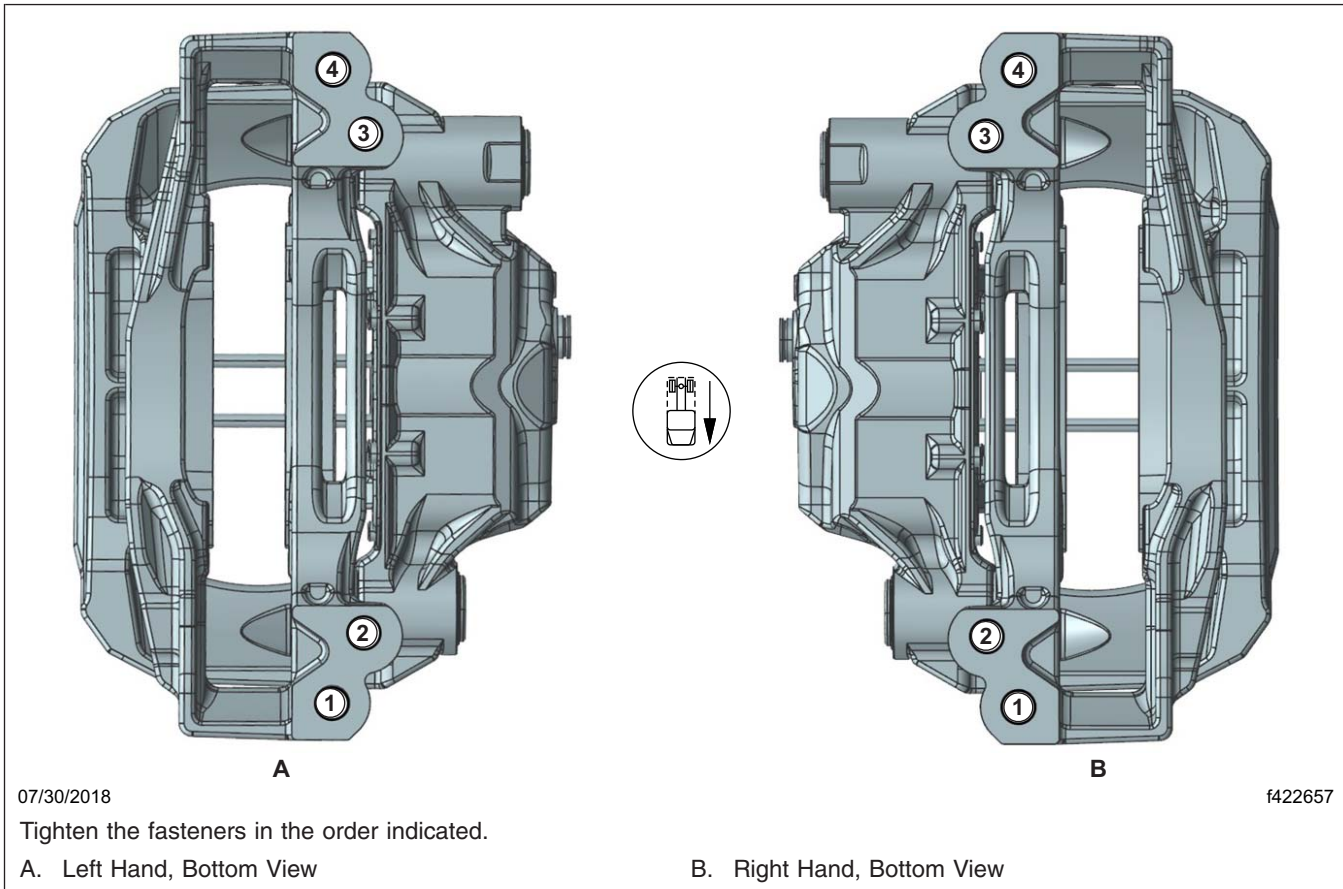

Fig. 9, Wabco Maxxus Radial Mounted Caliper Tightening Pattern

for improper operation or adjustment of the automatic slack adjuster. See **Group 42** of the vehicle workshop manual for inspection and troubleshooting procedures.

5. Check all of the foundation brake components for damage, wear, and loose or missing parts. Repair as needed. See **Group 42** of the vehicle workshop manual for repair procedures.

Brake Chamber Stroke Specifications			
Chamber			Max Applied Stroke: inch (mm)
Manufacturer	Type*	Size†	
Gunitite	Standard Stroke	9	1-3/8 (35)
		12	
		16	1-3/4 (45)
		20	
		24	
		30	2 (51)
	36‡	2-1/4 (57)	
	Long Stroke	16	2 (51)
		20	
		24	
24		2-1/2 (64)	
30			
Haldex	Standard Stroke	12	1-3/8 (35)
		16	1-3/4 (44)
		20	
		24	
	2-1/2-Inch Extended Stroke	24	2 (51)
	3-Inch Extended Stroke	24	2-1/2 (64)
	Standard Stroke	30	2 (51)
Long Stroke	30	2-1/2 (64)	
Meritor	Standard Stroke	9	Less than 1-1/2 (38)
		12	
		16	Less than 1-3/4 (44)
		20	
	24	Less than 1-7/8 (48)	
	Long Stroke	24	Less than 2 (51)
Standard Stroke	30		

* Long stroke design is indicated by a tag, or embossing, on the brake chamber.

† Specifications are relative to a brake application with 80 to 90 psi (550 to 620 kPa) air pressure in the brake chambers.

‡ If type 36 chamber is used, slack length should be less than 6 inches.

Table 2, Brake Chamber Stroke Specifications

42-06 Haldex Slack Adjuster Lubrication

Automatic slack adjusters that have a grease fitting must be lubricated periodically to ensure proper brake operation.

WARNING

Failure to lubricate slack adjusters could lead to dragging brakes or a brake failure, resulting in property damage, personal injury, or death.

CAUTION

Do not use moly-disulfide-loaded grease or oil. Both the life and reliability of the slack adjuster will be reduced if this type of grease is used.

Lubricate the automatic slack adjuster at the grease fitting. See Fig. 10. Use standard chassis lubricant for Haldex slack adjusters.

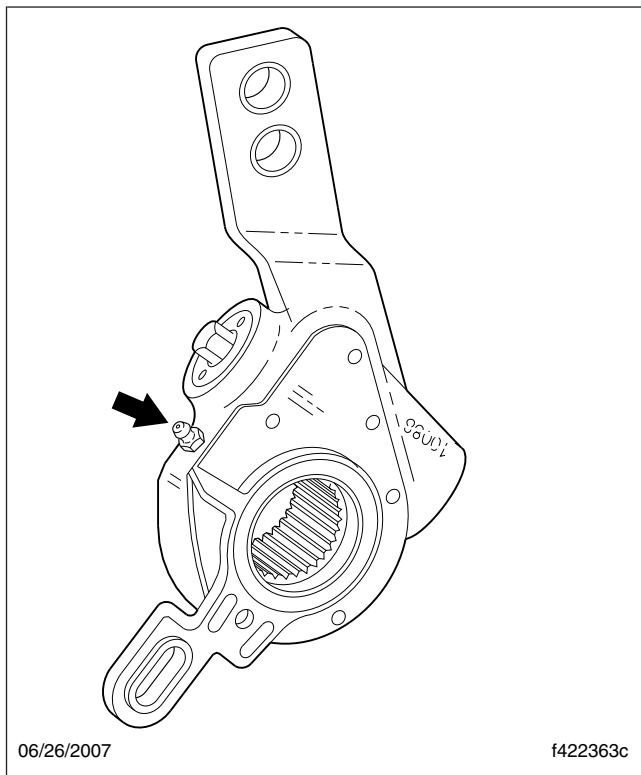

Fig. 10, Haldex Automatic Slack Adjuster Grease Fitting

42-07 Meritor Camshaft Bracket Lubrication

IMPORTANT: Perform a brake inspection before lubricating the camshaft bracket.

NOTE: If equipped with an extended-maintenance Q Plus™ brake system, the camshaft bracket will not have a grease fitting. These camshafts use a special NLGI Grade synthetic polyurea grease and do not require lubrication for 3 years or 500,000 miles (800 000 km), whichever comes first. The extended-maintenance camshaft bushings are lubricated during the brake reline service interval. For service and lubrication instructions, see **Group 42** of the vehicle Workshop Manual.

For camshaft brackets with grease fittings, use an NLGI Grade 1 or Grade 2 multipurpose chassis grease. Lubricate the camshaft bushings through the grease fitting on the camshaft bracket or the spider until new grease flows from the inboard seal. See Fig. 11.

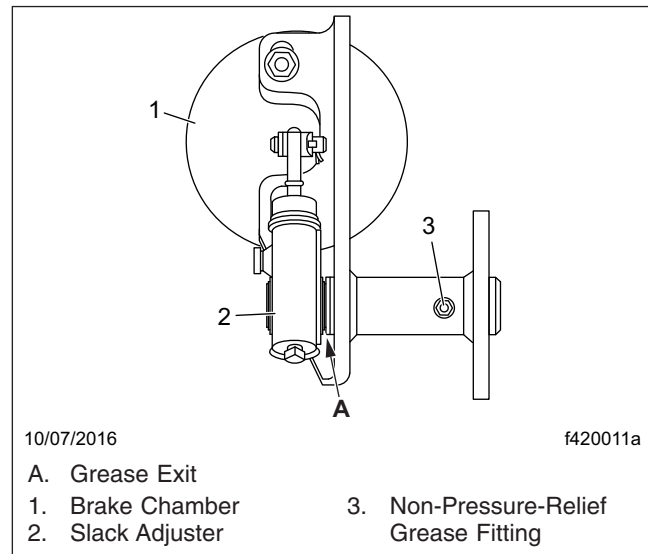

Fig. 11, Camshaft Bracket Lubrication

WARNING

If grease leaks out under the camhead, the camshaft bracket grease seal is worn or damaged. See Group 42 in the vehicle workshop manual for

grease seal replacement instructions. If this seal is not replaced, the brake linings could become contaminated with grease. The stopping distance of the vehicle will be increased, which could result in personal injury or property damage.

42–08 Meritor Slack Adjuster Lubrication

IMPORTANT: Perform a brake inspection following the instructions in this group before lubricating the slack adjusters.

WARNING

Failure to lubricate slack adjusters could lead to dragging brakes or a brake failure, resulting in property damage, personal injury, or death.

NOTE: If equipped with an extended-maintenance Q Plus™ brake system, the slack adjuster will not have a grease fitting. These slack adjusters use a special NLGI Grade synthetic polyurea grease and do not require lubrication for 3 years or 500,000 miles (800 000 km), whichever comes first. The extended-maintenance slack adjusters are lubricated during the brake reline service interval. For service and lubrication instructions, see **Group 42** of the vehicle Workshop Manual.

For slack adjusters with grease fittings and for operating temperatures above -40°F (-40°C), use an NLGI Grade 1 clay-base grease, or an NLGI Grade 1 or 2 lithium-base grease.

For slack adjusters with grease fittings and for operating temperatures below -40°F (-40°C) and above -65°F (-54°C), use an NLGI Grade 2 synthetic oil, clay-base grease.

Lubricate the slack adjuster at the grease fitting until grease is forced past the pressure-relief capscrew or past the gear splines around the inboard snap ring. See **Fig. 12**.

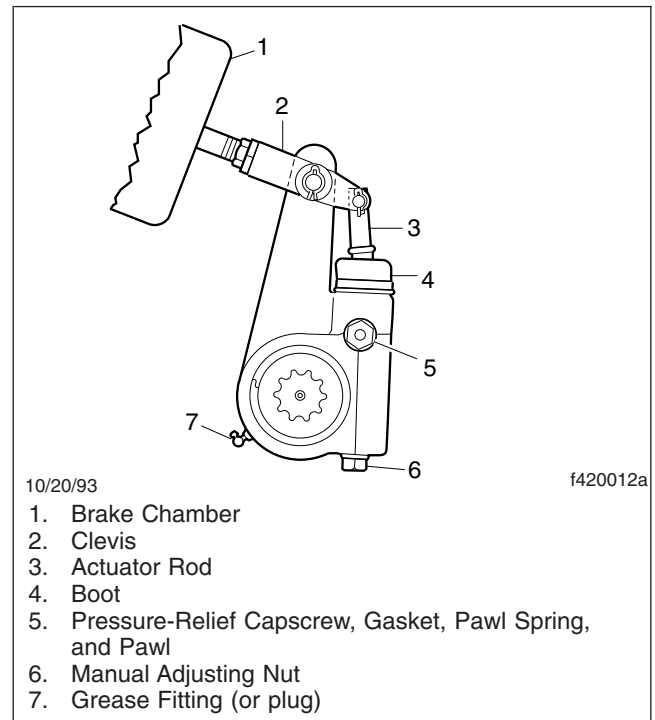

Fig. 12, Meritor Automatic Slack Adjuster

42–09 Bendix E-6 Foot Control Valve Inspection and Lubrication

1. Remove the brake valve from the vehicle; see **Group 42**, of the vehicle Workshop Manual.
2. Remove the roll pin from the brake pedal pivot pin. See **Fig. 13**.
3. Remove the brake pedal pivot pin.
4. Remove the brake pedal.
5. Check the brake pedal mounting plate adapter for signs of wear or cracks at the bosses (the area from which the pivot pin was removed). Replace it if necessary.
6. Check the brake pedal rollers for signs of wear or cracks. Replace the rollers as needed.
7. If the rollers are replaced, replace the roller pin, install a new cotter pin, bend it to 90 degrees and apply Torque Seal (OPG F900 White) to the cotter pin.

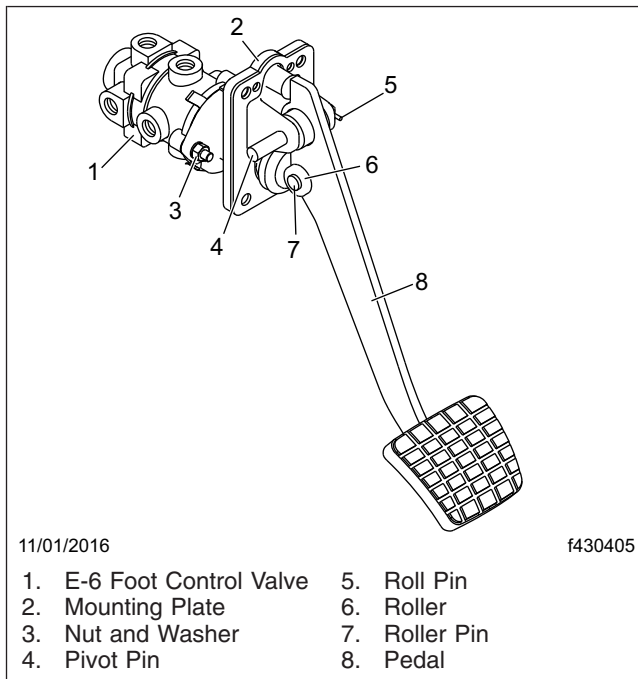

Fig. 13, Brake Pedal and Valve Assembly

8. Remove the plunger from the valve. Using alcohol, clean the existing grease from the plunger. Check the plunger for signs of wear or cracks. Replace it if necessary.
9. Lubricate the plunger with barium grease (BW 246671).
10. Insert the plunger in the valve.
11. Install the brake pedal with the pivot pin.
12. Install a new roll pin and apply Torque Seal (OPG F900 White) to the roll pin.
13. Install the brake valve assembly; see **Group 42**, of the vehicle Workshop Manual.
14. Test the brakes before returning the vehicle to service.

42-10 WABCO System Saver Air Dryer Desiccant Cartridge Replacement

NOTE: The following instructions apply to the System Saver 1200, 1200 Plus, and Twin air dryers.

NOTICE

The WABCO System Saver air dryers can use either a standard or oil coalescing desiccant cartridge. When replacing the desiccant cartridge, it is very important to use the same type of cartridge that was originally installed on the dryer. Oil coalescing cartridges can be used in any application, but require more frequent service intervals. Do not replace an oil coalescing cartridge with a standard cartridge, as this may result in contamination and malfunctioning of downstream air system components.

Refer to **Fig. 14** for cartridge replacement.

1. Drain the air system.

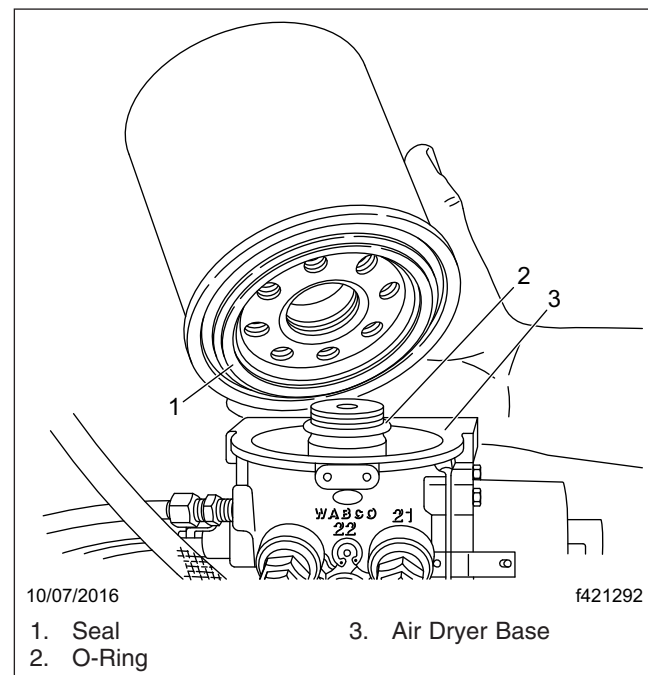

Fig. 14, Desiccant Cartridge Replacement

2. Using a strap wrench, turn the desiccant cartridge counterclockwise and remove it.
3. Remove and discard the O-ring.
4. Clean the top surface of the dryer base with a commercial cleaning solvent.

IMPORTANT: If the air dryer base is damaged, preventing a tight seal, replace the air dryer.

5. Using a multipurpose, high-temperature grease that resists water, steam, and alkali, lightly coat the surfaces of the new O-ring and the dryer base. Install the O-ring.
6. Thread the desiccant cartridge onto the dryer base (turn clockwise). When the seal contacts the base, tighten the cartridge one complete turn more. Do not overtighten.

42–11 Versajust Slack Adjuster Inspection and Lubrication

IMPORTANT: Perform the **Brake Inspection** maintenance operation before lubricating the slack adjusters.

1. Visually check for physical damage, such as broken air lines and broken or missing parts.
2. Using a quality multipurpose chassis lubricant, NLGI Grade 2, lubricate the slack adjuster through the grease fitting until clean lubricant flows from the grease relief opening in the boot.
3. Perform the "In Service Inspection."

In Service Inspection

1. Apply and release the brakes several times while observing the slack adjuster. The slack adjuster and brake actuator should move freely, without binding or interference, and should return to the full released position. Observe the looseness that exists between the clevis and adapter bushing and the yoke and link pins and their mating parts (clevis, body, link). Replace these parts if looseness appears excessive. Make certain the brake actuator pushrod jam nut is tightened securely.
2. Inspect the slack adjuster for physical damage, paying attention to the link, boot, and clevis. If any components are damaged, repair or replace them as necessary.
3. Measure the brake actuator pushrod stroke while making an 80 to 90 psi (552 to 621 kPa) brake application. Actuator pushrod strokes should not exceed the values shown in **Table 3** and **Table 4**. To achieve the correct pressure for this test, build the system pressure up to a 100 psi (690 kPa). Shut down the engine. Fan the brakes to attain a 90 to 95 psi (621 to 655 kPa)

reading. Make and hold a full brake application while the strokes are checked.

Actuator Stroke–Standard Stroke	
Brake Actuator Size	Recommended Maximum Operating Stroke (Inches)
30	2
24	1-3/4
20	1-3/4
16	1-3/4
12	1-3/8

Table 3, Actuator Stroke–Standard Stroke

Actuator Stroke–Long Stroke	
Brake Actuator Size	Recommended Maximum Operating Stroke (Inches)
30 Long Stroke	2-1/2
24 Long	2
24 Long Stroke	2-1/2
20 Long	2
16 Long	2

Table 4, Actuator Stroke–Long Stroke

42–12 Bendix Automatic Drain Valve Operating and Leakage Tests

Operating Test

Perform the following test after repairing or replacing the DV-2 valve, to ensure that the valve is functioning properly.

With the system charged, apply the brakes several times. Each time the brakes are applied, an exhaust of air should occur from the exhaust port of the drain valve. If no air comes out, push the wire stem located inside the exhaust port. If no air comes out after pushing the wire stem, there may be a plugged filter in the adapter which should be replaced.

If the drain valve does not function properly, repair or replace it. See **Section 42.14** of the *Cascadia Workshop Manual*.

Leakage Test

Perform the following test after repairing or replacing the DV-2 valve, to ensure that the valve is functioning properly.

With the system charged and pressure stabilized in the system, there should be no leaks at the drain valve exhaust port. A constant slight exhaust of air at the drain valve exhaust port could be caused by excessive leakage in the air brake system.

If the drain valve is leaking excessively, repair or replace it. See **Section 42.14** of the *Cascadia Workshop Manual*.

Title of Maintenance Operation (MOP)	MOP Number
Bellows Replacement, Rack and Pinion Steering Gear	46-07
Drag Link Inspection.	46-01
Drag Link Lubrication.	46-05
Power Steering Fluid Level Inspection.	46-03
Power Steering Fluid and Filter Changing.	46-02
Power Steering Gear Lubrication.	46-04
Rack and Pinion Steering Gear Inspection	46-06
Safety Precautions.	46-00

46–00 Safety Precautions

Safety Precautions in this section apply to all procedures within this group.

DANGER

When working on the vehicle, shut down the engine or motor, set the parking brake, and chock the tires. Before working under the vehicle, always place jack stands under the frame rails to ensure the vehicle cannot drop. Failure to follow these steps could result in serious personal injury or death.

46–01 Drag Link Inspection

WARNING

All steering system components are critical for safe operation of the vehicle. Failure to maintain the steering system as specified may result in loss of steering control, which could lead to personal injury and property damage.

1. Park the vehicle on a level surface, shut down the engine, and set the parking brake. Chock the tires.
2. Have someone turn the steering wheel from left to right. Check for movement between the ball stud end and the pitman arm, and between the ball stud end and the steering arm.

If the ball stud end is loose, replace the drag link.

3. Check the ball stud castle nut for looseness. If the castle nut is loose, replace it and the cotter pin. Tighten the new castle nut as follows:
 - 3/4–16: 90 to 180 lbf·ft (122 to 230 N·m)
 - 7/8–14: 160 to 300 lbf·ft (217 to 407 N·m)
4. Inspect the boot of the drag link at both the pitman arm and the steering arm end for cracks, splits, or other damage. Replace the boot if needed.
5. Grasp the drag link near the pitman arm end, then push and pull laterally to check for axial movement in the ball stud end. If it is loose, replace the drag link. See **Group 46** of the *Casca-*

dia Workshop Manual for replacement instructions. If there is 1/8-inch (3-mm) movement or more, do not drive the vehicle until the drag link is replaced.

46–02 Power Steering Fluid and Filter Changing

WARNING

Fill only with approved clean fluid. Failure to use the proper fluid could cause seal deterioration and leaks. Fluid leaks could eventually cause loss of power steering assist. This could lead to an accident resulting in personal injury or property damage. Wear eye protection when changing the fluid and filter.

1. Park the vehicle on a level surface, shut down the engine, and set the parking brake. Chock the tires.
2. Place a drain pan under the power steering reservoir.
3. Remove the retaining ring from the reservoir. See **Fig. 1**.

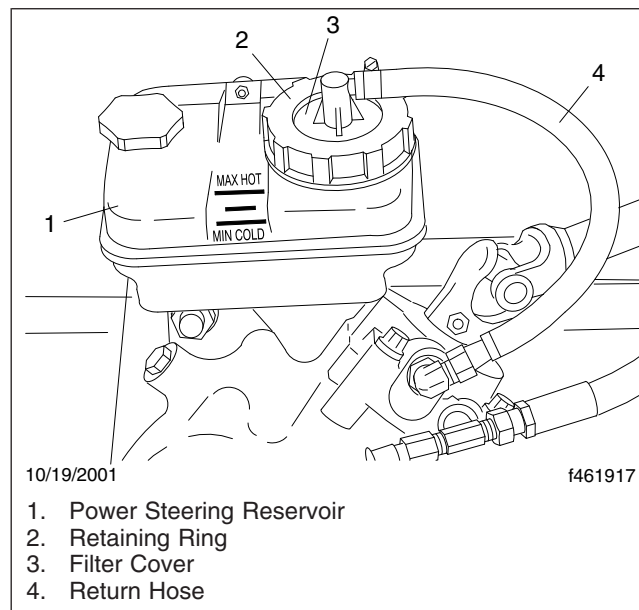

Fig. 1, Power Steering Reservoir

4. Remove the filter, filter cover, and gasket from the reservoir. Drain the fluid from the filter into the drain pan. Leave the filter hanging over the drain pan.
5. Remove the nuts, bolts, and washers that attach the power steering reservoir to the mounting bracket, but do not remove the supply line to the reservoir. Drain the power steering fluid from the reservoir.
6. Using the bolts, nuts, and washers, attach the reservoir to the mounting bracket.
7. Using ATF fluid that meets Dexron III or TES-389 specifications, fill the reservoir with an approved power steering fluid to the line between the MIN COLD and MAX HOT lines. See [Fig. 1](#).
8. Raise the front of the vehicle and support it with jack stands.
9. Start the engine and operate it at idle. Turn the steering wheel from full left to full right several times until clean fluid starts flowing from the power steering filter. Add fluid to the reservoir to maintain the fluid level between the MIN COLD and MAX HOT lines.
10. Shut down the engine.

NOTE: Always install a new power steering reservoir filter when changing the fluid.

11. Disconnect the filter from the filter cover, and discard the filter.
12. Apply a thin film of power steering fluid on the gasket of the new filter. Then attach the filter to the filter cover. Hand-tighten the filter, then turn it an additional 1/4-turn.
13. Install the filter and filter cover in the reservoir.
14. Make sure that the gasket under the filter cover is not damaged. If the gasket is damaged, replace it. Install the gasket on the reservoir.
15. Attach the retaining ring to the reservoir to secure the filter and filter cover.
16. Start the engine and check that the power steering fluid level is between the MIN COLD and MAX HOT lines. Add more power steering fluid if needed.
17. Lower the vehicle.

46–03 Power Steering Fluid Level Inspection

1. Park the vehicle on a level surface, shut down the engine, and set the parking brake. Chock the tires.
2. With the engine cool, use a shop towel or a clean rag to clean the area around the power steering reservoir fill cap.
3. Twist the cap counterclockwise to remove it. Check the cold power steering fluid level. The level should be between ADD COLD and FULL COLD with the engine off.
4. Start the engine and run it at idle until it reaches operating temperature.

Remove the dipstick, and check that power steering fluid level is between ADD HOT and FULL HOT lines. If necessary, add enough ATF fluid that meets Dexron III or TES-389 specifications to bring the level up to the FULL HOT mark on the dipstick.

46–04 Power Steering Gear Lubrication

NOTICE

Apply grease to the sector shaft with a hand-type grease gun only. Use of a high-pressure power grease gun will supply grease too quickly and could affect the high pressure seal, contaminating the hydraulic fluid.

Using a hand-type grease gun, apply NLGI Grade 2 or 3 multipurpose chassis grease until it starts to come out past the sector shaft seal. See [Fig. 2](#).

46–05 Drag Link Lubrication

1. Park the vehicle on a level surface, shut down the engine, and set the parking brake. Chock the tires.
2. Using a clean rag, wipe all dirt from the drag link grease fittings. See [Fig. 3](#).
3. Using a pressure gun and NLGI Grade 2 (8% 12-hydroxy lithium stearate grease) or NLGI

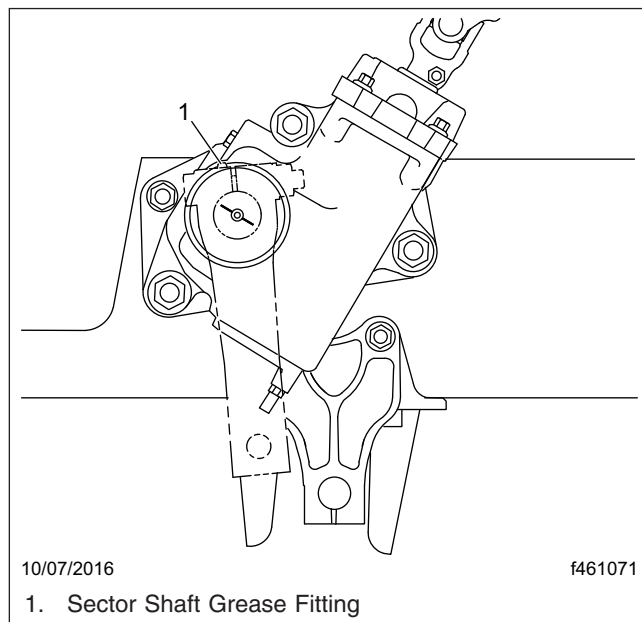

Fig. 2, Steering Gear Lubrication

Grade 1 (6% 12-hydroxy lithium stearate grease) chassis grease, apply clean grease at the grease fittings until old grease is forced out of the socket.

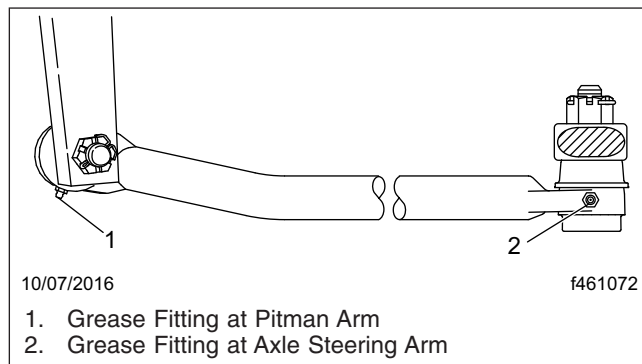

Fig. 3, Drag Link

46-06 Rack and Pinion Steering Gear Inspection

WARNING

All steering system components are critical for safe operation of the vehicle. Failure to maintain the steering system as specified may result in

loss of steering control, which could lead to personal injury and property damage.

Inspect the rack and pinion steering system as described below, and repair or replace any components that are worn or damaged. **Figure 4** shows the components of the rack and pinion steering system.

1. Park the vehicle on a level surface, shut down the engine, and set the parking brake. Chock the tires.
2. Check the steering I-shaft U-joints for evidence of looseness or binding. If any is found, replace the I-shaft.
3. Check the steering I-shaft slip joint for evidence of lateral movement, looseness, or binding. If any is found, replace the I-shaft.
4. Jack up one axle end at a time, and move the tire in and out by hand to check the tie rod ends for free play. No free play is allowed. If the outer tie rod ends are damaged or worn, replace them. See **Group 46** of the *Cascadia Workshop Manual* for replacement instructions.
5. Check the steering gear mounting bolts for security.
6. Check that the outer tie rod castle nuts are tight, and the cotter pins are properly installed.

IMPORTANT: Do not remove the bellows unless they are damaged and require replacement, or there is evidence of a loose inner tie rod or there is hydraulic fluid leak.

7. Use a clean rag to remove all dirt and debris from the bellows. Check the bellows for holes or tears. If any are found, replace the bellows.
8. Check for evidence of hydraulic fluid leakage from the bellows. If hydraulic fluid is found to be leaking from within the bellows, replace the steering gear.
9. Check the input shaft for any leakage around the input shaft seal cover. If there is evidence of leakage from inside the cover, remove it and replace the input shaft seal. See **Group 46** of the *Cascadia Workshop Manual* for instructions.

Check the steering system pressure and return lines and fittings for leaks and damaged lines or hoses. Repair or replace lines, hoses, and fittings as necessary.

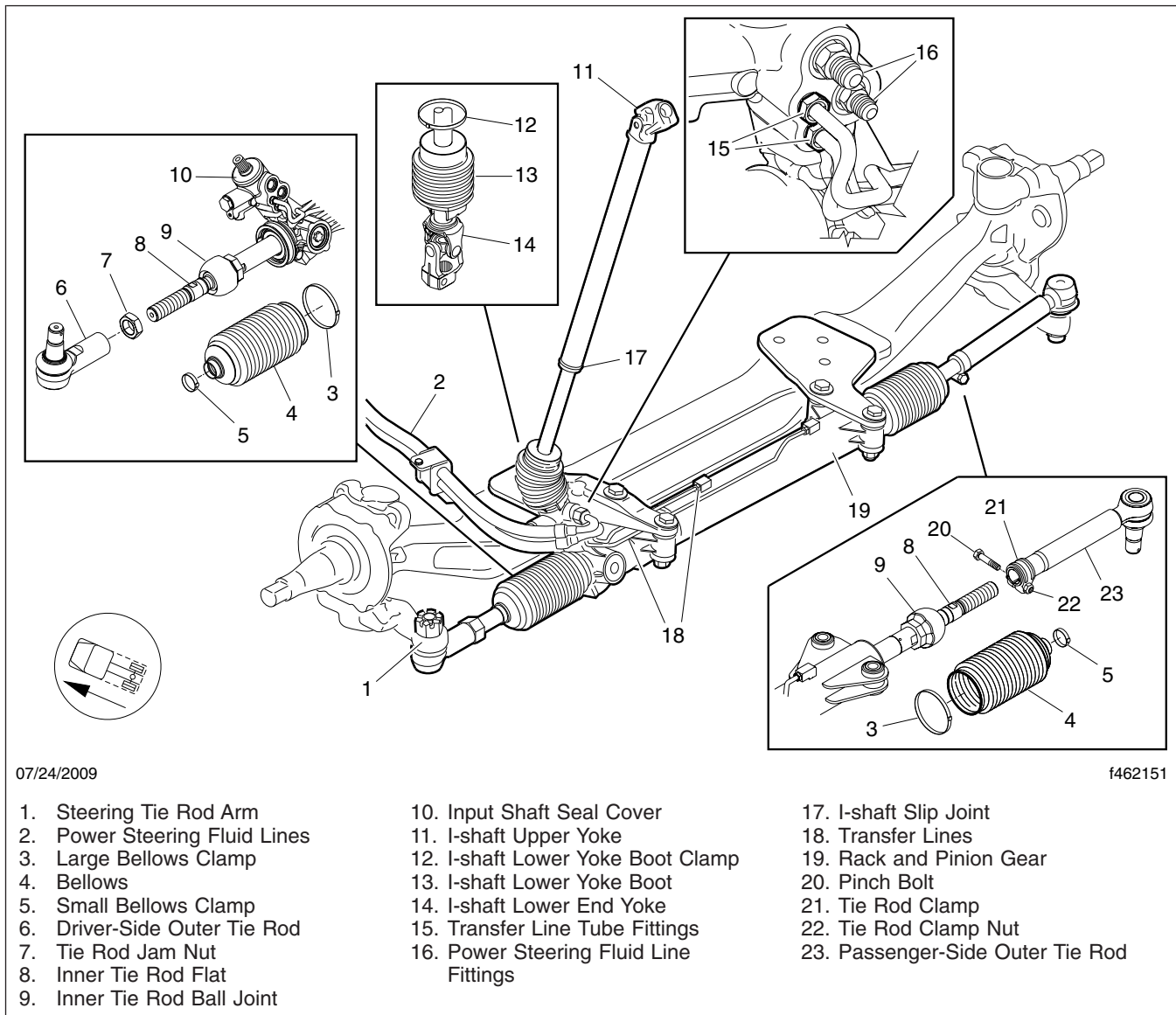

07/24/2009

f462151

- | | | |
|-------------------------------|----------------------------------------|----------------------------------|
| 1. Steering Tie Rod Arm | 10. Input Shaft Seal Cover | 17. I-shaft Slip Joint |
| 2. Power Steering Fluid Lines | 11. I-shaft Upper Yoke | 18. Transfer Lines |
| 3. Large Bellows Clamp | 12. I-shaft Lower Yoke Boot Clamp | 19. Rack and Pinion Gear |
| 4. Bellows | 13. I-shaft Lower Yoke Boot | 20. Pinch Bolt |
| 5. Small Bellows Clamp | 14. I-shaft Lower End Yoke | 21. Tie Rod Clamp |
| 6. Driver-Side Outer Tie Rod | 15. Transfer Line Tube Fittings | 22. Tie Rod Clamp Nut |
| 7. Tie Rod Jam Nut | 16. Power Steering Fluid Line Fittings | 23. Passenger-Side Outer Tie Rod |
| 8. Inner Tie Rod Flat | | |
| 9. Inner Tie Rod Ball Joint | | |

Fig. 4, Rack and Pinion Steering System

NOTICE

Do not tighten the tube fittings on the hard transfer lines. Tightening the tube fittings can cause tearing of the O-ring seal and increased fluid leakage.

10. Check the tube fittings on the hard transfer lines of the gear, see **Fig. 4**, Item 15. If there is leakage from either of the fittings, replace the steering gear.

46–07 Bellows Replacement, Rack and Pinion Steering Gear

1. Park the vehicle on a level surface, shut down the engine, and set the parking brake. Chock the tires.
2. Raise the front wheels off the ground and support the vehicle with jack stands.
3. Remove both wheels from the steer axle.

NOTE: A Tiger Tool Slack Adjuster Puller, part number 10406, may be used to assist with removal of the outer tie rods.

4. Disconnect the outer tie rods from the steering arms, as follows.
 - 4.1 Remove the cotter pins and castellated nuts.
 - 4.2 On the driver's side, loosen the jam nut. See [Fig. 4](#). Note the number of exposed threads and the position of the outer tie rod to ease installation.
 - 4.3 Disconnect the outer tie rods from the steering arms.
5. Use brake cleaner to remove dirt and debris from both bellows and surrounding areas.
6. Remove the small and large Oetiker clamps from both bellows. Discard the clamps.
7. Disconnect the outer tie rods from the inner tie rods. If necessary, use a backup wrench on the inner tie rod flat to turn the inner tie rod. See [Fig. 4](#).
8. Remove the bellows from both sides of the gear.

NOTE: A thin film of leftover Terostat MS 939 on the rack housing is acceptable when installing the new bellows.

9. If the housing has Terostat MS 939 on it from a previous replacement of the bellows, remove as much of the leftover Terostat from the housing sealing surface as possible. Wipe down the housing with brake cleaner to remove all remaining dirt and debris.

IMPORTANT: Only apply grease to the rack shaft on the driver side. Do not apply grease to

the teeth of the rack shaft. Do not apply grease to the shaft on the passenger side.

10. Turn the wheels all the way to the right to fully expose the driver-side rack. Without applying grease to the teeth of the rack shaft, evenly apply a light film of Renolit CX-FO 20 grease to the metal surfaces covered by the driver-side bellows.

NOTICE

Two syringes of the Terostat MS 939 are included in the Bellows Service Kit. Ensure only Terostat, which is white in color, is applied to the rack housing.

Do not allow Terostat MS 939 sealant to come into contact with the inner tie rods. Mistakenly applying sealant to the inner tie rods may cause damage to the bellows and the gear. See [Fig. 5](#).

IMPORTANT: Terostat MS 939 sealant must be applied at a temperature between 41 and 104°F (5 and 40°C) to effectively seal steering gear components. Because Terostat sealant sets within ten minutes of application, the bellows must be installed within ten minutes of sealant application to ensure a good seal.

11. Evenly apply Terostat MS 939 sealant to the outer diameter of the rack housing where the large ends of the bellows seat on the gear housing. See [Fig. 6](#).

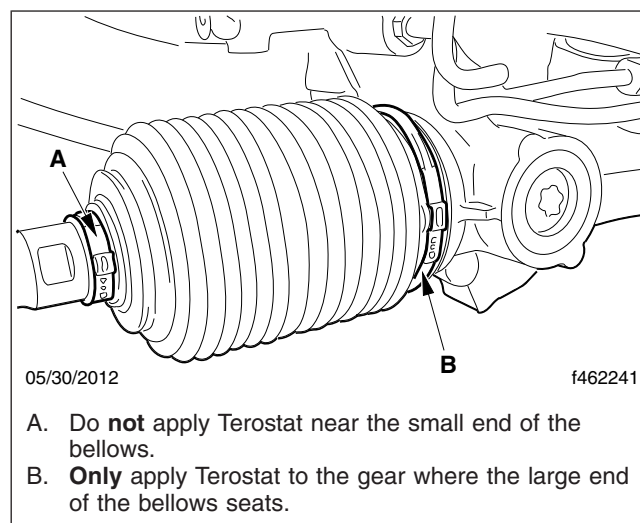

Fig. 5, Apply Terostat To Large End of Bellows

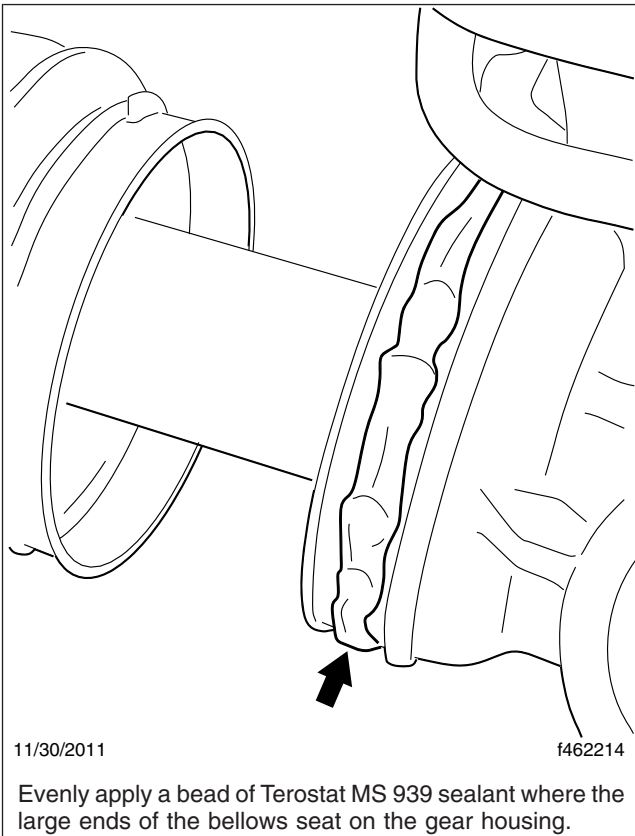

Fig. 6, Terostat MS 939 Sealant Application

NOTICE

Improper installation may cause moisture and contaminants to enter the gear, which may result in severe damage.

12. Install the new bellows on the gear. Ensure the bellows are seated properly on the gear housing and inner tie rods.
13. Rotate the bellows back and forth approximately 15 degrees to evenly disperse the sealant between the bellows and the gear housing.
14. Install new Oetiker clamps on each of the bellows as follows.

NOTICE

Fully opening an Oetiker clamp may cause permanent damage and render it ineffective.

- 14.1 Rotate the ears of the large Oetiker clamp forward on the bellows to avoid pinching the clamp in the next step.
- 14.2 Ensure the large Oetiker clamp is properly seated in the clamp groove on the bellows. Align the large Oetiker clamp ear with the small clamp ear. Both clamp ears should be aligned with the rack housing casting rib. See Fig. 7.

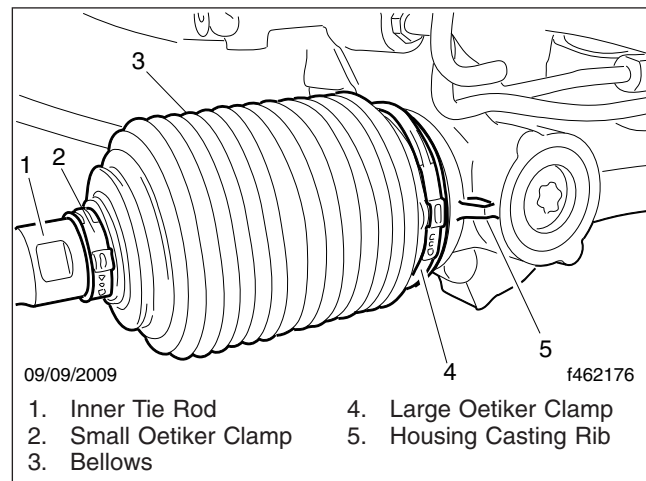

Fig. 7, Oetiker Clamp Alignment

NOTICE

Do not over-tighten the Oetiker clamps. Over-tightening may lead to stretching of the clamp, which could allow moisture intrusion and corrosion. If an Oetiker clamp stretches, remove and discard the clamp and install a new clamp.

All three barbs on the clamp must be engaged. If all three barbs are not engaged after crimping, remove and discard the clamp and install a new clamp. Oetiker clamps must be adequately crimped and the bellows must be tightly secured to the gear housing to prevent moisture intrusion and corrosion.

- 14.3 Using an Oetiker clamp tool like the one shown in Fig. 8, crimp the small and large Oetiker bellows clamp ears until the ear width is 0.08 to 0.16 in (2 to 4 mm). See Fig. 9 and Fig. 10.
15. Remove excess grease from the bellows and the gear housing.

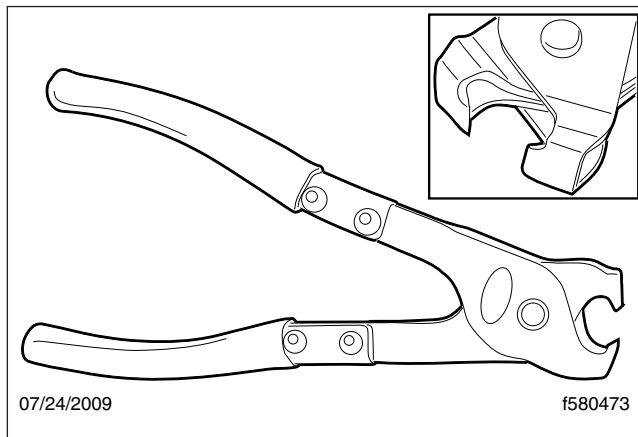

Fig. 8, Oetiker Clamp Tool, P/N 14100037 or 14100082

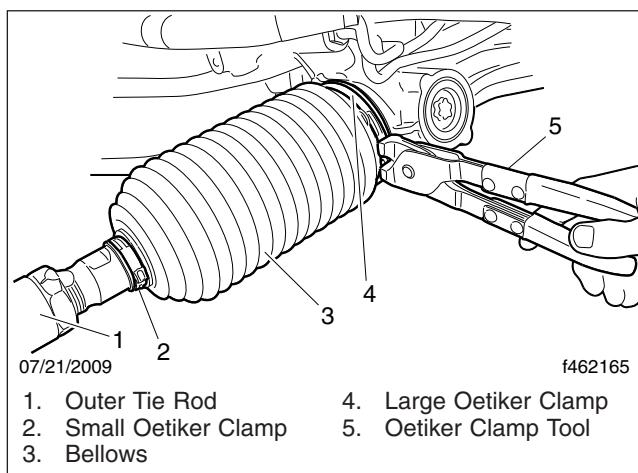

Fig. 9, Oetiker Clamp Installation

16. Install the jam nut on the driver-side inner tie rod, and the tie rod clamp on the passenger-side inner tie rod.
17. Thread the inner tie rods into the outer tie rods.
18. Attach the outer tie rods of the rack and pinion gear to the tie rod steering arms. Tighten the castellated nuts 240 lbf-ft (325 N·m). Continue to tighten until the next castellated nut slot aligns with the hole in the ball stud and insert the new cotter pin.
19. Tighten the jam nut on the driver side, and the tie rod clamp nut on the passenger side.
20. Align the steering gear.

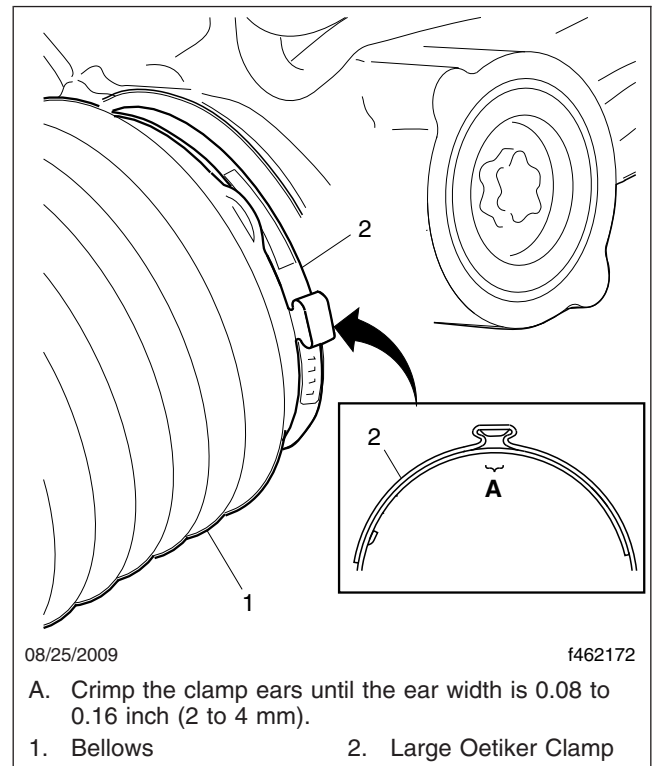

Fig. 10, Oetiker Clamp Ear Width

NOTE: Use a calibrated, computerized, multi-wheel alignment tool, operated by a certified service technician to complete the following steps. If this type of tool is not accessible, the alignment procedure must be done by a facility that has the appropriate tool.

When the alignment process requires that the steering wheel be pointed straight ahead, align the steering rack on-center pointers instead. See [Fig. 11](#).

- 20.1 Loosen the driver-side tie rod jam nut. If necessary, hold the inner tie rod in place with a backup wrench on the inner tie rod flat. See [Fig. 4](#).
- 20.2 Align the steering rack on-center pointers.
- 20.3 Place a wrench on the driver-side inner tie rod flat and align the left tire by rotating the inner tie rod.
- 20.4 Tighten the tie rod jam nut 285 to 305 lbf-ft (386 to 414 N·m).

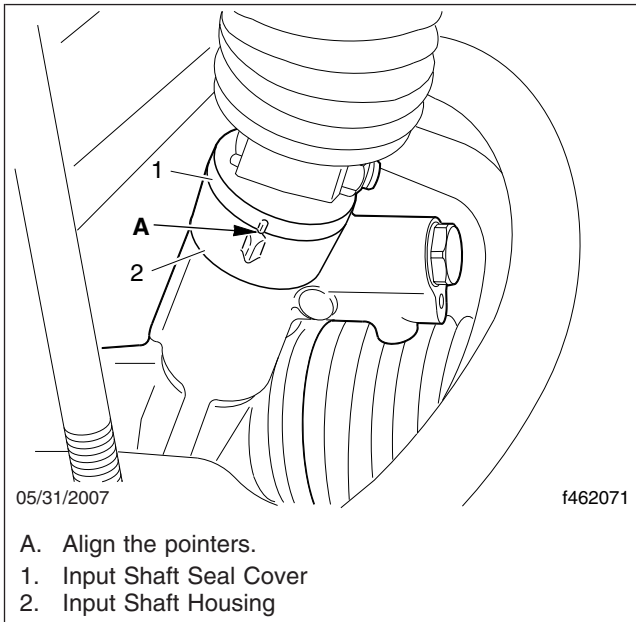

Fig. 11, Rack and Pinion Pointer Alignment

- 20.5 Loosen the passenger-side tie rod clamp nut.
- 20.6 With the gear on center, place a wrench on the passenger-side inner tie rod flat and align the right tire by rotating the inner tie rod.
- 20.7 Tighten the tie rod clamp nut 30 to 36 lbf-ft (41 to 49 N·m).

IMPORTANT: Total toe-in should be between 0 and 1/8 inch (3.2 mm), and the target is 1/16 inch (1.6 mm).

- 20.8 Check the clearance of the front wheels. With the tires on turnplates, and the wheels turned all the way to the right and left, there must be at least 1/2-inch (13 mm) clearance between the wheels and stationary components, and at least 3/4-inch (19 mm) clearance between the wheels/tires and moving components. If this is not the case, back out the stop bolts and adjust the jam nuts to limit the turning angles and to prevent possible contact with components.
- 20.9 Tighten the stop-bolt jam nuts 80 to 120 lbf-ft (108 to 163 N·m).

NOTICE

Maximum wheel cut is not to exceed 46 degrees. Excessive wheel cut may damage the inner tie rod.

- 20.10 Verify that wheel cut does not exceed 46 degrees. Adjust wheel cut if needed.
- 21. Install both wheels on the steer axle.
- 22. Remove the jack stands and lower the vehicle.

Title of Maintenance Operation (MOP)	MOP Number
CNG Fuel Cylinder Inspecting	47-08
CNG Fuel System Inspecting	47-06
CNG High-Pressure Fuel Filter Element Replacing	47-07
Fuel Filter Replacement	47-01
Fuel Tank Band-Nut Tightening	47-03
Fuel/Water Separator Element Checking and Replacement	47-02
LNG Fuel System Inspecting	47-04
LNG Vacuum Integrity Testing	47-05
Safety Precautions	47-00

47–00 Safety Precautions

Safety Precautions in this section apply to all procedures within this group.

DANGER

When working on the vehicle, shut down the engine or motor, set the parking brake, and chock the tires. Before working under the vehicle, always place jack stands under the frame rails to ensure the vehicle cannot drop. Failure to follow these steps could result in serious personal injury or death.

47–01 Fuel Filter Replacement

For engine-mounted fuel filter replacement, refer to the engine manufacturer's service manual for removal and installation procedures.

47–02 Fuel/Water Separator Element Checking and Replacement

Alliance/Racor

The only maintenance necessary on an Alliance or Racor fuel/water separator is to replace the filter element.

WARNING

Fluid circulated through the fuel/water separator to heat the fuel may be diesel fuel returned from the engine, or engine coolant. Drain the fuel/water separator only when the engine and fluids have cooled. Draining it when the engine is hot could cause severe personal injury due to scalding.

If returning fuel is released into the atmosphere, its vapors can ignite in the presence of any ignition source. Do not expose the fuel to, or work with the fuel system near, open flame or intense heat. To do so could cause fire, possibly resulting in serious personal injury or property damage.

1. Drain off some fuel by loosening the vent plug and opening the drain valve.

2. Disconnect the water sensor and heater connections if equipped.
3. Remove the element and bowl together, by turning counterclockwise.
4. Remove the bowl from the element and clean the O-ring land.
5. Apply a coating of clean fuel or motor oil to the new O-ring and element seal.
6. Spin the bowl onto the new element, then spin them both onto the filter head, snugly, by hand only.

IMPORTANT: Do not use tools to tighten the bowl and element.

7. Connect the water sensor and heater connectors if equipped.
8. If equipped with a primer pump, prime the fuel/water separator as follows.
 - 8.1 Loosen the vent plug. Then operate the primer pump until the fuel purges at the vent plug. See [Fig. 1](#).
 - 8.2 Close the vent plug.
9. Start the engine and check for fuel leaks.
10. Shut down the engine and correct any fuel leaks.

Davco Fuel Pro® 382 and 482

WARNING

Fluid circulated through the fuel/water separator to heat the fuel may be diesel fuel returned from the engine, or engine coolant. Drain the fuel/water separator only when the engine and fluids have cooled. Draining it when the engine is hot could cause severe personal injury due to scalding.

If returning fuel is released into the atmosphere, its vapors can ignite in the presence of any ignition source. Do not expose the fuel to, or work with the fuel system near, open flame or intense heat. To do so could cause fire, possibly resulting in serious personal injury or property damage.

The filter element should be changed only when the fuel level has reached the top of the filter element. There is no significant restriction to fuel flow until the element is completely clogged.

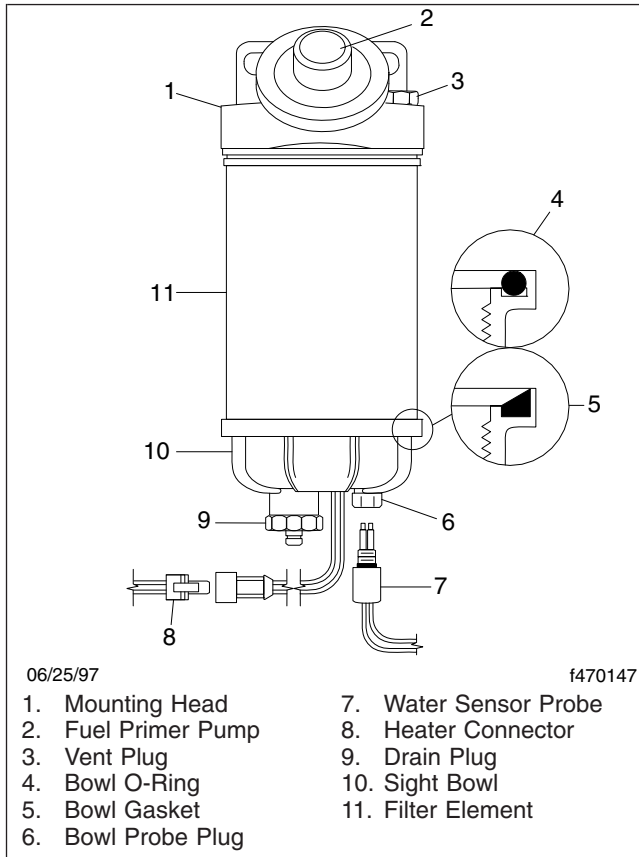

Fig. 1, Alliance Fuel/Water Separator

1. Shut down the engine, apply the parking brake, and chock the tires.
2. Check the fuel level in the fuel filter. Replace the fuel/water separator element **only** when the filter element is completely covered. If the fuel level has reached the top of the filter element, follow the procedure below to replace the element.

NOTE: In the event of an emergency, when the filter needs replacement but a Davco filter is not available for the Fuel Pro 382, a temporary filter can be used; see the procedure under the heading "Emergency Temporary Filter Replacement, Fuel Pro 382."

3. Put a clean receptacle under the fuel/water separator and attach a piece of hose to the drain valve, to direct fuel into the receptacle.

- The drain valve has a 1/2-inch (12.7-mm) pipe; use a hose with a 1/2-inch pipe thread to fit correctly.
4. Remove the vent cap (**Fig. 2**, Item 4) and open the drain valve (**Fig. 2**, Item 1) to drain the fuel completely, then close the drain valve.

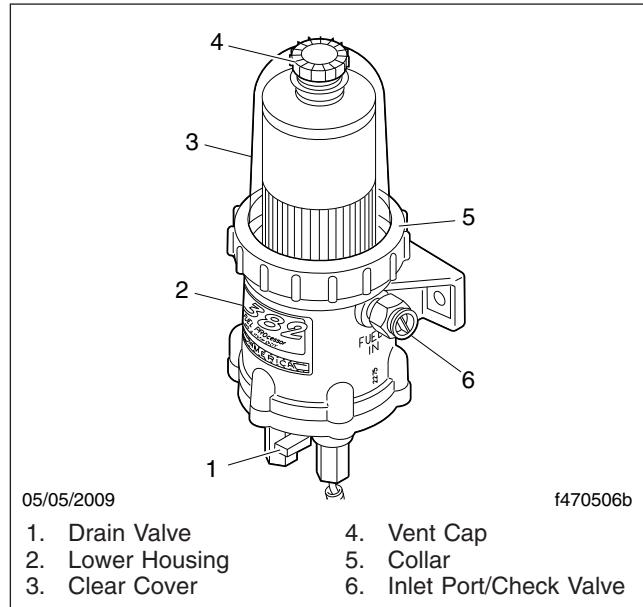

Fig. 2, DAVCO Fuel/Water Separator (Fuel Pro 382 Shown)

5. Using a DAVCO Collar Wrench, shown in **Fig. 3**, remove the clear cover and collar.

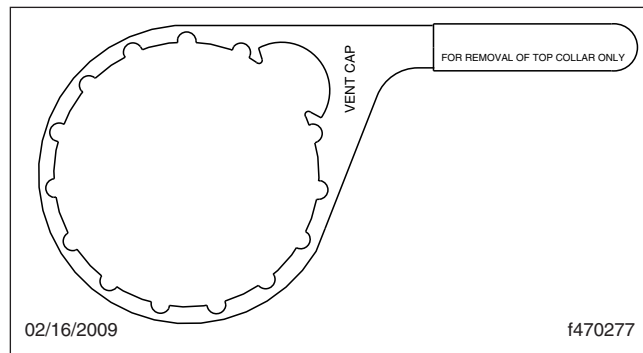

Fig. 3, DAVCO Collar Wrench

NOTE: Broken vent cap and collar warranty claims will not be accepted if any tool other than a DAVCO Collar Wrench is used for removal. During installation, the vent cap is to be **hand-**

tightened only, not tightened with a wrench. Use part number 482017 on Fuel Pro 482 units; part number 380134 on Fuel Pro 382 units.

6. Remove the filter, cover O-ring, and vent cap O-ring. Dispose of them in an environmentally acceptable manner. See [Fig. 4](#) or [Fig. 5](#).
7. Clean all threads and sealing surfaces very thoroughly. Even a small amount of dirt will prevent the fuel/water separator from sealing, and an air leak may result.
8. On Fuel Pro 382 units, install the grommet on the bottom of the new filter.
9. Install the new filter and grommet assembly and cover O-ring on the housing.
10. Install the clear cover and the collar. Simultaneously apply downward pressure to the top of the clear cover until it is seated on the body of the lower housing and hand tighten the collar until it no longer spins freely. Using the collar wrench, tighten the cover 18 lbf-ft (24 N-m). This is equivalent to rotating the collar clockwise two or three additional ribs, depending on the specific filter model.
11. Prime the system
 - 11.1 Ensure that the drain valve is closed.
 - 11.2 Fill the housing to the top of the filter element with clean diesel fuel.
 - 11.3 Install and hand-tighten the vent cap O-ring and vent cap.
 - 11.4 Start the engine. When the lubricating oil reaches its normal operating pressure, increase engine speed to high idle for one to two minutes to purge air from the system.
 - 11.5 While the engine is running, and after the air is purged from the system, loosen the vent cap until the fuel level falls to just above the collar, then hand-tighten the vent cap.
 - 11.6 Check for leaks and shut down the engine.

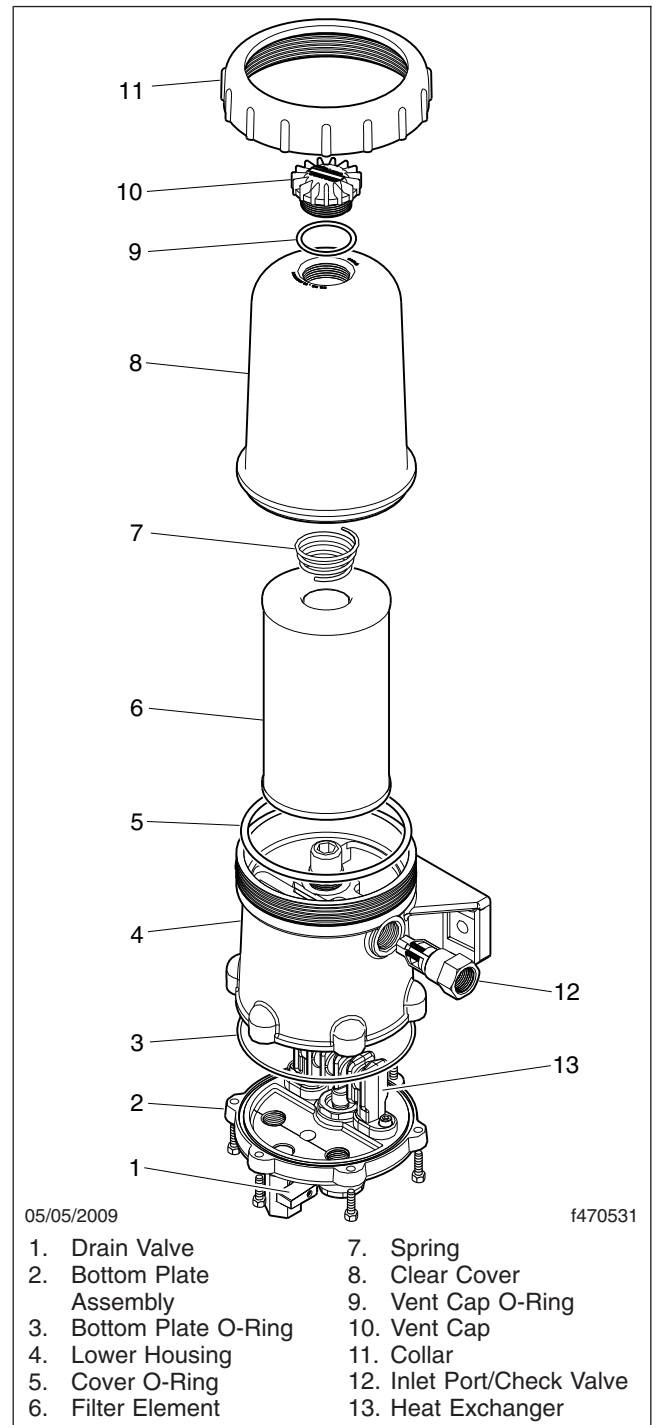

Fig. 4, DAVCO Fuel Pro 382

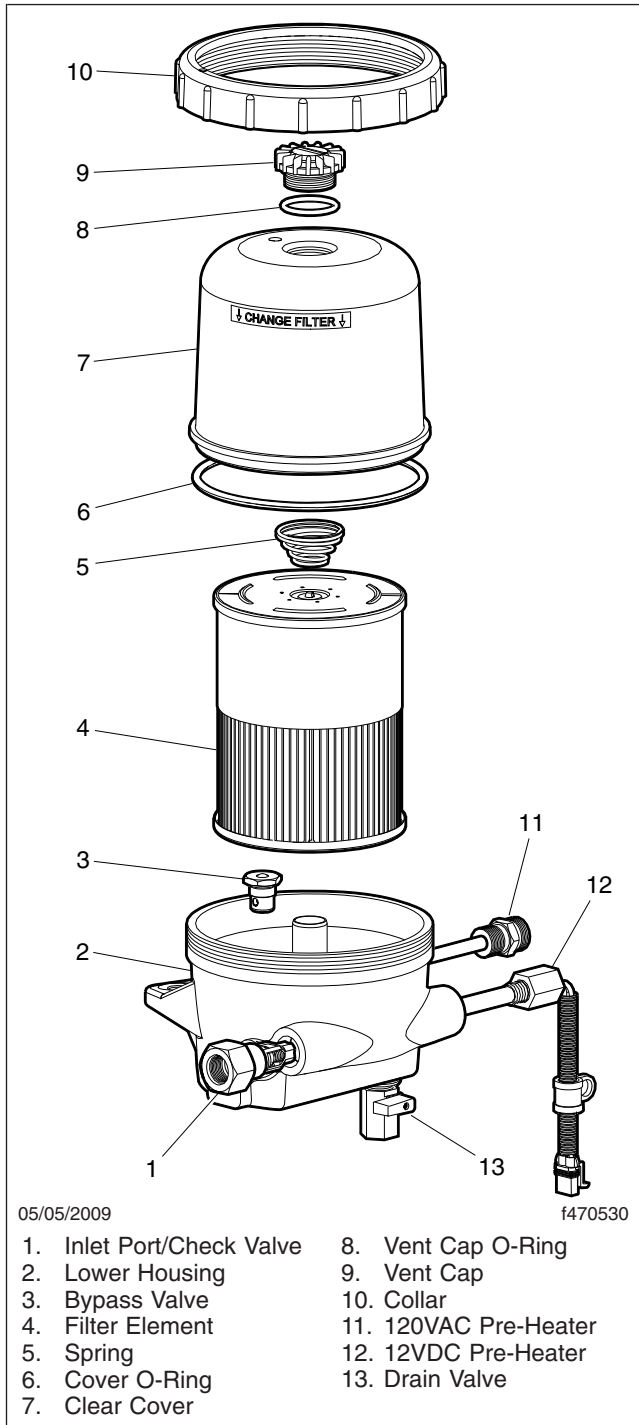

Fig. 5, DAVCO Fuel Pro 482

Emergency Temporary Filter Replacement, Fuel Pro 382

WARNING

Fluid circulated through the fuel/water separator to heat the fuel may be diesel fuel returned from the engine, or engine coolant. Drain the fuel/water separator only when the engine and fluids have cooled. Draining it when the engine is hot could cause severe personal injury due to scalding.

If returning fuel is released into the atmosphere, its vapors can ignite in the presence of any ignition source. Do not expose the fuel to, or work with the fuel system near, open flame or intense heat. To do so could cause fire, possibly resulting in serious personal injury or property damage.

1. Shut down the engine, apply the parking brake, and chock the tires.
2. Put a clean receptacle under the fuel/water separator and attach a piece of hose to the drain valve, to direct fuel into the receptacle.

The drain valve has a 1/2-inch (12.7-mm) pipe; use a hose with a 1/2-inch pipe thread to fit correctly.

3. Remove the vent cap (Fig. 2, Item 4) and open the drain valve (Fig. 2, Item 1) to drain the fuel completely, then close the drain valve.
4. Using a DAVCO Collar Wrench, shown in Fig. 3, remove the clear cover and collar.

NOTE: Broken vent cap and collar warranty claims will not be accepted if any tool other than a DAVCO Collar Wrench, part number 380134, is used for removal. During installation, the vent cap is to be **hand-tightened only**, not tightened with a wrench.

5. Remove the filter and dispose of it in an environmentally acceptable manner.
6. Clean all threads and sealing surfaces very thoroughly. Even a small amount of dirt will prevent the fuel/water separator from sealing, and an air leak may result.
7. Ensure that the drain valve is closed.
8. Remove the filter grommet from the filter stud, if equipped.

9. Fill the housing to the top of the filter element with clean diesel fuel.
10. Install a standard engine spin-on filter (part number FF105 or equivalent) on the filter stud.
11. Install the cover O-ring, clear cover, and the collar. Hand-tighten the collar.
12. Install and hand-tighten the vent cap O-ring and vent cap.
13. Start the engine. When the lubricating oil reaches its normal operating pressure, increase engine speed to high idle for one to two minutes to purge air from the system.
14. Check for leaks and shut down the engine.

DAVCO Fuel Pro® 487

WARNING

Fluid circulated through the fuel/water separator to heat the fuel may be diesel fuel returned from the engine, or engine coolant. Drain the fuel/water separator only when the engine and fluids have cooled. Draining it when the engine is hot could cause severe personal injury due to scalding.

If returning fuel is released into the atmosphere, its vapors can ignite in the presence of any ignition source. Do not expose the fuel to, or work with the fuel system near, open flame or intense heat. To do so could cause fire, possibly resulting in serious personal injury or property damage.

1. Shut down the engine, apply the parking brake, and chock the tires.
2. Check the fuel level in the fuel filter. Replace the fuel/water separator element **only** when the filter element is completely covered. If the fuel level has reached the top of the filter element, follow the procedure below to replace the element.
3. Put a clean receptacle under the fuel/water separator and attach a piece of hose to the drain valve, to direct fuel into the receptacle.

On older models, the drain valve has a 1/2-inch (12.7-mm) pipe with threads. Use a hose with a 1/2-inch pipe thread to fit correctly and open the drain valve by turning it one-quarter revolution.

On new models, the drain valve has a 3/4-inch (19-mm) slip-on hose connection; pipe threads

are no longer used. Open the drain valve by turning it one to one-and-a-half revolutions.

4. Remove the vent cap, shown in [Fig. 6](#), to drain the fuel completely, then close the drain valve.
5. Using a DAVCO Collar Wrench, shown in [Fig. 3](#), remove the clear cover and collar.

NOTE: Broken vent cap and collar warranty claims will not be accepted if any tool other than a DAVCO Collar Wrench (part number 482017) is used for removal. During installation, the vent cap is to be **hand-tightened only**, not tightened with a wrench.

6. Remove the filter, cover O-ring, and vent cap O-ring. Dispose of them in an environmentally acceptable manner. See [Fig. 6](#).
7. Clean all threads and sealing surfaces very thoroughly. Even a small amount of dirt will prevent the fuel/water separator from sealing, and an air leak may result.
8. Install the new filter and grommet assembly and cover O-ring on the housing.

Position the filter element so the key is lined up with the keyway on the separator plate of the housing. Use the arrow on the top of the endplate to align the filter. See [Fig. 7](#). Ensure the filter element is fully seated by firmly pushing on the endplate. The filter should not rotate freely.
9. Install the clear cover and the collar. Simultaneously apply downward pressure to the top of the clear cover until it is seated on the body of the lower housing and hand tighten the collar until it no longer spins freely. Using the collar wrench, tighten the cover 18 lbf-ft (24 N-m). This is equivalent to rotating the collar clockwise two or three additional ribs, depending on the specific filter model.
10. Prime the system

- 10.1 Ensure that the drain valve is closed.
- 10.2 Fill the housing to the top of the filter element with clean diesel fuel.
- 10.3 Install and hand-tighten the vent cap O-ring and vent cap.
- 10.4 Start the engine. When the lubricating oil reaches its normal operating pressure,

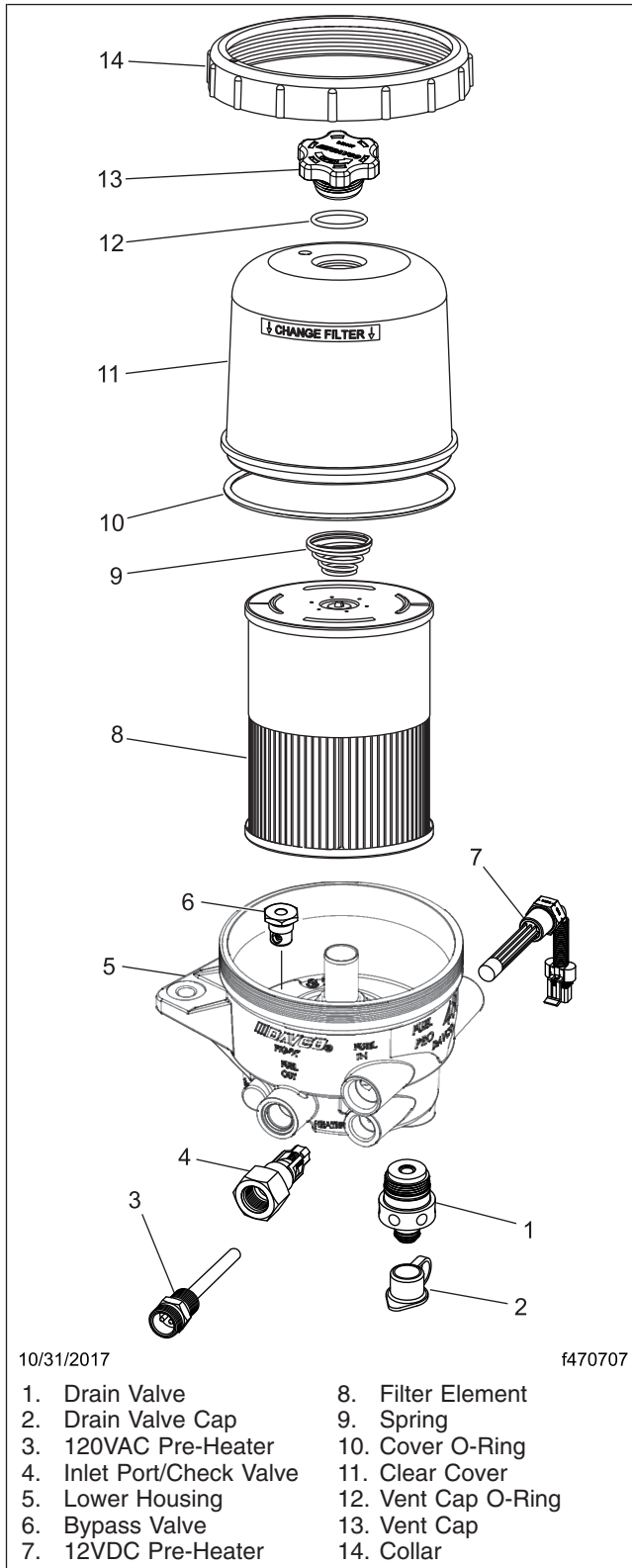

10/31/2017

f470707

- | | |
|---------------------------|---------------------|
| 1. Drain Valve | 8. Filter Element |
| 2. Drain Valve Cap | 9. Spring |
| 3. 120VAC Pre-Heater | 10. Cover O-Ring |
| 4. Inlet Port/Check Valve | 11. Clear Cover |
| 5. Lower Housing | 12. Vent Cap O-Ring |
| 6. Bypass Valve | 13. Vent Cap |
| 7. 12VDC Pre-Heater | 14. Collar |

Fig. 6, DAVCO Fuel Pro 487

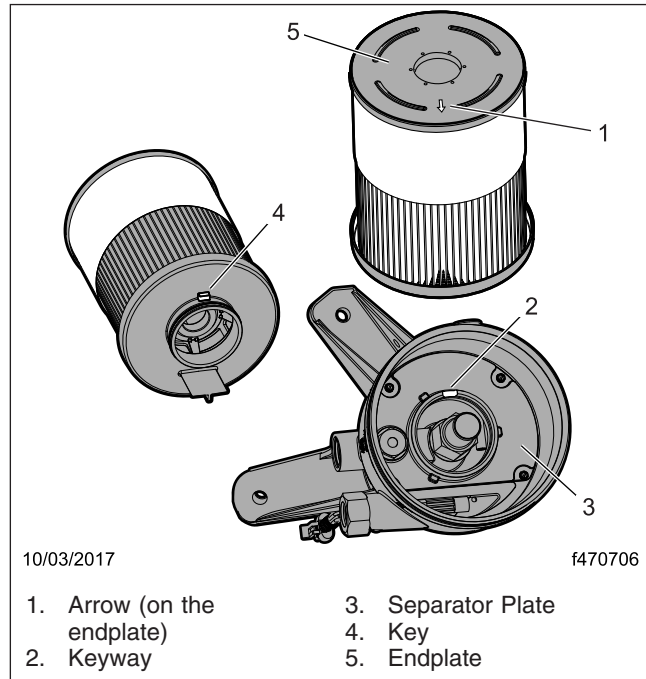

10/03/2017

f470706

- | | |
|----------------------------|--------------------|
| 1. Arrow (on the endplate) | 3. Separator Plate |
| 2. Keyway | 4. Key |
| | 5. Endplate |

Fig. 7, Positioning the Filter Element

increase engine speed to high idle for one to two minutes to purge air from the system.

- 10.5 While the engine is running, and after the air is purged from the system, loosen the vent cap until the fuel level falls to just above the collar, then hand-tighten the vent cap.
- 10.6 Check for leaks and shut down the engine.

Detroit

The only maintenance necessary on an Detroit fuel/water separator is to replace the filter element. See [Fig. 8](#).

WARNING

Fluid circulated through the fuel/water separator to heat the fuel may be diesel fuel returned from the engine, or engine coolant. Drain the fuel/water separator only when the engine and fluids have cooled. Draining it when the engine is hot could cause severe personal injury due to scalding.

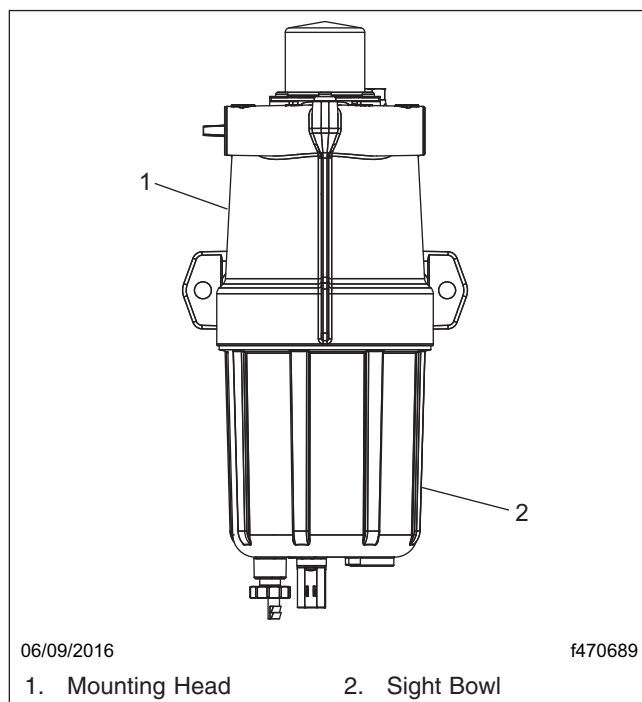

Fig. 8, Detroit Fuel/Water Separator

If returning fuel is released into the atmosphere, its vapors can ignite in the presence of any ignition source. Do not expose the fuel to, or work with the fuel system near, open flame or intense heat. To do so could cause fire, possibly resulting in serious personal injury or property damage.

1. Drain off some fuel by loosening the vent plug and opening the drain valve.
2. Disconnect the water sensor and heater connections if equipped.
3. Remove the bowl by turning counterclockwise.
4. Remove the element, bowl O-ring, and element o-ring. Dispose of them in an environmentally acceptable manner.
5. Thoroughly clean all of the threads and sealing surfaces. Even a small amount of dirt will prevent the fuel/water separator from sealing, and an air leak may result.
6. Apply a coating of clean fuel or motor oil to the new O-ring and to the new element o-ring.
7. Insert the new element into the upper housing.

IMPORTANT: Do not use tools to tighten the bowl and element.

8. Spin the bowl onto the upper housing by hand only.
9. Connect the water sensor and heater connectors if equipped.
10. If equipped with a primer pump, prime the fuel/water separator as follows.
 - 10.1 Loosen the vent plug. Then operate the primer pump until the fuel purges at the vent plug.
 - 10.2 Close the vent plug.
11. Start the engine and check for fuel leaks.
12. Shut down the engine and correct any fuel leaks.

47-03 Fuel Tank Band-Nut Tightening

Hold each fuel tank band retention nut with a wrench while backing off its jam nut, then tighten the retention nuts 30 to 35 lbf-ft (41 to 46 N·m). After the retention nuts have been tightened, hold each retention nut with a wrench while tightening its jam nut 30 lbf-ft (41 N·m).

IMPORTANT: Do not overtighten.

47-04 LNG Fuel System Inspecting

⚠ WARNING

As with all pressure vessels, CNG/LNG storage and fuel delivery systems are inherently dangerous and should be treated as such. Beyond the visual inspections listed below, all maintenance and repairs to compressed natural gas (CNG) or liquefied natural gas (LNG) systems should be performed by trained personnel. Individuals who are not trained in all aspects concerning CNG/ LNG fuel delivery systems are not permitted to service, maintain, test, or inspect a system in any way. Failure to comply with safety regulations may lead to fire or explosion, resulting in property damage, personal injury, or death.

The following inspections must be performed by a qualified technician, in accordance with the manufacturer's established inspection criteria.

All tank components should be allowed to defrost before conducting the following inspections.

NOTICE

Do not use a high-pressure washer or steam cleaner on natural gas fuel system plumbing components, as this can introduce moisture and contaminants into the threads of the fittings and damage the sealants.

Gas detection sensors are located on the cab overhead console and in the engine compartment on the frontwall. The sensors are located in high areas, where rising gas vapors will pass by or accumulate. Do not use a high-pressure washer, steam cleaner, or silicone-based chemicals on the gas detection sensors, as this may permanently disable the sensors. When cleaning the vehicle, cover the sensors with a plastic covering. Keep the sensors covered until the area has been cleared of any cleaning fumes. Harsh chemicals and extremely high temperatures may damage the sensor.

Fuel Tank and Shroud Inspecting

See [Fig. 9](#) for fuel tank and shroud component locations.

1. Inspect the fuel tank outer shell for dents or other signs of damage. Inspect the bottom of the tank for deep scratches, flat spots, or gouges.
Replace a leaking fuel tank.
2. Ensure that the fuel tank is secured to its mounting brackets and that the mounting brackets are secured to the frame. Inspect for any signs of looseness.
3. Ensure that all rubber isolator straps are present and secure.
4. Look for signs of abrasion between the fuel tank and mounting brackets.
5. Inspect the fuel fill fitting for signs of damage or leaks. Ensure the fuel fill cap is present and in good condition, and the fitting is mounted securely on the tank.
6. Inspect the fuel outlet line and fitting for signs of leaks or damage.
7. Inspect the primary relief vent and pipe-away line for damage, kinks, chafing, or loose connections.
8. Inspect the fill vent fitting for signs of damage.
9. Inspect the shroud cover for dents or other signs of damage. Ensure that the shroud cover latches are in working condition and fasten the shroud cover securely to the tank.
10. Replace leaking or damaged fuel lines. Repair or replace leaking or damaged fittings.

Plumbing Components Inspecting

See [Fig. 9](#) for plumbing component locations.

Use a bubble solution to check for leaks while performing the following visual inspection.

1. Check the following components for signs of damage or leaks.
 - Pressure control regulator
 - Vapor shutoff valve
 - Secondary relief valve
 - Primary relief valve and threaded connections
 - Excess flow valve
 - Fuel shutoff valve
 - Fill check valve
2. Inspect the fuel fill line for signs of damage, kinked or crushed piping, or chafing.
3. Ensure the red cap is present on the secondary relief valve.
4. Inspect the fuel tank pressure gauge for cracks in the sight glass. Ensure the indicator needle is present and in working condition. Inspect the gauge face for accuracy and legibility.
5. Inspect all vent lines for kinks, and signs of leaks or damage.
6. Replace leaking or damaged fuel lines. Repair or replace leaking or damaged fittings.

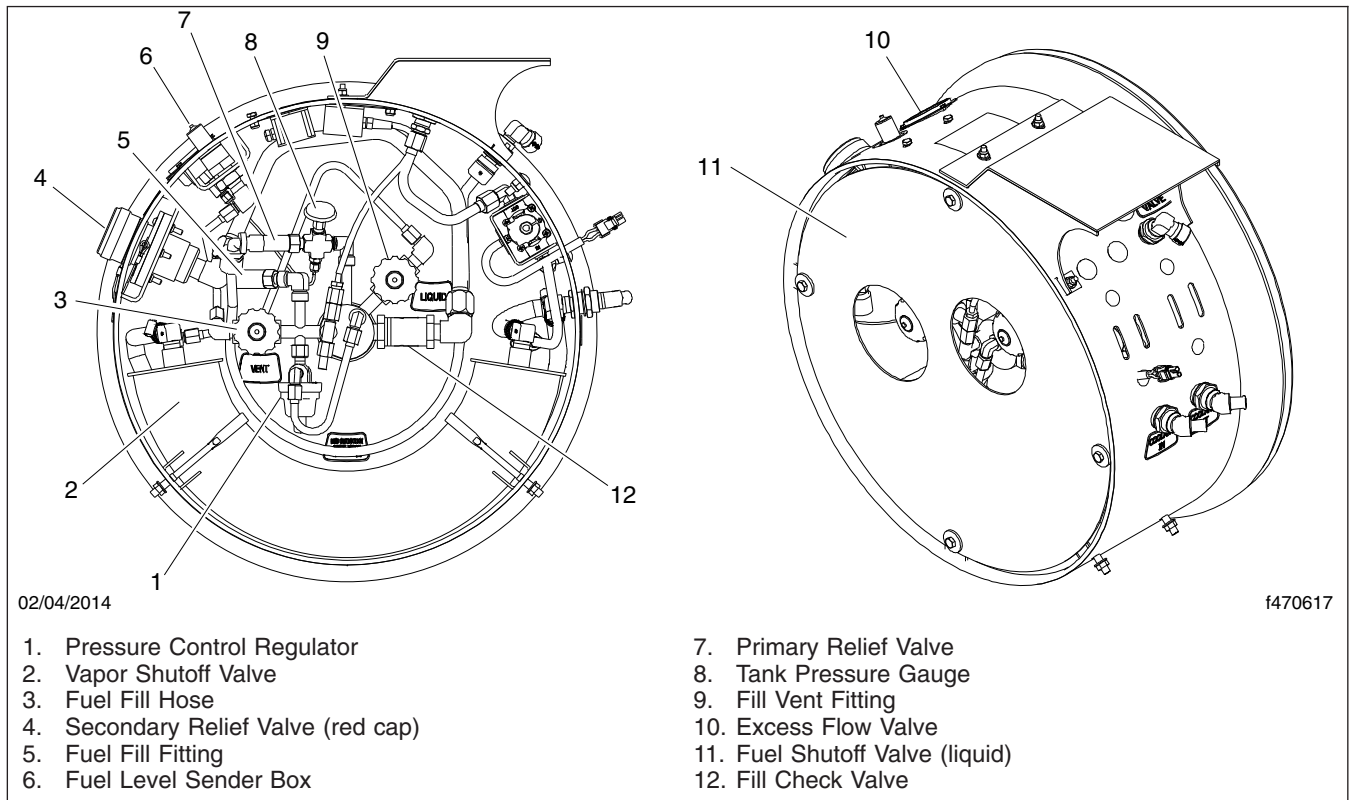

Fig. 9, LNG Tank Plumbing Components

Fuel Level Sender Component Inspecting

1. Inspect the fuel level sender wiring harness for signs of loose connections or damage. Look for cracking or signs of moisture intrusion.
2. Inspect the fuel level sender box ([Fig. 9](#)) for signs of leaks or damage. Ensure that the retainer clips are installed on the mounting ears.
3. Inspect all connectors and wiring for signs of loose connections, damage, or chafing.
4. Turn the ignition switch to the ON position and check for fuel gauge response.
5. Repair or replace any damaged fuel gauge components.

Vaporizer Inspecting

See [Fig. 9](#) for plumbing component locations.

1. Ensure that the vaporizer is secured to its mounting brackets and that the mounting brackets are secured to the frame. Inspect for any signs of looseness.
2. Inspect the vaporizer fuel inlet and outlet lines for signs of chafing, damage, or leaks.
3. Inspect the vaporizer coolant hoses for signs of chafing, damage, or leaks.
4. Inspect all fittings for leaks.
5. Inspect the fuel shutoff solenoid valve for signs of leaks or damage. Inspect the solenoid mounting bracket for looseness.
6. Inspect the overpressure regulator for signs of leaks or damage.
 - 6.1 Ensure that the regulator is mounted securely.
 - 6.2 Check the overpressure regulator fittings for signs of leaks or damage.

- 6.3 Ensure that the adjustment handle locking nut (at the bottom of the overpressure regulator) is tightened securely.
- 6.4 Inspect the pressure gauge for damage. Ensure that the gauge sight glass is clear and legible.
- 7. Repair or replace any leaking or damaged vaporizer components.

- 2. Check the fuel tank pressure gauge (Fig. 9, Item 8) to ensure that pressure is within the normal range of 120 to 150 psi (827 to 1034 kPa).
- 3. Inspect the fuel tank for signs of frost spots or outer surface sweating. Frosting or condensation on the outer surface of the fuel tank may indicate a loss of vacuum.
- 4. Check for a large variance in temperatures between the fuel tank and the fuel tank shroud. A large variance in temperatures between the fuel tank and the shroud may indicate a loss of vacuum.
- 5. Operate the vehicle for ten minutes. Shut down the engine, apply the parking brakes, and note the time.
- 6. Wait fifteen minutes after shutting down the engine, then record the fuel tank pressure and note the time.
- 7. Allow the vehicle to stand for at least eight hours, then record the fuel tank pressure again.
- 8. Use Table 1 to determine whether the pressure increase is within an acceptable range.

47–05 LNG Vacuum Integrity Testing

WARNING

Natural gas is highly flammable. See the safety precautions listed in Group 47 of the Cascadia Workshop Manual. Failure to observe these precautions could lead to the ignition of the natural gas, which could cause serious bodily injury or death.

- 1. Ensure the fuel tank is between 50 and 75 percent full.

Vacuum Integrity Test Results	
Pressure Increase Over Eight-Hour Period	Remedy
Less than 20 psi (138 kPa)	None – Tank is normal
20 to 50 psi (138 to 345 kPa)	Monitor tank and test vacuum integrity again at next maintenance date
More than 50 psi (345 kPa)	Remove vehicle from service and evacuate the tank per the tank manufacturer’s instructions

Table 1, Vacuum Integrity Test Results

47–06 CNG Fuel System Inspecting

WARNING

As with all pressure vessels, CNG/LNG storage and fuel delivery systems are inherently dangerous and should be treated as such. Beyond the visual inspections listed below, all maintenance and repairs to compressed natural gas (CNG) or liquified natural gas (LNG) systems should be performed by trained personnel. Individuals who are not trained in all aspects concerning CNG/ LNG

fuel delivery systems are not permitted to service, maintain, test, or inspect a system in any way. Failure to comply with safety regulations may lead to fire or explosion, resulting in property damage, personal injury, or death.

NOTICE

Do not use a high-pressure washer or steam cleaner on natural gas fuel system plumbing components, as this can introduce moisture and contaminants into the threads of the fittings and damage the sealants. It can also harm the integrity of

the CNG tank, and can cause premature failure of the pressure relief devices (PRDs) causing loss of CNG.

Gas detection sensors are located on the cab overhead console, the sleeper, and in the engine compartment on the frontwall. The sensors are located in high areas, where rising gas vapors will pass by or accumulate. Do not use a high-pressure washer, steam cleaner, or silicone-based chemicals on the gas detection sensors, as this may permanently disable the sensors. When cleaning the vehicle, cover the sensors with a plastic covering. Keep the sensors covered until the area has been cleared of any cleaning fumes. Harsh chemicals and extremely high temperatures may damage the sensor.

IMPORTANT: Use an approved NG leak checking solution while performing the following inspection.

For Fuel Managements System inspections refer to the suppliers procedures and best practices. These below should be completed in accordance with FMS inspections.

1. Ensure that the fuel cylinder storage box is secured to the frame. Inspect for any signs of looseness. If necessary, tighten the storage box mounting bolts 160 lbf-ft (217 N·m). See [Fig. 10](#).

If necessary, tighten frame-rail-mounted tank mounting nuts and bolts as follows. See [Fig. 11](#).

- Tank mounting bracket to frame rail nuts and bolts, 130 lbf-ft (176 N·m)
- Top plate bolts, 160 lbf-ft (217 N·m)
- Gusset bolts, 160 lbf-ft (217 N·m)

NOTE: During initial pre-delivery inspection (PDI), tighten the storage box mounting bolts (shown in [Fig. 10](#)) 180 lbf-ft (244 N·m).

2. Inspect the fuel fill port for signs of damage, oil residue, or leaks. Ensure the port dust cover and the O-ring inside the port are both present and in good condition. See [Fig. 12](#) and [Fig. 13](#).
3. Ensure that caps are present on all pressure relief devices.
4. Check the following components for signs of damage or leaks.
 - Manual fuel shutoff valve

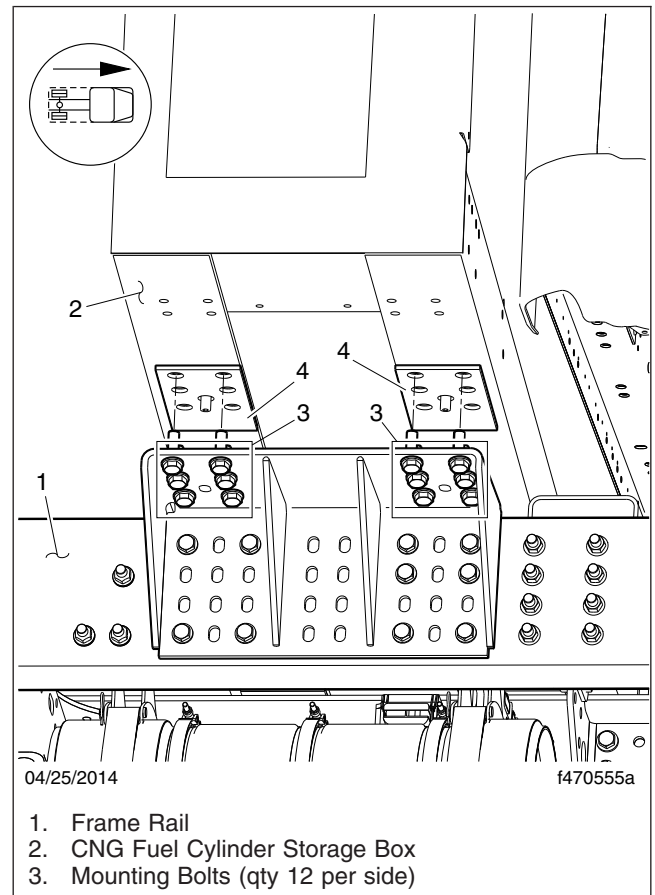

Fig. 10, Fuel Cylinder Storage Box Mounting Bracket (passenger side shown)

- Coolant hoses and fittings
 - Fuel lines and fittings along the frame rails to the low pressure filters and going in to the engine
 - All fittings, connections, and joints
5. Replace leaking or damaged fuel lines. Repair or replace leaking or damaged fittings.

47-07 CNG High-Pressure Fuel Filter Element Replacing

CNG filter element replacement cycles are an important factor in maintaining the CNG fuel system integrity and ensuring maximum operating performance. Actual frequency of the filter element replacement could increase or decrease depending on the cleanli-

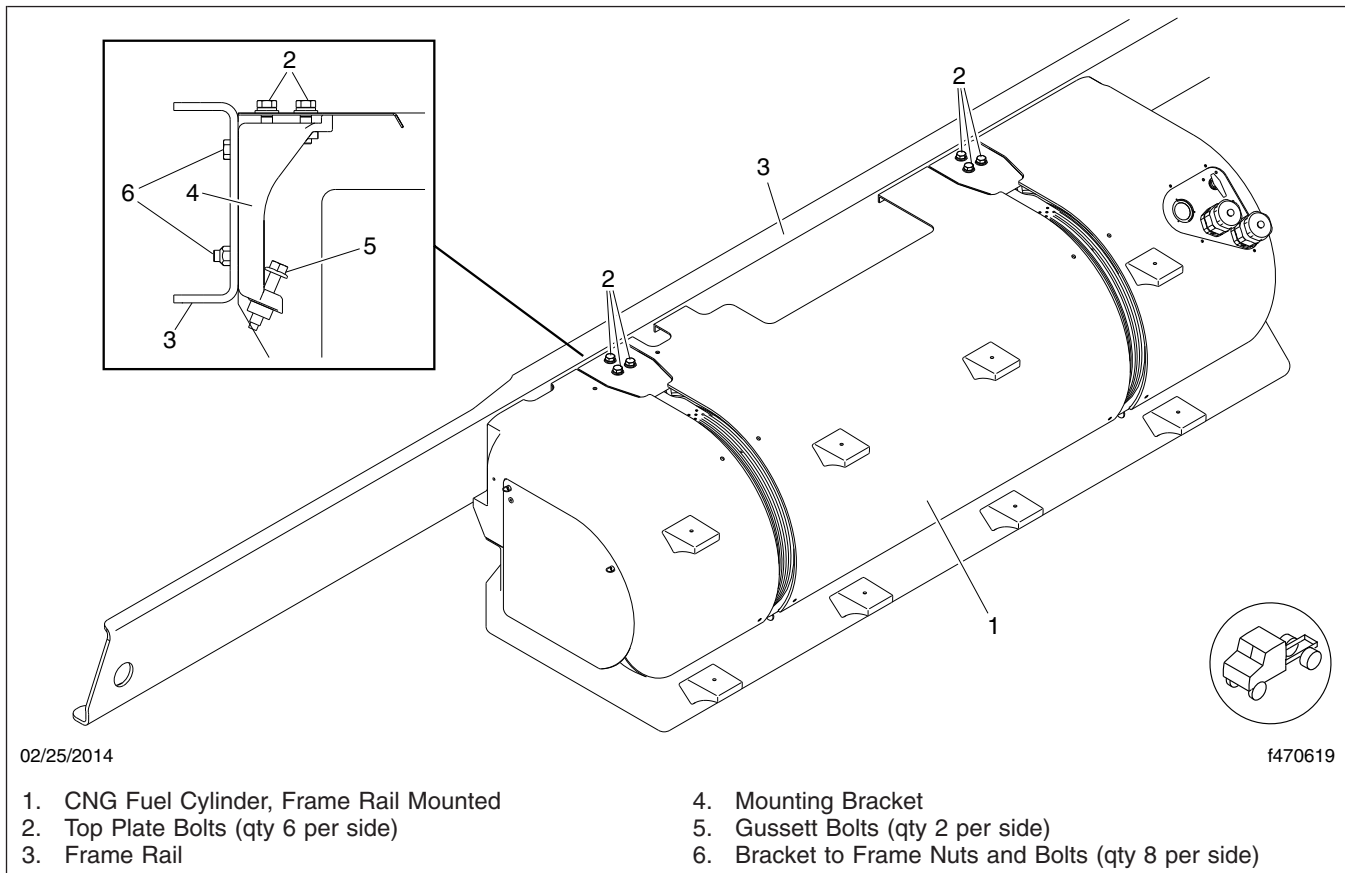

Fig. 11, Fuel Cylinder Mounting Bracket (frame-rail mounted tank)

ness of the fill station fueling system. Refer to manufacturer of the fuel management system (FMS) for the proper CNG high pressure fuel filter maintenance and procedures for replacing filter.

47-08 CNG Fuel Cylinder Inspecting

Have a qualified inspector inspect compressed natural gas (CNG) fuel cylinders for damage or deterioration. Note cuts, cracks, gouges, abrasions, discoloration, broken fibers, loose brackets, damaged gaskets or isolators, heat damage, or other problems.

Refer to the Compressed Gas Association's (CGA) pamphlet C-6.4, *Methods for External Visual Inspection of Natural Gas Fuel Containers and Their Installations*, for inspection requirements and inspector qualifications.

For more information, go to www.cganet.com.

After inspection, an accurate and reliable written report should be provided for each container inspected. Place an inspection label stating the inspection date and inspecting agency identification on each container.

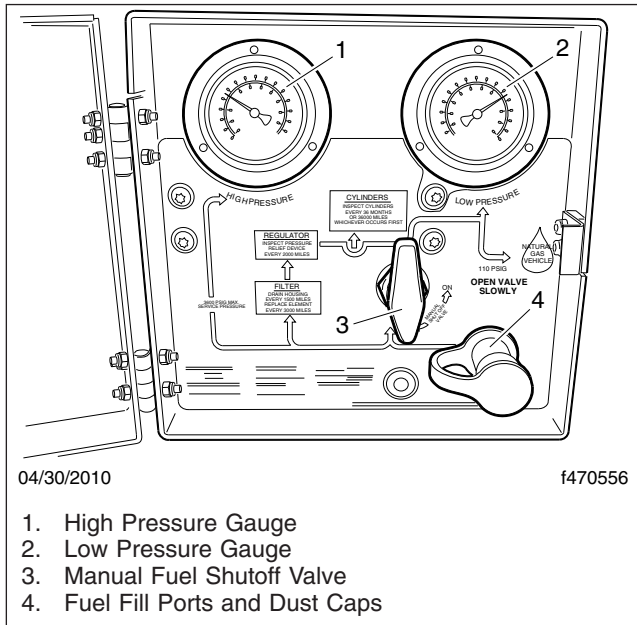

Fig. 12, CNG Fuel Panel (back-of-cab box only)

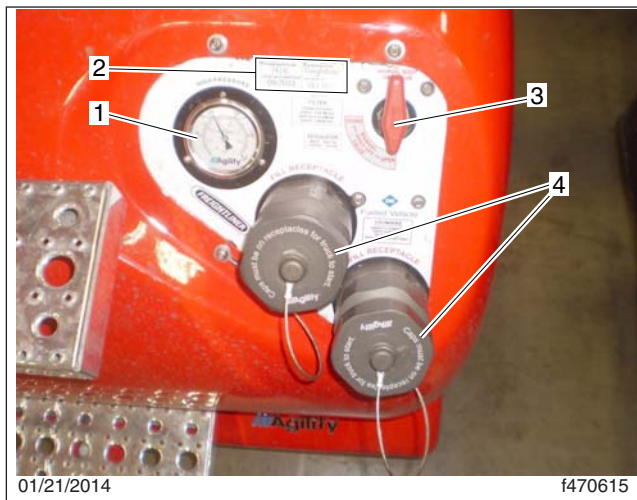

Fig. 13, CNG Fuel Panel (frame-rail mounted tank)

Title of Maintenance Operation (MOP)	MOP Number
CAT CGI Bellows Replacement.	49-02
Exhaust System Inspection (Noise Emission Control).	49-01
Safety Precautions.	49-00

49–00 Safety Precautions

Safety Precautions in this section apply to all procedures within this group.



When working on the vehicle, shut down the engine or motor, set the parking brake, and chock the tires. Before working under the vehicle, always place jack stands under the frame rails to ensure the vehicle cannot drop. Failure to follow these steps could result in serious personal injury or death.

49–01 Exhaust System Inspection (Noise Emission Control)

In addition to inspecting the exhaust system at the scheduled maintenance interval, inspect the exhaust system if the noise level of the vehicle has increased. Freightliner Trucks recommends replacing parts that show leakage, wear, or damage, with genuine Freightliner parts.

The exhaust system must be free of leaks, binding, grounding, and excessive vibrations. These conditions are usually caused by loose, broken, or misaligned clamps, brackets, or pipes. If any of these conditions exist, check the exhaust system components and alignment. Align or replace as necessary; see **Group 49** of the *Cascadia™ Workshop Manual*, or take the vehicle to an authorized Freightliner dealer.

It is a violation of US federal law to alter exhaust plumbing or aftertreatment in any way that would bring the engine out of compliance with certification requirements. (Ref: 42 U.S.C. S7522(a) (3).) It is the owner's responsibility to maintain the vehicle so that it conforms to EPA regulations.

EPA10 and Newer Exhaust System

Definitions of Aftertreatment (ATS) Terms

Refer to the following list of definitions of ATS terms and components.

- Aftertreatment System (ATS)—the entire exhaust system from the turbocharger to the exhaust stack or tail pipe.
- Aftertreatment Device (ATD)—a housing that contains the DOC and DPF (also the SCR and the mixing tube in one-box systems).
- BlueTec®—Daimler's proprietary SCR technology.
- Diesel Oxidation Catalyst (DOC)—a flow-through device that oxidizes soot in the ATD.
- Diesel Particulate Filter (DPF)—a component in the ATD that traps soot from the exhaust gas.
- Diesel Exhaust Fluid (DEF)—the chemical agent that reacts with the exhaust gases in the SCR to reduce NOx.
- DEF Pump—filters and supplies DEF to the DEF metering unit.
- DEF Tank—holds DEF and regulates its temperature.
- DEF Metering Unit—mixes DEF with compressed air, and meters this mixture into the exhaust flow via an injection nozzle.
- SCR Catalyst—the housing containing a treated ceramic flow-through block where the DEF and exhaust gases undergo selective catalytic reduction (SCR).
- Selective Catalytic Reduction (SCR)—a process used to reduce NOx emissions.

Inspection

To meet EPA10 emissions regulations for vehicles domiciled in the USA or Canada, engines manufactured after December 31, 2009 are equipped with an emission aftertreatment system. Vehicles domiciled outside of the USA and Canada may not have aftertreatment equipment, depending upon local statutory emissions guidelines.

IMPORTANT: The aftertreatment device (ATD), which is part of the aftertreatment system (ATS), requires special attention during regularly scheduled maintenance inspections. No leaks are allowed anywhere in the system. If any discrepancies are discovered, refer to the engine manufacturer's service literature for repair instructions.

1. Check for leakage at the clamp that attaches the exhaust pipe to the turbocharger exhaust outlet. If leakage exists, tighten the nut on the clamp to the required torque. If leakage persists, install a new clamp.
2. Check the exhaust pipe, bellows, and each exhaust seal clamp for leakage, wear, cracks, or damage. Replace damaged components as needed. If leakage exists at a clamp, tighten the nuts to the required torque. If leakage persists, install a new exhaust seal clamp. Do not reuse seal clamps. Once a seal clamp is loosened or removed, it must be replaced.
3. If present, check the condition of the insulation material around the exhaust pipe between the turbocharger and the ATD.
4. Check the ATD mounting bands for tightness. Tighten to 30 lbf·ft (41 N·m) if needed. Do not overtighten.
5. Check for leaks around the clamps that attach the ATD in the ATS, and around the clamps that retain the DPF in the ATD.
6. Check all sensors attached to the ATS for leaks or damaged wires. No leaks are allowed. See [Fig. 1](#), [Fig. 2](#), or [Fig. 3](#) for Detroit Diesel ATS sensor locations.
7. Check the DPF exterior surface for dents or other damage. A dent over 3 inches (76 mm) in diameter and 1/4-inch (6-mm) deep could cause internal damage to the DPF, causing it to malfunction.
8. Check the SCR catalyst for dents and other damage.
9. Check for heat discoloration on the surface of the ATD. Heat discoloration may indicate internal damage; especially around the DPF.

NOTE: Diesel exhaust fluid creeps, causing white crystals to form around the line fittings. The presence of crystals does not mean the system has a leak. Replacing fittings or troubleshooting components is not necessary unless there is a system failure or a fault code.

10. Check the DEF tank, pump, metering unit, and lines for leaks. See **Section 49.02** of the *Cascadia™ Workshop Manual* for repair procedures.
11. Check any wires, lines, or hoses within 4 inches (10 cm) of the exhaust system for heat damage. Repair or reroute as needed.

Diesel Exhaust Fluid (DEF) Filter Replacement

The Environmental Protection Agency's 2010 regulations require lower nitrogen oxide (NOx) exhaust emissions. Selective catalytic reduction (SCR) uses diesel exhaust fluid (DEF) to lower NOx emissions in the vehicle exhaust. A filter in the DEF pump prevents clogging of the DEF metering unit injection nozzle.

See the engine manufacturer's maintenance manual for filter replacement instructions and maintenance intervals.

EPA07 Exhaust System Definitions of ATS Terms

Refer to the following list of definitions of ATS components.

- Aftertreatment System (ATS)—the entire exhaust system from the turbocharger to the exhaust stack or tail pipe.
- Aftertreatment Device (ATD)—a muffler-like canister that houses a DPF, DOC, and sensors.
- Clean Gas Injection (CGI)—a Caterpillar (CAT) proprietary system that recirculates clean exhaust gasses back into the engine intake system.

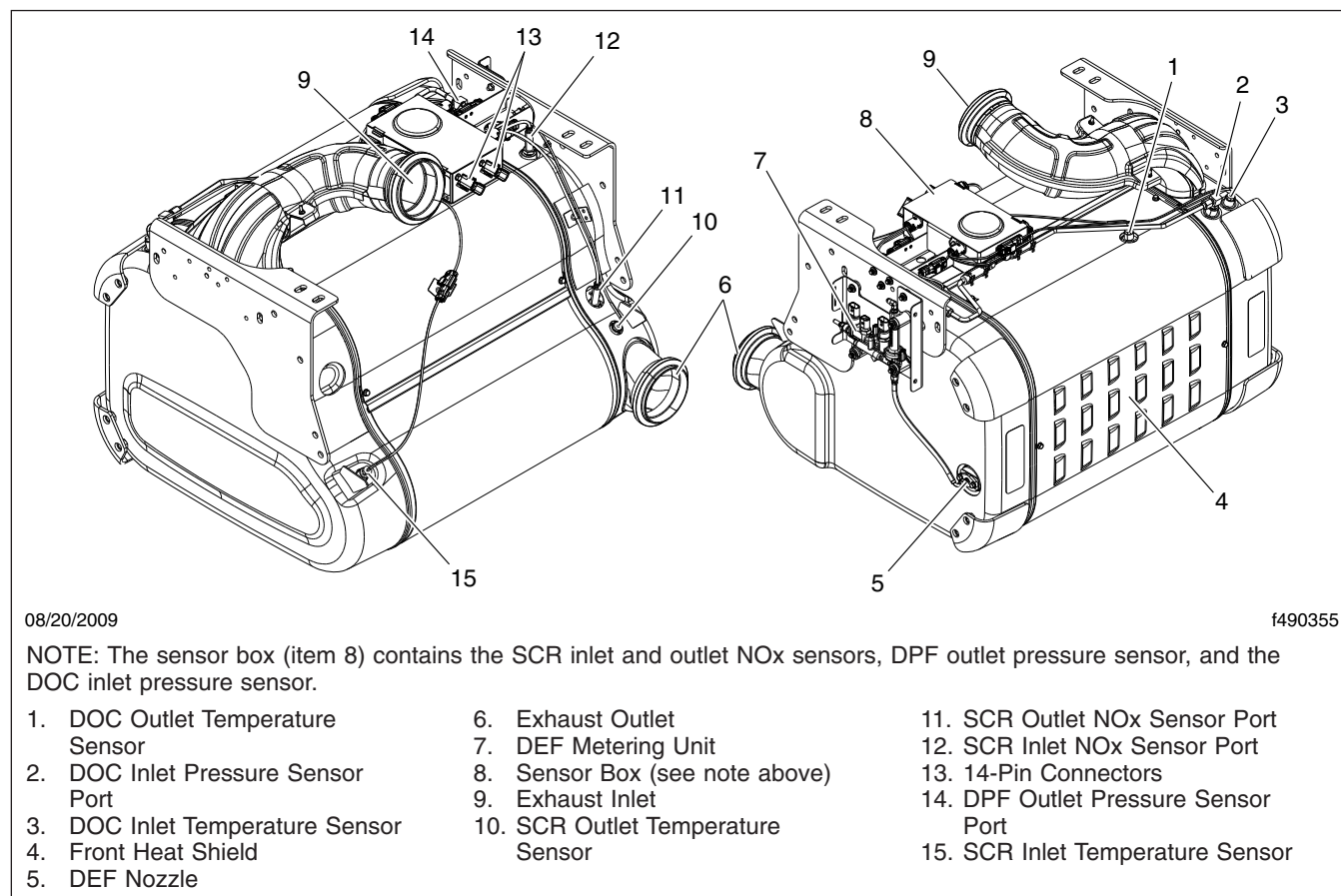

Fig. 1, One-Box ATS Sensor Locations

- Diesel Particulate Filter (DPF)—a filter that collects and holds particulate matter (soot and ash).
- Diesel Oxidation Catalyst (DOC)—oxidizes hydrocarbons and reduces NOx.
- Sensors—detect temperatures and pressures in the ATS.

Inspection

To meet EPA07 emissions regulations for vehicles domiciled in the USA or Canada, engines manufactured after December 31, 2006 are equipped with an emission aftertreatment system. Vehicles domiciled outside of the USA and Canada may not have aftertreatment equipment, depending upon local statutory emissions guidelines.

IMPORTANT: The aftertreatment device (ATD), which is part of the aftertreatment system (ATS), requires special attention during regularly scheduled maintenance inspections; see [Fig. 4](#). No leaks are allowed anywhere in the system. If any discrepancies are discovered, refer to the engine manufacturer's service literature for repair instructions.

1. Check for leakage at the clamp that attaches the exhaust pipe to the turbocharger exhaust outlet. If leakage exists, tighten the nut on the clamp to the required torque. If leakage persists, install a new clamp.
2. Check the exhaust pipe, bellows, and each exhaust seal clamp for leakage, wear, cracks, or damage. Replace damaged components as needed. If leakage exists at a clamp, tighten the nuts to the required torque. If leakage persists,

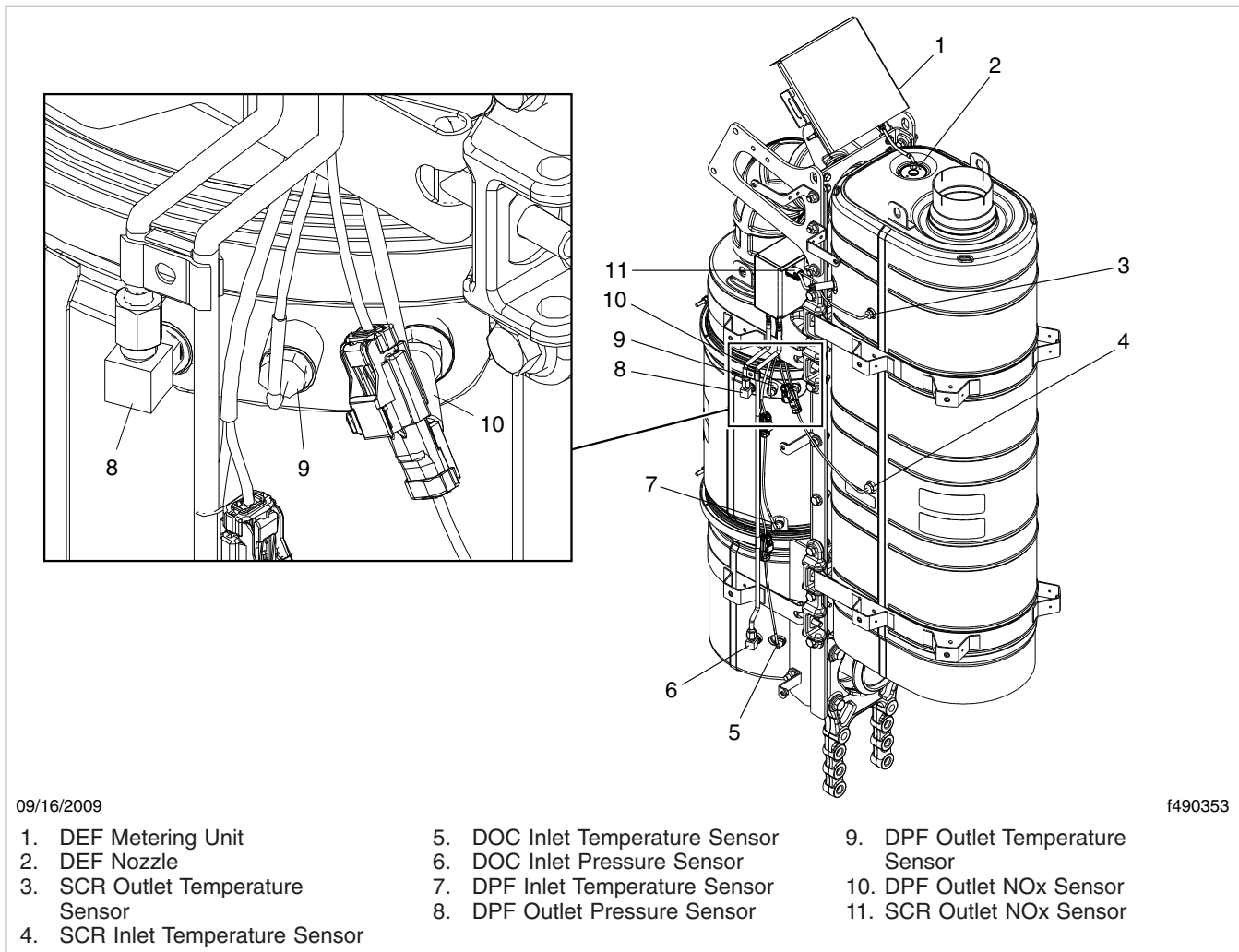

Fig. 2, 2V2 Two-Box ATS Sensor Locations

install a new exhaust seal clamp. Do not reuse seal clamps. Once a seal clamp is loosened or removed, it must be replaced.

NOTICE

A leak in the CGI piping, including the bellows, will allow unfiltered air and contaminants into the engine intake, and can cause serious engine damage.

NOTE: Because the CGI bellows is covered with a metal mesh, it is difficult to see cracks or damage that may cause a leak.

- On vehicles with CAT engines, inspect the CGI bellows and piping for evidence of damage or leakage. See [Fig. 5](#). If the bellows is damaged or leaking, replace it. See [49-02](#) for the replacement procedure.
- If present, check the condition of the insulation material around the exhaust pipe between the turbocharger and the ATD.
- Check the ATD mounting bands for tightness. If needed, tighten the mounting bands on horizontally and vertically mounted ATDs to 30 lbf-ft (41 N·m); on step-mounted ATDs, tighten the mounting bands to 15 lbf-ft (20 N·m). Do not over-tighten.

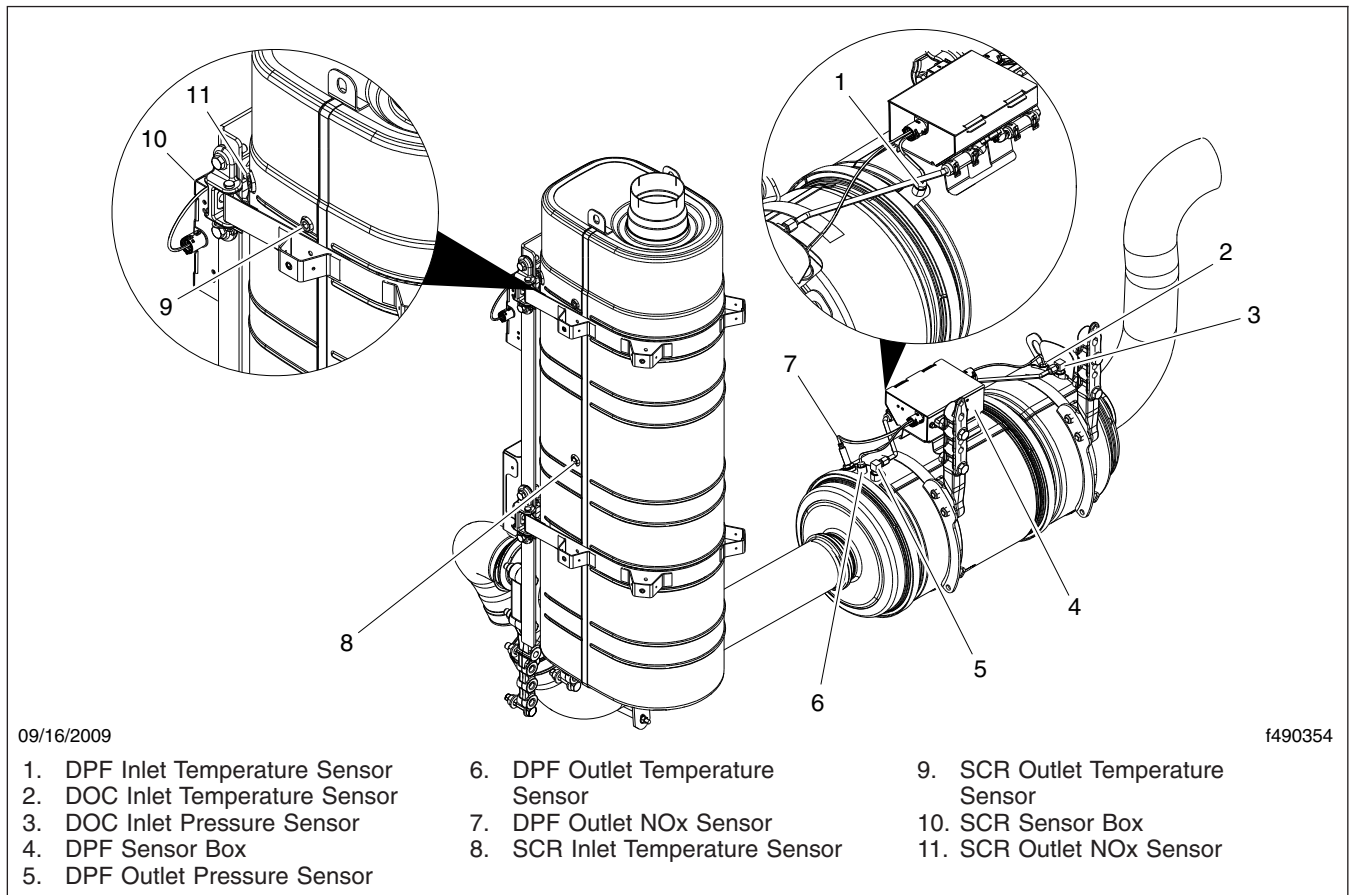

Fig. 3, 2HV Two-Box ATS Sensor Locations

6. Check for leaks around the clamps that attach the ATD in the ATS, and around the clamps that retain the DPF in the ATD.
7. Check all sensors attached to the ATD for leaks or damaged wires. No leaks are allowed.
8. Check the DPF exterior surface for dents or other damage. See Ref. A of [Fig. 4](#). A dent over 3 inches (76 mm) in diameter or 1/4-inch (6-mm) deep could cause internal damage to the DPF, causing it to malfunction.
9. Check for heat discoloration on the surface of the ATD. Heat discoloration may indicate internal damage; especially around the DPF.
10. Check any wires, lines, or hoses within 4 inches (10 cm) of the exhaust system for heat damage. Repair or reroute as needed.

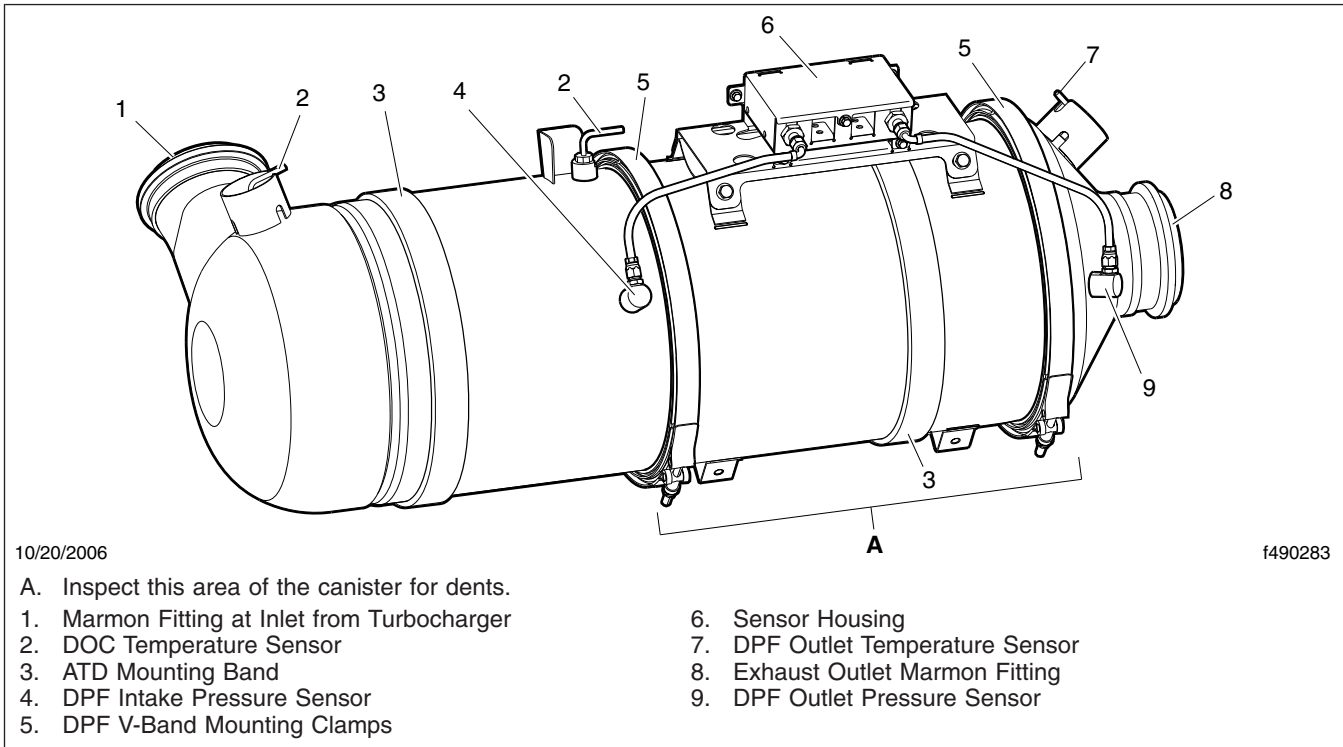

Fig. 4, Typical EPA07 Aftertreatment Device

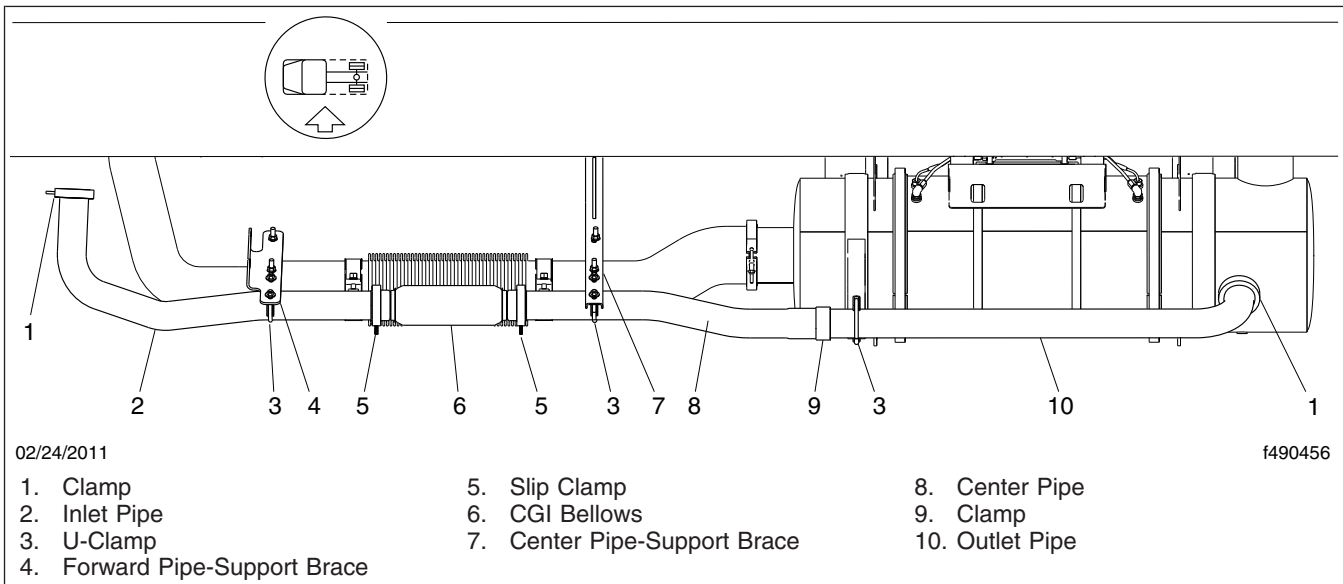

Fig. 5, CAT EPA07 Exhaust Installation with CGI Bellows

Pre-EPA07 Exhaust System

1. On all vehicles, check the condition of the muffler body and the top stack. Check the inlet/outlet tubes for leakage, dents, and corrosion, and check for holes in the muffler. Replace parts as required. Use new parts, equivalent to parts originally installed on the vehicle.
2. Inspect the exhaust flex hose (see [Fig. 6](#)) for leakage, wear, or damage. Replace with new parts if replacement is needed.
3. Check for leakage at the V-band coupling, which attaches the exhaust pipe to the turbocharger exhaust outlet. See [Fig. 6](#).

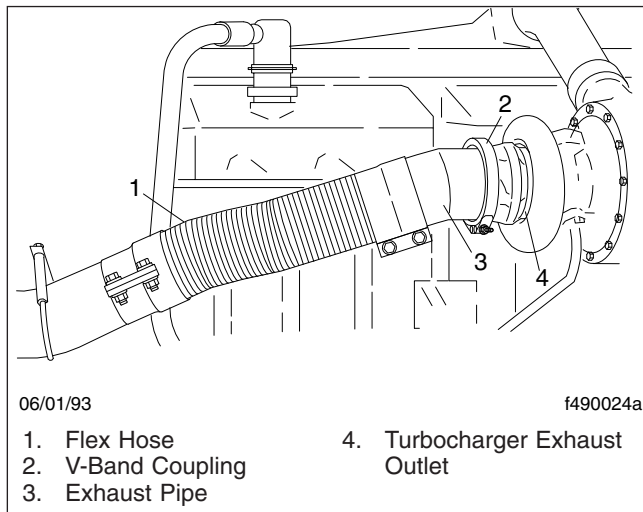

Fig. 6, V-Band Coupling and Flex Hose

4. If leakage exists, tighten the nut on the V-band coupling 85 lbf-in (940 N-cm). If leakage persists, install a new V-band coupling.
5. Inspect the turbo outlet pipe, and replace it as needed.
6. Check the U-bolt clamps for tightness, and tighten as needed.
7. Check the isolator at the base of the exhaust stack elbow(s) (see [Fig. 7](#)), for cracking, damage, and dry rot. Replace as needed.
8. Check for leakage at all wide-band exhaust clamps. See [Fig. 8](#).

If leakage exists, tighten the nuts 40 to 60 lbf-ft (54 to 81 N-m). If leakage persists, inspect the

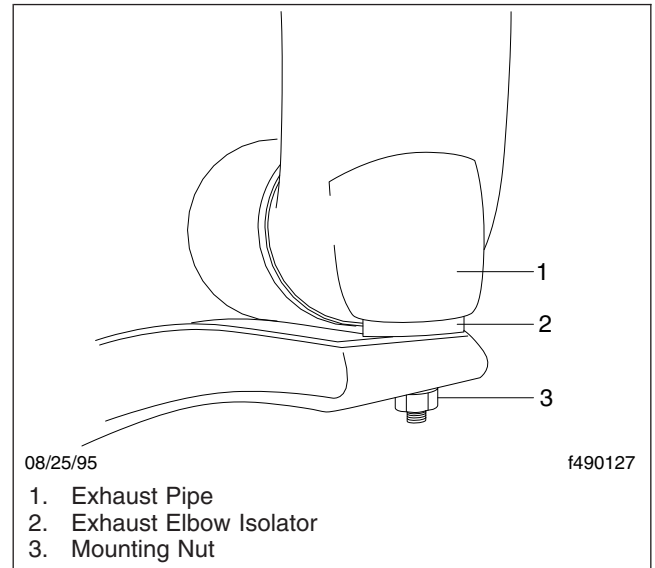

Fig. 7, Exhaust Elbow Isolator

sealclamps. If necessary, install a new wide-band exhaust clamp.

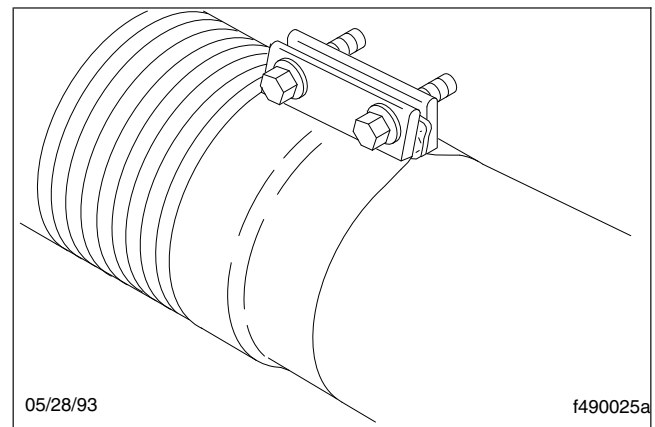

Fig. 8, Donaldson Sealclamp Wide-Band Exhaust Clamp

49-02 CAT CGI Bellows Replacement

On vehicles with CAT EPA07 compliant engines, replace the CGI bellows at the M3 maintenance interval to prevent a later failure.

NOTICE

A leak in the CGI piping, including the bellows, will allow unfiltered air and contaminants into the engine intake, and can cause serious engine damage.

1. Park the vehicle, set the parking brake, chock the wheels.
2. Open the hood.
3. Remove the right side inner fender/splash shield as needed.
4. Remove the CGI piping between the engine and aftertreatment device (ATD).

See [Fig. 5](#).

5. On the workbench, remove the CGI bellows from the exhaust piping. Do not damage the piping.

NOTE: The following step, and its substeps, is to be done without the bellows installed. This will align the pipes so that the bellows can be installed correctly.

6. Install the CGI piping (without CGI bellows) and align piping.
 - 6.1 Attach the aft CGI pipe to the ATD.
 - 6.2 Attach the forward CGI pipe to the engine.

NOTICE

When the CGI pipes and bellows are installed, there should be approximately 3/4 inch (19 mm) clearance from the main bellows. Contact between the bellows could result in an exhaust leak, which in this case may allow ingestion of contaminants into the engine causing engine damage.

- 6.3 Use a straightedge to align the pipes so that the pipe ends that attach to the bellows are parallel and concentric.

NOTICE

When shortening the CGI pipe(s), it is critical to leave a minimum of 1 inch (25.4 mm) of straight pipe on the end of each CGI pipe to allow for pipe insertion and clamp clearance. Failure to do this could result in an exhaust leak, which in this case

may allow ingestion of contaminants into the engine causing engine damage.

7. Once the pipes are aligned, measure the pipe gap between the CGI pipes and record the distance. See [Fig. 9](#), Ref. A.

The existing pipe gap is designed at 10 inches (254 mm). A 10.75 inches (273 mm) pipe gap is required for the replacement CGI bellows and clamps. This requires one or both of the CGI pipes to be shortened.

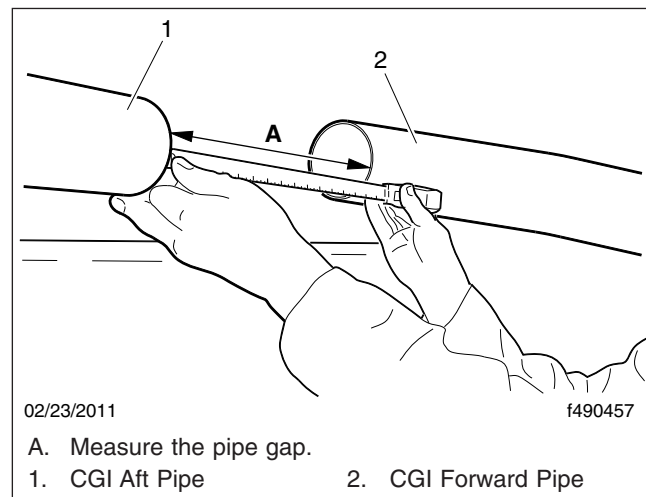

Fig. 9, Measuring the Pipe Gap (typical)

8. Using a yellow paint pen, mark the pipes 1.5 inches (38 mm) in from the end of each pipe. These two marks will be used to center the bellows between the two pipes.
9. Once the pipes are correctly aligned and separated at the correct distance, secure the aft CGI pipe to the ATD and to any CGI pipe support brackets.
10. Remove the forward CGI pipe from the truck.
11. Slide the slip clamp, with the retaining ring and graphite gasket ring, on the aft CGI pipe. See [Fig. 10](#) for proper installation.
12. Slide the new bellows onto the aft CGI pipe as far as it will go. See [Fig. 11](#), Ref. A. Measurement A should be at least 7/16 inch (10 mm) past the face of the flange.
13. Install the slip clamp with the retaining ring and graphite gasket ring onto the forward CGI pipe. See [Fig. 12](#) for proper installation.

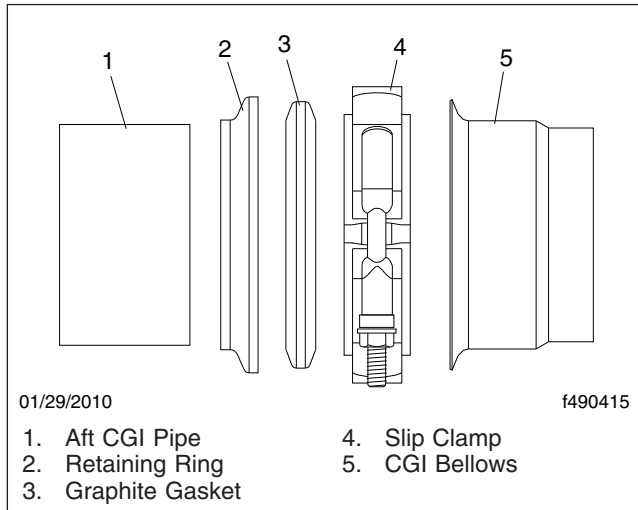

Fig. 10, Aft Facing Slip Clamp Installation

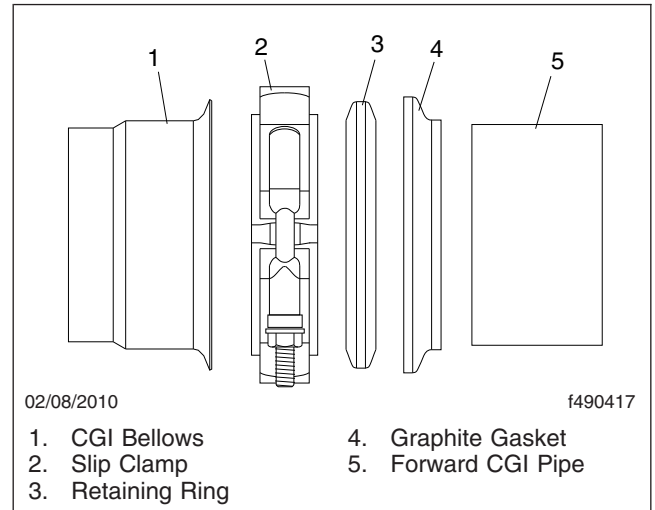

Fig. 12, Forward Facing Slip Clamp Installation

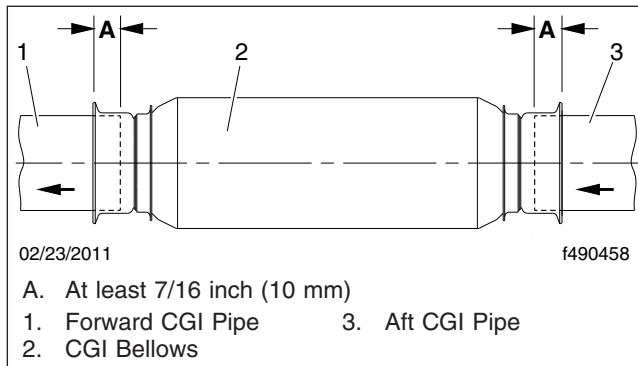

Fig. 11, CGI Bellows Installation

14. Slide the end of the forward CGI pipe into the bellows, and properly align the pipe.
15. Secure the forward CGI pipe to the engine and any CGI pipe support brackets.
16. Using the yellow marks, center the bellows between the exhaust pipes. Verify that the pipe is inserted at least 7/16 inch (10 mm) past the face of the flange. See [Fig. 11](#), Ref. A.
17. Install the slip clamps on the bellows. Tighten the slip clamps 11 lbf·ft (15 N·m).
18. Start the engine and check for exhaust leaks. Tighten any clamps as needed.

Title of Maintenance Operation (MOP)	MOP Number
Electrical Component Inspection.	54-02
Trailer Cable Inspection and Cleaning.	54-01

54–01 Trailer Cable Inspection and Cleaning

1. Disconnect the trailer electrical cables from the sockets at the cab.
2. Inspect the cables and sockets for evidence of corrosion, and clean as necessary. If a socket is too badly corroded to clean, replace it. Freightliner recommends also replacing the socket's harness as well, if the corrosion has gotten into the wires and connectors inside the socket.

IMPORTANT: If using a spray cleaner to remove corrosion, be careful to protect any surrounding painted surfaces.

3. Coat the inside of the sockets with a lithium-based dielectric grease such as Lubriplate FLP DS–ES.
4. Connect the cables.

54–02 Electrical Component Inspection

1. Park the vehicle, apply the parking brakes, and shut down the engine. Chock the tires.
2. Disconnect the batteries.
3. Inspect the condition of the electrical component. Check for signs of excess dirt/debris build up on or around component. If exterior cleaning is needed for a thorough inspection, clean exterior debris from the component using a dry method such as a vacuum cleaner or using an electrical contact cleaner such as CRC QD® Electronic Cleaner.
4. Check all mounting points for loose, broken, or missing parts. Component must be securely mounted. All loose, broken, or missing parts must be repaired to maintain proper component function.
5. Inspect the component protective cover for proper fit and function. Inspect cover for cracks, broken mounting, missing sealing surfaces, warped or bulged surfaces. The cover must prevent moisture and debris from entering the components protected area. Missing, leaking, or damaged covers will result in moisture and debris entering the component and will result in

component failure. When it is determined that a cover has not properly prevented moisture and debris from entering the component, the entire component must be replaced.

6. Inspect component exterior for signs of thermal distortion, warping, bulging, discoloration, amperage related heating, color variance or shading across component which could be a sign of internal failure requiring replacement of the component. The root source causing conditions of high heat, excess amperage, and/or circuit overload component failures must be diagnosed and repaired prior to replacing the component.
7. Inspect component housing sub-assembly clips and fasteners for correct fit and location and that component sub-assembly housing seams are tight and secure. Missing, leaking, or damaged component housings must be replaced.
8. Check main power cable connections for a clean and secure fit. Connections should be free of corrosion, dirt and moisture. Connections should not have signs of thermal distortion, warping, discoloration, high amperage heating or discoloring. If needed, disconnect cables, scrub and clean as needed using a nylon brush. Clean debris with vacuum or electrical contact cleaner such as CRC QD® Electronic Cleaner, inspect terminals and mating contact terminal plating. If the terminal plating exhibits signs of unrecoverable corrosion, the component and terminal will need replaced. Indications of unrecoverable corrosion on terminal plating are:
 - Heavy staining that cannot be cleaned off with nylon brush or contact cleaner;
 - erosion and pitting on terminal plating causing uneven surfaces; or
 - discoloration caused by outer layer of plating being removed by corrosion or wear exposing the under layer material of terminal.
9. Check all electrical connectors for correct fit and that the connector locking tabs are in place and will hold the connector firmly into the component. Inspect connector terminals for signs of corrosion, thermal distortion, warping, discoloration, high amperage heating or discoloring. If needed, remove connectors and terminals, scrub and clean as needed using a nylon brush. Clean debris with vacuum or electrical contact cleaner

such as CRC QD® Electronic Cleaner, inspect terminals and mating contact terminal plating. If the terminal plating exhibits signs of unrecoverable corrosion, the component and terminal will need to be replaced.

10. Inspect sealed harness connectors for presence of connector housing seals and connector pin seals designed to keep moisture and debris from entering the connector and component. Missing, leaking, or damaged seals will result in moisture and debris entering the connection and the component and will result in component failure. When it is determined that connector seals have not properly prevented moisture and debris from entering the component, the entire component must be replaced.
11. Inspect component harnesses for secured routing that prevents excess harness movement and prevents the harness from pulling too tight on the connector. Inspect harnesses for signs of rubbing or chafing that could result in wire circuit damage. Damaged wiring and/or damage to harness protective wrap must be repaired and harness must be wrapped and secured to prevent further damage. When possible, harness should be routed with drip loop.
12. Inspect fuses and relays for correct fit, and that the terminals hold the fuses and relays firmly in place. Inspect fuses and relays for signs of corrosion, thermal distortion, warping, discoloration, and high amperage heating or discoloring. If loose or corroded, remove, inspect, clean, and replace as needed.
13. Connect the batteries.

Title of Maintenance Operation (MOP)	MOP Number
Aerodynamic Component Inspection	60-03
Baggage Door and Sleeper Access Door Release Cable and Latch Lubrication	60-04
Cab Shock Absorber Bracket Torque Check	60-02
Mirror Folding Check	60-01

60–01 Mirror Folding Check

For vehicles with folding main mirrors, make sure that the mirrors fold freely on the pivot points. Pivot each mirror fully forward and backward two times to break loose any debris that may affect the fold-away feature of the mirror.

60–02 Cab Shock Absorber Bracket Torque Check

1. Apply the parking brake and chock the tires.
2. Check the torque on the upper bolt that attaches the shock absorber upper bracket to the cab. If loose, tighten the bolt 34 lbf-ft (46 N-m). See [Fig. 1](#).
3. From behind the cab skin, check the torque of each of the two lower nuts that attach shock absorber upper bracket to the cab, while holding the bolt in place with a box wrench. If loose, tighten the nuts 34 lbf-ft (46 N-m).

60–03 Aerodynamic Component Inspection

Inspect aerodynamic components, if equipped, for structural damage, cracks, or wear. These may include:

- Chassis fairings
- Battery access kickplate
- Side skirts
- Cab side extenders
- Roof fairing/deflector
- Bumper
- Hood

Replace or repair damaged or missing components as needed.

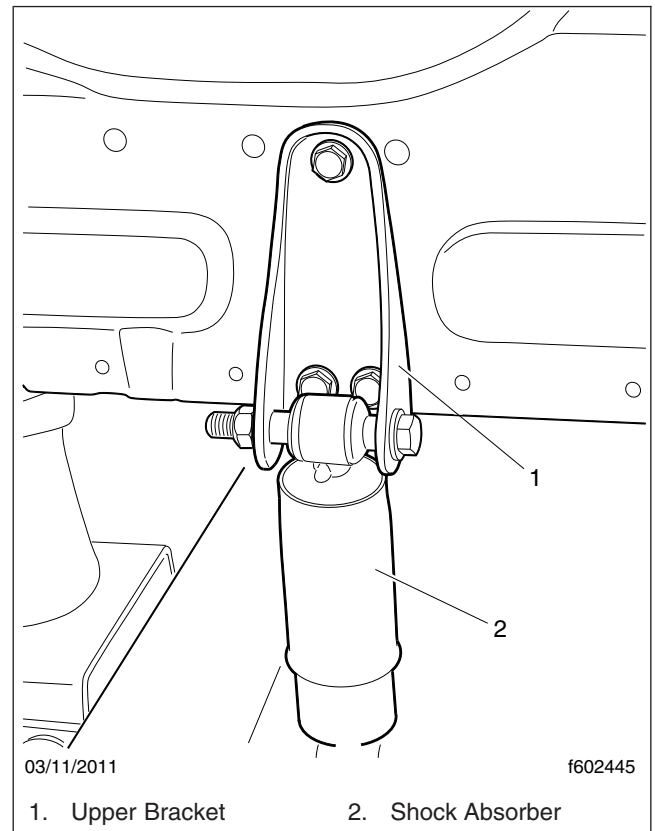

Fig. 1, Cab Shock Absorber and Upper Bracket

60–04 Baggage Door and Sleeper Access Door Release Cable and Latch Lubrication

NOTE: Use a silicone lubricant such as WD-40 or equivalent.

1. Open the baggage door and the sleeper access door (if equipped) by pulling the release handle(s) located inside the cab door opening. See [Fig. 2](#).
2. Pull out on the baggage door handle, and apply a light coating of lubricant to the exposed length of cable. Repeat for the sleeper access door cable, if equipped.
3. At the opened baggage door, apply a light coating of lubricant to the latch jaw and the exposed length of cable. See [Fig. 3](#). Repeat for the

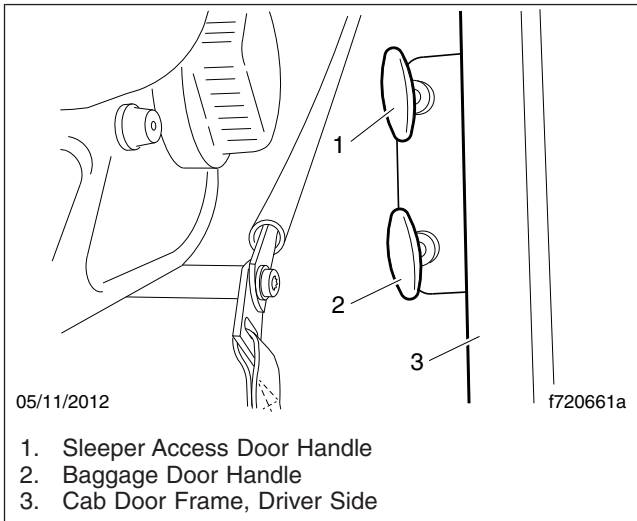

Fig. 2, Baggage Door and Sleeper Access Door Release Handles

sleeper access door, if equipped. Removal of trim panels is not required.

NOTE: Removal of trim panels is not required.

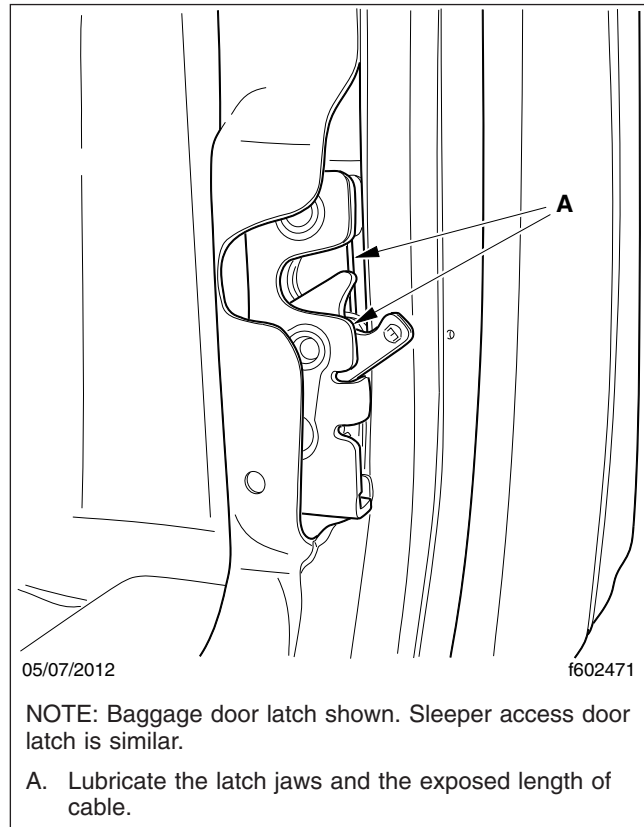

Fig. 3, Baggage Door Latch

Title of Maintenance Operation (MOP)	MOP Number
Air Conditioner Inspection	83-01
Air Filter Replacement	83-02
ParkSmart™ Inspection	83-03
Safety Precautions	83-00

83–00 Safety Precautions

Safety Precautions in this section apply to all procedures within this group.

DANGER

When working on the vehicle, shut down the engine or motor, set the parking brake, and chock the tires. Before working under the vehicle, always place jack stands under the frame rails to ensure the vehicle cannot drop. Failure to follow these steps could result in serious personal injury or death.

83–01 Air Conditioner Inspection

WARNING

Wear eye protection, gloves, and protective clothing when working on the air conditioning system. Leaking refrigerant from a damaged hose or line could cause blindness or serious skin burns.

Preliminary Checks

1. Park the vehicle on a level surface, apply the parking brakes, and chock the tires.
2. Check the appearance of the air conditioner compressor pulley assembly. If the friction surface of the pulley shows signs of excessive grooving due to belt slippage, replace both the pulley and the drive plate. Inspect the refrigerant compressor drive belt for damage and check that the belt is set at the proper tension. Also check the tightness of the compressor mounting fasteners. For instructions and torque values, see **Group 01** of the *Cascadia™ Workshop Manual*.
3. Inspect the drive plate. If the drive plate shows visible signs of damage due to excessive heat, replace the drive plate and pulley assembly. For removal and installation procedures, see **Group 83** of the *Cascadia™ Workshop Manual*.
4. Using a feeler gauge, check that the drive plate clutch clearance is within limits. See **Table 1** for clearance specifications. See **Fig. 1** for the checking method. If the drive plate clutch re-

quires adjustment, see **Group 83** of the *Cascadia™ Workshop Manual*.

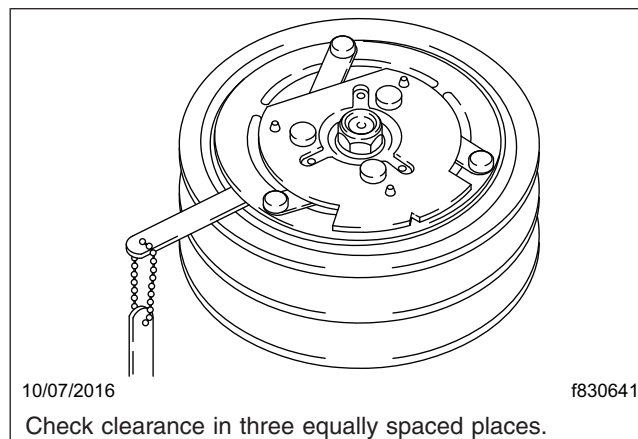

Fig. 1, Drive-Plate Clearance Inspection

Compressor Drive-Plate Clutch Clearance	
Manufacturer	Clearance: in (mm)
Sanden	0.016 to 0.040 (0.4 to 1.0)
Denso	0.014 to 0.024 (0.35 to 0.60)

Table 1, Compressor Drive-Plate Clutch Clearance

5. Inspect the compressor clutch coil wire. Check that the connector is not damaged or loose. Replace the wire if it is damaged.
6. Check the overall condition of the air conditioning hoses. Look for cracks, cuts, and abrasions on the hoses. Replace damaged hoses. For replacement instructions, see **Group 83** of the *Cascadia™ Workshop Manual*. Also check for loose fittings on all of the air conditioning components.
7. Check for a buildup of road debris on the condenser fins. For cleaning instructions, see **Group 83** of the *Cascadia™ Workshop Manual*.

83–02 Air Filter Replacement

The HVAC system has three filters that must be replaced periodically to maintain proper system operation. The cabin fresh-air-intake filter is accessed from under the hood, and the recirculation filter is accessed from inside the cab. The sleeper air filter is accessed through an access panel on the cabinet behind the driver's seat.

Cab Fresh-Air Filter Replacement

IMPORTANT: When replacing the air filter, use only a Freightliner-approved air filter.

1. Park the vehicle on a level surface, set the parking brake, and shut down the engine. Chock the tires.
2. Open the hood.
3. Remove the intake screen. See [Fig. 2](#).

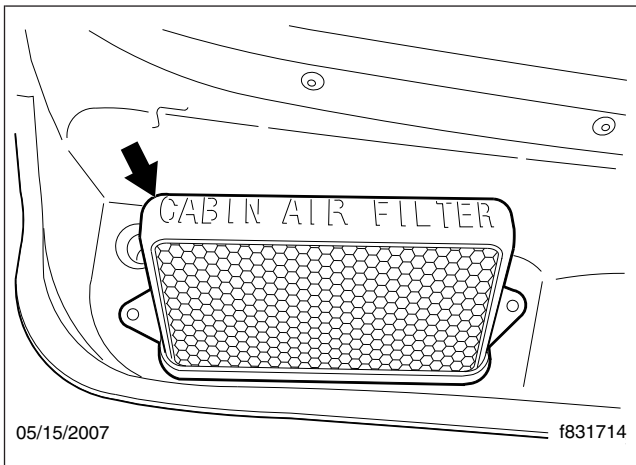

Fig. 2, Intake Screen

4. Lightly press on the filter tray handle to disengage the lock (see [Fig. 3](#)), and slide the tray out of the slot in the plenum.

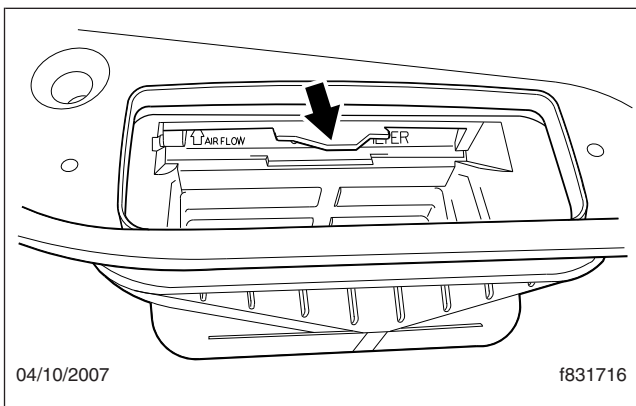

Fig. 3, Disengaging the Lock

5. Remove the filter from the tray. Note the airflow directional arrow on the filter's edge. When prop-

erly installed, the airflow arrow will point in the same direction as the marking on the front edge of the tray. Both will point toward the cab. See [Fig. 4](#).

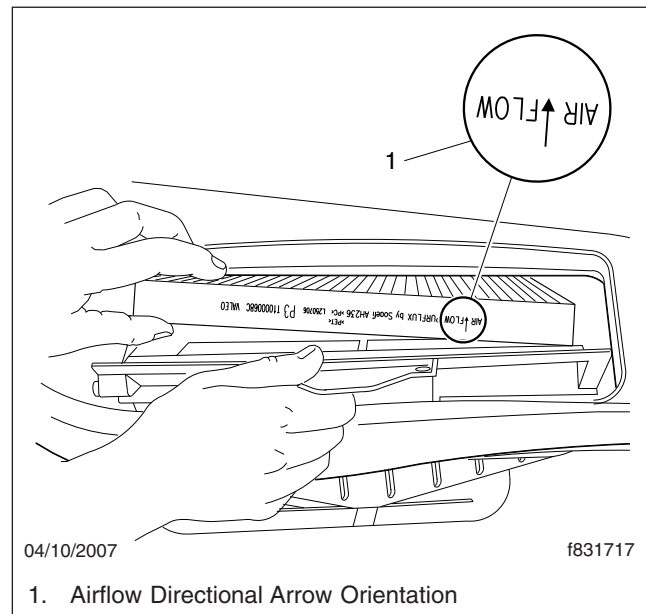

Fig. 4, Airflow Directional Arrow

6. Put a new filter in the tray, making sure the airflow arrow is correctly oriented, and install the tray in the slot in the plenum. Make sure the tray locks into position.
7. Install the intake screen.
8. Return the hood to the operating position.

Cab Recirculation-Air Filter Replacement

The recirculation air filter is located on the "back" side of the evaporator housing, in the corner formed by the frontwall and the right side of the cab. It is accessed from the underside of the unit. It is a coarse sponge, or fiber, filter. See [Fig. 5](#).

IMPORTANT: When replacing the air filter, use only a Freightliner-approved air filter.

NOTE: Filter replacement is done "blind."

1. Park the vehicle on a level surface, set the parking brake, and shut down the engine. Chock the tires.

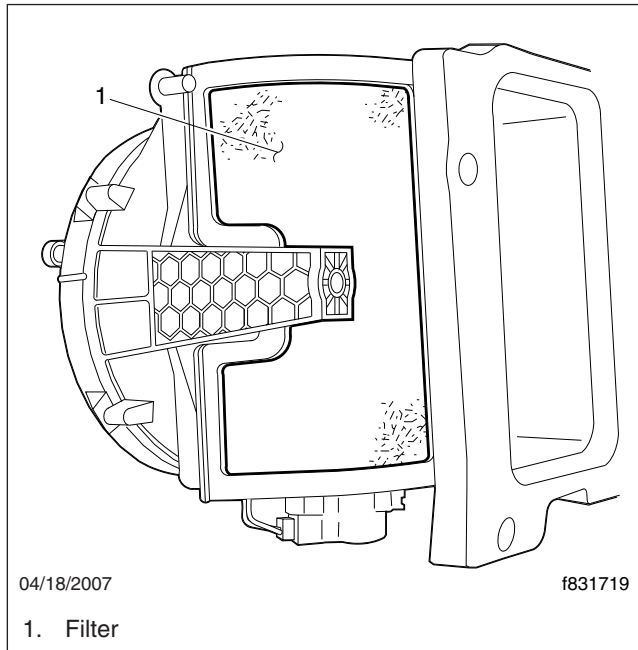

Fig. 5, Cab Recirculation Air Filter (shown out of the vehicle for clarity)

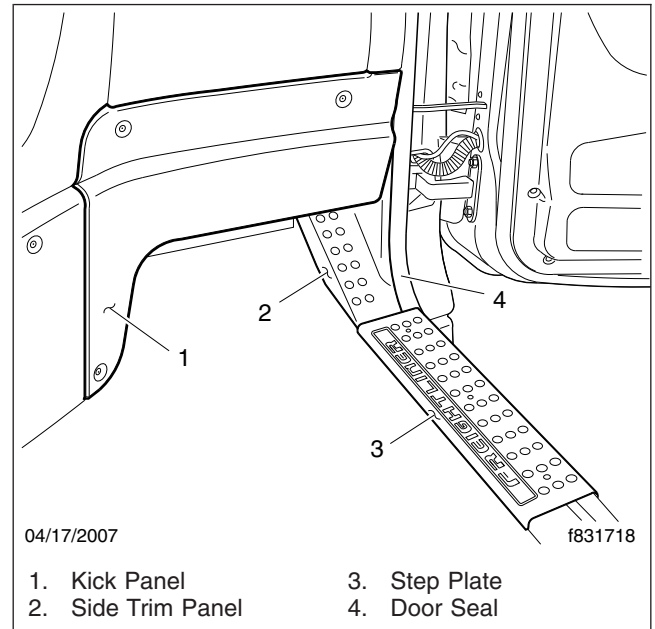

Fig. 6, Panels

2. Loosen the passenger-side kick panel, tilt it out, and carefully twist and remove the light bulb socket from the lens on the back of the panel. Move the panel out of the way. See [Fig. 6](#).
3. Remove the door step plate, and then pull the door seal loose from the bottom of the door opening to just above the filter area.
Remove the A-pillar trim panel. Remove the screw (located under the step plate) and disengage the spring clips by pushing the panel towards the center of the cab.
4. Remove the filter from the intake recess in the back of the plenum. Pull it loose along the bottom edge of the recess, and slide it straight down. See [Fig. 7](#).
5. Slide a new filter up into the recess slots of the plenum. Be sure that it fully seats into the slot all the way around the opening.
6. Install the A-pillar trim panel, then the door seal, and finally, the door step plate.
7. Position the passenger-side kick panel, and install the light bulb socket in the lens, then fasten the panel.

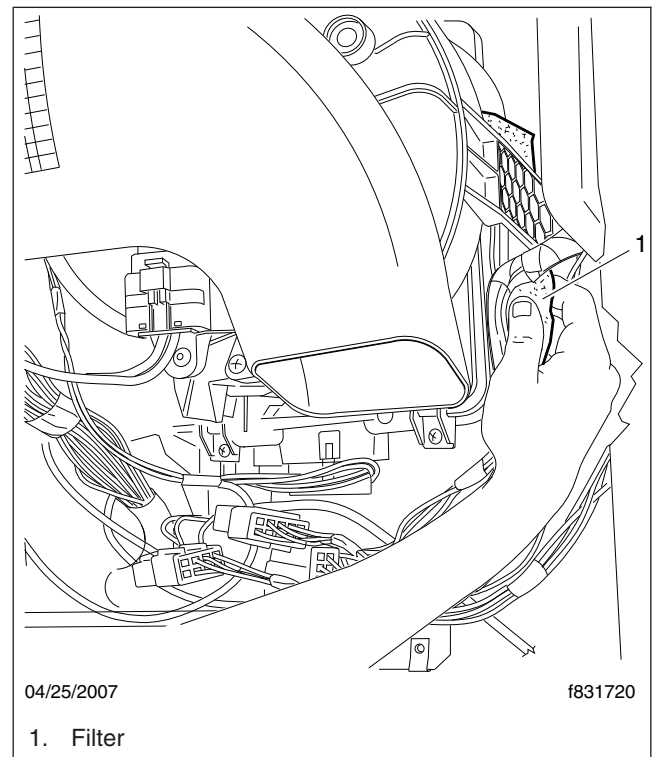

Fig. 7, Removing the Cab Filter

Sleeper Air Filter Replacement

In vehicles with 60-inch and 72-inch sleepers, the sleeper air filter is located on the forward side of the blower fan housing, under the cabinet, directly behind the driver's seat. In vehicles with 48-inch sleepers, the sleeper air filter is located on the forward side of the blower fan housing, under the bunk, directly behind the driver's seat.

IMPORTANT: When replacing the air filter, use only a Freightliner-approved air filter.

1. Park the vehicle on a level surface, set the parking brake, and shut down the engine. Chock the tires.
2. In vehicles with 60-inch and 72-inch sleepers, remove the sleeper HVAC access panel on the inboard side of the cabinet. See [Fig. 8](#). The panel is held in place with four spring clips. Pull straight out to remove it.

In vehicles with 48-inch sleepers, raise the lower bunk, and lift the access panel. See [Fig. 9](#).

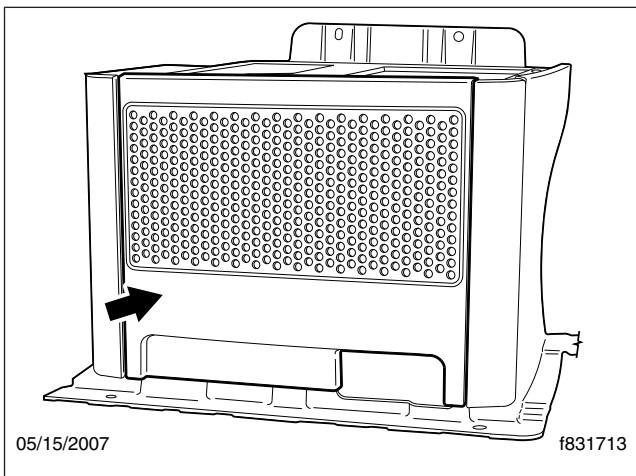

Fig. 8, Sleeper HVAC Access Panel, 60- and 72-inch Sleepers

3. Lift the filter out of the slot. See [Fig. 10](#) for 60- and 72-inch sleepers, or [Fig. 11](#) for 48-inch sleepers.
4. Install a new filter in the slot, making sure that it is completely seated in the slot.
5. Install the access panel.

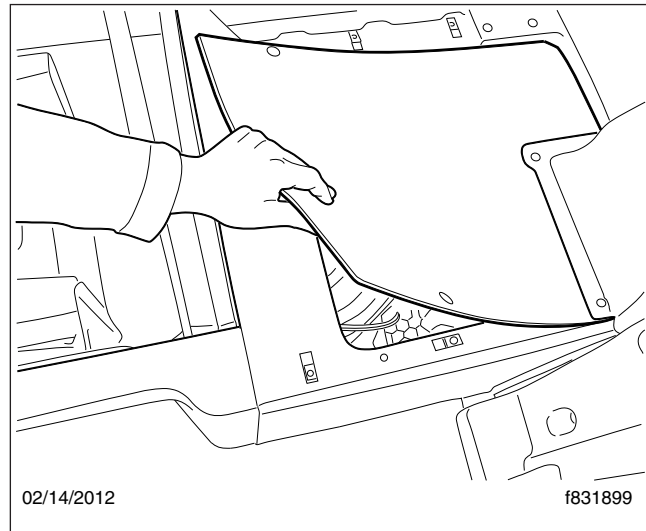

Fig. 9, Sleeper HVAC Access Panel, 48-inch Sleeper

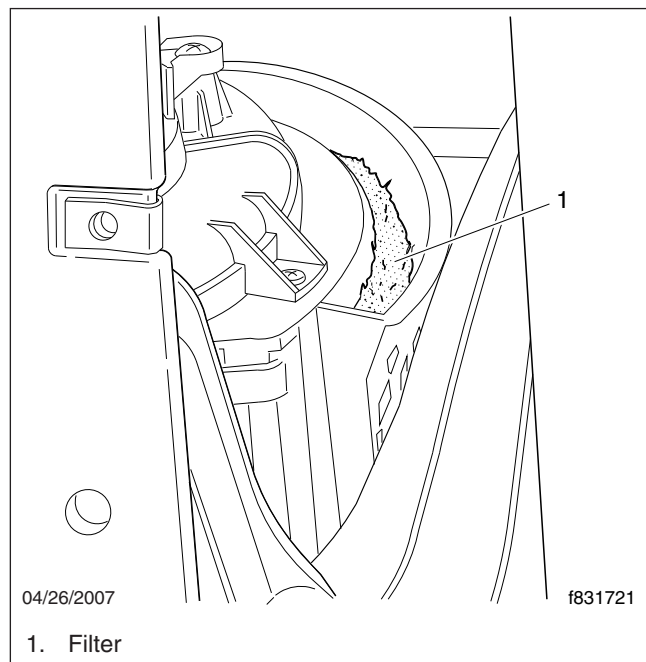

Fig. 10, Removing the Filter, 60- and 72-inch Sleepers

ParkSmart Air Filter Replacement

The ParkSmart air filter is located on the inboard side of the blower fan housing, under the cabinet, directly behind the driver's seat.

IMPORTANT: When replacing the air filter, use only a Freightliner-approved air filter.

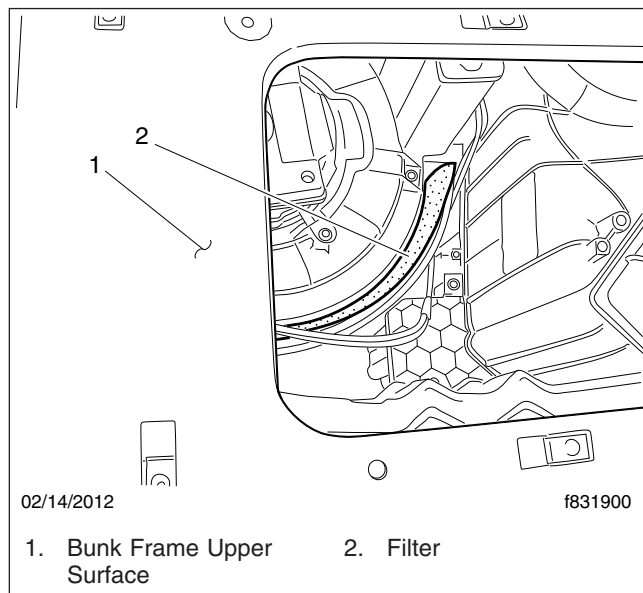

Fig. 11, Removing the Filter, 48-inch Sleeper

1. Park the vehicle on a level surface, set the parking brake, and shut down the engine. Chock the tires.
2. Remove the sleeper HVAC access panel on the inboard side of the cabinet. See Fig. 8. The panel is held in place with four spring clips. Pull straight out to remove it.
3. Pull the filter out of the slot. See Fig. 12.
4. Install a new filter, making sure that it is completely seated.
5. Install the access panel.

83-03 ParkSmart™ Inspection

Espar Heater Operational Check

1. Start the ParkSmart and set the control knob to maximum heat. Run the heater for 15 minutes to achieve operating temperature, and clear old fuel from the lines.
2. Verify that the unit completes the start-up cycle, and continues to produce warm exhaust.

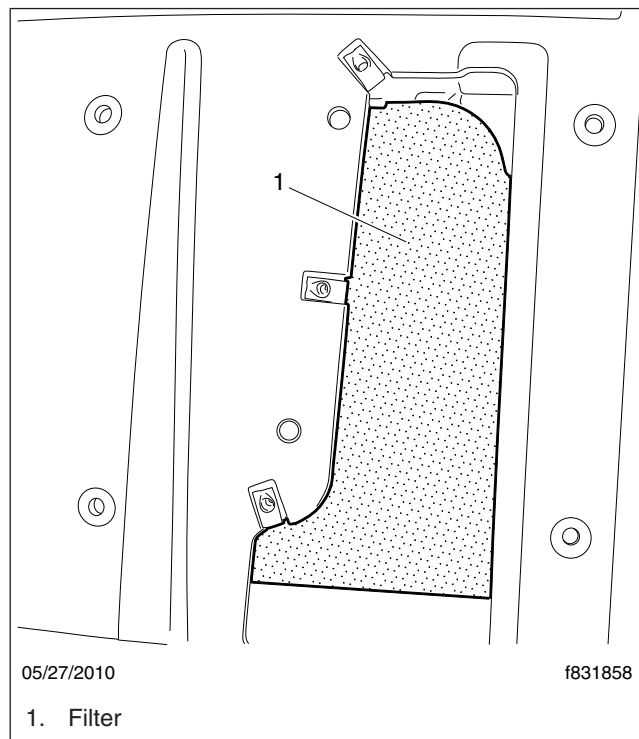

Fig. 12, Removing the ParkSmart Filter

Drain Tube Inspection

NOTICE

The ParkSmart drain tube(s) must be kept clear of debris. Failure to do so will cause excessive water build-up in the base of the unit and may cause damage to the internal components.

1. Remove the battery cover/step or forward side fairing, as needed, to improve access to the underside of the ParkSmart unit.
2. Remove the drain tube(s) from the bottom of the unit. See Fig. 13 for systems manufactured before July 2011, or Fig. 14 for systems manufactured from July 2011.
3. Check the drain tube(s) for debris, and clean as needed.
4. Install the drain tube(s).
5. Install any components that were removed for access.

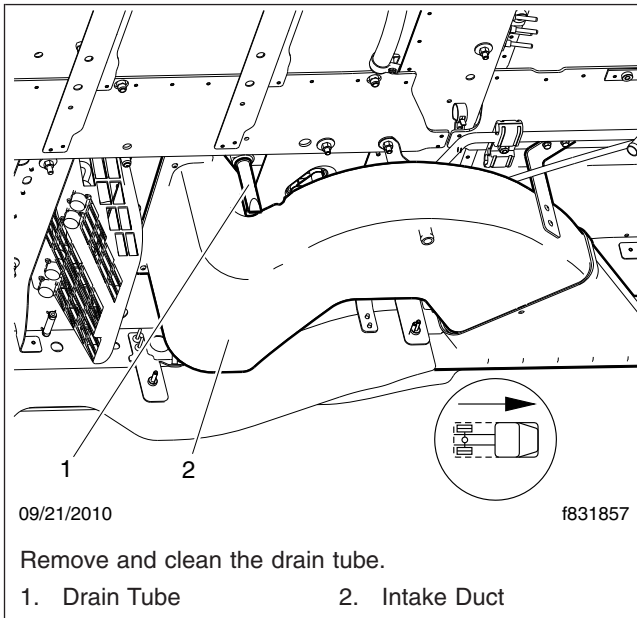

Fig. 13, Drain Tube Inspection (pre-July 2011)

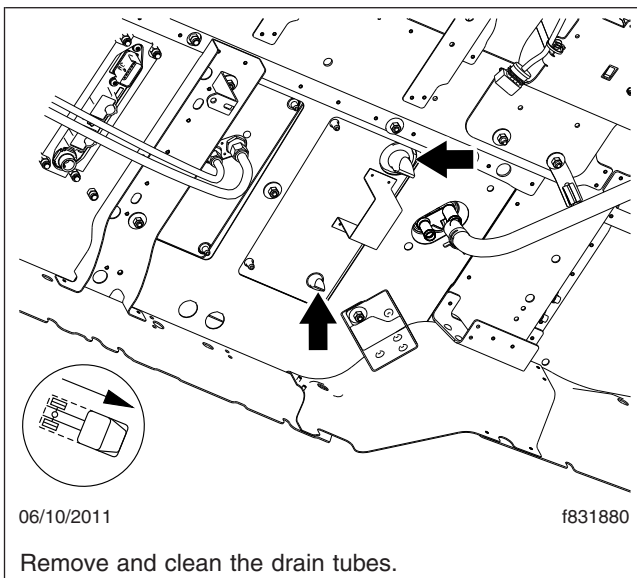

Fig. 14, Drain Tube Inspection (from July 2011)

External A/C Condenser Inspection and Cleaning

On vehicles manufactured from July 2011, the ParkSmart A/C condenser is located on the backwall of the sleeper. Inspect the condenser as follows.

1. Remove the inspection plate on the bottom of the condenser module. See [Fig. 15](#).

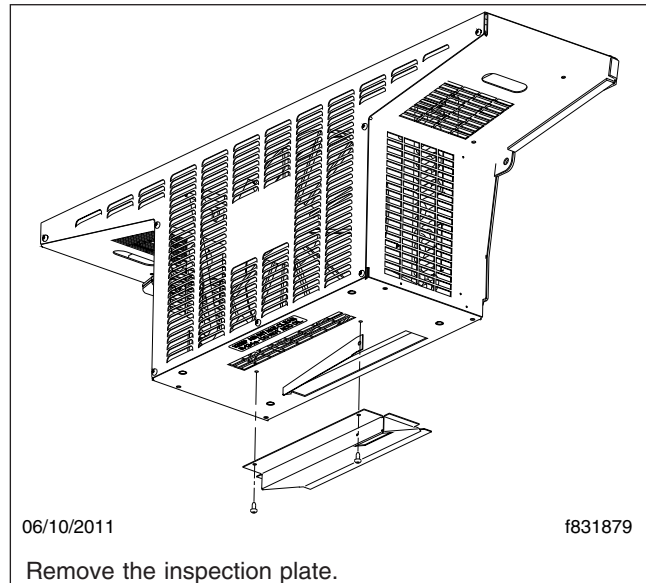

Fig. 15, Condenser Cleaning

NOTE: If the condenser core has a build up of fine debris, an A/C core cleaner, approved for copper and aluminum cores, and a low pressure water can be use to clean it.

2. Clean out any debris in the module.
3. Install the inspection plate.

Title of Maintenance Operation (MOP)	MOP Number
Hood Rear Support Lubrication	88-01

88–01 Hood Rear Support Lubrication

1. Park the vehicle on a level surface, shut down the engine, and set the parking brake. Chock the tires.
2. Open the hood.
3. Clean both the hood- and cab-mounted hood rear support components with a soapy water solution.
4. Cover all contact surfaces of the hood rear support brackets and isolators with an approved multi-purpose, lithium-complex, soap-based grease; see [Table 1](#).
5. Close the hood.

Approved Suppliers of Multi-Purpose Lithium Grease	
Supplier	Grease
Chevron	Delo Heavy Duty EP
Exxon	Unirex EP2
Mobil	Mobil Grease XHP 222
Shell	Retinax LC Grease
Texaco	Starplex 2

Table 1, Approved Suppliers of Multi-Purpose Lithium Grease

