



Table of Contents

4900SF - 123 BBC	6B-2
4900SB - 123 BBC	6B-3
4900SB TS - 123 BBC	6B-4
4900SF LowMax - 123 BBC Car Hauler	6B-5
4900SF EX - 132 BBC	6B-6

Section

6B

4900 123/132 BBC Model Layouts

This guide is to be used as a reference document only.
Please consult your Western Star CAE representative on
specific spec'ing needs as the information contained in
this document can change without notice.

4900SF - 123 BBC

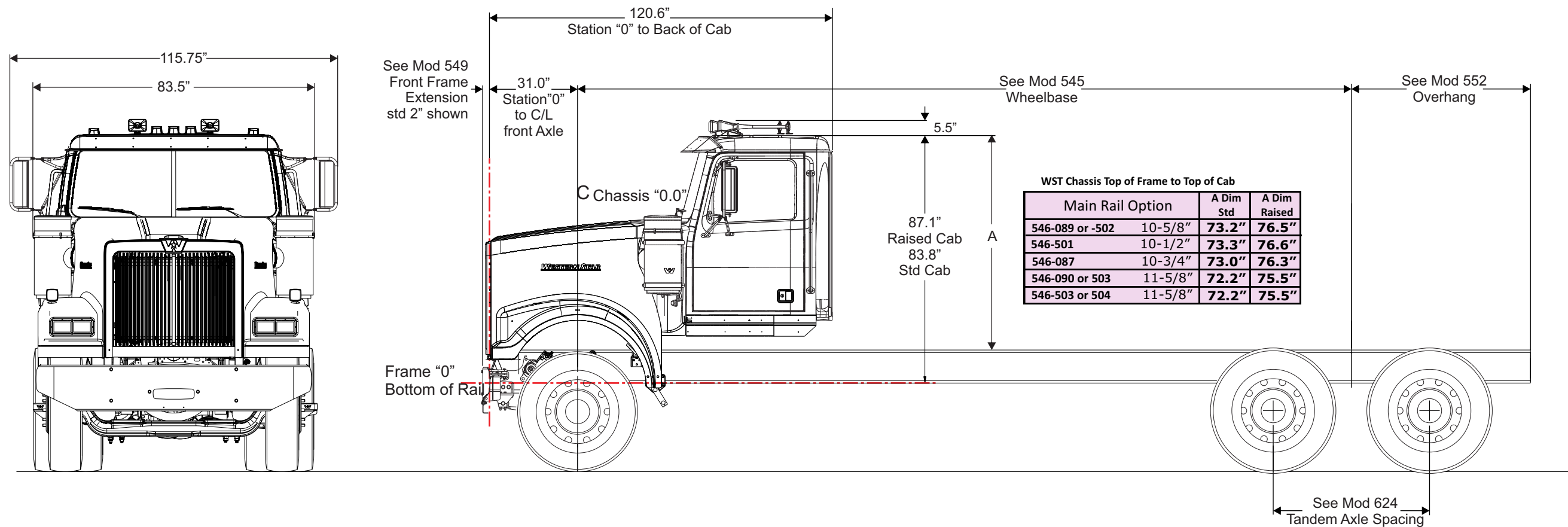
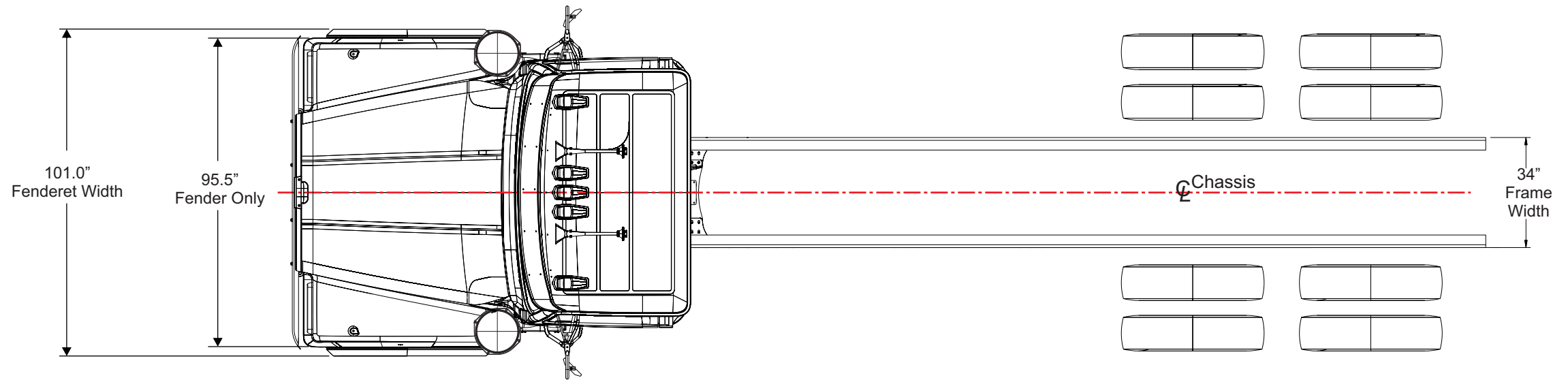

See Mod 624
Tandem Axle Spacing

4900SB - 123 BBC

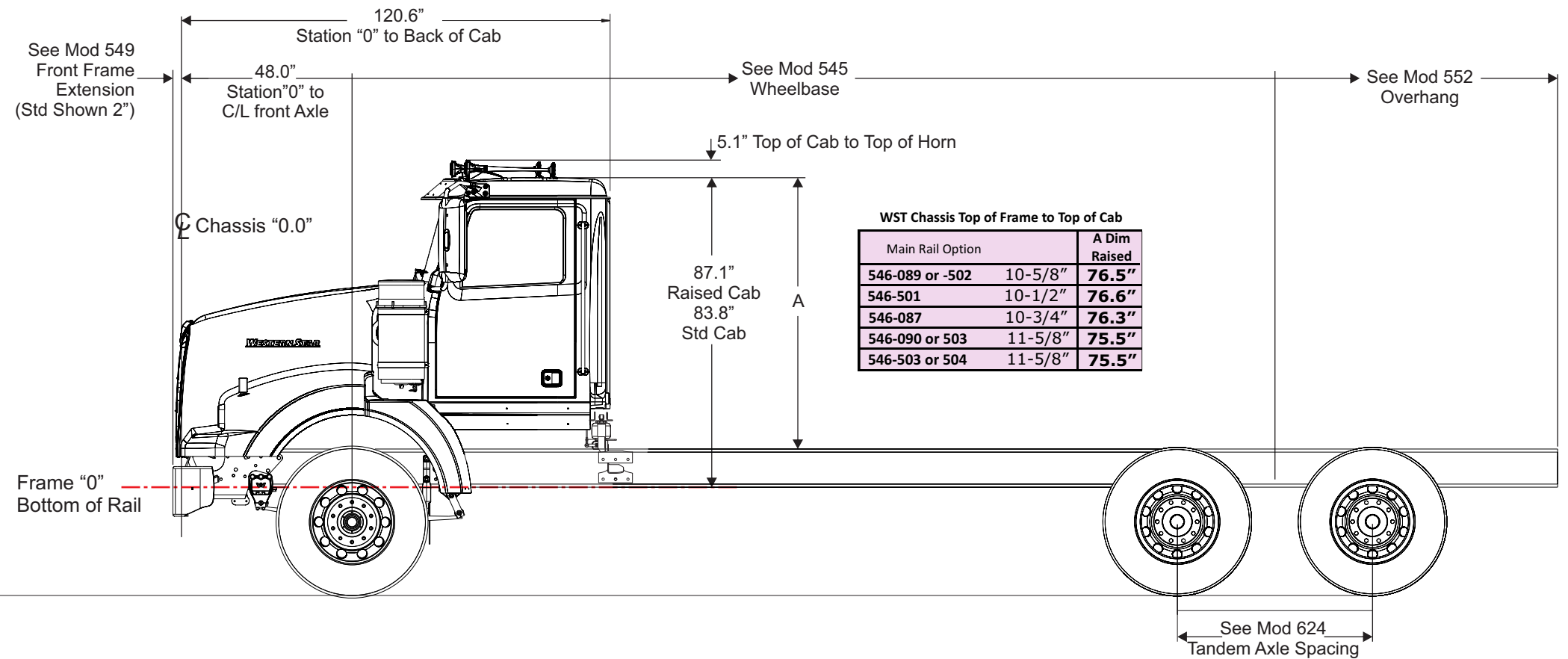
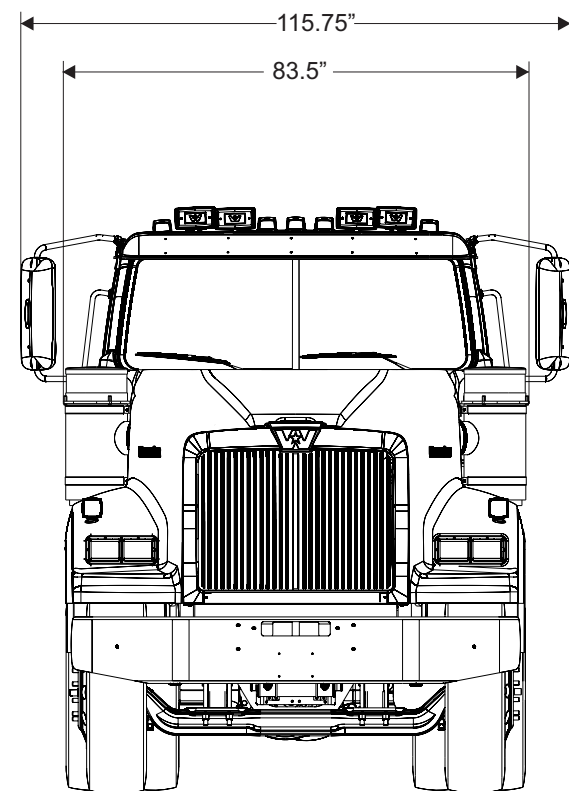
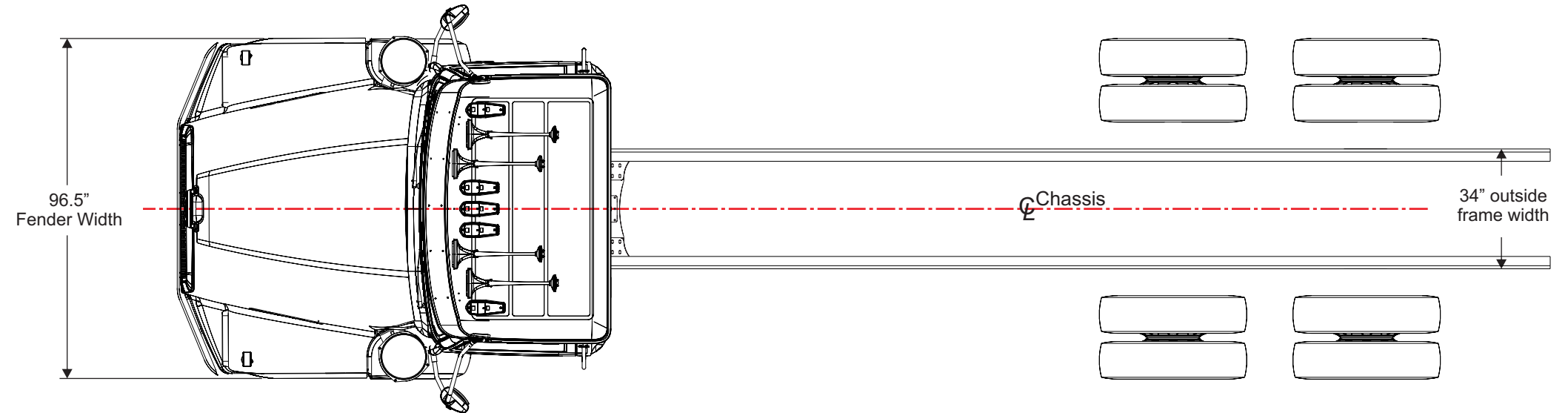

4900SB TS - 123 BBC

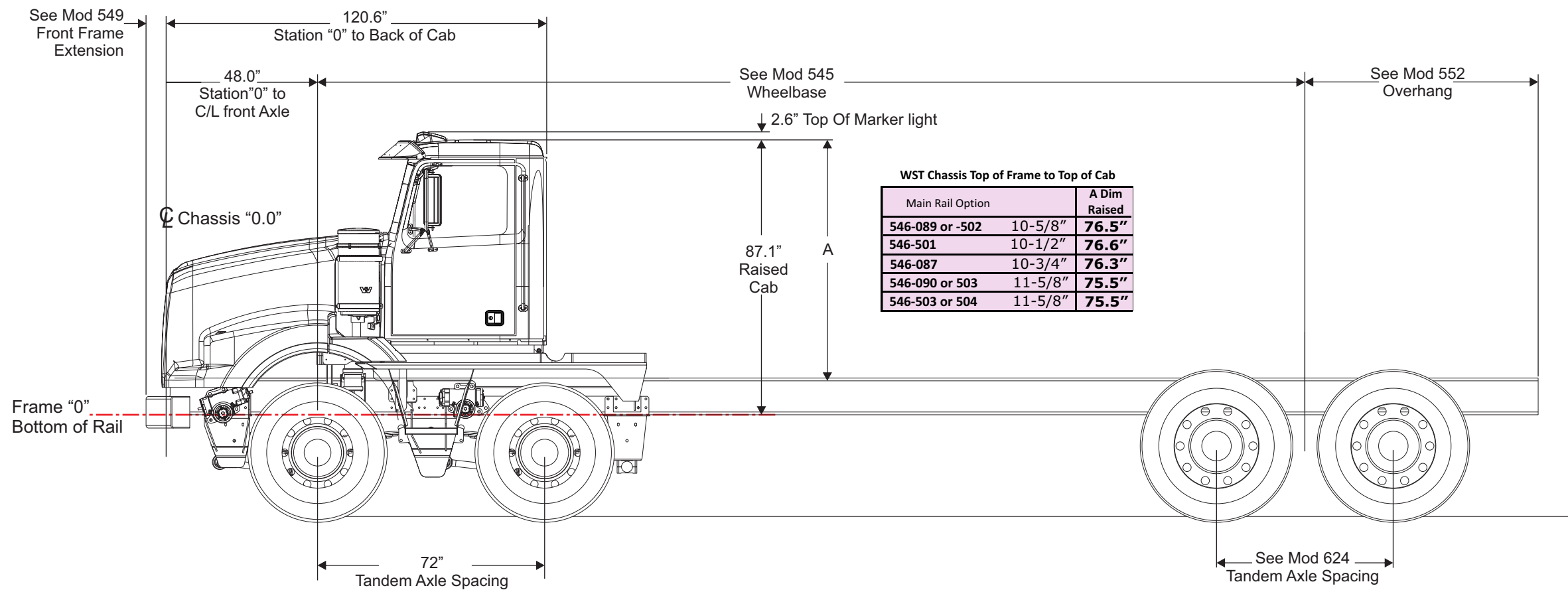
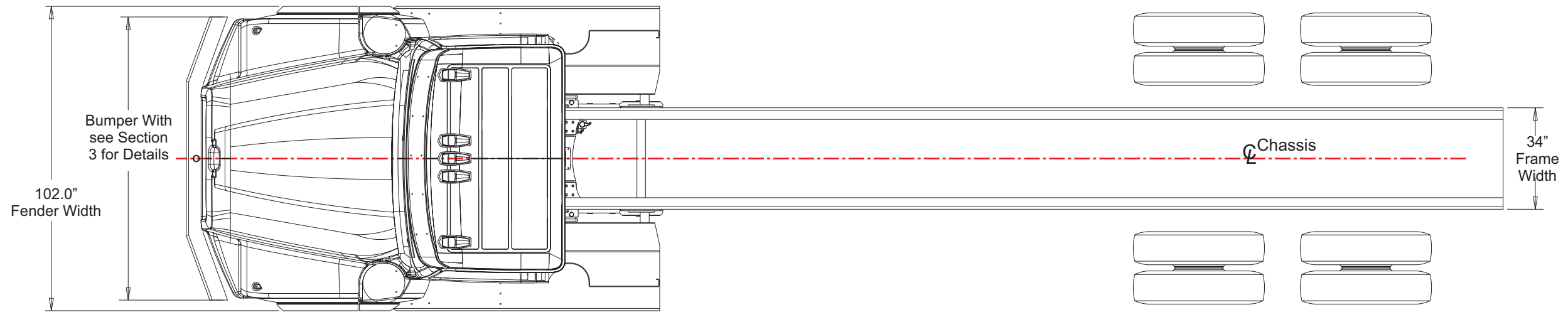



Western Star Bodybuilder Book: Revision 3.1

4900SF LowMax - 123 BBC Car Hauler

6B
P. 6B-5



- 063-047 Western star car hauler package (EPA 2010) **621-046 AIRLINER MID POSITION RIDE HEIGHT (6.3" Laden)**
- 063-048 LowMax 4900EX ISX Package (EPA 2010) **621-046 AIRLINER MID POSITION RIDE HEIGHT (6.3" Laden)**
- 063-049 MidMax 4900EX ISX Package (EPA 2010) **621-007 AIRLINER HIGH POSITION RIDE HEIGHT (10" Laden)**
- 063-050 MidMax 4900FA ISX Package (EPA 2010) **621-007 AIRLINER HIGH POSITION RIDE HEIGHT(10" Laden)**

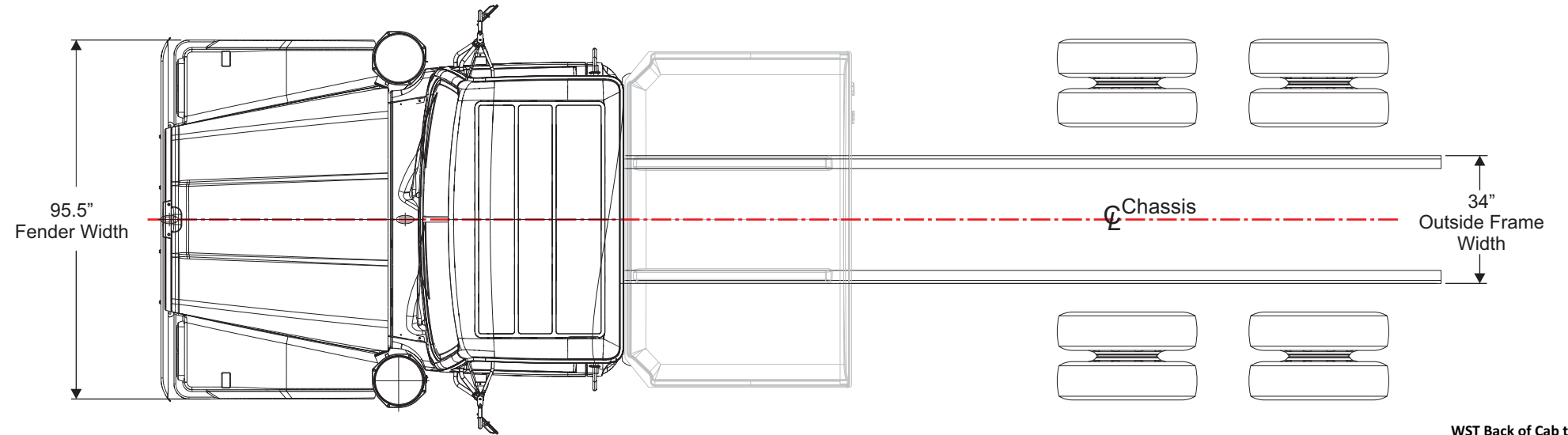

WST Back of Cab to Back of Sleeper

Sleeper	B Dim Low Roof
40" sleeper	32.3"
54" Sleeper	47.2"
62" Sleeper"	60.3"

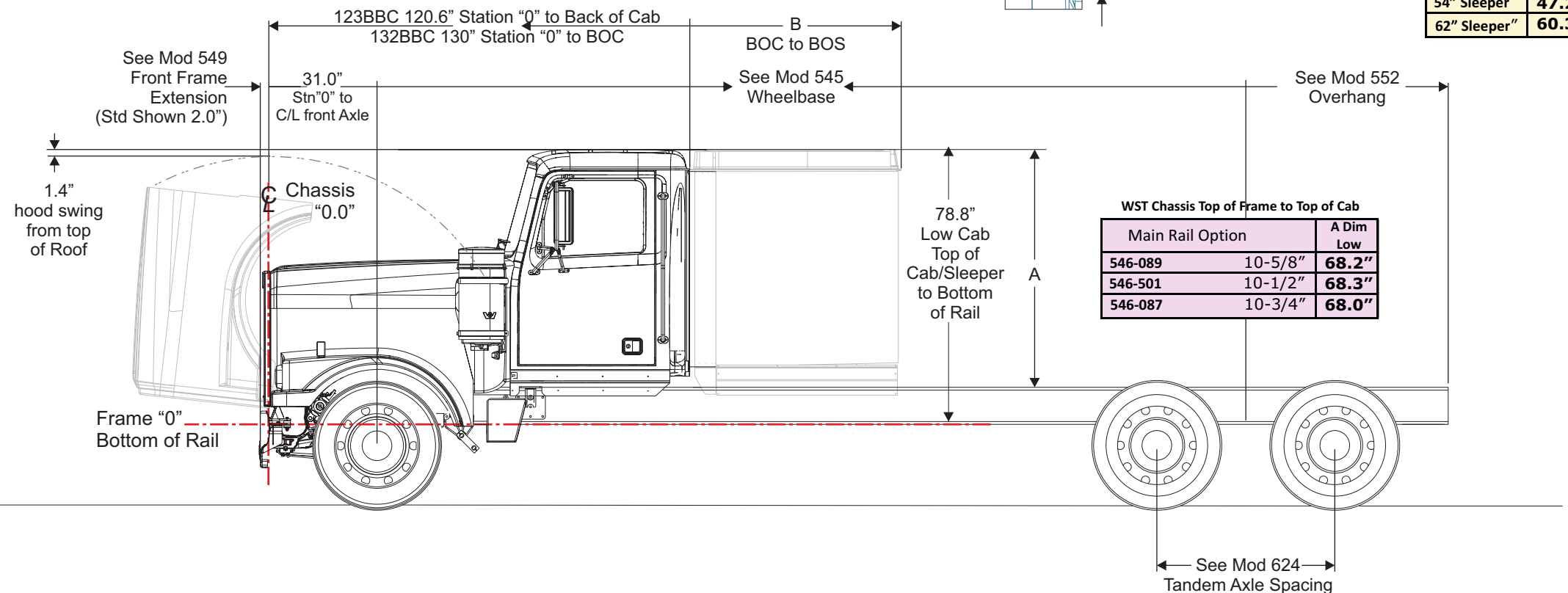
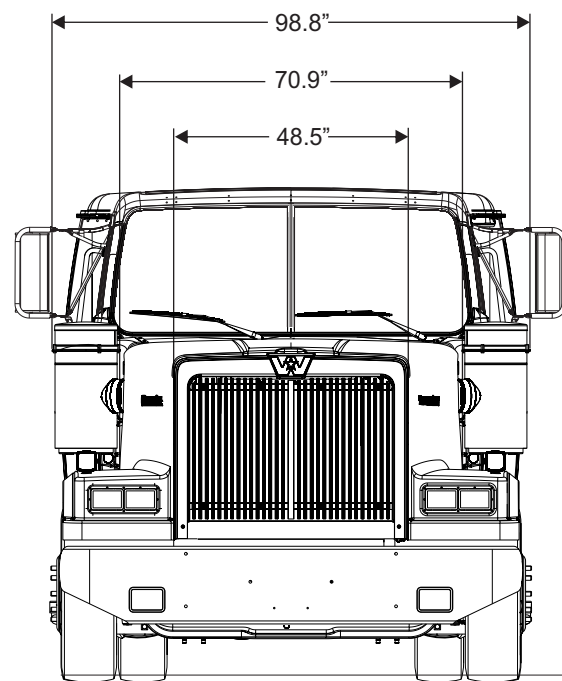

WST Chassis Top of Frame to Top of Cab

Main Rail Option	A Dim Low
546-089 10-5/8"	68.2"
546-501 10-1/2"	68.3"
546-087 10-3/4"	68.0"

4900SF EX - 132 BBC

