

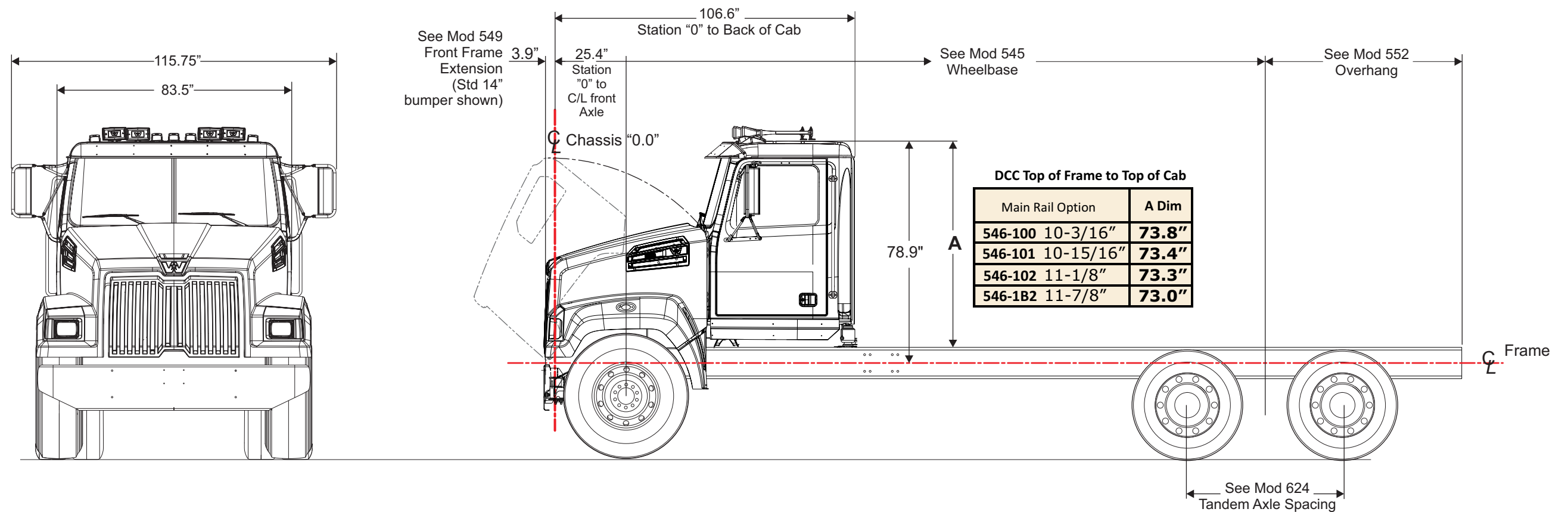
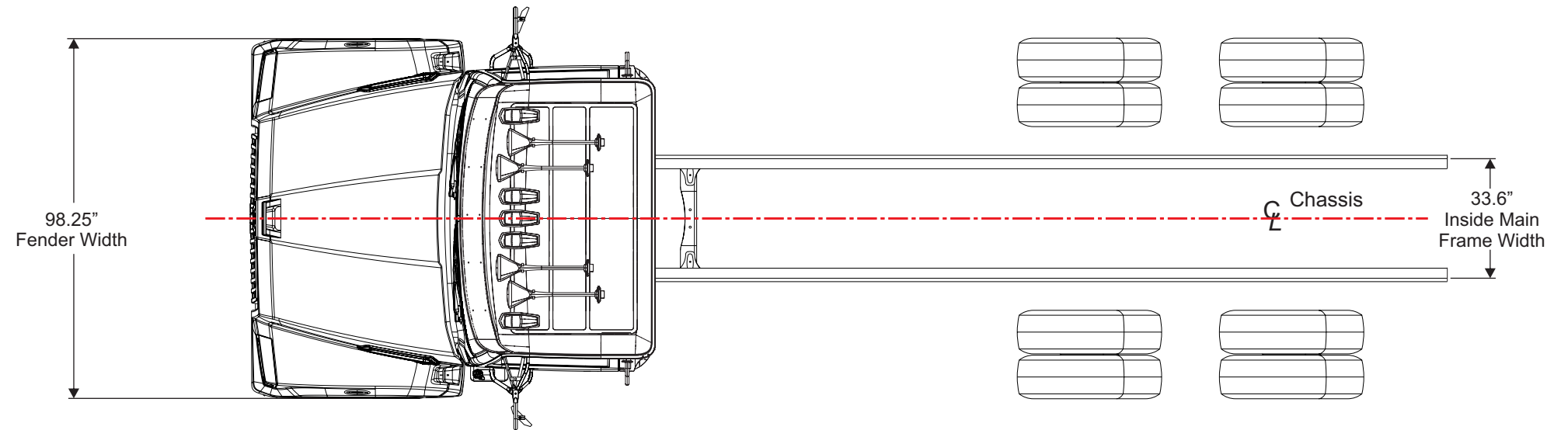

Table of Contents

Section
6A
4700/4800
Model Layouts

4700SF - 110 BBC - Standard Cab	6A-2
4700SB - 110 BBC - Standard Cab	6A-3
4700SB AWD - 110 BBC - Raised Cab <i>New!</i>	6A-4
4800SF - 109 BBC - Standard Cab	6A-5
4800SB - 109 BBC - Standard Cab	6A-6
4800SB - 109 BBC - Raised Cab	6A-7
4800SB AWD - 109 BBC - Raised Cab <i>New!</i>	6A-8
4800SB TS - 109 Tandem Steer Standard Cab	6A-9
4800SF TS - 109 Tandem Steer Raised Cab	6A-10

This guide is to be used as a reference document only.
Please consult your Western Star CAE representative on
specific spec'ing needs as the information contained in
this document can change without notice.



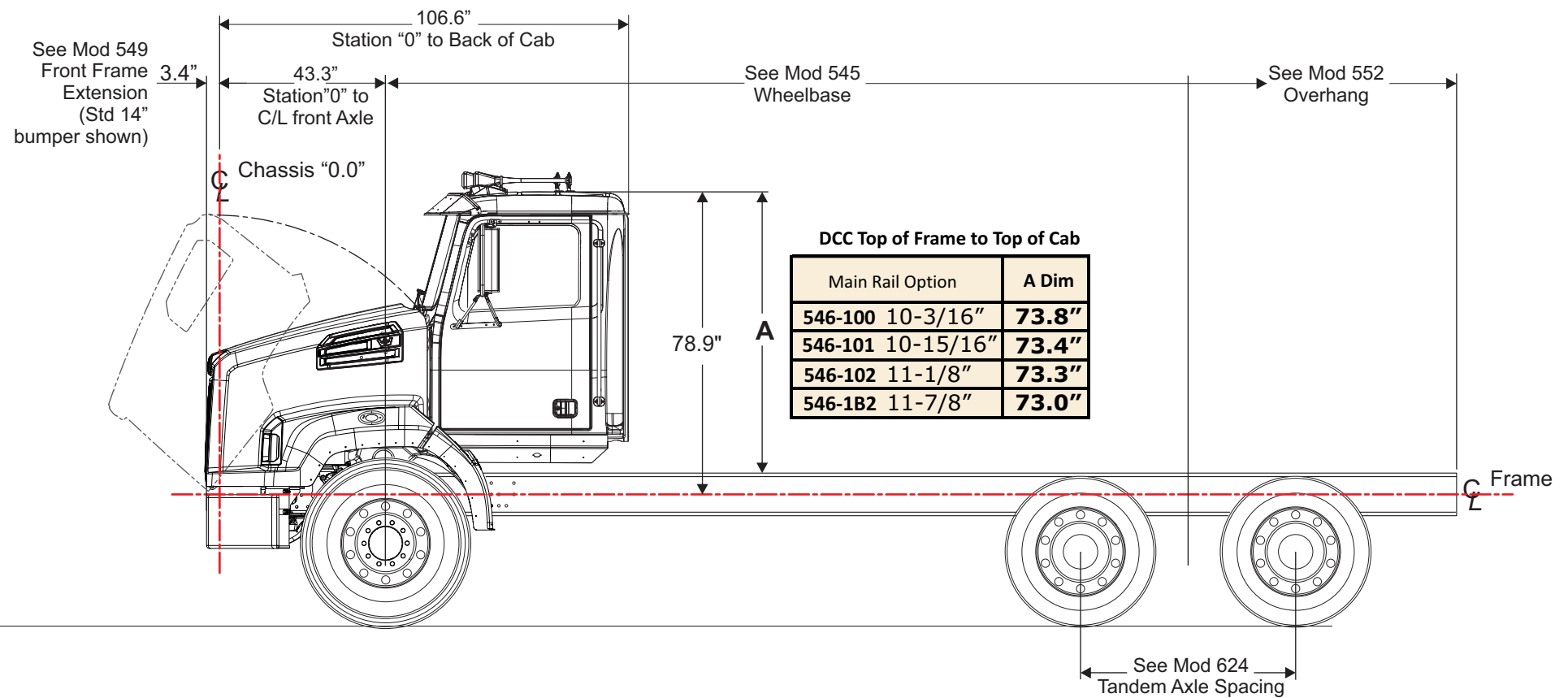
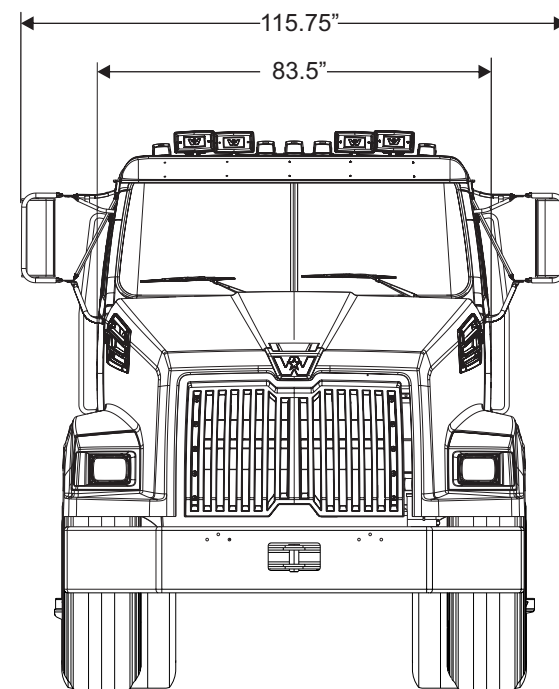
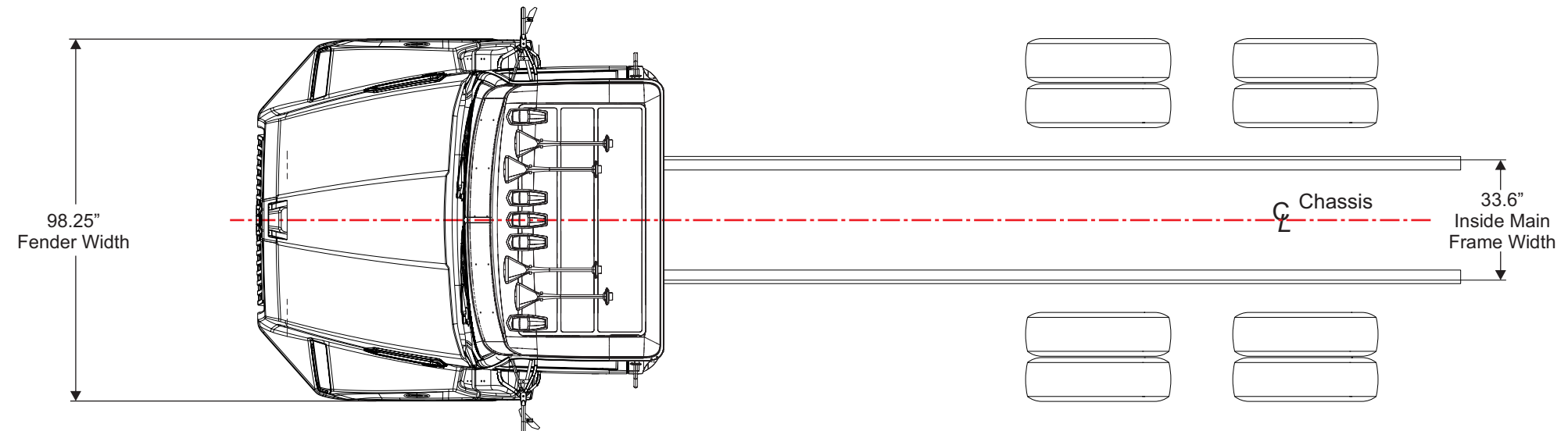

Western Star Bodybuilder Book: Revision 3.1

4700SB AWD - 110 BBC - Raised Cab

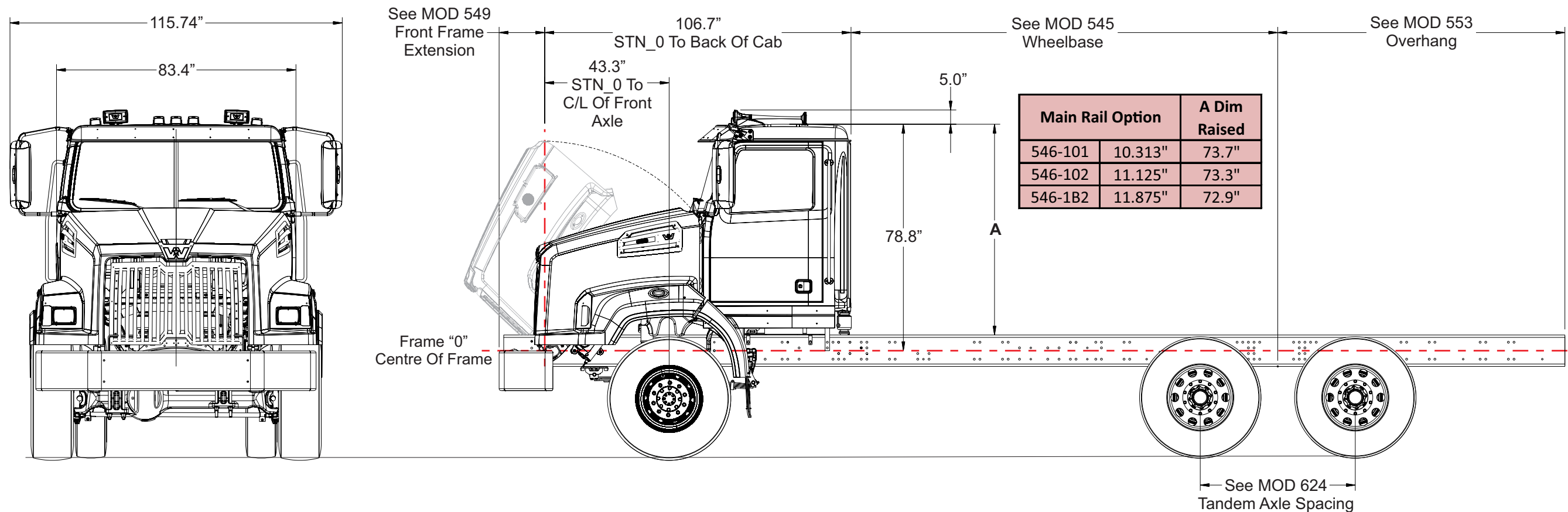
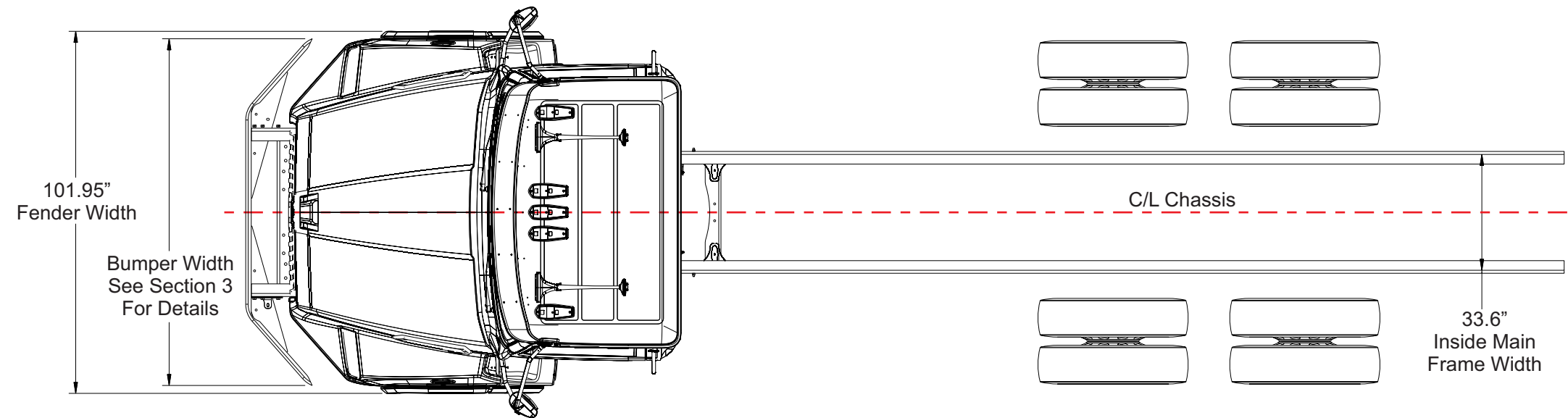

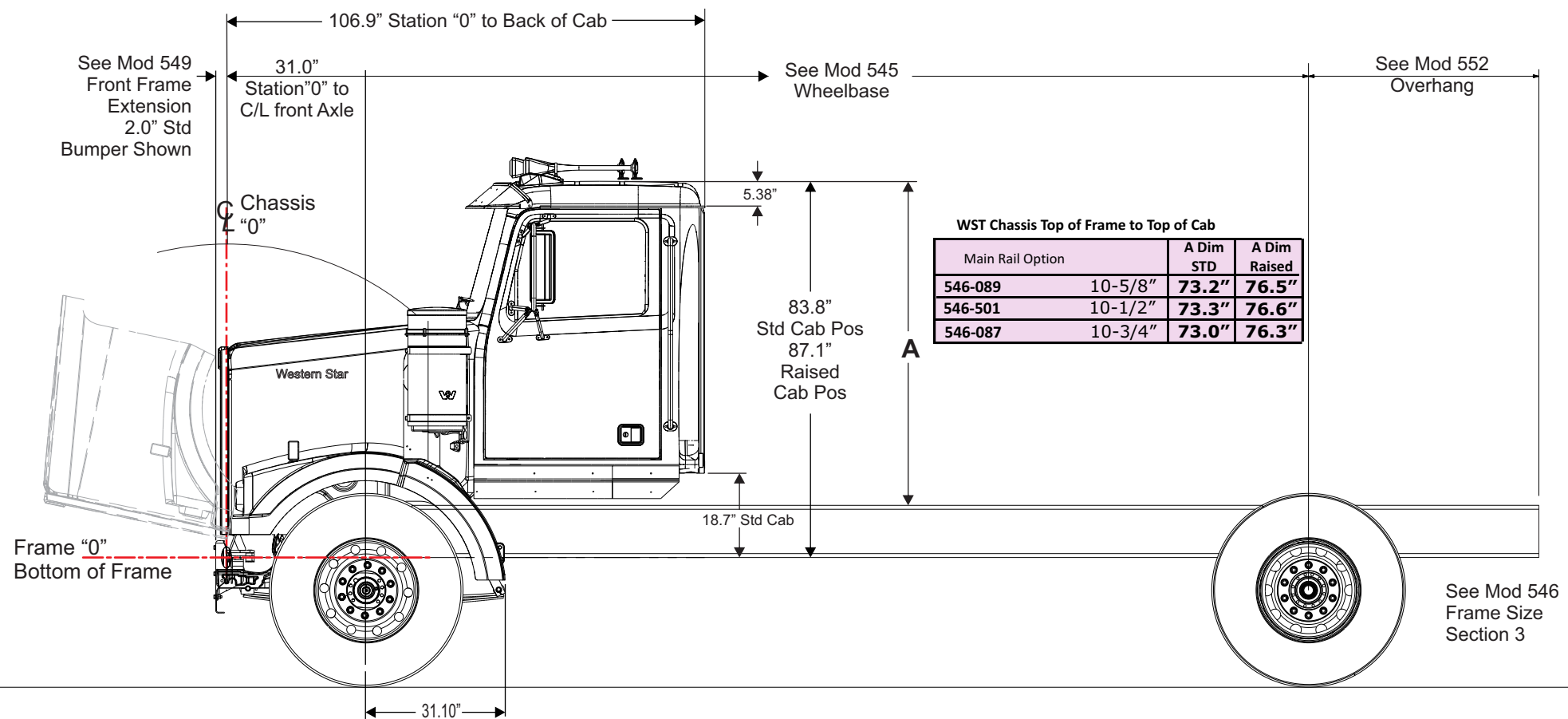
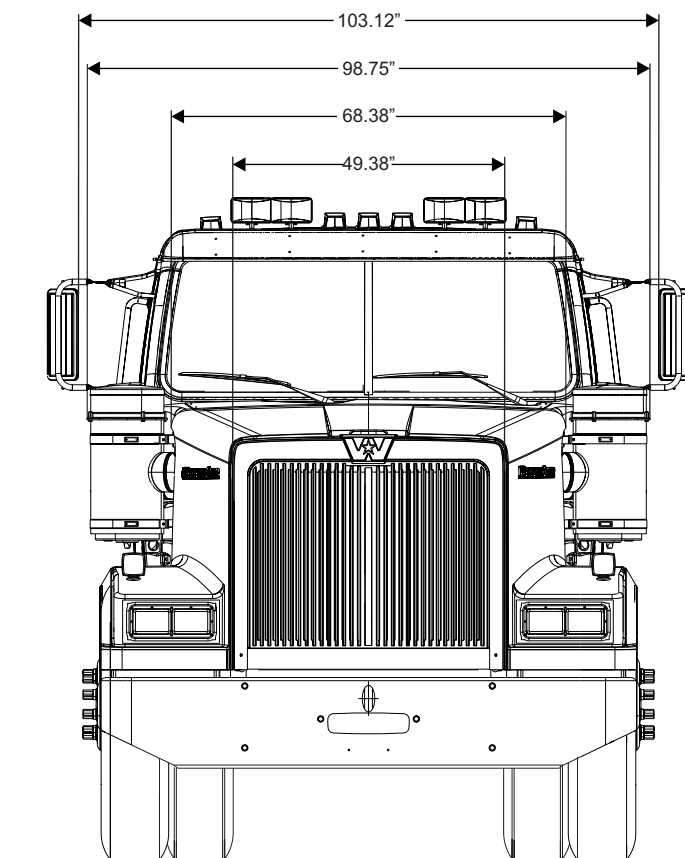
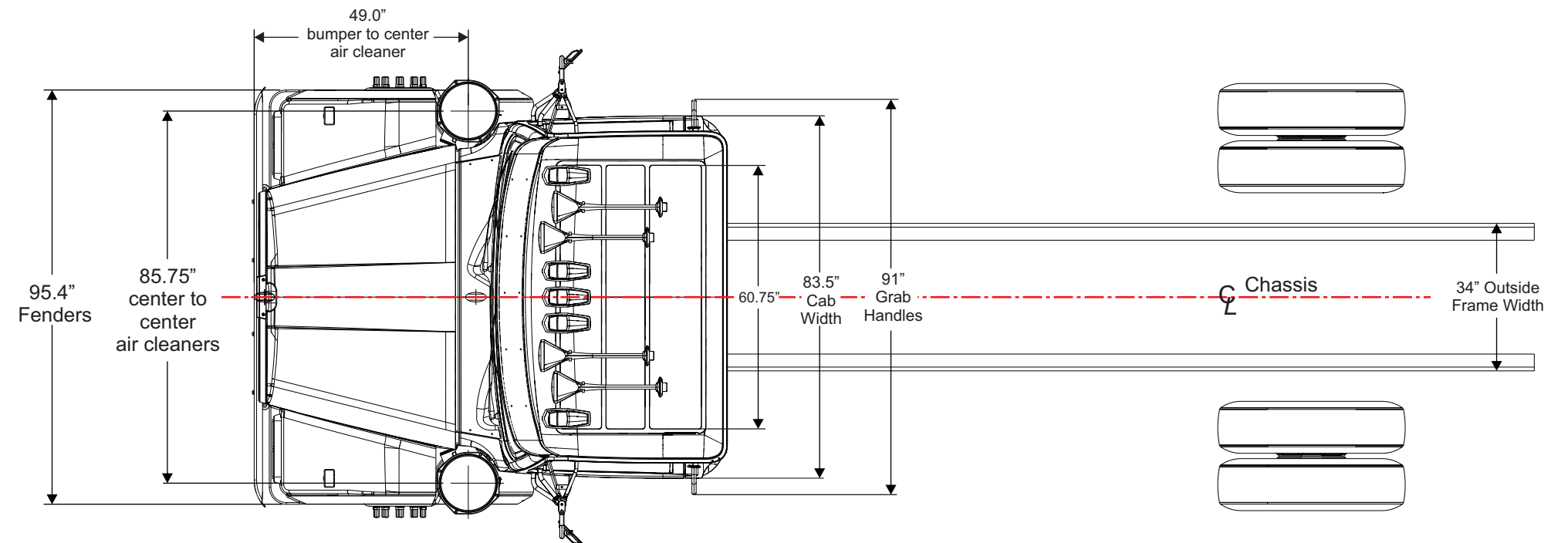

WST Chassis Top of Frame to Top of Cab

Main Rail Option	A Dim STD	A Dim Raised
546-089	10-5/8"	73.2" 76.5"
546-501	10-1/2"	73.3" 76.6"
546-087	10-3/4"	73.0" 76.3"

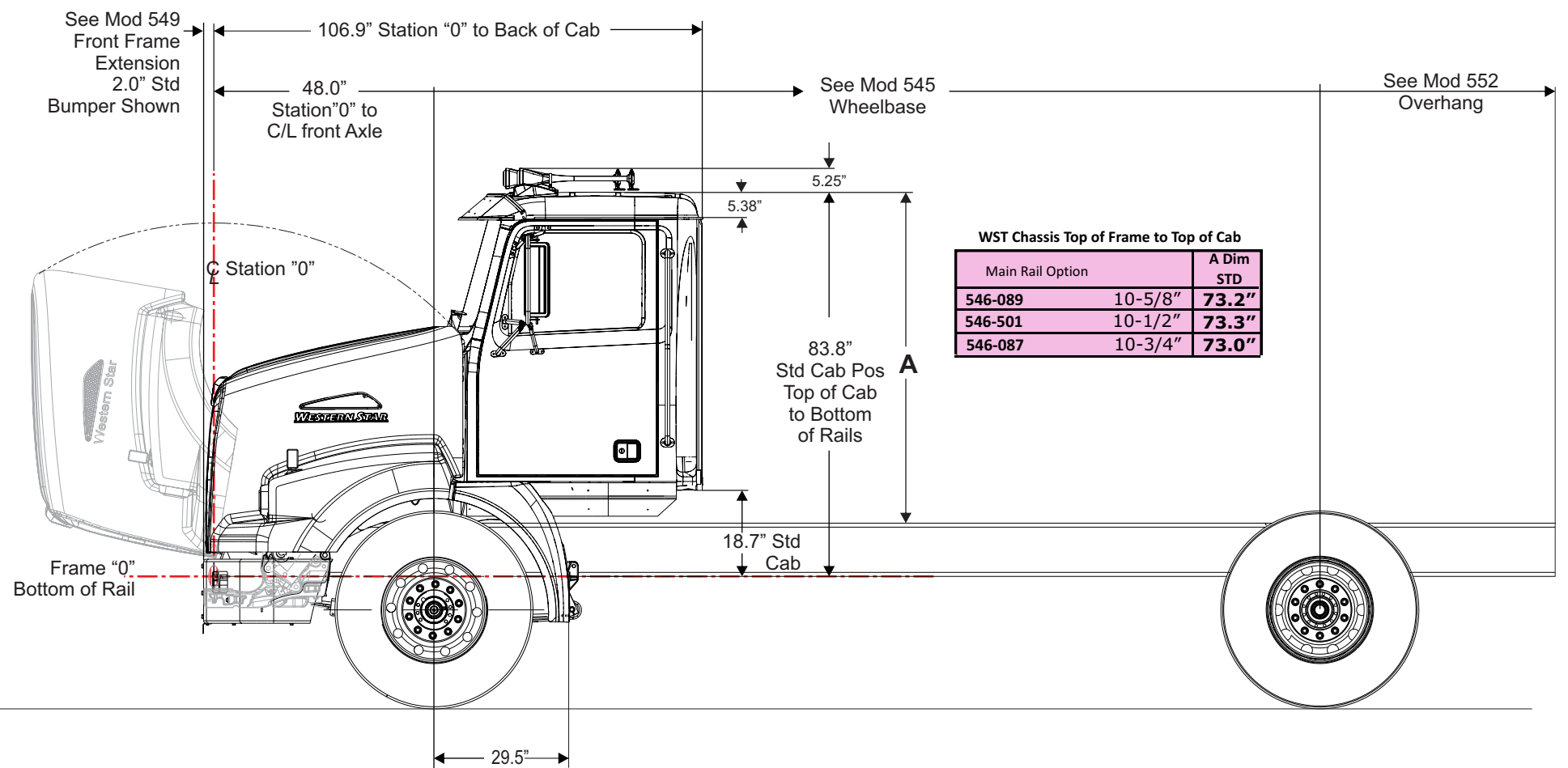
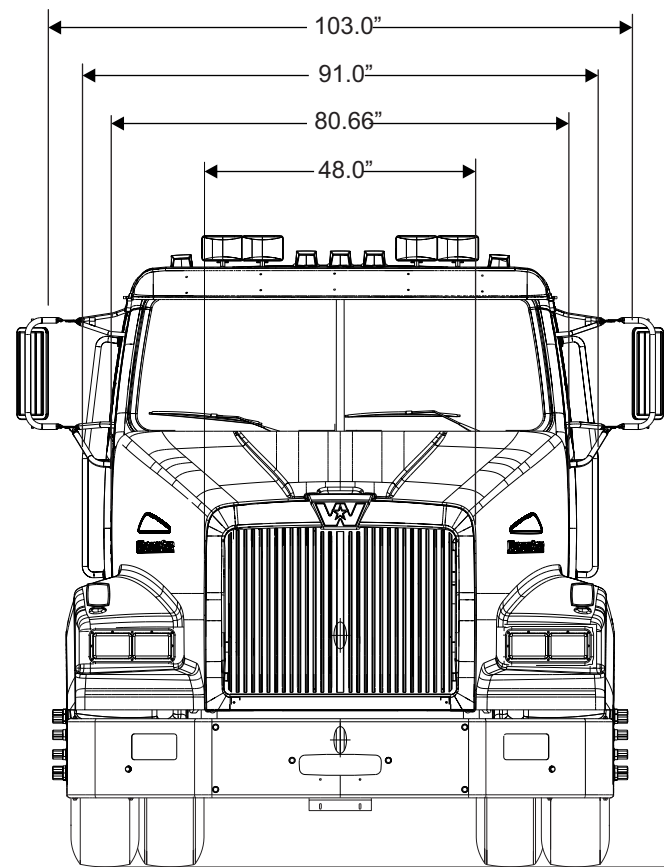
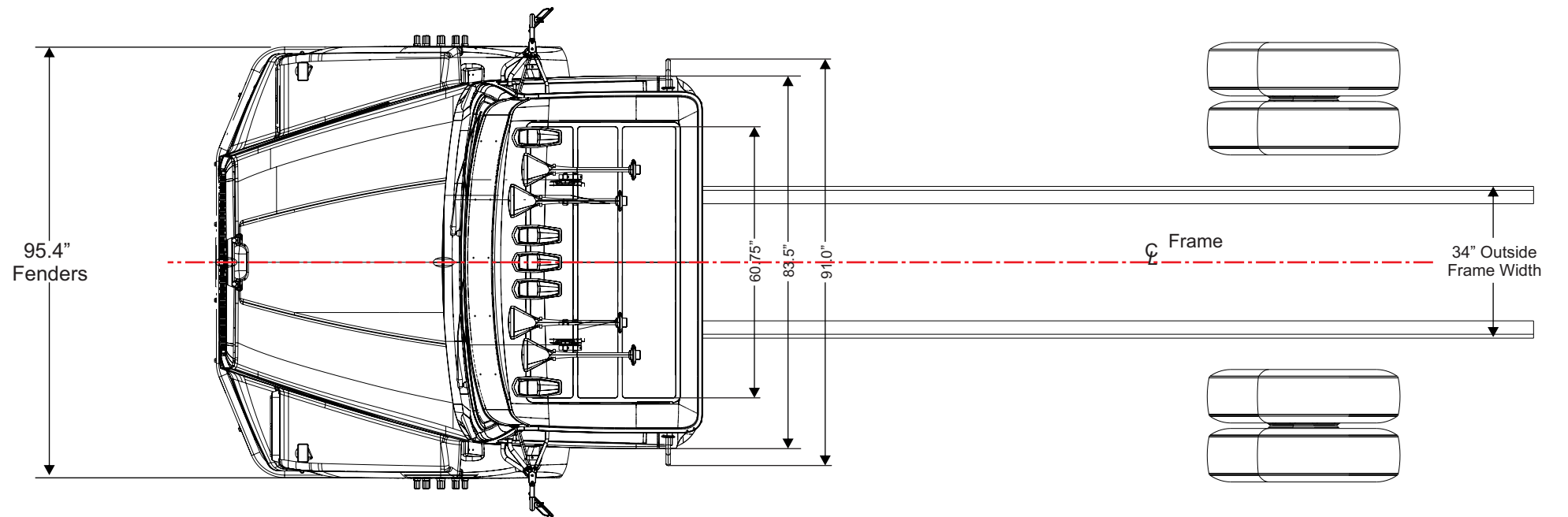



Western Star Bodybuilder Book: Revision 3.1

4800SB - 109 BBC - Raised Cab

6A

P. 6A-7

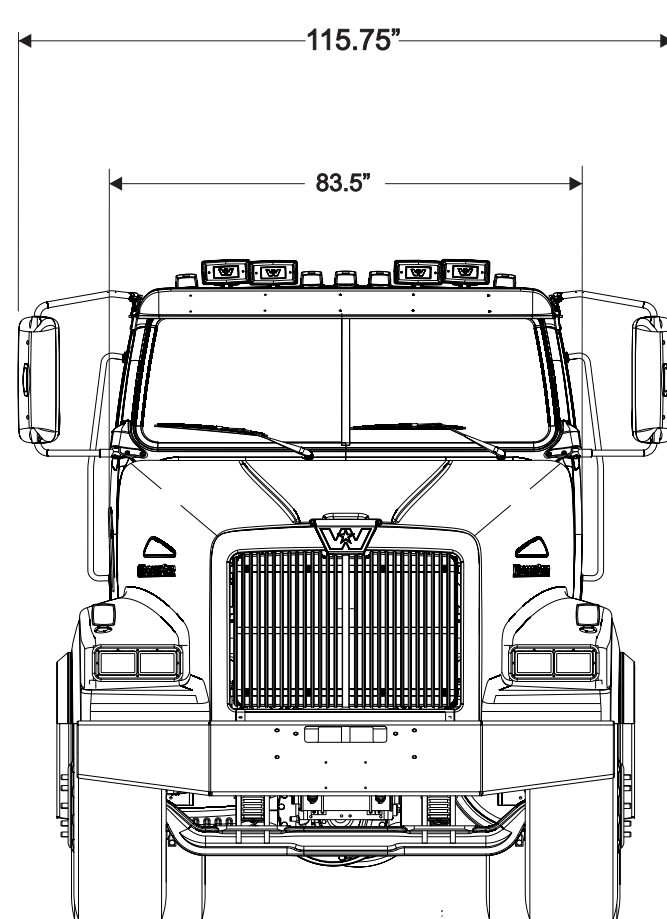
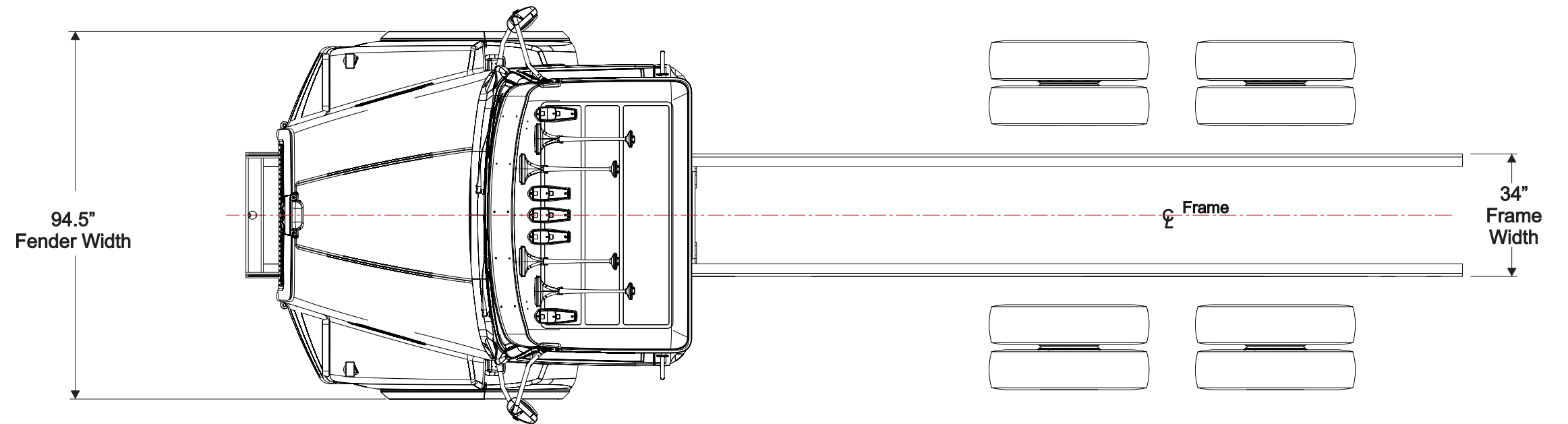

See Mod 549
Front Frame
Extension
(Logger
Shown 10")

106.9"
Station "0" to Back of Cab

48.0"
Station "0" to
C/L front Axle

See Mod 545
Wheelbase

See Mod 552
Overhang

Frame "0"
Bottom of Rail

Station "0"

5.38"

87.1"
Raised
Cab

A

22.1"

WST Chassis Top of Frame to Top of Cab

Main Rail Option	A Dim Raised	A Dim Raised
546-089 or -502	10-5/8"	76.5"
546-501	10-1/2"	76.6"
546-087	10-3/4"	76.3"
546-090 or 503	11-5/8"	75.5"
546-503 or 504	11-5/8"	75.5"

See Mod 624
Tandem Axle Spacing



4800SB AWD - 109 BBC - Raised Cab

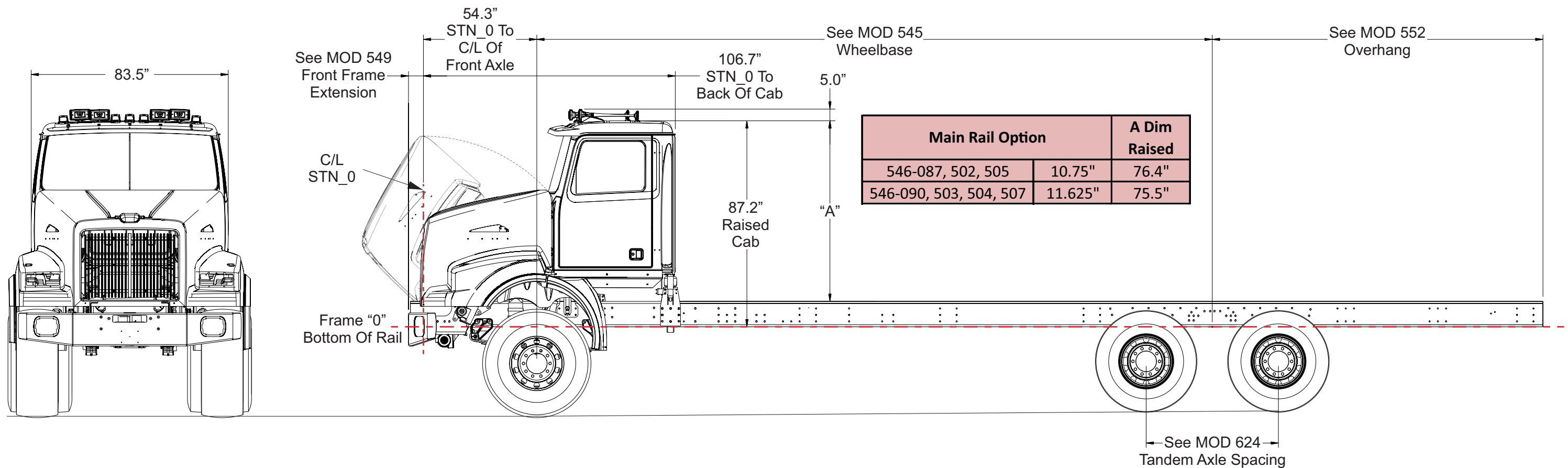
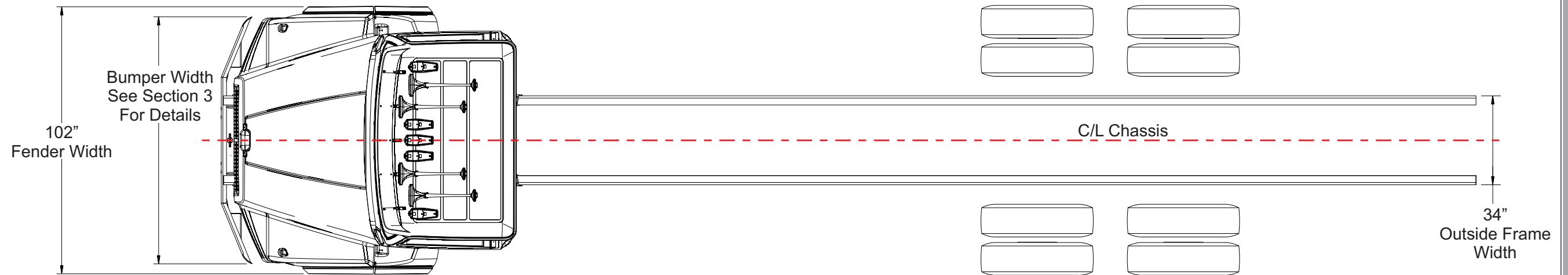



4800SB TS - 109 Tandem Steer Standard Cab

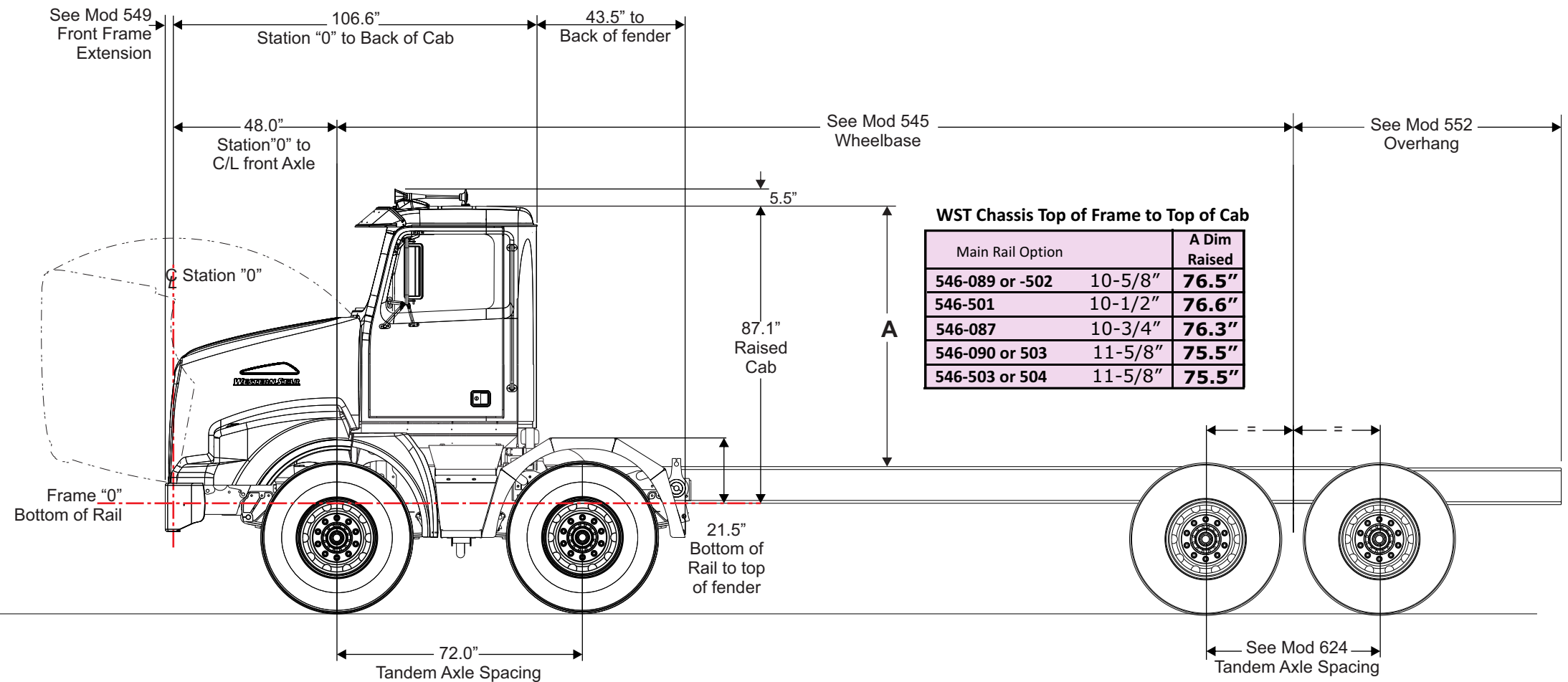
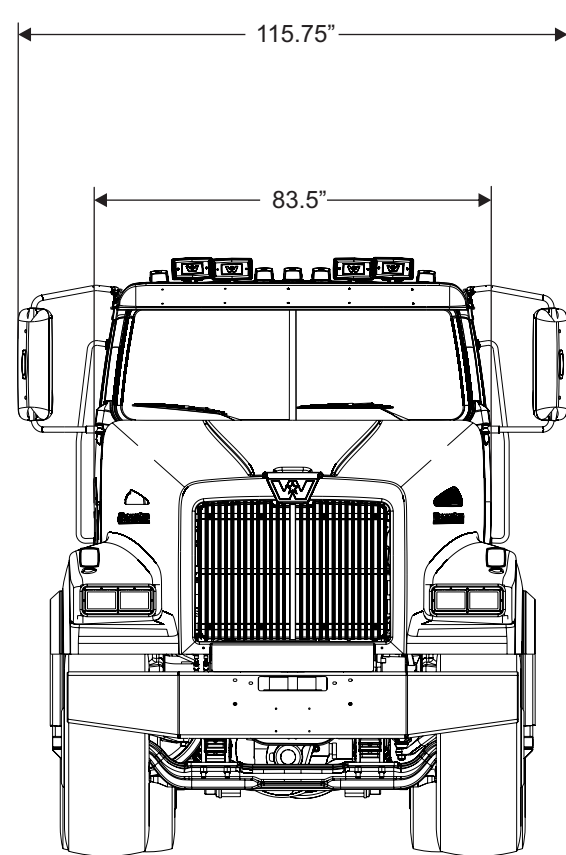
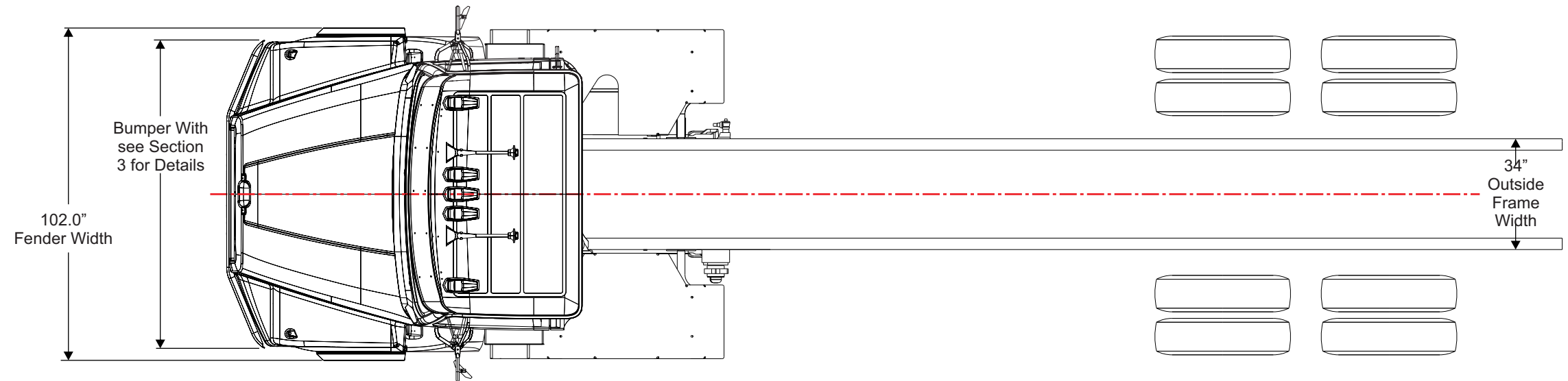

WST Chassis Top of Frame to Top of Cab

Main Rail Option	A Dim	Raised
546-089 or -502	10-5/8"	76.5"
546-501	10-1/2"	76.6"
546-087	10-3/4"	76.3"
546-090 or 503	11-5/8"	75.5"
546-503 or 504	11-5/8"	75.5"

4800SF TS - 109 Tandem Steer Raised Cab

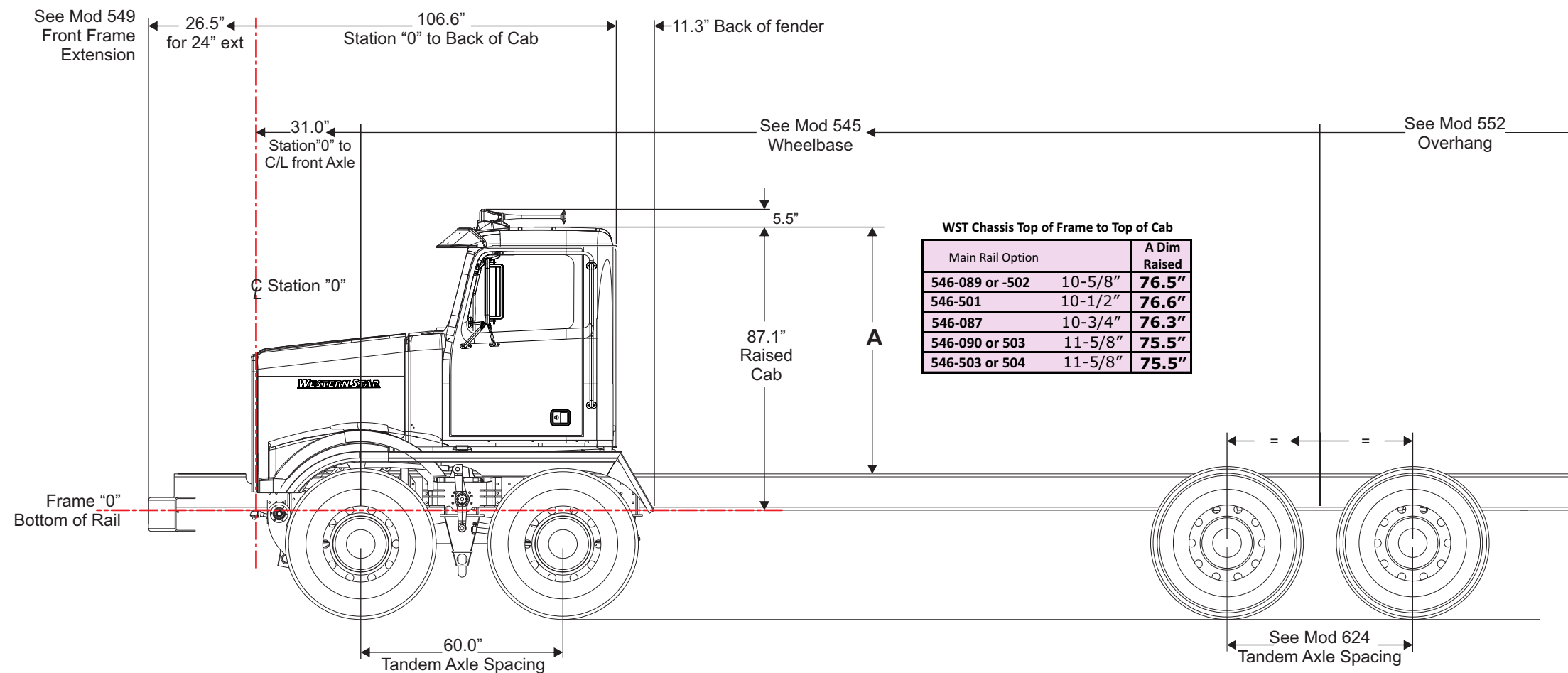
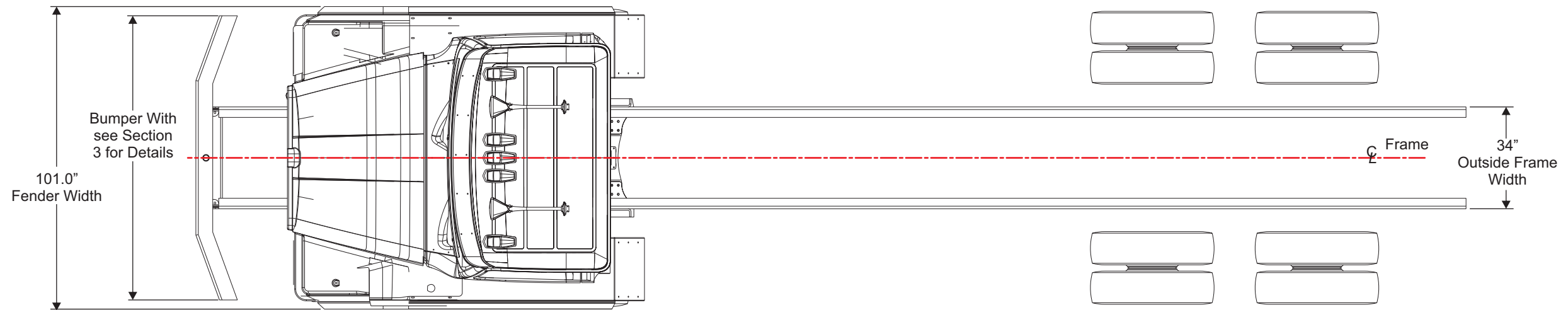

WST Chassis Top of Frame to Top of Cab

Main Rail Option	A Dim	Raised
546-089 or -502	10-5/8"	76.5"
546-501	10-1/2"	76.6"
546-087	10-3/4"	76.3"
546-090 or 503	11-5/8"	75.5"
546-503 or 504	11-5/8"	75.5"