

**TECHNICAL MANUAL
OPERATOR'S MANUAL**

**HYDRAULIC EXCAVATOR
JOHN DEERE
MODEL 230LCR
NSN 3805-01-463-0804**

AND

**MODEL 230LCRD WITH ROCK DRILL
NSN 3805-01-463-0806**

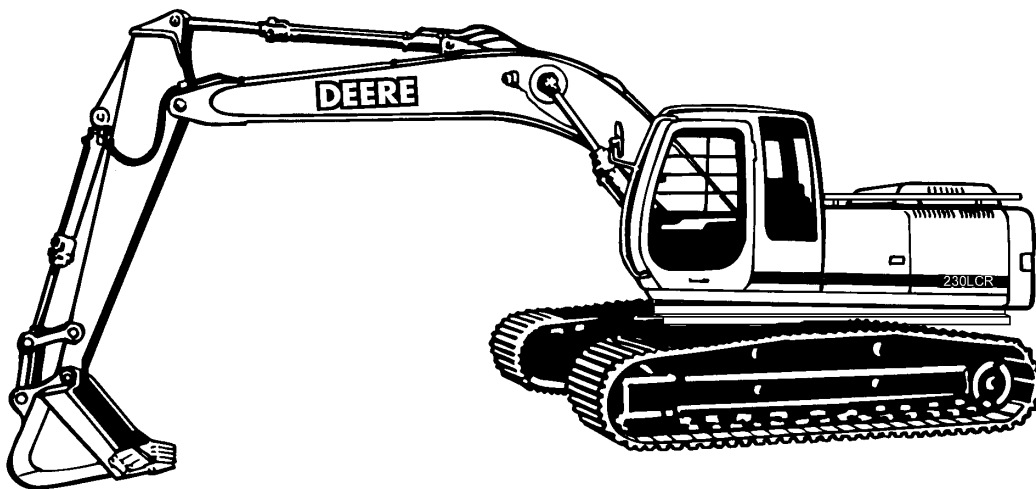

DISTRIBUTION STATEMENT A - Approved for public release; distribution is unlimited.

Reproduced by permission of Deere & Company, Moline, IL © 2000.
All rights reserved.

HEADQUARTERS, DEPARTMENT OF THE ARMY

15 FEBRUARY 2000

INSERT LATEST UPDATED PAGES. DESTROY SUPERSEDED DATA.

LIST OF EFFECTIVE PAGES

Note: The portion of text or illustration affected by the updates is indicated by a vertical line in the outer margins of the page. Updates to wiring diagrams are indicated by shaded areas.

Dates of issue for original and updated pages are:

Original .. 0 .. 15 February 2000

TOTAL NUMBER OF PAGES IS 397 CONSISTING OF THE FOLLOWING:

Page No.	*Revision No.	Page No.	*Revision No.	Page No.	*Revision No.
Cover.....	0	12-6 blank.....	0		
A.....	0	13-1 — 13-3.....	0		
B blank	0	13-4 blank.....	0		
i — xi	0	14-1 — 14-10	0		
xii blank	0	15-1 — 15-8.....	0		
1-1 — 1-37	0	16-1 — 16-8.....	0		
1-38 blank	0	17-1 — 17-8.....	0		
2-1 — 2-30	0	18-1 — 18-11	0		
3-1 — 3-3	0	18-12 blank.....	0		
3-4 blank	0	19-1 — 19-12	0		
4-1	0	20-1 — 20-28	0		
4-2 blank	0	21-1 — 21-31	0		
5-1 — 5-11	0	21-32 blank.....	0		
5-12 blank	0	22-1 — 22-18	0		
6-1 — 6-8.....	0	23-1 — 23-5.....	0		
7-1 — 7-55	0	23-6 blank.....	0		
7-56 blank	0	24-1 — 24-8.....	0		
8-1 — 8-14	0	A-1 — A-25.....	0		
9-1 — 9-12	0	A-26 blank	0		
10-1 — 10-4	0	B-1 — B-4.....	0		
11-1 — 11-7	0	C-1 — C-3	0		
11-8 blank	0	C-4 blank	0		
12-1 — 12-5	0				

*Zero in this column indicates an original page.

BLANK

OPERATOR'S MANUAL

**HYDRAULIC EXCAVATOR
JOHN DEERE
MODEL 230LCR
NSN 3805-01-463-0804**

AND

**MODEL 230LCRD WITH ROCK DRILL
NSN 3805-01-463-0806**

REPORTING ERRORS AND RECOMMENDING IMPROVEMENTS

You can help improve this publication. If you find any mistakes or if you know of a way to improve the procedures, please let us know. Submit your DA Form 2028-2 (Recommended Changes to Equipment Technical Publications), through the Internet, on the Army Electronic Product Support (AEPS) website. The Internet address is <http://aeprs.ria.army.mil>. If you need a password, scroll down and click on "ACCESS REQUEST FORM". The DA Form 2028 is located in the ONLINE FORMS PROCESSING section of the AEPS. Fill out the form and click on SUBMIT. Using this form on the AEPS will enable us to respond quicker to your comments and better manage the DA Form 2028 program. You may also mail, fax or email your letter, DA Form 2028, or DA Form 2028-2 direct to: Commander, U.S. Army Tank-automotive and Armaments Command, ATTN: AMSTA-LC-CI, Rock Island, IL 61299-7630. The email address is AMSTA-LC-CI@ria.army.mil. The fax number is DSN 793-0726 or Commercial (309) 782-0726.

DISTRIBUTION STATEMENT A - Approved for public release; distribution is unlimited.

NOTE

As this operator manual is a commercial product supplemented to include Army specific procedures, the manual may advise the operator to perform tasks that would normally not be assigned to the operator level in a DATM. Always follow the limits established in the PMCS. Also, references are made throughout the manual to see your authorized dealer or John Deere dealer for repair or information. In those instances, notify your supervisor or next higher maintenance level.

TABLE OF CONTENTS

	Page
Introduction	
Chapter 1 Safety and Safety Signs	
John Deere Excavator Safety Features	1-1
Recognize Safety Information.....	1-2
Understand Signal Words.....	1-2
Follow Safety Instructions	1-2
Avoid Injury From: Loading Machine on a Trailer, Fastening Machine to Trailer, and Unloading Machine From Trailer.....	1-3

TABLE OF CONTENTS (Continued)

	Page
Avoid Injury From Backover Accidents	1-4
Avoid Injury From Rollaway Accidents	1-5
Inspect Machine	1-5
Use Handholds and Steps	1-6
Use Seat Belt	1-6
Maintain Seat Belt	1-7
Move and Operate Machine Safely	1-7
Operate Only From Operator’s Seat	1-8
Secondary Exits	1-8
Operate Machine Safely	1-8
Dig With Caution	1-9
Operate With Caution	1-9
Avoid Tipping	1-9
Avoid Power Lines	1-10
Drive Machine Safely	1-10
Beware of Exhaust Fumes	1-10
Park Machine Safely	1-11
Keep Riders Off Machine	1-11
Operate Attachment Safely	1-12
Handle Fluids Safely—Avoid Fires	1-12
Prepare for Emergencies	1-13
Handle Starting Fluid Safely	1-13
Clean Trash From Machine	1-14
Protect Against Flying Debris	1-14
Wear Protective Clothing	1-14
Protect Against Noise	1-15
Handle Chemical Products Safely	1-15
Warn Others of Service Work	1-16
Stay Clear of Moving Parts	1-16
Support Machine Properly	1-17
Service Cooling System Safely	1-17
Practice Safe Maintenance	1-18
Remove Paint Before Welding or Heating	1-19
Avoid Heating Near Pressurized Fluid Lines	1-19
Avoid High-Pressure Fluids	1-20
Prevent Battery Explosions	1-20
Clean the Machine Regularly	1-21
Store Attachments Safely	1-21
Battery Terminals, Lifting Equipment, Dry Cleaning Solvent and Compressed Air	1-22
Dispose of Waste Properly	1-23
Drilling	1-24
Rock Drill Maintenance	1-24
Emergency Stops	1-25
Safety Signs	1-27

Chapter 2 Operator’s Station

Pedal, Levers and Panels	2-1
Right Front Panel and Right Console Panel	2-2
Monitor Panel	2-3
Engine Coolant Temperature Gauge	2-4
Warm-Up Indicator	2-4
Fuel Gauge	2-4
H/P (High Power) Mode Indicator	2-4
E (Economy) Mode Indicator	2-5
Auto-Idle Indicator	2-5

TABLE OF CONTENTS (Continued)

	Page
Hydraulic Oil Level Indicator	2-5
Hydraulic Oil Filter Restriction Indicator (Model 230LCRD).....	2-6
Fuel Level Indicator	2-6
Air Filter Restriction Indicator	2-6
Engine Coolant Temperature Indicator	2-7
Charge Air Temperature Indicator	2-7
Engine Oil Pressure Indicator.....	2-8
Alternator Voltage Indicator	2-8
Engine Oil Level Indicator	2-8
Coolant Level Indicator.....	2-9
Switch Panel.....	2-10
Buzzer and Buzzer Stop Switch	2-11
Wiper Switch.....	2-11
Washer Switch.....	2-12
Operating Lights Switch.....	2-12
Operating Rear Lights Switch	2-13
Cab Light.....	2-13
Overload Alarm and Indicator.....	2-13
Key Switch	2-14
Engine RPM Dial	2-14
Power Boost Switch	2-14
Horn	2-15
Hour Meter	2-15
Cab Heater and Air Conditioner.....	2-16
Control Panel Switches	2-17
Cab Heater Operation.....	2-18
Air Conditioner Operation.....	2-18
Defroster Operation.....	2-19
Front Console	2-19
Operating the AM/FM Radio	2-20
Setting the Clock	2-20
Cab Door Release Lever.....	2-21
Secondary Exit Tool.....	2-21
Opening Upper Front (Secondary Exit) Window.....	2-21
Closing Upper Front Window	2-22
Removing and Storing the Lower Front Window	2-23
Opening Side Windows.....	2-23
Opening and Closing the Roof Exit Cover.....	2-24
Removing and Storing Fire Extinguisher (Model 230LCR)	2-24
Rock Drill Start—Stop Selection Control Box (Model 230LCRD)	2-25
Compressor Remote Instrument Control Panel (Model 230LCRD)	2-26
Removing and Storing Rifle.....	2-26
J-Hooks	2-27
Toolbox Security Hasp.....	2-27
Decontamination Kit Bracket.....	2-28
Vandal Protection Panel Storage	2-28
Adjusting the Seat	2-29
Adjusting the Armrest	2-30
Seat Belt	2-30
Operator’s Manual Compartment.....	2-30

Chapter 3 Break-In

Engine Break-In Oil	3-1
Every 4 Hours.....	3-1

TABLE OF CONTENTS (Continued)

	Page
Every 10 Hours or Daily	3-2
After the First 50 Hours.....	3-2
After the First 100 Hours.....	3-3
Chapter 4 Pre-Start Inspection	
Inspect Machine Daily Before Starting	4-1
Chapter 5 Operating the Engine	
Check Instruments Before Starting	5-1
Level Check.....	5-1
Starting the Engine	5-2
Using Booster Batteries—24 Volt System	5-3
Slave Receptacle—24 Volt System.....	5-4
Starting Fluid (Cold Weather Starting Aid)	5-5
Using the Arctic Starter	5-7
Starting the Arctic Starter.....	5-8
Check Instruments After Starting.....	5-8
Warming the Machine	5-9
Cold Weather Warm-Up	5-10
Stopping the Engine	5-11
Chapter 6 Driving the Machine	
Steering the Machine Using Pedals	6-1
Steering the Machine Using Levers	6-3
Removing Propel Levers	6-5
Propel Speed Switch.....	6-6
Travel Alarm and Travel Alarm Cancel Switch	6-6
Parking the Machine.....	6-7
Parking Machine During Freezing Weather	6-8
Lock All Compartments	6-8
Chapter 7 Operating the Machine	
Control Levers.....	7-1
Control Lever Pattern Conversion.....	7-3
Control Levers John Deere Pattern.....	7-5
Pilot Control Shut-Off Lever.....	7-6
Auto-Idle Switch	7-7
Mode Selection Switch.....	7-8
Power Boost Switch	7-8
E (Economy) Mode	7-9
H/P (High Power) Mode	7-10
Standard Mode	7-10
Operating Tips.....	7-11
Driving Machine	7-11
Driving on Slopes.....	7-12
Driving Down a Slope.....	7-12
Driving Up a Slope.....	7-12
Driving Up a Steep or Slippery Slope—Boom on Uphill End of Machine.....	7-13
Driving Up a Steep or Slippery Slope—Boom on Downhill End of Machine	7-13
Moving Machine off an Embankment.....	7-14
Leveling Machine.....	7-15
Using Quick-Disconnect Hitch.....	7-16
Two Way Hydraulic Thumb Foot Pedal (Model 230LCR)	7-20
Using Hydraulic Thumb.....	7-21
Using Bucket.....	7-23

TABLE OF CONTENTS (Continued)

	Page
Planning Spoil Piles	7-25
Trenching	7-25
Backfilling.....	7-27
Truck Loading.....	7-28
Operating in Water and Mud.....	7-29
Clean Track Frame Area	7-29
Lifting.....	7-30
Air Compressor - Operating Instructions	7-32
Using Quick-Coupler Type Attachments	7-37
Rock Drill Attachment (Model 230LCRD).....	7-38
Install Rock Drill.....	7-38
Remove Rock Drill.....	7-41
Operating the Rock Drill Attachment.....	7-43
Remote Control Operator's Panel	7-43
Rod Changer.....	7-45
Start Up	7-49
Travelling	7-50
Drilling	7-51
Shut Down.....	7-53
Lower Boom With Engine Stopped	7-54
Using Hydraulic Hand Tools Hose Reel	7-55
Using Hydraulic Hand Tools Flow Rate Valve and Switch	7-55
Using Hand Held Air Tools.....	7-55
Chapter 8 Transporting	
Loading Machine on a Trailer	8-1
Tiedowns	8-2
Fasten Machine to Trailer	8-3
Loading and Fastening Rock Drill on a Trailer	8-6
Fasten Machine to Rail Car (Model 230LCR)	8-8
Fasten Machine and Rock Drill to Rail Car (Model 230LCRD).....	8-10
Unloading Machine From Trailer.....	8-12
Towing Machine	8-13
Lifting the Machine.....	8-14
Chapter 9 Fuels and Lubricants	
Diesel Fuel	9-1
Lubricity of Diesel Fuels.....	9-1
Low Sulfur Diesel Fuel Conditioner	9-2
Diesel Fuel Storage	9-2
Fuel Tank	9-3
Do Not Use Galvanized Containers	9-3
Diesel Engine and Pump Gearbox Oils	9-4
Hydraulic Oil.....	9-5
Swing Gearbox and Propel Gearbox Oils.....	9-6
Track Roller, Front Idler, and Carrier Roller Oil	9-6
Track Adjuster, Working Tool Pivot, Swing Bearing, and Swing Bearing Gear Grease	9-7
Oil Filters	9-7
Rock Drill Lubricants Specifications	9-8
Air Compressor Lubricants	9-10
Lubricant Storage	9-11
Alternative and Synthetic Lubricants	9-11
Mixing of Lubricants.....	9-12
Factory/Initial Fill Lubricants	9-12

TABLE OF CONTENTS (Continued)

	Page
Chapter 10 Periodic Maintenance—Excavator	
Service Your Machine at Specified Intervals	10-1
Check the Hour Meter Regularly	10-1
Use Correct Fuels and Lubricants	10-1
Prepare Machine for Maintenance.....	10-2
Open Access Doors for Service.....	10-3
Open Hood for Service.....	10-4
Chapter 11 Maintenance—As Required	
Sampling Engine Oil (GRP NO. 0400)	11-1
Sampling Hydraulic Oil (GRP NO. 3360)	11-2
Clean Fuel Tank Inlet Screen (GRP NO. 0560).....	11-3
Drain Fuel Tank Sump (GRP NO. 0560).....	11-3
Clean Radiator Air Inlet Screens (GRP NO. 0511).....	11-4
Drain Water Separator (GRP NO. 0560).....	11-4
Clean Air Cleaner Dust Unloader Valve (GRP NO. 0521).....	11-5
Check Track Sag (GRP NO. 0132)	11-5
Adjusting Track Sag (GRP NO. 0132).....	11-6
Windshield Washer Fluid Level.....	11-7
Chapter 12 Maintenance—Every 10 Hours or Daily	
Check Engine Oil Level (GRP NO. 0400)	12-1
Check Recovery Tank Coolant Level (GRP NO. 0510).....	12-2
Check Hydraulic Oil Level (GRP NO. 3360)	12-3
Chapter 13 Maintenance—Every 50 Hours	
Grease Working Tool Pivots (GRP NO. 3302).....	13-1
Chapter 14 Maintenance—Every 250 Hours	
Check Swing Gearbox Oil Level (GRP NO. 4351).....	14-1
Drain Hydraulic Tank Sump (GRP NO. 3364)	14-1
Check Pump Drive Gearbox Oil Level (GRP NO. 3361)	14-2
Change Engine Oil and Replace Filter (GRP NO. 0407)	14-3
Check Radiator Coolant Level	14-5
Check Battery Electrolyte Level and Terminals (GRP NO. 1671).....	14-6
Check Propel Gearbox Oil Level (GRP NO. 0250)	14-8
Clean Dusty Primary Element (GRP NO. 0521).....	14-9
Inspect Element (GRP NO. 0521).....	14-10
Chapter 15 Maintenance—Every 500 Hours	
Grease Swing Bearing (GRP NO. 4353).....	15-1
Grease Swing Bearing Gear (GRP NO. 4353).....	15-2
Replace Final Fuel Filter (GRP NO. 0420).....	15-3
Replace Primary Fuel Filter (Water Separator) (GRP NO. 0560).....	15-4
Check Air Intake Hoses (GRP NO. 0521).....	15-5
Replace Hydraulic Oil Filter (GRP NO. 3360)	15-6
Add Coolant Conditioner to Radiator (GRP NO. 0510)	15-8
Chapter 16 Maintenance—Every 1000 Hours	
Change Swing Gearbox Oil (GRP NO. 4351).....	16-1
Change Pilot Control Oil Filter (GRP NO. 3362)	16-1
Change Pump Drive Gearbox Oil (GRP NO. 3360)	16-2
Clean the Engine Crankcase Ventilation Tube.....	16-3
Check and Adjust Engine Valve Lash (Clearance)	16-3
Firing Order 6-Cylinder Engine	16-5

TABLE OF CONTENTS (Continued)

	Page
Check Engine Speeds	16-6
Engine Speed Learning Procedure	16-7
Change Air Cleaner Elements (GRP NO. 0521)	16-7
Inspect Fan Belt (GRP NO. 0429).....	16-8
Replace Air Cleaner Dust Valve (GRP NO. 0521)	16-8
Chapter 17 Maintenance—Every 2000 Hours	
Drain Cooling System (GRP NO. 0510)	17-1
Diesel Engine Coolant (GRP NO. 0510).....	17-2
Cooling System Fill and Deaeration Procedure (GRP NO. 0510)	17-3
Change Propel Gearbox Oil	17-4
Change Hydraulic Oil.....	17-5
Chapter 18 Maintenance—Air Compressor	
General	18-1
Scheduled Maintenance.....	18-1
Compressor Oil Maintenance.....	18-1
Air Cleaner	18-2
Gauges.....	18-3
Fuel Tank	18-3
Battery	18-3
Automatic Shutdown System	18-3
Compressor Oil Cooler.....	18-4
Radiator	18-4
Hoses.....	18-4
Compressor Oil Filters	18-5
Fasteners.....	18-6
Compressor Oil	18-6
Receiver-Separator Systems.....	18-6
Scavenge Line	18-6
Cooling Fan Drive.....	18-6
Oil Separator Element	18-7
Exterior Finish Care	18-8
Lubrication	18-10
Chapter 19 Maintenance—Rock Drill Attachment	
First Oil Change	19-1
When Required.....	19-3
Adjustment of Drilling Automatism	19-4
Replacing Rock Drill Dust Collector Filters	19-8
Daily Maintenance Hydraulic Dust Collector	19-9
Daily.....	19-10
Every 50 Hours.....	19-10
Every 1000 Hours.....	19-11
Every 2000 Hours.....	19-11
Drifter Maintenance	19-12
Chapter 20 Maintenance	
Do Not Service Injection Nozzles	20-1
Do Not Change Injection Pump	20-1
Bleeding the Fuel System.....	20-2
Precautions for Alternator and Regulator.....	20-2
Service Batteries Carefully.....	20-3
Checking Electrolyte Specific Gravity	20-5
Using Battery Charger.....	20-6

TABLE OF CONTENTS (Continued)

	Page
Replacing Batteries (GRP NO. 1671)	20-7
Removing Batteries (GRP NO. 1671)	20-7
Welding on Machine	20-8
Adding 12-Volt Accessories	20-9
Replacing Fuses.....	20-9
Fuse (Blade-Type) Color Codes.....	20-11
Checking Travel Alarm System (GRP NO. 1671)	20-11
Replacing Bucket Teeth (GRP NO. 3302)	20-12
Removing the Bucket (GRP NO. 3302).....	20-13
Replacing Bucket Tooth Tip—Heavy-Duty Bucket (GRP NO. 3302)	20-14
Do Not Service Control Valves, Cylinders, Pumps or Motors.....	20-14
Track Sag General Information	20-15
Hardware Torque Specifications	20-15
Check Track Shoe Torque.....	20-16
Unified Inch Bolt and Cap Screw Torque Values	20-17
Metric Bolt and Cap Screw Torque Values.....	20-18
Additional Metric Cap Screw Torque Values	20-19
Check Oil Lines and Fittings.....	20-20
Service Recommendations for O-Ring Boss Fittings.....	20-21
Service Recommendations for Flat Face O-Ring Seal Fittings	20-23
Service Recommendations for 37° Flare and 30° Cone Seat Connectors	20-24
Service Recommendations for Flared Connections—Straight or Tapered Threads.....	20-25
Service Recommendations for Inch Series Four Bolt Flange Fittings.....	20-26
Service Recommendations for Metric Series Four Bolt Flange Fitting.....	20-28
Chapter 21 Operational Checkout	
Operational Checkout.....	21-1
Operator Station Checks—Key Switch On, Engine Off	21-2
Operator Station Checks—Engine On.....	21-4
Hydraulic System Checks	21-8
Undercarriage Checks	21-15
Hydraulic Thumb Check	21-17
Quick-Disconnect Hitch Checks	21-17
Accessories Checks.....	21-18
Air Conditioning Checks.....	21-20
Seat, Doors, Windows, Latches, and Locks Checks.....	21-23
Coolant Checks	21-29
Chapter 22 Troubleshooting	
Using Troubleshooting Charts.....	22-1
Engine	22-2
Electrical System.....	22-8
Hydraulic System	22-14
Chapter 23 Storage	
Prepare Machine for Storage.....	23-1
Quick-Disconnect Hitch Storage Procedure.....	23-2
Monthly Storage Procedure.....	23-3
Chapter 24 Specifications	
230LCR/LCRD	24-1
230LCR/LCRD Working Ranges.....	24-3
230LCR/LCRD	24-4
230LCR/LCRD Drain and Refill Capacities.....	24-5

TABLE OF CONTENTS (Continued)

	Page
230LCR/LCRD Lift Capacity—KG (LB).....	24-6
Rock Drill Attachment - Technical Specifications.....	24-7
Air Compressor General Data	24-8
Appendix A Operator Preventive Maintenance Checks and Services (PMCS)	A-1
Appendix B Components of End Item and Basic Issue Items List.....	B-1
Appendix C References	C-1

WARRANTY

- 1. General.** This section explains the contractor's warranty for the Hydraulic Excavator (HYEX), including all of its components and subassemblies. It also contains information, instructions, methods and forms required to obtain services and/or supplies and for processing claims for items covered under warranty for the HYEX. If additional warranty information is required for the HYEX, contact your local Warranty Control Office/Officer (WARCO) or TACOM-WRN Logistics Assistance Representative (LAR). If your WARCO or TACOM LAR is not available, contact TACOM-WRN. The numbers at TACOM to call are DSN 786-7215/(810) 574-7215, DSN 786-7420/(810) 574-7420, or DSN 786-8297/(810) 574-8297. The caller should be prepared to provide: (1) name, (2) telephone number and/or electronic address, (3) complete unit designation, (4) identification of the vehicle to include serial number(s) and (5) a brief description of the problem.
- 2. Coverage Specific.** The information and data contained in this Technical Manual applies to the U.S. Army's Hydraulic Excavator (HYEX), model number 230LCR, NSN 3805-01-463-0804 and model number 230LCRD, NSN 3805-01-463-0806. The HYEX is manufactured by Deere & Company, Moline, IL under contract number DAAE07-98-D-S009.
- 3. Claim Procedures.** DA Form 2407, along with information and instructions provided by the contractor at time of delivery of the HYEX, shall be used to process warranty claims.
- 4. Claim Denial/Disputes.** All denials or disputes will be handled by TACOM. The contact point for warranty claim denials or disputes is:

Commander
U.S. Army Tank-Automotive and Armaments Command
ATTN: AMSTA-LC-CJBB
Warren, MI 48397-5000

Telephone: DSN 786-5314
Commercial: (810) 574-5314

- 5. Local WARCO.** Upon completion of warranty actions by the contractor, the WARCO shall complete and provide a copy of DA Form 2407 to TACOM for information and warranty tracking purposes only. **NOTE:** The DA Form 2407 shall be stamped or otherwise clearly marked "**FOR INFORMATION ONLY**". Send the completed DA Form 2407 to:

Commander
U.S. Army Tank-Automotive and Armaments Command
ATTN: AMSTA-LC-CJCB
Warren, MI 48397-5000

Telephone: DSN 786-7215
Commercial: (810) 574-7215

Forms may also be faxed to TACOM. Fax the forms to: DSN 786-5605, Commercial - (810) 574-5605. Include ATTN: AMSTA-LC-CJCB on all related materials being faxed to TACOM.

INTRODUCTION

READ THIS MANUAL carefully to learn how to operate and service your machine correctly. Failure to do so could result in personal injury or equipment damage. This manual and safety signs on your machine may also be available in other languages. (See your John Deere dealer to order.)

THIS MANUAL SHOULD BE CONSIDERED a permanent part of your machine and should remain with the machine when you sell it.

MEASUREMENTS in this manual are given in both metric and customary U.S. unit equivalents. Use only correct replacement parts and fasteners. Metric and inch fasteners may require a specific metric or inch wrench.

RIGHT-HAND AND LEFT-HAND sides are determined by facing in the direction of forward travel.

GROUP NUMBERS (e.g., GRP NO. XXXX) following maintenance task titles in the

Table of Contents refer to the John Deere Functional Group Coding system.

WARRANTY is provided as part of John Deere's support program for customers who operate and maintain their equipment as described in this manual. The warranty is explained on the warranty certificate, which you should have received from your dealer.

This warranty provides you the assurance that John Deere will back its products where defects appear within the warranty period. In some circumstances, John Deere also provides field improvements, often without charge to the customer, even if the product is out of warranty. Should the equipment be abused, or modified to change its performance beyond the original factory specifications, the warranty will become void and field improvements may be denied. Setting fuel delivery above specifications or otherwise overpowering machines will result in such action.

CALIFORNIA PROPOSITION 65 WARNING

Diesel engine exhaust and some of its constituents are known to the State of California to cause cancer, birth defects and other reproductive harm.

BLANK

CHAPTER 1
SAFETY AND SAFETY SIGNS

BLANK

John Deere Excavator Safety Features

JOHN DEERE EXCAVATOR SAFETY FEATURES

Safety

TM 5-3805-280-10

Please remember the **operator** is the key to preventing accidents.

11 Engine Fan Guard A secondary fan guard inside the engine compartment helps prevent contact with the engine fan blades.

1 Seatbelt A seatbelt is provided for the operator.

2 Window Guarding Window bars prevent contact with a moving boom.

3 Rearview Mirrors Rearview mirrors offer the operator a view of activity behind him.

4 Secondary Exit The front window provides a large exit path if the cab door is blocked in an emergency situation. A secondary exit tool is also provided.

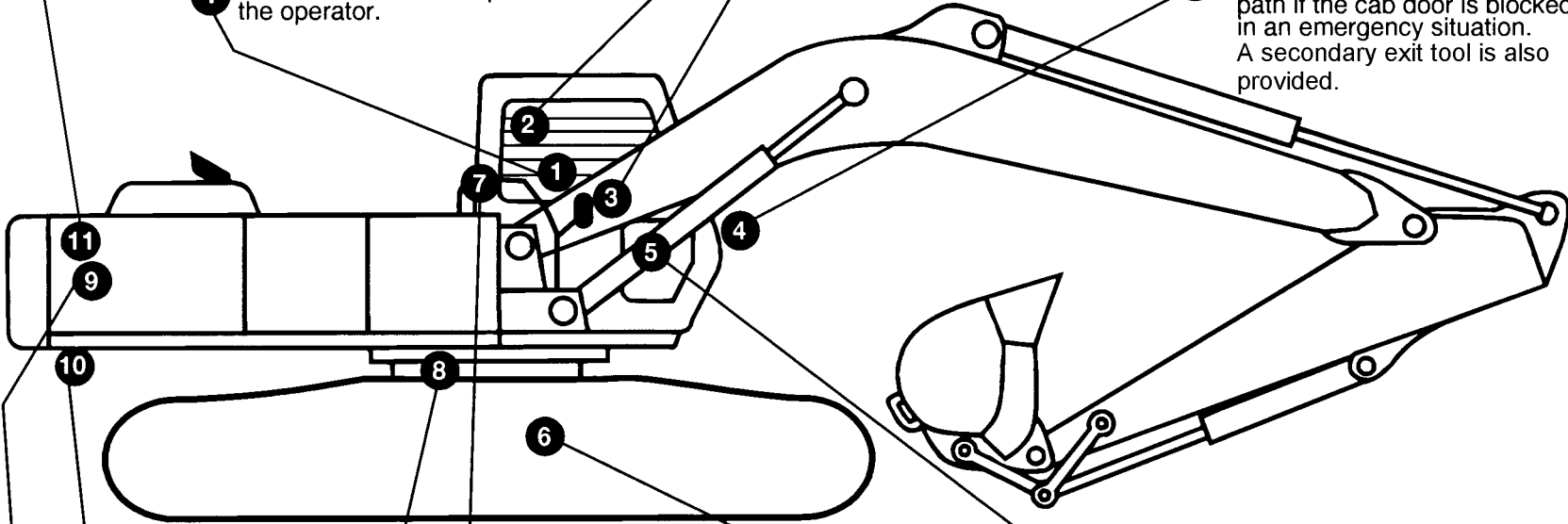

10 Travel Alarm Alerts bystanders of machine movement when propeling.

7 Handholds Large conveniently placed handholds make it easy to enter or exit the operator's station or service area.

5 Pilot Control Shut-Off A lever near the cab exit reminds the operator to deactivate hydraulic functions before leaving the machine.

6 Steps Wide slip resistant steps make entry and exit easier - also provides a place to clean shoes.

8 Swing Brake Swing brake engages automatically when engine is stopped - helps secure upperstructure when transporting the machine.

9 Bypass Start Protection Shielding over the starter helps prevent dangerous bypass starting.

TX-05.DH5854 -19-15AUG97-1/1

T111123 -19-14AUG97

RECOGNIZE SAFETY INFORMATION

This is the safety-alert symbol. When you see this symbol on your machine or in this manual, be alert to the potential for personal injury.

Follow recommended precautions and safe operating practices.



DX.ALERT -19-03MAR93-1/1

T81389 -JUN-07DEC88

UNDERSTAND SIGNAL WORDS

A signal word—DANGER, WARNING, or CAUTION—is used with the safety-alert symbol. DANGER identifies the most serious hazards.

DANGER or WARNING safety signs are located near specific hazards. General precautions are listed on CAUTION safety signs. CAUTION also calls attention to safety messages in this manual.



DX.SIGNAL -19-03MAR93-1/1

TS187 -19-30SEP88

FOLLOW SAFETY INSTRUCTIONS

Carefully read all safety messages in this manual and on your machine safety signs. Keep safety signs in good condition. Replace missing or damaged safety signs. Be sure new equipment components and repair parts include the current safety signs.

Learn how to operate the machine and how to use controls properly. Do not let anyone operate without instruction.

Keep your machine in proper working condition. Unauthorized modifications to the machine may impair the function and/or safety and affect machine life.



TX.05,DY336 -19-15MAY96-1/1

TS201 -JUN-23AUG88

**AVOID INJURY FROM:
LOADING MACHINE ON A TRAILER,
FASTENING MACHINE TO TRAILER,
UNLOADING MACHINE FROM TRAILER**

**ALWAYS USE CAUTION WHEN LOADING
AND UNLOADING MACHINES ON A TRAILER**

**ALWAYS KNOW AND FOLLOW THE
RECOMMENDED PROCEDURES FOR THE
MACHINE, BECAUSE ALL MACHINES ARE
NOT LOADED, FASTENED, AND UNLOADED
THE SAME WAY**

**ALWAYS KEEP BYSTANDERS CLEAR OF
THE AREA**

To avoid injury:

Keep the trailer bed clean.

Park the trailer on a firm, hard, level surface that will not give way when the weight of the machine is on the trailer.

Put chock blocks against truck wheels.

Use a ramp or loading dock. Ramps must be strong enough to adequately handle the load and have a low angle and correct height.

If machine is equipped with a seatbelt, fasten it before starting the engine.

Drive machine on or off the ramp slowly.

fasten chains or cables to machine tracks or track chain links. Do not place chains or cable over or against hydraulic lines or hoses.

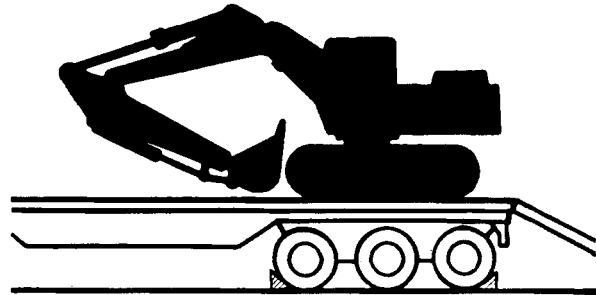
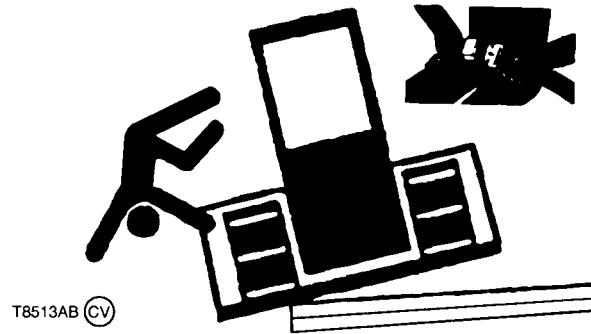

T8513AB -UN-28JUN95

T7405BJ -UN-29NOV90

AVOID INJURY FROM BACKOVER ACCIDENTS

BEFORE MOVING MACHINE, BE SURE ALL PERSONS ARE CLEAR OF AREA

ALWAYS BE ALERT FOR BYSTANDERS MOVING INTO THE WORK AREA. USE HORN OR OTHER SIGNAL TO WARN BYSTANDERS BEFORE MOVING MACHINE

WHEN USING A SIGNAL PERSON, KEEP PERSON IN VIEW AT ALL TIMES, BE SURE SIGNAL PERSON IS CLEAR BEFORE BACKING UP

To avoid backover accidents:

Always look around before you back up. Be sure that everyone is in the clear.

Keep travel alarm in working condition.

Use a signal person when backing up if view is obstructed. Always keep signal person in view.

Learn the meaning of all flags, signs, and markings used on the job and who has the responsibility for signaling.

Keep windows, mirrors, and lights clean and in good condition.

Dust, heavy rain, fog, etc., can reduce visibility. As visibility decreases, reduce speed and use proper lighting.

Read and understand the operating instructions in this operator's manual.

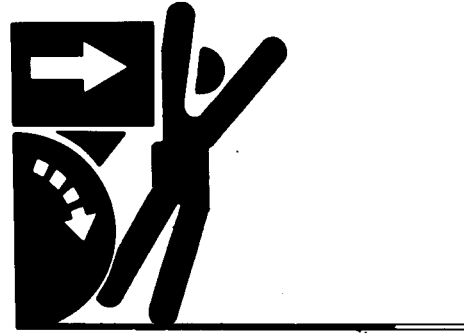

T7241AY -UN-21FEB90

AVOID INJURY FROM ROLLAWAY ACCIDENTS

TO PREVENT ROLLAWAY, ALWAYS MAKE SURE MACHINE IS PROPERLY SECURED BEFORE LEAVING OPERATOR'S SEAT

DEATH OR SERIOUS INJURY MAY RESULT IF YOU ATTEMPT TO MOUNT OR STOP A MOVING MACHINE

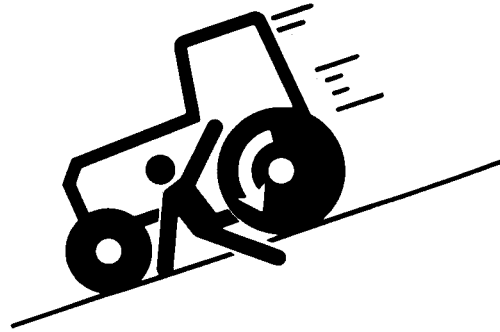

T7241AZ -UN-21FEB90

To avoid rollaways:

Select level ground when possible to park machine.

Pull pilot control shut-off lever to locked position.

Lower all equipment to ground.

Stop the engine.

Block all tracks if you must park on a grade. Position machine to prevent rolling.

Park a reasonable distance from other machines.

Read and understand the operating instructions in this operator's manual.

TX,05,FF2433 -19-22MAY91-1/1

INSPECT MACHINE

Inspect your machine carefully each day by walking around it before you start it. (See Pre-Start Inspection Chapter.)



T6607AQ -UN-18OCT88

T82,BHSA,CL -19-14MAR90-1/1

USE HANDHOLDS AND STEPS

Falling is one of the major causes of personal injury.

When you get on and off the machine, always maintain a three point contact with the steps and handrails and face the machine. Do not use any controls as handholds.

Never jump on or off the machine. Never mount or dismount a moving machine.

Be careful of slippery conditions on platforms, steps, and handrails when leaving the machine.



T6881AN -UN-15JUN89

TX,05,DH832 -19-16MAR92-1/1

USE SEAT BELT

Always use the seat belt when operating your machine.

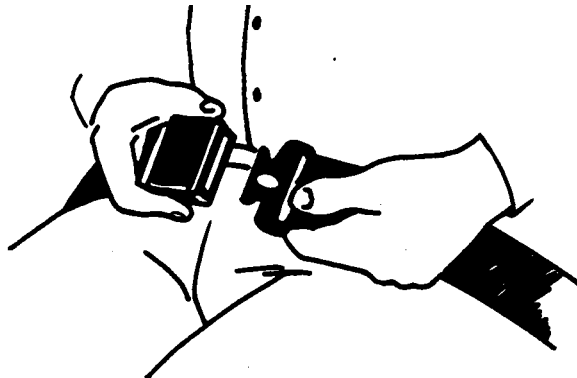

TS175 -UN-23AUG88

TX,05,DH3732 -19-18AUG95-1/1

MAINTAIN SEAT BELT

Keep the seat belt in good condition.

The complete seat belt assembly should be replaced after three years of usage, regardless of appearance.

Between replacement intervals:

Carefully examine buckle, webbing, and attaching hardware.

Be sure that the retractor, if equipped, locks to prevent belt extension after latching buckle.

Be sure that attaching hardware is in place. Tighten, if necessary.

Replace the seat belt if it does not operate properly, or if it is damaged, worn, or deteriorated.

TX,05,DH3729 -19-09AUG95-1/1

MOVE AND OPERATE MACHINE SAFELY

Bystanders can be run over. Know the location of bystanders before moving, swinging, or operating the machine.

Always keep the travel alarm in working condition. It warns people when the machine starts to move.

Use a signal person when moving, swinging, or operating the machine in congested areas. Coordinate hand signals before starting the machine.

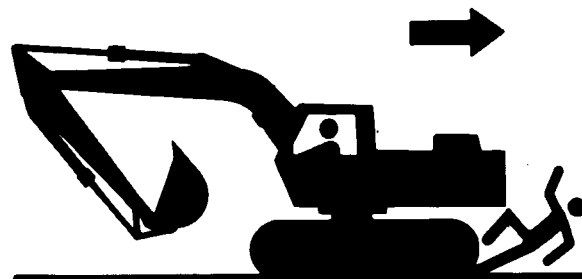

T7273AL -UN-08JUN90

TX,05,FF1806 -19-05OCT90-1/1

OPERATE ONLY FROM OPERATOR'S SEAT

Avoid possible injury or machine damage. Do not start engine by shorting across starter terminals.

NEVER start engine while standing on ground. Start engine only from operator's seat.

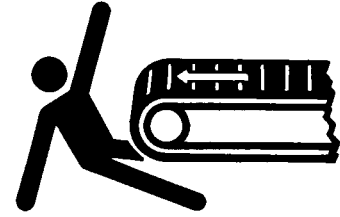

T6607AO -JUN-18OCT88

TX,05,FF1615 -19-14JUN90-1/1

SECONDARY EXITS

Machines equipped with cabs are equipped with secondary exits. For additional secondary exit information, see the topics "Secondary Exit Tool" and 'Opening Upper Front (Secondary Exit) Window' in chapter 10 of this manual.

TX,05,DH5848 -19-13AUG97-1/1

OPERATE MACHINE SAFELY

Clear all persons from area of operation and machine movement.

Use your seat belt.

Make sure the work site footing has sufficient strength to firmly support the machine. When working close to an excavation, position machine with propel motors at the rear.

Be cautious of tipping when working on frozen ground. Temperature increases will cause ground to become soft, making ground unstable.

When digging deep, avoid hitting bottom of boom or bucket cylinder hoses against the ground.

Use the bucket only for digging. Do not use it as a jack hammer or wrecking ball.



T7252AL -JUN-08JUN90

TX,05,DH3730 -19-09AUG95-1/1

Safety

DIG WITH CAUTION

Before digging, check the location of cables, gas lines, and water lines.

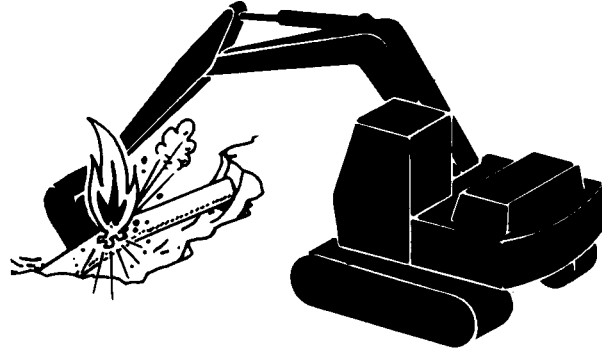

T7252AJ -UN-08JUN90

05,RR,592 -19-12JUN90-1/1

OPERATE WITH CAUTION

Avoid contact of boom or arm and overhead obstacles when you operate the machine.

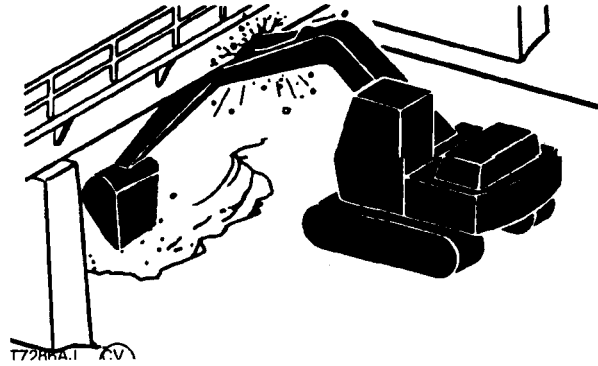

T7286AJ -UN-08JUN90

TX,05,RR,602 -19-26FEB91-1/1

AVOID TIPPING

Use your seat belt.

When operating on a slope, keep bucket low to ground and close to machine. Point tracks uphill.

Avoid tipping the machine when swinging heavy loads. Reduce swing speed as necessary.

Be cautious of tipping when working on frozen ground. Temperature increases will cause ground to become soft and make ground travel unstable.

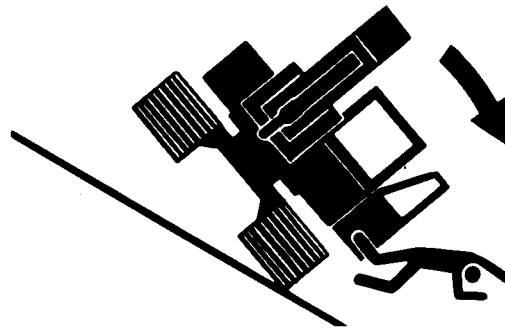

T7273AE -UN-08JUN90

TX,05,DH3731 -19-09AUG95-1/1

Safety

AVOID POWER LINES

Serious injury or death can result from contact with electric lines.

Never move any part of the machine or load closer to electric line than 3 m (10 ft) plus twice the line insulator length.

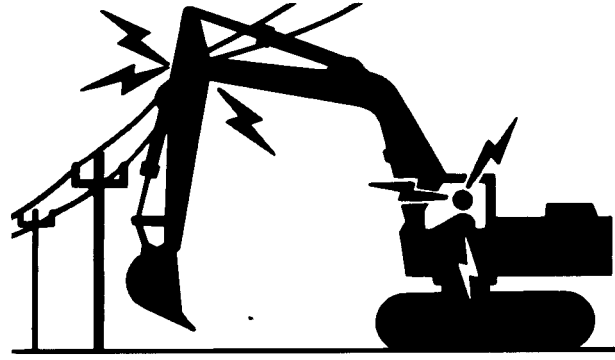

T7273AD -UN-08JUN90

TX,05,RR,594 -19-12JUN90-1/1

DRIVE MACHINE SAFELY

Use your seat belt.

Before moving machine, find out which way to move propel pedals/levers for the direction you want to go. Pushing down on the front of the propel pedals or pushing the levers moves the machine towards the idlers.

Keep the bucket on the uphill side, approximately 30 cm (12 in.) (A) above ground, when going up or down hill. If machine starts to slip or become unstable, lower the bucket immediately.

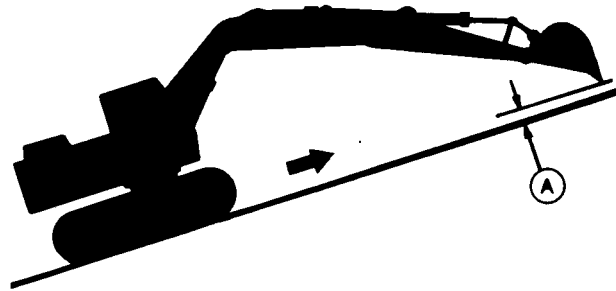

T7273AG -UN-08JUN90

TX,05,DH3733 -19-09AUG95-1/1

BEWARE OF EXHAUST FUMES

Prevent asphyxiation. Engine exhaust fumes can cause sickness or death.

If you must operate in a building, be positive there is adequate ventilation. Either use an exhaust pipe extension to remove the exhaust fumes or open doors and windows to bring enough outside air into the area.



T6458AO -UN-18OCT88

02T,05,J9 -19-07JAN91-1/1

PARK MACHINE SAFELY

Before working on the machine:

- Park machine on a level surface.
- Lower bucket to the ground.
- Turn auto-idle switch off.
- Run engine with engine rpm dial at 1/3 position for 2 minutes.
- Move engine rpm dial to slow idle position.
- Turn key switch to OFF. Remove key from switch.
- Pull pilot control shut-off lever to locked position.
- Allow engine to cool.

TX,05,DH5002 -19-28MAY96-1/1

KEEP RIDERS OFF MACHINE

Only allow the operator on the machine. Keep riders off.

Riders on machine are subject to injury such as being struck by foreign objects and being thrown off the machine. Riders also obstruct the operator's view resulting in the machine being operated in an unsafe manner.

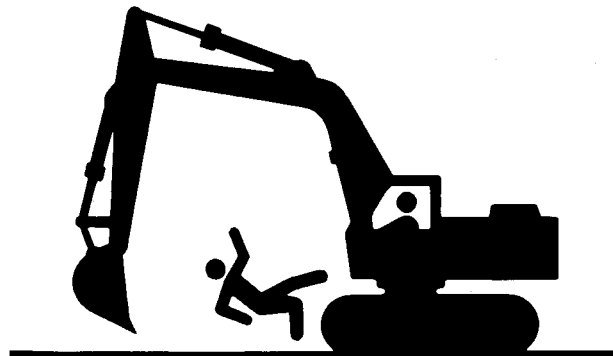

T7273AH -JUN-08JUN90

TX,05,RR,560 -19-05OCT90-1/1

OPERATE ATTACHMENT SAFELY

An attachment may change the capabilities of your machine in any or all of these ways:

- Safe range of motion
- Machine stability
- Hydraulic performance
- Engine performance

Read the attachment manual to learn how the attachment works.

In an area free of bystanders and obstructions, carefully operate the attachment to learn the available range of motion. Anticipate how objects manipulated by the attachment, or the attachment itself, may contact the machine, especially the operator's station. Consider adding guards to the machine to protect the operator, and if necessary, to prevent damage to machine.

See your dealer to match attachment demands to machine performance.

TX,05,FF2883 -19-29OCT92-1/1

HANDLE FLUIDS SAFELY—AVOID FIRES

Handle fuel with care; it is highly flammable. Do not refuel the machine while smoking or when near open flame or sparks. Always stop engine before refueling machine. Fill fuel tank outdoors.



TS202 -JUN-23AUG88

Continued on next page

TX,05,FF1622 -19-14JUN90-1/2

Safety

Store flammable fluids away from fire hazards. Do not incinerate or puncture pressurized containers.

Make sure machine is clean of trash, grease, and debris.

Do not store oily rags; they can ignite and burn spontaneously.



TS227 -UN-23AUG88

TX,05,FF1622 -19-14JUN90-2/2

PREPARE FOR EMERGENCIES

Be prepared if a fire starts.

Keep a first aid kit and fire extinguisher handy.

Keep emergency numbers for doctors, ambulance service, hospital, and fire department near your telephone.

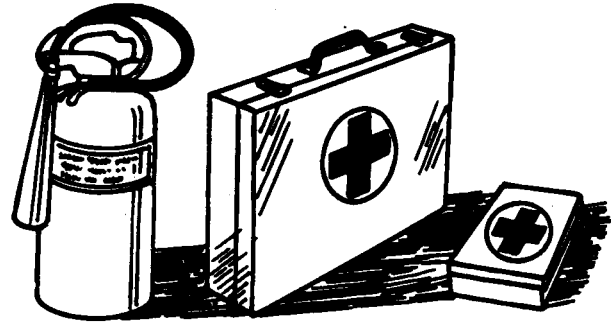

TS291 -UN-23AUG88

DX,FIRE2 -19-03MAR93-1/1

HANDLE STARTING FLUID SAFELY

Starting fluid is highly flammable.

Keep all sparks and flame away when using it. Keep starting fluid away from batteries and cables.

To prevent accidental discharge when storing the pressurized can, keep the cap on the container, and store in a cool, protected location.

Do not incinerate or puncture a starting fluid container.



TS1356 -UN-18MAR92

DX,FIRE3 -19-16APR92-1/1

CLEAN TRASH FROM MACHINE

Keep engine compartment, radiator, batteries, hydraulic lines, fuel tank, and operator's station clean.

Temperature in engine compartment may go up immediately after engine is stopped. BE ON GUARD FOR FIRES DURING THIS PERIOD.

Open access door(s) to cool the engine faster, and clean engine compartment.

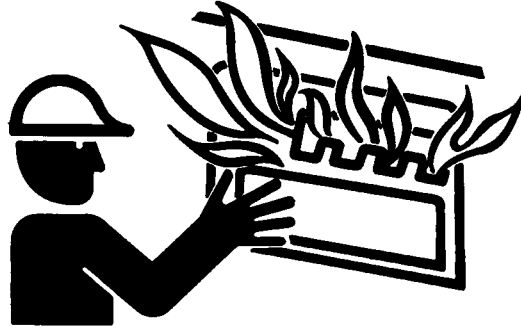

T6669AG -JUN-18OCT88

02T,05,J33 -19-14MAR90-1/1

PROTECT AGAINST FLYING DEBRIS

Guard against injury from flying pieces of metal or debris; wear goggles or safety glasses.

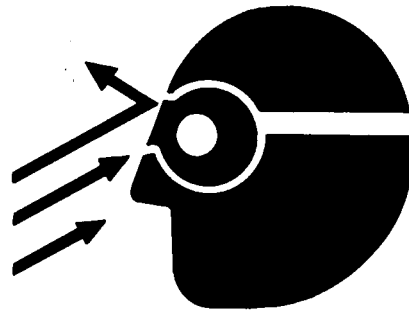

T6642DK -JUN-18OCT88

TX,05,FF1613 -19-14JUN90-1/1

WEAR PROTECTIVE CLOTHING

Wear close fitting clothing and safety equipment appropriate to the job.

Operating equipment safely requires the full attention of the operator. Do not wear radio or music headphones while operating machine.

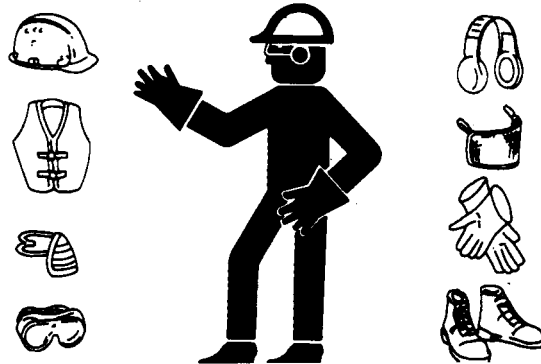

TS206 -JUN-23AUG88

DX,WEAR2 -19-03MAR93-1/1

PROTECT AGAINST NOISE

Prolonged exposure to loud noise can cause impairment or loss of hearing.

Wear a suitable hearing protective device such as earmuffs or earplugs to protect against objectionable or uncomfortable loud noises.

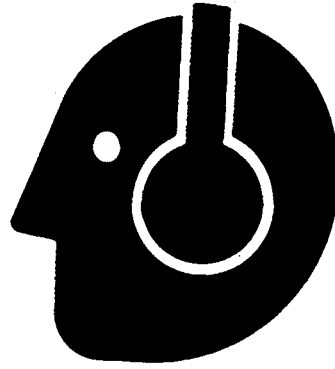

DX.NOISE -19-03MAR93-1/1

TS207 -UN-23AUG88

HANDLE CHEMICAL PRODUCTS SAFELY

Direct exposure to hazardous chemicals can cause serious injury. Potentially hazardous chemicals used with your machine include such items as lubricants, coolants, paints, and adhesives.

A Material Safety Data Sheet (MSDS) provides specific details on chemical products: physical and health hazards, safety procedures, and emergency response techniques.

Check the MSDS before you start any job using a hazardous chemical. That way you will know exactly what the risks are and how to do the job safely. Then follow procedures and recommended equipment.

See your authorized dealer for MSDS's on chemical products used with your machine.



TX,05,DH2500 -19-02OCT92-1/1

TS1132 -UN-26NOV90

WARN OTHERS OF SERVICE WORK

Unexpected machine movement can cause serious injury.

Before performing any work on the machine, attach a 'Do Not Operate' tag on the right control lever.

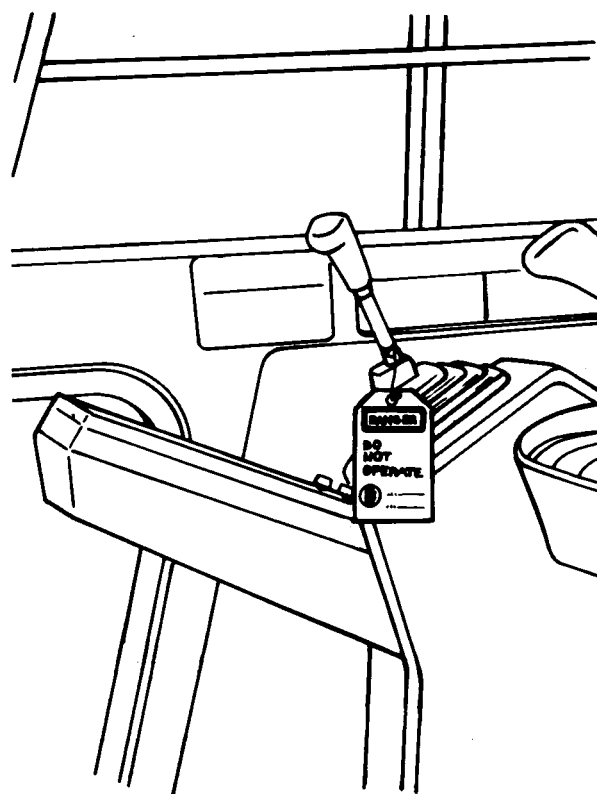

T7273AP -UN-08JUN90

TX,05,RR,566 -19-23JUL91-1/1

STAY CLEAR OF MOVING PARTS

Entanglements in moving parts can cause serious injury.

To prevent accidents, use care when working around rotating parts.

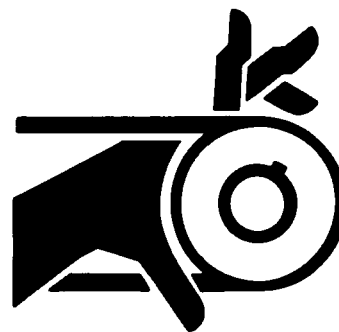

T7273AS -UN-08JUN90

TX,05,RR,572 -19-12JUN90-1/1

SUPPORT MACHINE PROPERLY

Always lower the attachment or implement to the ground before you work on the machine. If you must work on a lifted machine or attachment, securely support the machine or attachment.

Do not support the machine on cinder blocks, hollow tiles, or props that may crumble under continuous load. Do not work under a machine that is supported solely by a jack. Follow recommended procedures in this manual.

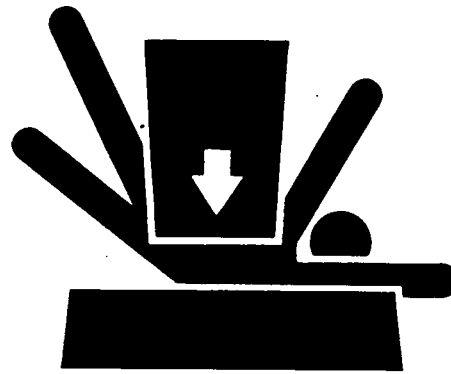

TS229 -UN-23AUG88

DX,LOWER -19-04JUN90-1/1

SERVICE COOLING SYSTEM SAFELY

Explosive release of fluids from pressurized cooling system can cause serious burns.

Shut off engine. Only remove filler cap when cool enough to touch with bare hands. Slowly loosen cap to first stop to relieve pressure before removing completely.



TS281 -UN-23AUG88

DX,RCAP -19-04JUN90-1/1

PRACTICE SAFE MAINTENANCE

Understand service procedure before doing work. Keep area clean and dry.

Never lubricate or service machine while it is moving. Keep hands, feet and clothing from power-driven parts.

Before servicing machine.

- Park machine on a level surface.
- Lower bucket to the ground.
- Turn auto-idle switch off.
- Run engine with engine rpm dial at 1/3 speed for 2 minutes.
- Move engine rpm dial to slow idle position.
- Turn key switch to OFF. Remove key from switch.
- Attach a 'Do Not Operate' tag on the right side controller lever.
- Pull pilot control shut-off lever to locked position.
- Allow engine to cool.

If maintenance procedure must be performed with engine running, do not leave machine unattended.

Securely support any machine elements that must be raised for service work. Never work under a machine raised by the boom. If the machine must be raised, keep a 90-110° angle between boom and arm.

Keep all parts in good condition and properly installed. Fix damage immediately. Replace worn or broken parts. Remove any buildup of grease, oil, or debris.

Disconnect battery ground cable (-) before making adjustments on electrical systems or welding on machine.



TS218 -JUN-23AUG88

REMOVE PAINT BEFORE WELDING OR HEATING

Avoid potentially toxic fumes and dust.

Hazardous fumes can be generated when paint is heated by welding, soldering, or using a torch.

Do all work outside or in a well ventilated area. Dispose of paint and solvent properly.

Remove paint before welding or heating:

- If you sand or grind paint, avoid breathing the dust. Wear an approved respirator.
- If you use solvent or paint stripper, remove stripper with soap and water before welding. Remove solvent or paint stripper containers and other flammable material from area. Allow fumes to disperse at least 15 minutes before welding or heating.

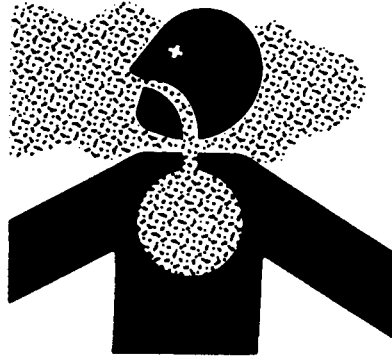

TS220 -UN-23AUG88

DX,PAINT -19-03MAR93-1/1

AVOID HEATING NEAR PRESSURIZED FLUID LINES

Flammable spray can be generated by heating near pressurized fluid lines, resulting in severe burns to yourself and bystanders. Do not heat by welding, soldering, or using a torch near pressurized fluid lines or other flammable materials. Pressurized lines can be accidentally cut when heat goes beyond the immediate flame area.



TS953 -UN-15MAY90

DX,TORCH -19-03MAR93-1/1

AVOID HIGH-PRESSURE FLUIDS

Escaping fluid under pressure can penetrate the skin causing serious injury.

Avoid the hazard by relieving pressure before disconnecting hydraulic or other lines. Tighten all connections before applying pressure.

Search for leaks with a piece of cardboard. Protect hands and body from high pressure fluids.

If an accident occurs, see a doctor immediately. Any fluid injected into the skin must be surgically removed within a few hours or gangrene may result. Doctors unfamiliar with this type of injury should reference a knowledgeable medical source. Such information is available from Deere & Company Medical Department in Moline, Illinois, U.S.A.

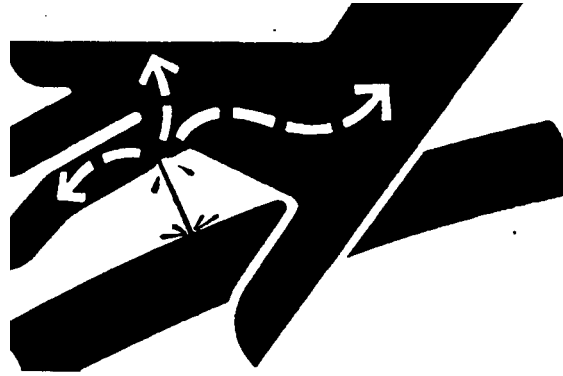

X9811 -UN-23AUG88

DX,FLUID -19-03MAR93-1/1

PREVENT BATTERY EXPLOSIONS

Keep sparks, lighted matches, and open flame away from the top of battery. Battery gas can explode.

Never check battery charge by placing a metal object across the posts. Use a volt-meter or hydrometer.

Do not charge a frozen battery; it may explode. Warm battery to 16°C (60°F).



TS204 -UN-23AUG88

DX,SPARKS -19-03MAR93-1/1

CLEAN THE MACHINE REGULARLY

Remove any grease, oil, fuel, or debris build-up to avoid possible injury or machine damage.

High pressure washing [greater than 1379 kpa (13.8 bar) (200 psi)] can damage freshly painted finishes. Paint should be allowed to air dry for 30 days minimum after receipt of machine before cleaning with high pressure. Use low pressure wash operations until 30 days have elapsed.

Do not spray oil cooler fins at an angle. Fins may bend.

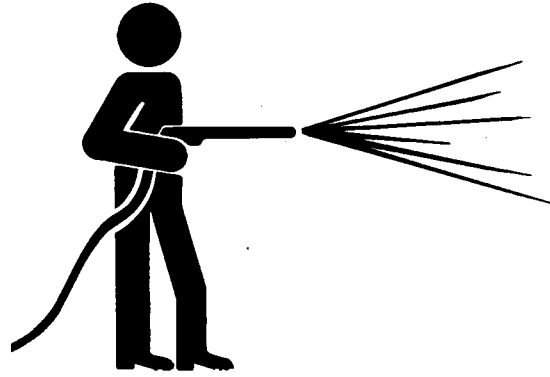

T6642EJ -UN-18OCT88

TX,05,FF2787 -19-27JUL94-1/1

STORE ATTACHMENTS SAFELY

Stored attachments such as buckets, hydraulic hammers, and blades can fall and cause serious injury or death.

Securely store attachments and implements to prevent falling. Keep playing children and bystanders away from storage area.

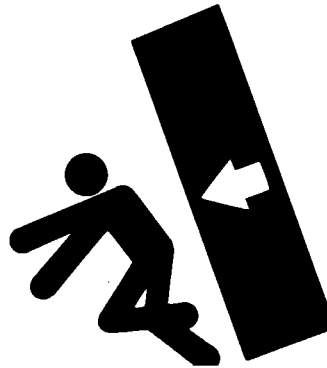

T5219 -UN-23AUG88

TX,05,RR,576 -19-26APR90-1/1

BATTERY TERMINALS, LIFTING EQUIPMENT, DRY CLEANING SOLVENT AND COMPRESSED AIR

WARNING: Avoid possible injury. Disconnect the negative terminal first and reconnect the negative terminal last when disconnecting/reconnecting battery terminals.

WARNING: When lifting equipment, ensure that the lifting device is capable of supporting the desired weights and the inspection date stamped on the lifting device has not expired.

WARNING: Dry cleaning solvent PD-680 Type III is toxic and flammable. Wear protective goggles and gloves and use only in a well ventilated area. Avoid contact with skin, eyes, and clothes and don't breathe vapors. Do not use near open flames or excessive heat. The flash point is 200°F (93°C). If you become dizzy while using solvent, get fresh air immediately and get medical aid. If contact with eyes is made, wash your eyes with water and get medical aid immediately.

WARNING: Compressed air used for cleaning purposes shall not exceed 30 psi. Use only with effective chip guarding and personnel protective equipment (goggles/shield/gloves, etc.).

DISPOSE OF WASTE PROPERLY

Improperly disposing of waste can threaten the environment and ecology. Potentially harmful waste used with your machine include such items as oil, fuel, coolant, brake fluid, filters, and batteries.

Use leakproof containers when draining fluids. Do not use food or beverage containers that may mislead someone into drinking from them.

Do not pour waste onto the ground, down a drain, or into any water source.

Air conditioning refrigerants escaping into the air can damage the Earth's atmosphere. Government regulations may require a certified air conditioning service center to recover and recycle used air conditioning refrigerants.

Inquire on the proper way to recycle or dispose of waste from your local environmental or recycling center, or from your authorized dealer.

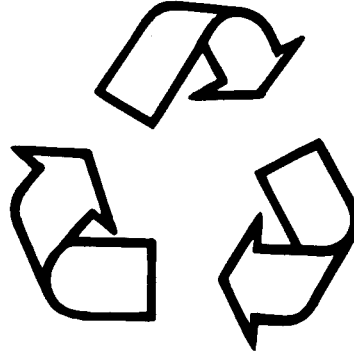

TS1133 -JUN-26NOV90

TX,05,DH2502 -19-26AUG92-1/1

Safety

DRILLING

Before starting work, the operator will make sure there are no buried electrical, gas, water or other pipes or lines.

Always be aware of previously drilled holes, and where they are located : any open hole can cause severe injury to the operator or someone else. The loss of tools, drill rods, drill bits or any other item can occur.

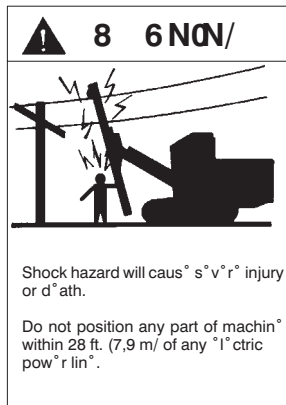

When rising the guide, take care of any overhead lines.

Always maintain a minimum distance of 25 Ft. (7.6 m) distance between the machine and any overhead lines during any operation.

The operator will make sure that everybody stands clear from the machine in operation and stays at a distance of 7 meters (25 ft.).

Nevertheless, some operations may need people to enter the restricted area (checking of coupling temperature during feed thrust adjustment for instance).

On such an occasion :

- the operator must supervise, from the cabin, the safety of the service man doing the work. He must

be ready to activate the cabin emergency stop if need be.

- communication must be established in a reliable manner.

Make sure any hand signal will be perfectly understood.

- the operator must make sure the following safety decal is affixed on the drill guide to warn the service man of risks incurred.

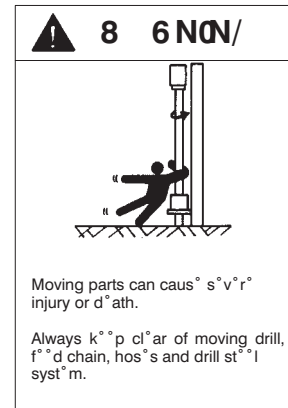

- the service man must be informed about the use of the emergency stop mounted on the guide.

Always have the cabin door closed and the dust collector running when drilling to prevent respiratory damage.

Keep all work areas clean and orderly.

ROCK DRILL MAINTENANCE

Keep hands, arms, legs and clothing away from moving or rotating parts.

Only use genuine replacement parts.

Stopping the drill for maintenance or bit change etc...

Prior to leaving the operators compartment, the excavators hydraulic safety arm must be raised to lock in the machines safety switch. This renders all controls inoperable thus preventing any unwanted movement.

Hydraulic cylinder

The hydraulic cylinder is equipped with 2 load-sustaining valves.

The load-sustaining valves allow the disconnecting of the hydraulic hoses from the cylinder if they need to be changed. But :

Safety

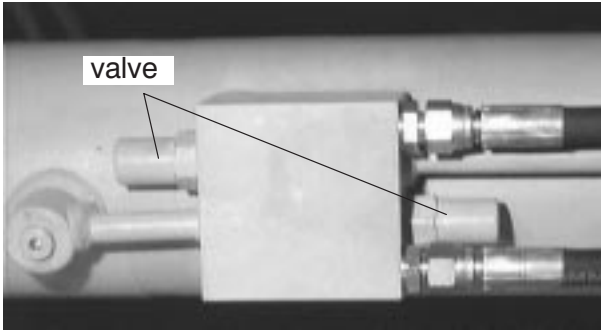

Never disconnect a valve from the cylinder without supporting the controlled element (drill guide ...).

Burn prevention

At operating temperature, the hydraulic tank, circuit and components are hot and can be under pressure. Any contact can cause severe burns.

Always release the pressure and wait for cooling before intervening on the hydraulic circuit.



Fire prevention

Fuel or hydraulic oil leaked or spilled onto hot surfaces or electrical components can cause a fire.

Repair immediately any leaks.

Regularly clean the machine to remove all flammable materials such as fuel, oil and other debris.

Always use approved safety solvent when cleaning parts or the machine.

Have all loose electrical wires connected and tight before operating the machine.

Prior to any welding operation, make sure that the surfaces and their environment are free of flammable debris.

Respiratory damage prevention

Dust coming out from the dust collector fan indicates that one or several filter elements are damaged.

Change the damaged elements immediately.

Always dismantle all the filters elements to check the functioning of the automatic filter cleaning sequence.

Compressed air

Compressed air can be dangerous.

Never point an air hose at yourself or co-workers.

Be sure all hoses and fittings are tightly secured.

A loose hose not only leaks but can come completely off and while whipping under pressure, can injure the operator and others in the area.

Never disconnect a pressurized air hose.

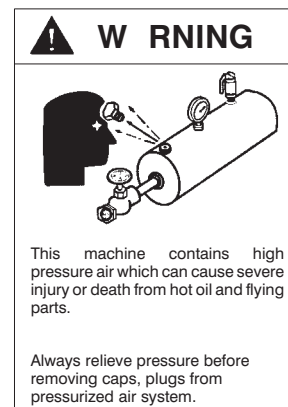

EMERGENCY STOPS

The CPA remote control assembly incorporates an emergency stops selector with allows to connect the CPA emergency stops to the machine circuit.

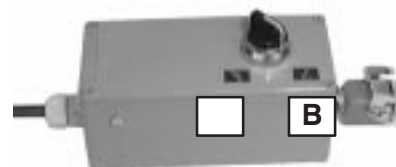

– When the CPA is installed, place the selector on position A to have the CPA emergency stops active.

– Place the selector on position B to refund the normal excavator safety circuit when the CPA is not used.

Safety

The CPA safety circuit incorporates 2 emergency stops.

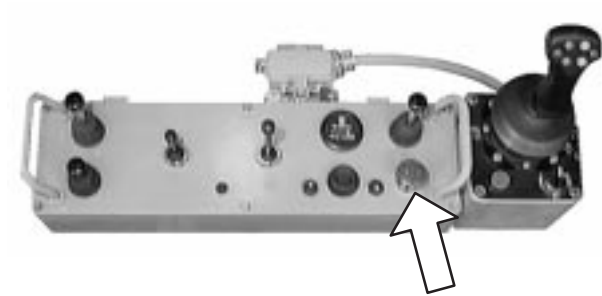

One mushroom type push-button is located in the cabin on the remote control panel.

Pressing on this button shuts down the engine.

Unlock the knob by pulling it up to be in position to restart the engine.

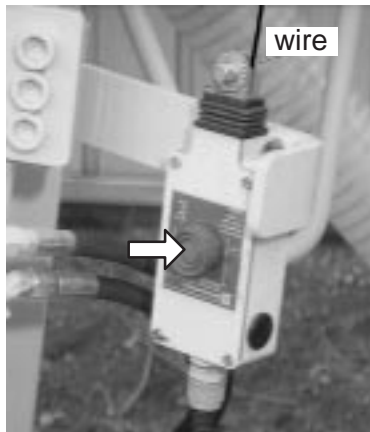

The second emergency stop is located on the guide rail, and stops the engine when pulling on the wire attached along the guide.

To unlock the safety device and be in position to restart the engine, press on the button.

WARNING: Take all necessary steps to safely start the engine after emergency stop.

Safety Signs

SAFETY SIGNS



T125071

Caution Decal (Model 230LCR)

T125071 -UN-28OCT99



T125070

Caution Decal (Model 230LCRD)

T125070 -UN-28OCT99

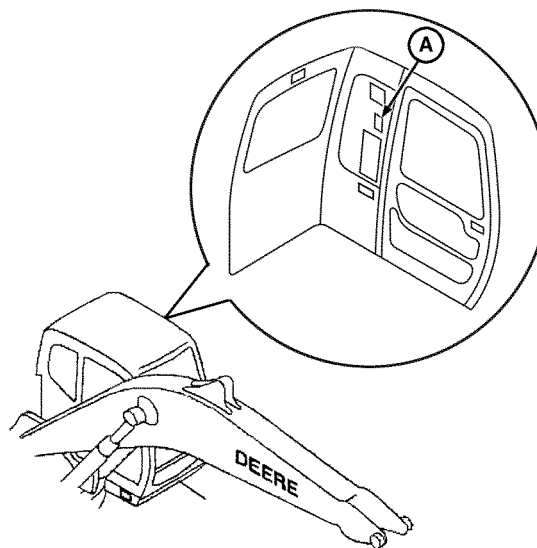

T125069

Caution Decal Location

T125069 -UN-28OCT99

Continued on next page

TX,06,DH5564 -19-22MAR99-1/11

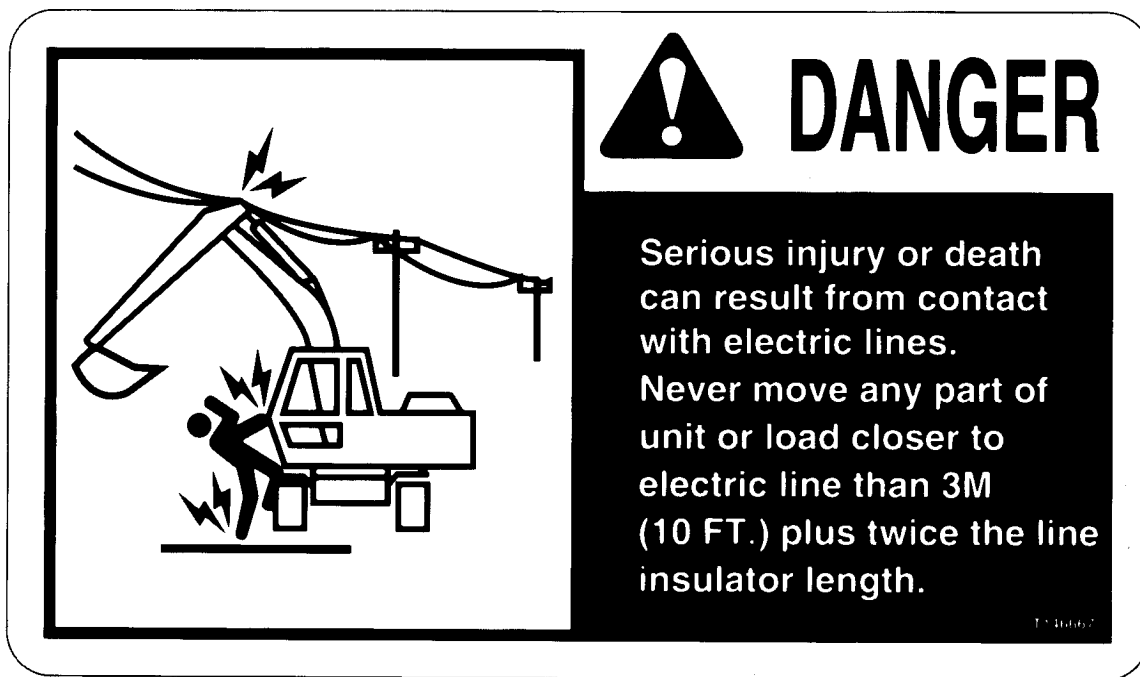

T7748CZ -19-14OCT92



T101484 -UN-27JUN96

A—Danger Decal Location

Continued on next page

TX,06,DH5564 -19-22MAR99-2/11



WARNING

- AVOID SERIOUS CRUSHING INJURY FROM BOOM
- **NEVER** place any part of body beyond window bars or frame. It could be crushed by the boom if boom control lever is accidentally bumped or otherwise engaged.
- **DO NOT** remove window bars. If window is missing or broken, replace immediately.

T146668



A—Warning Decal Location

T7748DA -19-14OCT92

T101485 -UN-27JUN96

Continued on next page

TX.06.DH5564 -19-22MAR99-3/11

⚠ CAUTION

- AVOID DEATH OR SERIOUS INJURY - READ AND UNDERSTAND THE OPERATOR'S MANUAL AND SAFETY MANUAL PRIOR TO OPERATING THIS MACHINE.
- Controls may be changed for attachment or operator preference. Try control pattern before operating.
- Always lower working tools to the ground and engage hydraulic control lockout lever before leaving operator's seat.
- Keep riders off machine..
- Avoid contact between boom/attachments and overhead obstacles whenever operating, traveling or transporting machine.
- Keep bystanders clear of machine; especially before moving boom, swinging upperstructure or traveling.
- Upperstructure position affects travel direction. Try pedals or levers to determine travel direction before moving machine.
- Avoid tipping - Do not lift or move objects that exceed machine stability.
- Avoid parking machine on an incline.

T159887

T102888

A-Caution Decal



A—Caution Decal Location

T102888 -19-23AUG96

T101483 -UN-27JUN96

Continued on next page

TX,06,DH5564 -19-22MAR99-4/11

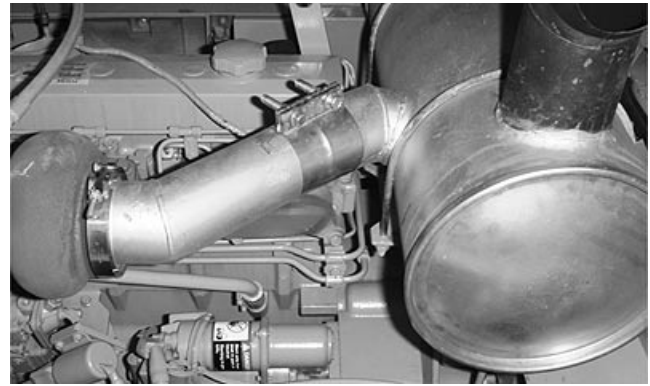

T7972AP -19-22MAR93

Continued on next page

TX,06,DH5564 -19-22MAR99-5/11



T7748DC -19-14OCT92

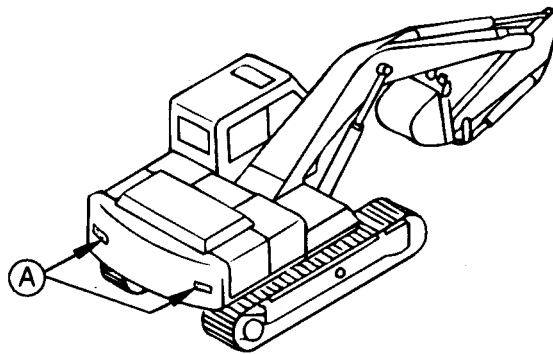

A—Warning Decal Location

T8167AL -UN-06FEB94

TX,06,DH5564 -19-22MAR99-6/11



T7748CX -19-14OCT92

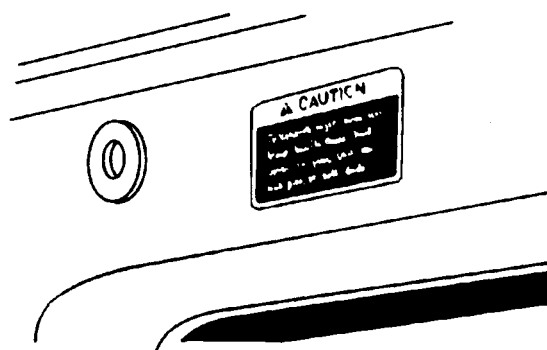

T7748DH -UN-15OCT92

Continued on next page

TX,06,DH5564 -19-22MAR99-7/11

Safety Signs

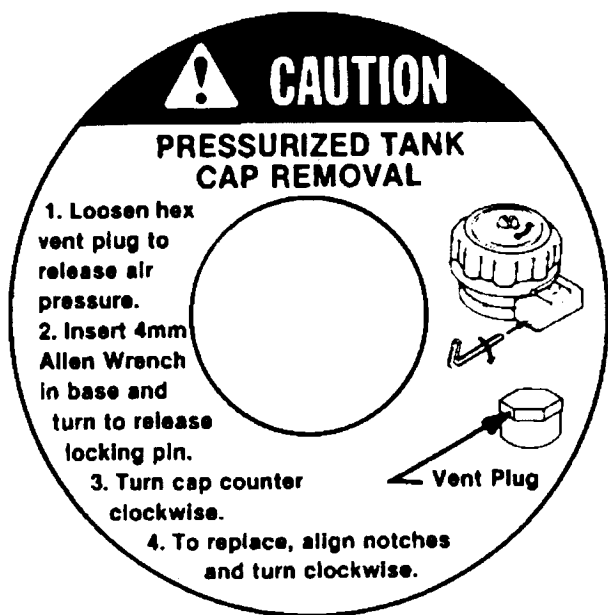

T147009

T7900AB -19-03DEC92

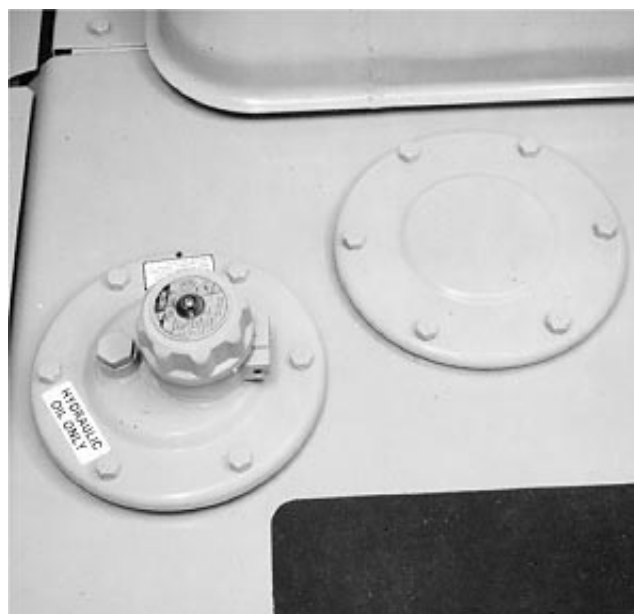

T7748DK -UN-22OCT92

TX,06,DH5564 -19-22MAR99-8/11



T101279 -19-14MAY96



T7869BZ -UN-05NOV92

A—Caution Decal Location

Continued on next page

TX,06,DH5564 -19-22MAR99-9/11

Safety Signs

 **DANGER**

EXPLOSIVE GASES
Cigarettes, flames or sparks could cause battery to explode. Always shield eyes and face from battery. Do not charge or use booster cables or adjust post connections without proper instruction and training. Keep vent caps tight and level.
T124343

POISON

CAUSES SEVERE BURNS
Contains sulfuric acid. Avoid contact with skin, eyes or clothing. In event of accident, flush with water and call a physician immediately. Keep out of reach of children.

Decal is located on top of each battery.

T6888AC -19-06/JAN89

Continued on next page

TX,06,DH5564 -19-22MAR99-10/11

Safety Signs

CAUTION - DO NOT USE ANY ATTACHMENT WITHOUT SAFETY LOCK PIN ENGAGED

ATTACHMENT PICKUP

1. WITH SAFETY LOCK PIN DISENGAGED AND SWITCH IN THE UNLATCH POSITION, FULLY EXTEND TOOL CYLINDER, PLACE OIL OVER RELIEF.
2. ROTATE LATCH TO VERTICAL POSITION, AND ENGAGE FRONT HOOK ON ATTACHMENT.

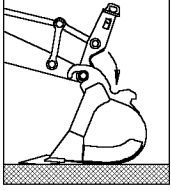

3. ROTATE LATCH TO SEAT OVER REAR SADDLE.

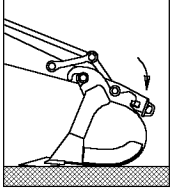

4. MOVE SWITCH TO THE LATCH POSITION AND FULLY EXTEND TOOL CYLINDER, PLACE OIL OVER RELIEF.
5. CHECK FOR WEDGE ENGAGEMENT AND MANUALLY ENGAGE SAFETY LOCK PIN.

ATTACHMENT REMOVAL

1. MANUALLY DISENGAGE SAFETY LOCK PIN.
2. WITH ATTACHMENT CLOSE TO GROUND, MOVE SWITCH TO THE UNLATCH POSITION, FULLY EXTEND TOOL CYLINDER, PLACE OIL OVER RELIEF.
3. LAY ATTACHMENT ON THE GROUND AND SLOWLY UNCURL LATCH, LOWER BOOM TO RELEASE ATTACHMENT FROM LATCH.

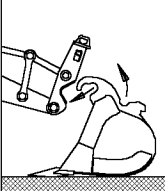

SAFETY LOCK DETAIL

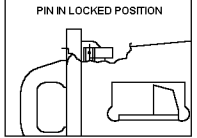

PIN IN LOCKED POSITION

SEE OWNERS MANUAL FOR COMPLETE OPERATING INSTRUCTIONS

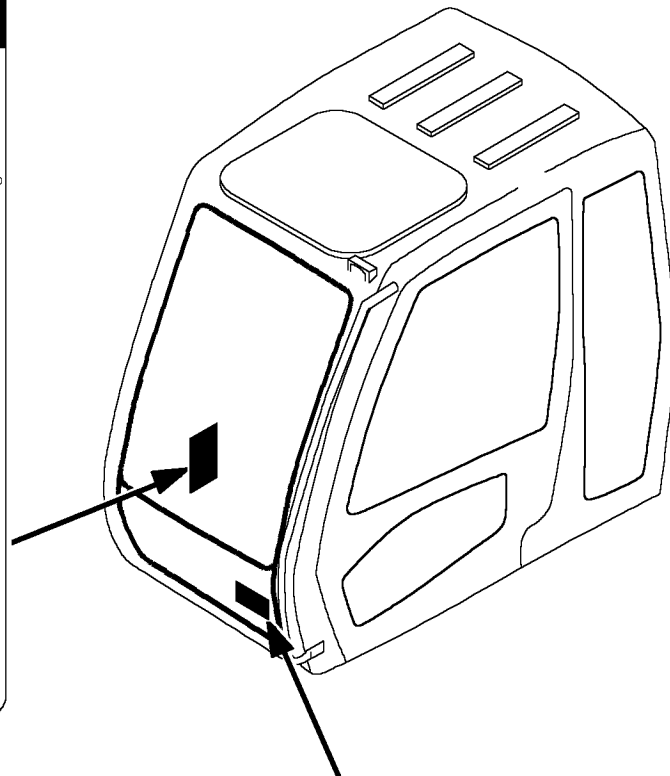

Located on inside right window



WARNING

ATTACHMENT (BUCKET, GRAPPLE, ETC.) CAN CONTACT CAB. ALWAYS MAINTAIN CLEARANCE BETWEEN ATTACHMENT AND CAB TO PREVENT DAMAGE TO CAB AND POSSIBLE INJURY. CLEARANCE WILL DECREASE WHEN WINDSHIELD IS OPEN.

Located on inside lower left windshield

T120457

T120457 -19-25MAR99

TX,06,DH5564 -19-22MAR99-11/11

Safety Signs

Look for these signs on machine, which points out potential hazards to the safety of you and others. Read and understand thoroughly. Heed warnings and follow instructions. If you do not understand, inform your supervisor.



Indicates the presence of a hazard which **WILL** cause serious injury, death or property damage, if ignored.



Indicates the presence of a hazard which **CAN** cause serious injury, death or property damage, if ignored.



Indicates the presence of a hazard which **WILL** or can cause injury or property damage, if ignored.



Indicates important set-up, operating or maintenance information.

DANGER

Air discharged from this machine can contain carbon monoxide or other contaminants which will cause serious injury or death. Do not breathe this air.

WARNING

Trapped air pressure. Can cause serious injury or death.
Close service valve and operate tool to vent trapped air before performing any service.

WARNING



Hot pressurized fluid.
Can cause serious burns.
Do not open radiator while hot.

WARNING

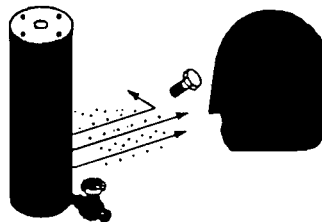

High pressure air. Can cause serious injury or death.

Relieve pressure before removing filler plugs/caps, fittings or covers.

WARNING

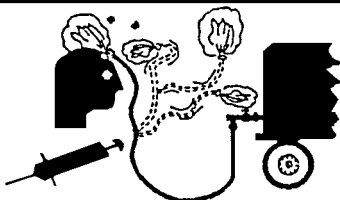

Disconnected Air Hoses Whip. CAN cause serious injury or death.

When using air tools attach safety device (OSHA Valve) at source of air supply for each tool.

WARNING



Combustible Gas. CAN cause serious burns, blindness or death.

Keep sparks and open flames away from batteries.

BLANK

CHAPTER 2
OPERATOR'S STATION

BLANK

Operator's Station

PEDALS, LEVERS AND PANELS

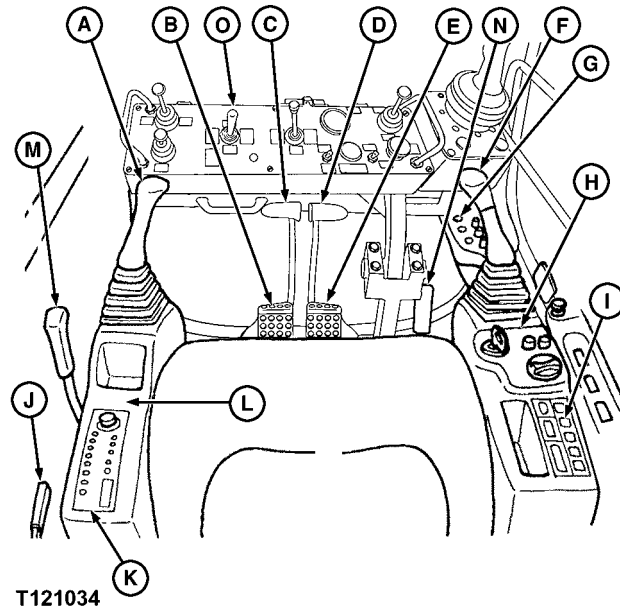

- A—Left Control Lever/Horn Switch (On Top of Lever)
- B—Left Travel Pedal
- C—Left Travel Lever
- D—Right Travel Lever
- E—Right Travel Pedal
- F—Right Control Lever/Power Boost Switch (On Top of Lever)
- G—Front Right Panel
- H—Right Console Panel
- I—Air Conditioner Panel—If Equipped
- J—Cab Door Release Lever
- K—Radio
- L—Left Console Panel
- M—Pilot Control Shut-Off Lever
- N—Hydraulic Thumb Pedal (Model 230LCR)
- O—Rock Drill Control Panel (Model 230LCRD)

RIGHT FRONT PANEL AND RIGHT CONSOLE PANEL

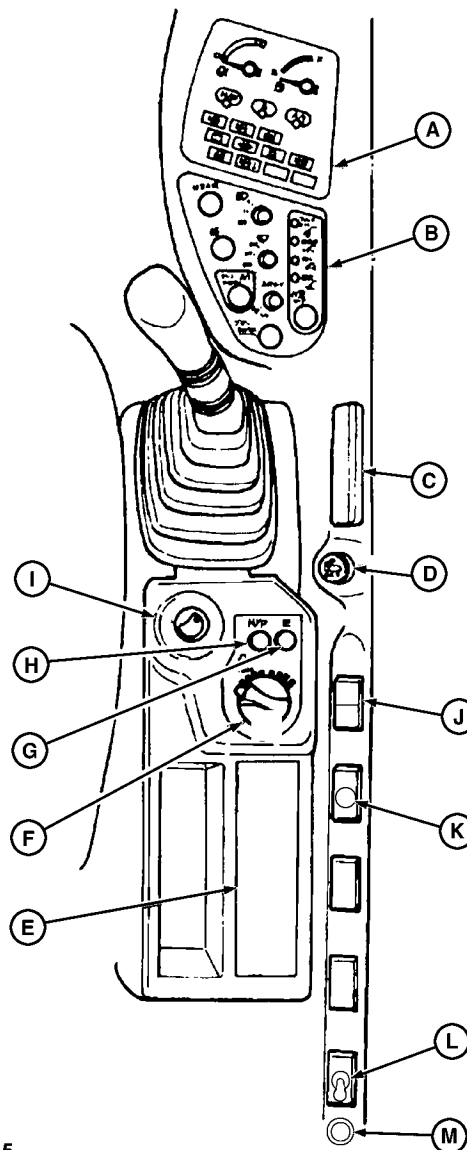

T121035

T121035 -UN-14APR99

- A—Monitor Panel
- B—Switch Panel
- C—Ash Tray
- D—Cigar Lighter
- E—Air Conditioner Panel-If Equipped
- F—Engine RPM Dial
- G—E (Economy) Mode Switch
- H—H/P (High Power) Mode Switch
- I—Key Switch
- J—Rear Light Switch
- K—Overload Alarm/Indicator
- L—Arctic Heater Switch
- M—Arctic Heater Indicator

MONITOR PANEL

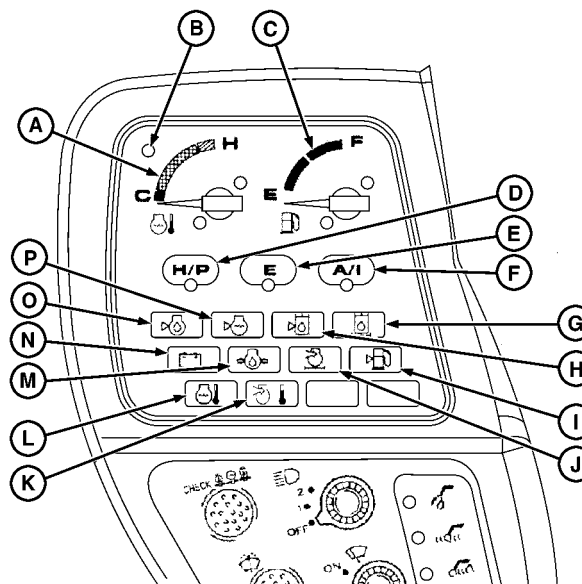

T120386

T120386 -UN-25MAR99

- A—Engine Coolant Temperature Gauge
- B—Warm-up Indicator
- C—Fuel Gauge
- D—H/P (High Power) Mode Indicator
- E—E (Economy) Mode Indicator
- F—Auto-Idle Indicator
- G—Hydraulic Oil Filter Restriction Indicator (Model 230LCRD)
- H—Hydraulic Oil Level Indicator
- I—Fuel Level Indicator
- J—Air Filter Restriction Indicator
- K—Charge Air Temperature Indicator
- L—Engine Coolant Temperature Indicator
- M—Engine Oil Pressure Indicator
- N—Alternator Voltage Indicator
- O—Engine Oil Level Indicator
- P—Engine Coolant Level Indicator

ENGINE COOLANT TEMPERATURE GAUGE

IMPORTANT: If needle points to 'RED' zone, idle engine to bring back needle to 'GREEN' zone before stopping engine. If needle continues to rise, shut engine OFF.

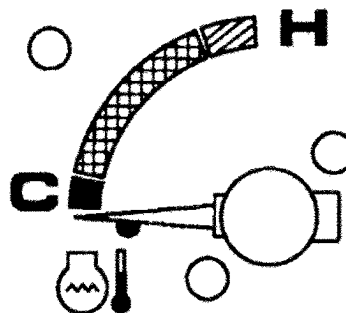

TX,10,DH5451 -19-25JUN96-1/1

T101569 -UN-11JUL96

WARM-UP INDICATOR

Yellow indicator will turn off when the engine coolant temperature reaches approximately 30°C (86°F).

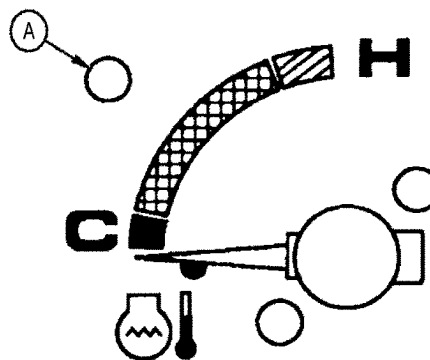

TX,10,DH5453 -19-04MAR97-1/1

T101574 -UN-11JUL96

FUEL GAUGE

Fuel machine before needle reaches "E".

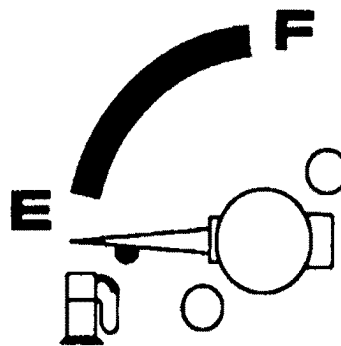

TX,10,DH5454 -19-04JUN96-1/1

T101570 -UN-11JUL96

H/P (HIGH POWER) MODE INDICATOR

Green indicator will light when the H/P mode switch is turned on.

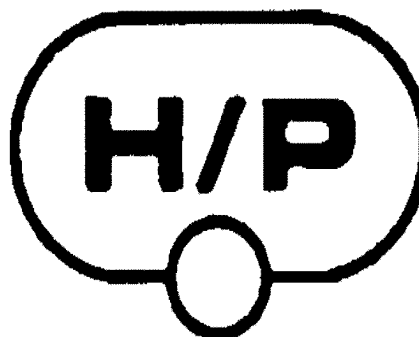

TX,10,DH5455 -19-11JUL96-1/1

T101571 -UN-11JUL96

Operator's Station

E (ECONOMY) MODE INDICATOR

Green indicator will light when the E mode switch is turned on.

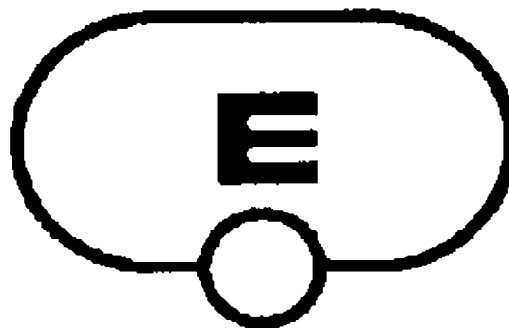

T101572 -UN-11JUL96

TX,10,DH5456 -19-17JUN96-1/1

AUTO-IDLE INDICATOR

Green indicator will light when the auto-idle switch is turned on.

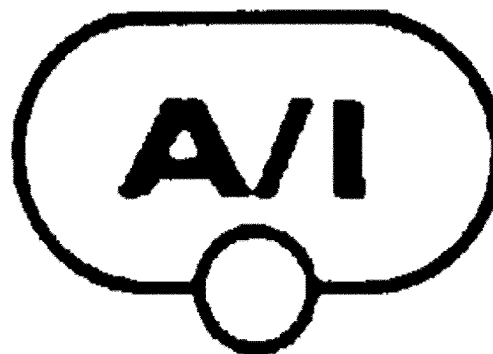

T101573 -UN-11JUL96

TX,10,DH5457 -19-17JUN96-1/1

HYDRAULIC OIL LEVEL INDICATOR

Park machine on level ground.

Position machine with arm cylinder fully retracted and bucket cylinder fully extended.

Pressing the level check switch before starting the machine will turn the indicator on if oil level is adequate for operation.

NOTE: This check does NOT take the place of daily inspection.

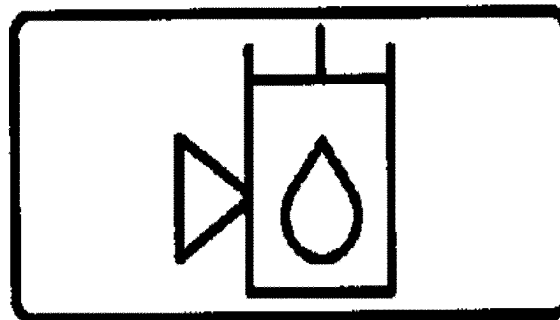

T101577 -UN-27JUN96

TX,10,DH5458 -19-04JUN96-1/1

HYDRAULIC OIL FILTER RESTRICTION INDICATOR (MODEL 230LCRD)

IMPORTANT: Prevent possible hydraulic pump damage. Change hydraulic oil filter as soon as possible when a problem occurs.

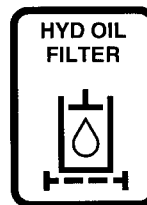

Indicator light will light and service required indicator light will light when filter elements are restricted. Change filter elements.

NOTE: Cold oil may cause hydraulic oil filter restriction indicator light to light temporarily.

T8881AG -UN-03JAN95

CED,OUOE020,16 -19-03MAR99-1/1

FUEL LEVEL INDICATOR

When red fuel indicator lights, approximately 30 liters (8 gal.) of fuel remain.

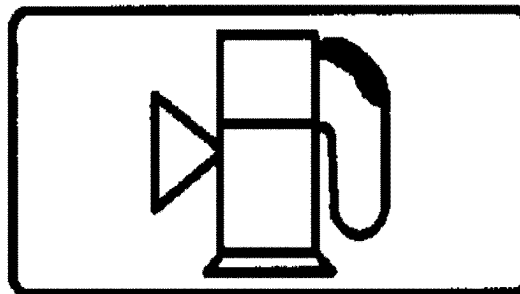

T101578 -UN-27JUN96

TX,10,DH5459 -19-25JUN96-1/1

AIR FILTER RESTRICTION INDICATOR

Red indicator will light when the air filter elements are clogged. Clean or replace elements.

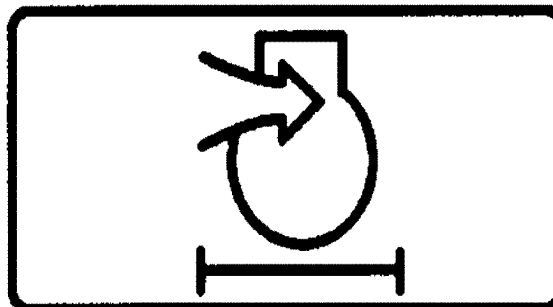

T101580 -UN-27JUN96

TX,10,DH5460 -19-04JUN96-1/1

ENGINE COOLANT TEMPERATURE INDICATOR

IMPORTANT: Do not stop engine when coolant temperature light comes on or temperature will rise further. Reduce load and run engine at slow idle. If temperature light continues to stay ON, shut engine OFF.

Red indicator will light and buzzer will sound when the engine coolant overheats. Reduce load immediately and run engine at slow idle. Inspect for debris around radiator. Check for low coolant level in the radiator recovery tank.

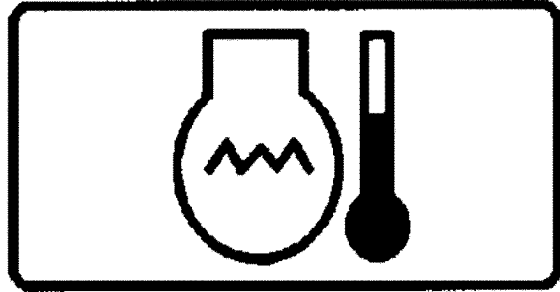

T101581 -UN-11JUL96

TX,10,DH5461 -19-04JUN96-1/1

CHARGE AIR TEMPERATURE INDICATOR

IMPORTANT: Prevent possible engine damage. If charge air indicator light comes on while operating, stop engine.

Red indicator will light when air intake temperature is excessively high. Stop engine. Check for debris on charge air cooler inlet screens. Check fan for proper operation. A clogged charge air system will reduce engine performance.

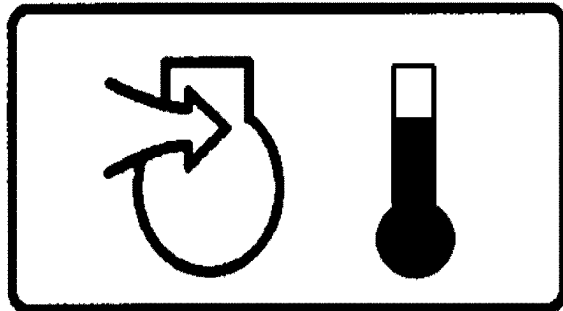

T107672 -UN-27FEB97

TX,10,DH5712 -19-21APR97-1/1

ENGINE OIL PRESSURE INDICATOR

IMPORTANT: If engine oil pressure light comes on while operating, stop engine immediately.

Red indicator will light and buzzer will sound when engine oil pressure is low. Stop engine immediately.

NOTE: Cold oil, low oil level, or extreme off level operation may cause indicator to light.

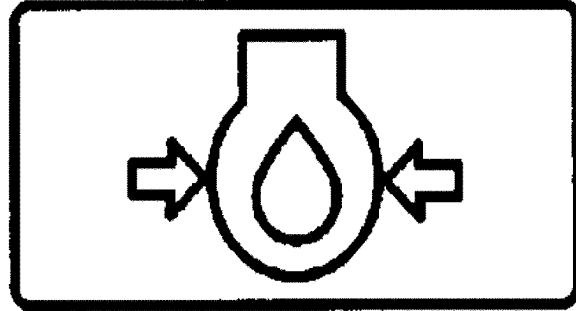

T101579 -UN-27JUN96

TX,10,DH5462 -19-04JUN96-1/1

ALTERNATOR VOLTAGE INDICATOR

Indicator will light with no alternator output. Check electrical system.

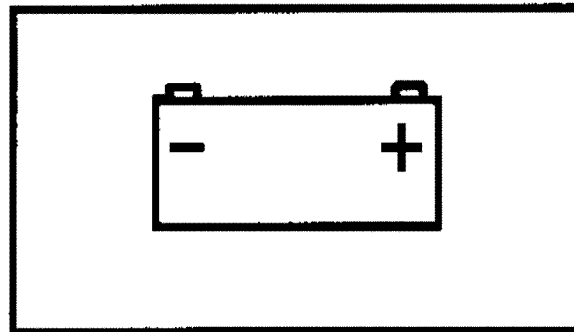

T101582 -UN-27JUN96

TX,10,DH5463 -19-09APR92-1/1

ENGINE OIL LEVEL INDICATOR

Pressing the level check switch before starting the machine will turn the indicator on if oil level is adequate for operation.

NOTE: This check does NOT take the place of daily inspection.

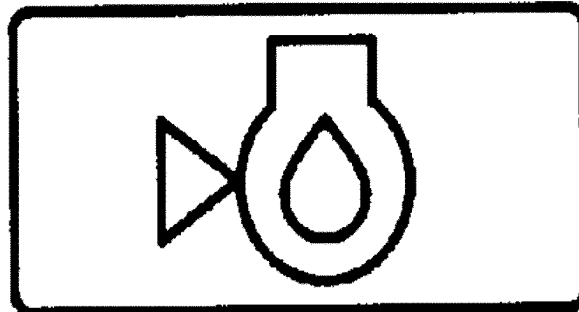

T101575 -UN-27JUN96

TX,10,DH5464 -19-18JUN96-1/1

COOLANT LEVEL INDICATOR

Pressing the level check switch before starting the machine will turn the indicator on if coolant level is adequate for operation.

NOTE: This check does NOT take the place of daily inspection.

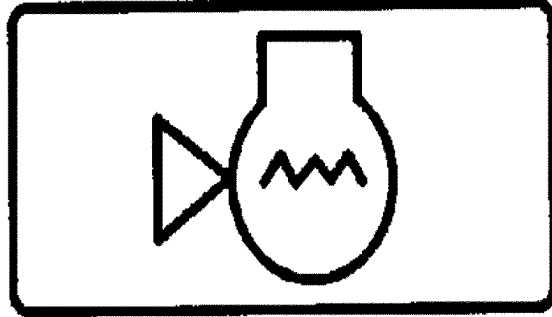

T101576 -UN-27JUN96

TX,10,DH5465 -19-04JUN96-1/1

SWITCH PANEL

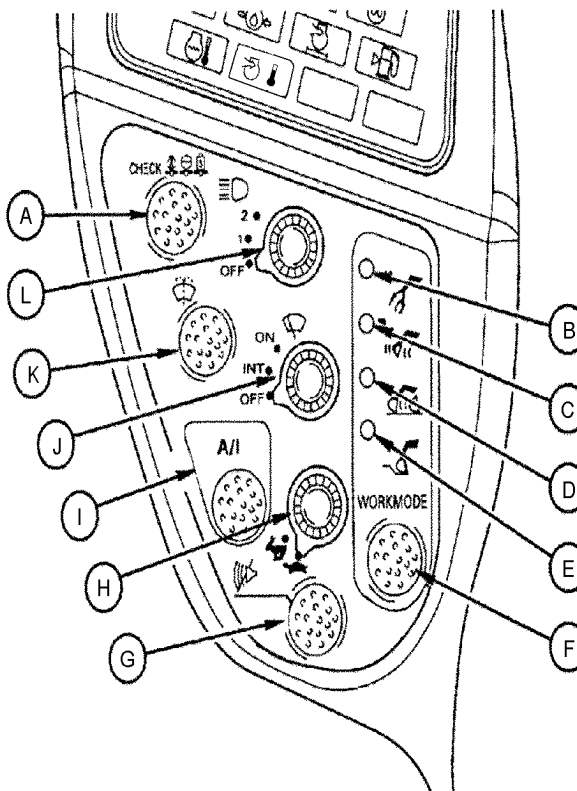

T107673 -UN-27FEB97

- A—Level Check Switch
- B—Attachment Mode Indicator
- C—Precision Mode Indicator
- D—Grading Mode Indicator
- E—Dig Mode Indicator
- F—Work Mode Switch
- G—Buzzer Stop Switch
- H—Propel Speed Switch
- I—Auto-idle Switch
- J—Wiper Switch
- K—Washer Switch
- L—Operating Lights Switch

BUZZER AND BUZZER STOP SWITCH

THE BUZZER SOUNDS WHEN:

- Engine oil pressure is low (indicator light (C) will also light). If engine oil pressure is low, stop the engine immediately.

NOTE: The buzzer cannot be turned off when engine oil pressure is low.

- Engine coolant overheats (indicator light (B) will also light). If coolant temperature is high, push buzzer stop switch (A), reduce load immediately, and run engine at decreased engine speed. If high temperature continues, stop the engine. Check fluid levels.

When the buzzer stop switch is pushed and released the buzzer stops sounding and the buzzer function is automatically reset for the engine coolant overheat function.

TO RESET THE BUZZER:

Turn the key switch to OFF. The buzzer will not sound more than once for the same problem unless the switch is reset.

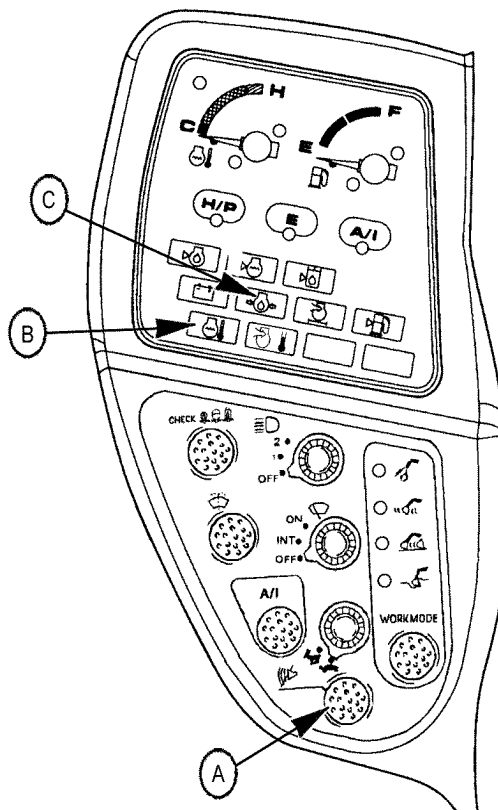

T107674 -UN-27FEB97

TX,10,DH5832 -19-24JUL97-1/1

WIPER SWITCH

Wiper switch (A) has three positions.

- INT position.....Wiper starts operating intermittently.
- ON position.....Wiper operates continuously
- OFF position.....Wiper automatically stops operating.

NOTE: The wiper and washer do not operate unless the upper front window is closed and the right-side lock pin is installed.

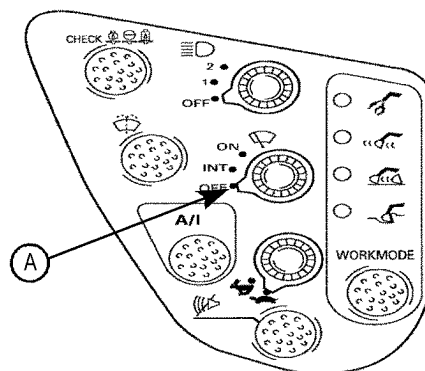

T101626 -UN-20JUN96

TX,10,DH5468 -19-18JUN96-1/1

WASHER SWITCH

IMPORTANT: Washer motor may be damaged if washer switch is held down for more than 20 seconds, or continually operated with no fluid in container.

Push switch (A) to squirt windshield washer fluid on windshield. Do not hold down switch for more than 20 seconds.

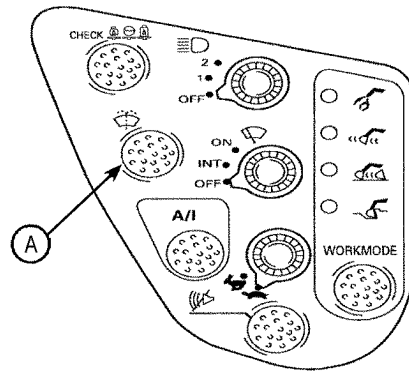

T101627 -UN-20JUN96

TX,10,DH5469 -19-04JUN96-1/1

OPERATING LIGHTS SWITCH

Turn light switch (A) to first position to turn on light (C).

Turn light switch to second position to turn on lights (B and C).

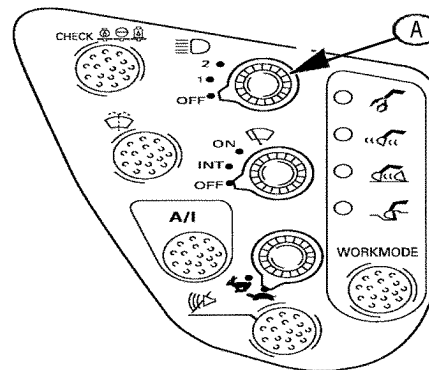

T101591 -UN-27JUN96

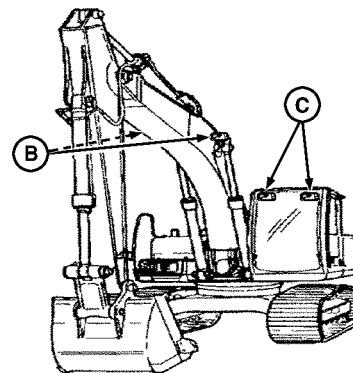

T120793

T120793 -UN-25MAR99

CED,OUOE042,23 -19-05MAR99-1/1

Operator's Station

OPERATING REAR LIGHTS SWITCH

Move switch (A) to turn the rear outside work lights on or off.

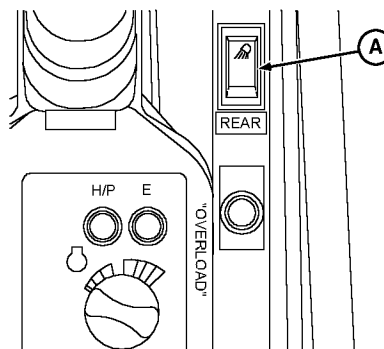

T120402

T120402 -UN-25MAR99

CED.OUOE042,19 -19-03MAR99-1/1

CAB LIGHT

Move switch (A) to turn the inside cab light on or off.

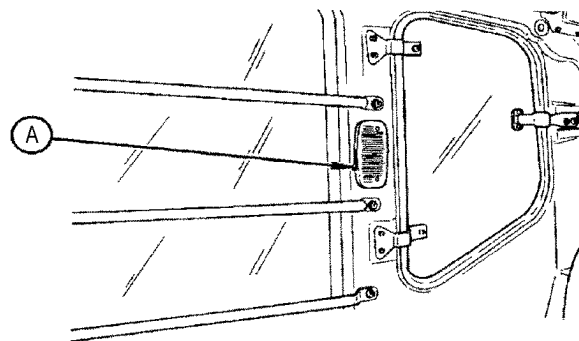

T101592 -UN-27JUN96

TX,10,DH5471 -19-18JUN96-1/1

OVERLOAD ALARM AND INDICATOR

The overload alarm and indicator (A) will activate when the digging capacity is exceeded, while the machine is digging from the side.

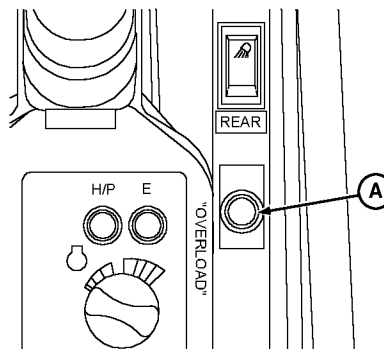

T120413

T120413 -UN-25MAR99

CED.OUOE020,18 -19-03MAR99-1/1

KEY SWITCH

Engine will stop when key switch is turned from ON to ACC. Always turn key to OFF position to prevent batteries from draining.

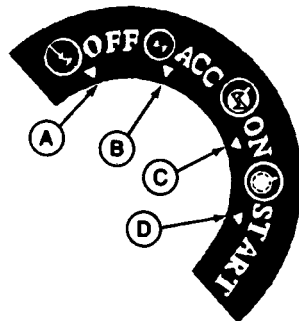

- A—Engine Off
- B—Accessory
- C—Engine On
- D—Start

T7396DS -UN-27JUN91

TX,10,DH5472 -19-29MAY96-1/1

ENGINE RPM DIAL

Use engine rpm dial (A) to adjust engine speed. Turn dial clockwise to increase engine speed or counterclockwise to decrease engine speed.

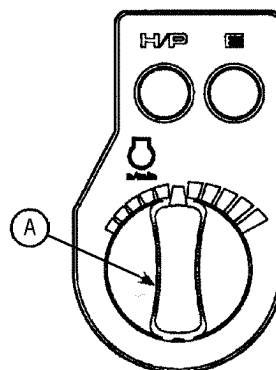

T101628 -UN-20JUN96

TX,10,DH5473 -19-19JUN96-1/1

POWER BOOST SWITCH

Power boost switch (A) is located on top of right control lever.

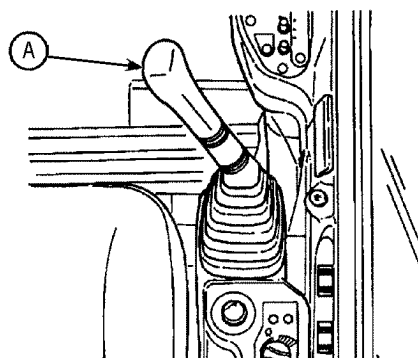

T101633 -UN-20JUN96

TX,10,DH5591 -19-22MAR97-1/1

Operator's Station

HORN

Horn switch (A) is located on top of left control lever.

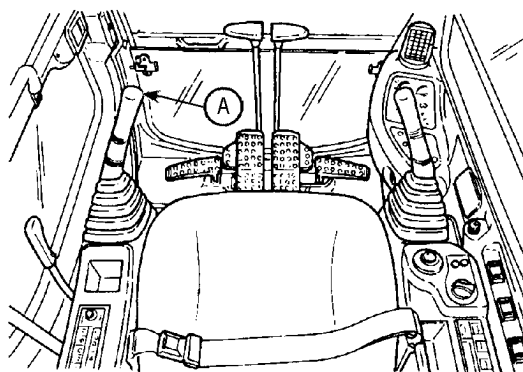

T101634 -UN-20JUN96

TX,10,DH5475 -19-04JUN96-1/1

HOURLY METER

The right hand number on the hour meter (A) indicates tenths of an hour (six minutes).

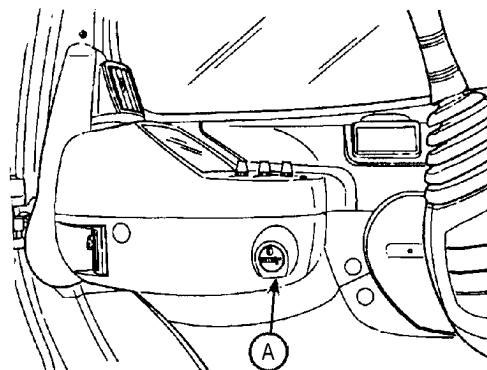

T101639 -UN-26JUN96

TX,10,DH5476 -19-24JUN96-1/1

CAB HEATER AND AIR CONDITIONER

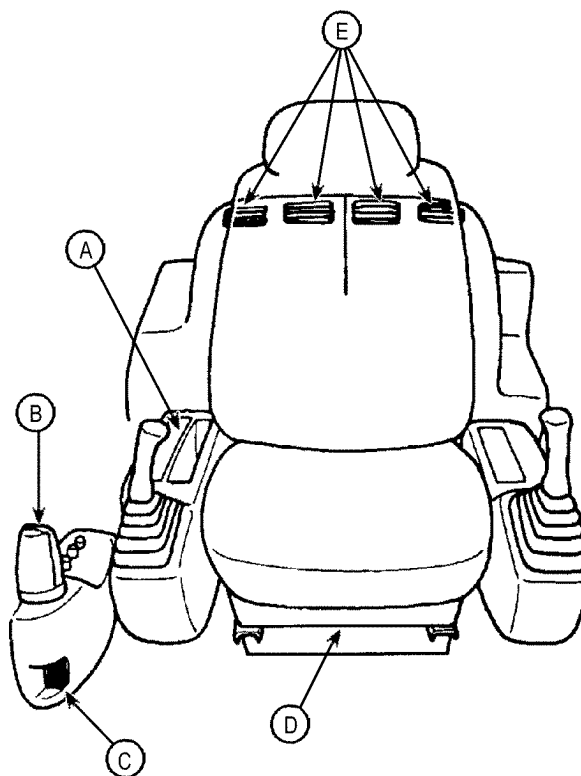

- A—Control Panel
- B—Front Vent
- C—Defroster Vent
- D—Foot Vent
- E—Rear Vents

T101645 -JUN-20JUN96

TX,10,DH5480 -19-19JUN96-1/1

CONTROL PANEL SWITCHES

Mode Switches

- (A) Air flows out of front vent and defroster vent.
- (B) Air flows out of front and rear vents, and defroster vent.
- (C) Air flows out of foot vent only.

Temperature Control Switches

Eight indicators are situated just above the temperature control switches (I). The indicators will turn red when the right arrow switch is pressed, and green when the left arrow switch is pressed. Air temperature is highest if all indicators are red, and coolest if all indicators are green. Either warm or cool air will flow out of vent(s) selected by the mode switches.

Blower Switches

Press blower switches (G) to select desired blower speed. Air conditioner will turn on when A/C switch (D) is pressed and any of the blower indicators is on. When blower OFF switch (H) is pressed, the blower and the air conditioner will turn off. The blower will turn on if one of the blower switches is pressed whether the air conditioner switch is turned on or off.

Fresh Air Vent Switch

Press fresh air vent switch (F) to route outside air into the cab. Press air vent switch (E) to close fresh air vent and circulate air already in cab.

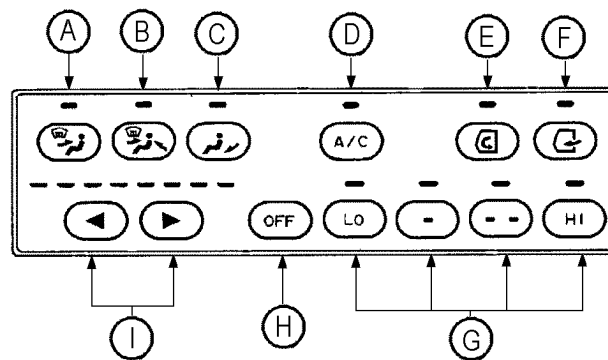

- A—Mode Switch
- B—Mode Switch
- C—Mode Switch
- D—Air Conditioner Switch
- E—Air Vent Switch
- F—Fresh Air Vent Switch
- G—Blower Switches
- H—Blower OFF Switch
- I—Temperature Control Switches

T102753 -JUN-05AUG96

CAB HEATER OPERATION

1. Press desired mode switch (A, B, or C).
2. Press right temperature control switch (I) until all indicators are red.
3. Press blower switch (G) to select desired blower speed.
4. Press air conditioner switch (D) to turn indicator off if not already off.
5. Press temperature control switches and blower switches to adjust cab temperature

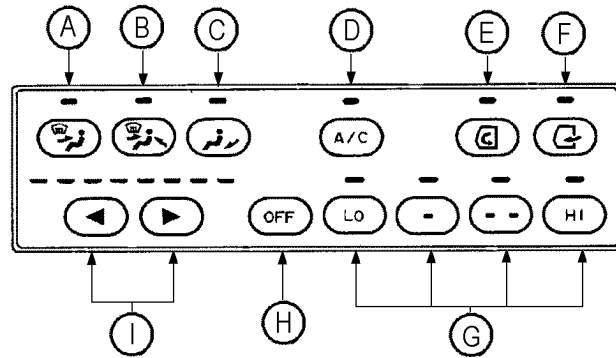

T102753 -UN-05AUG96

TX,10,DH5633 -19-26MAR97-1/1

AIR CONDITIONER OPERATION

1. Press desired mode switch (A, B, or C).
2. Press left temperature control switch (I) until all indicators are green.
3. Press blower switch (G) to select desired blower speed.
4. Press air conditioner switch (D) to turn indicator green if not already green.
5. Press temperature control switches and blower switches to adjust cab temperature

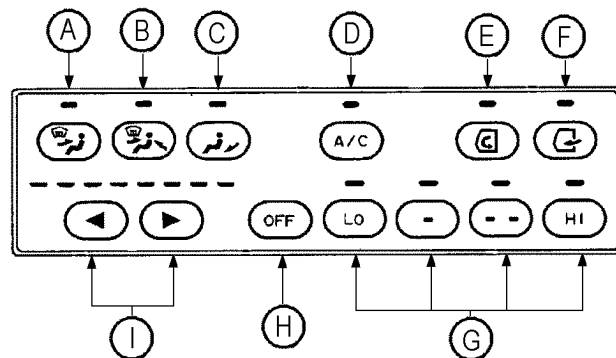

T102753 -UN-05AUG96

TX,10,DH5483 -19-20JUN96-1/1

DEFROSTER OPERATION

1. Press front vent mode switch (A) or rear vent mode switch (B).
2. Press temperature control switches (I) to select desired air temperature.
3. Press fresh air vent switch (F).
4. Press blower switches (G) to select desired blower speed.
5. Adjust the louvers on front vent and defroster vent as required.
6. Press temperature control switches and blower switches to adjust cab temperature.
7. Press air conditioner switch (F) on if windows become clouded or if dehumidifying is required.

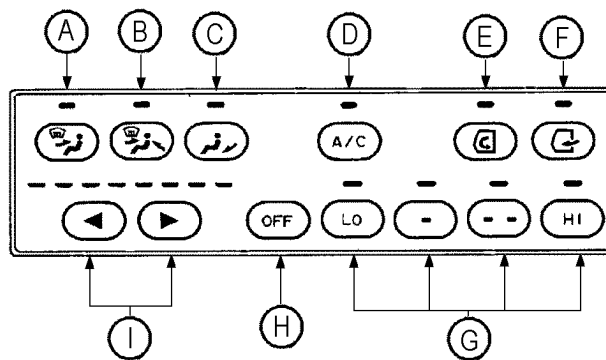

T102753 -UN-05AUG96

TX,10,DH5484 -19-20JUN96-1/1

FRONT CONSOLE

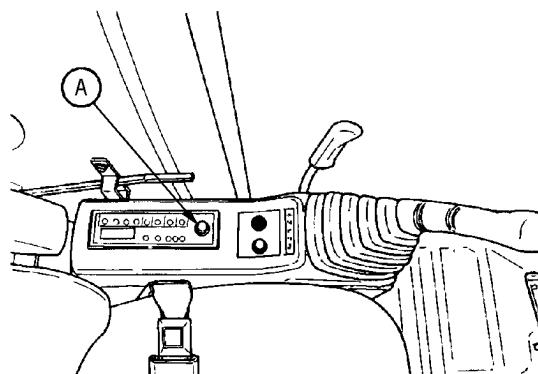

A—Radio/Clock

T101647 -UN-07AUG96

TX,10,DH5485 -19-20JUN96-1/1

Operator's Station

OPERATING THE AM/FM RADIO

Press power switch (A) to turn radio on, and repeatedly press one of tuning switches (D) until desired station is reached. To preset a station, select the desired station using tuning switches. Press and hold station preset (F) for more than 2 seconds until an electronic tone is heard. The frequency of the preset station will be indicated on digital display (G).

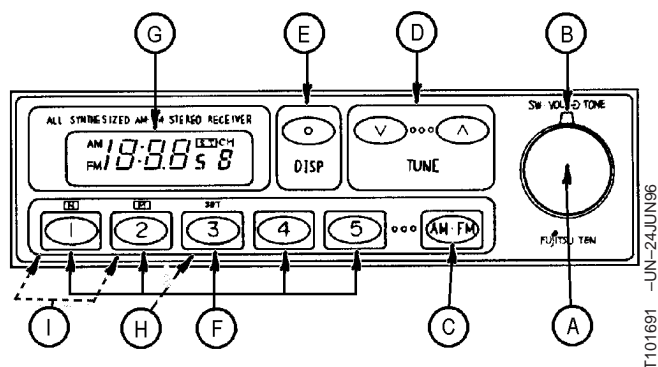

- A—Power Switch/Volume Control Knob
- B—Tone Adjustment Ring
- C—AM/FM Switch
- D—Tuning Switches
- E—Display Mode Change Switch
- F—Station Presets
- G—Digital Display
- H—Set Switch
- I—Time Set Switches

TX,10,DH5486 -19-06JUN96-1/1

SETTING THE CLOCK

NOTE: In order to set the clock, digital display (B) must be in the time display mode.

While pressing display mode change switch (A) use time set switches (C) and set switch (D) to set the clock.

Press set switch to reset the minute display to "00".

Press time set switch (H) to set correct hour.

Press time set switch (M) to set correct minute.

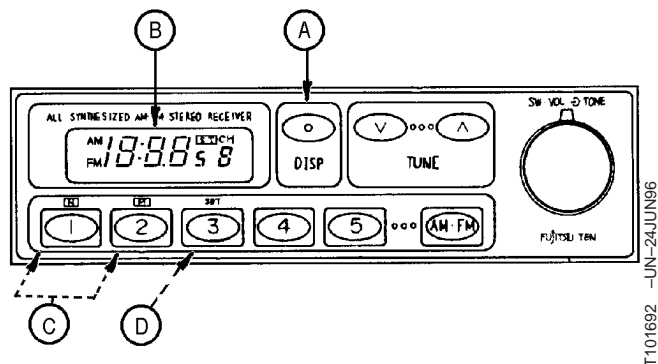

- A—Display Mode Change Switch
- B—Digital Display
- C—Time Set Switches
- D—Set Switch

TX,10,DH5487 -19-06JUN96-1/1

Operator's Station

CAB DOOR RELEASE LEVER

The cab door can be locked in the open position. Open the door all the way until it locks in the latch on the side of the cab.

To release the door from this locked position, push down on lever (A).

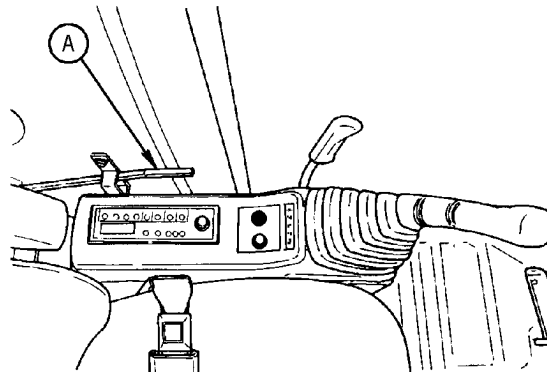

T101648 -UN-07AUG96

TX,10,DH5488 -19-04JUN96-1/1

SECONDARY EXIT TOOL

IMPORTANT: FOR SECONDARY EXIT. Use tool (A) to break window. Always keep tool in machine.

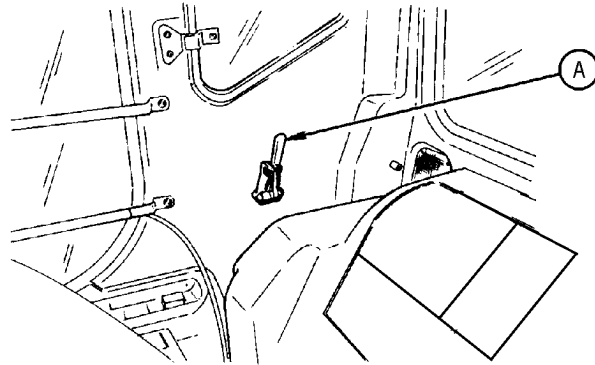

T105379 -UN-26NOV96

TX,10,DH5967 -19-26NOV96-1/1

OPENING UPPER FRONT (SECONDARY EXIT) WINDOW

NOTE: The washer and wiper cannot operate with the upper front window opened.

1. Move lock pins (A) toward center of window.

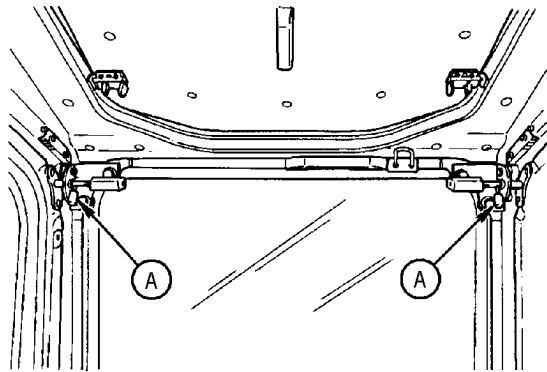

T101649 -UN-26JUN96

Continued on next page

TX,10,DH5489 -19-04JUN96-1/2

Operator's Station

2. Pull window up and back until it catches in latch (B) for convenient storage overhead.

CAUTION: Prevent possible injury from window closing. **DO NOT** rely on latch (B) alone to hold the window in the up position. Always lock the pins in the cab frame boss holes.

3. Slide the two pins (C) into the cab frame boss holes and turn to lock.

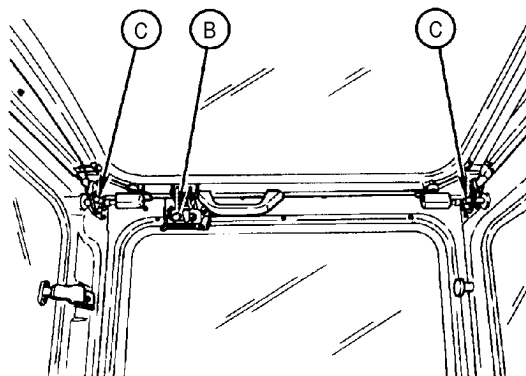

T101650 -UN-24JUN96

TX,10,DH5489 -19-04JUN96-2/2

CLOSING UPPER FRONT WINDOW

CAUTION: Prevent possible injury from window closing. Upper front window comes down very forcefully. Close window only when sitting on operator's seat. Guide window down slowly.

1. Pull out lock pins (A) to unlock window.

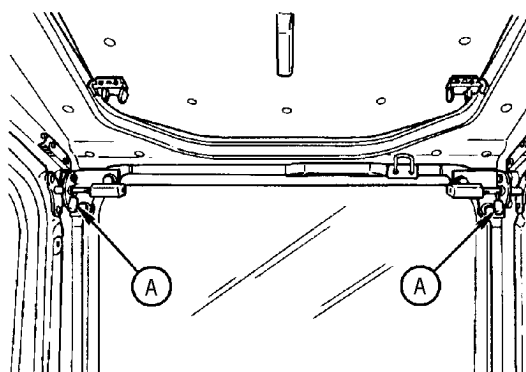

T101649 -UN-26JUN96

TX,10,DH5490 -19-21JUN96-1/2

2. Push lever (B) to release latch.
3. Pull window down slowly.
4. Slide the two pins (C) into the cab frame boss holes and turn to lock.

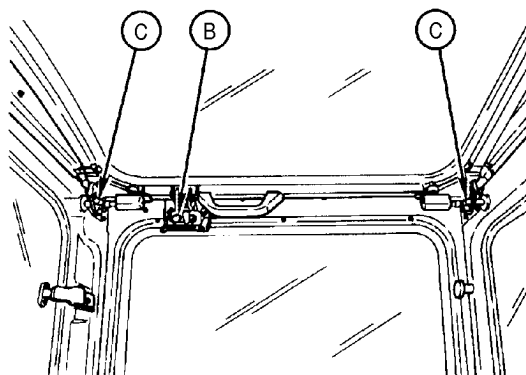

T101650 -UN-24JUN96

TX,10,DH5490 -19-21JUN96-2/2

Operator's Station

REMOVING AND STORING THE LOWER FRONT WINDOW

NOTE: Upper front window must be raised before lower front window can be removed.

1. Pull in on lock pins (A) to unlock and remove window.

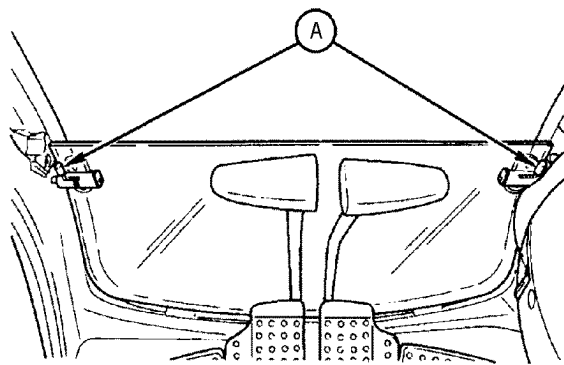

T101651 -UN-24JUN96

TX,10,DH5491 -19-27FEB97-1/2

2. The window can be stored by inserting tabs on bottom of window into brackets (B) and locking the pins into holes (C) located below rear window in cab.

NOTE: In cold weather some operators may choose to work with the top glass open and the bottom glass in place. This provides excellent visibility and tends to hold the heat being circulated around the operator's feet.

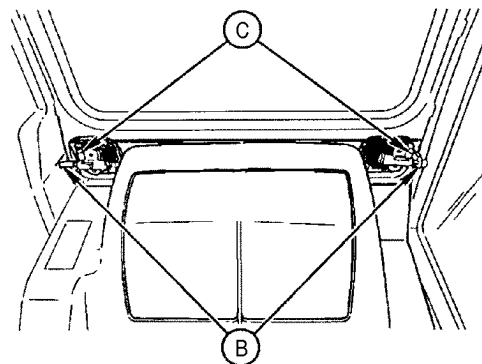

T105380 -UN-26NOV96

TX,10,DH5491 -19-27FEB97-2/2

OPENING SIDE WINDOWS

CAUTION: Avoid serious crushing injury from boom. Never place any part of body beyond window bar or frame. It could be crushed by the boom if boom control lever is accidentally bumped or otherwise engaged.

Do not remove window bars. If window or bars are missing or broken, replace immediately.

Both right side window and cab door window can be opened.

1. Right-rear side window: Unlatch the lock (A). Push joint part of lock to open window.
2. Cab door window: Slide front pane to the rear and rear pane to the front.

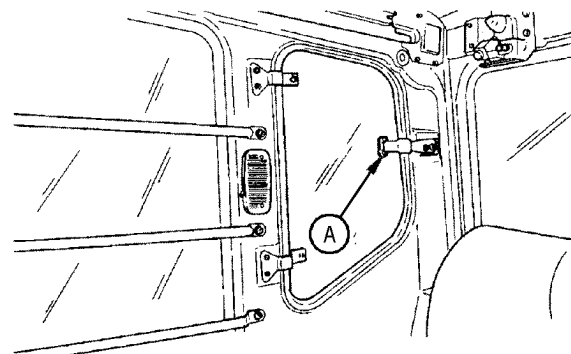

T101653 -UN-24JUN96

TX,10,DH5492 -19-04JUN96-1/1

OPENING AND CLOSING THE ROOF EXIT COVER

Opening:

1. Move lock pins (A) toward center of roof exit cover.
2. Push on handle (B) to open roof exit cover.

Closing:

Hold handle and pull cover down until pins lock in position.

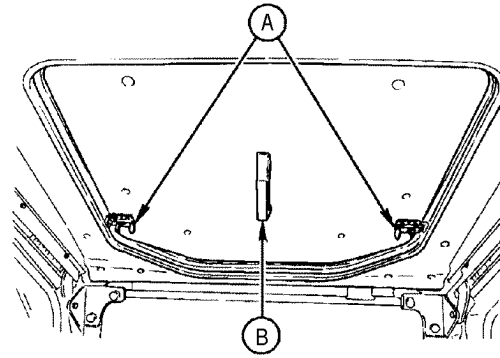

T101654 -UN-24JUN96

TX,10,DH5944 -19-01DEC97-1/1

REMOVING AND STORING FIRE EXTINGUISHER (MODEL 230LCR)

NOTE: On model 230LCRD the fire extinguisher is mounted in the battery compartment.

REMOVING

1. Pull the latch (A) outward.
2. Remove extinguisher.

STORING

1. Insert extinguisher into the seat.
2. Close latch assembly (A).

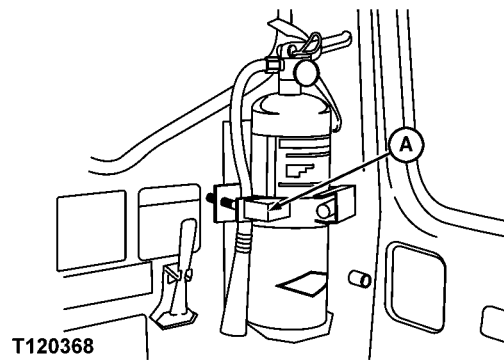

T120368

A—Latch Assembly

T120368 -UN-25MAR99

TX,OUOE042,10 -19-19FEB99-1/1

ROCK DRILL START—STOP SELECTION CONTROL BOX (MODEL 230LCRD)

Set the selector switch (B) to the B position for normal excavator operation.

Set the selector switch (B) to the A position to activate the electrical and hydraulic circuits for the rock drill. When set to the A position, all pilot hydraulics for the excavator are neutralized.

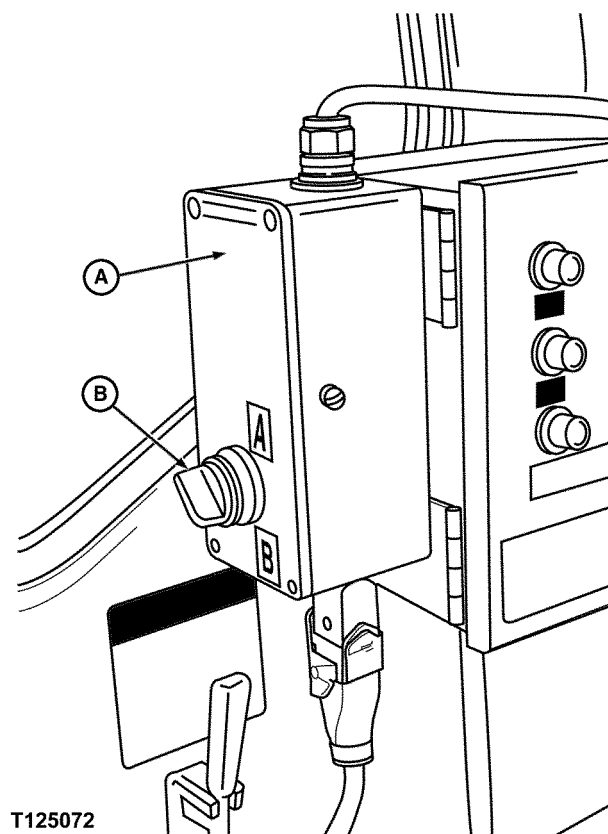

T125072

T125072 -UN-28OCT99

A—Rock Drill Start—Stop Selection Control Box
B—Selector Switch

CED,OUOEBAS.1 -19-19JAN00-1/1

COMPRESSOR REMOTE INSTRUMENT CONTROL PANEL (MODEL 230LCRD)

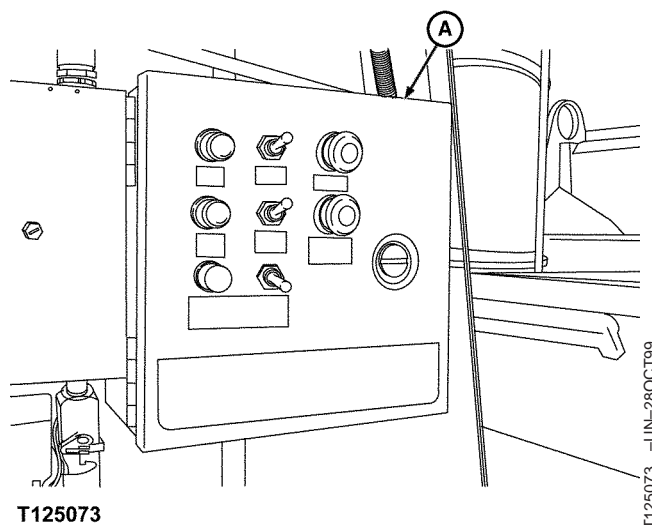

A—Compressor Remote Instrument Control Panel

CED,OUOE042,47 -19-19OCT99-1/1

REMOVING AND STORING RIFLE

REMOVING

1. Open latch (A) and remove barrel.
2. Lift rifle from saddle.

STORING

1. Insert rifle butt into saddle.
2. Snap barrel into latch (A).

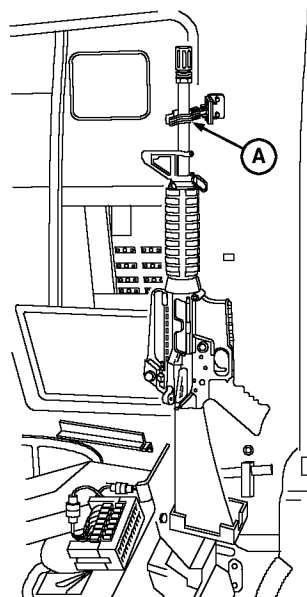

A—Latch

TX,OUOE042,11 -19-19FEB99-1/1

Operator's Station

J-HOOKS

The J-Hooks (A) are used to hang the operator's Load Bearing Equipment (LBE) and individual chemical equipment bag.

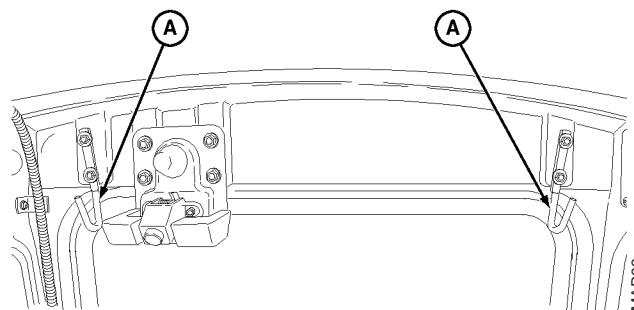

T120374

A—J-Hooks

T120374 -UN-25MAR99

TX,OUOE042,12 -19-19FEB99-1/1

TOOLBOX SECURITY HASP

The toolbox security hasp (A) is located on the inside corner of the toolbox. The hasp is used to secure the toolbox.

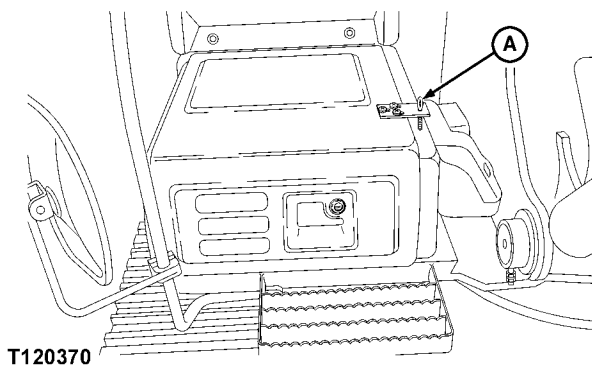

T120370

A—Toolbox Security Hasp

T120370 -UN-25MAR99

TX,OUOE042,16 -19-01MAR99-1/1

DECONTAMINATION KIT BRACKET

The decontamination kit bracket (A) is located between the toolbox and the boom. The decontamination kit is secured with a strap (B).

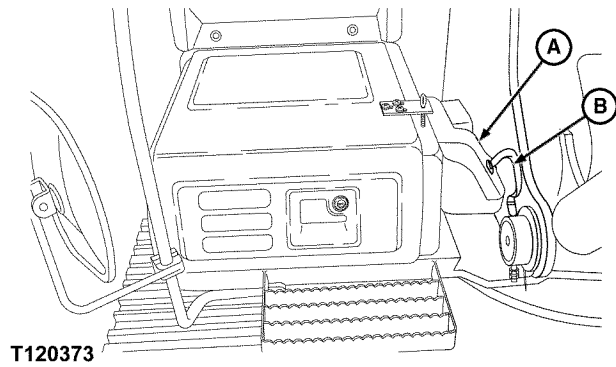

T120373

T120373 -UN-28OCT99

A—Decontamination Kit Bracket
B—Strap

TX,OUOE042,17 -19-01MAR99-1/1

VANDAL PROTECTION PANEL STORAGE

The upper section of the windshield panel stores on the left front access door of the machine. Use knob (A) to secure the panel to the door. The remaining panels store in the box (B) atop the machine.

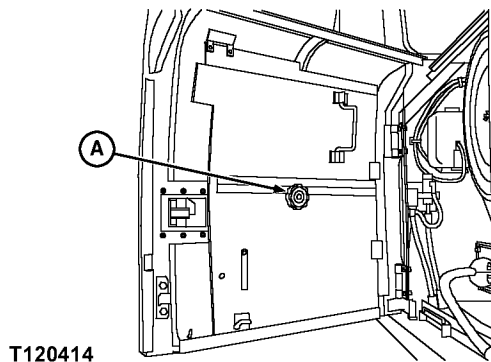

T120414

T120414 -UN-25MAR99

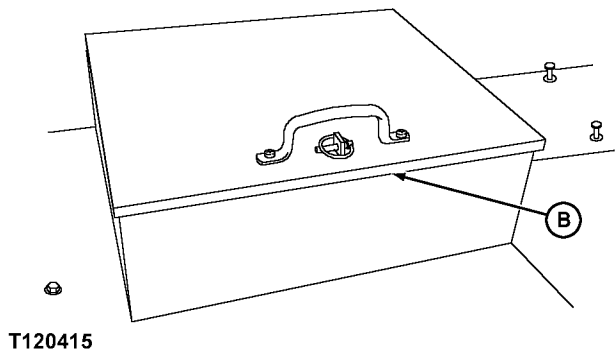

T120415

T120415 -UN-25MAR99

A—Knob
B—Storage Box

TX,OUOE042,20 -19-04MAR99-1/1

Operator's Station

ADJUSTING THE SEAT

Turn knob (A) to adjust seat to weight of operator. Weight is displayed on knob.

Push down lever (B) while sitting on seat or while standing and pulling up on seat to obtain desired height. Release lever. Push down lever while sitting on seat to adjust seat to desired angle. Release lever.

Push down lever (C) to adjust seat and both right and left consoles to desired distance from travel pedals and levers. Release lever to lock seat and consoles into position.

Pull up lever (D) to unlock seat from both consoles. Slide the seat to desired distance from control levers. Release lever.

Pull up lever (E) to release backrest lock. Move backrest to desired position and release lever.

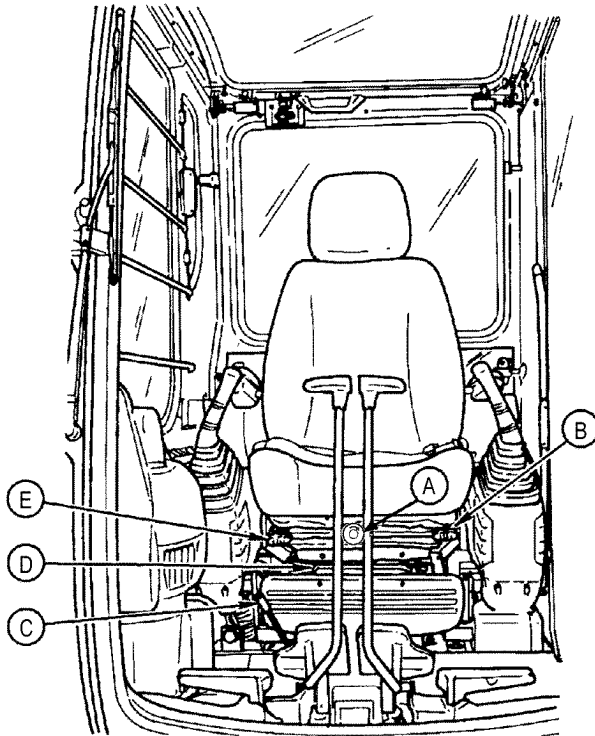

T102204 - JUN-26JUL96

- A—Weight Adjustment Knob
- B—Seat Height And Angle Adjustment
- C—Console And Seat Fore-Aft Adjustment Lever
- D—Seat Fore-Aft Adjustment
- E—Backrest Adjustment

TX,10,DH5494 -19-29JUL96-1/1

Operator's Station

ADJUSTING THE ARMREST

Pull up on armrest (A) to move armrest out of way when exiting.

Turn dial (B) to adjust angle of armrest.

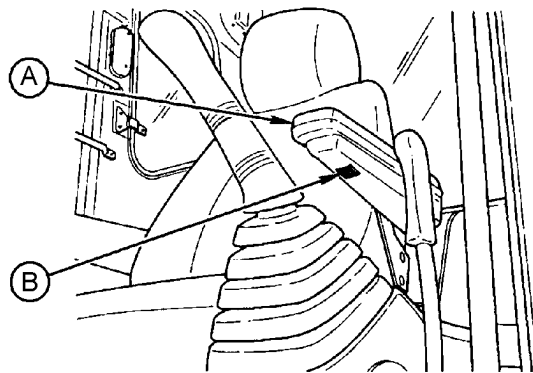

A—Armrest
B—Dial

T107760 -UN-27FEB97

TX,10,DH5412 -19-27FEB97-1/1

SEAT BELT

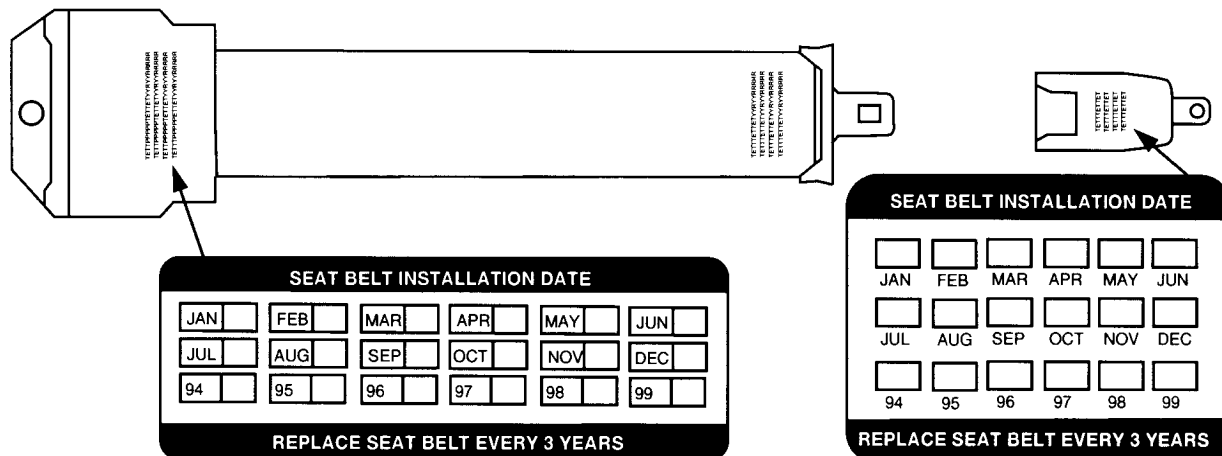

T8415AA -UN-09FEB95

Seat belt and mounting hardware must be inspected for wear or damage before operating the machine. Replace the belt or mounting hardware if worn or damaged.

Replace the complete seat belt assembly every three years regardless of appearance. A date label, to determine the age of the belt, is attached to each belt.

TX,10,DH3548 -19-22MAR99-1/1

OPERATOR'S MANUAL COMPARTMENT

Store operator's manual behind the seat.

TX,10,DH5064 -19-24JUN96-1/1

CHAPTER 3

BREAK-IN

BLANK

Break-In

ENGINE BREAK-IN OIL

New engines are filled at the factory with John Deere ENGINE BREAK-IN OIL. This is an SAE 5W-30 viscosity oil. During the break-in period (first 100 hours), add oil as needed to maintain the specified oil level. (See Fuels and Lubricants chapter.)

If at any time during the break-in period, the engine is exposed to air temperatures below -25°C (-13°F), change the oil and filter using specified oil. (See Fuels and Lubricants chapter.)

Change the oil and filter after the first 100 hours of operation. Refill with specified oil. (See Fuels and Lubricants chapter.)

- API Service Classification CE

- CCMC Specification D4

After the break-in period, use John Deere PLUS-50® or other diesel engine oil as recommended in this manual.

IMPORTANT: Do not use John Deere PLUS-50® oil or engine oils meeting API CG4, API CF4, or CCMC D5 performance levels during the first 100 hours of operation of a new or rebuilt engine. These oils will not allow the engine to break-in properly.

PLUS-50 is a trademark of Deere & Company.

CED,OUOE020,50 -19-13APR99-1/1

EVERY 4 HOURS

Lubricate boom, arm, and bucket linkage every 4 hours for the first 20 hours of operation. (See Maintenance—Every 50 Hours chapter.)

TX,15,DH5496 -19-12JUL96-1/1

*Break-In***EVERY 10 HOURS OR DAILY**

1. Perform 10 hours or daily service. (See Maintenance—Every 10 Hours or Daily chapter.)
2. Watch for fluid leaks.
3. Lubricate working tool pivots every 10 hours during the first 30—100 hours of operation and when working in mud or water. (See Maintenance—Every 50 Hours chapter.)

TX,15,DH5497 -19-12JUL96-1/1

AFTER THE FIRST 50 HOURS

1. Perform 10 hours or daily and 50 hour service. (See Maintenance—Every 10 Hours or Daily and Maintenance—Every 50 Hours chapters.)
2. Change hydraulic oil filter (See Maintenance—Every 500 Hours chapter) and pilot filter (See Maintenance—Every 1000 Hours chapter).
3. Check accessible hardware torque. (See Hardware Torque Specifications in Maintenance chapter.)

TX,15,DH5498 -19-06JUL94-1/1

AFTER THE FIRST 100 HOURS

1. Perform 10 hour or daily and 50 hour service. (See Maintenance—Every 10 Hours or Daily and Maintenance—Every 50 Hours chapters.)
2. Change engine oil and filter. (See Maintenance—Every 250 Hours chapter.)
3. Change fuel filter. (See Maintenance—Every 500 Hours chapter.)

BLANK

CHAPTER 4
PRE-START INSPECTION

BLANK

Pre-Start Inspection

INSPECT MACHINE DAILY BEFORE STARTING

Do periodic service checks in the Maintenance—Every 10 Hours or Daily chapter.

A—Check pedals and levers for freedom of movement.
Clean operator's station.

B—Check hydraulic reservoir oil level.

C—Check engine oil level.

D—Check coolant level at recovery tank.

E—Clean radiator and oil cooler fins.

ELECTRICAL SYSTEM: Check for worn or frayed wires and loose or corroded connections.

BOOM, BUCKET, SHEET METAL, TRACKS: Check for bent, broken, loose, or missing parts.

HARDWARE: Check for loose or missing parts.

FUEL SYSTEM: Drain fuel filter and fuel tank sump.

HYDRAULIC SYSTEM: Check for leaks, missing or loose clamps, kinked hoses, and lines or hoses that rub against each other or other parts.

LUBRICATION: Check lubrication points on Periodic Maintenance chart.

PROTECTIVE DEVICES: Check guards, shields, covers.

SAFETY: Walk around machine to clear all persons from machine area.

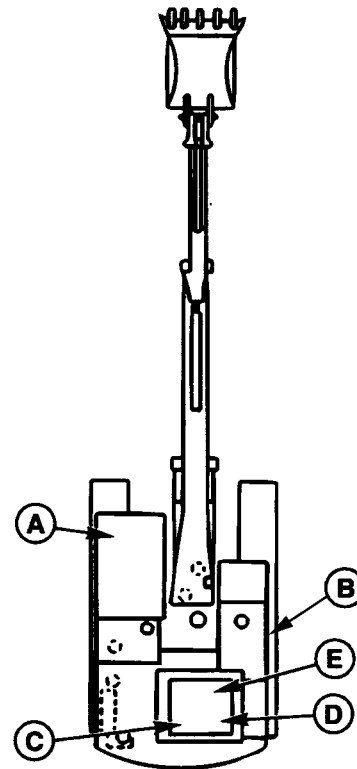

T105341 -UN-25NOV96

TX,20,DH5500 -19-25NOV96-1/1

BLANK

CHAPTER 5
OPERATING THE ENGINE

BLANK

Operating the Engine

CHECK INSTRUMENTS BEFORE STARTING

Turn key switch to ON position. All indicator lights will stay on for approximately 3 seconds.

The indicator lights will also stay on for approximately 3 seconds when the key switch is turned to START position.

If any lamp fails to light, the bulb may be burned out.

The fuel gauge will show the fuel level.

The coolant gauge should NOT go to the red zone.

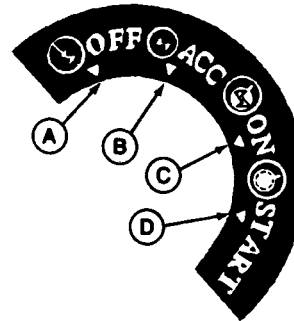

T7396DS -UN-27JUN91

TX,25,DH5501 -19-29MAY96-1/1

LEVEL CHECK

1. Turn key switch to ON position.
2. Press level check switch (A).
3. Hydraulic oil level (B) engine coolant level (C) and engine oil level (D) indicators will light if levels are adequate for operation.

IMPORTANT: The level check does NOT take the place of daily checks at hydraulic oil level window, engine coolant recovery tank, and engine oil level dipstick.

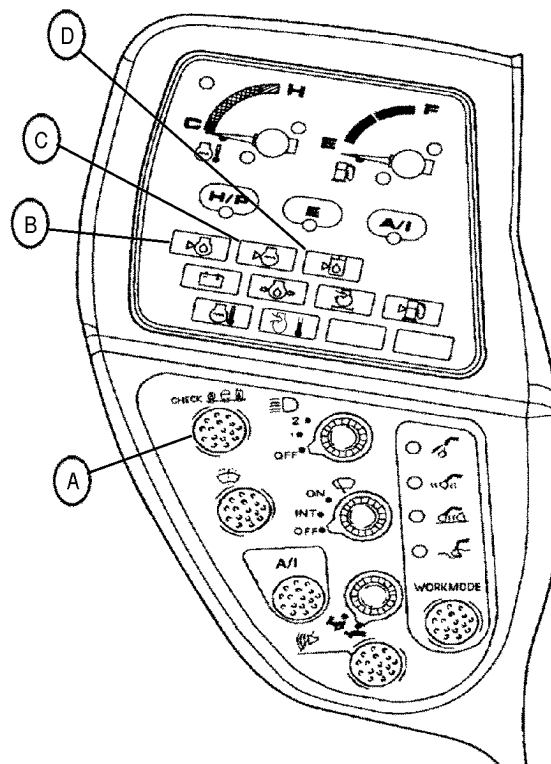

T107675 -UN-27FEB97

TX,25,DH5405 -19-27FEB97-1/1

STARTING THE ENGINE

IMPORTANT: Before starting the engine in extreme cold, unit must be prepared with proper grade lubricants.

1. Move engine rpm dial (A) to slow idle position.

IMPORTANT: Prevent starter damage. Never operate starter for more than 30 seconds at a time. If engine fails to start, return key switch to OFF. Wait for about 2 minutes, then try again. After a false start, do not turn key switch until engine stops.

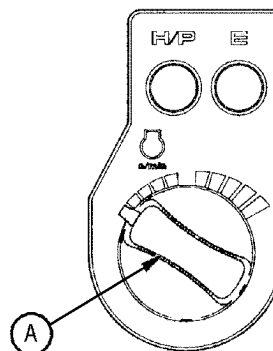

2. Sound horn to alert persons nearby.
3. Turn key switch to START. Release key; switch will return to ON position.

T101749 -JUN-27JUN96

TX,OUOE042.5 -19-17DEC99-1/1

USING BOOSTER BATTERIES—24 VOLT SYSTEM

Before boost starting, machine must be properly shut down to prevent unexpected machine movement when engine starts.

CAUTION: An explosive gas is produced while batteries are in use or being charged. Keep flames or sparks away from the battery area. Make sure the batteries are charged in a well ventilated area.

IMPORTANT: The machine electrical system is a 24-volt negative (-) ground. Connect two 12-volt booster batteries together in series as shown for 24 volts.

1. Connect one end of the positive cable to the positive terminal of the machine batteries and the other end to the positive terminal of the booster batteries.
2. Connect one end of the negative cable to the negative terminal of the booster batteries. Connect other end of the negative cable to the machine frame as far away from the machine batteries as possible.
3. Start engine. (See procedure on previous page.)
4. Immediately after starting engine disconnect end of the negative cable from the machine frame. Then disconnect the other end of the negative cable from the negative terminal of the booster batteries.
5. Disconnect positive cable from booster batteries and machine batteries.

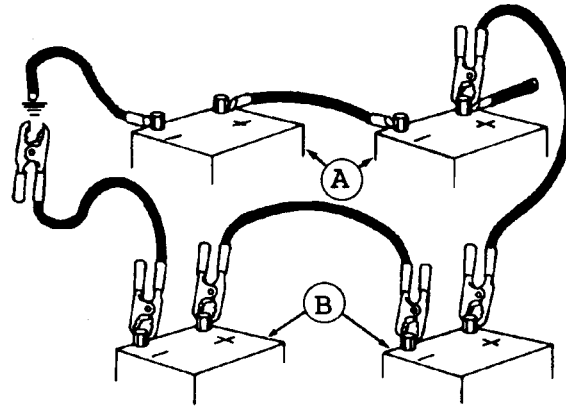

T6713AH1 (CV)

Two Battery Application

A—Machine Batteries
B—Booster Batteries

T6713AH1 -JUN-24OCT91

SLAVE RECEPTACLE—24 VOLT SYSTEM

Before boost starting, machine must be properly shut down to prevent unexpected machine movement when engine starts.



CAUTION: An explosive gas is produced while batteries are in use or being charged. Keep flames or sparks away from the battery area. Make sure the batteries are charged in a well ventilated area.

The slave receptacle can be used to charge the batteries and slave start the engine from an external power source. The slave receptacle can also be used to charge and slave other equipment.

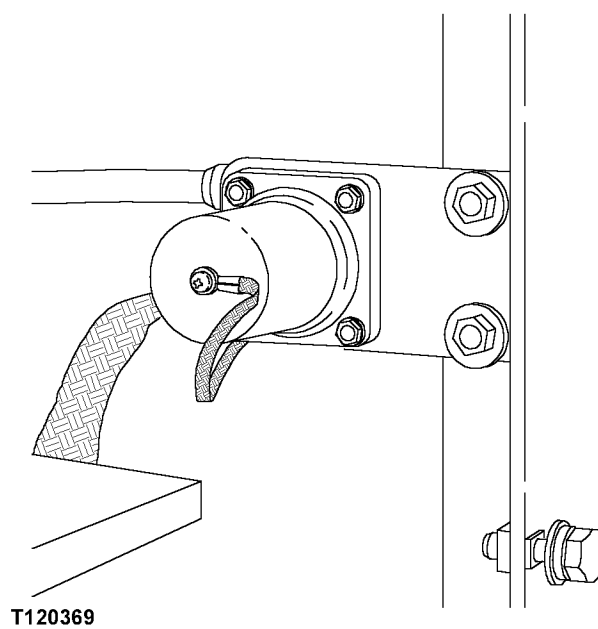

CED,OUOE042.62 -19-07APR99-1/1

STARTING FLUID (COLD WEATHER STARTING AID)



CAUTION: Prevent possible injury from exploding container. Starting fluid is highly flammable. Keep container away from heat, sparks, and open flame. Contents are pressurized. Do not puncture or incinerate container from machine if engine does not need starting fluid.

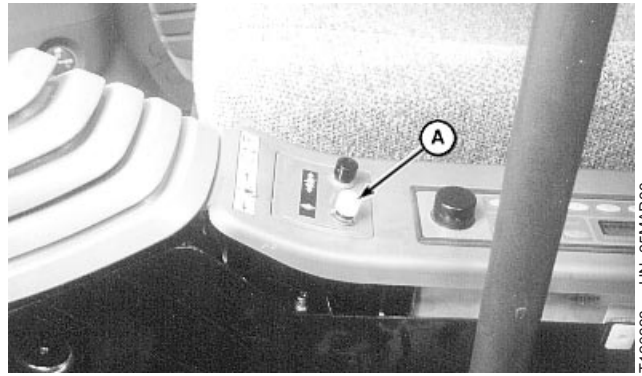

T120333 -UN-25MAR99

IMPORTANT: Prevent damage to engine. Use starting aid when temperatures are below 4.4°C (40°F) and only when engine is COLD.

A—Starting Aid Switch

USING STARTING FLUID

1. Move engine rpm dial to the slow idle position.
2. Turn key switch clockwise to the START position.
3. As soon as the engine starts cranking you must depress the starting aid switch (A).

IMPORTANT: Excess starting fluid could damage engine; push starting aid button only when engine is cold and cranking. Starting aid fluid is being injected into engine as long as you push switch.

4. If engine is cranking but no cylinders are firing you must crank the engine for a maximum of 30 seconds. Then release the starting aid switch (A) and turn the key switch to the OFF position.
5. If the engine is cranking and some cylinders are firing, continue cranking and pushing the starting aid switch (A) for a maximum of 50 seconds. Or until the engine is running.

Continued on next page

TX,OUOE042,7 -19-17FEB99-1/2

Operating the Engine

REPLACING STARTING AID CAN

1. Remove clamp (B) from container.
2. Turn container (C) counterclockwise to remove.
3. Turn container clockwise to install.

IMPORTANT: Protect starting aid components from possible damage. Install dust cap (D) on the starting valve when cylinder is not installed in starting valve.



T120335 -UN-25MAR99



T120336 -UN-25MAR99

B—Clamp
C—Container
D—Dust Cap

TX,OUOE042,7 -19-17FEB99-2/2

USING THE ARCTIC STARTER

The arctic starter is a fuel fired coolant heater located between the engine and the rear counterweight. The exhaust pipe comes out the bottom of the heater box and can be accessed by removing the lower bottom cover at the rear of the vehicle.



CAUTION: Prevent possibility of fire by keeping the area around the arctic starter exhaust pipe clean and free of debris. The exhaust pipe outlet must be directed away from electrical wiring, hydraulic hoses, fuel lines, and cold weather starting aid lines.

Prevent asphyxiation. Exhaust fumes from operating the arctic starter can cause sickness or death. Never operate in an enclosed area or building unless there is adequate ventilation to expel the exhaust fumes.

The arctic starter must be used when the engine has been off for at least eight hours at ambient temperatures below -32°C (-25°F) and is recommended at temperatures below -23°C (-10°F). Ignite the arctic starter and allow to run for 45 minutes. Then shut the arctic starter OFF and start the engine. (See Starting The Engine in this manual.)

NOTE: The arctic starter may not ignite at ambient temperatures below -40°C (-40°F).

The arctic starter does not preheat any oils. All oils must be of the proper viscosity depending upon the ambient air temperature. (See Fuels And Lubricants in this manual.)

Operating the Engine

STARTING THE ARCTIC STARTER

Move switch (A) to ON position.

A continuous green on the LED light (B) indicates the system is operating properly. There is a normal delay of up to 90 seconds before actual ignition of the heater burner.

If the LED light (B) flashes green something in the system sequence did not occur properly and default sensors have shut down the heater start-up. If this occurs, move switch (A) to OFF position for 15 seconds and then move switch to ON position.

If the LED light (B) does not stay a continuous green after four consecutive tries, move switch (A) to OFF position and contact maintenance shop.

NOTE: Move switch (A) to ON position for two minutes with a continuous green LED light (B) once a month when it is not used. This will prevent the water pump and combustion engine from seizing.

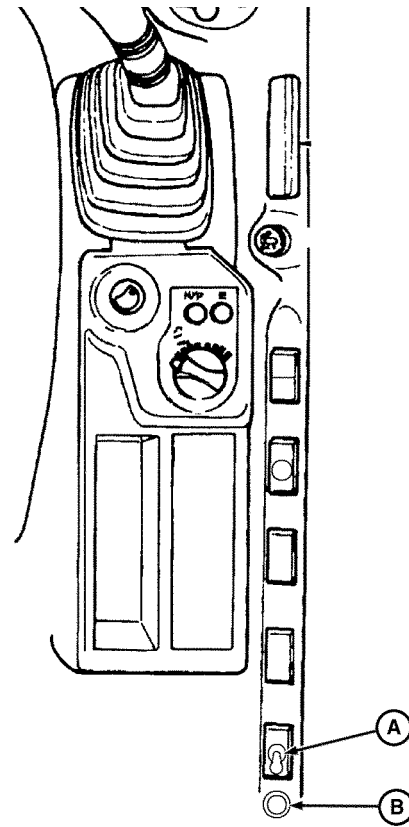

T125068

A—Heater Switch
B—LED Light

T125068 -UN-28OCT99

CED,OUOE020,14 -19-01MAR99-1/1

CHECK INSTRUMENTS AFTER STARTING

IMPORTANT: Prevent possible damage to engine. If indicator lights do not go out after starting engine, IMMEDIATELY STOP THE ENGINE. Find and correct the problem.

After the engine is started, the indicator lights should go out. If they do not, stop the engine immediately. Find and correct the problem.

TX,25,DH3613 -19-27JUN95-1/1

WARMING THE MACHINE

1. Start engine. Run engine at 1/3 speed for 30 seconds. Do not run engine at fast or slow idle. Do not accelerate rapidly during warm up.
2. Operate machine at less-than-normal loads and speeds until engine is at normal operating temperature.

TX,25,DH5503 -19-24JUN96-1/1

COLD WEATHER WARM-UP

CAUTION: Prevent possible injury from unexpected machine movement. If hydraulic oil is cold, hydraulic functions move slowly. DO NOT attempt normal machine operation until hydraulic functions move at close-to-normal cycle times.

In extremely cold conditions, an extended warm-up period will be necessary. Under such conditions, the radiator and oil cooler should be covered to maintain correct operating temperature.

Avoid sudden operation of all functions until the engine and hydraulic oil are thoroughly warm.

1. Run engine at 1/2 speed for 5 minutes. Do not run at fast or slow idle.



CAUTION: Prevent possible injury from unexpected machine movement. Clear the area of all persons before running your machine through the warm-up procedure. If machine is inside a building, warm the propel circuit first and move the machine to a clear area outside. Cold oil will cause machine functions to respond slowly.

2. Exercise propel and swing functions slowly, initially moving only short distances.
3. Operate boom, arm, and bucket functions by moving cylinders a short distance each direction for the first time.
4. Continue cycling cylinders by increasing the travel each cycle until full stroke is obtained.

5. Swing upperstructure so boom is perpendicular to tracks.



CAUTION: Prevent possible injury from machine sliding backwards. Keep angle between boom and arm 90—110°.

6. Keeping the angle between boom and arm 90—110°, fully actuate bucket close function (cylinder extend) and lower bucket to raise track off ground.

IMPORTANT: Holding function actuated for more than 10 seconds can cause damage from hot spots in the control valve.

7. While rotating raised track in forward direction, actuate bucket curl function (cylinder extend) for 10 seconds and release for 5 seconds for a period of 2-1/2 minutes.
8. Repeat procedure with track rotating in reverse direction.
9. Lower machine to ground.
10. Repeat steps 5—9 on opposite track.
11. Operate all hydraulic functions to distribute warm oil in all cylinders, motors, and lines.
12. If hydraulic functions still move slowly, repeat steps 6 and 7.

STOPPING THE ENGINE

IMPORTANT: Prevent possible engine damage. If engine stops when operating under load, remove load. Restart engine immediately. Run 30 seconds at 1/2 speed before adding load.

1. Park machine on a level surface.
2. Lower bucket to the ground.
3. Turn auto-idle switch off.

IMPORTANT: Turbocharger may be damaged if engine is not properly shut down.

4. Run engine with engine rpm dial at 1/3 position without load for 2 minutes.
5. Move engine rpm dial to slow idle position.
6. Turn key switch to OFF. Remove key from switch.
7. Pull pilot control shut-off lever to locked position.

BLANK

CHAPTER 6
DRIVING THE MACHINE

BLANK

Driving the Machine

STEERING THE MACHINE USING PEDALS

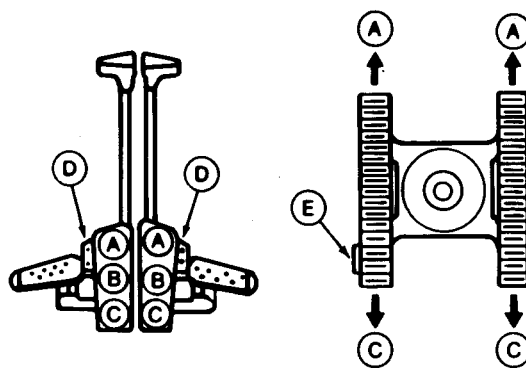

Steering with Pedals

T7405CO -UN-08APR91

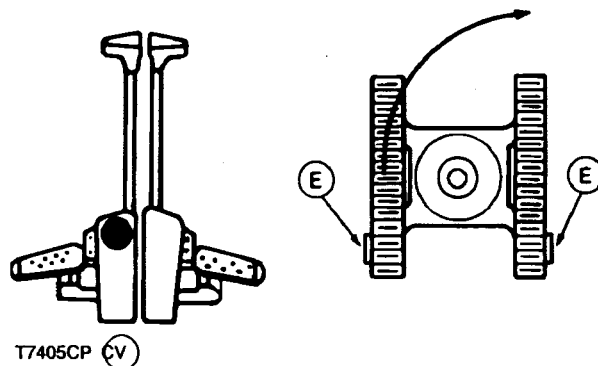

Right Turn

T7405CP -UN-08APR91

Continued on next page

TX,10,FF2292 -19-28OCT91-1/3

Driving the Machine

CAUTION: Keep bystanders clear of machine when traveling. Before moving machine, determine which way to press propel pedals.

Keep bystanders clear of machine when traveling.

The instructions below apply when the propel motors (E) are to the rear of the machine. If the propel motors are to the front of the machine, the machine moves OPPOSITE to the direction described.

FORWARD TRAVEL: Push down on front (A) of both pedals.

REVERSE TRAVEL: Push down on rear (C) of both pedals.

NEUTRAL POSITION (B): Propel brakes will automatically stop and/or hold the machine.

RIGHT TURN: Push down on front of left pedal.

LEFT TURN: Push down on front of right pedal.

SHORT TURN (COUNTERROTATE): Push down the front of one pedal and the rear of the other.

IMPORTANT: When traveling over long distances, swing upperstructure so propel motors are to the rear.

LONG DISTANCE TRAVEL: When traveling over long distances, swing upperstructure so propel motors are to the rear. Push down on pedal tabs (D) and rest feet on footrests.

CAUTION: Prevent possible injury from machine tipping. Operate control pedals slowly when traveling down a slope.

TRAVELING DOWN A SLOPE: Operate control pedals slowly when traveling down a slope.

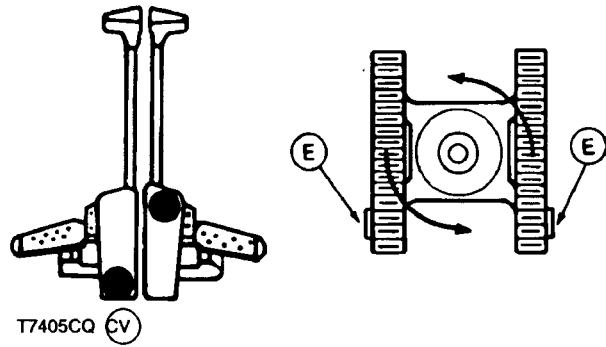

Short Turn (Counterrotate)

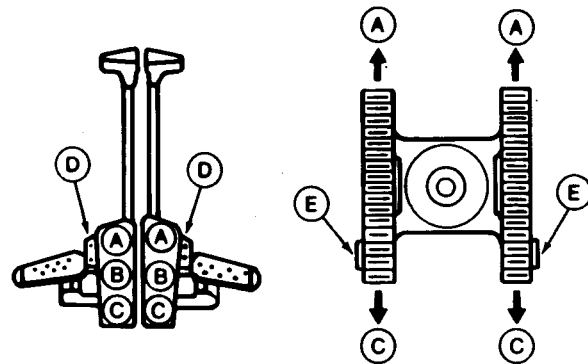

Long Distance Travel

T7405CQ -UN-08APR91

T7405CN -UN-08APR91

Driving the Machine

COLD WEATHER OPERATION: Propel pedal dampers are provided for smooth control. In extremely cold weather, pedal effort will increase. Operate pedal several times with pilot control shut-off lever in locked position.

TX,10,FF2292 -19-28OCT91-3/3

STEERING THE MACHINE USING LEVERS

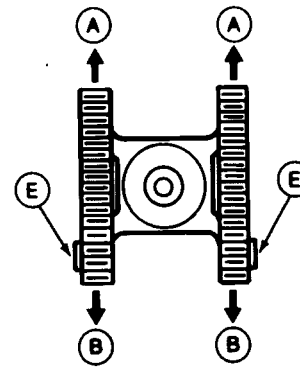
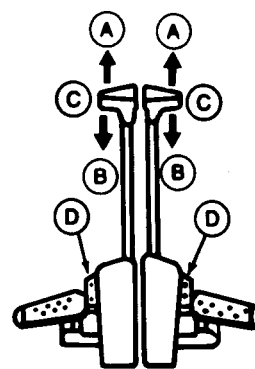

Steering With Levers

T7405CK -UN-08APR91

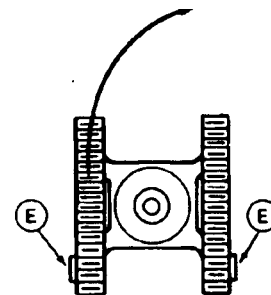
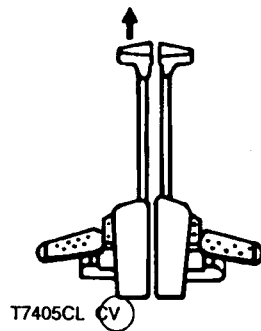

Right Turn

T7405CL -UN-08APR91

Continued on next page

TX,10,FF2293 -19-15MAY92-1/2

Driving the Machine

CAUTION: Keep bystanders clear of machine when traveling. Before moving machine, determine which way to move propel levers.

Keep bystanders clear of machine when traveling.

The instructions below apply when the propel motors (E) are to the rear of the machine. If the propel motors are to the front of the machine, the machine moves OPPOSITE to the direction described.

FORWARD TRAVEL: Push both levers forward (A).

REVERSE TRAVEL: Pull both levers rearward (B).

NEUTRAL POSITION (C): Propel brakes automatically will stop and/or hold the machine.

RIGHT TURN: Push left lever forward.

LEFT TURN: Push right lever forward.

SHORT TURN (COUNTERROTATE): Push one lever forward and pull the other rearward.

IMPORTANT: When traveling over long distances, swing upperstructure so propel motors are to the rear.

LONG DISTANCE TRAVEL: When traveling over long distances, swing upperstructure so propel motors are to the rear.

CAUTION: Prevent possible injury from machine tipping. Operate control levers slowly when traveling down a slope.

TRAVELING DOWN A SLOPE: Operate control levers slowly when traveling down a slope.

COLD WEATHER OPERATION: Propel lever dampers are provided for smooth control. In extremely cold weather, lever effort will increase. Operate lever several times with pilot control shut-off lever in locked position.

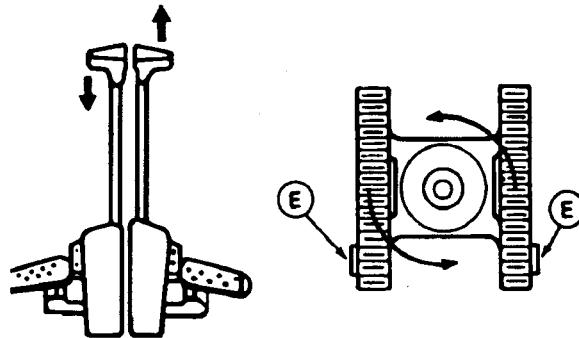

Short Turn (Counterrotate)

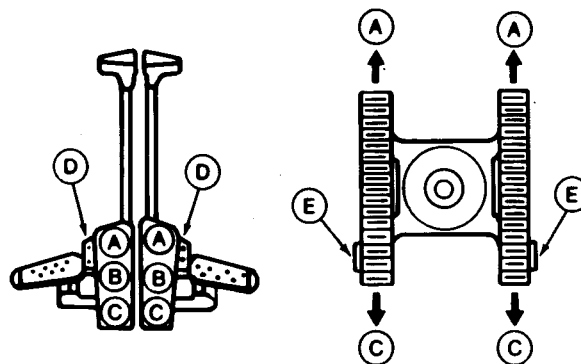

Long Distance Travel

T7405CM -UN-08APR91

T7405CN -UN-08APR91

REMOVING PROPEL LEVERS

Propel levers may be removed if desired.

Remove cap screws (B) (two on each lever) to remove levers (A) from brackets.

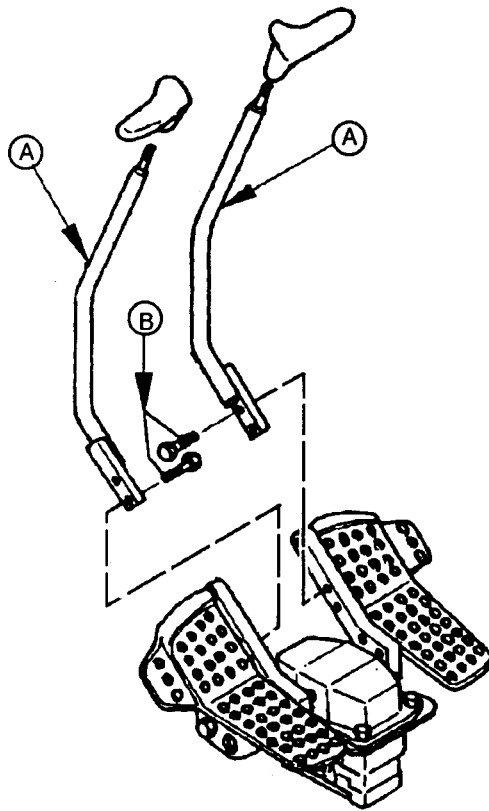

A—Lever
B—Cap Screw

T7386EA -UN-12NOV91

TX,90,FF2018 -19-14NOV91-1/1

PROPEL SPEED SWITCH

Fast speed or slow speed travel can be selected in each working mode by turning the propel speed switch (A).

To lower travel speed, such as traveling on a slope or moving in a tight space, turn switch to slow speed.

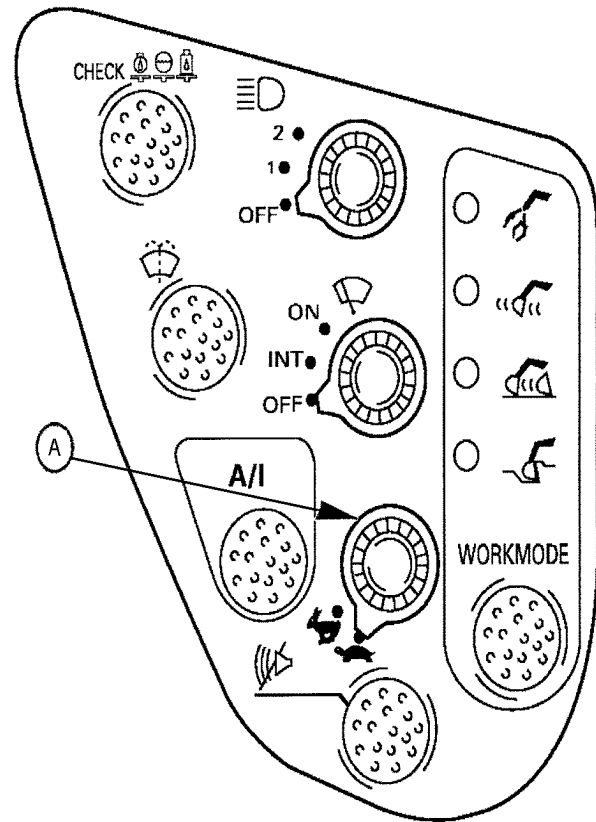

T101589 -UN-27JUN96

TX,30,DH5608 -19-25MAR97-1/1

TRAVEL ALARM AND TRAVEL ALARM CANCEL SWITCH

The travel alarm sounds when a propel pedal is depressed and will continue as long as the tracks are moving. When travel motion stops, the travel alarm switch is reset.

After the initial 12 second alarm, alarm can be silenced by depressing the travel alarm cancel switch (A).

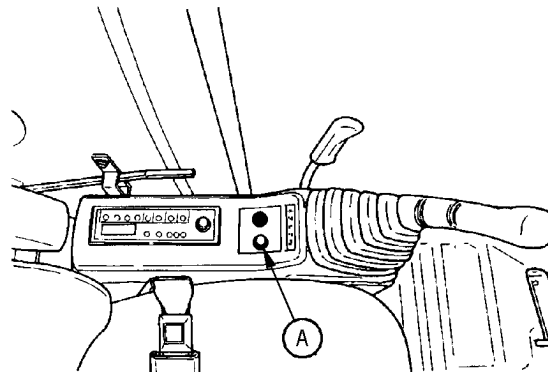

T102893 -UN-07AUG96

TX,30,DH5507 -19-24JUN96-1/1

PARKING THE MACHINE

1. Park machine on a level surface.
2. Lower bucket to the ground.
3. Turn auto-idle switch off.

IMPORTANT: Turbocharger may be damaged if engine is not properly shut down.

4. Run engine with engine rpm dial at 1/3 position without load for 2 minutes.
5. Move engine rpm dial to slow idle position.
6. Turn key switch to OFF. Remove key from switch.
7. Pull pilot control shut-off lever to locked position.

IMPORTANT: Prevent cab electrical component damage from bad weather. Always close windows, roof vent, and cab door.

8. Close windows, roof vent, and cab door.
9. Lock all access doors and compartments.

PARKING MACHINE DURING FREEZING WEATHER

IMPORTANT: Prevent damage to undercarriage. During freezing weather, park machine on a hard surface to prevent tracks from freezing to the ground. Clean debris from tracks and track frames.

If tracks are frozen to the ground, raise tracks using boom. Move machine carefully to prevent damage to drive train and tracks.

During freezing weather, park machine on a hard surface. Clean debris from tracks and track frames.

If tracks are frozen to the ground, raise the tracks using boom. Move machine carefully.

TX,30,DH5509 -19-06AUG91-1/1

LOCK ALL COMPARTMENTS

Your machine is equipped with locks on the side shields, fuel cap, hood, cab door, access door in hood, tool box, and vandal shields (if equipped). One key will fit all locks. The battery compartment has a lockable door. Use these locks to help safeguard your machine.

TX,30,DH5510 -19-09APR92-1/1

CHAPTER 7
OPERATING THE MACHINE

BLANK

Operating the Machine

CONTROL LEVERS



CAUTION: 230LCR:

Single hearing protection is required by ground personnel within 8 feet of the 230LCR vehicle at high idle.

Operators are required to wear single hearing protection when operating the vehicle with the cab windows or door open.

230LCRD:

Operators are required to wear single hearing protection when performing drilling operations with cab windows or door open.

Ground personnel are required to wear single hearing protection within 98 feet of the drill bit and double hearing protection when within 10 feet of the drill bit.

Single hearing protection is required by ground personnel within 8 feet of the 230LCRD vehicle at high idle.

When both engines are operating, single hearing protection is required within 12 feet of the vehicle at high idle.



CAUTION: Never place any part of body beyond window frame. It could be crushed by the boom if boom control lever is accidentally bumped or otherwise engaged. If window is missing or broken, replace immediately.

Prevent possible injury from unexpected machine movement. Make sure you know the location and function of each control before operating.

Never place any part of the body beyond the window frame. Replace missing or broken windows immediately.

Operating the Machine

The machine is factory equipped with the control pattern shown.

IMPORTANT: Prevent possible machine damage. When digging, avoid contacting tracks with boom cylinders or bucket.

When digging over the end of the tracks, propel motors should be at the rear to minimize chain and sprocket wear and to maximize machine stability and lift capacity.

NOTE: With this control pattern, functions must correspond to the black-on-white labels located on the control console.

Do not contact tracks with boom cylinders or bucket. When digging over the end of tracks, propel motors should be at the rear of machine.

When a lever is released, it will return to neutral. The machine will remain positioned.

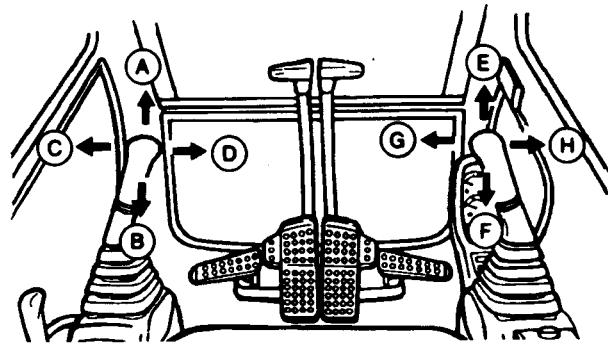

T7364AT -UN-10OCT90

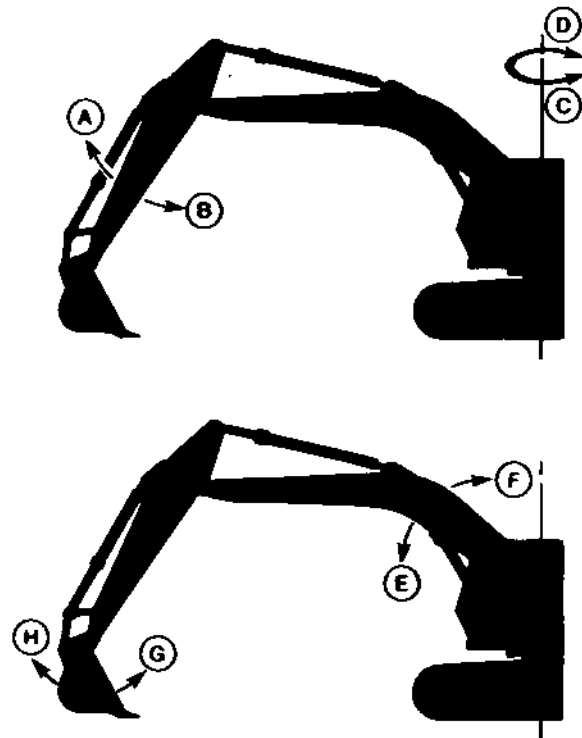

T6811AC -UN-18OCT88

- A—Arm Out
- B—Arm In
- C—Swing Left
- D—Swing Right
- E—Boom Down
- F—Boom Up
- G—Bucket Load
- H—Bucket Dump

CONTROL LEVER PATTERN CONVERSION

To change your machine pilot control levers from the standard pattern to a John Deere pattern:

1. Lower bucket to the ground. Turn auto-idle switch off.
2. Run engine with engine rpm dial at 1/3 position without load for 2 minutes.
3. Move engine rpm dial to slow idle position, and turn key switch to OFF to stop engine. Remove key from switch.
4. Move pilot control shut-off lever to locked position.



CAUTION: High pressure release of oil from pressurized system can cause serious burns or penetrating injury. The hydraulic tank is pressurized. Do not remove vent plug. Release pressure by loosening vent plug.

5. Loosen vent plug to relieve air pressure.
6. Open door on storage compartment behind cab.
7. Remove cover above flow regulator valve.

Continued on next page

TX,35,DH5038 -19-06JUN96-1/2

Operating the Machine

NOTE: DO NOT use manufacturer's line tags or markings on line ends to identify lines for this conversion procedure. The conversion must be done on the front (cab side) of the flow regulator valve.

- Switch hose (A) with hose (C).
- Switch hose (B) with hose (D).



CAUTION: Prevent injury from unexpected control lever function. Install new decals on control consoles.

8. Install new decals (black on yellow) on control consoles near the base of control levers. Decals are enclosed in Operator Manual package. Additional decals can be purchased from your John Deere dealer.

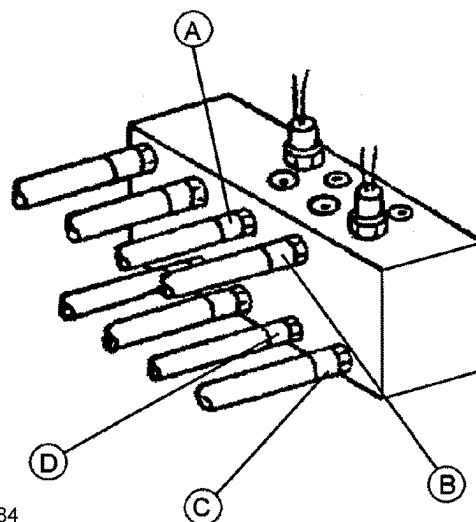

T102684

A—Hose
B—Hose
C—Hose
D—Hose

T102684 -JUN-07AUG96

TX,35,DH5038 -19-06JUN96-2/2

CONTROL LEVERS JOHN DEERE PATTERN

CAUTION: Avoid serious crushing injury from boom. Never place any part of body beyond window frame. It could be crushed by the boom if boom control lever is accidentally bumped or otherwise engaged. If window is missing or broken, replace immediately.

Prevent possible injury from unexpected machine movement. Make sure you know the location and function of each control before operating.

Never place any part of the body beyond the window frame. Replace missing or broken windows immediately.

A conversion kit is available from your John Deere dealer to change your controls to the pattern shown.

IMPORTANT: Prevent possible machine damage. When digging, avoid contacting tracks with boom cylinders or bucket.

When digging over the end of the tracks, propel motors should be at the rear to minimize chain and sprocket wear and to maximize machine stability and lift capacity.

NOTE: With this control pattern, functions must correspond to the black-on-yellow labels located on the control console.

Do not contact tracks with boom cylinders or bucket. When digging over the end of tracks, propel motors should be at the rear of machine.

When a lever is released, it will return to neutral. The machine will remain positioned.

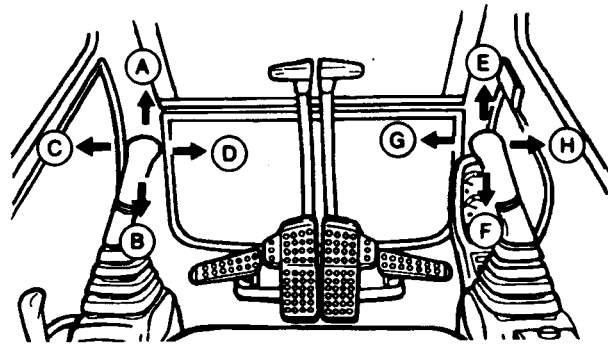

T7364AT -UN-10OCT90

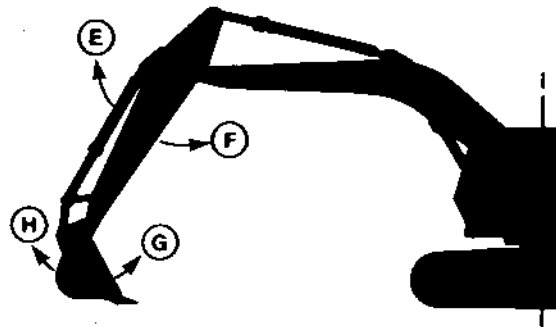
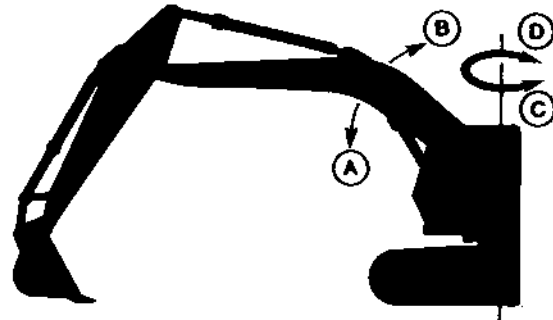

T6811AD -UN-18OCT88

- A—Boom Down
- B—Boom Up
- C—Swing Left
- D—Swing Right
- E—Arm Out
- F—Arm In
- G—Bucket Load
- H—Bucket Dump

*Operating the Machine***PILOT CONTROL SHUT-OFF LEVER**

The pilot control shut-off lever (A) shuts off hydraulic pilot pressure to all pilot control valves. When pilot control shut-off lever is in locked position, the machine will not move if a lever or pedal is accidentally moved.

Always pull pilot control shut-off lever to locked position when you stop the engine or leave the operator's station.

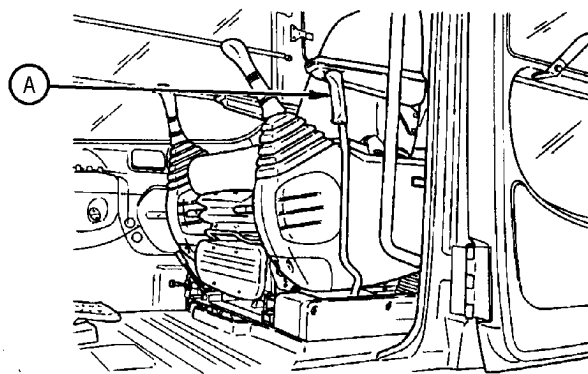

T101635 -UN-26JUN96

TX,35,DH5039 -19-07JUN96-1/1

AUTO-IDLE SWITCH

The auto-idle circuit automatically reduces engine speed after 4 seconds when control levers are placed in neutral position. Press switch (A) to turn circuit ON.

CAUTION: Turn auto-idle switch OFF when automatic acceleration of engine speed is not desired, and when stopping engine.

Always check auto-idle switch before operating any control levers. When ON, the engine speed lowers to auto-idle speed (regardless of the position of the engine speed control lever) approximately 4 seconds after the control levers are returned to neutral. By operating the control levers, the engine speed increases to the engine rpm dial setting.

Starting engine when auto-idle is ON:

1. When key switch is turned ON, buzzer will sound briefly.
2. The engine will run at the engine rpm dial setting for 4 seconds after turning the key switch ON. The auto-idle system will then slow the engine to auto-idle engine speed.
3. Engine speed increases to engine rpm dial setting when any control lever is operated.
4. Four seconds after control levers are returned to neutral, the engine speed is reduced automatically to auto-idle level. Engine will run at auto-idle speed if engine is started more than 4 seconds after turning key switch ON.

When the auto-idle switch is turned OFF, the engine speed is controlled by the engine rpm dial.

Indicator (B) will light when auto-idle is ON.

Turn auto-idle switch OFF and set engine rpm dial to improve machine control in difficult work areas, loading, and unloading.

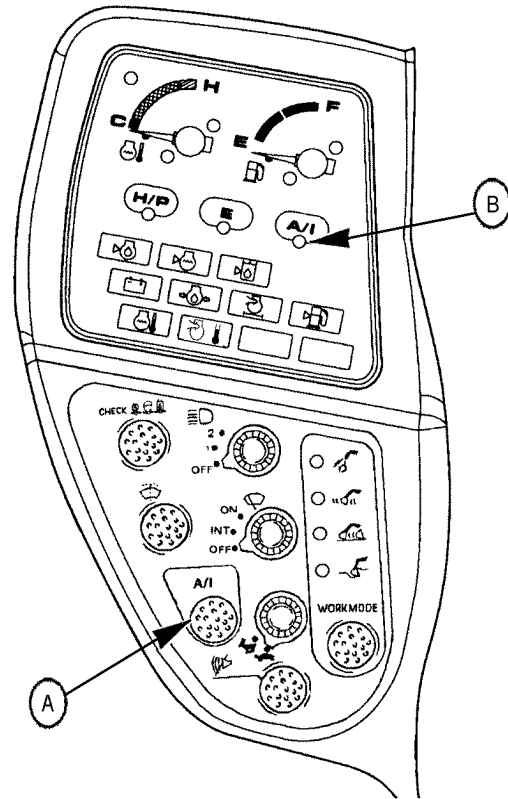

T107692 -JUN-27FEB97

MODE SELECTION SWITCH

Select operating modes by pressing the mode selection switch (A). In each mode, a microcomputer automatically selects the best combination of engine speed and pump flow rate that fits the working load. The dig mode (B) is automatically selected when the engine is started.

Use the following as a guide:

- Dig Mode (B)—Designed for general digging and truck loading.
- Grading Mode (C)—Arm roll-in is slower for grading and finishing work.
- Precision Mode (D)—For work that requires precision front movement.
- Attachment Mode (E)—When using attachments other than the bucket.

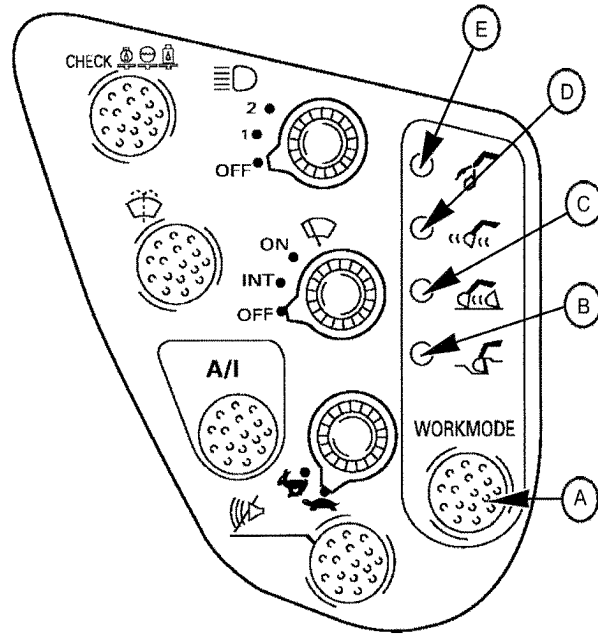

T101585 -UN-11JUL96

TX,35,DH5041 -19-10JUN96-1/1

POWER BOOST SWITCH

Push power boost switch (A) on top of right control lever for an 8 second, 6% increase in hydraulic power. Release switch to reset power boost function.

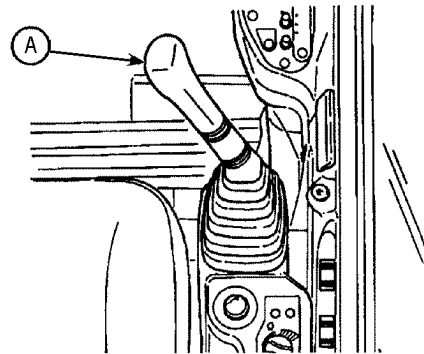

T101633 -UN-20JUN96

TX,35,DH5156 -19-12AUG96-1/1

E (ECONOMY) MODE

Use E mode to improve fuel efficiency and reduce noise level with a small difference in engine speed. E mode is effective when the dig mode is selected as the work mode.

Push down E mode switch (A). The switch will stay down and E mode indicator (B) will light. Push the E mode switch again. The switch will return to original position and will deactivate the E mode.

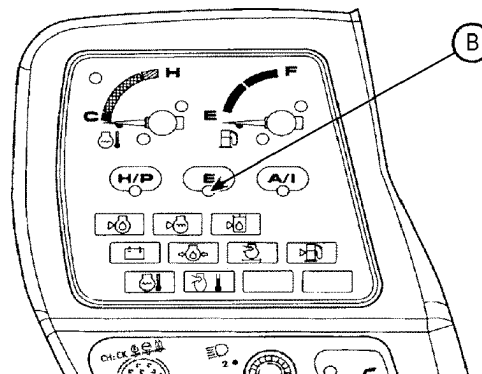
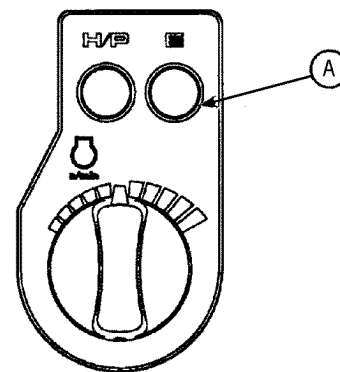

T101632 -UN-01JUL96

T107693 -UN-27FEB97

TX,35,DH5407 -19-27FEB97-1/1

Operating the Machine

H/P (HIGH POWER) MODE

NOTE: With both the H/P and E modes turned on, the digging power increases while achieving low fuel consumption.

Use H/P mode when extra horse power is needed for rolling in the arm in excavation work. The H/P mode is effective when the dig mode is selected as the work mode. H/P mode can also be used with the E mode turned on.

The H/P mode will be activated, automatically increasing the engine speed when:

- H/P mode switch (A) is pushed down.
- Engine speed is set to 1600 rpm or higher.
- Arm roll-in is operated.
- A load heavier than a specified amount is applied.

Push down H/P mode switch (A). The switch will stay down and H/P mode indicator will light. Push the H/P mode switch again. The switch will return to original position and will deactivate the H/P mode.

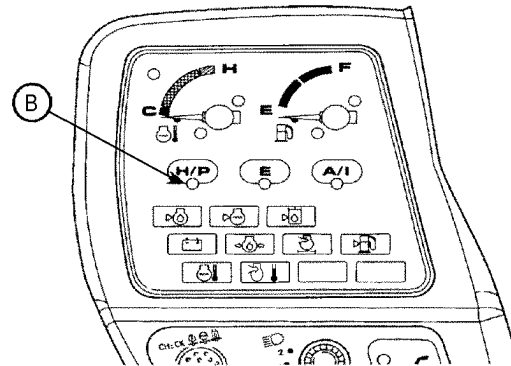
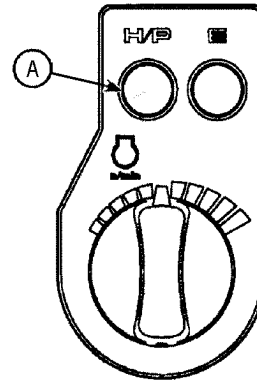

T101630 -UN-01JUL96

T107694 -UN-27FEB97

TX,35,DH5408 -19-27FEB97-1/1

STANDARD MODE

The engine is in standard mode when no switches are pushed down and no indicator lights are on.

TX,35,DH5135 -19-03AUG96-1/1

*Operating the Machine***OPERATING TIPS**

Before starting work, walk the site to uncover hazards and to plan the job. Check for buried utility lines and pipes, and for gas and oil pipelines

Keep site clean and level to maximize machine stability, reduce operator fatigue, and increase productivity.

Do not knock down stakes or grade markers. If you lose sight of your guides, you may have to re-work the job.

TX,35,DH5070 -19-27JUN96-1/1

DRIVING MACHINE

Use your seat belt.

Select a route that is as flat as possible. Steer machine as straight as possible making small, gradual changes in direction.

When driving over rough terrain, reduce speed to lessen possibility of undercarriage damage. Reduce speed when carrying a heavy load, or working in a congested area. When possible, avoid obstacles, rough terrain, rocks, curbs, and ditches. In general, decreasing speed increases control.

When driving, carry bucket or attachment low for good visibility and machine stability and to avoid overhead obstacles. Visibility may also be improved by rotating upperstructure slightly.



T7527DS -JUN-15-JUL91

TX,35,DH5784 -19-04JUN97-1/1

Operating the Machine

DRIVING ON SLOPES

Use your seat belt.

CAUTION: Prevent possible injury from machine rollover. Do not turn machine on a slope.

Do not turn machine on a slope.

TX,35,FF2441 -19-13AUG91-1/1

DRIVING DOWN A SLOPE

- Use your seat belt.
- Lower bucket near to ground as shown.
- Angle of boom to arm should be 90 degrees.
- Drive down slope with boom on the downhill end of the machine.
- If machine begins to slide, lower boom, placing bucket against or in the ground to slow the machine.

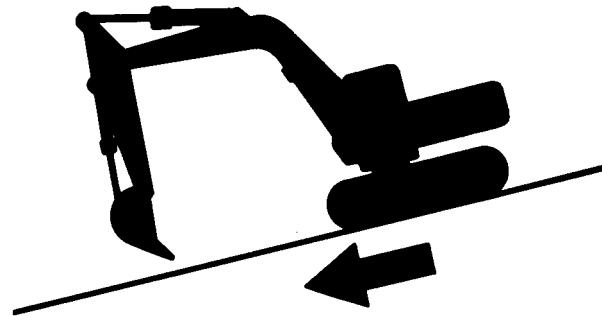

T7527CQ -UN-10JUL91

TX,35,FF2322 -19-02JUL91-1/1

DRIVING UP A SLOPE

- Use your seat belt.
- Position undercarriage so propel motors will be on uphill end of machine.
- Keep the bucket on the uphill side, approximately 30 cm (12 in.) (A) above ground.
- If machine starts to slip or become unstable, lower the bucket immediately.

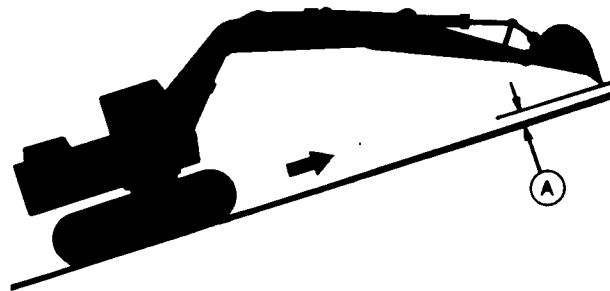

T7273AG -UN-08JUN90

TX,35,FF2337 -19-13AUG91-1/1

DRIVING UP A STEEP OR SLIPPERY SLOPE—BOOM ON UPHILL END OF MACHINE



CAUTION: Prevent possible injury from machine rollover. Use this technique only on a short slope. Machine depends on support of boom/arm/bucket during entire procedure until machine reaches top of slope. Repositioning the bucket during this procedure is NOT recommended. Do not swing upperstructure during this procedure.

- Use your seat belt.
- Position undercarriage so propel motors will be on uphill end of machine.
- Push bucket into the ground.
- Drive up slope. Pull machine using boom and arm cylinders to help propel motors. DO NOT reposition bucket during this procedure.

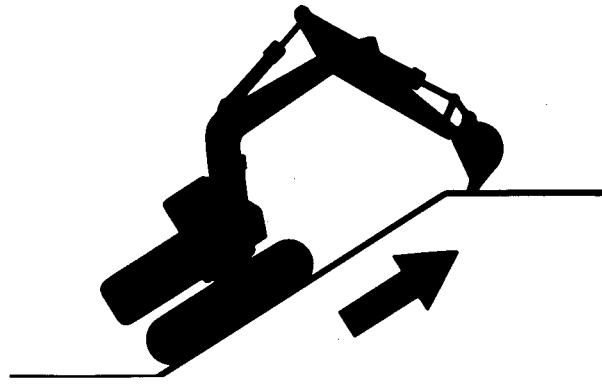

T7527CS -UN-10JUL91

TX,35,FF2338 -19-13AUG91-1/1

DRIVING UP A STEEP OR SLIPPERY SLOPE—BOOM ON DOWNHILL END OF MACHINE



CAUTION: Prevent possible injury from machine rollover. Use this technique only on a short slope. Machine depends on support of boom/arm/bucket during entire procedure until machine reaches top of slope. Repositioning the bucket during this procedure is NOT recommended. Do not swing upperstructure during this procedure.

- Use your seat belt.
- Position undercarriage so propel motors will be on uphill end of machine.
- Push bucket into the ground.
- Drive up slope. Push machine using boom and arm cylinders to help propel motors. Do NOT reposition bucket during this procedure.

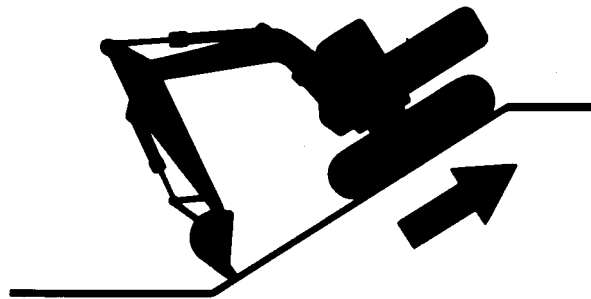

T7527CT -UN-10JUL91

TX,35,FF2339 -19-13AUG91-1/1

Operating the Machine

MOVING MACHINE OFF AN EMBANKMENT

1. To move machine over edge of embankment, position bucket with flat surface resting on ground. Angle (A) of arm to boom should be 90°.

Bucket must be on ground before machine begins to tip.

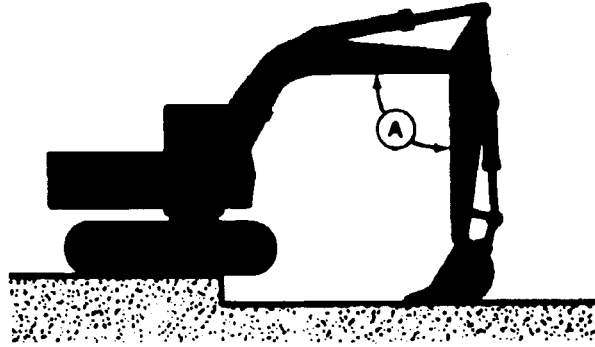

T7627DJ -UN-05JUN91

TX,35,DH5639 -19-26MAR97-1/3

IMPORTANT: To prevent machine damage, do not allow machine to impact ground with bucket absorbing force of the fall.

2. As machine moves forward, raise the boom and retract arm until front of tracks reaches the lower ground level.
3. Raise bucket off the ground. Rotate upperstructure 180°.

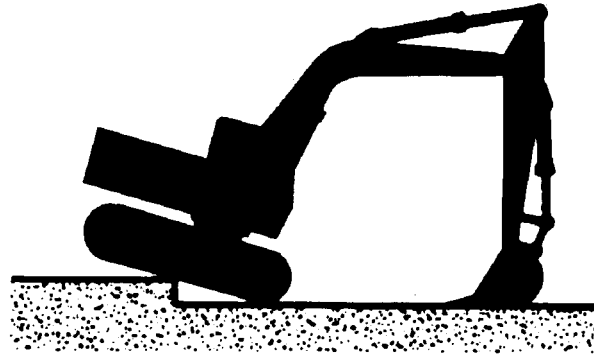

T7627DK -UN-05JUN91

TX,35,DH5639 -19-26MAR97-2/3

4. Position bucket on ground with flat surface of bucket resting on ground. Angle (A) of arm to boom should be 90°.
5. Lower boom slightly and propel machine towards lower level as the arm is extended.
6. When tracks clear embankment, raise boom to lower undercarriage on lower ground level.
7. To move machine onto an embankment, reverse procedure.

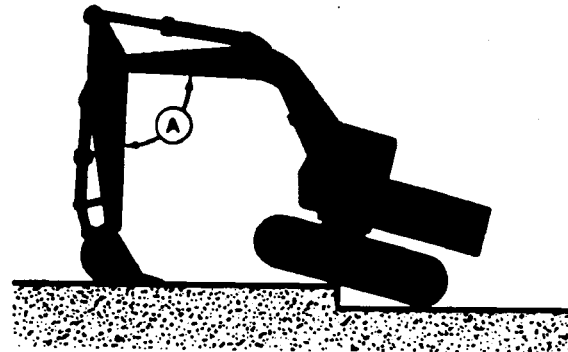

T7627DL -UN-05JUN91

TX,35,DH5639 -19-26MAR97-3/3

Operating the Machine

LEVELING MACHINE

Operating on a firm, level surface optimizes machine stability.

To create a level surface:

- Counterrotate tracks 30° to each side.

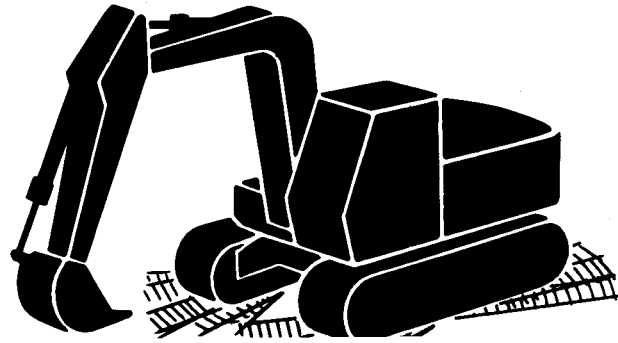

T7627CU -JUN-15JUL91

A—Quick-Disconnect Hitch Switch

TX,35,FF2324 -19-13FEB92-1/2

- Use bucket to add or remove material to level the worksite. When adding material to the worksite, drive over new material to compact it until the worksite feels stable.

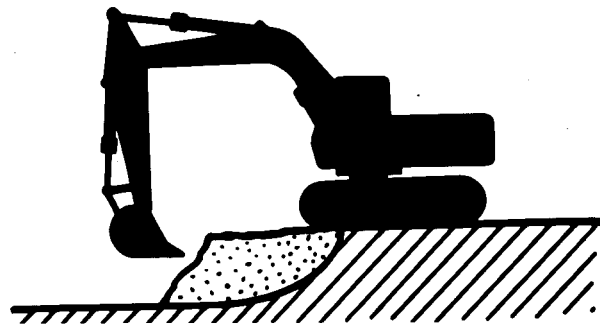

T7627DE -JUN-15JUL91

TX,35,FF2324 -19-13FEB92-2/2

USING QUICK-DISCONNECT HITCH

1. The cylinder in the Quick-Disconnect Hitch is powered by hydraulic oil from the excavator bucket cylinder which is diverted to the Quick-Disconnect by an electric solenoid valve. The switch is located on the left side rear cab glass.

NOTE: The solenoid coil is energized only in the unlatch position.

2. To attach the Quick-Disconnect Hitch to an attachment manually lift and rotate the safety lock pin lever on the top rear of the Quick-Disconnect Hitch. Fully extend the bucket cylinder and set the Quick-Disconnect Hitch switch (A) to the unlatch position. Extend the bucket cylinder again to place the oil over relief (except for rock drill attachment). This will activate the cylinder to the open position.

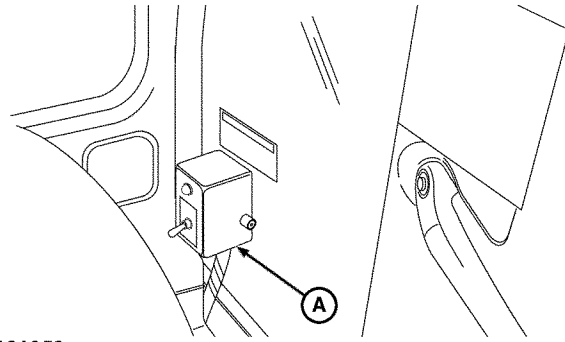

T121059

A—Quick-Disconnect Hitch Switch

T121059 -UN-28OCT99

CED,OUOE042,65 -19-09DEC99-1/8

3. Operate the excavator to position the Quick-Disconnect Hitch in the vertical position (B). The attachment must be level and resting on the ground.

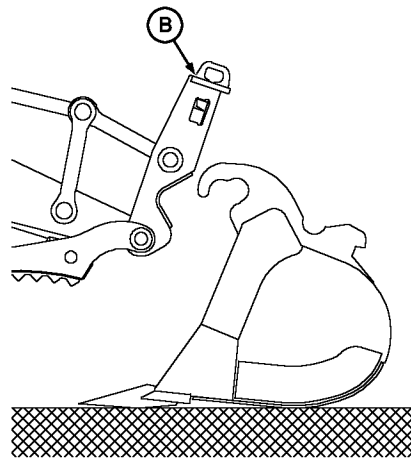

T120310

T120310 -UN-25MAR99

Continued on next page

CED,OUOE042,65 -19-09DEC99-2/8

Operating the Machine

- Position the Quick-Disconnect Hitch to engage the front hook of the attachment (C).

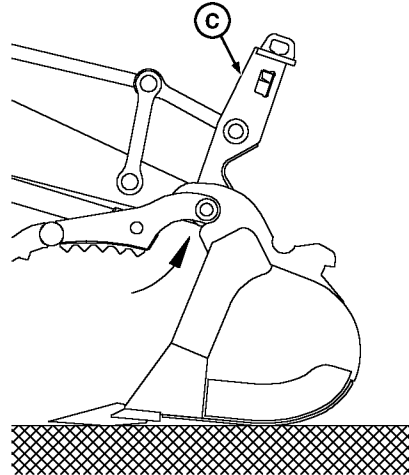

T120311

T120311 -UN-25MAR99

CED,OUOE042,65 -19-09DEC99-3/8

- Rotate the Quick-Disconnect Hitch to seat the rear of the latch over the rear attachment pins (D).

CAUTION: Do not raise the attachment without acceptable wedge engagement. The attachment can fall causing possible injury to people in the vicinity of attachment.

- Move the latch switch to the latch position and move the control in order to carefully curl the Quick-Disconnect Hitch and the attachment to full extension of the bucket cylinder. This will place oil over relief and divert oil to the hydraulic latch cylinder in order to engage the wedge into the attachment.

NOTE: Keep the attachment close to the ground during all latch and unlatch operations.

CAUTION: Wedge must be engaged into attachment.

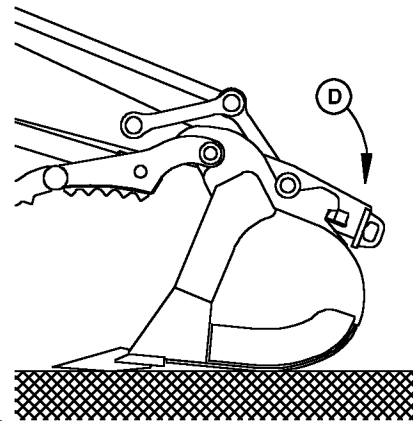

T120312

T120312 -UN-25MAR99

Continued on next page

CED,OUOE042,65 -19-09DEC99-4/8

IMPORTANT: The safety lock pin is a safety device to mechanically secure the attachment in the event of hydraulic system failure. The machine should not be operated without the safety lock pin in the locked position (E).

- The safety lock pin lever is at the rear of the Quick-Disconnect Hitch. Carefully rotate the spring loaded safety lock pin lever toward the excavator to engage the lock pin.

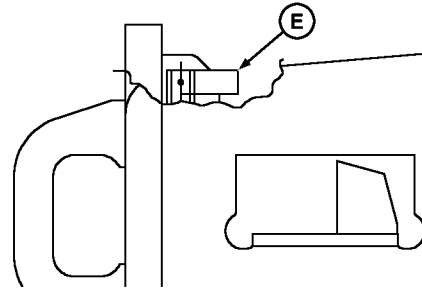

T120313

T120313 -UN-25MAR99

CED,OUOE042,65 -19-09DEC99-5/8

QUICK-DISCONNECT ATTACHMENT REMOVAL

1. Fully extend arm and curl bucket in. Place the attachment on the ground.
2. Manually lift and rotate the safety lock pin lever from its locked position and install it in the unlocked position (F).

NOTE: Alarm will sound when switch is in unlocked position.

3. To unlatch the Quick-Disconnect Hitch from an attachment fully extend the bucket cylinder. Move the Quick-Disconnect Hitch switch (A) in the operators cab to the unlatch position. Move the control to extend the bucket cylinder again to place hydraulic oil over relief (except for rock drill attachment). This will activate the latch cylinder to the open position.

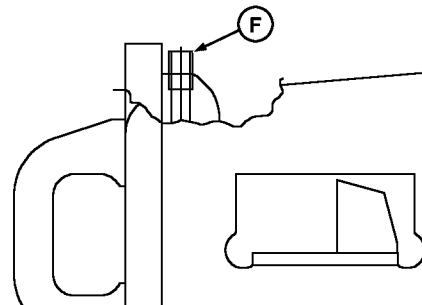

T120314

T120314 -UN-25MAR99

Continued on next page

CED,OUOE042,65 -19-09DEC99-6/8

Operating the Machine

4. Operate the excavator to rotate the Quick-Disconnect Hitch in the vertical position (G).

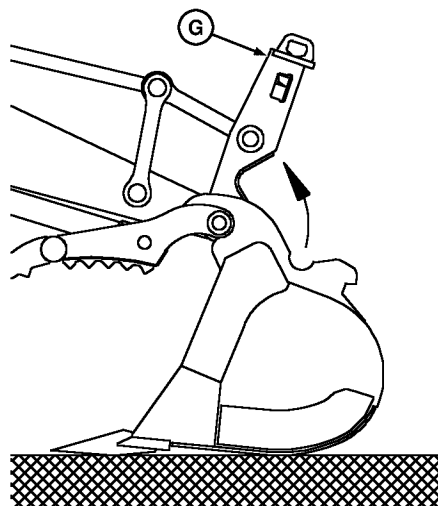

T120315

T120315 -UN-25MAR99

CED,OUOE042,65 -19-07APR99-7/8

5. Remove the Quick-Disconnect Hitch from the hook on the front of the attachment (H).

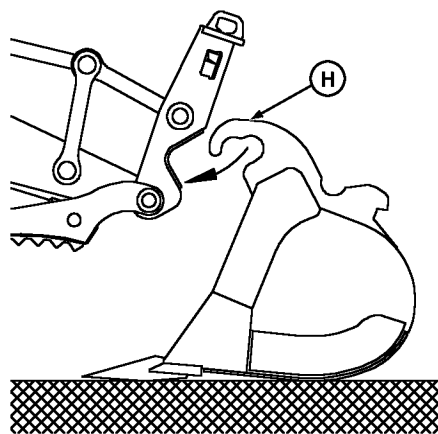

T120316

T120316 -UN-25MAR99

CED,OUOE042,65 -19-07APR99-8/8

*Operating the Machine***TWO WAY HYDRAULIC THUMB FOOT PEDAL (MODEL 230LCR)**

The Model 230LCR machine is equipped with a third foot pedal (A). This pedal controls the movement of the hydraulic thumb.

To close the hydraulic thumb, push down the top of the pedal (B).

To open the hydraulic thumb, push down the bottom of the pedal (C).

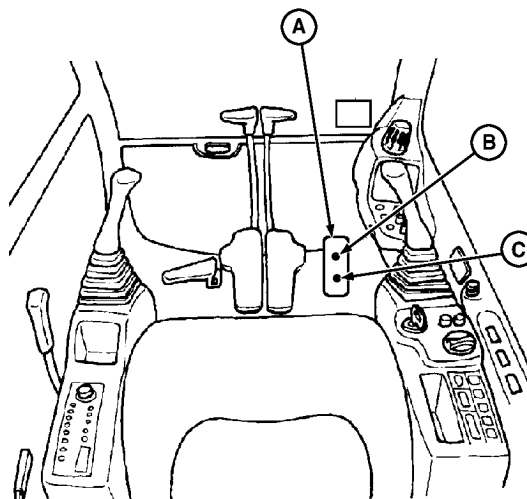

T120459

A—Foot Pedal
B—Top of Pedal
C—Bottom of Pedal

T120459 -JUN-25MAR99

TX,OUOE042,30 -19-09MAR99-1/1

USING HYDRAULIC THUMB

The hydraulic thumb was designed to be used for the following procedures.

- Clamping and lifting
- Medium duty scrap handling
- Demolition of wood and brick structures
- Medium duty land clearing/grubbing
- Bulky loose materials
- Logging

Do not use the hydraulic thumb for the following procedures.

- Ripping-up concrete and asphalt
- Quarry applications
- Heavy scrap handling
- Heavy land clearing
- Heavy grubbing
- Breaking ledge rock

Clamping with Bucket

From the stored position actuate and locate the hydraulic thumb near the object to be picked up. Curl-in the bucket (A) to the point where it begins to grasp and force the object being picked up into the face of the hydraulic thumb. The thumb is capable of large clamping forces and could crush the object. To prevent the bucket and thumb from crushing the object, "feather" the bucket control to the point where the object can be picked up but not crushed.

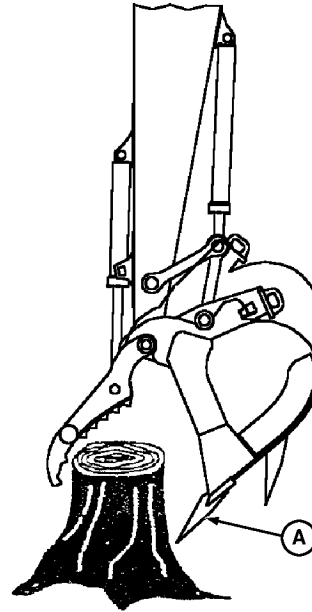

T120317

T120317 -UN-25MAR99

Clamping with Hydraulic Thumb

CAUTION: This method is less precise and should only be used where there is no concern about crushing the object to be clamped.

Retract the hydraulic thumb to the store position (B). This allows better operator visibility. Position the bucket behind and curl it in until it is near or in contact with the object being picked up. Actuate the hydraulic thumb and allow it to grasp and clamp. This method of grasping is usually less precise and objects may be crushed.

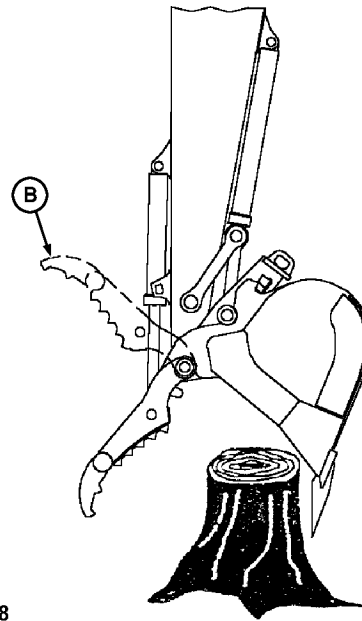

T120318

T120318 -UN-25MAR99

Lifting Objects

CAUTION: Always use caution when lifting and transporting objects with the hydraulic thumb and bucket. Excavators can lift heavy objects that are closer to the excavator. As heavy objects are moved further away from the machine via boom and arm actuation, the possibility of making the machine unstable exists. Use caution when lifting, moving and rotating heavy objects away from the excavator's main body.

Never lift clamped objects over people. The possibility always exists that the lifted objects could drop.

Releasing Clamped Objects

CAUTION: Always look before you release a clamped load. Never release a clamped load while moving or turning. Objects clamped in the jaws should be released one of two ways. Retract the material clamp or retract the bucket.

*Operating the Machine***USING BUCKET**

ARM DIGGING: For most general excavating, leveling material, and digging trenches.

To begin excavating, position arm in vertical position and then move it away from machine approximately 0.61 m (2 ft).

Using mainly the arm cylinder (A), retract the arm. As the bucket fills, curl the bucket while retracting the arm. The first cut should be approximately 1.2 m (4 ft) long and 75—100 mm (3—4 in.) deep. Remaining cuts should be approximately 1.2 m (4 ft) long and 100—150 mm (4-6 in.) deep.

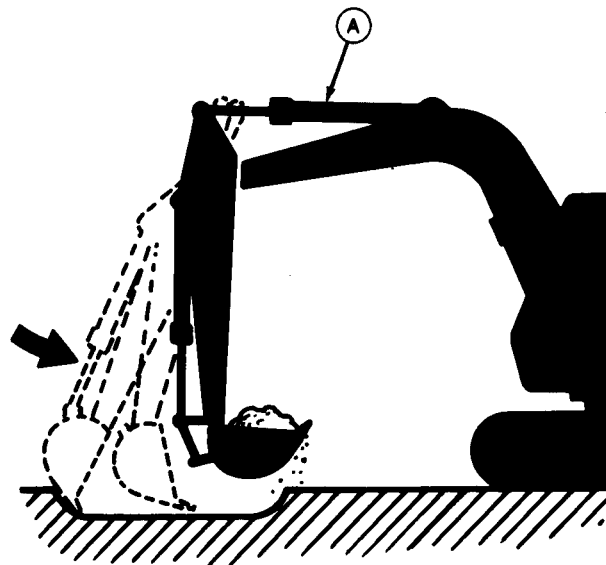

T7527CV -UN-10JUL91

Continued on next page

TX,35,FF2325 -19-28JAN92-1/3

Operating the Machine

BUCKET DIGGING: For power digging and for working in a small or cramped excavation. Use the bucket cylinder (A) for digging.

Lower bucket to the digging area and use boom to force the bucket into the ground. Work two functions at once; retracting the arm, and curling the bucket until the bucket is full.

If the bucket stalls, raise the boom slightly and continue to curl bucket.

If arm stalls, roll back bucket to break out.

IMPORTANT: To avoid damaging cylinder(s), do not strike ground with bucket or use bucket for tamping when bucket cylinder is fully extended (bucket completely curled under).

When bucket cylinder is fully extended, do not strike the ground with the bucket or use the bucket for tamping.

Do not use the bucket as a hammer or pile driver. Do not attempt to shift rocks and break walls using swing motion.

Do not sideload bucket. For example, do not swing bucket to level material or do not strike objects from the side with the bucket.

Match bucket, bucket teeth, or attachment to type of material being handled.

Loose, fragmented material dumps quickly from the bucket. To break up material as it enters the bucket, excavate material in thin layers rather than jamming it into the bucket. This is especially important with sticky materials.

If you clean the bucket by rapping it against the stop, to prevent cylinder damage, use the MINIMUM amount of force. Clean the bucket by hand if rapping bucket lightly does not work. Do not try to remove material from bucket by striking bucket against the ground or another object.

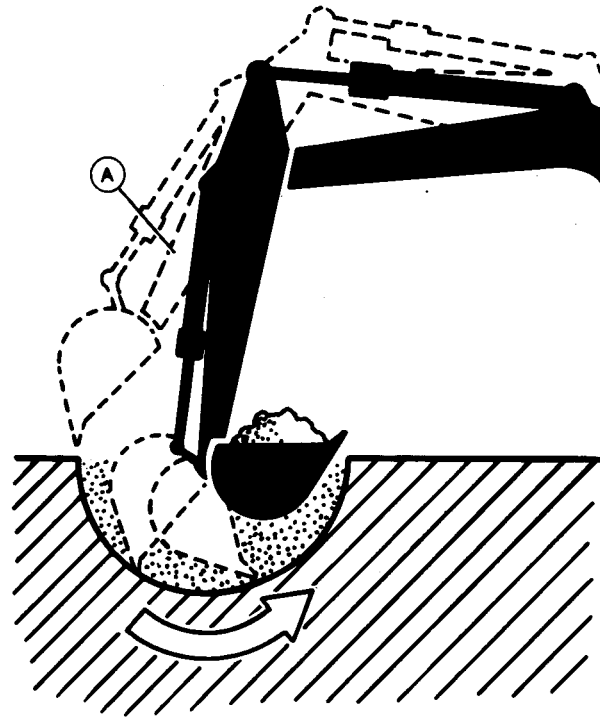

T7527CW -UN-10JUL91

Operating the Machine

To prevent cave-in's:

- Work perpendicular to or at an angle to excavation, with propel motors to the rear of the machine.
- Do not drive near the edge of an excavation or trench.
- Do not dig under the machine.

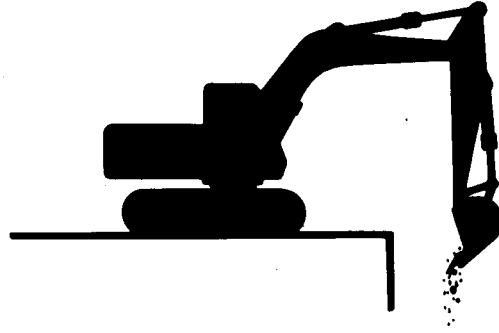

T7527CX -UN-10JUL91

TX,35,FF2325 -19-28JAN92-3/3

PLANNING SPOIL PILES

To prevent cave-in's, place spoil pile at least 1 m (3 ft) away from excavation. The deeper the excavation the further the spoil pile should be placed from the excavation. Place spoil piles for convenient truck loading or backfilling.

On slopes, place spoil piles on the upper side of the slope for improved machine stability and easier backfilling.

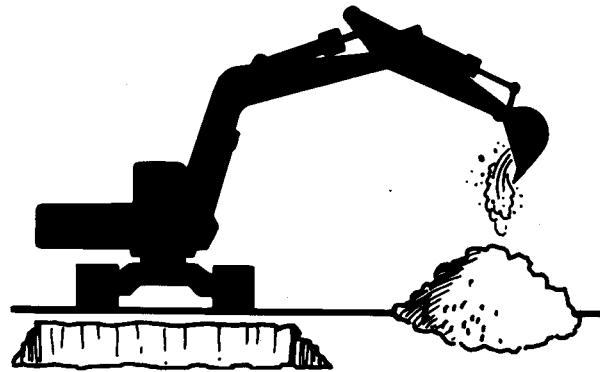

T7527CY -UN-10JUL91

TX,35,FF2323 -19-13AUG91-1/1

TRENCHING

Before starting work, walk the site to uncover hazards and to plan the job. Check for buried utility lines and pipes and for gas and oil pipelines.

To prevent cave-in's, dig a 'V' shaped trench and place spoil piles at least 1 m (3 ft) away from trench. The deeper the trench, the further the spoil pile should be placed from it.

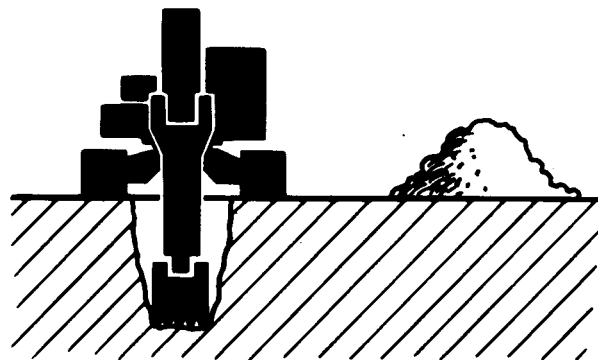

T7527CZ -UN-10JUL91

Continued on next page

TX,35,FF2327 -19-13AUG91-1/4

Operating the Machine

If you have to clean up a cave-in and cannot reach it from machine's present position, **DO NOT** back over the trench. Drive the machine beside the trench to the cave-in. Park the machine at a 90° angle to trench, with propel motors to the rear of the machine. Clean cave-in from the side of the trench.

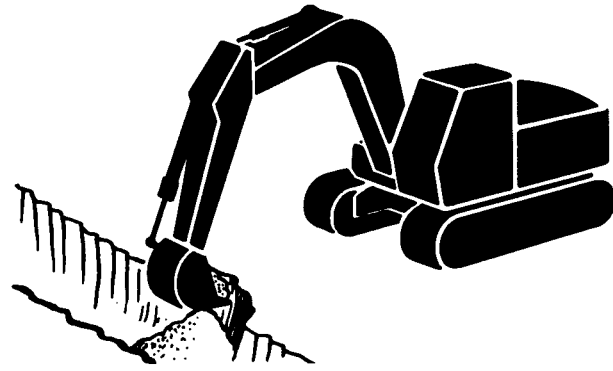

T7627DA -UN-10JUL91

TX,35,FF2327 -19-13AUG91-2/4

When trenching across a slope, level the machine so that bottom of trench will be level. Level machine by counterrotating tracks or by digging a shelf.

Place the spoil pile on the upper side of the trench. The machine is more stable and backfilling is easier.

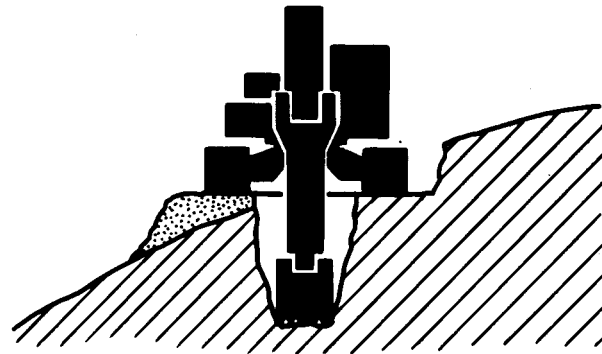

T7527DB -UN-10JUL91

TX,35,FF2327 -19-13AUG91-3/4

For straight line trenching, drive two stakes in at the beginning of the trench. Drive the first stake in immediately behind the starting point and the second stake approximately 9 m (30 ft) behind the first (A).

Use the stakes as a sight gauge. They are especially helpful if the machine is moved often.

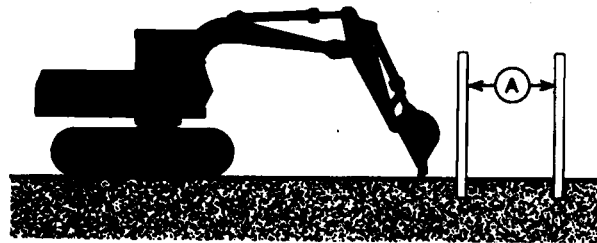

T6879AU -UN-06DEC88

TX,35,FF2327 -19-13AUG91-4/4

*Operating the Machine***BACKFILLING**

When backfilling, position machine at a 90° angle to the excavation, with propel motors to the rear of the machine.

To prevent machine damage **DO NOT** use the side of the bucket to backfill.

The bucket side can be used for finish grading.

Extra material can be backfilled around foundations to allow for settling.

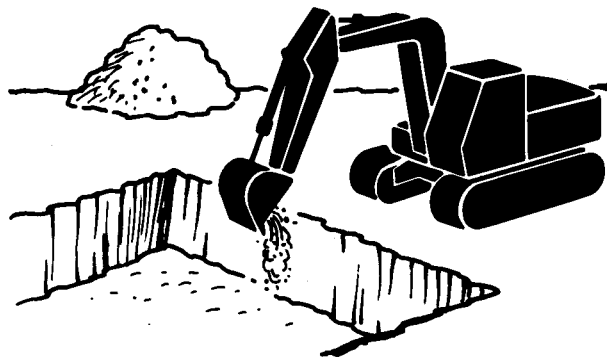

T7627DC -JUN-10JUL91

TX,35,FF2331 -19-02JUL91-1/1

*Operating the Machine***TRUCK LOADING**

Level loading area during wait time between trucks to maximize machine stability, decrease operator fatigue, and increase productivity.

Know location of all persons in working area, including truck driver. Do not load the truck unless the truck driver is in a safe place.

If possible, park truck where wind will be behind operator to keep dust of the dumped load out of operator's eyes and out of engine air cleaner.

Raise the bucket while swinging toward the truck.

Drop first load into truck from a minimum height to lessen the stress on the truck. The first material in the box will cushion following loads. Dump load into truck at a steady pace (rather than abruptly) to minimize stress on truck.

Load truck box from center front to center rear.

If loading large rock, first place a load of smaller rock into truck to cushion impact of large rock in truck.

Move bucket to excavation level while swinging away from the truck.

Do not swing the bucket over the cab.

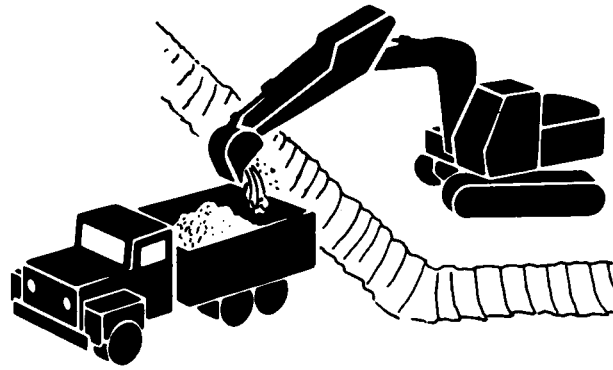

T7627DD -JUN-15JUL91

TX,35,FF2332 -19-02JUL91-1/1

OPERATING IN WATER AND MUD

Be careful not to operate the machine in water or mud above the upper deck surface of the undercarriage, causing the swing bearing and rotary manifold to be submerged.

If the swing bearing and rotary manifold are submerged, remove cover from underneath center of machine. Remove drain plug (A) to drain water and mud.

Clean swing gear area. Install plug and cover. Lubricate swing gear and swing bearing. (See Maintenance—Every 500 Hours chapter.)

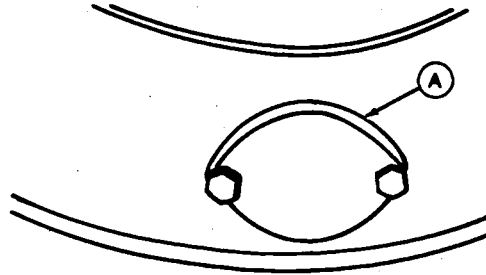

T6274AR -UN-20APR89

TX,35,FF2007 -19-06JUL94-1/1

CLEAN TRACK FRAME AREA

1. Swing upperstructure 90°.

CAUTION: Prevent possible injury from machine sliding backwards. Keep angle between boom and arm 90-110°.

2. Lower bucket (round side down) to raise track off ground, keeping angle (A) between boom and arm 90-110°.

3. Run track back and forth to remove mud and dirt.

4. Turn engine off.

CAUTION: Prevent possible injury from unexpected machine movement. Place blocks under machine frame to support machine while cleaning track frame area when track is stationary.

5. Place blocks under machine frame if further cleaning of track frame area is performed while track is stationary.

Clean track often during cold weather to prevent damage to track components.

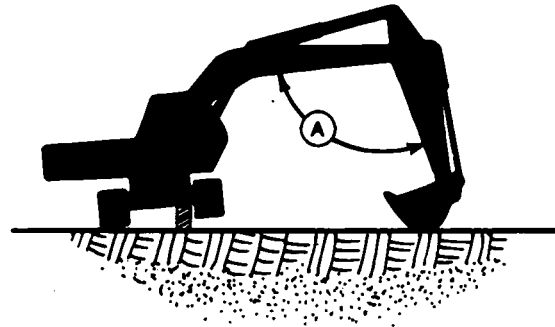

T6879AT -UN-06DEC88

TX,35,DH5513 -19-06AUG91-1/1

LIFTING

CAUTION: Prevent possible injury. Never move the load suddenly. Never move load over a person's head. Do not allow any persons near load.

Keep all persons away from raised load until blocks are supporting it or load is sitting on the ground.

Check chart on the right window or lifting capacity specification of this manual before lifting with machine. Position upperstructure so track sprockets are at the rear.

Do not attach sling/chain to bucket teeth. Do not lift with damaged or worn sling, chain, or bucket.

1. Secure sling/chain tightly to load being lifted.
2. Without bucket loop: Fasten chain/sling to pivot pin on machine, bucket curled, and arm retracted

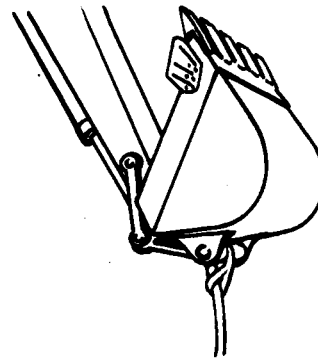

Without Bucket Loop

T6589AA -JUN-18OCT88

Continued on next page

TX,35,DH5145 -19-10AUG96-1/2

Operating the Machine

With bucket loop: Fasten sling/chain to bucket loop (A), bucket curled and arm retracted.

3. Coordinate hand signals with your signal man before starting.
4. Know location of all persons in working area.
5. Attach a hand line to load and make sure person holding it is away from load.
6. Before starting job, test your load.
 - Park your machine close to load.
 - Attach load to machine.
 - Raise load 50 mm (2 in.) above the ground.
 - Swing the load all the way to one side.
 - While keeping load close to the ground, move it away from machine.
 - If there is any indication of reduced stability of your machine, lower load to the ground.
7. Lift load only as high as necessary.

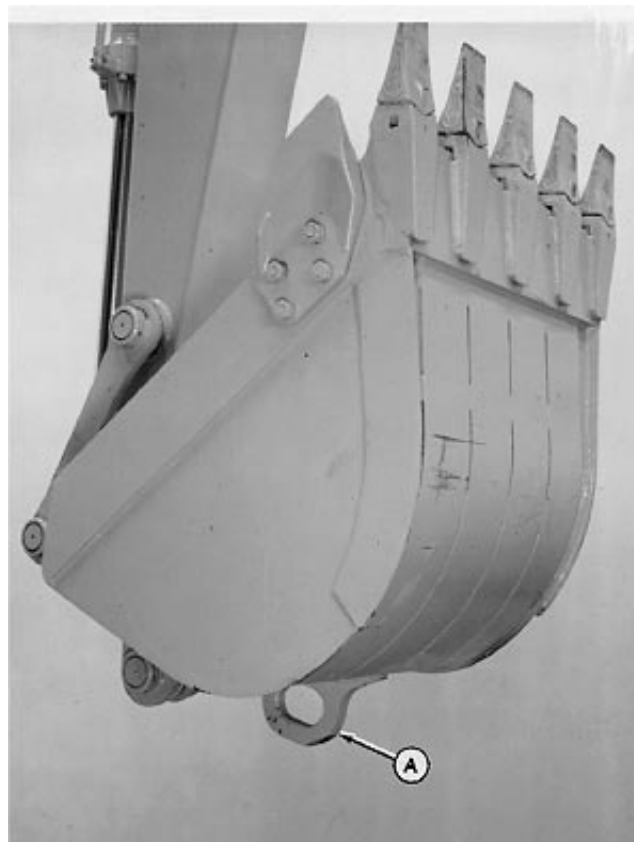

With Bucket Loop

T6886AC -UN-19OCT88

TX,35,DH5145 -19-10AUG96-2/2

AIR COMPRESSOR - OPERATING INSTRUCTIONS

CONTROL PANEL

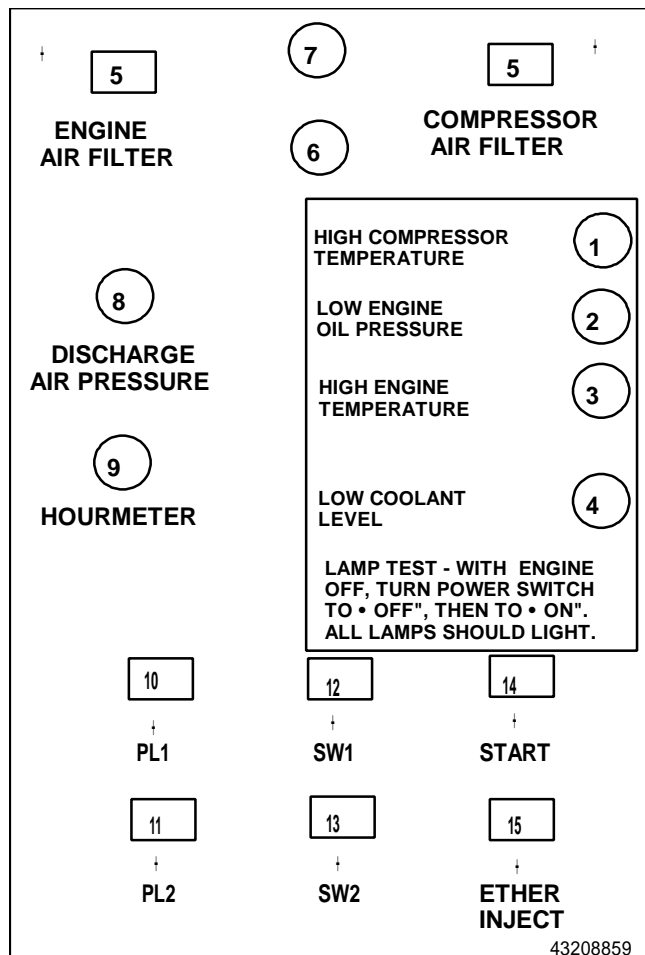

5. **Air Filter Service Indicators -**
Indicates when air filter elements need to be replaced.
6. **Heater Switch -** Flip "ON" in cold weather to activate control system heaters.
7. **Heater Indicator -** Indicates heaters are "ON" when lighted.
8. **Compressor Discharge Pressure Gauge -** Indicates pressure in receiver tank, psi (kPa).
9. **Hourmeter -**
Records running time for maintenance.

CONTROLS

10. **Panel Light (PL1) -**
When illuminated, indicates power is on.
When not illuminated, indicates power is off.
11. **Panel Light (PL2) -**
When illuminated along with PL1, indicates unit is ready to start. When not illuminated, but PL1 is, indicates compressor is operating at full pressure.
12. **Toggle Switch (SW1) -**
Flip "ON" to activate systems prior to starting.
Flip "OFF" to stop engine.
13. **Toggle Switch (SW2) -**
Flip "ON" to activate systems prior to starting.
Flip "OFF" after warmup to provide full air pressure.
14. **Start Button -**
Push to start engine.
15. **Ether Inject Button -**
Push to inject metered amount of ETHER to help start engine in cold weather. USE SPARINGLY.

DIAGNOSTICS/AUTO SHUTDOWN

1. **High Compressor Temperature -**
248°F (120°C) or more.
2. **Low Engine Oil Pressure -** 12 psi or less
3. **High Engine Temperature -**
Coolant above 220°F (104°C).
4. **Low Coolant Level -**
Must add coolant.

Note: Items 6, 7 and 10-15 are also remote mounted in the excavator cab.

Speed and Pressure Regulation Adjusting Instructions

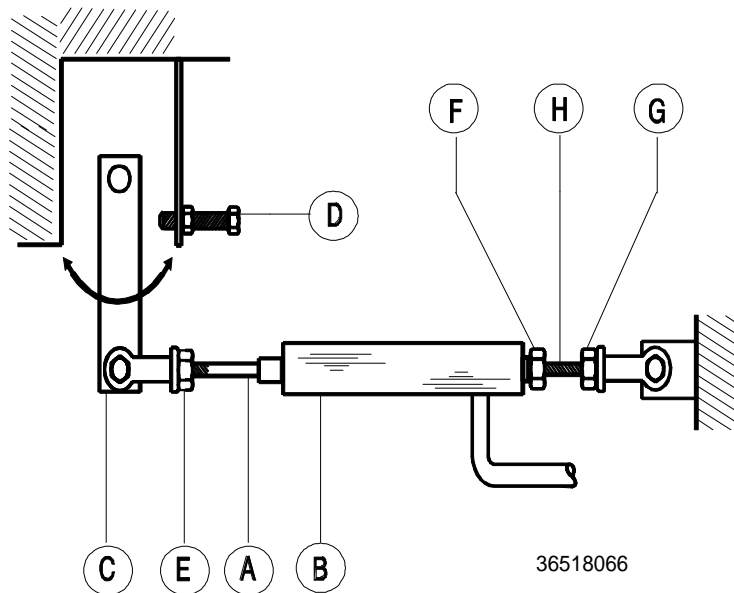

Normally, regulation requires no adjusting, but if proper adjustment is lost, proceed as follows:

Note: Refer to general data for machine rated speeds and pressure.

Before Starting Unit:

1. Atop separator tank cover at pressure valve, loosen locknut counterclockwise. Turn adjustment screw and locknut counterclockwise until no tension is felt at the screw. turn screw clockwise one full revolution.

After Starting Unit:

2. Allow unit to warm up. Then at control panel, push "Service Air" Button, if equipped.

3. Open and adjust service valve (on outside of the unit) to obtain the rated operating pressure on the discharge pressure gauge.

Note: If the rated operating pressure cannot be maintained with engine at full load speed and rod (A) of air cylinder (B) fully retracted, turn regulator

adjustment screw clockwise until throttle air (C) moves against full speed governor stop (D).

4. Insure that pressure is maintained at rated pressure, then turn regulator adjustment screw counterclockwise until throttle arm (C) just begins to move.

Note: Turning regulator adjustment screw clockwise will raise pressure at full speed.

5. Close service valve (engine will slow to idle speed). Loosen jam nut (E) on rod (A). Rotate rod (A) to adjust speed to obtain idle rpm.

6. If necessary, repeat steps 3 and 4.

7. At pressure regulator, tighten lock nut.

8. Limit full load engine speed by loosening jam nut (F) and (G) and rotating rod (H). When proper speed is reached, tighten jam nuts.

9. To obtain maximum CFM at any pressure between 80 PSI (550kPa) and the rated operating pressure, turn adjustment screw of pressure regulator to obtain desired discharge pressure at full load engine speed. Always lock pressure setting of adjusting screw.

BEFORE STARTING

CAUTION

Do not connect the air discharge on this unit into a common header with any other unit of any description, or any other source of compressed air, without first making sure a check valve is used between the header and the unit. If this unit is connected in parallel with another unit of higher discharge pressure and capacity, a safety hazard could occur in a back-flow condition.

WARNING

Unrestricted air flow from a hose will result in a whipping motion of the hose which can cause severe injury or death. A safety device must be attached to the hose at the source of supply to reduce pressure in case of hose failure or other sudden pressure release. Reference: OSHA regulation 29 CFR Section 1926.302 (b).

- Open manual blowdown valve to ensure pressure is relieved in receiver-separator system. Close valve in order to build up full air pressure and ensure proper oil circulation.

- Check battery for proper connections and condition.

- Check the compressor lubricating oil level. The proper oil level is mid-way on the sight gauge. Add oil if the level falls to the bottom of the sight gauge. Do not overfill.

- Check the engine lubricating oil level. Add oil if low on dipstick.

WARNING

Do not remove the cap from a HOT engine radiator. The sudden release of pressure from a heated cooling system can cause severe injury or death.

CAUTION

The use of water alone in this engine can result in major engine failure.

- **At overflow reservoir (plastic bottle) check coolant level and, if necessary, top off to “cold” mark.**

- **Roof access door has retaining pins on each side. After servicing cooling system, pins must be replaced for proper operation.**

- **Check the fuel level. Add only CLEAN DIESEL fuel for maximum service from the engine.**

Note: To minimize condensation (water) in the fuel tank, fill the tank at the end of each day.

WARNING

This machine produces loud noise with doors open. Extended exposure to loud noise can cause hearing loss. Wear hearing protection when doors or valve (s) are open.

Close the side doors to maintain a cooling air path and to avoid recirculation of hot air. This will maximize the life of the engine and compressor and protect the hearing of surrounding personnel. Be sure no one is IN or ON the compressor unit.

STARTING

WARNING

Do NOT operate machine with guards removed.

CAUTION

Do NOT operate machine with safety shutdown switches by-passed.

CAUTION

When attempting to start or stop the unit from the remote location, the operator should first use caution to assure no one is performing maintenance or inspecting the machine.

Low Ambient Temperature Operation

Two 24 volt DC heaters are provided at critical control system locations to prevent ice formation in the compressor capacity control system. One heater is attached to the surface of the pressure control valve. The other heater is attached to the bleed orifice connected to the compressor unloader valve. The heaters are turned on and off using the toggle switches located on either the local or remote compressor control panels.

Below 40 degrees Fahrenheit

Energize the heaters prior to starting the compressor drive engine. Allow the heaters to operate continuously during compressor operation.

Below -25 degrees Fahrenheit

Energize the heaters and wait 60 seconds prior to starting the excavator drive engine. Allow the heaters to operate continuously during compressor operation.

CAUTION

Ether is an extremely volatile, highly flammable gas. Use sparingly! If too much is injected, the uncontrolled explosion may result in costly damage to the engine.

Flip SW1 and SW2 until both panel lights are illuminated. All DIAGNOSTICS lamps will light (glow) for two (2) seconds. Then all lamps should go off except for ALTERNATOR NOT CHARGING and LOW ENGINE OIL PRESSURE.

In cold weather, open manual blow down valve and, press the ETHER INJECT button once and release. Then, while cranking, press release button once every five (5) seconds. This injects a measured amount of ether to the engine.

Press the START button to crank the engine. DO NOT OPERATE THE STARTER MOTOR FOR MORE THAN TEN (10) SECONDS WITHOUT ALLOWING AT LEAST ONE MINUTE COOLING TIME BETWEEN START ATTEMPTS.

Release the START button when the engine starts and sustains running. If the engine does not start after a couple of attempts, refer to Trouble Shooting Section.

All Diagnostic lamps should be off. If not, stop the machine and investigate. If opened above, close manual blowdown valve.

Allow the unit to warm up for at least (2) two minutes.

Flip switch SW2 to the opposite position. Panel light PL2 will go out. The engine should go to full speed and the discharge pressure rise to slightly over rated pressure. The compressor will unload (intake be throttled or closed) and the engine speed will drop to the idle speed.

Compressor is now ready to furnish air when the service valve is opened.

STOPPING

Close air service valve (s).

Allow the unit to run at "no load" for 3 to 5 minutes to reduce the engine temperatures.

The unit may be stopped from either the local panel on the compressor or the optional start/stop panel if so equipped.

Flip both toggle switches (SW1 and SW2) to the opposite position until both panel lights (PL1 and PL2) go out. Power is now off.

Note: Once the engine stops, the automatic blowdown valve will begin to relieve all pressure from the receiver-separator system.

CAUTION

Never allow the unit to sit stopped with pressure in the receiver-separator system. As a precaution, after the automatic blowdown period (2 minutes), open the manual blowdown valve.

EQUIPMENT PROTECTION

Note: Do NOT wire around or bypass a shutdown sensor or switch.

This unit is protected by sensors or switches at the following locations:

- (1) High engine COOLANT temperature in the engine.
- (2) Low engine oil pressure, in the engine.
- (3) Low Fuel Level.

High Discharge AIR Temperature -

- (4) At the airend outlet.
- (5) In the safety valve connection on the separator tank.

AUTOMATIC SHUTDOWN / DIAGNOSTICS

Should any of these problem situations occur, the unit will automatically shutdown and stop. **BEFORE** restarting the unit or flipping the POWER switch to "Off", check the DIAGNOSTICS area on the instrument panel.

The upper four (4) lamps are electronically "latched" to only respond to the first or primary signal for a shutdown. In other words, if the automatic shutdown is the result of one of these four problems, only that particular problem lamp will be lit. And the lamp will remain lit as long as the batteries provide power.

Refer to OPERATING CONTROLS AND INSTRUMENTS, for the various problem signal criteria (°F, psi, etc.). The indicated problem area should be inspected for a physical cause (low fluid, broken fan belt, evidence of excessive heat, etc.) and corrections made.

The shutdown will automatically reset when the problem condition is corrected.

Other possible causes for an unexpected shutdown are listed on the Trouble Shooting Chart.

USING QUICK-COUPLER TYPE ATTACHMENTS

GENERAL OPERATING TIPS

IMPORTANT: To avoid damaging machine cylinder(s), do not strike ground with attachment or operate with cylinders fully extended or retracted.

- Do not operate the attachment with the hydraulic cylinder rods fully extended or fully retracted.
- Do not strike the ground or other objects with the attachment.

KEEPING HYDRAULIC SYSTEM CLEAN

T120404

IMPORTANT: To prevent damage to hydraulic components, keep contamination from entering hydraulic system.

Use wrench to loosen connectors when connecting and disconnecting hydraulic lines to attachment.

While attaching or detaching attachments, the hydraulic lines are open. Contamination can enter the hydraulic system at this time, causing machine damage. If attachments are changed frequently, there are more opportunities for contamination to enter the hydraulic system. To keep hydraulic oil contamination to a minimum:

- Clean connectors before disconnecting hydraulic lines.
- Install caps and plugs on hydraulic lines as soon as possible.
- Change hydraulic return filter at half the normal interval (250 hours).
- Sample hydraulic oil every 500 hours. (See OILSCAN PLUS® in Periodic Maintenance chapter.) Follow OILSCAN PLUS® recommendations for oil change interval, but never change the oil less frequently than recommended for the machine.

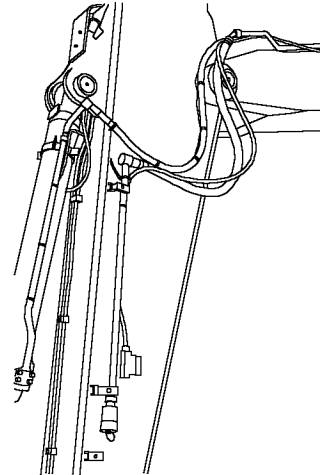

T120404 -UN-25MAR99

ROCK DRILL ATTACHMENT (MODEL 230LCRD)

Rock drill operation subjects the machine's hydraulic system to possible contamination and accelerated deterioration. The hydraulic return filter and hydraulic oil must be replaced more often to prevent damage to hydraulic pumps and other hydraulic components. Change the hydraulic return filter and oil at the intervals recommended below based on the amount of machine operating time the attachment is used.

Percentage of Operating Time Rock Drill Used	Hydraulic Return Filter Change Interval (Hours)	Hydraulic Oil Change Interval (Hours)
100	100	600
60	150	800
40	200	1000
20	300	1300

TX,35,FF2664 -19-13MAY93-1/1

INSTALL ROCK DRILL

1. Ensure that rock drill is level and legs are resting on ground.

NOTE: See Using Quick-Disconnect Hitch in this chapter for additional information when performing steps 2 through 7.

2. Manually place hitch safety lock pin in unlocked position.
3. Fully extend bucket cylinder and set quick-disconnect switch in cab to unlatch position.

Continued on next page

CED,OUOESLH,6 -19-09DEC99-1/3

Operating the Machine

4. Operate excavator to position hitch in vertical position and engage front hooks of rock drill adapter (A).
5. Rotate hitch downward to seat hitch and engage wedge into rock drill adapter (B).



CAUTION: Do not raise the rock drill without acceptable wedge engagement. The rock drill can fall causing possible injury to people in the vicinity of rock drill.

6. Set quick-disconnect switch in cab to latch position. Rotate hitch downward a small amount to engage wedge bar.
7. Check for wedge engagement and manually engage hitch safety lock pin.

NOTE: See Using Quick-Coupler Type Attachments in this chapter for general operation tips and information on keeping the hydraulic system clean when connecting attachments.

8. Remove cap from quick-disconnect fitting of high pressure hose on left side of excavator arm and plug from quick-disconnect fitting of low pressure hose on right side of excavator.

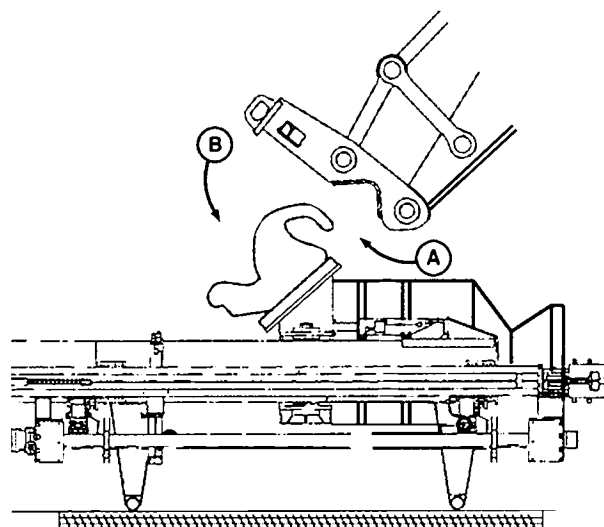

T126622

T126622 -UN-17DEC99

Continued on next page

CED,OUOESLH.6 -19-09DEC99-2/3

Operating the Machine

9. Connect high pressure hydraulic hose, grease hose, and electrical cable from rock drill to corresponding hoses and electrical connector on left side of excavator arm.
10. Connect low pressure hydraulic hose, vent hose, and air hose to corresponding hoses on right side of excavator arm.

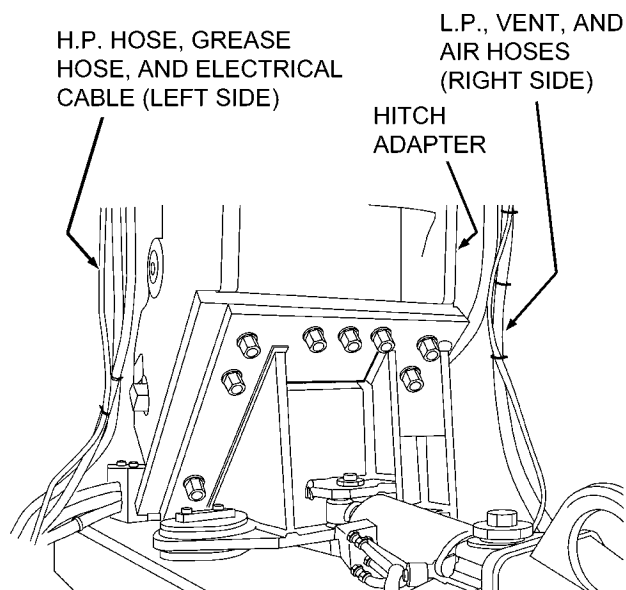

T126624

T126624 -19-17DEC99

CED,OUOESLH,6 -19-09DEC99-3/3

REMOVE ROCK DRILL

1. Operate excavator and position rock drill with legs on level ground.
2. Clean and disconnect three hydraulic hoses, one air hose, one grease hose, and one electrical cable from left and right sides of excavator arm. Cap and plug fittings to prevent contamination of hydraulic, air, and grease systems. Close cover over electrical connector. (See Using Quick-Coupler Type Attachments in this chapter.)
3. Install plug and cap on quick-disconnect fittings on excavator arm.

NOTE: See Quick-Disconnect Attachment Removal in this chapter for additional information when performing steps 4 through 7.

4. Manually place lock pin in unlocked position.
5. Set quick-disconnect hitch switch in cab to unlatch position.
6. Extend bucket cylinder slowly but do not extend bucket cylinder too far and cause rock drill to move. This will activate the wedge bar to the open position.

Continued on next page

CED,OUOESLH,7 -19-09DEC99-1/2

Operating the Machine

7. When latch bar is retracted, hitch can be rotated upward away from rock drill (A). The excavator arm can then be moved toward excavator (B) to completely disengage hitch from hooks of rock drill adapter.

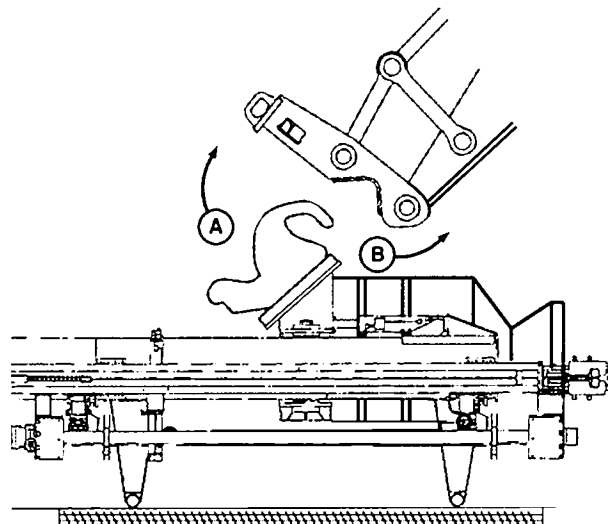

T126623

T126623 -UN-17DEC99

CED,OUOESLH,7 -19-09DEC99-2/2

Remote control operator's panel

OPERATING THE ROCK DRILL ATTACHMENT - REMOTE CONTROL OPERATOR'S PANEL

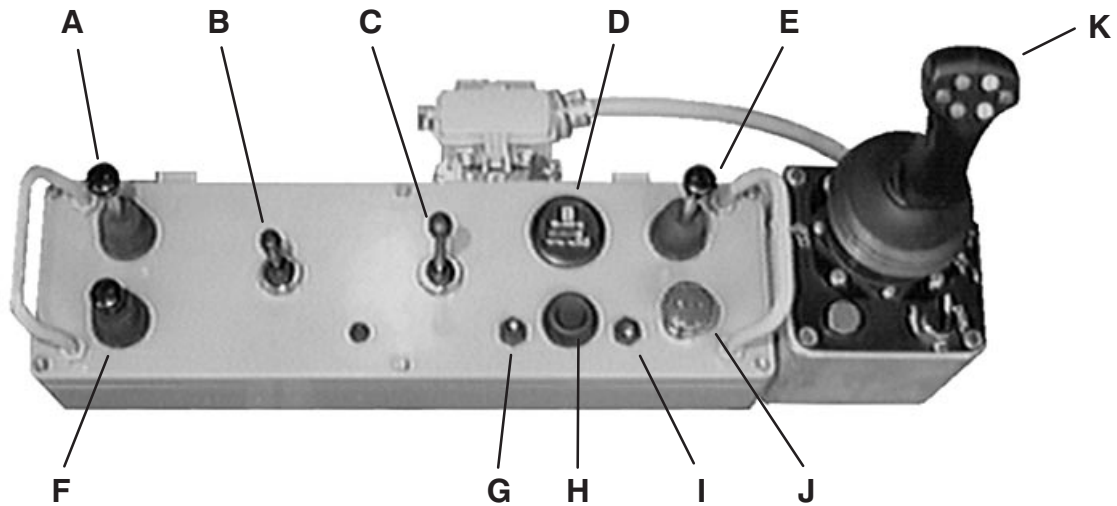

- A) Guide swing control
- B) Feed control
- C) Drifter control
- D) Drilling hourmeter
- E) Hydraulic centralizer control
- F) Air flushing switch
- G) Dust hood control
- H) Thread loosening button (percussion)
- I) HP / Dust collector selector
- J) Emergency stop button
- K) Rod changer control

Guide swing

This control allows operation of the CPA swing.

Swing the lever to the left to move the CPA foot piece to the left.

Swing the lever to the right to move the CPA foot piece to the right.

Feed control

This is a four-way lever with a push button on top.

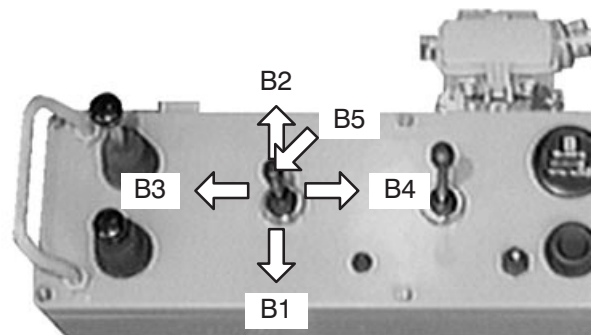

B1) Pull the lever to operate the feed forward. The lever is locked in position. This is the normal position when drilling.

B2) Push the lever to operate reverse feed. The lever must be held in position.

B3) Swing the lever in this direction to operate fast feed forward. The lever must be held in position.

B4) Swing the lever in this direction to operate fast reverse feed. The lever must be held in position.

B5) Pressing this button when the lever is pulled in B1 position operates the reduced feed for collaring.

Remote control operator's panel

Drifter control

This is a four-way lever.

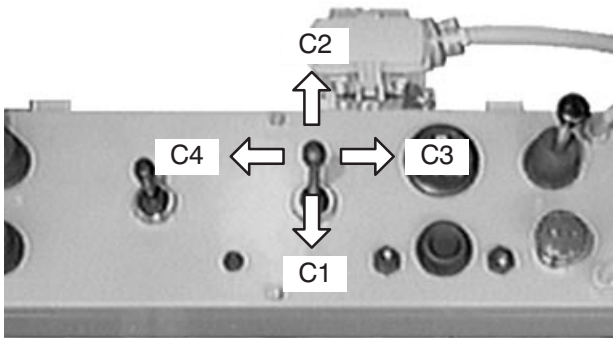

C1) Pull the lever to operate normal rotation only.

C2) Push the lever to operate reverse rotation only.

Note : these two functions are never used for thread coupling or uncoupling.

C3) Swing the lever in this direction to drill with automatic control.

This is the normal lever position when drilling.

The lever is locked in position.

C4) Swing the lever in this position to drill on manual.

In this specific position, the drilling automatics are inoperative.

This lever position is exceptionally used to get full reverse percussion (if the drifter is so equipped), or to force the drilling when encountering faults by over-riding the anti-jamming.

in such an occasion, rod jamming is risky. Carefully reduce the feed speed by switching the feed control in collaring position.

Drifter hourmeter

The drifter hourmeter indicates the total operating of the drifter.

It should be used to determine service maintenance.

Hydraulic centralizer control

Pull the lever to open the centralizer.

Push the lever to close the centralizer.

Air flushing

Pull the lever to operate air flushing.

Dust hood control

Pull the lever to slide the dust hood down.

Push the lever to slide the dust hood up.

Thread loosening button

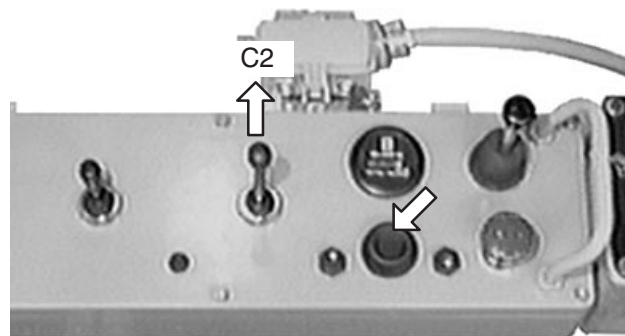

Depress this button to operate drifter percussion only. By successive impulses to the drifter control in C2 direction operate reverse rotation to break loose the threaded joints.

HP / Dust collector switch

This is a 3 positions switch.

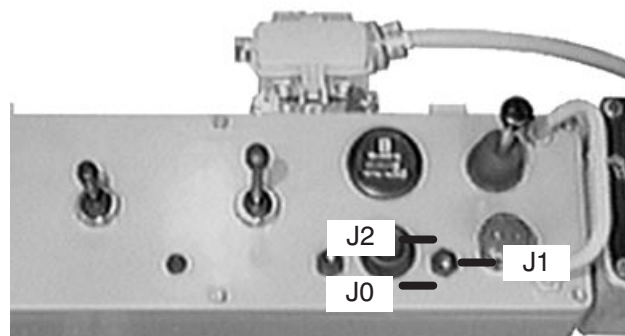

J0) Down, HP flow is diverted to tank.

J1) Middle, HP pressure built up to allow movements or auxiliaries.

J2) Up, the dust collector is activated.

Emergency stop button

Press the button to switch down the engine in case of emergency only.

The emergency stops selector must be placed on CPA position (refer to safety).

Rod changer

ROD CHANGER

The rod changer is a semi-automatic device which allows:

- the storage of 6 x 12' extension rods in a carousel.
- the handling of the rod to and from the drill guide.
- automatic operations for rod coupling and uncoupling. The synchronized drifter rotation and displacement are operated by a single lever.

When male/male extension rods are used, the upper rod clamp prevents hazardous sleeve loosening which might occur during drifter shank uncoupling.

Thread lubrication is also controlled from the operator's station.

CONTROL PANEL

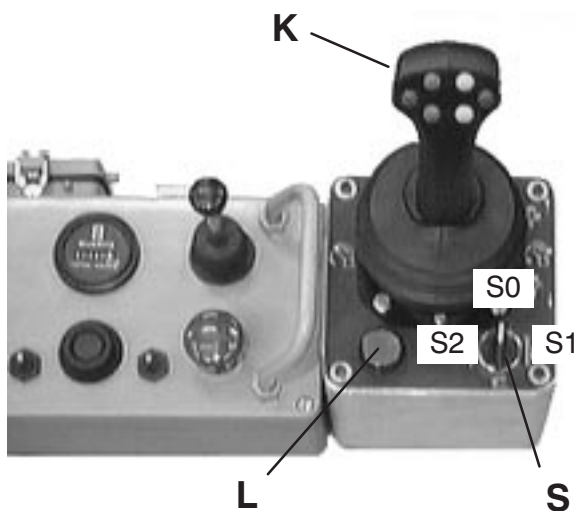

K) Rod changer control lever

The safety trigger located on the back of the lever must be depressed to allow any operation.

L) Indicator light

This indicator is alight when the carousel is well positioned for adding or removing a rod.

S) Mode selector :

- S0) Manual mode.
- S1) Automatic mode for rod adding.
- S2) Automatic mode for rod removing.

When an automatic mode is selected, the different movements of the rod clamp arms and those of the carousel are controlled automatically. This makes the different operations easiest and reduces the cycle time.

Functions

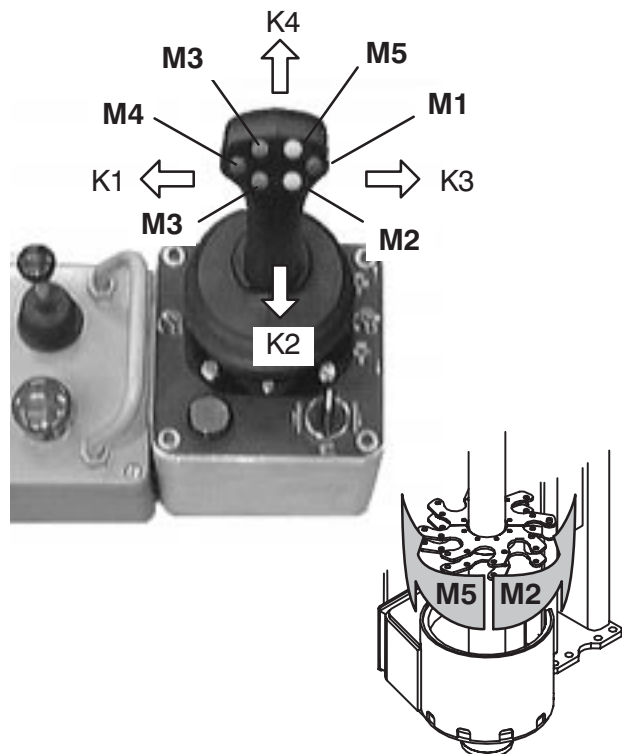

Depressed the indicated pushed button to operate :

- M1 Rod clamps closing (upper and lower).
- M2 Carousel rotation (manual mode only).
- M3 Rod / drifter shank threads lubrication.
- M4 Rod clamps opening (upper and lower).
- M5 Carousel rotation (manual mode only).

M1 + M4 Lower rod clamp closing, upper rod clamp opening (manual mode only).

Move the rod changer control lever in the indicated direction to operate :

- K1) Rod clamp arms swing towards the guide.
- K2) Rod coupling.
- K3) Rod clamp arms swing into the carousel.
- K4) Rod uncoupling.

Rod changer

LOADING THE CAROUSEL (MANUAL MODE S0)

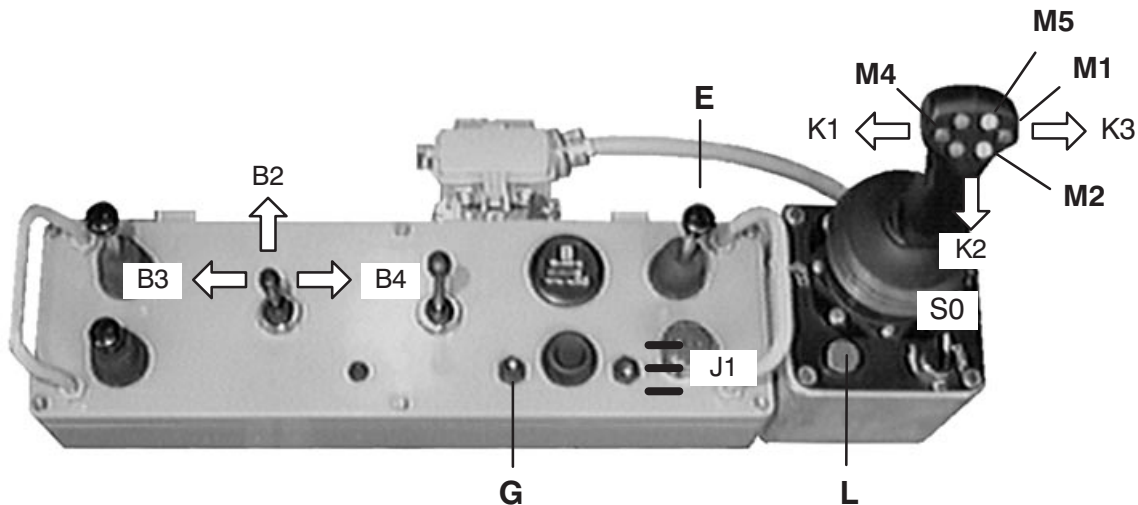

Loading the carousel with rods necessitates the presence of 1 or 2 assistants depending on the rods weight.

Make sure that any hand signal will be perfectly understood.

The CPA should be lowered in its rest position to load the rod.

1) Place the HP / Dust collector switch on position J1 (middle).

2) Select the manual mode (mode selector in S0 position).

3) Check the indicator (L) is alight. If not, depress M2 or M5 button to rotate the carousel.

Release the button when the indicator (L) is alight.

4) Swing the rod clamp arms towards the guide (rod changer lever in K1 direction).

5) Open the rod clamps (depress M4 button).

6) Mount a coupling on the rod to be loaded. Place the rod into the rod clamps.

7) Close the rod clamps onto the rod (depress M1 button).

8) Swing the rod clamp arms into the carousel (rod changer lever in K3 position).

9) Open the rod clamps (depress M4 button).

10) Depress M5 button to rotate the carousel.

Release the button when the indicator (L) is alight.

11) Perform steps 4 through 10 until the carousel is loaded with 4 extension rods (do not perform steps 9 and 10 after loading the last extension rod).

12) Make sure the centralizer is open (switch E).

13) Raise the dusthood (switch G).

14) Place the starter rod with a coupling into the centralizer. Close the centralizer onto the coupling (switch E).

15) Feed the drifter down to the centralizer end of the drill guide (feed lever in B3 direction).

16) Screw the drifter shank into the coupling (rod changer lever in K2 direction).

17) Open the centralizer (switch E). Feed the drifter back (feed lever in B2 direction) until the coupling is above the centralizer. Close the centralizer (switch E).

18) Feed the drifter back (feed lever in B4 direction) until the rod threads are below the dust hood. Screw on a bit to the rod. Retract the drifter so that the bit enters inside the dusthood (feed lever in B2 direction).

Rod changer

ADDING A ROD (AUTO MODE S1)

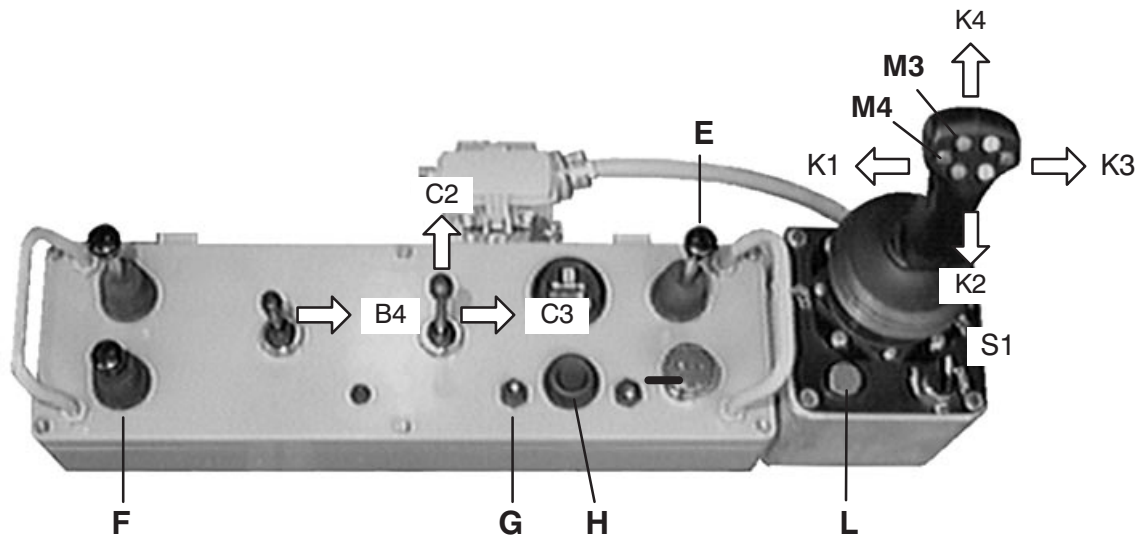

Make sure :

- the carousel is properly positioned i.e. a rod housing is in front of the opening of the rod catcher (the indicator L is then alight).
- the rod clamp arms are swung into the rod changer.
- the rod clamps are closed onto a rod.
- the mode selector is on S1 position.

1) When drilling with the first rod is completed, close the centralizer onto the coupling (switch E).

2) Break loose the drifter shank (depress the thread loosening button H and pull back the drifter control lever in C2 direction to reverse the rotation). The rotation of the shank must be visible when looking at the connection, air flows from the connection.

Stop air flushing (switch F).

3) Unscrew the drifter shank from the coupling (lever in K4 position).

4) After the drifter shank has been disconnected from the coupling, depress M3 button to lubricate the shank threads.

5) Raise the drifter to the top of the drill guide (feed lever in B4 direction).

6) Swing the next extension rod towards the drill guide (rod changer lever in K1 direction. Hold the position for 1 second.)

7) Depress M3 button to lubricate the rod threads.

8) Screw the drifter shank into the top coupling (rod changer lever in K2 direction).

9) Depress M4 button while keeping the lever in K2 direction to screw the rod into the bottom coupling.

10) Swing the rod changer lever in K3 direction. Hold the position for 1 second (the rod clamps open and the rod clamp arms swing into the carousel). #

11) Open the hydraulic centralizer (switch E).

12) Start air flushing (switch F) and drilling (drifter lever in C3 position).

The cycle will then end automatically : the carousel rotates to bring the following rod into the rod clamps, the rod clamps close onto the rod.

Rod changer

REMOVING A ROD (AUTO MODE S2)

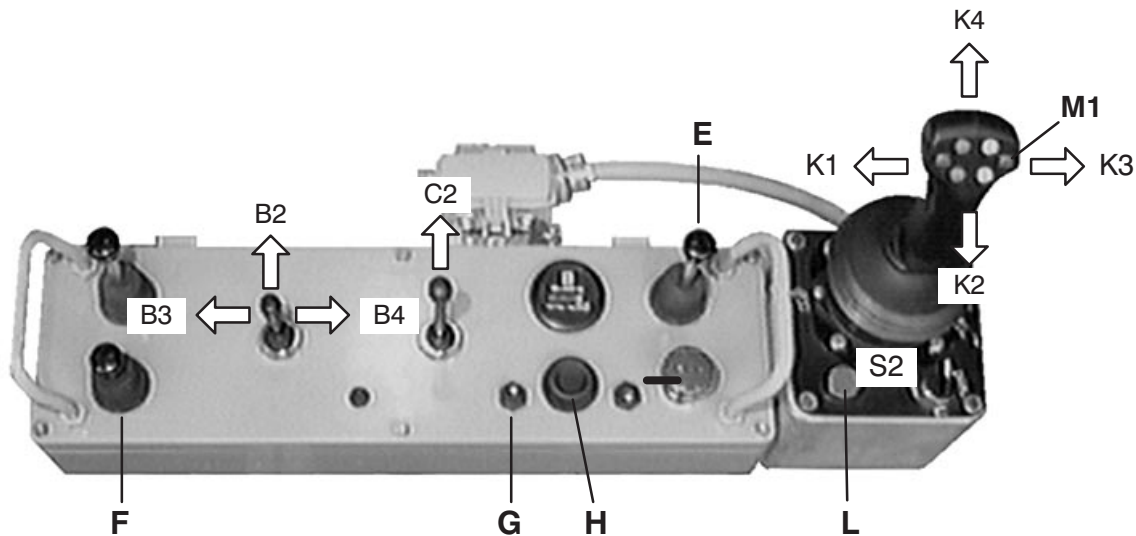

Make sure :

- the carousel is properly positioned i.e. a rod housing is in front of the opening of the rod catcher (the indicator L is then alight).
- the rod clamp arms are swung into the rod changer.
- the rod clamps are closed.
- the mode selector is on S2 position.

1) While drilling the end of the last rod and if the drifter has not reached its front end position, start to break loose the drifter shank (depress the thread loosening button H and pull back the drifter control lever in C2 direction to reverse the rotation).

Stop drilling.

2) Feed the drifter back (feed lever in B4 direction) until the bottom coupling is in the centralizer.

Close the centralizer onto the coupling (switch E)

3) Break loose the rod (depress the thread loosening button H and pull back the drifter control lever in C2 direction to reverse the rotation). The rotation of the rod must be visible when looking at the connection, air flows from the connection.

Stop air flushing (switch F).

4) Swing the rod changer lever in K1 direction. Hold the position for 1 second (the rod clamps open, the carousel rotate, the rod clamp arms swing towards the guide and the clamps close onto the rod).

5) Tighten the upper coupling onto the rod (rod changer lever in K2 direction, hold the position for few seconds).

6) Unscrew the rod from the bottom coupling (rod changer lever in K4 direction).

note : If during this sequence, the drifter shank or the upper coupling uncouples, returns to point 5).

7) After the rod has been disconnected from the bottom coupling and is high enough to enter into the carousel, close the clamps onto the rod : the drifter shank unscrews from the top coupling (depress M1 button while changer lever in K4 direction).

8) After the drifter shank has been disconnected from the top coupling swing the rod into the carousel (changer lever in K3 direction).

note : If the rod abuts against the rod holder plate,

– swing the rod toward the guide (changer lever in K1 direction).

– screw the drifter shank into the coupling (changer lever in K2 direction).

– depress M4 button to open the clamps and keeping M4 button depressed, adjust the position of the rod by acting on the feed control lever.

– swing the rod into the carousel (changer lever in K3 direction).

9) Feed the drifter down to the centralizer end of the drill guide (feed lever in B3 direction).

10) Screw the drifter shank into the coupling (rod changer lever in K2 direction).

11) Perform steps 2 through 10 to remove more rod.

Starting operation

START UP

- Make a walk-around inspection before mounting the machine and starting the engine.
- Look around and under the machine for loose bolts, broken or worn parts. Have the machine repaired before starting.
- Check engine oil and coolant, hydraulic and compressor oil levels. Refill if necessary.
- Check the emergency stop selector is placed on CPA position.



- Check all electric cables of the remote control are properly connected.
- Check excavator safety switch is in lock position.
- Check compressor is off.
- Start engine and warm by carrier manufacturer handbook.
- Set engine R.P.M mode.
- Set the guide in toe holes drilling position, to inspect the guide chains and wire rope. (#)
(#) [refer to maintenance section](#) for further information.

Travelling

TRAVELLING

- Excavator safety switch to unlock.
- Boom up, CPA vertical to 1.5 meter from ground.
- Base of CPA close but clear of tracks.
- Travel at a speed suitable to ground conditions.
- Be careful when tramping over rough terrain to prevent tipping or any hazardous conditions.
- Never use CPA to assist with slewing.

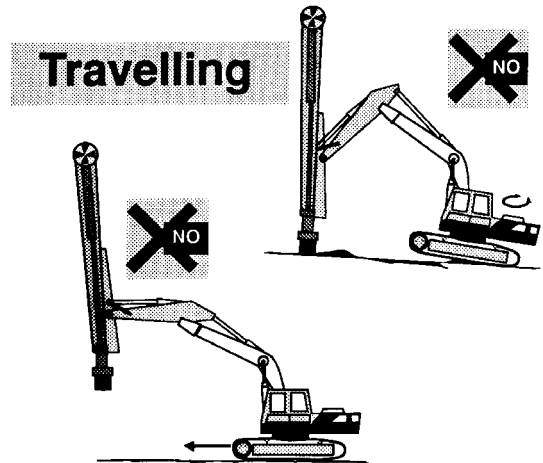
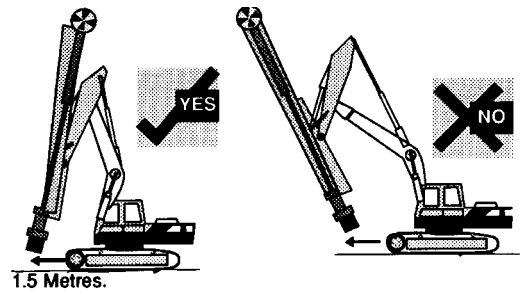

TRAVELLING HOLE TO HOLE

- Turn off CPA and compressor.
- Be sure of side and rear clearance from batters and machinery.
- Lift mast base clear of ground.
- Slew and travel slowly. Do not extend dipper to full length to reach hole.

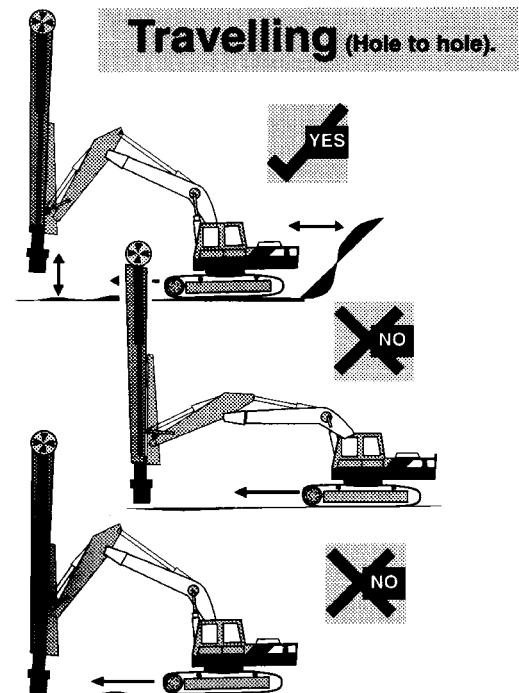

Drilling

DRILLING

POSITION FOR DRILLING

- Do not over reach.
- Position base of mast over top of hole..
- Place mast base on ground slowly.
- Do not jack machine off ground.
- Do not re-position boom or mast whilst resting on ground.

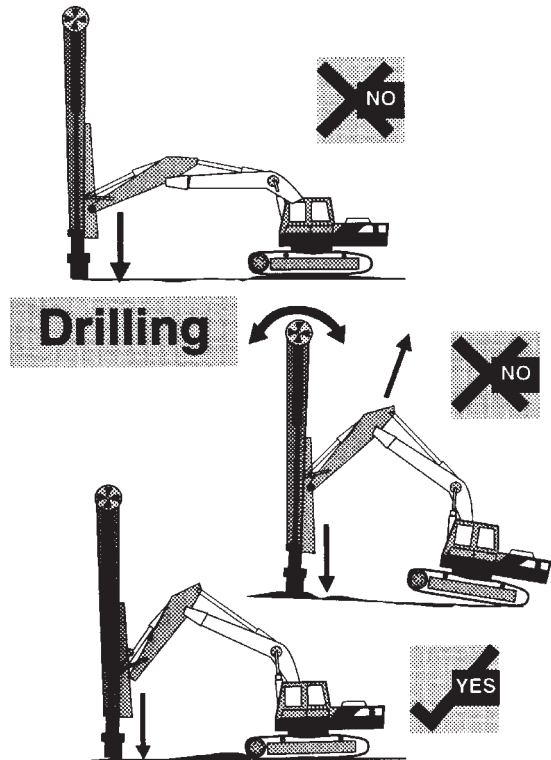

START UP DRILLING

- Check engine R.P.M mode setting.
- Start compressor.
- Close centralizer.
- Dust hood up.

START DRILLING

- Flush air to collar position and dust collector on.
- Rotation only feed bit to just above ground.
- Move drill lever to "AUTO" position.
- Depress button / Flick feed lever forward and stop several times till bit travels without deflection.

If not straight start new hole

- With bit straight hold lever forward and button depressed to complete collaring to required depth.

Use water if required but dust collector must be off (if machine is so equipped).

- Move feed up and down the collar with air off to solidify wall of hole.

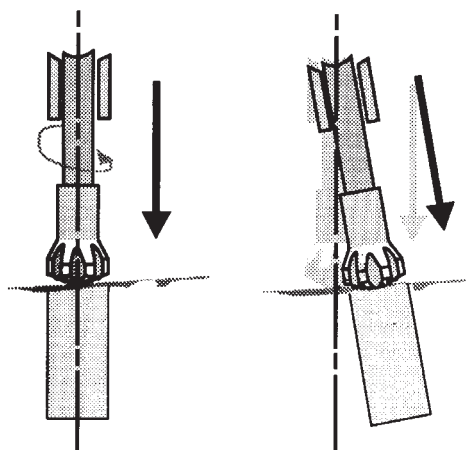
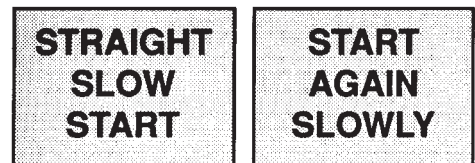

Drilling

DRILLING

- Dust collector on. Dust hood down.
- Flushing air on.
- Feed down without hammering till reaching end of collar (solid ground).
- Move drill lever to auto and start drilling.
- When sampling or completion of hole, turn dust collector off to purge filters (if machine is so equipped).

SETTING OF BIT ROTATION

The bit rotation speed can not be adjusted directly from the operator's control panel.

To modify the bit rotation, it is necessary to act on the rotation flow regulator.

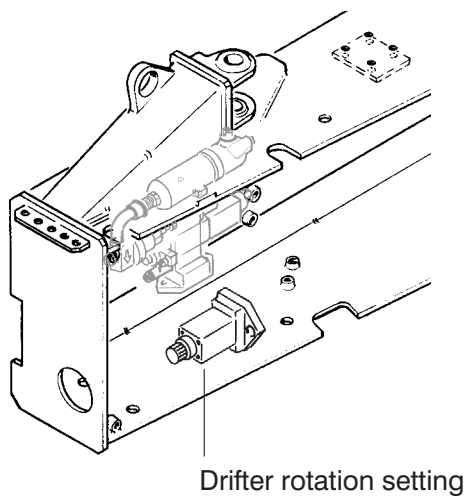

WATER POCKETS

As soon as the operator observes water going into the dust collector, shut it down. If shutdown was immediate and operator is sure that no water has entered the dust collector, drilling may be resumed until dust smoke is observed coming from the hole. Then the dust collector can be started again. If water has entered the dust collector, or in case of doubt, stop drilling and retract the drifter (do not stay in the water pocket). Wait 5 to 10 minutes with the dust collector running and air flushing so as to dry the filter cartridges. Then do 10 cycles of stopping, flushing and starting the dust collector again to clean the dry mud from the filter cartridge. Restart drilling with the dust collector shut off as long as no dust smoke is coming from the hole. Mud inside the hood and plastic hose has to be removed manually.

ROD CHANGING

Refer to Changing a Rod.

SHUT DOWN

- Switch off drill and compressor.
- Move carrier to park site.
- Position CPA vertical. mast base on ground.
- Position excavator safety switch to lock.
- Idle down engine to manufacturer specifications.

LOWER BOOM WITH ENGINE STOPPED

When an engine stops during operation, the boom cannot be lowered using the pilot controller because there is no pilot pressure oil to move the boom valve spool or to unlatch the boom load lowering valves.

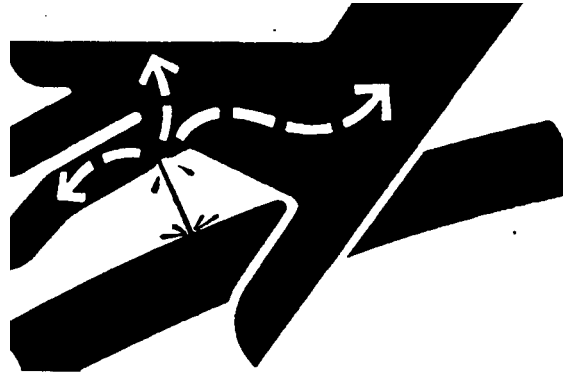

CAUTION: Prevent possible injury from unexpected machine movement. Clear all persons from the area before lowering the boom with the engine stopped.

To avoid injury from escaping fluid under pressure, stop engine and relieve the pressure in the system before disconnecting or connecting hydraulic or other lines. Tighten all connections before applying pressure.

1. Loosen jam nut on relief valve (A). Back off relief valve set screw, counting number of turns, until boom starts to lower slowly.
2. After bucket is on ground, reset relief valve (A) by turning set screw clockwise the same number of turns noted in step 1 and lock jam nut.

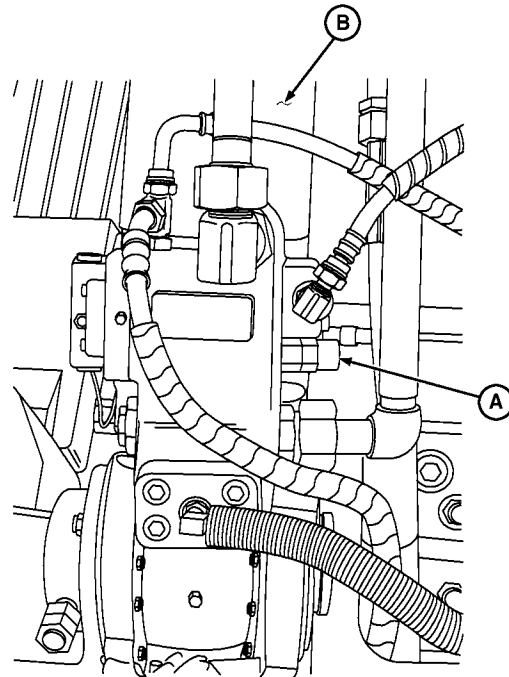

T127544

A—Relief Valve
B—Boom Cylinder

X9811 -UN-23AUG88

T127544 -UN-19JAN00

CED,OUOEBAS.2 -19-19JAN00-1/1

USING HYDRAULIC HAND TOOLS HOSE REEL

KEEPING HYDRAULIC SYSTEM CLEAN

IMPORTANT: To prevent damage to hydraulic components, keep contamination from entering hydraulic system.

Connect tool to corresponding hose ends (A and B).

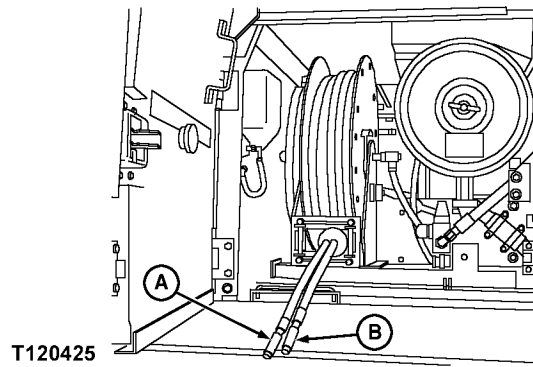

A—Male Hose End
B—Female Hose End

T120425 -UN-25MAR99

TX,OUOE042,21 -19-04MAR99-1/1

USING HYDRAULIC HAND TOOLS FLOW RATE VALVE AND SWITCH

Once tool is connected to hose ends, turn on switch (B). Set flow rate valve (A) to flow rate required to operate tool.

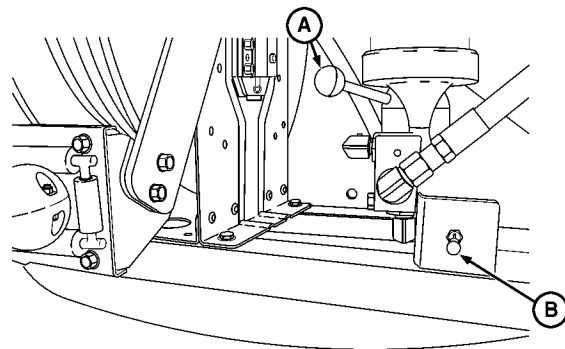

T120426 -UN-25MAR99

TX,OUOE042,22 -19-04MAR99-1/1

USING HAND HELD AIR TOOLS

CAUTION: Make sure the air tool outlet shutoff lever is in the Off position before attempting to remove the outlet cover or disconnecting hand tools.

1. Remove air tool outlet cover (A) and connect air tool hose to outlet.
2. Move outlet shutoff lever (B) to On.

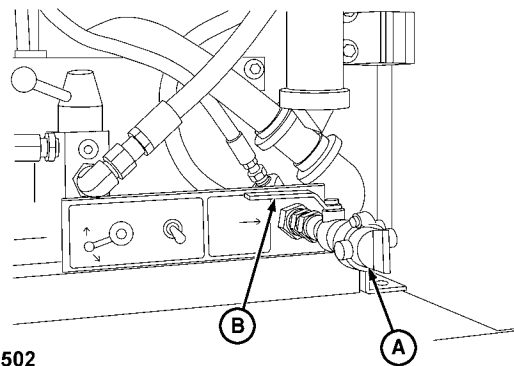

T121502 -UN-02JUN99

CED,OUOE012,186 -19-24MAY99-1/1

BLANK

CHAPTER 8
TRANSPORTING

BLANK

Transporting

LOADING MACHINE ON A TRAILER



WARNING: The M870 and M870A1 trailers may be used to haul/transport the John Deere Hydraulic Excavators (Model Numbers 230LCR and 230LCRD) providing the following precautions are adhered to:

- Position the longitudinal centerline of the hydraulic excavator as near as possible over the longitudinal centerline of the trailer, i.e., overhang of the hydraulic excavator tracks to be equal on both left and right outriggers.
- An M870 or M870A1 trailer shall be limited to primary and secondary roads (paved and gravel) when hauling a hydraulic excavator.
- The truck/tractor shall reduce its top speed by 50% when hauling an M870 or M870A1 trailer loaded with a hydraulic excavator.
- An M870 or M870A1 trailer loaded with a hydraulic excavator shall not be operated on roads with side slopes greater than 10%.

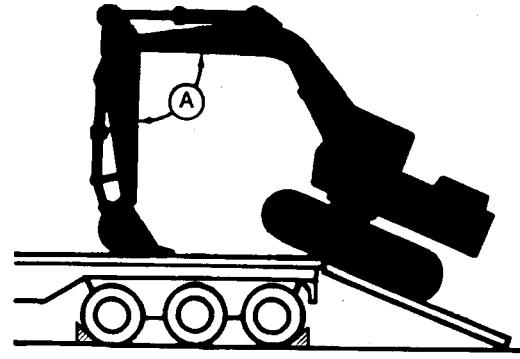

T7405E1 -UN-29NOV90

1. Keep trailer bed clean.
2. Put chocks against trailer wheels.
3. Use a ramp or loading dock. Ramps must be strong enough and have a low angle of 10—15°.



CAUTION: Prevent possible injury from unexpected machine movement. Turn auto-idle switch off and turn H/P mode switch off when loading or unloading the machine.

4. Turn auto-idle switch off and turn H/P mode switch off.
5. Load and unload machine on a level surface.
6. Drive machine onto ramps slowly.
7. The centerline of the machine should be over the centerline of the trailer.
8. Position bucket with flat surface resting on trailer. Angle (A) of arm to boom should be 90°.

IMPORTANT: To prevent machine or trailer damage, do not allow machine to impact trailer with bucket.

9. Bucket must be resting on trailer before machine begins to tip forward onto trailer.

TX,40,DH5074 -19-01JUL96-2/2

TIEDOWNS

Tiedown loops (A) are located on the front and rear frame of the machine. The tiedown are used to secure the machine to the transport medium.

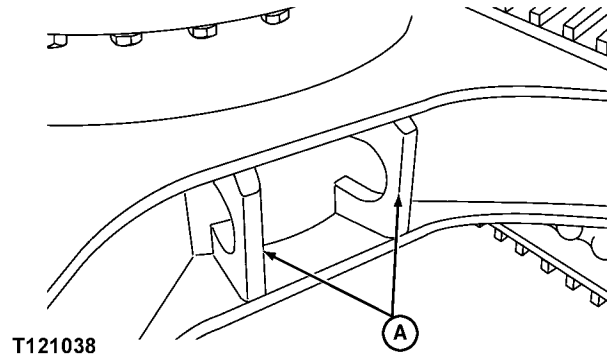

TX,OUOE042,18 -19-02MAR99-1/1

FASTEN MACHINE TO TRAILER

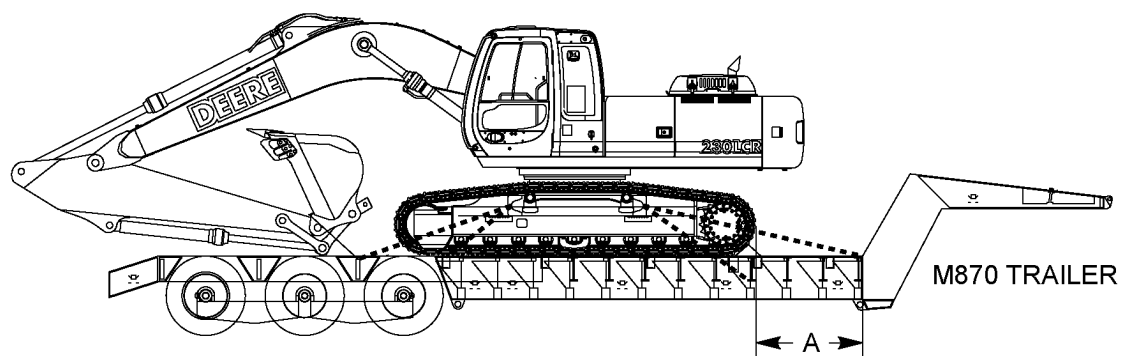
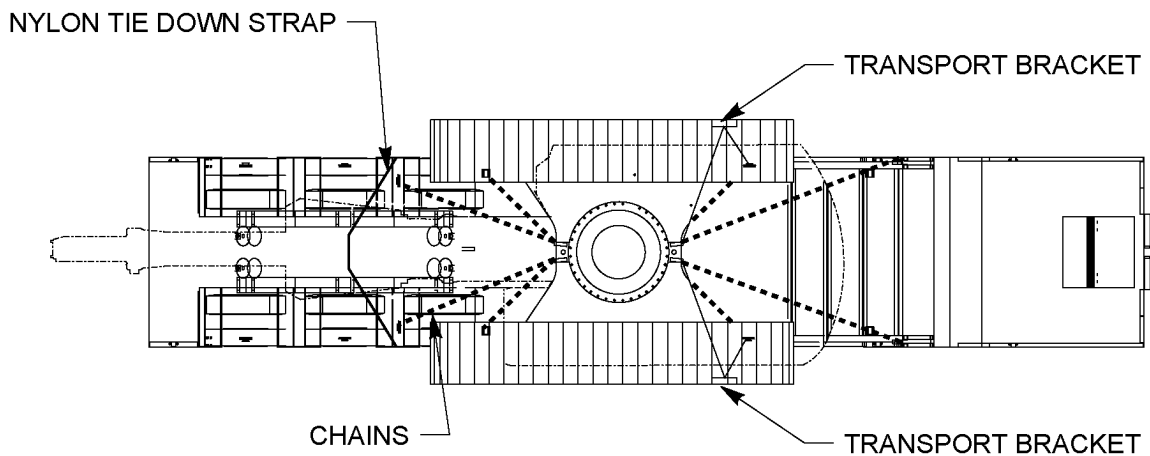

T125167

MODEL 230LCR ON M870 TRAILER

T125167 -19-28OCT99

Continued on next page

TX,40,DH5642 -19-26MAR97-1/3

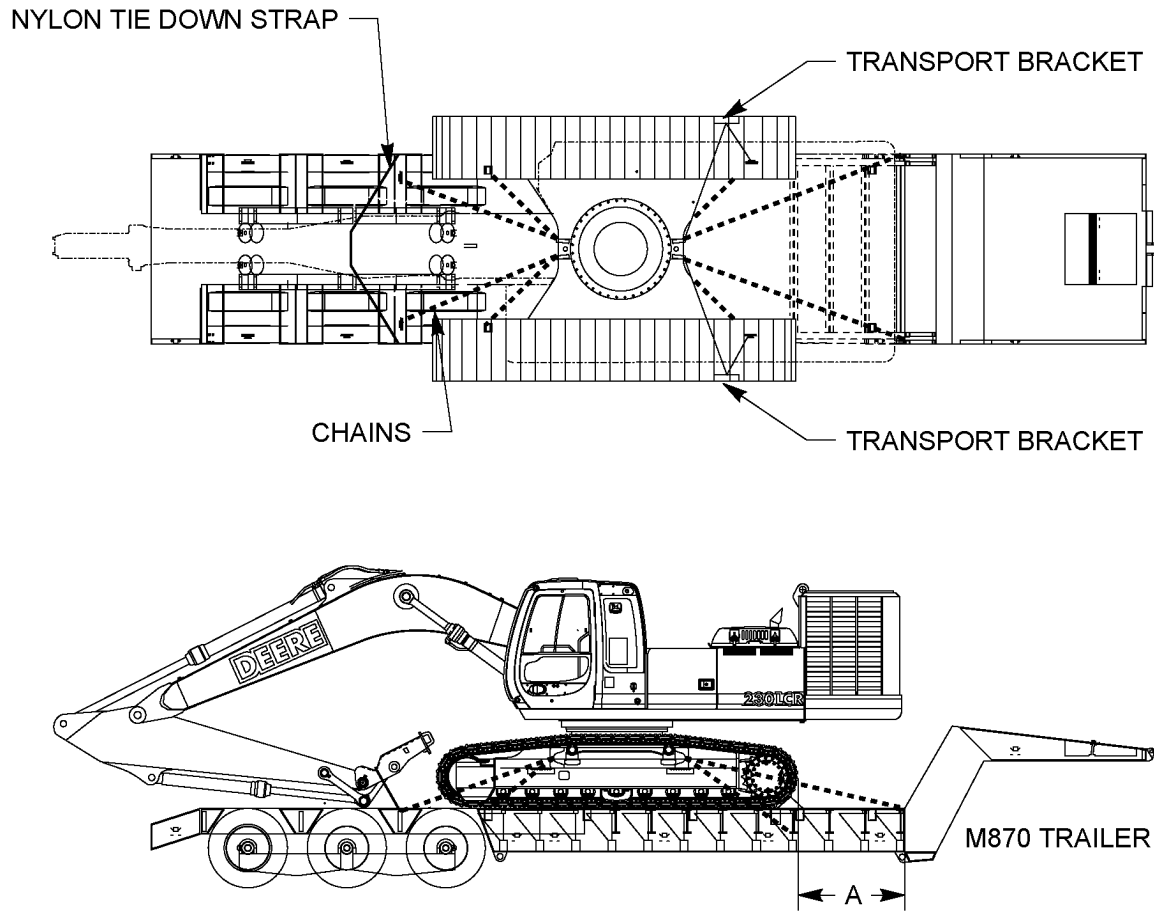

T125168

MODEL 230LCRD ON M870 TRAILER

Before leaving the operator's seat, perform steps 1—9.

1. Position machine on trailer so that dimension (A) is 1372 mm (54 in.).
2. Extend bucket cylinder fully.
3. Extend arm cylinder fully.

4. Lower the boom.

If machine cannot be transported with arm fully retracted, remove bucket or attachment and retract arm.

5. Lower bucket onto blocks.

Continued on next page

TX,40,DH5642 -19-26MAR97-2/3

T125168 -19-28OCT99

Transporting

IMPORTANT: Turbocharger may be damaged if engine is not properly shut down.

6. Run engine at 1/2 speed without load for 2 minutes.
7. Move engine speed rpm dial to slow idle position.
8. Turn key switch to OFF. Remove key from switch.
9. Pull pilot control shut-off lever to locked position.

IMPORTANT: Prevent cab electrical component damage from bad weather. Always close windows, roof vent, and cab door.

10. Close windows, roof vent, and cab door.

11. Cover exhaust opening to prevent entry of wind and water.

IMPORTANT: Prevent possible damage to hydraulic lines, rods, and hoses. Fasten chains to machine frame.

12. Install chock blocks and 2 transport brackets over track shoes. Fasten machine to trailer with chains and nylon strap.

TX,40,DH5642 -19-26MAR97-3/3

LOADING AND FASTENING ROCK DRILL ON A TRAILER

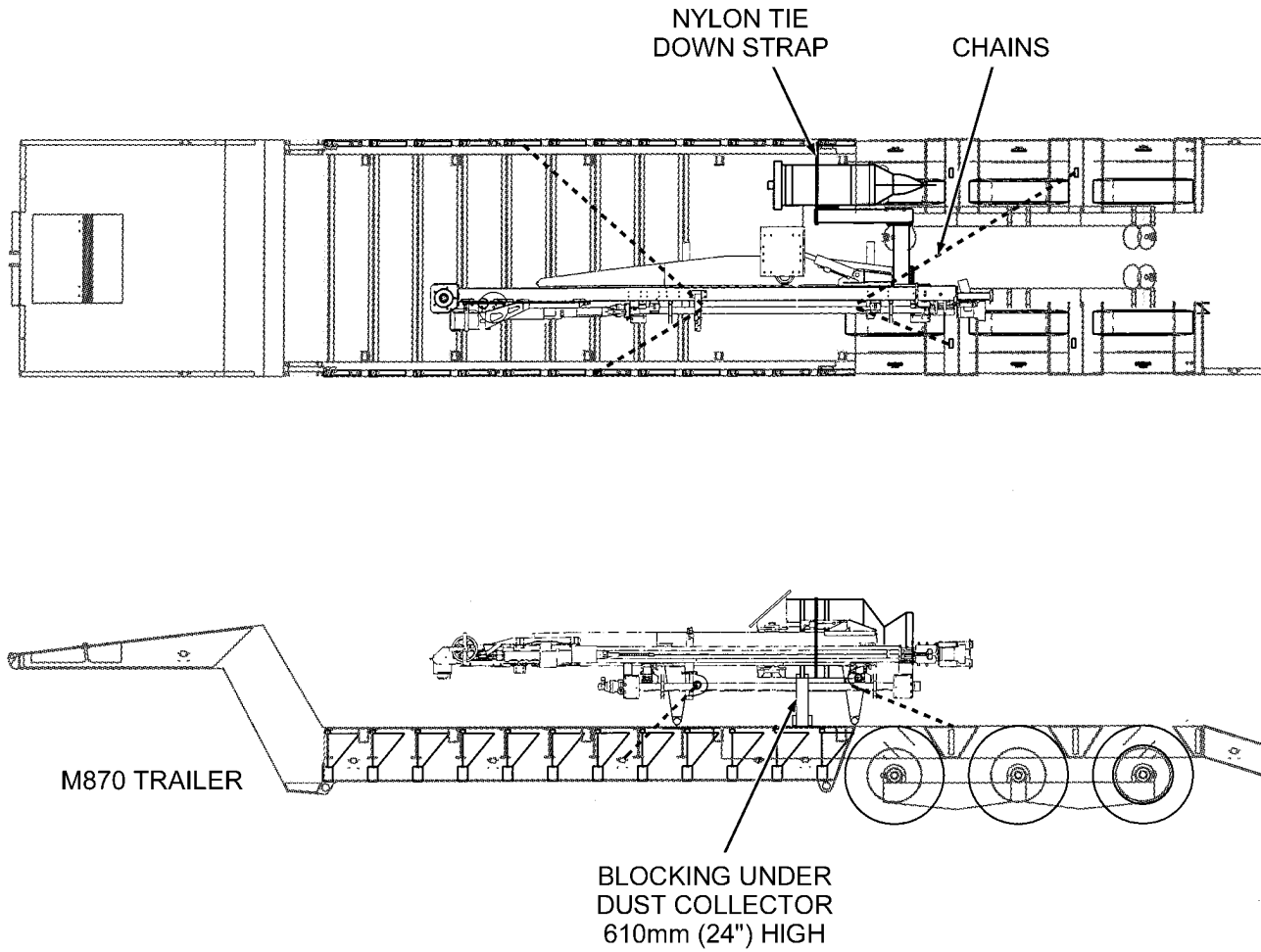

T125169

Rock Drill on M870 Trailer

1. Keep trailer bed clean.
2. Put chocks against trailer wheels.

Continued on next page

CED,OUOE042,48 -19-19OCT99-1/2

T125169 -19-03NOV99

Transporting

3. Load and unload rock drill on a level surface.

CAUTION: Ensure that the lifting device is capable of supporting the rock drill. The approximate weight of the rock drill is 4536 kg (10,000 lb). Keep all people clear of raised load.

4. Load rock drill onto trailer.

5. Install blocking (A) under rock drill dust collector.

6. Fasten rock drill to trailer with chains.

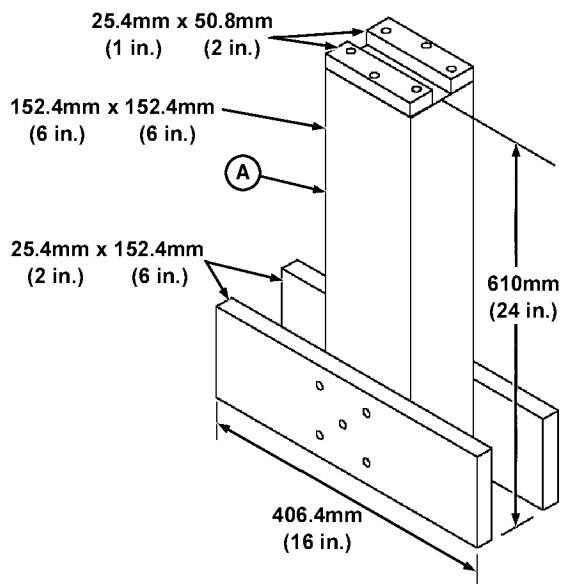

T125560

A—Rock Drill Dust Collector Blocking

T125560 -UN-03NOV99

CED,OUOE042,48 -19-19OCT99-2/2

FASTEN MACHINE TO RAIL CAR (MODEL 230LCR)

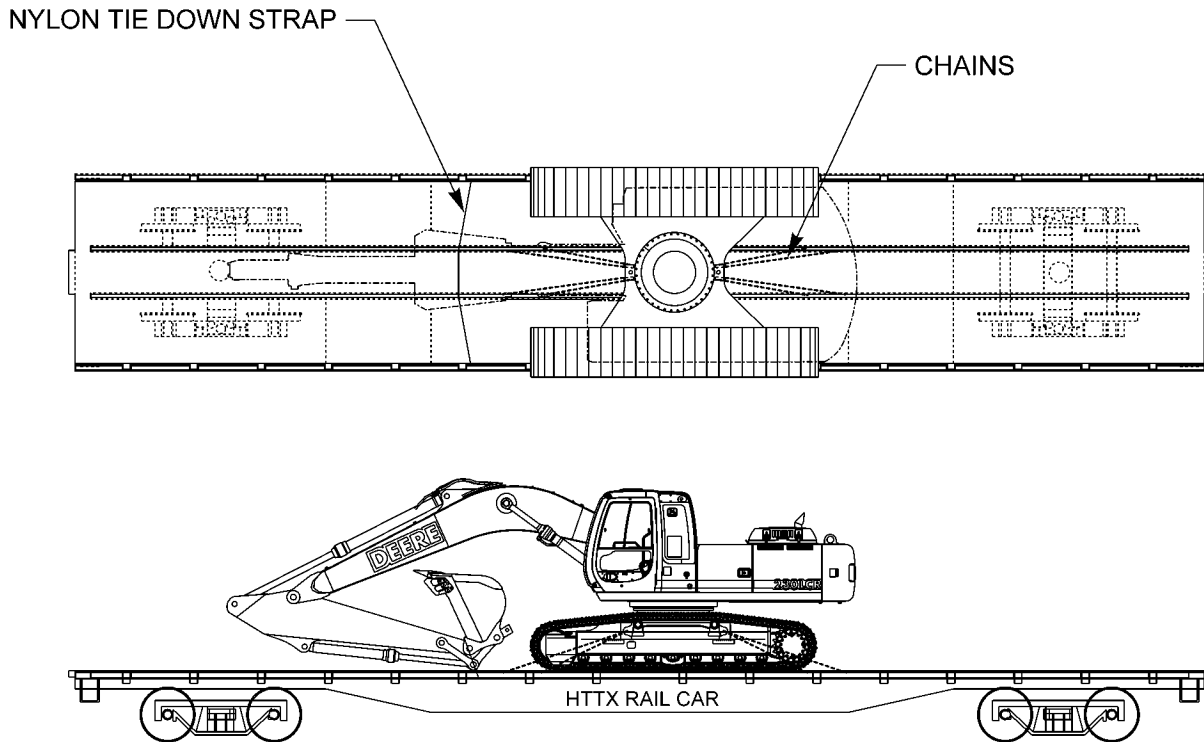

T125165

MODEL 230LCR ON RAIL CAR

Before leaving the operator's seat, perform steps 1—6.

1. Extend bucket cylinder fully.
2. Extend arm cylinder fully.
3. Lower the deck.

If machine cannot be transported with arm fully retracted, remove bucket or attachment and retract arm.

4. Lower bucket onto deck.

Continued on next page

CED,OUOE042,49 -19-19OCT99-1/2

T125165 -19-28OCT99

Transporting

IMPORTANT: Turbocharger may be damaged if engine is not properly shut down.

5. Run engine at 1/2 speed without load for 2 minutes.
6. Move engine speed rpm dial to slow idle position.
7. Turn key switch to OFF. Remove key from switch.
8. Pull pilot control shut-off lever to locked position.

IMPORTANT: Prevent cab electrical component damage from bad weather. Always close windows, roof vent, and cab door.

9. Close windows, roof vent, and cab door.

10. Cover exhaust opening to prevent entry of wind and water.

IMPORTANT: Prevent possible damage to hydraulic lines, rods, and hoses. Fasten chains to machine frame.

11. Fasten machine to rail car with 16 chains and nylon strap.

CED,OUOE042,49 -19-19OCT99-2/2

FASTEN MACHINE AND ROCK DRILL TO RAIL CAR (MODEL 230LCRD)

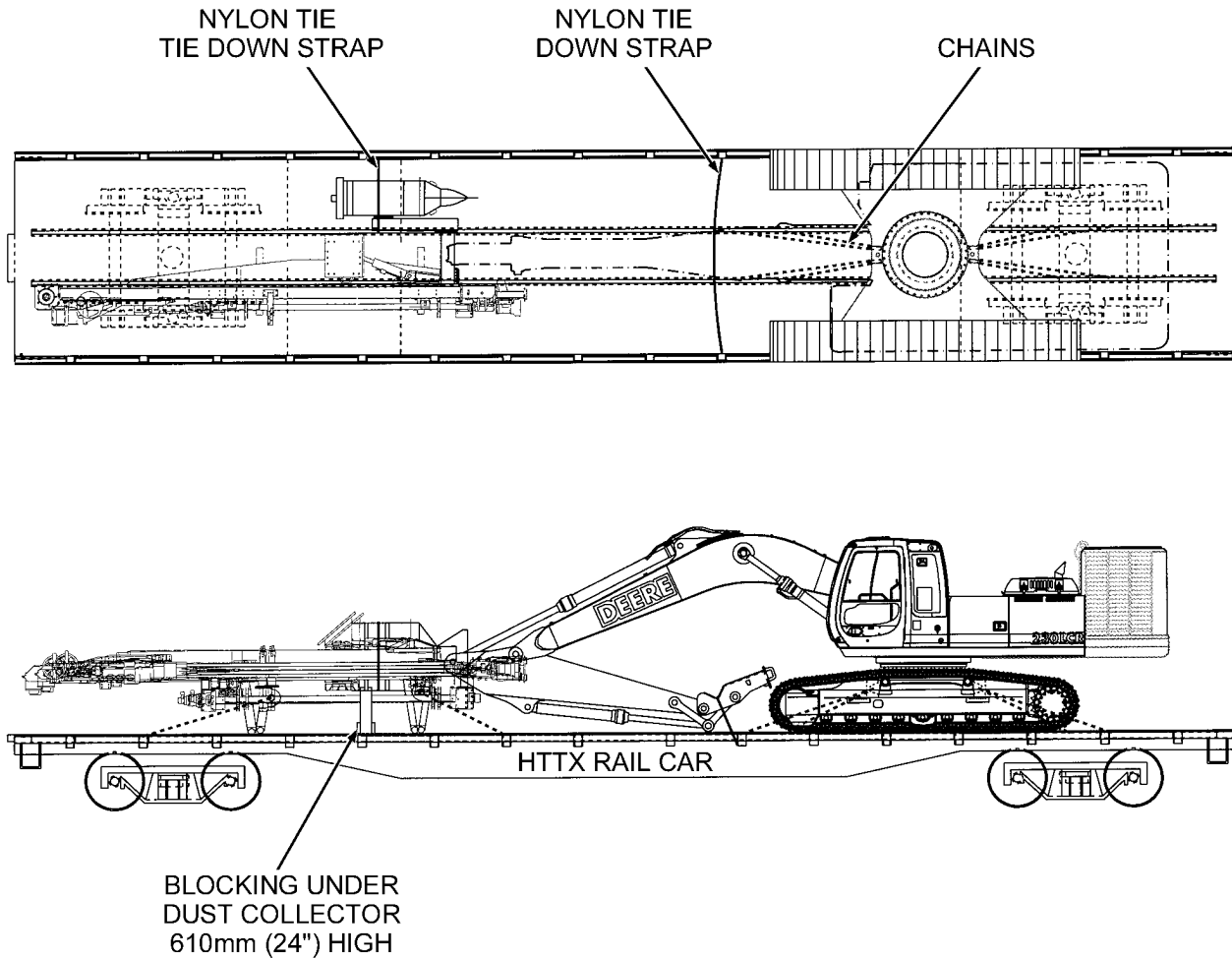

MODEL 230LCRD ON RAIL CAR

T125166

Before leaving the operator's seat, perform steps 1—6.

1. Extend bucket cylinder fully.
2. Extend arm cylinder fully.
3. Lower the boom.

If machine cannot be transported with arm fully retracted, remove bucket or attachment and retract arm.

4. Lower bucket onto deck.

Continued on next page

CED.OUOE042,50 -19-19OCT99-1/3

T125166 -19-11JAN00

Transporting

IMPORTANT: Turbocharger may be damaged if engine is not properly shut down.

5. Run engine at 1/2 speed without load for 2 minutes.
6. Move engine speed rpm dial to slow idle position.
7. Turn key switch to OFF. Remove key from switch.
8. Pull pilot control shut-off lever to locked position.

IMPORTANT: Prevent cab electrical component damage from bad weather. Always close windows, roof vent, and cab door.

9. Close windows, roof vent, and cab door.
10. Cover exhaust opening to prevent entry of wind and water.

IMPORTANT: Prevent possible damage to hydraulic lines, rods, and hoses. Fasten chains to machine frame.

11. Fasten machine to rail car with 16 chains and nylon strap.

CED,OUOE042,50 -19-19OCT99-2/3

CAUTION: Ensure that the lifting device is capable of supporting the rock drill. The approximate weight of the rock drill is 4536 kg (10,000 lb). Keep all people clear of raised load.

12. Load rock drill onto rail car.
13. Install blocking (A) under rock drill dust collector.
14. Fasten rock drill to rail car with chains and nylon strap.

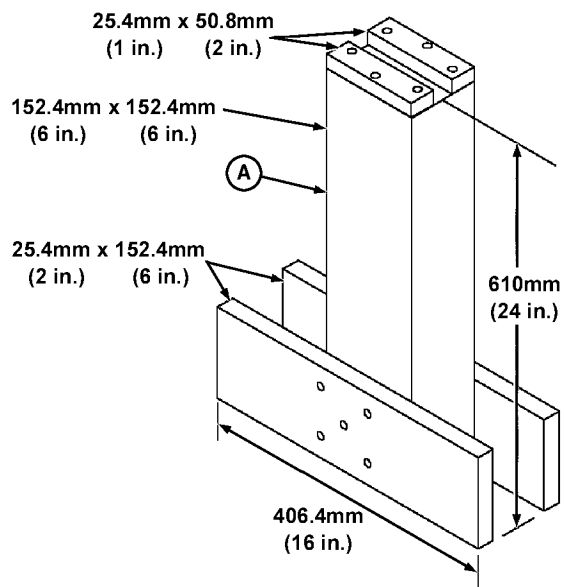

T125560

T125560 -UN-03NOV/99

CED,OUOE042,50 -19-19OCT99-3/3

UNLOADING MACHINE FROM TRAILER

CAUTION: Prevent possible injury from unexpected machine movement. Turn auto-idle switch off and turn H/P mode switch off when loading or unloading the machine.

1. Turn auto-idle switch off, turn H/P mode switch off, and move propel speed switch to slow speed.

CAUTION: Prevent possible injury from machine tipping while upperstructure is rotating. Keep arm tucked under and rotate upperstructure slowly for best stability.

2. Raise bucket slightly off trailer. Keeping arm tucked under, slowly rotate upperstructure 180°.

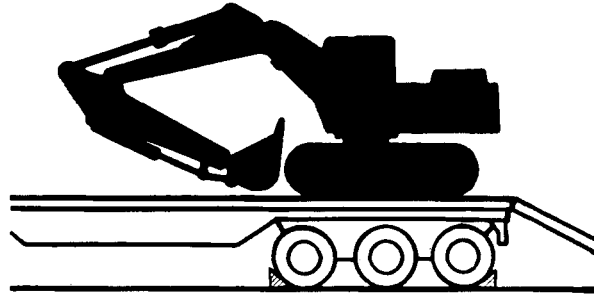

T7405BJ -UN-29NOV/90

TX,40,DH5146 -19-10AUG96-1/3

IMPORTANT: Prevent possible damage to front-end attachment. Always position arm at 90° to boom when unloading machine. Unloading machine with arm tucked may cause machine damage.

3. To move machine over end of trailer onto ramp, position bucket on ground with flat surface of bucket resting on ground. Angle (A) of arm to boom should be 90°.

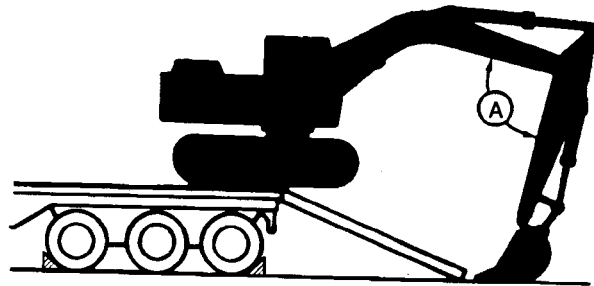

T7405BK -UN-29NOV/90

Continued on next page

TX,40,DH5146 -19-10AUG96-2/3

Transporting

IMPORTANT: Prevent possible damage to hydraulic cylinders. Do not allow machine to impact ground with bucket.

4. Bucket must be on ground before machine begins to tip forward.
5. As machine moves forward, raise the boom and extend arm until machine is completely off ramp.

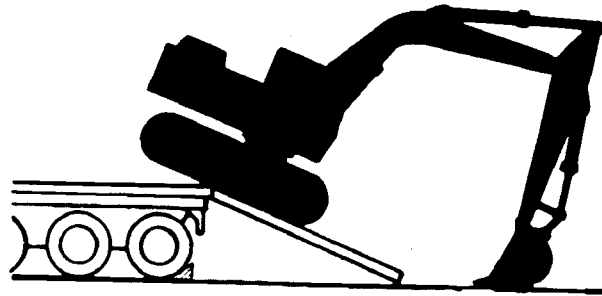

T7405BL -UN-29NOV90

TX,40,DH5146 -19-10AUG96-3/3

TOWING MACHINE

CAUTION: Prevent possible injury from unexpected machine movement. Block both tracks when disconnecting propel gearboxes. When propel gearboxes are disconnected, machine has no brakes and can move. The machine will roll free on a slope or while being towed.

1. Block tracks.
2. Drain oil from each propel gearbox. (See Change Propel Gearbox Oil in Maintenance—Every 2000 Hours chapter.)
3. Remove cover from each gearbox.
4. Remove sun gear (A) from each gearbox.
5. Install cover. Fill gearbox with oil.

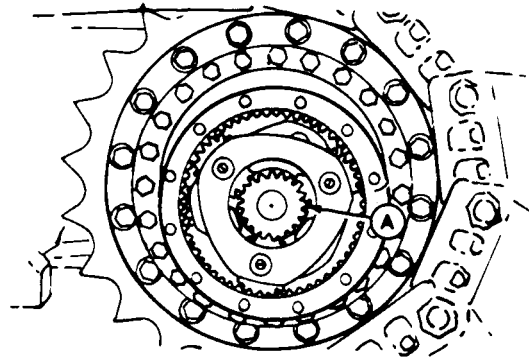

T6879EG -UN-06DEC88

TX,40,FF2193 -19-06JUL94-1/1

LIFTING THE MACHINE

Use all four lifting rings (A) to lift the machine.



CAUTION: Prevent possible injury from unexpected machine movement when lifting the machine. Check lifting capacity of crane before lifting the excavator. Lift load only as high as necessary.

Keep all people clear of raised load.

Approximate weight of machine, less bucket, is as follows:

230LCR

24 712 kg (54,480 lb)

230LCRD

25 056 kg (55,240 lb)

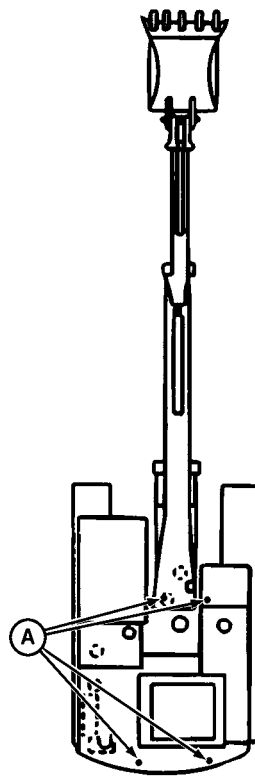

T120447

T120447 -UN-25MAR99

CED,OUOESLH,9 -19-14DEC99-1/1

CHAPTER 9
FUELS AND LUBRICANTS

BLANK

Fuels and Lubricants

DIESEL FUEL

Consult your local fuel distributor for properties of the diesel fuel available in your area.

In general, diesel fuels are blended to satisfy the low temperature requirements of the geographical area in which they are marketed.

Diesel fuels specified to A-A-52557, EN 590 or ASTM D975 are recommended.

In all cases, the fuel shall meet the following properties:

- **Cetane Number 40** minimum. Cetane number greater than 50 is preferred, especially for temperatures below -20°C (-4°F) or elevations above 1500 m (5000 ft).
- **Cold Filter Plugging Point (CFPP)** below the expected low temperature OR **Cloud Point** at least 5°C (9°F) below the expected low temperature.

- **Fuel Lubricity** should pass a minimum of 3100 gram load level as measured by the SL BOCLE scuffing test.
- **Sulfur content:**
 - Sulfur content should not exceed 0.5% Sulfur content less than 0.05% is preferred.
 - If diesel fuel with sulfur content greater than 0.5% sulfur content is used, reduce the service interval for engine oil and filter by 50%.
 - DO NOT use diesel fuel with sulfur content greater than 1.0%.

Bio-diesel fuels with properties and meeting DIN 51606 or equivalent specifications may be used.

Aviation fuel Grade JP-8 may be used.

DO NOT mix used engine oil or any other type of lubricant with diesel fuel.

CED,OUOE020,2 -19-11FEB99-1/1

LUBRICITY OF DIESEL FUELS

Diesel fuel must have adequate lubricity to ensure proper operation and durability of fuel injection system components.

Diesel fuels for highway use in the United States and Canada now require sulfur content less than 0.05%. Diesel fuel in the European Union will require sulfur content less than 0.05% by 1 October 1996.

Experience shows that some low sulfur diesel fuels may have inadequate lubricity and their use may reduce performance in fuel injection systems due to inadequate lubrication of injection pump components. The lower concentration of aromatic compounds in these fuels also adversely affects injection pump seals and may result in leaks.

Use of low lubricity diesel fuels may also cause accelerated wear, injection nozzle erosion or corrosion,

engine speed instability, hard starting, low power, and engine smoke.

Fuel lubricity should pass a minimum of 3100 gram load level as measured by the SL BOCLE scuffing test.

A-A-52557, ASTM D975 and EN 590 specifications do not require fuels to pass a fuel lubricity test.

If fuel of low or unknown lubricity is used, add John Deere PREMIUM DIESEL FUEL CONDITIONER or Inhibitor, Corrosion/Lubricity Improver, Fuel Soluble (MIL-PRF-25017) at the recommended concentration. John Deere PREMIUM DIESEL FUEL CONDITIONER is available in winter and summer formulas. Consult your John Deere engine distributor or servicing dealer for more information.

TX,45,JC1771 -19-08JAN97-1/1

LOW SULFUR DIESEL FUEL CONDITIONER

When possible, use existing fuel formulations for engines used off-highway. This fuel will not require any additives to provide good performance and engine reliability. However, many local fuel distributors will not carry both low and regular sulfur diesel fuels.

If only low sulfur fuel is available, Inhibitor, Corrosion/Lubricity Improver, Fuel Soluble should be added at the recommended concentration (MIL-PRF-25017). Nearly all other diesel fuel conditioners only improve cold weather flow and stabilize long-term fuel storage. They do not contain the lubrication additives needed by rotary fuel injection pumps.

TX,45,DH5857 -19-15AUG97-1/1

DIESEL FUEL STORAGE

Proper fuel storage is critically important. Use clean storage and transfer tanks. Periodically drain water and sediment from bottom of tank. Store fuel in a convenient place away from buildings.

IMPORTANT: DO NOT store diesel fuel in galvanized containers. Diesel fuel stored in galvanized containers reacts with zinc coating on container to form zinc flakes. If fuel contains water, a zinc gel will also form. The gel and flakes will quickly plug fuel filters, damage injection nozzles and injection pump.

DO NOT use brass-coated containers for fuel storage. Brass is an alloy of copper and zinc.

Store diesel fuel in plastic, aluminum, and steel containers specially coated for diesel fuel storage.

Avoid storing fuel over long periods of time. If fuel is stored for more than a month prior to use, or there is a slow turnover in fuel tank or supply tank, add a fuel conditioner such as John Deere PREMIUM DIESEL FUEL CONDITIONER or fuel conditioner meeting MIL-S-53021 to stabilize the fuel and prevent microbial growth in the fuel. John Deere PREMIUM DIESEL FUEL CONDITIONER is available in winter and summer formulas. Fuel conditioner also reduces fuel gelling and controls wax separation during cold weather.

Consult your John Deere engine distributor or servicing dealer for recommendations and local availability. Always follow manufacturer's directions on label.

TX,45,JC1772 -19-08JAN97-1/1

FUEL TANK



CAUTION: Handle fuel carefully. If the engine is hot or running, do not fill the fuel tank. Do not smoke while you fill fuel tank or work on fuel system.

To avoid condensation, fill the fuel tank at the end of each day's operation. Capacity is 560 L (148 gal).

Fuel Tank—Specification

Capacity..... 560 L (148 gal)

CED,TX14740,6018 -19-28JAN98-1/1

DO NOT USE GALVANIZED CONTAINERS

IMPORTANT: Diesel fuel stored in galvanized containers reacts with zinc coating on the container to form zinc flakes. If fuel contains water, a zinc gel will also form. The gel and flakes will quickly plug fuel filters and damage fuel injectors and fuel pumps.

DO NOT USE a galvanized container to store diesel fuel.

Store fuel in:

- plastic containers.
- aluminum containers.
- specially coated steel containers made for diesel fuel.

DO NOT USE brass-coated containers: brass is an alloy of copper and zinc.

DX,FLBT,C -19-04JUN90-1/1

DIESEL ENGINE AND PUMP GEARBOX OILS

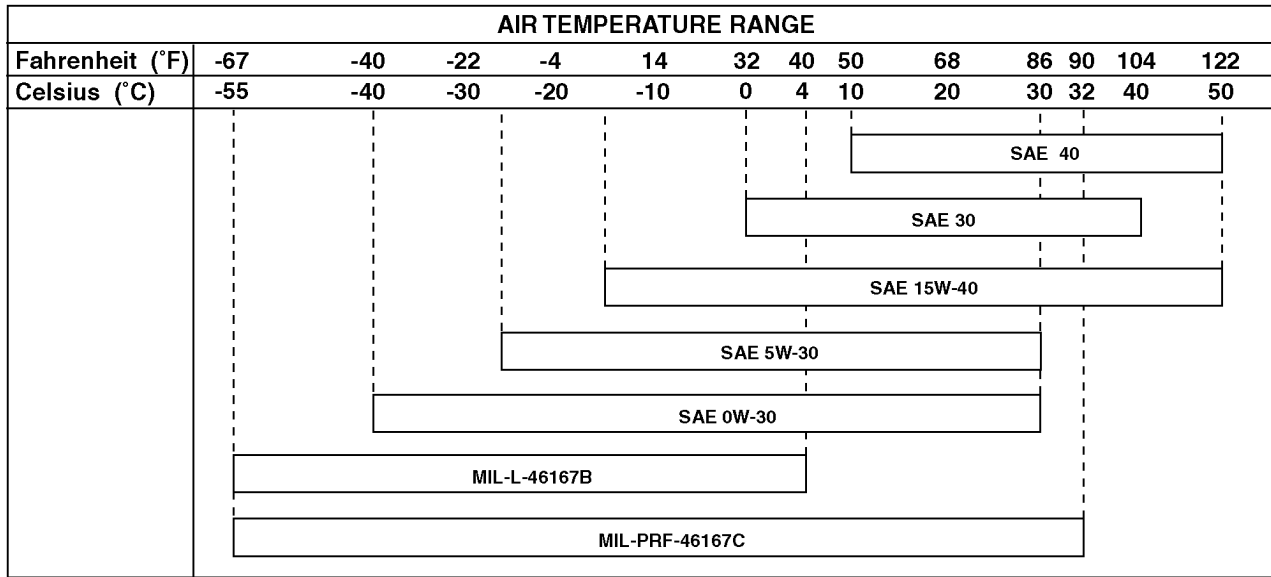

T125427

T125427 -19-28OCT99

Use oil viscosity based on the expected air temperature range during the period between oil changes.

- MIL-PRF-46167C
- API CG-4
- API CF-4

Other oils may be used if they meet one or more of the following:

- MIL-PRF-2104G
- MIL-L-46167B

Multi-viscosity diesel engine oils are preferred.

If diesel fuel with sulfur content greater than 0.5% is used, reduce the service interval by 50%.

HYDRAULIC OIL

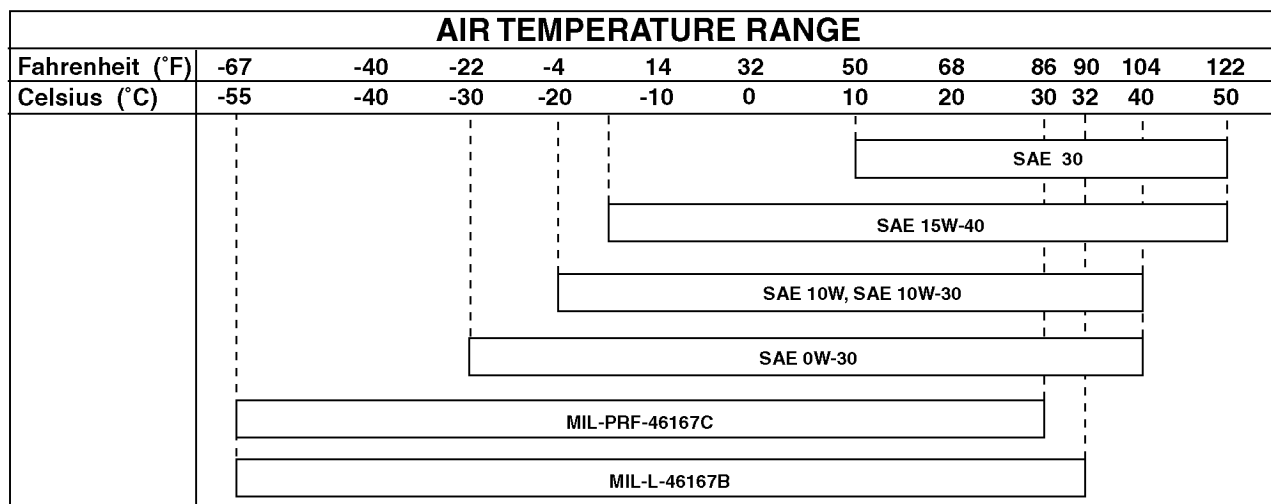

T125428

T125428 -19-17NOV99

Depending upon the expected air temperature range between oil changes, use oil viscosity shown on the temperature chart above.

Use oils meeting one or more of the following:

- MIL-PRF-2104G¹
- MIL-L-46167B
- MIL-PRF-46167C
- API CG-4¹
- API CF-4¹

¹Must contain a minimum zinc additive of 0.09 percent.

SWING GEARBOX AND PROPEL GEARBOX OILS

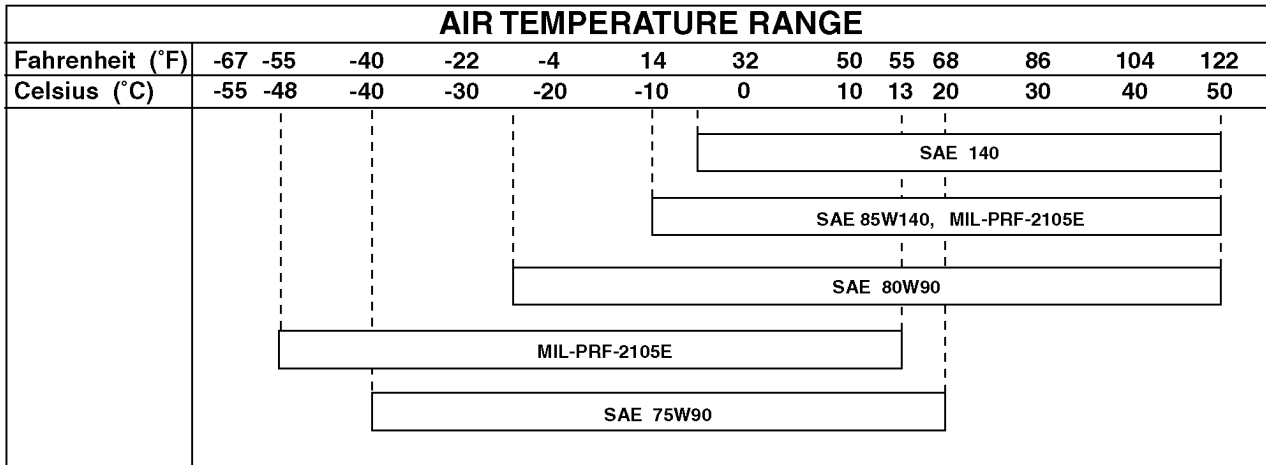

T125429

T125429 -19-17NOV99

Depending upon the expected air temperature range between oil changes, use oil viscosity shown on the temperature chart above.

- Oils meeting MIL-PRF-2105. MIL-PRF-2105E is updated.
- Oils meeting API Service GL-5 (MIL-L-2105E).

The following oils are recommended:

CED,OUOE020,5 -19-12FEB99-1/1

TRACK ROLLER, FRONT IDLER, AND CARRIER ROLLER OIL

Use oil viscosity based on the expected air temperature range during the period between oil changes.

The following oils are recommended:

- MIL-PRF-2105E (80W90).
- API Service Classification GL-5 gear oil (SAE 80W90).
- Arctic oil such as MIL-PRF-2105E (75W) should be used at temperatures below -30°C (-11°F).

CED,OUOE020,6 -19-12FEB99-1/1

TRACK ADJUSTER, WORKING TOOL PIVOT, SWING BEARING, AND SWING BEARING GEAR GREASE

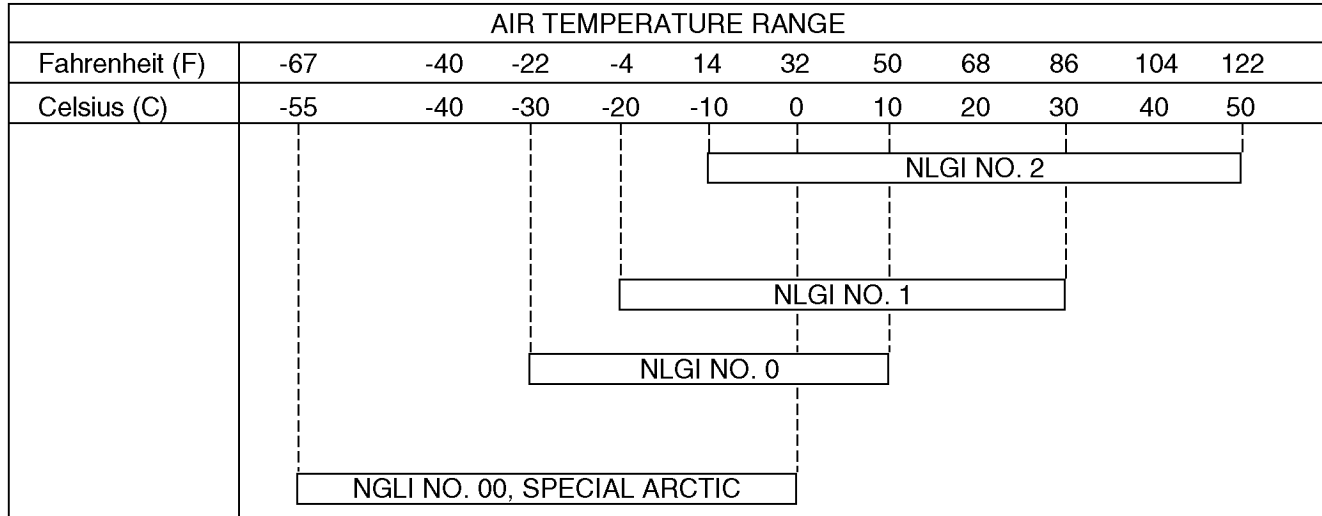

T120320

T120320 -19-25MAR99

Use grease based on NLGI consistency numbers and the expected air temperature range during the service interval.

Lithium complex grease containing high temperature, extreme pressure properties with 3-5 percent molybdenum disulfide is preferred, although those without the molybdenum disulfide are acceptable.

Use greases meeting MIL-PRF-10924G.

CED,OUOE020.7 -19-12FEB99-1/1

OIL FILTERS

Filtration of oils is critical to proper operation and lubrication. Always change filters regularly as specified in this manual.

Use filters meeting John Deere performance specifications.

DX,FILT -19-18MAR96-1/1

Lubricant specifications

ROCK DRILL LUBRICANTS SPECIFICATIONS

We recommend the use of the **MOBIL** lubricants. These are selected to get the best performances out of our equipments.

If the **MOBIL** products are not available, our warranty will apply only if high quality lubricants are used according to the following specifications and under the responsibility of your supplier.

HYDRAULIC CIRCUIT

Oil ISO VG 32 (*ISO VG 46 when $10^{\circ}\text{C} < t < 45^{\circ}\text{C}$*) with stabilized anti-wear additive

Specifications :

Viscosity at 40°C: 30 to 33 cSt (*46 cSt*)

Viscosity index VI: ≥ 150 (*140*)

Pour point: $< -40^{\circ}\text{C}$

De aïring: ≤ 5 mn

Performances :

Homologation: DENISON HFO

Anti wear: FZG ≥ 12

VICKERS 35 VQ 25 : total wear < 50 mg

ASTM D 130 : cotation 1 a

Anti corrosion: CINCINNATI P 70 – pass

Filterability: DENISON TP 02-100 :
t < 200 seconds with water 2%

Oxydation stability NFT 60150 t > 2200 h
for 1 a ≤ 2 ASTM D 943

Performances :

specifications: MIL-PRF-2105E

PNEUMATIC CIRCUIT

Anti wear oils for pneumatic equipment

ISO VG 46 for : t $\leq 0^{\circ}\text{C}$

ISO VG 100 for : t $> 0^{\circ}\text{C}$

Performances :

film resistance

reinforced anti-wear

anti-corrosion

anti-freeze (for : t $\leq 0^{\circ}\text{C}$)

Specifications :

Pour point $< -24^{\circ}\text{C}$

Flash point 218°C

Viscosity at 40° C: 150 cSt

Viscosity index Vi: 140

GEAR BOX

High pressure oil SAE 80 W 90 for transmissions.

Performances :

specifications: MIL-PRF-2105E

GREASE

MIL-PRF-10924G

SECTOR	0°C to -45°C PRODUCT	+30°C to -20°C PRODUCT	+45°C to +10°C PRODUCT
Hydraulic	MOBIL SHC 524	MOBIL DTE 13 M	MOBIL DTE 15 M
Pneumatic	MOBIL SHC 524	MOBIL ALMO 527 (t > 0°C) ALMO 325 (t < 0°C)	ALMO 527
Grease	MOBILTEMP SHC 100 SPECIAL	MOBILGREASE SPECIAL	MOBILGREASE SPECIAL
GCL/GCX reducer	MOBIL SHC 630	MOBIL SHC 630	MOBILGEAR 629 MOBIL SHC 630

AIR COMPRESSOR LUBRICANTS

FLUIDS AND LUBRICANTS TABLE

ITEM	FLUID	AMBIENT TEMP.	SPECIFICATION
Compressor Models: VHP - (200 + psi) HP - (150 psi) XP - (125 psi) P - (100 psi)	Airend Lubricant	-10°F to 125°F (-23°C to 52°C)	★ IR Pro-Tec™ MIL-PRF-2104G • A-A-52039 SAE 10W
		-40°F to 125°F (-40°C to 52°C)	★ IR Performance 500
		-40°F to 65°F (-40°C to 18°C)	• MIL-PRF-46167
NXP (Oil Free)	Refer to Operator's Manual		
<p>★ Recommended Ingersoll-Rand Fluids - Use of these fluids with original I-R filters can extend airend warranty. Refer to operator's manual warranty section for details or contact your I-R representative.</p>			
Recommended Fluid	1 Gal. (3.8 litre)	5 Gal. (19.0 litre)	55 Gal. (208.2 litre)
IR Pro-TecR	36899698	36899706	36899714
IR Performance 500	35382928	35382936	35382944

DexronR - Reg. T.M. of General Motors Corp.

Pro-Tec™ - T.M. of Ingersoll-Rand

For Parts, Service & nearest Distributor call 1-800-633-5206

LUBRICANT STORAGE

Your equipment can operate at top efficiency only when clean lubricants are used.

Use clean containers to handle all lubricants.

Whenever possible, store lubricants and containers in an area protected from dust, moisture, and other contamination. Store containers on their side to avoid water and dirt accumulation.

Make certain that all containers are properly marked to identify their contents.

Properly dispose of all old containers and any residual lubricant they may contain.

DX,LUBST -19-18MAR96-1/1

ALTERNATIVE AND SYNTHETIC LUBRICANTS

Conditions in certain geographical areas may require lubricant recommendations different from those printed in this manual. Some John Deere brand coolants and lubricants may not be available in your location. Consult your John Deere dealer to obtain information and recommendations.

Synthetic lubricants may be used if they meet the performance requirements as shown in this manual.

The temperature limits and service intervals shown in this manual apply to both conventional and synthetic oils.

Re-refined base stock products may be used if the finished lubricant meets the performance requirements.

DX,ALTER -19-18MAR96-1/1

MIXING OF LUBRICANTS

In general, avoid mixing different brands or types of oil. Oil manufacturers blend additives in their oils to meet certain specifications and performance requirements. Mixing different oils can interfere with the proper functioning of these additives and degrade lubricant performance.

Consult your John Deere dealer to obtain specific information and recommendations.

DX,LUBMIX -19-18MAR96-1/1

FACTORY/INITIAL FILL LUBRICANTS

The acceptable air temperature ranges for the initial fill lubricants are as follows:

Engine	-25°C (-13°F) to 40°C (104°F)
Pump Gearbox	-25°C (-13°F) to 50°C (122°F)
Hydraulic Oil	-29°C (-20°F) to 50°C (122°F)
Swing and Propel Gearbox	-20°C (-4°F) to 50°C (122°F)

CED,OUOE020,51 -19-13APR99-1/1

CHAPTER 10
PERIODIC MAINTENANCE—EXCAVATOR

BLANK

Periodic Maintenance

SERVICE YOUR MACHINE AT SPECIFIED INTERVALS

Lubricate, make service checks, and make adjustments at intervals shown on the periodic maintenance chart (A) and on the following pages.

Perform service on items at multiples of the original requirement. For example, at 500 hours also service those items (if applicable) listed under 250 hours, 100 hours, 50 hours and 10 hours or daily.

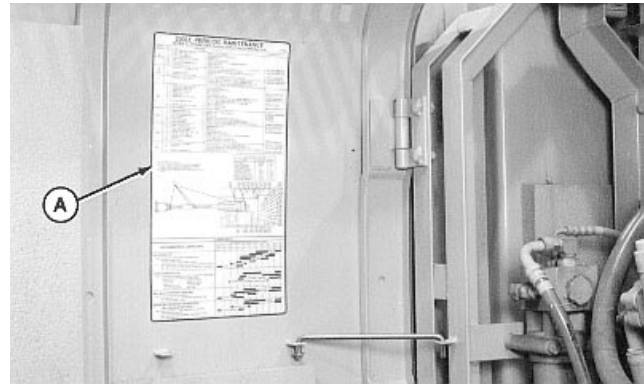

TX,50,DH5147 -19-10AUG96-1/1

CHECK THE HOUR METER REGULARLY

Check the hour meter (A) to determine when your machine needs periodic maintenance.

Intervals on the periodic maintenance chart are for operating in normal conditions. If you operate your machine in difficult conditions, you should service it at **SHORTER INTERVALS**.

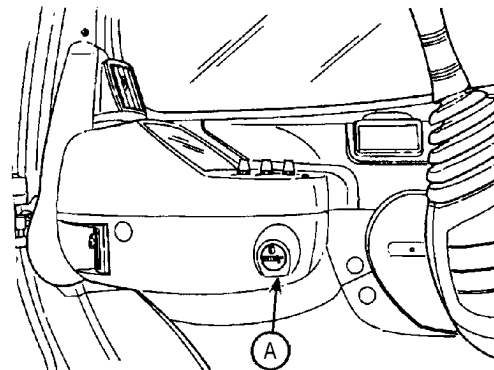

TX,50,DH5063 -19-24JUN96-1/1

USE CORRECT FUELS AND LUBRICANTS

IMPORTANT: To prevent machine damage, when servicing your machine use correct fuels and lubricants. (See Fuels and Lubricants chapter.)

TX,50,DH5112 -19-12JUL96-1/1

PREPARE MACHINE FOR MAINTENANCE

Before performing maintenance procedures given in the following chapters and before leaving the operator's seat, park the machine as described below unless another position is specified in the procedure.

1. Park machine on a level surface.
2. Lower bucket to the ground.
3. Turn auto-idle switch off.

IMPORTANT: Turbocharger may be damaged if engine is not properly shut down.

4. Run engine with engine rpm dial at 1/3 position without load for 2 minutes.
5. Move engine rpm dial to slow idle position.
6. Turn key switch to OFF. Remove key from switch.
7. Pull pilot control shut-off lever to locked position.

OPEN ACCESS DOORS FOR SERVICE

CAUTION: Prevent possible injury from door closing. Secure door in the OPEN position.

To hold door open, remove rod from stored position (A) and insert in tab (B) on door.

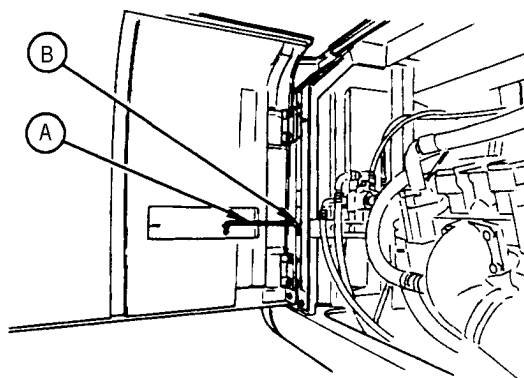

Right Side Access Door

T102125 -UN-26JUL96

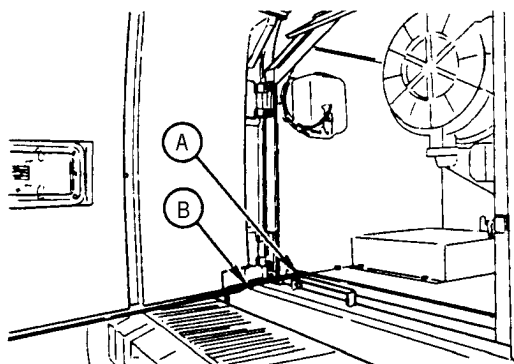

Front Left Side Access Door

T102126 -UN-26JUL96

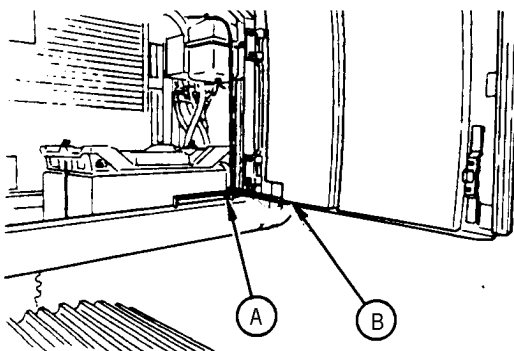

Rear Left Side Access Door

T102127 -UN-26JUL96

OPEN HOOD FOR SERVICE

CAUTION: Prevent possible injury. Unlock latch. Pull open latches to unlock hood. Raise the hood until the end of the bar is securely locked into catch.

Raise hood using handle on hood until the end of the rod is securely locked into catch (A).

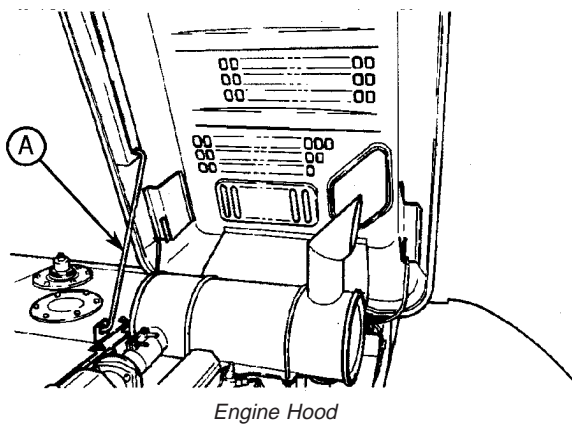

Engine Hood

T107777 -UN-03MAR97

TX,50,DH5439 -19-03MAR97-1/1

CHAPTER 11
MAINTENANCE—AS REQUIRED

BLANK

Maintenance—As Required

SAMPLING ENGINE OIL

NOTE: Sample engine oil every 50 hours or 90 days.

1. Run engine to warm oil.
2. Park machine on a level surface.
3. Lower bucket to the ground.

IMPORTANT: Turbocharger may be damaged if engine is not properly shut down.

4. Run engine with engine rpm dial at 1/3 position without load for 2 minutes.
5. Move engine rpm dial to slow idle position.
6. Attach a "Do Not Operate" tag on the right control lever.
7. Pull pilot control shut-off lever to locked position.
8. Open engine hood and secure hood in open position.
9. Clean valve (A) and use to sample engine oil.

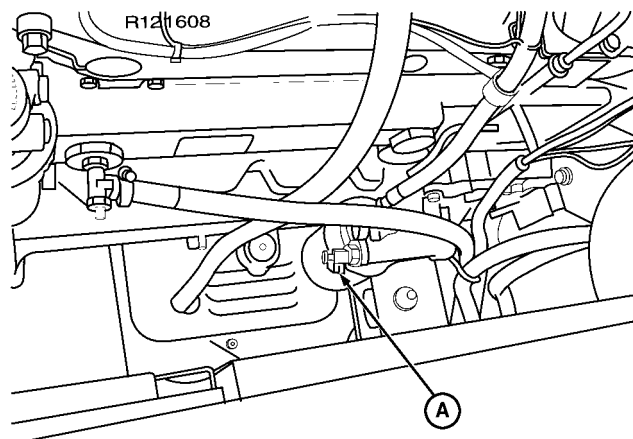

T125092

T125092 -UN-28OCT99

CED,OUOE020,19 -19-17DEC99-1/1

SAMPLING HYDRAULIC OIL

IMPORTANT: Prevent damage to hydraulic system components. **DO NOT** run engine without oil in hydraulic tank.

NOTE: Sample hydraulic oil once a year.

1. Park machine on a level surface.
2. Position machine with arm cylinder fully retracted and bucket cylinder fully extended.
3. Lower bucket to the ground.

IMPORTANT: Turbocharger may be damaged if engine is not properly shut down.

4. Run engine with engine rpm dial at 1/3 position without load for 2 minutes.
5. Move engine rpm dial to slow idle position.
6. Attach a "Do Not Operate" tag on the right control lever.
7. Pull pilot control shut-off lever to locked position.
8. Open rear right side access door and secure door in open position.
9. Clean valve (A), located on pilot filter housing assembly, and use to sample hydraulic oil.

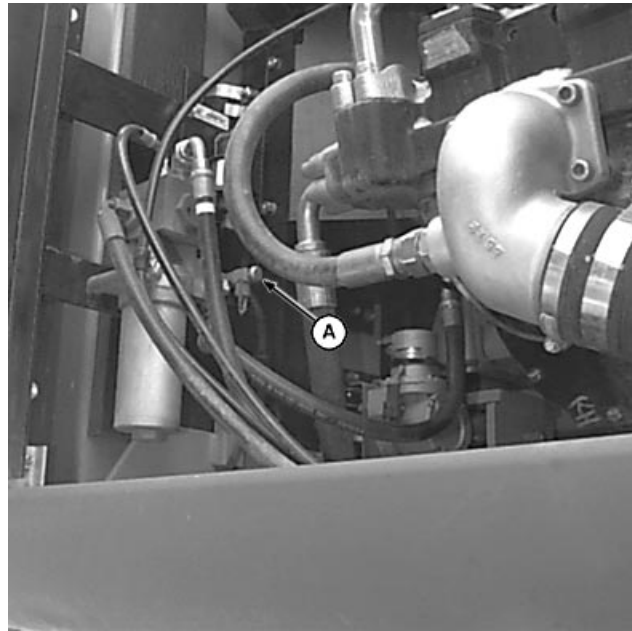

T127009 -UN-23DEC99

CLEAN FUEL TANK INLET SCREEN

Clean screen (A) to remove any debris. Use solvent or diesel fuel.

Replace screen if damaged.



T102894 -UN-07AUG96

TX,55,DH5138 -19-08AUG96-1/1

DRAIN FUEL TANK SUMP

1. Park machine on a level surface. Rotate upperstructure 90° for easier access.
2. Remove fuel tank fill cap.

NOTE: Plug is installed in drain cock to prevent vandalism.

3. Remove plug (A) and open drain cock (B) for several seconds to drain water and sediment into a container. Dispose of waste properly. Close drain cock.
4. Install and tighten plug.
5. Install fill cap.



T7396C1 -UN-18OCT90

TX,55,DH5081 -19-02JUL96-1/1

CLEAN RADIATOR AIR INLET SCREENS

Remove wing nut (A) and pull up on handles (B) to slide screens up for cleaning. Use pressurized air (30 psi max.) or low pressure water.

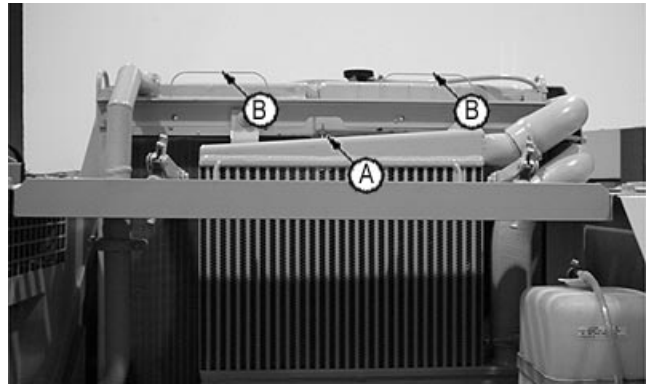

T108113B -UN-27MAR97

TX,55,DH5565 -19-02JUL96-1/1

DRAIN WATER SEPARATOR

1. Open right access door to access water separator.
2. Open drain valve (A) and press pump (B) to extract water from fuel system. Collect waste in a container and dispose of it properly.
3. Close drain valve.



T102299 -UN-30JUL96

TX,55,DH5083 -19-02JUL96-1/1

CLEAN AIR CLEANER DUST UNLOADER VALVE

IMPORTANT: A missing, damaged, or hardened dust unloader valve will make the dust cup precleaner ineffective, causing very short element life. Valve should suck closed above 1/3 engine speed.

Squeeze dust valve (A) to remove dust from the air cleaner.

If operating in high dust conditions, squeeze dust valve every couple of hours of operation to release dust.

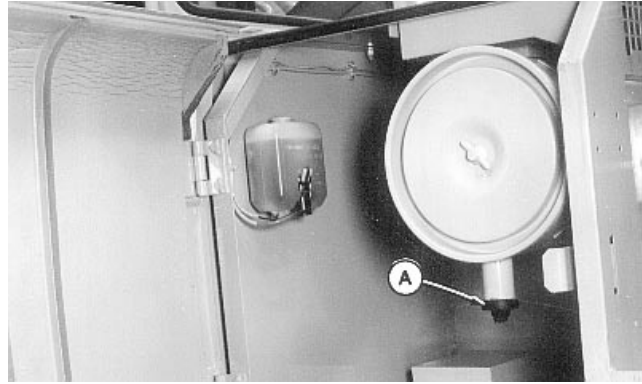

T101488 -UN-15JUL96

TX,55,DH5084 -19-02JUL96-1/1

CHECK TRACK SAG

1. Swing upperstructure 90° and lower bucket to raise track off ground.
2. Keep the angle (A) between boom and arm 90—110° and position the bucket's round side on the ground.

CAUTION: Prevent possible injury from unexpected machine movement. Place blocks under machine frame to support machine while measuring track sag.

3. Place blocks under machine frame to support machine.
4. Rotate track forward two full rotations and then in reverse two full rotations.

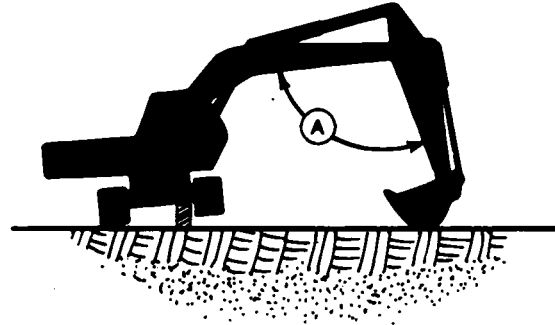

T6879AT -UN-06DEC88

Continued on next page

TX,55,DH5447 -19-04MAR97-1/2

Maintenance—As Required

5. Measure distance (A) at middle track roller from bottom of track frame to top surface of track shoe.

Normal Ground Condition—Specification

Track Sag 300—335 mm
(11-13/16—13-3/16 in.)

For general information on track sag, see Maintenance chapter.

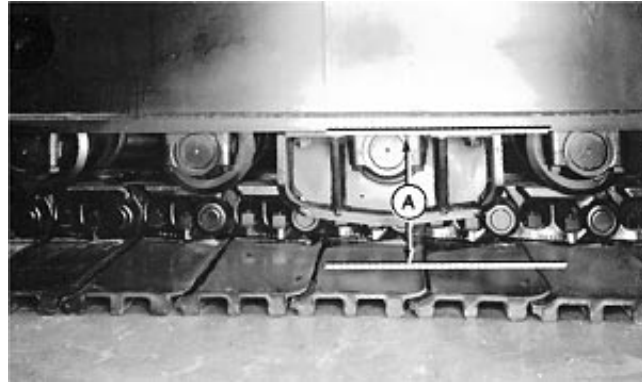

T7869AP -UN-22OCT92

TX,55,DH5447 -19-04MAR97-2/2

ADJUSTING TRACK SAG

IMPORTANT: Prevent possible damage to track components. **DO NOT** use the grease fitting on the track adjusting cylinder for lubrication. Use this fitting **ONLY** for track adjustment.

To tighten track, connect a grease gun to grease fitting (A) (located through access hole (D) in track frame). Add grease until sag is within recommended limits.

CAUTION: Prevent possible injury from high pressure grease. Do not remove grease fitting (A) from nut (B).

To loosen, slowly turn nut (B) counterclockwise; grease will escape through the bleed hole (C).

Nut—Specification

Torque 147 N•m (108 lb-ft)

When amount of track sag is satisfactory, turn nut clockwise to tighten.

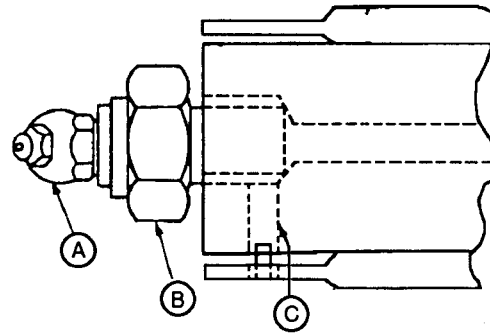

T7396DZ -UN-28NOV90

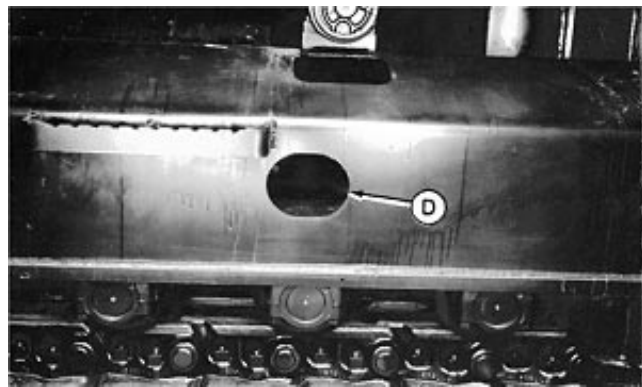

T7869AQ -UN-22OCT92

- A—Grease Fitting
- B—Nut
- C—Bleed Hole
- D—Access Hole

TX,55,FF2991 -19-29OCT92-1/1

WINDSHIELD WASHER FLUID LEVEL

Check fluid in windshield washer tank (A). If necessary, remove fill cap to add fluid.

During winter season, use all season windshield washer fluid which will not freeze.

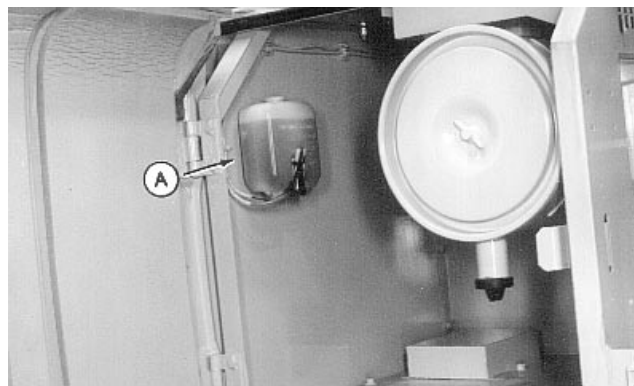

T101489 -JUN-15JUL96

TX.55.DH5086 -19-02JUL96-1/1

BLANK

CHAPTER 12

MAINTENANCE—EVERY 10 HOURS OR DAILY

BLANK

Maintenance—Every 10 Hours or Daily

CHECK ENGINE OIL LEVEL

IMPORTANT: Prevent engine damage. Do not run engine when oil level is below the ADD mark.

The most accurate oil level reading is obtained when the engine is cold before starting the engine for the day's operation.

1. Make sure dipstick (A) is fully seated.
2. Remove dipstick to check oil level.

BEFORE THE ENGINE IS STARTED: The engine is full when oil level is in the cross hatch area (C). It is acceptable to run the engine when the oil level is above the ADD mark.

AFTER THE ENGINE HAS BEEN RUN: Allow the oil to drain into the oil pan for 10 minutes before checking the oil level. Ten minutes after shutdown the engine oil level must be above the ADD mark.

3. If necessary, remove filler cap (B) to add oil. (See Fuels and Lubricants chapter.)

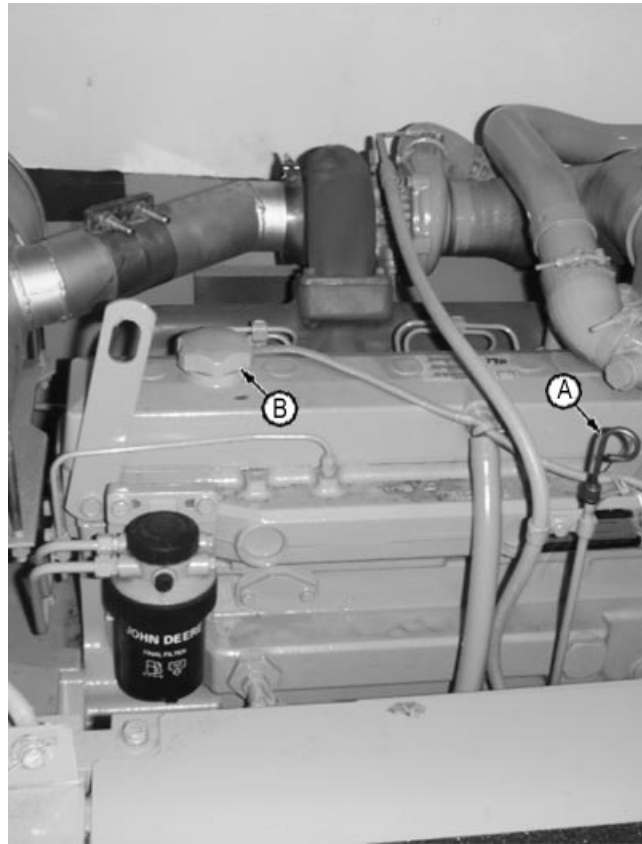

T108260B -UN-27MAR97

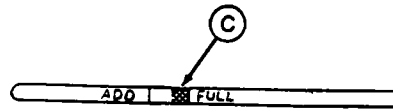

RG5421 -UN-15DEC88

TX,60,DH5572 -19-10AUG96-1/1

CHECK RECOVERY TANK COOLANT LEVEL

With the engine cold, coolant level must be at the FULL mark on the recovery tank (A).

If coolant is below the FULL mark, add coolant to the recovery tank.

CAUTION: Prevent possible injury from hot spraying water. **DO NOT** remove radiator filler cap unless engine is cool. Then turn cap slowly to the stop. Release all pressure before you remove cap.

If recovery tank is empty, check for leaks. Repair as required. Add coolant to the radiator and the recovery tank.

NOTE: If recovery tank is full and radiator is low, check for leaks in radiator cap and hose connections between radiator and coolant recovery tank.

Coolant level must be at bottom of the filler neck.

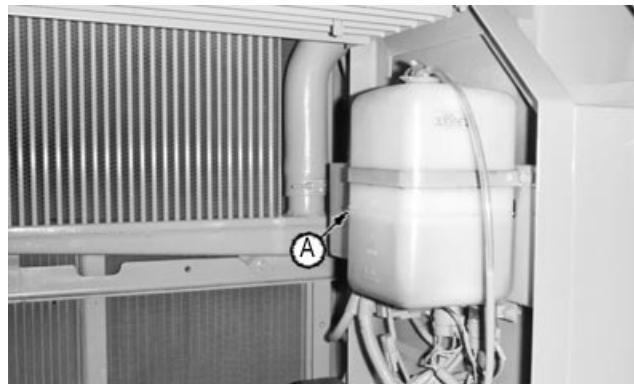

T108115B -UN-27MAR97

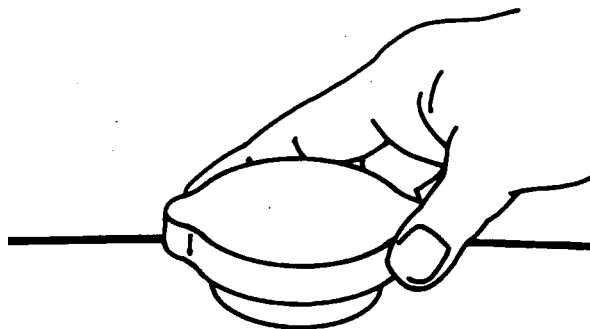

T6274AQ -UN-18OCT88

TX,60,DH5566 -19-17SEP96-1/1

CHECK HYDRAULIC OIL LEVEL

IMPORTANT: Prevent damage to hydraulic system components. DO NOT run engine without oil in hydraulic tank.

1. Park machine on a level surface.
2. Position machine with arm cylinder fully retracted and bucket cylinder fully extended.
3. Lower bucket to the ground.
4. Turn auto-idle switch off.

IMPORTANT: Turbocharger may be damaged if engine is not properly shut down.

5. Run engine with engine rpm dial at 1/3 position without load for 2 minutes.
6. Move engine rpm dial to slow idle position.
7. Turn key switch to OFF. Remove key from switch.
8. Attach a 'Do Not Operate' tag on the right control lever.
9. Pull pilot control shut-off lever to locked position.



T6811A1 -UN-18OCT88

TX,60,DH5096 -19-08JUL96-1/5

10. Check oil level window (A) on hydraulic tank. Oil must be between marks on window.

If necessary, add oil. (See Fuels and Lubricants chapter.)

To add oil:



T102301 -UN-30JUL96

Continued on next page

TX,60,DH5096 -19-08JUL96-2/5

CAUTION: High pressure release of oil from pressurized system can cause serious burns or penetrating injury. The hydraulic tank is pressurized. Do not remove vent plug (A). Release pressure by loosening vent plug.

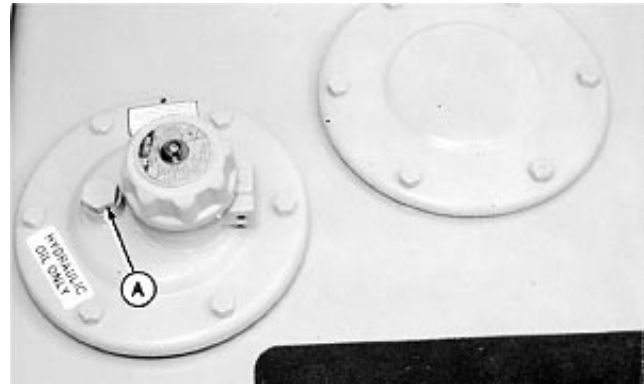

T7869AT -UN-12NOV92

11. Loosen vent plug (A) to release hydraulic pressure.

TX.60.DH5096 -19-08JUL96-3/5

12. Insert 4 mm (0.15 in.) hex wrench (D) into hole (E) and turn counterclockwise.
13. Slowly turn cap (A) counterclockwise. Remove cap.
14. Add oil. (See Fuels and Lubricants chapter.)
15. Install cap to case assembly (C) by aligning marks (B) and turning cap clockwise to lock position.

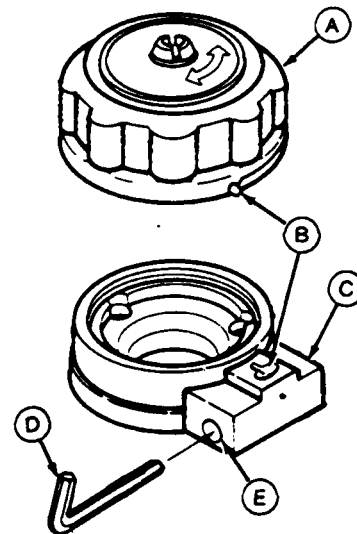

A—Cap
 B—Aligning Marks
 C—Case Assembly
 D—Hex Wrench
 E—Hole

T6457EI -UN-18OCT88

Continued on next page

TX.60.DH5096 -19-08JUL96-4/5

16. Tighten plug (A).

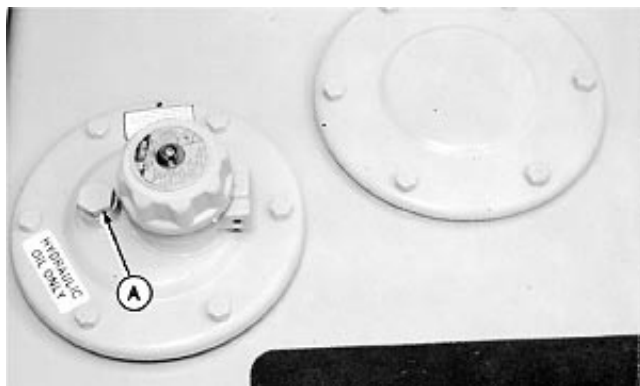

T7869AT -JN-12NOV92

TX.60.DH5096 -19-08JUL96-5/5

BLANK

CHAPTER 13
MAINTENANCE—EVERY 50 HOURS

BLANK

Maintenance—Every 50 Hours

GREASE WORKING TOOL PIVOTS

Grease working tool pivots (20 points, 230LCRD) (24 points, 230LCR) until grease escapes from joints.

Grease every 4 hours for first 20 hours. Grease every

10 hours during first 30—100 hours and when working in mud and water. (See Fuels and Lubricants chapter.)

Continued on next page

TX,OUOE042,31 -19-17DEC99-1/3

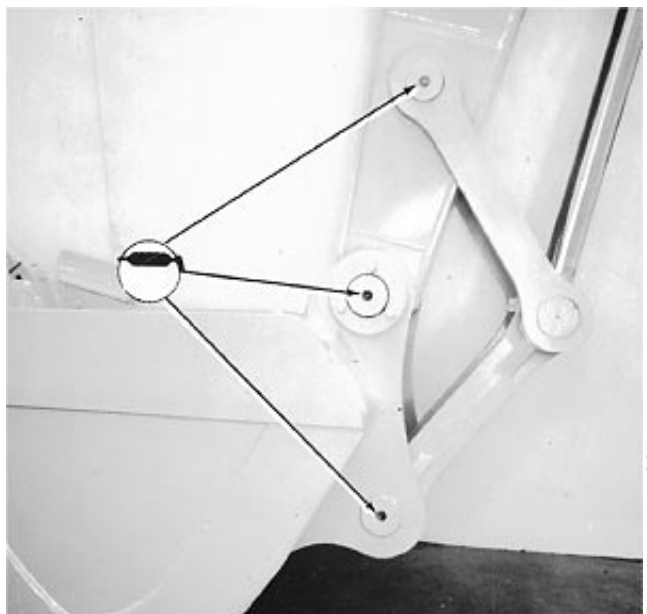

T7869AX -UN-22OCT92

Three Points

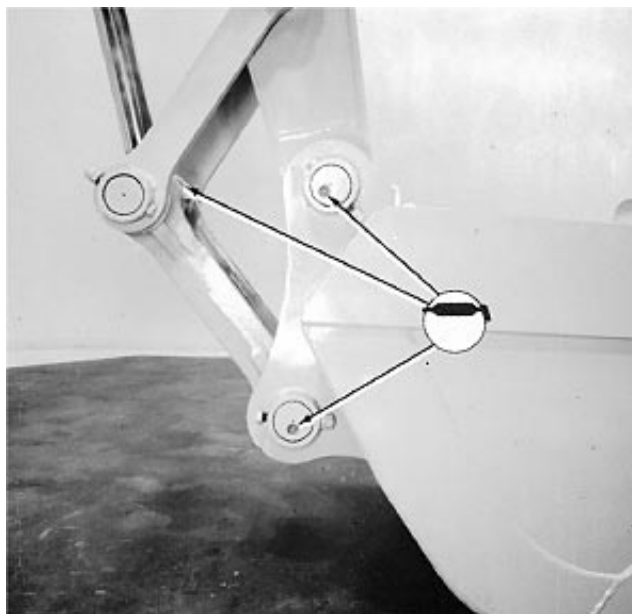

T7869AZ -UN-22OCT92

Three Points



T7869AY -UN-22OCT92

Two Points

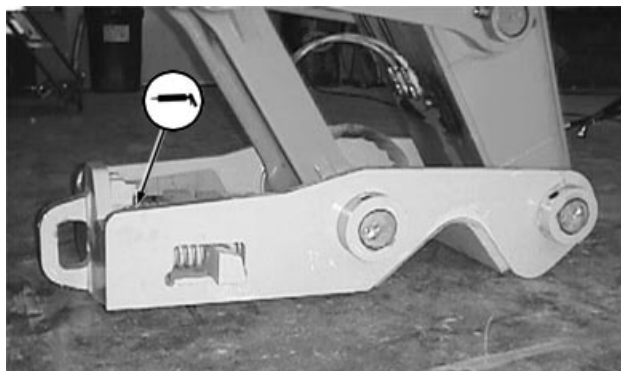

T120466 -UN-25MAR99

One Point

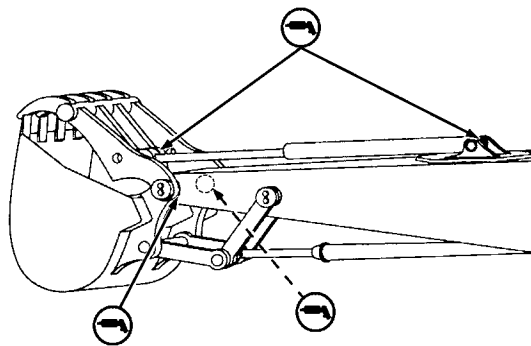

T126586

Four Points (230LCR)

T126586 -UN-17DEC99

Continued on next page

TX,OUOE042,31 -19-17DEC99-2/3

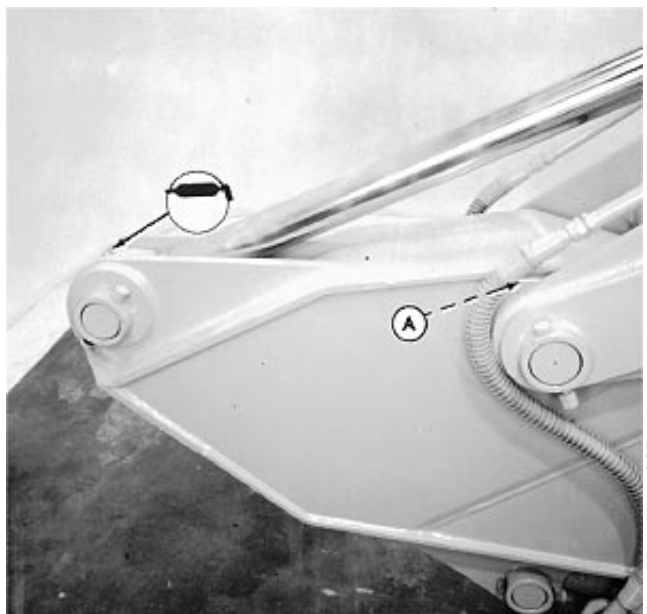

Three Points, A—Left Side Shown

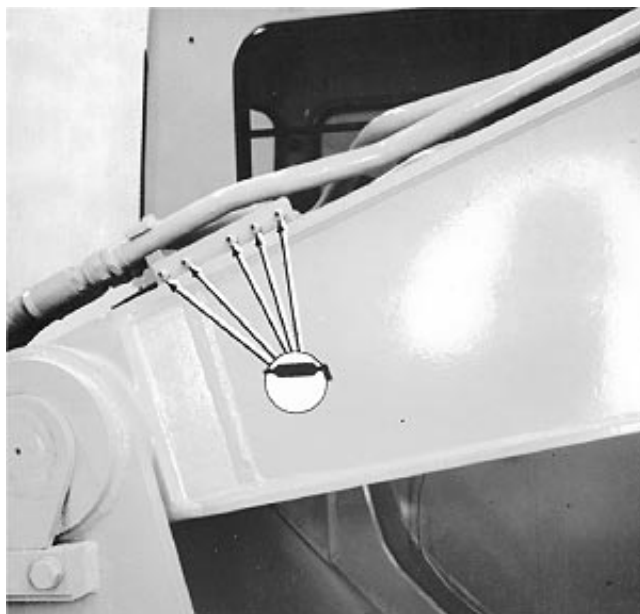

Five Points



One Point

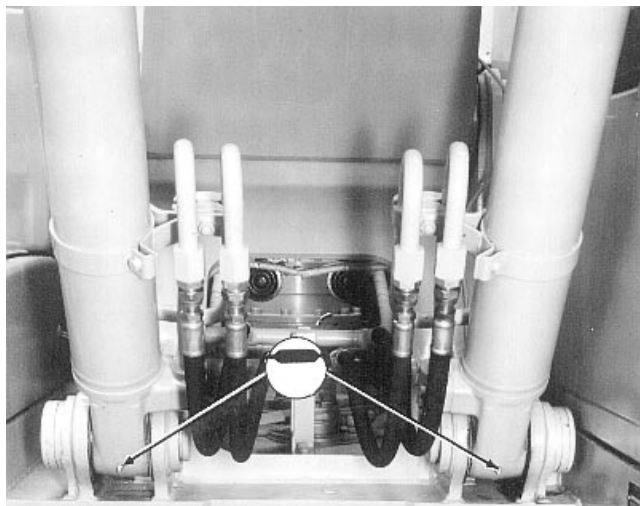

Two Points

BLANK

CHAPTER 14
MAINTENANCE—EVERY 250 HOURS

BLANK

Maintenance—Every 250 Hours

CHECK SWING GEARBOX OIL LEVEL

1. Park machine on a level surface.
2. Remove dipstick (A). Oil must be in the operating range.
3. If oil is needed, remove filler cap (B) and add oil. (See Fuels and Lubricants chapter.)
4. Check oil level.



T101491 -JUN-15JUL96

TX,75,DH5088 -19-03JUL96-1/1

DRAIN HYDRAULIC TANK SUMP

CAUTION: High pressure release of oil from pressurized system can cause serious burns or penetrating injury. The hydraulic tank is pressurized. Do not remove vent plug (A). Release pressure by loosening vent plug.

1. Loosen vent plug (A) to release hydraulic pressure.

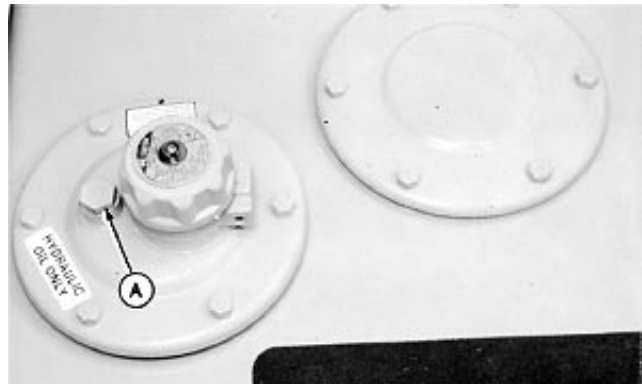

T7869AT -JUN-12NOV92

TX,75,DH5108 -19-11JUL96-1/2

2. Loosen plug (F) for several seconds to drain water and sediment into a container. Do not remove plug completely. Dispose of waste properly.
3. Tighten sump plug and vent plug.

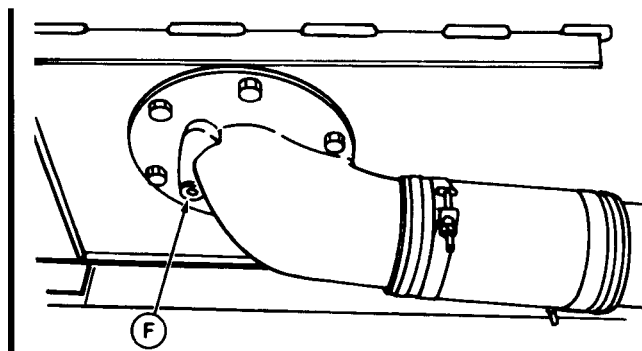

T7869BN -JUN-05NOV92

TX,75,DH5108 -19-11JUL96-2/2

CHECK PUMP DRIVE GEARBOX OIL LEVEL

To check oil:

1. Remove dipstick (A) to release air pressure.
2. Wipe dipstick clean and insert completely into tube.
3. Pull dipstick.
4. Oil must be approximately halfway below the 'H' (level) mark.

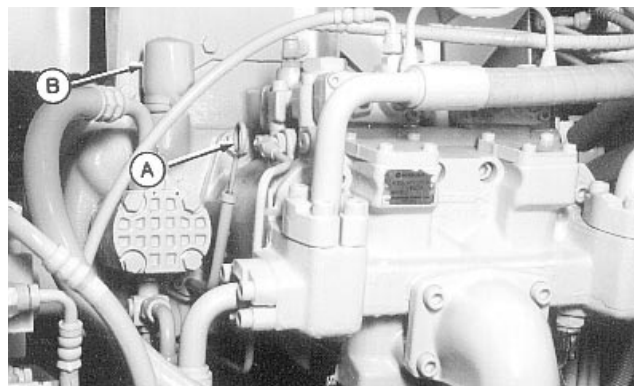

To add oil:

1. Remove filler cap (B).
2. Add oil. (See Fuels and Lubricants chapter.)
3. Install filler cap.

CHANGE ENGINE OIL AND REPLACE FILTER

IMPORTANT: If fuel sulfur content exceeds 0.5 percent, change the engine oil at 1/2 the normal interval.

NOTE: If engine has not run 250 hours before the season changes, change oil.

1. Run engine to warm oil.
2. Park machine on a level surface.
3. Lower bucket to the ground.
4. Turn auto-idle switch off.

IMPORTANT: Turbocharger may be damaged if engine is not properly shut down.

5. Run engine with engine rpm dial at 1/3 position without load for 2 minutes.
6. Move engine rpm dial to slow idle position.
7. Turn key switch to OFF. Remove key from switch.
8. Attach a 'Do Not Operate' tag on the right control lever.
9. Pull pilot control shut-off lever to locked position.

Continued on next page

TX,OUOE042,26 -19-08MAR99-1/2

10. Remove cover from under the engine. Remove drain plug (A) from bottom of engine oil pan, or open drain valve on side of engine oil pan. Allow oil to drain into a container. Dispose of waste oil properly.
11. Turn filter (B) counterclockwise to remove. Clean mounting surface on base.
12. Apply thin film of oil to rubber gasket of new filter.
13. Install new filter. Turn filter clockwise by hand until gasket touches mounting surface.
14. Tighten filter 1/2—3/4 turn more.
15. Install drain plug or close drain valve.
16. Remove fill cap (C).

Oil—Specification

Capacity with Filter Change 19 L (20 qt)

17. Fill engine with oil. (See Fuels and Lubricants chapter.)
18. Install fill cap.
19. Start engine.

Engine oil pressure indicator on monitor must go out within 15-20 seconds. If not, stop engine immediately and find the cause.
20. Stop engine. Check oil level.
21. Check for any leakage at filter. Tighten filter just enough to stop leakage.
22. Install cover from under the engine.

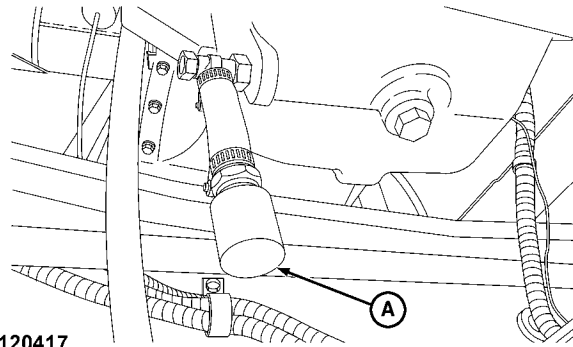

T120417 -UN-25MAR99

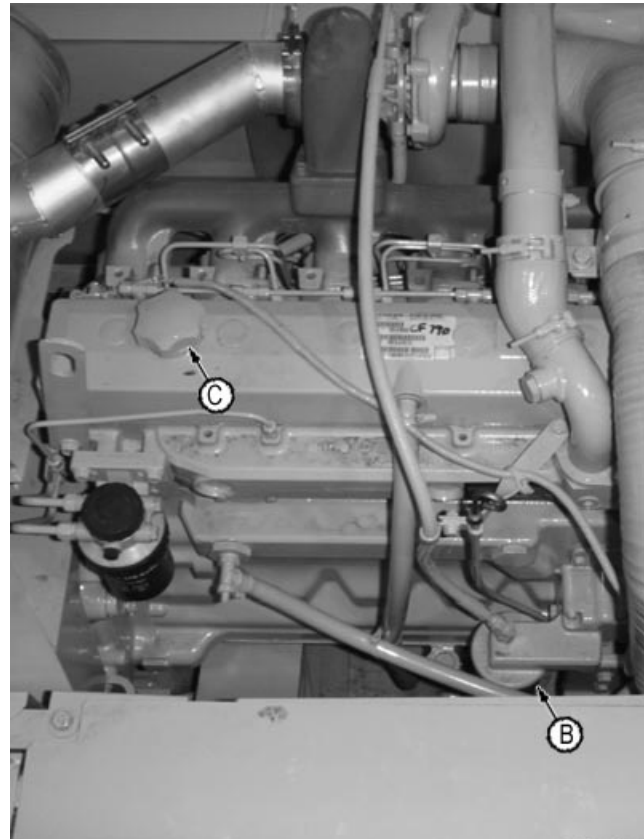

T108262B -UN-27MAR97

- A—Drain Hose
- B—Filter
- C—Fill Cap

CHECK RADIATOR COOLANT LEVEL

CAUTION: Prevent possible injury from hot spraying water. **DO NOT** remove radiator filler cap unless engine is cool. Then turn cap slowly to the stop. Release air to relieve all pressure before you remove cap.

1. Slowly remove cap. Coolant level must be at bottom of the filler neck.

NOTE: If radiator coolant level is low, check for leaks on radiator cap, and hose connections between radiator and coolant recovery tank.

2. Add coolant, if necessary.
3. Install filler cap.



T6642EK -UN-01NOV88

TX,75,DH3501 -19-29NOV94-1/1

CHECK BATTERY ELECTROLYTE LEVEL AND TERMINALS



CAUTION: Battery gas can explode. Keep sparks and flames away from batteries. Use a flashlight to check battery electrolyte level.

NEVER check battery charge by placing a metal object across the posts. Use a voltmeter or hydrometer.

ALWAYS remove grounded (-) battery clamp first and replace it last.

Sulfuric acid in battery electrolyte is poisonous. It is strong enough to burn skin, eat holes in clothing, and cause blindness if splashed into eyes.

Avoid the hazard by:

1. Filling batteries in a well-ventilated area.
2. Wearing eye protection and rubber gloves.
3. Avoiding breathing fumes when electrolyte is added.
4. Avoiding spilling or dripping electrolyte.
5. Use proper jump start procedure.

If you spill acid on yourself:

1. Flush your skin with water.
2. Apply baking soda or lime to help neutralize the acid.
3. Flush your eyes with water for 15—30 minutes. Get medical attention immediately.

If acid is swallowed:

1. Do not induce vomiting.
2. Drink large amounts of water or milk, but do not exceed 1.9 L (2 quarts).
3. Get medical attention immediately.

IMPORTANT: If water is added to batteries during freezing weather, batteries must be charged after water is added to prevent batteries from freezing. Charge battery using a battery charger or by running the engine.

1. Remove hold-down clamps and battery covers.

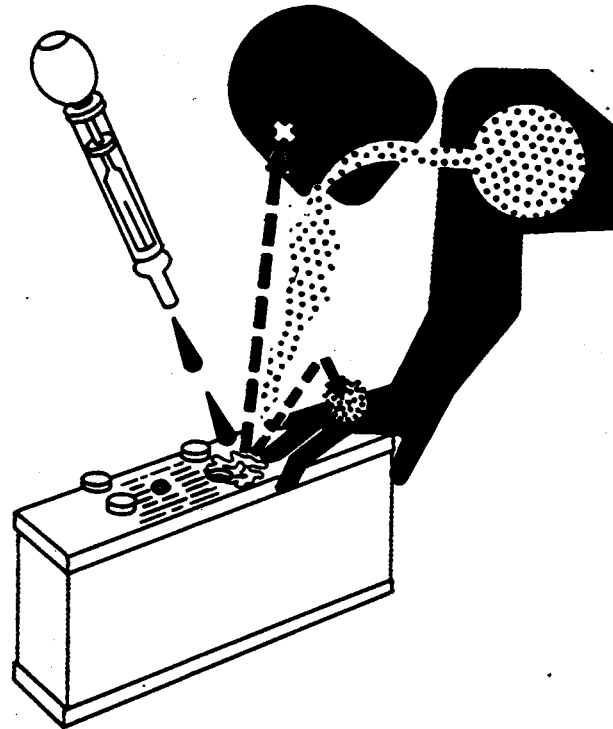

TS203 -JUN-23AUG88

- Fill each cell to within specified range with distilled water. DO NOT overfill.

CAUTION: Avoid possible injury. Always remove grounded (-) battery clamp first and replace it last.

- Disconnect battery clamps, grounded clamp first.

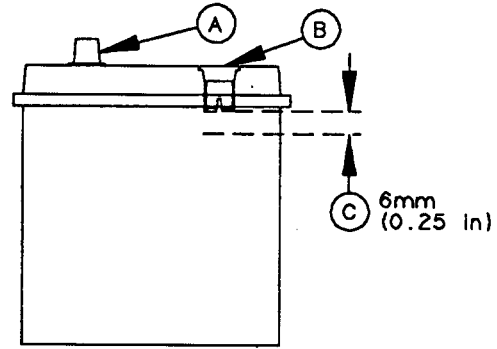

T6896DB -UN-10FEB89

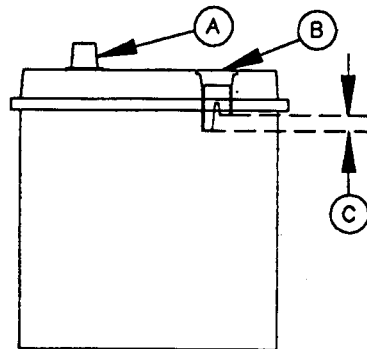

T6896DA -UN-10FEB89

A—Battery Post
B—Fill Tube
C—Electrolyte Level Range

TX,75,DH5594 -19-05MAY94-2/3

- Clean battery terminals (A) and clamps with a stiff brush.
- Apply lubricating grease (B) around battery terminal base only.
- Install and tighten clamps, grounded clamp last.
- Install battery covers and hold-down clamps.

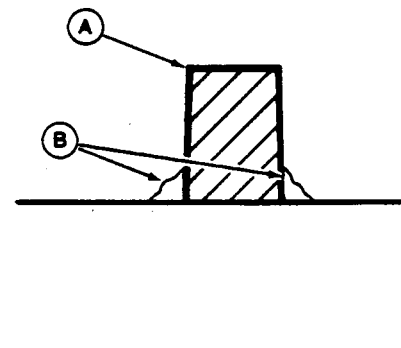

T6758AA -UN-21OCT88

TX,75,DH5594 -19-05MAY94-3/3

CHECK PROPEL GEARBOX OIL LEVEL

1. Park the machine on level ground rotating propel gearbox until bottom of the oil level check plug is even with the horizontal centerline.
2. Lower bucket to the ground.
3. Turn auto-idle switch off.

IMPORTANT: Turbocharger may be damaged if engine is not properly shut down.

4. Run engine with engine rpm dial at 1/3 position without load for 2 minutes.
5. Move engine rpm dial to slow idle position.
6. Turn key switch to OFF. Remove key from switch.
7. Attach a 'Do Not Operate' tag on the right control lever.
8. Pull pilot control shut-off lever to locked position.

Continued on next page

TX.75.DH5098 -19-08JUL96-1/2

CAUTION: High pressure release of fluids from pressurized system can cause serious burns. Wait for propel gearbox oil to cool. Keep body and face away from check plug. Gradually loosen check plug to release air to relieve pressure.

9. After propel gearbox has cooled, slowly loosen check plug (B) to release air to relieve pressure.
10. Remove check plug. Oil must be to bottom of hole.
11. If necessary, add oil until oil flows out of oil level check plug hole. (See Fuels and Lubricants chapter.)
12. Wrap threads of plug with sealing-type tape. Install plug. Tighten plug to 49 N•m (36 lb-ft).
13. Check second propel gearbox oil level.

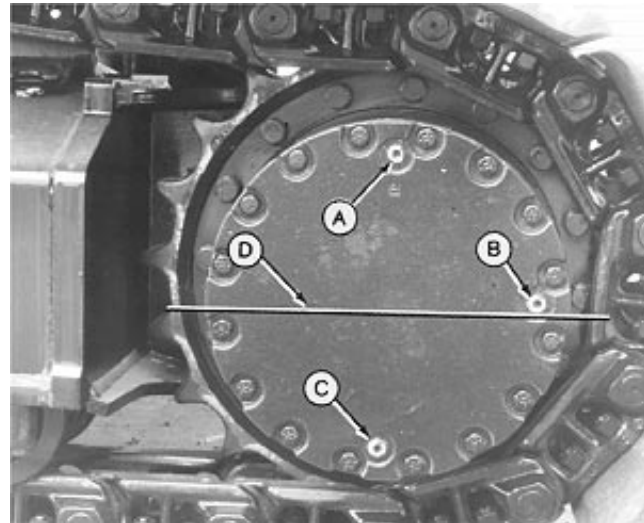

T7396CG -UN-18OCT190

A—Fill Plug
 B—Check Plug
 C—Drain Plug
 D—Horizontal Centerline

TX,75,DH5098 -19-08JUL96-2/2

CLEAN DUSTY PRIMARY ELEMENT

1. Tap element with the palm of your hand, NOT ON A HARD SURFACE.

CAUTION: Prevent possible injury from flying chips if compressed air is more than 210 kPa (2.1 bar) (30 psi). Reduce compressed air to less than 210 kPa (2.1 bar) (30 psi) when using for cleaning purposes. Clear area of bystanders, guard against flying chips, and wear personal protection equipment including eye protection.

2. If this does not remove dust, use compressed air under 210 kPa (2.1 bar) (30 psi).
3. Direct air up and down the pleats from inside to outside. Be careful not to make a break in the element.



T47764 -UN-09NOV88

03T,55,MM11 -19-18NOV92-1/1

INSPECT ELEMENT

IMPORTANT: A damaged or dirty element may cause engine damage.

Install a new primary element:

1. If the element shows damage.
2. If element will not clean.
3. After 1000 hours service or annually.

Install a new secondary element:

1. If the primary element is damaged and needs to be replaced.
2. If the element is visibly dirty.
3. After 1000 hours service or annually.

DO NOT clean a secondary element.
Install a new element carefully centering it in the canister.

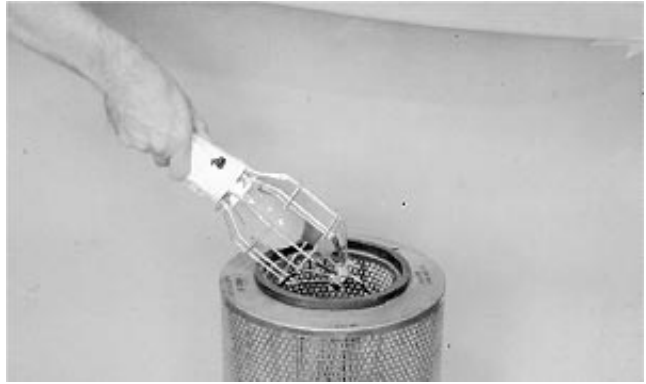

T90684 -JUN-10NOV88

1. Inspect element and gasket for damage.
2. Air restriction indicator will not signal correctly if an element has a break or is not correctly sealed in air cleaner housing. Throw away element that has the slightest damage. If gasket is broken or missing, install a new element.

CHAPTER 15
MAINTENANCE—EVERY 500 HOURS

BLANK

Maintenance—Every 500 Hours

GREASE SWING BEARING



CAUTION: Prevent possible injury from unexpected machine movement if controls are moved by another person. Lubricating swing bearing and rotating the upperstructure must be done by one person. Before you lubricate swing bearing, clear the area of all persons.

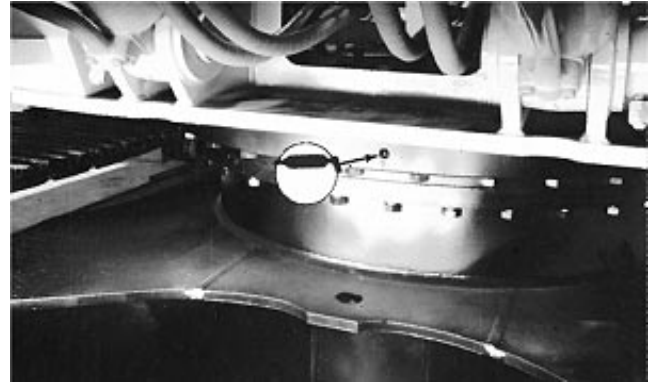

T7869BM -JUN-22OCT192

1. Park machine on a level surface.
2. Lower bucket to the ground.
3. Turn auto-idle switch off.

IMPORTANT: Turbocharger may be damaged if engine is not properly shut down.

4. Run engine with engine rpm dial at 1/3 position without load for 2 minutes.
5. Move engine rpm dial to slow idle position.
6. Turn key switch to OFF. Remove key from switch.
7. Attach a 'Do Not Operate' tag on the right control lever.
8. Pull pilot control shut-off lever to locked position.
9. Lubricate swing bearing with ten shots of grease at both grease fittings. (See Fuels and Lubricants chapter.)
10. Start engine. Raise bucket several inches off the ground and turn upperstructure 45 degrees.
11. Repeat steps 2—9 three times.

NOTE: *It is not necessary to start the engine the last time.*

GREASE SWING BEARING GEAR

CAUTION: Prevent possible injury from unexpected machine movement if controls are moved by another person. Lubricating swing bearing gear and rotating the upperstructure must be done by one person.

1. Remove access cover (A) to swing gear.
2. Grease must be 13—25 mm (1/2—1 in.) (B) deep measured from the bottom of the ring gear. The grease must also be free of contamination by dirt and water.

If the grease is contaminated, remove grease and replace with clean grease.

IMPORTANT: If water or mud is found in swing gear area, see *Operating in Water and Mud in Operating the Machine* chapter.

3. Add grease as required (approximately 0.113 kg (1/4 lb) every 90°). (See *Fuels and Lubricants* chapter.)

IMPORTANT: Excessive grease can damage the swing gearbox seal.

4. Remove excessive grease that extrudes over the top of the swing drive pinion.
5. Install access cover.

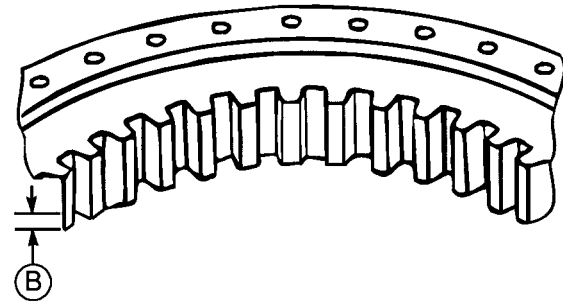
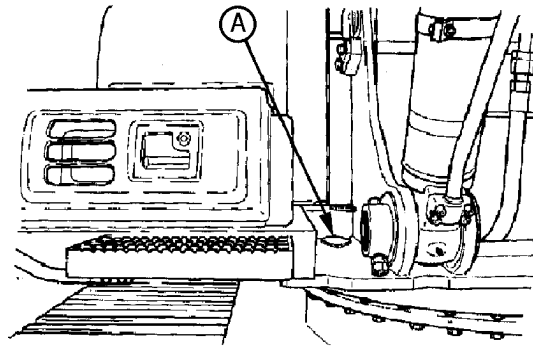

T107788 -UN-03MAR97

T8156AE -UN-13JAN94

REPLACE FINAL FUEL FILTER

1. Turn retaining ring (A) clockwise to remove filter. Allow sediment to drain into a container. Dispose of waste properly.
2. Clean filter base.
3. Install new filter. Follow instructions on filter.
4. Bleed fuel system. (See Bleeding Fuel System in Maintenance chapter)



T108280C -UN-27MAR97

TX,80,DH5574 -19-19JUL96-1/1

REPLACE PRIMARY FUEL FILTER (WATER SEPARATOR)

1. Turn retaining ring (A) counterclockwise to remove filter (B). Allow sediment to drain into a container. Dispose of waste properly.
2. Turn sediment bowl (C) counterclockwise to remove from filter assembly. Clean bowl.
3. Remove hand primer from fuel filter base. Disassemble hand primer assembly.

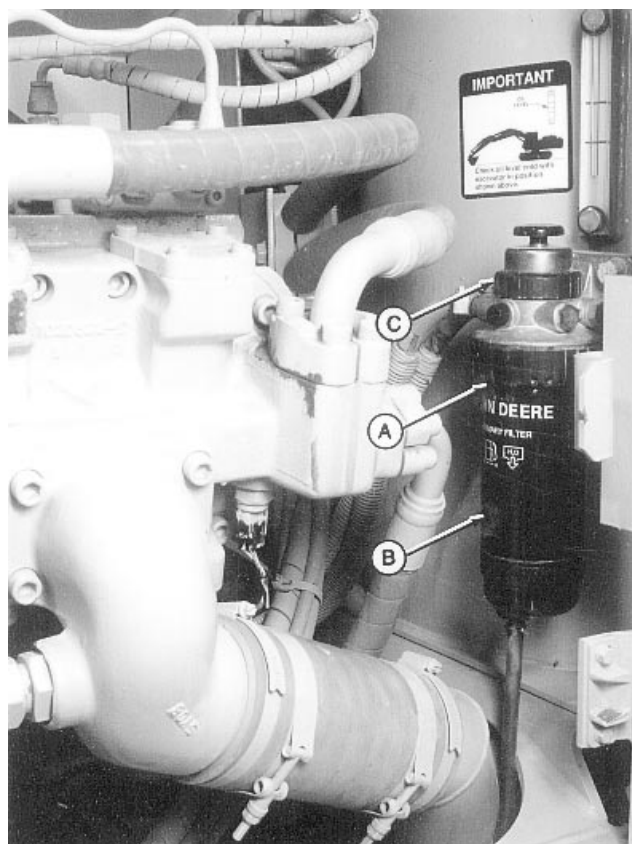

T102466 -UN-30JUL96

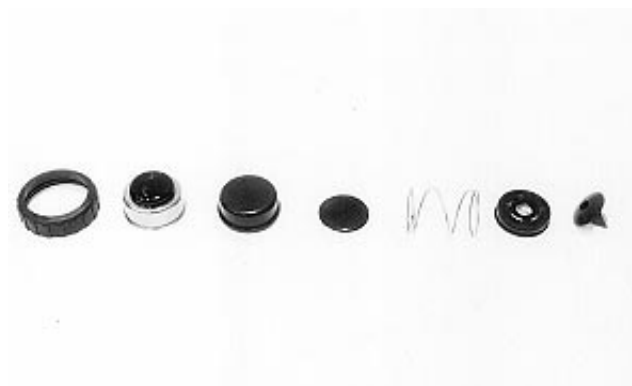

T8387AE -UN-17DEC94

Continued on next page

TX,80,DH5123 -19-26JUL96-1/2

4. Remove fuel inlet line (A) and plug (C).
5. Flush any debris from filter base (B).
6. Install fuel inlet plug and fuel inlet line.
7. Assemble primer assembly and install onto fuel filter base.
8. Install new filter. (Follow instructions on filter.)
9. Install sediment bowl.
10. Bleed fuel system. (See Bleeding Fuel System in Maintenance chapter.)

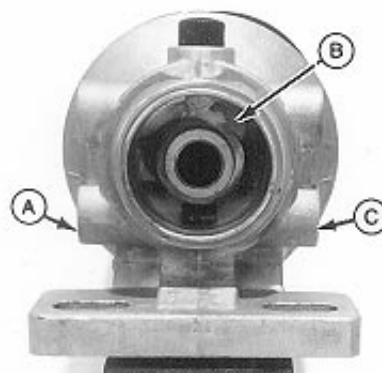

T8887AD -UN-17DEC94

TX,80,DH5123 -19-26JUL96-2/2

CHECK AIR INTAKE HOSES

Check hoses (A) for cracks. Replace as necessary.

Tighten clamps.

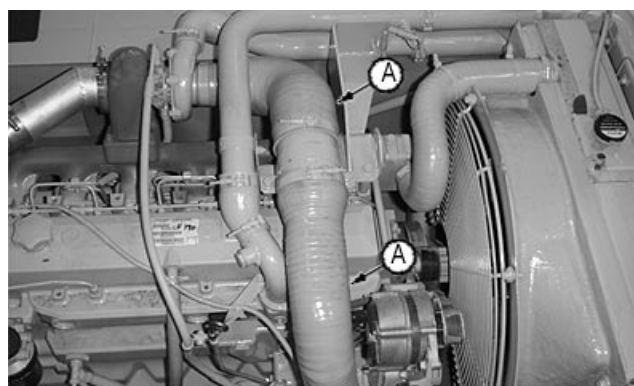

T108267B -UN-27MAR97

TX,80,DH5575 -19-25JUL96-1/1

REPLACE HYDRAULIC OIL FILTER

1. Park machine on a level surface.
2. Position machine with arm cylinder fully retracted and bucket cylinder fully extended.
3. Lower bucket to the ground.
4. Turn auto-idle switch off.

IMPORTANT: Turbocharger may be damaged if engine is not properly shut down.

5. Run engine with engine rpm dial at 1/3 position without load for 2 minutes.
6. Move engine rpm dial to slow idle position.
7. Turn key switch to OFF. Remove key from switch.
8. Attach a 'Do Not Operate' tag on the right control lever.
9. Pull pilot control shut-off lever to locked position.

TX,80,DH5100 -19-08JUL96-1/4

CAUTION: High pressure release of oil from pressurized system can cause serious burns or penetrating injury. The hydraulic tank is pressurized. Do not remove vent plug (A). Release pressure by loosening vent plug.

10. Loosen vent plug (A) to release hydraulic pressure.

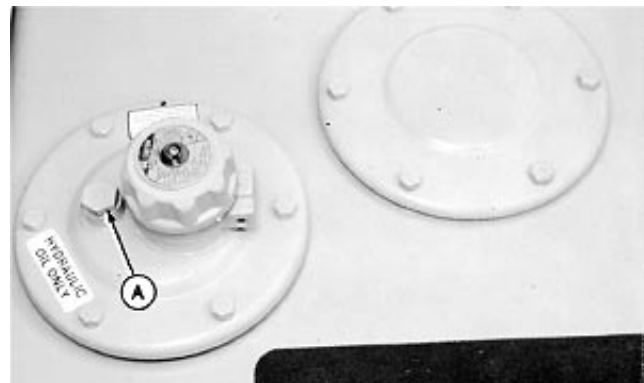

Continued on next page

TX,80,DH5100 -19-08JUL96-2/4

T7869AT -UN-12NOV92

11. Hold down filter cover (C) against light spring load when removing the last two cap screws.

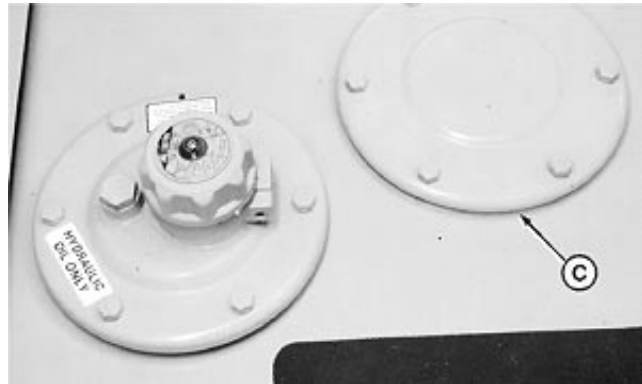

T7869AL -UN-12NOV92

TX.80.DH5100 -19-08JUL96-3/4

12. Remove spring (C), valve (E), and element (D).
13. Remove filter case and discard element and O-ring (F).

CAUTION: Prevent possible injury from flying chips if compressed air is more than 210 kPa (2.1 bar) (30 psi). Reduce compressed air to less than 210 kPa (2.1 bar) (30 psi) when using for cleaning purposes. Clear area of bystanders, guard against flying chips, and wear personal protection equipment including eye protection.

NOTE: Remove element and inspect for metal particles and debris in bottom of filter can. Excessive amounts of brass and steel particles can indicate a hydraulic pump, motor, or valve malfunction, or a malfunction in process. A rubber type of material can indicate cylinder packing problem.

14. Clean filter case with diesel fuel and dry with compressed air.
15. Install filter case, valve (E), and spring (C) in reservoir.
16. Install cover (A) and tighten cap screws (B).

Cover Cap Screw—Specification

Torque 49 N•m (36 lb-ft)

17. Tighten vent plug.

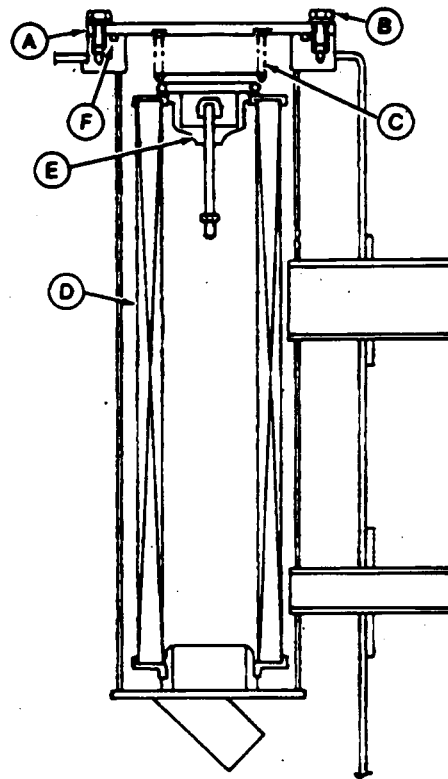

- A—Cover
- B—Cap Screw
- C—Spring
- D—Element
- E—Valve
- F—O-Ring

T6457ED -UN-18OCT88

TX.80.DH5100 -19-08JUL96-4/4

ADD COOLANT CONDITIONER TO RADIATOR

Coolant conditioner prevents rust, scale, and liner cavitation.



CAUTION: Prevent possible injury from hot spraying water. Do not remove radiator cap unless the engine is cool.

Turn cap slowly to the stop to release air to relieve pressure before removing cap.

1. Turn cap slowly to the stop to release pressure. Then remove radiator cap.
2. Add TY16004 John Deere Coolant Conditioner or equivalent non-chromate conditioner/rust inhibitor, following instructions on container.

Cooling System—Specification

Capacity..... Approx. 22 L (6 gal)

NOTE: Check coolant every 500 hours or 6 months, or if you replace 1/3 or more of coolant.

John Deere Liquid Coolant Conditioner does not protect against freezing.

CHAPTER 16
MAINTENANCE—EVERY 1000 HOURS

BLANK

Maintenance—Every 1000 Hours

CHANGE SWING GEARBOX OIL

1. Remove plug (A) mounted on end of drain pipe to drain oil into a container. Dispose of waste oil properly.

Swing gearbox oil—Specification

Capacity..... 13 L (14 qt)

2. Install plug.
3. Remove filler cap (B) and add oil.
4. Install filler cap.
5. Check oil level on dipstick.



T102305 -JUN-30JUL96

TX,85,DH5441 -19-03MAR97-1/1

CHANGE PILOT CONTROL OIL FILTER

CAUTION: High pressure release of oil from pressurized system can cause serious burns or penetrating injury. The hydraulic tank is pressurized. Do not remove vent plug (A). Release pressure by loosening vent plug.

1. Loosen vent plug (A) to relieve air pressure.

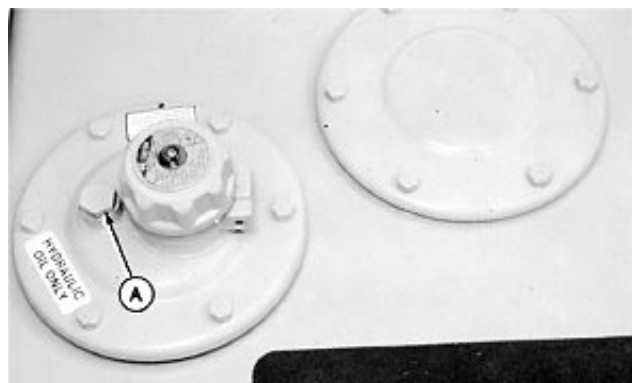

T7869AT -JUN-12NOV92

TX,85,DH5150 -19-10AUG96-1/3

2. Remove filter case (A).

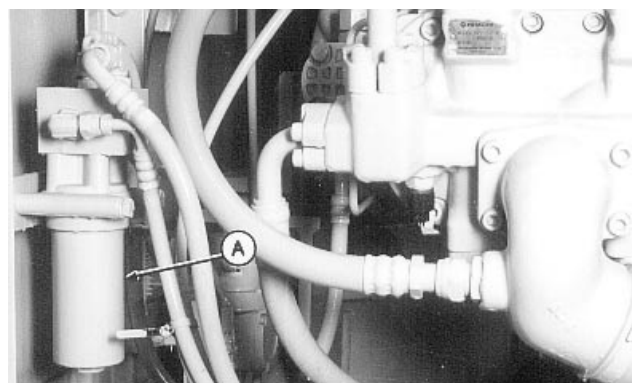

T101495 -JUN-15JUL96

Continued on next page

TX,85,DH5150 -19-10AUG96-2/3

3. Unscrew filter element (B).
4. Remove O-ring (C)
5. Install new O-ring and filter element.

Filter case—Specification

Torque 20-30 N•m (15-22 lb-ft)

6. Install filter case (A).
7. Tighten vent plug.

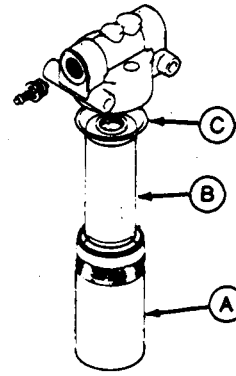

T6457ES -JUN-19OCT88

TX,85,DH5150 -19-10AUG96-3/3

CHANGE PUMP DRIVE GEARBOX OIL

1. Remove plastic cap and filler plug (A).
2. Remove drain plug (B). Allow oil to drain into a container. Dispose of waste oil properly.
3. Apply Liquid TEFLON Pipe Thread Sealant to drain plug. Install plug.
4. Add oil. (See Fuels and Lubricants chapter.)

Pump Gearbox—Specification

Capacity 1.0 L (1.1 qt)

5. Pull dipstick (C) and check oil level. Oil level must be approximately halfway below 'H' (level) mark.
6. Install filler cap. Install dipstick.

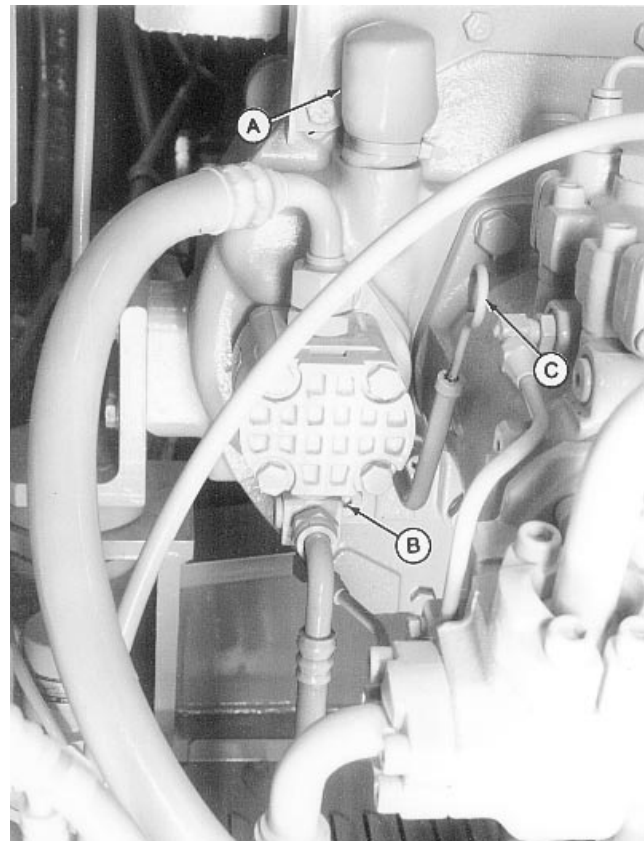

T101494 -JUN-15JUL96

TX,85,DH5685 -19-03MAR97-1/1

CLEAN THE ENGINE CRANKCASE VENTILATION TUBE

Clean the engine crankcase ventilation tube (A) when you measure and adjust engine valve clearance (lash).

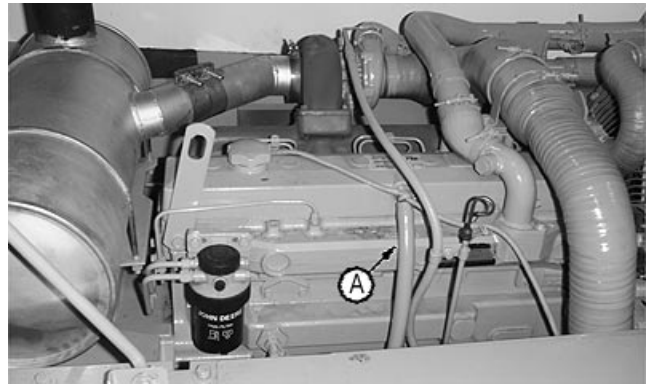

T108260D -UN-27MAR97

TX,85,DH5580 -19-10AUG96-1/1

CHECK AND ADJUST ENGINE VALVE LASH (CLEARANCE)

CAUTION: Prevent accidental starting of engine while performing valve adjustments. Always disconnect **NEGATIVE (-)** battery terminal.

IMPORTANT: Valve clearance **MUST BE** checked and adjusted with engine **COLD**.

1. Remove rocker arm cover and engine crankcase ventilation tube. Clean tube with solvent or diesel fuel. Check that O-ring in rocker arm cover is in good condition.

IMPORTANT: Visually inspect contact surfaces of valve tips and rocker arm wear pads. Check all parts for excessive wear, breakage, or cracks. Replace parts that show visible damage.

Rocker arms that exhibit excessive valve clearance should be inspected more thoroughly to identify damaged parts.

2. Remove plug (A). Install JDG820 Flywheel Turning Tool. Remove cap screw (B). Install JDE-81-4 Timing Pin.

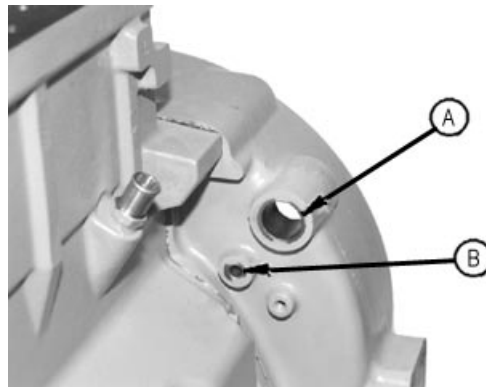

RG7408 -UN-06AUG96

Continued on next page

TX,86,DH5104 -19-09JUL96-1/2

3. Turn flywheel until timing pin goes into hole in flywheel.
4. Using engine rotation tool, rotate engine flywheel in running direction (clockwise viewed from front) until No. 1 cylinder is at "TDC" Compression stroke.

If No. 1 cylinder rocker arms are loose, the engine is at No. 1 "TDC" Compression. If No. 1 cylinder rocker arms are not loose, rotate engine one full revolution (360°) to No. 1 "TDC" Compression

To change piston position, remove timing pin and rotate flywheel.

5. Check and adjust valve clearance to specifications as directed in the following procedures.
6. Loosen jam nut (A) and adjust clearance with a screwdriver, as shown.

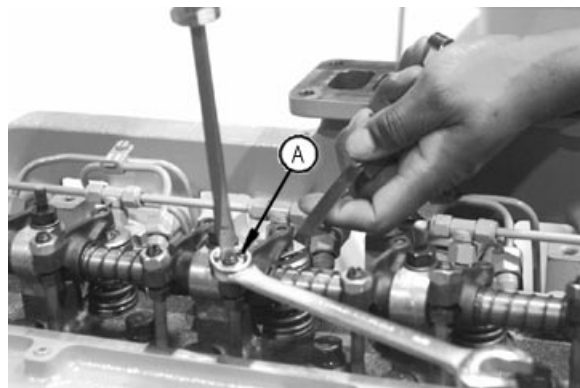

RG7409 -JUN-06AUG96

TX,86,DH5104 -19-09JUL96-2/2

FIRING ORDER 6—CYLINDER ENGINE:

NOTE: Firing order is 1-5-3-6-2-4.

1. Adjust No. 1, 3, and 5 exhaust valves and No. 1, 2, and 4 intake valves.

Exhaust Valves (E)—Specification

Clearance 0.46 mm (0.018 in.)

Intake Valves (I)—Specification

Clearance 0.36 mm (0.014 in.)

2. Rotate engine 360° and repeat step 1 for the remaining intake and exhaust valves.
3. Tighten jam nut to 27 N•m (20 lb-ft).
4. Clean cylinder head and rocker arm cover mating surfaces.
5. Install rocker arm cover gasket. Do not use sealant on the gasket.
6. Install rocker arm cover. Tighten screws to 35 N•m (26 lb-ft). Do not over tighten cap screws.
7. Remove turning tool and timing pin.
8. Install parts. Center muffler to turbocharger inlet tube before fastening muffler into place.

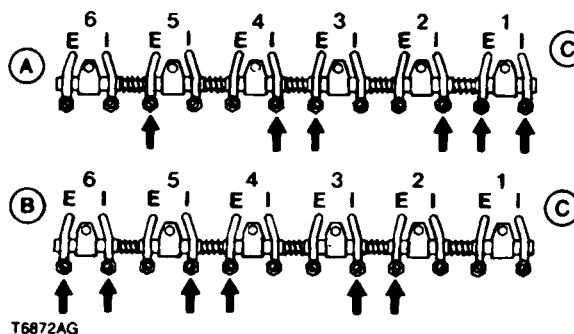

A—No. 1 TDC Compression Stroke
 B—No. 1 TDC Exhaust Stroke
 C—Fan End of Engine

T6872AG -JUN-18MAY94

CHECK ENGINE SPEEDS

1. Warm engine to normal operating temperature.

Slow idle—Specification

Speed 900 ± 25 rpm

Fast idle in Standard Mode—Specification

Speed 2180 ± 25 rpm

2. Connect a tachometer to check engine speeds

NOTE: Turn engine RPM dial to slow idle to check slow idle speed

Turn engine RPM dial to fast idle to check fast idle speed.

If engine speeds need adjustment, see your authorized dealer.

ENGINE SPEED LEARNING PROCEDURE

1. Stop engine.
2. Push engine learning switch (C) up to top position. The switch is a three position switch. Make sure it is in the top position.
3. Turn key switch ON. Wait for 5 seconds.
4. Turn key switch OFF. Wait for 5 seconds.
5. Push engine learning switch to middle position.
6. Check engine speeds.

Slow Idle—Specification

Speed 900 ± 25 rpm

Auto-Idle—Specification

Speed 1200 ± 25 rpm

E (Economy) Mode—Specification

Speed 1980 ± 25 rpm

Fast Idle in Standard Mode—Specification

Speed 2180 ± 25 rpm

NOTE: If engine RPM is not to specifications, see your authorized dealer.

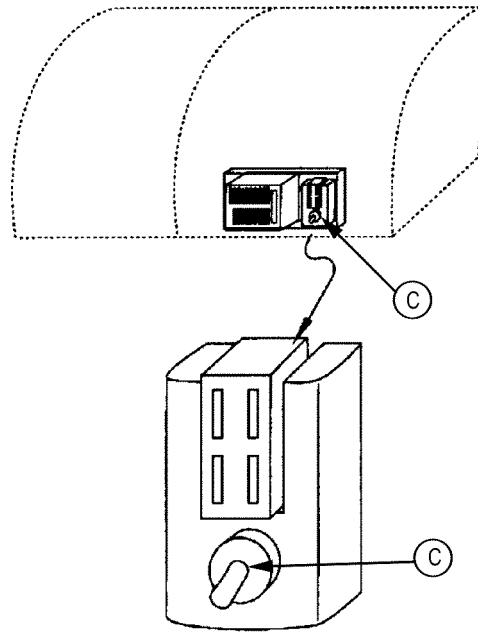

T103674

T103674 -JUN-11SEP96

TX,85,DH5728 -19-28APR97-1/1

CHANGE AIR CLEANER ELEMENTS

1. Open left front service door.
2. Loosen wing nut to remove cover.
3. Remove wing nut and primary element (A).

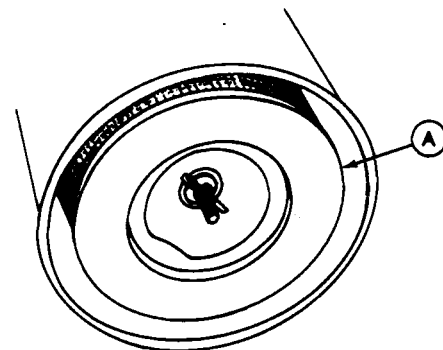

T6119AF -JUN-01NOV88

Continued on next page

TX,85,FF2318 -19-01NOV91-1/2

4. Remove wing nut and secondary element (B).
5. Install elements, making sure the secondary element is centered in canister.
6. Install cover.

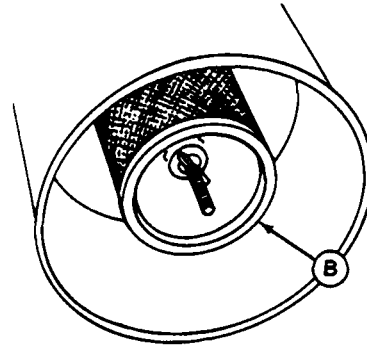

TX,85,FF2318 -19-01NOV91-2/2

T6119AG -UN-01NOV88

INSPECT FAN BELT

1. Check belt regularly for wear, especially for cracks at the bottom of grooves and for frayed edges.
2. If necessary, replace belt.
3. Install a 15 mm wrench to the TOP pulley (A) of belt tension adjuster. Turn wrench counterclockwise to pull tension adjuster pulley away from belt, releasing belt tension.
4. Hold tension adjuster away from belt while removing old belt and installing new belt.
5. Slowly release wrench tension to allow tension adjuster to move clockwise against new belt. Tension is automatically adjusted.
6. Remove wrench.

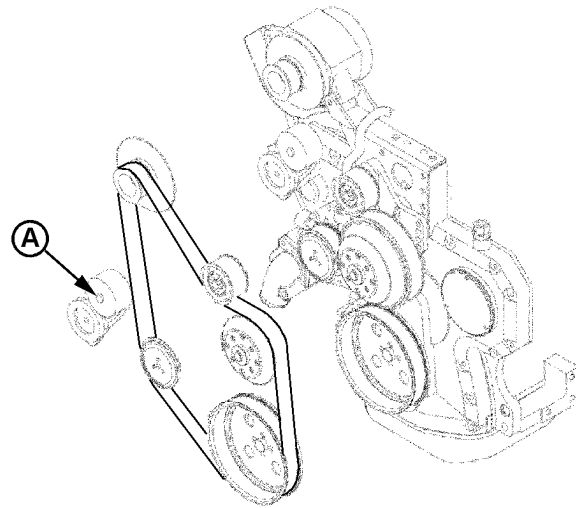

T108219

TX,85,DH5557 -19-17DEC96-1/1

T108219 -UN-25MAR97

REPLACE AIR CLEANER DUST VALVE

NOTE: A missing, damaged, or hardened dust valve will cause the air filter elements to be ineffective.

Replace dust valve (A).

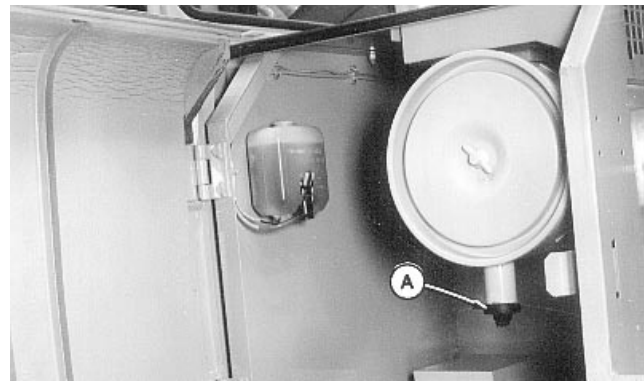

TX,85,DH5094 -19-08JUL96-1/1

T101488 -UN-15JUL96

CHAPTER 17
MAINTENANCE—EVERY 2000 HOURS

BLANK

Maintenance—Every 2000 Hours

DRAIN COOLING SYSTEM

Drain and flush cooling system using commercial products, replace thermostats, radiator cap, and refill with new coolant.

1. Check coolant hoses (A) for cracks and leaks. Replace if necessary.
2. Tighten clamps.
3. Check radiator and oil cooler for dirt, grease, leaks, and loose or broken mountings. Clean radiator and oil cooler fins.

! **CAUTION: Prevent possible injury from hot spraying water. DO NOT remove radiator filler cap unless engine is cool. Then turn cap slowly to the stop.**

4. Release air to relieve pressure. Remove filler cap.

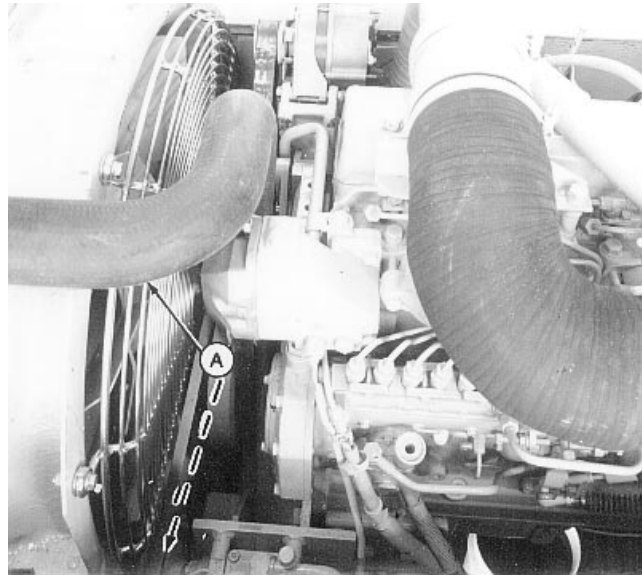

T102676 -UN-02AUG96

CED,OUOE042,72 -19-07APR99-1/3

5. Turn radiator petcock (A) counterclockwise to open valve. Allow coolant to drain into a container. Dispose of waste coolant properly.

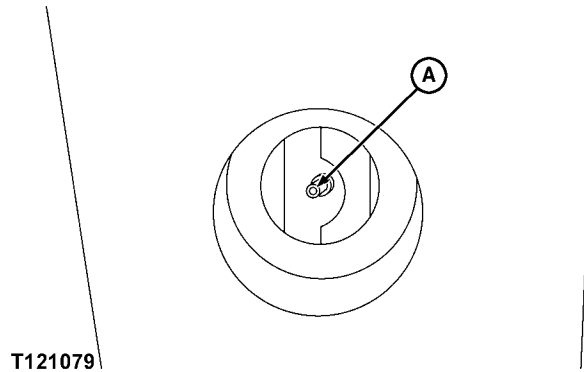

T121079

T121079 -UN-14APR99

CED,OUOE042,72 -19-07APR99-2/3

6. Turn engine block drain cock (A) counterclockwise to drain engine block. Drain coolant into a container. Dispose of waste properly.

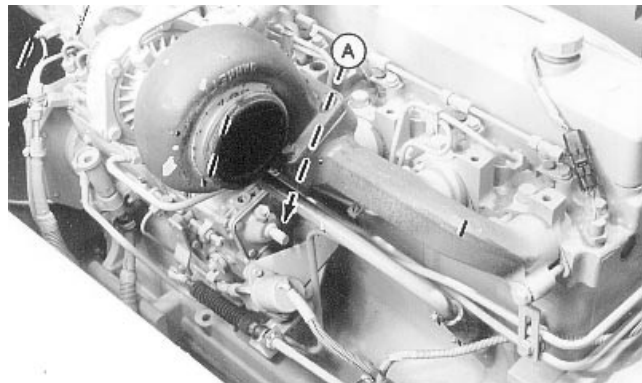

T102677 -UN-02AUG96

CED,OUOE042,72 -19-07APR99-3/3

DIESEL ENGINE COOLANT

The engine cooling system is filled to provide year-round protection against corrosion and cylinder liner pitting, and winter freeze protection to -37°C (-34°F).

The following engine coolant is preferred for service:

- CID A-A-52624 Type 1 is a fully formulated ethylene glycol-based engine coolant concentrate.
- CID A-A-52624 Type 1P is a prediluted (60% by vol. Glycol) fully formulated ethylene glycol-based engine coolant.
- CID A-A-52624 Type 11 is a fully formulated propylene glycol-based engine coolant concentrate.
- CID A-A-52624 Type 1 and Type 11 require dilution with water before use.
- CID A-A-52624 Type 1P is ready to use as packaged.
- John Deere PREDILUTED ANTIFREEZE/SUMMER COOLANT.
- John Deere COOL-GARD™, where available.

John Deere ANTIFREEZE/SUMMER COOLANT CONCENTRATE in a 40 to 60% mixture of concentrate with quality water is also recommended.

Other low silicate ethylene glycol base coolants for heavy-duty engines may be used if they meet one of the following specifications:

- ASTM D6210 (prediluted coolant)

- ASTM D6211 (coolant concentrate) in a 40 to 60% mixture of concentrate with quality water

Coolants meeting these specifications require use of supplemental coolant additives, formulated for heavy-duty diesel engines, for protection against corrosion and cylinder liner erosion and pitting.

A 50% mixture of ethylene glycol engine coolant in water provides freeze protection to -37°C (-34°F). If protection at lower temperatures is required, consult your John Deere dealer for recommendations.

Water quality is important to the performance of the cooling system. Distilled, deionized, or demineralized water is recommended for mixing with ethylene glycol base engine coolant concentrate.

IMPORTANT: Do not use cooling system sealing additives or antifreeze that contains sealing additives.

Coolant drain intervals

Drain and flush the cooling system and refill with fresh coolant every 24 months.

When John Deere PREDILUTED ANTIFREEZE/SUMMER COOLANT is used, the service interval may be extended to 36 months.

COOLING SYSTEM FILL AND DEAERATION PROCEDURE

IMPORTANT: Use only permanent-type low silicate ethylene glycol base antifreeze in coolant solution. Other types of antifreeze may damage cylinder seals.

FREEZING TEMPERATURES: Fill with permanent-type, low silicate, ethylene glycol antifreeze (without stop-leak additive) and clean, soft water.

FILL

Fill radiator to the bottom of the radiator fill neck.

Cooling System—Specification

Capacity..... Approx. 22 L (6 gal)

Fill the recovery tank to FULL mark.

DEAERATION

The cooling system requires several warm-up and cool down cycles to deaerate. It will NOT deaerate during normal operation. Only during warm-up and cool down cycles will the system deaerate.

1. Start engine. Run engine until coolant reaches a warm temperature.
2. Stop engine. Allow coolant to cool.
3. Check coolant level at recovery tank.
4. Repeat Steps 1—3 until recovery tank coolant level is repeatedly at the same level (stabilized).

NOTE: The level of the coolant in the cooling system MUST BE repeatedly checked after all drain and refill procedures to insure that all air is out of the system which allows the coolant level to stabilize. Check coolant level only when the engine is cold.

5. If necessary, fill recovery tank to FULL mark.
6. Install recovery tank and radiator caps.

CHANGE PROPEL GEARBOX OIL

1. Park the machine on level ground rotating propel gearbox until bottom of the oil level check plug (B) is even with the horizontal centerline.
2. Lower bucket to the ground.
3. Turn auto-idle switch off.

IMPORTANT: Turbocharger may be damaged if engine is not properly shut down.

4. Run engine with engine RPM dial at 1/3 position without load for 2 minutes.
5. Move engine RPM dial to slow idle and turn key switch to OFF. Remove key from switch.
6. Attach a 'Do Not Operate' tag on the right control lever.
7. Pull pilot control shut-off lever to locked position.

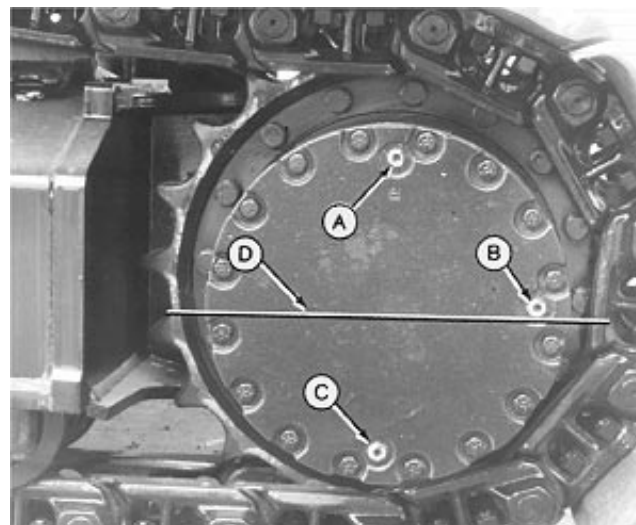

T7396CG -UN-18OCT90

A—Fill Plug
 B—Check Plug
 C—Drain Plug
 D—Horizontal Centerline

- ⚠ CAUTION: High pressure release of fluids from pressurized system can cause serious burns. Wait for propel gearbox oil to cool. Keep body and face away from check plug. Gradually loosen check plug to release pressure.**
8. After propel gearbox has cooled, slowly loosen check plug to release pressure.

Propel Gearbox Oil—Specification

Capacity..... Approx. 6 L (6.5 qt)

9. Remove drain plug (C). Allow oil to drain into a container. Dispose of waste oil properly.
10. Wrap threads of drain plug with a sealing-type tape. Install plug. Tighten plug to 49 N•m (430 lb-in.).
11. Remove oil fill plug (A).
12. Add oil until oil flows out of oil level check plug hole. (See Fuels and Lubricants chapter.)

13. Wrap threads of check plug and fill plug with sealing-type tape. Install plugs. Tighten plugs to 49 N•m (36 lb-ft).
14. Change oil of second propel gearbox.

TX,86,DH5152 -19-10AUG96-2/2

CHANGE HYDRAULIC OIL

IMPORTANT: DO NOT run engine without oil in the tank.

1. Park machine on level surface with upperstructure rotated 90° for easier access.
2. Position machine with arm cylinder fully retracted and bucket cylinder fully extended.
3. Lower bucket to the ground.
4. Turn auto-idle switch off.



T6811AJ -JUN-18OCT88

IMPORTANT: Turbocharger may be damaged if engine is not properly shut down.

5. Run engine with engine RPM dial at 1/3 position without load for 2 minutes.
6. Move engine RPM dial to slow idle position.
7. Turn key switch to OFF to stop engine. Remove key from switch.
8. Pull pilot control shut-off lever to locked position.

Continued on next page

TX,OUOE042,29 -19-08MAR99-1/7

CAUTION: High pressure release of oil from pressurized system can cause serious burns or penetrating injury. The hydraulic tank is pressurized. Do not remove vent plug (A). Release pressure by loosening vent plug.

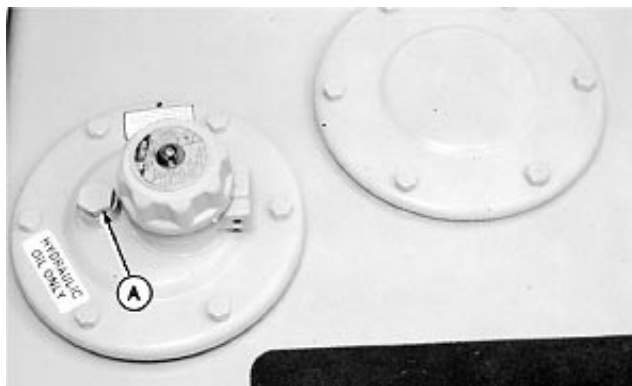

T7869AT -UN-12NOV92

9. Loosen vent plug (A) to relieve air pressure.

TX,OUOE042,29 -19-08MAR99-2/7

10. Insert 4 mm (0.15 in.) hex wrench (D) into hole (E) and turn counterclockwise.

11. Slowly turn cap (A) counterclockwise. Remove cap.

Hydraulic Tank Oil—Specification

Capacity 148 L (39 gal)

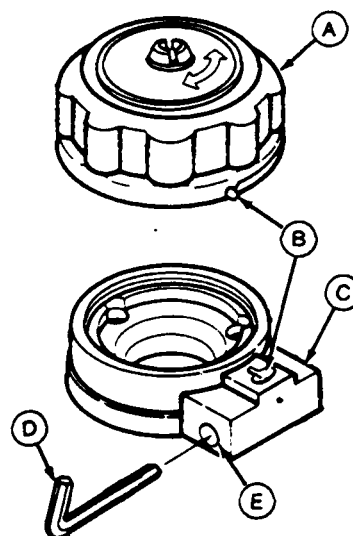

- A—Cap
- B—Aligning Marks
- C—Case Assembly
- D—Hex Wrench
- E—Hole

T6457E1 -UN-18OCT88

Continued on next page

TX,OUOE042,29 -19-08MAR99-3/7

Maintenance—Every 2000 Hours

12. Remove drain plug (F). Allow oil to drain into a container. Dispose of waste oil properly.

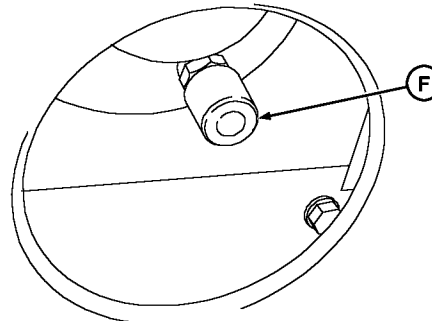

T120418

T120418 -UN-25MAR99

TX,OUOE042,29 -19-08MAR99-4/7

13. Remove cover (A) with suction filter.
14. Clean inside of tank and suction filter.
15. Change hydraulic oil filter. (See Maintenance-Every 500 Hours chapter.)
16. Change pilot control oil filter. (See Maintenance-Every 1000 Hours chapter.)

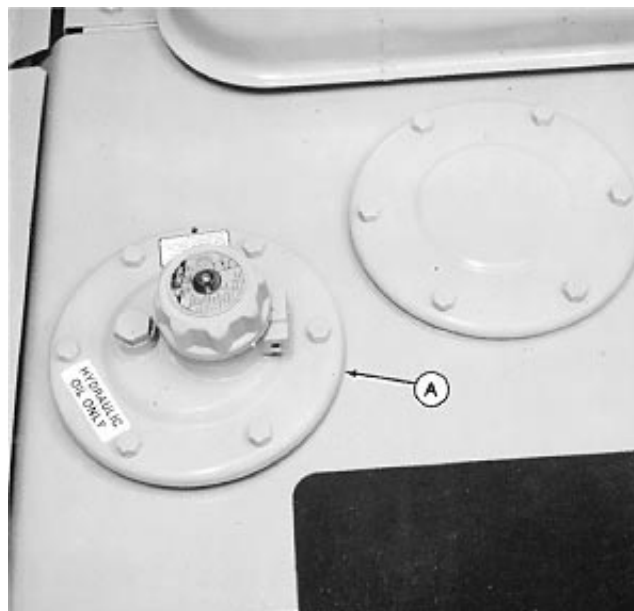

T7869BP -UN-12NOV92

Continued on next page

TX,OUOE042,29 -19-08MAR99-5/7

17. Install suction screen with cover. Suction screen must seal against outlet pipe in bottom of tank. If necessary, loosen nut (B) to adjust rod length

Suction Screen Rod—Specification

Length (A)..... 670 mm (26.4 in.)

Suction Screen Rod Nut—Specification

Torque (A) 17 N•m (12.5 lb-ft) (150 lb-in.)

Top of Rod to Top of Rod Nut—Specification

Length (C) 20 mm (0.8 in.)

Cover Cap Screw—Specification

Torque 49 N•m (36 lb-ft)

18. Install tank drain plug and bottom guard.
19. Add oil until it is between marks on sight glass. (See Fuels and Lubricants chapter.)

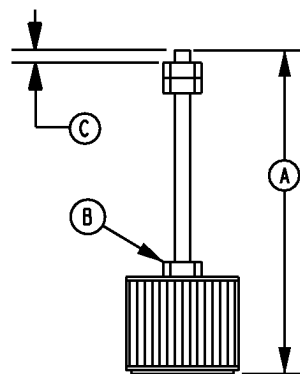

T108541

T108541 -UN-24MAR97

TX,OUOE042,29 -19-08MAR99-6/7

IMPORTANT: If the hydraulic pump is not filled with oil, it will be damaged when the engine is started.

20. Remove air bleed plugs (C) from hydraulic pump until oil flows from bleed holes.
21. Install air bleed plugs in hydraulic pump.
22. Check oil level in sight glass. Add oil, if necessary. Install tank cap. Tighten vent plug.
23. Purge air from cylinders and swing motor by cycling hydraulic functions.

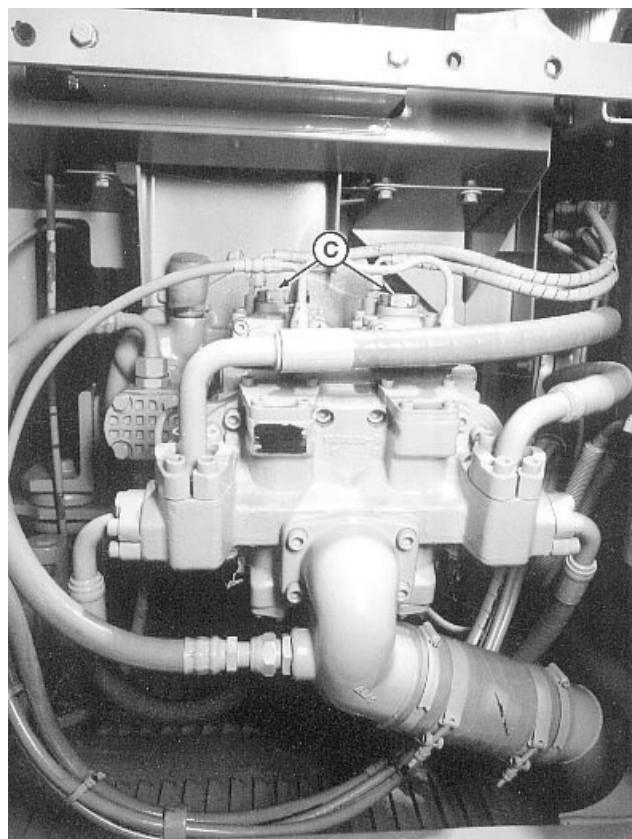

T101875 -UN-15JUL96

TX,OUOE042,29 -19-08MAR99-7/7

CHAPTER 18
MAINTENANCE—AIR COMPRESSOR

BLANK

MAINTENANCE – AIR COMPRESSOR

GENERAL

In addition to periodic inspections, many of the components in these units require periodic servicing to provide maximum output and performance. Servicing may consist of pre-operation and post-operation procedures to be performed by the operating or maintenance personnel. The primary function of preventive maintenance is to prevent failure, and consequently, the need for repair. Preventive maintenance is the easiest and the least expensive type of maintenance. Maintaining your unit and keeping it clean at all times will facilitate servicing.

Correct engine speed is critical to the operation of this machine. Check the idle and full load rpm every three months and adjust in accordance with the speed and pressure adjustment instructions in this manual and included on a decal on the machine. Correct speeds are on the general data decal.

SCHEDULED MAINTENANCE

The maintenance schedule is based on normal operation of the unit. This page can be reproduced and used as a checklist by the service personnel. In the event unusual environmental operating conditions exist, the schedule should be adjusted accordingly.

COMPRESSOR OIL LEVEL

The oil level is most consistent when the unit is **RUNNING AT FULL LOAD** and should be checked at this time. The optimum operating level is midway of the sight tube on the side of the receiver tank. See the decal beside the sight tube. If the oil level is not in the “OK” range, make appropriate corrections (Add or Drain). A totally filled sight tube in which the level is not visible indicates an over-full condition and requires that oil be drained.

Compressor Oil

This machine was factory filled with Ingersoll-Rand Pro TecR Compressor Fluid (Ingersoll-Rand XHP505 for XHP900 models).

The compressor oil must be replaced every 500 hours of operation or six (6) months, whichever comes first for models HP600 - P1600.

Refer to the fluids and lubricants chart for ambient temperature ranges and specifications, in the lubrication section of this manual.

The compressor oil must be replaced every 500 hours of operation or six (6) months, whichever comes first for models P100-P600. The compressor oil must be replaced every 1000 hours of operation or six (6) months, whichever comes first for models HP600-P1600.

Refer to the fluids and lubricants chart for ambient temperature ranges and specifications in the lubrication section of this manual.

AIR CLEANER

The Model XP330SCU is equipped with air cleaner service indicators mounted on the main instrument/control panel.

Inspect daily the air cleaner service indicator. Never guess about restriction in the air cleaner. Always know what condition your air cleaner is in with the assistance of the service indicator. If it is not working properly, or is missing, replace it.

Maximum compressor and engine protection against the ravages of dust is possible only if the air cleaner is serviced at regular intervals or whenever the service indicator shows red.

Visually inspect the position of the flag in the air cleaner restriction indicator. Normally, the flag in a service indicator shows green, indicating the filter element is still serviceable. If the flag shows red when the unit is operating at full speed or stopped, it is an indication that proper servicing of the filter element is necessary.

Also weekly squeeze the rubber valve (precleaner dirt dump) on each air cleaner housing to ensure that they are not clogged. NOTICE: Holes or cracks downstream of the air cleaner housing will cause the restriction indicators to be ineffective.

The air filters restricted sensor will automatically reset after the main power switch is flipped to "OFF."

To service the air cleaners on all units proceed as follows:

1. Loosen outer wing nut and remove with outer element. Inspect red window on special inner wing nut to find small dot. If dot is not visible, remove cotter pin and special wing nut and inner (safety) element.
2. Inspect air cleaner housing for any condition that might cause a leak and correct as necessary.
3. Wipe inside of air cleaner housing with a clean, damp cloth to remove any dirt accumulation, especially in the area where the element seals against the housing.
4. Inspect element by placing a bright light inside and rotating slowly. If any holes or tears are found in the paper, discard this element. If no ruptures are found, the element can be cleaned by one of the following procedures.
5. If a new air filter element is to be used check it closely for shipping damage. To reset the signal indicator in the special wing nut, apply suction to the red window.
6. Install cleaned or new elements in the reverse order to the above. Tighten wing nuts firmly and replace cotter pin.
7. Inspect to ensure that the end cap seals tightly 360 degrees around the air cleaner body.

In the event the element is contaminated with dry dirt, oil or greasy dirt deposits, and a new element is not available, cleaning can be accomplished by washing, using the air cleaner element manufacturer's recommendations.

NOTICE

To prevent damage to the element, never exceed a maximum air pressure of 100 psi (700 kPa).

NOTICE

It is highly recommended that new replacement elements be installed in the unit immediately in order that the unit be returned to service in the shortest possible time. In this manner, the elements just removed for cleaning can be washed and stored as future replacement elements.

In addition, the air cleaner system (housing and piping) should be inspected every month for any leakage paths or inlet obstructions. Make sure the air cleaner mounting bolts and clamps are tight. Check the air cleaner housing for dents or damage which could lead to a leak. Inspect the air transfer tubing from the air cleaner to the compressor and the engine for holes. Make sure that all clamps and flange joints are tight.

GAUGES

The instruments or gauges are essential for safety, maximum productivity and long service life of the machine. Inspect the gauges and test any diagnostic lamps prior to start-up. During operation observe the gauges and any lamps for proper functioning. Refer to Operating Controls, for the normal readings.

FUEL TANK

This unit is supplied with diesel fuel from an external, customer supplied fuel tank. Using clean fuel in the fuel tanks is vitally important and every precaution should be taken to ensure that only clean fuel is either poured or pumped into the tank. When filling the fuel tank on this unit, by methods other than a pump and hose, use a CLEAN non-metallic funnel.

Every six months the drain plugs should be removed from the tanks so that any sediment or accumulated condensate may be drained. When replacing the drain plugs, make sure they are tightened securely.

BATTERY

Electrical power to this unit is supplied from externally mounted batteries.

Keep the battery posts-to-cable connections clean, tight and lightly coated with a grease. Also the electrolyte level in each cell should cover the top of the plates. If necessary, top-up with clean distilled water.

AUTOMATIC SHUTDOWN SYSTEM

The high discharge air temperature switches will require approximately 248°F (120°C) to actuate. The engine coolant temperature switch will require approximately 220° F (104° C) to actuate. Replace any defective switch before continuing to operate the unit.

A low oil pressure switch may be tested by removing it and connecting it to a source of controlled pressure while monitoring an ohmmeter connected to the switch terminals. As pressure is applied slowly from the controlled source, the switch should close at 12 psi (.84 kgf per cm²) and show continuity through the contacts. As the pressure is slowly decreased to 8 psi (0.56 kgf per cm²) the contacts should open and the ohmmeter should show lack of continuity (infinite ohms) through the contacts. Replace a defective switch before continuing to operate the unit.

COMPRESSOR OIL COOLER

The compressor lubricating and cooling oil is cooled by means of the fin and tube-type oil cooler, located beside the radiator. The lubricating and cooling oil, flowing internally through the core section, is cooled by the air stream from the cooling fan flowing past the core section. When grease, oil and dirt accumulate on the exterior surfaces of the oil cooler, its efficiency is impaired.

Each month it is recommended that the oil cooler be cleaned by directing compressed air which contains a nonflammable safety solvent through the core of the oil cooler. This should remove the accumulation of grease, oil and dirt from the exterior surfaces of the oil cooler core so that the entire cooling area can transmit the heat of the lubricating and cooling oil to the air stream.

In the event foreign deposits, such as sludge and lacquer, accumulate in the oil cooler to the extent that its cooling efficiency is impaired, a resulting high discharge air temperature is likely to occur, causing shut down of the unit.

To correct this situation it will be necessary to clean it using a cleaning compound in accordance with the manufacturer's recommendations. Use only a dependable cleaning compound. This is of prime importance because different cleaners vary in concentration and chemical composition. After completing the cleaning procedure, the oil cooler must be flushed before returning to service.

RADIATOR**WARNING**

Do not remove the cap from a HOT engine radiator. The sudden release of pressure from a heated cooling system can result in a loss of coolant and possible severe personal injury.

The engine cooling system is filled at the factory with a 50/50 mixture of water and ethylene glycol. This permanent type antifreeze contains rust inhibitors and provides protection to -35° F (-37°C).

The use of such a mixture is recommended for both summer and winter operation. When using water alone, be sure to add a reputable brand of rust inhibitor to prevent internal corrosion.

It is recommended to test the freezing protection of the coolant every six months or prior to freezing temperatures. Replenish with a fresh mixture every twelve months. A drain for the system is located in the bottom radiator tank. An alternate method would be to disconnect a bottom radiator hose.

Each month, inspect the radiator exterior for obstructions (dirt, bugs, etc.). If present, blow water or compressed air containing a nonflammable solvent between the fins in a direction opposite the normal air flow. Should the radiator be clogged internally, standard automotive practices should be followed.

HOSES

Each month it is recommended that all of the intake lines to and from the air cleaners, the engine cooling system hoses and all of the flexible hoses used for air, oil, and fuel be inspected.

To ensure freedom from air leaks, all rubber hose joints and the screw-type hose clamps must be absolutely tight. Regular inspection of these connections for wear or deterioration is a definite "must" if regulator servicing of the air cleaners is not to prove futile.

Premature wear of both the engine and compressor is ASSURED whenever dust-laden air is permitted to enter the engine's combustion chamber or the compressor intake practically unfiltered.

The flexible hoses used in the fuel, oil and air lines on these units are primarily used for their ability to accommodate relative movement between components. It is extremely important they be periodically inspected for wear and deterioration. Clamps are used to prevent hose cover abrasion through vibration. This abrasion may occur when two hose lines cross, or when a hose line rubs against a fixed point; therefore, it is necessary that all clamps be replaced if missing. It is also important the operator does not use the hoses as convenient hand hold or steps. Such use can cause early cover wear and hose failure.

NOTICE

Piping systems operating at less than 150 psi (1050 kPa) may use a special nylon tubing. The associated fittings are also of a special “push-in” design. If so, features are as follows:

Pulling on the tubing will cause the inner sleeve to withdraw and compress, thus tightening the connection. The tubing can be withdrawn only while holding the sleeve against the fitting. The tubing can be removed and replaced numerous times without losing its sealing ability.

To install the nylon tubing, make a mark (with tape or grease pencil) approximately 7/8 inch from the end of the tubing. Insert the tubing into the sleeve and “push-in” past the first resistance to the bottom. The mark should be approximately 1/16 inch from the sleeve, for the 3/8 inch O.D. tubing; 1/8 inch for the 0.25 inch O.D. tubing. This will ensure that the tubing is fully engaged in the sealing mechanism.

COMPRESSOR OIL FILTERS

The compressor lubrication and cooling oil system includes dual spin-on, throw away type oil filters, each with an internal bypass valve. With a clean, new filter element, all of the oil flows through the full element area, from the outside/inside. As each element becomes contaminated with dirt, a pressure differential is created in the filter housing between the oil inlet and outlet ports. As this differential approaches 25 psi (175 kPa), the bypass valve starts to open, thus permitting a small quantity of oil to bypass the filter. As the contaminants continue to build up, more and more of the oil bypasses the filter media itself.

This bypass does not provide any filtration but does allow a maximum flow of compressor lubricating and cooling oil to preclude any possible damage from loss of oil. Also the design of the filter prevents any washing-off of any dirt during oil bypassing.

NOTICE

The oil filter must be replaced every 500 hours of operation. On new or overhauled units, replace the element after the first 50 and 150 hours of operation; thereafter, service the oil filter every 500 hours.

To service the oil filters it will first be necessary to shut the unit down. Wipe off any external dirt and oil from the exterior of the filter to minimize any contamination from entering the lubrication system. Proceed as follows:

WARNING

High pressure air can cause severe injury or death from hot oil and flying parts. Always relieve pressure before removing caps, plugs, covers or other parts from pressurized air system.

1. Open the service air valve(s) to ensure that system is relieved of all pressure. Close the valve(s).
 2. Turn the spin-on filter element counterclockwise to remove it from the filter housing. Inspect the filter element and then discard.
- Note:** If there is any indication of formation of varnishes, shellacs or lacquers on the oil filter element, it is a warning the compressor lubricating oil has improper characteristics and should be immediately changed.
3. Inspect the oil filter head to be sure the gasket was removed with the oil filter element. Clean the gasket seal area on the oil filter head.

Installing a new oil filter element when the old gasket remains on the oil filter head will cause an oil leak and can cause property damage.

4. Lubricate the new filter gasket with the same oil being used in the machine.
5. Install new filter by turning element clockwise until gasket makes initial contact. Tighten an additional 1/2 to 3/4 turn.
6. Start unit and allow to build up to rated pressure. Check for leaks before placing unit back into service.

FASTENERS

Visually check entire unit in regard to bolts, nuts and screws being properly secured. Spot check several capscrews and nuts for proper torque. If any are found loose, a more thorough inspection must be made. Take corrective action.

COMPRESSOR OIL

Refer to Maintenance Schedule.

RECEIVER-SEPARATOR SYSTEMS**WARNING**

High pressure air can cause severe injury or death from hot oil and flying parts. Always relieve pressure before removing caps, plugs, covers or other parts from pressurized air system.

* Open service valve at end of machine.

* Ensure pressure is relieved, with **BOTH**:
 - Discharge air pressure gauge reads zero (0).
 - No air discharging from service valve.

* When draining oil, remove and replace (make tight) plug at bottom of separator tank.

* When adding oil, remove and replace (make tight) plug on side of separator tank.

In the compressor lubricating and cooling system, separation of the oil from the compressed air takes place in the receiver-separator tank. As the compressed air enters the tank, the change in velocity and direction drop out most of the oil from the air.

Additional separation takes place in the oil separator element which is located in the top of the tank.

Any oil accumulation in this separator element is continuously drained off by means of a scavenge tube which returns the accumulated oil to the system.

SCAVENGE LINE**WARNING**

High pressure air can cause severe injury or death from hot oil and flying parts. Always relieve pressure before removing caps, plugs, covers or other parts from pressurized air system.

The scavenge line originates at the receiver-separator tank cover and terminates at the compressor airend through an orifice (.063 inch/1.6 mm). Once a year or every 2000 hours of operation, whichever comes first, remove this line and any orifice, thoroughly clean, then reassemble.

NOTICE

Excessive oil carry-over may be caused by an oil-logged separator element. Do not replace element without first performing the following maintenance procedure:

1. Check oil level. Maintain as indicated earlier in this section.
2. Thoroughly clean scavenge line, any orifice and check valve.
3. Assure minimum pressure valve (if so equipped) has proper setting.
4. Run unit at rated operating pressure for 30 to 40 minutes to permit element to clear itself.

COOLING FAN DRIVE

The heat exchanger or cooling fan is driven by a multiple V-belt arrangement from the engine. Inspect the cooling fan belts weekly or at 50 hour intervals. These V-belts should be maintained at the proper tension. Fan belts that are too tight impose an undue load on the fan shaft bearings and shorten the life of the belts. Fan belts that are too loose allow slippage and lower the fan speed, cause excessive belt wear, and can lead to overheating of the cooling systems.

OIL SEPARATOR ELEMENT

The life of the oil separator element is dependent upon the operating environment (soot, dust, etc.) and should be replaced every twelve months or 2000 hours. To replace the element proceed as follows:

- * Ensure the tank pressure is zero.
- * Disconnect the hose from the scavenge tube.
- * Remove scavenge tube from tank cover.
- * Disconnect service line from cover.
- * Remove (16) cover mounting screws.
- * Remove cover, element and inner shell.
- * Remove any gasket material left on cover or tank.
- * Install new gasket, inner shell and new element.
- * Place a straightedge across top of element and measure from bottom of straightedge to bottom of element (See Fig. 1).

*Replace scavenge tube in cover (cover is still off of tank).

*Measure from bottom of cover to end of scavenge tube (See Fig. 2). Measurement should be from 1/8" to 1/4" less than the element measurement. If not, cut to size.

*Remove scavenge tube.

*Reposition cover (use care not to damage gaskets). *Replace cover mounting screws: tighten in a crisscross pattern to 100 lbs.-ft.

*Reconnect service line. Replace scavenge tube. Reconnect hose.

*Close service valve. Start unit and look for leaks.

When replacing the element, the scavenge lines, orifice, filter, and check valve should be thoroughly cleaned and the oil changed.

Note: Do not remove staples from the element/gasket connection.

Figure No. 1 Element Measurement

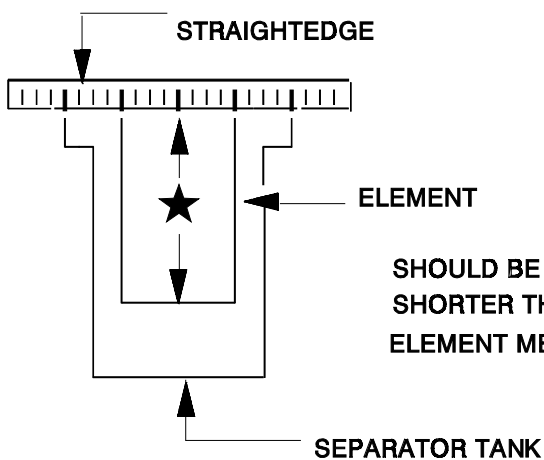
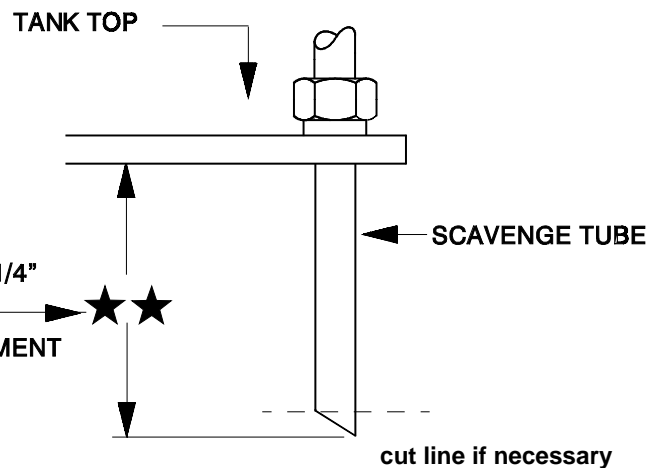

Figure No. 2 Tube Measurement



EXTERIOR FINISH CARE

This unit was painted and heat cured at the factory with a high quality, thermoset polyester powder coating. The following care will ensure the longest possible life from this finish.

1. If necessary to remove dust, pollen, etc. from housing, wash with water and soap or dish washing liquid detergent. Do not scrub with a rough cloth, pad, etc.
2. If grease removal is needed, a fast evaporating alcohol or chlorinated solvent can be used. Note: This may cause some dulling of the paint finish.
3. If the paint has faded or chalked, the use of a commercial grade, non-abrasive car wax may partially restore the color and gloss.

Field Repair of Texture Paint

1. The sheet metal should be washed and clean of foreign material and then thoroughly dried.
2. Clean and remove all grease and wax from the area to be painted using Duponts 3900S Cleaner prior to sanding.
3. Use 320 grit sanding paper to repair any scratches or defects necessary.
4. Scuff sand the entire area to be painted with a red scotch brite pad.
5. Wipe the area clean using Duponts 3900S.
6. Blow and tack the area to be painted.

7. Apply a smooth coat of Duponts 1854S Tuffcoat Primer to all bare metal areas and allow to dry.
8. Apply 2 medium - wet coats of Duponts 222S Adhesion Promoter over the entire area to be painted, with a 5 minute flash in between coats.
9. To apply the texture coat, use Duponts 1854S Tuffcoat Primer. The proper technique to do this is to spray the Tuffcoat Primer using a pressure pot and use about 2-5 pounds of air pressure. This will allow the primer to splatter causing the textured look. Note: you must be careful not to put too much primer on at one time, this will effect the amount of texture that you are trying to achieve. Allow the texture coat to flash for 20 minutes or until dry to touch.
10. Apply any of Duponts Topcoat Finishes such as Imron™ or Centari™ according to the label instructions.

Note: To re-topcoat the textured surfaces when sheet metal repairs are not necessary, follow steps 1, 2, 4, 5, 6, 8 and 10.

CAUTION

- Any unauthorized modification or failure to maintain this equipment may make it unsafe and out of factory warranty.
- If performing more than visual inspections, disconnect battery cables and open manual blowdown valve.
- Use extreme care to avoid contacting hot surfaces (engine exhaust manifold and piping, air receiver and air discharge piping, etc.).
- Never operate this machine with any guards removed.

- Inch and metric hardware was used in the design and assembly of this unit. Consult the parts manual for clarification of usage.

Notice: Disregard any maintenance pertaining to components not provided on your machine.

AIR COMPRESSOR - LUBRICATION

GENERAL INFORMATION

Lubrication is an essential part of preventive maintenance, affecting to a great extent the useful life of the unit. Different lubricants are needed and some components in the unit require more frequent lubrication than others. Therefore, it is important that the instructions regarding types of lubricants and the frequency of their application be explicitly followed. Periodic lubrication of the moving parts reduces to a minimum the possibility of mechanical failures.

The Preventive Maintenance Schedule shows those items requiring regular service and the interval in which they should be performed. A regular service program should be developed to include all items and fluids. These intervals are based on average operating conditions. In the event of extremely severe (hot, cold, dusty or wet) operating conditions, more frequent lubrication than specified may be necessary. Details concerning lubrication of the running gear are in Maintenance Section.

All filters and filter elements for air and compressor lubricant must be obtained through Ingersoll-Rand to assure the proper size and filtration for the compressor.

COMPRESSOR OIL CHANGE

These units are normally furnished with an initial supply of oil sufficient to allow operation of the unit for approximately 6 months or 1000 hours, whichever comes first. If a unit has been completely drained of all oil, it must be refilled with new oil before it is placed in operation. Refer to specifications in Lubrication Table.

NOTICE

Some oil types are incompatible when mixed and result in the formation of varnishes, shellacs, or lacquers which may be insoluble. Such deposits can cause serious troubles including clogging of the filters. Where possible, do NOT mix oils of different types and avoid mixing different brands. A type or brand change is best made at the time of a complete oil drain and refill.

If the unit has been operated for the time/hours mentioned above, it should be completely drained of oil. If the unit has been operated under adverse conditions, or after long periods in storage, an earlier change period may be necessary as oil deteriorates with time as well as by operating conditions.

WARNING

High pressure air can cause severe injury or death from hot oil and flying parts. Always relieve pressure before removing caps, plugs, covers or other parts from pressurized air system. Ensure the following conditions are met:

- Discharge air pressure gauge reads zero (0).
- No air discharging from an "open" manual blowdown valve.

An oil change is good insurance against the accumulation of dirt, sludge, or oxidized oil products.

Completely drain the receiver- separator, piping, and oil cooler. If the oil is drained immediately after the unit has been run for some time, most of the sediment will be in suspension and, therefore, will drain more readily. However, the fluid will be hot and care must be taken to avoid contact with the skin or eyes.

After the unit has been completely drained of all old oil, close the drain valve. Add oil in the specified quantity at the filler plug. Tighten the filler plug and run the machine to circulate the oil. Check the oil level WHEN RUNNING AT FULL LOAD. If not near the middle of the sight tube, stop the unit and make corrections. DO NOT OVERFILL.

NOTICE

Ingersoll-Rand provides compressor oil specifically formulated for Portable Compressors and requires the use of these fluids in order to obtain extended limited airtend warranty. Refer to Fuels and Lubricants Chapter.

BLANK

CHAPTER 19

MAINTENANCE—ROCK DRILL ATTACHMENT

BLANK

Maintenance intervals

MAINTENANCE - ROCK DRILL ATTACHMENT

These maintenance intervals only cover all routine operation and scheduled maintenance tasks by operation and maintenance staff. Major

overhauls are outside the scope of this section and should be referred to an authorized INGERSOLL-RAND service department.

MAINTENANCE SYMBOLS



Visual
inspection



Lubrication



Washing
under pressure



Reducer
oil change



Check
tightening

First oil change

Change the drill guide reducer oil after 50 operating hours.

Change the rod changer reducer oil after 150 operating hours.

Maintenance intervals

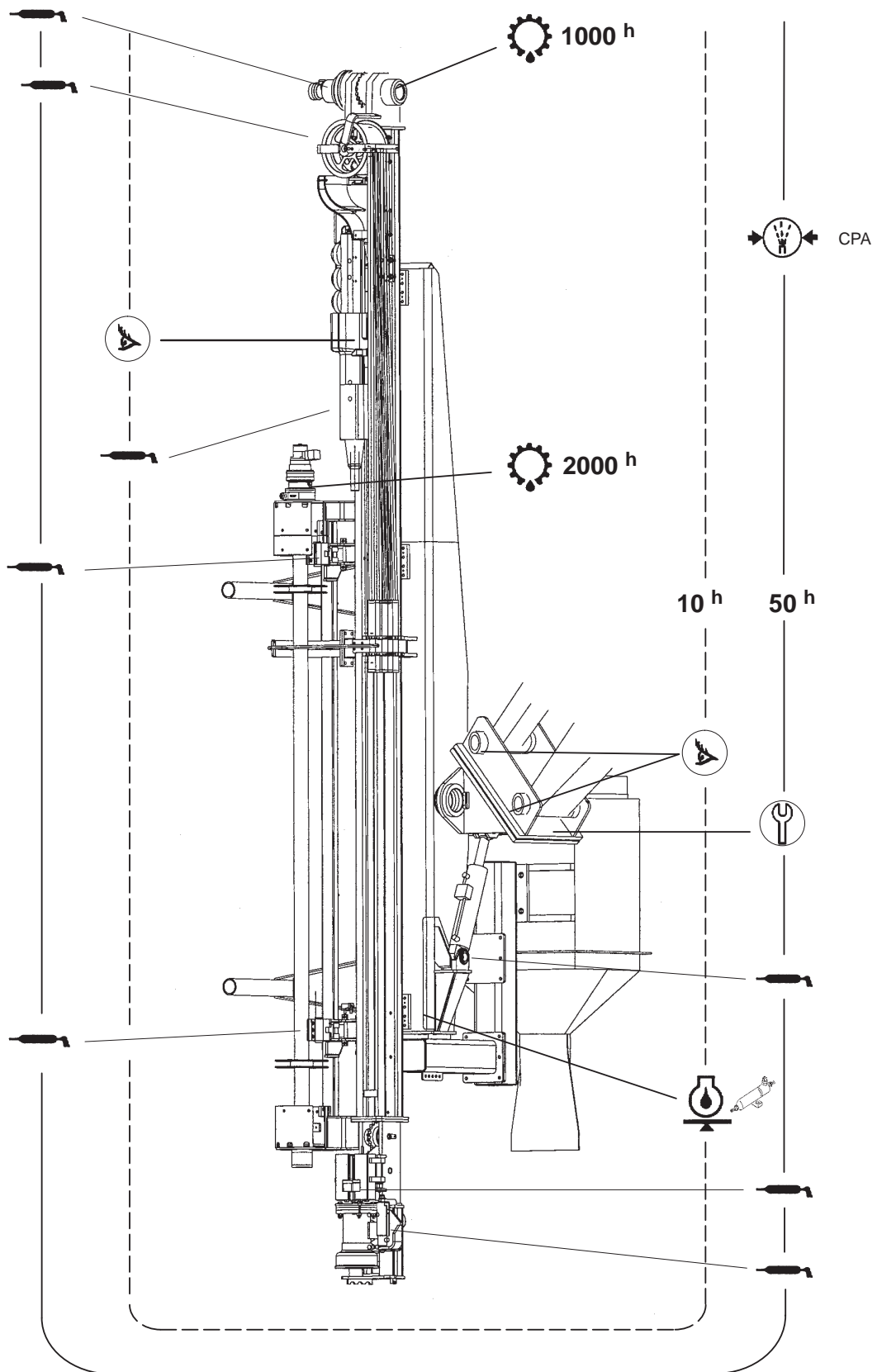

Maintenance intervals

WHEN REQUIRED

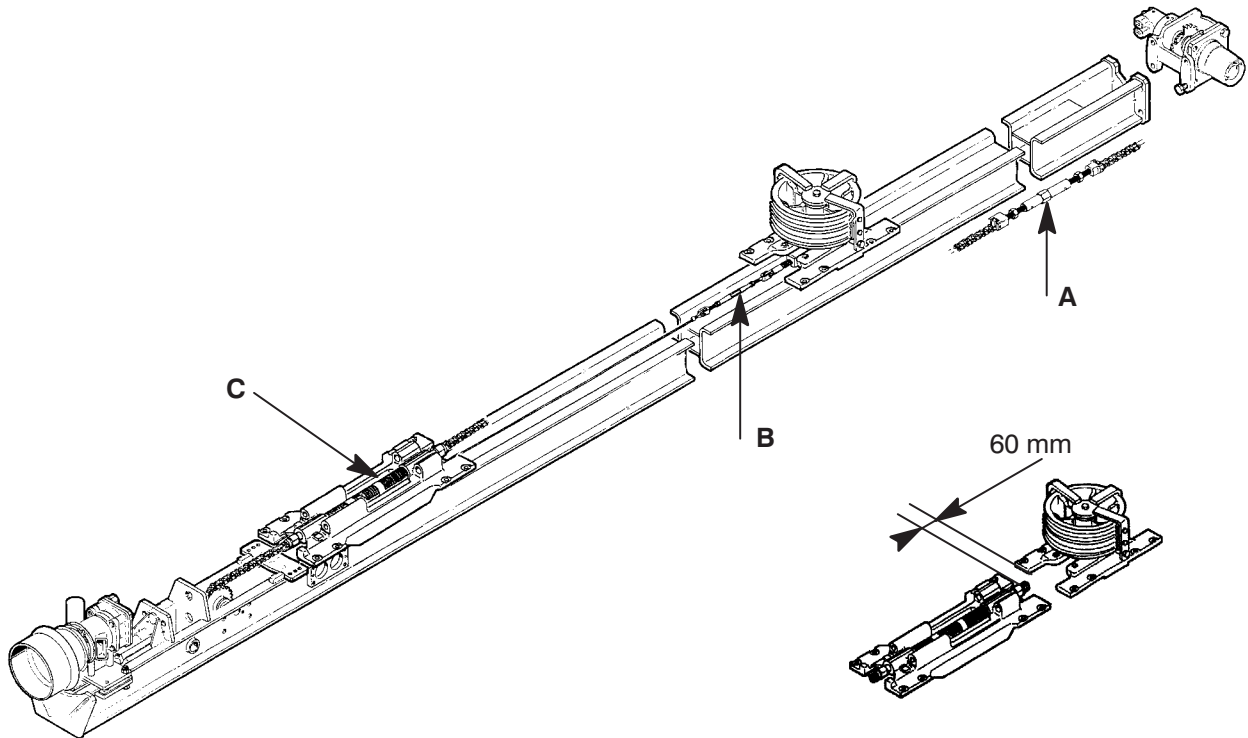

Drifter chain tension

The adjustment is carried out on the chain tightener A (see Figure). Generally speaking, the chains should not be too tight (the front chain vibrates abnormally during drilling) or too loose (the front chain lashes out against the feed box or the tightener strikes against the feed extension cylinder attachment).

Change the chains when the tightener no longer reaches their extension.

Hose reel chain tension

In the same way, the adjustment is carried out on the chain tightener B (see Figure). The cable should not sag.

Hose tension

All the hoses should be tightened with the exception of the drifter hoses (P1 and P2) which should sag slightly when they are not under pressure (the pressure tightens these hoses when in operation).

Chain replacement

The guide should be put in toe hole drilling position, horizontal, to prevent cradles from sliding when the chains or the reel rope are dismantled.

After chain (rope) replacement, move the drifter back to its rear end position. Verify the distance between the drifter cradle and the hose reel cradle is $60 \pm 15 \text{ mm}$ ($2.4 \pm .6 \text{ in}$) (see Figure).

Adjustment of drilling automatism

ADJUSTMENT OF DRILLING AUTOMATISMS

LOCATION OF ADJUSTING SCREWS

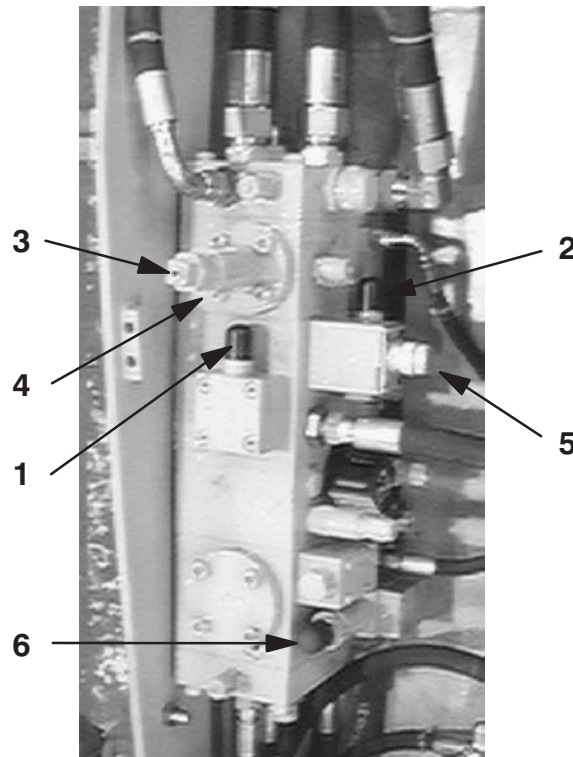

1) V1 Feed pressure

This valve setting is made while setting up the machine on site, to suit bit type and diameter.

Presetting can be made in a static mode prior to drilling by feeding the bit against some resistance.

Final setting is made at full percussion power while drilling in the hardest, most homogeneous competent rock encountered.

2) MP Maximum percussion pressure

It sets the drifter maximum percussion pressure when drilling with cold oil while starting up.

This factory setting **must not be altered**.

3) V2 Operating percussion pressure

It sets the drifter percussion power to a suitable level for bit size and rock hardness. The setting should be approximately :

- 120 – 130 bar (1715 – 1850 psi) for Hc 80
 - 130 – 140 bar (1850 – 2000 psi) for Hc 120
 - 140 – 160 bar (2000 – 2285 psi) for Hc 150
- depending upon the appropriate drifter power level.

4) V3 Drifter power regulation

V3 measures actual feed force by sensing both forward and return feed pressures.

The V3 adjustment sets the feed pressure limit below which the drifter power will be reduced.

This control will continue to reduce the drifter power level to a 60 bar (870 psi) preset minimum as rock resistance decreases.

5) Feed flow regulator

This flow regulator adjusts the feed maximum flow to slightly above the drill rate in the hardest rock encountered.

If the feed flow while drilling in softer rock conditions reaches the preset maximum, the resulting back pressure makes the feed force to decrease and act on V3.

This acts as both an Anti-Void and Collaring Control.

6) V4 Progressive feed control and anti-jam

V4 is an adjustable regulator which senses the pressure differential across the rotation motor and acts directly upon feed flows.

Adjustment of drilling automatisms

As drilling torque exceeds the presetting, V4 spool begins to shift to reduce the feed flows. These restricted feed flows result in lower feed force and feed motion slows down. As a second step and separate from the V4 adjustment described, V3 lowers drifter percussion pressure in response to the feed force reduction.

Far above the V4 setting, feed motion will first stop and then reverse before the bit gets stuck.

V4 setting is made just above normal drilling conditions to avoid reaction in homogeneous rock.

7) Flushing control valve

A flushing control valve will fully shift the V4 spool causing reverse feed motion when the bit is plugged. Drifter cycle operation clears the bit while the bit is retracting.

This feature is fully operative with reverse percussion drifters.

E.53734 PRESSURE GAUGES

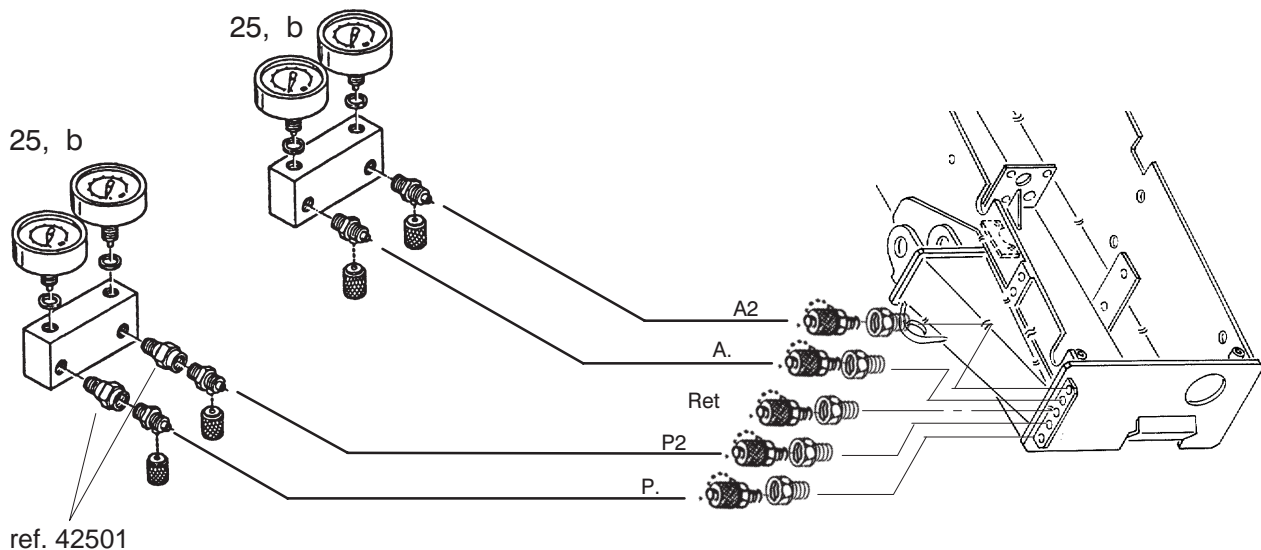

Connect the pressure gauges with hydraulic dampers (ref. 42501) to the pulsating P1 and P2 circuits. Connect the two other pressure gauges to the A1 and A2 feed circuits.

Adjustment of drilling automatisms

PRESETTING BEFORE DRILLING

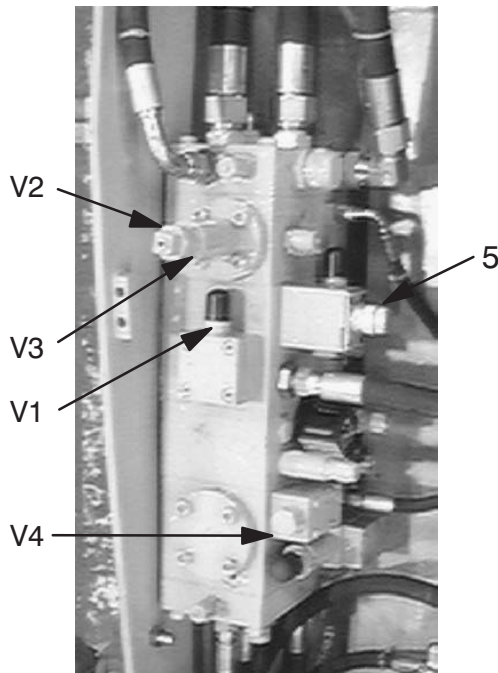

Machine off:

12) Unlock safety nut and loosen V3 screw until the internal spring becomes free (V3 screw returns to free rotation).

13) Unlock safety nut and fully tighten V2 screw (hold V3 screw to prevent re-tightening).

14) Set the feed flow regulator 5 on position 10.

15) Remove V4 cap, and fully tighten V4 setting.

Machine running:

16) Press the bit against the rock by acting on feed lever.

17) Preset drilling feed pressure (V1 setting) to 80 – 100 bar (1140 – 1430 psi).

PRESETTING WHILE DRILLING

These settings must be carried out when oil has reached its normal operation temperature.

18) Start drilling (flushing, rotation, percussion, feed) **in homogeneous, non fractured rock** with drifter percussion control in “Auto” position.

19) Set the operating percussion pressure to – 140 – 155 bar (2000– 2215 psi) for Hc 150 (or less depending of the bit size, rod diameters, rock hardness...) by loosening V2 screw. Check the pressure on “P2” gauge.

20) By acting on V1 screw, reset feed pressure for correct coupling motion : about 1 millimeter vibration and coupling temperature less than 100° C.

Control simultaneously penetration rate and coupling temperature.

If coupling temperature is above limit although coupling vibration is correct, reduce operating percussion pressure by tightening V2 screw.

SETTING WHILE DRILLING

Adjust flow regulator on feed return A2

21) While drilling the starter rod (or the rod drilled at the highest drilling rate) progressively close the flow regulator 5 until the feed back–pressure reaches 5 bar (check the pressure on “A2” gauge).

22) Then, re–open the flow regulator 5 by 1 division.

For example : if position 6 creates 5 bar back pressure, re–open the flow regulator to position 7.

V3 drifter power regulator setting

This setting must be carried out when drilling conditions allow maximum percussion pressure and actual feed force (i.e. hard, non fractured rock, feed back pressure “A2” = 0 bar).

23) With a wrench, hold V2 screw in position.

24) Tighten V3, until percussion pressure drops (check the pressure on “P2” gauge).

25) Loosen so as to recover the initial pressure plus an additional 1/4 turn.

26) While drilling with drifter percussion control alternatively in “Auto” and “Manual” positions, verify that the percussion pressure remains the same.

27) Secure all locking nuts.

V4 – Progressive feed control setting.

28) While drilling the last rod (or the rod drilled with the highest rotation torque) **in homogeneous ground**, loosen V4 setting until the feed back pressure slightly increases (check the pressure on “A2” gauge).

29) Then re–tighten V4 setting for 1 turn.

Air flushing valve

While drilling with the drifter percussion control in “auto” position, switch off air flushing and check the drifter reverses.

Adjustment of drilling automatisms

EXCEPTIONAL ADJUSTMENTS

Reverse percussion pressure

Note : The full drifter reverse percussion pressure is only obtained when drilling in “manual” position.

The factory set pressure (130 bar – 1860 psi) can be modified by setting the stop screw A :

- Tighten to reduce the pressure.
- Loosen to increase.

Check the pressure on “P2” gauge.

Do not exceed 130 bar (1860 psi)

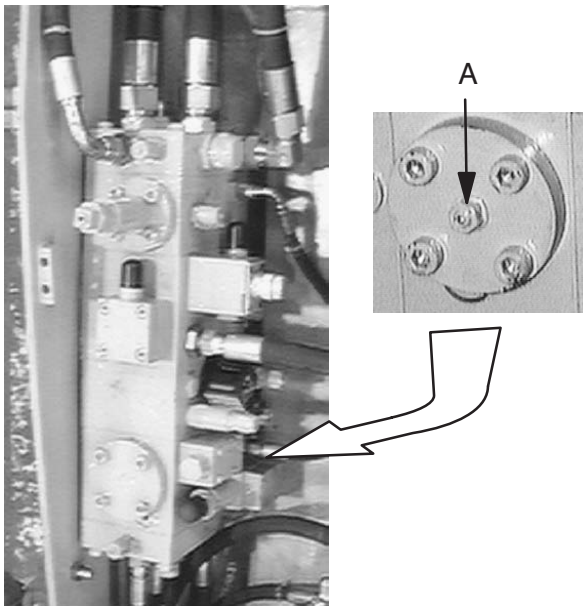

Maximum percussion pressure

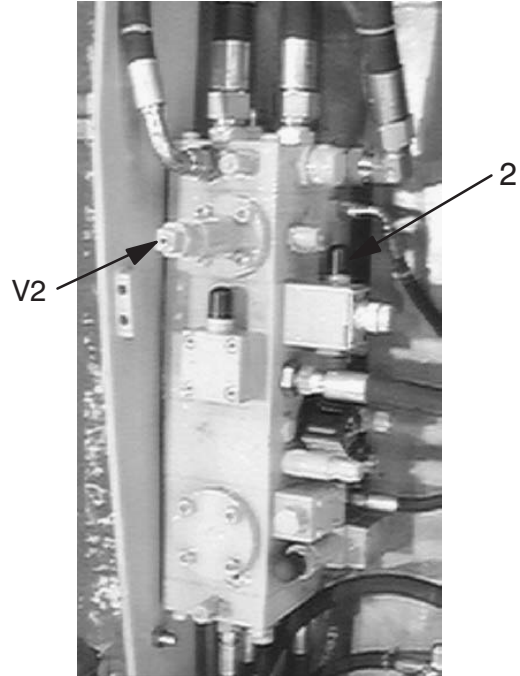

For checking or setting after part replacement,

- 1) Disconnect and plug the drifter percussion hose.
- 2) Remove the protection cap and loosen MP maximum percussion pressure relief valve (2).
- 30) Set the maximum percussion pressure to 190 bar (2720 psi) by tightening the relief valve (2). Check the pressure on “P2” gauge.
- 31) Secure the safety nut, remount the protection cap.

REPLACING ROCK DRILL DUST COLLECTOR FILTERS

1. Remove dust collector hopper (A) by releasing latches (B).
2. Release filter separating grid and use strap wrench to replace filters.

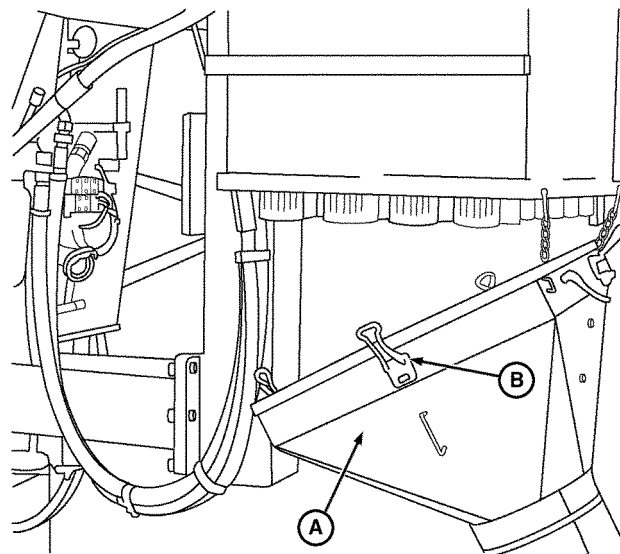

T125111

T125111 -UN-28OCT99

A—Dust Bin Hopper
B—Latches

CED,OUOE042,51 -19-19OCT99-1/1

DAILY MAINTENANCE HYDRAULIC DUST COLLECTOR

- 1 Start up the collector.
At low temperatures affecting hydraulic oil viscosity, let diesel motor warm up before starting the dust collector.
2. After start-up of the dust collector, first thing that happens, is that a free cleaning cycle automatically runs. When compressor produces correct working pressure - allow further one cleaning cycle without drilling.
3. Check that your dust collector sucks properly by looking at the rubber dump valve (or plastic bag) which shall **QUICKLY AND STRONGLY** be sucked up against dust collector bottom.
4. Check that GASKET in pick up hood A) and SKIRT B) are not worn out.
5. Check that suction hose is not damaged or bent.
6. Every day before stopping machine:
Clean filters as described under point 2 above

3

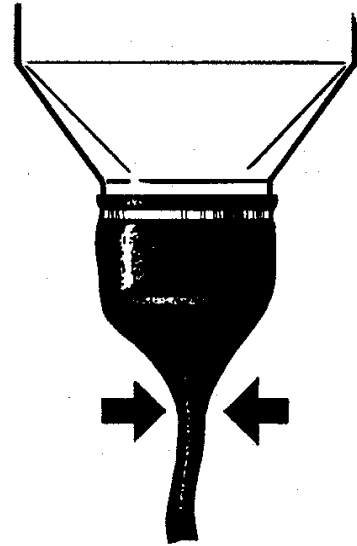

4

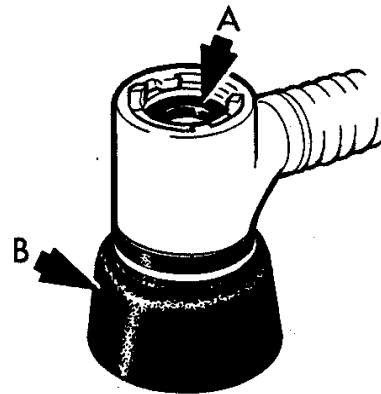

Maintenance intervals

DAILY

The CPA should be lowered in its rest position.

Attachment to carrier

Check the CPA attachment to the carrier boom end. Check all fixing pins are secured.

Pressurization air oiler

The oiler is located on the side of the CPA cradle, close to the oscillation cylinder. Remove the oil fill plug (Pos. 1) to add oil.

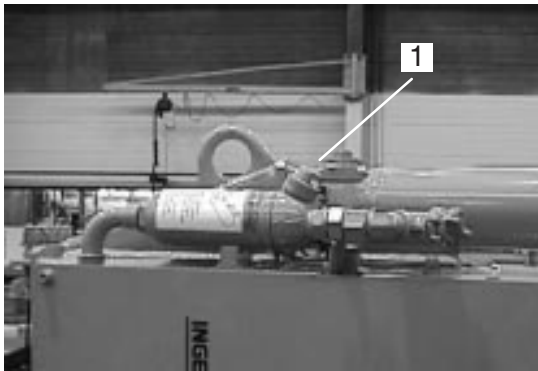

EVERY 50 HOURS

Wash the machine.

Check tightening of fixing cap bolts.

Wipe all fittings before lubricating.

Inspect all hoses. Replace if damaged.

Drifter Front head lubrication

Wipe the fitting before lubrication.

Guide chains and ropes inspection

– Examine the front chain in search of any signs of wear or corrosion. replace if required.

– Examine the whole length of the hose reel rope. In particular, check the attachment points on the tightener and the chain. The wire rope should not show signs of abnormal wear (flats on the outside strands, crushing, swelling or fraying).

In any case, replace the cable immediately if :

- **there are at least 2 broken wires at an interval of less than 36 mm (1.44 in) (6 times the nominal diameter of the cable)**

- **or, there are at least 4 broken wires at an interval of less than 180 mm (7.2 in) (30 times the nominal diameter of the cable)**

- **or, if the cable diameter is inferior to 5,4 mm (.21 in) (nominal diameter of the cable less 10%).**

Move the drifter at reduced speed until it reaches its front end position.

– Examine the chain reel in search of any signs of wear or corrosion. Replace if required.

Maintenance intervals

EVERY 1000 HOURS

Guide reducer oil change

Oil changes must be carried out after every 1000 hours or at least once a year.

The CPA should be lowered in its rest position.

Unscrew the top filling plug.

Using a seryng remove old oil.

Fill the reducer with oil (capacity 0.5 liter).

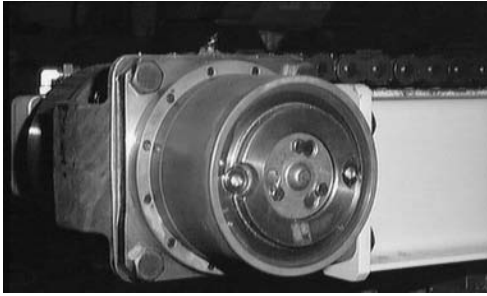

EVERY 2000 HOURS

Rod changer reducer oil change

Oil changes must be carried out after every 2000 hours.

The CPA should be lowered in its rest position.

Open plugs A and B. Allow oil to drain. Mount plug A. Fill the reducer with oil (capacity 0.3 liter). Mount plug B.

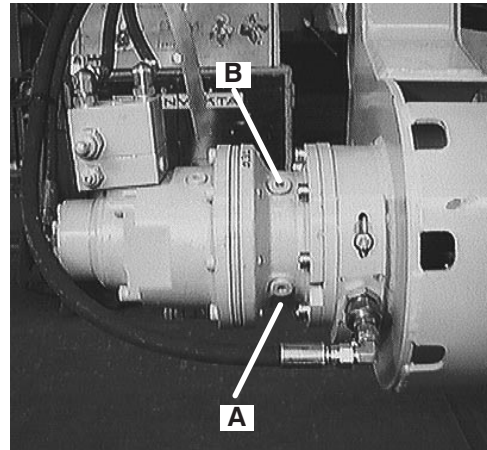

Drifter maintenance

DRIFTER MAINTENANCE

 , 8iMu

 2 eeDVI

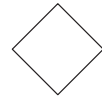
 . °ef u /(((u 9aM9
medæ

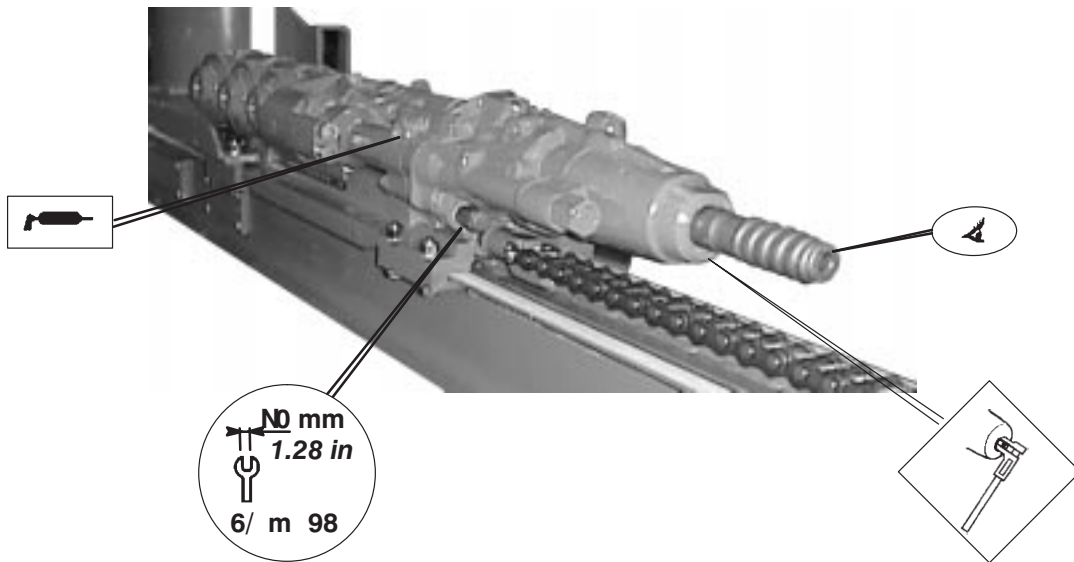

Daily

Lubricate the drifter front part (5 or 6 shots of a hand grease pump).

Weekly

Check tightening of drifter mounting bolts.

Every 1000 drilled meters

Dismount the shank adaptor to check the condition of the splines.

Replace shank if damaged.

Check the wear of the flushing nozzle bronze bush (or front guide for drifter with reverse percussion).

maximum wear = shank diameter+1 mm (.04 in).

Replace the complete flushing nozzle by a renovated one if damaged (or replace the bronze bush for drifter with reverse percussion).

CHAPTER 20
MAINTENANCE

BLANK

Maintenance

DO NOT SERVICE INJECTION NOZZLES

IMPORTANT: Do not service or remove injection nozzles. The service life of the injection nozzles may be shortened by:

- Overheating
- Improper operation
- Poor quality fuel
- Excessive idling

If injection nozzles are not working correctly or are dirty, the engine will not run normally. (See your authorized dealer for service.)

TX,90,FF3116 -19-18NOV92-1/1

DO NOT CHANGE INJECTION PUMP

IMPORTANT: Never steam clean or pour cold water on an injection pump while the pump is running, or while it is still warm. To do so may cause seizure of pump parts.

Clean trash regularly from under injection pump.

Changing the injection pump in any way not approved by the manufacturer will end the warranty. (See your copy of the John Deere warranty on this machine.)

Do not service an injection pump that is not operating correctly. (See your authorized injection pump service center.)

04T,90,C83 -19-16AUG93-1/1

BLEEDING THE FUEL SYSTEM

1. Open bleed screws (A) on fuel filter and on water separator.
2. Pump water separator primer (B) until fuel fills separator bowl and until fuel escapes from water separator bleed screw.
3. Tighten water separator bleed screw.
4. Pump water separator primer (B) until fuel escapes from final fuel filter bleed screw.
5. Tighten final fuel filter bleed screw.

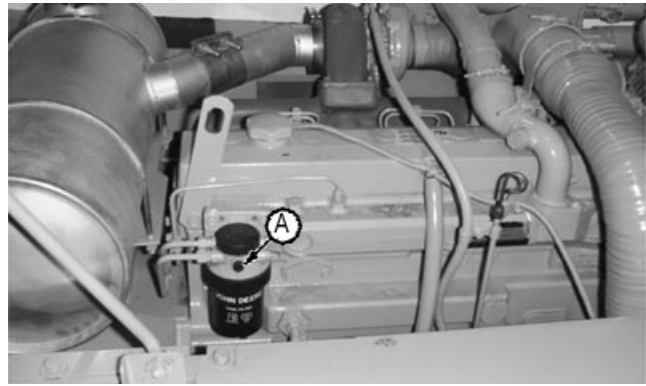

T108260E -UN-27MAR97

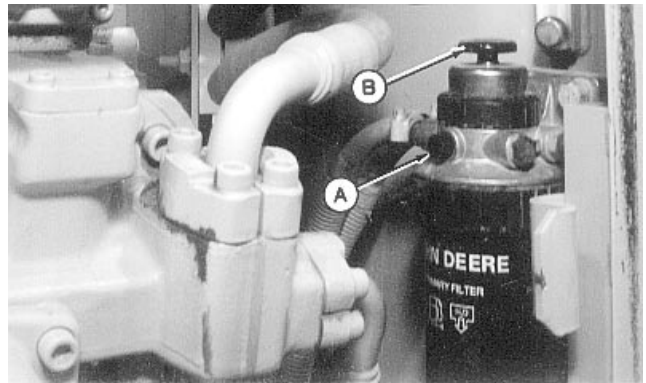

T102673 -UN-02AUG96

TX,90,DH5581 -19-26JUL96-1/1

PRECAUTIONS FOR ALTERNATOR AND REGULATOR

When batteries are connected, follow these rules:

1. Disconnect negative (-) battery cable when you work on or near alternator or regulator.
2. DO NOT TRY TO POLARIZE ALTERNATOR OR REGULATOR.
3. Be sure alternator wires are correctly connected BEFORE you connect batteries.
4. Do not ground alternator output terminal.
5. Do not disconnect or connect any alternator or regulator wires while batteries are connected or while alternator is operating.
6. Connect batteries or a booster battery in the correct polarity (positive [+] to positive [+] and negative [-] to negative [-]).
7. Do not disconnect the batteries when engine is running and alternator is charging.
8. Disconnect battery cables before you connect battery charger to the batteries.

T82,EXMA,I -19-03AUG92-1/1

SERVICE BATTERIES CAREFULLY

CAUTION: Battery gas can explode. Keep sparks and flames away from batteries. Use a flashlight to check battery electrolyte level.

Never check battery charge by placing a metal object across the posts. Use a voltmeter or hydrometer.

Always remove grounded (-) battery clamp first and replace it last.

Sulfuric acid in battery electrolyte is poisonous. It is strong enough to burn skin, eat holes in clothing, and cause blindness if splashed into eyes.

Avoid the hazard by:

1. Filling batteries in a well-ventilated area.
2. Wearing eye protection and rubber gloves.
3. Avoiding breathing fumes when electrolyte is added.
4. Avoiding spilling or dripping electrolyte.
5. Use proper jump start procedure.

If you spill acid on yourself:

1. Flush your skin with water.
2. Apply baking soda or lime to help neutralize the acid.
3. Flush your eyes with water for 15—30 minutes. Get medical attention immediately.

If acid is swallowed:

1. Do not induce vomiting.
2. Drink large amounts of water or milk, but do not exceed 1.9 L (2 quarts).
3. Get medical attention immediately.

If electrolyte spills on the floor, use one of the following mixtures to neutralize the acid: 0.5 kg (1 lb) baking soda in 4 L (1 gal) water, or 0.47 L (1 pt) household ammonia in 4 L (1 gal) water.



TS204 -JUN-23AUG88

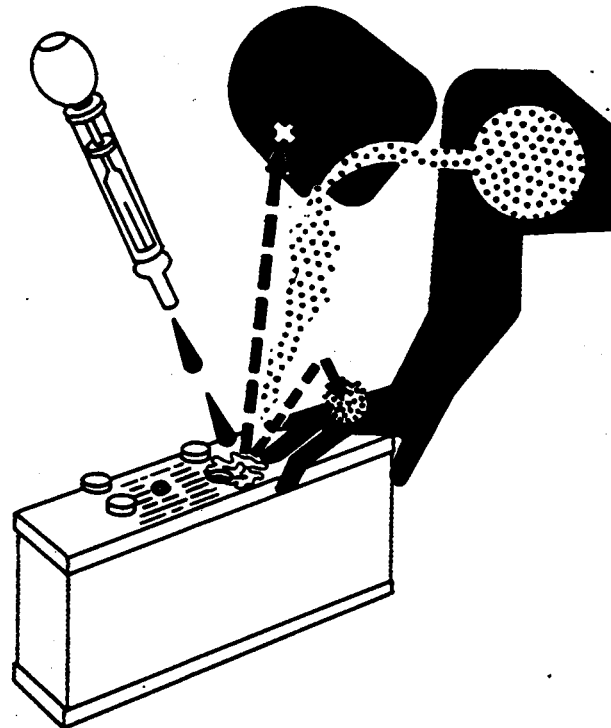

TS203 -JUN-23AUG88

IMPORTANT: Electrolyte can damage paint and metal surfaces of your machine. Do not overfill the battery cells.

CHECKING ELECTROLYTE SPECIFIC GRAVITY



CAUTION: Battery gas can explode. Keep sparks and flames away from batteries. Use a flashlight to check battery electrolyte level.

Never check battery charge by placing a metal object across the posts. Use a voltmeter or hydrometer.

Always remove grounded (-) battery clamp first and replace it last.

Sulfuric acid in battery electrolyte is poisonous. It is strong enough to burn skin, eat holes in clothing, and cause blindness if splashed into eyes.

Avoid the hazard by:

1. Filling batteries in a well-ventilated area.
2. Wearing eye protection and rubber gloves.
3. Avoiding breathing fumes when electrolyte is added.
4. Avoiding spilling or dripping electrolyte.
5. Use proper jump start procedure.

If you spill acid on yourself:

1. Flush your skin with water.
2. Apply baking soda or lime to help neutralize the acid.
3. Flush your eyes with water for 15—30 minutes. Get medical attention immediately.

If acid is swallowed:

1. Do not induce vomiting.
2. Drink large amounts of water or milk, but do not exceed 1.9 L (2 quarts).
3. Get medical attention immediately.

Check the specific gravity of electrolyte in each battery cell.



TS204 -JUN-23AUG88

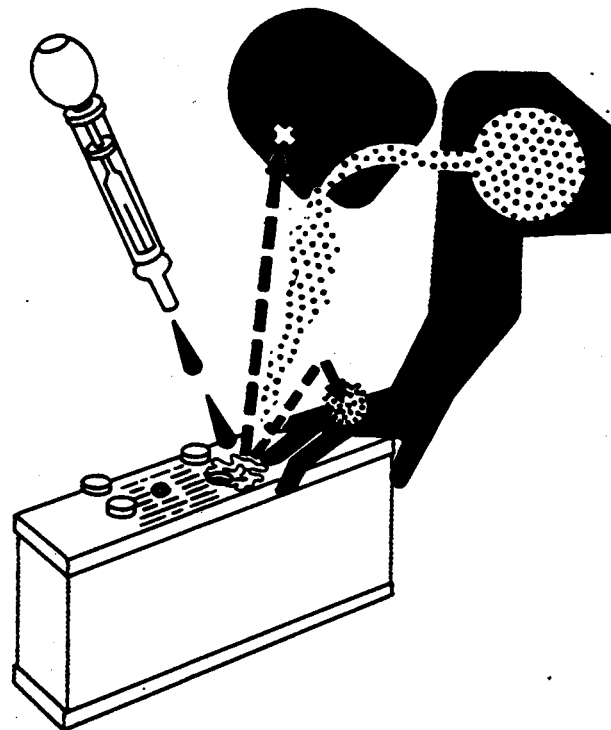

TS203 -JUN-23AUG88

Maintenance

See your John Deere dealer for JT05460 SERVICEGARD battery and coolant tester. Follow directions included with the tester.

A fully charged battery will have a corrected specific gravity reading of 1.260. If the reading is below 1.200, charge the battery.

NOTE: In tropical areas, use 1.225 for the full charge reading. In cold areas, use 1.280 for the full-charge reading.



T85402 -UN-10NOV88

04T,90,FF20 -19-12MAY93-2/2

USING BATTERY CHARGER

CAUTION: Disconnect battery ground before you charge batteries in the machine to prevent damage to electrical components.

A battery may explode if charged when it is frozen. Warm battery to 16°C (60°F) before charging.

A battery charger may be used as a booster to start engine.

IMPORTANT: Do not use battery charger as a booster if a battery has a 1.150 specific gravity reading or lower. Turn off charger before connecting or disconnecting it.



TS204 -UN-23AUG88

T82,EXMA,G -19-03AUG92-1/1

REPLACING BATTERIES

Your machine has two 12 volt batteries with negative (-) ground. Batteries must meet one of the specifications below.

Battery—Specification

Cold Cranking Amps 1400 at -18°C (0°F)
Minutes Reserve Capacity 440 at 25 amps

If one battery in a 24-volt system has failed but the other is still good, replace the failed battery with one of the same type. For example, replace a failed maintenance-free battery with a new maintenance-free battery. Different types of batteries may have different rates of charge. This difference could overload one of the batteries and cause it to fail.

CED,OUOE020,49 -19-13APR99-1/1

REMOVING BATTERIES

1. Remove two wing nuts from battery cover.
2. Disconnect negative (-) battery cables first, then positive (+) cables.
3. Remove hold down brackets.
4. Lift batteries out of compartment.

TX,90,DH5154 -19-10AUG96-1/1

WELDING ON MACHINE

IMPORTANT: Disconnect battery ground strap or turn battery disconnect switch to 'OFF' to prevent voltage spikes through alternator or monitor.

If machine is equipped with a controller (microprocessor) like Main Controller, disconnect harness connector from controller to prevent voltage spikes through microprocessor.

Connect welder ground clamp close to each weld area so electrical current does not arc inside any bearings.

ADDING 12—VOLT ACCESSORIES

IMPORTANT: This machine has a 24-volt electrical system. Installing 12-volt accessories without addition of 24-volt to 12-volt converter may cause battery failure.

When possible, use 24-volt accessories. If 12-volt accessories are added, use a 24-volt to 12-volt converter. Converters are available from your authorized dealer. (See the Industrial Equipment Attachment Guide.)

Converter capacity requirements depend on the load of the accessories installed. Follow electronic dealer and manufacturer's recommendations to determine the capacity of the converter required and its installation requirements.

IMPORTANT: DO NOT connect an accessory to one battery. Connecting a 12-volt accessory to one battery will cause one battery to overcharge, and the other battery to undercharge, causing battery failure.

TX,90,DH3734 -19-18AUG95-1/1

REPLACING FUSES

The fuse box is located behind the seat.

Remove cover (A).

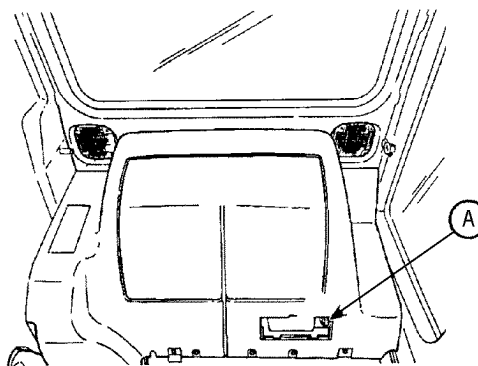

T105381 -UN-26NOV96

Continued on next page

TX,90,DH5331 -19-26NOV96-1/2

IMPORTANT: Install fuse with correct amperage rating to prevent electrical system damage from overload.

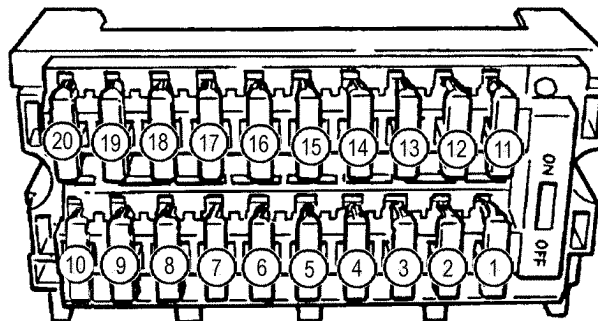

T101638 -UN-26JUN96

- 1—5 Amp—Back up
- 2—10 Amp—Controller
- 3—10 Amp—EC Motor
- 4—5 Amp—Solenoid
- 5—10 Amp—Pow. on
- 6—5 Amp—Sw box
- 7—5 Amp
- 8—10 Amp
- 9—5 Amp
- 10—5 Amp—Travel
- 11—20 Amp—Lamp
- 12—10 Amp—Wiper
- 13—20 Amp—Heater
- 14—5 Amp—Air con
- 15—10 Amp—Horn
- 16—5 Amp—Radio
- 17—10 Amp—Lighter
- 18—5 Amp—Room Lamp
- 19—10 Amp—Auxiliary
- 20—20 Amp—Lamp

TX,90,DH5331 -19-26NOV96-2/2

FUSE (BLADE-TYPE) COLOR CODES

Amperage Rating	Color
1	Black
3	Violet
4	Pink
5	Tan
7-1/2	Brown
10	Red
15	Light Blue
20	Yellow
25	Natural (White)
30	Light Green

04T,90,J22 -19-28SEP92-1/1

CHECKING TRAVEL ALARM SYSTEM

- Propel machine forward.
Travel alarm must sound.
- Stop machine.
Travel alarm must stop.
- Propel machine forward.
- Depress travel alarm cancel switch (A).
After an initial 12 second alarm, alarm must stop.
- Repeat test with machine traveling in reverse.
- If the travel alarm does not operate properly, do not operate machine. See your authorized dealer.

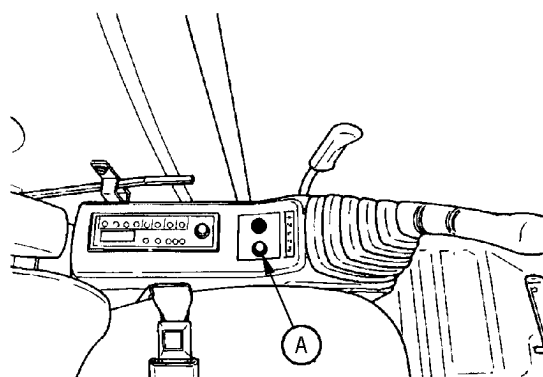

T102893 -UN-07AUG96

TX,90,DH5141 -19-08AUG96-1/1

REPLACING BUCKET TEETH

CAUTION: Guard against injury from flying pieces of metal; wear goggles or safety glasses.

IMPORTANT: Angle the drift toward the bucket to avoid damaging the rubber pin lock.

1. Use a hammer and drift to drive out locking pin.

NOTE: Alternate buckets may use different tooth assemblies.

2. Remove tooth.



T95784 -UN-10NOV88

04T,90,M16 -19-05APR91-1/3

3. Inspect rubber pin lock (A) for damage. Replace if necessary.

4. If rubber pin lock has moved, reposition in slot in adapter tooth shank.



T95785 -UN-10NOV88

04T,90,M16 -19-05APR91-2/3

5. Position the new tooth over the tooth shank.

6. Drive the locking pin into the hole fully.

NOTE: Check bucket teeth periodically so that wear does not extend to the bucket tooth shank.



T95786 -UN-10NOV88

04T,90,M16 -19-05APR91-3/3

REMOVING THE BUCKET

Remove bucket. (See Using Quick-Disconnect Hitch in this manual.)

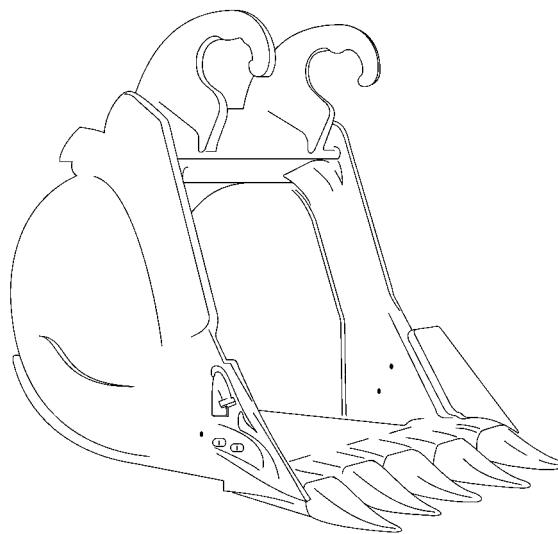

T120450

42 Inch Bucket

T120450 -UN-25MAR99

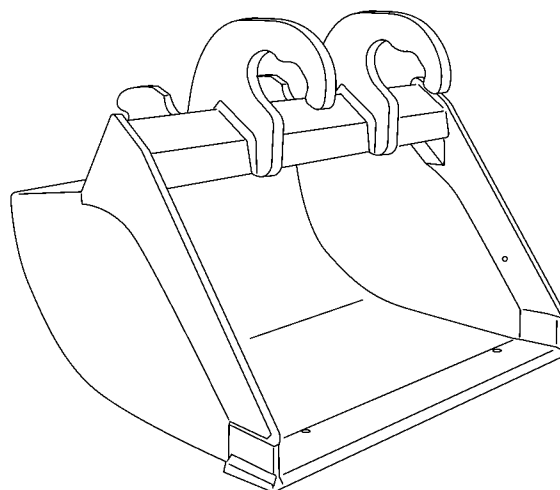

T120448

60 Inch Bucket

T120448 -UN-25MAR99

REPLACING BUCKET TOOTH TIP— HEAVY-DUTY BUCKET

1. Clean tooth (A) and tooth tip (B).
2. Insert lock removal tool under U-shaped pin (C).

CAUTION: Avoid possible injury. Pin may fly after it is released from tooth tip. Keep a firm grip on pin to prevent injury.

3. Remove pin.
4. Turn tooth tip counterclockwise and pull it towards you to remove.
5. Clean tooth shank.
6. Replace U-shaped pin at same time you replace tooth tip.
7. Insert tooth tip on shank turning pin clockwise.
8. Install U-shaped pin. Side of pin marked 'FRONT' (D) must face tooth tip. Make sure pin is firmly engaged over tooth tip.

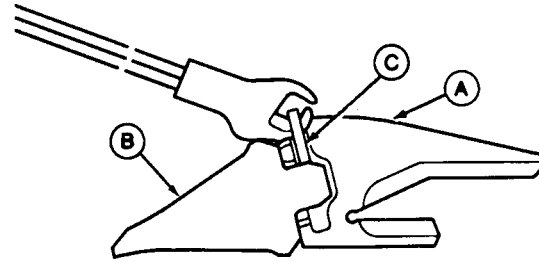

T6879EE

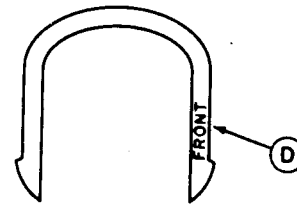

A—Tooth
B—Tooth Tip
C—Pin
D—'Front' Mark

T6879EE -JUN-06DEC88

T7527DO -JUN-27JUN91

04T,90,K273 -19-28JAN92-1/1

DO NOT SERVICE CONTROL VALVES, CYLINDERS, PUMPS OR MOTORS

Special tools and information are needed to service control valves, cylinders, pumps, or motors.

If these parts need service, see your authorized dealer.

TX,90,FF3114 -19-18NOV92-1/1

TRACK SAG GENERAL INFORMATION

To maximize undercarriage life, keep track sag within specification. Tracks may require adjustment several times during a working day due to changing soil type and moisture content.

Adjust tracks in the actual operating conditions.

TIGHT TRACK: Packing causes a tight track. If material packs in the undercarriage, adjust tracks with the material packed in the components.

While the track spring will recoil and the machine can continue to operate with a tight track, continued operation will result in excessive pin and bushing wear, sprocket popping, tooth tip wear, and excessive loads on the entire undercarriage and propel drive system.

Machine productivity and fuel consumption are also adversely affected because increased horsepower is needed to move the machine.

LOOSE TRACK: A loose track has more side to side motion, increasing side wear on the links, rollers and front idler. An excessively loose track will slap at high ground speeds, resulting in high impact loads on the sprocket teeth, bushings, and carrier rollers.

04T,90,M197 -19-07NOV90-1/1

HARDWARE TORQUE SPECIFICATIONS

Check cap screws and nuts to be sure they are tight. If hardware is loose, tighten to torque shown on the following charts unless a special torque is specified.

T82,SKMA,AT -19-01AUG94-1/1

CHECK TRACK SHOE TORQUE

Track shoe cap screw torque should be periodically checked. If the cap screws do not meet the minimum torque specifications, remove the shoes and clean the mating surfaces of the shoes and links before tightening the cap screws.

If unit is operated with loose track shoes, the cap screw holes in the shoes and links will wear and it may be difficult to keep the track shoes tight. Loose shoes can also cause hardware failure and loss of track shoes.

Install all track shoe nuts with rounded edges (A) against the link and chamfered edges (B) away from the link. Be sure nut is properly positioned in the link so there is full contact area between the nut and the link.

Cap Screw—Specification

Torque 298 N•m (220 lb-ft) Plus 1/2 turn (180°)



T82862 -UN-08NOV88

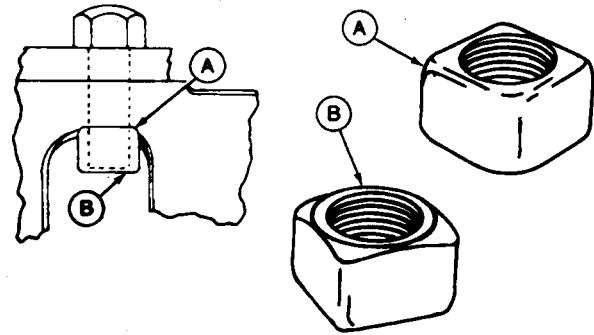











T6794AM -UN-23FEB89

A—Rounded Edge
B—Chamfered Edge

TX,90,FF,294 -19-09APR92-1/1

UNIFIED INCH BOLT AND CAP SCREW TORQUE VALUES

SAE Grade and Head Markings	NO MARK 	1 or 2 ^b	 5  5.1  5.2	 8  8.2
SAE Grade and Nut Markings	NO MARK 	2	 5 	 8 

Size	Grade 1				Grade 2 ^b				Grade 5, 5.1, or 5.2				Grade 8 or 8.2			
	Lubricated ^a		Dry ^a		Lubricated ^a		Dry ^a		Lubricated ^a		Dry ^a		Lubricated ^a		Dry ^a	
	N-m	lb-ft	N-m	lb-ft	N-m	lb-ft	N-m	lb-ft	N-m	lb-ft	N-m	lb-ft	N-m	lb-ft	N-m	lb-ft
1/4	3.7	2.8	4.7	3.5	6	4.5	7.5	5.5	9.5	7	12	9	13.5	10	17	12.5
5/16	7.7	5.5	10	7	12	9	15	11	20	15	25	18	28	21	35	26
3/8	14	10	17	13	22	16	27	20	35	26	44	33	50	36	63	46
7/16	22	16	28	20	35	26	44	32	55	41	70	52	80	58	100	75
1/2	33	25	42	31	53	39	67	50	85	63	110	80	120	90	150	115
9/16	48	36	60	45	75	56	95	70	125	90	155	115	175	130	225	160
5/8	67	50	85	62	105	78	135	100	170	125	215	160	240	175	300	225
3/4	120	87	150	110	190	140	240	175	300	225	375	280	425	310	550	400
7/8	190	140	240	175	190	140	240	175	490	360	625	450	700	500	875	650
1	290	210	360	270	290	210	360	270	725	540	925	675	1050	750	1300	975
1-1/8	400	300	510	375	400	300	510	375	900	675	1150	850	1450	1075	1850	1350
1-1/4	570	425	725	530	570	425	725	530	1300	950	1650	1200	2050	1500	2600	1950
1-3/8	750	550	950	700	750	550	950	700	1700	1250	2150	1550	2700	2000	3400	2550
1-1/2	1000	725	1250	925	990	725	1250	930	2250	1650	2850	2100	3600	2650	4550	3350

DO NOT use these values if a different torque value or tightening procedure is given for a specific application. Torque values listed are for general use only. Check tightness of fasteners periodically.

Fasteners should be replaced with the same or higher grade. If higher grade fasteners are used, these should only be tightened to the strength of the original.

Shear bolts are designed to fail under predetermined loads. Always replace shear bolts with identical grade.

Make sure fasteners threads are clean and that you properly start thread engagement. This will prevent them from failing when tightening.

Tighten plastic insert or crimped steel-type lock nuts to approximately 50 percent of the dry torque shown in the chart, applied to the nut, not to the bolt head. Tighten toothed or serrated-type lock nuts to the full torque value.

^a "Lubricated" means coated with a lubricant such as engine oil, or fasteners with phosphate and oil coatings. "Dry" means plain or zinc plated without any lubrication.

^b Grade 2 applies for hex cap screws (not hex bolts) up to 152 mm (6-in.) long. Grade 1 applies for hex cap screws over 152 mm (6-in.) long, and for all other types of bolts and screws of any length.

METRIC BOLT AND CAP SCREW TORQUE VALUES

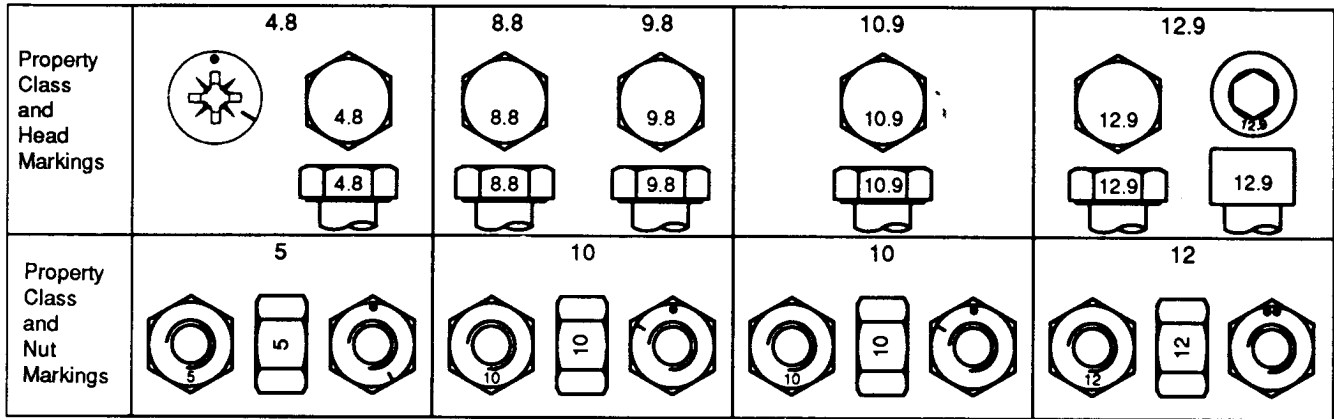

Size	Class 4.8				Class 8.8 or 9.8				Class 10.9				Class 12.9			
	Lubricated ^a		Dry ^a		Lubricated ^a		Dry ^a		Lubricated ^a		Dry ^a		Lubricated ^a		Dry ^a	
	N-m	lb-ft	N-m	lb-ft	N-m	lb-ft	N-m	lb-ft	N-m	lb-ft	N-m	lb-ft	N-m	lb-ft	N-m	lb-ft
M6	4.8	3.5	6	4.5	9	6.5	11	8.5	13	9.5	17	12	15	11.5	19	14.5
M8	12	8.5	15	11	22	16	28	20	32	24	40	30	37	28	47	35
M10	23	17	29	21	43	32	55	40	63	47	80	60	75	55	95	70
M12	40	29	50	37	75	55	95	70	110	80	140	105	130	95	165	120
M14	63	47	80	60	120	88	150	110	175	130	225	165	205	150	260	190
M16	100	73	125	92	190	140	240	175	275	200	350	255	320	240	400	300
M18	135	100	175	125	260	195	330	250	375	275	475	350	440	325	560	410
M20	190	140	240	180	375	275	475	350	530	400	675	500	625	460	800	580
M22	260	190	330	250	510	375	650	475	725	540	925	675	850	625	1075	800
M24	330	250	425	310	650	475	825	600	925	675	1150	850	1075	800	1350	1000
M27	490	360	625	450	950	700	1200	875	1350	1000	1700	1250	1600	1150	2000	1500
M30	675	490	850	625	1300	950	1650	1200	1850	1350	2300	1700	2150	1600	2700	2000
M33	900	675	1150	850	1750	1300	2200	1650	2500	1850	3150	2350	2900	2150	3700	2750
M36	1150	850	1450	1075	2250	1650	2850	2100	3200	2350	4050	3000	3750	2750	4750	3500

DO NOT use these values if a different torque value or tightening procedure is given for a specific application. Torque values listed are for general use only. Check tightness of fasteners periodically.

Shear bolts are designed to fail under predetermined loads. Always replace shear bolts with identical property class.

Fasteners should be replaced with the same or higher property class. If higher property class fasteners are used, these should only be tightened to the strength of the original.

^a "Lubricated" means coated with a lubricant such as engine oil, or fasteners with phosphate and oil coatings. "Dry" means plain or zinc plated without any lubrication.

Make sure fasteners threads are clean and that you properly start thread engagement. This will prevent them from failing when tightening.

Tighten plastic insert or crimped steel-type lock nuts to approximately 50 percent of the dry torque shown in the chart, applied to the nut, not to the bolt head. Tighten toothed or serrated-type lock nuts to the full torque value.

TS1657 -19-02APR97

ADDITIONAL METRIC CAP SCREW TORQUE VALUES

CAUTION: Use only metric tools on metric hardware. Other tools may not fit properly. They may slip and cause injury.

Check tightness of cap screws periodically. Torque values listed are for general use only. Do not use these values if a different torque value or tightening procedure is listed for a specific application.

Shear bolts are designed to fail under predetermined loads. Always replace shear bolts with identical grade.

Fasteners should be replaced with the same or higher grade. If higher grade fasteners are used, these should only be tightened to the strength of the original.

Make sure fastener threads are clean and you properly start thread engagement. This will prevent them from failing when tightening.

Tighten cap screws having lock nuts to approximately 50 percent of amount shown in chart.

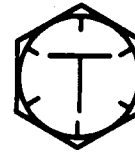

T6873AA



T6873AB



T6873AC

T6873AA -JUN-18OCT88

T6873AB -JUN-18OCT88

T6873AC -JUN-18OCT88

METRIC CAP SCREW TORQUE VALUES ^a						
Nominal Dia	T-Bolt		H-Bolt		M-Bolt	
	N•m	lb-ft	N•m	lb-ft	N•m	lb-ft
8	29	21	20	15	10	7
10	63	46	45	33	20	15
12	108	80	88	65	34	25
14	176	130	137	101	54	40
16	265	195	206	152	78	58
18	392	289	294	217	118	87
20	539	398	392	289	167	125
22	735	542	539	398	216	159
24	931	687	686	506	274	202
27	1372	1012	1029	759	392	289
30	1911	1410	1421	1049	539	398
33	2548	1890	1911	1410	735	542
36	3136	2314	2401	1772	931	687

^aTorque tolerance is ±10%.

CHECK OIL LINES AND FITTINGS



CAUTION: Escaping fluid under pressure can penetrate the skin causing serious injury. Avoid the hazard by relieving pressure before disconnecting hydraulic or other lines. Tighten all connections before applying pressure. Search for leaks with a piece of cardboard. Protect hands and body from high pressure fluids.

If an accident occurs, see a doctor immediately. Any fluid injected into the skin must be surgically removed within a few hours or gangrene may result. Doctors unfamiliar with this type of injury may call the Deere & Company Medical Department in Moline, Illinois, or other knowledgeable medical source.

Check all oil lines, hoses and fittings regularly for leaks or damage. Make sure all clamps are in position and tight. Make sure hoses are not twisted or touching machine parts which are moving.

Tubing with dents may cause the oil to overheat. If you find tubing with dents, install new tubing immediately.

IMPORTANT: Tighten fittings as specified in torque chart.

When you tighten connections, use two wrenches to prevent bending or breaking tubing and fittings.

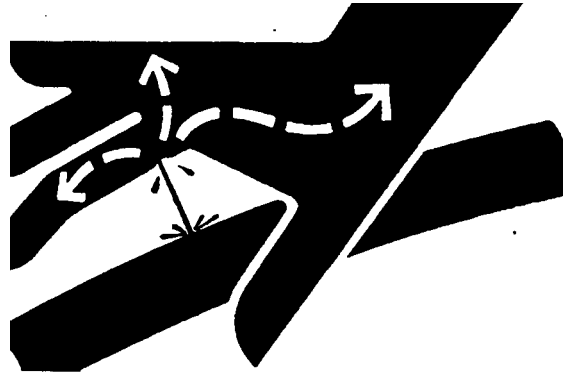

X9811 -JUN-23AUG88



T85401 -JUN-24JAN89

**SERVICE RECOMMENDATIONS FOR O-RING
BOSS FITTINGS****STRAIGHT FITTING**

1. Inspect O-ring boss seat for dirt or defects.
2. Lubricate O-ring with petroleum jelly. Place electrical tape over threads to protect O-ring. Slide O-ring over tape and into O-ring groove of fitting. Remove tape.
3. Tighten fitting to torque value shown on chart.

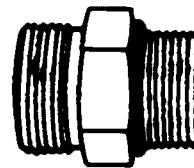

T6243AE -JUN-18OCT88

Continued on next page

04T,90,K66 -19-19MAR96-1/2

ANGLE FITTING

1. Back-off lock nut (A) and back-up washer (B) completely to head-end (C) of fitting.
2. Turn fitting into threaded boss until back-up washer contacts face of boss.
3. Turn fitting head-end counterclockwise to proper index (maximum of one turn).

NOTE: Do not allow hoses to twist when tightening fittings.

4. Hold fitting head-end with a wrench and tighten locknut and back-up washer to proper torque value.

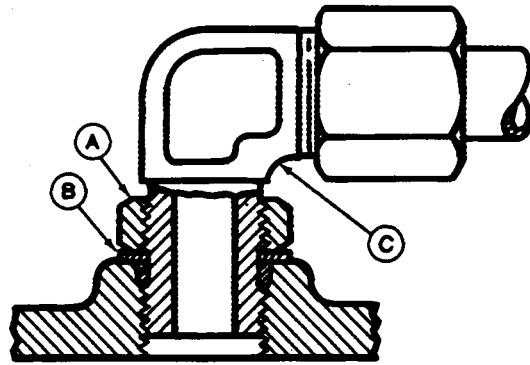

T6520AB -JUN-18OCT88

STRAIGHT FITTING OR SPECIAL NUT TORQUE CHART

Thread Size	N•m	lb-ft
3/8-24 UNF	8	6
7/16-20 UNF	12	9
1/2-20 UNF	16	12
9/16-18 UNF	24	18
3/4-16 UNF	46	34
7/8-14 UNF	62	46
1-1/16-12 UN	102	75
1-3/16-12 UN	122	90
1-5/16-12 UN	142	105
1-5/8-12 UN	190	140
1-7/8-12 UN	217	160

NOTE: Torque tolerance is ± 10%.

SERVICE RECOMMENDATIONS FOR FLAT FACE O-RING SEAL FITTINGS

1. Inspect the fitting sealing surfaces. They must be free of dirt or defects.
2. Inspect the O-ring. It must be free of damage or defects.
3. Lubricate O-rings and install into groove using petroleum jelly to hold in place.
4. Push O-ring into the groove with plenty of petroleum jelly so O-ring is not displaced during assembly.
5. Index angle fittings and tighten by hand pressing joint together to insure O-ring remains in place.
6. Tighten fitting or nut to torque value shown on the chart per dash size stamped on the fitting. Do not allow hoses to twist when tightening fittings.

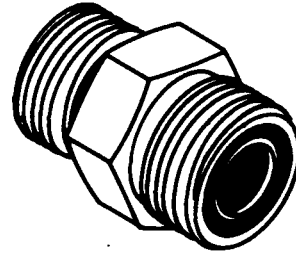

T6243AD -JUN-18OCT88

FLAT FACE O-RING SEAL FITTING TORQUE

Nominal Tube O.D.		Dash Size	Thread Size in.	Swivel Nut		Bulkhead Nut	
mm	in.			N•m	lb-ft	N•m	lb-ft
6.35	0.250	-4	9/16-18	16	12	5.0	3.5
9.52	0.375	-6	11/16-16	24	18	9.0	6.5
12.70	0.500	-8	13/16-16	50	37	17.0	12.5
15.88	0.625	-10	1-14	69	51	17.0	12.5
19.05	0.750	-12	1 3/16-12	102	75	17.0	12.5
22.22	0.875	-14	1 3/16-12	102	75	17.0	12.5
25.40	1.000	-16	1 7/16-12	142	105	17.0	12.5
31.75	1.250	-20	1 11/16-12	190	140	17.0	12.5
38.10	1.500	-24	2-12	217	160	17.0	12.5

NOTE: Torque tolerance is +15 -20%.

**SERVICE RECOMMENDATIONS FOR 37°
FLARE AND 30° CONE SEAT CONNECTORS**

1. Inspect flare and flare seat. They must be free of dirt or obvious defects.
2. Defects in tube flare cannot be repaired. Overtightening a defective flared fitting will not stop leaks.
3. Align tube with fitting before attempting to start nut.
4. Lubricate male threads with hydraulic fluid or petroleum jelly.
5. Index angle fittings and tighten by hand.
6. Tighten fitting or nut to torque value shown on torque chart. Do not allow hoses to twist when tightening fittings.

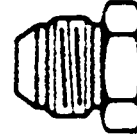

T6234AC -JUN-18OCT88

STRAIGHT FITTING OR SPECIAL NUT TORQUE CHART

Thread Size	N•m	lb-ft
3/8 - 24 UNF	8	6
7/16 - 20 UNF	12	9
1/2 - 20 UNF	16	12
9/16 - 18 UNF	24	18
3/4 - 16 UNF	46	34
7/8 - 14 UNF	62	46
1-1/16 - 12 UN	102	75
1-3/16 - 12 UN	122	90
1-5/16 - 12 UN	142	105
1-5/8 - 12	190	140
1-7/8 - 12 UN	217	160

NOTE: Torque tolerance is $\pm 10\%$.

T82,BHMA,EL -19-19MAR96-1/1

SERVICE RECOMMENDATIONS FOR FLARED CONNECTIONS—STRAIGHT OR TAPERED THREADS

1. Inspect flare and flare seat. They must be free of dirt or obvious defects.
2. Defects in the tube flare cannot be repaired. Overtightening a defective flared fitting will not stop leaks.
3. Align the tube with the fitting before attempting to start the nut.
4. Lubricate the male threads with hydraulic fluid or petroleum jelly.
5. Index angle fittings and tighten by hand.
6. Tighten fitting or nut to torque value shown on the chart. Do not allow hoses to twist when tightening fittings.

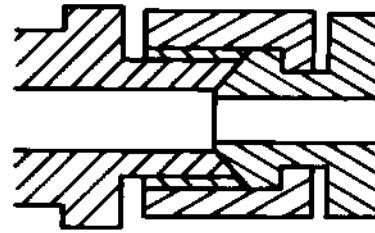

T6873AE

Straight Thread

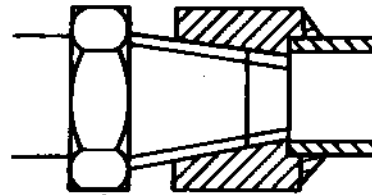

T6873AD

Tapered Thread

TORQUE CHART ^a

Thread Size	Straight Thread ^b		Tapered Thread	
	N•m	lb-ft	N•m	lb-ft
1/8	15	11		
1/4	20	15	45	33
3/8	29	21	69	51
1/2	49	36	93	69
3/4	69	51	176	130
1	157	116	343	253
1-1/2	196	145	539	398
2	255	188	588	434

^aTorque tolerance is $\pm 10\%$.

^bWith seat face.

NOTE: If female thread is cast iron (control valves, brake valves motors, etc.), torque must be reduced approximately 10%.

T6873AE -UN-18OCT88

T6873AD -UN-18OCT88

SERVICE RECOMMENDATIONS FOR INCH SERIES FOUR BOLT FLANGE FITTINGS

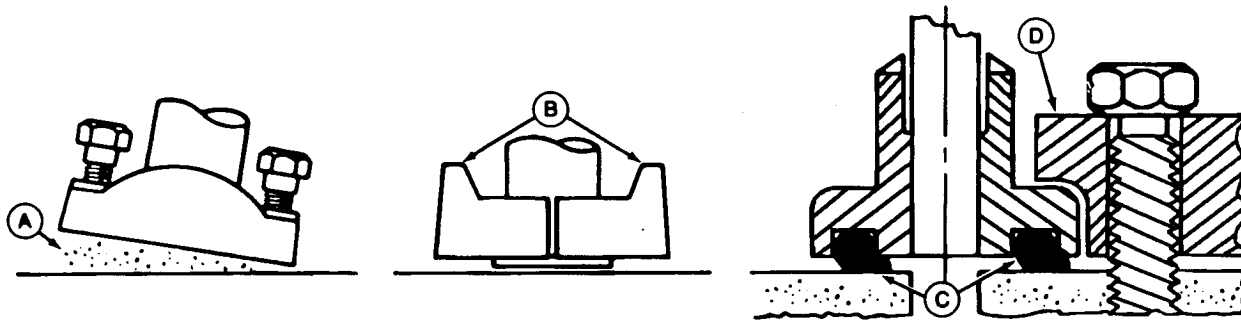

A—Sealing Surface

B—Split Flange

C—Pinched O-Ring

D—Single Piece Flange

1. Clean sealing surfaces (A). Inspect. Scratches cause leaks. Roughness causes seal wear. Out-of-flat causes seal extrusion. If defects cannot be polished out, replace component.
2. Install O-ring (and backup washer if required) into groove using petroleum jelly to hold it in place.
3. Split flange: Loosely assemble split flange (B) halves. Make sure split is centrally located and perpendicular to port. Hand tighten cap screws to hold parts in place. Do not pinch O-ring (C).
4. Single piece flange (D): Place hydraulic line in center of flange and install cap screws. Flange

must be centrally located on port. Hand tighten cap screws to hold flange in place. Do not pinch O-ring.

5. Tighten one cap screw, then tighten the diagonally opposite cap screw. Tighten two remaining cap screws. Tighten all cap screws as specified in the chart below.

DO NOT use air wrenches. DO NOT tighten one cap screw fully before tightening the others. DO NOT over tighten.

Continued on next page

04T,90,K174 -19-01AUG94-1/2

T6890BB -JUN-01MAR90

Maintenance

TORQUE CHART ^a

Nominal Flange Size	Cap Screw Size		N•m		lb-ft	
			Min	Max	Min	Max
1/2	5/16-18	UNC	20	31	15	23
3/4	3/8-16	UNC	28	54	21	40
1	3/8-16	UNC	37	54	27	40
1-1/4	7/16-14	UNC	47	85	35	63
1-1/2	1/2-13	UNC	62	131	46	97
2	1/2-13	UNC	73	131	54	97
2-1/2	1/2-13	UNC	107	131	79	97
3	5/8-11	UNC	158	264	117	195
3-1/2	5/8-11	UNC	158	264	117	195
4	5/8-11	UNC	158	264	117	195
5	5/8-11	UNC	158	264	117	195

^aTolerance ± 10%. The torques given are enough for the given size connection with the recommended working pressure. Torques can be increased to the maximum shown for each cap screw size if desired. Increasing cap screw torque beyond this maximum will result in flange and cap screw bending and connection failures.

SERVICE RECOMMENDATIONS FOR METRIC SERIES FOUR BOLT FLANGE FITTING

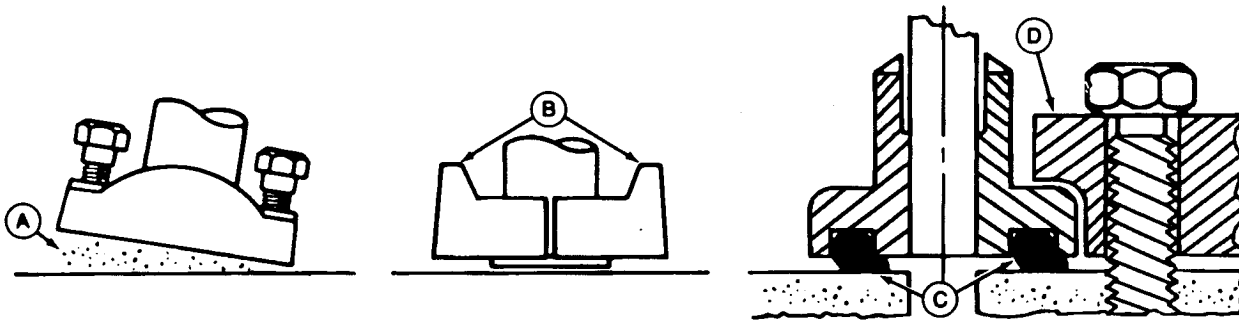

A—Sealing Surface

B—Split Flange

C—Pinched O-Ring

D—Single Piece Flange

1. Clean sealing surfaces (A). Inspect. Scratches cause leaks. Roughness causes seal wear. Out-of-flat causes seal extrusion. If defects cannot be polished out, replace component.
2. Install the correct O-ring (and backup washer if required) into groove using petroleum jelly to hold it in place.
3. Split flange: Loosely assemble split flange (B) halves. Make sure split is centrally located and perpendicular to the port. Hand tighten cap screws to hold parts in place. Do not pinch O-ring (C).
4. Single piece flange (D): Place hydraulic line in center of flange and install four cap screws. Flange must be centrally located on port. Hand tighten cap screws to hold flange in place. Do not pinch O-ring.
5. After components are properly positioned and cap screws are hand tightened, tighten one cap screw, then tighten the diagonally opposite cap screw. Tighten two remaining cap screws. Tighten all cap screws as specified in the chart below.

DO NOT use air wrenches. DO NOT tighten one cap screw fully before tightening the others. DO NOT over tighten.

TORQUE CHART ^a		
Thread ^b	N•m	lb-ft
M6	12	9
M8	30	22
M10	57	42
M12	95	70
M14	157	116
M16	217	160
M18	334	246
M20	421	318

^aTolerance ± 10%. The torques given are enough for the given size connection with the recommended working pressure. Increasing cap screw torque beyond these amounts will result in flange and cap screw bending and connection failures.

^bMetric standard thread.

T6890BB -JUN-01MAR90

CHAPTER 21
OPERATIONAL CHECKOUT

BLANK

Operational Checkout

OPERATIONAL CHECKOUT

Use this procedure to check all systems and functions on the machine. It is designed so you can make a quick check of machine operation while doing a walk around inspection and performing specific checks from the operator's seat.

Should you experience a problem with your machine, you will find helpful diagnostic information in this checkout that will pinpoint the cause. This information may allow you to perform a simple adjustment yourself which will reduce the down time of your machine. Use the table of contents to help find adjustment procedures.

The information you provide after completing the operational checkout will allow you or your authorized dealer to pinpoint a specific test or repair needed to restore the machine to design specifications.

A location will be required which is level and has adequate space to complete the checks. No tools or equipment are needed to perform the checkout.

Complete the necessary visual checks (oil levels, oil condition, external leaks, loose hardware, linkage, wiring, etc.) prior to doing the checkout. The machine must be at operating temperature for many of the checks.

Start at the top of the left column and read completely down column before performing check. Follow this sequence from left to right. In the far right column, if no problem is found, you will be instructed to go to next check. If a problem is indicated, you will be referred to either a section in this manual or to your authorized dealer for repair.

Operational Checkout

① OPERATOR STATION CHECKS—KEY SWITCH ON, ENGINE OFF

--1/1

**GAUGES, MONITOR,
AND BATTERY
DISCONNECT RELAY
CHECKS**

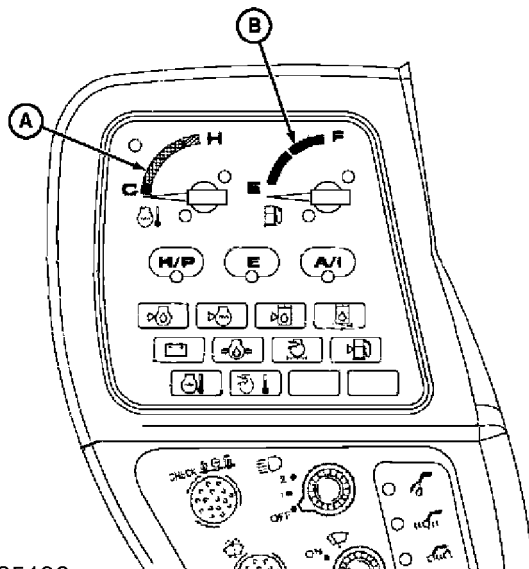

T125196

T125196 -UN-29OCT99

NOTE: Monitor buzzer is not checked during this procedure.

NOTE: If engine coolant temperature is below 30°C (86°F) engine temperature gauge needle may not move to the right. Run engine a few minutes to warm coolant before check.

Engine OFF.

Key switch ON.

Does battery relay click?

Do engine temperature gauge (A) and fuel gauge (B) needles move to the right?

Do all (10) monitor lights come on and after 2—3 seconds only the alternator indicator and engine oil pressure indicator remain on?

YES: Go to next check.

NO: Check monitor fuse.

NO: Check and replace bulb if any bulb fails to come on. Go to your authorized dealer.

--1/1

Operational Checkout

**FLUID LEVEL
(COOLANT, HYDRAULIC
OIL, AND ENGINE OIL)
INDICATOR CIRCUIT
CHECKS**

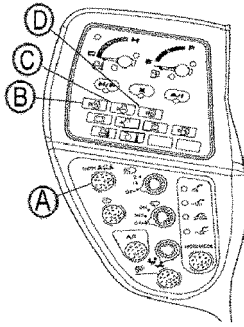

T107699 -UN-27FEB97

Engine OFF.

Key switch ON.

Push and hold level check switch (A).

Are the hydraulic oil level (B), coolant level (C), and engine oil level (D) indicator lights ON?

YES: Go to next check.

NO: Check fluid levels in radiator, recovery tank, hydraulic reservoir, or engine. If OK, check fluid level sensing switch for wiring. Check monitor fuse. If fuse is OK, go to your authorized dealer.

-- -1/1

**PROPEL LEVER AND
PEDAL CUSHION
CYLINDER CHECKS**

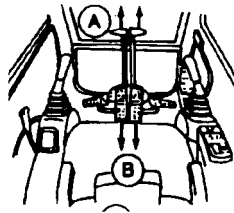

T7531AO -UN-07JUN91

Engine OFF.

Push each propel lever and pedal forward (A), then release.

Pull each propel lever and pedal rearward (B), then release.

Does each lever and pedal have equal effort to operate forward and reverse?

Does each lever and pedal return to neutral at the same time when released?

YES: Go to next check.

NO: Go to your authorized dealer.

-- -1/1

Operational Checkout

OPERATOR STATION CHECKS—ENGINE ON

--1/1

MONITOR CIRCUIT, GAUGE CHECKS

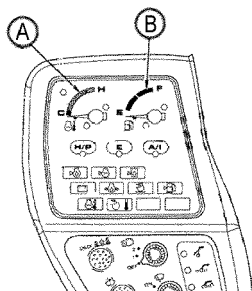

T107698 -UN-27FEB97

Start engine.

Are all monitor indicator lights OFF after engine starts?

Is coolant temperature gauge needle (A) in normal operating zone after a few minutes?

Does fuel gauge (B) indicate fuel level?

Stop engine.

YES: Go to next check.

NO: Check alternator belt if battery light is on after engine starts. Go to your authorized dealer.

--1/1

POWER MODE CIRCUIT CHECKS

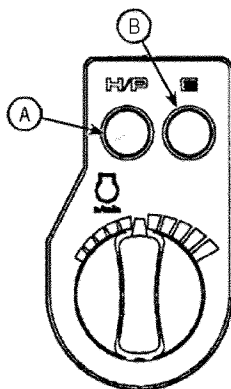

T102098 -UN-26JUL96

Start engine.

Auto-idle switch OFF.

Propel speed switch in fast position.

Pilot shut-off lever in LOCKED position.

Push power mode select switches (A) and (B) one at a time.

Do corresponding indicator lights come on as each switch is pushed?

YES: Go to next check.

NO: Check controller fuse. Go to your authorized dealer.

--1/1

Operational Checkout

WORK MODE CIRCUIT CHECKS

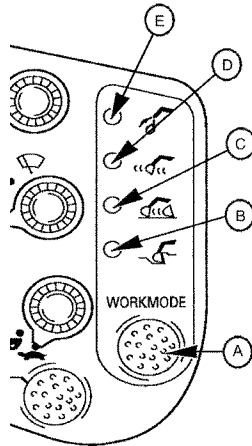

T102099 -UN-26JUL96

- Start engine.
- Auto-idle switch OFF.
- Pilot shut-off lever in LOCKED position.
- Push work mode select switch (A) to select desired work mode.
- Do corresponding indicator lights come on as switch is pushed?

YES: Go to next check.
NO: Check fuse. Go to your authorized dealer.

--1/1

ENGINE RPM DIAL CHECKS

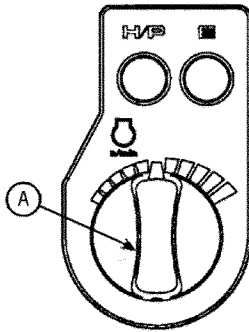

T102100 -UN-26JUL96

- Start engine.
- Auto-idle switch OFF.
- Pilot shut-off lever in LOCKED position.
- Move engine RPM dial (A) clockwise.
- Does engine speed increase?
- Move engine RPM dial counterclockwise.
- Does engine speed decrease?

YES: Go to next check.
NO: Go to your authorized dealer.

--1/1

Operational Checkout

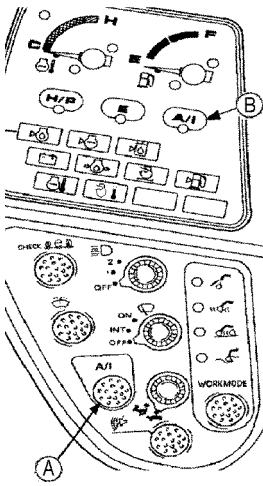
<p>AUTO-IDLE CIRCUIT CHECK</p>	 <p>T107700 -UN-27FEB97</p> <p>Run engine at fast idle.</p> <p>Mode select switch in H/P mode.</p> <p>Auto-idle switch OFF.</p> <p>Pilot shut-off lever in UNLOCKED position.</p> <p>Push auto-idle switch (A) to ON.</p> <p>Does auto-idle indicator (B) come on?</p> <p>Does engine speed decrease after 4 to 6 seconds?</p> <p>Slowly actuate any dig function control lever.</p> <p>Does engine speed return to fast idle?</p>	<p>YES: Go to next check.</p> <p>NO: Check fuse. Go to your authorized dealer.</p> <p style="text-align: right;">-- -1/1</p>
---------------------------------------	---	--

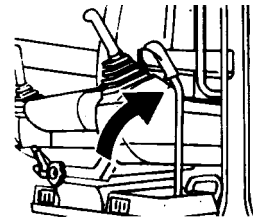
<p>PILOT SHUT-OFF VALVE CHECKS</p>	 <p>T7351CC -UN-22AUG90</p> <p>CAUTION: Machine may move during this check. Make sure area is clear, and large enough to operate all controls.</p> <p>Run engine at slow idle.</p> <p>Pilot shut-off lever in LOCKED (rearward) position.</p> <p>Actuate all dig and propel function controls.</p> <p>Do any dig or propel functions operate?</p>	<p>YES: Go to your authorized dealer.</p> <p>NO: Continue check,</p> <p style="text-align: right;">-- -1/1</p>
---	--	--

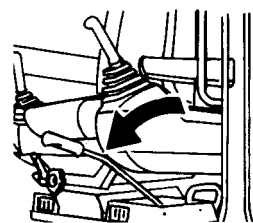
<p>PILOT SHUT-OFF VALVE CHECKS—(CONTINUED)</p>	 <p>T7351CB -UN-22AUG90</p> <p>Move pilot shut-off lever to UNLOCKED position (forward).</p> <p>Operate all dig and propel functions.</p> <p>Do all functions operate?</p>	<p>YES: Go to next check.</p> <p>NO: Go to your authorized dealer.</p> <p style="text-align: right;">-- -1/1</p>
---	---	--

Operational Checkout

TRAVEL ALARM CHECK

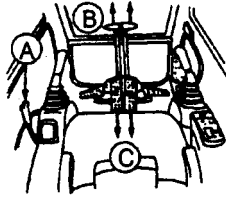

T7850AF -UN-22OCT92



CAUTION: Machine will move during this check. Make sure area is clear, and large enough to operate all controls.

Engine running.

Pilot shut-off lever (A) in UNLOCKED position (forward).

Push propel pedals or levers forward (B).

Does travel alarm sound?

Pull propel pedals or levers rearward (C).

Does travel alarm sound?

YES: Go to next check.

NO: Check motion alarm fuse. Go to your authorized dealer.

--1/1

TRAVEL ALARM STOP CIRCUIT

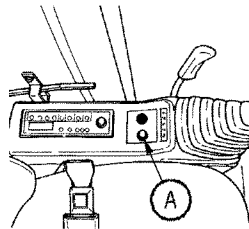

T102919 -UN-08AUG96



CAUTION: Machine will move during this check. Make sure area is clear, and large enough to operate all controls.

NOTE: Travel alarm must operate for this check.

Push propel pedals or levers and allow travel alarm to operate for a minimum of 12 seconds.

While continuing travel, push travel alarm cancel switch (A).

Does travel alarm stop sounding?

YES: Go to next check

NO: Go to your authorized dealer.

--1/1

Operational Checkout

③ HYDRAULIC SYSTEM CHECKS

--1/1

PRESSURIZED RESERVOIR CHECK

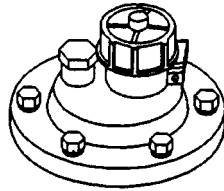

T7884AG -UN-12NOV92

Raise boom to full height, then lower boom to ground.

NOTE: Ensure that engine is properly shut down.

Slowly loosen vent plug on hydraulic reservoir.

Is air heard escaping from vent plug?

NOTE: The pressurized reservoir creates pressure at the inlet to the hydraulic pumps. If filler cap does not seal, hydraulic pumps could cavitate and be damaged.

YES: Go to next check.

NO: Replace cap. Go to your authorized dealer.

--1/1

PUMP GEARBOX OIL LEVEL CHECK

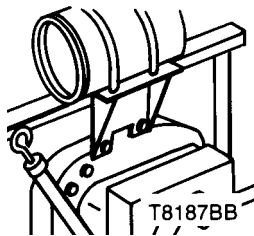

T8187BB -UN-08MAR94

NOTE: Ensure that engine is properly shut down.

Pull dipstick from tube, check oil level.

Is oil level below "H" (level) mark?

YES: Go to next check.

NO: Add oil if low.

--1/1

SWING GEARBOX OIL LEVEL CHECK



T8187BF

T8187BF -UN-08MAR94

NOTE: Ensure that engine is properly shut down.

Pull dipstick from tube, check oil level.

Is oil between marks?

YES: Go to next check.

NO: Add oil if low.

--1/1

Operational Checkout

**PILOT CONTROLLER
PATTERN CHECK (SAE
PATTERN)**



T102070 -UN-16JUL96

Left Control Lever



T102071 -UN-16JUL96

Right Control Lever

Engine at slow idle.

Operate machine in clear area.

Move pilot shut-off lever to UNLOCKED position. Slowly move hydraulic levers to all positions on decals.

Do bucket, boom, arm, and swing move as decals show?

NOTE: See John Deere control lever pattern in Operating the Machine chapter.

YES: Go to next test.

NO: Install decals for pattern (operator preference). Go to your authorized dealer.

Operational Checkout

**PILOT CONTROLLER
PATTERN CHECK (JOHN
DEERE PATTERN)**

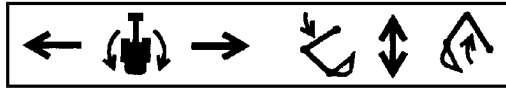

T102197 -UN-19JUL96

Left Control Lever

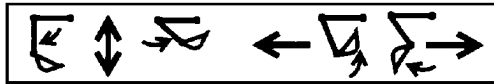

T102198 -UN-19JUL96

Right Control Lever

Engine at slow idle.

Operate machine in clear area.

Move pilot shut-off lever to UNLOCKED position. Slowly move hydraulic levers to all positions on decals.

Do bucket, boom, arm, and swing move as decals show?

NOTE: See John Deere control lever pattern in Operating the Machine chapter.

YES: Go to next test.

NO: Install decals for pattern (operator preference). Go to your authorized dealer.

---1/1

**(DYNAMIC) SWING
BRAKE CHECK**

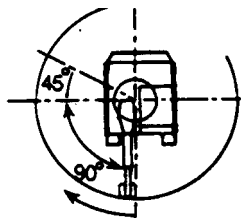

T6479AY -UN-19OCT88



CAUTION: Make sure area is clear and large enough to swing extended bucket. Machine must be on level ground.

Position upperstructure with boom in front.

Put boom, arm and bucket in fully extended position with bucket 900 mm (3 ft) above ground level.

Operate engine at fast idle.

Actuate swing control valve to full stroke. Swing around 90 degrees and release lever.

Does upperstructure stop within 45 degrees (1/8 turn) after releasing lever?



Repeat procedure in opposite direction.

YES: Go to next check.

NO: Go to your authorized dealer.

---1/1

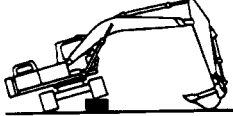
Operational Checkout

<p>SWING CIRCUIT LEAKAGE CHECK</p>	 <p>T6479AZ -UN-19OCT88</p> <p>Engine at slow idle.</p> <p>Position machine on a side hill or raise one side of machine 300 mm (1 ft) with the boom and ease block under track.</p> <p>Position bucket 300 mm (1 ft) off the ground at maximum reach.</p> <p>Bottom bucket cylinder and hold lever in the actuated position.</p> <p><i>NOTE: Actuating the bucket function releases the mechanical swing brake.</i></p> <p>Does upperstructure move only slightly?</p>	<p>YES: Go to next check.</p> <p>NO: Go to your authorized dealer.</p> <p style="text-align: right;">-- -1/1</p>
<p>DIG FUNCTION DRIFT CHECK</p>	 <p>T6290AF -UN-19OCT88</p> <p>Engine at slow idle.</p> <p>Fill bucket with dirt and position bucket at maximum reach with bucket 2 in. (50 mm) above ground.</p> <p>Observe bucket for 1 minute.</p> <p>Does bucket drift down to ground within 1 minute?</p>	<p>YES: Go to your authorized dealer.</p> <p>NO: Go to next check.</p> <p style="text-align: right;">-- -1/1</p>
<p>CONTROL VALVE LIFT CHECK TEST</p>	 <p>T6292AZ -UN-19OCT88</p> <p>Engine at slow idle.</p> <p>Position machine as illustrated.</p> <p>Slowly actuate pilot controller to lower boom, extend arm (retract cylinder), and dump bucket (retract cylinder).</p> <p>Do functions move in opposite direction as control levers are moved, then change direction as levers are moved further?</p>	<p>YES: If functions move in opposite direction first, a leak within the cylinder or lift check valve is indicated. Go to your authorized dealer.</p> <p>NO: Go to next check.</p> <p style="text-align: right;">-- -1/1</p>

Operational Checkout

<p>PROPEL SYSTEM TRACKING CHECKS (PROPEL ONLY)</p>	<p>Engine at fast idle.</p> <p>Propel speed switch in fast position.</p> <p>Propel machine at full speed forward on a flat and level area.</p> <p>Repeat procedure in reverse.</p> <p>Do both tracks move and machine does not mistrack excessively in forward or reverse?</p>	<p>YES: Go to next check.</p> <p>NO: Note which track does not move or if machine mistracks note the mistrack pattern. Go to your authorized dealer.</p> <p style="text-align: right;">-- -1/1</p>
---	--	--

<p>PROPEL SYSTEM TRACKING CHECKS (WHILE OPERATING A DIGGING FUNCTION)</p>	<p>Engine at fast idle.</p> <p>Propel speed switch in fast position.</p> <p>Propel machine at full speed forward on a flat and level area.</p> <p>After machine is moving, slowly move the arm control lever from neutral to full actuation to extend the arm.</p> <p>Does machine mistrack excessively when the arm is extended?</p> <p><i>NOTE: Machine will slow down during this test.</i></p>	<p>YES: Go to your authorized dealer.</p> <p>NO: Go to next check.</p> <p style="text-align: right;">-- -1/1</p>
--	--	--

<p>PROPEL SYSTEM MANEUVERABILITY CHECK</p>	<p>Engine at fast idle.</p> <p>Propel speed switch in fast position.</p> <p>Propel machine at full speed forward down a slope.</p> <p>Turn in each direction.</p> <p>Repeat the procedure in reverse.</p> <p>Does each track slow down in response to pedal/lever movement in order to turn?</p>	<p>YES: Go to next check.</p> <p>NO: Counterbalance valve malfunction. Go to your authorized dealer.</p> <p style="text-align: right;">-- -1/1</p>
---	--	--

Operational Checkout

**PROPEL SPEED
SELECTION CHECK**

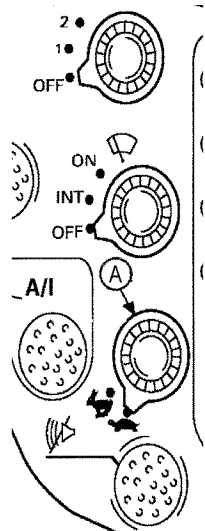

T102104 -UN-26JUL96

Engine at fast idle.

Turn propel speed switch (A) to slow speed (turtle).

Actuate propel function to full speed.

Turn propel speed switch to fast position (rabbit).

Does machine travel speed increase?

Actuate a dig function and then return to neutral.

Does machine travel speed decrease and then increase?

Turn propel speed switch to slow speed (turtle).

Does machine travel speed decrease?

YES: Go to next check.

NO: Go to your authorized dealer.

Operational Checkout

CYCLE TIMES CHECK



CAUTION: Make sure area is clear and large enough to operate all functions of machine.

IMPORTANT: Warm hydraulic oil to operating temperature for this check.

Engine at fast idle.

Auto-idle switch OFF.

BOOM

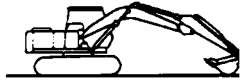

T6477AQ -UN-19OCT88

ARM, BUCKET, SWING, PROPEL
Move machine to position shown for each test.

Record cycle time for each function.



T7884AE -UN-10NOV92

Function	Typical New (Seconds)
Boom Raise (cylinder extend)	3.1 ± 0.3 with 2.96 m (9 ft 9 in.) arm
Boom Lower (cylinder retract)	2.5 ± 0.3 with 2.96 m (9 ft 9 in.) arm
Arm In (cylinder extend)	3.9 ± 0.3
Arm Out (cylinder retract)	2.6 ± 0.3
Bucket Load (cylinder extend)	4.1 ± 0.3
Bucket Dump (cylinder retract)	2.5 ± 0.3
Swing Left or Right 3 Revolutions From a Running Start	14.4 ± 1.0
Propel:	
20 m (65 ft) From a Running Start (check in forward and reverse)	
propel speed switch in FAST position	13.4 ± 0.6
propel speed switch in SLOW position	20.6 ± 2.0

Does machine perform within specifications?

YES: Go to next check.

NO: Go to your authorized dealer.

Operational Checkout

④ UNDERCARRIAGE CHECKS

--1/1

TRACK SAG ROLLER AND IDLER LEAKAGE CHECKS



T6915AN -UN-07APR89

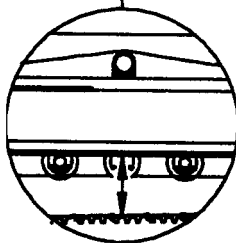

T7850AI -UN-22OCT92

Swing upperstructure to side and raise track off ground.

Operate track in reverse.

Stop engine.

Measure distance between top of track shoe to center of lower surface of track frame.

Track sag specifications:

Track Sag—Specification

Distance..... 300—335 mm (11-13/16—13-3/16 in.)

Check rollers and idlers for oil leaks.

Is oil leaking from rollers or idlers?

Raise other side of machine and repeat checks.

NOTE: If track sag is less than specified, track chain wear will be accelerated. If it is less than specified on one side only, the machine may mistrack.

YES: Go to your authorized dealer for repair if oil leakage is noted from idlers or rollers.

NO: Go to next check.

--1/1

Operational Checkout

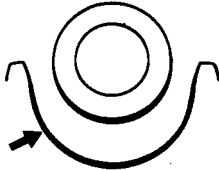
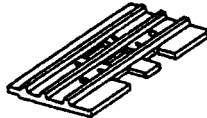
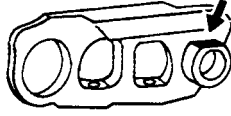
<p>SPROCKET WEAR CHECK</p>	 <p>T6981AC -UN-13MAR89</p> <p>Inspect drive sprocket.</p> <p>Is tooth wear excessive?</p> <p><i>NOTE: Do not evaluate sprocket by condition of tooth tip. Tooth tip wear does not affect sprocket operation if it does not extend into the bushing contact area.</i></p> <p><i>NOTE: Reverse drive side wear is generally more than forward drive side wear.</i></p>	<p>YES: Go to your authorized dealer.</p> <p>NO: Go to next check.</p> <p style="text-align: right;">-- -1/1</p>
<p>GROUSER WEAR, BENT TRACK SHOE, AND LOOSE HARDWARE CHECKS</p>	 <p>T7322AF -UN-21JUN90</p> <p>Inspect for worn grousers, bent track shoes, and loose shoe hardware.</p> <p>Are grouser bars worn excessively?</p> <p>Are track shoes bent?</p> <p>Is track shoe width appropriate for ground condition?</p> <p>Is track shoe hardware tight?</p> <p><i>NOTE: Excessive grouser wear weakens track shoes and may result in track shoes bending.</i></p>	<p>YES: If shoe hardware is loose, remove shoe and clean joint before tightening. Go to Check Track Shoe Torque in Maintenance chapter.</p> <p>NO: Go to next check.</p> <p style="text-align: right;">-- -1/1</p>
<p>TRACK LINK ROLLER AND FRONT IDLER WEAR CHECKS</p>	 <p>T6484AZ -UN-19OCT88</p> <p>Inspect track links for pin boss wear.</p> <p>Do link pin boss areas indicate contact with roller flanges or track guides?</p> <p><i>NOTE: Some contact or wear is normal. Excessive contact or wear indicates excessive rail wear.</i></p> <p>Inspect front idler flanges.</p> <p>Do idler flanges contact bushings?</p> <p><i>NOTE: Idler contact with bushings indicates excessive chain rail wear and idler tread surface wear.</i></p>	<p>YES: Go to your authorized dealer for additional track component information.</p> <p>NO: Go to next check.</p> <p style="text-align: right;">-- -1/1</p>

Operational Checkout

5 HYDRAULIC THUMB CHECK

--1/1

5a INSPECT THE HYDRAULIC THUMB

Is the hydraulic thumb hardware loose?
 Is there damage and weld cracks?
 Do pin joints have excess wear and play?

YES: Contact maintenance shop.
NO: Go to the next check.

--1/1

6 QUICK-DISCONNECT HITCH CHECKS

--1/1

6a HITCH CHECK

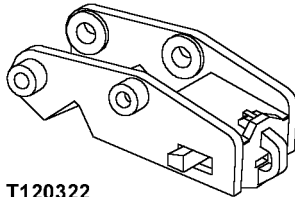

T120322
 T120322 -UN-29MAR99

Inspect hitch.
 Are there damage or weld cracks?

YES: Contact maintenance shop.
NO: Go to next check.

--1/1

6b LATCH CYLINDER, HOSES, AND CONNECTIONS CHECKS

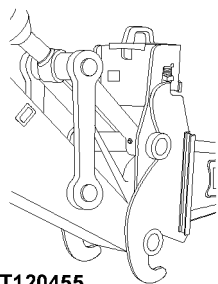

T120455
 T120455 -UN-25MAR99

Check latch cylinder, hoses, and connections for leaks.
 Is oil leaking from latch cylinder, hoses, or connections?

YES: Go to your authorized dealer for repair if oil leakage is noticed.
NO: Go to next check.

--1/1

Operational Checkout

7 ACCESSORIES CHECKS

-- -1/1

LIGHT CIRCUIT CHECKS

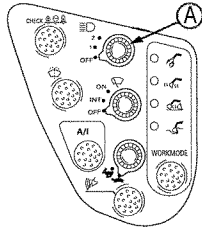

T102105 -UN-26JUL96

IMPORTANT: All accessories are powered from the fuse block. If any accessories do not function, check fuses in fuse block.

Turn key switch ON.

Turn light switch (A) to 1st on position.

Are monitor panel back lights and cab lights on?

Turn light switch to 2nd position.

Do work lights on boom come on also?

YES: Go to next check.

NO: Check fuse and/or monitor panel back light bulbs. Go to your authorized dealer.

-- -1/1

REAR LIGHT CIRCUIT CHECKS

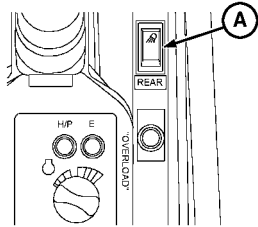

T121043

T121043 -UN-14APR99

IMPORTANT: All accessories are powered from the fuse block. If any accessories do not function, check fuses in fuse block.

Turn key switch ON.

Turn light switch (A) to the on position.

Are the rear lights on?

YES: Go to next check.

NO: Check fuse and/or monitor panel back light bulbs. Contact maintenance shop.

-- -1/1

Operational Checkout

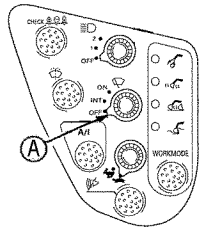
<p>WINDSHIELD WIPER CIRCUIT CHECK</p>	 <p>T102106 -UN-26JUL96</p> <p>Key switch ON.</p> <p>Turn wiper switch (A) to INT position.</p> <p>Does wiper operate intermittently?</p> <p>Turn wiper switch to ON position.</p> <p>Does wiper operate continuously?</p> <p>Move wiper switch to OFF position.</p> <p>Does wiper arm stop in park position?</p>	<p>YES: Go to next check.</p> <p>NO: Check if wiper harness and/or fuse is connected. Go to your authorized dealer.</p> <p style="text-align: right;">-- -1/1</p>
--	--	---

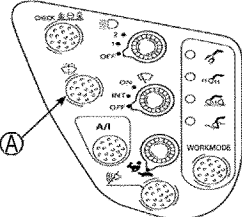
<p>WINDSHIELD WASHER CIRCUIT CHECK</p>	 <p>T102107 -UN-26JUL96</p> <p>IMPORTANT: Washer motor may be damaged if washer switch is held for more than 20 seconds, or continually operated with no fluid in the windshield washer tank.</p> <p>Key switch ON</p> <p>Push washer switch (A)</p> <p>Does washer fluid squirt on windshield?</p>	<p>YES: Go to next check.</p> <p>NO: Check washer fluid level and check wiper fuse. Go to your authorized dealer.</p> <p style="text-align: right;">-- -1/1</p>
---	--	---

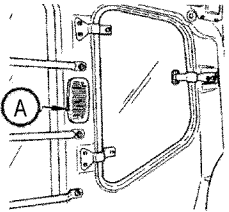
<p>CAB DOME LIGHT CIRCUIT CHECK</p>	 <p>T102183 -UN-26JUL96</p> <p>Key switch ON.</p> <p>Move switch (A) to on position.</p> <p>Does cab dome light come on?</p>	<p>YES: Go to next check.</p> <p>NO: Check fuse. Go to your authorized dealer.</p> <p style="text-align: right;">-- -1/1</p>
--	---	--

Operational Checkout

**LEFT CONTROL LEVER
HORN CIRCUIT CHECK**

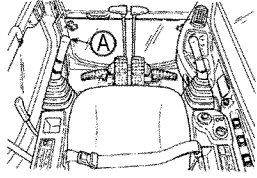

T102195 -UN-26JUL96

Key switch ON.
Press horn button (A) on top of left control lever.
Does horn sound?

YES: Go to next check.
NO: Check fuse. Go to your authorized dealer.

--1/1

AIR CONDITIONING CHECKS

--1/1

AIR CONDITIONER

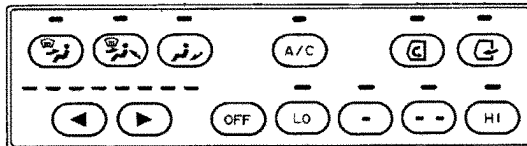

T103130
T103130 -19-29AUG96

Start engine and run at fast idle.
Turn air conditioner switch to ON position.
Turn blower switch to high speed.
Wait for any warm air in duct system to dissipate.
Is air from ducts cool?

YES: Check complete.
NO: Go to your authorized dealer.

--1/1

Operational Checkout

<p>ALL LINES AND HOSES</p>	<p>Engine OFF.</p> <p>Inspect all lines and hoses.</p> <p>Are lines and hoses straight, NOT kinked or worn from rubbing on other machine parts or "weather checked"?</p> <p>Are hose and line connections clean NOT showing signs of leakage, such as oil or dust accumulation at fittings?</p> <p>All hose and line clamps must be in place and tight. Clamps must have rubber inserts or cushions in place to prevent clamps from crushing or wearing into hoses or lines?</p>	<p>YES: Check complete.</p> <p>NO: Reposition hoses or lines and tighten or replace clamps. Tighten fittings or replace O-rings in fittings. Replace hoses or lines as required.</p> <p style="text-align: right;">-- -1/1</p>
-----------------------------------	--	--

<p>EVAPORATOR CORE CHECK</p>	<p>Engine ON.</p> <p>Blower switch on high.</p> <p>Is air from ducts cool and air flow good?</p> <p>Is water dripping from evaporator drain hose?</p>	<p>YES: Check complete.</p> <p>NO: Repair, replace or clean evaporator.</p> <p style="text-align: right;">-- -1/1</p>
-------------------------------------	---	---

<p>CONDENSER CHECK</p>	<p>Engine OFF.</p> <p>Inspect condenser cores.</p> <p>Is condenser core free of dirt or debris?</p> <p>Does condenser show signs of leakage, dust accumulation or oily areas?</p> <p>Are condenser fins straight, not bent or damaged?</p> <p>Inspect engine fan.</p> <p>Are fan blades in good condition, not worn, bent, broken or missing?</p>	<p>YES: Check complete.</p> <p>NO: Clean, repair or replace condenser core. Replace engine fan.</p> <p style="text-align: right;">-- -1/1</p>
-------------------------------	---	---

Operational Checkout

<p>COMPRESSOR CLUTCH CHECK</p>	<p>Engine OFF. Key switch ON. Blower switch on LOW. Air conditioner switch ON.</p> <p>Does compressor clutch "click" as switch is pushed?</p>	<p>YES: Check complete.</p> <p>NO: Replace compressor clutch.</p> <p style="text-align: right;">-- -1/1</p>
---------------------------------------	---	---

<p>RECEIVER DRYER CHECK</p>	<p>Engine OFF.</p> <p>Check hoses for damage and fittings for looseness.</p> <p>Are hoses not showing signs of leakage and fittings tight?</p>	<p>YES: Check complete.</p> <p>NO: Tighten fittings. Replace hoses, as required.</p> <p style="text-align: right;">-- -1/1</p>
------------------------------------	--	--

Operational Checkout

⑧ SEAT, DOORS, WINDOWS, LATCHES, AND LOCKS CHECKS

-- -1/1

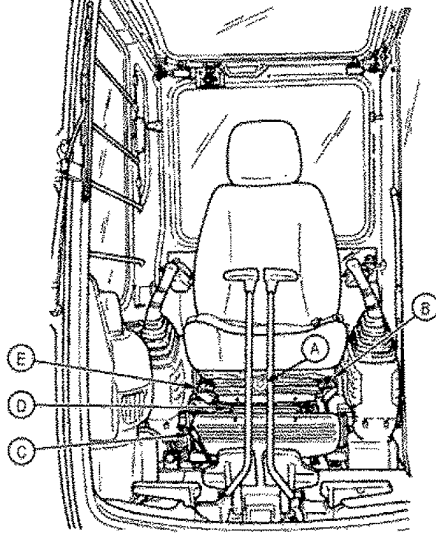
SEAT CONTROL
CHECKS

T102507 -UN-29JUL96

Push down lever (B) and raise and lower seat.

Does seat raise and lower easily?

Push down lever (B) and adjust angle of seat.

Does seat angle change easily?

Push down lever (C). Move seat and both side consoles forward and rearward. Release lever to lock seat and side consoles in position.

Does lever unlock easily and then lock to hold seat and consoles in position?

Pull up lever (D). Move seat forward and rearward. Release lever to lock seat in any position.

Does lever move easily to unlock seat support?

Does seat move forward and rearward easily?

Does lever lock seat support in position when released?

Pull up lever (E). Tilt seat back forward and rearward. Release lever to lock seat back in any position.

Does seat back tilt forward and rearward easily?

Does lever unlock and lock easily to hold seat back in position?

YES: Go to next check.

NO: Inspect linkage and repair. Go to your authorized dealer.

-- -1/1

Operational Checkout

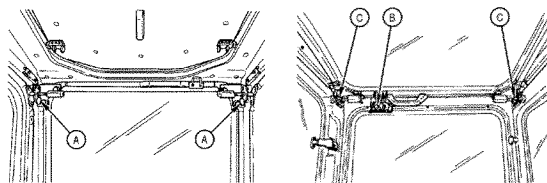
UPPER FRONT WINDOW
CHECK

T102109 -UN-26JUL96

T102110 -UN-26JUL96

Move lock pins (A) toward center of window.

Pull window up and back until it catches in latch (B) for convenient storage overhead.

Slide the two lock pins (C) into the cab frame boss holes and turn to lock.

Do pins move smoothly to lock and unlock window?

Does rear latch operate freely?

Do pins engage rear holes and lock window securely in full open position?

YES: Go to next check.

NO: Inspect. Repair.

-- -1/1

Operational Checkout

**WINDOW PROTECTION
KIT CHECK (MODEL
230LCRD)**

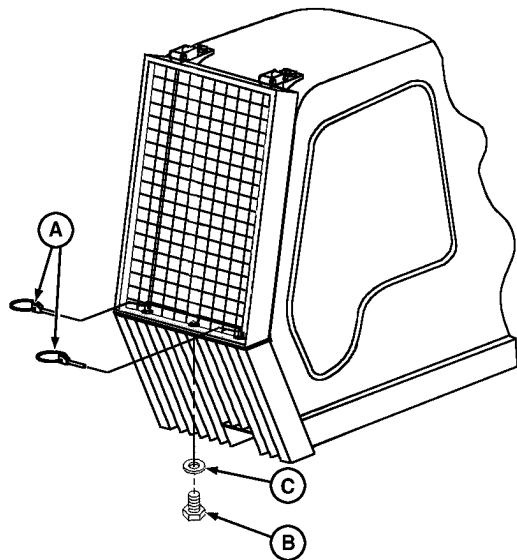

T121078

T121078 -UN-14APR99

- A—Lynch Pin**
- B—Cap Screw, 10 mm x 25 mm**
- C—Washer**

Upper screen:

Remove center cap screw (B) and washer (C).

Remove two lynch pins (A).

Raise upper screen.

Does screen move freely?

YES: Go to next check.

NO: Inspect. Repair.

Operational Checkout

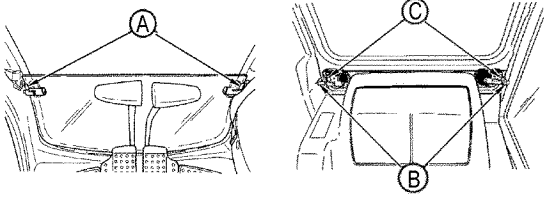
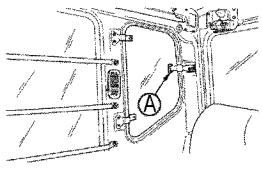
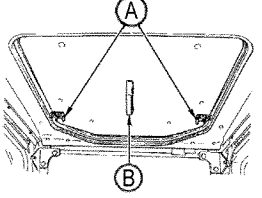
<p>LOWER FRONT WINDOW STORAGE CHECK</p>	 <p>T102111 -UN-26JUL96 T106163 -UN-07JAN97</p> <p><i>NOTE: Upper front window must be raised before lower window can be removed from window frame.</i></p> <p>Pull in on lock pins (A) to unlock window.</p> <p>Lift the lower front window from the frame.</p> <p>Insert tabs on bottom of window into brackets (B) and lock the pins into holes (C).</p> <p>Does window lock securely into holding bracket?</p>	<p>YES: Go to next check.</p> <p>NO: Inspect. Repair.</p> <p style="text-align: right;">-- -1/1</p>
<p>RIGHT SIDE AND LEFT SIDE WINDOW CHECKS</p>	 <p>T102113 -UN-26JUL96</p> <p>Right rear side window: Unlatch lock (A). Push joint part of lock to open window.</p> <p>Does latch operate smoothly?</p> <p>Does window remain opened when latched open?</p> <p>Left side cab window: Slide both window panes open and closed?</p> <p>Do both window panes slide freely to left and right?</p>	<p>YES: Go to next check.</p> <p>NO: Inspect. Repair. Go to your authorized dealer.</p> <p style="text-align: right;">-- -1/1</p>
<p>ROOF EXIT CHECK</p>	 <p>T102205 -UN-26JUL96</p> <p>Move lock pins (A) toward center of roof exit cover.</p> <p>Push on handle (B) until roof cover is in a secured position.</p> <p>Hold handle and pull cover down until pins lock in position.</p> <p>Does cover open and close freely?</p> <p>Does cylinder hold roof cover in the open position?</p>	<p>YES: Go to next check.</p> <p>NO: Inspect. Repair.</p> <p style="text-align: right;">-- -1/1</p>

Operational Checkout

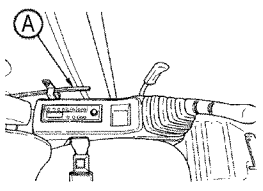
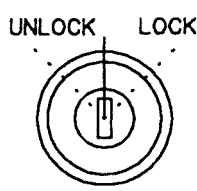
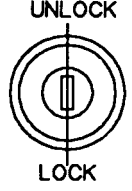
<p>CAB DOOR LATCH CHECK</p>	 <p>T102114 -UN-26JUL96</p> <p>Open cab door.</p> <p>Lock cab door in open position.</p> <p>Push down on lever (A) to release door from locked open position.</p> <p>Close door.</p> <p>Does door unlatch easily, lock in open position securely, unlock from open position easily, and latch closed securely?</p>	<p>YES: YES Go to next check.</p> <p>NO: Go to your authorized dealer.</p> <p style="text-align: right;">-- -1/1</p>
<p>CAB DOOR LOCK CHECK</p>	 <p>T7425AH -UN-10DEC90</p> <p>From outside cab, close cab door.</p> <p>Insert ignition key into door lock, turn clockwise 1/4 turn to lock.</p> <p>Allow key to return to vertical.</p> <p>Try to open door.</p> <p>Turn key 1/4 turn counterclockwise to unlock.</p> <p>Allow key to return to vertical.</p> <p>Remove key from lock.</p> <p>Does lock turn easily?</p> <p>Does lock prevent door from opening when locked?</p>	<p>YES: Go to next check.</p> <p>NO: Inspect. Repair.</p> <p style="text-align: right;">-- -1/1</p>
<p>LEFT AND RIGHT ACCESS DOORS LOCK CHECK</p>	 <p>T7425AG -UN-28NOV90</p> <p>Insert ignition key into lock and turn 180° clockwise to lock.</p> <p>Turn key 180° counterclockwise to unlock.</p> <p>Does lock turn easily and lock door and cap in position?</p> <p>Are all parts free of any visible damage?</p>	<p>YES: Go to next check.</p> <p>NO: Inspect. Repair.</p> <p style="text-align: right;">-- -1/1</p>

Operational Checkout

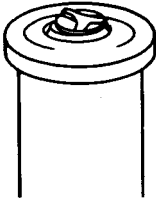
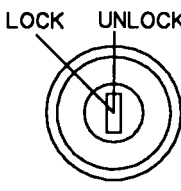
<p>FUEL CAP LOCK CHECK</p>	<div style="display: flex; justify-content: space-around; align-items: center;"> <div style="text-align: center;">  <p>T7351AH -UN-22AUG90</p> </div> <div style="text-align: center;">  <p>T7425AF -UN-04DEC90</p> </div> </div> <p>Turn lock cover to expose lock.</p> <p>Insert ignition key into fuel cap lock.</p> <p>Turn key 45° counterclockwise to lock fuel cap.</p> <p>Does lock prevent cap from being removed?</p> <p>Turn key 45° clockwise to unlock fuel cap.</p> <p>Does lock turn easily to lock and unlock?</p>	<p>YES: Go to next check.</p> <p>NO: Replace fuel cap.</p> <p style="text-align: right;">-- -1/1</p>
-----------------------------------	--	--

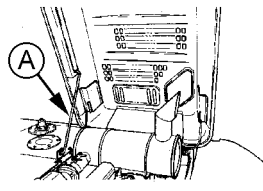
<p>HOOD CHECK</p>	<div style="display: flex; align-items: flex-start;"> <div style="margin-right: 20px;">  <p>T108577 -UN-26MAR97</p> </div> <div> <p>Unlock hood latch with ignition key.</p> <p>Release latches.</p> <p>Open hood.</p> <p>Engage hold-open rod (A).</p> <p>Does rod hold hood open?</p> <p>Close hood and engage latches.</p> <p>Do latches operate easily?</p> <p>Do latches hold hood closed?</p> </div> </div>	<p>YES: Go to next check.</p> <p>NO: Inspect. Repair.</p> <p style="text-align: right;">-- -1/1</p>
--------------------------	--	---

Operational Checkout

⑨ COOLANT CHECKS

--1/1

RADIATOR CAP

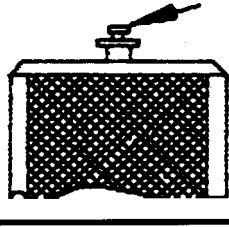

T6488FY -UN-19OCT88



CAUTION: Prevent possible injury. **DO NOT** remove radiator cap unless engine is cool. When engine is hot and cap is removed, hot coolant or steam will spray out causing serious burns.

Engine OFF and cool.

Remove radiator cap.

If coolant is warmer than surrounding air temperature is, a 'whoosh' sound heard when cap is loosened?

Does cap have a stop position that requires it to be pushed down to remove?

Does cap have a good seal (C) and gasket (A)?

Is spring (B) in good condition?

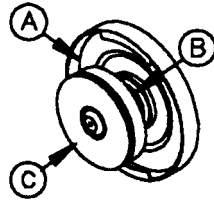

T7690AB -UN-23JAN92

YES: Go to next check.

NO: Replace radiator cap.

--1/1

COOLANT LEVEL AND COOLANT CONDITION IN RECOVERY TANK CHECKS



T6488FX -19-21MAR89

Engine OFF and cool.

Open radiator access door.

Inspect coolant level and coolant condition in recovery tank.

Is coolant level between FULL and LOW marks on recovery tank?



Is coolant clear, not oily, foamy, or rust colored?

YES: Go to next check.

NO: Add or replace coolant. (See 'Check Coolant Level' in Maintenance-Every 10 Hours or Daily chapter.)

--1/1

Operational Checkout

<p>COOLANT LEVEL AND COOLANT CONDITION IN RADIATOR CHECKS</p>	<p> CAUTION: Prevent possible injury. DO NOT remove cap unless engine is cool.</p> <p>Engine OFF and cool.</p> <p>Remove radiator cap.</p> <p>Inspect coolant level.</p> <p>Inspect coolant condition.</p> <p>Is coolant level at bottom of fill neck on radiator?</p> <p>Is coolant clear, not oily, foamy or rust colored?</p>	<p>YES: Go to next check.</p> <p>NO: Add or replace coolant. (See 'Check Coolant Level' in Maintenance-Every 250 Hours chapter.)</p> <p style="text-align: right;">-- -1/1</p>
<p>COOLANT HOSES AND CLAMPS CHECKS</p>	<p>Are radiator and heater hoses free of twists, kinks, cracks, leaks, or wear from rubbing on adjacent parts?</p> <p>Are hose clamps tight and installed correctly?</p>	<p>YES: Go to next check.</p> <p>NO: Replace hoses as required. Tighten or reinstall hose clamps.</p> <p style="text-align: right;">-- -1/1</p>
<p>FAN SHROUD AND FAN GUARD CHECKS</p>	<p></p> <p>T6488GN -UN-19OCT88</p> <p>Check fan to fan shroud clearance.</p> <p>Is fan centered in shroud?</p> <p>Is guard free of damage?</p> <p>Are all mounting brackets and hardware tight?</p>	<p>YES: Go to next check.</p> <p>NO: Adjust fan shroud to center fan. Repair or replace guard. Tighten loose hardware. Replace fan shroud if needed.</p> <p style="text-align: right;">-- -1/1</p>

Operational Checkout

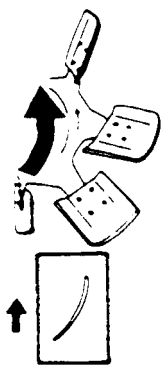
<p>FAN DIRECTION CHECK</p>	 <p>Is fan installed correctly with concave (cupped) side (Arrow) of fan blade towards engine?</p> <p><i>NOTE: If fan is installed backwards, about 50% of its capacity is lost.</i></p> <p>T6171CB -UN-25MAY89</p>	<p>YES: Check complete.</p> <p>NO: Install fan correctly.</p> <p style="text-align: right;">-- -1/1</p>
-----------------------------------	--	---

<p>RADIATOR OUTSIDE AIR FLOW CHECK</p>	<p>Inspect radiator screen for mud and debris.</p> <p>Inspect radiator fins for mud and debris.</p> <p>Inspect radiator for bent or damaged fins.</p> <p>Are radiator fins free of mud, leaves, grass, and other debris?</p> <p>Are fins straight, not broken or cracked?</p>	<p>YES: Go to next check.</p> <p>NO: Clean screen. Clean outside of radiator. Straighten fins. Replace radiator if severely damaged.</p> <p style="text-align: right;">-- -1/1</p>
---	---	--

<p>FAN BELT CHECK</p>	<p>Is fan belt free of oil or grease?</p> <p>Is inside surface of belt free of cracks or frayed edges?</p> <p>Is belt aligned with pulleys?</p>	<p>YES: Check complete.</p> <p>NO: Replace belt if oily, greasy, cracked, or otherwise damaged.</p> <p style="text-align: right;">-- -1/1</p>
------------------------------	---	---

BLANK

CHAPTER 22
TROUBLESHOOTING

BLANK

Troubleshooting

USING TROUBLESHOOTING CHARTS

NOTE: Troubleshooting charts are arranged from the simplest to verify, to least likely, more difficult to verify. When diagnosing a problem, use all possible means to isolate the problem to a single component or system. Use the following steps to diagnose problems:

- *Step 1. Operational Checkout Procedure.*
- *Step 2. Troubleshooting charts.*
- *Step 3. Adjustments.*
- *Step 4. See your authorized dealer.*

TX,100,DH5621 -19-26MAR97-1/1

ENGINE

Symptom	Problem	Solution
Engine Cranks But Will Not Start Or Hard To Start	No fuel	Add fuel. Bleed air.
	Wrong fuel	Use correct fuel.
	Fuel filter clogged	Replace filter. Bleed air. Clean fuel tank strainer.
	Leaks in fuel system	Check fuel system connections.
	Contaminated fuel	Drain tank. Clean tank strainer. Add clean fuel.
	Air in fuel system	Bleed air.
	Low battery power	Charge or install new batteries.
	Slow cranking speed (poor electrical connection)	Clean and tighten battery and starter connections.
	Wrong engine oil	Use correct oil.
	Air filter clogged	Clean or replace elements.
	Injection pump linkage	Go to your authorized dealer.
	Injection nozzles	Go to your authorized dealer.
	Injection pump	Go to your authorized dealer.
	Starter	Replace starter.
Engine compression low	Go to your authorized dealer.	
Engine Knocks, Runs Irregularly, Or Stops	Air filter clogged	Clean or replace elements. Clean system.
	Fuel filter clogged	Replace filter. Bleed air. Clean fuel tank strainer.
	Engine oil level low	Add oil.

Troubleshooting

Symptom	Problem	Solution
Engine Not Developing Full Power	Contaminated fuel	Drain tank. Clean tank strainer. Add clean fuel.
	Injection pump out of time	Go to your authorized dealer.
	Wrong valve clearance	Check and adjust valves.
	Injection nozzles	Go to your authorized dealer.
	Coolant temperature low	Thermostat not operating within correct temperature range. Replace thermostat or go to your authorized dealer.
	Injection pump	Go to your authorized dealer.
	Air filters clogged	Clean or replace filter elements.
	Fuel filter clogged	Change filter. Bleed air.
	Contaminated fuel	Drain fuel tank. Clean tank strainer. Add clean fuel.
	Wrong fuel	Use correct fuel.
	Fuel line restricted	Repair or replace fuel line.
	Clogged vent in fuel tank cap	Clean or install new cap.
	Injection pump linkage adjustment	Adjust or go to your authorized dealer.
	Intake system leakage	Go to your authorized dealer.
	Exhaust restriction	Remove muffler and run engine.
Wrong valve clearance	Check and adjust valves.	
Engine too hot or cold	See below.	
Wrong oil	Use correct oil.	
Injection nozzles	Go to your authorized dealer.	

Troubleshooting

Symptom	Problem	Solution
	Turbocharger	Go to your authorized dealer.
	Injection pump	Go to your authorized dealer.
	Engine malfunction	Go to your authorized dealer.
Engine Overheats	Coolant level low	Add coolant.
	Thermostat	Go to your authorized dealer.
	Radiator screen clogged	Remove and clean screen.
	Radiator core or oil cooler core clogged	Clean radiator and oil cooler.
	Air filter clogged	Clean or replace elements.
	Radiator cap	Install new cap.
	Fan belt malfunction	Go to your authorized dealer.
	Fan	Replace fan.
	Alternator/fan belt loose	Go to your authorized dealer.
	Engine overloaded	Check hydraulic relief valves.
	Cooling system passages dirty	Flush cooling system.
	Temperature gauge or sending unit	Go to your authorized dealer.
	Injection pump	Go to your authorized dealer.
	Pulley grooves worn	Replace pulleys.
Coolant Temperature Too Low	Thermostat	Go to your authorized dealer.
	Temperature gauge or sending unit	Go to your authorized dealer.
Low Engine Oil Pressure	Oil level low	Add oil.
	Oil filter clogged	Install new oil filter.
	Oil pump intake screen clogged	Go to your authorized dealer.

Continued on next page

TX,100,DH5155 -19-10AUG96-3/6

Troubleshooting

Symptom	Problem	Solution
	Wrong oil	Use correct oil.
	Oil leaks	Check for leaks.
	Engine oil pump or pump drive	Go to your authorized dealer.
	Engine oil pressure regulating valve	Go to your authorized dealer.
	Oil diluted with fuel or coolant	Go to your authorized dealer.
	Engine temperature too high	Check cooling system.
Engine Uses Too Much Oil	Wrong oil	Use correct oil.
	Oil leaks	Check engine oil drain plug.
	Engine temperature too high	Check cooling system.
	Air cleaner clogged	Clean element or install new element.
	Internal engine component wear	Go to your authorized dealer.
Engine Uses Too Much Fuel	Clogged or dirty air intake system	Clean air intake system.
	Wrong fuel	Use correct fuel.
	Hydraulic pump regulators set incorrectly	Go to your authorized dealer.
	Fuel injection nozzles	Go to your authorized dealer.
	Injection pump	Go to your authorized dealer.
Excessive Black Or Gray Exhaust Smoke	Wrong fuel	Use correct fuel.
	Hydraulic pump regulators set incorrectly	Go to your authorized dealer.
	Clogged or dirty air intake or exhaust system	Clean air intake and exhaust system.
	Injection pump	Go to your authorized dealer.

Troubleshooting

Symptom	Problem	Solution
	Injection nozzles	Go to your authorized dealer.
	Engine	Go to your authorized dealer.
Exhaust Gas Is White	Wrong fuel	Use correct fuel.
	Cold engine	Run engine until warm.
	Thermostat faulty or too 'cool'	Go to your authorized dealer.
	Injection pump	Go to your authorized dealer.
	Coolant leakage into engine cylinder	Go to your authorized dealer.
Turbocharger Excessively Noisy Or Vibrates	Bearings not lubricated	Insufficient oil pressure. Check for restricted turbocharger oil line.
	Worn bearings	Go to your authorized dealer.
	Air leak in engine, intake, or exhaust manifold	Inspect, repair.
	Improper clearance between turbine wheel and turbine housing	Go to your authorized dealer.
	Broken blades on turbine	Remove exhaust elbow and air inlet hose and inspect.
Oil Dripping From Turbocharger Adapter	Damaged or worn bearings and/or worn seals	Go to your authorized dealer.
	Excessive crankcase pressure	Check vent tube to ensure tube is not clogged. Clean.
	Turbocharger oil return line carbon buildup where line passes exhaust manifold	Remove line. Inspect, clean.
Excessive Drag In Turbocharger Rotating Members	Carbon buildup behind turbine wheel caused by combustion deposits	Inspect, clean.
	Dirt buildup behind compressor wheel caused by air intake leaks	Inspect, clean.

Continued on next page

TX,100,DH5155 -19-10AUG96-5/6

Troubleshooting

Symptom	Problem	Solution
	Bearing seizure or dirty or worn bearings, caused by excessive temperature, unbalanced wheel, dirty oil, oil starvation, or insufficient lubrication	Go to your authorized dealer.

TX,100,DH5155 -19-10AUG96-6/6

ELECTRICAL SYSTEM

Symptom	Problem	Solution
Nothing Works	Battery	Recharge or replace.
	Fusible link	Replace fusible link.
	Battery cables making poor connections	Clean connections.
Batteries Undercharged	Loose or corroded connections	Clean and tighten or replace batteries.
	Alternator/fan belt tension adjuster	Go to your authorized dealer.
	Alternator not charging	Go to your authorized dealer.
	Fuse	Replace fuse.
	Key switch	Replace key switch.
Batteries Will Not Take A Charge	Loose or corroded connections	Clean and tighten.
	Low battery power	Install new batteries.
	Alternator not charging	Go to your authorized dealer.
Battery Uses Too Much Water	Cracked battery case	Replace battery.
	High ambient temperature	Refill with water.
	Shorted cell	Check if one or more cells take more water than the others. Check specific gravity.
	Battery being overcharged	Go to your authorized dealer.
	Cracked Battery Case	No battery hold down clamp
Loose battery hold down clamp		Replace battery and install hold down clamp.
Battery hold down clamp too tight		Replace battery and install battery hold down clamp correctly.

Troubleshooting

Symptom	Problem	Solution
Low Battery Output	Frozen battery	Replace battery. Keep battery fully charged in cold weather.
	Low water level	Add water.
	Dirty or wet battery top, causing discharge	Clean and wipe battery top dry.
	Corroded or loose battery cables	Clean and tighten battery cables.
	Broken battery post	Wiggle battery post by hand. If post wiggles or turns, replace battery.
	Low battery voltage	Measure 'stabilized' battery voltage. Stabilize voltage by actuating horn for 30 seconds. If stabilized voltage is below 24 volts, charge battery.
	Battery cell	Measure specific gravity of each cell. If more than 50 points between cells, replace battery.
Starter Will Not Turn	Battery undercharged or dead	Recharge or replace battery.
	Battery cables making poor connections	Clean connections.
	Fusible link	Replace fusible link.
	Key switch	Go to your authorized dealer.
	Starter relay	Go to your authorized dealer.
	Starter solenoid	Go to your authorized dealer.
	Starter	Repair or replace starter motor.
	Starter pinion jammed in flywheel gear	Repair or replace starter.
Engine	Go to your authorized dealer.	
Starter Solenoid Chatters	Poor connections at batteries or starter	Clean connections.

Troubleshooting

Symptom	Problem	Solution
Starter Turns But Will Not Crank Engine	Low battery charge	Recharge or replace batteries.
	Starter solenoid 'hold-in' windings open	Go to your authorized dealer.
	Starter pinion gear not engaging flywheel ring gear	Go to your authorized dealer.
	Pinion shift mechanism jammed or malfunctioning	Go to your authorized dealer.
	Pinion gear teeth broken	Go to your authorized dealer.
Engine Cranks Slowly	Flywheel gear teeth broken	Go to your authorized dealer.
	Battery cables damaged or broken internally	Inspect and replace cables.
	Battery or starter cable connections loose or corroded	Clean and tighten connections.
Starter Continues To Run After Engine Starts	Battery discharged or will not hold a charge	Recharge or replace battery.
	Starter 'dragging'	Go to your authorized dealer.
	Low battery voltage	Recharge or replace battery.
	Starter relay stuck	Go to your authorized dealer.
	Starter solenoid stuck	Go to your authorized dealer.
Charging Indicator Light On, Engine Running	Starter not disengaging	Go to your authorized dealer.
	Key switch	Go to your authorized dealer.
	Loose or glazed alternator belt	Check belt. Replace if glazed.
	Engine rpm low	Adjust rpm to specifications.
	Excessive electrical load from added accessories	Remove accessories or install higher output alternator.

Continued on next page

TX,100,DH5361 -19-19DEC96-3/6

Troubleshooting

Symptom	Problem	Solution
	Loose or corroded electrical connections on battery, ground strap, starter, or alternator	Inspect, clean, or tighten electrical connections.
	Battery voltage low	Charge or replace battery.
	Alternator or regulator	Go to your authorized dealer.
	Indicator circuit	Go to your authorized dealer.
Noisy Alternator	Worn drive belt	Replace belt.
	Worn pulleys	Replace pulleys and belt.
	Pulley misaligned	Adjuster alternator mount.
	Alternator bearing	Loosen alternator belts. Turn pulley by hand. If any roughness is felt, repair alternator.
No Monitor Panel Indicators Work	Fuse	Replace fuse.
	Monitor panel logic module	Go to your authorized dealer.
	Wiring harness	Go to your authorized dealer.
Individual Light In Monitor Panel Is Not Working	Bulb	Replace bulb.
	Fuse	Replace fuse.
	Wiring harness	Go to your authorized dealer.
No Indicators In Gauge Panel Operate	Circuit board	Go to your authorized dealer.
	Wiring harness	Go to your authorized dealer.
	Fuse	Replace fuse.
Indicator Light In Gauge Panel Is Inoperative	Bulb	Replace bulb.
	Fuse	Replace fuse.

Continued on next page

TX,100,DH5361 -19-19DEC96-4/6

Troubleshooting

Symptom	Problem	Solution
Engine Water Temperature Gauge Does Not Work	Wiring harness	Go to your authorized dealer.
	Fuse	Replace fuse.
	Gauge	Go to your authorized dealer.
	Gauge sender	Go to your authorized dealer.
Indicator Lights Do Not Operate	Wiring harness	Go to your authorized dealer.
	Fuse	Replace fuse.
	Bulb	Replace bulb.
	Auto-idle switch	Go to your authorized dealer.
Fuel Gauge Does Not Work	Propel switch	Go to your authorized dealer.
	Fuse	Replace fuse.
	Gauge	Go to your authorized dealer.
Work Mode Selector Switch Does Not Work	Wiring harness	Go to your authorized dealer.
	Mode switches	Replace switches.
	Electrical connector	Repair or replace.
	Pilot pressure switch	Go to your authorized dealer.
Propel Speed Does Not Function	Wiring harness	Go to your authorized dealer.
	Speed switches	Go to your authorized dealer.
	Two speed travel solenoid valve	Go to your authorized dealer.
	Propel pilot pressure switch	Go to your authorized dealer.
	Propel motor	Go to your authorized dealer.
Auto-Idle Does Not Work	Rotary manifold	Go to your authorized dealer.
	Fuse	Replace fuse.

Continued on next page

TX,100,DH5361 -19-19DEC96-5/6

Troubleshooting

Symptom	Problem	Solution
	Engine speed too low	Increase speed to higher than auto-idle. Press auto-idle switch.
	Switch panel	Go to your authorized dealer.
	Electrical connector	Go to your authorized dealer.
	Wiring harness	Go to your authorized dealer.
Windshield Wiper Does Not Work	Fuse	Replace fuse.
	Upper front right window latch not locked	Lock upper front right window latch.

TX,100,DH5361 -19-19DEC96-6/6

Troubleshooting

HYDRAULIC SYSTEM

Symptom	Problem	Solution
Control Lever Moves Hard	Corroded joint, worn out pusher	Go to your authorized dealer.
Control Lever Does Nothing	Worn out pusher	Go to your authorized dealer.
	Pilot valve	Go to your authorized dealer.
Control Lever Does Not Return To Neutral	Pilot valve	Go to your authorized dealer.
Too Much Play In Control Lever	Worn out pivot joint	Go to your authorized dealer.
Control Lever Is Not Vertical In Neutral	Pilot valve	Go to your authorized dealer.
No Hydraulic Functions	Lack of hydraulic oil	Add oil.
	Pilot shut-off valve	Go to your authorized dealer.
	Pilot pump	Go to your authorized dealer.
	Pilot pressure regulating valve	Go to your authorized dealer.
	System relief valve	Go to your authorized dealer.
	Pressure switches	Go to your authorized dealer.
	Clogged suction filter	Clean.
	Damaged suction line or hose	Go to your authorized dealer.
	Hydraulic pump	Go to your authorized dealer.
	Some Functions Do Not Work	Pilot controller
Pilot shut-off valve not released		Go to your authorized dealer.
Pilot controller hoses pinched		Inspect and correct
Control valve		Go to your authorized dealer.
Circuit relief valves		Go to your authorized dealer.
Cylinders		Go to your authorized dealer.

Continued on next page

TX,100,DH3697 -19-18AUG95-1/5

Troubleshooting

Symptom	Problem	Solution
Hydraulic Functions Are Slow	Low oil level	Fill reservoir to full mark.
	Wrong oil	Use correct oil.
	Engine speed too slow	Increase speed or see your authorized dealer.
	Pilot circuit	Go to your authorized dealer.
	Worn pump	Go to your authorized dealer.
	Suction screen clogged	Inspect and clean.
	Restricted pump suction line	Go to your authorized dealer.
	Improperly adjusted relief valves	Go to your authorized dealer.
One Function Does Not Work	Pilot controller	Go to your authorized dealer.
	Relief valve pressure low	Go to your authorized dealer.
	Tube or hose damaged	Repair or replace.
	Hydraulic fittings loose	Tighten.
	Damaged O-rings in fittings	Install new O-ring.
	Pilot controller hose pinched	Inspect and correct.
	Cylinder	Go to your authorized dealer.
	Hydraulic pump	Go to your authorized dealer.
One Function Has Little Power	Control valve	Go to your authorized dealer.
	Pilot controller	Go to your authorized dealer.
	Pilot lines	Repair or replace.
	Control valve	Go to your authorized dealer.
	Circuit relief valve	Go to your authorized dealer.
	Cylinder seals leaking	Go to your authorized dealer.

Troubleshooting

Symptom	Problem	Solution
Hydraulic Cylinders Operate But Cannot Lift Load	Cylinder rod	Go to your authorized dealer.
	Hydraulic oil level low	Add oil.
	Suction screen clogged	Clean strainer and system.
	System or circuit relief valves	Go to your authorized dealer.
	Pump suction line leaking	Inspect suction line.
	Hydraulic pump worn	Go to your authorized dealer.
Low Or No Oil Pressure		Go to your authorized dealer.
	System relief valve	Go to your authorized dealer.
	No oil in system	Fill with correct oil.
	Wrong oil	Use correct oil.
	Improperly adjusted relief valves	Go to your authorized dealer.
Hydraulic Oil Overheats	Worn cylinder packings	Go to your authorized dealer.
	Tank cap	Replace cap.
	Wrong oil	Use correct oil.
	Clogged radiator or oil cooler	Clean and straighten fins.
	Radiator screen clogged	Remove and clean.
	Clogged filters	Install new filters.
	Low oil level	Fill tank to full mark.
	Oil line restricted	Go to your authorized dealer.
	Contaminated oil	Drain oil and refill.
	Oil cooler bypass	Go to your authorized dealer.
Relief valve	Go to your authorized dealer.	

Continued on next page

TX,100,DH3697 -19-18AUG95-3/5

Troubleshooting

Symptom	Problem	Solution
	Air leak in pump suction line	Go to your authorized dealer.
	Worn pump	Go to your authorized dealer.
	Propel motors	Go to your authorized dealer.
Oil Foams	High or low oil level	Correct level.
	Wrong oil	Use correct oil.
	Water in oil	Change oil.
	Kinks or dents in oil lines	Check lines.
	Air leak in line from reservoir to pump	Repair leak.
No Swing Function	Pilot controller	Go to your authorized dealer.
	Swing control valve spool	Go to your authorized dealer.
	Pilot control hoses pinched or kinked	Inspect and correct.
	Swing brake	Go to your authorized dealer.
	Swing motor	Go to your authorized dealer.
Swing Function Is 'Jerky'	Lack of grease	Fill with grease
	Swing gear	Go to your authorized dealer.
	Swing brake	Go to your authorized dealer.
	Swing bearing	Go to your authorized dealer.
Slow Propel System, Does Not Propel	Propel brake	Go to your authorized dealer.
	Rotary manifold	Go to your authorized dealer.
Individual Propel Function Is Slow	Rock under pedal	Remove
	Pilot controller hoses pinched or kinked	Inspect and correct.

Continued on next page

TX,100,DH3697 -19-18AUG95-4/5

Troubleshooting

Symptom	Problem	Solution
	Pilot controller	Go to your authorized dealer.
	Propel brake	Go to your authorized dealer.
	Rotary manifold	Go to your authorized dealer.
	Propel motor	Go to your authorized dealer.
Propel Is 'Jerky'	Track sag	Adjust tension.
	Track idler or rollers	Go to your authorized dealer.
	Track frame bent	Go to your authorized dealer.
	Rocks or mud jammed in track frame	Remove and repair.
	Propel gearbox	Go to your authorized dealer.
	Propel brake not releasing	Go to your authorized dealer.
Engine Stops When Propel Or Control Lever Is Moved	Engine	Go to your authorized dealer.
	Wiring harness	Repair.
	Fuel filter	Replace.
	Engine speed sensor	Go to your authorized dealer.

TX,100,DH3697 -19-18AUG95-5/5

CHAPTER 23

STORAGE

BLANK

Storage

PREPARE MACHINE FOR STORAGE

1. Repair worn or damaged parts. Install new parts, if necessary, to avoid needless delays later.
2. Clean primary air cleaner.



T47764 -UN-09NOV88

TX.105,FF2313 -19-03APR91-1/3

IMPORTANT: High pressure washing [greater than 1379 kPa (13.8 bar) (200 psi)] can damage freshly painted finishes. Paint should be allowed to air dry for 30 days minimum after receipt of machine before cleaning parts or machines with high pressure. Use low pressure wash operations until 30 days have elapsed.

3. Wash the machine. [Use low pressure wash operations (less than 1379 kPa (13.8 bar) (200 psi) until 30 days after receipt of machine have elapsed.) Paint areas to prevent rust. Replace decals, where needed.
4. Apply waste oil to track chains. Run machine back and forth several times. Park machine on a hard surface to prevent tracks from freezing to ground.
5. Store machine in a dry, protected place. If stored outside, cover with a waterproof material.

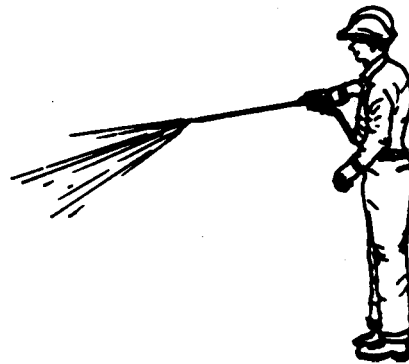

T5813AM -UN-09FEB89

Continued on next page

TX.105,FF2313 -19-03APR91-2/3

Storage

IMPORTANT: LPS® 3 Rust Inhibitor can destroy painted finish. Do not spray LPS® 3 Rust Inhibitor on painted areas.

6. Park machine as shown. Inspect cylinder rods for evidence of damage or rust. Report deficiencies to your supervisor. Coat exposed cylinder rods (A) with LPS® 3 Rust Inhibitor.

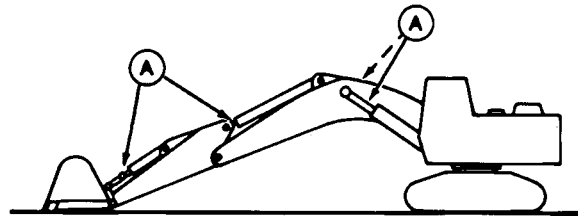

T7034AA -JUN-18APR89

IMPORTANT: Prevent possible machine damage from unauthorized persons operating machine. Attach a 'DO NOT OPERATE' tag to right control lever.

7. Place a 'DO NOT OPERATE' tag on the right control lever.
8. Lubricate all grease points.
9. Remove batteries.
10. Remove seat cushion and other perishable items.
11. Remove keys and lock all covers and doors.

A—Cylinder Rod Areas

LPS is a trademark of the Holt Lloyd Corporation.

TX.105,FF2313 -19-03APR91-3/3

QUICK-DISCONNECT HITCH STORAGE PROCEDURE

1. Plug cylinder ports.
2. Lubricate wedge bar.
3. Apply light coating of oil to all exposed metal parts.

CED,OUOE020,8 -19-19FEB99-1/1

MONTHLY STORAGE PROCEDURE

CAUTION: Engine exhaust fumes can cause sickness or death. Start engine ONLY in a well-ventilated area.

1. Drain water and sediment from fuel tank when air temperature is above freezing.
2. Remove LPS 3 Rust Inhibitor from cylinder rods with a cleaning solvent.

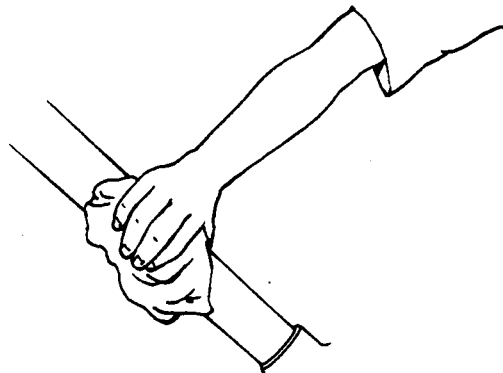

T6191AA -JUN-18OCT88

Continued on next page

TX,105,FF,400 -19-06SEP94-1/4

Storage

IMPORTANT: Prevent possible engine damage. During cold temperatures, check viscosity of engine oil on dipstick. If the oil appears waxy and/or jelly-like rather than liquid, **DO NOT** attempt to start engine. Use external heat source to warm the crankcase until oil appears fluid.



T6181AU -JUN-18OCT88

3. Check all fluid levels. If low, check for leaks and add oil as required.
4. Check belt.
5. Check condition of all hoses and connections.
6. Check electrolyte level. Charge and install battery.
7. Fill fuel tank. (See Fuels and Lubricants chapter.)
8. Start engine. Run engine at 1/2 speed for 5 minutes. Do not run at fast or slow idle.
9. Bleed fuel system. If engine fails to start or runs poorly after starting, change fuel filter(s). Bleed fuel system again.

! **CAUTION:** Prevent possible injury from unexpected machine movement. Clear the area of all persons before running machine through the operation procedure.

10. Make sure that area is clear to allow for movement. Operate (cycle) boom, arm, and bucket functions for three complete cycles.
11. Operate the swing function for three complete revolutions in each direction.
12. Check condition of tracks. Check track sag.

Continued on next page

TX,105,FF,400 -19-06SEP94-2/4

Storage

13. Operate the propel functions in forward and reverse directions. This can be performed by one of two methods.

a. Propelling the machine in forward and reverse for a distance of 30 m (100 ft).

CAUTION: Prevent possible injury from machine sliding backwards. Keep the angle between boom and arm 90-110°.

b. If machine is equipped with bucket, raise each track (keeping angle between boom and arm 90-110°) and propel in each direction for three revolutions.

14. Park the machine with cylinder rods retracted.

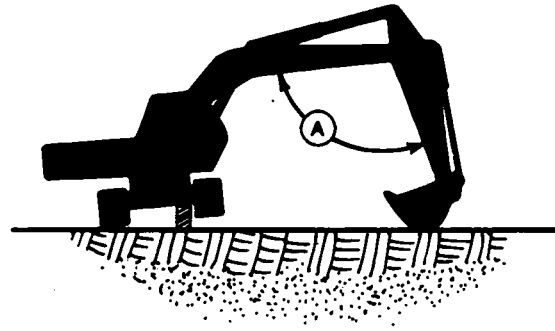

T6879AT -UN-06DEC88

TX,105,FF,400 -19-06SEP94-3/4

15. Apply LPS 3 Rust Inhibitor to the exposed cylinder rod areas (A).

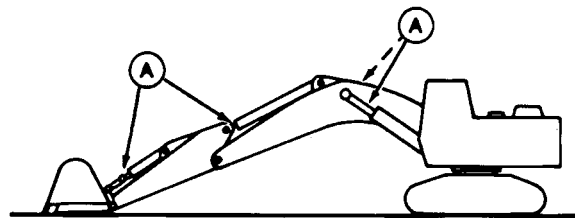

T7034AA -UN-18APR89

TX,105,FF,400 -19-06SEP94-4/4

BLANK

CHAPTER 24
SPECIFICATIONS

BLANK

Specifications

230LCR/LCRD

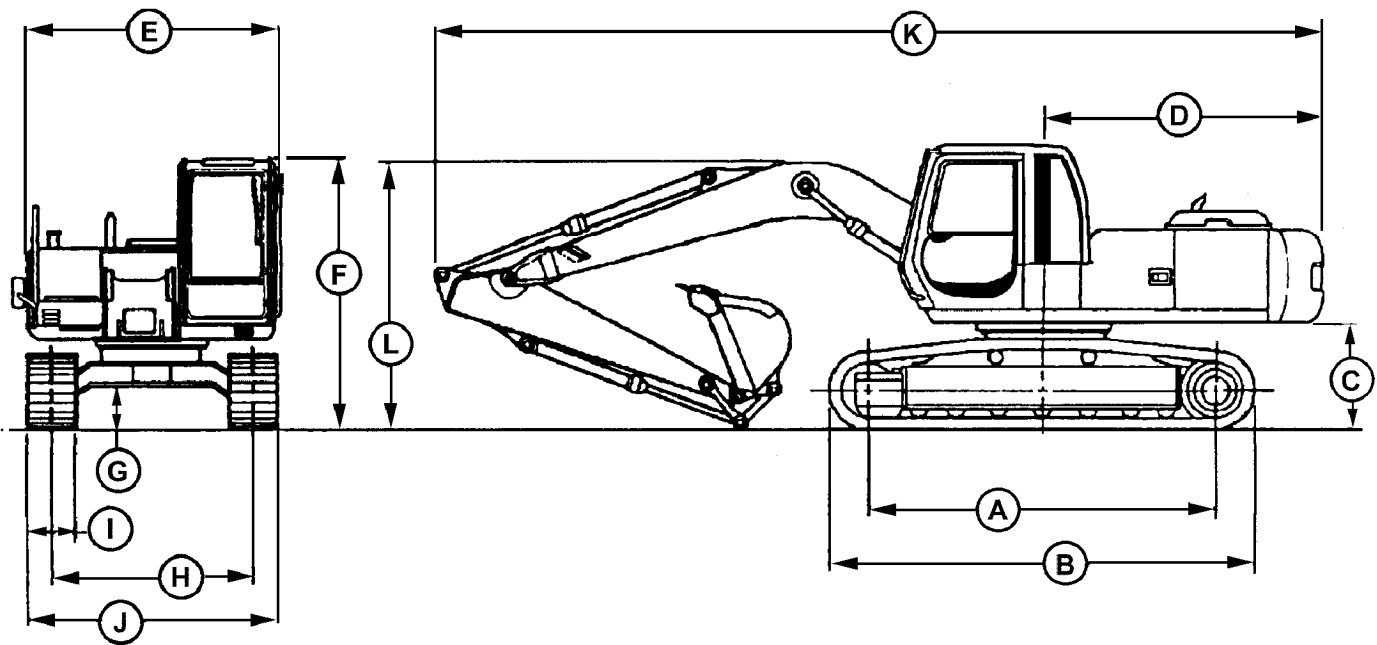

230LCR

T113215 -UN-03FEB98

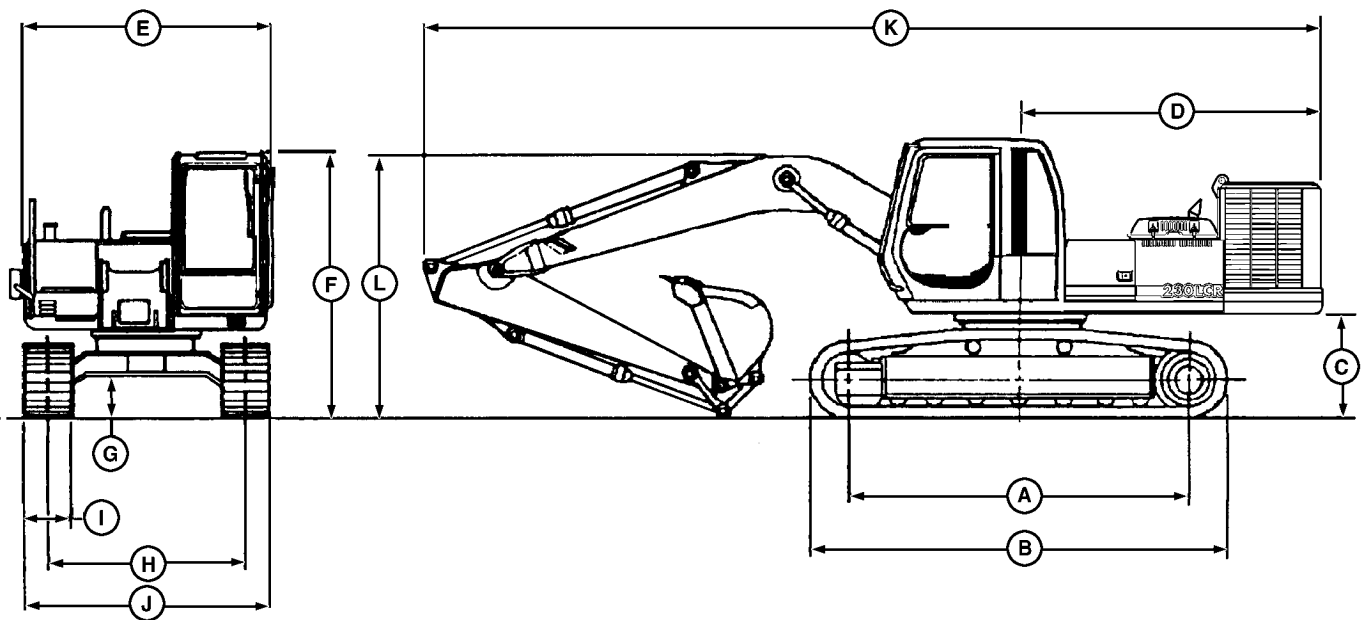

230LCRD

T125074

T125074 -UN-01NOV99

Continued on next page

TX.115.JC3513 -19-05FEB98-1/2

Specifications

NOTE: Specifications and design subject to change without notice. Wherever applicable, specifications are in accordance with PCSA and SAE standards. Except where otherwise noted these specifications are based on a machine equipped with 800 mm (32 in.) shoes, counterweight, 3.61 m (11 ft 10 in.) arm, 809 kg (1785 lb) 1.0 m³ (1.38 yd³) bucket, full fuel tank, 79 kg (175 lb) operator and standard equipment.

A	3840 mm (12 ft 7 in.)
B	4640 mm (15 ft 3 in.)
C	1090 mm (3 ft 7 in.)
D	
(230LCR)	2940 mm (9 ft 8 in.)
(230LCRD)	3683 mm (12 ft 1 in.)
E	2870 mm (9 ft 5 in.)
F	2940 mm (9 ft 8 in.)
G	460 mm (1 ft 6 in.)
H	2590 mm (8 ft 6 in.)
I	600 mm (24 in.) or 700 mm (28 in.) or 800 mm (32 in.)
J—With 2390 mm (7 ft 10 in.) undercarriage and	
With 600 mm (24 in.) shoes	3190 mm (10 ft 6 in.)
With 700 mm (28 in.) shoes	3290 mm (10 ft 10 in.)
With 800 mm (32 in.) shoes	3390 mm (11 ft 1 in.)
K—With 2960 mm (9 ft 9 in.) arm (230LCR)	10140 mm (33 ft 3 in.)
With 2960 mm (9 ft 9 in.) arm (230LCRD)	10261 mm (35 ft 8 in.)
L— With 2320 mm (7 ft 7 in.) arm	3290 mm (10 ft 10 in.)
With 2960 mm (9 ft 9 in.) arm	3100 mm (10 ft 2 in.)
With 3610 mm (11 ft 10 in.) arm	3320 mm (10 ft 11 in.)

230LCR/LCRD WORKING RANGES

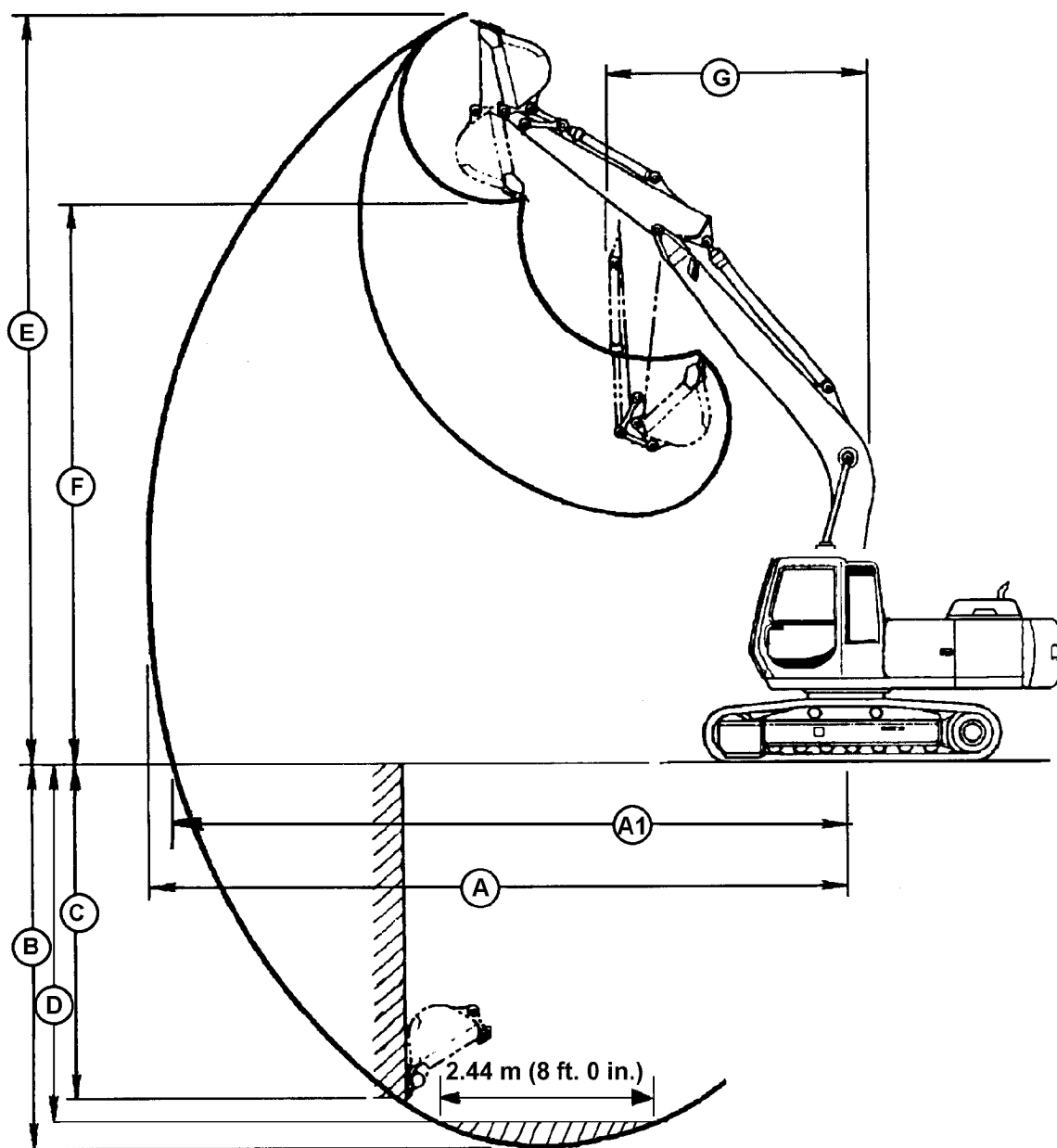

T102389 -JUN-24MAR97

Continued on next page

TX,115,DH5418 -19-01MAR97-1/2

Specifications

	2.32 m (7 ft 7 in.) Arm	2.96 m (9 ft 9 in.) Arm	3.61 m (11 ft 10 in.) Arm
A	9710 mm (31 ft 10 in.)	10270 mm (33 ft 8 in.)	10900 mm (35 ft 9 in.)
A1	9530 mm (31 ft 3 in.)	10100 mm (33 ft 2 in.)	10730 mm (35 ft 2 in.)
B	6300 mm (20 ft 8 in.)	6950 mm (22 ft 10 in.)	7590 mm (24 ft 11 in.)
C	6070 mm (19 ft 11 in.)	6740 mm (22 ft 1 in.)	7430 mm (24 ft 5 in.)
D	5400 mm (17 ft 9 in.)	6020 mm (19 ft 9 in.)	6740 mm (22 ft 2 in.)
E	9410 mm (30 ft 10 in.)	9630 mm (31 ft 7 in.)	9990 mm (32 ft 9 in.)
F	6540 mm (21 ft 5 in.)	6760 mm (22 ft 2 in.)	7100 mm (23 ft 4 in.)
G	3960 mm (13 ft 0 in.)	3870 mm (12 ft 8 in.)	3890 mm (12 ft 9 in.)

TX,115,DH5418 -19-01MAR97-2/2

230LCR/LCRD

Engine: John Deere POWERTECH® 6.8	
Type	4-stroke cycle, turbocharged, charge air cooled diesel
Bore and stroke	106 x 127 mm (4.17 x 5.0 in.)
Number of cylinders	6
Displacement	6.8 L (414 cu in.)
Maximum net torque @ 1400 rpm	716 N•m (528 lb-ft)
Cooling fan	Suction
Compression ratio	17:1
Lubrication	Pressure system with full-flow filter
Electrical system	24 volt
Batteries (2) 12 volt	Reserve capacity: 180 minutes
Power at 2100 rpm:	
Net SAE	127 kW (170 hp)
Operating Weight	23 773 kg (52, 410 lb)

POWERTECH is a trademark of Deere & Company.

TX,115,DH5419 -19-01MAR97-1/1

*Specifications***230LCR/LCRD DRAIN AND REFILL
CAPACITIES**

	Metric	U.S.
Fuel tank	310 L	82 gal
Cooling system	22 L	6 gal
Engine oil, including filter change	19 L	5 gal
Hydraulic tank	148 L	39 gal
Hydraulic system	270 L	71 gal
Swing gearbox	13 L	14 qt
Propel gearbox (each)	6.0 L	6.5 qt
Pump drive gearbox	1.0 L	1.1 qt

TX,115,DH5420 -19-01MAR97-1/1

Specifications

230LCR/LCRD LIFT CAPACITY—KG (LB)

--	--	--

Ratings are at bucket lift hook, using standard counterweight, situated on firm, level, uniform supporting surface.

Figures do not exceed 87 percent of hydraulic capacity or 75 percent of weight needed to tip machine. Figures marked with an (*) are hydraulically-limited capacities. Remaining figures are stability-limited capacities.

Power Boost: On

Arm: 2.96 m (9 ft 9 in.)		Bucket: 809 kg (1785 lb) 1.0 m ³ (1.38 yd ³)			Shoe: 800 mm (32 in.)	
LIFTING OVER FRONT						
Load Point Height	Horizontal Distance from Centerline of Rotation					
m (ft)	1.52 (5)	3.05 (10)	4.57 (15)	6.10 (20)	7.62 (25)	9.14 (30)
6.10 (20)	3567 (7863) ^a					
4.57 (15)	4644 (10238) ^a	4421 (9746) ^a				
3.05 (10)	7574 (16697) ^a	5744 (12664) ^a	4935 (10880) ^a			
1.52 (5)	10198 (22483) ^a	6986 (15402) ^a	5577 (12296) ^a	3987 (8789) ^a		
Ground (Line)	11563 (25492) ^a	7950 (17526) ^a	5576 (12292)	4002 (8824) ^a		
-1.52 (-5)	5450 (12015) ^a	11761 (25928) ^a	7844 (17293)	5480 (12082)		
-3.05 (-10)	12512 (27586) ^a	11222 (24741) ^a	8264 (18218) ^a	5480 (12081)		
-4.57 (-15)	13417 (29580) ^a	9858 (21733) ^a	7316 (16128) ^a			
LIFTING OVER SIDE						
m (ft)	1.52 (5)	3.05 (10)	4.57 (15)	6.10 (20)	7.62 (25)	9.14 (30)
(6.10 20)	3567 (7863) ^a					
4.57 (15)	4644 (10238) ^a	3921 (8645)				
3.05 (10)	7574 (16697) ^a	5744 (12664) ^a	3766 (8303)			
1.52 (5)	7972 (17575)	5147 (11348)	3586 (7905)	2590 (5711)		
Ground (Line)	7573 (16696)	4881 (10761)	3435 (7572)	2521 (5559)		
-1.52 (-5)	5450 (12015) ^a	7476 (16482)	4749 (10470)	3348 (7380)		
-3.05 (-10)	12513 (27586) ^a	7523 (16586)	4737 (10443)	3347 (7379)		
-4.57 (-15)	13417 (29580) ^a	7691 (16956)	4847 (10685)			

^aHydraulically-limited capacity

ROCK DRILL ATTACHMENT - TECHNICAL SPECIFICATIONS

IR-MONTABERT reference : CPN :	79700-V1 86372943	76500-V1 86361185	83948-V1 86389624	95220-V1 86489564
Model	CPA 200	CPA 220	CPA 225	CPA X-TEND
CARRIER REQUIREMENT				
Excavator weight metric tons	13 to 20	13 to 25	13 to 25	22 to 35
Min. power KW	55	55	55	74 / 80
Hydraulic flow l/min	140	140	140	180 / 200
GENERAL SPECIFICATIONS				
Weight kg	1100	1250	1300	2500 2900
Length mm	5800	5900	6000	7200 10200
Width mm	1300	950	900	1100
Height mm	1400	1170	1300	1600
Rotation from vertical axis degrees	± 27	± 27	± 180	± 27
DRIFTER				
	HC 40	HC 40	HC 40	<i>HC 105 / HC 150</i>
Input power KW	23	23	23	35 / 42
Frequency BPM	2900	2900	2900	2900 / 2530
Reverse percussion				Optional
FEED				
	ACH CPA	ACH CPA	ACH CPA	GCX
Type	14' / 12'	14' / 12'	14' / 12'	14' / 12' 24' / 20'
Rod type	R32 / T38	R32 / T38	R32 / T38	T45 / T51
Rod length				
Starter rod mm ft	4305 (14')	4305 (14')	4305 (14')	4305 7135 (14') (24')
Extension rod mm ft	3050 / 3600 (10' / 12')	3050 / 3600 (10' / 12')	3050 / 3600 (10' / 12')	3660 6100 (12') (20')
Drill depth m ft	18.3 (60')	18.3 19.5 (ACH 18/12) (64')	18.3 (60')	25 11.3 (82') (37')
Bit diameter mm in	38 to 76 (1.5' to 3')	38 to 76 (1.5' to 3')	38 to 76 (1.5' to 3')	76 to 115 3' to 4.5'
ROD HANDLING				
Rod rack	Standard	Standard	Standard	-
Single rod loader	-	-	option	Standard
Rod changer	-	-	-	6+1 or 4+1 (T51 x 20')
CONTROLS				
	Manual on guide	Electric remote	Electric remote	Electric in cabin
DUST COLLECTION				
pre-equipment	yes	yes	yes	yes
AIR REQUIREMENT				
An air compressor must be provided for flushing the drilled hole				
Compressor recommendation l/min @ 8 bar cfm @ 120 psi	5000 180	5000 180	5000 180	7400 9350 260 330

AIR COMPRESSOR GENERAL DATA

COMPRESSOR	MODEL XP330SJD
Rated Delivery - cfm (litres/sec).....	330 (155)
Rated Pressure - psi (kPa).....	125 (862)
Safety Valve Setting - psi (kPa)	175 (1207)
Engine - (Diesel)	John Deere Power Tech 4045T
Speed No Load (Full Load) - rpm	1400 (2500)
Electrical/Starting System - volts	24
Eng. Lube includes: filter, capacity - U.S. gal. (litres)	3.5 (13.2)
Eng. Coolant Capacity - U.S. gal (litres) nominal	5.8 (22.0)
Compressor Lube Capacity (refill) - U.S. gal. (litres)	9.5 (36.0)

UNITS MEASUREMENTS/WEIGHT

Overall Length - inches (mm).....	88 (2235)
Overall Height - inches (mm)	51 (1296)
Overall Width - inches (mm)	44 (1118)
Unit weight (all fluids) - pounds	2860 (1298)

APPENDIX A OPERATOR PREVENTIVE MAINTENANCE CHECKS AND SERVICES (PMCS)

A-1. GENERAL

Preventive Maintenance Checks and Services (PMCS) are performed to keep the Hydraulic Excavator in operating condition. The checks are used to find, correct, or report problems. Crewmembers are to do the PMCS jobs as shown in the PMCS table. PMCS are done every day the vehicle is operated, using the PMCS table. Pay attention to WARNING and CAUTION statements. A WARNING means someone could be hurt. A CAUTION means equipment could be damaged.

NOTE: As this operator manual is a commercial product supplemented to include Army specific procedures, the manual may advise the operator to perform tasks that would normally not be assigned to the operator level in a DATM. Always follow the limits established in the PMCS.

See also Chapter 3, Break-In, and Chapters 10 through 17, Scheduled Maintenance, for additional information.

Before you begin operating the Hydraulic Excavator, do Before PMCS.

During operation, do During PMCS.

After operation, do After PMCS.

Once a week do Weekly PMCS. If Hydraulic Excavator has not been operated in a week, also do Before PMCS at the same time.

Do Monthly PMCS once a month. If Hydraulic Excavator has not been operated in a month, also do After PMCS at the same time.

If you are operating the Hydraulic Excavator for the first time, do your Weekly and Monthly PMCS the first time you do your Before PMCS.

If you find something wrong when performing PMCS, fix it if you can using troubleshooting procedures and/or maintenance procedures in this manual or notify your supervisor.

The right-hand column of the PMCS table lists conditions that make the Hydraulic Excavator not fully mission capable. Write up items not fixed on DA Form 2404 for unit maintenance. For further information on how to use this form, see DA PAM 738-750.

A-2. LEAKAGE DEFINITION

CAUTION: Equipment operation is allowable with minor leakages (Class I or II) except for fuel leaks. Of course, consideration must be given to the fluid capacity of the item or system being checked. When in doubt, ask your supervisor.

When operating with Class I or II leaks, continue to check fluid levels as required in the PMCS.

Class III leaks should be reported immediately to your supervisor.

It is necessary to know how fluid leakage affects the status of the Hydraulic Excavator. The following are definitions of the classes of leakage an operator or crewmember needs to know to be able to determine the condition of the leak. Learn and then be familiar with them, and **REMEMBER-WHEN IN DOUBT, ASK YOUR SUPERVISOR.**

Leakage Definitions for Crew/Operator PMCS:

CLASS I-Seepage of fluid (as indicated by wetness or discoloration) not great enough to form drops.

CLASS II-Leakage of fluid great enough to form drops but not enough to cause drops to drip from item being checked.

CLASS III-Leakage of fluid great enough to form drops that fall from the item being checked.

A-3. INSPECTION

Look for signs of a problem or trouble. Senses help here. You can feel, smell, hear, or see many problems. Be alert when on the Hydraulic Excavator.

Inspect to see if items are in good condition. Are they correctly assembled, stowed, secured, excessively worn, leaking, corroded, or properly lubricated? Correct any problems found or notify unit maintenance.

There are some common items to check all over the Hydraulic Excavator. These include the following:

1. Bolts, clamps, nuts, and screws: Continuously check for looseness. Look for chipped paint, bare metal, rust, or corrosion around bolt and screw heads and nuts. Tighten them when you find them loose. If tools are not available, notify unit maintenance.
2. Welds: Many items on the Hydraulic Excavator are welded. To check these welds, look for chipped paint, rust, corrosion, or gaps. When these conditions exist, notify unit maintenance on DA Form 2404.
3. Electrical wires, connectors, and harnesses: Tighten loose connectors. Look for cracked or broken insulation, bare wires, and broken connectors. If any are found, notify unit maintenance.
4. Hoses and fluid lines: Look for wear, damage, and leaks, and make sure clamps and fittings are tight. Wet spots mean a leak. A stain by a fitting or connector can also mean a leak. When you find a leak, notify unit maintenance.

A-4. LUBRICATION SERVICE INTERVALS-NORMAL CONDITIONS

For safer, more trouble-free operations, make sure that the Hydraulic Excavator is serviced in accordance with the proper lubrication and service intervals specified in the PMCS.

A-5. LUBRICATION SERVICE INTERVALS-UNUSUAL CONDITIONS

The Hydraulic Excavator will require extra service and care when you operate under unusual conditions. High or low temperatures, long periods of hard use, or continued use, in sand, water, mud, or snow will break down the lubricant requiring you to add or change lubricant more often.

**OPERATOR PREVENTIVE MAINTENANCE CHECKS AND SERVICES
FOR HYDRAULIC EXCAVATOR 230LCR/230LCRD**

ITEM NO.	INTERVAL	ITEM TO BE INSPECTED PROCEDURE: DO THE PMCS AND HAVE ITEM REPAIRED, FILLED, OR ADJUSTED AS NEEDED	EQUIPMENT IS NOT READY/AVAILABLE IF:
		<p align="center">WARNING: Always remember the CAUTIONS, WARNINGS, and NOTES before operating this machine and prior to PMCS.</p> <p align="center">PREPARE MACHINE FOR MAINTENANCE</p> <p>Before performing PMCS and before leaving the operator's seat, park the machine as described below unless another position is specified in the procedure.</p> <ol style="list-style-type: none"> (1) Park machine on a level surface. (2) Lower bucket to the ground. (3) Turn auto-idle switch off. <p>CAUTION: Turbocharger may be damaged if engine is not properly shut down.</p> <ol style="list-style-type: none"> (4) Run engine with engine rpm dial at 1/3 position without load for 2 minutes. (5) Move engine rpm dial to slow idle position. (6) Turn key switch to OFF. Remove key from switch. (7) Pull pilot control shut-off lever to locked position. <p>Perform all weekly and before operations PMCS if:</p> <ol style="list-style-type: none"> (1) You are the assigned operator and have not operated the machine since the last weekly. (2) You are operating the machine for the first time. <p align="center">WALK-AROUND CHECKS/INSPECTION</p> <p>Inspect machine daily before starting and after operation.</p> <p>NOTE: If leakage is detected, further investigation is needed to determine the location and cause of the leak.</p>	

**OPERATOR PREVENTIVE MAINTENANCE CHECKS AND SERVICES
FOR HYDRAULIC EXCAVATOR 230LCR/230LCRD**

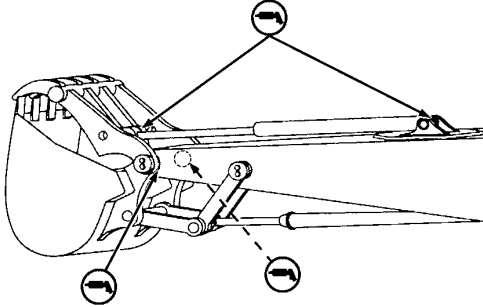
ITEM NO.	INTERVAL	ITEM TO BE INSPECTED PROCEDURE: DO THE PMCS AND HAVE ITEM REPAIRED, FILLED, OR ADJUSTED AS NEEDED	EQUIPMENT IS NOT READY/AVAILABLE IF:
1	Before	Check Fuel Tank (Fill at End of Day) NOTE: Items 2 through 4 are applicable to Model 230LCR only.	
2	Before	Grease All Material Clamp Joints (1) Pump grease into the four indicated grease points (see Fuels and Lubricants, Chapter 9). 	Fittings damaged or missing
3	Before	Check for Loose or Missing Material Clamp Bolts and Nuts	Any damage that will prevent operation
4	Before	Inspect Material Clamp for Damage or Weld Cracks	Damage or weld cracks are present
5	Before	Clean Dirt and Debris from Quick-Disconnect Hitch Attachment Front Hooks and Rear Saddles	
6	Before	Inspect for Damage and Clean Dirt and Debris from Overload Alarm Proximity Sensor NOTE: Items 7 through 16 are applicable to Model 230LCRD only.	Damaged sensor
7	Before	Check CPA Attachment of Rock Drill to Hitch Adapter (1) Ensure that all fixing pins are secure.	Fixing pins are loose or missing
8	Before	Inspect Guide Chains and Ropes of the Rock Drill (1) Inspect the front chain for wear. (2) Inspect hose reel rope. Specifically inspect attachment points on tightener and chain.	2 broken wires within 36 mm (1.44 in.) (6 times nominal diameter of cable) OR

**OPERATOR PREVENTIVE MAINTENANCE CHECKS AND SERVICES
FOR HYDRAULIC EXCAVATOR 230LCR/230LCRD**

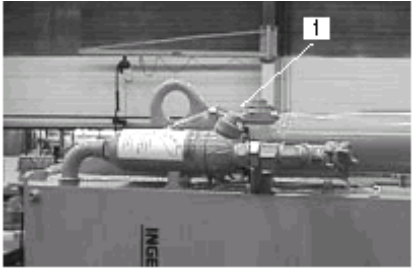
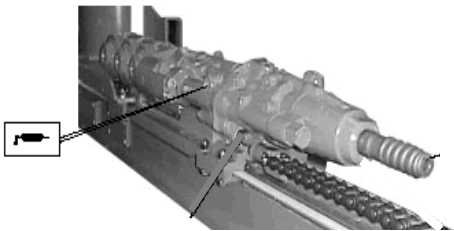
ITEM NO.	INTERVAL	ITEM TO BE INSPECTED PROCEDURE: DO THE PMCS AND HAVE ITEM REPAIRED, FILLED, OR ADJUSTED AS NEEDED	EQUIPMENT IS NOT READY/AVAILABLE IF:
9	Before	<p>Check rope for flats on outside strands, crushing, swelling, or fraying. If rope requires replacement, notify your supervisor.</p> <p>(3) Move drifter at slow speed to front end position.</p> <p>(4) Check chain reel for wear or corrosion. If reel requires replacement, notify your supervisor.</p> <p>Check Oil Level of Pressurization Air Oiler of Rock Drill</p> 	<p>4 broken wires within 180 mm (7.2 in.) (30 times nominal diameter of cable)</p> <p>OR</p> <p>Cable diameter is less than 5.4 mm (0.21 in.) (nominal diameter)</p>
10	Before	<p>(1) Remove oil fill plug (1).</p> <p>(2) Check oil level. Add oil if necessary (see Fuels and Lubricants, Chapter 9).</p> <p>Lubricate Hydraulic Drifter Front End Head of Rock Drill</p> 	<p>No oil visible or low level</p>
11	Before	<p>Check Compressor Oil Level</p> <p>(1) Open compressor left side access door.</p>	



**OPERATOR PREVENTIVE MAINTENANCE CHECKS AND SERVICES
FOR HYDRAULIC EXCAVATOR 230LCR/230LCRD**

ITEM NO.	INTERVAL	ITEM TO BE INSPECTED PROCEDURE: DO THE PMCS AND HAVE ITEM REPAIRED, FILLED, OR ADJUSTED AS NEEDED	EQUIPMENT IS NOT READY/AVAILABLE IF:
12	Before	<p>(2) Start unit (refer to air compressor operating instructions). Allow unit to warm up.</p> <p>(3) With compressor running at full load, check sight tube located on the side of the receiver tank. The optimum operating level is midway of the sight tube. Oil level should be within the "OK" range.</p> <p>(4) If oil level is not within the "OK" range, add oil to receiver tank (see Fuels and Lubricants, Chapter 9).</p> <p>NOTE: Ensure that access door is closed securely after inspection is complete.</p> <p>Check Compressor Engine Oil Level</p> <p>(1) Open compressor rear right access door.</p> <p>(2) Make sure dipstick is fully seated.</p> <p>(3) Remove dipstick and check oil level.</p> <p>(4) Add oil if level is below ADD mark (see Fuels and Lubricants, Chapter 9).</p> <p>NOTE: Ensure that access door is closed securely after inspection is complete.</p>	<p>Oil level not within "OK" range</p> <p>Oil level is below ADD mark on dipstick</p>
13	Before	<p>Check Compressor Gauges/Lamps</p> <p>(1) Open compressor rear left access door.</p> <p>(2) On control panel, set switches SW1 and SW2 to OFF, then to ON. Panel lights PL1 and PL2 should go on. All diagnostics lamps will light (glow) for approximately 2 seconds. Then all lamps should go off except for LOW ENGINE OIL PRESSURE.</p> <p>(3) Check and replace any lamp that fails to light.</p> <p>(4) Set switches SW1 and SW2 to OFF.</p>	<p>Any light fails to function</p>

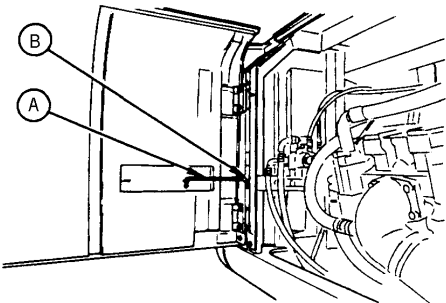
**OPERATOR PREVENTIVE MAINTENANCE CHECKS AND SERVICES
FOR HYDRAULIC EXCAVATOR 230LCR/230LCRD**

ITEM NO.	INTERVAL	ITEM TO BE INSPECTED PROCEDURE: DO THE PMCS AND HAVE ITEM REPAIRED, FILLED, OR ADJUSTED AS NEEDED	EQUIPMENT IS NOT READY/AVAILABLE IF:
14	Before	<p>Check Compressor Air Cleaner Service Indicators</p> <p>(1) Check ENGINE AIR FILTER AND COMPRESSOR AIR FILTER service indicators located on compressor instrument/control panel. The flag in a service indicator should show green.</p> <p>(2) If flag shows red, service or replace filter element(s).</p> <p>NOTE: Ensure that access door is closed securely after inspection is complete.</p>	Flag does not show green
15	Before	Check Compressor Fuel/Water Separator	
16	Before During	Check Rock Drill Dust Collector Filters	Damaged or clogged filters
17	Before After	Inspect Boom, Bucket, Arm, Cylinders, and Hoses for Bent, Broken, Loose, Leaking, or Missing Parts	Any damage that will prevent operation
18	Before After	<p>Check Track and Ground Under Machine and Propel Motors for Evidence of Leaks</p> <p>(1) Inspect track for missing or damaged parts.</p> <p>(2) Look for evidence of leakage.</p>	<p>Any Class III leak evident</p> <p>Any damage that will prevent operation</p> <p>Any Class III leak evident</p>
19	Before	<p>Inspect Hydraulic Oil Pump</p> <p>WARNING: Prevent possible injury from door closing. Secure door in the OPEN position.</p>  <p>To hold door open, remove rod from stored position (A) and insert in tab (B) on door.</p>	

**OPERATOR PREVENTIVE MAINTENANCE CHECKS AND SERVICES
FOR HYDRAULIC EXCAVATOR 230LCR/230LCRD**

ITEM NO.	INTERVAL	ITEM TO BE INSPECTED PROCEDURE: DO THE PMCS AND HAVE ITEM REPAIRED, FILLED, OR ADJUSTED AS NEEDED	EQUIPMENT IS NOT READY/AVAILABLE IF:
20	Before	<p>(1) Open right-side access door.</p> <p>(2) Look for evidence of hydraulic leaks.</p> <p>NOTE: Note the Arm, Boom, and Bucket position on the placard located to the left of the hydraulic sight gauge. This information will be used with the hydraulic oil level check to be performed later.</p>  <p>(3) Check oil level window (A) on hydraulic tank. Oil must be visible in sight gauge within safe operating range as indicated on sight gauge.</p> <p>(4) If empty or low, add oil (see Check Hydraulic Oil Level under During - Start and After-Start Checks).</p> <p>Check Pump Drive Gearbox Oil Level</p> <p>(1) Pull dipstick (A) from tube and check oil level.</p> <p>(2) Add oil if below “H” mark (see Monthly - Check Pump Drive Gearbox Oil Level).</p>  <p>NOTE: Ensure that access door is closed securely after inspection is complete.</p>	<p>Any Class III leak evident</p> <p>No hydraulic oil visible or not within safe operating range</p> <p>No oil in pump gearbox or below the ADD or SAFE mark on the dipstick</p>

**OPERATOR PREVENTIVE MAINTENANCE CHECKS AND SERVICES
FOR HYDRAULIC EXCAVATOR 230LCR/230LCRD**

ITEM NO.	INTERVAL	ITEM TO BE INSPECTED PROCEDURE: DO THE PMCS AND HAVE ITEM REPAIRED, FILLED, OR ADJUSTED AS NEEDED	EQUIPMENT IS NOT READY/AVAILABLE IF:
21	Before	<p>Check Recovery Tank Coolant Level</p>  <p>NOTE: On Model 230LCRD, the overflow lines for the main engine and compressor engine radiators are connected to a common recovery tank.</p> <ol style="list-style-type: none"> (1) Open left rear access door. (2) With engine cold, coolant level must be at the FULL mark on the recovery tank (A). (3) If coolant is below the FULL mark, add coolant to the recovery tank. <p>WARNING: Prevent possible injury from hot spraying water. DO NOT remove radiator filler cap unless engine is cool. Then turn cap slowly to the stop. Release all pressure before you remove cap.</p> <p>NOTE: If recovery tank is empty, check for leaks. Repair as required. Add coolant to the radiator(s) and the recovery tank.</p> <p>NOTE: Coolant level in radiator(s) must be at bottom of the filler neck.</p> <p>NOTE: If recovery tank is full and radiator(s) is low, check for leaks in radiator cap and the connections between radiator and recovery tank.</p>	<p>Coolant does not cover cooling tubes in top of radiator</p>

**OPERATOR PREVENTIVE MAINTENANCE CHECKS AND SERVICES
FOR HYDRAULIC EXCAVATOR 230LCR/230LCRD**

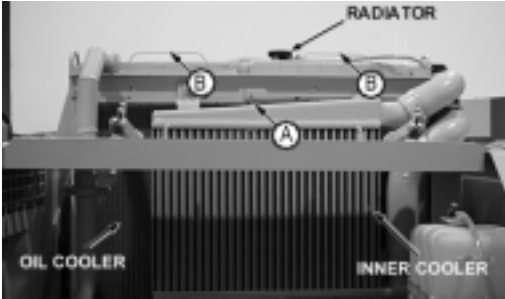
ITEM NO.	INTERVAL	ITEM TO BE INSPECTED PROCEDURE: DO THE PMCS AND HAVE ITEM REPAIRED, FILLED, OR ADJUSTED AS NEEDED	EQUIPMENT IS NOT READY/AVAILABLE IF:
22	Before	<p>Clean Radiator Air Inlet Screens</p>  <p>(1) Remove wing nut (A) and pull handles (B) to slide screens up for cleaning.</p> <p>WARNING: Compressed air used for cleaning purposes will not exceed 30 psi. Use only with effective chip guarding and personal protective equipment (goggles/shield/gloves, etc.).</p> <p>(2) Use pressurized air (30 psi maximum) or low-pressure water to clean screens.</p>	
23	Before	<p>Check Radiator and Oil Cooler Fins</p> <p>(1) Check radiator for damage and clean and remove any debris from radiator screens:</p> <ul style="list-style-type: none"> a. Inner cooler (top center) b. Oil cooler (lower left) 	<p>Any damage to radiator or oil cooler fins that may prevent cooling</p>
24	Before	<p>Check Batteries</p> <p>(1) Check battery for damage and connections for corrosion and secure connections.</p>	<p>Any damage that would prevent operation or battery will not hold charge</p>

**OPERATOR PREVENTIVE MAINTENANCE CHECKS AND SERVICES
FOR HYDRAULIC EXCAVATOR 230LCR/230LCRD**

ITEM NO.	INTERVAL	ITEM TO BE INSPECTED PROCEDURE: DO THE PMCS AND HAVE ITEM REPAIRED, FILLED, OR ADJUSTED AS NEEDED	EQUIPMENT IS NOT READY/AVAILABLE IF:
25	Before	<p>Check Windshield Washer Fluid Level</p> <p>(1) Check windshield washer fluid level in tank (A) and, if necessary, fill to full mark with all season windshield washer fluid.</p>  <p>NOTE: Ensure that access door is closed securely after inspection is complete.</p>	
26	Before	<p>Check Cab, All Glass, Windshield, and Wipers</p> <p>(1) Check cab and windshield for cracks and/or damage that may impair vision.</p> <p>(2) Check wiper arm and blade for damage.</p> <p>NOTE: Mount machine using the right side track footstep.</p>	Broken windows impair vision or missing glass
27	Before	<p>Check that Fire Extinguisher and Window Breaking Tool are Installed</p> <p>(1) Fire extinguisher and window breaking tool in cab (230LCR).</p> <p>(2) Fire extinguisher in engine compartment and window breaking tool in cab (230LCRD).</p>	Fire extinguisher or window breaking tool missing
28	Before	<p>Inspect Seat Belt and Mounting Hardware for Wear or Damage</p>	Any damage or wear that would prevent safe operation

**OPERATOR PREVENTIVE MAINTENANCE CHECKS AND SERVICES
FOR HYDRAULIC EXCAVATOR 230LCR/230LCRD**

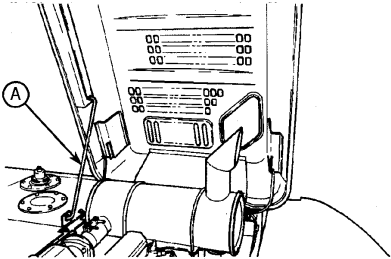
ITEM NO.	INTERVAL	ITEM TO BE INSPECTED PROCEDURE: DO THE PMCS AND HAVE ITEM REPAIRED, FILLED, OR ADJUSTED AS NEEDED	EQUIPMENT IS NOT READY/AVAILABLE IF:
29	Before	<p>Inspect Swing Gearbox Lines and Oil Level</p>  <ol style="list-style-type: none"> (1) Remove access panel. (2) Check swing gearbox hydraulic lines for evidence of leaks. (3) Check oil level. <ol style="list-style-type: none"> a. Pull dipstick (A) from tube and check oil level. b. Add oil (tube B) if level is below the ADD or SAFE mark on the dipstick (see Monthly - Check Swing Gearbox Oil Level). <p>NOTE: Ensure that access panel is closed securely after inspection is complete.</p>	<p>Any Class III leak evident</p> <p>Oil is below the ADD or SAFE mark on the dipstick</p>
30	Before After	<p>Check Engine Oil</p>  <p>Use the handle on the hood to raise hood until the end of the rod is securely locked into catch (A).</p> <ol style="list-style-type: none"> (1) Inspect oil cooling lines and hoses for cracks. (2) Look for evidence of leakage. 	<p>Any Class III leak evident</p>

**OPERATOR PREVENTIVE MAINTENANCE CHECKS AND SERVICES
FOR HYDRAULIC EXCAVATOR 230LCR/230LCRD**

ITEM NO.	INTERVAL	ITEM TO BE INSPECTED PROCEDURE: DO THE PMCS AND HAVE ITEM REPAIRED, FILLED, OR ADJUSTED AS NEEDED	EQUIPMENT IS NOT READY/AVAILABLE IF:
31	Before During	<div data-bbox="550 426 1029 802" data-label="Image"> </div> <p>(3) Make sure dipstick (A) is fully seated.</p> <p>(4) Remove dipstick and check oil level.</p> <p>(5) Add oil (filler cap [B]) if level is below ADD or cross-hatched area mark on the dipstick (see Fuels and Lubricants, Chapter 9).</p> <p>NOTE: BEFORE THE ENGINE IS STARTED: The engine is full when oil level is in the cross-hatched area.</p> <p>AFTER THE ENGINE HAS BEEN RUN: Allow the oil to drain into the oil pan for 10 minutes after engine stops before checking the oil level. The oil level must be above the ADD mark.</p> <p>If necessary, remove oil filler cap (B) and add oil.</p> <p>(6) Inspect engine compartment for loose or damaged components.</p> <p>NOTE: Ensure that engine access door is closed securely after inspection is complete.</p> <p>Check Instruments</p> <p>(1) Turn key switch to ON position. All instrument lights should stay on for approximately 3 seconds.</p> <p>(2) Check and replace any bulb that fails to light.</p> <p>(3) Check that gauge indicates fuel level and the coolant gauge does NOT go to the red zone.</p>	<p>Oil level is below ADD level on the dipstick</p> <p>Any damage that would prevent operation</p> <p>Coolant gauge in red zone</p>

**OPERATOR PREVENTIVE MAINTENANCE CHECKS AND SERVICES
FOR HYDRAULIC EXCAVATOR 230LCR/230LCRD**

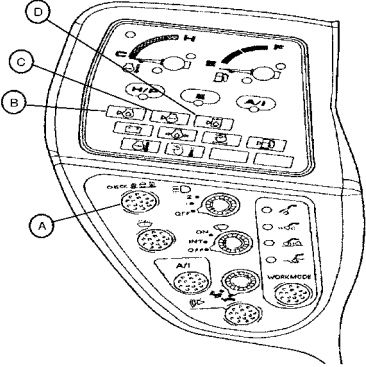
ITEM NO.	INTERVAL	ITEM TO BE INSPECTED PROCEDURE: DO THE PMCS AND HAVE ITEM REPAIRED, FILLED, OR ADJUSTED AS NEEDED	EQUIPMENT IS NOT READY/AVAILABLE IF:
32	Before During	<p>Level Check</p> <p>NOTE: The level check does NOT take the place of before operation check at hydraulic oil level window, engine coolant recovery tank, or engine oil level dipstick.</p>  <p>(1) With key switch in the ON position, press level CHECK switch (A).</p> <p>(2) Check that hydraulic oil level (B) engine coolant (C) and engine oil level light (D) illuminate to indicate levels are adequate for operation.</p>	Any WARNING light fails to function
33	During	<p>Start and After-Start Checks</p> <p>(1) Move engine rpm dial to slow idle position.</p> <p>CAUTION: Prevent starter damage. Never operate starter for more than 20 seconds at a time. If engine fails to start, return key switch to OFF. Wait 2 minutes, then try again. After a false start, do not turn key switch until engine stops.</p> <p>(2) Sound horn to alert nearby personnel.</p> <p>(3) Turn key switch to START. Release key when engine starts (key should return to ON position).</p>	

**OPERATOR PREVENTIVE MAINTENANCE CHECKS AND SERVICES
FOR HYDRAULIC EXCAVATOR 230LCR/230LCRD**

ITEM NO.	INTERVAL	ITEM TO BE INSPECTED PROCEDURE: DO THE PMCS AND HAVE ITEM REPAIRED, FILLED, OR ADJUSTED AS NEEDED	EQUIPMENT IS NOT READY/AVAILABLE IF:
		<p>CAUTION: Prevent possible damage to engine. If indicator lights do not go out after starting engine, IMMEDIATELY STOP THE ENGINE. Find and correct the problem.</p> <p>(4) Check that all indicator lights go out.</p> <p>(5) Check hydraulic oil level.</p> <ul style="list-style-type: none"> a. Park machine on level surface. b. Position machine with arm cylinder fully retracted, bucket cylinder fully extended, and bucket lowered to the ground. (Reference placard located to the left of the hydraulic sight gauge.) c. Turn auto-idle switch off. d. Run engine with engine rpm dial at 1/3 position without load for 2 minutes. e. Move engine rpm dial to slow idle position. f. Turn key switch OFF and remove key. g. Attach a "Do Not Operate" tag on the right control lever. h. Pull pilot control shut-off lever to locked position. i. Open right side access door. 	<p>One or more indicator lights do not go out after starting engine</p>

**OPERATOR PREVENTIVE MAINTENANCE CHECKS AND SERVICES
FOR HYDRAULIC EXCAVATOR 230LCR/230LCRD**

ITEM NO.	INTERVAL	ITEM TO BE INSPECTED PROCEDURE: DO THE PMCS AND HAVE ITEM REPAIRED, FILLED, OR ADJUSTED AS NEEDED	EQUIPMENT IS NOT READY/AVAILABLE IF:
		<div data-bbox="550 445 1081 764" data-label="Image"> </div> <p data-bbox="592 808 1081 926">j. Check oil level window (A) on hydraulic tank. (Oil must be visible in sight gauge within safe operating range as indicated on sight gauge.)</p> <p data-bbox="592 972 844 1001">k. If necessary, add oil.</p> <p data-bbox="500 1045 618 1075">To add oil:</p> <p data-bbox="548 1119 1073 1268">WARNING: High-pressure release of oil from pressurized system can cause serious burns or penetrating injury. The hydraulic tank is pressurized. Do not remove vent plug (A). Release pressure by loosening vent plug.</p> <div data-bbox="570 1325 1049 1612" data-label="Image"> </div> <p data-bbox="548 1656 1029 1713">(1) Loosen vent plug (A) to release hydraulic pressure.</p>	<p data-bbox="1166 808 1495 865">No hydraulic oil visible or not within safe operating range</p>

**OPERATOR PREVENTIVE MAINTENANCE CHECKS AND SERVICES
FOR HYDRAULIC EXCAVATOR 230LCR/230LCRD**

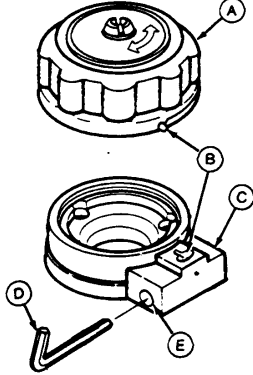
ITEM NO.	INTERVAL	ITEM TO BE INSPECTED PROCEDURE: DO THE PMCS AND HAVE ITEM REPAIRED, FILLED, OR ADJUSTED AS NEEDED	EQUIPMENT IS NOT READY/AVAILABLE IF:
		 <p>(2) Insert 4 mm (0.15 in.) Allen wrench (D) into hole (E) and turn counterclockwise.</p> <p>(3) Slowly turn cap (A) counterclockwise. Remove cap. Add oil (see Fuels and Lubricants, Chapter 9).</p> <p>(4) Install cap to case assembly (C) by aligning marks (B) and turning clockwise to lock position.</p> <p>(5) Tighten vent plug.</p> <p>NOTE: Ensure that access door is closed securely after inspection is complete.</p>	
34	Before During	Perform Operational Checks (See Operational Checkout, Chapter 21.)	
35	Before	<p>Check Decontamination Kit Holder and Holder Strap</p> <p>(1) Check decontamination kit holder strap for fraying, cutting, or wear. Replace if necessary.</p> <p>(2) Ensure that decontamination kit holder bolts are tight.</p> <p>NOTE: The following checks and services are to be performed weekly or sooner as required by adverse environmental conditions.</p>	

**OPERATOR PREVENTIVE MAINTENANCE CHECKS AND SERVICES
FOR HYDRAULIC EXCAVATOR 230LCR/230LCRD**

ITEM NO.	INTERVAL	ITEM TO BE INSPECTED PROCEDURE: DO THE PMCS AND HAVE ITEM REPAIRED, FILLED, OR ADJUSTED AS NEEDED	EQUIPMENT IS NOT READY/AVAILABLE IF:
36	After	Clean Rock Drill Dust Collector Filters (230LCRD) (1) Every day after drilling operations are completed and before stopping the machine, clean filters by allowing one cleaning cycle without drilling.	
37	Weekly	Inspect Material Clamp Pin Joint Movement (230LCR) (1) Operate material clamp and check for unusual slop. Make sure pin joints are snug.	Clamp action is sloppy
38	Weekly	Inspect Quick-Disconnect Hitch Attachment Points (1) Ensure that attachment is secure in front hooks and rear saddle. (2) Inspect quick-disconnect hitch and wedge for excessive wear, damage, or failure.	Any damage that would prevent operation
39	Weekly	Inspect Quick-Disconnect Hitch Lifting Hook (1) Visually inspect lifting hook for wear or damage. NOTE: Items 40 through 42 are applicable to Model 230LCRD only.	Any damage that would prevent operation
40	Weekly	Wash the Rock Drill	
41	Weekly	Inspect All Hoses of Rock Drill (1) Inspect hoses for cracking, wear, or damage. If hoses require replacement, notify your supervisor.	Hoses are damaged and leaking
42	Weekly	Check the Rock Drill Cap Bolts and the Mounting Bolts of the Hydraulic Drifter for Tightness	Bolts are loose or missing

**OPERATOR PREVENTIVE MAINTENANCE CHECKS AND SERVICES
FOR HYDRAULIC EXCAVATOR 230LCR/230LCRD**

ITEM NO.	INTERVAL	ITEM TO BE INSPECTED PROCEDURE: DO THE PMCS AND HAVE ITEM REPAIRED, FILLED, OR ADJUSTED AS NEEDED	EQUIPMENT IS NOT READY/AVAILABLE IF:
43	Weekly *As Required	<p>Grease Working Tool Pivots</p> <p>(1) Pump grease (see Fuels and Lubricants, Chapter 9) into the 20 indicated grease points. Grease until grease escapes from joints.</p> <p>(2) *As required:</p> <p>a. Grease every 4 hours during the first 20 hrs.</p> <p>b. Grease daily during the first 30—100 hrs and when working in mud and water or sand.</p>	Fittings damaged or missing



Three Points



Three Points



Two Points



One Point

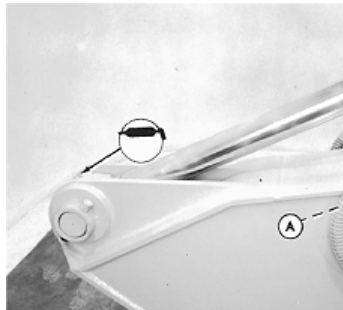

Three Points, A—Left Side Shown

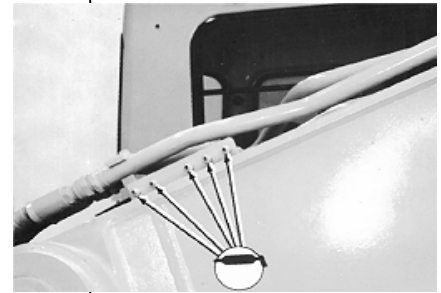

Five Points

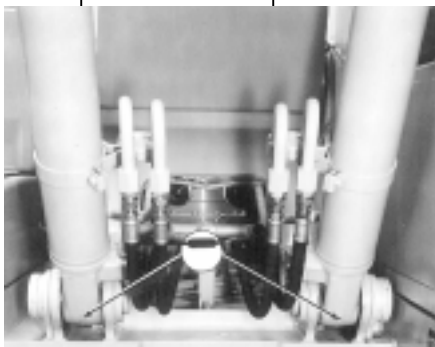

Two Points

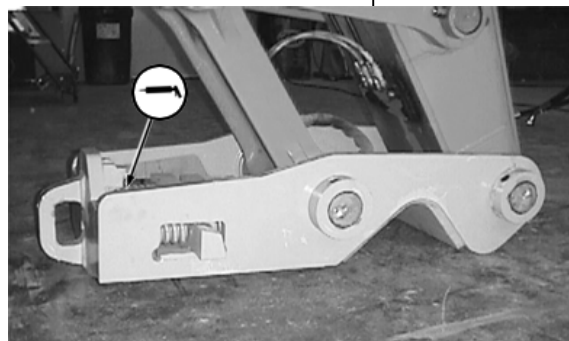

One Point

**OPERATOR PREVENTIVE MAINTENANCE CHECKS AND SERVICES
FOR HYDRAULIC EXCAVATOR 230LCR/230LCRD**

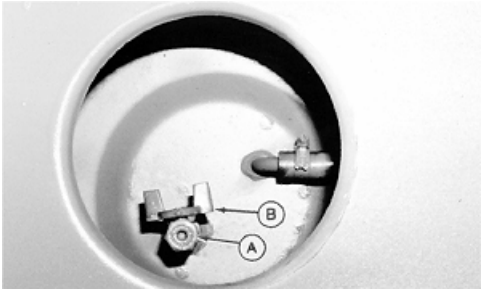
ITEM NO.	INTERVAL	ITEM TO BE INSPECTED PROCEDURE: DO THE PMCS AND HAVE ITEM REPAIRED, FILLED, OR ADJUSTED AS NEEDED	EQUIPMENT IS NOT READY/AVAILABLE IF:
44	Weekly *As Required	<p>Drain Fuel Tank Sump</p> <p>(1) Park machine on level surface. Rotate upper-structure 90° for easier access.</p> <p>(2) Remove fuel tank fill cap.</p> <p>NOTE: Plug is installed in drain cock to prevent vandalism.</p>  <p>(3) Remove plug (A) and open drain cock (B) for several seconds to drain water and sediment into a container. Dispose of waste properly. Close drain cock.</p> <p>(4) Install and tighten plug.</p> <p>(5) Install fill cap.</p>	
45	Weekly	<p>Check Arctic Starter Fuel Lines</p> <p>(1) Visually check all fuel lines for leaks. Replace damaged, worn, or corroded fuel lines.</p> <p>NOTE: Items 46 through 49 are applicable to Model 230LCRD only.</p>	Any Class III leak evident
46	Weekly	<p>Check Compressor Air Precleaner Dirt Dumps</p> <p>(1) Squeeze the rubber valve (precleaner dirt dump) on each air cleaner housing to ensure that valves are not clogged.</p>	
47	Weekly	<p>Check Compressor Fan Belts</p>	Damaged or loose belts
48	Quarterly	<p>Check All Compressor Hoses</p>	Damaged hoses

**OPERATOR PREVENTIVE MAINTENANCE CHECKS AND SERVICES
FOR HYDRAULIC EXCAVATOR 230LCR/230LCRD**

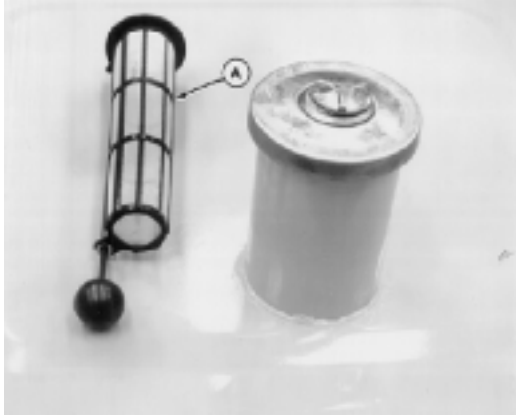
ITEM NO.	INTERVAL	ITEM TO BE INSPECTED PROCEDURE: DO THE PMCS AND HAVE ITEM REPAIRED, FILLED, OR ADJUSTED AS NEEDED	EQUIPMENT IS NOT READY/AVAILABLE IF:
49	Quarterly	Check Compressor Air Cleaner System (1) Inspect housing and piping for any leakage paths, inlet obstructions, dents and loose fasteners.	Any damage that would prevent operation
50	*As Required	Clean Fuel Tank Inlet Screen  <p>WARNING: Dry cleaning solvent PD-680 Type III is toxic and flammable. Wear protective goggles and gloves and use only in well-ventilated area. Avoid contact with skin, eyes, and clothes and don't breathe vapors. Do not use near open flames or excessive heat. The flash point is 200°F (94°C). If you become dizzy while using solvent, get fresh air immediately and get medical aid. If contact with eyes is made, wash your eyes with water and get medical aid immediately.</p> <p>Use solvent or diesel fuel to clean screen (A).</p>	Screen damaged or missing
51	*As Required	Drain Water Separator (1) Open right access door to access water separator.	

**OPERATOR PREVENTIVE MAINTENANCE CHECKS AND SERVICES
FOR HYDRAULIC EXCAVATOR 230LCR/230LCRD**

ITEM NO.	INTERVAL	ITEM TO BE INSPECTED PROCEDURE: DO THE PMCS AND HAVE ITEM REPAIRED, FILLED, OR ADJUSTED AS NEEDED	EQUIPMENT IS NOT READY/AVAILABLE IF:
52	*As Required	<div data-bbox="589 451 1036 852" data-label="Image"> </div> <p data-bbox="548 877 1089 968">(2) Open drain valve (A) and press pump (B) to extract water. Collect waste in a container and dispose of properly.</p> <p data-bbox="548 999 821 1031">(3) Close drain valve (A).</p> <p data-bbox="548 1062 1008 1121">NOTE: Ensure that access door is closed securely after inspection is complete.</p> <p data-bbox="500 1152 870 1182">Clean Air Cleaner Unloader Valve</p> <p data-bbox="548 1213 1057 1367">NOTE: A missing, damaged, or hardened dust unloader valve will make the dust cup precleaner ineffective, causing very short air filter life. Valve should suck closed above 1/3 engine speed.</p> <div data-bbox="589 1392 1070 1680" data-label="Image"> </div> <p data-bbox="548 1707 1097 1766">(1) Squeeze dust valve (A) to remove dust from the air cleaner.</p> <p data-bbox="548 1797 1068 1885">(2) When operating in high dust/sand conditions, squeeze dust valve every couple of hours of operation to release dust/sand.</p>	

**OPERATOR PREVENTIVE MAINTENANCE CHECKS AND SERVICES
FOR HYDRAULIC EXCAVATOR 230LCR/230LCRD**

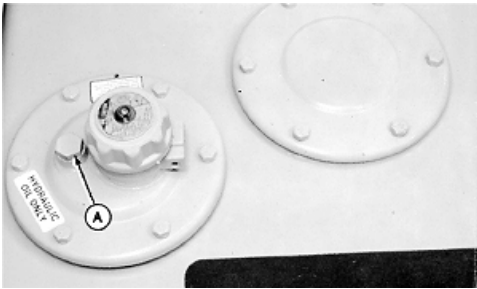
ITEM NO.	INTERVAL	ITEM TO BE INSPECTED PROCEDURE: DO THE PMCS AND HAVE ITEM REPAIRED, FILLED, OR ADJUSTED AS NEEDED	EQUIPMENT IS NOT READY/AVAILABLE IF:
53	Monthly	<p>Check Swing Gearbox Oil Level</p> <p>(1) Park machine on level surface.</p>  <p>(2) Remove dipstick (A). Oil must be in the operating range.</p> <p>(3) If oil is needed, remove filler cap (B) and add oil (see Fuels and Lubricants, Chapter 9).</p> <p>(4) Recheck oil level.</p>	Oil is below the ADD or SAFE mark on the dipstick
54	Monthly	<p>Drain Hydraulic Tank Sump</p> <p>WARNING: High-pressure release of oil from pressurized system can cause serious burns or penetrating injury. The hydraulic tank is pressurized. Do not remove plug (A). Release pressure by loosening vent plug.</p>  <p>(1) Loosen vent plug (A) to release hydraulic pressure.</p>	

**OPERATOR PREVENTIVE MAINTENANCE CHECKS AND SERVICES
FOR HYDRAULIC EXCAVATOR 230LCR/230LCRD**

ITEM NO.	INTERVAL	ITEM TO BE INSPECTED PROCEDURE: DO THE PMCS AND HAVE ITEM REPAIRED, FILLED, OR ADJUSTED AS NEEDED	EQUIPMENT IS NOT READY/AVAILABLE IF:
55	Monthly	<div data-bbox="548 466 1052 737" data-label="Image"> </div> <p data-bbox="548 764 1062 884">(2) Loosen plug (F) for several seconds to drain water and sediment into a container. Do not remove plug completely. Dispose of waste properly.</p> <p data-bbox="548 915 889 947">(3) Tighten sump plug and vent.</p> <p data-bbox="500 978 911 1010">Check Pump Drive Gearbox Oil Level</p> <div data-bbox="548 1031 1013 1308" data-label="Image"> </div> <p data-bbox="500 1339 643 1371">To check oil:</p> <p data-bbox="548 1402 1081 1612">(1) Remove dipstick (A). (2) Wipe dipstick clean and insert completely into tube. (3) Remove dipstick. Oil must be approximately halfway below the "H" (level) mark.</p> <p data-bbox="500 1644 618 1675">To add oil:</p> <p data-bbox="548 1707 1081 1854">(1) Remove filler cap (B). (2) Add oil (see Fuels and Lubricants, Chapter 9). (3) Install filler cap.</p>	<p data-bbox="1166 1549 1495 1612">Oil level is below the ADD or SAFE mark on the dipstick</p>

**OPERATOR PREVENTIVE MAINTENANCE CHECKS AND SERVICES
FOR HYDRAULIC EXCAVATOR 230LCR/230LCRD**

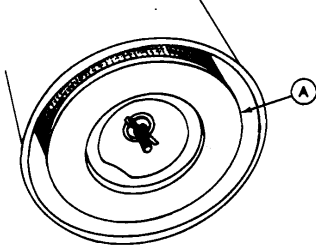
ITEM NO.	INTERVAL	ITEM TO BE INSPECTED PROCEDURE: DO THE PMCS AND HAVE ITEM REPAIRED, FILLED, OR ADJUSTED AS NEEDED	EQUIPMENT IS NOT READY/AVAILABLE IF:
56	Monthly	Run Arctic Starter Heater (1) Switch heater on (for 2 minutes with a “continuous green” LED light) once a month during periods when heater is not used. This will prevent the water pump and combustion engine from seizing.	
57	Monthly	Check Arctic Starter Glow Pin (1) Check glow plug cable and connection. Make sure that connection is not corroded or dirty.	
58	Monthly	Inspect Fire Extinguisher (1) Check gauge on fire extinguisher. Make sure the dial is within the green area on the gauge. (a) Fire extinguisher located in cab (230LCR). (b) Fire extinguisher located in battery compartment (230LCRD). (2) Check tightness of fire extinguisher bracket bolts. (3) Check the fire extinguisher hose for cracks, wear, or damage. Replace if necessary. (4) Check that tamper seal is intact.	Pressure is not within specification
59	Monthly	Inspect Primary Air Cleaner Element (1) Open front service door. (2) Loosen wing nut to remove cover.  (3) Remove wing nut and primary element (A). Clean the primary element. NOTE: Ensure that front service door is closed securely after inspection is complete.	Primary element is damaged or dirty

BLANK

APPENDIX B COMPONENTS OF END ITEM AND BASIC ISSUE ITEMS LIST

Section I. INTRODUCTION

B-1. SCOPE

This appendix lists integral components of the end item and basic issue items for the Hydraulic Excavator to help you inventory items required for safe and efficient operation.

B-2. GENERAL

The Components of End Item and Basic Issue Items Lists are divided into the following sections:

a. Section II. COMPONENTS OF END ITEM. This listing is for informational purposes only and is not authority to requisition replacements. These items are part of the end item but are removed and separately packaged for transportation or shipment. As part of the end item, these items must be with the end item whenever it is issued or transferred between property accounts. Illustrations are furnished to assist in identifying the items.

b. Section III. BASIC ISSUE ITEMS. These are the minimum essential items required to place the Hydraulic Excavator in operation, to operate it, and to perform emergency repairs. Although shipped separately packaged, BII must be with the Hydraulic Excavator during operation and whenever it is issued or transferred between property accounts. The illustrations will assist you with hard-to-identify items. This manual is your authority to requisition/request replacement BII, based on TOE/MTOE authorization of the end item.

B-3. EXPLANATION OF COLUMNS

The following provides an explanation of columns found in the tabular listings:

a. Column (1) – Illustration Item Number (ILLUST NUMBER). This column indicates the number of the illustration in which the item is shown.

b. Column (2) – NATIONAL STOCK NUMBER. Indicates the National stock number assigned to the item and will be used for requisitioning purposes.

c. Column (3) – DESCRIPTION. Indicates the Federal item name and, if required, a minimum description to identify and locate the item. The last line for each item indicates the Contractor And Government Entity (CAGE) code in parentheses, followed by the part number. If the item needed differs for different models of this equipment, the model is shown under the “USABLE ON CODE” heading in this column. These codes are identified as:

<u>Code</u>	<u>Used On</u>
A	Model 230LCR
B	Model 230LCRD

d. Column (4) – Unit of Measure (U/M). Indicates how the item is issued for the National Stock Number shown in Column 2.

e. Column (5) – Quantity Required (QTY RQR). Indicates the quantity required.

Section II. COMPONENTS OF END ITEM

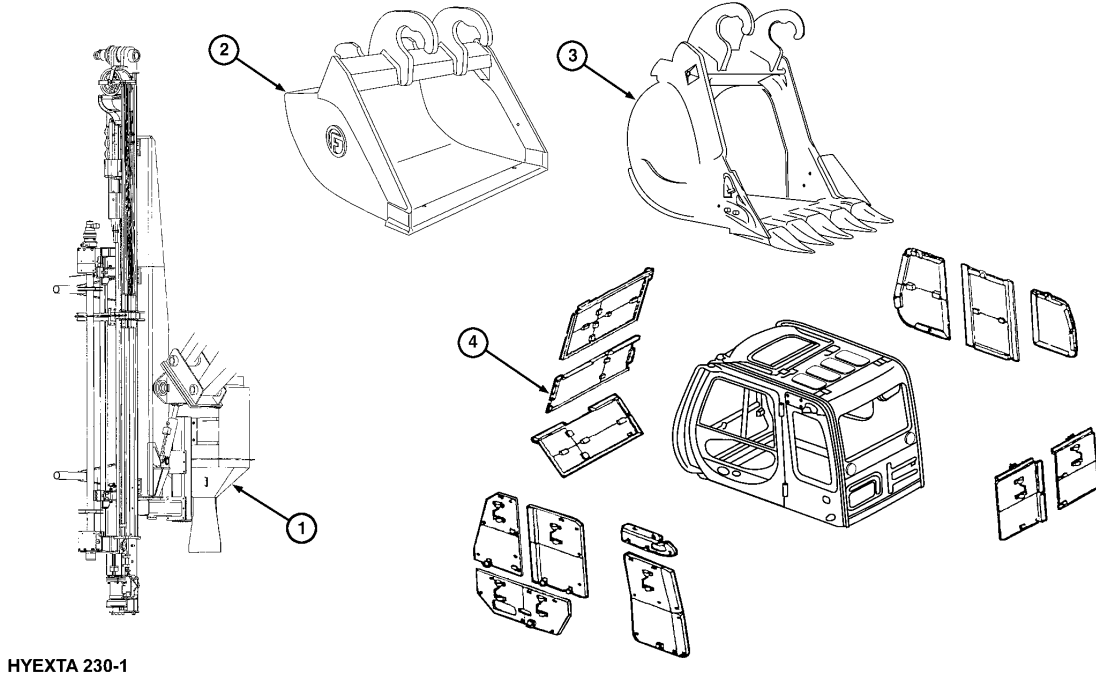

HYEXTA 230-1

Table 1. Components of End Item

(1) ILLUST NUMBER	(2) NATIONAL STOCK NUMBER	(3) DESCRIPTION CAGE & PART NUMBER	USABLE ON CODE	(4) U/M	(5) QTY RQR
1		Rock Drill (75755) AT188374	B	EA	1
2		Ditch Bucket, 60 in. (75755) AT188608	A	EA	1
3		Heavy Duty Bucket, 42 in. (75755) AT188607		EA	1
4		Vandal Protection Kit (75755) AP33356		EA	1

Section III. BASIC ISSUE ITEMS LIST

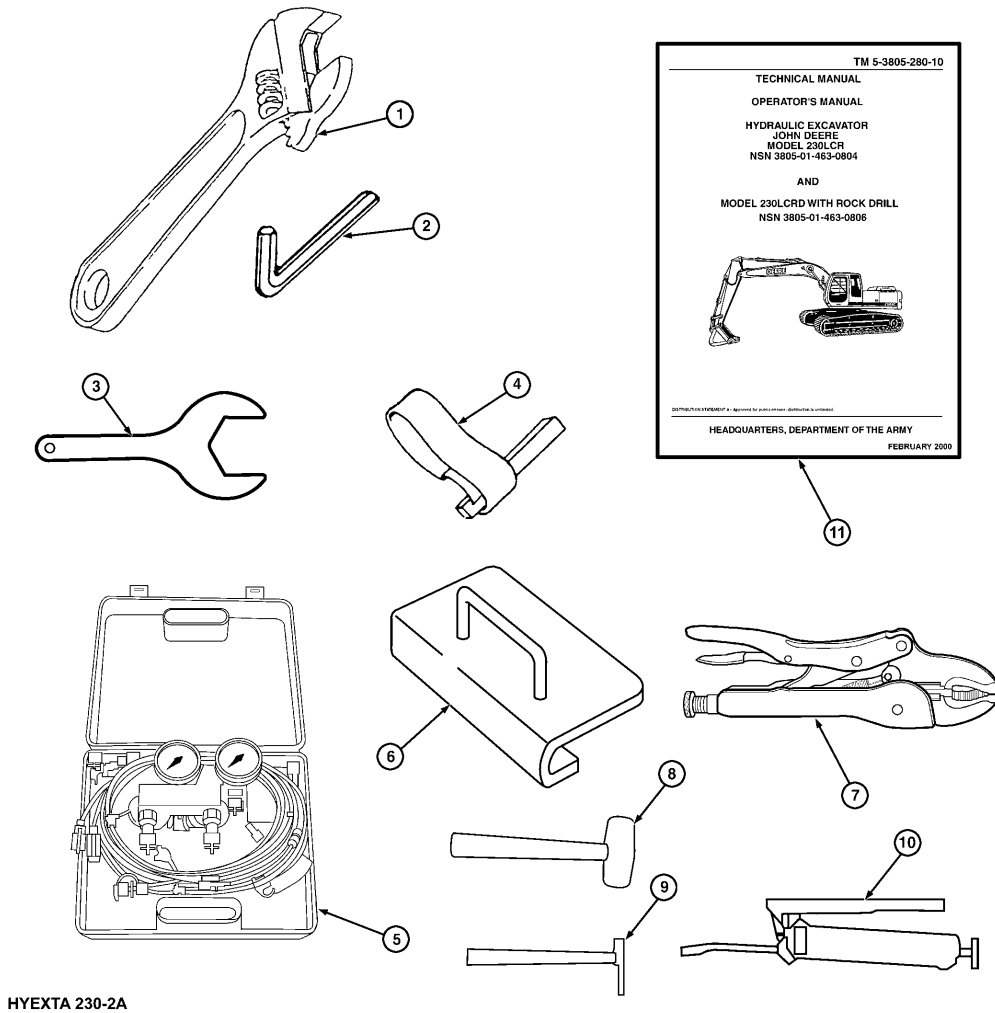

Table 2. Basic Issue Items List

(1) ILLUST NUMBER	(2) NATIONAL STOCK NUMBER	(3) DESCRIPTION CAGE & PART NUMBER	USABLE ON CODE	(4) U/M	(5) QTY RQR
1	5120-00-240-5328	Wrench, Open End, Adjustable .95 in. jaw opening, 8-in. long (19207) 11655778-3		EA	1
2	5120-01-045-4889	Wrench, Allen 4mm (0.15-in.) (74445) 57124		EA	1
3		Wrench, 3 in. (75755) T183966	B	EA	1

TM 5-3805-280-10

Table 2. Basic Issue Items List (Continued)

(1) ILLUST NUMBER	(2) NATIONAL STOCK NUMBER	(3) DESCRIPTION CAGE & PART NUMBER	USABLE ON CODE	(4) U/M	(5) QTY RQR
4		Wrench, Filter, Nylon Strap (75755) TY24252	B	EA	1
5		Gauges, Pressure (75755) 86310943	B	EA	1
6		Brackets, Track, Transport (75755) AT189507		EA	2
7		Pliers, Vise Grip, 8-inch PROTO 293R/Fed Spec GGG-W-00649	B	EA	1
8		Hammer, Wood Handle, 4 3/16 lb, 1 3/4 in. face dia., 9 7/8 in. overall length (75755) 5902A3		EA	1
9		Pin Removal Tool, 5 lb, 18 in. long (75755) PRT290		EA	1
10		Gun, Grease, Lever Action, 23 strokes per oz, 12 in. flexible hose (75755) 1055K14		EA	1
11		Operator's Manual TM 5-3805-280-10		EA	1

APPENDIX C REFERENCES

C-1. SCOPE

This appendix lists forms, field manuals, technical manuals, and other publications either referenced in this manual or which apply to the operation and maintenance of the Hydraulic Excavator. Web sites which may be useful are also included in this appendix.

C-2. DEPARTMENT OF THE ARMY PAMPHLETS

Consolidated Index of Army Publications and Blank Forms	DA Pam 25-30
Using Unit Supply System (Manual Procedures)	DA Pam 710-2-1
Functional Users Manual for The Army Maintenance Management System (TAMMS)	DA Pam 738-750

C-3. FORMS

Recommended Changes to Publications and Blank Forms	DA Form 2028
Recommended Changes to Equipment Technical Publications	DA Form 2028-2
Organizational Control Record for Equipment	DA Form 2401
Equipment Inspection and Maintenance Worksheet	DA Form 2404
Equipment Inspection and Maintenance Worksheet (Electronic)	DA Form 5988E
Maintenance Request	DA Form 2407
Preventive Maintenance Schedule and Record	DD Form 314
Product Quality Deficiency Report (NSN 7540-00-105-0078)	SF 368

C-4. FIELD MANUALS

NBC Contamination Avoidance	FM 3-3
NBC Protection	FM 3-4
NBC Decontamination	FM 3-5
NBC Handbook	FM 3-7
Camouflage	FM 20-3
Operation and Maintenance of Ordnance Materiel in Extreme Cold Weather (0° to -65°F)	FM 9-207

Recovery and Battlefield Damage Assessment and Repair	FM 9-43-2
Soldier's Manual for First Aid	FM 21-11
Basic Cold Weather Manual	FM 31-70
Northern Operations	FM 31-71
Army Motor Transport Units and Operators	FM 55-30
Desert Operations (How to Fight)	FM 90-3
Operational Symbols	FM 101-5-1
C-5. SUPPLY BULLETIN	
Storage Serviceability Standard – Tracked Vehicles, Wheeled Vehicles, and Component Parts	SB 740-98-1
C-6. TECHNICAL BULLETINS	
Equipment Improvement Report and Maintenance Digest (US Army Tank-Automotive Command) Tank-Automotive Equipment	TB 43-001-39-Series
Color, Marking, and Camouflage Painting of Military Vehicles, Construction Equipment, and Materiel Handling Equipment	TB 43-0209
Maintenance in the Desert	TB 43-0239
Use of Antifreeze and Cleaning Compounds in Engine Cooling Systems	TB 750-651
Inspection, Use and Tightening of Metal Fasteners Used on Tank-Automotive Equipment	TB 43-0218
C-7. TECHNICAL MANUALS	
Unit Maintenance, Direct Support and General Support Maintenance, Hydraulic Excavator, John Deere Model 230LCR/230LCRD	TM 5-3805-280-24-1 TM 5-3805-280-24-2
Chemical, Biological, and Radiological (CBR) Decontamination	TM 3-220
Inspection, Care, and Maintenance of Antifriction Bearings	TM 9-214
Care and Use of Hand Tools and Measuring Tools	TM 9-243
Materials Used for Cleaning, Preserving, Abrading, and Cementing Ordnance Materiel and Related Items Including Chemicals	TM 9-247
Tool Outfit Hydraulic System Test and Repair Unit (HYSTRU)	TM 9-4940-468-13
Operator, Unit, Direct Support, and General Support Maintenance Manual for Lead Storage Batteries	TM 9-6140-200-14
Preparing Hazardous Materials for Military Air Shipments	TM 38-250

Principals of Automotive Vehicles

TM 9-8000

Painting Instructions for Field Use

TM 43-0139

Procedures for Destruction of Tank-Automotive Equipment to
Prevent Enemy Use

TM 750-244-6

C-8. OTHER PUBLICATIONS

Army Logistics Readiness and Sustainability

AR 700-138

Expendable/Durable Items (Except Medical, Class V, Repair Parts,
and Heraldic Items)

CTA 50-970

Abbreviations and Acronyms

ASME Y14.38M

C-9. WEB SITES

Military Traffic Management Command (MTMC)

<http://www.tea.army.mil>

Logistical Support Activity (LOGSA)

<http://www.logsa.army.mil>

US Army Tank-Automotive and Armaments Command (TACOM)

<http://www.tacom.army.mil>

BLANK

By order of the Secretary of the Army:

ERIC K. SHINSEKI
General United States Army
Chief of Staff

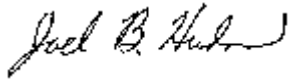

Official:

JOEL B. HUDSON
Administrative Assistant to the
Secretary of the Army
9930501

Distribution: To be distributed in accordance with Initial Distribution Number (IDN) 256560, requirements for TM 5-3805-280-10.



THEN... JOT DOWN THE DOPE ABOUT IT ON THIS FORM. CAREFULLY TEAR IT OUT. FOLD IT AND DROP IT IN THE MAIL!

SOMETHING WRONG WITH THIS PUBLICATION?

FROM: (PRINT YOUR UNIT'S COMPLETE ADDRESS)

Your mailing address

DATE SENT Date you fill out this form

PUBLICATION NUMBER

TM 5-2350-262-34

PUBLICATION DATE

Date of TM

PUBLICATION TITLE

M9 DS/GS MAINTENANCE MANUAL

BE EXACT... PIN-POINT WHERE IT IS

IN THIS SPACE TELL WHAT IS WRONG AND WHAT SHOULD BE DONE ABOUT IT:

PAGE NO.	PARA-GRAPH	FIGURE NO.	TABLE NO.
2-2			
4-185	B		
B-5		1	

Fuel tank removal and installation is now a DS/GS task. Delete this task from the unit maintenance list.

There are three clamps securing air cleaner duct, not the two as shown. Suggest changing text and art to show three clamps.

Road wheel jack does not have an NSN or P/N listed and cannot be found on AMDF. Request correct NSN and P/N be furnished.

SAMPLE

PRINTED NAME, GRADE OR TITLE, AND TELEPHONE NUMBERS

JOE DOE, SFC 555-1212

SIGN HERE:

Joe Doe, SFC

SAMPLE

FILL IN YOUR
UNIT'S ADDRESS



FOLD BACK

DEPARTMENT OF THE ARMY

PLACE
POSTAGE
HERE

TEAR ALONG PERFORATED LINE

Commander
U.S. Army Tank-automotive and Armaments Command
ATTN: AMSTA-AC-NML
Rock Island, IL 61299-7630



SOMETHING WRONG

WITH THIS PUBLICATION?

THEN . . . JOT DOWN THE DOPE ABOUT IT ON THIS FORM. CAREFULLY TEAR IT OUT. FOLD IT AND DROP IT IN THE MAIL!

FROM: (PRINT YOUR UNIT'S COMPLETE ADDRESS)

DATE SENT

PUBLICATION NUMBER

TM 5-3805-280-10

PUBLICATION DATE

PUBLICATION TITLE

**Hydraulic Excavator 230LCR / 230LCRD
Operator's Manual**

BE EXACT. . . PIN-POINT WHERE IT IS

IN THIS SPACE TELL WHAT IS WRONG
AND WHAT SHOULD BE DONE ABOUT IT:

PAGE NO.	PARA-GRAPH	FIGURE NO.	TABLE NO.

PRINTED NAME, GRADE OR TITLE, AND TELEPHONE NUMBERS

SIGN HERE:

FILL IN YOUR
UNIT'S ADDRESS



FOLD BACK

DEPARTMENT OF THE ARMY

PLACE
POSTAGE
HERE

TEAR ALONG PERFORATED LINE

Commander
U.S. Army Tank-automotive and Armaments Command
ATTN: AMSTA-AC-NML
Rock Island, IL 61299-7630

THE METRIC SYSTEM AND EQUIVALENTS

WEIGHT MEASURE

1 Centimeter = 10 Millimeters = 0.01 Meters = 0.3937 Inches
 1 Meter = 100 Centimeters = 1000 Millimeters = 39.37 Inches
 1 Kilometer = 1000 Meters = 0.621 Miles

WEIGHTS

1 Gram = 0.001 Kilograms = 1000 Milligrams = 0.035 Ounces
 1 Kilogram = 1000 Grams = 2.2 lb.
 1 Metric Ton = 1000 Kilograms = 1 Megagram = 1.1 Short Tons

LIQUID MEASURE

1 Milliliter = 0.001 Liters = 0.0338 Fluid Ounces
 1 Liter = 1000 Milliliters = 33.82 Fluid Ounces

SQUARE MEASURE

1 Sq. Centimeter = 100 Sq. Millimeters = 0.155 Sq. Inches
 1 Sq. Meter = 10,000 Sq. Centimeters = 10.76 Sq. Feet
 1 Sq. Kilometer = 1,000,000 Sq. Meters = 0.386 Sq. Miles

CUBIC MEASURE

1 Cu. Centimeter = 1000 Cu. Millimeters = 0.06 Cu. Inches
 1 Cu. Meter = 1,000,000 Cu. Centimeters = 35.31 Cu. Feet

TEMPERATURE

$5/9(^{\circ}\text{F} - 32) = ^{\circ}\text{C}$
 212° Fahrenheit is equivalent to 100° Celsius
 90° Fahrenheit is equivalent to 32.2° Celsius
 32° Fahrenheit is equivalent to 0° Celsius
 $9/5^{\circ}\text{C} + 32 = ^{\circ}\text{F}$

APPROXIMATE CONVERSION FACTORS

TO CHANGE	TO	MULTIPLY BY
Inches	Centimeters	2.540
Feet	Meters	0.305
Yards	Meters	0.914
Miles	Kilometers	1.609
Square Inches	Square Centimeters	6.451
Square Feet	Square Meters	0.093
Square Yards	Square Meters	0.836
Square Miles	Square Kilometers	2.590
Acres	Square Hectometers	0.405
Cubic Feet	Cubic Meters	0.028
Cubic Yards	Cubic Meters	0.765
Fluid Ounces	Milliliters	29.573
its	Liters	0.473
arts	Liters	0.946
allons	Liters	3.785
Ounces	Grams	28.349
Pounds	Kilograms	0.454
Short Tons	Metric Tons	0.907
Pound-Feet	Newton-Meters	1.356
Pounds per Square Inch	Kilopascals	6.895
Miles per Gallon	Kilometers per Liter	0.425
Miles per Hour	Kilometers per Hour	1.609

TO CHANGE	TO	MULTIPLY BY
Centimeters	Inches	0.394
Meters	Feet	3.280
Meters	Yards	1.094
Kilometers	Miles	0.621
Square Centimeters	Square Inches	0.155
Square Meters	Square Feet	10.764
Square Meters	Square Yards	1.196
Square Kilometers	Square Miles	0.386
Square Hectometers	Acres	2.471
Cubic Meters	Cubic Feet	35.315
Cubic Meters	Cubic Yards	1.308
Milliliters	Fluid Ounces	0.034
Liters	Pints	2.113
Liters	Quarts	1.057
ers	Gallons	0.264
ms	Ounces	0.035
ograms	Pounds	2.205
Metric Tons	Short Tons	1.102
Newton-Meters	Pounds-Feet	0.738
Kilopascals	Pounds per Square Inch	0.145
ometers per Liter	Miles per Gallon	2.354
ometers per Hour	Miles per Hour	0.621



PIN: 077618-000