

3050, 3350 and 3650 Tractors

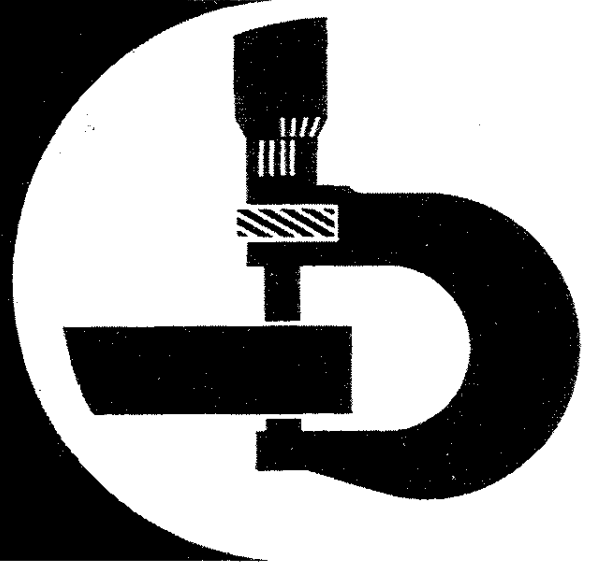

John Deere Werke Mannheim
TM4443 (Nov-90)

PRINTED IN GERMANY
ENGLISH



SUMMARY OF MOST IMPORTANT SPECIFICATIONS FOR 3050, 3350 and 3650 TRACTORS

NOTE: For further specifications, see relevant Technical Manual.

ENGINE

Valve clearance (engine hot or cold):	
Intake valves	0.35 mm (0.014 in.)
Exhaust valves	0.45 mm (0.018 in.)
Minimum engine oil pressure at 800 rpm and normal operating temperature	
	100 kPa (1 bar; 14 psi)
Compression	
	2100 kPa (21 bar; 300 psi)
Maximum difference in pressure between cylinders	
	350 kPa (3.5 bar; 50 psi)
Maximum blow-by at crankcase vent tube	
	80 l/kWh (2.8 cu.ft./kWh)
Rocker arm shaft to cylinder head	
	50 Nm (35 ft-lb)
Cylinder head to cylinder block (cap screws dipped in oil)	
1st step	85 Nm (65 ft-lb)
2nd step	135 Nm (100 ft-lb)
3rd step	+60°
Rocker cover to cylinder head	
	10 Nm (7 ft-lb)
Connecting rod cap screws (dipped in oil)	
	65 to 75 Nm (50 to 55 ft-lb)
Main bearings to cylinder block	
	120 Nm (85 ft-lb)
Flywheel to crankshaft	
	160 Nm (120 ft-lb)
Front axle carrier to engine	
<i>without increased lifting capacity</i>	230 Nm (170 ft-lb)
<i>with increased lifting capacity and 3650</i>	
upper TORX screws	100 Nm (75 ft-lb) + 60°
lower TORX screws	250 Nm (185 ft-lb)
Oil pan to front axle carrier	
	400 Nm (300 ft-lb)
Oil pan to clutch housing	
<i>without increased lifting capacity</i>	230 Nm (170 ft-lb)
<i>with increased lifting capacity and 3650</i>	400 Nm (300 ft-lb)
Clutch housing to engine	
<i>without increased lifting capacity</i>	230 Nm (170 ft-lb)
<i>with increased lifting capacity and 3650</i>	
upper and upper right-hand TORX screws	
	120 Nm (85 ft-lb) + 120°
upper left-hand TORX screw	
	120 Nm (85 ft-lb) + 90°
lower TORX screws	
	120 Nm (85 ft-lb) + 72°
Side frames to front axle carrier	
<i>without increased lifting capacity</i>	230 Nm (170 ft-lb)
<i>with increased lifting capacity and 3650</i>	
TORX screws	
	400 Nm (300 ft-lb)
Side frames to flywheel housing	
<i>without increased lifting capacity</i>	230 Nm (170 ft-lb)
<i>with increased lifting capacity and 3650</i>	
upper and lower cap screws	
	575 Nm (425 ft-lb)
center cap screws	
	325 Nm (240 ft-lb)

FUEL INJECTION NOZZLES

Opening pressure of a new or re- conditioned nozzle with new spring	
- Engine without turbocharger	21700 to 22400 kPa (217 to 224 bar; 3150 to 3250 psi)
- Engine with turbocharger	25100 to 25800 kPa (251 to 258 bar; 3650 to 3750 psi)
Minimum opening pressure with used nozzle	
- Engine without turbocharger	20700 kPa (207 bar; 3000 psi)
- Engine with turbocharger	24100 kPa (241 bar; 3500 psi)
Maximum difference in opening pressure	
	700 kPa (7 bar; 100 psi)
Fuel injection nozzle to cylinder head	
	30 Nm (23 ft-lb)

BATTERIES

Cold state testing current	395 amps.
----------------------------	-----------

ENGINE CLUTCH

Thickness of a new disk	10 mm (0.39 in.)
Wear limit	7 mm (0.26 in.)
Maximum permissible warpage of clutch disk	
	0.5 mm (0.02 in.)
Flywheel to crankshaft	
	160 Nm (120 ft-lb)
Clutch to flywheel	
	50 Nm (35 ft-lb)
Clutch pedal free play (mechanical operated clutch)	
	25 mm (approx. 1 in.)

HI-LO SHIFT UNIT

Operating pressure at 1500 rpm	1050 kPa (10.5 bar; 150 psi)
Operating pressure of automatic shift valve	
	500 to 700 kPa (5 to 7 bar; 75 to 100 psi)
Hi-Lo shift unit to clutch housing	
	50 Nm (35 ft-lb)

SYNCHRONIZED TRANSMISSION

Differential drive shaft

Rolling drag torque with	
New bearings	0.75 to 1.5 Nm (6.5 to 13 in-lb)
Used bearings	0.4 to 0.75 Nm (3.5 to 6.5 in-lb)
Special hex. nut or special nut of differential drive shaft	
	140 Nm (100 ft-lb)



SUMMARY OF MOST IMPORTANT SPECIFICATIONS FOR 3050, 3350 and 3650 TRACTORS

SYNCHRONIZED TRANSMISSION (Contd.)

Range shaft

Preload of taper roller bearings 0.05 to 0.10 mm
(0.002 to 0.004 in.)

Countershaft

Preload of transmission hollow drive shaft taper roller bearings 0.05 to 0.10 mm
(0.002 to 0.004 in.)

Rolling drag torque 1 to 2 Nm (9 to 18 in-lb)
End play of transmission drive shaft 0.03 to 0.13 mm
(0.001 to 0.005 in.)

Hex. nut of transmission hollow drive shaft 140 Nm (100 ft-lb)
Countershaft bearing quill 120 Nm (85 ft-lb)

Intermediate shaft

Preload of bearings 0.05 to 0.10 mm
(0.002 to 0.004 in.)
Grooved nut 140 Nm (100 ft-lb)

Clutch housing to transmission case
without increased lifting capacity 160 Nm (120 ft-lb)
with increased lifting capacity and 3650
upper cap screws 260 Nm (190 ft-lb)
Upper left and right-hand TORX screws 100 Nm (75 ft-lb) + 60°
Remaining TORX screws 100 Nm (75 ft-lb) + 40°

TRANSMISSION OIL PUMP

Minimum delivery of transmission oil pump with:
Oil temperature 40°C (100°F) and 2000 rpm 42 liters/min. (11 gpm)
Oil temperature 65°C (150°F) and 2000 rpm 38 liters/min. (10 gpm)

Minimum flow to hydraulic pump with:
Oil temperature 40°C (100°F) and 2000 rpm 38 l/min (10 gpm)
Oil temperature 65°C (150°F) and 2000 rpm 34 l/min (9 gpm)

Transmission oil pump cap screws 55 Nm (40 ft-lb)
Transmission oil pump to clutch housing 55 Nm (40 ft-lb)

DIFFERENTIAL

Preload of taper roller bearings 0.15 to 0.25 mm
(0.006 to 0.01 in.)

Backlash between ring gear and differential drive shaft pinion 0.30 mm (0.012 in.)

FINAL DRIVES

To measured rolling drag torque of final drive housing (before tightening 12-point screw) add 10 to 13.5 Nm
(7 to 10 ft-lb)

Final drives to transmission case 230 Nm (170 ft-lb)

PTO

Operating pressure at 1500 rpm 1050 kPa
(10.5 bar; 150 psi)

Drive gear to clutch drum 75 Nm (55 ft-lb)
Bearing quill to transmission case 115 Nm (85 ft-lb)
Preload of taper roller bearings (handshift PTO) 0.05 to 0.15 mm
(0.002 to 0.006 in.)

PTO shaft cover to bearing quill (handshift PTO) 30 Nm (23 ft-lb)

FRONT PTO

Operating pressure at 1500 rpm 1050 kPa
(10.5 bar; 150 psi)

Preload of taper roller bearings 0 to 0.05 mm (0 to 0.002 in.)
Front PTO to front axle carrier 400 Nm (300 ft-lb)

FRONT WHEEL DRIVE

Operating pressure at 1500 rpm 1050 kPa
(10.5 bar, 150 psi)

Disk clutch slips at a torque of:
3050 and 3350 without front PTO 1000 Nm (740 ft-lb)
3050 and 3350 with front PTO and 3650 1300 Nm (960 ft-lb)

Clutch shaft taper roller bearings
Preload 0.02 mm (0.0008 in.)
Up to axial play of 0.03 mm (0.0012 in.)
Front axle to front axle carrier 300 Nm (220 ft-lb)
Front axle axial play 0 to 0.5 mm (0 to 0.02 in.)
Universal-jointed drive shaft to drive hub 75 Nm (55 ft-lb)

STEERING

Adjustment pressure of double-acting shock valves 21000 kPa
(210 bar; 3050 psi)

Steering valve to steering column 50 Nm (35 ft-lb)

BRAKES

Return movement of pressure ring within 15 seconds 0.28 to 0.35 mm
(0.011 - 0.014 in.)

Test pressure for leakage test of pressure ring 300 kPa
(3 bar; 44 psi)

Maximum pressure drop within 10 seconds 10 kPa
(0.1 bar; 1.5 psi)

Retraction pin assembly to pressure ring 15 Nm (11 ft-lb)



SUMMARY OF MOST IMPORTANT SPECIFICATIONS FOR 3050, 3350 and 3650 TRACTORS

HYDRAULIC PUMP

Pump stand-by pressure	19000 kPa (190 bar; 2760 psi)
Minimum delivery at 2000 rpm and 17000 kPa (170 bar; 2450 psi) operating pressure:	
23 cm ³ (1.4 cu.in.) pump	34 l/min (9 gpm)
40 cm ³ (2.4 cu.in.) pump	68 l/min (18 gpm)
Hydraulic pump to front axle carrier	120 Nm (85 ft-lb)

ROCKSHAFT

Opening pressure of pressure relief valve	21000 to 23000 kPa (210 to 230 bar; 3050 to 3340 psi)
Rockshaft to transmission case	
Without increased lifting capacity	120 Nm (85 ft-lb)
With increased lifting capacity and 3650	
Hexagon socket screws	200 Nm (145 ft-lb)
Cap screws	120 Nm (85 ft-lb)

Adjusting Load Control Arm

Turn in control arm adjusting screw until it contacts arm and then back off	1/3 to 1/2 a turn
---	-------------------

Adjusting Valve Clearance

At commencement of lift turn adjusting screw clockwise	1/4 turn
Front edge of rockshaft control lever (Play between raising and lowering)	
With SG2 cab	12 to 15 mm (0.5 to 0.6 in.)
Without SG2 cab	2 to 4 mm (0.08 to 0.16 in.)

Adjusting Rockshaft Control Lever

With SG2 cab	
Front edge of rockshaft control lever in position	7 to 7.5
Without SG2 cab	
Front edge of rockshaft control lever to front end position of quadrant (measured at upper edge of quadrant)	12 + 1/-2 mm (0.47 +0.04/-0.08 in.)
Adjusting commencement of lift with load control	
With SG2 cab	
Front edge of control lever in position	2 to 2.5
Without SG2 cab	
Rear edge of control lever to rear end position of quadrant (measured at upper edge of quadrant)	50 ± 3 mm (2 ± 0.12 in.)

FRONT AXLE

Maximum permissible axial play of knuckle and spindle assy. in axle knee	0.76 mm (0.03 in.)
Front axle axial play	0 to 0.4 mm (0 to 0.015 in.)
Bearing pin to front axle carrier	100 Nm (75 ft-lb)
Axle knees to axle center	400 Nm (300 ft-lb)
Steering arm to knuckle and spindle assy.	230 Nm (170 ft-lb)

FRONT WHEELS

Wheel hub to axle spindle	50 Nm (35 ft-lb)
Steel disk to rim	
Bolts M16 × 120	250 Nm (185 ft-lb)
Bolts M16 × 74	280 Nm (210 ft-lb)
Wheel rim to hub	
Without front wheel drive	
Wheel bolts with cone	150 Nm (110 ft-lb)
Wheel bolts without cone	240 Nm (175 ft-lb)
With front wheel drive	300 Nm (220 ft-lb)
Front wheel toe-in	
Without front wheel drive	3 to 6 mm (1/8 to 1/4 in.)
With front wheel drive	0 to 3 mm (0 to 1/8 in.)

REAR WHEELS

Flanged Rear Axle

Steel disk to rim	
Bolts M16 × 120	250 Nm (185 ft-lb)
Bolts M16 × 74	280 Nm (210 ft-lb)
Cast disk to rim	230 Nm (170 ft-lb)
Rear wheels to rear axle	400 Nm (300 ft-lb)

Rack-and-Pinion Axle

Wheel rim to hub	
Steel type	400 Nm (300 ft-lb)
Cast type	230 Nm (170 ft-lb)
Pinion sleeve half to wheel hub	215 Nm (160 ft-lb)
Key sleeve half to wheel hub	400 Nm (300 ft-lb)



SUMMARY OF MOST IMPORTANT SPECIFICATIONS FOR 3050, 3350 and 3650 TRACTORS

SG2 CAB or RG2 ROLL-GUARD

SG2 cab or RG2 roll-guard to mounting brackets or final drives 200 Nm (145 ft-lb)
 Studs in final drive housings 35 Nm (25 ft-lb)

2-POST ROLL-GUARD

Supports of final drives 400 Nm (300 ft-lb)
 Supports to crossmember 230 Nm (170 ft-lb)

4-POST ROLL-GUARD

Roll-guard to fender 120 Nm (85 ft-lb)
 Fender to final drive 230 Nm (170 ft-lb)

CAPACITIES

Cooling system
Without SG2 cab 17 liters (4.5 U.S.gal.)
With SG2 cab 19 liters (5.0 U.S. gal.)

Crankcase
 Initial filling 12 liters (3.1 U.S.gal.)
 Oil change and renew filter 11.5 liters (3.0 U.S.gal.)

Transmission/Hydraulic System (with oil reservoir and oil cooler)

Initial filling
Without front wheel drive 53 liters (14.0 U.S.gal.)
With front wheel drive 56 liters (14.8 U.S.gal.)
With front PTO 58 liters (15.3 U.S.gal.)

Oil change and renew filter
Without front wheel drive 50 liters (13.2 U.S.gal.)
With front wheel drive 53 liters (14.0 U.S.gal.)
With front PTO 55 liters (14.55 U.S.gal.)

Front Wheel Drive

Front axle housing 7 liters (1.85 U.S.gal.)
 Wheel hub housings, each 0.75 liters (0.2 U.S.gal.)

Hydraulic Operated Clutch 250 cm³ (8.75 fl.oz.)

Air Conditioning System 1.8 kg (4 lb)

3050, 3350 AND 3650 TRACTORS TECHNICAL MANUAL TM4443 (Nov-90)

SECTION CONTENTS IN GROUPS – REPAIR

05 – SAFETY

10 – GENERAL

- 05 – Specifications
- 10 – Predelivery, delivery and after-sales inspections
- 15 – Lubrication and service
- 20 – Tune-up
- 25 – Tractor separation

20 – ENGINE

- 05 – Radiator, viscous fan drive and fan

30 – FUEL AND AIR INTAKE SYSTEM

- 05 – Fuel tank, auxiliary tank and water trap
- 10 – Cold weather starting aids
- 15 – Speed control linkage
- 20 – Air cleaner

40 – ELECTRICAL SYSTEM

- 05 – Wiring harnesses
- 10 – Controls and instruments (with SG2 cab)
- 15 – Controls and instruments (without SG2 cab)
- 16 – Adjusting digital speed-hour-meter
- 20 – Lighting system
- 25 – Starting motor
- 30 – Alternator

50 – POWER TRAIN

- 05 – Clutch operating systems
- 10 – Engine clutch
- 15 – Hi-Lo shift unit
- 20 – Creeper transmission
- 21 – Hydrostatic creeper transmission
- 25 – Transmission – console shift
- 30 – Transmission – center shift
- 35 – Synchronized transmission and transmission oil pump
- 40 – Differential
- 45 – Final drives
- 50 – PTO
- 55 – Front PTO
- 60 – Front wheel drive u.j. drive shaft and disk clutch

60 – STEERING SYSTEM AND BRAKES

- 05 – Hydrostatic steering
- 10 – Steering cylinder (without front wheel drive)
- 15 – Hydraulic brakes
- 20 – Handbrake
- 25 – Hydraulic trailer brake

70 – HYDRAULIC SYSTEM

- 05 – Valves
- 10 – Hydraulic pumps
- 15 – Rockshaft
- 20 – Front hitch
- 25 – Selective control valves (spool type)
- 30 – Selective control valves (poppet valve type)

COPYRIGHT © 1990 DEERE & CO.
European Office Mannheim
All rights reserved
A John Deere ILLUSTRATION™ Manual
PREVIOUS EDITIONS
COPYRIGHT © 1987, 1989

INHALT-LB201AE-010490

SECTION CONTENTS IN GROUPS – REPAIR

70 – HYDRAULIC SYSTEM (CONTD.)

- 35 – ISO breakaway couplers
- 40 – ISO quick couplers
- 45 – Remote cylinder







80 – MISCELLANEOUS

- 05 – Front axle
- 10 – Front and rear wheels
- 15 – AXLA trailer hitch
- 20 – Trailer hitch (height adjustable)

90 – SG2 CAB

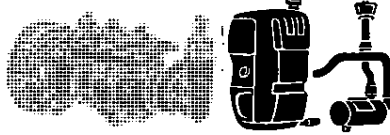
- 05 – Safe handling of refrigerants
- 06 – Servicing air conditioning system
- 07 – Compressor (up to tractor serial no. 646 949L)
- 08 – Compressor (from tractor serial no. 646 950L)
- 09 – Components of air conditioning system
- 10 – Cab ventilation and heating
- 15 – Cab ventilation and heating
(low profile cab)
- 20 – Operator's seats
- 25 – SG2 cab
- 30 – 2-post roll guard
- 35 – 4-post roll guard
- 40 – RG2 roll guard

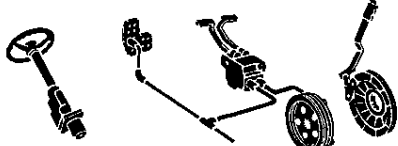
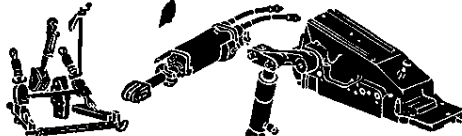
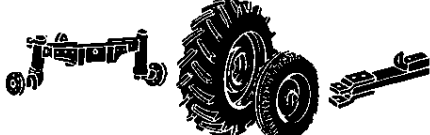
INHALT-LB202AE-010488

SAFETY	 05
GENERAL	 10
ENGINE	 20
FUEL AND AIR INTAKE SYSTEM	 30
ELECTRICAL SYSTEM	 40
POWER TRAIN	 50
STEERING SYSTEM AND BRAKES	 60
HYDRAULIC SYSTEM	 70
MISCELLANEOUS	 80
OPERATOR'S STATION	 90

FX 100006 19

FX100006 19-LB303AE-010490

SAFETY AND YOU

This is the safety-alert symbol. When you see this symbol on the machine or in this manual, be alert to the potential for personal injury.



T 81389

T81389;053;TMSAFE 19 07OCT85

IMPORTANT

The IMPORTANT message identifies potential problems which may cause consequential damage to machine. Following recommended procedure will instruct technician how to avoid problem.

A68;N01;0000 19 U 05NOV82

NOTES

The word NOTE is followed by a statement that identifies a qualification or exception to a previous statement. A "NOTE" may also identify nice-to-know information pertinent to, but not directly related to previous statement.

A68; N01;0000 19 V 05NOV82

OBSERVE SAFETY RULES

Avoid loose clothing that can catch in moving parts and put you out of work.

Wear your safety glasses while on the job.

Avoid working on equipment with the engine running. If it is necessary to make checks with the engine running, **ALWAYS USE TWO PEOPLE** – with the operator, at the controls, able to see the person doing the checking. Also, put the transmission in neutral, set the brake, and apply safety locks provided. **KEEP HANDS AWAY FROM MOVING PARTS.**

Keep transmission and brake control units properly adjusted at all times. Before making adjustments, stop engine.

Before removing any housing covers, stop engine. Take all objects from your pockets which could fall into the opened housings. Don't let adjusting wrenches fall into opened housings.

Don't attempt to check belt tension while the engine is running.

Don't adjust the fuel system while the machine is in motion.

Before repairing the electrical system, or performing a major overhaul, make sure the batteries are disconnected.

A69; N01;0000 19 S 05NOV82

PREPARE FOR EMERGENCIES

Be prepared if a fire starts.

Keep a first aid kit and fire extinguisher handy.

Keep emergency numbers for doctors, ambulance service, hospital and fire department near your telephone.

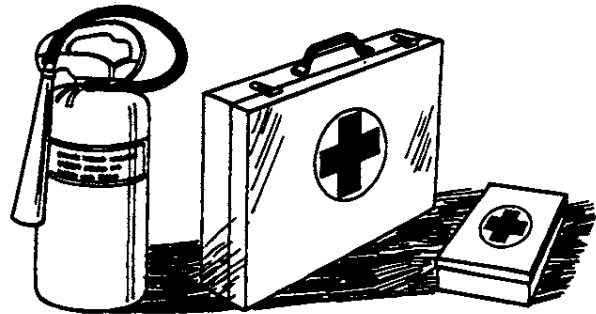

L 114 052

L114052;053;FIR2 19 15MAR89

WORK IN CLEAN AREA

Before starting a job:

- Clean work area and machine.
- Make sure you have all necessary tools to do your job.
- Have the right parts on hand.
- Read all instructions thoroughly; do not attempt shortcuts.

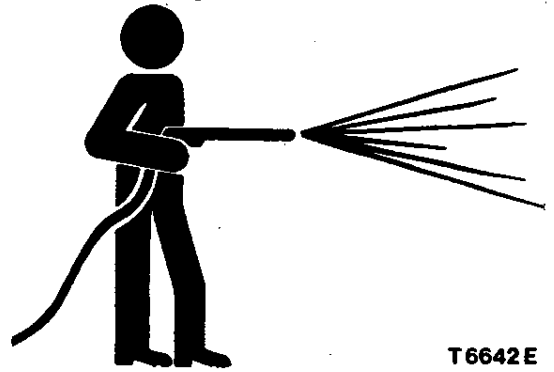

T6642 E

T6642E;053;CLEAN 19 19JAN88

WORK IN VENTILATED AREA

Engine exhaust fumes can cause sickness or death. If it is necessary to run an engine in an enclosed area, remove the exhaust fumes from the area with an exhaust pipe extension.

If you do not have an exhaust pipe extension, open the doors and get outside air into the area.



TS 220

TS220;053;AIR 19 05JAN88

PARK MACHINE SAFELY

Before working on the machine:

- Lower all equipment to the ground.
- Stop the engine and remove the key:
- Disconnect the battery ground strap.
- Hang a "DO NOT OPERATE" tag in operator station.

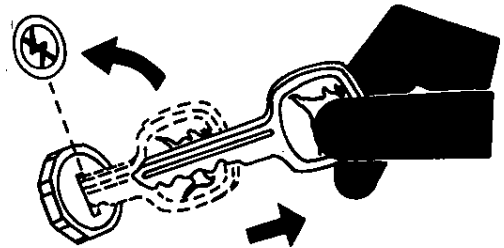

TS 230

TS230;053;PARK 19 05JAN88

USE PROPER LIFTING EQUIPMENT

Lifting heavy components incorrectly can cause severe injury or machine damage.

Follow recommended procedure for removal and installation of components in the manual.

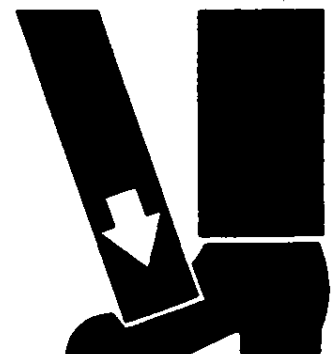

TS 226

TS226;053;LIFT 19 05JAN88

SUPPORT MACHINE PROPERLY

Always lower the attachment or implement to the ground before you work on the machine. If you must work on a lifted machine or attachment, securely support the machine or attachment.

Do not support the machine on cinder blocks, hollow tiles or props that may crumble under continuous load. Do not work under a machine that is supported solely by a jack. Follow recommended procedures in this manual.

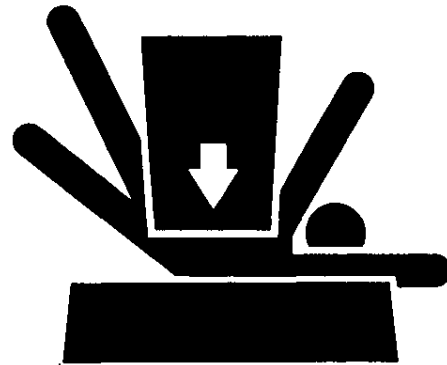

TS 229

TS229;053;LOWER 19 21DEC87

SERVICE FRONT-WHEEL DRIVE TRACTOR SAFELY

When servicing front-wheel drive tractor with the rear wheels supported off the ground and rotating wheels by engine power, always support front wheels in a similar manner. Loss of electrical power or transmission/hydraulic system pressure will engage the front driving wheels, pulling the rear wheels off the support if front wheels are not raised. Under these conditions, front drive wheels can engage even with switch in disengaged position.

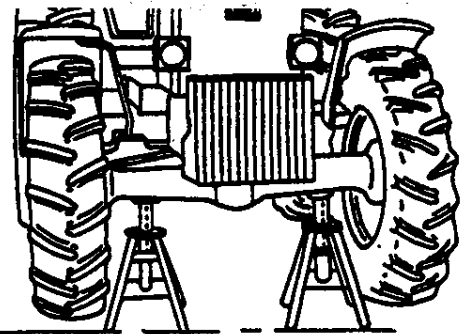

L114050

L114050-ESPDAE-140388

SERVICE HYDROSTATIC CREEPER TRANSMISSION SAFELY

Service work on the hydrostatic creeper transmission may be performed with the engine running only if front and rear wheels are raised and the tractor is safely supported.

Loss of electric power or transmission/hydraulic system pressure will engage hydrostatic creeper transmission, even if the toggle switch is in "OFF" position. Tractor could then start to move if wheels are in contact with the ground.



FXB 04001 UN

FXB04001UN, HYDRO1G 070290

PREVENT MACHINE RUNAWAY

Avoid possible injury or death from a machine runaway.

Do not start the engine by shorting across starter terminals. Machine will start in gear if normal circuitry is bypassed.

NEVER start engine while standing on ground. Start engine only from operator's seat, with the transmission in neutral or "Park".



TS177

TS177;053;BYPAS1 19 21MAY85

SERVICE MACHINE SAFELY

Tie long hair behind your head. Do not wear a necktie, scarf, loose clothing or necklace when you work near machine tools or moving parts. If these items were to get caught, severe injury could result.

Remove rings and other jewelry to prevent electrical shorts and entanglement in moving parts.

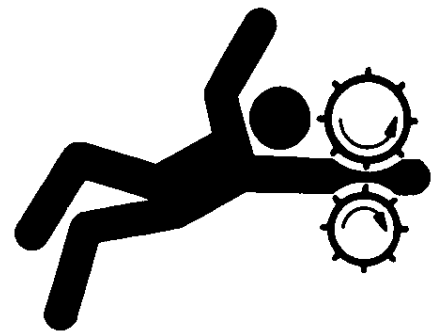

TS228

TS228;053;LOOSE 19 21DEC87

UNDERSTAND CORRECT SERVICE

Illuminate your work area adequately but safely. Use a portable safety light for working inside or under the machine. Make sure the bulb is enclosed by a wire cage. The hot filament of an accidentally broken bulb can ignite spilled fuel or oil.

Catch draining fuel, oil, or other fluids into suitable containers. Do not use food or beverage containers that may mislead someone into drinking from them. Wipe up spills at once.



TS 223

TS223;053;LIGHT 19 23FEB88

USE TOOLS PROPERLY

Use tools appropriate to the work. Makeshift tools, parts, and procedures will not make good repairs.

Use pneumatic and electric tools only to loosen threaded parts and fasteners. Never use such tools to tighten fasteners, especially on light alloy parts.

Use only replacement parts meeting John Deere specifications.

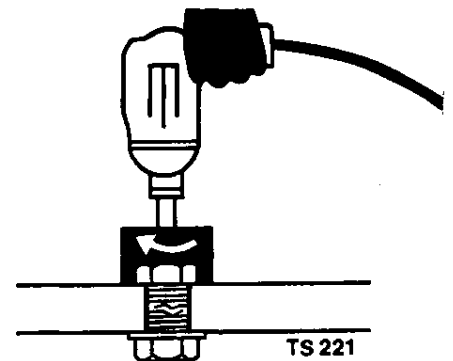

TS 221

TS221;053;REPAIR 19 21DEC87

HANDLE FLUIDS SAFELY – AVOID FIRES

When you work around fuel, do not smoke or work near heaters or other fire hazards.

Store flammable fluids away from fire hazards. Do not incinerate or puncture pressurized containers.

Make sure machine is clean of trash, grease and debris.

Do not store oily rags; they can ignite and burn spontaneously.



TS 227

TS227;053;FLAME 19 05JAN88

AVOID HIGH-PRESSURE FLUIDS

Escaping fluid (fuel or hydraulic oil) under pressure can penetrate the skin causing serious injury. Relieve pressure before disconnecting hydraulic or other lines. Tighten all connections before applying pressure. Keep hands and body away from pinholes and nozzles which eject fluids under high pressure. Use a piece of cardboard to search for leaks.

If ANY fluid is injected into the skin, it must be surgically removed within a few hours by a doctor familiar with this type of injury, or gangrene may result.

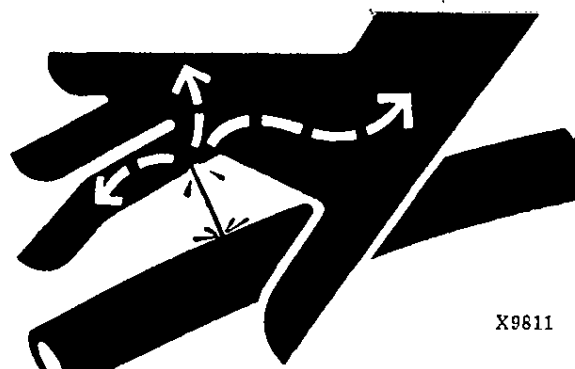

X9811

X9811;053;FLUID 19 18SEP87

REMOVE PAINT BEFORE WELDING OR HEATING

Avoid potentially toxic fumes and dust.

Hazardous fumes can be generated when paint is heated by welding, soldering, or using a torch.

Do all work outside or in a well ventilated area. Dispose of paint and solvent properly.

Remove paint before welding or heating:

- If you sand or grind paint, avoid breathing the dust. Wear an approved respirator.
- If you use solvent or paint stripper, remove stripper with soap and water before welding. Remove solvent or paint stripper containers and other flammable material from area. Allow fumes to disperse at least 15 minutes before welding or heating.

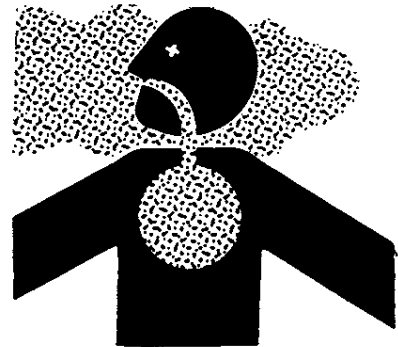

TS 220

TS220-ESPD AE-040690

AVOID HEATING NEAR PRESSURIZED FLUID LINES

Flammable spray can be generated by heating near pressurized fluid lines, resulting in severe burns to yourself and bystanders. Do not heat by welding, soldering, or using a torch near pressurized lines or other flammable materials.

Pressurized lines can be accidentally cut when heat goes beyond the immediate flame area. Install fire resisting guards to protect hoses or other materials.



TS 953

TS953-ESPD AE-040690

AVOID HARMFUL ASBESTOS DUST

Avoid breathing dust that may be generated when handling components containing asbestos fibers. Inhaled asbestos fibers may cause lung cancer.

Components in John Deere products that may contain asbestos fibers are brake pads, brake band and lining assemblies, clutch plates and some gaskets. The asbestos used in these components is usually found in a resin or sealed in some way. Normal handling is not hazardous as long as airborne dust containing asbestos is not generated.

Avoid creating dust. Never use compressed air for cleaning. Avoid brushing or grinding of asbestos-containing materials. When servicing, wear an approved respirator. A special vacuum cleaner is recommended to clean asbestos. If not available, wet the asbestos-containing materials with a mist of oil or water.

Keep bystanders away from the area.

Please note designations on spare parts.

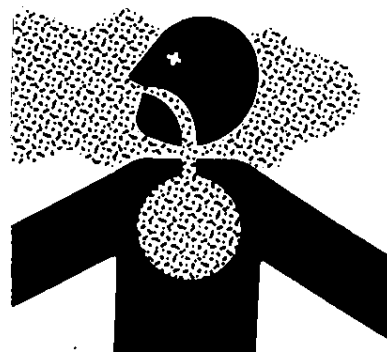

TS 220



L 114 051

TS220,L114051;053;DUST 19 14APR88

PREVENT ACID BURNS

Sulfuric acid in battery electrolyte is poisonous. It is strong enough to burn skin, eat holes in clothing and cause blindness if splashed into eyes.

Avoid the hazard by:

1. Filling the batteries in a well-ventilated area.
2. Wearing eye protection and rubber gloves.
3. Avoiding breathing fumes when electrolyte is added.
4. Avoiding spilling or dripping electrolyte.
5. Use proper jump start procedure.

If you spill acid on yourself:

1. Flush your skin with water.
 2. Apply baking soda or lime to help neutralize the acid.
 3. Flush your eyes with water for 10 – 15 minutes.
- Get medical attention immediately.

If acid is swallowed:

1. Drink large amounts of water or milk.
2. Then drink milk of magnesia, beaten eggs or vegetable oil.
3. Get medical attention immediately.

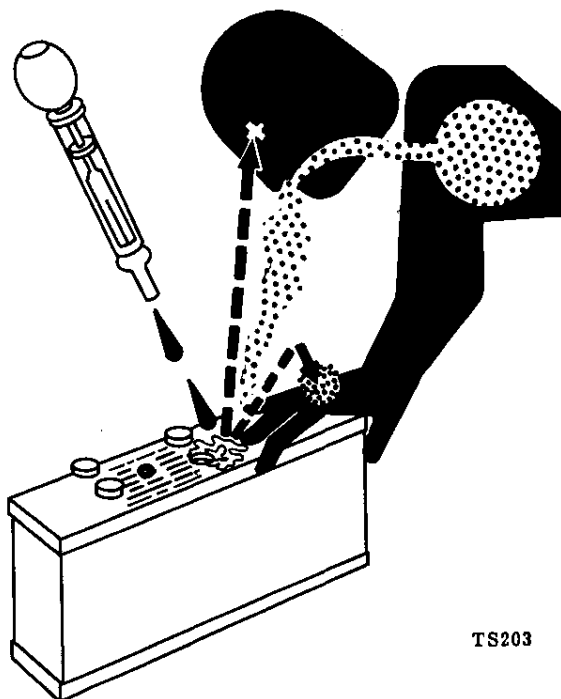

TS203

TS203;053;POISON 19 21DEC87

PREVENT BATTERY EXPLOSIONS

Keep sparks, lighted matches, and open flame away from the top of battery. Battery gas can explode.

Never check battery charge by placing a metal object across the posts. Use a volt-meter or hydrometer.

Do not charge a frozen battery; it may explode. Warm battery to 16°C (60°F).

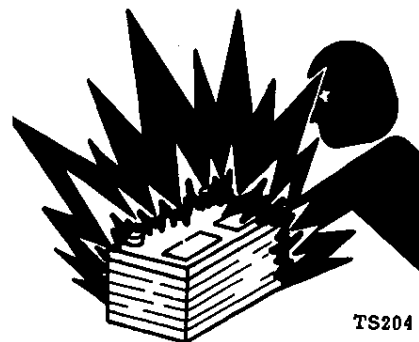

TS204

TS204;053;SPARKS 19 28JUN88

SERVICE TIRES SAFELY

Explosive separation of a tire and rim parts can cause serious injury or death.

Only attempt to mount a tire if you have the proper equipment and experience to perform the job.

Always maintain the correct tire pressure. Do not inflate tires above the recommended pressure.

When inflating tires, use a clip-on chuck and extension hose long enough to allow you to stand to one side and NOT in front of or over the tire assembly. Use a safety cage if available.

Check wheels for low pressure, cuts, bubbles, damaged rims or missing lug bolts and nuts.

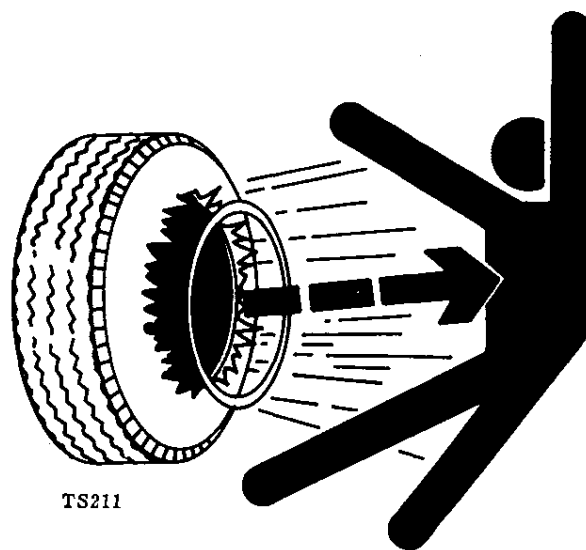

TS211

TS211;053;RIM 19 21DEC87

KEEP CAB/ROPS INSTALLED PROPERLY

Make certain all parts are reinstalled correctly if the cab or roll-over protective structure (ROPS) is loosened or removed for any reason. Tighten mounting bolts to specified torque.

Protection offered by cab or ROPS is impaired if subjected to structural damage, is involved in an overturn incident or is altered in any way by welding, bending, drilling or cutting. A damaged cab or ROPS should be replaced, not reused.

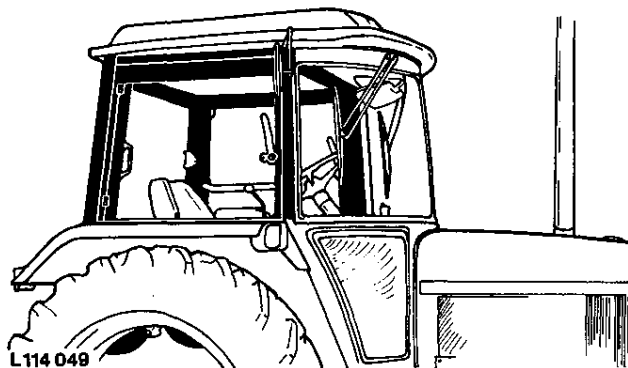

L114 049

L114049;053;ROPS 19 15MAR89

REPLACE SAFETY SIGNS

Replace missing or damaged safety signs. See the machine operator's manual for correct safety sign placement.

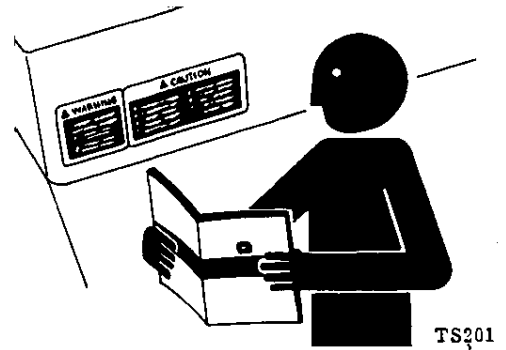

TS201

TS201,053;SIGNS1 19 22DEC87

OBSERVE ENVIRONMENTAL PROTECTION REGULATIONS

Be mindful of the environment and ecology.

Before draining any fluids, find out the correct way of disposing of them.

Observe the relevant environmental protection regulations when disposing of oil, fuel, coolant, brake fluid, filters and batteries.

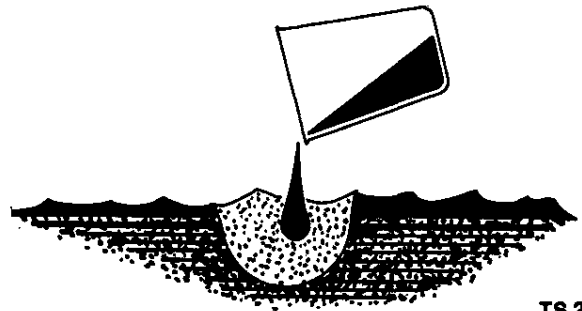

TS 222

TS222-ESPD AE-140388

Group 10 GENERAL

05 - SPECIFICATIONS

	3050	3350	3650
Specifications	X	X	X
- Serial number plates	X	X	X
- Product identification number	X	X	X
- Engine serial number	X	X	X
- Transmission serial number	X	X	X
- Front wheel drive axle serial number	X	X	X
- SG2 cab serial number	X	X	X
- RG2 roll guard serial number	X	X	X
- Model serial numbers	X	X	X
- Engine	X	X	X
- Engine clutch	X	X	X
- Cooling system	X	X	X
- Fuel system	X	X	X
- Electrical system	X	X	X
- Synchronized transmission	X	X	X
- Hi-Lo shift unit	X	X	X
- Creeper transmission	X	X	X
- Differential and final drives	X	X	X
- Differential lock	X	X	X
- PTO	X	X	X
- Front PTO	X	X	X
- PTO speeds	X	X	X
- Front wheel drive	X	X	X
- Hydrostatic steering	X	X	X
- Foot brakes	X	X	X
- Hand brake	X	X	X
- Hydraulic system	X	X	X
- Rockshaft	X	X	X
- Front hitch	X	X	X
- Ground travel speeds	X	X	X
- Front and rear wheels	X	X	X
- Dimensions and weights	X	X	X
- Capacities	X	X	X
- Standard torques for hardware	X	X	X

ALLGEM-LB21001AE-010488

10 – PREDELIVERY, DELIVERY AND AFTER-SALES INSPECTIONS

	3050	3350	3650
Special tools	X	X	X
Specifications	X	X	X
Capacities	X	X	X
Torques for hardware	X	X	X
Predelivery inspection	X	X	X
Delivery inspection	X	X	X
After-sales inspection	X	X	X

15 – LUBRICATION AND SERVICE

Capacities and service intervals	15-1	X	X	X
Lubricants and service intervals	15-2	X	X	X
General	15-3	X	X	X
Engine oil	15-3	X	X	X
Transmission/hydraulic oil	15-4	X	X	X
Oil for front wheel drive axle	15-4	X	X	X
EP multi-purpose grease	15-5	X	X	X
Storing lubricants	15-5	X	X	X
Brake fluid for hydraulic operated clutch	15-5	X	X	X
Engine coolant	15-6	X	X	X
Checking engine oil level	15-6	X	X	X
Changing engine oil	15-7	X	X	X
Changing engine oil filter	15-7	X	X	X
Checking fuel filter	15-8	X	X	X
Replacing fuel filter	15-8	X	X	X
Replacing coolant	15-9	X	X	X
Checking transmission/hydraulic system oil level	15-10	X	X	X
Changing transmission/hydraulic oil	15-11	X	X	X
Replacing transmission/hydraulic oil filter element	15-12	X	X	X
Replacing hydraulic oil return flow filter	15-12	X	X	X
Replacing hydrostatic steering filter (without SG2 cab or RG2 roll guard)	15-13	X	X	

BUY NOW

**Then Instant Download
the Complete Manual
Thank you very much!**

BUY NOW

**Then Instant Download
the Complete Manual
Thank you very much!**