

C/ #: 2B0 00001-UP 2B5 00001-UP 3S0 00001-UP
2B1 00001-UP 2B6 00001-UP 3S1 00001-UP
2B2 00001-UP 2B7 00001-UP 3S5 00001-UP
2B3 00001-UP 3S6 00001-UP

MANUAL

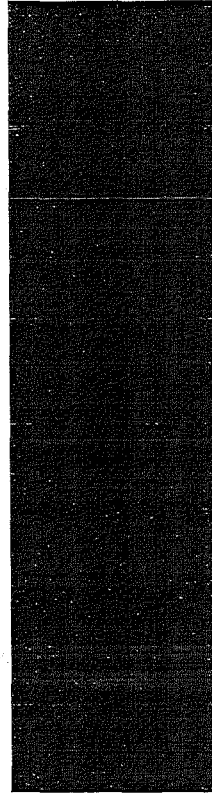

**MITSUBISHI
TRACTOR
BD2G**

**TRACTOR SHOVEL
BS3G**

 **MITSUBISHI**
HEAVY INDUSTRIES, LTD.

Chassis and Engine Serial Number Locations

Chassis and engine serial numbers are stamped in locations and forms shown.

When ordering replacement parts or asking your local Mitsubishi dealer to repair your machine, be sure to give these serial numbers and service meter reading.

- **BD2G**

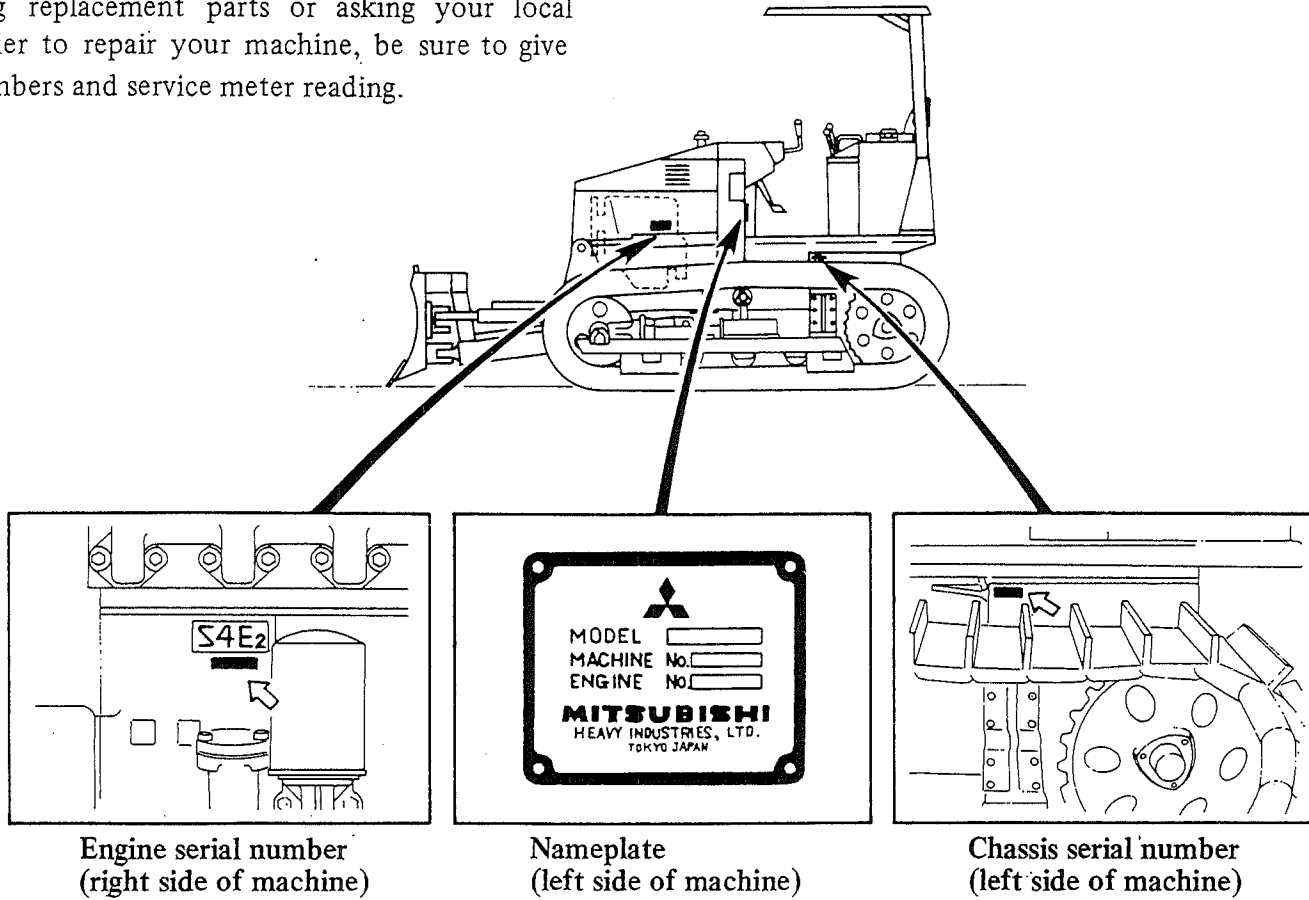

• BS3G

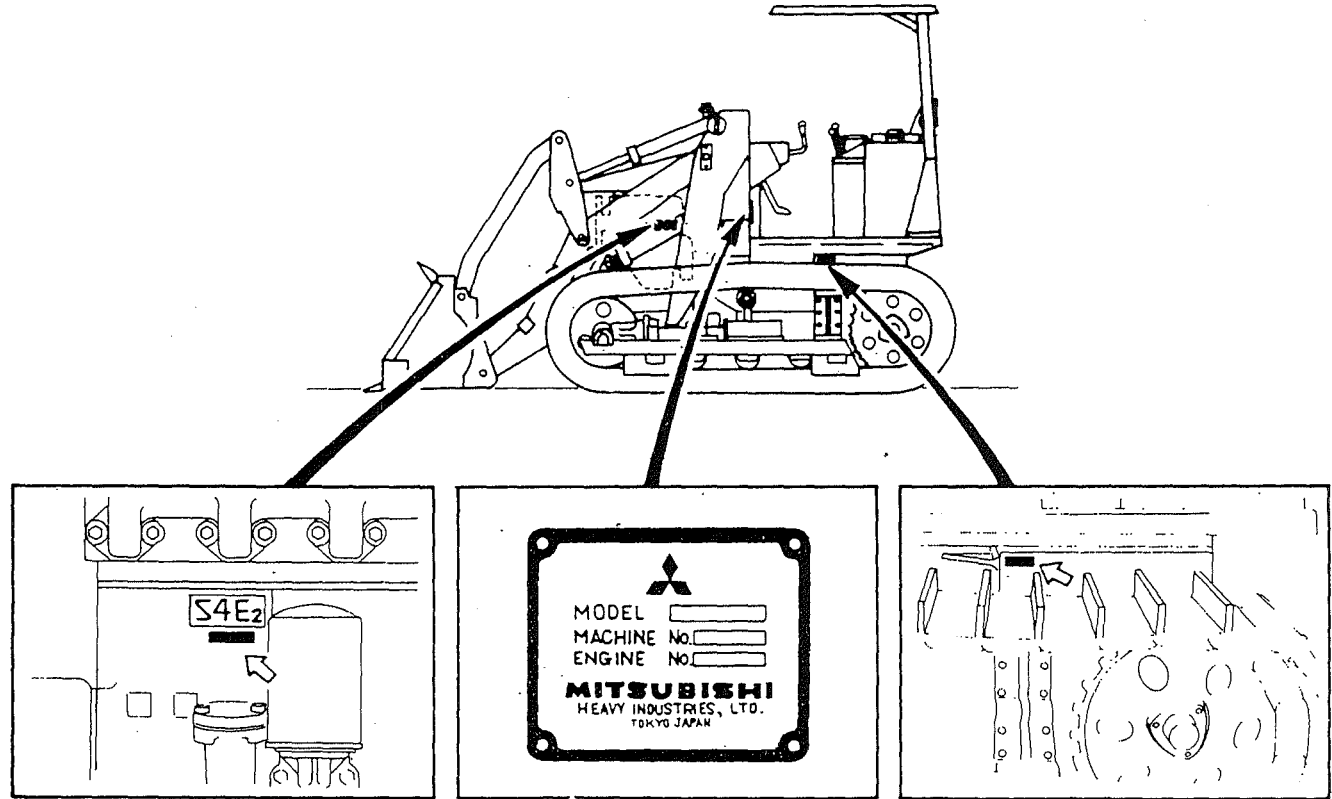

Engine serial number
(right side of machine)

Nameplate
(left side of machine)

Chassis serial number
(left side of machine)

BD2G

Major Components (BD2G)

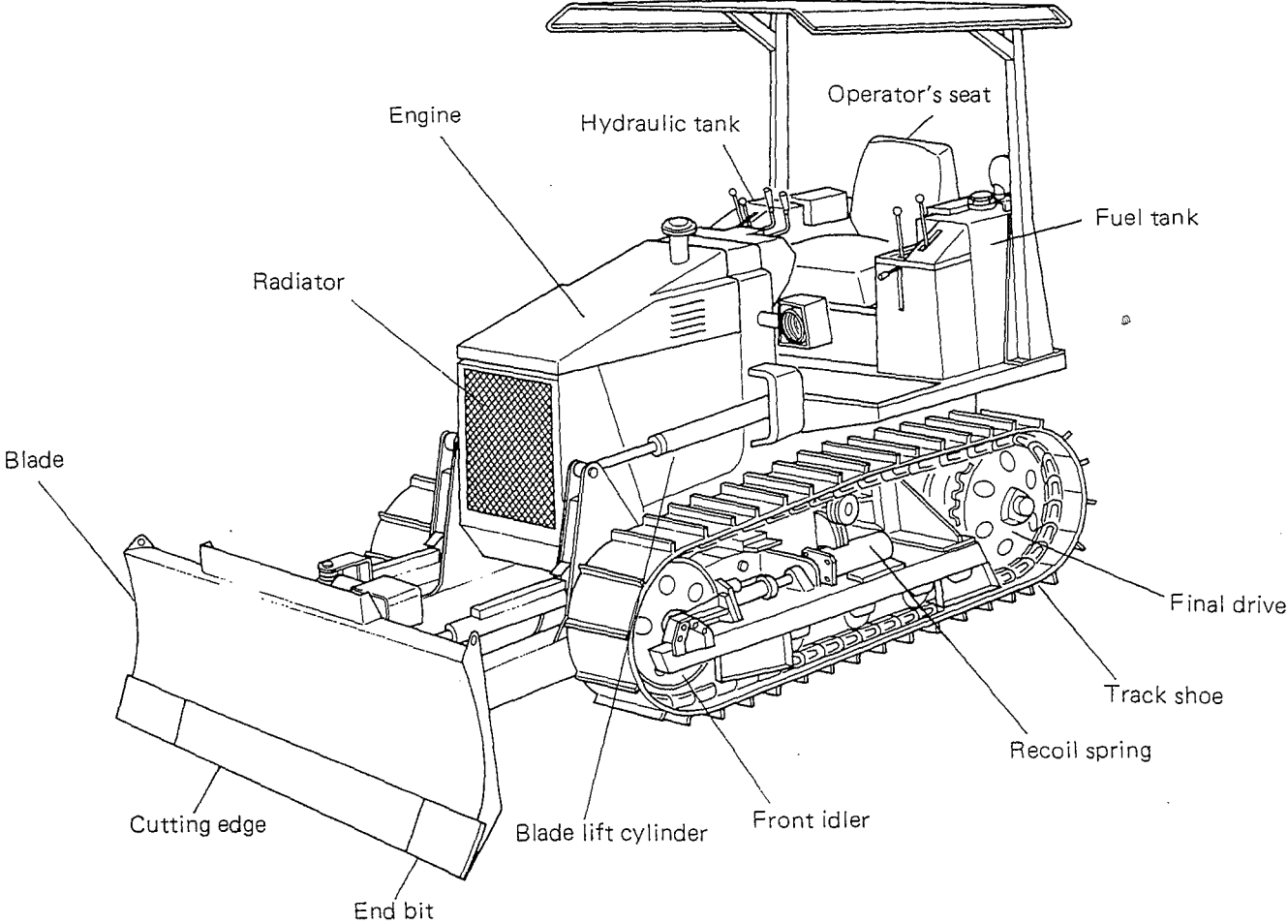

Operating Controls (BD2G)

Steering clutch levers

Left turn Right turn

Clutch ON Clutch OFF Brake ON

502654

Brake pedal lock-unlock lever

Unlock
Lock

502662

Transmission control lever [DD]

F3 F2 F1 R2 R1

502655

Accelerator lever

Increase speed Low idle

502656

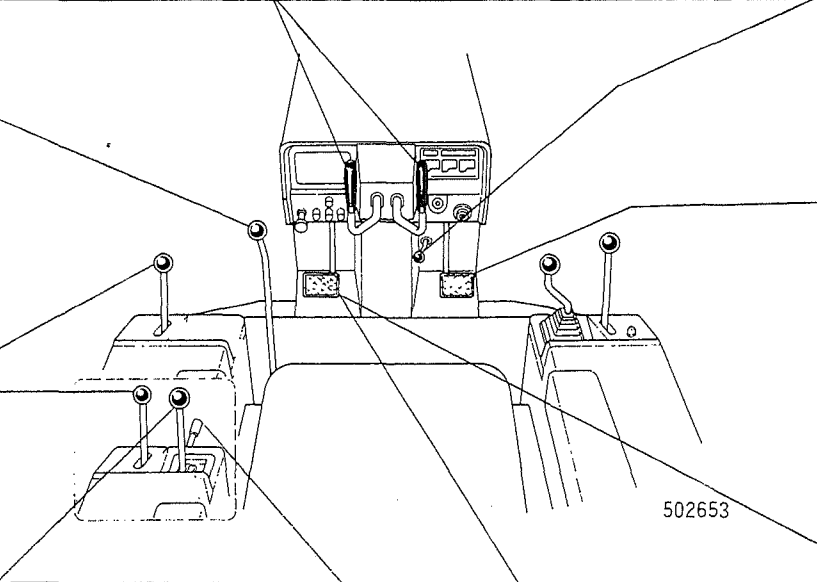

Brake pedal

Brake ON Brake OFF

502661

Transmission control lever [DPS]

N N R1 F1 R2 F2 R3 F3

502657

Transmission control lock-unlock lever [DPS]

Unlock
Lock

502658

Inching pedal [DPS]

Clutch OFF Clutch ON

502659

Clutch pedal [DD]

Brake ON Clutch ON
Clutch OFF

502660

Blade Controls (BD2G)

Power angling/tilt control lever and safety lock lever

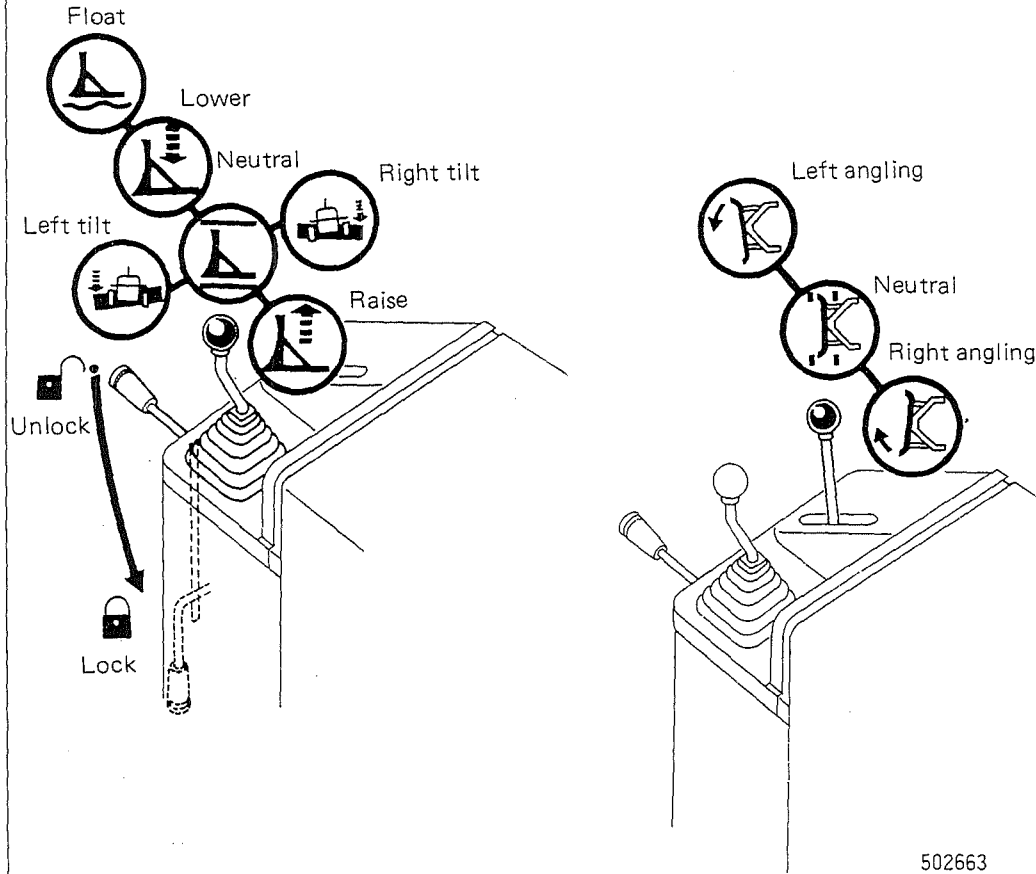

502663

Power tilt control lever and safety lock lever

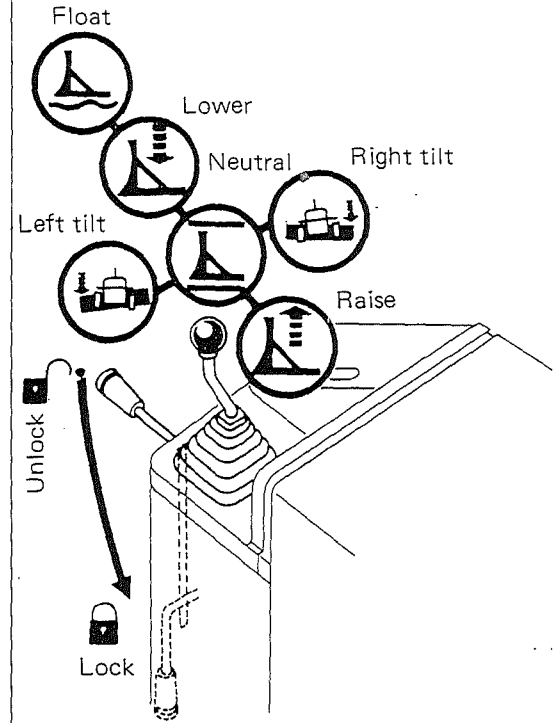

502664

Indicators, Gauges and Switches (BD2G)

OK monitor test switch

- When this switch is pushed with starter switch ON:

Alternator not charging and engine oil pressure warning lamps glow (with engine stopped).

Battery electrolyte level and air cleaner element warning lamps glow (with engine running).

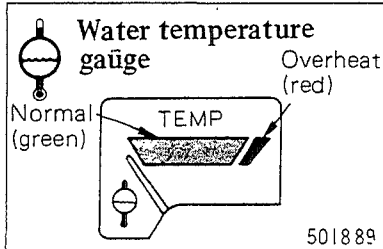

Service meter

Every 6 minutes dial advances one number.
1 hour



OK monitor

- When any lamp glows during operation, stop machine soon and check for cause. (See page 16.)

Battery switch

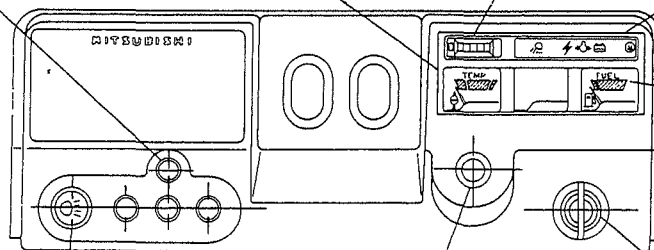
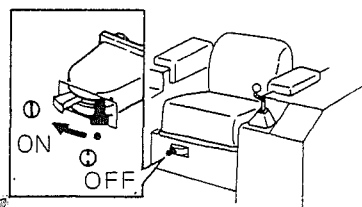

Fuel gauge



Empty (red)

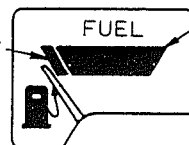

Lighting switch

Twist

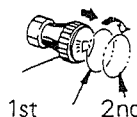

Position	1st		2nd	
		Twist		Twist
Head lamps				
Working lamp				
Instrument panel lamp				
[OP]				



Glow plug indicator



Glow when starter switch is turned to HEAT.



Starter switch

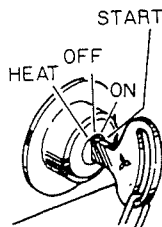

HEAT	Heat engine.
OFF	Insert or pull out key.
ON	Keep engine running.
START	Start engine.

501956

• Fuses (BD2G)

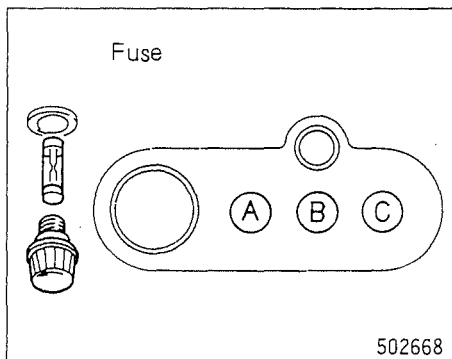

- Head lamps
● Instrument panel lamp
● Working lamp
● Working lamp indicator

- Horn

- Engine oil pressure warning lamp
● Battery electrolyte level warning lamp
● Air cleaner element warning lamp
● Fuel gauge
● Service meter
● OK monitor lamp switch
● Water temperature gauge

• OK monitor (BD2G)

Alternator not charging warning lamp
Okay if this lamp is OFF during operation.
■ When glows, stop engine and check charging system.

Engine oil pressure warning lamp
Okay if this lamp is OFF during operation.
■ When glows, stop engine and check for low oil level or oil leaks.

Battery electrolyte level warning lamp
Okay if this lamp is OFF during operation.
■ When glows, stop engine and add distilled water to battery. (See page 47.)

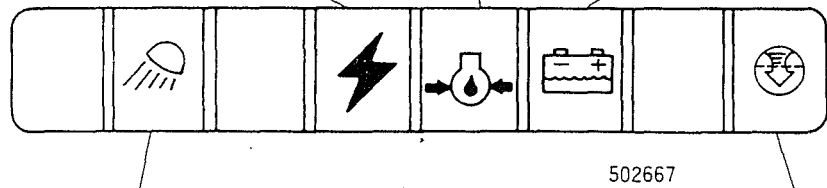

Working lamp indicator
■ Glows when working lamp is turned on.

Air cleaner element warning lamp
Okay if this lamp is OFF during operation.
■ When glows, clean or replace element. (See page 48.)

Others (BD2G)

Horn switch

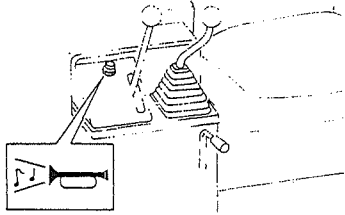

502669

Operator's seat
(fore-aft adjustment)

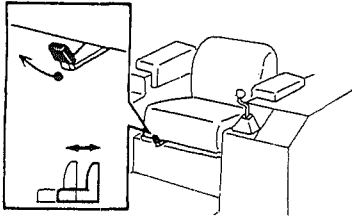

502670

Operator's seat (turning over)

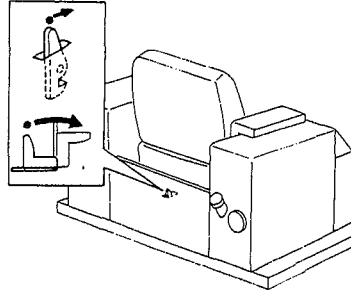

Seat support

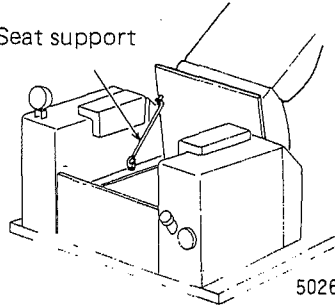

502671



WARNING

Be sure to support seat after turning it over.

BS3G

Major Components (BS3G)

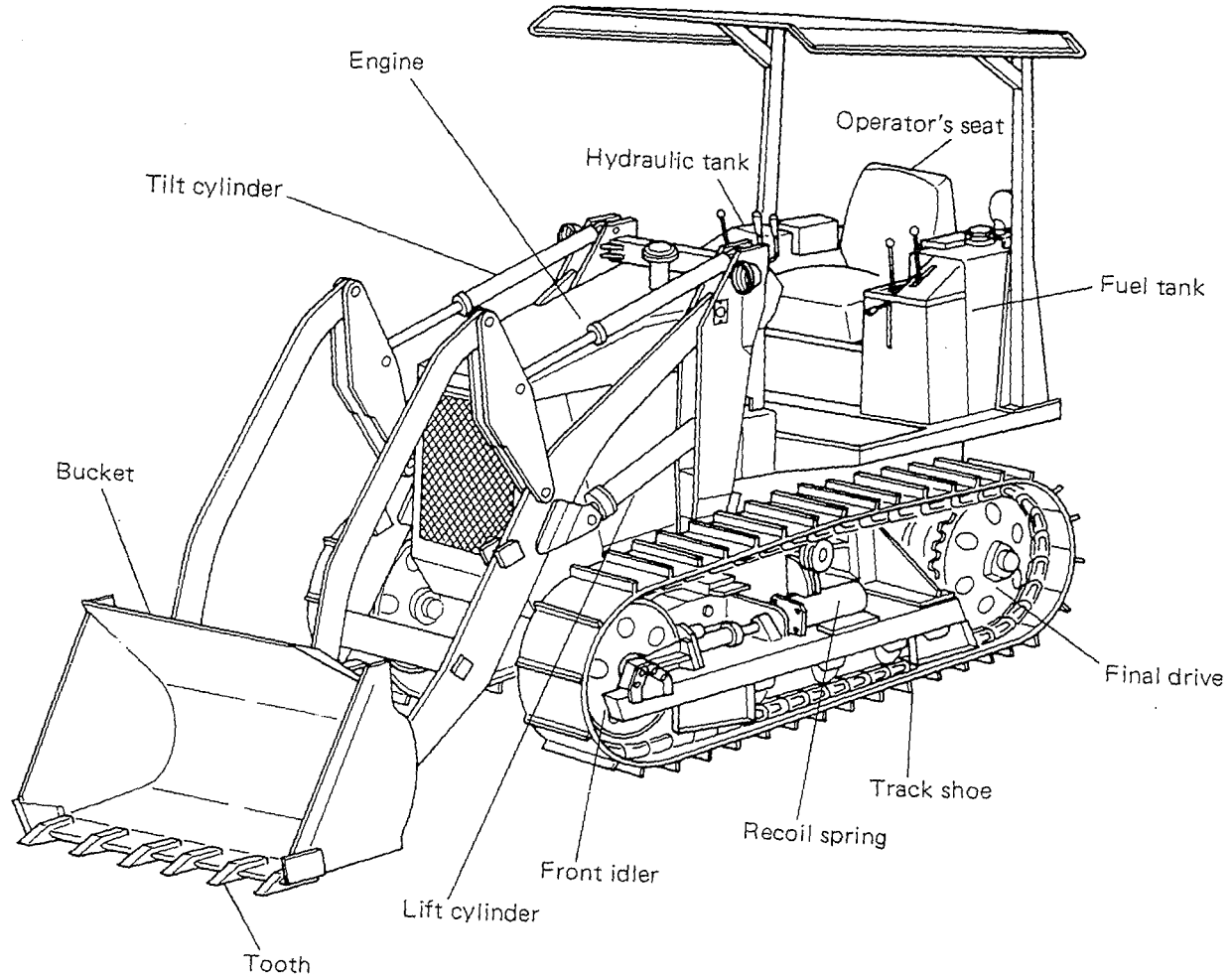

Operating Controls (BS3G)

Steering clutch levers

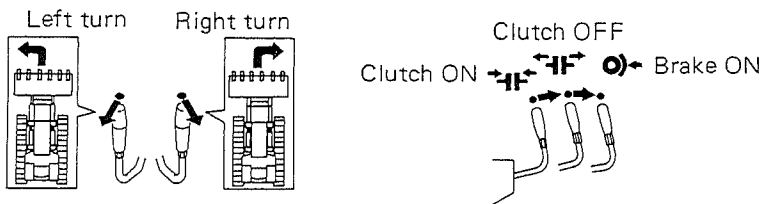

502674

Brake pedal lock-unlock lever

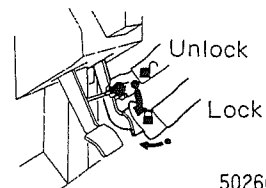

502662

Transmission control lever [DD]

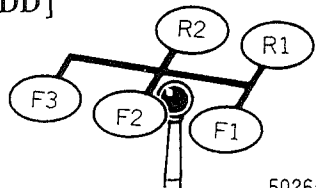

502655

Accelerator lever

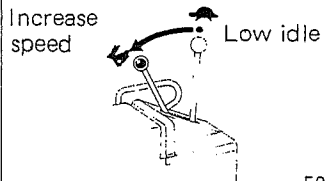

502656

Brake pedal

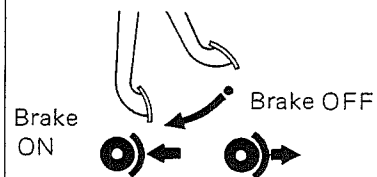

502661

Transmission control lever [DPS]

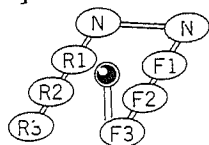

502657

Transmission control lock-unlock lever [DPS]

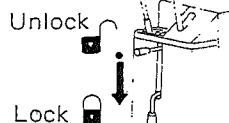

502658

Inching pedal [DPS]

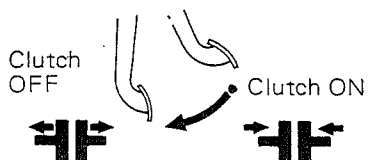

502659

Clutch pedal [DD]

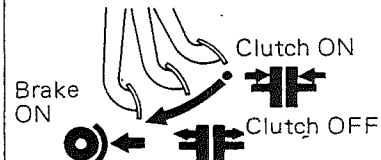

502660

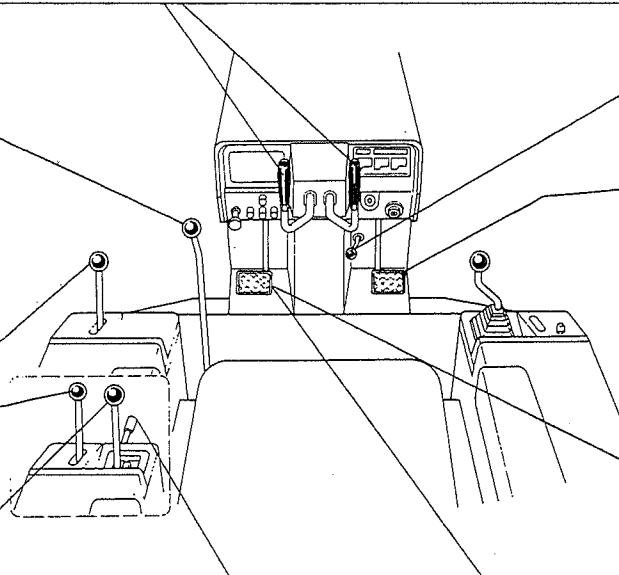

502673

Bucket Controls (BS3G)

Bucket control lever and safety lock lever

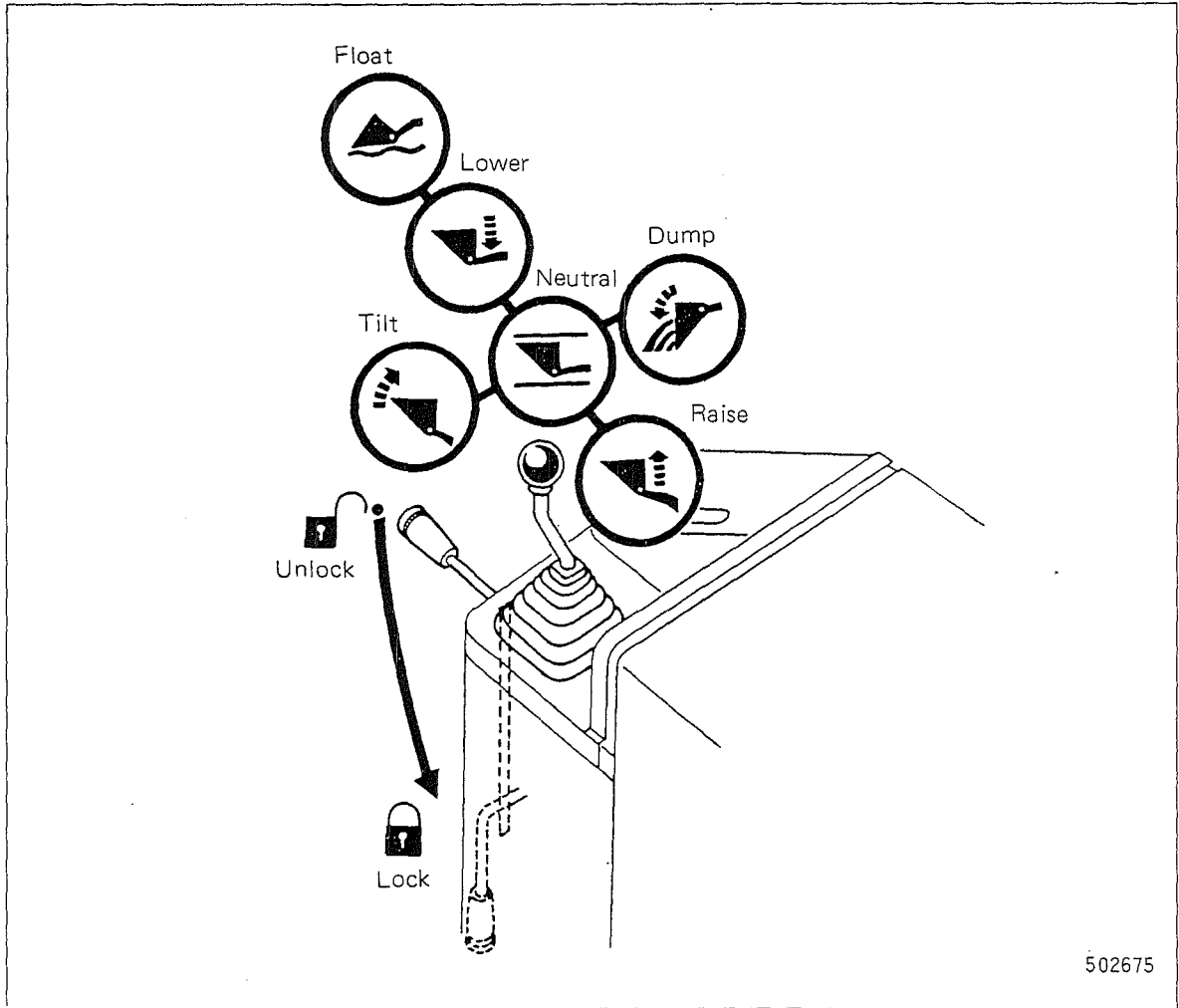

Indicators, Gauges and Switches (BS3G)

OK monitor test switch

- When this switch is pushed with starter switch ON:

Alternator not charging and engine oil pressure warning lamps glow (with engine stopped).

Battery electrolyte level and air cleaner element warning lamps glow (with engine running).

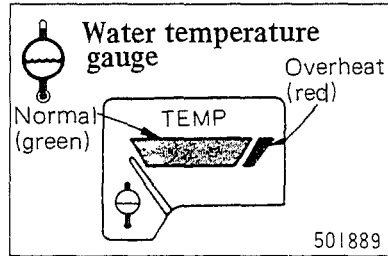

Service meter

Every 6 minutes dial advances 1 hour one number.

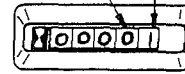

OK monitor

- When any lamp glows during operation, stop machine soon and check for cause. (See page 16.)

Battery switch

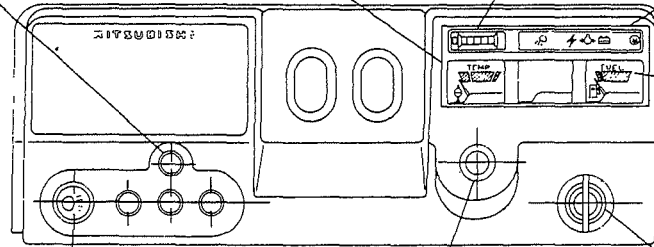
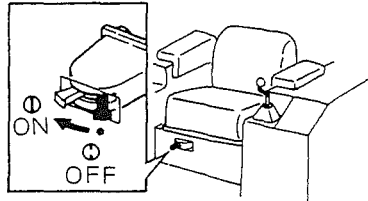

Fuel gauge

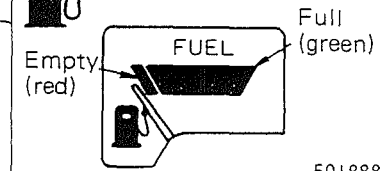

Lighting switch

Twist

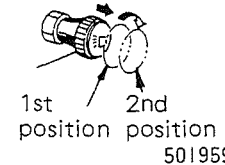

Position	1st		2nd	
	Twist		Twist	
Head lamps			☹	☹
Working lamp	☹		☹	
Instrument panel lamp	☹	☹	☹	☹
[OP]	☹	☹	☹	☹



Glow plug indicator



Glow when starter switch is turned to HEAT.



Starter switch

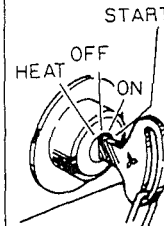

HEAT	Heat engine.
OFF	Insert or pull out key.
ON	Keep engine running.
START	Start engine.

501956

• Fuses (BS3G)

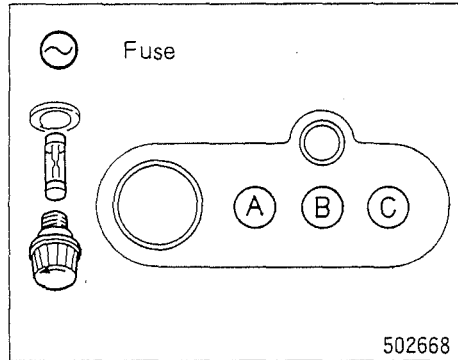

- Head lamps
- Instrument panel lamp
- Working lamp
- Working lamp indicator

- Horn

- Engine oil pressure warning lamp
- Battery electrolyte level warning lamp
- Air cleaner element warning lamp
- Fuel gauge
- Service meter
- OK monitor lamp switch
- Water temperature gauge

• OK monitor (BS3G)

Alternator not charging warning lamp
 Okay if this lamp is OFF during operation.

- When glows, stop engine and check charging system.

Engine oil pressure warning lamp
 Okay if this lamp is OFF during operation.

- When glows, stop engine and check for low oil level or oil leaks.

Battery electrolyte level warning lamp
 Okay if this lamp is OFF during operation.

- When glows, stop engine and add distilled water to battery. (See page 47.)

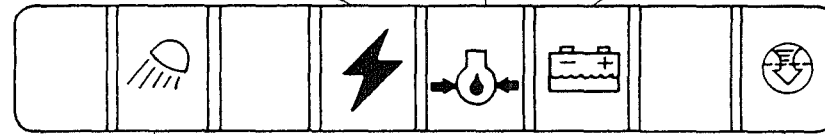

Working lamp indicator

- Glows when working lamp is turned on.

Air cleaner element warning lamp
 Okay if this lamp is OFF during operation.

- When glows, clean or replace element. (See page 48.)

Others (BS3G)

Horn switch

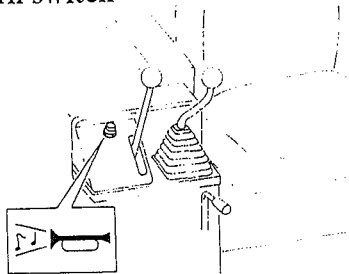

502669

Operator's seat (fore-aft adjustment)

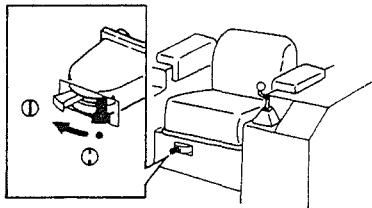

502670

Operator's seat (turning over)

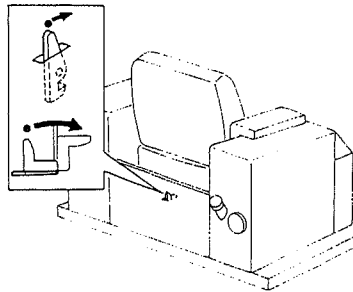

Seat support

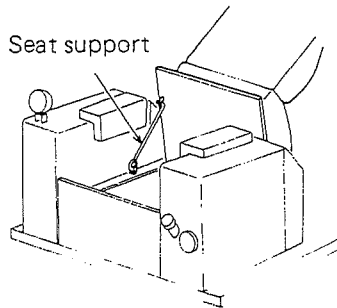

502671



Be sure to support seat after turning it over.

Precautions for Maintenance

- For special servicing jobs on your machine, rely on expert knowledge and service facilities of your Mitsubishi dealer.

◆ General

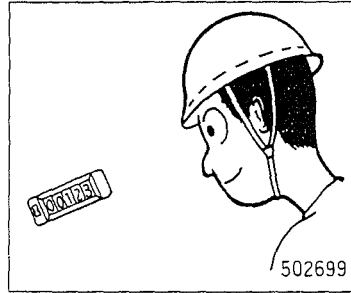

- Use service meter reading or calendar interval whichever occurs first to measure service interval.

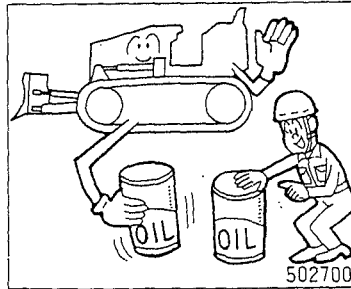

- Check oil level with machine level — blade or bucket lowered — and lock brake pedal.
- Use the same brand of oils.

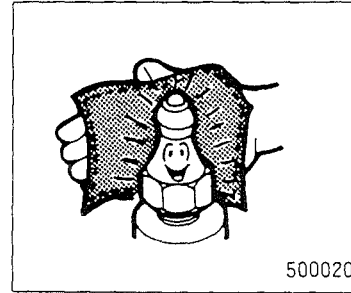

- Clean all grease fittings and filler ports before servicing.
- Maintain correct oil levels at all times.
- Before checking oil levels, stop engine and wait for **5 minutes**.
- Before draining oil, start engine and move machine for a while.

◆ Avoid accidents

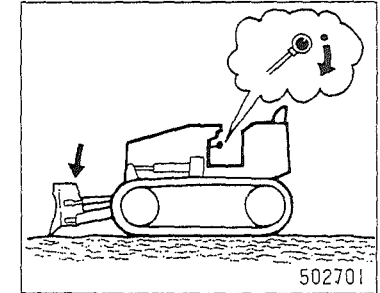

- Lower blade or bucket to ground.
- If necessary to raise blade or bucket for access to certain parts, securely support it by external means.
- Lock brake pedal — chock wheels — stop engine — and remove key from starter switch.
- Don't perform any work when engine is running.

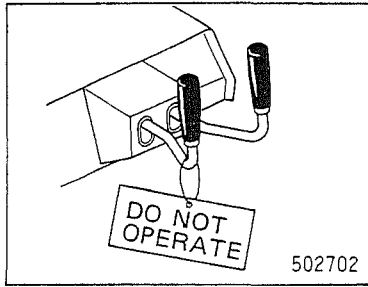

- Attach “DO NOT OPERATE” tag when servicing, adjusting or repairing machine.
- Keep off personnel while at work on machine.

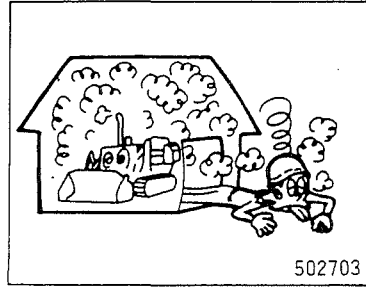

- Start and operate engine only in well ventilated area.



- Don't smoke while servicing fuel system — or refueling.
- Store oily rags and other combustible materials in a safe place.

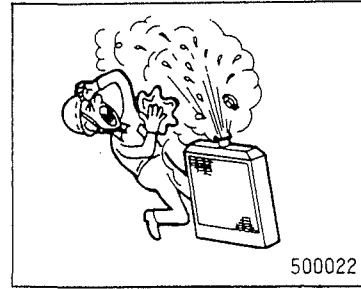

- Before removing radiator cap or hydraulic tank cap after operation, wait until machine cools down to avoid having scalding hot coolant or oil blown out.

Before removing filler cap, loosen it slowly to relieve pressure.

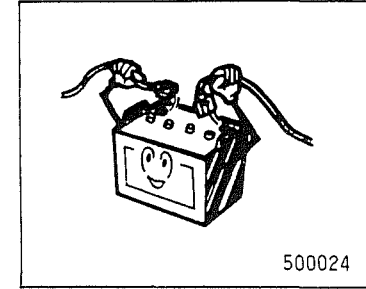

- Disconnect battery cables before servicing electrical system.
- Battery electrolyte is very corrosive. If you drip it on your skin or clothing, flush it off at once with water.

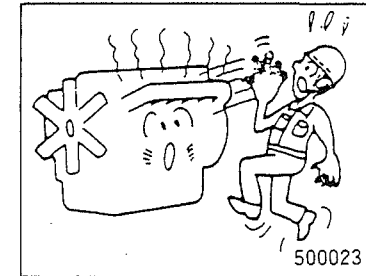

- Don't touch exhaust pipe immediately after shutting down engine.

Preparation for Use

- For your own safety and maximum service life of machine, make a walk-around inspection before mounting machine or starting engine. Check under and around for the following items:

Bolts and nuts

Check for loose or missing bolts, especially on blade, air cleaner and track parts.

Oil compartments

Check oil levels in oil pan and other compartments. Also check for leaks.

Fuel system

Check oil level in fuel tank. Check system for leaks.

Cooling system

Check coolant level in radiator.
Check for leaks.

Electrical system

Check electrolyte level in battery.
Check for loose terminals. Make sure gauges and lamps operate properly.

Hydraulic system

Check oil level in hydraulic tank.
Check for leaks from hoses and cylinders.

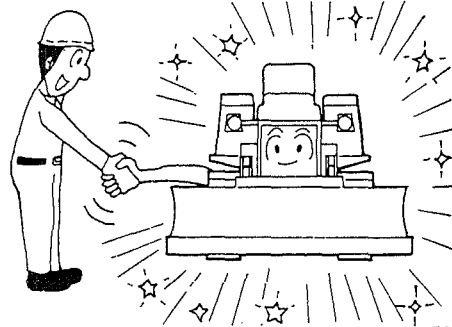

502676



CAUTION

- Break in your machine during initial **100 hours** of operation.
- After starting a cold engine, be sure to warm it up.
- Do not rev up engine unless absolutely necessary.

After initial **100 hours** of operation of a new or reconditioned machine:

Change engine oil	50
Change engine oil filter	50
Change main clutch case oil [DD]	51
Change bevel gear case and transmission case oil [DD]	51
Change transmission case oil [DPS]	51
Change transmission case oil filter [DPS]	52
Change hydraulic tank oil	52
Change hydraulic tank oil filter element	52
Check and adjust clutch brake [DD]	57

Starting and Stopping the Engine

Before starting



1. Perform daily inspection, and make sure all controls are in NEUTRAL.
2. Turn ON battery switch.
3. Move accelerator lever to START position.



Do not start engine from any position other than seat.

Starting

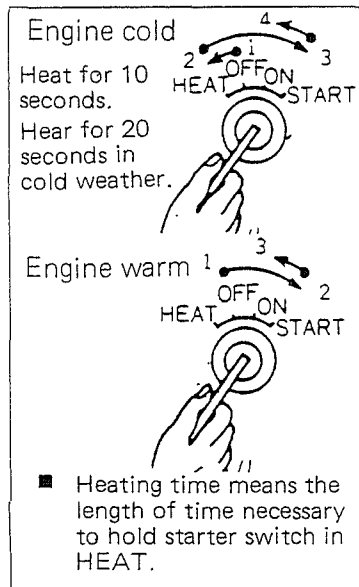

- Do not heat engine for more than 20 seconds.
- Do not turn starter switch to START for more than 30 seconds at a time, or during operation.
- If engine fails to start within 30 seconds, wait 2 minutes before cranking engine again.



After starting

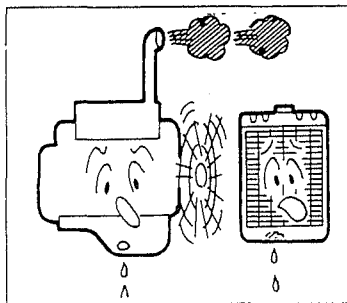

- Idle engine for 5 minutes, and –
1. Check water temperature gauge, fuel gauge and warning lamps for indication.
 2. Check for abnormal exhaust noise and color or vibration.
 3. Check for oil or water leaks.



Engine will not start unless transmission control lever is in NEUTRAL [DPS].

Stopping

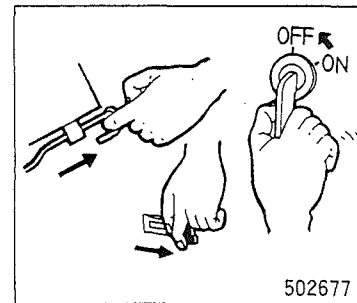

- Before stopping engine, idle it for 5 minutes.
1. Turn starter switch to OFF.
 2. Turn OFF battery switch.



WARNING

Make sure area is free of personnel and obstructions, and use horn.



WARNING

Test brakes, right and left, at slow speed.

Moving the Machine [DD]

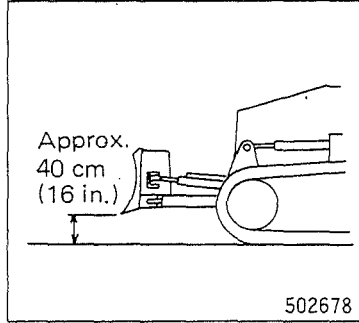

502678

1. Raise blade or bucket to a height of approximately 40 cm (16 in.) from ground.

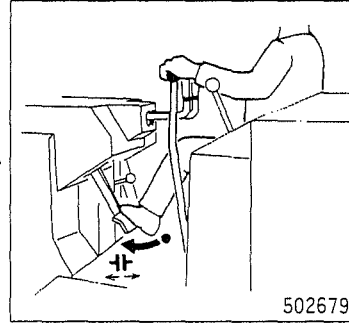

502679

2. Depress clutch pedal, and move transmission control lever to desired speed position.

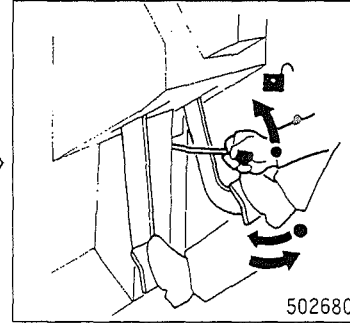

502680

3. Depress brake pedal to unlock it.

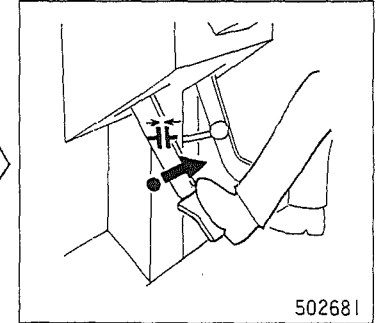

502681

4. Release clutch pedal slowly.

Moving the Machine [DPS]

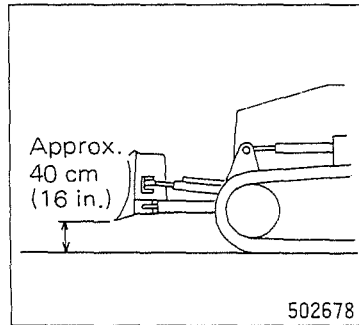

502678

1. Raise blade or bucket to a height of approxi-

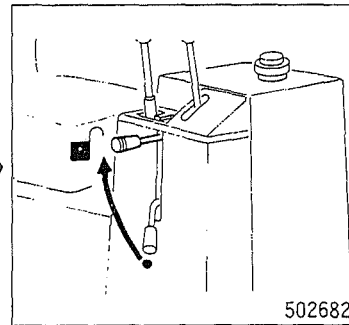

502682

2. Unlock transmission control lever.

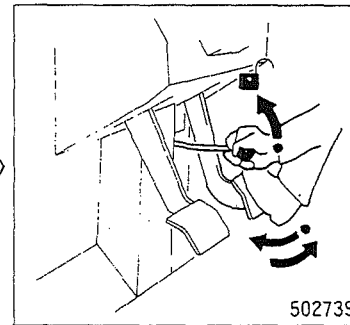

502739

3. Depress brake pedal to unlock it.

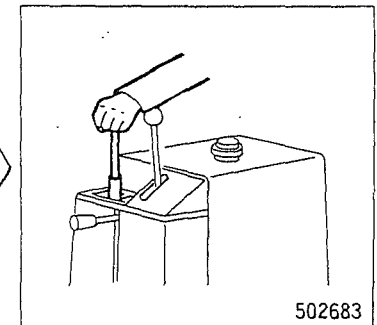

502683

4. Move transmission control lever to desired speed position.



WARNING

Avoid sharp starts, stops or turns whenever possible for your own safety, for maximum service life of your machine.



WARNING

Avoid sidehill travel whenever possible. Drive up and down a slope. The danger of tipping is always present. Sidehill travel can also cause uneven wear of track parts.



CAUTION

When shifting is difficult, depress clutch pedal all the way to apply clutch brake, and try again [DD].

Steering

- Right or left turns

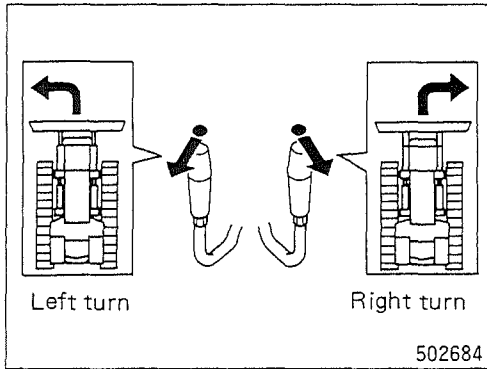

- Moderate or sharp turns

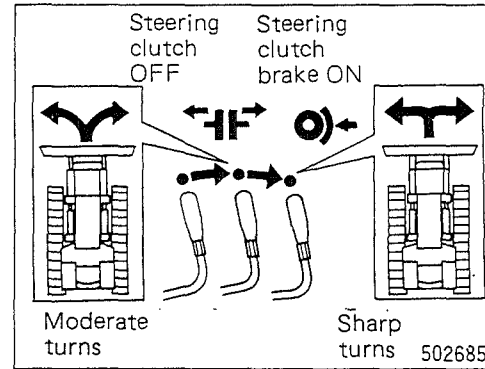

1. To make moderate turns, pull steering clutch lever slowly and accordingly.
2. To make sharp turns, pull steering clutch lever quickly all the way.



CAUTION

Do not drive your machine with your foot resting on clutch or brake pedal.



CAUTION

Avoid sharp turns, especially at high speeds. Such turns cause premature wear of track parts and, in the worst case, cause track to get out of place.

Changing Speed or Direction [DD]

1. Reduce machine speed by moving accelerator lever back, and depress clutch pedal.
2. Depress brake pedal, and move transmission control lever to desired position.
3. Release clutch pedal to start your machine moving again.

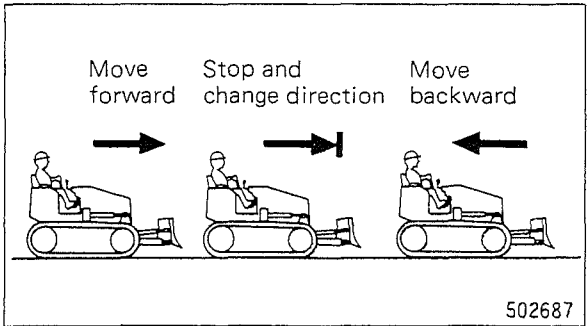
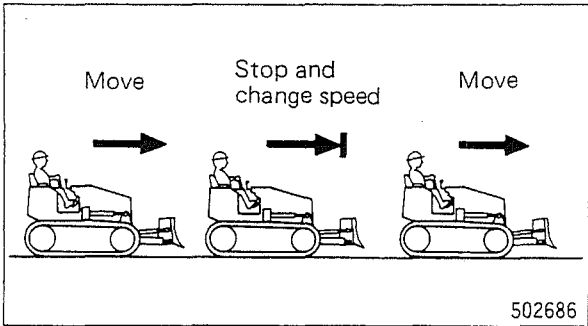

- When changing speed or direction, be sure to come to a complete stop by depressing brake pedal to avoid damage to transmission.
- When shifting is difficult, depress clutch pedal all the way to apply clutch brake, and try again [DD].

Changing Speed or Direction [DPS]

- | | | |
|---|---|--|
| <p>Move transmission control lever to desired position.</p> | <ul style="list-style-type: none"> ■ It is not necessary to depress inching pedal. | <ul style="list-style-type: none"> ■ When changing direction, be sure to come to a complete stop to avoid damage to transmission. |
|---|---|--|

Stopping [DD]

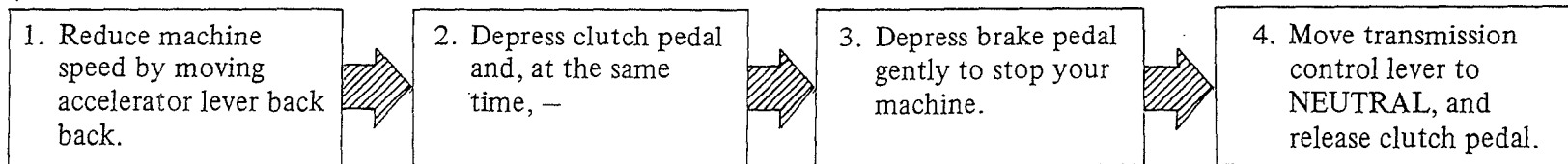

Stopping [DPS]

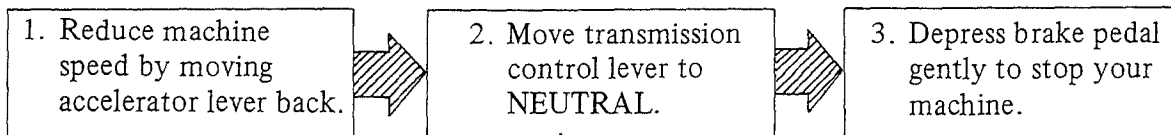

When leaving your machine unattended, be sure to:

1. Lower blade or bucket to ground. Lock blade control lever with safety lock lever on machine equipped with power angling-tilt control.
2. Make sure transmission control lever is in NEUTRAL. On DPS machine, lock transmission control with lock-unlock lever.
3. Lock brake pedal.
4. Shut off engine, and remove key from starter switch.
5. Turn OFF battery switch.



When parking your machine on a slope, position it at right angles to the slope – chock tracks – and penetrate blade into ground.

Operating Techniques

◆ Going up slopes

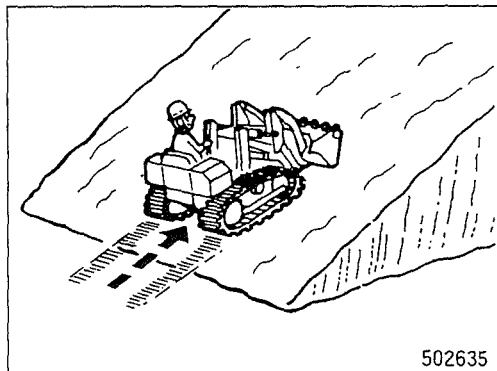

- Drive up as straight as possible. Sidehill travel can cause machine to slip sideways or track to slip off.
- Do not make quick turns. Steering effect becomes more effective than when on level surfaces.
- ◆ **Shifting on slopes**
- When shifting on a slope, depress brake pedal to stop machine, depress clutch pedal and move transmission control lever to desired position. If clutch pedal is depressed too late, shifting would be difficult. In such a case, move machine forward just a little and try again.

◆ Going down slopes

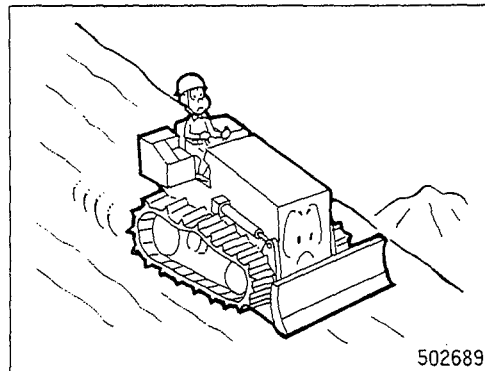

- In steep downhill operation, do not allow engine to overspeed. Select proper speed before starting machine downgrade.
- Steering controls sometimes reverse when machine is coasting downhill or being pushed by a load. If left steering clutch lever is pulled half-way, for instance, machine would make a right turn.



WARNING

Never free wheel downgrade in NEUTRAL. Always stay in gear.

◆ Going over obstacles

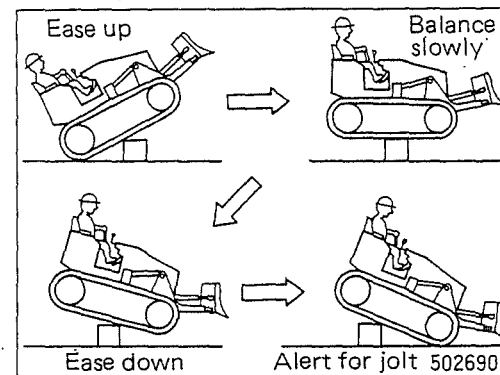

- Go over an obstacle with extreme care at an angle if possible. Reduce machine speed, and ease up to “breakover” point – balance slowly on an obstacle – and ease down to the other side, being alert for jolt of contact.



WARNING

Do not exceed maximum limit of machine stability indicated on nameplate attached to machine.

◆ Operating in deep mud or water

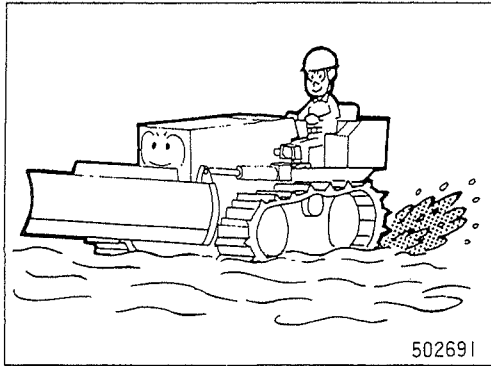

- Drive your machine at low speeds. Avoid sharp or frequent turns.
- Make sure drain plugs of all gear compartments are tight in place.
- When starting to mire down in mud, do not spin track or try to “see-saw” your machine. Get traction by dropping load, changing direction or placing planks under tracks for recovery.
- Check oil in final drives for entry of mud or water more often. Refill with new oil upon discovery of foreign matter in oil.

◆ Operating in rocky terrain

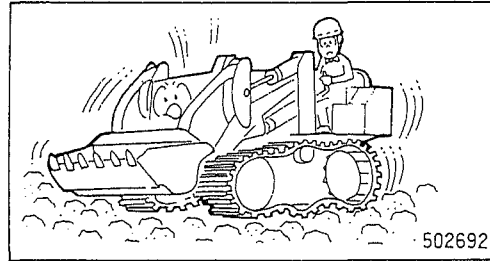

- On rocky footing, track parts are subject to excessive stress and strain. When operating in such a terrain, loosen track adjustment to obtain 4 to 6 cm (1-1/2 to 2-3/8 in.) sag. Refer to page 54 of this manual for track adjustment.

◆ Operating on snow

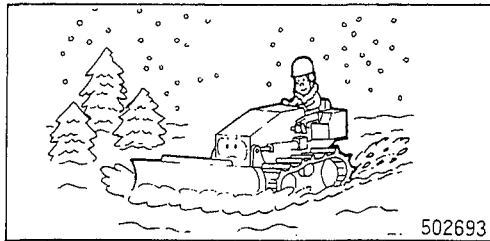

- Use snow-and-ice shoes whenever possible. These shoes are designed for good penetration and traction on ice or hard packed snow.
- At end of operating period, clean snow or mud from around track links, sprockets, idlers, rollers and guards to prevent freezing of tracks.

◆ Super swamp and ultra super swamp models

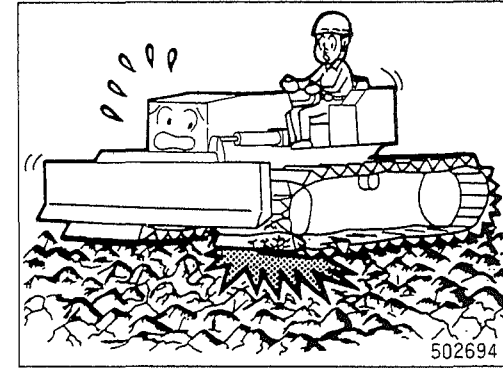

- Track shoes of the swamp models are designed for use only in swampy areas. Avoid operating these models in rocky terrain or going over rough, hard surfaces to prevent costly damage to the shoes.

◆ Stripping or leveling

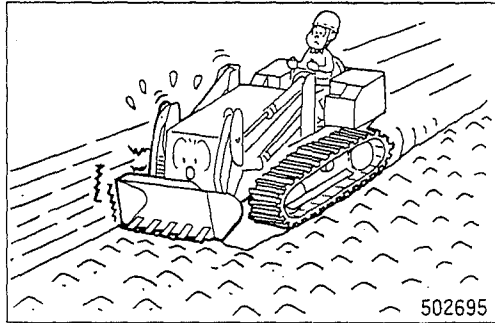

When stripping or leveling by driving machine forward, do not dump bucket fully; otherwise bucket, bucket linkage and frame would suffer costly damage.

- When moving one job site to another, be sure to lock bucket control lever to avoid accidents.

Transporting the Machine

- Check regulations covering transportation of construction equipment including tractors.

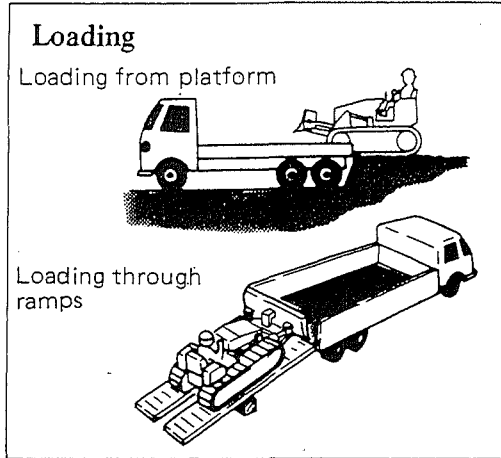

1. Loading platform must be wider than overall width of machine and thoroughly compacted along its length.
2. If loading platform is not available, use ramps. Ramps must be strong enough to load machine safely. Support each ramp with blocks from underside to prevent it from being weighed down by machine.
3. Platform or ramps must have a gradient of 10 to 15 deg.

4. Drive up machine forward when loading. Drive it backward when unloading.
5. Be sure to block truck wheels.

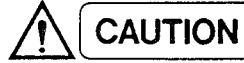

Drive up and down without steering. If machine starts slipping sideways, drive it down to ground immediately, and try again.

6. Upon loading, block tracks on both front and rear sides, and secure machine with tie-downs such as chains or ropes to prevent side slip.
7. Lower blade or bucket, lock brake pedal, and place all controls in NEUTRAL.
8. Plan travel route by checking state and local laws, weight limits, overpass clearance, etc.

Special Conditions

Operating in cold weather

◆ Lubricants and diesel fuels

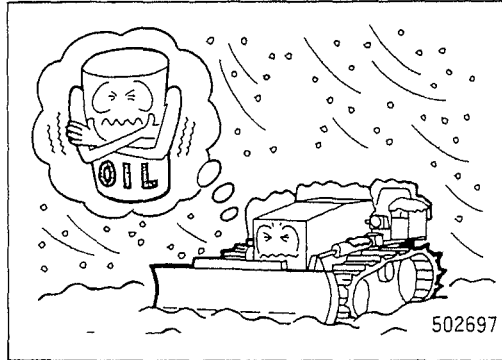

- Use lube oils of lower viscosity. See the chart, RECOMMENDED FUELS AND LUBRICANTS, in page 59.
- Use diesel fuels having lower pour point. See the chart, RECOMMENDED FUELS AND LUBRICANTS, in page 59.

◆ Battery

- Add distilled water to battery before starting engine for the day's run.
- Always keep battery fully charged so that electrolyte specific gravity is higher than 1.28 as corrected to 20°C (68°F).

◆ Coolant

- Engine cooling system of a new machine shipped from factory is filled with coolant containing 30% of Mitsubishi Long Life Coolant (antifreeze containing rust inhibitor).
- Long Life Coolant is effective for sub-zero temperatures down to -15°C (5°F).
- When using Long Life Coolant at temperatures below -15°C (5°F), rely on the following chart for correct percentage.

Starting temperature °C (°F)	-20 (-4)	-30 (-22)	-40 (-40)
Percentage of Long Life Coolant	35	45	55

- Change Long Life Coolant every 2 years. When changing, flush cooling system thoroughly.
- Use Long Life Coolant with soft water.



WARNING

- Long Life Coolant is poisonous; be careful not to drink it. If you drip it on your skin, flush it off at

- Long Life Coolant is highly flammable; keep it away from open flame.

◆ Starting in cold weather

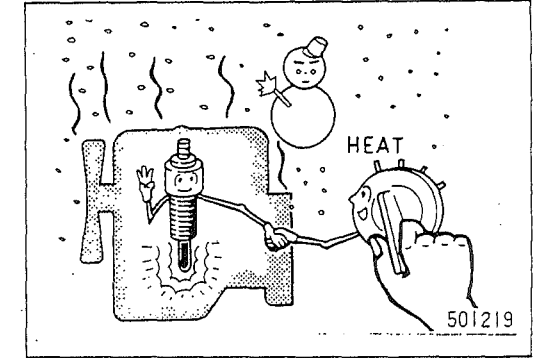

- Turn starter switch to HEAT position to heat engine thoroughly. After starting engine, warm it up thoroughly.
- ◆ After operating in cold weather
 - Clean snow or mud from around your machine to prevent freezing. Park on dry concrete floor, planks or logs to avoid freezing.
 - Wipe dirt and moisture from piston rods of hydraulic cylinders.
 - Drain water and sediment from fuel tank.

Operating in hot weather

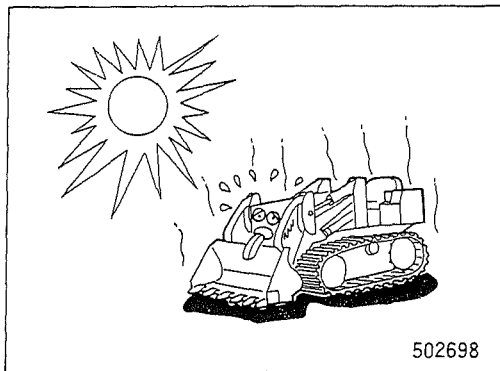

◆ Lubricants

Use lube oils of higher viscosity. See the chart, RECOMMENDED FUELS AND LUBRICANTS, in page 59.

◆ Battery

Check electrolyte level more often than in cold weather. Add distilled water to batteries whenever level is low.

◆ Coolant

Engine is likely to get overheated, especially in heavy duty operation for hours or in ascending a long, steep slope. Whenever water temperature gauge registers near or in RED range, slow down or stop machine, and let

engine cool. Check radiator for low coolant level, leaks or trash buildup.

◆ After operating in hot weather

- Before stopping engine, let it idle just longer than in cold weather for cooling.
- Check coolant level in radiator and electrolyte level in batteries.

Operating in extremely dusty conditions

- Check air cleaner element and change it more often.
- Clean air breathers of engine and fuel tank to help prevent premature wear of pistons and cylinders.
- Remove dust accumulated inside alternator and starter covers. Clean radiator core. Wash machine from time to time to keep it as clean as possible.

Recommended Fuels and Lubricants

Compartment	Lubricants, etc	Refill capacity liter (U.S. gal)	Ambient temperature °C (°F)						
			-25 (-13)	-15 (5)	-5 (23)	0 (32)	5 (41)	15 (59)	25 (77)
Fuel tank	Diesel fuel	60 (15.8)	Consult your Mitsubishi dealer						
* Engine	Engine oil CD	7 (1.8)	SAE10W		SAE 20			SAE 30	
* Main clutch [DD]	Engine oil CD	5.5 (1.5)	SAE 5W			SAE 10W			
* Damper case [DPS]	Engine oil CD	3.5 (0.9)	SAE 5W			SAE 10W			
* Transmission case [DD]	Gear oil GL-4*	9.5 (2.5)	SAE 80			SAE 90			
* Transmission case [DPS]	Engine oil CD	11 (2.9)	SAE 5W			SAE 10W			
* Transfer/bevel gear case [DPS]	Gear oil GL-4	7 (1.8)	SAE 80			SAE 90			
* Final drive gear cases	Gear oil GL-4	Each side: 6.5 (1.7) *1 9.5 (2.5) *2 13 (3.4)	SAE 80			SAE 90			
* Hydraulic tank	Engine oil CD	33 (8.7)	SAE 5W			SAE 10W			
Grease fittings on various points	Grease		NLGI No. 0		NLGI No. 1			NLGI No. 2	
Radiator	Soft water	13 (3.4)	Soft water with antifreeze			Soft water			

Mitsubishi Toughness Multi engine oil can be used in compartments marked *.

*1: Super swamp model *2: Ultra super swamp model

Factory-Filled Lubricants

The following list shows brands of lubricants used in Mitsubishi tractors and tractor shovels shipped from the factory:

Compartment	Brand name
Engine	SAE 30 (Diamond HD30 special)
Main clutch case [DD]	SAE 10W (Diamond HD S-3 10W)
Damper case [DPS]	SAE 10W (Diamond HD S-3 10W)
Transmission case [DD]	SAE 90 (Apolloil Gear HE90)
Transmission case [DPS]	SAE 10W (Diamond HD S-3 10W)
Transfer/bevel gear case [DPS]	SAE 90 (Apolloil Gear HE90)
Final drive gear cases	SAE 90 (Apolloil Gear HE90)
Hydraulic tank	SAE 10W (Diamond HD10Wspecial)

NOTE

- These brands are subject to change without notice.
- Avoid mixing lubricants. In some cases, different brands of lubricants are not compatible with each other and deteriorate when mixed. It is best to stick with one and the same brand at successive service intervals.
- Temperature range of Mitsubishi Toughness Multi engine oil is -20 to 40°C (-4 to 104°F).

Battery

◆ Inspection and charging

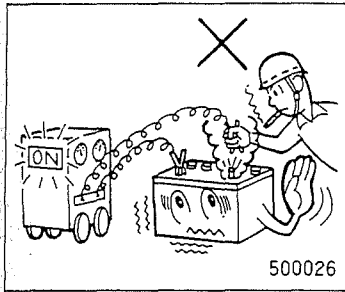

A battery that is being charged gives off high explosive gases. Never light a match or a cigarette near such a battery.

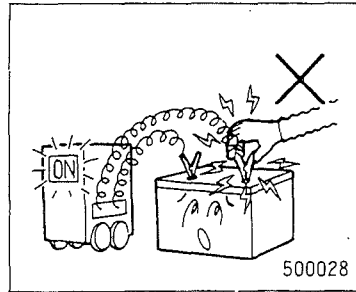

Don't disconnect charger cable from a battery that is being charged.

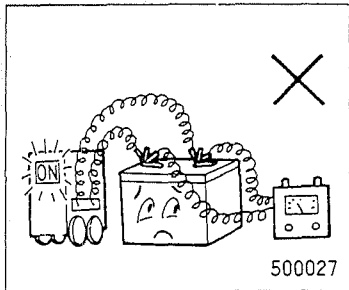

Don't connect a tester to a battery during charging.

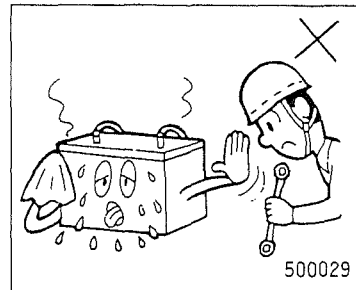

Don't touch battery terminals immediately after operation.

◆ Removal and installation

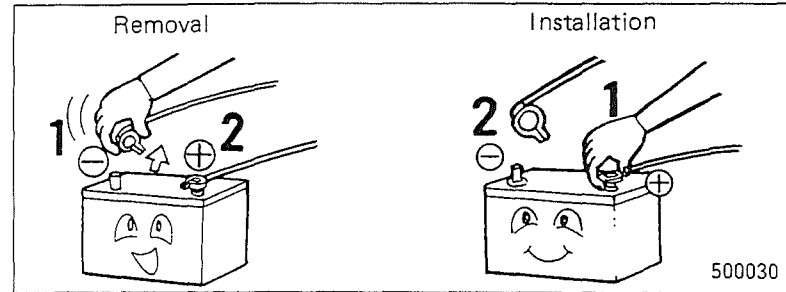

- Disconnect cables from negative (-) and positive (+) terminals in that order when removing battery. Connect cables to positive (+) and negative (-) terminals in that order when installing it.
- Never place a metal object across terminals.

◆ Jump-starting

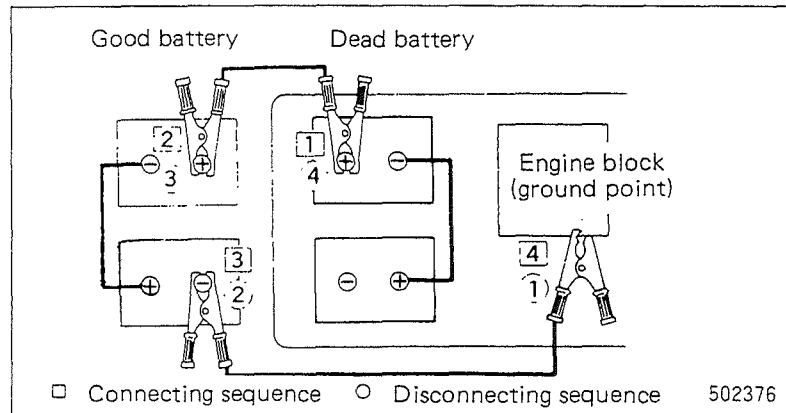

Storage

◆ Short-duration storage

- Store machine in a dry garage even if it is to be left standing for a short period of time. If machine has to be left outdoors, cover engine room and operator's seat with canvas or the like.
- Renew oil film once a week by running engine until it is thoroughly warm. This will circulate oil and prevent rusting from condensation.
- Drain cooling system if temperature will be below freezing and no anti-freeze is used in the system. When the system is drained, attach "No Coolant" tag to starter switch.

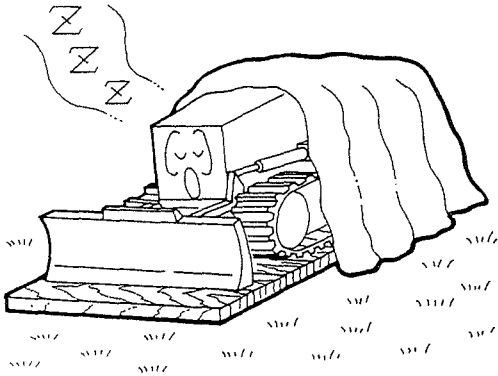

502750

◆ Long-duration storage

- Care of machine to be stored
 - If machine is to be stored for a long period of time, proceed as follows:
 - Wash machine clean, and store it in a dry garage. If machine has to be left outdoors, place it on blocks on level ground and cover it for protection against dust and moisture.
 - If preservative oil is to be used in engine, attach a tag reading "No Engine Oil" at an easy-to-recognize place.
 - Lubricate all grease fittings and change oils in all compartments.
 - Apply a thick coat of rust-preventive oil to exposed sliding surfaces of hydraulic cylinder piston rods and control linkages.
 - Disconnect battery cables and cover battery, or dismount battery and store it in a dry, cool place.
 - Lock all control levers in NEUTRAL, and place accelerator lever in IDLING position.
 - Block tracks instead of locking brake pedal.

- In freezing weather, drain cooling system, or refill it with coolant containing more anti-freeze.
- Care of machine during storage
 - At least once a month, start engine, and move machine and implement. This will circulate oil and prevent rusting from condensation.
 - When moving implement, wipe grease off hydraulic cylinder piston rods. After moving, apply grease.
 - Recharge battery at least once a month.
- Care of machine to be released from storage
 - Remove drain plug from each compartment, and allow moisture and sediment to drain. Check oil level, adding oil if necessary.
 - Wipe off rust-preventive grease.
 - Start engine, and warm it up thoroughly to circulate oil.



Start and operate engine only in well ventilated area.

Engine

◆ Starter will not crank engine or cranks slowly.

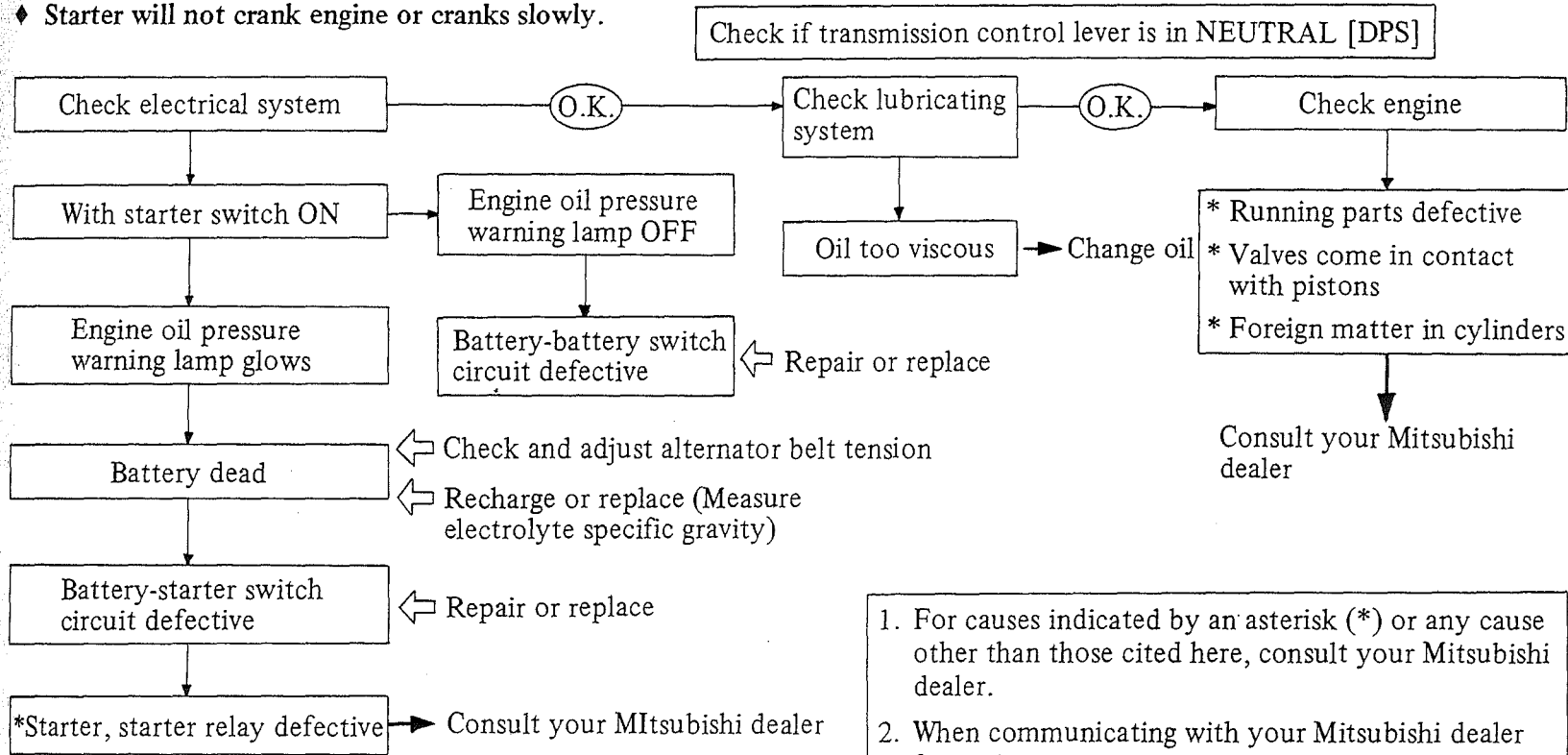

1. For causes indicated by an asterisk (*) or any cause other than those cited here, consult your Mitsubishi dealer.
2. When communicating with your Mitsubishi dealer for replacement part supply or any other service, be sure to give them the vehicle serial number, engine serial number and service meter reading.

◆ Starter will crank engine, but engine will not start.

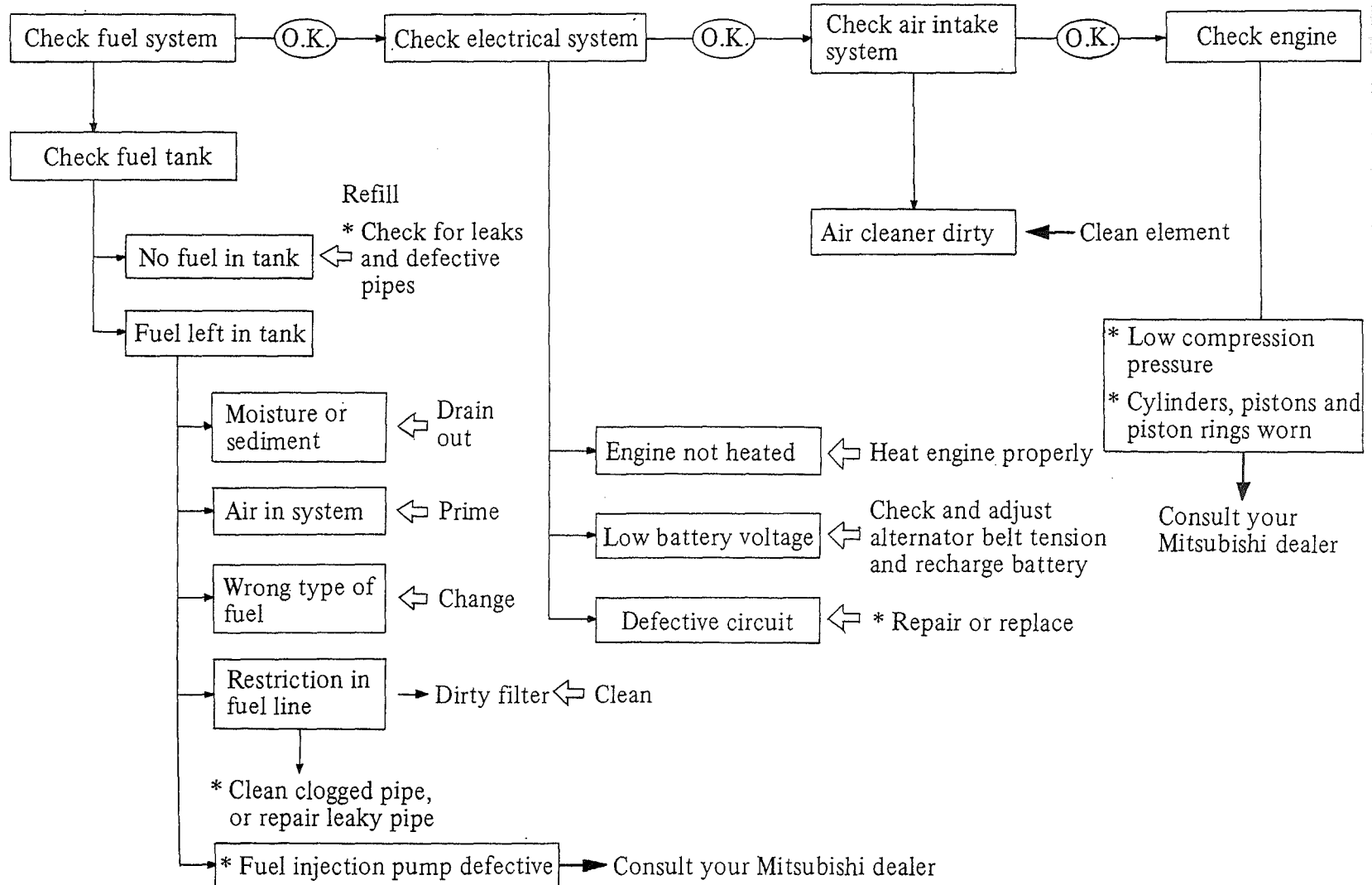

Engine lacks power



500040

Wrong grade of oil

Wrong type of fuel

Air cleaner restricted

Overcooling

Overheating

Abnormal coolant temperature
(due to defective thermostat)

Fuel injection quantity decreased

Valve clearance maladjusted

Fuel injection pump defective

Poor fuel spray from injection nozzles

Fuel injection mistimed.

Compression pressure too low (due to
worn cylinders, piston rings)

→ Change oil and follow lubrication recommendations.

→ Change fuel.

→ Clean or replace element.

→ Cover up radiator or replace parts.

→ Flush cooling system or replace parts.

→ * Replace thermostat.

→ Replace clogged fuel filter.

→ * Readjust.

→ * Readjust or replace.

→ * Readjust or replace.

→ * Retime.

→ * Repair or replace.

White or blue exhaust smoke



500041

Too much oil in crankcase

Low viscosity grade of oil

Overcooling

Fuel injection mistimed

Compression pressure too low

→ Fill only to correct level.

→ Change oil and follow lubrication recommendations.

→ Cover up radiator or replace parts.

→ * Retime.

→ * Repair or replace.

Black or gray exhaust smoke



500042

- Wrong type of fuel
- Valve clearance maladjusted
- Air cleaner restricted
- Fuel injection pump defective
- Compression pressure too low

- Change fuel.
- * Readjust.
- Clean or change element.
- * Readjust or replace.
- * Repair or replace.

High fuel consumption



500043

- Air cleaner restricted
- Fuel leaks
- Fuel injection pump defective
- Poor fuel spray from injection nozzles
- Compression pressure too low

- Clean or change element.
- Retighten or replace.
- * Readjust or replace.
- * Readjust or replace.
- * Repair or replace.

High oil consumption



500044

- Too much oil in crankcase
- Low viscosity grade of oil
- Oil leaks
- Cylinders and/or piston rings worn

- Fill only to correct level.
- Change oil and follow lubrication recommendations.
- * Retighten or replace.
- * Repair or replace.

Engine oil pressure
warning lamp glows



500046

- Low oil level
- Low viscosity grade of oil
- Oil filter clogged
- Oil pump defective
- Oil pressure regulating valve defective

- Fill only to correct level.
- Change oil and follow lubrication recommendations.
- Change element.
- * Readjust or replace.
- * Readjust or replace.

Chassis

◆ Main clutch [DD]

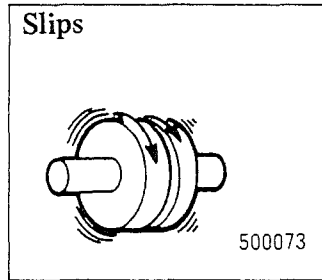

- Clutch pedal free play too small → Readjust.
- Clutch facing worn → * Replace.
- Clutch disc friction surfaces fouled with oil or dirt → * Wash or replace
- Clutch facing burnt, resulting in reduced friction → * Replace.
- Clutch springs weak → * Replace.

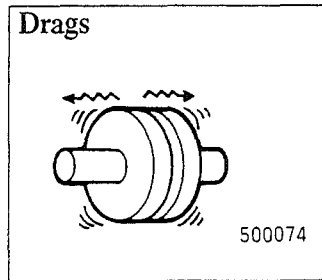

- Clutch pedal stroke too small → Readjust.
- Clutch pedal free play too large → Readjust.
- Clearance unequal in clutch → * Readjust.
- Clutch shifter or clutch disc binding on drive shaft → * Disassemble and repair or replace.
- Friction surfaces dirty → * Wash.

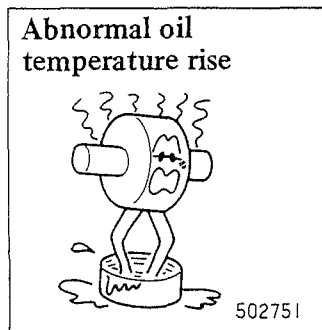

Oil level too high

- Lower oil level.

Chatters when disengaged

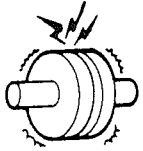

500075

Release bearing seized, worn or poorly lubricated

→ * Lubricate or replace.

◆ Transmission [DD]

Hard shifting

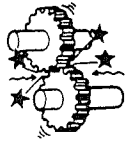

500076

High viscosity grade of oil

→ Change oil and follow lubrication recommendations.

Clutch brake maladjusted or worn

→ * Readjust.

Clutch drags

→ Readjust clutch control.

Shift fork and shift rail worn or damaged

→ * Repair or replace.

Gears worn or damaged

→ * Replace.

Gears slip out of mesh

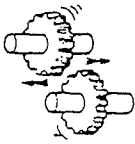

500077

- Gear meshing incomplete
- Gear teeth unevenly worn
- Gear shaft splines worn
- Detent springs weak
- Bearings or bushings worn

- * Repair or replace.
- * Replace.
- * Replace.
- * Replace.
- * Replace.

Noisy

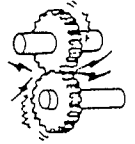

500078

- Gear teeth worn or improperly meshing
- Bearings or bushings worn
- Oil level too low or low viscosity grade of oil

- * Repair or replace.
- * Replace.
- Change oil and follow lubrication recommendations.

◆ Transmission [DPS]

Overheating



500050

- Oil level too high
- Gauge defective
- Oil filter clogged
- Hydraulic pressure too low
- Clutch drags
- Bearings worn or seized
- Air entrapped
- Water in oil
- Oil lines restricted

- Lower oil level.
- * Replace.
- Wash or replace.
- * Readjust or repair.
- * Replace clutch plates.
- * Repair or replace.
- * Retighten or replace gasket.
- Change oil.
- * Repair or replace.

No power transmission

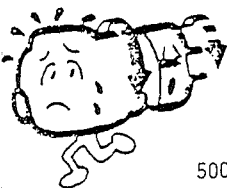

500051

- Oil level too low
- Oil pressure too low
- Control linkage maladjusted
- Forward and reverse clutches engaged simultaneously
- Clutch seized
- Clutch oil passage restricted
- Shaft splines worn

- Add oil.
- * Repair or replace oil pump.
- * Readjust.
- * Repair or replace.
- * Replace clutch plates.
- * Wash or replace.
- * Replace.

Noisy



500052

- Oil level too low or low viscosity grade of oil
- Gears damaged
- Bearings worn or seized
- Clutch seized
- Shaft splines worn

- Add up to level or change oil.
- * Replace.
- * Replace.
- * Replace clutch plates.
- * Replace.

◆ Steering clutches

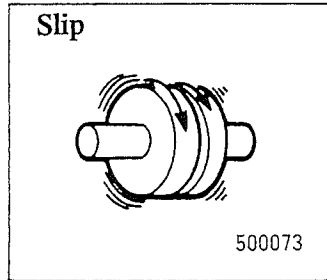

- Control linkage maladjusted
- Clutch plates worn
- Clutch springs weak or broken

- Readjust.
- * Replace.
- * Replace.

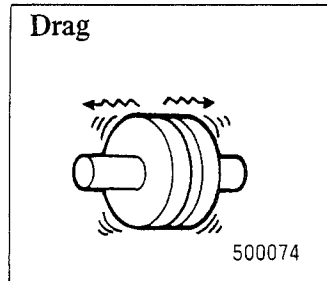

- Clearance unequal in clutch
- Control linkage maladjusted
- Booster pressure too low

- * Readjust.
- Readjust.
- Repair or replace main clutch pump.
Repair or replace DPS transmission pump.
Repair oil leaks from lines or steering cylinder.

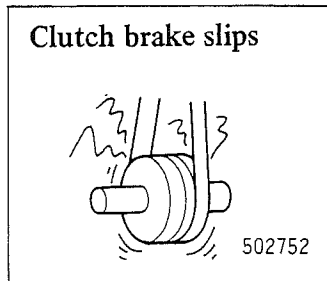

- Control linkage maladjusted

- Readjust.

◆ Final drives

Sprocket teeth
wear on side faces



501416

Tracks too loose

→ Readjust.

◆ Tracks

Slip off

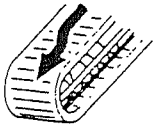

501417

Tracks too loose

→ Readjust.

◆ Implement

Blade or bucket
will not rise or
rise too slowly

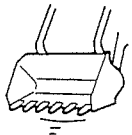

502753

Low oil level in hydraulic tank
Hydraulic pump internally worn
Oil lines bent

→ Add oil.
→ * Replace.
→ * Repair or replace.

Periodical Change of Safety Parts

To prevent personal injury and damage to machine, change parts listed below at recommended intervals.

These parts are made of materials which are apt to deteriorate or age in the course of time. Moreover, it is difficult to determine by visual inspection whether or not they have expired in safe service life. This is the reason for the need of such periodical change.

Change these parts whenever suspected of deterioration or aging even if change periods have not come yet.

Periodical change of these parts are not covered by **Warranty**.

Ref. No.	Change	Every
1	Fuel hoses	2 years
2	High-pressure hydraulic hoses	2 years

For parts to be replaced, see page 39.

- When replacing parts, be sure to use genuine Mitsubishi parts.

BD2G

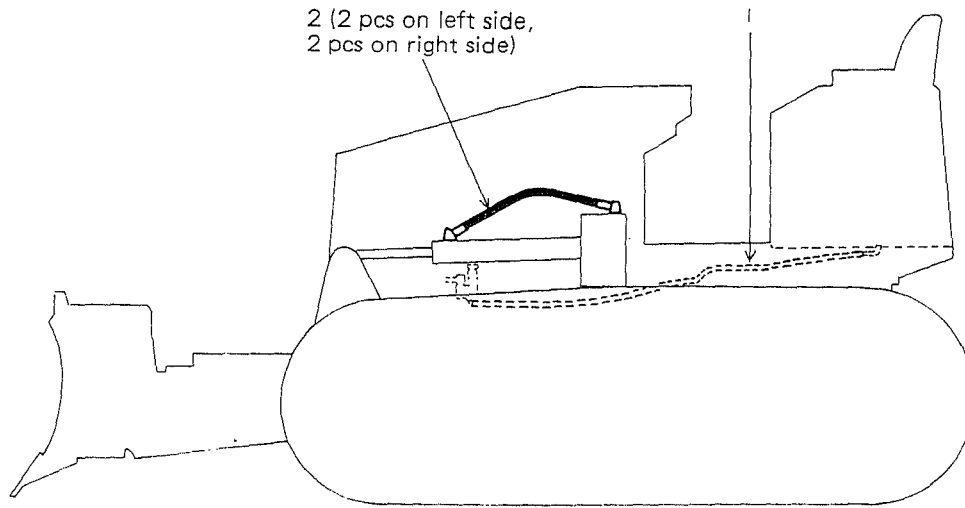

BS3G

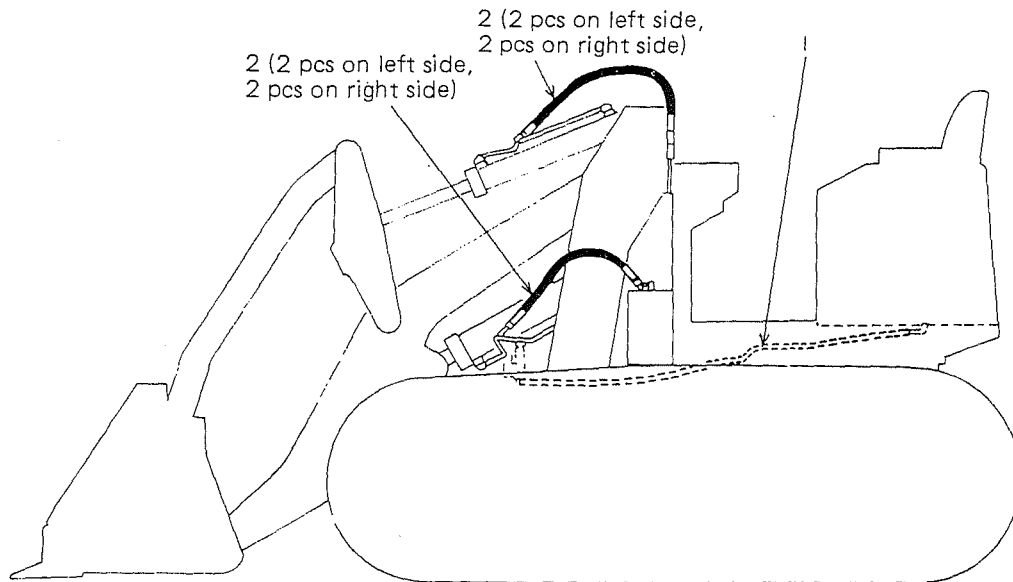

Maintenance Schedule

- Perform previous interval items at multiples of the original requirement. For example, at **250 service hours or monthly**, also perform those items listed under "Every 10 service hours or daily."

Ref. No.	Item	Service	Remarks	Page
EVERY 10 SERVICE HOURS OR DAILY (BEFORE OPERATION)				
①	Walk-around checks			43
②	Engine oil pan	Check oil level and add.		44
③	Radiator	Check coolant level and add.		44
④	Main clutch case [DD]	Check oil level and add.		44
⑤	Transmission case [DPS]	Check oil level and add.		44
⑥	Bevel gear case/transmission case [DD]	Check oil level and add.		44
⑦	Hydraulic tank	Check oil level and add.		44
⑧	Bevel gear case/transfer case [DPS]	Check oil level and add.		45
⑨	Fuel tank	Check oil level and add; drain moisture and sediment		45







Ref. No.	Item	Service	Remarks	Page
⑩	Brake pedal	Check free play/stroke and adjust.	Free play: 0.5 to 0.5 to 1 cm (3/16 to 3/8 in.) Stroke: 8 cm (3-1/8 in.)	45
⑪	Clutch pedal	Check free play/stroke and adjust.	Free play: 1.5 cm (9/16 in.) Stroke: 16 cm (6-5/16 in.)	45
⑫	Inching pedal [DPS]	Check stroke and adjust.	Stroke: 14.5 cm (5-11/16 in.)	45
⑬	Transmission control lever [DPS]	Check clearance in guide.	Clearance: 0.5 to 2 mm (0.02 to 0.08 in.)	45
⑭	Tracks	Check adjustment (sag).	Sag: 2 to 3 cm (3/4 to 1-3/16 in.)	46
⑮	Implement	Check for damage or wear.		46
⑯	Steering clutch levers	Check stroke.	Stroke: 20 to 22 cm (7-7/8 to 8-11/16 in.)	46
EVERY 250 SERVICE HOURS OR MONTHLY				
⑰	Fan belt	Check tension.	Sag: 1 to 1.5 cm (3/8 to 9/16 in.)	47
⑱	Battery	Check electrolyte level.		47
⑲	Implement	Lubricate.		48

Ref. No.	Item	Service	Remarks	Page
EVERY 500 SERVICE HOURS OR 3 MONTHS				
⑳	Fuel tank	Wash strainer.		49
㉑	Final drive gear cases	Check oil level and add.		49
㉒	Fuel feed pump	Wash filter.		49
㉓	Air cleaner	Clean element.		49
㉔	Steering clutch cases	Drain moisture.		49
㉕	Engine oil pan	Change oil.	7 liters: (1.8 U.S. gal)	49
EVERY 1000 SERVICE HOURS OR 6 MONTHS				
㉖	Engine oil filter	Change.		50
㉗	Fuel filter	Change element.		50
㉘	Universal joint	Lubricate.	2 fittings	50
EVERY 2000 SERVICE HOURS OR 1 YEAR				
㉙	Main clutch case [DD]	Change oil.	5.5 liters (1.5 U.S. gal)	51
㉚	Main clutch case [DD]	Wash strainer.		51

Ref. No.	Item	Service	Remarks	Page
㉛	Damper case [DPS]	Change oil.	3.5 liters (0.9 U.S. gal)	51
㉜	Bevel gear case/transmission case [DD]	Change oil.	9.5 liters (2.5 U.S. gal)	51
㉝	Bevel gear case/transfer case [DPS]	Change oil.	7 liters (1.8 U.S. gal)	51
㉞	Transmission case [DPS]	Change oil.	11 liters (2.9 U.S. gal)	51
㉟	Transmission case [DPS]	Change oil filter; wash strainer.		52
㊱	Hydraulic tank	Change oil.	33 liters (8.7 U.S. gal)	52
㊲	Hydraulic tank	Change oil filter element.		52
㊳	Final drive gear cases	Change oil.	Standard: 6.5 liters (1.7 U.S.gal) Super swamp: 9.5 liters (2.5 U.S.gal) Ultra swamp: 13 liters (3.4 U.S.gal) (Each side)	52
㊴	Radiator	Flush; change coolant.	13 liters (3.4 U.S. gal)	52
㊵	Air cleaner	Change element.		52









Ref. No.	Item	Service	Remarks	Page
AFTER INITIAL 100 SERVICE HOURS OF NEW OR RECONDITIONED MACHINE				
②⑤	Engine oil pan	Change oil.	7 liters (1.8 U.S. gal)	50
②⑥	Engine oil filter	Change.		50
②⑨	Main clutch case [DD]	Change oil.	5.5 liters (1.5 U.S. gal)	51
③②	Bevel gear case/trans- mission case [DD]	Change oil.	9.5 liters (2.5 U.S. gal)	51
③④	Transmission case [DPS]	Change oil.	11 liters (2.9 U.S. gal)	51
③⑤	Transmission case [DPS]	Change oil filter; wash strainer.		52
③⑥	Hydraulic tank	Change oil.	33 liters (8.7 U.S. gal)	52
③⑦	Hydraulic tank	Change oil filter element.		52
	Clutch brake [DD]	Adjust.		57

Legend

	CHECK OIL LEVEL
	DRAIN
	ADD OIL
	LUBRICATE
	OIL LEVEL GAUGE
	FUEL

Every 10 service hours or daily (I) (before operation)

① Walk-around checks

	Cooling system Check for leaks, worn hoses or trash buildup.		Implement Check for wear or damage.
	Engine compartment Check for oil or fuel leaks.		Sprockets Check for wear or damage.
	Hydraulic system Check for leaks, worn hoses or damaged lines.		Engine operation Check for abnormal exhaust color, sound or vibration.
	Gear cases Check for oil leaks.		Electrical system Check for loose wire connections or broken wires.

502688

- Make sure defects found during the previous day have all been repaired.

Every 10 service hours or daily (II) (before operation)

② Engine oil pan – Check oil level and add.

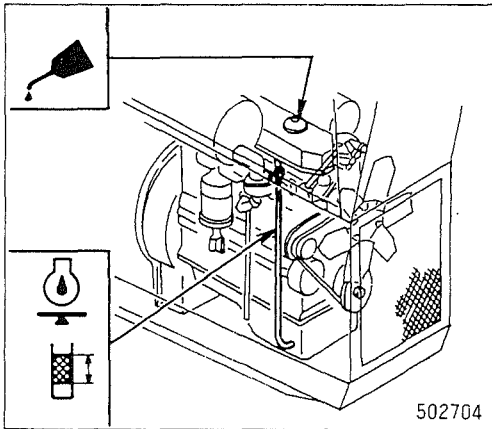

④ Main clutch case [DD] – Check oil level and add.

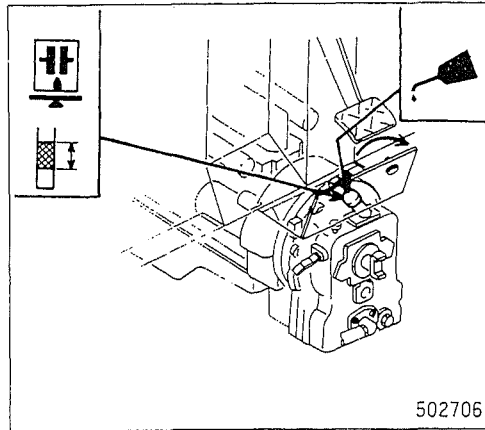

⑥ Bevel gear case/transmission case [DD] – Check oil level and add.

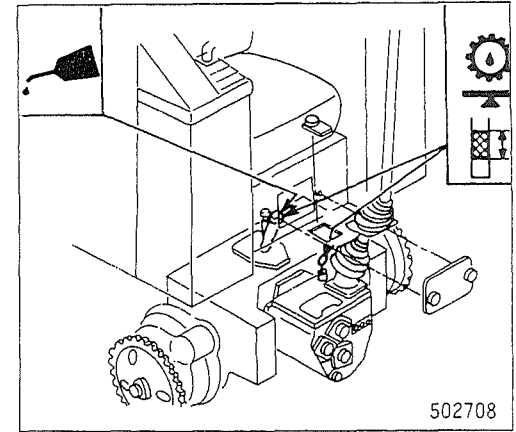

③ Radiator – Check coolant level and add.

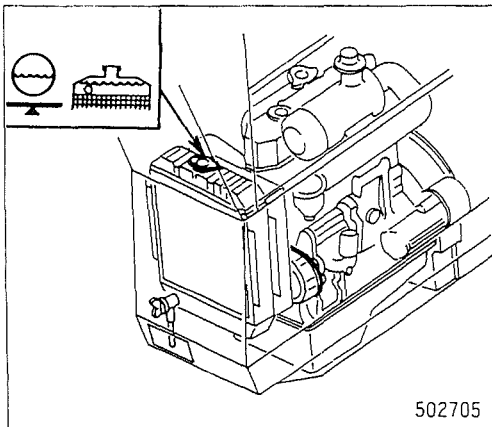

⑤ Transmission case [DPS] – Check oil level and add.

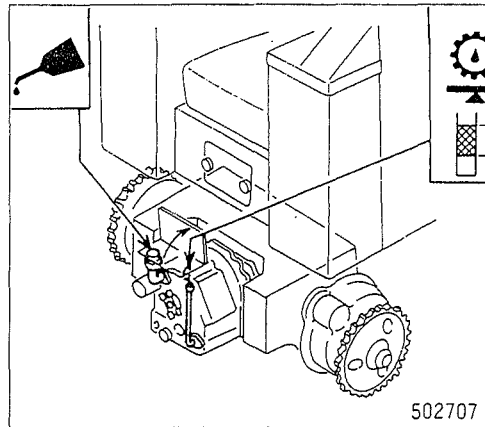

⑦ Hydraulic tank – Check oil level and add.

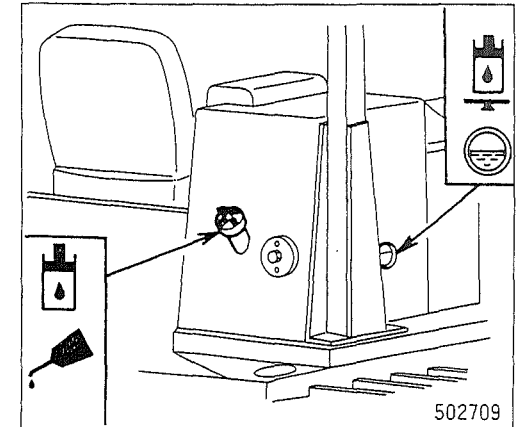

Every 10 service hours or daily (III) (before operation)

- ⑧ Bevel gear case/transfer case [DPS]
– Check oil level and add.

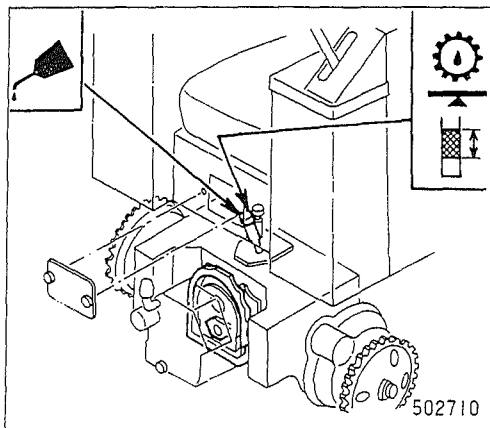

- ⑩ Brake pedal – Check free play/
stroke and adjust.

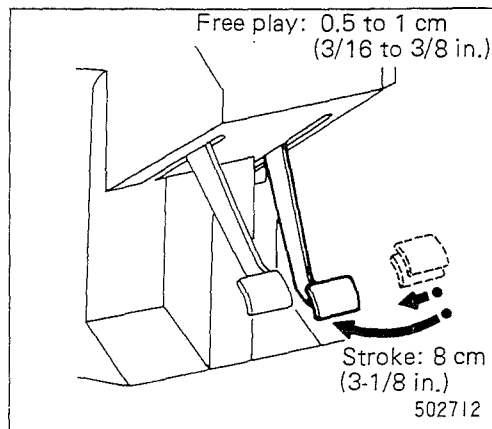

- ⑫ Inching pedal [DPS] – Check
stroke and adjust.

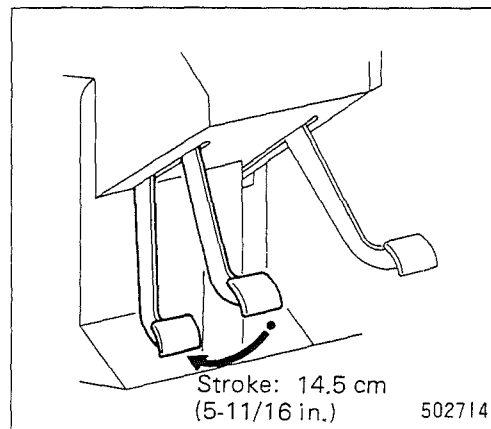

- ⑨ Fuel tank – Check oil level and
add; drain moisture and sediment.

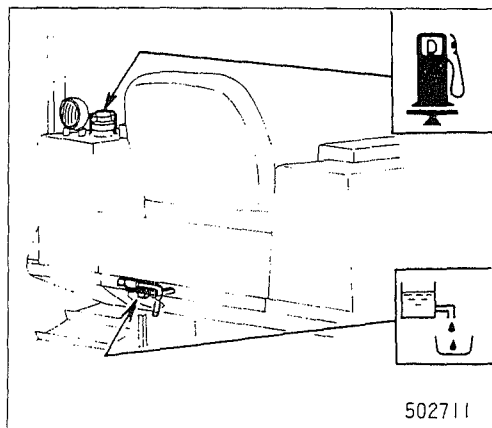

- ⑪ Clutch pedal [DD] – Check free
play/stroke and adjust.

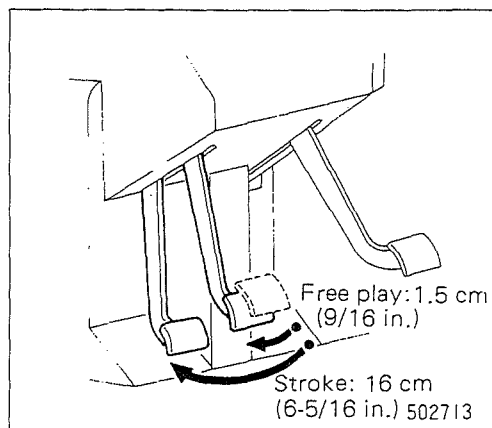

- ⑬ Transmission control lever [DPS] –
Check clearance in guide.

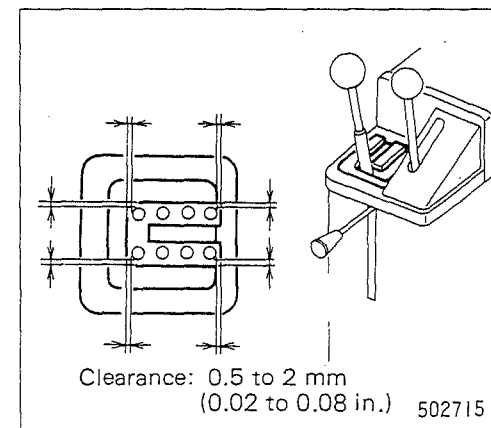

Every 10 service hours or daily (IV) (before operation)

- ⑭ Tracks – Check adjustment (sag).

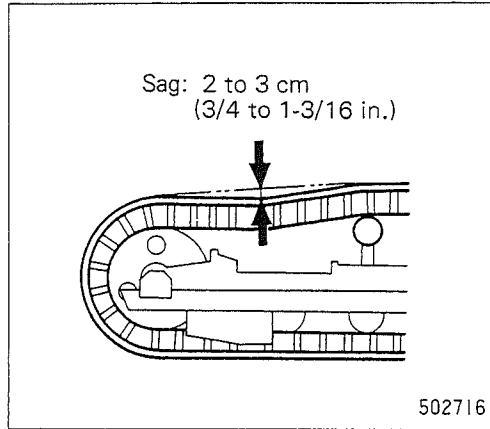

- ⑮ Steering clutch levers – Check stroke.

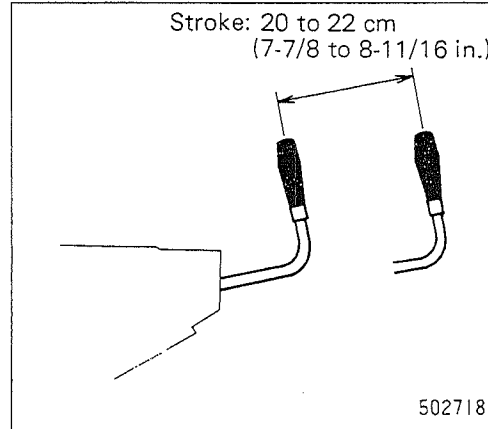

- ⑯ Implement – Check for damage or wear.

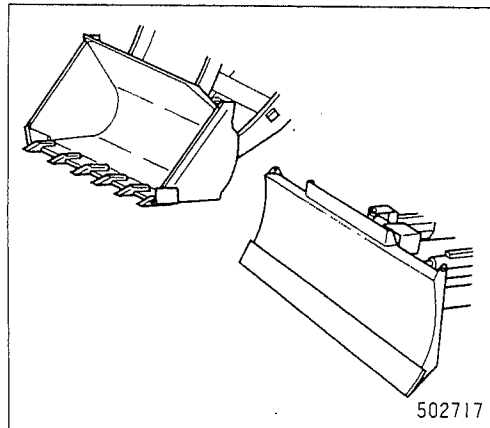

Every 250 service hours or monthly (I)

⑰ Fan belt – Check tension.

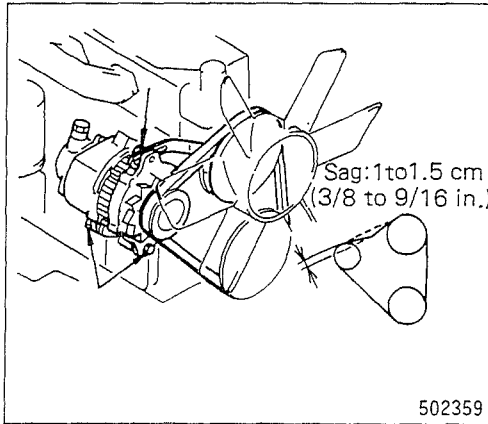

⑱ Battery – Check electrolyte level
(battery electrolyte level warning lamp
of OK monitor).

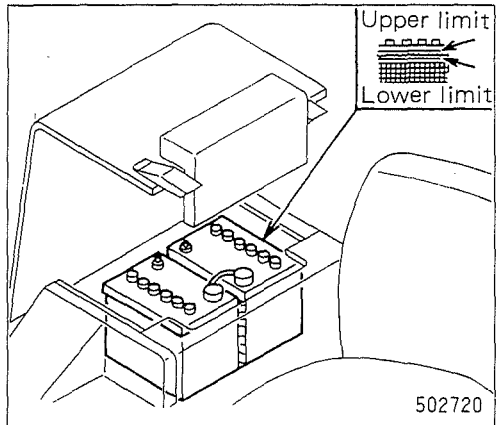

Every 250 service hours or monthly (II)

⑩ Implement – Lubricate.



3 strokes from
grease gun

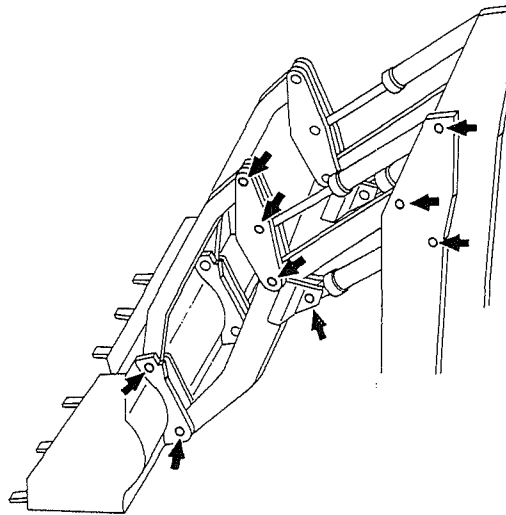

BS3G 18 fittings

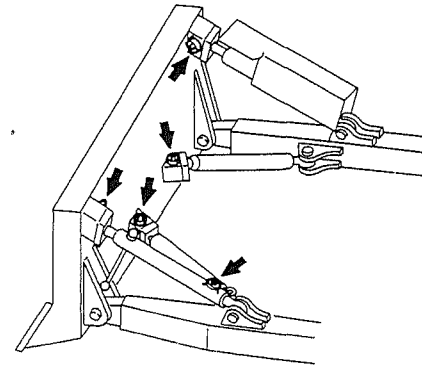

Straight blade 5 fittings

Every 500 service hours or 3 months

⑳ Fuel tank – Wash strainer.

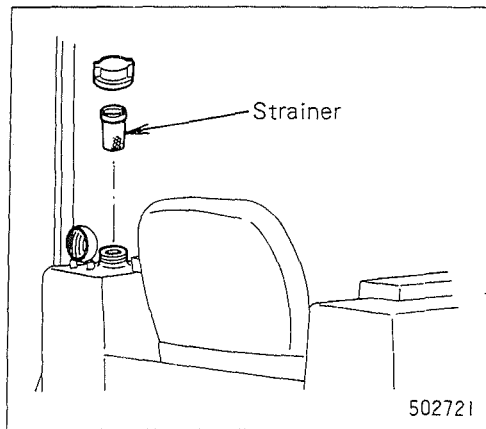

㉑ Fuel feed pump – Wash filter.

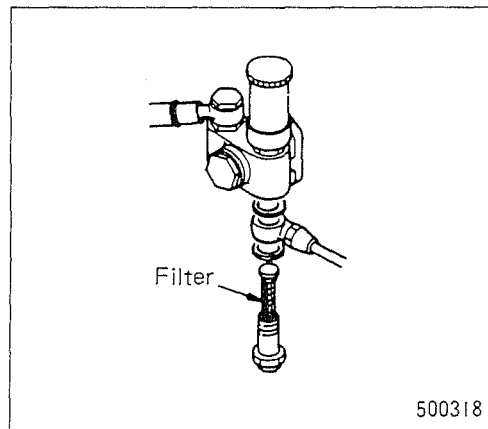

㉒ Steering clutch cases – Drain moisture.

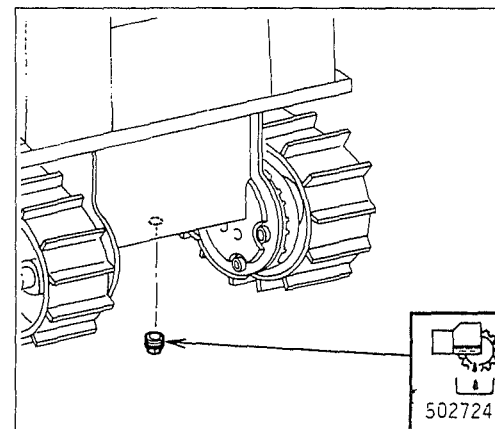

㉓ Final drive gear cases – Check oil level and add.

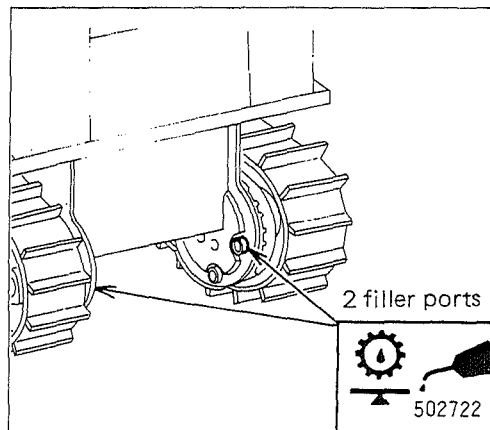

㉔ Air cleaner – Clean element.

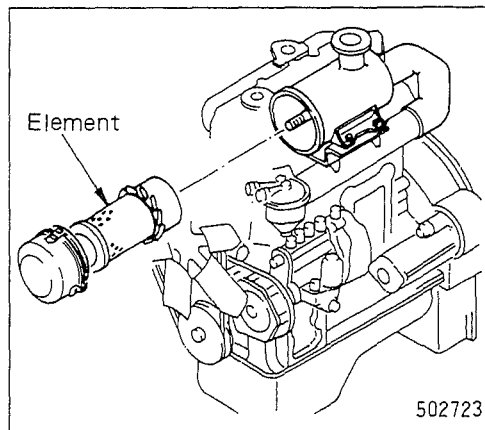

㉕ Engine oil pan – Change oil.

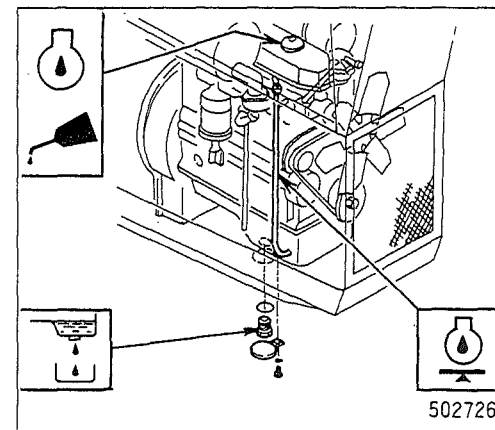

Every 1000 service hours or 6 months

26 Engine oil filter – Change.

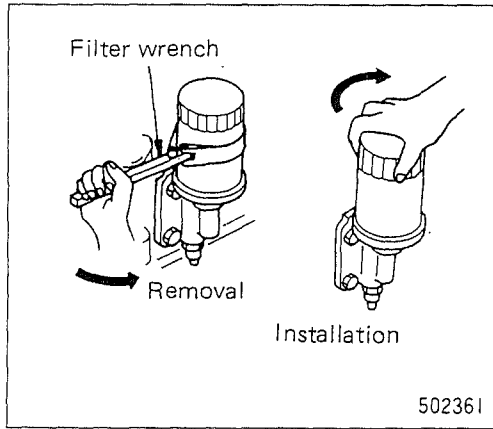

28 Universal joint – Lubricate.

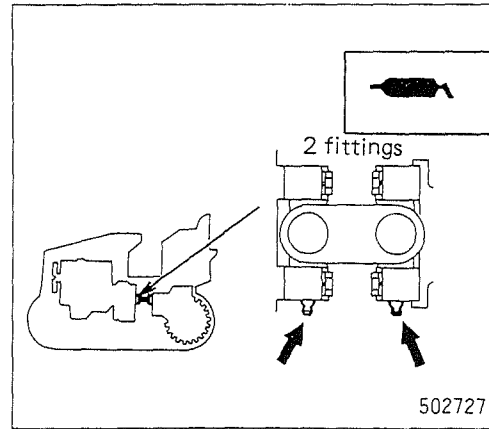

27 Fuel filter – Change element.

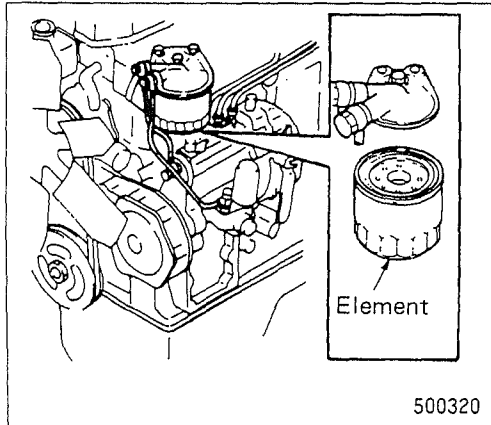

Every 2000 service hours or 1 year (I)

⑳ Main clutch case [DD] – Change oil.

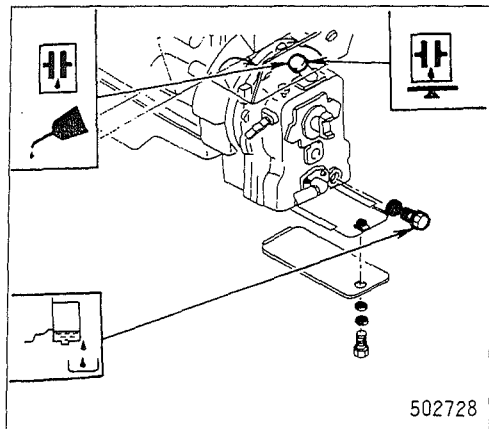

㉑ Damper case [DPS] – Change oil.

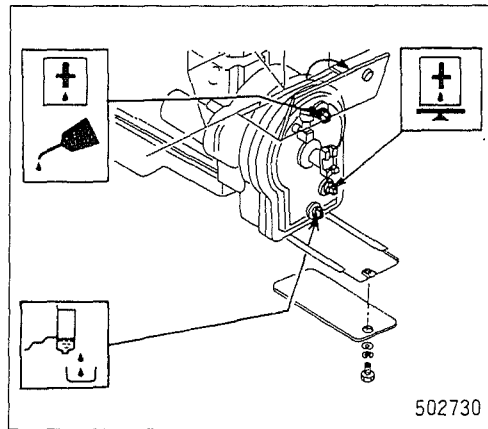

㉓ Bevel gear case/transfer case [DPS] – Change oil.

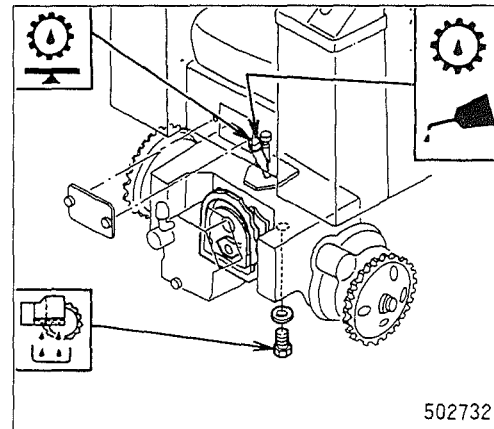

㉒ Main clutch case [DD] – Wash strainer.

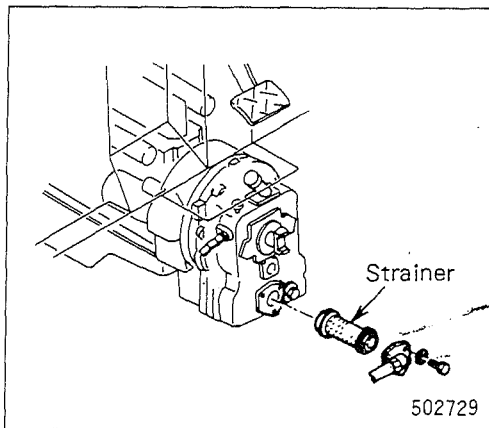

㉔ Bevel gear case/transmission case [DD] – Change oil.

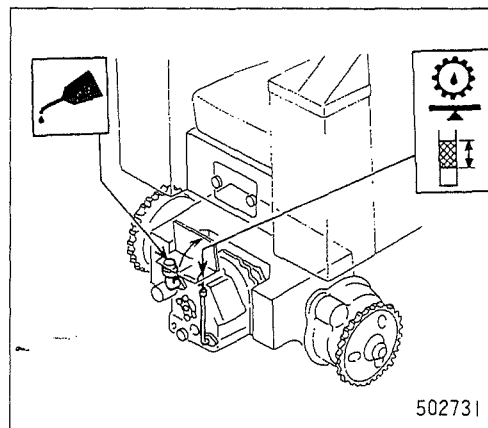

㉕ Transmission case [DPS] – Change oil.

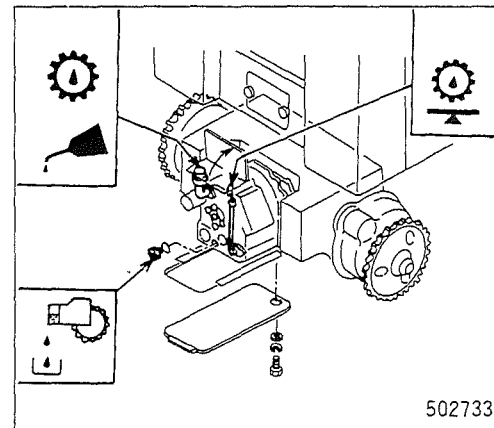

Every 2000 service hours or 1 year (II)

- ③5 Transmission case [DPS] – Change oil filter; wash strainer.

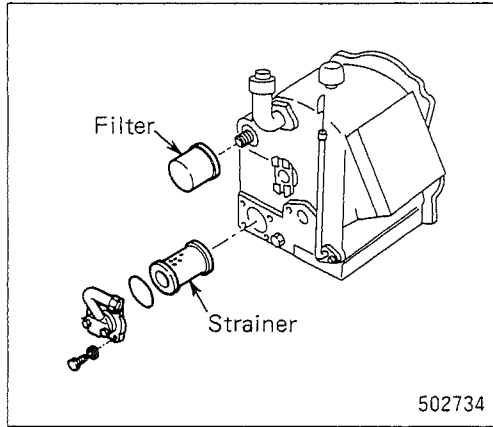

- ③7 Hydraulic tank – Change oil filter element.

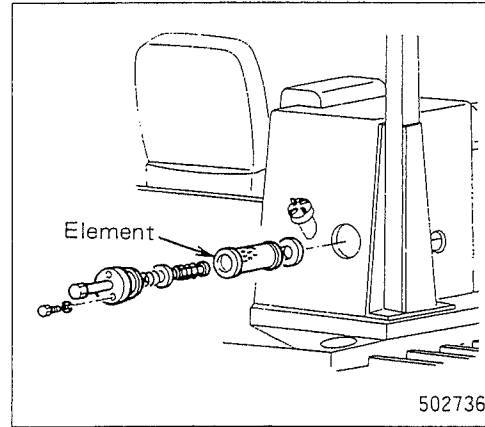

- ③9 Radiator – Flush; change coolant.

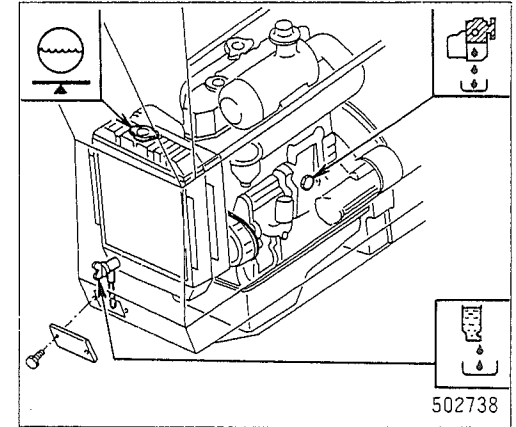

- ③6 Hydraulic tank – Change oil.

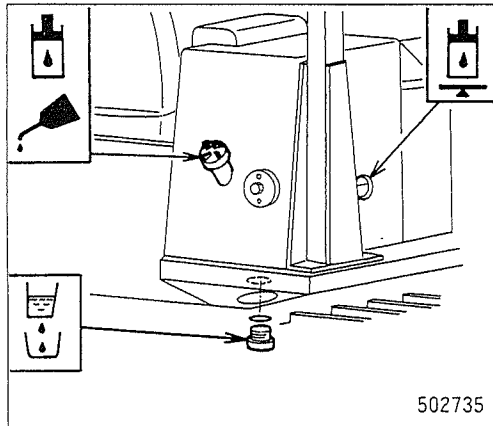

- ③8 Final drive gear cases – Change oil.

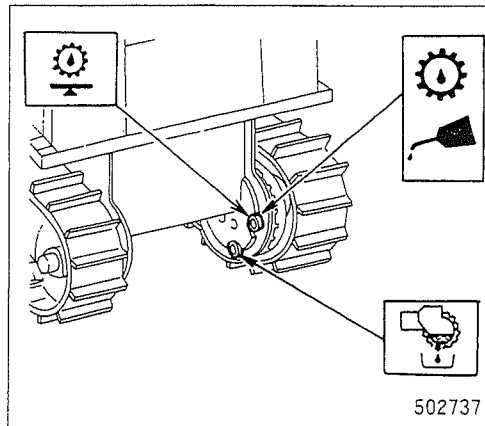

- ④0 Air cleaner – Change element.

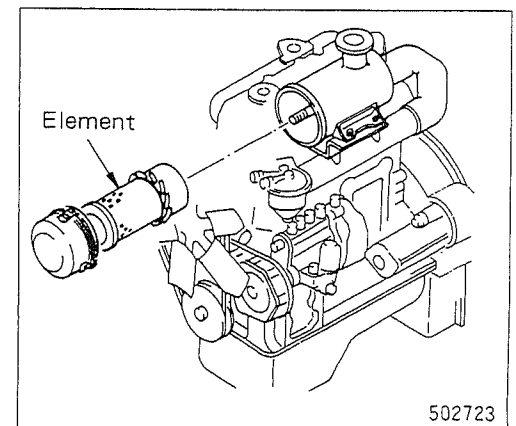

When Required

Cleaning air cleaner element

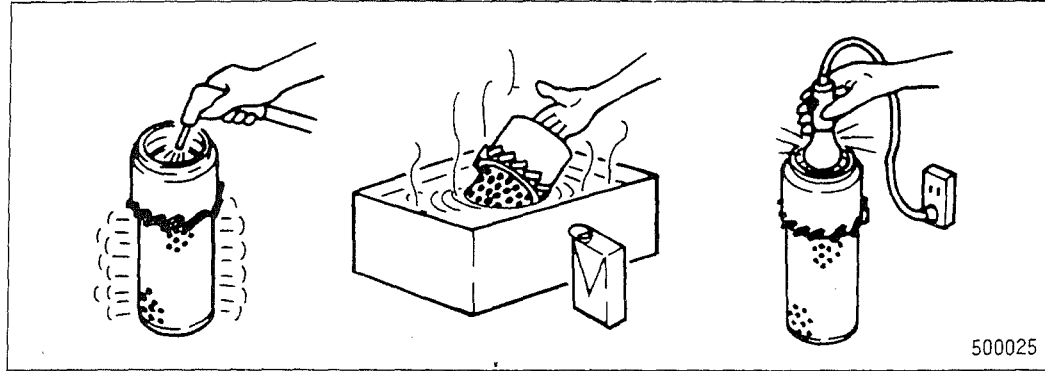

1. Use pressure air – 7 kg/cm² (100 psi) [0.7 MPa] maximum or water – 3 kg/cm² (40 psi) [0.3 MPa] maximum when cleaning dry dirty element.
 2. If element is dirty with soot or oily substance, immerse it in warm water and non-sudsing household detergent for approximately 30 minutes, and rinse it with clean water.
 3. After cleaning, insert light inside element and check for pinholes or tears.
- Have spare elements on hand to use while cleaning used element.
 - Dry element in breeze or current from an electric fan. Do not clean elements by bumping or tapping.



Wear safety goggles and protective clothing when using pressure air.

Priming fuel system

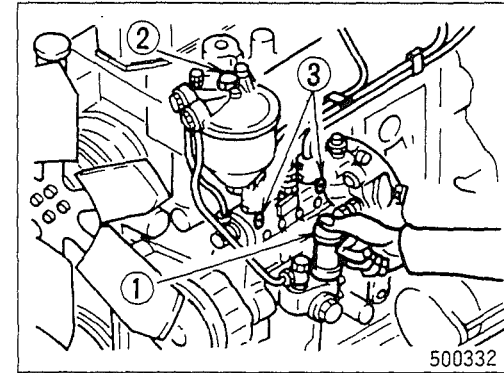

1. Unlock priming pump (1) by turning it counterclockwise.
2. Loosen air vent plug (2) of fuel filter. Operate priming pump until fuel flows from vent without bubbles, then tighten the plug.
3. Loosen air vent plugs (3) of injection pump, and prime the pump in the same manner as for fuel filter.
4. After completing priming operation, lock priming pump by turning it clockwise while depressing it downward.

Adjusting tracks

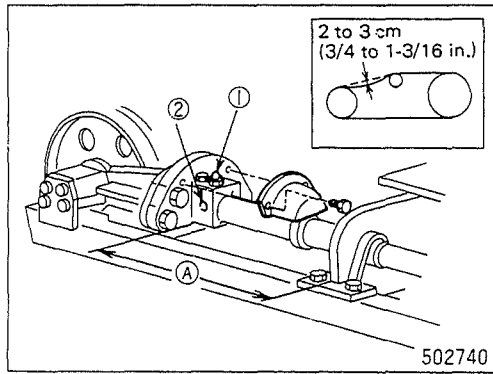

When properly adjusted, tracks should have a sag of **2 to 3 cm (3/4 to 1-3/16 in.)** as measured at a point half way between carrier roller and front idler, as shown.

• To adjust:

1. Remove cover, and apply grease, with a grease gun, into fill valve (1) until dimension (A) (between flange and rigid bar) is within **45 cm (17-3/4 in.)**.
 2. Operate machine backward and forward to equalize adjustment.
- If it is difficult to set dimension (A) within **45 cm (17-3/4 in.)**, consult your Mitsubishi dealer.

• To loosen:

Turn fill valve (1) counterclockwise and allow grease to escape from vent hole (2).



Keep your face away from fill valve when making an adjustment.

Adjusting steering clutches

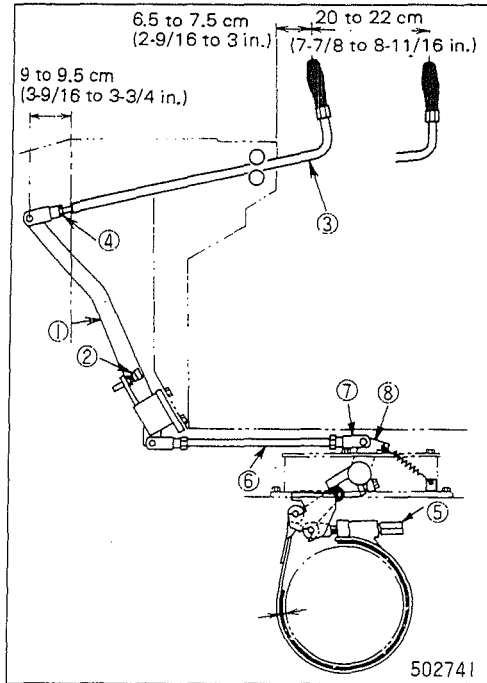

Adjust the following four items (A) through (D):

(A) Released position of steering clutch levers

(B) Clearance between brake band and drum

(C) Stroke of steering clutch levers

(D) Adjustment after connection to steering valve

(A) Released position of steering clutch levers

1. Reposition stopper bolt (2) so that position of lever (1) is 9 to 9.5 cm (3-9/16 to 3-3/4 in.). (Equalize right and left lever positions.)
2. To adjust released position of lever (3), loosen lock nut (4) and turn lever (3) in either direction. It should be 6.5 to 7.5 cm (2-9/16 to 8-11/16 in.) as measured from end face of instrument panel.

(B) Clearance between brake band and drum

Run in adjusting nut (5) all the way, and back it off 2-2/3 rotations from that position.

(C) Stroke steering clutch levers

Adjust length of rod (6) by means of clevis (7) so that levers (3) have 20 to 22 cm (7-7/8 to 8-11/16 in.) stroke when pulled all the way.

- When making a connection to lever (8), lightly push lever (8) forward.

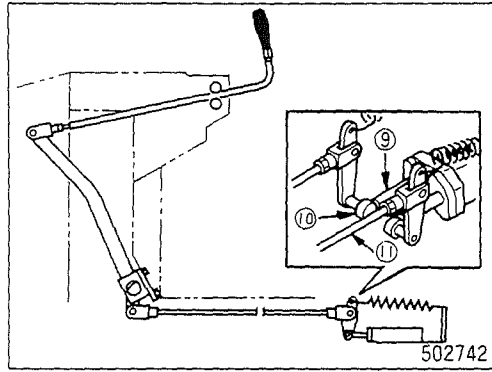

(D) Adjustment after connection to steering valve

Adjust length of rod (11) to bring steering valve plunger (9) into contact with roller (10).

- Do not push in plunger (9).

Adjusting brake pedal

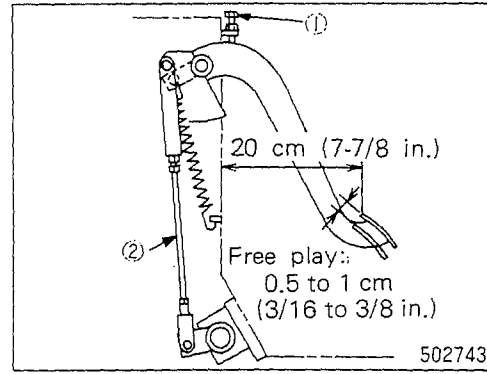

- There is no need of adjusting stroke of this pedal after steering clutch adjustment has been made properly. To be adjusted is its free play.

1. Reposition stopper bolt (1) so that pedal is **20 cm (7-7/8 in.)** as measured from dashboard wall. .
2. Adjust length of rod (2) so that free play of pedal is **0.5 to 1 cm (3/16 to 3/8 in.)**.

- Make sure right and left brakes move simultaneously when you start depressing pedal.

Adjusting inching pedal [DPS]

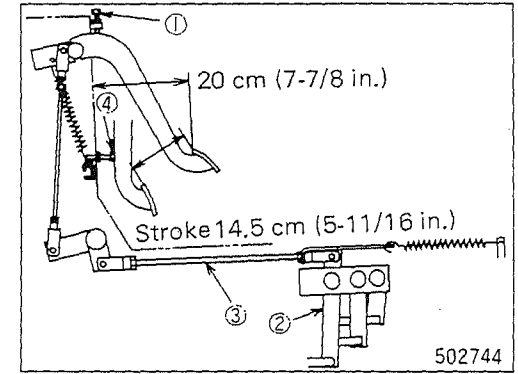

1. Reposition stopper bolt (1) so that inching pedal is **20 cm (7-7/8 in.)** as measured from dashboard wall.
2. Adjust length of rod (3) so that lever (2) starts moving soon when pedal is depressed.
3. Reposition stopper bolt (4) so that pedal stroke is **14.5 cm (5-11/16 in.)**.

Adjusting clutch pedal [DD]

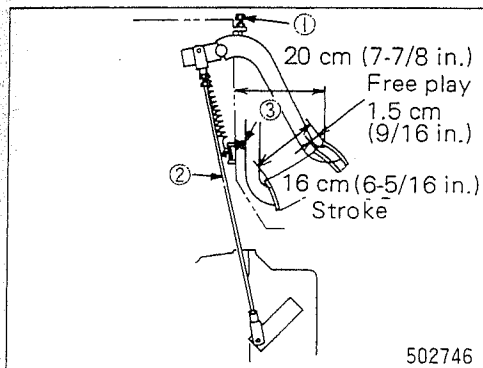

1. Reposition stopper bolt (1) so that clutch pedal is **20 cm (7-7/8 in.)** as measured from dashboard wall.
2. Adjust length of rod (2) so that free play of pedal is **1.5 cm (9/16 in.)**.
3. Reposition stopper bolt (3) so that pedal stroke is **16 cm (6-5/16 in.)**.

Adjusting clutch brake [DD]

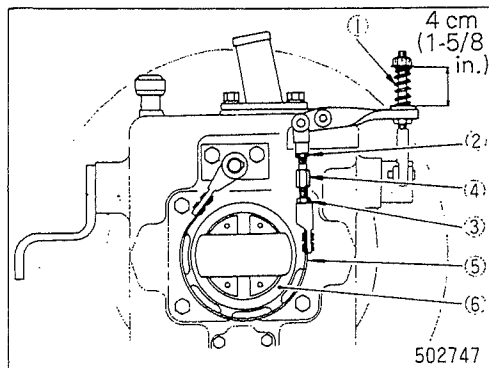

- This brake should be capable of stopping a rotating universal joint in about **2.5 seconds** when clutch pedal is depressed all the way with engine running at maximum speed.

1. Adjust as-installed length of spring (1) to **4 cm (1-5/8 in.)**.
2. Loosen lock nuts (2) (3), and run in adjusting bolt (4) until brake band (5) comes in full-face contact with drum (6).
3. Back off adjusting bolt (4) **2.5 to 3 rotations** from that position to obtain correct clearance between band and drum.

Adjusting transmission control lever [DPS]

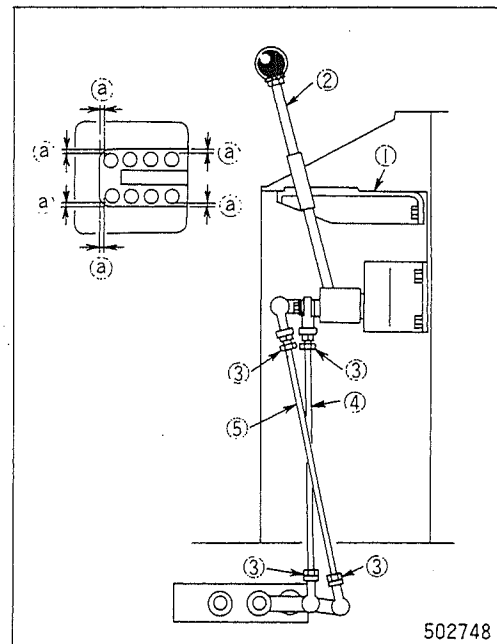

- Clearance (a) between guide (1) and lever (2) should be **0.5 to 2 mm (0.02 to 0.08 in.)** in any position.

Loosen lock nuts (3), and turn rods (4) (5) to adjust clearance (a).

- If it is difficult to obtain correct clearance, lever parts would be badly worn. In such a case, consult your Mitsubishi dealer.

Adjusting tip angle (straight blade)

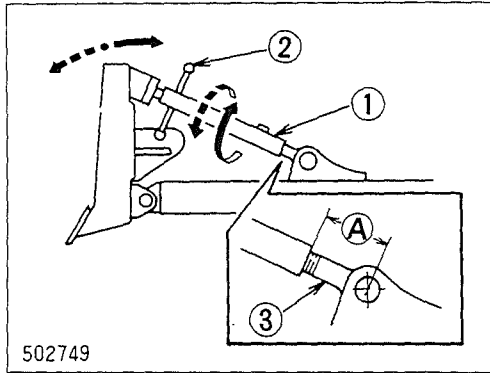

■ To vary tip angle of blade for giving blade a better digging action, making for quick, plow-like penetration into ground or for giving dirt a rolling action ahead of blade, proceed as follows:

1. Set blade at large angle by turning left brace (1) counterclockwise with handle (2).
2. Set blade at smaller angle by turning left brace (1) clockwise with handle (2).



CAUTION

Do not increase exposed length (A) of eye bolt (3) more than **10.5 cm (4 in.)**.