



# Introduction of the New Truck Generation The New Arocs (Model 964)

Introduction into Service Manual



Mercedes-Benz

# Introduction of the New Truck Generation The New Arocs (Model 964)

### Product Portfolio

You can also find comprehensive information on our complete product portfolio in our Internet portal:

Link: <http://aftersales.mercedes-benz.com>

### Questions and suggestions

If you have any questions or suggestions concerning this product, please write to us.

E-mail: [customer.support@daimler.com](mailto:customer.support@daimler.com)

Fax: +49-(0)18 05/0 10-79 78

© 2013 by Daimler AG

This document, including all its parts, is protected by copyright. Any further processing or use requires the previous written consent of Daimler AG, Department GSP/OIR, HPC R822, W002, D-70546 Stuttgart. This applies in particular to reproduction, distribution, alteration, translation, microfilming and storage and/or processing in electronic systems, including databases and online services.

Image no. of title image: W00.01-1025-00  
Order no. of this publication: HLI 000 000 11 04

01/13

<b>Preface</b>	5
----------------	---

## Overview

<b>New features/modifications</b>	6
-----------------------------------	---

## Overall vehicle

<b>Product groups</b>	13
-----------------------	----

<b>Increased gross combination weights</b>	16
--	----

<b>Equipment</b>	17
------------------	----

## Drive

<b>Engines</b>	19
----------------	----

<b>Engine OM 473</b>	20
----------------------	----

<b>Technical data</b>	22
-----------------------	----

<b>Engine air intake</b>	24
--------------------------	----

<b>Exhaust system</b>	25
-----------------------	----

## Transmission

Clutch	27
Turbo retarder coupling	28
Transmission data	29
Gearshift, manual (G5H)	34
Transmission modes	37
Power take-off	40

## Transfer case

Transmission overview	42
-----------------------	----

## Hydraulic Auxiliary Drive (HAD)

General	44
Front axle	46
High-pressure pump/side module	47

## Chassis

Frame	48
Axles	50
Suspension	57
Brakes	58
Wheels and tires	59
Steering	60
Fuel tank	64

## Body

Cab	65
-----	----

## Networking

Overall network	71
-----------------	----

## Lights

Exterior lights	78
-----------------	----

## Special tools

Engine OM 936	80
Engine OM 470	82
Transmission G 140-8	83
Transmission G 280-16	85
VG 2800-3W, VG 3000-3W	86
Models 963, 964	87

## Annex

Abbreviations	88
Index	92

Dear Reader,

This Introduction into Service manual presents the new Arocs (model 964) and new features for the Actros and Antos (model 963).

This brochure is intended for the use of technical personnel familiar with the service and maintenance of Mercedes-Benz trucks. It is assumed here that the reader is already familiar with the Mercedes-Benz model series currently on the market.

In terms of the contents, the emphasis in this Introduction into Service Manual is on presenting new and modified components and systems.

All of the data in this brochure correspond to the technical status as of the copy deadline in November 2012 and may therefore differ from the current production configuration.

We will publicize modifications and new features in the relevant WIS documents only. Individual details in this brochure may therefore differ from more up-to-date versions published in WIS.

Daimler AG

Wörth Plant, GSP/TTH

November 2012

**i** **Note**

All of the information and messages of the multi-function display are shown in German because the corresponding versions in other languages were not available at the copy deadline.

**i** **Note**

Information about the vehicles and about operating the vehicle functions can also be found in the interactive owner's manual on the internet at:

[www.mercedes-benz.de/betriebsanleitung](http://www.mercedes-benz.de/betriebsanleitung)

This Introduction into Service manual is also available in digital form as a PDF in SDmedia.



## New features/modifications

### General

In early 2013, following the successful launch of the new Actros and Antos, the new Arocs model 964 heavy construction vehicles will be presented.

They will be introduced in 4 stages:

In February 2013 the steel-sprung non-AWD vehicles with the axle configurations 4x2, 6x4 and 8x4/4 will be launched.

In May 2013 these will be followed by the 6x2/2 VLA variants with leading axles and the 6x2 ENA/DNA with trailing axles.

From July 2013 the air-sprung construction vehicles and all-wheel-drive variants will be available.

The 6x2/4 vehicles will follow in November 2013.

For construction vehicles the product group Grounder (V1Z) will be introduced as well as the Loader (V1Y) product group.

Grounders are vehicles with "overloadable" chassis with steel suspension. They have 9 mm thick longitudinal frame members (standard is 8 mm) and strengthened springs. Large tires are also available for extreme conditions.

Loaders are vehicles with weight-optimized standard and special equipment. Among the construction vehicles, these are primarily payload-optimized concrete mixers and the semitrailer tractor 964.403 for tanker/silo service.



W00.01-1026-00

*The new Arocs*



### Distinguishing features of the model series



W00.00-1068-00

***Actros (V1A) model 963***

#### Long-haul vehicles

- L cabs with width 2300 mm or 2500 mm
- Interior trim almond beige
- Rear axles only with air suspension
- Only automated manual transmissions with Mercedes PowerShift 3 (G5G)
- Rigid frame design



W00.00-1069-00

***Antos (V1C) model 963***

#### Distribution vehicles

- S and M cabs with width 2300 mm
- Interior trim flannel gray/greige
- Rear axles only with air suspension
- Only automated manual transmissions with Mercedes PowerShift 3 (G5G)
- Rigid frame design



W00.00-1070-00

***Arocs (V1B) model 964***

#### Construction vehicles

- S, M and L cabs with width 2300 mm or 2500 mm
- Interior trim anthracite/greige
- Straight front axle for greater ground clearance
- Unique radiator grille design
- Unique mirror covers
- Also with steel suspension on the rear axle
- Variants with all-wheel drive
- Also with drum brakes
- Front axle set back 100 mm
- Transmission with manual shift available
- Flexible frame

## New features/modifications

### Construction

- Large number of entirely new vehicle concepts (axle configurations/tonnages)
- Easier mounting of various bodies through a wide selection of wheelbases for the different chassis variants that can be ordered ex factory. The rear frame overhang can be selected in 300 mm increments
- 2 frame variants for the various operating conditions. A narrow, soft frame for steel-sprung vehicles, and a wide, moderately rigid frame for air-sprung vehicles
- A wide choice of air-sprung construction vehicles, some overloadable
- All vehicles in the construction model series feature automated manual transmissions with Mercedes PowerShift 3 (G5G) as standard equipment
- Manual shift transmissions with the new cable shift (Cable Power Shift (G5H)) with power-assisted gear shifting are available as special equipment
- Turbo retarder coupling for heavy-duty trucks in combination with the automated Mercedes PowerShift 3 transmission G 280-16
- New semi-clutch-independent live power take-offs (NMV) with two different ratios
- Virtually all the cab variants from the two long-haul and distribution model series are also available for the construction vehicles
- Unique cab design with fixed entry step for all air-sprung construction vehicles and with movable step for all steel-sprung construction trucks and all dumper/concrete mixer chassis
- Different axle drops can be selected for the front axle to produce a variety of ground clearances
- Introduction of the Grounder product group

- Servotwin<sup>®</sup> electrohydraulic steering (C6H) as special equipment for 4-axle vehicles and standard for front axle loads > 7.5 t
- Wide rear axle for single tires
- Air suspension at the rear axle also for models with max. GVW from 20 t to 32 t

### Distribution haulage/long-distance haulage

- New air-sprung 20 t 4x2 platform trucks and semitrailer tractors
- New air-sprung 33 t 6x4 platform trucks and semitrailer tractors
- New air-sprung 25 t 6x2/4 VLA 22.5" platform trucks and semitrailer tractors

### Distribution haulage/long-distance haulage/construction

- Engine OM 473 with turbocompound
- Hydraulic Auxiliary Drive (HAD)  
Hydraulic drive of the front axle with wheel hub motors
- DuraFlange aluminum rims in sizes 9.00x22.5 and 11.75x22.5

#### Note

Various components of the Arocs, such as the safety and support systems, are identical to those in the Actros and Antos model 963, and are therefore not described again here.

The new construction vehicles of model series 964 and six new vehicles of model series 963 that will be available from 2013 are listed below.

Vehicles launched in February 2013				
Model	Wheel configuration	Permissible gross vehicle weight	Rear suspension	Frame width
<b>Semitrailer tractors</b>				
964.403	4x2	18 t	Air	834 mm
964.401	4x2	20 t	Steel	744 mm
963.402	4x2	20 t	Air	834 mm
964.414	6x4	26 t	Steel	744 mm
964.416	6x4	33 t	Steel	744 mm
<b>Platform trucks</b>				
964.000	4x2	18 t	Steel	744 mm
964.001	4x2	20 t	Steel	744 mm
963.002	4x2	20 t	Air	834 mm
964.014	6x4	26 t	Steel	744 mm
964.030	8x4/4	32 t	Steel	744 mm
964.016	6x4	33 t	Steel	744 mm
964.031	8x4/4	41 t	Steel	744 mm
<b>Dumpers</b>				
964.200	4x2	18 t	Steel	744 mm
964.201	4x2	20 t	Steel	744 mm
964.214	6x4	26 t	Steel	744 mm
964.230	8x4/4	32 t	Steel	744 mm
964.216	6x4	33 t	Steel	744 mm
964.231	8x4/4	41 t	Steel	744 mm
<b>Concrete mixers</b>				
964.314	6x4	26 t	Steel	744 mm
964.330	8x4/4	32 t	Steel	744 mm
964.316	6x4	33 t	Steel	744 mm
964.331	8x4/4	41 t	Steel	744 mm

## New features/modifications

### Vehicles launched in May 2013

Model	Wheel configuration	Permissible gross vehicle weight	Rear suspension	Frame width
<b>Semitrailer tractors</b>				
964.423	6x2/2 VLA 22.5"	24 t/ 25 t	Air	834 mm
964.420	6x2 ENA	25 t	Air	834 mm
964.425	6x2 DNA	25 t	Air	834 mm
<b>Platform trucks</b>				
964.020	6x2 ENA	25 t	Air	834 mm
964.025	6x2 DNA	25 t	Air	834 mm

### Vehicles launched in July 2013

Model	Wheel configuration	Permissible gross vehicle weight	Rear suspension	Frame width
<b>Semitrailer tractors</b>				
964.407	4x4	18 t	Steel	744 mm
964.408	4x4	20 t	Steel	744 mm
964.402	4x2	20 t	Air	834 mm
964.424	6x4	26 t	Air	834 mm
964.418	6x6	33 t	Steel	744 mm
963.426	6x4	33 t	Air	834 mm
964.426	6x4	33 t	Air	834 mm
<b>Platform trucks</b>				
964.007	4x4	18 t	Steel	744 mm
964.003	4x2	18 t	Air	834 mm
964.008	4x4	20 t	Steel	744 mm
964.002	4x2	20 t	Air	834 mm
964.024	6x4	26 t	Air	834 mm
964.038	8x4/4	32 t	Air	834 mm
964.041	8x4 ENA	32 t	Air	834 mm



### Vehicles launched in July 2013

Model	Wheel configuration	Permissible gross vehicle weight	Rear suspension	Frame width
<b>Platform trucks</b>				
964.018	6x6	33 t	Steel	744 mm
963.026	6x4	33 t	Air	834 mm
964.026	6x4	33 t	Air	834 mm
<b>Dumpers</b>				
964.207	4x4	18 t	Steel	744 mm
964.203	4x2	18 t	Air	834 mm
964.208	4x4	20 t	Steel	744 mm
964.202	4x2	20 t	Air	834 mm
964.224	6x4	26 t	Air	834 mm
964.238	8x4/4	32 t	Air	834 mm
964.241	8x4 ENA	32 t	Air	834 mm
964.218	6x6	33 t	Steel	744 mm
964.226	6x4	33 t	Air	834 mm
964.232	8x6/4	41 t	Steel	744 mm
964.233	8x8/4	41 t	Steel	744 mm
<b>Concrete mixers</b>				
964.324	6x4	26 t	Air	834 mm
964.330	8x4/4	32 t	Air	834 mm
964.338	8x4/4	32 t	Air	834 mm
964.341	8x4 ENA	32 t	Air	834 mm
964.326	6x4	33 t	Air	834 mm

## New features/modifications

### Vehicles launched in December 2013

Model	Wheel configuration	Permissible gross vehicle weight	Rear suspension	Frame width
<b>Semitrailer tractors</b>				
963.422	6x2/4 VLA 22.5"	25 t	Air	834 mm
964.422	6x2/4 VLA 22.5"	25 t	Air	834 mm
<b>Platform trucks</b>				
963.022	6x2/4 VLA 22.5"	25 t	Air	834 mm
964.022	6x2/4 VLA 22.5"	25 t	Air	834 mm

### Vehicles launched in January 2014

Model	Wheel configuration	Permissible gross vehicle weight	Rear suspension	Frame width
<b>Concrete mixers</b>				
964.338	8x4/4	41 t	Steel	834 mm



**Product group: Grounder (V1Z)**

The new Arocs will see the introduction of the product group (PG) Grounder (V1Z). Grounders are vehicles with maximum load rating, robustness and offroad capability for customers in the construction business.



W00.00-1060-00

**The main features of the Grounder PG with the example of a dumper**

- 1 Strengthened frame
- 2 Strengthened steel suspension
- 3 Planetary hub reduction axles
- 4 Stabilizer bar
- 5 Steel rims
- 6 Large tires



## Product groups

### Product group: Loader (V1Y)

The product group (PG) Loader (V1Y), first introduced with the Antos, is also available for the Arocs model 964.

Customers in the construction industry are offered a payload-optimized semitrailer tractor (964.403), e.g. for dumper semitrailers, as well as extremely payload-efficient concrete mixers (964.330/338).



W00.01-1027-00

#### Equipment packages for the Loader PG with the example of a concrete mixer

##### Loader standard equipment, not deselectable

- 1 Compressed air reservoir, aluminum (B4L)
- 2 Omission of guard plate under bumper (M9V)

##### Loader standard equipment, selectable/deselectable

- 3 Omission of front passenger seat (D9Z)
- 4 Bumper, center section with towing eyes (F7C)

##### Loader standard equipment, exclusive, not deselectable

- 5 Windshield, weight-optimized (F6G)
- 6 Floor covering, weight-optimized (D5V)
- 7 Aluminum battery lines (Z7J)
- 8 Omission of engine suspension lugs

##### Loader standard equipment, exclusive, selectable/deselectable

- 9 Rear axle, ring gear 390, hypoid, 9.5 t, single (A20)
- 10 Tubeless tires, 385/65 R 22.5 on rear axle (I2Q)
- 11 Batteries 2 x 12 V/140 Ah, low-maintenance (E1F)
- 12 Omission of roof hatch/roof vent flap (D9T)

Models in the Grounder product group

Model	Axle configuration	Version	Max. GVW
964.001	4x2	Platform	20 t
964.008	4x4	Platform	20 t
964.016	6x4	Platform	33 t
964.018	6x6	Platform	33 t
964.031	8x4/4	Platform	41 t
964.201	4x2	Dumper	20 t
964.208	4x4	Dumper	20 t
964.216	6x4	Dumper	33 t
964.218	6x6	Dumper	33 t
964.231	8x4/4	Dumper	41 t
964.232	8x6/4	Dumper	41 t
964.233	8x8/4	Dumper	41 t
964.316	6x4	Concrete mixer	33 t
964.331	8x4/4	Concrete mixer	41 t
964.401	4x2	Semitrailer tractor	20 t
964.408	4x4	Semitrailer tractor	20 t
964.416	6x4	Semitrailer tractor	33 t
964.418	6x6	Semitrailer tractor	33 t

Models in the Loader product group

Model	Axle configuration	Version	Max. GVW
964.330	8x4/4	Concrete mixer	33 t
964.338	8x4/4	Concrete mixer	41 t
964.403	4x2	Semitrailer tractor	18 t

## Increased gross combination weights

### Gross combination weights above 44 t

Increased gross combination weights (GCW) can now be selected by code for the first time. The code covers all the components necessary to achieve the desired GCW. The vehicle can then be licensed with the required GCW.

At gross combination weights above 120 t the turbo retarder coupling (G3Y) is recommended. Furthermore, on 2-axle vehicle of 44 t GCW and above, a parking brake on the front axle (B2Z) is necessary.

### Codes for increased gross combination weights

Code	G0A	G0B	G0C	G0D
<b>GCW</b>	up to 68 t	up to 80 t	up to 120 t	above 120 t
<b>Drive</b>	one driven axle	at least 2 driven axles		
<b>Clutch</b>	1-plate	2-plate	2-plate, also turbo retarder coupling	
<b>Transmission</b>	G 260-16 (G1J)	G 260-16 (G1J)	G 260-16 (G1J)	
	G 280-16 (G2D)	G 280-16 (G2D)	G 280-16 (G2D)	
	G 281-12 (G2E)	G 330-12 (G2F)		
	G 330-12 (G2F)			
<b>Rear axle</b>	Planetary hub reduction rear axle with ring gear 300 (A2G) or hypoid rear axle with ring gear 485 (A2I)	Planetary hub reduction rear axle with ring gear 300 (A2G) or (A2H)		

## General

In addition to the basic equipment and the various standard equipment packages installed according to the vehicle model/product group, a number of additional safety and comfort features are also available. These are bundled in packages that are coded at the factory, such as the Safety Pack or the Comfort Pack. The scope of these packages is already described in the Introduction into Service manuals for the new Actros and Antos.

A new package specifically for the Arocs is the Protection Pack (Z9E).

The Protection Pack comprises a number of items of protective equipment for construction site operations.

The Protection Pack is only available for left-hand drive vehicles (Z5X) and not for semitrailer tractors (964.4xx) or the models 964.211 and 964.013.

Code	Scope of Protection Pack (Z9E)
K5R	Guard plate for tank
L4Z	Stone impact protection, metal, for headlamps
L1Q	Rear lamps for construction vehicles, in metal surround with mesh
F7Z	Step, with handrail on roof



W88.30-1036-00

**Step, with handrail on roof (F7Z)**



## Equipment

### Axle load compensation

8x6 and 8x8 vehicles are equipped with axle load compensation as standard.

The axle load compensation system distributes the load almost equally between the two front axles when the vehicle is driven over bumps and obstacles. This prevents damage due to overloading and reduces wear on the axle suspension, steering and tires.



W33.00-1035-00

*Axle load compensation*

The engines OM 936, OM 470 and OM 471 that are already available for the Actros and Antos (model 963) are also offered for the Arocs (model 964).

#### OM 936

- 175 kW (238 hp), 1000 Nm (M2A)
- 200 kW (272 hp), 1100 Nm (M2C)
- 220 kW (299 hp), 1200 Nm (M2D)
- 235 kW (320 hp), 1300 Nm (M2E)
- 260 kW (354 hp), 1400 Nm (M2F)

#### OM 470

- 240 kW (326 hp), 1700 Nm (M2N)
- 265 kW (360 hp), 1800 Nm (M2P)
- 290 kW (394 hp), 1900 Nm (M2Q)
- 315 kW (428 hp), 2100 Nm (M2R)

#### OM 471

- 310 kW (421 hp), 2100 Nm (M3A)
- 330 kW (449 hp), 2200 Nm (M3B)
- 350 kW (476 hp), 2300 Nm (M3C)
- 375 kW (510 hp), 2500 Nm (M3D)

A new addition for the models 963 and 964 is the OM 473, a 6-cylinder inline engine with a displacement of 15.6 l, which is available in 3 power categories.

#### OM 473

- 380 kW (517 hp), 2600 Nm (M3N)
- 425 kW (578 hp), 2800 Nm (M3P)
- 460 kW (625 hp), 3000 Nm (M3V)

#### **i** Note

Engine OM 473 will be available as of December 2013 and March 2014 (all-wheel drive vehicles).



W01.10-1144-00

**Engine OM 473 Euro VI**

## Engine OM 473

The OM 473 is technically based on the engines OM 470 and OM 471 that have already been introduced, but also features a turbocompound.

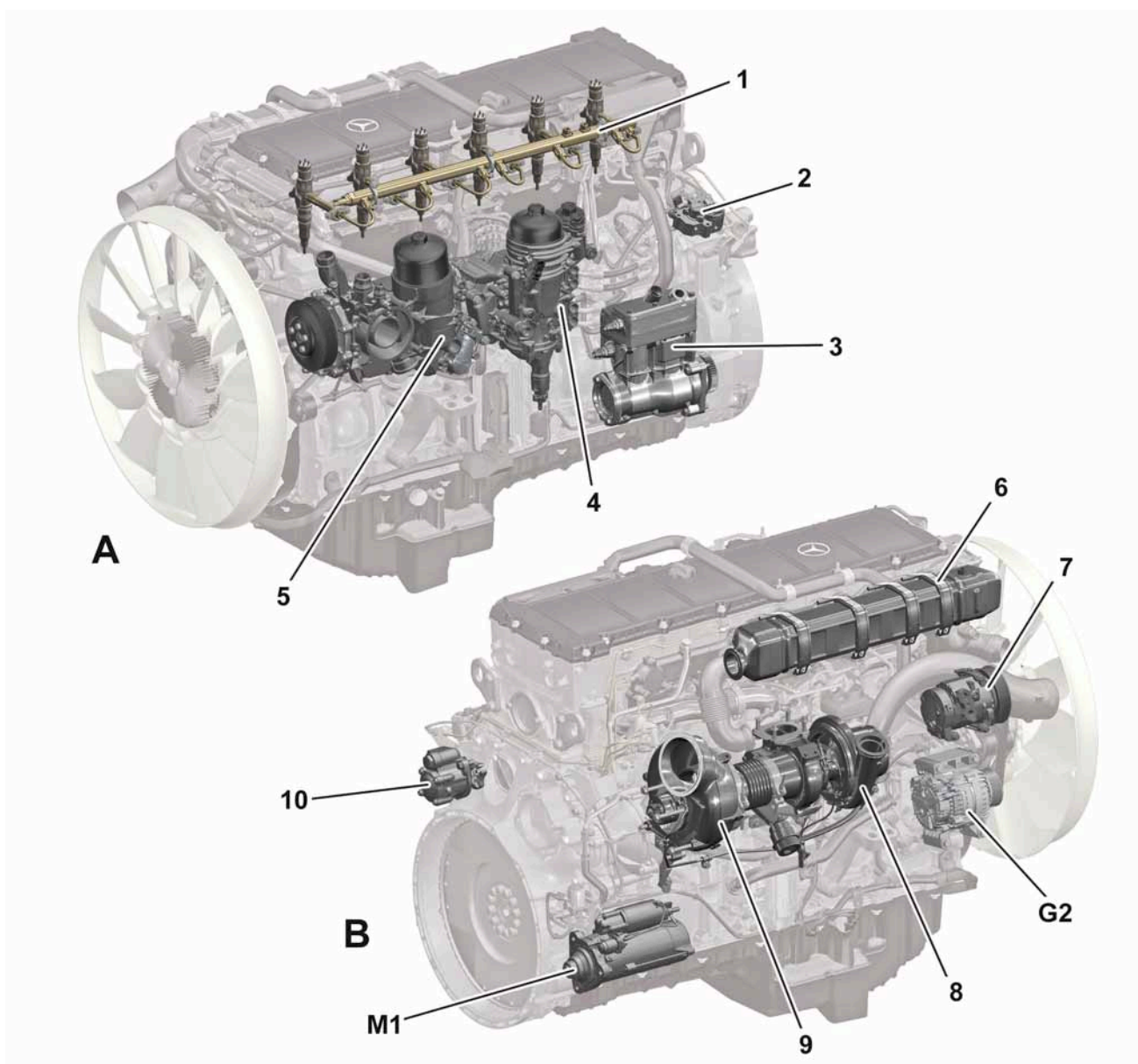

W01.10-1143-00

### Overview of engine OM 473

- |   |                                |
|---|--------------------------------|
| 1 Rail  | 8 Turbocharger                 |
| 2 Diesel fuel metering unit (for regeneration of diesel particulate filter) | 9 Turbocompound                |
| 3 Compressor  | 10 Power steering pump         |
| 4 Fuel filter module  | G2 Alternator                  |
| 5 Oil/coolant module with coolant pump                                      | M1 Starter                     |
| 6 Exhaust gas recirculation cooler  |                                |
| 7 Refrigerant compressor  |                                |
|   | A Left ("cold") side of engine |
|   | B Right ("hot") side of engine |



## Turbocompound

The turbocompound is a power turbine that is installed downstream of the turbocharger in the exhaust stream and which converts the energy of the exhaust gas into kinetic energy. The kinetic energy is delivered directly to the crankshaft of the engine via a 2-gear train with an intermediate hydrodynamic coupling. This means that up to 35 kW more power can be delivered with simultaneous reductions in fuel consumption and CO<sub>2</sub> emissions.

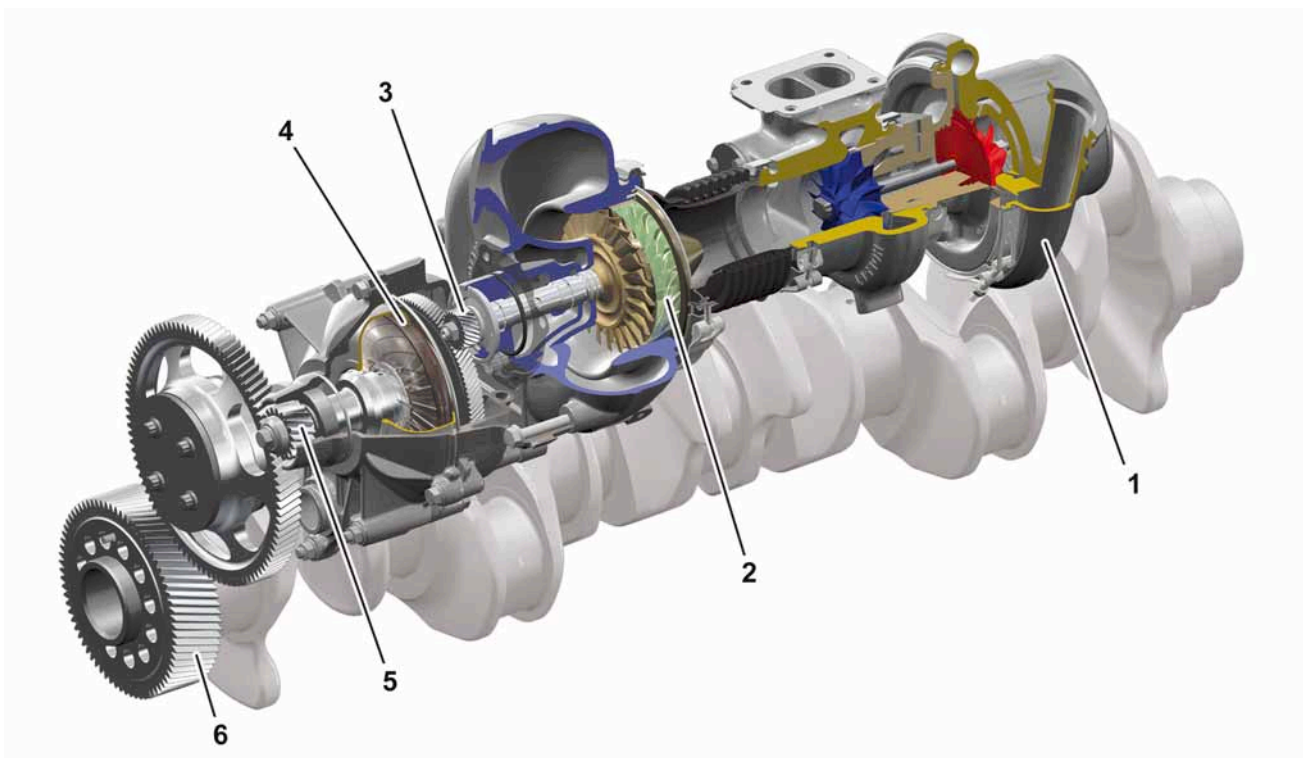

W09.40-1257-00

### Turbocompound

- |                               |                            |
|-------------------------------|----------------------------|
| 1 Turbocharger                | 4 Hydrodynamic coupling    |
| 2 Turbocompound turbine wheel | 5 Secondary reduction gear |
| 3 Primary reduction gear      | 6 Crankshaft gear          |



## Technical data

	Unit	OM 936	OM 470	OM 471	OM 473
Displacement	cm <sup>3</sup>	7698	10677	12809	15569
Cylinder number/arrangement		6/inline	6/inline	6/inline	6/inline
Valve timing		DOHC	DOHC	DOHC	DOHC
Number of valves per cylinder (intake/exhaust)		2/2	2/2	2/2	2/2
Idle speed	rpm	600	500	560	500
Power	kW	175 (M2A) 200 (M2C) 220 (M2D) 235 (M2E) 260 (M2F)	240 (M2N) 265 (M2P) 290 (M2Q) 315 (M2R)	310 (M3A) 330 (M3B) 350 (M3C) 375 (M3D)	380 (M3N) 425 (M3P) 460 (M3V)
Torque	Nm	1000 (M2A) 1100 (M2C) 1200 (M2D) 1300 (M2E) 1400 (M2F)	1700 (M2N) 1800 (M2P) 1900 (M2Q) 2100 (M2R)	2100 (M3A) 2200 (M3B) 2300 (M3C) 2500 (M3D)	2600 (M3N) 2800 (M3P) 3000 (M3V)
Compression ratio $\epsilon$		17.0	17.6	17.3	17.3
Stroke	mm	135	145	156	171
Bore	mm	110	125	132	139
Total piston height	mm	110	105	113.5	119.5
Connecting rod length	mm	215	245.5	268	274
Cylinder spacing	mm	128	155	165	173
Rail pressure (max.)	bar	2400	900	900	900
Weight (DIN-GZ)	kg	666 <sup>1</sup>	951 <sup>1</sup>	1092 <sup>1</sup>	1243 <sup>1</sup>
<sup>1</sup> with max. power					



Performance graph: OM 473

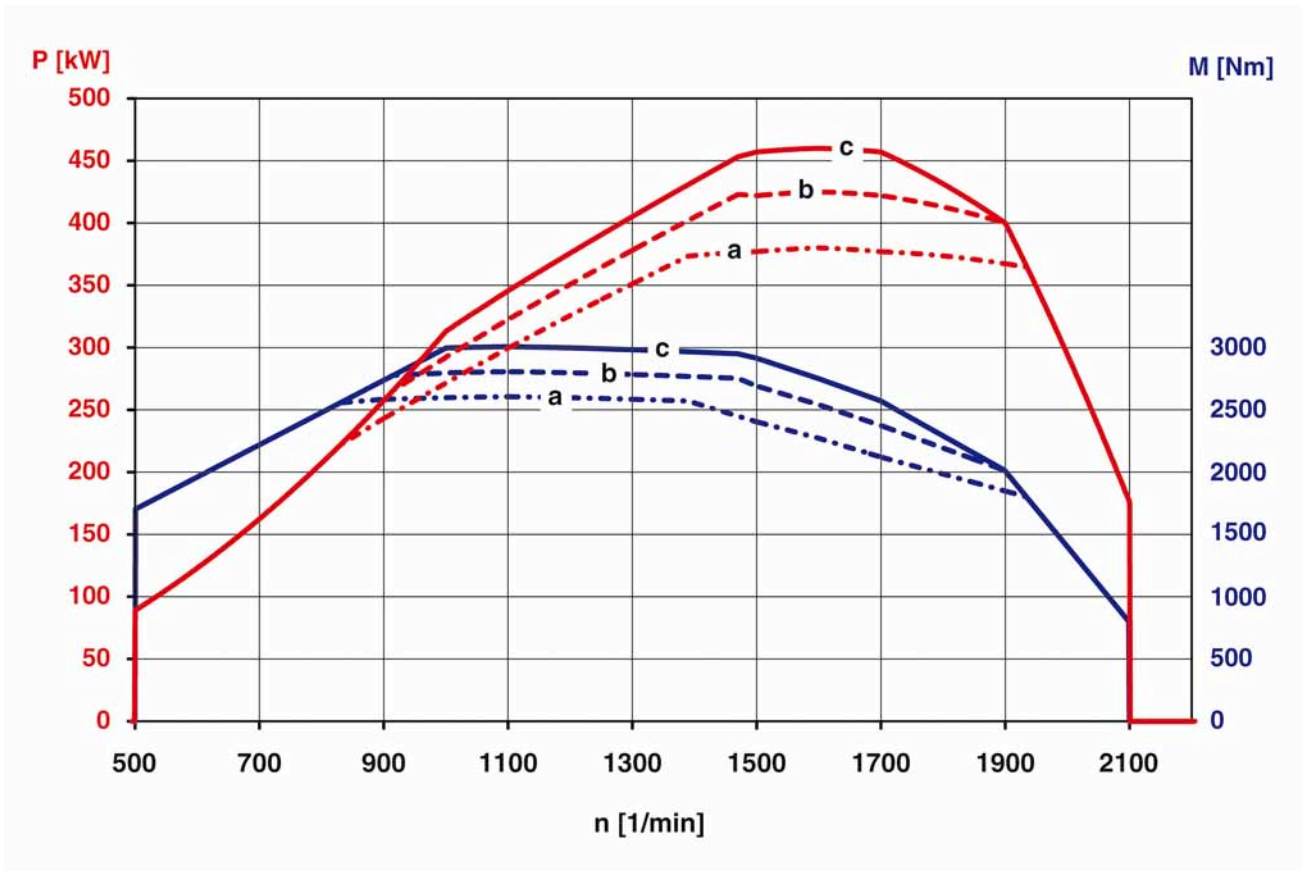

W01.00-1113-00

- a OM 473, 380 kW/2600 Nm (M3N)
- b OM 473, 425 kW/2800 Nm (M3P)
- c OM 473, 460 kW/3000 Nm (M3V)

█ M Torque  
█ P Power  
 n Rpm

## Engine air intake

### Cyclone prefilter for coarse dust (M8L)

A cyclone prefilter for coarse dust (M8L) is available for all model 963 and model 964 vehicles.

The cyclone prefilter protects the paper air filter from coarse dust and sand. The cyclone prefilter can be cleaned easily by pressing the rubber lips on the two dust expulsion valves.

The cyclone prefilter is only available in conjunction with the optional air intake, behind cab, top mounted (M8B) or air intake from front (M8A), but with the air intake from the front only in combination with the body floor height of 420 mm, OM 936 and steel-sprung cab mounting.

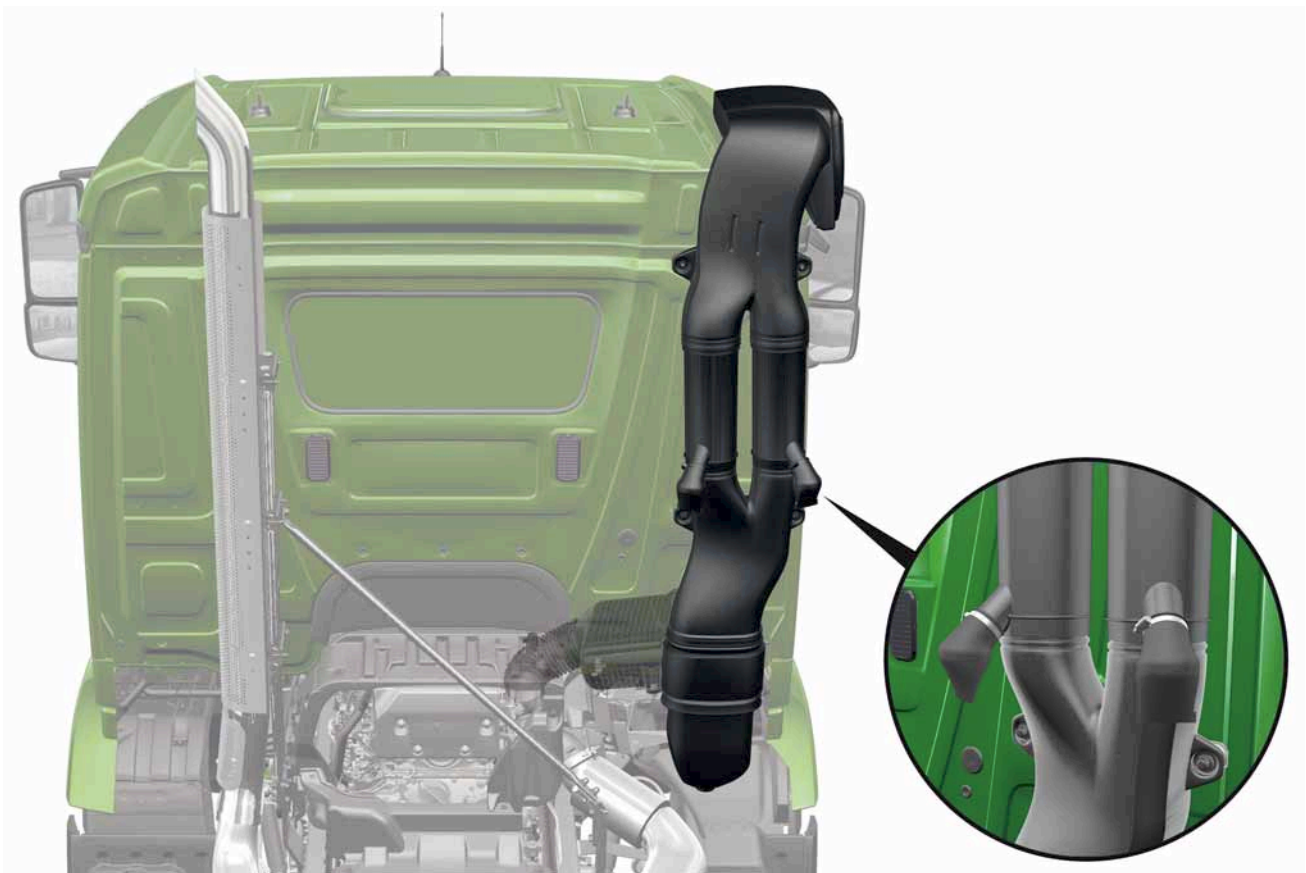

W09.00-1018-00

**Cyclone prefilter for coarse dust (M8L)**

The following exhaust systems are now available to meet the needs of construction site operations:

Code	Description
K7A	Exhaust system, end pipe upwards
K7E	Exhaust system, end pipe upwards, outlet variable
K7F	Exhaust system, offset, with large tires
K7G	Exhaust system, with connection for dumper bucket heater

The following codes describe the routing of the exhaust system in 4-axle vehicles. In these vehicles the exhaust pipe initially runs on the right-hand side of the vehicle over the 2nd axle as far as the exhaust aftertreatment unit.

From the exhaust aftertreatment unit it runs under the frame and back over the 2nd axle towards the front again to the upright end pipe behind the cab.

Code	Description
K7R	Exhaust pipe, straight, over second axle
K7S	Exhaust pipe, curved, over second axle
K7T	Exhaust pipe, over fender, second axle

## Exhaust system

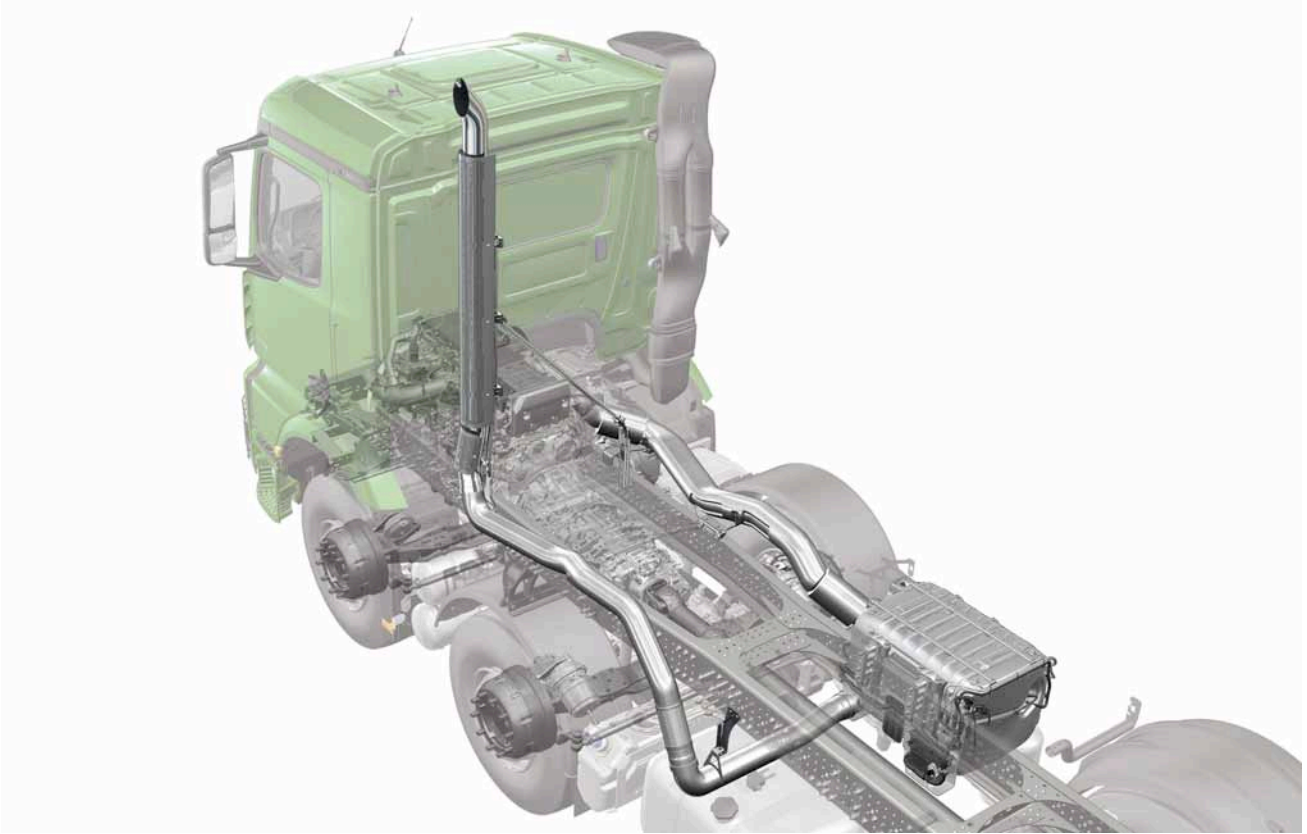

W49.00-1007.00

*Exhaust system, end pipe downwards (K7A) in combination with exhaust pipe, straight, over second axle (K7R)*

### Single-plate clutch (G5A)

The vehicles with manual shift transmission are also fitted with a clutch with thicker linings and a self-adjusting pressure plate. It is operated by a clutch release fork and a release bearing. The control force is reduced by means of a clutch booster mounted on the outside of the transmission.

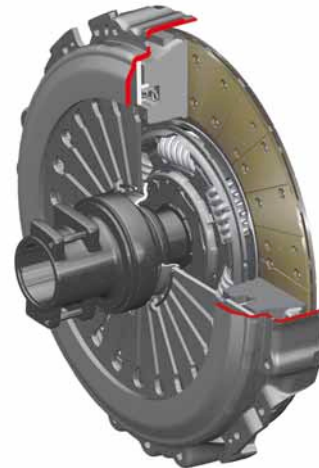

*Single-plate clutch*

W25.10-1085-00

### Double-plate clutch (G5B)

The double-plate clutch with a diameter of 2 x 400 mm is standard for the OM 473 engine with 425 kW and above, and optional equipment for all OM 470/471/473 engines. It allows torques of up to 3000 Nm to be transmitted.

With the double-plate clutch gross combination weights of up to 170 t can be pulled with a dry clutch.

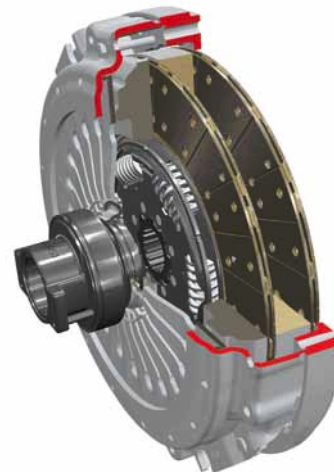

*Double-plate clutch*

W25.10-1080-00

#### Overview of clutch variants

Engine power	Engine	Ø 395 mm SAE2	Ø 430 mm SAE1	2 x Ø 400 mm SAE1
175 - 260 kW	OM 936	S	X	—
240 - 380 kW	OM 470/1/3	—	S	X
425 - 460 kW	OM 473	—	—	S

S = standard; X = special equipment



## Turbo retarder coupling

### Turbo retarder coupling (G3Y)

The turbo retarder coupling (G3Y) is a system the main component of which is a fill-regulated, hydrodynamic coupling (turbo coupling).

The turbo retarder coupling unites the "hydrodynamic start-up" and "hydrodynamic braking" functions into one system.

The characteristic of the unit can be varied by specific filling and emptying of the hydrodynamic circuit.

The turbo retarder coupling will be available as of 11/2013 in combination with the engines OM 471 and OM 473 and the transmission G 280-16 for heavy-duty applications as special equipment for the Actros 6x4 and for the Arocs with the wheel configurations 6x4, 6x6, 8x4/4, 8x4 ENA, 8x6/4 and 8x8/4, with the exception of concrete mixer chassis.

#### Moving off:

In normal driving the turbo retarder coupling is not filled with oil. When starting off, it is filled with the necessary quantity of oil according to the accelerator pedal position. The power is transmitted to the transmission input shaft via the hydrodynamic circuit and a downstream overrunning clutch. A conventional friction clutch is arranged in parallel with the circuit to act as a lockup clutch.

#### Braking:

When braking, the turbine wheel is locked with the turbine brake, turning the system into an effective engine retarder when the friction clutch is closed.

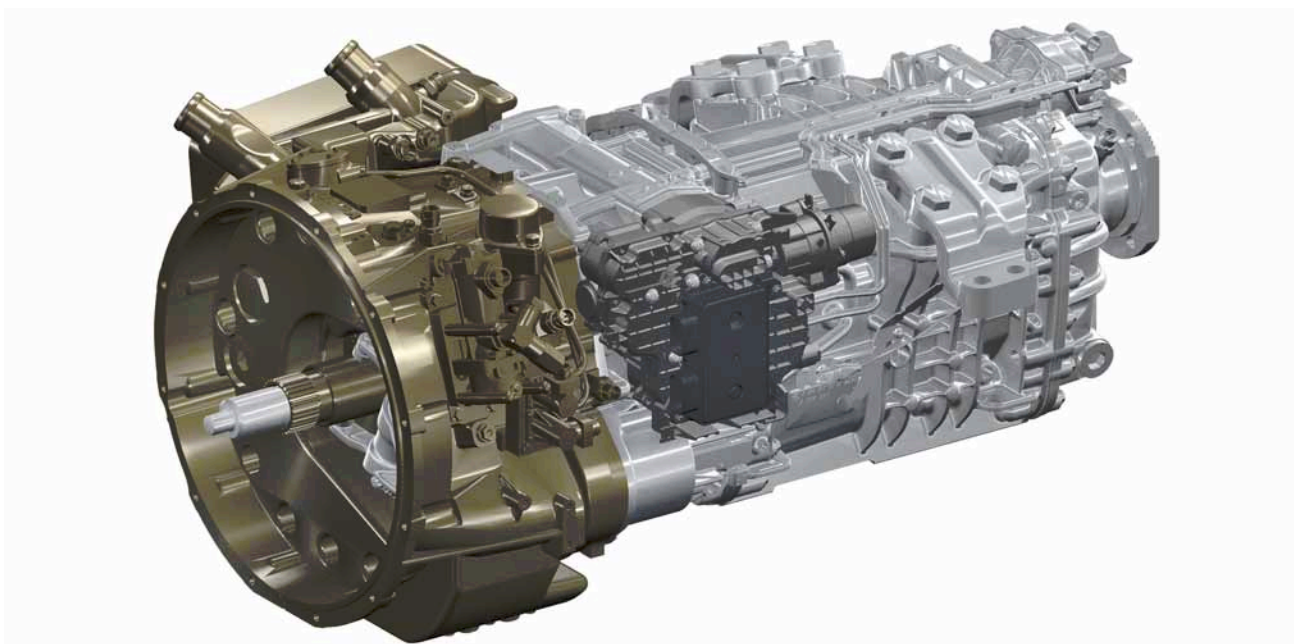

**Turbo retarder coupling**

W25.40-1143-00

## General

Automated manual transmissions with Mercedes PowerShift 3 (G5G) are standard equipment for the new Arocs model 964.

In addition to the automated manual transmissions familiar from the new Actros and Antos:

- G 211-12 (G2B)/715.352
- G 281-12 (G2E)/715.371
- G 330-12 (G2F)/715.381
- G 140-8 (G1E)/715.310
- G 230-12 (G2C)/715.360
- G 280-16 (G2D)/715.523

manual shift synchromesh transmissions are also available for the new Arocs under the special equipment designation "Gearshift, manual" (G5H):

- G 141-9 (G1F)/715.571
- G 230-16 (G1H)/715.508
- G 231-16 (G1I)/715.518
- G 260-16 (G1J)/715.528

The most powerful engine variant for the manual shift transmission is the OM 473 at 380 kW.

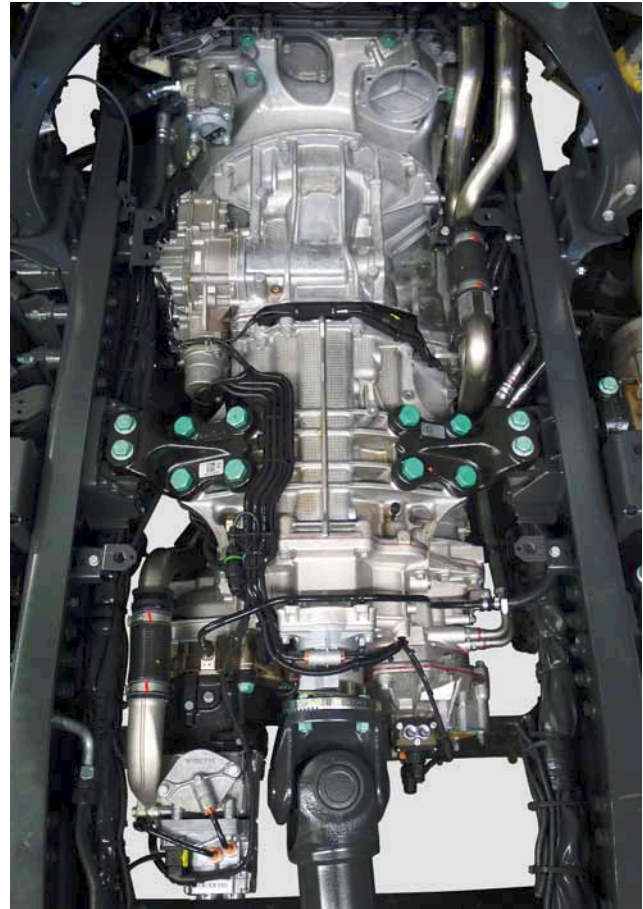

*Transmission G 330-12 (G1F)*

W26.10-1161-00

## Bolted transmission support arms

The transmission housings of model 964 and model 963 vehicles differ in the way that the transmission support arms are connected.

On the transmissions for model 963 the transmission support arms are cast on the housing.

The support arms on the transmissions for model 964 are fastened to the housing with four bolts.

This makes it easier to remove the transmission for repairs in vehicles with a fixed body.



*Transmission with bolted support arms*

W26.00-1058-00



## Transmission data

### Transmission G 141-9

The newly developed G 141-9 (G1F) is a manual shift synchromesh transmission with cable shift and pneumatic shift force and clutching assistance. It has a gear ratio spread of 14.57-1.00 and is specially adapted for the OM 936 inline engine.

The G 141-9 is a direct drive transmission, with its first gear designed as a crawler gear. The transmission is characterized by its highly compact construction and low weight.

The transmission consists of a 4-speed synchromesh transmission with synchronized range group and crawler gear.

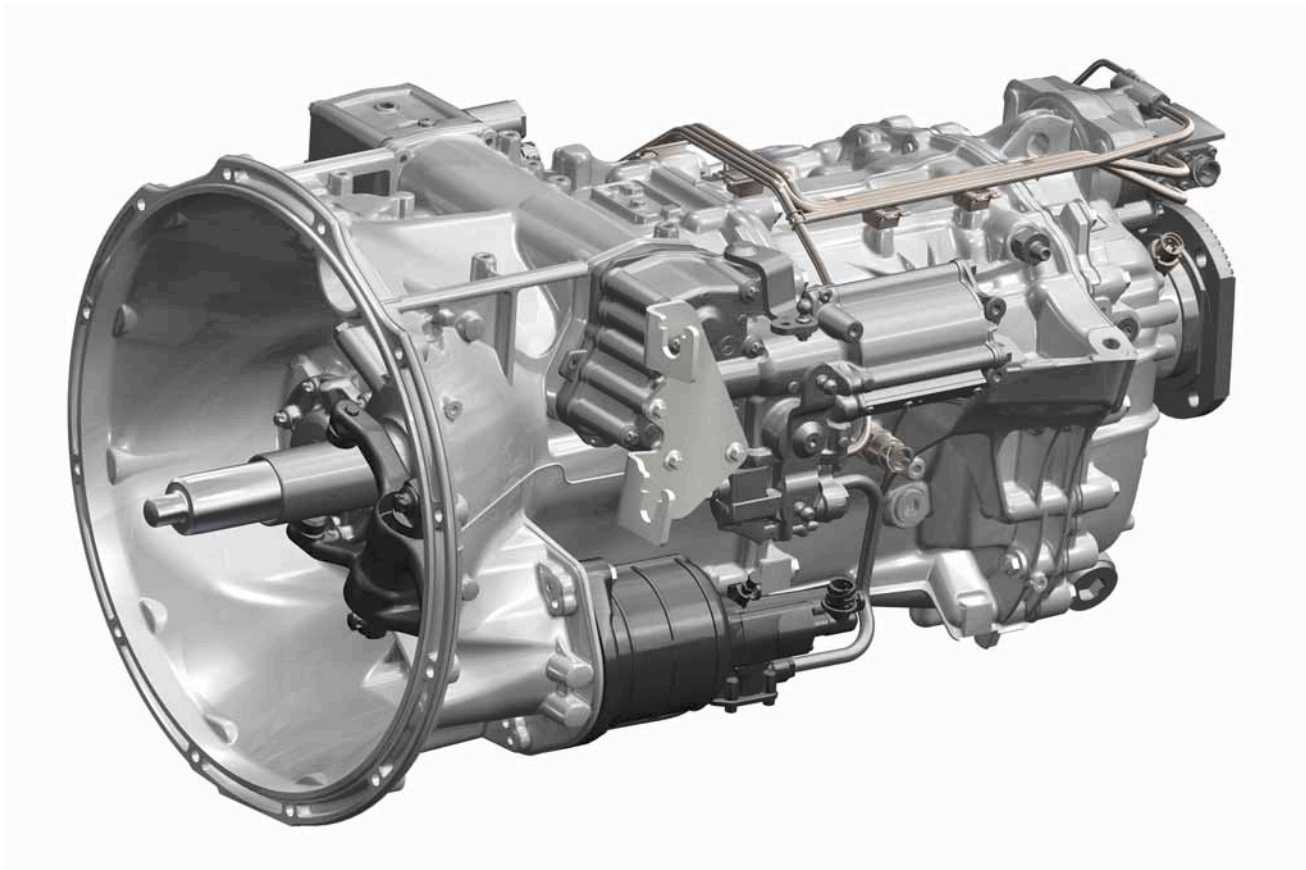

*Transmission G 141-9 (G1F)*

W26.10-1156-00

### Transmission G 230-16/G 231-16/ G 260-16

The new 16-speed transmissions G 230-16 (G1H), G 231-16 (G1I) and G 260-16 (G1J) are manually shifted synchromesh transmissions with 16 forward and 2 reverse gears. They consist of a 4-speed main transmission with splitter group and range group. All the transmissions feature a cable shift and pneumatic shift force and clutching assistance.

The transmissions can be connected to power take-offs up to 2000 Nm, also combined with a secondary water retarder.

#### G 230-16 (G1H)

Overdrive transmission with gear ratio spread of 14.17-0.83, maximum input torque = 2300 Nm.

#### G 231-16 (G1I)

Direct drive transmission with gear ratio spread of 17.03-1.00, maximum input torque = 2300 Nm.

#### G 260-16 (G1J)

Dual overdrive transmission with gear ratio spread of 11.72-0.69, maximum input torque = 2600 Nm. The G 260-16 is suitable for higher gross combination weights.



W26.60-1302-00

*Shift unit*

## Transmission data

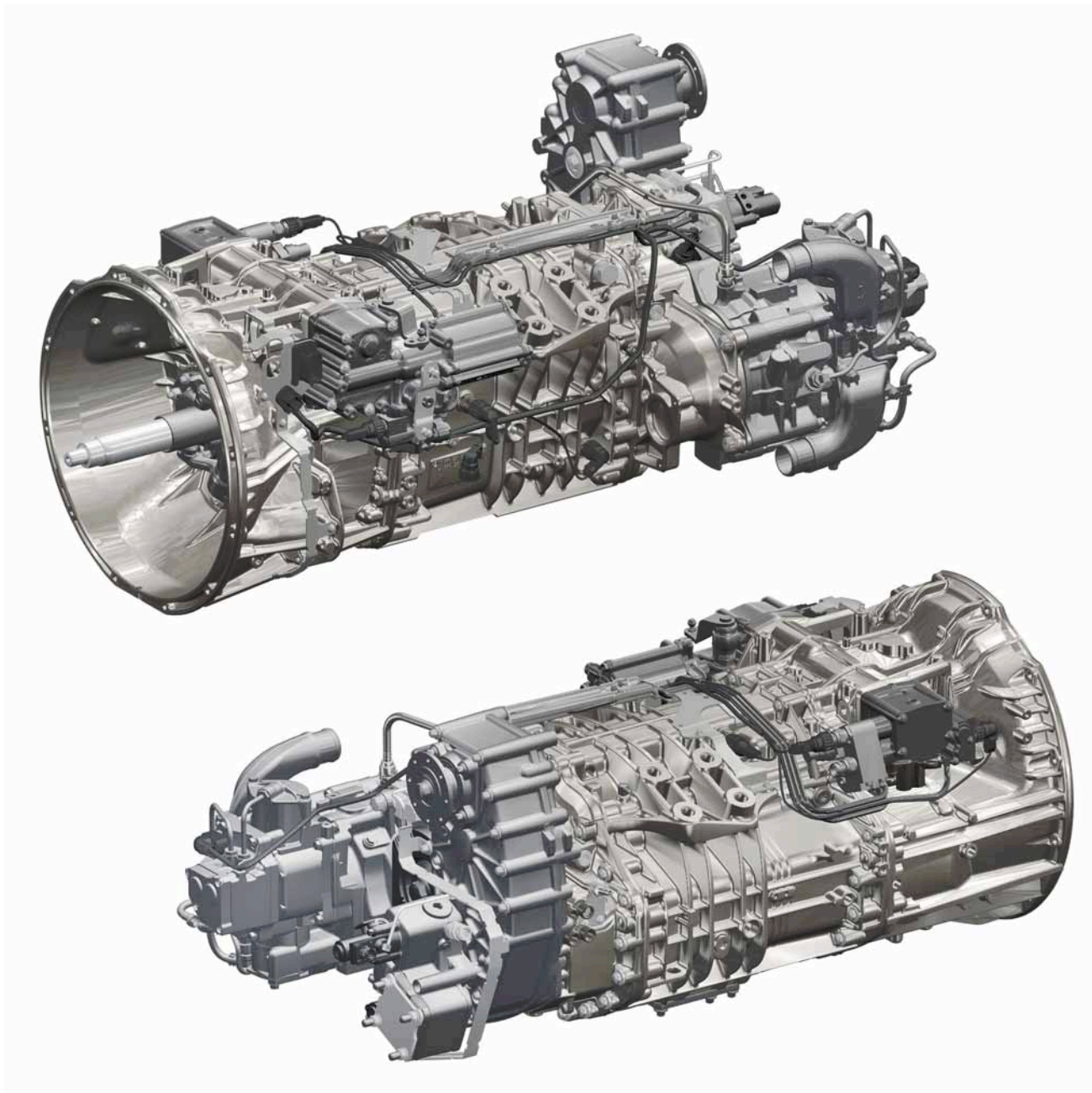

W26.10-1155-00

***Transmission G 260-16 with secondary water retarder (B3H) and DNA MB 135-11b/2c dual power take-off (N4L)***

## Transmission data

Designation	G 141-9	G 230-16	G 231-16	G 260-16
Version	Direct drive	Single overdrive	Direct drive	Dual overdrive
Code	G1F	G1H	G1I	G1J
Model designation	715.571	715.508	715.518	715.528
Nominal input torque (Nm)	1400	2300	2300	2600
1st gear	14.57 (crawler)	14.17	17.03	11.72
2nd gear	9.48	11.73	14.18	9.75
3rd gear	6.63	9.58	11.50	7.92
4th gear	4.82	7.92	9.58	6.58
5th gear	3.67	6.50	7.79	5.29
6th gear	2.58	5.37	6.49	4.40
7th gear	1.81	4.40	5.28	3.64
8th gear	1.31	3.64	4.40	3.02
9th gear	1.00	3.22	3.87	2.66
10th gear	-	2.66	3.22	2.21
11th gear	-	2.18	2.61	1.80
12th gear	-	1.78	2.17	1.48
13th gear	-	1.48	1.77	1.208
14th gear	-	1.22	1.47	1.00
15th gear	-	1.00	1.20	0.83
16th gear	-	0.83	1.00	0.69
1st reverse gear	13.86	12.90	15.48	10.66
2nd reverse gear	-	10.66	12.89	8.86
iTot. (ratio spread)	14.57	17.17	17.03	16.99
Weight (kg)	215	290	290	294
Oil filling capacity (l)	11	14	14	14



## Gearshift, manual (G5H)

### General

In combination with the optionally available transmissions G 141-9, G 230-16, G 231-16 and G 260-16, the new Arocs features a newly developed cable shift system (Cable Power Shift (CPS)).

CPS is a manual shift system with manual power transmission of the shift and selector command from the driver to the transmission over a shift and selector cable. An additional power-assisted gear shifting function reduces the control forces that need to be applied.

The cables mean that driveline vibrations are not transmitted to the gearshift lever. Together with the power-assisted gear shifting function the new shift system provides car-like comfort with short shift travel and low control forces.

In the cab the manual shift consists of the shift unit mounted on the engine tunnel which transmits the driver's shift command over two cables to the shift mechanism at the transmission.

The armored cables can transmit both pull and push forces.

The manual shift is only available in cabs with a width of 2300 mm and not in vehicles with flat cab floor.

In semitrailer tractors the manual shift cannot be combined with the secondary water retarder (B3H) or the hazardous goods package (ADR).



W26.10-1151-00

*Overview of cable shift (illustrated on the 6x4 dumper)*

## Shift unit and cables

The shift unit essentially comprises a base housing, the moving gearshift lever and several detent and return mechanisms.

The shift gate is designed as a double H shift. The splitter group switch (S24) at the front of the gearshift lever shifts the splitter group in the 16-speed transmissions.

The shift unit has 3 detents for the gearshift lever for "even gear", "odd gear" and "neutral".

There are no detents for the gate selection. This attached return spring holds the lever in the default position (gate 3/4 or 5/6) or guides it back to this position.

The cables transmit the shift command and shift forces from the driver to the transmission. The two cables are the "shift cable" (for the gear selection) and the "selector cable" (for the gate selection). No adjustment work is necessary because the connection pieces of the shift and selector cables compensate for component tolerances.

The connections at both ends of the cables are fitted with elastomer elements to decouple shocks and improve haptic feedback.

**i Note**

The cables must be attached to the shift unit in a specified sequence; instructions can be found in the current WIS literature.

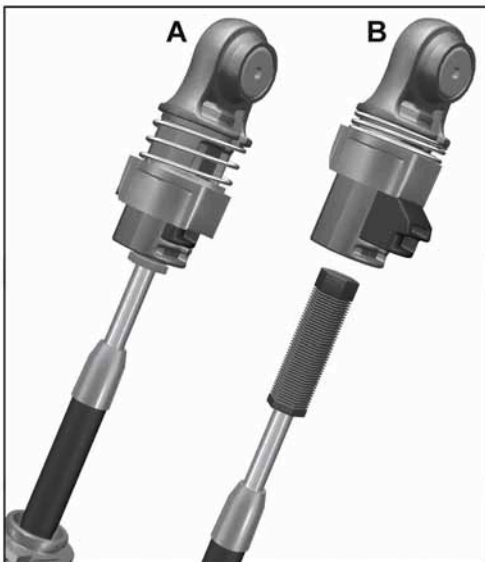

W26.10-1152-00

### Shift unit

- 1 Shift cable
- 2 Shift cable connection piece
- 3 Selector cable
- 4 Selector cable connection piece

S24 Splitter group switch

- A Connection piece locked
- B Connection piece unlocked

## Gearshift, manual (G5H)

### Power-assisted gear shifting (SKU)

The power-assisted gear shifting system ensures that the control forces of the gearshift lever remain consistently low.

It consists of a dual action pneumatic cylinder and control valves that are actuated by the shift cable.

If the SKU fails, the manual shift remains capable of shifting the transmission in an emergency.

The SKU is not activated if the clutch is not fully operated or if the engine speed is too high.

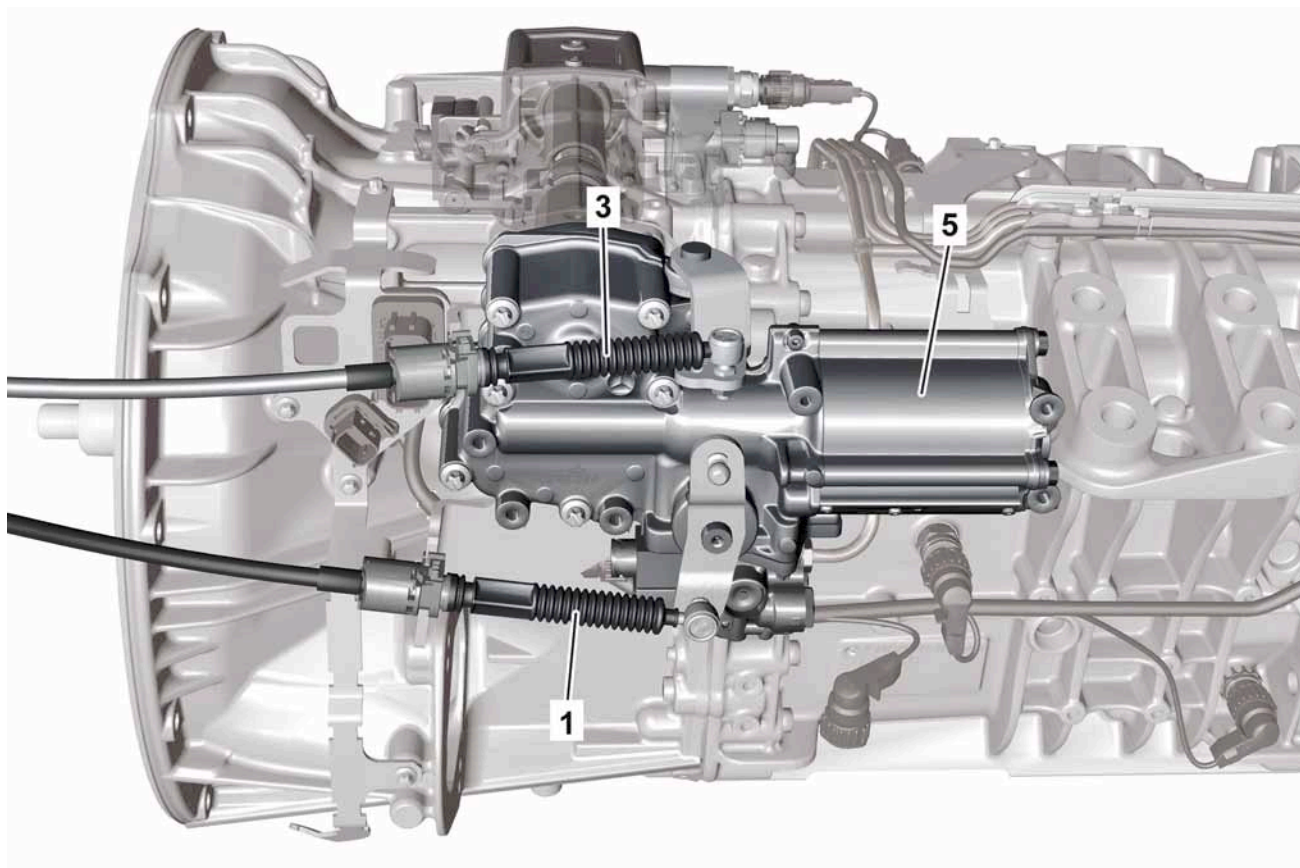

W26.10-1153-00

#### **SKU unit on transmission**

- 1 Shift cable
- 3 Selector cable
- 5 Power-assisted gear shifting pneumatic cylinder

### "power" transmission mode (GOV)

The "power" transmission mode (GOV) familiar from the new Actros and Antos is standard equipment in the Arocs with automated manual transmission. In "power" mode the shift operations are performed at an engine speed that is 100 rpm higher than in EcoRoll mode. However, the shift rpm is only increased if a corresponding torque is demanded.

### "offroad" transmission mode (GOW)

The "offroad" transmission mode (GOW) is standard in all AWD vehicles and optional in the vehicles without all-wheel drive. In "offroad" mode the shift operations are performed at an engine speed that is 100 rpm higher, regardless of the torque demanded. This enables power-oriented, dynamic driving at higher engine speeds and better utilization of the engine braking effect.

In addition to the "power" and "offroad" modes, the following new transmission modes are available for the new Arocs:

- **"fire-service" (GOX):** Special equipment for fire-fighting vehicles
- **"heavy" (GOY):** Standard in vehicles with turbo retarder coupling (G3Y) and preinstallation for heavy-duty trucks (V9A)
- **"municipal" (GOS):** Special equipment for municipal vehicles



W54.32-1034-00

*"offroad" transmission mode display in the multifunction display*

#### **i** Note

"heavy" mode will be available from 11/2013.

"municipal" mode will be available from 11/2014.



## Transmission modes

### Overview of new transmission modes

Code	Name	Description
G0W	offroad	<p>Standard in AWD vehicles</p> <p>Start-off always in 1st gear, upshifts only ever by one gear</p> <p>Upshifts only at 100 rpm higher engine speed</p> <p>Specially adapted for GCWs up to max. 32 t</p> <p>EcoRoll is deactivated in offroad mode</p> <p>When the ignition is switched on, the most recently selected mode is activated</p>
G0X	fire-service	<p>Shifts only at higher rpm for optimum acceleration</p> <p>Meets acceleration provisions for fire-fighting vehicles as per DIN 1846-2 (not for airport fire engines)</p> <p>When the ignition is switched on, the fire-service transmission mode is always activated</p>
G0Y	heavy	<p>Only in combination with the optional turbo retarder coupling (G3Y), OM 473 and transmission G 280-16 (G2D) and preinstallation for heavy-duty trucks (V9A)</p> <p>Designed for high torque to manage loads up to 250 t</p> <p>Late upshifting for maximum possible power</p> <p>Quick gearchanges for shortest possible power interruptions</p> <p>When the ignition is switched on, the most recently selected mode is activated</p>
G0S	municipal	<p>Available as of 11/2014, only for solo vehicles with OM 936 and OM 470</p>



Assignment of transmission modes to transmissions					
Transmission	Transmission mode				
	G0W	G0V	G0X	G0S	G0Y
	offroad	power	fire-service	municipal	heavy
G 140-8	X	S	X	X	–
G 140-8 AWD	S	–	X	–	–
G 211-12	X	S	X	X	–
G 211-12 AWD	S	–	X	–	–
G 230-12	X	S	X	X	–
G 230-12 AWD	S	–	X	–	–
G 281-12	X	S	X	–	–
G 330-12	X	S	X	–	–
G 330-12 AWD	S	–	–	–	–
G 280-16	X	S	–	–	–
G 280-16 AWD	S	–	–	–	–
G 280-16 with turbo retarder coupling (G3Y) and heavy-duty truck (SLT) option (V9A)	–	–	–	–	S

S = standard; X = special equipment

## Power take-off

### General

An extensive range of transmission-driven power take-offs is offered for the new Arocs.

On all-wheel drive vehicles only the NA 125 can be used, because all the other PTOs have the propeller shaft flange in front of the transfer case. It is therefore impossible to attach a propeller shaft.

### Power take-off NA 135

The new NA 135 power take-off has the same power and gear ratios as the familiar NA 125. However, in order to cater for the modified drivetrain length in the new Actros, Antos and Arocs, the propeller shaft flange on the NA 135 is located approx. 70 mm higher.

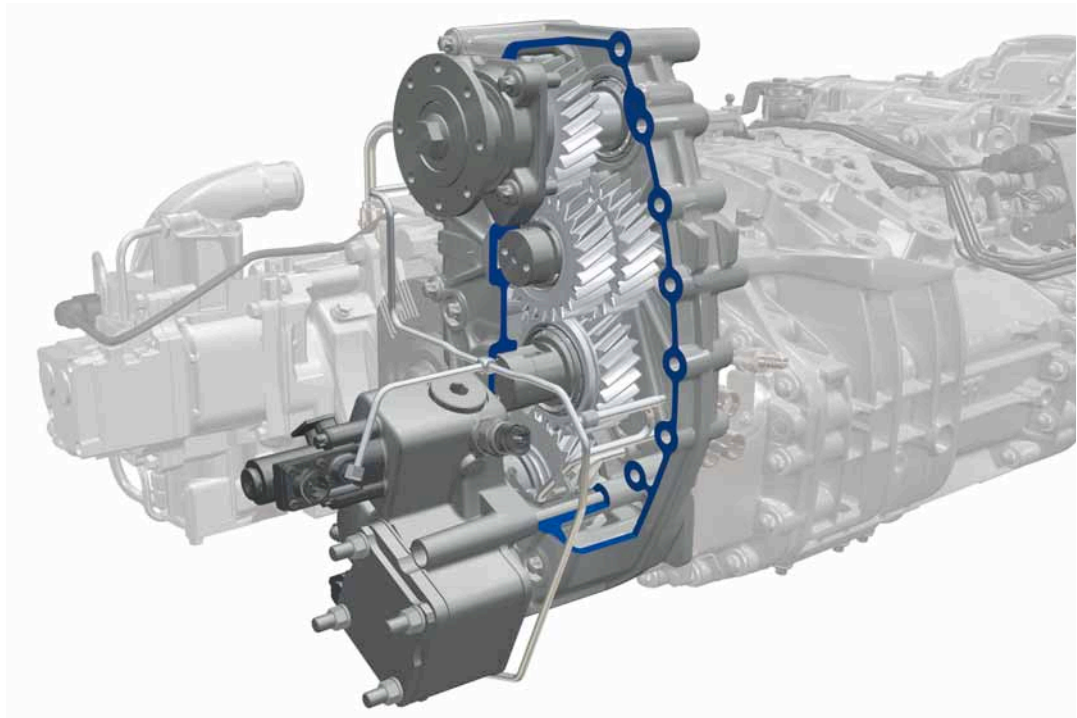

*DNA MB 135-11b/2c, flange + MPA*

W26.45-1342-00

### Overview of NA 135 power take-offs

Code	Name	i
N1X	NA MB 135-10b, flange, L speed	1.32
N1Y	NA MB 135-10b, flange, M speed	1.77
N1Z	NA MB 135-10b, flange, H speed	2.60
N4L	DNA MB 135-11b/2c, flange + MPA, L speed	1.32
N4M	DNA MB 135-11b/2c, flange + MPA, M speed	1.77
N4N	DNA MB 135-11b/2c, flange + MPA, H speed	2.60

**Live power take-off (NMV)**

The entirely redeveloped live PTO is located above the clutch housing and can transfer torques of 2000 – 3000 Nm.

It is available in 2 ratios (1.65 and 1.2) and is designed for continuous operation.

The clutch-dependent variant is driven by the transmission input shaft and can only be operated while stationary; the transmission is locked in the neutral position by an interlock.

The semi-clutch-dependent variant has 2 input shafts, a drive shaft for the transmission and a hollow shaft for the live PTO. It is then possible to drive with the NMV running, although it is not possible to activate the semi-clutch-dependent NMV while driving.

The power consumption of the NMV is limited to 1100 Nm when the vehicle is moving.



W27.45-1017-00

**Live power take-off (NMV)**

Overview of live PTOs	
Code	Power take-offs
N4Z	NMV, clutch-dependent, MB, 1.65
N4Y	NMV, clutch-dependent, MB, 1.2
N4X	NMV, semi-clutch-dependent, MB, 1.65
N4W	NMV, semi-clutch-dependent, MB, 1.2
Code	Flange
N9U	PTO flange, cross geared, D=120 mm
N9W	PTO flange, cross geared, D=150 mm
N9V	PTO flange, cross geared, D=180 mm
N9S	PTO flange, smooth, D=150 mm
Code	Transmission lock
N6L	Live PTO transmission lock

## Transmission overview

Three different transfer cases are available for the new Arocs depending on its operating conditions and engine variant.

An oil cooler for the transfer case (G4Z) is available as an option.



W28.10-1081-00

**VG 3000-3W/1.04 (G4E)**

### Transfer case VG 1600-3W/1.42-1.04 (G4C)

The transfer case with permanent all-wheel drive is only available for engine OM 936.

- Max. input torque: 1600 Nm
- Road step-down ratio: 1.04
- Offroad step-down ratio: 1.42

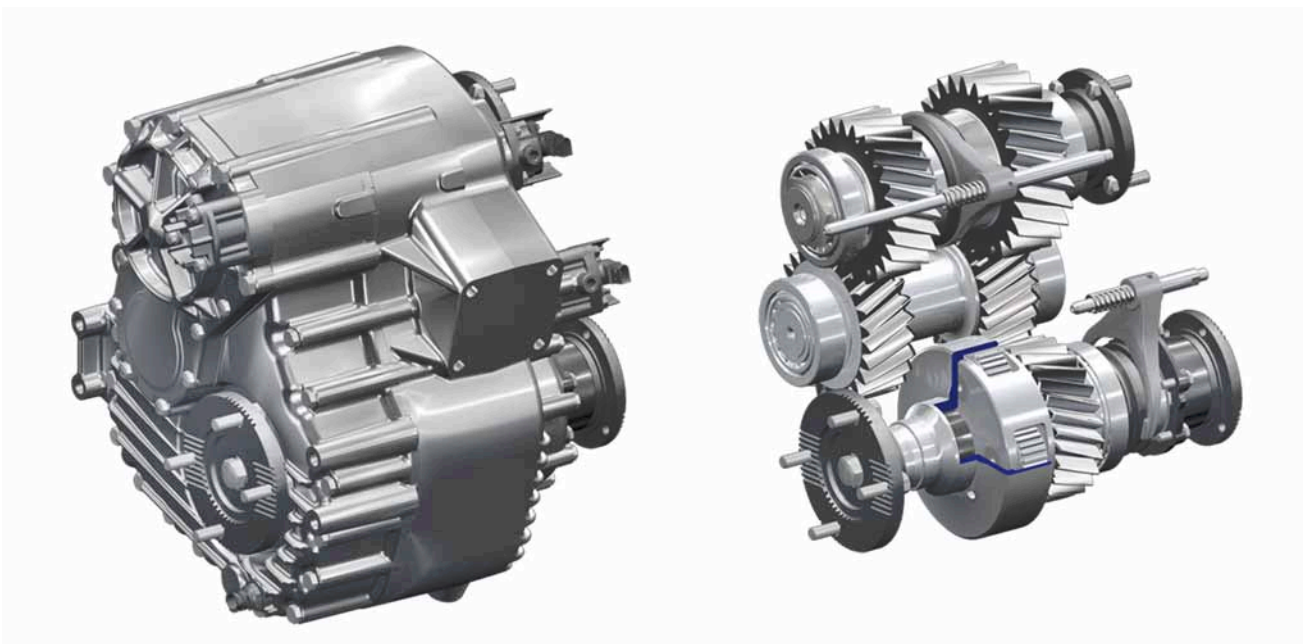

W28.10-1078-00



### Transfer case VG 2800-3W/1.45-1.04 (G4D)

The transfer case with permanent all-wheel drive is only available for engines OM 470, 471 and 473.

- Max. input torque: 2800 Nm
- Road step-down ratio: 1.04
- Offroad step-down ratio: 1.45

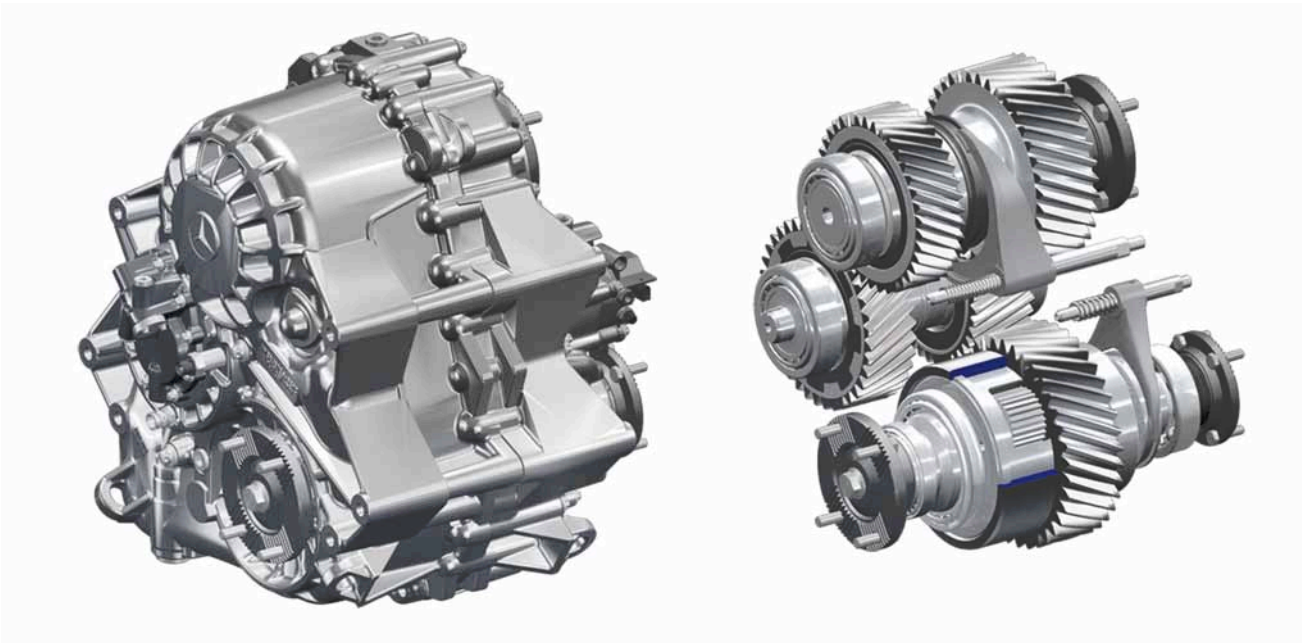

W28.10-1079-00

### Transfer case VG 3000-3W/1.04 (G4E)

The transfer case with engageable all-wheel drive and without an offroad step-down ratio is offered for all engine variants.

- Max. input torque: 3000 Nm
- Road step-down ratio: 1.04

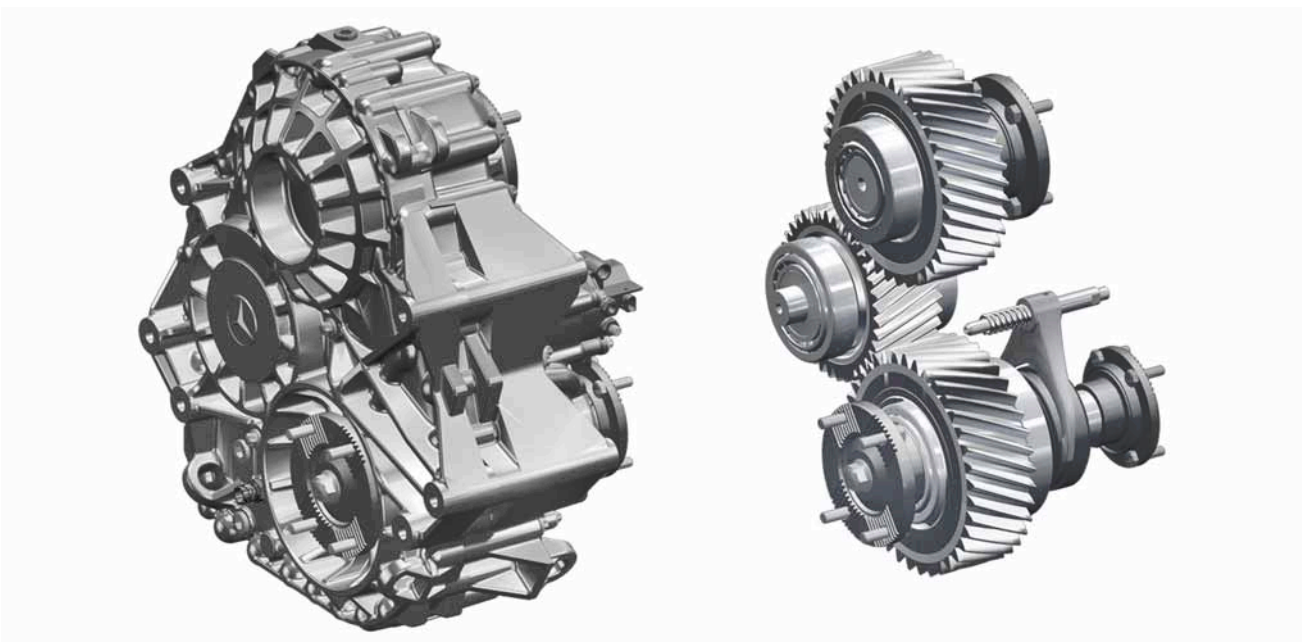

W28.10-1080-00



## General

For the first time the Hydraulic Auxiliary Drive (HAD) for the front axle is available for models 963 and 964.

In this system the front axle is fitted with hydraulically powered wheel hub motors which are supplied by a high-pressure pump mounted on the rear of the engine.

Together with the automated manual transmission (including those with secondary water retarder and the transmission power take-offs NA 121, NA 123 and NA 131), traction can be achieved on slippery ground without interrupting the powertrain.

The HAD is available for the following vehicles:

- Model 963 4x2 with engine 471 (late 2014)
- Model 964 4x2 with engine 471 (early 2015)
- Model 963/964 6x2/6x4 with engine 470/471 (mid-2014)

The HAD is a starting-off aid, not a continuous drive system. Depending on the drivetrain configuration, the HAD can be used in the first 5 gears up to a speed of approx. 30 km/h.

It should be noted, however, that the system is designed for a total operating time of 5% of the vehicle's mileage.

The HAD is a torque-controlled system that sets the optimum drive torque at the front axle according to the driving situation. To do this, the system establishes whether a torque is necessary at the front axle, and regulates the distribution of torque between the front and rear axles automatically and independently of the driver. Compared to a conventionally powered all-wheel drive vehicle with transfer case, the HAD provides a weight advantage of up to 340 kg and can also be used with a EURO trailer.

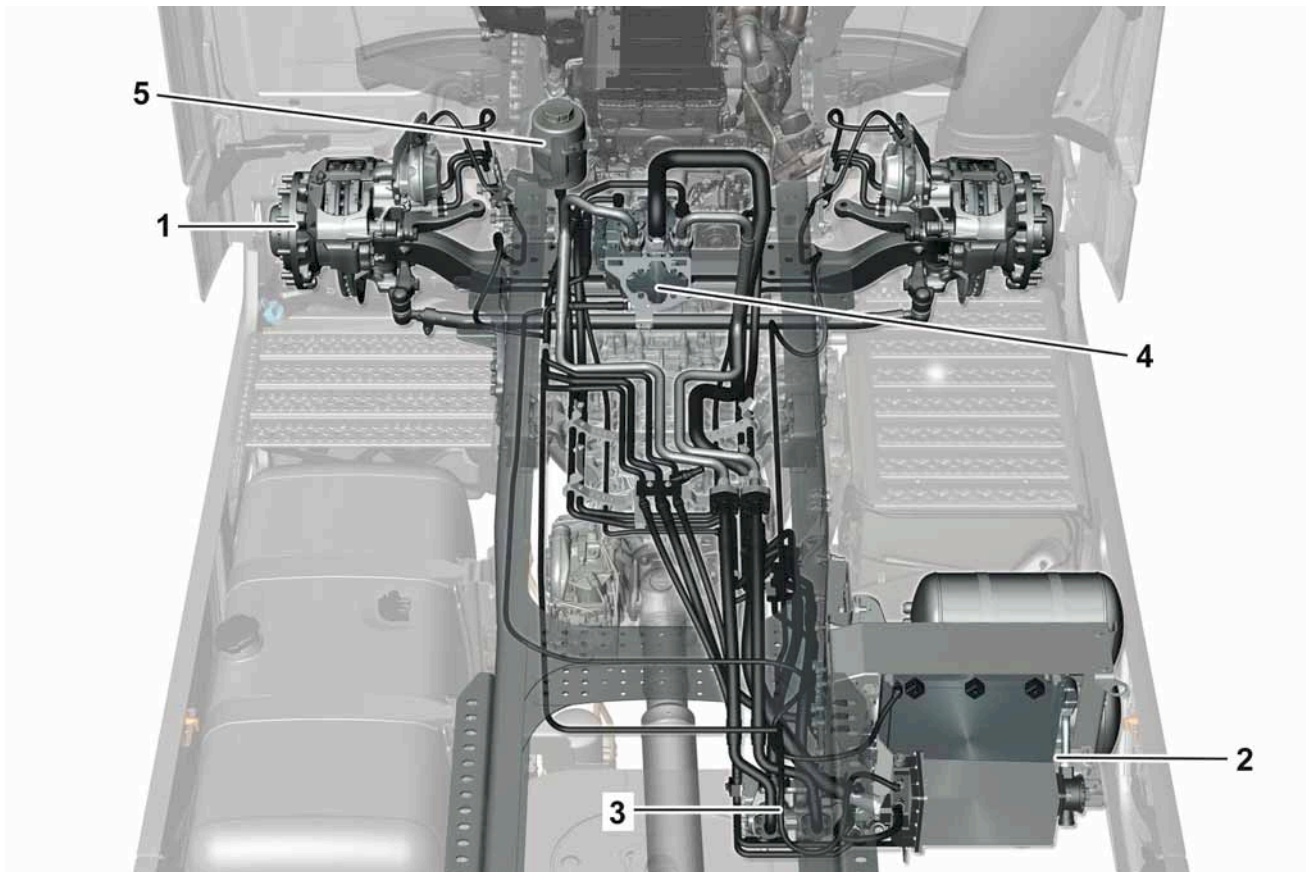

W55.90-1000-00

**Overview of HAD system components**

- |                       |                       |
|-----------------------|-----------------------|
| 1 Front axle          | 4 High-pressure pump  |
| 2 Side module         | 5 Expansion reservoir |
| 3 Valve control block |                       |

## Front axle

### Front axle model designation 739.578

The front axle corresponds to the non-driven steel-sprung front axle with disk brakes and is available with 2 drops (130/5 and 70/10).

The steering knuckle and the wheel head have been redeveloped in order to integrate the wheel hub motors and the feed line for the hydraulic fluid.

The wheel hub motors are supplied with hydraulic fluid directly via the axle journals and spindles. This means that the hose lines only need to compensate for the motion of the springs (flexing) and not for steering movements (torsion), which increases the service life and reliability of the system.

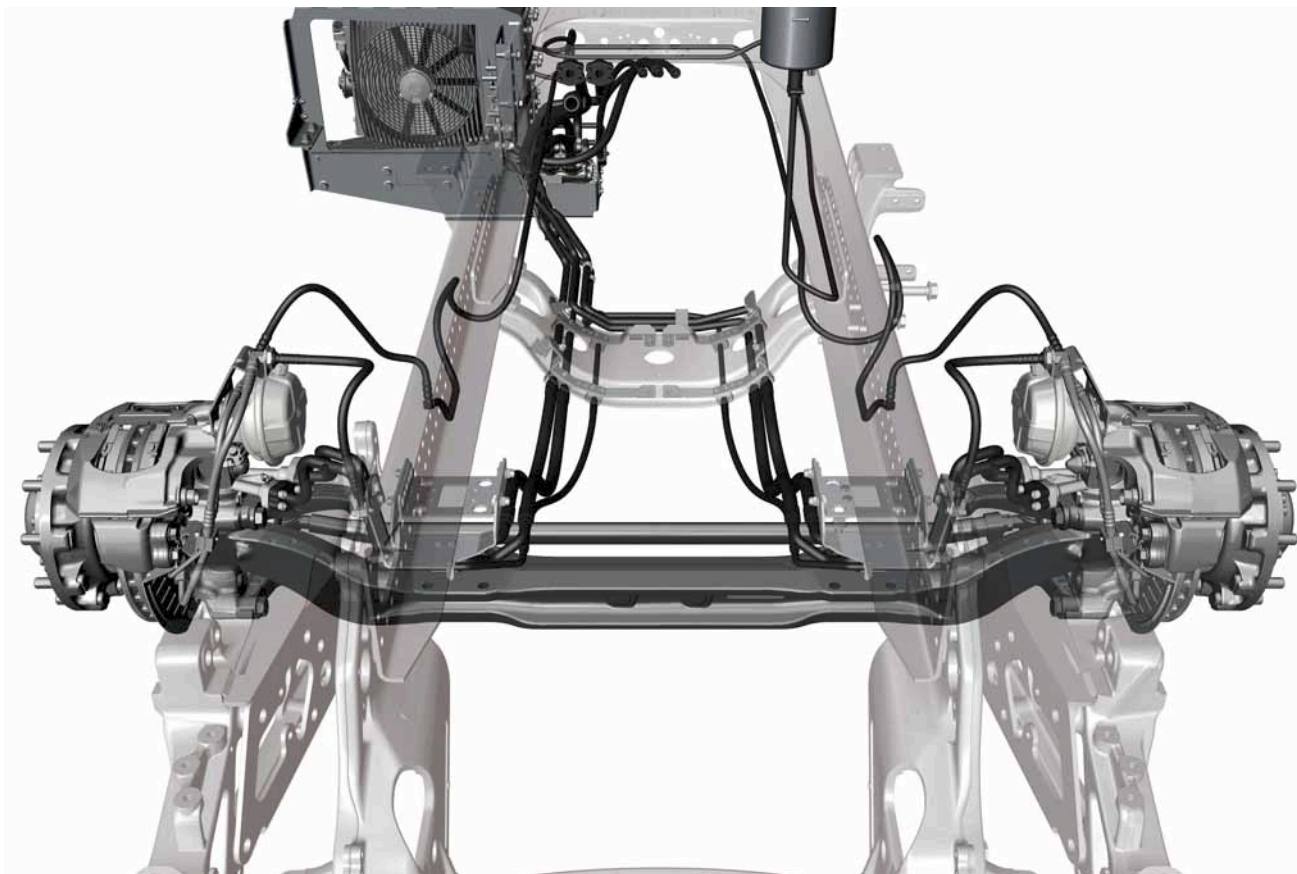

W55.90-1001-00

*Overview of front axle with wheel hub motors*

### High-pressure pump

The hydraulic pressure and volumetric flow required to drive the wheel hub motors are produced by a high-pressure pump. The high-pressure pump is located on a modified timing case beside the power steering pump. On engine OM 470 the rear PTO is not installed.

The high-pressure pump delivers a volumetric flow of up to 350 l/min. The power output of the high-pressure pump is 112 kW, of which 40 kW is available to each wheel hub motor.

At a maximum pump pressure of  $p = 420$  bar, a torque of up to 12500 Nm can be built up at the front axle.

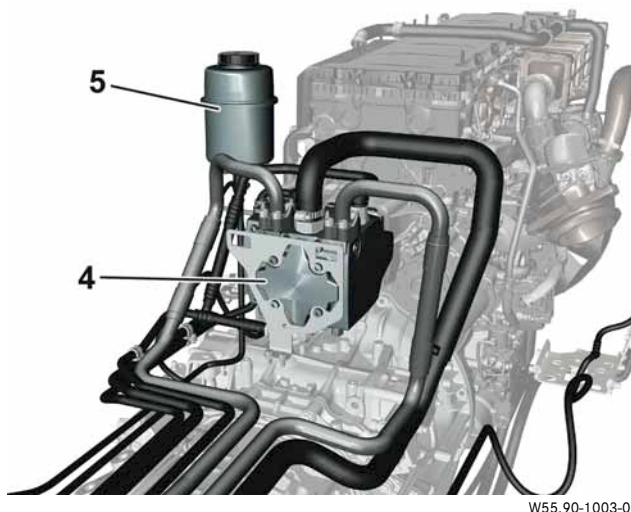

W55.90-1003-00

- 4 High-pressure pump
- 5 Expansion reservoir

### Side module

The side module is attached to the right side of the frame. It consists of:

- Hydraulic fluid cooler with fan
- Hydraulic fluid tank
- Hydraulic fluid filter
- Control block

The HAD is controlled via the transmission control module (TCM) (A5). The transmission control module (TCM) transmits the control parameters to the Hydraulic Auxiliary Drive (HAD) control unit (A83), which actuates the hydraulic pump, the control block and the fan in the cooling module.

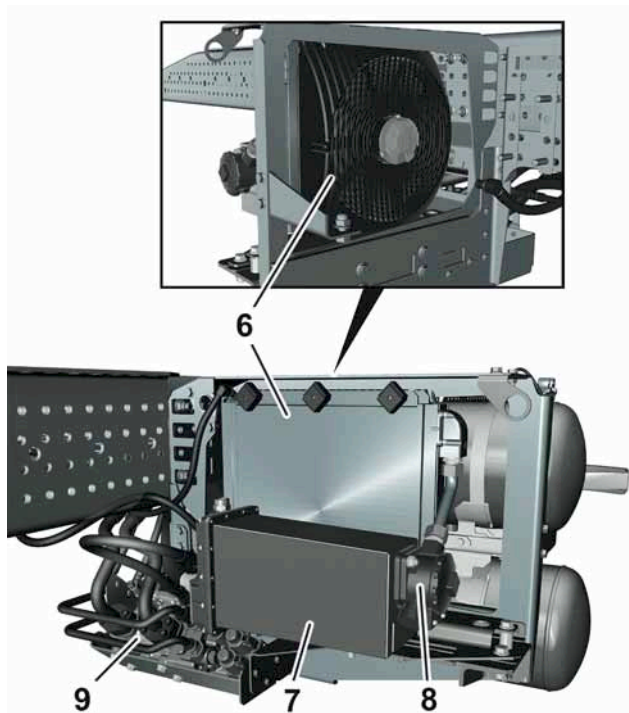

W55.90-1002-00

- 6 Hydraulic fluid cooler with fan
- 7 Hydraulic fluid tank
- 8 Hydraulic fluid filter
- 9 Control block

#### **i** Note

Information on the HAD system is stored in WIS under the function (sub-) group 55.90.

## Frame

### General

Two different frames are used for the new Arocs depending on the field of application. Both start at the front with a uniform width of 900 mm (outside edges of longitudinal frame members), while the rear section is made in two different widths for air-sprung and steel-sprung vehicles:

- 834 mm for air-sprung vehicles used primarily for on-road operations
- 744 mm for steel-sprung vehicles operated primarily on construction sites and offroad

The frame of the air-sprung Arocs (model 964) has the same dimensions as the frames of the Actros and Antos (model 963), but it is designed to be more torsionally flexible through various measures aimed at improving its offroad capabilities.

The frame of the steel-sprung Arocs is designed to be even more flexible to enable all the wheels to touch the ground even on very rugged terrain.

The front axle of model 964 is 100 mm further back than on model 963 in order to allow large tires to be fitted.

The range of wheelbases for the new Arocs has been expanded significantly, so much longer and much shorter wheelbases are available than for the successful Actros construction vehicle. The wheelbase and rear frame overhang are variable at 300 mm intervals.

Body mounting options are assisted by a full-length 50 x 50 mm hole grid in the frame and application-specific attaching parts for flatbeds (C5I), dumper beds (C5J) and concrete mixers (C5K), or the shear-resistant mounting parts (C5H).

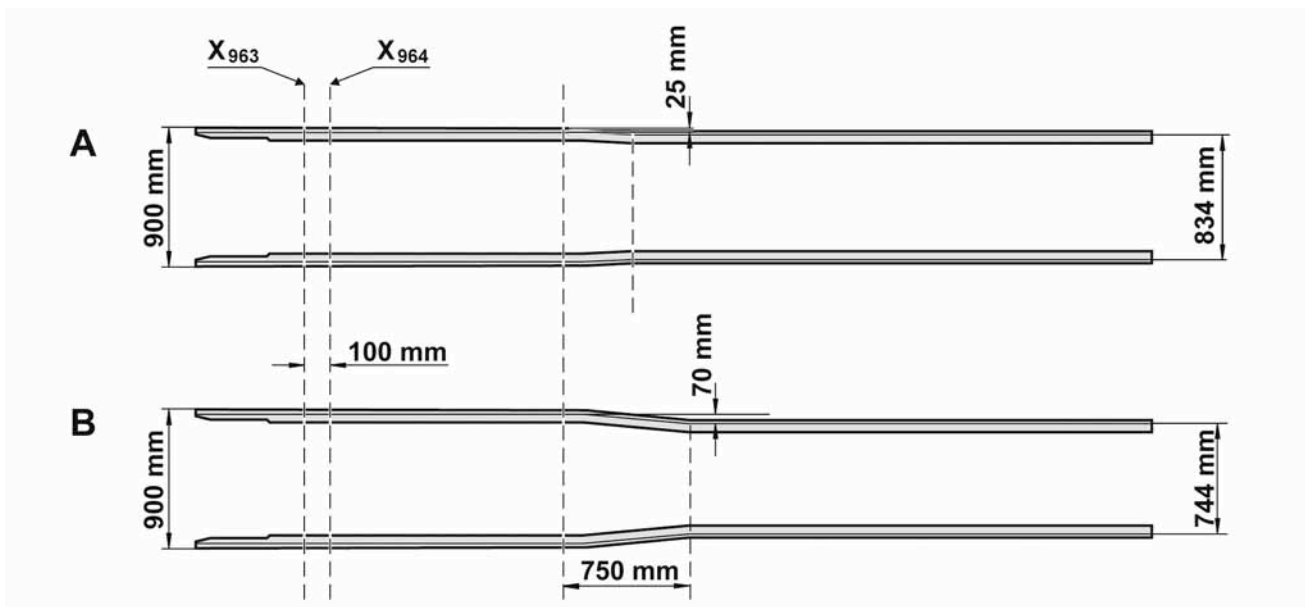

W31.10-1092-00

#### Frame with air and steel suspension

A Frame with air suspension

B Frame with steel suspension

X<sub>963</sub> Position of front axle on model 963

X<sub>964</sub> Position of front axle on model 964



### **Bumper, center section with towing eyes, coupling jaw (F7D)**

All Arocs are fitted as standard with a front bumper with coupling jaw; the exception is the 8x2/4 VLA/DNA.

For safe maneuvering of trailers, a Duo-Matic trailer brake connection at the front (B5M) is available for all Arocs vehicles with front coupling jaw, although not in combination with the guard plate under the bumper (M7J) and concrete mixers.



W31.10-1030-00

***Bumper, center section with towing eyes, coupling jaw (F7D)***

### **Frame clearances**

The different frame clearances presented in the Introduction into Service manual for the Antos will also be available for the Arocs. The planned production breakpoint is 08/2013. When the new Arocs is launched, other combination options for the Actros and Antos will also be approved.

Due to the wide variety of different model designations and wheelbases, an overview of the possible clearances cannot be given here.

## Axles

### Non-driven front axles

In order to guarantee the necessary ground clearances in construction and offroad operations, the Arocs is usually fitted with straight front axles with a drop of 15 + 10 or 60 + 10. These provide 55 mm and 100 mm more ground clearance respectively than the axle with a drop of 120 + 5 that is used in the Actros and Antos.



W33.10-1023-00

*Front axle with drum brakes*

### Wheel hub with compact bearing on front axles with drum brakes

In contrast to the Actros or Antos, the front axles for the new Arocs are also available with drum brakes. This variant features a newly designed wheel hub with compact bearing.

This makes the hub lighter and easier to maintain; adjustment of the wheel bearing is unnecessary.

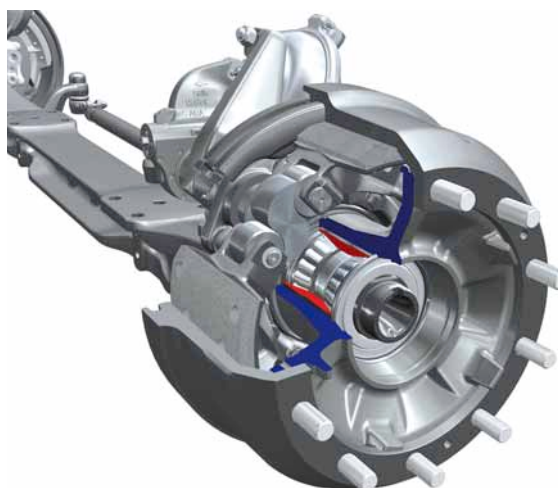

W33.20-1049-00

*Wheel hub with compact bearing*

### Driven front axle on all-wheel drive vehicles

The all-wheel drive vehicles are fitted with the planetary hub reduction axles familiar from the successful Actros with a ring gear diameter of 233 mm.

The front axle is only available with drum brakes as a 7.5 t and 9 t variant; the 9 t variant is also available with through-drive for operation as a 2nd front axle on 8x8 vehicles.

The ground clearance under the differential is about 347 mm with 315/80 R22.5 tires.

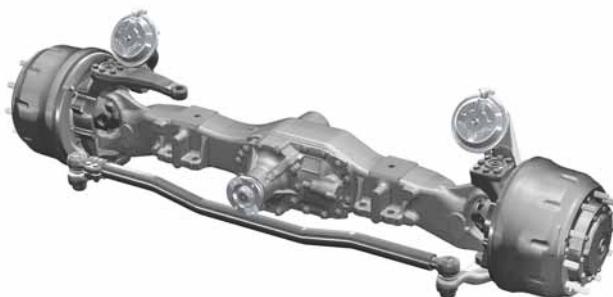

W33.35-1002-00

*Front planetary hub reduction axle*

## Overview of straight front axles

Code	Name	Model designation	Designation	Drop [mm]	Remarks	
A1C A1D	Front axle 7.5 t Front axle 8.0 t	730.516 (1st FA) 730.517 (2nd FA)	F - 8.0 / C 22.5	60 + 10	Disk brakes	
A1E	Front axle 9.0 t	730.566 (1st FA) 730.567 (2nd FA)	F - 9.0 / C 22.5			
A1C A1D	Front axle 7.5 t Front axle 8.0 t	730.508 (1st FA) 730.509 (2nd FA)	F - 8.0 / C 22.5	15 + 10		
A1E	Front axle 9.0 t	730.526 (1st FA) 730.527 (2nd FA)	F - 9.0 / C 22.5			
A1C A1D	Front axle 7.5 t Front axle 8.0 t	730.514 (1st FA) 730.515 (2nd FA)	F - 8.0 / S 22.5	60 + 10		Drum brakes
A1E	Front axle 9.0 t	730.564 (1st FA) 730.565 (2nd FA)	F - 9.0 / S 22.5			
A1C A1D	Front axle 7.5 t Front axle 8.0 t	730.506 (1st FA) 730.507 (2nd FA)	F - 8.0 / S 22.5	15 + 10		
A1E	Front axle 9.0 t	730.568 (1st FA) 730.569 (2nd FA)	F - 9.0 / S 22.5			

## Overview of front planetary hub reduction

Code	Name	Model designation	Designation	Remarks
A1C	Front axle, ring gear 233, planet gears, 7.5 t	730.150	FD 233 P - 7.5 / S 22.5	Drum brakes
A1E	Front axle, ring gear 233, planet gears, 9.0 t	730.151 (1st FA) 730.152 (2nd FA)	FD 233 P - 9.0 / S 22.5	

## Axles

### Axle drop

In order to ensure that the ground clearance of the new Arocs can be properly adapted to its operating conditions, the front axle can be supplied with a number of different drop measurements. The drop (for example 60 mm + 10 mm) describes the distance from the axle center to the spring contact surface, and then from this surface to the axle beam.

Different drop measurements are only possible on non-driven (dead) front axles, therefore not on all-wheel drive vehicles.



W33.00-1034-00

*Front axle, straight version (A1Y)*

### Front axle, front axle straight, ground clearance increased (A1X)

Drop: 15 mm + 10 mm

Special equipment for the Arocs with steel-sprung rear axle.

Ground clearance with 315/80 R22.5 tires approx. 365 mm.

Not in combination with rear axle, ring gear 390, hypoid, 10.0 t (code A2J) or rear axle, ring gear 390, hypoid, 9.5 t (code A2O).

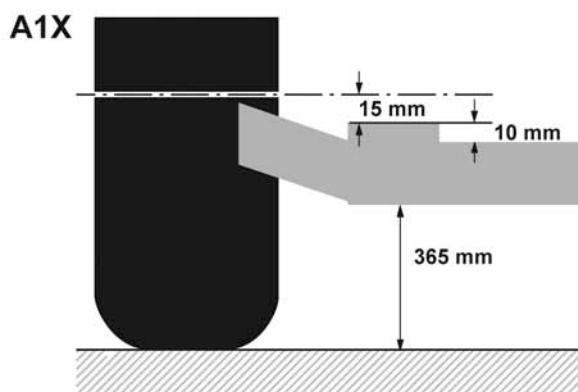

W33.00-1031-00

### Front axle, straight version (A1Y)

Drop: 60 mm + 10 mm

Standard for the Arocs.

Ground clearance with 315/80 R22.5 tires approx. 320 mm. The exact dimension depends on the tonnage of the front axle.

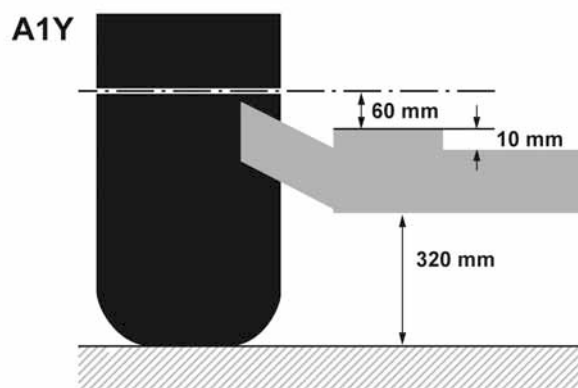

W33.00-1032-00

### Front axle, dropped version (A1Z)

Drop: 120 mm + 5 mm

Standard for all road vehicles (Actros/Antos) and for some air-sprung 4-axle construction vehicles (Arocs).

Ground clearance with 315/80 R22.5 tires approx. 265 mm. The exact dimension depends on the tonnage of the front axle.

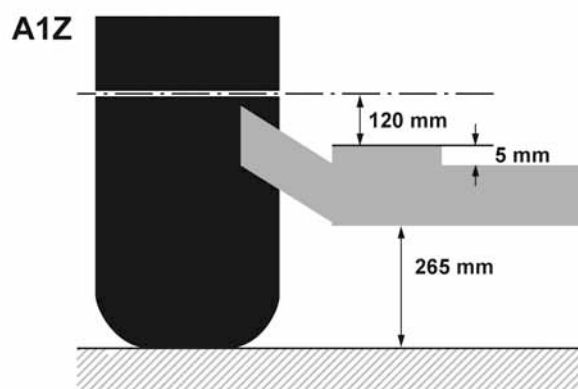

W33.00-1033-00



## Axles

### Rear axle

In addition to the familiar hypoid axles with 390, 440 and 485 mm ring gear diameters and disk brakes, the planetary hub reduction rear axles with drum and disk brakes are also available for the Arocs. Overloadable vehicles and all-wheel drive vehicles can also be fitted with a 16-tonne version of the planetary hub reduction rear axle as special equipment.

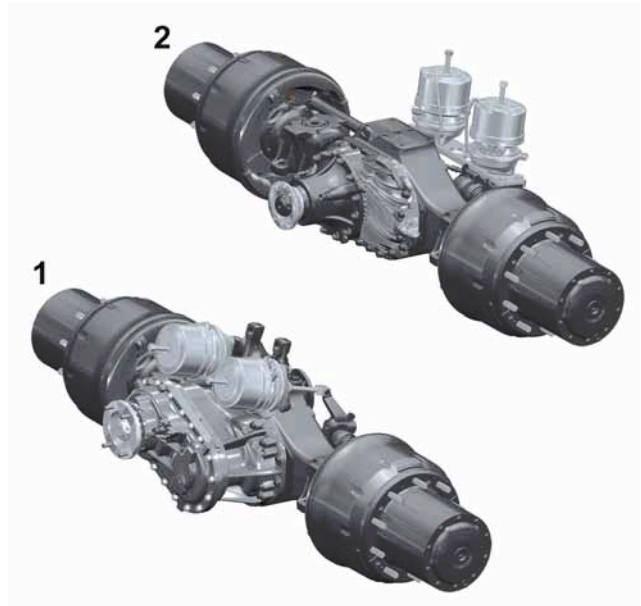

W35.10-1059-00

**Planetary hub reduction rear axles with drum brakes**

- 1 1st rear axle with through-drive
- 2 2nd rear axle

### Rear axle, ring gear 390, hypoid, 9.5 t, single (A20)

The wide 9.5 t rear axle for single 385/55 R 22.5 HA (I2N) or 385/65 R 22.5 HA (I2Q) tires has been developed especially for payload-optimized four-axle vehicles. It is available only in combination with the Loader option (V1Y) and is standard equipment on the 964.330/338 concrete mixers.

Due to its greater track width, it is not possible to convert this axle to twin tires.

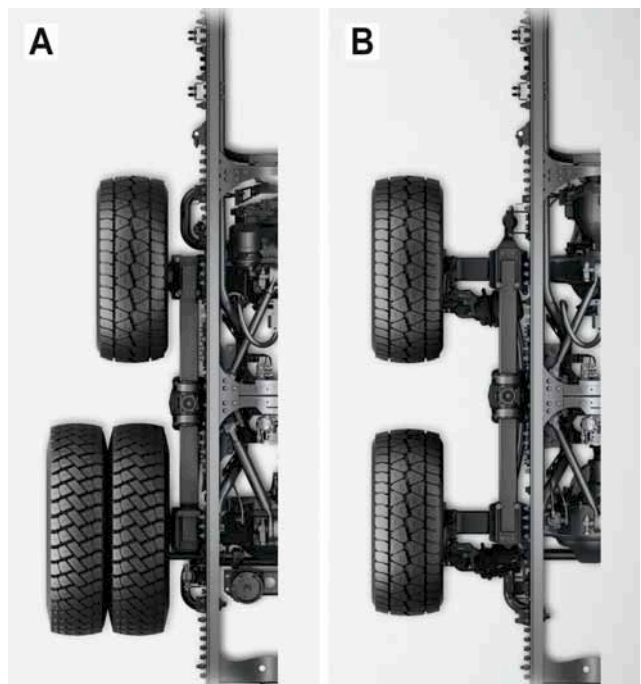

W35.10-1060-00

- A Rear axles for single and twin tires
- B Wide rear axles for single tires

## Overview of driven rear axles for the new Arocs

Code	Name	Model designation	Designation	Remarks
A2J	Rear axle, ring gear 390, hypoid, 10.0 t	771.010	RT 390 - 10 / C 22.5	Disk brakes
		771.011	RT 390 T - 10 / C22.5	
A2O	Rear axle, ring gear 390, hypoid, 9.5 t	771.014	RT 390 - 9.5 / C 22.5	Disk brakes
		771.015	RT 390 T - 9.5 / C22.5	
A2F	Rear axle, ring gear 233, planet gears, 13.0 t	748.280	R 233 P -13 / C 22.5	Disk brakes
		748.281	RT 233 P -13 / C 22.5	
		748.290	R 233 P -13 / S 22.5	Drum brakes
		748.291	RT 233 P -13 / S 22.5	
A2G	Rear axle, ring gear 300, planet gears, 13.0 t	748.282	R 300 P -13 / C 22.5	Disk brakes
		748.283	RT 300 P -13 / C 22.5	
		748.292	R 300 P -13 / S 22.5	Drum brakes
		748.293	RT 300 P -13 / S 22.5	
A2H	Rear axle, ring gear 300, planet gears, 16.0 t	748.294	R 300 P -16 / S 22.5	Drum brakes
		748.295	RT 300 P -16 / S 22.5	
A2E	Rear axle, ring gear 440, hypoid, 13.0 t	746.301	R 440 - 13 A / C 22.5	Disk brakes
		746.302	RT 440 - 13 A / C22.5	
A2I	Rear axle, ring gear 485, hypoid, 13.0 t	748.595	R 485 - 13 A / C 22.5	Disk brakes

## Axles

### Leading axle, 7.5 t, steered, load relief (A4B)

For the first time since the introduction of the Euro IV emissions standard, vehicles with steered leading axle will once again be available ex factory from the end of 2013.

Air-sprung 6x2/4 vehicles of model series 963 and 964 are available as platform trucks or semitrailer tractors. The axle in these vehicles is based on the axle housing of the air-sprung front axle with a drop of 150 mm + 5 mm.

### Trailing axle, 7.5 t, steered, load relief, liftable (A4Y)

The new vehicles in model series 964 include air-sprung 4-axle vehicles with triple axle. Triple-axle trucks are 8x4 vehicles with another single-tire, steered trailing axle behind the two driven rear axles. The triple-axle vehicles are available in platform, dumper and concrete mixer variants (964.x41) and are all fitted with the trailing axle, 7.5 t, steered, load relief, liftable (A4Y) as standard.



W35.50-1102-00

*Triple axle configuration*

Code	Name	Model des.	Designation	Remarks
A4B	Leading axle, 7.5 t, steered, load relief	749.113	M - 7.5 SA / C 22.5	Disk brakes
A4Y	Trailing axle, 7.5 t, steered, load relief, liftable	749.112	T - 7.5 SLA / C 22.5	Disk brakes

## Front springs

The new Arocs has steel-sprung front axles.

The coding for the suspension of 4-axle vehicles is new, as the code now includes the springs for both front axles.

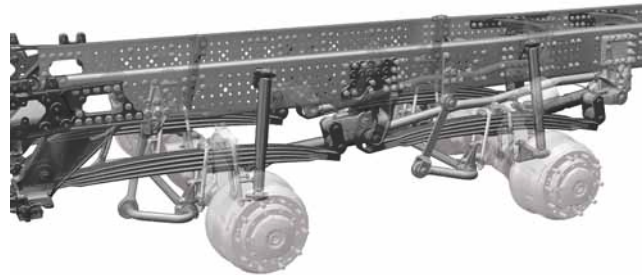

W32.20-1037-00

**Steel suspension with 2 driven front axles**

## Rear springs

In contrast to the Actros and Antos, the Arocs is available with air and steel suspension on the rear axle. The air suspension is the same as on the Actros and Antos. All-wheel drive vehicles are always equipped with planetary hub reduction axles and steel suspension.

The designation of the steel springs has been changed. The new designation refers firstly to the load capacity and secondly to the number of rear axles. The load capacity stated in the designation refers to both springs combined, in other words per axle. On vehicles with 2 driven rear axles, only one spring package is installed on each side in spite of the designation. 2 x 10.0 t means 2 times 10 t load capacity, i.e. a total of 20 t on the rear axles.



W32.20-1036-00

**Steel suspension with 2 driven rear axles**

## Brakes

### General

Apart from disk brakes all round, drum brakes are also available for the Arocs, as well as the combination of disk brakes on the front axle and drum brakes on the rear axle.

The Arocs uses the disk brakes introduced with the new Actros (model 963), while the drum brakes have been adopted from the original Actros (model 93x).

### Disk brakes with partial protection (B2D)

Vehicles for occasional construction site use can be fitted with a cover panel on the brake disk to protect it against excessive soiling. Special equipment for all semitrailer/platform/concrete mixer vehicles (except all-wheel drive vehicles and 8x2/4 VLA/DNA).

### Disk brakes with full protection (B2E)

For all dumpers with disk brakes all round or only on the front axle.

Code B2E contains:

- On the 1st FA: Brake disk cover panel
- On the 2nd FA: Brake disk cover panel, rim without hand holes

For disk brakes on the rear axle, also:

- On the 1st RA: Brake disk cover panel, rim without hand holes, brake cylinder cover panel
- On the 2nd RA: Brake disk cover panel, rim without hand holes, brake cylinder cover panel

### Drum brakes, on FA and RA (B2B)

Standard for all AWD vehicles, special equipment for the Arocs without air-sprung rear axle. Particularly for higher GCWs.

### Disk brakes on FA, drum brakes on RA (B2C)

Special equipment for selected model 964 vehicles. Only in combination with rear axle, ring gear 300, planet gears, 16.0 t (A2H).



W42.00-1030-00

### Disk brakes with full protection (B2E)

Front axle



W42.00-1031-00

### Disk brakes with full protection (B2E)

Rear axle



## Large tires

The dimensional design of the Arocs model 964 allows for tire sizes up to 12.00 R24. For this reason the front axle has been moved 100 mm further back than on model 963, and the vehicle overhang at the front has therefore increased to 1500 mm (= 750 mm front frame overhang). Because of this, there is no additional code for relocation of the front axle. Accordingly, the wheelbases on model 964 are 100 mm shorter than on model 963.

## Vehicle adapted for large tires (ROV)

When 14.00 R20, 325/95 R24 or 12.00 R24 are fitted, the distance between the two rear axles is increased by 100 mm to 1450 mm. The 1st rear axle is 50 mm further forward, and the 2nd rear axle 50 mm further back. The result is a wheelbase and frame overhang that is 50 mm shorter in real terms. The front axle interval and the front overhang are identical with large and regular tires.

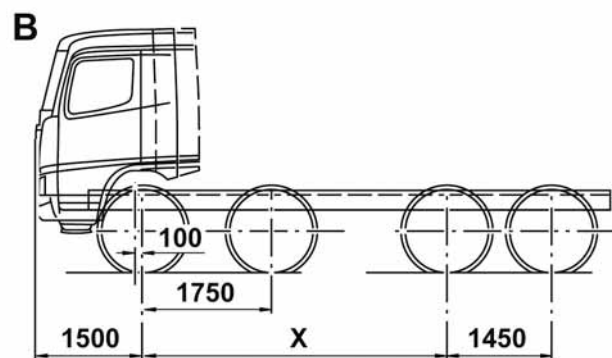
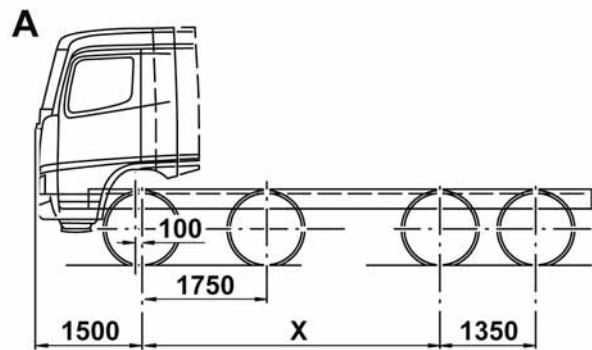

W40.10-1024-00

- A Vehicle with standard tires
- B Vehicle with large tires
- X Wheelbase

## Single tires on the rear axle

Specifically for weight-optimized vehicles (Loaders) with 6x4 and 8x4 axle configurations, single tires on the rear axle are available in the sizes 385/55 R 22.5 (I2N) and 385/65 R 22.5 (I2Q).

Single tires can only be fitted in combination with the option rear axle, ring gear 390, hypoid, 9.5 t, single (A20).



W40.10-1025-00

## Steering

### Electrohydraulic power steering, Servotwin® (C6H)

The Servotwin® electrohydraulic power steering system is standard equipment in all 4-axle vehicles with 9 t front axle load; its use in vehicles with front axle loads below 9 t is dictated by the wheelbase and the tires. For 4-axle vehicles that do not meet the above criteria, the Servotwin® steering is available as special equipment.

The Servotwin® system combines a conventional hydraulic steering gear with an electric drive system. This replaces the second hydraulic steering circuit previously used in 4-axle vehicles.

Servotwin® features an electrical emergency steering function in the event of a hydraulics failure. If the electrical system fails, the hydraulic steering assistance remains intact.

The electrical power assistance means that a speed-dependent control force can be produced and the wheels are actively returned to their straightahead position.

Overall, this provides a substantial improvement in steering comfort and dynamics.

If the on-board electrical system fails and the engine stops at the same time while driving, the electrical steering system is powered by a buffer battery.

## Overview of Servotwin<sup>®</sup> electrohydraulic power steering

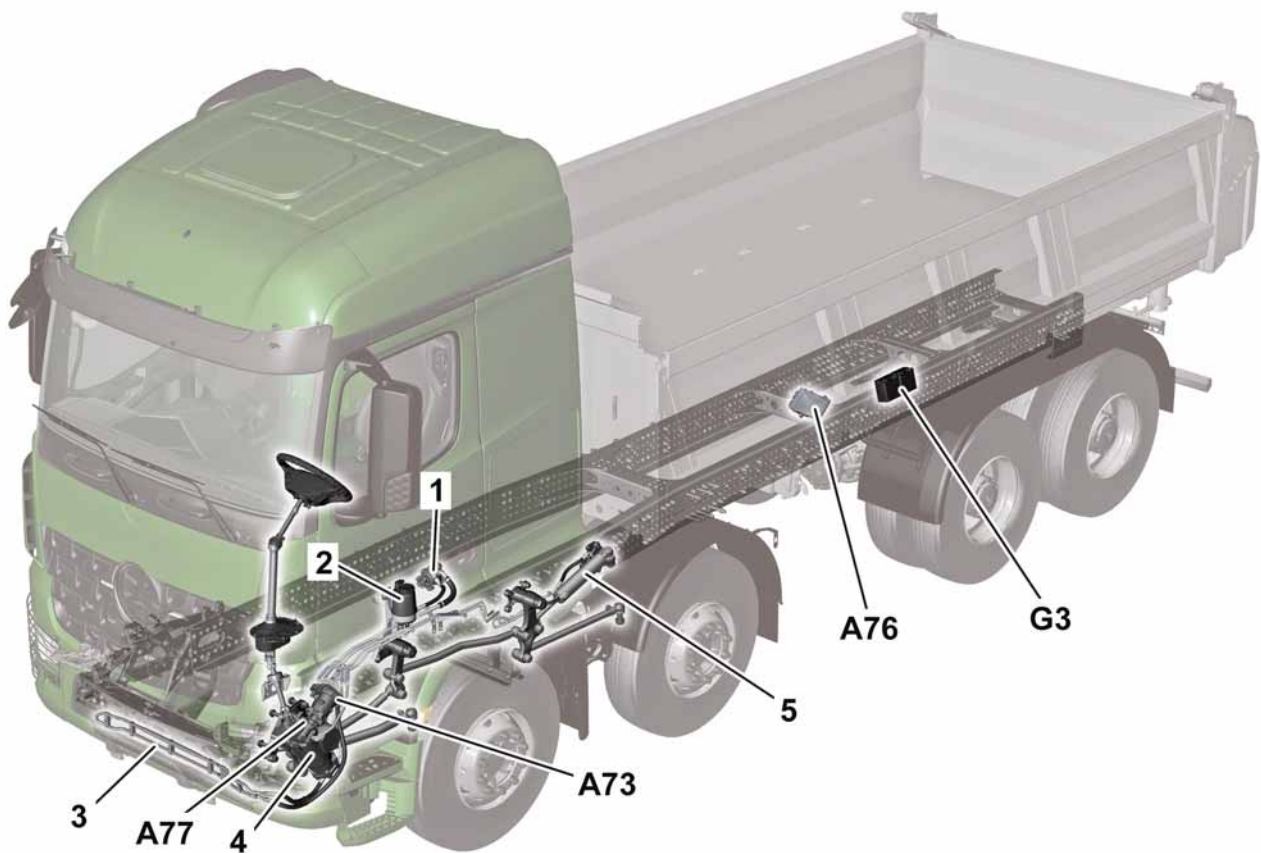

W46.00-1009-00

- 1 Power steering pump
- 2 Power steering fluid reservoir
- 3 Power steering fluid cooler
- 4 Servotwin<sup>®</sup> steering gear
- 5 Working cylinder

- A73 Electrohydraulic power steering (APS) control unit
- A76 Redundant power supply (RPS) control unit
- A77 Steering angle sensor
- G3 Buffer battery

# Steering

## Function overview of Servotwin®

- 1 Power steering pump
- 4 Servotwin® steering gear
- 6 Torsion bar with torque sensor
- 7 Worm gear
- 8 Electric motor
- A73 Electrohydraulic power steering (APS) control unit
- A76 Redundant power supply (RPS) control unit
- A77 Steering angle sensor
- G3 Buffer battery
- $M_H$  Manual torque at steering wheel
- $M_L$  Output torque at steering gear
- $M_M$  Electrical torque
- $M_P$  Hydraulic torque

- A Electric steering assist
- B Hydraulic steering assist

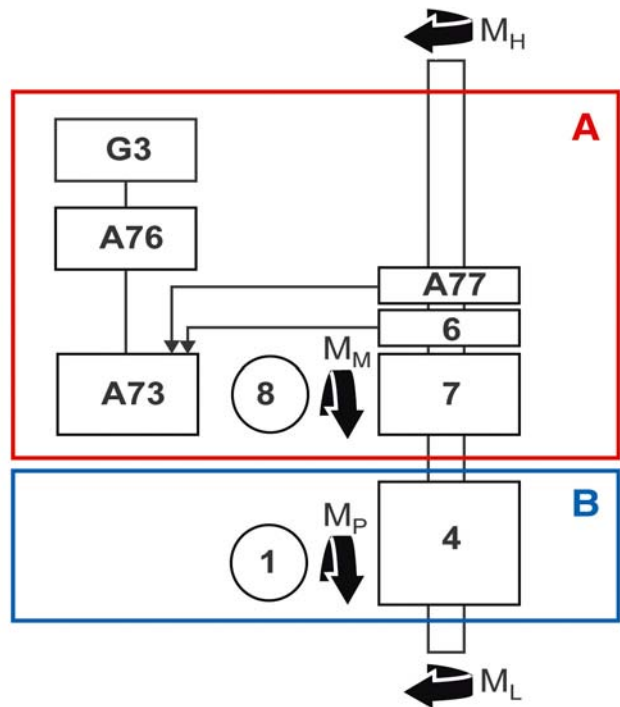

W46.00-1010-00

## Steering gear

The ZF steering gear already familiar from the Actros is supplemented by an electromechanical unit for the Servotwin® system.

The electromechanical unit consists of:

- Torsion bar with torque sensor (6)
- Electric motor (8)
- Worm gear (9)
- Electrohydraulic power steering (APS) control unit (A73)
- Steering angle sensor (A77)

The electric motor and the worm gear ensure that an additional torque acts on the input of the steering gear in parallel with the steering wheel torque.

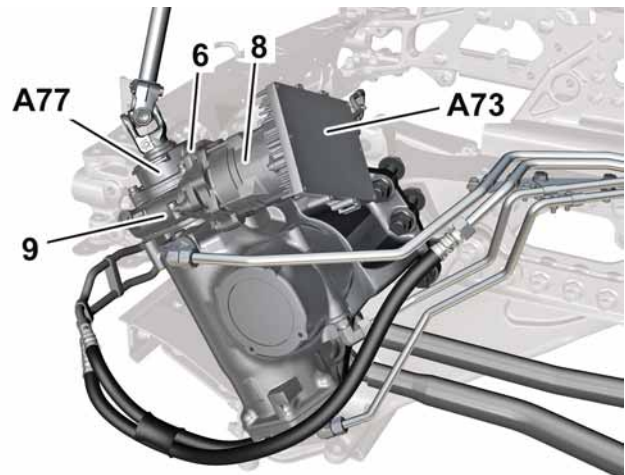

W46.20-1067-00

### Buffer battery (G3) and redundant power supply (RPS) control unit (A76)

If the on-board electrical system fails and the engine stops at the same time while driving, the buffer battery (G3) supplies the electric steering assist.

The buffer battery is located on the left longitudinal frame member in the vicinity of the 1st rear axle. It consists of two 12 V blocks.

The buffer battery is connected to the on-board electrical system via the redundant power supply (RPS) control unit (A76). In steel-sprung vehicles, the control unit is installed on the crossmember in front of the 1st rear axle.

The buffer battery supplies only the electric steering assist with a voltage of 24 V when the normal power supply has failed.

The buffer battery can only be replaced at the workshop.

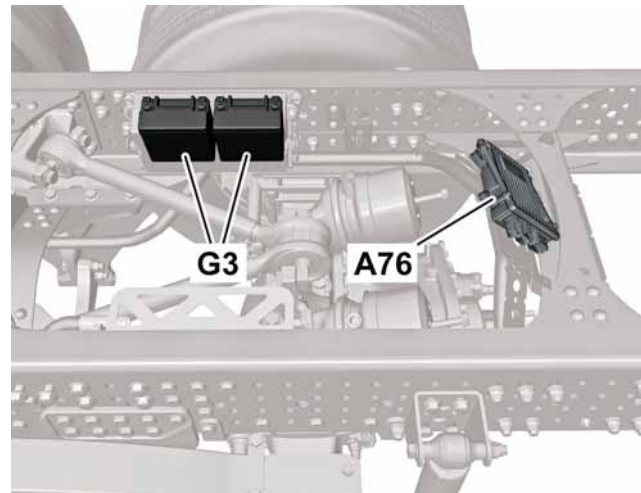

W54.10-1165-00

G3 Buffer battery

A76 Redundant power supply (RPS) control unit

### Warning indicators

A red warning indicator in the speedometer and a virtual indication in the display alert the driver to a failure or malfunction of the steering system.

The virtual indication in the display is a redundancy feature in the event of failure of the real warning indicator, and ensures that the fault message remains visible when the pop-up has been acknowledged.

With the warning indicators there appears a display pop-up with a symbol and text messages:

1st page: Steering wheel symbol and brief text message (restricted function)

2nd page: With long text (driver instructions) when the right arrow steering wheel button is pressed



W54.32-1035-00

Warning indicators in instrument cluster



## Fuel tank

The following fuel tanks will become available on the launch of the Arocs:

Code	Position	Volume [liters]	Width [mm]	Height [mm]	Length [mm]
K2E	Left	300 + 25	650	700	900
K1S	Left	260	735	565	750
K1Y	Left	330	735	565	950
K1A	Left	410	650	700	1070
K4L	Right	510	650	700	1300
K4W	Right	260	735	565	750
K5A	Left	290	650	565	950
K5B	Left	390	650	565	1250

### Guard plate, for tank (K5R)

A guard plate for protecting the fuel tank from damage when driving offroad is available as special equipment for the new Arocs.

The guard plate is part of the Protection Pack (Z9E) or can be ordered separately (K5R).

The guard plate can be fitted on fuel tanks with a cross section of 650 mm x 565 mm or 735 mm x 565 mm and a max. volume of 390 l.



W88.30-1035-00

**Guard plate, for tank (K5R)**

## General

The S, M, and L cabs introduced with the new Actros and Antos will also be available for the Arocs, with the exception of the GigaSpace and CompactSpace L cabs.

The cabs differ from the long-haul and distribution models in terms of:

- Unique radiator grille design ("excavator teeth")
- Mirror covers
- Movable cab entry step
- Plastic components in the interior in anthracite color with easy-to-clean surfaces

The cabs are installed at different body floor heights depending on the conditions of service, the engine variants and the drive components (all-wheel drive). The body floor height of 765 mm produces a flat floor on in the long cab; with medium and short cabs the tunnel height is 170mm. With a body floor height of 600 mm the tunnel height can be 170 mm and 320 mm (e.g. in the all-wheel drive vehicles).



W00.00-1073-00

**Radiator grille with excavator tooth design**

## Mirror cover, construction vehicle (FOY)

The mirror cover for construction vehicles (FOY) is standard equipment on the new Arocs.



W88.70-1037-00

**Mirror cover, construction vehicle (FOY)**

Cab



W00.00-1071-00

**ClassicSpace S cab, body floor height 600 mm**



W00.00-1074-00

**ClassicSpace S cab, body floor height 600 mm**



W00.00-1075-00

**ClassicSpace M cab, body floor height 600 mm**



W00.00-1076-00

**ClassicSpace M cab, body floor height 600 mm**



W00.00-1077-00

**StreamSpace L cab, body floor height 600 mm**



W00.00-1072-00

**BigSpace L cab, body floor height 765 mm**

## Overview of available cabs

	GigaSpace		BigSpace		StreamSpace		Compact-Space		Classic-Space		Compact-Space			ClassicSpace			
	F1J	F1H/F1L	F1F/F1I	F1E/F1W	F1K/F1V	F1D/F1M/F1T	F1C	F1N	F1B	F1O	F1A/F1S	F1C	F1N	F1B	F1O	F1A/F1S	
<b>Code</b>	F1J	F1H/F1L	F1F/F1I	F1E/F1W	F1K/F1V	F1D/F1M/F1T	F1C	F1N	F1B	F1O	F1A/F1S	F1C	F1N	F1B	F1O	F1A/F1S	
<b>Length</b>	2300	2300	2300	2300	2300	2300	2300	2000	2000	2000	1700	2000	2000	2000	2000	1700	
<b>Width</b>	2500	2500	2300/2500	2300	2300	2300	2300	2300	2300	2300	2300	2300	2300	2300	2300	2300	
<b>Cab height</b>	2300	2100	2100	2100	1486	1750	1486	1486	1750	1750	1750	1486	1486	1750	1750	1750	
<b>Floor-to-ceiling height in front of seat</b>	1910	1910	1840	1840	1397	1590	1397	1397	1590	1600	1600	1397	1397	1600	1600	1600	
<b>Body floor height</b>	765	600/765	765	600/420	600/420	600/420	600/420	600/420	600/420	600/420	600/420	600/420	600/420	600/420	600/420	600/420	
<b>Height of engine tunnel</b>	0	0/170	0	170/320	170/320	0/170/320	170/320	170/320	0/170/320	170	320	170	320	170	320	170	320
<b>Long-distance haulage</b>	X	X	X	X	X	X	X	X	X	X	X	X	X	X	X	X	X
<b>Distribution haulage</b>	-	-	-	-	-	-	-	-	-	-	-	X	X	X	X	X	X
<b>Construction</b>	-	X	X	X	-	X	X	-	X	X	X	X	X	X	X	X	X

All dimensions in mm



Cab



W68.10-1102-00

*Interior concept (when equipped with manual shift)*



W68.10-1103-00

*Interior concept (when equipped with Mercedes PowerShift 3)*





W68.10-1101-00

*Interior concept (when equipped with Mercedes PowerShift 3)*

**i** Note

The body floor height (ASH) designates the distance from the lower edge of the floor panel to the uppermost row of holes in the longitudinal frame member. When the cab floor is flat, the body floor height is always 765 mm; if there is an engine tunnel, then always 600 mm.

## Cab

### Cab entry step

All vehicles with steel suspension on the rear axle are fitted with a movable cab entry step. The non-slip step is made of thermoplastic and is mounted on sturdy but flexible rubber tabs.

These vehicles, with the exception of the all-wheel drive vehicles, can optionally be equipped with the fixed cab entry step, but this can only be installed together with the front underride guard (ECE), aluminum (C7F).

Air-sprung vehicles feature the fixed cab entry step as standard.



W60.80-1180-00

*Fixed cab entry step (F7X)*



W60.80-1181-00

*Movable cab entry step (F7Y)*

### Guard plate under bumper (M7J)

All vehicles with steel suspension are equipped with a guard plate under the bumper (M7J) as standard.

The guard plate is available as an option for air-sprung vehicles.

The guard plate is made of 2 mm thick stainless steel sheet.

The option for the omission of the guard plate under the bumper (M9V) increases the front angle of approach.



W88.30-1034-00

*Guard plate under bumper (M7J)*





Overall network

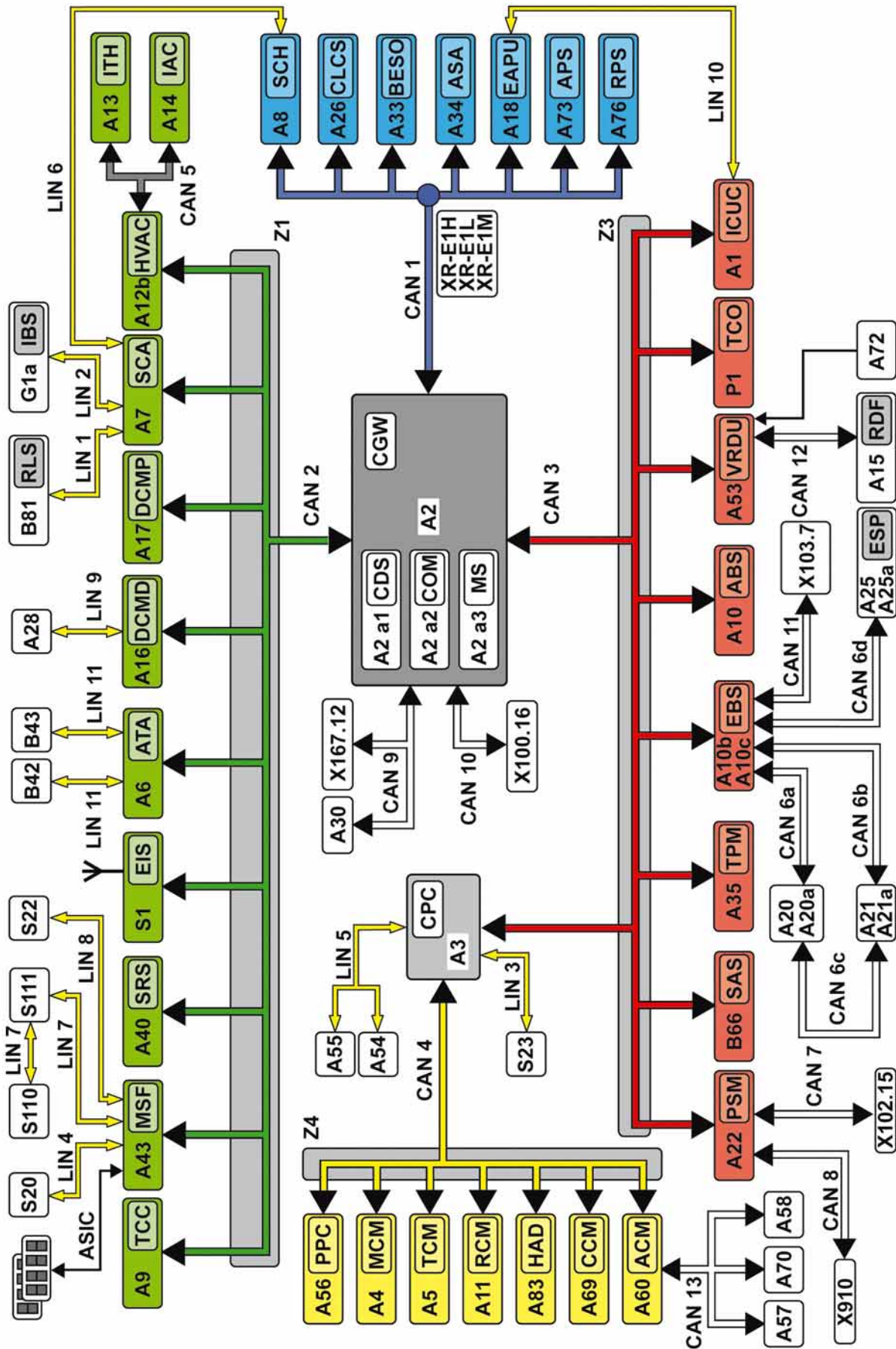

W00.19-1096-00

Overall network without single SAM (Z3L)





## Overall network

A1	Instrument cluster (ICUC) control unit
A2	Central gateway (CGW) control unit
A2 a1	Central data memory (CDS)
A2 a2	Communications interface (COM) control unit
A2 a3	Maintenance system (MS) control unit
A3	Drive control (CPC) control unit
A4	Engine management control unit (MCM)
A5	Transmission control module (TCM)
A6	Anti-theft alarm system (ATA) control unit
A7	Sensor and actuator module, cab (SCA) control unit
A7a	Single signal acquisition and actuation module (SSAM) control unit
A8	Sensor and actuator module, chassis (SCH) control unit
A9	Truck Control Center (TCC)
A10	4-channel anti-lock braking system (ABS) control unit
A10b	Electronic brake control (EBS) control unit
A10c	Electronic brake control (EBS) control unit
A11	Retarder control unit (RCM)
A12b	Heating, ventilation and air conditioning (HVAC) control unit
A13	TRUCK auxiliary heater (IH) control unit
A14	Stationary air conditioning (IAC) control unit
A15	Front radar sensor (RDF) control unit
A16	Driver door module (DCMD) control unit
A17	Passenger door module (DCMP) control unit
A18	Electronic Air-Processing Unit (EAPU) control unit
A20	Front axle axle modulator (Wabco)
A20a	Front axle axle modulator (Knorr)
A21	Rear axle axle modulator (Wabco)
A21a	Rear axle axle modulator (Knorr)
A22	Parameterizable special module (PSM) control unit
A25	Electronic Stability Program (ESP®) control unit
A25a	Electronic Stability Program (ESP®) control unit
A26	Level control (CLCS) control unit
A28	Driver switch group
A30	FleetBoard® control unit
A33	Battery disconnect switch (BESO) control unit
A34	Additional steering axle (ASA) control unit
A35	Tire pressure monitor (TPM) control unit
A40	Supplemental restraint system (SRS) control unit
A43	Modular switch panel (MSF) control unit
A44	Instrument panel switch module 1
A45	Instrument panel switch module 2
A46	Instrument panel switch module 3
A47	Special equipment switch module
A53	Driver assistance system (VRDU) control unit
A54	Lower radiator shutters controller unit
A55	Upper radiator shutters controller unit
A56	Predictive Powertrain Control (PPC) control unit
A57	NOx sensor control unit, exhaust aftertreatment unit outlet
A58	SCR control unit
A60	Exhaust aftertreatment control unit (ACM)
A69	Fluid coupling control unit (CCM)

A70	NOx sensor control unit, exhaust aftertreatment unit inlet	X100.16	Diagnostic socket	CAN 1	Exterior CAN	LIN 1	Rain/light sensor LIN
A72	Lane Assistant camera	X102.15	Trailer socket (15-pin)	CAN 2	Interior CAN	LIN 2	Battery sensor LIN
A73	Electrohydraulic power steering (APS) control unit	X12.7	ABS trailer socket (7-pin)	CAN 3	Frame CAN	LIN 3	Right multifunction control lever LIN
A76	Redundant power supply (RPS) control unit	X167.12	Fleet management system electrical connector	CAN 4	Drive train CAN	LIN 4	Left multifunction control lever LIN
A78	Waistail switch module 3	X910	Electrical connector for body manufacturers	CAN 5	Climate control CAN	LIN 5	Radiator shutters LIN
A83	Hydraulic Auxiliary Drive (HAD) control unit	Z1	CAN bus star point, cab/instrument panel	CAN 6a	Front axle brakes CAN	LIN 6	SCA/SCH redundancy LIN
B42	Alarm siren	Z3	CAN bus star point, frame	CAN 6b	Rear axle brakes CAN	LIN 7	Button group LIN
B43	Interior protection sensor	Z4	CAN bus star point, powerplant	CAN 6c	Redundancy brakes CAN	LIN 8	Level control LIN
B66	Steering wheel angle sensor (SAS)	ASIC	ASIC data bus (Application System Integrated Circuit)	CAN 6d	ESP® brakes CAN	LIN 9	Driver switch panel LIN
B81	Rain and light sensor (RLS)			CAN 7	Trailer CAN (PSM)	LIN 10	EAPU LIN
G1a	Battery sensor (IBS)			CAN 8	Body manufacturer CAN (PSM)	LIN 11	ATA LIN
P1	Tachograph (TCO)			CAN 9	Telematics CAN		
S1	Electronic ignition lock (EIS)			CAN 10	Diagnostic CAN		
S19	Exterior lights switch			CAN 11	Trailer CAN (EBS)		
S20	Left multifunction control lever			CAN 12	Radar CAN		
S21	Headlamp range adjustment switch			CAN 13	NOx CAN		
S22	Level control operating unit						
S23	Right multifunction control lever						
S110	Left multifunction steering wheel button group						
S111	Right multifunction steering wheel button group						

## Overall network

### Single SAM (Z3L)

In vehicles with code (Z3L) the sensor and actuator module, cab (SCA) control unit (A7) and the sensor and actuator module, chassis (SCH) control unit (A8) are replaced by the single signal acquisition and actuation module (SSAM) control unit (A7a). The single SAM is connected to the exterior CAN (CAN 1) and interior CAN (CAN 2) bus systems.

Information is distributed across the bus systems by the central gateway (CGW) control unit (A2).

The SSAM is located in the electronics compartment on the passenger side in place of the SCA.

The function of the modular switch panel (MSF) is integrated in the SSAM. The integrated MSF module is linked directly to the switch modules over the LIN bus.



Single SAM, front view

W54.21-1617-00

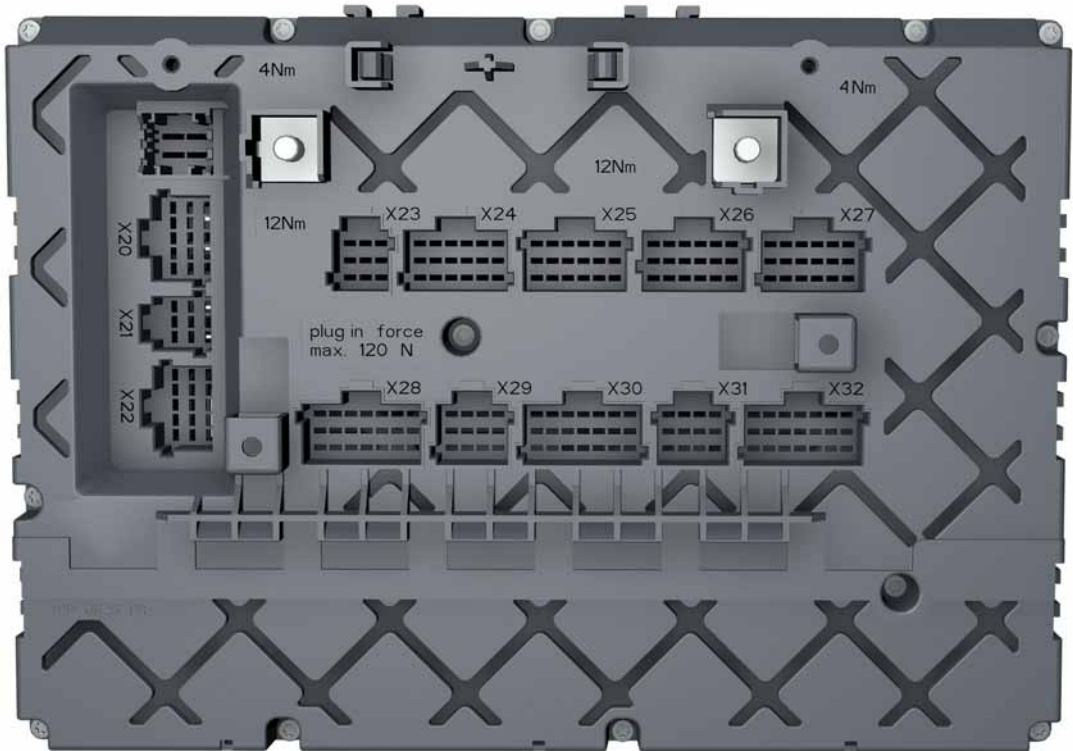

Single SAM, rear view

W54.21-1618-00

**Cab/chassis connection**

The frames for the cab/chassis connections will be modified as of 05/2013:

- 1 LHD vehicles up to 04/2013
- 2 RHD vehicles up to 04/2013
- 3 LHD vehicles as of 05/2013
- 4 RHD vehicles as of 05/2013

All the connectors at the cab/chassis interface are 18-pin as standard. From 05/2013 connectors with up to 40 pins will be used.

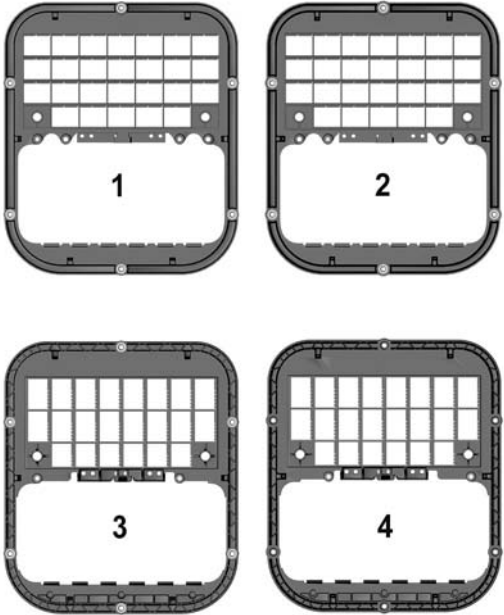

W00.16-1099-00

## Exterior lights

### General

The new Arocs is fitted with the same headlamps as the Antos.

The following lights are standard equipment:

- Standing lights, low beams and high beams with additional "Ambient illumination" function
- Turn signals and hazard warning system with additional "One-touch turn signaling" function
- Front fog lamps
- Rear foglamp, backup lamps and brake lights
- LED clearance lamps
- LED side marker lamps

Available as special equipment:

- Bi-xenon headlamps (L1A)
- Daytime running lights (L1B)
- Front fog lamps, halogen (L1H)
- Front fog lamps, LED daytime running lights (L1I)
- Front fog lamps, LED daytime running lights, cornering lights (L1N)
- Lower work lamps (L3A)
- Work lamps at top of cab rear panel (L3C)
- Illuminated Mercedes star (FOT)

Because they require an automatic headlamp range adjustment system, bi-xenon headlamps are only available for air-sprung vehicles.

The front fog lamps, LED daytime running lights, cornering lights (L1N) package is not available on all-wheel drive vehicles and 8x2/4 VLA/DNA platform trucks.



W82.10-1149-00

**Halogen headlamp with front fog lamp (L1H)**

### Preinstallation, additional headlamps (L9B)

The preinstallation for additional headlamps (L9B) allows additional headlamps to be retrofitted, e.g. under the windshield (for winter service vehicles etc.).

The preinstallation includes the routing of the electrical lines as far as the connecting point in the passenger footwell.



### Stone impact protection, metal, for headlamps (L4Z)

The stone impact protection mesh protects the headlamps from damage in offroad operations. It is available as part of the Protection Pack (Z9E) or separately (L4Z) for all Arocs.



W82.10-1147-00

### Rear lamps for construction vehicles, in metal surround with mesh (L1Q)

Rear lamps protected by a metal surround and mesh are available as special equipment for all Arocs. The specially protected rear lamps are available as part of the Protection Pack (Z9E) or separately (L1Q).



W82.10-1148-00

## Engine OM 936

### Sleeve

<b>Use</b>	Insertion device for the rear crankshaft radial sealing ring.
<b>Special tool number</b>	W 936 589 01 14 00
<b>FG</b>	01
<b>Set</b>	B
<b>Category</b>	Mercedes-Benz Truck - Basic Operation
<b>Note</b>	In combination with W 457 589 01 43 00



W58.20-1094-00

### Puller

<b>Use</b>	For pulling the drive gear off the fuel system high-pressure pump.
<b>Special tool number</b>	W 936 589 05 33 00
<b>FG</b>	07
<b>Set</b>	B
<b>Category</b>	Mercedes-Benz Truck - Basic Operation



W58.20-1095-00

Removal and installation tool

<b>Use</b>	For removing/installing the complete engine.
<b>Special tool number</b>	W 936 589 01 62 00
<b>FG</b>	01
<b>Set</b>	B
<b>Category</b>	Mercedes-Benz Truck - Special Operation
<b>Note</b>	In combination with an engine hoist



W58.20-1096-00

## Engine OM 470

### Collet

<b>Use</b>	For removing the water channel cap in the cylinder head.
<b>Special tool number</b>	W 470 589 00 34 00
<b>FG</b>	01
<b>Set</b>	B
<b>Category</b>	Mercedes-Benz Truck - Basic Operation
<b>Note</b>	



W58.20-1097-00

### Set of lifting eyes

<b>Use</b>	For removing/installing the engine or cylinder head.
<b>Special tool number</b>	W 470 589 07 62 00
<b>FG</b>	01
<b>Set</b>	B
<b>Category</b>	Mercedes-Benz Truck - Basic Operation
<b>Note</b>	For vehicles without factory-installed lifting eyes



W58.20-1098-00

## Adapter (spacer ring)

<b>Use</b>	For installing the radial shaft sealing ring of the output flange.
<b>Special tool number</b>	W 750 589 28 63 00
<b>FG</b>	26
<b>Set</b>	B
<b>Category</b>	Mercedes-Benz Truck - Basic Operation
<b>Note</b>	In combination with drift W 750 589 01 15 00



W58.20-1099-00

## Adjusting sleeve with pressure plate and spacer

<b>Use</b>	For adjusting the bearing play of the K2 gear.
<b>Special tool number</b>	W 715 589 11 21 00
<b>FG</b>	26
<b>Set</b>	B
<b>Category</b>	Mercedes-Benz Truck - Basic Operation



W58.20-1086-00



## Transmission G 140-8

### Lifting device

<b>Use</b>	For lifting the main shaft, drive shaft and countershaft as an assembly out of or into the transmission housing.
<b>Special tool number</b>	W 715 589 04 59 00
<b>FG</b>	26
<b>Set</b>	B
<b>Category</b>	Mercedes-Benz Truck - Basic Operation



W58.20-1100-00

### Adapter

<b>Use</b>	For pulling off the rear main shaft bearing.
<b>Special tool number</b>	W 715 589 15 33 00
<b>FG</b>	26
<b>Set</b>	B
<b>Category</b>	Mercedes-Benz Truck - Basic Operation
<b>Note</b>	In combination with W 715 589 02 33 15



W58.20-1087-00

Centering drift	
<b>Use</b>	For inserting the oil pipe into the clutch housing on transmissions with live power take-off.
<b>Special tool number</b>	W 715 589 09 15 00
<b>FG</b>	26
<b>Set</b>	B
<b>Category</b>	Mercedes-Benz Truck - Basic Operation
<b>Note</b>	In combination with W 715 589 02 07 00



W58.20-1085-00

## VG 2800-3W, VG 3000-3W

## Reduction adapter M24x1.5

<b>Use</b>	For removing/installing the transfer case.
<b>Special tool number</b>	W 750 589 00 40 00
<b>FG</b>	28
<b>Set</b>	B
<b>Category</b>	Mercedes-Benz Truck - Basic Operation



W58.20-1101-00

**Adapter**

<b>Use</b>	Angle piece and holder with magnets, for various inclination measurements on the propeller shaft and the propeller shaft flange.
<b>Special tool number</b>	W 001 589 91 21 00
<b>FG</b>	41
<b>Set</b>	B
<b>Category</b>	Mercedes-Benz Truck - Basic Operation
<b>Note</b>	In combination with W 001 589 88 21 00



W58.20-1102-00

## Abbreviations

### ABS

Anti-lock Braking System

### ACM

Aftertreatment Control Module

### ADR

Accord européen relatif au transport international des marchandises Dangereuses par Route (European Agreement Concerning the International Carriage of Dangerous Goods by Road)

### AGR

Exhaust gas recirculation

### APS

Automatic Power Steering

### ASA

Additional Steering Axle

### ASH

Body floor height

### ASIC

Application System Integrated Circuit

### ASR

Acceleration skid control

### ATA

Anti-theft alarm system

### BESO

Battery Emergency Shutoff (battery disconnect switch)

### BUB

Backup Battery

### CAN

Controller Area Network

### CC

Car Carrier

### CCM

Fluid coupling control unit

### CDS

Central Data Storage (central data memory)

### CGW

Central Gateway control unit

### CLCP

Chassis Level Control Panel

### CLCS

Chassis Level Control System

### COM

Communications interface



<b>CPC</b>	<b>EIS</b>
Common Powertrain Controller	Electronic Ignition Switch
<b>CPCA</b>	<b>ENA</b>
Concentric Pneumatic Clutch Actuator	Single-tire trailing axle
<b>CPS</b>	<b>ESP<sup>®</sup></b>
Cable Power Shift	Electronic Stability Program
<b>DCMD</b>	<b>FHS</b>
Door Control Module Driver	Cab
<b>DCMP</b>	<b>HA</b>
Door Control Module Passenger	Rear axle (RA)
<b>DNA</b>	<b>HAD</b>
Twin-tire trailing axle	Hydraulic Auxiliary Drive
<b>DOHC</b>	<b>HVAC</b>
Double Overhead Camshaft	Heating Ventilation Air Conditioning
<b>DPF</b>	<b>IAC</b>
Diesel Particulate Filter	Independent Air Conditioning (stationary air conditioner)
<b>EAPU</b>	<b>IBS</b>
Electronic Air-Processing Unit	Battery sensor
<b>EBS</b>	<b>ICUC</b>
Electronic Brake Control	Instrument Cluster Unit Common
<b>ECE</b>	<b>ITH</b>
Economic Commission for Europe	Independent Truck Heating (TRUCK auxiliary heater)

## Abbreviations

**LED**

Light Emitting Diode

**LIN**

Local Interconnect Network

**LzGG**

Gross combination weight (GCW)

**MCM**Motor Control Module  
(engine management control unit)**MS**

Maintenance System

**MSF**

Modular switch panel

**NA**

Power take-off (PTO)

**NMV**

Live power take-off

**NLA**

Trailing axle

**OBD**

On-Board Diagnosis

**OM**

Diesel engine

**PG**

Product Group

**PM**

Particulate Mass

**PPC**

Predictive Powertrain Control

**PSM**

Parameterizable Special Module

**PWM**

Pulse Width Modulation

**RCM**

Retarder Control Module

**RDF**Radar Front End  
(front radar sensor)**RLS**

Rain/Light Sensor

**SA**

Special equipment

**SAE**

Society of Automotive Engineers

**SAM**

Signal acquisition and actuation module

**SAS**

Steering wheel angle sensor

<b>SCA</b>	<b>TCC</b>
Sensor and Actuator Module, Cab	Truck Control Center
<b>SCH</b>	<b>TCM</b>
Sensor and Actuator Module, Chassis	Transmission Control Module
<b>SCR</b>	<b>TCO</b>
Selective Catalytic Reduction	Tachograph
<b>SKU</b>	<b>TPM</b>
Power-assisted gear shifting	Tire Pressure Monitoring System
<b>SLT</b>	<b>VA</b>
Heavy-duty truck	Front axle
<b>SRS</b>	<b>VLA</b>
Supplemental Restraint System	Leading axle
<b>SSAM</b>	<b>VRDU</b>
Single SAM	Video and Radar Decision Unit (driver assistance system control unit)
<b>SWR</b>	<b>zGG</b>
Secondary Water Retarder	Permissible gross vehicle weight (max. GVW)
<b>SZF</b>	
Semitrailer tractor	

## Index

<b>A</b>		<b>P</b>	
Axle drop . . . . .	.52	Performance graph . . . . .	23
<b>B</b>		Power take-off NA 135 . . . . .	40
Buffer battery . . . . .	.63	Power take-off, live . . . . .	41
<b>C</b>		Power-assisted gear shifting (SKU) . . . . .	36
Cab entry step . . . . .	.70	Protection Pack . . . . .	17
Cable Power Shift (CPS) . . . . .	.34	<b>R</b>	
Clutch		Rear axle . . . . .	54
Double-plate clutch . . . . .	.27	<b>S</b>	
Single-plate clutch . . . . .	.27	ServoTwin . . . . .	60
Compact bearing . . . . .	.50	Shift unit . . . . .	35
Coupling jaw . . . . .	.49	Side module (HAD) . . . . .	47
Cyclone prefilter . . . . .	.24	Single SAM . . . . .	76
<b>F</b>		Single tires . . . . .	59
Front axle (HAD) . . . . .	.46	Steering gear . . . . .	62
Front axles . . . . .	.50	Stone impact protection . . . . .	79
<b>G</b>		<b>T</b>	
Gross combination weight . . . . .	.16	Towing eyes . . . . .	49
Grounder . . . . .	13, 15	Trailing axle . . . . .	56
Guard plate under bumper . . . . .	.70	Transfer case	
Guard plate, for tank . . . . .	.64	VG 1600-3W . . . . .	42
<b>H</b>		VG 2800-3W . . . . .	43
High-pressure pump (HAD) . . . . .	.47	VG 3000-3W . . . . .	43
Hydraulic Auxiliary Drive (HAD) . . . . .	.44	Transmission	
<b>L</b>		G 141-9 . . . . .	30
Large tires . . . . .	.59	G 230-16 . . . . .	31
Leading axle . . . . .	.56	G 231-16 . . . . .	31
Loader . . . . .	14, 15	G 260-16 . . . . .	31
<b>M</b>		Transmission mode "offroad" . . . . .	37
Mirror cover . . . . .	.65	Transmission mode "power" . . . . .	37
		Transmission ratios . . . . .	33, 42
		Transmission support arms . . . . .	29
		Turbo retarder coupling . . . . .	28
		Turbocompound . . . . .	21

