

The following diagrams show the wiring circuits installed by Sterling. For detailed engine wiring, see the applicable Caterpillar™ manual.

See **Fig. 1** for a full view of the Caterpillar C10, C12 and 3406 engine controls wiring.

See **Fig. 2**, **Fig. 3** and **Fig. 4** for partial views of the Caterpillar C10, C12 and 3406 engine controls wiring.

See **Fig. 5** for a full view of the Caterpillar 3126 engine controls wiring.

See **Fig. 6**, **Fig. 7** and **Fig. 8** for partial views of the Caterpillar 3126 engine controls wiring.

See **Fig. 9** for a full view of the Caterpillar 3306 engine ground summary.

See **Fig. 10** for a full view of the Caterpillar 3126 and 3406 engine ground summary.

See **Fig. 11** for a full view of the Caterpillar C10 and C12 engine ground summary.

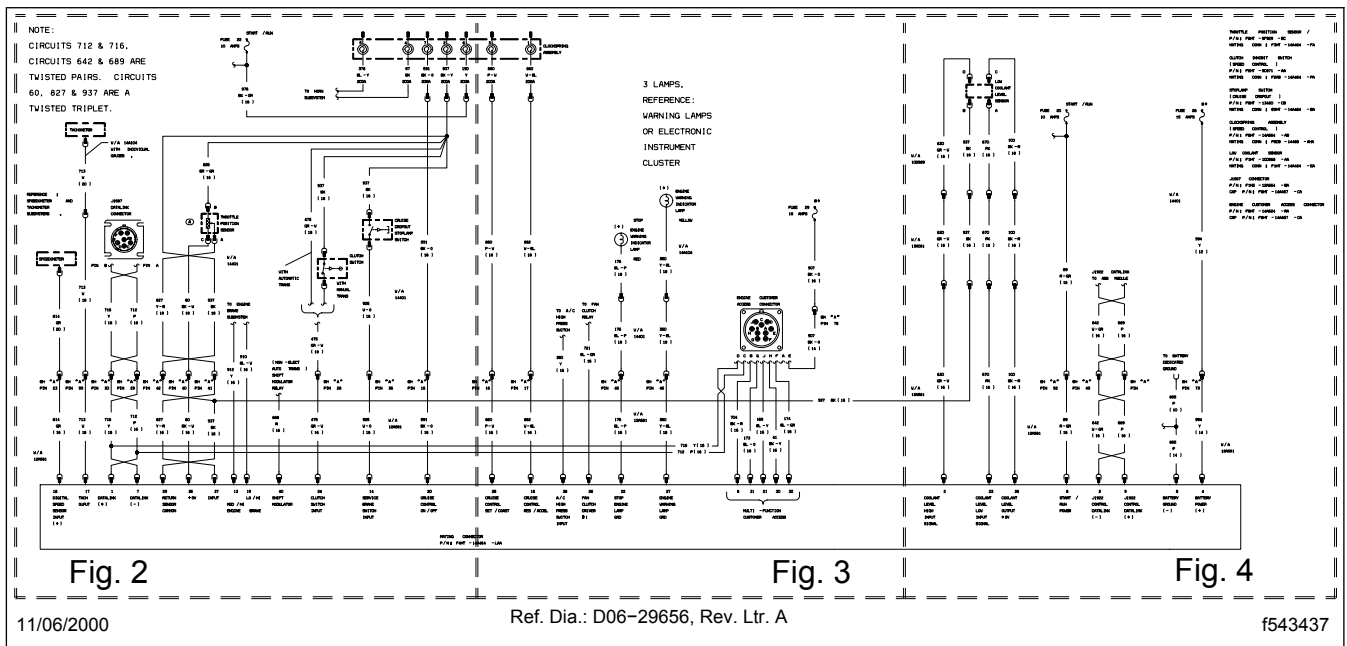

Fig. 1, Caterpillar C10, C12 and 3406 Engine Controls Wiring (full view)

54.17

Engine Wiring, Caterpillar

Specifications

NOTE :

CIRCUITS 712 & 716,
CIRCUITS 642 & 689 ARE
TWISTED PAIRS. CIRCUITS
60, 827 & 937 ARE A
TWISTED TRIPLET.

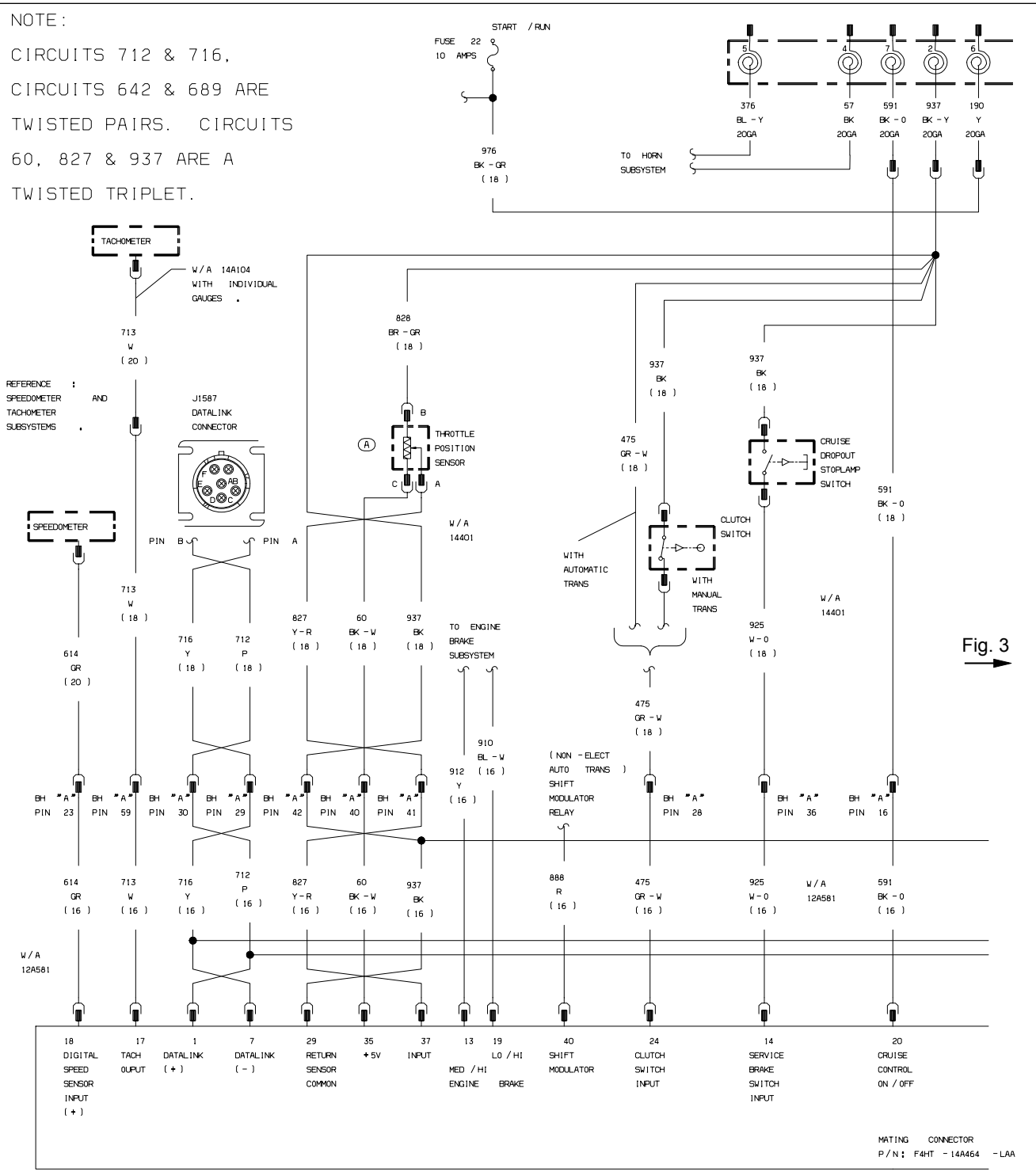

Fig. 3

11/06/2000

Ref. Dia.: D06-29656, Rev. Ltr. A

f543443

Fig. 2, Caterpillar C10, C12 and 3406 Engine Controls Wiring (partial view)

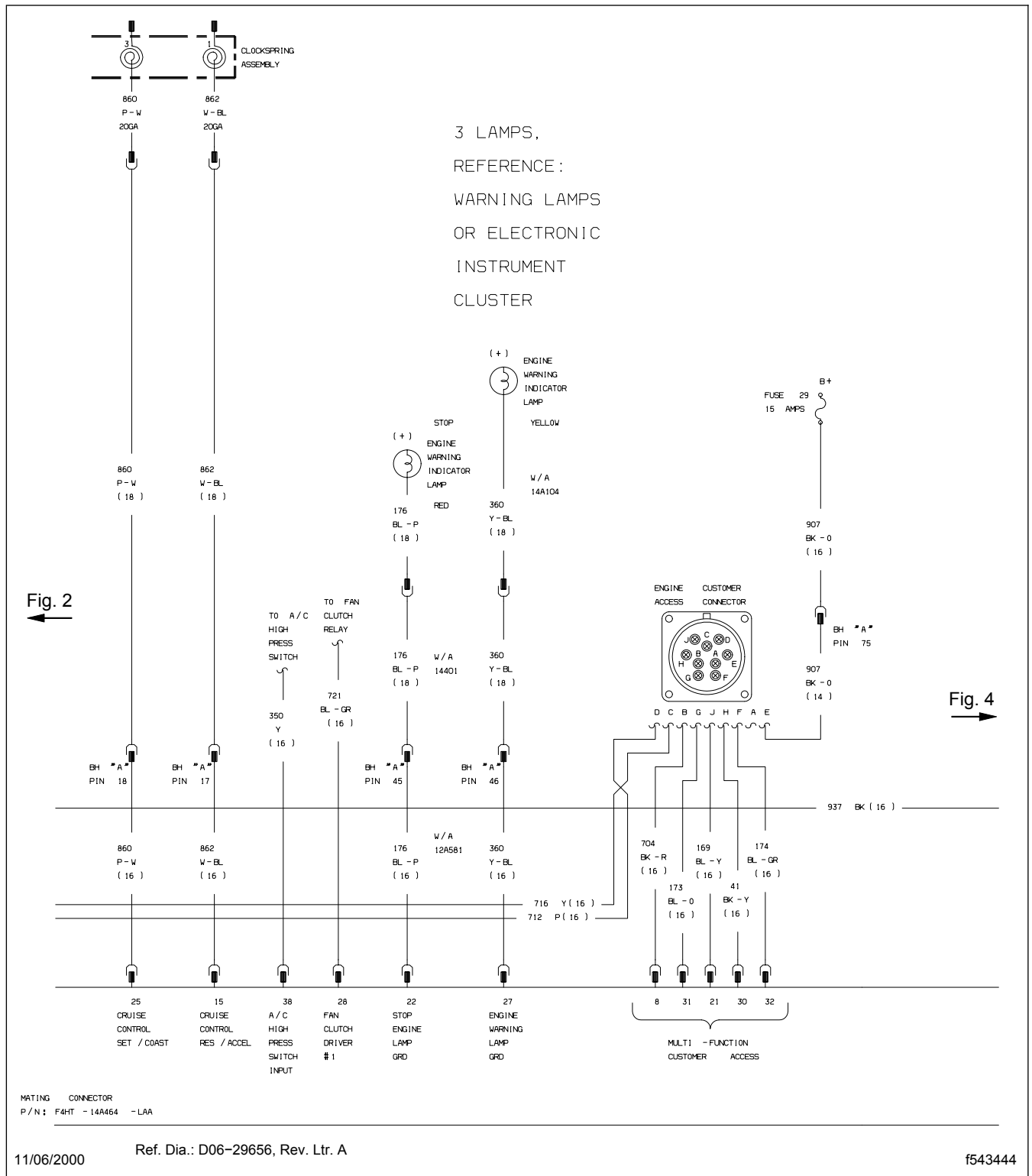

Fig. 3, Caterpillar C10, C12 and 3406 Engine Controls Wiring (partial view)

Specifications

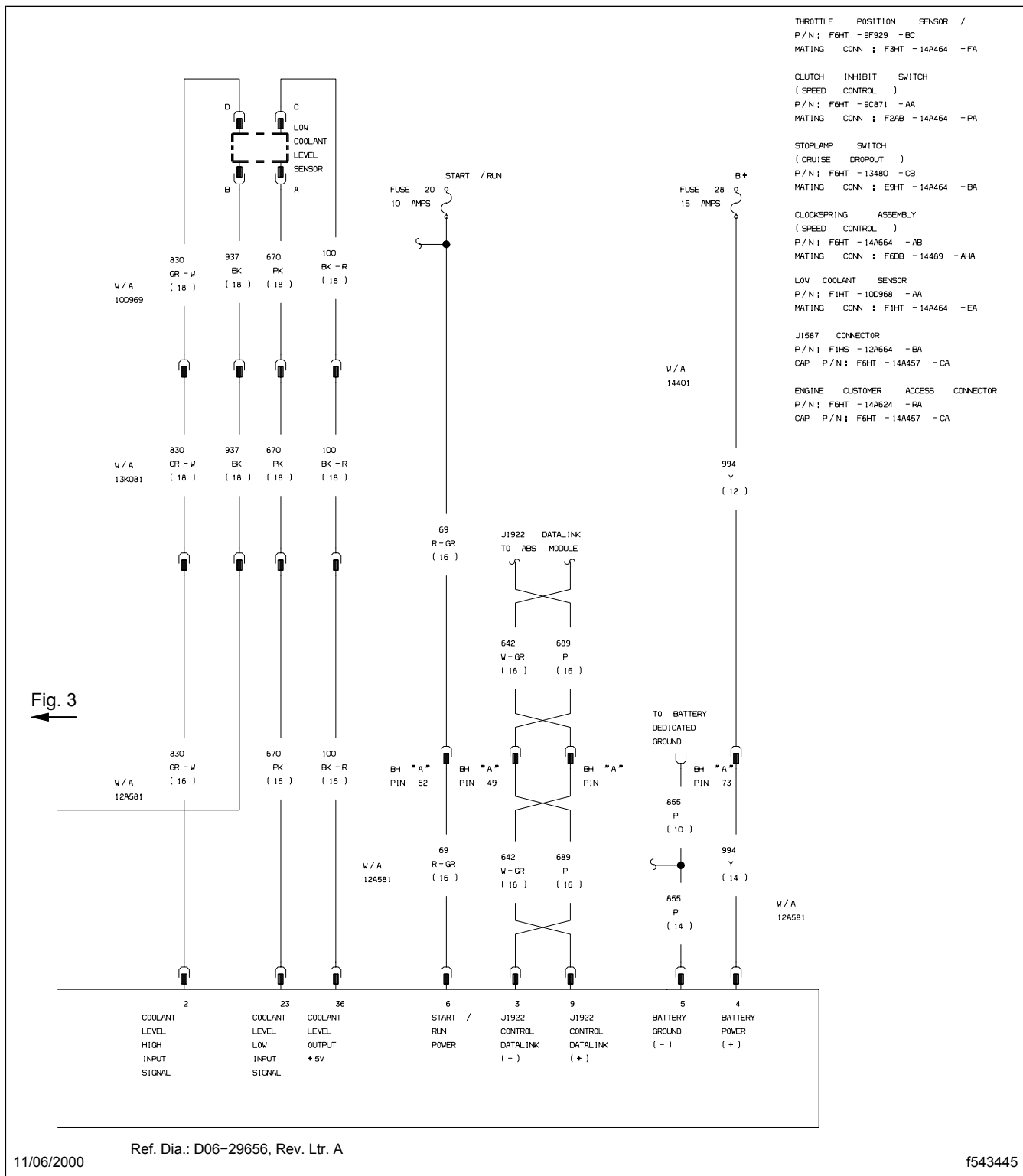

Fig. 4, Caterpillar C10, C12 and 3406 Engine Controls Wiring (partial view)

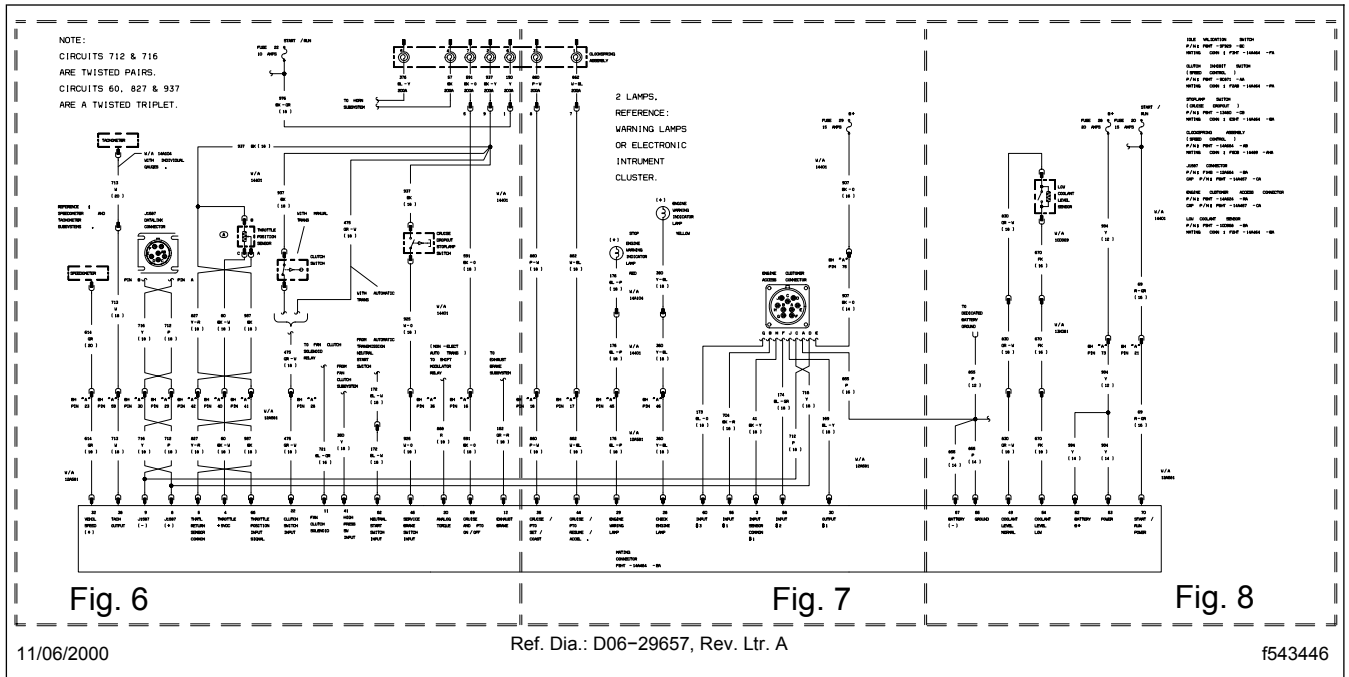

Fig. 5, Caterpillar 3126 Engine Controls Wiring (full view)

54.17

Engine Wiring, Caterpillar

Specifications

NOTE:

CIRCUITS 712 & 716
ARE TWISTED PAIRS.

CIRCUITS 60, 827 & 937
ARE A TWISTED TRIPLET.

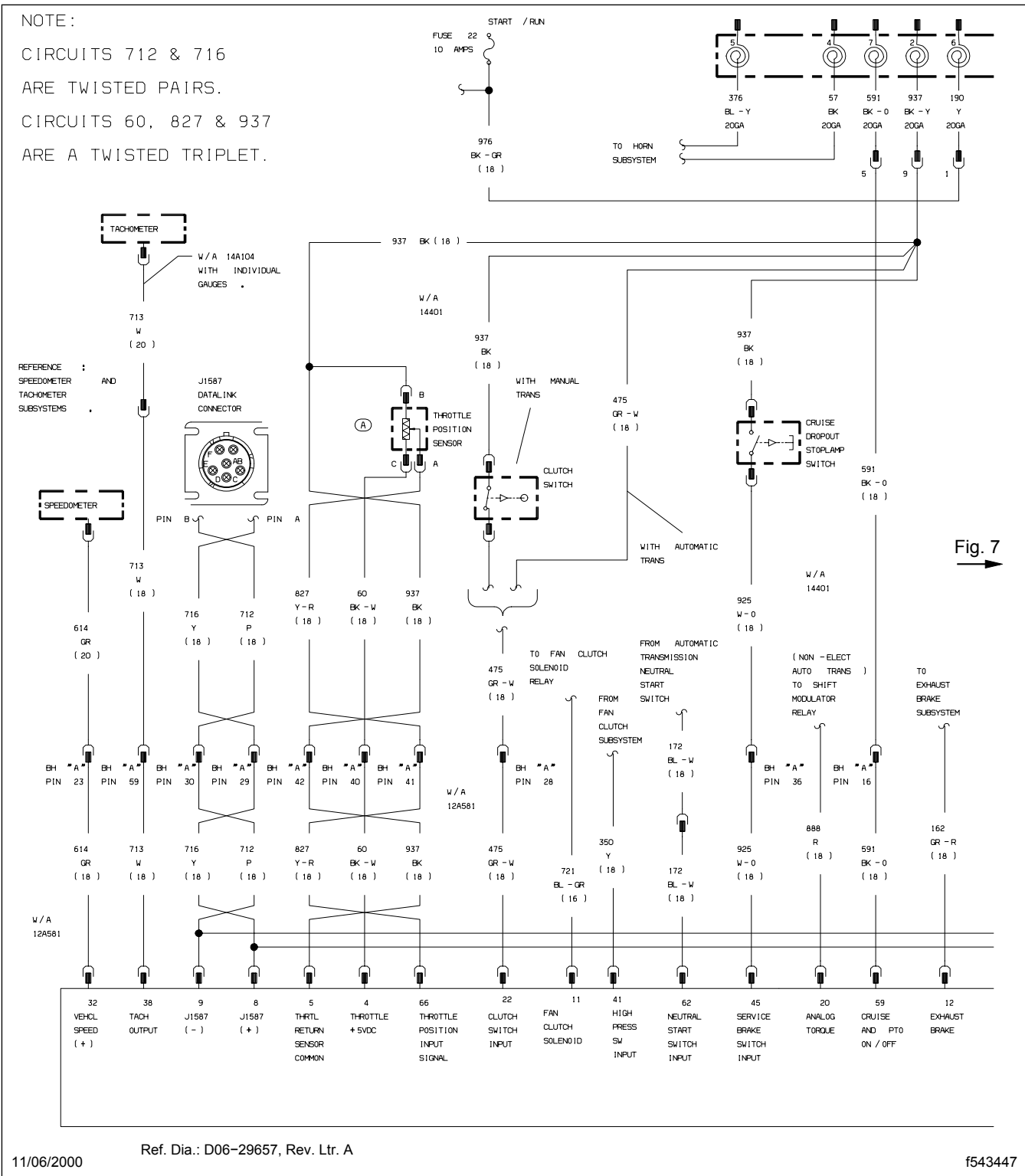

Fig. 6, Caterpillar 3126 Engine Controls Wiring (partial view)

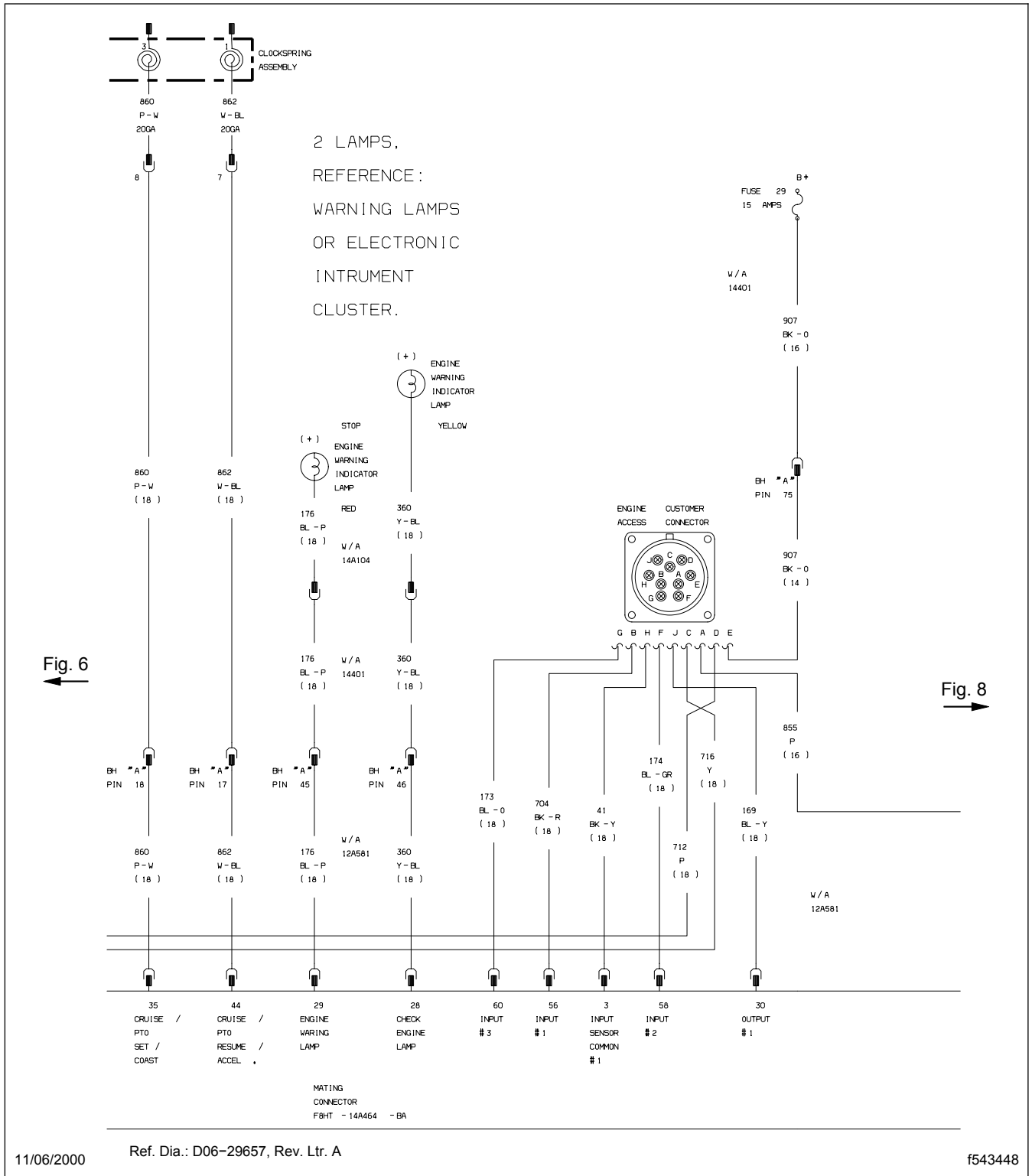

Fig. 7, Caterpillar 3126 Engine Controls Wiring (partial view)

Specifications

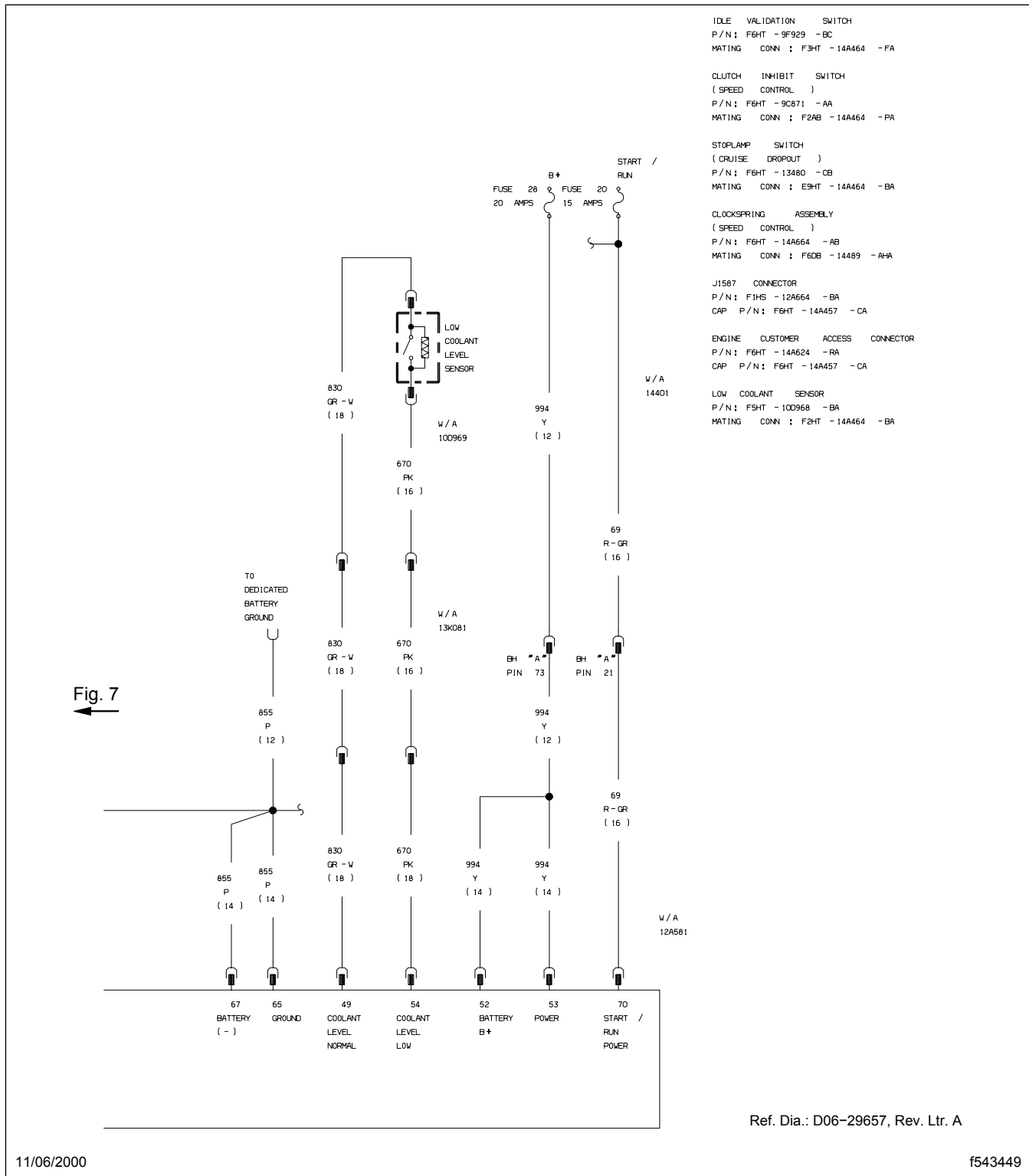

Fig. 8, Caterpillar 3126 Engine Controls Wiring (partial view)

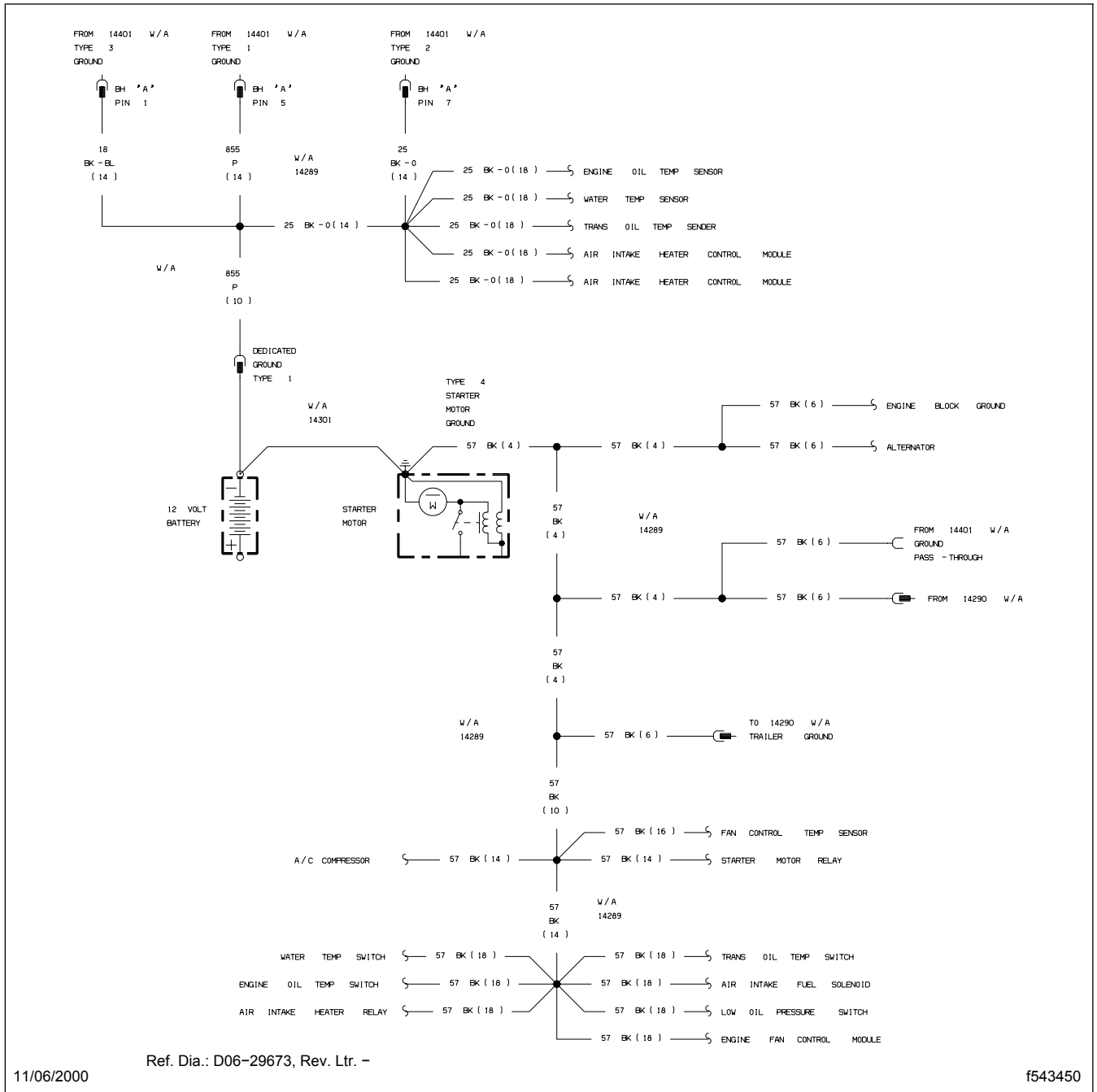

Fig. 9, Caterpillar 3306 Engine Ground Summary (full view)

54.17

Engine Wiring, Caterpillar

Specifications

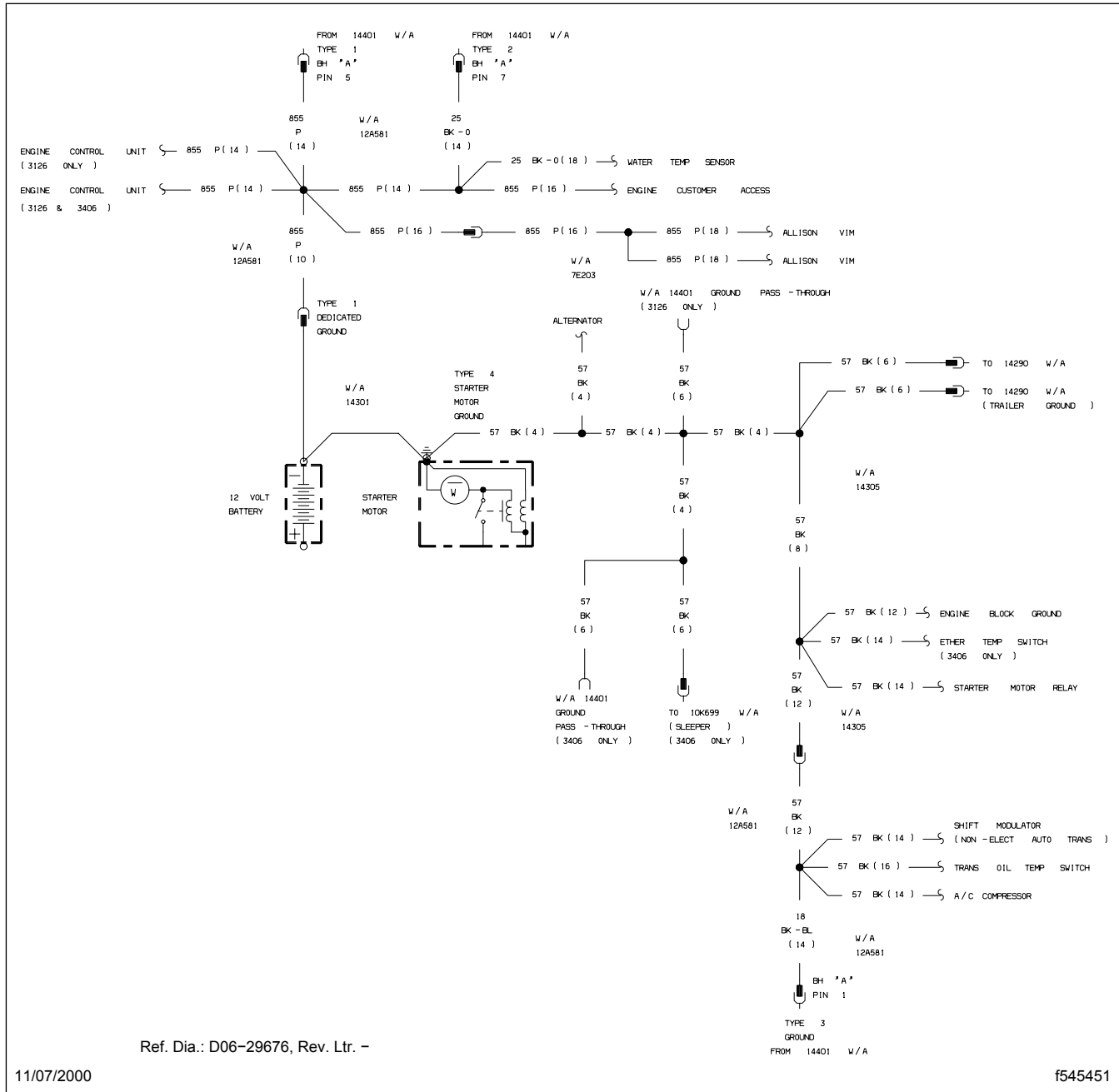

Fig. 10, Caterpillar 3126 and 3406 Engine Ground Summary (full view)

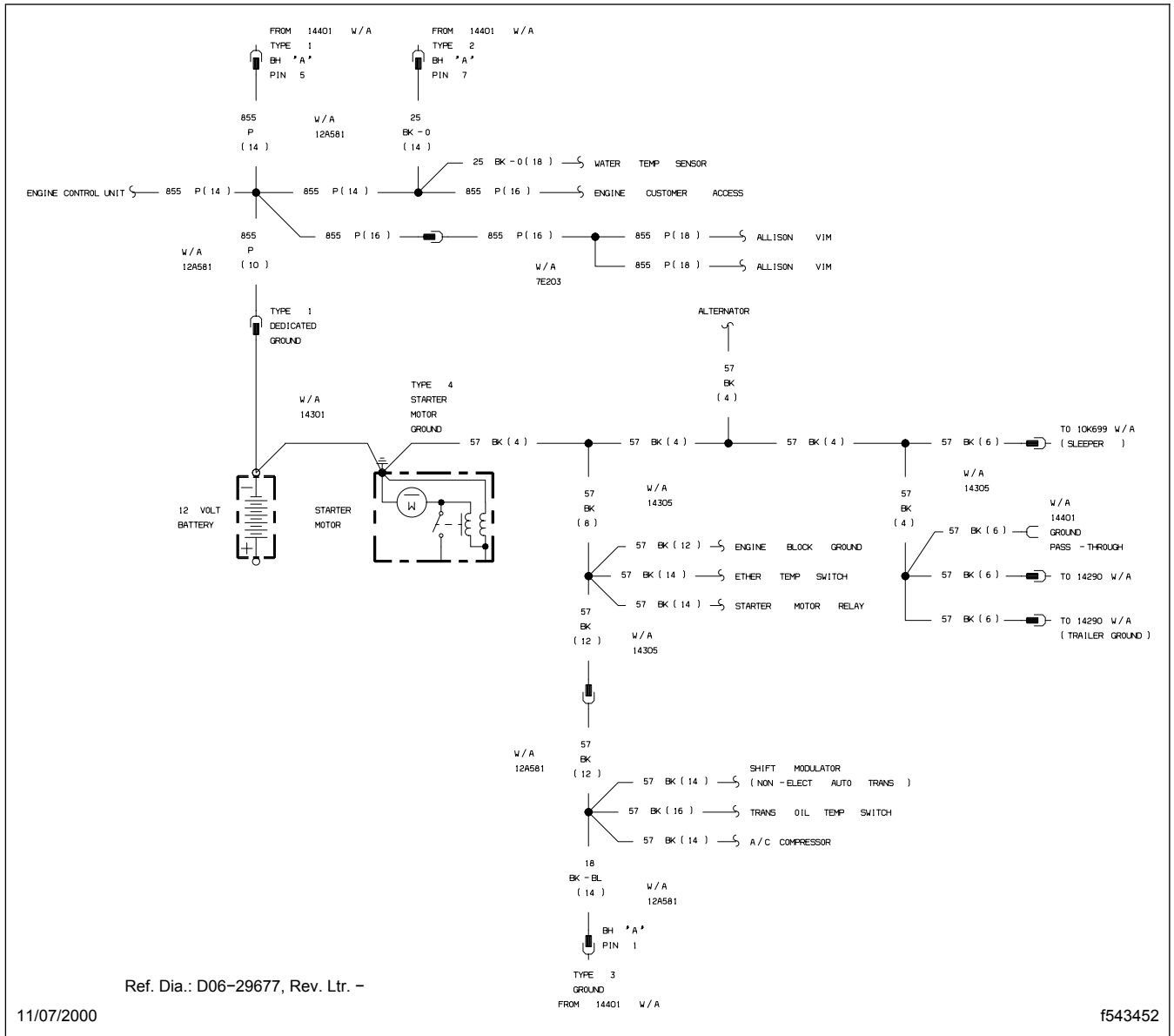

Fig. 11, Caterpillar C10 and C12 Engine Ground Summary (full view)