

POWER DISTRIBUTION

WIRING DIAGRAM: AA-0

BATT
IGN
EMS
ILLUM

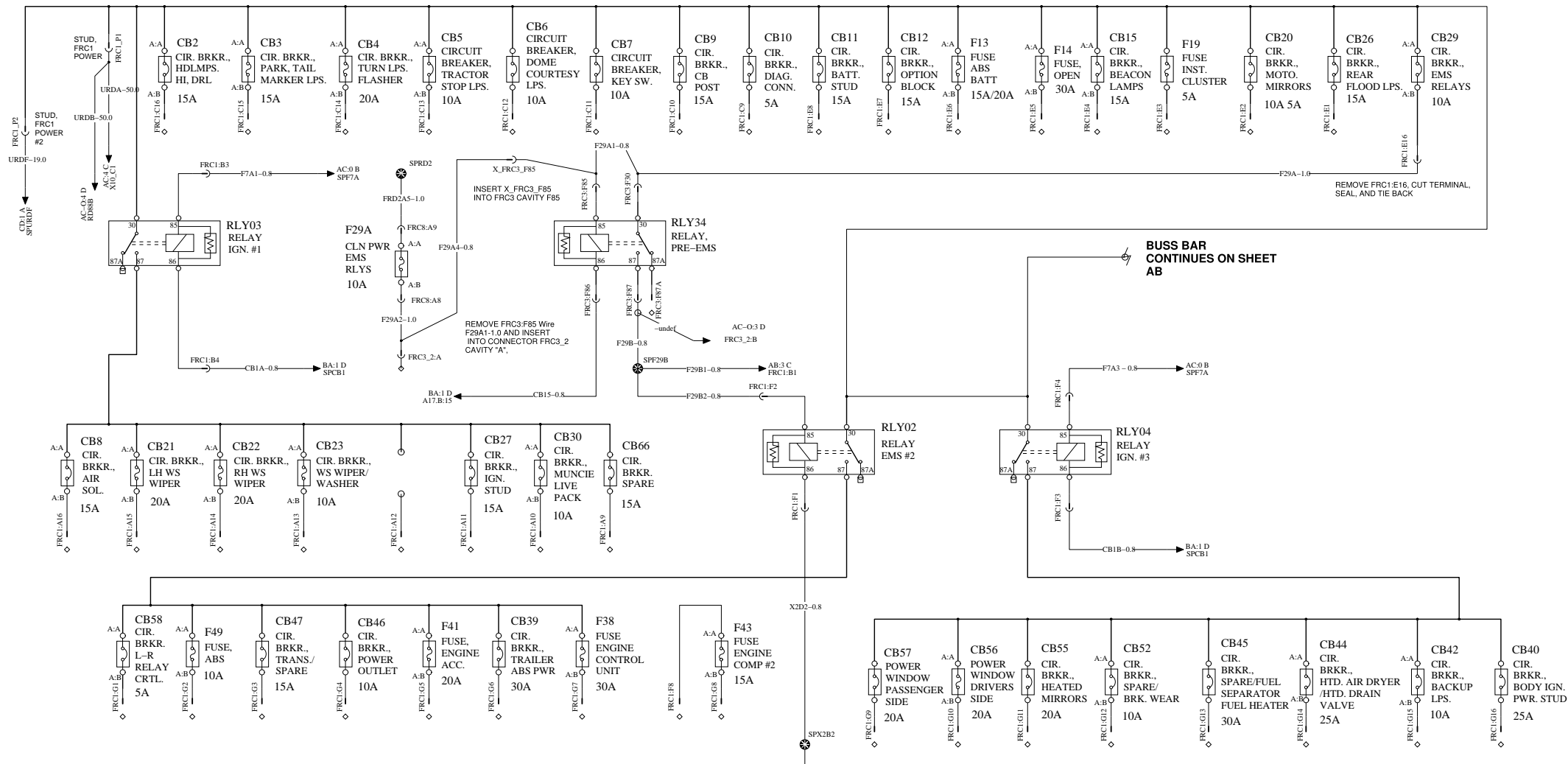

MACK

Mack Trucks Inc.

Document title
WIRING DIAGRAM
Document type
PRODUCT SCHEMATIC

Drawing No.
22760318

Revision
02

Page
2 (17)

NYC_IGN_DISCONNECT

WIRING DIAGRAM: AC-O

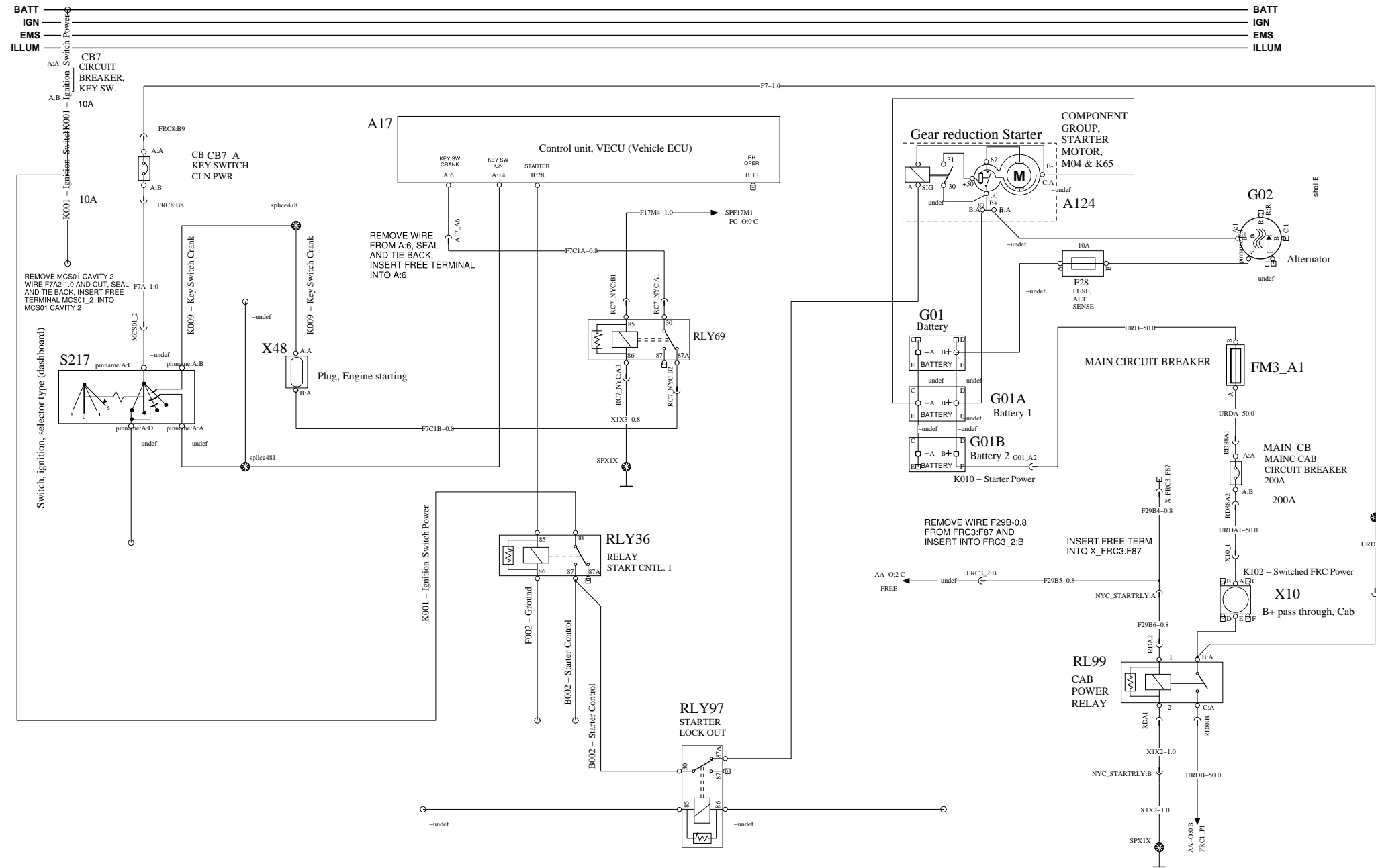

MACK

Mack Trucks Inc.

Document title
WIRING DIAGRAM - TYPE OL L1EH1 - NYC DS
 Document type
PRODUCT SCHEMATIC

Drawing No.
22760318

Revision
02

Page
3 (17)

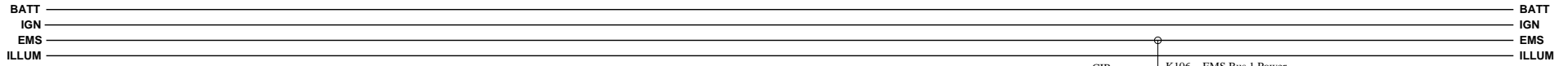

X21A
Socket, Body builder connector

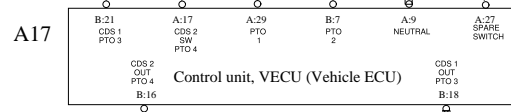
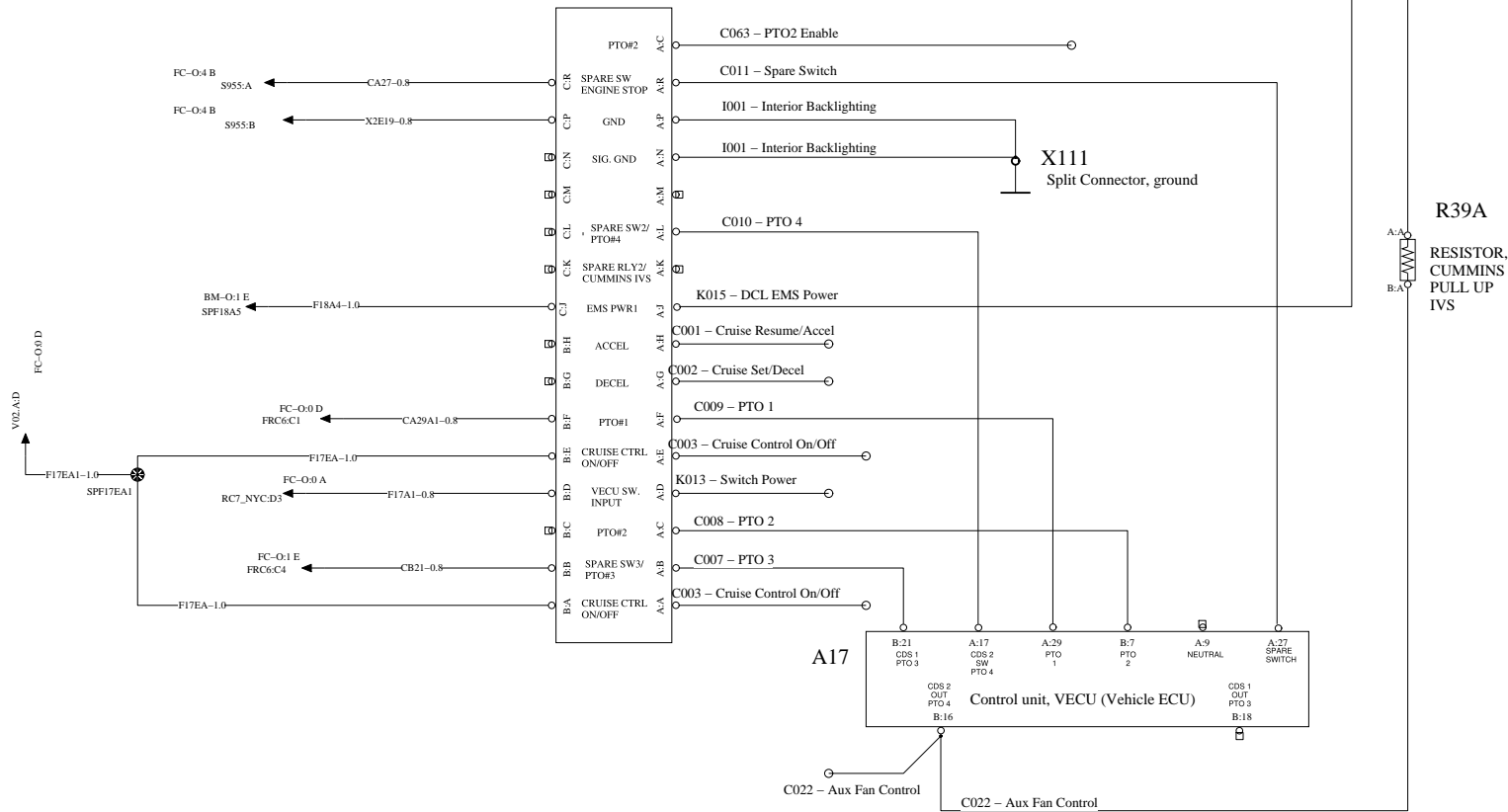

NYC_BBM_V3

WIRING DIAGRAM: BH-O

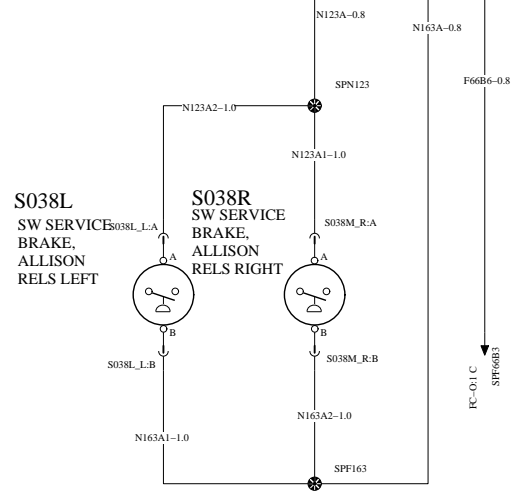
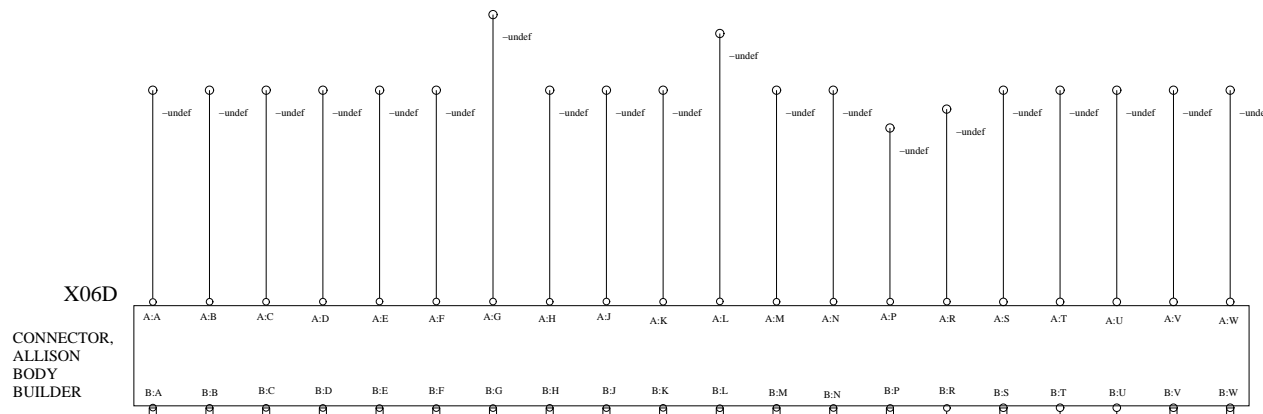
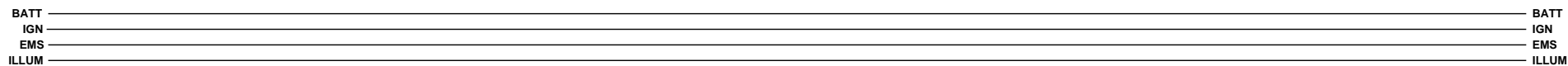

MACK

Mack Trucks Inc.

Document title
WIRING DIAGRAM - TYPE OL L1EH1 - NYC DS

Document type
PRODUCT SCHEMATIC

Drawing No.
22760318

Revision
02

Page
5 (17)

NYC_SINGLE_DUAL_BIN_BB

WIRING DIAGRAM: BN-O

BATT
IGN
EMS
ILLUM

BATT
IGN
EMS
ILLUM

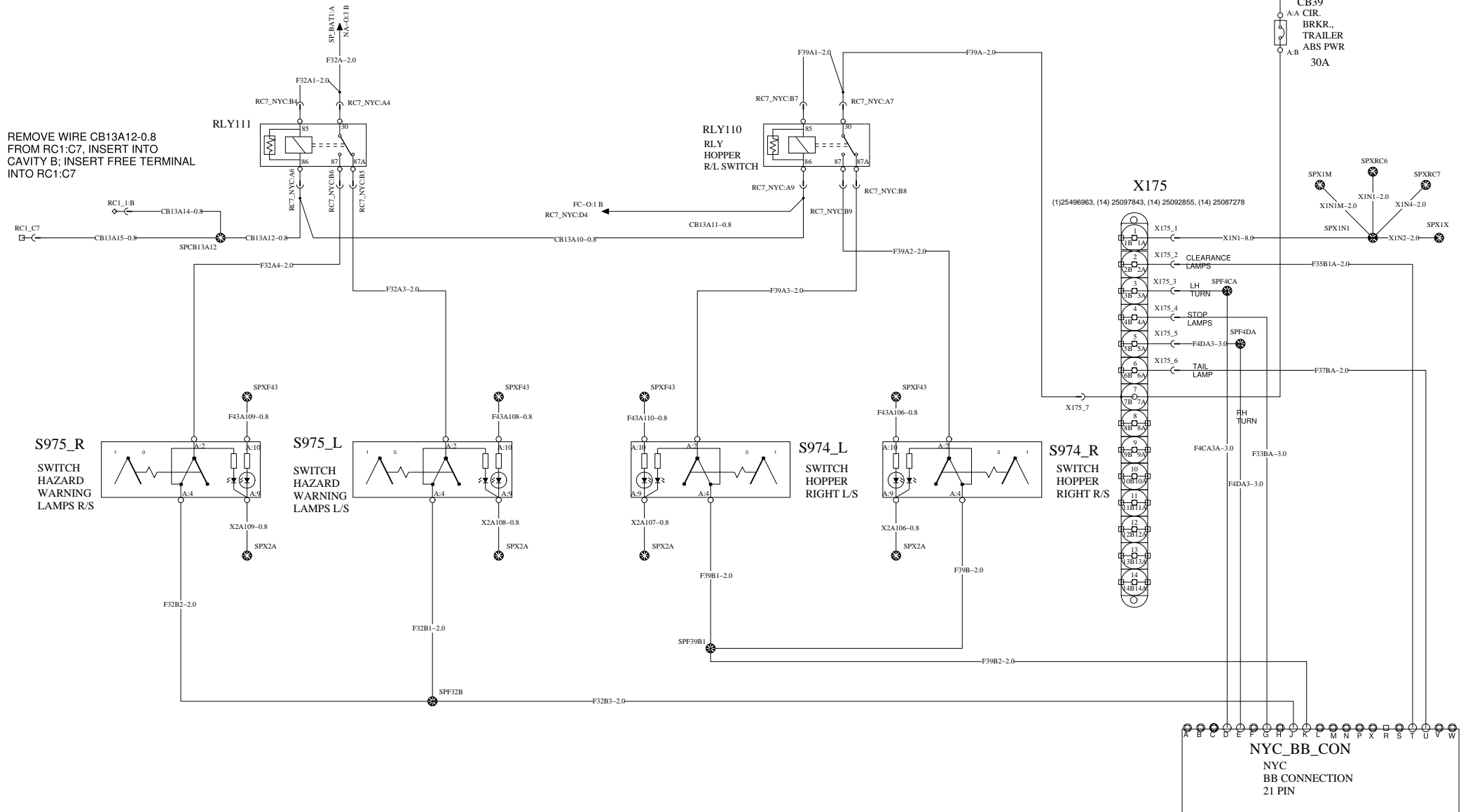

REMOVE WIRE CB13A12-0.8 FROM RC1:C7, INSERT INTO CAVITY B; INSERT FREE TERMINAL INTO RC1:C7

NYC_DPF_ALERT

WIRING DIAGRAM: CK-O

BATT
IGN
EMS
ILLUM

F64
FUSE,
DPF,
IGN
10A 15A 5A

FRC1:A3
INSERT FREE TERMINAL INTO LOCATION

F64A9-0.8

H06
BUZZER
CAB
DPF

X2E7-0.8

SPXE6

V05
Diode

V04
Diode

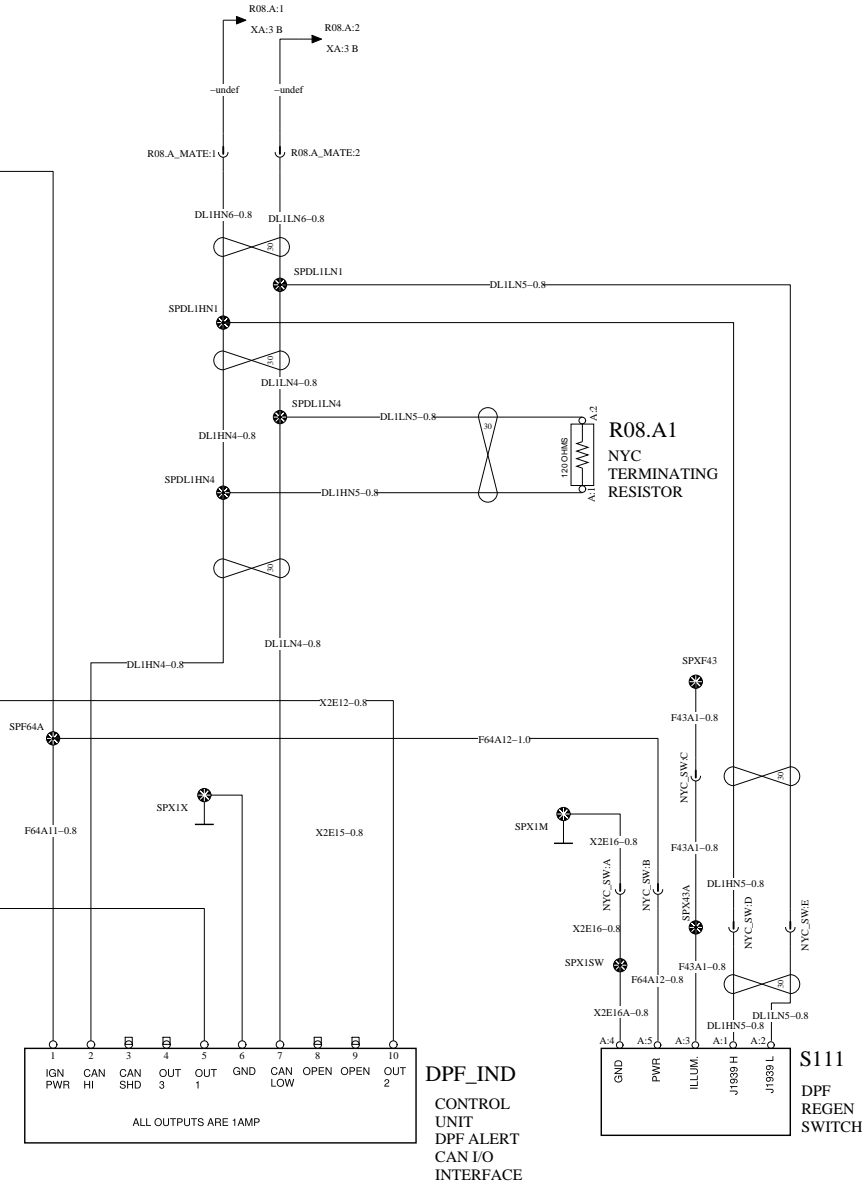

DPF_IND
CONTROL
UNIT
DPF ALERT
CAN I/O
INTERFACE

S111
DPF
REGEN
SWITCH

MACK

Mack Trucks Inc.

Document title
WIRING DIAGRAM - TYPE OL L1EH1 - NYC DS

Document type
PRODUCT SCHEMATIC

Drawing No.
22760318

Revision
02

Page
8 (17)

NYC_DUAL_BIN_BB

BATT
IGN
EMS
ILLUM

WIRING DIAGRAM: FC-A-O

BATT
IGN
EMS
ILLUM

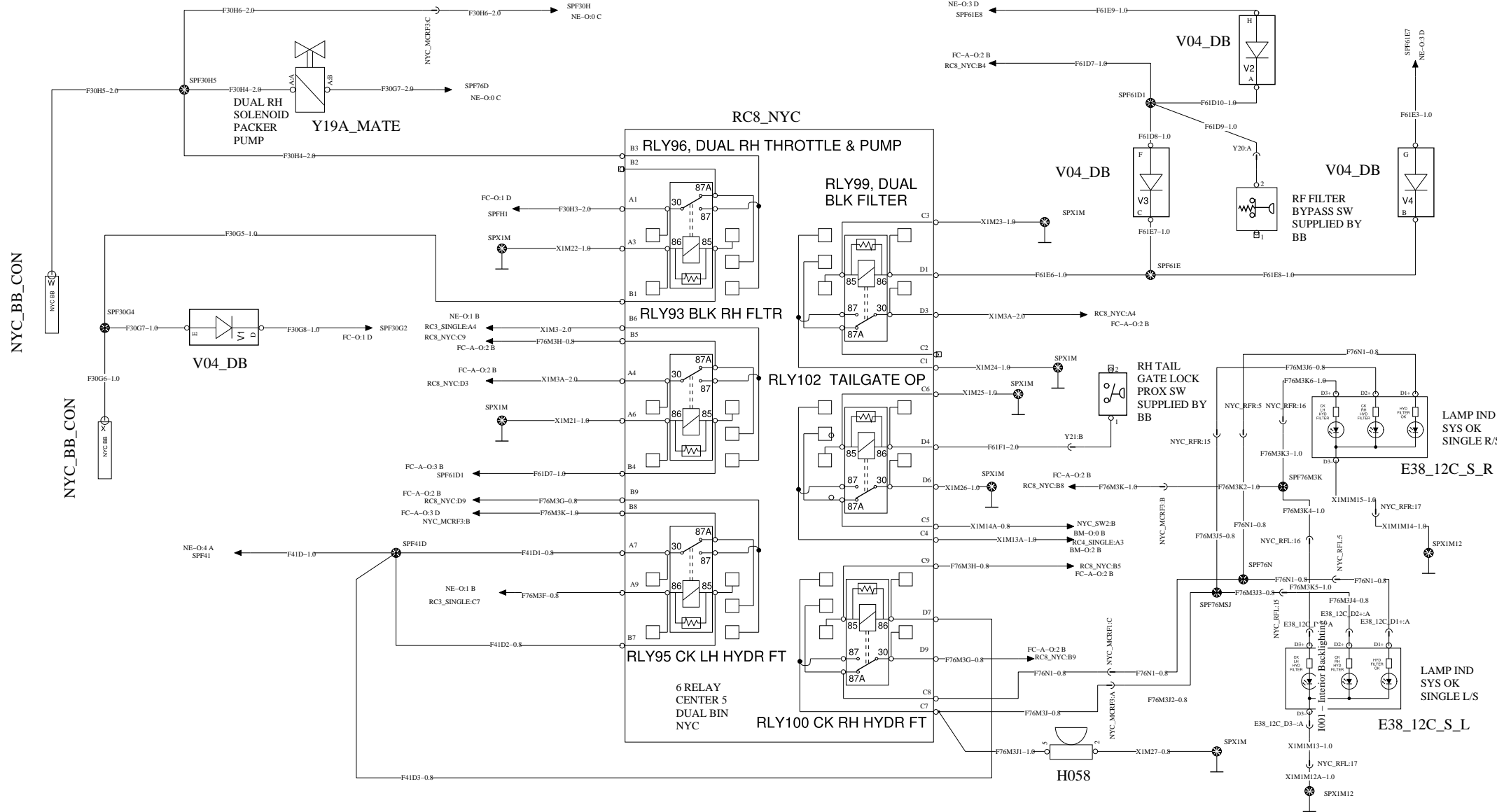

MACK

Mack Trucks Inc.

Document title
WIRING DIAGRAM
Document type
PRODUCT SCHEMATIC

Drawing No.
22760318

Revision
02

Page
9 (17)

BATT
IGN
EMS
ILLUM

BATT
IGN
EMS
ILLUM

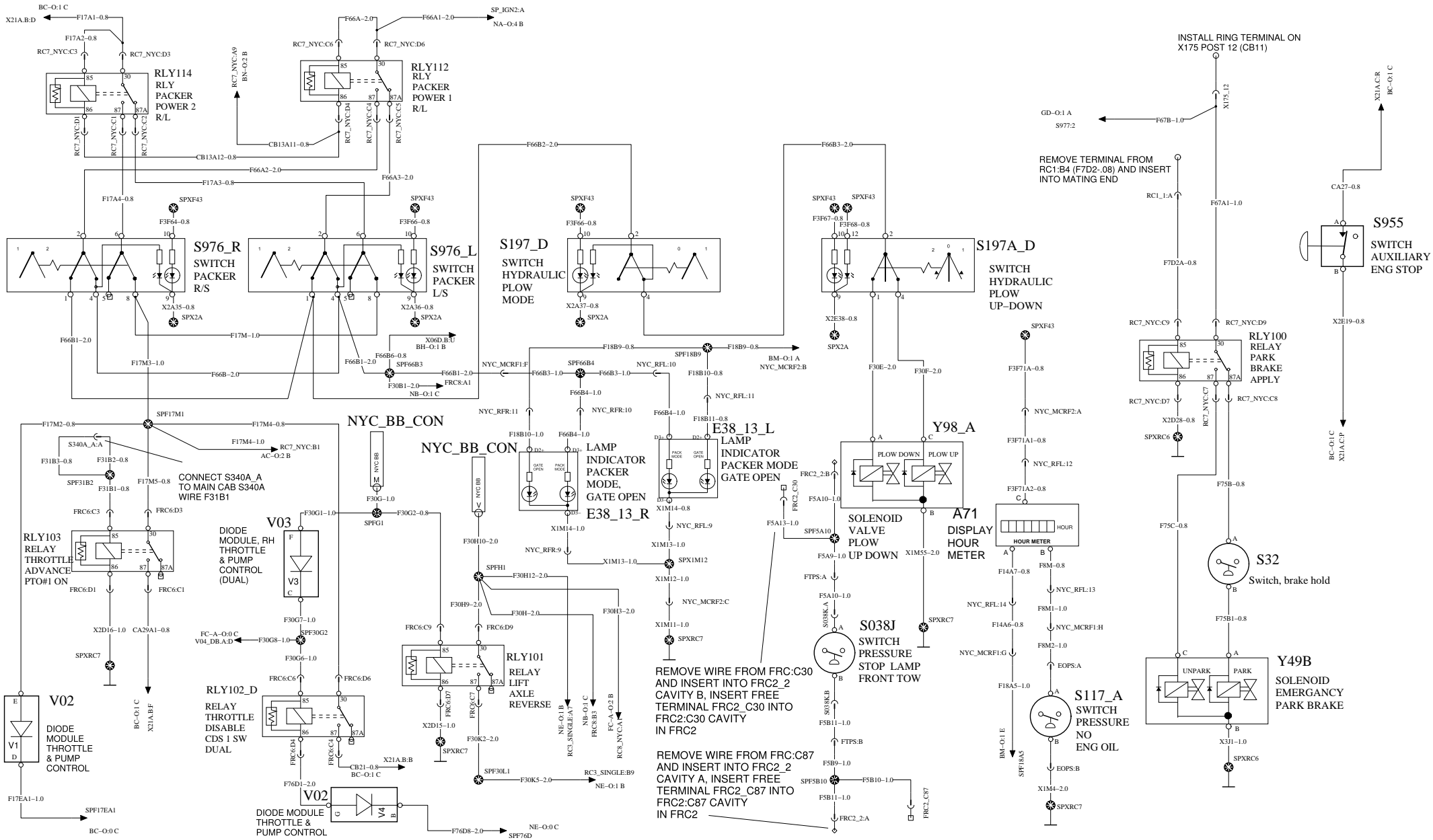

MACK

Mack Trucks Inc.

Document title
WIRING DIAGRAM - TYPE OL L1EH1 - NYC DS

Document type
PRODUCT SCHEMATIC

Drawing No.
22760318

Revision
02

Page
10 (17)

BATT _____ BATT
 IGN _____ IGN
 EMS _____ EMS
 ILLUM _____ ILLUM

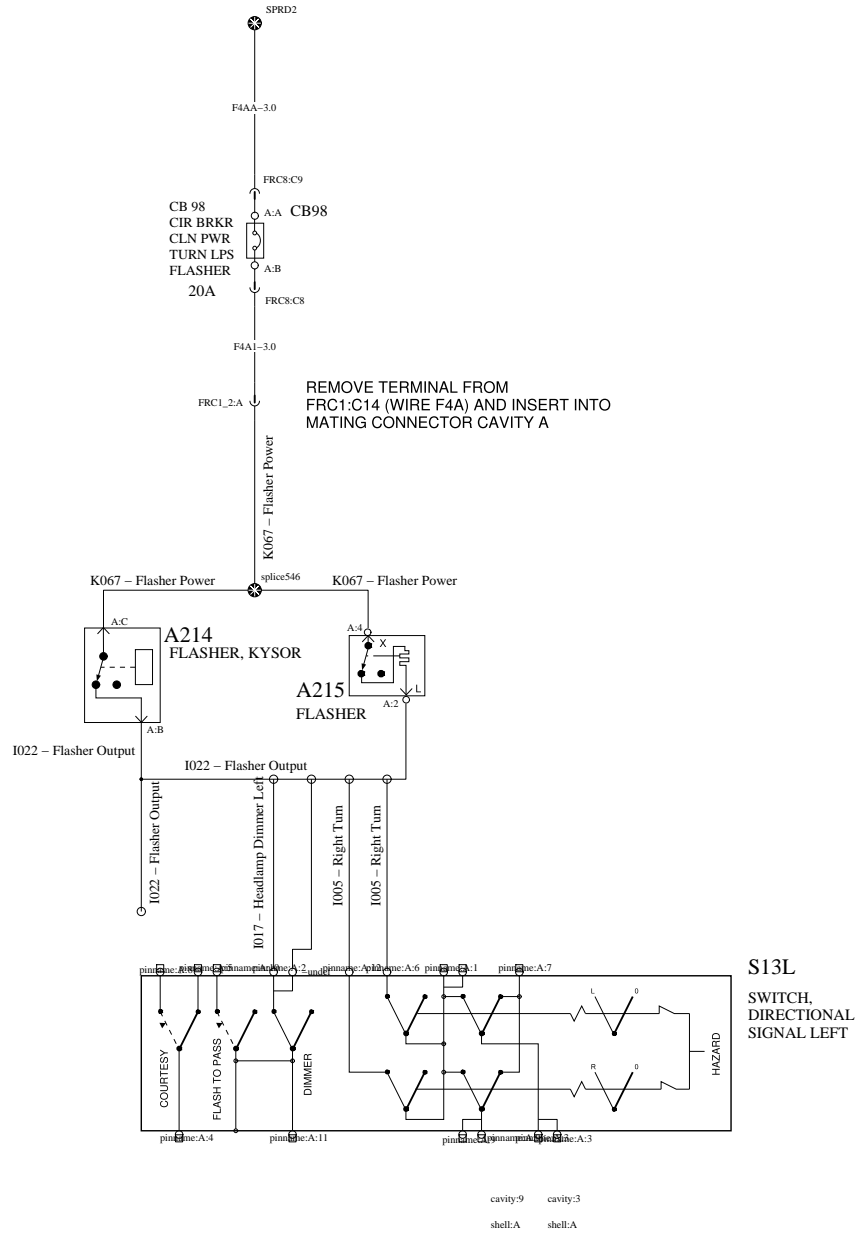

Mack Trucks Inc.

Document title WIRING DIAGRAM - TYPE OL L1EH1 - NYC DS
Document type PRODUCT SCHEMATIC

Drawing No. 22760318	Revision 02	Page 11 (17)
-------------------------	----------------	-----------------

NYC_LIGHTING_PLOW_LIGHTS

WIRING DIAGRAM: GD-O

BATT
IGN
EMS
ILLUM

BATT
IGN
EMS
ILLUM

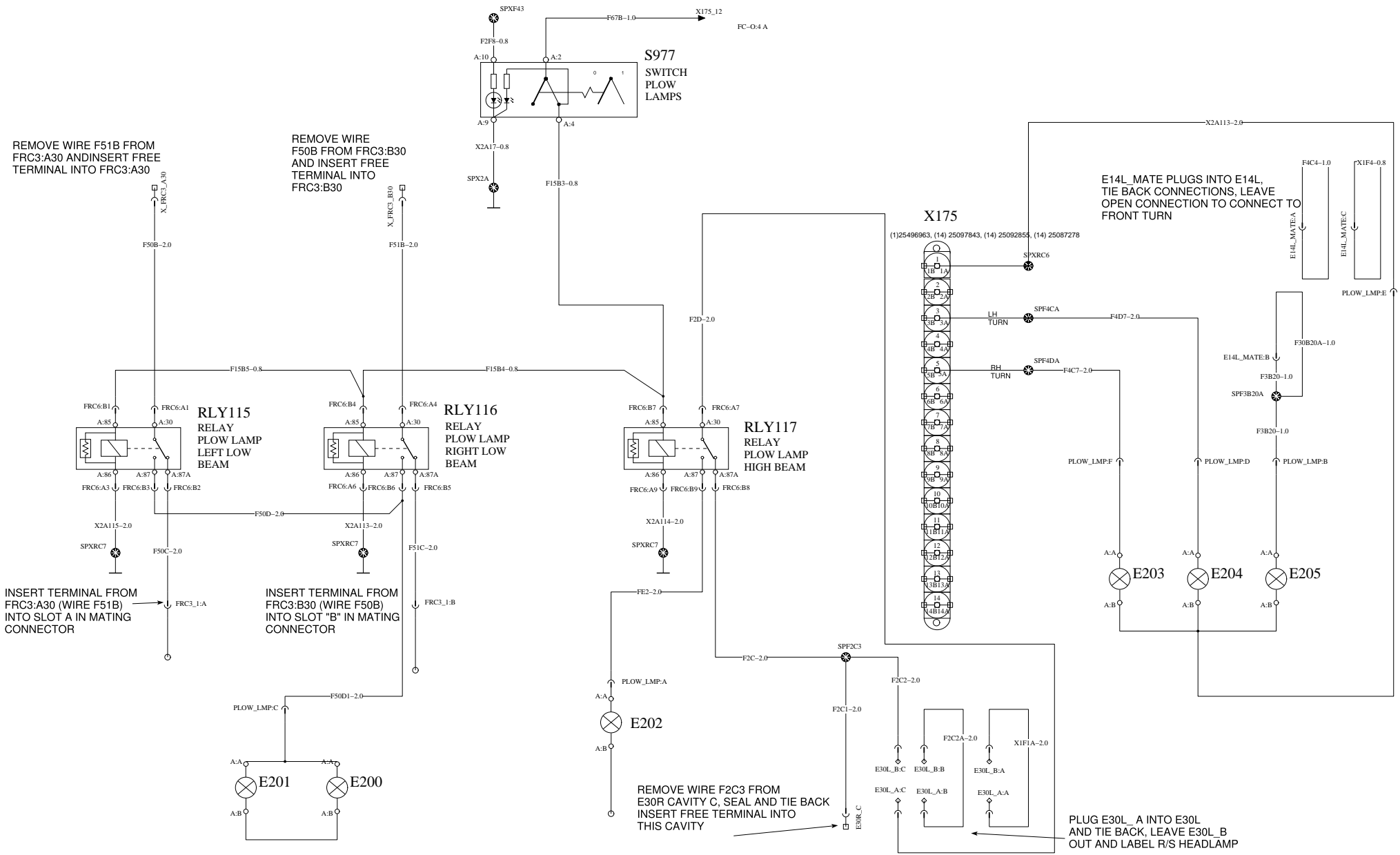

MACK

Mack Trucks Inc.

Document title
WIRING DIAGRAM - TYPE OL L1EH1 - NYC DS

Document type
PRODUCT SCHEMATIC

Drawing No.
22760318

Revision
02

Page
12 (17)

NYC_SPARE_CONNECTORS_&_FEEDS

WIRING DIAGRAM: NA-O

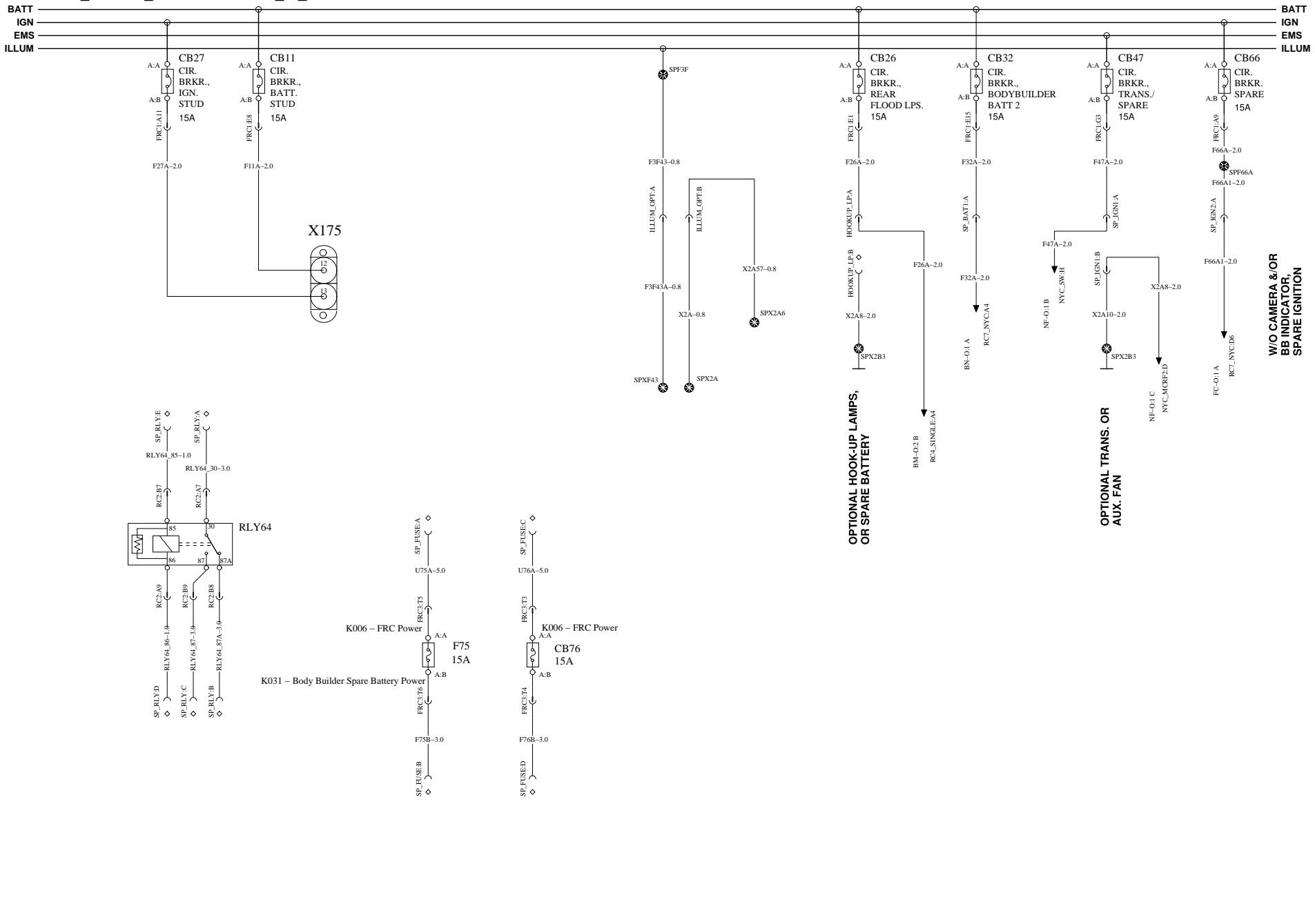

MACK

Mack Trucks Inc.

Document title
 WIRING DIAGRAM - TYPE OL L1EH1 - NYC DS

Document type
 PRODUCT SCHEMATIC

Drawing No.
 22760318

Revision
 02

Page
 13 (17)

WIRING DIAGRAM: NE-O

NYC_DUAL_BIN_BB

BATT
IGN
EMS
ILLUM

BATT
IGN
EMS
ILLUM

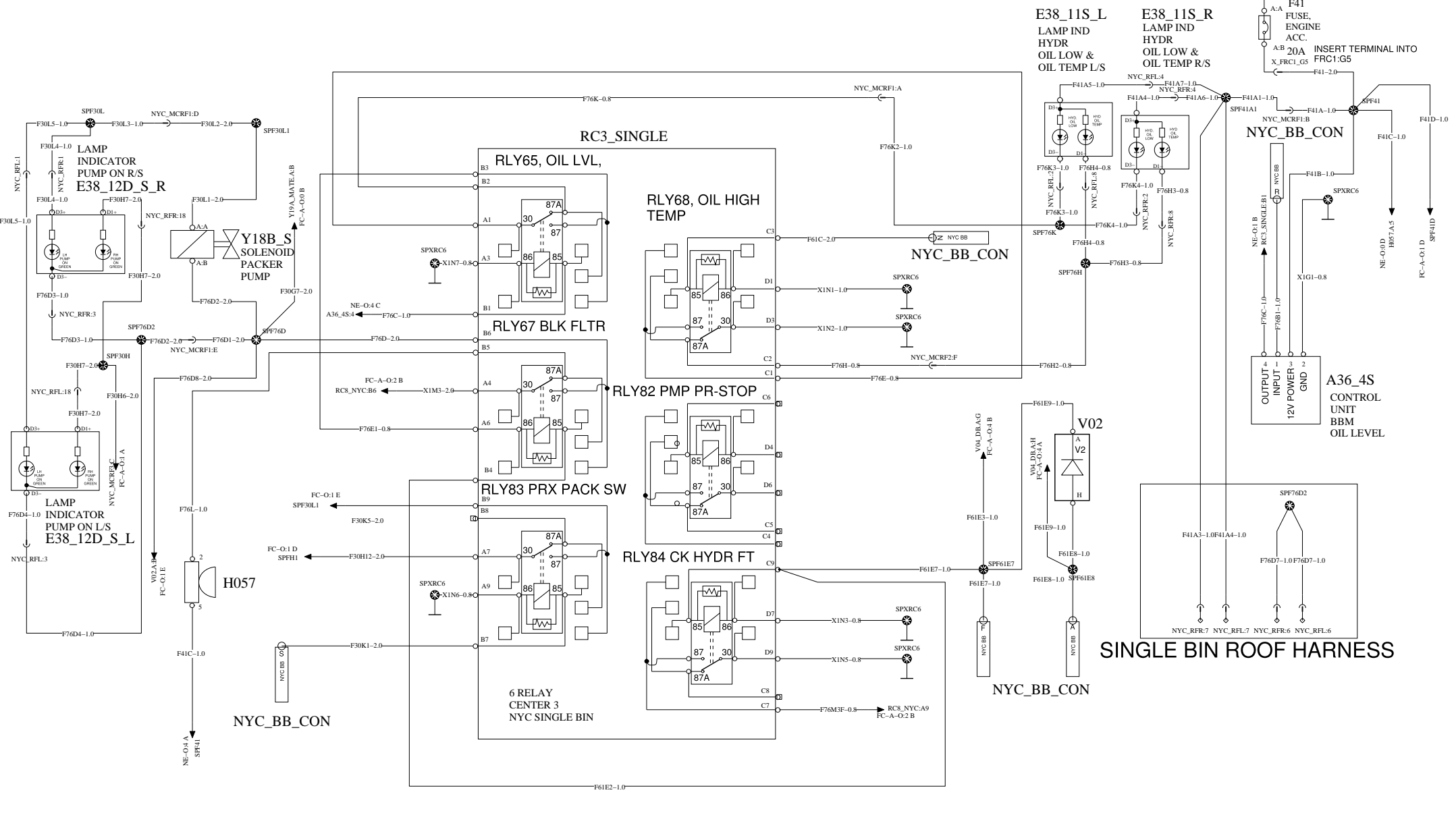

MACK

Mack Trucks Inc.

Document title WIRING DIAGRAM - TYPE OL L1EH1 - NYC DS
Document type PRODUCT SCHEMATIC

Drawing No. 22760318	Revision 02	Page 15 (17)
-------------------------	----------------	-----------------

NYC_SINGLE_DUAL_BIN_ELECTRIC_FUEL_PRIMER_PUMP_&_VENT_FANS

WIRING DIAGRAM: NF-O

BATT
IGN
EMS
ILLUM

BATT
IGN
EMS
ILLUM

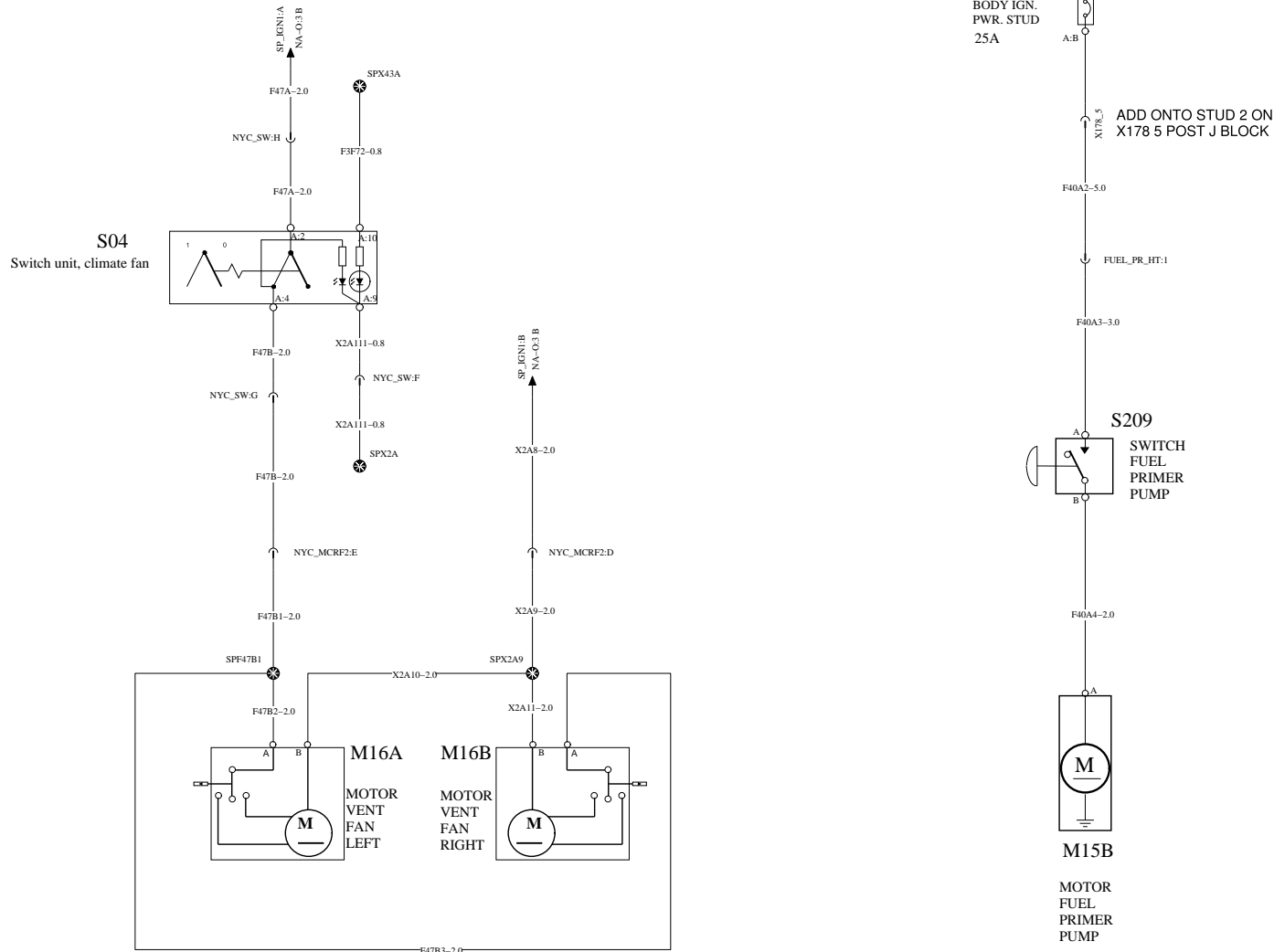

MACK

Mack Trucks Inc.

Document title
WIRING DIAGRAM - TPE OL L1EH1 - NYC DS

Document type
PRODUCT SCHEMATIC

Drawing No.
22760318

Revision
02

Page
16 (17)

BATT _____ BATT
 IGN _____ IGN
 EMS _____ EMS
 ILLUM _____ ILLUM

