

FAULTS AND REMEDIAL ACTIONS

1. Warning and fault messages

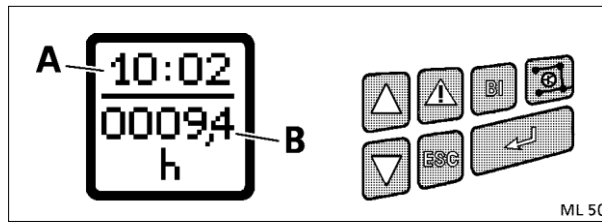

Fig.1

Warning and fault messages are indicated on the multiple display. The warning lamp also flashes and a warning tone is sounded.

Fault codes are stored and can be called up for more accurate definition of the fault. These codes are memorised to be called up in the workshop for rapid fault location.

In normal status, display shows the clock (A) and the number of operating hours (B).

1.1 Warning messages

No fault code, no storage.

Calling up several concurrently existing warnings



Press the button to show the symbols for existing warning messages one after the other. If the button is not pressed for 3 seconds, the symbol for the warning message indicated first reappears.



A89

1. Engine temperature

Display accompanied by a continuous beep and warning light.
Unload the engine immediately, then switch off.

Cause

Clogged radiator fins.
Not enough cooling water.
V-belt is loose or torn.
Thermostat does not open.
Coolant circuit dirty.
Viscous fan faulty.

Remedial Action

Blow or spray fin from inside to outside.
Top up with warm water while the engine is running.
Re-tension or change the belt.
Replace thermostat (workshop task).
Clean out the inside of the system with hot flushing liquid, e.g. P3 (at workshop).
Replace viscous fan (at workshop).

FAULTS AND REMEDIAL ACTIONS



2. Engine oil pressure

Display accompanied by a continuous beep and warning light.
Switch off engine immediately.
Check the oil level.

Cause

Engine oil pressure too low as a result of insufficient or excessively thin oil.
Oil control valve in filter head dirty.

Remedial Action

Top up engine oil or fill with correct oil.
Clean oil control valve (workshop task).



3. Charge air temperature

Display accompanied by a continuous beep and warning light.
Unload the engine immediately, then switch off.

Cause

Charge air dirty.
Cracked V-belt.
Viscous fan faulty.

Remedial Action

Check charge air cooler, and clean if necessary.
Replace V-belt.
Replace viscous fan (at workshop).



4. Hydraulic oil temperature

Display accompanied by a continuous beep and warning light.
Relieve the hydraulic system of load and switch off the engine.

Cause

When carrying out hydraulic operations, the control valve does not engage in 'Neutral'.
Three-point implement is non-standard / lateral support set too narrow.
Three-point implement too heavy / overpressure valve continuously activated in upper limit position of power lift.
Insufficient oil supply for the operation concerned.
Final shutoff incorrectly adjusted.

Remedial Action

Set control valve to "Neutral" and lock / have fault corrected at workshop.
Adapt three-point implement to standard / change side support. If necessary make lifting struts longer, if lifting height is sufficient.
Connect upper link to a different point on the implement; measure pressure during the lifting process (at workshop).
Check and top up oil level.
Re-adjust final shutoff (at workshop).

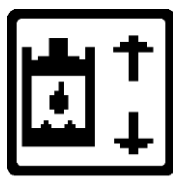

5. Hydraulic oil level (early warning)

Display accompanied by a continuous beep and warning light.
Hydraulic tank could be empty.
Flow rate is limited to 10 l/min for all valves.

FAULTS AND REMEDIAL ACTIONS



ML38

6. Contaminated transmission oil filter

Display accompanied by warning light.

Note: Change the cartridge as soon as the display appears. The display may go out again, still change the cartridge.

Cause

Contaminated hydraulic oil filter element.

Remedial Action

Replace filter unit.

7. Excessive transmission oil temperature (95° - only in range II)

Cause

Heavy traction work over extended period in range II.

Cooler soiled.

Turboclutch function active for too long.

Clutch pedal depressed for too long.

Remedial Action

Switch to driving mode I.

Clean the transmission oil cooler.

Increase engine speed (above 1400 rpm).

Release clutch pedal.

8. Transmission oil temperature too high (105°)

Cause

Transmission oil too hot.

Cooler soiled.

Remedial Action

Allow transmission oil to cool down.

Clean the transmission oil cooler.



A96

9. Oil level too low in brake and clutch system

Indication accompanied by intermittent audible signal and warning lamp.

Cause

Oil leakage.

Remedial Action

Check brake system for leaks. If necessary, fill up with hydraulic oil (Pentosin CHF 11 S).

FAULTS AND REMEDIAL ACTIONS



A100

10. Contaminated air filter

Indication accompanied by intermittent audible signal and warning lamp.

Cause

Air filter main cartridge dirty.

Remedial Action

Check air filter main cartridge. If necessary, clean or replace the air filter main cartridge.



A200

11. Instrument cluster memory

Display accompanied by a continuous beep and warning light.

Cause

Invalid programming of combination instrument.

Remedial Action

Re-programme (at workshop).



A98

12. Hand brake on

Indication accompanied by intermittent audible signal and warning lamp.
Note: only when tractor moving.

Cause

Hand brake applied.

Remedial Action

Release parking brake.



ML 64

13. Engine speed too high

Indication accompanied by intermittent audible signal and warning lamp.

Cause

Engine speed too high.

Remedial Action

Reduce engine speed.



FEHL18

14. Rear PTO on neutral

Display accompanied by warning light.

Cause

PTO speed not preselected.

Remedial Action

Pre-select PTO speed.

FAULTS AND REMEDIAL ACTIONS



FEHL20

15. Engine speed below 500 rpm and turboclutch function switched off

Indication accompanied by intermittent audible signal and warning lamp.

Cause

Engine speed too low.

Remedial Action

Increase engine speed.

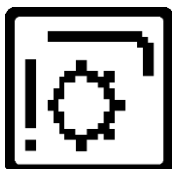

FEHL25

16. Front /rear PTO overspeed

Display accompanied by warning light.

Cause

In PTO stage **1000**, from 1170 rpm.

In PTO stage **540E** as of 630 rpm.

In rear PTO **540** setting, from 630 rpm.

Remedial Action

Reduce PTO speed.

Reduce PTO speed.

Reduce PTO speed.



A119

17. Valve prioritisation

Display accompanied by warning light.

Cause

Prioritised valve is requiring more oil than the pump can provide.

Remedial Action

Valve priority is deactivated temporarily until the pump is able to provide the required quantity again.



A120

18. Driving mode selector

Indicator goes off after about 3 seconds.

Cause

Range control oil too cold.

Remedial Action

Repeat operating range selection at oil temperatures above 10°C or shift while at a standstill.

19. Variotronic Ti

Cause

Engine speed below 400 rpm when playback is started.

Remedial Action

Increase engine speed. Start playback again.

FAULTS AND REMEDIAL ACTIONS

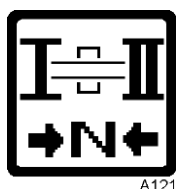

20. Driving mode selection not completed. Mechanical neutral position!

Repeat driving mode selection.



21. Variotronic Ti

Cause

Ground speed too low when playback started.

Remedial Action

Increase the ground speed. Start playback again.



22. Variotronic Ti

Cause

Speed greater than 25 km/h when a playback process starts.

Remedial Action

Reduce speed of travel. Start playback process again.

23. Seat switch

Cause

Driver seat empty for more than 3 seconds.

Remedial Action

Sit on the driver seat.

If the Tractor Management System (TMS) is active, engine speed is reduced.

In accelerator pedal mode, the direction of travel must be actuated again while the tractor is actively stopped.

Playback of Variotronic Ti functions must be started again.

1.2 Fault messages

Indication accompanied by intermittent audible signal and warning lamp.

Fault codes are stored and can be called up for more accurate definition of the fault. These codes are memorised to be called up in the workshop for rapid fault location.

In the event of a fault message, proceed as follows:

- Make the system operative by turning ignition off-on (reset).
- If it was a temporary fault, the system is operative again.

If the fault is displayed again:

- Call up fault code and refer to the code table for what measures to take.

Reading out a fault code

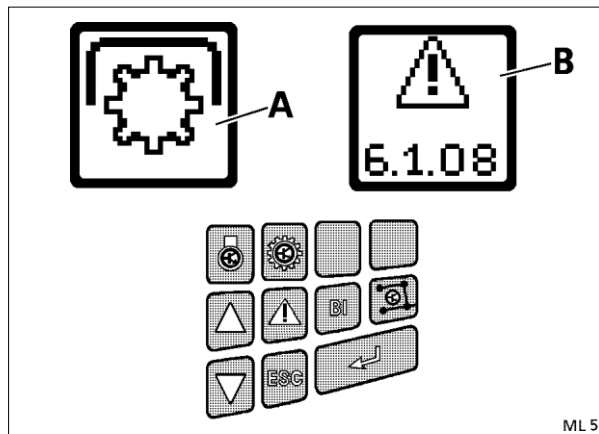

Fig.2



Press button, fault code (B) is shown on the multiple display.

Showing more than one fault message at the same time



If the button is pressed repeatedly, the symbols for all existing faults are displayed one after the other, then symbol (A), code (B), next symbol, next code, and so on. If the button is not pressed for 3 sec., the symbol for the first fault displayed appears again.

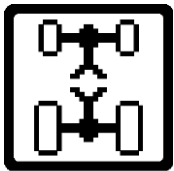

A103

1. Four-wheel drive

Try activating with alternate key.
Switching off may no longer be possible.

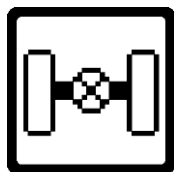

A104

2. Differential lock

Try activating with alternate key.
Switching on may no longer be possible.

FAULTS AND REMEDIAL ACTIONS

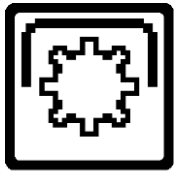

A105

3. Front or rear PTO

Try engaging with another button (5 seconds).



ML33

4. EPC rear lifting gear

Move Quick Lift switch fully or turn ignition off and on again.



ML34

5. Front power lift

Move Quick Lift switch fully or turn ignition off and on again.



ML32

6. Multifunction control lever

Rear/front automatic mode on/off switch faulty.
Automatic mode stop button faulty.



A106

7. Transmission control

Call up fault code and refer to the code table for what measures to take.



A107

8. Sensors

No pressure, speed or volume monitoring.
It is essential to determine the cause of the fault immediately using the code table (see FAULTS AND REMEDIAL ACTIONS Section 5).

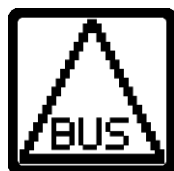

A108

9. Electronic system

Display accompanied by a continuous beep and warning light.
Electronic connections between components are faulty or cut. Other fault codes may occur.



A109

10. Indicator lamps

In the event of failure of the forward/reverse indicator lamps, the backup indicators can be activated (see also OPERATION Section 26.5).



B63

11. Failure of (one) steering pump

Display accompanied by a continuous beep and warning light.
Steering pump or control pump failed. Reduce vehicle speed. Contact the workshop immediately and have the fault corrected.

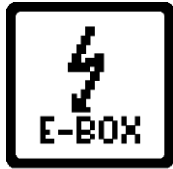

XYL45

12. E-box (not EPC)

E-box hardware fault.
Replace corresponding E-box (at workshop).



A201

13. Memory E-box (not EPC)

E-box basic programming invalid
(reprogramming, workshop task).

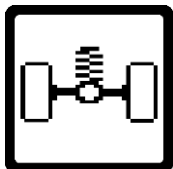

B62

14. Front axle suspension

No longer functioning.
Suspension remains in the last position selected.



XYL 64

15. Emergency operation

Partial failure of the electronic monitoring system.
Use the emergency mode only to move the tractor out of potential danger or to drive to the workshop.



ML 65

16. Excessive transmission slip

Specified/actual transmission slip limit exceeded. This fault may occasionally occur under extreme conditions (e.g. at very low gear oil temperature) even if transmission is mechanically sound. If the problem persists in normal operating conditions, contact the workshop immediately.

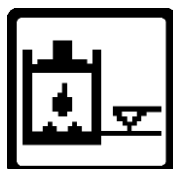

FEHL17

17. Hydraulic (oil level)

Hydraulic tank empty.
Valves, front power lift and rear EPC are locked.

Refill hydraulic oil or switch the valve to floating position manually, so that oil can flow back out of the external cylinder (see also OPERATION Section 17.4).

Switch ignition OFF and ON (Reset).

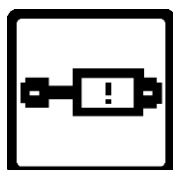

FEHL12

18. Hydraulic valves

Valve remains incorrectly positioned or goes into neutral.

FAULTS AND REMEDIAL ACTIONS



FEHL13

19. Hydraulic valves (crossgate lever)

Valves cannot be actuated.

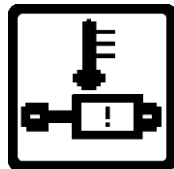

FEHL14

20. Hydraulic valves (oil temperature)

Hydraulic oil temperature too low.
Operate until the oil has warmed up and unlock the valve again.



FEHL15

21. Hydraulic valves (manual operation)

After manual operation, the valves cannot only be operated again with the crossgate lever or toggle switches after a Reset (engine OFF then ON).



FEHL19

22. Engine coolant (level)

Level of coolant too low.
Top up with coolant.



FEHL23

23. Initialisation error on communication driver

CAN bus communication restricted.



A116

24. Fault of mounted implement in implement control mode

Impossible to control the mounted implement via Vario Terminal.
Check operating manual of the implement manufacturer or contact their service.



FEHL27

25. Right or left draft sensing pin overloaded

Relieve right or left draft sensing pin of load.



FEHL39

26. Seat switch defective

In accelerator pedal mode, the driving direction must be re-entered if the tractor is in active stationary mode.
Variotronic Ti functions cannot be played back.



27. Fault in the Variotronic Ti

One or more functions defective.
Variotronic Ti functions cannot be played back.



28. Memory function

One or more functions faulty when activating the memory function.
Start tractor again, if the fault message is still there. Call workshop.



29. Fault in Tractor Management System

Restricted operation. Call workshop.



30. Fault in the PTO power lift automatic function

Call workshop.



31. When starting tractor, activating key depressed or jammed

Release activating key.



32. Plausibility error accelerator rotary control

Accelerator mode is no longer possible.



33. Driving mode selector calibration error

Calibrate the driving mode selector.

1.3 Clearing a warning or fault message



Press key and hold.



Then press button.

Each stored fault messages must be cleared individually. Clearing a fault message does not remove the fault, it is simply no longer displayed.

If the fault is still present, it is indicated again the next time the tractor is started.

FAULTS AND REMEDIAL ACTIONS

1.4 General faults

1. Engine does not start	
<p><u>Cause</u></p> <p>Air in the fuel system.</p> <p>Fuel system clogged with dirt.</p> <p>In very cold conditions: failing cold-start system.</p> <p>In winter, at temperatures under -5 °C: fuel feed blocked by ice or paraffin.</p> <p>No starter contact / faulty starter unit.</p> <p>No power supply to electric shut-off.</p>	<p><u>Remedial Action</u></p> <p>Bleed air from the fuel system.</p> <p>Clean the filter inlet. If necessary, change filter box; vent system.</p> <p>Flame heater system needs repair (in workshop).</p> <p>Unblock filter duct and fuel filter. Use to winter-grade fuel. Bleed air from system.</p> <p>Main shift lever in neutral (starter lockout!). Check power connection of battery starter.</p> <p>Check fuses and connectors.</p>
2. Engine cuts out	
<p><u>Cause</u></p> <p>Air in the fuel system.</p> <p>Fuel system clogged with dirt.</p> <p>In winter, at temperatures under -5 °C: fuel feed blocked by ice or paraffin.</p>	<p><u>Remedial Action</u></p> <p>Bleed air from the fuel system.</p> <p>Clean the filter inlet. If necessary, replace filter element.</p> <p>Bleed air from system.</p> <p>Unblock filter duct and fuel filter. Use to winter-grade fuel. Bleed air from system.</p>
3. Poor engine performance	
<p><u>Cause</u></p> <p>Fuel filter soiled.</p> <p>Fuel delivery pump dirty.</p> <p>Engine brake is not fully open.</p> <p>Turbocharger: leaky intake system / charger damaged.</p>	<p><u>Remedial Action</u></p> <p>Replace filter box. Bleed air from the fuel system.</p> <p>Clean supply pump and bleed air from the system (workshop task).</p> <p>Check engine brake (setting and ease of operation).</p> <p>Check intake and exhaust ducts / check turbocharger (workshop task).</p>
4. Engine produces a lot of smoke	
<p><u>Cause</u></p> <p>Injection nozzles not working properly.</p> <p>Injection volume / start of delivery incorrectly set.</p>	<p><u>Remedial Action</u></p> <p>Check pressure and spray pattern of nozzles (at workshop).</p> <p>Adjust settings (at workshop).</p>
5. Engine causes a lot of noise	
<p><u>Cause</u></p> <p>Imbalance on fan shroud due to soiling.</p>	<p><u>Remedial Action</u></p> <p>Clean the fan shroud.</p>

FAULTS AND REMEDIAL ACTIONS

6. Tractor does not start off

<u>Cause</u>	<u>Remedial Action</u>
Actuator not functioning.	Mechanical Auxiliary mode.
No operating range selected.	Select operating range I or II. Use auxiliary lever, if necessary.
Adjustment not functioning.	Measure servo pressure (too low).
Inlet circuit does not work.	Measure feed and outlet pressure.
Leak in the main circuit.	Measure feed and outlet pressure.
Internal leak in the main circuit.	Check transmission characteristic (at workshop).
High-pressure limiting valve does not shut.	Measure control pressure.
Flush valve stuck open.	Start off in the other direction of travel
Transmission characteristic not programmed.	Record the transmission characteristic (at workshop).
Rpm adjustment not set.	Set the rpm adjustment.

7. Transmission oil temperature too high

<u>Cause</u>	<u>Remedial Action</u>
Cooler soiled.	Clean the radiator.
Heavy traction in operating range II.	Switch to driving mode I.
Clutch operated over extended period.	Fully engage the clutch.
Turboclutch function active for long period.	Increase engine speed.
Leak in the main circuit.	Measure feed and outlet pressure.
Leakage in feed circuit.	Measure feed and outlet pressure.
Leakage in outlet line.	Measure outlet pressure.
High-pressure limiting valve does not shut.	Measure control pressure.
Internal leak in the main circuit.	Check transmission characteristic (at workshop).

8. Interruption of tractive power while reversing or during acceleration-deceleration changes

<u>Cause</u>	<u>Remedial Action</u>
Flush valve stuck open.	Replace purge valve.
High-pressure limiting valve does not shut.	Replace high-pressure limiting valve.

9. Tractor no longer reaches maximum speed

<u>Cause</u>	<u>Remedial Action</u>
Incorrect transmission calibration.	Record the transmission characteristic (at workshop).
Adjustment does not function properly.	Measure servo pressure (too low).
Leak in the main circuit.	Measure feed and outlet pressure.

FAULTS AND REMEDIAL ACTIONS

9. Tractor no longer reaches maximum speed	
Valve for mechanical speed limitation either faulty or incorrectly set.	Replace valve.
Fuel filter soiled.	Replace filter box. Bleed air from the fuel system.
Intercooler pressure too low.	Check the charge air pressure.
10. Tractor does not pull	
<u>Cause</u>	<u>Remedial Action</u>
Feed quantity too flow.	Measure feed and outlet pressure.
Leak in the main circuit.	Measure feed and outlet pressure.
High-pressure limiting valve does not shut.	Measure control pressure.
Flush valve stuck open.	Drive in opposite direction of travel.
11. System pressure too low	
<u>Cause</u>	<u>Remedial Action</u>
No feed for servo pump.	Check lubricating pressure.
Servo pump does not deliver.	Check servo pump pressure.
Leakage in pressure or suction line.	Check oil level in clutch housing (too high).
40 bar pressure limiting valve does not close.	Measure servo pump pressure (= lubrication pressure).
18 bar pressure control valve does not close.	Measure feed pressure (= system pressure).
Leak in comfort circuit.	Measure feed pressure, visual check.
12. Inlet pressure too low	
<u>Cause</u>	<u>Remedial Action</u>
No feed for servo pump.	Check lubricating pressure (= 0)
Servo pressure less than 18 bar.	Measure servo pressure.
Leak in comfort circuit.	Measure servo pressure, visual check.
Leak in feed line.	Measure output pressure (too low).
Leak in outlet line.	Measure output pressure (too low).
Hydrostatic drive leaks or lifts off.	Measure output pressure (too low).
High-pressure valve is loose.	Measure output pressure (too low).
Output pressure control valve does not shut.	Measure output pressure (too low).
Input pressure control valve does not shut.	Measure output pressure (= input pressure).
13. Output pressure too low	
<u>Cause</u>	<u>Remedial Action</u>
Input pressure too low.	Measure input pressure (too low).
Leak in outlet line.	Measure input pressure (under load too low, without load OK).

FAULTS AND REMEDIAL ACTIONS

13. Output pressure too low	
<p>Hydrostatic unit leaks.</p> <p>High-pressure valve is loose.</p> <p>Outlet pressure limiting valve does not close.</p>	<p>Measure input pressure (too low).</p> <p>Measure feed pressure (too low), tighten.</p> <p>Output pressure = pre-cooler flow pressure.</p>
14. Battery charge indicator lamp lit	
<p><u>Cause</u></p> <p>Contact problem on alternator connector.</p> <p>Cable from alternator to charging indicator lamp has interrupted ground connection or wire.</p> <p>Fault in alternator.</p>	<p><u>Remedial Action</u></p> <p>Check connectors (in workshop).</p> <p>Eliminate the short circuit (in workshop).</p> <p>Check the alternator. Repair, or replace if necessary (at workshop).</p>
15. No reading on the digital display	
<p><u>Cause</u></p> <p>Interrupted power supply.</p>	<p><u>Remedial Action</u></p> <p>Replace fuse and check connectors.</p> <p>Check fuses and connectors.</p>
16. General faults in the electrical system	
<p><u>Cause</u></p> <p>No contact between terminals and battery cables.</p>	<p><u>Remedial Action</u></p> <p>Remove any oxidation from terminals and clamps, tighten the clamp screws; coat terminals with anticorrosion grease.</p>
17. Turn signal / hazard warning system not functioning	
<p><u>Cause</u></p> <p>Power supply interrupted; hazard warning flasher inoperative.</p>	<p><u>Remedial Action</u></p> <p>Check fuse / power supply and replace signal pulse generator if necessary.</p>
18. Turn signal indicator lamps do not come on	
<p><u>Cause</u></p> <p>Bulbs faulty in corresponding turn signal lamps on tractor or trailer.</p>	<p><u>Remedial Action</u></p> <p>Replace bulbs; establish current / ground contact; check trailer cable connectors.</p>
19. Brakes do not function properly (to be dealt with at the service workshop)	
<p><u>Cause</u></p> <p>Brake pedals have too much free travel / uneven braking effect.</p> <p>Brake pedal movement is spongy and too long.</p> <p>Oil loss in brake and clutch system.</p>	<p><u>Remedial Action</u></p> <p>Adjust foot brake, repair if necessary.</p> <p>Bleed air from the foot brake circuit. Eliminate cause of leak, as necessary.</p> <p>Remedy the cause of oil loss.</p>

FAULTS AND REMEDIAL ACTIONS

20. Electronic control hydraulics (EPC) rear, position control at front not functioning.	
<p><u>Cause</u></p> <p>Safety lock active.</p> <p>Rear EPC: lifting gear switched to operation with dual-action additional control unit / lever cannot be changed over.</p> <p>Lifting height limitation is set to min. lift.</p> <p>Fuses blown.</p>	<p><u>Remedial Action</u></p> <p>Press quick lift switch beyond Stop position until indicator lamps light up.</p> <p>Relieve the lifting gear of load, switch off engine, switch the lever fully and release the safety lock.</p> <p>If necessary, increase lift.</p> <p>Change fuses.</p>
21. Fault in the lifting gear control	
<p><u>Cause</u></p> <p>For example, loose electrical connections, failure of an electronic component, etc.</p>	<p><u>Remedial Action</u></p> <p>Call up fault code on the multiple display, if necessary contact the after-sales service workshop.</p>
22. Slip control operating inaccurately	
<p><u>Cause</u></p> <p>Speed signals in the EPC E-box are inaccurate.</p>	<p><u>Remedial Action</u></p> <p>Adjust the radar sensor.</p>
23. Hydraulic traction control unsatisfactory (insufficient number of governor pulses)	
<p><u>Cause</u></p> <p>Position / traction setting is set too far towards Position.</p> <p>Plough blade is blunt (no cutting action).</p> <p>Working implement unsuitable for control hydraulics.</p>	<p><u>Remedial Action</u></p> <p>If necessary, set more towards 'Traction.</p> <p>Sharpen plough blade.</p> <p>Use an implement suitable for the control hydraulics.</p>
24. Lifting gear does not lower	
<p><u>Cause</u></p> <p>Lowering speed setting too far towards. No lowering.</p>	<p><u>Remedial Action</u></p> <p>If necessary, set more towards "Max. lowering speed".</p>
25. Excessive noise in hydraulic system	
<p><u>Cause</u></p> <p>Hydraulic oil still cold.</p> <p>Insufficient oil in the hydraulic oil reservoir.</p> <p>Air drawn in through suction line connections or pump shaft seal.</p> <p>Suction filter soiled.</p>	<p><u>Remedial Action</u></p> <p>Let engine run for a few minutes at average speed before any hydraulic work.</p> <p>Top up oil level in accordance with specifications.</p> <p>Seal the connections and/or replace the hydraulic pump (at workshop).</p> <p>Replace suction filter.</p>

FAULTS AND REMEDIAL ACTIONS

26. Hydraulic system does not lift	
<p><u>Cause</u></p> <p>Hydraulic oil still cold.</p> <p>Insufficient oil in the hydraulic oil reservoir.</p> <p>Air drawn in through suction line connections.</p> <p>Suction filter soiled.</p>	<p><u>Remedial Action</u></p> <p>Let engine run for a few minutes at average speed before any hydraulic work.</p> <p>Top up oil level in accordance with specifications.</p> <p>Seal the connections (at workshop).</p> <p>Replace suction filter.</p>
27. Heater ineffective	
<p><u>Cause</u></p> <p>Heating water valve is partially closed / air filter dirty.</p>	<p><u>Remedial Action</u></p> <p>Open the heating water valve / replace air filter.</p>
28. Heater fan not working	
<p><u>Cause</u></p> <p>Power supply to blower interrupted or blower failed / blocked.</p>	<p><u>Remedial Action</u></p> <p>Check fuse / power supply, remove foreign bodies (in workshop).</p>
29. Air-sprung seat fails to adjust	
<p><u>Cause</u></p> <p>Compressed air compressor not functioning.</p>	<p><u>Remedial Action</u></p> <p>Check fuse / power supply.</p>
30. Air conditioning does not work	
<p><u>Cause</u></p> <p>Fresh air fan not switched on / not functioning / temperature selector set at '0'.</p> <p>AC compressor not functioning - magnetic clutch not engaging / V-belt is too slack or cracked.</p> <p>Insufficient refrigerant in the system (system on, engine speed 2,000 rpm; ball must be floating in sight glass on fluid reservoir).</p>	<p><u>Remedial Action</u></p> <p>Switch on fan / set temperature selector to desired outlet air temperature / check fuse and power supply.</p> <p>Check fuse / power supply for magnetic clutch or V-belt.</p> <p>Top up refrigerant (at workshop).</p>
31. Cooling effect of air conditioning inadequate	
<p><u>Cause</u></p> <p>Condenser dirty (upstream of engine radiator).</p> <p>Fresh air/ recirculating air filter dirty.</p> <p>Evaporator iced up.</p> <p>Insufficient refrigerant in the system (system on, engine speed 2,000 rpm; ball in sightglass of fluid tank must be floating).</p>	<p><u>Remedial Action</u></p> <p>Blow out or spray condenser from inside out.</p> <p>Blow out recirculated air filter, tap out the fresh air filter; replace if necessary.</p> <p>Reset temperature selector; have the cause rectified (at workshop).</p> <p>Top up refrigerant (at workshop).</p>

FAULTS AND REMEDIAL ACTIONS

32. Blue ball in fluid tank turned pink	
<u>Cause</u> Dryer in fluid reservoir is saturated.	<u>Remedial Action</u> Replace fluid reservoir (workshop job - refer to workshop manual, air conditioning section).
33. Water drips from fan casing (air conditioning)	
<u>Cause</u> Condensation outlet blocked (line ends at left and right cab access ladders).	<u>Remedial Action</u> Clear the water outlet (blow through if necessary).

2. Variotronic Ti fault messages

Fault messages are displayed as symbols on the Vario terminal.

Each stored fault messages must be cleared individually. Clearing a fault message does not remove the fault, it is simply no longer displayed.

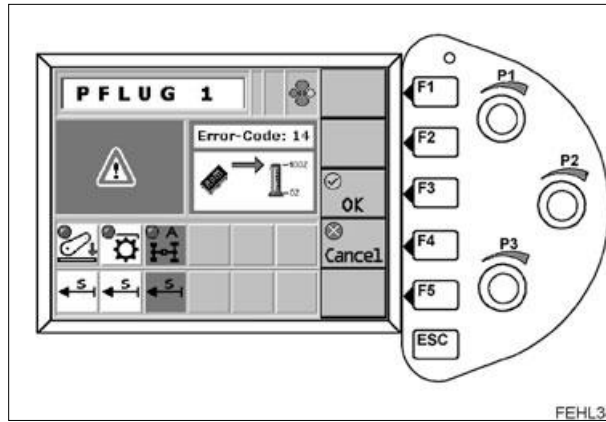

Fig.3

- Press key (F3). Confirm fault message.
- Press key (F4). Cancel process.



FEHL51

1. Fault in a sub-function

Read error code from the multi-display. Consult workshop.

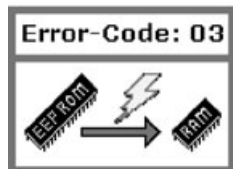

FEHL52

2. Memory fault (EEPROM)

If this occurs several times, consult workshop.

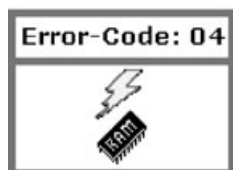

FEHL53

3. Memory fault (system)

If this occurs several times, consult workshop.

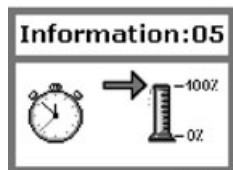

FEHL26

4. Specified/actual value error

Process is cancelled.

FAULTS AND REMEDIAL ACTIONS

5. Timeout exceeded (max. 120 seconds)

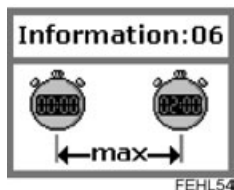

Process is cancelled.

6. Distance exceeded (max. 300 meters)

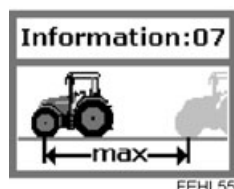

Process is cancelled.

7. No configuration available



Create configuration. Start recording again.

8. Communication error on operating console

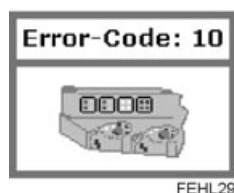

Call workshop.

9. Joystick faulty



Call workshop.

10. Automatic mode memory error

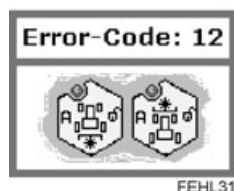

Call workshop.

11. Fault in a sub-function



Read error code from the multi-display. Consult workshop.

12. Button on joystick faulty

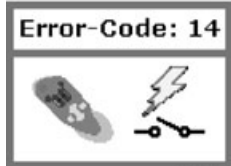

Call workshop.

13. Button on control terminal faulty



Call workshop.

14. Rear PTO setting pre-selection

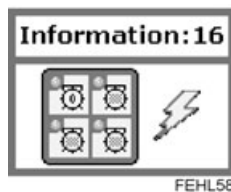

Setting different in recording/playback. Change the setting pre-selection.

15. Memory function

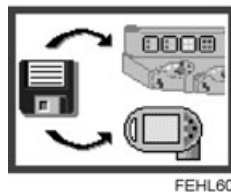

Press F4 key. Latest settings are activated.
Press F5 key. Base settings are activated.

16. Incorrect direction of travel when starting playback



Change the direction of travel (drive forward). Start playback again.

17. Incorrect direction of travel when starting playback



Change direction of travel (to reverse). Start playback again.

18. Automatic mode memory error

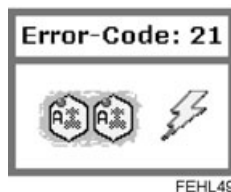

Call workshop.

FAULTS AND REMEDIAL ACTIONS

Information:24



FEHL30

19. operating sequence too long

Recording is stopped.

Error-Code:255

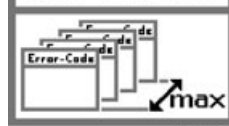

FEHL35

20. Too many fault messages

Confirm fault messages.

3. Warning and information messages for implementation settings

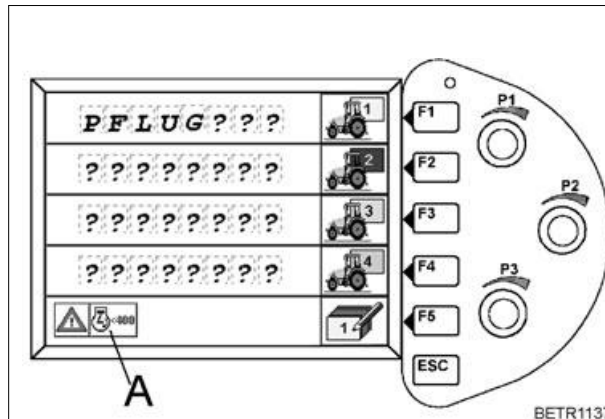

Fig.4

Warning and information messages (A) are shown on the Vario terminal.



1. Engine speed is less than 400 rpm

Process is not started.
Increase engine speed.

FEHL66



2. Transmission not in neutral

Process is not started.
Put transmission into neutral.

FEHL65



3. FRONT power lift/PTO automatic mode active on the operating console

Process is not started.
End **FRONT** power lift/PTO automatic function on the control console.

FEHL62



4. REAR power lift/PTO automatic mode active on the operating console

Process is not started.
Switch off **REAR** power lift/PTO automatic mode on the operating console.

FEHL64



5. FRONT and REAR power lift/PTO automatic mode active on the operating console

Process is not started.
Switch off **FRONT and REAR** power lift/PTO automatic mode on the operating console.

FEHL63

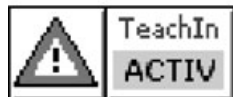

6. Variotronic Ti information message active

FEHL61

FAULTS AND REMEDIAL ACTIONS

4. Flame starting system faults

The flame starting system control unit detects faults in the flame starting system, and indicates these with flash codes on the preheating indicator lamp.

The flashing duration is about 60 secs.

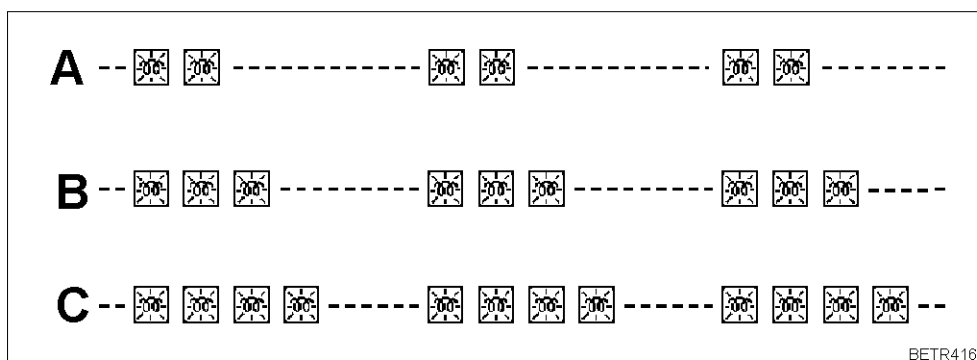

Fig.5

The following faults are detected:

Fault code A:

- Break in the flame glow plug element loop or its supply line.

Fault code B:

- Faulty fuse for the flame start control unit or no supply voltage (B+).

Fault code C:

- Break in the solenoid valve line or coil.

In all cases, only the indicator lamp flashes. Solenoid valve and flame heater plug remain switched off.

5. Fault code tables

General

Fault code	Cause	Effect and remedy
0.0.11 0.0.12 0.0.13 0.0.14 0.0.15 0.0.16 0.0.17 0.0.18 0.0.1A 0.0.20	Data transfer from Tractor electronic system for instrument cluster inoperative.	No forward/reverse indicator, 4-WD, diff. lock and Front/rear PTO speed.
0.0.1B	Variotronic Ti data transfer faulty.	Auxiliary operation.
0.0.1F	Joystick data transfer faulty.	Valves, electronic accelerator, transmission functions not functioning.
0.1.50	Combination instrument not programmed.	Programme combination instrument.
0.1.51	Engine oil pressure sensor faulty.	No more monitoring of engine oil pressure.
0.1.54	Sensor for compressed air supply is faulty.	Display no longer valid.
0.1.55	Hydraulic oil supply sensor faulty.	No monitoring of hydraulic oil level.
0.1.56	Engine temperature sensor faulty.	Engine temperature is not monitored.
0.1.57	Charge air temperature sensor.	No monitoring of intercooler temperature.
0.1.59	Sensor for fuel supply faulty.	No monitoring of fuel supply indicator.

Electronic engine control

Fault code	Cause	Effect and remedy
1.1.01	EDC control unit line discontinuity.	Normal operation - fault indication.
1.1.03	Foot throttle potentiometer plausibility error.	Accelerator pedal mode not functioning.
1.1.04	Tractor Management System (TMS) checksum error.	Tractor Management System (TMS) not functioning, EOL programming.
1.1.05	Engine configuration could not be read by the electrical engine control module.	Tractor Management System (TMS) not operational.
1.1.7 E	FENDT control unit, line discontinuity.	Loss of enhanced features, only foot throttle available.
1.1.7F	Hand throttle memory buttons faulty.	Loss of enhanced features, only foot throttle available.
1.1.9 E	Operating console, line discontinuity.	Loss of enhanced features, only foot throttle available.
1.1.9F	Operating console, line discontinuity.	Loss of enhanced features, only foot throttle available.
1.1.A0	Connection to EDC control unit, EDC control unit faulty.	Normal operation - fault indication.
1.1.A1	FENDT control module to EDC control module connection faulty.	Reduced engine power.

FAULTS AND REMEDIAL ACTIONS

Fault code	Cause	Effect and remedy
1.1.BO	Communication driver initialisation error; limited CAN bus communication.	EOL programming.
1.1.EO	Calibrated values from manual throttle rotary control incorrect.	Manual throttle rotary control calibration.

Electronic engine control

Fault code	Cause	Effect and remedy
1.2.13	Battery voltage too low.	Reduced engine operation.
1.2.17	Engine overspeed.	After the overspeed is left, normal operation.
1.2.18	Start of injection incorrectly set.	Reduced end speed, reduced engine power. Check fuel system.
1.2.1A	Needle movement sensor incorrect values.	Engine control changed.
1.2.9B	Solenoid valve has incorrect values.	Reduced end speed, reduced engine power.
1.2.1E	Injection pump.	Reduced speed, reduced engine power.
1.2.1F	Engine control unit or connection interrupted.	Auxiliary operation.
1.2.21	FENDT control module to transmission bus connection interrupted.	Optimum engine control not possible.
1.2.23	FENDT control module to EDC control module connection interrupted.	Loss of enhanced features, only foot throttle available.
1.2.25	Main relay does not open.	Battery is discharged.
1.2.2A	FENDT control module to EDC control module connection interrupted.	Normal operation - fault indication.
1.2.2B	FENDT control module to EDC control module connection interrupted.	No control of engine brake.
1.2.2C	FENDT control unit connection to engine brake interrupted.	No control of engine brake.
1.2.2D	FENDT control module to EDC control module connection interrupted.	Loss of enhanced features, only foot throttle available.
1.2.2 E	FENDT control module to EDC control module connection interrupted.	Optimum engine control not possible.
1.2.38	Control unit.	Reduced speed, reduced engine power.
1.2.42	Injection pump.	Reduction in power.
1.2.46	Control unit.	Loss of enhanced features, only foot throttle available.
1.2.81	Pedal position sensor signal wrong.	Normal operation - fault indication.
1.2.82	Injection pump, supply of flow.	Engine cuts out, engine does not start.
1.2.84	Engine speed sensor, control module.	Reduced speed, reduced engine power.
1.2.85	Boost pressure sensing device.	Reduced engine power.
1.2.87	Temperature sensor (coolant), control module.	Reduced engine power.
1.2.89	Injection pump.	Engine does not start.
1.2.91	rpm sensor.	Reduced speed, reduced engine power.
1.2.92	Injection pump, engine control module.	Reduced end speed, reduced engine power.

FAULTS AND REMEDIAL ACTIONS

Fault code	Cause	Effect and remedy
1.2.96	Control unit.	Engine cuts out.
1.2.99	Control unit to injection pump connection is interrupted.	Reduced speed, reduced engine power.
1.2.A2	Engine control unit or injection pump.	Reduced speed, reduced engine power.
1.2A6	Engine control unit or injection pump.	Reduced speed, reduced engine power.
1.2.A8	Engine control unit has wrong value.	Normal operation - fault indication.
1.2.A9	Injection pump.	Reduced end speed, reduced engine power.
1.2.B1	Control unit to injection pump connection is interrupted.	Reduced speed, reduced engine power.
1.2.B2	Control unit, injection pump.	Reduced speed, reduced engine power.
1.2.B3	Interrupted power supply.	Engine stops, engine does not start.
1.2.B4	Control unit to injection pump connection is interrupted.	Loss of enhanced features, only foot throttle available.
1.2.B5	Control unit, injection pump.	Reduced speed, reduced engine power.
1.2.B6	Control unit, injection pump.	Reduced speed, reduced engine power.
1.2.B7	Engine speed sensor.	Reduced speed, reduced engine power.
1.2.B9	Control unit, injection pump.	Engine stops.
1.2.C1	Pump control unit faulty.	Engine goes into idle.
1.2.C3	EDC control module - pump controller connection interrupted.	Engine goes into idle.
1.2.C4	Injection pump.	Engine goes into idle.
1.2.C5	Stop solenoid valve.	Reduced speed, reduced engine power.
1.2.C7	Injection pump, fuel lines faulty.	Engine stops. Check fuel system.
1.2.C8	Control unit, needle movement sensor, boost pressure sensor.	Engine stops.
1.2.C9	Injection pump.	Normal operation - fault indication.
1.2.CA	Injection timing mechanism values not within tolerance.	Reduced rpm, reduced engine power. Check fuel system.
1.2CB	Control unit to injection pump connection is interrupted.	Loss of enhanced features, only foot throttle available.
1.2.CD	Injection pump.	Reduced speed, reduced engine power.
1.2.DE	Control unit.	Loss of enhanced features, only foot throttle available.
1.2.E0	EDC control unit not connected.	Normal operation - fault indication.
1.2.E1	PTO rpm or speed signal incorrect.	Normal operation - fault indication.

Implement control

Fault code	Cause	Effect and remedy
2.1.E0	CAN communication E-Box - CAN joystick defective.	Implements can no longer be controlled using the joystick.
2.1.EE	LBS job computer inoperative.	Check CAN bus system for implement control.
2.1.EF	Error message from mounted implement.	Refer to implement manufacturer's manual.

FAULTS AND REMEDIAL ACTIONS

Operating console

Fault code	Cause	Effect and remedy
3.1.01 3.1.02 3.1.03 3.1.04 3.1.05 3.1.06	Programming error.	Call workshop.

Transmission

Fault code	Cause	Effect and remedy
4.1.01	Joystick acceleration switch I-IV faulty.	Auxiliary operation.
4.1.04	Clutch pedal potentiometer faulty.	No monitoring of transmission ratios.
4.1.05	Pressure sensor II defective.	Reduced comfort.
4.1.06	Accelerator rotary control faulty.	Load limit control not functioning.
4.1.07	High-pressure sensor faulty.	Peak loads in the transmission are no longer monitored.
4.1.08	Operating range I/II analogue device (function angle device) faulty.	Operating range switching I/II not operational.
4.1.20	Accelerator cancellation rotary control incorrectly calibrated or not calibrated.	Accelerator mode not working.
4.1.21	Reverse mode switch is defective.	Reverse mode operation and accelerator mode no longer possible.
4.1.22	Accelerator cancellation rotary control faulty.	Restriction in operation of accelerator mode.
4.1.23	Joystick signal Tempomat on faulty.	Auxiliary operation.
4.1.24	Hand brake switch faulty.	Hand brake automatic mode not working.
4.1.25	Joystick F-R quick reverse signal faulty.	Auxiliary operation.
4.1.26	Joystick signal accelerator mode faulty.	Accelerator mode not working.
4.1.27	Armrest signal rapid reversal (F/R rocker) faulty.	Rapid reverse not working.
4.1.28	Track width adjustment faulty.	Auxiliary operation.
4.1.29	Joystick park position signal faulty.	Auxiliary operation.
4.1.2A	Bevel pinion rpm sensor direction signal faulty.	Auxiliary operation.
4.1.2B	Driving mode I/II selection button faulty.	Tractor remains in current driving mode. No further selection until ignition ON/OFF.
4.1.2C	'Neutral selection' button faulty.	Auxiliary operation.
4.1.2D	Quick Reverse button (steering column) faulty.	Quick Reverse only available with the joystick.
4.1.2E	Joystick key 'v+' faulty.	Auxiliary operation.
4.1.2F	Joystick v- faulty.	Auxiliary operation.
4.1.31	Direction signal speed sensor for hydrostatic unit faulty.	Auxiliary operation.
4.1.32	Joystick activating button faulty.	Auxiliary operation.
4.1.42	Speed sensor hydrostatic unit faulty.	Auxiliary operation.

FAULTS AND REMEDIAL ACTIONS

Fault code	Cause	Effect and remedy
4.1.44	Speed sensor engine 1 faulty.	Auxiliary operation.
4.1.45	Bevel pinion speed sensor faulty.	Auxiliary operation.
4.1.50	Transmission oil filter dirty.	Auxiliary operation.
4.1.53	Transmission oil temperature over 110°.	Damage to traction drive.
4.1.58	Slip values of transmission ratios beyond acceptable limits.	Occasional occurrences in extreme conditions have no effect. If the problem persists in normal conditions, contact the workshop immediately.
4.1.59	Emergency operation manually induced or by electrical activation; emergency operation defective when operated non-manually.	Fault code not in the memory.
4.1.61	Faulty activation of operating range I valve.	Auxiliary operation.
4.1.62	Faulty activation of operating range II valve.	Auxiliary operation.
4.1.63	Faulty activation of valve for mechanical speed limitation.	Max. speed 30 km/h only.
4.1.64	Faulty actuation of turboclutch valve.	Auxiliary operation.
4.1.65	Faulty activation of cardan brake.	Call workshop.
4.1.66	Faulty activation of cardan brake.	Call workshop.
4.1.67	Faulty activation of cardan brake.	Call workshop.
4.1.70	Tempomat cruise control 1 key faulty.	No Tempomat cruise control.
4.1.71	Tempomat cruise control 2 key faulty.	No Tempomat cruise control.
4.1.72	Filter contamination switch defective.	No monitoring of filter contamination.
4.1.73	Temperature output sensor faulty.	No temperature output monitoring.
4.1.74	Parking brake position recognition switch faulty.	Hand brake position not detected, no hand brake automatic mode.
4.1.76	Engine brake switch faulty.	No engine brake function.
4.1.77	Joystick acceleration rate I-IV faulty.	Operation only possible in acceleration rate III.
4.1.78	Starting cut-out seat switch for accelerator mode faulty.	Selection of direction of travel is always deactivated in accelerator mode when vehicle stationary for 3 seconds.
4.1.82	Plausibility error (engine speed) between hydrostatic unit speed sensor and bevel pinion speed sensor.	Auxiliary operation.
4.1.83	Plausibility error (direction) between hydrostatic unit speed sensor and bevel pinion speed sensor.	Auxiliary operation.
4.1.84	Plausibility error between the joystick controls (F/R, Tempomat cruise control).	Auxiliary operation.
4.1.85	Engine speed sensor I plausibility error.	Auxiliary operation.

FAULTS AND REMEDIAL ACTIONS

Fault code	Cause	Effect and remedy
4.1.86	Plausibility error between pressure sensor I and pressure sensor II.	Reduced comfort.
4.1.87	Plausibility error on F/R button on steering column.	No F/R function on steering column.
4.1.88	Plausibility error on ON/OFF button for accelerator pedal drive.	No function.
4.1.94	CAN communication E-Box and joystick faulty.	Joystick functions restricted. Call workshop.

Transmission

Fault code	Cause	Effect and remedy
4.1.A0	Adjuster actuation faulty.	Auxiliary operation.
4.1.A1	Control unit mechanical stop defective.	Auxiliary operation.
4.1.A2	Faulty CAN bus connection to control unit.	Auxiliary operation.
4.1.A3	Control unit incremental sensor faulty / not plausible.	Auxiliary operation.
4.1.A4	Adjuster EST track signal faulty/missing.	Auxiliary operation.
4.1.A5	Adjuster reference not found.	Auxiliary operation.
4.1.A6	Incorrect control unit reference point during operation.	Auxiliary operation.
4.1.B0	Initialisation error on communication driver. CAN bus communication restricted.	Restricted operation.
4.1.B1	Fatal error range control with subsequent emergency operation (e.g. valve fault).	Auxiliary operation.
4.1.B2	Transmission ratio limiting faulty.	EOL programming.
4.1.B3	Quick Reverse acceleration rate parameters out of tolerance.	EOL programming.
4.1.B4	Engine speed sensor I plausibility error.	EOL programming.
4.1.B5	Rapid reversing ramp parameter for Tractor Management System (TMS) checksum error.	Rapid reversing not operational in the Tractor Management System (TMS).
4.1.E0	Turboclutch characteristic faulty/incorrectly memorised.	EOL programming.
4.1.E1	Traction control pressure regulator parameter fault/read error.	EOL programming.
4.1.E2	Pressure regulator parameters in traction control are not plausible or read in incorrectly.	No traction control function.
4.1.E3	Accelerator checksum error.	EOL programming.
4.1.E4	Brake control checksum error.	EOL programming.
4.1.E9	Values of operating range shift II-I not within tolerance.	Only shift while at a standstill.
4.1.EA	Incorrect EOL programming.	Auxiliary operation.
4.1.EB	Range-change values out of tolerance or range-change not calibrated.	Auxiliary operation.

FAULTS AND REMEDIAL ACTIONS

Fault code	Cause	Effect and remedy
4.1.EC	Accelerator rotary control values not within tolerances or no calibration of accelerator rotary control.	Auxiliary operation.
4.1.ED	Clutch pedal potentiometer values out of tolerance or clutch not calibrated.	Auxiliary operation.
4.1.EE	Transmission characteristic values out of tolerance or no calibration of transmission.	Auxiliary operation.
4.1.EF	Turboclutch values out of tolerance or no calibration.	Auxiliary operation.
4.1.FF	Error in transmission EST control unit.	Auxiliary operation.

Four-wheel drive and differential lock

Fault code	Cause	Effect and remedy
5.1.31	100% 4-WD button faulty.	'4-WD automatic mode' available only.
5.1.32	Key for automatic 4WD faulty.	'100% 4-WD' available only.
5.1.33	Faulty 4-WD clutch solenoid valve.	Function terminated, 4-WD engages.
5.1.34	Steering angle sensor 1 faulty.	4-WD / differential lock automatic mode Stop not functioning.
5.1.35	Steering angle sensor 2 faulty.	4-WD / differential lock automatic mode Stop not functioning.
5.1.51	100% differential lock button faulty.	Only 'Differential lock automatic mode' function available.
5.1.52	Key for automatic differential lock faulty.	'100% differential lock' is only function still available.
5.1.53	Differential lock solenoid actuation faulty.	End of function, differential lock not disengaging.
5.1.54	Left brake pedal switch faulty.	'100% differential lock' is only function still available.
5.1.55	Right brake pedal switch faulty.	'100% differential lock' is only function still available.

Suspension

Fault code	Cause	Effect and remedy
5.1.61	Front axle suspension position sensor faulty.	Front axle suspension does not function. Possible to continue without suspension.
5.1.62	Front axle suspension "Raise" solenoid actuation faulty.	Front axle suspension does not function. Possible to continue without suspension.
5.1.63	Incorrect activation of solenoid valve 'lower' for front axle suspension.	Front axle suspension does not function. Possible to continue without suspension.
5.1.64	Front axle suspension on/off key defective.	Front axle suspension does not function. Possible to continue without suspension.
5.1.65	Lock front axle suspension key faulty.	Locking of front axle suspension no longer possible.
5.1.6 E	No calibration of position sensor.	Front axle suspension does not function. Readjust position sensor.

FAULTS AND REMEDIAL ACTIONS

Power lift and PTO automatic mode

Fault code	Cause	Effect and remedy
5.1.91	Joystick rear automatic mode on/off button faulty.	Rear automatic mode not working.
5.1.93	Joystick front automatic mode on/off button faulty.	Front automatic mode not functioning.
5.1.95	Joystick automatic mode stop button faulty.	Automatic mode cannot be switched on and off.

Hydraulic system (push button / flow controller)

Fault code	Cause	Effect and remedy
5.1.98	Control pump oil pressure monitoring faulty.	Possible failure of work hydraulics.
5.1.99	Signal of flow control sensor disturbed or no oil pressure on the auxiliary pump.	Possible failure of auxiliary pump (constant displacement pump).

Other fault codes

Fault code	Cause	Effect and remedy
5.1.00	Control unit fault.	E-Box faulty.
5.1.8D	Checksum error. Old automatic mode configuration data.	Reduced comfort.
5.1.8F	Checksum error. Old automatic function sequential data.	Reduced comfort.
5.1.9A	Plausibility check error on flow controller with ignition ON and engine OFF.	No pressure monitoring.
5.1.9B	8 bar pressure switch faulty.	No pressure monitoring.
5.1.B0	Initialisation error on communication driver. CAN bus communication restricted.	EOL programming.
5.1.9E	Engine coolant level too low or empty.	Risk of engine damage. Once the warning has been confirmed, the error message is output every 120 sec. if the coolant has not be topped up.
5.1.9F	Engine coolant level sensor defective.	No coolant level monitoring.
5.1.FF	Comfort E-box no longer receiving CAN data for engine speed and PTO speed.	Various indicators no longer available or comfort E-box fails completely.

Rear PTO

Fault code	Cause	Effect and remedy
6.1.01	Button in cab faulty.	Does not function, PTO disengages.
6.1.02	Key on right mudguard faulty.	PTO can only be switched on/off with the cab button. Button must be pressed for at least 5 secs.
6.1.03	Button on left mudguard faulty.	PTO can only be switched on/off with the cab button. Button must be pressed for at least 5 secs.
6.1.04	PTO shaft clutch solenoid valve faulty.	Does not function, PTO disengages.

FAULTS AND REMEDIAL ACTIONS

Fault code	Cause	Effect and remedy
6.1.05	PTO shaft rpm sensor faulty.	PTO can only be switched on/off with the cab button. Button must be pressed for at least 5 secs.
6.1.10	Speed sensor shaft faulty.	
6.1.11	Automatic mode on operating console faulty.	Automatic mode is ended and PTO disengages.
6.1.15	Neutral speed selection key faulty.	Does not function, PTO disengages.
6.1.16	Selection range key 540 faulty.	No function of range selection key 540.
6.1.17	Setting 540E selection button faulty.	Setting 540E selection button does not function.
6.1.18	Speed selection key 1000 faulty.	No function of speed selection key 1000.
6.1.1A	Setting 540 valve faulty.	Does not function, PTO disengages.
6.1.1B	Control valve 540E faulty.	Does not function, PTO disengages.
6.1.1C	Control valve 1000 faulty.	Does not function, PTO disengages.
6.1.41	Cab button plausibility error.	Does not function, PTO disengages.
6.1.42	Right mudguard button plausibility error.	Does not function, PTO disengages.
6.1.43	Left mudguard button plausibility error.	Does not function, PTO disengages.
6.1.45	PTO clutch rpm sensor plausibility error.	PTO can only be operated via keys inside the cab, key must be kept pressed for at least 5 secs.
6.1.50	Speed sensor PTO shaft plausibility error.	When engaging, the button must be pressed for at least 5 secs.
6.1.55	Plausibility error in speed selection key neutral.	Does not function, PTO disengages.
6.1.56	Plausibility error in speed selector key 540.	No function of 540 selection.
6.1.57	540E setting pre-selection button plausibility error.	No function of 540E selection.
6.1.58	Plausibility error in speed selection key 1000.	No function of 1000 selection.
6.1.60	Plausibility error between PTO clutch rpm and PTO stub shaft speed.	Does not function, PTO disengages.
6.1.BO	Initialisation error on communication driver. CAN bus communication restricted.	EOL programming.
6.1.C1	Switch-on speed not reached for PTO/power lift automatic mode.	Increase ground speed to more than 1 km/h.
6.1.E0	Checksum parameter current control for range shifting faulty.	EOL programming.
6.1.E1	Checksum PTO parameter faulty.	EOL programming.

FAULTS AND REMEDIAL ACTIONS

Front PTO

Fault code	Cause	Effect and remedy
7.1.01	PTO key inside the cab faulty.	Does not function, PTO disengages.
7.1.04	Clutch operation solenoid faulty.	
7.1.05	PTO shaft rpm sensor faulty.	To engage, the button must be pressed for at least 5 sec.
7.1.09	Automatic front PTO key on operating console defective.	Automatic mode is ended and PTO disengages.
7.1.41	Cab button plausibility error.	Does not function, PTO disengages.
7.1.C1	Switch-on speed not reached for PTO/power lift automatic mode.	Increase ground speed to more than 1 km/h.

EPC-C rear power lift

Fault code	Cause	Effect and remedy
8.3.11	Lift final stage defective.	Control is terminated and locked.
8.3.12	Lower final stage defective.	Control is terminated and locked.
8.3.14	Rear left 'Lift' key is defective.	Control is terminated and locked.
8.3.15	Left rear "Lower" button faulty.	Control is terminated and locked.
8.3.16	V regulator less than 1 Volt.	Control is terminated and locked.
8.3.17	Battery voltage over 18 V.	Control is terminated and locked.
8.3.18	Rear right 'Lift' key is defective.	Control is terminated and locked.
8.3.19	Rear right 'Lower' key is defective.	Control is terminated and locked.
8.3.22	Position sensor defective.	Control is terminated and locked.
8.3.23	Setpoint rotary control defective.	Control is terminated and locked.
8.3.26	Faulty external sensor.	Control is terminated and locked.
8.3.31	Right draught sensing pin defective.	Control is continued
8.3.32	Left load sensor pin faulty.	Control is continued
8.3.33	Battery voltage less than 10.5 V.	Control is continued
8.3.40	Quick Lift switch faulty.	Raise and Lower only possible with the rear controls.
8.3.41	Fast feed-in button faulty.	Fast feed-in does not function.
8.3.42	Hitch button faulty.	Hitch key not functioning.
8.3.43	Automatic rear lifting gear key (control console) defective.	Automatic rear lifting gear key not operational.
8.3.50	Warning, right load sensor pin overloaded.	Warning is not stored. Relieve drafting sensing pin of load.
8.3.51	Warning, left load sensor pin overloaded.	Warning is not stored. Relieve drafting sensing pin of load.

Front power lift

Fault code	Cause	Effect and remedy
9.1.50	Valve not registered on CAN-bus.	Valve actuation not possible.
9.1.5F	Incorrect messages sent on CAN bus. Electronics in valve faulty.	Valve goes into neutral position.
9.1.51	Electronics in valve faulty.	Valve goes into neutral position. Replace valve.

FAULTS AND REMEDIAL ACTIONS

Fault code	Cause	Effect and remedy
9.1.52	Voltage in the valve less than 8 V.	Valve goes into neutral position.
9.1.53	Voltage in excess of 18 V.	Valve goes into neutral position.
9.1.54	Valve actuator falls short. Drops in control pressure or oil too viscous at low temperatures.	Valve goes into neutral position.
9.1.5A	Valve actuator goes too far.	Valve goes into neutral position.
9.1.5B	Floating position not reached.	Valve goes into neutral position.
9.1.5C	Manual actuation.	None.
9.1.55	High overvoltage over 45 V.	Valve goes into neutral position.
9.1.56	Final stage error (pilot control solenoid valve).	Valve goes into neutral position.
9.1.57	Position pickup sensor error.	Valve goes into neutral position.
9.1.58	Valve actuator does not return.	Valve slide jams.
9.1.59	Slide valve jams because of dirt.	Valve slide jams.
9.1.A0	No memorised values after engine re-start.	Reduced driving comfort.
9.1.A1		
9.1.B0	Position sensor is not calibrated.	No position control possible.
9.1.B1	Position sensor transmits no values or wrong values.	No position control possible.
9.1.B2	Set point rotary control not calibrated.	Setpoint values cannot be set.
9.1.B3	Setpoint potentiometer sends no values or incorrect values.	Setpoint values cannot be set.
9.1.C0	Operating console not available.	No automatic mode, no general locking.
9.1.C1	Automatic mode button faulty.	No automatic mode.
9.1.C2	Overall locking key faulty.	No overall locking of valves.
9.1.C3	Floating position button faulty.	No floating position.
9.1.C4	Front power lift Raise button faulty.	Front power lift cannot be raised properly.
9.1.C5	Front power lift 'Lower' faulty.	Front power lift cannot be lowered properly.
9.1.C6	Possible fault on CAN bus to operating console.	Status changes cannot be detected. Engagement/disengagement possibly being overridden.
9.1.C7		
9.1.C8		
9.1.C9		
9.1.CA		
9.1.D0	External Lift key faulty.	Front power lift cannot be lowered properly.
9.1.D1	External Lower key faulty.	Front power lift cannot be lowered properly.
9.1.D2	External key actuates twice or key sticks.	Front power lift cannot be lowered properly.

FAULTS AND REMEDIAL ACTIONS

Electric valves (operating console)

Fault code	Cause	Effect and remedy
A.1.C0	Control console not available, e.g. CAN-bus not connected.	No automatic mode. No general locking of valves.
A.1.C1	Automatic mode button faulty.	No automatic mode.
A.1.C2	Overall locking key faulty.	No overall locking of valves.
A.1.C3	Floating position button faulty.	No floating position.
A.1.C4	Timer function button faulty.	No timer function.
A.1.C5	Crossgate lever/joystick switch-over button faulty.	Not possible to switch between crossgate lever operation and joystick operation.
A.1.C6 A.1.C7 A.1.C8 A.1.C9 A.1.CA	Operating console CAN bus faulty.	Change of status not detected. Switching on/off is ignored. Valve locked.
A.1.CB	CAN joystick not available.	Not possible to operate valves.
A.1.CC	E-Box and CAN joystick CAN connection faulty.	Limited operation of valves.

Electric valves (crossgate lever)

Fault code	Cause	Effect and remedy
A.1.B0	Crossgate lever not adjusted.	Valves cannot be actuated. Carry out adjustment.
A.1.B1 A.1.B2 A.1.B3 A.1.B4	Signal fault.	Valve position cannot be controlled properly.
A.1.B5	Crossgate lever recognition of centre position faulty.	Valve position cannot be operated accurately. Calibrate.

Electric valves (buttons / switches)

Fault code	Cause	Effect and remedy
A.1.FA	External valve actuation. Spool valve external pushbutton for rear LIFT faulty.	Rear external controls not working.
A.1.FB	External valve actuation. Spool valve external pushbutton for rear LOWER faulty.	Rear external controls not working.
A.1.FC	External valve actuation. Spool valve external pushbutton rear actuates twice or pushbutton is faulty.	Change controls or exchange keys.
A.1.D1	Valve 3, signal disturbed or faulty valve.	'Lift' and/or 'Lower' valve 3 faulty.
A.1.D3	Valve 4, signal disturbed or faulty valve.	'Lift' and/or 'Lower' valve 4 faulty.
A.1.D4	Faulty solenoid switch for release of external controls of standard front power lift.	Position of shutoff cock for front power lift cannot be detected.
A.1.D5	External front power lift 'Lower' button faulty.	Front power lift cannot be lowered properly.

FAULTS AND REMEDIAL ACTIONS

Fault code	Cause	Effect and remedy
A.1.D6	External front power lift 'Raise' button faulty.	Front power lift cannot be raised properly.
A.1.D7	Hydraulic oil level sensor faulty.	Hydraulic oil level no longer monitored.
A.1.D9	Hydraulic tank is empty.	Possible damage to pump or undesired valve responses.
A.1.DA	Kickout push button faulty.	No Kickout function.
A.1.DB	Hydraulic oil characteristic not plausible.	Incorrect display of hydraulic oil supply. Reprogramme EOL.
A.1.DC	Priority volume of hydraulic oil greater than pump volume.	Reduce priority hydraulic oil quantity.
A.1.DD	Front external key actuates twice or key sticks.	Front power lift cannot be lowered properly.

Electrical valves (valve 1)

Fault code	Cause	Effect and remedy
A.1.10	Valve not registered on CAN bus.	Valve actuation not possible.
A.1.1F	CAN-BUS error, valves.	Valves locked.
A.1.11	Electronics in valve faulty.	Valve goes into neutral position.
A.1.12	Voltage in the valve less than 8 Volt.	Valve goes into neutral position.
A.1.13	Voltage in excess of 18 V.	Valve goes into neutral position.
A.1.14	Valve actuator falls short.	Valve goes into neutral position.
A.1.1A	Valve actuator goes too far.	Valve goes into neutral position.
A.1.1B	Floating position not reached.	Valve goes into neutral position.
A.1.1C	Manual actuation.	
A.1.15	High overvoltage over 45 V.	Valve goes into neutral position.
A.1.16	End stage error (end stage for pilot control solenoid).	Valve goes into neutral position.
A.1.17	Position pickup sensor error.	Valve goes into neutral position.
A.1.18	Valve actuator does not return to neutral position.	Valve remains set.
A.1.19	Valve actuator not in neutral position when switched on.	Valve remains set.

FAULTS AND REMEDIAL ACTIONS

Spool valves (valve 2)

Fault code	Cause	Effect and remedy
A.1.20	Valve not registered on CAN bus.	Valve actuation not possible.
A.1.2F	CAN-BUS error, valves.	Valves locked.
A.1.21	Electronics in valve faulty.	Valve goes into neutral position.
A.1.22	Voltage in the valve less than 8 Volt.	Valve goes into neutral position.
A.1.23	Voltage in excess of 18 V.	Valve goes into neutral position.
A.1.24	Valve actuator falls short.	Valve goes into neutral position.
A.1.2A	Valve actuator goes too far.	Valve goes into neutral position.
A.1.2B	Floating position not reached.	Valve goes into neutral position.
A.1.2C	Manual actuation.	
A.1.25	High overvoltage over 45 V.	Valve goes into neutral position.
A.1.26	End stage error (end stage for pilot control solenoid).	Valve goes into neutral position.
A.1.27	Position pickup sensor error.	Valve goes into neutral position.
A.1.28	Valve actuator does not return to neutral position.	Valve remains set.
A.1.29	Valve actuator not in neutral position when switched on.	Valve remains set.

Spool valves (valve 3)

Fault code	Cause	Effect and remedy
A.1.30	Valve not registered on CAN bus.	Valve actuation not possible.
A.1.3F	Valve CAN BUS error.	Valves locked.
A.1.31	Electronics in valve faulty.	Valve goes into neutral position.
A.1.32	Voltage in the valve less than 8 Volt.	Valve goes into neutral position.
A.1.33	Voltage in excess of 18 V.	Valve goes into neutral position.
A.1.34	Valve actuator falls short.	Valve goes into neutral position.
A.1.3A	Valve actuator goes too far.	Valve goes into neutral position.
A.1.3B	Floating position not reached.	Valve goes into neutral position.
A.1.3C	Manual actuation.	
A.1.35	High overvoltage over 45 V.	Valve goes into neutral position.
A.1.36	End stage error (end stage for pilot control solenoid).	Valve goes into neutral position.
A.1.37	Position pickup sensor error.	Valve goes into neutral position.
A.1.38	Valve actuator does not return to neutral position.	Valve remains set.
A.1.39	Valve actuator not in neutral position when switched on.	Valve remains set.

FAULTS AND REMEDIAL ACTIONS

Spool valves (valve 4)

Fault code	Cause	Effect and remedy
A.1.40	Valve not registered on the CAN bus.	Valve actuation not possible.
A.1.4F	CAN-BUS error, valves.	Valves locked.
A.1.41	Electronics in valve faulty.	Valve goes into neutral position.
A.1.42	Voltage in the valve less than 8 Volt.	Valve goes into neutral position.
A.1.43	Voltage in excess of 18 V.	Valve goes into neutral position.
A.1.44	Valve actuator falls short.	Valve goes into neutral position.
A.1.4A	Valve actuator goes too far.	Valve goes into neutral position.
A.1.4B	Floating position not reached.	Valve goes into neutral position.
A.1.4C	Manual actuation.	
A.1.45	High overvoltage over 45 V.	Valve goes into neutral position.
A.1.46	End stage error (end stage for pilot control solenoid).	Valve goes into neutral position.
A.1.47	Position pickup sensor error.	Valve goes into neutral position.
A.1.48	Valve actuator does not return to neutral position.	Valve remains set.
A.1.49	Valve actuator not in neutral position when switched on.	Valve remains set.

Electric valves (E-box)

Fault code	Cause	Effect and remedy
A.1.A0	EEPROM error.	Loss of enhanced features when operating valves.
A.1.A1		
A.1.A2	More valves connected than are registered through end-of-line programming. Undertake programming.	Not all valves can be operated.
A.1.FO	Valve control for the switching of the pilot control of all electrical valves with front power lift faulty.	All valves go into neutral position.
A.1.F1	Valve control for the heating of all electrical valves with front power lift faulty.	Reduced operation in cold conditions.
A.1.F2	Valve control for switching the pilot control of all spool valves with front power lift faulty.	Call workshop.
A.1.F3	Valve control for switching the pilot control of all spool valves with front power lift has interrupted supply line.	Call workshop.

FAULTS AND REMEDIAL ACTIONS

Variotronic Ti

Fault code	Cause	Effect and remedy
B.1.11	Electrical fault, automatic mode.	Call workshop.
B.1.12	Electrical fault, terminal.	Call workshop.
B.1.21	Communications error, internal communication.	Call workshop.
B.1.22	Communications error between terminal and Variotronic Ti.	Call workshop.
B.1.23	Communications error between control console and Variotronic Ti.	Call workshop.
B.1.24	Communications error between joystick and Variotronic Ti.	Call workshop.
B.1.41	Communications error, internal communication.	Call workshop.
B.1.42	Communications error between terminal and Variotronic Ti.	Call workshop.
B.1.43	Communications error between control console and Variotronic Ti.	Call workshop.
B.1.44	Error counter between joystick and Variotronic Ti.	Call workshop.
B.1.B0	Error reader Variotronic Ti.	Call workshop.
B.1.B4	Error in the memory function.	Restart tractor. If error is still there, consult workshop.