



SERVICE MANUAL

Pallet Trucks

6HBW30	27,000 and up	6HBE30	27,000 and up
6HBE40	27,000 and up	6HBC30	27,000 and up
6HBC40	27,000 and up	6TB50	27,000 and up

© 2004 by Toyota Industrial Equipment

All rights reserved. No portion of this manual may be reproduced mechanically, electronically or by any other means, including photocopying, electronic retrieval or transfer, or recording without the written permission of the publisher.

Toyota Industrial Equipment believes the information in this manual is accurate and current as of the publication date; such information is subject to change without notice. Toyota Industrial Equipment is not responsible for any errors that may appear in the manual.

Table of Contents

How to Use This Manual	1-1
Map of the Manual	1-2
Manual Design	1-3
START Page	1-5
Safety	2-1
Definitions	2-2
General Safety	2-3
Battery Safety	2-5
Jacking Safety	2-8
Fork Section	2-8
Tractor	2-8
Tie-down for Transport	2-9
Towing	2-10
Welding Safety	2-11
Systems Overview	3-1
Truck Model Identification	3-2
Vehicle Specifications	3-3
General System Data	3-4
Special Tools	3-6
Programmable Maintenance Tool	3-6
Theory of Operation	3-7
Lift/Lower	3-7
Directional/Speed Control	3-7
Strip Curtain Bypass (Models 6HBE30/40 only)	3-8
Manual Coast Mode (Standard on 6HBE30/40, Optional on 6HBW30)	3-8
Motor Controller	3-9
Scheduled Maintenance	4-1
Introduction	4-2
Maintenance Guidelines	4-2
General Truck Operation	4-2
Perform Daily or Every Eight (8) Operating Hours	4-3
Perform Every Two Months or 250 Operating Hours	4-4
Perform Annually or Every 1500 Operating Hours	4-5
Lubrication Points	4-6
Troubleshooting	5-1
How to Use This Chapter	5-2
Electrical Troubleshooting Guidelines	5-3
Checking for Shorts from Battery to Truck Frame	5-3
Checking for Shorts from Components to Truck Frame	5-4
Hydraulic Troubleshooting Guidelines	5-5
Definitions	5-6
Acceleration Rate	5-6
Brake Switch	5-6
Brake Rate	5-6
Continuity	5-6
Creep Speed	5-6
Current Limiting	5-6
Emergency Reverse	

(6HBW30 and 6HBE30/40)	5-6
Fault Codes	5-6
High Pedal Disable (HPD)	5-6
Operating Mode	5-7
Open Circuit	5-7
Overtemperature (Motor Controller)	5-7
Overvoltage Cutoff	5-7
Plugging (Plug Braking)	5-7
Pulse Width Modulation	5-7
Ramp Shape	5-7
Regenerative Braking	5-8
Sequencing Delay	5-8
Short Circuit or "Short"	5-8
Speed Limiting	5-8
Static Return To Off (SRO)	5-8
Throttle Map	5-8
Tractor	5-9
Undertemperature	5-9
Undervoltage Cutback	5-9
Electrical Connector Locator Chart	5-10
Fault Codes	5-11
Programmable Maintenance Tool	5-13
Program Mode	5-13
Monitor Mode	5-15
Faults Mode	5-16
Functions Mode	5-17
Information Mode	5-17
Programmer Mode	5-17
List of Troubleshooting Charts	5-19
Symptom Tables:	5-19
Troubleshooting Flowcharts	5-21
Symptom Tables: Lift/Lower System	5-25
Symptom Tables: Travel	5-28
Symptom Tables: Wiring System	5-35
Component Procedures	6-1
List of Component Procedures	6-2
Component Locators	6-5
Tractor Cover	6-7
Removal	6-7
Installation	6-7
Battery	6-8
Trucks Equipped with Battery Gates and Rollers (optional)	6-8
Trucks Without Battery Gates and Rollers	6-9
Battery Exterior Cleaning	6-9
Charging	6-10
Adding Water	6-11
Specific Gravity	6-11
Voltage Check	6-11
Maintenance-Free Batteries	6-12
Storage	6-12
Power Cables	6-13
Battery/Charger/Truck Connectors	6-13

Wiring Harness	6-14
Terminology	6-14
Inspection	6-14
Fuses	6-15
Test/Inspection	6-15
Switches (General)	6-16
Test/Inspection	6-16
Key Switch	6-17
Inspection	6-17
Removal	6-17
Installation	6-17
Brake Switch	6-18
Adjustment	6-18
Removal	6-18
Installation	6-18
Lift Cut-Out Switch	6-20
Adjustment	6-20
Grab Rail Switches	6-21
Removal	6-21
Installation	6-21
Hydraulic Solenoids	6-22
Removal	6-22
Installation	6-22
Manual Coast	6-23
Removal	6-23
Installation	6-23
Gauges	6-24
Hour Meter	6-24
Combination Hour/Battery Discharge Meter	6-24
Control Handle	6-26
Return Spring Adjustment	
6HBW30, 6HBE30 and 6HBE40	6-26
Horn	6-27
Removal	6-27
Installation	6-27
Motor Controller	6-28
Cleaning	6-28
Removal	6-28
Installation	6-29
Programming	6-29
Emergency Reverse Check	6-29
Travel Potentiometer	6-29
Contactors	6-31
Tip Inspection	6-31
Main Contactor	6-31
Brake	6-35
Models 6HBW30, 6HBE30, and 6HBE40	6-35
Models 6HBC30, 6HBC40, and 6TB50	6-36
Motors, General	6-39
Motor Brushes	6-39
Motor Brush Spring Tension	6-40
Commutator	6-40

Terminal Nuts	6-43
Electric Motor Tests	6-43
Drive Motor	6-46
Removal	6-46
Installation	6-46
Drive Unit	6-49
Removal	6-49
Tooth Pattern of Drive Unit	6-53
Drive Unit Vent Plug	6-55
Drive Housing Lubrication	6-55
Drive Housing Steering Bearing	6-56
Drive Wheel	6-57
Casters	6-61
Removal	6-61
Disassembly	6-61
Assembly	6-62
Installation	6-62
Load Wheels	6-63
Replacement	6-63
Load Wheels	
Model 6TB50	6-64
Removal	6-64
Pallet Entry Sliders	6-65
Replacement	6-65
Fork Height Adjustment	6-66
6000 Lb. Models (Single Pallet)	6-66
Long-John Models (Double Pallet)	6-66
Hydraulic Components	6-69
General Guidelines	6-69
Hydraulic Fluid	6-70
Fluid Level	6-70
Changing Fluid	6-70
Adjusting Hydraulic Pump Relief Valve Pressure	6-72
Relief Valve Settings	6-72
Check Valve	6-73
Hydraulic Ram	6-74
Inspection	6-74
Removal	6-74
Installation	6-76
Hydraulic Cylinder Seals	6-77
Hydraulic Unit	6-80
Removal	6-80
Installation	6-80
Hydraulic Reservoir	6-81
Filter Screen and Suction Tube	6-81
Hydraulic Pump	6-82
Lift Motor	6-84
General Data	6-84
Cold Storage Conditioning	6-86
Appendix	A-1
Lubrication Equivalency Chart	A-2
Torque Chart - Standard (Ferrous)	A-3

Torque Chart - Metric	A-4
Decimal Equivalent Chart	A-5
Standard/Metric Conversions	A-7
Electrical Schematics	A-9
Index	I-1

This page intentionally left blank.

Section 1. How to Use This Manual

Map of the Manual

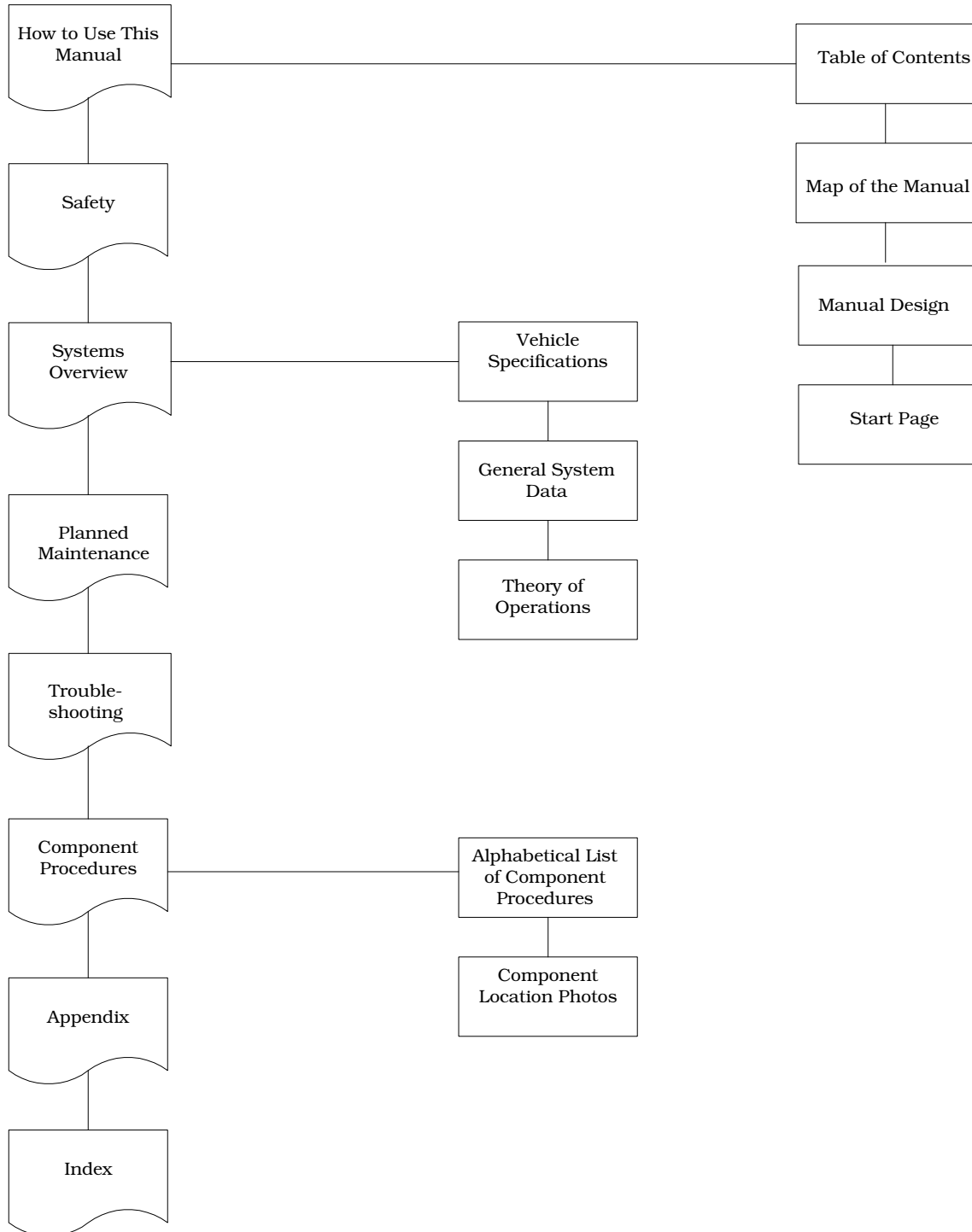

Manual Design

Manual Design

The Toyota Pallet Truck Service Manual is designed with the following objectives in mind:

- Provide technical coverage for expected levels of user expertise
- Anticipate your needs and reduce your decisions regarding maintenance
- Reduce page flipping through a “one-stop shopping” approach

The two-line running page header at the top of each page tells you:

- Name of the manual
(Toyota Pallet Truck Service Manual)
- Current Chapter Title
(for example, this page *How to Use This Manual*)
- Current topic
(for example, this page *Manual Design*)

It is recommended that you go to the START page for guidance to the correct chapter.

- **How to Use This Manual** explains the manual format and design and contains the Table of Contents and START page.
- **Safety** explains warning and caution notes, general safety rules and safety rules for batteries, static, jacking, and welding.
- **Systems Overview** includes truck specifications and theory of operation information.
- **Planned Maintenance** outlines the recommended schedule of preventive services to keep your truck working most efficiently.
- **Troubleshooting** is a set of “decision-tree” charts and tables designed to take you from a symptom to a specific sequence of tests in order to isolate a failing component.
 - Chart “TS1: START TROUBLESHOOTING” on page 5-22 will guide you to the individual troubleshooting symptom chart you need.

- When you’re familiar with the symptoms listed, you may instead simply find the symptom chart. See “List of Troubleshooting Charts” on page 5-19.
- When you complete a troubleshooting procedure, be sure to follow the steps in chart “**END1: End of Troubleshooting Procedure**” on page 5-24.
- **Component Procedures** gives step-by-step procedures for testing, removal, installation, and adjustment of individual truck components. Components are listed in an order which considers:
 - Frequency of attention
 - Physical attachment (for example, brake must be removed before drive motor)
 - Functional relation (for example, drive motor and drive unit components are grouped together)

To find a component procedure, you may use one of three methods:

- Look up the component name in the “**List of Component Procedures**” on page 6-2.
- Find the component in the “**Component Locators**” on page 6-5.
- Look up the component name in the maintenance manual Index.
- **Appendix** contains reference information such as torque values, lubricants and schematics.
- **Index** lists subjects alphabetically.

This page intentionally left blank.

START Page

START Page

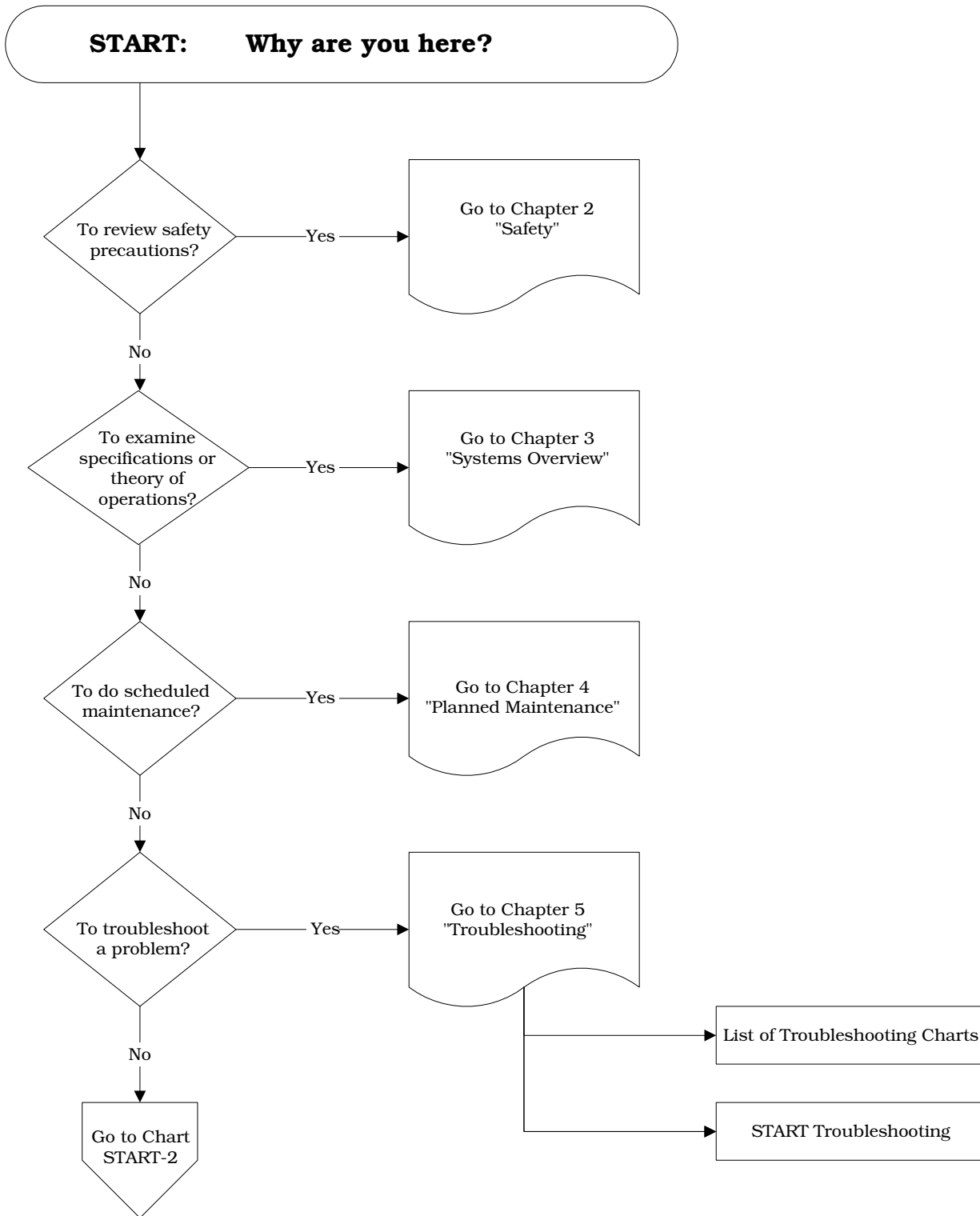

START Page

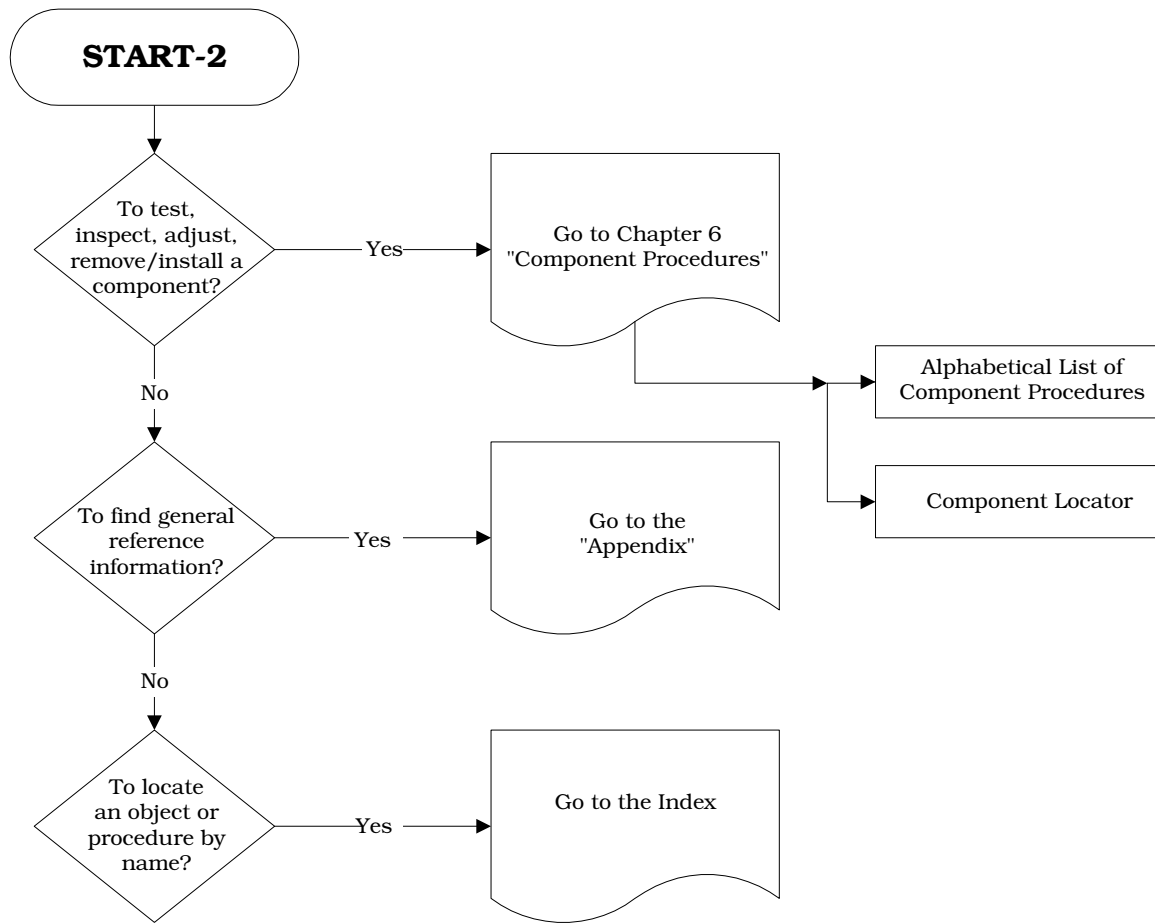

This page intentionally left blank.

Section 2. Safety

Definitions

Throughout this manual, you will see two kinds of safety reminders:

WARNING

Warning means a potentially hazardous situation exists that, if not avoided, could result in death or serious injury.

CAUTION

Caution means a potentially hazardous situation exists that, if not avoided, could result in minor or moderate injury or in damage to the truck or nearby objects.

General Safety

General Safety

Do *not* operate or work on this truck unless you are trained, qualified and authorized to do so.

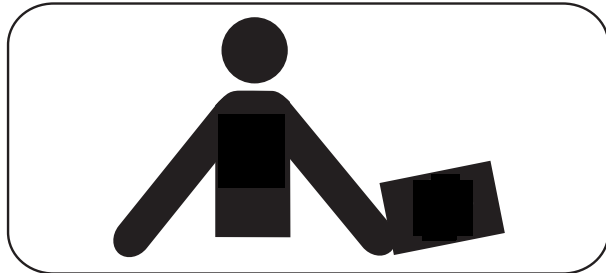

Know the truck's controls and what they do.

Do *not* operate this truck if it needs repair or if it is in any way unsafe.

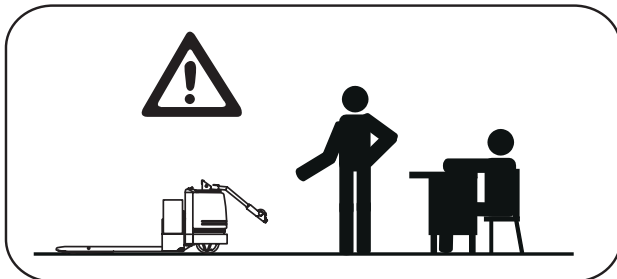

Operate this truck only from the operator's position.

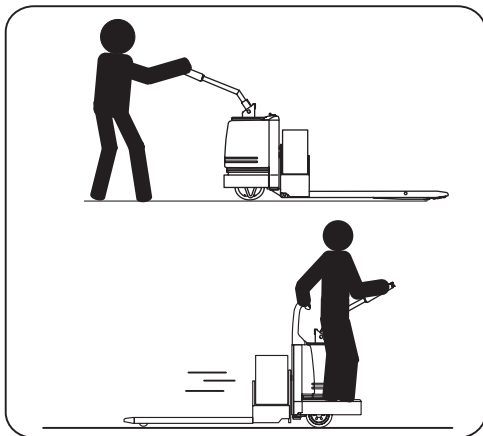

Before working on this truck, always turn the key switch to OFF and disconnect the truck's battery connector (unless this manual tells you otherwise).

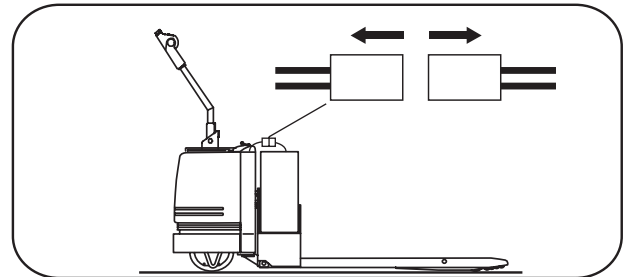

Do *not* wear watches, rings, or jewelry when working on this truck.

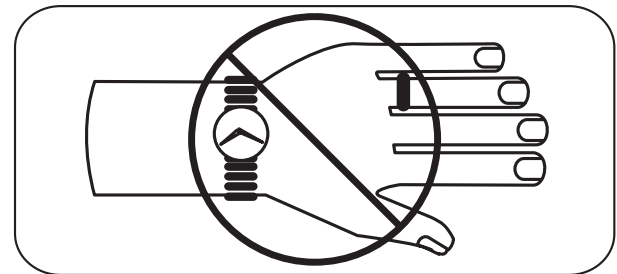

Follow the scheduled lubrication, maintenance and inspection steps.

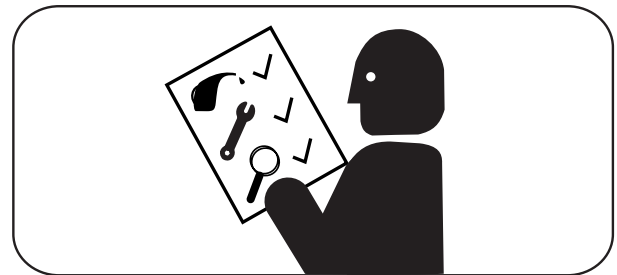

Follow exactly the safety and repair instructions in this manual. Do *not* take “shortcuts.”

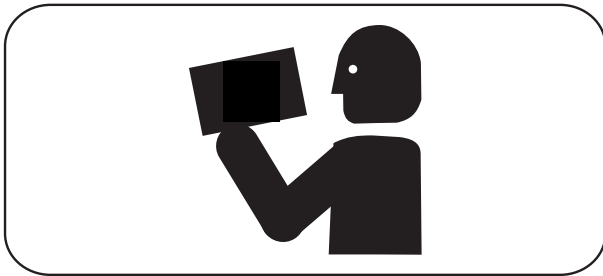

Always park this truck indoors.



Do *not* use an open flame near the truck.

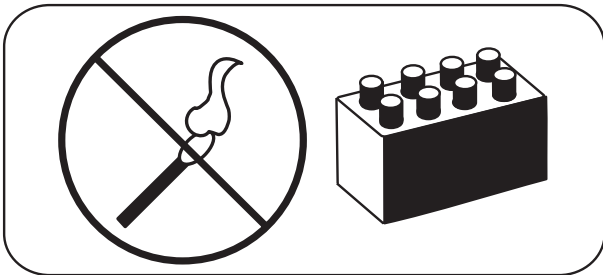

Do *not* wash this truck with a hose.

Do *not* add to or modify this truck until you contact your local Toyota Dealer to receive written manufacturer approval.

Do *not* use gasoline or other flammable liquids for cleaning parts.

Clean up any hydraulic fluid, oil or grease that has leaked or spilled on the floor.



Battery Safety

Battery Safety**⚠ WARNING**

As a battery is being charged, an explosive gas mixture forms within and around each cell. If the area is not properly ventilated, this explosive gas can remain in or around the battery for several hours after charging. Be sure there are no open flames or sparks in the charging area. An open flame or spark can ignite this gas, resulting in serious damage or injury.

⚠ WARNING

Battery electrolyte is a solution of sulfuric acid and water. Battery acid causes burns. If any electrolyte comes in contact with your clothing or skin, flush the area immediately with cold water. If the solution gets on your face or in your eyes, flush the area with cold water and get medical help immediately.

Wear personal protective equipment to protect eyes, face and skin when checking, handling or filling batteries. This equipment includes goggles or face shield, rubber gloves (with or without arm shields) and a rubber apron.

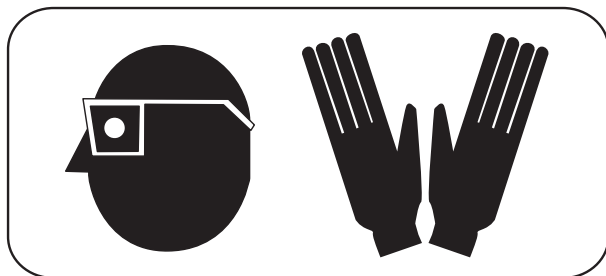

Make sure a shower and eyewash station are nearby in case there is an accident.

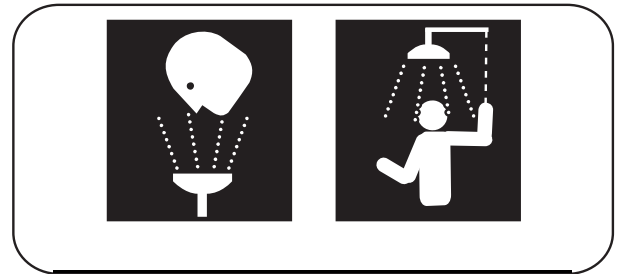

A battery gives off explosive gases. *Never* smoke, use an open flame, or use anything that gives off sparks near a battery.

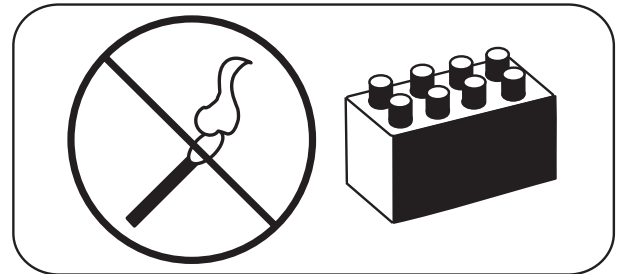

Keep the charging area well-ventilated to avoid hydrogen gas concentration.

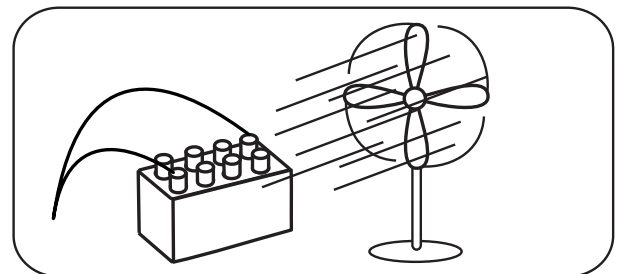

Turn the key switch OFF *before* disconnecting the battery from the truck at the battery connector. Do *not* break live circuits at the battery terminals. A spark often occurs at the point where a live circuit is broken.

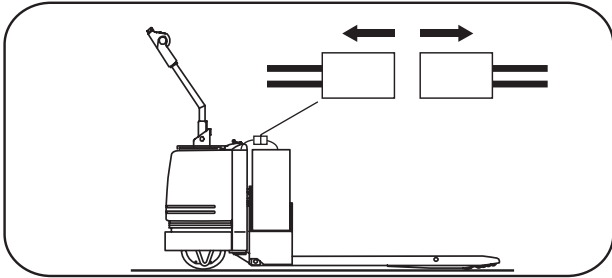

Do *not* lay tools or metal objects on top of the battery. A short circuit or explosion could result.

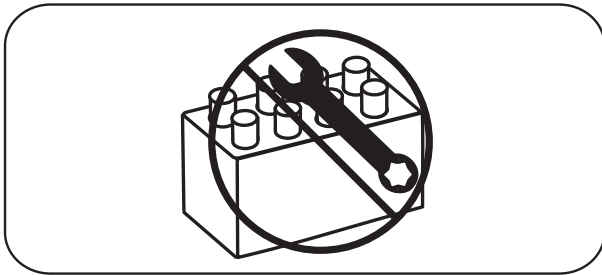

Keep batteries clean. Corrosion causes shorts to the frame and possibly sparks.

Keep plugs, terminals, cables and receptacles in good condition to avoid shorts and sparks.

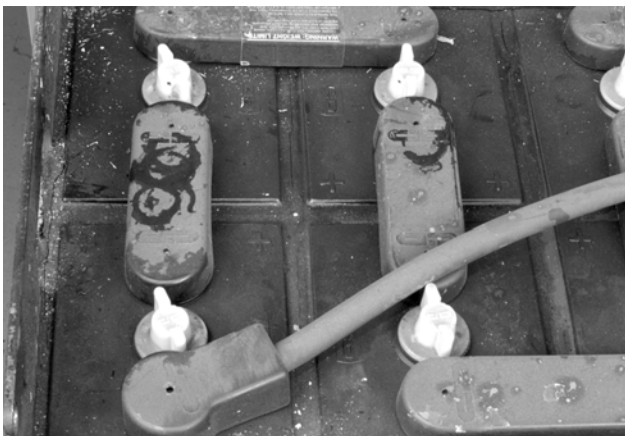

Keep filler plugs firmly in place at all times *except* when the electrolyte level is checked, when water is added to the cells, or when the specific gravity is checked.

Make sure the vent holes in the filler plugs are open to permit the gas to escape from the cells.



Do *not* permit cleaning solution, dirt or any foreign matter to enter the cells.

Make sure you install the correct size battery. A smaller or lighter weight battery could seriously effect truck stability. See the truck's specification plate for more information.

Never plug a battery charger into the truck's battery connector. Plug the battery charger only into the battery connector from the battery.

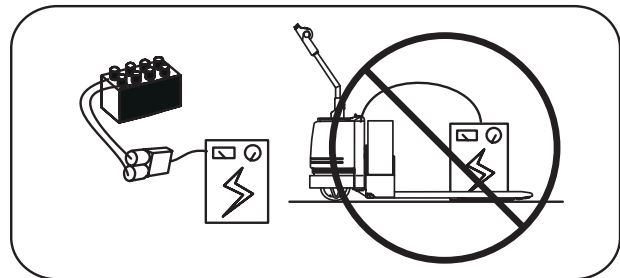

Battery Safety

Follow the charging procedures in the Battery Instruction Manual and in the Battery Charger Instruction Manual.

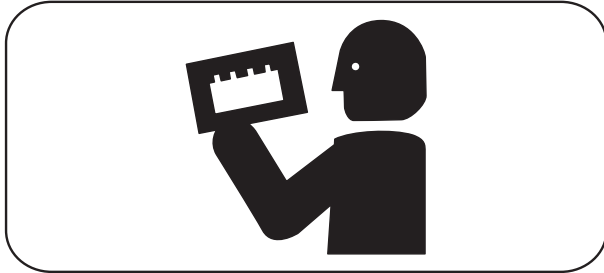

Jacking Safety

You may need to jack up the truck off the floor to perform maintenance procedures. When doing so, observe the correct safety precautions:

1. Lower the forks completely. Remove any load.
2. Place all controls in neutral.
3. Block the wheels to prevent movement of the vehicle.
4. Disconnect the battery connector.
5. Place the jack under the designated jacking points. See Figure 2-2.

WARNING

Use extreme care when the truck is jacked up. Keep hands and feet clear from vehicle while jacking the truck. After the truck is jacked, place solid blocks beneath it to support it. DO NOT rely on the jack alone to support the truck.

Fork Section

6. Using the lift button, raise the forks to maximum height.
7. Block the fork section as shown in Figure 2-1. The tractor section will remain on the floor.



Figure 2-1. Blocking the Fork Section

8. Lower the forks on the blocks.
9. Turn the key switch OFF and disconnect the battery connector.

Tractor

10. Place the jack under the designated jacking position. See Figure 2-2.



Figure 2-2. Jacking Tractor Section

11. Jack one side of the truck so that the drive tire is off the floor no more than 1 in. (25.4 mm).
12. Block that side of the truck in place.
13. Jack up the other side of the truck level with the first side.
14. Block that side of the truck in place.

NOTE: After working on a vehicle, test all controls and functions to assure correct operation.

Tie-down for Transport

Tie-down for Transport

To transport your Toyota pallet truck in an over-the-road vehicle or rail car, follow these steps:

1. Lower the forks and locate the truck in the center of the transport vehicle.
2. Using suitable lifting device, remove the battery. See "Battery" on page 6-8.
3. Position the adjustable chain over and through the battery compartment.
4. Position an additional adjustable chain over and through the battery compartment.
5. Position the chain ends of one chain toward the front of the vehicle bed and the chain ends of the other chain to the rear of the vehicle bed and draw taut.

NOTE: This will secure the truck to the vehicle bed and prevent tip-over and forward or backward movement.

6. Secure the battery according to the battery manufacturer's instructions. If equipped, remove the battery cover or storage tray from the top of the battery and store separately.

Towing

To safely tow a Toyota pallet truck:

1. Lower the forks and remove any load.
2. Turn the key switch OFF and disconnect the battery connector.
3. Using a suitable towing vehicle, lift the tractor end of the pallet truck until the drive tire is no more than 1 in. (25.4 mm) off the floor.
4. Tow the truck slowly in the tractor-first direction.

Welding Safety

Welding Safety**⚠ WARNING**

Flame cutting or welding on painted surfaces may produce potentially harmful fumes, smoke and vapors. Before performing flame cutting or welding operations, remove the coating in the vicinity where the operation(s) will be performed. Coating removal may be by mechanical methods, chemical methods or a combination of methods. Flame cutting and/or welding operations must be carried out only in well ventilated areas using local exhaust if necessary.

Before working on this truck, make sure that:

- fire protection equipment is nearby
- you know the location of the nearest eyewash station

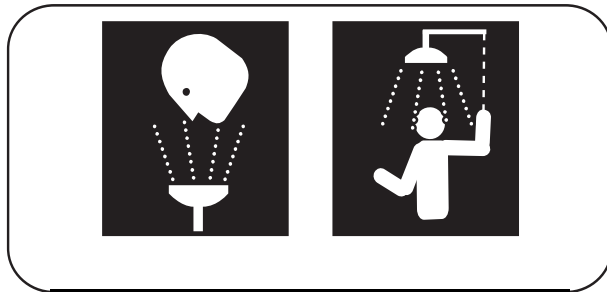

- the key switch is turned OFF and the battery is disconnected before you attempt to inspect, service or repair the lift truck. Discharge residual charge in the motor controller by pressing the horn button.
- check for shorts to frame as described on Page 5-3. If any shorts are detected, remove them before you proceed with the welding operation.
- the area to be welded is clean
- all truck components are protected from heat, weld spatter and debris
- the ground cable is attached as close to the weld area as possible

- no welding operations are performed near electrical components
- if welding must be done near the battery compartment, the battery is removed from the truck
- When you are finished welding, perform all ground tests and electrical inspections before the vehicle is operated.

This page intentionally left blank.

Section 3. Systems Overview

Truck Model Identification

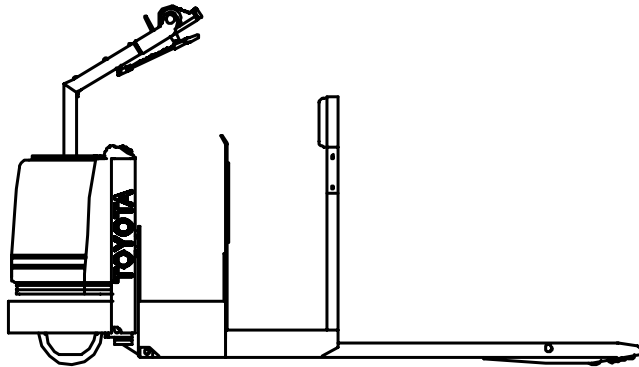

**Model 6HBC30 and Model 6HBC40
Center Rider**

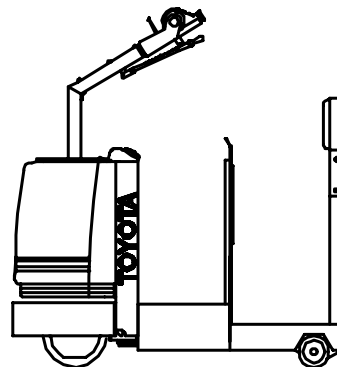

Model 6TB50 Tow Tractor

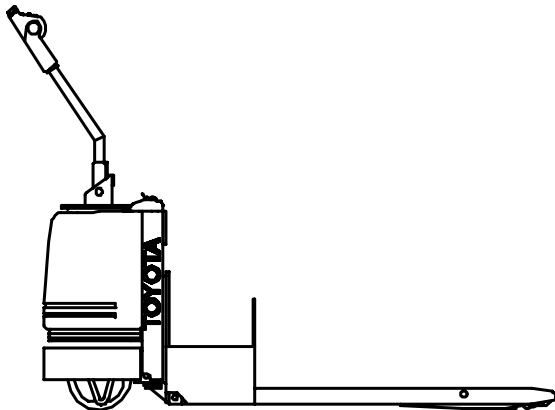

Model 6HBW30 Low-Lift Pallet Truck

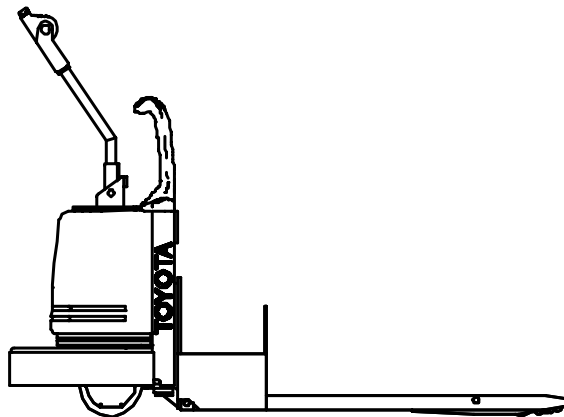

Model 6HBE30 and Model 6HBE40 End Rider

Vehicle Specifications

Vehicle Specifications

Category	6HBW30	6HBE30/40	6HBC30/40	6TB50
Max. Load Capacity	6,000 lb (2,724 kg)	6,000 lb (2,724 kg)*	6,000 lb (2,724 kg)**	N/A
Normal Rated Drawbar Pull	N/A			200 lb (91 kg)
Max. Drawbar Pull***	N/A			700 lb (318 kg)
Upright Height	60.1 in. (152.7 cm)		54.1 in. (137.4 cm)	
Overall Length	up to 91.7 in. (232.9 cm)	up to 102.4 in. (260.1 cm)†	up to 114.3 in. (290.3 cm)‡	53.11 in. (134.9 cm)
Overall Width	32.5 in. (82.6 cm)	36 in. (91 cm)	32.5 in. (82.6 cm)	
Max. Lift Height	9 in. (22.9 cm)			N/A
Coast Travel Speed	N/A	3.5 mph (4 kph) Max.		
Regular Speed	3.9 mph (6.3 kph)	6.0 mph (9.6 kph) Max.		
Rabbit Speed	N/A	8.8 mph (14.2 kph) Max.		
Stopping Distance	6 ft. (1.83 m)			
Battery Compartment Width	9.19 in. (23 cm)	13.44 in. (34.1 cm)		
Battery Voltage	24V			
Min. Battery Weight	575 lb (261 kg)	965 lb (438 kg)		
Max. Battery Weight	625 lb (284 kg)	1500 lb (681 kg)		
Truck Weight Without Battery	1058 lb (480 kg)	1234 lb (560 kg)	1320 lb (599 kg)	1190 lb (540 kg)
<p>* Model 6HBE40 has 8000 lb (3632 kg) capacity. ** Model 6HBC40 has 8000 lb (3632 kg) capacity. *** when equipped with rubber drive tire † with 8000 lb (3632 kg) trucks, overall length is up to 146 in. (370.9 cm) ‡ with 8000 lb (3632 kg) trucks, overall length is 156.3 in. (397 cm)</p>				

⚠ WARNING

The total weight of the load must include the pallet, the container or the device holding the load and the operator (on rider models).

General System Data

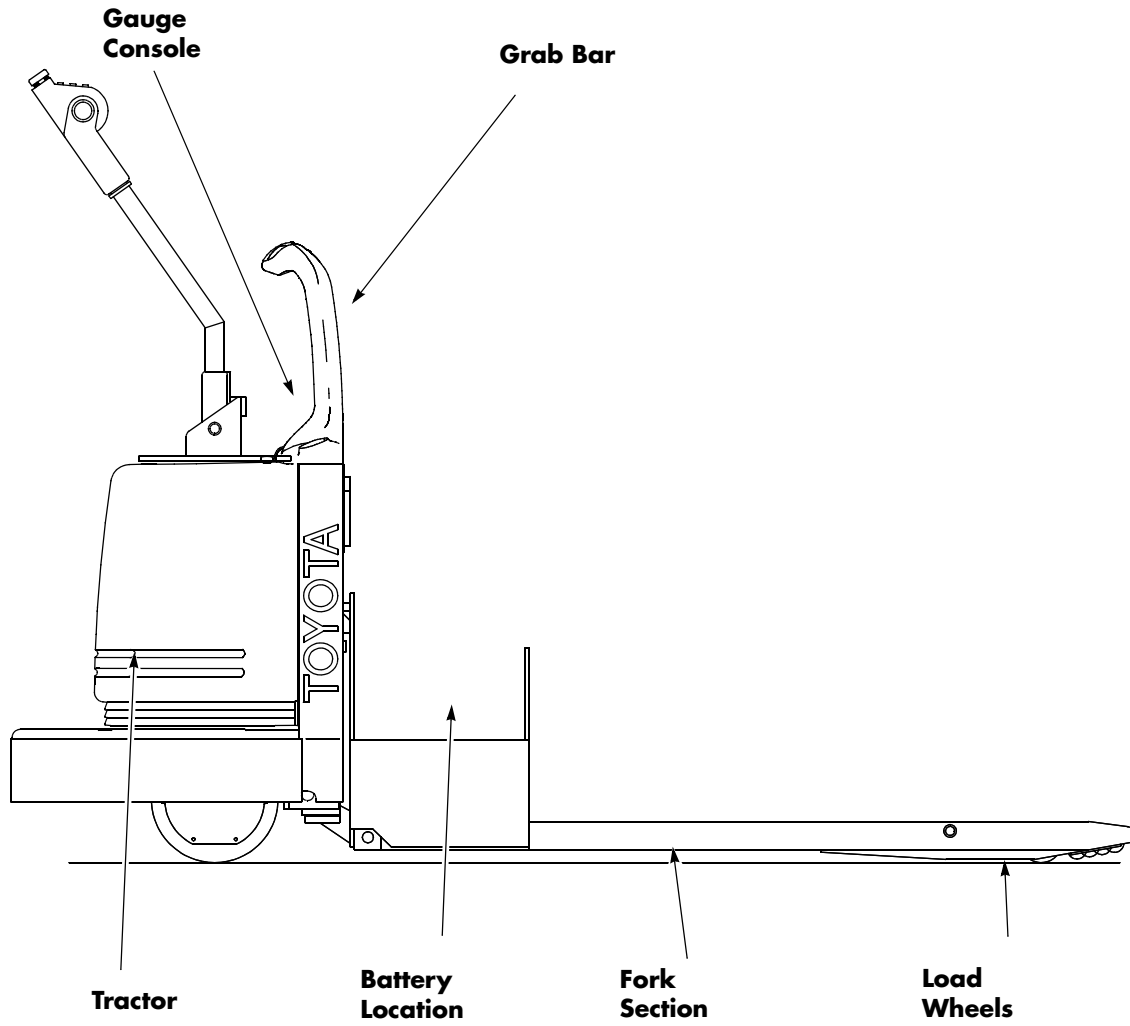

Figure 3-1. Model 6HBE30

General System Data

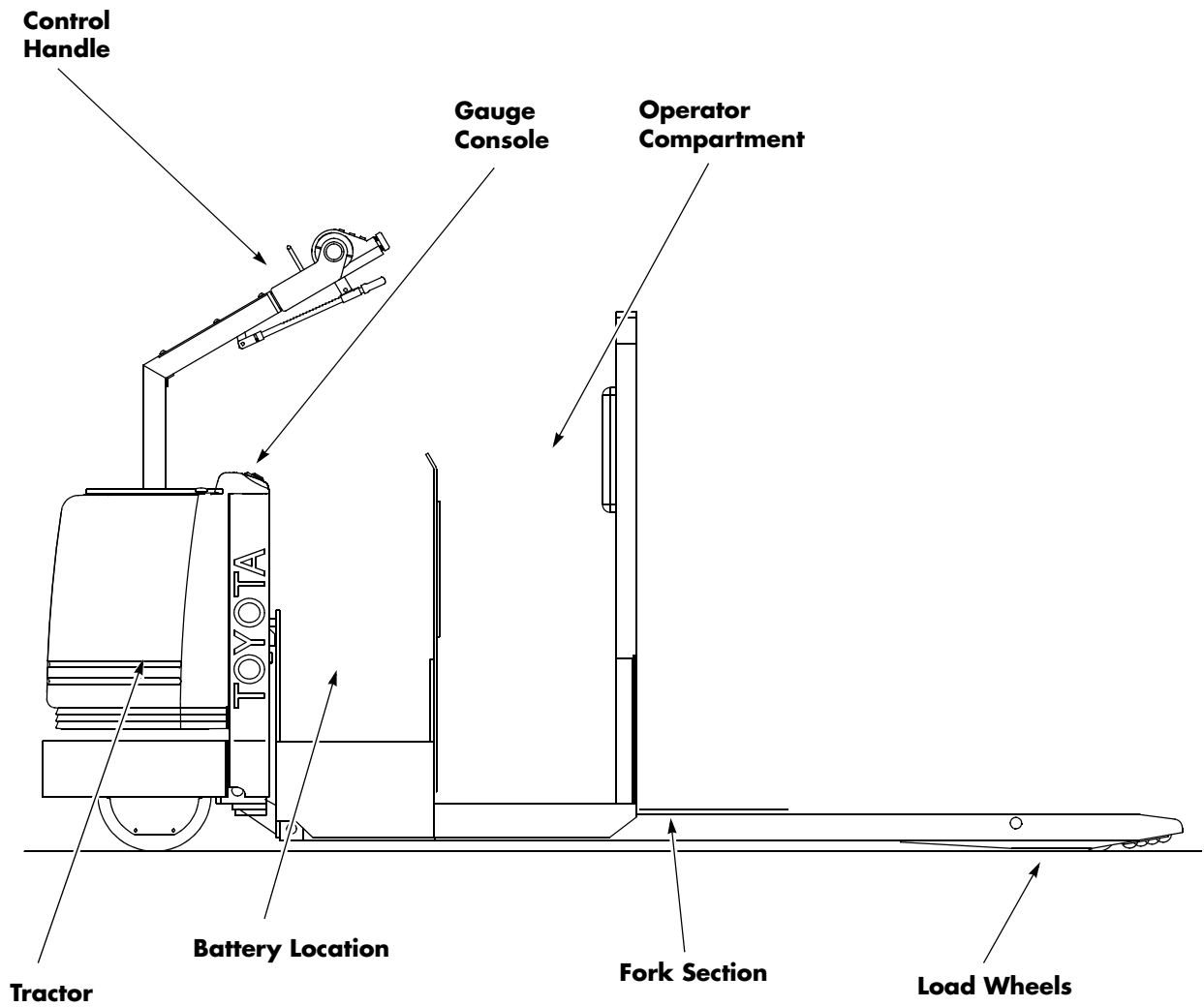

Figure 3-2. Model 6HBC30

Special Tools

Programmable Maintenance Tool

The optional Programmable Maintenance Tool (P/N 00590-49981-71) permits you to test, diagnose, and program the motor controller in this pallet truck.

The Programmable Maintenance Tool (PMT) is powered by the host controller through the four-pin connector at the bottom of the controller. See Figure 3-3.



Figure 3-3. Programmable Maintenance Tool

Theory of Operation

Theory of Operation

Lift/Lower

The lift/lower system consists of an electrically operated hydraulic pump and related components.

The hydraulic pump assembly consists of a positive displacement rotary gear pump with reservoir mounted to an adapter. A DC electric motor is mounted to the opposite side of the pump adapter. An adjustable relief valve, check valve, and a solenoid operated release valve are located within the adapter.

With the forks elevated, the normally-closed solenoid valve and the check valve prevent hydraulic fluid from returning to the reservoir.

Lift

When the battery is plugged in, the key switch (SW1) is ON and the lift button is pressed:

- the lift switch closes
- the lift pump contactor closes, causing the lift pump to operate
 - Hydraulic fluid is drawn through the screen in the reservoir into the lift pump and is forced into the lift cylinders.
 - As the pump rotates, oil is forced out the pressure port through the lift hose to the lift cylinders. Oil cannot return to the reservoir because of the closed pressure relief valve and closed lowering solenoid valve.
 - Hydraulic pressure in the lift cylinders raises the forks. Lift cutout switch will interrupt power to the lift motor when the forks reach a preset lift limit.

When the lift switch is open:

- the pump contactor coil is de-energized, stopping the lift motor and pump. The forks are held in position by hydraulic fluid trapped in the lift cylinders by the check valve (static position of the relief valve) and the closed lowering solenoid.

The relief valve will open if the hydraulic pressure exceeds the preset limit.

Lower

When the battery is plugged in, the key switch is ON and the lower button is pressed:

- the lower switch is closed
- the lowering solenoid opens
- hydraulic fluid in the lift cylinders returns to the hydraulic reservoir through the lowering valve and the flow control valve
- the forks lower

Directional/Speed Control

The directional/speed control descriptions assume the battery is charged and connected and the key switch is ON.

The control handle must be in the correct position to close the brake (deadman) switch (SW2) and release the brake. See "Brake Switch" on page 6-18. When the brake switch is closed, the main contactor (M1) is energized.

NOTE: When the control handle is released and the brake (deadman) switch opened, the main contactor (M1) will remain energized for several seconds before de-energizing.

Forward

When the directional/speed control is rotated in the forward direction from neutral:

- the forward directional switch (SW3) is closed and B+ is applied to PMC-10 of the motor controller
- resistance across the throttle potentiometer (VR-4 to VR-2) increases from zero ohms to a maximum of 6,500 ohms. Throttle input voltage is then generated at PMC-16 with respect to (wrt) PMC-14. As throttle input voltage rises above the neutral band threshold, the motor controller begins to provide current

flow through the drive motor armature at M-. It also provides current flow through the field windings in the correct polarity at F1 and F2.

- the drive wheel begins to rotate in a forward direction at a speed proportionate to throttle input.

Reverse

When the directional/speed control is rotated in the reverse direction from neutral:

- the reverse directional switch (SW4) is closed and B+ voltage is applied to PMC-11 of the motor controller
- resistance across the throttle potentiometer (VR-4 to VR-2) increases from zero ohms to a maximum of 6,500 ohms. Throttle input voltage is then generated at PMC-16 wrt PMC-14. As throttle input voltage rises above the neutral band threshold, the motor controller begins to provide current flow through the drive motor armature at M-. It also provides current flow through the field windings in the correct polarity (F1 and F2).
- The drive wheel begins to rotate in a reverse direction at a speed proportionate to the throttle input.

Emergency Reverse

(Models 6HBW30, 6HBE30 and 6HBE40)

When the emergency reverse switch (belly button switch SW7) is closed with the control handle lowered in travel mode (SW2 closed), the control system responds in various ways, depending upon how the truck was operating when SW7 closed.

- *Truck traveling in tractor-first direction:* full braking torque is applied to the drive motor and then accelerates in the forks-first direction.
- *Truck stopped or traveling in forks-first direction:* full accelerating torque for forks-first direction is applied to the drive motor.

Travel in forks-first direction will continue until the emergency reverse switch (SW7) is released. When the emergency reverse mode is activated, the motor controller ceases to respond to the normal travel command from the directional/speed control. To reset the truck for normal travel, return the directional/speed control to the neutral position.

Strip Curtain Bypass

(Models 6HBE30/40 only)

When the truck is traveling tractor first and the horn button on the grab rail is pressed, the emergency reverse switch is disabled until the horn button is released.

Manual Coast Mode

(Standard on 6HBE30/40, Optional on 6HBW30)

Manual Coast is an operating mode where the brake remains released at all times and speed is restricted to 3.5 mph (5.6 km/h). Manual coast is intended for order picking while walking beside the pallet truck.

The manual coast system uses a manually actuated spring loaded plunger to keep the control handle in the travel (brake released) position.

To engage manual coast, the control handle is lowered into the operating range and the “flip over” coast selector is engaged. Manual coast is disengaged by reversing the above process.

When manual coast is engaged, coast interlock switch (SW27) activates RLY2, supplying a Mode Select 1 input at PMC-3. This input, in conjunction with the status of the mode select input at PMC-4, creates a fixed PWM (40%) to the traction motor armature circuit. This limits the fixed speed to 3.5 mph (5.6 km/h).

Even with the manual coast lever in the no coast position, maximum speed is limited to 3.5 mph (5.6 km/h) as the motor controller is restricted to speed mode M1. Top (rabbit) speed in both directions is selected by pressing and releasing the rabbit button while forward or reverse travel is requested through the twist

Theory of Operation

grip. This shifts the motor controller from speed mode M1 to mode M2 (forks first) or mode M4 (tractor first). The rabbit command is “latched” until the twist grip is returned to neutral or the brake (deadman) switch is opened.

Motor Controller

The basic functions of the motor controller include:

- *Direction Control* section: controls the drive motor direction by manipulating the drive motor field polarity according to the directional switch inputs (SW3, SW4).
- *Throttle Control* section: controls the drive motor speed and torque by monitoring relative position change of the wiper in the travel potentiometer wrt the static neutral position. Infinitely variable motor speed is accomplished by separate control of field and armature current.
- *Emergency Reverse* circuitry: controls the override of the directional travel control.
- *Main Contactor (M1)* control
- *Diagnostics* section: continuously monitors the travel circuits for fault conditions and responds appropriately, shutting down travel in some cases.

This page intentionally left blank.

Section 4. Scheduled Maintenance

Introduction

Maintenance Guidelines

A regularly scheduled maintenance program will ensure:

- Maximum truck performance
- Maximum truck life
- Reduction of costly down time
- Avoidance of unnecessary repairs

Scheduled maintenance includes:

- Cleaning
- Inspection
- Lubrication
- Service

Perform all of the scheduled checks and maintenance during the suggested intervals. The intervals given in this guide are based on normal operating conditions. When operating under abnormal or severe conditions, perform these services more often as required to keep the unit in good operating condition.

Refer to the Appendix for lubrication equivalents. Refer to the manufacturer's supplements for components not listed on the following pages.

General Truck Operation

- Operate all functions of the truck and check for any abnormal operation.
- Talk to the driver to see if any problems were noticed.
- Check to see that all the safety and operational decals are in place and legible.
- List repairs required.

Introduction

Perform Daily or Every Eight (8) Operating Hours

Item	Daily or Eight-Hour Checklist
Battery	<p>Check cleanliness and exterior condition. See "Battery Exterior Cleaning" on page 6-9.</p> <p>Check the charge.</p> <p>Check the weight.</p> <p>Make sure there are solid electrical connections and no damage.</p> <p>Check the connector. Make sure all powered functions are shut down when disconnected.</p> <p>Make sure battery is properly installed.</p> <p>Check the battery gates (if so equipped) for bending or cracks. Replace if necessary. Check the "free play" of the battery. Make sure the battery does not move more than 1/2 in. (13mm).</p>
Brake	<p>Check that the control handle returns to the vertical position when released.</p> <p>Check that travel is cut out and the brake is applied when the control handle is within 10° of the fully raised or lowered position.</p>
Forks	<p>Inspect for damage, bending, cracking, or signs of unauthorized modification. Check for minimum thickness.</p>
Hydraulic System	<p>Check hydraulic connections and hoses for leaks.</p>
Lift Items	<p>Inspect lift cylinders for damage or leaks.</p> <p>Check lift cylinder yokes and lift stop bolts.</p>
Switches	<p>Check that each switch controls the assigned function.</p> <p>Check for intermittent switch operation.</p>
Wheels	<p>Inspect the condition of the drive wheel and load wheels. Remove any steel chips and foreign material to prevent damage to the wheels. Check for gouging and chunking of the surface.</p>
General Operation	<p>Check that the horn operates when you press the horn button. (Battery must be connected.)</p> <p>Check the speed and directional controls.</p> <p>Check the hour meter (optional). It must operate when the key is turned ON and the handle is in the operating position.</p> <p>Check the steering operation.</p> <p>Check the lift/lower functions.</p> <p>Check all other components and hardware, inspecting for looseness as necessary.</p> <p>Check the operation of the emergency reverse switch.</p>
<p>NOTE: List repairs and report any damage to the supervisor or maintenance personnel.</p>	

Perform Every Two Months or 250 Operating Hours

Item	Every Two Months or 250-Hour Checklist
Daily Checklist	Perform Daily Checklist.
Brake	Check for satisfactory brake operation. Check the brake actuation and deadman switch adjustment.
Contactor Tips	Check the contactor tips. Replace if: <ul style="list-style-type: none"> • they are burned or worn • the silver facings are almost worn through or the copper is showing in the contact area • there is a curved surface between the mating tips
Drive Unit	Check the oil level of the drive housing. Check and clean the drive housing breather. Lubricate the steering bearing through grease fittings.
Electrical System	Visually inspect all cables for damage and poor connections. Check for battery leakage to truck frame. Check for shorts to truck frame. Check for dielectric grease when cold storage. Check for correct cable tie installation.
General Operation	Check the condition of cables and hoses. Check for looseness of all mounting bolts and nuts.
Hydraulic System	Inspect hydraulic connections and mountings. Inspect hoses, tubes and fittings for leaks. Check for correct fluid level in hydraulic reservoir. Clean the hydraulic fluid breather cap.
Motor Brushes	Check the condition of brushes, springs and holders. Check that the brush length exceeds the minimum length: Drive motor - 9/16 in. (14.3 mm) Lift/Aux. motor - 1/2 in. (13 mm)
Lift Linkage	Inspect, lubricate, and adjust linkage. Examine for wear.
Stabilizer Pads	Check that stabilizer pads are still at the required length.
Wheel	Check the tightness of the drive wheel mounting cap screws. Check and lubricate the load wheel bearings and fork trails.
Caster Assembly	Check operation, adjustment, grease.
NOTE: List repairs and report any damage to the supervisor or maintenance personnel.	

Introduction

Perform Annually or Every 1500 Operating Hours

Item	Annually or Every 2000-Hour Checklist
Daily Checklist	Perform Daily (8-hour) Checklist on Page 4-3.
250-Hour Checklist	Perform the Monthly (250-hour) Checklist on Page 4-4.
Hydraulic System	Change the filter. Change the hydraulic fluid.
Drive Unit	Change drive unit oil.
NOTE: List repairs and report any damage to the supervisor or maintenance personnel.	

Lubrication Points

Figure 4-1 through Figure 4-5 show the lubrication points on the truck.

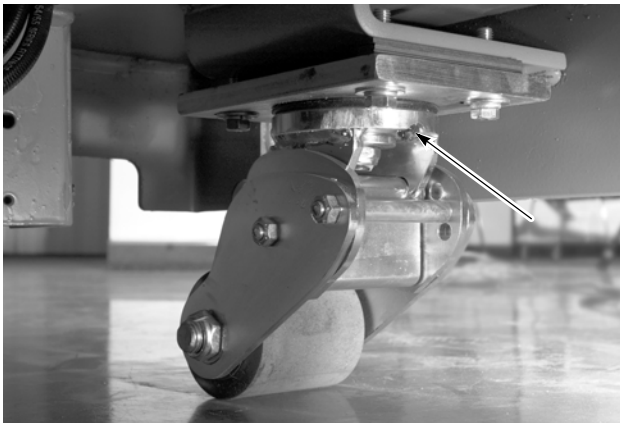

Figure 4-1. Caster Grease Fittings

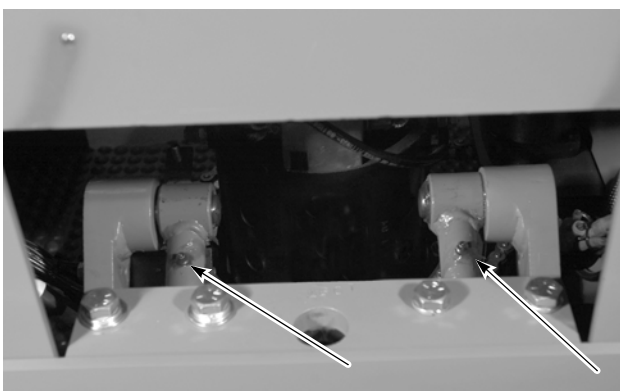
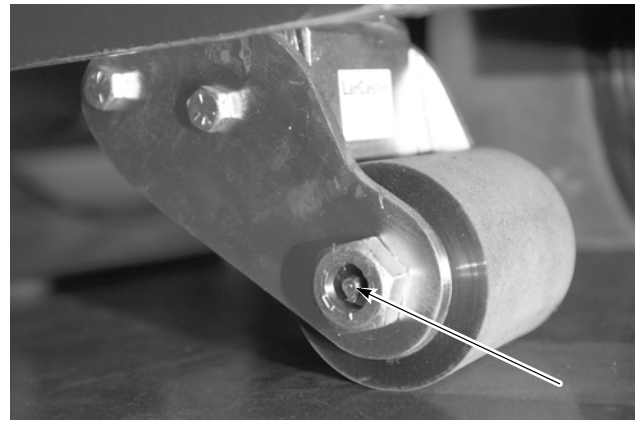

Figure 4-2. Upper Bell Crank Grease Fittings (Between Tractor and Fork Section)

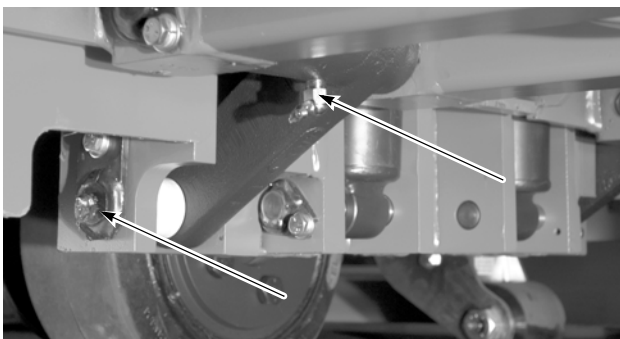
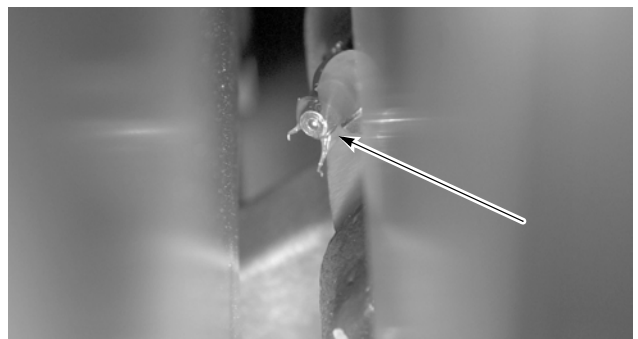

Figure 4-3. Lower Bell Crank Grease Fittings-Left side shown (Between Tractor and Fork Section)



Introduction

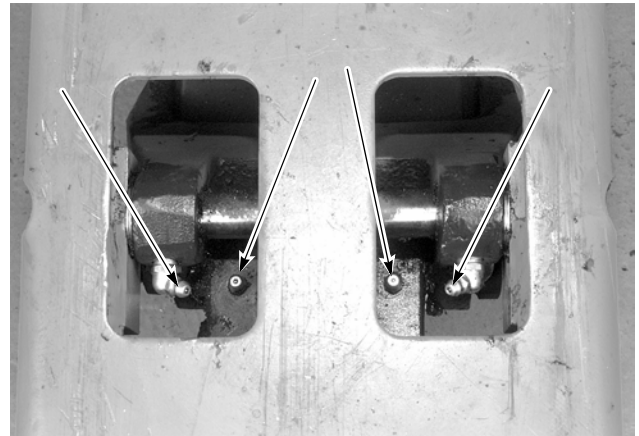
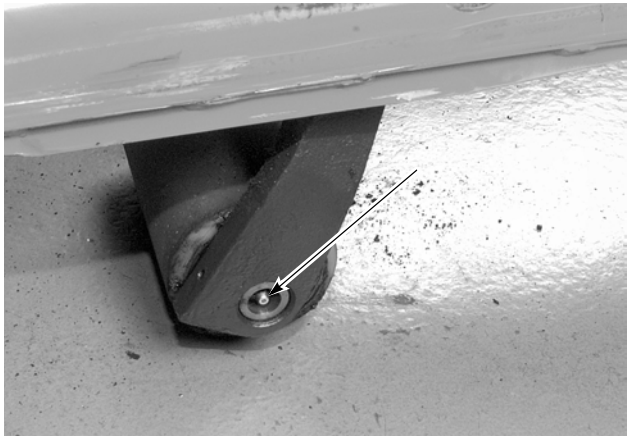

Figure 4-4. Load Wheel Grease Fittings and Fork Grease Fittings (Top View)

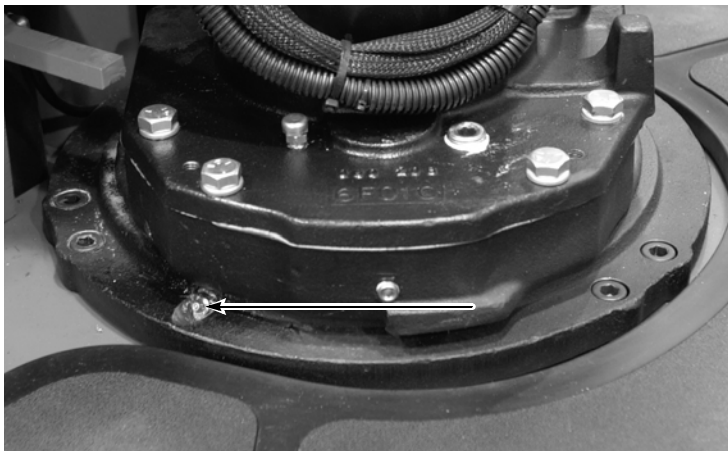

Figure 4-5. Drive Unit Grease Fittings (2), 180° Apart (front location shown)

**Thank you very much
for your reading.**

Please Click Here

**Then Get More
Information.**