



Doosan Infracore

Operation & Maintenance Manual

GENERATOR DIESEL ENGINE

D1146, D1146T, P086T1

POWER UNIT ENGINE

PU086, PU086T

◎ POWER RATING

Engine Speed rev/min	Type of Operation	Engine Power	
		kWm	Ps
1800	Continuous Power	186	253
	Prime Power	205	279
	Standby Power	223	303
1500	Continuous Power	151	205
	Prime Power	177	240
	Standby Power	199	270

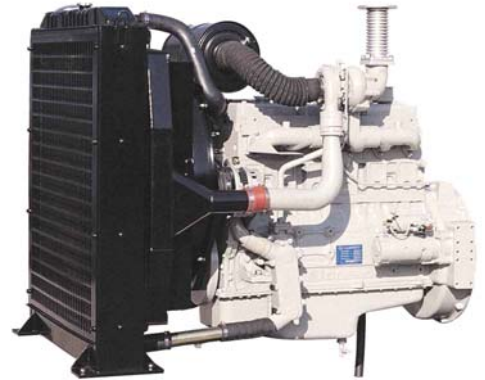

Note : -. The engine performance corresponds to ISO 3046, BS 5514 and DIN 6271.

-. Ratings are based on ISO 8528.

→ **Prime power** available at variable load. The permissible average power out put (during 24h period) shall not exceed 70% of the prime power rating.

→ **Standby power** available in the event of a main power network failure. No overload is permitted.

◎ MECHANICAL SYSTEM

○ Engine Model	P086TI
○ Engine Type	In-line 4 cycle, water cooled Turbo charged & intercooled (air to air)
○ Combustion type	Direct injection
○ Cylinder Type	Replaceable dry liner
○ Number of cylinders	6
○ Bore x stroke	111(4.37) x 139(5.47) mm(in.)
○ Displacement	8.071(492.49) lit.(in ³)
○ Compression ratio	16.4 : 1
○ Firing order	1-5-3-6-2-4
○ Injection timing	12° BTDC
○ Compression pressure	Above 28 kg/cm ² (398 psi) at 200rpm
○ Dry weight	Approx. 790 kg (1,742 lb)
○ Dimension (LxWxH)	1,242 x 918 x 1,099.5 mm (48.9 x 36.1 x 43.3 in.)
○ Rotation	Counter clockwise viewed from Flywheel
○ Fly wheel housing	SAE NO.1
○ Fly wheel	Clutch NO.14

◎ MECHANISM

○ Type	Over head valve
○ Number of valve	Intake 1, exhaust 1 per cylinder
○ Valve lashes at cold	Intake 0.30mm (0.0118 in.) Exhaust 0.30mm (0.0118 in.)

◎ VALVE TIMING

	Opening	Close
○ Intake valve	16 deg. BTDC	36 deg. ABDC
○ Exhaust valve	46 deg. BBDC	14 deg. ATDC

◎ FUEL CONSUMPTION

○ Prime Power (lit/hr)	1,500 rpm	1,800 rpm
25%	11.3	13.8
50%	21.1	25.1
75%	31.7	37.7
100%	43.1	50.6
○ Standby Power (lit/h)	1,500 rpm	1,800 rpm
25%	12.7	15.2
50%	23.7	27.7
75%	35.5	41.6
100%	48.4	56.8

◎ FUEL SYSTEM

○ Injection pump	Zexel in-line "P" type
○ Governor	Electric type
○ Feed pump	Mechanical type
○ Injection nozzle	Multi hole type
○ Opening pressure	224 kg/cm ² (3,186 psi)
○ Fuel filter	Full flow, cartridge type
○ Used fuel	Diesel fuel oil

◎ LUBRICATION SYSTEM

○ Lub. Method	Fully forced pressure feed type
○ Oil pump	Gear type driven by crankshaft
○ Oil filter	Full flow, cartridge type
○ Oil pan capacity	High level 15.5 liters (4.09 gal.) Low level 12 liters (3.17 gal.)
○ Angularity limit	Front down 25 deg. Front up 25 deg. Side to side 25 deg.
○ Lub. Oil	Refer to Operation Manual

◎ COOLING SYSTEM

- Cooling method Fresh water forced circulation
- Water capacity 14 liters (3.70 gal.)
(engine only)
- Pressure system Max. 0.9 kg/cm² (12.8 psi)
- Water pump Centrifugal type driven by belt
- Water pump Capacity 150 liters (39.6 gal.)/min
at 1,800 rpm (engine)
- Thermostat Wax – pellet type
Opening temp. 71°C
Full open temp. 85°C
- Cooling fan Blower type, plastic
660.4 mm diameter, 7 blade

◎ ELECTRICAL SYSTEM

- Charging generator 24V x 45A alternator
- Voltage regulator Built-in type IC regulator
- Starting motor 24V x 6.0kW
- Battery Voltage 24V
- Battery Capacity 100 AH (recommended)
- Starting aid (Option) Block heater

◎ ENGINEERING DATA

- | | |
|-----------------------------|-------------------------------------|
| ○ Water flow | 130 liters/min @1,500 rpm |
| ○ Heat rejection to coolant | 17.3 kcal/sec @1,500 rpm |
| ○ Heat rejection to CAC | 4.5 kcal/sec @1,500 rpm |
| ○ Air flow | 12.1 m ³ /min @1,500 rpm |
| ○ Exhaust gas flow | 33.9 m ³ /min @1,500 rpm |
| ○ Exhaust gas temp. | 580 °C @1,500 rpm |
-
- | | |
|-----------------------------|-------------------------------------|
| ○ Water flow | 150 liters/min @1,800 rpm |
| ○ Heat rejection to coolant | 20.3 kcal/sec @1,800 rpm |
| ○ Heat rejection to CAC | 10.8 kcal/sec @1,800 rpm |
| ○ Air flow | 16.8 m ³ /min @1,800 rpm |
| ○ Exhaust gas flow | 38.8 m ³ /min @1,800 rpm |
| ○ Exhaust gas temp. | 530 °C @1,800 rpm |
-
- Max. permissible restrictions
 - .Intake system 220 mmH₂O initial
635 mmH₂O final
 - .Exhaust system 600 mmH₂O max.

◆ CONVERSION TABLE

- | | |
|------------------------------------|------------------------------------|
| in. = mm x 0.0394 | lb/ft = N.m x 0.737 |
| PS = kW x 1.3596 | U.S. gal = lit. x 0.264 |
| psi = kg/cm ² x 14.2233 | kW = 0.2388 kcal/s |
| in ³ = lit. x 61.02 | lb/PS.h = g/kW.h x 0.00162 |
| hp = PS x 0.98635 | cfm = m ³ /min x 35.336 |
| lb = kg x 2.20462 | |

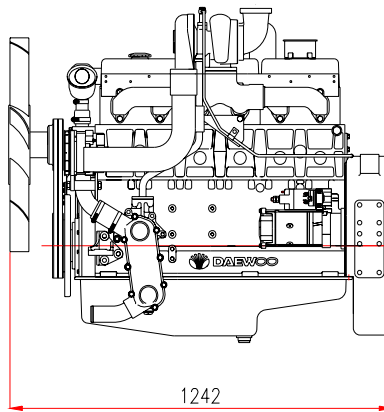
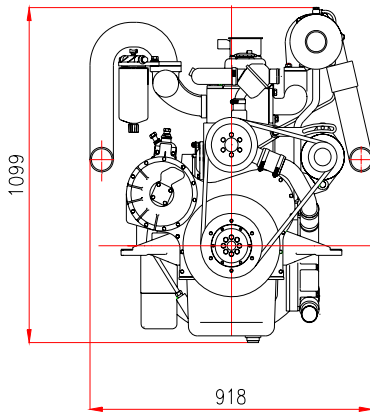

Head office
7-11, Hwasu-Dong, Dong-Gu, Incheon, Korea
TEL : 82-32-760-1437, 1964 FAX : 82-32-760-1964

Seoul Office
Doosan Infracore Co. Ltd.,
22nd Floor, Doosan Tower, 18-12, Euljiro 6-ga, Jung-gu,
Seoul, Korea.
TEL : 82-2-3398-8521~8535 FAX : 82-2-3398-8509
Web site : www.doosaninfracore.com

※ Specifications are subject to change without prior notice















FOREWORD

This manual is designed to serve as an instruction for the Operation & Maintenance of the generating-set engines of Doosan POLUS series and the power unit engines: P086TI /P086TI-1/ D1146T/ D1146/ PU086T/ PU086. The POLUS means 'Power Plus' that is represented more powerful Doosan generating-set engines and it is marked on engine name as an initial P. On the other hand, initial PU stands for 'Power Unit' and Initial D stands for standard engine prior to POLUS version.

The first half is for operation and the latter half is for maintenance like disassembling, inspecting and re-assembling etc in order to help an understanding for the maintenance procedure more easily.

To keep the best performance and the durability of engine for a long time, CORRECT OPERATION and PROPER MAINTENANCE are essential.

In this manual, the following symbols are used to indicate the type of service operations to be performed.

	Removal		Adjustment
	Installation		Cleaning
	Disassembly		Pay close attention-Important
	Reassembly		Tighten to specified torque
	Align the marks		Use special tools of manufacturer
	Directional Indication		Lubricate oil
	Inspection		Lubricate grease
	Measurement		

If you have any question or recommendation in connection with this manual, please do not hesitate to contact our head office, dealers or authorized service shops near by your location for any services. Also some figures in this manual may be different from the actual appearance of the engine because of explaining them with the representative figure among these models.

For the last, the contents of this instruction manual may be changed without prior notice for some quality improvement. Thank you.

CONTENTS

<Operation>

1. Safety Regulations	1
1.1. General Notes	1.4. Regulations Designed to Prevent Pollution
1.2. Regulations Designed to Prevent Accidents	1.5. Notes on Safety in Handling Used Engine Oil
1.3. Regulations Designed to Prevent Damage to Engine and Premature Wear	
2. General Information	5
2.1. Engine Assembly	2.2. Engine Specification
3. Technical Information	12
3.1. Engine Model and Serial Number	3.7. Fuel System
3.2. Engine Type	3.8. Cooling System
3.3. Engine Timing	3.9. V-belt Tension Check and Adjust
3.4. Valves	3.10. Turbocharger
3.5. Lubrication System	3.11. Electrical Equipment
3.6. Air Cleaner	
4. Commissioning and Operation	28
4.1. Preparation	4.4. Operation in Winter Time
4.2. Breaking-in	4.5. Tuning the Engine
4.3. Inspections after Starting	
5. Maintenance and Care	32
5.1. Periodical Inspection and Maintenance	5.5. Fuel System
5.2. Lubrication System	5.6. Injection Nozzle Maintenance
5.3. Cooling System	5.7. Turbocharger
5.4. Air Intake System	
6. Checking and Setting	46
6.1. Adjustment of Valve Clearance	6.3. Cylinder Compression Pressure
6.2. Adjustment of Injection Timing	6.4. V-belts
7. Operation Tip	52
7.1. Periodic Inspection Cycle	7.3. Causes and Remedies
7.2. Trouble Shooting	

<Maintenance>

8. General Information 63

- 8.1. General Repair Instructions
- 8.2. Engine Characteristic

9. Maintenance 66

- 9.1. Engine Disassembly
- 9.2. Inspection
- 9.3. Reassembly
- 9.4. Breaking-in

10. Maintenance of Major Components 121

- 10.1. Cooling System
- 10.2. Lubricating System
- 10.3. Fuel Injection Pump
- 10.4. Turbocharger

11. Special Tool List 167

- **Appendix**
- **Part & After service center**
- **Applications for Doosan Engine**

1. Safety Regulations

1.1. General Notes

Handling diesel engines and the necessary resources is no problem when the personnel commissioned with operation and maintenance are trained accordingly and use their common sense.

This summary is a compilation of the most important regulations. These are broken down into main sections which contain the information necessary for preventing injury to persons, damage to property and pollution. In addition to these regulations those dictated by the type of engine and its site are to be observed also.



IMPORTANT

If, despite all precautions, an accident occurs, in particular through contact with caustic acids, fuel penetrating the skin, scalding from oil, antifreeze being splashed in the eyes etc., consult a doctor immediately.

1.2. Regulations Designed to Prevent Accidents

1.2.1. During commissioning, starting and operation

Before putting the engine into operation for the first time, read the operating instructions carefully and familiarize yourself with the "critical" points. If you are unsure, ask your DAEWOO representative.

- For reasons of safety we recommend you attach a notice to the door of the engine room prohibiting the access of unauthorized persons and that you draw the attention of the operating personnel to the fact that they are responsible for the safety of persons who enter the engine room.
- The engine must be started and operated only by authorized personnel. Ensure that the engine cannot be started by unauthorized persons.
- When the engine is running, do not get too close to the rotating parts. Wear close-fitting clothing.
- Do not touch the engine with bare hands when it is warm from operation risk of burns.
- Exhaust gases are toxic. Comply with the installation instructions for the installation of DAEWOO generator diesel engines which are to be operated in enclosed spaces. Ensure that
- there is adequate ventilation and air extraction.
- Keep vicinity of engine, ladders and stairways free of oil and grease. Accidents caused by slipping can have serious consequences.

1.2.2. During maintenance and care

- Always carry out maintenance work when the engine is switched off. If the engine has to be maintained while it is running, e.g. changing the elements of change-over filters, remember that there is a risk of scalding. Do not get too close to rotating parts.
- Change the oil when the engine is warm from operation.



CAUTION :

There is a risk of burns and scalding. Do not touch oil drain valve or oil filters with bare hands.

- Take into account the amount of oil in the sump. Use a vessel of sufficient size to ensure that the oil will not overflow.
- Open the coolant circuit only when the engine has cooled down. If opening while the engine is still warm is unavoidable, comply with the instructions in the chapter entitled "Cooling".
- Neither tighten up nor open pipes and hoses (lube oil circuit, coolant circuit and any additional hydraulic oil circuit) during the operation. The fluid which flows out can cause injury.
- Fuel is inflammable. Do not smoke or use naked lights in its vicinity. The tank must be filled only when the engine is switched off.
- Keep service products (anti-freeze) only in containers which can not be confused with drinks containers.
- Comply with the manufacturer's instructions when handling batteries.



CAUTION :

Accumulator acid is toxic and caustic. Battery gases are explosive.

1.2.3. When carrying out checking, setting and repair work

- Checking, setting and repair work must be carried out by authorized personnel only.
- Use only tools which are in satisfactory condition. Slip caused by the worn open-end wrench could lead to injury.
- When the engine is hanging on a crane, no-one must be allowed to stand or pass under it. Keep lifting gear in good condition.
- When checking injectors, do not put your hands under the jet of fuel. Do not inhale atomized fuel.
- When working on the electrical system disconnect the battery earth cable first. Connect it up again last to prevent short circuits.

1.3. Regulations Designed to Prevent Damage to Engine and Premature Wear

- 1) Never demand more of the engine than it was designed to yield for its intended purpose. Detailed information on this can be found in the sales literature. The injection pump must not be adjusted without prior written permission of DAEWOO.
- 2) If faults occur, find the cause immediately and have it eliminated in order to prevent more serious damage.
- 3) Use only genuine DAEWOO spare parts. DAEWOO will accept no responsibility for damage resulting from the installation of other parts which are supposedly "just as good".
- 4) In addition to the above, note the following points.
 - Never let the engine run when dry, i.e. without lube oil or coolant. Use only DAEWOO-approved service products. (engine oil, anti-freeze and anticorrosion agent)
 - Pay attention to cleanliness. The Diesel fuel must be free of water. See "Maintenance and care".
 - Have the engine maintained at the specified intervals.
 - Do not switch off the engine immediately when it is warm, but let it run without load for about 5 minutes so that temperature equalization can take place.
 - Never put cold coolant into an overheated engine. See "Maintenance and care".
 - Do not add so much engine oil that the oil level rises above the max. marking on the dipstick. Do not exceed the maximum permissible tilt of the engine. Serious damage to the engine may result if these instructions are not adhered to.
 - Always ensure that the testing and monitoring equipment (for battery charge, oil pressure, and coolant temperature) function satisfactorily.
 - Comply with instructions for operation of the alternator. See "Commissioning and operation".
 - Do not let the water pump run dry. If there is a risk of frost, drain the water when the engine is switched off.

1.4. Regulations Designed to Prevent Pollution

1.4.1. Engine oil, filter element, fuel filter

- Take old oil only to an oil collection point. Take strict precautions to ensure that oil does not get into the drains or into the ground.
- The drinking water supply may be contaminated.
- Oil and fuel filter elements are classed as dangerous waste and must be treated as such.

1.4.2. Coolant

- Treat undiluted anti-corrosion agent and / or antifreeze as dangerous waste.
- When disposing of spent coolant comply with the regulations of the relevant local authorities.

1.5. Notes on Safety in Handling Used Engine Oil

Prolonged or repeated contact between the skin and any kind of engine oil decreases the skin. Drying, irritation or inflammation of the skin may therefore occur. Used engine oil also contains dangerous substances which have caused skin cancer in animal experiments. If the basic rules of hygiene and health and safety at work are observed, health risks are not to the expected as a result of handling used engine oil.



Health precautions

- Avoid prolonged or repeated skin contact with used engine oil.
- Protect your skin by means of suitable agents (creams etc.) or wear protective gloves.
- Clean skin which has been in contact with engine oil.
 - Wash thoroughly with soap and water, A nailbrush is an effective aid.
 - Certain products make it easier to clean your hands.
 - Do not use petrol, Diesel fuel, gas oil, thinners or solvents as washing agents.
- After washing apply a fatty skin cream to the skin.
- Change oil-soaked clothing and shoes.
- Do not put oily rags into your pockets.



Ensure that used engine oil is disposed of properly.

- Engine oil can endanger the water supply -

For this reason do not let engine oil get into the ground, waterways, the drains or the sewers. Violations are punishable. Collect and dispose of used engine oil carefully.

For information on collection points please contact the seller, the supplier or the local authorities.

2. General Information

2.1. Engine Assembly

2.1.1. Engine sectional view (longitudinal)

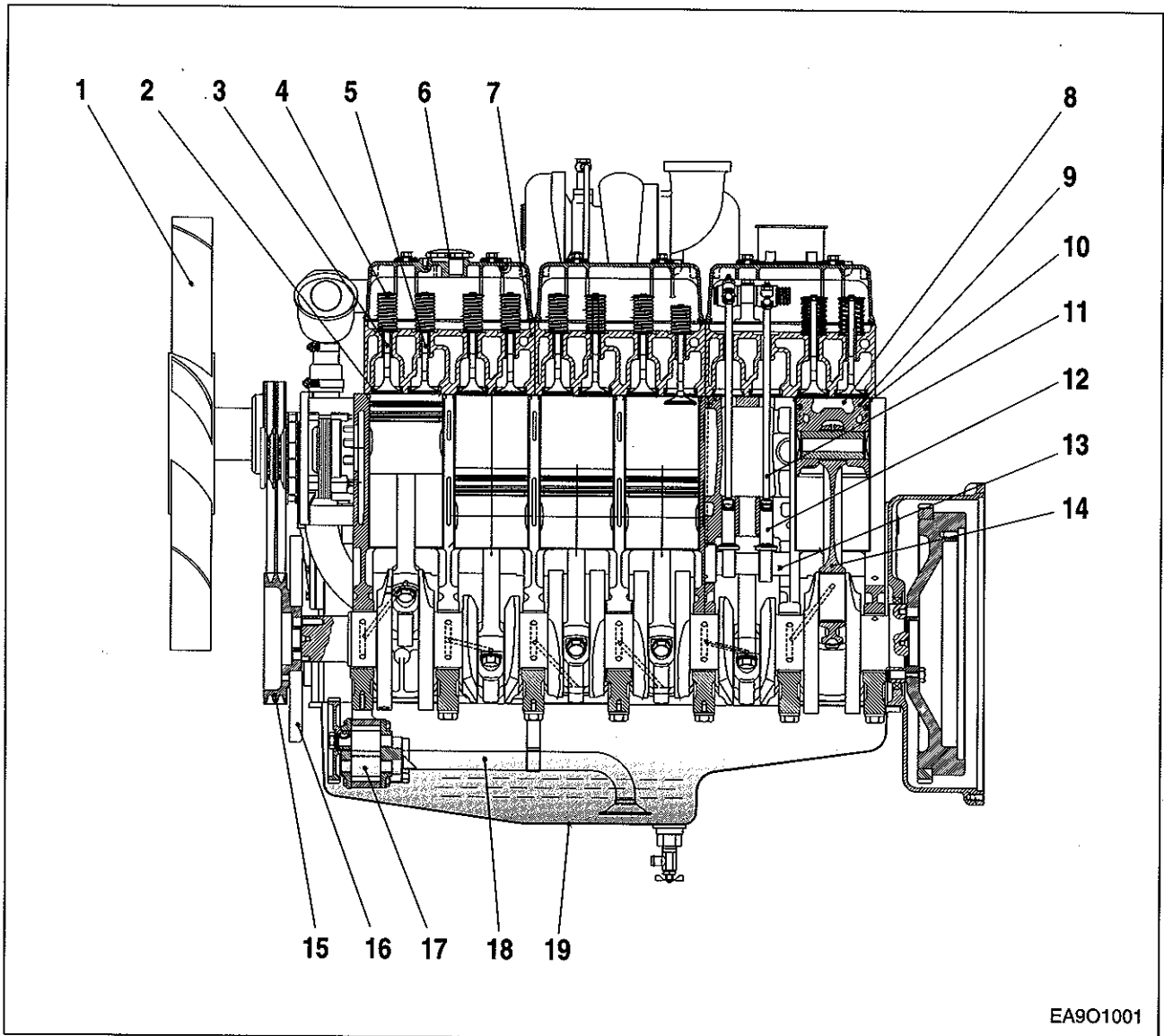

EA901001

- | | | |
|----------------------|-----------------------|-----------------------|
| 1. Cooling fan | 2. Valve seat | 3. Intake valve |
| 4. Valve spring | 5. Exhaust valve | 6. Oil filter cap |
| 7. Cylinder head | 8. Combustion chamber | 9. Piston |
| 10. Cylinder liner | 11. Push rod | 12. Tappet |
| 13. Camshaft | 14. Connecting rod | 15. Crankshaft pulley |
| 16. Vibration damper | 17. Oil Pump | 18. Oil suction pipe |
| 19. Oil pan | | |

2.1.2. Engine sectional view (cross)

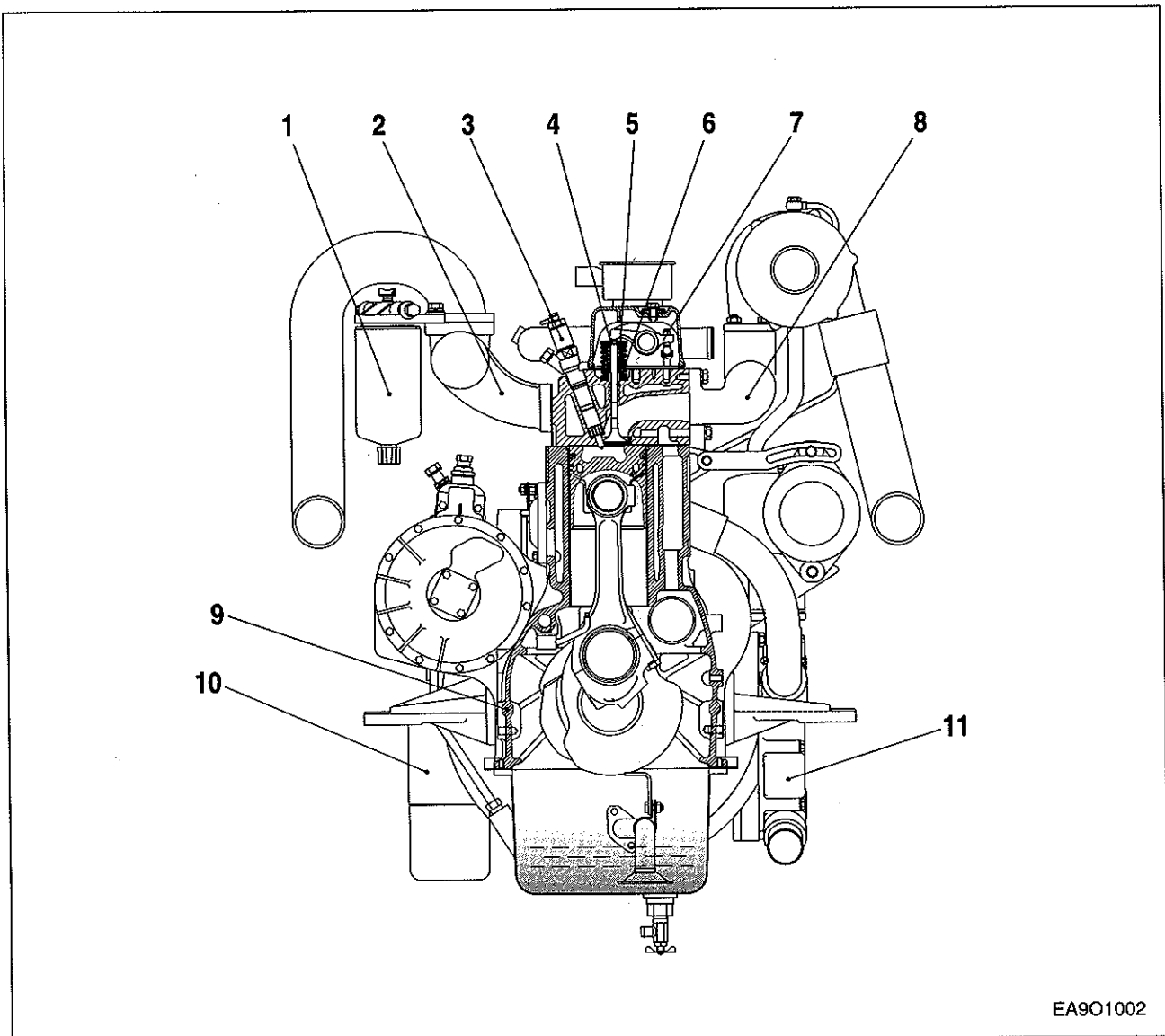

EA901002

- | | |
|------------------------------|---------------------|
| 1. Fuel filter | 7. Rocker arm |
| 2. Intake manifold | 8. Exhaust manifold |
| 3. Injection nozzle assembly | 9. Cylinder block |
| 4. Valve cotter | 10. Oil filter |
| 5. Valve stem seal | 11. Oil cooler |
| 6. Valve guide | |

2.1.3. Engine assembly views

1) D1146/PU086

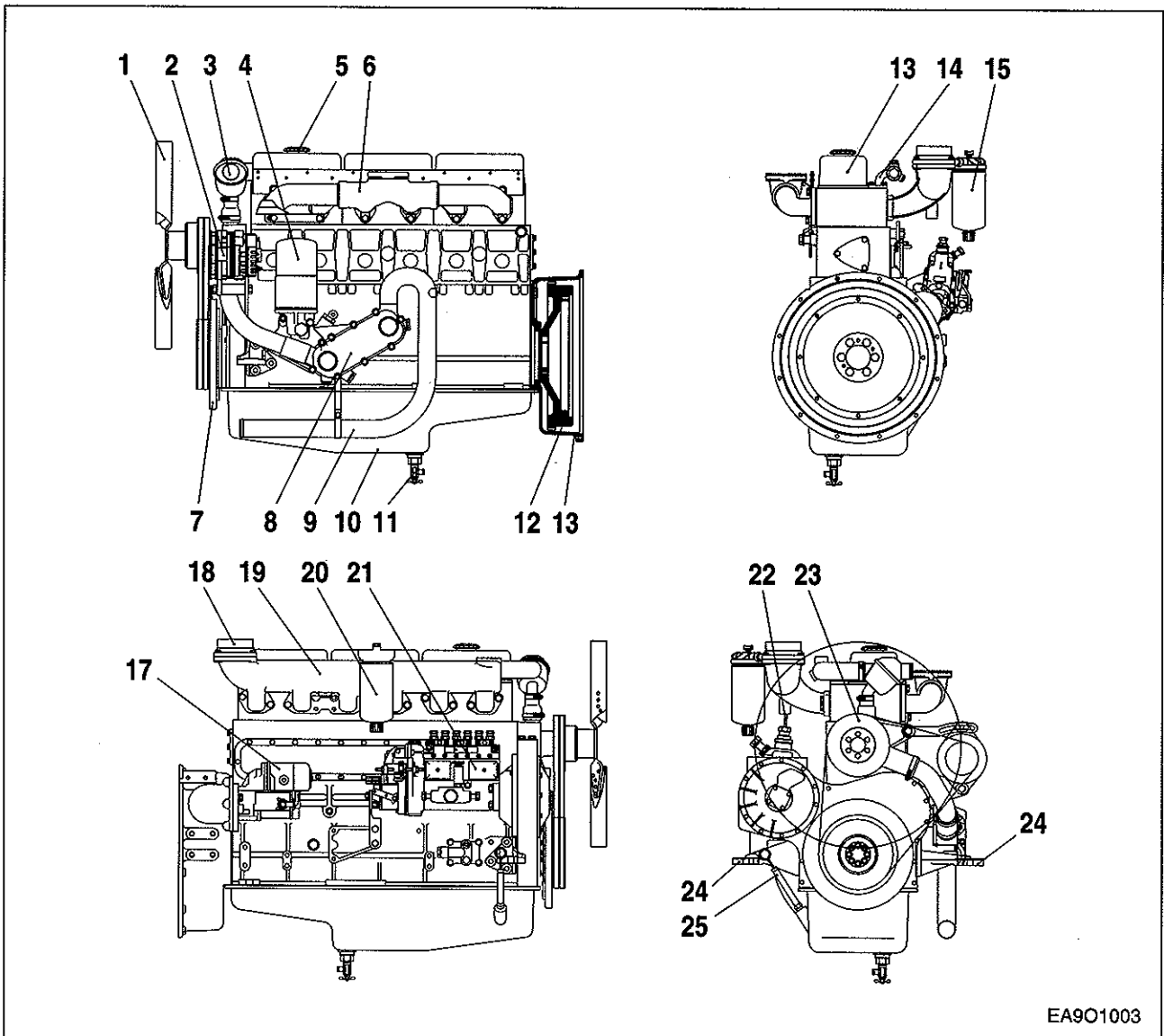

EA901003

- | | | |
|--|-------------------------|----------------------|
| 1. Cooling fan | 10. Oil pan | 19. Intake manifold |
| 2. Alternator | 11. Oil drain valve | 20. Fuel filter |
| 3. Thermostat | 12. Flywheel | 21. Injection pump |
| 4. Oil filter | 13. Flywheel housing | 22. Injection pipe |
| 5. Oil filter cap | 14. Cylinder head cover | 23. Water pump |
| 6. Exhaust manifold | 15. Cooling water pipe | 24. Mounting bracket |
| 7. Vibration damper | 16. Fuel pipe | 25. Oil level gauge |
| 8. Oil cooler | 17. Starter | |
| 9. Cooling water pipe
(from radiator) | 18. Intake stake | |

2) D1146T/PU086T

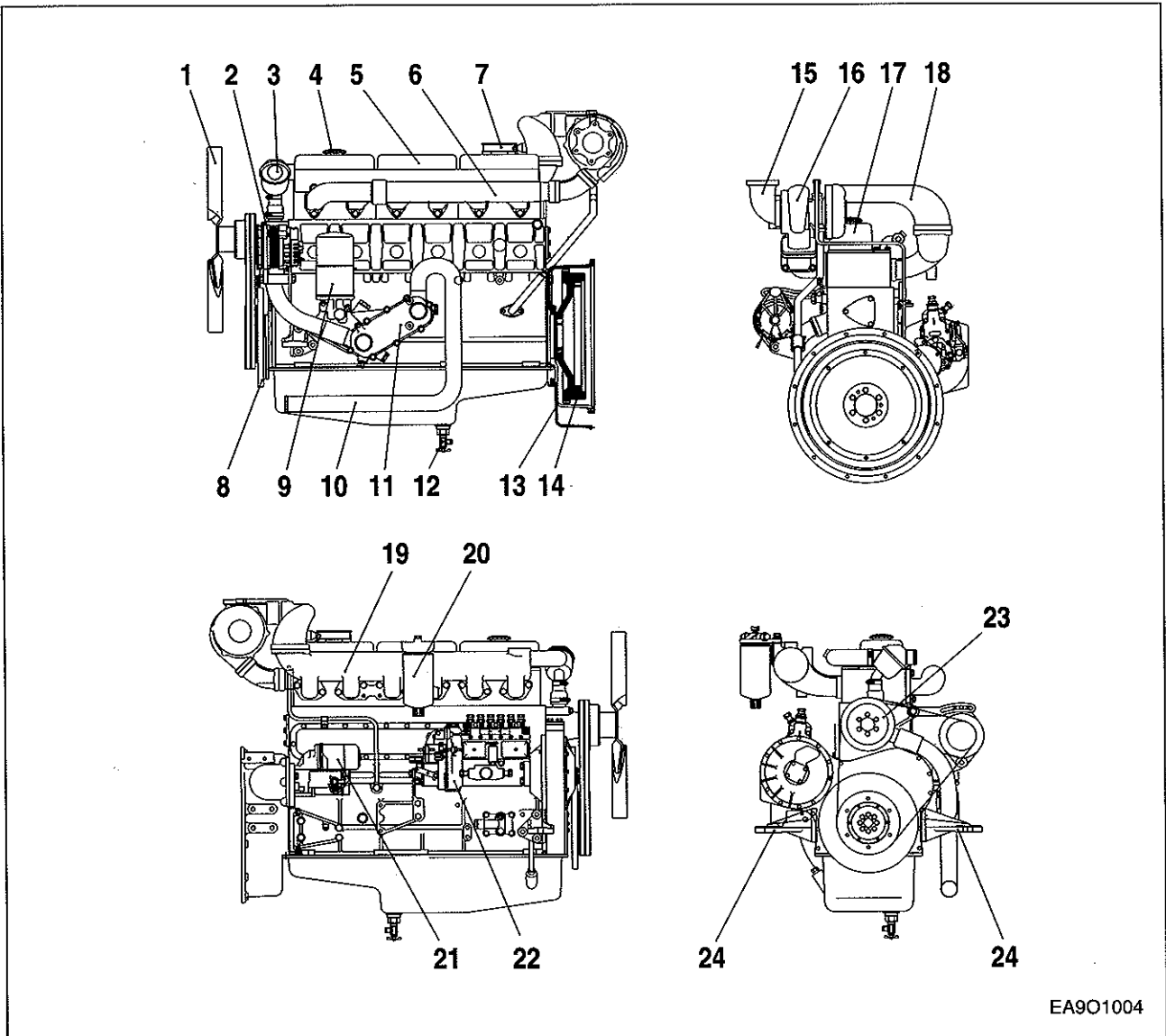

EA901004

- | | | |
|------------------------|---|--|
| 1. Cooling fan | 10. Cooling water pipe
(from radiator) | 18. Air pipe
(Turbocharger to
Intake manifold) |
| 2. Alternator | 11. Oil cooler | 19. Intake manifold |
| 3. Thermostat | 12. Oil drain valve | 20. Fuel filter |
| 4. Oil filter cap | 13. Flywheel housing | 21. Starter |
| 5. Cylinder head cover | 14. Flywheel | 22. Injection pump |
| 6. Exhaust manifold | 15. Exhaust elbow | 23. Water pump |
| 7. Breather | 16. Turbocharger | 24. Mounting bracket |
| 8. Vibration damper | 17. Cylinder head cover | |
| 9. Oil filter | | |

3) P086TI

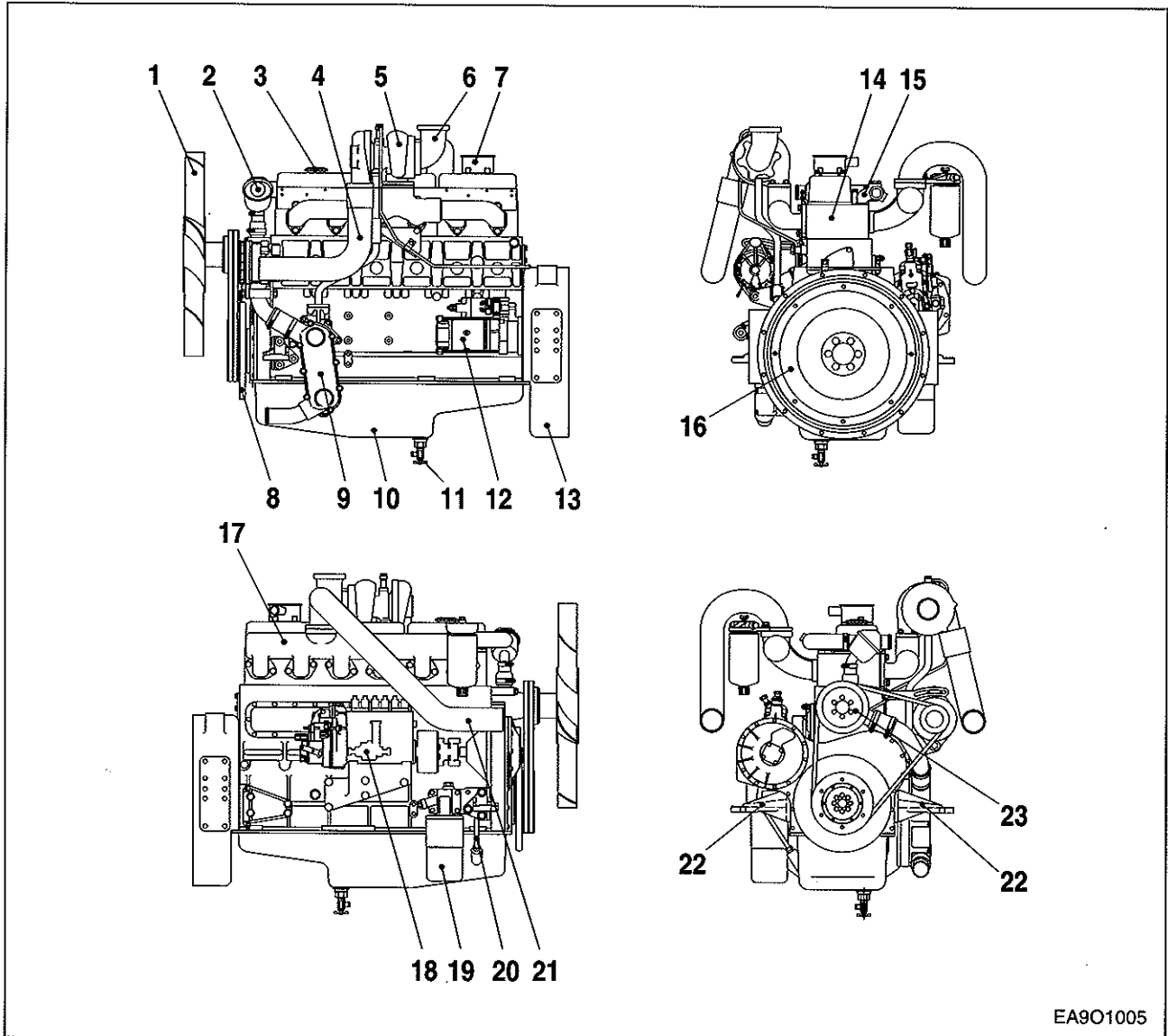

EA901005

- | | | |
|---|------------------------|--|
| 1. Cooling fan | 8. Vibration damper | 17. Intake manifold |
| 2. Thermostat | 9. Oil cooler | 18. Injection pump |
| 3. Oil filter cap | 10. Oil fan | 19. Oil filter |
| 4. Air pipe
(Turbocharger to
Intake manifold) | 11. Oil drain valve | 20. Oil level gauge |
| 5. Turbocharger | 12. Starter | 21. Air pipe
(Intercooler to Intake manifold) |
| 6. Exhaust elbow | 13. Flywheel housing | 22. Mounting bracket |
| 7. Breather | 14. Cylinder head | 23. Water pump |
| | 15. Cooling water pipe | |
| | 16. Flywheel | |

2.2. Engine Specification

2.2.1. Specification

Engine Model		D1146/PU086	D1146T/PU086T	P086TI
Items				
Engine type		4 cycle in - line, Water - cooled type Naturally aspirated	4 cycle in - line, Water - cooled type Turbo charged	4 cycle in - line, Water - cooled type Turbo charged intercooled
Combustion chamber type		Direct injection type		
Cylinder liner type		Replaceable dry liner		
Timing gear system		Gear driven type		
No. of piston ring		Compression ring 2, oil ring 1		
No. of cylinder-bore x stroke	(mm)	6 - 111 x 139		
Total piston displacement	(cc)	8,071		
Compression ratio		17.6 : 1	16.8 : 1	16.7 : 1
Engine dimension (length x width x height)	(mm)	1,224 x 830 x 974	1,224 x 830 x 1,081.5	1,242 x 918 x 1,102
Engine weight	(kg)	720/780	780/780	790
Fuel injection order		1 - 5 - 3 - 6 - 2 - 4		
Fuel injection timing (B.T.D.C static)		18°	18°/12°	12°
Injection pump type		Zexel in - line "AD" type		Zexel in - line "P" type
Governor type		Mechanical governor type(RSV)		Electrical governor type(Ghana Control)
Injection nozzle type		Multi-hole type (5 hole)		
Fuel injection pressure	(kg/cm ²)	214	214	214
Compression pressure	(kg/cm ²)	28 (at 200 rpm)		
Intake and exhaust valve clearance (at cold)	(mm)	0.3		
Intake valve	Open at	16°C (B.T.D.C)		
	Close at	36°C (A.B.D.C)		
Exhaust valve	Open at	46°C (B.B.D.C)		
	Close at	14°C (A.T.D.C)		
Lubrication method		Full forced pressure feed type		
Oil pump type		Gear type driven by camshaft		
Oil filter type		Full-flow, cartridge type		
Lubricating oil capacity (max./min.)	(lit)	15.5		23
Oil cooler type		Water cooled		
Water pump		Centrifugal type driven by belt		
Cooling Method		Fresh water forced circulation		
Cooling water capacity (engine only)	(lit)	14/11	14/14	19
Thermostat type		Wax pallet type (71 ~ 85 °C)		
Alternator voltage - capacity	(V - A)	24 - 45		
Starting motor voltage - output	(V - kW)	24 - 4.5		24 - 6.0

2.2.2. Engine power

Production tolerance : ±5%

Generating-Set Engines			Condition		
			Continuous	Prime	Stand by
D1146	Standard	50 HZ (1,500 rpm)	-	105 PS (77 kW)	116 PS (85 kW)
		60 HZ (1,800 rpm)	-	130 PS (96 kW)	143 PS (105 kW)
D1146T	Standard	50 HZ (1,500 rpm)	-	145PS (107 kW)	160 PS (118 kW)
		60 HZ (1,800 rpm)	-	170 PS (125 kW)	187 PS (138 kW)
P086TI	Standard	50 HZ (1,500 rpm)	205 PS (151 kW)	240 PS (177 kW)	270 PS (199 kW)
		60 HZ (1,800 rpm)	253 PS (186 kW)	279 PS (205 kW)	303 PS (223 kW)
	P086TI-I	50 HZ (1,500 rpm)	-	203 PS (149 kW)	223 PS (164 kW)
		60 HZ (1,800 rpm)	-	237 PS (174 kW)	260 PS (191 kW)

Production tolerance.: ±5%

Power-Unit Engines			Max. Output		
			rpm	PS	kW
PU086	6 Cyl.	Naturally Aspirated	2,200	160	118
PU086T	6 Cyl.	Turbo Charged	2,200	205	151

* Note : All data are based on operation without cooling fan at ISO 3046.

3. Technical Information

3.1. Engine Model and Serial Number

The engine model and serial number is located on the engine as illustrated. These numbers are required when requesting warranty and ordering parts. They are also referred to as engine model and serial number because of their location.

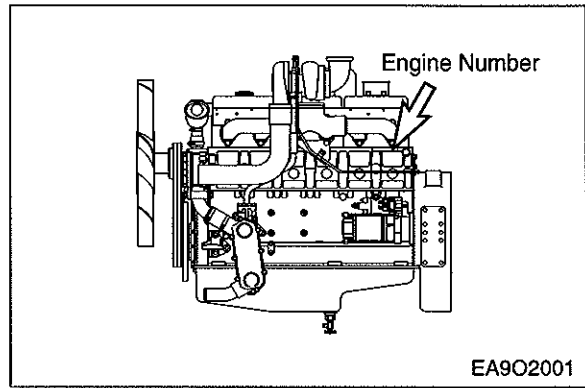

EA9O2001

● Engine serial No. (example 1 : D1146)

EACOA300001

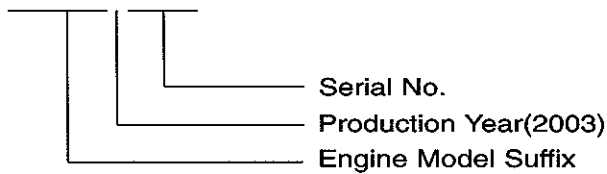

● Engine serial No. (example 1 : D1146T)

EADOA300001

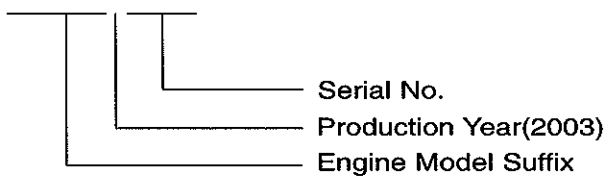

● Engine serial No. (example 1 : P086TI)

EBPOA300001

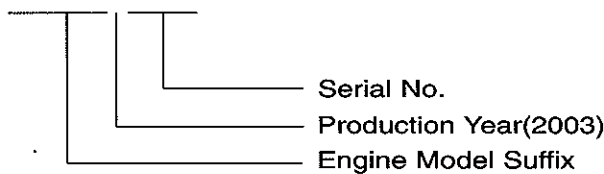

● Engine serial No. (example 1 : PU086)

EACPA300001

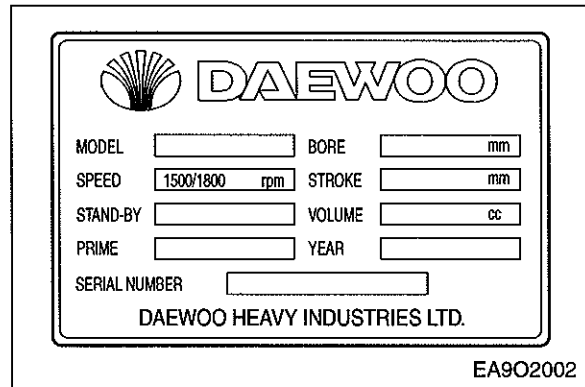
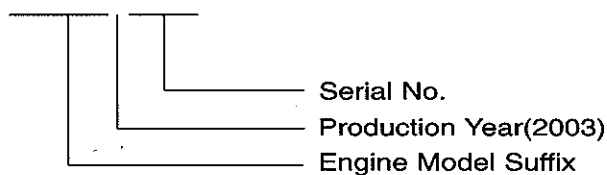

EA9O2002

<Name Plate : General>

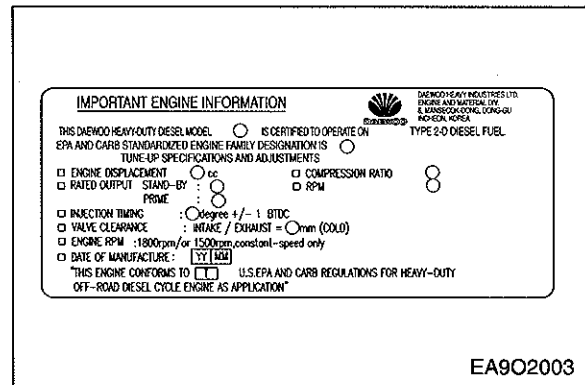

EA9O2003

<Name Plate : EPA & CARB>

● **Engine serial No. (example 1 : PU086T)**

EADPA300001

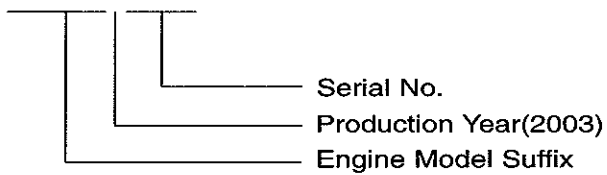

3.2. Engine Type

The Engines D1146/ D1146T/ P086TI/PU086/PU086T are in-line vertical water-cooled 6-cylinder four-stroke diesel engines with direct injection. D1146/PU086 are natural aspiration engine, D1146T/PU086T are turbo-charged type, and P086TI is turbo-charged and inter-cooled engine.

3.2.1. Cylinder block

The cylinder block is a single piece of alloy cast iron. To increase its stiffness, it is extended to a level below the crankshaft center line. The engine has replaceable dry cylinder liners and individual cylinder heads with struck-in valve seat rings and replaceable valve guides.

3.2.2. Piston con-rod / crankshaft

The forged crankshaft is a ingrate type (Counterweight is integrated with crank shaft body). Radial oil seal on crankshaft and flywheel are provided to seal the flywheel housing inside penetrations.

The con-rods (connecting rods) are die-forged, diagonally split and can be removed through the top of the cylinders together with the pistons. Crankshaft and connecting rods run in steel-backed lead bronze ready-to fit type bearings.

3.3. Engine Timing

Camshaft, oil pump and injection pump are driven by a gear train arranged at the front end.

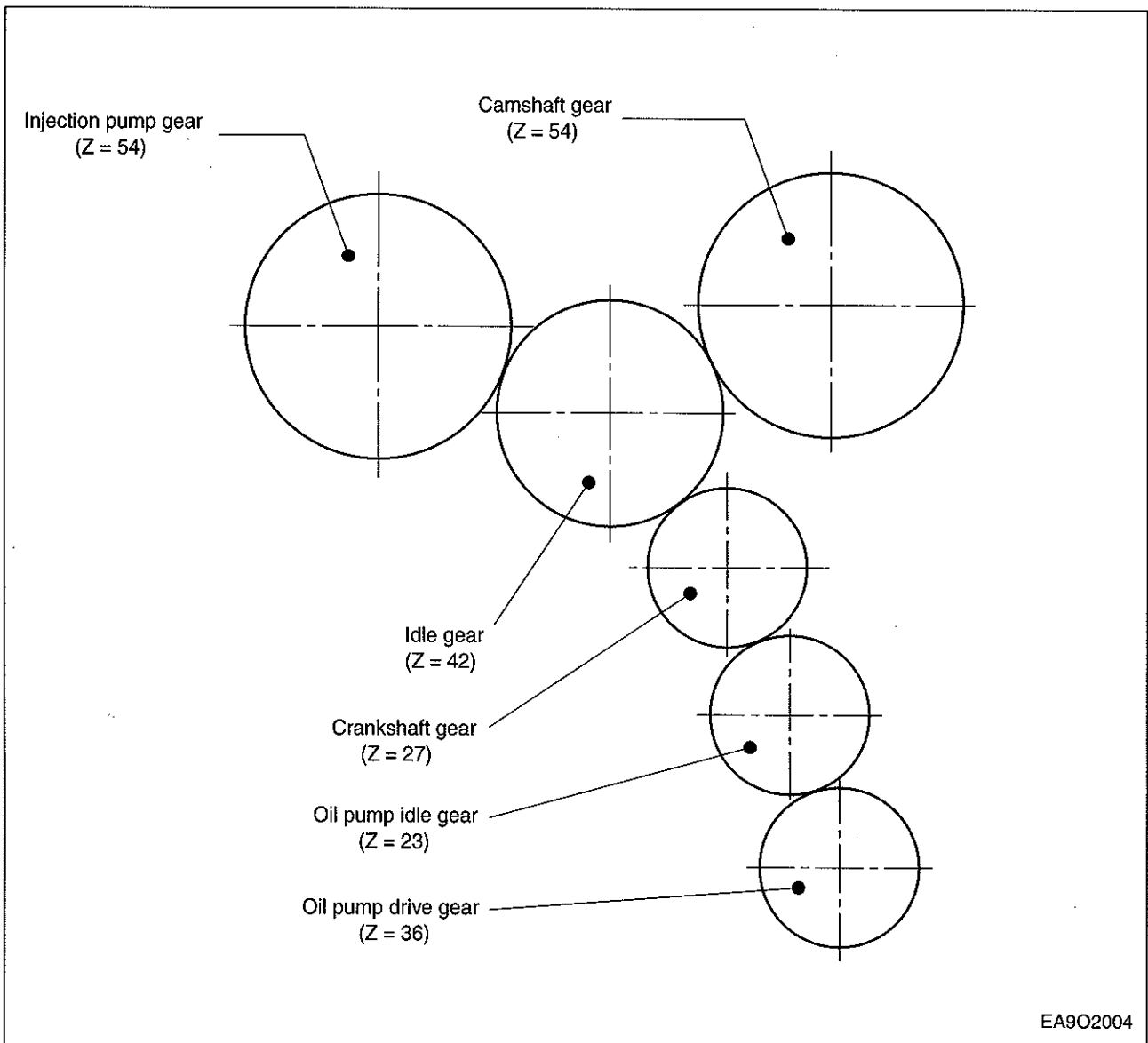

3.4. Valves

The overhead valves are actuated via chilled cast iron tappets, push rods and rocker arms from the camshaft.

3.5. Lubrication System

The engine is equipped with force-feed lubrication.

The pressure is produced by a gear pump whose drive gear is in direct mesh with the crankshaft gear at the front end of cylinder block.

The oil pump draws the oil from the oil sump and delivers it through the oil cooler and oil filter to the main distributor gallery and from there to the main bearings, big-end bearings and camshaft bearings as well as to the small-end bearings and the rocker arms.

The injection pump and the turbocharger are also connected to the engine lubricating system.

The cylinder walls and timing gears are splash-lubricated.

Each cylinder has an oil jet provided for cooling the underside of the pistons.

The lube oil is cleaned in a full-flow oil filter.

• D1146/D1146T/ P086TI/PU086/PU086T

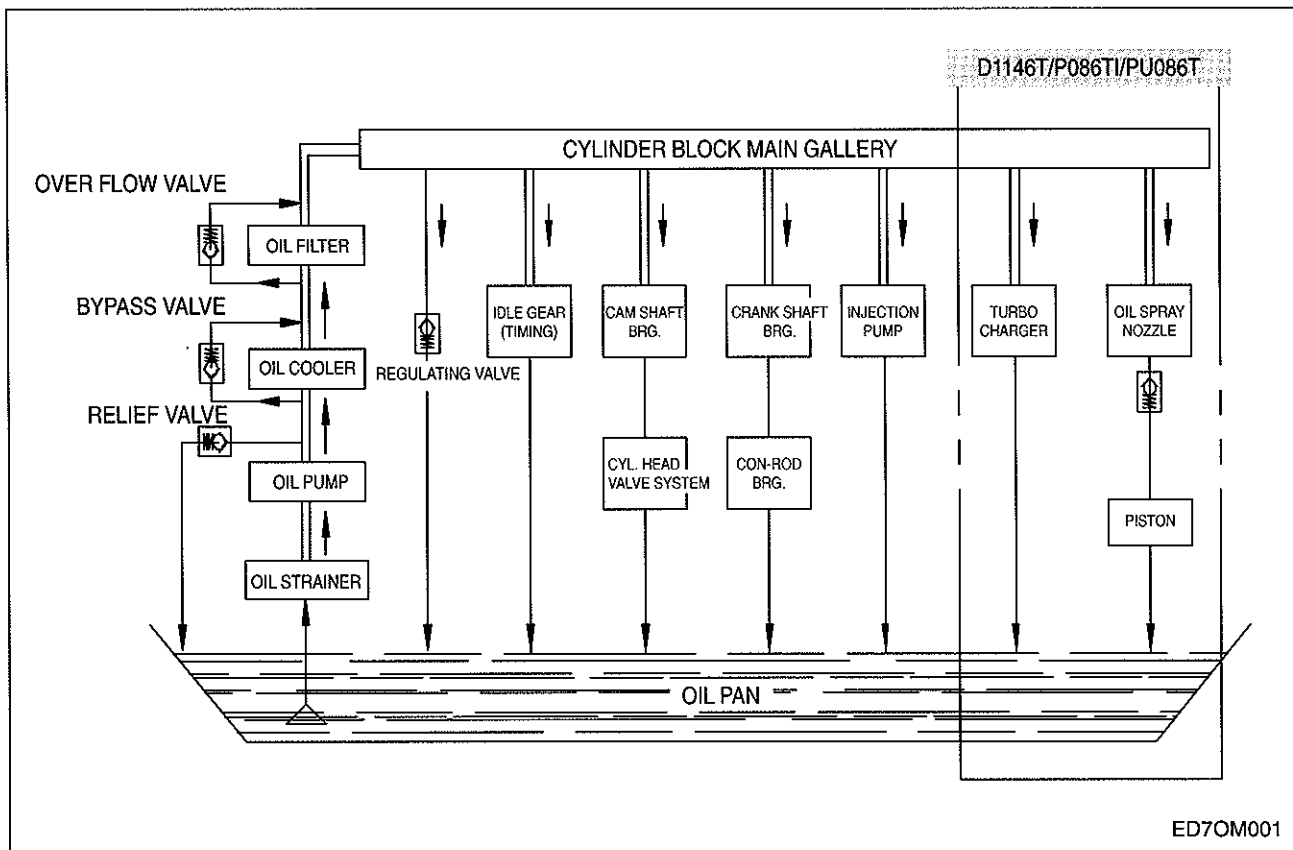

ED70M001

3.5.1. Oil cooler

An oil cooler is provided between the oil filter and the cylinder block. This cooler is a flat tube type with turbulence inserts and operated by the coolant.

3.5.2. Oil filter

Check for oil pressure and oil leaks, and repair or replace the oil filter if necessary. Change the oil filter cartridge simultaneously at every replacement of engine oil.

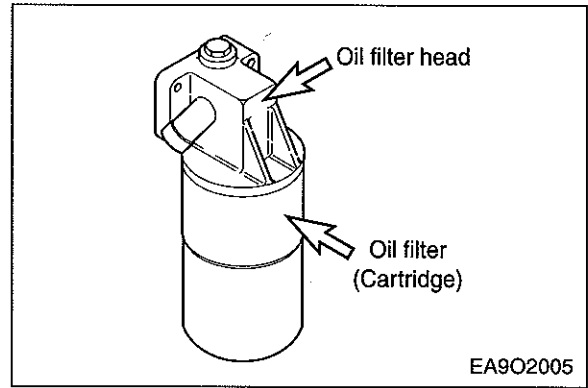

3.6. Air Cleaner

In case that elements are deformed, damaged or if the air cleaner has a crack, replace it.

By the definite interval, the elements must be cleaned and replaced.

- *Cleaning of air cleaner element : Every 200 hours.*
- *Changing of air cleaner element : Every 400 hours.*

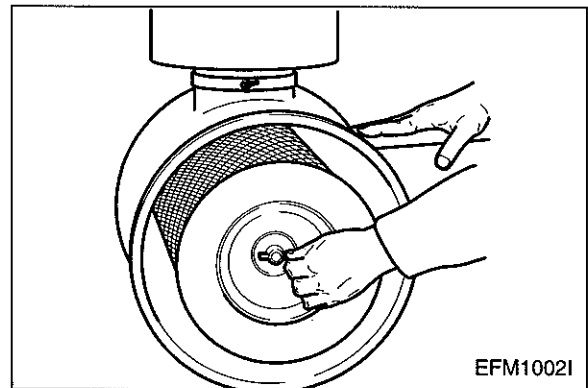

3.7. Fuel System

The fuel is delivered by the fuel feed pump via the fuel filter to the injection pump and from there to the injection nozzles.

The fuel is sprayed into the cylinders through nozzles fitted in screw-fit injection nozzle holders in the cylinder heads.

Excessively delivered fuel and leak fuel from the nozzle flow through the return pipe back to the tank.

A strainer is arranged ahead of the fuel feed pump.

3.7.1. Fuel filter

This fuel filter has two functions not only oil filtering but also water separating. Before entering the suction chamber of the injection pump, the fuel is cleaned in a strainer of fuel feed pump and a fuel filter. Drain water in cartridge with loosening the cock under filter manually (6) from time to time.

The fuel filter should be replaced at every 400 hours.

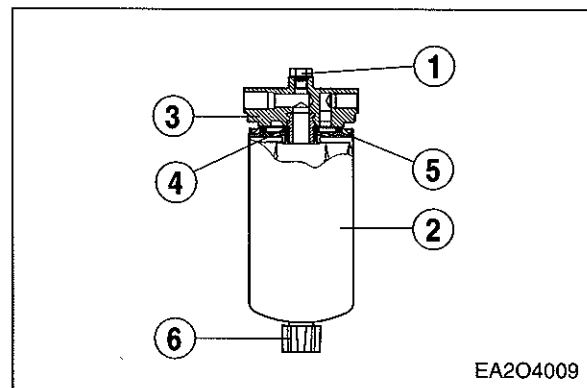

3.7.2. Fuel requirements

DAEWOO marine diesel engines was designed to use Number 2-D diesel fuel or equivalent that meets specification DIN 51601-DK. For maximum fuel economy, Number 2-D fuel whenever possible. When temperatures are below -7°C (20°F), use Number 1-D fuel. If Number 1-D fuel is not available, the mixture of one kerosene to two gallons of Number 2-D fuel can be used. Once kerosene has been added, the engine should be run for several minutes to mix the fuel.

3.7.3. How to select fuel oil

Fuel quality is an important factor in obtaining satisfactory engine performance, long engine life, and acceptable exhaust emission levels. DAEWOO engines are designed to operate on most diesel fuels marketed today. In general, fuels meeting the properties of ASTM Designation D975 (grades 1-D and 2-D) have provided satisfactory performance.

The ASTM 975 specification, however, does not in itself adequately define the fuel characteristics needed for assurance of fuel quality.

The properties listed in the fuel oil selection chart below have provided optimum engine performance. Grade 2-D fuel is normally available for generator service. Grade 1-D fuel should not be used in pleasure craft engines, except in an emergency.



Fuel Oil Selection Chart

General Fuel Classification	ASTM Test	No. 1 ASTM 1-D	No. 2 ASTM 2-D	DIN 51601
Gravity, °API #)	D 287	40 ~ 44	33 ~ 37	0.815 ~ 0.855
Flash Point Min. °F (°C)	D 93	100 (38)	125 (52)	131 (55)
Viscosity, Kinematic CST 100 °F (40 °C)	D 445	1.3 ~ 2.4	1.9 ~ 4.1	1.8 ~ 10
Cloud Point °F #)	D 2500	See Note 1)	See Note 1)	See Note 1)
Sulfur Content wt%, Max.	D 129	0.5	0.5	0.15
Carbon Residue on 10%, wt%, Max.	D 524	0.15	0.35	0.1
Accelerated Stability Total Insolubles mg/100 ml, Max. #)	D 2274	1.5	1.5	
Ash, wt%, Max.	D 482	0.01	0.01	
Cetane Number, Min. +)	D 613	45	45	> 45
Distillation Temperature, °F (°C) IMP, Typical #) 10% Typical #) 50% Typical #) 90% +) End Point #)	D 86	350(177) 385(196) 45(218) 500 (260) Max. 550(288) Max.	375(191) 430(221) 510(256) 625(329) Max. 675(357) Max.	680(360)
Water & Sediment %, Max.	D 1796	0.05	0.05	0.05

#) Not specified in ASTM D 975

+) Differs from ASTM D 975

NOTE : 1. The cloud point should be 6°C (10°F) below the lowest expected fuel temperature to prevent clogging of fuel fitters by crystals.

3.8. Cooling System

The engine has a liquid-cooling system. The fresh water pump is a maintenance-free by V-belt from the crankshaft pulley.

Depending on the agreed extent of delivery and the design of the engine, the coolant circuit can be equipped with temperature monitors which, in the event of loss of coolant, shut the engine down.

- Check the coolant level of the expansion tank by removing the expansion tank filler cap, and add coolant if necessary.
- When injecting antifreeze solution, first drain out the old coolant from the cylinder block and radiator, and then clean them with cleaning solution.
- Be sure to mix soft water with antifreeze solution.

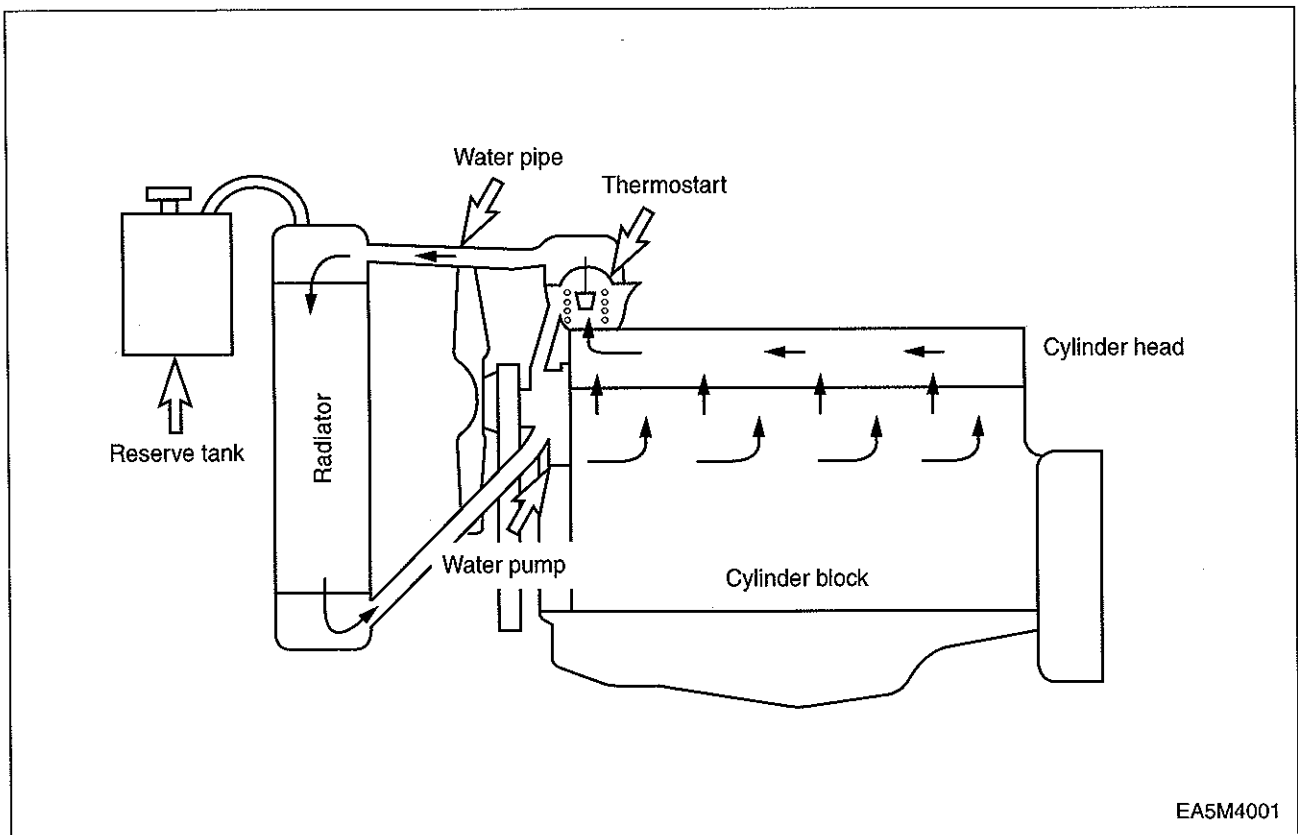

EA5M4001

3.8.1. Coolant pressure cap

Check the pressure valve opening pressure using a expansion tank cap tester. Replace the filler cap assembly if the measured valve does not reach the specified limit. (pressure valve opening pressure : 0.9 kg/cm²)



NOTE : *Because it is dangerous to open the pressure cap quickly when coolant is hot, after lowering the inside pressure of the tank by slow-opening at first open it fully.*

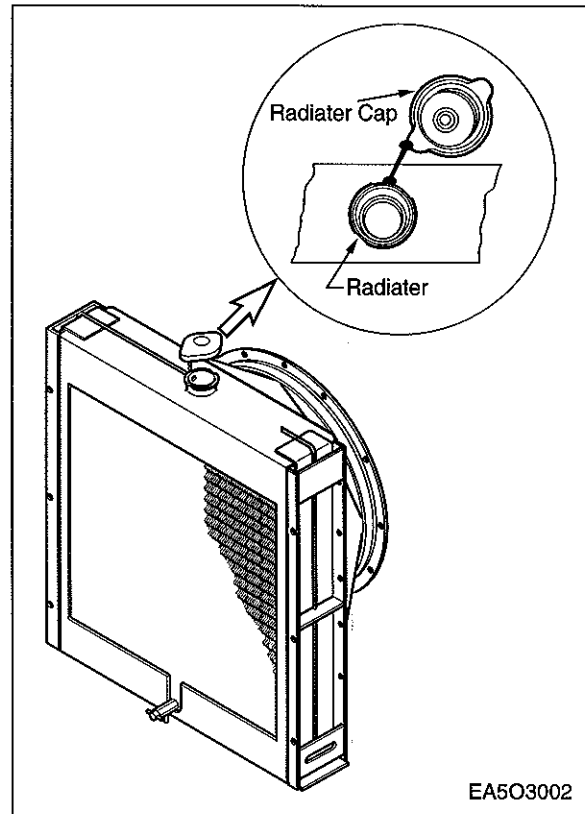

3.8.2. Cooling water

- Regarding the cooling water that is to be used for engine, the soft water not the hard water must be used.
- The engine cooling water can be used diluting it with antifreezing solution 40% and the additive for rust prevention (DCA4) 3 ~ 5 %.
- The density of above solution and additive must be inspected every 500 hours to maintain it properly.



Note : *The proper density control of antifreezing solution and rust preventing additive will be able to prevent the rusting effectively and maintain the stable quality of engine. For the improper control might give the fatal damage to the cooling water pump and cylinder liners, detail care is needed.*

- Since D1146/PU086, D1146T/PU086T and P086TI cylinder liner is dry type, particularly the cooling water control should be applied thoroughly.
- The density of antifreezing solution and additive for rust prevention is able to be confirmed by the cooling water test kit. (Fleetguard CC2602M or DAEWOO 60.99901-0038)
- How to use the cooling water test kit
 - (1) When the cooling water temp. of engine is in the range of 10 ~ 55 °C, loosen the plug for cooling water discharge and fill the plastic cup about a half.



Note : *In taking the cooling water sample, if the water in auxiliary tank were taken, it is hard to measure the accurate density. Take the cooling water sample necessarily loosening the cooling water discharge plug.*

- (2) At the state of a test paper soaked in the sampled water, after taking the paper out through water agitation, shake off the water.
- (3) Wait for about 45 sec. till the color change of test paper.



Note : *However, it should not elapse longer than 75 sec, and if it did, the hue would change.*

- (4) Make the numerical value by comparing the test paper which hue has changed with the color list of label on storage bottle.
- (5) By comparing the hue changed into yellowish green or so with the green color indication of test paper storage bottle, confirm the density. (Then, the density indication must be in the hue range of 33% to 50%).
- (6) The brown at the middle of test paper and the lower pink color indication represent the additive state for rust prevention, and the proper range is that the meeting numerical value of brown (vertical) and pink color (horizontal) locates in the range of 0.3 to 0.8 at the color list of label on the test paper storage bottle.
- (7) In case of less than 0.3, replenish the additive for rust prevention (DCA4), and in case of more than 0.8, pour out the cooling water about 50% and then readjust the density after refilling with clean fresh water.

● **Amount of Anti-freeze in winter**

Ambient Temperature (°C)	Cooling water (%)	Anti-freeze (%)
Over -10	85	15
-10	80	20
-15	73	27
-20	67	33
-25	60	40
-30	56	44
-40	50	50

3.9. V-belt Tension Check and Adjust

By the finger-pressure the belt is pressed by 10mm ~ 15mm between the fan pulley and the alternator pulley in normal condition. For the adjustment of the tension, loosen the adjusting bolts which support the alternator, adjust the tension and tighten the bolts again.

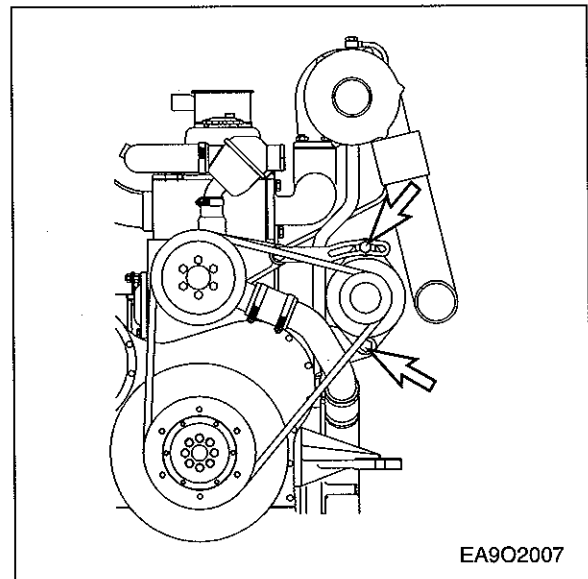
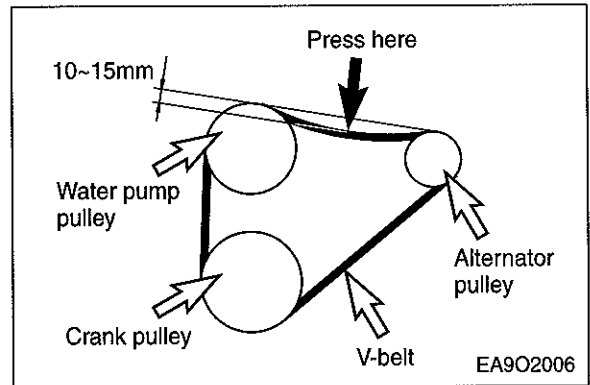

3.10. Turbocharger (for D1146T, P086TI, PU086T)

The exhaust gases of the engine are passed through the turbine rotor of the turbocharger. Air compressor impeller mounted on the same shaft draws in fresh air and delivers it at a higher pressure to the cylinders.

The turbocharger is naturally air-cooled. Lubrication of the main bearing is by oil under pressure from the engine lubricating system.

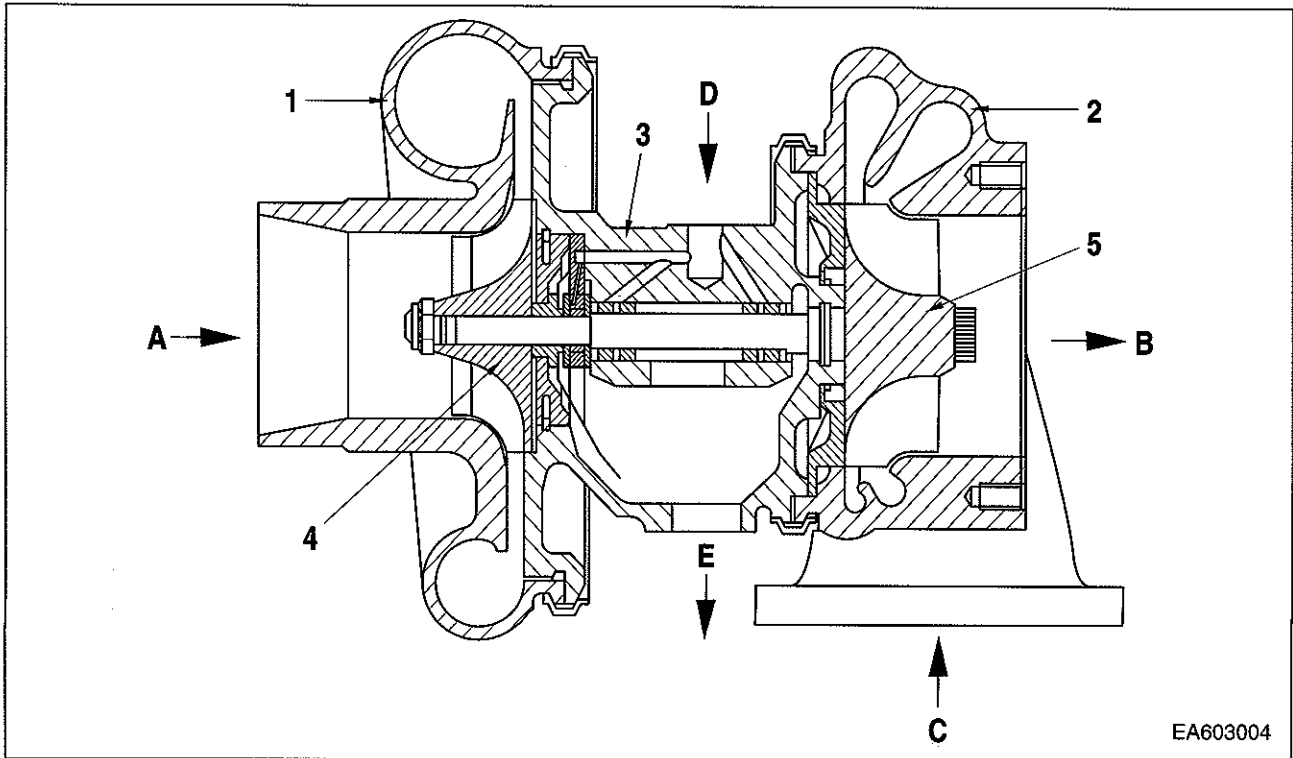

- 1. Compressor casing
- 2. Turbine casing
- 3. Compressor wheel
- 4. Impeller
- 5. Turbine

- A. Air inlet
- B. Gas outlet
- C. Gas inlet
- D. Oil supply
- E. Oil return

3.11. Electrical Equipment

3.11.1. Wiring circuit

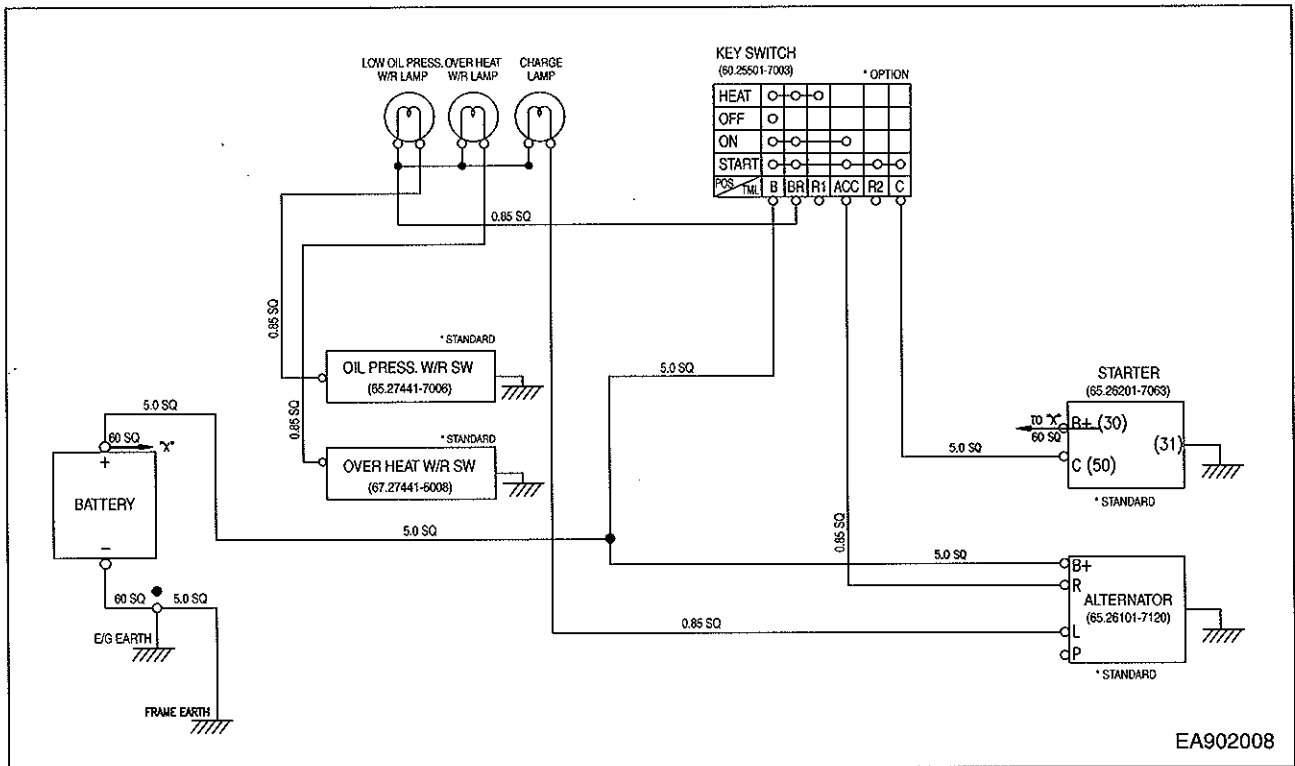

3.11.2. Alternator

The alternator is fitted with integral silicon rectifiers. A transistorized regulator mounted on the alternator body interior limits the alternator voltage. The alternator should not be operated except with the regulator and battery connected in circuit to avoid damage to the rectifier and regulator.

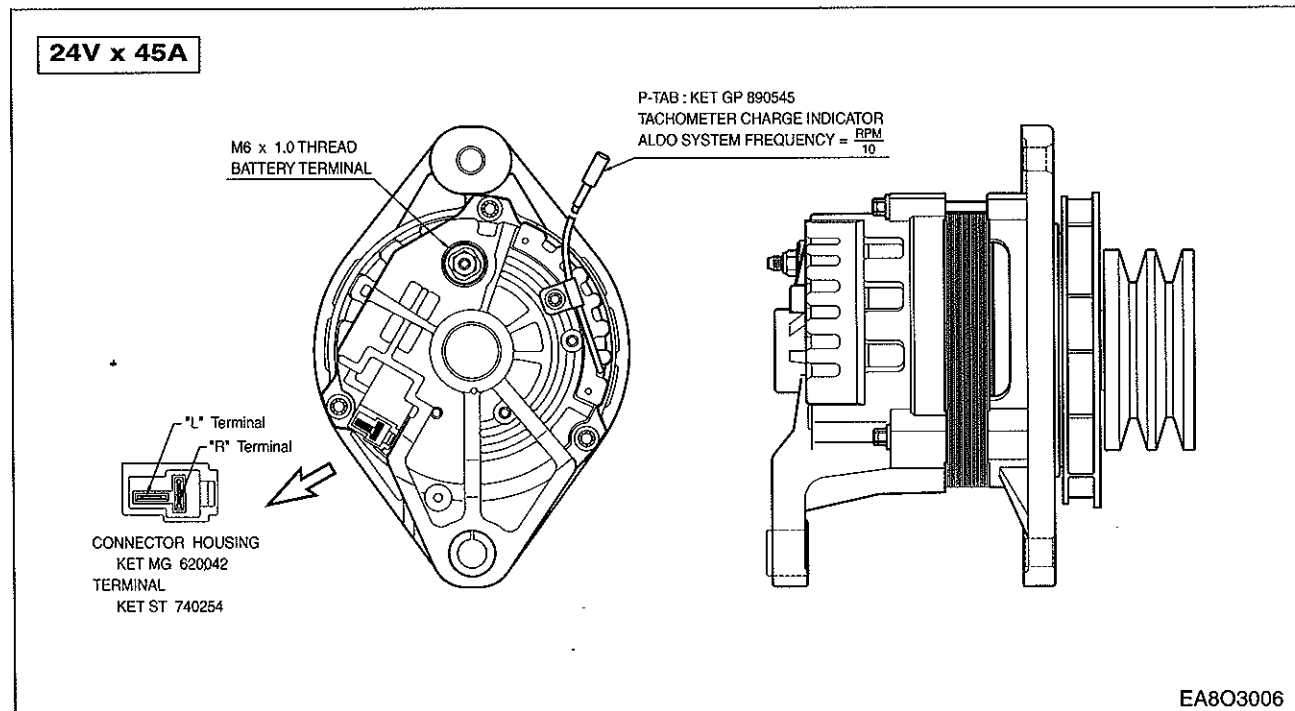

The alternator is maintenance-free, nevertheless, it must be protected against dust and, above all, against moisture and water.

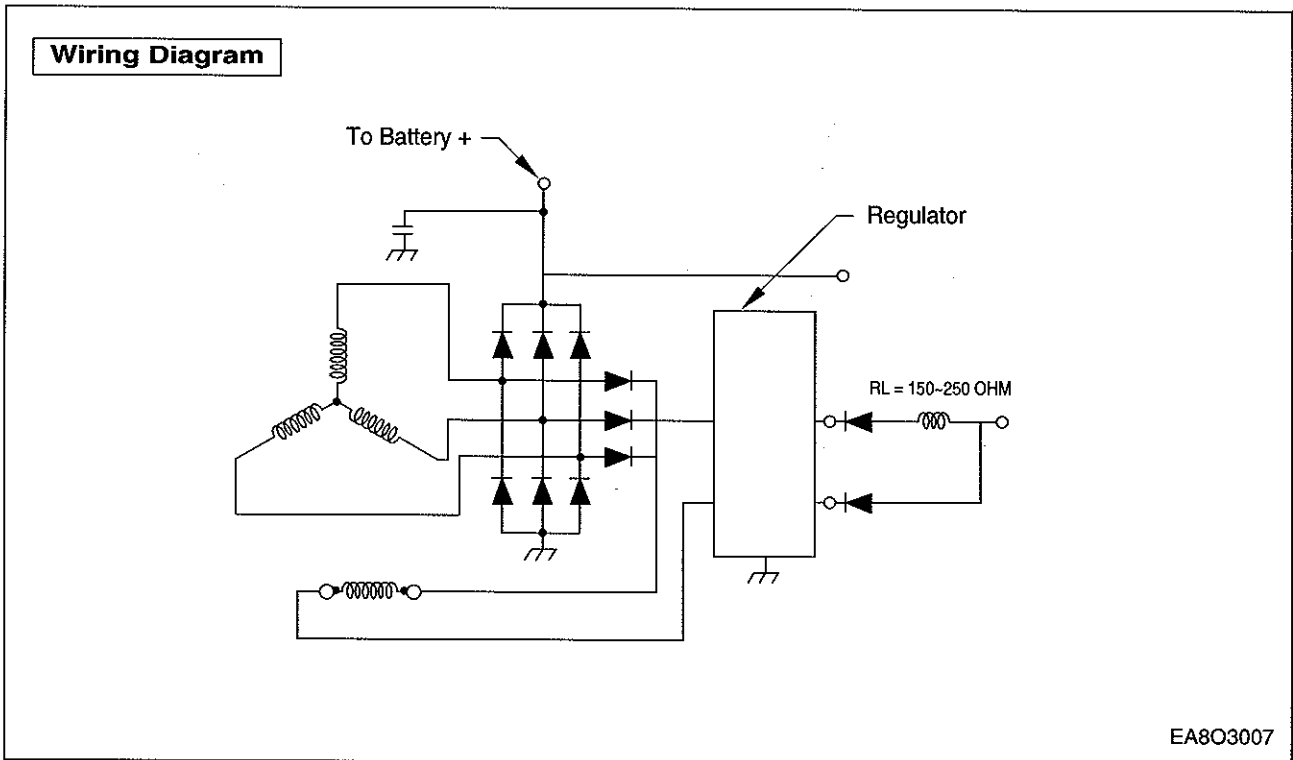

Operate the alternator according to the instructions given in the chapter.

3.11.3. Starter motor

The sliding-gear starter motor is flanged to the rear of the flywheel housing on the left-hand side. When the starting key switch is turned on, the starter motor pinion flies out and engages the ring gear of the flywheel. Then the main contact is closed, current flows, and the engine is started. After the engine starts, the pinion automatically returns to its initial position when the starting key switch is released. Once the engine starts, the starting key switch should be released immediately. Otherwise, the starter motor may be damaged or burned out.

In case of repairing the engine dip the pinion of the starter and ring gear into the fuel and remove the corrosion with brush. After that apply the grease on them to protect the corrosion.

Whenever you clean the starter, always pay attention not to occur the electric short due to entering the water.

● P086TI (24V X 6.0kW)

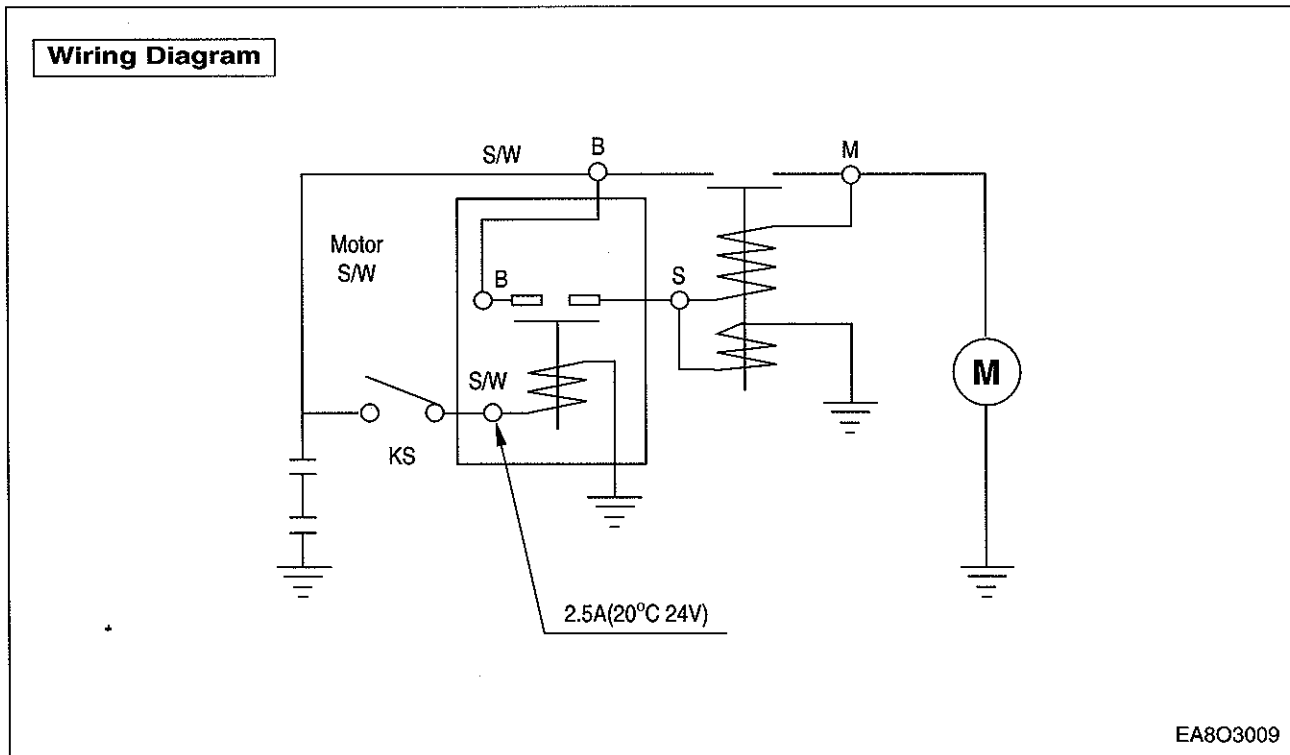
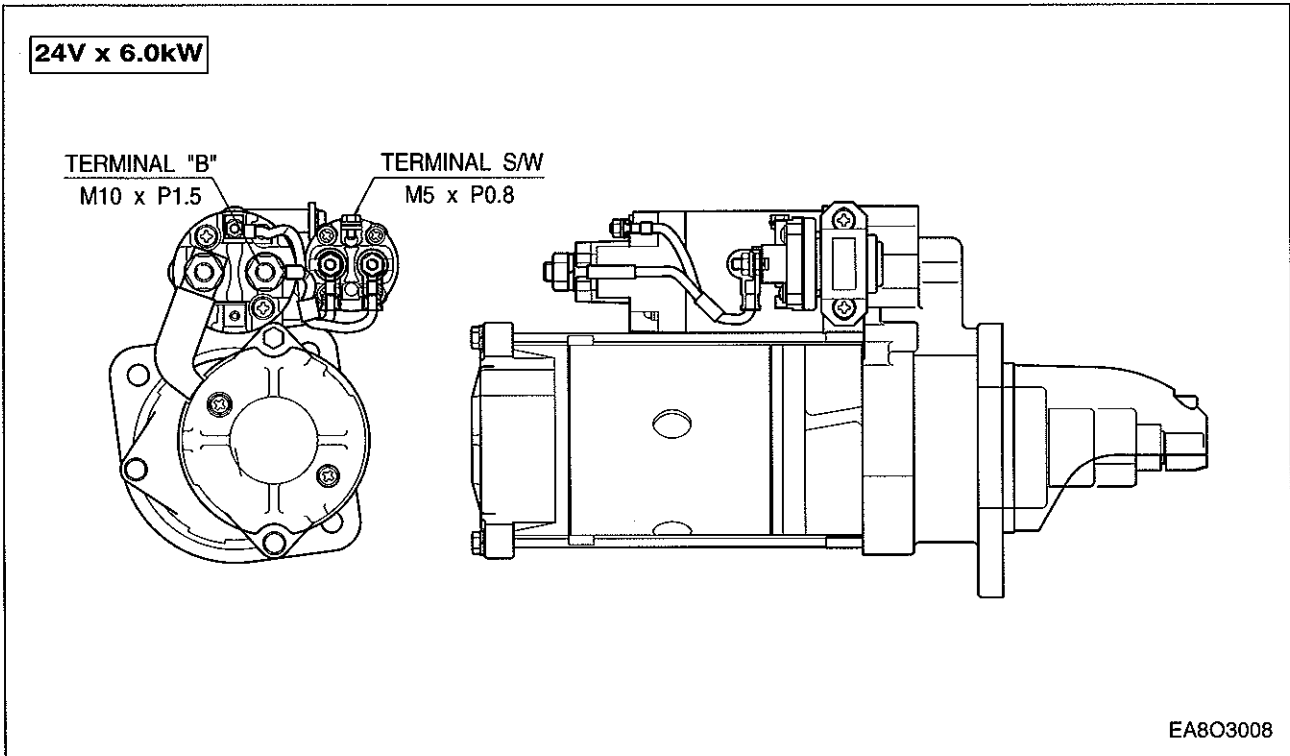

• D1146 / D1146T / PU086 / PU086T (24V X 4.5kW)

24V X 4.5kW

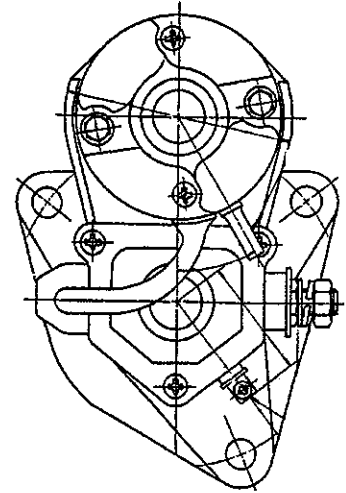
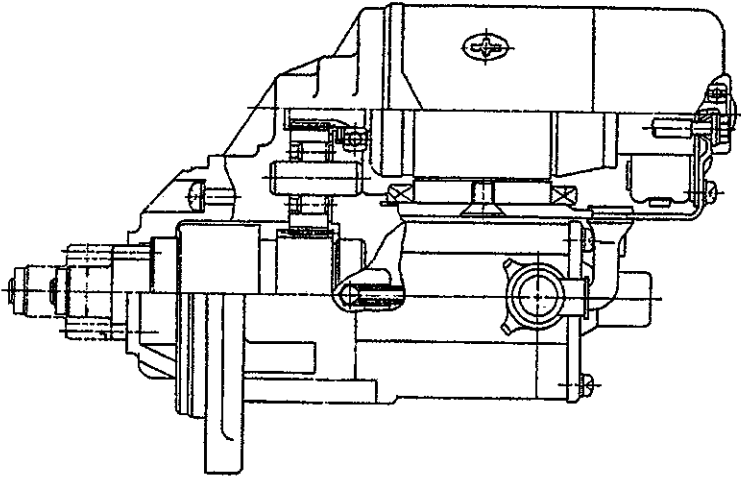

EA902009

Wiring Diagram

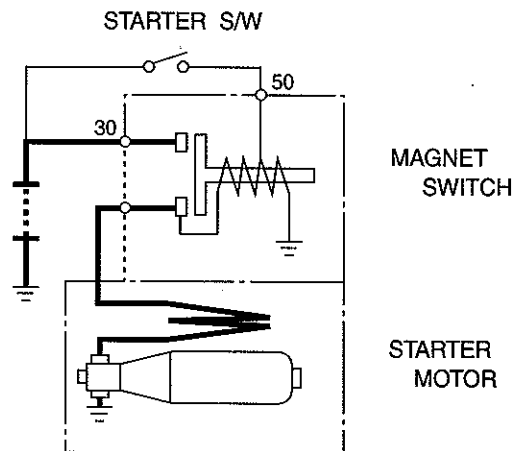

EA902010



Always protect starter motor against moisture.



WARNING :

Always disconnect the battery earth cable before starting work on the electrical system. Connect up the earth cable last, as there is otherwise a risk of short-circuits.

4. Commissioning and Operation

4.1. Preparation

At the time of initial commissioning of a new or overhauled engine make sure to have observed the "Technical Information for the installation DAEWOO generator engines".

- Oil filler neck on cylinder head cover

Before daily starting of the engine, check the fuel, coolant and oil level, replenish if necessary.

The notches in the dipstick indicate the highest and lowest permissible oil levels

The oil required in the sump is specified in the "Engine Specification.



NOTE : *The oil required to fill the oil fillers and pipes depends upon the engine and use and must be determined individually at the time of initial commissioning. (Make the Max and Min. marks of the determined quantity on the oil level gauge.)*

- Cleanliness

Ensure utmost cleanliness when handling fuels, lubricants and coolants

4.2. Breaking-in

4.2.1. Operation of a new engine (Break-in)

Because the sliding surfaces of a new engine are not lapped enough, the oil film can be destroyed easily by overload or overspeed and the engine life-time may be shortened.

Therefore the following things must be obeyed by all means.

Up to the first 2,000 km (150 hours)

- ▲ Engine should be run at fast idling until the temperature of the engine becomes normal operating condition.
- ▲ Overload or continuous high speed operation should be avoided.
- ▲ High speed operation with no load should be prevented.
- ▲ Abrupt start and stop of the engine should be avoided.
- ▲ Engine speed must be under 70% of its maximum speed.
- ▲ Maintenance and inspection must be accomplished thoroughly.

4.2.2. Check points for break-in

During the break-in (the initial running of the engine) period, be particularly observant as follows:

- a) Check engine oil level frequently. Maintain oil level in the safe range, between the "min." and "max." marks on dipstick.



NOTE : *If you have a problem getting a good oil level reading on dipstick, rotate dipstick 180° and re-insert for check.*

b) Watch the oil pressure warning lamp. If the lamp blinks, it may be the oil pick-up screen is not covered with oil. Check oil dipstick. Add oil to the oil pan, if required.

Do not overfill. If level is correct and the status still exists, see your DEALER for possible switch or oil pump and line malfunction.



NOTE : *Oil pressure will rise as RPM increases, and fall as RPM decreases. In addition, cold oil will generally show higher oil pressure for any specific RPM than hot oil. Both of these conditions reflect normal engine operation.*

c) Watch the engine water temperature gauge and be sure there is proper water circulation.

The water temperature gauge needle will fluctuate if water level in expansion tank is too low.

At the end of the break-in period, remove break-in oil and replace the oil filter. Fill oil pan with recommended engine oil. Refer to following table.

<Recommended engine oil and capacity>

Model	Oil pan (only)	Engine oil
D1146/PU086	15.5 liter	SAE 15W40 API CD or CE
D1146T/PU086T	15.5 liter	
P086TI	23 liter	

4.2.3. Operating after break-in

When starting a cold engine, always allow the engine to warm up gradually. Never run the engine at full throttle until the engine is thoroughly warmed up. Be sure to check the oil level frequently during the first 50 hours of operation, since the oil consumption will be high until the piston rings are properly seated.

4.3. Inspections after Starting

During operation the oil pressure in the engine lubrication system must be monitored. If the monitoring devices register a drop in the lube oil pressure, switch off the engine immediately. And the charge warning lamp of the alternator should go out when the engine is running.

- Do not disconnect the battery or pole terminals or the cables!
- If, during operation, the battery charge lamp suddenly lights up, stop the engine immediately and remedy the fault in the electrical system!
- Engine should be stopped if the color, the noise or the odor of exhaust gas is not normal.
- Confirm the following things through warning lamps and gauge panel.

4.3.1. Pressure of lubricating oil

The normal pressure comes up to 1 kg/cm² (1.0 bar) at idling and 3 ~ 5 kg/cm² (3.0 ~ 4.9 bar) at maximum speed. If the pressure fluctuates at idling or does not reach up to the expected level at high speed, shut down the engine immediately and check the oil level and the oil line leakage.

4.3.2. Temperature of cooling water

The cooling water temperature should be 71 ~ 85 °C in normal operating conditions. Abnormally high cooling water temperature could cause the overheating of engine and the sticking of cylinder components. And excessively low cooling water temperature increases the fuel consumption, accelerates the wears of cylinder liners and shortens the engine life-time.

4.4. Operation in Winter Time

Pay special attention to the freezing of cooling water and the viscosity of lubricating oil.

4.4.1. Prevention against the freeze of cooling water

When not using anti-freeze, completely discharge the whole cooling water after engine running. The freeze of cooling water causes the fatal damages of the engine. Because the anti-freeze is used to prevent cooling water from freeze, consult "The amount of anti-freeze".

4.4.2. Prevention against excessive cooling

Drop of thermal efficiency caused by excessive cooling increases fuel consumption, therefore prevent the engine from excessive cooling. If the temperature of coolant does not reach to normal condition (71 ~ 85 °C) after continuous operation, examine the thermostat or the other cooling lines.

4.4.3. Lubricating oil

As cold weather leads to the rise of oil viscosity, engine speed becomes unstable after starting. Therefore the lubricating oil for winter should be used to prevent this instability. Refer to Lubricating System section.

4.5. Tuning the Engine

The purpose of an engine tune-up is to restore power and performance that's been lost through wear, corrosion or deterioration of one or more parts or components. In the normal operation of an engine, these changes can take place gradually at a number of points, so that it's seldom advisable to attempt an improvement in performance by correction of one or two items only. Time will be saved and more lasting results will be obtained by following a definite and thorough procedure of analysis and correction of all items affecting power and performance.

Economical, trouble-free operation can better be ensured if a complete tune-up is performed once every years, preferably in the spring. Components that affect power and performance to be checked are:

- Components affecting fuel injection ;
Nozzle, delivery valve, fuel filter, water separator, etc.
- Components affecting Intake & exhaust ;
Air filter, inter-cooler, turbo, silencer, etc.
- Components affecting lubrication & cooling ;
Air & oil filter, anti- freeze, etc.

5. Maintenance and Care

5.1. Periodical Inspection and Maintenance

In order to insure maximum, trouble-free engine performance at all times, regular inspection, adjustment and maintenance are vital.

- Daily inspections in below figure should be checked every day.
- The maintenance should be executed thoroughly at regular intervals.
(Refer to "7.1. Periodic Inspection Cycle".)

5.2. Lubrication System

5.2.1. Exchanging of lubrication oil

Engine oil and the oil filter are important factors affecting engine life. They affect ease of starting, fuel economy, combustion chamber deposits and engine wear. Refill and drain oil pan every 50 hours of operation or 6 months whichever occurs first. At the end of the break-in period (50 hours), change the oil sump oil and replace the oil filter.

5.2.2. Oil level

Check the oil level in the engine sump daily with a dipstick.

- The notches in dipstick must indicate the oil level between the max. and the min. permissible.
- The oil level should be checked with the engine horizontal and only after it has been shut down for about 5 minutes.
- Examining the viscosity and the contamination of the oil smeared at the dipstick replace the engine oil if necessary.

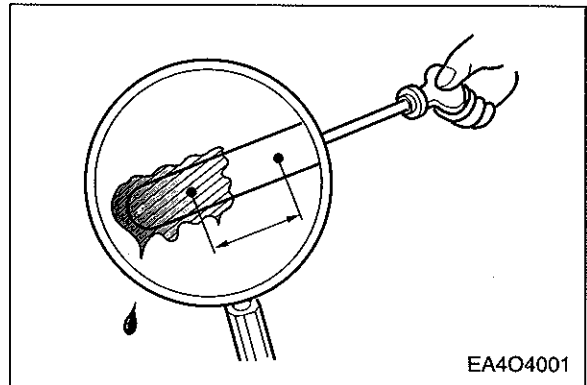

CAUTION :

Do not add so much engine oil that the oil level rises above the max. marking on the dipstick. Over lifting will result in damage to the engine.

5.2.3. Oil exchange procedure

While the oil is still hot, exchange oil as follows:

- Take out the oil dip dipstick.
- Remove the drain valve from oil pan, then drain out the engine oil into a container.
- Reassemble the drain valve with the oil pan and the drain plug with oil filter head after draining out the engine oil.

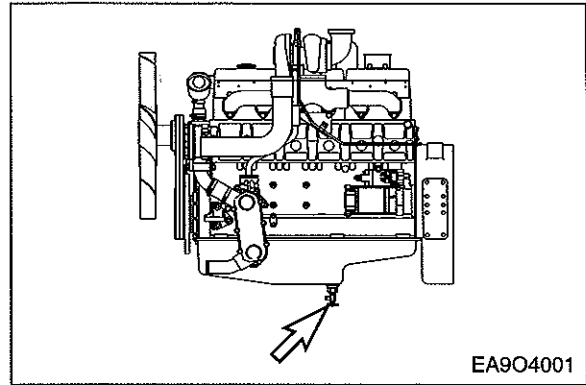

- Refill with new engine oil at the oil filler neck on the head cover and the lubricating oil in accordance with the oil capacity of the engine through oil filler. Be careful about the mixing of dust or contaminator during the supplement of oil. Then confirm that oil level gauge indicates the vicinity of its maximum level.
- For a few minutes, operate the engine at idling in order to circulate oil through lubrication system.
- Thereafter shut down the engine. After waiting for about 10 minutes measure the quantity of oil and refill the additional oil if necessary.

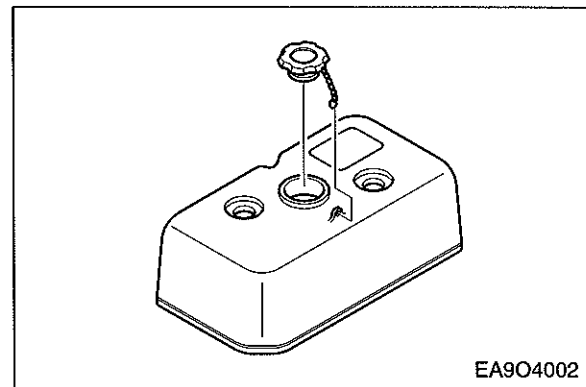

● Recommend of lubricating oil



Initial factory filling is high quality break-in oil (API Service CH-4 grade). During the break-in period (50 hours), check the oil level frequently. Somewhat higher oil consumption is normal until piston rings are seated. The oil level should be maintained in the safe range between Min. and Max. mark on the dipstick. To obtain the best engine performance and engine life, Engine oil is specified by API Service, lettered designations and SAE viscosity numbers. If the specified engine oil is not available, use a reputable brand of engine oil labeled for API Service CH-4 and SAE viscosity 15W40 or 10W40. Refer to oil identification symbol on the container.

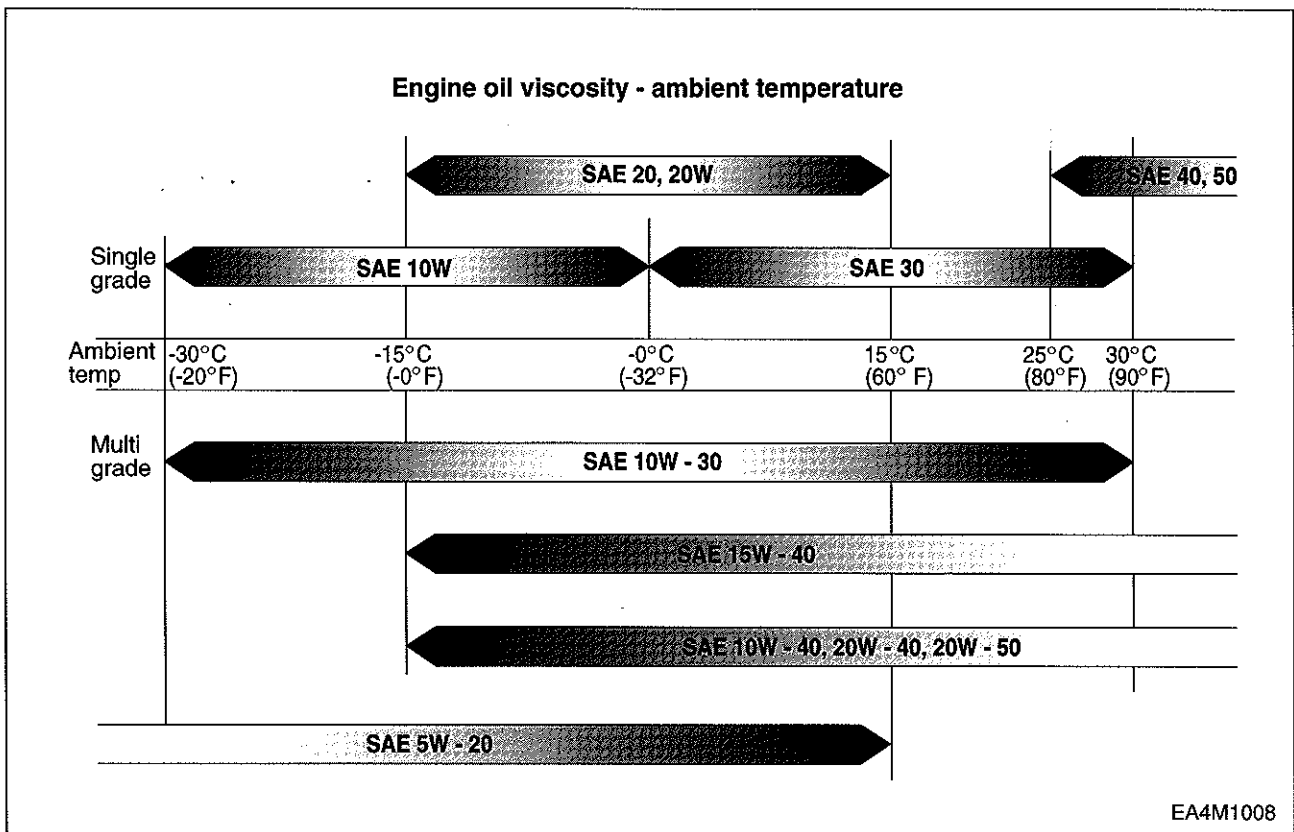

5.2.4. Replacement of oil filter cartridge

At the same times of oil exchanges, replace the oil filter cartridge.



CAUTION :

Don't forget tightening the drain valve after having drained engine oil.

- Loosen the oil filter by turning it counter-clockwise with a filter wrench.
- With a rag wipe clean the fitting face of the filter body and the oil filter body so that new oil filter cartridge can be seated properly.
- Lightly oil the O-ring and turn the oil filter until sealing face is fitted against the O-ring. Turn 1-1/4 turns further with the filter wrench.

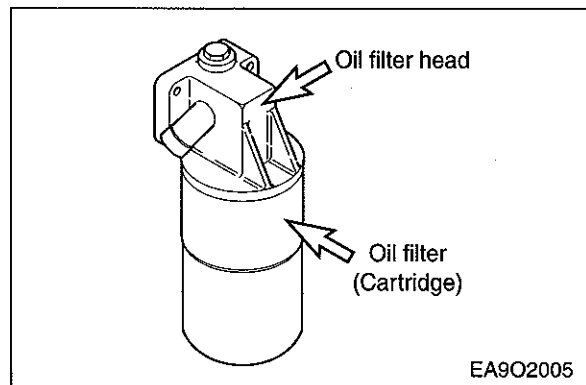

NOTE : *It is strongly advisable to use DAEWOO genuine oil filter cartridge for replacement.*

5.3. Cooling System

The coolant must be changed at intervals of 1,200 hours operation or six months whichever comes first. If the coolant is being fouled greatly, it will lead an engine overheat or coolant blow off from the expansion tank.

5.3.1. Coolant draining

- a) Remove the pressure cap.
- b) Open the drain valve at the radiator lower part to drain the coolant as the right figure.

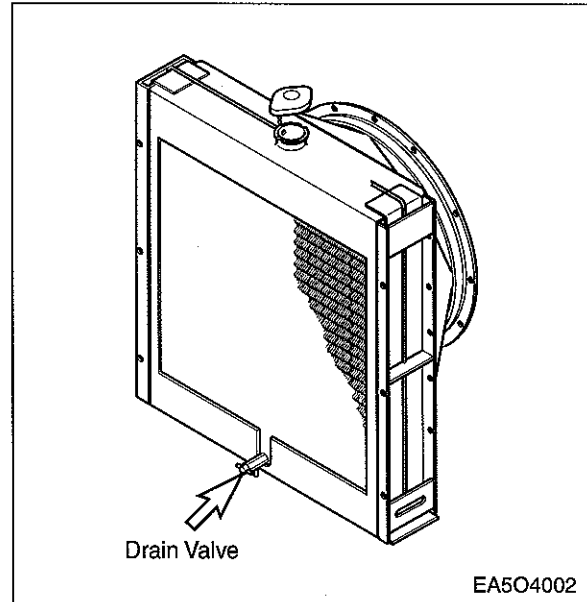

- c) Loosen the coolant drain plug.
Loosen the coolant drain plug of the cylinder block and oil cooler.



CAUTION :

When removing the pressure filler cap while the engine is still hot, cover the cap with a rag, then turn it slowly to release the internal steam pressure. This will prevent a person from scalding with hot steam spouted out from the filler port.

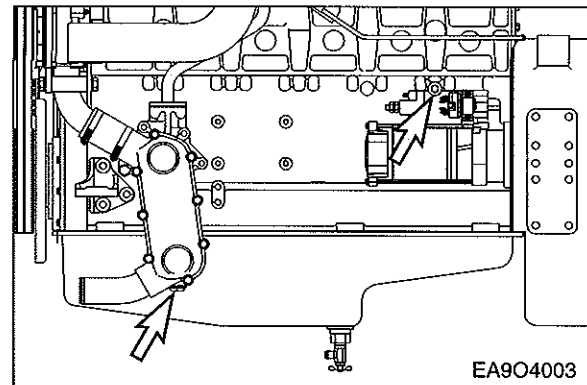

5.3.2. Cleaning of the cooling system inside circuit

(by authorized specialist personnel)

When the cooling system circuit are fouled with water scales or sludge particles, the cooling efficiency will be lowered.

Investigations have shown that in many cases the poor condition of the coolant and /or the cooling system accounts for damage to the water pump mechanical seal. The poor condition of the cooling system is normally due to use of unsuitable or no anti-freezing agents and corrosion inhibitor or defect, not early enough replaced covers for filler neck and working valves. If twice in a short time the water pump of an engine develops leaks or the coolant is heavily contaminated (dull, brown, mechanically contaminated, gray or black signs of a leakage on the water pump casing) clean the cooling system prior to removing that water pump as follows.

- a) Drain coolant.
- b) Remove thermostats, so that the whole cooling system is immediately flown through when cleaned.
- c) Fill the cooling system with a mixture of potable water and 1.5% by volume of cleaner. (Henkel P3T5175)
- d) Warm up engine under load. After a temperature of 60°C is reached, run engine for a further 15 minutes.
- e) Drain cleaning fluid.
- f) Repeat steps c) and d).
- g) Flush cooling system.
- h) Replace drain plug by drain plug with a bore of 8mm diameter.
- i) Fill cooling system with hot water.
- j) Run engine at idle for 30 minutes. At the same time continuously replenish the water leaking from the bore in drain plug by adding fresh water.



Periodically clean the circuit interior with a cleaner.

- Cooling system cleaning interval: Every 1,200 hours.

5.3.3. Intercooler (for P086TI)

The intercooler is air to air type and has a large cooling fan capacity. The intercooler life and performance depends on the intake air condition greatly. Fouled air pollutes and clogs the air fins of intercooler. As a result of this, the engine output is decreased and engine malfunction is occurred. So you always check whether the intake air systems like air filter element are worn or polluted.

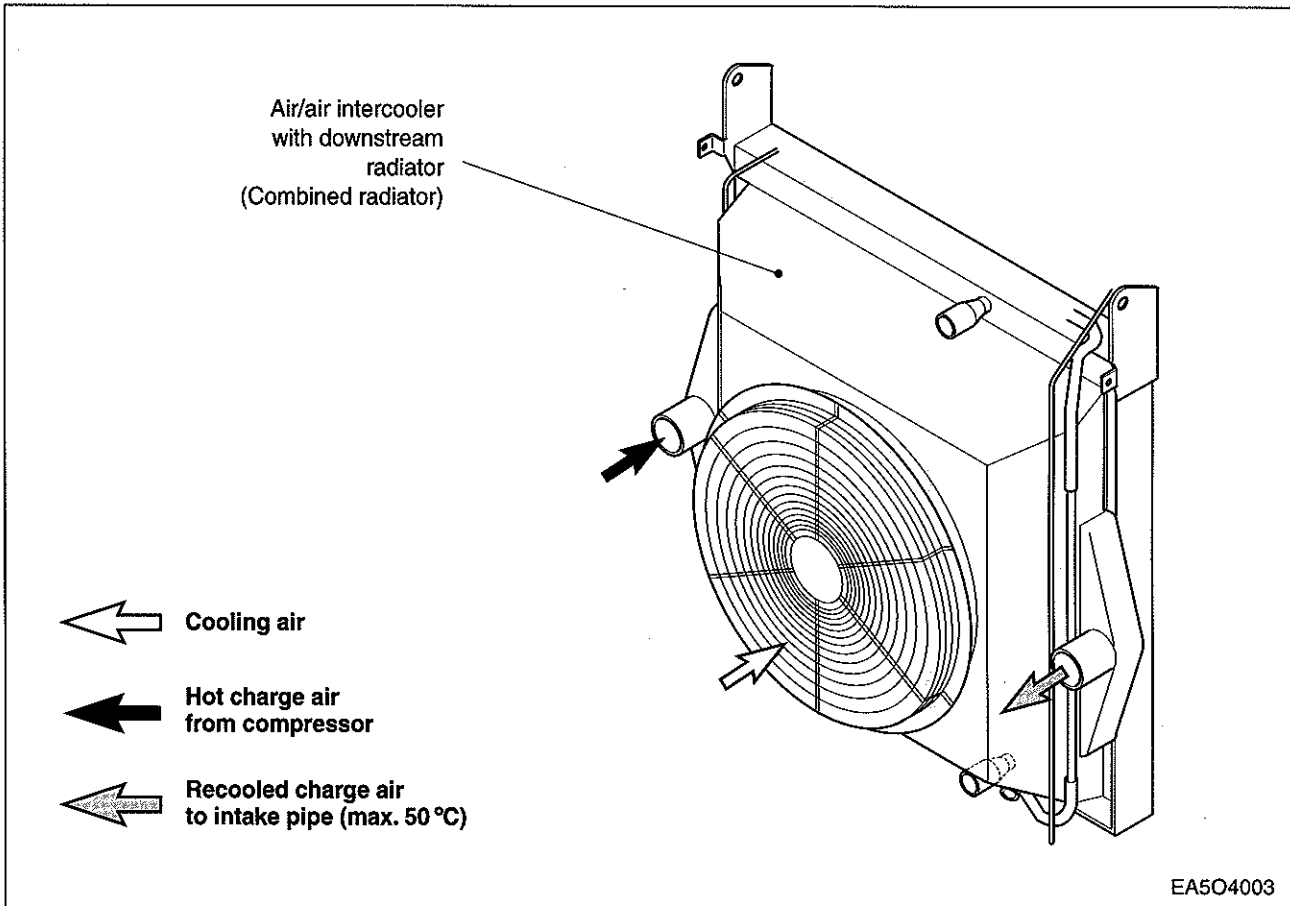

- **Cleaning**

In order to maintain the heat transfer efficiency of the intercooler, it is necessary to clean it at regular intervals.



Cleaning of intercooler fins : Every 600 hours.

5.4. Air Intake System

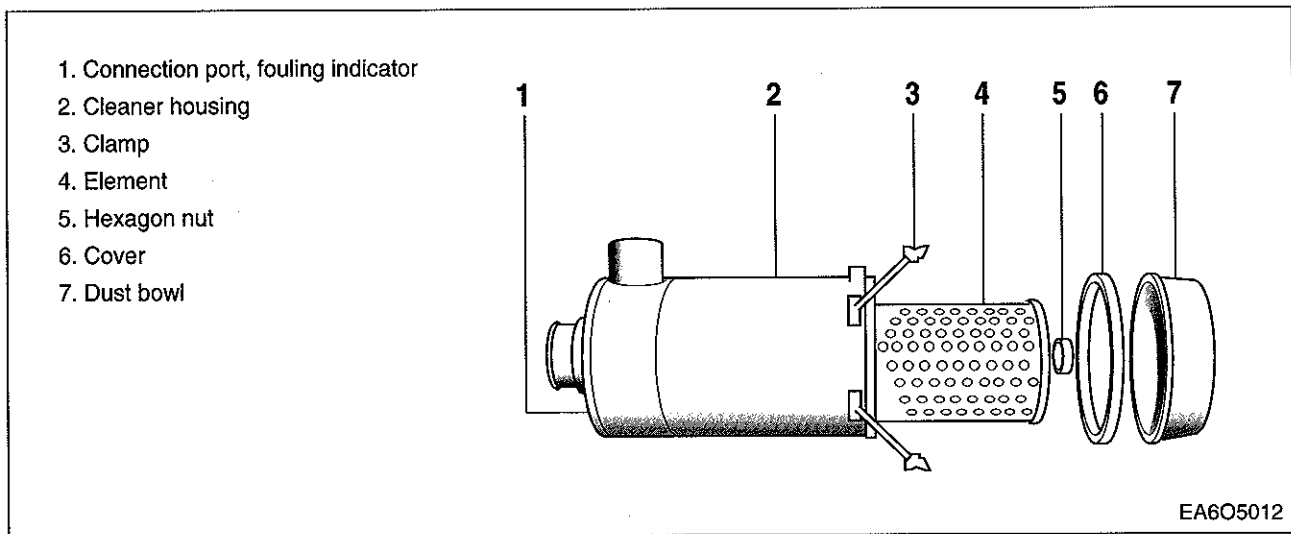

5.4.1. Maintenance

(only when engine is switched off)

Empty the dust bowl (7) regularly. The bowl should never be filled more than halfway with dust. On slipping off the two clamps (3), the dust bowl can be removed. Take off the cover (6) of the dust bowl and empty.

Be careful to assemble cover and bowl correctly.

There is a recess in the cover rim and a lug on the collector which should register.

Where the filter is installed horizontally, watch for "top" mark on cleaner bowl.

5.4.2. Changing filter element



CAUTION : *Do not allow dirt to get into the clean air end.*

On removing the hexagon nut, take out the dirty cartridge and renew or clean.

Wipe the cleaner housing with a damp cloth, in particular the sealing surface for the element.

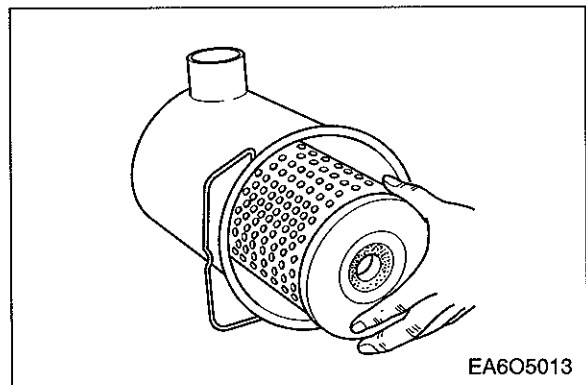

NOTE : *Unless the maximum number of cleanings (up to 5 x) have been done, the filter cartridge should be renewed every two years or 4,000 hours operation.*

5.4.3. Cleaning filter elements

- **By compressed air**

(wear goggles)

For the purpose, the air gun should be fitted with a nozzle extension which is bent 90° at the discharge end and which is long enough to reach down inside to the bottom of the element.

Moving the air gun up and down, blow out the element from the inside (maximum 500kPa - 5 bar) until no more dust comes out of the filter pleats.

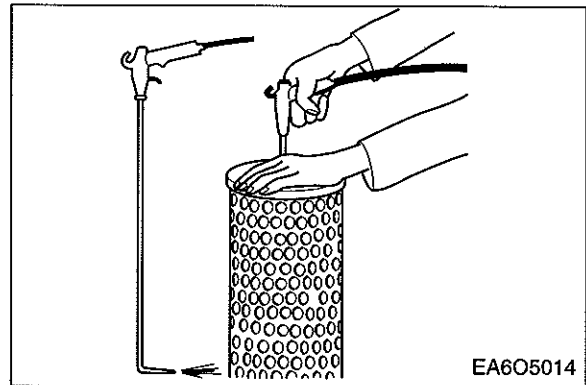

- **By washing**

Before washing, the element should be precleaned by means of compressed air, as described above.

Then allow the element to soak in lukewarm washing solvent for 10 minutes, and then move it to and for in the solvent for about 5 minutes.

Rinse thoroughly in clean water, shake out and allow drying at room temperature.

The cartridge must be dry before it is reinstalled. Never use steam sprayers, petrol (gasoline), alkalis or hot liquids etc. to clean the filter elements.

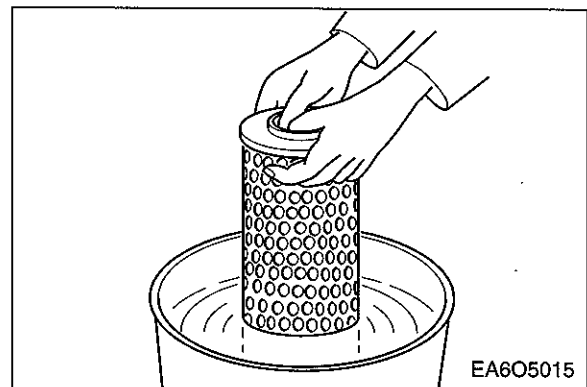

- **Knocking out dirt by hand**

In emergencies, when no compressed air or cleaning agent is available, it is possible to clean the filter cartridge provisionally by hitting the end disk of the cartridge with the ball of one's thumb.

Under no circumstances should the element be hit with a hard object or knocked against a hard surface to loosen dirt deposits.

- **Checking the filter cartridge**

Before reinstalling the cartridge, it must be checked for damage e.g. to the paper pleats and rubber gaskets, or for bulges and dents etc. in the metal jacket.

Cracks and holes in the paper pleating can be established by inspecting the cartridge with a flashlight.

Damaged cartridges should not be reused under any circumstances. In cases of doubt, discard the cartridge and install a new one.

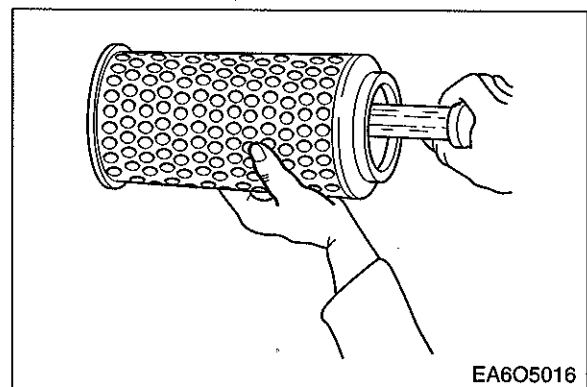

5.5. Fuel System

5.5.1. Fuel filter

- After every 200 hour of operation, drain the water and sediment from the fuel-water separator.
- Shut off the engine. Use your hand to open the drain valve ①.
- Turn the valve counter clockwise approximately 2 ~ 3 turns until draining occurs. Drain the filter sump of water until close fuel is visible.
- Turn the valve clockwise to close the drain valve. Do not over tighten the valve, overtightening can damage the threads.

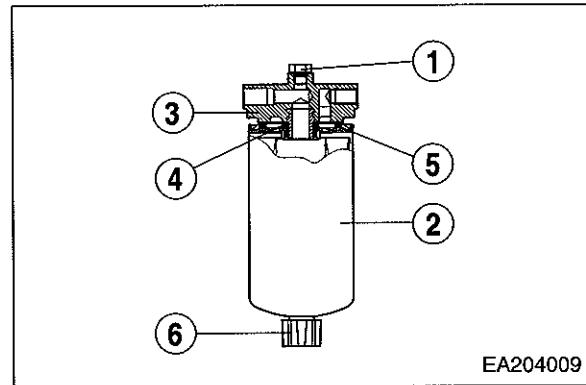

5.5.2. Replacement of fuel filter

- Clean the area around the fuel filter head ③.
- Remove the fuel filter ② by turning it counter-clockwise with filter wrench. (Discard the used filter.)
- Remove the fuel filter thread adapter seal ring ④.
- Use a clean lint free cloth to clean the gasket surface of the fuel filter head ③.
- Install the new thread adapter seal ring ④ supplied with the new filter.
- Use clean oil to lubricate the filter seal ⑤, and fill the new filter with clean fuel.
- Install the filter on the filter head ③.
- Tighten the filter until the gasket contacts the filter head surface.
- Tighten the filter on additional one-half to three-fourths of a turn with the filter wrench, on as specified by the filter manufacturer.

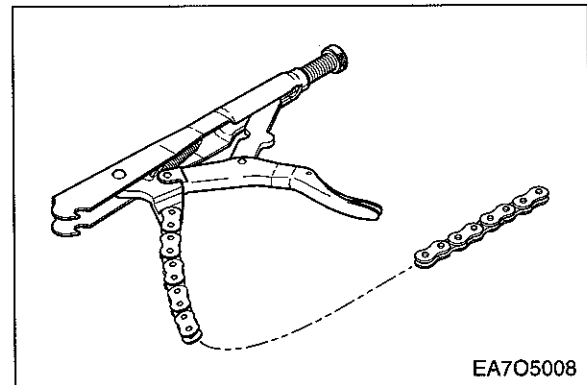

NOTE : Mechanical over tightening of the filter can distort the thread or damage the filter element seal.

5.5.3. Fuel system checks

Fill the tank with the recommended fuel. Keeping tanks full reduces water condensation and helps keep fuel cool, which is important to engine performance.

Make sure fuel supply valves (if used) are open.

To insure prompt starting and even running, the fuel system must be primed with the fuel feed pump manually before starting the engine the first time, or after a fuel filter change.

Refill at the end of each day's operation to prevent condensation from contaminating the fuel. Condensation formed in a partially filled tank promotes the growth of microbial organisms that can clog fuel filters and restrict fuel flow.

If the engine is equipped with a fuel water separator, drain off any water that has accumulated. Water in fuel can seriously affect engine performance and may cause engine damage.

DAEWOO recommends installation of a fuel water separator on generator units.

● Air removal of fuel system

The suction room of fuel injection pump has the function of air removal continuously during the operation through a relief valve.

In case that the suction room lacks fuel at all, for instance, in case of new installation of injection pump, after loosening the air removing screws of cartridge filter respectively, remove the air by operating the manual pump of fuel supply pump until bubble will disappear.

● Fuel supply pump

Every time of engine oil replacement, the fuel strainer installed at the fuel supply pump should be removed and cleaned.

5.5.4. Fuel contamination and water trap

In the generator environment, the most likely fuel contaminants are water amicrobial growth (black "slime"). Generally, this type of contamination is the result of poor fuel handling practices. Black "slime" requires water in the fuel to form and grow, so the best prevention is to keep water content to a minimum in storage tanks.

If diesel fuel which contains moisture is used the injection system and the cylinder liners / pistons will be damaged. This can be prevented to same extent by filling the tank as soon as the engine is switched off while the fuel tank is still warm (formation of condensation is prevented). Drain moisture from storage tanks regularly. Installation of a water trap upstream of the fuel filter is also advisable.



NOTICE:

A galvanized steel tank should never be used for fuel storage, because the fuel oil reacts chemically with the zinc coating to form powdery flakes which can quickly clog the fuel filters and damage the fuel pump and injection nozzles.

5.5.5. Priming pump strainer cleaning

Clean the priming pump strainer filter every 200 operation hours.

The strainer filter is incorporated in the priming pump inlet side.

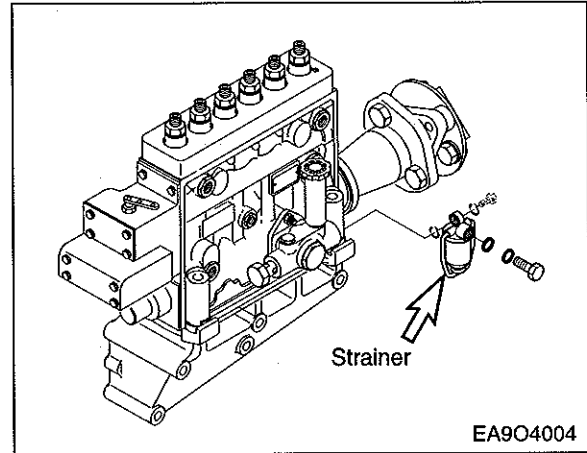

5.5.6. Bleeding the fuel system

Whenever fuel filter is changed or the engine is stopped by cause of the fuel lack, the air of fuel line must be removed as follows.

Bleed the fuel by manually operating the priming pump with fuel filter outlet joint bolt and injection pump bleeder screw loosened.

- Press the feed pump cap repetitively until the fuel without bubbles overflows from the bleeding plug screw.
- After the whole air is pulled out, close the plug screws of the filter and the pump.
- Confirm the resistance of fuel delivery by repetition pressing of the feed pump cap, Pressure and turn the priming pump cap simultaneously to close it.

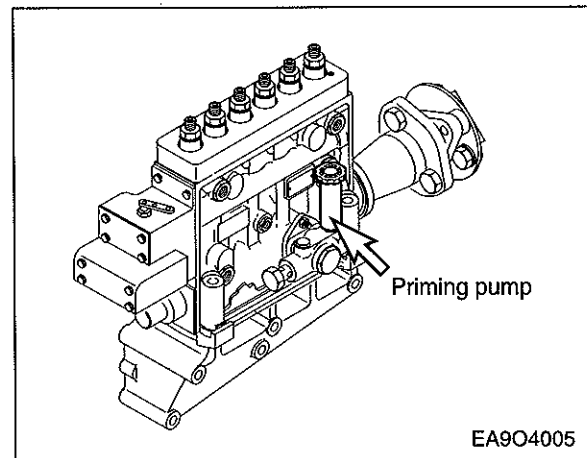

5.5.7. Injection pump

- Check the fuel injection pump housing for cracks or breaks, and replace if damaged.
- Check and see if the lead seal for idling control and speed control levers have not been removed.
- No alterations must be made to the injection pump. If the lead seal is damaged the warranty on the engine will become null and void.
- We strongly recommended that any faults developing in the injection pump should be taken care of by authorized specialist personnel.

5.6. Injection Nozzle Maintenance

(by authorized specialist personnel)

The injectors are designed to spray the fuel delivered by the injection pump directly into the spherical combustion chamber in the piston crown.

The injector consists of the nozzle and the nozzle holder.

A copper seal fitted to the injector ensures gas-tight seating and good heat dissipation. The opening pressure of the nozzle is adjusted by means of shims at the compression spring.

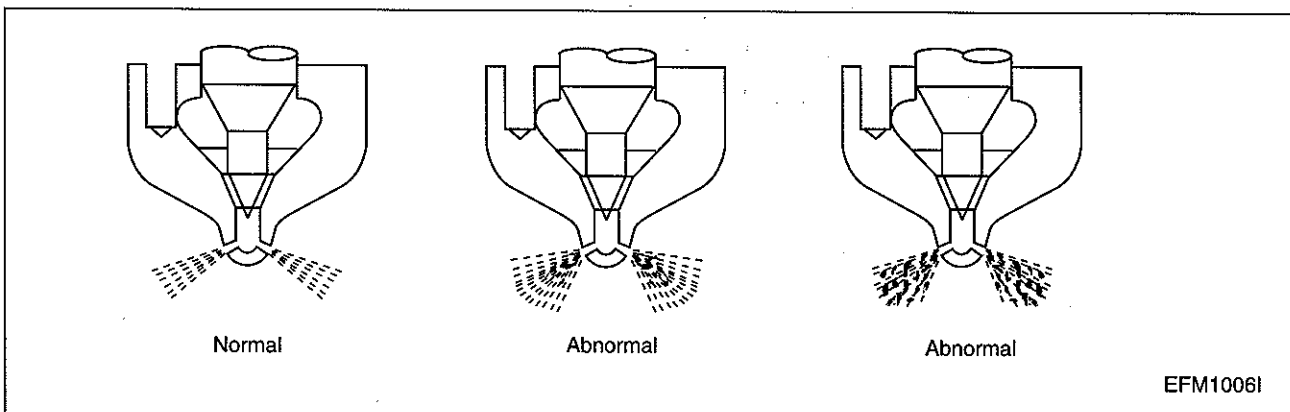
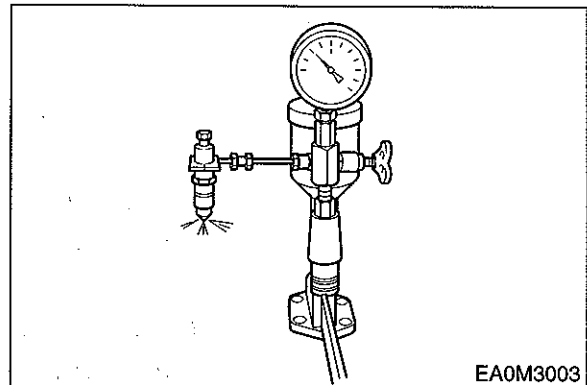

- Install a nozzle to a nozzle tester.
- Check injection pressure, and adjust the nozzle using the adjusting shim if the pressure does not meet the specified limit.

Engine Model	D1146/PU086	D1146T/PU086T	P086TI
Opening pressure	214 kg/cm ²	214 kg/cm ²	214 kg/cm ²

- Check nozzle spray patterns and replace if damaged.



CAUTION :

The injection lines are designed for high operating pressures and should thus be handled with particular care.

- When mounting the pipes to the engine take care of good fitness.
- Do not bend pipes to permanent deformation (not for replacing the nozzles either).
- Do not mount any heavily bent pipes.
- Avoid bending the pipes at the ends by more than 2 to 3 degrees.

In case of faults in the injection system which might have resulted in excessive operating pressures, not only the failed part but also the injection line has to be replaced.

5.7. Turbocharger (for D1146T/PU086T, P086TI)

5.7.1. Maintenance

(by authorized specialist personnel)

The turbochargers do not call for any specific maintenance.

The only points to be observed are the oil pipes which should be checked at every oilchange for leakage and restrictions.

The air cleaners should be carefully serviced.

Furthermore, a regular check should be kept on charge air exhaust gas pipes. Any leakages should be attended to at once because they are liable to cause overheating of the engine.

When operating in highly dust or oil-laden atmospheres, cleaning of the air impeller may be necessary from time to time. To this end, remove compressor casing (**Caution , Do not skew it!**) and clean in a non-acid solvent, if necessary using a plastic scraper.

If the air compressor should be badly fouled, it is recommended that the wheel be allowed to soak in a vessel with solvent and to clean it then with a stiff brush. In doing so, take care to see that only the compressor wheel is immersed and that the turbocharger is supported on the bearing casing and not on the wheel.

5.7.2. Special hints

It is recommended that the radial and axial clearances of the rotor be checked after every 3,000 hours operation.

This precaution will enable any wear of the Measuring of axial clearance bearings to be detected in good time before serious damage is caused to the rotor and bearings.

- Measuring rotor axial clearance

Axial clearance	0.2 mm
-----------------	--------

- Measuring radial clearance

Radial clearance	0.65 mm
------------------	---------

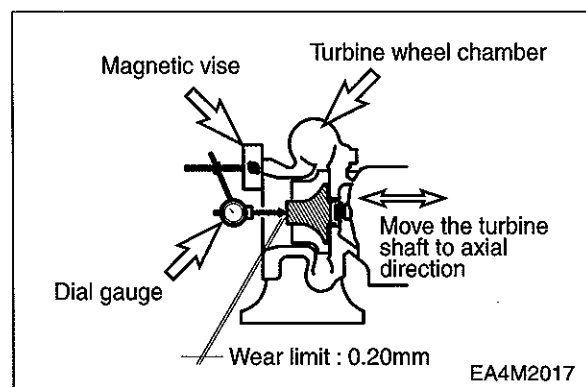

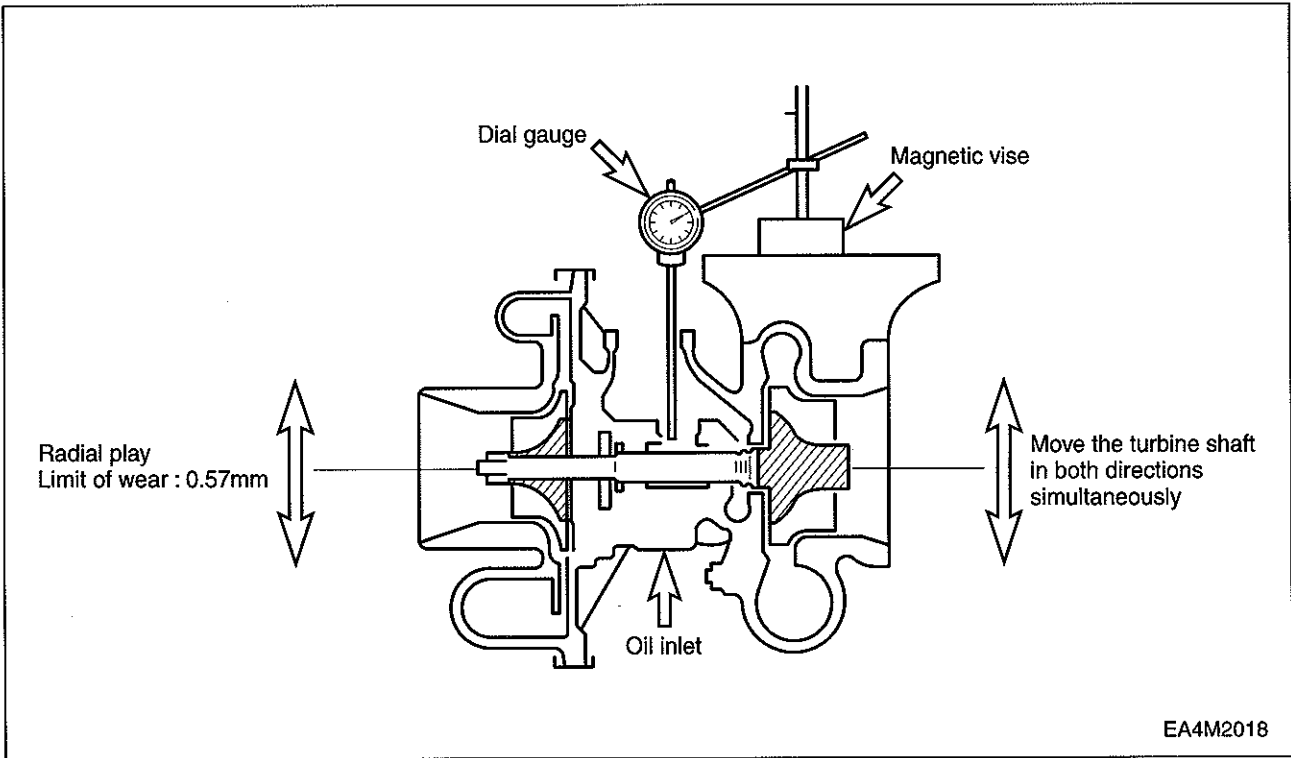

6. Checking and Setting

6.1. Adjustment of Valve Clearance

6.1.1. General information

The valve clearances are to be adjusted at the times of the following situations.

- After initial 50 hour's operation.
- When the engine is overhauled and the cylinder heads are disassembled.
- When severe noise comes from valve train.
- When the engine is not normally operated, even though there is no trouble in the fuel system. The valve clearance of the cold engine are as follows.

6.1.2. Adjusting order of the valve clearance

- Cylinder No. 1 begins from the rear side where the flywheel is mounted but cylinder No. 6 begins from the front side of the engine on the contrary.

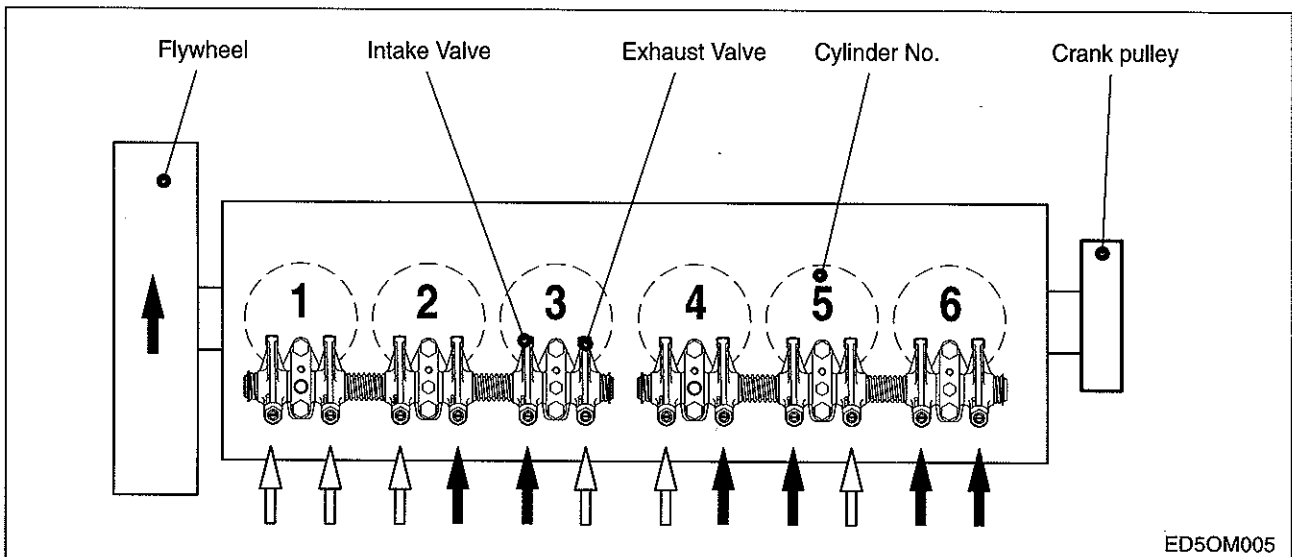

Step 1:



- After letting the cylinder No.6 in the overlap TDC position by turning the crankshaft, adjust the valves corresponding to "↑" of following figure. At this time cylinder No. 1 should be at the ignition TDC position(O.T).

Step 2:

- After adjusting upper valves turn the crank pulley 360° to adjust the other valve clearance until the cylinder No. 1 comes to overlap TDC position.
At this time cylinder No. 6 should be at the ignition TDC position(O.T).
- Adjust the valves corresponding to "↑" in upper figure.
After reconfirming the valve clearances, retighten it if necessary.



- Loosen the lock nuts of the rocker arm adjusting screws and push the specified feeler gauge and adjust the valve clearance with adjusting screw respectively.

Model	Intake Valve	Exhaust Valve
D1146/PU086 D1146T/PU086T P086TI	0.3 mm	0.3 mm

6.1.3. Method of adjusting the valve clearance

- 1) Loosen the lock-nuts ① using a ring spanner.
- 2) Insert a thickness gauge of 0.3mm between valve stem ② and rocker arm ③.
- 3) Turn the adjusting bolts ④ using a screw driver until the gauge can be pulled out with some restriction.
- 4) After the adjustment fix the adjusting bolt not to rotate and tighten the lock-nut at the same time.
- 5) Measure the clearance one more time and if necessary adjust again.

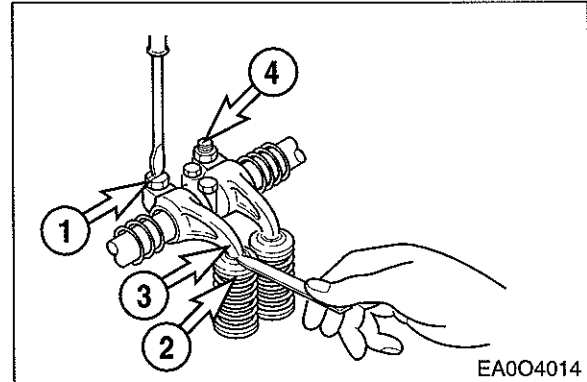

6.2. Adjustment of Injection Timing

6.2.1. Method of adjusting injection timing

- Turn the flywheel until No. 1 piston is placed in the "OT" position of notch marks on the flywheel, and then turn again the flywheel clockwise until showing the notch mark of the right figure corresponding to the injection timing is aligned with the pointer (\downarrow) on the flywheel housing.

	D1146/PU086 D1146T	P086TI /PU086T
Fuel injection timing (B.T.D.C static)	18°	12°

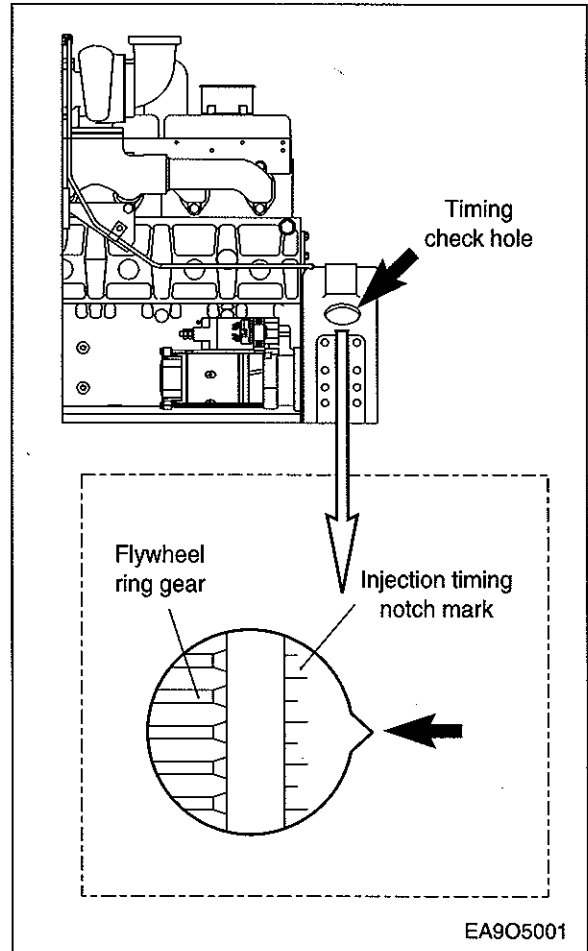

- Turn the timer until the notch mark of the indicator plate attached to the fuel injection pump is aligned with the notch mark of the timer.

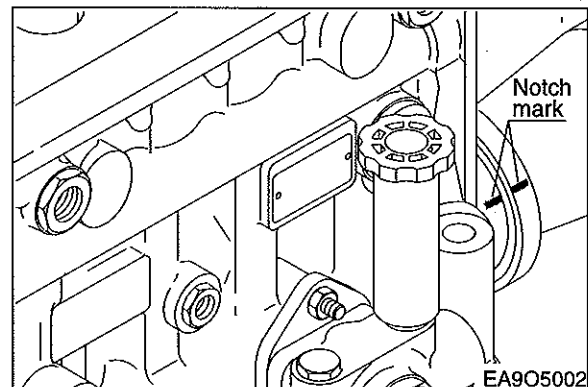

- Tighten the coupling fixing bolts and nuts to specified torque.

Torque	6.0 ~ 6.5 kg.m
---------------	----------------

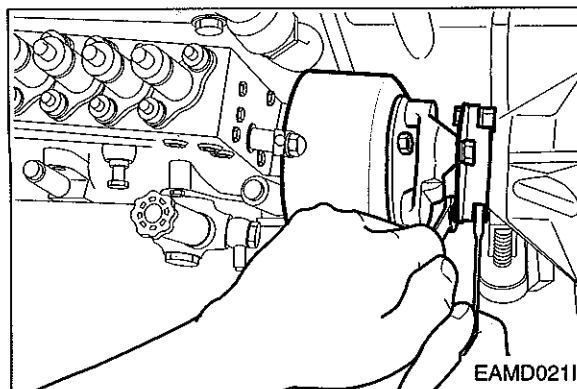

6.3. Cylinder Compression Pressure

- 1) Stop the engine after warming it up, then remove the nozzle assemblies.

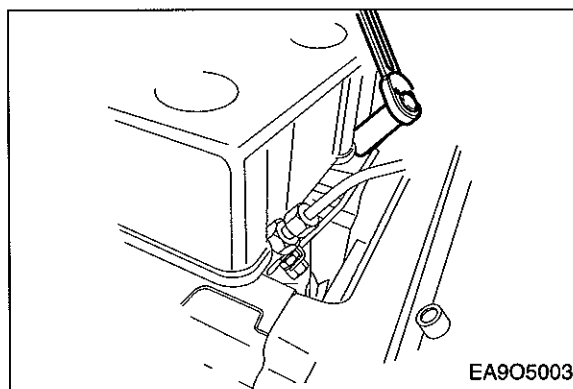

- 2) Install a special tool (gauge adapter) in nozzle holder hole and connect the compression pressure gauge to the adapter.

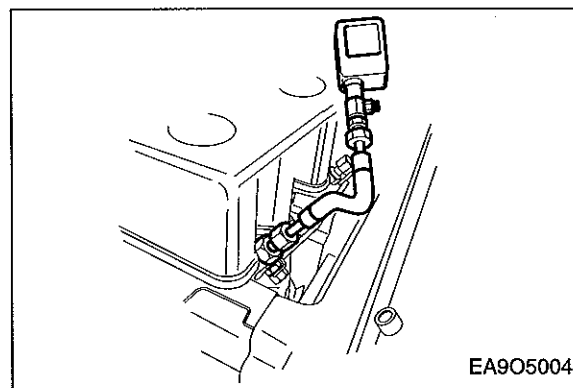

- 3) Cut off fuel circulation, rotate the starter, then measure compression pressure of each cylinder.

Standard value	25 ~ 28 kg/cm ²
Limit	24 kg/cm ² or less
Difference between each cylinders	Within ± 10%

※ Testing conditions : at water temperature of 20°C and speed of 200 rpm (10 turns)

6.4. V-belts

The tension of the V-belts should be checked after every 2,000 hours of operation.

1) Change the V-belts if necessary

If in the case of a multiple belt drive, wear or differing tensions are found, always replace the complete set of belts.

2) Checking condition

Check V-belts for cracks, oil, overheating and wear.

3) Testing by hand

The tension is correct if the V-belts can be pressed in by about the thickness of the V-belt. (no more midway between the belt pulleys)

A more precise check of the V-belt tension is possible only by using a V-belt tension tester.

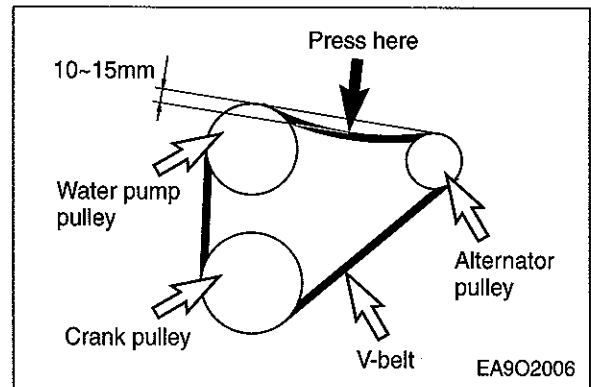

4) Measuring tension

① Lower indicator arm (1) into the scale.

- Apply tester to belt at a point midway between two pulleys so that edge of contact surface (2) is flush with the V-belt.
- Slowly depress pad (3) until the spring can be heard to disengage.

This will cause the indicator to move upwards.

If pressure is maintained after the spring has disengaged a false reading will be obtained!

② Reading of tension

- Read of the tensioning force of the belt at the point where the top surface of the indicator arm (1) intersects with the scale.
- Before taking readings make ensure that the indicator arm remains in its position.

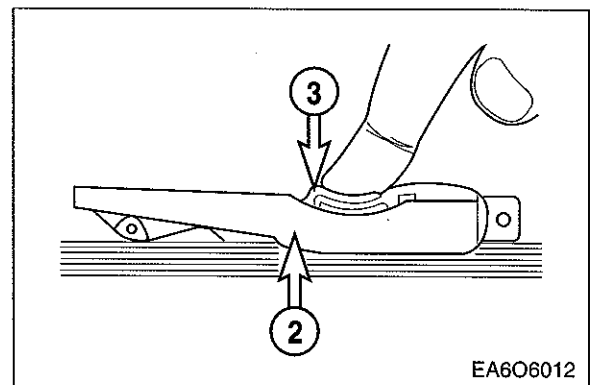
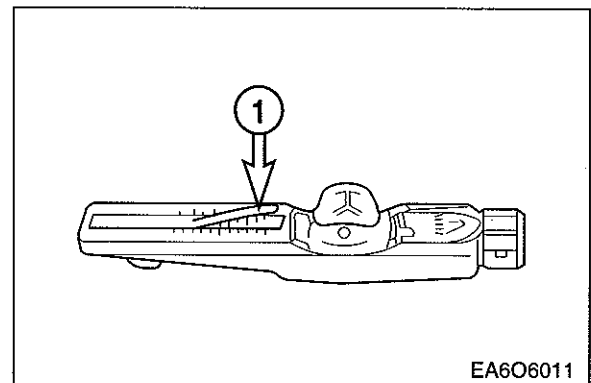

Type	Drive belt width	Tensioning forces on the tester		
		new installation		When servicing after long running time
		Installation	After 10 min. running time	
M	9.5 mm	50 kg	45 kg	40 kg
A *	11.8 mm	55 kg	50 kg	45 kg
B	15.5 mm	75 kg	70 kg	60 kg
C	20.2 mm	75 kg	70 kg	60 kg

* : Adopted in D1146/PU086, D1146T/PU086T and P086T1

5) Tensioning and changing V-belt

- Loosen fixing bolts and nuts.
- Adjust the alternator until V-belts have correct tensions.
- Retighten fixing bolts and nuts.

To change the V-belts loosen fixing bolts and nuts. Then push the alternator toward water pump pulley by hand.

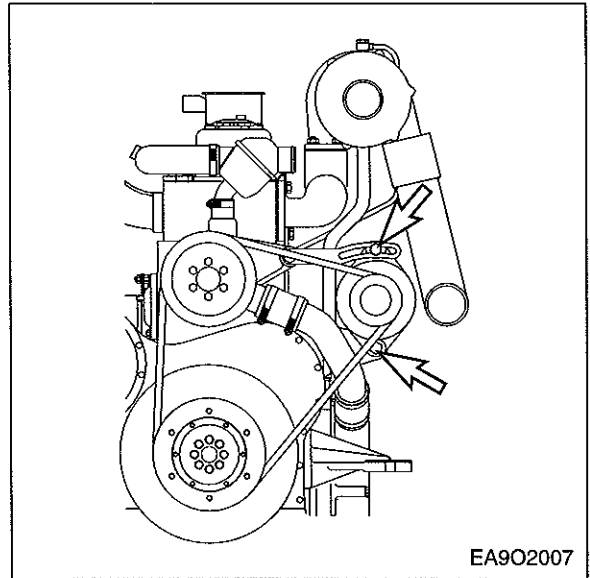

EA902007

7. Operation Tip

7.1. Periodic Inspection Cycle

○ : Check & adjust ● : Replace

Inspection		Daily	Every 50hrs	Every 200hrs	Every 400hrs	Every 800hrs	Every 1200hrs	Remark
Cooling System	Check for leakage(hoses, clamp)	○						
	Check the water level	○						
	Change the coolant water						●	
	Adjust the V-belt tension	○						Every 2,000hrs
	Clean the radiator						○	
Lubrication System	Check for leakage	○						
	Check the oil level gauge	○						
	Change the lubricating oil		● 1st	○				
	Replace the oil filter cartridge		● 1st	○				
Intake & Exhaust System	Check the leakage for intercooler (hoses, clamp)	○						
	Clean and change the air cleaner element			○ clean	●			
	Clean the inter-cooler air fins				○			
	Clean the turbo-charger							Every 2,000hrs
Fuel System	Check the leakage fuel line	○						
	Clean the fuel strainer of fuel feed pump						○	
	Remove sediment from fuel tank						○	
	Drain the water in separator			○				
	Replace the fuel filter element				●			
	Check fuel Injection timing			○				When necessary
	Check the injection nozzles			○				When necessary
Engine Adjust	Check the state of exhaust gas	○						
	Check the battery charging	○						
	Check the compression pressure						○	When necessary
	Adjust Intake/Exhaust valve clearance		○ 1st					When necessary

7.2. Trouble Shooting

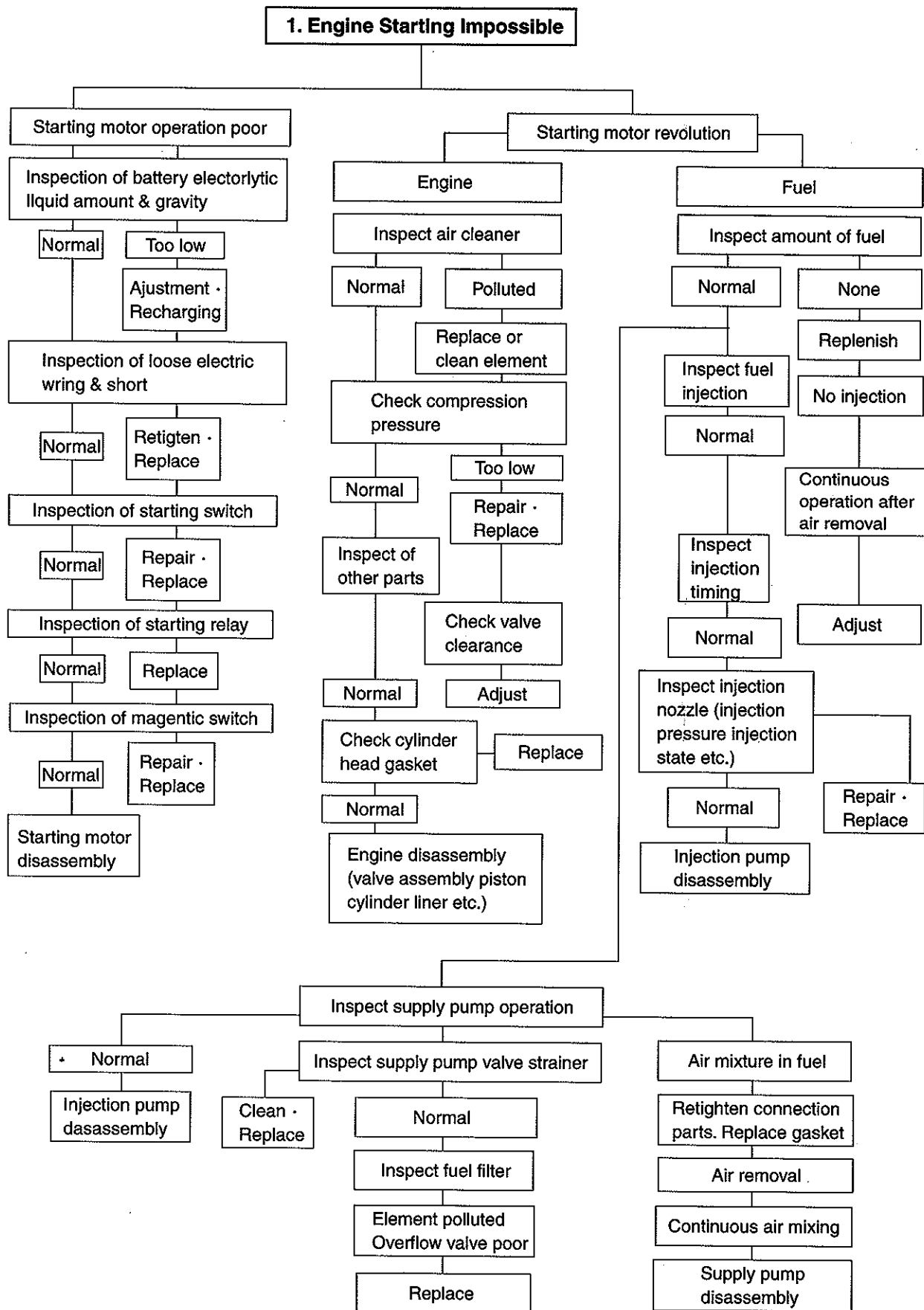

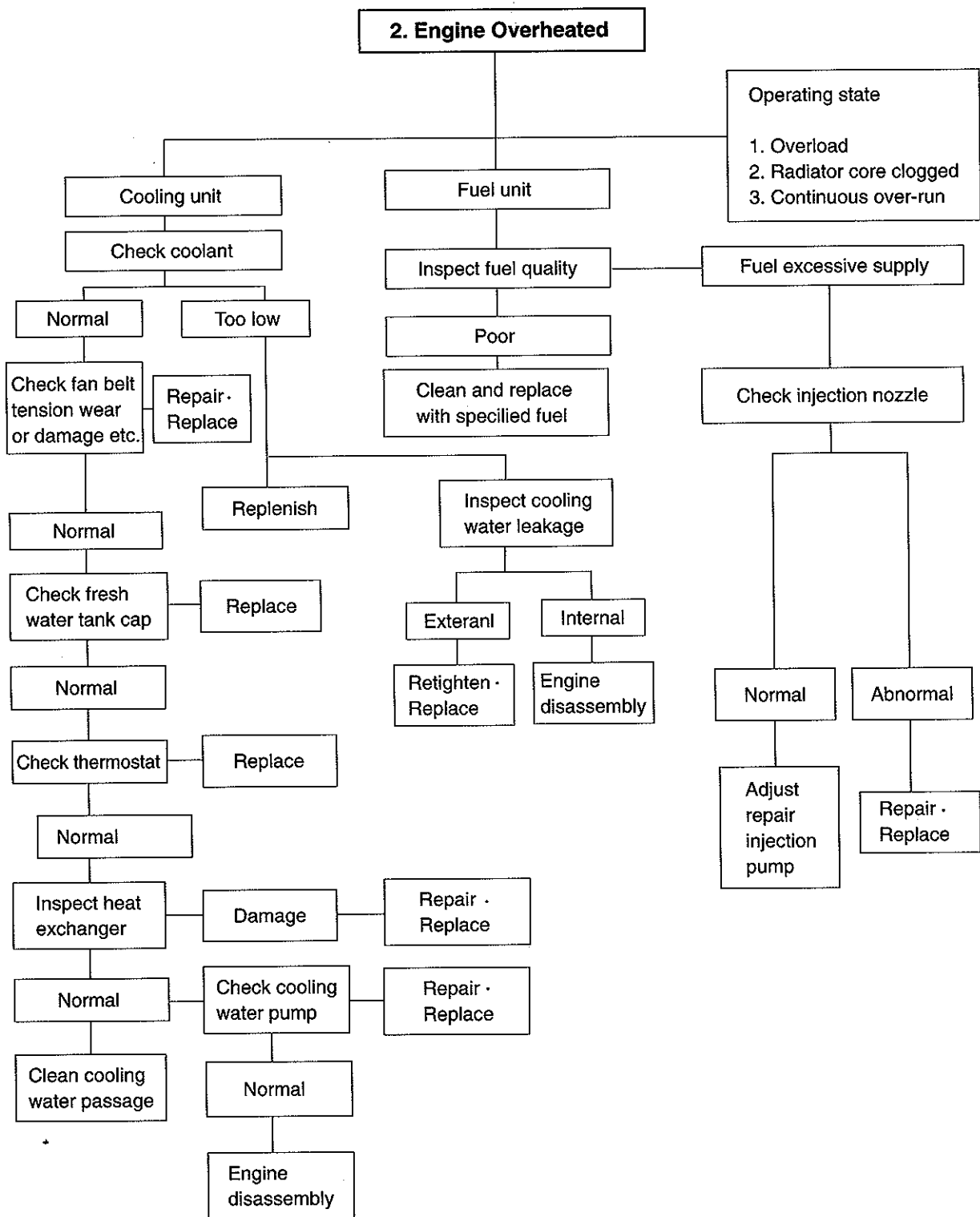

3. Output Insufficient

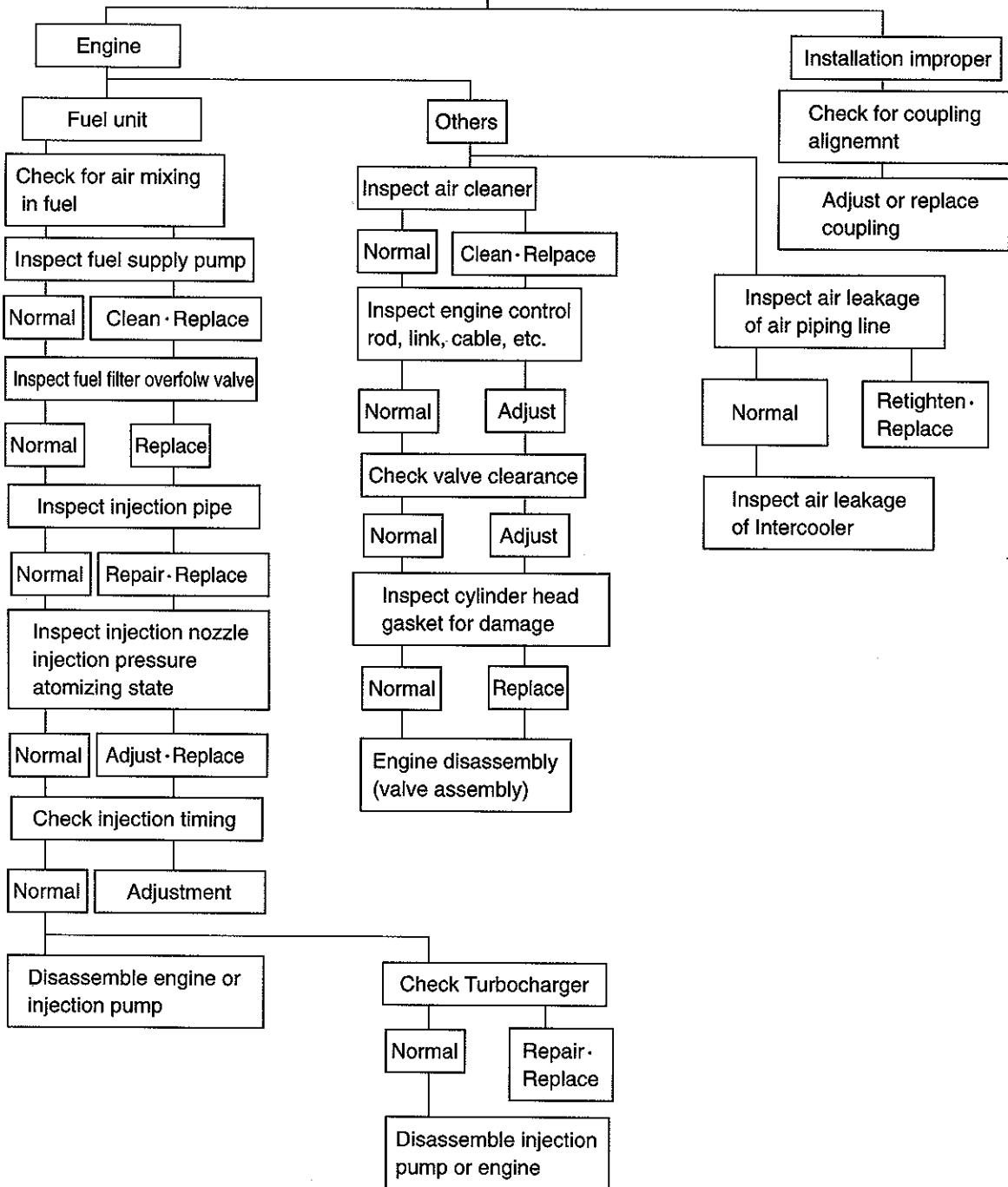

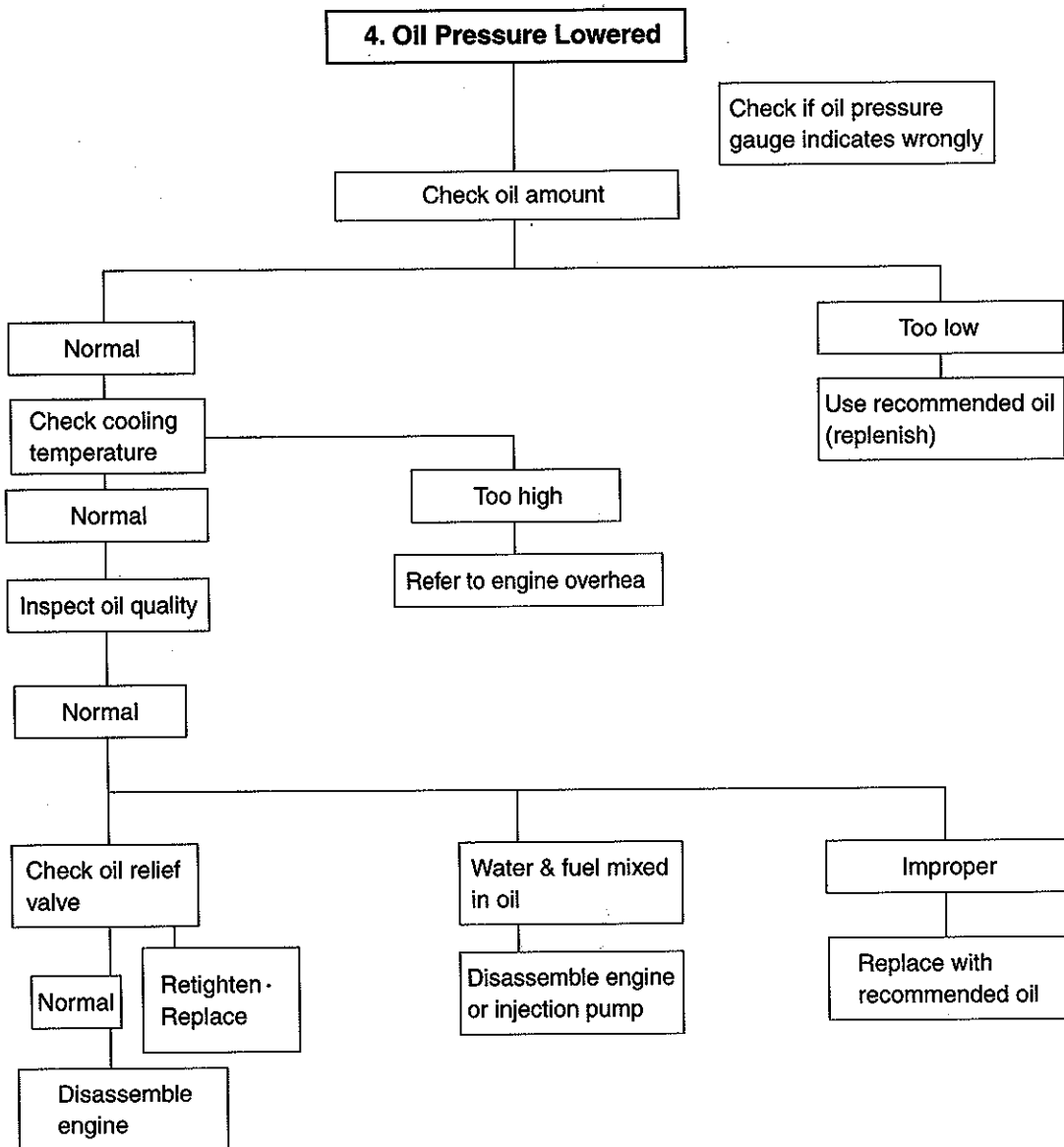

5. Fuel Consumption Excessive

- Causes according to Use Conditions
1. Overload
 2. Governor's Arbitrary Adjustment
 3. Full Speed Operation for Long time
 4. Sudden Speed Change from Low to High Speed

Inspect fuel leakage

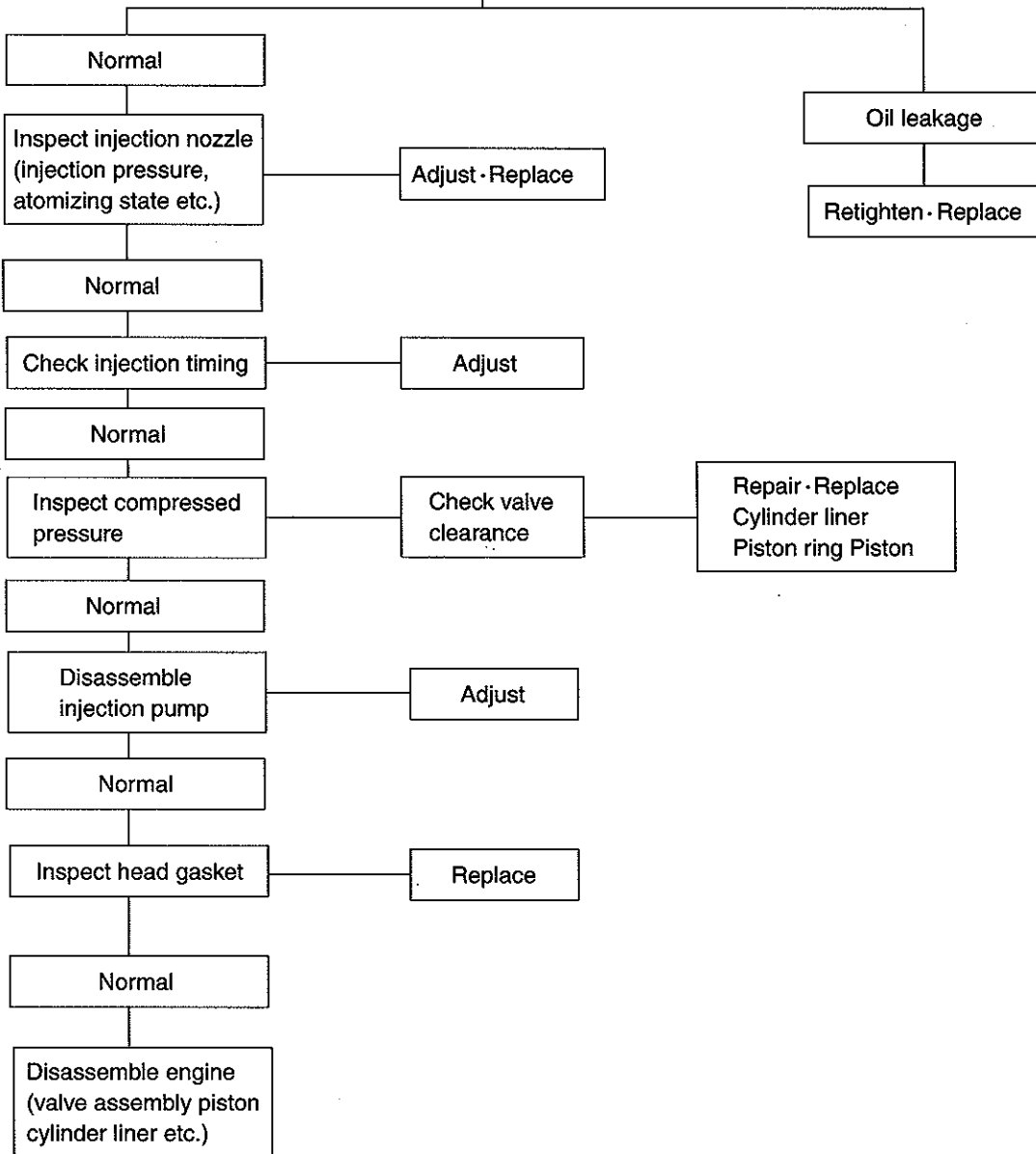

6. Oil Consumption Excessive

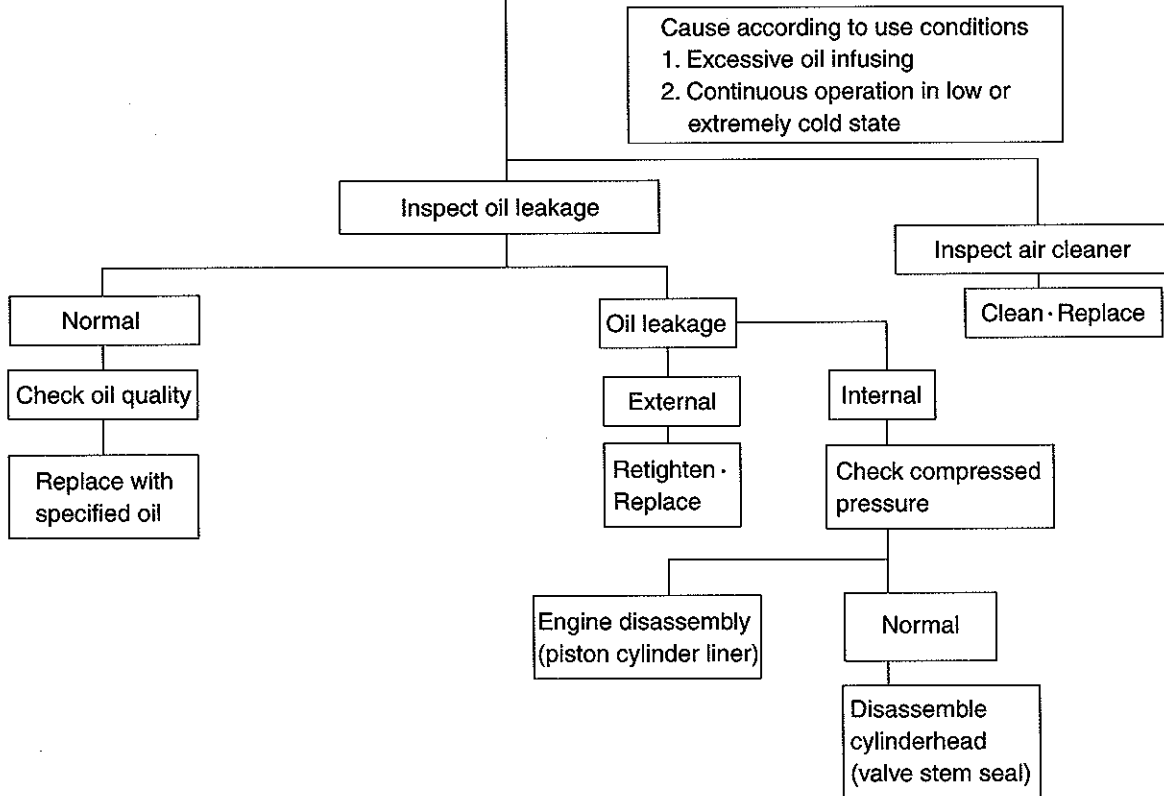

7. Engine Knocking

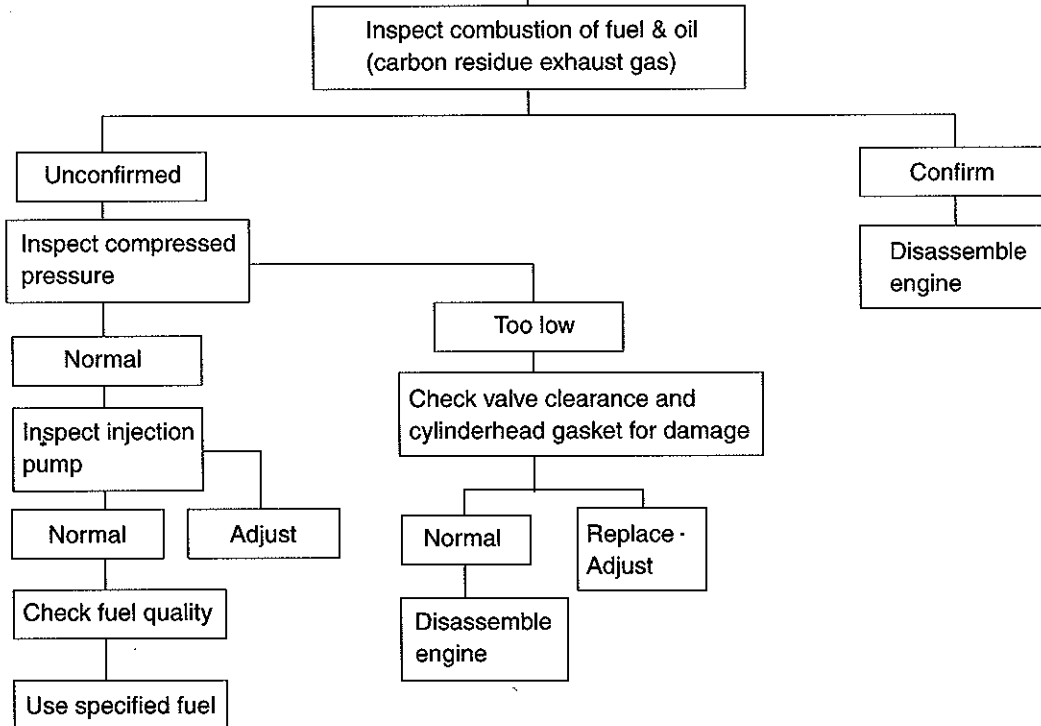

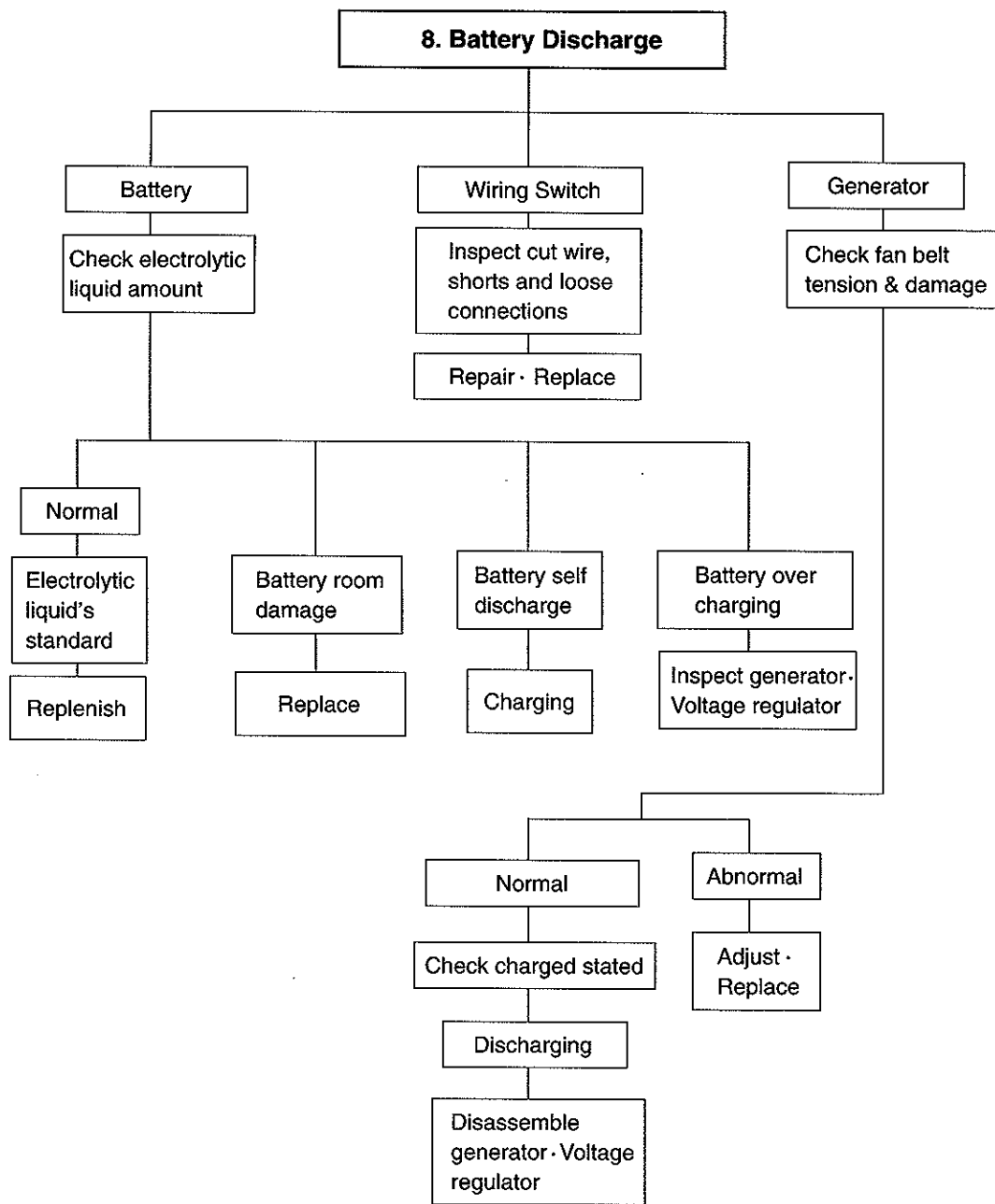

7.3. Causes and Remedies

Condition	Causes	Remedies
1) Starting difficult (1) Compression pressure	<ul style="list-style-type: none"> ● Valve's poor shut, stem distortion ● Valve spring damage ● Cylinder head gasket's leak ● Wear of piston, piston ring or liner 	Repair or replace Replace valve spring Replace gasket Adjust
2) Idle operation abnormal	<ul style="list-style-type: none"> ● Injection timing incorrect ● Air mixing at injection pump 	Adjust Remove air
3) Engine output insufficient (1) Continuous output	<ul style="list-style-type: none"> ● Valve clearance incorrect insufficient ● Valve tightness poor ● Cylinder head gasket's leak ● Wear, stick, damage of piston ring ● Injection timing incorrect ● Fuel injection amount insufficient ● Nozzle injection pressure improper or stuck ● Supply pump's function lowered ● Fuel pipe system clogged ● Air suction amount insufficient ● Supercharger poor 	Adjust Repair Replace gasket Replace piston ring Adjust Adjust injection pump Adjust or replace Repair or replace Repair Clean or replace air cleaner Repair or replace
(2) Output insufficient when in acceleration	<ul style="list-style-type: none"> ● Compression pressure insufficient ● Injection timing incorrect ● Fuel injection amount insufficient ● Injection pump timer's function insufficient ● Nozzle infection pressure, infection angle improper ● Supply pump's function lowered ● Air intake amount insufficient 	Disassemble engine Adjust Adjust injection pump Repair or replace Repair, replace Repair or replace Clean or replace air cleaner

Condition	Causes	Remedies
4) Overheating	<ul style="list-style-type: none"> ● Engine oil insufficient or poor ● Cooling water insufficient ● Fan belt loosened, worn, damaged ● Cooling water pump's function lowered ● Water temp. regulator's operation poor ● Valve clearance incorrect ● Exhaust system's resistance increased 	<p>Replenish or replace</p> <p>Replenish or replace</p> <p>Adjust or replace</p> <p>Repair or replace</p> <p>Replace</p> <p>Adjust</p> <p>Clean or replace</p>
5) Engine noisy	<p>For noises arise compositely such as rotating parts, lapping parts etc., there is necessity to search the cause of noises accurately.</p>	
(1) Crankshaft	<ul style="list-style-type: none"> ● As the wear of bearing or crankshaft progress, the oil clearances increase. ● Lopsided wear of crankshaft ● Oil supply insufficient due to oil passage clogging ● Stuck bearing 	<p>Replace bearing & grind crankshaft</p> <p>Grind or replace</p> <p>Clean oil passage</p> <p>Replace bearing & Grind</p>
(2) Con rod and Con rod bearing	<ul style="list-style-type: none"> ● Lopsided wear of con rod bearing ● Lopsided wear of crank pin ● Connecting rod distortion ● Stuck bearing ● Oil supply insufficiency as clogging at oil passage progresses 	<p>Replace bearing</p> <p>Grind crankshaft</p> <p>Repair or replace</p> <p>Replace & grind crankshaft</p> <p>Clean oil passage</p>
(3) Piston, piston pin & piston ring	<ul style="list-style-type: none"> ● Piston clearance increase as the wear of piston and piston ring progresses ● Wear of piston or piston pin ● Piston stuck ● Piston insertion poor ● Piston ring damaged 	<p>Replace piston & piston ring</p> <p>Replace</p> <p>Replace piston</p> <p>Replace piston</p> <p>Replace piston</p>

Condition	Causes	Remedies
(4) Others	<ul style="list-style-type: none"> ● Wear of crankshaft, thrust bearing ● Camshaft end play increased ● Idle gear end play increased ● Timing gear backlash excessive ● Valve clearance excessive ● Abnormal wear of tappet, cam ● Supercharger inner part damaged 	<ul style="list-style-type: none"> Replace thrust bearing Replace thrust plate Replace thrust washer Repair or replace Adjust valve clearance Replace tappet, cam Repair or replace
6) Fuel Consumption Excessive	<ul style="list-style-type: none"> ● Injection timing incorrect ● Fuel injection amount excessive 	<ul style="list-style-type: none"> Adjust Adjust injection pump
7) Oil Consumption Excessive (1) Oil level elevated	<ul style="list-style-type: none"> ● Clearance between cylinder liner & piston ● Wear of piston ring, ring groove ● Piston ring's damage, stick, wear ● Piston ring opening's disposition improper ● Piston skirt part damaged or abnormal wear ● Oil ring's oil return hole clogged ● Oil ring's contact poor 	<ul style="list-style-type: none"> Replace Replace piston, piston ring Replace piston ring Correct position Replace piston Replace piston ring Replace piston ring
(2) Oil level lowered	<ul style="list-style-type: none"> ● Looseness of valve stem & guide ● Wear of valve stem seal ● Cylinder head gasket's leak 	<ul style="list-style-type: none"> Replace in set Replace seal Replace gasket
(3) Oil leak	<ul style="list-style-type: none"> ● Looseness of connection parts ● Various parts' packing poor ● Oil seal poor 	<ul style="list-style-type: none"> Replace gasket, repair Replace packing Replace oil seal

8. General Information

8.1. General Repair Instructions

1. Before performing service operation, disconnect the grounding cable from the battery for reducing the chance of cable damage and burning due to short-circuiting.
2. Use covers for preventing the components from damage or pollution.
3. Engine oil and anti-freeze solution must be handled with reasonable care as they cause paint damage.
4. The use of proper tools and special tools where specified is important to efficient and reliable service operation.
5. Use genuine DAEWOO parts necessarily.
6. Used cotter pins, gaskets, O-rings, oil seals, lock washer and self-lock nuts should be discarded and new ones should be prepared for installation as normal function of the parts can not be maintained if these parts are reused.
7. To facilitate proper and smooth reassemble operation, keep disassembled parts neatly in groups. Keeping fixing bolts and nut separate is very important as they vary in hardness and design depending on position of installation.
8. Clean the parts before inspection or reassembly. Also clean oil ports, etc. using compressed air to make certain they are free from restrictions.
9. Lubricate rotating and sliding faces of parts with oil or grease before installation.
10. When necessary, use a sealer on gaskets to prevent leakage.
11. Carefully observe all specifications for bolts and nuts torques.
12. When service operation is completed, make a final check to be sure service has been done property.

8.2. Engine Characteristic

8.2.1. Toroidal combustion mode (D1146/PU086)

The D1146 engine is operated in the toroidal combustion mode that was developed by this company with AVL Co. Australia.

The feature of this mode in the fundamental structure is that there are combustion chambers in the centers of piston heads and swirling passages in the cylinder heads.

This swirling passages when intake stroke generates the strong swirling motion in the combustion chambers by giving the intake air a big moment, and when compression stroke, the special piston's shapes causing very complicated and distorted flows by means of eddy current and squashed flows will make the air and fuel mix more smoothly.

Also, when explosion stroke, a considerable output increase came to be expected with the accomplishment of nearly perfect combustion by the more smooth mixing of air and fuel which was injected through multi-nozzles in the combustion chamber.

This engine by means of Toroidal Combustion Mode has the specific character such as quiet and stable revolutionary motion, multi-purpose application, economical fuel and oil consumption, etc.

8.2.2. OMEGA combustion bowl (D1146T, P086TI)

The OMEGA combustion bowl is a unit designed to perform high efficiency, low emission combustion. As the rim around the combustion bowl port of the upper of the piston has been machined in a smaller size than the interior of the combustion bowl, strong swirl is produced in the combustion bowl and strong squish flow makes the fuel be mixed more sufficiently with air.

Due to the application of OMEGA combustion system and optimal utilization of intake and exhaust port configuration within the cylinder head, the D1146T and POLUS P086TI generator diesel engines discharge very low level of hazardous exhaust gases such as smoke, nitrogen oxide, hydrocarbon, or carbon monoxide and thus ensure high performance and low fuel consumption.

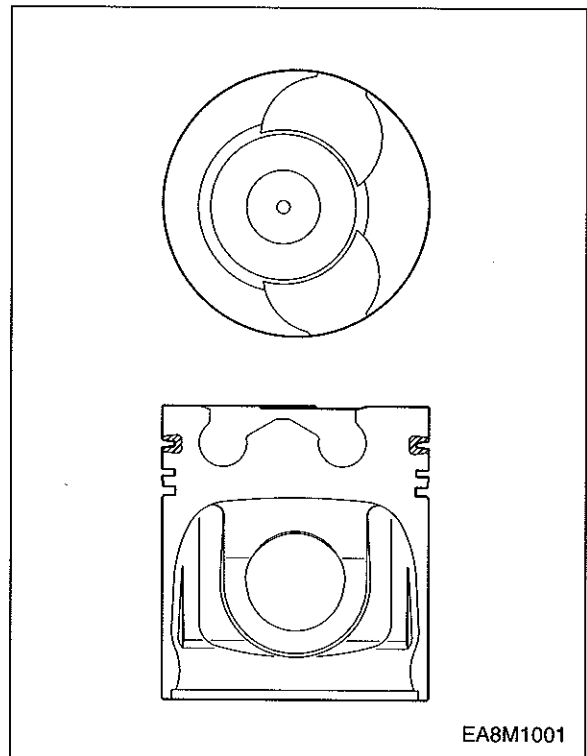

8.2.3. Oil gallery cooling type piston (P086TI)

Oil gallery cooling is used for the piston of P086TI generator engine.

When thermal loading is high, piston cooling by means of an oil gallery in the crown is normally necessary to prevent crown cracking and ring sticking. The design of the gallery, the design and location of the oil spray nozzle and the quantity of oil flowing in the gallery are critical in order to achieve the desired temperature reduction.

The cross section shape of the gallery should be designed to achieve sufficient oil movement to maximize cooling efficiency.

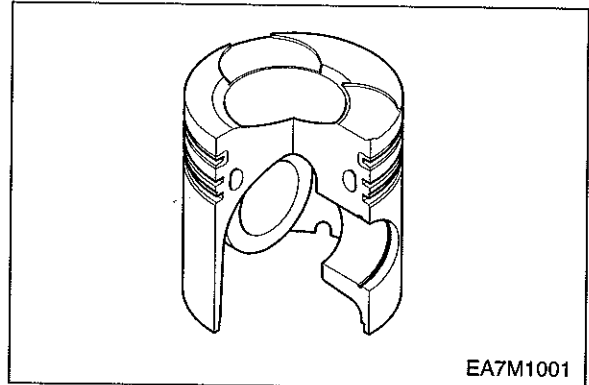

9. Maintenance

9.1. Engine Disassembly

9.1.1. Heed at disassembly



- Before disassembly, the part shelf should be prepared for various tools and repair parts.
- When assembling, clean empty hand should be used and clean environment maintained.
- In case of storing the disassembled parts, each part should not touch each other.
- In case of disassembly, the parts should be laid in order.

9.1.2. Oil level gauge

- Pull out the oil level gauge.

9.1.3. Cooling water

- Remove the radiator cap. Open the drain plug at the radiator lower part to drain the coolant as the right figure.



Caution :

When removing radiator filler cap while the engine is still hot, cover the cap with a rag, then turn it slowly to release the internal steam pressure. This will prevent a person from scalding with hot steam spouted out from the filler port.

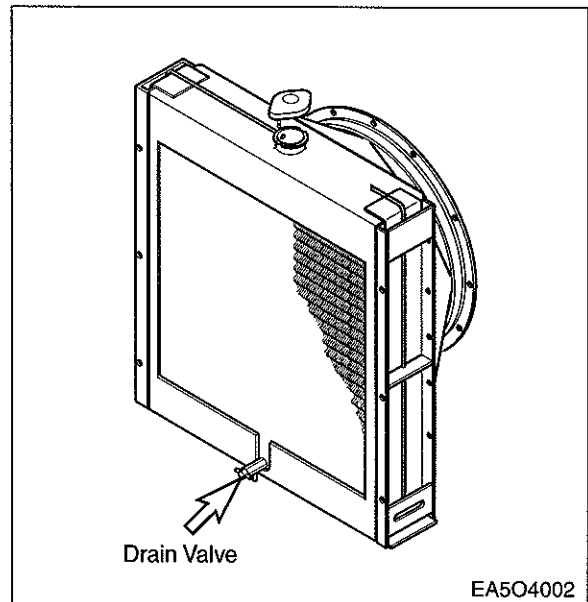

EA5O4002

- Remove the drain plug from the cylinder block and drain out the cooling water into a container.

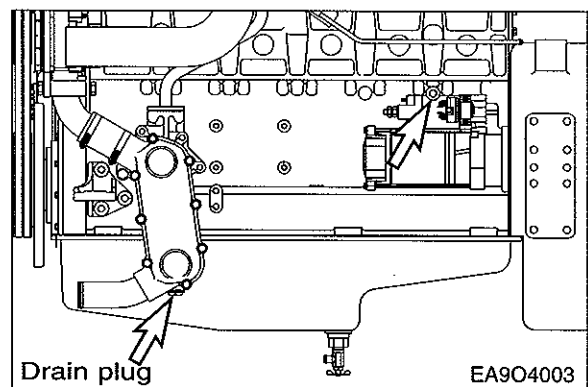

EA9O4003

9.1.4. Engine oil

- Remove the oil drain cock of oil pan and pour the engine oil into the prepared vessel.

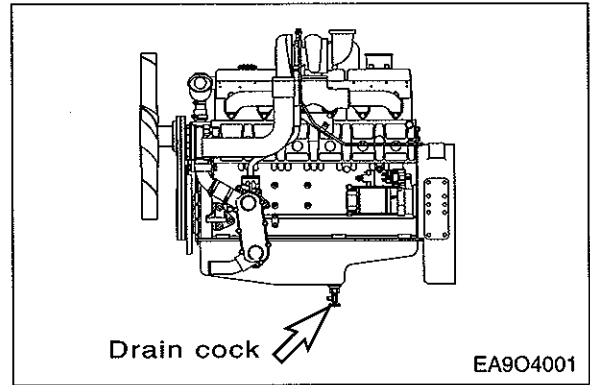

9.1.5. Cooling fan

- Remove the flange fixing bolts, then take off the flange and cooling fan.

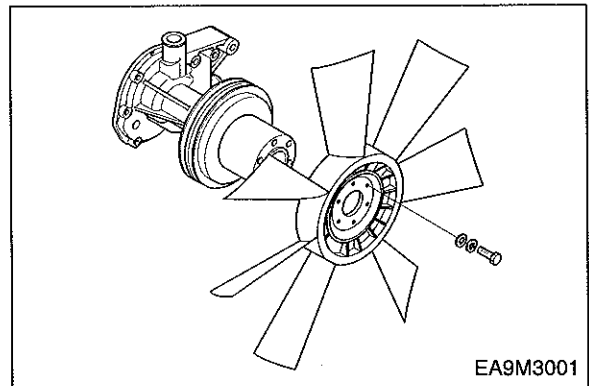

9.1.6. V-belt

- Remove the V-belt by loosening the alternator tension adjusting bolt and tighten the bolt.

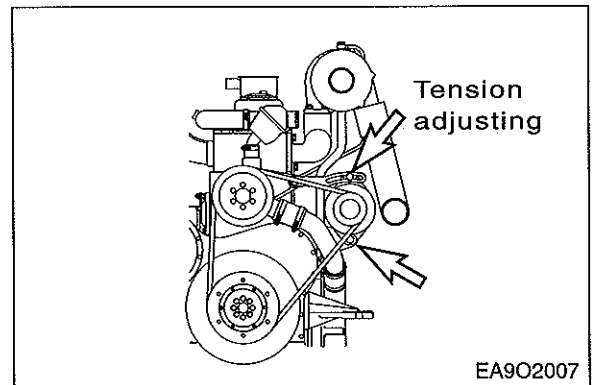

9.1.7. Starter

- Loosen the starter assembling nuts and remove the starter being careful not to damage its gears.

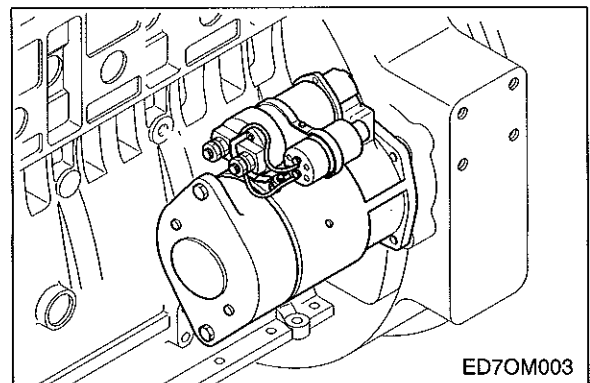

9.1.8. Fuel filter

- Remove the hollow screws of filter and tear down fuel supply and discharge rubber hose.
- Remove fuel filter assembling bolts and disassemble the fuel filter.

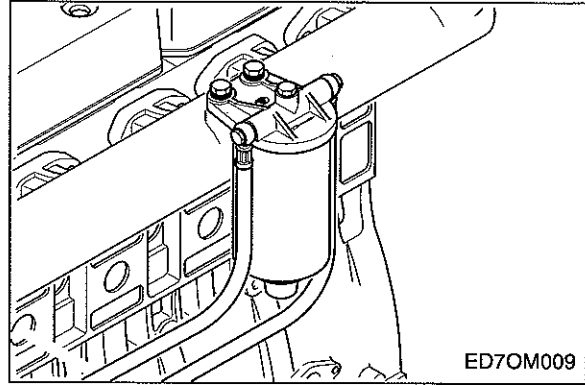

9.1.9. Breather

- Loosen the clamp screw to remove the rubber hose.

9.1.10. Intercooler (P086TI only)

- Tear down the various hoses and air pipes from the inter cooler.
- Remove the intercooler fixing bolts and tear it down.

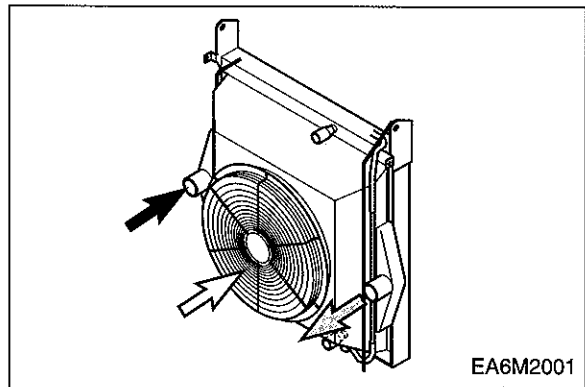

9.1.11. Alternator

- Remove the alternator fixing bolts and disassemble the alternator.
- Remove the tension adjusting bolts and bracket.

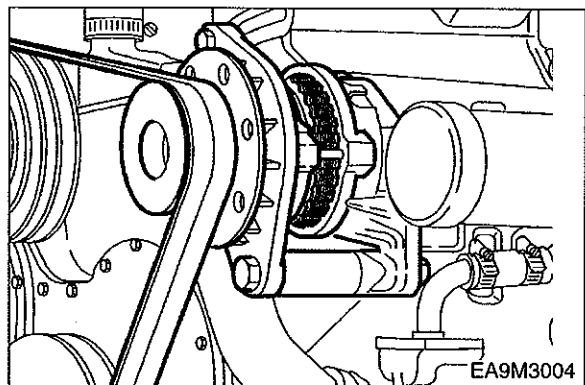

9.1.12. Oil cooler

- Loosen the cooling water pump and the rubber hose clamps of connected pipes, and disassemble it.
- Remove the oil cooler assembling nuts and disassemble it.

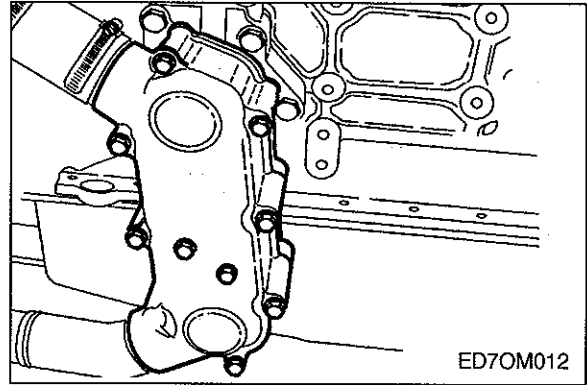

9.1.13. Oil filter

- Remove the oil filter assembling bolts and disassemble the oil filter assembly.

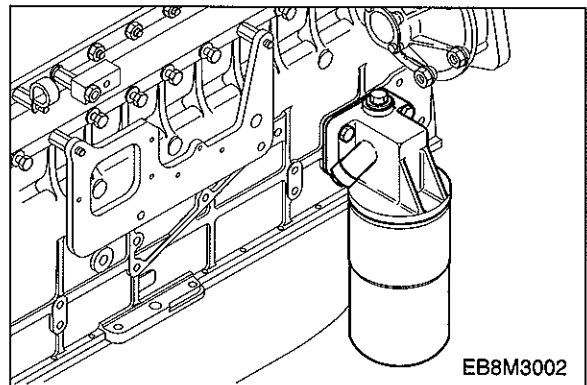

9.1.14. Water pump

- Remove the water pump assembling bolts and disassemble the water pump.

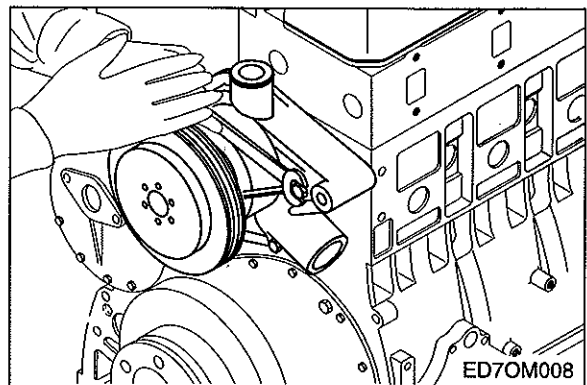

9.1.15. Cylinder head cover

- Remove the head cover assembling bolts and lift the cover.

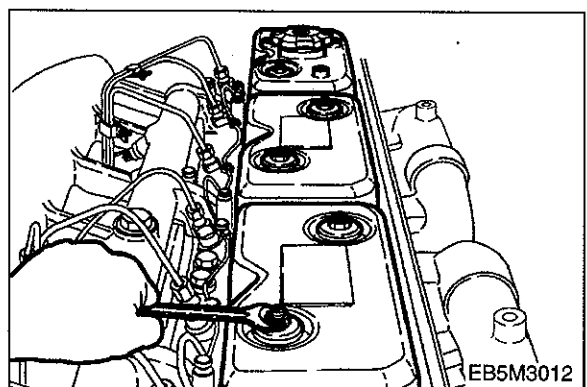

9.1.16. Nozzle

- Remove the fuel supply high pressure pipe and its assembling nuts that are connected between fuel injection pump and nozzle and disassemble the pipes.



- After installing the special tool for removing nozzle temporarily, loosen the holder and then hammer up with a hammer which is a special tool so as for nozzle assembly to be disassembled.

(Be careful not to damage the nozzle at disassembled.)

- Pull the seal ring out through the nozzle hole of cylinder head and scrap it.

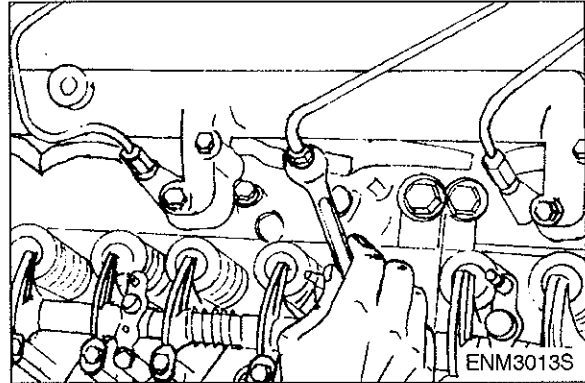

9.1.17. Turbo charger

(D1146T/PU086T, P086TI)

- Disassemble the oil supply pipe that supplies oil from cylinder block to turbo charger and the oil discharge pipe that discharges oil from turbo charger to cylinder block.
- Remove the turbo charger assembling nuts and disassemble it from the exhaust manifold.

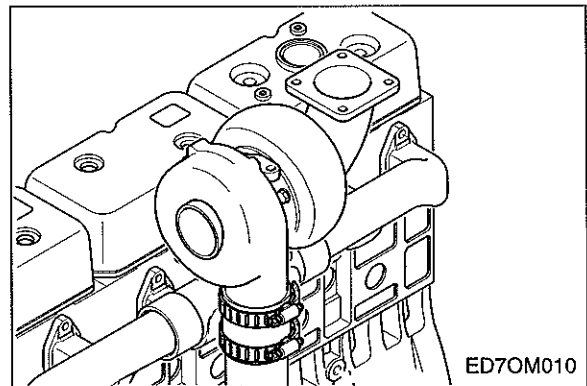

9.1.18. Exhaust manifold

- Remove the exhaust manifold assembling nuts and disassemble the heat shield from the exhaust manifold.
- Then disassemble the exhaust manifold and gasket.
- Scrap the used gasket.

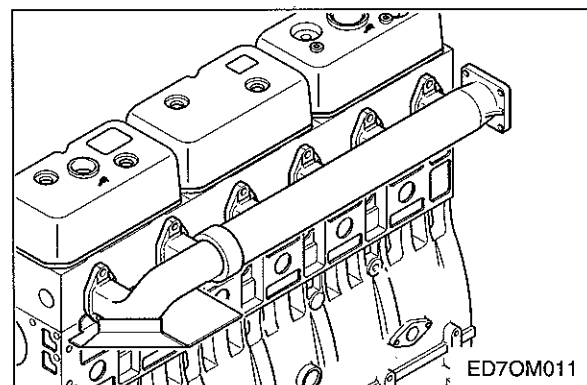

9.1.19. Intake manifold

- Remove the Intake manifold assembling bolts and disassemble it from the cylinder head.
- Disassemble the intake manifold gasket and scrap it.

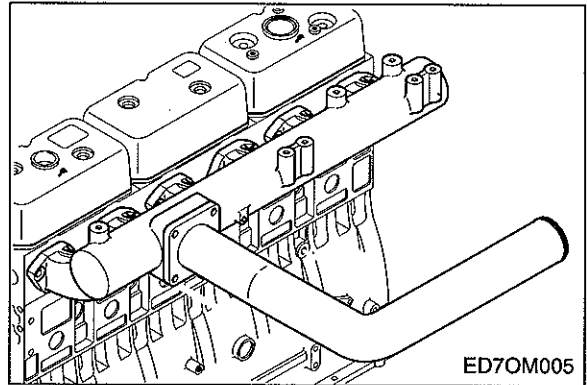

9.1.20. Cooling water pipe

- Remove the cooling water pipe assembling bolts and disassemble the pipe for the cylinder head.
- Remove the gasket of cooling water pipe with a scraper thoroughly.



Caution :

Be careful for the gasket pieces not to get in the passage of cooling water.

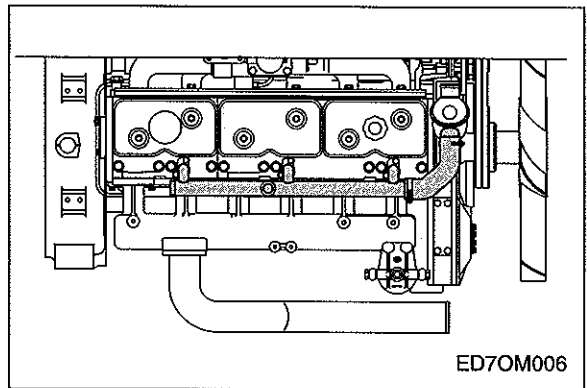

9.1.21. Rocker arm

- Remove the rocker arm bracket assembling bolts in the reverse order (zigzag method) of assembling and disassemble the rocker arm.
- Disassemble the push rod.

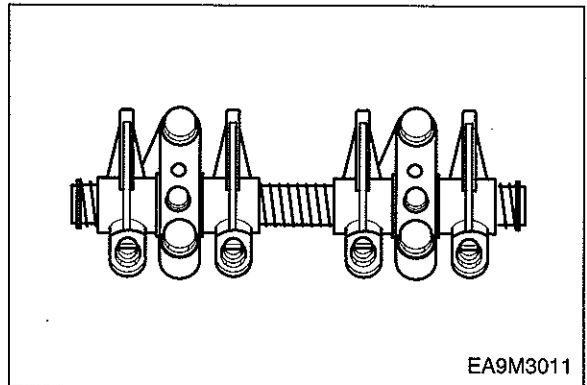

9.1.22. Cylinder head

- Remove the cylinder head bolts in the reverse order of tightening but remove it step by step.
First step : Loosen 1 ~ 2 threads
Second step : Remove by loosening fully.
However, remove the total bolts simultaneously by the step of 1 and 2.

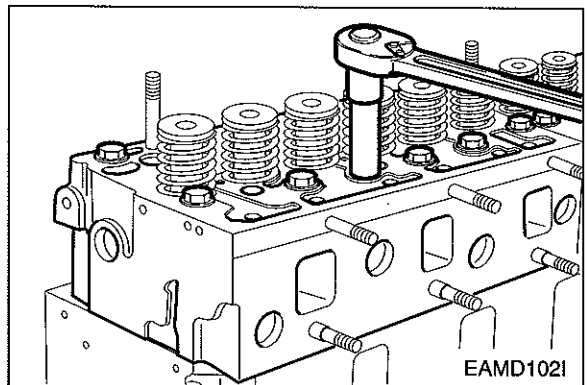

- Lay the removed bolts orderly not to damage the threads at all and store.



Caution :

Prevent a collision between the bolt thread each other.

- Take out the cylinder head gasket and scrap it.
- Remove the foreign residues from the cylinder head surface and block surface.



Caution :

Try not to make any damage on the contact surfaces.

9.1.23 Oil pan

- Remove the oil pan assembling bolts and disassemble the pan.
- After removing the oil pan gasket, scrap it.

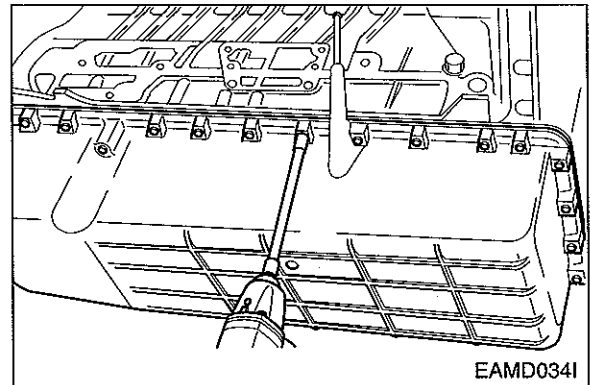

9.1.24. Vibration damper

- Remove the vibration damper assembling bolts in the reverse order of assembling and disassemble the damper assembly

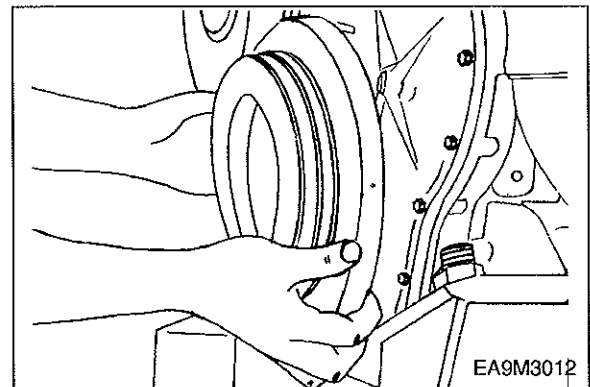

9.1.25. Timing gear case cover



- Disassemble the oil seal using an oil seal removing jig.
- Remove the cover fixing bolts and disassemble the cover from the timing gear case.

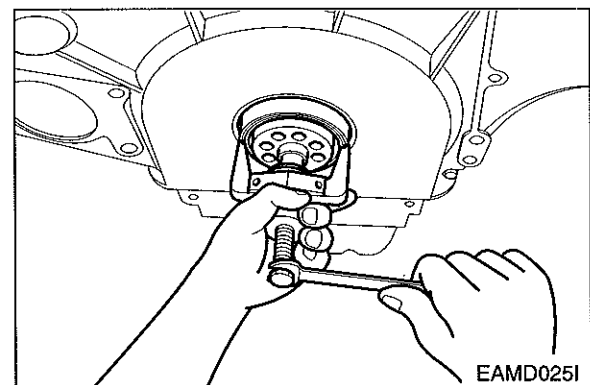

9.1.26. Oil pump

- Remove the bracket fixing bolts of oil intake pipe.
- Remove the pipe assembling bolts of oil pump and disassemble intake and supply pipe.
- Remove the oil pump assembling bolts, and disassemble the oil pump.

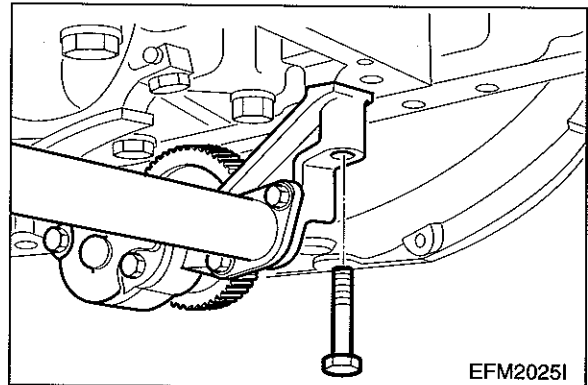

9.1.27. Piston

- Remove the connecting rod cap bolts in the reverse order of assembling but do same as the cylinder head bolt removal.
- Disassemble the upper/lower of connecting rod caps by tapping lightly with urethane hammer, and remove the bearing.
- By pushing the connecting rod with wooden bar from the direction of oil pan toward cylinder head, disassemble the piston assembly.
- The disassembled piston assembly should be handled to prevent bumping each other, and stored as the cylinder's order.
- In order for connecting rod cap not to be swapped, temporarily assemble to the corresponding connecting rod.

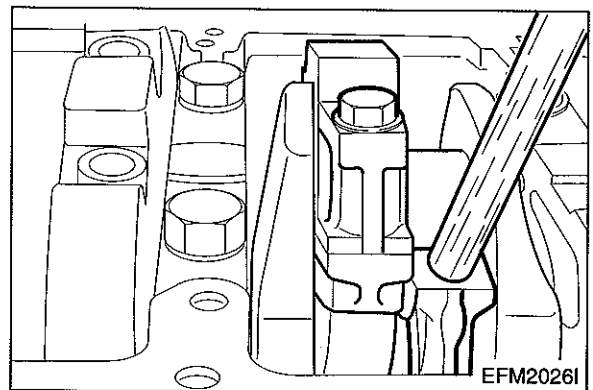

<Disassembly of piston>

-  (1) Remove the snap rings by means of a plier.

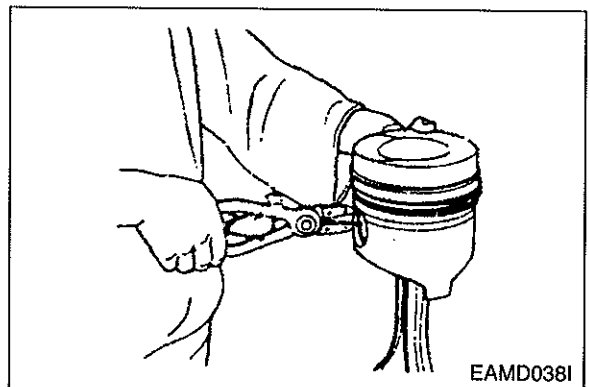

- (2) Heat the piston with a electric heater, then take out the piston pin from the piston as tapping it with a round wooden bar.

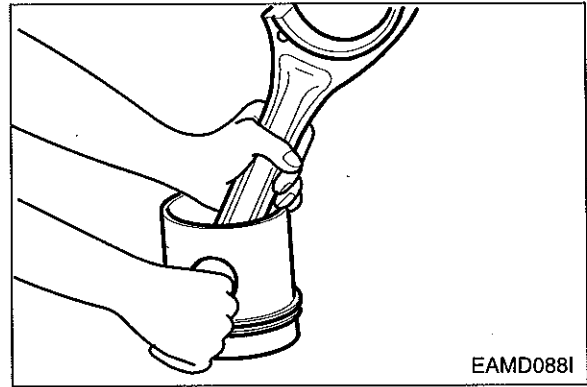

- (3) Remove the piston ring with a plier.



- (4) Clean the piston thoroughly.

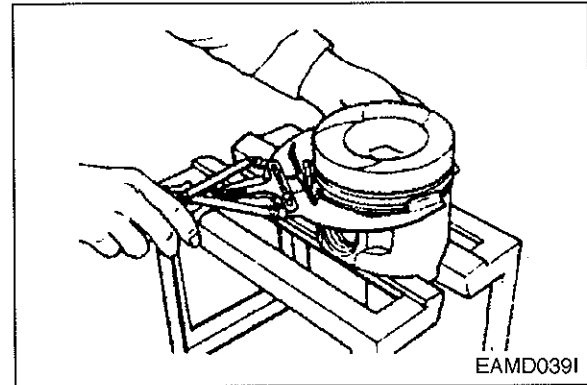

9.1.28. Cylinder liner



- Disassemble the cylinder liner with a special tool or hand but be careful not to generate any damage at cylinder block.

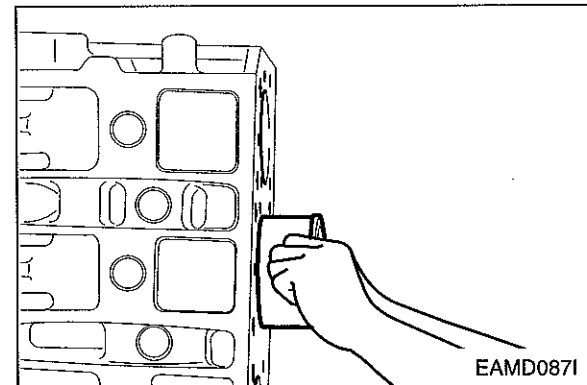

9.1.29. Gear and idle gear pin

- Remove the camshaft gear assembling bolts and disassemble the camshaft gear.

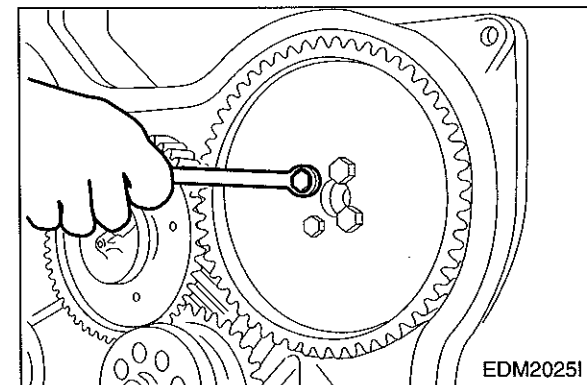

- Remove the idle gear assembling bolts and disassemble the idle gear pin.

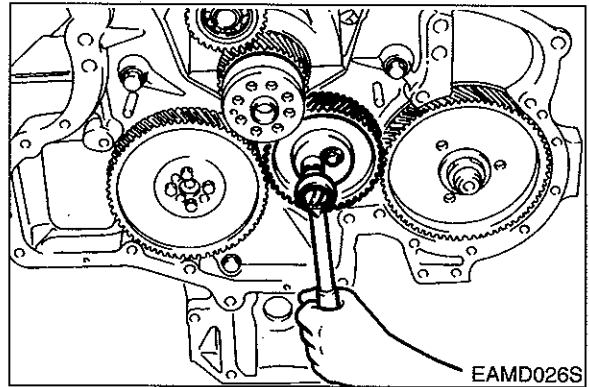

9.1.30. Fuel injection pump

- Disassembly the oil hose for lubrication.
- Remove the injection pump flange assembling nuts

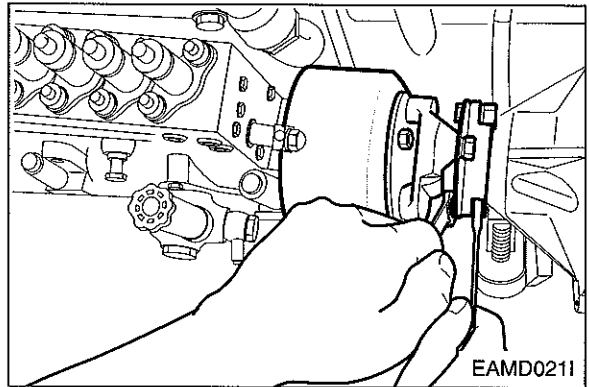

- Remove the bracket fixing bolts of injection pump, and disassemble by pulling the injection pump backward.

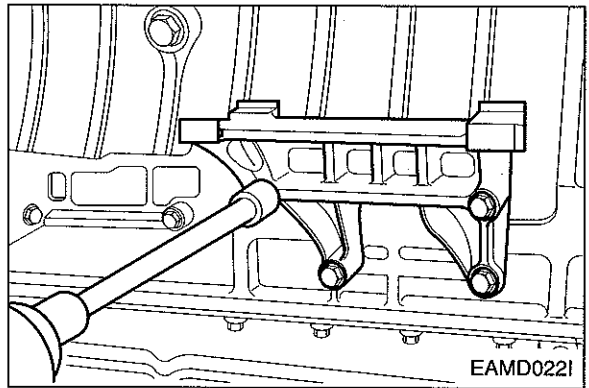

9.1.31. Water chamber cover

- Remove the assembling bolts and disassemble the water chamber cover.
- Remove the remnant gasket thoroughly.

9.1.32. Fly wheel

- Remove the flywheel assembling bolts and disassemble it.
- The bolt removal is done by the reverse order of assembling and by the steps.

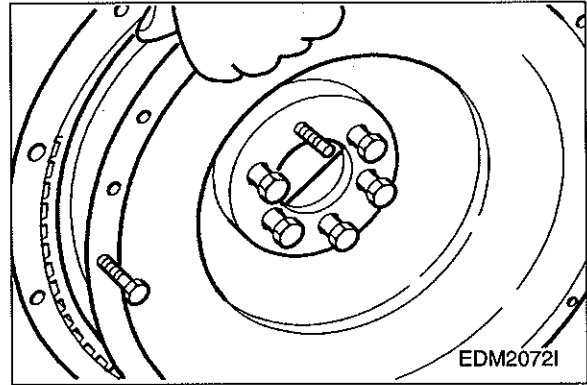

9.1.33. Fly wheel housing

- Remove the flywheel housing assembling bolts and disassemble the flywheel housing.
- Disassemble the oil seal of flywheel housing.

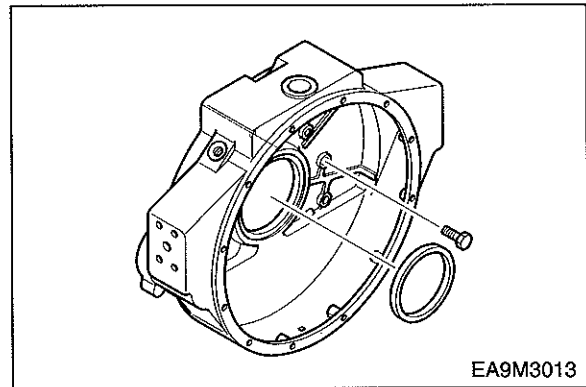

9.1.34. Injection pump drive gear

- Remove the assembling nuts of drive gear.
- Remove the drive gear housing assembling nuts and disassemble the gear assembly.

9.1.35. Timing gear case

- Remove the timing gear case assembling bolts.
- By tapping lightly with a urethane hammer the right and left back of timing gear case's connecting part, disassemble the timing gear case.

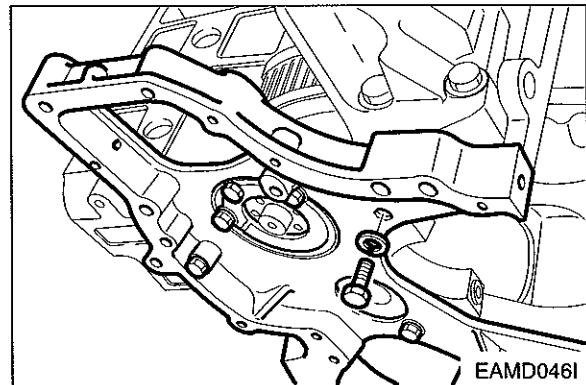

9.1.36. Bearing cap

- Remove the bearing cap assembling bolts by the step in the reverse order of assembling, and disassemble the bearing cap. (Remove by the same way as the cylinder head bolts' removal.)
- Disassembled bearing caps are kept laid in order.

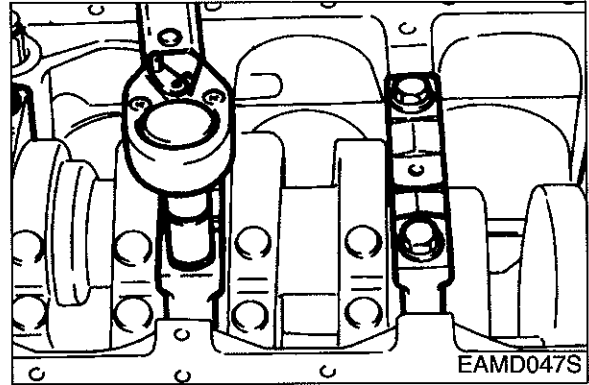

9.1.37. Crankshaft

- Assemble the bolts on the both side of crankshaft temporarily.
- Connect the rope to the bolts and lift the crankshaft by means of crane being careful not to give any damage on it.
- In order for the disassembled crankshaft to be prevented from bends or damage, put it on the special lathe and store.
- Disassemble the metal bearings in turn and store them.



Note : *Do not mingle with the metal bearings and bearing caps randomly. To prevent mixing, temporarily assemble the metal bearings to the corresponding bearing caps in turn.*

9.1.38. Camshaft and tappet

- In order for camshaft not to be damaged, disassemble turning it.
- In order for the disassembled camshaft to be prevented from bends or damage, put it on the special lathe and store.
- Pull out the tappet.
- As required, pull out the camshaft bush from the cylinder block by a press.

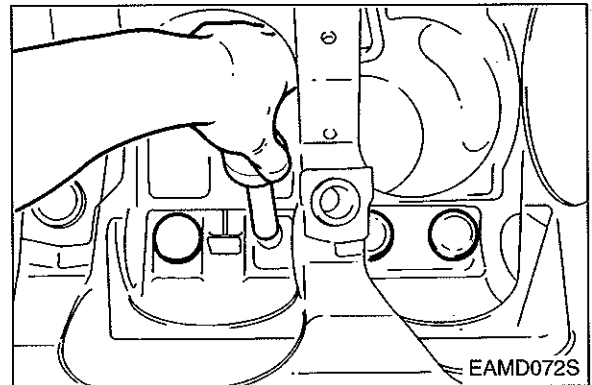

- Check for damage, scratch, and wearing state and if abnormal, tear down.

9.1.39. Oil spray nozzle (D1146T, P086TI only)

- Remove the valve screws of oil injection nozzle and disassemble it.

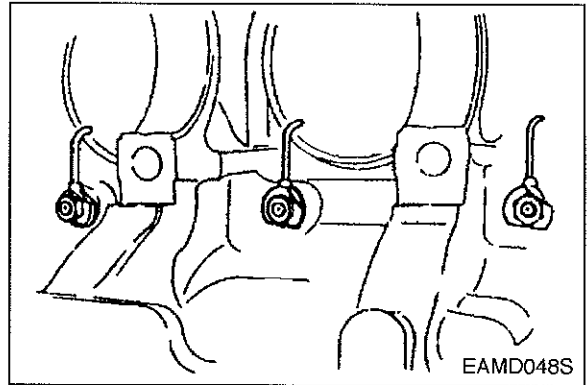

9.2. Inspection

9.2.1. Cylinder block



- Clean the cylinder block thoroughly, and check for any crack or damage.

- If there is any crack or severe damage, replace it and if there is minor one, correct it.



- Check for any clogging or corrosion in the oil passage and water passage.

- Carry out a leakage test for any crack or air leaking.

Hydraulic test :

Plug each cylinder block's water and oil discharge ports, and apply the air pressure of about 4kg/cm² to intake port and soak it in water for about 1 minute to check if there is any leakage. (Water temperature : 70°C)

9.2.2. Cylinder head

1) Cylinder head assembly disassembly

(1) Disassemble the cylinder assembly, and put it on the shelf for assembly or clean lathe.



Caution :

Prevent any damage to gasket's contact surface of the cylinder head.



(2) Disassemble the cotter pin, spring, spring seat pushing valve spring by a special tool.

(3) Pull out the intake and exhaust valves.

(4) The disassembled parts are kept laid in turn.

(5) Disassemble the valve stem seal.



(6) By means of the special tool, punch, pull out a valve guide.

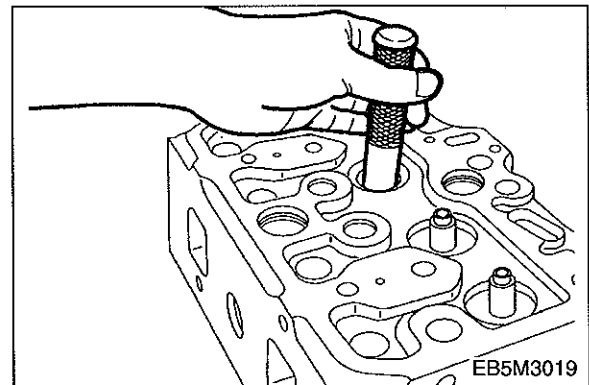
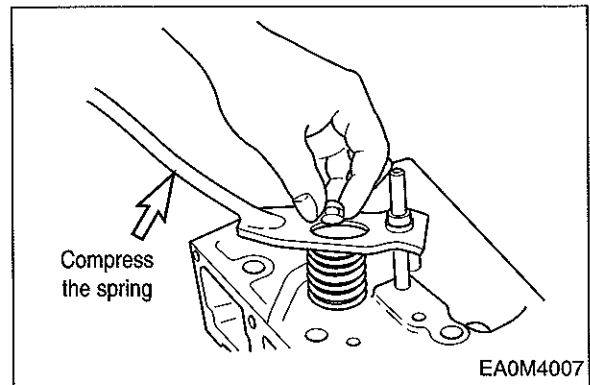

2) Inspection of cylinder head

(1) Check for the cylinder head.



- Remove carbon from the cylinder head lower surface, and then should be careful not to scratch the surface.



- Check any crack or damage that can not found by naked eyes through the hydraulic or magnetic particle test.

(2) Distortion of lower surface



- As shown in figure, measure the cylinder head's distortion at 6 directions with horizontal ruler and clearance gauge.
- If the measured value is beyond the limit value, correct it by means of the fine grinding paper or grinding machine.
- If it is beyond the max. allowable value, replace the cylinder head

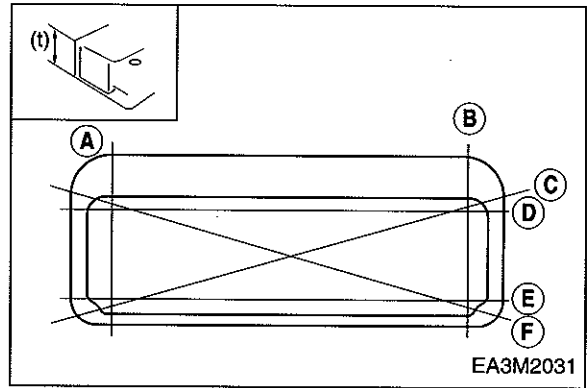

<Lower face warp and height>

	Standard	Limit
Warp	0.2 mm or less	0.3 mm
Thickness : t (reference)	109.9 ~ 110.1 mm	108.4 mm

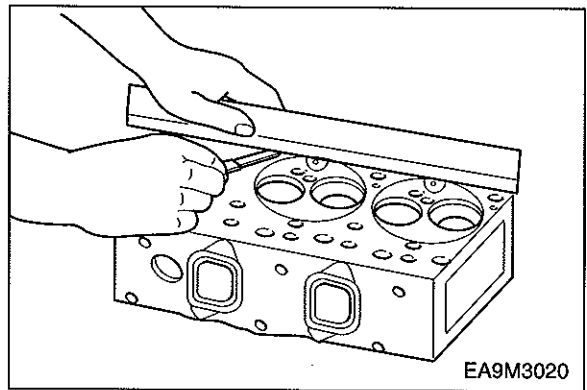

(3) Flatness



Check the flatness of the installing surface of cylinder head's intake and exhaust manifolds with horizontal ruler and clearance gauge.

Standard	Limit
0.05 mm	0.2 mm

(4) The hydraulic test



The hydraulic test of cylinder head is same as the cylinder block test.

3) Inspection of valve and valve guide

(1) Valve



After cleaning valve with fuel, check it.



● Valve stem outer diameter

Measure the valve stem outer diameter at 3 positions (top, middle, and bottom), and check for any wear and if beyond the limit value, replace the valve.

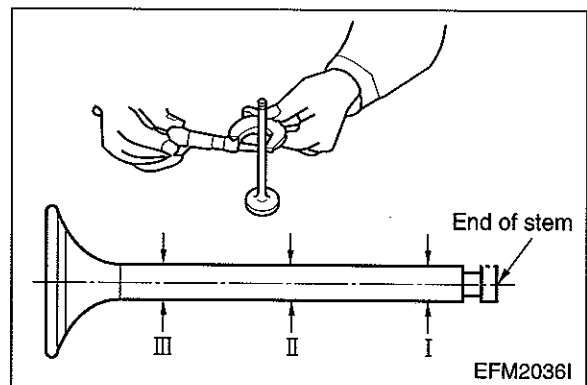

Dimension Description	Standard	Limit
Intake valve stem	$\phi 8.950 \sim \phi 8.970$ mm	$\phi 8.93$ mm
Exhaust valve stem	$\phi 8.935 \sim \phi 8.955$ mm	$\phi 8.91$ mm



● **Valve seat contacting faces**

Check the valve seat contact surface for any crack and wear, and if necessary, correct with grinding paper, and if excessive, replace it.



● **Valve head thickness**

Measure the thickness of valve head and if beyond the limit value, replace the valve.

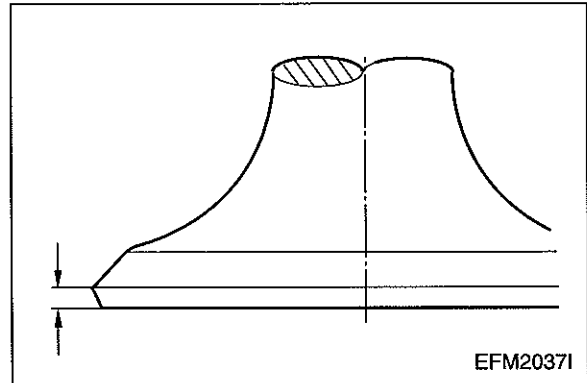

Dimension Description	Standard	Limit
Intake valve	2.7 mm	1 mm or less
Exhaust valve	2.2 mm	1 mm or less

(2) Valve guide

- Insert a valve into cylinder head and measure the clearance between valve guide and valve by valve movement. If the clearance is excessive, measure the valve and replace the excessively worn valve or valve guide.

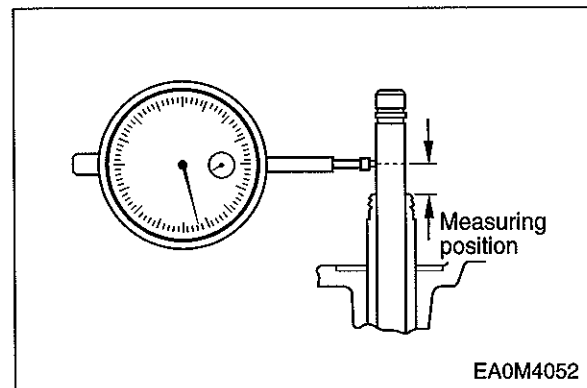

<Valve stem end play>

	Standard	Limit
Intake valve	0.04 ~ 0.07 mm	0.2 mm
Exhaust valve	0.06 ~ 0.09 mm	0.25 mm



- Assemble the valve at cylinder head's valve guide and see if it is centered with the valve seat using a special tool.



(3) Valve seat



● Contacting face amount

As for the valve seat's wear, measure the width of the contact surface with intake valve seat and exhaust valve seat. If beyond the limit value, replace the valve seat.

- Assemble the valve at the valve seat of the cylinder head, and check the amount of depression of the valve from the lower portion of the cylinder head using a dial gauge.

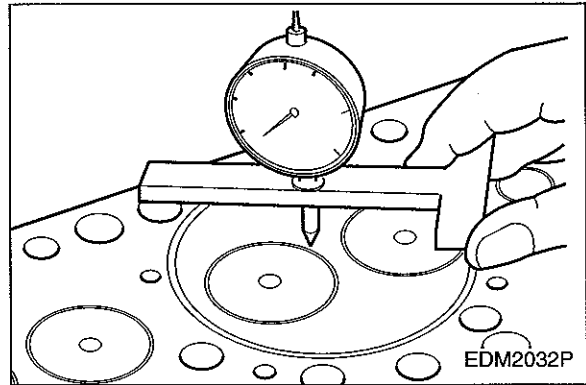

<Valve depression>

	Standard	Limit
Intake & Exhaust	0 ~ 0.3 mm	0.55 mm

If the amount of depression is beyond the specified limit, replace the valve seat.

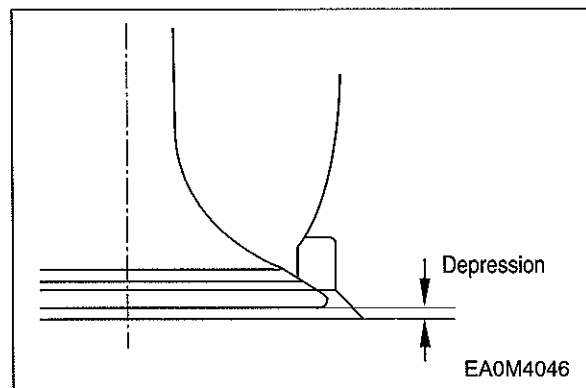

- For the disassembling of valve seat, by welding the welding bead to a valve seat rotating tool or valve seat, pull it out with a special tool.

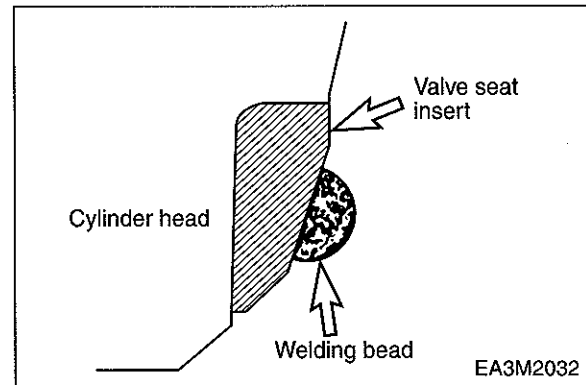

- For the assembling of a new valve seat, by putting it among the dry ices of an ice box previously for about 2 hours for the cold shrinkage, and press it in the cylinder head by a special tool. (bench press)
- Apply valve lapping compound to the valve head seating face on the valve seat and lap the valve seat by turning it until it is seated in position, then wipe out the lapping compound.



(4) Valve spring

● Visual check

Check the appearance of valve spring and if necessary replace the spring.



● Valve spring free length

Use a vernier caliper to measure the valve spring free length.

If the measured value is less than the specified limit, the valve spring must be replaced.

Spring free Length		Standard
Intake valve		64 mm
Exhaust valve	Inner	60 mm
	Outer	71 mm

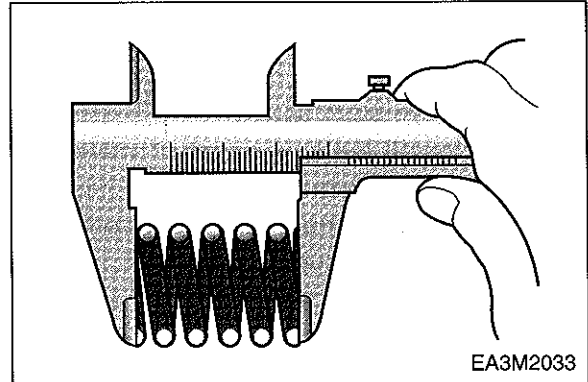

EA3M2033



● Valve spring inclination

Use a surface plate and a square to measure the valve spring inclination.

If the measured value exceeds the specified limit, the valve spring must be replaced.

(unit : mm)	Standard	Limit
Valve Spring Inclination	less than 1.8 mm	2.7 mm

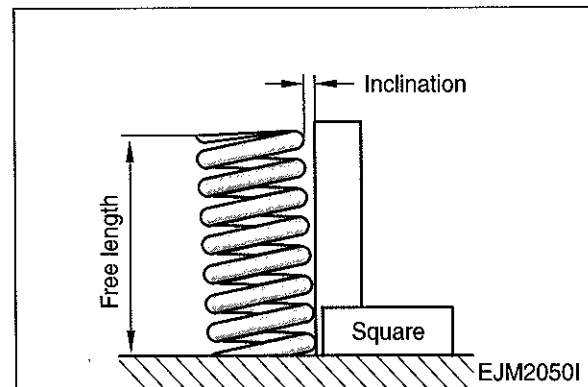

EJM20501



● Valve spring tension

Use a spring tester to measure the valve spring tension if the measured value is less than the specified limit, the valve spring must be replaced.

	Set Length		Spring force	Limit
Intake valve	Valve Spring Tension at 41mm Set Length		70 kg	± 3kg
Exhaust valve	Inner	38 mm	28.6 kg	± 6 %
	Outer	41 mm	66 kg	± 5 %

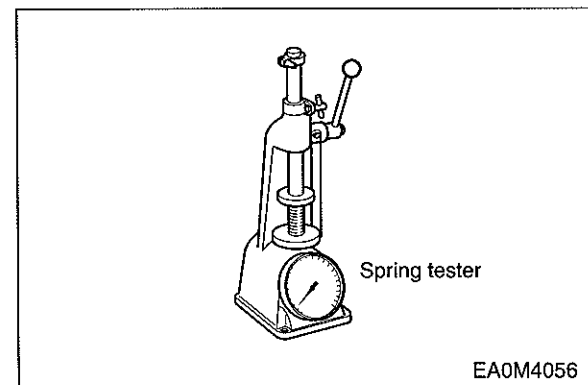

Spring tester

EA0M4056



(5) Assembling cylinder head



- Clean the cylinder head thoroughly.
- Replace the valve stem seal with new one, and by means of a special tool, press the stem seal into the valve guide of cylinder head.
- Coat engine oil to valve stem and valve guide and assemble the valve. However, be careful for the damage of valve stem seal.
- Install the lower seat of valve spring to the valve guide of cylinder head.
- After putting inner, outer springs, install the spring upper seat on it.
- Assemble the valve by inserting the valve cotter pressing the valve spring with a special tool.
- After installing the valve, check whether the valve is correctly installed or not tapping it lightly with urethane hammer.

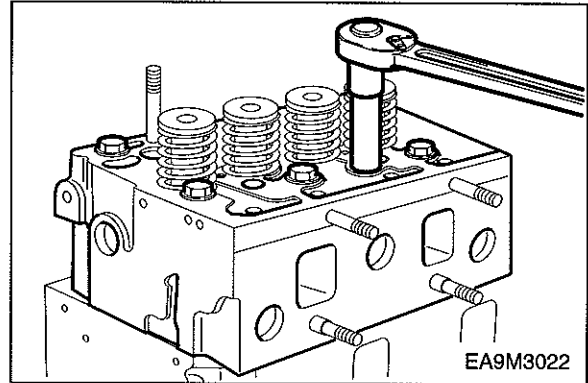

9.2.3. Rocker arm assembly

1) Disassembly

- (1) Disassemble the snap rings that are located at both ends of rocker arm shaft by a plier.
- (2) Disassemble in the order of washer, rocker arm bracket, rocker arm spring, rocker arm.

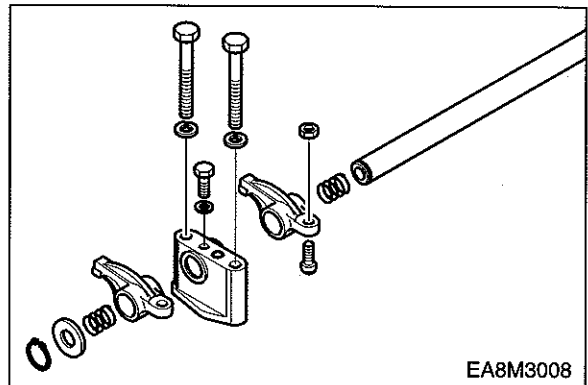

2) Inspection of rocker arm assembly

(1) Rocker arm shaft



● Rocker arm shaft run-out

Place the rocker arm shaft on two V blocks and inspect the shaft for bend using a dial gauge.

If the amount of this run-out is small, press the shaft with a bench press to correct the run-out. Replace the shaft if the measured value exceeds the limit.

Limit	0.2 mm
--------------	--------

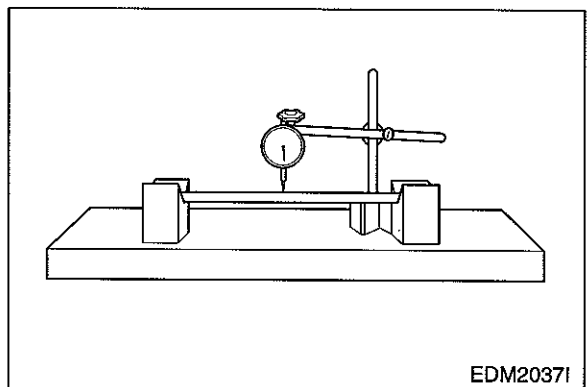



● **Rocker arm shaft diameter**

With an outside micrometer, measure the rocker arm shaft diameter at the point where the rocker arms have been installed. Replace the rocker arm if the amount of wear is beyond the specified limit.

Standard	Limit
∅23.978 ~ ∅23.959 mm	∅23.75 mm

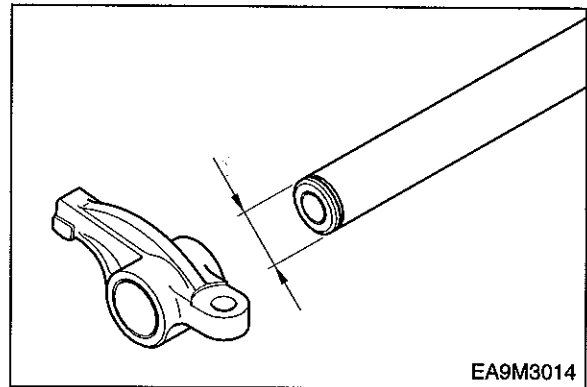

2) **Rocker arm**



● **Visual check**

Visually check the face of the rocker arm in contact with the valve stem end for scores and step wear. If the wear is small, correct it with an oil stone or grinding paper of fine grain size. Rocker arm with a considerable amount of step wear should be replaced.



● **Rocker arm bushing diameter**

Measure the inside diameter of the rocker arm bushing with an inside micrometer or vernier calipers, and compare the measured values with the rocker arm shaft diameter. If the clearance exceeds the limit, replace either bushing or shaft, whichever worn more.

Standard	Limit
0.020 ~ 0.093 mm	0.3 mm or less

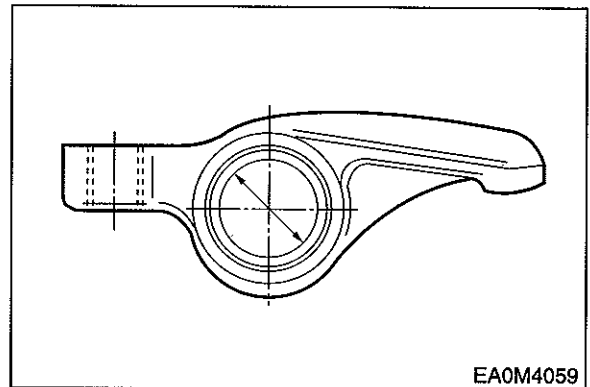

3) **Tappet and push rod**



● **Clearance**

Measure the clearance of the tappet and tappet holes of the cylinder block. If the value is beyond the specified limit, replace tappets.

Standard	Limit
0.035 ~ 0.077 mm	0.15 mm



● **Visual check of tappet**

Visually check the face of the tappets in contact with the cam for pitting, scores or cracks, and replace if severely damaged. If the amount of cracks or pitting is small, correct with an oil stone or grinding paper.

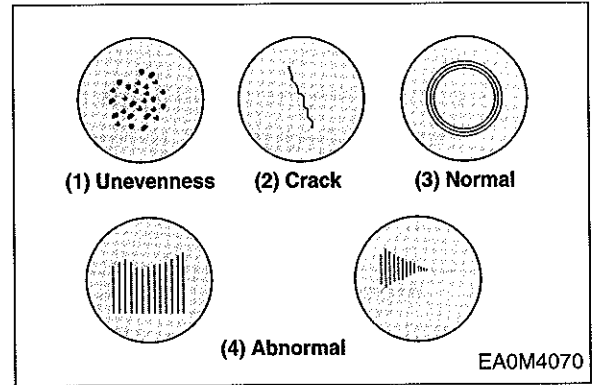

● **Outside diameter of tappet**

With an outside micrometer, measure the tappet outside diameter. If the measured value is beyond the limit, replace tappets.

Standard	$\phi 19.944 \sim \phi 19.965 \text{ mm}$
-----------------	---

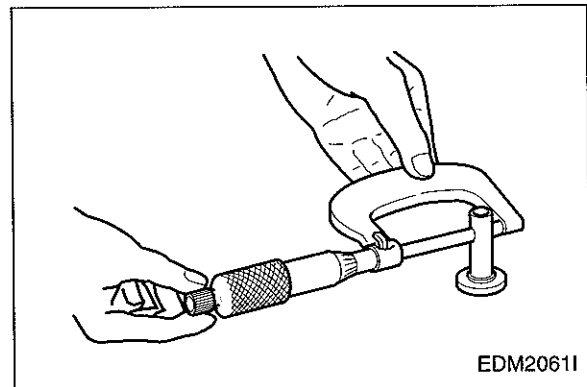

● **Push rod run-out**

Limit	0.3 mm or less
--------------	----------------

Use a feeler gauge to measure the push rod run-out.

Roll the push rod along a smooth flat surface as shown in the figure.

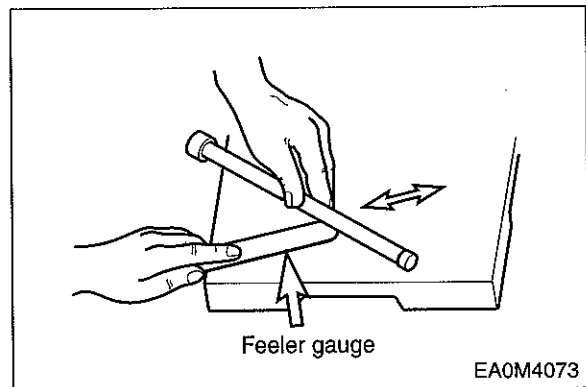

4) Reassembling rocker arm assembly

Reassembling can be done in the reverse order of disassembling and following things should be heeded

- Check the oil supply hole of rocker arm shaft for any clog and clean thoroughly.
- Be careful not to occur any swap of position and reverse assembly.

9.2.4. Camshaft

1) Camshaft End play



- Push the thrust plate toward the cam gear.
- With a feeler gauge, measure the clearance between the thrust plate and camshaft journal.
- If the end play is excessive, replace the thrust plate.

Standard	Limit
0.28 ~ 0.43 mm	0.6 mm

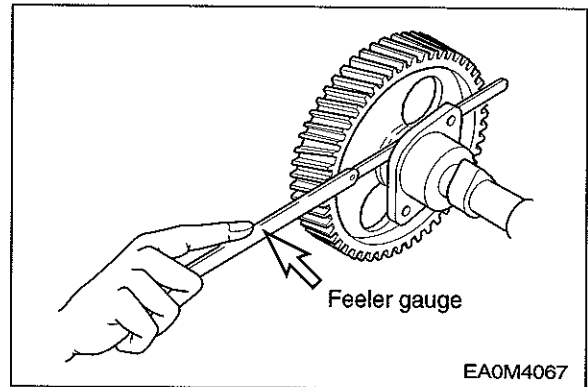

2) Cam



- Cam lobe height

	Standard	Limit
Cam journal diameter (A,B)	$\phi 57.86 \sim \phi 57.88$ mm	$\phi 57.52$ mm

Use a micrometer to measure the cam lobe height and journal diameter. If the measured number is less than the specified limit, the camshaft must be replaced.

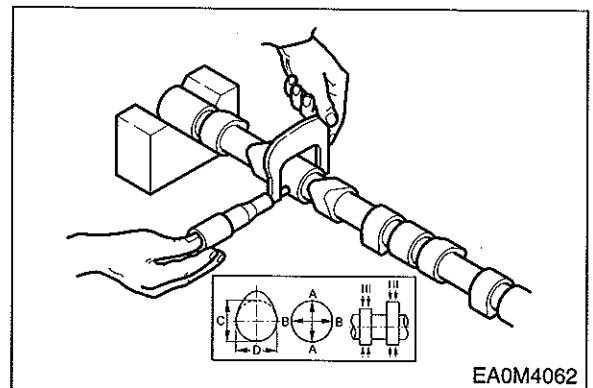

- **Cam surface**

Inspect the cam face for scratch or damage.

Slight step wear or damage on the cam face may be corrected with oil stone or oiled grinding paper. But, replace if severely damaged.

3) Cam shaft



- **Clearance**

between camshaft journal and camshaft bush

- With an outside micrometer, measure the camshaft journal diameter.
- Measure the inside diameter of the camshaft bushing on the cylinder block using a cylinder bore indicator, and compare the measured value with the camshaft outside diameter to determine the clearance.

<Clearance>

Standard	Limit
0.12 ~ 0.17 mm	0.24 mm

Replace the bushing if the measured value is beyond the specified limit.

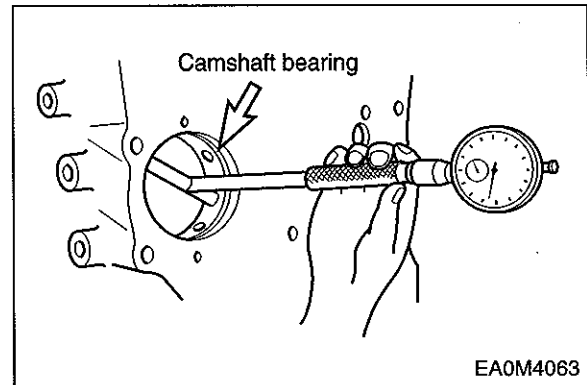

● Run-out

Support the camshaft on two V blocks and check for run-out using a dial indicator. Correct or replace the cam shaft if the amount of run-out is beyond the value indicating need for servicing.

Standard	Limit
0.05 mm	0.2 mm

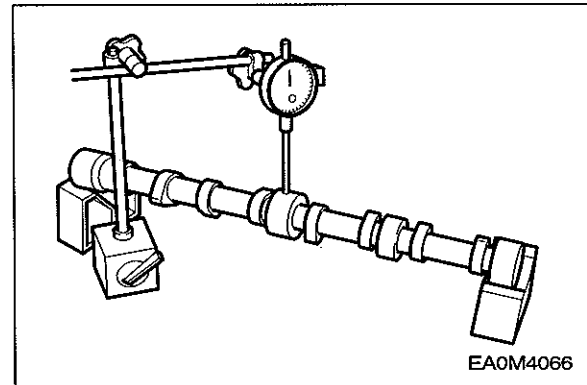

9.2.5. Crankshaft

1) Inspection of crankshaft

(1) Defect check



- By naked eyes, check for any scratch or damage on the crankshaft journal and crank pin.
- By means of magnetic particle test and color check, check the crankshaft for any crack and if found, replace it.

(2) Wear measuring



- With an outside micrometer measure the diameter of the crankshaft journals and pins in the directions as shown, and compare the measured values to determine the amount of wear.

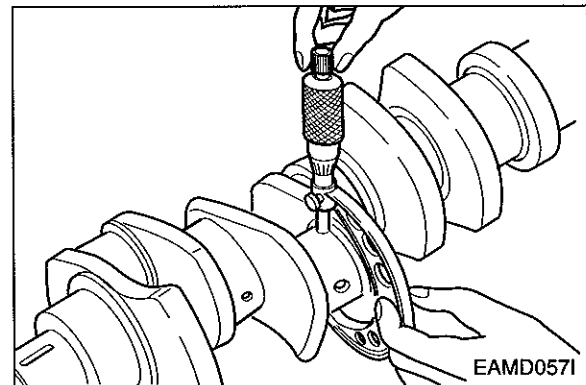

- If the amount of wear is beyond the limit, have the crankshaft ground and install undersize bearings. However, if the amount of wear is within the limit, you can correct the wear using an oil stone or oiled grinding paper of fine grain size. (Be sure to use grinding paper which has been immersed in oil.)

	Standard	Limit
Journal diameter	$\phi 83.966 \sim \phi 83.988$ mm	$\phi 83.000$ mm
Pin diameter	$\phi 70.971 \sim \phi 70.990$ mm	$\phi 70.000$ mm

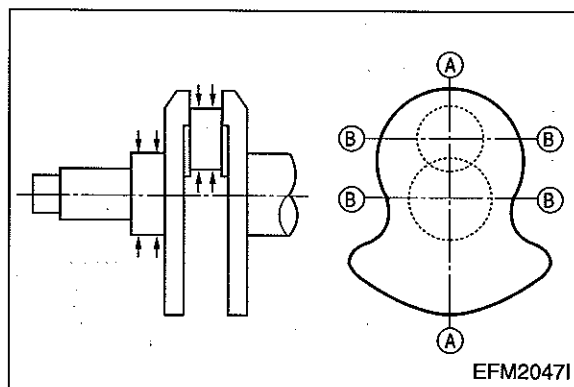

- In case that pin's wear is more than the limit value, grind the crankshaft journal and crank pin, and use the undersized bearings.



Be sure to use grinding paper which has been immersed in oil.

* Standard values of 'R'

- ① Crank Pin 'R' : $4.5_{-0.2}^0$
- ② Crank journal 'R' : $4_{-0.2}^0$

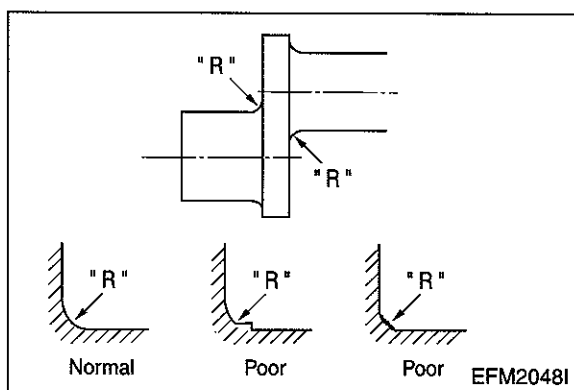

<Undersize bearings available>

- Standard
- 0.25 (Inside diameter is 0.25 mm lesser than the standard size.)
- 0.50 (Inside diameter is 0.50 mm lesser than the standard size.)
- 0.75 (Inside diameter is 0.75 mm lesser than the standard size.)
- 1.00 (Inside diameter is 1.00 mm lesser than the standard size.)

Undersize bearings are available in 4 different sizes as indicated above, and the crankshaft can be reused through the regrinding as described above.



Caution : In case of regrinding, the grinding the "R" part of bearing end should be correctly done and keep in mind to remove any jaws or coarse surface absolutely.

(3) Crankshaft run-out

- Support the crankshaft on V blocks.



- Turn the crankshaft with a dial indicator placed on the surface plate and take the amount of crankshaft run-out.

Standard	Limit
0.05 mm	0.1 mm

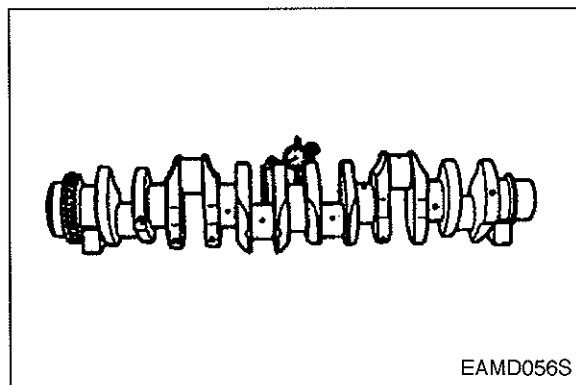

2) Crankshaft bearing and connecting rod

(1) Visual check



Visually check the crankshaft bearing and connecting rod bearing for scores, uneven wear or damage.

(2a) Oil clearance between crankshaft and bearing (Method 1 : dial gauge)

- Main bearing clearance



Install the main bearing in the cylinder block, tighten the bearing cap to specified torque, then measure the inside diameter.



Torque	30 kg-m
Crank journal diameter	83.966 ~ 83.988mm

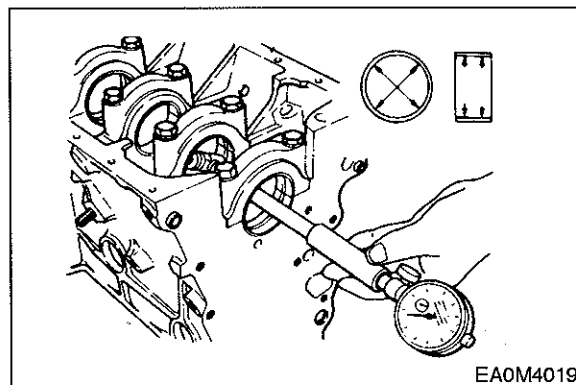

Compare the two values obtained through measurement of main bearing inside diameter with the outside diameters of crankshaft journals to determine the oil clearance.

<Main bearing oil clearance>

Standard	Limit
0.052 ~ 0.122 mm	0.25 mm



● **Connecting rod bearing clearance**



Install the connecting rod bearing in the connecting rod bearing cap, tighten the connecting rod cap bolts to the specified torque, then measure the inside diameter.

Torque	18 kg·m
Crank pin diameter	70.791 ~ 70.990 mm

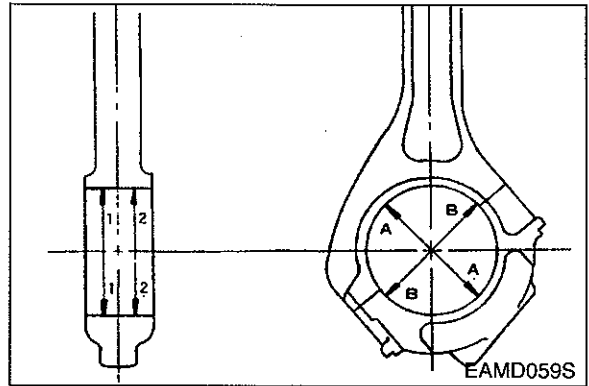

Compare the two values obtained through measurement of connecting rod bearing inside diameter with the outside diameters of crankshaft pins to determine the oil clearance.

Standard	Limit
0.034 ~ 0.098 mm	0.25 mm

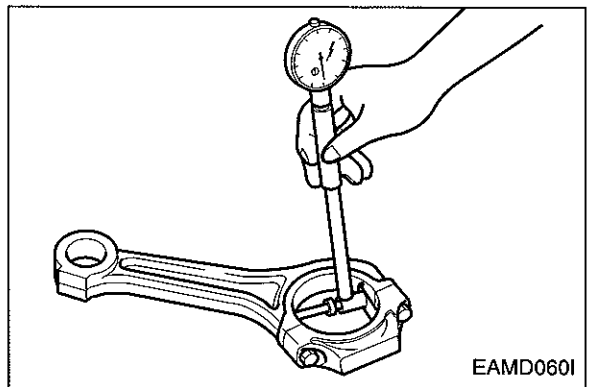

- If the clearance deviates from the specified range, have the crankshaft journals and pins ground and install undersize bearings.

**(2b) Oil clearance between crankshaft and bearing
(Method 2 : plastic gauge)**



- Assemble the crankshaft on the cylinder block and put plastic gauge on the journal and pin of crankshaft and then after assembling bearing cap, tighten the bolts at the specific torque. Again after disassembling the bearing cap by removing the bolts, take out the flatted plastic gauge and measure the width of plastic gauge by means of plastic gauge measuring scale. This is the oil clearance.

- The oil clearance too can be measured in the same manner.

3) Bearing spread and crush



● Inspection

Check to see that the bearing requires a considerable amount of finger pressure at reassembly operation.

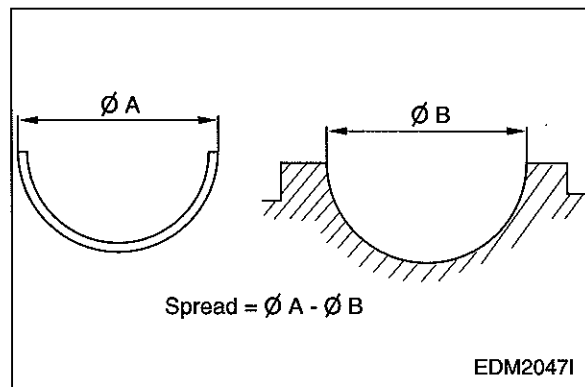
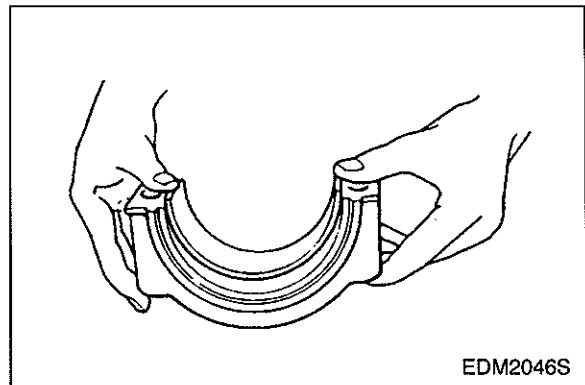

● Crankshaft bearing crush

Install the bearing and cap in the cylinder block, retighten the bolts to specified torque, unscrew out one bolt completely, then measure the clearance between the bearing cap and cylinder block using a feeler gauge.

Standard	0.19 ~ 0.22 mm
-----------------	----------------

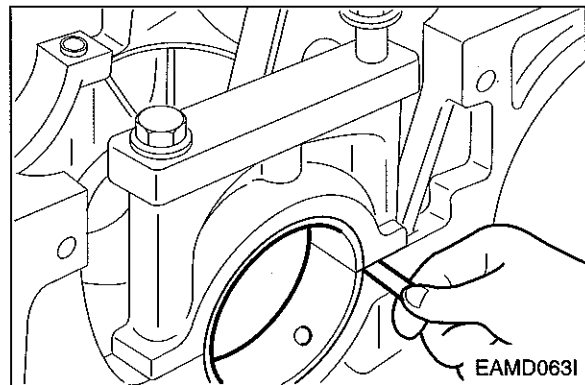



● Connecting rod bearing crush

Install the bearing and cap in the connecting rod big end, retighten the bolts to specified torque, unscrew out one bolt completely, then measure the clearance between the bearing cap and connecting rod big end using a feeler gauge.

Standard	0.3 ~ 0.5 mm
-----------------	--------------

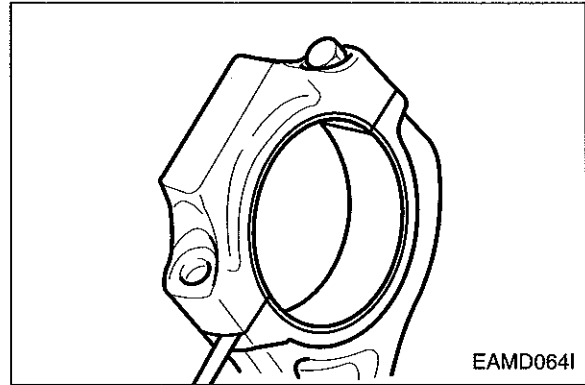

4) Crank shaft end play

● Assemble the crankshaft to the cylinder block.



● With a dial gauge, measure crankshaft end play.

Standard	Limit
0.15 ~ 0.325 mm	0.5 mm

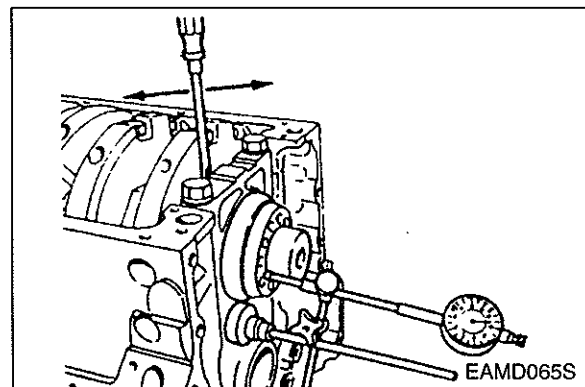

9.2.6. Piston assembly

1) Disassembly of piston assembly

Disassemble piston according to the disassembly process of "3.1.28. Piston".

2) Piston inspection

(1) Visual check



Visually check the pistons for cracks, scuff or wear, paying particular attention to the ring groove.

(2) Clearance between the piston and cylinder liner



● With an outside micrometer, measure the piston outside diameter at a point 13mm away from the lower end of piston skirt in a direction at a right angle to the piston pin hole.

Standard	$\phi 110.833 \sim \phi 110.897$ mm
-----------------	-------------------------------------

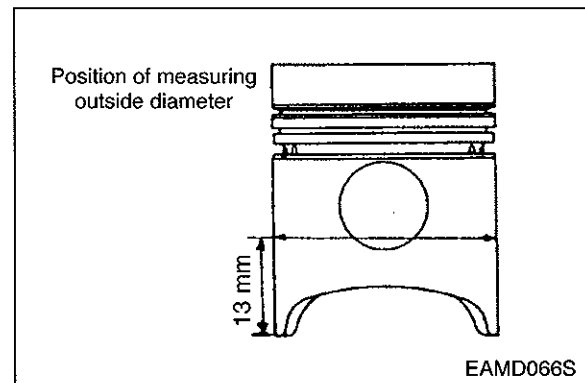



- Using a cylinder bore gauge, measure cylinder liner inside diameter at 3 points (cylinder top ring contacting face, middle, and oil ring contacting face on BDC) in a direction at an angle of 45°. Take the mean value with the largest and smallest values excepted.

Standard	Limit
$\phi 111 \sim \phi 111.022 \text{ mm}$	$\phi 111.122 \text{ mm}$

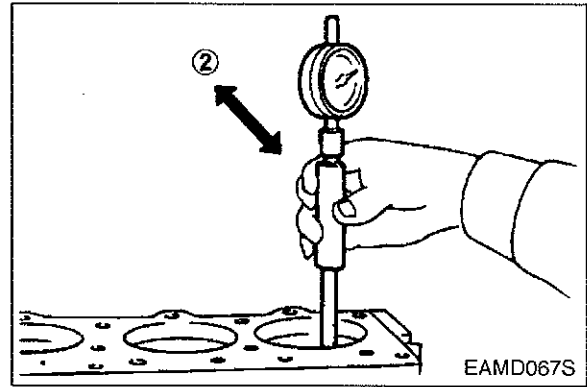

- The clearance is computed by subtracting the piston outside diameter from the cylinder liner inside diameter. Replace either piston or cylinder liner, whichever damaged more, if the clearance is beyond the specified limit.

<Clearance between piston and liner>

Standard	0.103 ~ 0.139 mm
----------	------------------

3) Piston rings

(1) Visual check



- Replace the piston rings with new ones if detected worn or broken when the engine is overhauled.

(2) Piston ring gap

- Insert the piston ring into the upper portion of the cylinder liner bore so that it is held at a right angle to the cylinder liner wall.



- Measure the piston ring gap with a feeler gauge.

	Standard	Limit
Top ring	0.40 ~ 0.60 mm	1.5 mm
2nd ring	0.40 ~ 0.60 mm	1.5 mm
Oil ring	0.30 ~ 0.50 mm	1.5 mm

Replace piston rings with new ones if the gap is beyond the limit.

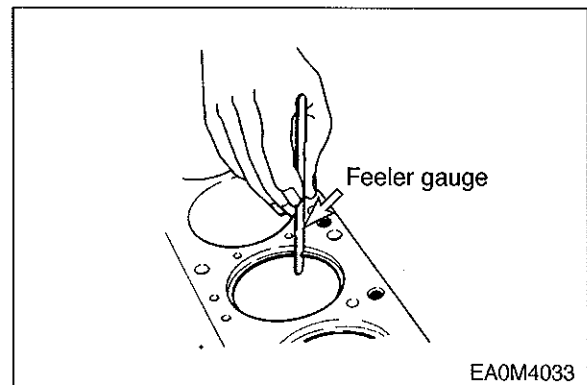

(3) Piston ring side clearance

- Fit the compression ring and oil ring in the piston ring groove.
- With a feeler gauge, measure side clearance of each ring, and replace either the ring or piston if the measured value is beyond the specified limit.



	Standard	Limit
Top ring	-	-
2nd ring	0.07 ~ 0.102 mm	0.15 mm
Oil ring	0.05 ~ 0.085 mm	0.15 mm

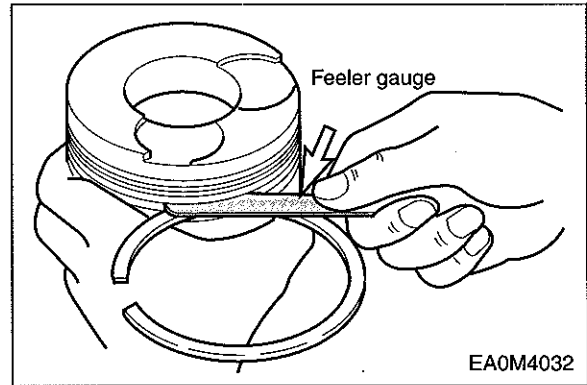

(4) Piston ring tension

- With a tension tester, measure piston ring tension. Replace the piston ring if the measured value is beyond the limit.



	Standard
Top ring	2.58 ~ 3.88 kg
2nd ring	1.81 ~ 2.71 kg
Oil ring	3.57 ~ 5.03 kg

4) Piston pin inspection

(1) Wear

- Measure the amount of wear on the piston pin at the points as shown. The measured values are beyond the limit (0.08 mm or greater), replace the pin.



Standard	Limit
ø41.994 ~ ø42.000 mm	ø41.940 mm

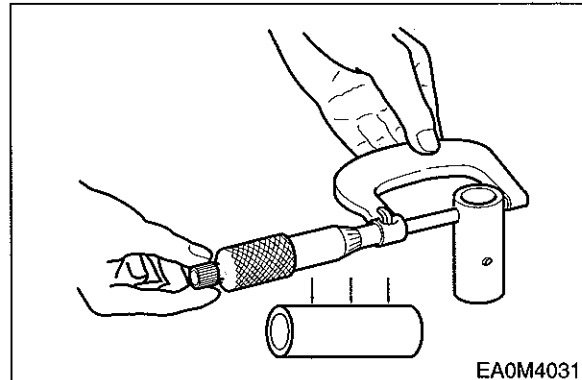

(2) Clearance



Measure the clearance between the piston pin and connecting rod bushing, and replace either of them, whichever damaged more, if the measured value is beyond the limit.

Standard	Limit
0.009 ~ 0.015 mm	0.08 mm

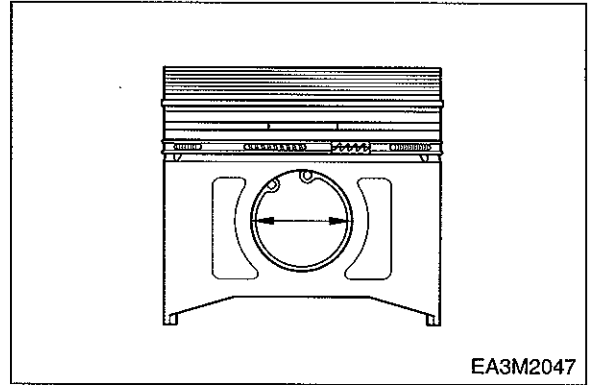

(3) Condition check



Check the engaged condition of the piston and piston pin. If it is possible to force the pin into the piston heated with piston heater, the piston is normal. When replacing the piston, be sure to replace the piston pin together.

5) Connecting rod inspection

(1) Distorsion



Check the connecting rod for distortion. As shown in the figure below, install the connecting rod to the connecting rod tester, and check for distortion using a feeler gauge. If the connecting rod is found distorted, never re-use it but replace with a new one.

(2) Holes alignment (parallelism)



Measure the alignment of the connecting rod piston pin bushing holes with connecting rod big end holes. At this time also, use both connecting rod tester and feeler gauge.

Standard	Limit
0.05 mm	0.1 mm or less

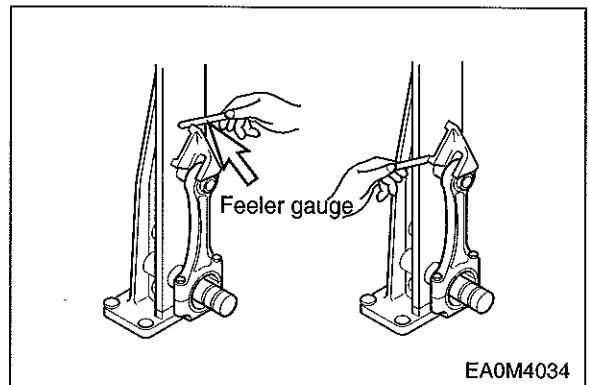

(3) Wear



- Assemble the connecting rod to the crankshaft and measure connecting rod big end side clearance using a feeler gauge.
- Assemble the connecting rod to the piston and measure connecting rod small end side clearance.
- If the measured values are beyond the limit, replace the connecting rod.

Limit	0.5 mm

9.3. Reassembly

9.3.1. General precautions

- Clean all the disassembled parts, particularly oil and water ports, using compressed air, then check that they are free from restrictions.
- Arrange the general and special tools in order for engine assembly operation.
- To wet each sliding part, prepare the clean engine oil.
- Prepare service materials such as sealant, gaskets, etc.
- Discard used gaskets, seal rings, and consumable parts, and replace with new ones.
- Apply only the specified torque for bolts in the specified tightening order and avoid over-tightening.
- Be sure to check that all the engine parts operate smoothly after being reassembled.
- Check the bolts for looseness after reassembly.
- After completing the engine reassembly operation, check if there is missing parts or shortage of parts.
- Keep your hands clean during the working.

9.3.2. Cylinder block

Cover the floor of the workshop with wood plate or thick paper to prevent damage to the cylinder head and place the cylinder block with the head fitting surface facing downward.

9.3.3. Oil spray nozzle (for D1146T/PU086T/ P086TI)



Tighten and assemble the oil spray nozzle flange with fixing bolts using the spray nozzle jig.

Torque	8 kg-m
---------------	--------

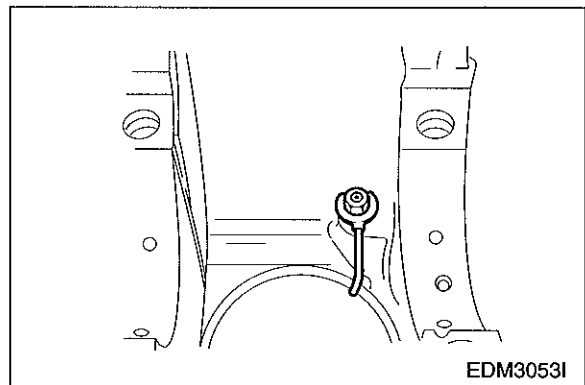

9.3.4. Tappet and cam shaft



- Undercool a new bush with dry ice for about 2 hours and press it into position in the cylinder block using a bench press. After the pressing operation, measure the inside diameter of the cam bush to check if it is not deformed.



- Apply engine oil to the entire face of the tappets and slide them into the tappet holes on the cylinder block.

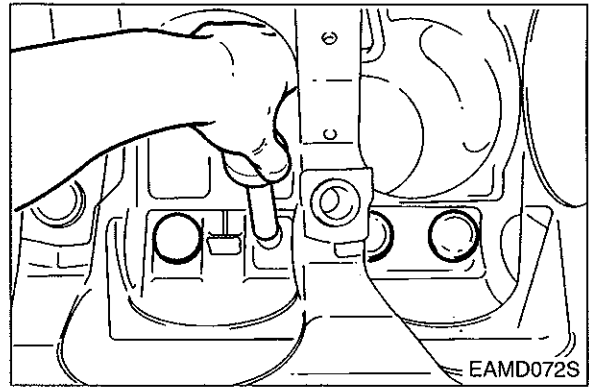

- Wet the cam bush inside diameter and camshaft with oil, and carefully assemble them while turning the camshaft.



Caution :

Be careful not to generate a damage to camshaft and bush.



- Check to see that the camshaft rotates smoothly.

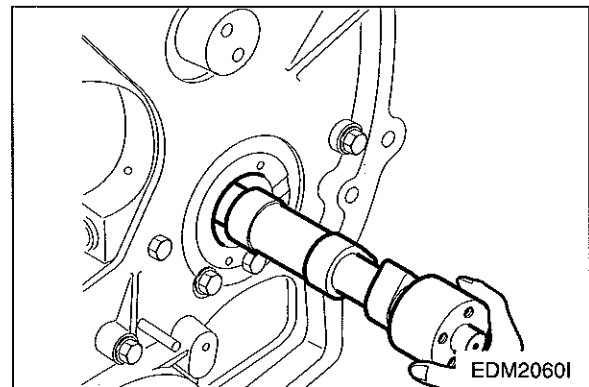

9.3.5. Crankshaft



- Install the main bearing (refer to assemble sequence : right figure) machined with two holes in the cylinder block so that the key is aligned with the key groove, then apply oil to the bearing surface.

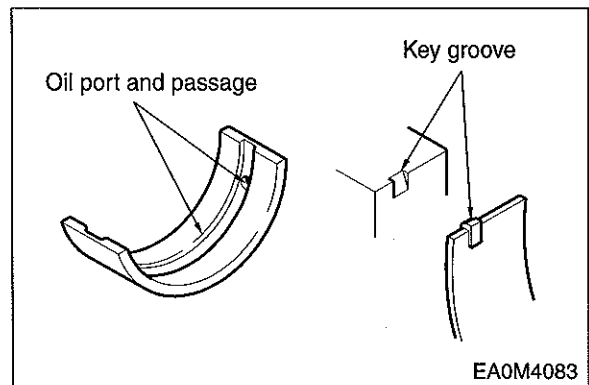
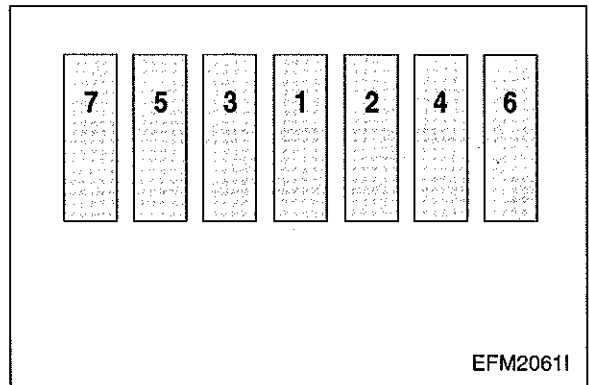

- Heat the crankshaft gear for at least 10 minutes to 120°C, then apply sealant (Loctite # 641) to the inside wall of the heated crankshaft gear evenly before inserting it to the end of crankshaft.

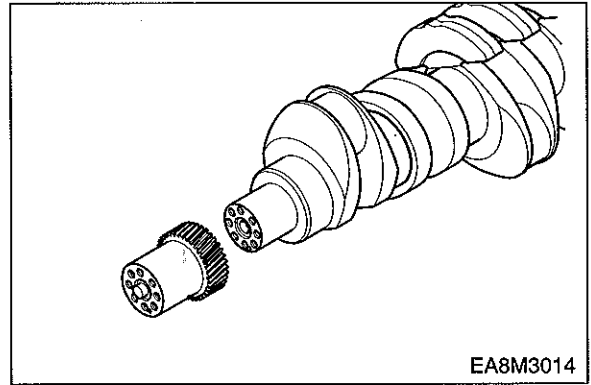

- Semi-tighten a bolt at both sides of the crankshaft, apply engine oil to journals and pins, then assemble the crankshaft with the cylinder block by tightening the fixing bolts.



Caution :

Coat engine oil to the pin and journal of crankshaft.

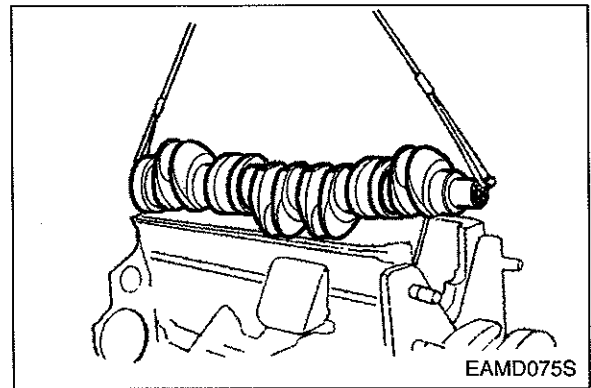

- Install the oiled thrust washers with the oil groove facing outward.

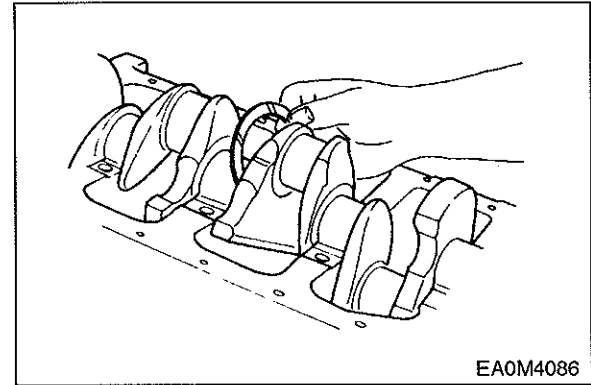

- Install the bearing and thrust washers to the bearing cap and apply oil to the bearing and thrust washers.

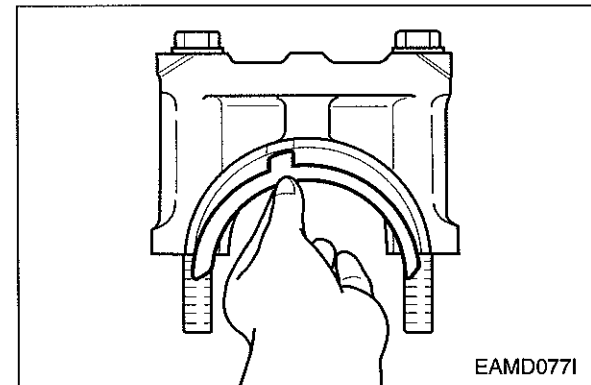



- Install the bearing cap by matching the cylinder block No. with the bearing cap No.

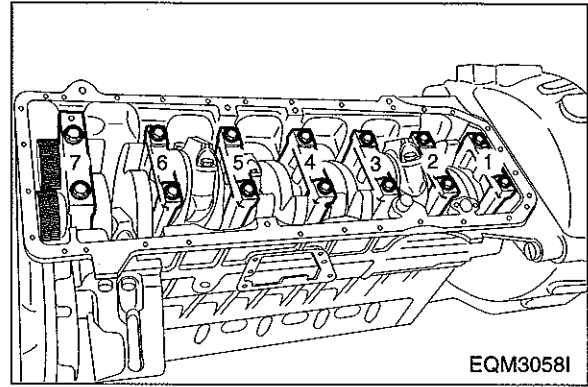

- Apply oil to the entire part of the bearing cap bolts, then tighten in tightening sequence to specified torque.



Torque	30 kg·m
---------------	---------



- After semi-tightening both bolts evenly, tighten them diagonally to the specified torque using a torque wrench as follows.

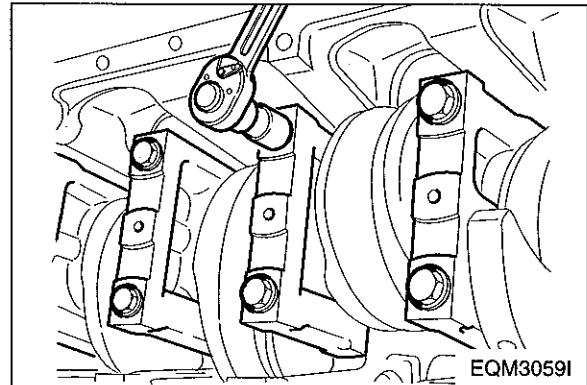

<Tightening order>

- (1) First stage : Coat engine oil over bolts.
 - (2) Second stage : Temporary bolt screwing about 1 ~ 2 threads
 - (3) Third stage : With impact wrench, tighten up to about 15 kg·m
 - (4) Fourth stage : With torque wrench, tighten up to about 25 kg·m
 - (5) Fifth stage : By means of torque wrench, tighten finally in the specified torque. (30 kg·m).
- Tighten the bearing cap in the sequence of 4-3-5-2-6-1-7.
 - Check to see that the assembled crankshaft turns smoothly.



9.3.6. Flywheel housing

- Temporarily install the guide bar on the cylinder block.
- Apply gasket to the cylinder block.
- Using the dowel pin and guide bar, install the flywheel housing and tighten the fixing bolts in a diagonal sequence to specified torque. (Zigzag method)



Torque	8 kg·m
---------------	--------

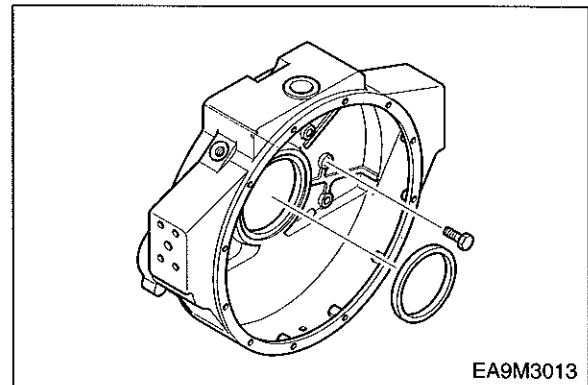



Caution :

When the bolts are tightened, remove the guide bar.

- The flywheel housing is assembled after the new oil seal was pressed (Coat engine oil over the outside of oil seal) before in the housing by a press. If any peripheral scar was generated due to oil seal at the oil seal contact surface of crankshaft, after inserting about 1 mm shim or thereabout in front of oil seal (Direction toward crankshaft.), measure and adjust.

9.3.7. Rear oil seal



- Apply lubricating oil to the outside of the oil seal and flywheel housing inside diameter and fit them over the crank shaft, then assemble the oil seal using an oil seal fitting jig.

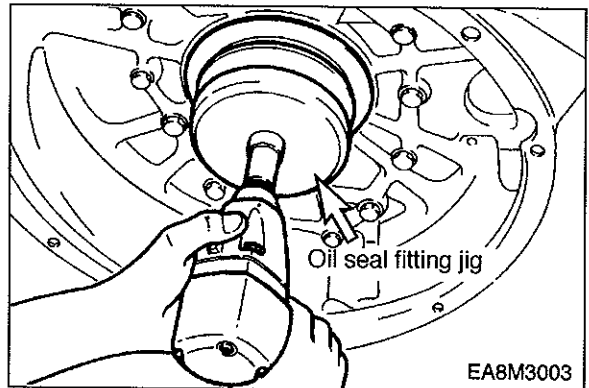

9.3.8. Flywheel

- Installation of flywheel ring gear With a gas burner, heat the ring gear evenly until heat expansion takes place, then install it using a hammer.



Caution :

Do not allow the temperature of the ring gear to exceed 200 °C (390 °F).

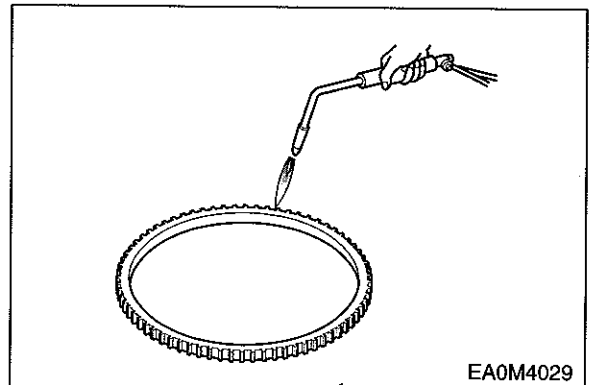

- By means of mandrel, assemble pilot bearing to the flywheel.
- By means of mandrel, press in the wear ring at the backward face.

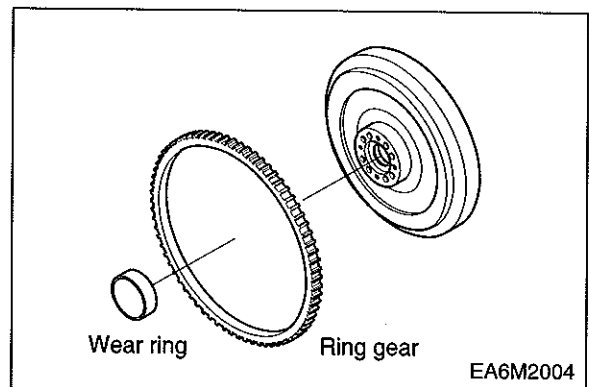



- Install a guide bar into a bolt hole on the crank shaft, and lift the flywheel to align the dowel pin with the pin hole on the flywheel for temporary assembly operation.

- Coat the adhesive (#271 Loctite) over the assembling bolts and install bolts in the remaining holes. After that take out the guide bar, then install a bolt in the hole where the guide bar had been inserted.



- According to the order of tightening tighten the fixing bolts using a torque wrench in a diagonal sequence to specified torque.

Torque	18.5 kg·m
---------------	-----------

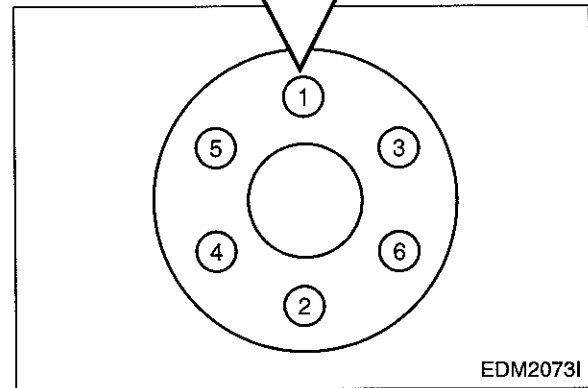
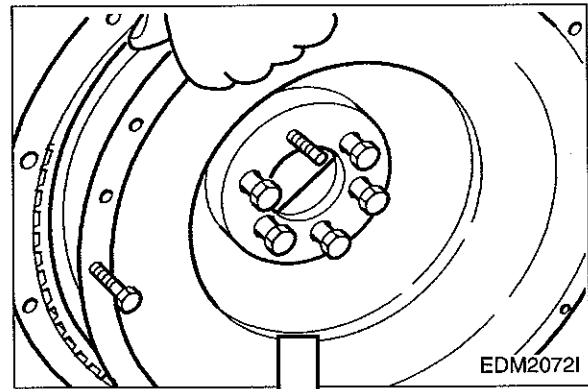

9.3.9. Tacho sensor (Pick-up sensor)

- Move the lock nut to hexagonal side of sensor completely.
- Rotate (CW) the tacho sensor on fly wheel housing, until the end of it reach on fly wheel ring gear.
- Rotate (CCW) the tacho sensor for 270° (gap 1.0 mm) and fix lock nut.
- Tolerancé limit is 27°. (gap ± 0.1 mm)

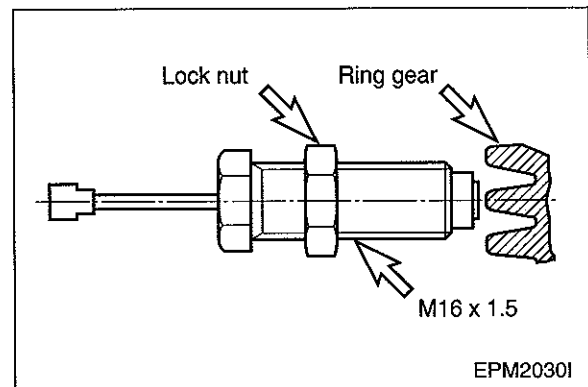

9.3.10. Water chamber cover

- Coat the adhesive over the water chamber cover (Particular around bolt holes) and after attaching the gasket, assemble it to the cylinder block using the bolts for assembling.
- As for tightening of bolts, after primarily tightening the bolts located at the both ends of cover (4ea at both sides) and middle bolts (Upper, lower 2ea) , tighten the rest.

9.3.11. Cylinder liner

- Stand the cylinder block so that the fly-wheel faces downward.



- Thoroughly clean the liner flange fitting surface and bore inside with compressed air to prevent the entry of foreign substances.

- After the cleaning operation, make the cylinder liner dried up and push it into the cylinder block by hand.



- Wet the liner inside diameter with engine oil.

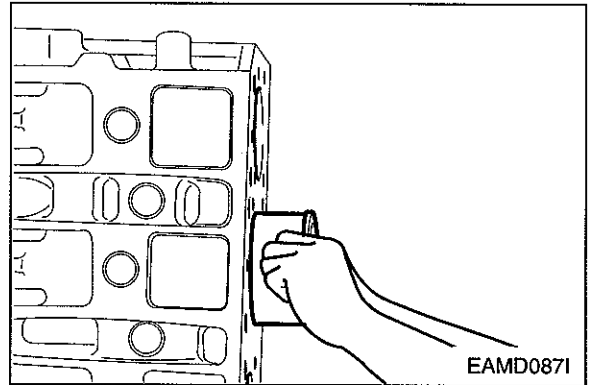

9.3.12. Piston and connecting rod



- Use a piston heater to heat the piston approximately 100°C (212°F) for 5 minutes.

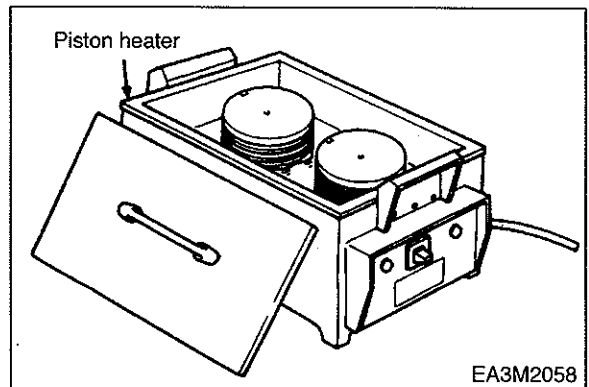

- Align the piston pin hole with the oiled connecting rod small end and press the piston pin (by lightly tapping with a rubber hammer) to assemble the connecting rod with the piston.

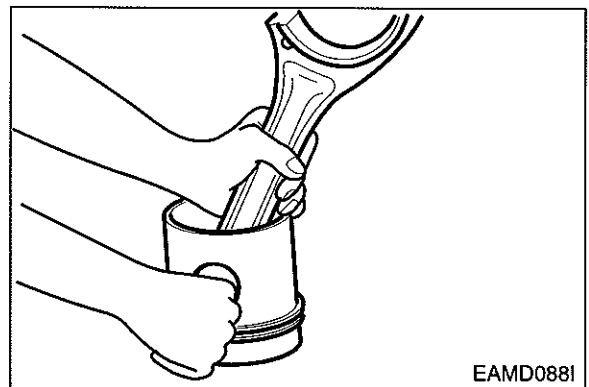



- Noticing the direction of the piston, make the longer side (machined with key groove on the bearing) of the connecting rod big end and the mark of '☀' impressed on the inside of the piston face each other in opposite directions. On the piston head surface, the longer side of the connecting rod big end is in opposite direction from the valve seat surface.

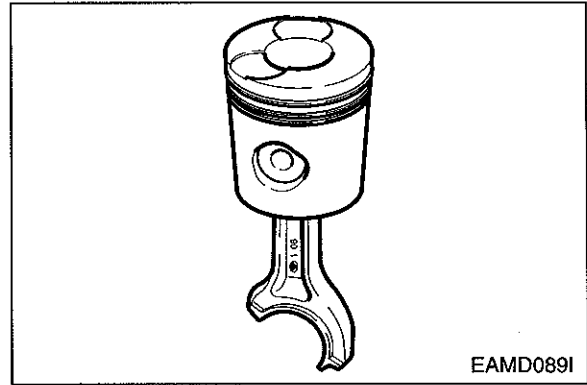

- Install the snap rings and check to see that it is securely assembled.



- Install the piston ring in the piston using piston ring pliers.



- Identify the mark "Y" or "TOP" on the ring end to prevent the top and bottom of the piston ring from being interchanged and make the marked portion face upward. (The surface marked as "Y" is upper surface.)

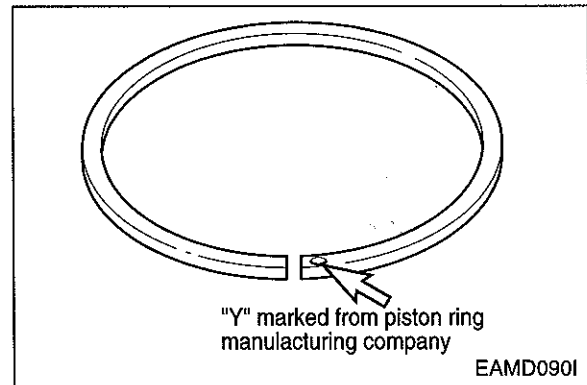

- Adjust the angle among individual piston ring gaps to 90° and fit a piston assembling jig onto the piston. Use care not to match the ring gaps with the pin direction.



- Install the bearing by aligning it with the connecting rod key groove and apply oil to the bearing and piston.

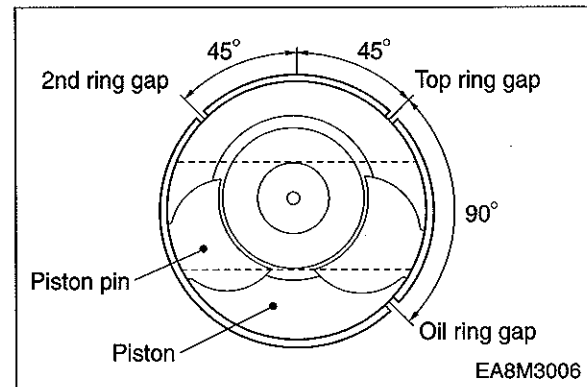

- Position the valve seating surface toward the tappet hole and insert the piston with hand.



Caution :

Use care not to damage the cylinder liner and piston, and slightly lift and insert the piston into the cylinder so that the ring may not be damaged by the fillet of the liner.

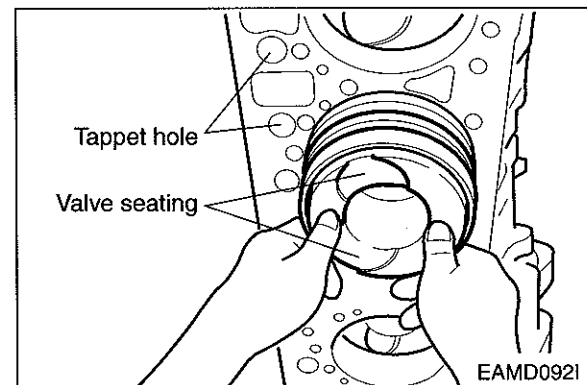



- Install the bearing in the connecting rod cap and apply oil.



Caution :

Make sure that the manufacture serial numbers impressed on the connecting rod cap and connecting rod big end are identical, and install the connecting rod cap by aligning it with dowel pin.



- Wet the fixing bolts with oil, semi-tighten them with hand, tighten them to the specified torque using a torque wrench as follows.

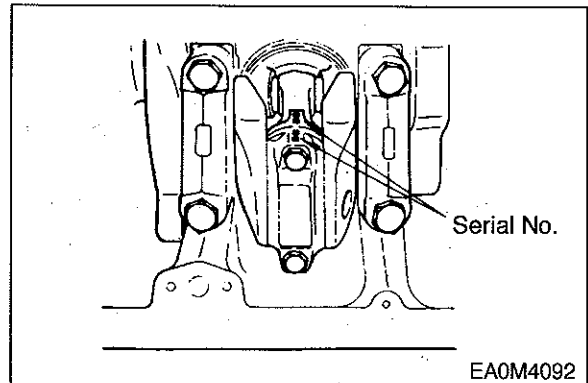

<Tightening order>

- (1) First stage : Coat engine oil over bolts.
- (2) Second stage : Temporary bolt screwing about 1 ~ 2 threads
- (3) Third stage : With torque wrench, tighten up to about 10 kg·m
- (4) Fourth stage : With torque wrench, tighten up to about 15 kg·m
- (5) Fifth stage : By means of torque wrench, tighten finally in the specified torque. (18 kg·m).

Torque	18 kg·m
---------------	---------



- Move the bearing cap with hand, and release and reassemble it if no movement is detected.

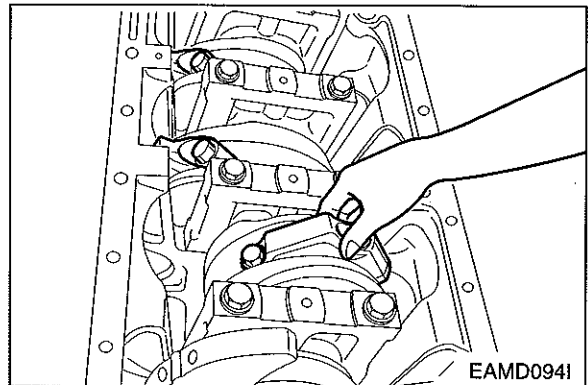

9.3.13. Timing gear case



- Mount a new gasket using dowel pin on the cylinder block.
- Put the time gear case to the cylinder block by aligning the dowel pin hole of timing gear case with its pin, and then assemble it by tapping lightly with an urethane hammer to the right and left (Particularly around dowel pin).
- Tighten the bolts for assembling to the specified torque. However, in case of tightening the bolts, tighten primarily the bolts of both end parts and then do the rest.

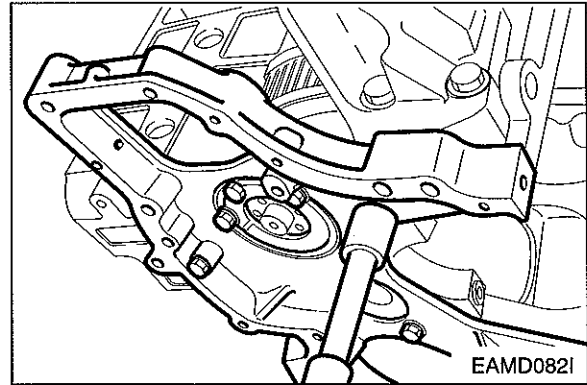

9.3.14. Timing gear and idle gear pin



- Install the oil pump idle gear onto the No.7 bearing cap.
- With the oil port on the idle gear pin facing the cylinder block, install the idle gear pin.



- Idler gear pin with oil hole is assembled toward cylinder block.

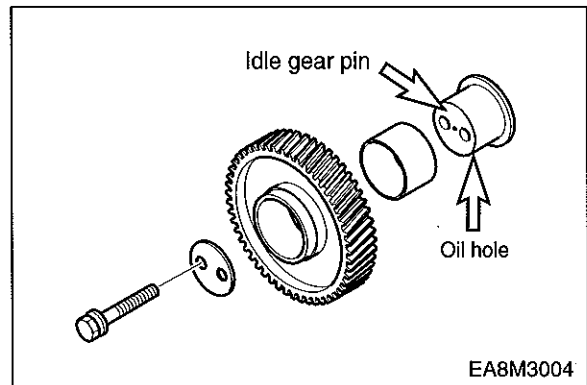

- Install a thrust washer over the camshaft and assemble the cam gear by aligning it with camshaft key groove. Tighten the cam gear assembling bolts to the specified torque. (Zigzag method)

Torque	2.2 kg·m
---------------	----------

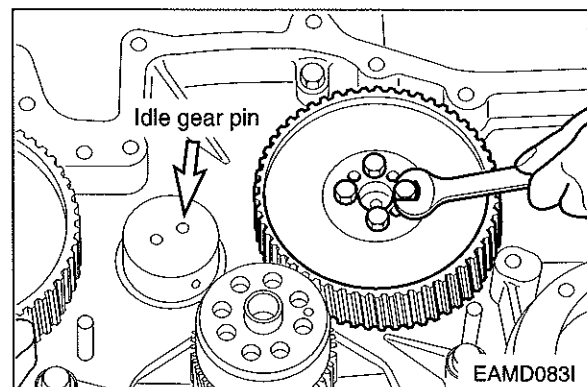



- Install the idle gear by coinciding the marks impressed on the crank gear, cam gear, fuel injection pump drive gear, and idle gear.



- Install a thrust washer on the idle gear and tighten to specified torque.

Torque	3.1 kg-m
---------------	----------

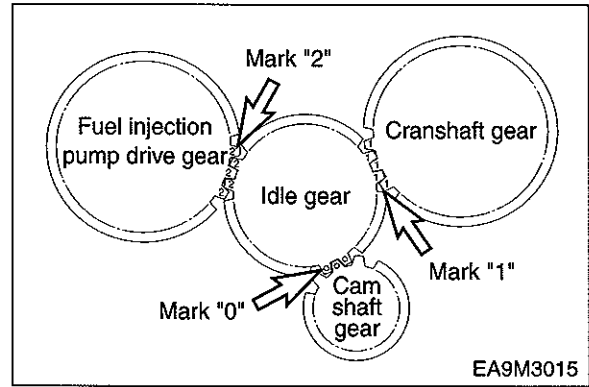

- Check and adjust the amount of backlash between gears using a feeler gauge.

Measuring position (between)	Backlash	Limit
Cam gear & idle gear	0.16 ~ 0.28 mm	0.35 mm
Crank gear & idle gear	0.16 ~ 0.28 mm	0.35 mm
Injection pump & idle gear	0.16 ~ 0.28 mm	0.35 mm

9.3.15. Injection pump flange

- After assembling the fuel injection pump gear to the idle gear, tighten the assembling bolts of the injection pump flange.
- Mount gasket by aligning the bolt holes with the pin holes on the bearing housing.
- Turning the flywheel, adjust the pointer to the 19° position of the engraved scale.
- After adjusting the injection timing of fuel injection pump drive gear, tighten the fixing bolts in the direction of fuel injection pump.

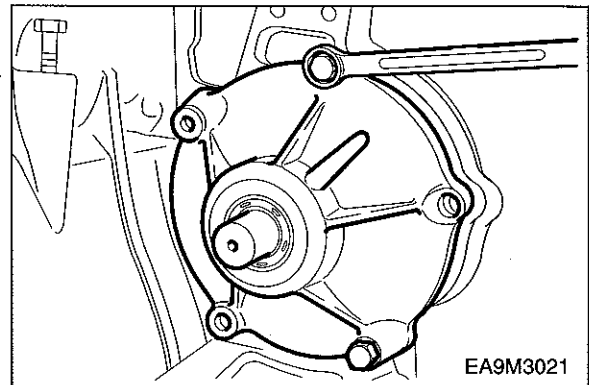

9.3.16. Injection pump

- Install the injection pump bracket in the cylinder block.
- After measuring the amount of run-out with an alignment setting jig, disassemble the bracket, adjust the shims, then reassemble it.



Run out	0.2 mm or less
----------------	----------------

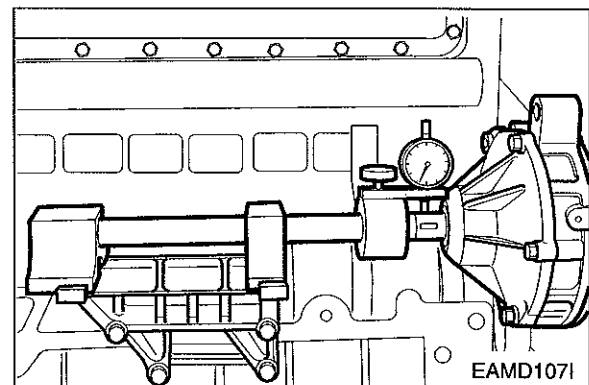



- Mount the top/bottom adjusting shims in the bracket and then mount the fuel injection pump.



- Tighten the fixing bolts in a diagonal sequence to specified torque.

Torque	4.4 kg-m
---------------	----------

<Injection timing adjustment>

- Bring the piston of #1 cylinder to the compression TDC (OT) by turning the crankshaft. Again, turn 60° in the reverse direction of engine rotation.
- Disassemble the fuel injection pipe that connect the fuel injection pump and #1 injection nozzle.
- Disassemble the fuel injection pump delivery valve holder, and after removing the valve and valve spring, again assemble the valve holder and then, on it assemble the pipe of "U" shape on it.
- Operating the priming pump of supply pump, turn the crankshaft slowly in the direction of engine rotation until the fuel will drop at the rate of a drop for 6 ~8 sec.
- Confirm then whether the indication point at the flywheel housing inspection hole and the engraved specified injection angle are coincided or not, and if the injection timing is not correct, adjust as follows.

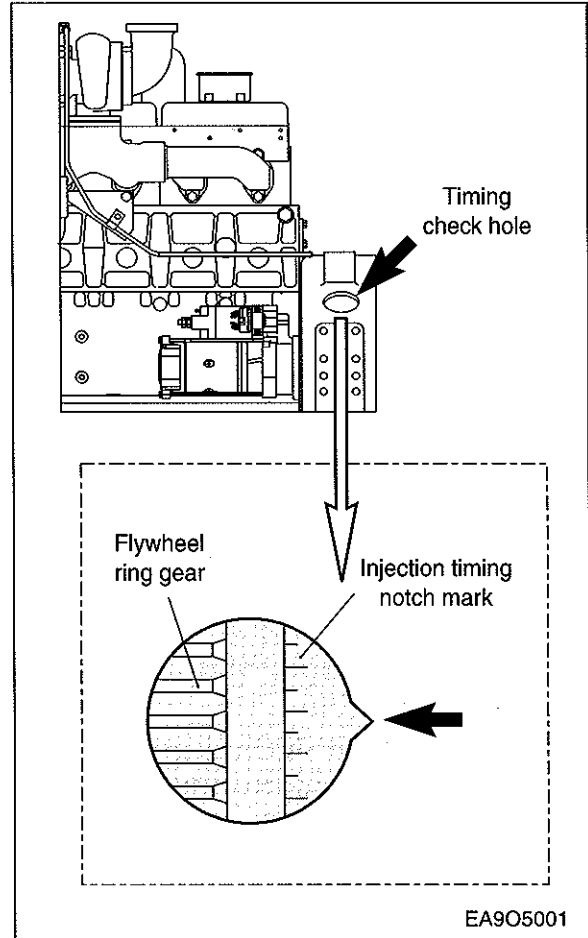

- (1) As above adjusting method, Please coincide the indication point(↓) at the flywheel housing's inspection hole with the flywheel's inspection angle.

<Fuel injection timing>

Model	Timing angle
D1146/PU086/D1146T	BTDC 18°
PU086T/P086TI	BTDC 12°

(2) Loosen the drive gear fixing bolt of injection pump a bit.

(3) After turning slowly the coupling of injection pump until the fuel will drop from #1 plunger at the rate of a drop for 6 ~ 8 sec., tighten the driving gear fixing bolt of fuel pump.

- After the adjustment of injection timing, disassemble the "U" shape pipe, readjust the delivery valve and the valve spring.

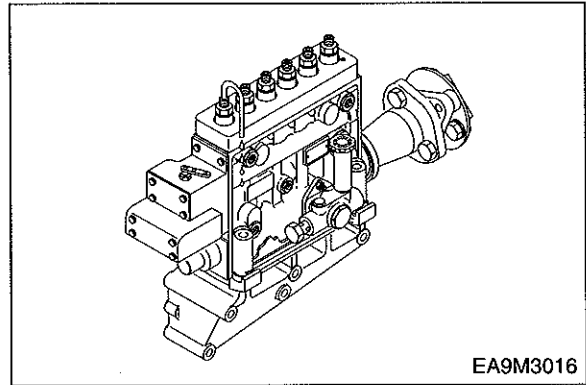

- Turn the coupling until the notch mark of the indicator plate attached to the fuel injection pump is aligned with the notch mark of the coupling.

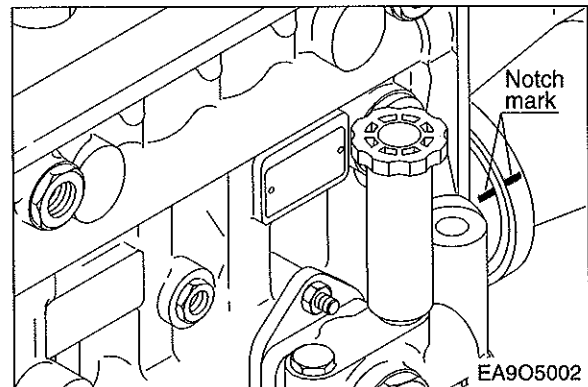

- Tighten the Coupling fixing bolts and nuts to specified torque.

Torque	6.0 ~ 6.5 kg·m
---------------	----------------

- Install the oil delivery pipe and return pipe.

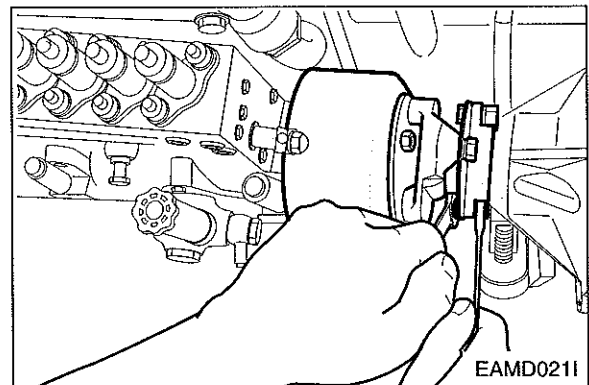

9.3.17. Oil pump and oil pipe



- Install a dowel pin in the No.7 bearing cap, then assemble the oil pump by tapping lightly with urethane hammer.
- Insert the lock washers and tighten the assembling bolts with specified torque.

Torque	4.4 kg·m
---------------	----------

- Assemble the oil suction pipe with the delivery pipe to oil pump by the bolts.

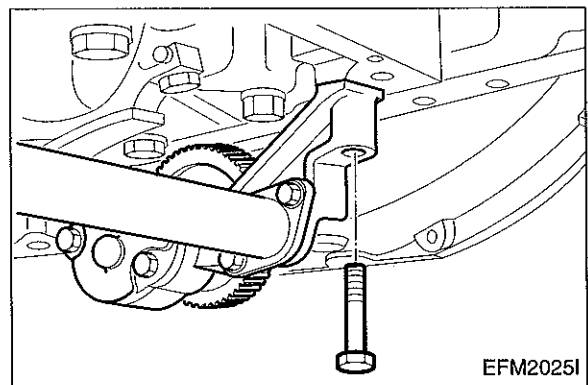

9.3.18. Water pump

- Mount a new gasket.
- Install the water pump on the cylinder block and tighten the assembling bolts with specified torque.



Torque	2.2 kg·m
---------------	----------

- Connect water pipes and by-pass pipe to the water pump.
- Connect a water pipe to the expansion tank.

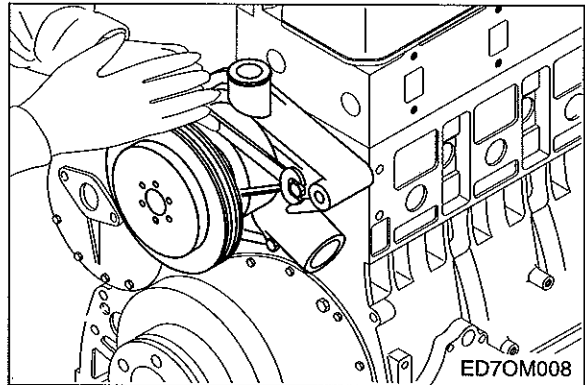

9.3.19. Front oil seal

- Apply lubricating oil to the outside of the oil seal and the oil seal hole of the timing gear case cover.
- Put the new oil seal on the oil seal hole of timing gear case cover aligning the center of them, then assemble the oil seal using an oil seal fitting jig.

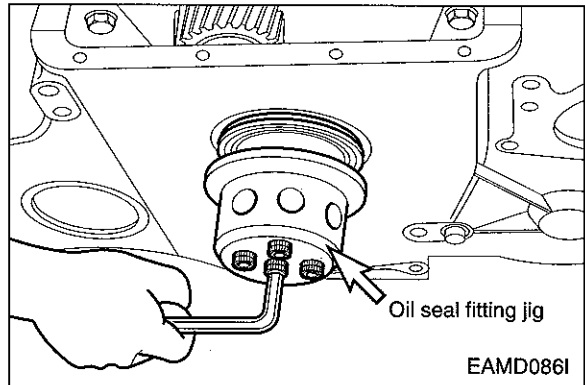

9.3.20. Timing gear case cover

- Install dowel pin on the timing gear case.
- Mount a gasket by aligning the fixing bolt holes with those on the gasket.
- Align the dowel pin with the cover pin hole; then install the cover with light tap.
- Tighten the fixing bolts beginning with the oil pan fitting face.



Caution :

* In the assembling, be careful not to be damaged by the crankshaft.

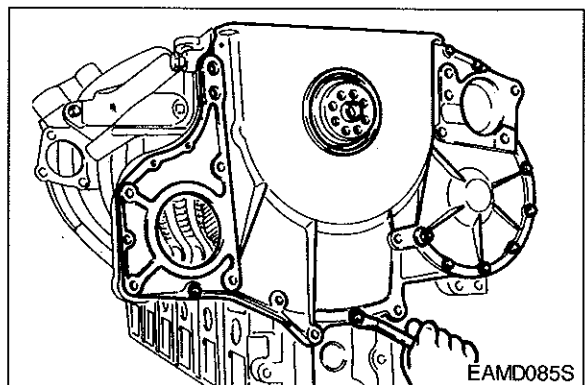

9.3.21. Vibration damper



- Insert the vibration damper to the crankshaft, and assemble by tightening the assembling bolts at the specified tightening torque according to bolt tightening order. (refer to right figure.)

Torque	13 kg·m
---------------	---------

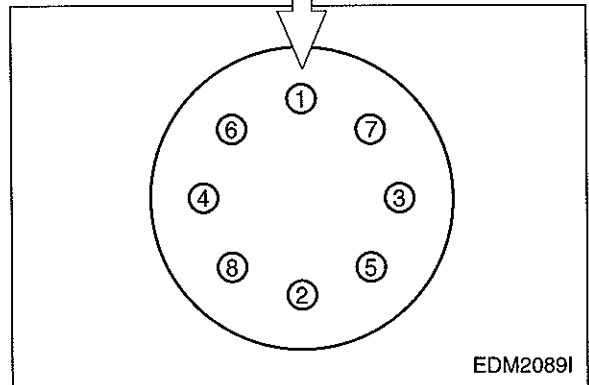
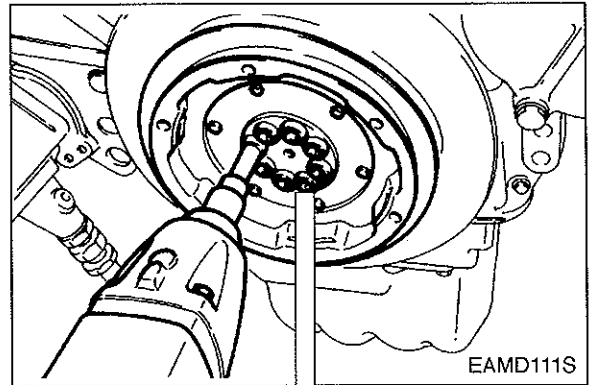

9.3.22. Oil pan

- Remove the gaskets thoroughly that project at the timing gear case, case cover of cylinder block, and the contacting part of flywheel housing by means of a scraper.



Caution :

Be careful for the gasket pieces not fall into the engine during the work.

- Coat the silicone at the gasket part that was removed (Contacting part), and attach the new oil pan gasket.



- Assemble the oil pan by tightening the oil pan assembling bolts, and when tightening bolts, primarily tighten the bolts (4ea) at the both ends, and then tighten the rest bolts to specified torque.

Torque	2.2 kg·m
---------------	----------

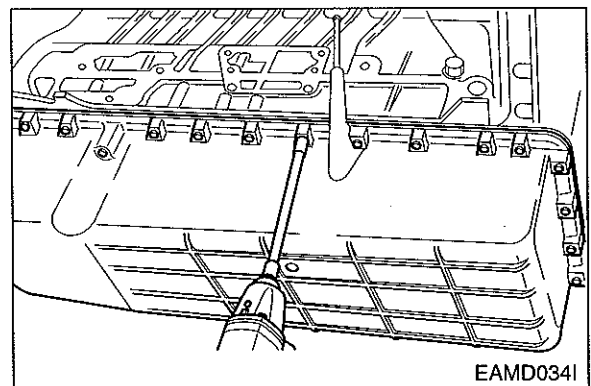



Caution :

Align the bolt holes with gasket holes to prevent damage to the gasket and tighten.

9.3.23. Oil filter

- Install the oil filter onto the cylinder block, and tighten the fixing bolts.

Torque	2.2 kg·m
---------------	----------

- Install packing and assemble the cartridge using a filter wrench.

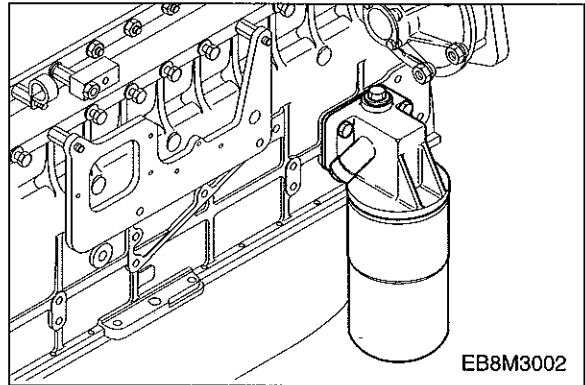

9.3.24. Oil cooler

- Coat a grease at the oil hole of the oil cooler housing and insert the O-ring.
- Assemble the oil cooler assembly by tightening the assembling nuts.
- Connect the cooling water pipe with the cooling water pump and tighten a hose clamp.

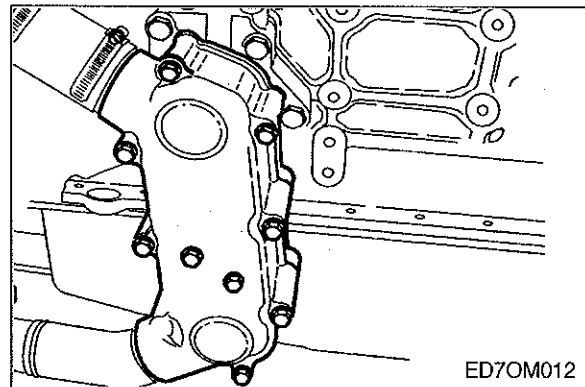

9.3.25. Starter

- Assemble the starter in position on the flywheel housing.

Torque	4.4 kg·m
---------------	----------

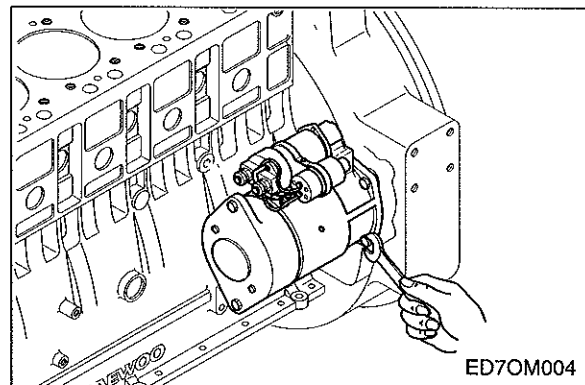

9.3.26. Intake and exhaust valves



- Identify the marks of "IN" and "EX" impressed on the valve head before assembling the valve with the valve head.



- With a valve stem seal fitting jig, assemble the valve stem seal with the valve guide.

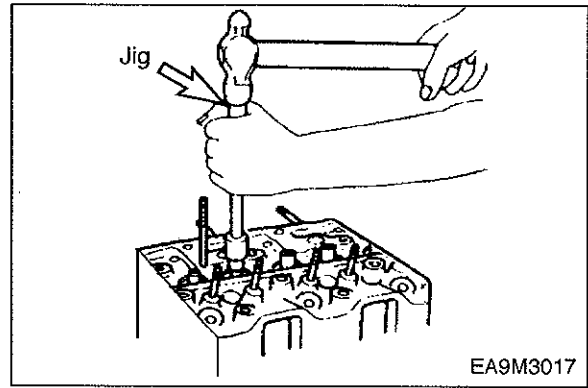

- After installing valve springs and spring retainer, press the retainer with a jig, then install cotter pin.



- Tap the valve stem lightly with a rubber hammer to check that the valve is assembled correctly.

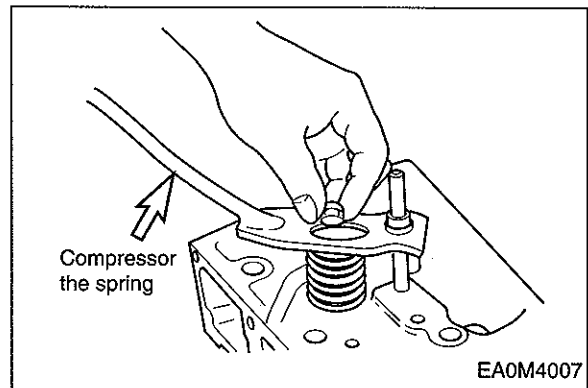

9.3.27. Cylinder head

- Blow the bolt holes of cylinder block with a compressed air and remove the foreign matter.
- Clean the head gasket contact surface thoroughly.



Caution :

However, be careful for the foreign material not to enter into the combustion chamber.



- Assemble the new head gasket by aligning the holes with dowels of cylinder block with 'TOP' mark facing upward.

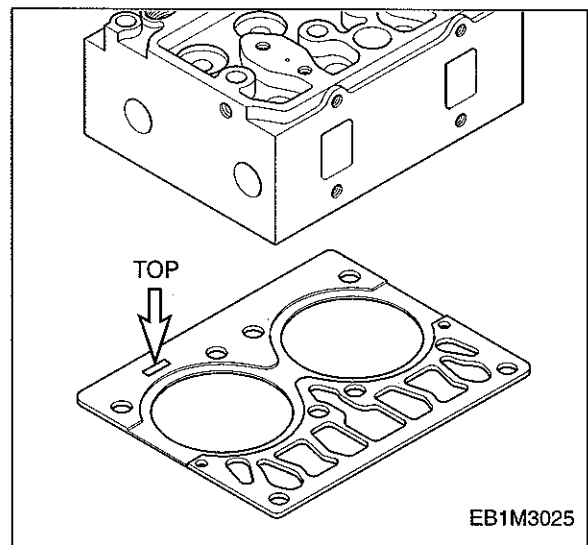



- Check the inside of combustion chamber for foreign substances, and carefully mount the cylinder head assembly in the block by aligning the dowel pin with the dowel pin hole.



Caution :

Be careful not to damage the cylinder head gasket. If the dowel pin is not in alignment, lift the cylinder head again and then remount it.



- After tightening the cylinder head bolts, even at disassembling, the cylinder head gasket should be changed a new one.

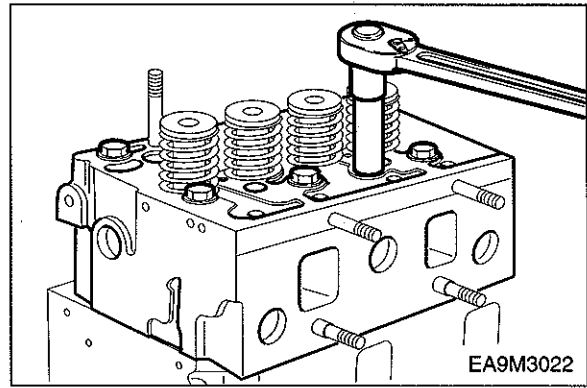

- Coat the cylinder head bolts with engine oil, and tighten in proper sequence to the specified torque according to bolt tightening order. (refer to the figure.).



<Cylinder Head Bolts>

	Type 1	Type 2
Specification	 M14x1.5x146	 M14x1.5x150
Torque	24.5 kg·m	6 kg·m +180°+150° (Angle torque)

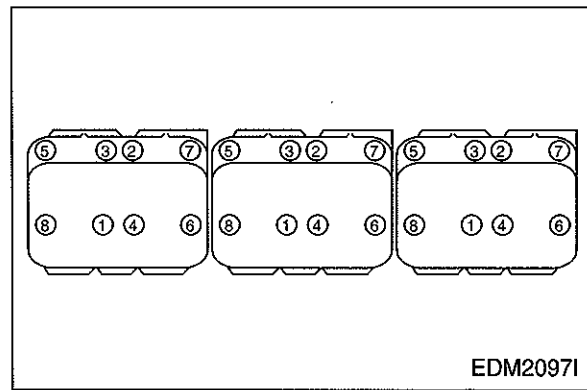

However, before tightening bolts, the side parallel degree between cylinder heads should be adjusted.

<Tightening order of bolts by steps>

- (1) First stage : Coat the bolts with engine oil.
- (2) Second stage : Tighten 1 ~ 2 threads with hands.
- (3) Third stage : Tighten at about 6 kg·m with a wrench.
- (4) Fourth stage : Tighten at rotating angle method 180° with a wrench.
- (5) Fifth stage : Finally, tighten at rotating angle method 150° with a torque wrench .

However, all bolts are tightened simultaneously by above steps.



- Coat the push rod with engine oil and insert it into the push rod hole.



- Adjust the valve clearance as following guide.

<Guide for valve clearance adjustment>

- By turning the crankshaft, when the intake and exhaust of #6 cylinder (the first cylinder from the flywheel) overlap, that is, when #1 cylinder's piston come at the compression top dead center (OT), adjust the valve clearances by ↑ mark indicated.
- After having turned the crankshaft by 360° and Intake & exhaust valves of #1 cylinder overlap, that is, when #6 cylinder is in the state of compression TDC (OT), the clearance indicated by ↑ mark is adjusted.

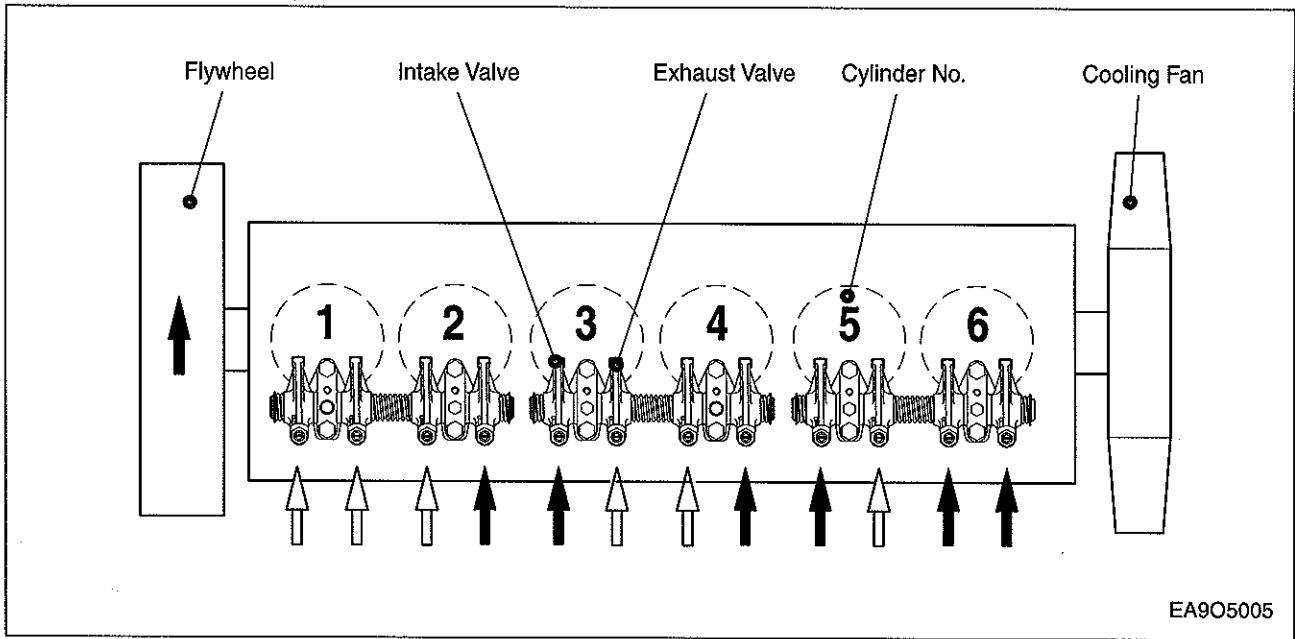

EA9O5005



- To adjust the clearance, loosen the lock nuts of rocker arm adjusting screws and push the feeler gauge of specified value between a rocker arm and a valve stem (to measure the clearance of the valve and rocker arm contacting part) and adjust the clearance with adjusting screw respectively and then tighten with the lock nut.
- As for the valve clearance, adjust it when in cold.

Model	Intake Valve	Exhaust Valve
D1146/PU086 D1146T/PU086T P086TI	0.3 mm	0.3 mm



Caution :

- (1) Crankshaft revolution is done by hands without using a starting motor.
- (2) Turn it to the direction of engine rotation, but do not use the installing bolts at the turn.
- (3) The cylinder no. and the order of intake and exhaust can be determined from the flywheel housing.



- Adjust valve clearance with a feeler gauge and tighten the fixing nuts to specified torque.

Torque	5.0 kg·m
---------------	----------

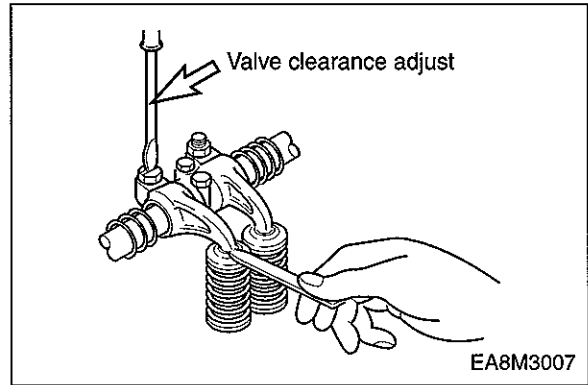

9.3.28. Rocker arm assembly



- Apply lubricating oil to the rocker arm bush and shaft, and assemble the intermediate bracket with the rocker arm (rocker arm assembly) on the cylinder block using fixing bolts. In tightening the bolts, it must be done at the specified value using zigzag method.

Torque	M10: 4.4kg·m M12: 8.0kg·m
---------------	------------------------------

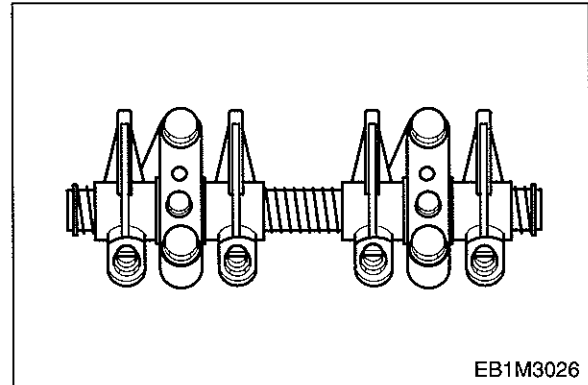

- Semi-install valve clearance adjusting bolts onto the rocker arm.
- Install the spring, rocker arm, bracket, rocker arm, spring, washer, and snap ring in the described sequence.



- Install the rocker arm and bracket in the same direction.

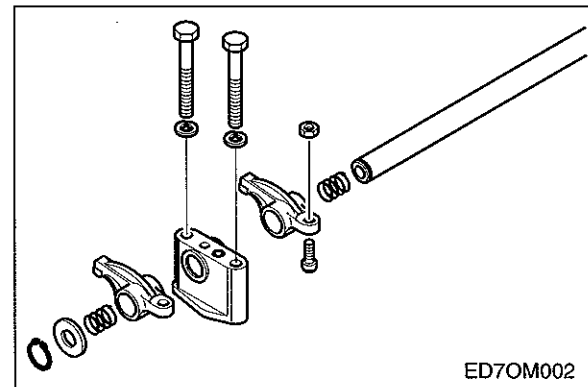

9.3.29. Intake manifold

- Put in the new gasket between the cylinder head and manifold, and assemble the intake manifold by tightening the assembling bolts.

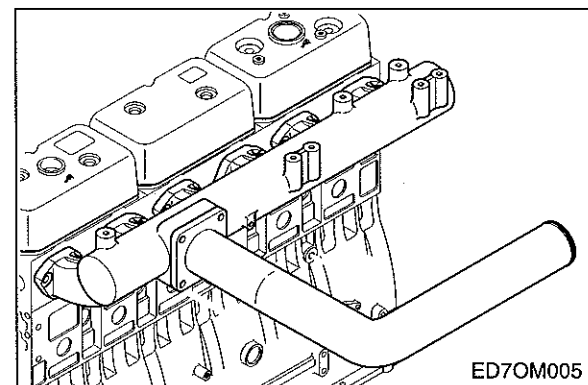

9.3.30. Exhaust manifold

- Install the exhaust manifold gasket over the stud bolts by aligning the gasket with the exhaust port on the cylinder head so that the face and back of the gasket can be positioned correctly.
- Semi-assemble the exhaust manifold and install the heat resisting plate.
- Assemble them by tightening the assembling bolts. The tightening order of bolts is from the middle to left and right alternately.

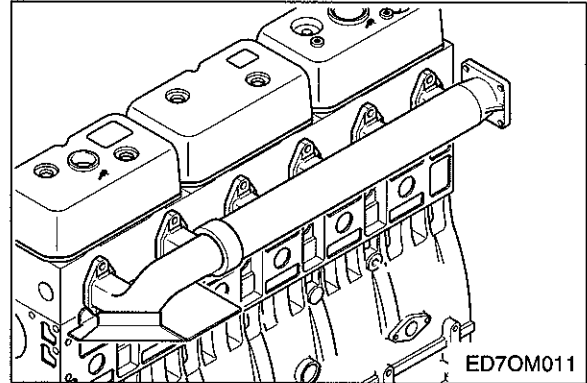

Caution :

For upper and lower bolts differ in the length, so use the correct bolts.

9.3.31. Turbocharger (for D1146T/PU086T, P086TI)

- Fit a new gasket over the stud bolts of the exhaust manifold before tightening those turbocharger fixing bolts.
- Install the oil supply pipe and return pipe.
- Tighten the clamps of rubber hose that is connected air pipe to the intercooler.

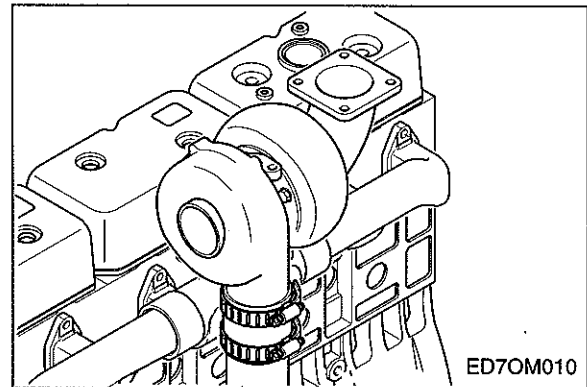

9.3.32. Cooling water pipe

- Attach new cylinder head gasket.
- Assemble the cooling water pipe by tightening the assembling bolts.

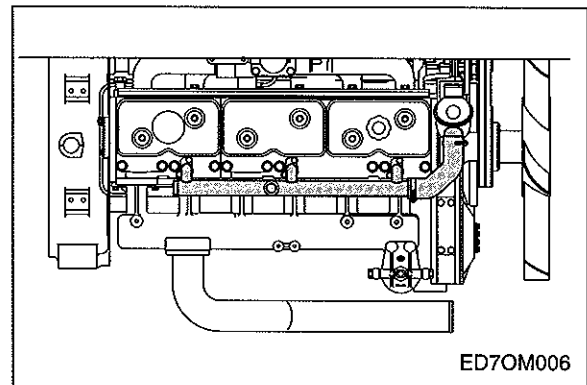

9.3.33. Alternator

- Install the alternator mounting bracket.
- Install the alternator with fixing bolts to the mounting bracket.

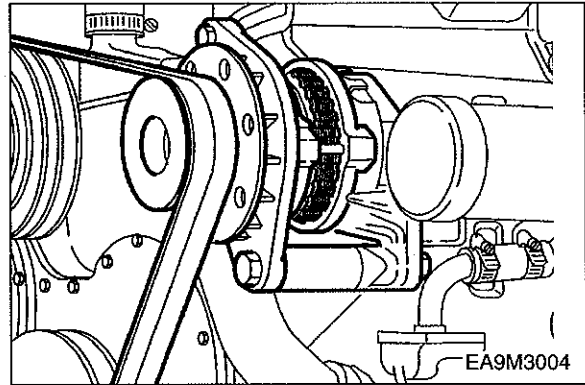

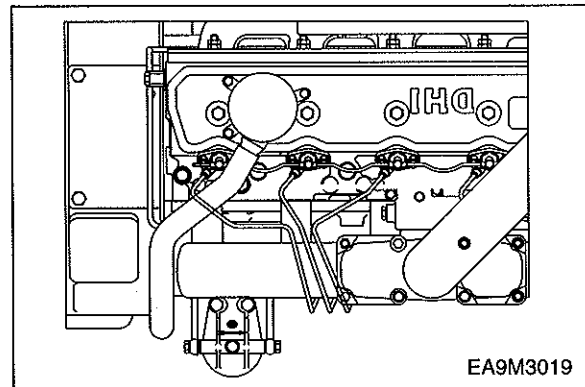

9.3.34. Fuel filter

- Assemble the fuel filter with the intake manifold.
- 
 - Assemble the fuel feed hose according to the direction of an arrow impressed on the fuel filter head so that fuel can be fed in the sequence of FUEL FEED PUMP → FUEL FILTER → FUEL INJECTION PUMP.



9.3.35. Injection nozzle

- 
 - Install the dust seal with its round portion facing downward.
 - Mount a seal ring on the seal ring seating surface of the cylinder head and assemble nozzle holder assembly with the nozzle pipe installing direction facing outward.
- 
 - Be sure to follow the specified torque.

Torque	7.0 kg-m
---------------	----------

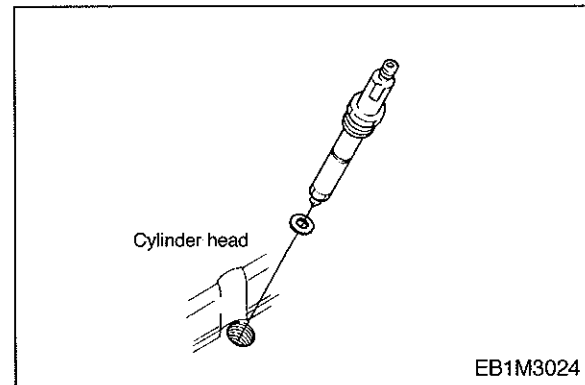

9.3.36. Injection pipe



- Semi-assemble a nut at both ends of the fuel high pressure pipe and tighten them up one by one to specified torque.

Torque	3.0 kg·m
---------------	----------

- Tighten hollow screws to assemble the fuel return pipe.
- Assemble the fuel return hose on the fuel injection pump.

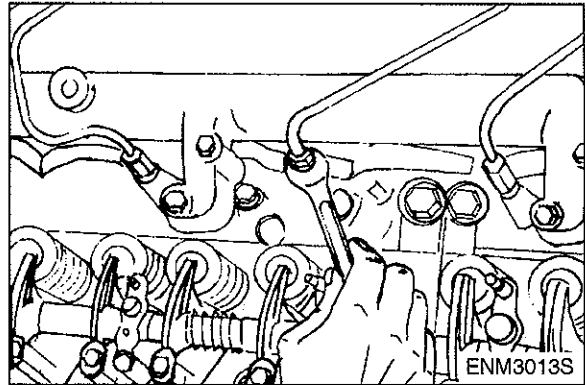

9.3.37. Cylinder head cover



- Assemble the new gasket with the cylinder cover, install the cover on the cylinder head, then tighten the fixing bolts in sequence to specified torque.

Torque	1.2 kg·m
---------------	----------

- Assemble the breather hose with PCV valve.
- Insert the oil filler cap in the cylinder head cover.

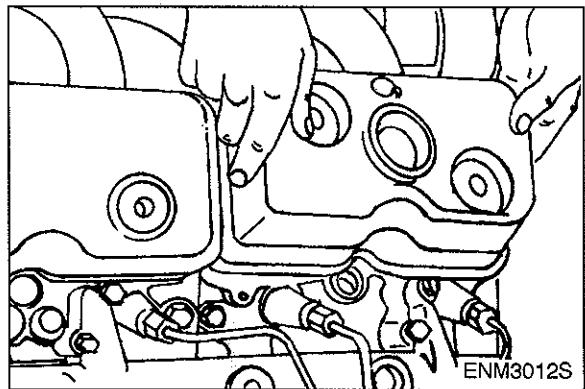

9.3.38. Cooling fan

- Install the fan drive pulley onto the timing gear case cover.
- Install the fan flange and cooling fan onto the cooling water pump.

Torque	4.4 kg·m
---------------	----------

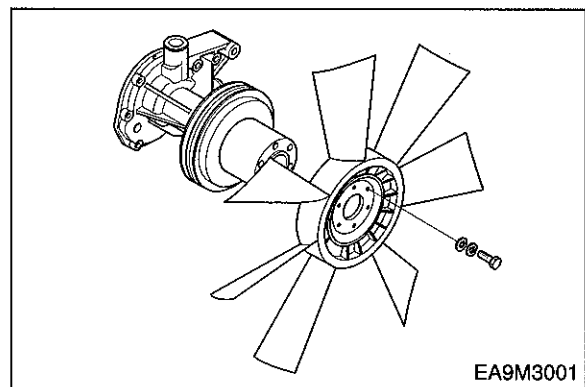

9.3.39. V- Belt

- Install the V-belt on the crank pulley, alternator pulley and water pump pulley.
- Adjust the V-belt tension using the tension adjusting support.

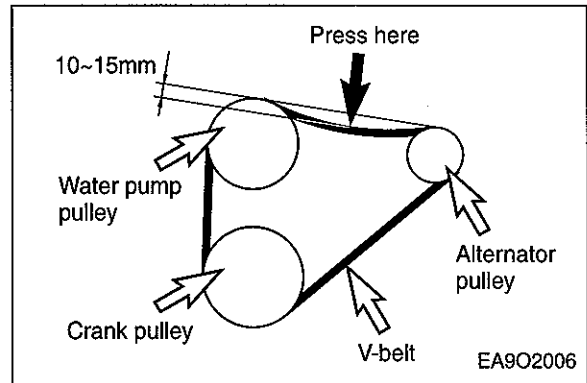

9.3.40. Oil level gauge

- Apply sealant (Loctite #262) to the bottom side of the guide tube.
- Then assemble the guide tube and oil level gauge on the oil pan.

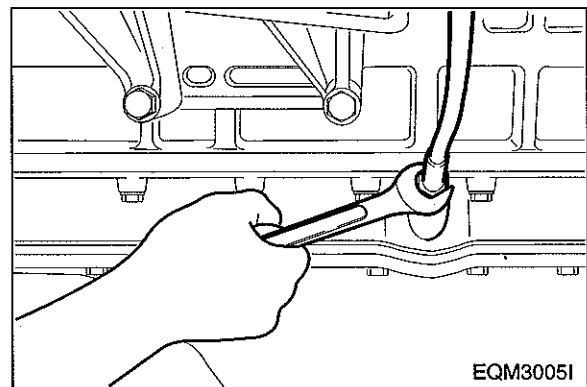

9.3.41. Others

- Assemble by connecting the other oil and fuel hoses.

9.4. Breaking-in

Refer to "Breaking-in" in chapter of "Commissioning and Operation".

10. Maintenance of Major Components

10.1. Cooling System

10.1.1. General information

This engine is water-cooling type. Heat from the combustion chamber and engine oil heat are cooled down by coolant and radiated to the outside, resulting in the normal operation of the engine.

Looking into the cooling system, the water pumped up by the water pump circulates around the oil cooler through the water pipe to absorb the oil heat, and then flows through the water jacket of the cylinder block and water passage of the cylinder head to absorb the heat of the combustion chamber.

The water absorbing the oil heat and combustion chamber heat goes on to the thermostat through the water pipe, and circulates to the water pump if water temperature is lower than the valve opening temperature on the thermostat, while circulating to the radiator at water temperature higher than the valve opening temperature. At the radiator, the heat absorbed in the coolant is radiated to cool down and the coolant recirculates to the water pump.

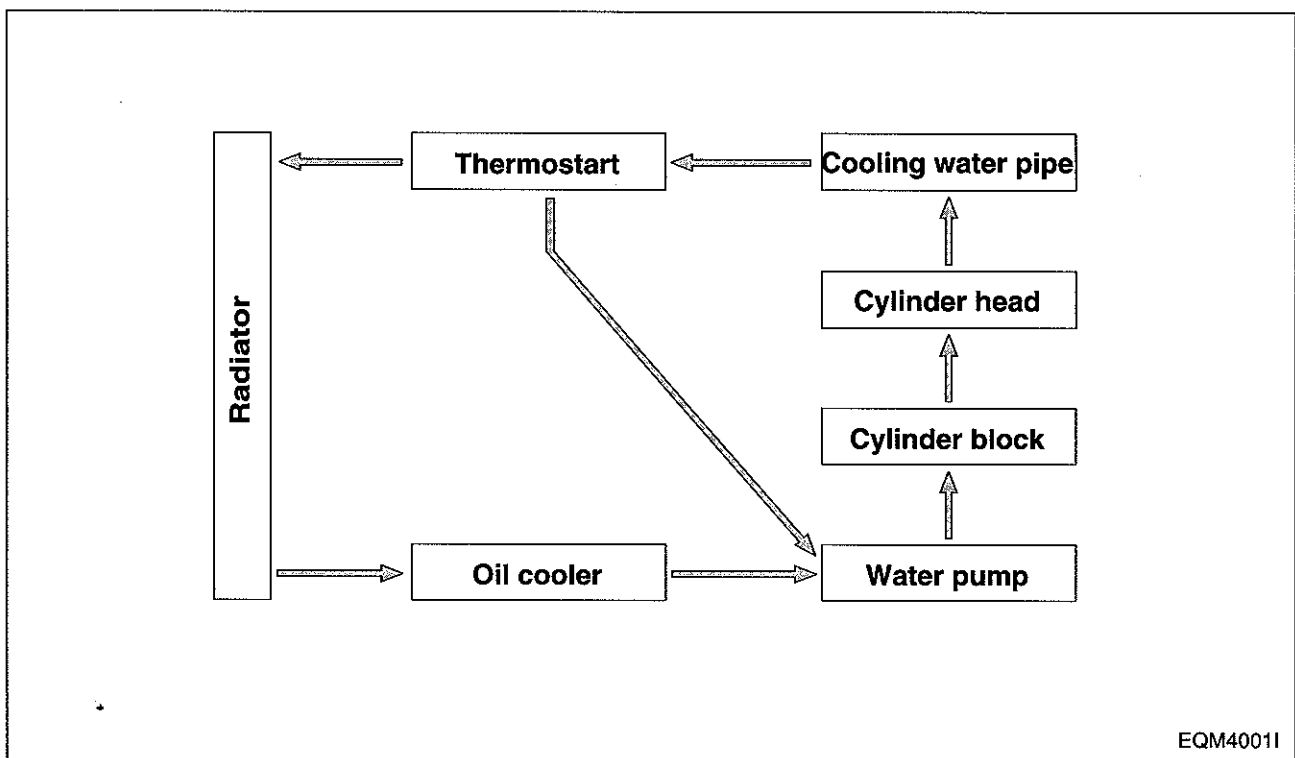

10.1.2. Specification

Item	D1146/T, P086TI	PU086/T
1. Water pump Type Delivery Pump speed Pumping back pressure	Centrifugal type About 150 liter/min About 190 liter/min 1,800 rpm 2,200 rpm 0.5 bar	
2. Thermostat Operating temperature Valve lift Operating temperature	71°C 8 mm or more (at 85°C) 71 ~ 85°C	
3. Cooling fan and belt Fan diameter - Number of blades Fan belt tension	D1146/T, PU086/T : ϕ 590mm - 6 P086TI : ϕ 755mm - 7 15mm/ deflection by thumb	

10.1.3. Thermostat

● **General descriptions and main data**

The thermostat maintains a constant temperature of coolant and improves thermal efficiency of the engine by preventing heat loss.

Namely, when the temperature of coolant is low, the thermostat valve is closed to make the coolant bypass to directly enter the water pump; when the coolant temperature rises to open wide the thermostat valve, the bypass circuit is closed and the water passage to the radiator is opened so that the coolant is forced to flow into the radiator.

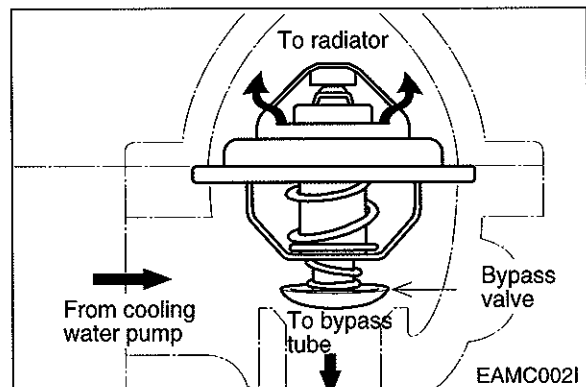

Item	Specifications	
	D1146/ T	P086TI
Type	Wax-pallet type	Wax-pallet type
Open at	71 °C	71 °C
Open wide at	85 °C	85 °C
Valve lift	8 mm or more	10 mm or more



There are 2 kinds of thermostats according to surrounding and operating conditions. One is named by 71 °C type and the other is 79 °C.

● Inspecting

- (1) Check the wax pallet and spring for damage.
- (2) Put the thermostat in a container of water, then heat the water slowly and check temperature with a thermometer. If the valve lift is 0.1 mm (starting to open) at temperature of 71 °C and 8 mm or more (full open) at temperature of 85 °C, the thermostat is normal.

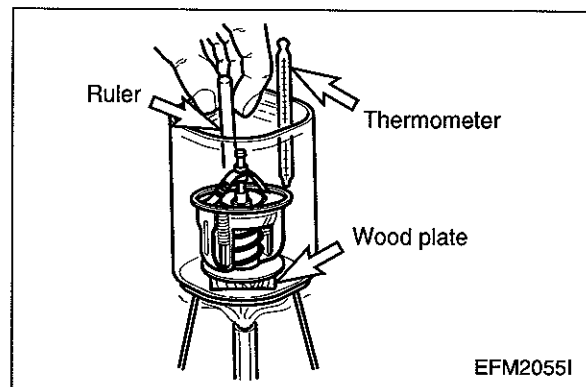

● Replacing thermostat and precautions for handling

- (1) Precautions for handling

The wax pallet type thermostat does not react as quickly as bellows type one to a variation of temperature of coolant. Such relatively slow reaction is mainly due to the large heat capacity of the wax pallet type thermostat. Therefore, to avoid a sharp rise of coolant temperature, it is essential to idle the engine sufficiently before running it. In cold weather, do not run the engine at overload or overspeed it immediately after starting off.

- (2) When draining out or replenishing coolant, do it slowly so that air is bled sufficiently from the entire cooling system.
- (3) Replacing thermostat
If the thermostat is detected defective, retrace with a new one.

10.1.4. Diagnostics and troubleshooting

Complaints	Possible causes	Corrections
1. Engine overheating	<ul style="list-style-type: none"> ● Lack of coolant ● Radiator cap pressure valve spring weakened ● Fan belt loosened or broken ● Fan belt fouled with oil ● Thermostat inoperative ● Water pump defective ● Restrictions in water passages due to deposit of scales ● Injection timing incorrect ● Restriction in radiator core ● Gases leaking into water jacket due to broken cylinder head gasket 	<ul style="list-style-type: none"> ● Replenish coolant ● Replace cap ● Adjust or replace fan belt ● Replace fan belt ● Replace thermostat ● Repair or replace ● Clean radiator and water passages ● Adjust injection timing correctly ● Clean exterior of radiator ● Replace cylinder head gasket
2. Engine overcooling	<ul style="list-style-type: none"> ● Thermostat inoperative ● Ambient temperature too low 	<ul style="list-style-type: none"> ● Replace thermostat ● Install radiator curtain
3. Lack of coolant	<ul style="list-style-type: none"> ● Radiator leaky ● Radiator hoses loosely connected or damaged ● Radiator cap valve spring weakened ● Water pump leaky ● Heater hoses loosely connected or broken ● Cylinder head gasket leaky ● Cylinder head or cylinder block cracked 	<ul style="list-style-type: none"> ● Correct or replace ● Retighten clamps or replace hoses ● Replace cap ● Repair or replace ● Tighten or replace hoses ● Replace cylinder head gasket ● Replace cylinder head block
4. Cooling system noisy	<ul style="list-style-type: none"> ● Water pump bearing defective ● Fan loosely fitted or bent ● Fan out of balance ● Fan belt defective 	<ul style="list-style-type: none"> ● Replace bearing ● Retighten or replace fan ● Replace fan ● Replace fan belt

10.2. Lubricating System

10.2.1. General descriptions

● General descriptions

All the engine oil pumped up from the oil pan by the gear type oil pump is filtrated through the oil cooler and oil filter, and this filtrated oil is forced through the main oil gallery in the cylinder block from where it is distributed to lubricate the various sliding parts, and fuel injection pump in order to ensure normal engine performance.

● Specifications

Item	Specifications	Item	Specifications
Lubricating system	Forced pressure circulation	Oil filter type	Full flow
Oil pump type	Gear type	Bypass for filter element	
Relief valve opening pressure	$10 \pm 1.5 \text{ kg/cm}^2$	Valve opening pressure	$1.8 \sim 2.3 \text{ kg/cm}^2$
Bypass for oil cooler		Bypass for entire oil filter	
Opening pressure	$5+1 \text{ kg/cm}^2$	Valve opening pressure	$4.0 \sim 4.8 \text{ kg/cm}^2$
Adjusting valve for spray nozzle			
Opening pressure	$1.5 \sim 1.8 \text{ kg/cm}^2$		

● Diagram of lubricating system

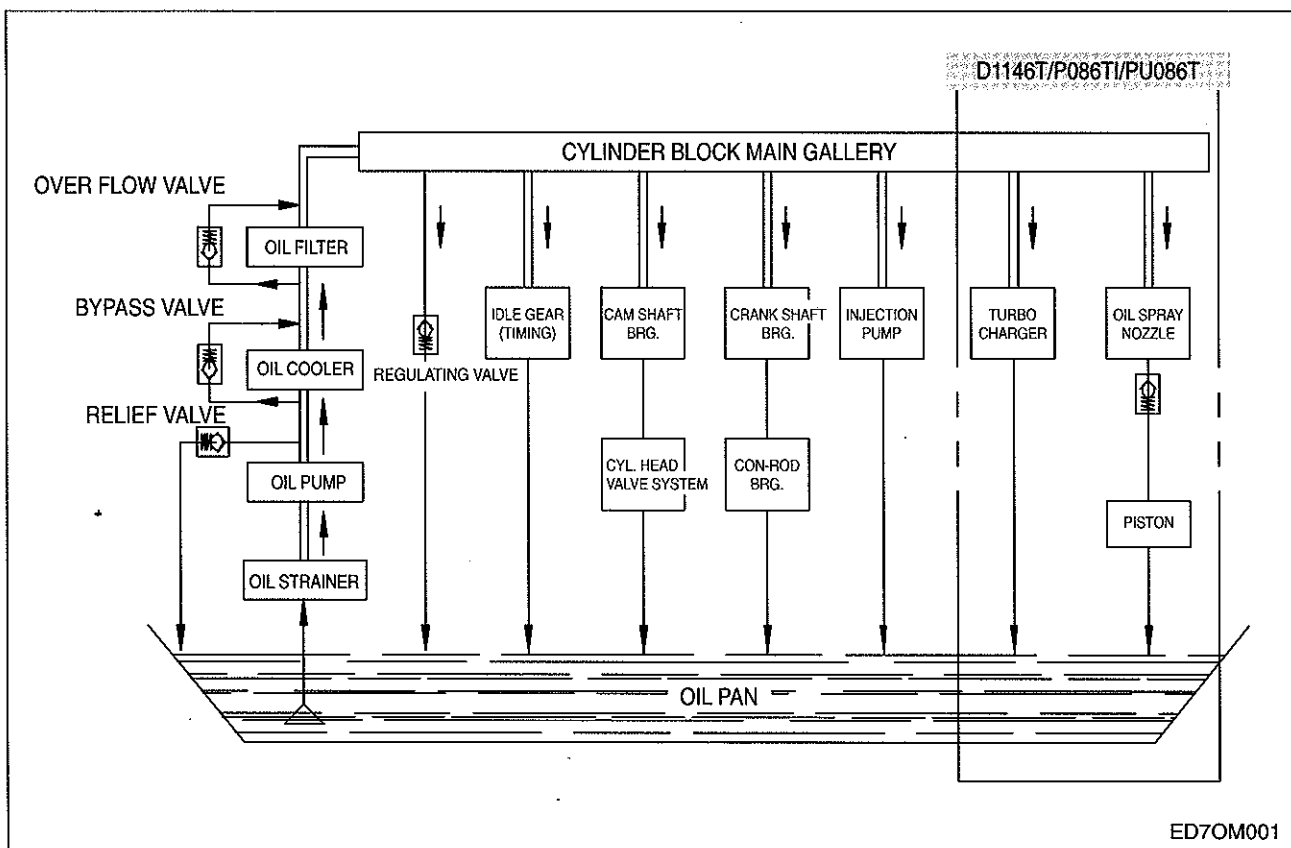

10.2.2. Oil pump

● Disassembly

- (1) Disassembly of oil pump drive gear
 - a. Unscrew the screw and disassemble the oil relief valve.
 - b. Unfold the washer for the oil pump drive gear fixing nut and remove the nut.
 - c. Disassemble the drive gear.

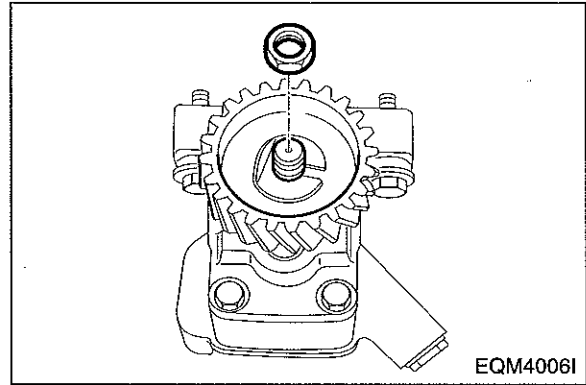

- (2) Remove the oil pump cover fixing nuts and disassemble the oil pump cover. The oil pump cover is fixed with the two dowel pins.
- (3) Disassemble the drive gear and driven gear.

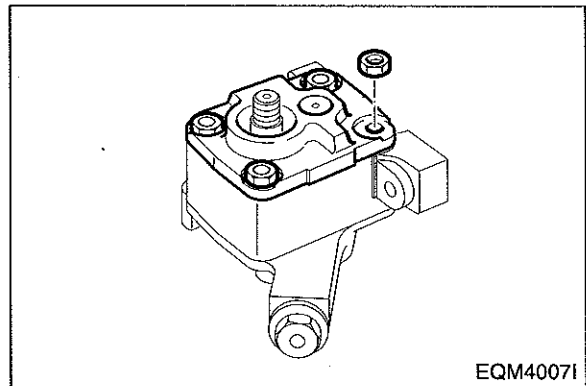

● Inspection and correction

- (1) With steel rule and feeler gauge, measure the axial end play of the oil pump gear. Replace if the measured value is beyond the limit.

End play Limit	0.025 ~ 0.089 mm
-----------------------	------------------

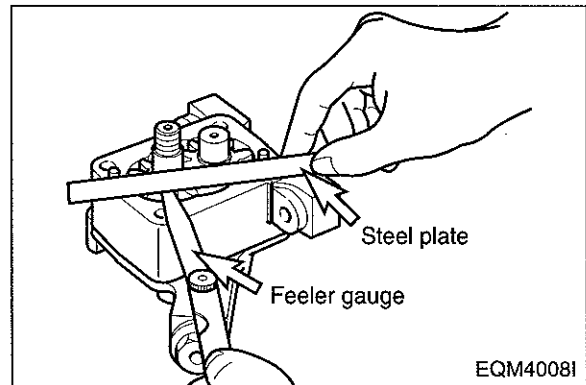

- (2) With a feeler gauge, measure the amount of backlash between the oil pump drive gear and driven gear. Replace if the measured value is beyond the limit.

Backlash limit	0.50 ~ 0.64 mm
-----------------------	----------------

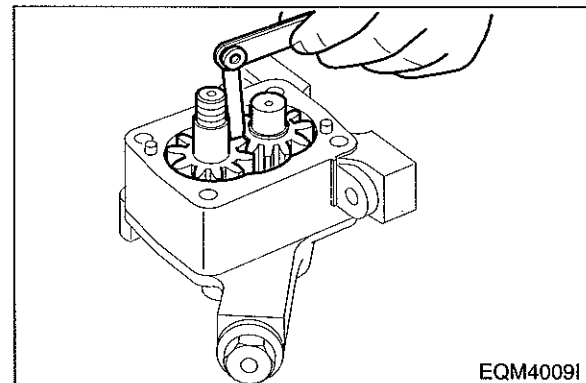

(3) Measuring clearance between drive shaft and bushing

- a. Measure the outside diameters of the drive shaft and driven shaft, and replace if the measured values are less than the limit ($\phi 16.95\text{mm}$)

Standard	$\phi 16.95 \sim \phi 16.968 \text{ mm}$
-----------------	--

- b. Measure the inside diameter of the pump body bushing to determine the clearance between the bushing and shaft, and compare the measured value with the standard value to determine whether to replace or not.

Clearance	$0.032 \sim 0.077 \text{ mm}$
------------------	-------------------------------

● **Reassembly**

- (1) For reassembly, reverse the disassembly sequence.

10.2.3. Diagnostics and troubleshooting

Complaints	Possible causes	Corrections
1. Oil consumption excessive	<ul style="list-style-type: none"> ● Poor oil ● Oil seal or packing leaky ● Pistons or piston rings worn ● Cylinder liner worn ● Piston rings sticking ● Valve guide oil seals or valve guides, or valve stem worn 	<ul style="list-style-type: none"> ● Use suggested oil ● Replace ● Replace pistons and/or piston rings ● Replace cylinder liner ● Replace pistons and/or piston rings ● Replace
2. Oil pressure too low	<ul style="list-style-type: none"> ● Poor oil ● Relief valve sticking ● Restrictions in oil pump strainer ● Oil pump gear worn ● Oil pump feed pipe cracked ● Oil pump defective ● Oil pressure gauge defective ● Various bearings worn 	<ul style="list-style-type: none"> ● Use suggested oil ● Replace ● Clean strainer ● Replace ● Replace ● Correct or replace ● Correct or replace ● Replace
3. Oil deteriorates quickly	<ul style="list-style-type: none"> ● Restriction in oil filter ● Gases leaking ● Wrong oil used 	<ul style="list-style-type: none"> ● Replace filter element ● Replace piston rings and cylinder liner ● Use suggested oil

10.3. Fuel Injection Pump

10.3.1. General information of fuel system

The fuel system consists of the fuel tank, injection pump, injection nozzle, fuel filter, and fuel lines such as pipes and hoses necessary to connect those components.

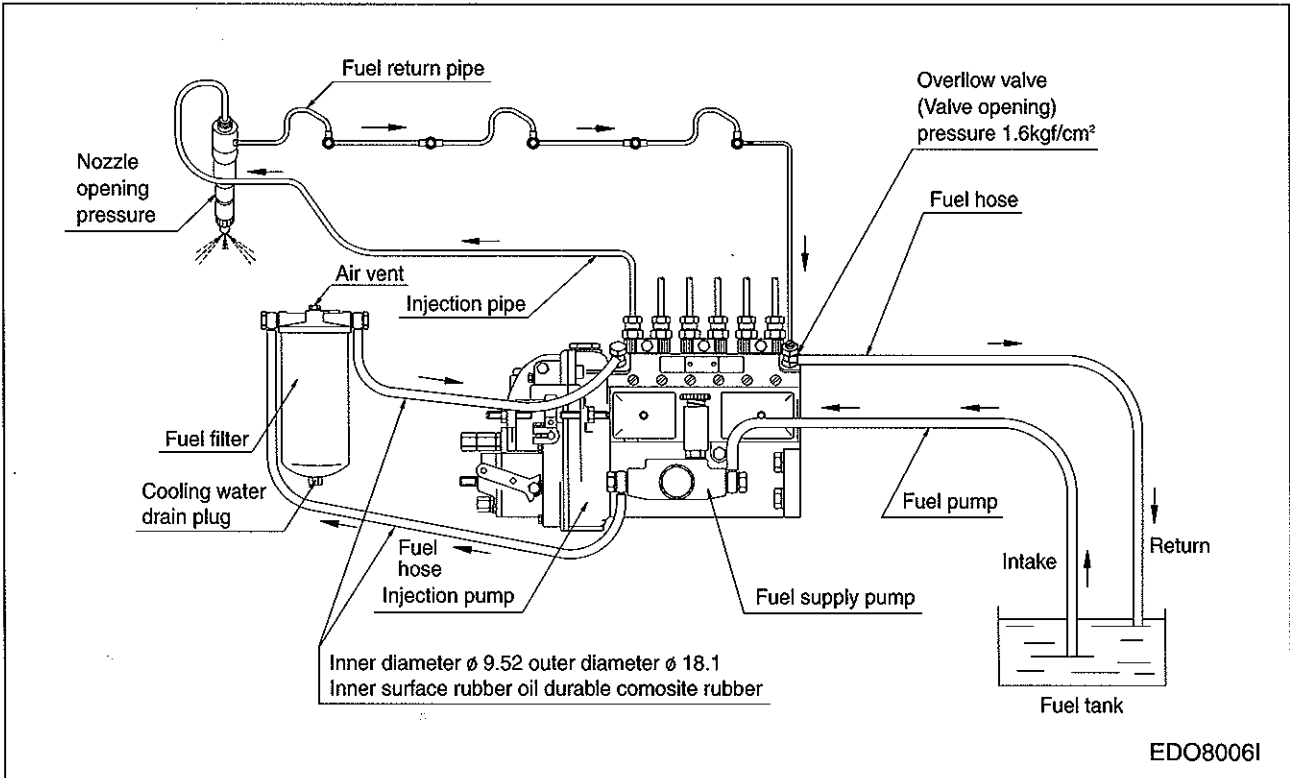

10.3.2. Injection pump

The components relating to the injection pump should be serviced at regular intervals as the plunger and delivery valve may be worn after a given length of time for use and cause the deterioration of the engine.

Make sure that servicing should be performed at the professional maintenance shop as authorized by Bosch or Zexel Company.

For adjustment of fuel injection volume, refer to the 'Specifications of fuel injection pump' described on the following pages.

1) D1146

(1) Injection pump : 65.11101-7269A

- Model : KP-PES6AD95B410RS2 (101061-8820 ZEXEL)
- Governor : KP-EP/RSV200-1350AQ49C311(105419-3930)
- Plunger & barrel : 131153-1720
- Delivery valve : 131110-5120
- Feed pump : KP-FP/KE-ADS(105210-5280)
- Prestroke : 4.6 ± 0.05mm

(2) Nozzle holder assembly : 65.10101-7050 (9134-153C LUCAS)

(3) Nozzle : 65.10102-6026 (9135-143 LUCAS)

(4) Injection pipe : 65.10301-6048

(5) Injection order: : 1 - 5 - 3 - 6 - 2 - 4

(6) Injection timing : BTDC 18°

(A) Test condition for injection pump	Nozzle & Holder Ass'y	105780-8140	Opening pressure :175kg/cm ²
	Injection pipe(ID ,OD ,L)	-	∅2.0 x ∅6.0 – 600 mm
	Test oil	ISO4113	Temperature : 40 ± 5°C
(B) Engine standard parts	Nozzle & holder Ass'y	65.10101-6026	Nozzle (5 x ∅0.29)
		65.10101-7050	214 kg/cm ²
	Injection pipe (ID, OD, L)	65.10301-6048	∅2 x ∅6 – 650 mm

Rack diagram and setting valve at each point

Standby power	Check point	Rack position (mm)	Pump speed (rpm)	Injection Q'ty on RIG (mm ³ / 1,000st)		Press. (mmHg)
				(A) Test condition for inj. Pump	(B) Engine standard parts	
				A	-	
B	-	875	-	(103)	-	
C	-	100	-	(135)	-	
D	≠ 7.7	370	-	±2	-	
-	-	-	-	-	-	-
Boost pressure : zero boost						
Governor weight	740 g	Lever ratio(min/max)		1 : 2		
Governor spring	k = 10.0 kgf/mm	Plunger		∅9.5 Left hand 20+45lead		
Idle spring	k = 1.9 kgf/mm	Delivery valve	retraction pressure		70mm ³ /st , t=0.11	
Start spring	k = 0.01 kgf/mm		opening pressure		23.1kgf/cm ²	
Feed pump	105210-5280		spring		k=1.63kgf/mm	

(7) Governor adjustment (D1146)

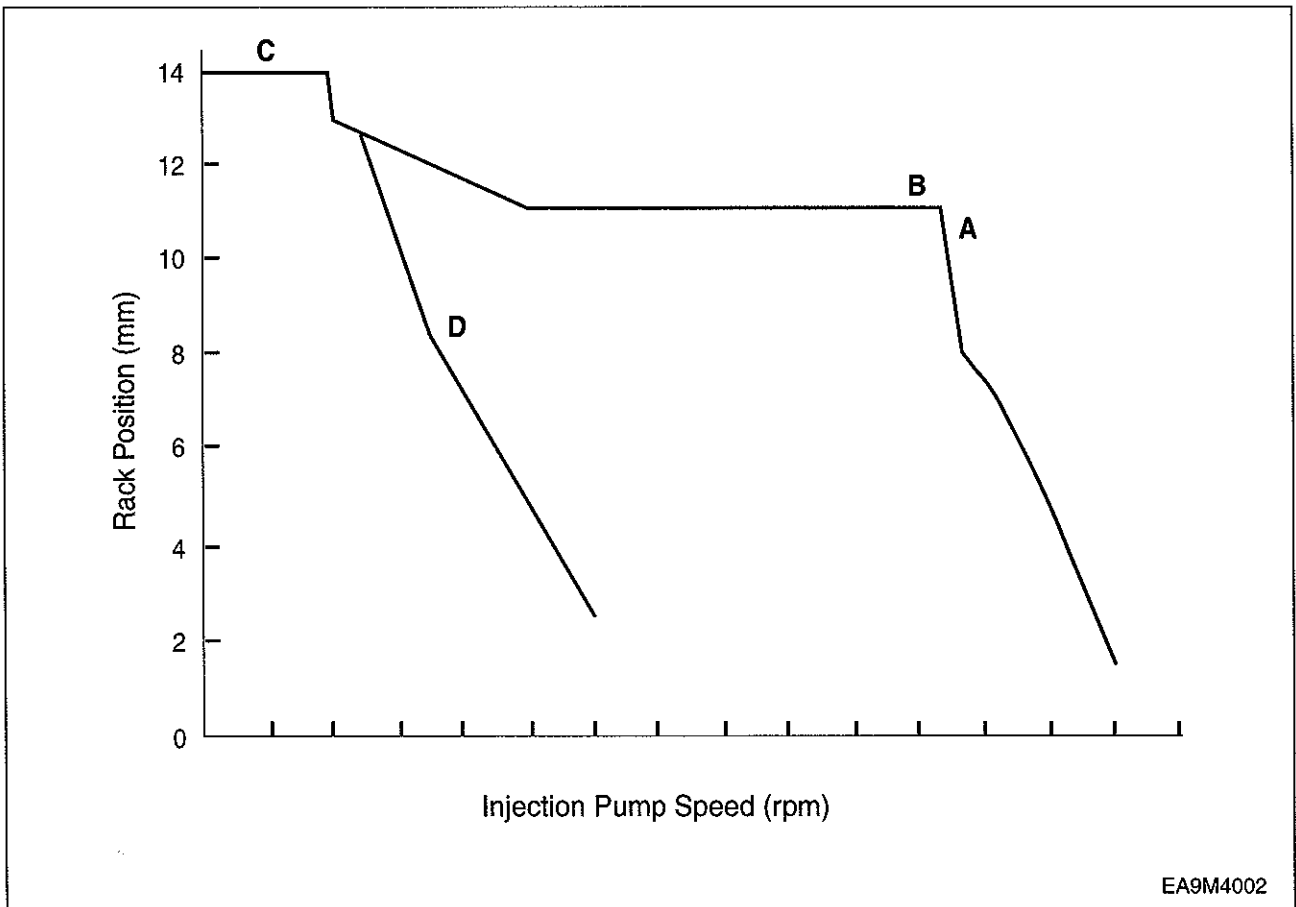

2) D1146T

(1) Injection pump : 65.11101-7271A

- Model : KP-PES6AD95B410RS2 (101061-8820 ZEXEL)
- Governor : KP-EP/RSV200-1350AQ49C311(105419-3930)
- Plunger & barrel : 131153-1720
- Delivery valve : 131110-5120
- Feed pump : KP-FP/KE-ADS(105210-5280)
- Prestroke : 4.6 ± 0.05mm

(2) Nozzle holder assembly : 65.10101-7050 (9134-153C LUCAS)

(3) Nozzle : 65.10102-6026 (9135-143 LUCAS)

(4) Injection pipe : 65.10301-6048

(5) Injection order: : 1 - 5 -3 - 6 - 2 - 4

(6) Injection timing : BTDC 18°

(A) Test condition for injection pump	Nozzle & Holder Ass'y	105780-8140	Opening pressure :175kg/cm ²
	Injection pipe(ID ,OD ,L)	-	∅2.0 x ∅6.0 – 600 mm
	Test oil	ISO4113	Temperature : 40 ± 5°C
(B) Engine standard parts	Nozzle & holder Ass'y	65.10102-6026	Nozzle (5 x ∅0.29)
		65.10101-7050	214 kg/cm ²
	Injection pipe (ID, OD, L)	65.10301-6048	∅2 x ∅6 – 650 mm

Rack diagram and setting valve at each point

Standby power	Check point	Rack position (mm)	Pump speed (rpm)	Injection Q`ty on RIG (mm ³ / 1,000st)		Press. (mmHg)
				(A) Test condition for inj. Pump	(B) Engine standard parts	
				A	-	
B	-	875	-	(126)	-	
C	14 or more	100	-	(140)	-	
D	≠ 7.7	370	-	12.8 ± 2	-	
-	-	-	-	-	-	
Boost pressure : zero boost						
Governor weight	740 g	Lever ratio(min/max)			1 : 2	
Governor spring	k = 10.0 kgf/mm	Plunger			∅9.5 Left hand 20+45lead	
Idle spring	k = 1.9 kgf/mm	Delivery valve	retraction pressure		70mm ³ /st , t=0.11	
Start spring	k = 0.01 kgf/mm		opening pressure		23.1kgf/cm ²	
Feed pump	105210-5280		spring		k=1.63kgf/mm	

(7) Governor adjustment (D1146T)

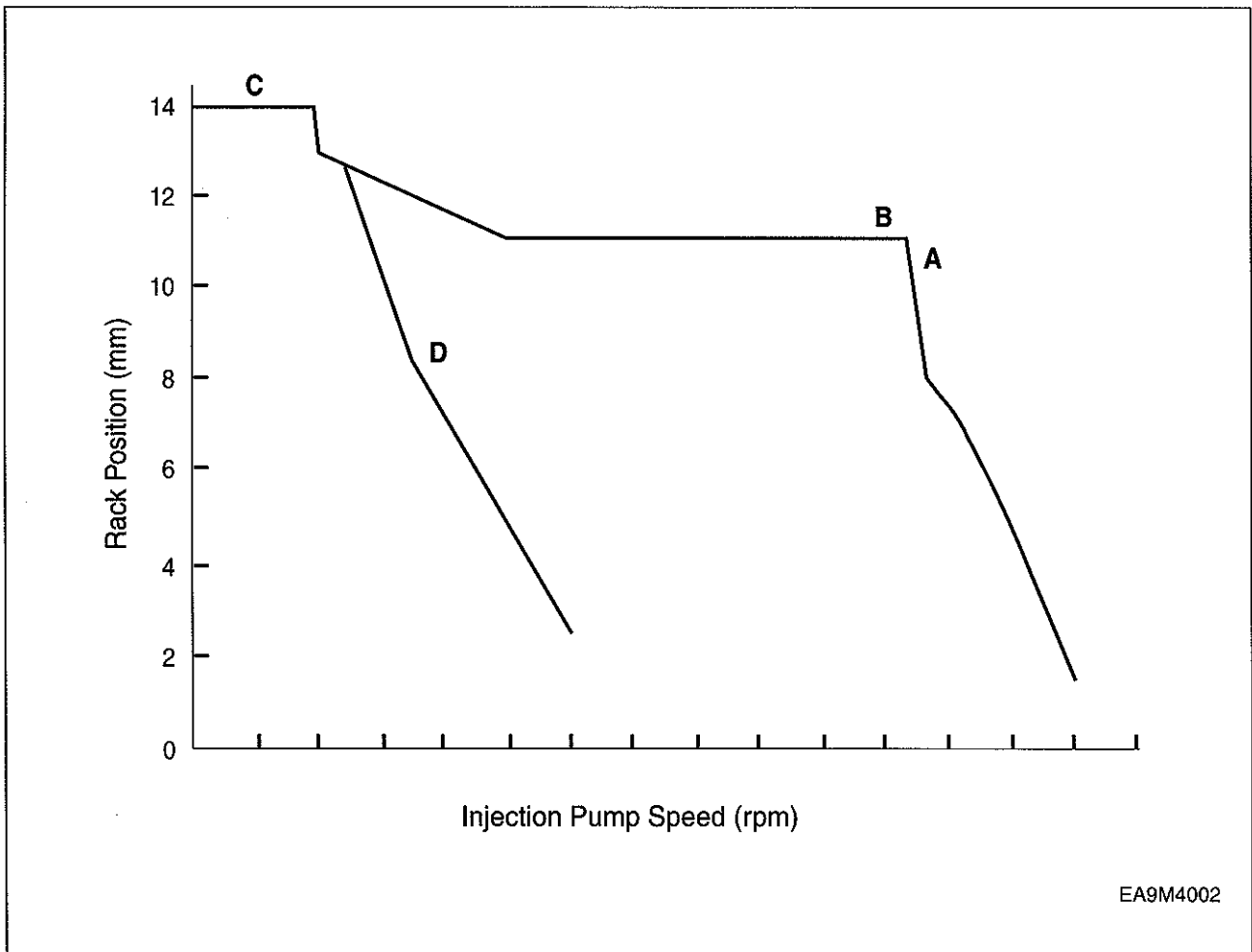

3) P086TI

(1) Injection pump : 65.11101-7309 (106674-4120 ZEXEL)

- Model : NP-PE6P120/700RS3S (106067-6010 ZEXEL)
- Governor : Ghana electric control
- Plunger & barrel : 134153 -2020
- Delivery valve : 134110 - 1420
- Feed pump : NP-FP/KD-PS(105237-5470)
- Prestroke : $3.9 \pm 0.05\text{mm}$

(2) Nozzle holder assembly : 65.10101-7055 (9135-293A LUCAS)

(3) Nozzle : 65.10102-6049 (9135-291 LUCAS)

(4) Injection pipe : 65.10301-6049 , 65.10301-6052

(5) Injection order: : 1 - 5 - 3 - 6 - 2 - 4

(6) Injection timing : BTDC 12°

(A) Test condition for injection pump	Nozzle & Holder Ass'y	9135-293A	Opening pressure : 214 ± 8 bar
	Injection pipe(ID ,OD ,L)	-	$\phi 2.2 \times \phi 6.35 - 650$ mm
	Test oil	ISO4113	Temperature : $40 \pm 5^\circ\text{C}$
(B) Engine standard parts	Nozzle & holder Ass'y	65.10102-6049	Nozzle (5 x $\phi 0.34$)
		65.10101-7055	214 kg/cm ²
	Injection pipe (ID, OD, L)	65.10301-6049 65.10301-6052	$\phi 2.2 \times \phi 6.35 - 650$ mm

Rack diagram and setting valve at each point

Standby power	Check point	Rack position (mm)	Pump speed (rpm)	Injection Q`ty on RIG (mm ³ / 1,000st)		Press. (mmHg)
				(A) Test condition for inj. Pump	(B) Engine standard parts	
				A	12.2	
						-
						-
						-
						-
Boost pressure : zero boost						
Governor weight	26kg	Lever ratio(min/max)			1 : 2	
Governor spring	-	Plunger			$\phi 12$ Left hand 30lead	
Idle spring	-	Delivery valve	retraction pressure		100mm ³ /st , t=0.09	
Start spring	-		opening pressure		18.5kgf/cm ²	
Feed pump	105210-5280		spring		k=0.87kgf/mm	

4) PU086

(1) Main Specification

Fuel Injection Pump : 65.11101-7269A
 Model Type : PES6AD
 Governor Type : RSV
 Fuel Feed Pump : 105210-4830
 Cam Lift : 11 mm
 Injection Timing : BTDC 18° ± 1°
 Injection Order : 1-5-3-6-2-4
 Rotating Direction : Clockwise (Viewed at driving gear side)

(2) Calibration Data

(A) Test condition for injection pump	Nozzle & Holder Ass'y	105780-8140	Opening pressure :175kg/cm ²			
	Injection pipe(ID ,OD ,L)	-	ø2.0 x ø8.0 – 600 mm			
	Test oil	ISO4113	Temperature : 40 ± 5°C			
(B) Engine standard parts	Nozzle & holder Ass'y		Nozzle (5 x ø0.36)			
		65.10101-7050	214 + 8 kg/cm ²			
	Injection pipe (ID, OD, L)	-	ø6 x ø2.2 – 650 mm			
Rack diagram and setting valve at each point						
Refer to (3) Rack Diagram	Check point	Rack position (mm)	Pump speed (rpm)	Injection Q`ty on RIG (mm ³ / 1,000st)		Press. (mmHg)
				(A) Test condition for inj. Pump	(B) Engine standard parts	
	A	10.5	1100	88.5 ± 2	± 2.5	Full
	B	7.7	370	11.5 ± 2	± 25	Idle
C	≈	100	(135)	-	-	
Balance Weight	740g	Lever ratio(min/max)		1 : 1.2		
Governor spring	k = 7.2 kg/mm	Plunger		ø9.5 , 20+45 lead		
Idle spring	k = 1.9 kg/mm	Delivery valve retraction volume		70 mm ³ /st, t=0.11		
Idle sub spring	k = 3.0 kg/mm	Delivery valve opening pressure		23.1 kg/cm ²		
Start spring	k = 0.01 kg/mm	Delivery valve spring		k = 1.63 kg/mm		
Max. discharge pressure	k = 3.4 kg/mm ²	Feed pump		105210-5280 (KP-FP/KE-ADS)		

(3) Rack Diagram

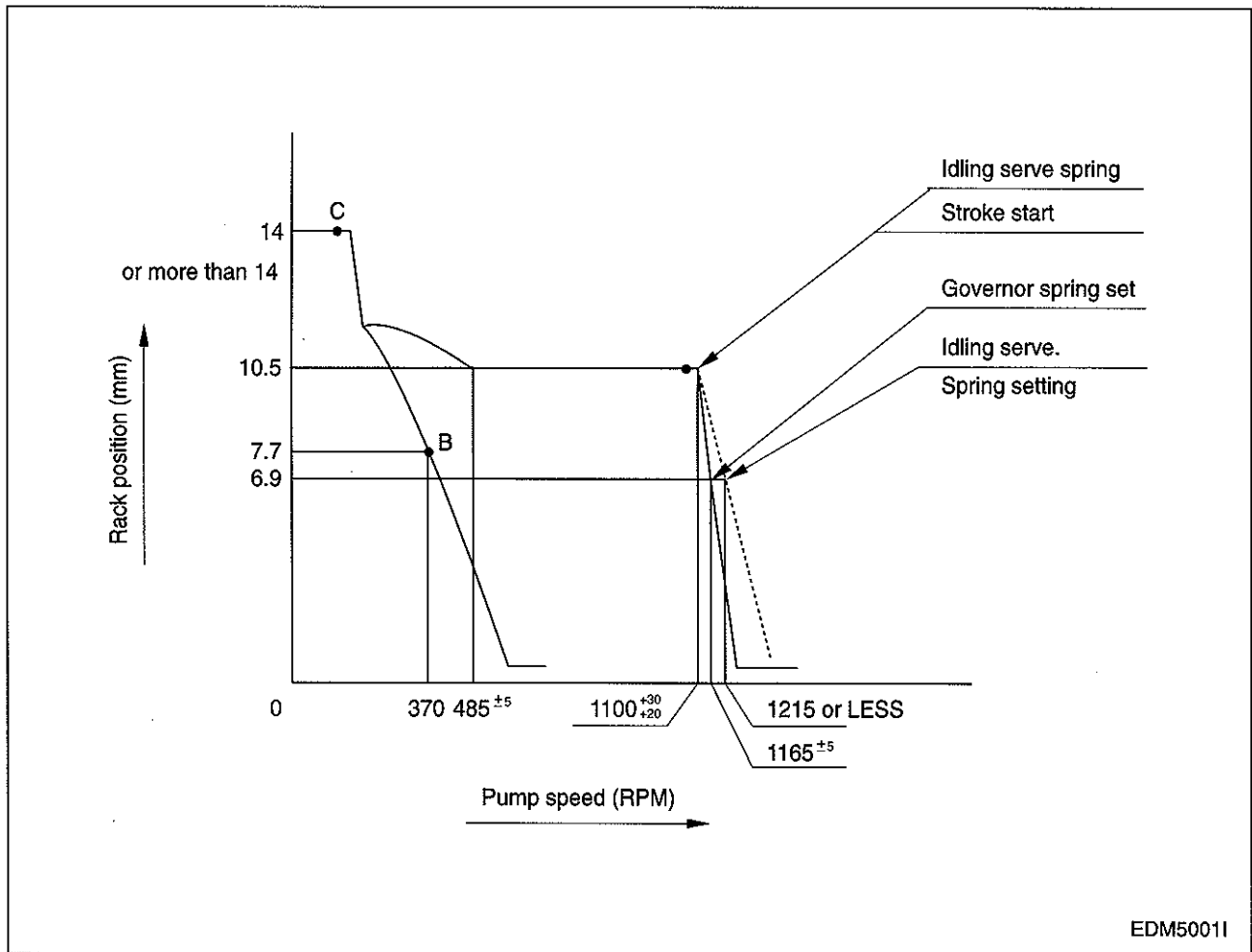

EDM50011

5) PU086T

(1) Main Specification

Fuel Injection Pump	: 65.11101-7271A
Model Type	: PES6AD
Governor Type	: RSV
Fuel Feed Pump	: 105210-4830
Cam Lift	: 11 mm
Injection Timing	: BTDC 12° ± 1°
Injection Order	: 1-5-3-6-2-4
Rotating Direction	: Clockwise (Viewed at driving gear side)

(2) Calibration Data

(A) Test condition for injection pump	Nozzle & Holder Ass'y	105780-8140	Opening pressure :175kg/cm ²			
	Injection pipe(ID ,OD ,L)	-	ø2.0 x ø8.0 – 600 mm			
	Test oil	ISO4113	Temperature : 40 ± 5°C			
(B) Engine standard parts	Nozzle & holder Ass'y		Nozzle (5 x ø0.36)			
		65.10101-7050	214 + 8 kg/cm ²			
	Injection pipe (ID, OD, L)	-	ø6 x ø2.2 – 650 mm			
Rack diagram and setting valve at each point						
Refer to (3) Rack Diagram	Check point	Rack position (mm)	Pump speed (rpm)	Injection Q`ty on RIG (mm ³ / 1,000st)		Press. (mmHg)
				(A) Test condition for inj. Pump	Max. Var. Bet. Cyl. (%)	
	A	10.5	1100	113.5 ± 2	± 2.5	Full
	B	7.9	370	11.5 ± 2	± 25	Idle
	C	≈	100	-	-	-
Balance Weight	740g	Lever ratio(min/max)		1 : 1.2		
Governor spring	k = 7.2 kg/mm	Plunger		ø9.5 , 20+45 lead		
Idle spring	k = 1.9 kg/mm	Delivery valve retraction volume		70 mm ³ /st, t=0.11		
Idle sub spring	k = 3.0 kg/mm	Delivery valve opening pressure		23.1 kg/cm ²		
Start spring	k = 0.01 kg/mm	Delivery valve spring		k = 1.63 kg/mm		
Max. discharge pressure	k = 3.4 kg/mm ²	Feed pump		105210-5280 (KP-FP/KE-ADS)		

(3) Rack Diagram

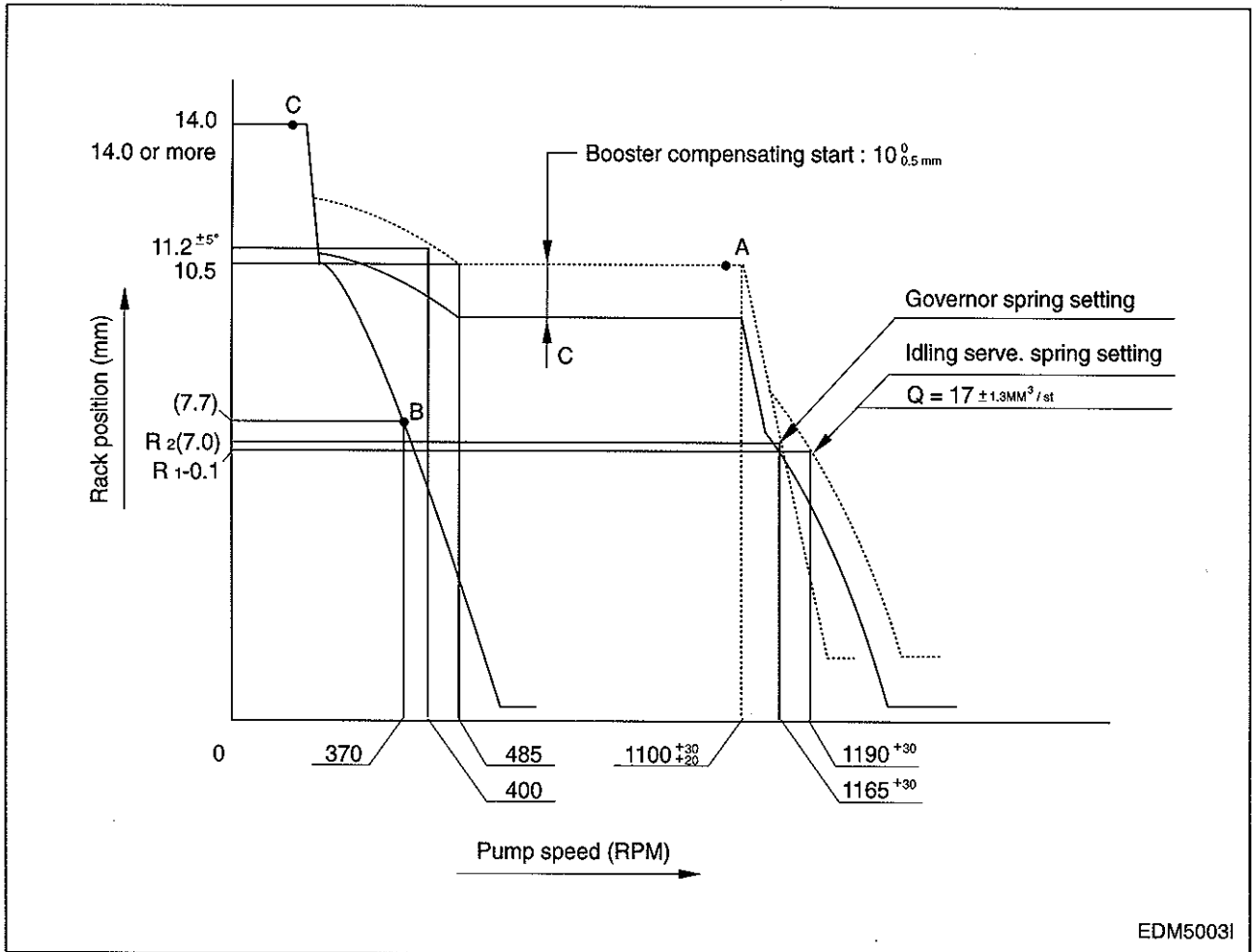

EDM5003I

10.3.3. Governor system (P086TI Only)

Governor system for fuel injection pump consists of "Integral Actuator" and "Speed Control Unit".

1) Integral Actuator

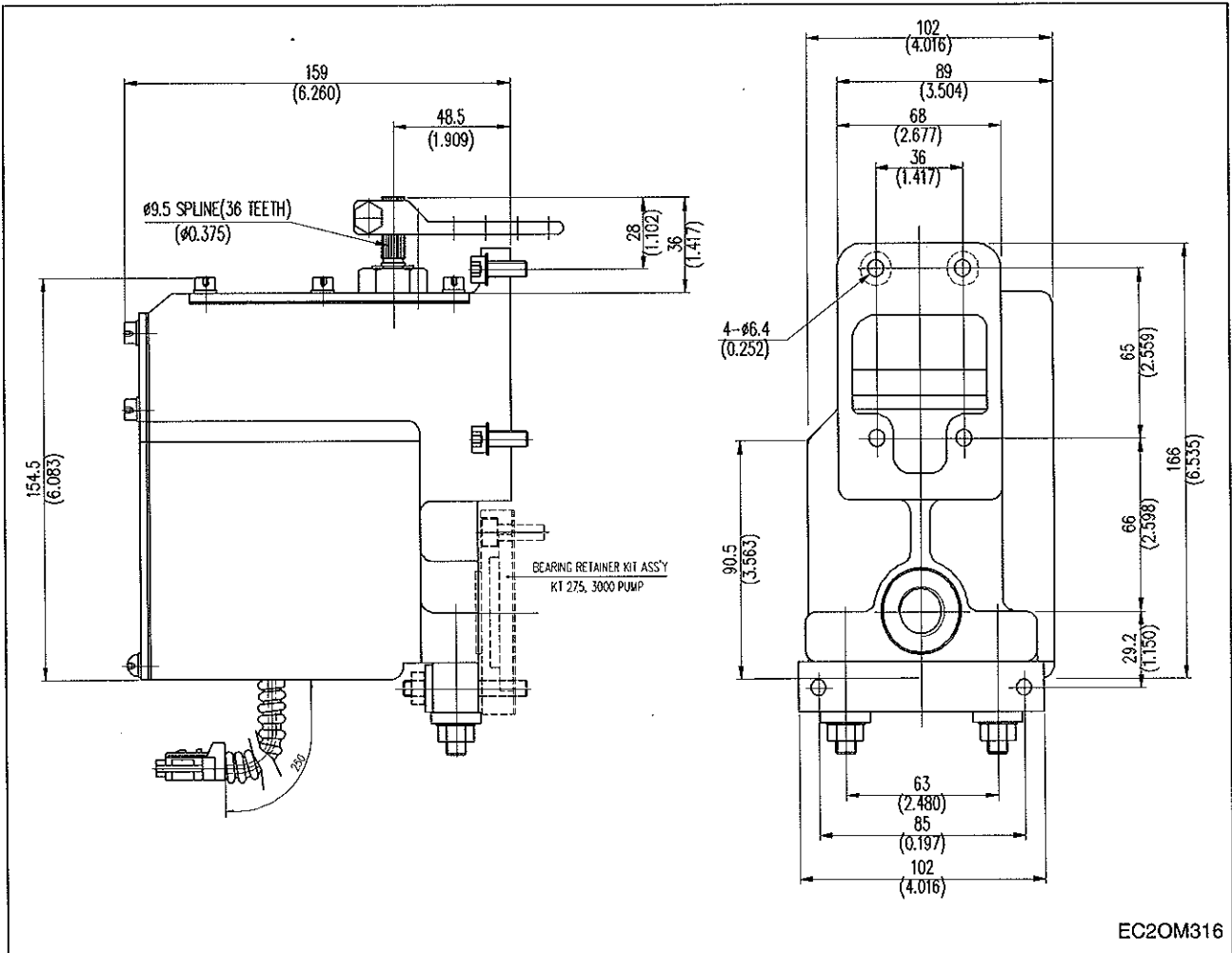

EC20M316

<Dimension View>

Fig. No.	Description	Q'ty	Remark
1	Frame	1	
2	Bearing retainer kit Ass'y	1	
3	Mounting bar	1	
8	SWP connector	1	Mg610320
11	Front cover	1	T3.2
13	Shaft	1	
15	Return spring guide Ass'y	1	
16	Oil seal	1	SC 0283 E0
17	Allen screw	8	M5 x 0.8 x L12
23	Manual stop device Ass'y	1	
30	Stop plate	1	T3.2
52	Return shaft Ass'y	1	
54	Stop level	1	
62	Lead wire		LG 16AWG
63	Corrugate tube		Dia.10, L250+-10

2) Speed control unit for governor system
 (DWC-2000 SERIES SPEED CONTROL UNIT)

<Introduction>

This speed control unit performs the electronic function of the engine governing system. The speed control unit senses the pulses from the magnetic speed sensor, compares them with the speed control unit's set point and supplies the appropriate current output to the actuator to control the engine's fuel system.

An integral, independent single element speed switch is provided internally which can be used to initiate engine shutdown in the event that an overspeed condition is reached. The performance of the speed control unit is fast and responsive in either isochronous or droop operation.

Adjustments are provided for: operating speed, idle speed, overspeed shutdown setting, droop, run ramp, crank ramp, starting fuel, speed ramping and two performance adjustments (gain and stability). All adjustments are accessible from the front cover. The primary features of the DWC-2000 Series speed control unit are the engine STARTING FUEL and SPEED RAMPING adjustments. The use of these features will minimize engine exhaust smoke experienced prior to attain engine operating speed. The speed control unit also includes other features such as adjustable droop and idle operation, inputs for accessories used in multi-engine or special applications and protection against reverse voltage polarity, transient voltages and accidental short circuit of the actuator. Loss of battery supply, loss of speed sensor and overspeed signaling are built-in to provide engine shutdown.

<Description>

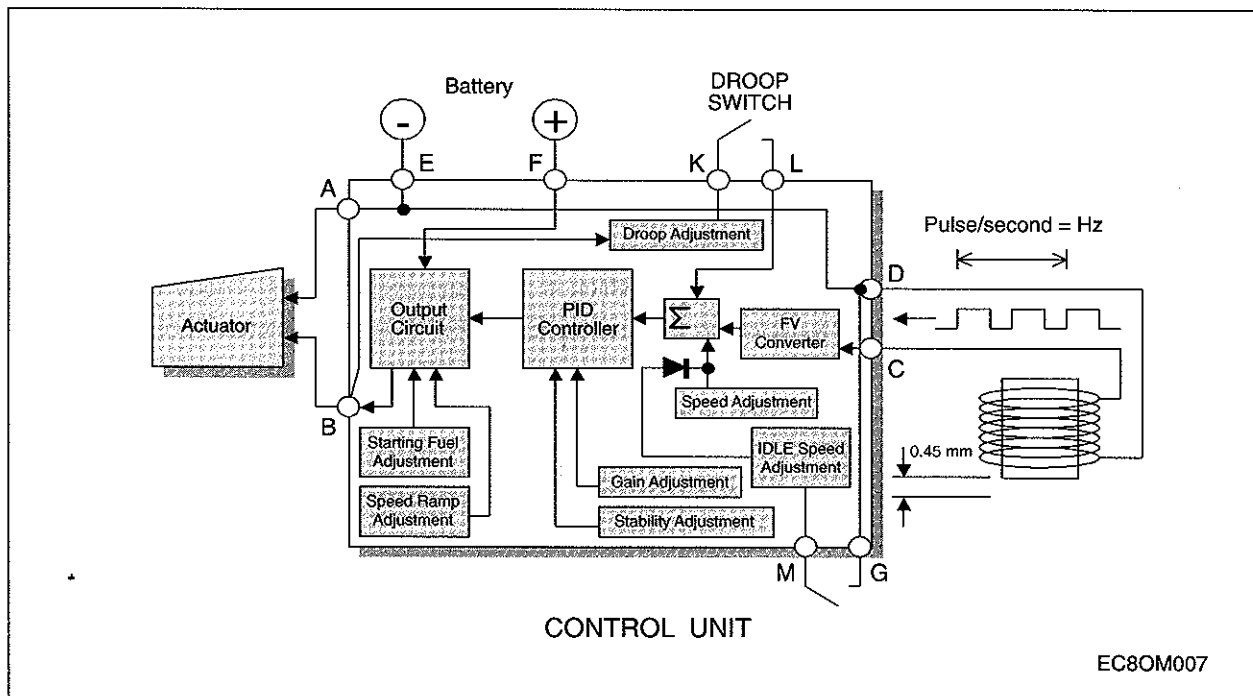

Figure 1. Governor system schematic.

The engine speed signal is usually obtained from a magnetic speed sensor mounted in close proximity to the teeth of a ferrous ring gear that is driven by the engine. The frequency of the speed sensor signal is proportional to the engine speed. The speed control unit will accept any signal if the frequency is proportional to engine signal, and in the frequency range of the speed control unit (1K to 7.5K Hz.). The speed sensor is typically mounted in close proximity to an engine driven ferrous gear, usually the engine ring gear. As the teeth of the gear pass the magnetic sensor, a signal is generated which is proportional to engine speed. The signal strength must also be within the range of the input amplifier. An amplitude of 1 to 120 volts RMS is required to allow the unit to function within its design specifications. The speed control unit has an input impedance of 20K-ohms between the speed sensor input terminals. ("C" & "D"). Terminal "D" is connected internally to the battery negative. Only one end of the shielded cable should be connected.

When a speed sensor signal is received by the controller, the signal is amplified and shaped by an internal circuit to form constant area pulses. If the speed sensor monitor does not detect a speed sensor signal, the output circuit of the speed control unit will turn off all current to the actuator.

The summing point of the speed sensor and the speed adjust control is the input to the dynamic control section of the governor. The dynamic control circuit, of which the gain and stability adjustments are part, has a control function that will provide isochronous and stable performance for most engine types and fuel systems.

The speed control unit circuit is influenced by the gain and stability performance adjustments. The governor system sensitivity is increased with clockwise rotation of the gain adjustment. The gain adjustment has a non-linear range of 33:1. The stability adjustment, when advanced clockwise, increases the time rate of response of the governor system to match the various time constants of a wide variety of engines. The speed control unit is a PID device, the "D", derivative portion can be varied when required. (See Instability section.)

During the engine cranking cycle, STARTING FUEL can be adjusted from an almost closed, to a nearly full fuel position. Once the engine has started, the speed control point is determined, first by the IDLE speed set point and the SPEED RAMPING circuit. After engine speed ramping has been completed, the engine will be at its governed operating speed. At the desired governed engine speed, the actuator will be energized with sufficient current to maintain the desired engine speed, independent of load (isochronous operation).

The output actuator current switching circuit provides current to drive the actuator. The output transistor is alternately switched off and on at a frequency of 300Hz. which is well beyond the natural frequency of the actuator, hence no visible motion from the switching results. Switching the output transistors reduces its internal power dissipation for efficient power control. The output circuit can provide current of up to 10amps continuous at 25°C for 24VDC battery systems. The actuator responds to the average current to position the engine fuel control lever.

In standard operation, the speed control unit performance is isochronous. Droop governing can be selected by connecting terminals K & L and the percent of droop governing can be varied with the droop adjustment control. The droop range can be decreased by connecting Terminals G and H.

The speed control unit has several performance and protection features which enhance the governor system. A speed anticipation circuit minimizes speed overshoot on engine startup or when large increments of load are applied to the engine.

1) Specification

● Performance

Isochronous Operation / Steady State Stability	±0.25% or better
Speed Range/Governor	1K~7.5 K Hz continuous
Speed Drift with Temperature	±0.5% Maximum
Idle Adjust CW	60% of set speed
Idle Adjust CCW	Less than 1200Hz
Droop Range	1-5% regulation *
Droop Adj. Max.(K-L Jumpered)	450 Hz., ± 90 Hz. per 1.0A change
Droop Adj. min.(K-L Jumpered)	20 Hz., ± 8 Hz. per 1.0A change
Speed Trim Range	±210 Hz
Remote Variable Speed Range	500~7.5 Hz. or any part thereof
Terminal Sensitivity	
J	100 Hz ± 15 Hz/Volt @ 6.0K Impedence
L	680 Hz ± 50 Hz/Volt @ 165K Impedence
N	135 Hz ± 10 Hz/Volt @ 1MΩ Impedence
P	10 VCD Supply @ 20 [mA] Max.

● Environmental

Ambient Operating Temperature Range	-40~85°C
Relative Humidity	up to 95%
All Surface Finishes	Fungus Proof and Corrosion Resistant

● Power input

Supply	24VDC Battery System(Transient and Reverse Voltage Protected)**
Polarity	Negative Ground(Case Isolated)
Power Consumption	50[mA] continuous plus actuator current
Maximum controllable actuator current at 25°C-(Inductive Load)	10{A} continuous***
Magnetic Speed Sensor Signal	1~120[V] RMS

● Reliability

vibration	1G @ 20~100 Hz
Testing	100% Functionally Tested

● Physical

Dimensions	See Outline(Dia. 1)
Weight	705 grams
Mounting	Any Position, Vertical Preferred

* Droop is based on a speed sensor frequency of 4000Hz. and an actuator current change of 1amp from no load to full load. Applications with higher speed sensor signals will experience less percentage of droop. See droop description for specific details on operation of droop ranges.

** Protected against reverse voltage by a series diode. A 15 amp fuse must be installed in the positive battery lead.

*** Protected against short circuit to actuator(shuts off current to actuator), unit automatically turns back on when short is removed.

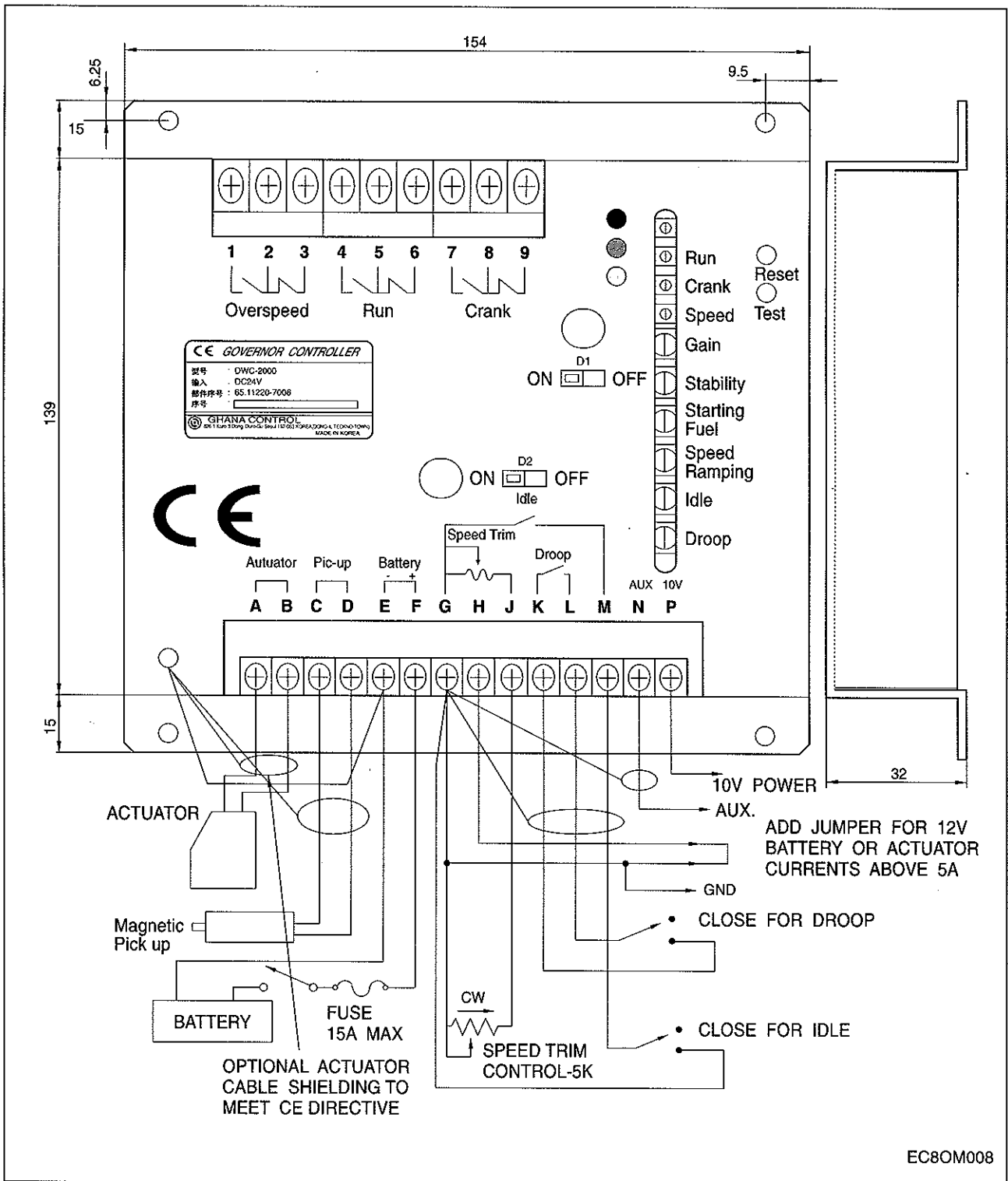

Diagram 1. DWC-2000 Wiring and Outline

EC80M008

2) Application and installation information

The speed control unit is rugged enough for mounting in a control cabinet or engine mounted enclosure or in a remote console up to 20 meters(65ft.) from the engine. Care should be taken to insure that the speed control unit, mount it vertically so that condensation will not accumulate in the speed control unit.

<Warning>

An overspeed shutdown device, independent of the governor system, should be provided to prevent loss of engine control which may cause personal injury or equipment damage. Do not rely exclusively on the governor system electric actuator to prevent over speed. A Secondary shutoff device, such as a fuel solenoid must be used.

3) Wiring

Wiring to the speed control unit should be as shown in Diagram 1. Wire leads to the battery and actuator from the speed control unit terminals A, B, E and F should be #16 AWG(1.3 mm sq.) or larger. Long cables require an increased wire size to minimize voltage drops. An external 15amp fuse is recommended in series with terminal F, the positive (+) battery input terminal.

The magnetic speed sensor leads must be twisted and/or shielded for their entire length. If shielded cables are used, connect all the shields to terminal D only. The shield should be insulated to insure no other part of the shield comes in contact with engine ground, otherwise stray speed signals may be introduced to the speed control unit. With the engine stopped, adjust the gap between the magnetic speed sensor and the ring gear teeth. The gap should not be any smaller than 0.020 in.(0.45mm). Usually, gear tooth will achieve a satisfactory air gap. The magnetic speed sensor voltage should be at least 1 VAC RMS during cranking.

4) Adjustments

● Before starting engine

Confirm the following adjustment positions. The adjustments are factory pre-set as follows :

Check to insure the GAIN and STABILITY adjustments, and if applied, the external SPEED TRIM CONTROL are set to mid position.

Preset the DWC-2000 as follows:

Gain	Minimum CCW
Stability	Mid-range
Speed Adjust	3650Hz
Idle	1950Hz
Droop	Maximum CCW (minimum setting)
Overspeed	Maximum CW
Run Ramp	Maximum CW
CRANK Ramp	Maximum CW
STARTING FUEL	FULL CW(Maximum Fuel)
SPEED RAMPING	FULL CCW(Fastest)

- **Start engine**

The speed control unit governed speed setting is factory set at approximately engine idle speed. Crank the engine with DC power applied to the governor system. The actuator will energize to the maximum fuel position until the engine starts. The governor system should control the engine at a low idle speed. If the engine is unstable after starting, turn the GAIN and STABILITY adjustments counterclockwise until the engine is stable.

- **Governor speed setting**

The governed speed set point is increased by clockwise rotation of the SPEED adjustment control. Remote speed adjustment can be obtained with an optional 5K Speed Trim Control.
(See Diagram 1.)

- **Governor performance**

Once the engine is at operating speed and at no load, the following governor performance adjustment can be made.

- A. At no load, turn the gain control CW until instability results. Then back-off slightly CCW (1/8 turn) beyond the point where stability returns.
- B. Turn the stability control CW until instability results. Then back-off slightly CCW (1/8 turn) beyond the point where stability returns. Excellent performance should result from these adjustments.

If instability cannot be corrected or further performance improvements are required, refer to the section on SYSTEM TROUBLESHOOTING.

- **Starting fuel adjustment**

The engine's exhaust smoke at start-up can be minimized by completing the following adjustments.

- A. Place the engine in idle by connecting Terminals M & G.
- B. Adjust the IDLE speed for as low a speed setting as the application allows.
- C. Adjust the STARTING FUEL CCW until the engine speed begins to fall. Increase the STARTING FUEL slightly so that the idle speed is returned to the desired level.
- D. Stop the engine.

One of two methods of operation for the DWC-2000 may now be selected.

Method 1 : Start the engine and accelerate directly to the operating speed(Gen Sets, etc.).

- ✘ Remove the connection between Terminals M & G. Start the engine and adjust the SPEED RAMPING for the least smoke on acceleration from idle to rated speed. If the starting smoke is excessive, the STARTING FUEL may need to be adjusted slightly CCW. If the starting time is too long, the STARTING FUEL may need to be adjusted slightly CW.

Method 2 : Start the engine and control at an idle speed for a period of time prior to accelerating to the operating speed. This method separates the starting process so that each may be optimized for the lowest smoke emissions.

✘ Replace the connection between Terminals M & G with a switch, usually an oil pressure switch. Start the engine. If the starting smoke is excessive, the STARTING FUEL may need to be adjusted slightly CCW. If the starting time is too long, the STARTING FUEL may need to be adjusted slightly CW.

When the switch opens, adjust the SPEED RAMPING for the least amount of smoke when accelerating from idle speed to rated speed.

● Idle speed setting

If the IDLE speed setting was not adjusted as detailed in "Starting Fuel Adjustment" section, then place the optional external selector switch in the IDLE position. The idle speed set point is increased by clockwise rotation of the IDLE adjustment control. When the engine is at idle speed, the speed control unit applies droop to the governor system to insure stable operation

● Speed droop operation

Droop is typically used for the paralleling of engine driven generators.

Place the optional external selector switch in the DROOP position, DROOP is increased by clockwise rotation of the DROOP adjustment control. When in droop operation, the engine speed will decrease as engine load increases. The percentage of droop is based on the actuator current change from engine no load to full load. A wide range of droop is available with the internal control. Droop level requirements above 10% are unusual.

If droop levels experienced are higher or lower than those required, contact the factory for assistance.

After the droop level has been adjusted, the rated engine speed setting may need to be reset. Check the engine speed and adjust the speed setting accordingly.

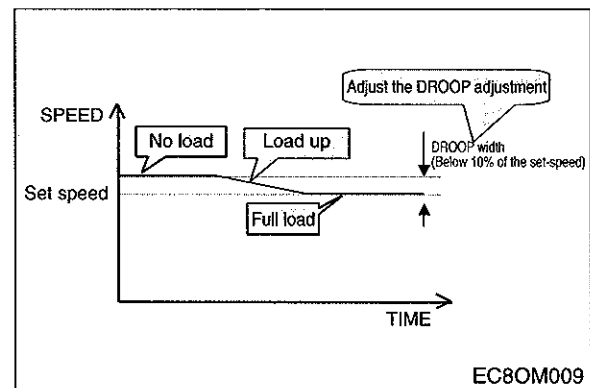

Figure 3. The relation between the speed and a amount of load.

● **Accessory input**

The AUXiliary Terminal N accepts input signals from load sharing units, auto synchronizers, and other governor system accessories, DWC accessories are directly connected to this terminal. It is recommended that this connection from accessories be shielded as it is a sensitive input terminal. If the auto synchronizer is used alone, not in conjunction with a load sharing module, a 3M ohm resistor should be connected between Terminals N and P. This is required to match the voltage levels between the speed control unit and the synchronizer.

when an accessory is connected to Terminal N, the speed will decrease and the speed adjustment must be reset.

when operating in the upper end of the control unit frequency range, a jumperwire or frequency trim control may be required between Terminals G and J. This increases the frequency range of the speed control to over 7000Hz.

● **Accessory supply**

the +10 volt regulated supply, Terminal P, can be utilized to provide power to DWC- 2000 governor system accessories. Up to 20ma of current can be drawn from this supply. Ground reference is Terminal G. Caution : a short circuit on this terminal can damage the speed control unit.

● **Wide range remote variable speed operation**

Simple and effective remote variable speed can be obtained with the DWC-2000 Series control unit. A single remote speed adjustment potentiometer can be used to adjust the engine speed continuously over specific speed range. Select the desired speed range and the corresponding potentiometer value.(Refer to TABLE 1.) If the exact range cannot be found, select the next higher range potentiometer. An additional fixed resistor may be placed across the potentiometer to obtain the exact desired range. Connect the speed range potentiometer as shown in Diagram 2.

To maintain engine stability at the minimum speed setting, a small amount of droop can be added using the DROOP adjustment. At the maximum speed setting the governor performance will be near isochronous, regardless of the droop adjustment setting.

TABLE 1. Variable Speed Range Potentiometer Value

Speed Range	Potentiometer Value
900 Hz	1K
2,400 Hz	5K
3,000 Hz	10K
3,500 Hz	25K
3,700 Hz	50K

Diagram 2.

● **OVERSPEED shutdown setting**

DWC-2000 has a Test switch to determine the OVERSPEED set point and test the engine shutdown function. If you want to adjust the OVERSPEED set point at the speed about 10% higher than the RUN set speed, use the Test switch. When the engine is operating at the Run set speed in pushing the Test switch, rotate the Overspeed Adjust. by CCW until the Overspeed shutdown function is operated. When the Test switch is pushed, the Overspeed set point is reduced to 10/11 of the real set point.

● **RUN ramp turn-on speed setting**

When the engine is operating at the Run set speed, adjust the Run lamp adjustment CCW until the lamp is on. Then, more rotate 1/2 turn by CCW.

● **CRANK ramp turn-on speed setting**

When the engine is operating at the Idle set speed(800rpm), adjust the Crank lamp adjustment CCW until the lamp is on. Then, more rotate 1.5 turns by CCW.

5) System troubleshooting

● **System Inoperative**

If the engine governing system does not function, the fault may be determined by performing the voltage tests described in steps 1,2,3,and 4. (+) and (-) refer to meter polarity. Should normal values be indicated as a result of following the trouble shooting steps, the fault may be with the actuator or the wiring to the actuator. See the actuator publication for testing details.

STEP	TERMINALS	NORMAL VALUE	PROBABLE CAUSE OF ABNORMAL READING
1	F(+) & E(-)	Battery Supply Voltage(24V)	<ol style="list-style-type: none"> 1. DC battery power not connected. Check for blown fuse. 2. Low battery voltage. 3. Wiring error.
2	C & D	1.0VAC RMS min., while cranking	<ol style="list-style-type: none"> 1. Gap between speed sensor and gear teeth too great. Check gap. 2. Improper or defective wiring to the speed sensor. Resistance between terminals C and D should be 30 to 1200ohms 3. Defective speed sensor.
3	P(+) & G(-)	10VDC, Internal Supply	<ol style="list-style-type: none"> 1. Short on terminal P. (This will cause a defective unit.) 2. Defective Speed Control.
4	F(+) & A(-)	1.0 - 2.0 VDC while cranking	<ol style="list-style-type: none"> 1. SPEED adjustment set too low. 2. Short/open in actuator wiring. 3. Defective speed control. 4. Defective actuator. See Actuator Troubleshooting.

● **Unsatisfactory performance**

If the governing system functions poorly, perform the following tests.

SYMPTOM	TEST	PROBABLE FAULT
Engine overspeeds	Do not crank. Apply DC power to the governor system.	<p>Actuator goes to full fuel. then, disconnect speed sensor at Terminals C & D.</p> <ul style="list-style-type: none"> ● If actuator still at full fuel → speed control unit defective. ● If actuator at minimum fuel position → erroneous speed signal. Check speed sensor data.
	Manually hold the engine at the desired running speed. Measure the DC voltage between Terminals A(-)&F(+) on the speed control unit.	<ol style="list-style-type: none"> 1. If the voltage reading is 4.0to6.0VDC <ol style="list-style-type: none"> a) SPEED adjustemnt set above desired speed b) Defective speed control unit. 2. If the voltage reading is above 6.0VDC. <ol style="list-style-type: none"> a) Actuator or linkage binding. 3. if the voltage reading is below 4.0VDC. 4. Gain set too low.
Actuator does not energize fully.	Measure the voltage at the battery while cranking.	If the voltage is less than 15V for a 24V system, replace the battery if it is weak or undersized.
	Momentarily connect Terminals A and F. The actuator should move to the full fuel position.	<ol style="list-style-type: none"> 1. Actuator or battery wiring in error. 2. Actuator or linkage binding. 3. Defective actuator. See actuator troubleshooting. 4. Fuse opens. Check for short in actuator or actuator wiring harness.
Engine remains below desired governed speed.	Measure the actuator output. Terminals A&B, while running under governor control	<ol style="list-style-type: none"> 1. If voltage measurement is within approximately 3 volts of the battery supply voltage, then fuel control restricted from reaching full fuel position. Possibly due to interference from the mechanical governor, carburetor spring or linkage alignment. 2. Speed setting too low.

● **Insufficient magnetic speed sensor signal**

A strong magnetic speed sensor signal will eliminate the possibility of missed or extra pulses. The speed control unit will govern well with 0.5volts RMS speed sensor signal. A speed sensor signal of 3 volts RMS or greater at governed speed is recommended. Measurement of the signal is made at Terminals C and D.

The amplitude of the speed sensor signal can be raised by reducing the gap between the speed sensor tip and the engine rind gear. The gap should not be any smaller than 0.020 in (0.45mm). when the engine is stopped, back the speed sensor out by 3/4 turn after touching the ring gear tooth to achieve a satisfactory air gap.

- **Electromagnetic compatibility (EMC)**

EMI SUSCEPTIBILITY - The governor system can be adversely affected by large interfering signals that are conducted through the cabling or through direct radiation into the control circuits.

All DWC-2000 speed control units contain filters and shielding designed to protect the units sensitive circuits from moderate external interfering sources.

Although it is difficult to predict levels of interference, applications that include magnetos, solid state ignition systems, radio transmitters, voltage regulators or battery chargers should be considered suspect as possible interfering sources.

If it is suspected that external fields, either those that are radiated or conducted, are or will affect the governor systems operation, it is recommended to use shielded cable for all including the speed sensor shield, is connected to a single point on the case of the speed control unit. Mount the speed control unit to a grounded metal back plate or place it in a sealed metal box.

Conduction is when the interfering signal is conducted through the interconnecting wiring to the governor system electronics. Shielded cables and installing filters are common remedies.

As an aid to help reduce the levels of EMI of a conductive nature, a battery line filter and shielded cables are conveniently supplied by DWC.

- **Instability**

Instability in a closed loop speed control system can be categorized into two general types. PERIODIC appears to be sinusoidal and at a regular rate. NON-PERIODIC is a random wandering or an occasional deviation from a steady state band for no apparent reason.

Switch D1 controls the Differential function. When the position of switch D1 is "ON", the function is operated. Move the switch to the "OFF" position if there is fast instability in the system.

The PERIODIC type can be further classified as fast or slow instability. Fast instability is a 3Hz. or faster irregularity of the speed and is usually a jitter. Slow periodic instability is below 3Hz., can be very slow, and is sometimes violent.

If fast instability occurs, this is typically the governor responding to engine firings. Raising the engine speed increases the frequency of instability and vice versa. In this case, placing switch D1 in the "OFF" position will reduce the speed control unit's sensitivity to high frequency signals. Should instability still be present, placing switch D2 to the "OFF" position may help stabilize the engine. Again, readjust the GAIN and STABILITY for optimum control. Interference from powerful electrical signals can also be the cause. Turn off the battery chargers or other electrical equipment to see if the system disappears.

Slow instability can have many causes. Adjustment of the GAIN and STABILITY usually cures most situations by matching the speed control unit dynamics. If slow instability is unaffected by this procedure, evaluate the fuel system and engine performance. Check the fuel system linkage for binding, high friction, or poor linkage. Be sure to check linkage during engine operation. Also look at the engine fuel system. Irregularities with carburetion or fuel injection systems can change engine power with a constant throttle setting. This can result in speed deviations beyond the control of the governor system. Adding a small amount of droop can help stabilize the system for troubleshooting.

NON-PERIODIC instability should respond to the GAIN control. If increasing the gain reduces the instability, then the problem is probably with the engine. Higher gain allows the governor to respond faster and correct for disturbance. Look for engine mis-firings, an erratic fuel system, or load changes on the engine generator set voltage regulator. If the throttle is slightly erratic, but performance is fast, move switch D1 to the "OFF" position. This will tend to steady the system.

10.3.4. Fuel feed pump

1) General descriptions and construction

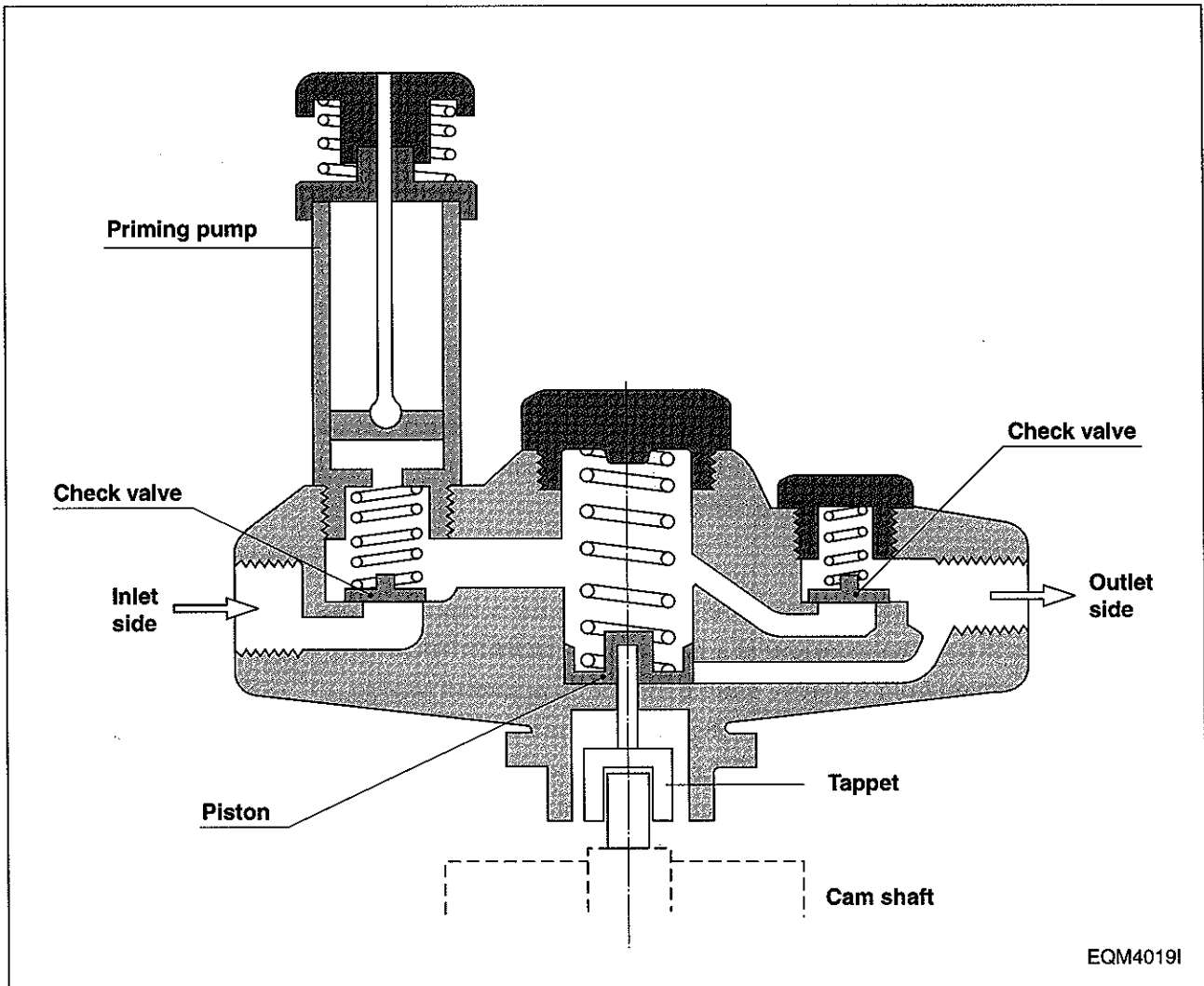

The P-type injection pump is mounted with K-ADS or KP type feed pump. These pumps have the same basic construction and operation, and the general descriptions of the KP type pump are given below:

The figures show its construction (above figure) and operation (following figure). The piston in the fuel feed pump is driven by the push rod and tappet via the camshaft of injection pump and performs reciprocating operation to control the suction and delivery of fuel. When the cam reaches the Bottom Dead Center as shown in the figure, the fuel is drawn in through the check valve on the inlet side.

The fuel pressurized as the cam rotates on flows through the check valve on the outlet side as shown in (B). If the feeding pressure increases abnormally, the spring is compressed, resulting in interrupting further delivery of fuel as shown in (C).

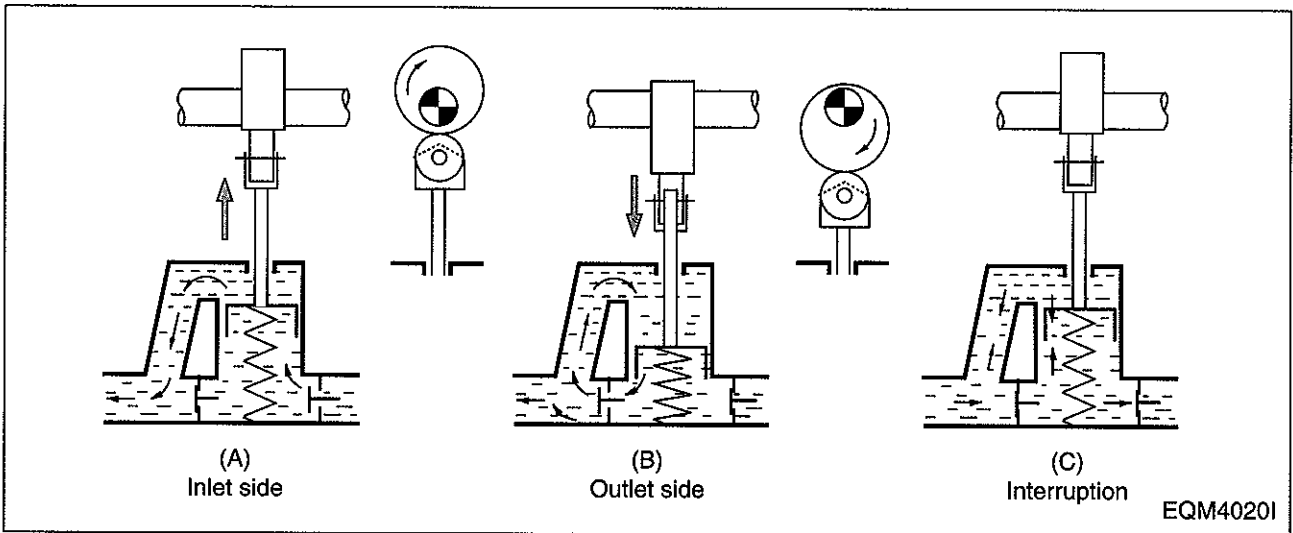

This feed pump is mounted with a priming pump designed to permit manual feeding of fuel from the fuel tank with the injection pump mounted in the engine. During the manual feeding operation, air must be bled from the fuel lines.

When using the priming pump, fix it securely to prevent the possible entry of moisture or other foreign substances in the inside of feed pump.

In addition, a strainer is fitted into joint bolt on the inlet side of the fuel feed pump to filtrate any foreign substances possibly mixed in fuel.

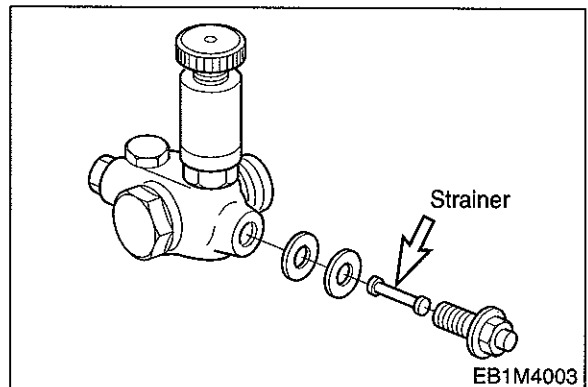

2) Disassembly

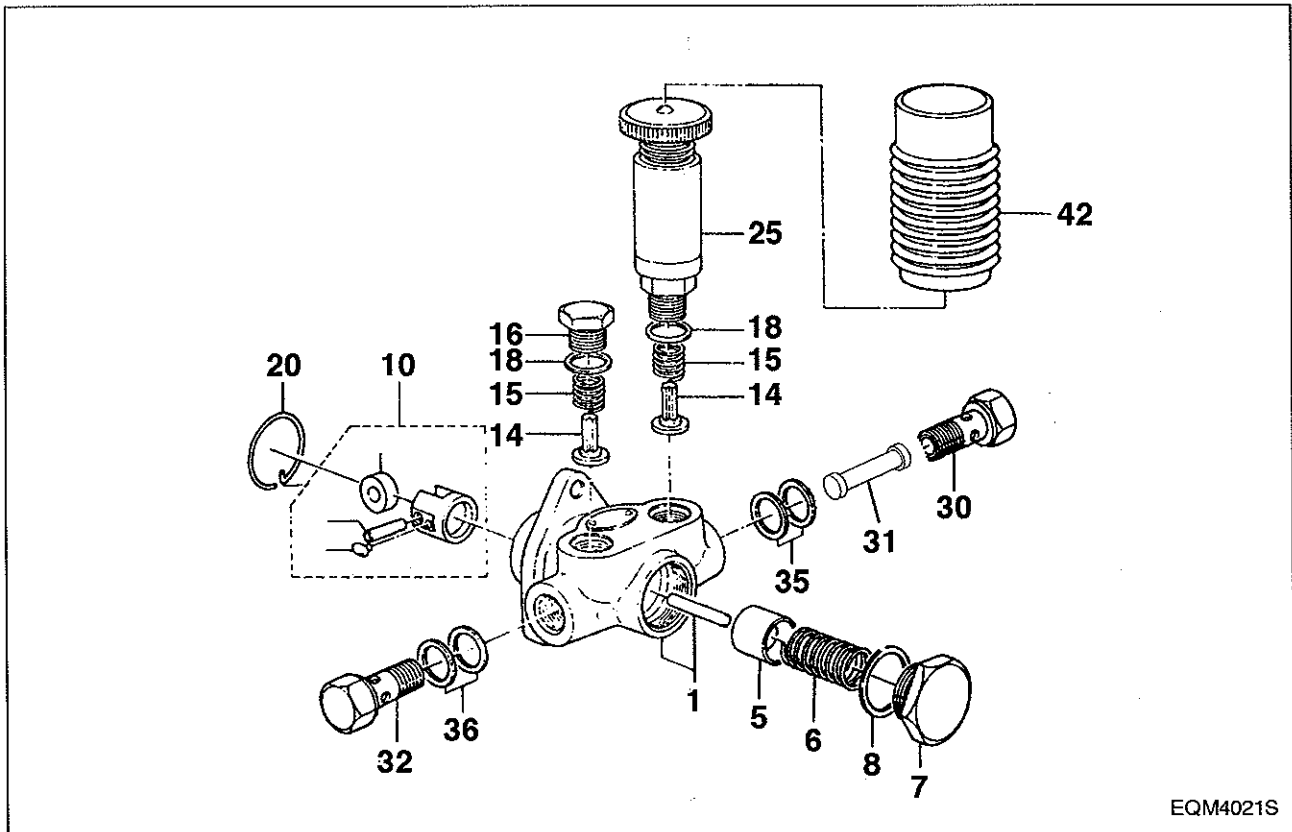

- Clamp the feed pump with a vise and disassemble the plugs (30, 32), strainer (31) and gaskets (35, 36).
- Take off the priming pump (25), plug (16), both gaskets (18), spring (15), and check valve (14).
- Take off the prig (7), gasket (8), spring (6), and piston (5) on the piston side.
- Pull out the snap ring (20) holding the tappet (10).
- Disassemble the snap ring, then take off the tappet (10) and push rod (1).

3) Inspection

- If the check valve is damaged or scored on its seat face, replace it with a new one.
- Inspect the piston and tappet for damage.
- Replace the push rod if excessively worn, and replace together with the pump housing if required. The inspection for wear should be performed in the same procedure as for suction pressure test described below.

4) Reassembly

Reassembly operation is performed in reverse order of disassembly. All the gaskets must be replaced with new ones at reassembly.

5) Testing

(1) Suction capacity test

Connect one end of a hose to the inlet side of the feed pump and immerse the other end of it into the fuel tank as illustrated.

Hold the feed pump in position about 1 m above the level of fuel in the fuel tank.

Operate the tappet at the rate of 100 rpm and check to see if fuel is drawn in and delivered for 40 seconds or so.

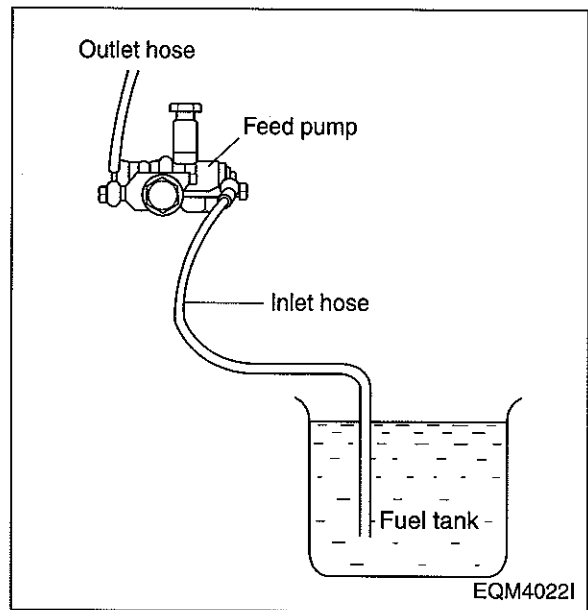

(2) Delivery test

Make a test with the feed pump mounted on a pump tester as illustrated.

Operate the pump at the rate of 1,000 rpm and check to see if the pump delivery is more than 405 cc/15 seconds.

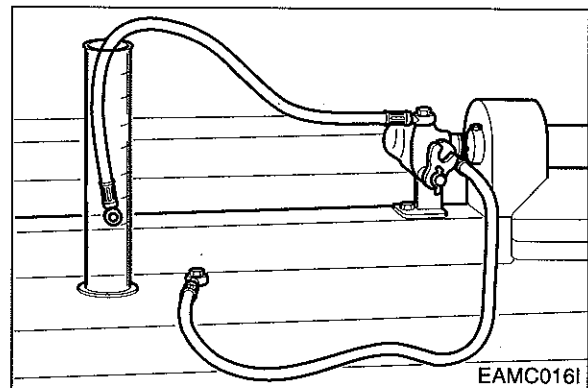

(3) Sealing test

Plug up the delivery port on the feed pump and apply compressed air of 2 kg/cm² into the inlet side.

Submerge the feed pump in a container of diesel fuel and check for air leak.

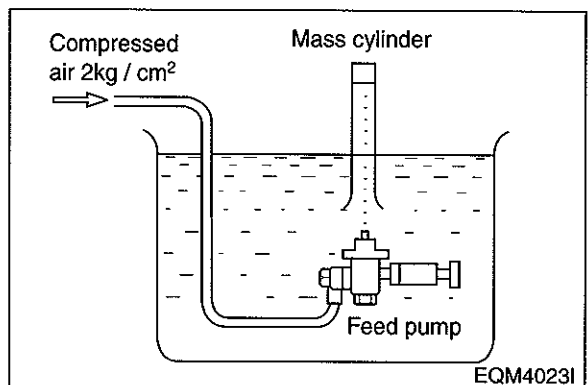

10.3.5. Injection nozzle

1) General descriptions

Pressurized fuel delivered from the fuel injection pump is sprayed into the combustion chamber past the injection nozzle at proper spray pressure and spray angle, then burnt completely to achieve effective engine performance.

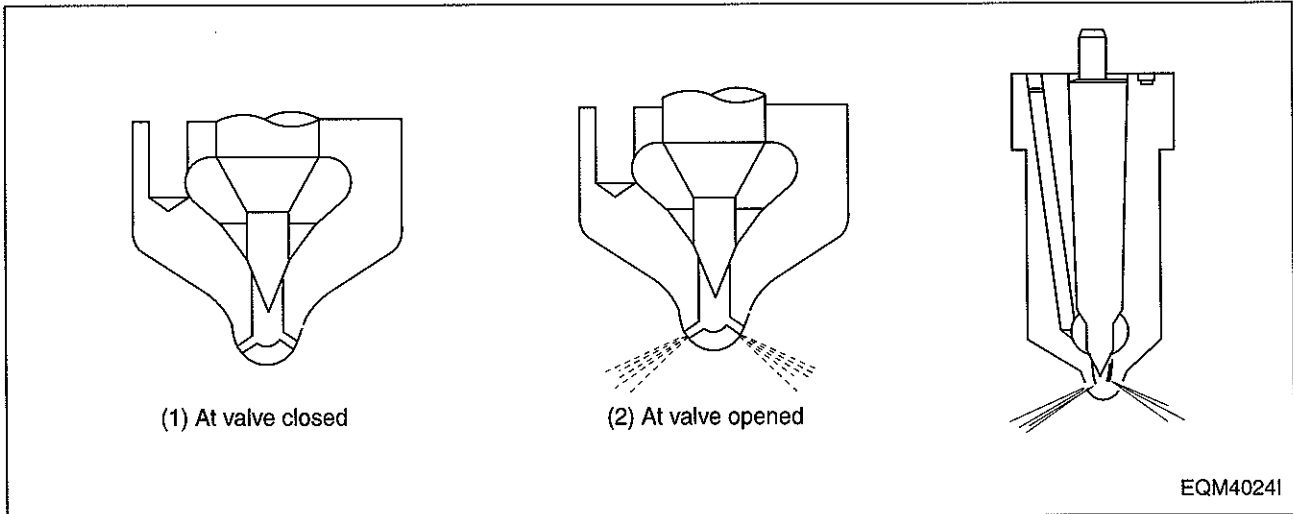

2) Construction

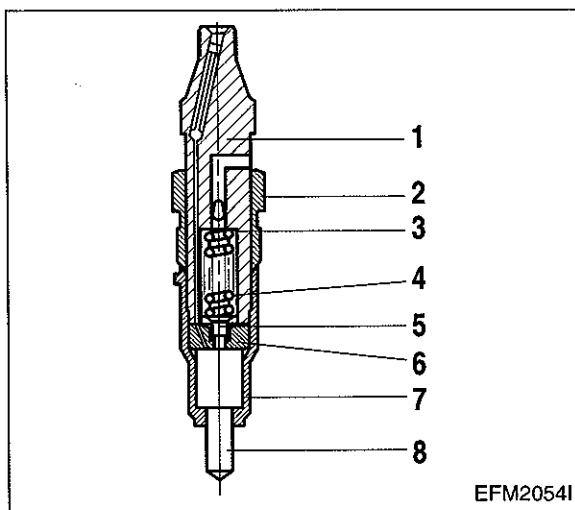

1. Nozzle holder
2. Union nut
3. Shim
4. Coil spring
5. Guide bush
6. Intermediate washer
7. Cap nut
8. Nozzle

3) Disassembly

- Clamp the nozzle assembly and remove the nozzle holder.
- Remove the nozzle nut and components inside.

4) Inspection

- Visually inspect the disassembled components for damage.

5) Reassembly

- After removing carbon deposit, submerge the nozzle in diesel oil and clean it.
- Replace all the gaskets with new ones.
- Assemble the parts and tighten them to specified torque.

6) Adjustment

- the cap nut and assemble a nozzle to a nozzle tester.
- With the adjusting screw loosened, operate the nozzle 2 ~ 3 times to bleed it.
- Operate the nozzle tester lever at the specified rate.
- Adjust the injection pressure to the standard pressure using the adjusting screw.
- After adjusting the injection pressure, tighten the cap nut to specified torque.
- Re-check the injection pressure and see if the spray pattern is normal. Spray pattern should be uniform and free of spattering.

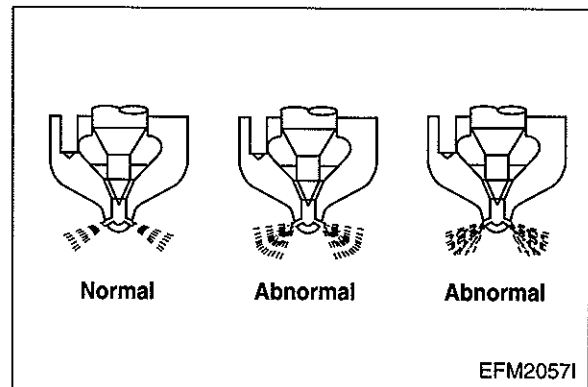
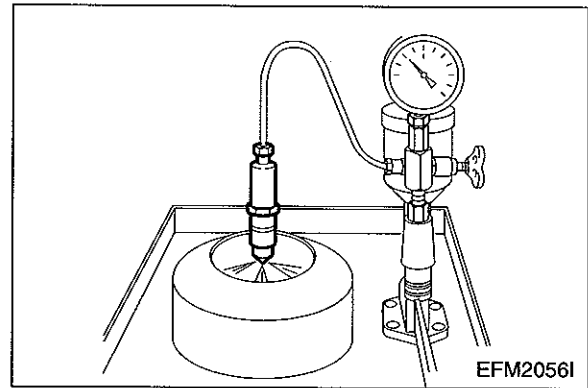

7) Testing

With the nozzle assembled to a nozzle tester and specified pressure applied, check the nozzle for fuel leakage.

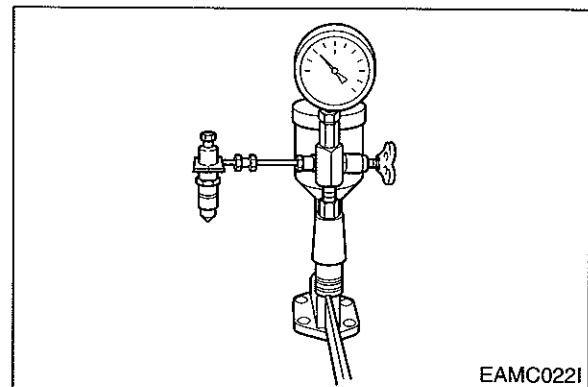

Engine Model	D1146/PU086	D1146T/PU086T	P086TI
Opening pressure	214 kg/cm ²	214 kg/cm ²	214 kg/cm ²

10.3.6. Diagnostics and troubleshooting

Complaints	Possible causes	Corrections
1. Engine won't start 1) Fuel not being pumped out from feed pump 2) Fuel not being injected from injection pump 3) Fuel injection timing Incorrect 4) Injection nozzles inoperative	<ul style="list-style-type: none"> ● Fuel pipes clogged or air into pipe fine ● Feed pump valve defective ● Feed pump piston or Push rod sticking 	Correct Replace Disassemble, correct
	<ul style="list-style-type: none"> ● Fuel filter element restricted ● Air in fuel filter or injection pump ● Plunger and/or delivery valve sticking or defective 	Clean Bleed Disassemble, correct
	<ul style="list-style-type: none"> ● Injection pump not properly installed on pump bracket ● Injection pump tappet incorrectly adjusted ● Cams on cam shaft worn excessively 	Check, correct Check, correct Replace
	<ul style="list-style-type: none"> ● Needle valves sticking ● Fuel leaking past clearance between nozzle and needle valve ● injection pressure incorrect 	Correct or replace Correct or replace Adjust
2. Engine starts but stalls immediately	<ul style="list-style-type: none"> ● Pipe from feed pump to injection pump clogged or filter clogged ● Air in fuel ● Feed pump delivery insufficient ● Fuel delivery insufficient due to clogging of fuel tank air breather 	Clean Bleed Disassemble, correct Replace breather
3. Engine lacks power	<ul style="list-style-type: none"> ● Plunger worn excessively ● Injection timing incorrect ● Delivery valves defective ● Nozzle leaks excessively ● Nozzle not working normally 	Replace Adjust Replace Correct or replace Disassemble, correct
4. Engine knocking	<ul style="list-style-type: none"> ● Injection timing too fast ● Nozzle injection pressure too high ● Nozzles not working normally 	Adjust Adjust Disassemble, correct
5. Engine knocks seriously producing excessive exhaust smoke	<ul style="list-style-type: none"> ● Injection timing incorrect ● Nozzle injection pressure too low ● Nozzle spring broken ● Nozzles not working normally ● Plungers worn excessively ● Delivery valves seat defective ● Supply of fuel excessively 	Adjust Adjust Replace Replace Adjust Replace Check feed pump

Complaints	Possible causes	Corrections
6. Engine output unstable	<ul style="list-style-type: none"> ● supply of fuel insufficient ● Air in fuel ● Water in fuel ● Operation of plungers unsmooth ● Movement of control rack sluggish ● Nozzles defective ● Injection starting pressure of each barrel incorrect ● Automatic timer defective 	<p>Check feed pump</p> <p>Bleed</p> <p>Replace fuel</p> <p>Disassemble, correct</p> <p>Disassemble, correct</p> <p>Disassemble, correct</p> <p>Adjust</p> <p>Disassemble, correct</p>
7. Engine does not reach maximum speed	<ul style="list-style-type: none"> ● Nozzles not working normally ● Governor defective 	<p>Disassemble, correct</p> <p>Disassemble, correct</p>
8. Engine idling unstable sluggish	<ul style="list-style-type: none"> ● Movement of control rod ● Operation of plungers unsmooth ● Control pinions not engaged 0 with control rod correctly 	<p>Disassemble, correct</p> <p>Disassemble, correct</p> <p>Disassemble, correct</p>

10.4. Turbocharger

10.4.1. Main data and specifications

1) Main data and specifications

Specification		D1146T/PU086T	P086TI
Turbocharger Model		Allied Signal 466721-13	Allied Signal 466721-16
At maximum output	Air pressure at compressor outlet	50Hz: Approx. 0.76 kg/cm ² 60Hz: Approx. 1.00 kg/cm ²	50Hz: Approx. 1.56 kg/cm ² 60Hz: Approx. 1.76 kg/cm ²
	Air suction volume	50Hz: Approx. 8.2 m ³ /min 60Hz: Approx. 10.3 m ³ /min	50Hz: Approx. 13.0 m ³ /min 60Hz: Approx. 16.4 m ³ /min
	Speed of turbine revolution	50Hz: Approx 72,000 rpm 60Hz: Approx. 78,000 rpm	50Hz: Approx. 102,000 rpm 60Hz: Approx. 110,000 rpm
Maximum allowable speed		126,000 rpm	126,000 rpm
Max. allowable temperature of exhaust gas at turbine inlet		750 °C	750 °C
Lubricating system		External oil supply	External oil supply
Weight		9.3 kg	9.3 kg

2) Construction

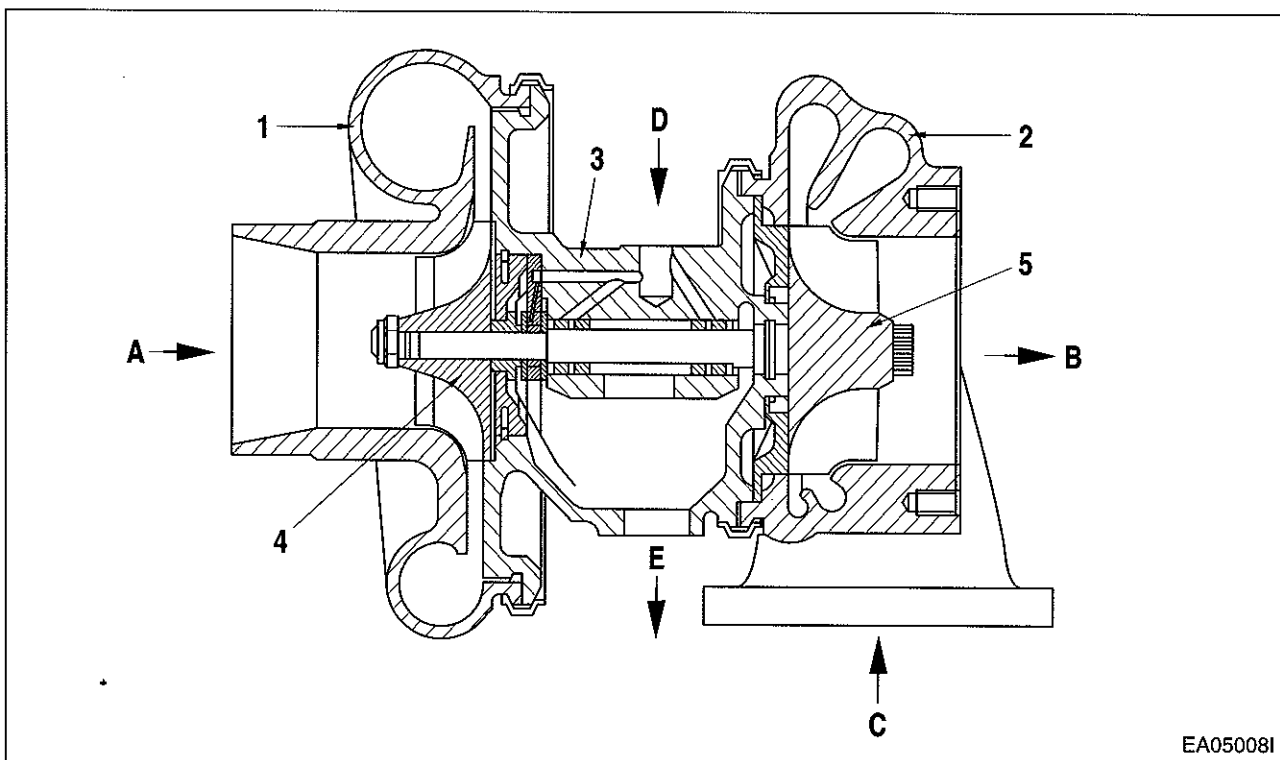

1. Impeller casing
2. Turbine casing
3. Bearing casing
4. Impeller
5. Turbine

- A. Air inlet
- B. Gas outlet
- C. Gas inlet
- D. Oil supply
- E. Oil return

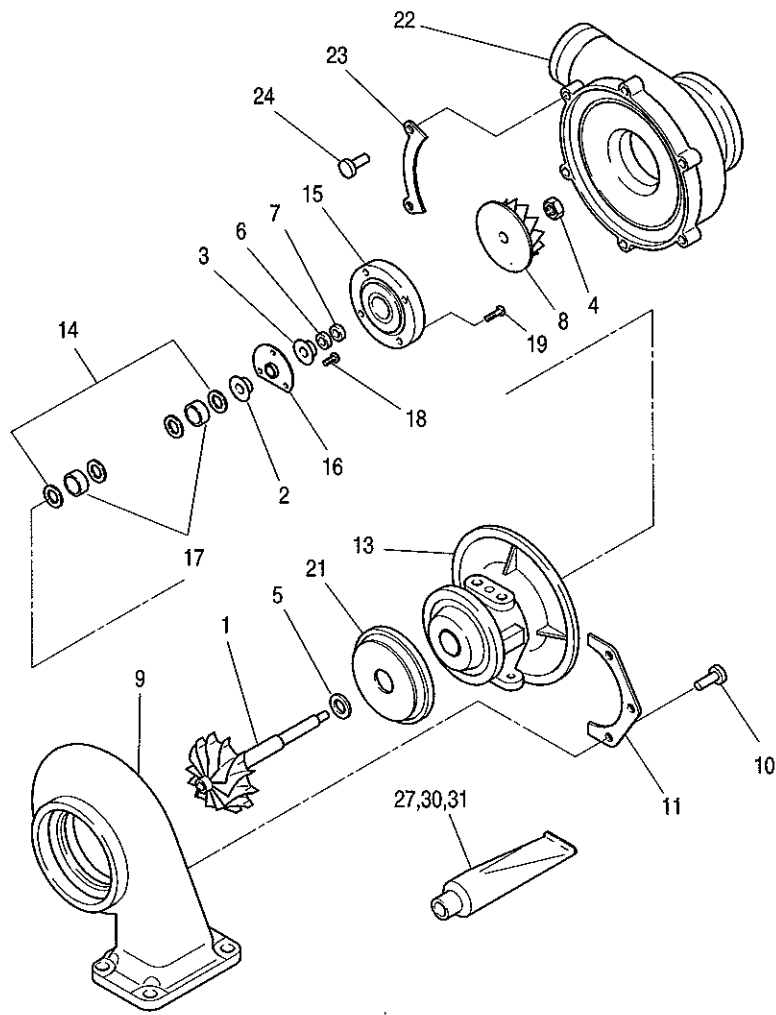

EFM3001I

- | | |
|--------------------------|-----------------------------|
| 1. Turbine shaft | 15. Seal plate |
| 2. Thrust bush | 16. Thrust bearing |
| 3. Oil shut off | 17. Journal bearing |
| 4. Fixing nut | 18. Screw |
| 5. Seal ring | 19. Screw |
| 6. Seal ring | 21. Heat dissipator |
| 7. Seal ring | 22. Compressor housing |
| 8. Compressor wing wheel | 23. Clamp |
| 9. Turbine housing | 24. Bolt |
| 10. Bolt | 27. Liquid gasket |
| 11. Clamp | 30. Loctite |
| 13. Bearing housing | 31. Liquid anti-burn agents |
| 14. Retainer ring | |

3) Operating principle

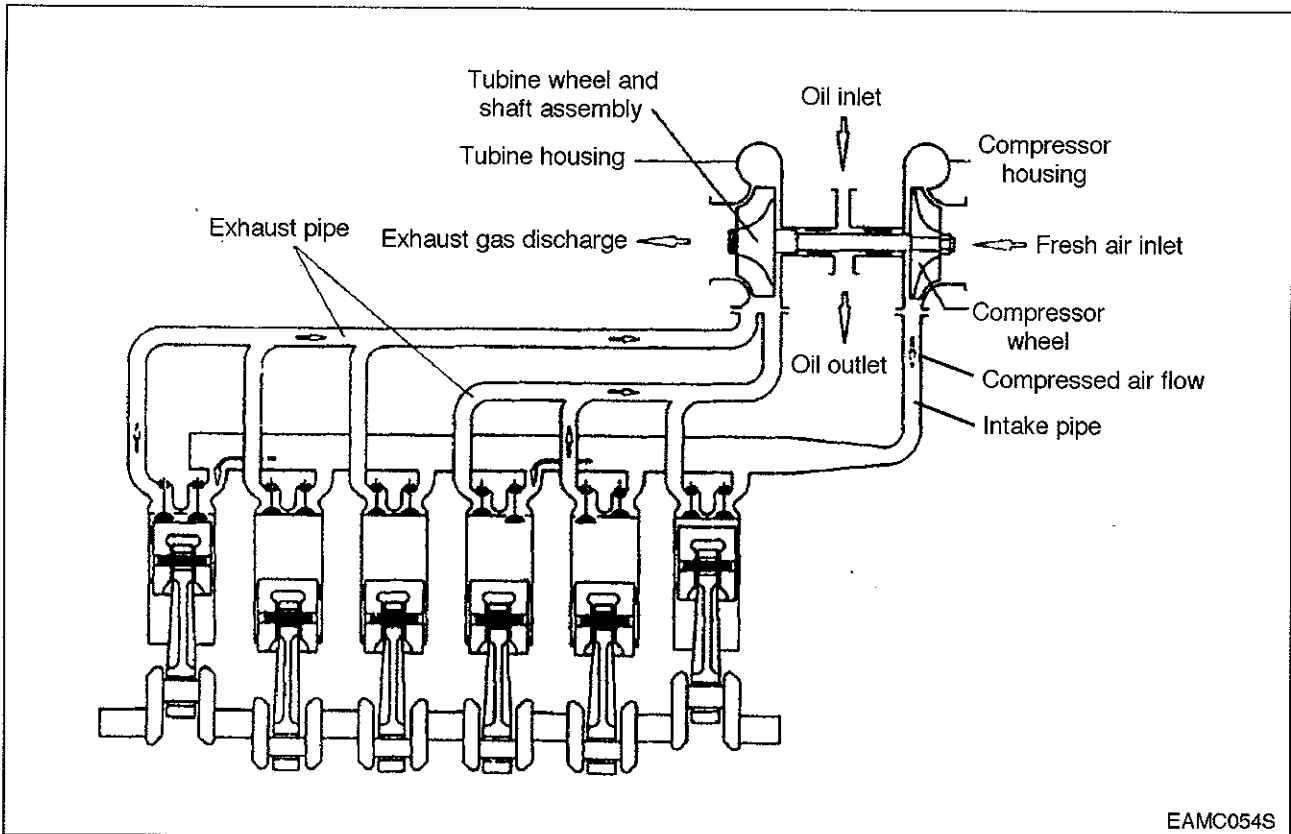

The turbocharger is a system designed to make use of the engine exhaust gas energy to charge high-density air into the cylinders, thereby to increase the engine output.

10.4.2. General descriptions

The engine output is determined by the fuel delivery volume and engine efficiency. To burn the supplied fuel completely to change into effective power for the engine, the volume of air enough to burn the fuel completely should be supplied into the cylinders. Therefore, the engine output is determined substantially by the cylinder capacity, and a greater volume of compressed air is charged into cylinders of given capacity, the greater engine output can be obtained as a greater volume of air charged into the cylinders burns so much more fuel.

As explained, the compressing of air to supply into the cylinders is called "Supercharging" and the making use of the energy of exhaust gas discharged from the combustion chamber to charge the compressed air into the cylinders is called "Turbocharging".

10.4.3. Functions

1) Turbine

Exhaust gas discharged from the combustion chamber distributes its own energy to the turbine blades while passing the inside of the turbine housing, with the result that the turbine shaft can get rotating force. This is the operating principle of 'turbine', which is mounted with seal rings and heat protector to prevent exhaust gas from affecting the bearings adversely.

2) Compressor

The compressor, which is connected to the turbine over the one and same shaft to form a rotating body, takes in and compresses ambient air with rotating force transmitted from the turbine shaft. Then, the compressed air is delivered to the intake stake. This is the operating principle of the compressor.

3) Bearings

(1) Thrust bearing

The turbine wheel creates thrust force. Therefore, exercise care so that the shaft is not deviated from its the original position due to this thrust.

(2) Journal bearing

This journal bearing of floating type forms a dual oil film on both the inside and outside of the bearing so that the bearing can rotate independently. As the dual oil film plays a role as a damper, the sliding speed of the bearing surface becomes lower than the rotating speed of the shaft, resulting in assurance of stability in its movement.

4) Sealing-Compressor shaft

The compressor is of a dual construction type composed of seal plate and seal ring to prevent the leak of compressed air or lubricating oil.

10.4.4. Precautions for operation

1) Precautions for operation of engine

The following precautions should be observed when starting, operating, or stopping the engine:

Operations	Precautions	Reasons
When starting the engine	1) Check oil level 2) Crank the engine with starter to check the increase in oil pressure (until the needle of pressure gauge starts to move or pressure indicator lamp is actuated) before starting the engine. 3) When having replaced oil, oil filter element, or lubricating parts, or when having stopped the engine for extended period of time, or in a cold place, loosen the oil pipe connections and operate the starter motor until oil is discharged. After completing the operation, be sure to retighten the oil pipe connections portion before starting the engine.	2) Abrupt starting of the engine causes the engine to rotate with oil not being distributed not only to each part but also to the turbocharger, resulting in abnormal wear or seizure on the bearing due to insufficient supply of oil. 3) In the case of the engine stopped for extended time or in a cold place, oil fluidity within the pipes can be deteriorated
Immediately after starting	1) Run the engine at idle for 5 minutes after starting off. 2) Check each part for leakage of oil, gas, and air, and take proper measure.	1) Applying load abruptly If load is abruptly applied with the engine and turbocharger rotating unsmoothly, such parts that a sufficient amount of oil has not reached can be seized up. 2) Leakage of oil, gas, and air (especially, oil leak) causes drop in oil pressure and loss of oil results in seizure of the bearing.
During operation	Check the followings: 1) Oil pressure At idle: 0.8 kg/cm ² or more At full load: 3.0 ~ 4.8 kg/cm ² 2) If unusual sound or vibration is heard or felt, reduce engine revolutions slowly and locate the cause.	1) Excessively low oil pressure causes unusual wear or seizure of the bearing. Too high pressure causes oil leakage. 2) The engine is operated continuously with unusual sound or vibration not corrected, it can be damaged beyond repair.
When stopping the engine	1) Run the engine at idle for 5 minutes before stopping.	1) If the engine is put to a stop after being operated at high load, heat from the red-hot turbine blades is transmitted to the bearing portion and burns oil to cause seizure of the bearing metal and rotating shaft.

10.4.5. Walk-around check and servicing

As the condition of turbocharger depends greatly on how well the engine is serviced, it is very important to maintain the engine in accordance with the specified maintenance procedure.

1) Intake system

Pay particular attention to the air cleaner when servicing the intake system.

In the case of wet-type air cleaner, if the level of oil surface is lower than specified, cleaning effect is poor; if too high, the cleaner draws in oil to foul the case.

Especially, if the rotor is fouled, the sophisticatedly-tuned balance is broken to create vibration and to cause seizure and unusual wear to the bearing.

Therefore, it is very important to use a good quality air cleaner all the time.

In the case of dry-type air cleaner, it is essential to clean it to reduce intake resistance as much as possible.

2) Exhaust system

Pay particular attention to prevent gas leaks and seizure when servicing the exhaust system because leakage of exhaust gas from discharge pipes, turbocharger fixing portions, etc. lowers charging effect.

As such components as turbine chamber that becomes red-hot during operation use heat resisting steel nuts, do not interchange these nuts with ordinary steel nuts. In addition, apply anti-seizure coating to fixing nuts on the portions as designated.

3) Fuel system

If the full load stopper regulating the maximum injection volume and the maximum speed stopper regulating the maximum speed in the fuel injection pump are adjusted without using a pump tester, the turbocharger rotates at excessively rapid speed and may suffer damage.

Besides of it, if spray pattern from the fuel injection nozzles is bad or the injection timing is incorrect, temperature of exhaust gas rises up to affect the turbocharger adversely. To avoid such trouble, be sure to make a nozzle test.

4) Lubricating system

Pay particular attention to oil quality and oil filter change intervals when servicing the lubricating system. Deteriorated engine oil affects adversely not only the engine but torso the turbocharger. Suggested engine oils for the turbocharger-mounted engine are as follows:

- SAE 15W40
- API grade CD or CE

10.4.6. Periodical checking and servicing

Make it a rule to check the turbocharger assembly for condition and contamination periodically.

1) Guide for checking the rotor for rotating condition

The inspection of the rotor assembly for rotating condition should be performed by the degree of unusual sound. If a sound detecting bar is used, install its tip on the turbocharger housing and increase the engine revolutions slowly. If a high-pitch sound is heard continuously, it means that the rotor assembly is not normal. In this case, as the metal bearing and rotor are likely to be in abnormal conditions, the turbocharger should be replaced or repaired.

2) Guide for checking rotor end play

Disassemble the turbocharger from the engine, then check the rotor axial play and radial play.

When disassembling the turbocharger, be sure to plug the oil inlet and outlet ports with taps, etc.

(1) Rotor axial play

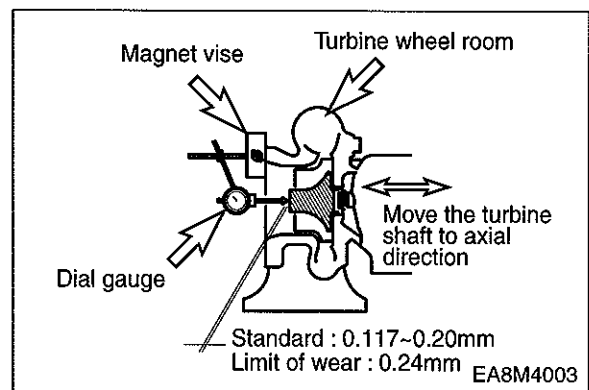

(2) Rotor radial play

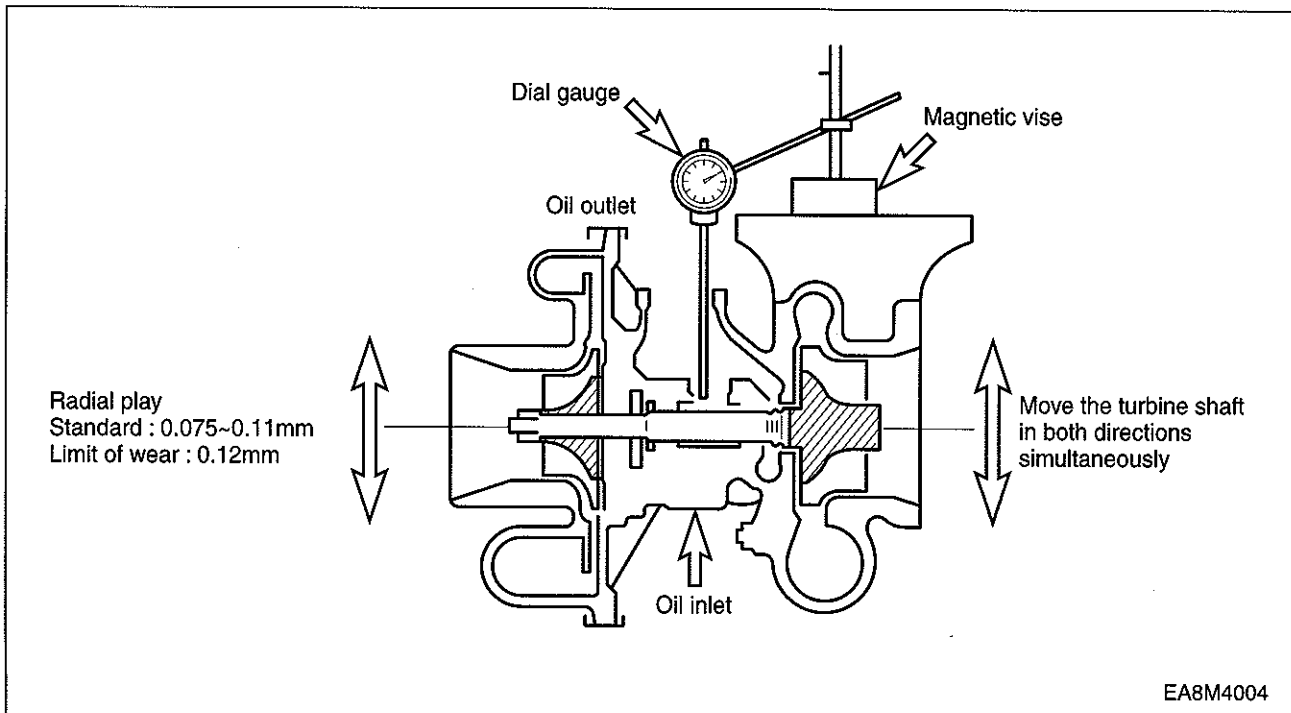

(3) If the measured axial and radial plays are beyond the limit of wear, replace or repair the turbocharger.

3) Guide for disassembling/cleaning and checking the turbocharger

First, disassemble the turbocharger from the engine and clean/check it with the oil inlet and outlet plugged with tape and so on.

4) Precautions for reassembling the turbocharger onto the engine

For reassembly of the turbocharger or handling it after reassembly operation, be sure to observe the following precautions:

Especially, exercise extreme care to prevent foreign matters from entering the inside of the turbocharger.

(1) Lubricating system

- Before reassembling the turbocharger onto the engine, inject new oil in the oil inlet port and lubricate the journal and thrust bearings by rotating them with hand.
- Clean not only the pipes installed between the engine and oil inlet port but also the oil outlet pipe and check them for damage or foreign matters.
- Assemble each joint on oil pipes securely to prevent oil leaks.

(2) Intake system

- Check the inside of the intake system for foreign matters.
- Assemble each joint on the intake duct and air cleaner securely to prevent air leaks.



(3) Exhaust system

- Check the inside of the exhaust system for foreign matters.
- Be sure to use heat resisting steel bolts and nuts. Do not interchange them with ordinary steel bolts and nuts when performing reassembly operation.
Apply anti-seizure coating to the bolts and nuts.
- Assemble each joint on the exhaust pipes securely to prevent gas leaks.

10.4.7. Diagnostics and troubleshooting

Complaints	Possible causes	Corrections
1. Excessive black smoke	1) Air cleaner element clogged 2) Restrictions in air duct 3) Leakage at intake manifold 4) Turbocharger seized up and not rotating 5) Turbine blades and compressor blades coming in contact with each other or damaged 6) Exhaust piping deformed or clogged	Replace or clean Check and correct Check and correct Disassemble/repair or replace Disassemble/repair or replace Check and correct
2. Excessive white smoke	1) Oil leak into turbine and compressor 2) Worn or damaged seal ring due to excessive wear of bearing	Disassemble/repair or replace Disassemble/repair or replace
3. Low engine output	1) Gas leak at each part of exhaust system 2) Air cleaner element restricted 3) Turbocharger fouled or damaged 4) Leakage at discharge port on compressor side	Check and correct Replace or clean Disassemble/repair or replace Check and correct
4. Unusual sound or vibration	1) Rotor assembly coming in contact 2) Unbalanced rotation of rotor 3) Seized up 4) Each joint loosened	Disassemble/repair or replace Disassemble/repair or replace Disassemble/repair or replace Check and correct

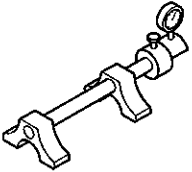
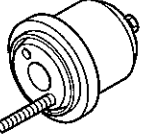
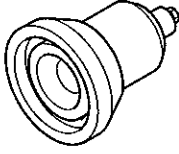
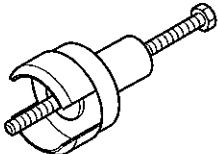
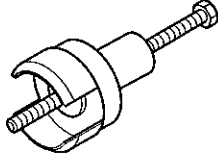
11. Special Tool List

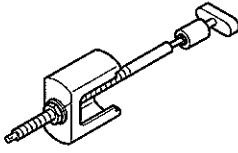
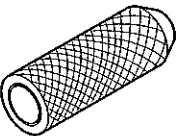
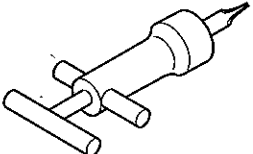
No.	Part No.	Figure	Tool Name
1	EF.123-014		Injection pump setting ass'y (for D1146/T,PU086/T)
	EF.123-015		Injection pump setting ass'y (for P086TI)
2	EF.123-127		Oil seal(CR) insert ass'y (Front) (Up to 2000.Apr)
	EF.123-173		Oil seal(NOK)insert ass'y (Front) (From 2000.May)
3	EF.123-043		Oil seal(CR) insert ass'y (Rear) (Up to 2000.Apr)
	EF.123-184		Oil seal(NOK)insert ass'y (Rear) (From 2000.May)
4	EF.123-052		Oil seal(CR) puller ass'y (Front) (Up to 2000.Apr)
	EF.123-317A		Oil seal(NOK)puller ass'y (Front) (From 2000.May)
5	EF.123-048		Oil seal(CR) puller ass'y (Rear) (Up to 2000.Apr)
6	EF.123-345		Cylinder pressure tester adapter
7	EF.123-086		Cylinder liner puller ass'y
8	EF.123-179		Valve stem seal punch
9	EU.2-0131		Valve clearance adjust ass'y

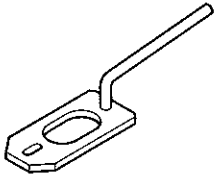
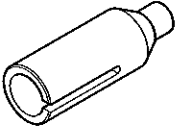
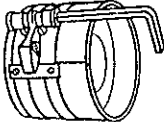
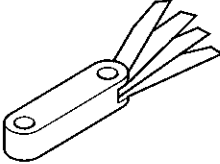
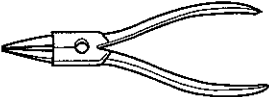
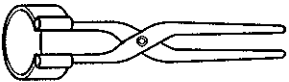
No.	Part No.	Figure	Tool Name
10	EF.123-065		Valve spring press
11	EU.2-0647		Crankshaft gear punch
12	EF.120-208		Piston sleeve
13	60.99901-0027		Feeler gauge
14	T7610001E		Snap ring plier
15	T7621010E		Piston ring plier

Appendix

● Tightening torque for major parts

Major Parts	Screw (Diameter x pitch)	Strength (grade)	Tightening Torque	Remarks
Cylinder head bolt	M14 x 1.5	10.9T	1st : 6.0 kg·m 2nd : 180° 3rd : 150° (Angle method)	
Connecting rod bearing cap bolt	M14 x 1.5	12.9T	1st : 10 kg·m 2nd : 15 kg·m 3rd : 18 kg·m	
Crankshaft main bearing cap bolt	M16 x 1.5	12.9T	1st : 15 kg·m 2nd : 25 kg·m 3rd : 30 kg·m	
Balance weight fixing bolt	M12 x 1.5	10.9T	9.0 kg·m	
Flywheel housing fixing bolt	M14 x 1.5	10.9T	8.0 kg·m	
Flywheel fixing bolt	M14 x 1.5	10.9T	18.0 kg·m	
Crankshaft pulley fixing bolt	M12 x 1.5	10.9T	13.4 kg·m	
Oil spray nozzle	M14 x 1.5	-	8.0 kg·m	

● Tightening torque for fuel injection pump system

Major Parts	Screw (Diameter x pitch)	Strength (grade)	Tightening Torque	Remarks
Injection nozzle nut	M28 x 1.5	-	7.0 ± 0.5 kg·m	
Injection pump bracket bolt	M10	8.8T	4.4 kg·m	
Injection pump coupling bolt	-	-	6.0 ~ 6.5 kg·m	
Injection pump driving gear nut	M24 x 1.5	8.8T	25.0 kg·m	
Injection pipe nut	M14 x 1.5	8.8T	3.0 kg·m	
Injection pump delivery valve holder	-	-	11.0 ~ 12.0 kg·m	

● **Standard bolt tightening torque table**

Refer to the following table for bolts other than described above.

Diameter x pitch (mm)	Degree of strength										
	3.6	4.6	4.8	5.6	5.8	6.6	6.8	6.9	8.8	10.9	12.9
	(4A)	(4D)	(4S)	(5D)	(5S)	(6D)	(6S)	(6G)	(8G)	(10K)	(12K)
	Limit value for elasticity (kg/mm ²)										
	20	24	32	30	40	36	48	54	64	90	108
Tightening torque (kg·m)											
M5	0.15	0.16	0.25	0.22	0.31	0.28	0.43	0.48	0.5	0.75	0.9
M6	0.28	0.30	0.45	0.4	0.55	0.47	0.77	0.85	0.9	1.25	0.5
M7	0.43	0.46	0.7	0.63	0.83	0.78	1.2	1.3	1.4	1.95	2.35
M8	0.7	0.75	1.1	1	1.4	1.25	1.9	2.1	2.2	3.1	3.8
M8 x 1	0.73	0.8	1.2	1.1	1.5	1.34	2.1	2.3	2.4	3.35	4.1
M10	1.35	1.4	2.2	1.9	2.7	2.35	3.7	4.2	4.4	6.2	7.4
M10 x 1	1.5	1.6	2.5	2.1	3.1	2.8	4.3	4.9	5	7	8.4
M12	2.4	2.5	3.7	3.3	4.7	4.2	6.3	7.2	7.5	10.5	12.5
M12 x 1.5	2.55	2.7	4	3.5	5	4.6	6.8	7.7	8	11.2	13.4
M14	3.7	3.9	6	5.2	7.5	7	10	11.5	12	17	20
M14 x 1.5	4.1	4.3	6.6	5.7	8.3	7.5	11.1	12.5	13	18.5	22
M16	5.6	6	9	8	11.5	10.5	17.9	18.5	18	26	31
M16 x 1.5	6.2	6.5	9.7	8.6	12.5	11.3	17	19.5	20	28	33
M18	7.8	8.3	12.5	11	16	14.5	21	24.2	25	36	43
M18 x 1.5	9.1	9.5	14.5	12.5	18.5	16.7	24.5	27.5	28	41	49
M20	11.5	12	18	16	22	19	31.5	35	36	51	60
M20 x 1.5	12.8	13.5	20.5	18	25	22.5	35	39.5	41	58	68
M22	15.5	16	24.5	21	30	26	42	46	49	67	75
M22 x 1.5	17	18.5	28	24	34	29	47	52	56	75	85
M24	20.5	21.5	33	27	40	34	55	58	63	82	92
M24 x 1.5	23	25	37	31	45	38	61	67	74	93	103

Others : 1. The above torque rating have been determined to 70% or so of the limit value for bolt elasticity.

2. Tension is calculated by multiplying tensile strength by cross section of thread.

3. Special screws should be tightened to 85% or so of the standard value.

For example, a screw coated with MoS₂ should be tightened to 60% or so of the standard value.

● **Tightening torque for hollow screw (4-hole)**

Material	M8	M10	M12	M14	M16	M18	M22	M26	M30	M38
SM25C	-	1.6	2.5	3.5	4.5	5.5	9.0	13.0	18.0	30.0
*SUM22L	0.8	1.8	3.0	4.0	5.5	6.5	11.0	16.0	20.0	35.0
STS304	0.8	1.8	3.0	4.0	5.5	6.5	11.0	16.0	20.0	35.0

* : Adopted in DAEWOO engine

● Maintenance specification table

Group	Part	Inspection Item	Stand value for assembly	Limit for use	Correction	Remark	
Engine body	Cylinder block & liner	Inside diameter of cylinder liner for wear	$\phi 111 \sim \phi 111.022$	$\phi 111.222$ (limit 0.2)	Replace liner	-	
		Amount of liner projection	0.03~0.08		Need amount of projection without fail	Projection difference between adjacent liners : 0.15 ↓	
		The flatness of upper surface of cylinder block	0.05/200		Correct with a surface grinder	Referenced length : 200mm	
		Hydraulic test for 1 minute (kg/cm ²)	4		Replace if leaky		
	Cylinder head & valve	Valve seat depression	Intake	0~0.3	-	Replace valve seat	
			Exhaust	0~0.3	-		
		Cylinder head height	109.9 ~110.1	108.4	Replace cyl. head		
	Hydraulic test for 1 minute (kg/cm ²)	4		Replace if leaky	Water temp. 70°C		
Major moving parts	Piston	Outer dia. piston	$\phi 110.801 \sim \phi 110.959$		Replace liner	Measure at 13mm away from lower surface of piston	
		Clearance between piston and liner	0.041~0.221	0.3	Replace one worn more		
		Width of piston ring grooves	Top ring	3.50		Replace piston if groove width is beyond specified value	
			2nd ring	3.06~3.08			
			Oil ring	4.04~4.06			
		Piston projection from cylinder block upper surface	0~0.12		Must exist	Measure unworn portion beneath the rim of the upper side	
	Permissible weight difference of each piston	±15 g	96 g ↓	Replace piston			
	Piston ring	Piston ring gap	Top ring	0.40~0.65	1.5	Replace ring	Standard gauge inside diameter : $\phi 108$
			2nd ring	0.40~0.65	1.5		
			Oil ring	0.30~0.60	1.5		
		Piston ring side clearance	Top ring			Replace ring or piston	Limit for use if for standard clearance
			2nd ring	0.07~0.102	0.15		
		Oil ring	0.05~0.085	0.15			
		Direction of ring gap			Cross Install by 120°C		
Piston pin	Outer diameter of piston pin	$\phi 41.994 \sim \phi 42$		Replace piston pin			
	Clearance between piston pin and its bush	0.009~0.015		Replace one worn more			

Group	Part	Inspection Item	Stand value for assembly	Limit for use	Correction	Remark
Major moving parts	Crank shaft	Radial run-out of journal and pin		0.01	Correct with a grinder	Measure In horizontal and vertical directions
		Outside diameter of journal	$\phi 83.966 \sim \phi 83.988$	$\phi 83$	Use under sized bearings respectively(0.25, 0.5, 0.75, 1.0)	
		Outside diameter of pin	$\phi 70.971 \sim \phi 70.990$	$\phi 70$		
		Ellipticity of journal and pin	0.008	0.025		
		Concentricity of journal and pin	0.01	0.03		
		Taper of journal and pin	0.01	0.03		
		Clearance between crankshaft and bearing	0.052~0.122	0.25	Replace bearing	Measure at crown part not parting line
		End play of crankshaft	0.15~0.325	0.5	Replace thrust bearing	
		Run-out of crankshaft	0.1 \downarrow		Adjust by a press if bended	Measure at No.4 bearing(No. 1 & 7 bearing supported)
		Balance of crankshaft(g-cm)	60 \downarrow	60 or less	Check dynamic balance	Measure at 400 rpm
		Torque valve journal bearing cap bolt (kg-m)	30		Coat the bolt with engine oil	Clean out foreign objects on joining surface
		Crush height of journal bearing	0.08~0.110			Measure after tightening metal cap and releasing one stud
		Oil seal for wear(crank shaft rear)			Replace oil seal if oil leaking	
	Connecting rod	End play of con-rod	0.170 ~ 0.248	0.50	Replace con-rod	
		Clearance between con-rod bearing and crank pin	0.034 ~ 0.098	0.25	Replace bearing	
		Clearance between small end bush & piston pin	0.050~0.081	0.12		Measure after installing the bearing and releasing one bolt
		Crush height of con-rod bearing	0.30~0.50			After completing of bearing loosen one stud bolt & measure
		Side clearance of big-end and small-end		0.50	Replace con-rod	
		Allowable weight difference per con-rods	18 g \downarrow			
		Torque valve of con-rod bearing cap bolt (kg-m)	18		Coat the bolt with engine oil	Clean out foreign objects on joining surface
	Cam shaft	Diameter of cam shaft journal	$\phi 57.86 \sim \phi 57.88$			
		Clearance between cam shaft and cam bush	0.12~0.17	0.24	Replace cam bush	
		End play of camshaft	0.28~0.43	0.6	Replace thrust washer	
		Run-out of camshaft		0.1	Correct or replace the cam shaft	
	Timing gear	Clearance between idle shaft bush and idle shaft	0.025~0.091	0.15		
		End play of idle gear shaft	0.043~0.167	0.3	Correct or replace gear	
		Back-lash between gears(cam, idle, crank and injection)	0.16~0.28	0.35	Replace gear	

Group	Part	Inspection Item	Stand value for assembly	Limit for use	Correction	Remark	
Valve system	Valve	Diameter of intake valve stem	$\phi 8.950 \sim \phi 8.970$	0.02	Replace valve & valve guide	When replacing valve, replace valve guide alike	
		Diameter of exhaust valve stem	$\phi 8.935 \sim \phi 8.955$	0.02			
		Clearance between valve stem and valve guide	Intake	0.030~0.065	0.15	Replace valve & valve guide	Replace one worn more
			Exhaust	0.045~0.080	0.15		
		Thickness of valve head	Intake	2.7	Max. 1	Replace valve	
			Exhaust	2.2			
		Clearance between valve guide and valve spring seat	Intake	1.0			
			Exhaust	1.0			
		Clearance between valve guide and cyl. head installing hole		-0.039~-0.010 (Press fit)			Spread oil over valve guide and press it into the hole
		Concentricity between valve stem and valve head		0.15			Without spring seat
		Intake valve spring	Free length	Approx.64		Replace valve spring	
			Tension force (when pressed to 41mm)kg	67.9~72.1	66.5		
			Squareness (along free length direction)	2.5°			
		Exhaust valve spring	Free length	Approx.60		Replace valve spring	
			Tension force(when pressed to 38mm)kg	26.9~30.3	-		
			Squareness (along free length direction)	2.5°C			
		Outer	Free length	Approx. 71		Replace valve spring	
			Tension force(when pressed to 41mm)kg	62.7~69.3	-		
			Squareness (along free length direction)	2.5°C	-		
	Valve clearance (at cold)	Intake	0.3		Adjust		
Exhaust		0.3					
		Joining surface of valve stem and rocker arm bush			Grind or replace if severely pitted on tip of rocker arm and stem		
		Clearance between rocker arm shaft & rocker arm bush	0.020~0.093	0.3	Replace bush or shaft		
		Diameter of rocker arm shaft for wear	$\phi 23.939 \sim \phi 23.96$	$\phi 23.75$	Replace		
		Run-out of push rod	-	0.3	Replace		

Group	Part	Inspection Item	Stand value for assembly	Limit for use	Correction	Remark	
Valve system	Tappet	Clearance between tappet & cyl. block	0.035 ~ 0.077	0.1	Replace tappet		
		Diameter of tappet	φ 19.94~ φ 19.965	19.89	Replace tappet		
		Tappet face in contact with cam	-	-	Replace if severely worn or deformed		
Lubricating system	Oil pressure	Oil pressure (normal speed)kg/cm ²	4.8 or less	3.5	Check oil leakage and clearance between each part		
		Oil pressure (idling)kg/cm ²	0.8~1.4	0.6	Use recommended oil		
	Oil temperature	Max. permissible oil temperature °C	-	105		Must not exceed this valve	
		Permissible oil temperature in short time °C	-	120			
	Oil pump	Axial play of oil pump gear		0.055 ~ 0.105	-	Replace gear or cover	
		Clearance between drive gear shaft & oil pump cover hole		0.032 ~ 0.077	-		
		Clearance between drive gear shaft and cover hole		0.040 ~ 0.094	-	Replace bush or cover	
		Diameter of gear shaft		φ 16.950 ~ φ 16.968		Replace gear shaft	φ 17e7
		Diameter of driving gear bush		φ 28.000 ~ φ 28.033		Replace bush	φ 28e7
		Backlash	Between crank gear & idle gear	0.15 ~ 0.25	0.8	Adjust back-lash	
			Between oil pump drive gear & idle gear	0.15 ~ 0.25	0.8		
	Valve opening pressure	Oil pressure control valve (kg/cm ²)		4.0 ~ 4.8	0.8	Replace valve	
		By-pass valve for filter element (kg/cm ²)		1.8 ~ 2.3	0.8		
		By-pass valve for full oil filter (kg/cm ²)		4.0 ~ 4.8			
		Relief valve for oil pump (kg/cm ²)		8.5 ~ 11.5		Replace valve	
Spray nozzle control valve (kg/cm ²)		1.5 ~ 2.0					
Oil filter	Damage of oil filter cartridge				Clean or replace		

Group	Part	Inspection Item	Stand value for assembly	Limit for use	Correction	Remark
Cooling system	Radiator	Radiator & water pump for corrosion, damage & improper connecting			Correct or replace	
		Test for leakage (air pressure) (kg/cm ²)	1.0		Submerge in water and replace if air bubbles found	
		Pressure valve for opening pressure (kg/cm ²)	0.5			
		Negative pressure valve for opening pressure (mmHg)	20			
	Water pump	Delivery volume l/min - Pump speed 2,300rpm - Water temp.85 °C - Back pressure : 0.5 kg/cm ²	Approx. 260		Check the water passage	For any restrictions
		Clearance between impeller & housing	0.35		Replace if impeller & housing are intact	
		Perpendicularity of pulley	0.3		Adjust by a bench press	
	Cooling water temp	Fan belt depression(with thumb)	Approx.10~15	15	Adjust	
		Operating temperature (permissible temp) °C	85	95	Must not exceed this valve	
	Thermostat	Permissible temperature in a short time. °C	103			
		Thermostat opening temp. °C (under atmospheric pressure)	71		Replace	
	Fuel system	Piping & others	Fuel pipe, injection pipe & nozzle holder for damage, cracks, improper packing, etc.			Repair or replace
Fuel filter cartridge for damage or dimple					Replace cartridge	
Injection pressure of injection nozzle (kg/cm ²)		220		Adjust by shim	1st :160 , 2nd : 220	
Operating pressure of overflow valve (kg/cm ²)		1.0 ~ 1.5		Replace valve		
Projection height of nozzle from the cyl. head surface(mm)		3.6 ~ 4.1		Replace cyl. head & nozzle		
Inspection at completion	Running-in the engine				Refer to supplement "running-in"	
	Cylinder pressure	Compression pressure of cylinder (kg/cm ²)	25 ~ 28	24 or less	Correct	at 200rpm or more more(20 °C)
		Compression pressure difference of each cylinder	±10% or less against average		Correct	

Parts & After Service Center

■ Parts Service Center

85-1 Palgok Ei-dong, Sangnok-gu Ansan-shi Kyunggi-do, Korea

Tel. : 82-31-400-2231

Fax. : 82-31-400-2255

<http://www.doosaninfracore.co.kr>

■ After Service Center

7-11, Hwasu-dong, Dong-gu Incheon, Korea

Tel. : [Vehicle engine] 82-32-211-2242

[Industrial engine] 82-32-211-2244

[Marine engine] 82-32-211-2247

[Generator engine] 82-32-211-2246

Fax. : 82-32-761-2759

<http://www.doosaninfracore.co.kr>

● Applications for DOOSAN Engine

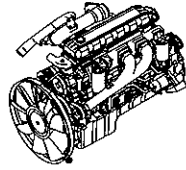

■ Automotive & Industrial Engines

Model		Power kW(PS)/rpm	Model	Power kW(PS)/rpm
For Vehicle	D1146	133(181)/2,500	DL08	235(320)/2,200
	D1146TI	158(215)/2,200	DV11	309(420)/1,800
	DE08TIS	176(240)/2,300	DV15T	272(370)/2,300
	DE12	169(230)/2,200	DV15TI	309(420)/2,100
	DE12T	220(300)/2,200	DV15TIS	309(420)/2,100
	DE12TI	250(340)/2,100	GE08TI	191(260)/2,300
	DE12TIS	250(340)/2,100	GE12TI	250(340)/2,100
For Industrial	D1146	115(156)/2,200	DB58TIS	127(173)/2,000
	D1146T	140(190)/2,200	DE08TIS	151(205)/1,900
	D1146TI	162(220)/2,200	DE12T	188(255)/2,000
	DB33	53(72)/3,000	DE12TI	213(290)/2,000
	DB33A	46(63)/2,300	DE12TIS	238(323)/2,000
	DB58	96(130)/2,800	DV15T	238(324)/2,300
	DB58S	75(102)/2,200	DL08	191(260)/1,750
	DB58T	104(142)/2,500	DV11	245(333)/1,800
	DB58TI	112(152)/2,200		

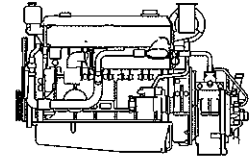

■ Marine Propulsion Engines

Model	Power kW(PS)/rpm	Model	Power kW(PS)/rpm
L034	51(70)/3,000	MD196T	206(280)/2,000
L034TIH	88(120)/3,000	MD196TI	235(320)/2,000
L034TIM	107(145)/3,300	V158TIH	353(480)/1,800
L086TI	265(360)/2,500	V158TIM	397(540)/2,100
L086TIH	210(285)/2,100	V158TIL	500(680)/2,300
L086TIM	232(315)/2,300	V180TIH	441(600)/1,800
L126TIH	265(360)/2,000	V180TIM	478(650)/2,100
L126TIM	294(400)/2,100	V180TIL	820(603)/2,300
L136	118(160)/2,200	V222TIH	530(720)/1,800
L136T	147(200)/2,200	V222TIM	588(800)/2,100
L136TI	169(230)/2,200	V222TIL	736(1,000)/2,300
L136TL	177(240)/2,500		

■ Generator Set Engines (G-Drive & G-Pac)

Model	Power (Output ISO 3046)				Model	Power (Output ISO 3046)			
	@1,800rpm		@1,500rpm			@1,800rpm		@1,500rpm	
	Power (Stand-by)	Power (Prime)	Power (Stand-by)	Power (Prime)		Power (Stand-by)	Power (Prime)	Power (Stand-by)	Power (Prime)
	kW(PS)	kW(PS)	kW(PS)	kW(PS)		kW(PS)	kW(PS)	kW(PS)	kW(PS)
D1146	105(143)	96(130)	85(116)	77(105)	P158LE-1	402(546)	366(498)	362(492)	327(444)
D1146T	138(187)	125(170)	118(160)	107(145)	P158LE-2	361(491)	329(447)	321(437)	293(399)
DB33	35(47)	32(43)	29(39)	26(35)	P158LE-S	481(654)	441(660)	441(600)	402(546)
DB58	70(95)	64(87)	59(80)	54(73)	P180LE	540(734)	497(676)	496(674)	443(602)
DE12T	199(270)	180(245)	166(226)	151(205)	P180LE-1	498(677)	454(617)	442(601)	403(548)
P034TI	60(82)	55(75)	48(65)	42(57)	P180LE-S	567(771)	519(705)	496(674)	452(615)
P086TI	223(260)	205(237)	199(223)	177(203)	P222LE	649(883)	591(803)	574(781)	532(723)
P086TI-1	191(303)	174(279)	164(270)	149(420)	P222LE-1	625(850)	563(765)	552(750)	496(675)
P126TI	298(405)	278(378)	272(370)	241(328)	P222LE-S	682(927)	625(850)	603(820)	552(750)
P126TI-1	288(392)	262(356)	-	-	P158FE	492(669)	441(600)	441(600)	402(546)
P126TI-II	342(465)	-	-	-	P222FE	711(967)	659(896)	612(832)	569(774)
P158LE	443(602)	402(547)	414(563)	363(494)					

■ Natural Gas Engines

Model	Power (Output ISO 3046)				Model	Power (Output ISO 3046)			
	@1,800rpm		@1,500rpm			@1,800rpm		@1,500rpm	
	Power (Stand-by)	Power (Prime)	Power (Stand-by)	Power (Prime)		Power (Stand-by)	Power (Prime)	Power (Stand-by)	Power (Prime)
	kW(PS)	kW(PS)	kW(PS)	kW(PS)		kW(PS)	kW(PS)	kW(PS)	kW(PS)
GE08TIC	165(224)	150(204)	141(192)	128(174)	GV180TIC	375(510)	340(462)	319(434)	290(394)
GE12TIC	225(306)	200(272)	187(254)	175(238)	GV222TIC	451(613)	410(557)	385(523)	350(476)
GV158TIC	300(408)	270(367)	253(344)	230(313)					

■ Marine Auxiliary Engines

Model	Power (Output ISO 3046)	Model	Power (Output ISO 3046)	Model	Power (Output ISO 3046)	Model	Power (Output ISO 3046)
	kW(PS) @ 1,500rpm		kW(PS) @ 1,500rpm		kW(PS) @ 1,800rpm		kW(PS) @ 1,800rpm
AD034F	26(35)	AD136TIF	121(165)	AD034S	32(43)	AD136TIS	143(195)
AD034TIF	42(57)	AD158TIF	302(410)	AD034TIS	55(75)	AD158TIS	353(480)
AD086TIF	151(205)	AD180TIF	357(485)	AD086TIS	186(253)	AD180TIS	441(600)
AD126TIF	206(280)	AD196TF	155(210)	AD126TIS	247(336)	AD196TS	181(246)
AD136F	77(105)	AD196TIF	173(235)	AD136S	93(126)	AD196TIS	199(270)
AD136TF	107(145)	AD222TIF	446(606)	AD136TS	125(170)	AD222TIS	530(720)

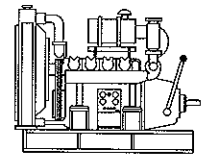
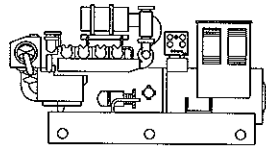

■ Marine Generator Sets

Generator Set	Engine Model	Power (kW/kVA)	
		1800rpm(60Hz)	1500rpm(50Hz)
		Power (Prime)	Power (Prime)
		kW/kVA	kW/kVA
PNM	DB33	24/30	20/25
PNB	AD034TI	50/63	36/45
PNJ	AD136	80/100	68/85
PNK	AD136T	104/130	96/120
PND	AD136TI	132/165	108/135
PNE	AD086TI	172/215	136/170
PNL	AD196TI	176/220	160/200
PNI	AD126TI	224/280	192/240
PNZ	AD158TI	328/410	276/345
PNS	AD180TI	400/500	332/415
PNY	AD222TI	500/625	408/510

■ Power Units

Model	Power kW(PS)/rpm
PU034	50(68)/3,000
PU066	85(116)/2,800
PU086	116(158)/2,200
PU086T(EADPA)	151(205)/2,200
PU086T(EADPB)	151(205)/2,300
PU086TI	213(290)/2,200
PU126TI	294(400)/2,100
PU158TI	397(540)/2,100
PU180TI	478(650)/2,100
PU222TI	588(800)/2,100

DOOSAN INFRACORE CO., LTD. AROUND THE WORLD

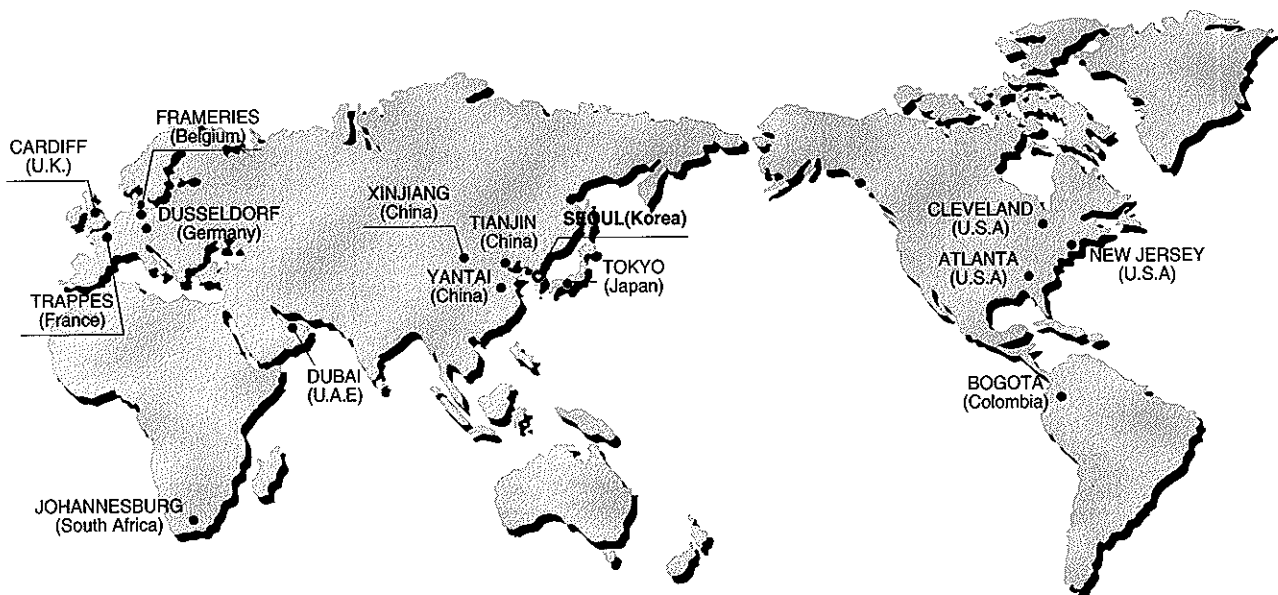

Head Office

Hwasu-Dong 7-11, Dong-Gu, Incheon, Korea.
Tel : +82-32-211-1114 Fax : +82-32-211-1231

Seoul Office

Doosan Tower 18-12, Euljiro-6Ga,
Jung-Gu, Seoul, Korea 100-730
Tel : +82-2-2167-3281 Fax : +82-2-3389-8117

ASIA & OCEANIA

Doosan Infracore Machine Tools Yantai Co.,Ltd.

1, Dayu Road 1, ETZD, Yantai, Shandong, China
Tel : +86-0535-693-5060 , Fax : +86-0535-693-5619

Doosan Infracore Liaoning Machinery Co.,Ltd.

No.32 DongLing Road, DongLing District, ShenYang,
Liaoning, China
Tel : +86-24-8841-1407, Fax : +86-24-8841-1404

Doosan Infracore Xinjiang Machinery Co.,Ltd.

No.178, Hetanbei Road, Wurumuqi, Xinjiang, China
Tel : +86-991-469-7217 , Fax : +86-991-469-8641

Dajian(Tianjin) Mechanical Construction Co., Ltd

No.87 Gongxing Road, Tanggu, Tianjin, china
Tel : +86-22-2521-0540 Fax : +86-22-2521-0714

Doosan Infracore (China) Co., Ltd.

#28, Wuzhishan Road, Eco. & Tech, Development Zone,
Yantai, Shandong, China
Tel : +86-535-638-2000 Fax : +86-535-638-2004

Doosan Infracore Japan Corporation

3rd Floor, k-1 Bld., 19-4, Nishi-shinbashi 2-Chome,
Minato-Ku, Tokyo, Japan
Phone : +81-3-3434-2547 Fax : +81-3-3434-2548

Doosan Infracore Middle East Center(Dubai)

183127, Al-Serkal Building, Air Port Road, Dubai, U.A.E
Phone : +971-4-295-2781, 2782 Fax : +971-4-295-2783

NORTH AMERICA

Doosan Infracore America Corporation

2905 Shawnee Industrial Way, Suwanee,
Georgia 30024, U. S. A
Tel : +1-770-831-2200 Fax : +1-770-831-0480

Doosan Infracore America Corporation Cleveland Office

4530 Renaissance Parkway, Warrensville Heights, OH 44128, U.S.A
Tel : +1-216-595-1212 Fax : +1-216-595-1214

Doosan Infracore America Corporation N.J. Office

8 York Avenue, West Caldwell, N.J. 07006, U.S.A
Tel : +1-973-618-2500 Fax : +1-973-618-2501

EUROPE

Doosan Infracore U.K., Ltd.

Doosan House, Unit 6.3, Nantgarw Park, Cardiff
CF47QU, U.K.
Tel : +44-1443-84-2273 Fax : +44-1443-84-1933

Doosan Infracore Germany GmbH

Hans-Boeckler strasse 27-29, D-40764, Langenfeld-Fuhrkamp,
Germany / Tel : +49-2173-8509-20 Fax : +49-2173-8509-60

Doosan Infracore Europe S.A. (Europe Head Office)

1A, Rue Achille Degrace, 7080 Frameries, Belgium
Tel : +32-65-61-3231 Fax : +32-65-61-3238

Doosan Infracore France SARL

(Doosan Infracore Europe S.A. France Office)

2Eme Etage, 1/3 Avenue Pavlov, Z.A.I. Des Bruyeres, 78190 Trappes France
Tel : +33-1-3016-2140 Fax : +33-1-3016-2144

Doosan Infracore Europe S.A. Italy Office

Via Monfalcone 41, 20090 Cinisello B.mo (MI)
Tel : +39-2-612-0565 Fax : +39-2-612-6322

SOUTH AMERICA

Colombia Liaison Office

Diagonal127 A No. 17-34 Oficina 302
Bogota, Colombia
Tel : +57-1-625-3470 Fax : 57-1 -625-3883

AFRICA

Doosan Infracore South Africa (PTY)Ltd.

60C Electron Road, Isando 1600, Johannesburg, South Africa
Tel : +27-11-974-2095 Fax : +27-11 -974-2778

DOOSAN

Doosan Infracore Co., Ltd.

HEAD OFFICE : 7-11, Hwasu-dong, Dong-gu, Incheon, KOREA

Tel : 82-32-211-1114

<http://www.doosaninfracore.co.kr>