

SECTION 8 DISASSEMBLY AND ASSEMBLY

Group 1	Precaution	8-1
Group 2	Tightening Torque	8-4
Group 3	Pump Device	8-7
Group 4	Main Control Valve	8-30
Group 5	Swing Device	8-47
Group 6	Travel Device	8-102
Group 7	RCV Lever	8-134
Group 8	Turning Joint	8-149
Group 9	Boom, Arm and Bucket Cylinder	8-154
Group 10	Undercarriage	8-171
Group 11	Work Equipment	8-183

SECTION 8 DISASSEMBLY AND ASSEMBLY

GROUP 1 PRECAUTIONS

1. REMOVAL WORK

- 1) Lower the work equipment completely to the ground.
If the coolant contains antifreeze, dispose of it correctly.
- 2) After disconnecting hoses or tubes, cover them or fit blind plugs to prevent dirt or dust from entering.
- 3) When draining oil, prepare a container of adequate size to catch the oil.
- 4) Confirm the match marks showing the installation position, and make match marks in the necessary places before removal to prevent any mistake when assembling.
- 5) To prevent any excessive force from being applied to the wiring, always hold the connectors when disconnecting the connectors.
- 6) Fit wires and hoses with tags to show their installation position to prevent any mistake when installing.
- 7) Check the number and thickness of the shims, and keep in a safe place.
- 8) When raising components, be sure to use lifting equipment of ample strength.
- 9) When using forcing screws to remove any components, tighten the forcing screws alternately.
- 10) Before removing any unit, clean the surrounding area and fit a cover to prevent any dust or dirt from entering after removal.
- 11) When removing hydraulic equipment, first release the remaining pressure inside the hydraulic tank and the hydraulic piping.
- 12) If the part is not under hydraulic pressure, the following corks can be used.

Nominal number	Dimensions		
	D	d	L
06	6	5	8
08	8	6.5	11
10	10	8.5	12
12	12	10	15
14	14	11.5	18
16	16	13.5	20
18	18	15	22
20	20	17	25
22	22	18.5	28
24	24	20	30
27	27	22.5	34

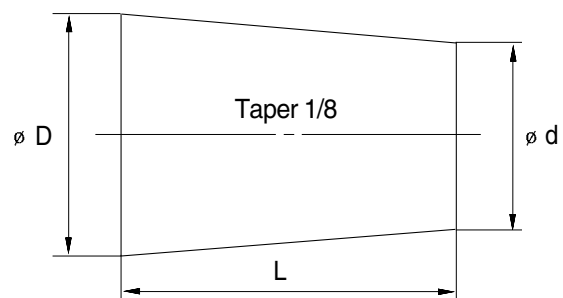

2. INSTALL WORK

- 1) Tighten all bolts and nuts(Sleeve nuts) to the specified torque.
- 2) Install the hoses without twisting or interference.
- 3) Replace all gaskets, O-rings, cotter pins, and lock plates with new parts.
- 4) Bend the cotter pin or lock plate securely.
- 5) When coating with adhesive, clean the part and remove all oil and grease, then coat the threaded portion with 2-3 drops of adhesive.
- 6) When coating with gasket sealant, clean the surface and remove all oil and grease, check that there is no dirt or damage, then coat uniformly with gasket sealant.
- 7) Clean all parts, and correct any damage, dents, burrs, or rust.
- 8) Coat rotating parts and sliding parts with engine oil.
- 9) When press fitting parts, coat the surface with antifriction compound(LM-P).
- 10) After installing snap rings, check that the snap ring is fitted securely in the ring groove(Check that the snap ring moves in the direction of rotation).
- 11) When connecting wiring connectors, clean the connector to remove all oil, dirt, or water, then connect securely.
- 12) When using eyebolts, check that there is no deformation or deterioration, and screw them in fully.
- 13) When tightening split flanges, tighten uniformly in turn to prevent excessive tightening on one side.
- 14) When operating the hydraulic cylinders for the first time after repairing and reassembling the hydraulic cylinders, pumps, or other hydraulic equipment or piping, always bleed the air from the hydraulic cylinders as follows:
 - (1) Start the engine and run at low idling.
 - (2) Operate the control lever and actuate the hydraulic cylinder 4-5 times, stopping 100mm before the end of the stroke.
 - (3) Next, operate the piston rod to the end of its stroke to relieve the circuit. (The air bleed valve is actuated to bleed the air.)
 - (4) After completing this operation, raise the engine speed to the normal operating condition.
 - ※ If the hydraulic cylinder has been replaced, carry out this procedure before assembling the rod to the work equipment.
 - ※ Carry out the same operation on machines that have been in storage for a long time after completion of repairs.

3. COMPLETING WORK

- 1) If the coolant has been drained, tighten the drain valve, and add water to the specified level. Run the engine to circulate the water through the system. Then check the water level again.
- 2) If the hydraulic equipment has been removed and installed again, add engine oil to the specified level. Run the engine to circulate the oil through the system. Then check the oil level again.
- 3) If the piping or hydraulic equipment, such as hydraulic cylinders, pumps, or motors, have been removed for repair, always bleed the air from the system after reassembling the parts.
- 4) Add the specified amount of grease(Molybdenum disulphied grease) to the work equipment related parts.

GROUP 2 TIGHTENING TORQUE

1. MAJOR COMPONENTS

No.	Descriptions	Bolt size	Torque		
			kgf · m	lbf · ft	
1	Engine mounting bolt, nut, rear	M24 × 3.0	97 ± 7.0	702 ± 51	
	Engine mounting bolt, nut, front	M20 × 2.5	55 ± 3.5	398 ± 25	
2	Engine	Radiator mounting bolt	M16 × 2.0	29.7 ± 4.5	215 ± 32.5
3		Coupling mounting socket bolt	M18 × 2.0	32 ± 1.0	231 ± 7.2
4		Main pump housing mounting bolt	M10 × 1.5	4.8 ± 0.3	34.7 ± 2.2
5		Main pump mounting socket bolt	M20 × 2.5	42 ± 4.5	304 ± 32.5
6	Hydraulic system	Main control valve mounting nut	M12 × 1.75	12.2 ± 1.3	88.2 ± 9.4
7		Fuel tank mounting bolt	M20 × 2.5	45 ± 5.1	325 ± 36.9
8		Hydraulic oil tank mounting bolt	M20 × 2.5	45 ± 5.1	325 ± 36.9
9		Turning joint mounting bolt, nut	M12 × 1.75	12 ± 1.3	86.8 ± 9.4
10		Power train system	Swing motor mounting bolt	M20 × 2.5	57.9 ± 8.7
11	Swing bearing upper part mounting bolt		M20 × 2.5	57.8 ± 6.4	418 ± 46.3
12	Swing bearing lower part mounting bolt		M20 × 2.5	57.8 ± 6.4	418 ± 46.3
13	Travel motor mounting bolt		M16 × 2.0	23 ± 2.5	166 ± 18.1
14	Sprocket mounting bolt		M16 × 2.0	26 ± 2.5	188 ± 18.1
15	Under carriage	Carrier roller mounting bolt, nut	M16 × 2.0	29.7 ± 4.4	215 ± 31.8
16		Track roller mounting bolt	M20 × 2.5	54.7 ± 5.0	396 ± 36.2
17		Track tension cylinder mounting bolt	M16 × 2.0	29.7 ± 4.5	215 ± 32.5
18		Track shoe mounting bolt, nut	M20 × 1.5	78 ± 8.0	564 ± 57.9
19		Track guard mounting bolt	M20 × 2.5	57.9 ± 8.7	419 ± 62.9
20	Others	Counterweight mounting bolt	M36 × 3.0	308 ± 46	2228 ± 333
21		Cab mounting bolt	M12 × 1.75	12.8 ± 3.0	92.6 ± 21.7
22		Operator's seat mounting bolt	M 8 × 1.25	4.05 ± 0.8	29.3 ± 5.8

※ For tightening torque of engine and hydraulic components, see engine maintenance guide and service manual.

2. TORQUE CHART

Use following table for unspecified torque.

1) BOLT AND NUT

(1) Coarse thread

Bolt size	8T		10T	
	kgf · m	lbf · ft	kgf · m	lbf · ft
M 6 × 1.0	0.85 ~ 1.25	6.15 ~ 9.04	1.14 ~ 1.74	8.2 ~ 12.6
M 8 × 1.25	2.0 ~ 3.0	14.5 ~ 21.7	2.73 ~ 4.12	19.7 ~ 29.8
M10 × 1.5	4.0 ~ 6.0	28.9 ~ 43.4	5.5 ~ 8.3	39.8 ~ 60
M12 × 1.75	7.4 ~ 11.2	53.5 ~ 79.5	9.8 ~ 15.8	71 ~ 114
M14 × 2.0	12.2 ~ 16.6	88.2 ~ 120	16.7 ~ 22.5	121 ~ 167
M16 × 2.0	18.6 ~ 25.2	135 ~ 182	25.2 ~ 34.2	182 ~ 247
M18 × 2.5	25.8 ~ 35.0	187 ~ 253	35.1 ~ 47.5	254 ~ 343
M20 × 2.5	36.2 ~ 49.0	262 ~ 354	49.2 ~ 66.6	356 ~ 482
M22 × 2.5	48.3 ~ 63.3	350 ~ 457	65.8 ~ 98.0	476 ~ 709
M24 × 3.0	62.5 ~ 84.5	452 ~ 611	85.0 ~ 115	615 ~ 832
M30 × 3.5	124 ~ 168	898 ~ 1214	169 ~ 229	1223 ~ 1655
M36 × 4.0	174 ~ 236	1261 ~ 1703	250 ~ 310	1808 ~ 2242

(2) Fine thread

Bolt size	8T		10T	
	kgf · m	lbf · ft	kgf · m	lbf · ft
M 8 × 1.0	2.17 ~ 3.37	15.7 ~ 24.3	3.04 ~ 4.44	22.0 ~ 32.0
M10 × 1.25	4.46 ~ 6.66	32.3 ~ 48.2	5.93 ~ 8.93	42.9 ~ 64.6
M12 × 1.25	7.78 ~ 11.58	76.3 ~ 83.7	10.6 ~ 16.0	76.6 ~ 115
M14 × 1.5	13.3 ~ 18.1	96.2 ~ 130	17.9 ~ 24.1	130 ~ 174
M16 × 1.5	19.9 ~ 26.9	144 ~ 194	26.6 ~ 36.0	193 ~ 260
M18 × 1.5	28.6 ~ 43.6	207 ~ 315	38.4 ~ 52.0	278 ~ 376
M20 × 1.5	40.0 ~ 54.0	289 ~ 390	53.4 ~ 72.2	386 ~ 522
M22 × 1.5	52.7 ~ 71.3	381 ~ 515	70.7 ~ 95.7	512 ~ 692
M24 × 2.0	67.9 ~ 91.9	491 ~ 664	90.9 ~ 123	658 ~ 890
M30 × 2.0	137 ~ 185	990 ~ 1338	182 ~ 248	1314 ~ 1795
M36 × 3.0	192 ~ 260	1389 ~ 1879	262 ~ 354	1893 ~ 2561

2) PIPE AND HOSE(FLARE TYPE)

Thread size(PF)	Width across flat(mm)	kgf · m	lbf · ft
1/4"	19	4	28.9
3/8"	22	5	36.2
1/2"	27	9.5	68.7
3/4"	36	18	130.2
1"	41	21	151.9
1-1/4"	50	35	253.2

3) PIPE AND HOSE(ORFS TYPE)

Thread size(UNF)	Width across flat(mm)	kgf · m	lbf · ft
9/16-18	19	4	28.9
11/16-16	22	5	36.2
13/16-16	27	9.5	68.7
1-3/16-12	36	18	130.2
1-7/16-12	41	21	151.9
1-11/16-12	50	35	253.2

4) FITTING

Thread size	Width across flat(mm)	kgf · m	lbf · ft
1/4"	19	4	28.9
3/8"	22	5	36.2
1/2"	27	9.5	68.7
3/4"	36	18	130.2
1"	41	21	151.9
1-1/4"	50	35	253.2

GROUP 3 PUMP DEVICE

1. REMOVAL AND INSTALL

1) REMOVAL

- (1) Lower the work equipment to the ground and stop the engine.
- (2) Operate the control levers and pedals several times to release the remaining pressure in the hydraulic piping
- (3) Loosen the breather slowly to release the pressure inside the hydraulic tank.

▲ Escaping fluid under pressure can penetrate the skin causing serious injury.

- (4) Loosen the drain plug under the hydraulic tank and drain the oil from the hydraulic tank.

· Hydraulic tank quantity : 180 l

- (5) Remove socket bolts(74) and disconnect pipe(1, 2).
- (6) Disconnect pilot line hoses(4, 5, 6, 7, 8, 9, 10, 11).

- (7) Remove socket bolts(72) and disconnect pump suction tube(3).

※ When pump suction tube is disconnected, the oil inside the piping will flow out, so catch it in oil pan.

- (8) Sling the pump assembly and remove the pump mounting bolts.

· Weight : 120kg(265lb)

※ Pull out the pump assembly from housing. When removing the pump assembly, check that all the hoses have been disconnected.

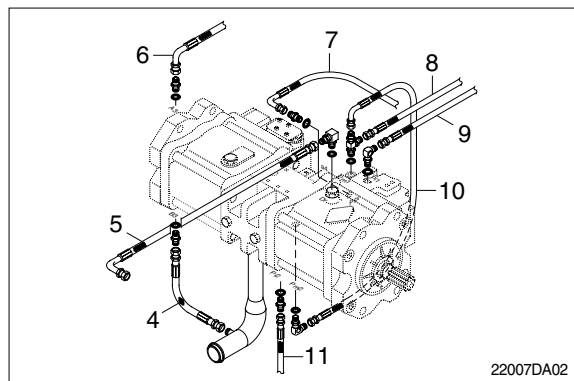
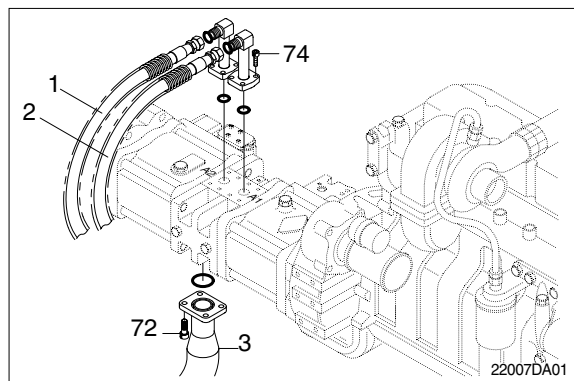

2) INSTALL

- (1) Carry out installation in the reverse order to removal.
- (2) Remove the suction strainer and clean it.
- (3) Replace return filter with new one.
- (4) Remove breather and clean it.
- (5) After adding oil to the hydraulic tank to the specified level.
- (6) Bleed the air from the hydraulic pump.
 - ① Remove the air vent plug(2EA).
 - ② Tighten plug lightly.
 - ③ Start the engine, run at low idling, and check oil come out from plug.
 - ④ Tighten plug.
- (7) Start the engine, run at low idling(3~5 minutes) to circulate the oil through the system.
- (8) Confirm the hydraulic oil level and check the hydraulic oil leak or not.

2. MAIN PUMP(1/2)

1) STRUCTURE

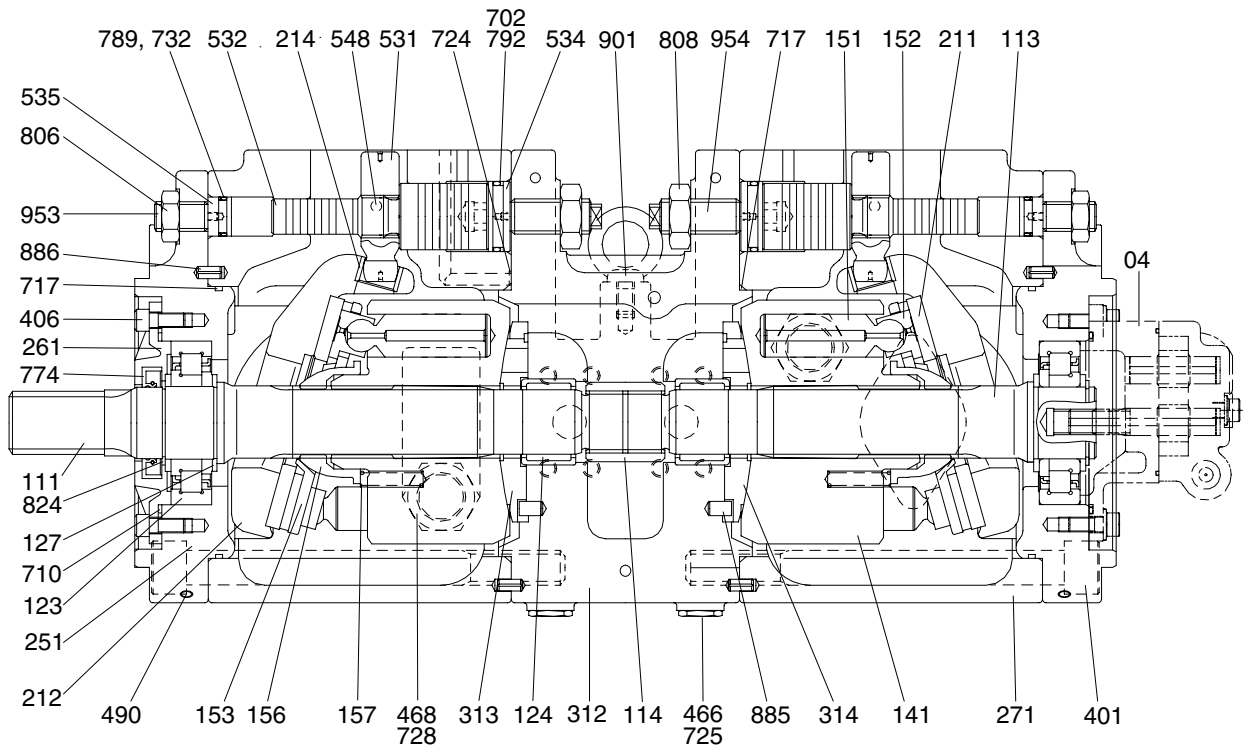

RD21072SF02

04	Gear pump	261	Seal cover(F)	717	O-ring
111	Drive shaft(F)	271	Pump casing	724	O-ring
113	Drive shaft(R)	312	Valve block	725	O-ring
114	Spline coupling	313	Valve plate(R)	728	O-ring
123	Roller bearing	314	Valve plate(L)	732	O-ring
124	Needle bearing	401	Hexagon socket bolt	774	Oil seal
127	Bearing spacer	406	Hexagon socket bolt	789	Back up ring
141	Cylinder block	466	VP Plug	792	Back up ring
151	Piston	468	VP Plug	806	Hexagon head nut
152	Shoe	490	Plug	808	Hexagon head nut
153	Set plate	531	Tilting pin	824	Snap ring
156	Bushing	532	Servo piston	885	Pin
157	Cylinder spring	534	Stopper(L)	886	Spring pin
211	Shoe plate	535	Stopper(S)	901	Eye bolt
212	Swash plate	548	Pin	953	Set screw
214	Bushing	702	O-ring	954	Set screw
251	Support	710	O-ring		

MAIN PUMP(2/2)

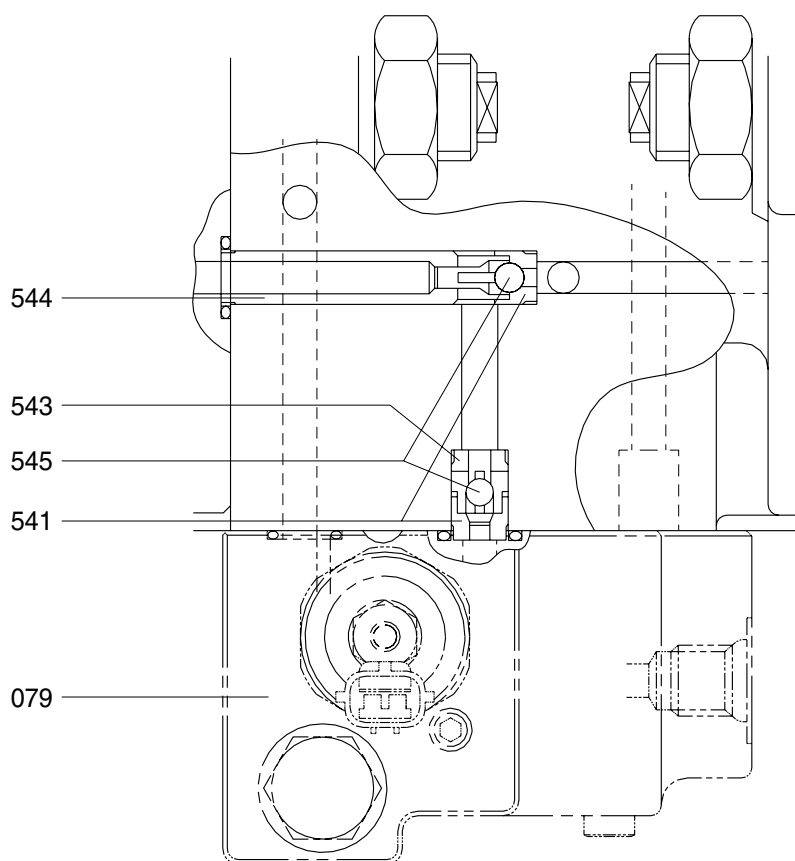

VIEW A

(210-7) 8-10

541 Seat
543 Stopper 1



544 Stopper 2
545 Steel ball

079 Proportional reducing valve

2) TOOLS AND TIGHTENING TORQUE

(1) Tools

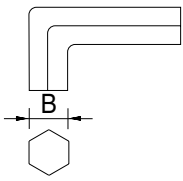
The tools necessary to disassemble/reassemble the pump are shown in the follow list.

Tool name & size		Part name			
Name	B	Hexagon socket head bolt	PT plug (PT thread)	PO plug (PF thread)	Hexagon socket head setscrew
Allen wrench 	4	M 5	BP-1/16	-	M 8
	5	M 6	BP-1/8	-	M10
	6	M 8	BP-1/4	PO-1/4	M12, M14
	8	M10	BP-3/8	PO-3/8	M16, M18
	17	M20, M22	BP-1	PO-1, 1 1/4, 1 1/2	-
Double ring spanner, socket wrench, double(Single) open end spanner 	-	Hexagon socket head bolt	Hexagon nut	VP plug (PF thread)	
	19	M12	M12	VP-1/4	
	24	M16	M16	-	
	27	M18	M18	VP-1/2	
	30	M20	M20	-	
	36	-	-	VP-3/4	
Adjustable angle wrench		Medium size, 1 set			
Screw driver		Minus type screw driver, Medium size, 2 sets			
Hammer		Plastic hammer, 1 set			
Pliers		For snap ring, TSR-160			
Steel bar		Steel bar of key material approx. 10×8×200			
Torque wrench		Capable of tightening with the specified torques			

(2) Tightening torque

Part name	Bolt size	Torque		Wrench size	
		kgf · m	lbf · ft	in	mm
Hexagon socket head bolt Material : SCM435)	M 5	0.7	5.1	0.16	4
	M 6	1.2	8.7	0.20	5
	M 8	3.0	21.7	0.24	6
	M10	5.8	42.0	0.31	8
	M12	10.0	72.3	0.39	10
	M14	16.0	116	0.47	12
	M16	24.0	174	0.55	14
	M18	34.0	246	0.55	14
	M20	44.0	318	0.67	17
PT Plug(Material : S45C) ※ Wind a seal tape 1 1/2 to 2 turns round the plug	PT1/16	0.7	5.1	0.16	4
	PT 1/8	1.05	7.59	0.20	5
	PT 1/4	1.75	12.7	0.24	6
	PT 3/8	3.5	25.3	0.31	8
	PT 1/2	5.0	36.2	0.39	10
PF Plug(Material : S45C)	PF 1/4	3.0	21.7	0.24	6
	PF 1/2	10.0	72.3	0.39	10
	PF 3/4	15.0	109	0.55	14
	PF 1	19.0	137	0.67	17
	PF 1 1/4	27.0	195	0.67	17
	PF 1 1/2	28.0	203	0.67	17

3) DISASSEMBLY

- (1) Select place suitable to disassembling.
 - ※ Select clean place.
 - ※ Spread rubber sheet, cloth or so on on overhaul workbench top to prevent parts from being damaged.
- (2) Remove dust, rust, etc, from pump surfaces with cleaning oil or so on.
- (3) Remove drain port plug(468) and let oil out of pump casing(Front and rear pump).
- (4) Remove hexagon socket head bolts(412, 413) and remove regulator.

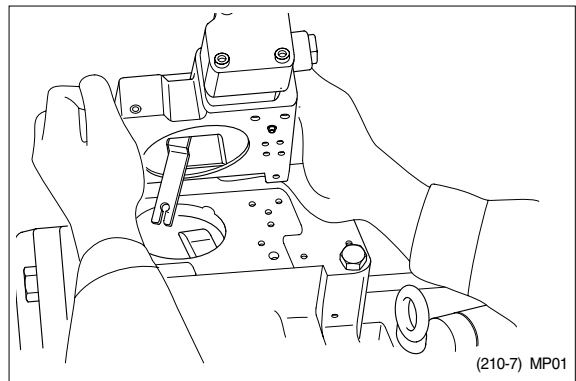

- (5) Loosen hexagon socket head bolts(401) which tighten swash plate support(251), pump casing(271) and valve block(312).
 - ※ If gear pump and so on are fitted to rear face of pump, remove them before starting this work.

- (6) Place pump horizontally on workbench with its regulator-fitting surface down and separate pump casing(271) from valve block(312).
 - ※ Before bringing this surface down, spread rubber sheet on workbench without fail to prevent this surface from being damaged.

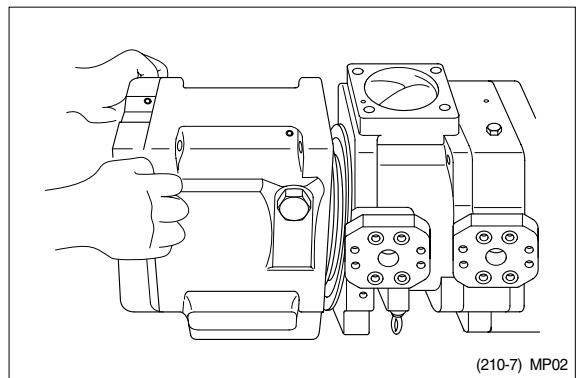

(7) Pull cylinder block(141) out of pump casing(271) straightly over drive shaft(111). Pull out also pistons(151), set plate(153), spherical bush(156) and cylinder springs(157) simultaneously.

※ Take care not to damage sliding surfaces of cylinder, spherical bushing, shoes, swash plate, etc.

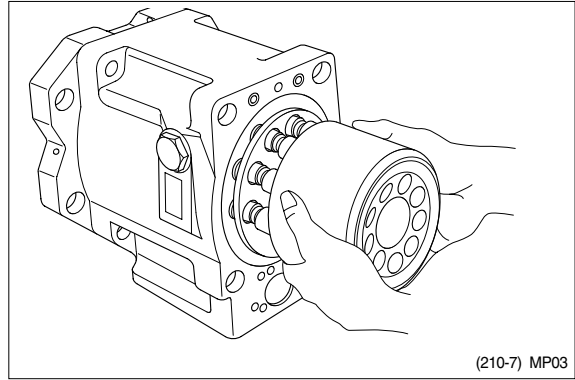

(8) Remove hexagon socket head bolts(406) and then seal cover(F, 261).

※ Fit bolt into pulling out tapped hole of seal cover(F), and cover can be removed easily.

※ Since oil seal is fitted on seal cover(F), take care not to damage it in removing cover.

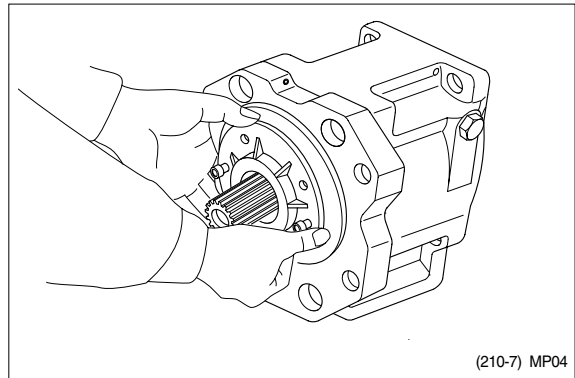

(9) Remove hexagon socket head bolts(408) and then seal cover(R, 262).

In case fitting a gear pump, first, remove gear pump.

(10) Tapping lightly fitting flange section of swash plate support(251) on its pump casing side, separate swash plate support from pump casing.

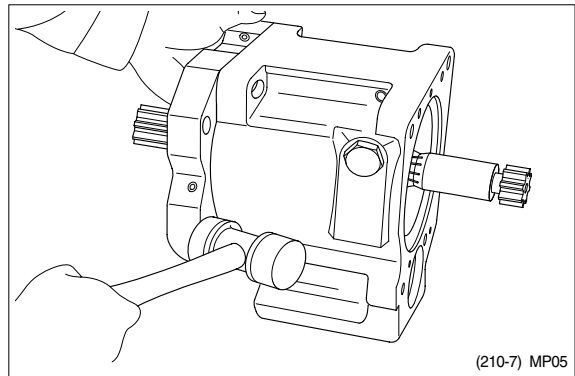

(11) Remove shoe plate(211) and swash plate(212) from pump casing(271).

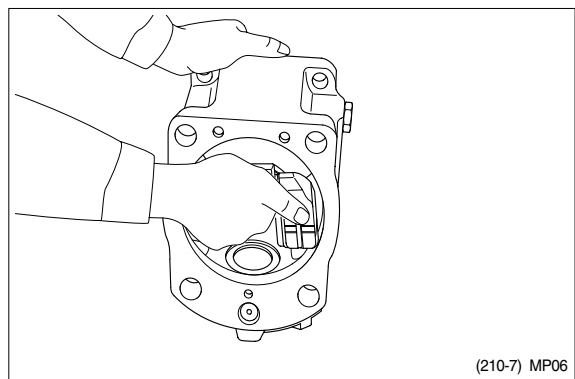

- (12) Tapping lightly shaft ends of drive shafts (111, 113) with plastic hammer, take out drive shafts from swash plate supports.

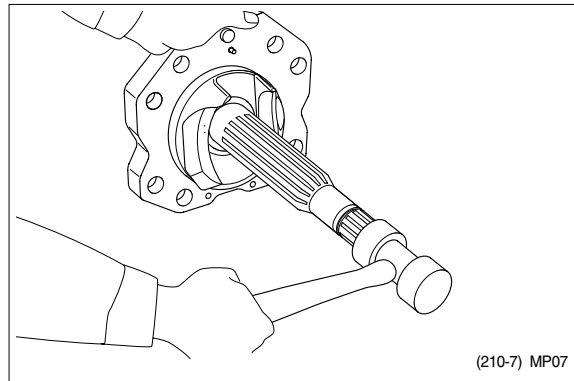

- (13) Remove valve plates(313, 314) from valve block(312).

※ These may be removed in work(6).

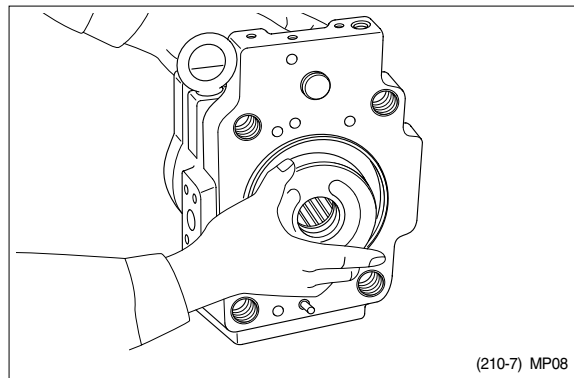

- (14) If necessary, remove stopper(L, 534), stopper(S, 535), servo piston(532) and tilting pin(531) from pump casing(271), and needle bearing(124) and splined coupling(114) from valve block(312).

- ※ In removing tilting pin, use a protector to prevent pin head from being damaged.
- ※ Since loctite is applied to fitting areas of tilting pin and servo piston, take care not to damage servo piston.
- ※ Do not remove needle bearing as far as possible, except when it is considered to be out of its life span.
- ※ Do not loosen hexagon nuts of valve block and swash plate support.
If loosened, flow setting will be changed.

4) ASSEMBLY

(1) For reassembling reverse the disassembling procedures, paying attention to the following items.

- ① Do not fail to repair the parts damaged during disassembling, and prepare replacement parts in advance.
- ② Clean each part fully with cleaning oil and dry it with compressed air.
- ③ Do not fail to apply clean working oil to sliding sections, bearings, etc. before assembling them.
- ④ In principle, replace seal parts, such as O-rings, oil seals, etc.
- ⑤ For fitting bolts, plug, etc., prepare a torque wrench or so on, and tighten them with torques shown in page 8-11, 12.
- ⑥ For the double-pump, take care not to mix up parts of the front pump with those of the rear pump.

(2) Fit swash plate support(251) to pump casing(271), tapping the former lightly with a hammer.

- ※ After servo piston, tilting pin, stopper(L) and stopper(S) are removed, fit them soon to pump casing in advance for reassembling.
- ※ In tightening servo piston and tilting pin, use a protector to prevent tilting pin head and feedback pin from being damaged. In addition, apply loctite(Medium strength) to their threaded sections.

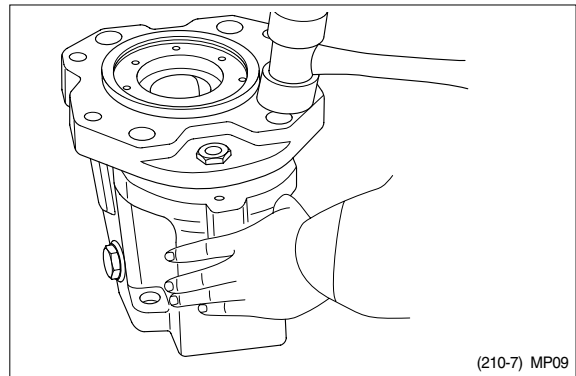

(210-7) MP09

- (3) Place pump casing with its regulator fitting surface down, fit tilting bush of swash plate to tilting pin(531) and fit swash plate (212) to swash plate support(251) correctly. Confirm with fingers of both hands that
- ※ swash plate can be removed smoothly.
- Apply grease to sliding sections of swash plate and swash plate support, and drive shaft can be fitted easily.

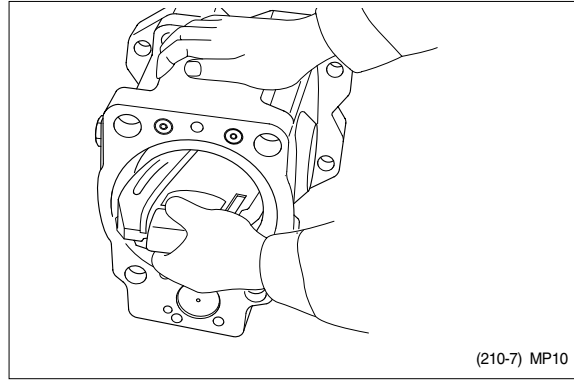

- (4) To swash plate support(251), fit drive shaft(111) set with bearing(123), bearing spacer(127) and snap ring(824).
- ※ Do not tap drive shaft with hammer or so on.
 - ※ Assemble them into support, tapping outer race of bearing lightly with plastic hammer.
- Fit them fully, using steel bar or so on.

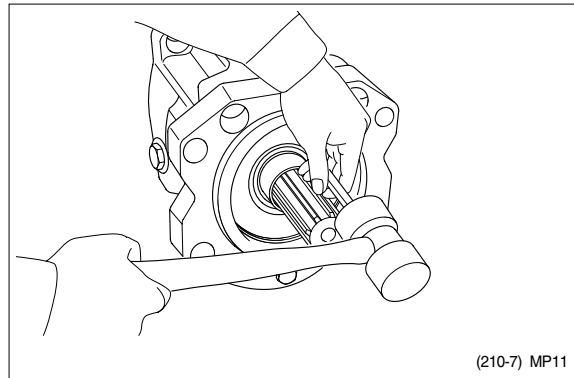

- (5) Assemble seal cover(F, 261) to pump casing(271) and fix it with hexagon socket head bolts(406).
- ※ Apply grease lightly to oil seal in seal cover(F).
 - ※ Assemble oil seal, taking full care not to damage it.
 - ※ For tandem type pump, fit rear cover(263) and seal cover(262) similarly.

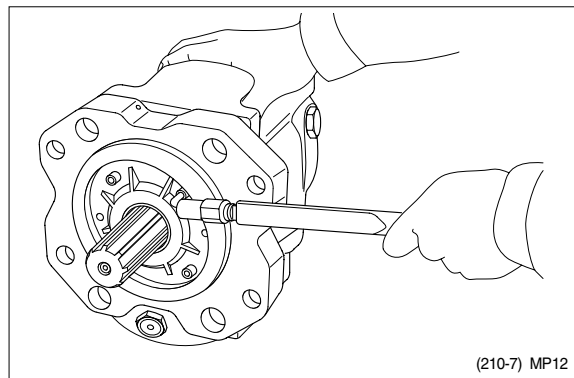

- (6) Assemble piston cylinder subassembly [cylinder block(141), piston subassembly (151, 152), set plate(153), spherical bush (156) and cylinder spring (157)]. Fit spline phases of retainer and cylinder. Then, insert piston cylinder subassembly into pump casing.

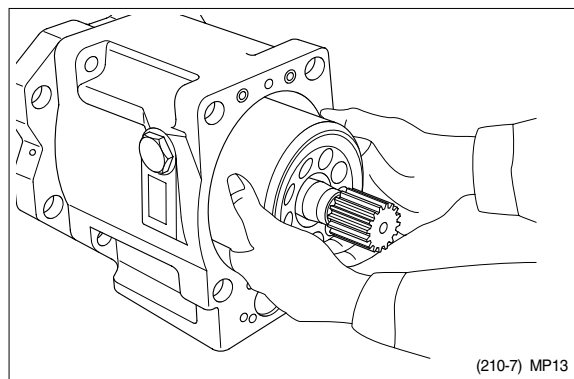

(7) Fit valve plate(313) to valve block(312), entering pin into pin hole.

- ※ Take care not to mistake suction / delivery directions of valve plate.

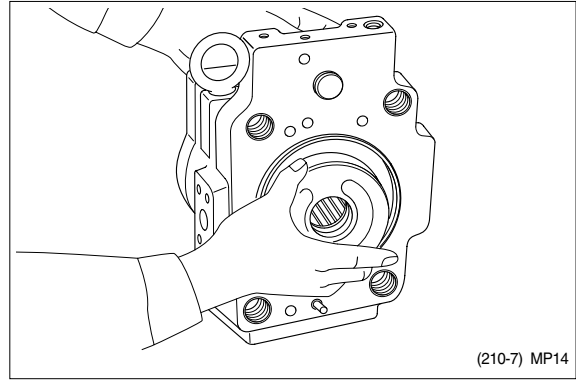

(8) Fit valve block(312) to pump casing(271) and tighten hexagon socket head bolts (401).

- ※ At first assemble this at rear pump side, and this work will be easy.
- ※ Take care not to mistake direction of valve block.
- ※ Clockwise rotation(Viewed from input shaft side) - Fit block with regulator up and with delivery flange left, viewed from front side.
- ※ Counter clockwise rotation(Viewed from input shaft side) - Fit block with delivery flange right, viewed from front side.

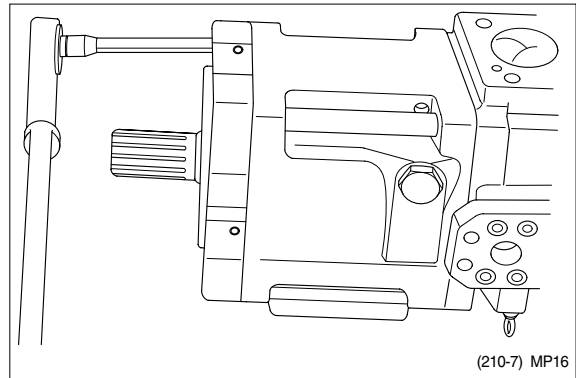

(9) Putting feedback pin of tilting pin into feedback lever of regulator, fit regulator and tighten hexagon socket head bolts (412, 413).

- ※ Take care not to mistake regulator of front pump for that of rear pump.

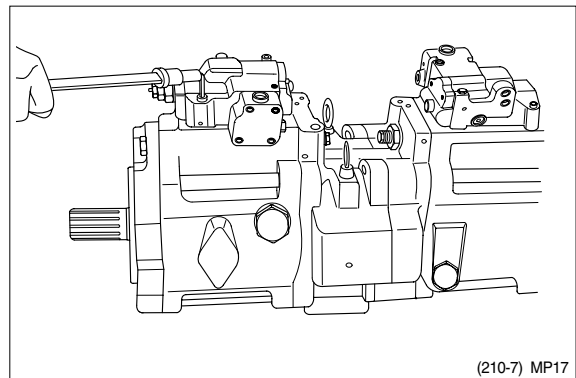

(10) Fit drain port plug(468).

This is the end of reassembling procedures.

3. REGULATOR

1) STRUCTURE(1/2)

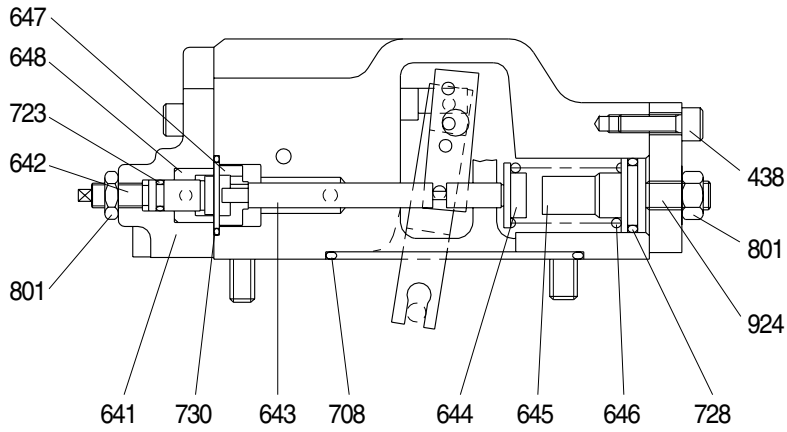
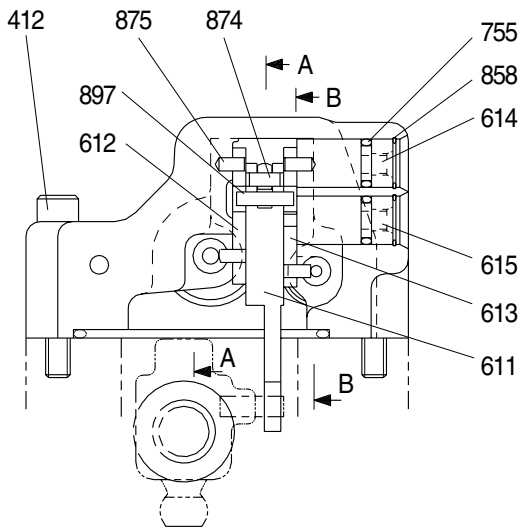

SECTION B-B

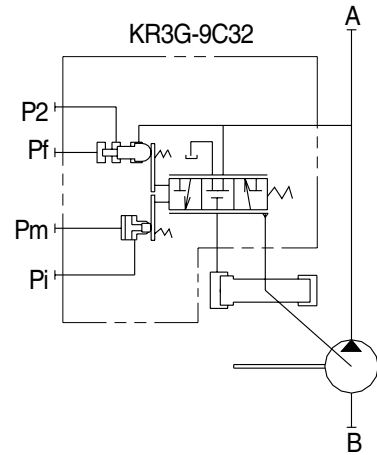

(210-7) 8-19

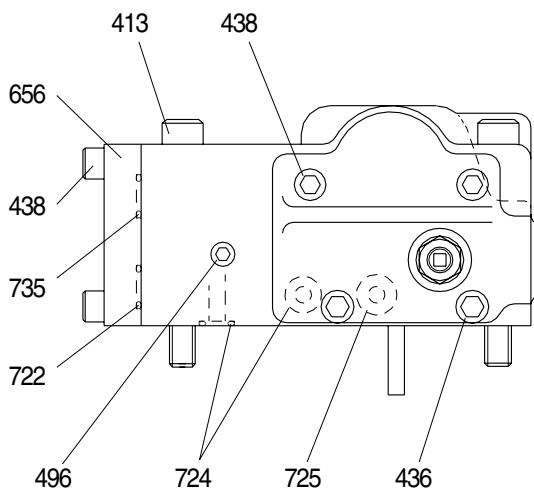

VIEW C

REGULATOR(2/2)

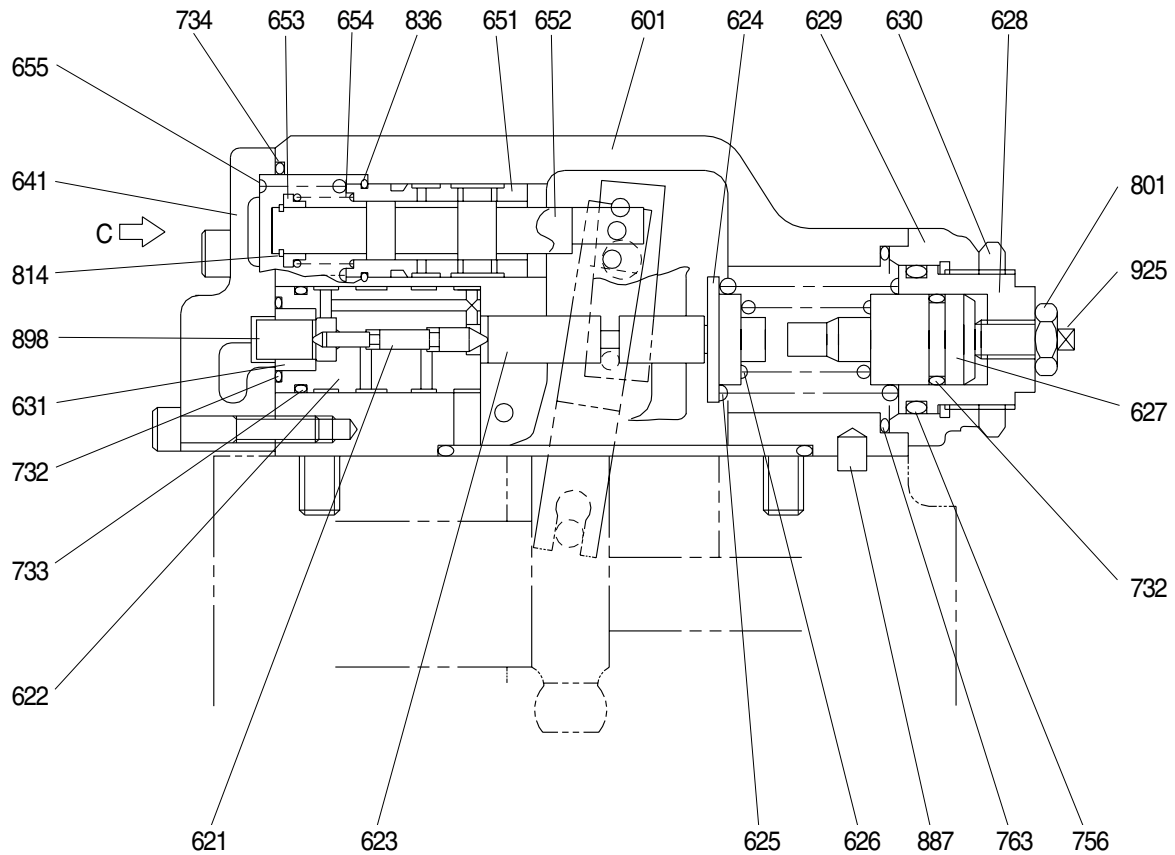

SECTION A-A



(210-7) 8-20

412 Hexagon socket screw	630 Nut	728 O-ring
413 Hexagon socket screw	631 Sleeve	730 O-ring
436 Hexagon socket screw	641 Pilot cover	732 O-ring
438 Hexagon socket screw	642 Pilot cover(QMC)	733 O-ring
496 Plug	643 Pilot piston	734 O-ring
601 Casing	644 Spring seat(Q)	735 O-ring
611 Feed back lever	645 Adjust stem(Q)	755 O-ring
612 Lever(1)	646 Pilot spring	756 O-ring
613 Lever(2)	647 Stopper	763 O-ring
614 Fulcrum plug	648 Piston(QMC)	801 Nut
615 Adjust plug	651 Sleeve	814 Snap ring
621 Compensator rod	652 Spool	836 Snap ring
622 Piston case	653 Spring seat	858 Snap ring
623 Compensator rod	654 Return spring	874 Pin
624 Spring seat(C)	655 Set spring	875 Pin
625 Outer spring	656 Block cover	887 Pin
626 Inner spring	708 O-ring	897 Pin
627 Adjust stem(C)	722 O-ring	898 Pin
628 Adjust screw(C)	724 O-ring	924 Set screw
629 Cover(C)	725 O-ring	925 Adjust screw(Q)

2) TOOLS AND TIGHTENING TORQUE

(1) Tools

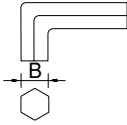
The tools necessary to disassemble/reassemble the pump are shown in the follow list.

Tool name & size		Part name			
Name	B	Hexagon socket head bolt	PT plug (PT thread)	PO plug (PF thread)	Hexagon socket head setscrew
Allen wrench 	4	M 5	BP-1/16	-	M 8
	5	M 6	BP-1/8	-	M10
	6	M 8	BP-1/4	PO-1/4	M12, M14
Double ring spanner, socket wrench, double(Single) open end spanner 	-	Hexagon head bolt	Hexagon nut	VP plug (PF thread)	
	6	M 8	M 8	-	
Adjustable angle wrench		Small size, Max 36mm			
Screw driver		Minus type screw driver, Medium size, 2 sets			
Hammer		Plastic hammer, 1 set			
Pliers		For snap ring, TSR-160			
Steel bar		4 × 100mm			
Torque wrench		Capable of tightening with the specified torques			
Pincers		-			
Bolt		M4, Length : 50mm			

(2) Tightening torque

Part name	Bolt size	Torque		Wrench size	
		kgf · m	lbf · ft	in	mm
Hexagon socket head bolt Material : SCM435)	M 5	0.7	5.1	0.16	4
	M 6	1.2	8.7	0.20	5
	M 8	3.0	21.7	0.24	6
	M10	5.8	42.0	0.31	8
	M12	10.0	72.3	0.39	10
	M14	16.0	116	0.47	12
	M16	24.0	174	0.55	14
	M18	34.0	246	0.55	14
	M20	44.0	318	0.67	17
PT Plug(Material : S45C) ※ Wind a seal tape 1 1/2 to 2 turns round the plug	PT1/16	0.7	5.1	0.16	4
	PT 1/8	1.05	7.59	0.20	5
	PT 1/4	1.75	12.7	0.24	6
	PT 3/8	3.5	25.3	0.31	8
	PT 1/2	5.0	36.2	0.39	10
PF Plug(Material : S35C)	PF 1/4	3.0	21.7	0.24	6
	PF 1/2	10.0	72.3	0.39	10
	PF 3/4	15.0	109	0.55	14
	PF 1	19.0	137	0.67	17
	PF 1 1/4	27.0	195	0.67	17
	PF 1 1/2	28.0	203	0.67	17

3) DISASSEMBLY

Since the regulator consists of small precision finished parts, disassembly and assembly are rather complicated.

For this reason, replacement of a regulator assembly is recommended, unless there is a special reason, but in case disassembly is necessary for an unavoidable reason, read through this manual to the end before starting disassembly.

- (1) Choose a place for disassembly.
 - ※ Choose a clean place.
 - ※ Spread rubber sheet, cloth, or so on on top of work-bench to prevent parts from being damaged.
- (2) Remove dust, rust, etc. from surfaces of regulator with clean oil.
- (3) Remove hexagon socket head screw (412, 413) and remove regulator main body from pump main body.
 - ※ Take care not to lose O-ring.

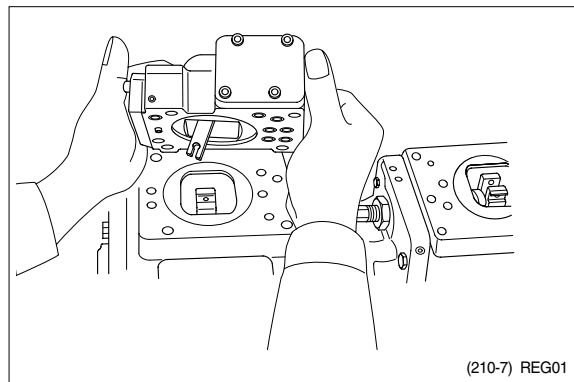

- (4) Remove hexagon socket head screw (438) and remove cover(C,629)
 - ※ Cover(C) is fitted with adjusting screw (C,QI) (628, 925), adjusting ring(C, 627), lock nut(630), hexagon nut(801) and adjusting screw(924).
Do not loosen these screws and nuts.
If they are loosened, adjusted pressure-flow setting will vary.

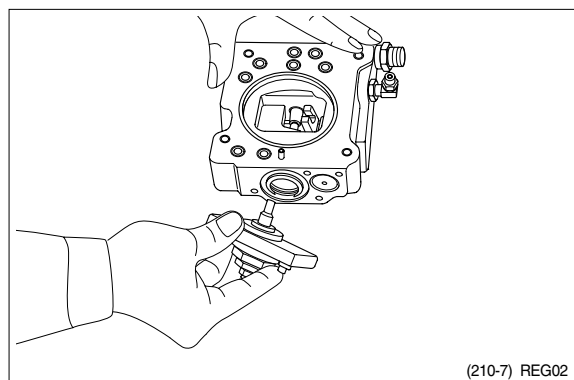

- (5) After removing cover(C, 629) subassembly, take out outer spring(625), inner spring (626) and spring seat(C, 624) from compensating section.

Then draw out adjusting ring(Q, 645), pilot spring(646) and spring seat(644) from pilot section.

- ※ Adjusting ring(Q,645) can easily be drawn out with M4 bolt.

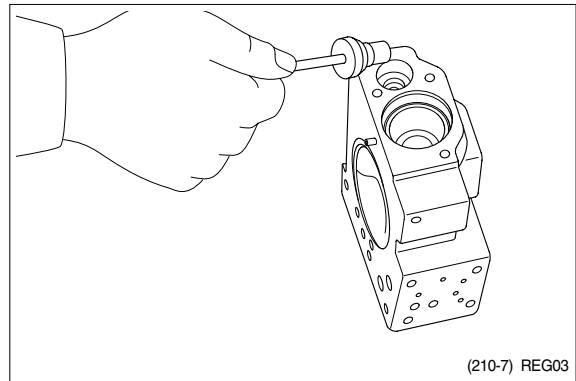

- (6) Remove hexagon socket head screws (436, 438) and remove pilot cover(641).

After removing pilot cover, take out set spring(655) from pilot section.

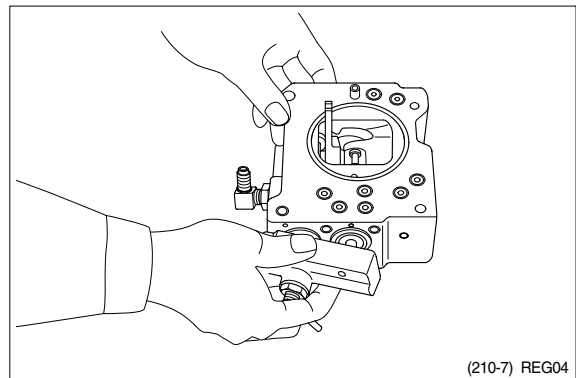

- (7) Remove snap ring(814) and take out spring seat(653), return spring(654) and sleeve(651).

- ※ Sleeve(651) is fitted with snap ring(836).
- ※ When removing snap ring(814), return spring(654) may pop out. Take care not to lose it.

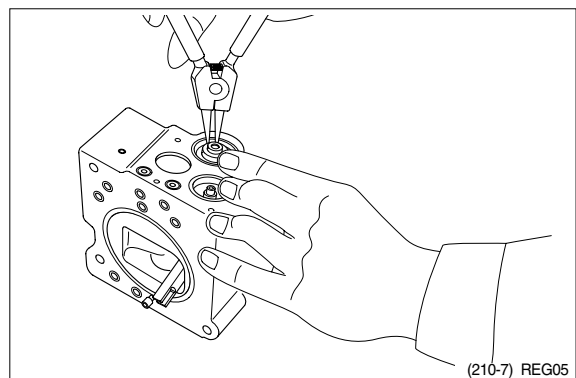

- (8) Remove locking ring(858) and take out fulcrum plug(614) and adjusting plug (615).

- ※ Fulcrum plug(614) and adjusting plug (615) can easily be taken out with M6 bolt.

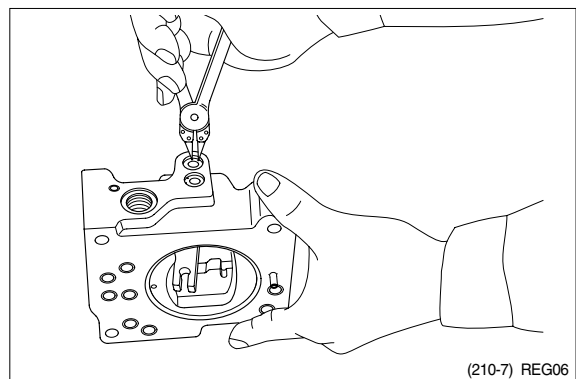

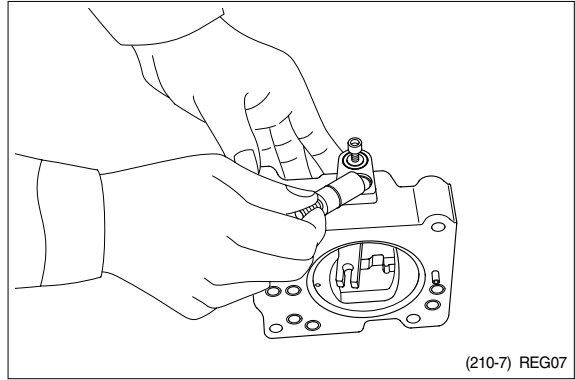

- (9) Remove lever(2, 613). Do not draw out pin(875).
※ Work will be promoted by using pincers or so on.

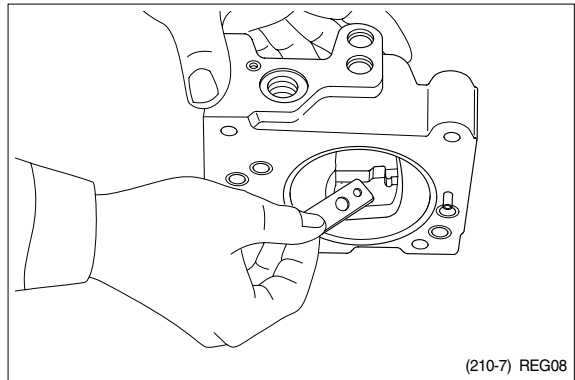

- (10) Draw out pin(874) and remove feedback lever(611).
Push out pin(874, 4mm in dia.) from above with slender steel bar so that it may not interfere with lever(1, 612).

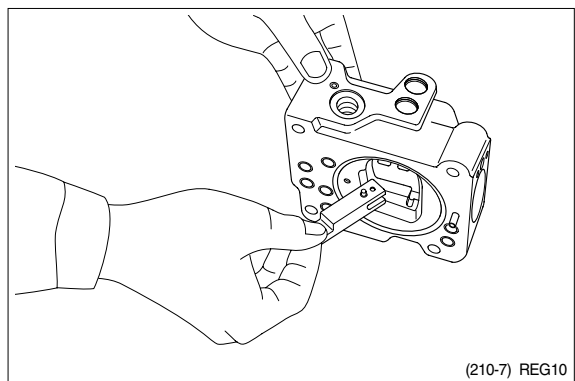
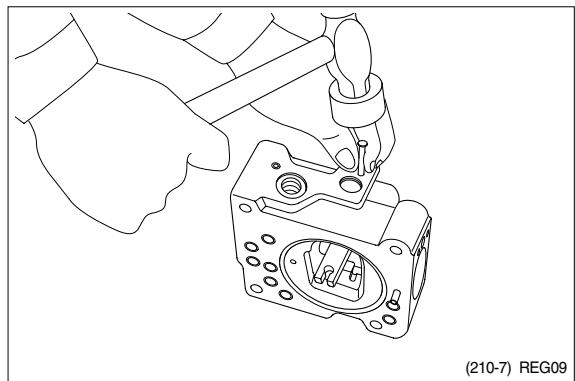

(11) Remove lever(1, 612). Do not draw out pin(875).

(12) Draw out pilot piston(643) and spool(652).

(13) Draw out piston case(622), compensating piston(621) and compensating rod(623).

※ Piston case(622) can be taken out by pushing compensating rod(623) at opposite side of piston case.

This completes disassembly.

4) ASSEMBLY

(1) For assembly, reverse disassembly procedures, but pay attention to the following items.

- ① Always repair parts that were scored at disassembly.
- ② Get replacement parts ready beforehand.
Mixing of foreign matter will cause malfunction.
Therefore, wash parts well with cleaning oil, let them dry with jet air and handle them in clean place.
- ③ Always tighten bolts, plugs, etc. to their specified torques.
- ④ Do not fail to coat sliding surfaces with clean hydraulic oil before assembly.
- ⑤ Replace seals such as O-ring with new ones as a rule.

(2) Put compensating rod(623) into compensating hole of casing(601).

(3) Put pin force-fitted in lever(1, 612) into groove of compensating rod and fit lever (1) to pin force-fitted in casing.

(4) Fit spool(652) and sleeve(651) into hole in spool of casing.

- ※ Confirm that spool and sleeve slide smoothly in casing without binding.
- ※ Pay attention to orientation of spool.

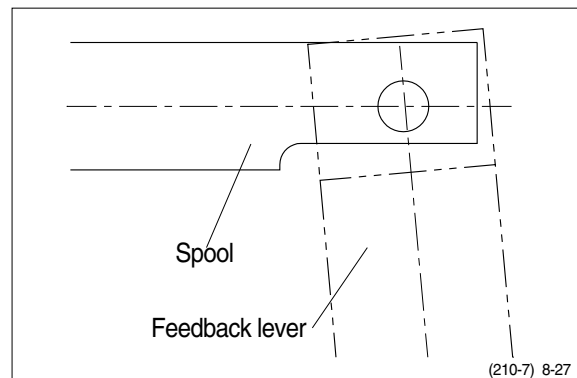

- (5) Fit feedback lever(611), matching its pin hole with pin hole in spool.
Then insert pin(874).
- ※ Insert pin in feedback lever a little to ease operation.
 - ※ Take care not to mistake direction of feedback lever.

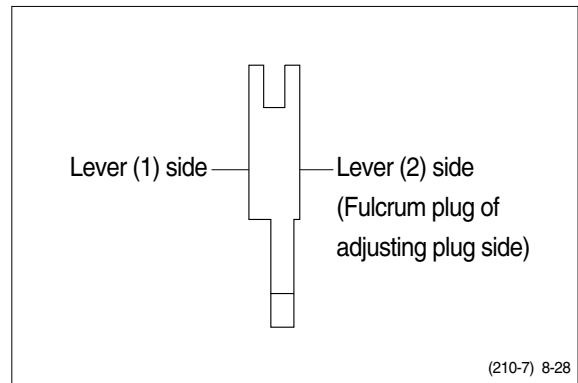

- (6) Put pilot piston(643) into pilot hole of casing.
- ※ Confirm that pilot piston slides smoothly without binding.
- (7) Put pin force-fitted in lever(2, 613) into groove of pilot piston.
Then fix lever(2).

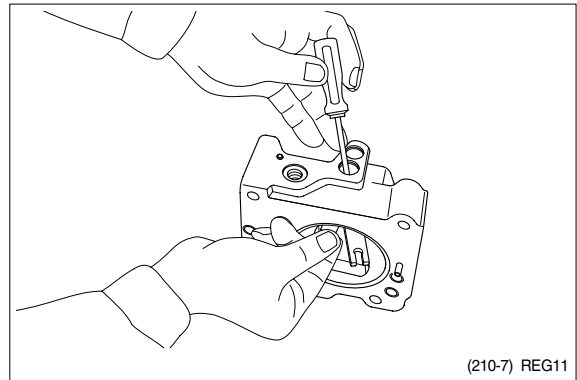

- (8) Fit fulcrum plug(614) so that pin force-fitted in fulcrum plug(614) can be put into pin hole of lever(2).
Then fix locking ring(858).
- (9) Insert adjusting plug(615) and fit locking ring.
- ※ Take care not to mistake inserting holes for fulcrum plug and adjusting plug.
- At this point in time move feedback lever to confirm that it has no large play and is free from binding.

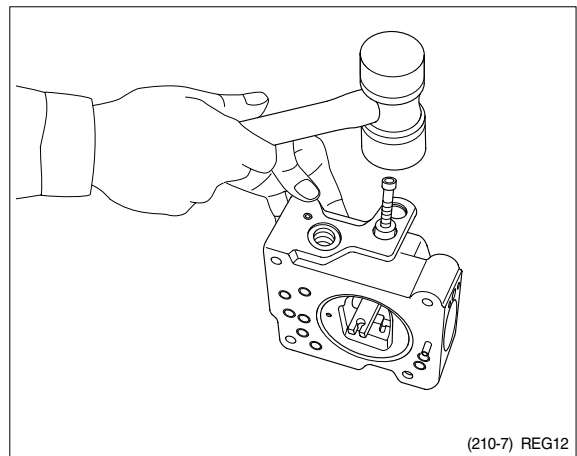

- (10) Fit return spring(654) and spring seat (653) into spool hole and attach snap ring (814).

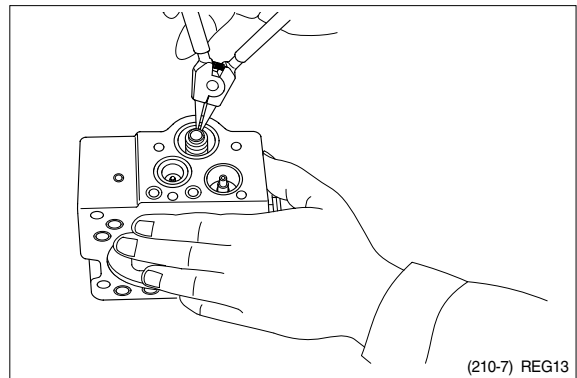

- (11) Fit set spring(655) to spool hole and put compensating piston(621) and piston case(622) into compensating hole.
Fit pilot cover(641) and tighten it with hexagonal socket head screws(436, 438).

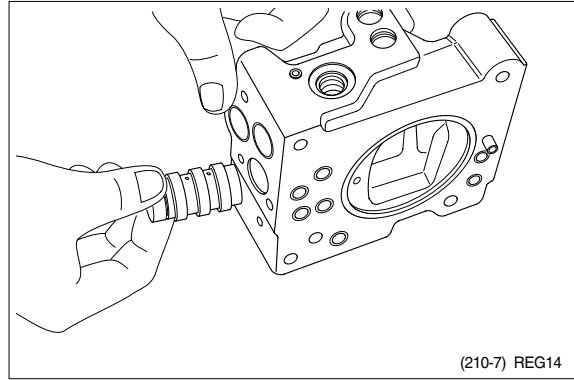

- (12) Put spring seat(644), pilot spring(646) and adjusting ring(Q, 645) into pilot hole.
Then fix spring seat(624), inner spring (626) and outer spring(625) into compensating hole.
※ When fitting spring seat, take care not to mistake direction of spring seat.

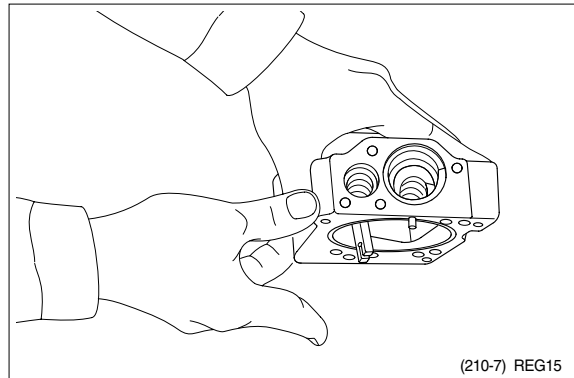

- (13) Install cover(C, 629) fitted with adjusting screws(628, 925), adjusting ring(C, 627), lock nut(630), hexagon nut(801) and adjusting screw(924).
Then tighten them with hexagonal socket head screws(438).

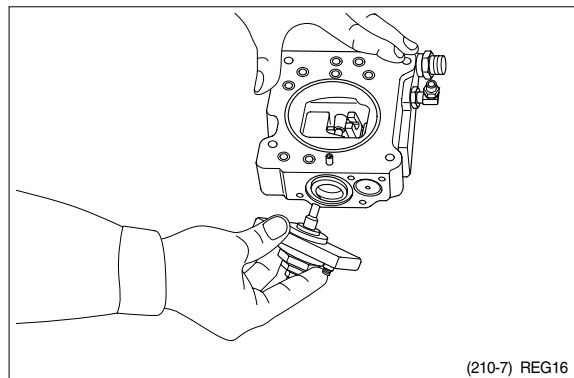

This completes assembly.

GROUP 4 MAIN CONTROL VALVE

1. REMOVAL AND INSTALL OF MOTOR

1) REMOVAL

- (1) Lower the work equipment to the ground and stop the engine.
- (2) Operate the control levers and pedals several times to release the remaining pressure in the hydraulic piping.
- (3) Loosen the breather slowly to release the pressure inside the hydraulic tank.

▲ Escaping fluid under pressure can penetrate the skin causing serious injury.

- ※ When pipes and hoses are disconnected, the oil inside the piping will flow out, so catch it in oil pan.
- (4) Remove the wirings for the pressure sensor and so on.
 - (5) Remove bolts and disconnect pipe.
 - (6) Disconnect pilot line hoses.
 - (7) Disconnect pilot piping.
 - (8) Sling the control valve assembly and remove the control valve mounting bolt.
 - Weight : 200 kg (441lb)
 - (9) Remove the control valve assembly.
When removing the control valve assembly, check that all the piping have been disconnected.

2) INSTALL

- (1) Carry out installation in the reverse order to removal.
- (2) Bleed the air from below items.
 - ① Cylinder (boom, arm, bucket)
 - ② Swing motor
 - ③ Travel motor
 - ※ See each item removal and install.
- (3) Confirm the hydraulic oil level and recheck the hydraulic oil leak or not.

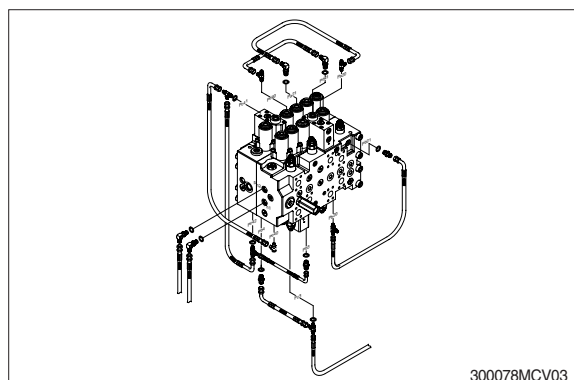
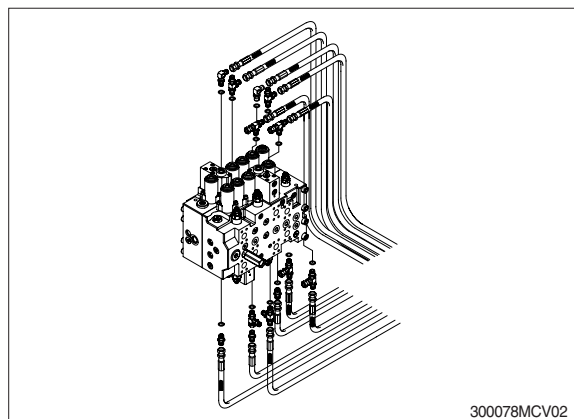
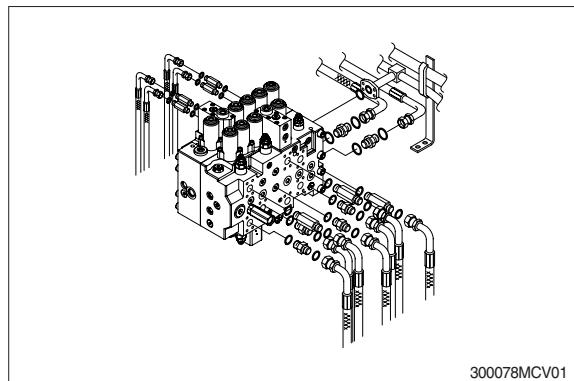

2. STRUCTURE

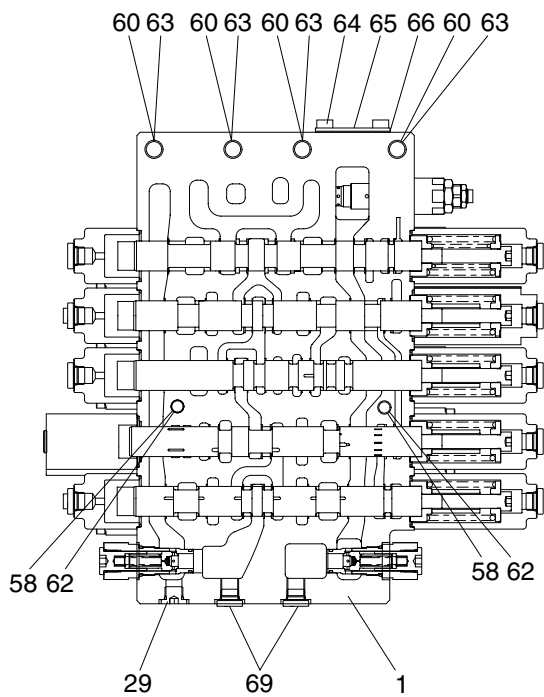

P1 BLOCK SPOOL SECTION

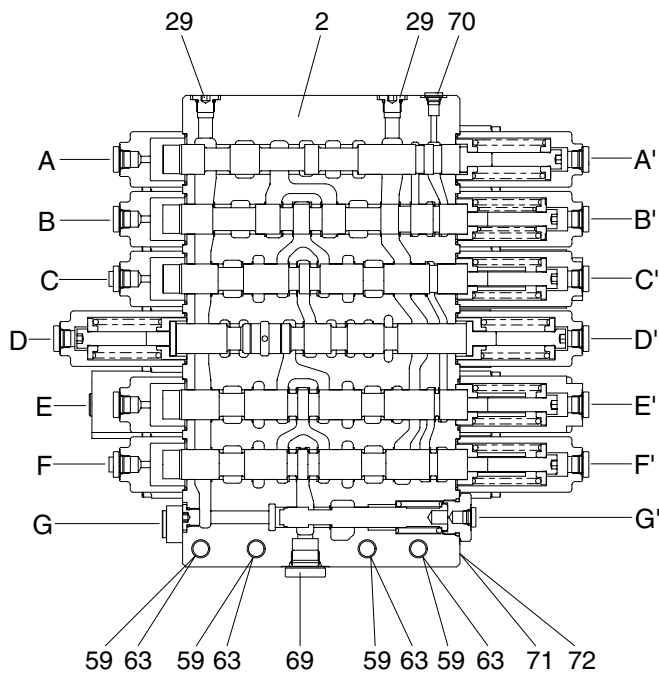

P2 BLOCK SPOOL SECTION

- 1 Housing P1
- 2 Housing P2
- 29 Plug kit
- 58 Socket bolt
- 59 Socket bolt
- 60 Socket bolt
- 62 Spring washer
- 63 Spring washer
- 64 Hexagon bolt
- 65 Cover 2
- 66 Gasket 2
- 69 Dust cap
- 70 Dust cap
- 71 Name plate
- 72 Rivet

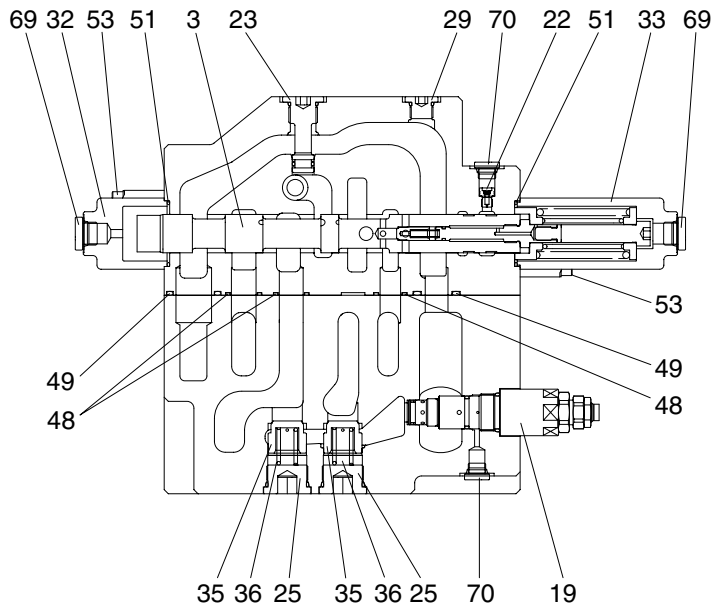

SECTION A-A' (STRAIGHT-TRAVEL & SUPPLY)

- 3 Spool assy
- 4 Spool assy
- 18 Overload R/V plug assy
- 19 Main relief valve assy
- 22 Signal orifice assy
- 23 Parallel block plug assy
- 25 Load check plug kit
- 27 Plug kit
- 29 Plug kit
- 32 Pilot cover A
- 33 Pilot cover B1
- 35 Load check poppet 1
- 36 Load check spring 1
- 41 Cover 1
- 42 Gasket 1
- 43 Poppet signal
- 44 Spring signal
- 46 Plug
- 47 O-ring
- 48 O-ring
- 49 O-ring
- 51 O-ring
- 53 Socket bolt
- 56 Hexagon bolt
- 69 Dust cap
- 70 Dust cap

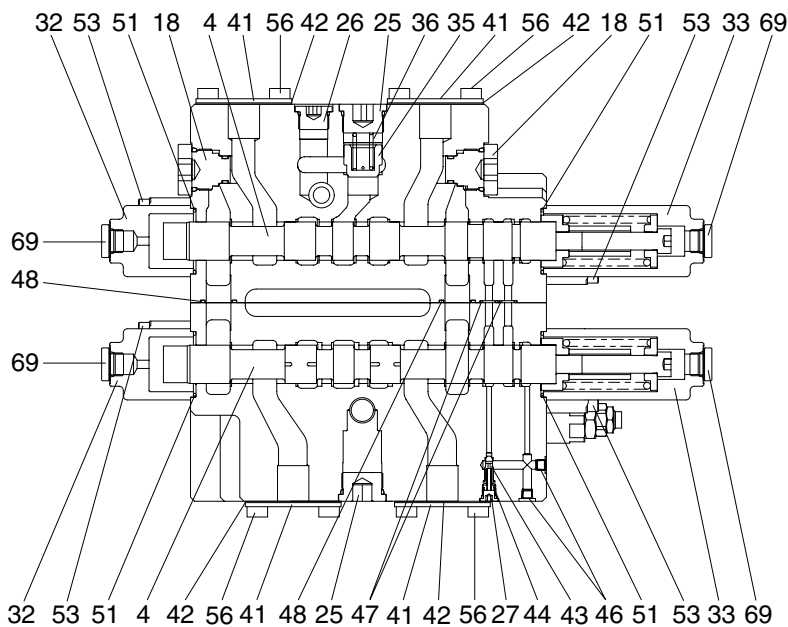

SECTION B-B' (TRAVEL RIGHT & LEFT)

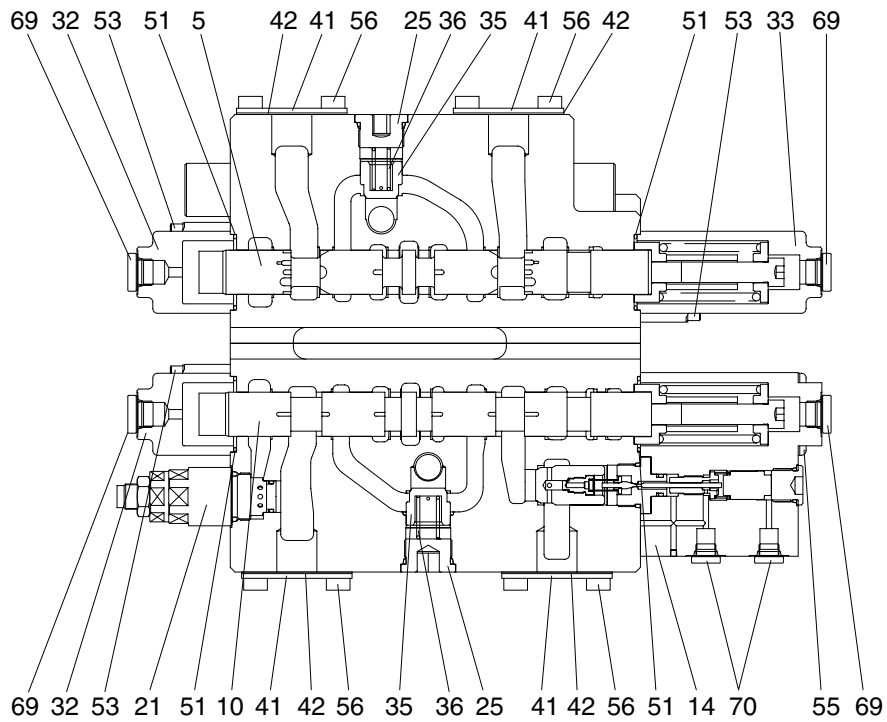

SECTION C-C' (SWING & BOOM 1)

2107V2MC42

5	Swing spool assy	33	Pilot cover B1	53	Socket bolt
10	Boom 1 spool	35	Load check poppet 1	55	Socket bolt
14	Holding valve assy	36	Load check spring 1	56	Haxagon bolt
21	Overload relief assy	41	Cover 1	69	Dust cap
25	Load check plug kit	42	Gasket 1	70	Dust cap
32	Pilot cover A	51	O-ring		

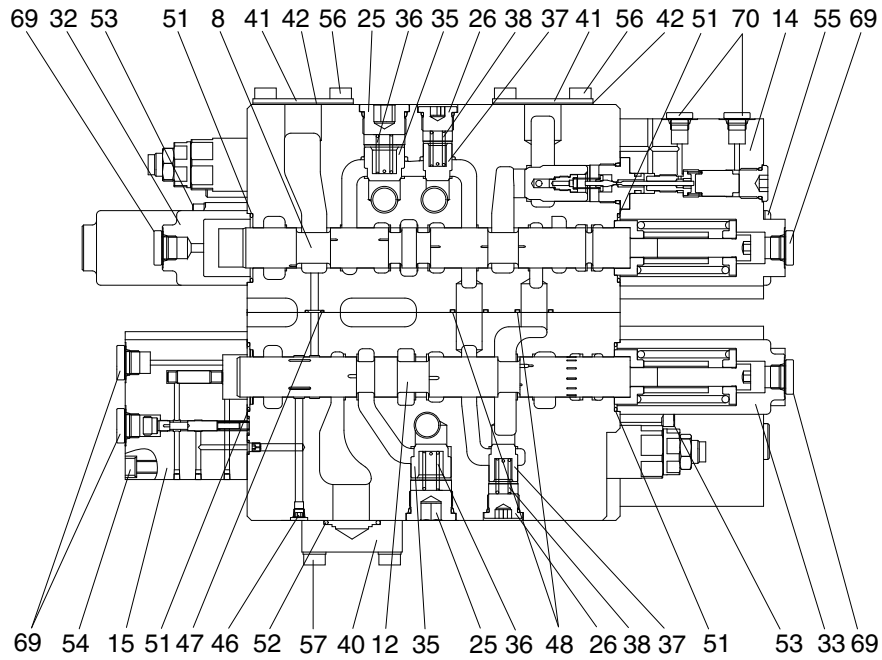

SECTION E-E ' (ARM 1 & ARM REGENRATION)

2107V2MC44

8	Arm 1 spool assy	37	Load check poppet 1	53	Socket bolt
12	Arm regen spool assy	38	Load check spring 2	54	Socket bolt
14	Holding valve assy	40	Flange	55	Socket bolt
15	Regen valve assy	41	Cover 1	56	Haxagon bolt
25	Load check plug kit	42	Gasket 1	57	Socket bolt
26	Load check plug kit	46	Plug	62	Spring washer
32	Pilot cover A	47	O-ring	69	Dust cap
33	Pliot cover B1	48	O-ring	70	Dust cap
35	Load check poppet 1	51	O-ring		
36	Load check spring 1	52	O-ring		

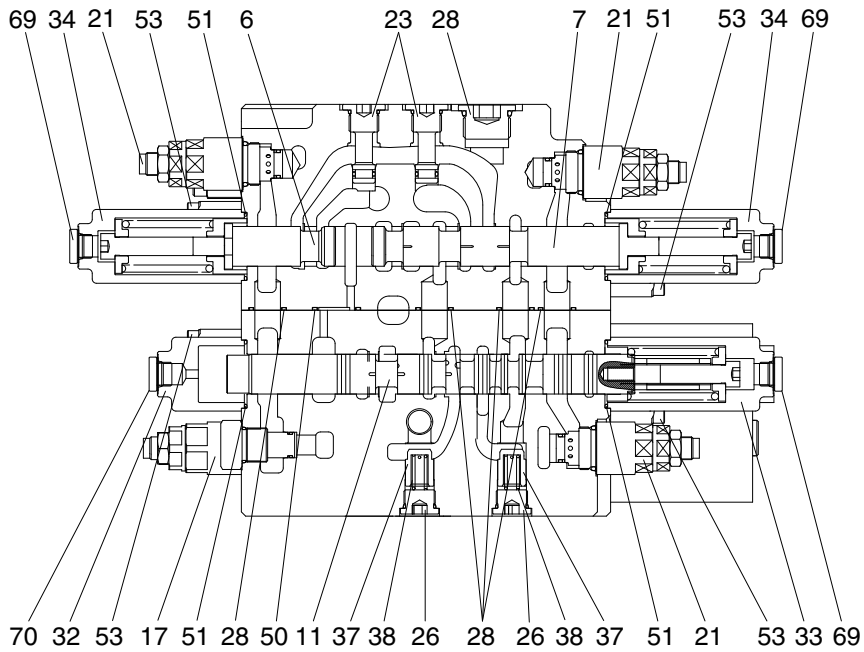

SECTION D-D ' (SWING PRIORITY & BOOM 2 & ARM 2)

D21072MC43

6	Swing priority spool assy	26	Load check plug kit	38	Load check spring 2
7	Boom 2 spool assy	28	Plug kit	50	O-ring
11	Arm 2 spool assy	32	Pilot cover A	51	O-ring
17	Overload relief plug assy	33	Pilot cover B1	53	Socket bolt
21	Overload relief assy	34	Pilot cover B2	69	Dust cap
23	Parallel block plug assy	37	Load check poppet 2		

3. DISASSEMBLY AND ASSEMBLY

1) GENERAL PRECAUTIONS

- (1) As hydraulic equipments, not only this valve are constructed precisely with very small clearances, disassembling and assembling must be carefully done in a clean place with preventing dusts and contaminants from entering.
- (2) Prepare the section drawing and study the structure of MCV and then start disassembly work.
- (3) When removing the control valve from the machine, install caps on every ports, and wash the outside of the assembly with confirming the existence of caps before disassembling.
Prepare a suitable table and some clean papers or rubber mat on the table for disassembling.
- (4) If the components are left disassembled, they may get rust. Make sure to measure the greasing and sealing.
- (5) For carrying the control valve, never hold with pilot cover or relief valve and overload relief valve and carefully treat the valves.
- (6) Do not tap the valve even if the spool movement is not smooth.
- (7) Several tests for such as relief characteristics, leakage, overload relief valve setting and flow resistance are required after re-assembling, and the hydraulic test equipments for those tests are needed.
Therefore, do not disassemble what cannot perform test adjustment, even if it can disassemble.

※ Be sure to observe the mark (※) description in the disassembly and assembly procedures.

2) TOOLS

Before disassembling the control valve, prepare the following tools beforehand.

Name of tool	Quantity	Size (mm)
Vice mounted on bench (soft jaws)	1 unit	
Hexagon wrench	Each 1 piece	5, 6, 10, 12 and 14
Socket wrench	Each 1 piece	27 and 32
Spanner	Each 1 piece	26 and 32 (main relief valve)

3) DISASSEMBLY

(1) Removing spool

① The case of the section without holding valve

Instruction for removing the travel spool (for instance) is follows :

Remove two hex socket bolts by 5 mm allen key wrench, then remove pilot cover.

- ※ Pay attention not to lose the O-ring under the pilot cover.

As the return spring portion of travel spool comes out, pull the spring straight slowly, by which spool assembly is removed.

- ※ The spools have to remove from the spring side.

Other spools (no lock valve type) can be removed in the same manner but the swing priority spool is reversed.

- ※ When spool replace, do not disassemble of a spool by any cases. Please replace by spool assembly.

- ※ Please attach using a tag etc. in the case of two or more kinds of spool replace, and understand a position.

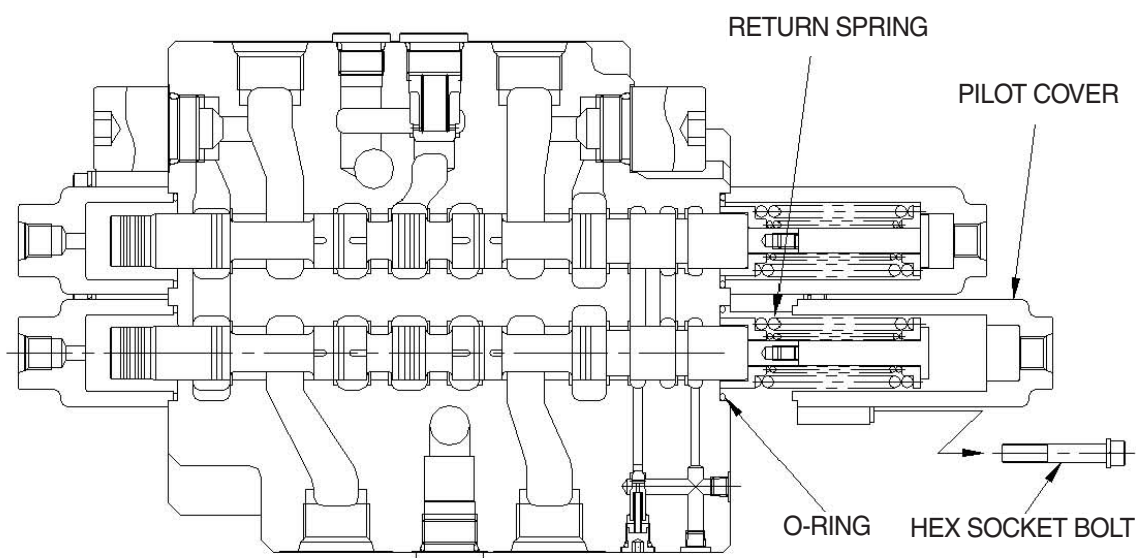

D21072MC34

② **The case of the section with holding valve**

Instruction for removing the boom spool (for instance) is follows :

Remove five hex socket bolts with washer by 5 mm allen key wrench. Then remove pilot cover with internal parts below figure.

- ※ Be careful not to separate O-ring and poppet under pilot cover.
- ※ Pay attention not to damage the exposed piston A under pilot cover.

As the return spring portion of boom 1 spool comes out, pull the spring straight slowly, by which spool assembly is removed.

- ※ The spools have to remove form the spring side.
- ※ When spool replace, do not disassemble of a spool by any cases, please replace by spool assembly.

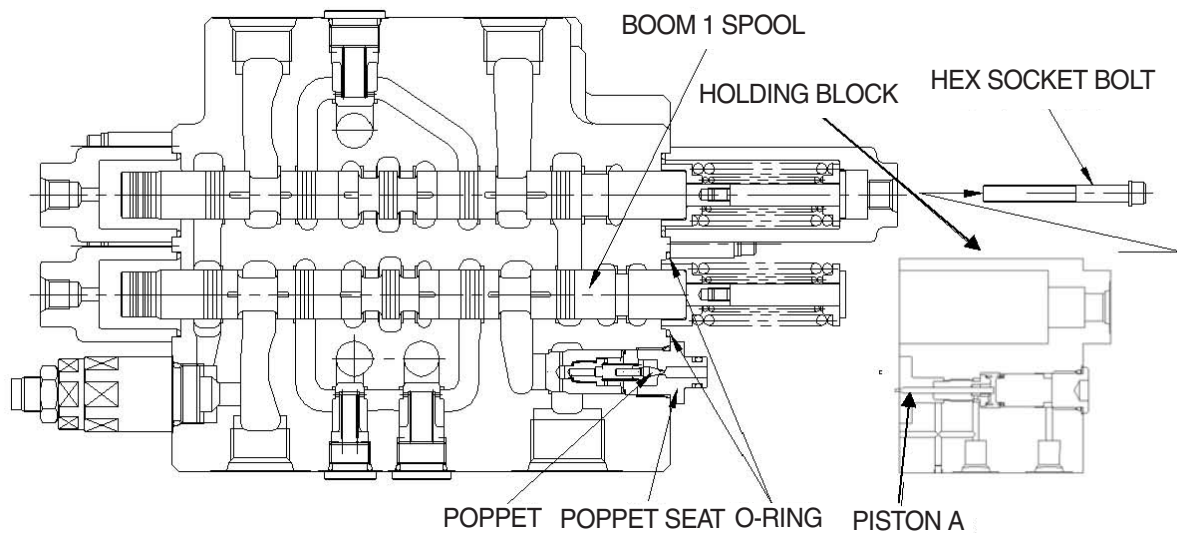

D21072MC35

(2) Removing holding valve

Remove the pilot cover with the holding valve as described on previous page.

- ※ Do not disassemble internal parts of the pilot cover.

Loosen the poppet seat by 26 mm spanner and remove the poppet, the spring seat, the spring and the check in order.

- ※ Pay attention not to lose the poppet.
- ※ Do not disassemble internal parts of the check because the plug, functioning orifice, can damage easily.

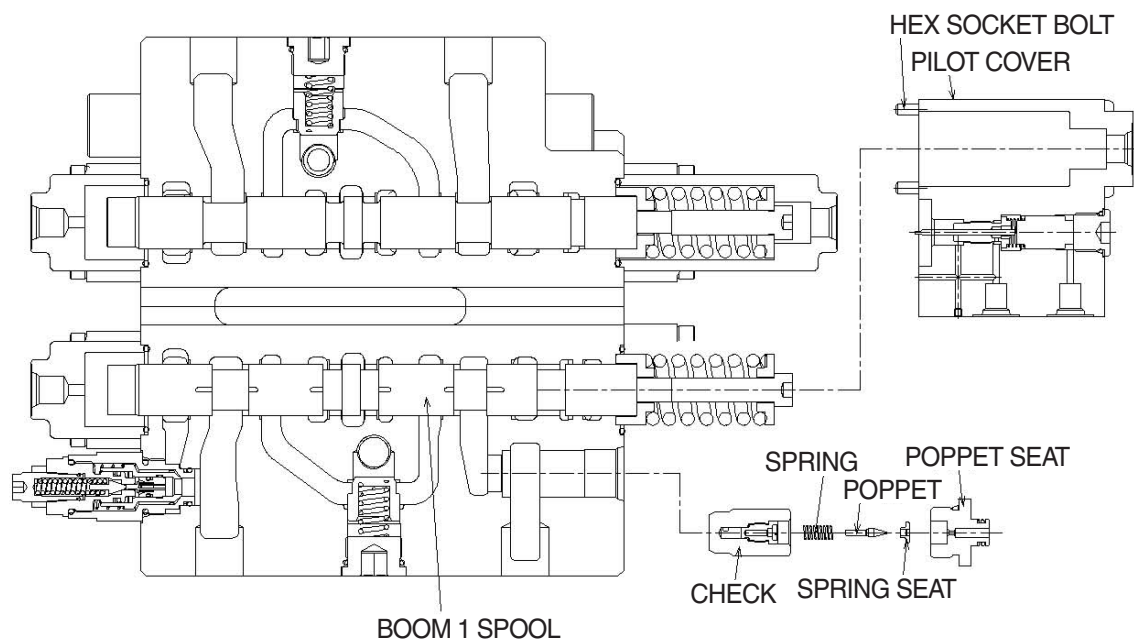

D21072MC36

(3) Removing load check valve and negative relief valve

① The load check valve

- Fix the body to suitable work bench. Loosen the plug by 10 mm allen key wrench.
- Remove the spring and the load check valve with pincers or magnet.

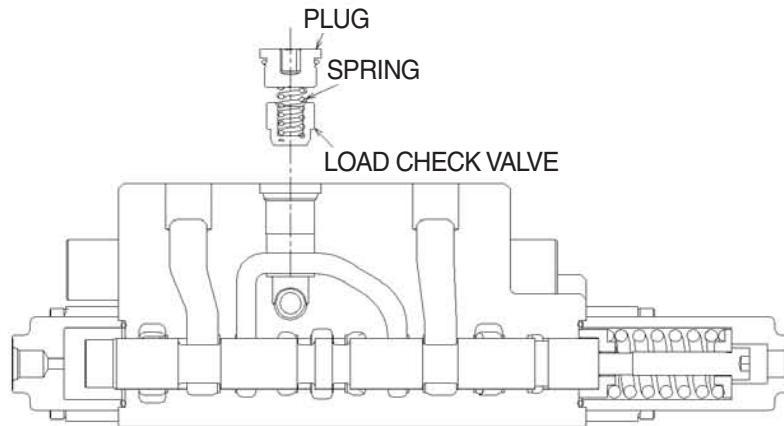

D21072MC37

② The negative relief valve

- Loosen the socket by 12 mm allen key wrench.
- Remove the spring, the spring holder, the piston and the negative control poppet.

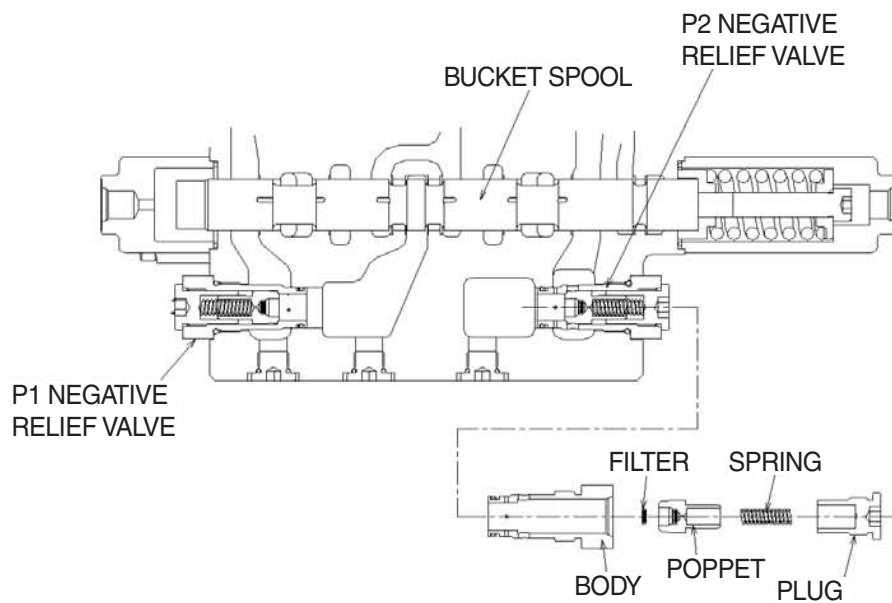

D21072MC38

※ Do not disassemble the coin filter inside the negative control poppet because of forced fit.

(4) Removing main relief valve and overload relief valve

Fix the valve body to suitable work bench. Remove the main relief valve by 32 mm spanner and remove the overload relief valve 32 mm spanner (standard) or 36 mm spanner (optional).

- ※ When disassembled, tag the relief valve for identification so that they can be reassembled correctly.
- ※ Pay attention not to damage seat face of disassembled main relief and overload relief valve.
- ※ Main relief and overload relief valve are very critical parts for performance and safety of the machine. Also, the pressure set is very difficult. Therefore, any abnormal parts are found, replace it with completely new relief valve assembly.

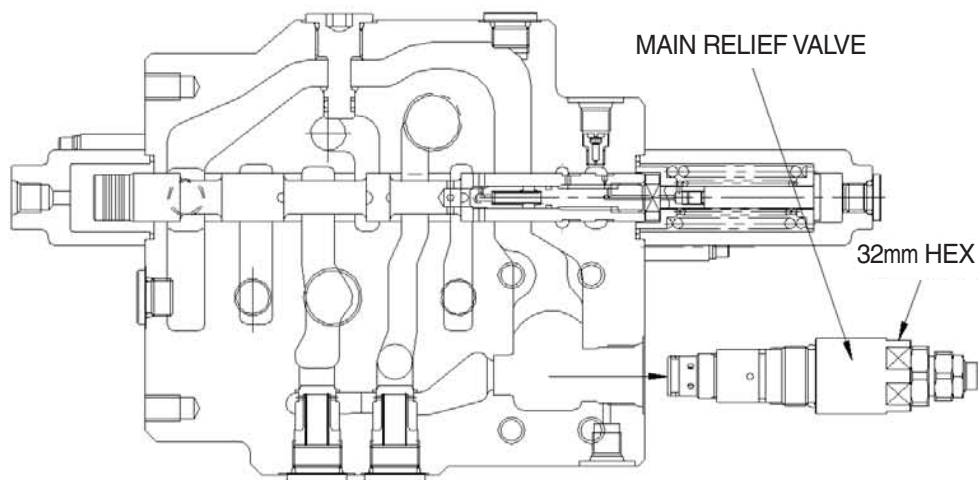

D21072MC39

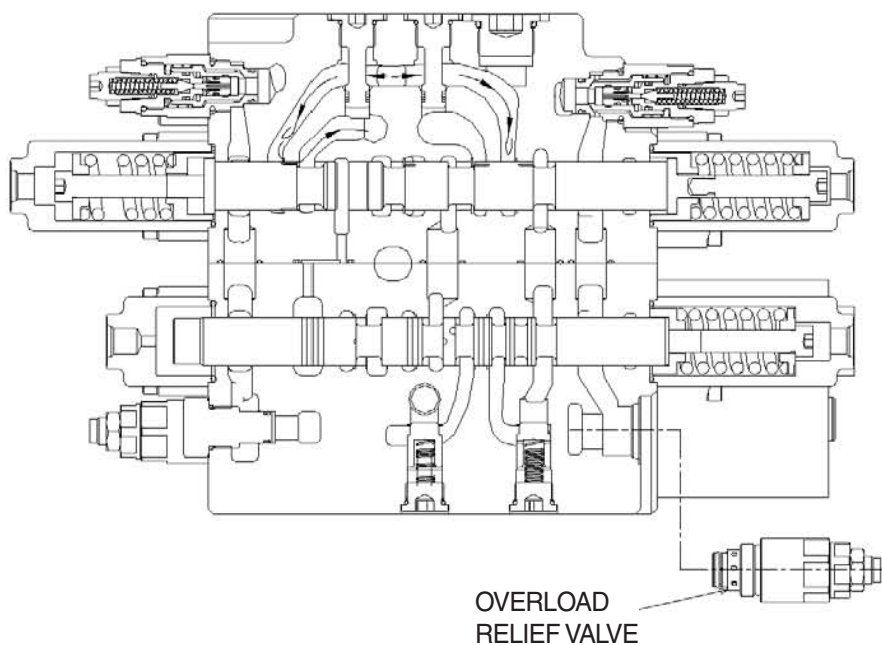

D21072MC46

4) ASSEMBLY

(1) Precaution

- ① When you assemble, please wash all parts by pure cleaning liquid.
- ② For re-assembling, basically use only brand new seals for all portions.
- ③ Apply grease or hydraulic oil to the seals and seal fitting section to make the sliding smooth, unless otherwise specified.
- ④ Pay attention not to roll the O-ring when fitting and it may cause oil leakage.
- ⑤ Do not tap the valve even if the spool movement is not smooth.
- ⑥ Prepare the section drawing and study the structure of MCV and then start disassembly work.
- ⑦ Tighten bolt and parts with thread for all section by torque wrench to the respective tightening torque.

(2) Assembly

Explanation only is shown for the assembly, refer to the figures shown in the previous disassembly section.

① Main relief and overload relief valve

Fix the valve body to suitable work bench.

Install main relief valve and overload relief valve into the body and tighten to the specified torque by 32 mm torque wrench.

- Tightening torque : 8~9 kgf·m (57.8~65.1 lbf·ft)

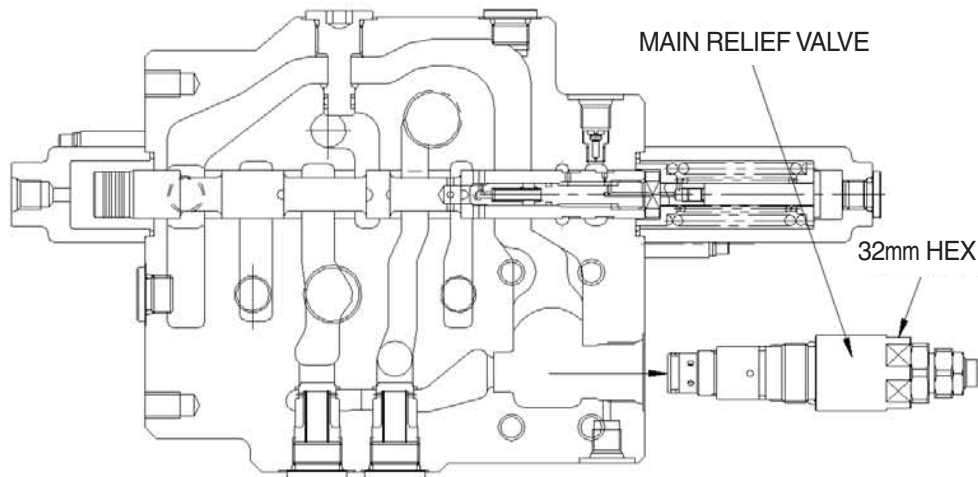

D21072MC39

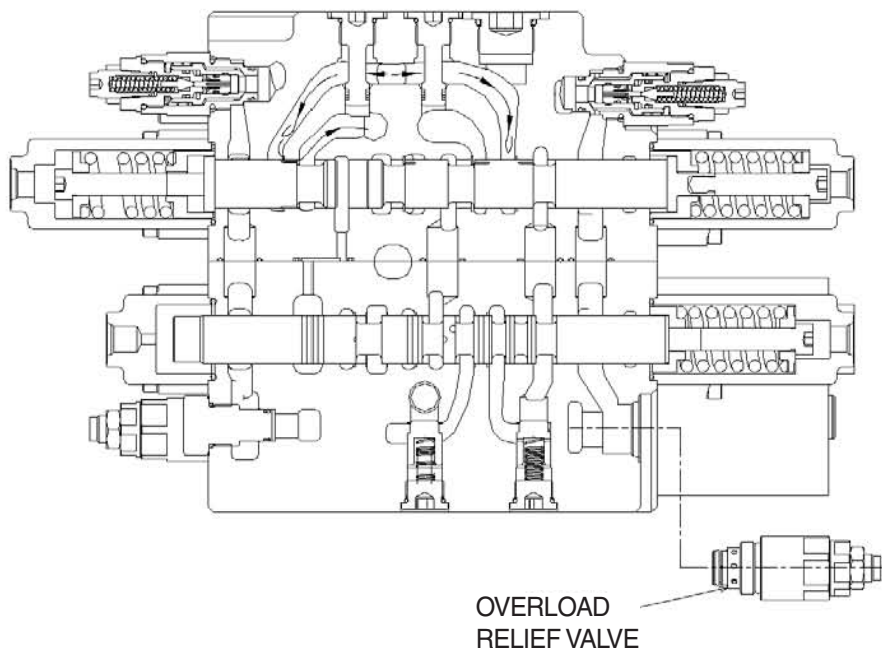

D21072MC46

② Load check valve

Assemble the load check valve and spring.

Put O-rings on to plug and tighten plug to the specified torque by 10 mm torque wrench.

- Tightening torque : 6~7 kgf·m (43.4~50.6 lbf·ft)

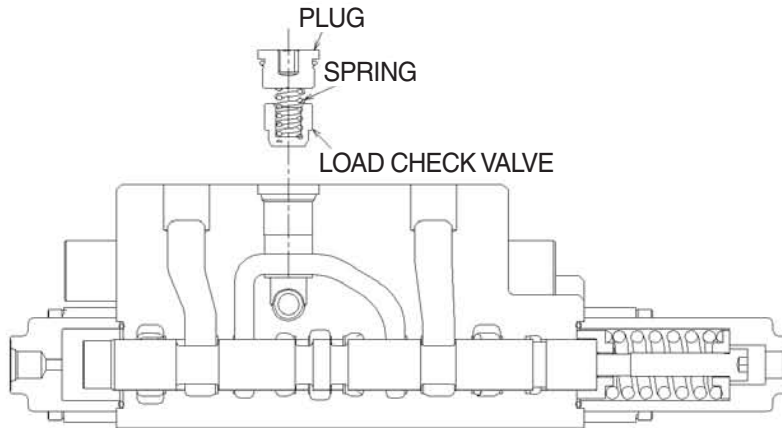

D21072MC37

③ Negative control relief valve

Assemble the nega-con poppet, piston, spring holder and spring into body in order and tighten the socket to the specified torque by 12 mm torque wrench.

- Tightening torque : 8~9 kgf·m (57.8~65.1 lbf·ft)

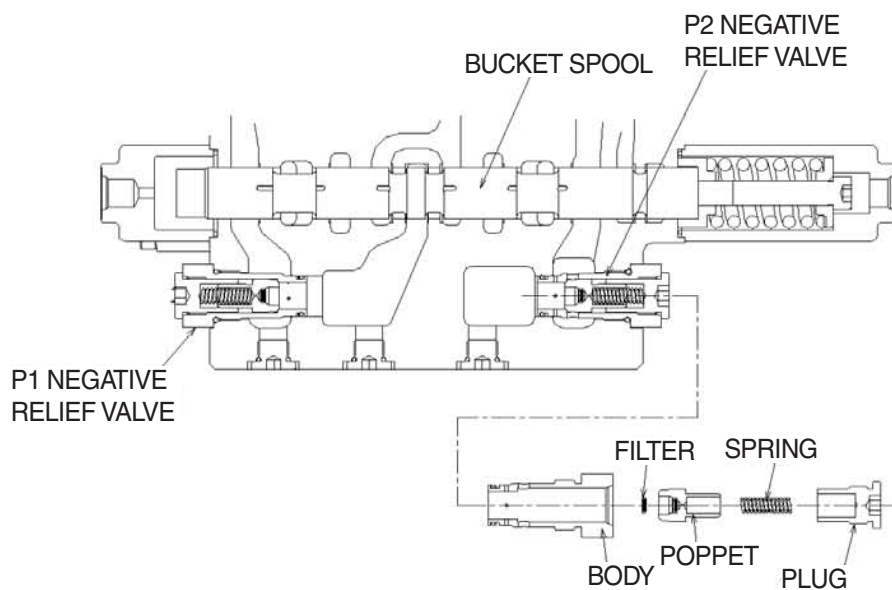

D21072MC38

④ Holding valves

Assemble the check, spring seat and poppet into the hole of valve body in order.

Tighten the poppet seat to the specified torque by 25 mm torque wrench.

· Tightening torque : 6~7 kgf·m (43.4~50.6 lbf·ft)

Fit the "piston A" under pilot cover with internal parts into hole on the poppet seat.

Tighten hexagon socket head bolt to specified torque by 5 mm torque wrench.

· Tightening torque : 1~1.1 kgf·m (7.2~7.9 lbf·ft)

※ Pay attention poppet not to separation.

※ Confirm that O-rings have been well fitted on the groove of body. (Apply grease on O-ring)

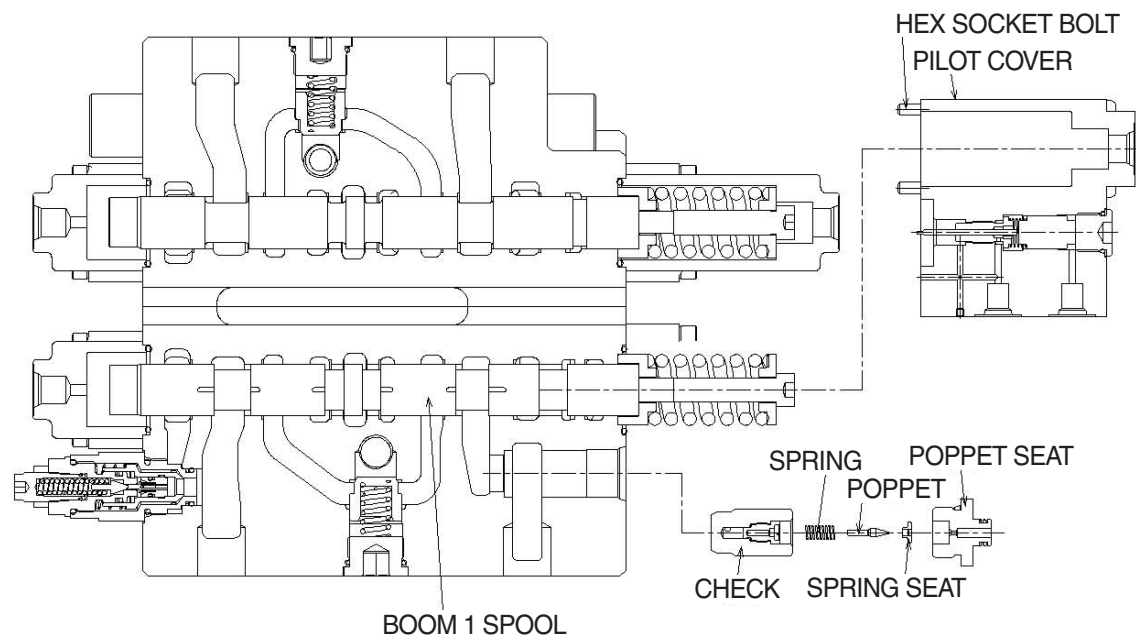

D21072MC36

⑤ Main spool

Put the spool position upward and fix it to the vise. Carefully insert the previously assembled spool assemblies into their respective bores within of body.

Fit spool assemblies into body carefully and slowly. Do not under any circumstances push them forcibly in.

Fit the pilot cover to the groove of the valve body.

Confirm that O-rings have been fitted on the groove of body. (Apply grease on O-ring)

Tighten the two socket bolt to the specified torque by 5 mm torque wrench.

- Tightening torque : 1~1.1 kgf·m (7.2~7.9 lbf·ft)

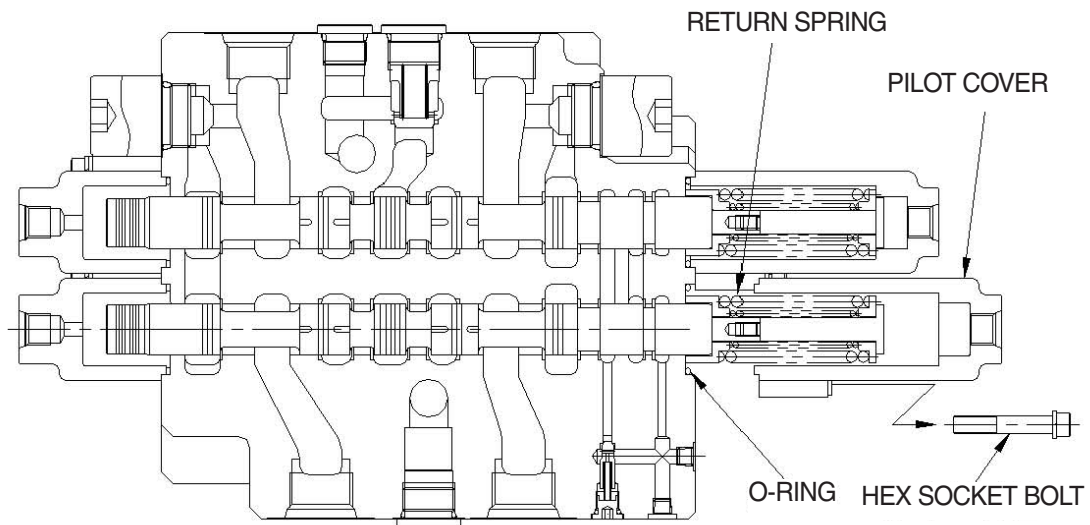

D21072MC34

GROUP 5 SWING DEVICE (TYPE 1)

1. REMOVAL AND INSTALL OF MOTOR

1) REMOVAL

- (1) Lower the work equipment to the ground and stop the engine.
- (2) Operate the control levers and pedals several times to release the remaining pressure in the hydraulic piping.
- (3) Loosen the breather slowly to release the pressure inside the hydraulic tank.

▲ Escaping fluid under pressure can penetrate the skin causing serious injury.

※ When pipes and hoses are disconnected, the oil inside the piping will flow out, so catch it in oil pan.

- (4) Disconnect hose assembly(2).
- (5) Disconnect pilot line hoses(3, 4, 5, 6, 7).
- (6) Sling the swing motor assembly(1) and remove the swing motor mounting bolts (8).

· Motor device weight : 230kg(507lb)

- (7) Remove the swing motor assembly.
※ When removing the swing motor assembly, check that all the piping have been disconnected.

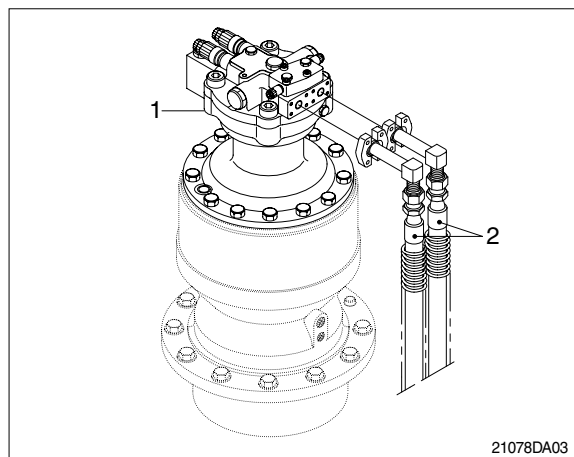

2) INSTALL

- (1) Carry out installation in the reverse order to removal.
- (2) Bleed the air from the swing motor.
 - ① Remove the air vent plug.
 - ② Pour in hydraulic oil until it overflows from the port.
 - ③ Tighten plug lightly.
 - ④ Start the engine, run at low idling and check oil come out from plug.
 - ⑤ Tighten plug fully.
- (3) Confirm the hydraulic oil level and check the hydraulic oil leak or not.

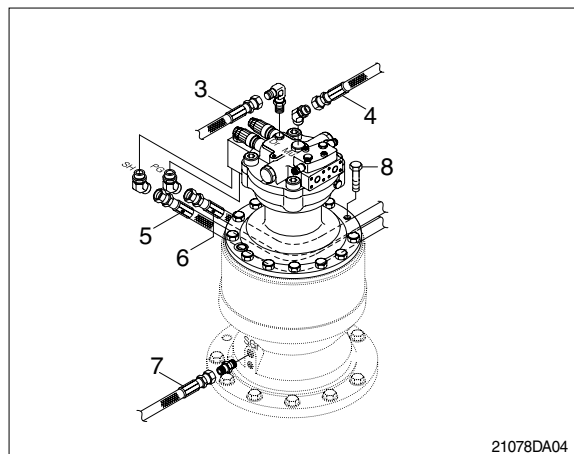

2. DISASSEMBLY AND ASSEMBLY OF SWING MOTOR

1) STRUCTURE

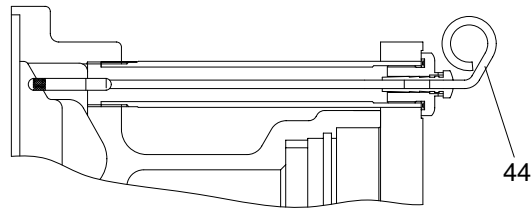

DETAIL K

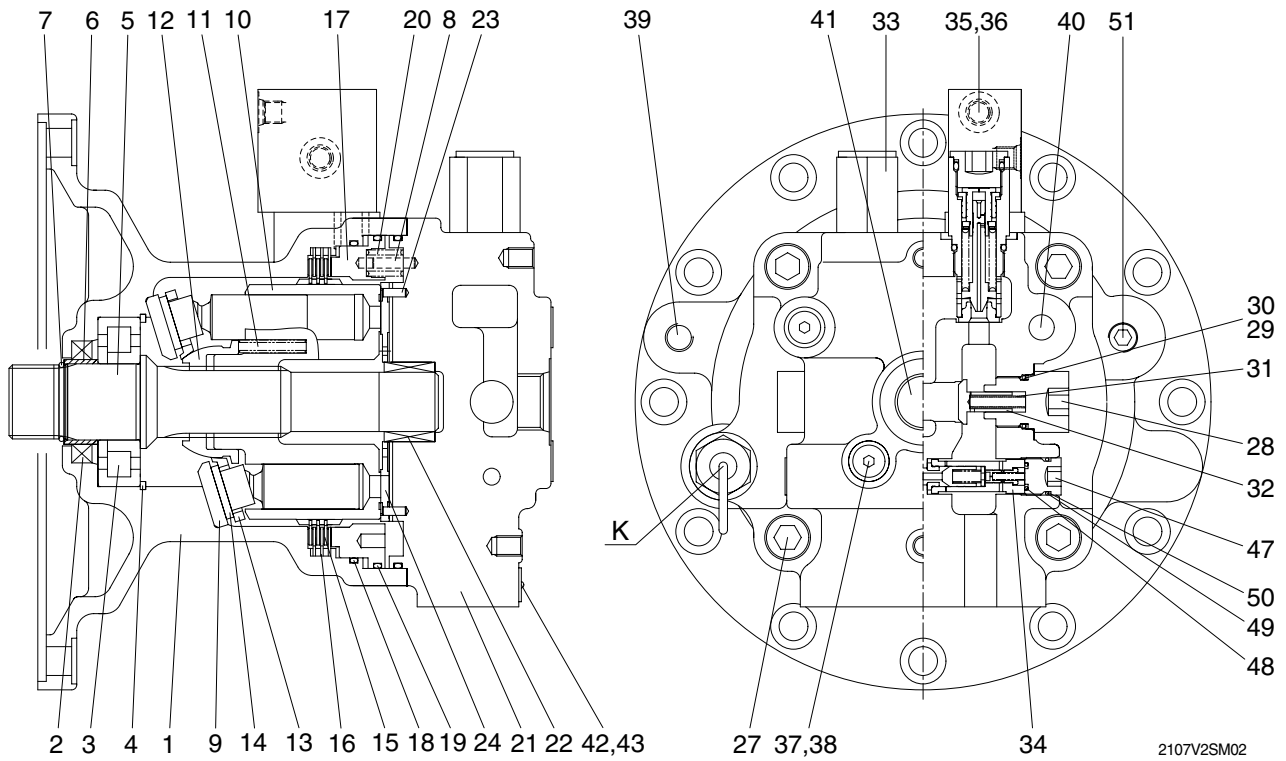

2107V2SM02

1	Body	18	O-ring	35	Time delay valve assy
2	Oil seal	19	O-ring	36	Wrench bolt
3	Roller bearing	20	Brake spring	37	Plug
4	Snap ring	21	Rear cover	38	O-ring
5	Shaft	22	Needle bearing	39	Plug
6	Bushing	23	Pin	40	Plug
7	Stop ring	24	Valve plate	41	Plug
8	Pin	25	O-ring	42	Name plate
9	Shoe plate	26	O-ring	43	Rivet
10	Cylinder block	27	Wrench bolt	44	Level gauge
11	Spring	28	Plug	45	Flange
12	Ball guide	29	Back up ring	46	O-ring
13	Set plate	30	O-ring	47	Plug
14	Piston assy	31	Spring	48	O-ring
15	Friction plate	32	Check	49	O-ring
16	Separate plate	33	Relief valve assy	50	Back up ring
17	Brake piston	34	Anti-inversion valve assy	51	Plug

2) DISASSEMBLING

(1) Disassemble the sub of a TURNING AXIS

- ① Unloosing wrench bolt and disassemble time delay valve assy(35) from rear cover(21)



14078SM201/201A

- ② Disassemble level gauge(44) from body (1).

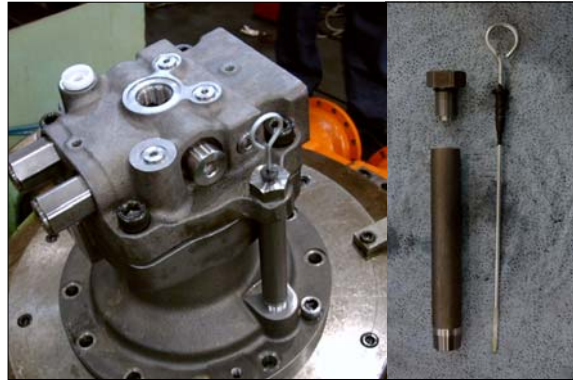

14078SM202/202A

- ③ Hang rear cover(21) on hoist, unloose wrench bolt(27) and disassemble from body(1).



14078SM203/203A

- ④ Using a jig, disassemble break piston(17) from body(1).

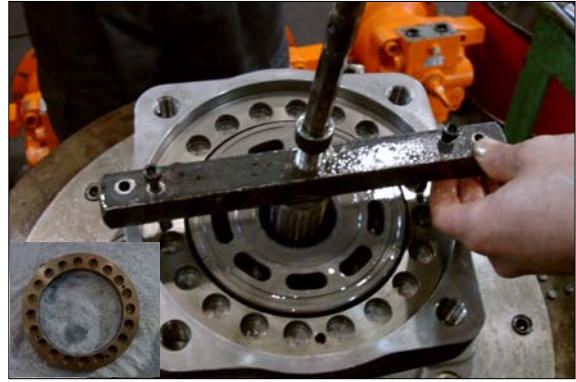

14078SM204/204A

- ⑤ Disassemble respectively cylinder block assy, friction plate(15), plate(16) from body(1).

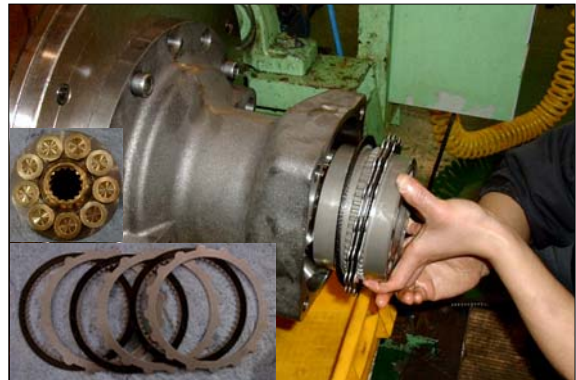

14078SM205/205A/B

(2) Disassemble cylinder block assy

① sub

Disassemble piston assy(14), set plate (13) from cylinder block assy.



14078SM206/205B

- ② Disassemble ball guide(12) from cylinder block(10).



14078SM207/207A

- ③ Disassemble spring(11) from cylinder block(10).

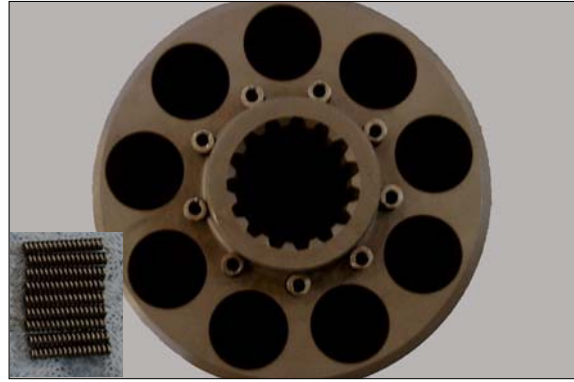

14078SM208/208A

- ④ Disassemble shoe plate(9) from body(1).

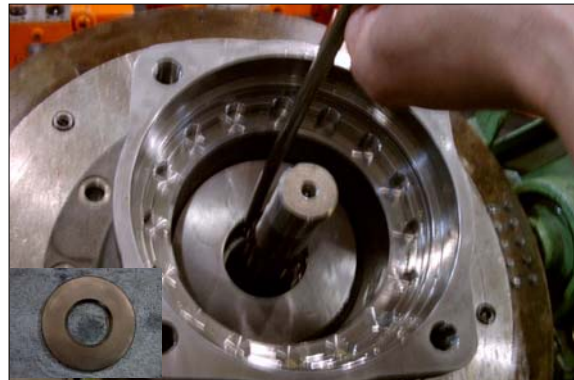

14078SM209/209A

- ⑤ Using a plier jig, disassemble snap ring (4) from shaft(5).



14078SM210/210A

- ⑥ Disassemble shaft assy from body(1).

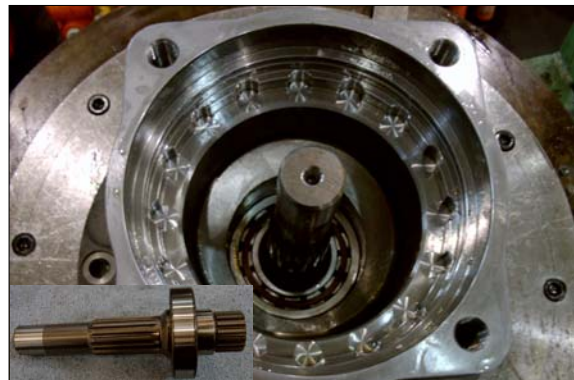

14078SM211/211A

(3) Disassemble rear cover assy sub

- ① Disassemble pin(8, 23), valve plate(24) from rear cover(21).

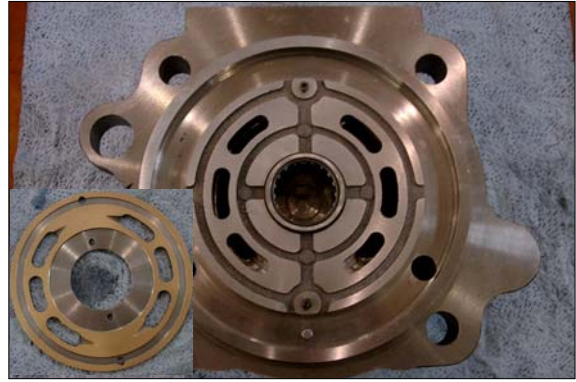

14078SM212/212A

- ② Using a torque wrench, disassemble relief valve assy(33) 2 set from rear cover(21).



14078SM213/213A

- ③ After disassembling plug with a L-wrench from rear cover(21), disassemble respectively back up ring, O-ring, O-ring, spring, anti-inversion valve assy(34)

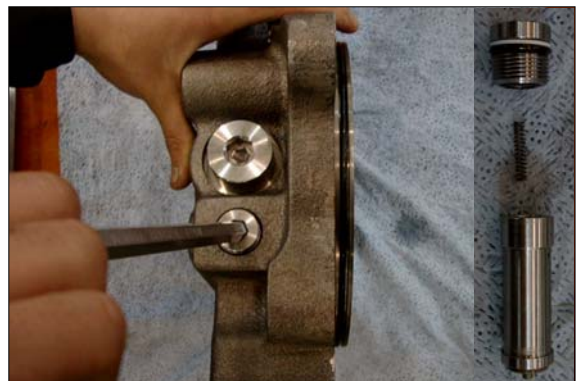

14078SM214/214A

- ④ Disassemble make up check valve assy with a torque wrench from rear cover(21).

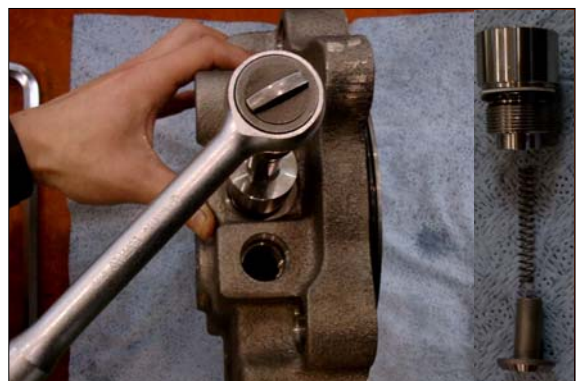

14078SM215/215A

- ⑤ Disassemble respectively plug(37, 40, 41), with a L-wrench from rear cover(21).

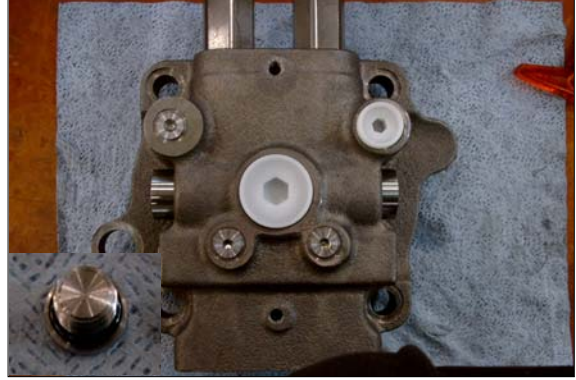

14078SM216/216A

3) ASSEMBLING

(1) Assemble the sub of a turning axles

- ① Put roller bearing(3), bushing(6) on preheater and provide heat to inner wheel (compressing temp : 290°C for 2minutes)
 - Roller bearing × 1EA
 - Bushing × 1EA

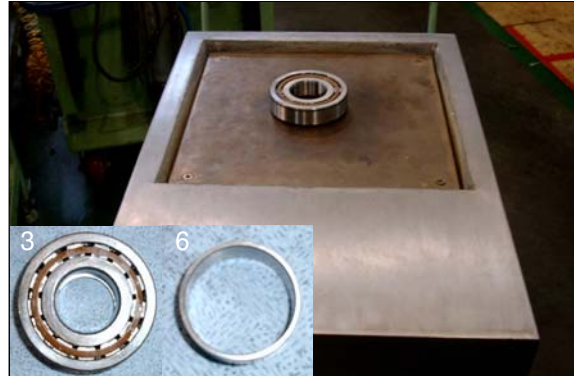

- ② After assembling and compressing preheated roller bearing(3), bushing(6) into shaft(5).
 - Stop ring × 1EA
 - Shaft × 1EA

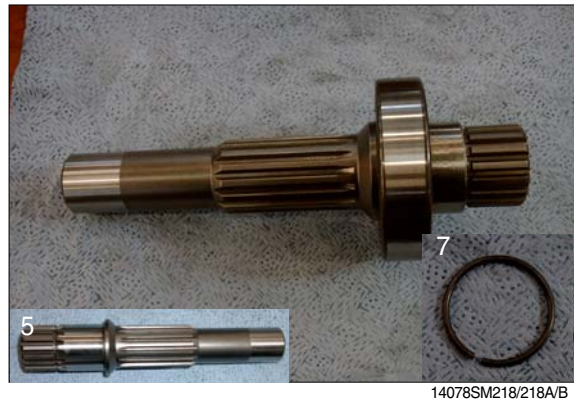

- ③ Put body(1) on a assembling jig, fix it with bolts to prohibit moving.

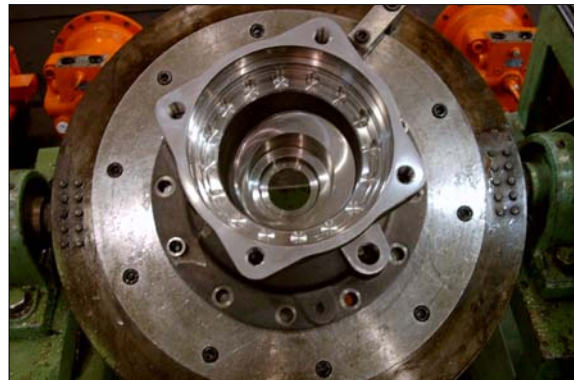

- ④ Using a compressing tool and steel stick, assemble oil seal(2) into body(1).
· Oil seal × 1EA



- ⑤ Insert above shaft sub into body(1) and assemble it with a steel stick.

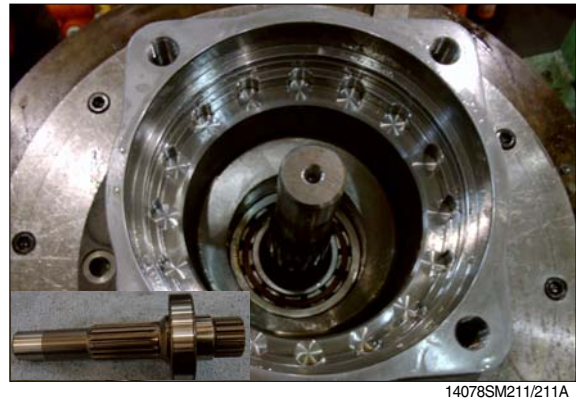

- ⑥ Fix snap ring(4) to shaft with a plier jig.
· Snap ring × 1EA



- ⑦ Spread grease on shoe plate(9) and assemble on the body.
· Shoe plate × 1EA

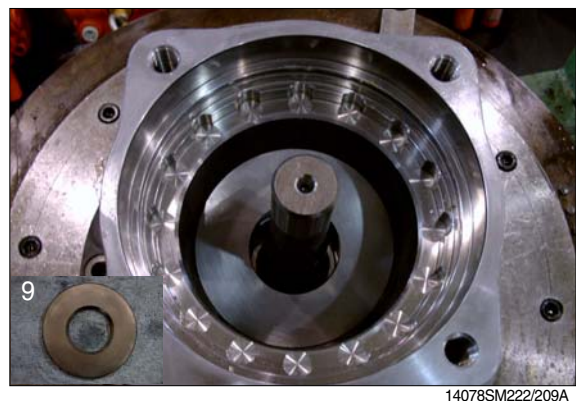

(2) Assemble the sub of cylinder block assy

- ① Assemble spring(11) 9 set into cylinder block(10).
· Spring × 9EA

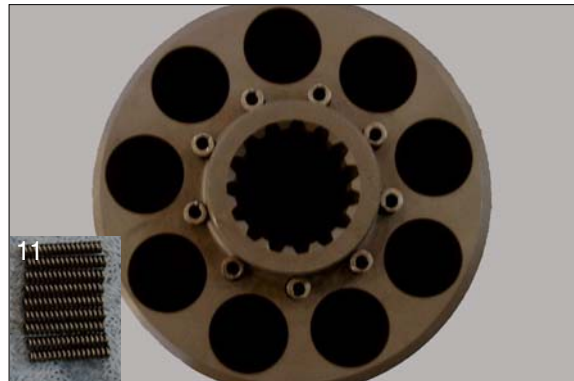

14078SM208/208A

- ② Assemble ball guide(12) into cylinder.
· Ball guide × 1EA



14078SM207/207A

- ③ Assemble piston assy(14) 9 set into set plate(13).
· Piston assy × 9EA
· SET plate × 1EA



14078SM223/223A

- ④ Assemble above item ② and ③.



14078SM224

- ⑤ Assemble cylinder block assy into body (1).

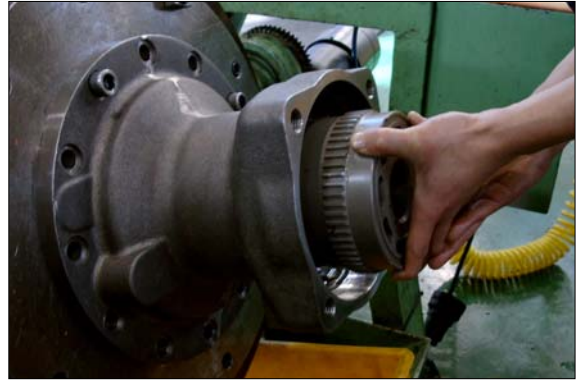

14078SM225

- ⑥ Assemble O-ring(18) into body(1).
· O-ring × 1EA

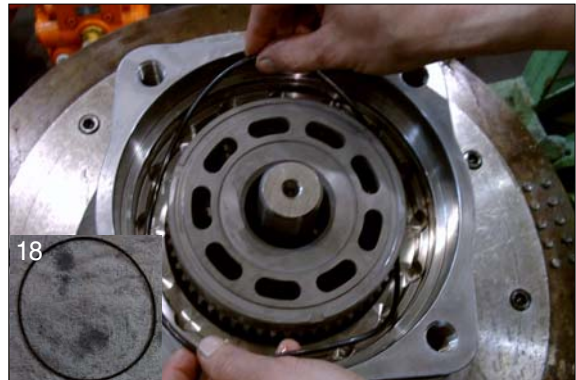

14078SM226/226A

- ⑦ Assemble 3 set of plate(16), friction plate(15) respectively into body.
· Plate × 3EA
· Friction plate × 3EA



14078SM227/205A

- ⑧ Assemble O-ring(19) into break piston (17).
· O-ring × 2EA



14078SM228/226A

- ⑨ Insert break piston assy into body(1) and compress it with a jig and hammer.



14078SM229/229A

- ⑩ Assemble spring(20)(20EA) into break piston(17).
 · Spring × 20EA

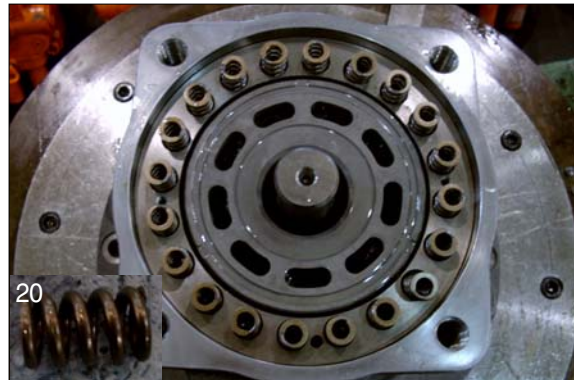

14078SM230/230A

(3) Assemble the sub of rear cover assy sub

- ① Assemble the sub of make up check valve assy.
 Assemble O-ring(30), back up ring(29) into plug(28) with a O-ring assembling jig.
 · Plug × 1EA
 · Back up ring × 1EA
 · O-ring × 1EA



14078SM231/231A/B

- ② Assemble respectively make up check valve assy spring(31), check(32), plug(28) into rear cover(21) after then screw it torque wrench.
 · Make up check sub × 2set
 · Spring × 2EA
 · Check × 3EA

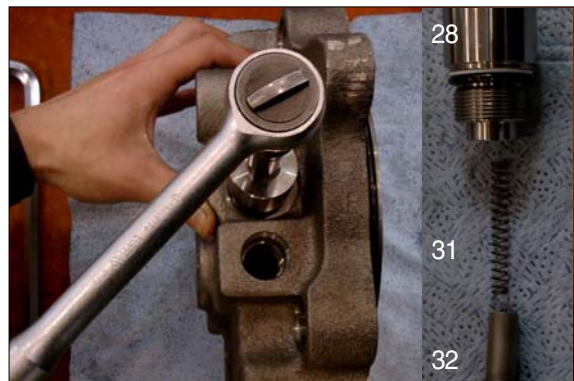

14078SM215/215A

- ③ Assemble respectively plug(47), back up ring, O-ring, O-ring, spring, anti-rotating valve assy(34) into rear cover(21).
(Bilateral symmetry assembling)
- Anti-Inversion v/v assy × 2set
 - O-ring(P12) × 2EA
 - O-ring(P18) × 2EA
 - Back up ring(P18) × 2EA

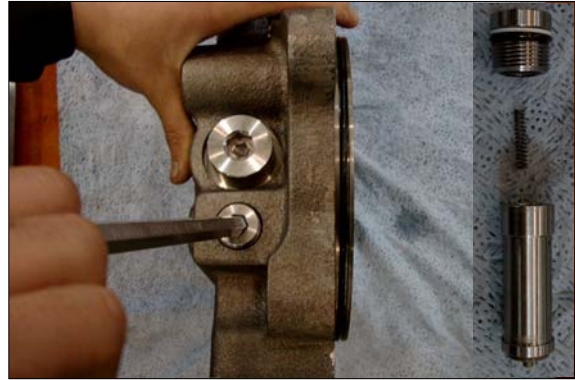

14078SM214/214A

- ④ Assemble relief valve assy(33) 2set into rear cover(21) with a torque wrench.
(Bilateral symmetry assembling)

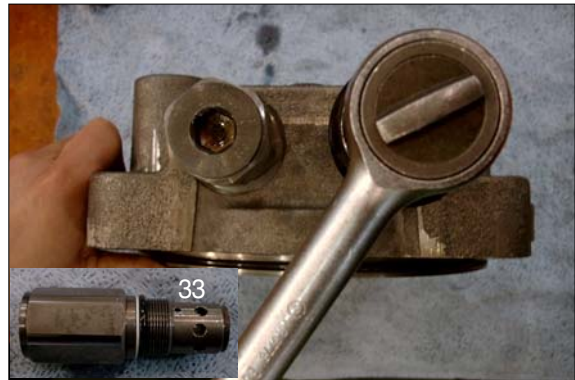

14078SM213/213A

- ⑤ Assemble plug(37), plug(40, 41) into rear cover(21) with a L-wrench.
* Plug × 3EA(PF1/4)

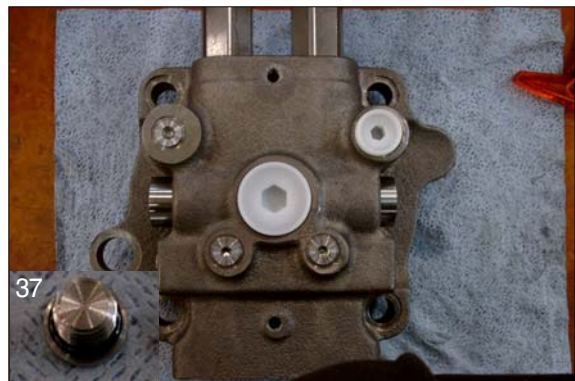

14078SM216/216A

- ⑥ After assembling needle bearing(22) into rear cover(21), with a hammer assemble pin(8, 23).
* Pin × 1EA
* Pin × 2EA



14078SM212

- ⑦ Spreading grease on valve plate(24),
assemble into rear cover(21).
· Valve plate × 1EA

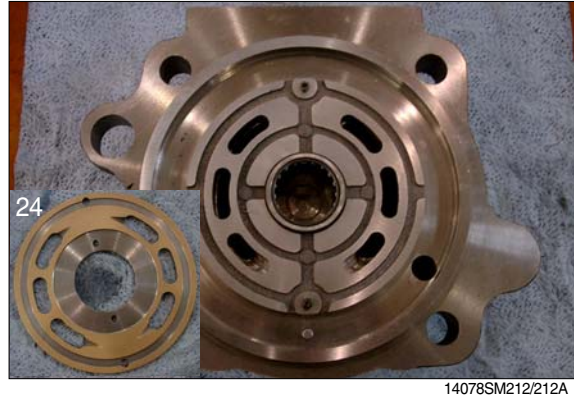

- ⑧ Lift up rear cover assy on body(1) by a crane and assemble it with a wrench bolt(27).



- ⑨ Assemble level gauge(44) into body(1).

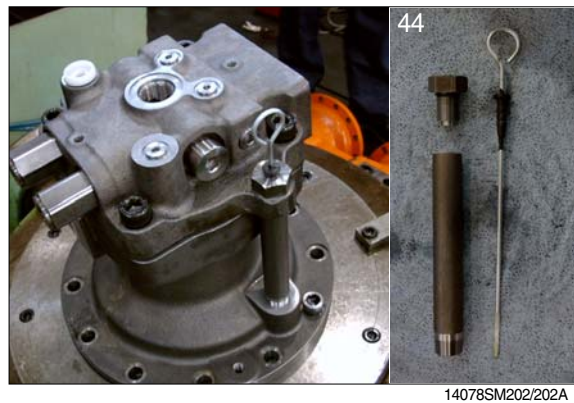

- ⑩ Assemble time delay valve assy(35) into rear cover(21) with a wrench bolt(36).

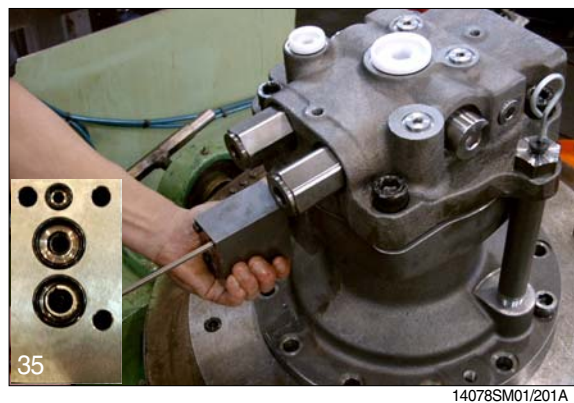

(4) Air pressing test

Be sure of leakage, after press air into assembled motor



14078SM232

(5) Leakage check

After cleaning motor by color check No.1, paint No.3 and be sure of leakage.



14078SM233/233A

(6) Mount test bench

Mounting motor test bench, test the availability of each part.



220078SM14

3. REMOVAL AND INSTALL OF REDUCTION GEAR

1) REMOVAL

- (1) Remove the swing motor assembly.
For details, see **removal of swing motor assembly**.
- (2) Sling reduction gear assembly(1) and remove mounting bolts(2).
- (3) Remove the reduction gear assembly.
 - Reduction gear device weight : 180kg
(396lb)



2) INSTALL

- (1) Carry out installation in the reverse order to removal.
 - Tightening torque : 49.2~66.6kgf · m
(356~481 lbf · ft)

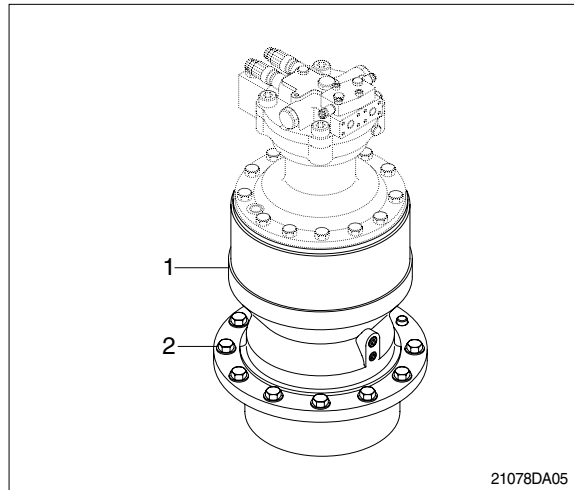

4. DISASSEMBLY AND ASSEMBLY OF REDUCTION GEAR

1) STRUCTURE

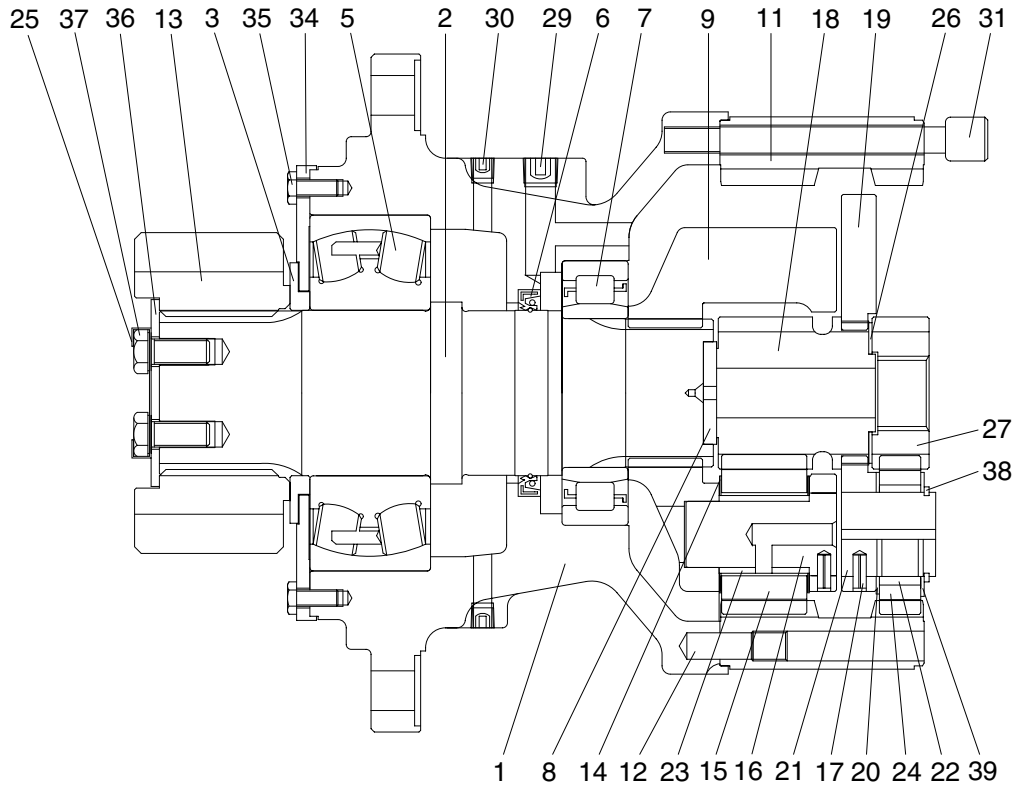

2107V2SM03

1	Casing	15	Planet gear 2	26	Side plate 3
2	Drive shaft	16	Pin & bushing	27	Sun gear 1
3	Spacer	17	Spring pin	29	Plug
5	Roller bearing	18	Sun gear 2	30	Plug
6	Oil seal	19	Carrier 1	31	Socket bolt
7	Roller bearing	20	Side plate 1	34	Cover plate
8	Thrust plate	21	Pin 1	35	Hexagon bolt
9	Carrier 2	22	Needle cage	36	Lock plate
11	Ring gear	23	Bushing 2	37	Hexagon bolt
12	Knock pin	24	Planet gear 1	38	Stop ring
13	Pinion gear	25	Lock washer	39	Side plate 2
14	Thrust washer				

2) DISASSEMBLY

- (1) Spread off the 4 corners of lock washer (25) with a tool.
 - ※ Do not reuse lock washer(25).Loosen the bolts(37) and then remove lock washer(25) and lock plate (36) from the pinion gear(13). Remove pinion gear(13) and spacer(3) from the drive shaft(2). Remove cover plate(34) from the casing (1) by loosening the hexagon bolts (35).

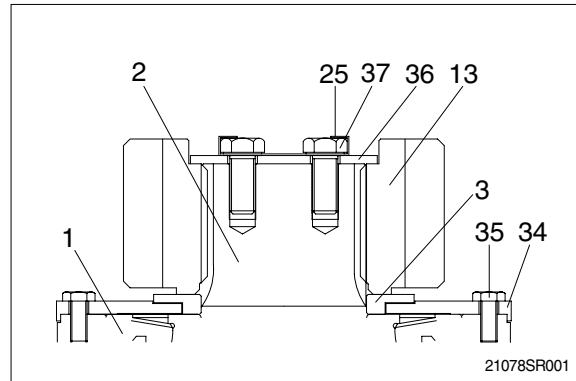

- (2) Remove gauge bar and gauge pipe from the swing motor casing.
 - ※ Pour the gear oil out of reduction gear into the clean bowl to check out the friction decrease.

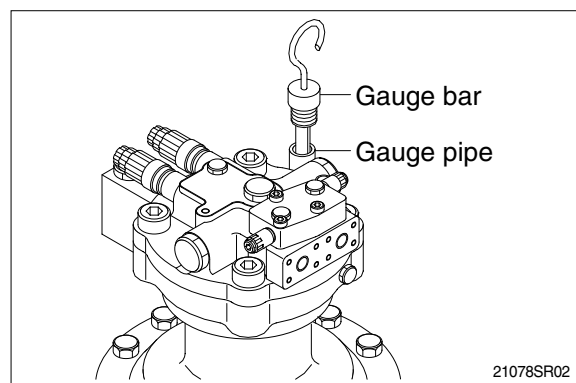

- (3) Loosen the socket bolts(31) to separate swing motor from reduction gear.

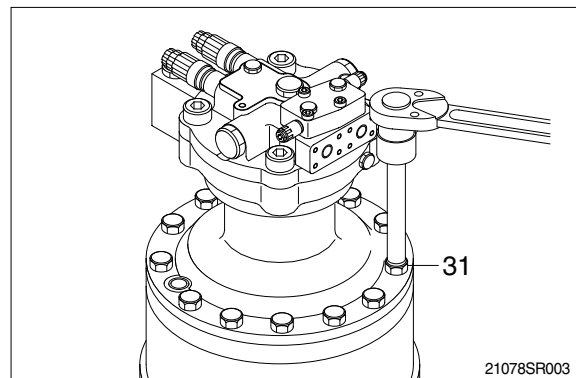

- (4) Tighten 3 M16 eye bolts to the ring gear (11) and then lift the ring gear(11) out of the casing(1).

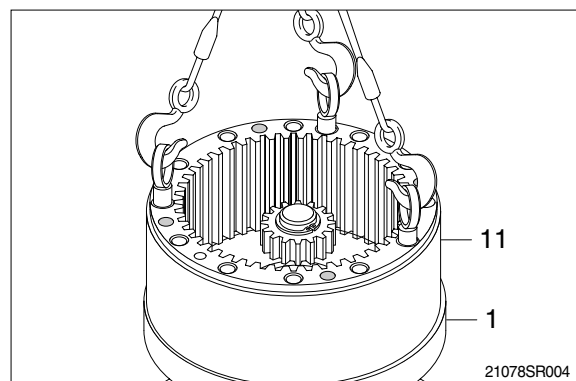

(5) Remove sun gear1 (27).

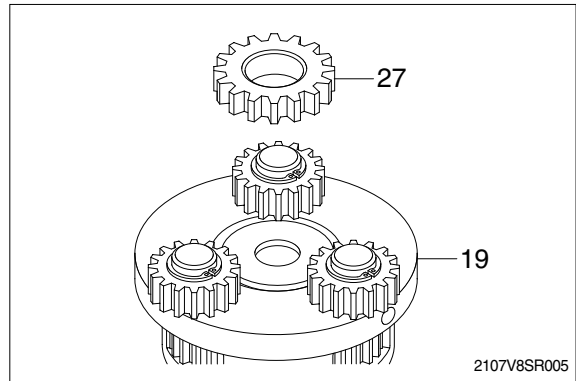

(6) Tighten two M10 eye bolts to carrier1(19) and lift up and remove carrier1(19) as subassembly.

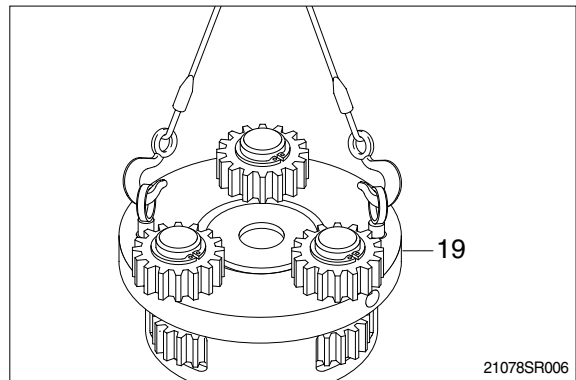

(7) Disassembling carrier1(19) assembly.

- ① Remove stop ring(38).
- ② Remove side plate2(39), planet gear1 (24), needle cage(22), side plate1(20) and side plate3(26) from the carrier.
- ③ Using M8 solid drill, crush spring pin(17) so that the pin1(21) can be removed by hammering.
- ④ Remove side plate3(26) from carrier1(19).
 - ※ Do not reuse spring pin(17).
 - ※ Do not remove pin1(21), carrier1(19) and spring pin(17) but in case of replacement.
 - ※ Put matching marks on the planet gear1 (24) and the pin1(21) for easy reassembly.

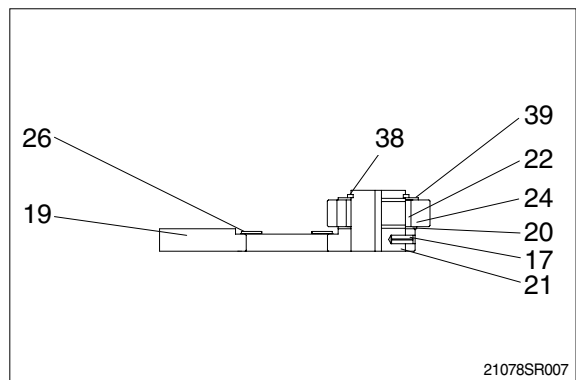

- (8) Remove sun gear2(18) and thrust washer (14).

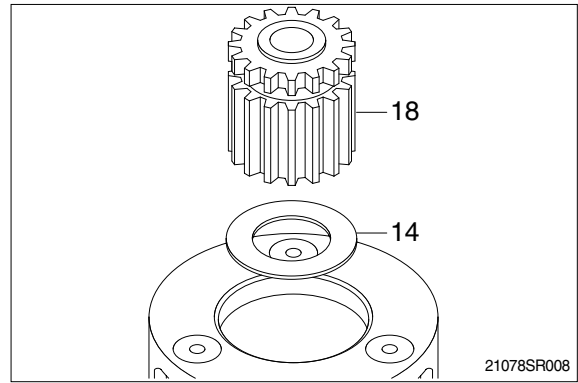

- (9) Remove carrier2(9) assembly from casing (1).

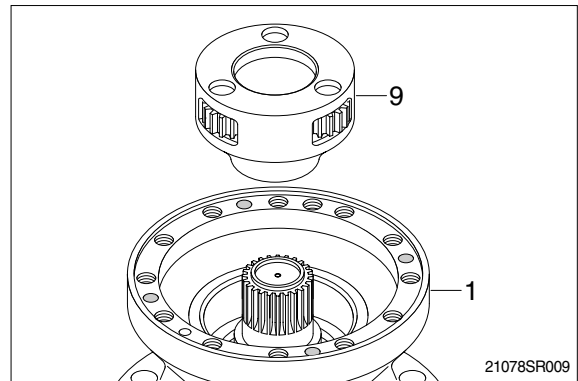

- (10) Disassembling carrier2(9) assembly

① Using M8 solid drill, crush spring pin(17) so that the pin & bushing(16) can be removed.

② Do not reuse spring pin(17).

Remove pin & bushing(16), planet gear2(15) and bush2(23) from the carrier2(9).

※ Put matching marks on the planet gear2 (15) and the pin & bushing(16) for easy reassembly.

Do not disassemble pin & bushing(16), carrier2(9) and spring pin(17) but in case of replacement.

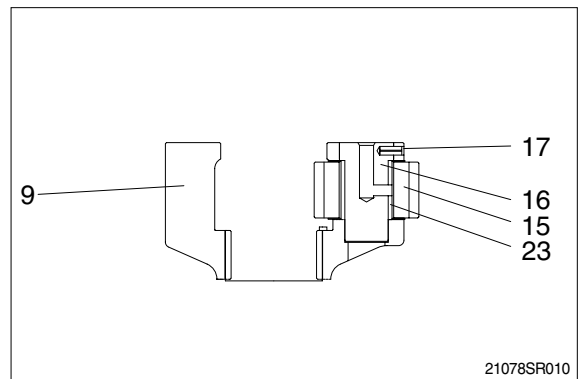

- (11) Remove thrust plate(8) from the drive shaft(2).

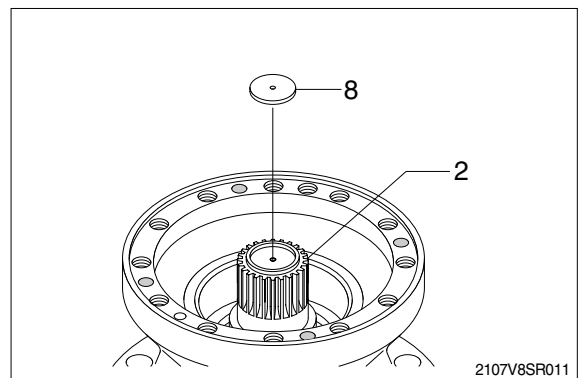

- (12) Remove drive shaft(2) with roller bearing(7) and oil seal(6) assembled.
Remove knock pin(12) from the casing(1).

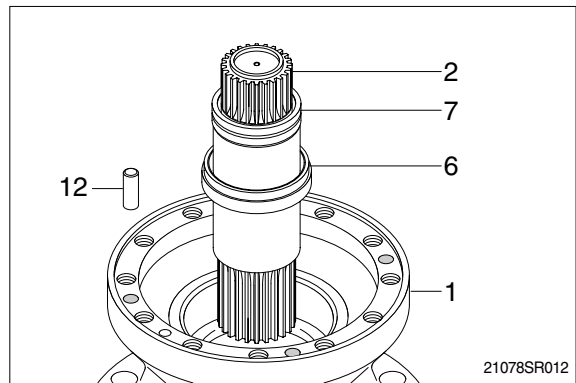

- (13) Remove roller bearing(7) and oil seal(6) from the drive shaft(2).
※ Do not reuse oil seal(6) once removed.

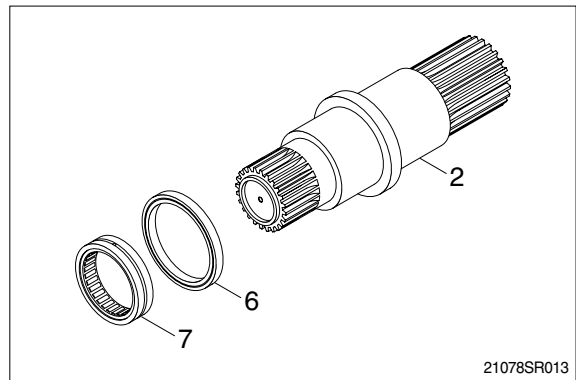

- (14) Using the bearing disassembly tool, remove roller bearing(5).

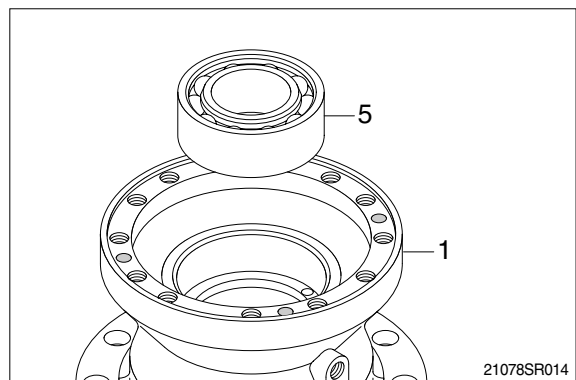

- (15) Remove plugs(29, 30) from the casing(1).

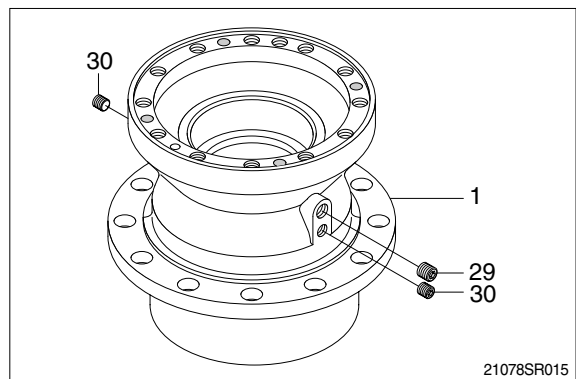

3) ASSEMBLY

- (1) Assemble roller bearing(5) inside the casing(1).

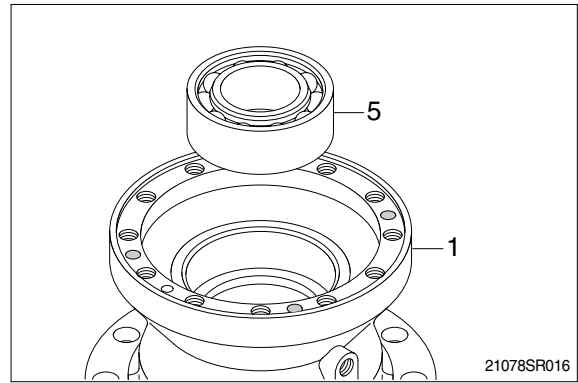

- (2) Assemble the drive shaft(2) into the casing(1) and then install oil seal(6) and roller bearing(7).

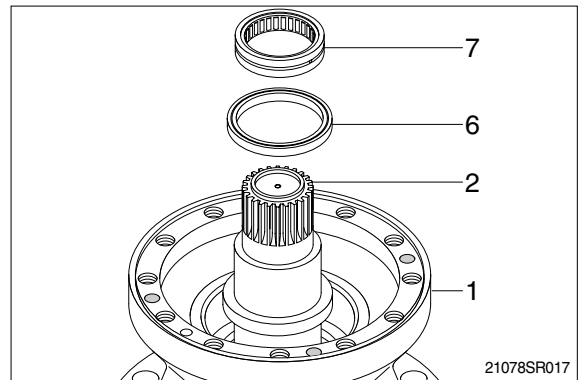

- (3) Install thrust plate(8) on top of drive shaft(2).

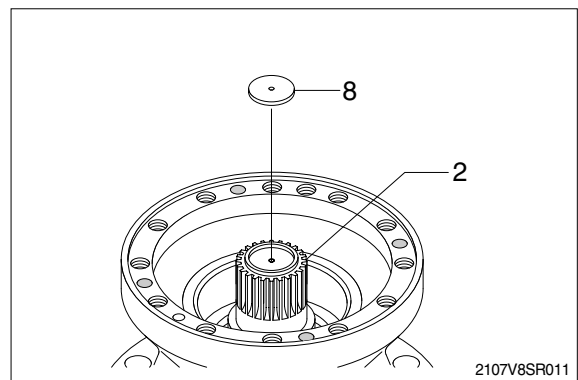

- (4) Assembling carrier2(9) assembly.

- ① Install thrust washer(14) inside the carrier2 (9).
- ② Install bushing2(23) inside the planet gear2 (15) and then assemble them to the carrier2(9).
- ③ Assemble the pin & bushing(16) to the carrier2(9) and then press the spring pin(17) by hammering.
- ④ Punch 2 points of the spring pin(17) lip.
※ Take care not to mistake the matching marks of each part.

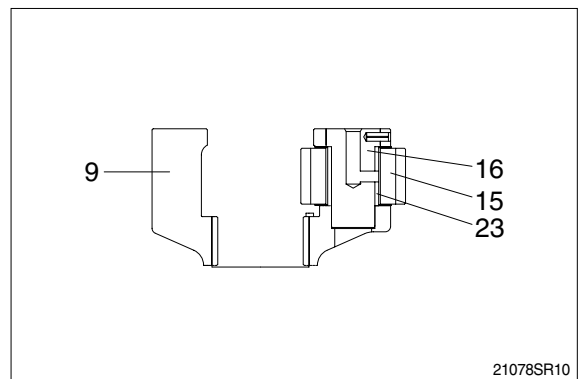

- (5) Assemble carrier2(9) assembly correctly to the drive shaft(2).

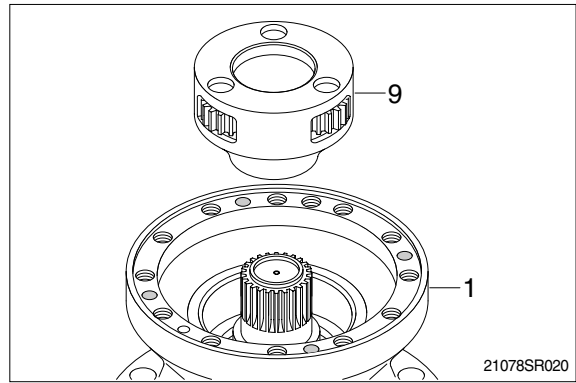

- (6) Assemble sun gear2(18) and thrust washer(14) to the center of the carrier2(9) assembly.

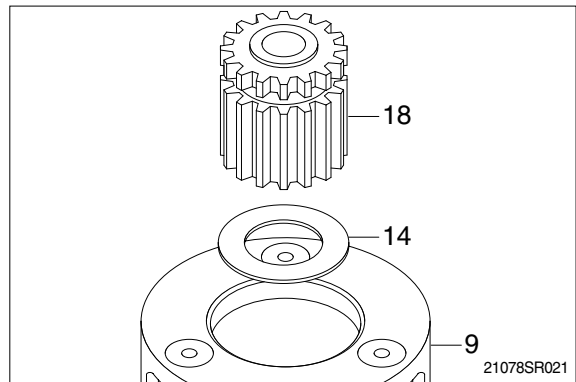

- (7) Assembling carrier1(19) assembly.

- ① Assemble the pin1(21) to the carrier1(19) and then press the spring pin(17) by hammering.
 - ② Punch 2 points of the spring pin's(17) lip.
 - ③ Install side plate3(26) onto the center of carrier1(19).
 - ④ Install needle cage(22) into the planet gear1(24).
 - ⑤ Assemble side plate(20), planet gear1 (24), side plate2(39) and then stop ring (38) to the pin1(21).
- ※ Take care not to mistake the matching marks of each part.

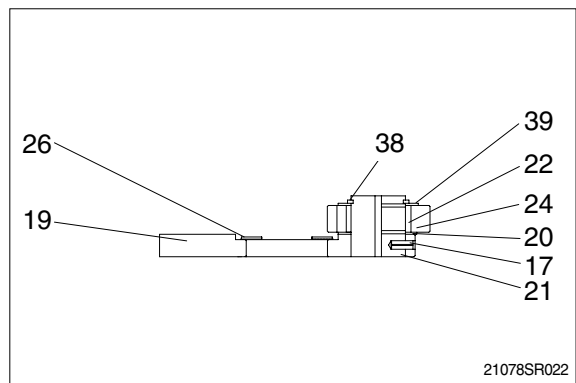

- (8) Install sun gear(27) onto the side plate3 (26).

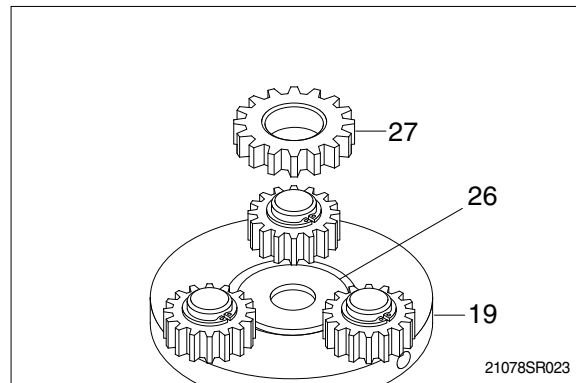

- (9) Assemble carrier1(19) assembly onto the carrier2 assembly.

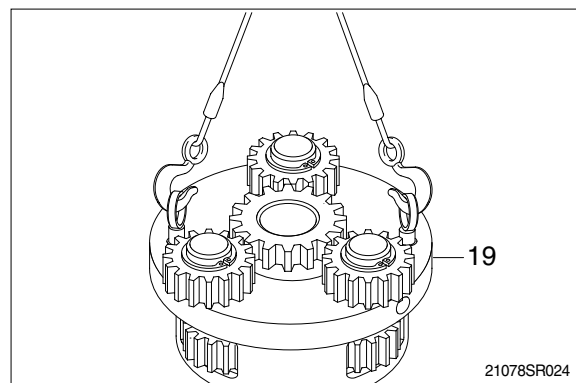

- (10) Apply loctite to the tapped holes of casing (1).

- (11) Tighten 3 M16 eye bolts to the ring gear(11) and lift up and then assemble it onto the casing(1).

- ※ Don't fail to coincide the knock pin(12) holes.

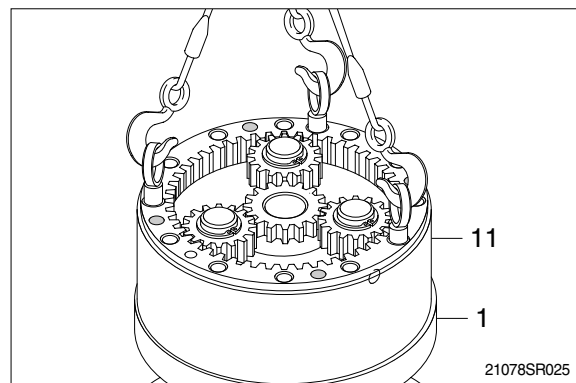

- (12) Hammer 4 knock pins(12) around the ring gear(11).

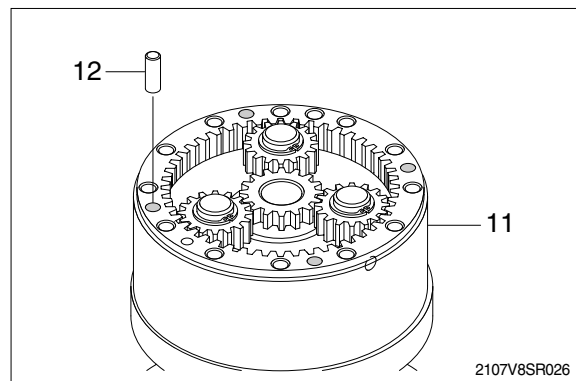

(13) Apply loctite to the tapped holes of the ring gear(11) and then mount swing motor onto the ring gear(11).

※ Don't fail to coincide the gauge bar(33) hole.

(14) Tighten socket bolts(31) around the swing motor assembly.

· Tightening torque : 24kgf · m(173lbf · ft)

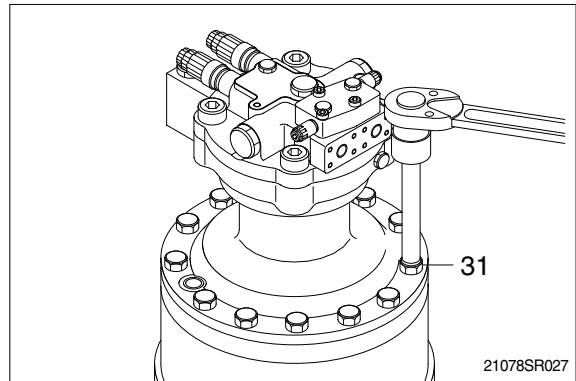

(15) Assemble plugs(29, 30).

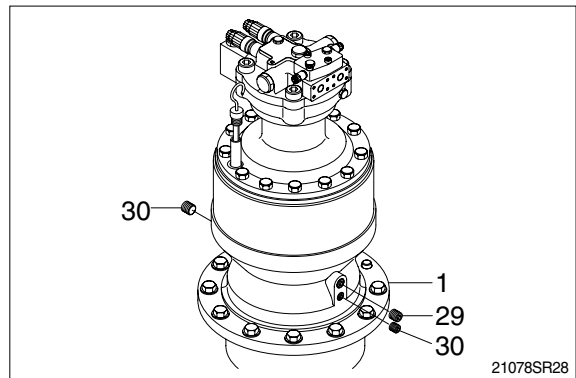

(16) Turn the swing motor assembly upside down and assemble cover plate(34) by tightening the hexagon bolts(35).

Install spacer(3) and pinion gear(13) to the drive shaft(2).

Assemble lock plate(36) on the pinion gear(13).

Assemble 2 lock washers(25) on the lock plate(36) with their 2 hole coincided individually to the tapped holes of drive shaft(2).

Tighten hexagon bolts(37) to the drive shaft(2) and then fold all the lock washer(25) corners over the hexagon bolts(37).

· Tightening torque : 24kgf · m(173lbf · ft)

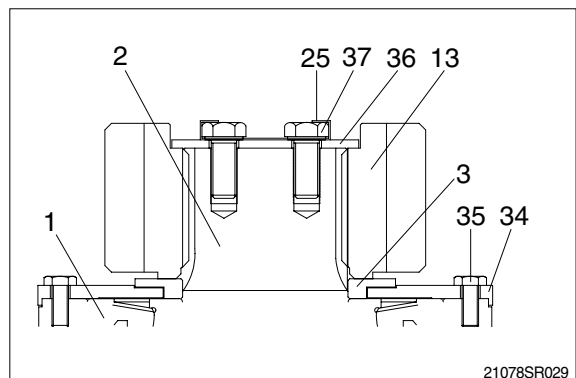

(17) Inject oil into the reduction gear.

GROUP 5 SWING DEVICE (TYPE 2 & TYPE 3)

1. REMOVAL AND INSTALL OF MOTOR

1) REMOVAL

- (1) Lower the work equipment to the ground and stop the engine.
- (2) Operate the control levers and pedals several times to release the remaining pressure in the hydraulic piping.
- (3) Loosen the breather slowly to release the pressure inside the hydraulic tank.

▲ Escaping fluid under pressure can penetrate the skin causing serious injury.

※ When pipes and hoses are disconnected, the oil inside the piping will flow out, so catch it in oil pan.

- (4) Disconnect hose assembly (2).
- (5) Disconnect pilot line hoses (3, 4, 5, 6, 7, 8).
- (6) Sling the swing motor assembly (1) and remove the swing motor mounting socket bolts (9).

· Motor device weight : 61 kg (135 lb)

- (7) Remove the swing motor assembly.
※ When removing the swing motor assembly, check that all the piping have been disconnected.

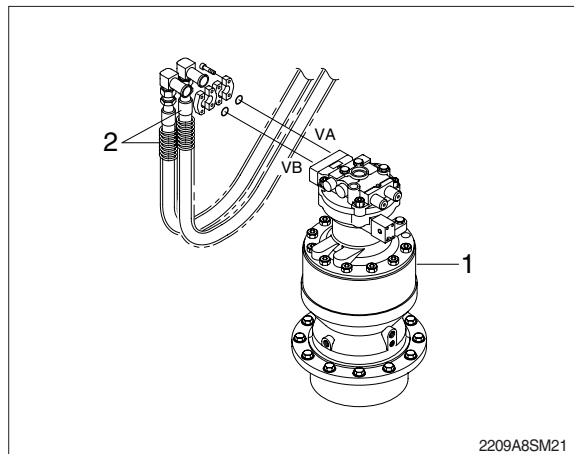

2) INSTALL

- (1) Carry out installation in the reverse order to removal.
- (2) Bleed the air from the swing motor.
 - ① Remove the air vent plug.
 - ② Pour in hydraulic oil until it overflows from the port.
 - ③ Tighten plug lightly.
 - ④ Start the engine, run at low idling and check oil come out from plug.
 - ⑤ Tighten plug fully.
- (3) Confirm the hydraulic oil level and check the hydraulic oil leak or not.

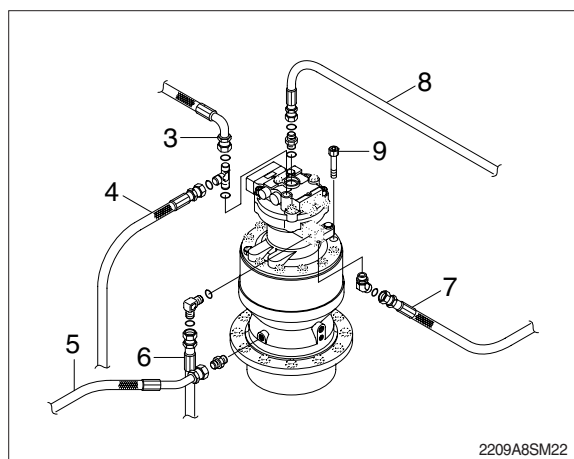

2. DISASSEMBLY AND ASSEMBLY OF SWING MOTOR

1) STRUCTURE

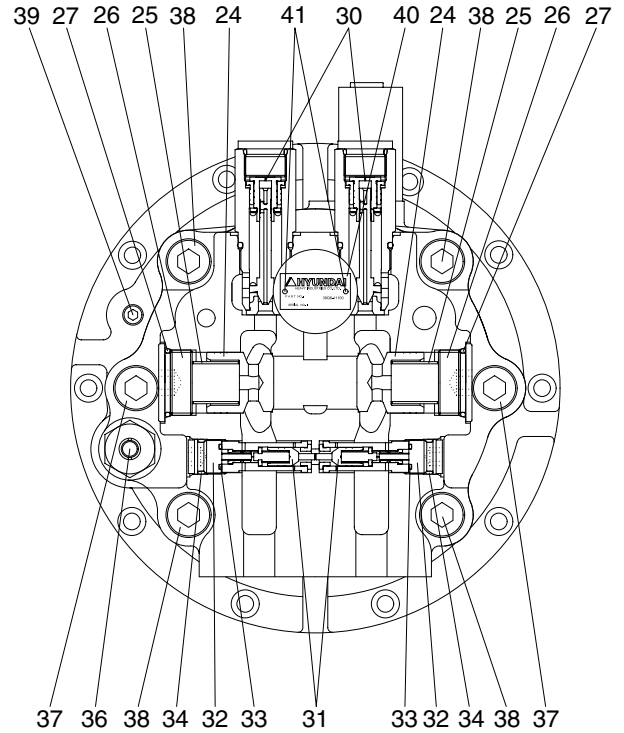
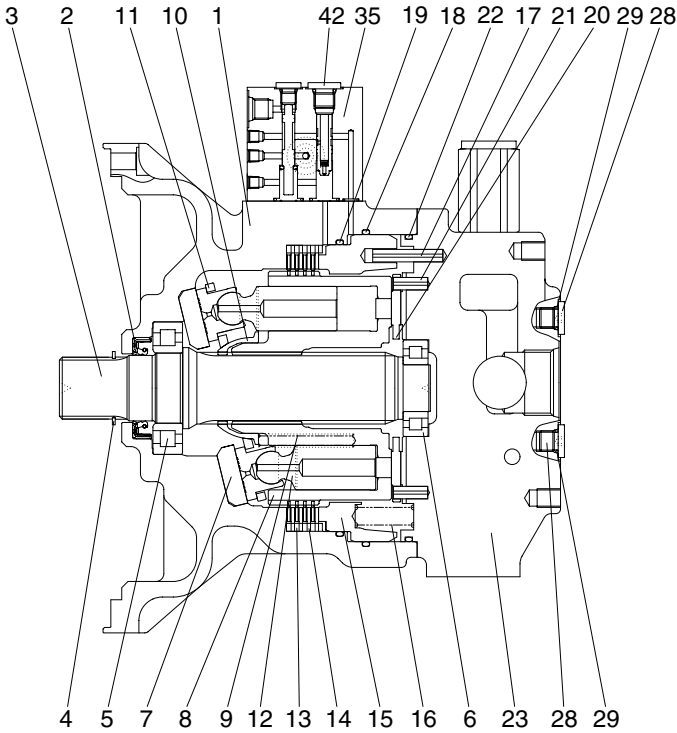

2209A8SM23

1	Casing	15	Parking piston	29	O-ring
2	Oil seal	16	Spring	30	Relief valve assy
3	Shaft	17	Spring pin	31	Reactionless valve assy
4	Snap ring	18	O-ring	32	Plug
5	Roller bearing	19	O-ring	33	O-ring
6	Needle bearing	20	Valve plate	34	O-ring
7	Swash plate	21	Spring pin	35	Time delay valve assy
8	Cylinder block	22	O-ring	36	Level gauge
9	Spring	23	Valve casing	37	Socket bolt
10	Ball guide	24	Check valve	38	Socket bolt
11	Retainer plate	25	Spring	39	Plug
12	Piston assy	26	Plug	40	Name plate
13	Friction plate	27	O-ring	41	Rivet
14	Separate plate	28	Plug	42	Socket bolt

2) DISASSEMBLY

(1) Disassemble drive shaft

- ① Unloosing socket bolt (time delay valve, 42) and disassemble time delay valve assy (35) from casing (1).



2209A8SM51

- ② Disassemble level gauge (36) from casing (1).



2209A8SM52

- ③ Hang valve casing (23) on hoist, unloose socket bolt (37, 38) and disassemble from casing (1).



2209A8SM53

- ④ Disassemble spring (16) and using a jig, disassemble parking piston (15) from casing (1).

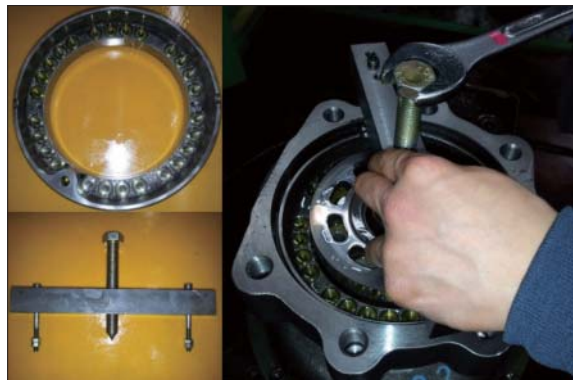

2209A8SM54

- ⑤ Disassemble respectively cylinder block sub (8), friction plate (13), separate plate (14) from casing (1).



2209A8SM55

- ⑥ Disassemble swash plate (7) from casing (1).



2209A8SM56

- ⑦ Using a plier jig, disassemble snap ring (4) from casing (1).



2209A8SM57

- ⑧ Disassemble shaft assy (3), oil seal (2) and O-ring (18, 22) from casing (1).



2209A8SM58

(2) Disassemble cylinder block sub

- ① Disassemble piston assy (12) from cylinder block (8).



- ② Disassemble ball guide (10) and spring (cylinder block, 9) from cylinder block (8).
 - Ball guide × 1EA
 - Spring × 9EA



(3) Disassemble valve casing sub

- ① Disassemble spring pin (17, 21), valve plate (20), O-ring (22) from valve casing (23).



- ② Using a torque wrench, disassemble relief valve (30) from valve casing (23).



- ③ Using a torque wrench, disassemble plug (32) from valve casing (23) and disassemble O-ring (33, 34) and reactionless valve assy (31).



2209A8SM63

- ④ Using a torque wrench, disassemble check valve (24) from valve casing (23).



2209A8SM64

- ⑤ Disassemble plug (28), O-ring (29) from valve casing (23).



2209A8SM65

3) ASSEMBLING

(1) Assemble shaft sub

- ① Put roller bearing (3) on preheater and provide heat to inner race.
(Temperature in conveyor : 120°C for 3~5 minutes)



2209A8SM66

- ② Using a robot machine, assemble and press preheated roller bearing (3) into shaft (5).

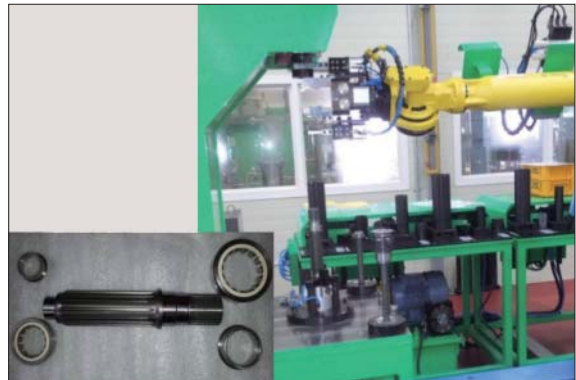

2209A8SM67

(2) Assemble cylinder block sub

- ① Assemble 9 springs (cylinder block, 9) into cylinder block (8).
 - Spring × 9EA



2209A8SM68

- ② Assemble ball guide (10) into cylinder block (8).
 - Ball guide × 1EA



2209A8SM69

③ Assemble 9 piston assy (12) into retainer plate (11).

- Piston assy × 9EA
- Retainer plate × 1EA



2209A8SM70

④ Assemble parts of procedure ② and ③.



2209A8SM71

(3) Assemble valve casing sub

① Assemble make up check valve sub

Assemble check valve (24), O-ring (27), plug (26) in that order and then screw it torque wrench.

- Make up check valve × 2EA
- Spring × 2EA
- Plug × 2EA
- O-ring × 2EA



2209A8SM72

② Assemble reactionless valve assy

Assemble reactionless valve assy (31), plug (32), O-ring (33, 34) in that order and then screw it a torque wrench.

- Reactionless valve assy (31) × 2EA
- Plug (32) × 2EA
- O-ring (33, 34) × 2EA



2209A8SM73

- ③ Using a torque wrench, assemble relief valve (30) 2 sets into valve casing (23).
- Relief valve (30) × 2EA



2209A8SM74

- ④ Assemble plug (28) and O-ring (27) into valve casing (23).
- Plug (28) × 3EA
 - O-ring (27) × 3EA



2209A8SM75

- ⑤ Assemble needle bearing (6) into valve casing (23) and assemble spring pin (17, 21) into valve casing (23).
- Needle bearing (6) × 1EA
 - Spring pin (17, 21) × 1EA



2209A8SM76

- ⑥ Apply some grease valve plate (20) and assemble it into valve casing (23).



2209A8SM77

(4) Assemble drive shaft sub

- ① Using a jig, assemble oil sealing (2) into casing (1).



2209A8SM78

- ② Fit shaft sub (shaft+roller bearing) into casing (1).



2209A8SM79

- ③ Using a plier jig, assemble snap ring (4) to shaft (3).
 - Snap ring × 1EA



2209A8SM80

- ④ Apply some grease swash plate (7) and assemble it into casing (1).
 - Swash plate × 1EA



2209A8SM81

⑤ Insert O-ring (18, 19) into casing (1).

- O-ring (18) × 1EA
- O-ring (19) × 1EA



2209A8SM82

⑥ Assemble cylinder block (8) into casing (1).



2209A8SM83

⑦ Assemble separate plate (14) and friction plate (13) 4 sets into casing (1) and fit parking piston (15) into casing (1) by a jig or a press.

- Separate plate × 4EA
- Friction plate × 4EA
- Parking piston × 1EA



2209A8SM84

⑧ Assemble spring (parking piston, 16) into parking piston (15).

- Spring × 26EA



2209A8SM85

- ⑨ Lift up valve casing (23) on casing (1) by a crane and assemble it with socket bolts (37, 38).



2209A8SM86

- ⑩ Assemble level gauge (36) and plug (39) into casing (1).



2209A8SM87

- ⑪ Assemble time delay valve assy (35) into valve casing (23) with socket bolt (42).
- Time delay valve × 1EA
 - Socket bolt × 3EA



2209A8SM88

⑫ **Air pressing test**

Be sure of leakage, after press air into assembled motor and put it in water for 1 minute (pressure : 2 kgf/cm²).



2209A8SM89

⑬ **Leakage check**

Place motor on a bench tester and after cleaning motor by color check No.1, paint No.3 and be sure of leakage.



2209A8SM90

⑭ **Mount test bench**

Mounting motor a test bench, test the availability of each part.

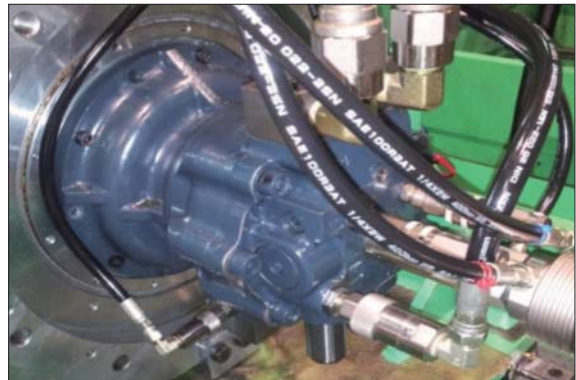

2209A8SM91

3. DISASSEMBLY AND ASSEMBLY OF REDUCTION GEAR

1) STRUCTURE

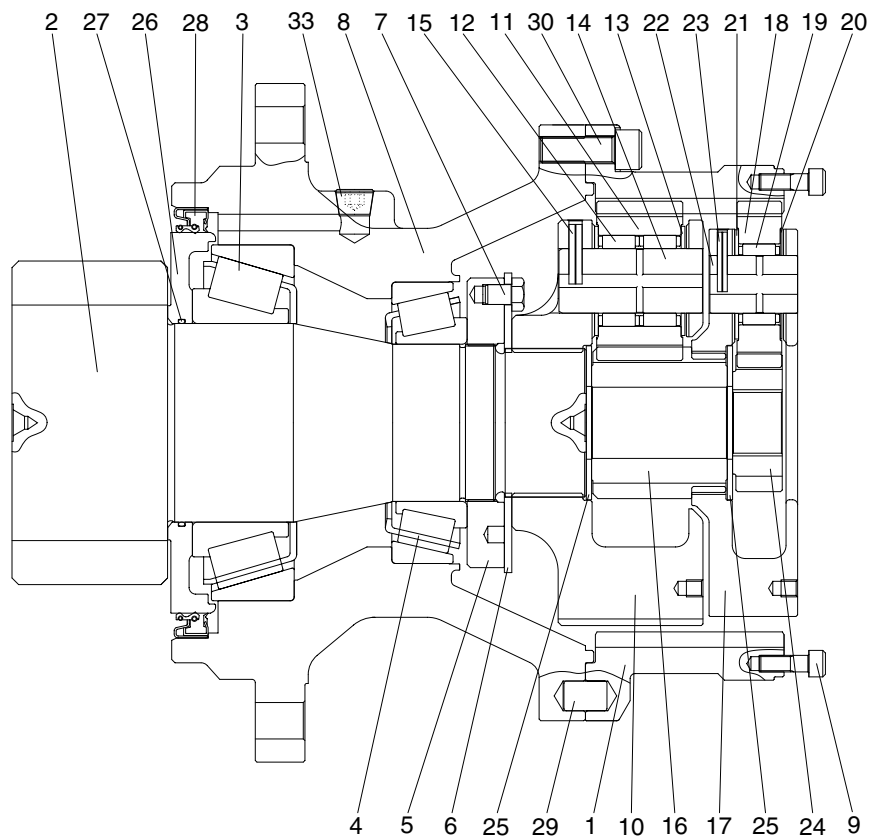

2209A2SM23

- | | | | | | |
|----|--------------|----|------------------|----|-----------------|
| 1 | Ring gear | 11 | Planetary gear 2 | 21 | Thrust washer 1 |
| 2 | Drive shaft | 12 | Needle bearing 2 | 22 | Carrier pin 1 |
| 3 | Bearing | 13 | Thrust washer 2 | 23 | Spring pin |
| 4 | Bearing | 14 | Carrier pin 2 | 24 | Sun gear 1 |
| 5 | Ring nut | 15 | Spring pin | 25 | Thrust plate |
| 6 | Lock plate | 16 | Sun gear 2 | 26 | Sleeve |
| 7 | Hexagon bolt | 17 | Carrier 1 | 27 | O-ring |
| 8 | Casing | 18 | Planetary gear 1 | 29 | Parallel pin |
| 9 | Socket bolt | 19 | Needle bearing 1 | 30 | Socket bolt |
| 10 | Carrier 2 | 20 | Thrust washer 1 | 33 | Plug |

2) DISASSEMBLY

(1) Preparation

- ① The reduction gear removed from machine is usually covered with mud.
Wash out side of reduction gear and dry it.
 - ② Setting reduction gear on work stand for disassembling.
 - ③ Mark for mating
Put marks on each mating parts when disassembling so as to reassemble correctly as before.
- ▲ Take great care not to pinch your hand between parts while disassembling not let fall parts on your foot while lifting them.

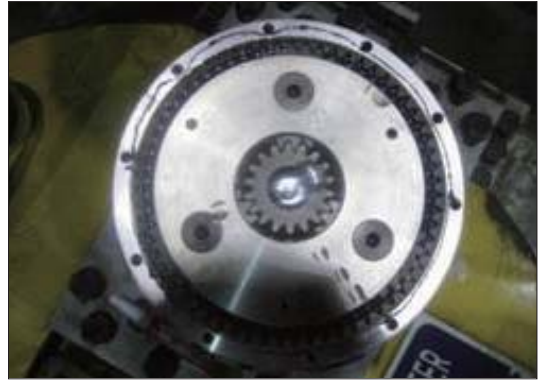

2209A8SM01

(2) Disassembly

- ① Remove every "Socket bolt (M10)" that secure swing motor and reduction gear.
- ② Removing carrier sub assy & sun gear
 - a. Removing No.1 sun gear from No.1 carrier sub assy.
※ Be sure maintaining it vertical with ground when disassembling No.1 sun gear.



2209A8SM02

- b. Removing No.1 carrier sub assy screwing I-bolt to tab hole (M10) in No.1 carrier.
Lifting it gradually maintaining it vertical with ground.
※ It's impossible to disassemble No.1 spring pin. If No.1 spring pin has problem, change whole No.1 carrier sub assy.



2209A8SM03

- c. Removing No.2 sun gear from No.2 carrier sub assy.
- ※ Be sure maintaining it vertical with ground when disassembling No.2 sun gear.



2209A8SM04

- d. Removing No.2 carrier sub assy screwing I-bolt to tab hole (M10) in No.2 carrier. Lifting it gradually maintaining it vertical with ground.
- ※ It's impossible to disassemble No.2 spring pin. If No.2 spring pin has problem, change whole No.2 carrier sub assy.



2209A8SM05

③ **Removing ring gear**

After unscrewing every socket bolt (M16), remove ring gear from casing.

- ※ Because of liquid gaskets between ring gear and casing, put sharp punch between ring gear and casing and tapping it to remove them.



2209A8SM06

④ **Removing drive shaft sub assy**

- Unscrew every hex head bolt (M12) to remove lock plate.

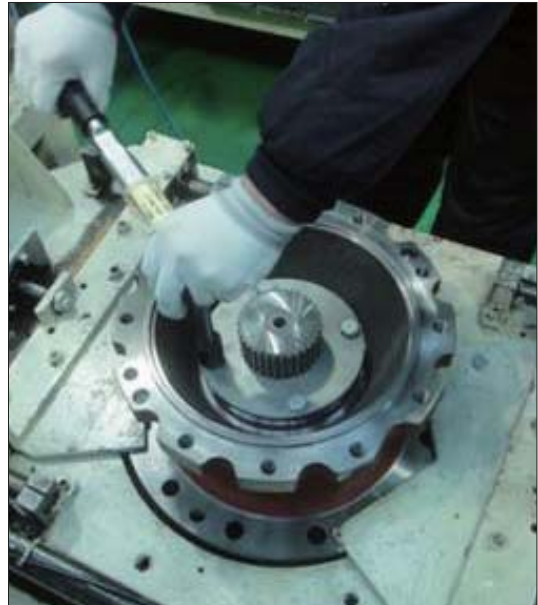

2209A8SM07

- Rolling ring nut for removing them from drive shaft sub assy.

- ※ Use special tool to roll ring nut to counter clockwise.

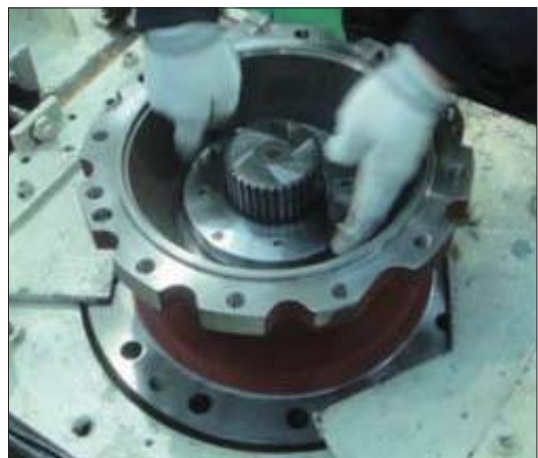

2209A8SM08

- c. Remove drive shaft sub assy from casing.
※ Set a rack for flange of casing, and remove drive shaft sub assy from casing by using press.



2209A8SM09

- d. Remove oil seal & taper bearing (small) from casing.
※ Do not re-use oil seal. It is impossible to disassemble drive shaft sub assy.



2209A8SM10



2209A8SM11

4. ASSEMBLY REDUCTION UNIT

1) GENERAL NOTES

- (1) Clean every part by kerosene and dry them in a cool and dry place.
- (2) Loctite on surface must be removed by solvent.
- (3) Check every part for any abnormal.
- (4) Each hexagon socket head bolt should be used with loctite #242 applied on its threads.
- (5) Apply gear oil slightly on each part before assembling.

▲ Take great care not to pinch your hand between parts or tools while assembling nor let fall parts on your foot while lifting them.

Inspection before assembling.

Thrust washer

- Check the seizure, abnormal wear or uneven wear.
- Check the unallowable wear.

Gear

- Check the pitting or seizure on tooth surface.
- Check the cracks on the root of tooth.

Bearing

- Rotate it by hands to check such noise or uneven rotation.

2) ASSEMBLING NO.1 CARRIER SUB ASSY

- (1) Put thrust plate firmly in No.1 carrier.
- (2) After assembling No.1 needle bearing to No.1 planetary gear, put a pair of No.1 thrust washer on both sides of bearing and install them to No.1 carrier.

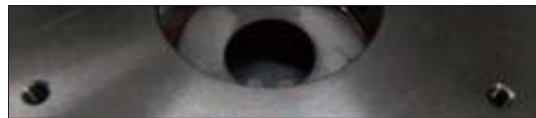

2209A8SM12



2209A8SM13

- (3) Make of spring pin hole No.1 pin and No.1 carrier of spring pin hole in line, press No.1 spring pin into the holes.
 Make No.1 spring pin hole head for No.1 planetary gear.



2209A8SM14

- (4) Caulk carrier holes to make No.1 spring pin settle down stably.



2209A8SM15

- ※ Refer to “Caulking details”
 Use paint marker for marking after caulking.

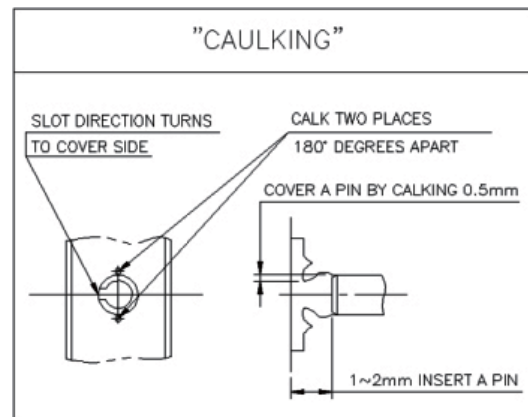

2209A8SM16

2) ASSEMBLING NO.2 CARRIER SUB ASSY

(1) Put thrust plate in firmly No.2 carrier.



2209A8SM17

(2) After assembling No.2 needle bearing to No.2 planetary gear, put 2 pieces of No.2 thrust washer on both sides of bearing and install them to No.2 carrier.



2209A8SM18

(3) Align No.2 spring pin hole and No.2 carrier spring pin hole, put No.2 spring pin into the holes.
Make No.2 spring pin cutting line face to No.2 planetary gear.



2209A8SM19

(4) Caulk carrier holes to make No.2 spring pin settle down stably.

※ Refer to “Caulking details”

Use paint marker for marking after caulking.

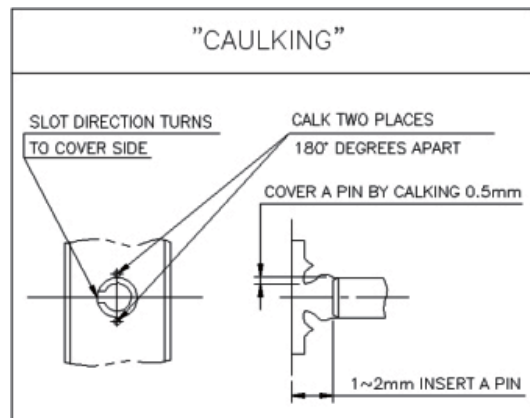

2209A8SM20

3) ASSEMBLING PINION GEAR SUB ASSY

- (1) Prepare drive shaft pinion gear vertical with ground.



2209A8SM21

- (2) Fully apply grease (albania EP02) to O-ring groove of sleeve.
※ Be sure to maintain it vertical with ground when assembling it.
- (3) Put O-ring into O-ring groove of sleeve.
Fully apply grease on O-ring.

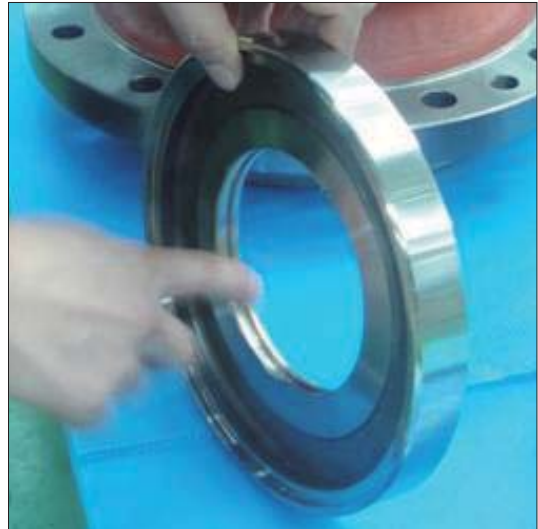

2209A8SM22

- (4) Assemble taper bearing and sleeve into drive shaft using press jig.
Use special jig for pressing. Leave no space between sleeve and taper bearing.



2209A8SM23



2209A8SM24

4) ASSEMBLING BEARING CUP & OIL SEAL (PRESSING)

- (1) Put top, bottom bearing cup into casing.
Use special jig for pressing. Pay attention to foreign materials while assembling bearing cup.
- ※ Flip over casing to assemble oil seal.



2209A8SM25



2209A8SM26

- (2) Assemble oil seal to casing.
Use special jig for pressing. Pay attention to direction of dust seal and dent.



2209A8SM27

※ WHILE ASSEMBLING OIL SEAL

1. Be sure to set dust seal to gear oil.
2. Before assembling, charge enough grease in oil seal.
3. Before assembling, apply enough grease inside and outside of oil seal.

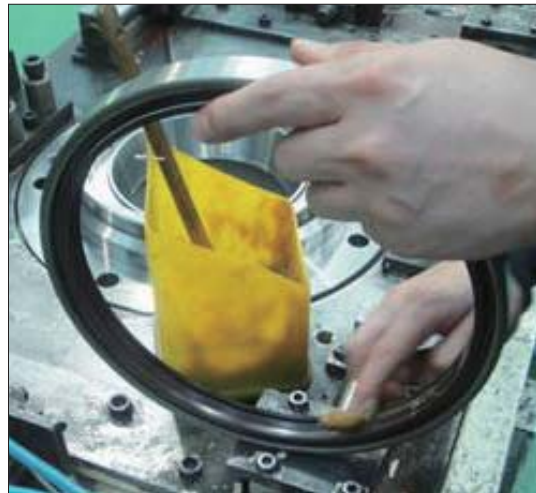

2209A8SM28

5) ASSEMBLING SHAFT SUB ASSY & RING NUT

- (1) After assembling casing & drive shaft sub
assy, flip it over.



2209A8SM29

- (2) Put drive shaft sub assy into casing.
※ Be sure to maintain it vertical with ground when assembling it.



2209A8SM30

- (3) Put taper bearing into it.
Rotate bearing by hands for checking after assembly.



2209A8SM31

- (4) Put ring nut into drive shaft sub assy by using special jig.

The tightening torque (M95) = 3.5 ± 0.4 kgf·m
(25.3 ± 2.9 lbf·ft)



2209A8SM32

- ※ Apply enough loctite #242 before screwing bolts.



2209A8SM33

(5) Align bolt screw of ring nut with lock plate's hole.

In case of misalign between bolt screw ring nut and lock plate's hole, put lock plate as near as possible to hole of bolt screw of ring nut and make it in line by increasing tightening torque.



2209A8SM34



2209A8SM35

(6) Screw 4 bolts (M12 × 16) to connect ring nut and lock plate by using torque wrench.

Bolt (M12, 4EA) = 10.9T

The tightening torque = 8.8 ± 0.9 kgf·m
(63.7 ± 6.5 lbf·ft)

※ Apply enough loctite #242 before screwing bolts.

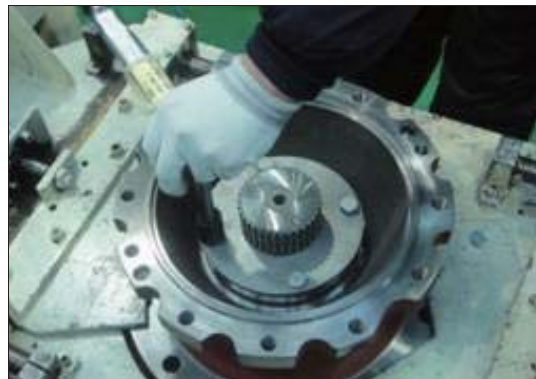

2209A8SM36

(7) Use paint marker for checking surplus parts after assembling.



2209A8SM37

6) ASSEMBLING RING GEAR

- (1) Apply loctite #515 bottom of casing sub assy contacting with ring gear without disconnection.



2209A8SM38

Refer to loctite detail.

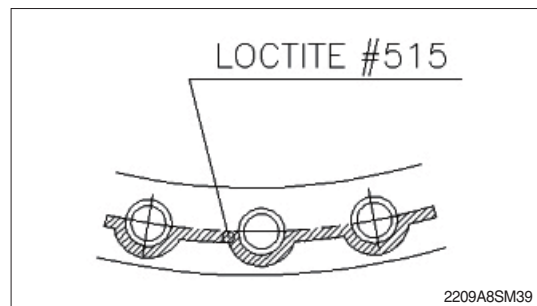

2209A8SM39

- (2) Put parallel pin into hole of casing sub assy.
Mark parallel pin position using paint marker.



2209A8SM40

- (3) Align ring gear with parallel pin to put them into casing sub assy.
※ Be sure to maintain them vertical with ground while using press.



2209A8SM41

- (4) Screw 12 bolts (M16×45) to connect casing sub assy and ring gear (01) by using torque wrench.

Bolt (M16, 12EA) = 12.9T

The tightening torque = 27 ± 2.7 kgf·m
(195 ± 19.5 lbf·ft)

- ※ Apply enough loctite #242 before screwing bolts.



2209A8SM42

- (5) Use paint marker for checking surplus parts after assembling.



2209A8SM43



2209A8SM44

7) ASSEMBLING CARRIER SUB ASSY & SUN GEAR

- (1) Put No.2 carrier sub assy along spline of drive shaft spline.
- Screw M10 I-bolt to No.2 carrier sub assy.
 - Lifting up No.2 carrier sub assy and align planetary gear and tooth of ring gear by rotating planetary gear by hands.
 - Rotate No.2 carrier sub assy by hands to fit No.2 carrier sub assy into drive shaft spline.



2209A8SM45

- (2) Put No.2 sun gear into No.2 carrier sub assy.



2209A8SM46

(3) Put No.1 carrier sub assy into No.2 sun gear along spline.

- Screw M10 I-bolt to No.1 carrier sub assy.
- Lifting up No.1 carrier sub assy and align planetary gear and tooth of ring gear by rotating planetary gear by hands.
- Rotate No.1 carrier sub assy by hands to fit No.1 carrier into No.2 sun gear spline.



2209A8SM47

(4) Put No.1 sun gear into No.1 carrier sub assy. Be sure to maintain it vertical with ground. And align with No.1 planetary gear spline.

(5) Rotate No.1 carrier sub assy by hands to check noise.



2209A8SM48

8) MEASURING CLEARANCE & ASSEMBLING NAME PLATE

(1) Check the clearance between ring gear and No.1 sun gear using a tool with dial gauge.

Check the clearance

Dial gauge = -0.3 ~ +2.95



2209A8SM49

GROUP 6 TRAVEL DEVICE

1. REMOVAL AND INSTALL

1) REMOVAL

- (1) Swing the work equipment 90° and lower it completely to the ground.
- (2) Operate the control levers and pedals several times to release the remaining pressure in the hydraulic piping.
- (3) Loosen the breather slowly to release the pressure inside the hydraulic tank.
- ⚠ Escaping fluid under pressure can penetrate the skin causing serious injury.
- ※ When pipes and hoses are disconnected, the oil inside the piping will flow out, so catch it in oil pan.
- (4) Remove the track shoe assembly.
For details, see **removal of track shoe assembly**.
- (5) Remove the cover.
- (6) Remove the hose.
※ Fit blind plugs to the disconnected hoses.
- (7) Remove the bolts and the sprocket.
- (8) Sling travel device assembly(1).
- (9) Remove the mounting bolts(2), then remove the travel device assembly.
· Weight : 300kg(660lb)

2) INSTALL

- (1) Carry out installation in the reverse order to removal.
- (2) Bleed the air from the travel motor.
 - ① Remove the air vent plug.
 - ② Pour in hydraulic oil until it overflows from the port.
 - ③ Tighten plug lightly.
 - ④ Start the engine, run at low idling, and check oil come out from plug.
 - ⑤ Tighten plug fully.
- (3) Confirm the hydraulic oil level and check the hydraulic oil leak or not.

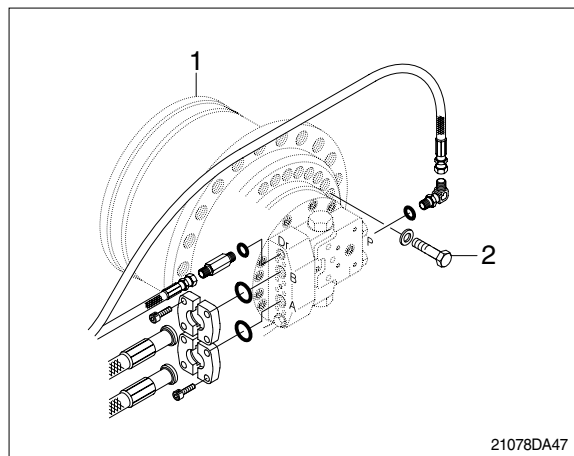

2. TRAVEL MOTOR

1) STRUCTURE

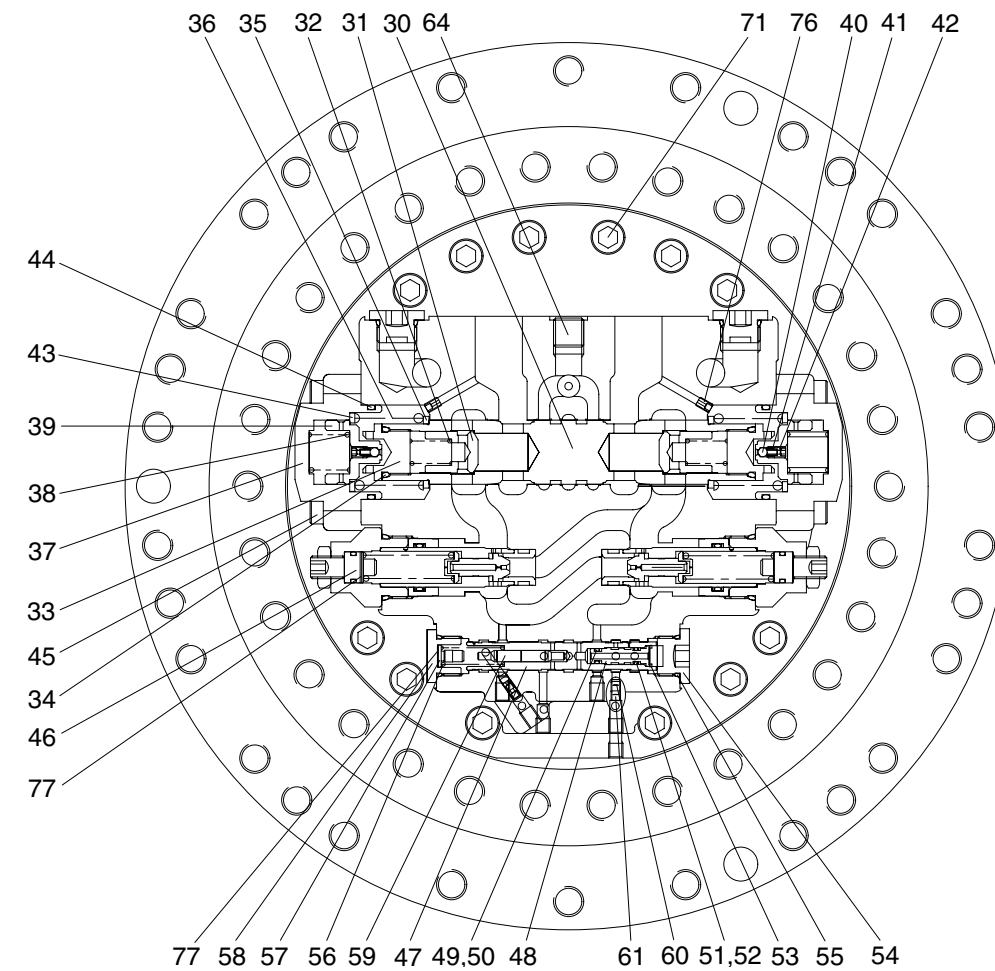
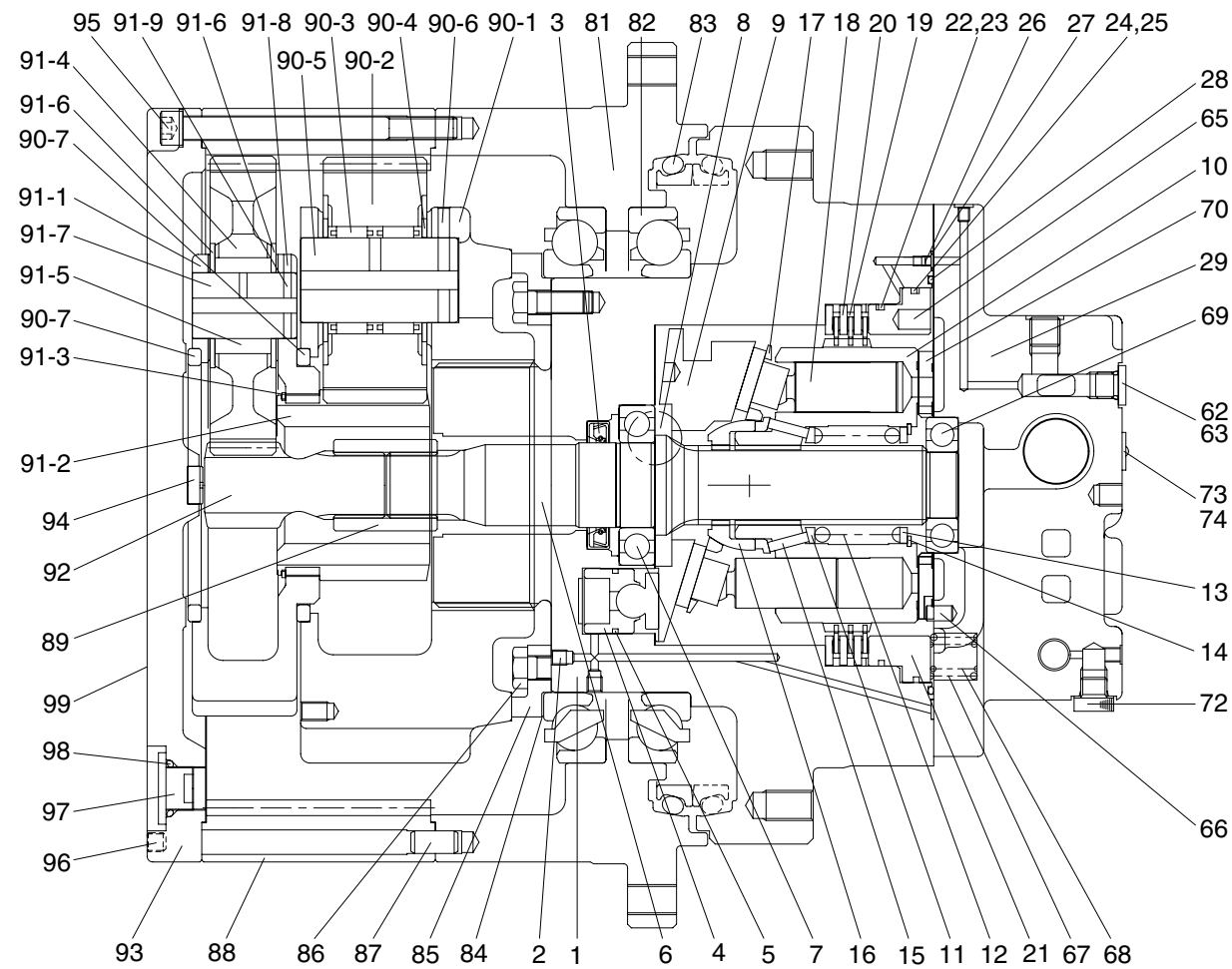

1 Shaft casing	20 Plate	39 Spool	58 Plug	77 Shim	91-1 Carrier No.1
2 Plug	21 Packing piston	40 Steel ball	59 Spool	81 Housing	91-2 Sun-gear No.2
3 Oil seal	22 O-ring	41 Spring	60 Orifice	82 Main bearing	91-3 Retaining ring
4 Swash piston	23 Back up ring	42 Plug	61 Orifice	83 Floating seal	91-4 Planetary gear No.1
5 Piston ring	24 O-ring	43 Spring seat	62 Plug	84 Shim	91-5 Needle bearing No.1
6 Shaft	25 Back up ring	44 O-ring	63 O-ring	85 Retainer	91-6 Thrust washer
7 Bearing	26 Orifice	45 Wrench bolt	64 Plug	86 Hex head bolt	91-7 Pin No.1
8 Steel ball	27 O-ring	46 Relief valve assy	65 Pin	87 Parallel pin	91-8 Spring pin
9 Swash plate	28 O-ring	47 Spool	66 Pin	88 Ring gear	91-9 Spring pin
10 Cylinder block	29 Rear cover	48 Guide	67 Spring	89 Coupling	92 Sun gear No.1
11 Spring seat	30 Spool	49 O-ring	68 Spring	90 Carrier assy No.2	93 Cover
12 Spring	31 Check	50 Back up ring	69 Bearing	90-1 Carrier No.2	94 Pad
13 End plate	32 Spring	51 O-ring	70 Valve plate	90-2 Planetary gear No.2	95 Hex socket head bolt
14 Snap ring	33 Plug	52 Back up ring	71 Wrench bolt	90-3 Needle bearing No.2	96 Hex socket Screw
15 Pin	34 O-ring	53 Snap ring	72 Plug	90-4 Thrust washer	97 Hydraulic plug
16 Ball guide	35 Spring seat	54 plug	73 Name plate	90-5 Pin No.2	98 O-ring
17 Set plate	36 Spring	55 O-ring	74 Rivet	90-6 Spring pin	99 Name plate
18 Piston assy	37 Cover	56 Spring	75 Seal kit	90-7 Thrust ring	
19 Friction plate	38 Spring	57 Spring seat	76 Orifice	91 Carrier assy No.1	

2107V2TM02

2) TOOLS AND TIGHTENING TORQUE

(1) Tools

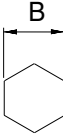
Tool name		Remark	
Allen wrench		2.5, 4, 6, 10	
Socket for socket wrench, spanner	Socket	8, 14, 24, 27	
Torque wrench		Capable of tightening with the specified torques	
Pliers		-	
Plastic and iron hammer		Wooden hammer allowed. Normal 1 or so	
Monkey wrench		-	
Oil seal inserting jig		-	
Bearing pliers		-	
Seal tape		-	
Eye bolt		M10, M12, M14	
Press(0.5 ton)		-	
Oil stone		-	
Bearing assembling jig		-	

(2) Tightening torque

Part name	Item	Size	Torque	
			kgf · m	lbf · ft
Plug	2	NPTF 1/16	1 ± 0.1	7.2 ± 0.7
Orifice	26	M5	0.7 ± 0.1	5 ± 0.7
Wrench bolt	45	M12 × 40L	10 ± 1.0	72 ± 7.0
Relief valve	46	HEX 27	18 ± 1.0	130 ± 7.0
Plug	54	PF 1/2	8.5 ± 1.0	61 ± 7.0
Plug	58	HEX 24	5 ± 1.0	36 ± 7.0
Plug	62	PF 1/4	5 ± 1.0	36 ± 7.0
Wrench bolt	71	M10 × 35L	10 ± 1.0	72 ± 7.0
Hex head bolt	-	M12 × 25L	11 ± 1.5	79 ± 10
Hex socket head bolt	-	M12 × 155L	11 ± 1.5	79 ± 10
Hex socket head plug	-	PF 3/4	19 ± 1	137 ± 7.0

3. OUTLINE OF DISASSEMBLING

1) GENERAL SUGGESTIONS

- (1) Select a clean place for dismantling.
Spread a rubber plate on a working table in order to prohibit the damage of parts.
- (2) Clean a deceleration equipment and a motor part, washing out dirt and unnecessary substances.
- (3) Without any damage of O-ring, oil seal, the adhered surface of other seals, a gear, a pin, the adhered surface of other bearings, and the surface of moisturized copper, treat each parts.
- (4) Numbers written in the parenthesis, (), next to the name of a part represent the part numbers of a cross-sectional view annexed with a drawing.
- (5) The side of a pipe in a motor can be written as a rear side; the side of out-put as a front side.
- (6) Using and combining a liquid gasket, both sides must be dried completely before spraying a liquid gasket.
- (7) In case of bonding volts, combine a standard torque by torque wrench after spraying locktight 262 on the tab parts. (It can be dealt as assembling NPTF screws and an acceleration equipment.)

3.1 DISASSEMBLING

- 1) Unloosing wrench bolt and disassemble cover(37).
※ Wrench bolt = M12×40L-8EA
(Purchasing goods)

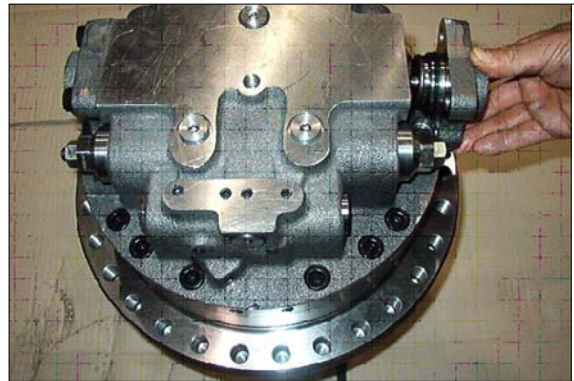

21078TM21

- 2) Disassemble parts related to C.B.V.



21078TM22

- 3) Unloosing wrench bolt(M12×35L, 16EA) and disassemble rear cover assembly from motor assembly.

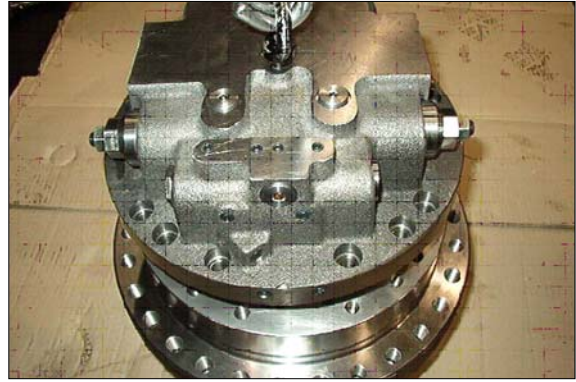

21078TM23



21078TM24

- 4) Dismantle packing piston(21) using compressed air.



21078TM25

- 5) Disassembly rotary kit from motor assembly(Cylinder block assembly, piston assembly, ball guide, set plate, friction plate, steel plate...)

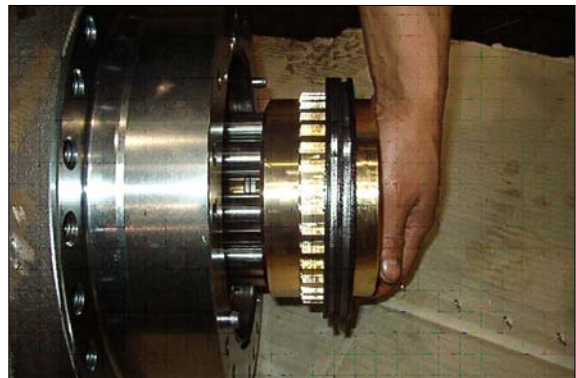

21078TM26

6) Using a jig, disassemble swash plate(9) from shaft casing.

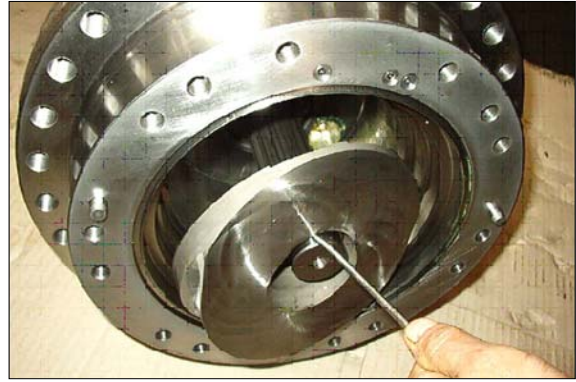

21078TM27

7) Using compressed air, disassemble piston swash(4) piston ring(5), respectively.

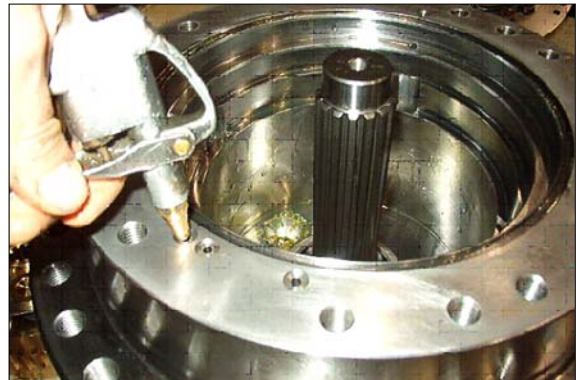

21078TM28



21078TM29

8) Using a hammer, disassemble shaft(6) from shaft casing(1).

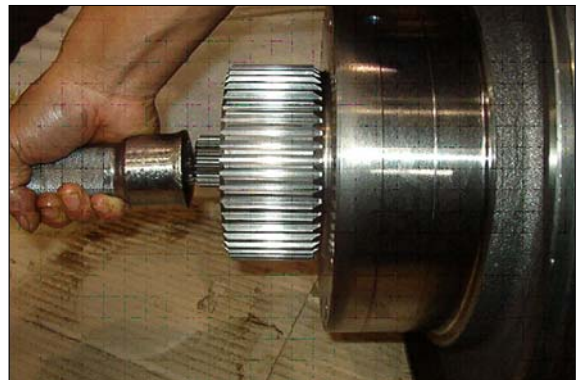

21078TM30

■ **Disassemble cylinder sub.**

- 9) Disassemble cylinder block assembly, piston assembly(9) and seat plate(M).

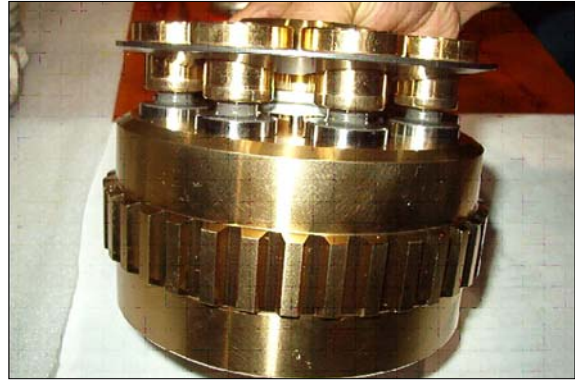

21078TM31



21078TM32

- 10) Disassemble ball guide(16), ring and pin(15) from cylinder block, respectively.



21078TM33



21078TM34



21078TM35

11) Pushing spring(12) by an assembling jig, disassemble snap ring(14), spring seat(13), spring(12) and spring seat(11), respectively.

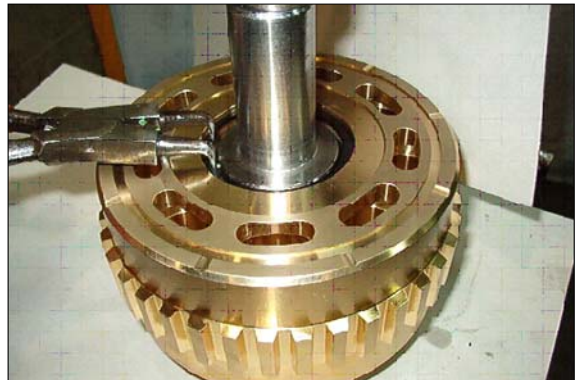

21078TM36



21078TM37

■ **Disassemble valve casing sub.**

12) Using an hexagon wrench, unloosing wrench bolt(45) and disassemble cover(37), spring(38), spool(39), spring seat(43), spring(36) and spring seat(35), respectively. (Same balance on both sides)

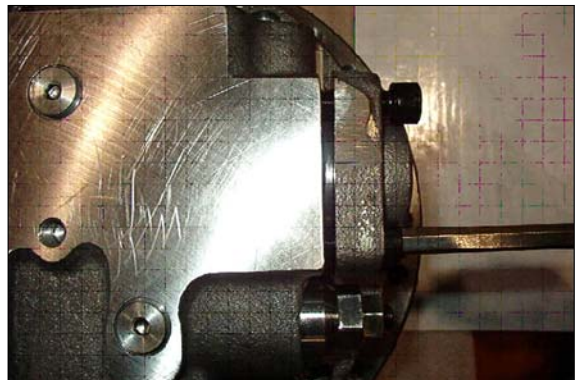

21078TM38



21078TM39

13) Disassemble spool(59), spool(47), O-ring (51), guide(48) and snap ring(53) on rear cover, respectively.

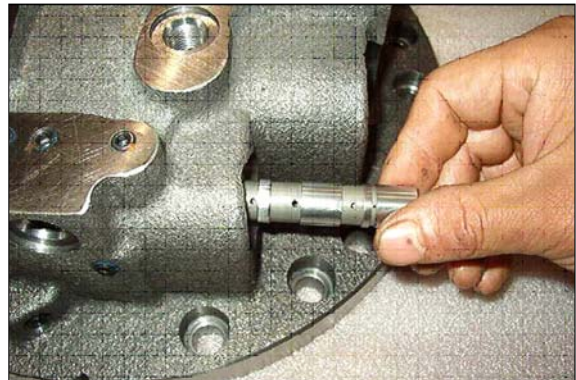

21078TM40



21078TM41

14) Using a torque wrench, disassemble relief assembly(46) on rear cover.

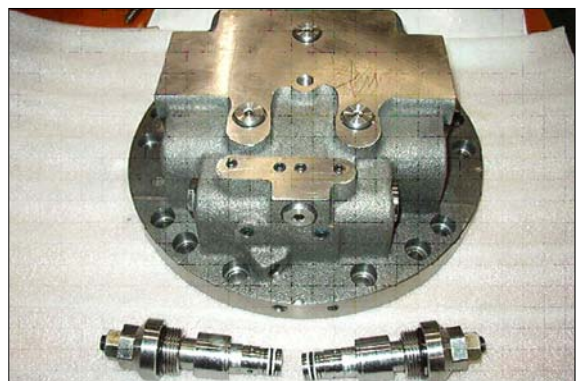

21078TM42

4. OUTLINE FOR ASSEMBLING

1) GENERAL SUGGESTIONS

- (1) After washing each parts cleanly, dry it with compressed air.
Provided that you do not wash friction plate with treated oil.
- (2) In bonding each part, fasten bond torque.
- (3) When using a hammer, do not forget to use a plastic hammer.

4.1 ASSEMBLING

- Assemble the sub of turning axis

- 1) Using a jig, assemble oil seal(3) into shaft casing(1)

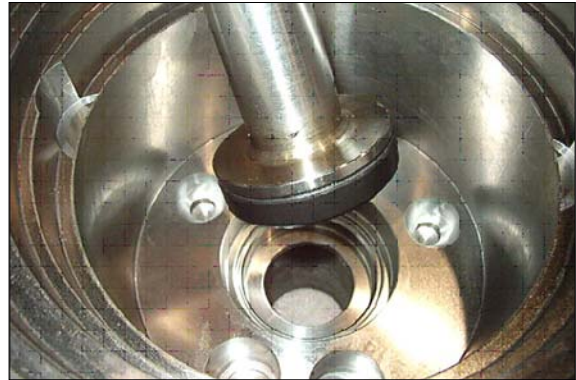

21078TM43

- 2) Have a bearing(8) thermal reacted into shaft(6).



21078TM44



21078TM45



21078TM46

3) Using a jig, assemble shaft assembly into shaft casing(1).



21078TM47

4) After spreading grease on steel ball(8) assemble into shaft casing(1).



21078TM48

5) Assemble swash piston assembly(4, 5) into shaft casing(1).



21078TM49

- 6) Assemble swash plate(9) into shaft casing (1).



21078TM50

■ Assemble cylinder block sub.

- 7) Assemble spring seat(13), spring(12), spring seat(11) into cylinder block(10) respectively, pushing spring(12) using by a jig, assemble snap ring(14) with a snap ring(14).



21078TM51



21078TM52

8) Assemble ring, pin(15) on cylinder block(10) ball guide(16) respectively.



21078TM53



21078TM54



21078TM55

9) Assemble cylinder block assembly, piston assembly(9), seat plate(17).



21078TM56

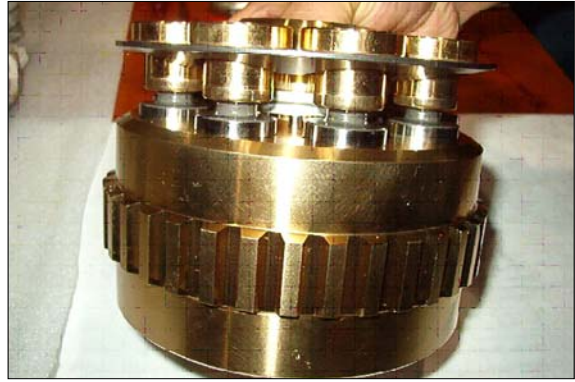

10) Assemble cylinder block assembly(9) into shaft casing(a).

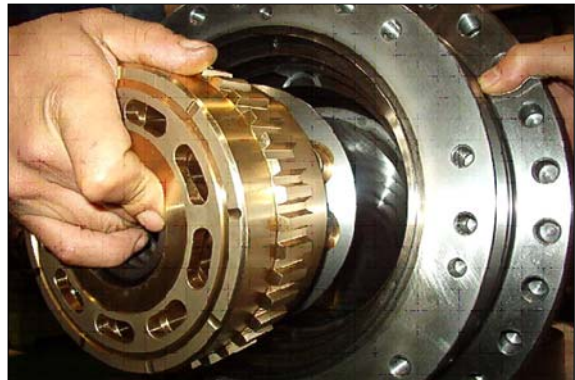

11) Assemble friction plate(19) and plate(20) into shaft casing(1) respectively, prepare 6 set.



12) Assemble O-ring(22, 23) into packing piston (21).



21078TM60

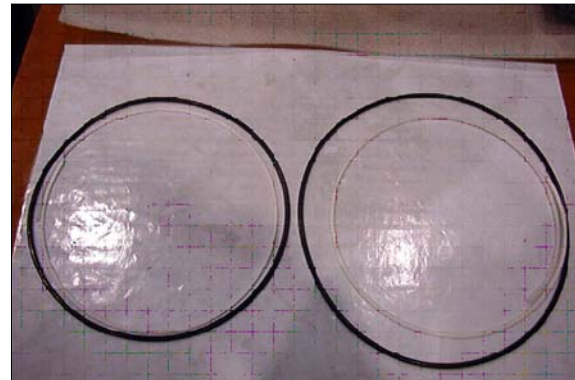

21078TM60-1

13) After spreading grease on packing piston(21) bond wrench bolt and assemble shaft casing(1).



21078TM61

■ **Assemble rear cover sub.**

14) Using a jig, assemble bearing(69) into rear cover(29).



21078TM62

15)After assembling spool(59), spool(47), O-ring(51), guide(48) and snap ring(53) respectively into rear cover(29). Using torque wrench, assemble it.



21078TM63

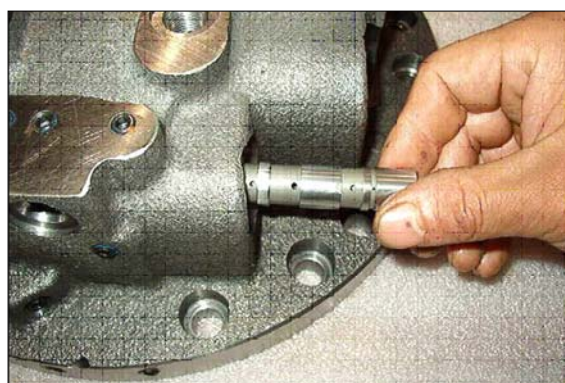

21078TM64

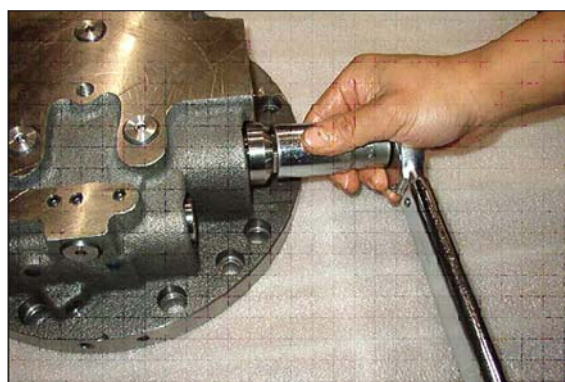

21078TM65

16) Assemble spring seat(35), spring(36), spring seat(43), spool(39), spring(38), cover(37) respectively and assemble wrench bolt(45).
(Same balance on both sides)

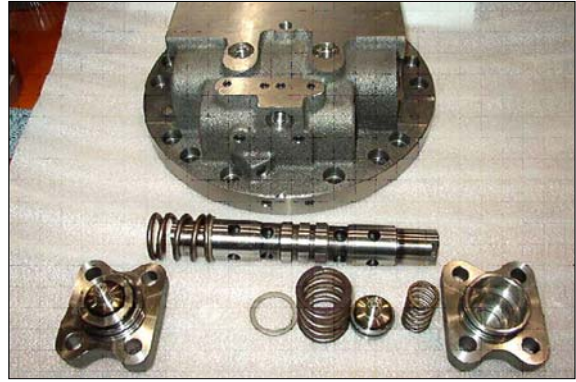

21078TM66

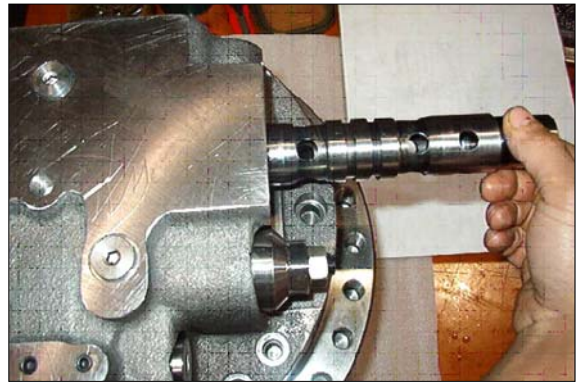

21078TM67

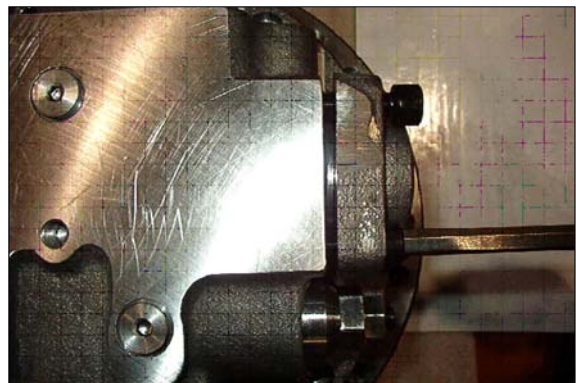

21078TM67-1

17) Assemble plug(2).

※ Plug(NPT1/16) - 11EA



21078TM68



21078TM69

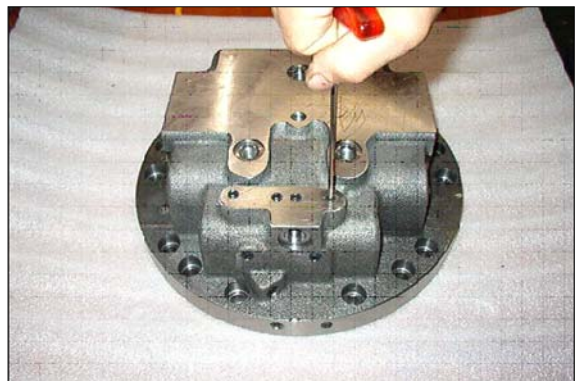

21078TM70



21078TM71

- 18) Assemble plug(64).
※ Plug(PT3/8) - 11EA

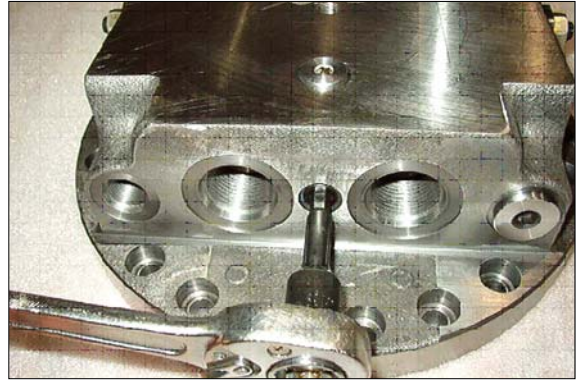

21078TM72

- 19) Assemble plug(62, 63) into rear cover(29)
and assemble relief valve assembly.

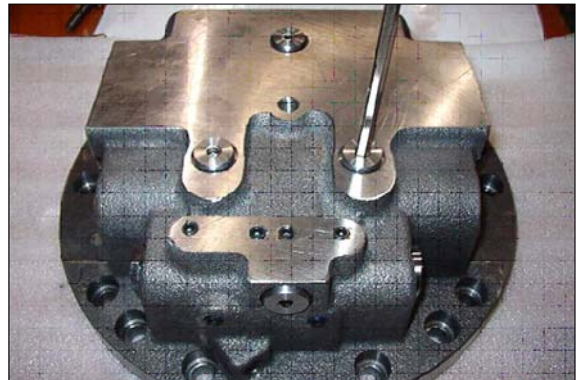

21078TM73

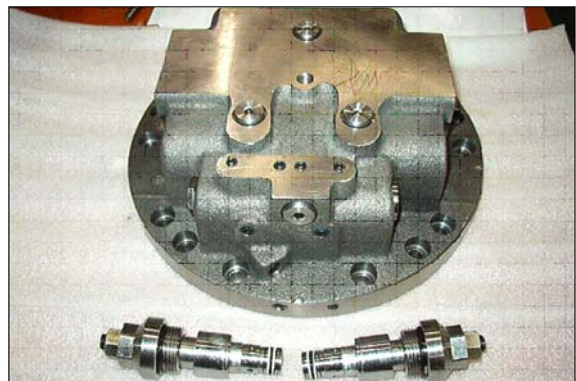

21078TM74

- 20) Put spring(67, 68) together into rear cover
(29), prepare 6 set.

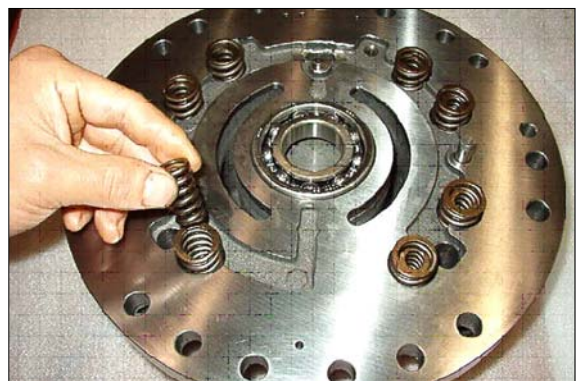

21078TM75



21078TM76

21) Assemble valve plate(70) into rear cover (29).



21078TM77

22) After assembling shaft casing(1) and rear cover(29).
Assemble spool assembly(30), spring(38), spool(39), cover(37) after then complete assembly with wrench bolt(45).

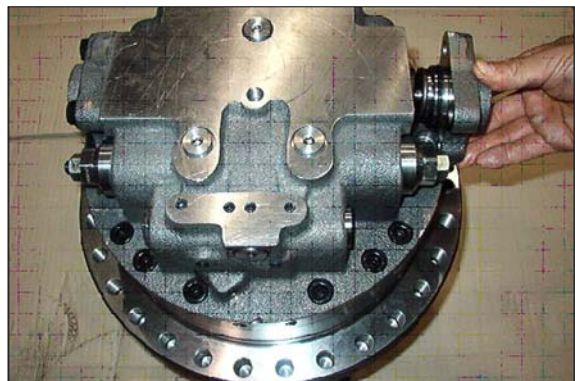

21078TM78

23) Finish assembly.



21078TM79

5.1 DISASSEMBLING REDUCTION UNIT

1) Preparation for disassembling

- (1) The reduction units removed from excavator are usually covered with mud. Wash outside of propelling unit and dry it.
- (2) Locate reducer in order for drain port to be at the lowest level loosen taper screw plug of drain port, and drain oil from reduction gear.
 - ※ While oil is still hot, inside of the unit may be pressurized.

▲ Take care of the hot oil gushing out of the unit when loosening the plug.

(3) Mark for mating

Put marks on each mating parts when disassembling so as to reassemble correctly as before.

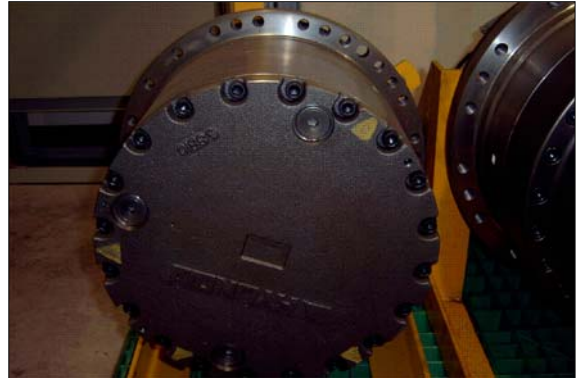

21078TM80

2) Setting reduction unit(or whole propelling unit) on work stand for disassembling

- (1) Remove M12 hexagon socket head bolts(95) at 3 places from cover(93) almost equally apart each other, and then install M12 ×155L eye bolts. Lift up the unit using them and place it on work stand with cover upward.

▲ Take great care not to pinch your hand between parts while disassembling nor let fall parts on your foot while lifting them.



21078TM81

3) Removing cover

- (1) Remove the rest of M12 hexagon socket head bolts(95) that securering gear and housing. Loosen all the socket bolts and then, disassemble cover.
- (2) As the cover(93) is adhered to ring gear (88), disassemble ring gear(88) and cover (93) vy lightly hammering slantwise upward using sharpen punch inserted between the cover and ring gear.

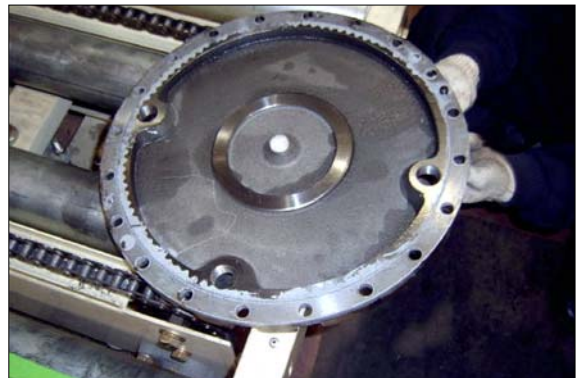

21078TM82

4) Removing No.1 carrier sub assembly

- (1) Screw three M10 eye-bolt in No.1 carrier and lift up and remove No.1 carrier assy.



21078TM83

- (2) Remove No.1 sun gear

- ※ Be sure to maintain it vertical with the ground when disassembling No.1 sun gear.



21078TM84

5) Removing No.2 carrier sub assembly

- (1) Screw three M10 eye-bolt in No.2 carrier and lift up and remove No.2 carrier assy.



21078TM85

- (2) Remove No.2 sun gear

- ※ Be sure to maintain it vertical with the ground when disassembling No.2 sun gear.



21078TM86

6) Removing ring gear

- (1) As the ring gear(88) is adhered to housing(81), disassemble ring gear(88) and housing(81) by lightly hammering slantwise upward using sharpen punch inserted between the ring gear and housing.
 - ※ Carefully disassembling ring gear not to make scratch on it.
- (2) Screw M14 eye-bolt in ring gear and lift up and remove it.

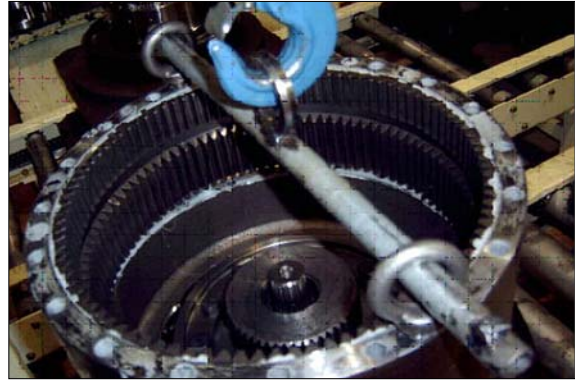

21078TM87

7) Removing coupling

- (1) Remove coupling.

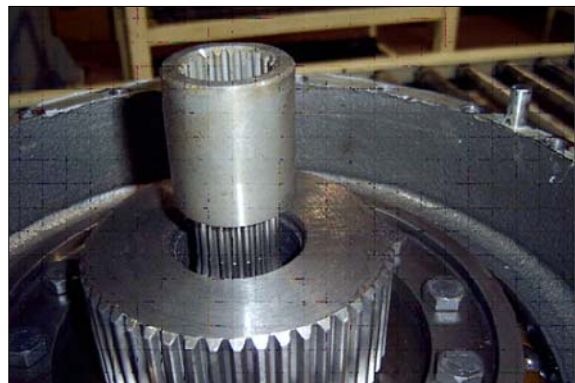

21078TM88

8) Removing retainer & shim

- (1) Remove M12 hexagon socket head bolts that secure retainer and motor.
- (2) Remove retainer & shim.

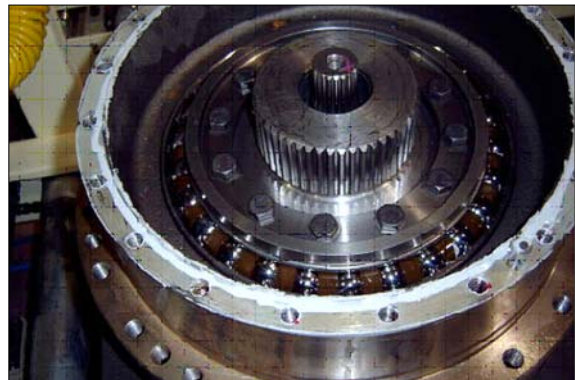

21078TM89

9) Removing housing sub assembly

- (1) Screw M12 eye bolt in housing and lift up housing assembly including angular bearing and floating seal.



21078TM90

10) Removing floating seal

- (1) Lift up a piece of floating seal of motor side.

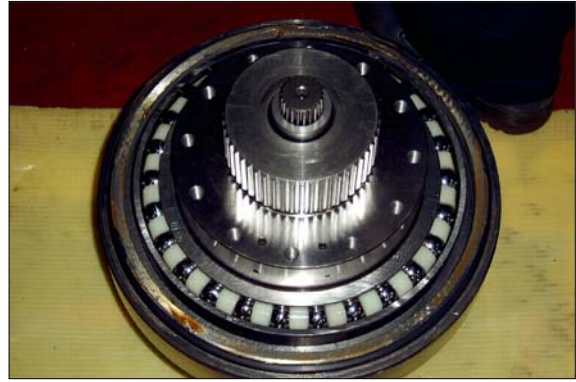

21078TM91

11) Disassembling housing assembly

- (1) After turning housing, lift up a piece of floating seal from housing and then remove it.
- ※ Don't disassemble angular bearing.

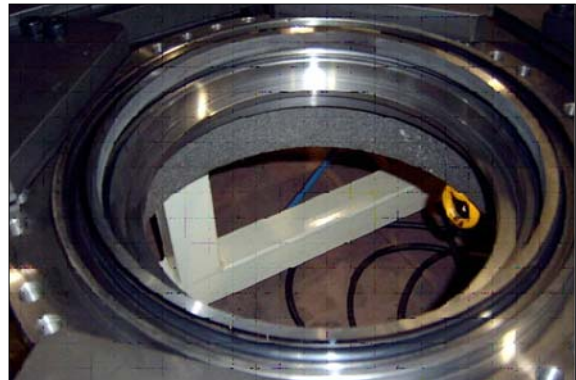

21078TM92

12) Disassembling No.1 carrier

- (1) Remove thrust ring(90-7) from carrier.
- (2) Knock spring pin(91-8) fully into No.1 pin (91-7).
- (3) Remove planetary, thrust washer, No.1 pin, bearing from carrier.



21078TM93



21078TM94



21078TM95

13) Disassembling No.2 carrier

- (1) Disassemble No.2 carriers, using the same method for No.1 carrier assembly.



21078TM96



21078TM97

6.1 ASSEMBLY REDUCTION GEAR

■ General notes

Clean every part by kerosene and dry them by air blow.

Surfaces to be applied by locktite must be decreased by solvent.

Check every part for any abnormalities.

Each hexagon socket head bolt should be used with locktite No. 262 applied on its threads.

Apply gear oil slightly on each part before assembling.

Take great care not to pinch your hand between parts or tools while assembling nor let fall parts on your foot while lifting them.

Inspection before reassembling

Thrust washer

- Check if there are seizure, abnormal wear or uneven wear.
- Check if wear is over the allowable limit.

Gears

- Check if there are pitting or seizure on the tooth surface.
- Check if there are cracks on the root of tooth by die check.

Bearings

- Rotate by hand to see if there are something unusual such as noise or uneven rotation.

Floating seal

- Check flaw or score on sliding surfaces or O-ring.

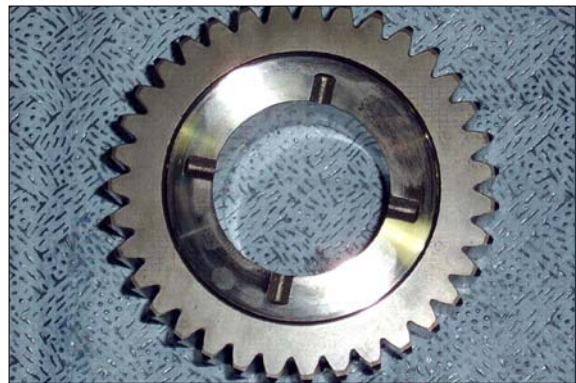

21078TM98

1) Assembling No.1 carrier

- (1) Put No.1 carrier(91-1) on a flat place.
- (2) Install No.1 needle bearing(91-5) into No.1 planetary gear(91-4), put 2EA of No.1 thrust washer(91-6) on both sides of bearing, and then, install it into carrier.

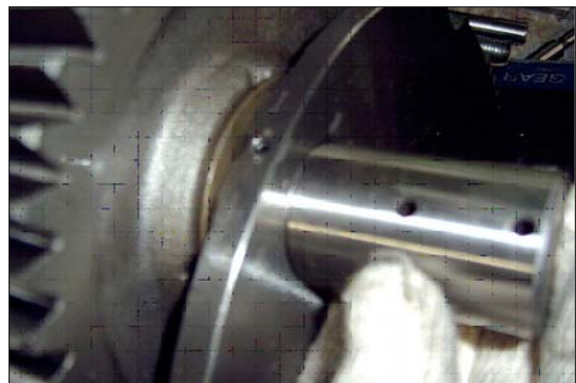

21078TM99

- (3) Install No.1 pin(91-5) into No.1 carrier where the holes for No.1 pin(91-5) are to be in line with those of No.1 carrier, and then, install spring pins into the holes.

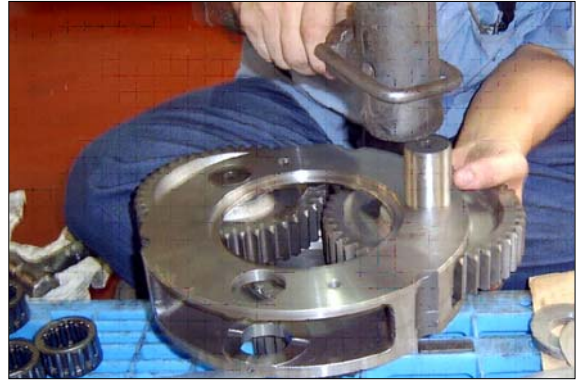

21078TM100

- (4) Caulk carrier holes as shown on the picture.
 (5) Assembly ring thrust(90-7) into carrier.

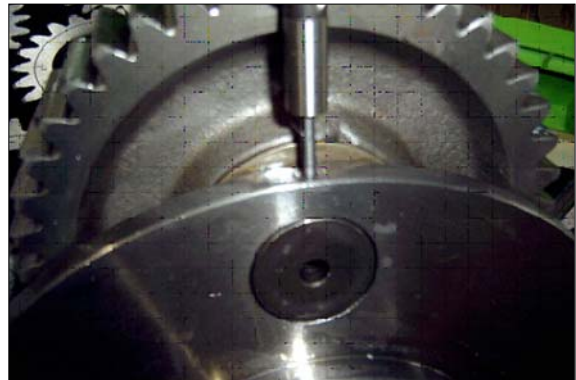

21078TM101

2) Assembling No.2 carrier

- (1) Put No.2 carrier(90-1) on a flat place.
 (2) Install No.2 needle bearing(90-3) into No.2 planetary gear(90-2), put 2EA of No.2 thrust washer(90-4) on both sides of bearing, and then, install it into carrier.

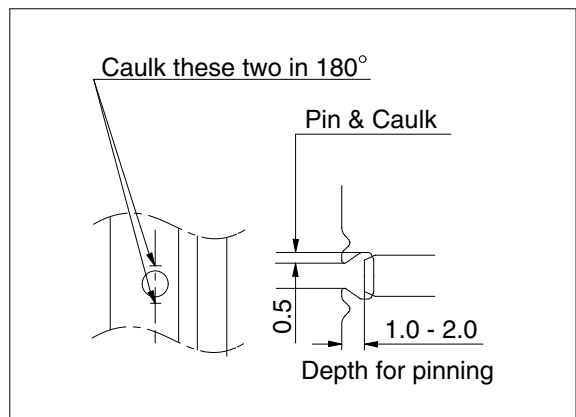

21078TM102

- (3) Install No.2 pin(90-5) into No.2 carrier where the holes for No.2 pin(90-5) are to be in line with those of No.2 carrier, and then, install spring pins into the holes.



21078TM103

- (4) Caulk carrier holes as shown on the picture.
- (5) Assembly ring thrust(90-7) into carrier.



21078TM104

3) Assembling floating seal(83) and main bearing(82)

- (1) Assemble floating seal into motor by use of pressing jig. Grease the contact parts for floating seal which is assembled into motor.
- (2) Heat bearing at 60~70°C and then, put into the motor side.

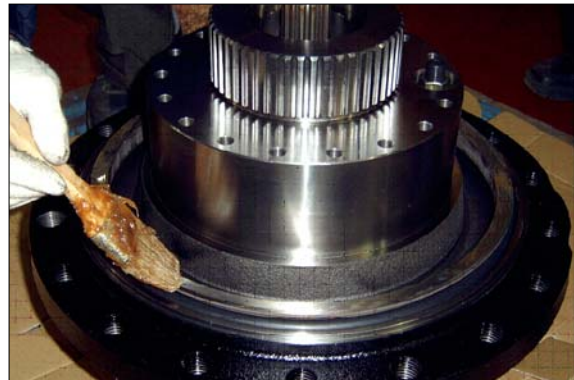

21078TM105

- ※ Be sure to maintain it vertical with the ground when assembling bearing and floating seal.



21078TM106

4) Assembling housing

- (1) Heat housing at 60~70°C while clearing it out and then, assemble floating seal into housing by use of pressing jig.
- ※ Be sure to maintain it vertical with the ground when assembling floating seal.

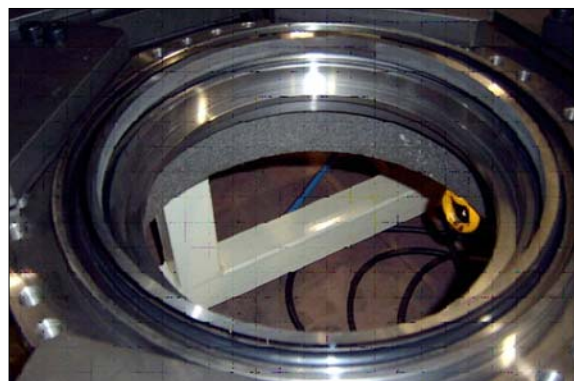

21078TM705

5) Installing housing assembly

- (1) Install 2EA of M12 eye-bolt into housing assembly.
 - (2) Assemble housing into motor by use of hoist and eye-bolt.
- ※ Be sure to tighten eye-bolt deep enough.



21078TM108

6) Installing main bearing(82)

- (1) Heat main bearing at 60~70°C and then, install.
- ※ Be sure to maintain it vertical with the ground when assembling bearing.



21078TM109

7) Installing retainer(86) and shim(85)

- (1) Measure clearance between main bearing and retainer by use of jig to decide the thickness of shim and select an appropriate shim, and then, assemble retainer.
- (2) Apply locktite(#262) on M12 hexagon head bolt, and then, bolt.

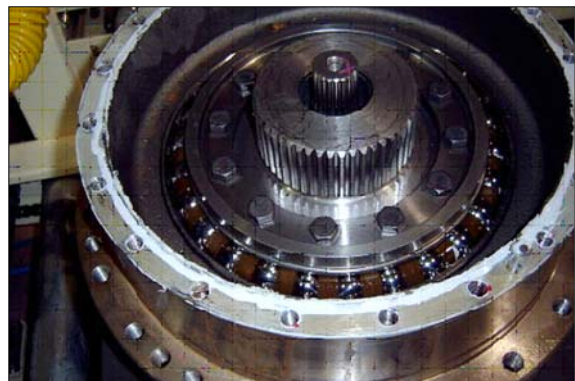

21078TM110

8) Installing coupling

- (1) Install coupling on spline of the motor.

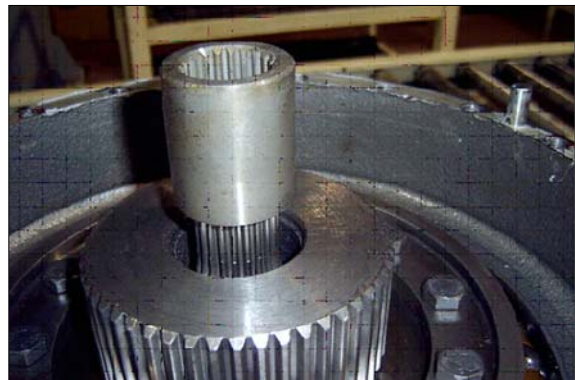

21078TM111

9) Installing ring gear

- (1) Apply three bone #1104(locktite #515) on housing for ring gear without gap.
- (2) Insert lock pin into housing hole.
- (3) Install M14 eye-bolt on the tap of ring gear.
- (4) Lift ring gear and then, assemble into housing in order for hole of ring gear and parallel pin of housing to be in line.
- (5) Temporarily secure 4EA of M12 hexagon socket bolt and shim with cover thickness having appropriate torque.

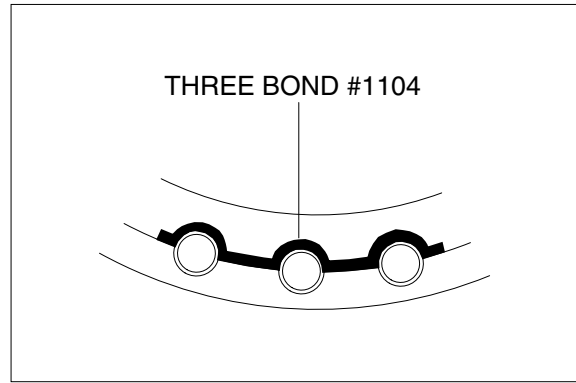

21078TM112A

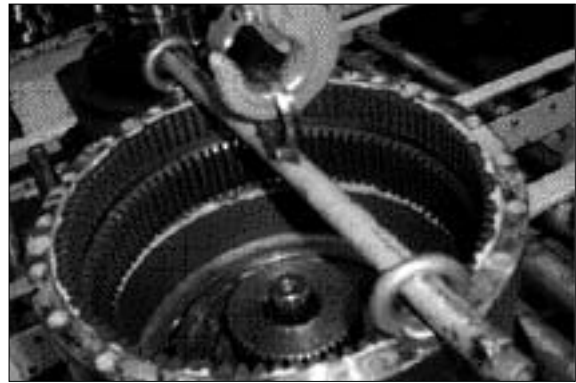

21078TM113

10)Installing No.2 carrier sub assembly

- (1) Install M10 eye-bolt on No.2 carrier assembly.
- (2) Lift No.2 carrier assembly and then, slowly put it down on ring gear.
- (3) Rotate planetary gear by hands and install on ring gear.



21078TM114

11)Installing No.2 sun gear(91-2)

- (1) Install No.2 sun gear on the spline of No.2 carrier and No.2 planetary gear, matching teeth of them.



21078TM115

- (2) Install No.2 sun gear on the spline of No.2 carrier and No.2 planetary gear, matching teeth of them.

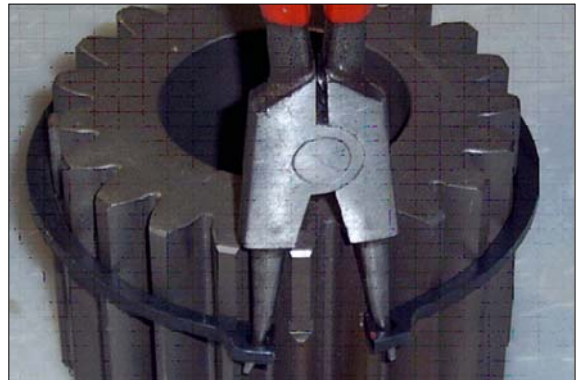

21078TM116

12)Installing No.1 carrier sub assembly

- (1) Install M10 eye-bolt on No.2 carrier assembly.
- (2) Lift No.1 carrier assembly and then, slowly put it down on ring gear.
- (3) Rotate planetary gear by hands and install on ring gear.



21078TM117

13)Installing No.1 sun gear(92)

- (1) Put down No.1 sun gear on No.1 carrier, maintaining it vertical with spline of coupling.
- (2) Install No.1 sun gear on No.1 planetary gear, matching their teeth.



21078TM118

14) Installing cover(93)

- (1) Beat pad(94) with plastic hammer, and press it into the center of cover.
- (2) Apply three bond #1104(locktite#515) on the ring gear for cover without gap.
- (3) Put cover on ring gear, apply locktite (#262) on M12 hexagon socket head bolt, and then, bolt.

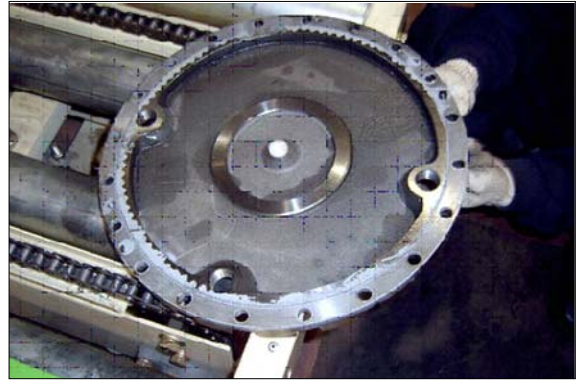

21078TM119

- (4) Fill gear oil(7.5liter) into drain port.
- (5) Apply gear oil on PF3/4 hydraulic plug(97) and then, bolt.



21078TM120

GROUP 7 RCV LEVER

1. REMOVAL AND INSTALL

1) REMOVAL

- (1) Lower the work equipment to the ground and stop the engine.
- (2) Operate the control levers and pedals several times to release the remaining pressure in the hydraulic piping.
- (3) Loosen the breather slowly to release the pressure inside the hydraulic tank.
- ▲ Escaping fluid under pressure can penetrate the skin causing serious injury.
- (4) Loosen the socket bolt(1).
- (5) Remove the cover of the console box.
- (6) Disconnect pilot line hoses(3).
- (7) Remove the pilot valve assembly(2).
- ※ When removing the pilot valve assembly, check that all the hoses have been disconnected.

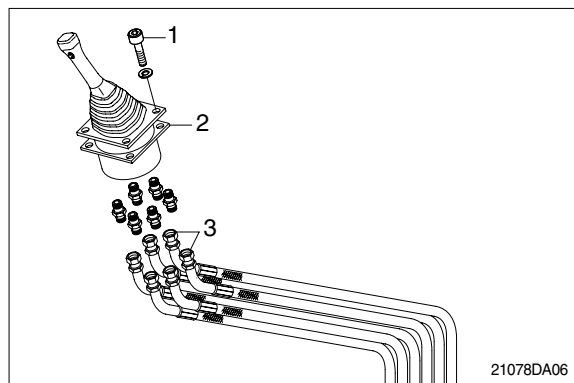

2) INSTALL

- (1) Carry out installation in the reverse order to removal.
- (2) Confirm the hydraulic oil level and check the hydraulic oil leak or not.

2. DISASSEMBLY AND ASSEMBLY

1) STRUCTURE

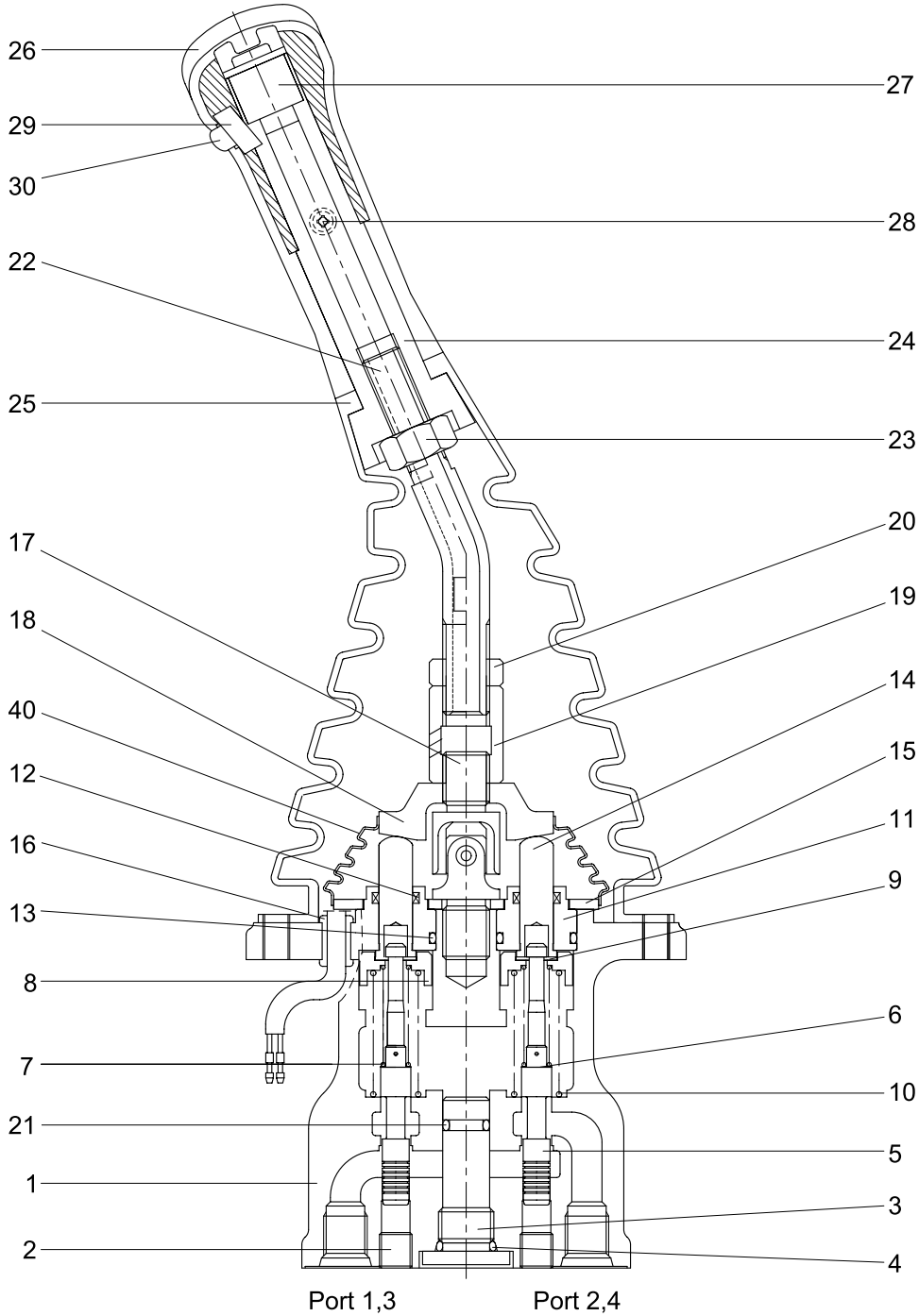

14072SF80

1	Case	11	Plug	21	O-ring
2	Plug	12	Rod seal	22	Handle connector
3	Plug	13	O-ring	23	Nut
4	O-ring	14	Push rod	24	Insert
5	Spool	15	Plate	25	Boot
6	Shim	16	Bushing	26	Handle
7	Spring	17	Joint assembly	27	Switch assembly
8	Spring seat	18	Swash plate	28	Screw
9	Stopper	19	Adjusting nut	29	Switch assembly
10	Spring	20	Lock nut	30	Switch cover
				40	Boot

2) TOOLS AND TIGHTENING TORQUE

(1) Tools

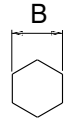
Tool name	Remark	
Allen wrench	6	
Spanner	22	
	27	
(+) Driver	Length 150	
(-) Driver	Width 4~5	
Torque wrench	Capable of tightening with the specified torques	

(2) Tightening torque

Part name	Item	Size	Torque	
			kgf · m	lbf · ft
Plug	2	PT 1/8	3.0	21.7
Joint	18	M14	3.5	25.3
Swash plate	19	M14	5.0±0.35	36.2±2.5
Adjusting nut	20	M14	5.0±0.35	36.2±2.5
Lock nut	21	M14	5.0±0.35	36.2±2.5
Screw	29	M 3	0.05	0.36

3) DISASSEMBLY

- (1) Clean pilot valve with kerosene.
 - ※ Put blind plugs into all ports
- (2) Fix pilot valve in a vise with copper(or lead) sheets.
- (3) Remove end of boot(25) from case(1) and take it out upwards.

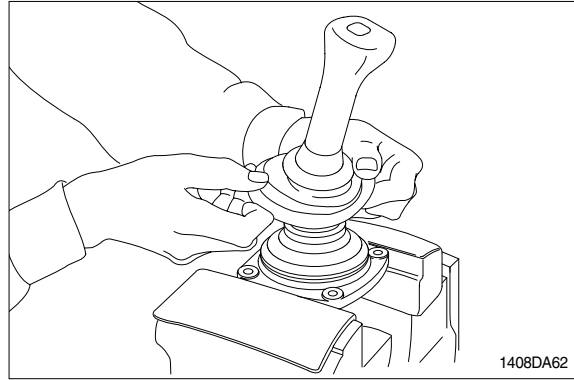

- ※ For valve with switch, remove cord also through hole of casing.

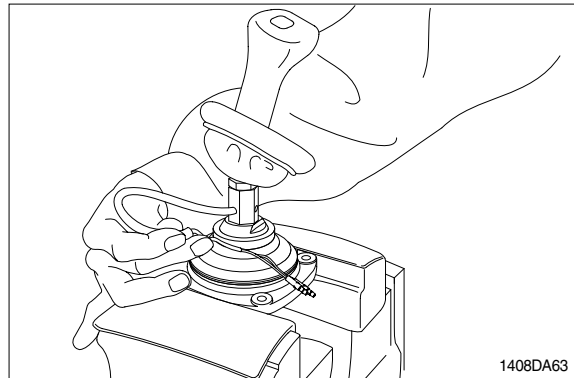

- (4) Loosen lock nut(20) and adjusting nut(19) with spanners on them respectively, and take out handle section as one body.

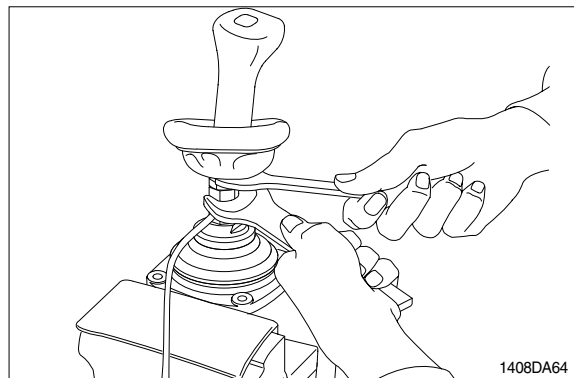

- (5) Remove the boot(40)

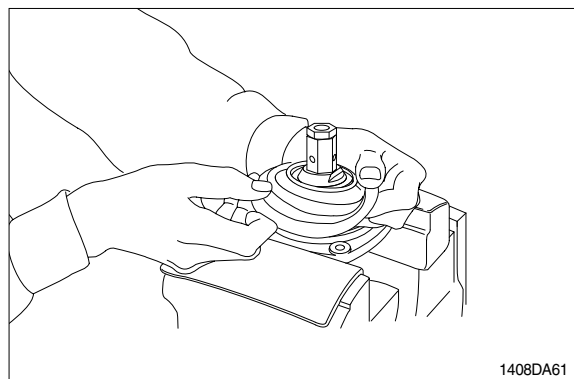

- (6) Loosen adjusting nut(19) and plate(18) with spanners on them respectively, and remove them.

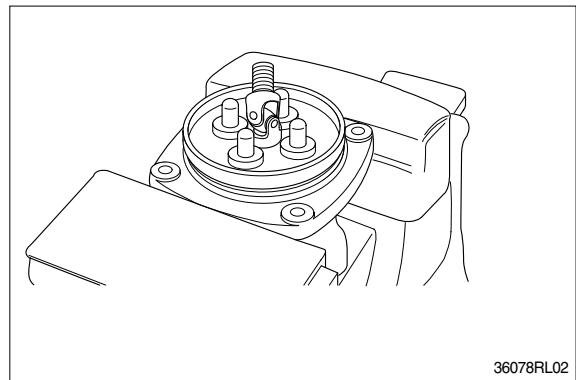
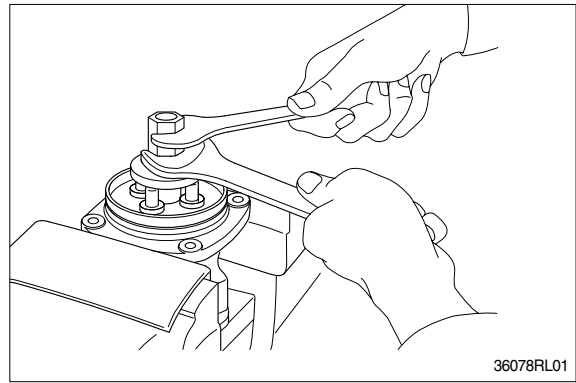

- (7) Turn joint anticlockwise to loosen it, utilizing jig(Special tool).

- ※ When return spring(10) is strong in force, plate(15), plug(11) and push rod(14) will come up on loosening joint. Pay attention to this.

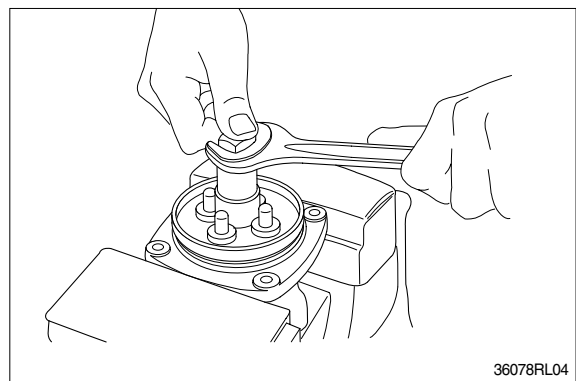
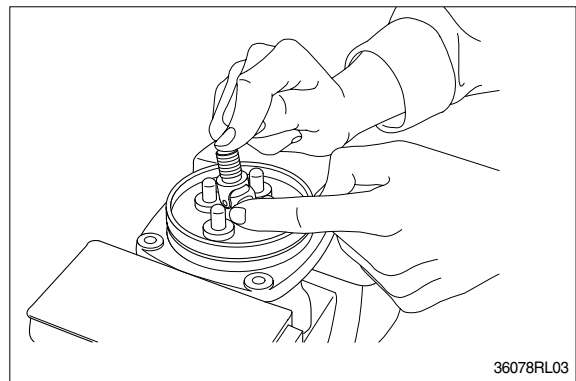

(8) Remove plate(15).

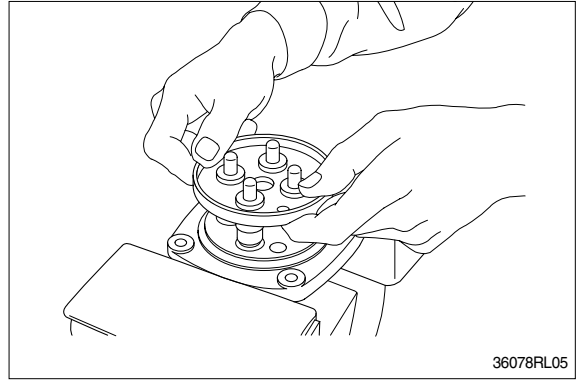

(9) When return spring(10) is weak in force, plug(11) stays in casing because of sliding resistance of O-ring.

- ※ Take it out with minus screwdriver.
Take it out, utilizing external periphery groove of plug and paying attention not to damage it by partial loading.
- ※ During taking out, plug may jump up due to return spring(10) force.
Pay attention to this.

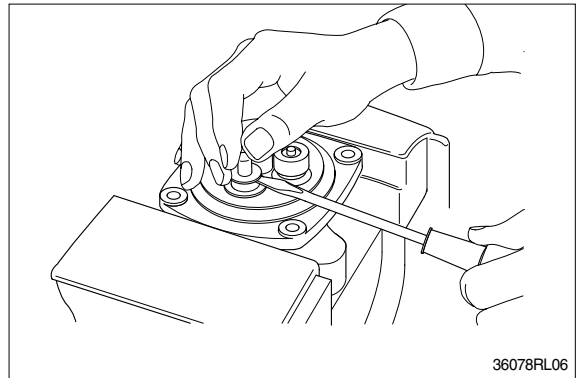

(10) Remove reducing valve subassembly and return spring(10) out of casing.

- ※ Record relative position of reducing valve subassembly and return springs.

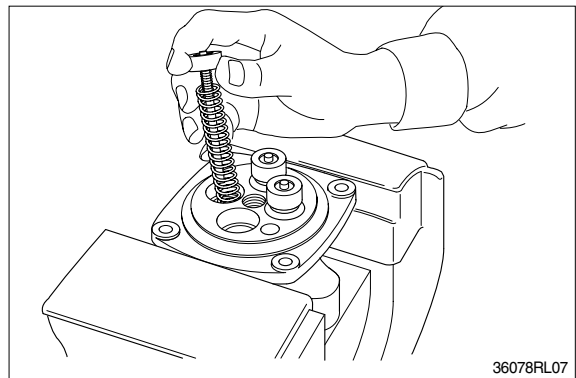

(11) Loosen hexagon socket head plug(2) with hexagon socket screw key.

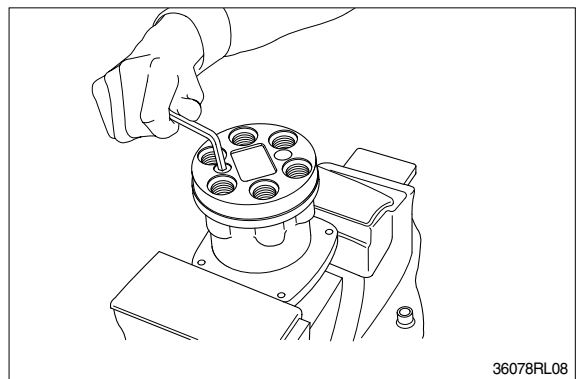

(12) For disassembling reducing valve section, stand it vertically with spool(5) bottom placed on flat workbench. Push down spring seat(8) and remove two pieces of semicircular stopper(9) with tip of small minus screwdriver.

- ※ Pay attention not to damage spool surface.
- ※ Record original position of spring seat(8, 31).
- ※ Do not push down spring seat more than 6mm.

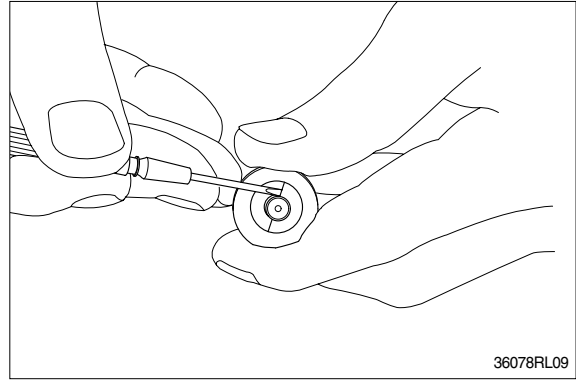

(13) Separate spool(5), spring seat(8), spring(7) and shim(6) individually.

- ※ Until being assembled, they should be handled as one subassembly group.

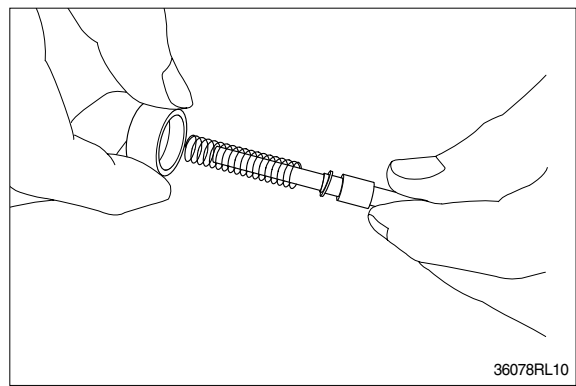

(14) Take push rod(14) out of plug(11).

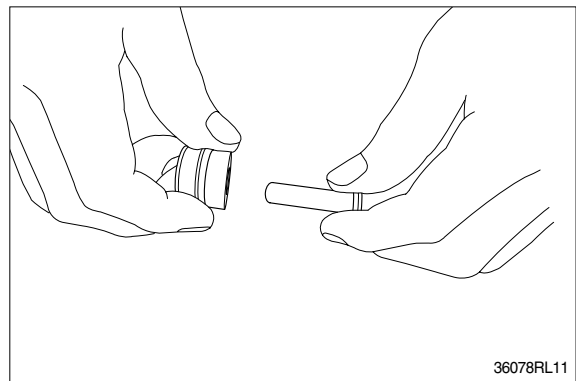

(15) Remove O-ring(13) and seal(12) from plug(11).

Use small minus screwdriver or so on to remove this seal.

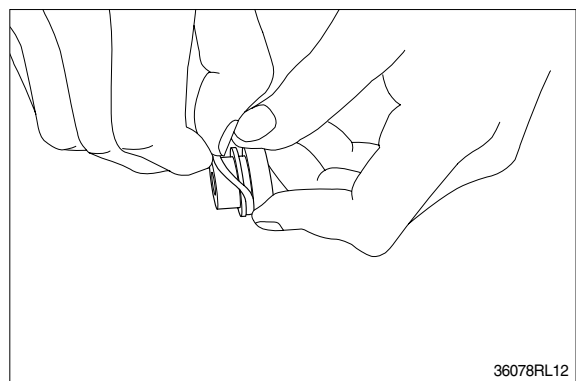

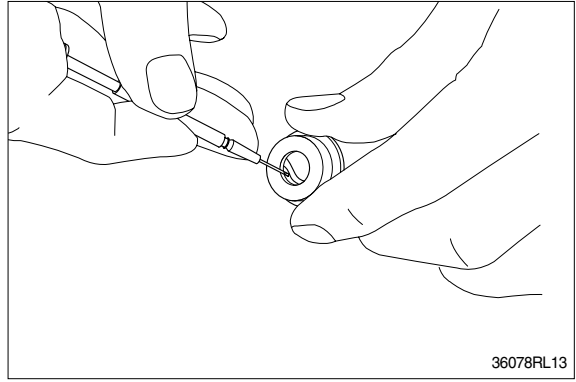

(16) Remove lock nut(20) and then boot(25).

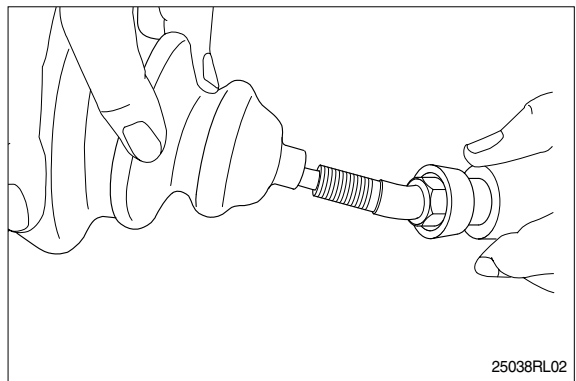
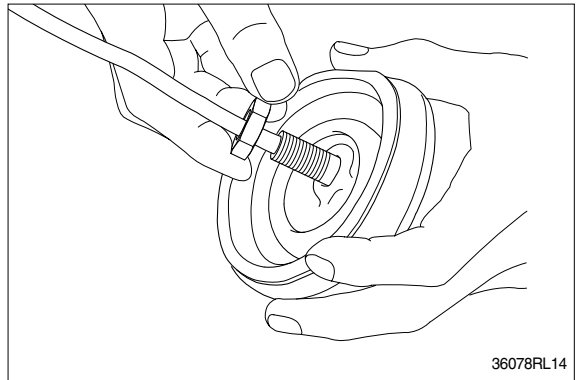

(17) Cleaning of parts

- ① Put all parts in rough cleaning vessel filled with kerosene and clean them (Rough cleaning).
 - ※ If dirty part is cleaned with kerosene just after putting it in vessel, it may be damaged. Leave it in kerosene for a while to loosen dust and dirty oil.
 - ※ If this kerosene is polluted, parts will be damaged and functions of reassembled valve will be degraded.
Therefore, control cleanliness of kerosene fully.
- ② Put parts in final cleaning vessel filled with kerosene, turning it slowly to clean them even to their insides (Finish cleaning).
 - ※ Do not dry parts with compressed air, since they will be damaged and/or rusted by dust and moisture in air.

(18) Rust prevention of parts.

- Apply rust-preventives to all parts.
- ※ If left as they are after being cleaned, they will be rusted and will not display their functions fully after being reassembled.

4) ASSEMBLY

(1) Tighten hexagon socket head plug(2) to the specified torque.

※ Tighten two bolts alternately and slowly.

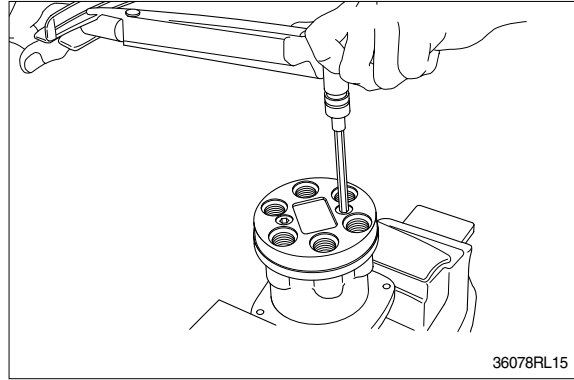

(2) Put shim(6), springs(7) and spring seat(8) onto spool(5) in this order.

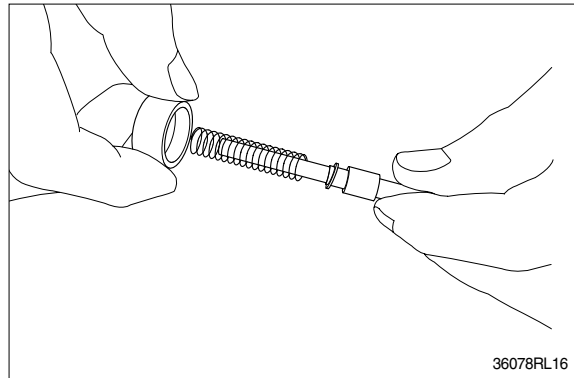

(3) Stand spool vertically with its bottom placed on flat workbench, and with spring seat pushed down, put two pieces of semicircular stopper(9) on spring seat without piling them on.

※ Assemble stopper(9) so that its sharp edge side will be caught by head of spool. Do not push down spring seat more than 6mm.

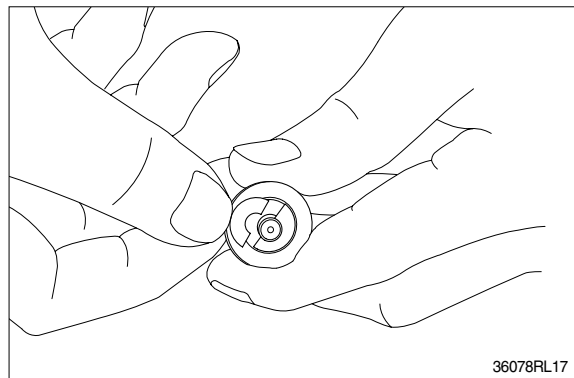

(4) Assemble spring(10) into casing(1).
Assemble reducing valve subassembly into casing.

※ Assemble them to their original positions.

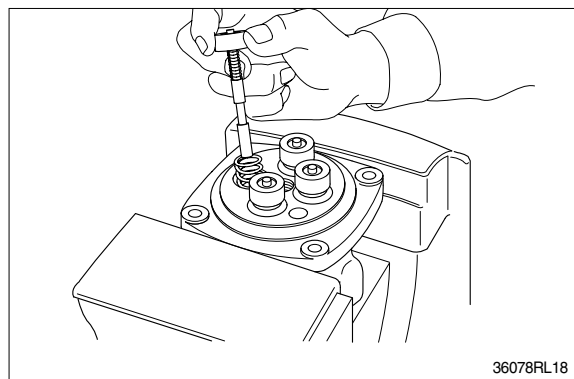

(5) Assemble O-ring(13) onto plug(11).

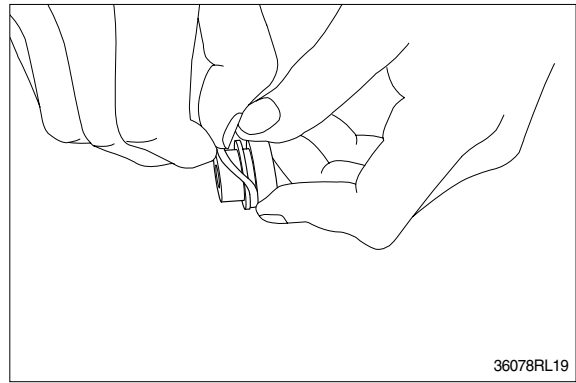

(6) Assemble seal(12) to plug(11).

※ Assemble seal in such lip direction as shown below.

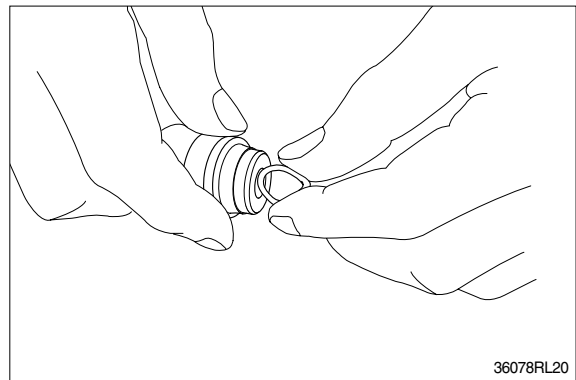

(7) Assemble push rod(14) to plug(11).

※ Apply working oil on push-rod surface.

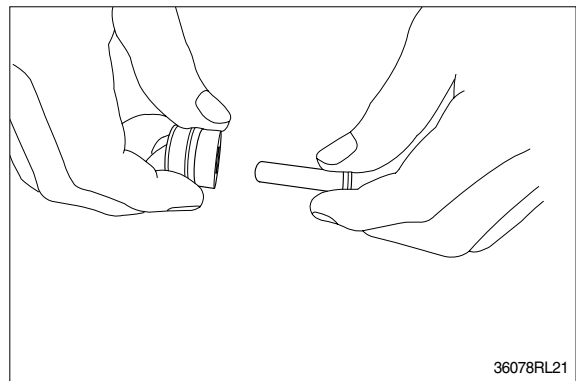

(8) Assemble plug subassembly to casing.

※ When return spring is weak in force, subassembly stops due to resistance of O-ring.

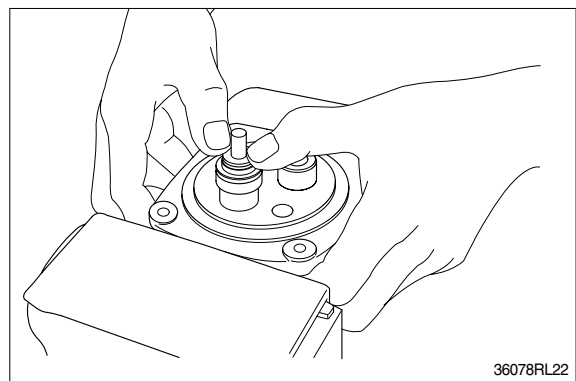

- (9) When return spring is strong in force, assemble 4 sets at the same time, utilizing plate(15), and tighten joint(17) temporarily.

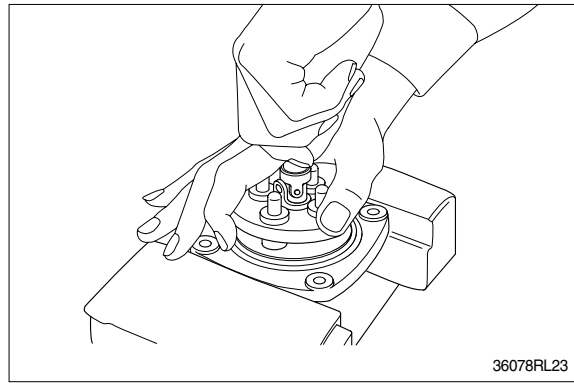

- (10) Fit plate(15).

- (11) Tighten joint(17) with the specified torque to casing, utilizing jig.

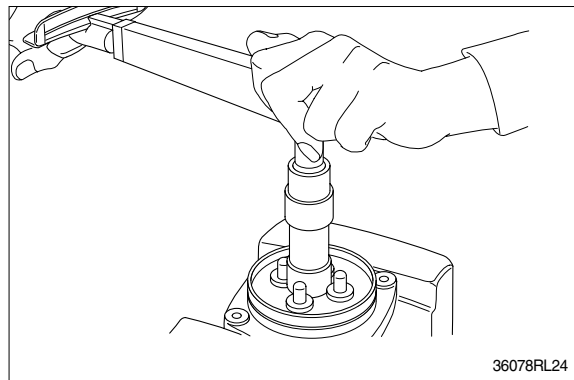

- (12) Assemble swash plate(18) to joint(17).

- ※ Screw it to position that it contacts with 4 push rods evenly.
- ※ Do not screw it over.

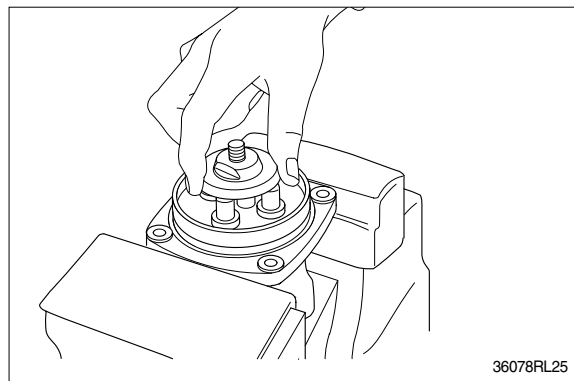

- (13) Assemble adjusting nut(19), apply spanner to width across flat of plate(18) to fix it, and tighten adjusting nut to the specified torque.

- ※ During tightening, do not change position of disk.

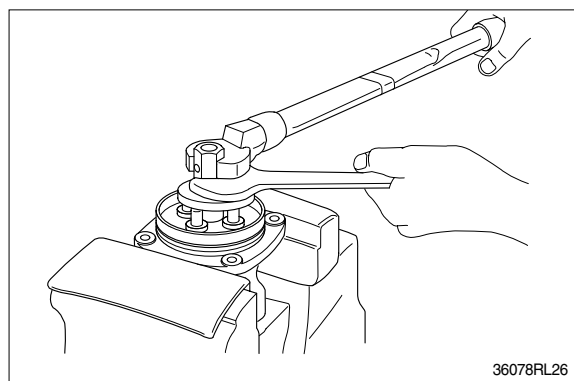

(14) Fit boot(40) to plate.

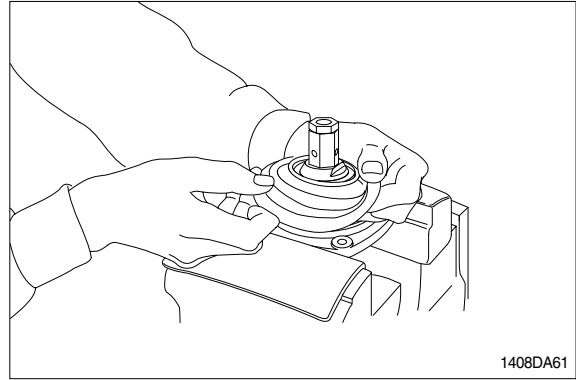

(15) Fit boot(25) and lock nut(20), and handle subassembly is assembled completely.

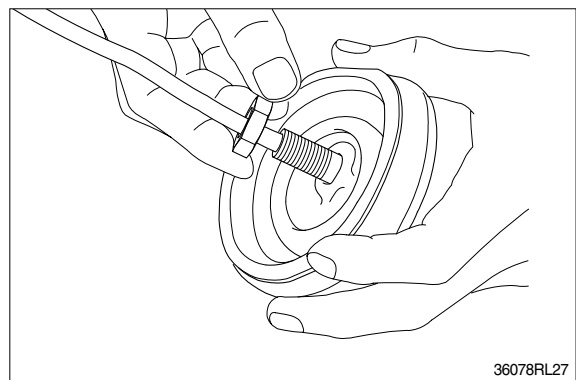
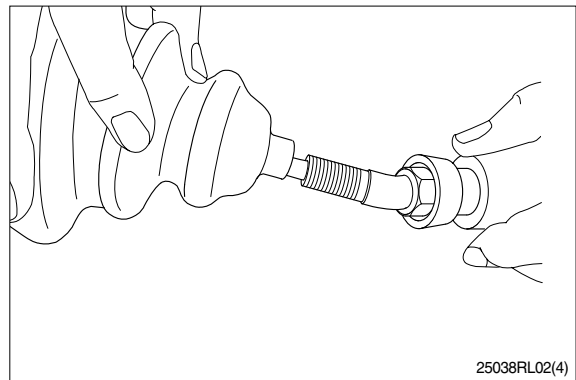

(16) Pull out cord and tube through adjusting nut hole provided in direction 60° to 120° from casing hole.

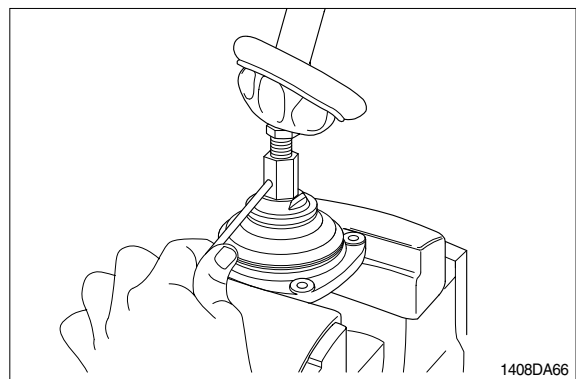

(17) Assemble bushing(16) to plate and pass cord and tube through it.

※ Provide margin necessary to operation.

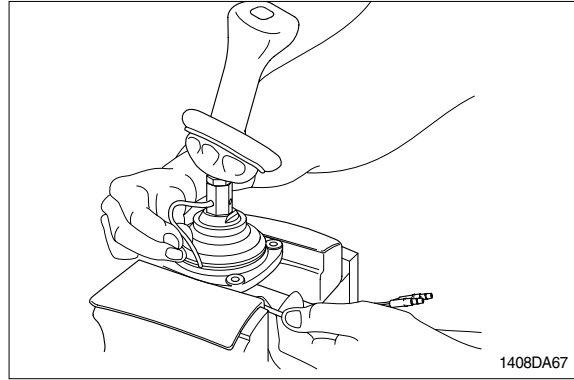

(18) Determine handle direction, tighten lock nut(20) to specified torque to fix handle.

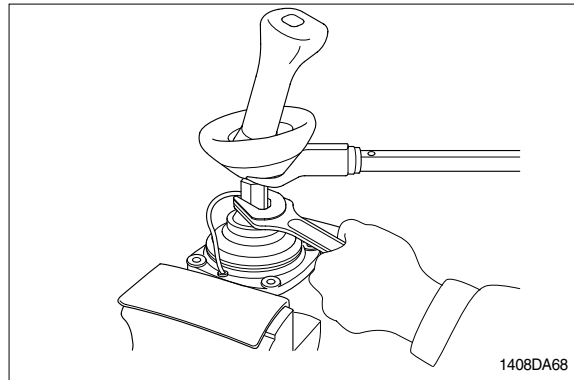

(19) Apply grease to rotating section of joint and contacting faces of disk and push rod.

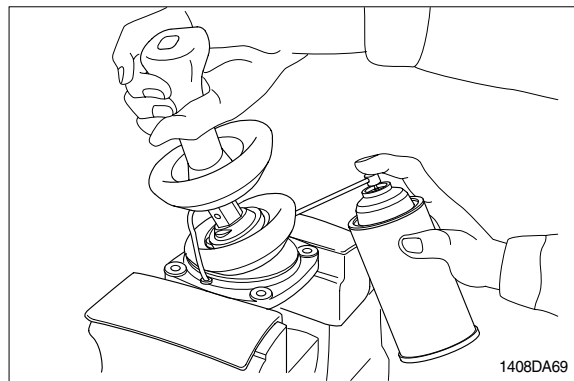

(20) Assemble lower end of bellows to casing.

(21) Inject volatile rust-preventives through all ports and then put blind plugs in ports.

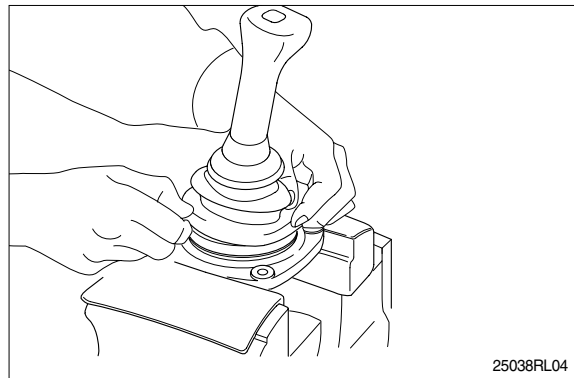

GROUP 8 TURNING JOINT

1. REMOVAL AND INSTALL

1) REMOVAL

- (1) Lower the work equipment to the ground and stop the engine.
- (2) Operate the control levers and pedals several times to release the remaining pressure in the hydraulic piping.
- (3) Loosen the breather slowly to release the pressure inside the hydraulic tank.
- ▲ Escaping fluid under pressure can penetrate the skin causing serious injury.
- ※ When pipes and hoses are disconnected, the oil inside the piping will flow out, so catch it in oil pan.
- (4) Disconnect all hoses.
- (5) Sling the turning joint assembly (1) and remove the mounting bolt(2).
 - Weight : 54kg(119lb)
 - Tightening torque : $12.3 \pm 1.3\text{kgf} \cdot \text{m}$
($88.9 \pm 9.4\text{lb} \cdot \text{ft}$)
- (6) Remove the turning joint assembly.
 - ※ When removing the turning joint, check that all the hoses have been disconnected.

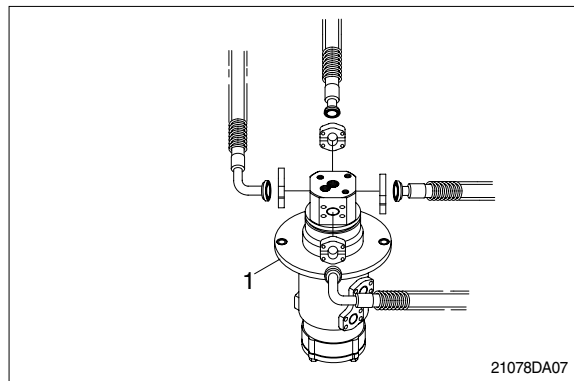

2) INSTALL

- (1) Carry out installation in the reverse order to removal.
 - ※ Take care of turning joint direction.
 - ※ Assemble hoses to their original positions.
 - ※ Confirm the hydraulic oil level and check the hydraulic oil leak or not.

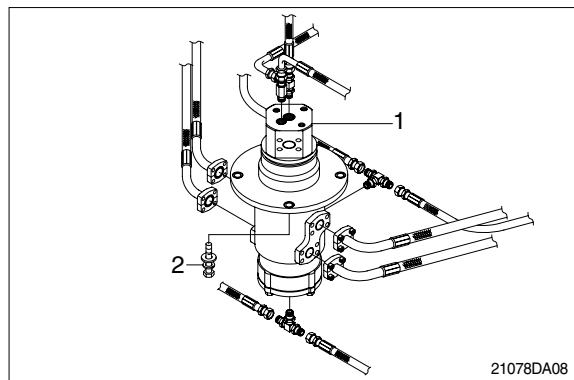

2. DISASSEMBLY AND ASSEMBLY

1) STRUCTURE

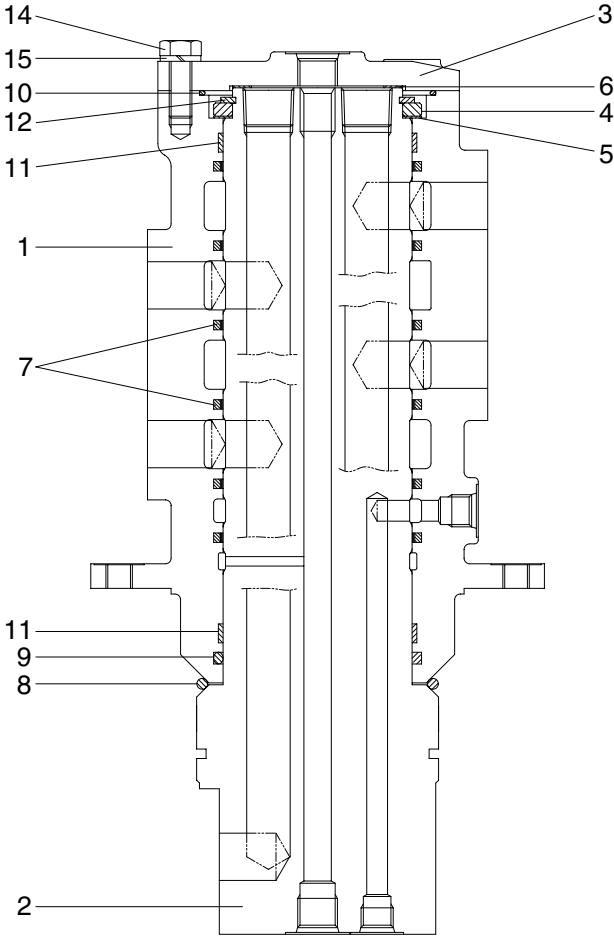

21078DA09

- | | | | | | |
|---|--------|----|--------------|----|---------------|
| 1 | Hub | 6 | Shim | 11 | Wear ring |
| 2 | Shaft | 7 | Slipper seal | 12 | Retainer ring |
| 3 | Cover | 8 | O-ring | 13 | Plug |
| 4 | Spacer | 9 | O-ring | 14 | Hexagon bolt |
| 5 | Shim | 10 | O-ring | 15 | Spring washer |

2) DISASSEMBLY

※ Before the disassembly, clean the turning joint.

(1) Remove bolts(14), washer(15) and cover(3).

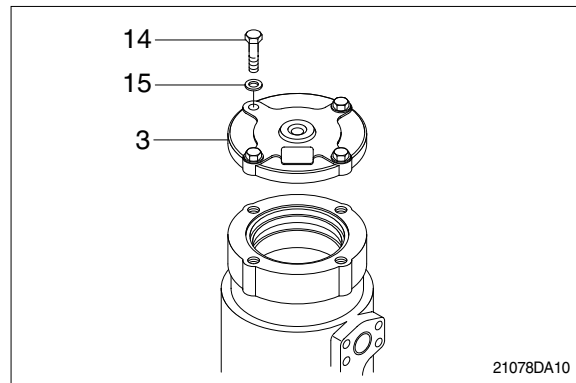

(2) Remove shim(6) and O-ring(10).

(3) Remove retainer ring(12), spacer(4) and shim(5).

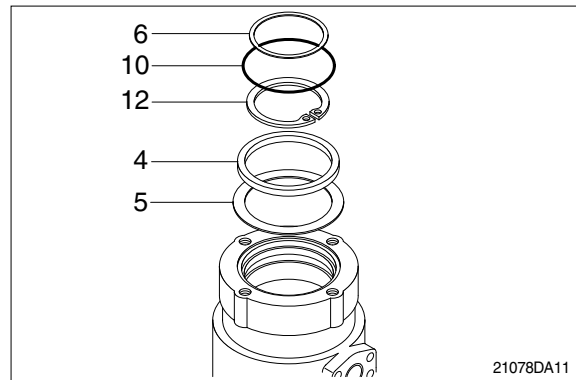

(4) Place hub(1) on a V-block and by using a wood buffer at the shaft end, hit out shaft(2) to about 1/2 from the body with a hammer.

※ Take care not to damage the shaft(2) when remove hub(1) or rest it sideways.

※ Put a fitting mark on hub(1) and shaft(2).

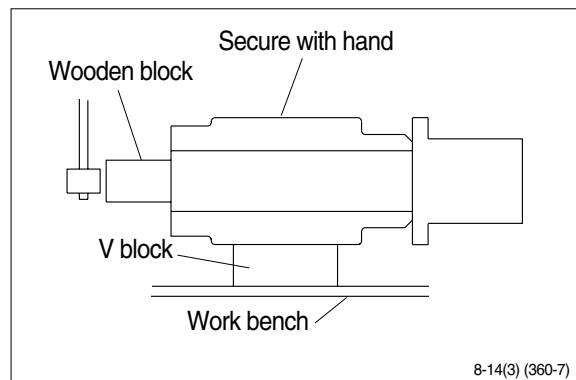

(5) Remove six slipper seals(7) and O-ring(9), two ring wear(11) from hub(1).

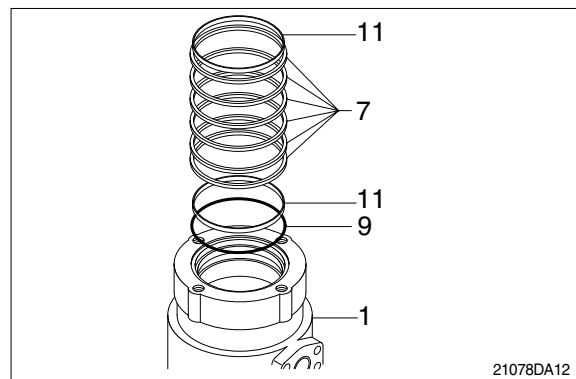

3) ASSEMBLY

- ※ Clean all parts.
- ※ As a general rule, replace oil seals and O-ring.
- ※ Coat the sliding surfaces of all parts with engine oil or grease before installing.

- (1) Fix seven slipper seal(7) and O-ring(9), two ring wear(11) to hub(1).
- (2) Fit O-ring(8) to shaft(2).

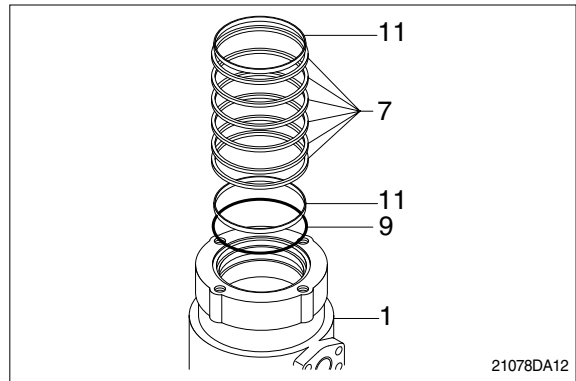

- (3) Set shaft(2) on block, tap hub(1) with a plastic hammer to install.

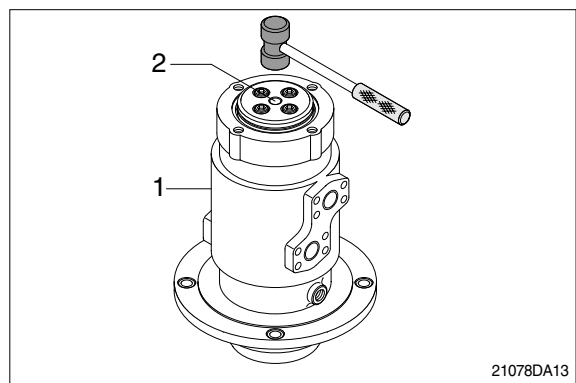

- (4) Fit shim(5), spacer(4) and retainer ring (12) to shaft(2).
- (5) Fit O-ring(10) to hub(1).
- (6) Fit shim(6) to shaft(2).

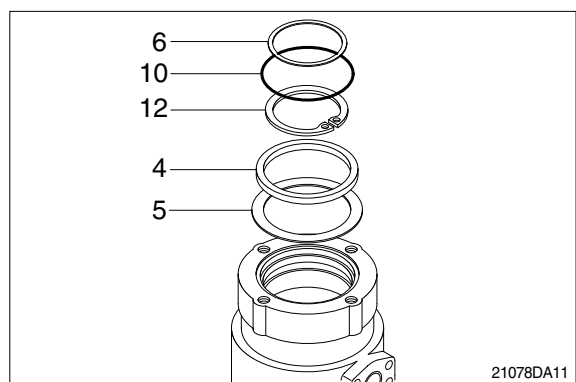

- (7) Install cover(3) to body(1) and tighten bolts(14).
· Torque : 10~12.5kgf · m(72.3~90.4lbf · ft)

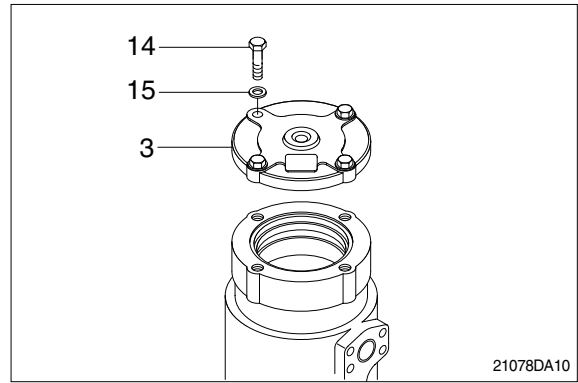

GROUP 9 BOOM, ARM AND BUCKET CYLINDER

1. REMOVAL AND INSTALL

1) BUCKET CYLINDER

(1) Removal

- ※ Expand the arm and bucket fully, lower the work equipment to the ground and stop the engine.
 - ※ Operate the control levers and pedals several times to release the remaining pressure in the hydraulic piping.
 - ▲ Loosen the breather slowly to release the pressure inside the hydraulic tank.
 - ※ Escaping fluid under pressure can penetrate the skin causing serious injury. Fit blind plugs in the hoses after disconnecting them, to prevent dirt or dust from entering.
- ① Set block between bucket cylinder and arm.

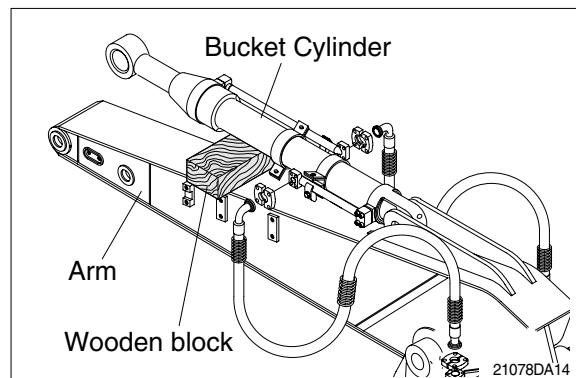

- ② Remove bolt(2), nut(3) and pull out pin (1).
- ※ Tie the rod with wire to prevent it from coming out.

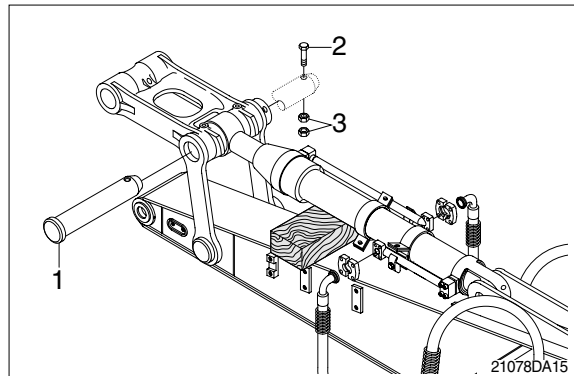

- ③ Disconnect bucket cylinder hoses(4) and put plugs(5) on cylinder pipe.

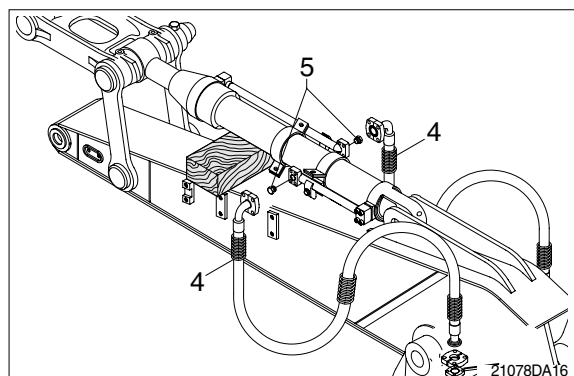

- ④ Sling bucket cylinder assembly(8) and remove bolt(6) then pull out pin (5).
- ⑤ Remove bucket cylinder assembly(8).
 - Weight : 174kg(384lb)

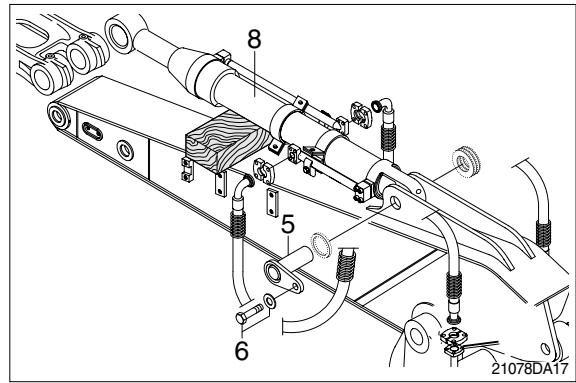

(2) Install

- ① Carry out installation in the reverse order to removal.
- ▲ When aligning the mounting position of the pin, do not insert your fingers in the pin hole.
 - ※ Bleed the air from the bucket cylinder.
 - ※ Confirm the hydraulic oil level and check the hydraulic oil leak or not.

2) ARM CYLINDER

(1) Removal

- ※ Expand the arm and bucket fully, lower the work equipment to the ground and stop the engine.
 - ※ Operate the control levers and pedals several times to release the remaining pressure in the hydraulic piping.
 - ▲ Loosen the breather slowly to release the pressure inside the hydraulic tank.
 - ※ Escaping fluid under pressure can penetrate the skin causing serious injury. Fit blind plugs in the hoses after disconnecting them, to prevent dirt or dust from entering.
- ① Set block between arm cylinder and boom.

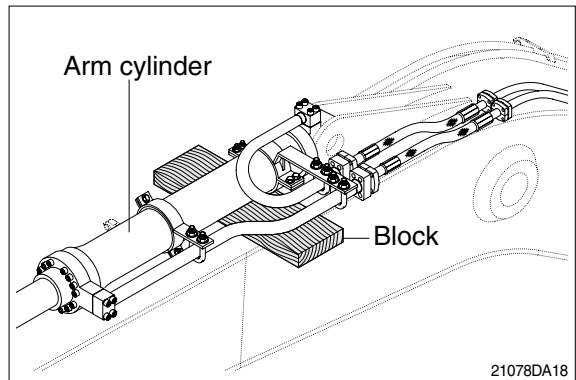

- ② Remove bolt(2) and pull out pin(1).
- ※ Tie the rod with wire to prevent it from coming out.

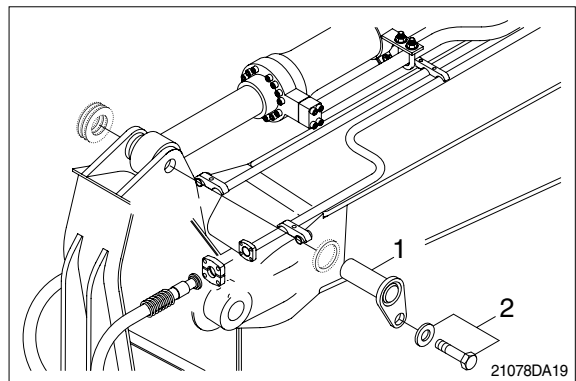

- ③ Disconnect arm cylinder hoses(4) and put plugs on cylinder pipe.
- ④ Disconnect greasing pipings(5).

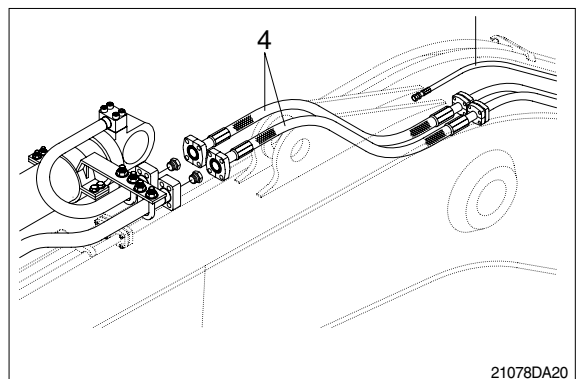

- ⑤ Sling arm assembly(8) and remove bolt (7) then pull out pin(6).
- ⑥ Remove arm cylinder assembly(8).
 - Weight : 288kg(635lb)

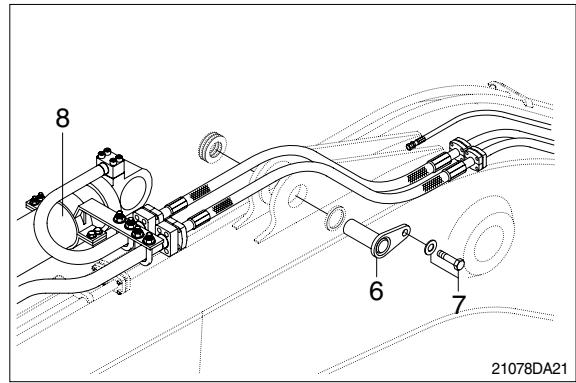

(2) Install

- ① Carry out installation in the reverse order to removal.
- ⚠ When aligning the mounting position of the pin, do not insert your fingers in the pin hole.
 - ※ Bleed the air from the arm cylinder.
 - ※ Confirm the hydraulic oil level and check the hydraulic oil leak or not.

3) BOOM CYLINDER

(1) Removal

- ※ Expand the arm and bucket fully, lower the work equipment to the ground and stop the engine.
- ※ Operate the control levers and pedals several times to release the remaining pressure in the hydraulic piping.
- ▲ Loosen the breather slowly to release the pressure inside the hydraulic tank.
- ※ Escaping fluid under pressure can penetrate the skin causing serious injury. Fit blind plugs in the hoses after disconnecting them, to prevent dirt or dust from entering.

- ① Disconnect greasing hoses(1).
- ② Sling boom cylinder assembly.

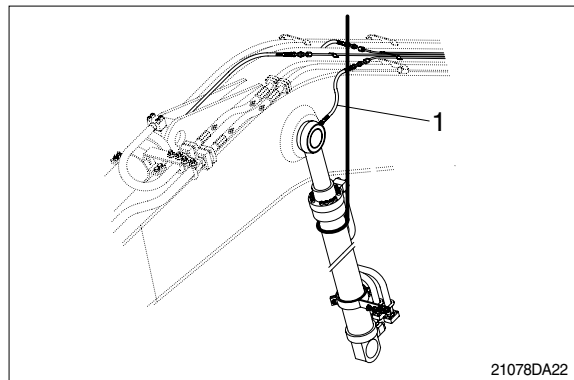

- ③ Remove bolt(4), stop plate(5) and pull out pin(2).
- ※ Tie the rod with wire to prevent it from coming out.

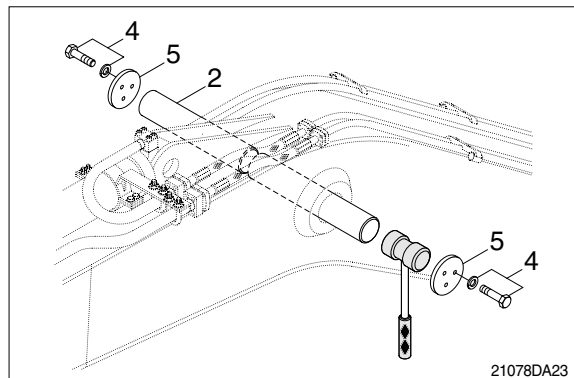

- ④ Lower the boom cylinder assembly(6) on a stand.

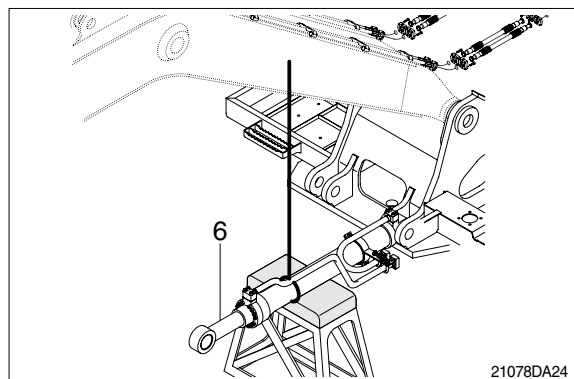

- ⑤ Disconnect boom cylinder hoses(7) and put plugs on cylinder pipe.

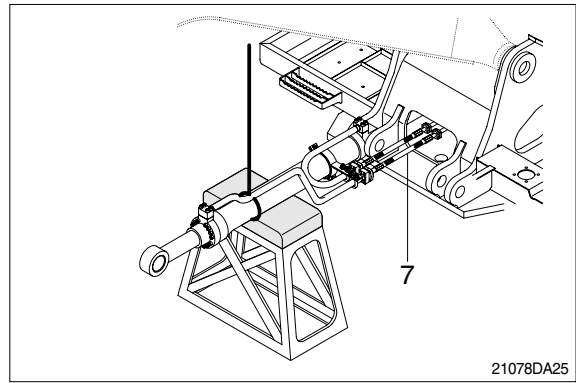

- ⑥ Remove bolt(9) and pull out pin(8).
⑦ Remove boom cylinder assembly(6).
· Weight : 182kg(386lb)

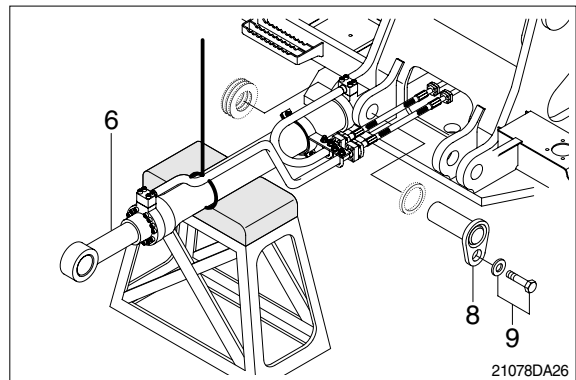

(2) Install

- ① Carry out installation in the reverse order to removal.
- ⚠ When aligning the mounting position of the pin, do not insert your fingers in the pin hole.
- ※ Bleed the air from the boom cylinder.
 - ※ Confirmed the hydraulic oil level and check the hydraulic oil leak or not.

2. DISASSEMBLY AND ASSEMBLY

1) STRUCTURE

(1) Bucket cylinder

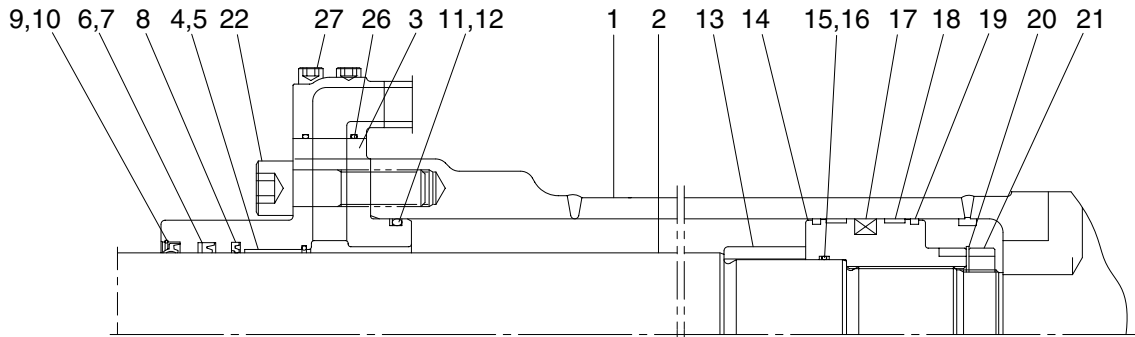

Internal detail

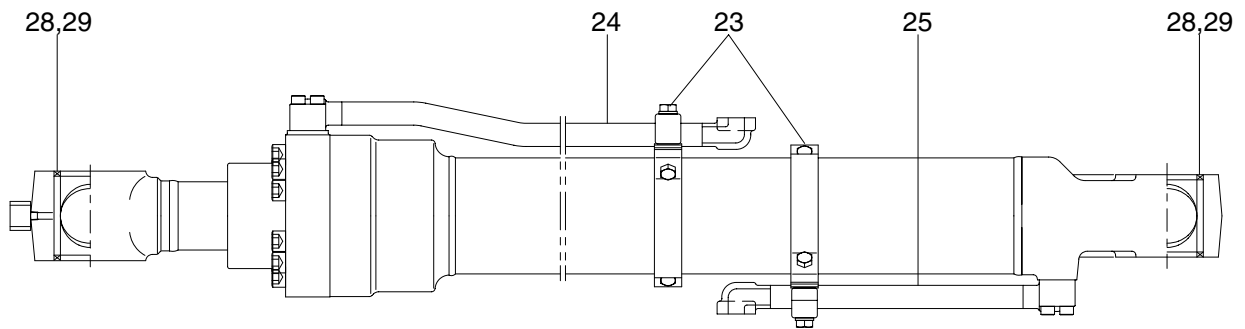

21078DA27

1	Tube assembly	11	O-ring	21	Lock nut
2	Rod assembly	12	Back up ring	22	Hexagon socket head bolt
3	Gland	13	Cushion ring	23	Band assembly
4	DD2 bushing	14	Piston	24	Pipe assembly(R)
5	Snap ring	15	O-ring	25	Pipe assembly(B)
6	Rod seal	16	Back up ring	26	O-ring
7	Back up ring	17	Piston seal	27	Hexagon socket head bolt
8	Buffer ring	18	Wear ring	28	Pin bushing
9	Dust wiper	19	Dust ring	29	Dust seal
10	Snap ring	20	Lock washer		

(2) Arm cylinder

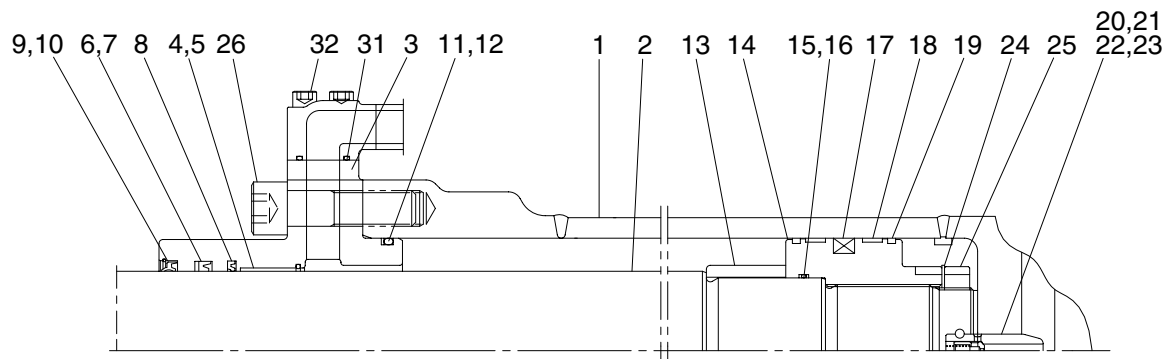

Internal detail

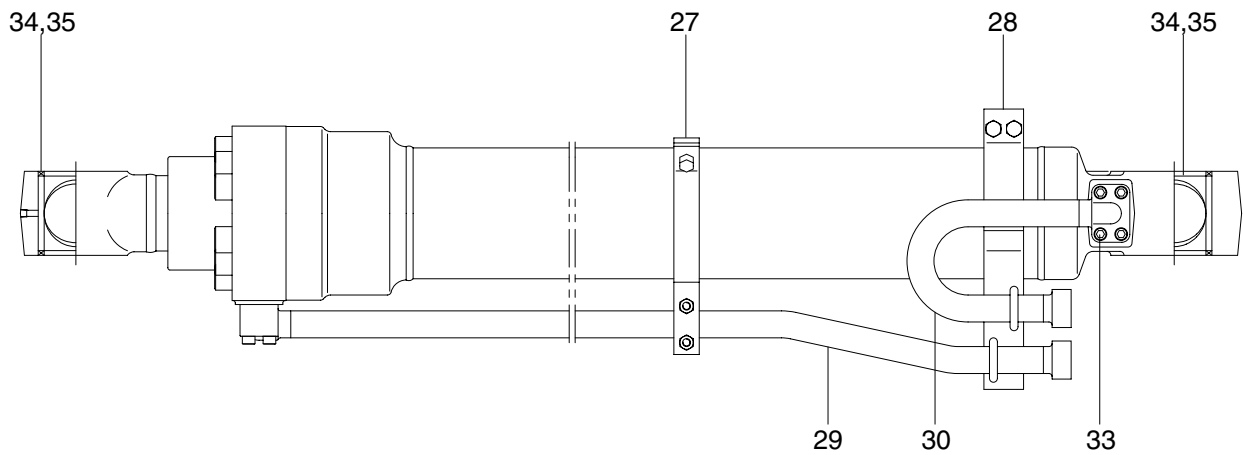

21078DA28

1	Tube assembly	13	Cushion ring	25	Lock nut
2	Rod assembly	14	Piston	26	Hexagon socket head bolt
3	Gland	15	O-ring	27	Band assembly(R)
4	DD2 bushing	16	Back up ring	28	Band assembly(B)
5	O-ring	17	Piston seal	29	Pipe assembly(R)
6	rod seal	18	Wear ring	30	Pipe assembly(B)
7	Back up ring	19	Dust ring	31	O-ring
8	Buffer ring	20	Cushion spear	32	Hexagon socket head bolt
9	Dust wiper	21	Check valve	33	Hexagon socket head bolt
10	Snap ring	22	Coil spring	34	Pin bushing
11	O-ring	23	Stop ring	35	Dust seal
12	Back up ring	24	Lock washer		

(3) Boom cylinder

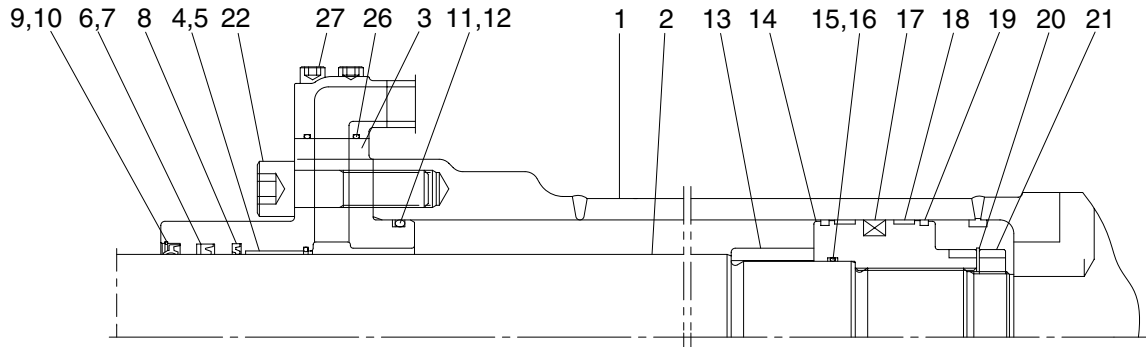

Internal detail

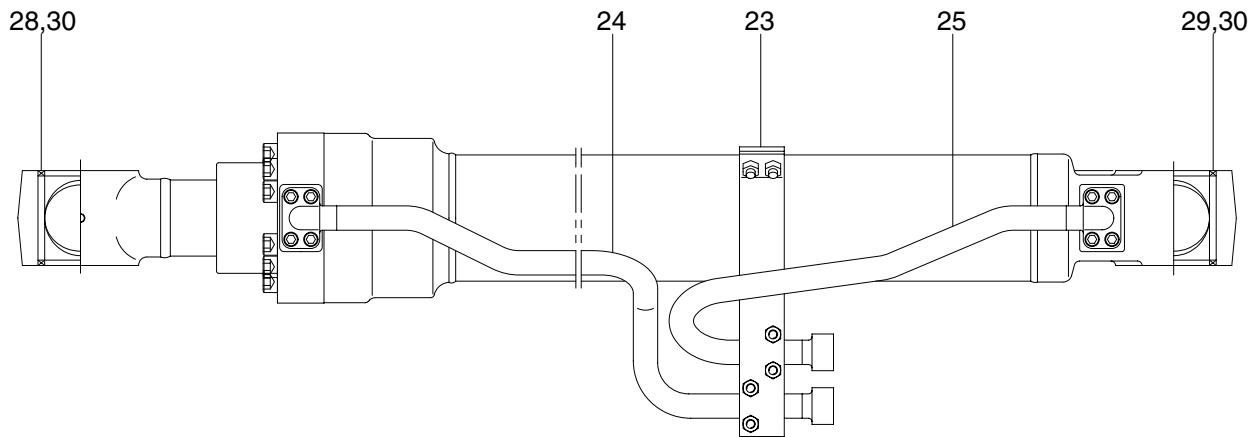

21078DA29

- | | | | | | |
|----|---------------|----|--------------|----|--------------------------|
| 1 | Tube assembly | 11 | O-ring | 21 | Lock nut |
| 2 | Rod assembly | 12 | Back up ring | 22 | Hexagon socket head bolt |
| 3 | Gland | 13 | Cushion ring | 23 | Band assembly |
| 4 | DD2 bushing | 14 | Piston | 24 | Pipe assembly(R) |
| 5 | Snap ring | 15 | O-ring | 25 | Pipe assembly(B) |
| 6 | Rod seal | 16 | Back up ring | 26 | O-ring |
| 7 | Back up ring | 17 | Piston seal | 27 | Hexagon socket head bolt |
| 8 | Buffer ring | 18 | Wear ring | 28 | Pin bushing |
| 9 | Dust wiper | 19 | Dust ring | 29 | Pin bushing |
| 10 | Snap ring | 20 | Lock washer | 30 | Dust seal |

2) TOOLS AND TIGHTENING TORQUE

(1) Tools

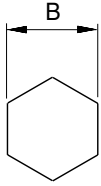
Tool name	Remark		
Allen wrench	6		
	8		
	14		
	17		
Spanner	7		
	8		
(-) Driver	Small and large sizes		
Torque wrench	Capable of tightening with the specified torques		

(2) Tightening torque

Part name		Item	Size	Torque	
				kgf · m	lbf · ft
Socket head bolt	Bucket cylinder	22	M16	23.0±2.0	166± 14.5
	Boom cylinder	22	M16	23.0±2.0	166± 14.5
	Arm cylinder	26	M18	32.0±3.0	232± 21.7
Socket head bolt	Bucket cylinder	27	M10	5.4±0.5	39.1± 3.6
	Boom cylinder	27	M10	5.4±0.5	39.1± 3.6
	Arm cylinder	32	M12	9.4±1.0	68.0± 7.2
		33	M10	5.4±0.5	39.1± 3.6
Lock nut	Bucket cylinder	21	M60	100±10.0	723± 72.3
	Boom cylinder	21	M60	100±10.0	723± 72.3
	Arm cylinder	25	M70	100±10.0	723± 72.3
Piston	Bucket cylinder	14	-	150±15.0	1085± 109
	Boom cylinder	14	-	150±15.0	1085± 109
	Arm cylinder	14	-	150±15.0	1085± 109

3) DISASSEMBLY

(1) Remove cylinder head and piston rod

- ① Hold the clevis section of the tube in a vise.
 - ※ Use mouth pieces so as not to damage the machined surface of the cylinder tube. Do not make use of the outside piping as a locking means.

- ② Pull out rod assembly(2) about 200mm (7.1in). Because the rod assembly is rather heavy, finish extending it with air pressure after the oil draining operation.

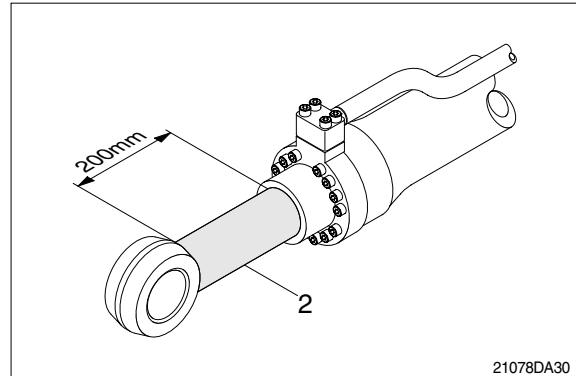

- ③ Loosen and remove socket bolts(22) of the gland in sequence.
 - ※ Cover the extracted rod assembly(2) with rag to prevent it from being accidentally damaged during operation.

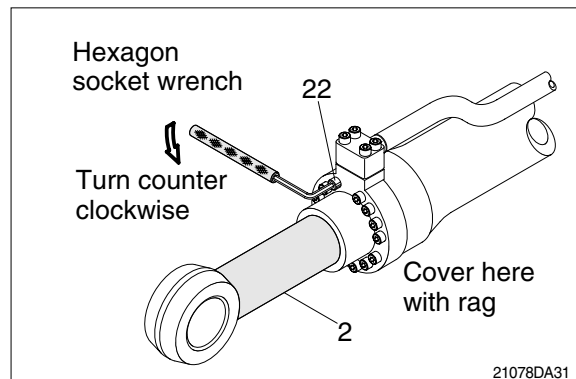

- ④ Draw out cylinder head and rod assembly together from tube assembly(1).
 - ※ Since the rod assembly is heavy in this case, lift the tip of the rod assembly(2) with a crane or some means and draw it out. However, when rod assembly(2) has been drawn out to approximately two thirds of its length, lift it in its center to draw it completely.

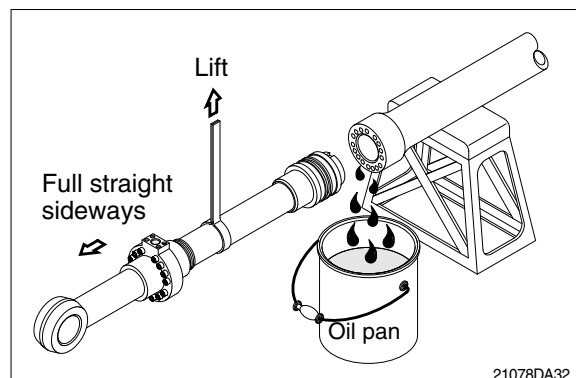

Note that the plated surface of rod assembly(2) is to be lifted. For this reason, do not use a wire sling and others that may damage it, but use a strong cloth belt or a rope.

- ⑤ Place the removed rod assembly on a wooden V-block that is set level.
- ※ Cover a V-block with soft rag.

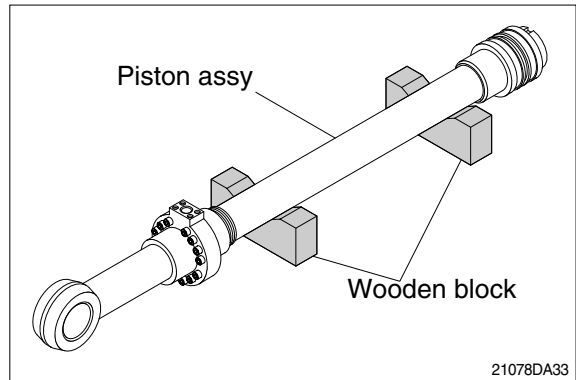

(2) Remove piston and cylinder head

- ① Remove lock nut(21).
- ※ Since lock nut(21) and lock washer(22) is tightened to a high torque, use a hydraulic and power wrench that utilizes a hydraulic cylinder, to remove the lock nut(21) and lock washer (22).
- ② Remove piston assembly(14), back up ring(16), and O-ring(15).

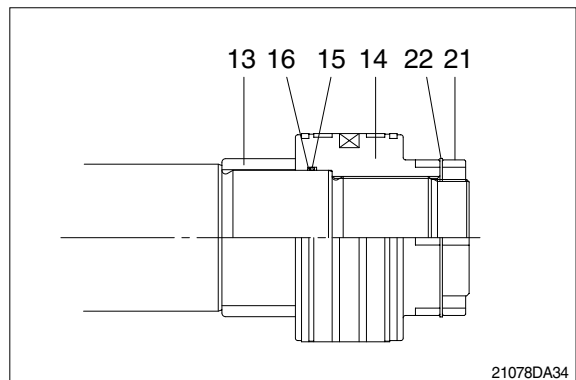

- ③ Remove the cylinder head assembly from rod assembly(2).
 - ※ If it is too heavy to move, move it by striking the flanged part of cylinder head with a plastic hammer.
 - ※ Pull it straight with cylinder head assembly lifted with a crane.
- Exercise care so as not to damage the lip of rod bushing(4) and packing (5,6,7,8,9,10) by the threads of rod assembly(2).

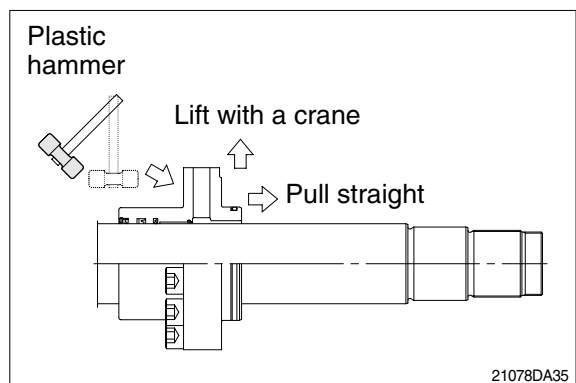

(3) Disassemble the piston assembly

- ① Remove wear ring(18).
 - ② Remove dust ring(19) and piston seal (17).
- ※ Exercise care in this operation not to damage the grooves.

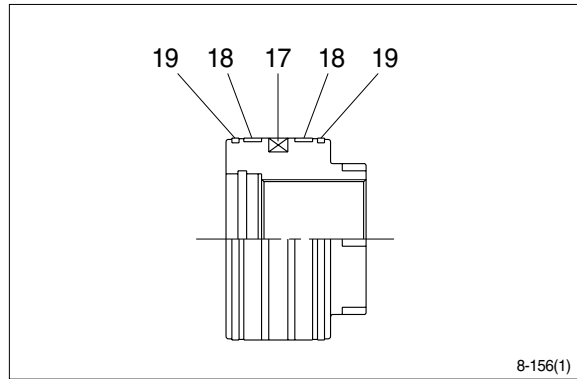

(4) Disassemble cylinder head assembly

- ① Remove back up ring(12) and O-ring (11).
 - ② Remove snap ring(10), dust wiper(9).
 - ③ Remove back up ring(7), rod seal(6) and buffer ring(8).
- ※ Exercise care in this operation not to damage the grooves.
- ※ Do not remove seal and ring, if does not damaged.

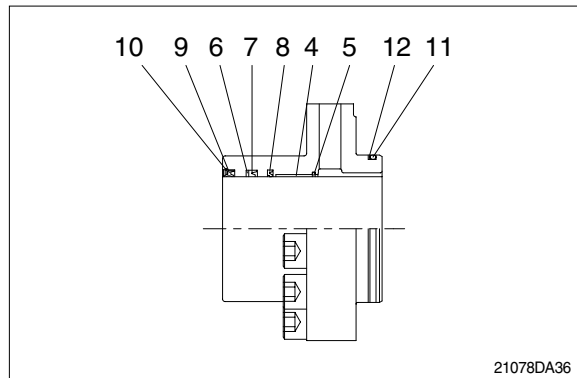

3) ASSEMBLY

(1) Assemble cylinder head assembly

※ Check for scratches or rough surfaces if found smooth with an oil stone.

- ① Coat the inner face of gland(3) with hydraulic oil.

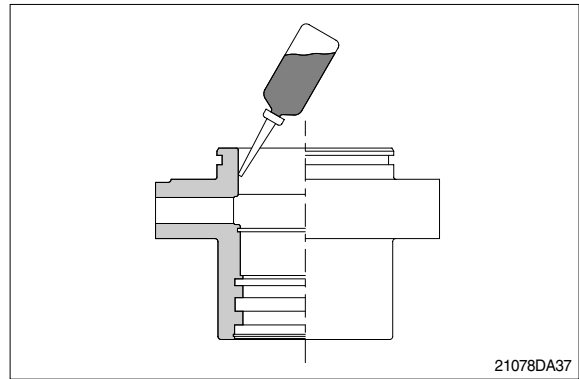

- ② Coat dust wiper(9) with grease and fit dust wiper(9) to the bottom of the hole of dust seal.

At this time, press a pad metal to the metal ring of dust seal.

- ③ Fit snap ring(10) to the stop face.

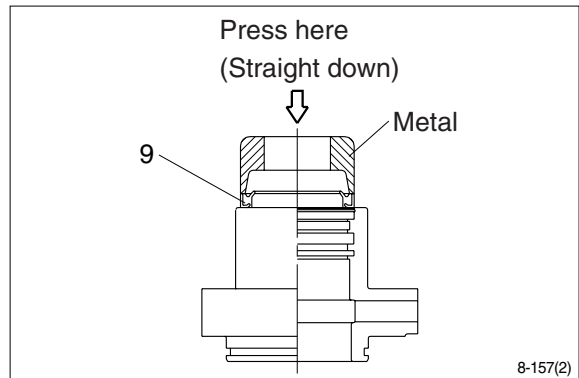

- ④ Fit back up ring(7), rod seal(6) and buffer ring(8) to corresponding grooves, in that order.

※ Coat each packing with hydraulic oil before fitting it.

※ Insert the backup ring until one side of it is inserted into groove.

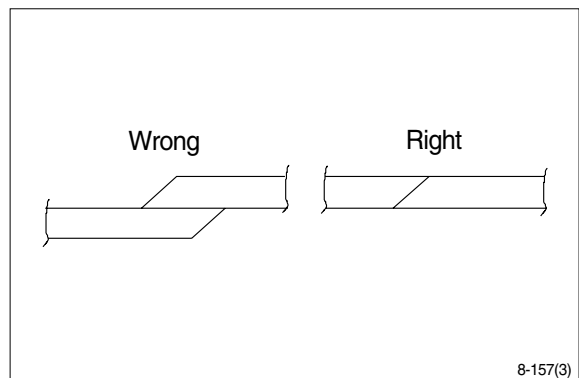

※ Rod seal(6) has its own fitting direction. Therefore, confirm it before fitting them.

※ Fitting rod seal(6) upside down may damage its lip. Therefore check the correct direction that is shown in fig.

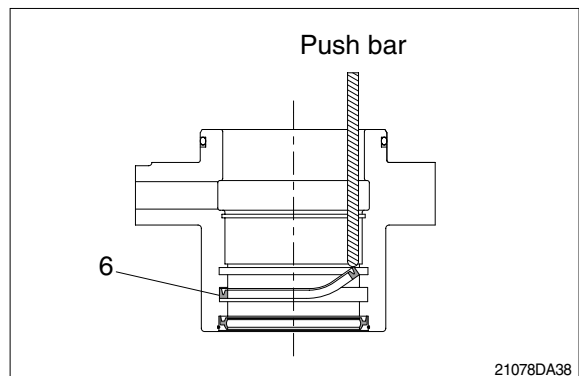

- ⑤ Fit back up ring(12) to gland(3).
- ※ Put the backup ring in the warm water of 30~50°C.
- ⑥ Fit O-ring(11) to gland(3).

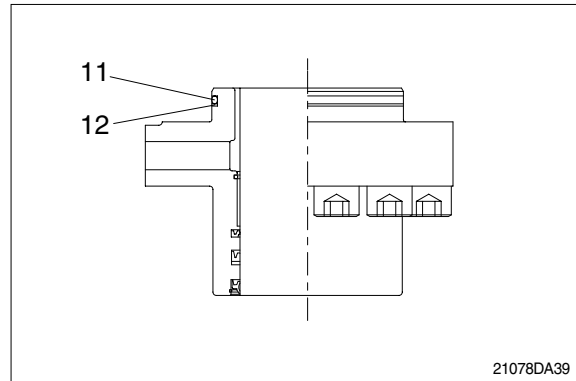

(2) Assemble piston assembly

- ※ Check for scratches or rough surfaces.
If found smooth with an oil stone.
- ① Coat the outer face of piston(14) with hydraulic oil.

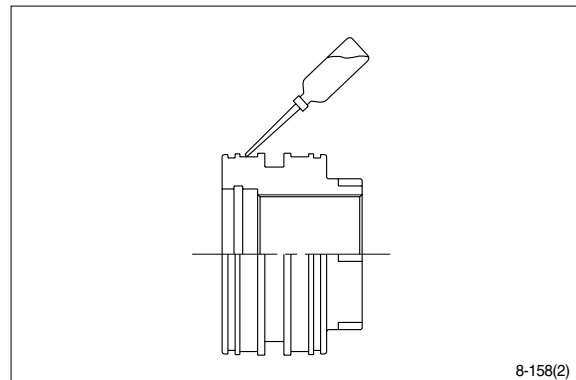

- ② Fit piston seal(17) to piston.
- ※ Put the piston seal in the warm water of 60~100°C for more than 5 minutes.
- ※ After assembling the piston seal, press its outer diameter to fit in.

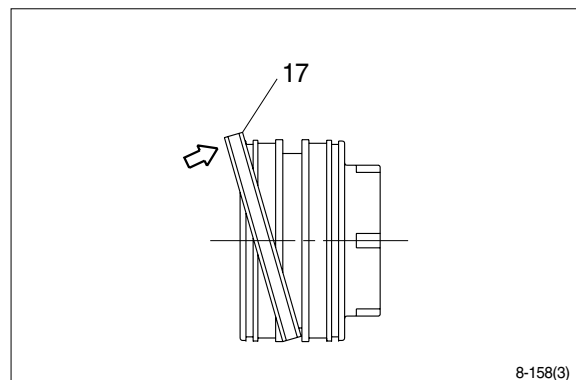

- ③ Fit wear ring(18) and dust ring(19) to piston(14).

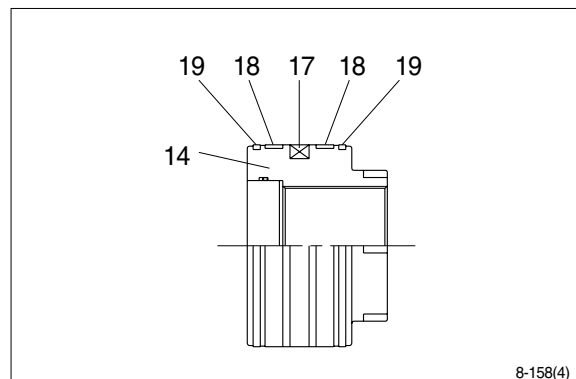

(3) Install piston and cylinder head

- ① Fix the rod assembly to the work bench.
- ② Apply hydraulic oil to the outer surface of rod assembly(2), the inner surface of piston and cylinder head.
- ③ Insert cylinder head assembly to rod assembly.

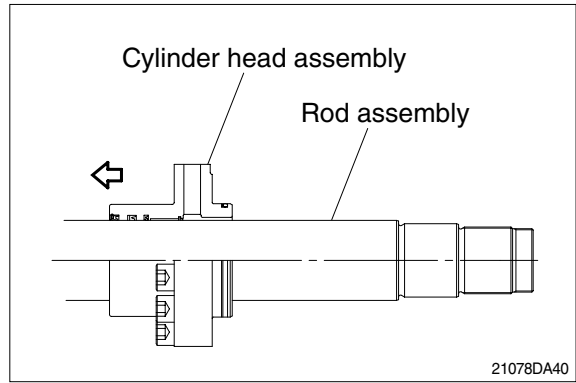

- ④ Insert cushion ring(13) to rod assembly.
- ※ Note that cushion ring(13) has a direction in which it should be fitted.

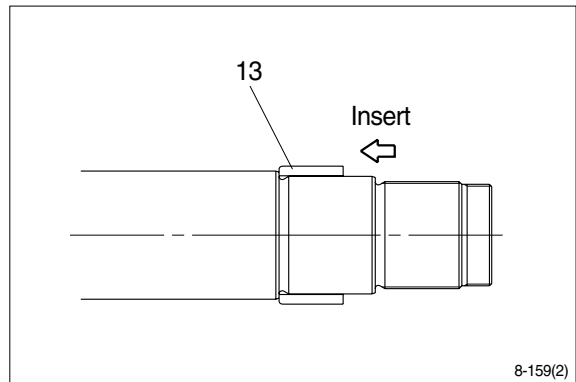

- ⑤ Fit piston assembly to rod assembly.
- Tightening torque : $100 \pm 10 \text{ kgf} \cdot \text{m}$
($723 \pm 72 \text{ lbf} \cdot \text{ft}$)

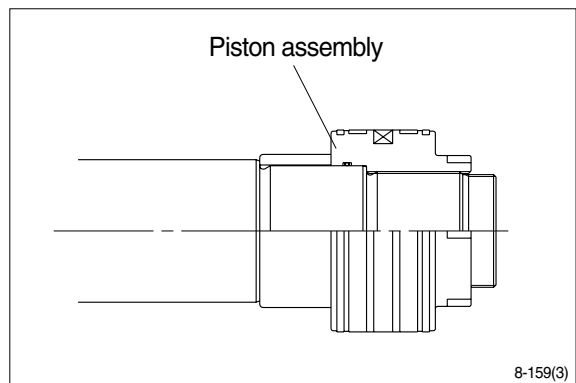

- ⑥ Fit lock nut(20) to piston.
- Tightening torque :

Item		kgf · m	lbf · ft
Bucket	21	100 ± 10	723.3 ± 72.3
Boom	21	100 ± 10	723.3 ± 72.3
Arm	25	100 ± 10	723.3 ± 72.3

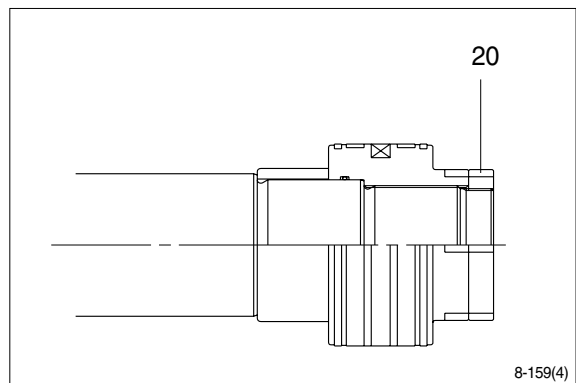

(3) Overall assemble

- ① Place a V-block on a rigid work bench.
Mount the tube assembly(1) on it and fix the assembly by passing a bar through the clevis pin hole to lock the assembly.
- ② Insert the rod assembly in to the tube assembly, while lifting and moving the rod assembly with a crane.
 - ※ Be careful not to damage piston seal by thread of tube assembly.
- ③ Match the bolt holes in the cylinder head flange to the tapped holes in the tube assembly and tighten socket bolts to a specified torque.
 - ※ Refer to the table of tightening torque.

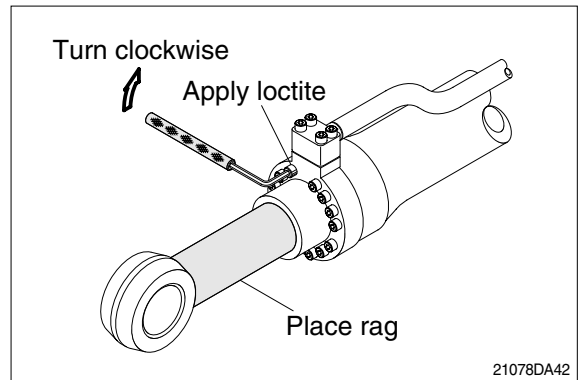
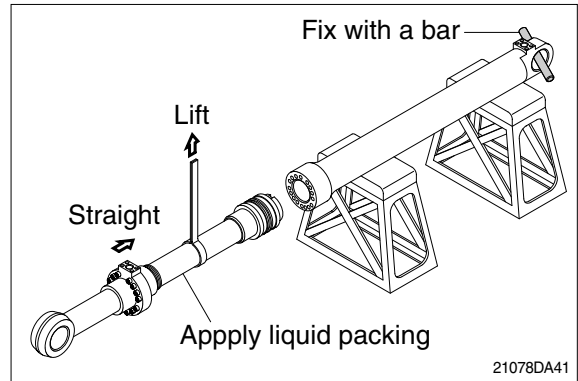

GROUP 10 UNDERCARRIAGE

1. TRACK LINK

1) REMOVAL

- (1) Move track link until master pin is over front idler in the position put wooden block as shown.
- (2) Loosen tension of the track link.
 - ※ If track tension is not relieved when the grease valve is loosened, move the machine backwards and forwards.
- (3) Push out master pin by using a suitable tool.

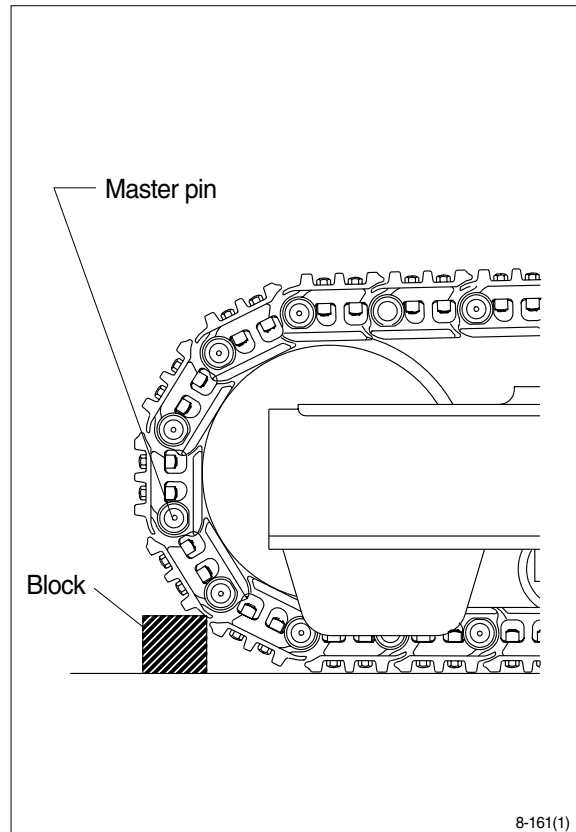

- (4) Move the machine slowly in reverse, and lay out track link assembly (1).
 - ※ Jack up the machine and put wooden block under the machine.
 - ※ Don't get close to the sprocket side as the track shoe plate may fall down on your feet.

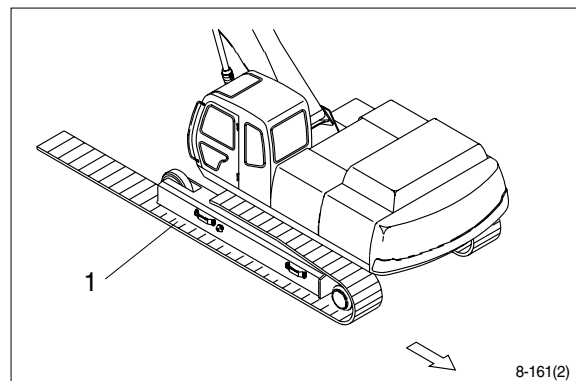

2) INSTALL

- (1) Carry out installation in the reverse order to removal.
 - ※ Adjust the tension of the track link.

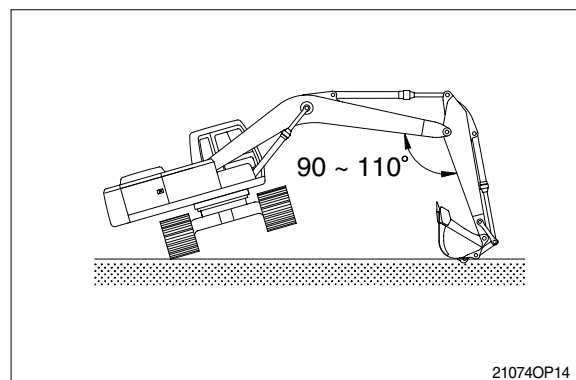

2. CARRIER ROLLER

1) REMOVAL

- (1) Loosen tension of the track link.

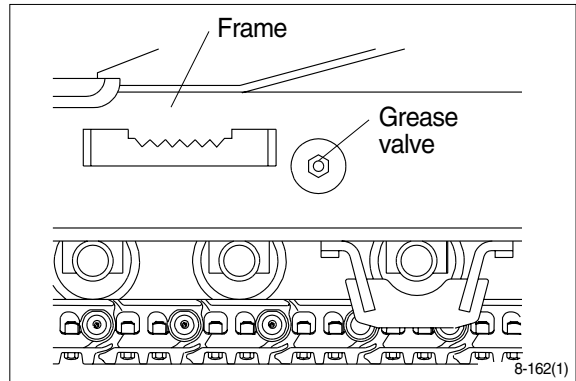

- (2) Jack up the track link height enough to permit carrier roller removal.

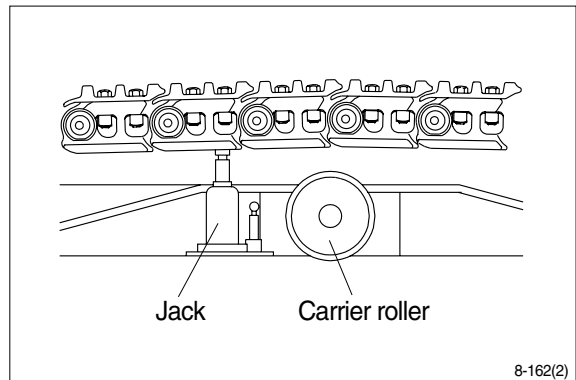

- (3) Loosen the lock nut (1).
- (4) Open bracket(2) with a screwdriver, push out from inside, and remove carrier roller assembly.
 - Weight : 21kg(46lb)

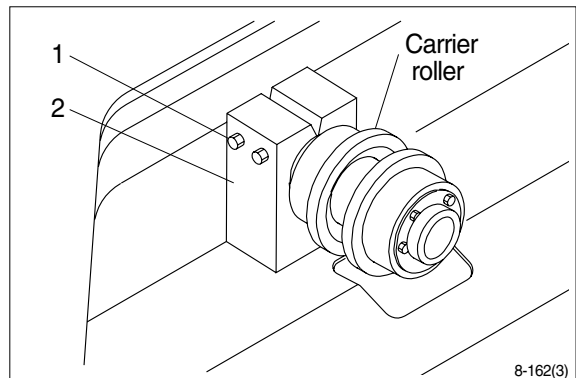

2) INSTALL

- (1) Carry out installation in the reverse order to removal.

3. TRACK ROLLER

1) REMOVAL

- (1) Loosen tension of the track link.

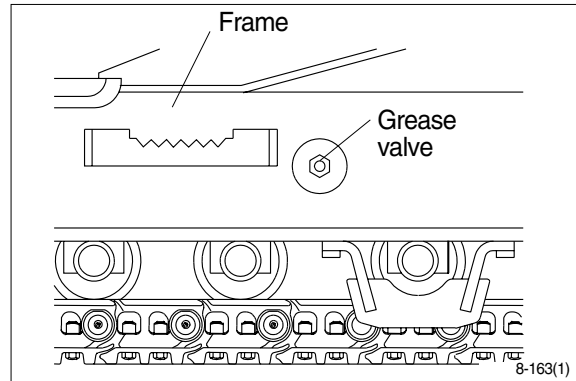

- (2) Using the work equipment, push up track frame on side which is to be removed.
※ After jack up the machine, set a block under the unit.

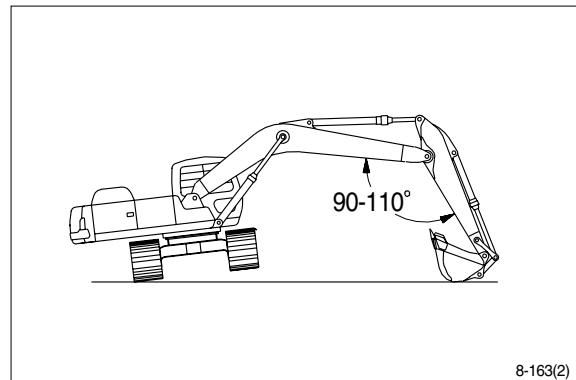

- (3) Remove the mounting bolt(1) and draw out the track roller(2).
· Weight : 38.3kg(84.4lb)

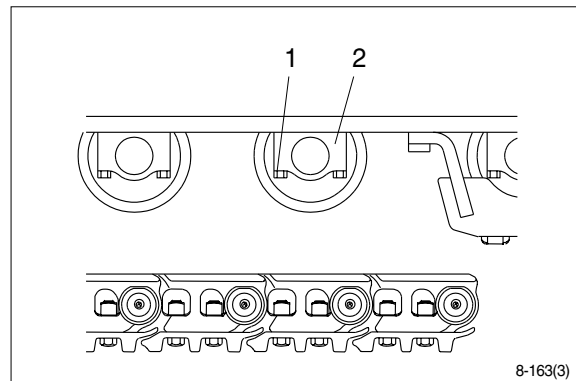

2) INSTALL

- (1) Carry out installation in the reverse order to removal.

4. IDLER AND RECOIL SPRING

1) REMOVAL

- (1) Remove the track link.
For detail, see **removal of track link**.

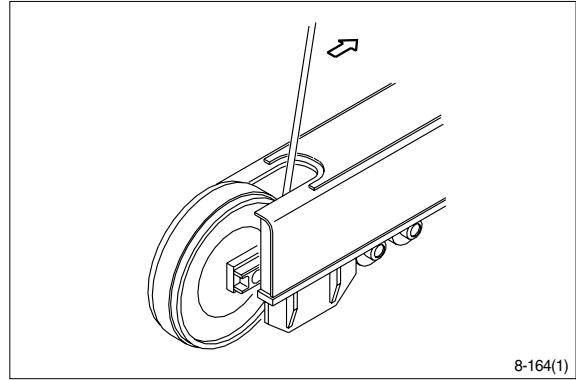

- (2) Sling the recoil spring(1) and pull out idler and recoil spring assembly from track frame, using a pry.
· Weight : 270kg(595lb)

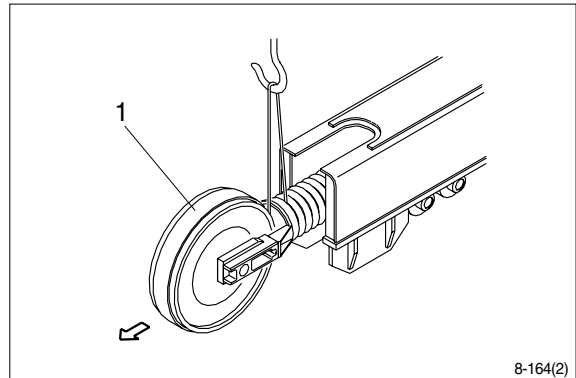

- (3) Remove the bolts(2), washers(3) and separate idler from recoil spring.

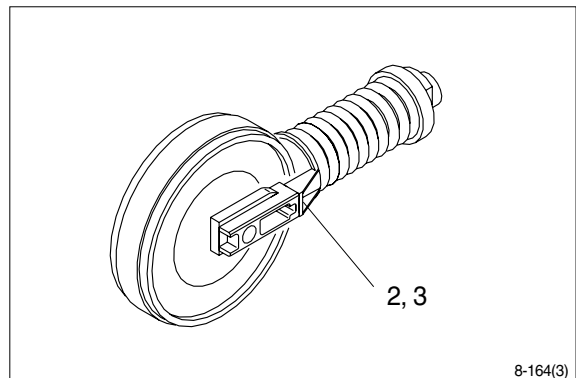

2) INSTALL

- (1) Carry out installation in the reverse order to removal.
※ Make sure that the boss on the end face of the recoil cylinder rod is in the hole of the track frame.

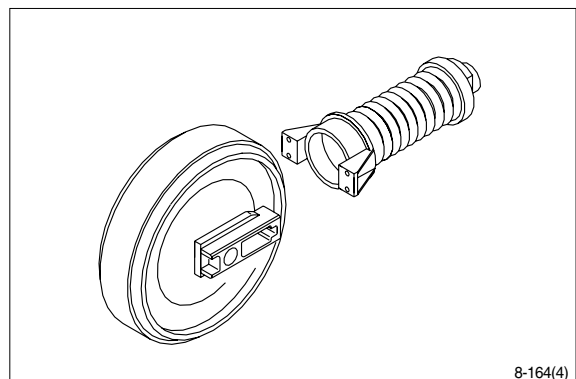

3) DISASSEMBLY AND ASSEMBLY OF IDLER

(1) Structure

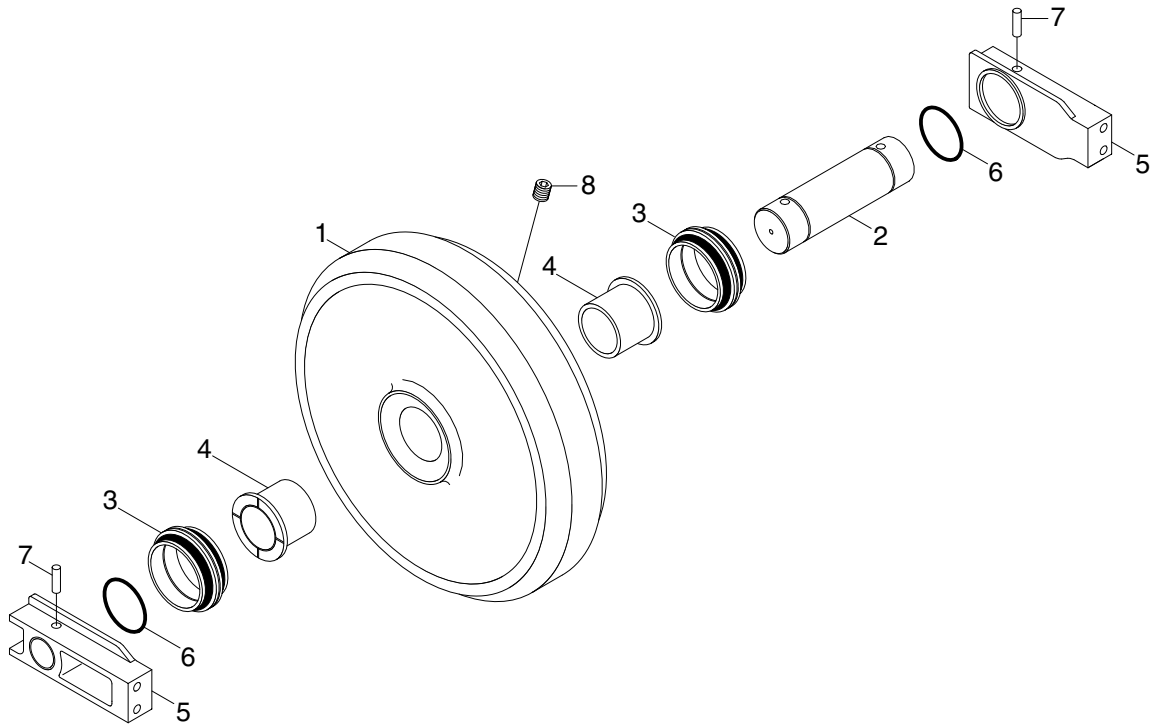

21078DA43

- 1 Shell
- 2 Shaft
- 3 Seal assembly

- 4 Bushing
- 5 Bracket
- 6 O-ring

- 7 Spring pin
- 8 Plug

(2) Disassembly

- ① Remove plug and drain oil.
- ② Draw out the spring pin(7), using a press.

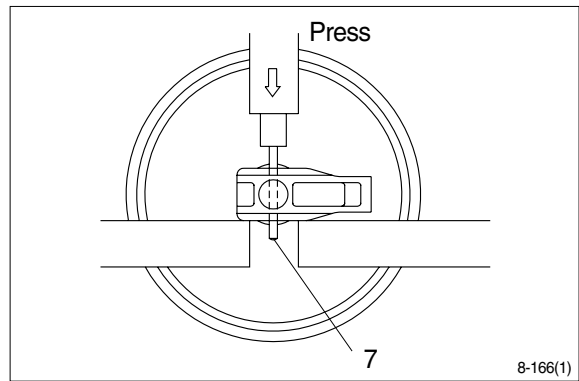

- ③ Pull out the shaft(2) with a press.
- ④ Remove seal(3) from idler(1) and bracket (5).
- ⑤ Remove O-ring(6) from shaft.

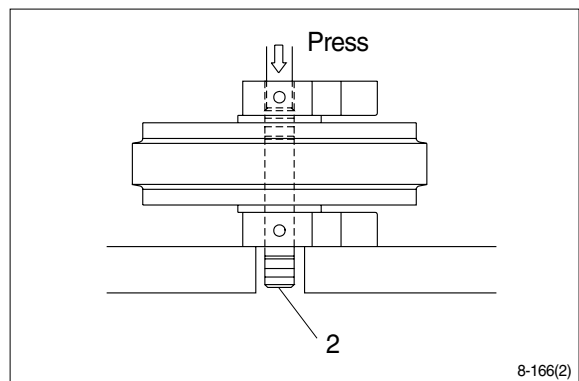

- ⑥ Remove the bushing(4) from idler, using a special tool.
- ※ Only remove bushing if replacement is necessary.

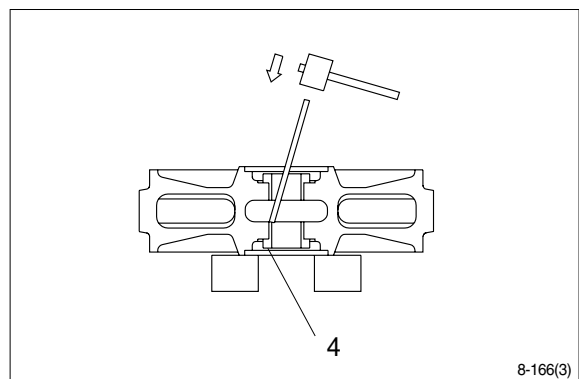

(3) Assembly

- ※ Before assembly, clean the parts.
- ※ Coat the sliding surfaces of all parts with oil.
- ① Cool up bushing(4) fully by some dry ice and press it into shell(1).
Do not press it at the normal temperature, or not knock in with a hammer even after the cooling.

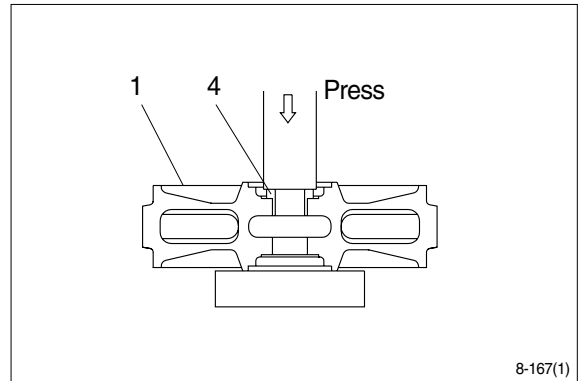

- ② Coat O-ring(6) with grease thinly, and install it to shaft(2).
- ③ Insert shaft(2) into bracket(5) and drive in the spring pin(7).

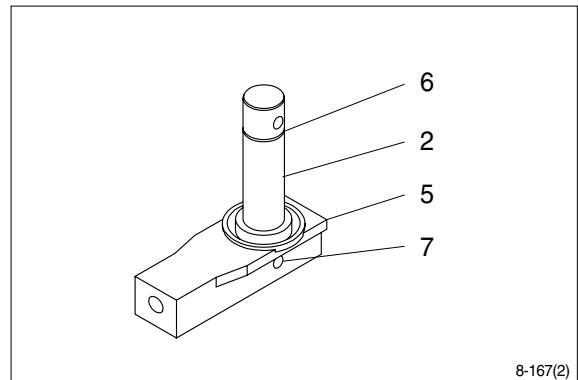

- ④ Install seal(3) to shell(1) and bracket(5).

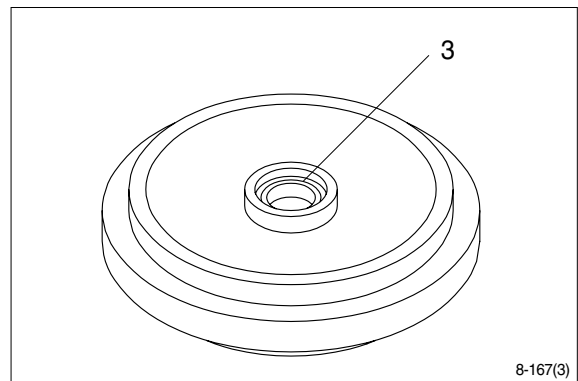

- ⑤ Install shaft(2) to shell(1).

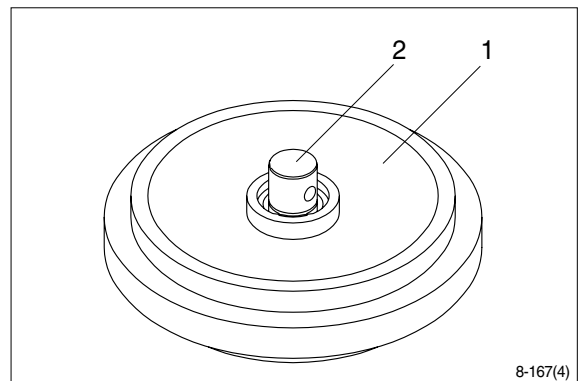

⑥ Install bracket(5) attached with seal(3).

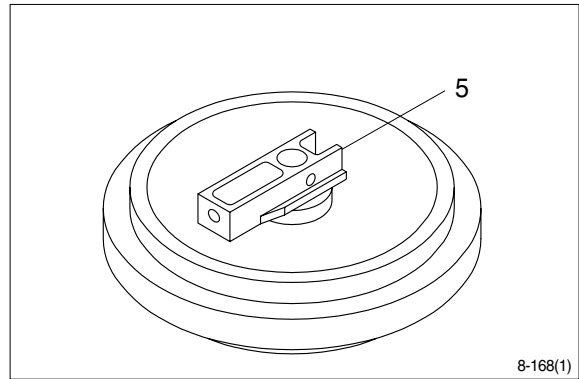

⑦ Knock in the spring pin(7) with a hammer.

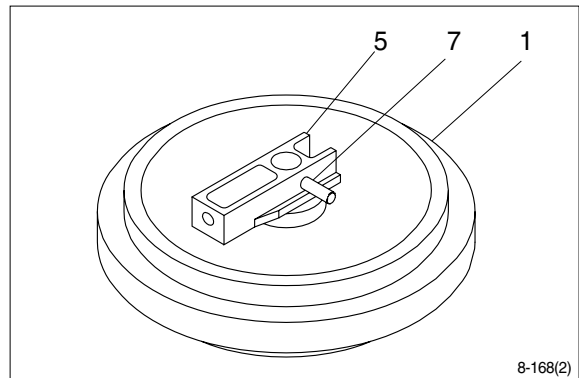

⑧ Lay bracket(5) on its side.
Supply engine oil to the specified level,
and tighten plug.

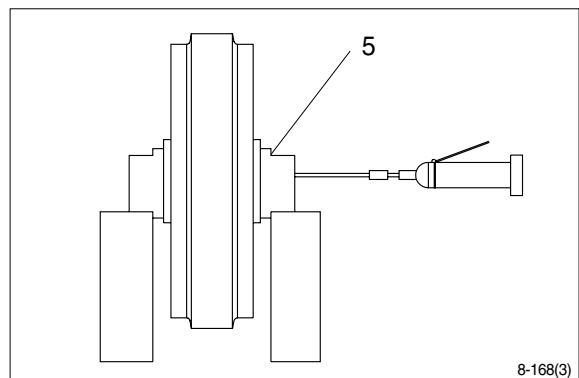

4) DISASSEMBLY AND ASSEMBLY OF RECOIL SPRING

(1) Structure

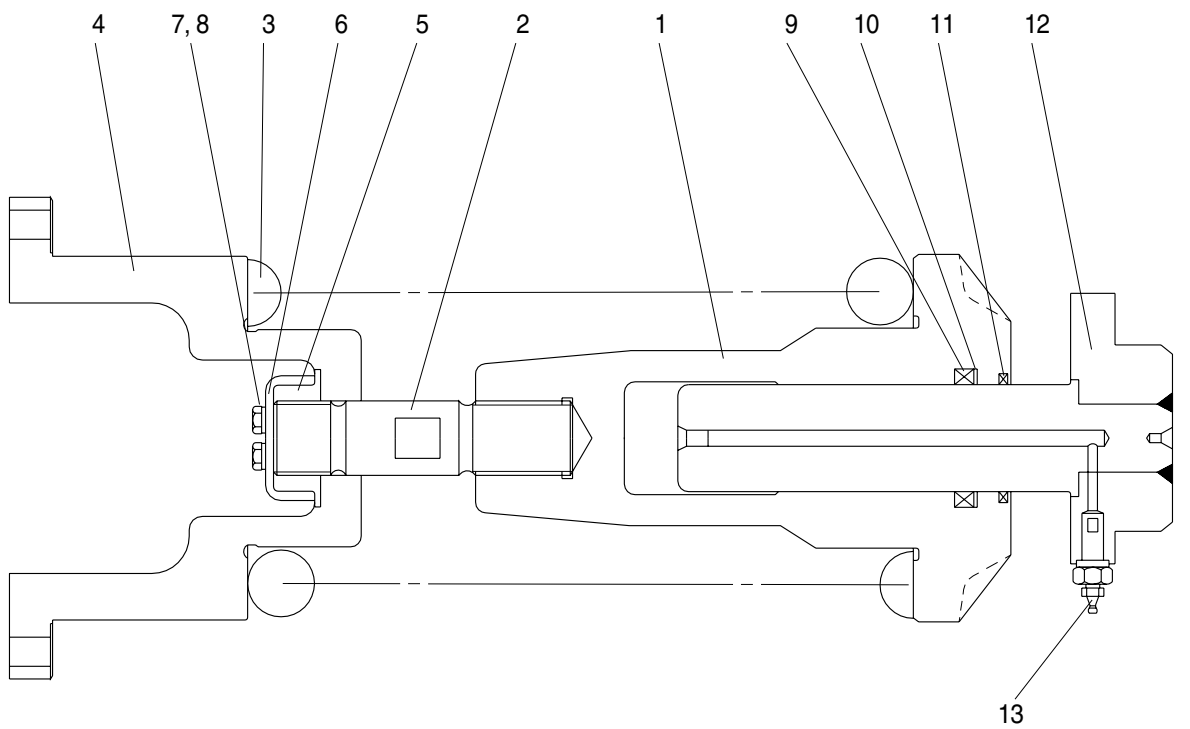

R210UCG01

- | | | | | | |
|---|----------|----|---------------|----|--------------|
| 1 | Body | 6 | Lock plate | 11 | Dust seal |
| 2 | Tie bar | 7 | Bolt | 12 | Rod assembly |
| 3 | Spring | 8 | Spring washer | 13 | Grease valve |
| 4 | Bracket | 9 | Rod seal | | |
| 5 | Lock nut | 10 | Back up ring | | |

(2) Disassembly

- ① Apply pressure on spring(3) with a press.
 - ※ The spring is under a large installed load. This is dangerous, so be sure to set properly.
 - Spring set load : 13716kg(30238lb)
- ② Remove bolt(7), spring washer(8) and lock plate(6).
- ③ Remove lock nut(5).

Take enough notice so that the press which pushes down the spring, should not be slipped out in its operation.
- ④ Lighten the press load slowly and remove bracket(4) and spring(3).

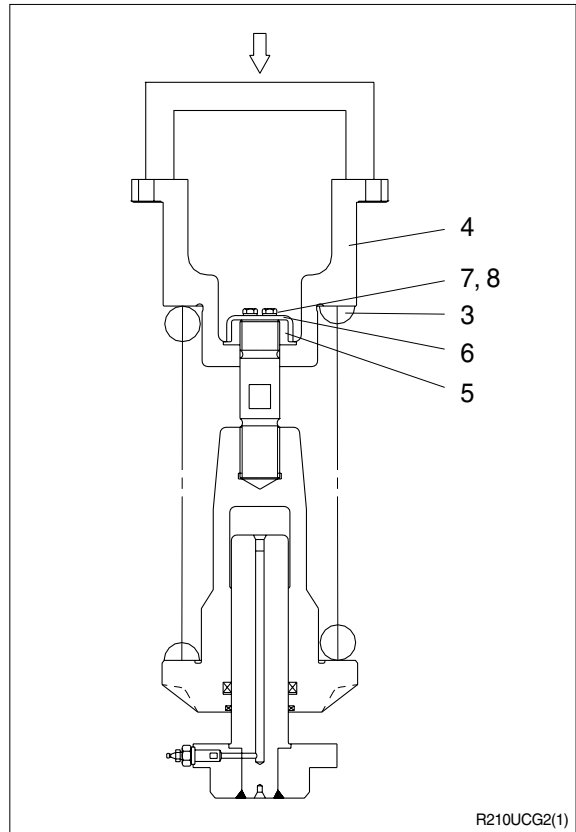

- ⑤ Remove rod(12) from body(1).
- ⑥ Remove grease valve(13) from rod(12).

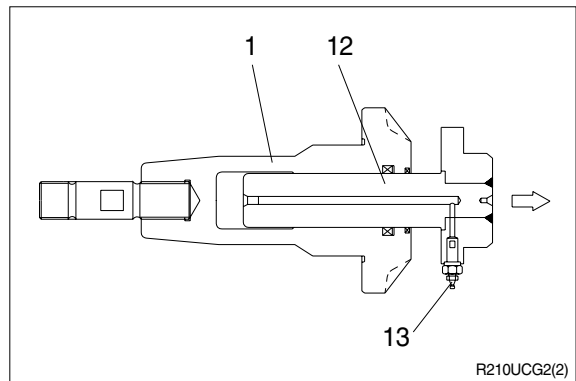

- ⑦ Remove rod seal(9), back up ring(10) and dust seal(11).

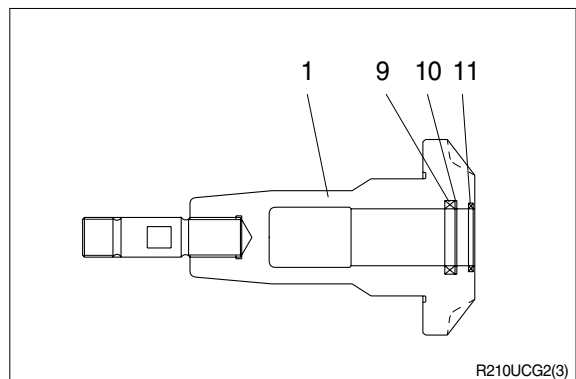

(3) Assembly

- ① Install dust seal(11), back up ring(10) and rod seal(9) to body(1).
- ※ When installing dust seal(11) and rod seal(9), take full care so as not to damage the lip.

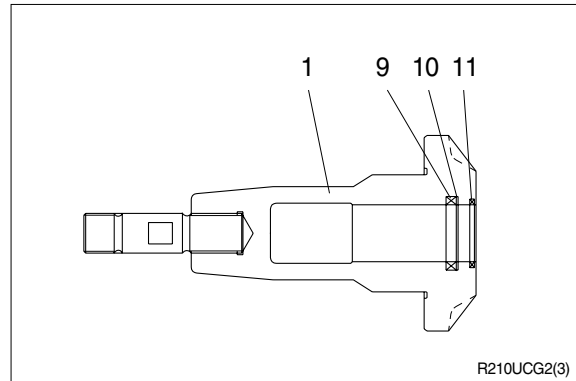

- ② Pour grease into body(1), then push in rod(12) by hand.
After take grease out of grease valve mounting hole, let air out.
- ※ If air letting is not sufficient, it may be difficult to adjust the tension of crawler.
- ③ Fit grease valve(13) to rod(12).
 - Tightening torque : $10 \pm 0.5 \text{ kg} \cdot \text{m}$
($72.3 \pm 3.6 \text{ lb} \cdot \text{ft}$)

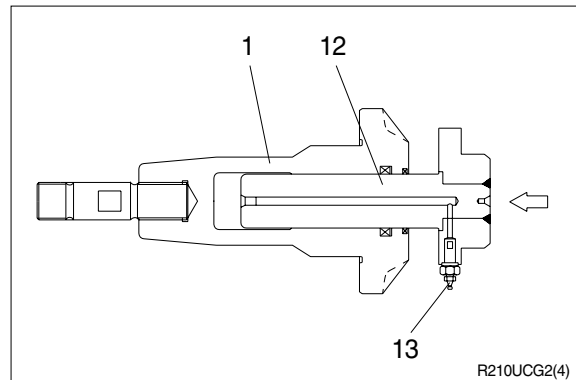

- ④ Install spring(3) and bracket(4) to body (1).
- ⑤ Apply pressure to spring(3) with a press and tighten lock nut(5).
- ※ Apply sealant before assembling.
- ※ During the operation, pay attention specially to prevent the press from slipping out.

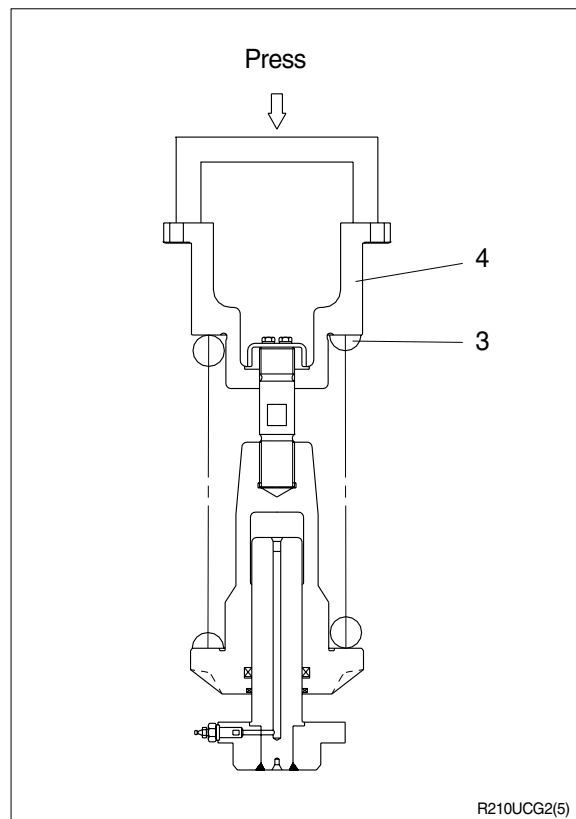

- ⑥ Lighten the press load and confirm the set length of spring(3).
- ⑦ After the setting of spring(3), install lock plate(6), spring washer(8) and bolt(7).

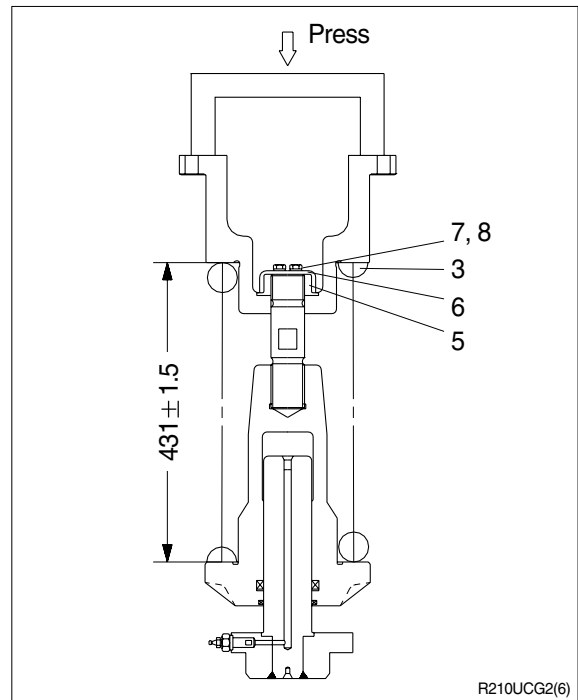

GROUP 11 WORK EQUIPMENT

1. STRUCTURE

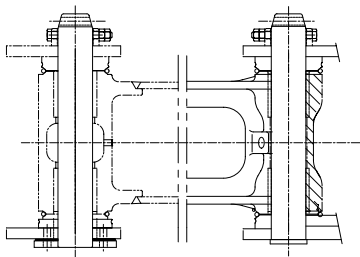
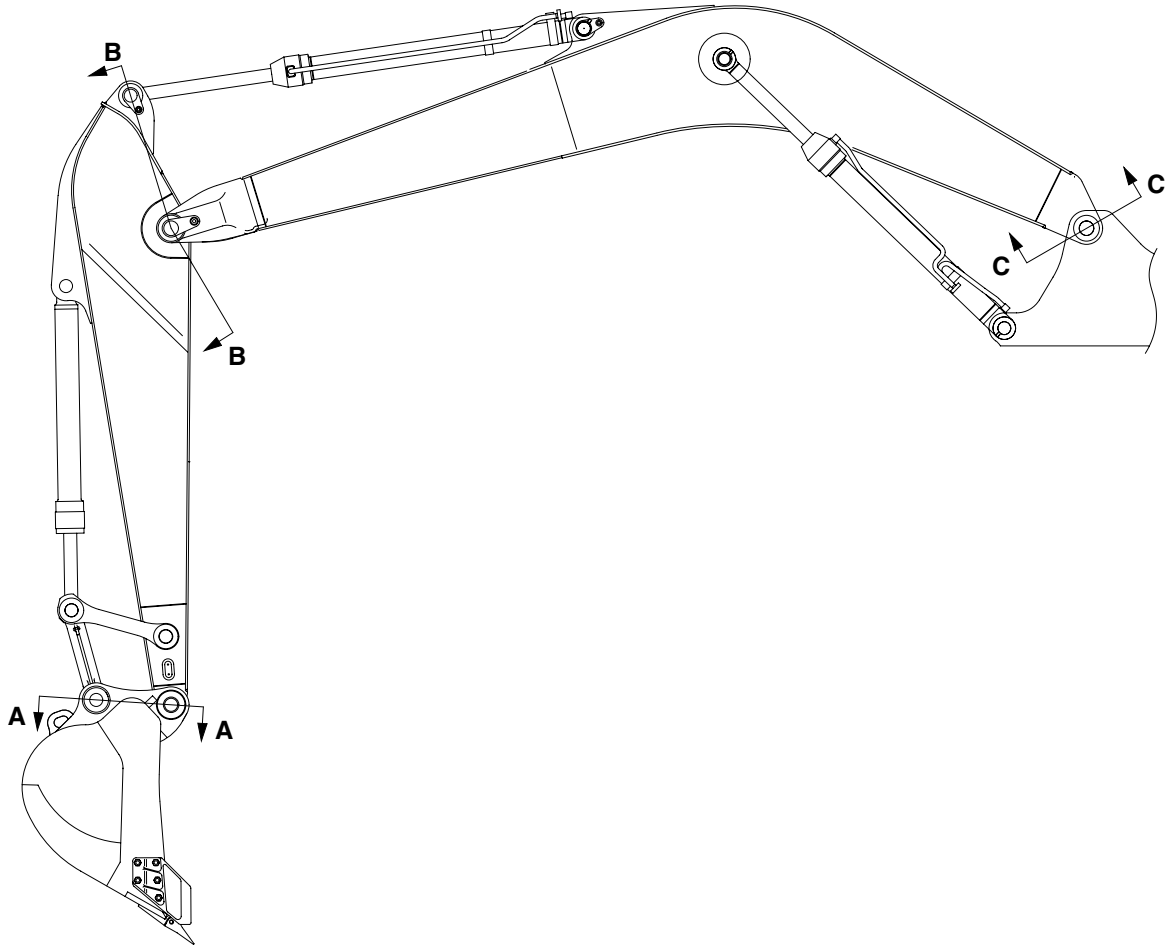

SECTION A

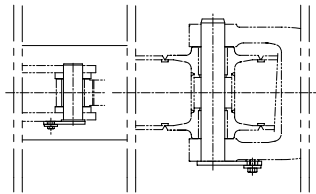

SECTION B

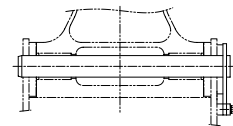

SECTION C

21078DA44

2. REMOVAL AND INSTALL

1) BUCKET ASSEMBLY

(1) Removal

- ① Lower the work equipment completely to ground with back of bucket facing down.

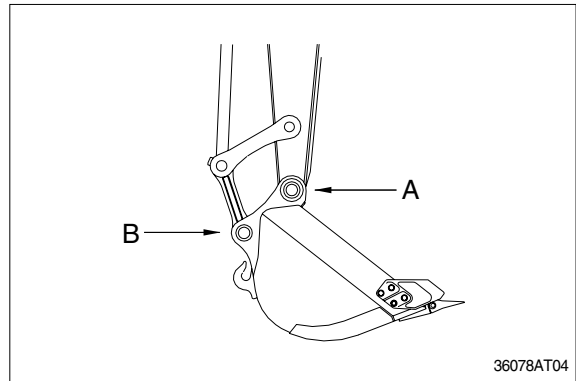

- ② Remove nut(1), bolt(2) and draw out the pin(A).

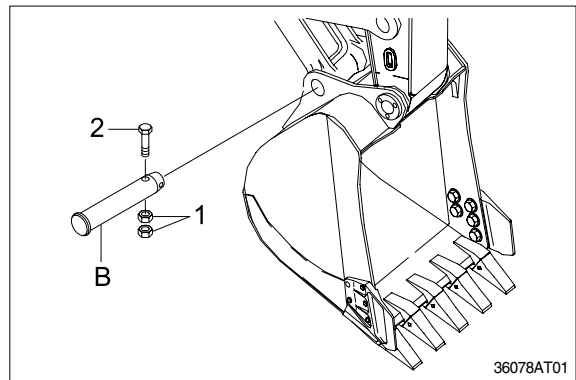

- ③ Remove nut(3), bolt(4) and draw out the pin(B).

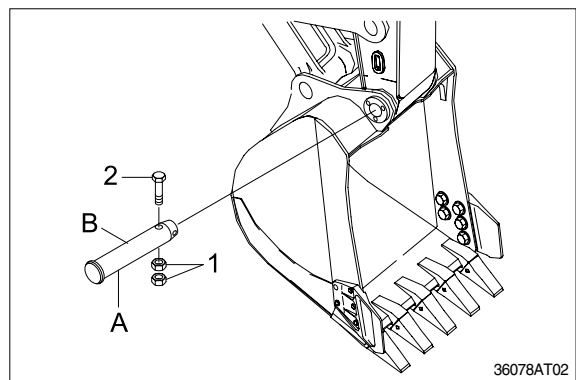

(2) Install

- ① Carry out installation in the reverse order to removal.
- ▲ When aligning the mounting position of the pin, do not insert your fingers in the pin hole.
- ※ Adjust the bucket clearance.
For detail, see **operation manual**.

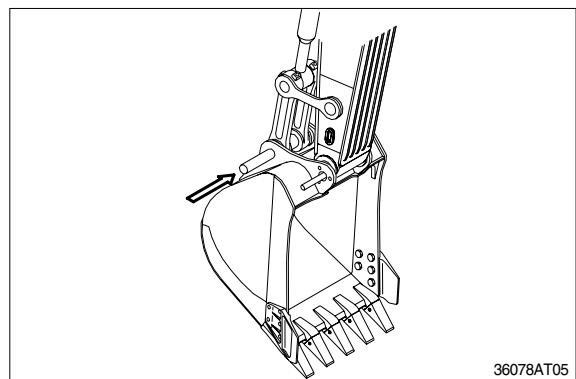

2) ARM ASSEMBLY

(1) Removal

- ※ Loosen the breather slowly to release the pressure inside the hydraulic tank.
- ▲ Escaping fluid under pressure can penetrate the skin causing serious injury.
- ① Remove bucket assembly.
For details, see **removal of bucket assembly**.
- ② Disconnect bucket cylinder hose(1).
- ▲ Fit blind plugs(5) in the piping at the chassis end securely to prevent oil from spurting out when the engine is started.
- ③ Sling arm cylinder assembly, remove spring, pin stopper and pull out pin.
※ Tie the rod with wire to prevent it from coming out.
- ④ For details, see **removal of arm cylinder assembly**.
Place a wooden block under the cylinder and bring the cylinder down to it.
- ⑤ Remove bolt(2), plate(3) and pull out the pin(4) then remove the arm assembly.
· Weight : 1050kg(2310lb)
※ When lifting the arm assembly, always lift the center of gravity.

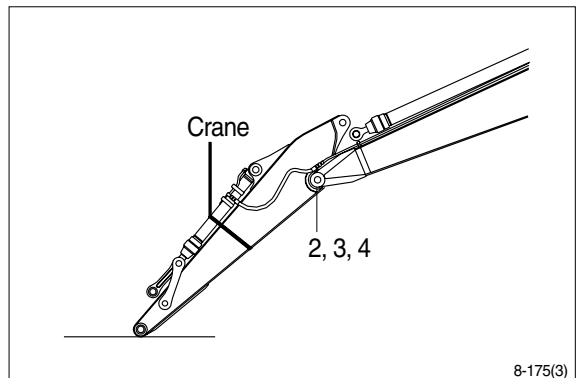
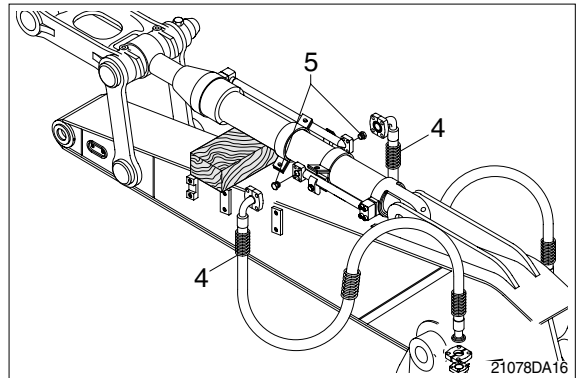
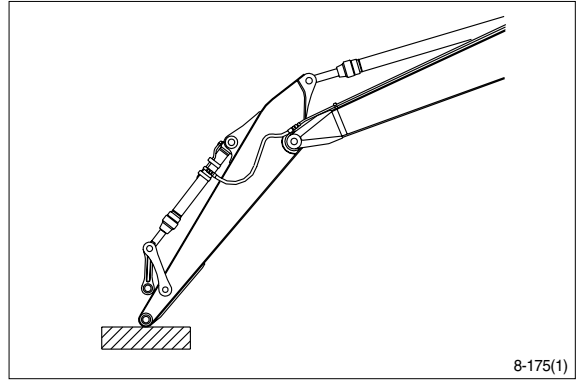

(2) Install

- ① Carry out installation in the reverse order to removal.
- ▲ When lifting the arm assembly, always lift the center of gravity.
- ※ Bleed the air from the cylinder.

3) BOOM CYLINDER

(1) Removal

- ① Remove arm and bucket assembly.
For details, see **removal of arm and bucket assembly**.
- ② Remove boom cylinder assembly from boom.
For details, see **removal of arm cylinder assembly**.

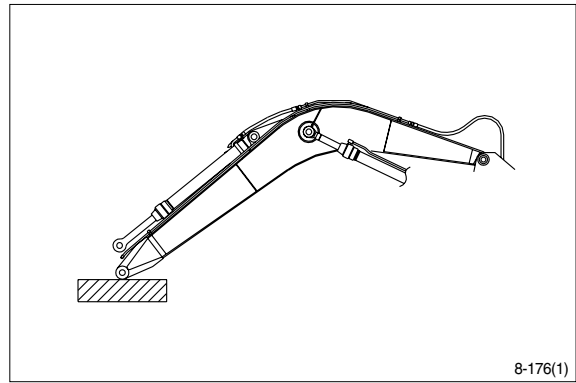

- ③ Disconnect head lamp wiring.
- ④ Disconnect bucket cylinder hose(2) and arm cylinder hose(1).
- ※ When the hose are disconnected, oil may spurt out.
- ⑤ Sling boom assembly(3).

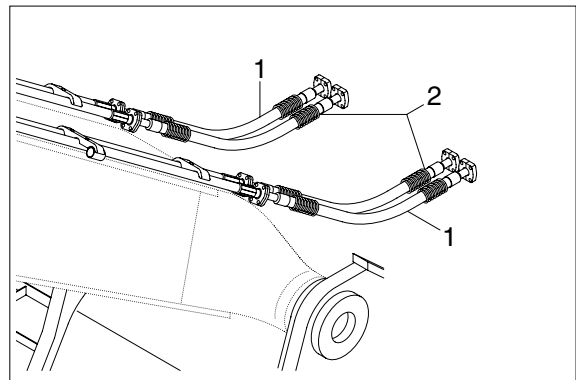

- ⑥ Remove bolt(4), plate(5) and pull out the pin(6) then remove boom assembly.
· Weight :1950kg(4300lb)
- ※ When lifting the boom assembly always lift the center of gravity.

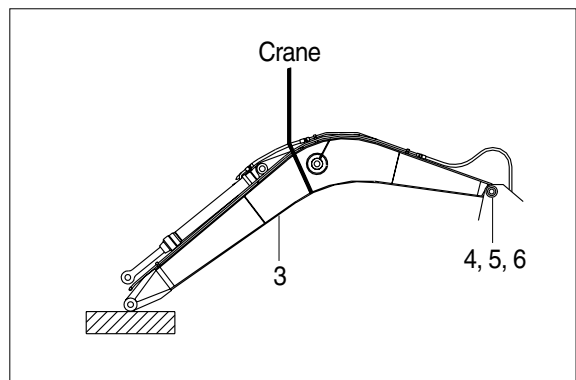

(2) Install

- ① Carry out installation in the reverse order to removal.
- ▲ When lifting the arm assembly, always lift the center of gravity.
- ※ Bleed the air from the cylinder.

