

SHOP

MANUAL

KOMATSU

PC290LC-6K

PC290NLC-6K

MACHINE MODEL

PC290LC-6K

PC290NLC-6K

SERIAL NUMBER

K30001 and up, K34001 and up

K30001 and up, K34001 and up

- This shop manual may contain attachments and optional equipment that are not available in your area. Please consult your local Komatsu distributor for those items you may require. Materials and specifications are subject to change without notice
- PC290LC-6K, PC290NLC-6K mount the SA6D102EA-1 engine.
for details of the engine, see the 102 Service Engine Shop Manual.

CONTENTS

	No. of page
01 GENERAL	01-1
10 STRUCTURE AND FUNCTION	10-1
20 TESTING AND ADJUSTING	20-1
30 DISASSEMBLY AND ASSEMBLY	30-1
40 MAINTENANCE STANDARD	40-1

The affected pages are indicated by the use of the following marks. It is requested that necessary actions be taken to these pages according to the table below.

Mark	Indication	Action required
○	Page to be newly added	Add
●	Page to be replaced	Replace
()	Page to be deleted	Discard

Pages having no marks are those previously revised or made additions.

LIST OF REVISED PAGES

Mark	Page	Time of revision	Mark	Page	Time of revision	Mark	Page	Time of revision	Mark	Page	Time of revision	Mark	Page	Time of revision
●	00-1	②		10-18			10-57			10-97			10-136	
	00-2	①		10-19			10-58			10-98			10-137	
●	00-3	②		10-20			10-59			10-99			10-138	
●	00-4	②		10-21			10-60			10-100			10-139	
●	00-5	②		10-22			10-61			10-101			10-140	
	00-6			10-23			10-62			10-102			10-141	
	00-7			10-24			10-63			10-103			10-142	
	00-8			10-25			10-64			10-104			10-143	
	00-9			10-26			10-65			10-105			10-144	
	00-10			10-27			10-66			10-106			10-145	
	00-11			10-28			10-67			10-107			10-146	
	00-12			10-29			10-68			10-108			10-147	
	00-13			10-30			10-69			10-109			10-148	
	00-14			10-31			10-70			10-110			10-149	
	00-15			10-32			10-71			10-111			10-150	
	00-16			10-33			10-72			10-112			10-151	
	00-17			10-34			10-73			10-113			10-152	
	00-18			10-35			10-74			10-114			10-153	
	00-19			10-36			10-76			10-115			10-154	
	00-20			10-37			10-77			10-116			10-155	
	00-21			10-38			10-78			10-117			10-156	
				10-39			10-79			10-118			10-157	
	10-1			10-40			10-80			10-119			10-158	
	10-2			10-41			10-81			10-120			10-159	
	10-3			10-42			10-82			10-121			10-160	
	10-4			10-43			10-83			10-122			10-161	
	10-5			10-44			10-84			10-123			10-162	
	10-6			10-45			10-85			10-124			10-163	
	10-7			10-46			10-86			10-125			10-164	
	10-8			10-47			10-87			10-126			10-165	
	10-9			10-48			10-88			10-127			10-166	
	10-10			10-49			10-89			10-128			10-167	
	10-11			10-50			10-90			10-129			10-168	
	10-12			10-51			10-91			10-130			10-169	
	10-13			10-52			10-92			10-131			10-170	
	10-14			10-53			10-93			10-132			10-171	
	10-15	①		10-54			10-94			10-133			10-172	
	10-16	①		10-55			10-95			10-134			10-173	
	10-17			10-56			10-96			10-135				

Mark	Page	Time of revision	Mark	Page	Time of revision	Mark	Page	Time of revision	Mark	Page	Time of revision	Mark	Page	Time of revision
	20-1			20-58			20-113			20-170	①		20-227	
	20-2			20-59			20-114			20-171			20-228	
	20-3			20-60			20-115			20-172			20-229	
	20-4			20-61			20-116			20-173			20-230	
	20-5			20-62			20-117			20-174			20-231	
	20-6			20-63			20-118			20-175			20-232	
	20-7			20-64			20-119			20-176			20-233	
	20-8			20-65			20-120			20-177			20-234	
	20-9			20-66			20-121			20-178			20-235	
	20-10			20-67			20-122			20-179			20-236	
	20-11			20-68			20-123	①		20-180			20-237	
	20-12			20-69			20-124			20-181			20-238	
	20-13			20-70	①		20-125			20-182			20-239	
	20-14			20-71	①		20-126			20-183			20-240	
	20-15			20-72	①		20-127			20-184			20-241	
	20-16			20-73	①		20-128			20-185			20-242	①
	20-17			20-74			20-129			20-186			20-243	①
	20-18			20-74-1			20-130			20-187			20-244	①
	20-19			20-74-2			20-131			20-188			20-245	
	20-20			20-75			20-132			20-189			20-246	
	20-21			20-76			20-133			20-190			20-247	
	20-22			20-77			20-134			20-191			20-248	
	20-23			20-78			20-135			20-192			20-249	
	20-24			20-79			20-136			20-193			20-250	
	20-25			20-80			20-137			20-194			20-251	
	20-26			20-81			20-138			20-195			20-252	①
	20-27			20-82			20-139			20-196			20-253	
	20-28			20-83			20-140			20-197			20-254	
	20-29			20-84			20-141			20-198			20-255	
	20-30			20-85			20-142			20-199			20-256	
	20-31			20-86			20-143			20-200			20-257	
	20-32			20-87			20-144			20-201			20-258	
	20-33			20-88			20-145			20-202			20-259	
	20-34			20-89			20-146			20-203	①		20-260	
	20-35			20-90			20-147			20-204			20-261	
	20-36			20-91			20-148			20-205			20-262	
	20-37			20-92			20-149			20-206			20-263	
	20-38			20-93			20-150			20-207			20-264	
	20-39			20-94			20-151			20-208			20-265	
	20-40			20-95			20-152			20-209			20-266	
	20-41			20-96			20-153			20-210			20-267	
	20-42			20-97			20-154			20-211			20-268	
	20-43			20-98			20-155			20-212			20-269	
	20-44			20-99			20-156			20-213			20-270	
	20-45			20-100			20-157			20-214			20-271	
	20-46			20-101			20-158			20-215			20-272	
	20-47			20-102			20-159			20-216			20-273	
	20-48			20-103	①		20-160			20-217			20-274	
	20-49			20-104			20-161			20-218			20-275	
	20-50			20-105			20-162			20-219			20-276	
	20-51			20-106			20-163			20-220			20-277	
	20-52			20-107			20-164			20-221			20-278	①
	20-53			20-108			20-165			20-222			20-279	
	20-54			20-109			20-166			20-223			20-280	
	20-55			20-110			20-167			20-224				
	20-56			20-111			20-168			20-225	①			
	20-57			20-112	①		20-169	①		20-226				

Mark	Page	Time of revision	Mark	Page	Time of revision	Mark	Page	Time of revision	Mark	Page	Time of revision	Mark	Page	Time of revision
	30-1		30-55			30-109			40-26					
	30-2		30-56			30-110			40-27					
	30-3		30-57			30-111			40-28					
	30-4		30-58			30-112			40-29					
	30-5		30-59			30-113			40-30					
	30-6		30-60			30-114			40-31					
	30-7		30-61			30-115			40-32					
	30-8		30-62			30-116			40-33					
	30-9		30-63			30-117			40-34					
	30-10		30-64			30-118			40-35					
	30-11		30-65			30-119			• 40-36		②			
	30-12		30-66			30-120			(40-36-1		①)			
	30-13		30-67			30-121			40-37					
	30-14		30-68			30-122			40-38					
	30-15		30-69			30-123			40-39					
	30-16		30-70			30-124			40-40					
	30-17		30-71			30-125								
	30-18		30-72			30-126								
	30-19		30-73			30-127								
	30-20		30-74			30-128								
	30-21		30-75			30-129								
	30-22		30-76			30-130								
	30-23		30-77			30-131								
	30-24		30-78			30-132								
	30-25		30-79			30-133								
	30-26		30-80			30-134								
	30-27		30-81			30-135								
	30-28		30-82			30-136								
	30-29		30-83											
	30-30		30-84			40-1								
	30-31		30-85			40-2								
	30-32		30-86			40-3								
	30-33		30-87			40-4								
	30-34		30-88			40-5								
	30-35		30-89			40-6								
	30-36		30-90			40-7								
	30-37		30-91			40-8								
	30-38		30-92			40-9								
	30-39		30-93			40-10								
	30-40		30-94			40-11								
	30-41		30-95			40-12								
	30-42		30-96			40-13								
	30-43		30-97			40-14								
	30-44		30-98			40-15								
	30-45		30-99			40-16								
	30-46		30-100			40-17								
	30-47		30-101			40-18								
	30-48		30-102			40-19								
	30-49		30-103			40-20								
	30-50		30-104			40-21								
	30-51		30-105			40-22								
	30-52		30-106			40-23								
	30-53		30-107			40-24								
	30-54		30-108			40-25								

SAFETY SAFETY NOTICE

IMPORTANT SAFETY NOTICE

Proper service and repairs extremely important for safe machine operation. The service and repair techniques recommended by Komatsu and described in this manual are both specially designed by Komatsu for the specific purpose.

To prevent injury to workers, the symbol  is used to mark safety precautions in this manual. The cautions accompanying these symbols should always be followed carefully. If any dangerous situation arises or may possibly arise, first consider safety, and take the necessary actions to deal with the situation.

GENERAL PRECAUTIONS

Mistakes in operation are extremely dangerous. Read the Operation and Maintenance carefully BEFORE operating the machine.

1. Before carrying out any greasing or repairs, read all the precautions given on the decals which are fixed to the machine.
2. When carrying out any operation, always wear safety shoes and helmet. Do not wear loose work clothes, or clothes with buttons missing.
 - Always wear safety glasses when hitting parts with a hammer.
 - Always wear safety glasses when grinding parts with a grinder, etc.
3. If welding repairs are needed, always have a trained, experienced welder carry out the work. When carrying out welding work, always wear welding gloves, apron, glasses, cap and other clothes suited for welding work.
4. When carrying out any operation with two or more workers, always agree on the operating procedure before starting. Always inform your fellow workers before starting any step of the operation. Before starting work, hang UNDER REPAIR signs on the controls in the operator's compartment.
5. Keep all tools in good condition and learn the correct way to use them.

6. Decide a place in the repair workshop to keep tools and removed parts. Always keep the tools and parts in their correct places. Always keep the work area clean and make sure that there is no dirt or oil on the floor. Smoke only in the areas provided for smoking. Never smoke while working.

PREPARATIONS FOR WORK.

7. Before adding the oil or making any repairs park the machine on hard, level ground, and block the wheels or tracks to prevent the machine from moving.
8. Before starting work, lower blade, ripper, bucket or any other work equipment to the ground. If this is not possible, insert the safety pin or use blocks to prevent the work equipment from falling. In addition, be sure to lock all the control levers and hang warning signs on them.
9. When disassembling or assembling, support the machine with blocks, jacks or stands before starting work.
10. Remove all mud and oil from the steps or other places used to get on and off the machine. Always use the handrails, ladders or steps when getting on or off the machine. Never jump on or off the machine. If it is impossible to use the handrails, ladders or steps, use a stand to provide safe footing.

PRECAUTIONS DURING WORK

11. When removing the oil filter cap, drain plug or hydraulic pressure measuring plugs, loosen them slowly to prevent the oil from spurting out. Before disconnecting or removing components of the oil, water or air circuits, first remove the pressure completely from the circuit.
12. The water and oil in the circuits are hot when the engine is stopped, so be careful not to get burned.
Wait for the oil and water to cool before carrying out any work on the oil or water circuits.
13. Before starting work, remove the leads from the battery. Always remove the lead from the negative (-) terminal first.
14. When raising heavy components, use a hoist or crane.
Check that the wire rope, chains and hooks are free from damage.
Always use lifting equipment which has ample capacity.
Install the lifting equipment at the correct places.
Use a hoist or crane and operate slowly to prevent the component from hitting any other part.
Do not work with any part still raised by the hoist or crane.
15. When removing covers which are under internal pressure or under pressure from a spring, always leave two bolts in position on opposite sides. Slowly release the pressure, then slowly loosen the bolts to remove.
16. When removing components, be careful not to break or damage the wiring. Damaged wiring may cause electrical fires.
17. When removing piping, stop the fuel or oil from spilling out. If any oil or fuel drops onto the floor, wipe it up immediately. Fuel or oil on the floor can cause you to slip, or can even start fires.
18. As a general rule, do not use gasoline to wash parts. In particular, only use the minimum of gasoline when washing electrical parts.
19. Be sure to assemble all parts again in their original places.
Replace any damaged parts with new parts.
 - When installing hoses and wires, be sure that they will not be damaged by contact with other parts when the machine is being operated.
20. When installing high pressure hoses, make sure that they are not twisted. Damaged tubes are dangerous, so be extremely careful when installing tubes for high pressure circuits. Also, check that connecting parts are correctly installed.
21. When assembling or installing parts, always use the specified tightening torques. When installing protective parts such as guards, or parts which vibrate violently or rotate at high speed, be particularly careful to check that they are installed correctly.
22. When aligning two holes, never insert your fingers or hand. Be careful not to get your fingers caught in a hole.
23. When measuring hydraulic pressure, check that the measuring tool is correctly assembled for taking any measurements.
24. Take care when removing or installing the tracks of track-type machines. When removing the track, the track separates suddenly, so never let anyone stand at either end of the track.



FOREWORD GENERAL

This shop manual has been prepared as an aid to improve the quality of repairs by giving the serviceman an accurate understanding of the product and by showing him the correct way to perform repairs and make judgements. Make sure you understand the contents of this manual and use it to full effect at every opportunity.

This shop manual mainly contains the necessary technical information for operations performed in a service workshop. For ease of understanding, the manual is divided into the following chapters: these chapters are further divided into the each main group of components.

STRUCTURE AND FUNCTION

This section explains the structure and function of each component. It serves not only to give an understanding of the structure, but also serves as reference material for troubleshooting.

TESTING AND ADJUSTING

This section explains checks to be made before and after performing repairs, as well as adjustments to be made at completion of the checks and repairs. Troubleshooting charts correlating "problems" to "Causes" are also included in this section.

DISASSEMBLY AND ASSEMBLY

This section explains the order to be followed when removing, installing, disassembling or assembling each component, as well as precautions to be taken for these operations.

MAINTENANCE STANDARD

This section gives the judgement standards when inspecting disassembled parts.

NOTICE

The specifications contained in this shop manual are subject to change at any time and without any advance notice. Use the specifications given in the book with the latest date.

HOW TO READ THE SHOP MANUAL

VOLUMES

Shop manuals are issued as a guide to carrying out repairs. They are divided as follows:

Chassis volume: Issued for every machine model
Engine model: Issued for each engine series

Electrical volume: } Each issued as one
Attachments volume: } volume to cover all
 models

These various volumes are designed to avoid duplicating the same information. Therefore, to deal with all repairs for any model, it is necessary that chassis, engine, electrical and attachment volumes be available.

DISTRIBUTION AND UPDATING

Any additions, amendments or other changes will be sent to KOMATSU distributors. Get the most up-to-date information before you start any work.

FILING METHOD

1. See the page number on the bottom of the page. File the pages in correct order.
2. Following examples show how to read the page number
 Example 1 (Chassis volume:)

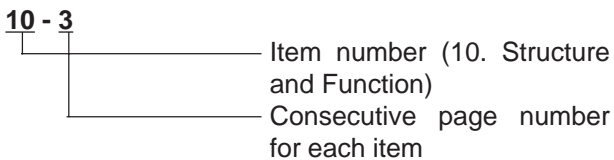

Example 2 (Engine Volume:)

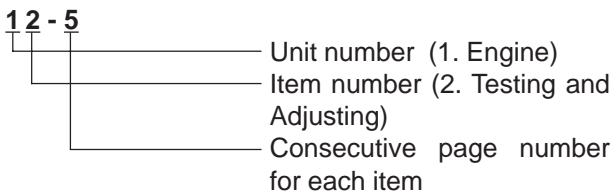

3. Additional pages: Additional pages are indicated by a hyphen (-) and number after the page number. File as in the example.

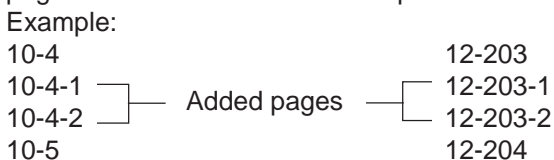

REVISED EDITION MARK

When a manual is revised, an edition mark (①,②,③,...) is recorded on the bottom of the pages.

REVISIONS

Revised pages are shown in the LIST OF REVISED PAGES next to the CONTENTS page.

SYMBOLS

So that the shop manual can be of ample practical use, important safety and quality portions are marked with the following symbols.

Symbol	Item	Remarks
	Safety	Special safety precautions are necessary when performing the work.
	Caution	Special technical precautions or other precautions for preserving standards are necessary when performing the work.
	Weight	Weight of parts of systems. Caution necessary when selecting hoisting wire, or when working posture is important, ect.
	Tightening torque	Places that require special attention for the tightening torque during assembly.
	Coat	Places to be coated with adhesives and lubricants, etc.
	Oil, water	Places where oil, water or fuel must be added, and the capacity.
	Drain	Places where oil or water must be drained, and quantity to be drained.

HOISTING INSTRUCTIONS

HOISTING

 Heavy parts (25 kg or more) must be lifted with a hoist, etc. In the **DISASSEMBLY AND ASSEMBLY** section, every part weighing 25 kg or more is indicated with the symbol 

- If a part cannot be smoothly removed from the machine by hoisting, the following checks should be made:
 - 1) Check for removal of all bolts fastening the part to the relative parts.
 - 2) Check for existence of another part causing interference with the part to be removed.

WIRE ROPES

- 1) Use adequate ropes depending on the weight of parts to be hoisted, referring to

Wire ropes (Standard "Z" or "S" twist ropes without galvanizing)	
Rope diameter (mm)	Allowable load (tons)
10	1.0
11.2	1.4
12.5	1.6
14	2.2
16	2.8
18	3.6
20	4.4
22.4	5.6
30	10.0
40	18.0
50	28.0
60	40.0

the table below:

- ★ The allowable load value is estimated to be one-sixth or one-seventh of the breaking strength of the rope used.
- 2) Sling wire ropes from the middle portion of the hook.

Slinging near the edge of the hook may cause the rope to slip off the hook during hoisting, and a serious accident can result. Hooks have a maximum strength at the middle portion.

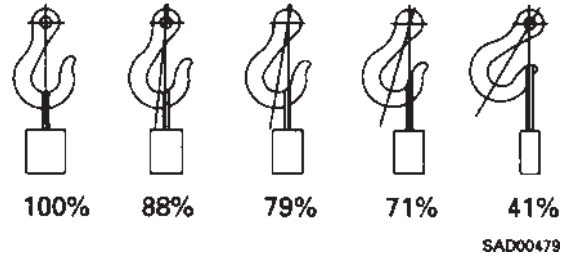

- 3) Do not sling a heavy load with one rope alone, but sling with two or more ropes symmetrically wound onto the load.

 Slinging with one rope may cause turning of the load during hoisting, untwisting of the rope, or slipping of the rope from its original winding position on the load, which can result in a dangerous accident.

- 4) Do not sling a heavy load with ropes forming a wide hanging angle from the hook. When hoisting a load with two or more ropes, the force subjected to each rope will increase with the hanging angles. The table below shows the variation of allowable load (kg) when hoisting is made with two ropes, each of which is allowed to sling up to 1000 kg vertically, at various hanging angles.

When two ropes sling a load vertically, up to 2000 kg of total weight can be suspended. This weight becomes 1000 kg when two ropes make a 120° hanging angle. On the other hand, two ropes are subjected to an excessive force as large as 4000 kg if they sling a 2000 kg load at a lifting angle of 150°.

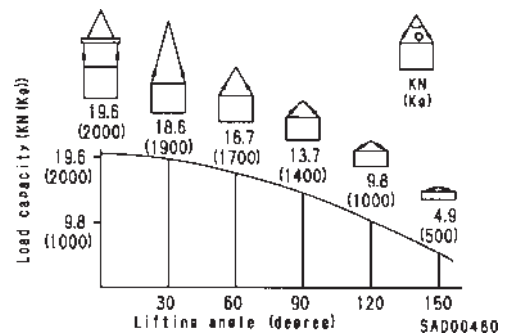

COATING MATERIALS

The recommended coating materials prescribed in Komatsu Shop Manuals are listed below.



Category	Komatsu code	Part No.	Q'ty	Container	Main applications, features
Adhesive	LT-1A	790-129-9030	150 g	Tube	<ul style="list-style-type: none"> Used to prevent rubber gaskets, rubber cushions, and cork plugs from coming out
	LT-1B	790-129-9050	20 g (x2)	Plastic container	<ul style="list-style-type: none"> Used in places requiring an immediately effective, strong adhesive. Used for plastics (except polyethylene, polypropylene, tetrafluoroethylene and vinyl chloride), rubber, metal, and non-metal.
	LT-2	09940-00030	50 g	Plastic container	<ul style="list-style-type: none"> Features: resistance to heat, chemicals Used for anti-loosening and sealant purposes for bolts and plugs
	LT-3	790-129-9060 (Set of adhesive and hardening agent)	Adhesive : 1 kg Hardening agent : 500 g	Can	<ul style="list-style-type: none"> Used as adhesive or sealant for metal, glass, plastic
	LT-4		250 g	Plastic container	<ul style="list-style-type: none"> Used as sealant for machined holes
	(Loctite 648-50)	790-129-9040	50 cc	-	<ul style="list-style-type: none"> Features: Resistance to heat, chemicals Used at joint portions subject to high temperature
Gasket sealant	LG-1	79A-129-9110	200 g	Tube	<ul style="list-style-type: none"> Used as adhesive or sealant for gaskets and packings of power train case, etc.
	LG-3	790-129-9070	1kg	Can	<ul style="list-style-type: none"> Features: Resistance to heat Used as sealant for flange surfaces and bolts at high temperature locations, used to prevent seizure Used as sealant for heat resistant gasket for high temperature locations such as engine precombustion chamber, exhaust pipe
	LG-4	790-120-9020	200 g	Tube	<ul style="list-style-type: none"> Features: Resistance to water, oil Used as sealant for flange surface, thread Also possible to use as sealant for flanges with large clearance Used as sealant for mating surfaces of final drive case, transmission case.
	LG-5	790-129-9080	1 kg	Plastic container	<ul style="list-style-type: none"> Used as sealant for various threads, pipe joints, flanges Used as sealant for tapered plugs, elbows, nipples of hydraulic piping
	LG-6	09940-00011	250 g	Tube	<ul style="list-style-type: none"> Features: Silicon based, resistance to heat, cold Used as sealant for flange surface, thread Used as sealant for oil pan, final drive case, etc.
	LG-7	09920-00150	150 g	Tube	<ul style="list-style-type: none"> Features: Silicon based, quick hardening type Used as sealant for flywheel housing, intake manifold, oil pan, thermostat housing, etc.
	Rust prevention lubricant	-	09940-00051	60 g	Can
Molybdenum disulphide lubricant	-	09940-00040	200 g	Tube	<ul style="list-style-type: none"> Used to prevent seizure or scuffing of the thread when press fitting or shrink fitting Used as lubricant for linkage, bearings, etc.
Lithium grease	G2-LI	SYG350LI SYG-400LI SYG-400LI-A SYG-160LI SYGA-160CNLI	Various	Various	<ul style="list-style-type: none"> General purpose type
Calcium grease	G2-CA	SSG2-400CA SYG2-350CA SYG2-400CA-A SYG2-160CA SYGA-16NCA	Various	Various	<ul style="list-style-type: none"> Used for normal temperature, light load bearing at places in contact with water or steam
Molybdenum disulphide grease	-	SYG2-400M	400 g (10 per case)	Bellows type	<ul style="list-style-type: none"> Used for places with heavy load

STANDARD TIGHTENING TORQUE

STANDARD TIGHTENING TORQUES OF BOLTS AND NUTS

The following charts give the standard tightening torques of bolts and nuts. Exceptions are given in section of **DISASSEMBLY AND ASSEMBLY**.

1 Kgm = 9.806 Nm

Thread diameter of bolt mm	Width across flats mm		
		SAD00481 kgm	SAD00482 Nm
6	10	1.35 ± 0.15	13.2 ± 1.4
8	13	3.2 ± 0.3	31.4 ± 2.9
10	17	6.7 ± 0.7	65.7 ± 6.8
12	19	11.5 ± 1.0	112 ± 9.8
14	22	18.0 ± 2.0	177 ± 19
16	24	28.5 ± 3	279 ± 29
18	27	39 ± 4	383 ± 39
20	30	56 ± 6	549 ± 58
22	32	76 ± 8	745 ± 78
24	36	94.5 ± 10	927 ± 98
27	41	135 ± 15	1320 ± 140
30	46	175 ± 20	1720 ± 190
33	50	225 ± 25	2210 ± 240
36	55	280 ± 30	2750 ± 290
39	60	335 ± 25	3280 ± 340

- ★ This torque table does not apply to the bolts with nylon packaging or other nonferrous metal washers are to be used, or which require tightening to otherwise specified torque.

TIGHTENING TORQUE OF SPLIT FLANGE BOLTS

Use these torques for split flange bolts.

Thread diameter of bolt	Width across flats	Tightening torque	
		kgm	Nm
mm	mm		
10	14	6.7 ± 0.7	65.7 ± 6.8
12	17	11.5 ± 1	112 ± 9.8
16	22	28.5 ± 3	279 ± 29

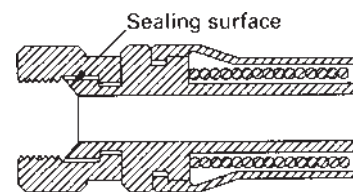
**TIGHTENING TORQUE FOR FLARED NUTS**

Use these torques for flared part of nut.

SAD00483

Thread diameter of bolt	Width across flats	Tightening torque	
		kgm	Nm
mm	mm		
14	19	2.5 ± 0.5	24.5 ± 4.9
18	24	5 ± 2	49 ± 19.6
22	27	8 ± 2	78.5 ± 19.6
24	32	14 ± 3	137.3 ± 29.4
30	36	18 ± 3	176.5 ± 29.4
33	41	20 ± 5	196.1 ± 49
36	46	25 ± 5	245.2 ± 49
42	55	30 ± 5	294.2 ± 49

ELECTRIC WIRE CODE

In the wiring diagrams, various colors and symbols are employed to indicate the thickness of wires. This wire code table will help you understand WIRING DIAGRAMS.

Example: 5WB indicates a cable having a nominal number 5 and white coating with black stripe.

CLASSIFICATION BY THICKNESS

Nominal number	Copper wire			Cable O.D. (mm)	Current rating (A)	Applicable circuit
	Number of strands	Dia. of strands (mm)	Cross section (mm ²)			
0.85	11	0.32	0.88	2.4	12	Starting, lighting, signal etc.
2	26	0.32	2.09	3.1	20	Lighting, signal etc.
5	65	0.32	5.23	4.6	37	charging and signal
15	84	0.45	13.36	7.0	59	Starting (Glow plug)
40	85	0.80	42.73	11.4	135	Starting
60	127	0.80	63.84	13.6	178	Starting
100	217	0.80	109.1	17.6	230	Starting

CLASSIFICATION BY COLOR AND CODE

Priority	Classification	Circuits							
		Charging	Ground	Starting	Lighting	Instrument	Signal	Other	
1	Primary	Code	W	B	B	R	Y	G	L
		Color	White	Black	Black	Red	Yellow	Green	Blue
2		Code	WR	-	BW	RW	YR	GW	LW
		Color	White & Red	-	Black & White	Red & White	Yellow & Red	Green & White	Blue & White
3		Code	WB	-	BY	RB	YB	GR	LR
		Color	White & Black	-	Black & Yellow	Red & Black	Yellow & Black	Green & Red	Blue & Red
4	Auxiliary	Code	WL	-	BR	RY	YG	GY	LY
		Color	White & Blue	-	Black & Red	Red & Yellow	Yellow & Green	Green & Yellow	Blue & Yellow
5		Code	WG	-	-	RG	YL	GB	LBB
		Color	White & Green	-	-	Red & Green	Yellow & Blue	Green & Black	Blue & Black
6		Code	-	-	-	RL	YW	GL	-
		Color	-	-	-	Red & Blue	Yellow & White	Green & Blue	-

CONVERSION TABLE

METHOD OF USING THE CONVERSION TABLE

The Conversion Table in this section is provided to enable simple conversion of figures. For details of the method of using the Conversion Table, see the example given below.

EXAMPLE

- Method of using the Conversion Table to convert from millimeters to inches
1. Convert 55 mm to inches
 - (1) Locate the number 50 in the vertical column at the left side, take this as **Ⓐ**, then draw a horizontal line from **Ⓐ**.
 - (2) Locate the number 5 in the row across the top, take this as **Ⓑ**, then draw a perpendicular line down from **Ⓑ**.
 - (3) Take the point where the two lines cross as **Ⓒ**. This point **Ⓒ** gives the value when converting from millimeters to inches. Therefore, 55mm = 2.165 inches.

 2. Convert 550 mm into inches.
 - (1) The number 550 does not appear in the table, so divide by 10 (move the decimal point one place to the left) to convert it to 55 mm.
 - (2) Carry out the same procedure as above to convert 55 mm to 2.165 inches.
 - (3) The original value (550 mm) was divided by 10, so multiply 2.165 inches by 10 (move the decimal point one place to the right) to return to the original value. This gives 550 mm = 21.65 inches.

Ⓑ

Millimeters to inches 1 mm = 0.03937 in

	0	1	2	3	4	5	6	7	8	9
0	0	0.039	0.079	0.118	0.157	0.197	0.236	0.276	0.315	0.354
10	0.394	0.433	0.472	0.512	0.551	0.591	0.630	0.669	0.709	0.748
20	0.787	0.827	0.866	0.906	0.945	0.984	1.024	1.063	1.102	1.142
30	1.181	1.220	1.260	1.299	1.339	1.378	1.417	1.457	1.496	1.536
40	1.575	1.614	1.654	1.693	1.732	1.772	1.811	1.850	1.890	1.929
Ⓐ — 50	1.969	2.008	2.047	2.087	2.126	2.165	2.205	2.244	2.283	2.323
60	2.362	2.402	2.441	2.480	2.520	2.559	2.598	2.638	2.677	2.717
70	2.756	2.795	2.835	2.874	2.913	2.953	2.992	3.032	3.071	3.110
80	3.150	3.189	3.228	3.268	3.307	3.346	3.386	3.425	3.465	3.504
90	3.543	3.583	3.622	3.661	3.701	3.740	3.780	3.819	3.858	3.898

Ⓒ

Millimeters to Inches

1 mm = 0.03937 in

	0	1	2	3	4	5	6	7	8	9
0	0	0.039	0.079	0.118	0.157	0.197	0.236	0.276	0.315	0.354
10	0.394	0.433	0.472	0.512	0.551	0.591	0.630	0.669	0.709	0.748
20	0.787	0.827	0.866	0.906	0.945	0.984	1.024	1.063	1.102	1.142
30	1.181	1.220	1.260	1.299	1.339	1.378	1.417	1.457	1.496	1.536
40	1.575	1.614	1.654	1.693	1.732	1.772	1.811	1.850	1.890	1.929
50	1.969	2.008	2.047	2.087	2.126	2.165	2.205	2.244	2.283	2.323
60	2.362	2.402	2.441	2.480	2.520	2.559	2.598	2.638	2.677	2.712
70	2.756	2.795	2.835	2.874	2.913	2.953	2.992	3.032	3.071	3.110
80	3.150	3.189	3.228	3.268	33.07	3.346	3.386	3.425	3.465	3.504
90	3.543	3.583	3.622	3.661	3.701	3.740	3.780	3.819	3.858	3.898

Kilogram to Pound

1kg = 2.2046 lb

	0	1	2	3	4	5	6	7	8	9
0	0	2.20	4.41	6.61	8.82	11.02	13.23	15.43	17.64	19.84
10	22.05	24.25	26.46	28.66	30.86	33.07	35.27	37.48	39.68	41.89
20	44.09	46.30	48.50	50.71	51.91	55.12	57.32	59.53	61.73	63.93
30	66.14	68.34	70.55	72.75	74.96	77.16	79.37	81.57	83.78	85.98
40	88.18	90.39	92.59	94.80	97.00	99.21	101.41	103.62	105.82	108.03
50	110.23	112.44	114.64	116.85	119.05	121.25	123.46	135.66	127.87	130.07
60	132.28	134.48	136.69	138.89	141.10	143.30	145.51	147.71	149.91	152.12
70	154.32	156.53	158.73	160.94	163.14	165.35	167.55	169.76	171.96	174.17
80	176.37	178.57	180.78	182.98	185.19	187.39	189.60	191.80	194.01	196.21
90	198.42	200.62	202.03	205.03	207.24	209.44	211.64	213.85	216.05	218.26

Litre to U.S. Gallon

1ℓ = 0.2642 U.S. Gal

	0	1	2	3	4	5	6	7	8	9
0	0	0.264	0.528	0.793	1.057	1.321	1.585	1.849	2.113	2.378
10	2.642	2.906	3.170	3.434	3.698	3.963	4.227	4.491	4.755	5.019
20	5.283	5.548	5.812	6.076	6.3340	6.604	6.869	7.133	7.397	7.661
30	7.925	8.189	8.454	8.718	8.982	9.246	9.510	9.774	10.039	10.303
40	10.567	10.831	11.095	11.359	11.624	11.888	12.152	12.416	12.680	12.944
50	13.209	13.473	13.737	14.001	14.265	14.529	14.795	15.058	15.322	15.586
60	15.850	16.115	16.379	16.643	16.907	17.171	17.435	17.700	17.964	18.228
70	18.492	18.756	19.020	19.285	19.549	19.813	20.077	20.341	20.605	20.870
80	21.134	21.398	21.662	21.926	22.190	22.455	22.719	22.983	23.247	23.511
90	23.775	24.040	24.304	24.568	24.832	25.096	25.361	25.625	25.889	26.153

Litre to U.K. Gallon

1ℓ = 0.21997 U.K. Gal

	0	1	2	3	4	5	6	7	8	9
0	0	0.220	0.440	0.660	0.880	1.100	1.320	1.540	1.760	1.980
10	2.200	2.420	2.640	2.860	3.080	3.300	35.20	3.740	3.950	4.179
20	4.399	4.619	4.839	5.059	5.279	5.499	5.719	5.939	6.159	6379
30	6.599	6.819	7.039	7.259	7.479	7.969	7.919	8.139	8.359	8.579
40	8.799	9.019	9.239	9.459	9.679	9.899	10.119	10.339	10.559	10.778
50	10.998	11.281	11.438	11.658	11.878	12.098	12.318	12.528	12.758	12.978
60	13.198	13.418	13.638	13.858	14.078	14.298	14.518	14.738	14.958	15.178
70	15.398	15.618	15.838	16.058	16.278	16.498	16.718	16.938	17.158	17.378
80	17.598	17.818	18.037	18.257	18.477	18.697	18.917	19.137	19.357	19.577
90	19.797	20.017	20.237	20.457	20.677	20.897	21.117	21.337	21.557	21.777

kgm to ft. lb

1 kgm = 7.233 ft. lb

	0	1	2	3	4	5	6	7	8	9
0	0	7.2	14.5	21.7	28.9	36.2	43.4	50.6	57.9	65.1
10	72.3	79.6	86.8	94.0	101.3	108.5	115.7	123.0	130.2	137.4
20	144.7	151.9	159.1	166.4	173.6	180.8	188.1	195.3	202.5	209.8
30	217.0	224.2	231.5	238.7	245.9	253.2	260.4	267.6	274.9	282.1
40	289.3	296.6	303.8	311.0	318.3	325.5	332.7	340.0	347.2	354.4
50	361.7	368.9	376.1	383.4	390.6	397.8	405.1	412.3	419.5	426.8
60	434.0	441.2	448.5	455.7	462.9	470.2	477.4	484.6	491.8	499.1
70	506.3	513.5	520.8	528.0	535.2	542.5	549.7	556.9	564.2	571.4
80	578.6	585.9	593.1	600.3	607.6	614.8	622.0	629.3	636.5	643.7
90	651.0	658.2	665.4	672.7	679.9	687.1	694.4	701.6	708.8	716.1
100	723.3	730.5	737.8	745.0	752.2	759.5	766.7	773.9	781.2	788.4
110	795.6	802.9	810.1	817.3	824.6	831.8	839.0	846.3	853.5	860.7
120	868.0	875.2	882.4	889.7	896.9	904.1	911.4	918.6	925.8	933.1
130	940.3	947.5	954.8	962.0	969.2	976.5	983.7	990.9	998.2	1005.4
140	1012.6	1019.9	1027.1	1034.3	1041.5	1048.8	1056.0	1063.2	1070.5	1077.7
150	1084.9	1092.2	1099.4	1106.6	1113.9	1121.1	1128.3	1135.6	1142.8	1150.0
160	1157.3	1164.5	1171.7	1179.0	1186.2	1193.4	1200.7	1207.9	1215.1	1222.4
170	1129.6	1236.8	1244.1	1251.3	1258.5	1265.8	1273.0	1280.1	1287.5	1294.7
180	1301.9	1309.2	1316.4	1323.6	1330.9	1338.1	1245.3	1352.6	1359.8	1367.0
190	1374.3	1381.5	1388.7	1396.0	1403.2	1410.4	1417.7	1424.9	1432.1	1439.4

kg/cm² to lb/in²

1 kg/cm² = 14.2233 lb/in²

	0	1	2	3	4	5	6	7	8	9
0	0	14.2	28.4	42.7	56.9	71.1	85.3	99.6	113.8	128.0
10	142.2	156.5	170.7	184.9	199.1	213.4	227.6	241.8	256.0	270.2
20	284.5	298.7	312.9	327.1	341.4	355.6	369.8	384.0	398.3	412.5
30	426.7	440.9	455.1	469.4	483.6	497.8	512.0	526.3	540.5	554.7
40	568.9	583.2	597.4	611.6	625.8	640.1	654.3	668.5	682.7	696.9
50	711.2	725.4	739.6	753.8	768.1	782.3	796.5	810.7	825.0	839.2
60	853.4	867.6	881.8	896.1	910.3	924.5	938.7	953.0	967.2	981.4
70	995.6	1010	1024	1038	1053	1067	1081	1095	1109	1124
80	1138	1152	1166	1181	1195	1209	1223	1237	1252	1266
90	1280	1294	1309	1323	1337	1351	1365	1380	1394	1408
100	1422	1437	1451	1465	1479	1493	1508	1522	1536	1550
110	1565	1579	1593	1607	1621	1636	1650	1664	1678	1693
120	1707	1721	1735	1749	1764	1778	1792	1806	1821	1835
130	1849	1863	1877	1892	1906	1920	1934	1949	1963	1977
140	1991	2005	2020	2034	2048	2062	2077	2091	2105	2119
150	2134	2148	2162	2176	2190	2205	2219	2233	2247	2262
160	2276	2290	2304	2318	2333	2347	2361	2375	2389	2404
170	2418	2432	2446	2460	2475	2489	2503	2518	2532	2546
180	2560	2574	2589	2603	1617	2631	2646	2660	2674	2688
190	2702	2717	2731	2745	2759	2773	2788	2802	2816	2830
200	2845	2859	2873	2887	2901	2916	2930	2944	2958	2973
210	2987	3001	3015	3030	3044	3058	3072	3086	3101	3115
220	3129	3143	3158	3172	3186	3200	3214	3229	3243	3257
230	3271	3286	3300	3314	3328	3343	3357	4471	3385	3399
240	3414	3428	3442	3456	3470	3485	3499	3513	3527	3542

Temperature

Fahrenheit-Centigrade Conversion; a simple way to convert a Fahrenheit temperature reading into a Centigrade temperature reading or vice is to enter the accompanying table in the center or boldface column of figures.

These figures refer to the temperature in either Fahrenheit or Centigrade degrees.

If it desired to convert from Fahrenheit to Centigrade degrees, consider the center column as a table of Fahrenheit temperatures and read the corresponding Centigrade temperature in the column at the left.

If it is desired to convert from Centigrade to Fahrenheit degrees, consider the center column as a table of Centigrade values, and read the corresponding Fahrenheit temperature on the right.

$$1^{\circ}\text{C} = 33.8^{\circ}\text{F}$$

°C		°F	°C		°F	°C		°F	°C		°F
-40.4	-40	-40.0	-11.7	11	51.8	7.8	46	114.8	27.2	81	117.8
-37.2	-35	-31.0	-11.1	12	53.6	8.3	47	116.6	27.8	82	119.6
-34.4	-30	-22.0	-10.6	13	55.4	8.9	48	118.4	28.3	83	121.4
-31.7	-25	-13.0	-10.0	14	57.2	9.4	49	120.2	28.9	84	123.2
-28.9	-20	-4.0	-9.4	15	59.0	10.0	50	122.0	29.4	85	125.0
-28.3	-19	-2.2	-8.9	16	60.8	10.6	51	123.8	30.0	86	126.8
-27.8	-18	-0.4	-8.3	17	62.6	11.1	52	125.6	30.6	87	128.6
-27.2	-17	1.4	-7.8	18	64.4	11.7	53	127.4	31.1	88	130.4
-26.7	-16	3.2	-7.2	19	66.2	12.2	54	129.2	31.7	89	132.2
-26.1	-15	5.0	-6.7	20	68.0	12.8	55	131.0	32.2	90	134.0
-25.6	-14	6.8	-6.1	21	69.8	13.3	56	132.8	32.8	91	135.8
-25.0	-13	8.6	-5.6	22	71.6	13.9	57	134.6	33.3	92	137.6
-24.4	-12	10.4	-5.0	23	73.4	14.4	58	136.4	33.9	93	139.4
-23.9	-11	12.2	-4.4	24	75.2	15.0	59	138.2	34.4	94	141.2
-23.3	-10	14.0	-3.9	25	77.0	15.6	60	140.0	35.0	95	143.0
-22.8	-9	15.8	-3.3	26	78.8	16.1	61	141.8	35.6	96	144.8
-22.2	-8	17.6	-2.8	27	80.6	16.7	62	143.6	36.1	97	146.6
-21.7	-7	19.4	-2.2	28	82.4	17.2	63	145.4	36.7	98	148.4
-21.1	-6	21.2	-1.7	29	84.2	17.8	64	147.2	37.2	99	150.2
-20.6	-5	23.0	-1.1	30	86.0	18.3	65	149.0	37.8	100	152.0
-20.0	-4	24.8	-0.6	31	87.8	18.9	66	150.8	38.4	101	153.8
-19.4	-3	26.6	0	32	89.6	19.4	67	152.6	39.0	102	155.6
-18.9	-2	28.4	0.6	33	91.4	20.0	68	154.4	39.6	103	157.4
-18.3	-1	30.2	1.1	34	93.2	20.6	69	156.2	40.2	104	159.2
-17.8	0	32.0	1.7	35	95.0	21.1	70	158.0	40.8	105	161.0
-17.2	1	33.8	2.2	36	96.8	21.7	71	159.8	41.4	106	162.8
-16.7	2	35.6	2.8	37	98.6	22.2	72	161.6	42.0	107	164.6
-16.1	3	37.4	3.3	38	100.4	22.8	73	163.4	42.6	108	166.4
-15.6	4	39.2	3.9	39	102.2	23.3	74	165.2	43.2	109	168.2
-15.0	5	41.0	4.4	40	104.0	23.9	75	167.0	43.8	110	170.0
-14.4	6	42.8	5.0	41	105.8	24.4	76	168.8	44.4	111	171.8
-13.9	7	44.6	5.6	42	107.6	25.0	77	170.6	45.0	112	173.6
-13.3	8	46.4	6.1	43	109.4	25.6	78	172.4	45.6	113	175.4
-12.8	9	48.2	6.7	44	111.2	26.1	79	174.2	46.2	114	177.2
-12.2	10	50.0	7.2	45	113.0	26.7	80	176.0	46.8	115	179.0

MEMORANDA

10 STRUCTURE AND FUNCTION

ENGINE RELATED PARTS	10-6
RADIATOR • OIL COOLER	10-7
POWER TRAIN	10-8
FINAL DRIVE	10-9
PC290	
SWING CIRCLE	10-10
SWING MACHINERY	10-11
PC290LC, PC290NLC	
TRACK FRAME • RECOIL SPRING	10-12
TRACK SHOE	10-13
HYDRAULIC PIPING DRAWING	10-14
HYDRAULIC CIRCUIT DIAGRAM	10-15 a/b
HYDRAULIC TANK	10-16
HYDRAULIC PUMP	10-17
Basic pump	10-17
Outline	10-17
Function	10-20
Structure	10-20
Operation	10-21
LS and PC valve	10-24
Function	10-25
Operation	10-26
CONTROL VALVE	10-36
Outline	10-36
9-spool valve (standard + 3 service valves)	10-37
Main structure	10-38
6-spool valve	10-41

SAFETY-SUCTION VALVE FOR SERVICE VALVE	10-42
SELF-REDUCING PRESSURE VALVE	10-43
Function	10-45
Operation	10-45
CLSS	10-48
Outline of CLSS	10-48
Features	10-48
Structure	10-48
Basic Principle	10-49
Operation for each function and valve	10-51
Hydraulic circuit diagram for system	10-51
Unload valve	10-54
Main relief valve (2-stage type)	10-55
Introduction of LS pressure	10-57
LS bypass valve	10-58
Pressure compensation valve	10-59
Shuttle valve inside pressure compensation valve	10-62
Variable type pressure compensation valve (for service valve)	10-63
Boom regeneration circuit	10-65
Arm regeneration circuit	10-67
Pump merge-divider valve	10-68
LS select valve	10-70
Spool stroke modulation	10-71
Timing valve	10-72
2-stage safety valve (installed to boom cylinder head)	10-73
Operation of CLSS system as a whole	10-74
When all work equipment is at neutral	10-74
Pump flow divided, one side actuated, other side neutral	10-76
Pump flow merged, arm OUT, standard mode relief (cut-off control)	10-78
Pump flow divided, bucket DUMP, power max. relief	10-80
Pump flow merged, boom RAISE	10-82
Pump flow merged, swing operated independently	10-84
Pump flow divided, travel operated independently	10-86
Pump flow merged, compound operation	10-88
SWING MOTOR	10-90
BASIC MOTOR	10-90
Swing lock valve	10-92
Operation	10-92
CENTER SWIVEL JOINT	10-96
TRAVEL MOTOR	10-97
Operation of motor	10-99
Operation of parking brake	10-101
Operation of brake valve	10-102
VALVE CONTROL	10-106
WORK EQUIPMENT • SWING PPC VALVE	10-107
Operation	10-109
TRAVEL PPC VALVE	10-111
Operation	10-113

SERVICE PPC VALVE	10-115
Operation	10-116
SAFETY LOCK VALVE	10-119
PPC ACCUMULATOR	10-119
STRAIGHT-TRAVEL SYSTEM.....	10-120
Function	10-120
EPC SOLENOID VALVE	10-121
Operation	10-122
OVERLOAD WARNING DEVICE	10-123
Outline.....	10-123
Operation	10-124
HOSE BURST PROTECTION VALVE (boom)	10-125
Function	10-125
Operation	10-126
WORK EQUIPMENT	10-128
ELECTRICAL WIRING DIAGRAM	10-129
ELECTRICAL CIRCUIT DIAGRAM	10-131
ENGINE CONTROL SYSTEM	10-132
Function	10-132
Operation of system	10-133
Components of system	10-134
Fuel control dial	10-134
Governor motor	10-135
Engine throttle • pump controller	10-136
ELECTRONIC CONTROL SYSTEM	10-138
Control function	10-138
Total system diagram	10-139
Pump and engine mutual control function	10-140
Function	10-141
Control method in each mode	10-142
Pump control function when travelling	10-144
Control function when pump prolix switch is ON	10-144
Pump and valve control function	10-145
Function	10-146
Power maximizing • Swift slow-down function	10-148
Function	10-148
Auto-deceleration function	10-149
Function	10-150
Operation	10-150
Automatic warming-up and engine overheat prevention function	10-151
Function	10-151
Swing control function	10-153
Function	10-154
Travel control function	10-155
Function	10-156

Active mode function	10-157
Function	10-157
Components of system	10-160
Engine speed sensor	10-160
PPC oil pressure switch	10-150
Pump pressure sensor	10-161
PC Prolix resistor	10-162
MACHINE MONITOR SYSTEM	10-163
Function	10-164
Monitor panel	10-164
Outline	10-164
Monitor display	10-165
Content of display	10-166
Oil maintenance function	10-167
Function and operation	10-167
Setting change interval	10-167
Display timing, content	10-168
Elapsed time reset	10-168
Demo mode	10-168
Switches	10-169
Switch actuation table	10-169
HOW TO SET TELEPHONE NUMBER	10-170
SENSORS	10-171
Coolant level sensor	10-171
Engine oil level sensor	10-172
Hydraulic oil sensor	10-172
Engine oil pressure sensor	10-172
Coolant temperature sensor	10-173
Fuel level sensor	10-173
Air cleaner clogging sensor	10-173
Overload caution sensor	10-173

MEMORANDA

ENGINE RELATED PARTS

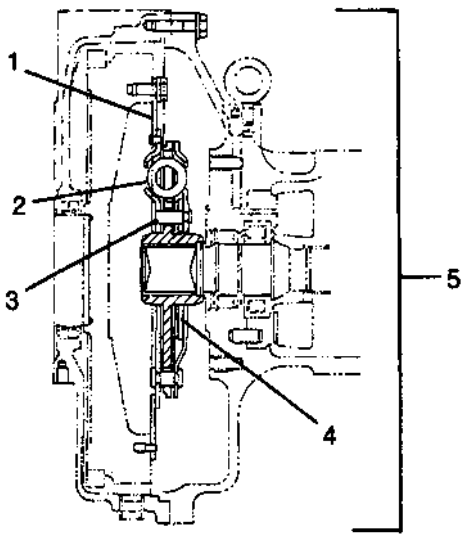

SECTION A-A

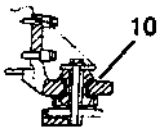
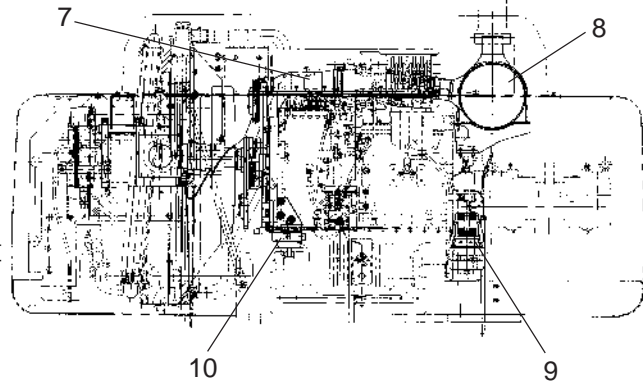
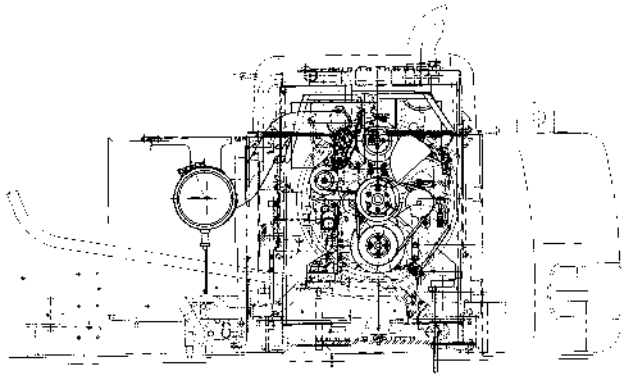
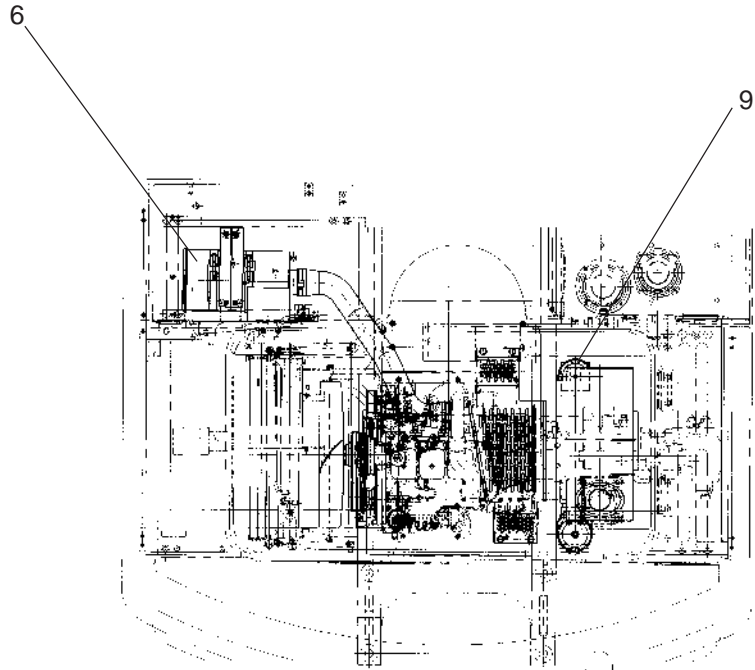

SECTION B-B

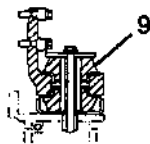

SECTION C-C

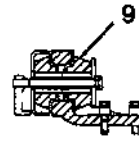

SECTION D-D



SECTION E-E

1. Drive plate
2. Torsion spring
3. Stopper pin
4. Friction plate
5. Damper assembly
6. Air cleaner
7. Intake connector
8. Muffler
9. Rear engine mount
10. Front engine mount

SPECIFICATIONS

The damper assembly is a wet type
 Oil capacity: 0.75 l.

RADIATOR • OIL COOLER

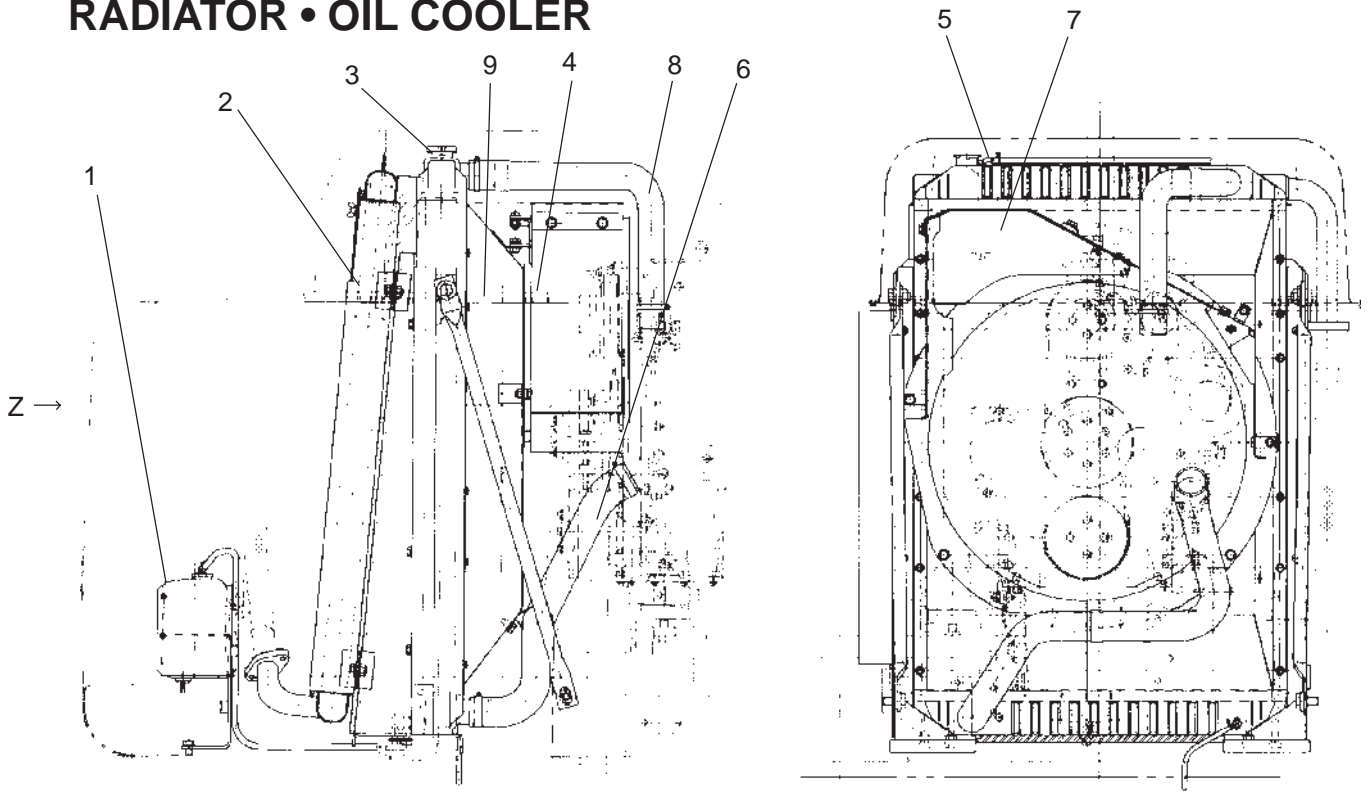

- 1. Reservoir tank
- 2. Oil cooler
- 3. Radiator
- 4. Fan
- 5. Radiator cap

- 6. Radiator outlet hose
- 7. Guard
- 8. Radiator inlet hose
- 9. Shroud

SPECIFICATIONS
Radiator: CWX-4
Oil cooler: SF-3

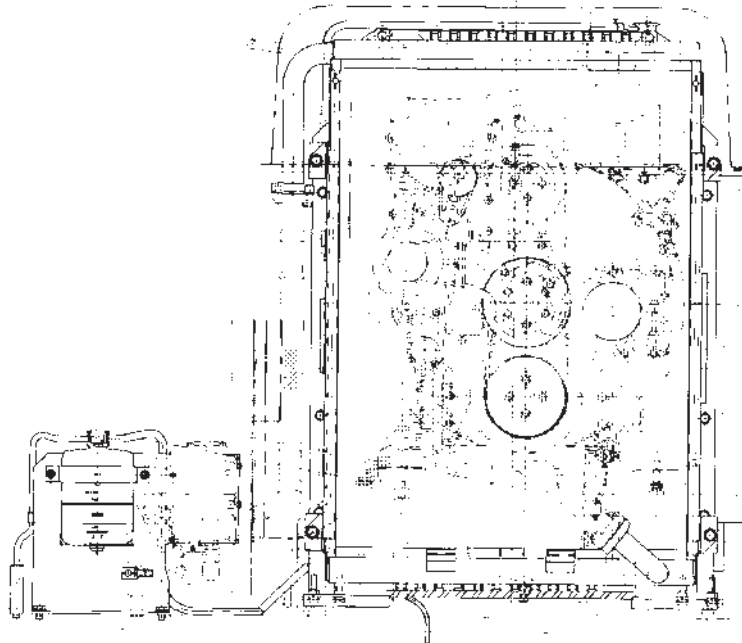

Z

POWER TRAIN

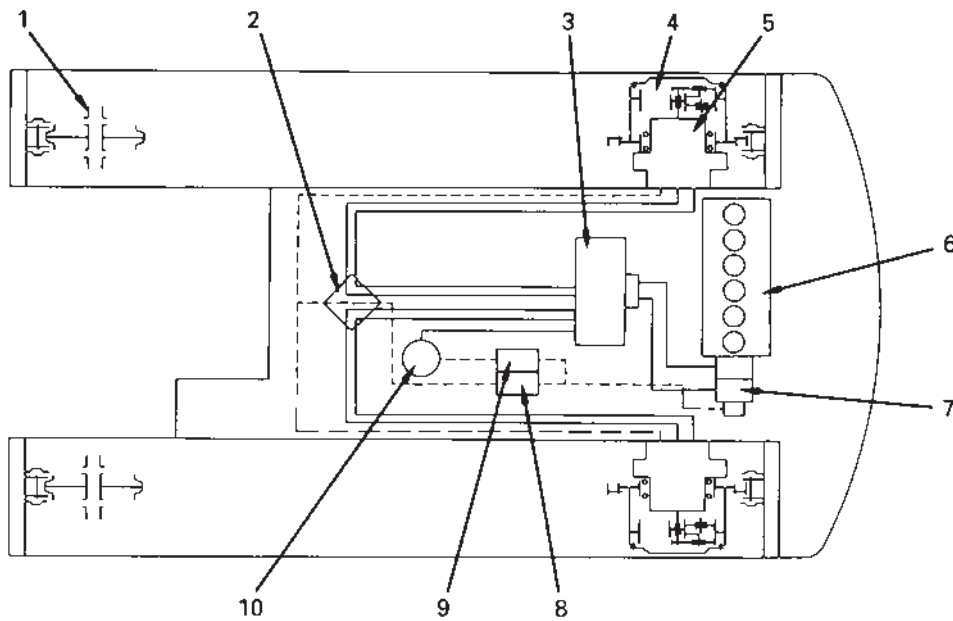

- | | |
|------------------------|--------------------------------|
| 1. Idler | 6. Engine |
| 2. Center swivel joint | 7. Hydraulic pump |
| 3. Control valve | 8. Travel speed solenoid valve |
| 4. Final drive | 9. Swing brake solenoid valve |
| 5. Travel motor | 10. Swing machinery |

FINAL DRIVE

PC290-6k

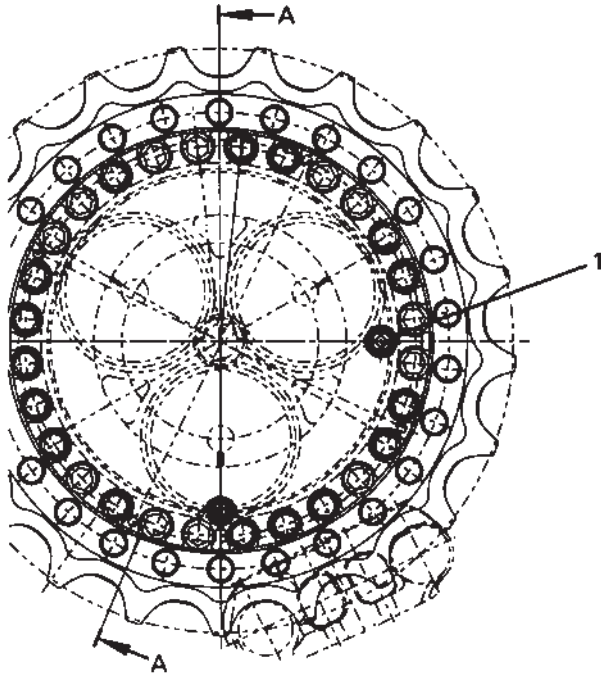

1. Level plug
2. Drain plug
3. No. 1 planetary gear (No. of teeth: 42)
4. No. 1 sun gear (No. of teeth: 11)
5. No. 2 sun gear (No. of teeth: 19)
6. No. 1 planetary carrier
7. No. 2 planetary carrier
8. Cover
9. Ring gear (No. of teeth: 97)
10. Hub
11. Sprocket
12. Floating seal
13. Travel motor
14. No. 2 planetary gear (No. of teeth: 38)

Specifications

Reduction ratio: $-\left(\frac{11+97}{11}\right) \times \left(\frac{19+97}{19}\right) + 1$
 = -58.943

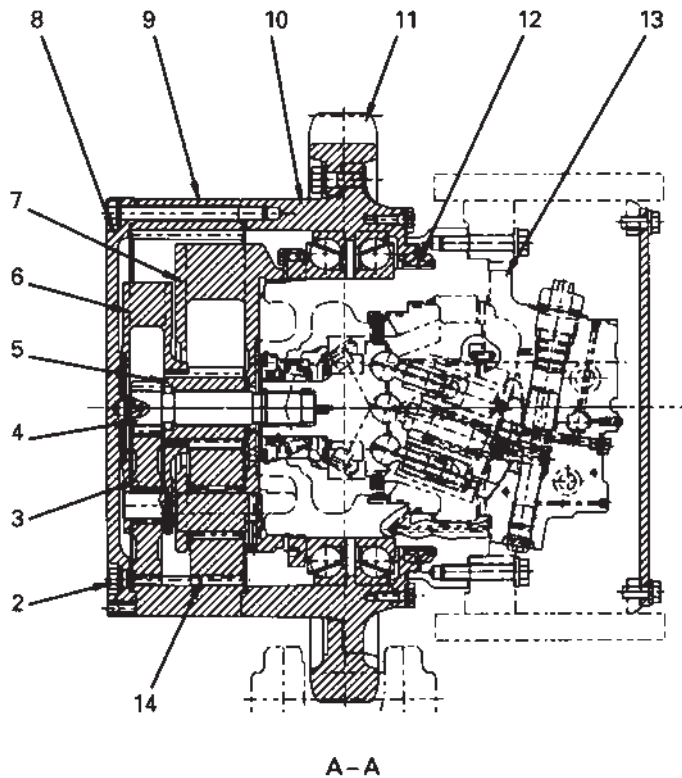

SAP00142

SWING CIRCLE

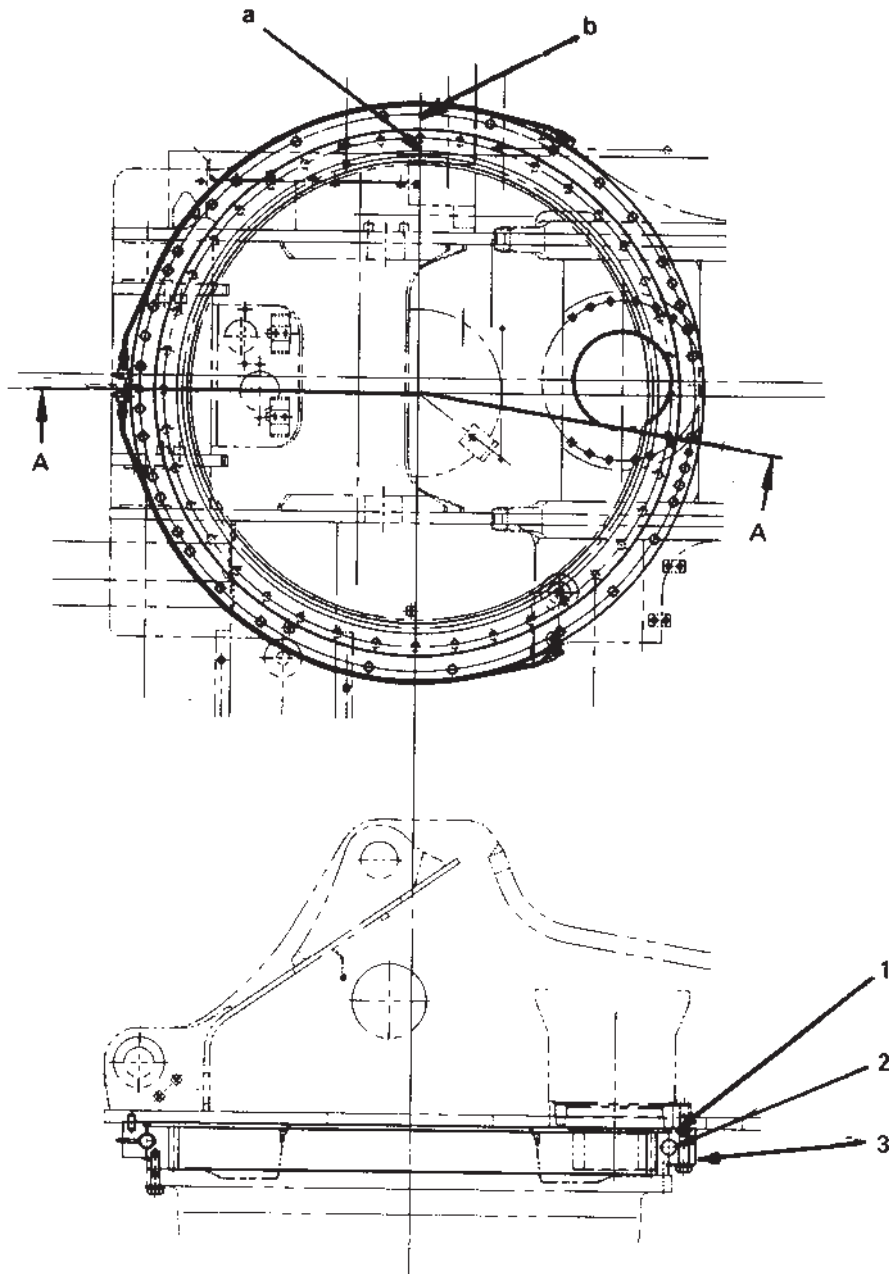

- 1. Swing circle inner race (No. of teeth: 90)
- 2. Ball
- 3. Swing circle outer race
- a. Inner race soft zone "S" position
- b. Outer race soft zone "S" position

Specifications

Reduction ration: $\frac{90}{11} = 8.182$

Amount of grease: 33 / (G2-LI)

SWING MACHINERY

PC290LC, PC290NLC

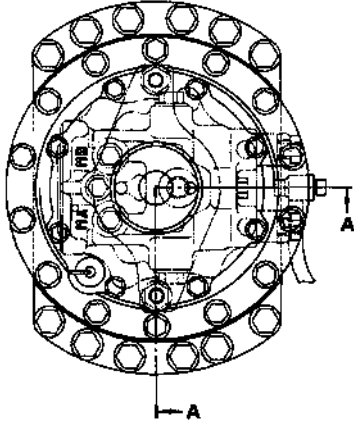

1. Swing pinion (11 teeth)
2. Cover
3. Case
4. No. 2 planetary carrier
5. No. 2 sun gear (15 teeth)
6. No. 2 ring gear (72 teeth)
7. Case
8. No. 1 ring gear (72 teeth)
9. No. 1 sun gear (21 teeth)
10. Oil level gauge
11. Cover
12. No. 1 planetary gear (25 teeth)
13. No. 1 planetary carrier
14. Coupling
15. No. 2 planetary gear (28 teeth)
16. Drain plug

Specifications

Reduction ration: $\left(\frac{21 + 72}{21}\right) \times \left(\frac{15+72}{15}\right) = 25.686$

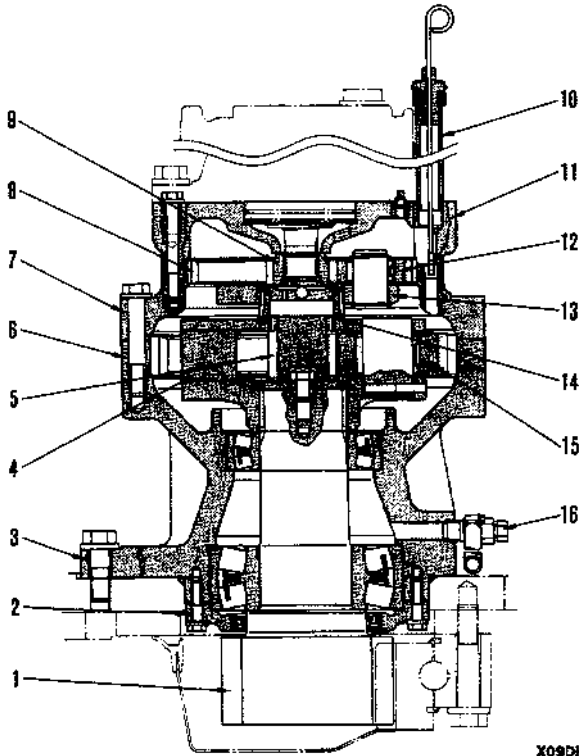

A-A

TRACK FRAME, RECOIL SPRING

★ The diagram shows the PC290-6k

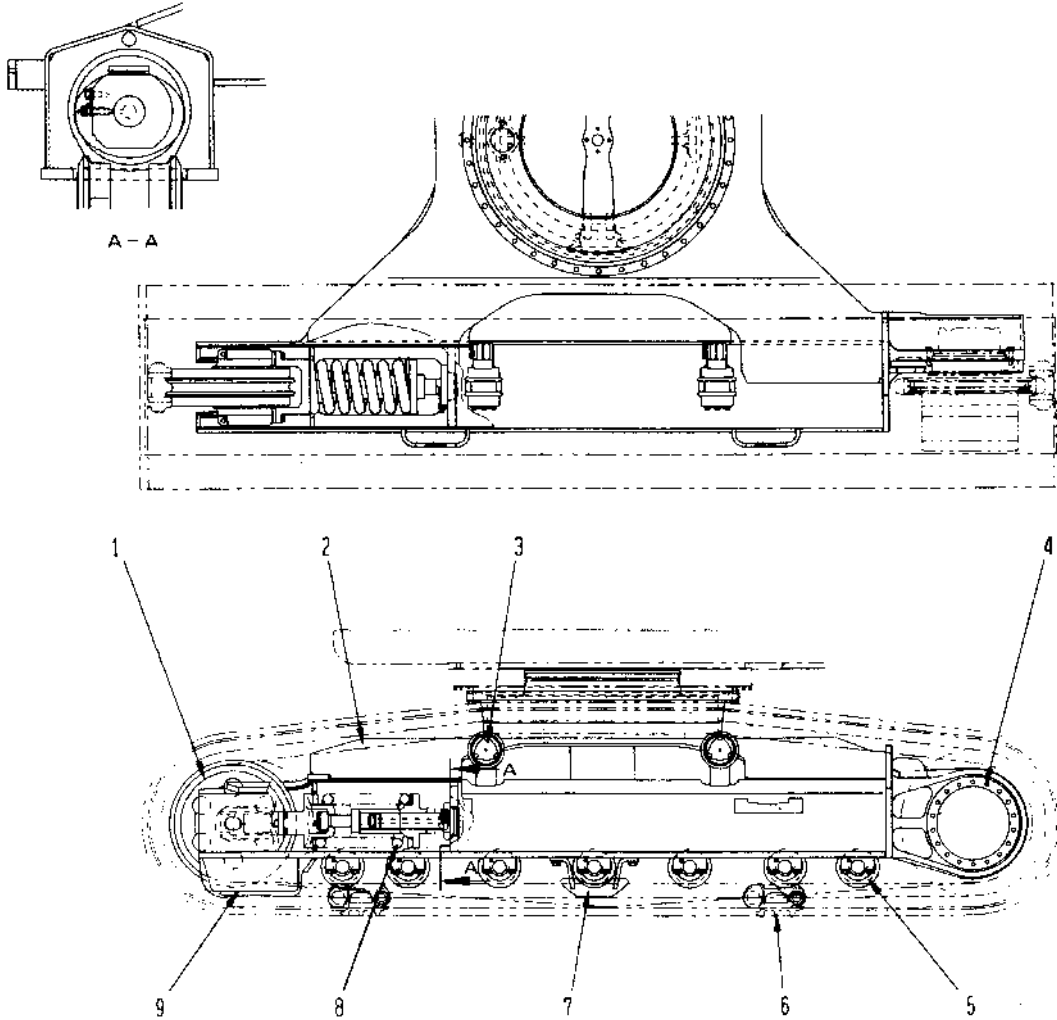

205CA06015

- 1. Idler
- 2. Track frame
- 3. Carrier roller
- 4. Final drive
- 5. Track roller
- 6. Track shoe
- 7. Center guard
- 8. Recoil spring
- 9. Front guard

Model	No. of rollers (each side)
PC290LC-6k	7
PC290NLC-6k	7

TRACK SHOE

Standard shoe

Item	Model	PC290LC-6K PC290NLC-6K
	Shoe width (mm) (triple shoe)	600mm
Link pitch (mm)	190 mm	
No. of shoes (each side)	45	

Selection of track shoe

- Select the most suitable track shoe from the following table

Model	PC290LC-6K		PC290NLC-6K	
	Specification	Category	Specification	Category
Standard	600 mm triple	A	700 mm triple	A
Option	700 mm triple	B	600 mm triple	B
Option	800 mm triple	C	800 mm triple	C
Option	900 mm triple	C	900 mm triple	C
Option	-	-	-	-
Option	-	-	-	-
Option	-	-	-	-

Category	Use	Precautions when using
A	Rocky ground, normal river soil	<ul style="list-style-type: none"> Travel in Lo speed when traveling on rough ground with obstacles such as large boulders and fallen trees.
B	Normal soil, soft land	<ul style="list-style-type: none"> Cannot be used on rough ground where there are large obstacles such as boulders and fallen trees. Travel in Hi speed only on flat ground; when it is impossible to avoid traveling over obstacles, lower the travel speed to approx. half of Lo speed.
C	Extremely soft ground (swampy ground)	<ul style="list-style-type: none"> Use only for ground wher "A" and "B" sink and are impossible to use. Cannot be used on rough ground where ther are large obstacles such as boulders and fallen trees. Travel in Hi speed only on flat ground; when it is impossible to avoid traveling over obstacles, lower the travel speed to approx. half of Lo speed.

★ Categories "B" and "C" are wide shoes, so there are restrictions on their use. Therefore, before using, check the restrictions and consider carefully the conditions of use before recommending a suitable shoe width. If necessary, give the customer guidance in their use.

★ When selecting the shoe width, select the narrowest shoe possible within the range that will give no problem with flotation and ground pressure. If a wider shoe than necessary is used, there will be a large load on the shoe, and this may lead to bending of the shoe, cracking of the links, breakage of the pins, loosening of the shoe bolts, or other problems.

HYDRAULIC TANK

Serial K30001 and up

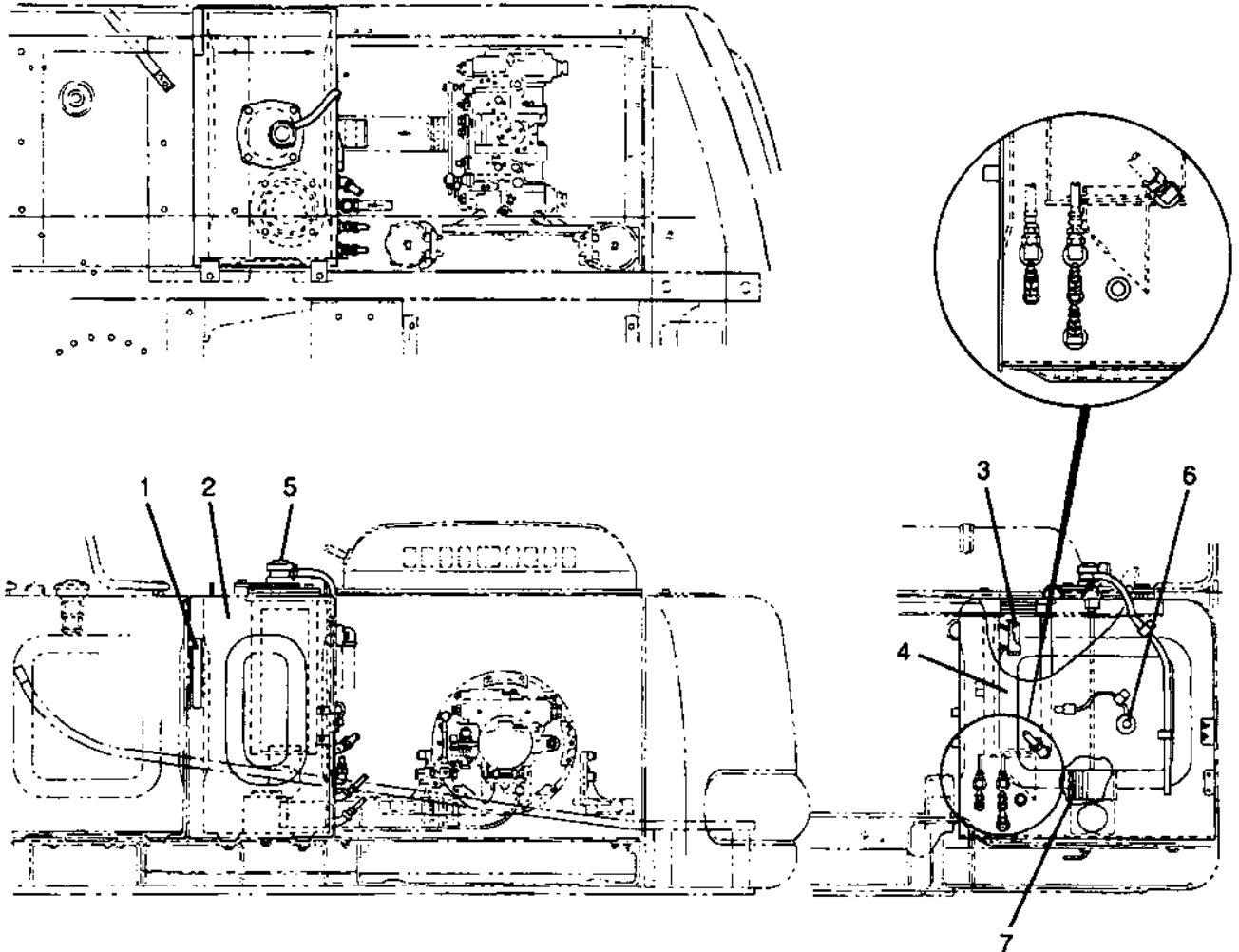

X10BV083

1. Sight gauge
2. Hydraulic tank
3. Bypass valve
4. Filter element
5. Oil filler cap
6. Hydraulic oil level sensor
7. Suction strainer

Specifications

Tank capacity: 230 /

Amount of oil inside tank: 166 /

Pressure valve

- Relief cracking pressure: 16.7 ± 3.9 kPa
(0.17 ± 0.04 kg/cm²)
- Suction cracking pressure: $0 - 0.49$ kPa
($0 - 0.005$ kg/cm²)
- Bypass valve set pressure: $0.102.9 \pm 19.6$ kPa
(1.05 ± 0.2 kg/cm²)

HYDRAULIC TANK

Serial K34001 and up

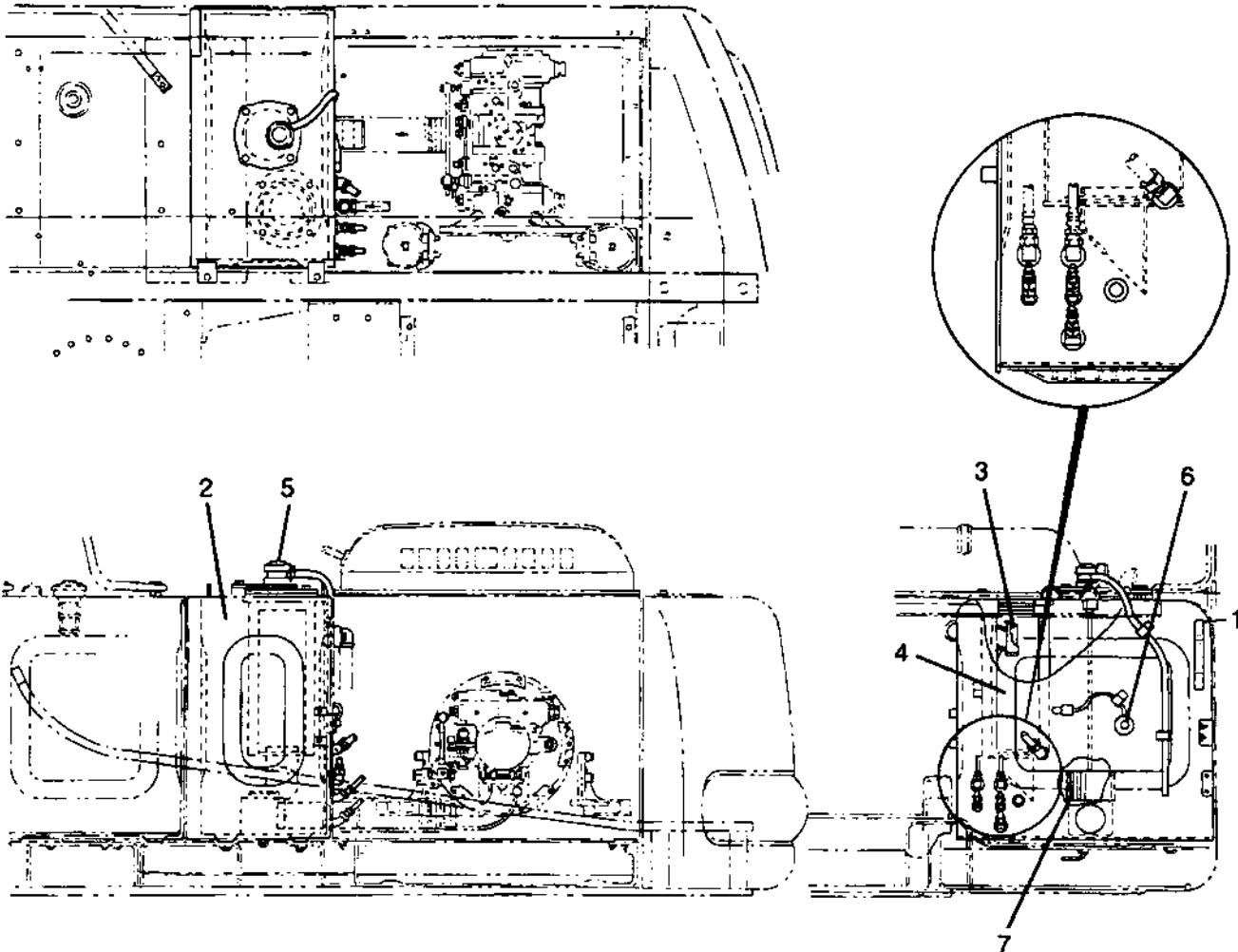

X10BV083B

1. Sight gauge
2. Hydraulic tank
3. Bypass valve
4. Filter element
5. Oil filler cap
6. Hydraulic oil level sensor
7. Suction strainer

Specifications

Tank capacity: 230 /

Amount of oil inside tank: 166 /

Pressure valve

- Relief cracking pressure: 16.7 ± 3.9 kPa
(0.17 ± 0.04 kg/cm²)
- Suction cracking pressure: 0 - 0.49 kPa
(0 - 0.005 kg/cm²)
- Bypass valve set pressure: $0.102.9 \pm 19.6$ kPa
(1.05 ± 0.2 kg/cm²)

HYDRAULIC PUMP

Basic pump

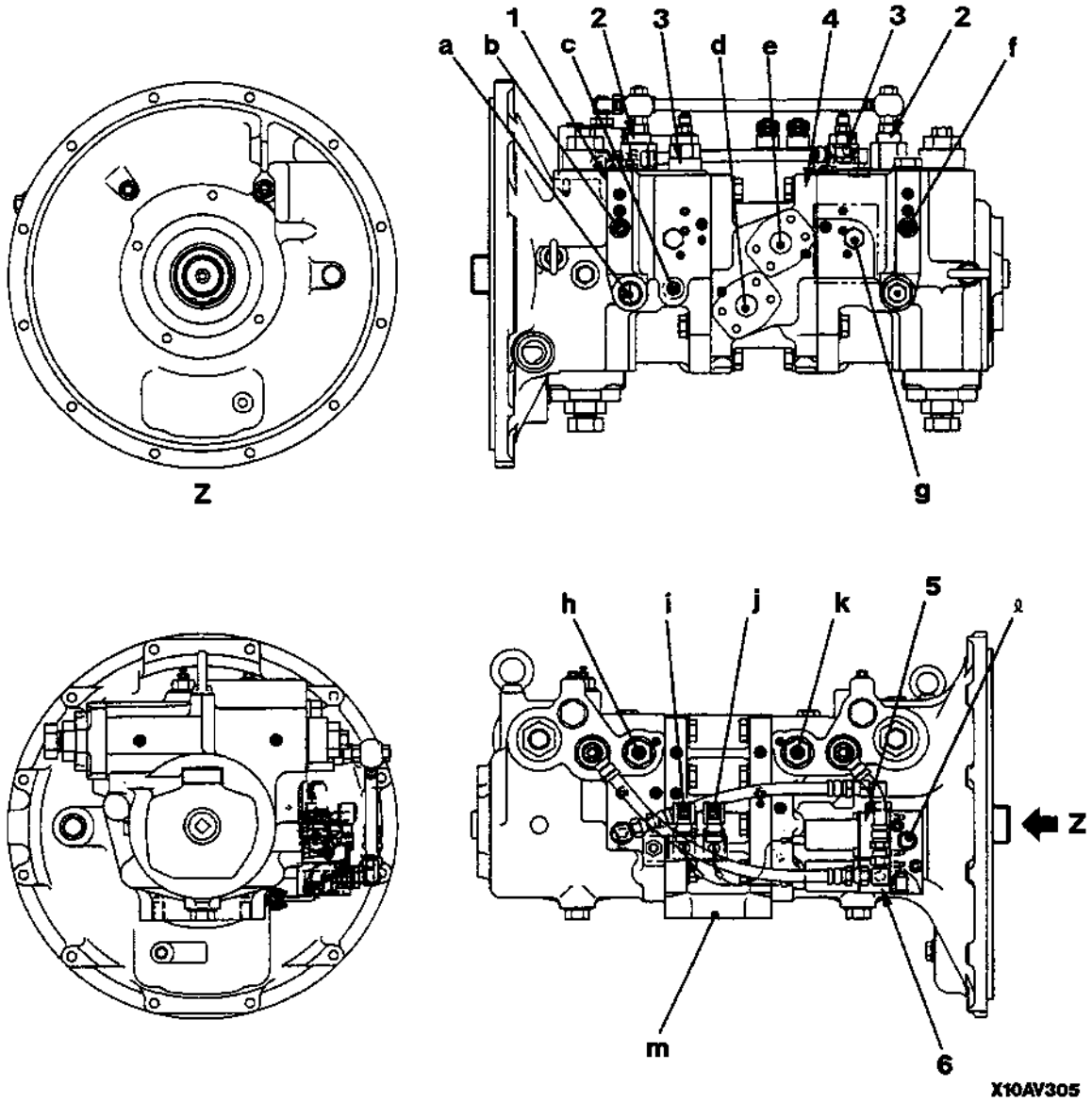

- 1. Front main pump
- 2. PC valve
- 3. LS valve
- 4. Rear main pump
- 5. LS-EPC valve
- 6. PC-EPC valve

Outline

- This pump consists of 2 variable capacity swash plate piston pumps, a PC valve, one" LS-EPC value and one PC-EPC valve.

- a. Pd1F port (pump drain)
- b. PenF port (front control pressure detection)
- c. PBF port (pump pressure input)
- d. PAF port (front pump delivery)
- e. PAR port (rear pump delivery)
- f. PenR port (rear control pressure detection)
- g. Psig port (LS set selector pilot)
- h. Im (PC mode selector current)
- i. PLSR port (rear load pressure input)
- j. Lsig (LS set selector current)
- k. PLSF port (front load pressure input)
- l. EPC basis pressure detection port (input)
- m. Ps port (pump suction)

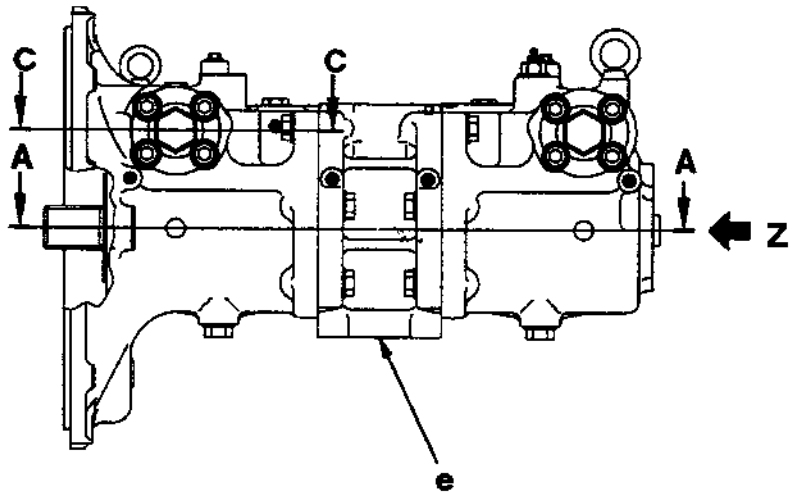
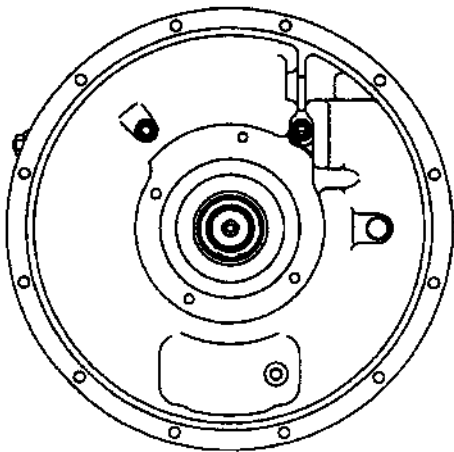
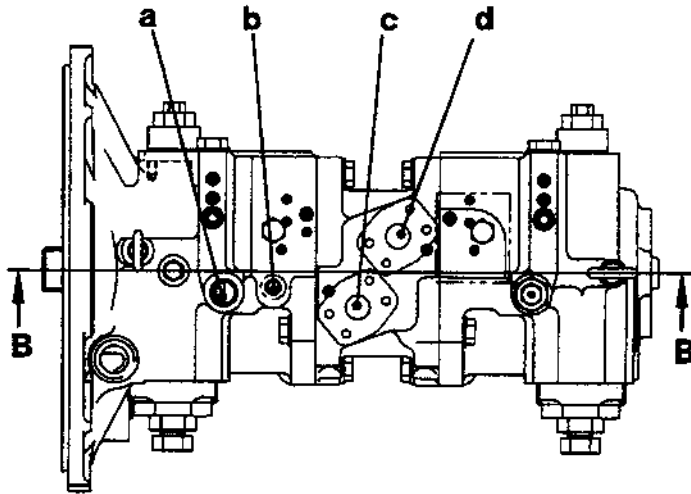
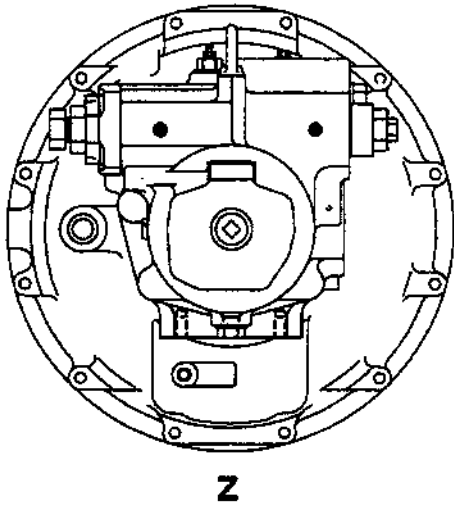

X10AV306

- a. **Pd1F** port (pump drain)
- b. **PBF** port (pump pressure input)
- c. **PAF** port (rear pump delivery)
- d. **PAR** port (rear pump delivery)
- e. **Ps** port (suction)

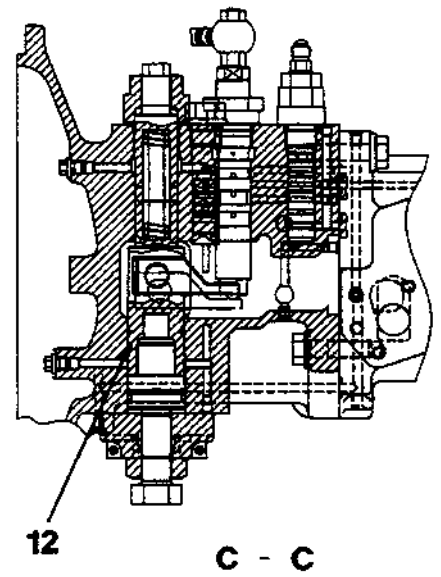
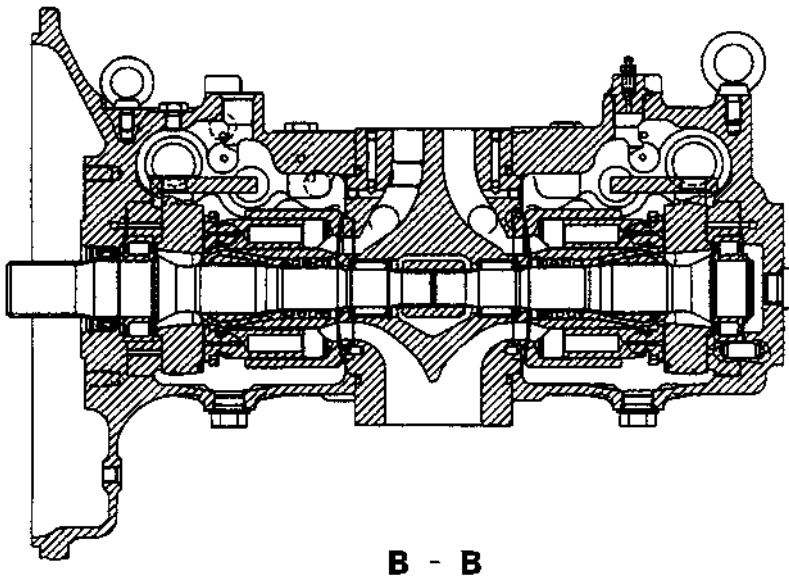
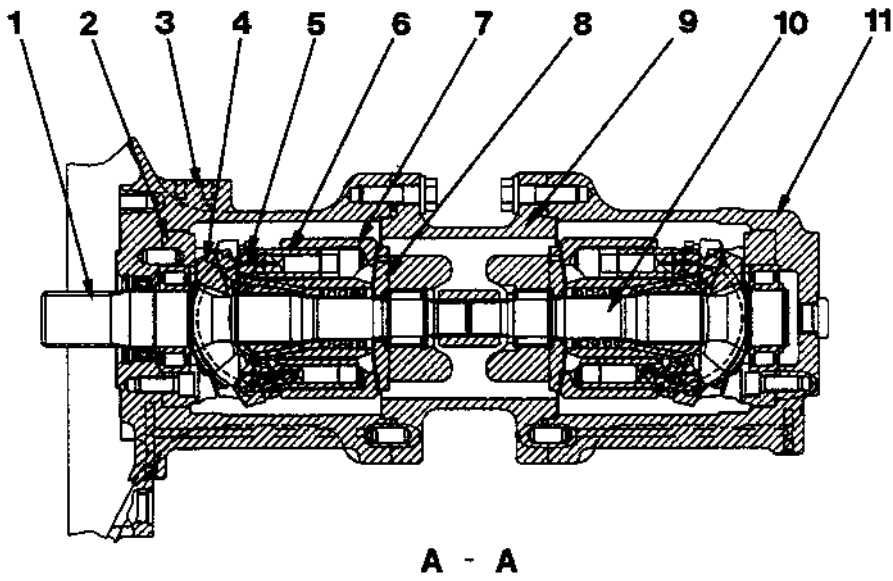

X10AV307

1. Shaft (front)
2. Cradle
3. Case (front)
4. Rocker cam
5. Shoe
6. Piston
7. Cylinder block
8. Valve plate
9. End cap
10. Shaft (rear)
11. Case (rear)
12. Servo piston

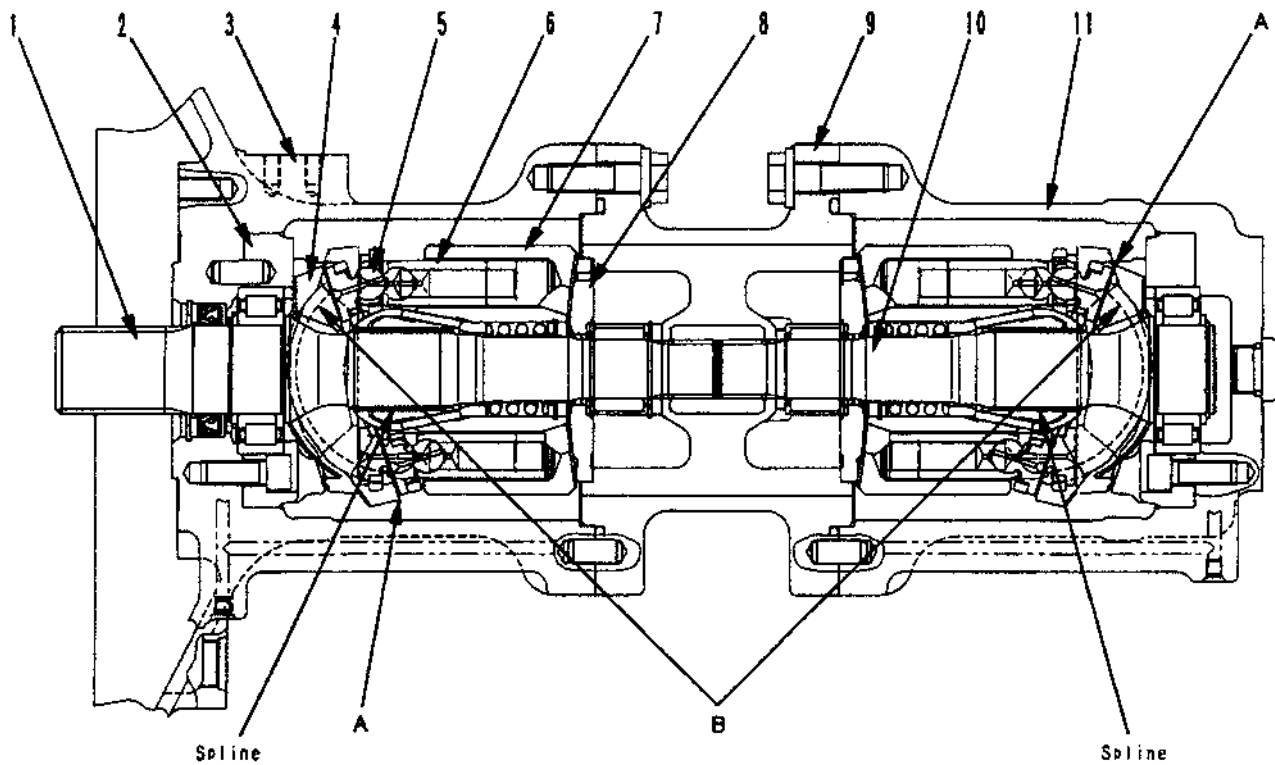

X10AV308

Function

- The rotation and torque transmitted to the pump shaft is converted into hydraulic energy, and pressurized oil is discharged according to the load.
- It is possible to change the discharge amount by changing the swash plate angle.

Structure

- Cylinder block (7) is supported to shaft (1) by a spline, and shaft (1) is supported by the front and rear bearings.
- The top of piston (6) is a concave ball, and shoe (5) is caulked to it to form one unit. Piston (6) and shoe (5) form a spherical bearing.
- Rocker cam (4) has flat surface **A**, and shoe (5) is always pressed against this surface while sliding in a circular movement. Rocker cam (4) brings high pressure oil at cylindrical surface **B** with cradle (2), which is secured to the case and forms a static pressure bearing when it slides.
- Piston (6) carries out relative movement in the axial direction inside each cylinder chamber of cylinder block (7).
- The cylinder block seals the pressure oil to valve plate (8) and carries out relative rotation. This surface is designed so that the oil pressure balance is maintained at a suitable level. The oil inside each cylinder chamber of cylinder block (7) is sucked in and discharged through valve plate (8).

Operation

1. Operation of pump

a. Cylinder block (7) rotates together with shaft (1), and shoe (5) slides on flat surface A. When this happens, rocker cam (4) moves along cylindrical surface B, so angle α between center line X of rocker cam (4) and the axial direction of cylinder block (7) changes. (Angle α is called the swash plate angle.)

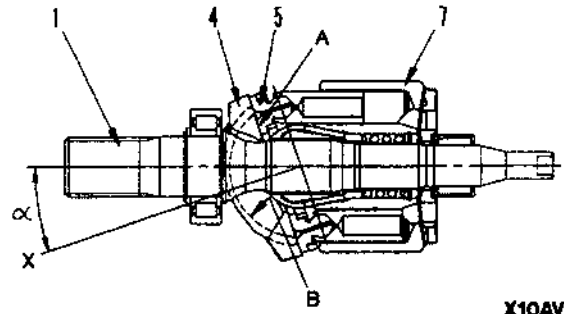

X10AV309

b. Center line X of rocker cam (4) maintains swash plate angle α in relation to the axial direction of cylinder block (7), and flat surface A moves as a cam in relation to shoe (5). In this way, piston (6) slides on the inside of cylinder block (7), so a difference between volumes E and F is created inside cylinder block (7). The suction and discharge is carried out by this difference F-E. In other words, when cylinder block (7) rotates and the volume of chamber E becomes smaller, the oil is discharged during that stroke. On the other hand, the volume becomes larger, the oil is sucked in.

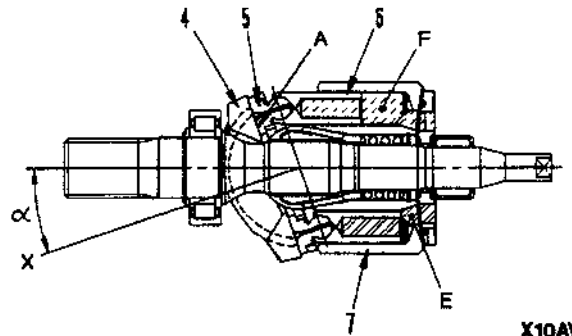

X10AV310

c. If center line X of rocker cam (4) is in line with the axial direction of cylinder block (7) (swash plate angle = 0), the difference between volumes E and F inside cylinder block (7) becomes 0, so the pump does not carry out any suction or discharge of oil. (In fact, the swash plate angle can never become 0.)

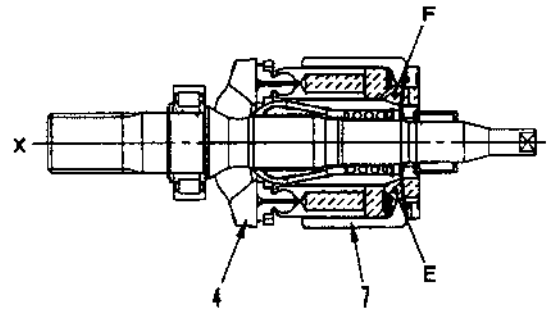

X10AV311

2. Control of discharge amount
 - a. If swash plate angle α becomes larger, the difference between volumes **E** and **F** becomes larger and discharge amount **Q** increases. Swash plate angle α is changed by servo piston (12).

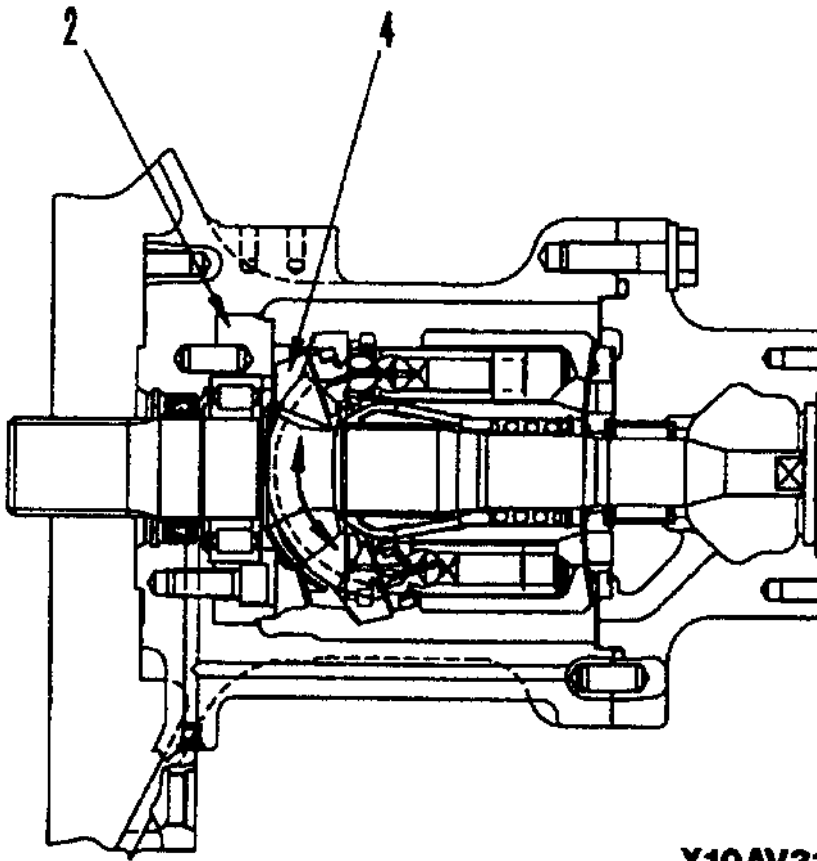
**X10AV312**

- b. Servo piston (12) moves in a reciprocal movement (↕) according to the signal pressure from the PC and LS valves. This straight line movement is transmitted through rod (13) to rocker cam (4), and rocker cam (4), which is supported by the cylindrical surface to cradle (2), slides in a rotating movement in direction (↻).

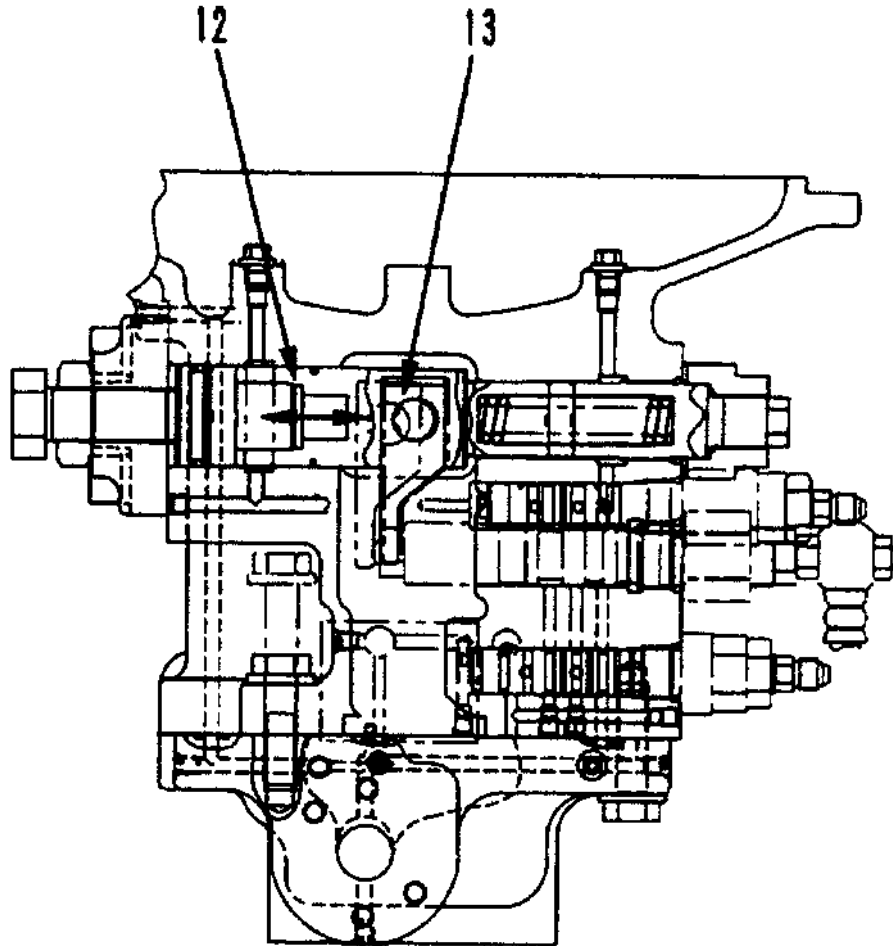
**X10AV313**

- c. With servo piston (12), the area receiving the pressure is different on the left and right, so main pump discharge pressure (self pressure) **PP** is always brought to the chamber receiving the pressure at the small diameter piston end. Output pressure **Pen** of the LS valve is brought to the chamber receiving the pressure at the large diameter piston end. The relationship in the size of pressure **PP** at the small diameter piston end and pressure **Pen** at the large diameter end, and the ratio between the area receiving the pressure of the small diameter piston and the large diameter piston controls the movement of servo piston (12).

LS and PC valve
LS VALVE

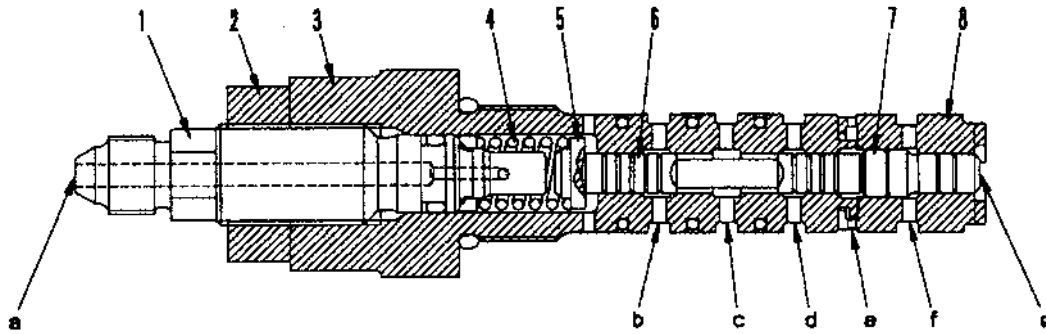

X10BH228

- | | |
|--|------------|
| a. Port PLS (control valve LS pressure inlet port) | 1. Plug |
| b. Port PA (pump discharge pressure inlet port) | 2. Locknut |
| c. Port PLP (LS valve signal pressure outlet port) | 3. Sleeve |
| d. Port PPL (PC valve signal pressure outlet port) | 4. Spring |
| e. Port Pa (drain pressure outlet port) | 5. Seat |
| f. Port P_{sig} (LS control EPC valve output pressure inlet port) | 6. Spool |
| g. Port PA (pump discharge pressure inlet port) | 7. Piston |
| | 8. Sleeve |
- PC VALVE

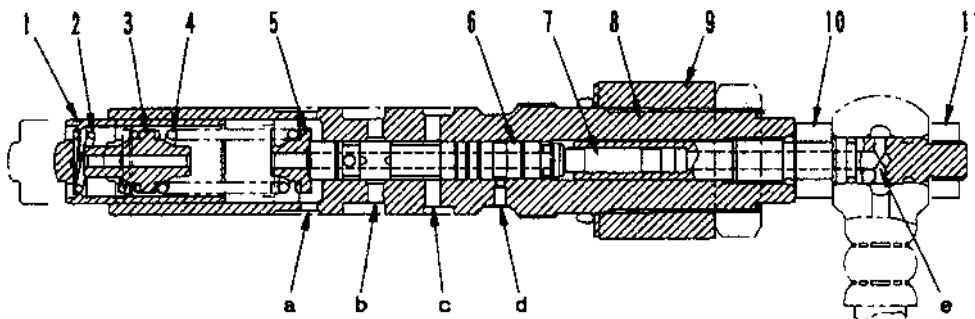

X10BH229

- | | |
|---|-------------|
| a. Port Pa (drain pressure outlet port) | 1. Piston |
| b. Port PPL (PC valve signal pressure outlet port) | 2. Spring |
| c. Port Pa (pump discharge pressure inlet port) | 3. Seat |
| d. Port PA2 (pump discharge pressure inlet port) | 4. Spring |
| e. Port PM (PC moede selector pressure inlet port) | 5. Seat |
| | 6. Spool |
| | 7. Piston |
| | 8. Sleeve |
| | 9. Locknut |
| | 10. Plug |
| | 11. Locknut |

Function

LS valve

- The LS valve detects the load and controls the discharge amount. This valve controls main pump discharge amount **Q** according to differential pressure $\Delta PLS (=PP - PLS)$ [[called the LS differential pressure]] (the difference between main pump pressure **PP** and control valve outlet port pressure **PLS**). Main pump pressure **PP**, pressure **PLS** [[called the LS pressure]] coming from the control valve output, and pressure **PSIG** [[called the LS selector pressure]] from the proportional solenoid valve enter this valve. The relationship between discharge amount **Q** and differential pressure ΔPLS changes as shown in the diagram on the right according to LS selector current **isig** of the LS-EPC valve. When **isig** changes between O and 1A, the set pressure of the spring changes according to this and the selector for point for the pump discharge amount changes at the rated central value between 0.74 - 2.2 Mpa (7.5 - 22.5 kg/cm²).

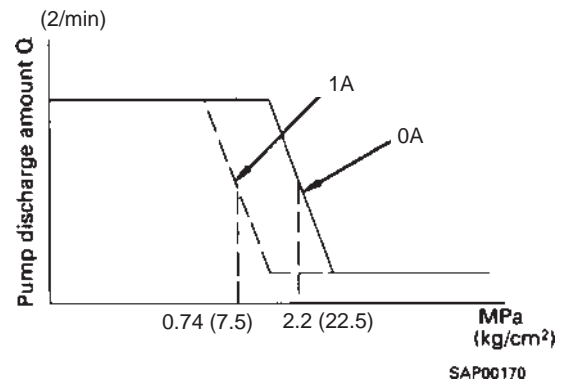

PC valve

- When the pump discharge pressure **PP1** (self-pressure) and **PP2** (other pump pressure) are high, the PC valve controls the pump so that no more oil than the constant flow (in accordance with the discharge pressure) flows even if the stroke of the control valve becomes larger. In this way, it carries out equal horsepower control so that the horsepower absorbed by the pump does not exceed the engine horsepower. In other words, if the load during the operation becomes larger and the pump discharge pressure rises, it reduces the discharge amount from the pump; and if the pump discharge pressure drops, it increases the discharge amount from the pump. The relationship between the average of the front and rear pump discharge pressure (average discharge amount of F, R pumps $(PP1 + PP2)/2$) and pump discharge amount **Q** is shown on the right, with the current given to the PC-EPC valve solenoid shown as a parameter. The controller senses the actual speed of the engine and if the speed drops because of an increase in the load, it reduces the pump discharge in the pump to allow the speed to recover. In other words, when the load increases and the engine speed drops below a set value, the command current to the PC-EPC valve solenoid from the controller increases according to the drop in the engine speed to reduce the pump swash plate angle.

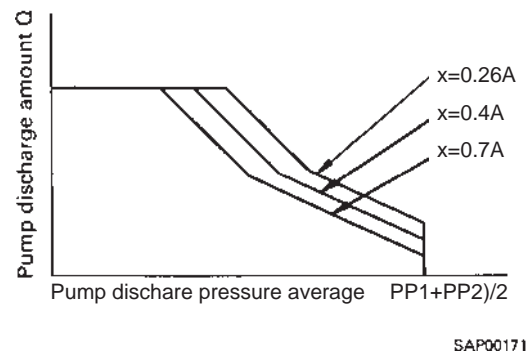

Operation

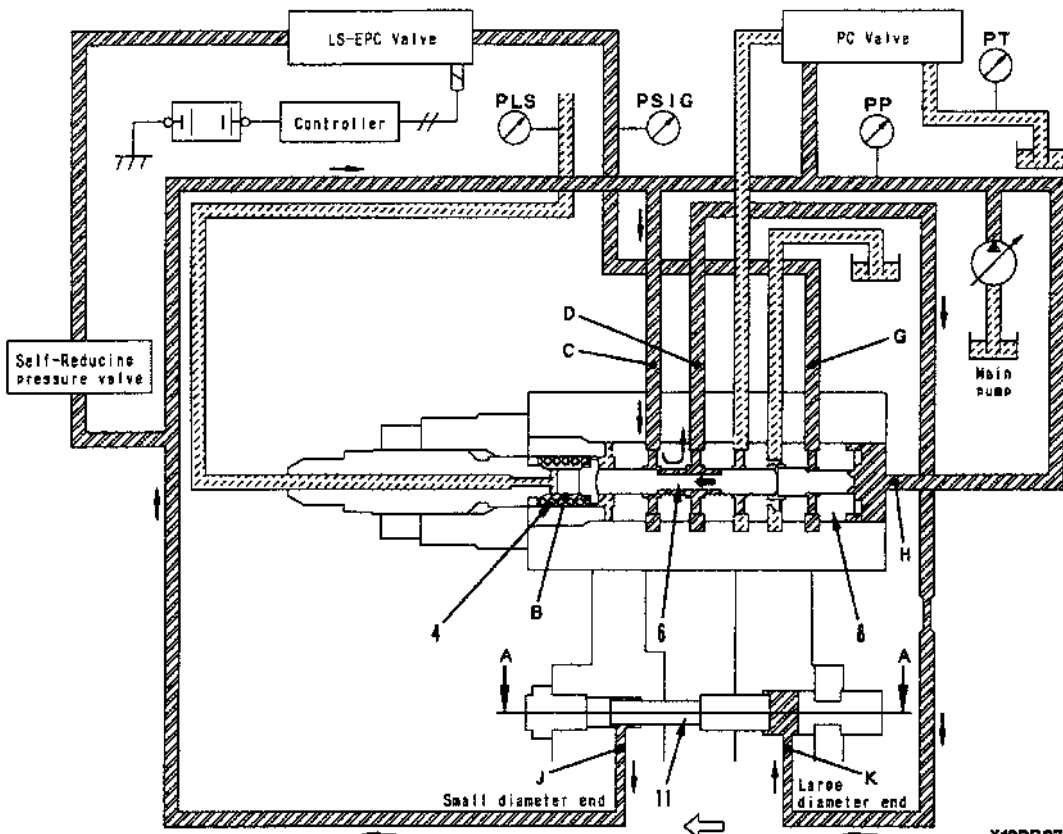

LS valve

1. When the control valve is at a neutral position
 - a. The LS valve is a three-way selector valve, with pressure **PLS** (LS pressure) from the inlet port of the control valve brought to spring chamber **B**, and main pump discharge pressure **PP** brought to port **H** of sleeve (8). The size of **PLS** + force **Z** of spring (4) and the main pump pressure (self pressure) **PP** determines the position of spool (6). However, the size of the output pressure **PSIG** of the EPC valve for the LS valve entering port **G** also changes the position of spool (6). (The set pressure of the spring changes.)
 - b. Before the engine is starting, servo piston (11) is pushed to the right. (See the diagram on the right).
 - c. When the engine is started and the control lever is at the neutral position, LS pressure **PLS** is 0 MPa. (It is interconnected with the drain circuit through the control valve spool.) At this point, spool (6) is pushed to the left, and port **C** and port **D** are connected. Pump pressure **PP** enters the large diameter end of the piston from port **K**, and the same pump pressure **PP** also enters port **J** at the small diameter end of the piston, so the swash plate is moved to the minimum angle by the difference in area of piston (11).

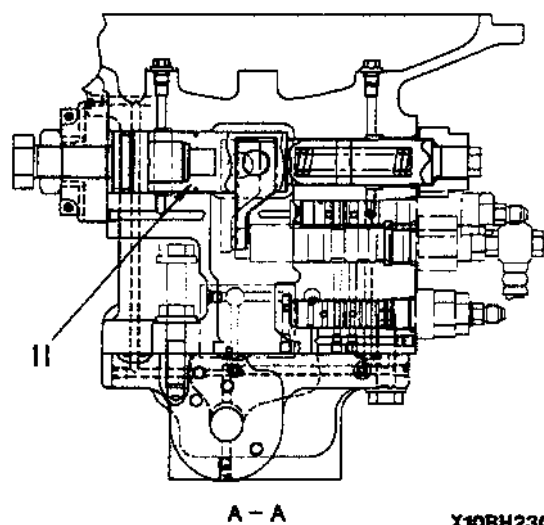

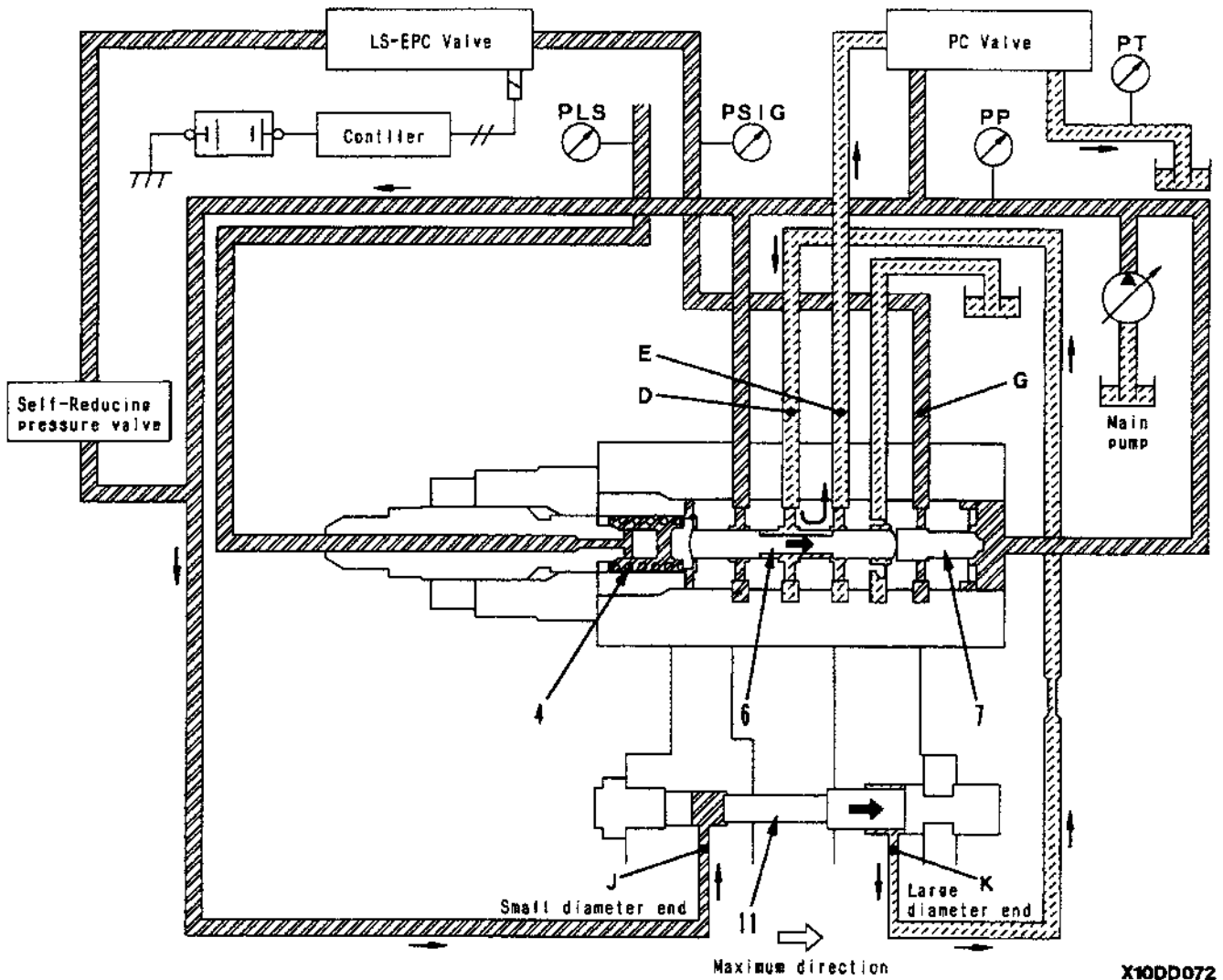

X10DD072

2. Operation in maximum direction for pump discharge amount
 - a. When the LS differential pressure ΔPLS becomes smaller (for example, when the area of the opening of the control valve becomes larger and pump pressure **PP** drops), spool (6) is pushed to the right by the combined force of LS pressure **PLS** and the force of spring (4).
 - b. When spool (6) moves, port **D** and port **E** are joined and connected to the PC valve. When this happens, the PC valve is connected to the drain port, so circuit **D-K** becomes drain pressure **PT**. (The operation of the PC valve is explained later.)
 - c. For this reason, the pressure at the large diameter end of servo piston (11) becomes drain pressure **PT**, and pump pressure **PP** enters port **J** at the small diameter end, so servo piston (11) is pushed to the right. Therefore, the swash plate moves in the direction to make the discharge amount larger.
 - d. If the output pressure of the EPC valve for the LS valve enters port **G**, this pressure creates a force to move piston (7) to the left. If piston (7) is pushed to the left, it acts to make the set pressure of spring (4) weaker, and the difference between **PLS** and **PP** changes when ports **D** and **E** of spool (6) are connected.

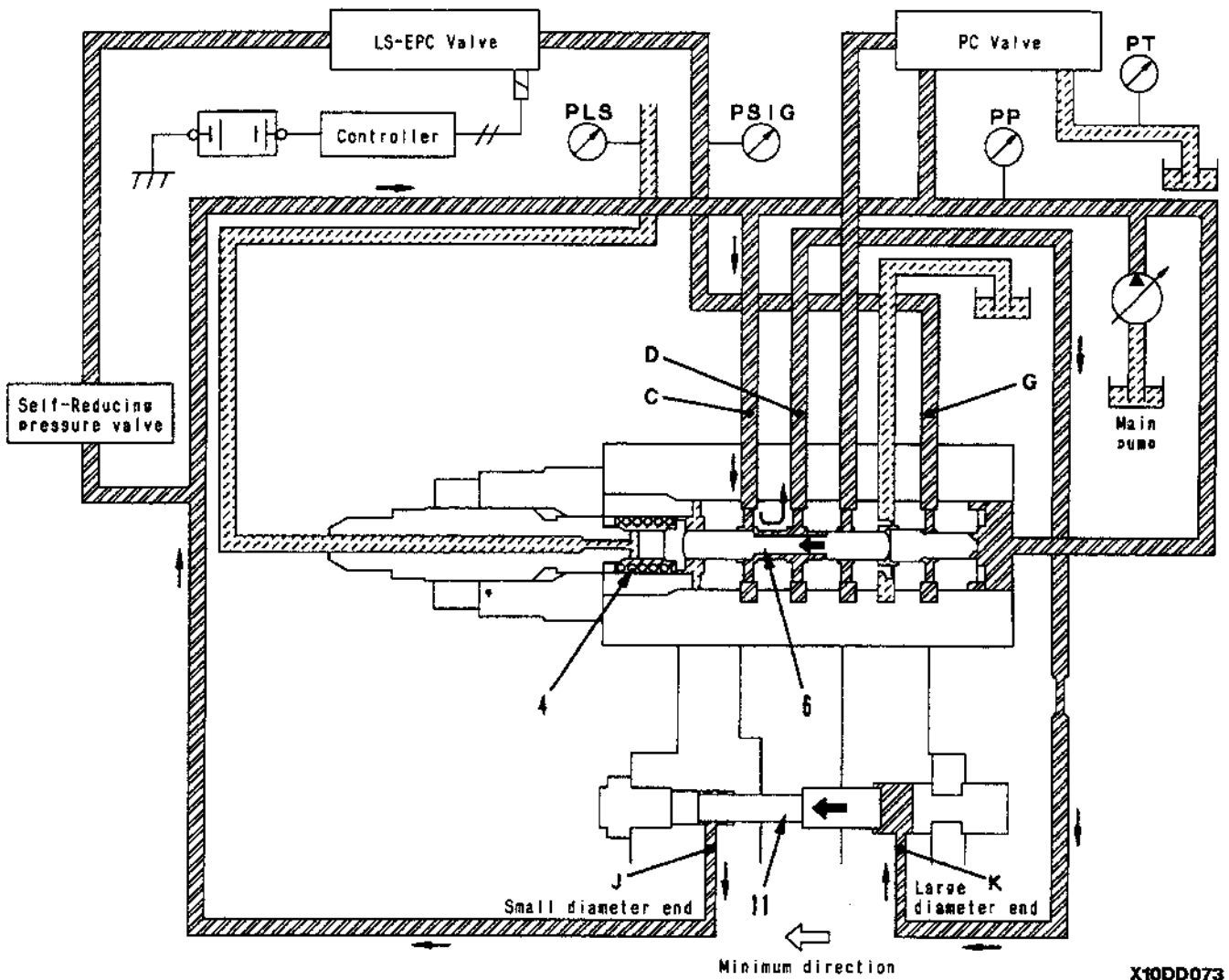

3. Operation in minimum direction for pump discharge amount
 - a. When LS differential pressure ΔPLS becomes larger (for example, when the area of the opening of the control valve becomes smaller and pump pressure **PP** rises), pump pressure **PP** pushes spool (6) to the left.
 - b. When spool (6) moves, main pump pressure **PP** flows from port **C** to port **D**, and from port **K**, it enters the large diameter end of the piston.
 - c. Main pump pressure **PP** also enters port **J** at the small diameter end of the piston, but because of the difference in area between the large diameter end and the small diameter end of servo piston (11), servo piston (11) is pushed to the left. As a result, the swash plate moves in the direction to make the angle smaller.
 - d. If LS selection pressure **PSIG** enters port **G**, it acts to make the set pressure of spring (4) weaker.

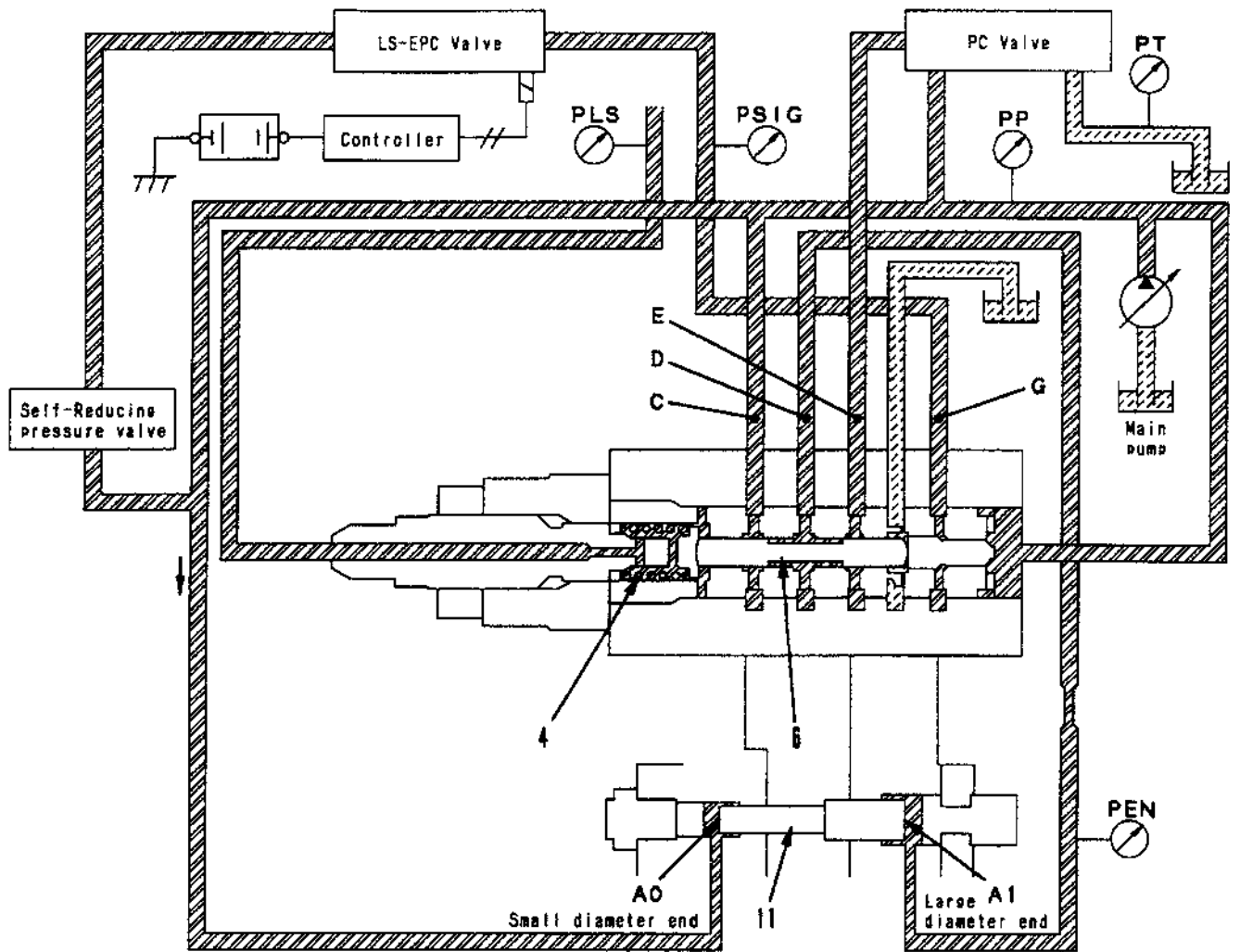

X10DD074

4. When servo piston balanced
 - a. Let us take area receiving the pressure at the large diameter end of the piston as **A1**, the area receiving the pressure at the small diameter end as **A0**, and the pressure flowing into the large diameter end of the piston as **Pen**. If the main pump pressure **PP** of the LS valve and the combined force of force **Z** of spring (4) and LS pressure **PLS** are balanced, and the relationship is $A0 \times PP = A1 \times Pen$, servo piston (11) will stop in that position, and the swash plate will be kept at an intermediate position. (It will stop at a position where the opening of the throttle from port **D** to port **E** and from port **C** to port **D** of spool (6) is approximately the same.)
 - b. At this point, the relationship between the area receiving the pressure at both ends of piston (11) is $A0:A1 = 1:2$, so the pressure applied to both ends of the piston when it is balanced becomes **PP: Pen = 2:1**.
 - c. The position where spool (6) is balanced and stopped is the standard center, and the force of spring (4) is adjusted so that it is determined when $PP - PLS = 2.2 \text{ MPa}$ (22.5 kg/cm^2). However, if **PSIG** is applied to port **G**, the balance stop position will change in proportion to pressure **PSIG** between $PP - PLS = 2.2 - 0.74 \text{ MPa}$ ($22.5 - 7.5 \text{ kg/cm}^2$).

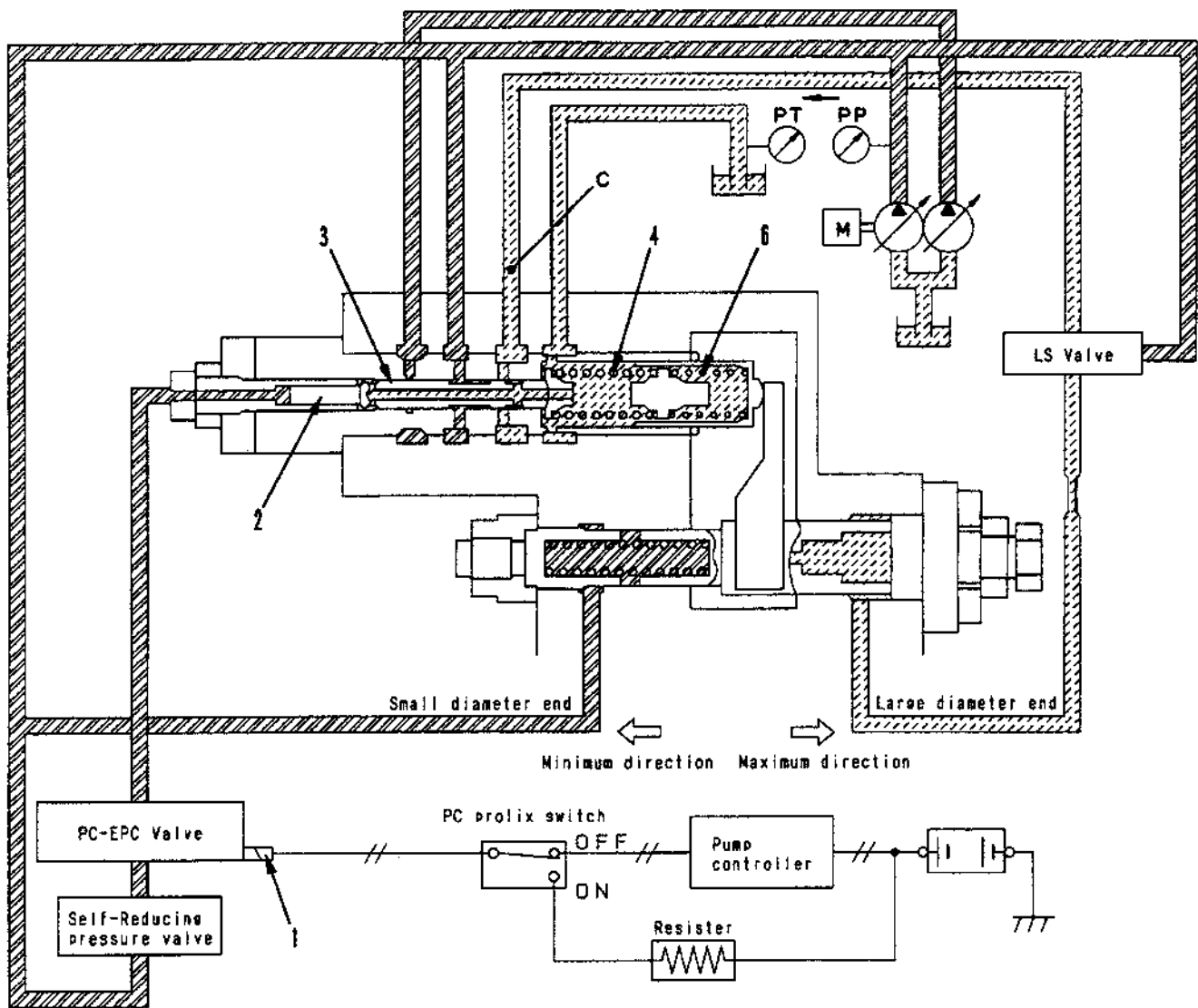

X10DD075

PC valve

1. When the pump controller is normal
 - a. When the load on the actuator is small and pump pressures **PP1** and **PP2** are low.
 - i. Movement of PC-EPC solenoid (1).
 - (1) The command current from the pump controller flows to PC-EPC solenoid (1). This command current acts on the PC-EPC valve and outputs the signal pressure. When this signal pressure is received, the force pushing piston (2) is changed.
 - (2) On the opposite side to the force pushing piston (2) is the spring set pressure of springs (4) and (6) and pump pressure **PP1** (self pressure) and **PP2** (other pump pressure) pushing spool (3). Piston (2) stops at a position where the combined force pushing spool (3) is balanced, and the pressure (pressure of port C) output from the PC valve changes according to this position.
 - (3) The size of command current **X** is determined by the nature of the operation (lever operation), the selection of the working mode, and the set value and the actual value for the engine speed.
 - (4) Other pump pressure. This is the pressure of the pump at the opposite end. For the front pump, it is the rear pump pressure. For the rear pump, it is the front pump pressure.

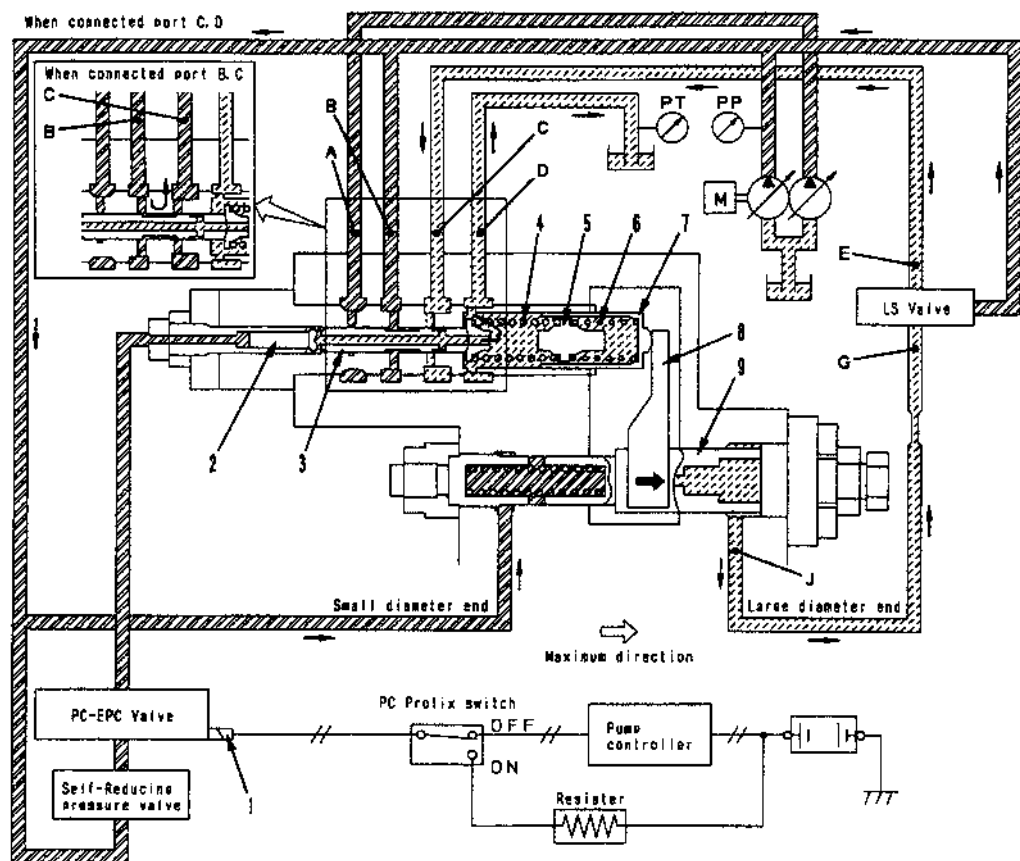

X100D076

ii. Action of spring

- (1) The spring load of springs (4) and (6) in the PC valve is determined by the swash plate position.
- (2) When servo piston (9) moves, piston (7), which is connected to slider (8), also moves to the left or right.
- (3) If piston (7) moves to the left, spring (6) is compressed, and if it moves further to the left, spring (6) contacts seat (5) and is fixed in position. In other words, the spring load is changed by piston (5) extending or compressing springs (4) and (6).
- (4) If the command current input to PC-EPC valve solenoid (1) changes further, the force pushing piston (2) changes, and the spring load of springs (4) and (6) also changes according to the value of the PC-EPC valve solenoid command current.
- (5) Port **C** of the PC valve is connected to port **E** of the LS valve (see LS valve). Self pressure **PP1** enters port **B** and the small diameter end of servo piston (9), and other pump pressure **PP2** enters port **A**.
- (6) When pump pressures **PP1** and **PP2** are small, spool (3) is on the left. At this point, port **C** and **D** are connected, and the pressure entering the LS valve becomes drain pressure **PT**. If port **E** and **G** of the LS valve are connected (see LS valve), the pressure entering the large diameter end of the piston from port **J** becomes drain pressure **PT**, and servo piston (9) moves to the right. In this way, the pump discharge amount moves in the direction of increase.
- (7) As servo piston (9) moves further, piston (7) is moved to the left by slider (8). Springs (4) and (6) expand and the spring force becomes weaker. When the spring force becomes weaker, spool (3) moves to the right, so the connection between port **C** and **D** is cut, and the pump discharge pressure ports **B** and **C** are connected. As a result, the pressure at port **C** rises, and the pressure at the large diameter end of the piston also rises, so the movement of piston (9) to the right is stopped. In other words, the stop position for piston (9) (= pump discharge amount) is decided at the point where the force of springs (4) and (6) and the pushing force from the PC-EPC valve solenoid and the pushing force created by pressures **PP1** and **PP2** acting on spool (3) are in balance.

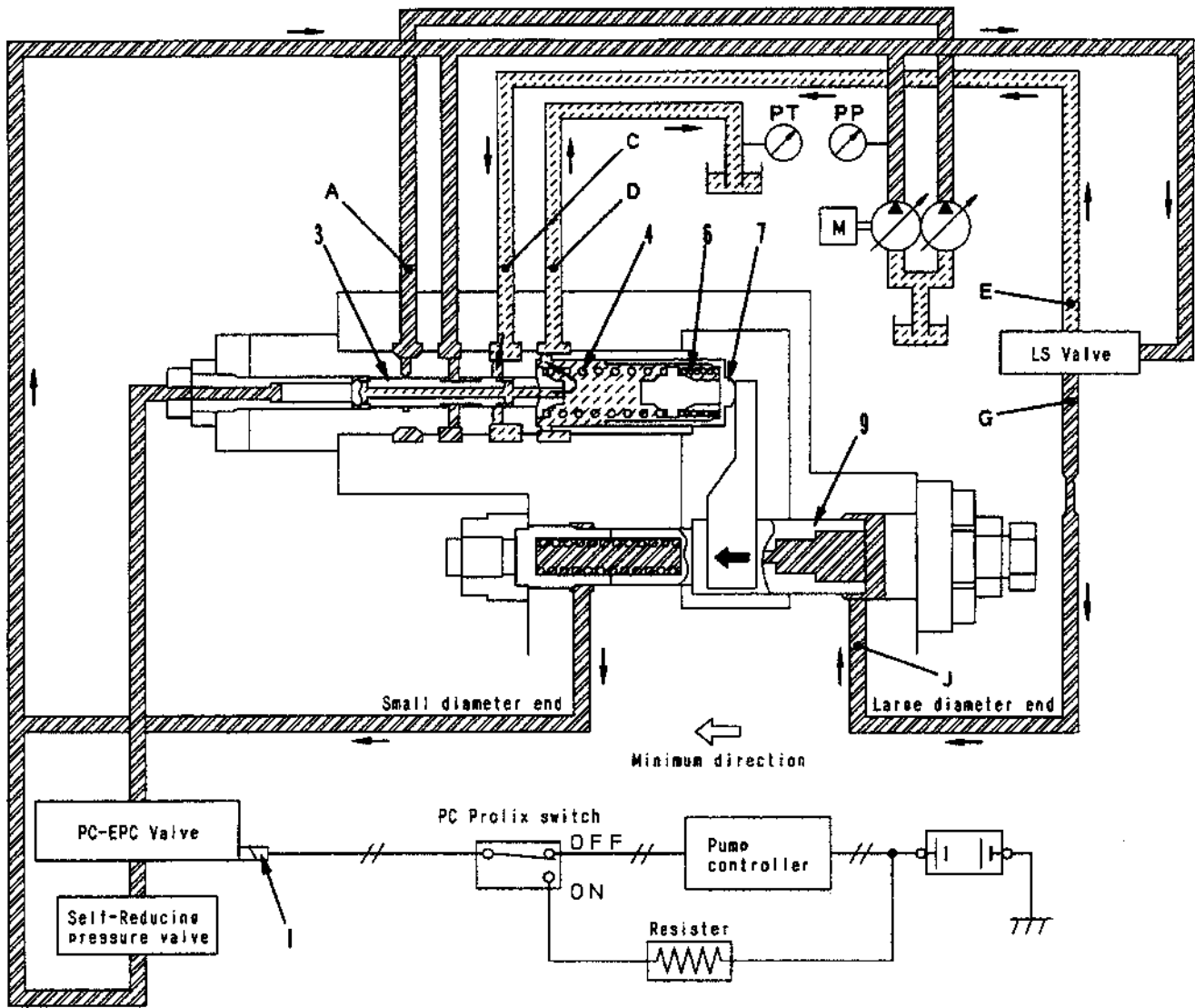

X10DD077

- b. When load on actuator is large and pump discharge pressure is high.
 - i. When the load is large and pump discharge pressure **PP1** and **PP2** are high, the force pushing spool (3) to the left becomes larger and spool (3) moves to the position shown in the diagram above. When this happens, as shown in the diagram above, part of the pressurized oil from port **A** flows out through the LS valve from port **C** to port **D** and the pressurized oil flowing from port **C** to the LS valve becomes approximately half of main pump pressure **PP**.
 - ii. When port **E** and **G** of the LS valve are connected (see LS valve), the pressure from port **J** enters the large diameter end of servo piston (9), and servo piston (9) stops.
 - iii. If main pump pressure **PP** increases further and spool (3) moves further to the left, main pump pressure **PP1** flows to port **C** and acts to make the discharge amount the minimum. When piston (9) moves to the left, piston (7) is moved to the left. For this reason, springs (4) and (6) are compressed and push back spool (3). When spool (3) moves to the left, the opening of port **C** and **D** becomes larger. As a result, the pressure at port **C** (= **J**) drops, and piston (9) stops moving to the left. The position in which piston (9) stops when this happens is further to the left than the position when pump pressure **PP1** and **PP2** are low.

iv. The relation of average pump pressure $(PP1 + PP2)/2$ and the position of servo piston (9) forms a bent line because of the double spring effect of springs (4) and (6). The relationship between average pump pressure and pump discharge amount Q is shown in the figure on the right.

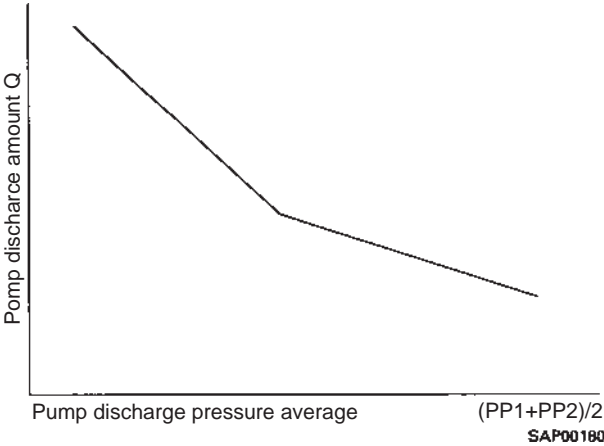

v. If command voltage X sent to PC-EPC valve solenoid (1) increases further, the relationship between average pump pressure $(PP1 + PP2)/2$, and pump discharge amount Q is proportional to the pushing force of the PC-EPC valve solenoid and moves is parallel. In other words, the pushing force of PC-EPC solenoid (1) is added to the force pushing to the left because of the pump pressure applied to the spool (3), so the relationship between average pump pressure and Q moves from 1* to 2* in accordance with the increase in X .

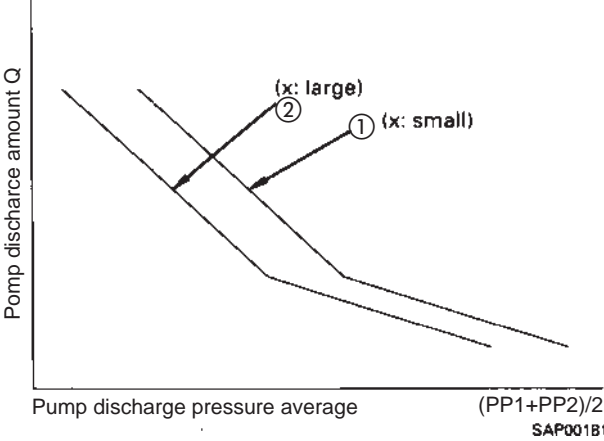

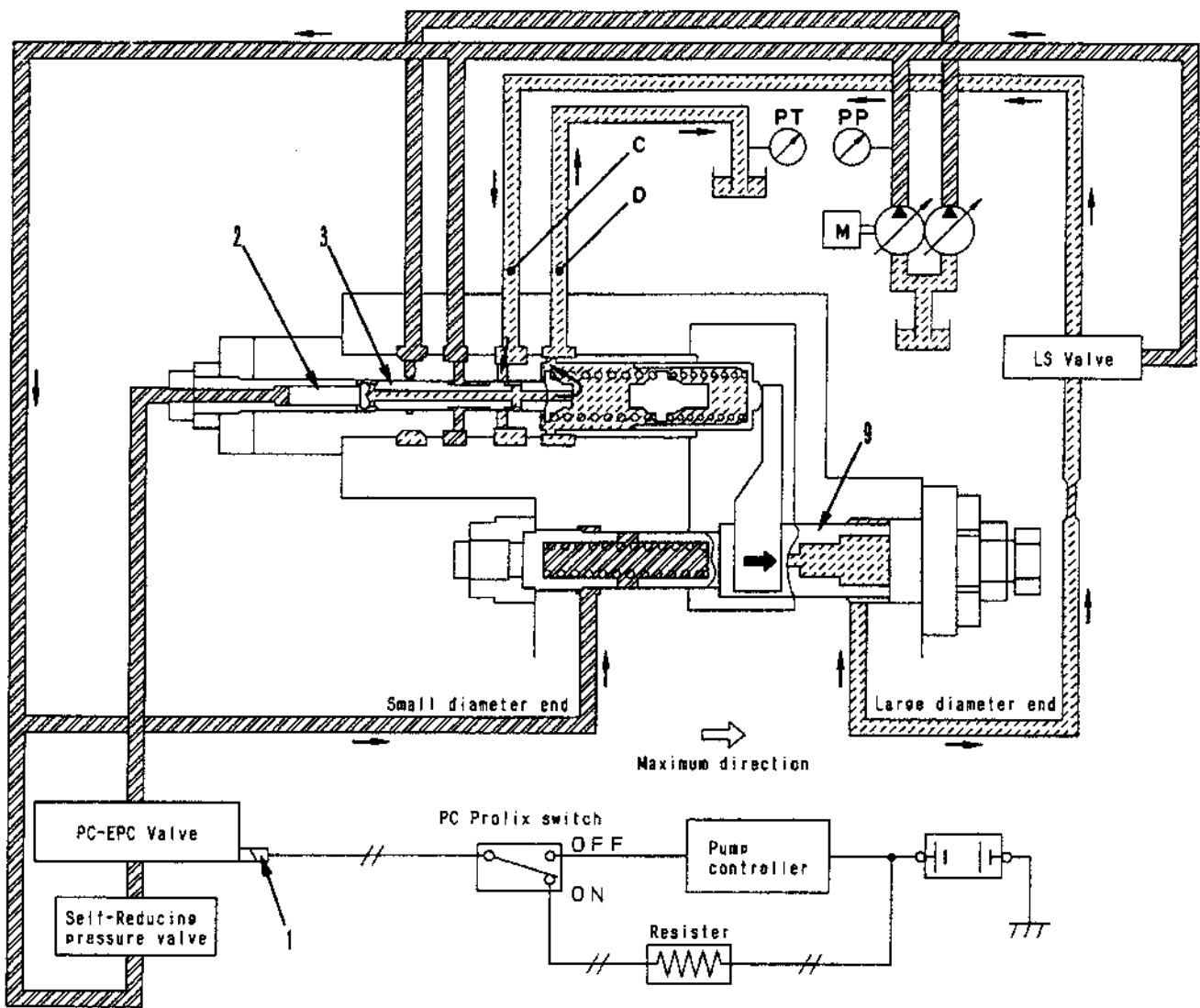

X10DD080

2. When pump controller is abnormal and PC prolux switch in ON.
 - a. When load on main pump is light.
 - i. If there is a failure in the pump controller, turn PC prolux switch **ON** to switch to the resistor side. In this case, the power source is taken directly from the battery. But if the current is used as it is, it is too large, so use the resistor to control the current flowing to PC-EPC valve solenoid (1).
 - ii. When this is done, the current becomes constant, so the force pushing piston (2) is also constant.
 - iii. If main pump pressures **PP1** and **PP2** are low, the combined force of the pump pressure and the force of PC-EPC valve solenoid (1) is weaker than the spring set force, so spool (3) is balanced at a position to the left.
 - iv. At this point, port **C** is connected to the drain pressure of port **D**, and the large diameter end of the piston of servo piston (9) also becomes the drain pressure **PT** through the LS valve. When this happens, the pressure at the small diameter end of the piston is large, so servo piston (9) moves in the direction to make the discharge amount larger.

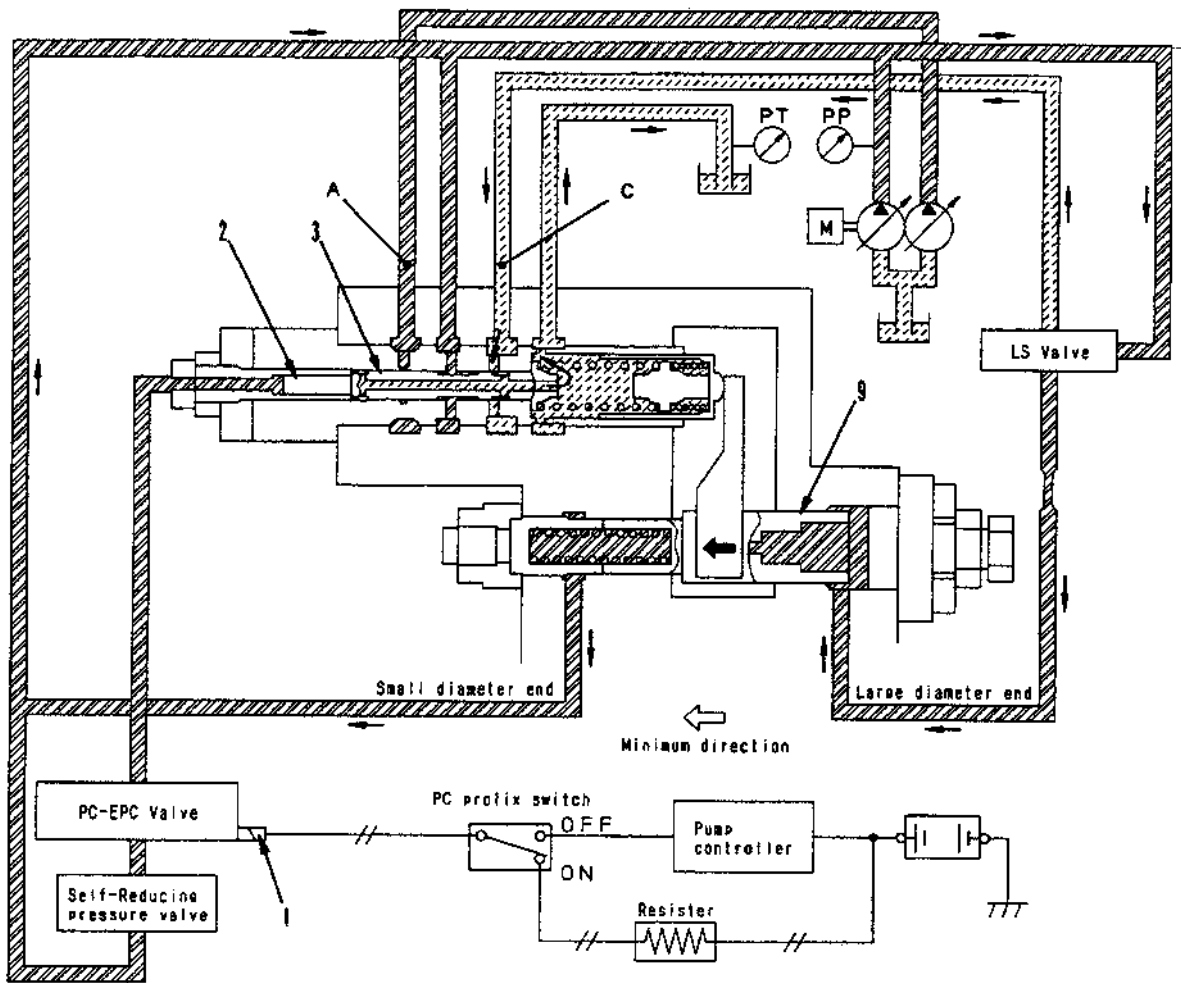

X10DD081

- b. When main pump load is heavy.
 - i. In the same way as in the previous item, when the PC prox switch is **ON**, the command current sent to the PC-EPC valve solenoid becomes constant. For this reason, the force of piston (2) pushing spool (3) is constant.
 - ii. If main pump pressures **PP1** and **PP2** increase, spool (3) moves further to the left than when the main pump load is light, and is balanced at the position in the diagram above.
 - iii. In this case, the pressure from port **A** flows to port **C**, so servo piston (9) moves to the left (to make the discharge amount smaller) by the same mechanism as explained in step 2) -b) (see page 10-36), and stops at a position to the left of the position when the load on the pump is light. In other words, even when the PC prox is **ON**, the curve for the pump pressure **PP** and discharge amount **Q** is determined as shown

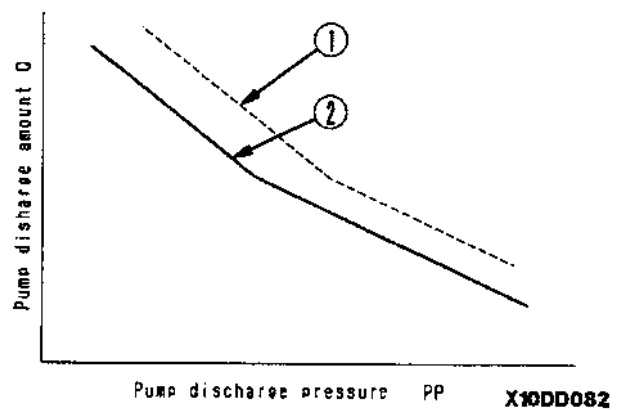

in the diagram below for the value of the current sent to the PC-EPC valve solenoid through the resistor. The curve when the PC prox switch is **ON** is curve ②, which is to the left of curve ① for when the pump controller is normal.

CONTROL VALVE

1. 6-spool valve
 2. Cover 1
 3. Cover 2
 4. Merge/flow divider valve
 5. Service valve
 6. Service valve
 7. Service valve
- a. Port **PP1** (from rear main pump)
 - b. Port **PP2** (from front main pump)
 - c. Port **A6** (to arm cylinder head)
 - d. Port **B6** (to arm cylinder bottom)
 - e. Port **A5** (to L.H. travel motor)
 - f. Port **B5** (to L.H. travel motor)
 - g. Port **A4** (to swing motor)
 - h. Port **B4** (to swing motor)
 - i. Port **A3** (to boom cylinder bottom)
 - j. Port **B3** (to boom cylinder head)
 - k. Port **A2** (to R.H. travel motor)
 - l. Port **B2** (to R.H. travel motor)
 - m. Port **A1** (to bucket cylinder head)
 - n. Port **B1** (to bucket cylinder bottom)
 - o. Port **A-1** (to attachment)
 - p. Port **B-1** (to attachment)
 - q. Port **A-2** (to attachment)
 - r. Port **B-2** (to attachment)
 - s. Port **A-3** (to attachment)
 - t. Port **B-3** (to attachment)
 - u. Port **T** (to tank)
 - v. Port **CP1** (to port CP3)
 - w. Port **CP2** (to port CP4)
 - x. Port **CP3** (to port CP1)
 - y. Port **PC4** (to port CP2)
 - aa. Port **PLS1** (to rear pump control)
 - ab. Port **PLS2** (to front pump control)
 - bb. Port **TS** (to tank)
 - cc. Port **PS** (from merge/flow divider solenoid valve)
 - dd. Port **BP1** ("from" boom RAISE PPC output pressure)

Outline

- This control valve consists of the 6-spool valve (an integrated composition), up to 3 service valves, and a merge/flow divider valve.
 - Each valve is formed into one unit by the connection bolt, and the passages are internally connected, so the structure is compact and is very easy to service.
 - This control valve consists of one spool for one item of the work equipment, so it has a simple structure
- ee. Port **PX1** (from 2-stage relief solenoid valve)
 - ff. Port **PX2** (from 2-stage relief solenoid valve)
 - gg. Port **BP3** (from travel PPC valve)
 - hh. Port **BP2** (from travel PPC valve)
 - ii. Port **BP4** (from active mode solenoid valve)
 - jj. Port **BP5** (from 2-stage boom down safety valve solenoid valve)
 - kk. Port **SA** (pressure sensor mount port)
 - mm. Port **SB** (pressure sensor mount port)
 - pa. Port **P12** (from arm PPC/EPC valve)
 - pb. Port **P11** (from arm PPC/EPC valve)
 - pc. Port **P10** (from L.H. travel PPC valve)
 - pd. Port **P9** (from L.H. travel PPC valve)
 - pe. Port **P8** (from swing PPC/EPC valve)
 - pf. Port **P7** (from swing PPC/EPC valve)
 - pg. Port **P6** (from boom PPC/EPC valve)
 - ph. Port **P5** (from boom PPC/EPC valve)
 - pi. Port **P4** (from R.H. travel PPC valve)
 - pj. Port **P3** (from R.H. travel PPC valve)
 - pk. Port **P2** (from bucket PPC/EPC valve)
 - pl. Port **P1** (from bucket PPC/EPC valve)
 - pm. Port **P-2** (from service PPC valve)
 - pn. Port **P-1** (from service PPC valve)
 - po. Port **P-4** (from service PPC valve)
 - pp. Port **P-3** (from service PPC valve)
 - pq. Port **P-6** (from service PPC valve)
 - pr. Port **P-5** (from service PPC valve)

Main structure

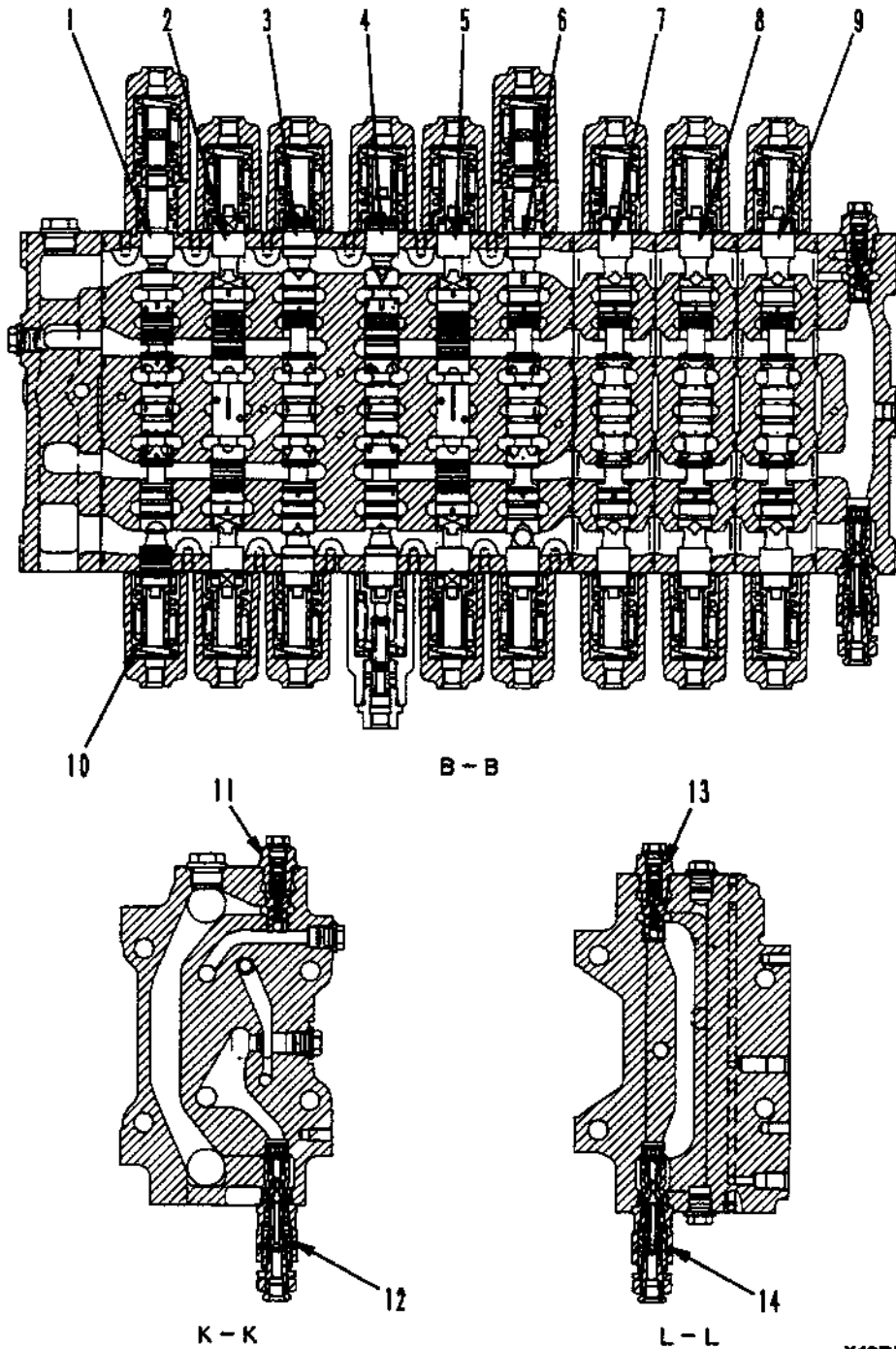

- 1. Spool (arm)
- 2. Spool (L.H. travel)
- 3. Spool (swing)
- 4. Spool (boom)
- 5. Spool (R.H. travel)
- 6. Spool (bucket)
- 7. Spool (service)

- 8. Spool (service)
- 9. Spool (service)
- 10. Spool return spring
- 11. Unload valve (arm end group)
- 12. Main relief valve (arm end group)
- 13. Unload valve (bucket end group)
- 14. Main relief valve (bucket end group)

X10BH232

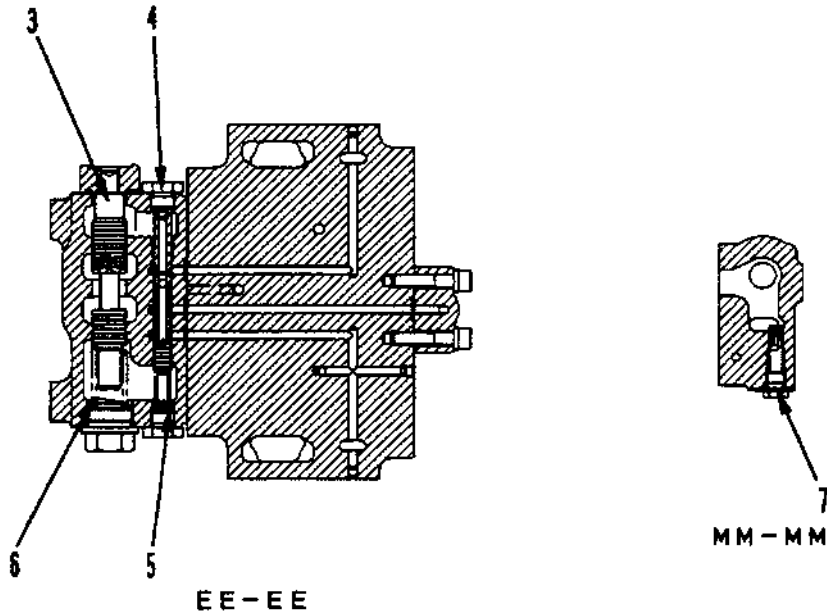
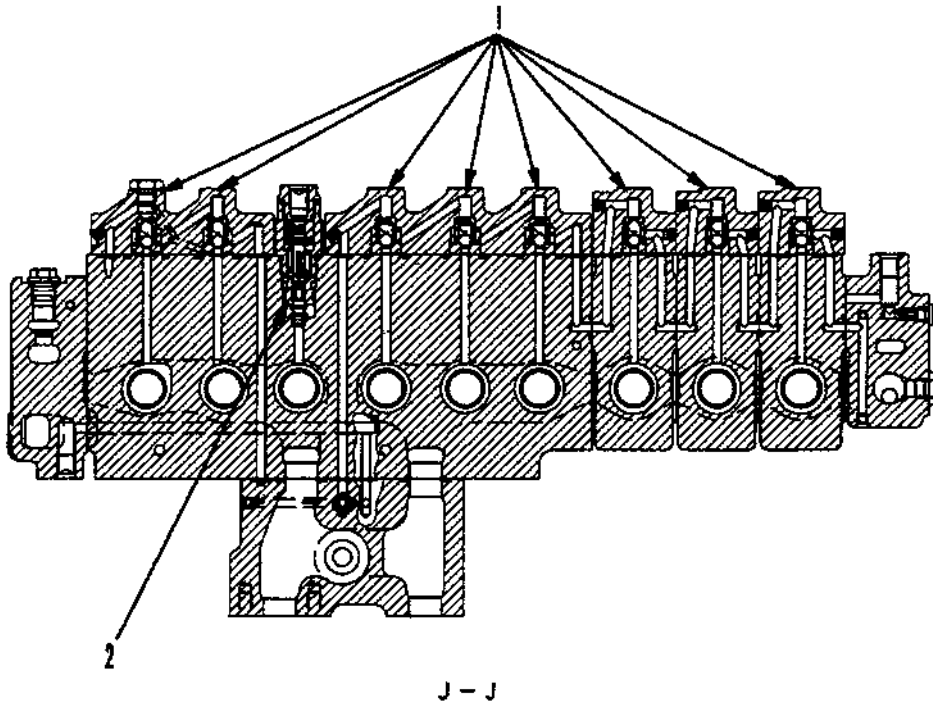

X10BH233

1. LS shuttle valve
2. LS select valve
3. Merge/flow divider valve (main)
4. Merge/flow divider valve (for LS)
5. Return spring
6. Return spring
7. LS bypass valve

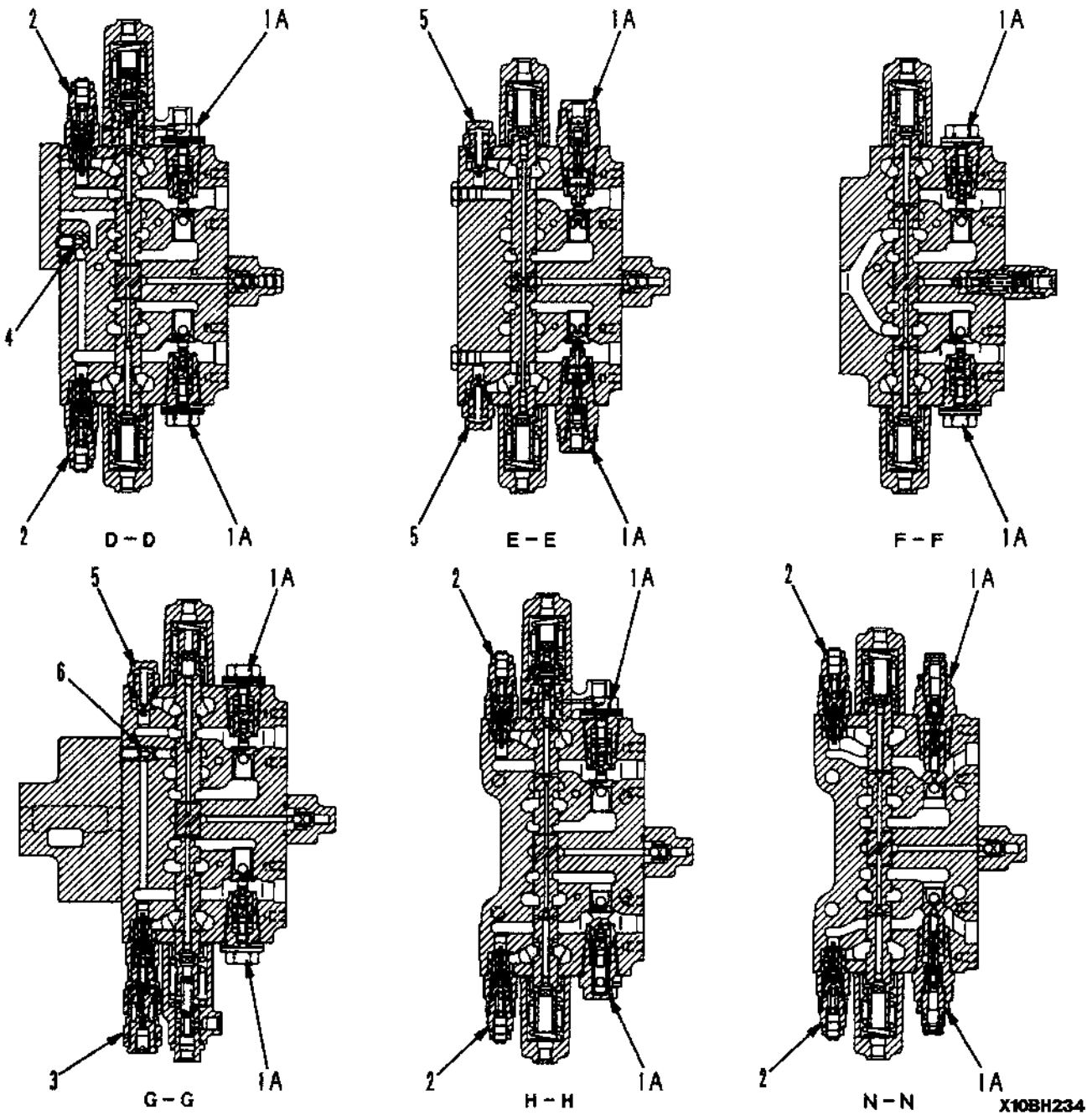

X10BH234

- 1A. Pressure compensation valve
- 1B. Variable pressure compensation valve
- 2. Safety-suction valve
- 3. Safety-suction valve
- 4. Check valve for regeneration circuit (arm)
- 5. Suction valve
- 6. Check valve for regeneration circuit (boom)

SAFETY-SUCTION VALVE FOR SERVICE VALVE

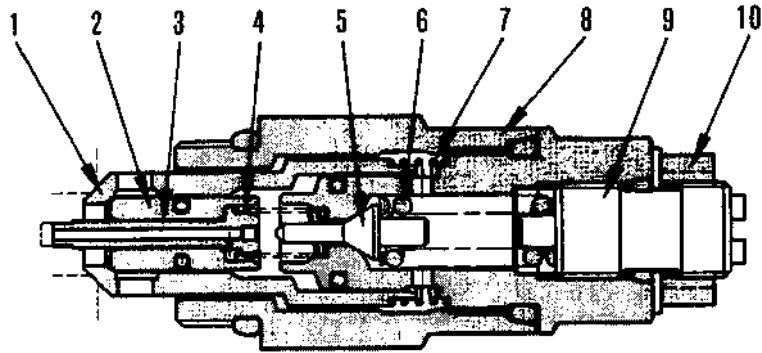

- 1. Suction valve
- 2. Main valve
- 3. Piston
- 4. Piston spring
- 5. Poppet
- 6. Poppet spring
- 7. Suction valve spring
- 8. Sleeve
- 9. Adjustment screw
- 10. Locknut

X10BH151

Part No.	Set pressure	Use
709-70-74600	24.5 MPa (250 kg/cm ²) at 5 ℓ/min	For crusher (Okada)

SELF-REDUCING PRESSURE VALVE

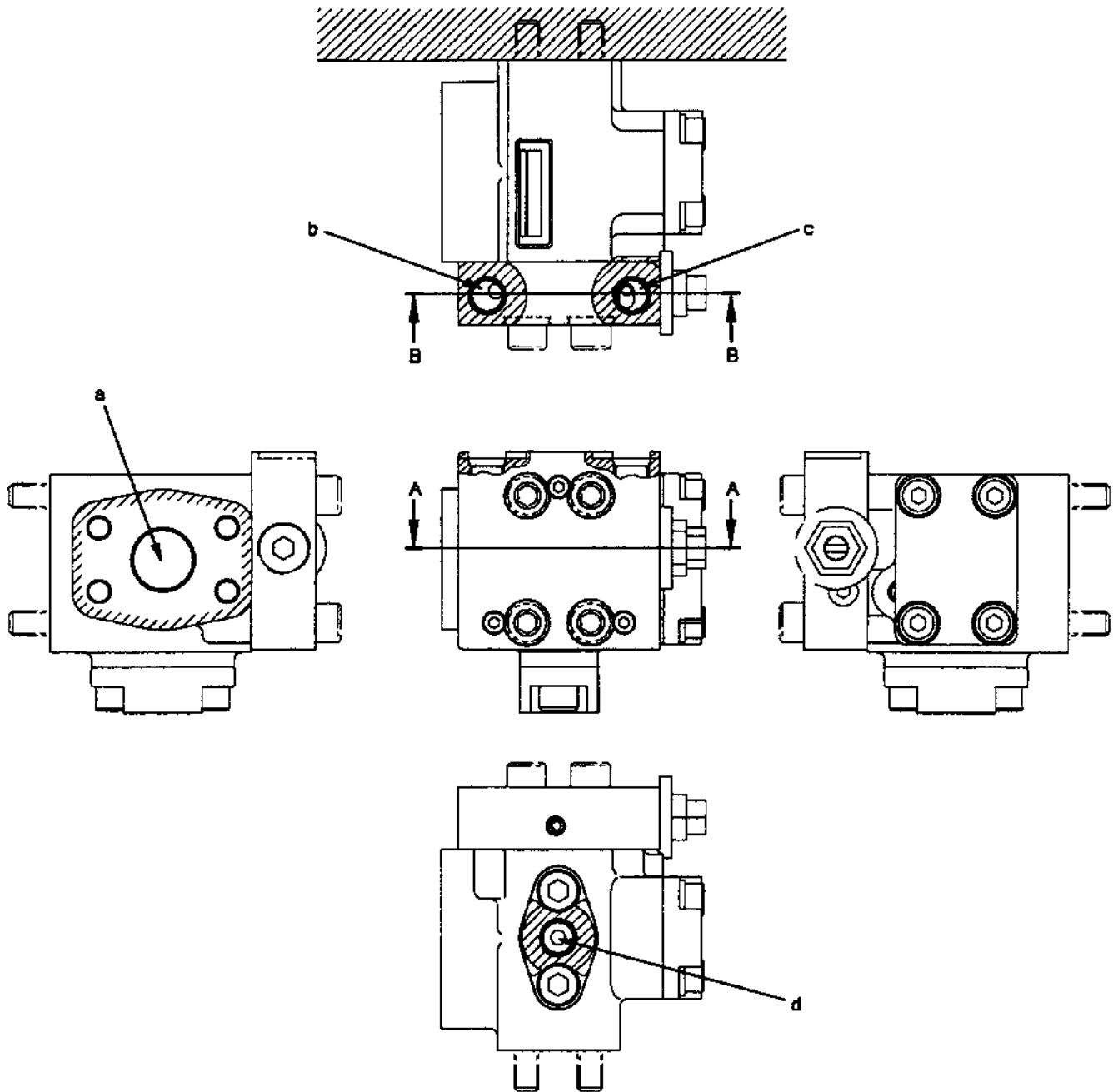

X10BH236

- a. Port **P1** (from front pump)
- b. Port **PR** (supply to electromagnetic valve, PPC valve, EPC valve)
- c. Port **T** (to hydraulic tank)
- d. Port **PC** (to front pump LS valve)

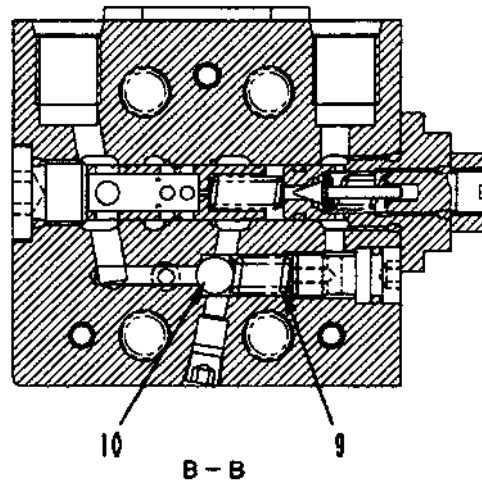
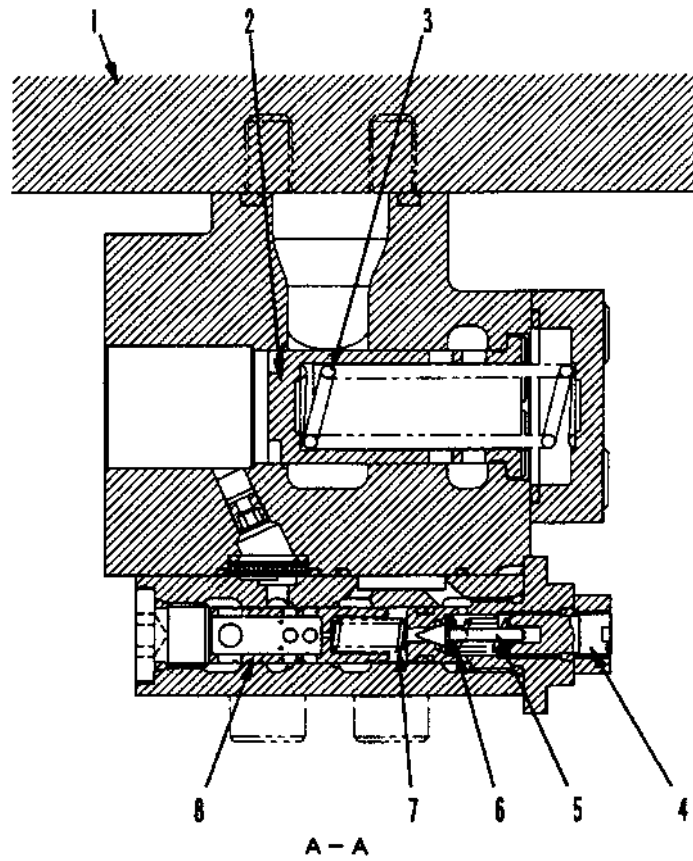

X10BH237

1. Control valve block
2. Valve (sequent valve)
3. Spring
4. Screw
5. Poppet
6. Spring (reduced valve pilot)
7. Spring (reducing valve main)
8. Spring (reducing valve)
9. Spring (safety valve)
10. Ball

Function

- This valve reduces the discharge pressure of the main pump and supplies it as the control pressure for the solenoid valve and the PPC valve.

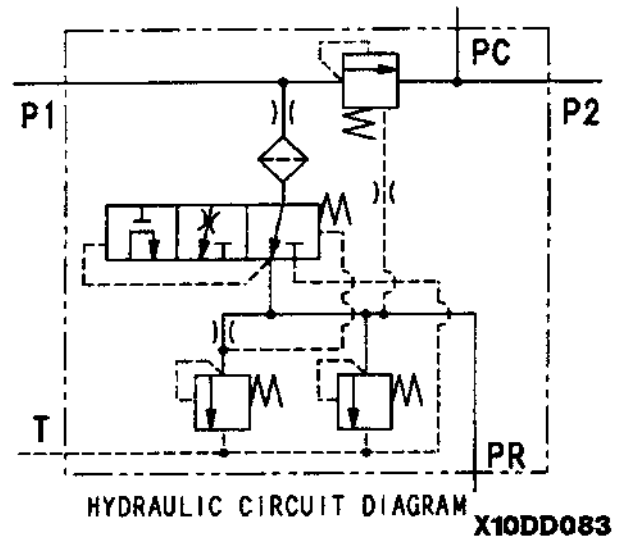

Operation

1. When engine is stopped.
 - a. Poppet (5) is pushed against the seat by spring (6), and the passage from port PR → T is closed.
 - b. Valve (8) is pushed to the left by spring (7), and the passage from port P1 → PR is open.
 - c. Valve (2) is pushed to the left by spring (3), so the passage between port P1 → P2 is closed.

(See figure at right)

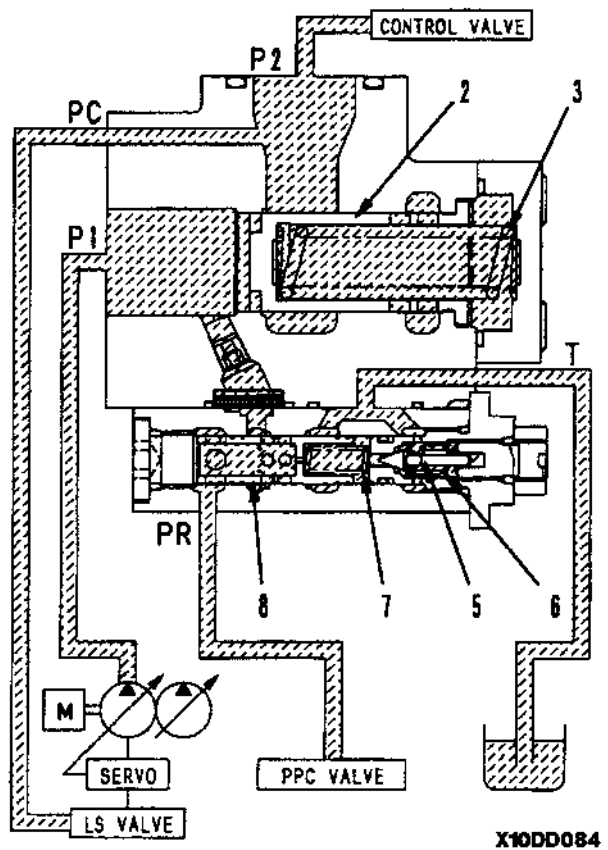

2. At neutral and when load pressure **P2** is low (when moving down under own weight (boom LOWER or arm IN)).

Note: When load pressure **P2** is lower than output pressure **PR** of the self-reducing pressure valve.

- a. Valve (2) receives force in the direction to close the passage from port **P1** → **P2** from spring (3) and pressure **PR** (when engine is stopped, the pressure is 0 MPa [[0 kg/cm²]]). However, when hydraulic oil flows in from port **P1**, the pressure is balanced so that pressure **P1** = force of spring (7) + (area $\varnothing d$ X pressure **PR**), and the opening from port **P1** → **P2** is adjusted so that pressure **P1** is kept at a certain value above pressure **PR**.
- b. When pressure **PR** goes above the set pressure, poppet (5) opens, and the hydraulic oil flows in the following circuit: port **PR** → hole **a** inside spool (8) → opening of poppet (5) → tank port **T**. As a result, a pressure difference is created on both sides of hole **a** inside spool (8), so spool (8) moves in the direction to close the opening from port **P1** → **PR**. Pressure **P1** is reduced to a certain pressure (set pressure) by the amount of opening at this point, and is supplied as pressure **PR**. (See figure at right).

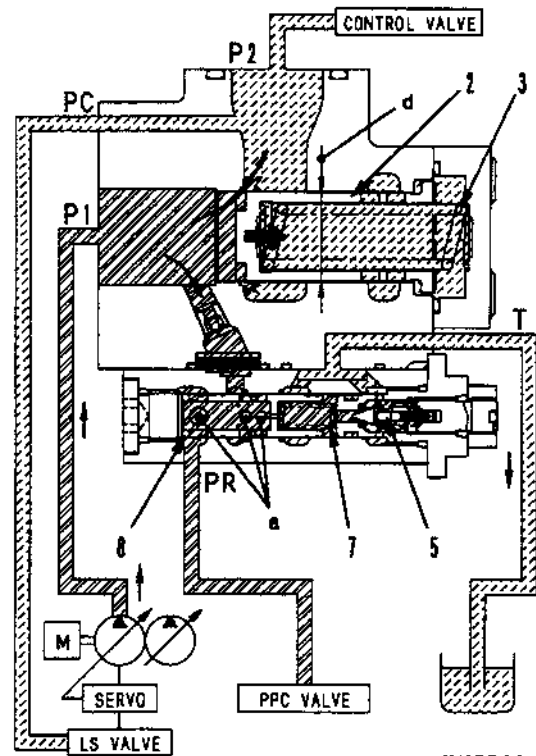

3. When the load pressure **P2** is high.

- a. If load pressure **P2** increases and the pump discharge amount also increases because of digging operations, pressure **P1** also increases (pressure **P1** >> force of spring (7) + area $\varnothing d$ X pressure **PR**), so valve (2) moves to the right to the end of the stroke. As a result, the amount of opening from port **P1** → **P2** increases and the resistance in the passage is reduced, so the loss of engine horsepower is reduced.
- b. If pressure **PR** goes above the set pressure, poppet (5) opens and the hydraulic oil flows in the following circuit: port **PR** → hole **a** inside spool (8) → opening of poppet (5) → tank port **T**. As a result, a pressure difference is created on both sides of hole **a** inside of spool (8), so that spool (8) moves in the direction to close the opening from port **P1** → **PR**. Pressure **P1** is reduced to a certain pressure (set pressure) by the amount of opening at this point, and is supplied as pressure **PR**. (See figure at right)

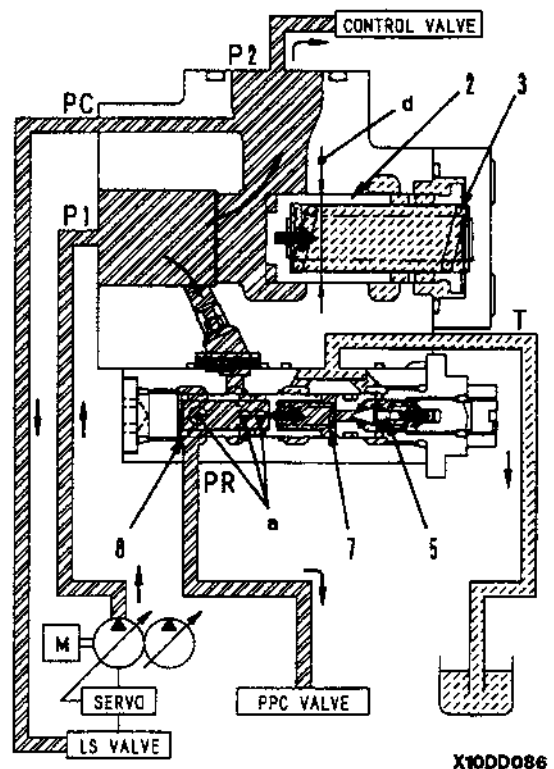

4. When there is abnormal high pressure.
 - a. When pressure **PR** of the self-reducing pressure valve becomes abnormally high, ball (10) pushes against the force of spring (9), separates from the seat, and allows hydraulic oil to flow from output port **PR** → **T**, so pressure **PR** goes down. This action protects the equipment at the destination for the hydraulic pressure supply (PPC valve, electromagnetic valve, etc.) from abnormally high pressure. (See figure at the right).

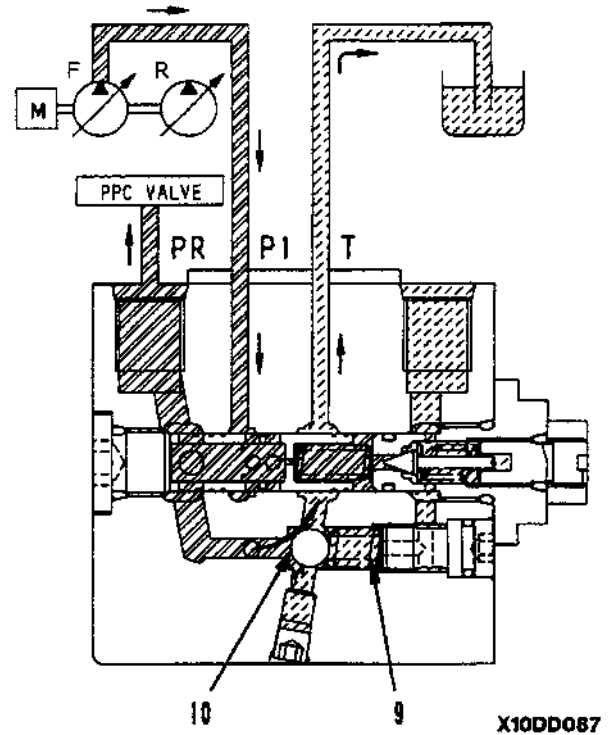

CLSS

Outline of CLSS

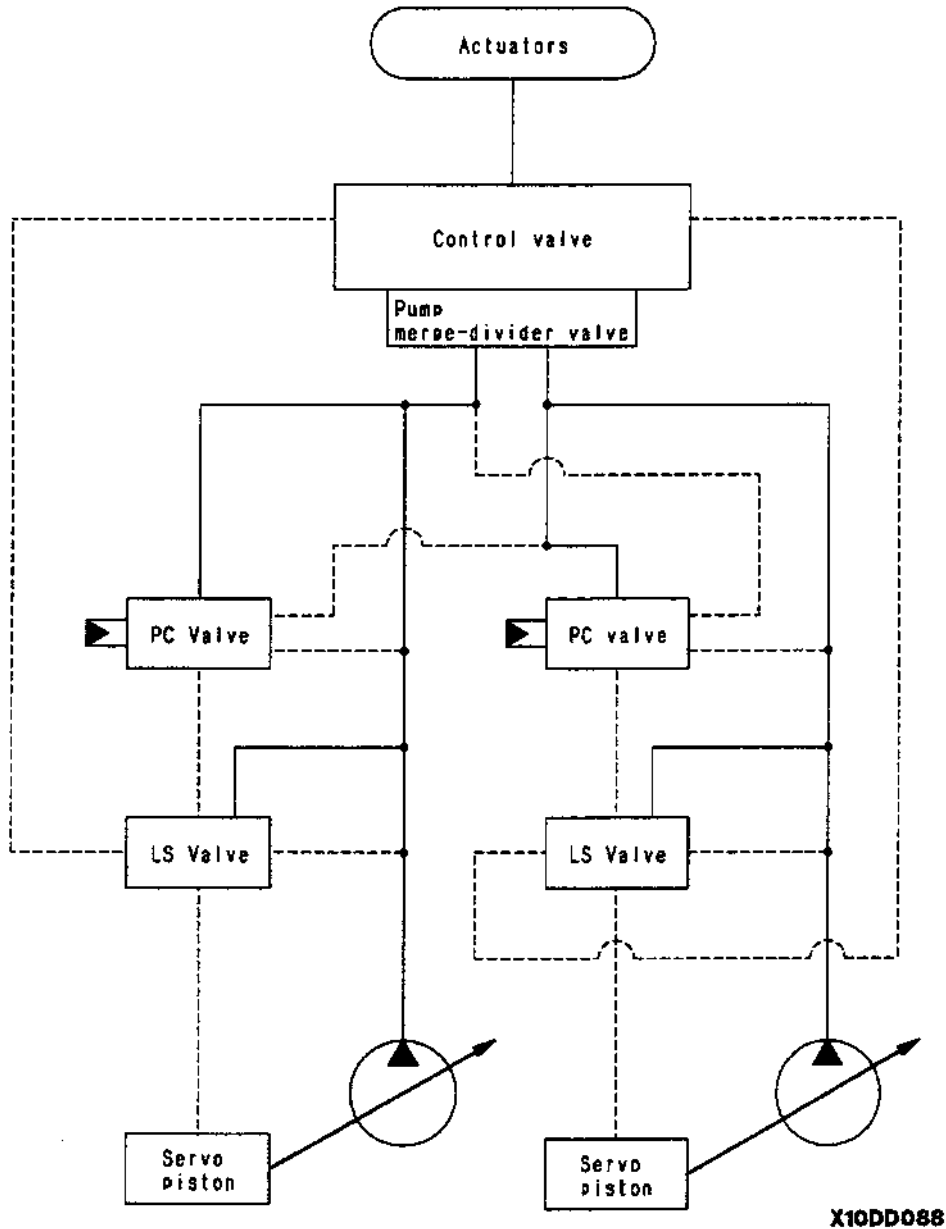

Features

- CLSS stands for **C**losed center **L**oad **S**ensing **S**ystem, and has the following features.
 - 1) Fine control not influenced by load.
 - 2) Control enabling digging even with fine control.
 - 3) Ease of compound operation ensured by flow divider function using area of opening of spool during compound operations.
 - 4) Energy saving using variable pump control.

Structure

- The CLSS consists of a main pump (2 pumps), control valve, and actuators for the work equipment.
- The main pump body consists of the pump itself, the PC valve and the LS valve.

Basic principle

1. Control of pump swash plate angle.
 - a. The pump swash plate angle (pump discharge amount) is controlled so that LS differential pressure ΔPLS (the difference between pump pressure **PP** and control valve outlet port LS pressure **PLS**) (load pressure of actuator) is constant. (LS pressure $\Delta PLS = \text{Pump discharge pressure } PP - \text{LS pressure } PLS$)

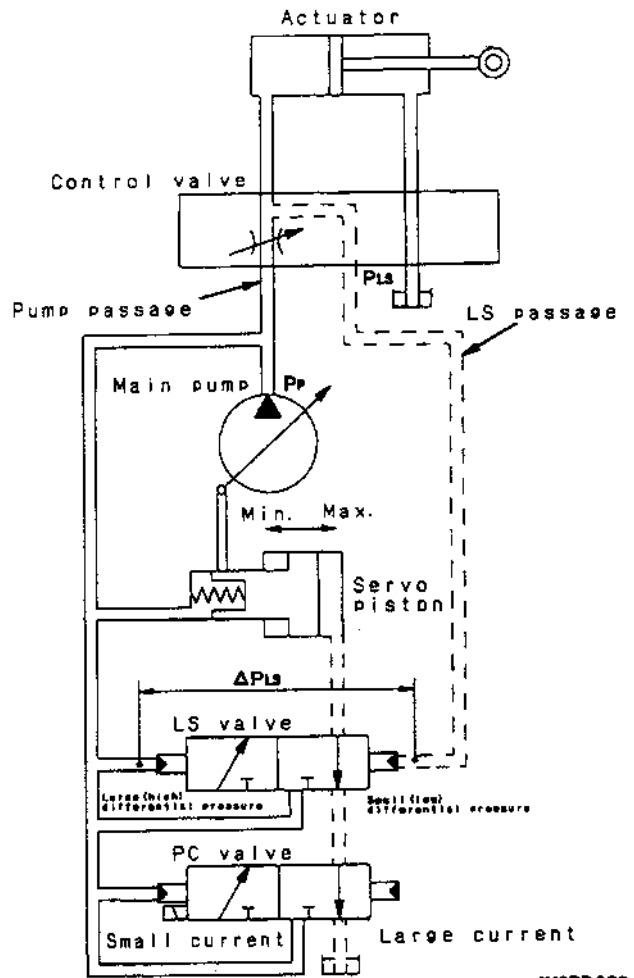

X10DD089

- b. If LS differential pressure ΔPLS becomes lower than the set pressure of the LS valve (when the actuator load pressure is high), the pump swash plate moves towards the maximum position; if it becomes higher than the set pressure of the LS valve (when the actuator load pressure is low), the pump swash plate moves towards the minimum position.

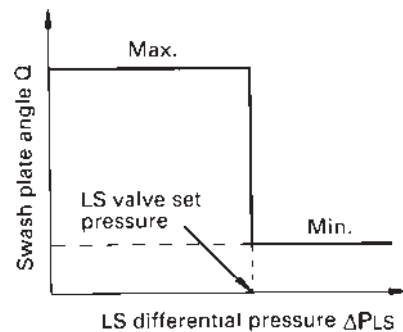

SAP00384

2. Pressure compensation

- a. A pressure compensation valve is installed to the outlet port side of the control valve to balance the load. When the two actuators are operated together, this valve acts to make the pressure difference ΔP between the upstream (inlet port) and downstream (outlet port) of the spool of each valve the same regardless of the size of the load (pressure). In this way, the flow of oil from the pump is divided (compensated) in proportion to the area of openings **S1** and **S2** of each valve.

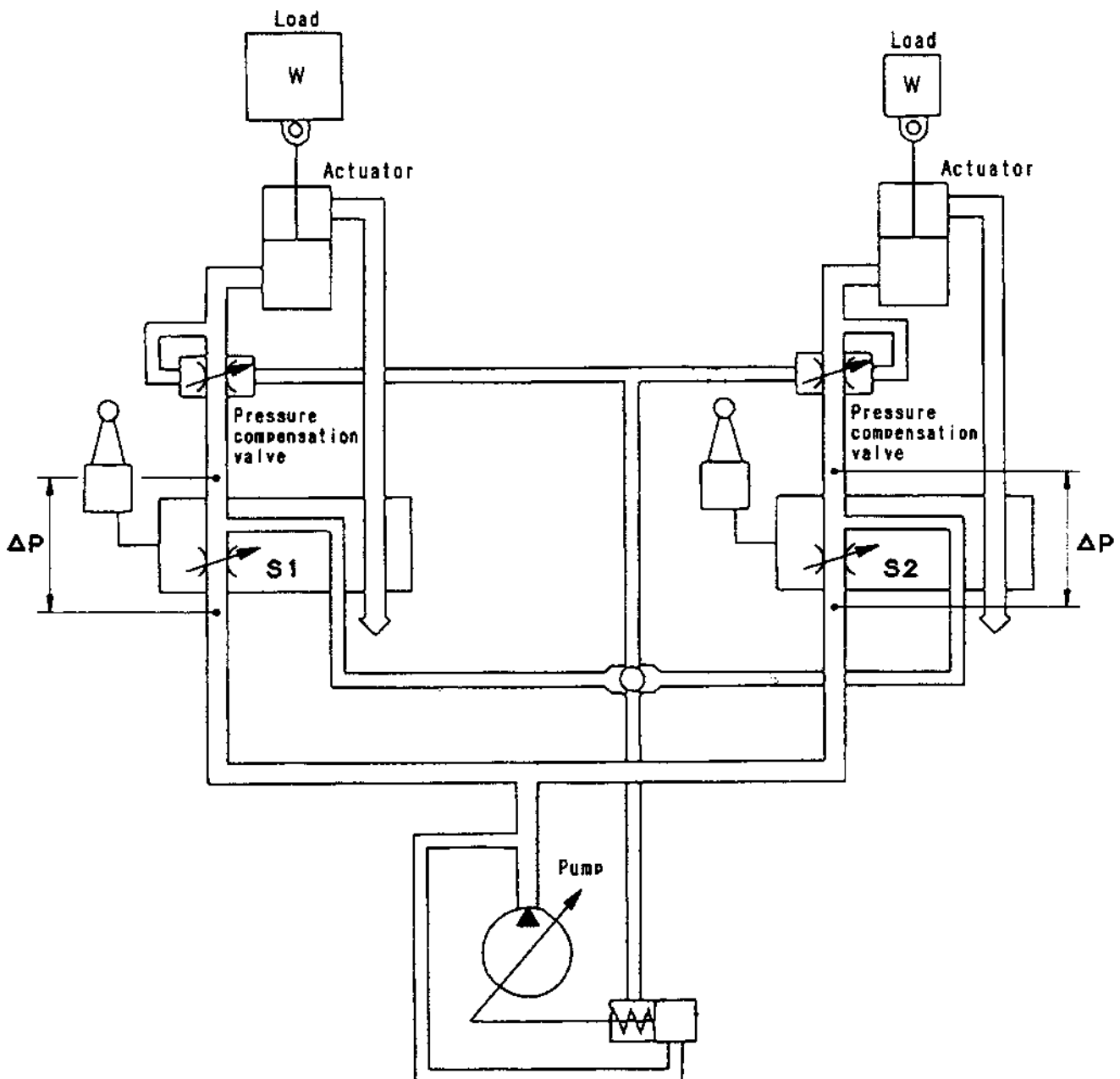

X10DD091

Operation for each function and valve
Hydraulic circuit diagram for system

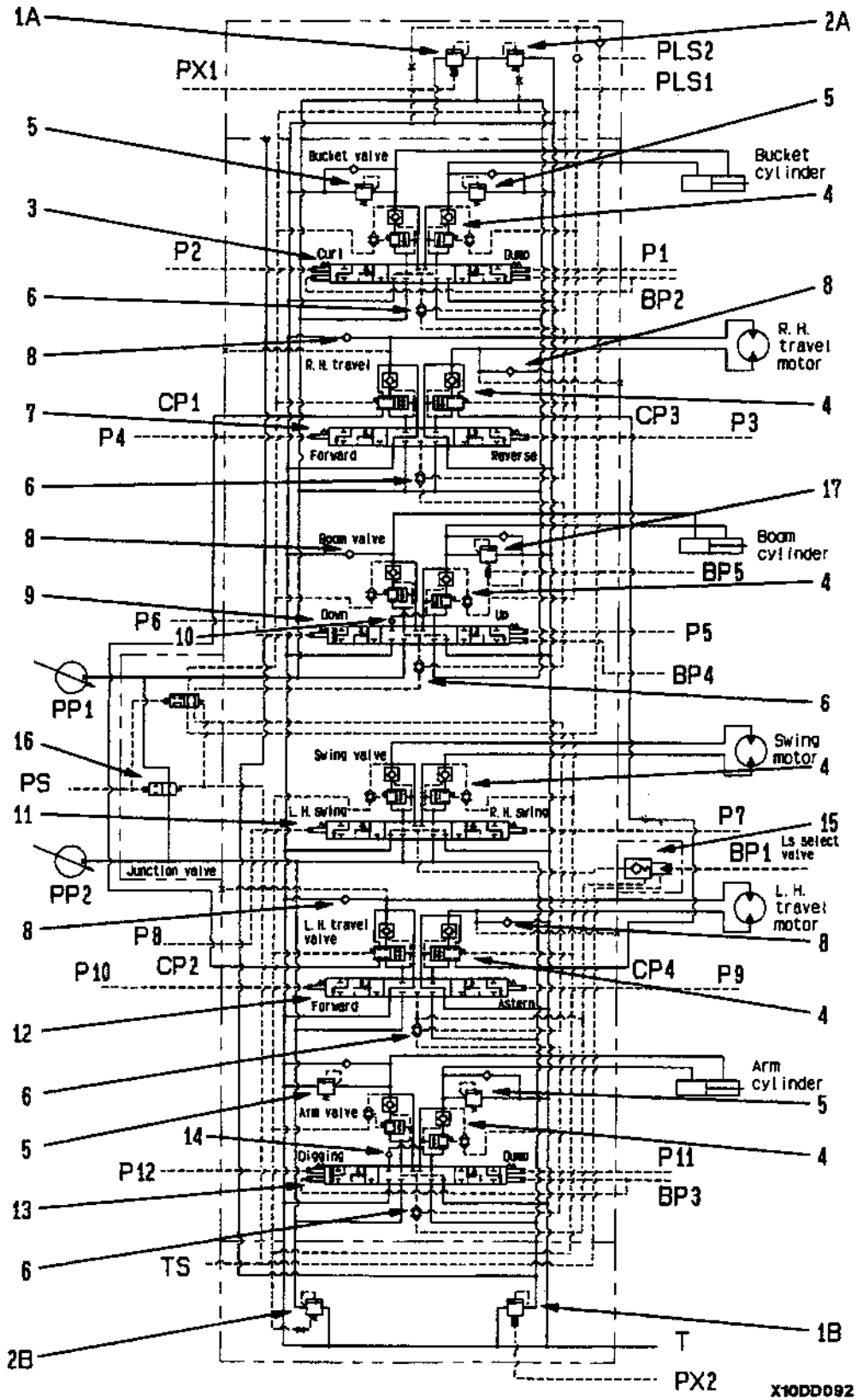

X10DD092

- 1A. Main relief valve (bucket end group)
Set pressure: 31.9 MPa (325 kg/cm²) (34.8 MPa (355 kg/cm²))
 - 1B. Main relief valve (arm end group)
Set pressure: 31.9 MPa (325 kg/cm²) (34.8 MPa (355 kg/cm²))
 - 2A. Unload valve (bucket end group)
Set pressure: 2.9 MPa (30 kg/cm²)
 - 2B. Unload valve (arm end group)
Set pressure: 2.9 MPa (30 kg/cm²)
 3. Bucket spool
 4. Pressure compensation valve
 5. Safety-suction valve
Set pressure: 35.8 MPa (365 kg/cm²)
 6. LS shuttle valve
 7. R.H. travel spool
 8. Suction valve
 9. ↓ Boom spool
 10. Check valve (for boom regeneration circuit)
 11. ↑ Swing spool
 12. L.H. travel spool
 13. Arm spool
 14. Check valve (for arm regeneration circuit)
 15. LS select valve
 16. Merge/flow divider valve
 17. Safety-suction valve
Set pressure: 35.8 MPa (365 kg/cm²) (28.4 MPa (290 kg/cm²))
-
- A. To bucket cylinder
 - B. To R.H. travel motor
 - C. ↓ To boom cylinder
 - D. To swing motor
 - E. To L.H. travel motor
 - F. To arm cylinder
 - H. ↑ To travel junction valve

SYSTEM DIAGRAM

★ This shows actuator (6A) at stroke end relief in the merge mode.

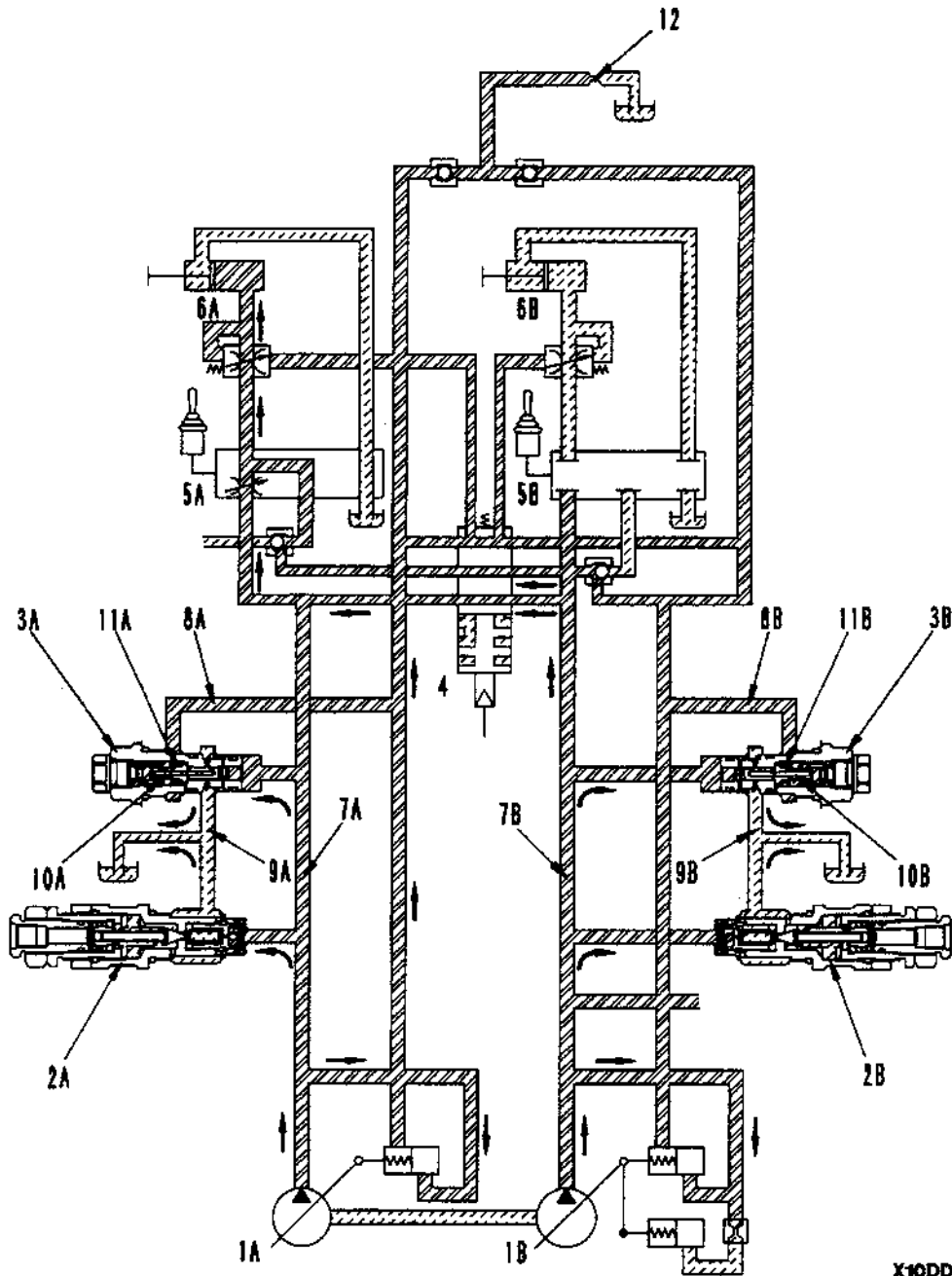

X10DD093

- | | | | | | |
|-----|--------------------------|-----|---------------|------|-----------------|
| 1A. | Main pump | 5B. | Control valve | 9B. | Tank passage |
| 1B. | Main pump | 6A. | Actuator | 10A. | Valve |
| 2A. | Main relief valve | 6B. | Actuator | 10B. | Valve |
| 2B. | Main relief valve | 7A. | Pump passage | 11A. | Spring |
| 3A. | Unload valve | 7B. | Pump passage | 11B. | Spring |
| 3B. | Unload valve | 8A. | LS circuit | 12. | LS bypass valve |
| 4. | Pump merge-divider valve | 8B. | LS circuit | | |
| 5A. | Control valve | 9A. | Tank passage | | |

Unload valve

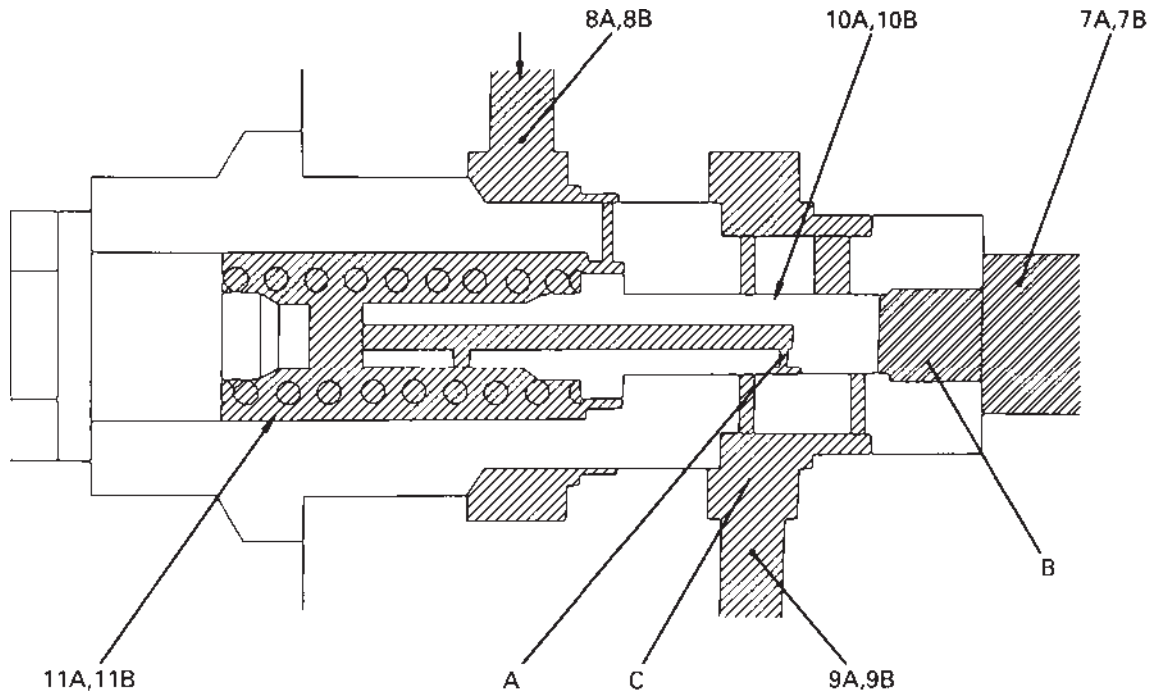

SBP00205

Function

- When all the control valves are at neutral, the oil discharged when the pump is at the minimum swash plate angle is drained. When this happens, the pump pressure becomes a pressure that matches the set load of springs (11A, 11B) inside the valve (P1 pressure). The LS pressure is drained from LS bypass valve, so LS pressure = tank pressure = 0 MPa (0 kg/cm²).

- When the unload operation is carried out, the differential pressure (pump discharge pressure - LS circuit pressure) is greater than the pump LS control pressure, so a signal is sent to move the pump swash plate to the minimum angle.

Operation

- The pressure in pump passages (7A, 7B) is received by the end face of valves (10, 10B). The control valve is at neutral, so the pressure in LS circuits (8A, 8B) is 0 MPa (0 kg/cm²).
- The pressurized oil in pump passages (7A, 7B) is stopped by valves (10A, 10B). There is no way for the pressurized oil discharged by the pump to escape, so the pressure rises. When this pressure becomes larger than the force of springs (11A, 11B), valves (10A, 10B) move to the left, ports B and C are connected and the pump pressure flows to tank passages (9A, 9B). In addition, the pressurized oil in LS circuits (8A, 8B) passes from orifice A through port C, and is drained to tank passages (9A, 9B). Therefore, when the valve is actuated, LS pressure = tank pressure.

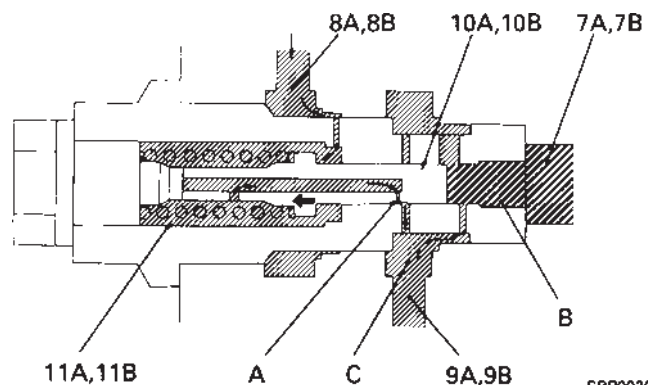

SBP00206

Main relief valve (2-stage type)

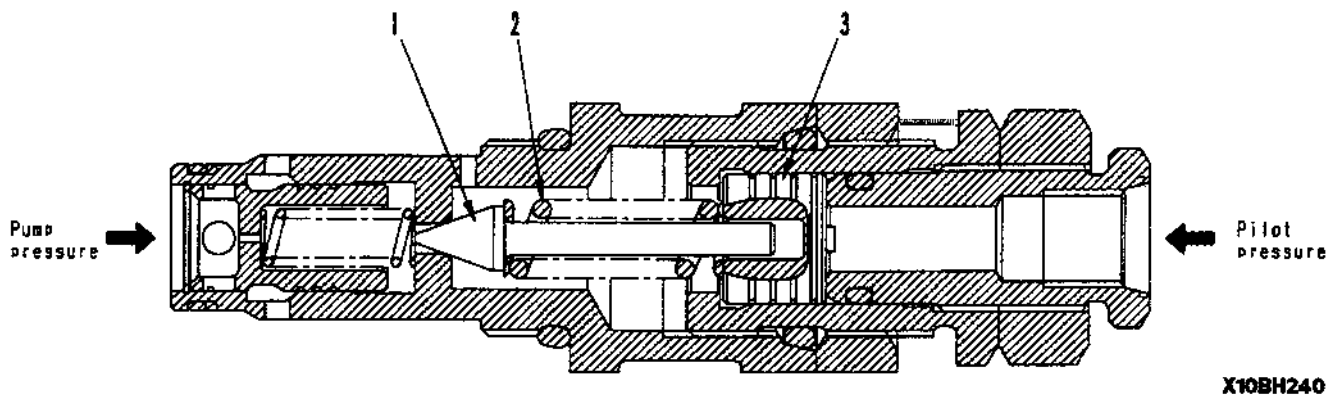

1. Poppet
2. Spring
3. Piston

Function

- The low set pressure and high set pressure can be changed by the external pilot pressure.
- The relief pressure is determined by the pump pressure acting on poppet (1) and the set load of spring (2).
- When the pilot pressure is OFF, the system is set to the low pressure. When the pilot pressure is ON, piston (3) is pushed fully to the left, so the force of spring (2) increases and the relief pressure becomes the high set pressure.

During cut-off control

Function

- This function uses the pump pressure sensor, pump controller, and PC valve. When pump discharge pressure **PP** is greater than the set pressure, pump discharge amount **Q** is the minimum.

Operation

1. If the pump pressure sensor detects that pump discharge pressure **PP** has become higher than the set pressure, it informs the pump controller.
2. When the pump controller receives this signal, it increases the value of the signal current going to the PC valve and reduces pump discharge amount **Q** to the minimum (minimum swash plate angle).
3. When this happens, the oil discharged from the pump passes through the relief valve (low set pressure) and is drained.

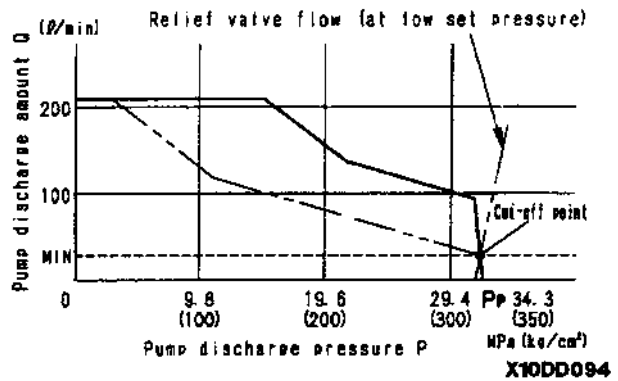

When power max. is actuated (when cut-off is canceled)

Function, operation

- In the power max. mode, the torque cut-off signal is not output, so the torque moves along the pump discharge curve.
- When this happens, the oil discharged from the pump is relieved through the relief valve to maintain the overall balance.

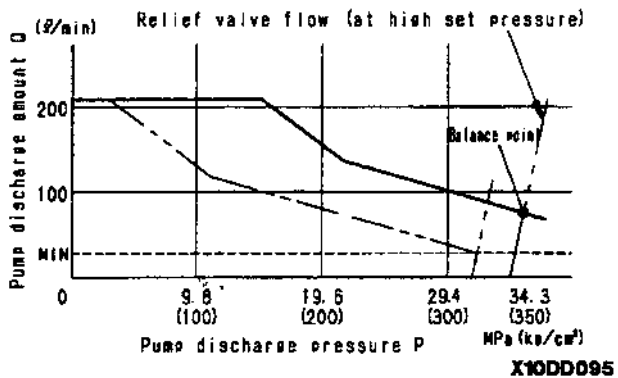

Introduction of LS pressure

★ The diagram shows the condition for arm IN.

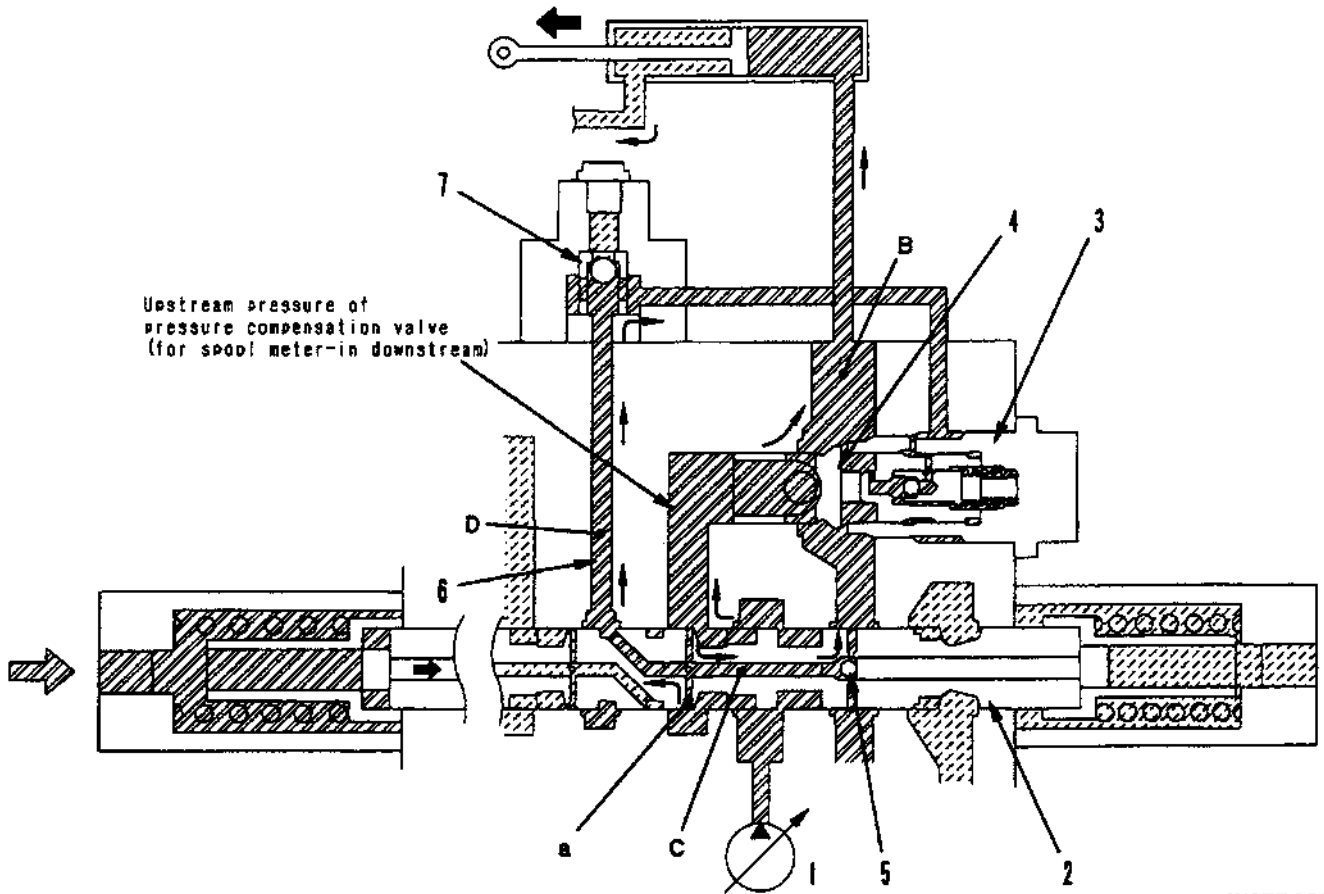

X10DD096

- 1. Main pump
- 2. Main spool
- 3. Pressure compensation valve
- 4. Valve
- 5. Ball valve
- 6. LS circuit
- 7. LS shuttle valve

Function

- The upstream pressure (= spool meter-in downstream pressure) of pressure compensation valve (3) is introduced and goes to shuttle valve (7) as the LS pressure. When this happens, it is connected to port **B** of the actuator through valve (4), and LS pressure = actuator load pressure. Introduction hole **a** inside the spool has a small diameter, so it also acts as a throttle.

Operation

1. When spool (2) is operated, the pump pressure passes through introduction hole **a**, enters port **C**, and is taken to the LS circuit (6). When the pump pressure rises and reaches the load pressure of port **B**, ball valve (5) opens.

LS bypass valve

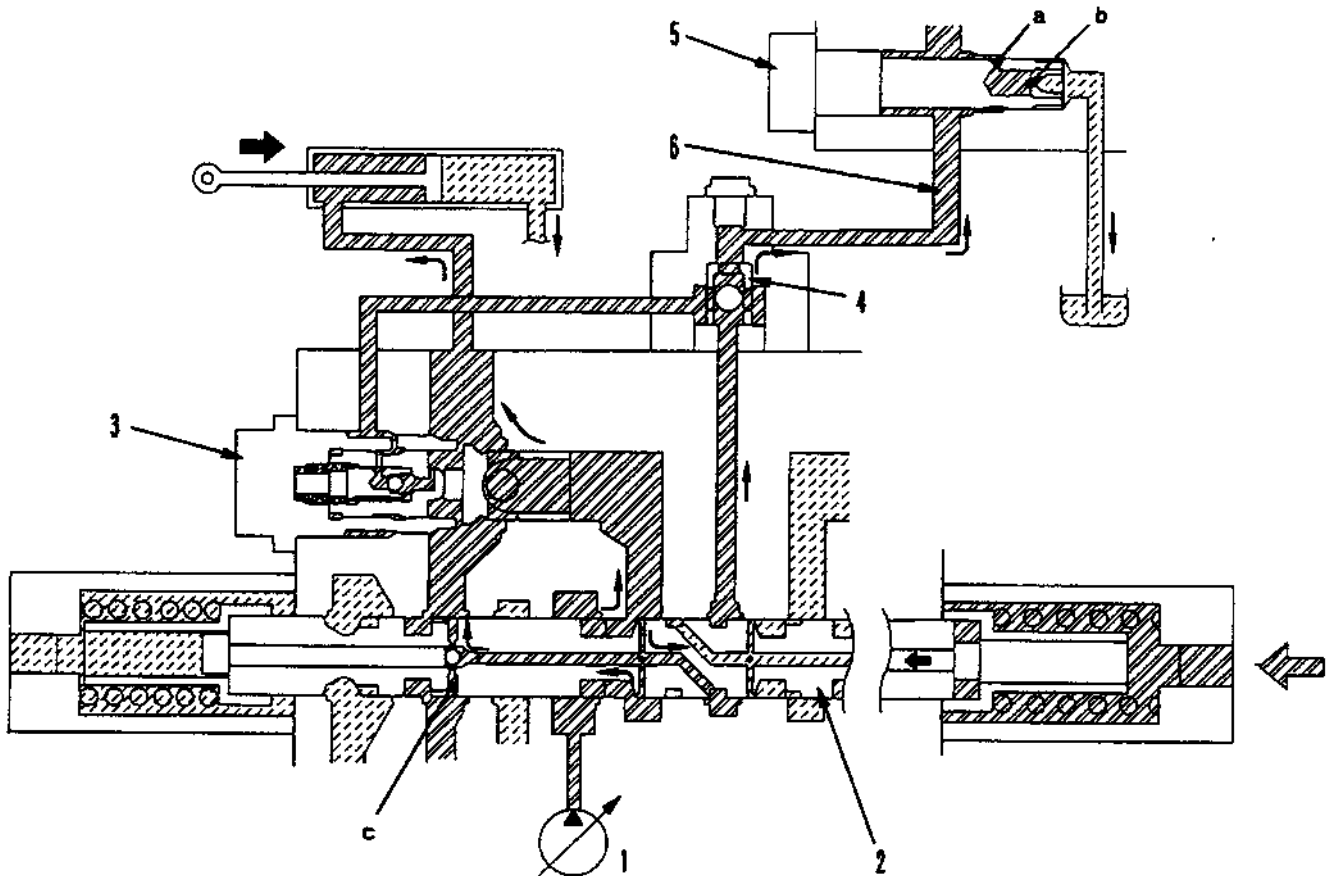

X10DD097

1. Main pump
2. Main spool
3. Pressure compensation valve
4. LS shuttle valve
5. LS bypass valve
6. LS circuit

Function

- The residual pressure in LS circuit (6) is released from orifices **a** and **b**.
- This reduces the speed of the rise in the LS pressure, and prevents any sudden change in the oil pressure. Furthermore, a pressure loss is generated by the circuit resistance between LS shuttle valve (4) and throttle **c** of main spool (2) according to the bypass flow from LS differential pressure drops, and the dynamic stability of the actuator is increased.

Pressure compensation valve

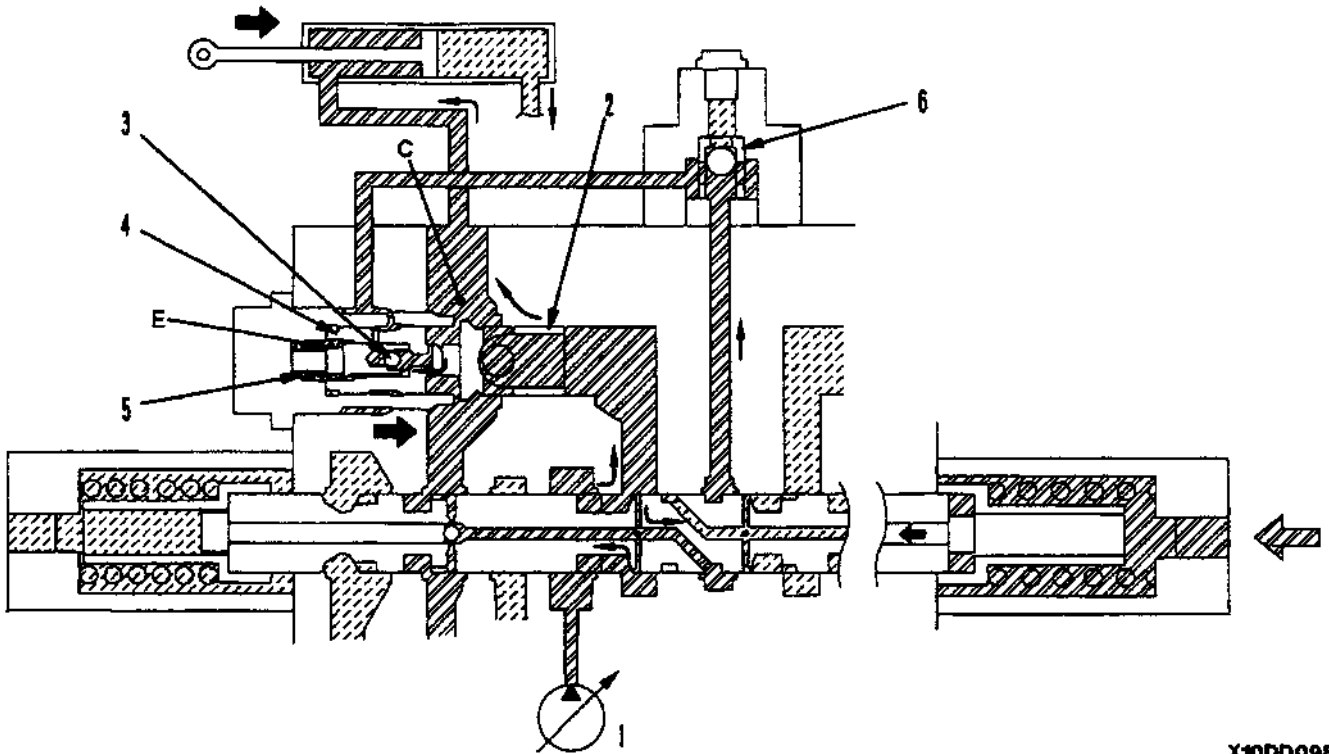

X10DD098

- 1. Main pump
- 2. Valve
- 3. Shuttle valve
- 4. Piston
- 5. Spring
- 6. LS shuttle valve

Function during independent operation and at maximum load pressure (during compound operations, when load pressure is higher than other work equipment)

- The pressure compensation valve acts as a load check valve.

Operation

1. If the pump pressure (LS pressure) is lower than the load pressure at port C, shuttle valve (3) inside the pressure compensation valve piston (4) moves to interconnect spring chamber E and port C. From this condition, the force of spring (5) acts to move piston (4) and valve (2) in the direction of closing.

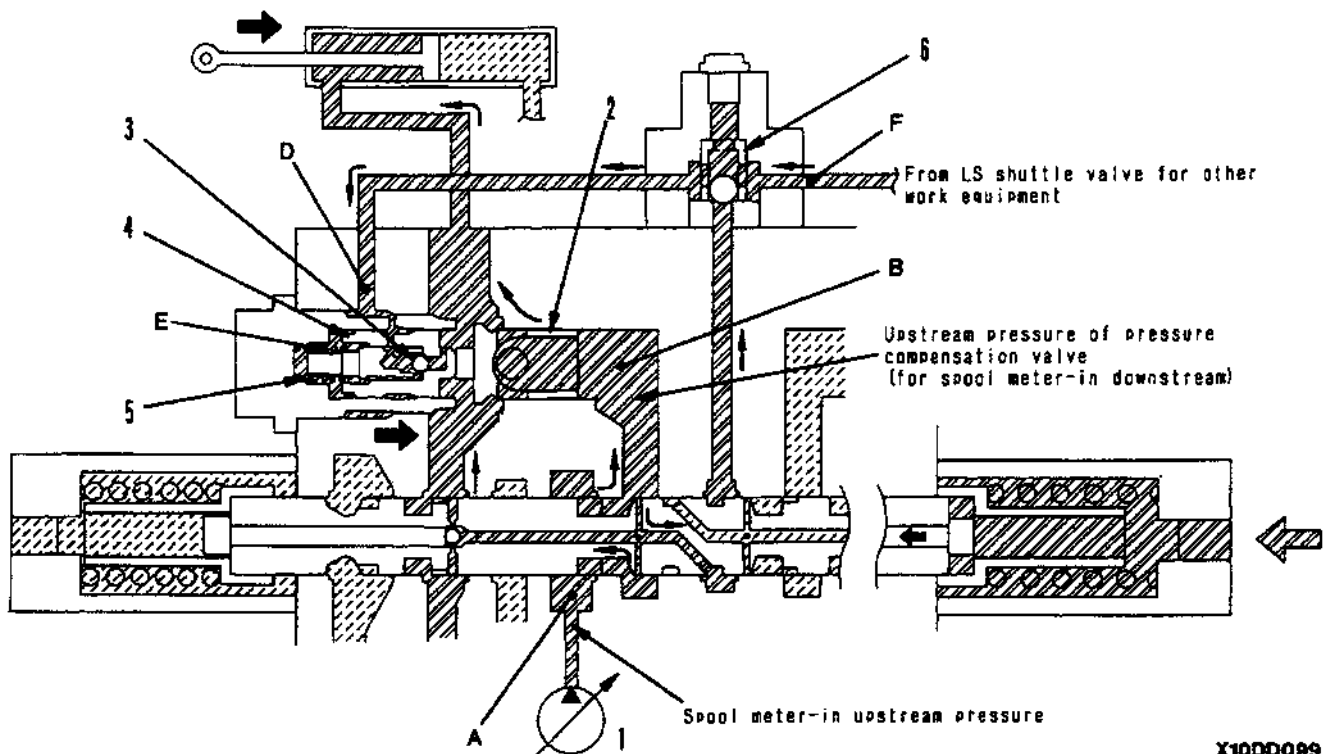

Function when receiving compensation
(during compound operations, when load pressure is lower than other work equipment)

- The pressure compensation valve is closed by the LS pressure of port **D**, and the spool meter-in downstream pressure of port **B** becomes the same as the maximum pressure of the other work equipment. The spool meter-in upstream pressure of port **A** is the pump pressure, so spool meter-in differential pressure (upstream pressure (pressure of port **A**) - downstream pressure (pressure of port **B**)) becomes the same for all spools that are being operated. Therefore, the pump flow is divided in proportion to the area of the meter-in opening.

Operation

- Spring chamber **E** is interconnected with port **D**. Piston (4) and valve (2) are actuated by the LS circuit pressure from the other work equipment at port **F** in the direction of closing (to the right). In other words, the valve upstream pressure of port **B** (= spool meter-in downstream pressure) is controlled by the LS pressure.

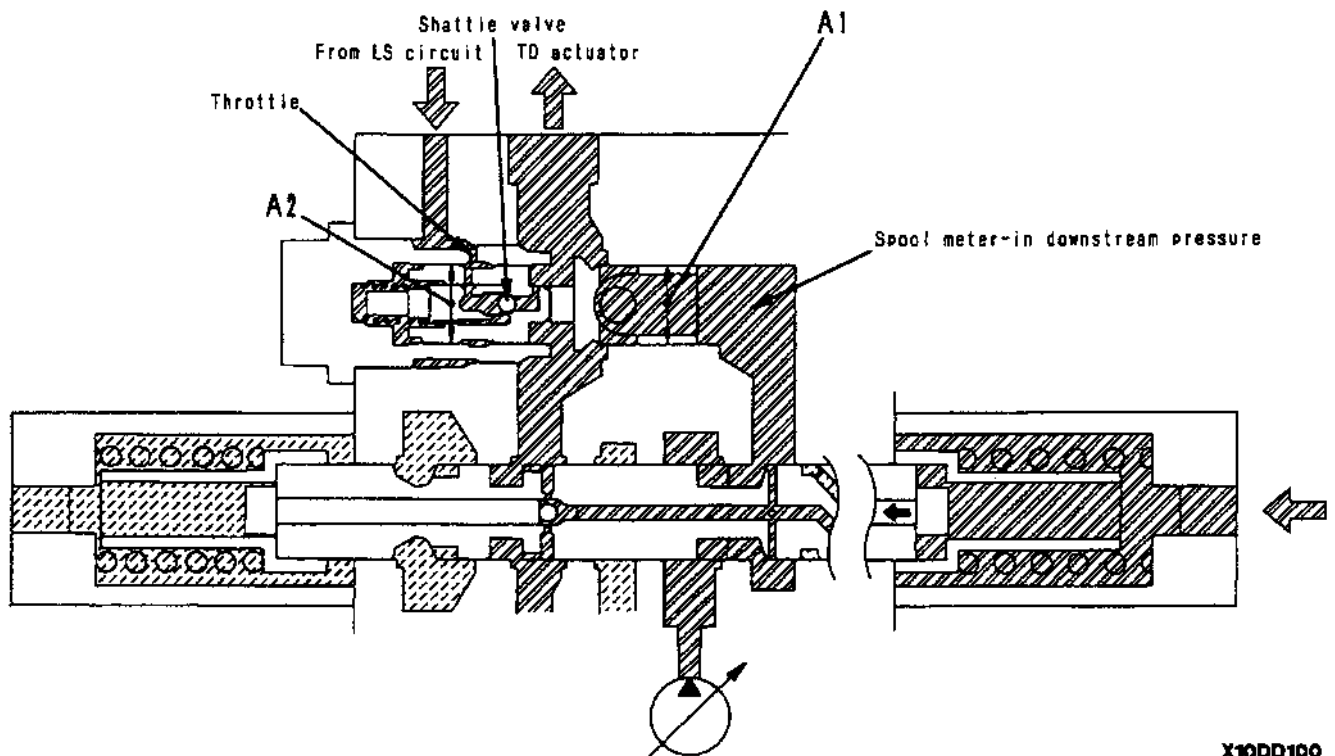

Surface area ratio of pressure compensation valve

The condition of the flow division changes according to the ratio of the area of portion **A1** and portion **A2** of the pressure compensation valve.

Area ratio = $A2/A1$.

- When area ratio = 1:
Spool meter-in downstream pressure = Max. load pressure, and oil flow is divided in proportion to area of opening of spool.
- When ratio is more than 1:
Spool meter-in downstream pressure > Max. load pressure, and oil flow is divided in a proportion less than area of opening of spool.
- When ratio is less than 1:
Spool meter-in downstream pressure < Max. load pressure, and oil flow is divided in a proportion more than area of opening of spool.

Pressure compensation valve for service valve

- The service valve uses a variable type pressure compensation valve, so it can adjust the division of the oil flow suitably to match the attachment installed.

Shuttle valve inside pressure compensation valve

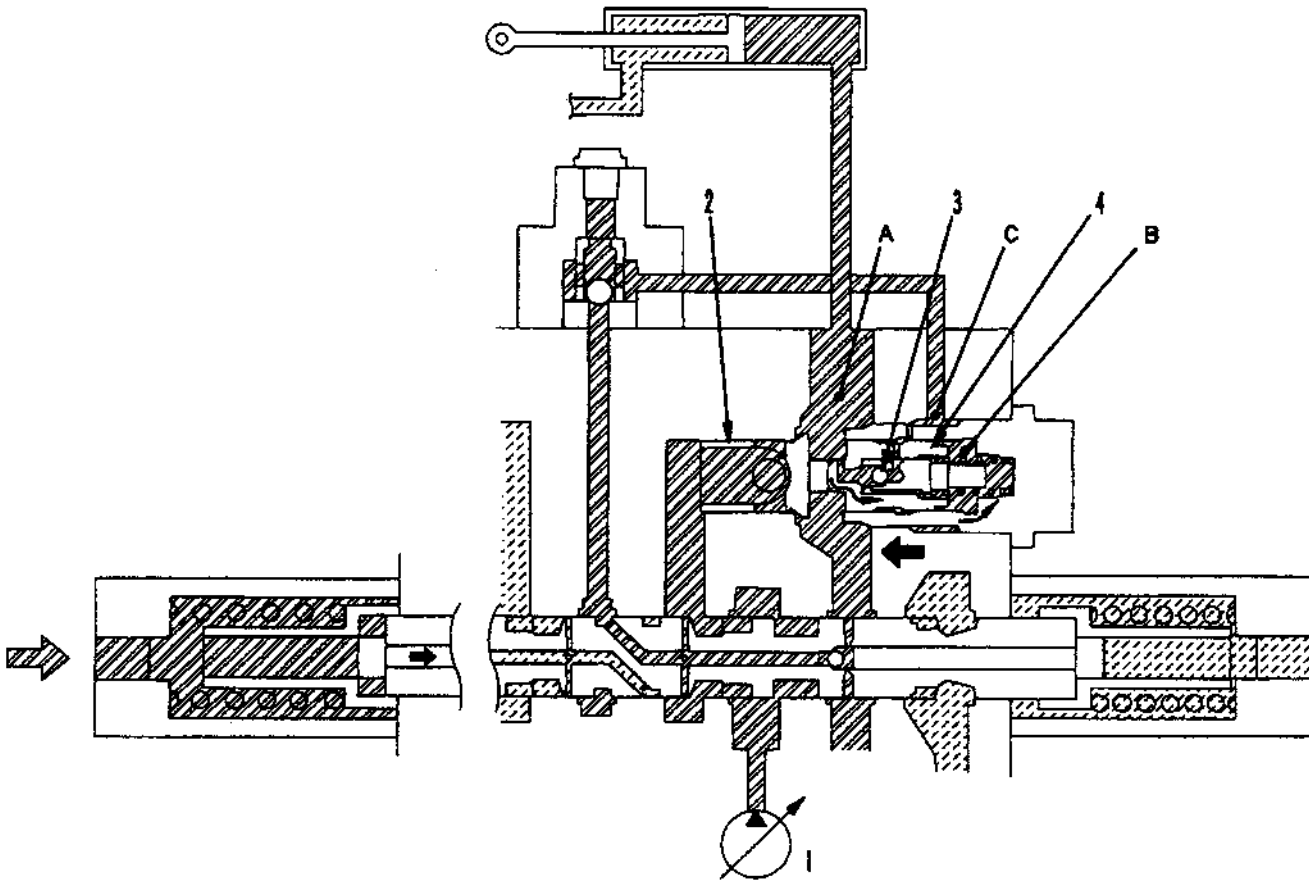

X10DD101

1. Main pump
2. Valve
3. Shuttle valve inside pressure compensation valve
4. Piston

Function

When holding pressure at port **A** >> LS pressure in spring chamber **B**.

- Shuttle valve (3) is pushed to the right by the pressure of port **A**, and the circuit between ports **A** and **C** is shut off. In this condition, the holding pressure at port **A** is taken to spring chamber **B**, and pushes piston (4) to the left to prevent piston (4) and valve (2) from separating.

Variable type pressure compensation valve (for service valve)

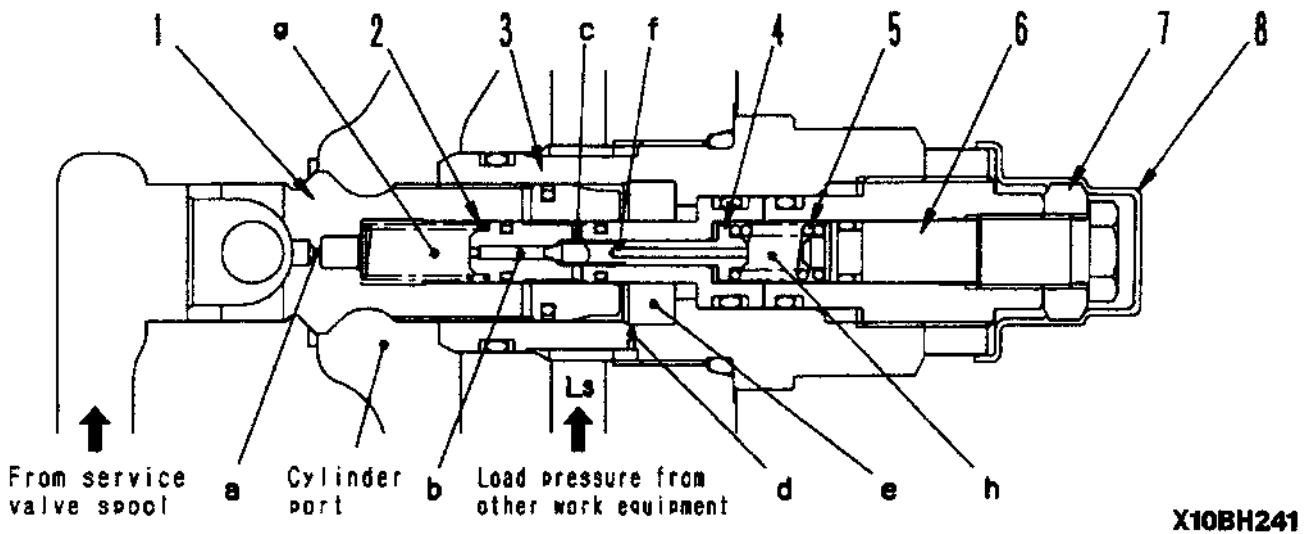

1. Valve
2. Spring
3. Sleeve
4. Poppet
5. Spring
6. Screw
7. Locknut
8. Plastic cap

Function

- It is possible to adjust the division of the oil flow to the service valve when the service valve (for attachment) is operated together with the main control valve (boom RAISE, etc.). (Variable in proportion to surface area)
- The pump pressure leaving the service valve spool acts on the left end of valve (1), and at the same time passes through throttle **a** and enters chamber **g**. The maximum **LS** pressure passes through throttle **d** and enters chamber **e**. At the same time, the cylinder port pressure passes through passage **c** and throttle **f**, and goes to chamber **h**. In addition, the force of spring (2) acts on valve (1), and the force of spring (5) acts on poppet (4). The force of spring (5) can be adjusted with screw (6).

Operation

Simultaneous operation with work equipment under heavy load (boom RAISE, etc.)

1. The pump pressure and LS pressure are determined by the pressure of the other work equipment, but the cylinder port pressure becomes the actuating pressure of the attachment. When the difference between the pump pressure and the cylinder pressure is less than the force of spring (5), then balance of the force acting on valve (1) is as follows.

$$P \times A1 = P \times A2 + LS (A2 - A1) + F$$

A1: Cross-sectional area of diameter D1

A2: Cross-sectional area of diameter D2

F: Force of spring

2. If the difference between pump pressure **P** and the cylinder pressure becomes greater than the force of spring (5), poppet (4) is pushed to the right and the passage opens, so the pump passage is connected to the cylinder port through throttle **a**, chamber **g** and passages **b** and **c**, and the oil flows to the cylinder port. When this happens, a differential pressure is formed between the upstream and downstream sides of throttle **a**, and the pressure in chamber **g** goes down, so the force pushing valve (1) to the left is reduced. In other words, the area ratio becomes smaller, so valve (1) moves to the right and increases the flow from the pump to the cylinder.

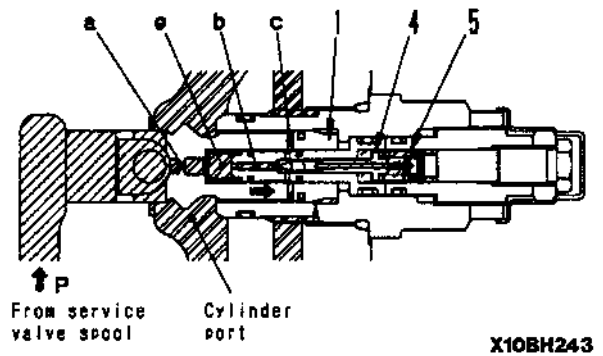
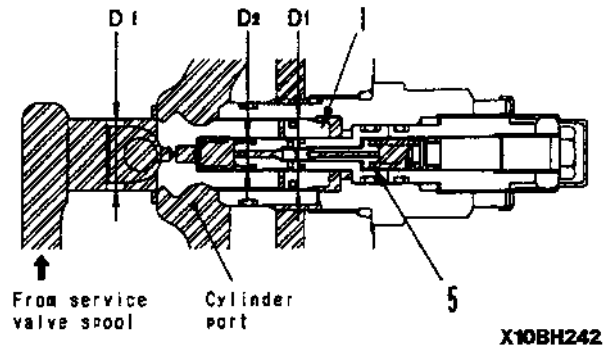

Boom regeneration circuit

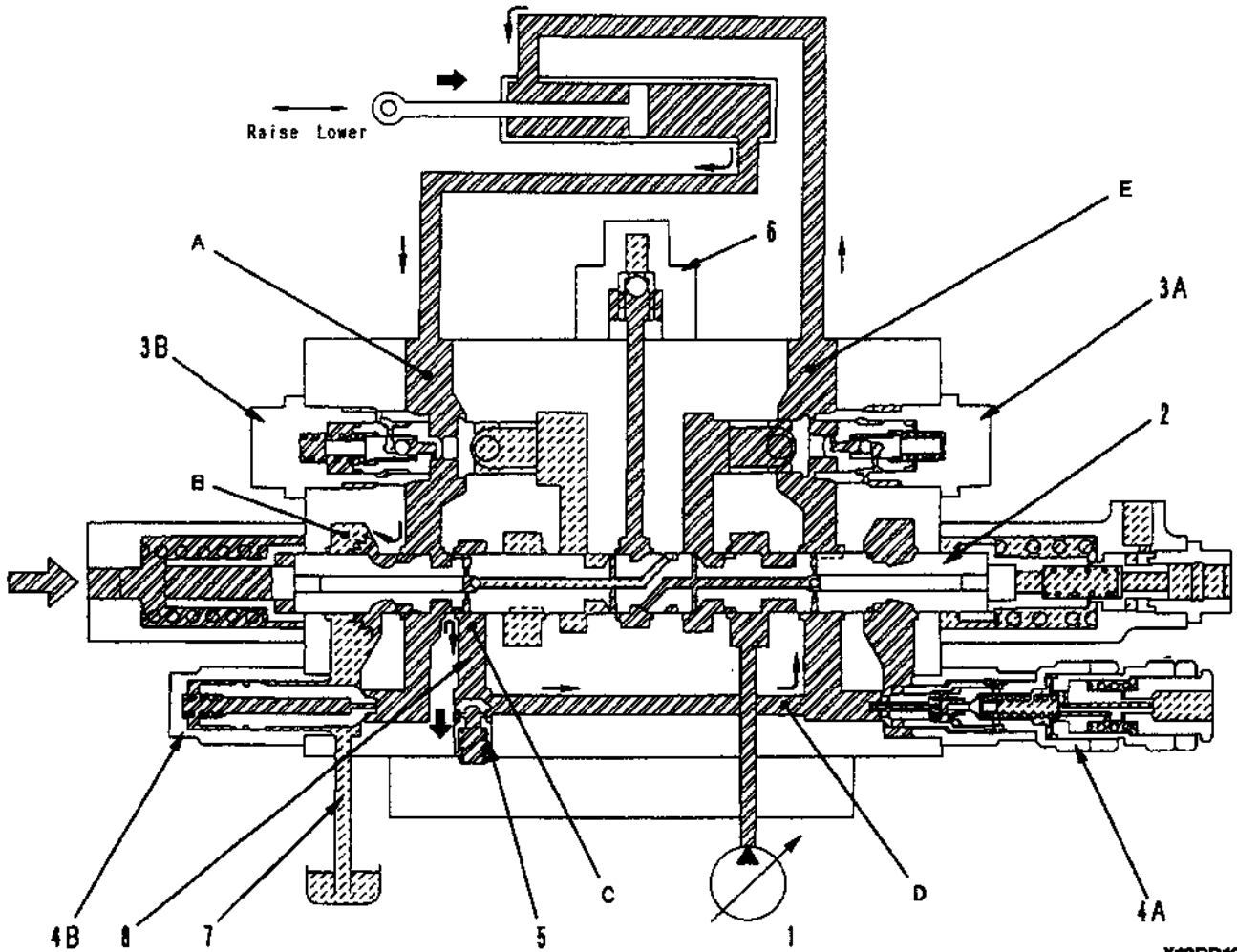

X10DD102

- 1. Main pump
- 2. main spool
- 3A. Pressure compensation valve
- 3B. Pressure compensation valve
- 4A. Safety-sunction valve
- 4B. Suction valve
- 5. Check valve
- 6. LS shuttle valve
- 7. Drain circuit
- 8. Regeneration circuit

Function

Cylinder head pressure < cylinder bottom pressure (free fall, etc.)

- A return flow circuit is provided from the cykinder bottom to the cylinder head so that when the bottom is lowerde, the return flow can be used to increase the flow of oil from the pump to the cylinder bottom.

Operation

1. When the cylinder head pressure < cylinder bottom pressure, part of the pressurized oil from the cylinder bottom passes through the notch in spool (2), goes through port B, and enters drain circuit (7). The rest of the oil goes from port C, enters regeneration circuit (8), opens check valve (5), and passes through ports C and D to flow back to the cylinder head.

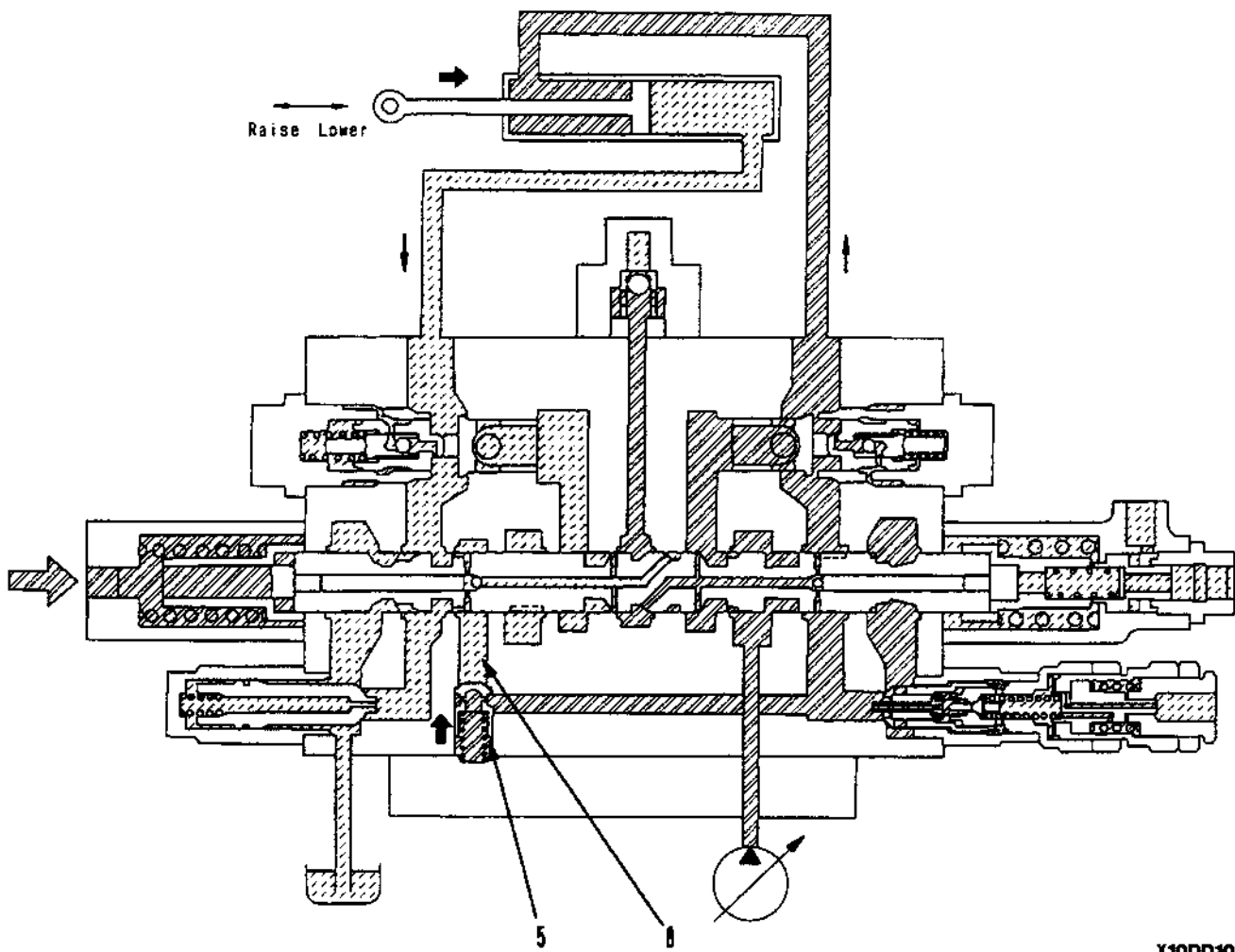

X10DD103

Function

Cylinder head pressure > cylinder bottom pressure (digging operations, etc.)

- Check valve (5) in regeneration circuit (8) acts to shut off the flow from the cylinder head to the cylinder bottom.

Arm regeneration circuit

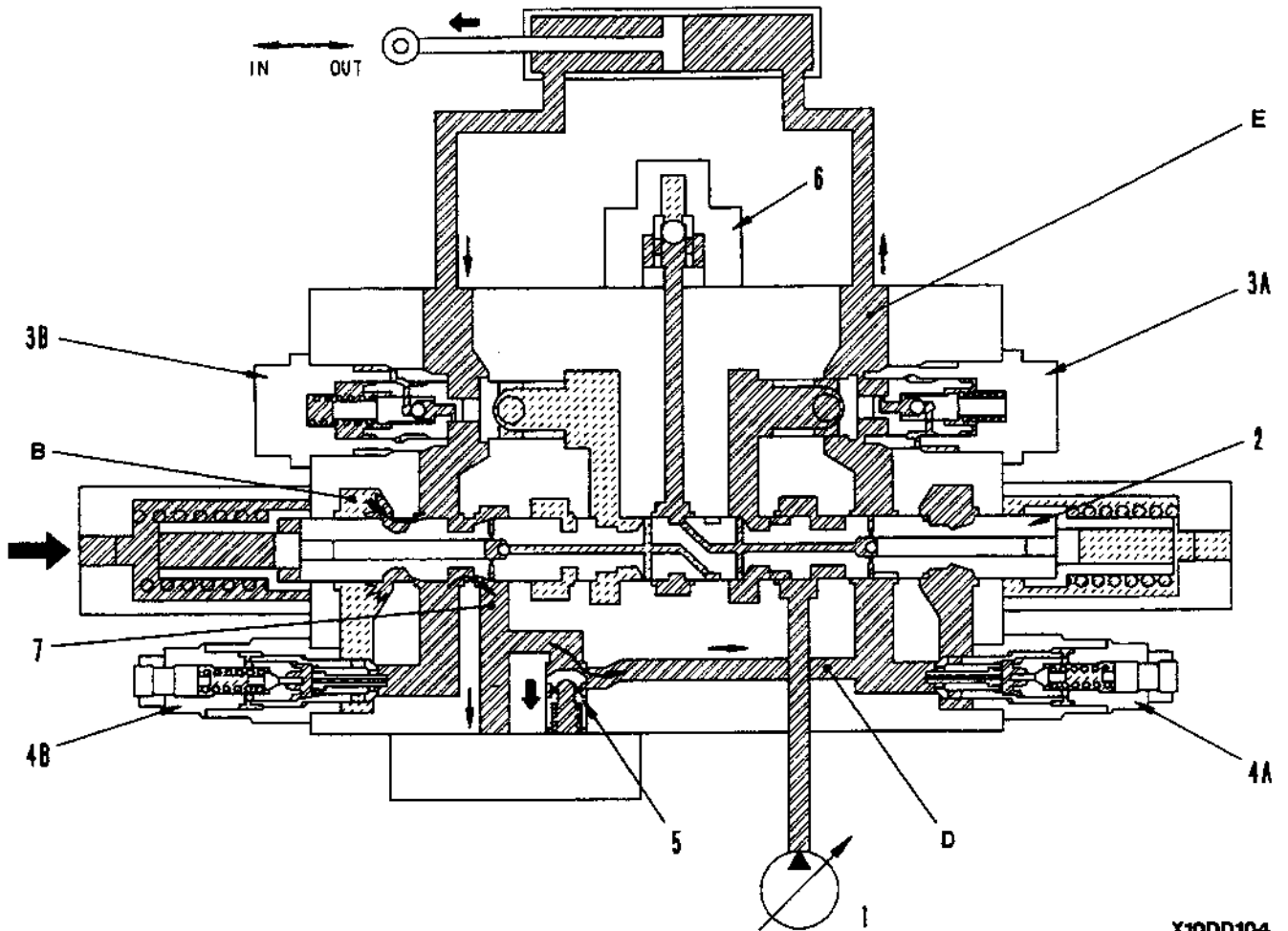

X10DD104

- 1. Main pump
- 2. Main spool
- 3A. Pressure compensation valve
- 3B. Pressure compensation valve
- 4A. Safety valve
- 4B. Safety valve
- 5. Check valve
- 6. LS shuttle valve
- 7. Regeneration circuit

Function

Cylinder head pressure > cylinder bottom pressure

- A return flow circuit is provided from the cylinder head to the cylinder bottom so that when the arm is moved in, the flow of oil to the cylinder becomes the pump discharge amount + the return flow, and this increases the cylinder speed.

Operation

1. When the cylinder head pressure > cylinder bottom pressure, the pressurized oil from the cylinder head passes through the notch in spool (2), enters regeneration circuit (7) and opens check valve (5), then passes through ports D and E to flow back to the cylinder bottom.

Pump merge-divider valve

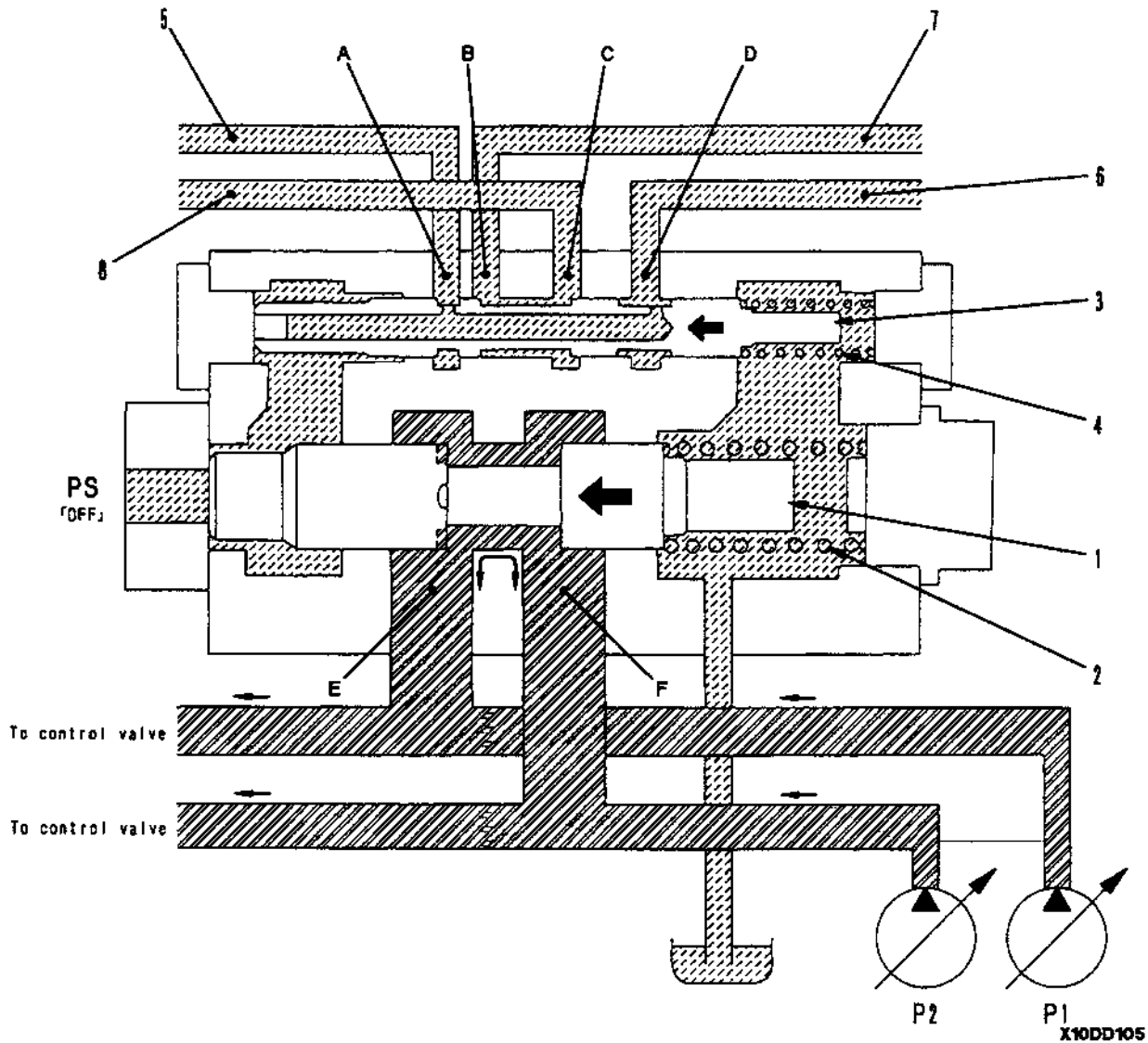

1. Main spool
2. Spring
3. LS spool
4. Spring
5. LS circuit (bucket end)
6. LS circuit (arm end)
7. LS circuit (arm end)
8. LS circuit (bucket end)

Function

- This acts to merge or divide (send to its own control valve group) oil flows **P1** and **P2** of pressurized oil discharged from the two pumps.
- At the same time, it also carries out merging and dividing of the LS circuit pressure.

Operation

1. When merging pump flow (when pilot pressure PS is OFF)
 - a. Pilot pressure **PS** is OFF, so main spool (1) is pushed to the left by spring (2), and ports **E** and **F** are interconnected. Therefore, pressurized oil **P1** and **P2** discharged from the two pumps is merged at ports **E** and **F**, and is sent to the control valve that demands the oil.
 - b. In the same way, LS spool (3) is also pushed to the left by spring (4), so the ports are connected as follows.
Connected ports: **A ↔ D, B ↔ C**
 - c. Therefore, the LS pressure supplied from the spools of each control valve to LS circuits (5), (6), (7), and (8) are all sent to the pressure compensation valve and the other valve.

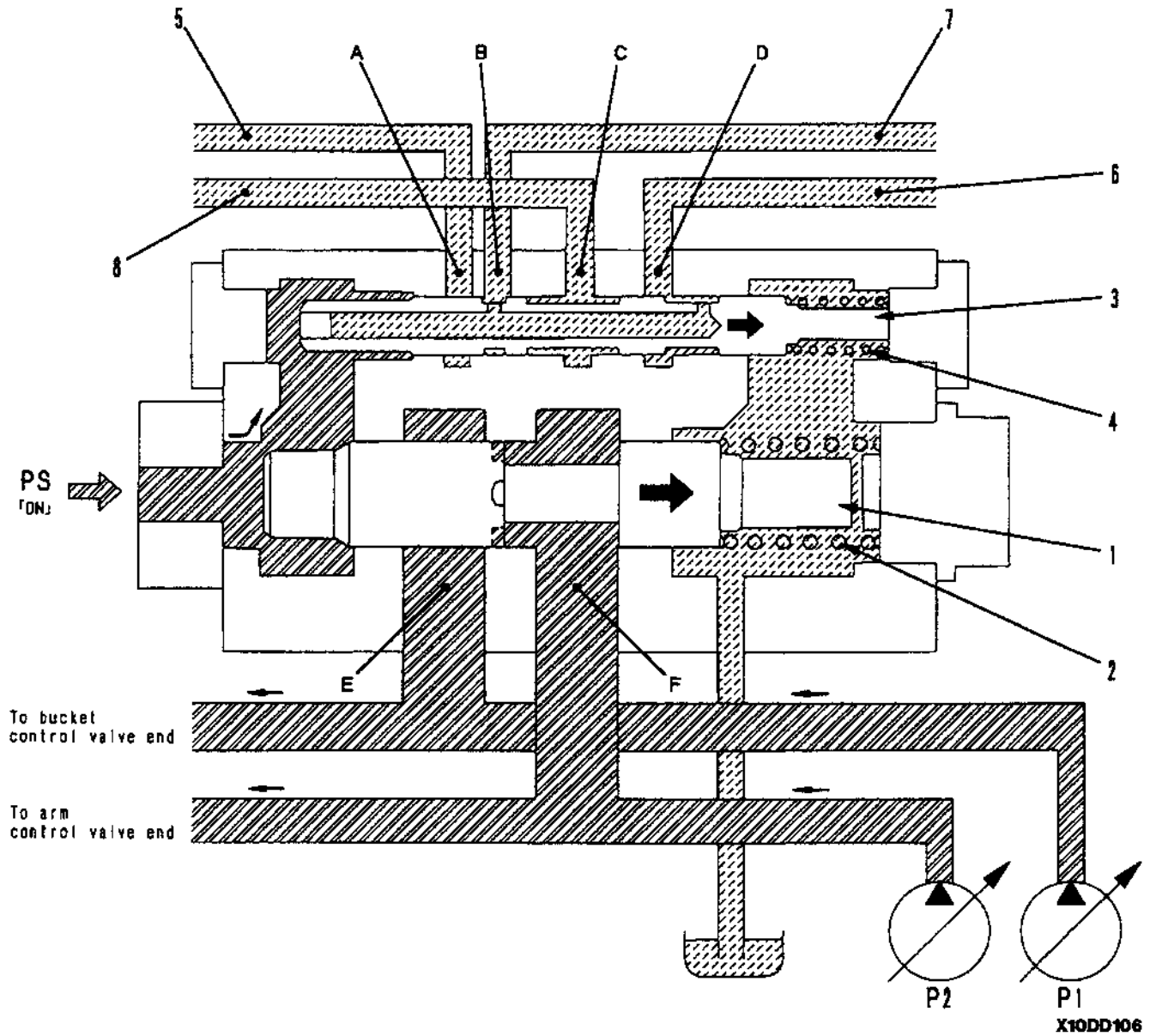

2. When dividing pump flow (when pilot pressure PS is ON)
 - a. When pilot pressure **PS** is ON, main spool (1) is moved to the right by the **PS** pressure, and ports **E** and **F** are disconnected. Therefore, the pressurized oil discharged from each pump is sent to its own control valve group. (Pressure **P1**: To bucket, R.H. travel, boom group; Pressure **P2**: To swing, L.H. travel, arm group)
 - b. In the same way, LS spool (3) is also moved to the right by the **LS** pressure, and the ports are connected as follows. Connected ports: **B** ↔ **D**, others are not connected. Therefore, LS circuits (5), (6), (7), and (8) are all sent to their own control valve group.

LS select valve

★ The diagram shows the situation when the swing, the left travel and the boom up are operated at the same time. (**BP** pressure ON = boom up activated)

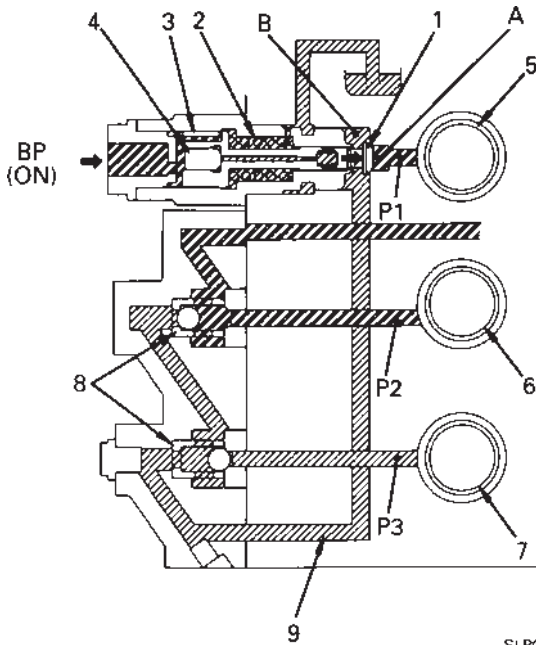

1. Valve
2. Spring
3. Piston
4. Piston
5. Swing pool
6. L.H. travel spool
7. Arm spool
8. L.H. shuttle valve
9. LS circuit

SLP00225

Function

- This valve is used to increase the ease of operating the work equipment. It prevents high pressure from being generated when the swing is operated. It also prevents the high LS pressure from the swing circuit from flowing into any other LS circuit when the swing is operated together with the work equipment. (BOOM UP ONLY)

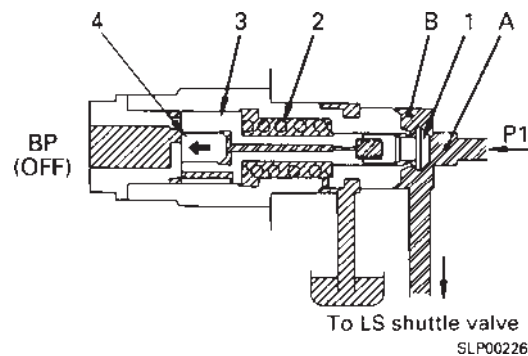

SLP00226

Operation

1. When a pilot pressure **BP** is OFF. (BOOM OP = 0)
 - a. Pilot pressure **BP** is OFF, so piston (3) is pushed to the left by spring (2). If the swing is then operated, swing LS pressure **P1** passes through swing pool (5) and enters port **A**. It pushes valve (1) to the left and connects ports **A** and **B**. Therefore, swing LS pressure **P1** flows to LS shuttle valve (8).
2. When pilot pressure **BP** is ON. (BOOM UP ACTIVATED)
 - a. When pilot pressure **BP** is ON, piston (3) is moved to the right against spring (2) by the **BP** pressure. It pushes valve (1) to the right and closes the circuit between ports **A** and **B**. As a result, swing LS pressure **P1** stops flowing to LS shuttle valve (8), and even if swing LS pressure **P1** rises to a high pressure, it does not influence any other LS circuit.

Boom LOWER modulation (ACTIVE MODE)

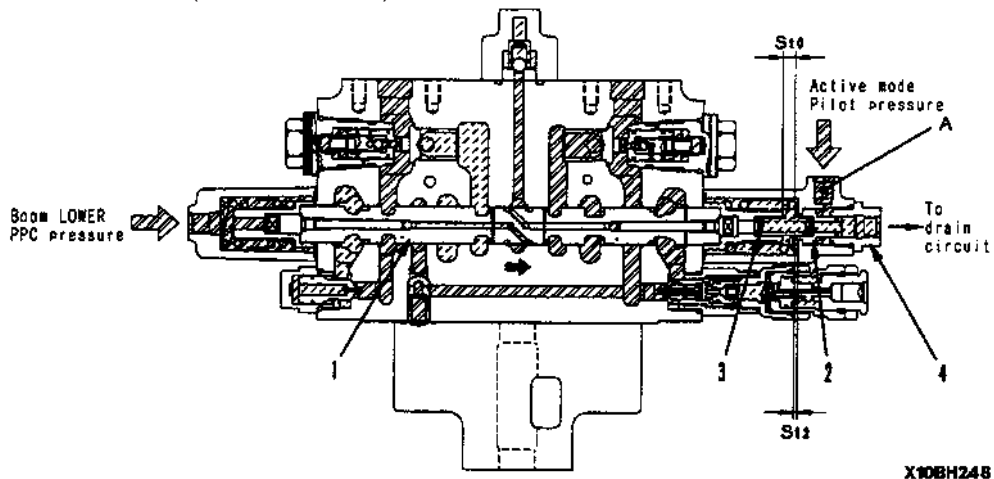

- 1. Spool
- 2. Piston
- 3. Spring
- 4. Plug

St0: Spool stroke
St2: Piston stroke

Function

- In the active mode, the maximum stroke of the boom LOWER spool is increased and the flow of oil through the spool is increased, so the boom LOWER speed increases and it becomes possible to carry out work speedily.

Operation

1. When active mode is switched OFF (SOLENOID IS ON)
 - a. The pilot pressure passes through port A and acts on the right end of piston (2), so piston (2) is pushed to the left. When this happens, the maximum stroke of spool (1) becomes **St0**.

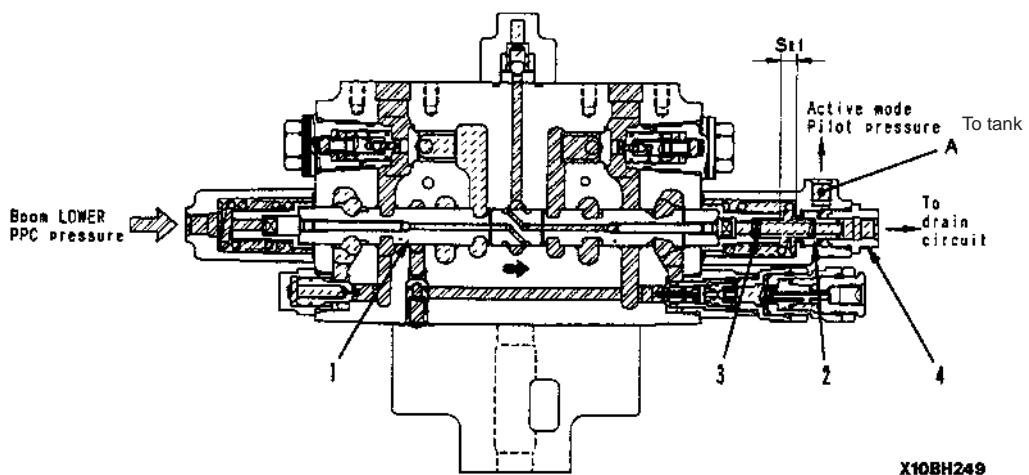

2. When active mode is switched ON (SOLENOID IS OFF)

- a. Port A is connected to the drain, and the right end of piston (2) becomes the drain pressure, so the force of spring (3) acts on piston (2), and moves it to the right. It stops when it contacts plug (4).
- b. When this happens, the maximum stroke of spool (1) becomes greater by the amount (**St1**) that piston (2) moves, so the amount of oil flowing through is increased.

Arm IN modulation (with travel)

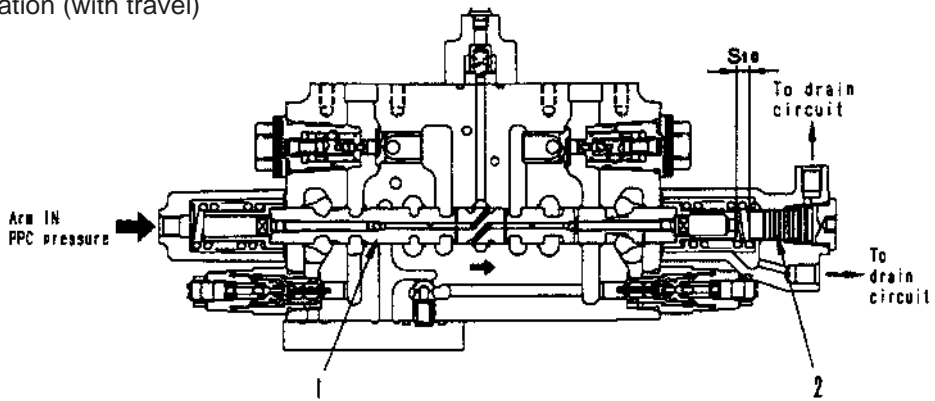

X10BH250

- 1. Spool
- 2. Piston

St0: Spool stroke

Function

- If the arm IN is operated when travelling up a steep slope, the arm stroke is restricted in order to control the flow of oil to the arm cylinder so that the pump pressure does not drop. When this happens, the pump merge/divider valve is in the divide condition, so the oil from the pump passes through the travel junction valve and is supplied to the left travel motor.

Operation

1. When travel is not operated
 - a. When the arm IN is operated, spool (1) moves to the right by stroke **St0** until it contacts piston (2).

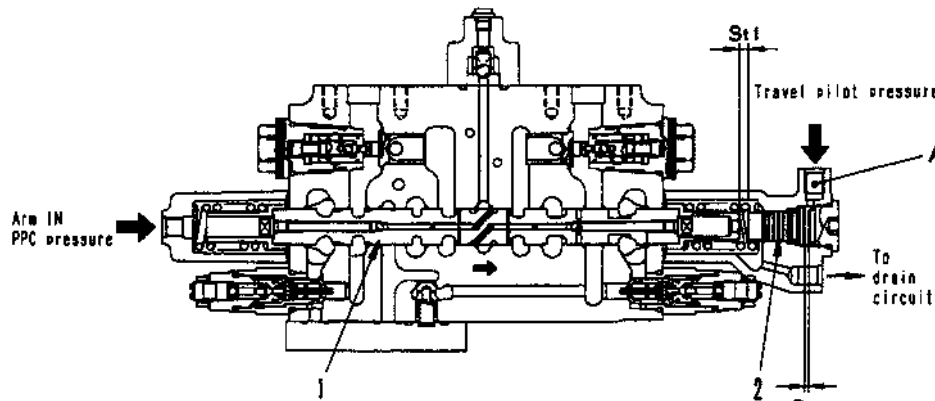

X10BH251

St1: Spool stroke
St2: Piston stroke

2. When travel is operated
 - a. The travel PPC pressure passes through port **A** and acts on the right end of piston (2) to push piston (2) to the left.

- b. When the arm IN is operated, spool (1) moves to the right, but the maximum spool stroke (**St1**) is restricted by the amount (**St2**) that piston (2) moves.

3. Note: Arm out, bucket curl and bucket dump are also modulated with travel.

2-stage safety valve (installed to boom cylinder head)

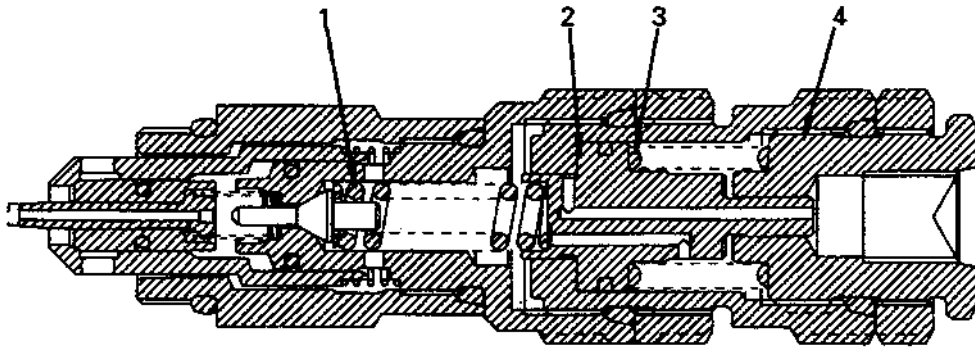

- 1. Spring
- 2. Piston
- 3. Spring
- 4. Holder

X10BH254

Function

- The set pressure of the safety valve can be set to two stages and the low pressure setting can be made smaller. Because of this, when digging with boom, even if high pressure is brought to bear on the boom cylinder, it is possible to let the boom escape without operating the control lever. This makes it possible to carry out operations with high efficiency and with little vibration of the chassis.

Operation

- The set pressure of the safety is determined by the load pressure of spring (1).
- 1. When pilot pressure **P** is OFF: high pressure setting (active mode ON)
 - a. Pilot pressure **P** is OFF, so piston (2) is pushed to the left by spring (3). (Installed load of spring (1) << installed load of spring (3)). When this happens, the installed load of spring (1) becomes the maximum, and the set pressure is set to high pressure. In addition, passage **B** is connected to the drain circuit through passage **C** and chamber **D**
- 2. When pilot pressure **P** is ON: low pressure setting (active mode OFF)
 - a. When pilot pressure **P** is ON, the pilot pressure goes to portion **A** through passage **B**, and piston (2) acts on the diameter of portion **A** receiving the pressure ($d_2 - d_1$). Piston (2) is moved to the right against spring (3) by this pilot pressure. It moves the full stroke until it contacts holder (4). As a result, spring (1) extends, the installed load becomes the minimum, and the set pressure is set to low pressure. In addition, an amount of oil equivalent to the piston stroke passes through passage **C** and chamber **D**, and is drained.

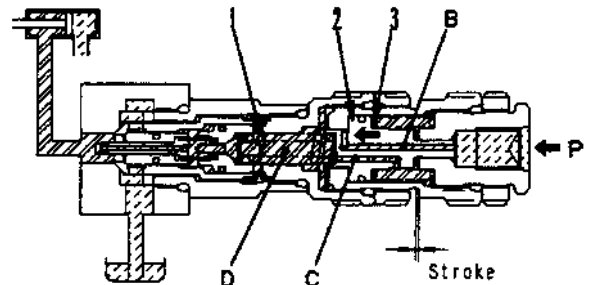

X10BH255

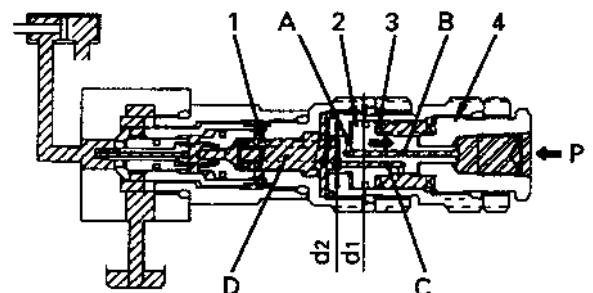

X10BH256

1. Hydraulic tank
- 2A. Main pump (front)
- 2B. Main pump (back)
- 3A. PC valve (front)
- 3B. PC valve (rear)
- 4A. LS valve (front)
- 4B. LS valve (rear)
- 5A. Pump merge-divider valve (for main)
- 5B. Pump merge-divider valve (for LS)
6. Bucket spool
7. R.H. travel spool
8. Boom spool
9. Swing spool
10. L.H. travel spool
11. Arm spool
12. Pressure compensation valve (bucket)
13. Pressure compensation valve (without shuttle valve) (R.H. travel)
14. Pressure compensation valve (boom)
15. Pressure compensation valve (swing)
16. Pressure compensation valve (without shuttle valve) (L.H. travel)
17. Pressure compensation valve (arm)
- 18A. Safety-suction valve
- 18B. Safety-suction valve (2-stage)
19. Suction valve
20. LS shuttle valve (bucket)
21. LS shuttle valve (R.H. travel)
22. LS shuttle valve (boom)
23. LS shuttle valve (L.H. travel)
24. LS shuttle valve (arm)
25. Check valve (for boom regeneration circuit)
26. Check valve (for arm regeneration circuit)
- 27A. Main relief valve (bucket group)
- 27B. Main relief valve (arm group)
- 28A. Unload valve (bucket group)
- 28B. Unload valve (arm group)
29. LS select valve
30. LS check valve
31. LS bypass valve
32. Self-reducing pressure valve

Note: Groups of control valves by main pump circuit

- Bucket group: Bucket, R.H. travel, boom
- Arm group: Swing, L.H. travel, arm

Operation

- When the levers are at neutral, the pump is at the minimum swash plate angle, and the oil flow is drained from unload valve (28A).
- The LS pressure is connected to hydraulic tank (1) by LS bypass valve (31). The LS differential pressure ΔPLS (unload pressure - tank pressure) at this point is $\Delta PLS > \text{pump LS control pressure}$, so the pump swash plate angle is minimum.

Operation

- Pilot pressure **PA** of pump merge-divider valve (5A) ON.
1. Bucket group
 - a. When the bucket is operated, pressurized oil from main pump (2B) flows to the bucket group. The swash plate angle of main pump (2B) is controlled to match the operation of bucket spool (6).
 - b. The LS pressure passing through the inside of bucket spool (6) goes to unload spool (28A), and the unload valve is closed.
 2. Arm group
 - a. When the pump flow is divided, all spools are at neutral, so the oil flow from the minimum swash plate angle of main pump (2A) is all drained from unload valve (28B) of the arm group. All spools in the arm group are at neutral, so no LS pressure is generated.
 - b. If the pump pressure - LS pressure becomes greater than the set pressure of unload valve (28B), the unload valve is actuated and the oil is drained. The LS differential pressure ΔPLS at this point is $\Delta\text{PLS} > \text{pump LS control pressure}$, so the pump swash plate angle is the minimum.

Operation

1. When pump swash plate angle is controlled to minimum.
 - a. When the arm is operated to OUT, if the load increases, the LS pressure passing through the inside of arm spool (11) rises.
 - b. The LS pressure also goes to unload valve (28) and unload valve (28) is closed. The main circuit pressure rises and is relieved at the standard mode relief pressure.
2. When this happens, the pump pressure sensor detects it and increases the PC-EPC current (electronic cut-off control) to set the pump swash plate angle to the minimum.

Operation

- Pump merge-divider valve (5A) pilot pressure **PA** ON. Relief valve (27) pilot pressure **PB** ON.
- 1. When the bucket is being operated, if the power max. button is turned ON, pilot pressure **PB** acts on relief valve (27), so the set pressure of the relief valve is raised.
- 2. When the bucket is operated to DUMP and the load increases, pump pressure **P1** and LS pressure **PLS1** both rise. When this happens, pilot pressure **PB** controls relief valve (27) to the same relief pressure as when the power max. button is operated.

Operation

1. When the boom RAISE is operated, main pumps (2A) and (2B) are both at the maximum swash plate angle, and unload valve (28A) is closed.
2. At this point for the meter-in opening of boom spool (8), even if both pumps are at the maximum swash plate angle, the LS differential pressure is set to be smaller than the pump LS control pressure. In other words, LS differential pressure ΔPLS is $\Delta PLS < \text{pump LS control pressure}$, so the pump swash plate angle becomes the maximum.
3. In addition, the flow of main pump (2A) passes through pump merge-divider valve (5A) and flows to boom spool (8).

Operation

1. When the swing is operated, unload valve (28) is closed.
2. When this happens, the oil flow from main pumps (2A, 2B) is controlled by the LS differential pressure and is discharged to match the area of opening of the meter-in of the swing pool.

Operation

- Pump merge-divider valve (5A0 pilot pressure **PA ON**).
- 1. When the straight travel is operated, an oil flow supplied from the main pump to match the amount of movement of left and right travel spools (10) and (7). Main pump (2A) oil flow: to left travel spool (10) (arm group). Main pump (2B) oil flow: to right travel spool (7) (bucket group).
- 2. The ability to travel in a straight line is ensured by actuating the pressure compensation valves and interconnecting the right travel and the left travel through the pistons of pressure control valves (13) and (16) and through the external piping.
- 3. From the above condition 1., if the steering control levers are returned (the oil flow is reduced) or operated in opposite directions (FORWARD and REVERSE), the travel junction circuit through the above piston is cut off, and the left and right sides are operated independently to enable the steering to be operated.

Operation

1. When the arm and boom are operated simultaneously, the swash plate angle for both pumps becomes the maximum. When this happens, the load pressure at the boom RAISE side is higher than at the arm side, so the LS pressure passes through ports **E** and **F** of boom spool (8), enters LS shuttle valve (22) and is sent to the LS circuit. This LS pressure is transmitted to port **G** of arm pressure compensation valve (17), and acts to increase the set pressure of the pressure compensation valve. Because of this, the pressure between port **H** of arm spool (11) and port **I** of pressure compensation valve (17) rises, and spool meter-in LS differential pressure (pump pressure - LS pressure = ΔPLS) becomes the same as that at the boom end.
2. Because of the above operation, the oil flow is divided in proportion to the size of the opening area of boom spool (8) and the opening area of arm spool (11). Meter-in LS differential pressure ΔPLS during boom RAISE + arm IN is $\Delta\text{PLS} < \text{boom LS control pressure}$, so the main pump swash plate angle is set to maximum.

CENTER SWIVEL JOINT

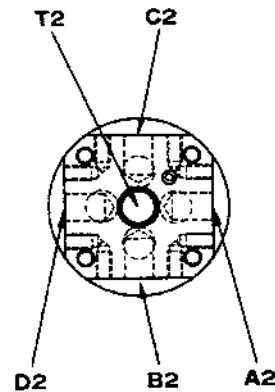
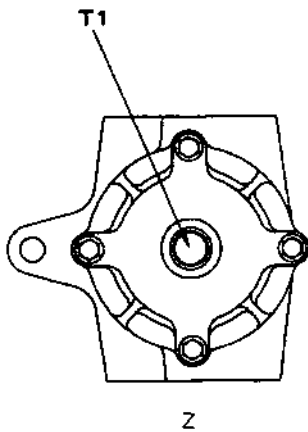
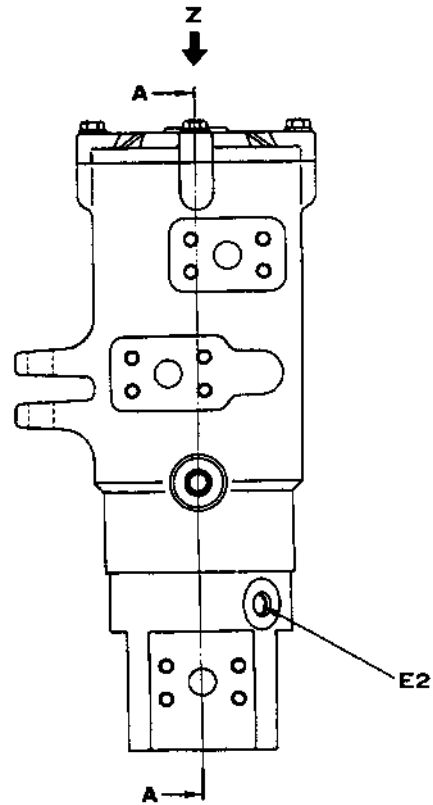
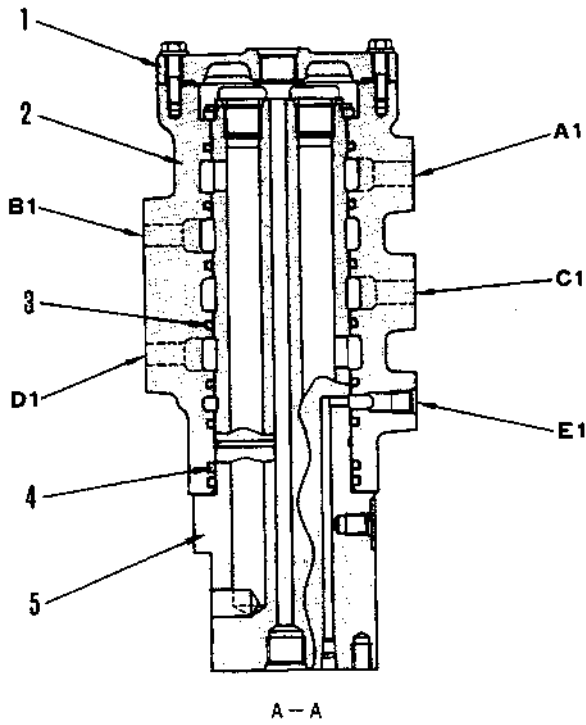

X10ZZ020

- 1. Cover
- 2. Body
- 3. Slipper seal
- 4. O-ring
- 5. Shaft

- A1. From control valve port B2
- A2. To R.H. travel motor port PB
- B1. From control valve port B5
- B2. To L.H. travel motor port PA
- C1. From control valve port A2
- C2. To R.H. travel motor port PA

- D1. From control valve port A5
- D2. To L.H. travel motor port PB
- E1. From travel speed solenoid valve
- E2. To L.H. and R.H. travel motors port P
- T1. To tank
- T2. From L.H. and R.H. travel motors port T

SWING MOTOR
BASIC MOTOR

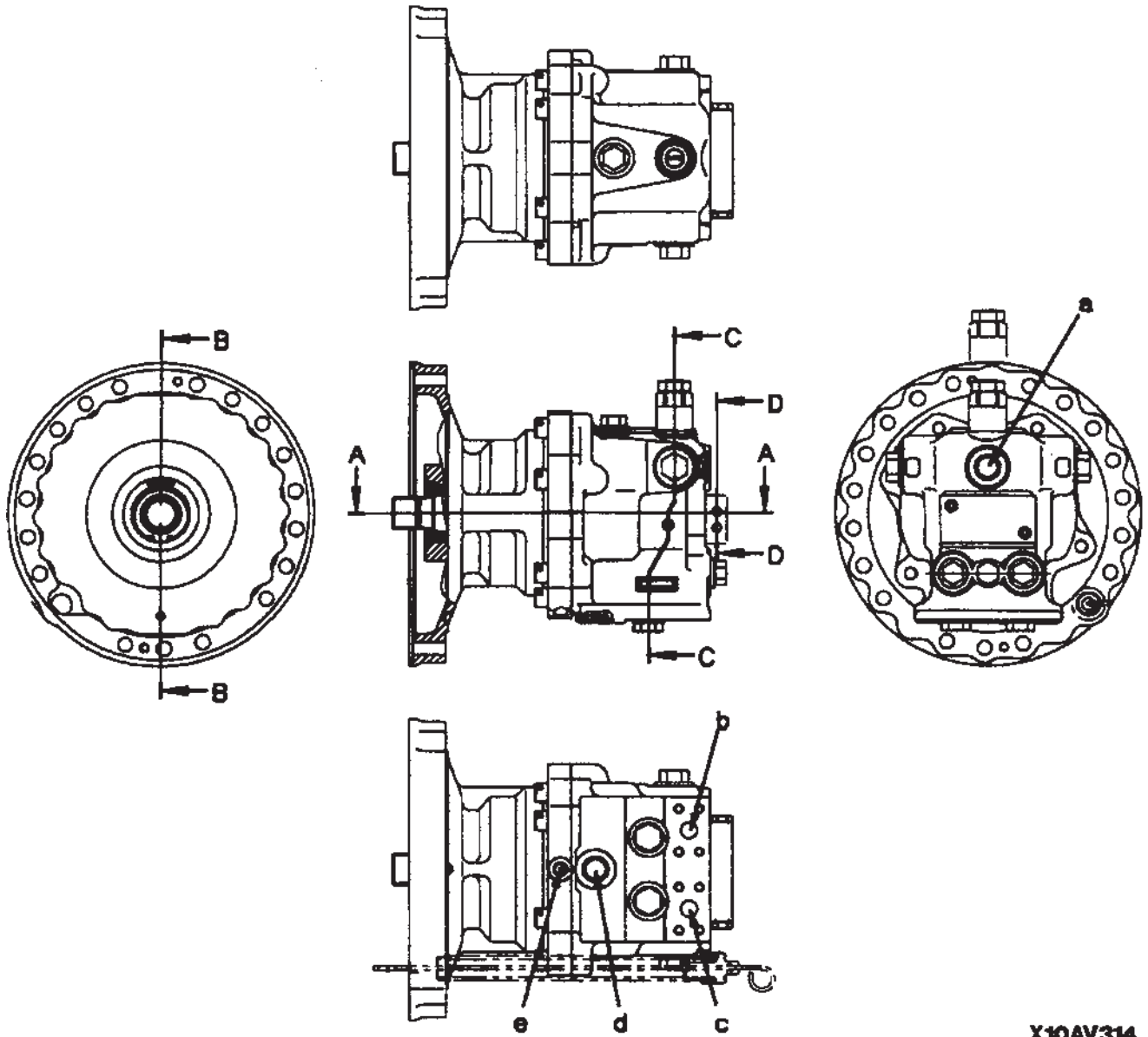

X10AV314

- a. Port **S**
- b. Port **MB** (from control valve)
- c. Port **MA** (from control valve)
- d. Port **T1** (to tank)
- e. Port **B** (from swing brake solenoid valve)

Specifications

Type	: KMF90ABE-3
Theoretical delivery	: 87.8 cc/rev
Safety valve set pressure	: 27.9 MPa (285 kg/cm ²)
Rated speed	: 2,260 rpm
Brake release pressure	: 2.1 MPa (21 kg/cm ²)

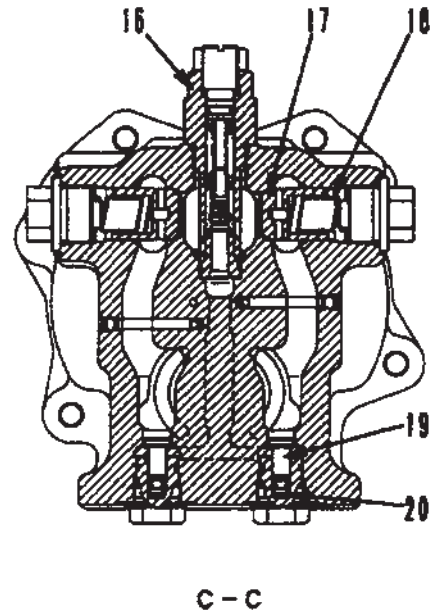
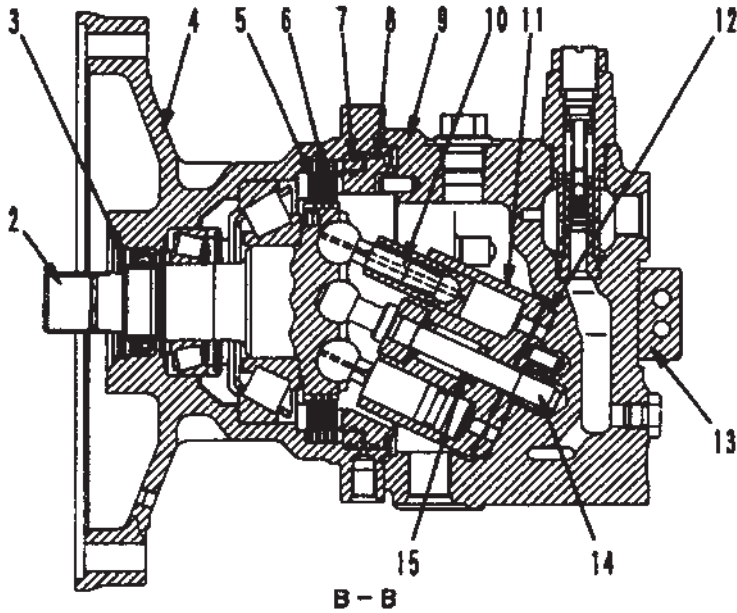
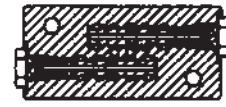
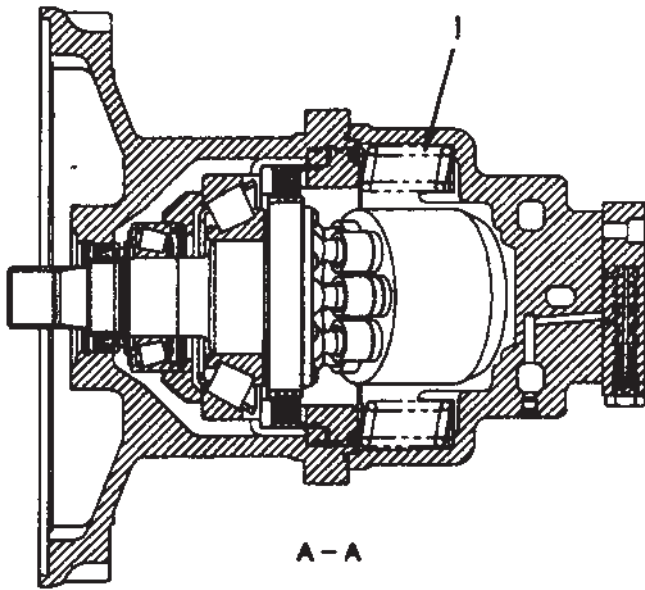

X10AV315

- | | |
|-----------------|------------------------------|
| 1. Brake spring | 11. Cylinder |
| 2. Drive shaft | 12. Valve plate |
| 3. Spacer | 13. Reverse prevention valve |
| 4. Case | 14. Center shaft |
| 5. Disc | 15. Center spring |
| 6. Plate | 16. Safety valve |
| 7. Brake ring | 17. Check valve |
| 8. Brake piston | 18. Check valve spring |
| 9. Housing | 19. Shuttle valve |
| 10. Piston | 20. Shuttle valve spring |

Swing lock valve

Operation

1. When swing lock solenoid valve is deactivated
 - a. When the swing lock solenoid valve is deactivated, the pressurized oil from the main pump is shut off and port **B** is connected to the tank circuit. Because of this, brake piston (7) is pushed down in the direction of the arrow by brake spring (1), so disc (5) and plate (6) are pushed together and the brake is applied.

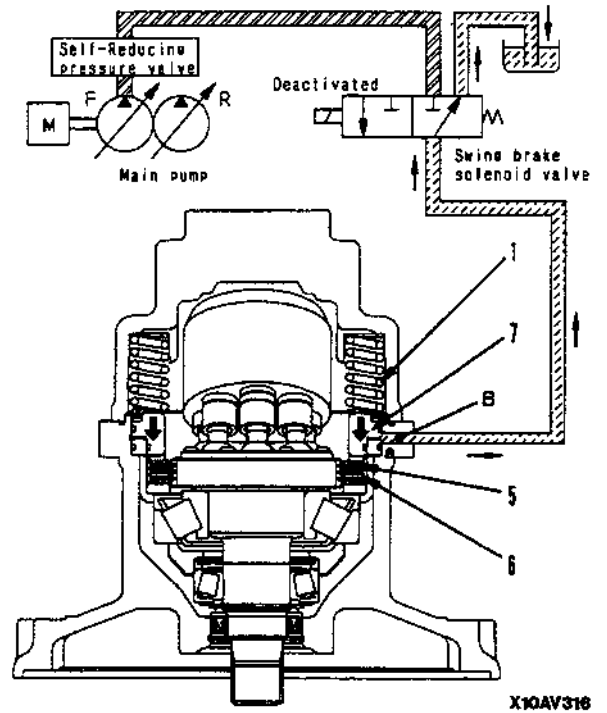

2. When swing lock solenoid is excited
 - a. When the swing lock solenoid valve is excited, the valve is switched, and the pressurized oil from the main pump enters port **B** and flows to brake chamber **a**. The pressurized oil entering chamber **a** overcomes the force of brake spring (1), and brake piston (7) is pushed up in the direction of the arrow. Because of this, disc (5) and plate (6) separate, and the brake is released.

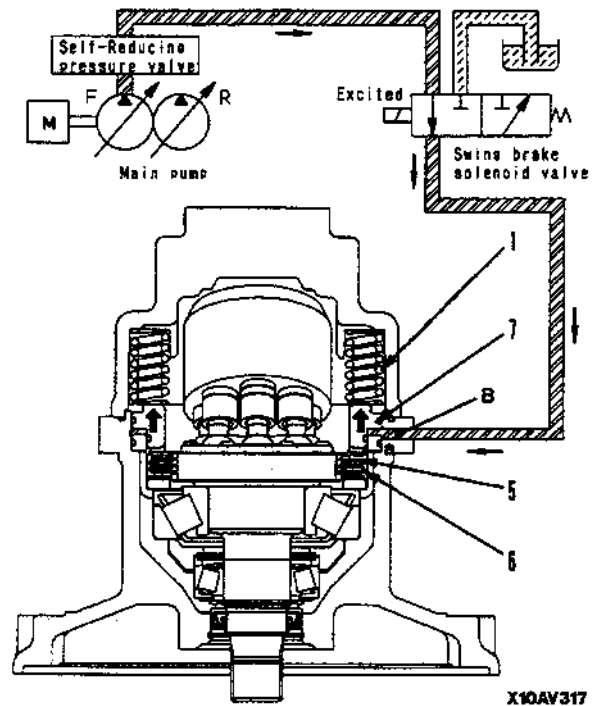

Relief valve portion

Outline

The relief valve portion consists of check valves (2) and (3), shuttle valves (4) and (5), and relief valve (1).

Function

When the swing is stopped, the outer port circuit of the motor from the control valve is closed, but the motor continues to rotate under inertia, so the pressure at the output side of the motor becomes abnormally high and this may damage the motor. To prevent this, the abnormally high pressure oil is relieved to port **S** from the outlet port of the motor (high-pressure side) to prevent any damage to the motor.

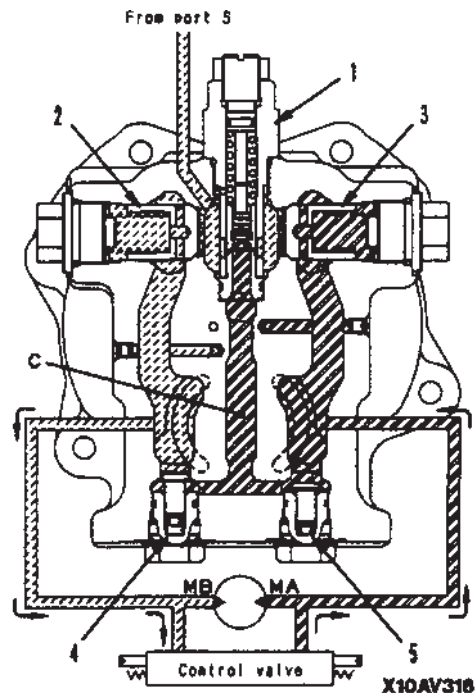

Operation

1. When starting swing
 - a. When the swing control lever is operated to swing right, the pressure oil from the pump passes through the control valve and is supplied to port **MA**. As a result, the pressure at port **MA** rises, the starting torque is generated in the motor and the motor starts to rotate. The oil from the outlet port of the motor passes from port **MB** through the control valve and returns to tank.
2. When stopping swing
 - a. When the swing control lever is returned to neutral, the supply of pressure oil from the pump to port **MA** is stopped. With the oil from the outlet port of the motor, the return circuit to the tank is closed by the control valve, so the pressure at port **MB** rises. As a result, rotation resistance is generated in the motor, so the braking effect starts.
 - b. If the pressure at port **MB** becomes higher than the pressure at port **MA**, it pushes shuttle valve **A** (4) and chamber **c** becomes the same pressure as port **MB**. The oil pressure rises further until it reaches the set pressure of relief valve (1). As a result, a high braking torque acts on the motor and stops the motor.
 - c. When the relief valve (1) is being actuated, the relief oil and oil from port **S** passes through check valve **B** (3) and is supplied to port **MA**. This prevents cavitation at port **MA**.

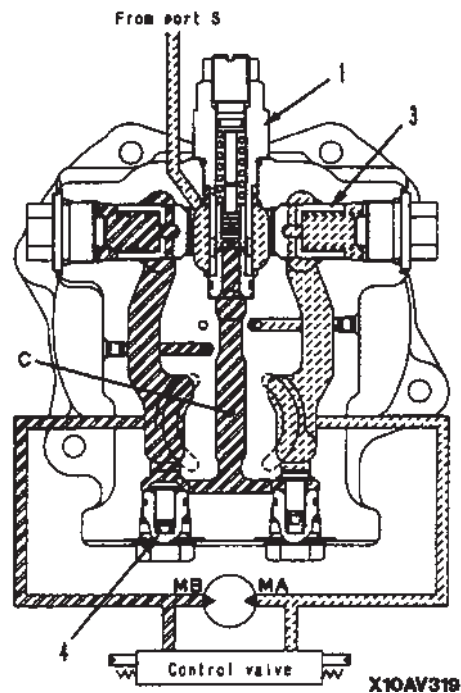

Reverse prevention valve (swing dampening)
Operation diagram

1. Valve body
2. Spool (MA side)
3. Spring (MA side)
4. Plug
5. Spool (MB side)
6. Spring (MB side)
7. Plug

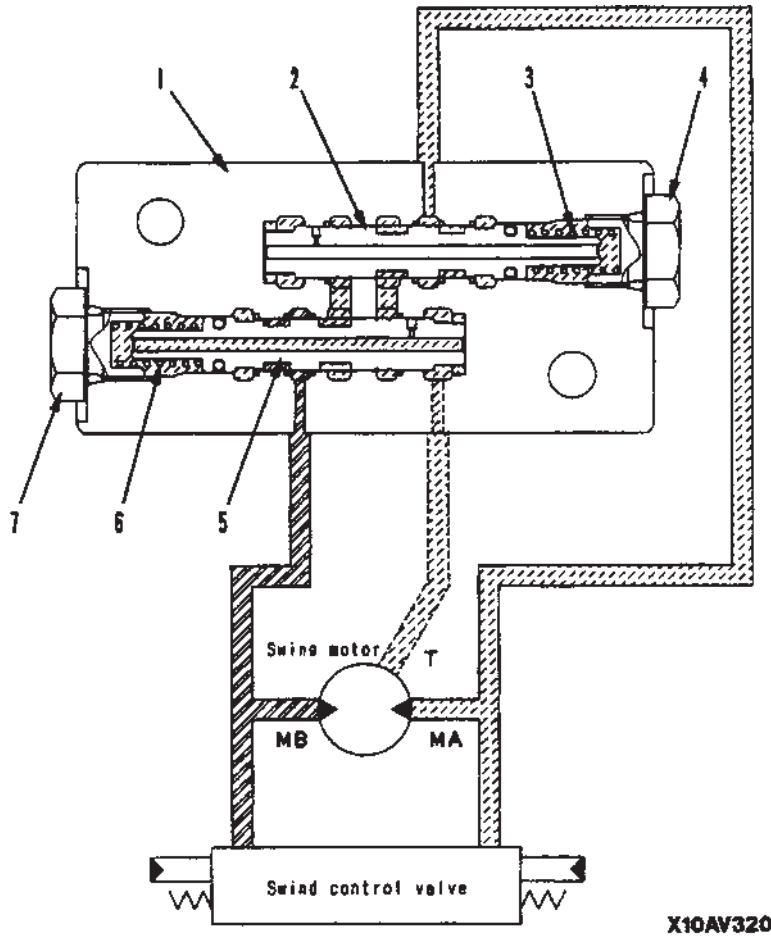

Explanation of effect

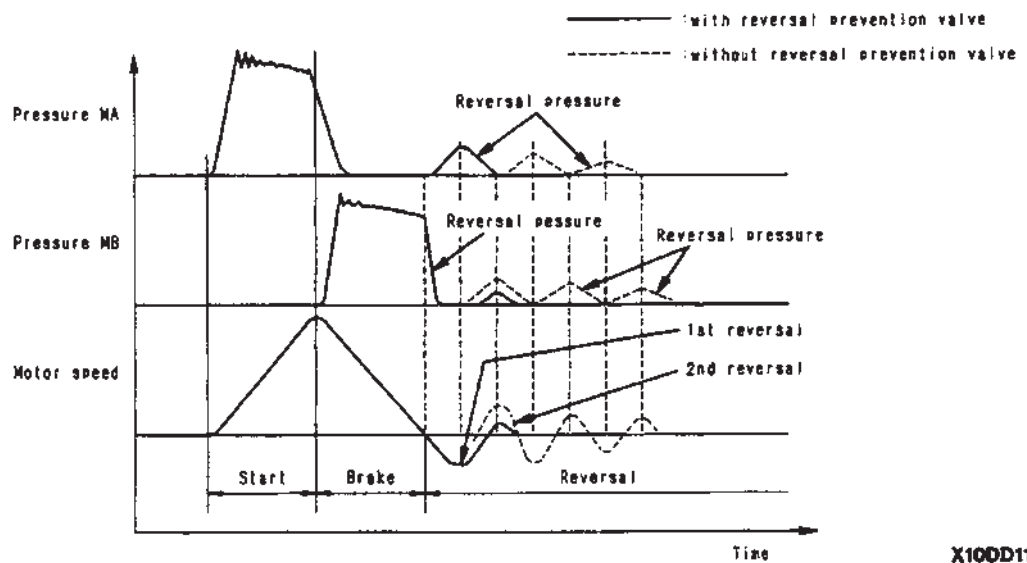

Outline

This valve reduces the swing back generation in the swing body by the inertia of the swing body, the backlash and rigidity of the machinery system, and the compression of the hydraulic oil when the swing is stopped. This is effective in preventing spillage of the bad and reducing the cycle time when stopping the swing (the positioning ability is good and it is possible to move swiftly to the next job).

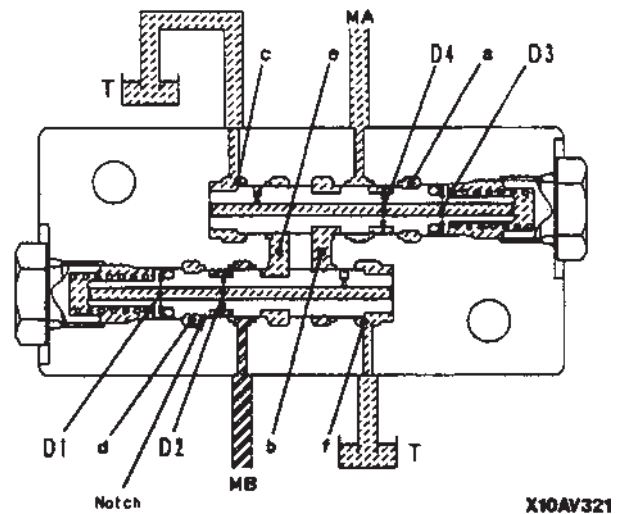

Operation

1. When brake pressure is being generated at port **MB**

- a. Pressure **MB** passes through the notch and goes to chamber **d**, spool (5) pushes spring (6) according to the difference in area $D1 > D2$, moves to the left, and **MB** is connected to **e**.
- b. When this happens, pressure **MA** is below the set pressure of spring (3), so spool (2) does not move. For this reason, the pressure oil is closed by spool (2) and the braking force is ensured.

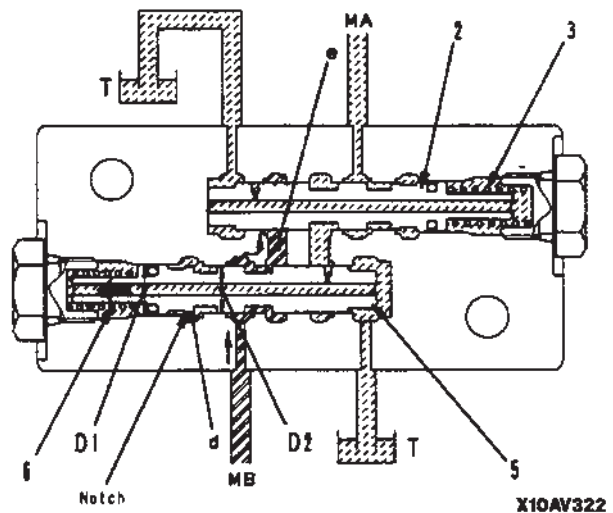

2. After motor stops

- a. The motor is reversed by the closing pressure generated at port **MB**. (1st reversal) When this happens, reversal pressure is generated at port **MA**. Pressure **MA** goes to chamber **a**, so spool (2) pushes spring (3) and moves to the right, and **MA** is connected to **b**. At the same time, **b** is connected to **f** through the drill hole in spool (5), so the reversal pressure at port **MA** is bypassed to port **T** to prevent the 2nd reversal.

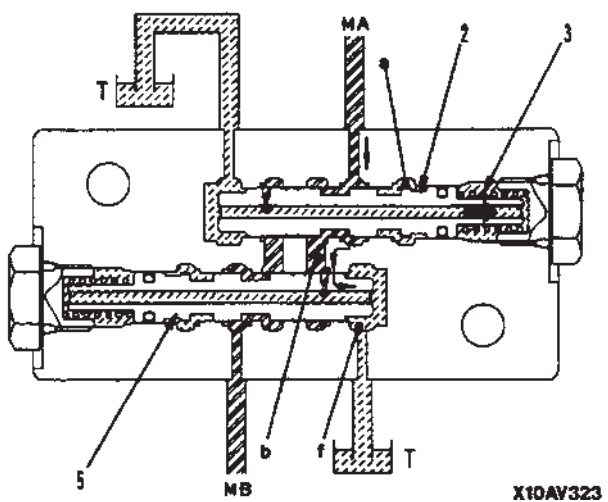

TRAVEL MOTOR

PC290LC-6k, PC290NLC-6k
HMV160ADT-2

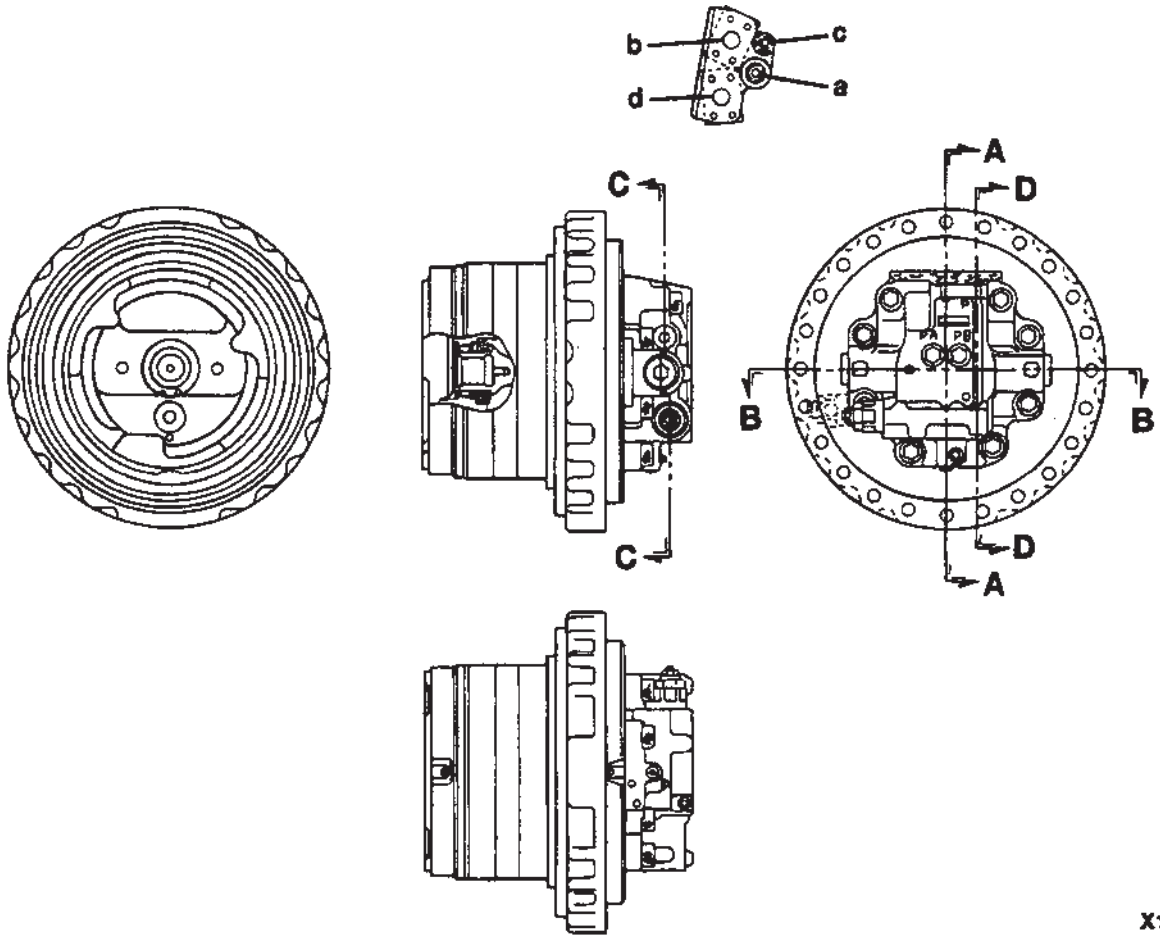

X10AV324

- a. Port **PB** (from control valve)
- b. Port **PA** (from control valve)
- c. Port **T** (to tank)
- e. Port **P** (from travel speed solenoid valve)

Specifications

Model			
Item		PC290LC-6k	PC290NLC-6k
Type	HMV60ADT-2		
Theoretical Delivery	Min	100 cc/rev	100 cc/rev
	Max.	160.8 cc/rev	
Set pressure	34.79 MPa (355 kg/cm ²)		
Rated speed	Lo	1310 rpm	1310 rpm
	Hi	2107 rpm	2107 rpm
Brake releasing pressure	1.18 MPa (12 kg/cm ²)		
Travel speed switch pressure	0,78 MPa (8 kg/cm ²)		

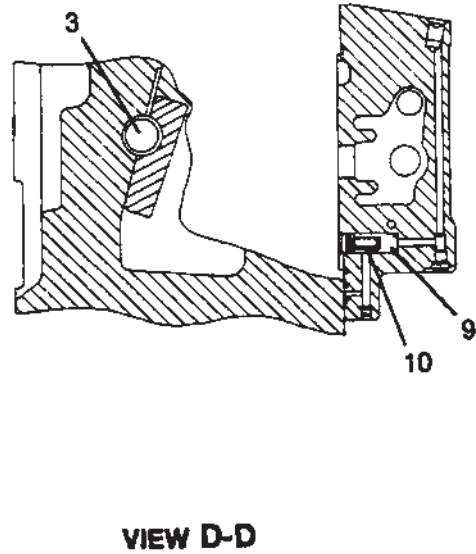
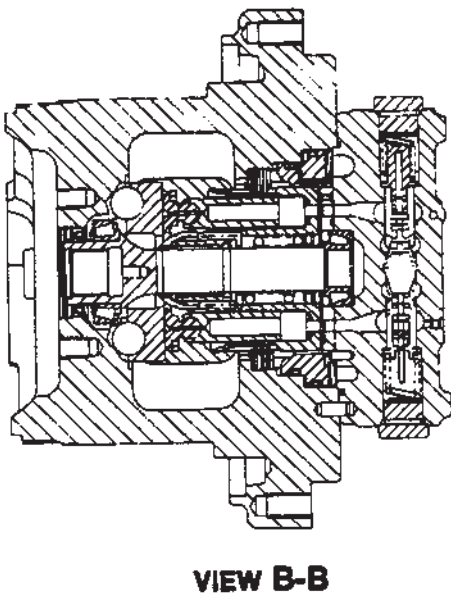
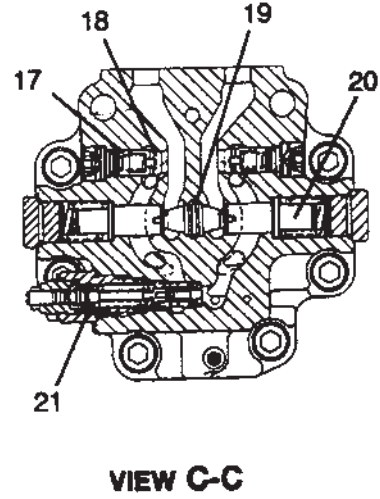
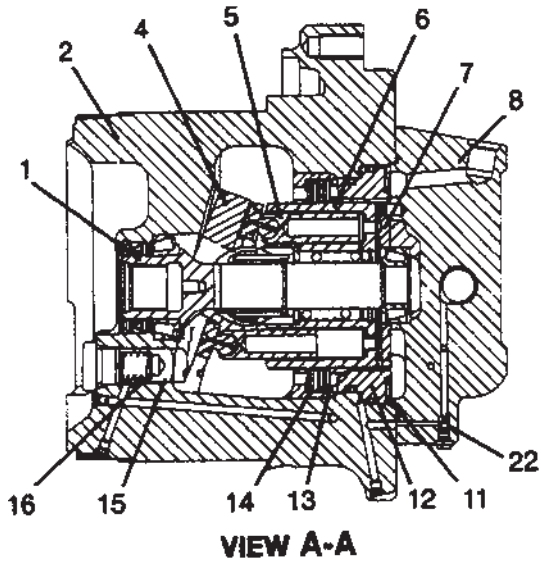

X10AV325

- | | | |
|-----------------|----------------------|--------------------------|
| 1. Output shaft | 9. Regulator valve | 17. Check valve spring |
| 2. Motor case | 10. Spring | 18. Check valve |
| 3. Ball | 11. Brake spring | 19. Counterbalance valve |
| 4. Rocker cam | 12. Brake piston | 20. Spool return valve |
| 5. Piston | 13. Plate | 21. Safety valve |
| 6. Cylinder | 14. Disc | 22. Slow return valve |
| 7. Valve plate | 15. Regulator piston | |
| 8. End cover | 16. Spring | |

Operation of motor

1. Motor swash plate (capacity) at maximum (Lo speed)

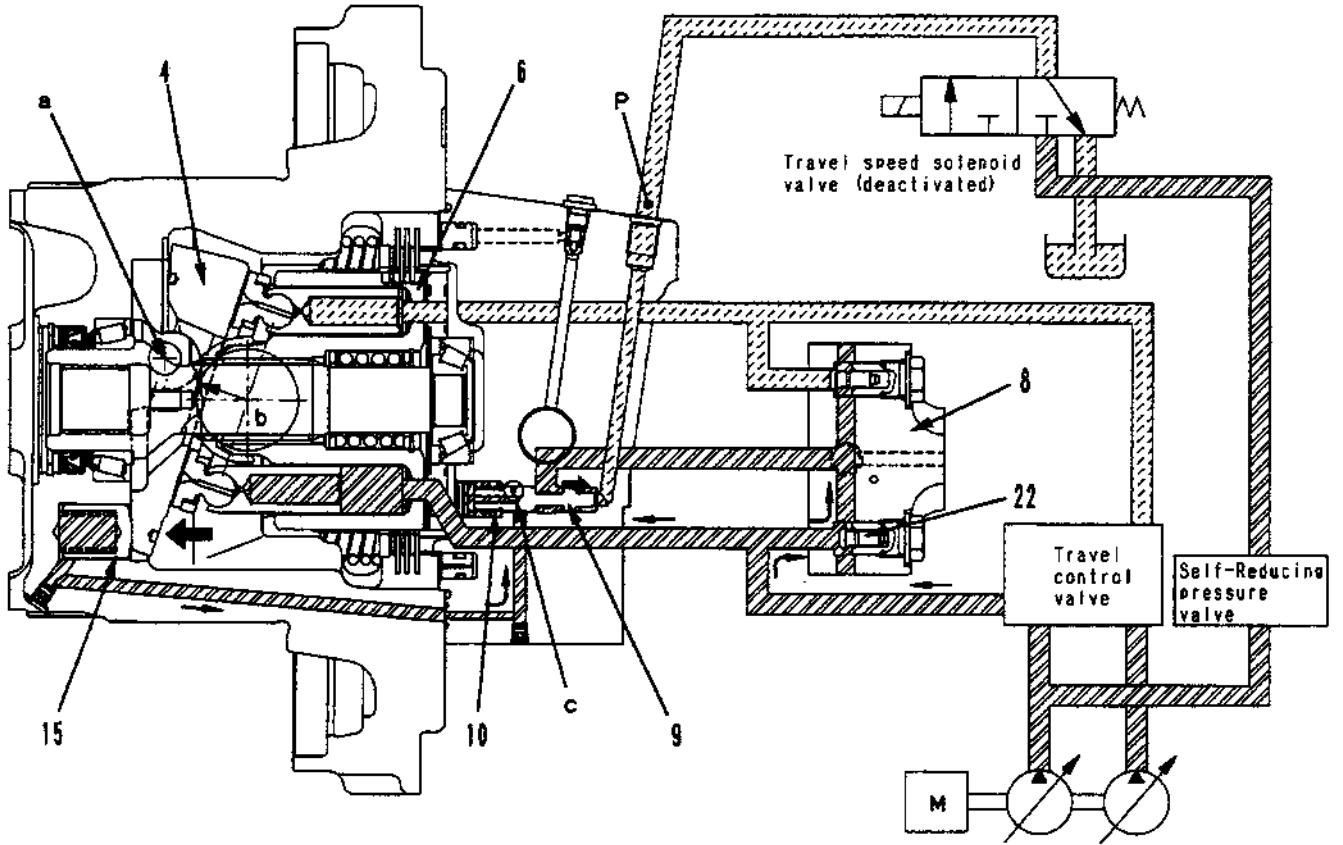

X10AV326

- a. The solenoid valve is deactivated, so the pilot pressure oil from the main pump does not flow to port P. For this reason, regulator valve (9) is pushed to the right in the direction of the arrow by spring (10).
- b. Because of this, it pushes check valve (22), and the main pressure oil from the control valve going to end cover (8) is shut off by regulator valve (9).
- c. Fulcrum a of swash plate (4) is eccentric to the point of force b of the combined force of the propulsion force of cylinder (6), so the combined force of the piston propulsion force acts as a moment the angle swash plate (4) in the direction of the maximum swash plate angle.
- d. At the same time, the pressurized oil at regular piston (15) passes through orifice c in the regulator valve (9) and is drained to the motor case.
- e. As a result, swash plate (4) moves in the maximum swash plate angle direction, the motor capacity becomes maximum.

2. Motor swash plate angle (capacity) at minimum (Hi speed)

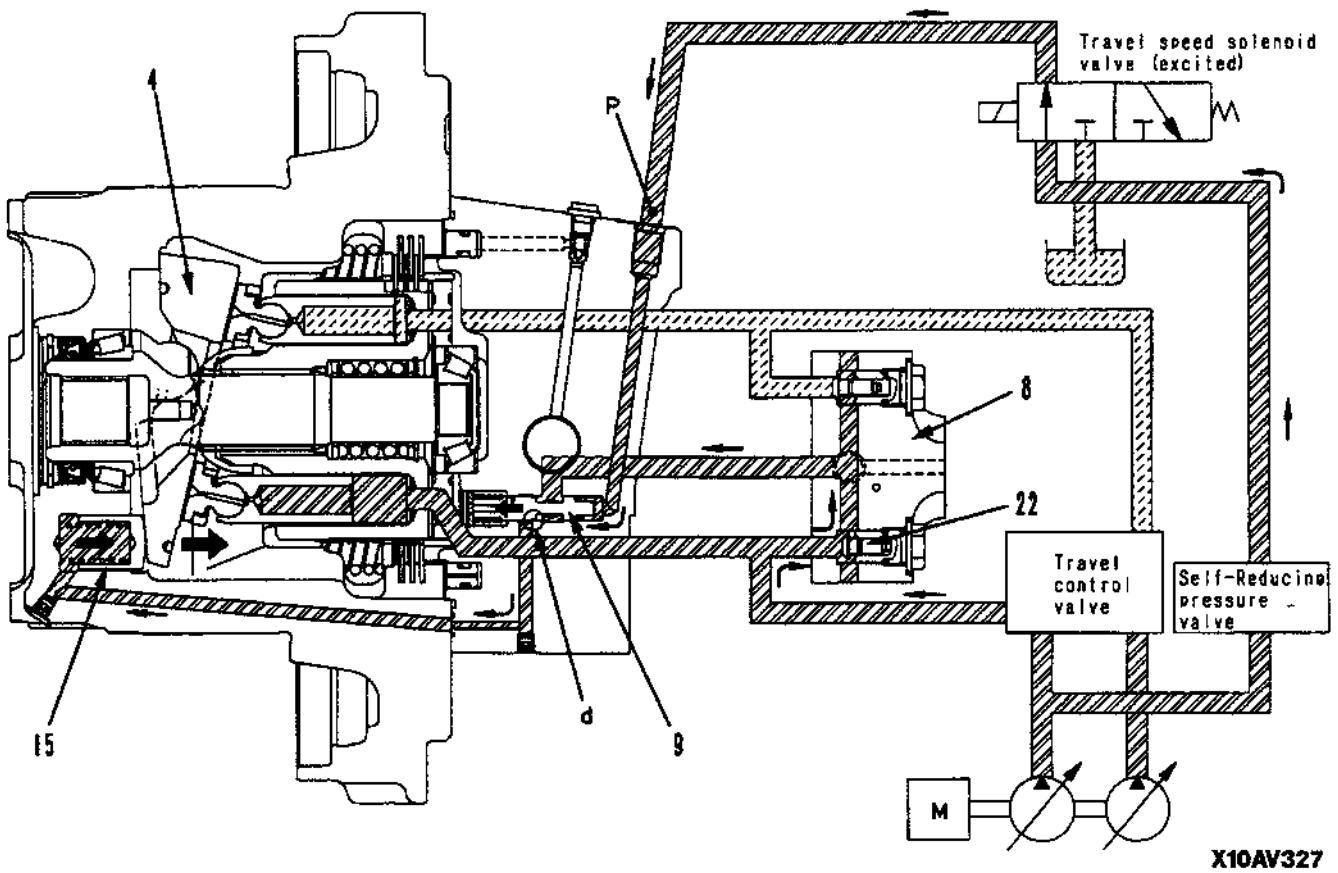

X10AV327

- a. When the solenoid valve is excited, the pilot pressure oil from the main pump flows the port P, and pushes regulator valve (9) to the left in the direction of the arrow
- b. Because of this, the main pressure oil from the control valve passes through passage d in regulator valve (9), enters regulator piston (15) at the bottom, and pushes regulator piston (15) to the right in the direction of the arrow.
- c. As a result, swash plate (4) moves in the minimum swash plate angle direction, the motor capacity becomes minimum.

Operation of parking brake

1. When starting the travel
 - a. When the travel lever is operated, the pressurized oil from the pump actuates counterbalance valved spool (19), opens the circuit to the parking brake, and flows into chamber **A** of brake piston (12). It overcomes the force of spring (11), and pushes piston (12) to the left in the direction of the arrow. When this happens, the force pushing plate (13) and disc (14) together is lost, so plate (13) and disc (14) separate and the brake is released.

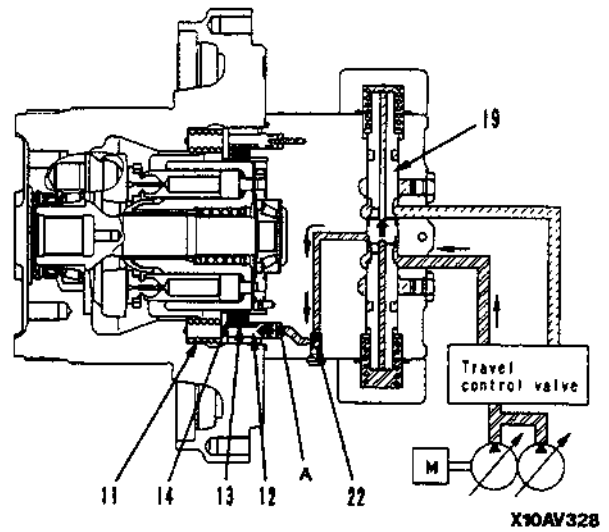

2. When stopping travel
 - a. When the travel lever is placed in neutral, counterbalance valve spool (19) returns to the neutral position and the circuit to the parking brake is closed. The pressurized oil in chamber **A** of brake piston (12) is drained and pushed to the right in the direction of the arrow by spring (11). As a result, plate (13) and disc (14) are pushed together, and the brake is applied. A time delay is provided by having the pressurized oil pass through a throttle in slow return valve (22) when the brake piston return, and this ensures that the brake is still effective after the machine stops.

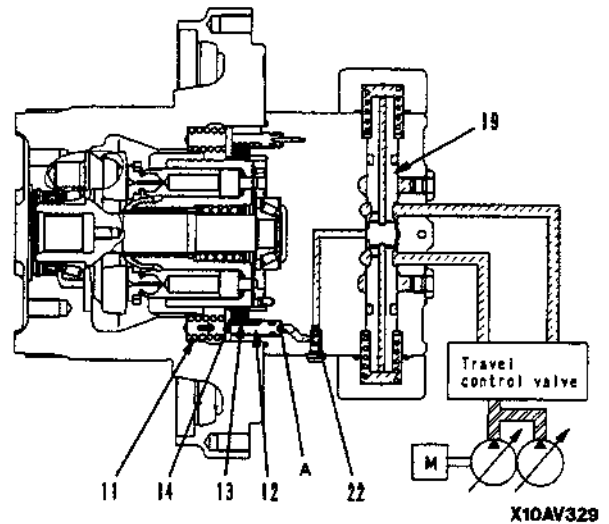

Operation of brake valve

- The brake valve consists of a suction safety valve (18A), counterbalance valve (18) in a circuit as shown in the diagram on the right.
- The function and operation of each component is as given below.

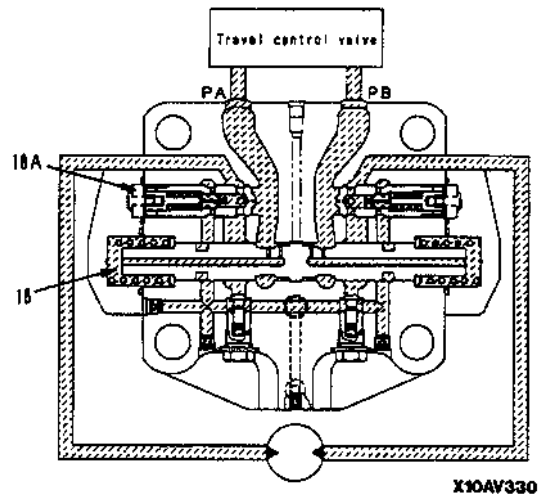

1. Counterbalance valve, check valve
 - a. Function
 - i. When travelling downhill, the weight of the machine makes it try the travel faster than the speed of the motor. As a result, if the machine travel with the engine at low speed, the motor will rotate without load and the machine will run away, which is extremely dangerous. To prevent this, these valves act to make the machine travel according to the engine speed (pump discharge amount).
 - b. Operation when pressure oil is supplied
 - i. When the travel lever is operated, the pressurized oil from the control valve is supplied to the port **PA**. It pushes open suction safety valve (18A) and flows from motor inlet port **MA** the motor outlet port **MB**. However, the motor outlet port is closed by suction safety valve (18B) and spool (189), so the pressure at the supply side rises.
 - ii. The pressurized oil at the supply side flows from orifice **E1** and **E2** in spool (19) to the chamber **S1**. When the pressure in chamber **S1** goes above the switching pressure, spool (19) is pushed to the right in the direction of the arrow. As a result, port **MB** and **PB** are connected, the outlet port side of the motor is opened, and the motor starts to rotate.

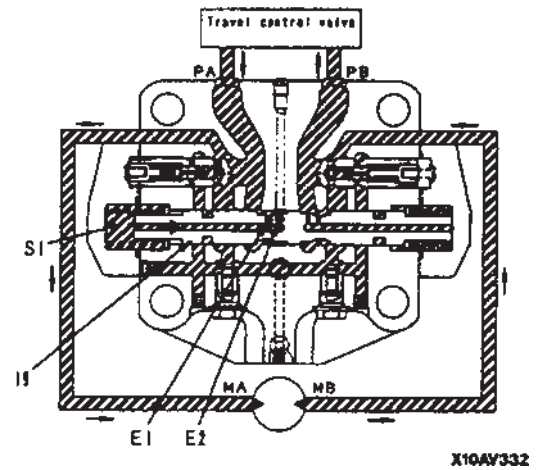
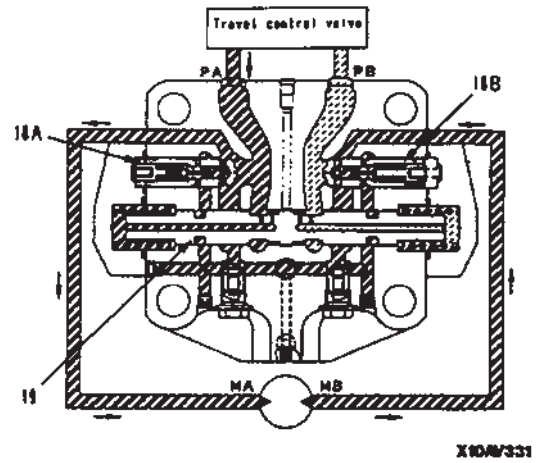

- c. Operation of brake when traveling downhill
 - i. If the machine tries the run away when traveling downhill, the motor will turn under no load, so the pressure at the motor inlet port will drop, and the pressure in chamber **S1** through orifices **E1** and **E2** will also drop. When the pressure in chamber **S1** drops below the spool switching pressure, spool (19) is returned to the left in the direction of the arrow by spring (20), and outlet port **MB** is throttled. As a result, the pressure at the outlet port side rises, resistance is generated to the rotation of the motor, and this prevents the machine from running away. In other words, the spool moves to a position where the pressure at outlet port **MB** balances the pressure at the inlet port and the force generated by the weight of the machine. It throttles the outlet port circuit and controls the travel speed according to the amount of oil discharged from the pump.

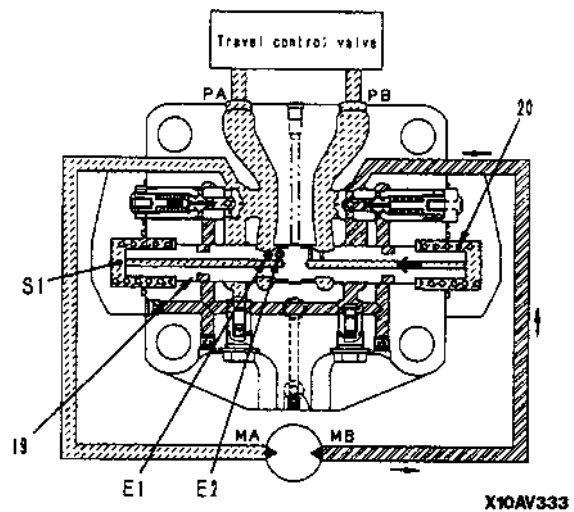

2. Safety valve

a. Function

- i. When travel is stopped (or when travelling downhill), the circuits at the inlet and outlet ports of the motor are closed by the counterbalance valve, but the motor is rotated by inertia, so the pressure at the outlet port of the motor will become abnormally high and damage the motor or piping. The safety valve acts the release this abnormal pressure and send it to the inlet port side of the motor the prevent damage to the equipment.

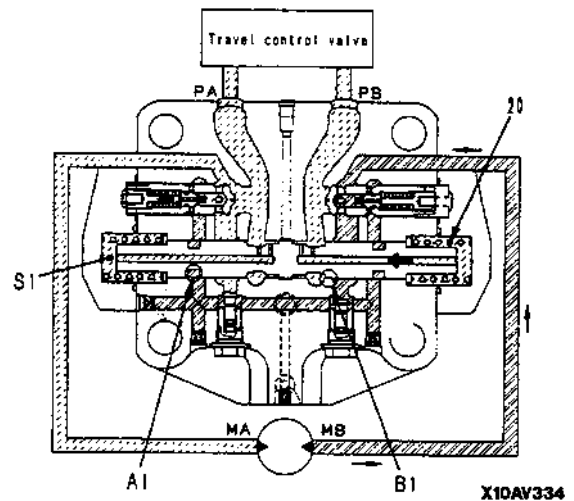

b. Operation when travel is stopped (or when traveling downhill, rotating to the right)

- i. When the motor inlet port pressure (pressure **PA**) goes down, the pressure in chamber **S1** also goes down. When it goes below the switching pressure of the spool, spool (19) is returned to the left by spring (20), and outlet port passage **B1** is throttled. When this happens, the motor continues the rotate under inertia, so the outlet pressure (pressure **MB**) rises.

- ii. If the pressure goes above the set pressure of suction-safety valve (18A), the poppet opens. The oil then passes through large notch **A1** in counterbalance valve spool (19) and flows the chamber **MA** in the circuit on the opposite side.
- c. When rotating to the left
 - i. The operation is the reverse of when rotating to the right.
- d. When starting travel (or during normal travel)
 - i. When the travel lever is operated, the pressurized oil from the pump moves counterbalance valve spool (19) to the right. When this happens, the passage to the suction-safety valve becomes the circuit flowing through the small notch in the counterbalance valve spool. As a result, a big difference in pressure is created, and the pump pressure rises to provide a powerful drawbar pull.

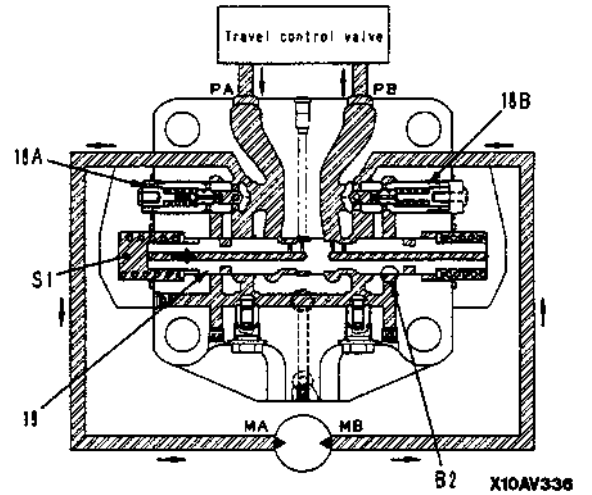
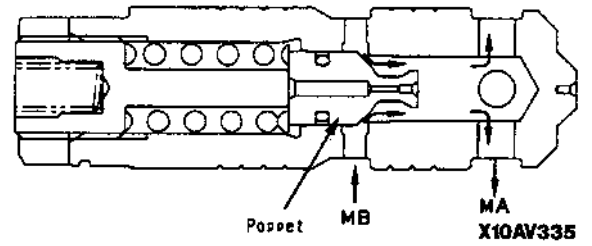

VALVE CONTROL

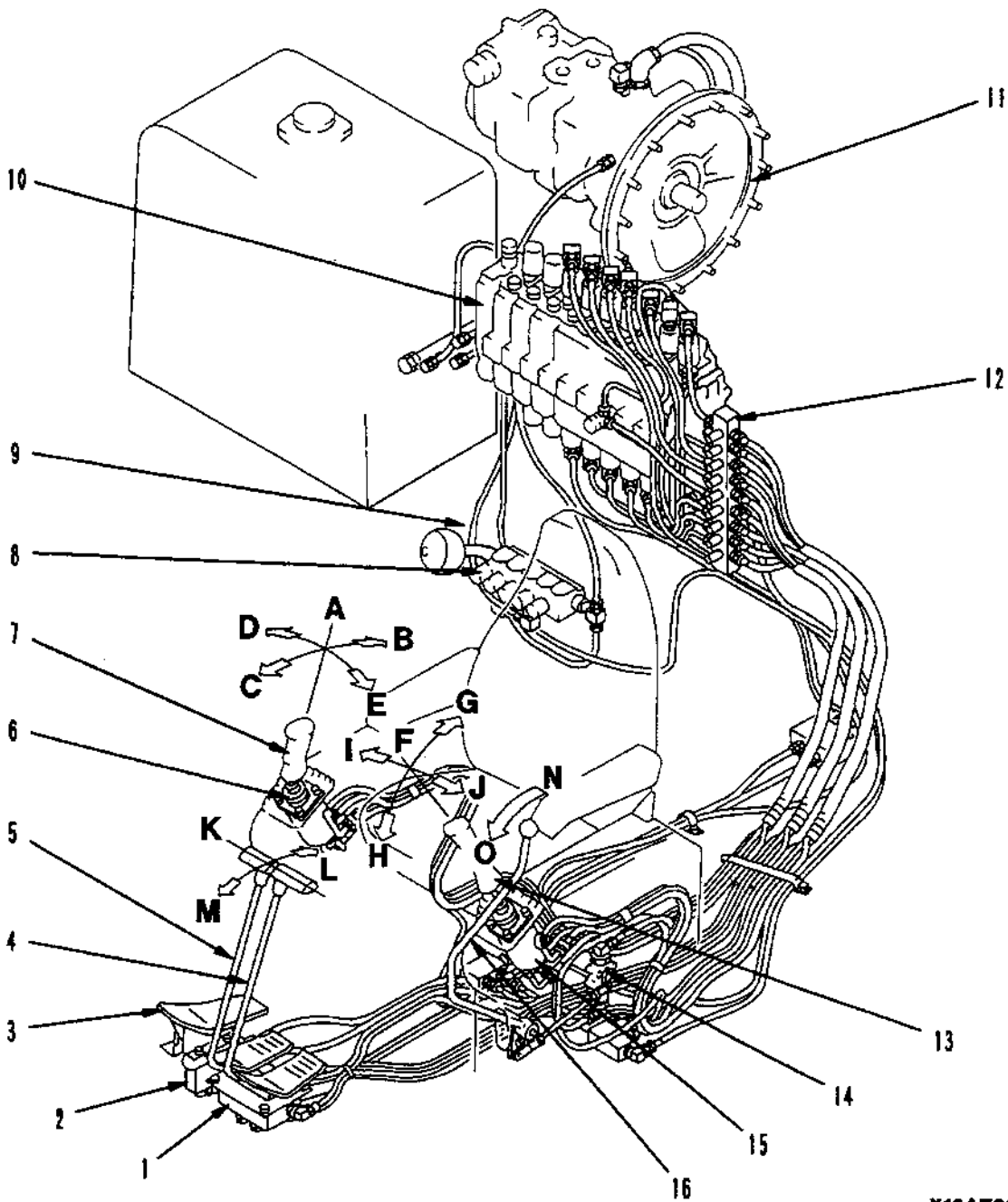

X10AZ067

- | | |
|------------------------------|-------------------------------|
| 1. Travel PPC valve | 10. Control valve |
| 2. Service PPC valve | 11. Hydraulic pump |
| 3. Service pedal | 12. Junction box |
| 4. L.H. travel lever | 13. L.H. work equipment lever |
| 5. R.H. travel lever | 14. PPC safety lock valve |
| 6. R.H. PPC valve | 15. L.H. PPC valve |
| 7. R.H. work equipment lever | 16. Safety lock lever |
| 8. Solenoid valve | |
| 9. Accumulator | |

Lever positions

- | | |
|----------------|-------------------|
| A. HOLD | I. Swing RIGHT |
| B. Boom RAISE | J. Swing LEFT |
| C. Boom LOWER | K. NEUTRAL |
| D. Bucket DUMP | L. Travel REVERSE |
| E. Bucket CURL | M. Travel FORWARD |
| F. HOLD | N. LOCK |
| G. Arm IN | O. FREE |
| H. Arm OUT | |

WORK EQUIPMENT • SWING PPC VALVE

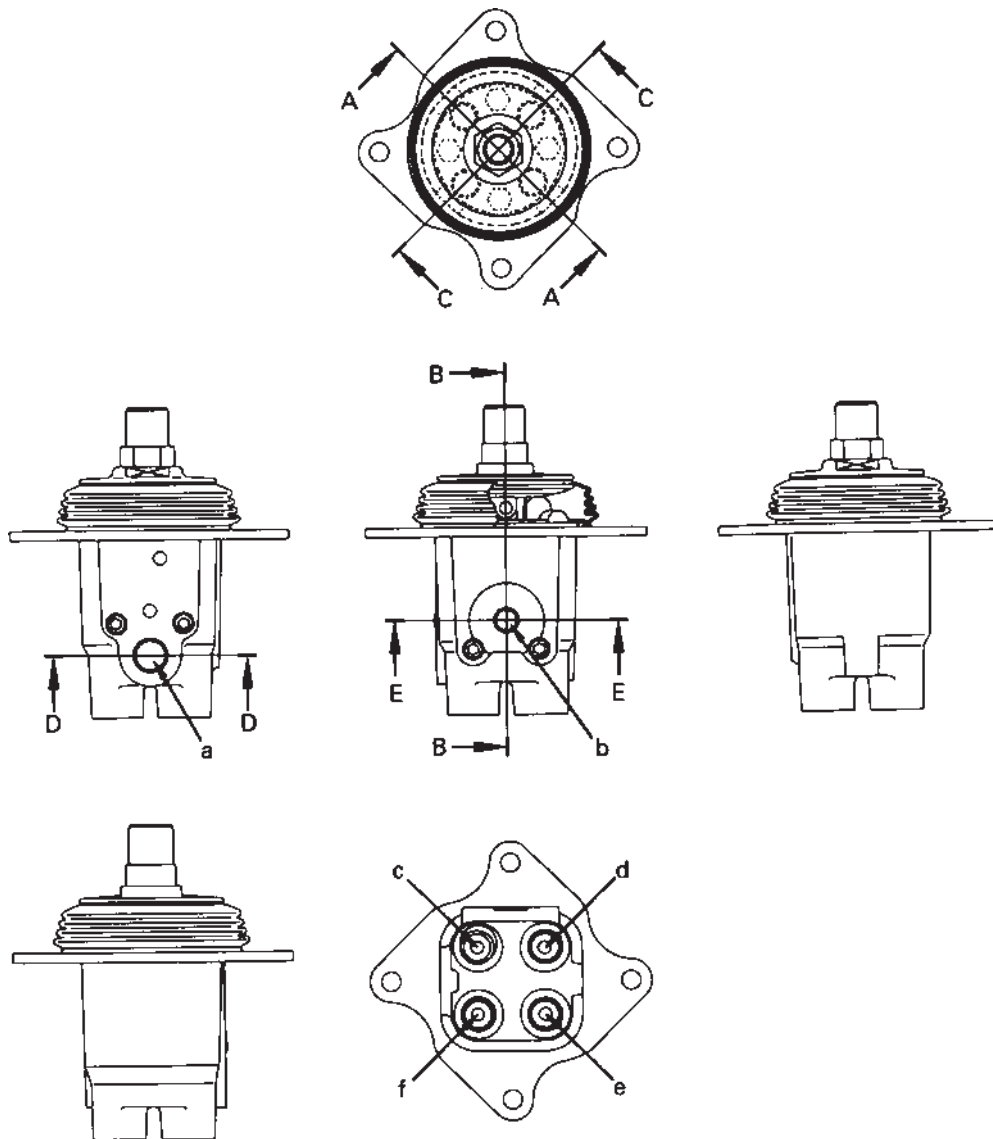

SBP00273

- a. Port **P** (from main pump)
- b. Port **T** (the tank)
- c. Port **P2** (L.H.: Arm I/R.H.: Boom RAISE)
- d. Port **P4** (L.H.: Swing LEFT/R.H.: Bucket DUMP)
- e. Port **P1** (L.H.: Arm OUT/R.H.: Boom LOWER)
- f. Port **P3** (L.H.: Swing RIGHT/R.H.: Bucket CURL)

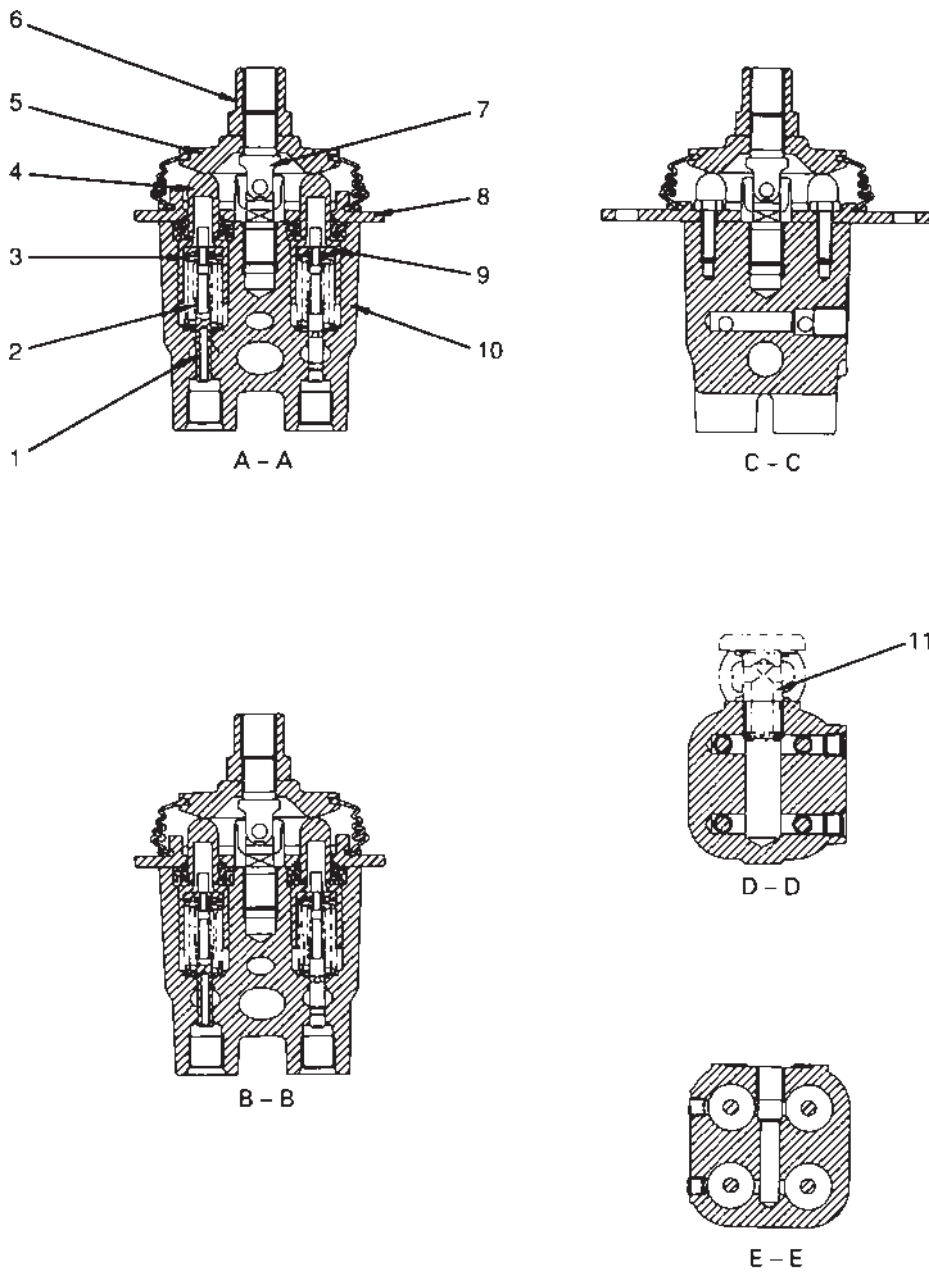

SBP00274

- | | |
|-------------------------------|-------------|
| 1. Spool | 7. Joint |
| 2. Metering spring | 8. Plate |
| 3. Centering spring | 9. Retainer |
| 4. Piston | 10. Body |
| 5. Disc | 11. Filter |
| 6. Nut (for connecting lever) | |

Operation

1. At neutral
 - a. Ports **A** and **B** of the control valve and ports **P1** and **P2** of the PPC valve are connected the drain chamber **D** through fine control hole **f** in spool (1).

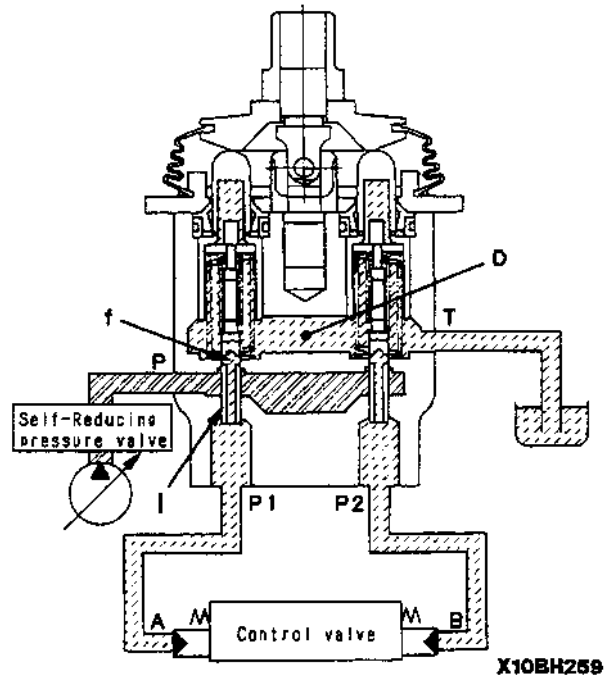

2. During fine control (neutral $\Delta E \Delta E$ fine control)
 - a. When piston (4) starts to be pushed by disc (5), retainer (9) is pushed; spool (1) is also pushed by metering spring (2), and moves down.
 - b. When this happens, fine control hole **f** is shut off from drain chamber **D**, and at almost the same time, it is connected the pump pressure chamber **PP**, so pilot pressure oil from the main pump passes through fine control hole **f** and goes from port **P1** the port **A**.
 - c. When the pressure at port **P1** becomes higher, spool (1) is pushed back and fine control hole **f** is shut off from pump pressure chamber **PP**. At almost the same time, it is connected the drain chamber **D** the release the pressure at port **P1**. When this happens, spool (1) moves up and down so that the force of metering spring (2) is balanced with the pressure at port **P1**. The relationship in the position of spool (1) and body (10) (fine control hole **f** is at a point midway between drain hole **D** and pump pressure chamber **PP**) does not change until retainer (9) contacts spool (1).
 - d. Therefore, metering spring (2) is compressed proportionally to the amount of movement of the control lever, so the pressure at port **P1** also rises in proportion to the travel of the control lever. In this way, the control valve spool moves to a position where the pressure in chamber **A** (the same as the pressure at port **P1**) and the force of the control valve spool return spring are balanced.

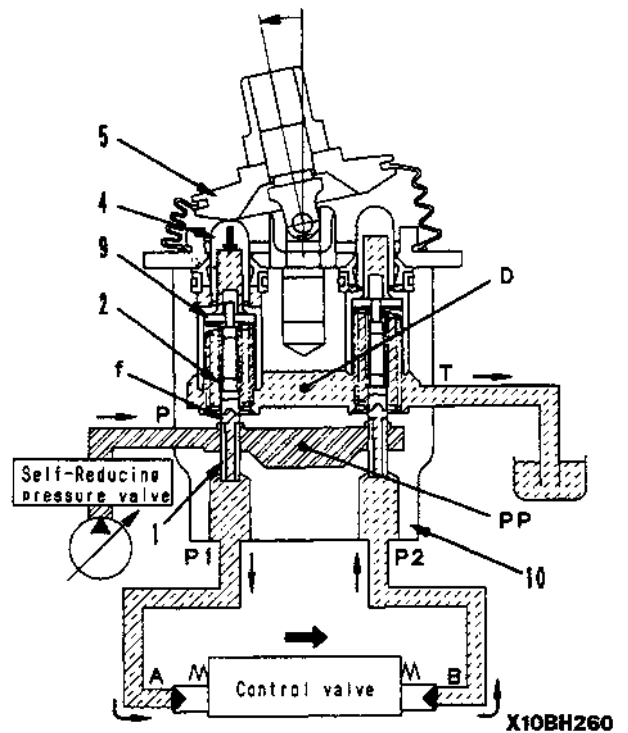

3. During fine control (when control lever is returned)
 - a. When disc (5) starts to be returned, spool (1) is pushed up by the force of centering spring (3) and the pressure at port **P1**. When this happens, fine control hole **f** is connected to drain chamber **D** and the pressurized oil at port **P1** is released.
 - b. If the pressure at port **P1** drops too far, spool (1) is pushed down by metering spring (2), and fine control hole **f** is shut off from drain chamber **D**. At almost the same time, it is connected to pump pressure chamber **PP**, and the pump pressure is supplied until the pressure at port **P1** recovers to a pressure that corresponds to the lever position.
 - c. When the spool of the control valve returns, oil in drain chamber **D** flows in from fine control hole **f** in the valve on the side that is not working. The oil passes through port **P2** and enters chamber **B** to fill the chamber with oil.

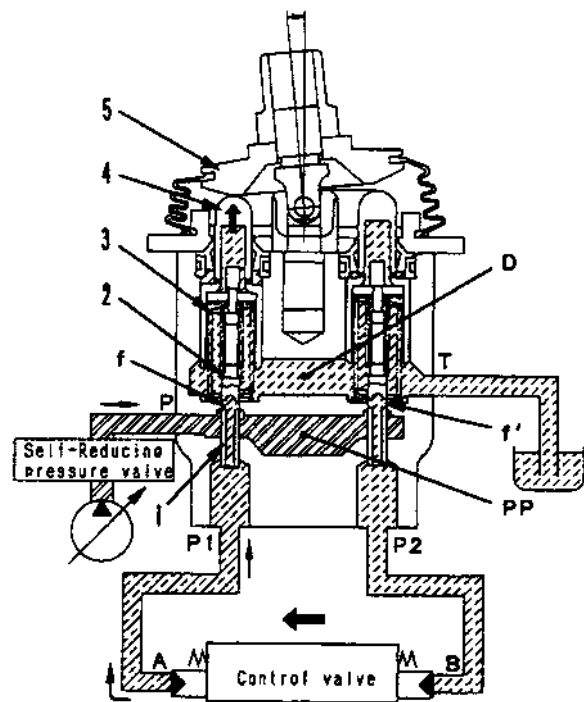

X10BH261

4. At full stroke
 - a. When disc (5) pushes down piston (4), and retainer (9) pushes down spool (1), fine control hole **f** is shut off from drain chamber **D**, and is connected with pump pressure chamber **PP**. Therefore, the pilot pressure oil from the main passes through fine control hole **f** and flows to chamber **A** from port **P1**, and pushes the control valve spool.
 - b. The oil returning from chamber **B** passes from port **P2** through fine control hole **f** and flows to drain chamber **D**.

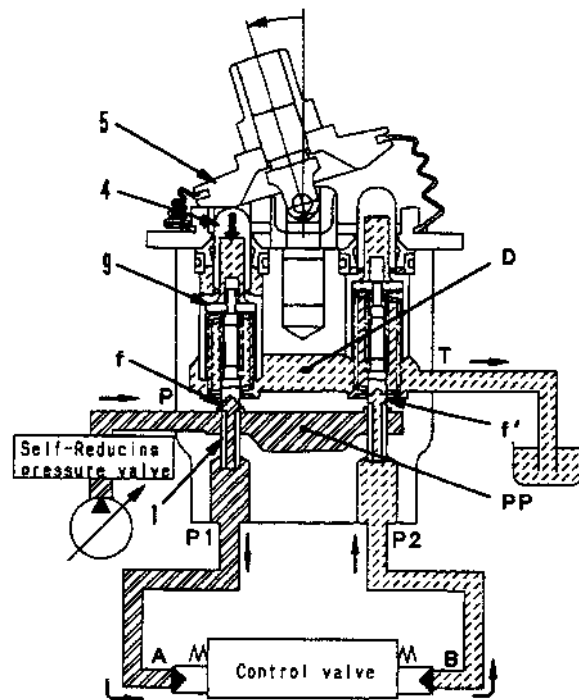

X10BH262

TRAVEL PPC VALVE

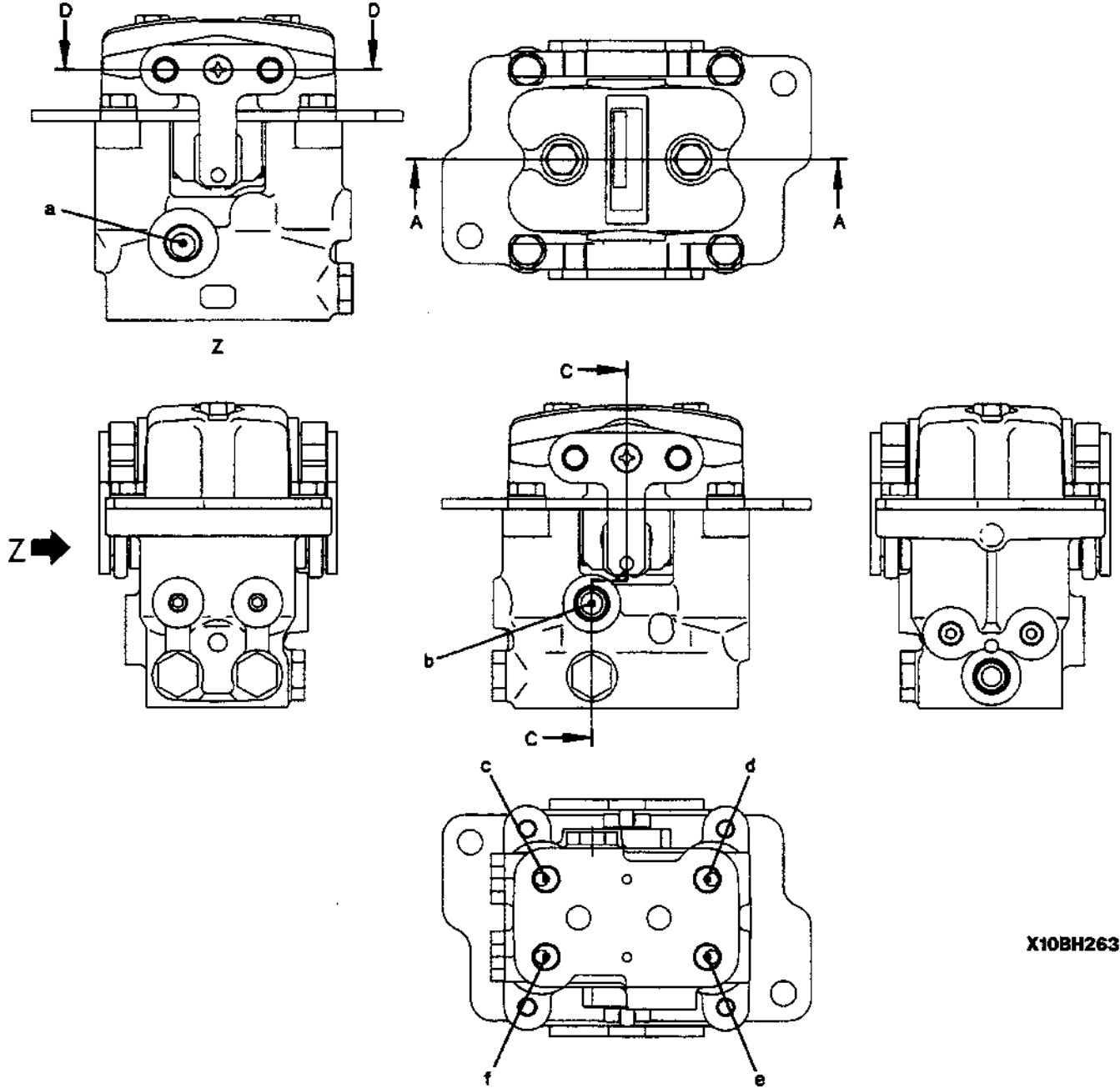

X10BH263

- a. Port **P** (from main pump)
- b. Port **T** (to tank)
- c. Port **P2** (L.H. travel FORWARD)
- d. Port **P1** (L.H. travel REVERSE)
- e. Port **P3** (R.H. travel REVERSE)
- f. Port **P4** (R.H. travel FORWARD)

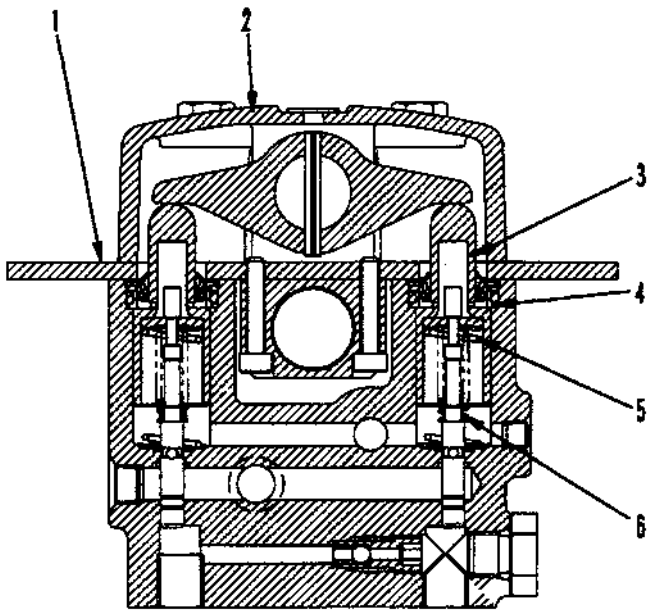

B - B

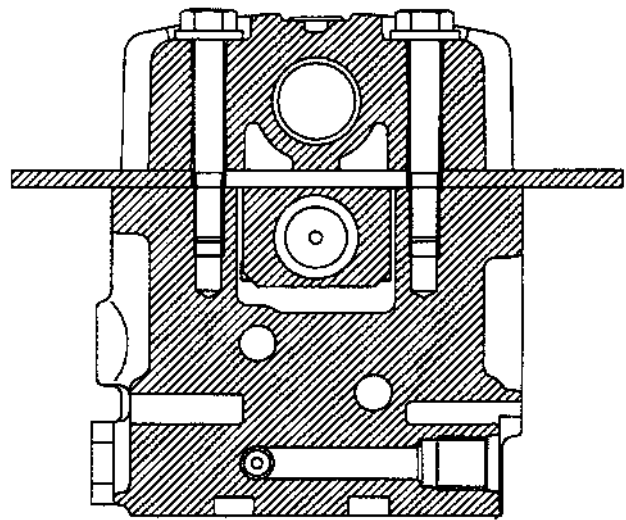

A - A

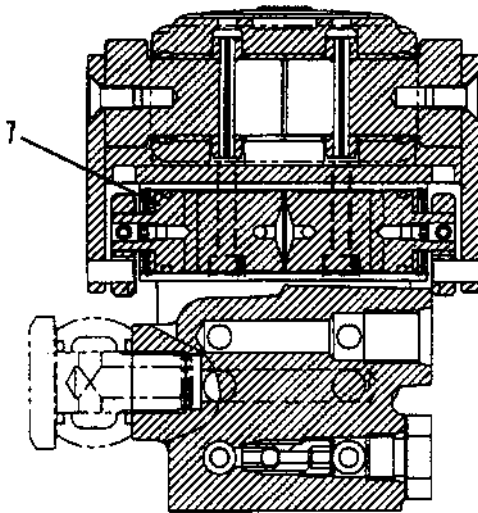

C - C

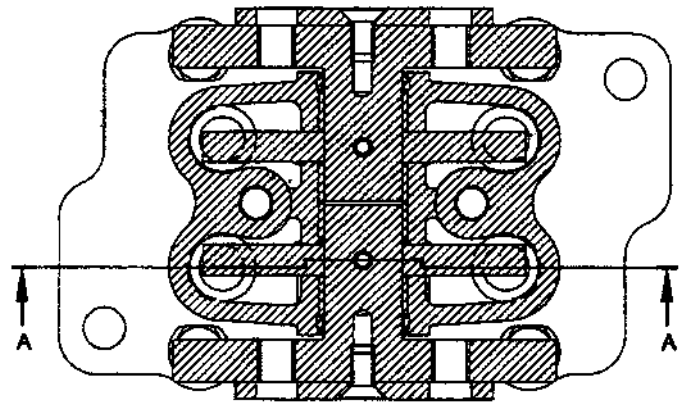

D - D

X10BH264

- 1. Plate
- 2. Body
- 3. Piston
- 4. Collar

- 5. Metering spring
- 6. Centering spring
- 7. Valve
- 8. Bolt

Operation

1. At neutral
 - a. Ports **A** and **B** of the control valve and ports **P1** and **P2** of the PPC valve are connected to drain chamber **D** through fine control hole **f** in spool (1).

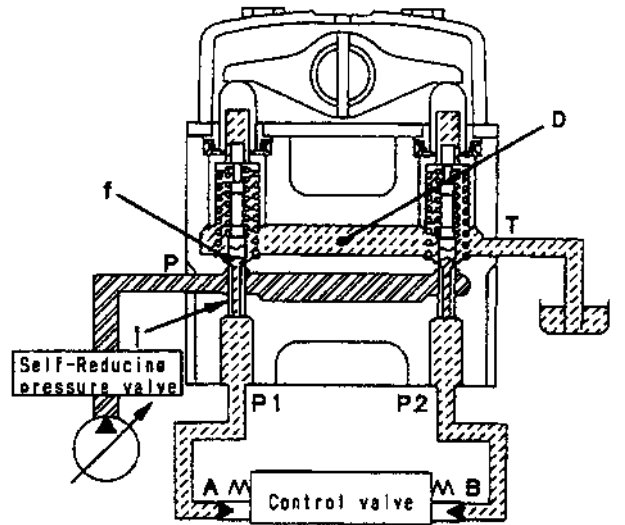

X10BH265

2. Fine control (neutral → fine control)
 - a. When piston (4) starts to be pushed by disc (5), retainer (9) is pushed. Spool (1) is also pushed by metering spring (2) and moves down.
 - b. When this happens, fine control hole **f** is shut off from drain chamber **D**. At almost the same time, it is connected to pump pressure chamber **PP**, and the pilot pressure of the main pump is sent from port **A** through fine control hole **f** to port **P1**..
 - c. When the pressure at port **P1** rises, spool (1) is pushed back. Fine control hole **f** is shut off from pump pressure chamber **PP**. At almost the same time, it is connected to drain chamber **D**, so the pressure at port **P1** escapes.
 - d. As a result, spool (1) moves up and down until the force of metering spool (2) is balanced with the pressure of port **P1**. The relationship of the position of spool (1) and body (10) (fine control hole **f** is in the middle between drain hole **D** and pump pressure chamber **PP**) does not change until retainer (9) contacts spool (1).
 - e. Therefore, metering spring (2) is compressed in proportion to the travel of the control lever, so the pressure at port **P1** also rises in proportion to the travel of the control lever. In this way, the spool of the control valve moves to a position where the pressure of chamber **A** (same as pressure at port **P1**) and the force of the return spring of the control valve spool are balanced.

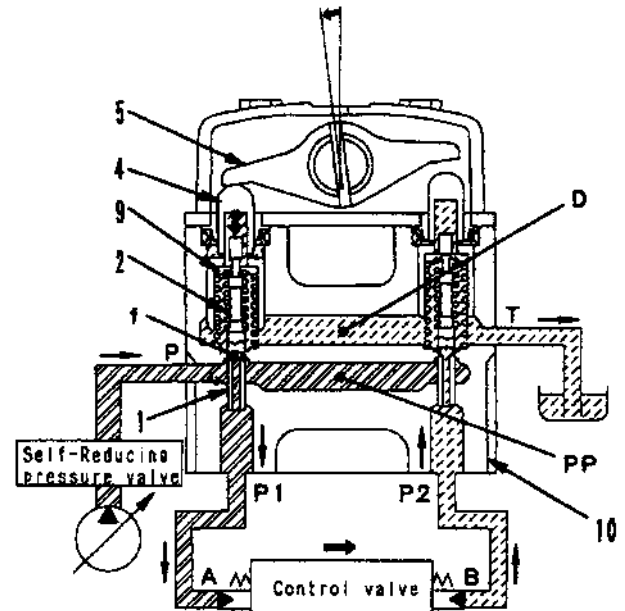

X10BH266

3. Fine control (control lever returned)
 - a. When disc (5) starts to be returned, spool (1) is pushed up by the force of centering spring (3) and the pressure at port **P1**. Because of this, fine control hole **f** is connected to drain chamber **D**, and the pressurized oil at port **P1** is released.
 - b. If the pressure at port **P1** drops too much, spool (1) is pushed up by metering spring (2), so fine control hole **f** is shut off from drain chamber **D**. At almost the same time, it is connected to pump pressure chamber **PP**, so the pressure at port **P1** supplies the pump pressure until the pressure recovers to a pressure equivalent to the position of the lever.
 - c. When the control valve returns, oil in drain chamber **D** flows in from fine control hole **f** of the valve on the side that is not moving. It passes through port **P2** and goes to chamber **B** to charge the oil.

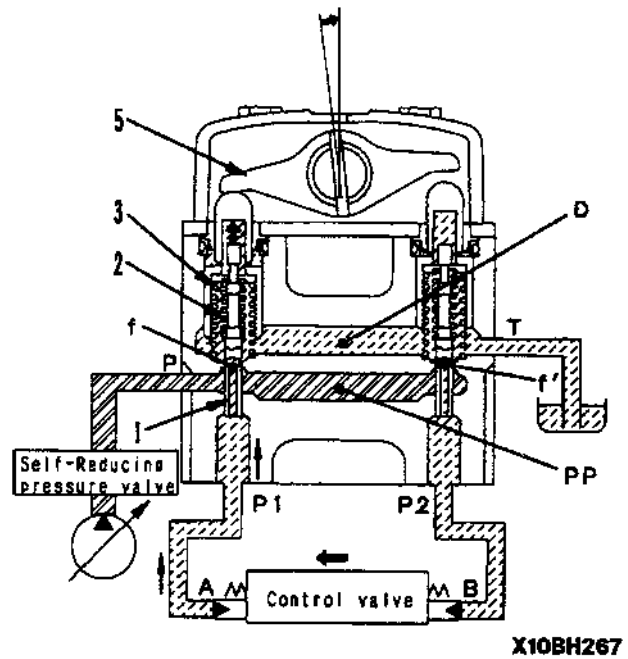

4. At full stroke
 - a. Disc (5) pushes down piston (4), and retainer (9) pushes down spool (1). Fine control hole **f** is shut off from drain chamber **D**, and is connected to pump pressure chamber **PP**. Therefore, the pilot pressure oil from the main pump passes through fine control hole **f** and flows to chamber **A** from port **P1** to push the control valve spool. The return oil from chamber **B** passes from port **P2** through fine control port **P2** through fine control hole **f** and flows to drain chamber **D**.

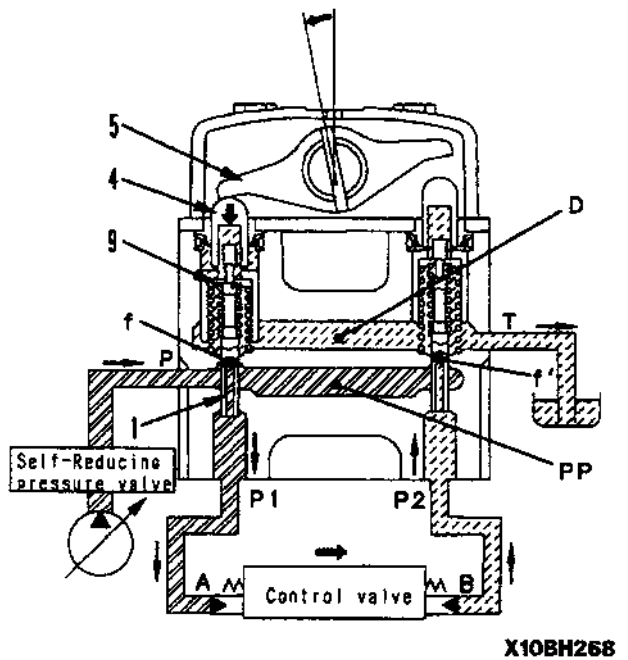

SERVICE PPC VALVE

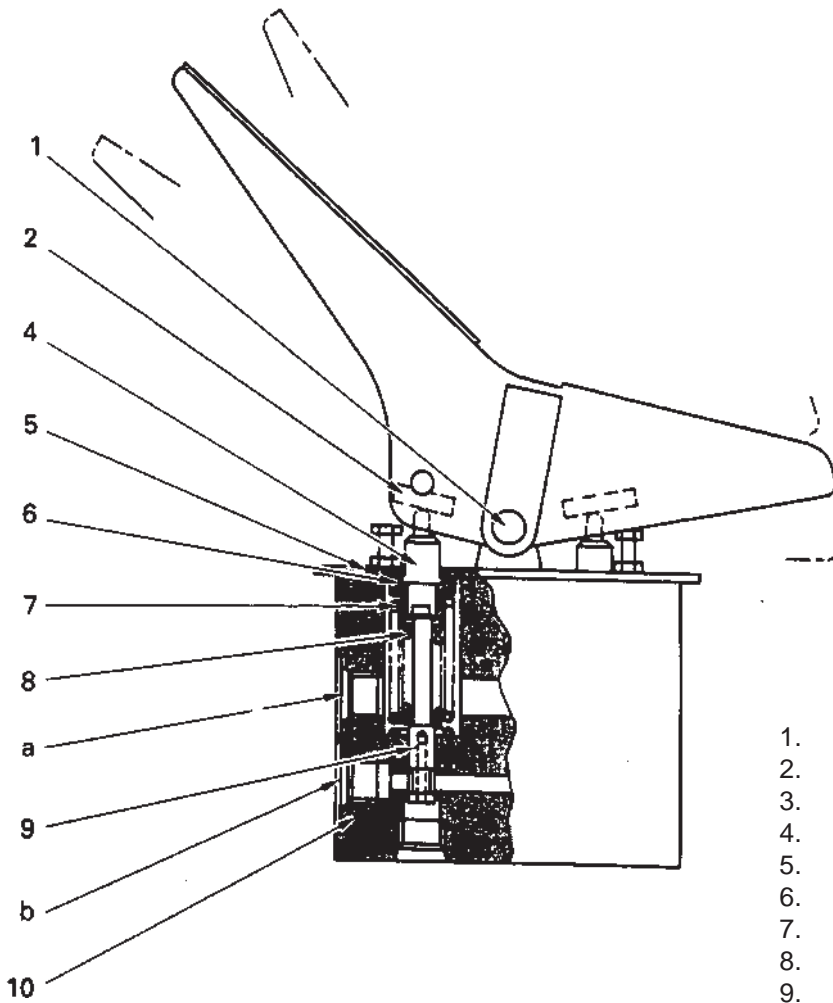

- 1. Pin
- 2. Cam
- 3. Ball
- 4. Piston
- 5. Cover
- 6. Sleeve
- 7. Centering spring
- 8. Metering spring
- 9. Spool
- 10. Body
- a. Port T (to tank)
- b. Port P (from control pump)
- c. Port A (to service valve P1)
- d. Port B (to service valve P2)

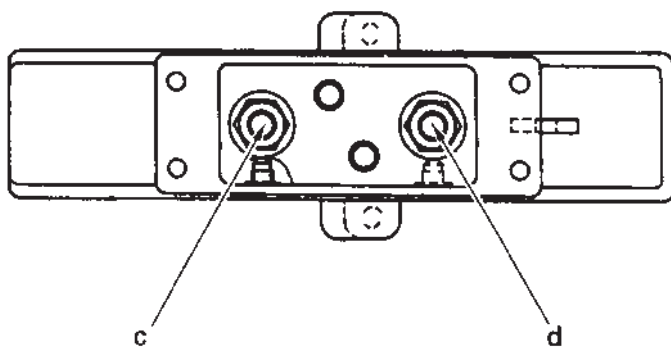

OPERATION

At neutral

- The pressurized oil from the control pump enter from port **P** and is blocked by spool (9).
- Port **A** and **B** of the control valve and port "a" and "b" of the PPC valve are connected to drain port **T** through fine control hole **X** of spool (9).

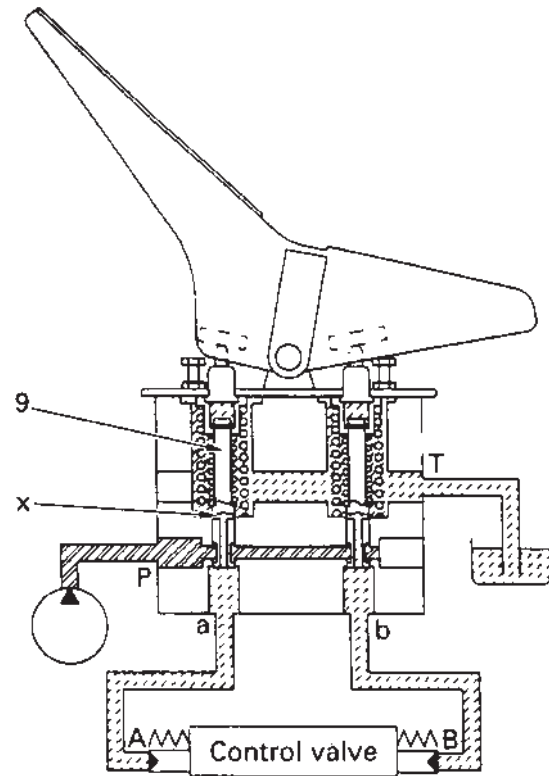

When operated

- When cam (2) is moved, metering spring (8) is pushed by ball (3), piston (4), and sleeve (6), and spool (9) is also pushed down by this.
- As a result, fine control hole **X** is shut off from the drain circuit. At almost the same time, fine control proportion **Y** is connected with port "a", and the pressurized oil from port **P** flows from port "a" to port **A** of the control valve.

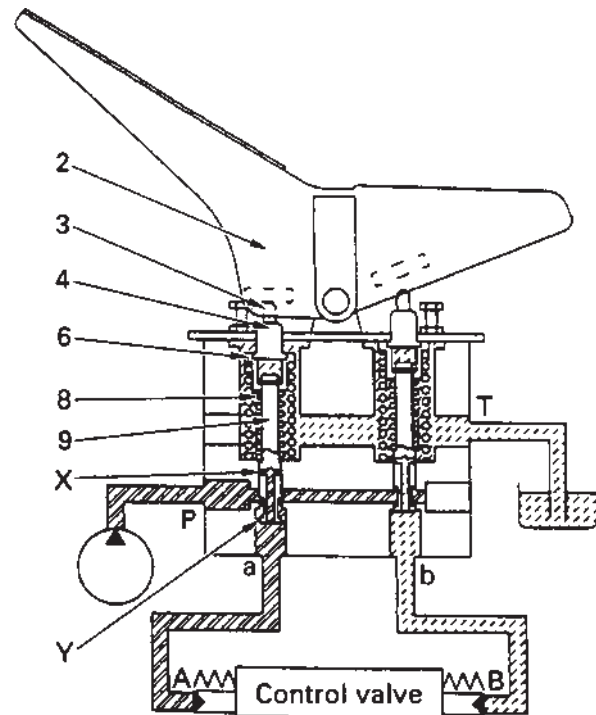

- When the pressure at port “a” becomes higher, spool (9) is pushed back by the force acting on the end of the spool. When fine control proportion Y closes, fine control hole X is connected to the drain circuit at almost the same time.
- As a result, spool (9) moves up and down to balance the force at port “a” and the force at metering spring (8).
- Therefore, metering spring (8) is compressed in proportion to the amount the control lever is moved. The spring force becomes larger, so the pressure at port “a” also increases in proportion to the amount the control lever is operated.
- In this way, the control valve spool moves to a position where the pressure of port A (the same as the pressure at port “a”) is balanced with the force of the return spring of the control valve spool.

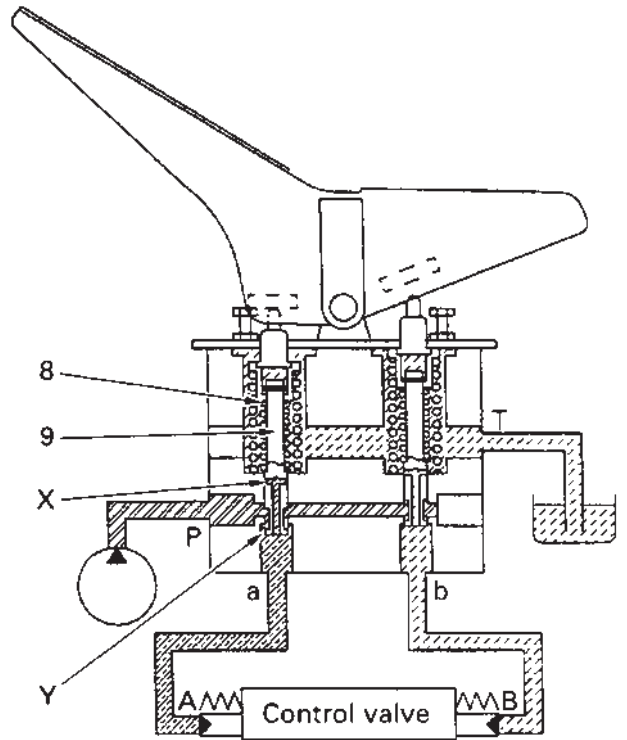

The purpose of the attachment flow control system is to limit the maximum flow of oil through the first attachment circuit on machines that are so equipped. The flow setting is selected by means of a thumbwheel switch fitted in the operators cab switch panel.

The layout of the system is shown as follow:

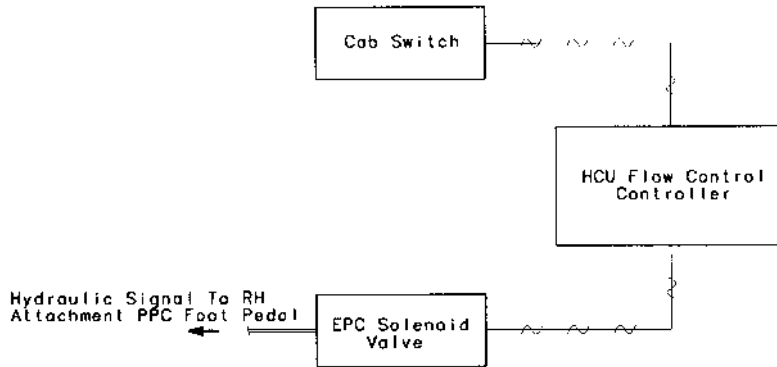

The flowcontroller sends a steady current signal to the E.P.C. solenoid valve dependent on the switch position selected at the operator’s cab switch. The E.P.C. solenoid then sets the pressure of the hydraulic oil supply to the right hand attachment pedal, this limiting the maximum PPC signal pressure taht can be applied to the attachment spool.

See also page 10-114 for description of the attachment pedal)

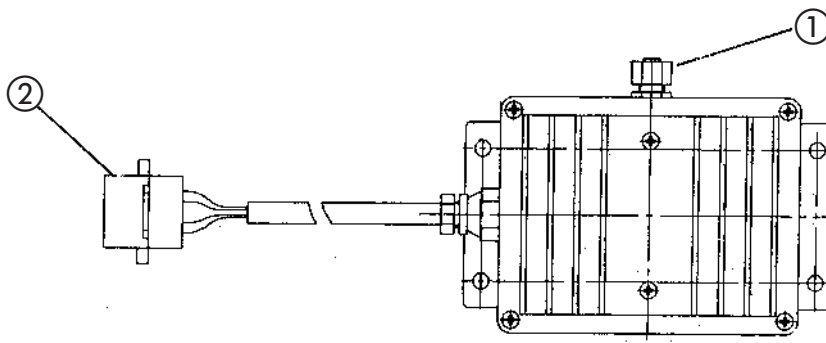

- ① Adjustment knob
- ② Wiring connector

SAFETY LOCK VALVE

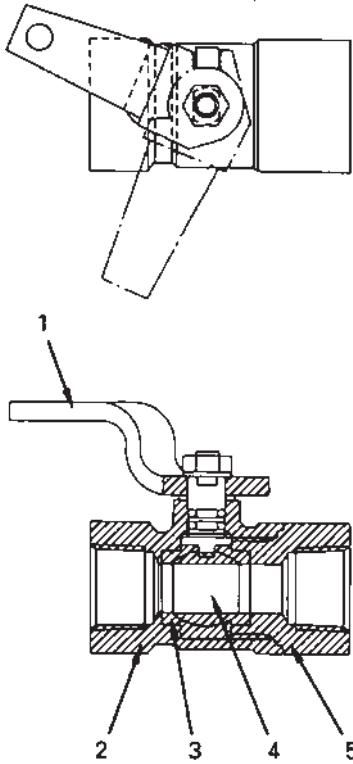

- 1. Lever
- 2. Body
- 3. Seat
- 4. Ball
- 5. End cap

SBP00289

PPC ACCUMULATOR

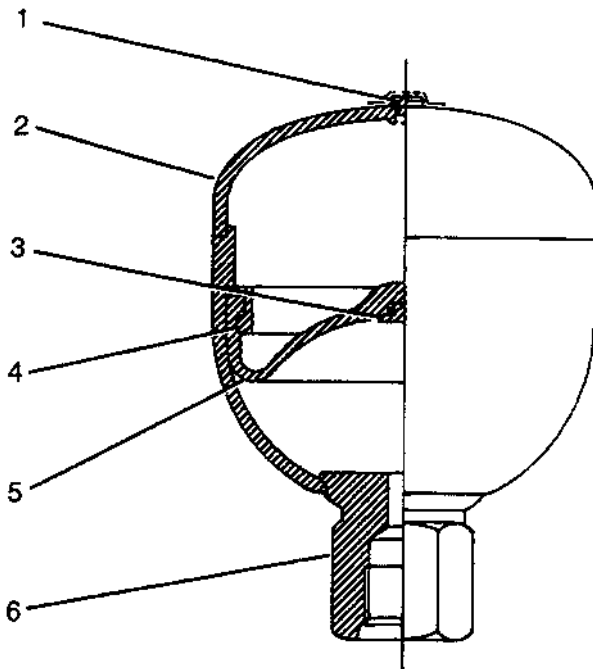

- 1. Gas plug
- 2. Shell
- 3. Poppet
- 4. Holder
- 5. Bladder
- 6. Oil port

Specifications
Gas capacity: 327 cc

X10CD011

STRAIGHT-TRAVEL SYSTEM

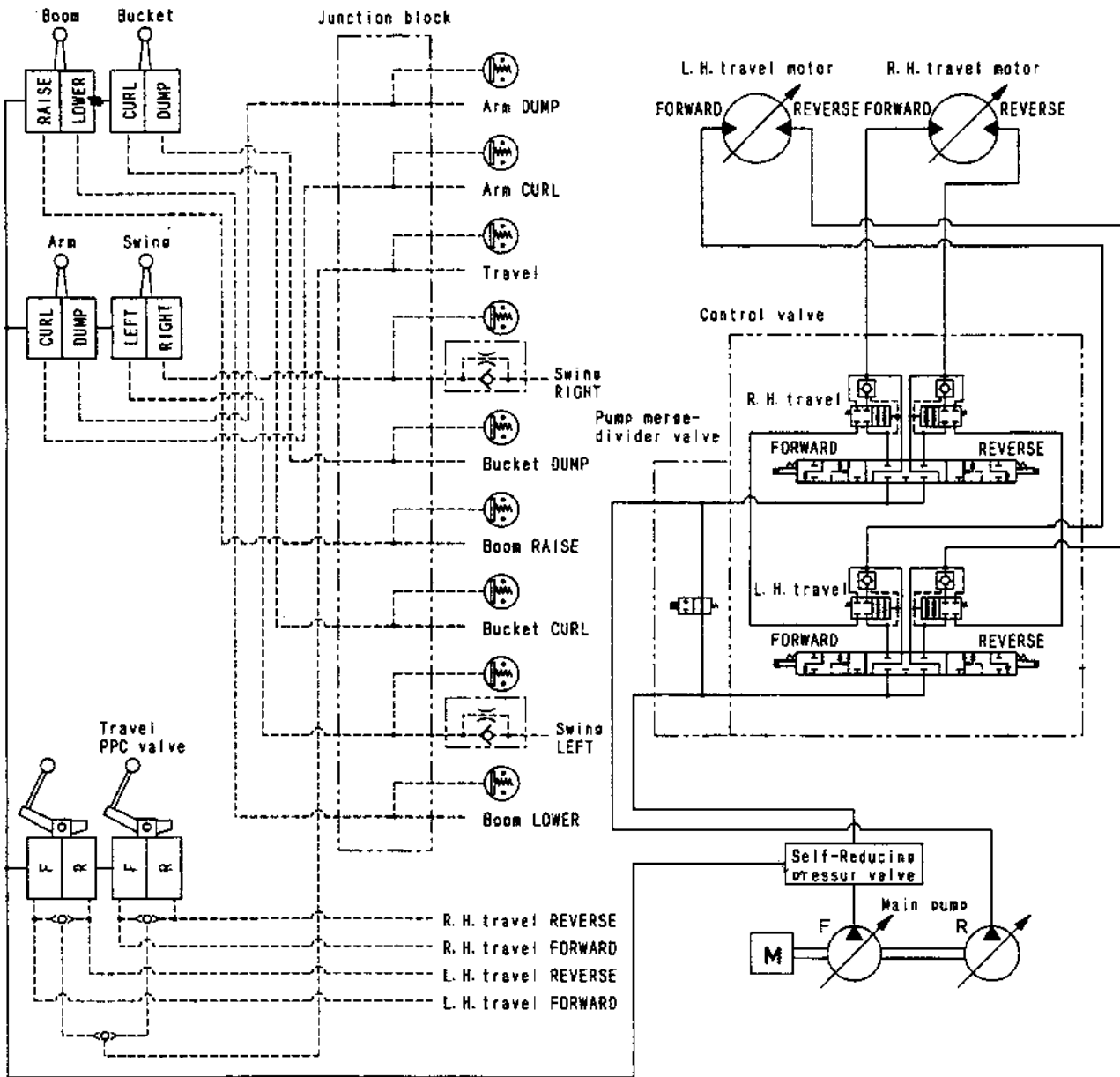

X10DD111

Function

- This system interconnects the pressure compensation valves for L.H. and R.H. travel FORWARD and REVERSE with external piping to ensure the ability in a straight line.
- As shown in the diagram on the right, the left and right ports are interconnected through passage a inside travel pressure compensation valve (1).
- By setting the throttle in junction circuit a to a suitable value, it is possible to fulfill the requirements for steering ability and the ability to maintain a straight line.

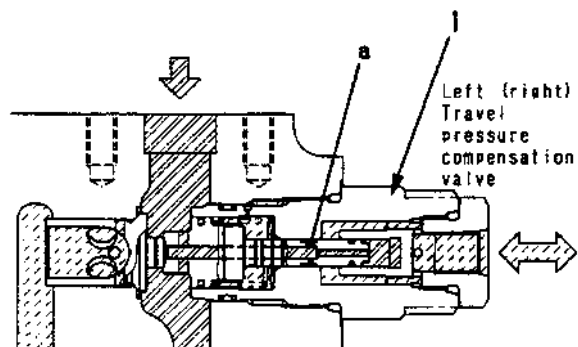

X10BH274

EPC SOLENOID VALVE

For active mode, pump merge-divider, 2-stage relief, travel speed, swing brake solenoid valve

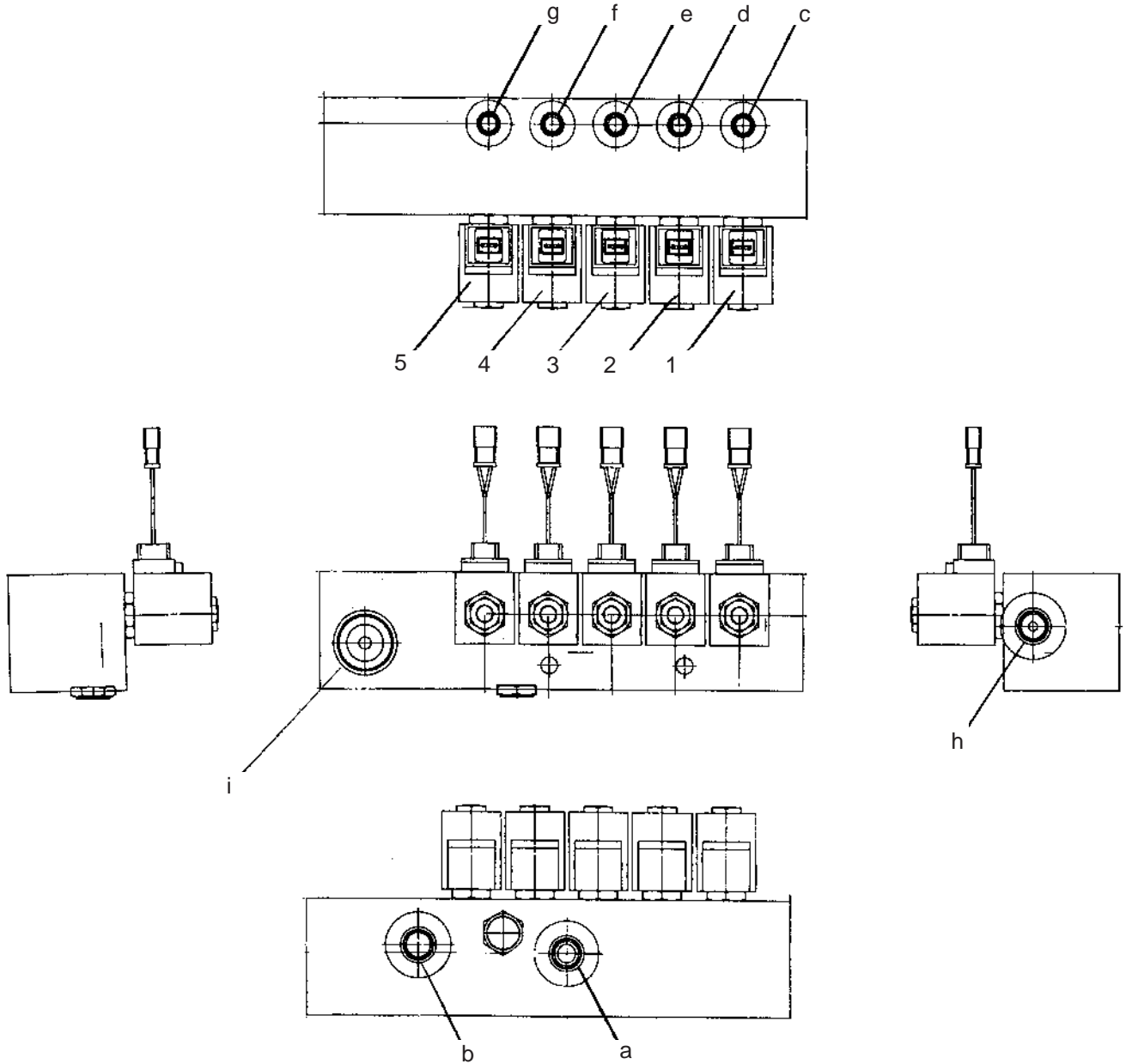

X10BH275

- | | |
|--|--|
| <ul style="list-style-type: none"> 1. Active mode solenoid valve 2. 2-stage relief solenoid valve 3. Pump merge-divider solenoid valve 4. Travel speed solenoid valve 5. Swing brake solenoid valve | <ul style="list-style-type: none"> a. To tank b. To PPC/EPC valve c. To main valve (active mode) d. To main valve (2-stage relief valve) e. To main valve (pump merge-divider valve) f. To L.H. and R.H. travel motor g. To swing motor h. From main pump i. To accumulator |
|--|--|

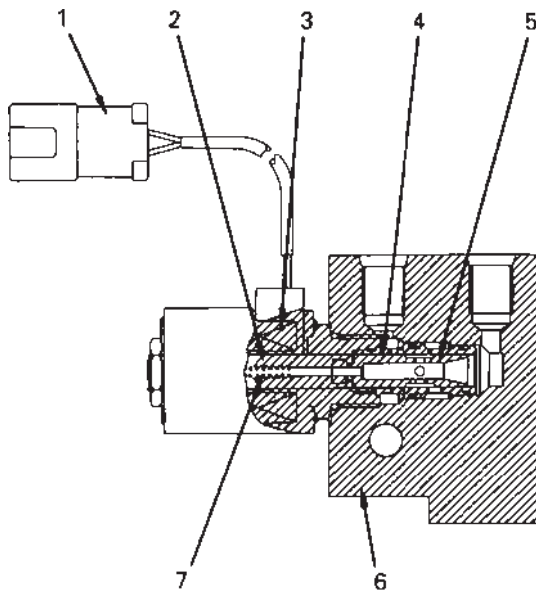

1. Connector
2. Variable core
3. Coil
4. Cage
5. Spool
6. Block
7. Spring

SBP00299

Operation

1. When solenoid is deactivated
 - a. The signal current does not flow from the controller, so coil (3) is deactivated. For this reason, spool (5) is pushed to the right in the direction of the arrow.
 - b. As a result, the circuit between ports **P** and **A** closes and the pressurized oil from the main pump does not flow to the actuator. At the same time, the pressurized oil from the actuator flows from port **A** to port **T**, and is then drained to the tank.

2. When solenoid is excited
 - a. When the signal current flows from the controller to coil (3), coil (3) is excited. For this reason, spool (5) is pushed to the left in the direction of the arrow.
 - b. As a result, the pressurized oil from the main pump flows from port **P** through the inside of spool (5) to port **A**, and then flows to the actuator. At the same time, port **T** is closed, and this stops the oil from flowing to the tank.

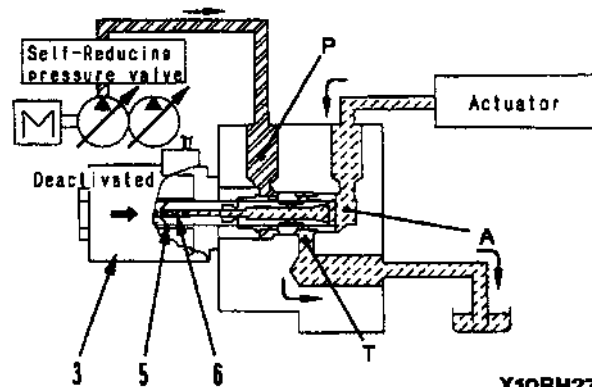

X10BH277

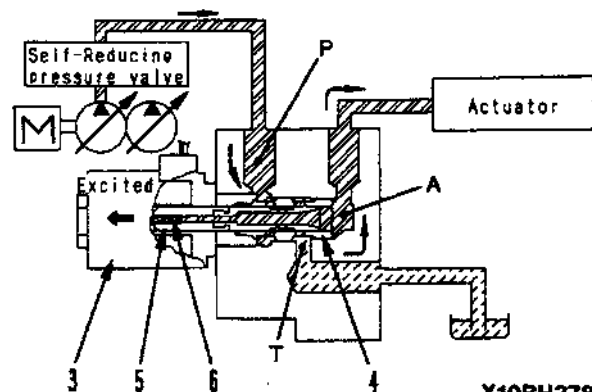

X10BH278

OVERLOAD WARNING DEVICE

1) OUTLINE

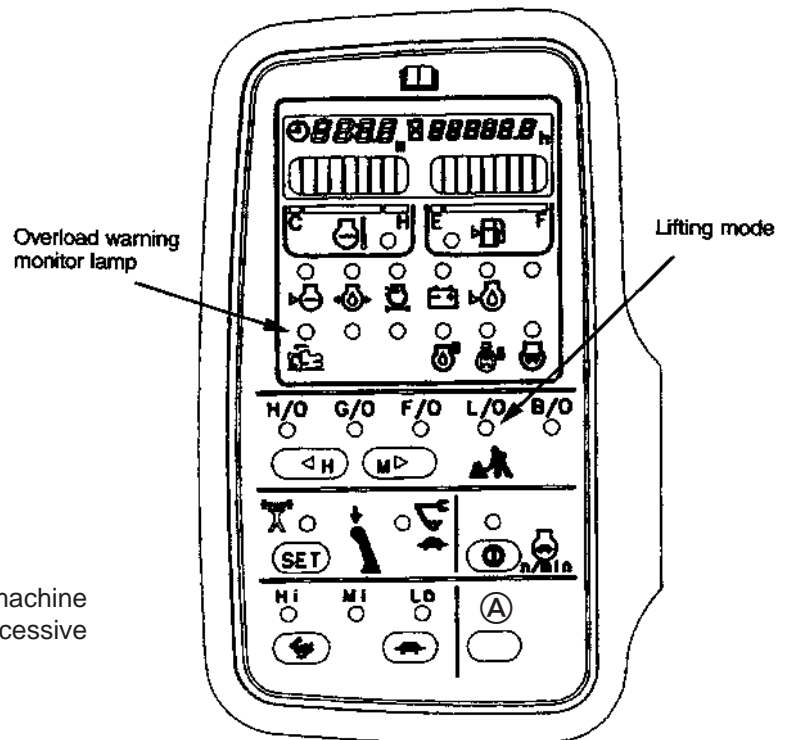

Function

- This device is installed to prevent the machine from tipping over when it lifts an excessive weight while being used as a crane.

Structure

- When an excessive weight is lifted, the oil pressure goes up at the bottom side of the boom cylinders. When this happens the pressure switch senses the rising pressure and when the pressure exceeds the safe limit value the pressure switch is activated. This causes a warning buzzer to sound inside the cab and the overload monitor lamp to flash on and off. Immediately these warnings are activated, the operator must either lower the work equipment to the ground or bring the work equipment arm closer to the machine to prevent the machine tipping over.

2) OPERATION

1. Boom cylinder safety valve
2. Boom cylinder
3. Tee-piece
4. Pressure sensor
5. Wiring harness

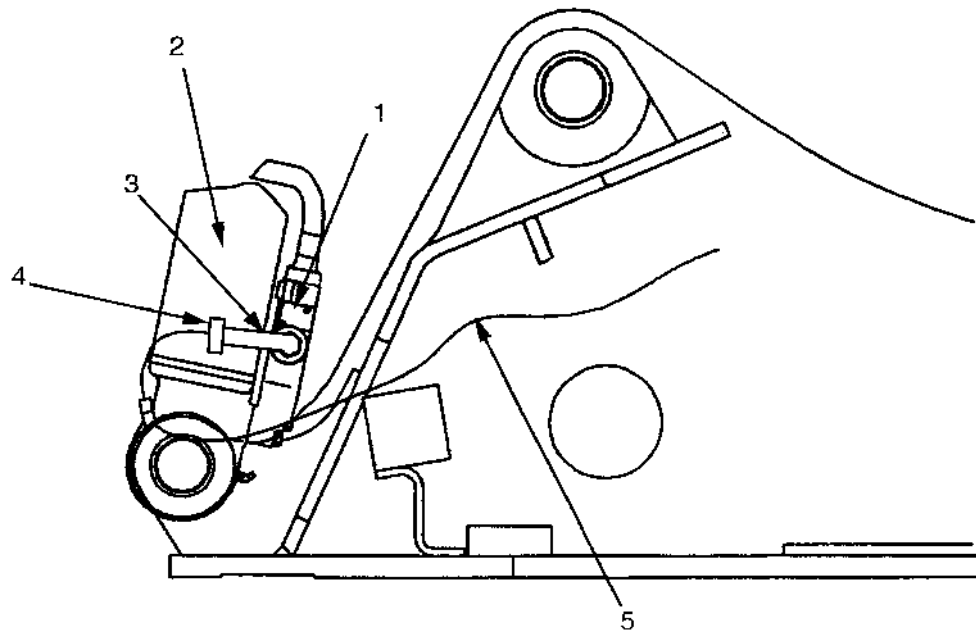

The overload caution system is operated by pressure alone (it does not take into account the position of the boom).

The pressure sensor (4) located on the hose balance line between each hose burst safety valve is activated when the oil pressure exceeds 190 kg/cm^2 during lifting operation.

NOTE: the overload caution system can only be activated when the L/O mode (lifting operation) is activated on the monitor panel, with active mode switched off.

HOSE BURST PROTECTION VALVE (BOOM)

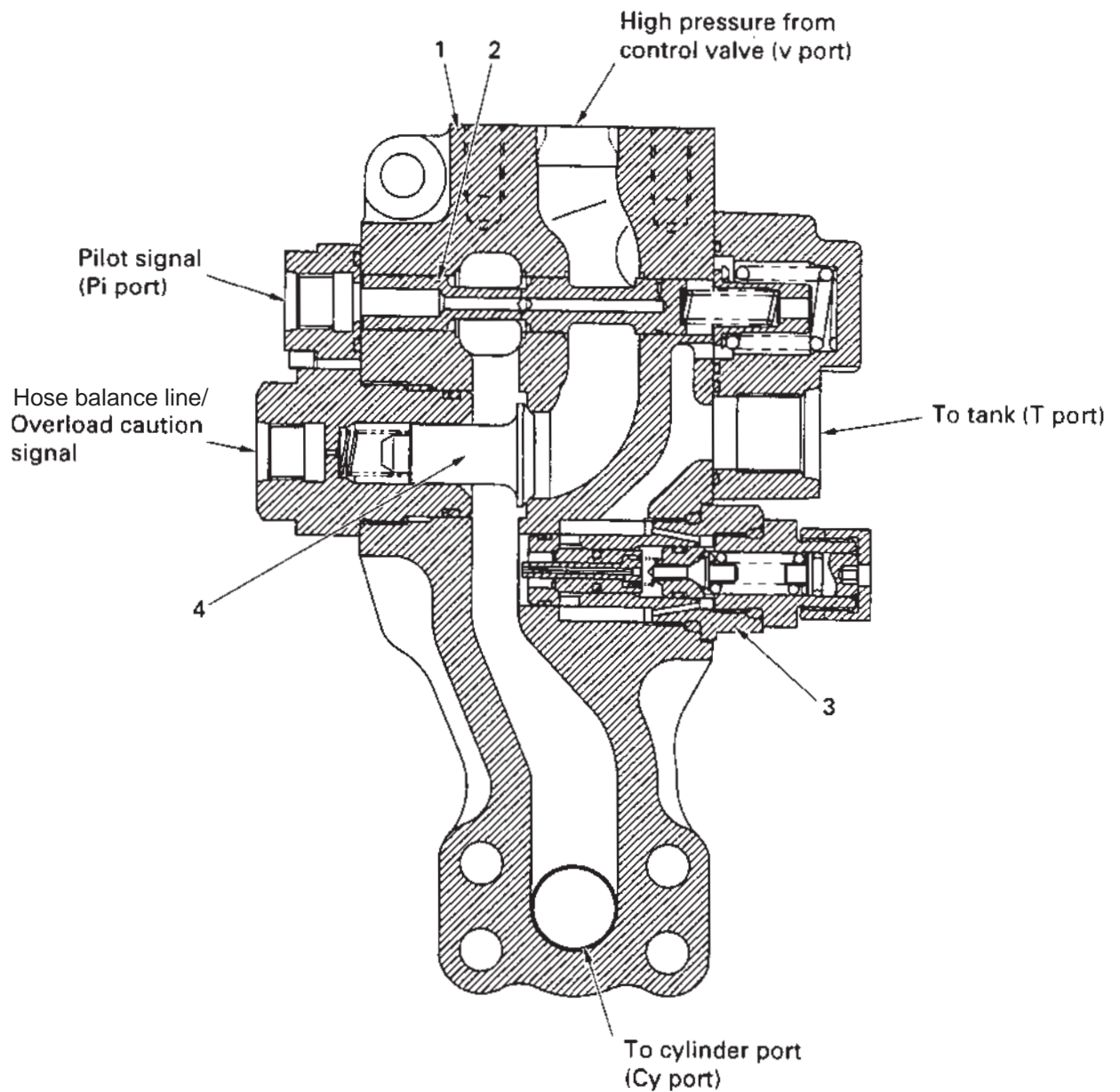

FUNCTION

- This valve prevents sudden uncontrolled lowering of the boom, when lifting, due to the burst of a hose in the boom cylinder line. In such a condition this valve will hold the load until operator lowers the boom in a controlled way using the normal wrist control.

OPERATION
BOOM RAISE

- During boom raising the pilot signal from wrist control operates control valve spool to direct high pressure oil to port **V** of hose burst valve.
- This pressure lifts check valve (4) from seat & high pressure oil flows in the bottom of the cylinder raising the boom.

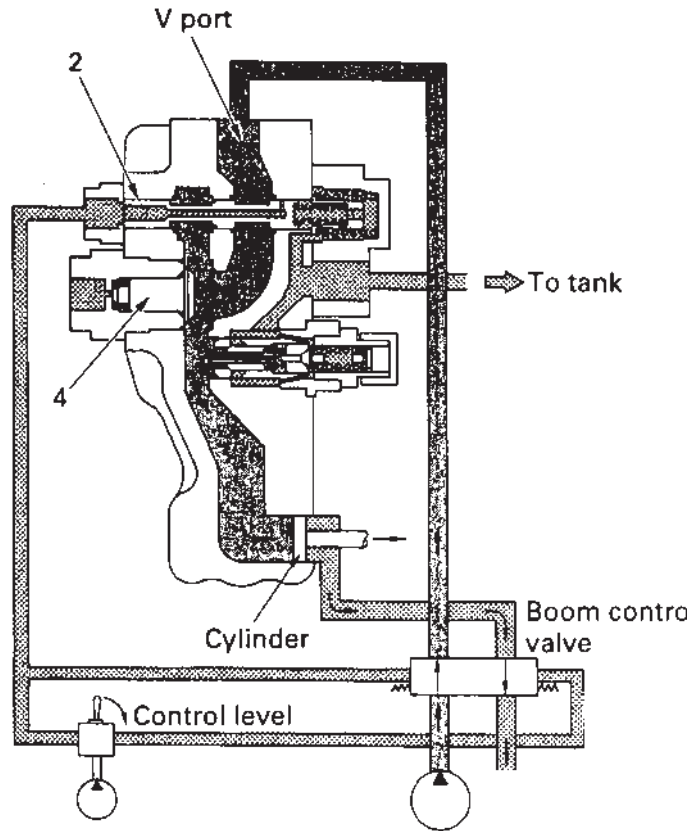

BOOM LOWER

- During boom lowering the pilot signal reverses the front through the control valve spool. High pressure oil flows to the head side of the cylinder. Oil in the bottom side of the cylinder flows through the port **Cy** of the valve but cannot flow past the check valve, the pilot signal also opens the spool (2) of the hose burst valve and allows oil to flow back to tank.

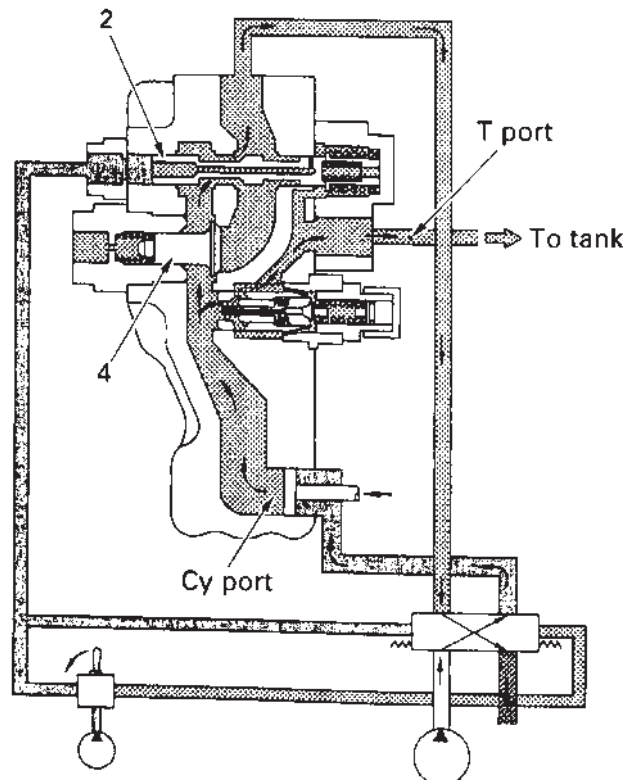

**When hose burst occurs
(Operation to lower safety)**

- The sudden loss of pressure at port **V** will cause check valve (4) to re-seat and so the valve is locked.
- The boom can be lowered in a controlled way by operating the wrist control in the normal way.

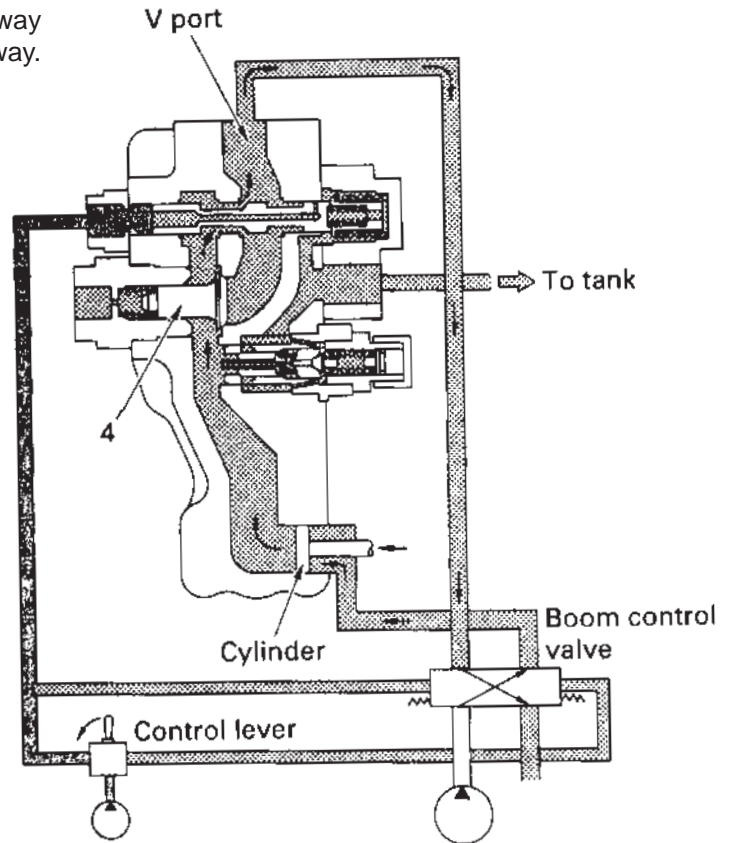

WORK EQUIPMENT

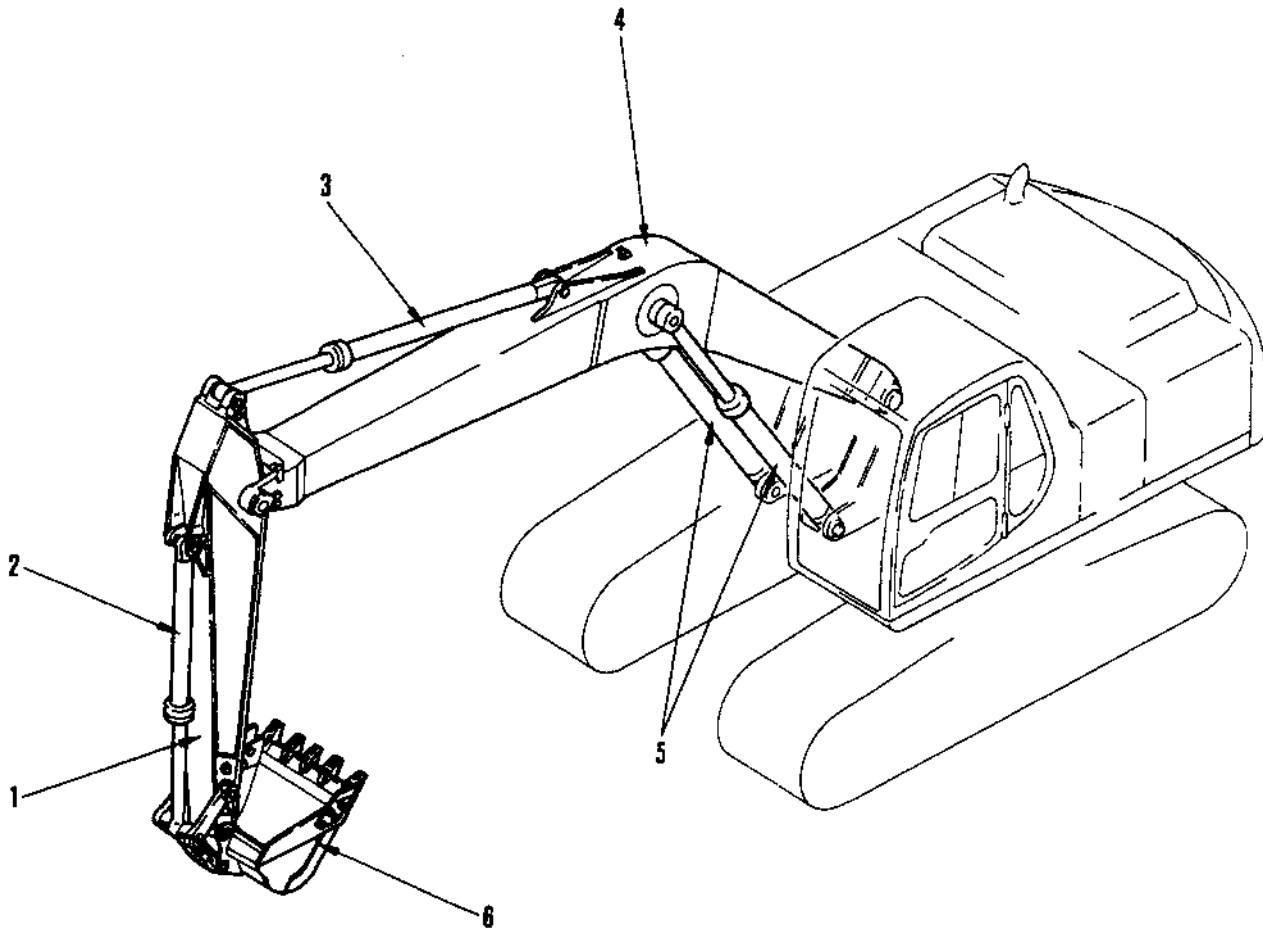

X17ZZ023

1. Arm
2. Bucket cylinder
3. Arm cylinder
4. Boom
5. Boom cylinder
6. Bucket

ENGINE CONTROL SYSTEM

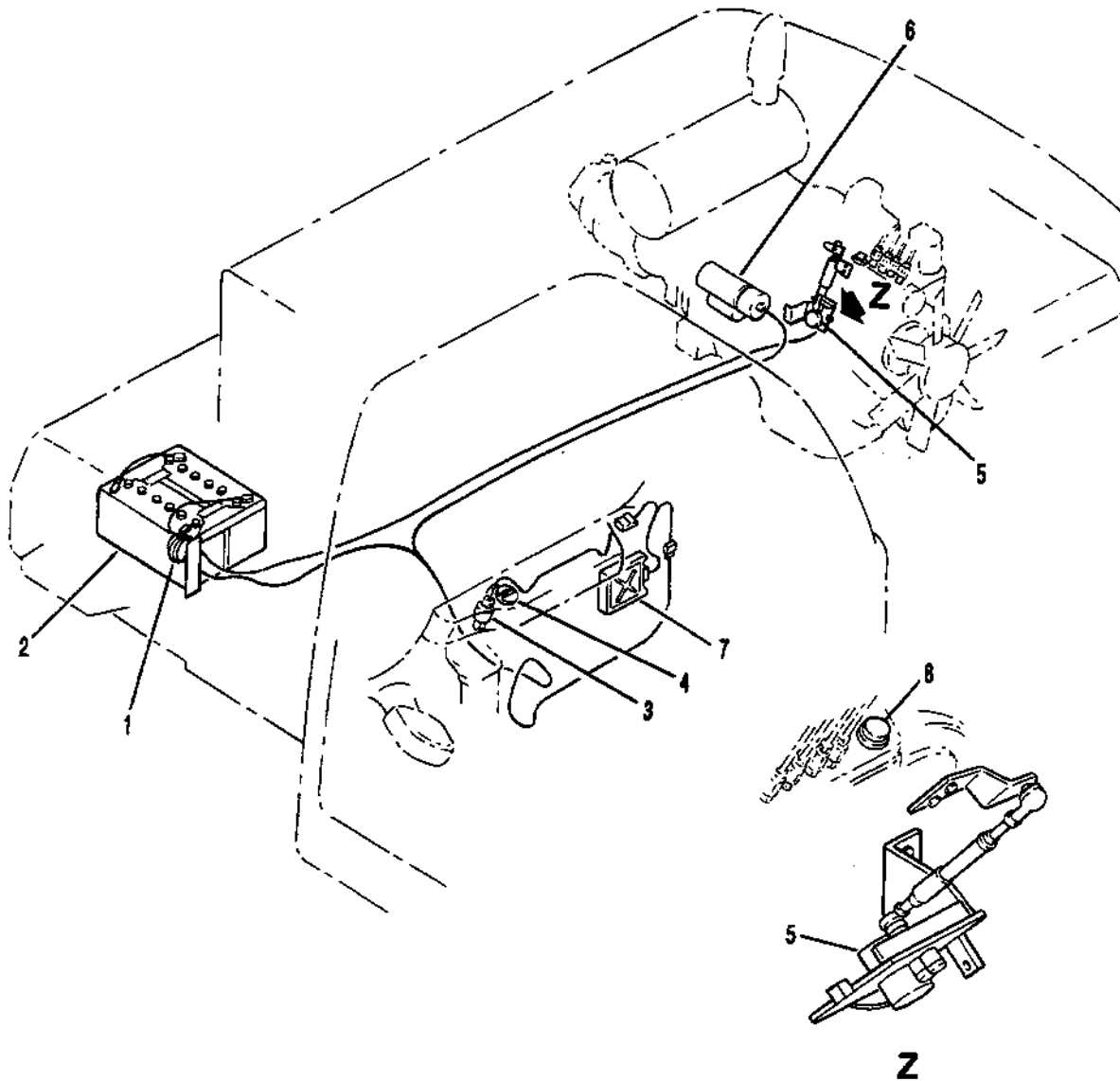

X12BV121

1. Battery relay
2. Battery
3. Starting switch
4. Fuel control dial
5. Governor motor
6. Starting motor
7. Engine throttle • pump controller
8. Fuel injection pump

Function

- The engine can be started and stopped simply by using the starting switch.
- A dial type engine control is used to control the engine speed. The engine throttle • pump controller receives the control signal from the fuel control dial, sends a drive signal to the governor motor, and controls the angle of the governor lever in the fuel injection pump.
- At the same time, the engine throttle • pump controller also receives signals from other controllers to control the engine speed.

Operating of system

1. Starting engine

- a. When the starting switch is turned to the START position, the starting flows to the starting motor, and the starting motor turns to start the engine. Power also flows to the fuel shut-off solenoid, exciting the solenoid and allowing fuel to flow into the engine.
- b. When this happens, the engine throttle • pump controller checks the signal from the fuel control dial and sets the engine speed to the speed set by the fuel control dial.

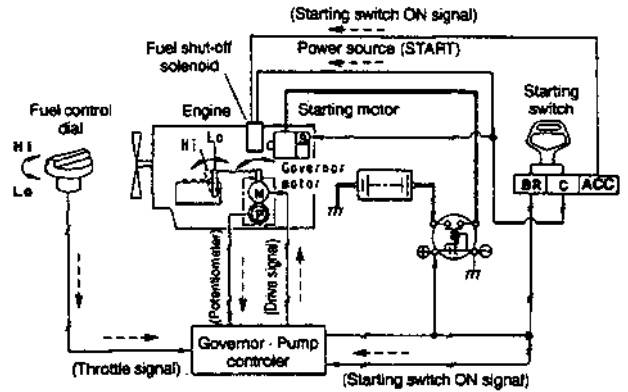

X12BV122

2. Engine speed control

- a. The fuel control dial sends a signal to the engine throttle • pump controller according to the position of the dial. The engine throttle • pump controller calculates the angle of the governor motor according to this signal, and sends a signal to drive the governor motor so it is at that angle.
- b. When this happens, the operating angle of the governor motor is detected by the potentiometer, and the feedback is sent to the engine throttle • pump controller, so that it can observe the operation of the governor motor.

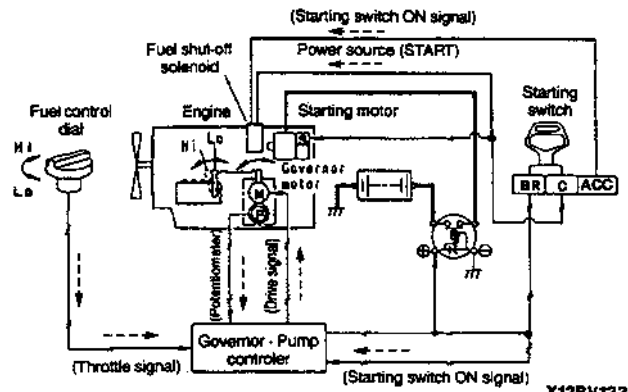

X12BV123

3. Stopping engine

- a. When the starting switch is turned to the OFF position, the engine throttle • pump controller drives the governor motor to the low idle position. The fuel shut-off solenoid is de-energized when starting switch signal is turned OFF, so the supply of fuel to the engine is shut off and the engine stops.
- b. When this happens, to maintain the electric power in the system until the engine stops completely, the engine throttle • pump controller itself drives the battery relay.

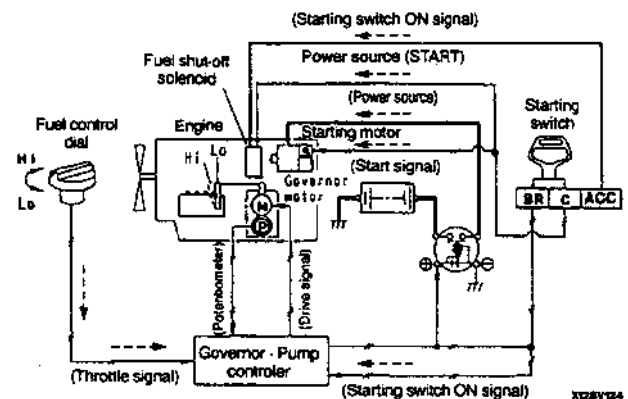

X12BV124

Components of system

Fuel control dial

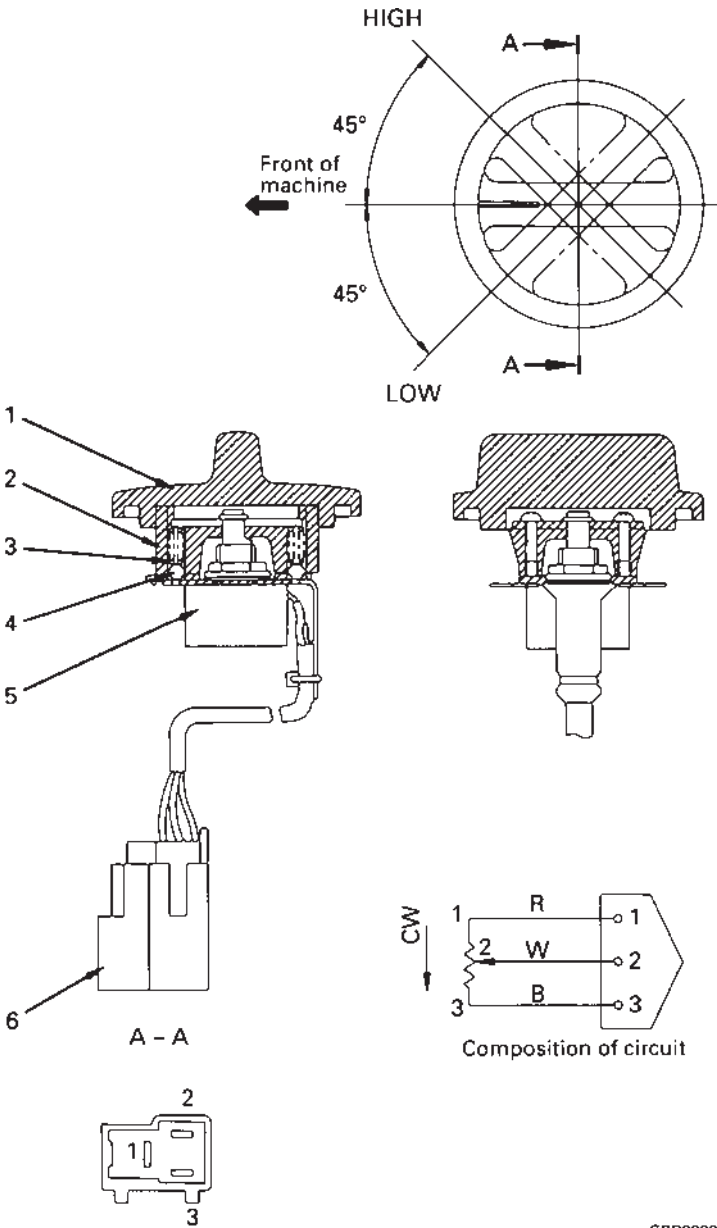

1. Knob
2. Dial
3. Spring
4. Ball
5. Potentiometer
6. Connector

SBP00324

Function

- The fuel control dial is installed at the bottom of the monitor panel. A potentiometer is installed under the knob, and when the knob is turned, it rotates the potentiometer shaft
- When the shaft rotates, the resistance of the variable resistor inside the potentiometer changes, and the desired throttle signal is sent to the engine throttle • pump controller.
- The shaded area in the graph on the right is the abnormality detection area and the engine speed is set at low idling.

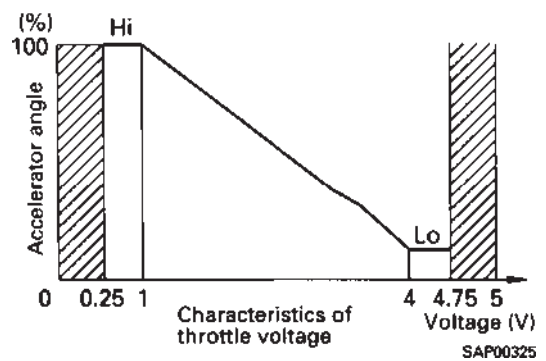

SAP00325

Governor motor

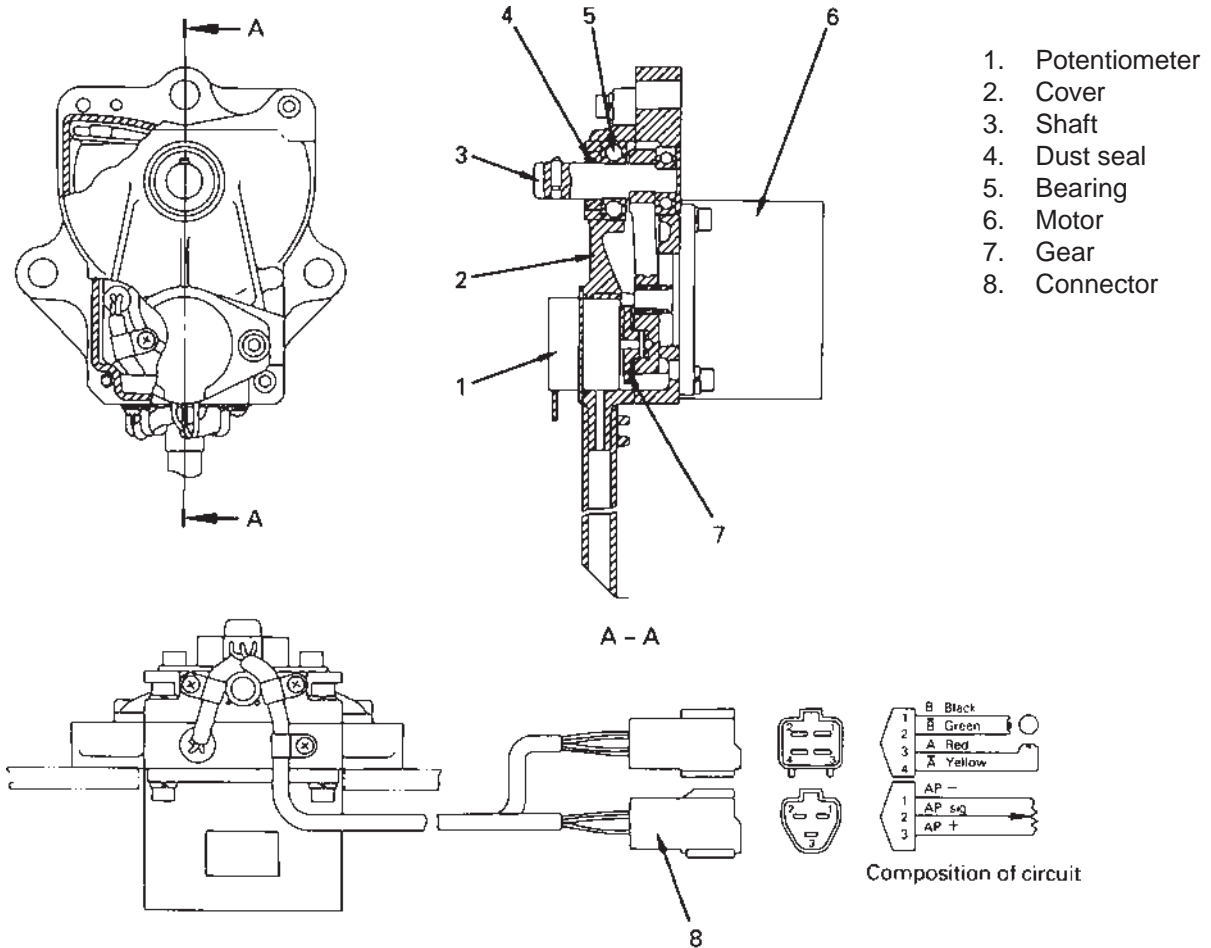

SBP00326

Function

- The motor is rotated and the governor lever of the fuel injection pump is controlled by the drive signal from the engine throttle • pump controller.
- A stepping motor is used for the motor which provides the motive power. In addition, a potentiometer for giving feedback is installed to allow observation of the operation of the motor.
- The rotation of the motor is transmitted to the potentiometer through a gear.

Operation

1. Motor stationary
 Both A phase and B phase of the motor are continuous, and a holding torque is generated in the motor.
2. Motor rotating
 A pulse current is applied to the A phase and B phase from the engine throttle • pump controller to give synchronous rotation with the pulse.

Engine throttle • pump controller

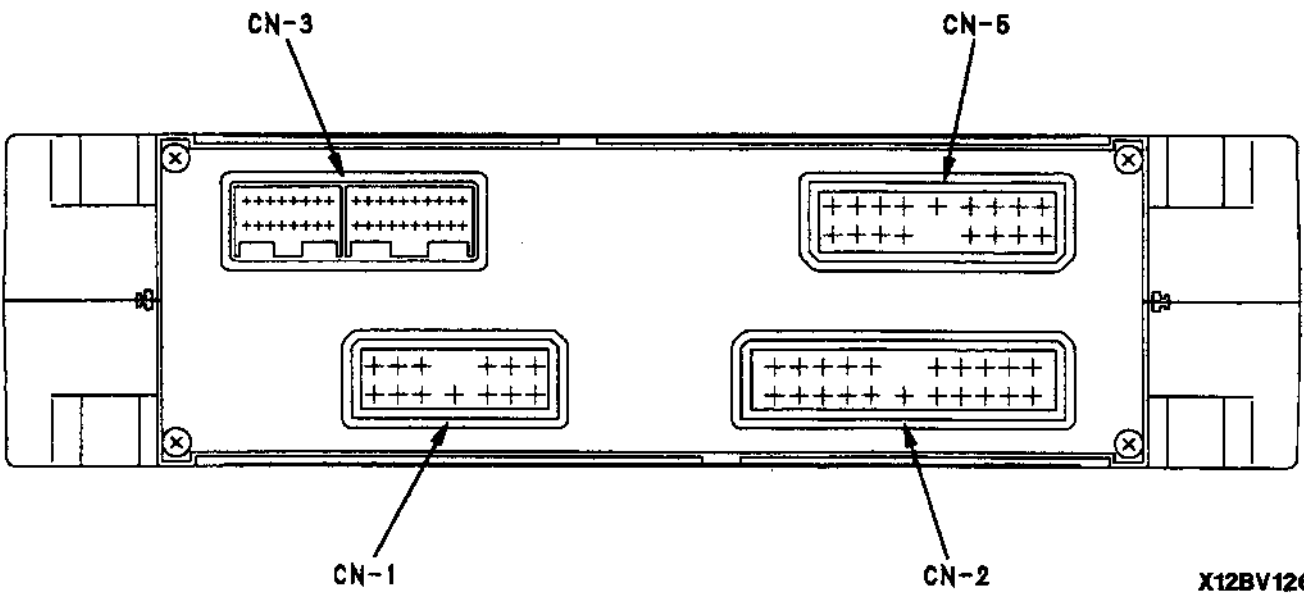
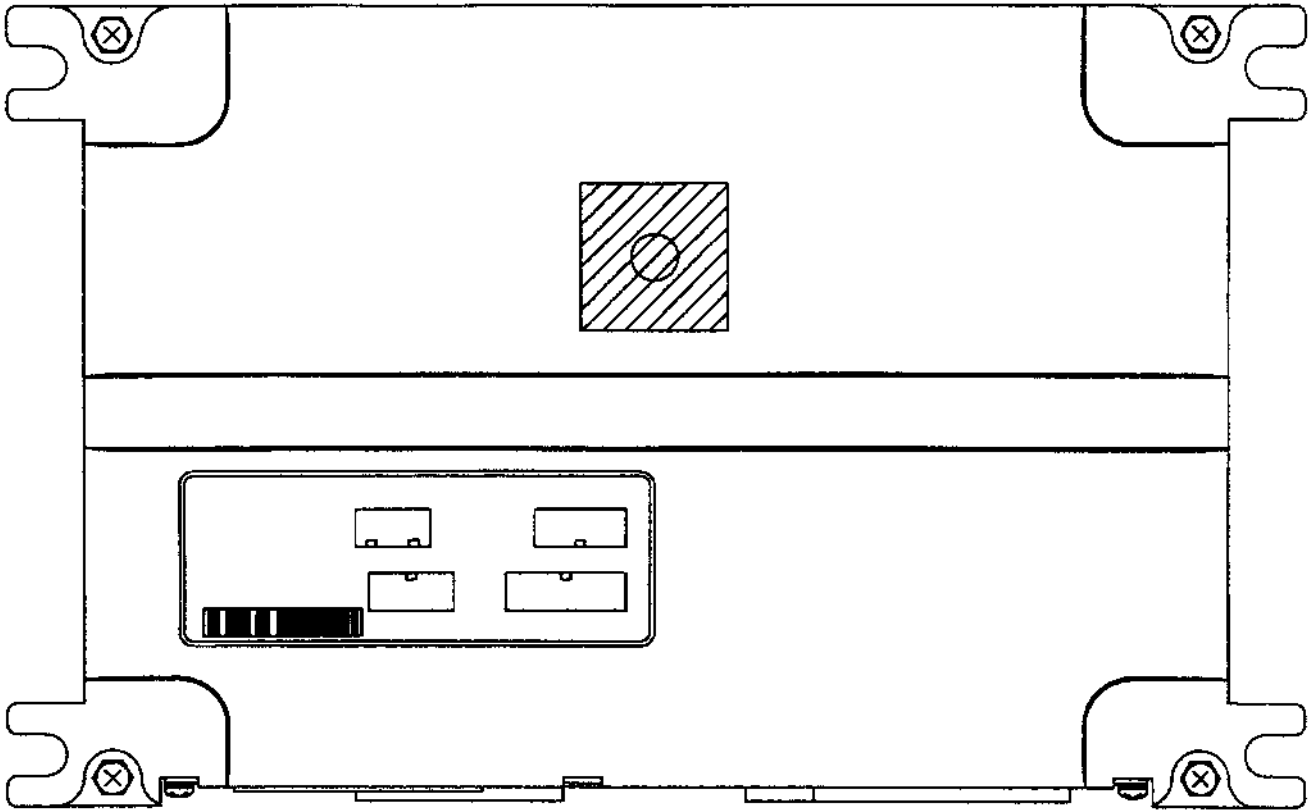

Input and output signals

CN-1

Pin. No.	Name of signal	Input/output
1	Battery relay drive output	Output
2	Pump merge/divider solenoid	Output
3	Swing holding brake solenoid	Output
4	NC	-
5	NC	-
6	GND	Input
7	Power source (+24V)	Input
8	Active mode solenoid	Output
9	Travel selector solenoid	Output
10	2-stage relief solenoid	
11	NC	
12	GND	Input
13	Power source (-24V)	Input

CN-2

Pin. No.	Name of signal	Input/output
1	Solenoid power source (+24V)	Input
2	Governor motor phase A (+)	Output
3	Governor motor phase A (-)	Output
4	Governor motor phase B (+)	Output
5	Governor motor phase B (-)	Output
6	NC	-
7	LS-EPC solenoid (+)	Output
8	PC-EPC solenoid (+)	Output
9	NC	Output
10	NC	-
11	PGND	Input
12	Solenoid power source (+24V)	Input
13	NC	-
14	NC	-
15	NC	-
16	NC	-
17	LS-EPC solenoid (-)	Output
18	PC-EPC solenoid (-)	Output
19	NC	-
20	NC	-
21	PGND	Input

CN-3

Pin. No.	Name of signal	Input/output
1	Engine water temperature sensor	Input
2	Fuel level sensor	Input
3	Pump F pressure input	Input
4	Throttle potentiometer input	Input
5	Overload caution	Input
6	Pressure sensor power source (+24V)	Output
7	Potentiometer power source (+5V)	Output
8	Starting switch (ACC)	Input
9	Knob switch	Input
10	NC	-
11	NC	-
12	Battery charge (alternator terminal R)	Input
13	Pump R pressure input	Input
14	Feedback potentiometer input	-
15	NC	Input
16	Pressure sensor GND	Input
17	Potentiometer GND	Input
18	Starting switch (terminal C)	Input
19	Auto grene up	Input
20	NC	-
21	PPC pressure	Input
22	Boom RAISE pressure switch	Input
23	Arm IN pressure switch	Input
24	S-NET(+)	Both
25	Model selection 1	Input
26	Model selection 3	Input
27	Model selection 5	Input
28	Swing prolix switch	Input
29	NC	-
30	Boom LOWER pressure switch	Input
31	Arm OUT pressure switch	Input
32	S-NET(+)	Both
33	Model selection 2	Input
34	Model selection 4	Input
35	NC	-
36	Swing lock switch	Input

CN-5

Pin. No.	Name of signal	Input/output
1	Engine speed sensor GND	Input
2	Engine speed sensor	Input
3	GND	Input
4	GND	Input
5	Swing pressure switch	Input
6	Service valve pressure switch	Input
7	NC	-
8	Radiator water level sensor	Input
9	Hydraulic oil level sensor	Input
10	Engine speed sensor GND	Input
11	Bucket CURL pressure switch	Input
12	Bucket DUMP pressure switch	Input
13	Travel pressure switch	Input
14	NC	-
15	Engine oil pressure sensor (Low)	Input
16	Engine oil level sensor	Input
17	Air cleaner clogging sensor	Input

ELECTRONIC CONTROL SYSTEM

CONTROL FUNCTION

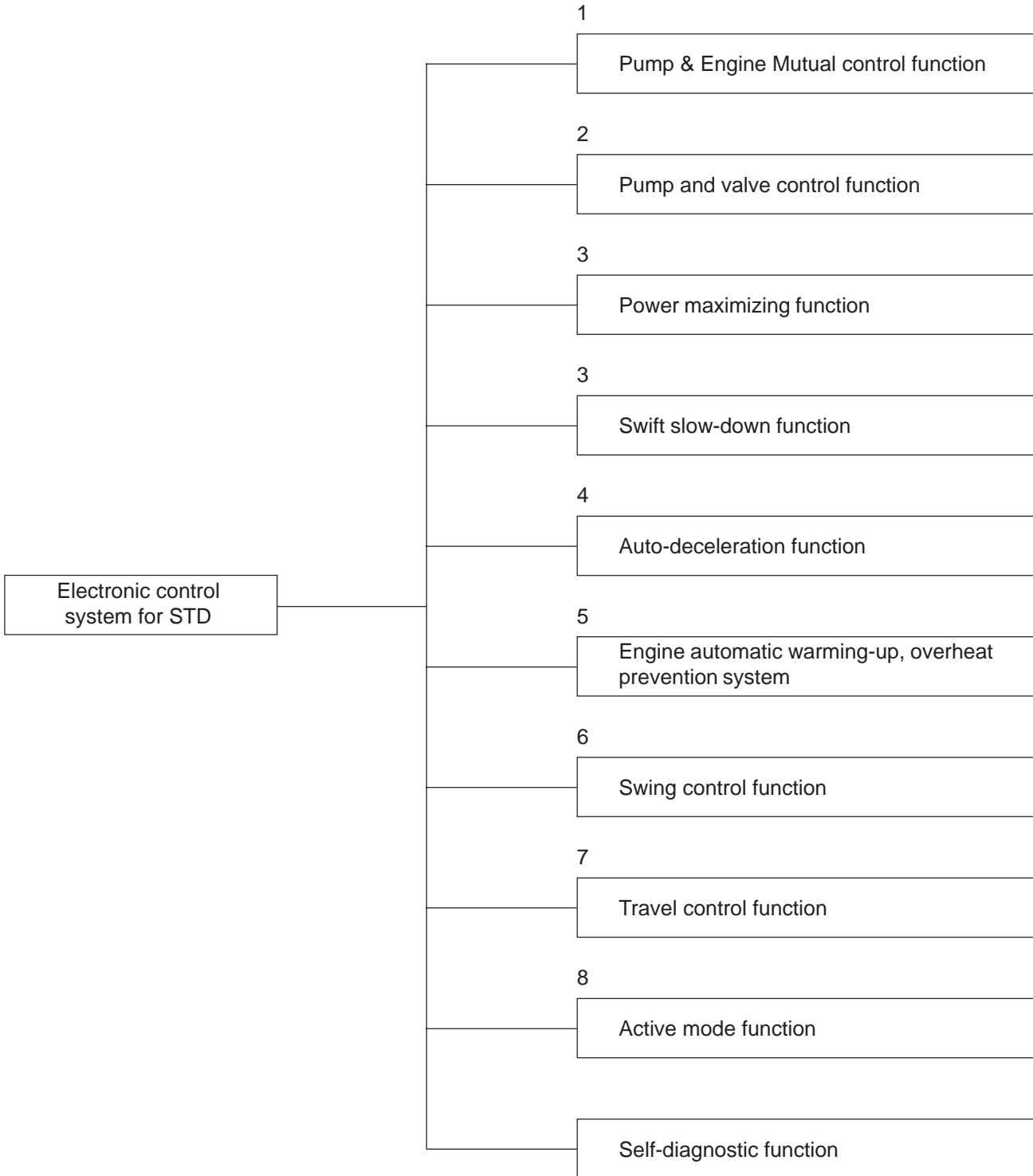

★ For details of the self-diagnostic function, see TROUBLESHOOTING

Pump and engine mutual control function

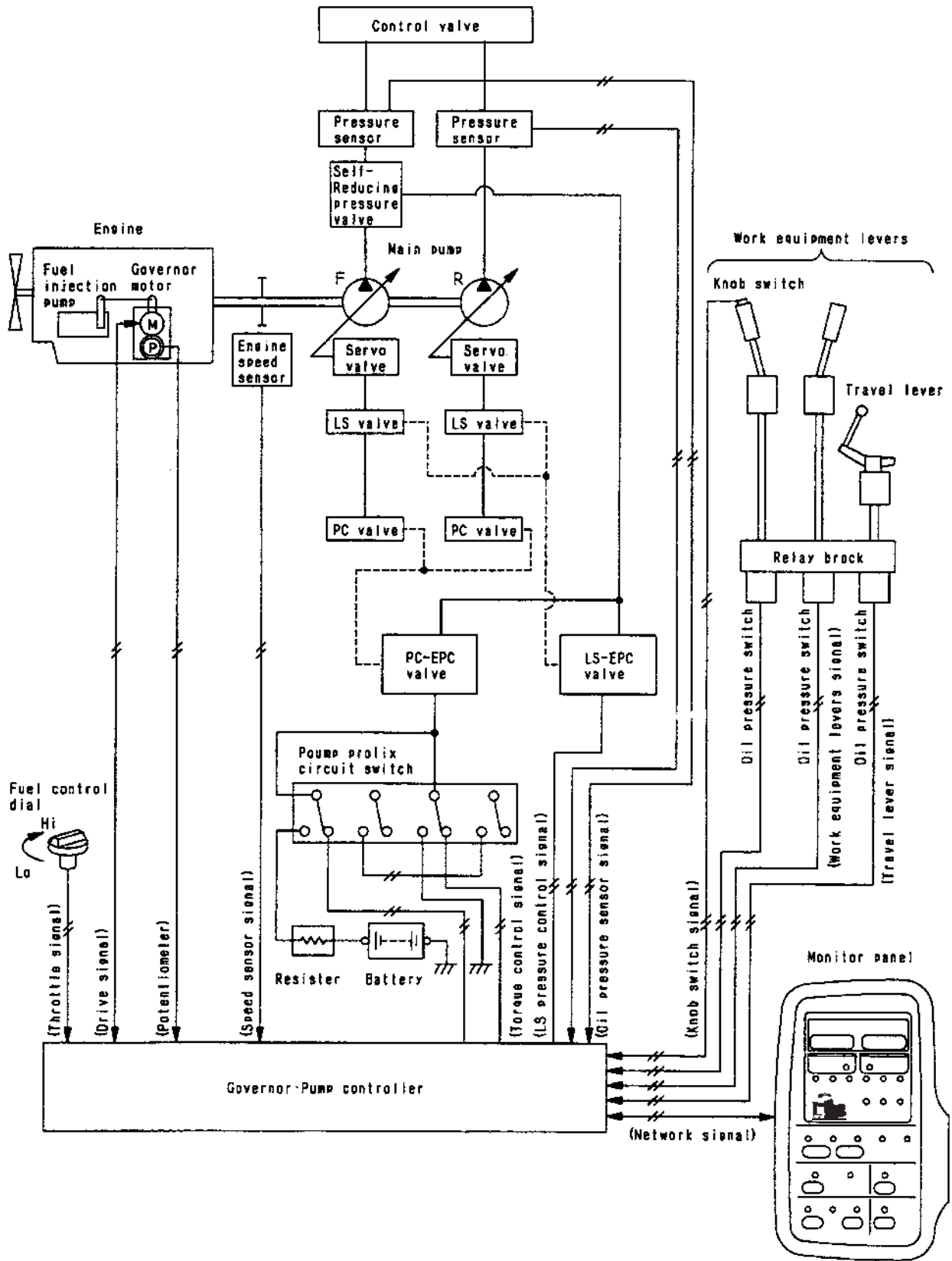

X08DD179

Function

- There are five modes available for selection with the working mode switch on the monitor panel. These modes are the heavy-duty operation (H/O) mode, general operation (G/O) mode, finishing operation (F/O) mode, lifting operation (L/O) mode, and the breaker operation (B/O) mode. It is possible to select the most suitable engine torque and pump absorption torque to match the nature of the work.
- The engine throttle • pump controller detects the actual engine speed and the speed set by the engine governor through the fuel control dial in accordance with the pump absorption torque set for each mode, and carries out control so that the pump absorbs all of the torque at each output point of the engine.

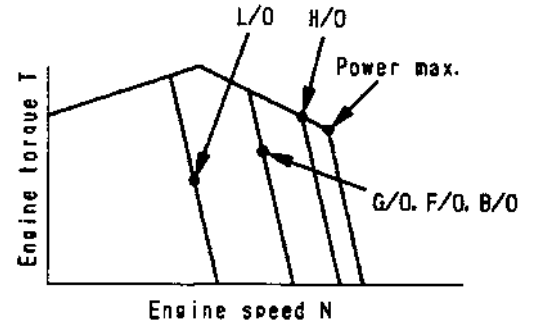

X08DD180

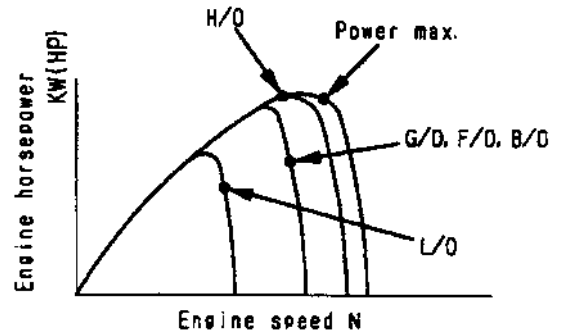

X08DD181

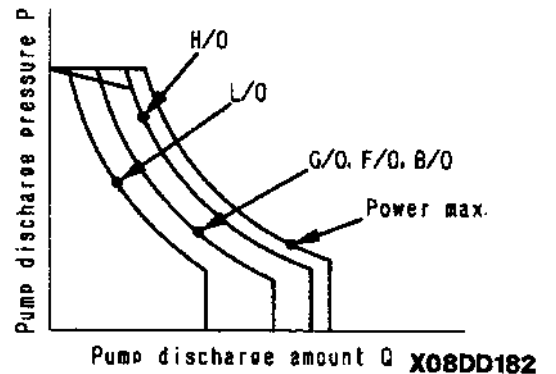

X08DD182

Control method in each mode

Heavy-duty operation (H/O) mode

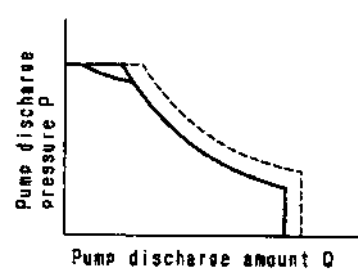
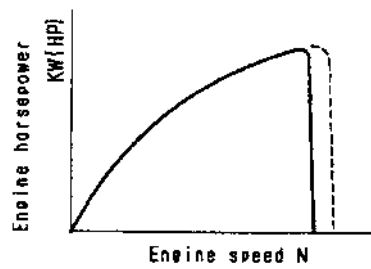
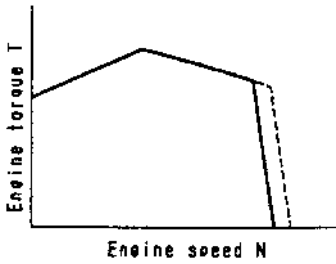

X08DD183

- Matching point in heavy-duty operation mode: 95% partial output point

Model	PC290LC-6k	PC290NLC-6k
Mode		
Heavy-duty operation (H/O)	123 kW/2100 rpm 165 HP/2100 rpm	123 kW/2100 rpm 165 HP/2100 rpm

- When the load on the pump rises and the pressure rises, the engine speed goes down. When this happens, the pump discharge amount is reduced, and the engine speed is controlled so that it becomes near the 95% partial output point. If the reverse happens and the pressure goes down, the system is controlled so that the pump discharge amount is increased until the engine speed becomes near the 95% partial output point. By repeating this control, the engine can always be used at near the 95% partial output point.

General operation (G/O), finishing operation (F/O), and breaker operation (B/O) mode

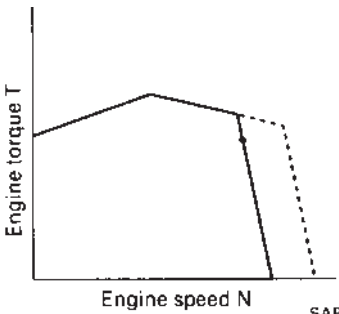

SAP00336

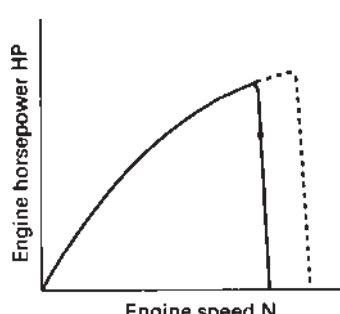

SAP00337

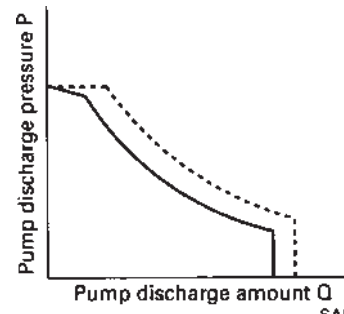

SAP00338

- Matching point in general operation, finishing operation, and breaker operation mode: 80% partial output point

Model	PC290LC-6k	PC290NLC-6k
Mode		
General operation (G/O), finishing operation (F/O), breaker operation (B/O)	103 kW/1920 rpm 132 HP/1920 rpm	103 kW/1920 rpm 132 HP/1920 rpm

- When the load on the pump rises and the pressure rises, the engine speed goes down. When this happens, mutual control of the engine and pump is used to control the system so that the pump absorption torque follows the equal horsepower curve of the engine, and the engine speed is lowered while keeping the torque constant. In this way, the engine is used in a range which provides good fuel efficiency.

Lifting operation (L/O) mode

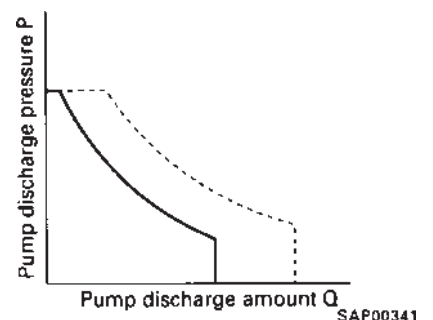
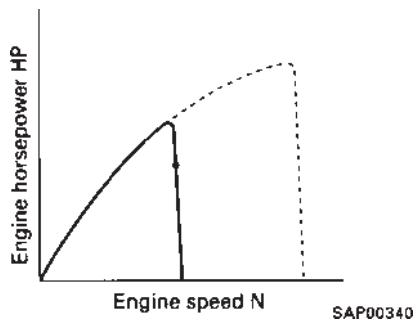
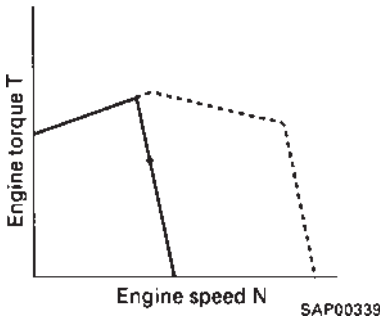

- Matching point in lifting operation mode: 62% partial output point

- When the lifting operation mode is selected, the engine speed is automatically lowered to the partial position. In this condition, control is carried out in the same way as for the general operation, finishing operation, and breaker operation modes to match the load on the pump. In this way, the fuel consumption is reduced and the fine control ability is improved.

Model	PC290LC-6k	PC290NLC-6k
Mode		
Lifting operation (L/O)	81 kW/1570 rpm 108 HP/1570 rpm	81 kW/1570 rpm 108 HP/1570 rpm

Power maximizing mode

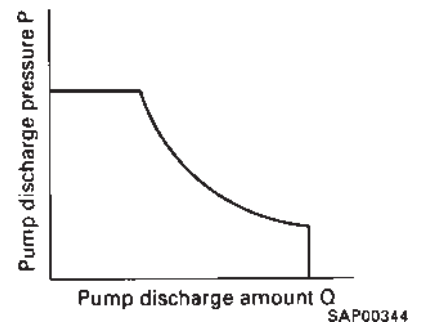
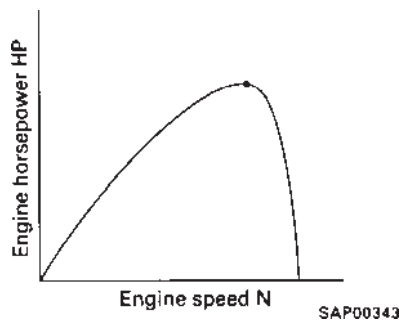
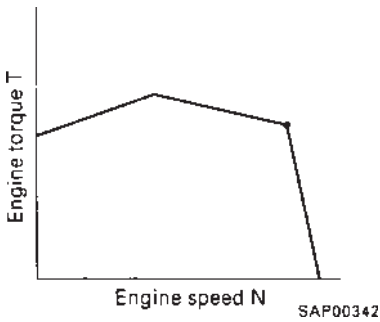

- Matching point in power max. mode: Rated output point

- When the pump load increases, the engine speed drops. When this happens, the pump discharge is reduced to prevent the engine speed from going down and to ensure that the engine is used at near the rated output point.

Model	PC290LC-6k	PC290NLC-6k
Mode		
POWER MAX.	130 kW/2200 rpm 174 HP/2200 rpm	130 kW/2200 rpm 174 HP/2200 rpm

Pump control function when traveling

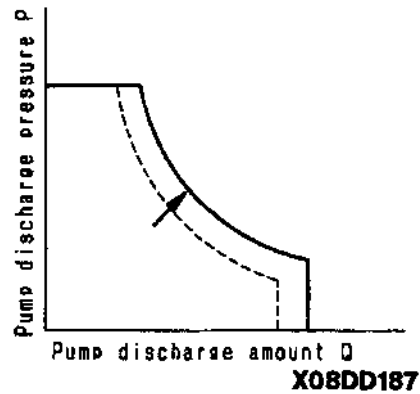
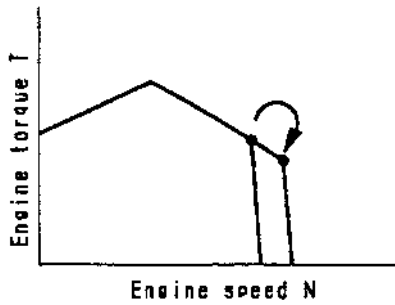

- When the machine travels in the heavy-duty operation (H/O) mode, the engine speed rises, and the pump is controlled in the same way as when in the power maximizing mode.

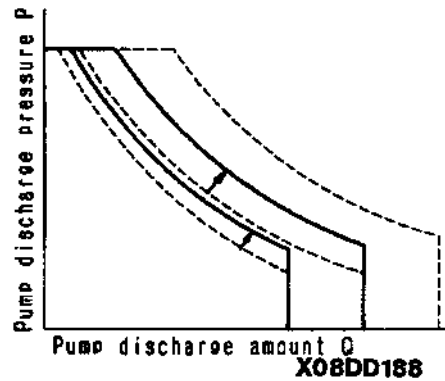
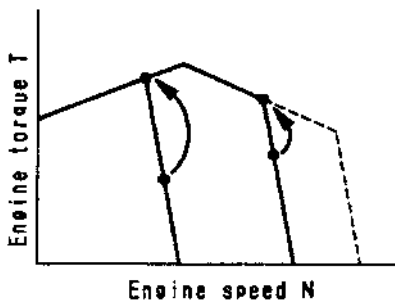

- When the machine travels in any mode other than the heavy-duty operation (H/O) mode, the working mode and the engine speed are kept as they are, and the pump absorption torque is increased.

Control function when pump prolix switch is ON

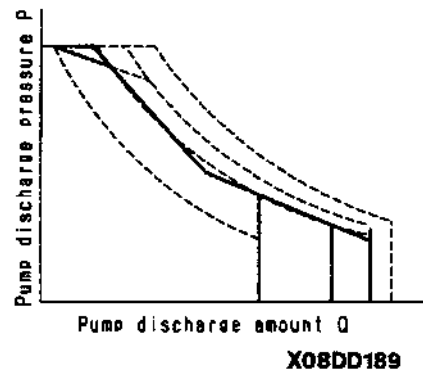
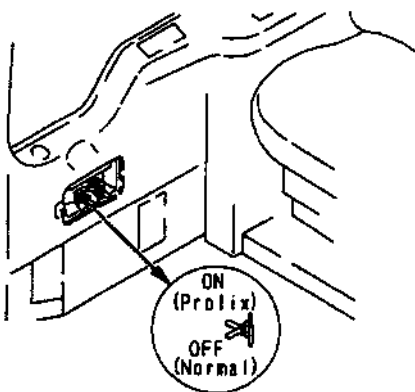

- Even if any abnormality should occur in the controller or sensor, the pump prolix switch can be turned ON to provide an absorption torque more or less equivalent to the general operation (G/O) mode, thereby allowing the machine to maintain its functions.
- In this case, it is designed to allow a constant current to flow from the battery to the PC-EPC valve, so oil pressure sensing is carried out only by the PC valve.

Pump and valve control function

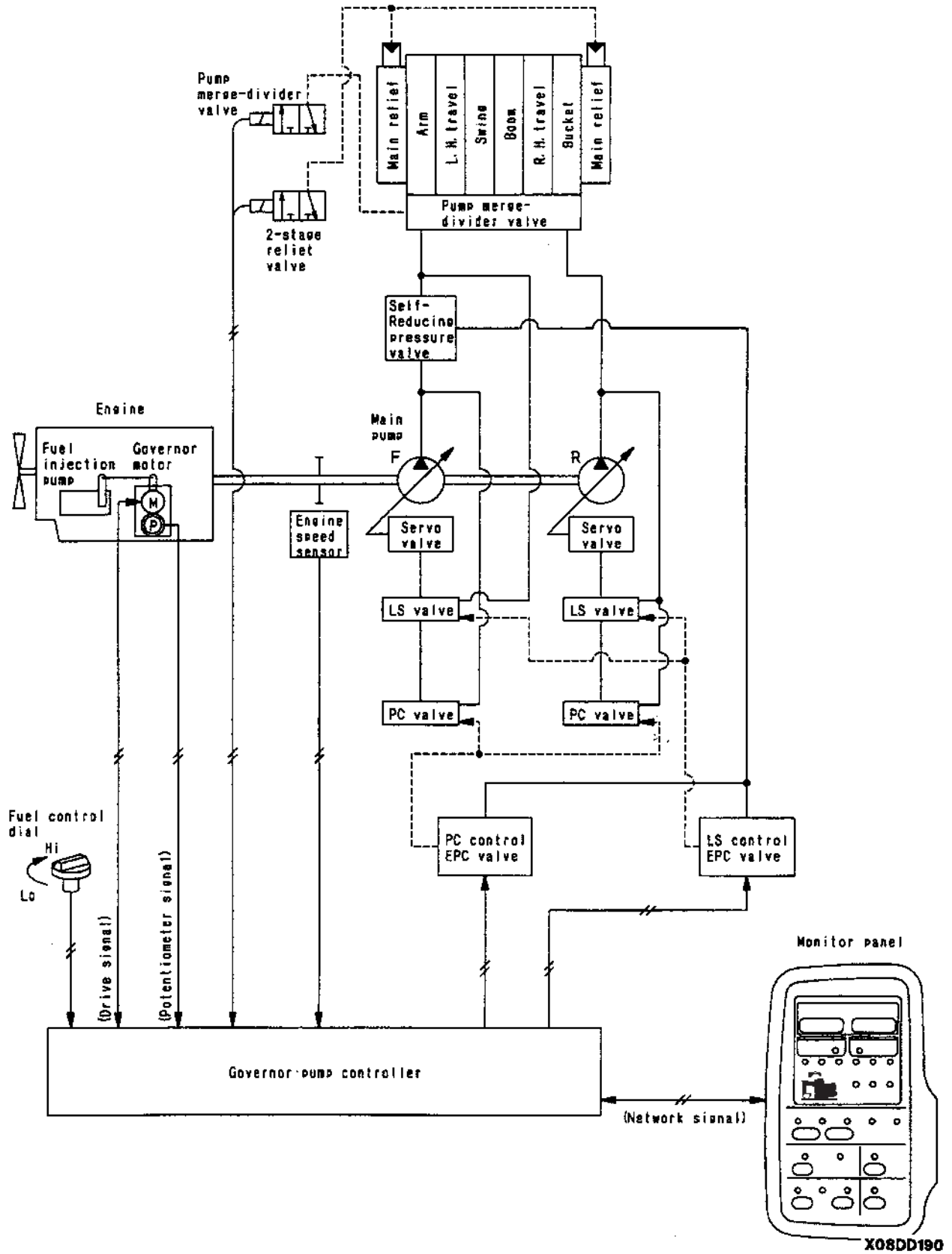

Function

- The following two functions are available to provide the optimum matching under various working conditions: a 2-stage relief function which increases the digging power, and a fine control mode function which improves the ease of fine control.

LS control function

- The switching point (LS set differential pressure) for the pump discharge amount inside the LS valve is changed by changing the output pressure from the LS control EPC valve to the LS valve according to the engine speed and operating condition of the actuator.
- Because of this, the timing for starting the discharge amount from the pump can be optimized, to give excellent ease of compound operation and fine control.

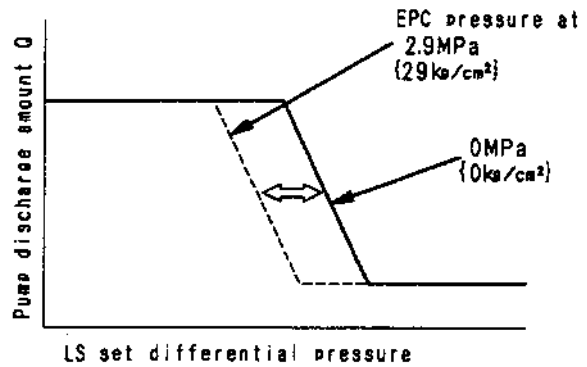

X08DD191

Cut-off function

For details of the operation, see CLSS.

- When the cut-off function is actuated, the PC-EPC current is increased to near the maximum value. In this way, the flow at relief is made smaller and the fuel consumption is reduced.
- Actuation conditions for cut-off function. When the front or rear pressure sensor is above 30.9 MPa (315 kg/cm²) and the power max. or quick slow-down functions are not being actuated.

Note: When traveling or when using the lifting operation mode, the cut-off is not actuated.

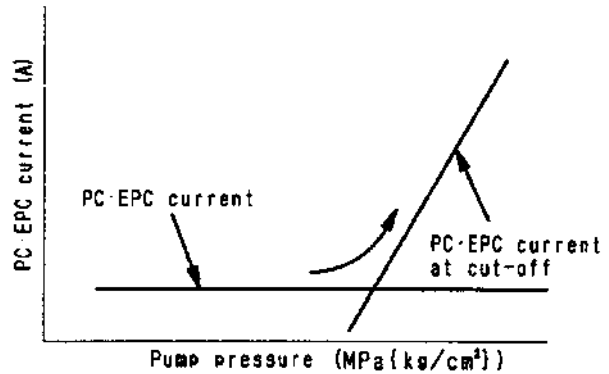

X08DD192

2-stage relief function

- The relief pressure for normal operations is 31.85 MPa (325 kg/cm²), but when the 2-stage relief function is actuated, the relief pressure rises to approximately 34.79 MPa (355 kg/cm²). Because of this, the hydraulic pressure is increased by one stage.
- Actuating conditions for 2-stage relief function

Conditions	Relief pressure
<ul style="list-style-type: none"> • When traveling • When swing lock switch is On • In lifting operation (L/O) mode • When power max. function or swift slow-down function are actuated 	<p>31.85 MPa (325 kg/cm²)</p> <p>34.79 MPa (355 kg/cm²)</p>

Fine control mode function

- When the finished operation (F/O) mode is selected from the working mode, the pump LS valve is controlled, and the pump discharge amount is reduced to improve the ease of fine control and the precision when finishing.
- Relationship between working mode and pump discharge amount (for independent operation)

Actuator Mode	Boom		Arm		Bucket	Swing	Swing
	RAISE	LOWER	IN	OUT			
Heavy-duty operation (H/O) General operation (G/O)	100	40	100	100	50	50	–
Finishing operation (F/O)	100 <50>	40	50	100	50	50	–
Lifting operation (L/O)	50		50	50	35	35	–
Breaker operation (B/O)	100	40	100	100	50	50	60

- ★ The figures in < > are for when arm IN is operated.
- ★ In each working mode, the full flow of the pump at the set engine speed is taken as 100%.

Power maximizing • Swift slow-down function

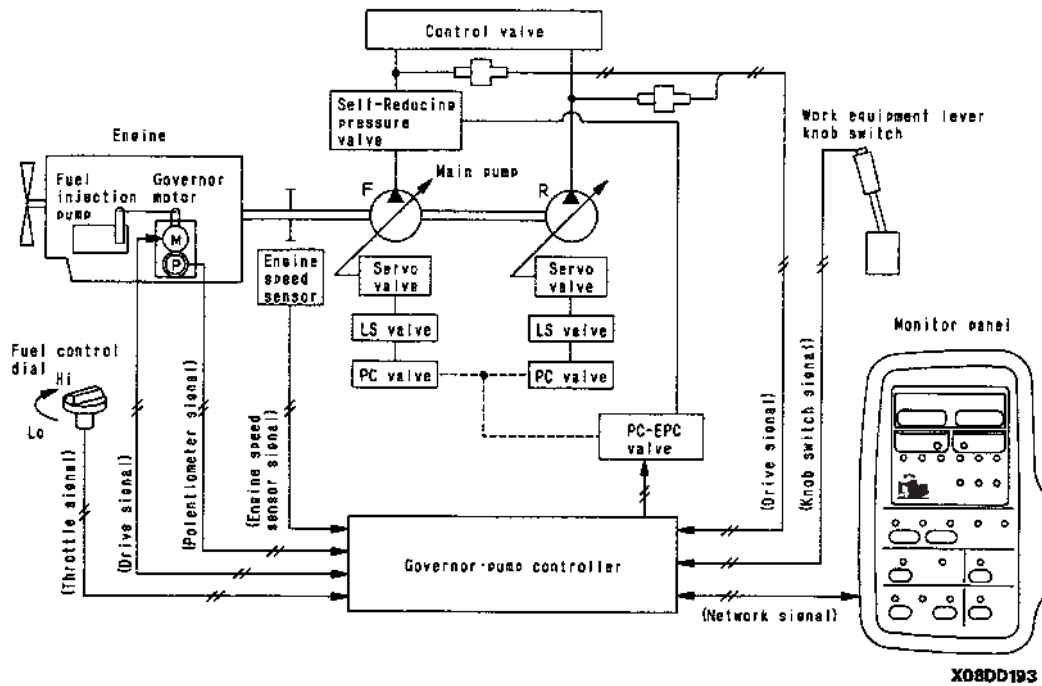

Function

- lifting operation (L/O) and reduces the speed. It is operated using the L.H. knob switch to momentarily match the operating conditions.
- The power max. function and the swift slow-down function are operated with the same switch. Only one of these functions can be selected at any time; they cannot both be operated together.

Power maximizing function

- During digging operations, when that extra bit of digging power is needed (for example, when digging up boulders), the L.H. knob switch can be pressed to raise the hydraulic pressure by approximately 10% and increase the digging force.
If the L.H. knob switch is pressed ON when the working mode is H/O or G/O, each function is automatically set as follows.

Working mode	Engine pump control	2-stage relief function	Actuating time
Heavy-duty operation	Matching at rated output point	Actuated 31.9 MPa → 34.8 MPa (325 → 355 kg/cm ²)	Automatically cancelled after 8.5 sec.

Swift slow-down function

- During normal operations, if it is desired to carry out lifting operations or finishing operations for a moment, the working mode can be switched to lifting operation (L/O) mode by operating the L.H. knob switch.
- If the L.H. knob switch is pressed ON when the working mode is at H/O or G/O, each function is automatically set as follows.

Working mode	Actuating time
Lifting operation	While switch is kept pressed

Auto-deceleration function

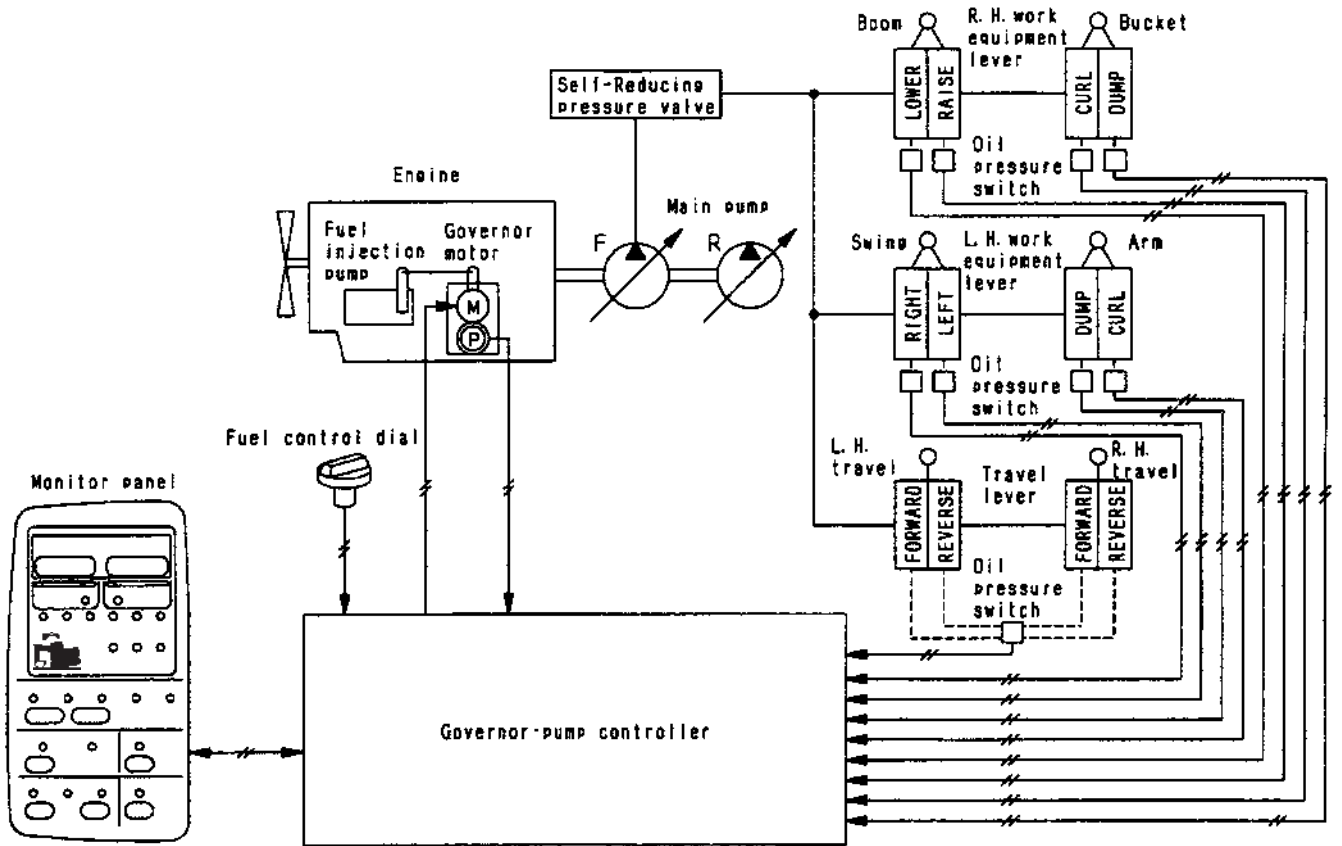

X08DD194

Function

- If all the control levers are at neutral when waiting for work or waiting for a dump truck, the engine speed is automatically reduced to a mid-range speed to reduce fuel consumption and noise.
- If any lever is operated, the engine speed returns immediately to the set speed.

Operation

- Control levers at neutral
 - If the engine is running at above the deceleration actuation speed (approximately 1400 rpm), and all the control levers are returned to neutral, the engine speed will drop immediately to approximately 100 rpm below the set to the No. 1 deceleration position.
 - If another 4 seconds pass, the engine speed is reduced to the No. 2 deceleration position (approximately 1400 rpm), and is kept at that speed until a lever is operated.
- When any control lever is operated
 - If any control lever is operated when the engine speed is at the No. 2 deceleration position, the engine speed will immediately rise to the speed set by the fuel control dial.

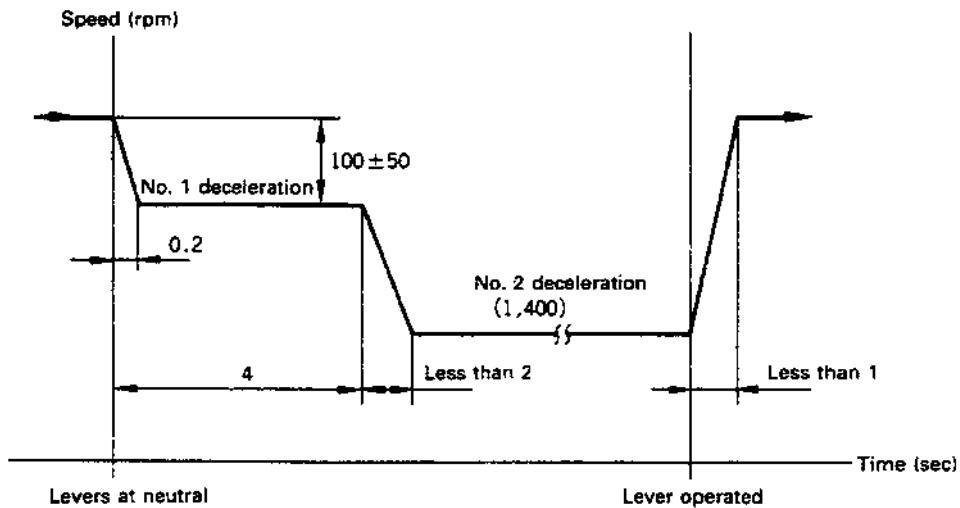

X12BV101

Automatic warming-up and engine overheating prevention function

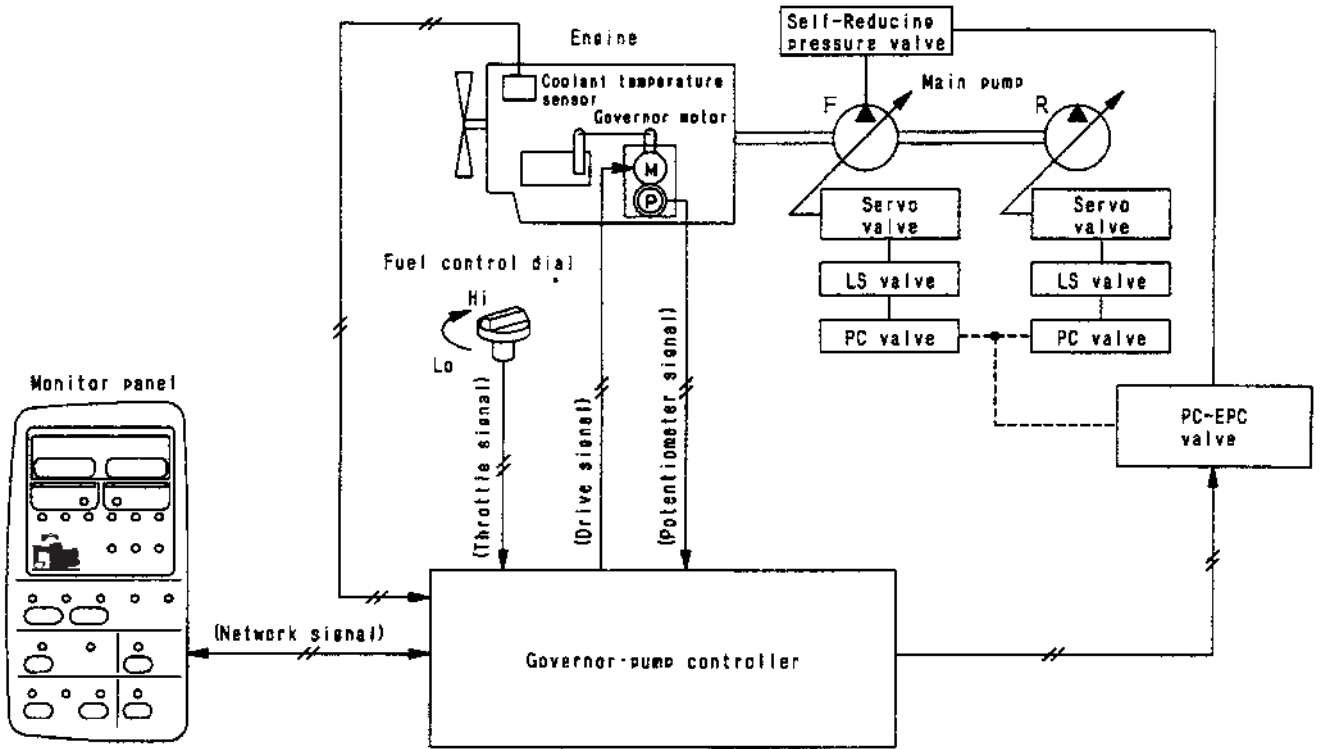

X06DD195

Function

- If the coolant temperature is low, this automatically raises the engine speed to warm up the engine after it is started. (Automatic warming-up function)
In addition, if the coolant temperature rises too high during operations, it reduces the load of the pump to prevent overheating. (Engine overheating prevention function)

Engine automatic warming-up function

- After the engine is started, if the engine coolant temperature is low, the engine speed is automatically raised to warm up the engine.

Conditions for actuation (both are necessary)	
Coolant temperature:	Less than 30°C
Engine speed:	Less than 1400 rpm

Actuation	
Engine speed: 1400 rpm	

Conditions for cancellation (any one)	
Automatic	Coolant temperature: 30°C or above
	Automatic warming-up time: 10 minutes or more
Manual	Fuel control dial: Held at more than than 3 seconds

Cancellation	
Engine speed: As desired	

Engine overheat prevention function

- This function protects the engine by lowering the pump load and engine speed to prevent the overheating when the engine coolant temperature has risen too high.
- This system is actuated in two stages. The first stage is when the coolant temperature is between 102°C and 105°C, and the second stage is when the coolant temperature is 105°C and above.

Normal operation (Coolant temperature below 102°C)

Normal operation	<p>Coolant temperature: Below 102°C</p> <p>Coolant temperature gauge: Green range</p>
-------------------------	---

Actuation condition

1st stage (Coolant temperature between 102°C and 105°C)

Actuation condition		Actuation condition		Cancel condition
1st stage	Coolant temperature: Between 102°C and 105°C Coolant temperature gauge: Red range	Working mode	81 kW (108 HP)	Coolant temperature: Below 102°C
		Heavy-duty, general, finishing, breaker		
			Lifting	Mode kept as it is, output reduced

2nd stage (Coolant temperature 105°C and above)

Actuation condition		Actuation condition		Cancel condition
2nd stage	Coolant temperature: 105°C and above Coolant temperature gauge: Red range	Working mode	In any mode	Coolant temperature: Below 102°C Fuel control dial: Return temporarily to low idling position
		Engine speed	Low idling	
		Monitor caution lamp	Lights up	<ul style="list-style-type: none"> • When the above conditions are met, the system return tot the condition before the overheat prevention function was actuated (manual reset)
		Caution buzzer	Sound	

7. Swing control system

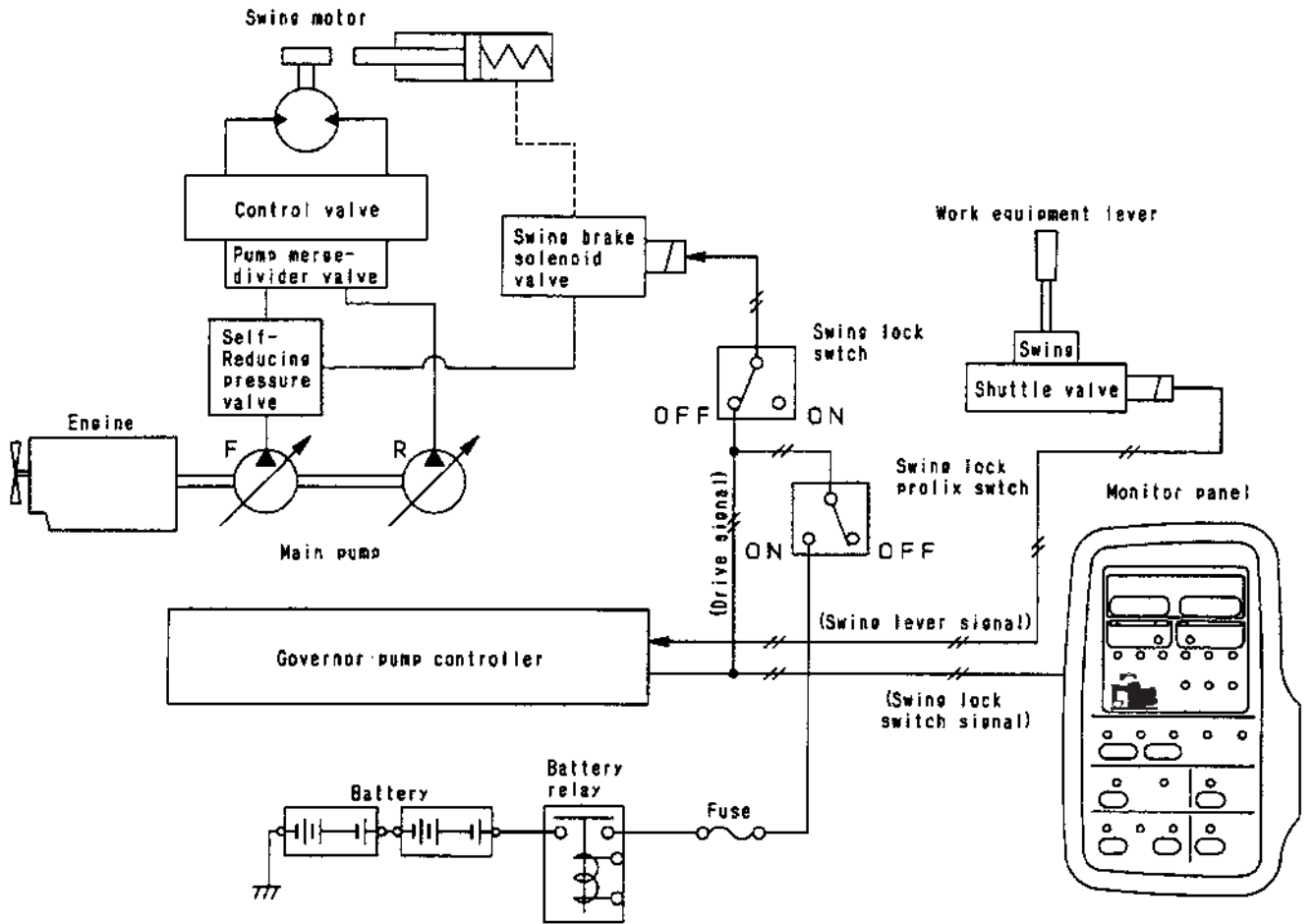

X08DD196

Function

- The system is provided with a swing lock and swing holding brake function

Swing lock, swing holding brake function

- The swing lock (manual) can be locked at any desired position, and the swing holding brake (automatic) is interconnected with the swing, so it prevents any hydraulic drift after the swing is stopped.

Lock switch	Lock lamp	Function	Operation
OFF	OFF	Swing holding brake	Approx 4 sec after swing lever is returned to neutral, swing brake is actuated. When swing lever is operated, brake is released and upper structure can swing freely.
ON	ON	Swing lock	Swing lock is actuated and swing is held in position. Even when swing lever is operated, swing lock is not cancelled and swing does not move.

Operation of swing lock prolix switch

- If any abnormality should occur in the controller, and the swing holding brake is not actuated normally and the swing cannot be operated to cancel the swing lock and allow the swing to be operated.
- Even when the swing lock prolix switch is turned ON, the swing lock swing lock switch stays ON and the swing brake is not cancelled.
- When the swing brake is cancelled, the swing has only a hydraulic brake operated by the safety valve, so if the swing is stopped on a slope, there may be hydraulic drift.

Swing lock prolix switch	On (When controller is abnormal)		OFF (when controller is normal)	
	ON	OFF	ON	OFF
Swing lock switch	Swing lock applied	Swing lock canceled	Swing lock applied	Swing holding brake applied

Hydraulic oil quick warm-up function when swing lock switch is ON

- When the swing lock switch is turned ON, the pump cut-off function is cancelled and the relief pressure rises from 31.85 MPa (325 kg/cm²) to 34.79 MPa (355 kg/cm²). In this condition, if the work equipment circuit is relieved, the hydraulic oil temperature rises more quickly and this makes it possible to reduce the warming-up time.
- Swing lock switch and swing lock, swing holding brake

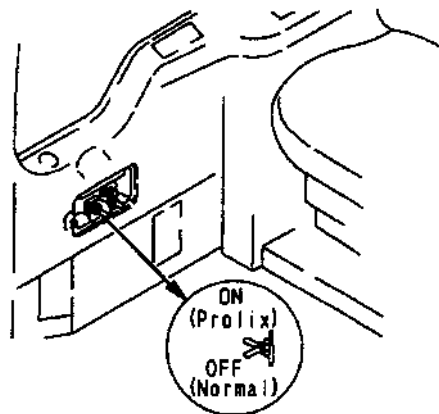

X10BV110

Travel control function

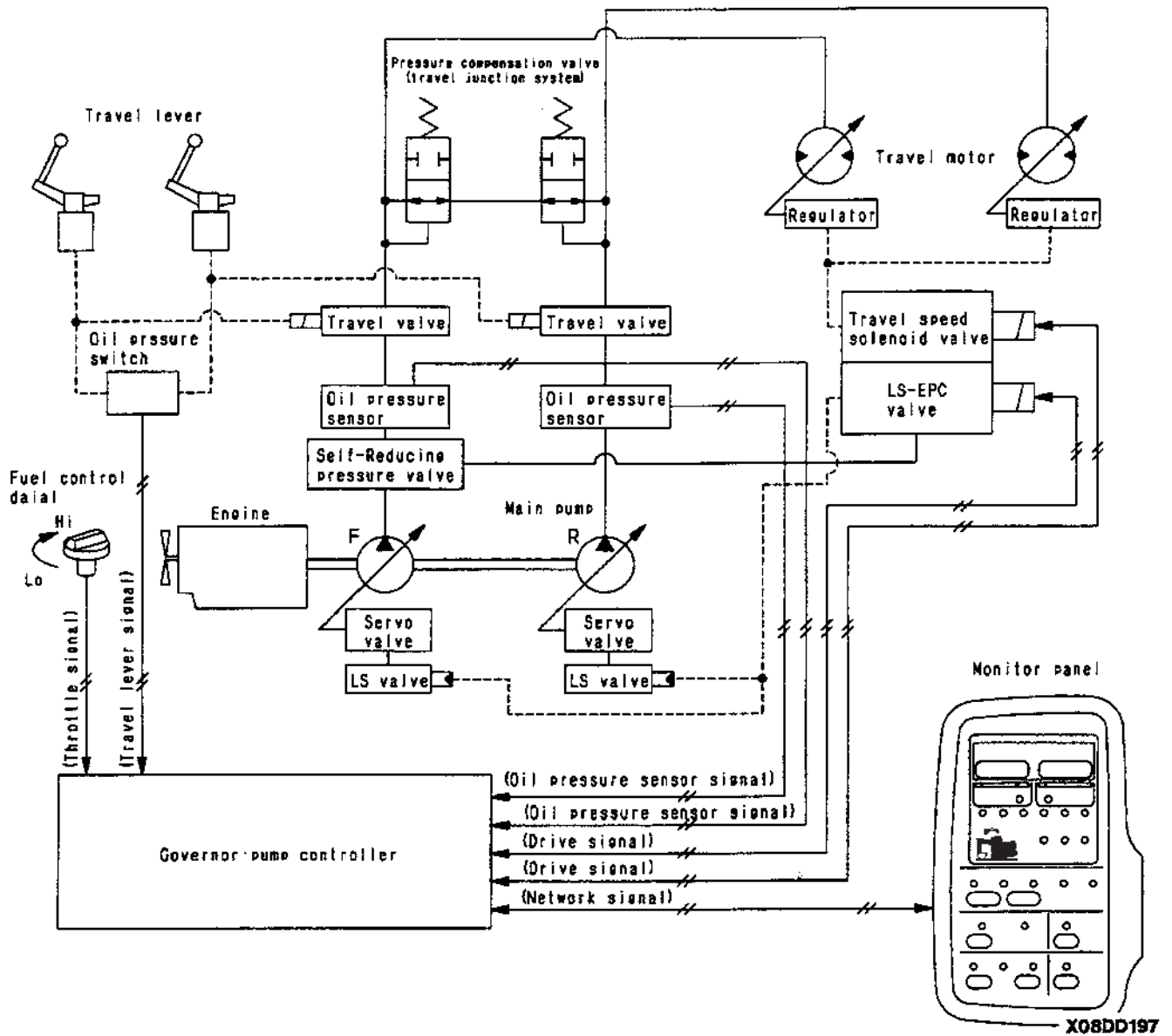

Function

- When travelling, the pump control is carried out, and the travel speed can be selected manually or automatically to give a travel performance that suits the nature of the work or the jobsite.

Pump control function when travelling

- If the travel is operated in any working mode other than the heavy-duty operation (H/O) mode, this increases the pump absorption torque while keeping the working mode and engine speed as they are.
- For details, see Pump and engine mutual control system.

Travel speed selection function

- Manual selection using the travel speed switch. If the travel speed switch is set to Lo, Mi, or Hi, the pump controller controls the pump flow and motor volume at each speed range to switch the travel speed (See chart to the right).
- Automatic selection according to the engine speed. If the engine speed is reduced to below 1400 rpm by the fuel control dial:
If the machine is travelling in Lo, it will not shift even if Mi or Hi are selected.
If the machine is travelling in Mi, it will not shift even if Hi is selected.
If the machine is travelling in Hi, it will automatically shift to Mi.
- Automatic selection according to the pump discharge pressure.
If the machine is travelling with the travel speed switch at Hi, and the load increases, such as when travelling up a steep hill, if the travel pressure continues at 33.32 MPa (340 kg/cm²) for more than 0.5 sec, the motor volume is automatically switched and the travel speed changes to Mi. (The travel speed switch stays at Hi.)
The machine continues to travel in Mi, and when the load is reduced, such as when the machine travel again on flat ground or goes downhill, and the travel pressure stays at 17.64 MPa (180 kg/cm²) or less for more than 0.5 sec, the motor volume is automatically switched and the travel speed returns to Hi.

Travel speed switch	Lo (Low speed)	Mi (Mid-range speed)	Hi (High speed)
Pump flow (%)	75	75	100
Motor volume	Max.	Min.	Min.
Travel speed (km/h)	2.6	4.2	5.3

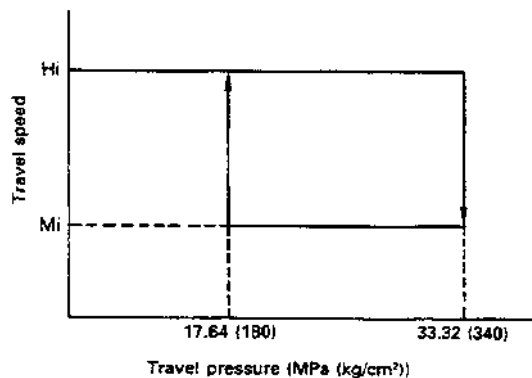

X12BV112

Active mode function

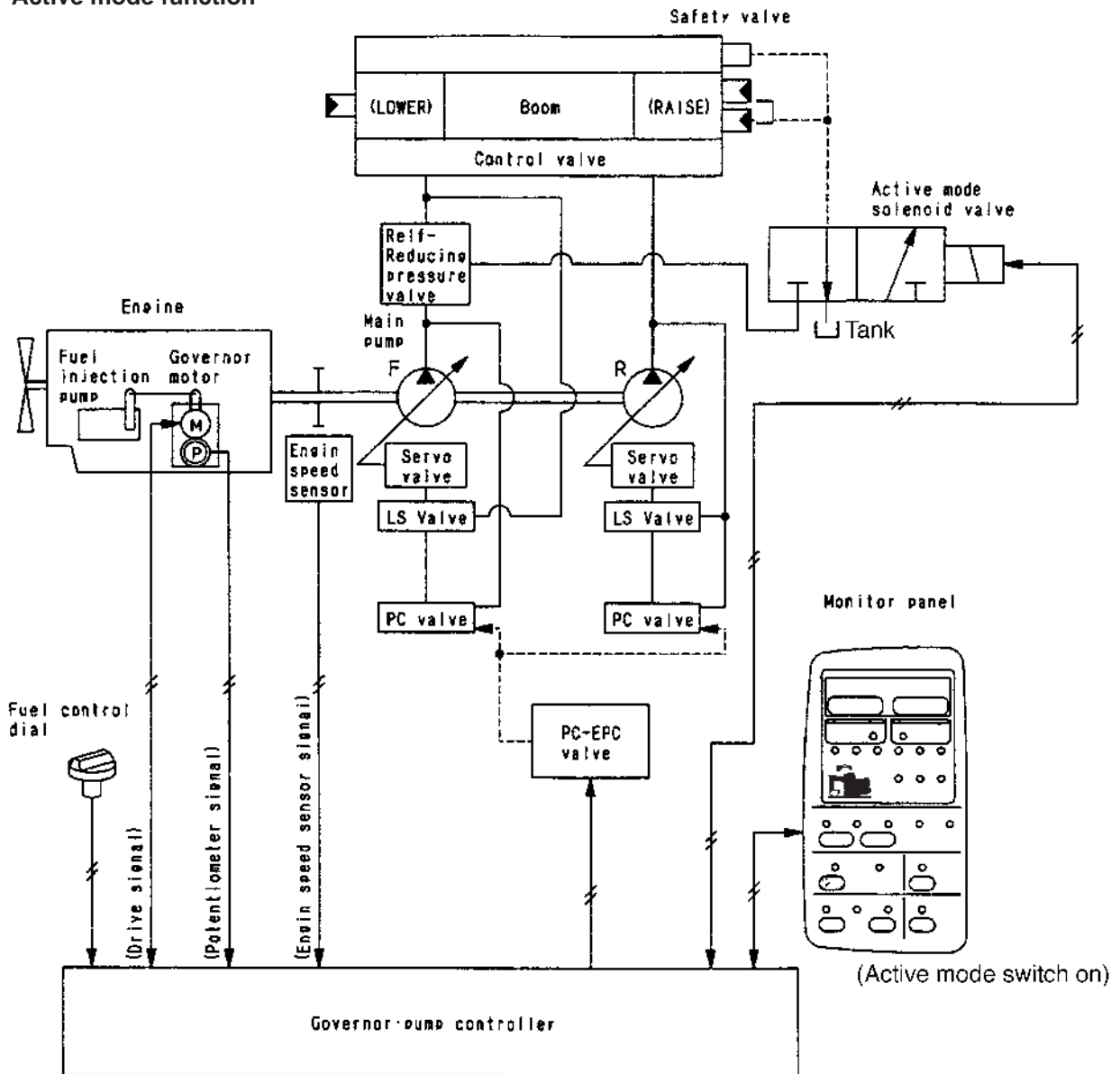

X08DD198

Function

- When the active mode switch on the monitor panel is turned ON (lamp lights up), it is possible to increase the speed of the operation by increasing the speed when there is a light load and by detecting the load when there is a heavy load.
- The active mode is actuated only when the fuel control dial is at the Max. position. If the fuel control dial is not at the Max. position, the load sensing function is actuated but the pump discharge increase function is not actuated.

Pump absorption horsepower increase, engine speed increase, cut-off cancel function

- The cycle time is reduced by increasing the engine speed and pump absorption torque and by cancelling the cut-off function. The increase in the absorption horsepower increases the bucket lifting height and is effective in loading dump trucks in hoist and swing operations.

2-stage boom lowering speed, engine speed-up function

- When the active mode switch is ON, the stroke of the boom LOWER spool in the control valve is switched from 9mm to 11.5mm to increase the speed.

When the engine speed is increased, the oil flow at light load is increased the rough finishing speed.

2-stage boom cylinder head safety valve function

- When the active mode switch is ON, the boom cylinder head pressure is changed from 28.4 MPa (290 kg/cm²) " 35.8 MPa (365 kg/cm²) to improve the thrusting force of the machine.

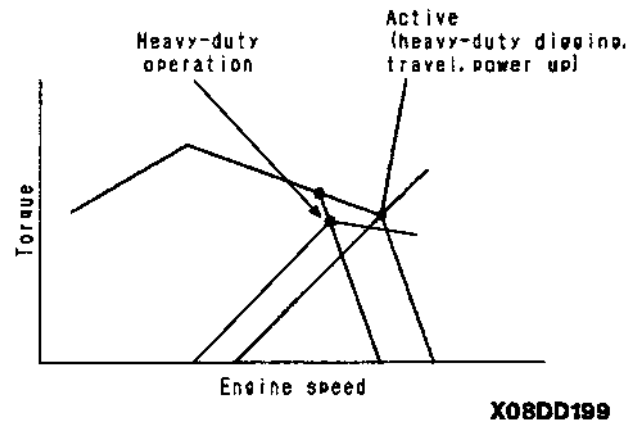

H/O	Active
123kW/2100	130kW/2200
165HP/2100	174HP/2200

Active power-max function

- In the active mode, if the power max. function is selected, the left knob switch can be operated to increase the digging power.

MODE	L.H. KNOB SWITCH	ENGINE - PUMP CONTROL	2 STAGE RELIEF FUNCTION	ACUATION TIME
ACTIVE	OFF	MATCHING AT RATED OUTPUT POINT	OFF	-
	ON		ACTUATED → 355 kg/cm ² (34.8 MPa)	AUTOMATIC CANCEL AFTER 8.55

9. Components of system

1) Engine speed sensor

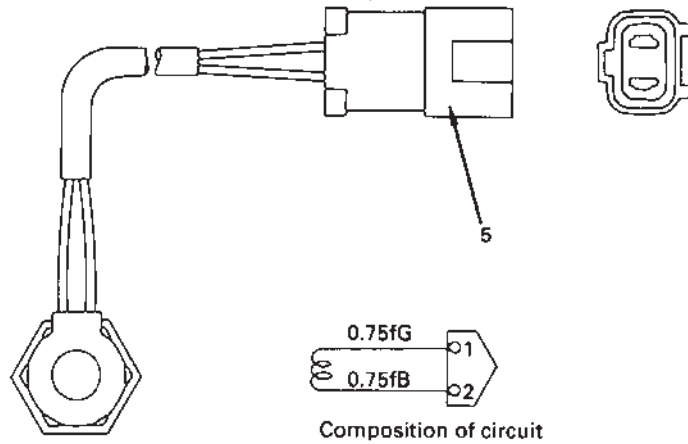
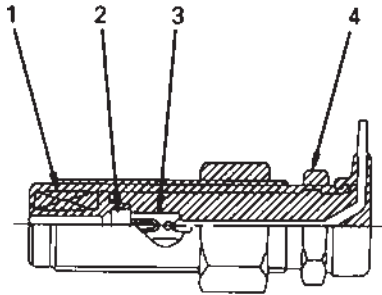

- 1. Wire
- 2. Magnet
- 3. Terminal
- 4. Housing
- 5. Connector

Function

- The engine speed sensor is installed to the ring gear portion of the engine flywheel. It counts electrically the number of gear teeth that pass in front of the sensor, and sends the results to the engine throttle • pump controller.
- This detection is carried out by a magnet, and an electric current is generated every time the gear tooth passes in front of the magnet.

SBP00365

2) PPC hydraulic switch

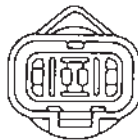
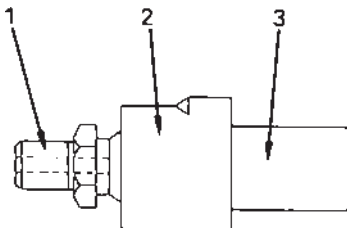

- 1. Plug
- 2. Switch
- 3. Connector

Specifications

Composition of points :
N.O. points

Actuation (ON) pressure :
0.49 ± 0.1 MPa
5.0 ± 1.0 kg/cm²

Reset (OFF) pressure: :
0.29 ± 0.05 MPa
3.0 ± 0.5 kg/cm²

Function

- There are switches installed to the junction box. The operating condition of each actuator is detected from the PPC pressure, and this is sent to the engine throttle • pump controller.

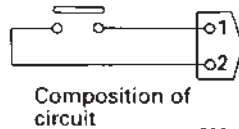
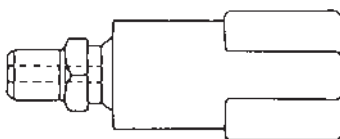

Composition of circuit

SBP00366

Pump pressure sensor

- 1. Sensor
- 2. Connector

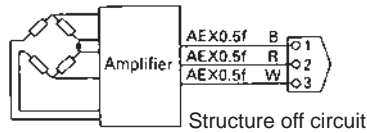
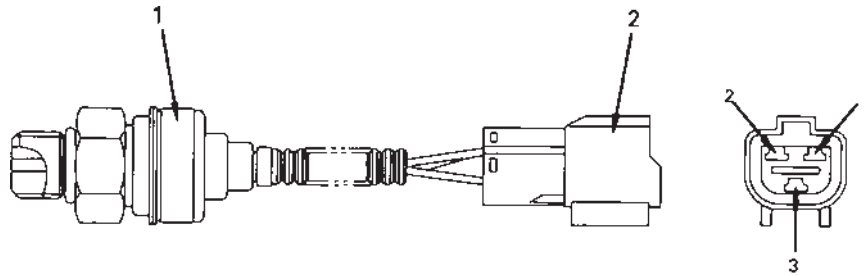

SBP00367

Function

- Two sensors are mounted in each actuator circuit of the boom and arm (four sensors in all). The load pressure on the actuator is converted to the voltage and sent to the controller.

Operation

1. When the oil entering from the pressure inlet applies pressure to the diaphragm of the oil pressure detector, the diaphragm is deflected and deformed.
2. A gauge layer is mounted at the opposite side of the diaphragm and the resistance value of the gauge converts the deflection of the diaphragm into the output voltage and sends it to the amplifier (voltage amplifier).
3. The amplifier sends the signal to the governor and pump controller.
4. The relational expression of the pressure P (MPa (kg/cm²)) and the output voltage V: $V = 0.008 \times P + 1.0$

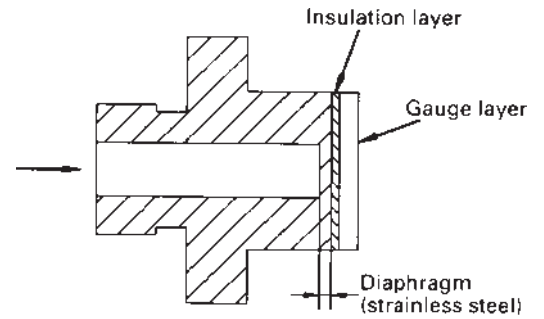

SAP00368

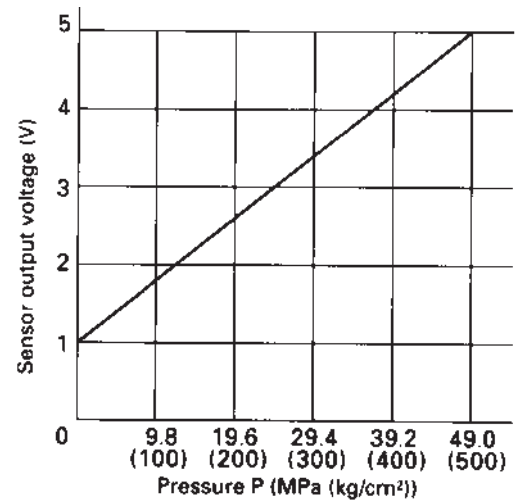

SAP00369

PC prolix resistor

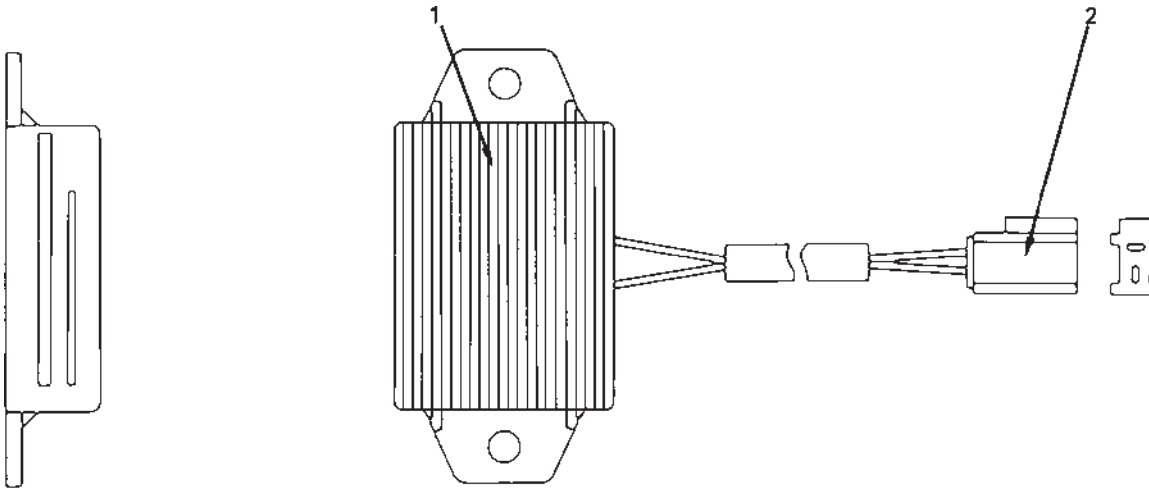

SBP00370

1. Resistor
2. Connector

Specification
Resistance: 40

Fuel control dial, governor motor, engine throttle \$\$
pump controller

★ See Engine control system

Monitor panel

★ See Engine control system

PC valve

★ See Hydraulic pump

LS control EPC valve, PC control EPC valve, Pump
merge-divider solenoid valve, 2-stage relief sole-
noid valve, travel speed solenoid valve, swing brake
solenoid valve, active mode solenoid valve

★ See EPC solenoid valve

Function

- This resistor acts to allow a suitable current to flow to the EPC solenoid when the PC prolix switch is ON.
- No current flows when the PC prolix switch is OFF.

MACHINE MONITOR SYSTEM

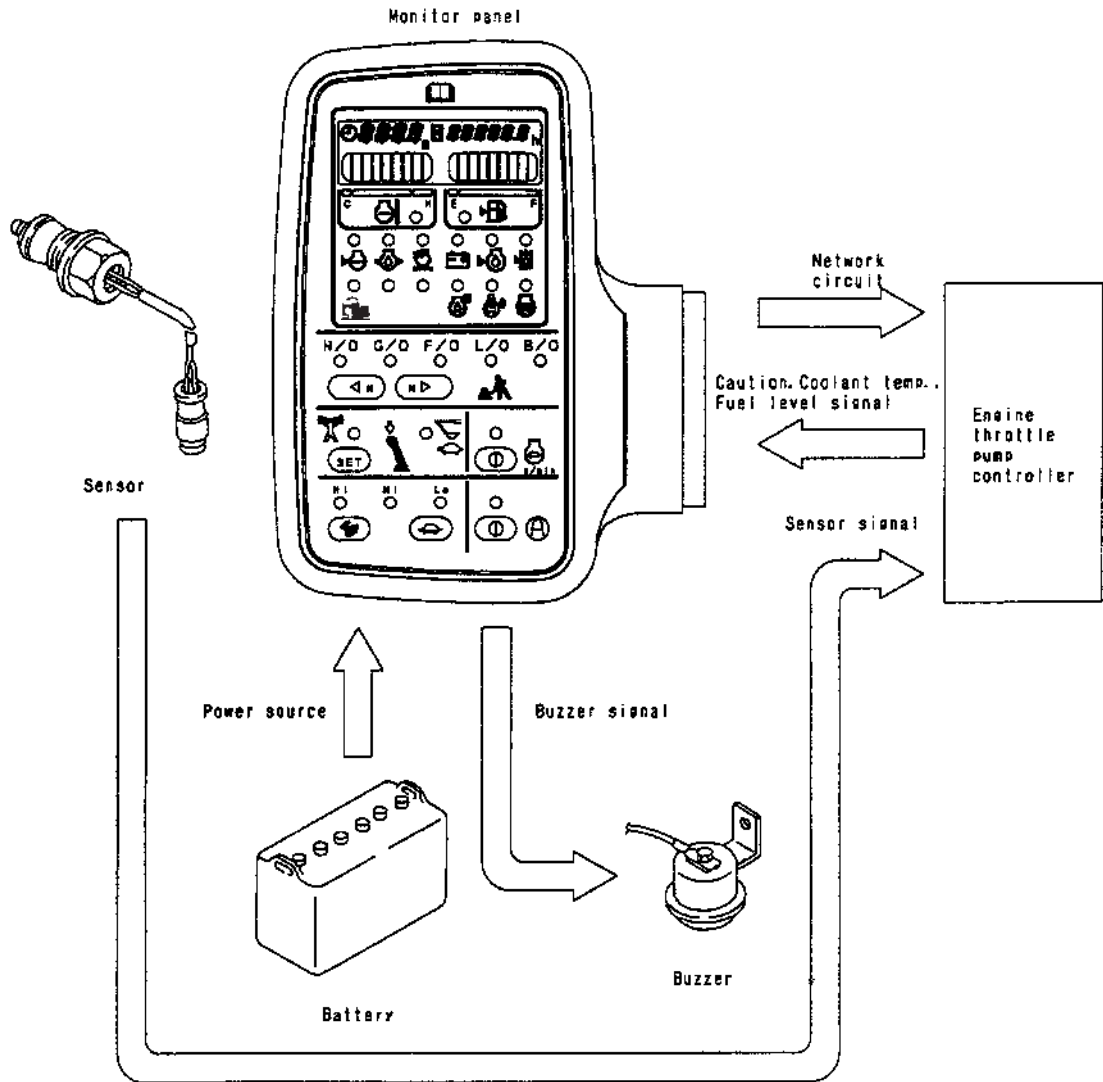

X71AJ209

Function

- The machine monitor system uses the network circuits between the controllers and sensors installed to all parts of the machine to observe the condition of the machine. It processes this information, and displays it on a panel to inform the operator of the condition of the machine.
- The content of the information displayed on the machine can broadly be divided as follows.
 1. Monitor portion – This gives an alarm if any abnormality occurs in the machine
 2. Gauge portion – This always displays the coolant temperature and the fuel level.
 3. Time display
 - a. This normally displays the time.
 - b. If this is set to the machine data monitoring mode, internal data from each controller, including the monitor panel itself, are displayed.
 - c. If it is set to the trouble data memory mode, the trouble data for each controller, including the monitor panel itself, are displayed.
 - d. In emergencies, it displays abnormalities in any controller.
- ★ For details of the content of the display and the method of operation, see Troubleshooting.
- The monitor panel has various built-in mode selector switches, and also functions as the control panel for the electronic control system.

Monitor panel

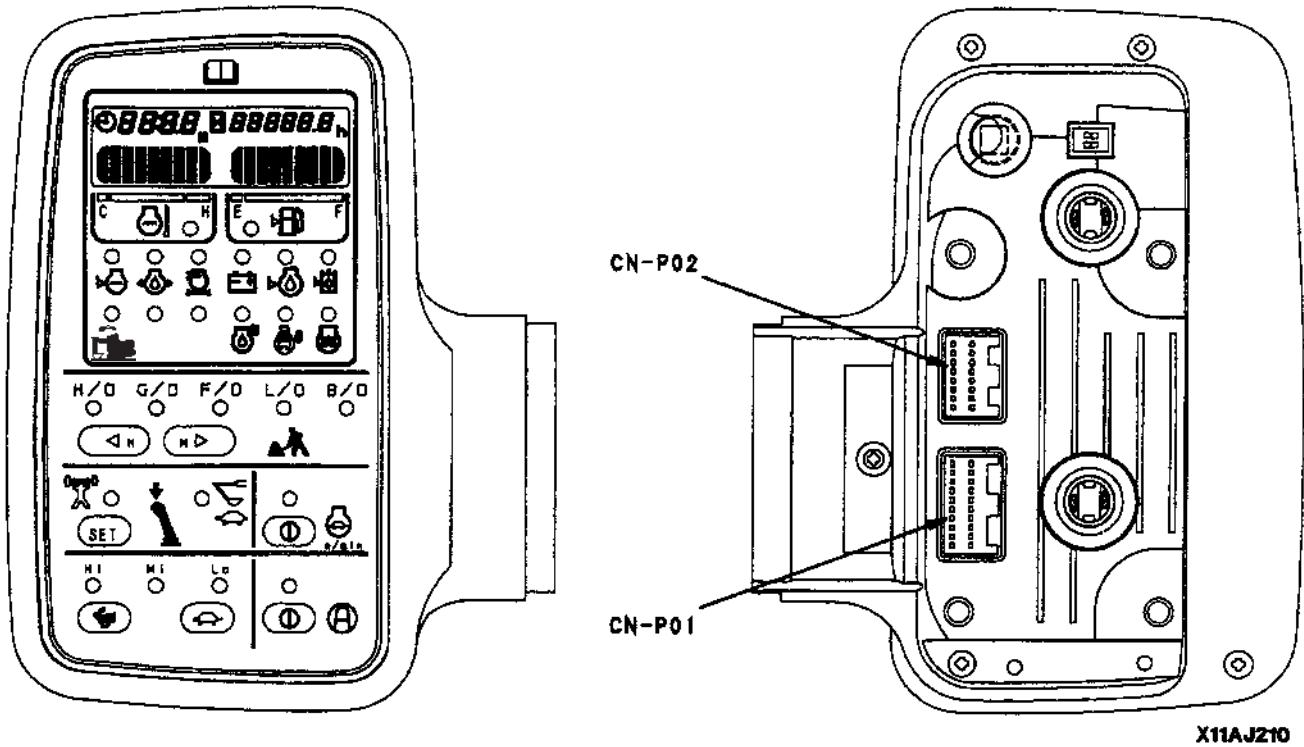

X11AJ210

Outline

- The monitor panel consists of the time display, monitor display, and mode selector switches.
- It has a built-in CPU (Central Processing Unit), and processes, displays, and outputs the data from the sensors and controllers.
- The monitor display and monitor display panels use a liquid crystal display (LCD) and LED lamps. The mode switches are flat sheet switches.

Input and output signals

CN-P01

Pin No.	Name of signal
1	NC
2	NC
3	NC
4	Network signal
5	Swing lock
6	Buzzer lock
7	Buzzer drive
8	Light
9	KEY ON signal
10	BR terminal
11	Network signal
12	Network GND
13	NC
14	Network GND

Pin No.	Name of signal
15	NC
16	NC
17	NC
18	Preheating
19	Start signal
20	NC

CN-P01

Pin No.	Name of signal
1	GND
2	Washer drive
3	Motor drive (reverse)
4	Wiper switch (ON)
5	Wiper switch (washer)
6	Limit switch

Pin No.	Name of signal
7	NC
8	+ VB
9	GND
10	Washer drive
11	Motor drive (normal)
12	Wiper switch (INT)
13	Limit switch (window)
14	+ VB
15	Limit switch (P)
16	NC



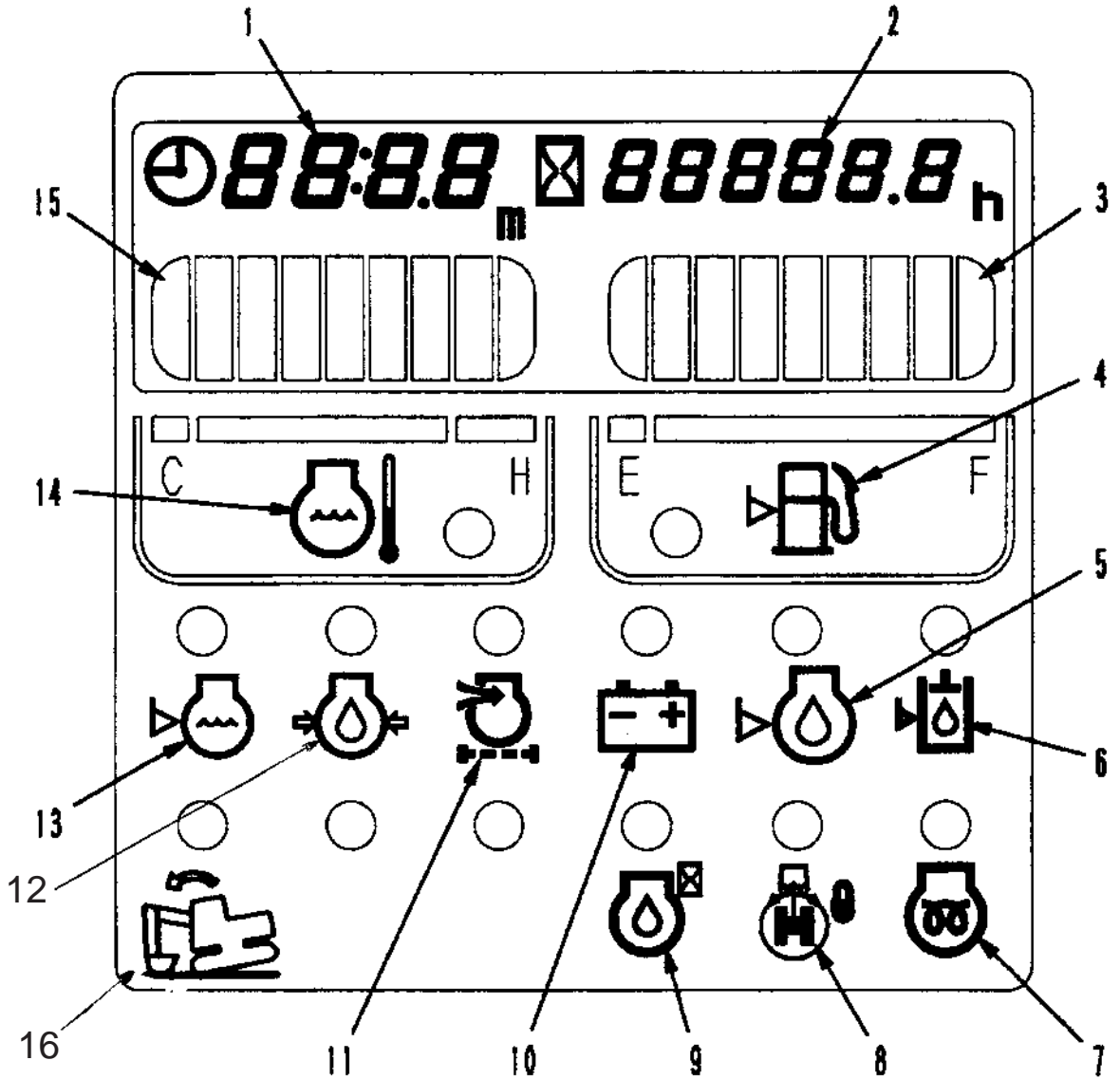











Monitor display

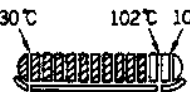

X11AJ211

1. Clock (displays error when there is an error)
2. Service meter (displays telephone number when there is an error)
3. Fuel level gauge
4. Fuel level caution lamp
5. Engine oil level caution lamp
6. Hydraulic oil level caution lamp
7. Preheating pilot lamp
8. Swing holding brake pilot lamp
9. Oil maintenance pilot lamp
10. Battery charge caution lamp
11. Air cleaner clogging caution lamp
12. Engine oil pressure caution lamp
13. Coolant level caution lamp
14. Coolant temperature caution lamp
15. Coolant temperature gauge
16. Overload caution monitor (Dip switch must be turned on for this mode)

Content of display

Symbol	Display item	Display range	When engine is stopped	When engine is running
	Coolant level	Below low level	Flashes when abnormal	Flashes and buzzer sounds when abnormal
	Engine oil pressure	Below 1500 rpm: below 0.05 MPa (0.5 kg/cm ²) Above 1500 rpm: above 0.15 MPa (1.5 kg/cm ²)	Lights up when normal (goes out when engine starts)	Flashes and buzzer sounds when abnormal
	Air cleaner clogging	When clogged	Flashes when abnormal	OFF
	Charge level	When charging is defective	Lights up when normal (goes out when engine starts)	Flashes when abnormal
	Engine oil level	Below low level	Flashes when abnormal	OFF
	Hydraulic oil level	Below low level	Flashes when abnormal	OFF
	Parking (Swing lock)	When swing is locked	Lights up when swing lock is ON, flashes when swing prolix switch is ON	
	Oil maintenance	See next page		
	Preheating	During preheating	Lights up for 30 seconds when starting switch is at HEAT, then flashes for 10 seconds to indicate that preheating is completed	
	Coolant temperature	Flashes when above 102°C, flashes and buzzer sounds when above 105°C		
	Fuel level	Flashes when below low level		
	Overload caution	WHEN OPERATING IN LO MODE IF LIFTING LOAD EXCEEDS OVERLOAD WARNING DECAL ALLOWANCE		

Oil maintenance function

Function and operation

- The oil maintenance function uses LED lamps on the monitor panel to inform the operator at a fixed interval after the engine oil is changed that the oil change interval has been reached. At the same time, it also functions to display the service contact telephone number on the liquid crystal display.

- Oil change display**
When the elapsed time to the next oil change is less than 10 hours from the set time, the service meter display gives the elapsed time and the LED flashes when the key is turned ON.
- Confirmation of elapsed time**
Normally, no display is given if the elapsed time has not reached a time 10 hours before the change interval. However, if the buzzer cancel switch is pressed and the key is turned to the ON position (with the buzzer cancel switch held for 2.5 seconds), the elapsed time is displayed on the service meter display.

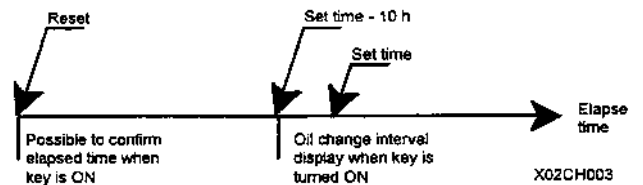

Setting change interval

- The change interval can be set by using the interval setting mode. The times that can be set are [125 h], [250 h], [500 h], [no setting], and [demo mode]. The default setting is [no setting].
- To enter the change interval setting mode, keep the time switch and active mode switch (swing priority switch) pressed simultaneously for 2.5 seconds.
- If the buzzer cancel buzzer switch is pressed in the change interval setting mode, the time display will change from [...] "[125]" [250]" [500]" [d] ([...] indicates [no setting] and [d] indicates [demo mode]).
- To save the change interval time, set the monitor panel display to the desired time (mode), then keep the time switch and active mode switch pressed simultaneously to 2.5 seconds.

Display timing, content

1. Oil change display
After all the lamps lights up, the elapsed time is displayed for 10 seconds. For the next 10 seconds, the telephone number is displayed. However, if no telephone number has been input, the elapsed time is displayed for 20 seconds after all the lamps light up.
2. Elapsed time confirmation
After all the lamps light up, the elapsed time is displayed for 10 seconds.

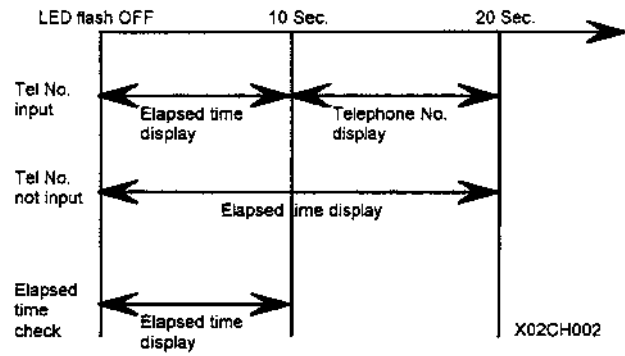

Elapsed time reset

1. During the oil change interval display and the elapsed time display, for 10 seconds after all lamps light up (during the elapsed time display), if the buzzer cancel switch is pressed and held for 3 seconds, the elapsed time is reset. When the elapsed time is reset, the elapsed time shows [0h] for 1 second.
2. When the set time is changed, the elapsed time is reset to [0h].

Demo mode

1. The set time in the demo mode is 250h and the elapsed time is set to 240h. When the key is turned ON, the oil change display is given. However, the elapsed time does not increase. It is also possible to carry out the reset operation during this display. In the demo mode, after the key is turned ON three times, the interval setting is automatically set to [no setting] from the 4th time. In addition, the elapsed time is reset to 0h and the elapsed time count starts.

"How to set telephone number" procedure see page 10-169

MODE SELECTION SWITCHES

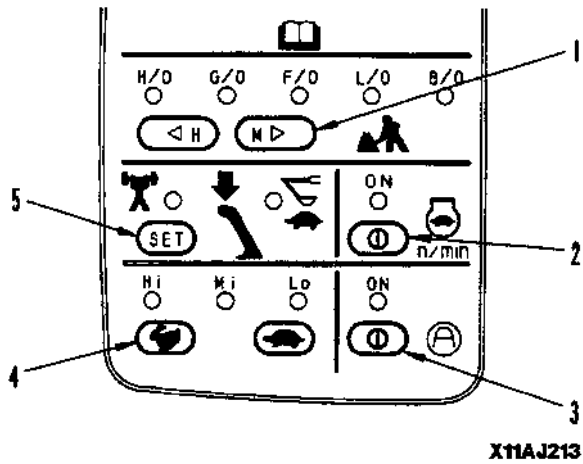

1. Working mode switches
2. Auto deceleration switch
3. Swing priority mode switch
4. Travel speed switch
5. Power max./Swift slow-down switch

- The switch portion consists of five mode selection switches, and the condition of the machine changes each time that any switch is pressed. The LED above the switch lights up to display the present condition of the machine.

Switch actuation table

Switch	Item	Action
 SDP00692	WORKING MODE	H/O ↔ G/O ↔ F/O ↔ L/O ↔ B/O
 SDP00693	KNOB BUTTON	 (POWER UP) ↔ (SPEED DOWN) SDP00694
 n/min SDP00695	AUTO DECEL	ON ↔ OFF
 SDP00696	TRAVEL SPEED	Hi ↔ Mi ↔ Lo
	ACTIVE MODE	OFF ↔ ON

★ The bold letter indicate the default position of the switch when the starting switch is turned ON.

HOW TO SET TELEPHONE NUMBER

The service contact telephone number may be changed by the following procedure.

- (i) Enter the telephone number change mode by keeping the time switch and the auto-decel switch pressed for 2.5 seconds. The display will change to show the current telephone number in the monitor panel memory (or ten zeros if no number is stored).

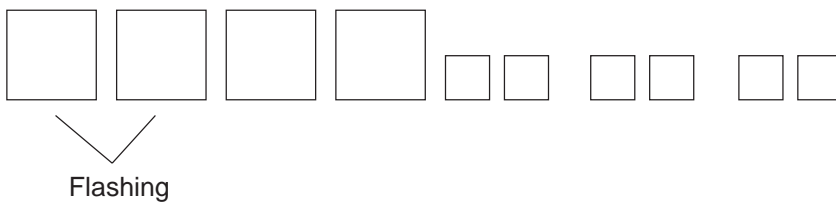

- (ii) The first two digits will flash. The first digit may be set by pressing the “travel speed up” button. The second digit may be set by pressing the “travel speed down” button. Note that pressing either button once will **increase** the respective digit by 1.
- (iii) The next pair of numbers be adjusted by pressing the time switch and the “working mode select M arrow” button.

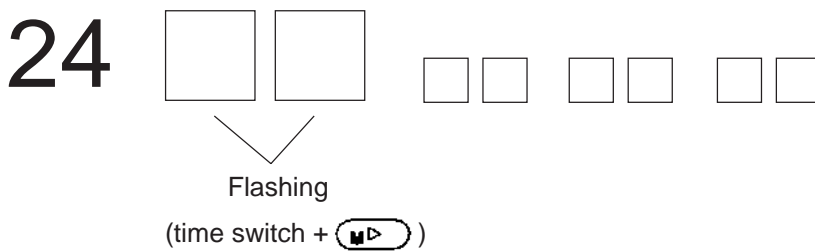

Note: It is possible to move back to the previous pair of digits by pressing the time switch and the “working mode select H arrow” button ().

- (iv) follow the procedure given in (ii) to change the third & fourth digits. Once these have been set the fifth and sixth digits may be selected the procedure shown in (iii) above. Repeat this method until all the digits have been set successfully.
- (v) To **store** the new number and return to normal monitor display, keep the time switch and auto-decel buttons pressed for 2.5 seconds.

2. Sensors

- The signals from the sensors are input directly to the monitor panel.
The contact type sensors are always connected at one end of the chassis GND.

Name of sensor	Type of sensor	When normal	When abnormal
Coolant level	Contact type	ON (closed)	OFF (open)
Engine oil level	Contact type	ON (closed)	OFF (open)
Hydraulic oil level	Contact type	ON (closed)	OFF (open)
Engine oil pressure	Contact type	OFF (open)	ON (closed)
Coolant temperature	Resistance type	-	-
Fuel level	Resistance type	-	-
Air cleaner clogging	Contact type	ON (closed)	OFF (open)

1. Sub-tank
2. Float
3. Sensor
4. Connector

Coolant level sensor

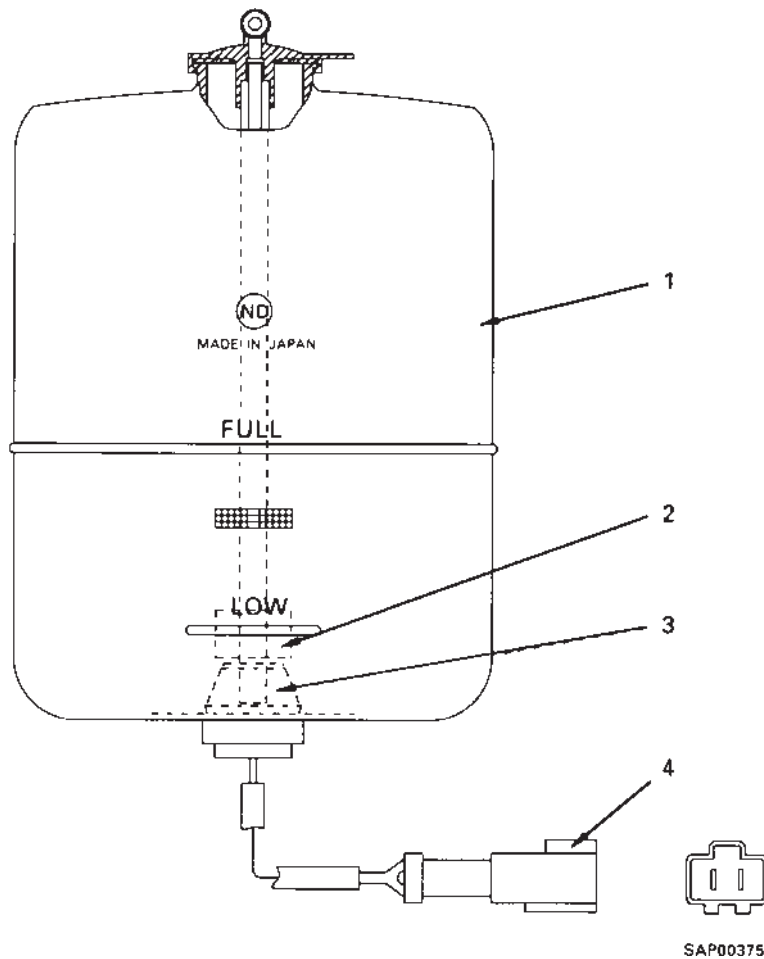

SAP00375

Engine oil level sensor

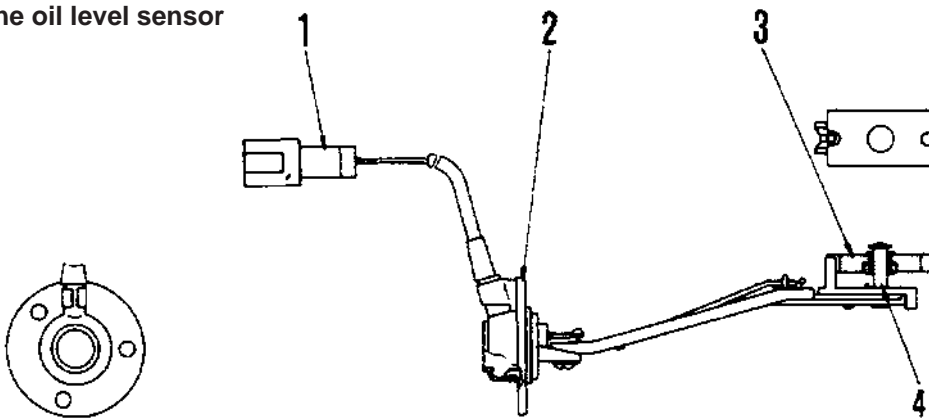

- 1. Connector
- 2. Bracket
- 3. Float
- 4. Switch

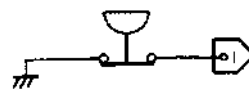

Composition of circuit

X11AJ108

Hydraulic oil sensor

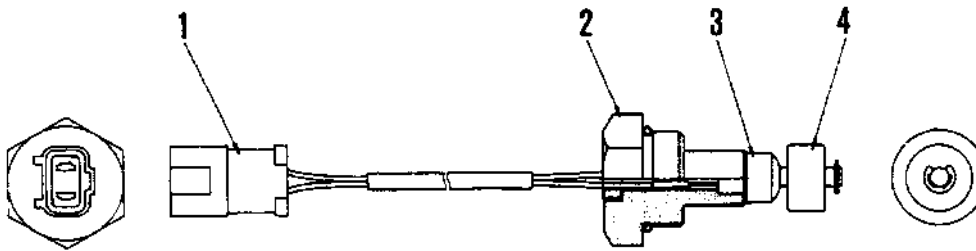

- 1. Connector
- 2. Plug
- 3. Switch
- 4. Float

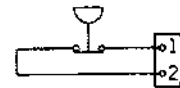

X11AJ109

Engine oil pressure sensor

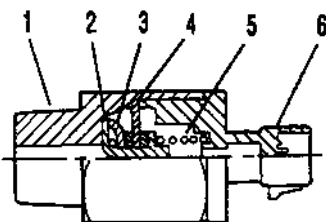

- 1. Plug
- 2. Contact ring
- 3. Contact
- 4. Diaphragm
- 5. Spring
- 6. Terminal



X08CD049

Coolant temperature sensor

1. Connector
2. Plug
3. Thermistor

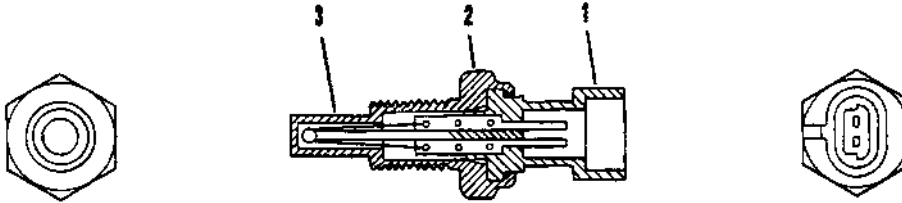

X08CD051

Fuel level sensor

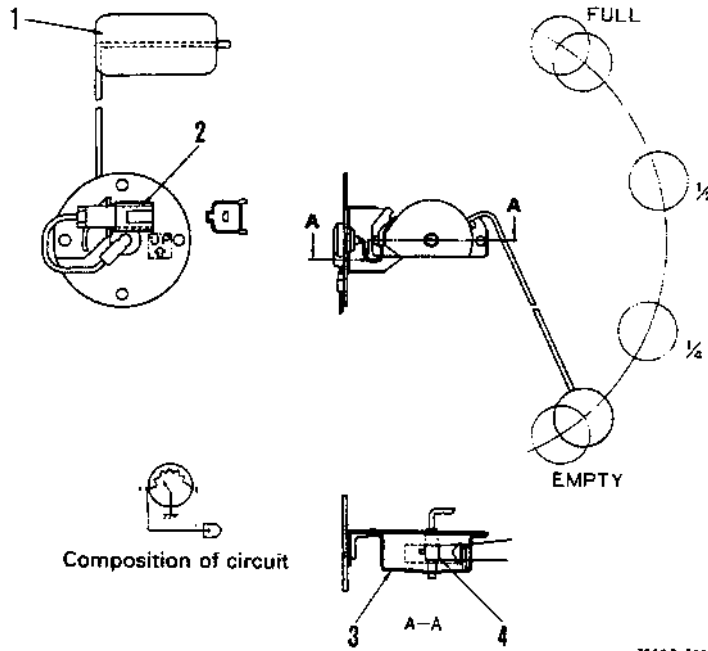

1. Float
2. Connector
3. Cover
4. Variable resistor

X11AJ112

Air cleaner clogging sensor

Actuation (OFF) pressure : -7.47 ± 0.49 kPa (-762 ± 50 mmH₂O)

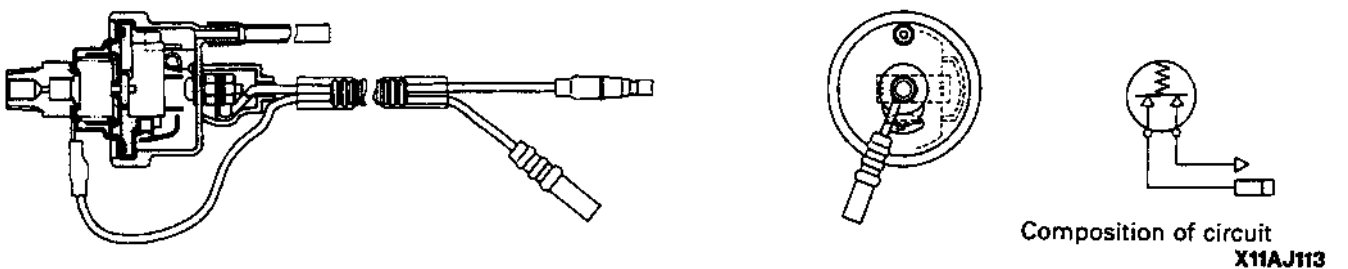

X11AJ113

20 TESTING AND ADJUSTING

TESTING AND ADJUSTING	20-6
STANDARD VALUE TABLE	20-7
For engine – PC290-6K	20-8
For chassis	20-9
TOOLS FOR TESTING, ADJUSTING AND TROUBLESHOOTING	20-24
MEASURING ENGINE SPEED	20-25
MEASURING EXHAUST GAS COLOR	20-26
ADJUSTING VALVE CLEARANCE	20-27
MEASURING COMPRESSION PRESSURE	20-28
MEASURING BLOW-BY PRESSURE	20-28
TESTING AND ADJUSTING FUEL INJECTION TIMING	20-29
MEASURE ENGINE OIL PRESSURE	20-30
TESTING AND ADJUSTING FAN BELT TENSION	20-31
MEASURING SPEED SENSOR	20-32
TESTING AND ADJUSTING GOVERNOR MOTOR LEVER STROKE	20-33
TESTING AND ADJUSTING HYDRAULIC PRESSURE IN WORK EQUIPMENT, SWING, AND TRAVEL CIRCUIT	20-34
TESTING AND ADJUSTING PC VALVE OUTPUT PRESSURE (SERVO PISTON INPUT PRESSURE)	20-37
TESTING AND ADJUSTING LS VALVE OUTPUT PRESSURE (SERVO PISTON INPUT PRESSURE AND LS DIFFERENTIAL PRESSURE)	20-38
TESTING AND ADJUSTING CONTROL CIRCUIT OIL PRESSURE	20-41
TESTING SOLENOID VALVE OUTPUT PRESSURE	20-42
MEASURING PPC VALVE OUTPUT PRESSURE	20-44
Pressure switch piping diagram	20-45
ADJUSTING WORK EQUIPMENT • SWING PPC VALVE	20-46
ADJUSTMENT OF FLOW FLOW CONTROL SYSTEM	20-47
Graph of PPC Pressure Against HCU Circuit Oil Flow	20-49
TESTING TRAVEL DEVIATION	20-50
TESTING LOCATIONS CAUSING HYDRAULIC DRIFT OF WORK EQUIPMENT	20-51
MEASURE OIL LEAKAGE	20-53
RELEASING REMAINING PRESSURE IN HYDRAULIC CIRCUIT	20-55
TESTING CLEARANCE OF SWING CIRCLE BEARING	20-55
TESTING AND ADJUSTING TRACK SHOE TENSION	20-56
BLEEDING AIR	20-57
TROUBLESHOOTING	
SEQUENCE OF EVENTS IN TROUBLESHOOTING	20-59
POINTS TO REMEMBER WHEN CARRYING OUT MAINTENANCE	20-60
Points to remember when handling electric equipment	20-60
Points to remember when troubleshooting electric circuits	20-65
Points to remember when handling hydraulic equipment	20-66
CHECKS BEFORE TROUBLESHOOTING	20-68
CONNECTOR TYPES AND MOUNTING LOCATIONS	20-70
CONNECTION TABLE FOR CONNECTOR PIN NUMBERS	20-74

EXPLANATION OF CONTROL MECHANISM FOR ELECTRICAL SYSTEM	20-82
DISPLAY METHOD AND SPECIAL FUNCTIONS OF MONITOR PANEL	20-83
METHOD OF USING JUDGEMENT TABLE	20-92
METHOD OF USING TROUBLESHOOTING CHARTS	20-94
DETAILS OF TROUBLESHOOTING AND TROUBLESHOOTING PROCEDURE	20-96
SERVICE CODE TABLE	20-101
TROUBLESHOOTING OF COMMUNICATION ABNORMALITY SYSTEM (N MODE)	20-102
N-1 [E218] Communications abnormality	20-102

TROUBLESHOOTING OF ENGINE THROTTLE • PUMP CONTROLLER

(GOVERNOR CONTROL SYSTEM) (E MODE)	20-104
POINTS TO REMEMBER WHEN CARRYING OUT TROUBLESHOOTING OF ENGINE THROTTLE • PUMP CONTROLLER SYSTEM	20-104
ACTION TAKEN BY CONTROLLER WHEN ABNORMALITY OCCURS AND PROBLEMS ON MACHINE	20-105
JUDGEMENT TABLE FOR ENGINE THROTTLE • PUMP CONTROLLER (GOVERNOR CONTROL SYSTEM) AND ENGINE RELATED PARTS	20-109
ELECTRICAL CIRCUIT DIAGRAM FOR E MODE SYSTEM	20-111
E-1 Abnormality in engine throttle • pump controller power source (controller LED is OFF)	20-113
E-2 [E308] Abnormality in fuel control dial input value is displayed	20-114
E-3 [E317] Abnormality (disconnection) in motor drive system is displayed	20-115
E-4 [E318] Abnormality (short circuit) in motor drive system is displayed	20-116
E-5 [E306] Abnormality in feedback potentiometer system is displayed	20-117
E-6 [E315] Abnormality (short circuit) in battery relay output system is displayed	20-118
E-7 [E316] Abnormality (step-out) in motor is displayed	20-119
E-8 Engine does not start	20-121
E-9 Engine speed is irregular	20-124
E-10 Lack of output (engine high idling speed is too low)	20-128
E-11 Engine does not stop	20-130
E-12 Defective operation of battery relay system (engine does not stop)	20-132

TROUBLESHOOTING OF ENGINE SYSTEM (S MODE)

METHOD OF USING TROUBLESHOOTING CHARTS	20-134
S-1 Starting performance is poor (starting always takes time)	20-139
S-2 Engine does not start	20-141
S-3 Engine does not pick up smoothly (follow-up is poor)	20-144
S-4 Engine stops during operations	20-145
S-5 Engine does not rotate smoothly (hunting)	20-146
S-6 Engine lacks output (no power)	20-147
S-7 Exhaust smoke is black (incomplete combustion)	20-148
S-8 Oil consumption is excessive (or exhaust smoke is blue)	20-149
S-9 Oil becomes contaminated quickly	20-150
S-10 Fuel consumption is excessive	20-151
S-11 Oil is in coolant, or coolant spurts back, or coolant level goes down	20-152
S-12 Oil pressure caution lamp lights up (drop in oil pressure)	20-153
S-13 Oil level rises (coolant, fuel in oil)	20-154
S-14 Coolant temperature becomes too high (overheating)	20-155
S-15 Abnormal noise is made	20-156
S-16 Vibration is excessive	20-157

TROUBLESHOOTING OF ENGINE THROTTLE • PUMP CONTROLLER

(PUMP CONTROL SYSTEM) (C MODE)	20-158
POINTS TO REMEMBER WHEN TROUBLESHOOTING PUMP CONTROLLER SYSTEM	20-158
ACTION TAKEN BY CONTROLLER WHEN ABNORMALITY OCCURS AND PROBLEMS ON MACHINE	20-159

JUDGEMENT TABLE FOR ENGINE THROTTLE • PUMP CONTROLLER

(PUMP CONTROL SYSTEM) AND HYDRAULIC RELATED PARTS	20-167
ELECTRICAL CIRCUIT DIAGRAM FOR C MODE AND F MODE	20-169
C-1 Abnormality in controller power source system (controller LED is OFF)	20-171
C-2 [E232] Short circuit in pump EPC solenoid system is displayed	20-172
C-3 [E233] Disconnection in PC-EPC solenoid system is displayed	20-174
C-4 [E213] Disconnection in swing holding brake solenoid system is displayed	20-176
C-5 [E203] Short circuit in swing holding brake solenoid system is displayed	20-178
C-6 [E204] Short circuit in pump merge/divider solenoid system is displayed	20-180
C-7 [E214] Disconnection in pump merge/divider solenoid system is displayed	20-181
C-8 [E207] Short circuit in active mode solenoid system is displayed	20-182
C-9 [E208] Disconnection in active mode solenoid system is displayed	20-183
C-10 [E206] Short circuit in travel speed solenoid system is displayed	20-184
C-13 [E215] Disconnection in 2-stage relief solenoid system is displayed	20-185
C-14 [E217] Model selection input error is displayed	20-186
C-15 [E222] Short circuit in LS-EPC solenoid system is displayed	20-188
C-16 [E223] Disconnection in LS-EPC solenoid system is displayed	20-189
C-17 [E224] Abnormality in front pump pressure sensor system is displayed	20-190
C-18 [E225] Abnormality in rear pump pressure sensor system is displayed	20-191
C-19 [E226] Abnormality in pressure sensor power source system is displayed	20-192
C-20 [E227] Abnormality in engine speed sensor system is displayed	20-193

TROUBLESHOOTING OF ENGINE THROTTLE • PUMP CONTROLLER

(INPUT SIGNAL SYSTEM) (F MODE)	20-194
F-1 Bit pattern 20-(1) Swing oil pressure switch does not light up	20-194
F-2 Bit pattern 20-(2) Travel oil pressure switch does not light up	20-195
F-3 Bit pattern 20-(3) Boom LOWER oil pressure switch does not light up	20-196
F-4 Bit pattern 20-(4) Boom RAISE oil pressure switch does not light up	20-197
F-5 Bit pattern 20-(5) Arm IN oil pressure switch does not light up	20-198
F-6 Bit pattern 20-(6) Arm OUT oil pressure switch does not light up	20-199
F-7 Bit pattern 21-(1) Bucket CURL oil pressure switch does not light up	20-200
F-8 Bit pattern 21-(2) Bucket DUMP oil pressure switch does not light up	20-201
F-9 Bit pattern 21-(3) Swing lock switch does not light up	20-202
F-10 Bit pattern 22-(6) L.H. knob switch does not light up	20-204

TROUBLESHOOTING OF HYDRAULIC AND MECHANICAL SYSTEM (H MODE)





TABLE OF FAILURE MODES AND CAUSES FOR HYDRAULIC AND MECHANICAL SYSTEM	20-205
PUMP MERGE/DIVIDER LOGIC	20-209
SOLENOID ACTUATION TABLE	20-210
H-1 Speeds of all work equipment, swing, travel are slow	20-211
H-2 There is excessive drop in engine speed, or engine stalls	20-213
H-3 No work equipment, travel, swing move	20-213
H-4 Abnormal noise generated (around pump)	20-214
H-5 Auto-deceleration does not work (PPC shuttle valve is equipped only in travel PPC valve)	20-214
H-6 FINE control ability is poor or response is poor	20-215
H-7 Boom is slow or lacks power	20-217
H-8 Arm is slow or lacks power	20-219
H-9 Bucket is slow or lacks power	20-221
H-10 Work equipment (boom, arm, bucket) does not move (but travel and swing are normal)	20-222
H-11 Excessive hydraulic drift (boom, arm, bucket)	20-222
H-12 Excessive time lag (engine at low idling)	20-223
H-13 Other equipment moves when single circuit is relieved	20-223

H-14	Lack of power when pressure rises	20-226
H-15	In L/O, F/O modes, work equipment speed is faster than specified speed	20-227
H-16	In compound operations, work equipment with large load is slow	20-227
H-17	In swing + boom RAISE, boom RAISE is slow	20-228
H-18	In swing + travel, travel speed drops excessively	20-228
H-19	Travel deviation	20-228
H-20	Travel speed is slow	20-229
H-21	Steering does not turn easily or lacks power	20-231
H-22	Travel speed does not switch or is faster than specified speed	20-233
H-23	Travel does not move (one side only)	20-233
H-24	Does not swing	20-234
H-25	Swing acceleration is poor or swing speed is slow	20-235
H-26	Excessive overrun when stopping swing	20-237
H-27	Excessive shock when stopping swing (one direction only)	20-237
H-28	Excessive abnormal noise when stopping swing	20-238
H-29	Excessive hydraulic drift of swing	20-238
H-30	Swing speed is faster than specified speed in L/O and F/O modes	20-239

TROUBLESHOOTING OF MACHINE MONITOR SYSTEM (M CODE) 20-240

ACTION TAKEN BY MONITOR PANEL WHEN ABNORMALITY OCCURS		
AND PROBLEMS ON MACHINE		20-240
ELECTRICAL CIRCUIT DIAGRAM FOR M MODE SYSTEM		20-242
M-1	[E101] Abnormality in error data is displayed; [E102] Error in clock data is displayed	20-244
M-2	[E103] Short circuit in buzzer output or contact of 24V wiring harness with buzzer drive harness is displayed	20-245
M-3	[E104] Air cleaner clogging detected is displayed	20-246
M-4	[E108] Engine coolant temperature 105°C detected is displayed	20-246
M-5	When starting switch is turned ON, none of the lamps or monitor panel light up for 3 seconds	20-247
M-6	When starting switch is turned ON, monitor panel lamps all stay lighted up and do not go out	20-249
M-7	When starting switch is turned ON, items lighted up on monitor panel are different from actual machine model	20-249
M-8	When starting switch is turned ON (engine stopped), basic check items flash	20-250
M-9	Preheating is not being used but (preheating monitor) lights up	20-253
M-10	When starting switch is turned ON and engine is started, basic check items flash	20-254
M-11	When starting switch is turned ON (engine stopped), caution items, emergency items flash (battery, engine oil pressure lamps do not light up)	20-256
M-12	When starting switch is turned ON and engine is started, caution items, emergency items flash (when there is no abnormality in engine or items to check before troubleshooting)	20-258
M-13	When starting switch is turned ON (engine stopped), buzzer does not sound for 1 second. Caution item flashes but buzzer does not sound	20-261
M-14	No abnormality is displayed on monitor but buzzer sounds	20-261
M-15	Night lighting on monitor panel does not light up (liquid crystal display in normal)	20-262
M-16	Coolant temperature gauge does not rise	20-263
M-17	Coolant temperature gauge does not give any display (none of the gauge lamps light up during operation)	20-264
M-18	Fuel level gauge always displays FULL	20-265
M-19	Fuel level gauge does not give display	20-265
M-20	Swing lock switch is turned ON (LOCK) but (swing lock monitor) does not light up	20-266
M-21	Swing prolix switch is turned ON (prolix), but (swing lock monitor) does not flash	20-267
M-22	Service meter does not advance while engine is running	20-268

M-23 When starting switch is at OFF and time switch is pressed, time and service meter are not displayed	20-268
M-24 Defective fuel level sensor system	20-269
M-25 Defective coolant temperature sensor system	20-270
M-26 Defective engine oil sensor system	20-271
M-27 Defective coolant level sensor system	20-272
M-28 Defective hydraulic oil level sensor system	20-273
M-29 Wiper does not work, or switch is not being used but wiper is actuated	20-274
M-30 Washer motor does not work, or switch is not being used but washer motor is actuated	20-279

-  When carrying out testing, adjusting, or troubleshooting, park the machine on level ground, inset the safety pins, and blocks to prevent the machine from moving.
-  When carrying out work together with other workers, always use signals and do not let unauthorized people near the machine.
-  When checking the water level, always wait for the water to cool down. If the radiator cap is removed when the water is still hot, the water will spurt out and cause burns.
-  Be careful not to get caught in the fan, fan belt or other rotating parts.

TESTING AND ADJUSTING

STANDARD VALUE TABLE

For engine PC290-6K

Machine models			PC290LC/NLC-6K	
Engine model			SAGD102EA-1	
Item	Measurement condition	Unit	Standard value for new machine	Service limit value
Engine speeds	High Idle	H/O Travel	2400 ± 70	2400 ± 70
		H/O Mode	2300	2300
		G/O Mode	2100	2100
		F/O Mode	2100	2100
		L/O Mode	1750	1750
	Low idle in H/O mode			950
Engine rating	Rated gross power/ rated speed	kW/rpm	138/2200	138/2200
Intake manifold pressure	At rated speed of 2200 rpm	mm Hg	1118 - 1270	1118 - 1270
Intake air restriction	At rated speed of 2200 rpm	mm H ₂ O	New element: 380 Used element: 760	Max. 760
Lubricating oil pressure with SAE 15W-40 oil and coolant temperature in operating range	Minimum at low idle	kPa (kg/cm ²)	70 (0.70)	70 (0.70)
	Minimum at rated speed of 2200 rpm		276 (2.76)	276 (2.76)
Fuel inlet restriction to fuel lift pump	Maximum at high idle	kPa (kg/cm ²)	13.5 (0.135)	13.5 (0.135)
Blow-by pressure	Coolant temperature in operating range: ● Service tool orifice size: 5.613 mm ● At rated speed of 2200 rpm	mm H ₂ O	Max 85	Max 407
Exhaust back pressure	Maximum at rated speed of 2200 rpm	mm Hg	76	76
Coolant temperature	Maximum operating temperature	°C	100	100
Valve clearance	Engine cold:	mm	0.254 0.508	.0254 0.508
	Intake valves Exhaust valves			

★ For further detailed information, refer to Engine Shop Manual.

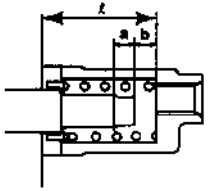

For chassis

★ The standard values and permissible values shown in this table are values for H/O (heavy-duty operation) mode.



Machine model				PC290-6k					
Category	Item	Measurement conditions	Unit	Standard value			Permissible value		
				ℓ	a	b	ℓ	a	b
Engine speed	At 2-pump relief	<ul style="list-style-type: none"> Engine at high idle Hydraulic oil • Swing lock on temperature: 45 - 55 °C Coolant temperature: within operating range 2-pump relief: Arm relief 	rpm	2110 ± 100			—		
	At 2-pump relief + one touch power up	<ul style="list-style-type: none"> Arm relief One touch power up Engine at high idling 		2200 ± 100			2200 ± 100		
	Speed when auto-deceleration is operated	<ul style="list-style-type: none"> Engine control dial at MAX Control lever at neutral 		1400 ± 120			1400 ± 120		
Spool stroke	Boom control valve	 <p>X1081107</p>	mm	ℓ	a	b	ℓ	a	b
	Arm control valve			—	9.5 ± 0.5	9.5 ± 0.5 Boom lower only (11.5 ± 0.5)	—	9.5 ± 0.5	9.5 ± 0.5 Boom lower only (11.5 ± 0.5)
	Bucket control valve			—	9.5 ± 0.5	9.5 ± 0.5 Boom lower only (11.5 ± 0.5)	—	9.5 ± 0.5	9.5 ± 0.5 Boom lower only (11.5 ± 0.5)
	Swing control valve			—	9.5 ± 0.5	9.5 ± 0.5 Boom lower only (11.5 ± 0.5)	—	9.5 ± 0.5	9.5 ± 0.5 Boom lower only (11.5 ± 0.5)
	Travel control valve			★ The value inside () is the value when the active mode is actuated	—	9.5 ± 0.5	9.5 ± 0.5 Boom lower only (11.5 ± 0.5)	—	9.5 ± 0.5
Travel of control levers	Boom control lever	<ul style="list-style-type: none"> Center of lever knob Read max. value to end of travel Engine stopped Excluding neutral play 	mm	76 ± 8			Max. 94 Min. 58		
	Arm control lever			76 ± 8			Max. 94 Min. 58		
	Bucket control lever			76 ± 8			Max. 94 Min. 58		
	Swing control lever			76 ± 8			Max. 94 Min. 58		
	Travel control lever			115 ± 12			Max. 127 Min. 103		
	Play of control lever			Max. 10			Max. 15		

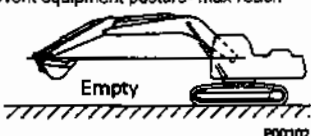
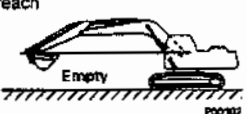

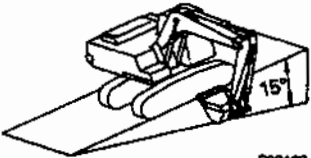
★ Bucket and arm when traveling both limited stroke.

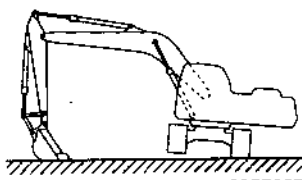
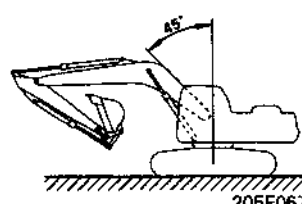
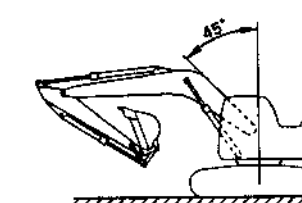
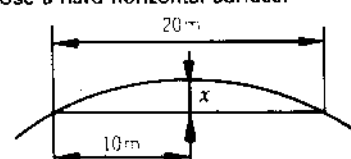
		Machine model		PC290-6K			
Category	Item	Measurement conditions	Unit	Standard value		Permissible value	
Operating force of control levers	Boom control lever	<ul style="list-style-type: none"> ● Engine at high idling ● Oil temperature: 45 - 55 °C ● Fit push-pull scale to center of control lever knob to measure ● Measure max. value to end of travel 	N (kg)	17.6 ± 2.9 (1.8 ± 0.3)		Max. 27.4 (Max. 2.8)	
	Arm control lever			17.6 ± 2.9 (1.8 ± 0.3)		Max. 27.4 (Max. 2.8)	
	Bucket control lever			14.7 ± 2.9 (1.5 ± 0.3)		Max. 24.5 (Max. 2.5)	
	Swing control lever			14.7 ± 2.9 (1.5 ± 0.3)		Max. 24.5 (Max. 2.5)	
	Travel control lever			24.5 ± 5.9 (2.5 ± 0.6)		Max. 39.2 (Max. 4.0)	
	Travel control pedal			74.5 ± 18.6 (7.6 ± 1.9)		Max. 107.8 (Max. 11)	
Hydraulic pressure	Unload pressure	<ul style="list-style-type: none"> ● H/O mode ● Oil temperature: 45 - 55 °C ● Engine at high idling ● All levers at neutral 	MPa (kg/cm ²)	3.92 ± 0.98 (40 ± 10)		3.92 ± 0.98 (40 ± 10)	
	Boom	<ul style="list-style-type: none"> ● Oil temperature: 45 - 55 °C ● Relief pressure with engine at high idling (Relieve only circuit to be measured) ● In H/O mode ● Figures is [] are when power max function is used (reference) ● Pump outlet port pressure ★ 1: For travel, measure oil pressure for relief on one side ★ 2: For swing, measure oil pressure with swing lock off ★ 3: The boom pressure is the oil pressure at RAISE and at the high pressure setting (active mode) 		31.85 ± 0.98 (325 ± 10)		Max. 33.81 (Max. 345) Min. 30.38 (Min. 310)	
	Arm			[34.79 + 1.47 - 0.98]		[Max. 37.24 (Max. 380)] [Min. 33.81 (Min. 345)]	
	Bucket			[(355 + 15 - 10)]			
	Swing			27.96 + 1.47 - 0.98 (285 + 15 - 10)		Max. 29.43 (Max. 300) Min. 26.98 (Min. 275)	
	Travel			34.79 + 1.47 - 0.98 (355 + 15 - 10)		Max. 37.24 (Max. 380) Min. 33.81 (Min. 345)	
	Self-pressure reducing valve			3.23 ± 0.20 (33 ± 2)		Max. 3.43 (Max. 35) Min. 2.84 (Min. 29)	
	LS differential pressure				<ul style="list-style-type: none"> ● Hydraulic oil temperature 45 - 55 °C ● Engine at high idling ● In H/O mode 		2.94 ± 0.98 (30 ± 10)
		<ul style="list-style-type: none"> ● Levers at neutral ● Travel speed Hi, rotating under no load ● Travel lever half 	2.16 ± 0.98 (22 ± 1)				2.16 ± 0.98 (22 ± 1)

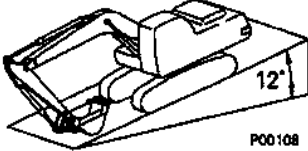
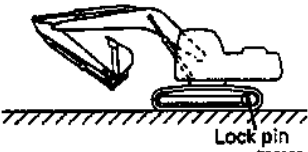
Machine model				PC290-6k	
Category	Item	Measurement conditions	Unit	Standard value	Permissible value
Swing	Swing brake angle	Work equipment posture- max reach  Empty P00102 <ul style="list-style-type: none"> ● Engine at high idling ● Hydraulic oil temperature: 45 - 55 °C ● Stop after swinging one turn and measure distance that swing circle moves 	mm	Max 130	Max 160
	Time taken to start swing	Work equipment posture - Max reach  Empty P00102 <ul style="list-style-type: none"> ● Engine at high idling ● Hydraulic oil temperature: 45-55 °C ● In H/O mode ● Time taken to swing 90° and 180° from starting positions 	90°	3.1 ± 0.3	Max. 3.7
			180°	4.4 ± 0.8	Max 5.6
	Time taken to swing	Work equipment posture - Max reach  Empty P00102 <ul style="list-style-type: none"> ● Engine at high idling ● Hydraulic oil temperature: 45-55°C ● In H/O mode ● Swing one turn, and measure time taken to swing next 5 turns 	Sec.	27.3 ± 3.5	Max 33
	Hydraulic drift of swing	 P00103 <ul style="list-style-type: none"> ● Engine stopped ● Hydraulic oil temperature: 45-55°C ● Set machine on 15° slope and set upper structure at 90° to the side. ● Make match marks on swing circle outer race and track frame ● Measure distance that match marks move apart after 5 min. 	mm	0	0
Leakage from swing motor	<ul style="list-style-type: none"> ● Engine at high idling ● Hydraulic oil temperature: 45-55°C ● Swing lock switch ON ● Relieve swing circuit 	l/min	Max 5	Max 10	

Machine model				PC290-6k		
Category	Item	Measurement conditions	Unit	Standard value	Permissible value	
Travel	Travel speed (1)	 <ul style="list-style-type: none"> • Engine at high idling • Hydraulic oil temperature: 45 – 55°C • In H/O mode • Raise track on one side at a time, rotate one turn, then measure time taken for next 5 turns with no load. 	Lo	sec.	60 - 76	60 - 80
			Mi		36.5 - 47.5	36.5 - 49.5
			Hi		30.5 - 35.5	30.5 - 38
	Travel speed (2)	 <ul style="list-style-type: none"> • Engine at high idling • Hydraulic oil temperature: 45 – 55°C • In H/O mode • Run up for at least 10 m, and measure time taken to travel next 20 m on flat ground. 	Lo	sec.	- 27.7	20 - 28
			Mi		17.1	14.5 - 21
			Hi		13.6	12 - 15
	Travel deviation	 <ul style="list-style-type: none"> • Engine at high idling • Hydraulic oil temperature: 45 – 55°C • Run up for at least 10 m, and measure deviation when traveling next 20 m on flat ground. ★ Use a hard horizontal surface.  <ul style="list-style-type: none"> ★ Measure dimension x 	mm	Max. 200	300	

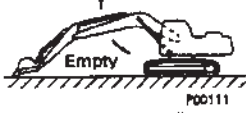
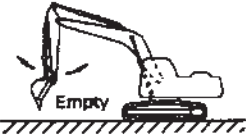
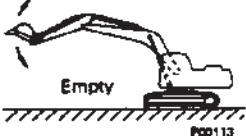
Machine model				PC290-6k			
Category	Item	Measurement conditions	Unit	Standard value		Permissible value	
	Hydraulic drift of travel	 <p>P00108</p> <ul style="list-style-type: none"> ● Engine stopped ● Hydraulic oil temperature: 45-55°C ● Stop machine on 12° slope with sprocket facing straight up the slope. ● Measure the distance the machine moves in 5 min. 	mm		0		0
	Leakage of travel motor	 <p>Lock pin P00109</p> <ul style="list-style-type: none"> ● Engine at high idling ● Hydraulic oil temperature: 45-55°C ● Lock shoes and relieve travel circuit. 	l/min		15		30
Work equipment	Hydraulic drift of work equipment	Total work equipment (hydraulic drift at tip of bucket teeth)	Posture for measurement  <p>P00843</p>	mm		Max 600	Max 900
		Boom cylinder (amount of retraction of cylinder)	<ul style="list-style-type: none"> ● Place in posture and measure extension or retraction of each cylinder and downward movement at tip of bucket teeth. 			Max 18	Max 27
		Arm cylinder (amount of extension of cylinder)	<ul style="list-style-type: none"> ● Bucket: Rated load 2268 kg ● Horizontal, flat ground ● Levers at neutral ● Engine stopped ● Hydraulic oil temperature: 45-55°C 			Max 160	Max 240
		Bucket cylinder (amount of retraction of cylinder)	<ul style="list-style-type: none"> ● Start measuring immediately after setting. ● Measure hydraulic drift every 5 min. and judge from results for 15 min. 			Max 35	Max 53

Machine model				PC290-6K	
Category	Item	Measurement conditions	Unit	Standard value	Permissible value
Work equipment	Work equipment speed	Boom Bucket teeth in contact with ground ⇕ Cylinder fully extended  <ul style="list-style-type: none"> ● Engine at high idling ● Hydraulic oil temperature: 45-55°C ● In H/O mode 	RAISE	3.8	Max 4.5
			LOWER	3.1	Max 3.3
		Arm Cylinder fully retracted ⇕ Fully extended  <ul style="list-style-type: none"> ● Engine at high idling ● Hydraulic oil temperature: 45-55°C ● In H/O mode 	IN	3.8	Max 4.7
			OUT	3.1	Max 3.7
		Bucket Cylinder fully retracted ⇕ Fully extended  <ul style="list-style-type: none"> ● Engine at high idling ● Hydraulic oil temperature: 45-55°C ● In H/O mode 	CURL	3.5	Max 4.0
			DUMP	2.6	Max 3.0
	Time lag	Boom  <ul style="list-style-type: none"> ● Lower boom and measure time taken from point where bucket contacts ground to point where chassis rises from ground. ● Engine at low idling. ● Hydraulic oil temperature: 45-55°C 		Max 1.0	Max 1.2
		Arm  <ul style="list-style-type: none"> ● Stop arm suddenly and measure time taken for arm to stop. ● Engine at low idling. ● Hydraulic oil temperature: 45-55°C 		Max 1.0	Max 3.2

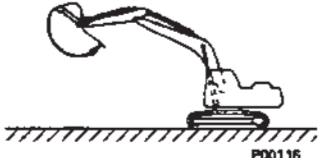
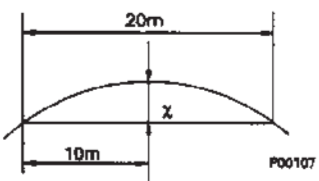
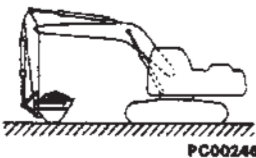
Machine model				PC290-6k		
Category	Item	Measurement conditions	Unit	Standard value	Permissible value	
Work equipment	Time lag	 <ul style="list-style-type: none"> ● Stop bucket suddenly and measure time taken for bucket to stop at bottom and then start again. ● Engine at low idling ● Hydraulic oil temperature: 45-55°C 	Sec.	Max 1.0	Max 3.6	
	Internal leakage	Cylinders	<ul style="list-style-type: none"> ● Hydraulic oil temperature: 45-55°C ● Engine at high idling ● Relieve circuit to be measured 	cc/min	4.5	20
		Center swivel joint			10	50
Performance in compound operation	Travel deviation when work equipment + travel are operated	<ul style="list-style-type: none"> ● Engine at high idling ● Hydraulic oil temperature: 45-55°C ★ Use a hard horizontal surface  <ul style="list-style-type: none"> ★ Measure dimension x 	mm	Max 200	Max 220	
	Time taken for boom RAISE and starting swing	 <ul style="list-style-type: none"> ● Engine at high idling ● Hydraulic oil temperature: 45-55°C ● In H/O mode ● Load the bucket with the rated load and measure the time taken from the position of starting the swing to the point of passing the 90° position. 	Sec.	4.6 ± 0.4	4.6 ± 0.4	

Category	Discharge amount of main piston pump (in H/O mode)
----------	--

Performance of hydraulic pump

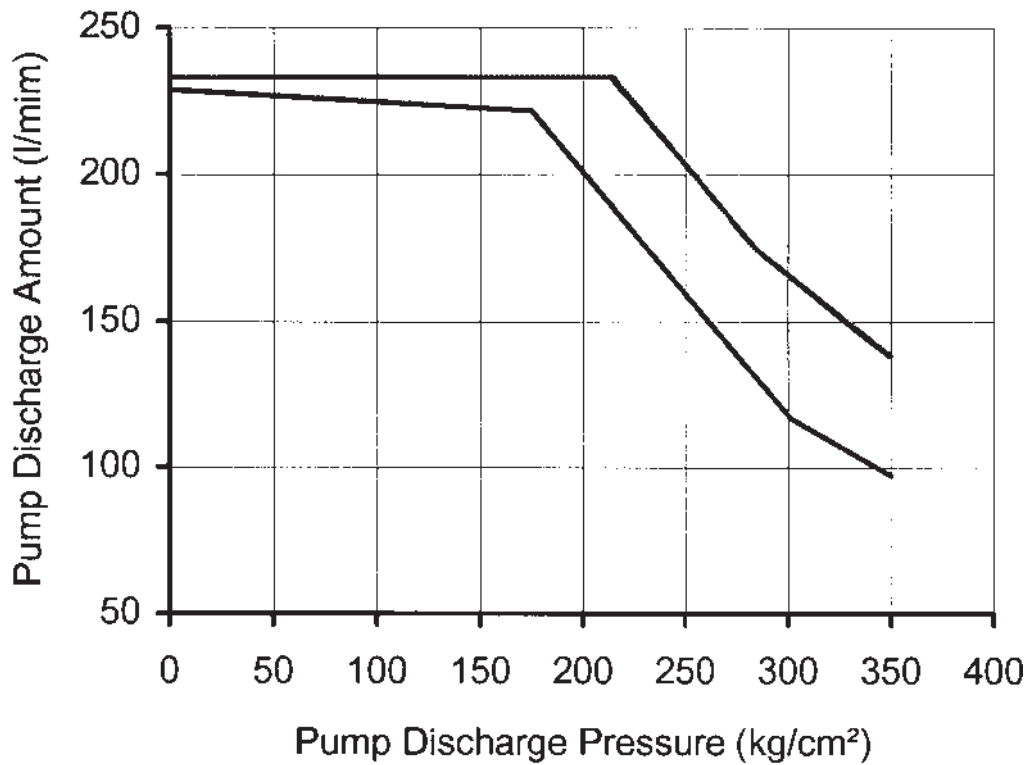

- Pump speed: At 2200 rpm, PC current 180 mA

Check point	Test pump discharge pressure (kg/cm ²)	Discharge pressure of other pump (kg/cm ²)	Average pressure (kg/cm ²)	Standard value for discharge amount Q (l/min)	Judgement standard lower limit Q (l/min)
As desired	P1	P2	$\frac{P_1 + P_2}{2}$	See graph	See graph

- ★ As far as possible, bring pump discharge pressures P₁ and P₂ as close as possible to the average pressure when measuring.
The error is large near the point where the graph curves, so avoid measuring at this point.
- ★ When measuring with the pump mounted on the machine, if it is impossible to set the engine speed to the specified speed with the fuel control dial, take the pump discharge amount and the engine speed at the point of measurement, and use them as a base for calculating the pump discharge amount at the specified speed.

STANDARD VALUE TABLE FOR ELECTRICAL PARTS

System	Name of component	Connector No.	Inspection method	Judgement table	Measurement conditions		
Control system	Fuel control dial	E06 (male)	Measure resistance	If the condition is within the range shown in the table below, it is normal	1) Turn starting switch OFF. 2) Disconnect connector.		
				Between (1) - (2)		0.25 - 7 kΩ	
				Between (2) - (3)		0.25 - 7 kΩ	
	Between (1) - (3)	4 - 6 kΩ					
	Governor motor Potentiometer	E04 (male)		If the condition is within the range shown in the table below, it is normal		1) Turn starting switch OFF. 2) Disconnect connector.	
				Between (1) - (2)			0.25 - 7 kΩ
				Between (2) - (3)			0.25 - 7 kΩ
	Between (1) - (3)	4 - 6 kΩ					
	Governor motor Motor	E05 (male)		If the condition is as shown in the table below, it is normal			1) Turn starting switch OFF. 2) Disconnect connector.
			Between (1) - (2)	2.5 - 7.5 Ω			
Between (3) - (4)			2.5 - 7.5 Ω				
Between (1) - (3)			No continuity				
Between (1) - chassis			No continuity				
Between (3) - chassis	No continuity						
Engine speed sensor	E07	Measure resistance	If the condition is within the range shown in the table below, it is normal	1) Turn starting switch OFF. 2) Disconnect connector.			
			Between(male) (1) - (2)		500 - 1,000 Ω		
			Between(male) (2) - chassis		Min. 1 MΩ		
		Measure voltage	Measure with AC range		1) Start engine. 2) Insert T-adapter.		
			Between (1) - (2)			0.5 - 3.0 V	
		Adjust	1) Screw in rotation sensor until it contacts ring gear, then turn back $1 \pm 1/6$ turns. 2) It must work normally when adjusted as above.				
PPC oil pressure switch	Travel S01 Boom RAISE S02 Arm OUT S03 Boom LOWER S04 Arm IN S05 Bucket CURL S06 Bucket DUMP S07 Right Swing S08 Left Swing S10	Measure resistance	If the condition is as shown in the table below, it is normal	1) Start engine (or with engine stopped and accumulator charged) 2) Disconnect connectors S01 - S09			
			When boom, arm, and bucket levers are operated				
			Between (male) (1) - (2)		All levers at neutral Levers operated	No continuity Max. 1 Ω	
			Between (male) (1), (2) - chassis		No continuity		

System	Name of component	Connector No.	Inspection method	Judgement table	Measurement conditions							
Control system	Pump pressure sensor	C07 (male) (rear) C08 (male) (front)	Measure voltage	<p>If the condition is as shown in the table below, it is normal</p> <table border="1"> <tr> <td>Between (2) - (1)</td> <td>18 - 28 V</td> </tr> <tr> <td rowspan="2">Between (3) - (1)</td> <td>All levers at neutral</td> <td>0.5 - 1.5 V</td> </tr> <tr> <td>At arm IN relief</td> <td>3.1 - 4.5 V</td> </tr> </table>	Between (2) - (1)	18 - 28 V	Between (3) - (1)	All levers at neutral	0.5 - 1.5 V	At arm IN relief	3.1 - 4.5 V	<ol style="list-style-type: none"> 1) Start engine. 2) Turn fuel control dial to MAX position 3) Insert T - adapter
	Between (2) - (1)	18 - 28 V										
	Between (3) - (1)	All levers at neutral	0.5 - 1.5 V									
		At arm IN relief	3.1 - 4.5 V									
	Swing lock switch	X05 (female)	Measure resistance	<p>If the condition is as shown in the table below, it is normal</p> <table border="1"> <tr> <td rowspan="2">Between (1) - (2) Between (3) - (4)</td> <td>When switch is OFF</td> <td>No continuity</td> </tr> <tr> <td>When switch is ON</td> <td>Max. 1 Ω</td> </tr> </table>	Between (1) - (2) Between (3) - (4)	When switch is OFF	No continuity	When switch is ON	Max. 1 Ω	<ol style="list-style-type: none"> 1) Turn starting switch OFF. 2) Disconnect connector. 		
	Between (1) - (2) Between (3) - (4)	When switch is OFF		No continuity								
		When switch is ON		Max. 1 Ω								
PC-EPC solenoid valve	C13 (male)	<p>If the condition is as shown in the table below, it is normal</p> <table border="1"> <tr> <td>Between (1) - (2)</td> <td>10 - 14 Ω</td> </tr> <tr> <td>Between (1), (2) - chassis</td> <td>No continuity</td> </tr> </table>		Between (1) - (2)	10 - 14 Ω	Between (1), (2) - chassis	No continuity	<ol style="list-style-type: none"> 1) Turn pump prolix switch OFF. 2) Turn starting switch OFF. 3) Disconnect connectors 				
Between (1) - (2)	10 - 14 Ω											
Between (1), (2) - chassis	No continuity											
Swing holding brake solenoid	V04 (male)	<p>If the condition is within the range shown in the table below, it is normal</p> <table border="1"> <tr> <td>Between (1) - (2)</td> <td>20 - 60 Ω</td> </tr> <tr> <td>Between (1), (2) - chassis</td> <td>No continuity</td> </tr> </table>	Between (1) - (2)	20 - 60 Ω	Between (1), (2) - chassis	No continuity	<ol style="list-style-type: none"> 1) Turn starting switch OFF. 2) Disconnect connector 					
Between (1) - (2)	20 - 60 Ω											
Between (1), (2) - chassis	No continuity											
Travel speed solenoid	V06 (male)											
2-stage relief solenoid	V05 (male)											
Junction solenoid	V03 (male)											
Active mode solenoid	V02 (male)											
LS-EPC solenoid	C10 (male)	<p>If the condition is within the range shown in the table below, it is normal</p> <table border="1"> <tr> <td>Between (1) - (2)</td> <td>20 - 14 Ω</td> </tr> <tr> <td>Between (1), (2) - chassis</td> <td>No continuity</td> </tr> </table>	Between (1) - (2)	20 - 14 Ω	Between (1), (2) - chassis	No continuity						
Between (1) - (2)	20 - 14 Ω											
Between (1), (2) - chassis	No continuity											
Engine throttle • pump controller	Power source voltage	C01 C02	Measure voltage	<p>If the condition is within the range shown in the table below, it is normal</p> <table border="1"> <tr> <td>Between C01 (7),(13) - (6),(12)</td> <td>20 - 30 V</td> </tr> <tr> <td>Between C02 (11),(21) - C01 (6),(12)</td> <td>20 - 30 V</td> </tr> </table>	Between C01 (7),(13) - (6),(12)	20 - 30 V	Between C02 (11),(21) - C01 (6),(12)	20 - 30 V	<ol style="list-style-type: none"> 1) Turn starting switch ON. 2) Insert T - adapter. 			
Between C01 (7),(13) - (6),(12)	20 - 30 V											
Between C02 (11),(21) - C01 (6),(12)	20 - 30 V											

System	Name of component	Connector No.	Inspection method	Judgement table	Measurement conditions							
Control system	Governor • pump controller	Fuel control dial	C03	Measure voltage	<p>If the condition is as shown in the table below, it is normal</p> <table border="1"> <tr> <td>Between (7) - (17) (power source)</td> <td>4.75 - 5.25 V</td> </tr> <tr> <td>Between (4) - (17) (low idling)</td> <td>4.0 - 4.75 V</td> </tr> <tr> <td>Between (4) - (17) (high idling)</td> <td>0.25 - 1.0 V</td> </tr> </table>	Between (7) - (17) (power source)	4.75 - 5.25 V	Between (4) - (17) (low idling)	4.0 - 4.75 V	Between (4) - (17) (high idling)	0.25 - 1.0 V	<ol style="list-style-type: none"> 1) Turn starting switch ON. 2) Insert T - adapter
		Between (7) - (17) (power source)	4.75 - 5.25 V									
		Between (4) - (17) (low idling)	4.0 - 4.75 V									
		Between (4) - (17) (high idling)	0.25 - 1.0 V									
		Governor potentiometer	C03	Measure voltage	<p>If the condition is as shown in the table below, it is normal</p> <table border="1"> <tr> <td>Between (14) - (17) (low idling)</td> <td>2.9 - 3.3 V</td> </tr> <tr> <td>Between (14) - (17) (high idling)</td> <td>0.5 - 0.9 V</td> </tr> </table> <table border="1"> <tr> <td>Between (7) - (17) (power source)</td> <td>4.75 - 5.25 V</td> </tr> </table>	Between (14) - (17) (low idling)	2.9 - 3.3 V	Between (14) - (17) (high idling)	0.5 - 0.9 V	Between (7) - (17) (power source)	4.75 - 5.25 V	<ol style="list-style-type: none"> 1) Turn starting switch ON. 2) Insert T - adapter
Between (14) - (17) (low idling)	2.9 - 3.3 V											
Between (14) - (17) (high idling)	0.5 - 0.9 V											
Between (7) - (17) (power source)	4.75 - 5.25 V											
Coolant temperature sensor	P07 (male)	Measure resistance	<p>If the condition is as shown in the table below, it is normal</p> <table border="1"> <tr> <td>Normal temperature (25°C)</td> <td>Approx. 37 - 50 kΩ</td> </tr> <tr> <td>100°C</td> <td>Approx. 3.5 - 4.0 kΩ</td> </tr> </table>	Normal temperature (25°C)	Approx. 37 - 50 kΩ	100°C	Approx. 3.5 - 4.0 kΩ	<ol style="list-style-type: none"> 1) Turn starting switch OFF. 2) Disconnect connector 3) Insert T - adapter into connector at sensor end. 				
Normal temperature (25°C)	Approx. 37 - 50 kΩ											
100°C	Approx. 3.5 - 4.0 kΩ											
Governor motor	C02	Measure voltage	<p>If the condition is as shown in the table below, it is normal</p> <table border="1"> <tr> <td>Between (2) - (3)</td> <td>1.8 - 4.6 V</td> </tr> <tr> <td>Between (4) - (5)</td> <td>1.8 - 4.6 V</td> </tr> </table>	Between (2) - (3)	1.8 - 4.6 V	Between (4) - (5)	1.8 - 4.6 V	<ol style="list-style-type: none"> 1) Turn starting switch ON. 2) Insert T - adapter. 				
Between (2) - (3)	1.8 - 4.6 V											
Between (4) - (5)	1.8 - 4.6 V											
Battery relay	C01	<p>If the condition is within the range shown in the table below, it is normal</p> <table border="1"> <tr> <td>Between (2) - (3)</td> <td>1.8 - 4.6 V</td> </tr> </table> <p>★This is only for 2.5 sec after the starting switch i operated ON → OFF; at other times it must be 0 V.</p>	Between (2) - (3)	1.8 - 4.6 V	<ol style="list-style-type: none"> 1) Turn starting switch ON. 2) Insert T - adapter. 							
Between (2) - (3)	1.8 - 4.6 V											
Overload caution pressure sensor	K03 (male) (rear)	Measure voltage	<p>If the condition is as shown in the table below, it is normal</p> <table border="1"> <tr> <td>Between (2) - (1)</td> <td>18 - 28 V</td> </tr> </table> <table border="1"> <tr> <td rowspan="2">Between (3) - (1)</td> <td>All levers at neutral</td> <td>0.5 - 1.5 V</td> </tr> <tr> <td>Boom raise relief</td> <td>3.1 - 4.5 V</td> </tr> </table>	Between (2) - (1)	18 - 28 V	Between (3) - (1)	All levers at neutral	0.5 - 1.5 V	Boom raise relief	3.1 - 4.5 V	<ol style="list-style-type: none"> 1) Start engine. 2) Turn fuel control dial to max position. 3) Insert T - adapter. 	
Between (2) - (1)	18 - 28 V											
Between (3) - (1)	All levers at neutral	0.5 - 1.5 V										
	Boom raise relief	3.1 - 4.5 V										

System	Name of component	Connector No.	Inspection method	Judgement table	Measurement conditions					
Control system	Governor • pump controller	C01	Measure voltage	<p>If the condition is as shown in the table below, it is normal</p> <table border="1"> <tr> <td>When either swing or work equipment control lever is operated (solenoid ON, swing holding brake canceled)</td> <td rowspan="2">Between (3) - (6), (12)</td> <td>20 -30 V</td> </tr> <tr> <td>Approx. 5 sec after swing lever and work equipment levers are placed at neutral (solenoid OFF, swing holding brake applied)</td> <td>0 - 3 V</td> </tr> </table>	When either swing or work equipment control lever is operated (solenoid ON, swing holding brake canceled)	Between (3) - (6), (12)	20 -30 V	Approx. 5 sec after swing lever and work equipment levers are placed at neutral (solenoid OFF, swing holding brake applied)	0 - 3 V	<ol style="list-style-type: none"> 1) Start engine. 2) Turn swing lock switch OFF. 3) Turn swing lock prolix switch OFF. 4) Insert T - adapter. <p>★ The lever can be operated slightly (without moving the equipment).</p>
				When either swing or work equipment control lever is operated (solenoid ON, swing holding brake canceled)	Between (3) - (6), (12)		20 -30 V			
				Approx. 5 sec after swing lever and work equipment levers are placed at neutral (solenoid OFF, swing holding brake applied)		0 - 3 V				
				<p>If the condition is as shown in the table below, it is normal</p> <table border="1"> <tr> <td>With travel speed switch at Hi or Mi (solenoid ON, travel motor swash plate angle MIN)</td> <td rowspan="2">Between (9) - (6), (12)</td> <td>20 -30 V</td> </tr> <tr> <td>When travel speed switch is at Lo (solenoid OFF travel motor swash plate angle MAX)</td> <td>0 - 3 V</td> </tr> </table>	With travel speed switch at Hi or Mi (solenoid ON, travel motor swash plate angle MIN)	Between (9) - (6), (12)	20 -30 V	When travel speed switch is at Lo (solenoid OFF travel motor swash plate angle MAX)	0 - 3 V	<ol style="list-style-type: none"> 1) Start engine. 2) Insert T - adapter. 3) Turn fuel control dial to MAX position. 4) Operate the lever slightly not enough to move the machine. <p>To check that the solenoid is OFF, measure with the fuel control dial at LOW (1200 rpm or below)</p>
With travel speed switch at Hi or Mi (solenoid ON, travel motor swash plate angle MIN)	Between (9) - (6), (12)	20 -30 V								
When travel speed switch is at Lo (solenoid OFF travel motor swash plate angle MAX)		0 - 3 V								
<p>If the condition is as shown in the table below, it is normal</p> <table border="1"> <tr> <td>When swing lock switch is OFF, and swing + travel levers are operated simultaneously (solenoid ON, LS not divided)</td> <td rowspan="2">Between (8) - (6), (12)</td> <td>20 -30 V</td> </tr> <tr> <td>When sing lock switch is ON (solenoid OFF, LS not divided)</td> <td>0 - 3 V</td> </tr> </table>	When swing lock switch is OFF, and swing + travel levers are operated simultaneously (solenoid ON, LS not divided)	Between (8) - (6), (12)	20 -30 V	When sing lock switch is ON (solenoid OFF, LS not divided)	0 - 3 V	<ol style="list-style-type: none"> 1) Turn starting switch ON. 2) Isert T - adapter. <p>★ The lever can be operated slightly (without moving the equipment).</p>				
When swing lock switch is OFF, and swing + travel levers are operated simultaneously (solenoid ON, LS not divided)	Between (8) - (6), (12)		20 -30 V							
When sing lock switch is ON (solenoid OFF, LS not divided)		0 - 3 V								
<p>If the condition is as shown in the table below, it is normal.</p> <table border="1"> <tr> <td>When travel is operated independently (solenoid ON, divided)</td> <td rowspan="2">Between (2) - (6), (12)</td> <td>20 -30 V</td> </tr> <tr> <td>When levers and pedals are at neutral (solenoid OFF, merged)</td> <td>0 - 3 V</td> </tr> </table>	When travel is operated independently (solenoid ON, divided)	Between (2) - (6), (12)	20 -30 V	When levers and pedals are at neutral (solenoid OFF, merged)	0 - 3 V	<ol style="list-style-type: none"> 1) Turn starting switch ON. 2) Insert T - adapter. <p>★ The lever can be operated slightly (without moving the equipment).</p>				
When travel is operated independently (solenoid ON, divided)	Between (2) - (6), (12)		20 -30 V							
When levers and pedals are at neutral (solenoid OFF, merged)		0 - 3 V								

System	Name of component	Connector No.	Inspection method	Judgement table	Measurement conditions																			
Control system	Governor, pump controller	2-stage relief solenoid	C01	Measure voltage	<p>If the condition is as shown in the table below, it is normal.</p> <table border="1"> <tr> <td>Swing lock switch ON (solenoid ON: High pressure)</td> <td rowspan="2">Between (10) - (6), (12)</td> <td>20 - 30 V</td> </tr> <tr> <td>Swing lock switch OFF (solenoid OFF: Low pressure)</td> <td>0 - 3 V</td> </tr> </table>	Swing lock switch ON (solenoid ON: High pressure)	Between (10) - (6), (12)	20 - 30 V	Swing lock switch OFF (solenoid OFF: Low pressure)	0 - 3 V	<ol style="list-style-type: none"> 1) Start engine 2) Insert T-adapter 													
		Swing lock switch ON (solenoid ON: High pressure)	Between (10) - (6), (12)	20 - 30 V																				
		Swing lock switch OFF (solenoid OFF: Low pressure)		0 - 3 V																				
		PC solenoid valve (default value)	C02	Measure current	<p>If the condition is as shown in the table below, it is normal</p> <table border="1"> <tr> <td>Between (8) - (18)</td> <td>515 ± 100 mA</td> </tr> </table>	Between (8) - (18)	515 ± 100 mA	<ol style="list-style-type: none"> 1) Turn starting switch ON. 2) Turn fuel control dial to MAX position 3) Turn prolix switch OFF. 4) All levers at neutral. 																
		Between (8) - (18)	515 ± 100 mA																					
		LS-EPC solenoid valve (default value)	C02	Measure current	<p>If the condition is as shown in the table below, it is normal</p> <ul style="list-style-type: none"> • H/O mode <table border="1"> <tr> <td>Between (7) - (17)</td> <td>900 ± 80 mA</td> </tr> </table>	Between (7) - (17)	900 ± 80 mA	<ol style="list-style-type: none"> 1) Turn starting switch ON. 2) Turn fuel control dial to MAX position 3) All levers at neutral. 																
		Between (7) - (17)	900 ± 80 mA																					
L.H. knob switch	C03	Measure voltage	<p>If the condition is as shown in the table below, it is normal</p> <table border="1"> <tr> <td>When switch is ON</td> <td rowspan="2">Between (9) - GND</td> <td>20 - 28 V</td> </tr> <tr> <td>When switch is OFF</td> <td>0 - 1 V</td> </tr> </table>	When switch is ON	Between (9) - GND	20 - 28 V	When switch is OFF	0 - 1 V	<ol style="list-style-type: none"> 1) Turn starting switch ON. 2) Insert T - adapter. 															
When switch is ON	Between (9) - GND	20 - 28 V																						
When switch is OFF		0 - 1 V																						
S-NET	C17	Measure voltage	<p>If the condition is as shown in the table below, it is normal</p> <table border="1"> <tr> <td>Between (4), (12) - GND</td> <td>4 - 8 V</td> </tr> </table>	Between (4), (12) - GND	4 - 8 V	<ol style="list-style-type: none"> 1) Turn starting switch ON. 2) Insert T - adapter 																		
Between (4), (12) - GND	4 - 8 V																							
No. 2 throttle signal	Monitoring code 16	Engine speed	<p>If the condition is as shown in the table below, it is normal</p> <table border="1"> <tr> <td></td> <td>PC290</td> </tr> <tr> <td>Active mode</td> <td>Approx 2300</td> </tr> <tr> <td>H/O (working)</td> <td>Approx 2300</td> </tr> <tr> <td>H/O (travelling)</td> <td>Approx 2400</td> </tr> <tr> <td>G/O</td> <td>Approx 2100</td> </tr> <tr> <td>F/O</td> <td>Approx 2100</td> </tr> <tr> <td>L/O</td> <td>Approx 1750</td> </tr> <tr> <td>B/O</td> <td>Approx 2100</td> </tr> <tr> <td>Power Max (H/O, G/O)</td> <td>Approx 2400</td> </tr> <tr> <td>Swift slow down (H/O, G/O)</td> <td>Approx 1750</td> </tr> </table>		PC290	Active mode	Approx 2300	H/O (working)	Approx 2300	H/O (travelling)	Approx 2400	G/O	Approx 2100	F/O	Approx 2100	L/O	Approx 1750	B/O	Approx 2100	Power Max (H/O, G/O)	Approx 2400	Swift slow down (H/O, G/O)	Approx 1750	<ol style="list-style-type: none"> 1) Start engine. 2) Set monitoring code to 10 or 16 (command value). 3) Operate working mode switch and L.H. knob switch.
	PC290																							
Active mode	Approx 2300																							
H/O (working)	Approx 2300																							
H/O (travelling)	Approx 2400																							
G/O	Approx 2100																							
F/O	Approx 2100																							
L/O	Approx 1750																							
B/O	Approx 2100																							
Power Max (H/O, G/O)	Approx 2400																							
Swift slow down (H/O, G/O)	Approx 1750																							
Model selection	C17 - C02	Continuity	<p>If the condition is as shown in the table below, it is normal</p> <table border="1"> <tr> <td>Between selection 1</td> <td>C17 (5) - C02 (11)</td> <td>No continuity</td> </tr> <tr> <td>Between selection 2</td> <td>C17 (13) - C02 (11)</td> <td>Continuity</td> </tr> <tr> <td>Between selection 3</td> <td>C17 (6) - C02 (11)</td> <td>Continuity</td> </tr> <tr> <td>Between selection 4</td> <td>C17 (14) - C02 (11)</td> <td>Continuity</td> </tr> <tr> <td>Between selection 5</td> <td>C17 (7) - C02 (11)</td> <td>No continuity</td> </tr> </table>	Between selection 1	C17 (5) - C02 (11)	No continuity	Between selection 2	C17 (13) - C02 (11)	Continuity	Between selection 3	C17 (6) - C02 (11)	Continuity	Between selection 4	C17 (14) - C02 (11)	Continuity	Between selection 5	C17 (7) - C02 (11)	No continuity	<ol style="list-style-type: none"> 1) Turn starting switch OFF. 2) Disconnect connector. 3) Connect T - adapter to wiring harness end. 					
Between selection 1	C17 (5) - C02 (11)	No continuity																						
Between selection 2	C17 (13) - C02 (11)	Continuity																						
Between selection 3	C17 (6) - C02 (11)	Continuity																						
Between selection 4	C17 (14) - C02 (11)	Continuity																						
Between selection 5	C17 (7) - C02 (11)	No continuity																						

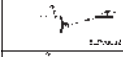
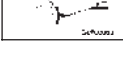
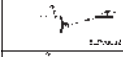
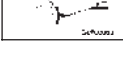
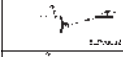
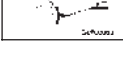
System	Name of component	Connector No.	Inspection method	Judgement table	Measurement conditions						
Monitor	Air cleaner clogging sensor	P11 (male) P12 (female)	Continuity	<p>If the condition is as shown in the table below, it is normal</p> <table border="1"> <tr> <td>Air cleaner normal</td> <td>Between P11 - P12</td> <td>Continuity</td> </tr> <tr> <td>Air cleaner clogged</td> <td></td> <td>No continuity</td> </tr> </table>	Air cleaner normal	Between P11 - P12	Continuity	Air cleaner clogged		No continuity	<ol style="list-style-type: none"> Turn starting switch ON. Disconnect connector.
	Air cleaner normal	Between P11 - P12	Continuity								
	Air cleaner clogged		No continuity								
	Engine speed sensor	E07	Measure resistance	<p>If the condition is within the range shown in the table below, it is</p> <table border="1"> <tr> <td>Between (male) (1) - (2)</td> <td>500 - 1000 Ω</td> </tr> <tr> <td>Between (male) (1) - (2) chassis</td> <td>No continuity</td> </tr> </table>	Between (male) (1) - (2)	500 - 1000 Ω	Between (male) (1) - (2) chassis	No continuity	<ol style="list-style-type: none"> Turn starting switch OFF. Disconnect connector. 		
			Between (male) (1) - (2)	500 - 1000 Ω							
			Between (male) (1) - (2) chassis	No continuity							
Measure voltage	<p>Measure with AC range</p> <table border="1"> <tr> <td>Between (1) - (2)</td> <td>0.5 - 3.0 V</td> </tr> </table>	Between (1) - (2)	0.5 - 3.0 V	<ol style="list-style-type: none"> Start engine. Insert T - adapter. 							
Between (1) - (2)	0.5 - 3.0 V										
Adjust	<ol style="list-style-type: none"> Screw in rotation sensor until it contacts ring gear, then turn back $1 \pm 1/6$ turns It must work normally when adjusted as above. 										
Coolant level sensor	P08 (male)	Measure resistance	<p>If the condition is as shown in the table below, it is normal</p> <table border="1"> <tr> <td>Above LOW level in sub-tank</td> <td>Max. 1Ω</td> </tr> <tr> <td>Below LOW level in sub-tank</td> <td>No continuity</td> </tr> </table>	Above LOW level in sub-tank	Max. 1Ω	Below LOW level in sub-tank	No continuity	<ol style="list-style-type: none"> Turn starting switch OFF. Disconnect connector. Insert T - adapter into connector at sensor end. 			
Above LOW level in sub-tank	Max. 1Ω										
Below LOW level in sub-tank	No continuity										
Engine oil level sensor	P05 (male)	Measure resistance	<p>If the condition is as shown in the table below, it is normal</p> <table border="1"> <tr> <td> Raise float</td> <td>Max. 1Ω</td> </tr> <tr> <td> Lower float</td> <td>No continuity</td> </tr> </table>	 Raise float	Max. 1Ω	 Lower float	No continuity	<ol style="list-style-type: none"> Turn starting switch OFF. Disconnect connector. Drain oil, then remove sensor. 			
 Raise float	Max. 1Ω										
 Lower float	No continuity										
Coolant temperature sensor	P07 (male)	Measure resistance	<p>If the condition is as shown in the table below, it is normal</p> <table border="1"> <tr> <td>Normal temperature (25°C)</td> <td>Approx. 37 - 50 kΩ</td> </tr> <tr> <td>100°C</td> <td>Approx. 3.5 - 4.0 kΩ</td> </tr> </table>	Normal temperature (25°C)	Approx. 37 - 50 kΩ	100°C	Approx. 3.5 - 4.0 kΩ	<ol style="list-style-type: none"> Turn starting switch OFF. Disconnect connector . Insert T - adapter into connector at sensor end. 			
Normal temperature (25°C)	Approx. 37 - 50 kΩ										
100°C	Approx. 3.5 - 4.0 kΩ										

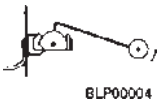
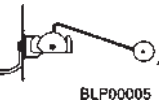
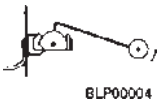
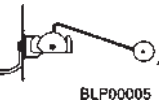
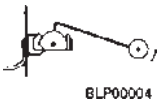
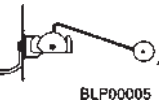
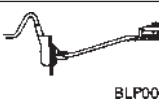
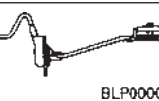
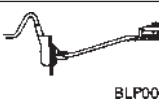
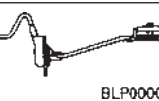
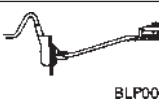
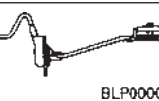
System	Name of component	Connector No.	Inspection method	Judgement table	Measurement conditions				
Monitor	Engine oil pressure sensor	S11	Measure resistance	<p>If the condition is as shown in the table below, it is normal.</p> <table border="1"> <tr> <td>Engine oil pressure above 0.07 MPa</td> <td>No continuity</td> </tr> <tr> <td>Engine oil pressure below 0.03 MPa</td> <td>Max 1MΩ</td> </tr> </table>	Engine oil pressure above 0.07 MPa	No continuity	Engine oil pressure below 0.03 MPa	Max 1MΩ	<ol style="list-style-type: none"> 1) Install oil pressure measuring gauge. 2) Remove wiring harness terminal. 3) Start engine. 4) Put tester in contact between sensor terminals A & C.
	Engine oil pressure above 0.07 MPa	No continuity							
	Engine oil pressure below 0.03 MPa	Max 1MΩ							
	Fuel level sensor	P06 (male)	Measure resistance	<p>If the condition is as shown in the table below, it is normal</p> <table border="1"> <tr> <td>  <p>BLP00004</p> <p>Raise float to stopper</p> </td> <td>Approx. 12 Ω or below</td> </tr> <tr> <td>  <p>BLP00005</p> <p>Lower float to stopper</p> </td> <td>Approx. 85 - 110 Ω</td> </tr> </table>	 <p>BLP00004</p> <p>Raise float to stopper</p>	Approx. 12 Ω or below	 <p>BLP00005</p> <p>Lower float to stopper</p>	Approx. 85 - 110 Ω	<ol style="list-style-type: none"> 1) Turn starting switch OFF. 2) Disconnect connector P06. 3) Drain fuel, then remove sensor. 4) Insert T - adapter into sensor. <p>★ Connect the T - adapter to the connector and sensor flange.</p>
 <p>BLP00004</p> <p>Raise float to stopper</p>	Approx. 12 Ω or below								
 <p>BLP00005</p> <p>Lower float to stopper</p>	Approx. 85 - 110 Ω								
Hydraulic oil level sensor	P09 (male)	Measure resistance	<p>If the condition is as shown in the table below, it is normal</p> <table border="1"> <tr> <td>  <p>BLP00002</p> <p>Raise float</p> </td> <td>Approx. 12 Ω or below</td> </tr> <tr> <td>  <p>BLP00003</p> <p>Lower float</p> </td> <td>No continuity</td> </tr> </table>	 <p>BLP00002</p> <p>Raise float</p>	Approx. 12 Ω or below	 <p>BLP00003</p> <p>Lower float</p>	No continuity	<ol style="list-style-type: none"> 1) Turn starting switch OFF. 2) Disconnect connector P09 3) Drain oil, then remove sensor. 4) Insert T - adapter into sensor. 	
 <p>BLP00002</p> <p>Raise float</p>	Approx. 12 Ω or below								
 <p>BLP00003</p> <p>Lower float</p>	No continuity								
Air Cleaner	P11 (male)	Continuity	<p>If the condition is as shown in the table below, it is normal</p> <table border="1"> <tr> <td>Air cleaner normal</td> <td>Continuity</td> </tr> <tr> <td>Air cleaner clogged</td> <td>No continuity</td> </tr> </table>	Air cleaner normal	Continuity	Air cleaner clogged	No continuity	<ol style="list-style-type: none"> 1) Start engine. 2) Disconnect connectors. 3) Put tester in contact with connector at sensor end to measure. 	
Air cleaner normal	Continuity								
Air cleaner clogged	No continuity								
Clogging sensor	P12 (female)								
Alternator	Between alternator terminal R and chassis	Measure voltage	<p>When engine is running (1/2 throttle or above) below, the voltage should be → 27.5 - 29.5 V</p> <p>★ If the battery is old, or after starting in cold areas, the voltage may not rise for some time.</p>	<ol style="list-style-type: none"> 1) Start engine 					

System	Name of component	Connector No.	Inspection method	Judgement table	Measurement conditions																															
Gauges		If the condition is as shown in the table below, it is normal.																																		
			Position of gauge display	Display level resistance (Monitor panel input resistance) kΩ																																
			Starting switch ON	Starting switch OFF																																
	Coolant temp gauge Measure resistance between C03 (female) (1) - (16)	Right side Display position Left side	<table border="1" style="width: 100%; border-collapse: collapse;"> <tr> <td style="text-align: center;">All OFF</td> <td style="text-align: center;">Min</td> <td style="text-align: center;">Max</td> </tr> <tr> <td style="text-align: center;">9</td> <td></td> <td style="text-align: center;">0.646</td> </tr> <tr> <td style="text-align: center;">8</td> <td style="text-align: center;">0.575</td> <td style="text-align: center;">0.342</td> </tr> <tr> <td style="text-align: center;">7</td> <td style="text-align: center;">3.156</td> <td style="text-align: center;">3.708</td> </tr> <tr> <td style="text-align: center;">6</td> <td style="text-align: center;">3.422</td> <td style="text-align: center;">3.900</td> </tr> <tr> <td style="text-align: center;">5</td> <td style="text-align: center;">3.600</td> <td style="text-align: center;">4.349</td> </tr> <tr> <td style="text-align: center;">4</td> <td style="text-align: center;">4.015</td> <td style="text-align: center;">5.122</td> </tr> <tr> <td style="text-align: center;">3</td> <td style="text-align: center;">4.728</td> <td style="text-align: center;">6.818</td> </tr> <tr> <td style="text-align: center;">2</td> <td style="text-align: center;">6.294</td> <td style="text-align: center;">10.774</td> </tr> <tr> <td style="text-align: center;">1</td> <td style="text-align: center;">9.946</td> <td style="text-align: center;">36.535</td> </tr> <tr> <td></td> <td style="text-align: center;">33.725</td> <td></td> </tr> </table>	All OFF	Min	Max	9		0.646	8	0.575	0.342	7	3.156	3.708	6	3.422	3.900	5	3.600	4.349	4	4.015	5.122	3	4.728	6.818	2	6.294	10.774	1	9.946	36.535		33.725	
All OFF	Min	Max																																		
9		0.646																																		
8	0.575	0.342																																		
7	3.156	3.708																																		
6	3.422	3.900																																		
5	3.600	4.349																																		
4	4.015	5.122																																		
3	4.728	6.818																																		
2	6.294	10.774																																		
1	9.946	36.535																																		
	33.725																																			
	Fuel level gauge Measure resistance between C03 (female) (2) - chassis	Right side Display position Left side	<table border="1" style="width: 100%; border-collapse: collapse;"> <tr> <td style="text-align: center;">9</td> <td style="text-align: center;">Min</td> <td style="text-align: center;">Max</td> </tr> <tr> <td style="text-align: center;">8</td> <td></td> <td style="text-align: center;">13.82</td> </tr> <tr> <td style="text-align: center;">7</td> <td style="text-align: center;">11.71</td> <td style="text-align: center;">21.25</td> </tr> <tr> <td style="text-align: center;">6</td> <td style="text-align: center;">18.90</td> <td style="text-align: center;">28.45</td> </tr> <tr> <td style="text-align: center;">5</td> <td style="text-align: center;">25.82</td> <td style="text-align: center;">31.85</td> </tr> <tr> <td style="text-align: center;">4</td> <td style="text-align: center;">29.18</td> <td style="text-align: center;">39.91</td> </tr> <tr> <td style="text-align: center;">3</td> <td style="text-align: center;">37.00</td> <td style="text-align: center;">44.60</td> </tr> <tr> <td style="text-align: center;">2</td> <td style="text-align: center;">41.77</td> <td style="text-align: center;">55.14</td> </tr> <tr> <td style="text-align: center;">1</td> <td style="text-align: center;">50.42</td> <td style="text-align: center;">77.07</td> </tr> <tr> <td style="text-align: center;">ALL OFF</td> <td style="text-align: center;">72.98</td> <td style="text-align: center;">691.50</td> </tr> <tr> <td></td> <td style="text-align: center;">638.00</td> <td></td> </tr> </table>	9	Min	Max	8		13.82	7	11.71	21.25	6	18.90	28.45	5	25.82	31.85	4	29.18	39.91	3	37.00	44.60	2	41.77	55.14	1	50.42	77.07	ALL OFF	72.98	691.50		638.00	
9	Min	Max																																		
8		13.82																																		
7	11.71	21.25																																		
6	18.90	28.45																																		
5	25.82	31.85																																		
4	29.18	39.91																																		
3	37.00	44.60																																		
2	41.77	55.14																																		
1	50.42	77.07																																		
ALL OFF	72.98	691.50																																		
	638.00																																			

TOOLS FOR TESTING, ADJUSTING AND TROUBLESHOOTING

Check or measurement item	Symbol	Part No.	Part Name	Remarks	
Engine speed	A	799-203-8001 or 799-608-1000	Multi-tachometer Tachometer (electrical type)	0 - 3,000 rpm Digital display L: 60 - 2,000 rpm H: 60 - 19,999 rpm	
Coolant and oil temperatures	B	799-101-1502	Digital temperature gauge	-99 - 1,299°C	
Oil pressure	C	1	799-101-5002	Hydraulic tester	Pressure gauge: 2.5, 5.9, 39.2, 58.8 MPa (25,60,400,600 kg/cm ²)
			790-261-1203	Digital hydraulic tester	Pressure gauge: 69 MPa (700 kg/cm ²)
		2	799-401-2320	Hydraulic gauge	1.0 MPa (10 kg/cm ²)
		3	790-261-1311	Adapter	Both male and female 14 X 1.5 (female PT $\frac{1}{8}$)
			790-261-1321		Both male and female 18 X 1.5 (female PT $\frac{1}{8}$)
			790-261-1331		Both male and female 22 X 1.5 (female PT $\frac{1}{8}$)
		4	799-401-2700	Differential pressure gauge	(12V)
		5	790-261-1360	Adapter	Both male and female 14 X 1.5 (female PT $\frac{1}{8}$)
			790-261-1370	Nut	For 14 X 1.5 blind
			07003-31419	Gasket	For blind
			07040-11409	Plug	For 14 X 1.5 blind
Compression pressure	D	1	795-502-1205	Compression gauge	0 - 6.9 MPa (0 - 70 kg/cm ²)
		2	795-502-1700	Adapter	
Blow-by pressure	E	799-201-1504	Blow-by checker	0 - 4.9 MPa (0 - 500 mm H ₂ O)	
Valve clearance	F	Commercially available	Feeler gauge	—	
Exhaust color	G	1	799-201-9000	Handy Smoke Checker	Discoloration 0 - 70% (with standard color)
		2	Commercially available	Smoke meter	(Discoloration % X 1/10 = Bosch index)
Air supply pressure (boost pressure)	H	799-401-2201	Pressure gauge	199.9 kPa (-760 - 1,500 mm H ₂ O)	
Operating effort	J	79A-264-0020	Push-pull scale	0 - 294N (0 - 30 kg)	
		79A-264-0090		0 - 490N (0 - 50 kg)	
Stroke, hydraulic lift	K	Commercially available	Scale	—	
Work equipment speed	L	Commercially available	Stop watch	—	
Measuring voltage and resistance values	M	79A-264-0210	Tester	—	
Troubleshooting of wiring harnesses and sensors	N	1	799-601-7100	T-adapter assembly	—
		2	799-601-7070	Adapter	For SWP14P
			799-601-7360		For relay 5P
Measuring wear of sockets	P	796-427-1190	Wear gauge	—	
Fuel injection timing valve clearance	Q	795-799-1130	Adapter	—	

MEASURING ENGINE SPEED

⚠ When removing or installing the measuring equipment, be careful not to touch any high temperature parts.

★ Measure the engine speed under the following conditions.

- Coolant temperature: Within operating range
- Hydraulic oil temperature: 45 – 55 °C

1. Installation of tachometer

a. Mechanical meter

- i. Remove the cover under the front pulley, then set probe ① of tachometer **A** on stand ② facing pulley (1)
- ii. Stick silver paper to pulley (1).
- iii. Connect probe 1* and tachometer **A** with the cable.

⚠ When measuring the speed, be careful not to touch any rotating or high temperature part.

b. Electric meter

- i. Install T-adaptor **N1** to connector CN E01 (2) of the engine speed sensor.
- ii. Connect the power source cable to the battery (24V).

2. Start the engine, and measure the engine speed when it is set to the conditions for measuring.

- a. Measuring at low and high idling: Measure the engine speed with the fuel control dial set to low idling and high idling.
- b. Measuring speed at pump relief: Run the engine at full throttle and measure the engine speed when the pump is relieved.
- c. Measure speed at near the rated speed: Run the engine at full throttle, operate the arm lever, and measure the speed when the arm circuit is relieved.

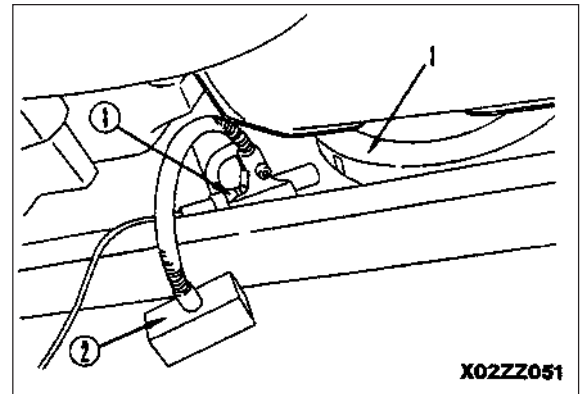

X02ZZ051

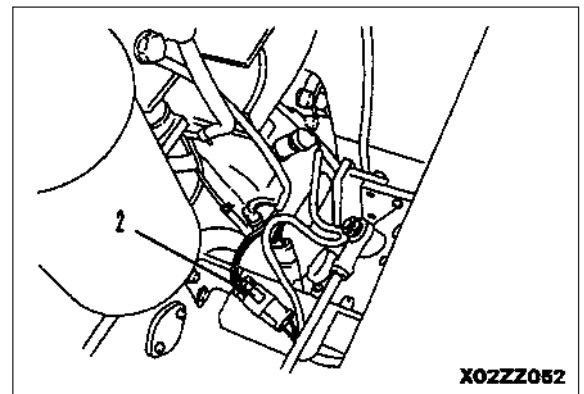

X02ZZ052

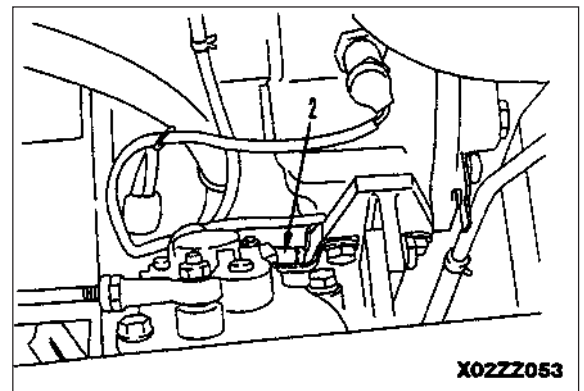

X02ZZ053

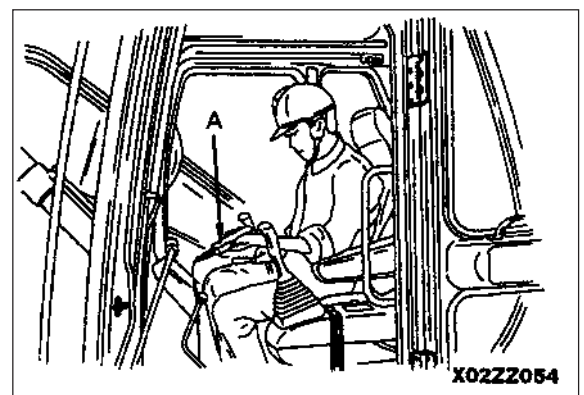

X02ZZ054

MEASURING EXHAUST GAS COLOR

- When measuring in the field when there is no air or power supply, use smoke checker **G1**, when recording official data, use smoke meter **G2**.
- ★ Raise the coolant temperature to the operating range before measuring.
- ⚠ When removing or installing the measuring equipment, be careful not to touch any high temperature parts.

1. Measuring with handy smoke checker **G1**
 - a. Fit filter paper in tool **G1**.
 - b. Insert the exhaust gas intake port into the exhaust pipe, accelerate the engine suddenly, and at the same time operate the handle of tool **G1** to catch the exhaust gas on the filter paper.
 - c. Remove the filter paper and compare it with the scale provided to judge the condition.

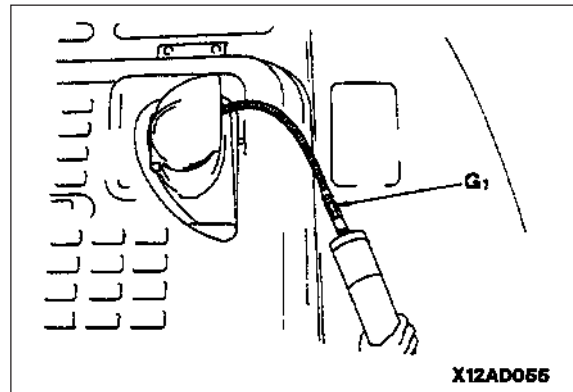

2. Measuring with smoke meter **G2**
 - a. Insert probe 1* into the outlet port of exhaust pipe, then tighten the clip to secure it to the exhaust pipe.
 - b. Connect the probe hose, accelerator switch plug, and air hose to tool **G2**
- ★ The pressure of the air supply should be less than 1.47 MPa (15 kg/cm²).
- c. Connect the power cord to the AC100V outlet.
- ★ When connecting the port, check first that the power switch of tool **G2** is OFF.
- d. Loosen the cap nut of suction pump, then fit the filter paper.
- ★ Fit the filter paper securely so that the exhaust gas does not leak.
- e. Turn the power switch of tool **G2** ON.
- f. Accelerate the engine suddenly, and at the same time, depress the accelerator pedal of tool **G2** and catch the exhaust gas color on the filter paper.
- g. Lay the filter paper used to catch the exhaust gas color on top of unused filter papers (10 sheets or more) inside the filter paper holder, and read the indicated value.

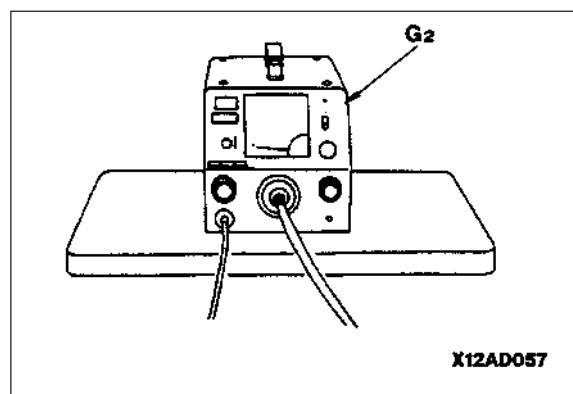
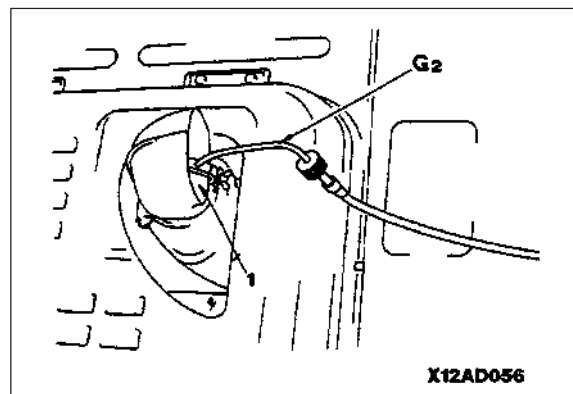

ADJUSTING VALVE CLEARANCE

1. Remove the cylinder head cover.
 2. Using cranking tool **Q**, rotate the crankshaft in the normal direction until timing pin (1) enters the hole in the gear.
- ★ This position is the No. 1 cylinder compression top dead center.

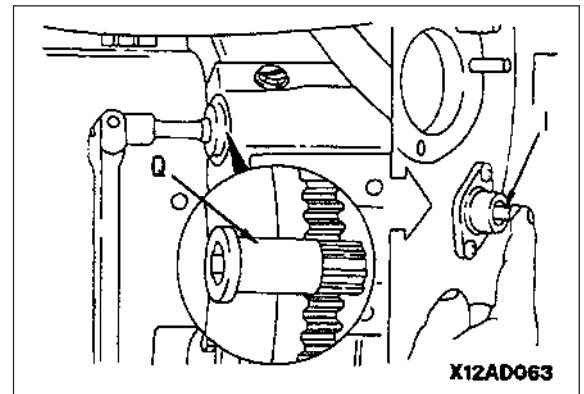

3. When No. 1 cylinder is at compression top dead center, adjust the valves marked ●. Next, rotate the crankshaft one turn (360°) in the normal direction and adjust the valve clearance of the remaining valves marked ○.
- ★ Make match marks on the crankshaft pulley or damper, then rotate 360°.

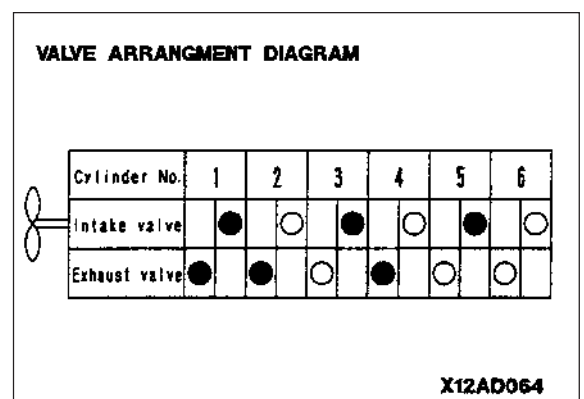

4. To adjust the valve clearance, loosen locknut (6), then insert feeler gauge **F** between rocker lever (3) and valve stem (4), and turn adjustment screw (5) until the clearance is a sliding fit. Then tighten locknut (6) to hold the adjustment screw in position.

 **kgm** Lock nut: 44.1 ± 4.9 Nm (4.5 ± 0.5 kgm)

- ★ After adjusting No. 1 cylinder at compression top dead center, it is also possible to turn the crankshaft 180° each time and adjust the valve of each cylinder according to the firing order.
- Firing order: 1 - 5 - 3 - 6 - 2 - 4
- ★ There is no timing mark on the front pulley, so set to compression top dead center as follows;
- a. If the firing order is followed, the next cylinder after No. 1 cylinder is No. 5 cylinder, so watch the movement of the No. 2 cylinder valves and rotate in the normal direction.
 - b. When the clearance of both the intake and exhaust valves of the No. 2 cylinder is 0, the No. 5 cylinder is at compression top dead center. (For the No. 3 cylinder, watch the movements of the No. 4 cylinder valves).

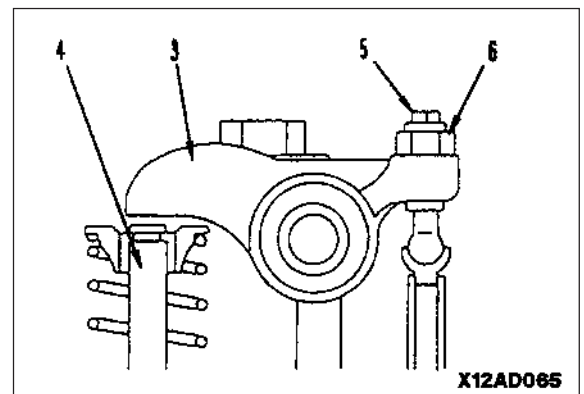

MEASURING COMPRESSION PRESSURE

⚠ When measuring the compression pressure, be careful not to touch the exhaust manifold or muffler, or to get your clothes caught in the fan, fan belt, or other rotating part.

1. Adjust the valve clearance.
For details, see ADJUSTING VALVE CLEARANCE.
 2. Warm up the engine to make the oil temperature 40 - 60°C.
 3. Remove the nozzle holder assembly from the cylinder to be measured.
 4. **Install adapter D2 in the mount of the nozzle holder, then connect pressure gauge D1.**
 5. **Set tachometer A in position.**
 6. Disconnect the fuel control rod, place the governor lever of the injection pump in the NO INJECTION position, then crank the engine with the starting motor and measure the compression.
- ★ Measure the compression pressure at the point where the pressure gauge indicator remains steady.
 - ★ When measuring the compression pressure, measure the engine speed to confirm that it is within the specified range.
 - ★ After measuring the compression pressure, install the nozzle holder assembly.

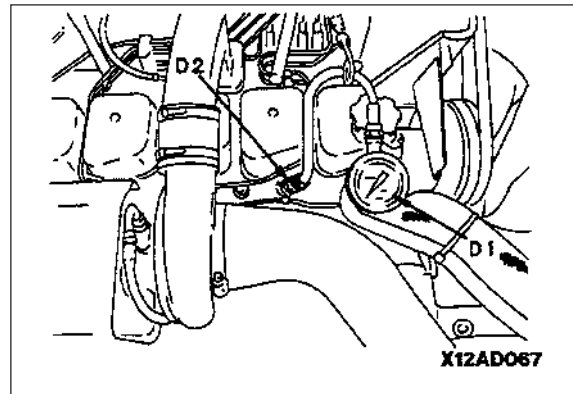
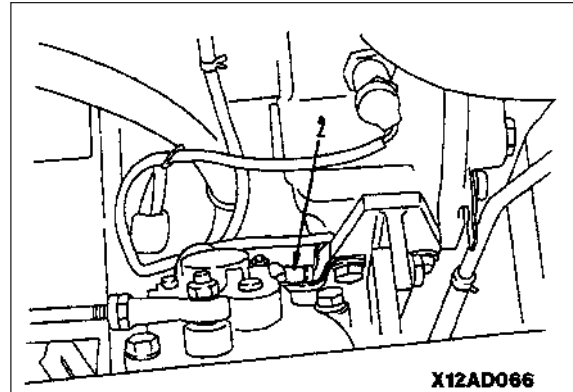

MEASURING BLOW-BY PRESSURE

- ★ Measure the blow-by pressure under the following conditions.
 - Coolant temperature: Within operating range.
 - Hydraulic oil temperature: 50 - 80°C
1. **Install the nozzle of blow-by checker E to blow-by hose.**
 2. Connect the nozzle and gauge with the hose.
 3. Set the working mode to the H/O mode, fit a block between the sprocket and frame, then run the engine at high idling and relieve the travel circuit.
 4. Measure the blow-by at the point where the gauge indicator remains steady.

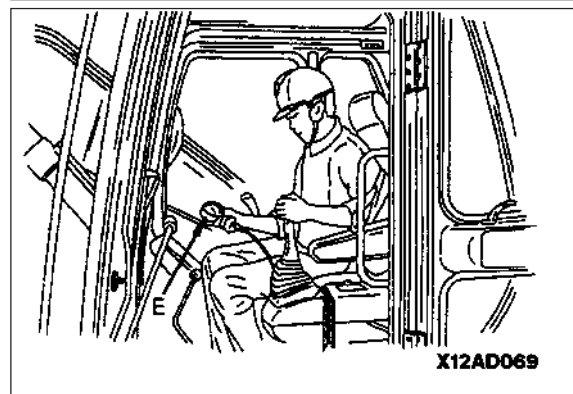
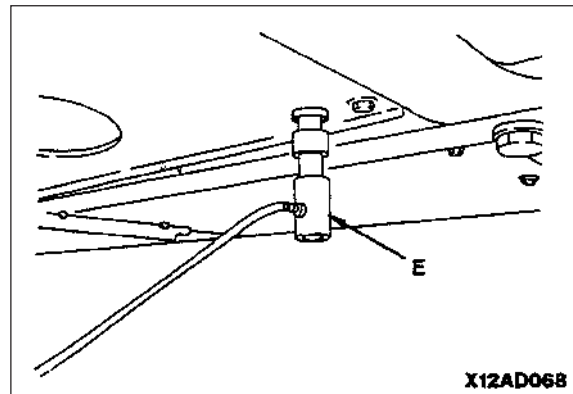

TESTING AND ADJUSTING FUEL INJECTION TIMING

1. Testing
 - a. Using cranking tool Q, rotate the crankshaft in the normal direction until timing pin (1) enters the hole in the gear.
 - b. Remove plug (2), reverse timing pin (3), and check that pin (3) is meshed with timing pin pointer (4) at the injection pump side.

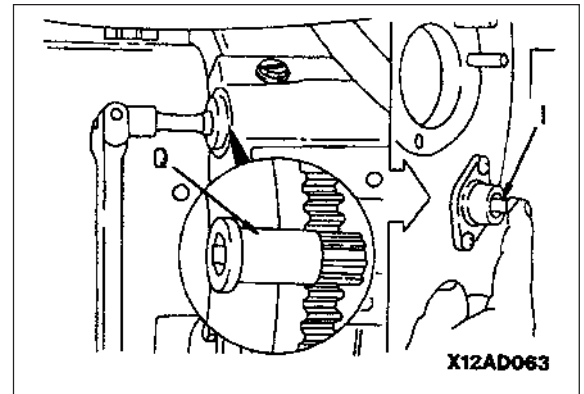

2. Adjusting
 - If the timing pin does not mesh.
 - a. Remove the fuel injection pump. For details, see REMOVAL OF FUEL INJECTION PUMP ASSEMBLY.
 - b. Rotate the camshaft of the injection pump and mesh timing pin (3) with timing pin pointer (4).
 - c. Install the fuel injection pump assembly. For details, see INSTALLATION OF FUEL INJECTION PUMP ASSEMBLY.

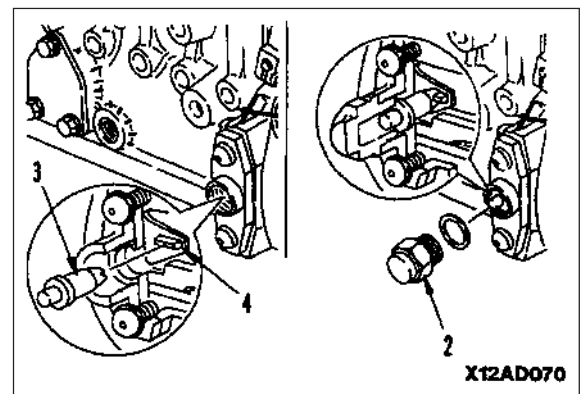

MEASURE ENGINE OIL PRESSURE

- ★ Measure the engine oil pressure under the following conditions.
- Coolant temperature: Within operating range.
- 1. Install oil pressure gauge C2 (1.0 MPa (10 kg/cm²)) at fitting (1) on the top of the oil filter.
- 2. Start the engine, and measure the oil pressure at the low pressure end with the engine at low idling and at the high pressure end with the engine at high idling.

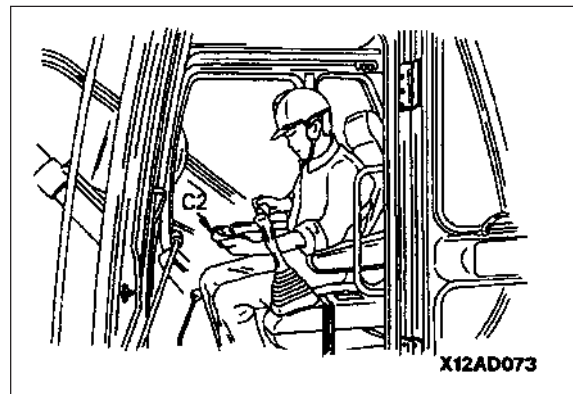
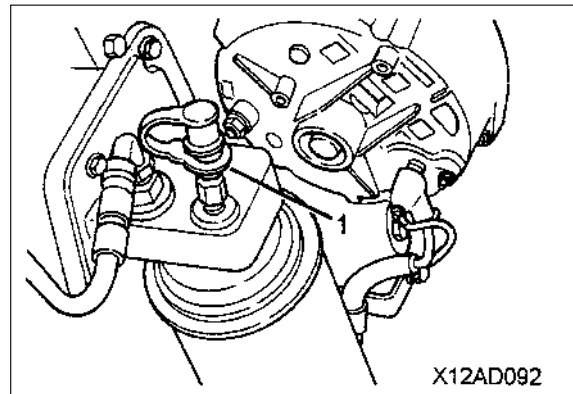

TESTING AND ADJUSTING FAN BELT TENSION

1. Tensing
 - a. Check the deflection of the belt when the belt is pressed with a finger force of approximately 58.8 N (6 kg) at a point midway between the tension pulley and fan pulley.
 2. Adjusting
 - a. Loosen mounting bolts (2) and (3), bolt (4), nut (5), and belt tension adjustment bolt (6) of tension pulley.
 - b. Lever the tension pulley and watch the tension of the fan belt through the clearance from the cylinder block. When the tension is correct, tighten the adjustment bolt (6) first, then tighten tension pulley mounting bolts (2) and (3), and nut (5).
 - c. After adjusting the belt tension, check again to confirm that the belt tension is within the standard value.
- ★ After adjusting the belt, run the engine for at least 15 minutes, then measure the deflection of the belt again.

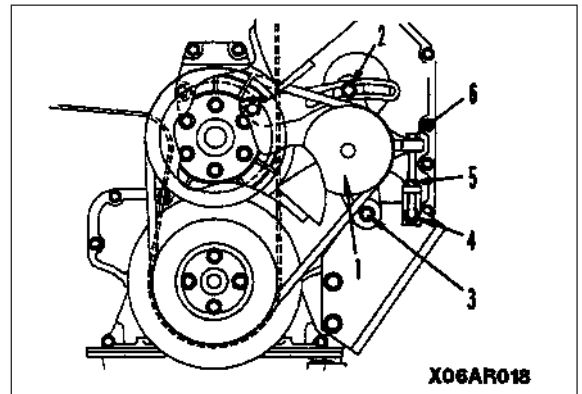

X06AR018

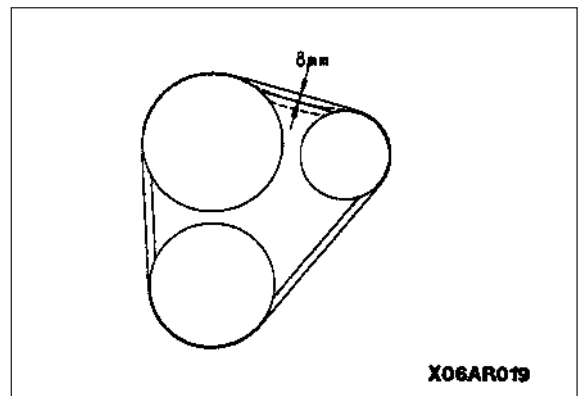

X06AR019

MEASURING SPEED SENSOR

1. Screw in until the tip of sensor (1) contacts gear (2).
 2. When gear (2) contacts sensor (1), turn back one turn, to give clearance a .
 3. Tighten locknut (3).
- ★ Be particularly careful when securing the sensor wiring to ensure that no excessive force is brought to bear on the wiring.
 - ★ Be careful not to let the tip of the sensor be scratched or to let any iron particles stick to the sensor tip.

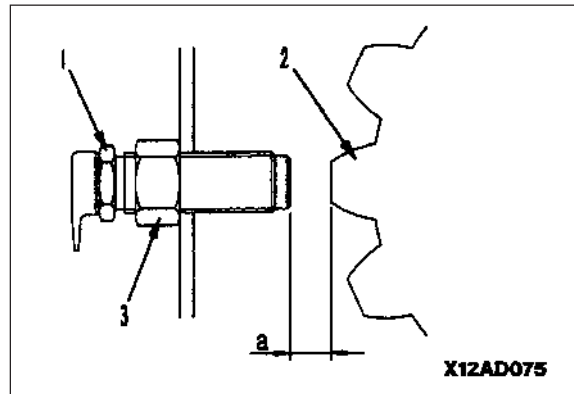
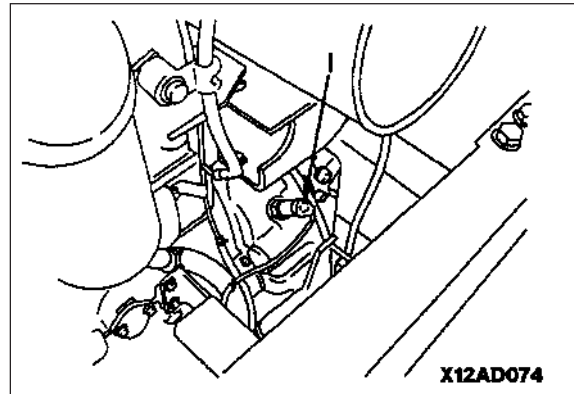

TESTING AND ADJUSTING GOVERNOR MOTOR LEVER STROKE

1. Testing
 - ★ Use the governor motor adjustment mode.
 - a. Preparatory work
 - i. In the time mode display, keep the time switch + travel speed R.H. switch + working mode R.H. switch pressed for 2.5 seconds.
 - ★ The engine output when the engine is running at full throttle is the output when the power max. switch in the active mode is ON, so use this mode instead of turning the power max. switch ON.
 - ii. Set the fuel control dial to MAX and the autodeceleration switch to OFF.
 - ★ Any working mode can be used.
 - b. In this condition, check that governor lever (4) is in contact with FULL stopper (5) of the injection pump.
 - c. After checking, repeat the procedure in Step 1-a. to complete the governor motor adjustment mode.
 - 2. Adjusting
 - a. Turn the starting switch OFF, then remove the nut and disconnect joint (1) from governor lever (4).
 - b. Repeat the procedure in Step 1-a. above to set to the governor motor adjustment mode.
 - c. Set governor lever (4) to a position where it contacts FULL stopper (5) of the injection pump, then adjust the length of spring assembly (2) and rod (3), and connect joint (1) with the nut.
 - d. From the above position, turn rod (3) back 2 turns (retract the rod approximately 2.5 mm) and secure in position with locknuts (6) and (7).

Caution

When the spring assembly is removed and the starting switch is at the OFF position, if the governor motor lever is moved suddenly, the governor motor will generate electricity, and this may cause a failure in the governor controller.

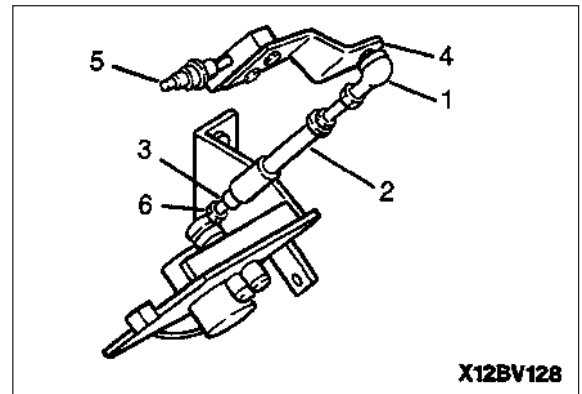

X12BV128

TESTING AND ADJUSTING HYDRAULIC PRESSURE IN WORK EQUIPMENT, SWING AND TRAVEL CIRCUIT

1. Measuring

★ Hydraulic oil temperature when measuring: 45-55°C

⚠ Lower the work equipment to the ground and stop the engine. Loosen the oil filler cap slowly to release the pressure inside the hydraulic tank. Then put the safety lock lever in the LOCK position. Install oil pressure gauge **C1** (58.8 MPa (600 kg/cm²)) to the quick disconnect (1) or (2) for the circuit to be measured.

a. Measuring main unload pressure

- i. Unload pressure when front and rear pump flows are merged. Measure the oil pressure in H/O mode with the engine at high idling and the control levers at neutral.

★ With this procedure, the unload pressure of the unload valve of the left and right control valves is measured.

See opposite pages for pictures of kuk pump in this area.

b. Measuring *unload pressure

★ Use this procedure to measure when it is desired to measure each unload circuit.

- The unload pressure in the circuit which is not under load when the front and rear pump flows are divided.

- i. Set to H/O mode.
- ii. Operate the travel lever a little a time (or connect a short connector to the travel oil pressure switch connector (CN-S01)), then measure the pressure in the pump circuit on the opposite side when the arm or bucket circuit is relieved.

★ Arm relief: load on front pump, rear pump unloaded.

★ Bucket relief: load on rear pump, front pump unloaded.

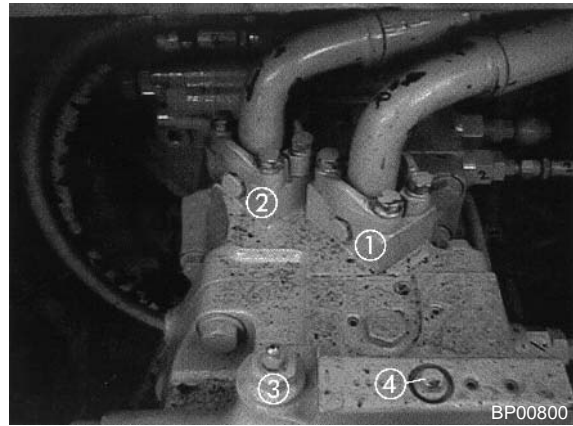

① - ② Rear and front pump discharge pressure rest points

③ Pump bleed point

④ Servo piston input pressure test point of rear pump

Table 1 Combination of pumps and actuators controlled when flow from front and rear pumps is divided.

Pump	Controlled actuator
Front pump	<ul style="list-style-type: none"> • Arm cylinder • Swing motor * • L.H. travel motor
Rear pump	<ul style="list-style-type: none"> • Boom cylinder * • Bucket cylinder • R.H. travel motor

* The set pressure of the safety valve at the head end and the swing motor (active mode OFF) is lower than the set pressure of the main relief valve.

TESTING AND ADJUSTING

- c. Measuring pump relief pressure
- i. Low setting (oil pressure: 31.9 MPa (325 kg/cm²))
 - (1) Measure the pressure when each actuator except the travel actuator is relieved in H/O mode with the engine at full throttle.
 - ★ Note that the set pressure of the safety valve for the swing motor and head end of the boom is lower than the main relief low set pressure, so the value measured will be the relief pressure will rise, so always keep the lock switch OFF when measuring.
 - ★ When measuring the swing relief pressure, measure with the swing lock turned switch ON.
-
- ii. High setting (oil pressure: 34.8 MPa (355 kg/cm²))
 - (1) When travel is operated. Measure the oil pressure when the travel is relieved on each side separately in H/O mode with the engine at full throttle.
 - ★ To relieve the travel circuit, put block 1 under the track shoe grouser, or put block 2 between the sprocket and frame to lock the track.
 - (2) When power max. function is actuated. When measuring the oil pressure in G/O or H/O mode with the engine at full throttle and the power max. function actuated, relieve one of the boom, arm, or bucket circuits, and measure the oil pressure.

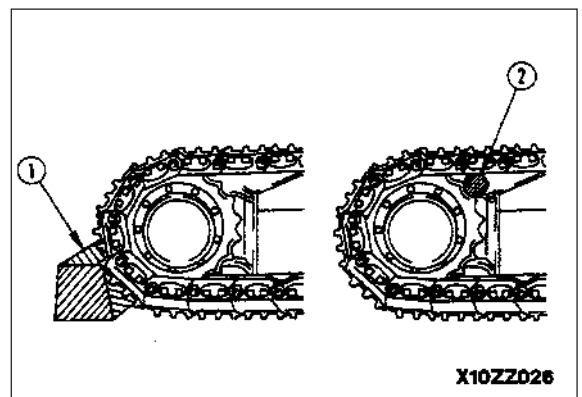
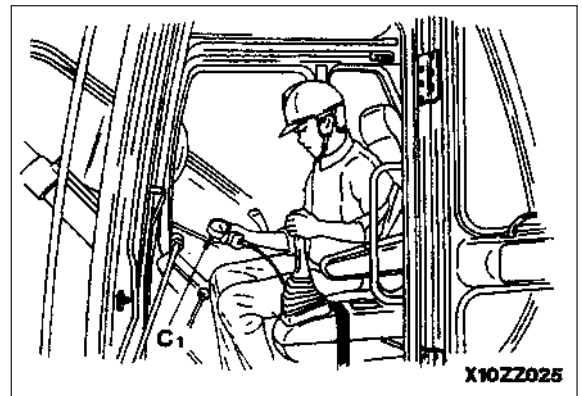

TESTING AND ADJUSTING

2. Adjusting

- (1): For front pump
- (2): For rear pump adjusting high pressure setting.
Loosen locknut (3), then turn holder (4) to adjust.

- ★ Turn the holder to adjust as follows:
To INCREASE pressure, turn CLOCKWISE.
To DECREASE pressure, turn COUNTERCLOCKWISE.

- ★ Amount of adjustment for one turn of holder: approximately 12.5 MPa (128 kg/cm²).

 **kgm** Locknut: 53.5 ± 4.9 Nm (5.5 ± 0.5 kgm)

- ★ When the high pressure setting is adjusted, the low pressure setting will also change, so adjust the low pressure setting also.

- a. Adjusting low pressure setting. Loosen locknut (5), then turn holder (6) to adjust.

- Turn the holder to adjust as follows:
To INCREASE pressure, turn CLOCKWISE.
To DECREASE pressure, turn COUNTERCLOCKWISE.

- ★ Amount of adjustment for one turn of holder: Approximately 12.5 MPa (128 kg/cm²).

 **kgm** Locknut: 53.5 ± 4.9 Nm (5.5 ± 0.5 kgm)

- ★ Normally, the pressure applied to port **PX1** is 0 MPa (0 kg/cm²); at the high pressure setting, it is 2.9 MPa (30 kg/cm²).

- b. Swing motor safety valve. Loosen locknut (1), then turn adjustment screw (2) to adjust.

- ★ Turn the adjustment screw to adjust as follows:
To INCREASE pressure, turn CLOCKWISE.
To DECREASE pressure, turn COUNTERCLOCKWISE.

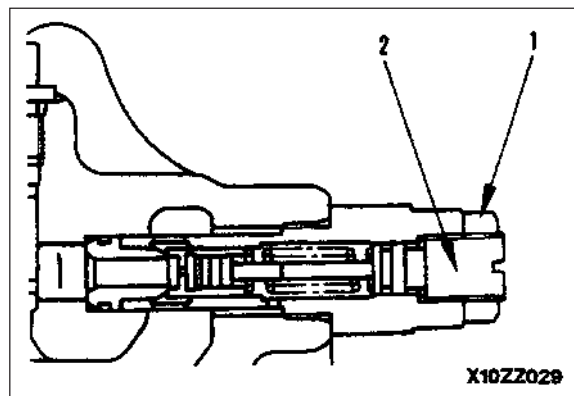
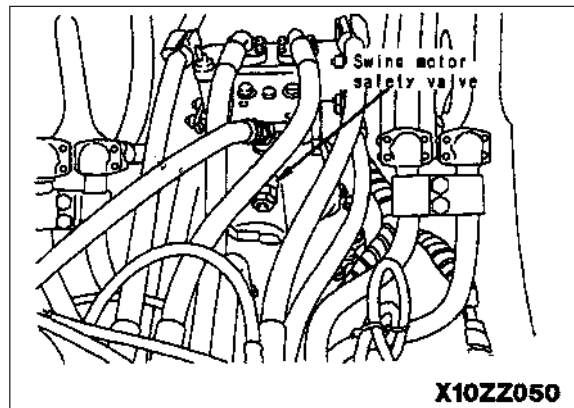
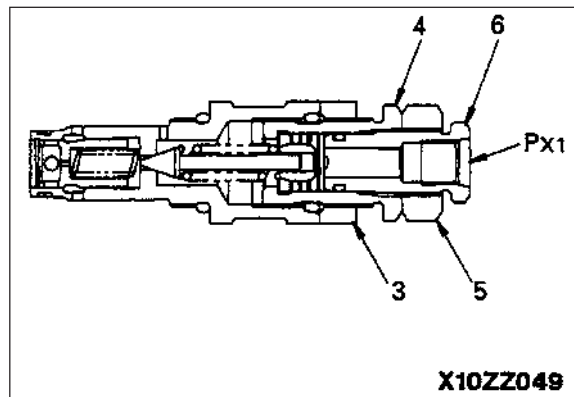
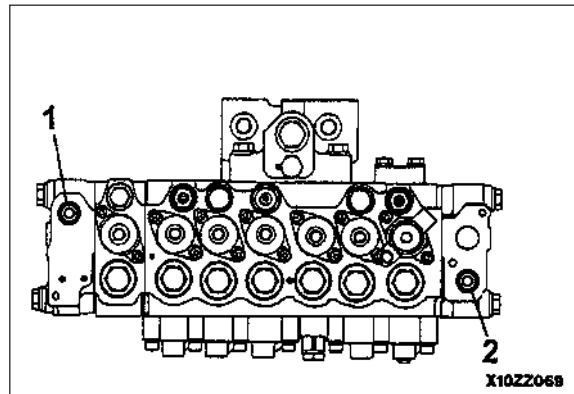

TESTING AND ADJUSTING PC VALVE OUTPUT PRESSURE (SERVO PISTON INPUT PRESSURE)

1. Measuring
 - ★ Oil temperature when measuring: 45 - 55°C
 - Measure the oil pressure when the circuit is relieved in the pressure rise mode.
 - a. Install oil pressure gauge **C1** to quick disconnects (1), (2), (3), and (4).
 - ★ Install a 39.2 MPa (400 kg/cm²) gauge to the servo valve end, and a 58.8 MPa (600 kg/cm²) gauge to the pump outlet port end.
 - b. Turn the swing lock switch ON.
 - c. Set the working mode to H/O mode.
 - d. Run engine at full throttle, turn the knob switch ON, and measure the oil pressure when the arm (IN) circuit is relieved.
 - ★ Check that the servo piston input pressure is 1/2 of the pump discharge pressure.

Note: If there is any abnormality in the LS valve or servo piston, the servo piston input pressure will be 0 or almost the same as the pump discharge pressure.

2. Adjusting
 - ★ If the load becomes larger, the engine speed will drop. Or if the engine speed remains normal, the work equipment speed will drop. In such cases, if the pump discharge pressure and LS differential pressure are normal, adjust the PC valve as follows.
 - a. Loosen locknut (4), and if the equipment speed is slow, turn screw (5) to the right; if the engine speed drops, turn the screw to the left.
 - ★ If the screw is turned to the right, the pump absorption torque will be increased, and if it is turned to the left, the pump absorption torque will be reduced.
 - ★ The adjustment range for the screw is a maximum of 1 turn to the left and 180° to the right.
 - ★ The amount of adjustment for one turn of the screw: 1.5 mm of servo piston stroke movement.
 - b. After completing the adjustment, tighten the locknuts.

 Locknut (3): 34.3 ± 4.9 Nm (3.5 ± 0.5 kgm)
 Locknut (4): 100.5 ± 12.3 Nm (10.25 ± 1.25 kgm)

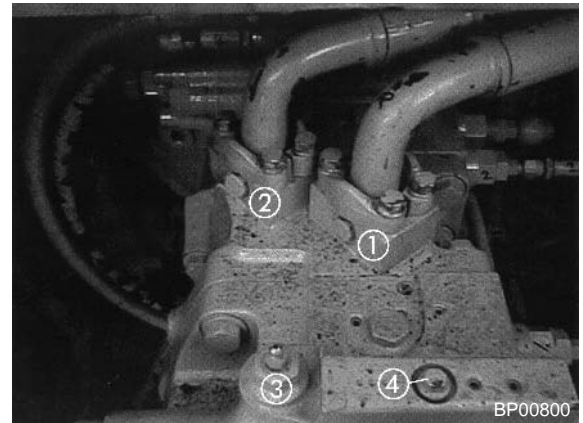

- ① - ② Rear and front pump discharge pressure rest points
- ③ Pump bleed point
- ④ Servo piston input pressure test point of rear pump

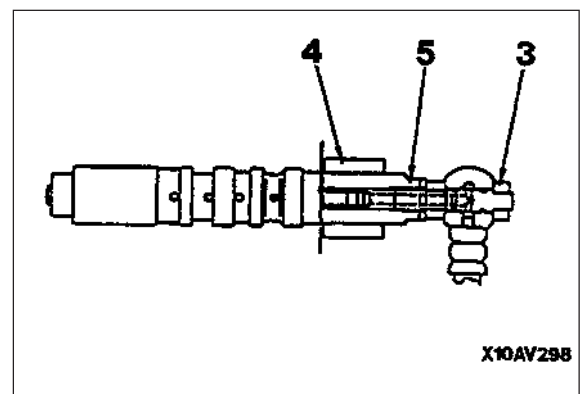
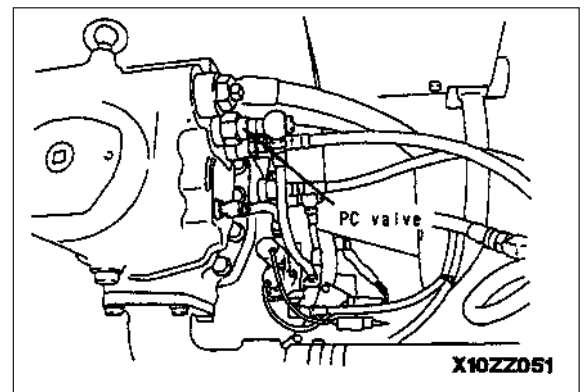
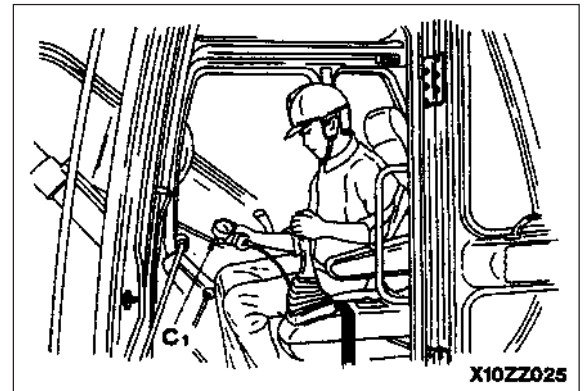

TESTING AND ADJUSTING LS VALVE OUTPUT PRESSURE (SERVO PISTON INPUT PRESSURE AND LS DIFFERENTIAL PRESSURE)

- ★ Oil temperature when measuring: 45 - 55°C
- 1. Measuring LS valve output pressure (servo piston input pressure).
 - a. Install oil pressure gauge **C1** to quick disconnects (1), (2), (3) and (4).
- ★ Install a 39.2 MPa (400 kg/cm²) gauge to the servo valve end, and a 58.8 MPa (600 kg/cm²) gauge to the pump outlet port end.
- Oil pressure when travel is rotating under no load on one side.
 - i. Set the working mode to H/O mode, and turn the travel speed selector switch to Hi.
 - ii. Use the work equipment to raise the track assembly on one side.
 - iii. Run the engine at full throttle and operate the travel lever to the end of its stroke and measure the oil pressure with the track rotating under no load.

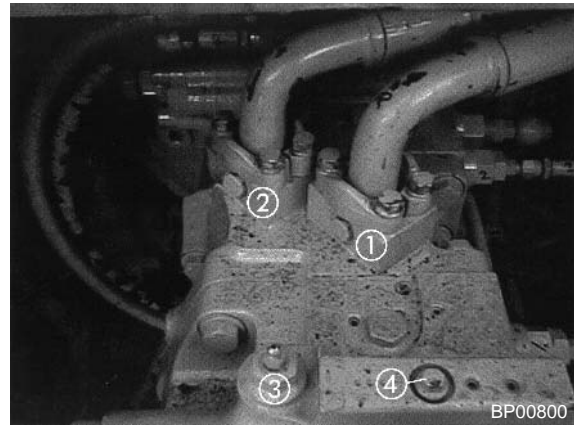

- ① - ② Rear and front pump discharge pressure rest points
- ③ Pump bleed point
- ④ Servo piston input pressure test point of rear pump

Table 1

Working mode	Travel lever	Pump pressure (MPa (kg/cm ²))	Servo inlet port pressure (MPa (kg/cm ²))	Remarks
H/O mode	Neutral	3.72 ± 0.69 (38 ± 7)	3.72 ± 0.69 (38 ± 7)	About the same as pump pressure
H/O mode	Half	6.86 ± 0.98 (70 ± 10)	3.43 ± 0.49 (35 ± 5)	About 60% of pump pressure

2. Measuring LS differential pressure
 - a. Measuring with a differential pressure gauge.
 - i. Install one line of differential pressure gauge **C4** to the main pressure port of the front (or rear) pump.
 - ii. Install the second line of pressure gauge to the quick disconnects on the LS lines at the main control valve (⑤ and ⑥). (The LS lines are color coded at each end. Make sure to use the same LS line on both the pump end and the main valve end.)
 - iii. Set the conditions in Table 2 and measure the LS differential pressure.

Table 2

Working mode	Fuel control dial	Operation	LS differential pressure (MPa (kg/cm ²))
H/O mode	MAX	Levers at neutral	2.94 ± 0.98 (30 ± 10)
H/O mode	MAX	Travel speed: Hi Travel circuit under no load (lever half operated)	2.16 ± 0.1 (22 ± 1)

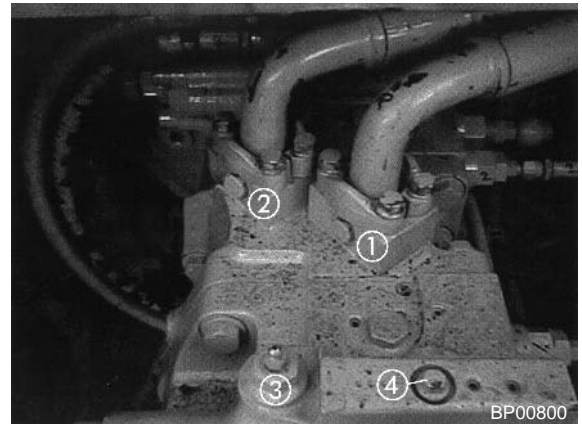
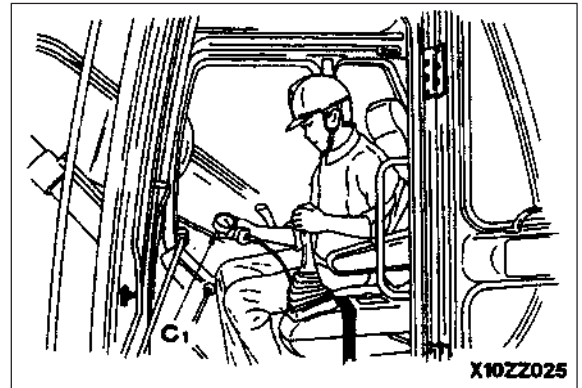

① - ② Rear and front pump discharge pressure test points

⑤ Rear LS pressure test point.

④ Front LS pressure test point.

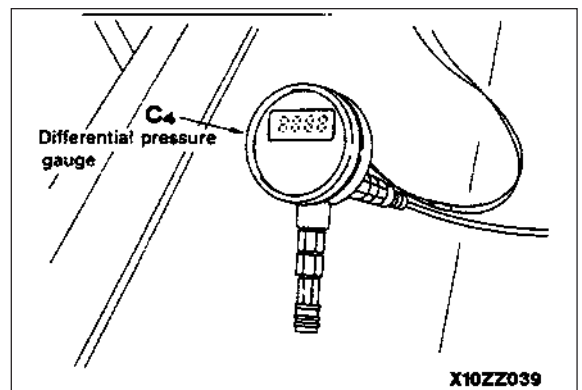
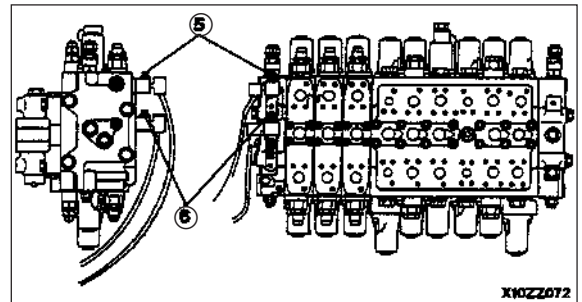

3. Adjusting LS valve

When the differential pressure is measured under the conditions above, and the results show that the differential pressure is not within the standard value, adjust as follows.

- a. Loosen locknut (4) and turn screw (5) to adjust the differential pressure.
- Turn the screw to adjust the differential pressure as follows:
To INCREASE pressure, turn CLOCKWISE
To DECREASE pressure, turn COUNTERCLOCKWISE.
- ★ Amount of adjustment (LS differential pressure) for one turn of screw: 1.3 MPa (13.3 kg/cm²).
- b. After adjusting, tighten locknut (4).

 Locknut: 56.4 ± 7.4 Nm (5.75 ± 0.75 kgm).

Note: Always measure the differential pressure while adjusting.

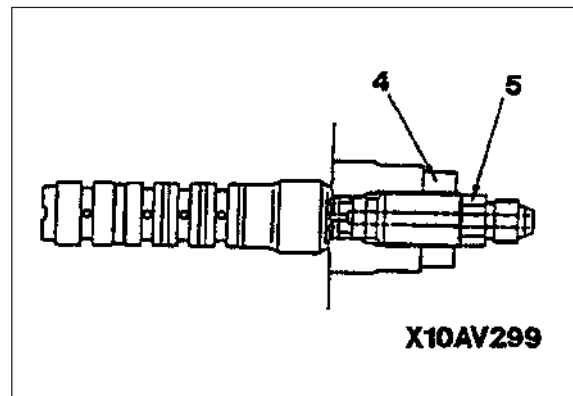

TESTING AND ADJUSTING CONTROL CIRCUIT OIL PRESSURE

1. Measuring

★ Oil temperature when measuring: 45 – 55°C

⚠ Lower the work equipment to the ground and stop the engine. Loosen the oil filler cap slowly to release the pressure inside the hydraulic tank. Then set the safety lock lever to the LOCK position.

- a. Install oil pressure gauge **C1** (5.8 Mpa (60 kg/cm²) to quick disconnect nipple.
- b. Start the engine and measure with the engine at full throttle.

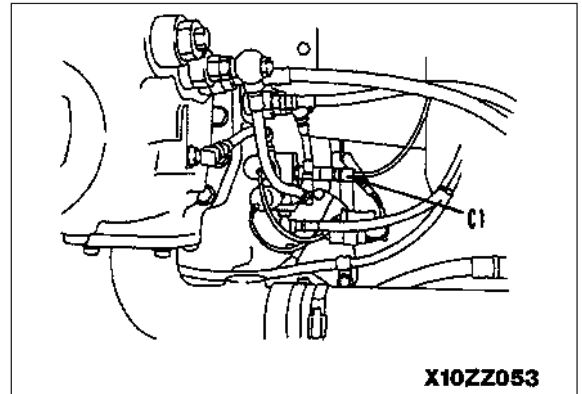

X10ZZ053

TESTING SOLENOID VALVE OUTPUT PRESURE

1. Measuring
 - ★ Oil temperature when measuring: 45 – 55°C
 - a. Measuring output pressure of LS-EPC solenoid valve.
 - i. Disconnect output hose (1) of the LS-EPC solenoid valve, then use adapter **C3** in the oil pressure gauge kit to install oil pressure gauge **C1** (5.9 Mpa (60 kg/cm²)).
 - ii. Measure the output pressure under the conditions in Table 1.

Table 1

Operation and working mode	Engine speed (rpm)	Output pressure (MPa (kg/cm ²))	Current (A) [Reference]
All control levers at neutral	Min. 1500	2.94 (30)	900 ± 30
H/O mode or G/O mode, travel circuit at neutral, any work equipment lever is operated	Min. 1900	0 (0)	0

- ★ Monitoring code 10 or 40 for engine speed
 - ★ Monitoring code 15 for LS control EPC current
2. Measuring output pressure of ON/OFF solenoid valve
 - a. Measuring output hose (2) of the solenoid valve, then use adapter **C3** in the oil pressure gauge kit **C1** (5.9 Mpa (60 kg/cm²)).
 - b. Measure the output pressure under the conditions in Table 2.

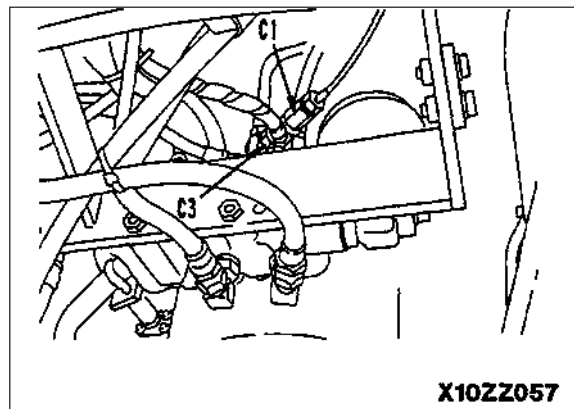
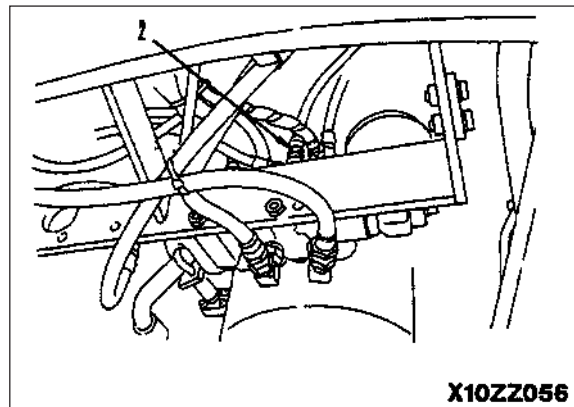
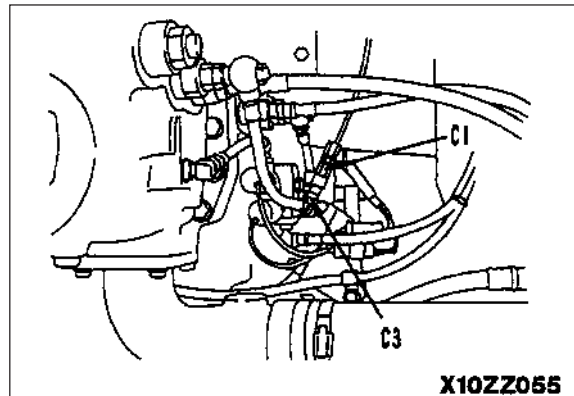
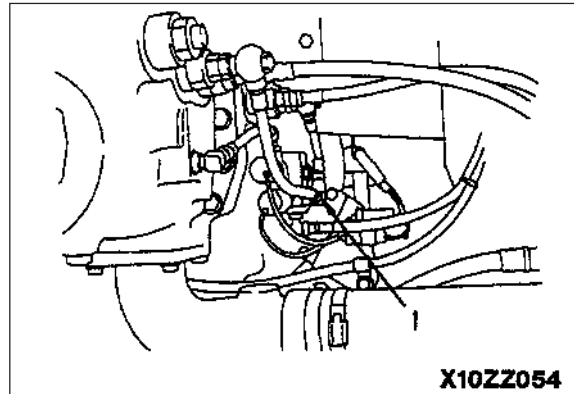

Table 2

Name of solenoid		Measurement conditions	Operating conditions	Condition of solenoid	Oil pressure Mpa (kg/cm ²)	Remarks
1	Swing brake solenoid	Swing or work equipment lever operated	Brake cancelled	ON	Min 2.74 (Min 28)	
		All levers except travel at neutral (5 sec. after returning to neutral)	Brake cancelled	OFF	0 (0)	
2	Travel speed solenoid	Travel speed switch at Hi or Mi, engine speed 1500 rpm or above, travel lever operated	Travel speed Hi	ON	Min 2.74 (Min 28)	Motor swash plate angle at minimum
		Travel speed switch at Lo or engine speed below 1500 rpm	Travel speed Lo	OFF	0 (0)	Motor swash plate angle at maximum
3	2-stage relief solenoid	Swing lock switch ON + work equipment lever operated	Pressure rise	ON	Min 2.74 (Min 28)	
		All levers at neutral	Normal pressure	OFF	0 (0)	
4	Active mode solenoid	Active mode OFF	Normal pressure	ON	Min 2.74 (Min 28)	
		Active mode ON	Pressure rise	OFF	0 (0)	
5	Pump merge-divider solenoid	Travel operated independently	Flow from front and rear pumps divided	ON	Min 2.74 (Min 28)	LS pump merge-divider valve actuated at same time
		Lever at neutral, or boom, arm, bucket operated independently	Flow from rear pumps merged	OFF	0 (0)	

- ★ Operation of solenoid valve
ON: Continuous (oil pressure generated)
OFF: Not continuous (oil pressure: 0)
- ★ Check at the same time that the solenoid is switched ON/OFF electrically with monitoring code 23.
- ★ The measurement conditions in the table show the typical conditions for measuring the output pressure.
- ★ The solenoid valve may be actuated (ON/OFF) even under conditions not listed for measurement conditions.

 When operating the levers, operate them slightly (not enough to make the machine move).

MEASURING PPC VALVE OUTPUT PRESSURE

- ★ Oil temperature when measuring: 45 – 55°C
- 1. Measuring PPC valve output pressure.
 - a. Disconnect hose (1) of the circuit to be measured.
 - b. Install adapter **C3** between hose (1) and elbow (2).
 - c. Install oil pressure gauge **C1** (5.9 Mpa (60 kg/cm²)) to adapter **C3**.
 - d. Run the engine at full throttle, operate the control lever of the circuit to be measured, and measure the oil pressure.
- * If the output at the control valve end is low, measure the input pressure of the PPC valve. If it is normal, there is a defective actuation of the PPC valve.

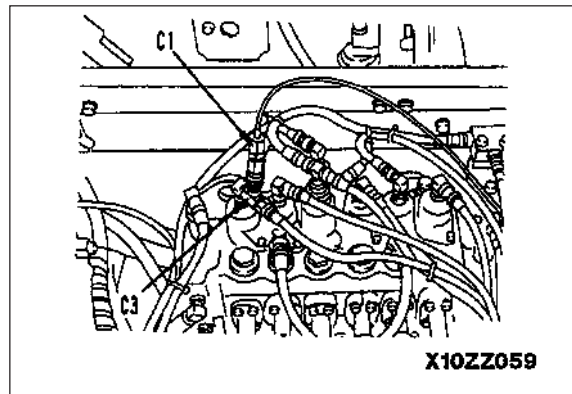
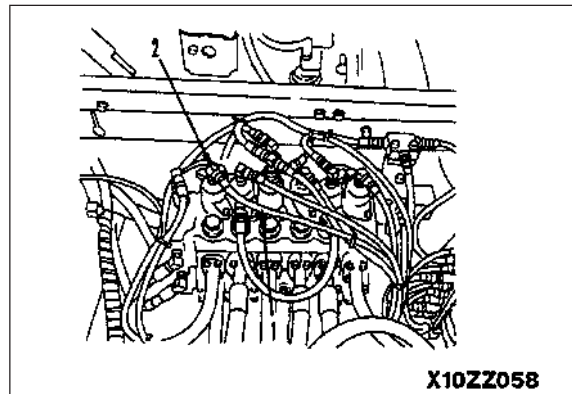

Pressure switch piping diagram

Interruption block seen from the rear of the machine.

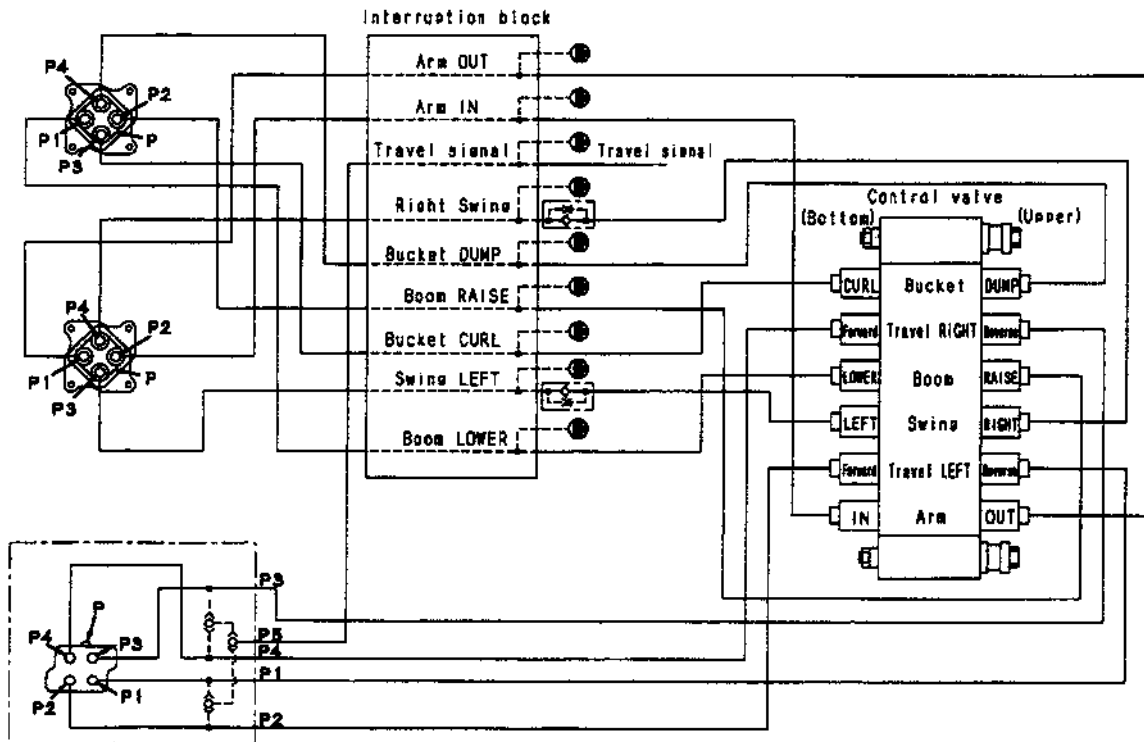
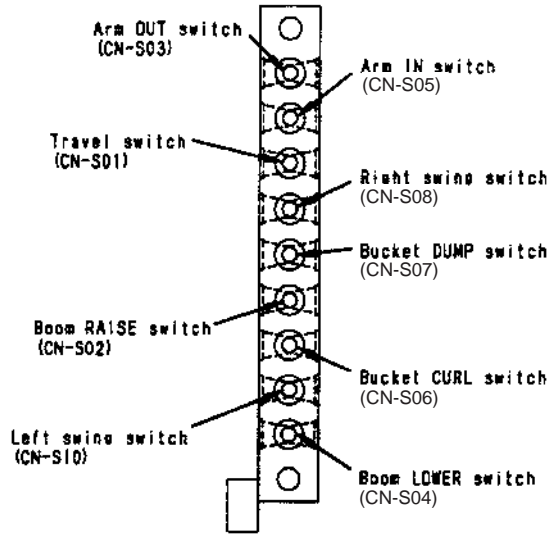

X10ZZ060

ADJUSTING WORK EQUIPMENT • SWING PPC VALVE

★ If there is excessive play in the work equipment or swing lever, adjust as follows.

⚠ Lower the work equipment to the ground and stop the engine. Loosen the oil filler ca slowly to release the pressure inside the hydraulic tank. Then set the safety lock lever to the LOCK position.

1. Remove the PPC valve;
 2. Remove boot (1).
 3. Loosen locknut (2), then screw in disc (3) until it contacts the 4 heads of piston (4).
- ★ When doing this, do not move the piston.
4. Screw disc (3) in position, then tighten locknut (2) to the specified torque.

 **kgm** Locknut: $107.8 \pm 9.8 \text{ Nm}$ ($11 \pm 1 \text{ kgm}$)

5. Install boot (1).

★ With the above adjustment, the clearance between disc (3) and piston (4) becomes 0.

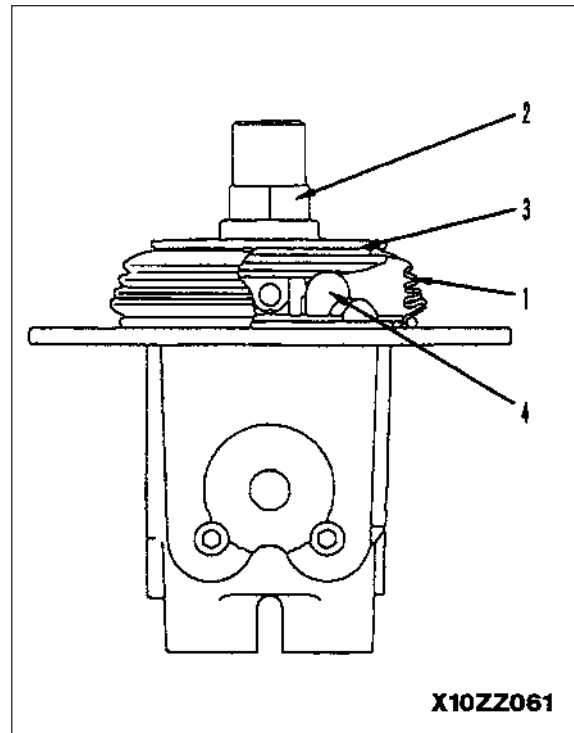

ADJUSTMENT OF FLOW CONTROL SYSTEM

Purpose

The flow control system limits the maximum flow of oil through the first attachment circuit dependent on the switch setting selected on the thumbwheel switch in the operator's cab. It is possible to adjust the factory settings for oil flow rate by using the adjustment screw on the flow control unit itself.

Special Equipment Required

1. Oil pressure gauge. To be of suitable range for accurate measurement of PPC pressure (0 kg/cm² to 30 kg/cm²).
2. Test Gauge Adaptor. To allow fitment of the above gauge to the excavator hydraulic system. Adaptor to suit KES # 02 type elbow and hose.

Method

1. Fit the pressure gauge at a suitable point in the pilot line between the output of the EPC valve and the control valve. A suggested position is the port P₂ on the main valve.
2. Start the machine and run it at high idle in HO mode.
3. Select the desired switch setting on the cab switch (see section 2.3) then fully depress and hold down the RH attachment pedal. Take note of the pressure reading and refer to fig (i) to obtain a system flow rate for this pilot pressure.
4. If the measured value is acceptable then there is no need to alter the controller output. Switch the machine off and remove the test equipment.
5. If the measured value requires adjustment, then remove the rear panel behind the operator's seat to gain access to the controller (refer to section 2.3 for location of the controller). The adjustment screw is uppermost on the controller. To adjust the controller output proceed as shown below:
 - Slacken off the lock-nut.
 - Turn the adjust screw clockwise to increase PPC pressure or anticlockwise to reduce PPC pressure.

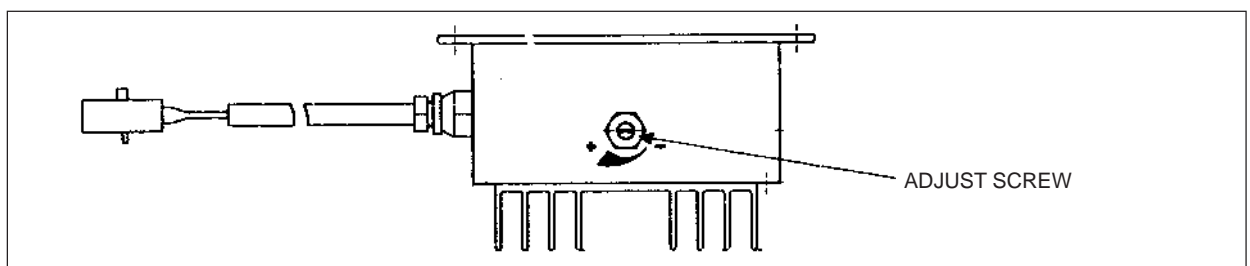

6. Once the controller setting has been changed, fully depress and hold down the RH attachment pedal. Take note of the steady pressure reading then adjust the controller output (as described in 5 above) again if necessary. It is important that the foot pedal is **released** between pressure checks otherwise the gauge will not give a true reading. Repeat this process until the measured PPC pressure is within 5% of the required value. Use fig (i) to establish the PPC pressure required to generate the desired oil flow rate.

Note: The adjustment screw allows the controller output to be varied by $\pm 10\%$. The effect of the adjustment operates on all of the controller switch settings (ie a 5% adjustment alters all of the switch settings by 5%).

7. After correctly setting the controller output, tighten the lock-nut on the controller to prevent the setting from changing during operation of the machine. Replace the rear panel. Remove the pressure gauge.

Graph of PPC Pressure Against HCU Circuit Oil Flow

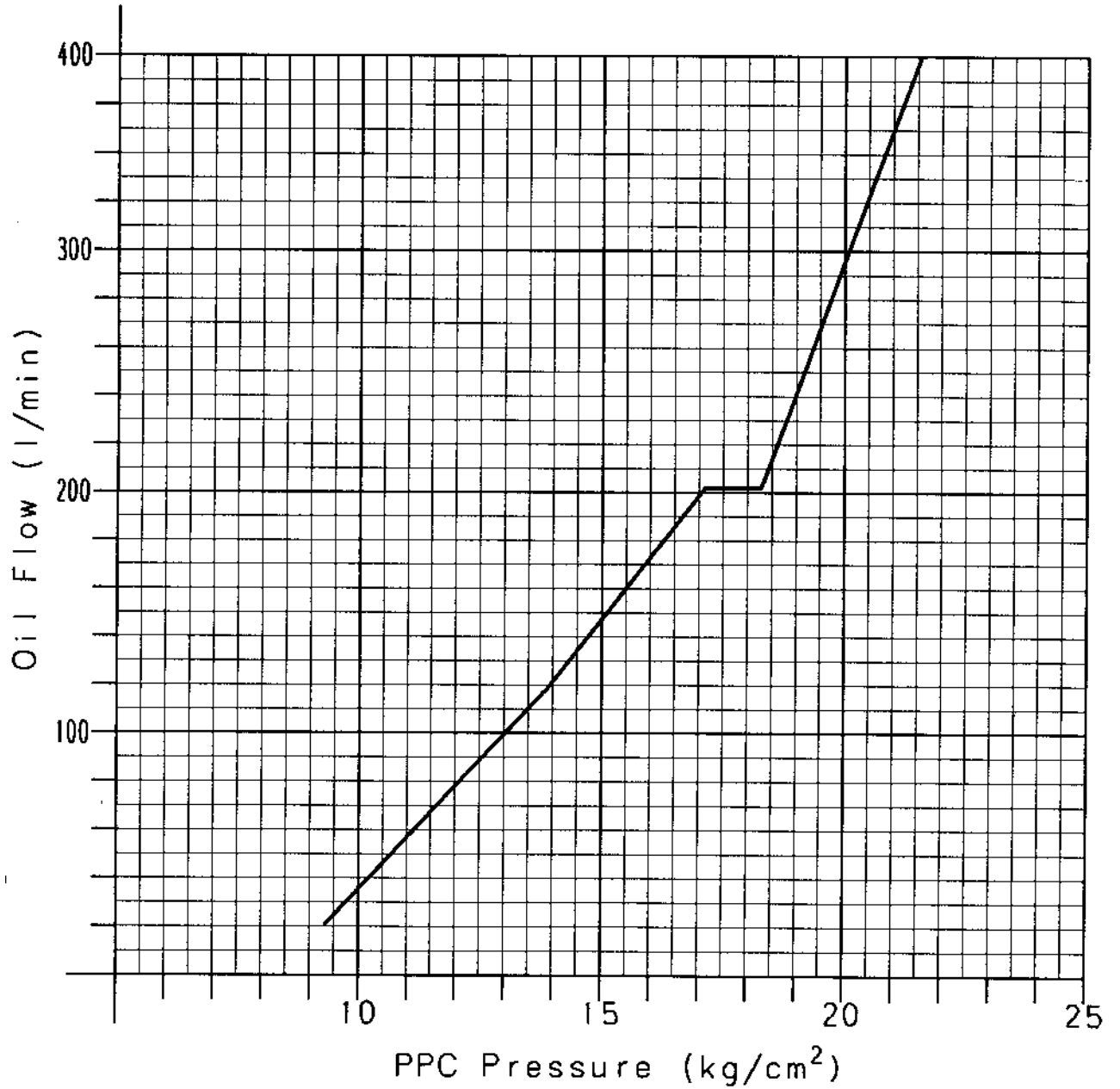

Note: The above diagram is intended as a guide only. Actual oil flow in the HCU circuit is affected by a number of variables such as manufacturing tolerances of the main valve and hydraulic oil temperature.

TESTING TRAVEL DEVIATION

- ★ When travelling on level ground.
- 1. Set the machine in the travel posture.
- ★ For the travel posture, extend the bucket and arm cylinder rods fully, and hold the boom angle at 45°.
- 2. Travel for 10 m, then measure the deviation when travelling for the next 20 m.
- ★ Set to H/O mode and measure with the engine at high idling.
- ★ Install the hydraulic pressure gauge and measure the pump discharge pressure at the same time.

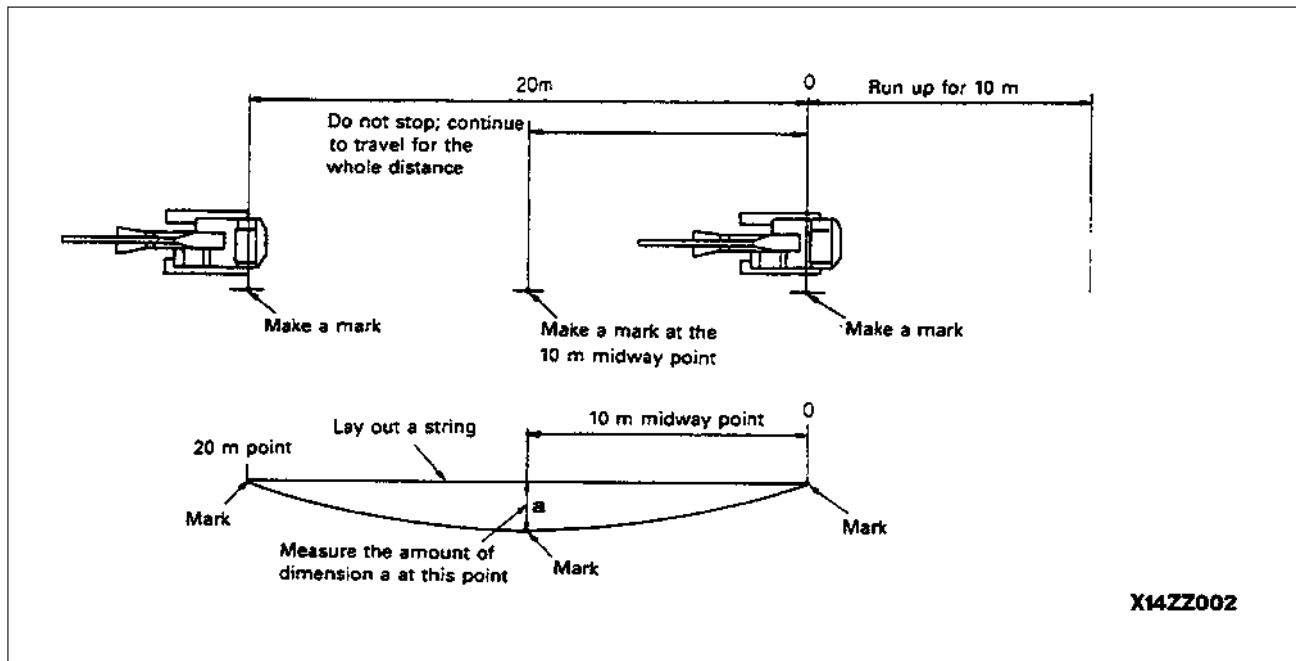
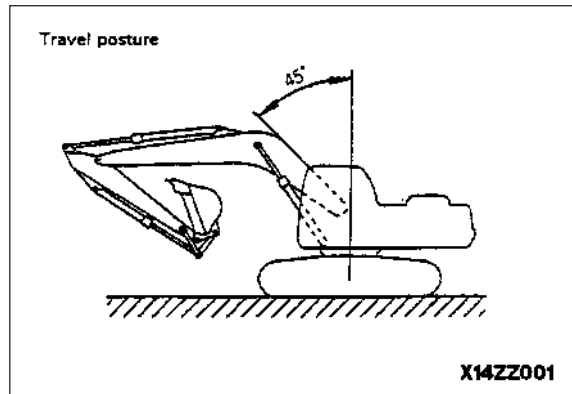

TESTING LOCATIONS CAUSING HYDRAULIC DRIFT OF WORK EQUIPMENT

- ★ If there is any hydraulic drift in the work equipment (cylinders), check as follows to determine if the cause is in the cylinder packing or in the control valve.
 1. Checking for defective cylinder packing.
 - a. Checking boom and bucket cylinders.
 - i. Set in the same posture as when measuring hydraulic drift, and stop the engine.
 - ii. Operate the boom control lever to RAISE or the bucket control lever to CURL. If the lowering speed increases, the packing is defective. If there is no change, the boom holding valve (boom) or the control valve (bucket) is defective.
 - b. Checking arm cylinder.
 - i. Operate the arm cylinder to move the arm in fully, then stop the engine.
 - ii. Operate the control lever to arm IN. If the lowering speed increases, the packing is defective. If there is no change, the control valve is defective.
- ★ If the pressure in the accumulator has dropped, run the engine for approximately 10 seconds to change the accumulator again before operating.

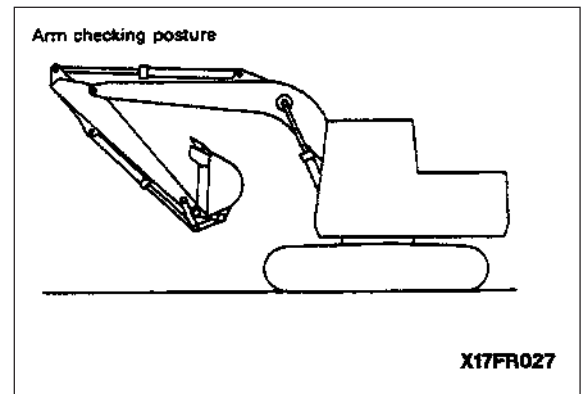
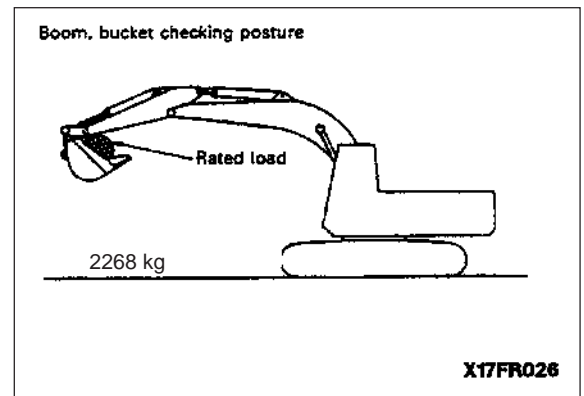

- Reference:** If the cause of the hydraulic drift is in the packing, and the above operations are carried out, the downward movement becomes faster for the following reasons.
1. If the work equipment is set to the above posture (holding pressure applied to the bottom end), the oil at the bottom end leaks to the head end. However, the volume at the end is smaller than the volume at the bottom end by the volume of the rod, so the internal pressure at the head end increases because of the oil flowing in from the bottom end.
 2. When the internal pressure at the head end increases, the pressure at the bottom end also rises in proportion to this. The balance is maintained at a certain pressure (this differs according to the amount of leakage) by repeating this procedure.
 3. When the pressure is balanced, the downward movement becomes slower. If the lever is then operated according to the procedure given above, the circuit at the head end is opened to the drain circuit (the bottom end is closed by check valve), so the oil at the head end flows to the drain circuit and the downward movement becomes faster.

TESTING AND ADJUSTING

2. Checking boom holding valve.

- ⚠ Set the work equipment at the maximum reach, and the top of the boom horizontal, then stop the engine.
 - a. Lock the work equipment control levers and release the pressure inside the hydraulic tank.
 - i. Disconnect pilot hose (1) of the boom holding valve, and install a blind plug in the hose.

- ★ Blind plug: 07376-50315
- ★ Leave the boom holding valve end open.
- ★ If any oil leaks from the port that is left open, the boom holding valve is defective.

3. Checking the PPC valve

- a. If the hydraulic drift differs when the safety lock lever is in the LOCK or FREE position, (engine running), the PPC valve is defective.

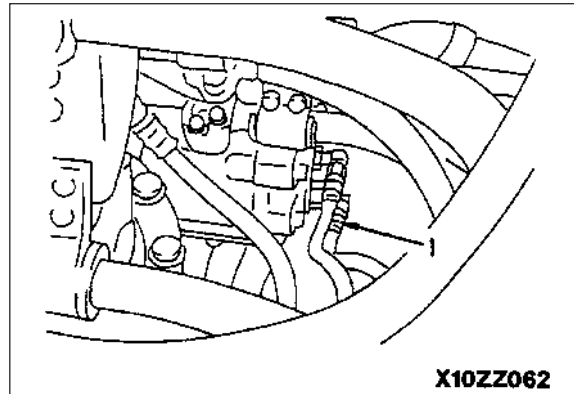

MEASURE OIL LEAKAGE

- ★ Oil temperature when measuring: 45 – 55°C
- 1. Work equipment cylinder
- ★ If the hydraulic drift of the work equipment is outside the standard value, measure the leakage inside the cylinder as follows, and judge if the cause of the hydraulic drift is in the cylinder or in the control valve.
 - If the leakage is within the standard value, the problem is in the control valve.
 - If the leakage is within the standard value, the problem is in the cylinder.
 - a. Fully extend the rod of the cylinder to be measured, then stop the engine.
 - b. Disconnect piping (1) at the head end, then block the piping at the chassis end with a blind plug.
- ⚠ Be careful not to disconnect the piping at the bottom end.
 - c. Start the engine and apply the relief pressure to the bottom end of the cylinder with the engine at high idling.
 - d. Continue this condition for 30 seconds, then measure the oil leakage for one minute.

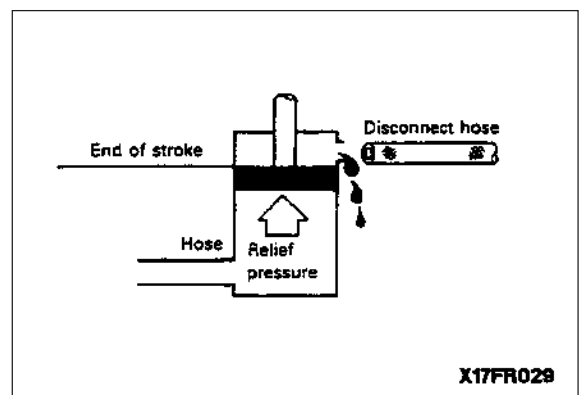
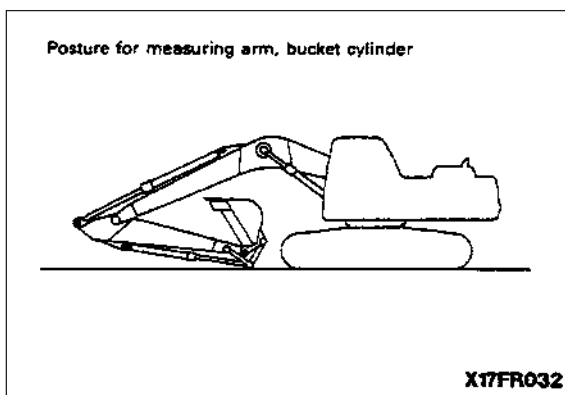
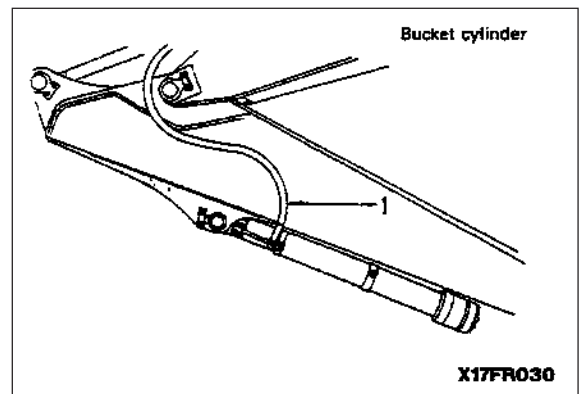
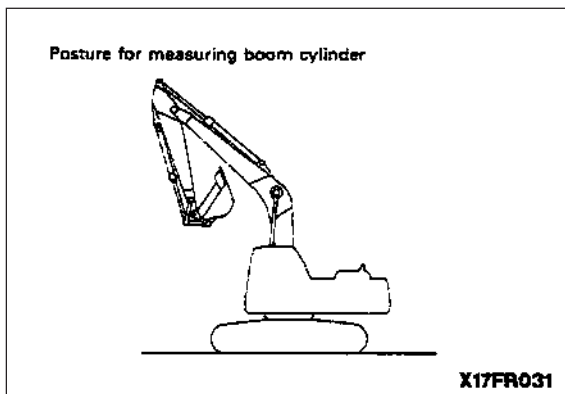
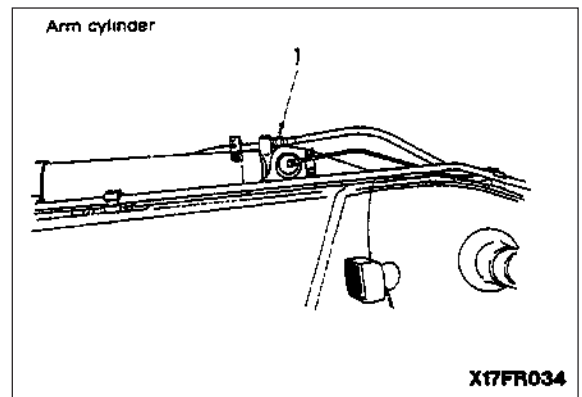
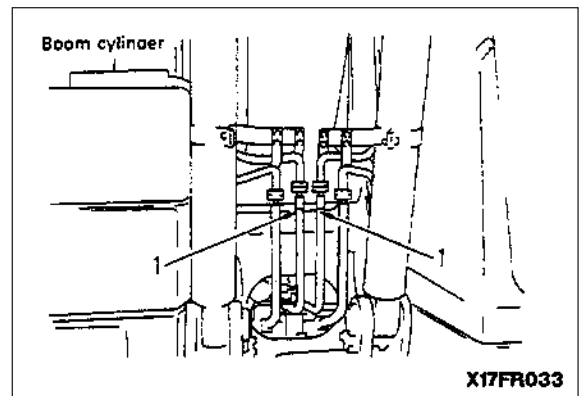

2. Swing motor
 - a. Disconnect drain hose (1) from the swing motor, then fit a blind plug at the tank end.
 - b. Set the swing lock switch ON.
 - c. Start the engine and operate the swing relief with the engine at high idling.
 - d. Continue this condition for 30 seconds, then measure the oil leakage for one minute.
- ★ After measuring, swing 180° and measure again.

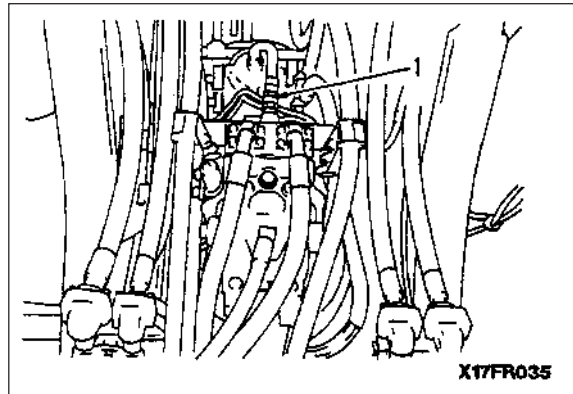

3. Travel motor
 - a. Disconnect drain hose (2) from the travel motor, then fit a blind plug at the hose end.
 - b. Fit block ① under the track shoe grouser, or fit block ② between the sprocket and frame to lock the track.
 - c. Start the engine and operate the travel relief with the engine at high idling.

⚠ When measuring the oil leakage from the travel motor, mistaken operation of the control lever may lead to a serious accident, so always use signals and check when carrying out this operation.

- d. Continue this operation for 30 seconds, then measure the oil leakage for one minute.
- ★ When measuring, move the motor slightly (to change the position between the valve plate and cylinder, and piston and cylinder), and measure several times.

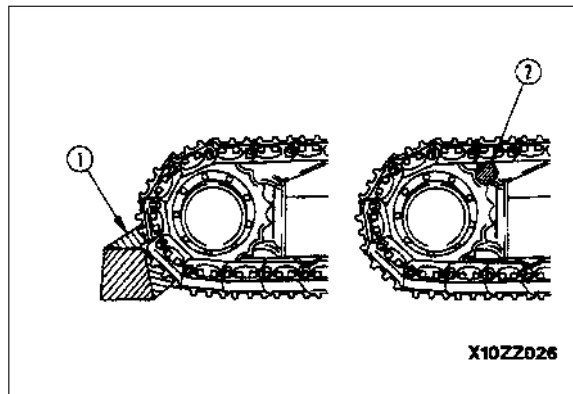
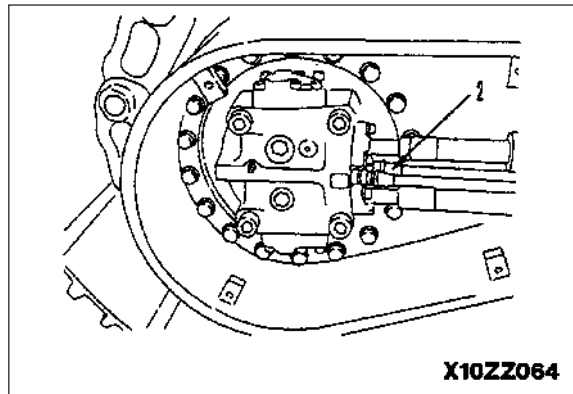

RELEASING REMAINING PRESSURE IN HYDRAULIC CIRCUIT

- ★ If the piping between the hydraulic cylinder and the control valve is disconnected, release the remaining pressure from the circuit as follows. The travel circuit is an open circuit, so there is no remaining pressure. It is enough to remove the oil filler cap.
1. Loosen the oil filler cap slowly to release the pressure inside the tank.
 2. Operate the control levers. When the levers are operated 2 – 3 times, the pressure stored in the accumulator is removed.
 3. Start the engine, run at low idling for approximately 5 minutes, then stop the engine and operate the control levers. Repeat the above operation 2 – 3 times to release all the remaining pressure.

TESTING CLEARANCE OF SWING CIRCLE BEARING

1. Method of testing clearance of swing circle bearing when mounted on machine.

- a. Fix a magnet-type dial gauge to the outer circle (or inner circle) of the swing circle, and put the tip of the probe in contact with the inner circle (or outer circle). Set the dial gauge at the front or rear.

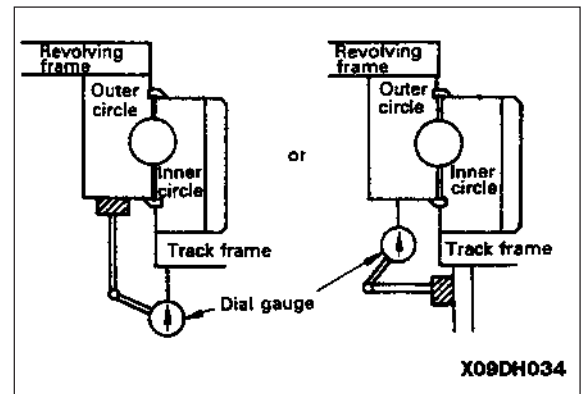

- b. Extend the work equipment to the maximum reach, and set the tip of the bucket to the same height as the bottom of the revolving frame. When this is done, the upper structure will tilt forward, so the front will go down and the rear will rise.
- c. Set the dial gauge to the zero point.

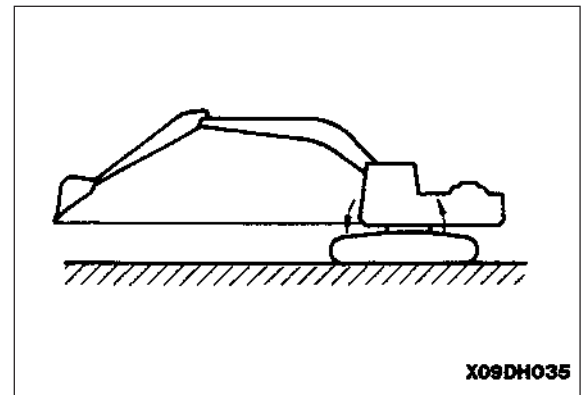

- d. Set the arm more or less at right angles to the ground surface, then lower the boom until the front of the machine comes off the ground. When this is done, the upper structure will tilt back, so the front will rise and the rear will go down.
- e. Read the value on the dial gauge at this point. The value on the dial gauge is the clearance of the swing circle bearing.

⚠ When carrying out the measurement, do not put your hand or feet under the undercarriage.

- f. Return to the condition in Step b., and check that the dial gauge has returned to the zero point. If it has not returned to the zero point, repeat Steps b. To e.

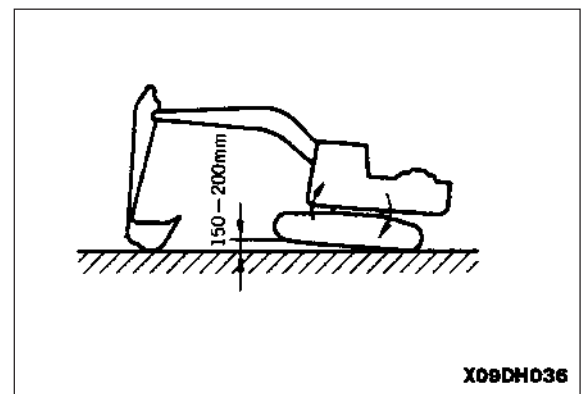

TESTING AND ADJUSTING TRACK SHOE TENSION

1. Testing

- a. Raise the track frame using the arm and boom, and measure the clearance between the bottom of the track frame and the top of the track shoe.
- Clearance: 331 ± 20 mm
- Measurement position
 - 4th track roller from the sprocket.
 - Midway between the 5th and 6th track roller from the sprocket.

2. Adjusting

- ★ If the track shoe tension is not within the standard value, adjust as follows.
 - a. When the tension is too high
 - i. Loosen plug (1) gradually, and release the grease.
- ⚠ There is a danger that the plug may fly out under the high internal pressure of the grease, so never loosen the plug (1) more than one turn.
- ★ If the grease does not come out easily, move the machine backwards or forwards slowly.
 - b. If track is too loose.
 - i. Pump in grease through grease fitting (2).
- ★ If the grease cannot be pumped in easily, move the machine backwards and forwards slowly.

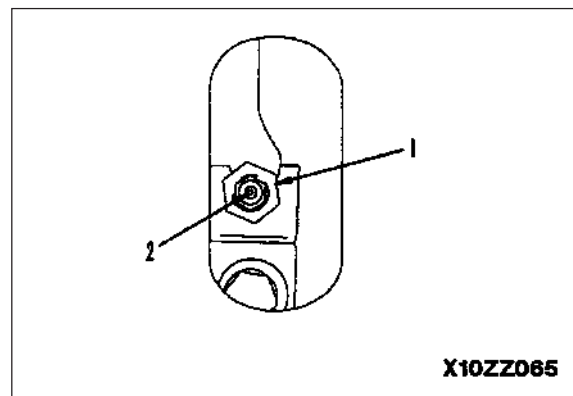
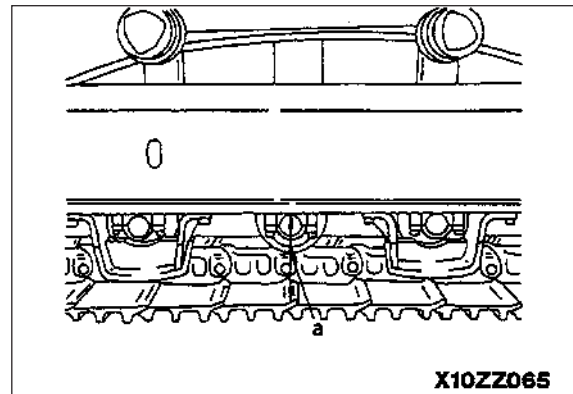

BLEEDING AIR

Order for operation and procedure for bleeding air

Air bleeding item	Air bleeding procedure					
	1	2	3	4	5	6
Nature of work	Bleeding air from pump	Start engine	Bleeding air from cylinder	Bleeding air from swing motor	Bleeding air from travel motor	Start operations
Replace hydraulic oil Clean strainer	○	○	○	○ Note 1	○ Note 1	○
Replace return filter element		○	○			○
Replace, repair pump Remove suction piping	○	○	○			○
Replace, repair control valve		○	○			○
Replace cylinder Remove cylinder piping		○		○		○
Replace swing motor Remove swing motor piping		○			○	○
Replace travel motor, swivel Remove travel motor, swivel piping		○				○

Note 1: Bleed the air from the swing and travel motors only when the oil inside the motor case has been drained.

1. Bleeding air from the pump
 - a. Loosen air bleed plug (1), and check that oil oozes out from the plug.
 - b. When oil oozes out, tighten plug (1).

 **kgm** Plug: 17.15 ± 2.45 Nm (1.75 ± 0.25 kgm)

- ★ If no oil oozes out from the air bleed plug:
 - c. Leave plug (1) loosened and remove hose (2) and elbow (3).
 - d. Pour in oil through the elbow mount hole until oil oozes out from plug (1).
 - e. Fit elbow (3) and install hose (2).
 - f. Tighten air bleed plug (1).

 **kgm** Plug: 17.15 ± 2.45 Nm (1.75 ± 0.25 kgm)

- ★ Precautions when starting the engine. After completing the above procedure and starting the engine, run the engine at low idling for 10 minutes.
- ★ If the coolant temperature is low and automatic warming-up is carried out, cancel it by using the fuel control dial after starting the engine.

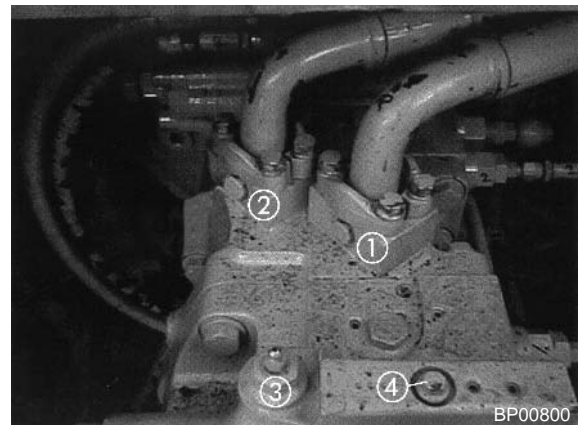

① - ② Rear and front pump discharge pressure rest points
 ③ Pump bleed point
 ④ Servo piston input pressure test point of rear pump

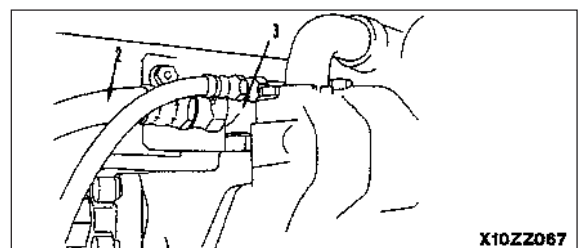

X10ZZ067

2. Bleeding air from hydraulic cylinders
 - a. Start the engine and run at idling for approximately 5 minutes.
 - b. Run the engine at low idling, then raise and lower the boom 4-5 times in succession.
- ★ Operate the piston rod to approximately 100 mm before the end of its stroke. Do not relieve the circuit under any circumstances.
 - c. Run the engine at full throttle and repeat Step b. After that, run the engine at low idling and operate the piston rod to the end of its stroke to relieve the circuit.
 - d. Repeat Steps b. and c. to bleed the air from the arm and bucket cylinders.
- ★ When the cylinder had been replaced, bleed the air before connecting the piston rod. Be particularly careful not to operate the cylinder to the end of its stroke when the piston rod had been connected to the LOWER end of the boom cylinder.

3. Bleeding air from swing motor
 - a. Run the engine at low idling, loosen air bleed plug (1), and check that oil oozes out.
- ★ If no oil oozes out from the air bleed plug:
 - b. Stop the engine and pour oil into the motor case through plug (1).
 - c. Tighten air bleed plug (1).

 **kgm** Plug: 166.6 ± 19.6 Nm (17 ± 2 kgm)

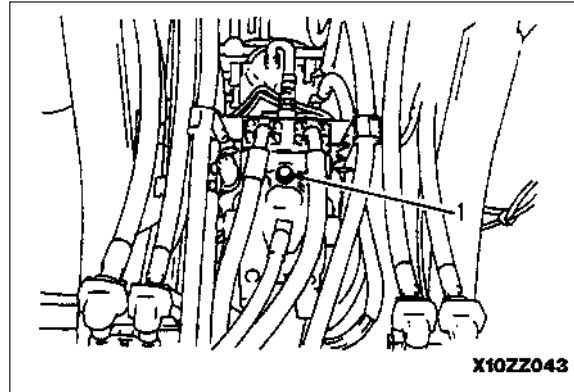

X10ZZ043

4. Bleeding air from travel motor

Run the engine at low idling, loosen air bleed plug (2), and when oil flows out, tighten the plug again.

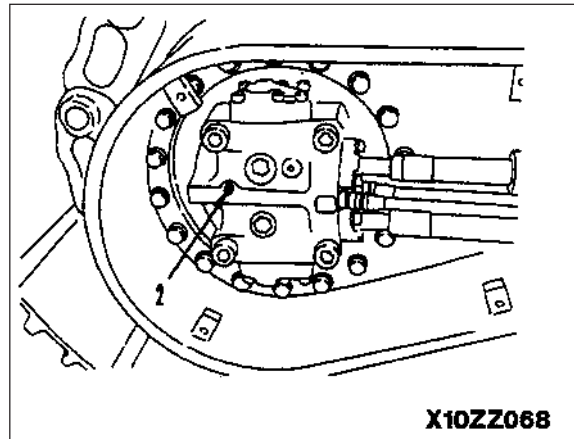

X10ZZ068

SEQUENCE OF EVENTS IN TROUBLESHOOTING

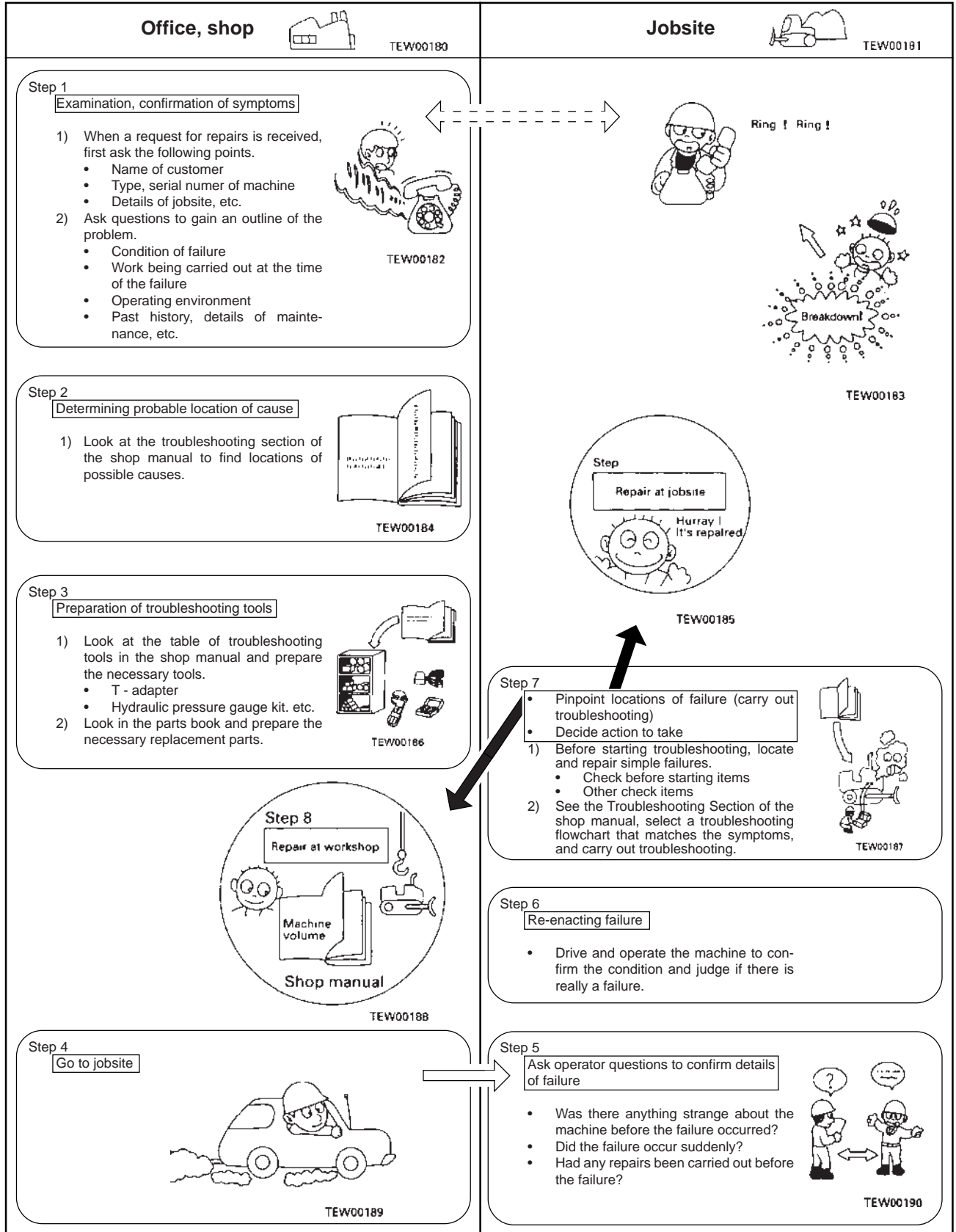

POINTS TO REMEMBER WHEN CARRYING OUT MAINTENANCE

To maintain the performance of the machine over a long period, and to prevent failures or other troubles before they occur, correct operation, maintenance and inspection, troubleshooting and repairs must be carried out. This section deals particularly with correct repair procedures for mechanics and is aimed at improving the quality of repairs. For this purpose, it gives sections on "Handling electric equipment" and "Handling hydraulic equipment" (particularly gear oil and hydraulic oil).

Points to remember when handling electric equipment

1. Handling wiring harnesses and connectors.

Wiring harnesses consist of wiring connecting one component to another component, connectors used for connecting and disconnecting one wire from another wire, and protectors or tubes used for protecting the wiring.

Compared with other electrical components fitted in boxes or cases, wiring harnesses are more likely to be affected by the direct effects of rain, water, heat or vibration. Furthermore, during inspection and repair operations, they are frequently removed and installed again, so they are likely to suffer deformation or damage. For this reason, it is necessary to be extremely careful when handling wiring harnesses.

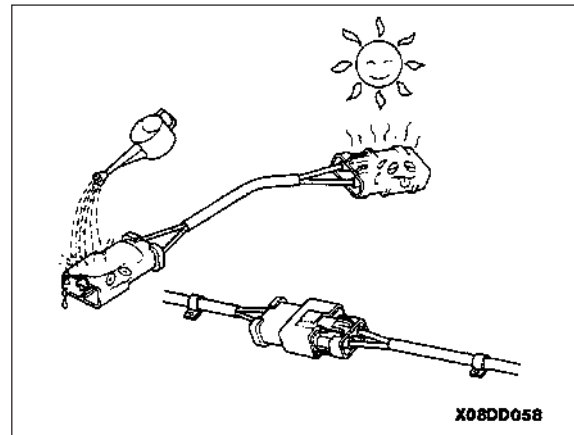

a. Main failures occurring in wiring harness.

- i. Defective contact of connectors (defective contact between male and female). Problems with defective contact are likely to occur because the male connector is not properly inserted into the female connector, or because one or both of the connectors is deformed or the position is not correctly aligned, or because there is corrosion or oxidation of the contact surfaces.

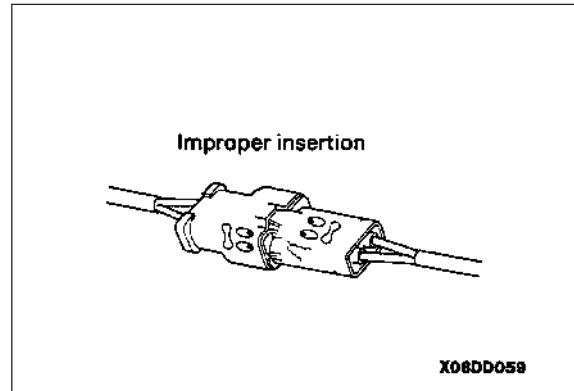

- ii. Defective crimping or soldering of connectors. The pins of the male and female connectors are in contact at the crimped terminal or soldered portion, but if there is excessive force brought to bear on the wiring, the plating at the joint will peel and cause improper connection or breakage.

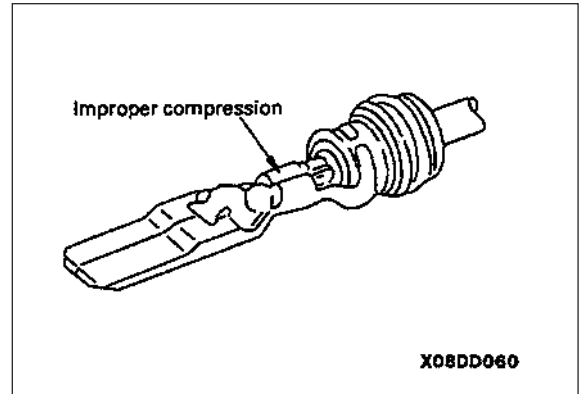

- iii. Disconnections in wiring. If the wiring is held and the connectors are pulled apart, or components are lifted with a crane with the wiring still connected, or a heavy object hits the wiring, the crimping of the connector may separate, or the soldering may be damaged, or the wiring may be broken.

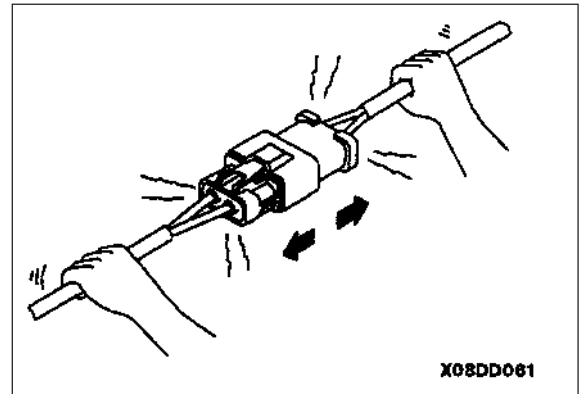

- iv. High-pressure water entering connector. The connector is designed to make it difficult for water to enter (drop-proof structure), but if high-pressure water is sprayed directly on the connector, water may enter the connector, depending on the direction of the water jet. Since the connector is designed to prevent water from entering, but at the same time, if water does enter, it is difficult for it to be drained. Therefore, if water should get into the connector, the pins will be short-circuited by the water, so if any water gets in, immediately dry the connector or take other appropriate action before passing electricity through it.

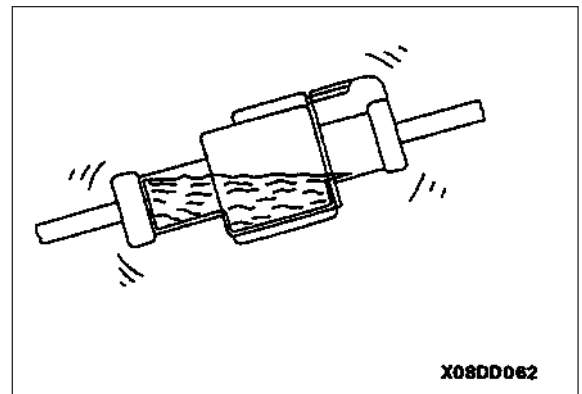

- v. Oil or dirt stuck to connector. If oil or grease is stuck to the connector and an oil film is formed on the mating surface between the male and female pins, the oil will not let the electricity pass, so there will be defective contact. If there is oil or grease stuck to the connector, wipe it off with a dry cloth or blow dry with compressed air and spray it with a contact restorer.

- ★ When wiping the mating portion of the connector, be careful not to use excessive force or deform the pins.
- ★ If there is oil or water in the compressed air, the contacts will become even dirtier, so remove the oil and water from the compressed air completely before cleaning with compressed air.

2. Removing, installing, and drying connectors and wiring harnesses.

a. Disconnecting connectors

- i. Hold the connectors when disconnecting. When disconnecting the connectors, hold the connectors and not the wires. For connectors held by a screw, loosen the screw fully, then hold the male and female connectors in each hand and pull apart. For connectors which have a lock stopper, press down the stopper with your thumb and pull the connectors apart.

- ★ Never pull with one hand.

b. When removing from clips

- i. When removing a connector from a clip, pull the connector in a parallel direction to the clip.

- ★ If the connector is twisted up and down or to the left or right, the housing may break.

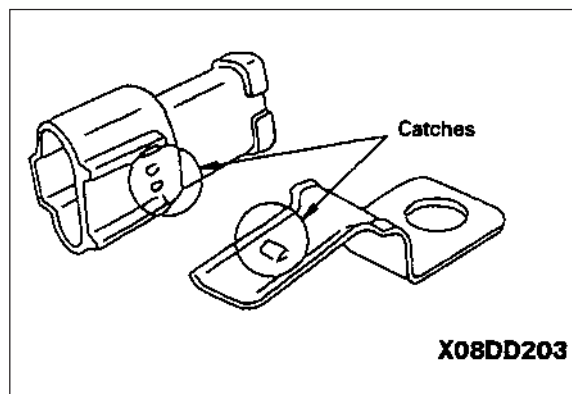
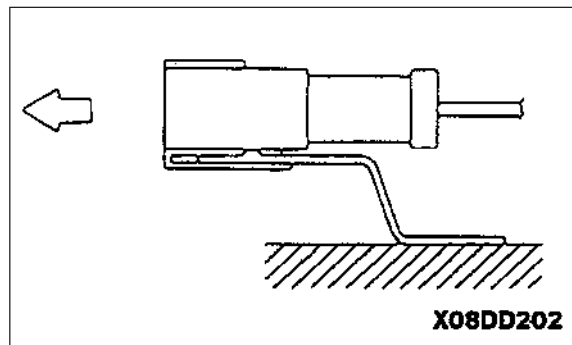
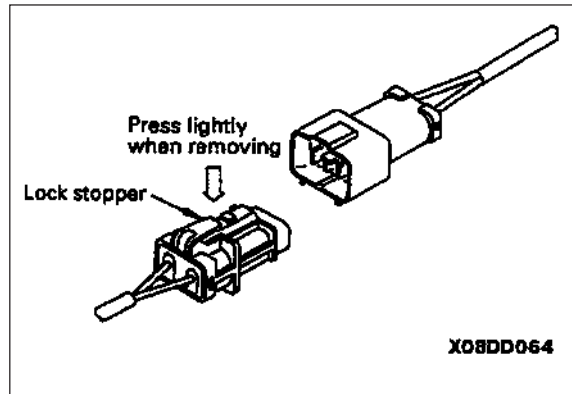
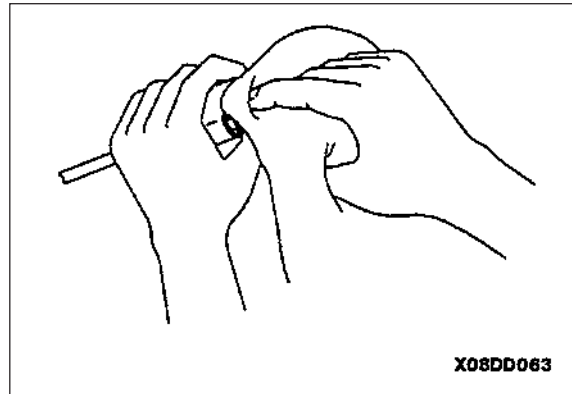

- c. Action to take after removing connectors
 - i. After removing any connector, cover it with a vinyl bag to prevent any dust, dirt, oil or water from getting in the connector portion.
- ★ If the machine is left disassembled for a long time, it is particularly easy for improper contact to occur, so always cover the connector.
- d. Connecting connectors
 - i. Check the connector visually
 - ii. Check that there is no oil, dirt, or water stuck to the connector pins (mating portion).
 - iii. Check that there are no deformation, defective contact, corrosion, or damage to the connector pins.
 - iv. Check that there is no damage or breakage to the outside of the connector.
- ★ If there is any oil, water, or dirt stuck to the connector, wipe it off with a dry cloth. If any water has got inside the connector, warm the inside of the wiring with a dryer, but be careful not to make it too hot as this will cause short circuits.
- ★ If there is any damage or breakage, replace the connector.
 - v. Fix the connector securely
 - vi. Align the position of the connector correctly, then insert it securely.
 - vii. For connectors with lock stopper, push in the connector until the stopper clicks into position.
 - viii. Correct any protrusion of the boot and any misalignment of the wiring harness.
 - ix. For connectors fitted with boots, correct any protrusion of the boot. In addition, if the wiring harness is misaligned, or the clamp is out of position, adjust it to its correct position.
- ★ If the connector cannot be corrected easily, remove the clamp and adjust the position.
 - x. If the connector clamp has been removed, be sure to return it to its original position. Check also that there are not loose clamps.

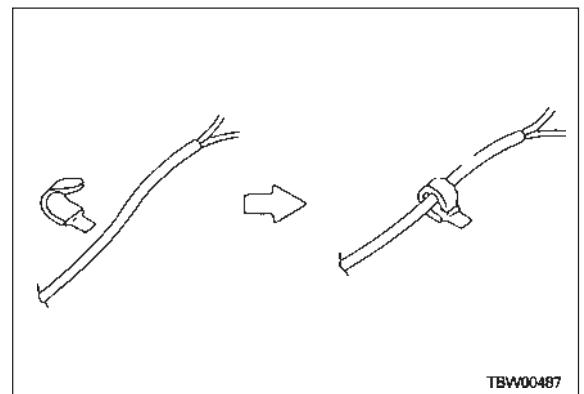
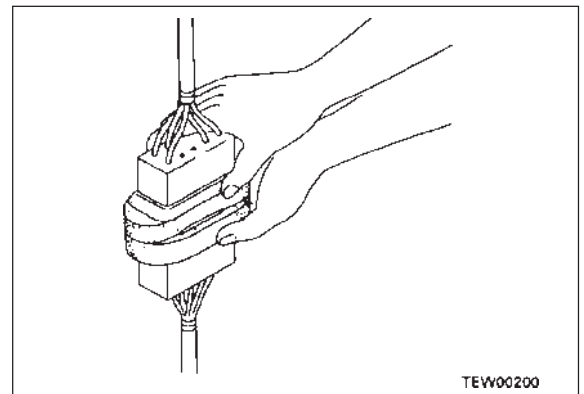
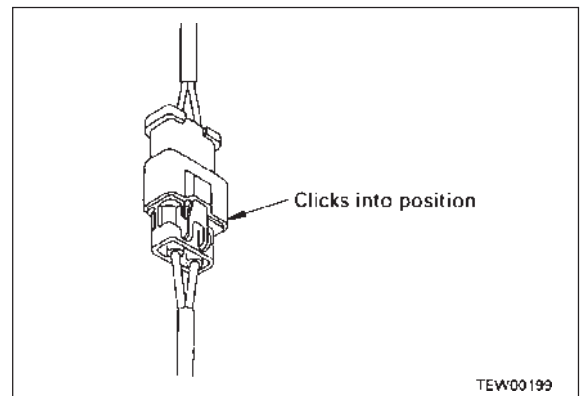
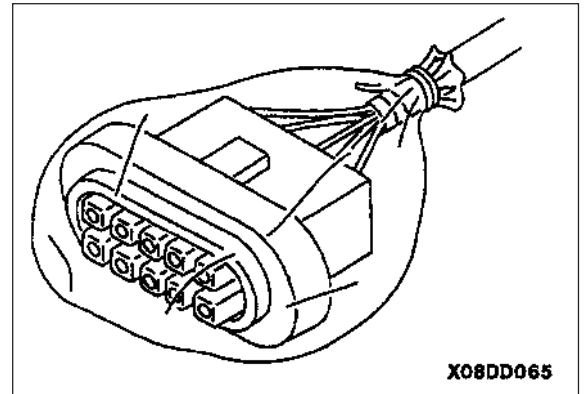

e. Drying wiring harness. If there is any oil or dirt on the wiring harness, wipe it off with a dry cloth. Avoid washing it in water or using steam. If the connector must be washed in water, do not use high-pressure water or steam directly on the wiring harness. If water gets directly on the connector, do as follows.

i. Disconnect the connector and wipe off the water with a dry cloth.

★ If the connector is blown dry with compressed air, there is the risk that oil in the air may cause defective contact, so remove all oil and water from the compressed air before blowing with air.

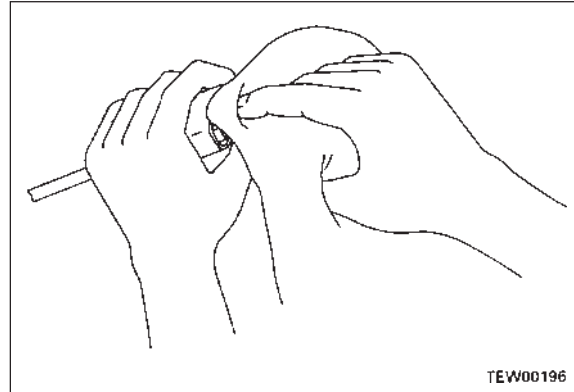

ii. Dry the inside of the connector with a dryer. If water gets inside the connector, use a dryer to dry the connector.

★ Hot air from the dryer can be used, but regulate the time that the hot air is used in order not to make the connector or related parts too hot, as this will cause deformation or damage to the connector.

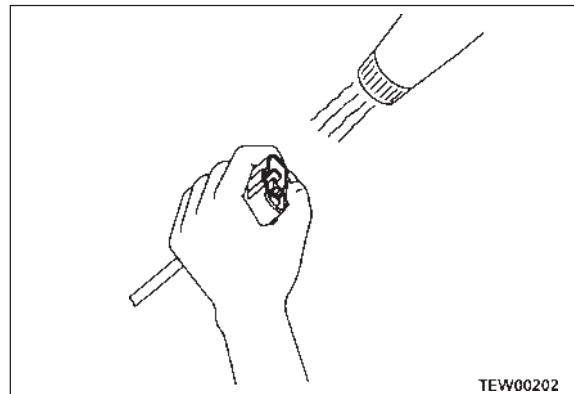

iii. Carry out a continuity test on the connector. After drying, leave the wiring harness disconnected and carry out a continuity test to check for any short circuits between pins caused by water.

★ After completely drying the connector, blow it with contact restorer and reassemble.

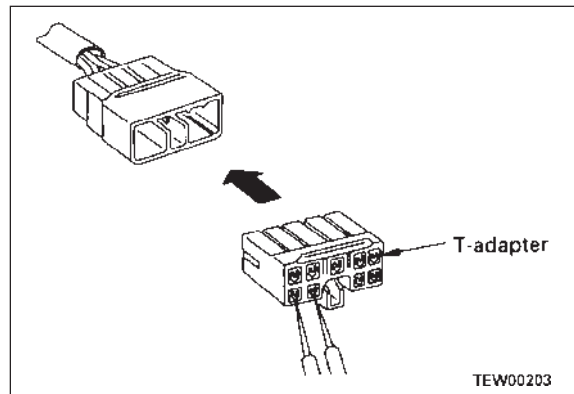

3. Handling control box

- a. The control box contains a microcomputer and electronic control circuits. These control all of the electronic circuits on the machine, so be extremely careful when handling the control box.
- b. Do not open the cover of the control box unless necessary.

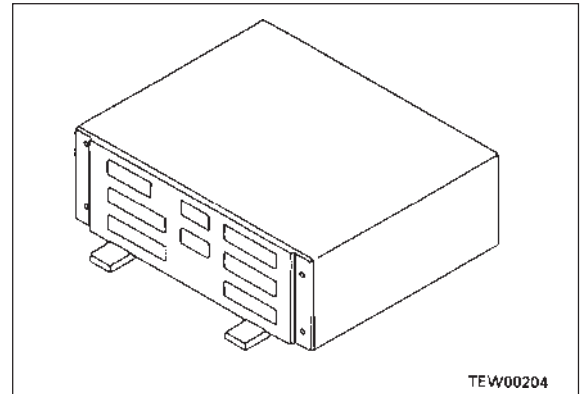

- c. Do not place objects on top of the control box.
- d. Cover the control connectors with tape or a vinyl bag. Never touch the connector contacts with your hand.
- e. During rainy weather, do not leave the control box in a place where it is exposed to rain.

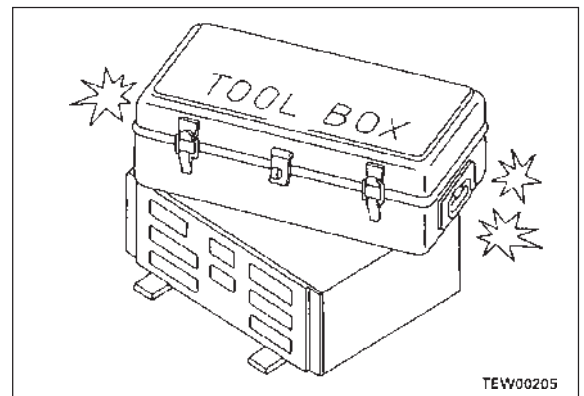

- f. Do not place the control box on oil, water, or soil, or in any hot place, even for a short time. (Place it on a suitable dry stand).
- g. Precautions when carrying out arc welding. When carrying out arc welding on the body, disconnect all wiring harness connectors connected to the control box. Fit an arc welding ground close to the welding point.

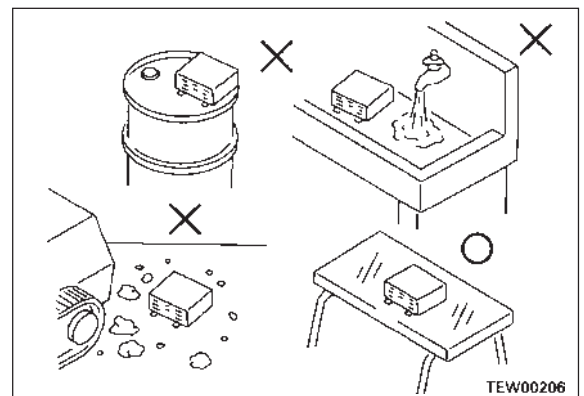
**Points to remember when troubleshooting electric circuits**

1. Always turn the power OFF before disconnecting or connecting connectors.
2. Before carrying out troubleshooting, check that all the related connectors are properly inserted.
 - ★ Disconnect and connect the related connectors several times to check.
3. Always connect any disconnected connectors before going on to the next step.
 - ★ If the power is turned ON with the connectors still disconnected, unnecessary abnormality displays will be generated.
4. When carrying out troubleshooting of circuits (measuring the voltage, resistance, continuity, or current), move the related wiring and connectors several times and check that there is no change in the reading of the tester.
 - ★ If there is any change, there is probably defective contact in that circuit.

Points to remember when handling hydraulic equipment

With the increase in pressure and precision of hydraulic equipment, the most common cause of failure is dirt (foreign material) in the hydraulic circuit. When adding hydraulic oil, or when disassembling or assembling hydraulic equipment, it is necessary to be particularly careful.

1. Be careful of the operating environment. Avoid adding hydraulic oil, replacing filters, or repairing the machine in rain or high winds, or in places where there is a lot of dust.
2. Disassembly and maintenance work in the field. If disassembly or maintenance work is carried out on hydraulic equipment in the field, there is danger of dust entering the equipment. It is also difficult to confirm the performance after repairs, so it is desirable to use a unit exchange. Disassembly and maintenance of hydraulic equipment should be carried out in a specially prepared dustproof workshop, and the performance should be confirmed with special test equipment.
3. Sealing openings. After any piping or equipment is removed, the openings should be sealed with caps, tapes, or vinyl bags to prevent any dirt or dust from entering. If the opening is left open or is blocked with a rag, there is a danger of dirt entering or of the surrounding area being made dirty by leaking oil. Do not simply drain oil out on to the ground. Collect it and ask the customer to dispose of it, or take it back with you for disposal.
4. Do not let any dirt or dust get in during refilling operations. Always keep the oil filler and the area around it clean, and always use clean pumps and oil containers. If an oil cleaning device is used, it is possible to filter out the dirt that has collected during storage.

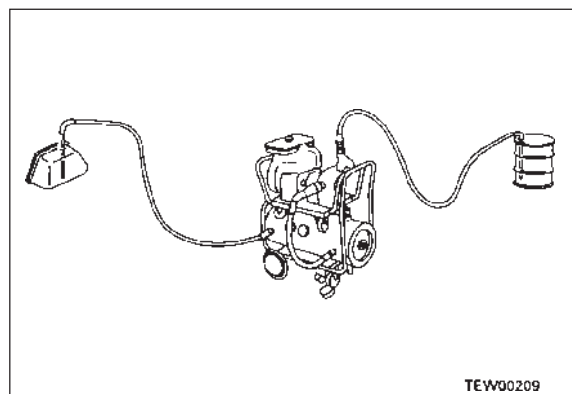
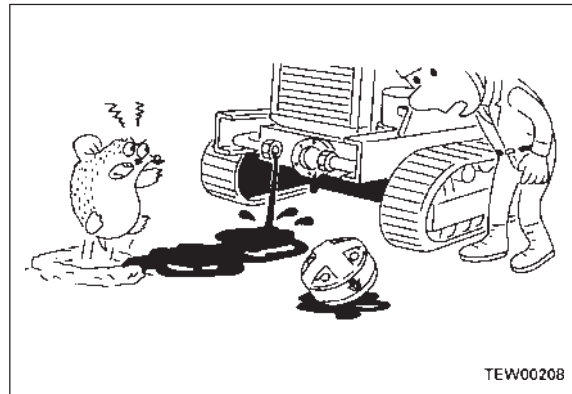
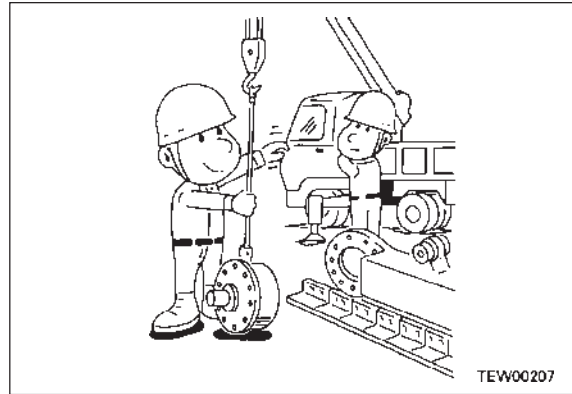

5. Change hydraulic oil when the temperature is high. When hydraulic oil or other oil is warm, it flows easily. In addition, the sludge can also be drained out easily from the circuit together with the oil, so it is best to change the oil when it is still warm. When changing the oil, as much as possible of the old hydraulic oil must be drained out. (Drain the oil from the hydraulic tank; also drain the oil from the filter and from the drain plug in the circuit.) If any old oil is left, the contaminants and sludge in it will mix with the new oil and will shorten the life of the hydraulic oil.

6. Flushing operations. After disassembling and assembling the equipment, or changing the oil, use flushing oil to remove the contaminants, sludge, and old oil from the hydraulic circuit. Normally, flushing is carried out twice: primary flushing is carried out with flushing oil and secondary flushing is carried out with the specified hydraulic oil.

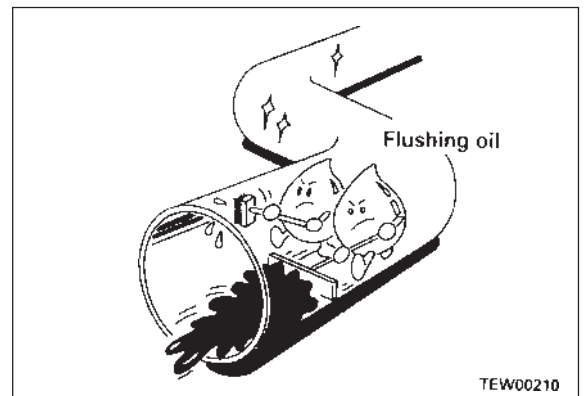

7. Cleaning operations. After repairing the hydraulic equipment (pump, control valve, etc.) or when running the machine, carry out oil cleaning to remove the sludge or contaminants in the hydraulic oil circuit. The oil cleaning equipment is used to remove the ultrafine (about 3μ) particles that the filter built into the hydraulic equipment cannot remove, so it is an extremely effective device.

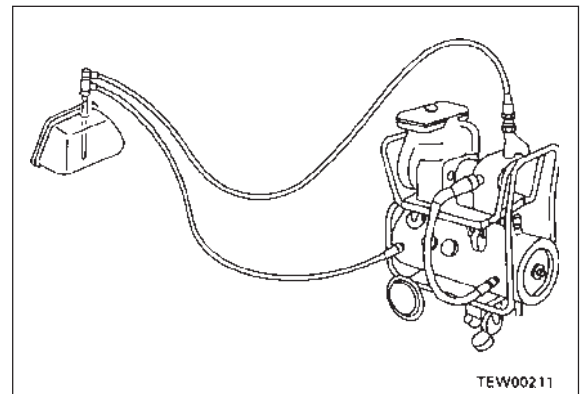

CHECKS BEFORE TROUBLESHOOTING

	Item	Judgement value	Action
Lubricating oil, coolant	1. Check fuel level, type of fuel	-	Add fuel
	2. Check for impurities in fuel	-	Clean, drain
	3. Check hydraulic oil level	-	Add oil
	4. Check hydraulic strainer	-	Clean, drain
	5. Check swing machinery oil level	-	Add oil
	6. Check engine oil level (oil pan oil level, type of oil)	-	Add oil
	7. Check coolant level	-	Add water
	8. Check dust indicator for clogging	-	Clean or replace
	9. Check hydraulic filter	-	Replace
Electrical equipment	1. Check for looseness, corrosion of battery terminal, wiring	-	Tighten or replace
	2. Check for looseness, corrosion of alternator terminal, wiring	-	Tighten or replace
	3. Check for looseness, corrosion of starting motor terminal, wiring	-	Tighten or replace
Hydraulic, mechanical equipment	1. Check for abnormal noise, smell	-	Repair
	2. Check for oil leakage	-	Repair
	3. Carry out air bleeding	-	Bleed air
Electrics, electrical equipment	1. Check battery voltage (engine stopped)	20-30V	Replace
	2. Check battery electrolyte level	-	Add or Replace
	3. Check for discolored, burnt, exposed wiring	-	Replace
	4. Check for missing wiring clamps, hanging wiring	-	Repair
	5. Check for water leaking on wiring (be particularly careful attention to water leaking on connectors or terminals)	-	Disconnect connector and dry
	6. Check for blown, corroded fuses	-	Replace
	7. Check alternator voltage (engine running at 1/2 throttle or above)	27.5 - 29.5 V	Replace
	8. Check operating sound of battery (when switch is turned ON/OFF)	-	Replace

MEMORANDA

CONNECTOR TYPES AND MOUNTING LOCATIONS

★ The Address column in the table below shows the address in the connector arrangement drawing.
(3-dimensional drawing)

Connector No.	Type	No. of pins	Mounting location	Address
A01	KES1	2	Window washer circuit	R-8
A03	KES1	2	Active mode solenoid circuit	Q-6
A04	KES1	2	Pump merge/divider solenoid circuit	R-6
A05	KES1	2	Swing holding brake solenoid circuit	R-7
A06	KES1	2	2-stage relief solenoid circuit	R-6
A07	KES1	2	Travel speed selector solenoid circuit	R-7
A09	KES1	2	Lower wiper circuit	D-1
A11	KES1	2	Alarm buzzer circuit	R-8
A13	KES1	2	Battery relay drive circuit	R-7
A14	KES1	2	Battery relay drive circuit	R-8
A17	KES1	2	Heater relay circuit	R-7
A26	KES1	2	Swing holding brake solenoid	R-7
BR	Terminal	1	Battery relay terminal BR	-
C01	MIC	13	Engine throttle • pump controller	Q-6
C02	MIC	21	Engine throttle • pump controller	Q-6
C03	040	20	Engine throttle • pump controller	P-6
C05	S	10	Pump prolix circuit switch	N-5
C06	M	2	Pump prolix resistor	P-5
C07	X	3	Rear pump pressure sensor	J-9
C08	X	3	Front pump pressure sensor	J-9
C09	S	8	Model selection connector	Q-6
C10	X	2	LS-EPC solenoid valve	G-9
C13	X	2	Pump EPC solenoid valve	H-9
C16	MIC	17	Engine throttle, pump controller	R-9
C17	040	16	Engine throttle, pump controller	I-5
E04	X	3	Governor potentiometer	I-9
E05	X	4	Governor motor	I-9
E06	M	3	Fuel control dial	N-8
E07	X	2	Engine speed sensor	L-2
E08	X	1	Engine	L-3
E10	Packard	3	Fuel shut-off solenoid	J-1
E11	Terminal	1	Electrical intake air heater relay	A-2
E13	Terminal	1	Starting motor terminal C	-
E14	Terminal	1	Electrical intake air heater relay	-
E15	Terminal	1	Electrical intake air heater	-

Connector No.	Type	No. of pins	Mounting location	Address
G26	X	2	Accessory connector	J-5
G27	X	2	Accessory connector	J-5
G28	X	2	Accessory connector	J-5
G29	X	2	Accessory connector	J-5
G30	X	2	Accessory connector	J-5
G31	X	2	Accessory connector	J-5
H07	S	12	Cab under harness	Q-9
H08	M	6	Base harness	Q-9
H12	S (white)	16	Base wiring harness	R-9
H13	S (blue)	16	Base wiring harness	R-9
H14	M	6	Base wiring harness	R-9
H15	L	2	Base wiring harness	R-9
K03	X	3	Overload caution pressure sensor	F-4
M02	X	2	Starting motor relay	C-3
M08	M	2	Right front light	E-6
M09	M	2	Working lamp (boom)	F-8
M10	M	1	Working lamp (boom)	F-5
M11	L	2	Fusible link	F-5
M13	KES0	8	Speaker	G-3
M14	L	2	Fusible link	F-5
M16	-	1	Horn (high tone)	G-4
M17	-	1	Horn (lowtone)	G-4
M18	M	4	Wiper, washer switch	N-8
M20	Terminal	2	Cigarette lighter	N-8
M21	PA	2	Radio	P-5
M22	M	2	Horn switch	I-4
M23	M	2	L. H. knob switch intermediate connector	G-1
M23	M	2	L.H. knob switch	G-1
M26	M	6	Air conditioner	I-4
M28	KES0	2	Window washer motor	J-5
M34	X	1	Electromagnetic clutch for A/C compressor	I-1
M38	M	2	Lamp switch (option)	O-9
M40	M	2	Cab roof lamp (R.H.)	D-3
M41	M	2	Cab roof lamp (L.H.)	D-3
M42	M	2	Cab roof lamp (Rear)	F-4
M43	X	2	Cab roof lamp	D-2

Connector No.	Type	No. of pins	Mounting location	Address
M45	M	3	Network bus	N-5
M46	M	3	Troubleshooting of wiper motor controller	P-6
M49	-	1	Refuelling pump	H-9
M50	-	1	Rear work lamp	I-9
M51	M	2	Left deck lamp	E-1
M52	X	2	Overload caution switch	G-4
M53	-	2	Heated seat (option)	H-4
M55	-	2	Air suspension seat (option)	H-4
M56	M	2	Heated seat switch	P-9
M70	1-pin connector	1	Intermediate connector	M-6
M71	1-pin connector	1	Intermediate connector (room lamp)	O-5
P01	040	20	Monitor	M-7
P02	040	16	Monitor	M-6
P03	M	2	Buzzer cancel switch	O-9
P04	M	2	Alarm buzzer	M-8
P05	X	1	Engine oil level sensor	J-1
P06	X	1	Fuel level sensor	F-5
P07	Packard	2	Engine coolant temperature sensor	M-2
P08	X	2	Radiator coolant level sensor	K-9
P09	X	1	Hydraulic oil level sensor	G-9
P11	1-pin connector	1	Air cleaner clogging sensor	K-9
P12	1-pin connector	1	Air cleaner clogging sensor	K-9
P-16	KES0	2	12V Supply	P-9
R04	Shinagwa	6	Light relay	O-5
R05	Shinagwa	6	Light relay (option)	O-5
RB	Terminal	1	Battery relay terminal B	-
RE	Terminal	1	Battery relay terminal E	-
RM	Terminal	1	Battery relay terminal M	-
S01	X	2	Travel pressure switch	Q-2
S02	X	2	Boom RAISE pressure switch	Q-2



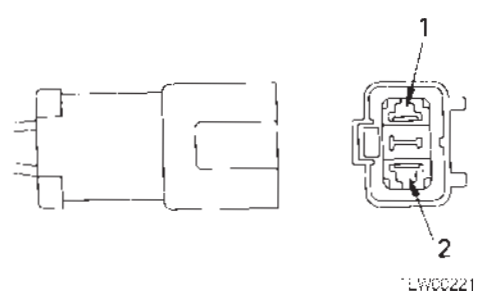
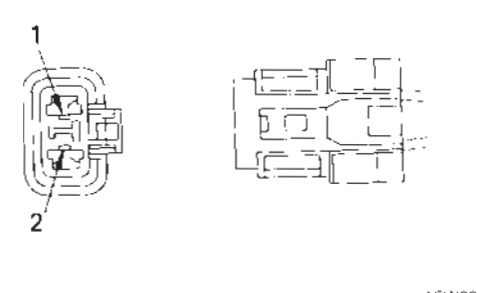
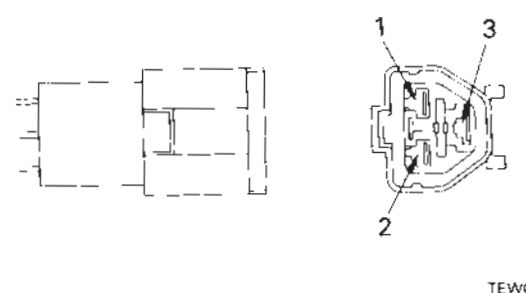
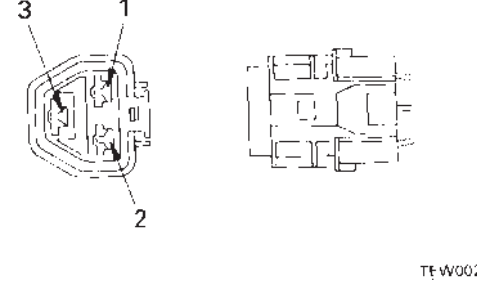
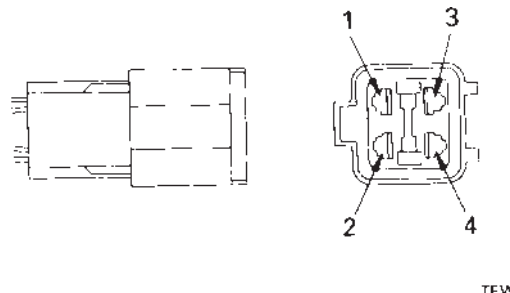
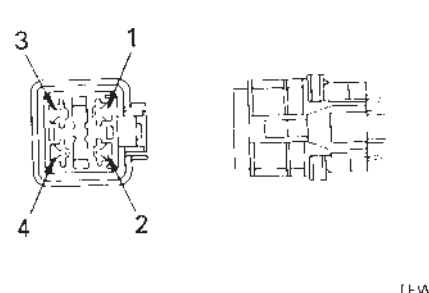

Connector No.	Type	No. of pins	Mounting location	Address
S03	X	2	Arm OUT pressure switch	Q-2
S04	X	2	Boom LOWER pressure switch	Q-3
S05	X	2	Arm IN pressure switch	Q-3
S06	X	2	Bucket CURL pressure switch	Q-3
S07	X	2	Bucket DUMP pressure switch	Q-3
S08	X	2	Right swing pressure switch	Q-3
S09	X	2	Service pressure switch (option)	Q-3
S10	X	2	Leftswing	Q-3
S11	Packard	3	Engine oil pressure switch	-
SC	Terminal	1	Starting motor terminal C	-
T02	Terminal	1	Revolving frame ground	-
T04	Terminal	1	Revolving frame ground	-
T05	Terminal	1	Floor ground	-
T13	Terminal	1	Starter motor	-
T15	Terminal	1	Resistor for Delco alternator	-
T16	Terminal	1	Resistor for Delco alternator	-
T17	Terminal	1	Starter motor	-
V02	X	2	Active mode solenoid valve	M-1
V03	X	2	Pump merge/divider solenoid valve	N-1
V04	X	2	Swing holding brake solenoid valve	N-1
V05	X	2	2-stage relief solenoid valve	M-1
V06	X	2	Travel speed selector solenoid valve	N-1
W04	M	6	Wiper motor	M-5
W08	070	18	Wiper motor controller	P-5
W15	KES0	4	Lower wiper	D-1
W16	M	2	Lower wiper switch	O-9
X01	MIC	21	Panel wiring harness	P-9
X05	M	4	Swing lock switch	N-8
X07	MIC	17	Panel wiring harness	P-9

CONNECTION TABLE FOR CONNECTOR PIN NUMBERS

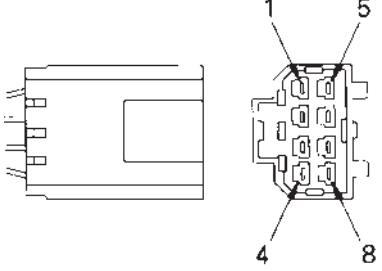
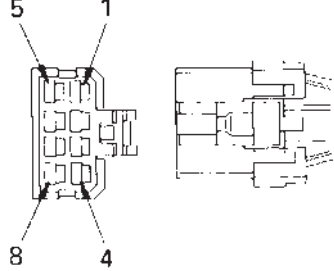
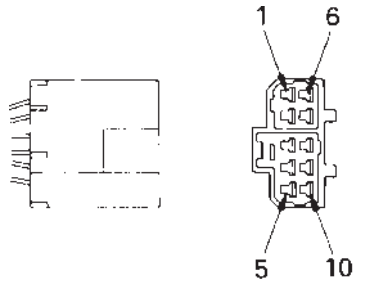
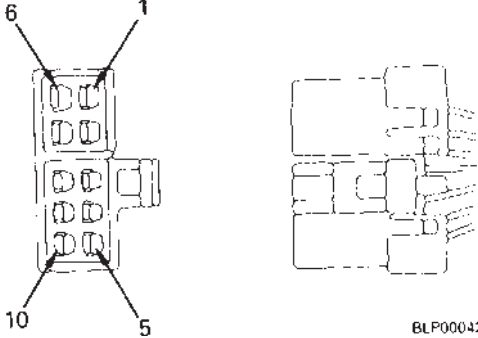
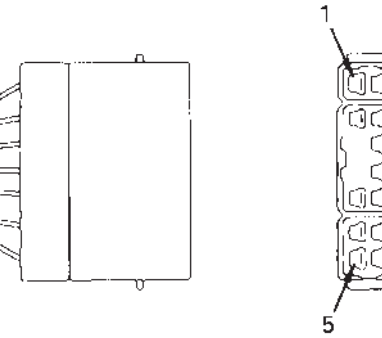
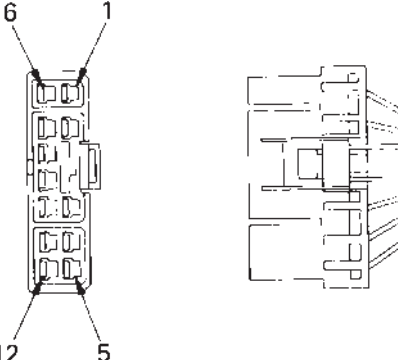
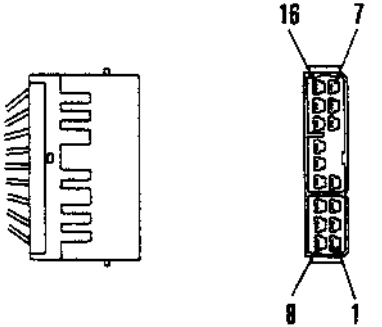
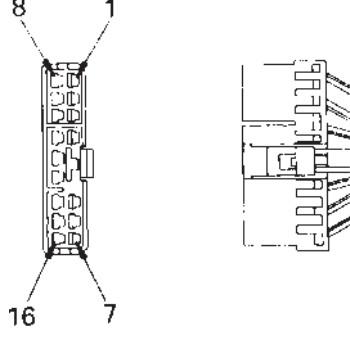
★ The terms male and female refer to the pins, while the terms male housing and female housing refer to the mating portion of the housing.

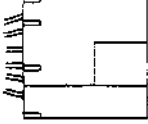
No. of pins	X type connector	
	Male (female housing)	Female (male housing)
2	 <p>TEW00221</p>	 <p>TEW00222</p>
3	 <p>TEW00223</p>	 <p>TEW00224</p>
4	 <p>TEW00225</p>	 <p>TEW00225</p>

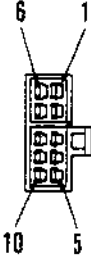
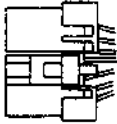
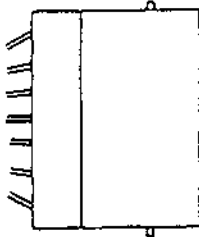
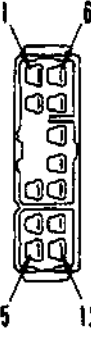
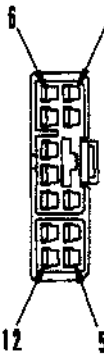
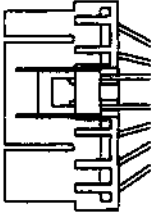
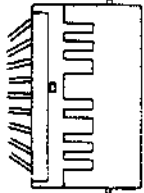
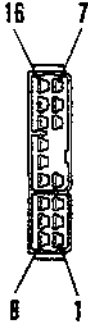

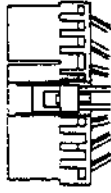
No. of pins	S type connector	
	Male (female housing)	Female (male housing)
8	 <p>TEW00249</p>	 <p>TEW00250</p>
10 (white)	 <p>TEW00251</p>	 <p>BLP00042</p>
12 (white)	 <p>BLP00043</p>	 <p>TEW00254</p>
16 (white)	 <p>X08DD095</p>	 <p>TEW00256</p>

No. of pins	S type connector			
	Male (female housing)		Female (male housing)	
10 (Blue)		 <p>X08DD093</p>		 <p>X08DD094</p>
12 (Blue)		 <p>X08DD217</p>		 <p>X08DD218</p>
16 (Blue)		 <p>X08DD095</p>		 <p>X08DD096</p>

No. of pins	MIC type connector	
	Male (female housing)	Female (male housing)
5		
9		
13		
17		
21		

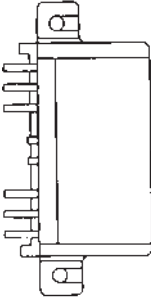
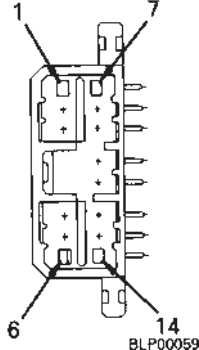
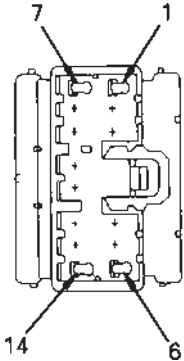
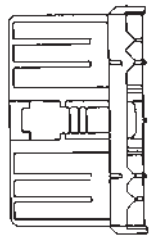
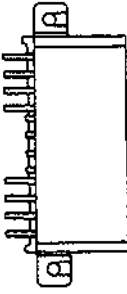
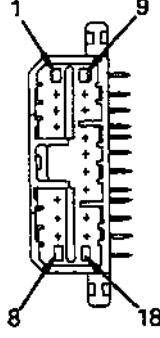
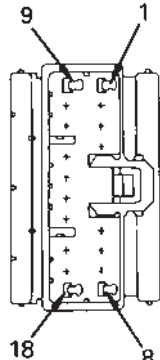
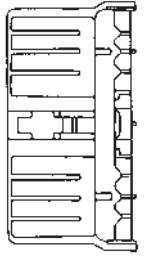
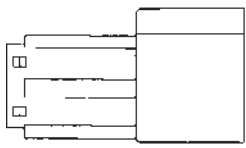
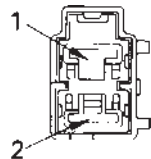
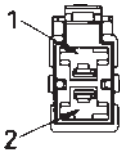
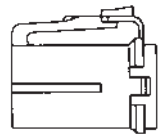
No. of pins	AMP040 type connector			
	Male (female housing)		Female (male housing)	
8		 BLP00053	 BLP00054	
12		 BLP00055	 BLP00056	
16		 BLP00057	 TEW00232	
20		 BLP00058	 TEW00234	

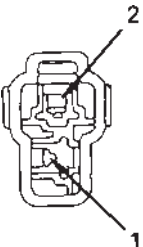
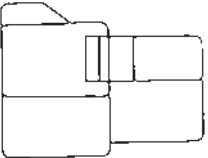
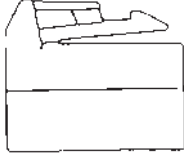
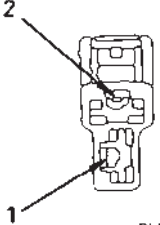
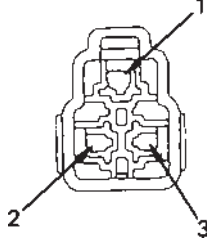
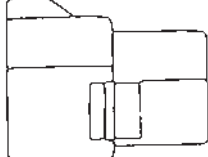
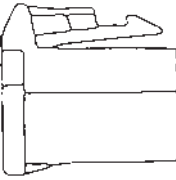
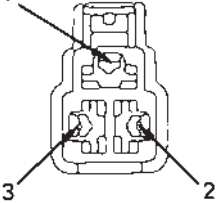
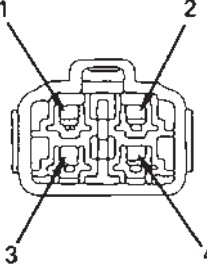
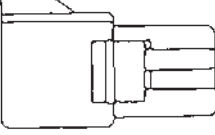
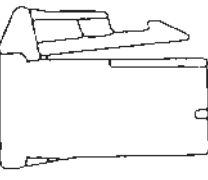
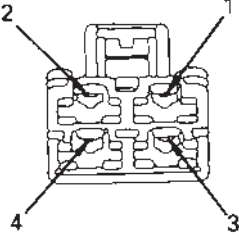
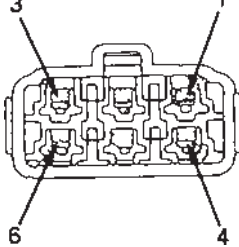
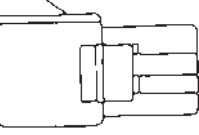
No. of pins	AMP070 type connector			
	Male (female housing)		Female (male housing)	
8		 BLP00059		 BLP00060
12		 X08DD239		 BLP00062
No. of pins	L type connector			
	Male (female housing)		Female (male housing)	
2		 TEW00257		 TEW00258

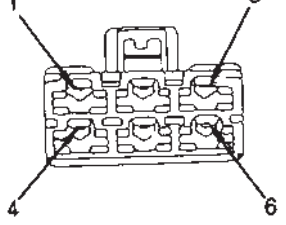
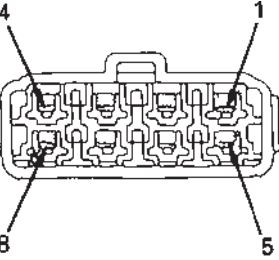
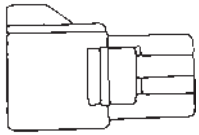
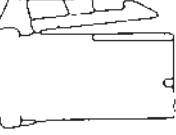
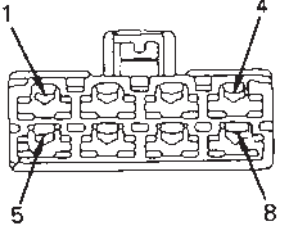
No. of pins	Automobile connector			
	Male (female housing)		Female (male housing)	
2	  <p>BLP00063</p>	  <p>BLP00064</p>		
3	  <p>BLP00065</p>	  <p>BLP00066</p>		
4	  <p>BLP00067</p>	  <p>BLP00068</p>		
6	  <p>BLP00069</p>	  <p>BLP00070</p>		
8	  <p>BLP00071</p>	  <p>BLP00072</p>		

No. of pins	Relay connector	
	Male (female housing)	Female (male housing)
5	<p>BLP00073</p>	<p>BLP00074</p>
6	<p>BLP00075</p>	<p>BLP00078</p>

EXPLANATION OF CONTROL MECHANISM FOR ELECTRICAL SYSTEM

The control mechanism for the electrical system consists of the monitor panel, and the engine throttle • pump controller. The monitor panel and the engine throttle • pump controller all input the signals that are necessary, and together with the signals selected by the monitor panel, the engine throttle • pump controller outputs or inputs the necessary signals and controls the pump absorption torque and engine output.

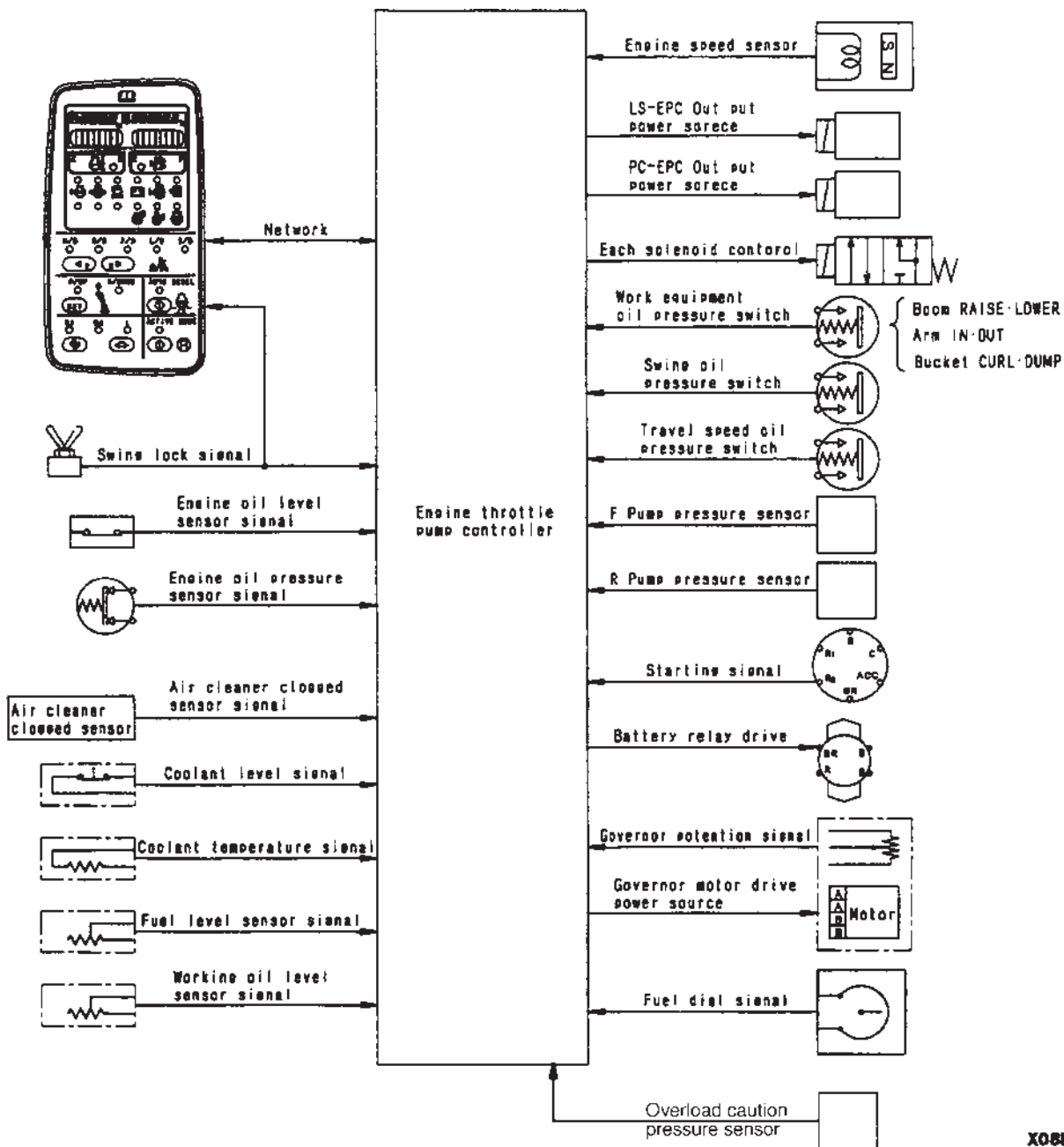

X0800257

DISPLAY METHOD AND SPECIAL FUNCTIONS OF MONITOR PANEL

1. Display on machine monitor
 When the starting switch is turned on, all the monitor and gauge lamps light up for approximately 3 seconds, and the buzzer sounds for approximately 1 second. During this time, the monitor itself carries out self diagnosis, and after it has finished, it returns to the normal display.
 2. Recording of abnormality codes and user code display function
 - a. All the abnormality data for the engine throttle controller, pump controller, and valve controller are received by the monitor panel. When the monitor panel receives the data, it records the abnormality data, and at the same time, depending on the nature of the abnormality, it displays the user code on the time display panel or CALL on the service meter display to advise the operator of the action to take. However, in cases of abnormalities which are not urgent and do not require the user code or CALL to be displayed, only the content of the abnormality is recorded, and no display is given.
 - b. Types of user code and system.
 - E02 (PC-EPC system)
 - E03 (swing holding brake system)
 - E05 (governor motor system)
 - c. Displaying user code. If it becomes necessary to display the user code, the time displayed panel is automatically switched to advise the operator to take the necessary action.
- Actual display (Example: Disconnection in the swing holding brake solenoid system)

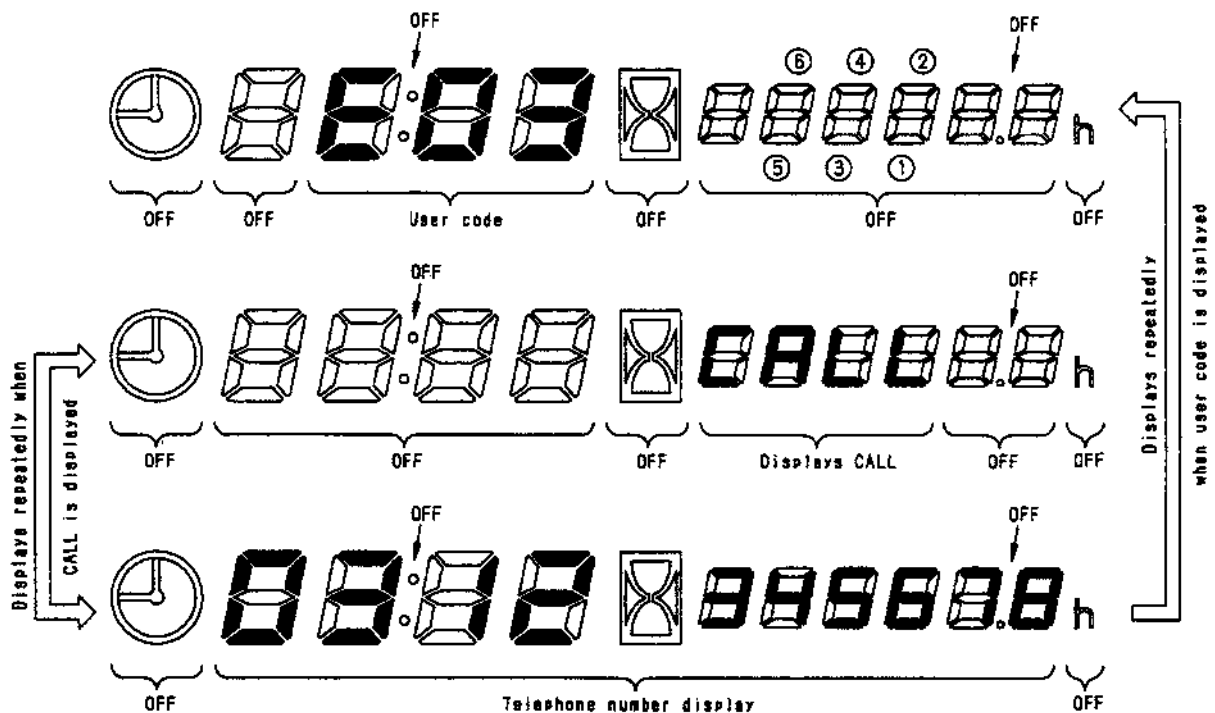

X08DD258

d. Display of trouble data

The monitor panel records both service codes which are included in the user code and service codes which are not included. This data can be displayed on the time display as follows.

- ★ For details of the service codes that are not included in the user code, see ACTION TAKEN BY CONTROLLER WHEN ABNORMALITY OCCURS AND PROBLEMS ON MACHINE or the JUDGEMENT TABLE.

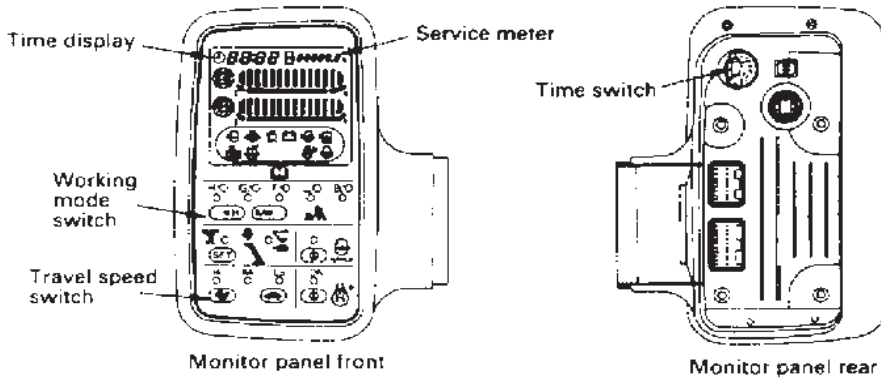

TAP00175

i) Method of displaying trouble data

Operation	Display
<p>1. To set to the trouble data display mode, keep the TIME switch + L.H. travel speed switch pressed for 2.5 seconds. Note: It is possible to call it up at the following tiems.</p> <ol style="list-style-type: none"> 1) In the normal mode. 2) In the user code display mode. 3) In the machine data monitoring mode. 4) In the time adjustment mode. <p>2. To go to the next service code display, press the time switch + R.H. working mode switch.</p> <p>3. To go back to the previous service code display, press time switch + L.H. working mode switch.</p>	<p>1. On the time display and service meter display, the service code and number of hours (service meter hours) that have elapsed since the occurrence of the abnormality are displayed.</p> <ul style="list-style-type: none"> • Example of display: When E212 has occurred 12 hours before (service meter). <p>1) Display of service code and elapsed time</p> <p>2) If any abnormality exists at this time, the E mark is displayed.</p> <p>BKP00079</p> <p>BKP00080</p>

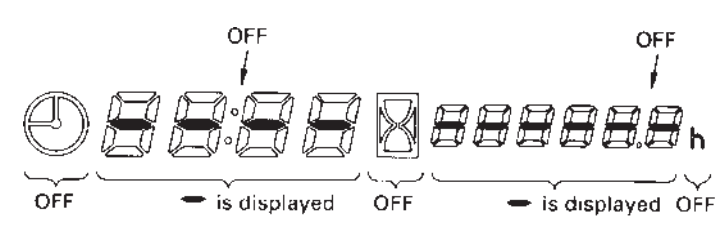
Operation	Display
<p>4. To finish with the trouble data display mode, keep the TIME switch + L.H. travel speed switch pressed for 2.5 seconds.</p> <p>5. To erase the memory, keep the time switch pressed, turn the starting switch from OFF to ON, and keep the time switch pressed for 5 seconds.</p>	<p>3) If there is no abnormality code in memory</p>  <p style="text-align: right;">BKP00081</p>

3. Machine data monitoring function

The input signals from the sensors and the output signals to drive the solenoid are displayed on the time display and service meter display.

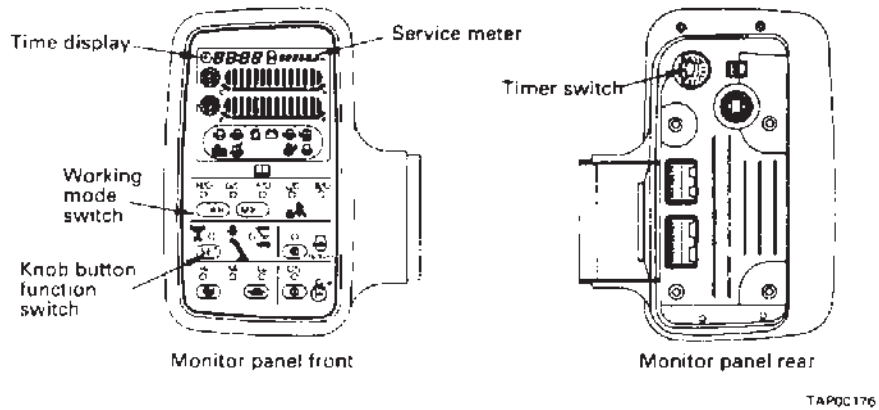

a. Method of displaying monitoring code

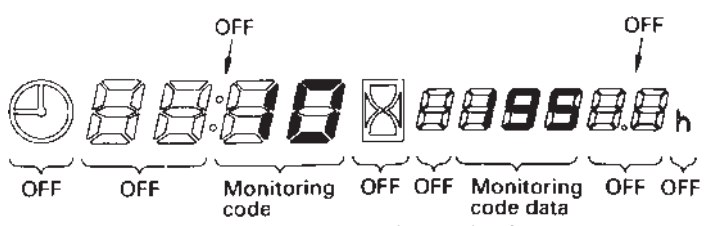
Operation	Display
<p>1. To set to the machine data monitoring mode, do as follows. Keep the time switch + knob button function switch pressed for 2.5 seconds. Note: This is possible at the following times.</p> <ol style="list-style-type: none"> 1) During the normal mode 2) During the user code display mode 3) During the time adjustment mode 4) During the trouble data display mode 	<p>1. On the time display and service meter display, the monitoring code and data are displayed.</p> <ul style="list-style-type: none"> • Example of display <ol style="list-style-type: none"> 1) When engine speed is monitored (monitoring code 10)  <p style="text-align: right;">(example of 1950 rpm) BKP00083</p>

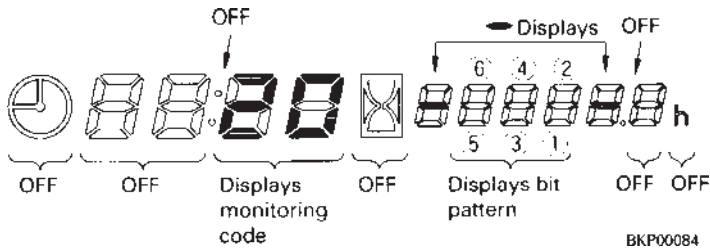
Operation	Display
<p>2. To go to the next monitoring code display, press the time switch + R.H. working mode switch.</p> <p>3. To go back to the previous monitoring code display, press the time switch + L.H. working mode switch.</p> <p>4. To finish with the machine data monitoring code mode, keep the time switch + knob button function switch pressed for 2.5 seconds.</p>	<p>2) When displaying bit pattern</p> <ul style="list-style-type: none"> For monitoring codes 08, 20 - 24, 36, 37, 47 - 49, 4A, display the bit pattern. Example of monitoring code 20  <ul style="list-style-type: none"> The code No. is displayed in the monitoring code portion, and the display lights up to display bit patterns (1) - (6).

b. Table of machine data monitoring codes

★ For details of the B in the Unit column, see the bit pattern chart in the next section.

No.	Item	Unit	Name of component
01	Monitor model code	-	Monitor panel
02	Engine throttle • pump controller model code	-	Engine throttle • pump controller
03	Engine throttle • pump controller model code	-	Engine throttle • pump controller
08	S-Net component condition display	B	Engine throttle • pump controller
10	Engine speed	10 rpm	Engine throttle • pump controller
11	Pump discharge pressure (F) input	MPa(kg/cm ²)	Engine throttle • pump controller
12	Pump discharge pressure (R) input	MPa(kg/cm ²)	Engine throttle • pump controller
13	PC-EPC current output	10 mA	Engine throttle • pump controller
14	Spare	10 mA	Engine throttle • pump controller
15	LS-EPC current output	10 mA	Engine throttle • pump controller
16	No. 2 throttle command	10 mA	Engine throttle • pump controller
20	Engine throttle • pump controller PPC oil pressure switch input signal (1)	B	Engine throttle • pump controller
21	Engine throttle • pump controller PPC oil pressure switch input signal (2)	B	Engine throttle • pump controller
22	Engine throttle • pump controller PPC oil pressure switch input signal (3)	B	Engine throttle • pump controller
23	Engine throttle • pump controller solenoid actuation	B	Engine throttle • pump controller
24	Input condition of sensor for engine throttle • pump controller monitoring warning	B	Engine throttle • pump controller
30	Fuel control dial input value	10 mV	Engine throttle • pump controller
31	Governor motor feedback potentiometer input value	10 mV	Engine throttle • pump controller
32	VBB voltage (battery voltage)	100 mV	Engine throttle • pump controller
33	Governor motor A phase current	10 mV	Engine throttle • pump controller

Code	Content	Bit	Details (condition when lighted up)
20	Input condition of engine throttle • pump controller PPC switches	(1) (2) (3) (4) (5) (6)	Swing switch ON Travel switch ON Boom LOWER switch ON Boom RAISE switch ON Arm IN switch ON Arm OUT switch ON
21	Input condition of engine throttle • pump controller PPC switches and other switches	(1) (2) (3) (4) (5) (6)	Bucket CURL switch ON Bucket DUMP switch ON Swing lock switch ON Service switch On Model selection 5 Swing prolix switch ON
22	Input condition of engine throttle • pump controller mode selection and other switches. Drive condition of governor	(1) (2) (3) (4) (5) (6)	Model selection 1 GND connected Model selection 2 GND connected Model selection 3 GND connected Model selection 4 GND connected Kerosene mode input GND connected Knob switch ON
23	Engine throttle • pump controller ON/OFF solenoid valves	(1) (2) (3) (4) (5) (6)	(Solenoid ON) Active mode OFF (STD mode) Swing holding brake solenoid ON Pump merge/divider solenoid ON 2-stage relief solenoid ON Travel speed selector solenoid ON
24	Input condition 1 of sensor for engine throttle • pump controller monitor warning	(1) (2) (3) (4) (5) (6)	Above engine oil pressure sensor normal (above set pressure) Radiator coolant level sensor abnormal Engine oil level sensor abnormal Hydraulic oil level sensor abnormal Air cleaner clogging sensor abnormal
36	Input condition of engine throttle • pump controller	(1) (2) (3) (4) (5) (6)	Starting switch ON

Code	Content	Bit	Details (condition when lighted up)
37	Output condition of engine throttle • pump controller	(1) (2) (3) (4) (5) (6)	Battery relay: Actuated
47	Monitor panel output condition 1	(1) (2) (3) (4) (5) (6)	Alarm buzzer: when machine is operated Wiper motor drive (R): When actuated Wiper motor drive (L): When actuated Window washer driver: When actuated
48	Monitor panel input condition 1	(1) (2) (3) (4) (5) (6)	Wiper (ON): OFF Wiper (INT): OFF Wiper (washer): OFF
49	Monitor panel input condition 2	(1) (2) (3) (4) (5) (6)	KEY ON SW: OFF Terminal BR: Voltage Hi LIGHT SW: OFF Preheating switch: OFF START C: Sometimes turns ON Monitor panel LED lighting output: OFF
4A	Monitor panel input condition 3	(1) (2) (3) (4) (5) (6)	Time switch: OFF PPC oil pressure Selector switch: OFF Swing lock switch: OFF Buzzer cancel switch: OFF

Code	Content	Bit	Details (condition when lighted up)
4C	Monitor panel input condition 4	(1)	
		(2)	Wiper motor normal rotation relay output: When specified voltage is abnormal
		(3)	Wiper motor reverse rotation relay output: When specified voltage is abnormal
		(4)	Window washer motor driver output: When specified voltage is abnormal
		(5)	
		(6)	

4. Governor motor adjustment mode

This is used when adjusting the linkage between the governor motor and the injection pump. (For details of the procedure, see TESTING AND ADJUSTING.)

Operation	Display
<p>1. To set to the governor motor adjustment mode, press the time switch + R.H. travel speed switch + R.H. working mode switch.</p>	<p>1.</p> <p style="text-align: right;">BKP00086</p>
<p>2. To return to the time display mode use the same procedure as above.</p>	<p>2. Buzzer sounds once a second</p>

5. Time adjustment mode

To adjust the time, do as follows.

Operation	Display
<p>1. To set to the time adjustment mode, keep the time switch depressed for 2.5 seconds.</p> <p>2. Use the L.H. working mode switch to advance the hour.</p> <p>3. Use the R.H. working mode switch to advance the minute.</p> <p>4. To return to the time display mode use the same procedure as in Step 1.</p>	<p>1. The time mark portion flashes</p> <p style="text-align: right;">BKP00087</p> <p>★ The example shows the situation when setting to 12:34.</p>

6. Telephone number input
 To input the telephone number, do as follows.

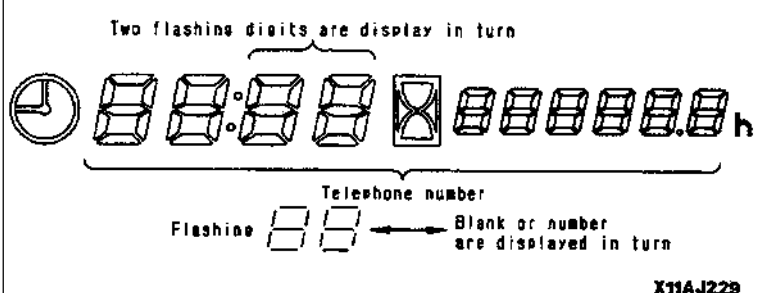
Operation	Display
<ol style="list-style-type: none"> To set to the telephone number input mode, keep the time switch + auto-deceleration switch depressed for 2.5 seconds. When the time switch + L.H. working mode switch are pressed, the position moves two digits to the left each time. When the time switch + R.H. working mode switch are pressed, the position moves two digits to the right each time. The two digits flash. When the time switch + R.H. travel speed switch are pressed, the number in the right digit of the two flashing digits changes [0] - [9] - [blank] - [0], and when the time switch + L.H. travel speed switch are pressed, the number in the left digit of the two flashing digits changes in the same way. After inputting the telephone number, keep the time switch + auto-deceleration switch pressed for 2.5 seconds to return to the time mode (normal mode). At the same time, the telephone number is recorded. 	 <p>The diagram illustrates the monitor panel display. On the left is a clock icon. To its right are two digits, followed by a colon and two more digits. Further right is an hourglass icon, followed by a series of eight digits and a decimal point, ending with an 'h' for hours. A bracket above the two digits and the two digits after the colon is labeled 'Two flashing digits are display in turn'. Below the entire display area, a bracket is labeled 'Telephone number'. Below this, two digits are shown with the label 'Flashine' to their left. An arrow points from the text 'Blank or number are displayed in turn' to these two digits.</p> <p style="text-align: right;">X11AJ229</p>

METHOD OF USING TROUBLESHOOTING CHARTS

1. Category of troubleshooting code number

Troubleshooting Code No.	Component	Service code
N-OO	Troubleshooting of communication abnormality system	E218 group
E-OO	Troubleshooting of electrical system for engine throttle • pump controller (governor control system)	E3-OO group
S-OO	Troubleshooting of engine related parts	-
C-OO	Troubleshooting of electrical system for engine throttle • pump controller (pump control system)	E2-OO group
F-OO	Troubleshooting of engine throttle • pump controller (input signal system)	-
H-OO	Troubleshooting of hydraulic, mechanical system	-
M-OO	Troubleshooting of machine monitor	E1-OO group

2. Method of using troubleshooting table for each troubleshooting mode.

- a. Troubleshooting code number and problem. The title of the troubleshooting chart gives the troubleshooting code, service code and failure mode (problem with the machine). (See example (1))
- b. Distinguishing conditions. Even with the same failure mode (problem), the method of troubleshooting may differ according to the model, component, or problem. In such cases, the failure mode (problem) is further divided into sections marked with small letters (for example, a), so go to the appropriate section to carry out troubleshooting. (See Example (3)) If the troubleshooting table is not divided into sections, start the troubleshooting from the first check item in the failure mode.
- c. method of following troubleshooting chart. (See Example (4))
 - i. Check or measure the item inside the left most box and, according to the answer, follow either the YES line or the NO line to go to the next condition box. (Note: The number at the top right corner of the condition box is an index number; it does not indicate the order to follow.)
 - ii. Following the YES or NO lines according to the results of the check or measurement will lead finally to the Cause column. Check the cause and take the action given in the Remedy column on the right.
 - iii. Below the condition box, there are the methods of inspection or measurement, and the judgement values. If the judgement values below the condition box are correct or the answer to the question inside the condition box is YES, follow the YES line. If the judgement value is not correct, or the answer to the question in NO, then follow the NO line.
 - iv. Below the condition box is given the preparatory work needed for inspection and measurement, and the judgement values. If this preparatory work is neglected, or the method of operation or handling is mistaken, there is the danger that it may cause mistaken judgement or the equipment may be damaged. Therefore, before starting inspection or measurement, always read the instructions carefully and start the work in order from the first item.
- d. When carrying out troubleshooting for the failure mode (problem), precautions that apply to all the items are given at the top of the page and marked with a ★. (See Example (2)) The precautions marked ★ are not given in the condition box, but must always be followed then carrying out the check inside the condition box.
- e. When carrying out troubleshooting, prepare the necessary troubleshooting tools. For details, see TOOLS FOR TESTING, ADJUSTING AND TROUBLESHOOTING.
- f. Installation position, pin number. A diagram or chart is given for the connector type, installation position, and connector pin number connection. When carrying out troubleshooting, see this chart for details of the connector pin number and location for inspection and measurement of the wiring connector number appearing in the troubleshooting flow chart for each failure mode (problem).

<Example>

- (1) **M-8 When starting switch is turned ON (engine stopped), basic check items flash**
- (2) ★ Before carrying out troubleshooting, check that all the related connectors are properly inserted.
- ★ Always connect any disconnected connectors before going on to the next step.

(3) a)  (coolant level) flashes
SAP00519

b)  (engine oil level) flashes
SAP00523

(4)

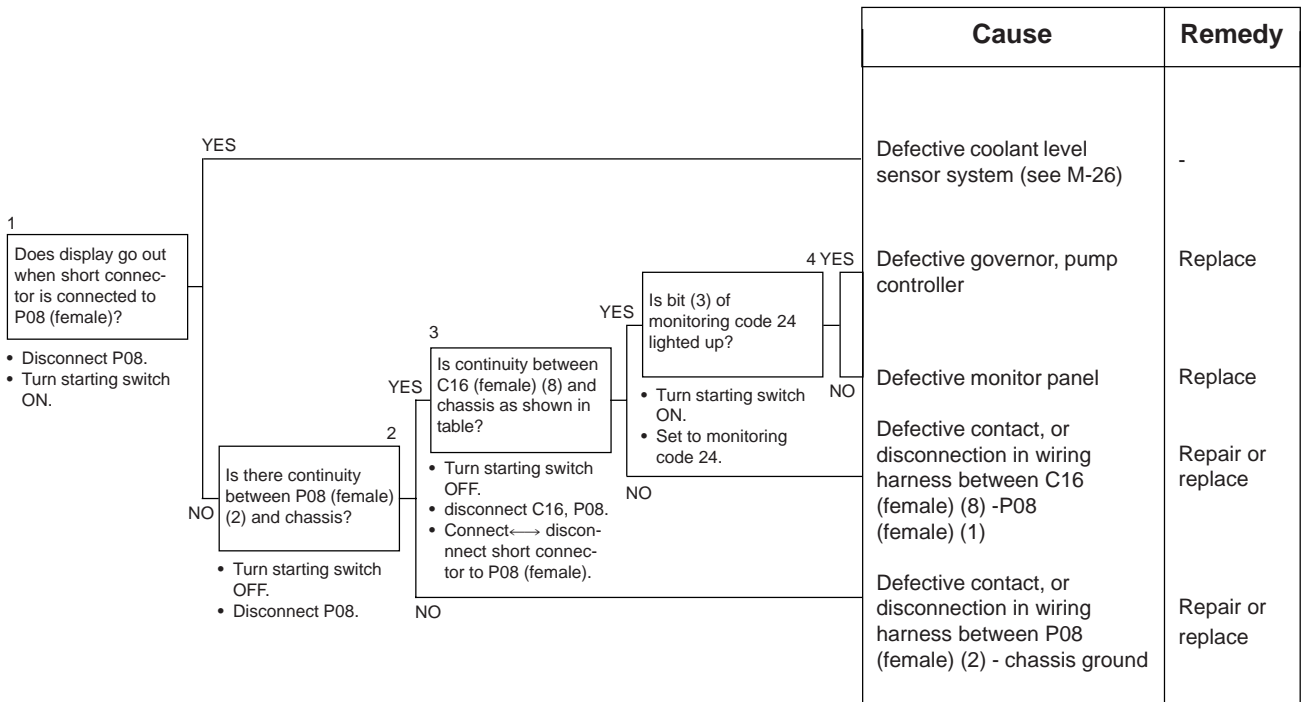

Table 1

Short connector	Continuity
Connected	Yes
Disconnected	No

DETAILS OF TROUBLESHOOTING AND TROUBLESHOOTING PROCEDURE

If there is a failure in the excavator, use the following procedure to determine which troubleshooting chart to use to repair the failure.

When carrying out troubleshooting, ask the operator as much as possible about the condition of the machine, and check the following items before starting.

1. Condition of controller connection (check with monitoring codes 02 - 03). The display should read 02:290 and 03:290. If not, check the model selection connector C09 and compare with the electrical schematic. If monitoring codes 02 - 03 read " - - ", continue with the following step.
2. Blown fuses.
3. Battery voltage (monitoring code 32). If the voltage is outside the standard range (see Standard Judgement Table), carry out Troubleshooting Chart E-1.
4. Electricity generation (charge input) voltage (monitoring code 43).

The procedure for carrying out check item No. 3 is in Step 1a. and check item No. 4 begins at Step 1b. on the following pages.

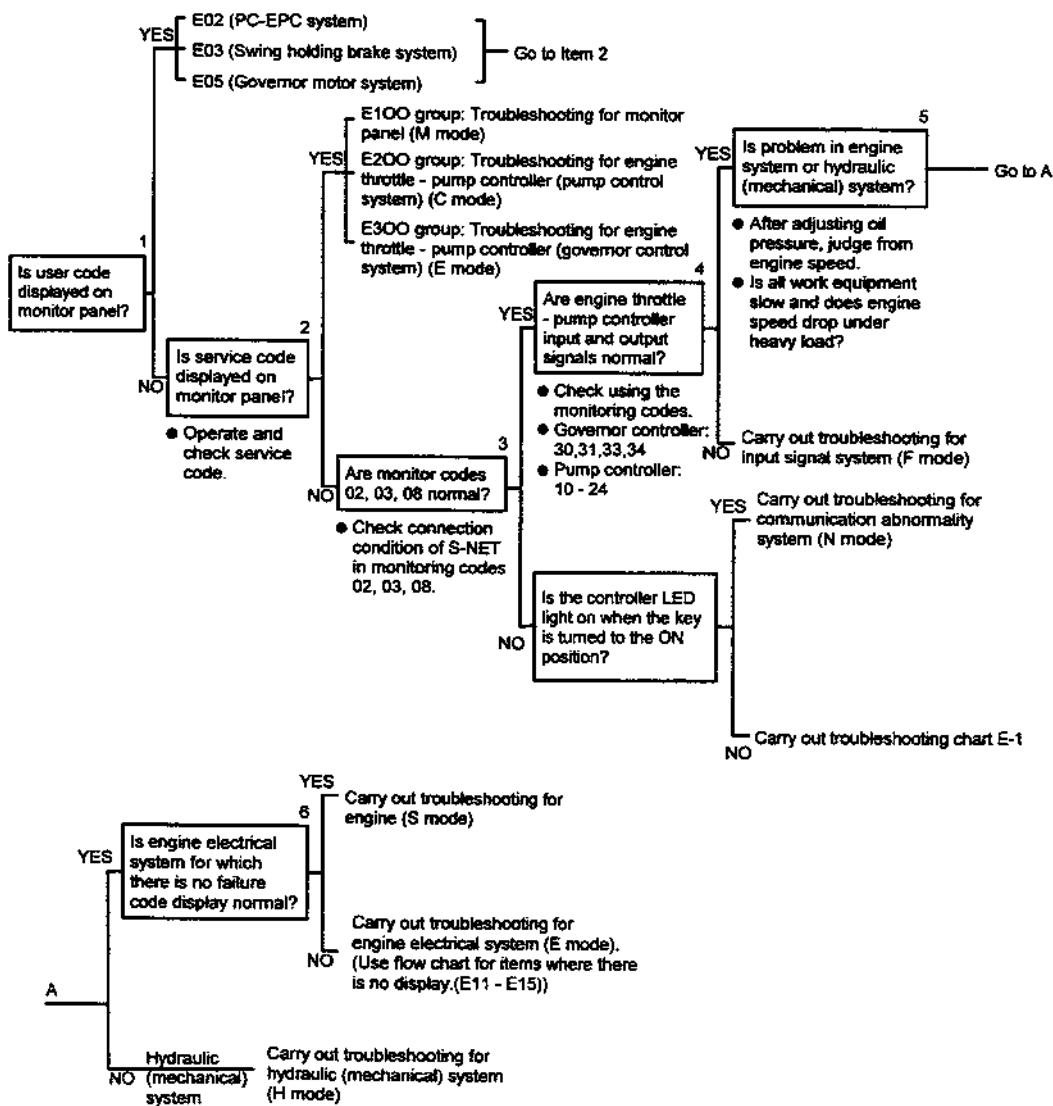

The “S-NET” is the communication connection between the monitor panel and the controllers. If there is a disconnection or short circuit in the S-NET, the controller will automatically go into a default mode. The following chart illustrates what the outputs of the controllers will be in the default mode.

Default mode of the controllers when the monitor panel, pump controller, and engine throttle controller cannot communicate through the S-NET.

Set mode	Pump Control	Governor control
1 Working mode	G/O mode	H/O mode
2 Throttle signal	FULL	FULL
3 Auto-deceleration	ON (deceleration mode)	ON (deceleration mode)
4 Coolant temperature signal	OFF	-
5 Priority mode	OFF	-
6 Power max. mode	ON (power max. possible)	-
7 Travel speed	Lo	-
8 Automatic warming up	-	ON (automatic warming-up mode)

1. Procedure for checking monitor panel output signal
 - ★ For details of operating the monitoring mode, see MONITOR PANEL DISPLAY AND SPECIAL FUNCTIONS.
 - a. To check the connection (S-NET) between the pump and engine throttle controller systems and the monitor panel:
 - i. Set to the monitoring mode and display monitoring code 08.
 - ii. Bit (1) will light up if the pump control system is connected properly. Bit (2) will light up if the engine governor control system is connected properly.
 - b. To check that the working mode signal is functioning properly:
 - i. Set to the monitoring mode and display monitoring code 16.
 - ii. Set the fuel control dial to maximum, then change the working modes and verify that the outputs match the engine speeds listed in Table 1.
 - iii. Set to the monitoring mode and display monitoring code 10.
 - iv. Start the engine, switch the working modes and check that the engine rpm is within 60 rpm of the engine speeds listed in Table 1.

Table 1		Swing lock off
Working mode	Operation	Engine speed - high idling
Active mode	Work equipment	Approx. 2300
	Travel	Approx. 2300
H/O	Work equipment	Approx. 2300
	Travel	Approx. 2400
G/O, F/O	Work equipment	Approx. 2100
	Travel	Approx. 2100
L/O	Work equipment	Approx. 1750
	Travel	Approx. 1750
B/O	Work equipment	Approx. 2100
	Travel	Approx. 2100

- c. Checking travel speed selection signal
 - i. Set to the monitoring mode and display monitoring code 23.
 - ii. Change the speed selector switch to Hi or Mi and run the engine at 1500 rpm or above. Check that bit (6) lights up when travelling at Hi or Mi (front or rear pump oil pressure: 17.7 - 23.5 MPa (180 - 240 kg/cm²).
- 2. Checking input signal of engine throttle pump controller
 - ★ Check the input signals for each controller as follows.
 - a. Pump control system.
 - i. Check input signal
 - (1) Check hydraulic switch
 - (a) Set to the monitoring mode and display monitoring codes 20 and 21.
 - (b) Operate each work equipment lever and check how the bit pattern lights up.
 - ★ For details of the bit pattern chart, see MONITOR PANEL DISPLAY AND SPECIAL FUNCTIONS.
 - (2) Check speed sensor (check engine speed)
 - (a) Set to the monitoring mode and display monitoring code 10.
 - (b) Use the fuel control dial to change the speed and measure the speed when this is done.
 - (3) Check pump discharge pressure sensor
 - (a) Set to the monitoring mode and display monitoring codes 11 and 12.
 - ★ Code 11 is for the front pump and code 12 is for the rear pump.
 - (b) Refer to Table 2 and measure the hydraulic pressure at the front or rear pump.

Table 2 Pump merge/flow logic and pump actuated by control levers
Independent operation (basic flow merged)

	Independent operation (basic flow merged)	
	Front pump	Rear pump
L.H. travel	○	
Swing	○	○
Arm	○	○
Boom	○	○
Bucket	○	○
R.H. travel		○

The pumps are only divided when the travel levers are operated either independently or together. If the travel and any other operation is actuated, the pumps are merged.

- (4) Check left hand joystick switch input signal
 - (a) Set to the monitoring mode and display monitoring code 22.
 - (b) Press the button on the left joystick and check that bit (6) lights up.

- ii. Check output signals
 - (1) Check LS-EPC solenoid output current
 - (a) Set to the monitoring mode and display monitoring code 15.
 - (b) Run the engine at high idling with all the levers at neutral and in the G/O or H/O mode, and measure the current.
- ★ All levers at neutral: 900 ± 80 mA.
- ★ Engine at high idling, any lever operated, travel speed at Hi: 0 A.
 - (2) No. 2 throttle signal
 - (a) Set to the monitoring mode and display monitoring code 23.
 - (b) Use the procedure in Step 1.-b. for checking the monitor panel output signal, and measure the engine speed.
 - (3) Checking ON n OFF solenoid condition
 - (a) Set to the monitoring mode and display monitoring code 23.
 - (b) Refer to Table 3 and check that the applicable bit lights up.

Table 3 Types of solenoid and conditions for actuation

Name of solenoid	Actuation condition	Bit that lights up
Active mode	Active mode switch OFF	(2)
Swing holding brake	Swing or work equipment lever operated ★	(3)
Pump merge/divider	Travel operated independently ★	(4)
2-stage relief	Travel lever operated ★	(5)
Travel speed selector	Travel speed selector switch Hi or Mi, engine above 1500 rpm and move travel lever slightly	(6)

- ★ Operate the lever slightly and not enough to move the machine.
 - (4) Check PC-EPC solenoid output current
 - (a) Set to the monitoring mode and display monitoring codes 13.
 - (b) With the starting switch kept at the ON position (G/O mode), measure the current when the fuel control dial is turned on the MAX position and the auto-deceleration is OFF.
- Start the engine, (G/O mode) and fuel control dial at MAX (auto-deceleration OFF), current should be 515 ± 100 mA.
 - b. Governor control system
 - i. Check input signal
 - (1) Check fuel control dial input voltage
 - (a) Set to the monitoring mode and display monitoring code 30.
 - (b) Measure the voltage when the fuel control dial is turned from low idling to high idling. (Voltage will decrease.)
 - ★ Voltage: 0.25 - 4.75 V
 - (2) Check governor potentiometer voltage
 - (a) Set to the monitoring mode and display monitoring code 31.
 - (b) Measure the potentiometer voltage when the fuel control dial is turned from low idling to high idling, then move travel lever slightly. (Voltage will increase.)
 - ★ Voltage: 0.5 - 4.2 V (Auto-deceleration OFF)
 - ii. Check output signal
 - (1) Check governor motor drive current
 - (a) Set to the monitoring mode and display monitoring codes 33 and 34.
 - ★ Code 33 is the A phase and code 34 is the B phase.
 - (b) Measure the governor motor drive current when the fuel control dial is turned in the acceleration direction and deceleration direction. (The current should change, then stabilize within specification.)
 - ★ Current 700 ± 70 mA

- (2) Measure battery relay drive output voltage
 - (a) Set to the monitoring mode and display monitoring code 35.
 - (b) Measure the battery relay drive output voltage when the starting switch is turned from ON to OFF.OR
 - (c) Set to the monitoring mode and display monitoring code 37.
 - (d) Check that bit (1) lights up when the starting switch is turned from ON to OFF.

SERVICE CODE TABLE

Service code	Abnormal system	User code
E101	Abnormality in error history data	
E102	Abnormality in time data	
E103	Short circuit in buzzer output, contact with 24V wiring harness for buzzer drive	
E104	Air cleaner clogging detected	
E106	Abnormality in engine oil pressure sensor (Hi) detected	
E108	Water temperature over 105°C	
E202	Short circuit in LS select solenoid system	
E203	Short circuit in swing holding brake solenoid system	E03
E204	Short circuit in pump merge/divider solenoid system	
E206	Short circuit in travel speed solenoid system	
E212	Disconnection in LS select solenoid system	
E213	Disconnection in swing holding brake solenoid system	E03
E214	Disconnection in pump merge/divider solenoid system	
E216	Disconnection in travel speed solenoid system	
E217	Error in model selection input	
E218	Network response overtime error	
E222	Short circuit in LS-EPC solenoid system	
E223	Disconnection in LS-EPC solenoid system	
E224	Abnormality in F pump pressure sensor system	
E225	Abnormality in R pump pressure sensor system	
E226	Abnormality in pressure sensor system power source	
E227	Abnormality in engine speed sensor	
E232	Short circuit in F pump PPC solenoid system	
E233	Disconnection in F pump PPC solenoid system	
E236	Short circuit in R pump PPC solenoid system	E02
E237	Disconnection in R pump PPC solenoid system	E02
E306	Abnormality in feedback potentiometer system	
E308	Abnormality in fuel control dial input value	E05
E315	Short circuit in battery relay output system	
E316	Step-out in governor motor	
E317	Disconnection in governor motor system	E05
E318	Short circuit in governor motor system	E05

- ★ For E101 - E114 see troubleshooting for the monitor panel system (M mode), for E203 - E237 see troubleshooting for the engine throttle • pump controller (pump control system) (C mode), and for E306 - E318 see troubleshooting for the engine throttle • pump controller (governor control system) (E mode).

TROUBLESHOOTING OF COMMUNICATION ABNORMALITY SYSTEM (N MODE)

N-1 [E218] Communications abnormality

- ★ This troubleshooting is carried out when there is still an abnormality, so when disconnecting the connector and inserting the T-adapter, or when removing the T-adapter and returning the connector to its original position, if an E service code is not displayed, the problem has been removed.
- ★ If the starting switch is turned OFF after an abnormality occurs, turn the starting switch ON and check if an E service code is displayed. (If it is not displayed, the problem has been removed.)
- ★ Before carrying out troubleshooting, check that all the related connectors are properly inserted.
- ★ Always connect any disconnected connectors before going on to the next step.

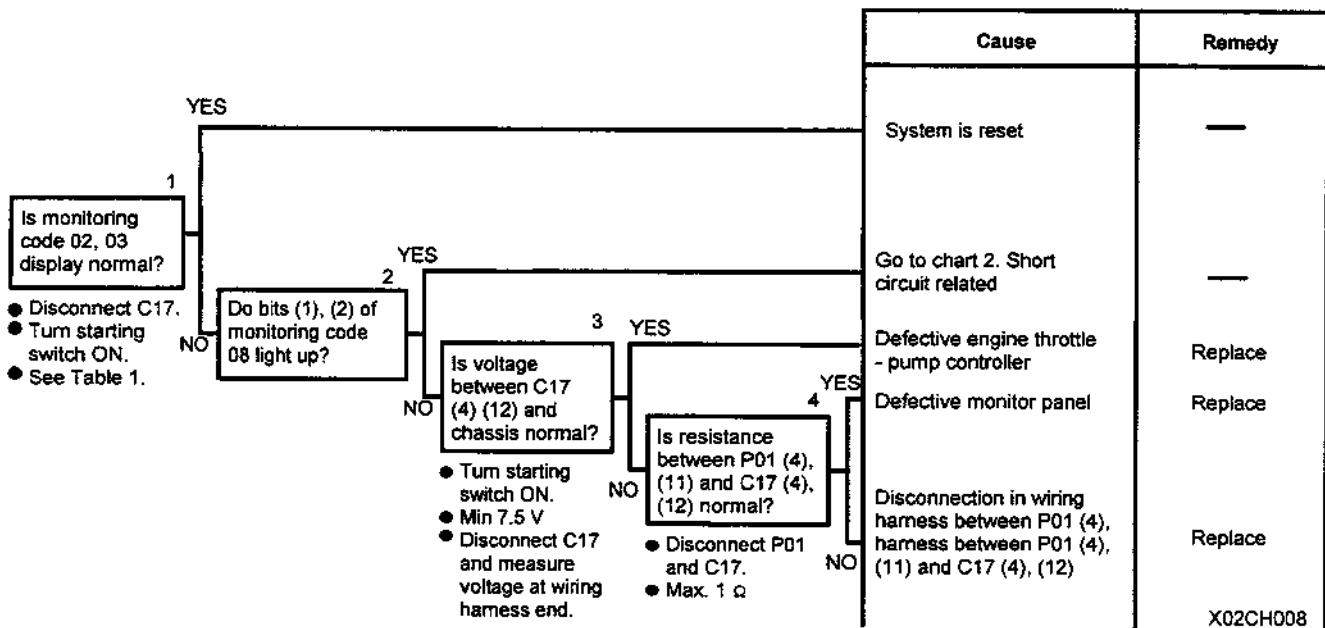

Chart 2. Short circuit related

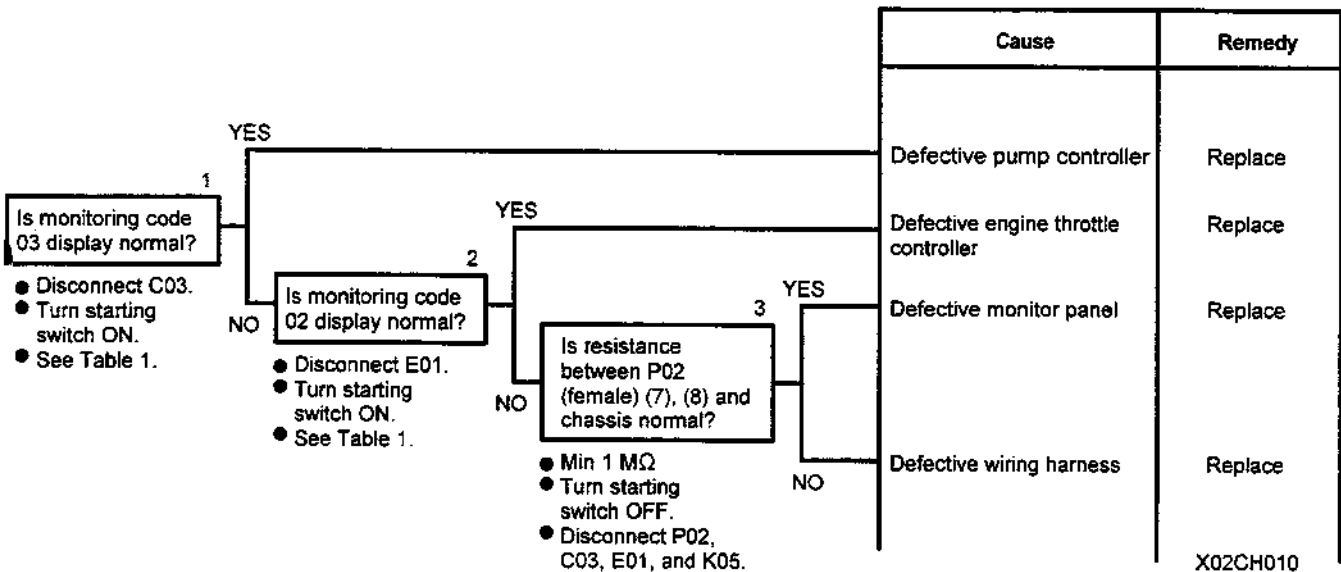



Table 1

Monitoring code		Display
01	Monitor panel model code	220
02	Engine throttle • pump controller model code	290
03	Engine throttle • pump controller model code	290

- When each controller is not connected to the network, “—” is displayed. If the correct letter or number is not displayed (another model is displayed), there is an abnormality in the controller model selection.

Table 2

Monitoring code		Display
08	Network connection condition	

- Light up when connected
- ① Engine throttle • pump controller; ② Engine throttle • pump controller; ③ EPC valve controller
- Checks can be carried out with code 08 only when there is a disconnection in the network. When there is a short circuit with the ground, the display does not change. Therefore, the basic situation is to use Table 1 to check the connection condition when there is a short circuit with the ground.

N-1 Related electric circuit diagram

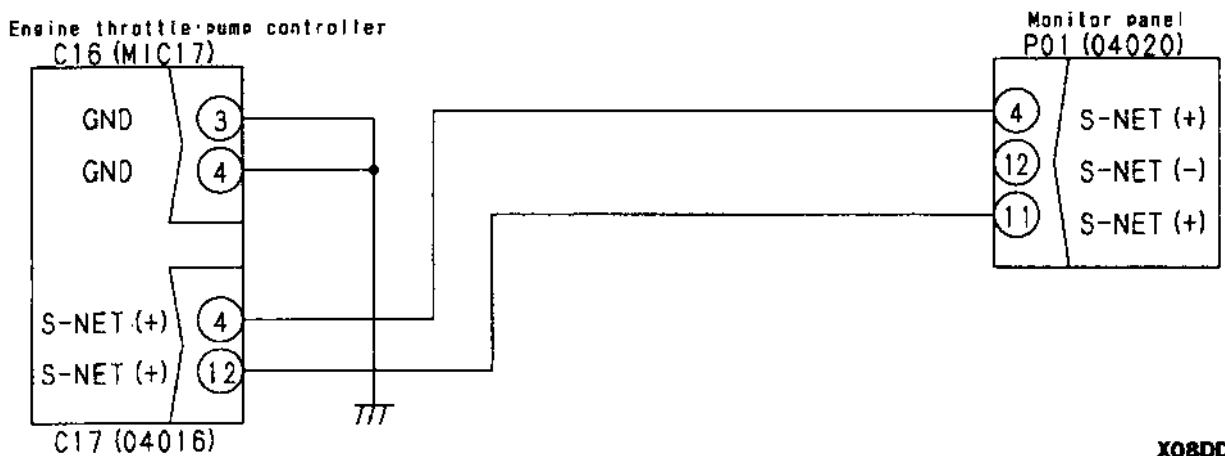

TROUBLESHOOTING OF ENGINE THROTTLE • PUMP CONTROLLER (GOVERNOR CONTROL SYSTEM) (E MODE)

POINTS TO REMEMBER WHEN CARRYING OUT TROUBLESHOOTING OF ENGINE THROTTLE • PUMP CONTROLLER SYSTEM

1. Points to remember when there is an abnormality which is not displayed by a user code.
The engine is controlled by the engine throttle • pump controller. The problems that may occur with this system include the following.
 - a. Idling speed is too high (too low)
 - b. High idling speed is too low
 - c. Auto-deceleration speed is too high (too low)
 - d. Engine speed for automatic warming-up operation is too high (too low)
 - e. There is hunting
 - f. Engine does not stop

If any abnormality occurs, and the abnormality is displayed on the time display portion of the monitor panel, use the troubleshooting table to determine the appropriate troubleshooting flow chart from E-1 to E-12. However, if there is any abnormality in the machine and no abnormality display is given, it is necessary to determine whether the problem is in the mechanical system or in the electrical system. If the linkage between the governor motor and the injection pump is not properly adjusted, problems a. to f. listed above may occur. Therefore, if there is no abnormality display, but one of the problems a. to f. above has occurred, carry out troubleshooting as follows.

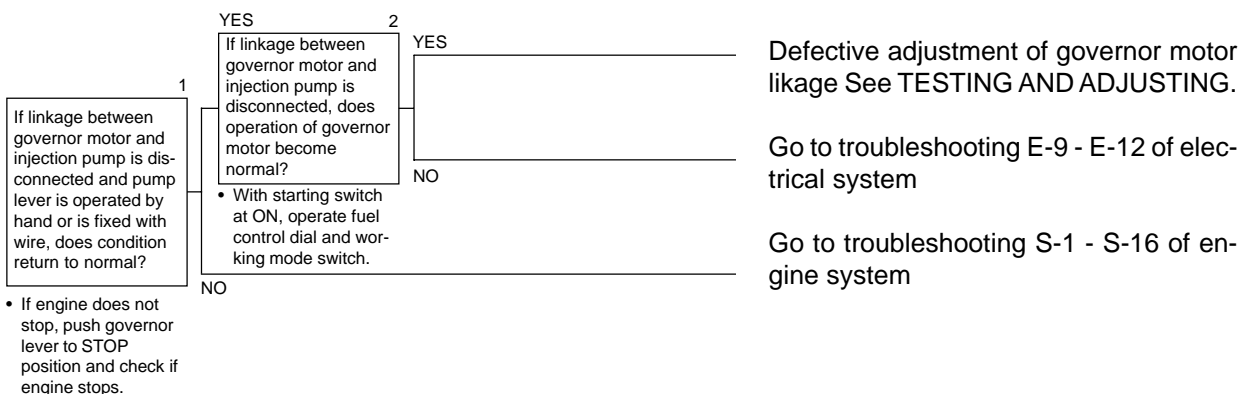

Disconnect the linkage as explained above, or check the adjustment and go to the troubleshooting flow chart for the mechanical system or electrical system. For details of the procedure for adjusting the linkage, see TESTING AND ADJUSTING.

2. Points to remember if abnormality returns to normal by itself
In the following two cases, there is a high probability that the same problem will occur again, so it is desirable to follow up this problem carefully.
 - a. If any abnormality returns to normal by itself, or
 - b. If the connector is disconnected and the T-adapter is inserted, or if the T-adapter is removed and the connector is returned to its original position when carrying out troubleshooting of the failure, and the service code is no longer displayed, or if the monitor display returns to normal.
 - c. After completing troubleshooting, always erase the service code from memory.
3. User code memory retention function
When displaying the abnormality code in memory and carrying out troubleshooting, note down the content of the display, then erase the display. After trying to re-enact the problem, carry out troubleshooting according to the failure code that is displayed. (There are cases where mistaken operation or abnormalities that occur when the connector is disconnected are recorded by the memory retention function. Erasing the data in this way saves any wasted work.)

ACTION TAKEN BY CONTROLLER WHEN ABNORMALITY OCCURS AND PROBLEMS ON MACHINE

User code	Service code	Abnormal system	Nature of abnormality
E05	E308	Abnormality in fuel control dial input value	<ol style="list-style-type: none"> 1. Short circuit in wiring harness between C03 (7) - (14), (7) - (17), (14) - (17) 2. Short circuit in wiring harness between E04 (1) - (2), (1) - (3), (2) - (3) 3. Short circuit in wiring harness between E06 (1) - (2), (1) - (3), (2) - (3) 4. Short circuit in wiring harness between C03 (7) - (4), (4) - (17) 5. Disconnection in wiring harness between C03 (7) - X07 (6) - E06 (1) 6. Disconnection in wiring harness between C03 (4) - X07 (5) - E06 (2) 7. Disconnection in wiring harness between C03 (17) - X07 (4) - E06 (3) 8. Defective fuel control dial 9. Defective contact of C03, X07, E06 connectors
	E317	Abnormality (disconnection) in motor drive system	<ol style="list-style-type: none"> 1. Disconnection inside governor motor 2. Disconnection in wiring harness between C02 (2) - E05 (1) 3. Disconnection in wiring harness between C02 (4) - E05 (3) 4. Disconnection in wiring harness between C02 (3) - E05 (2) 5. Disconnection in wiring harness between C02 (5) - E05 (4) 6. Defective contact of E05 connector
	E318	Abnormality (short circuit) in motor drive system	<ol style="list-style-type: none"> 1. Short circuit inside governor motor 2. Wiring harness between C02 (2) - E05 (1) and between C02 (4) - E05 (3) short circuiting with wiring harness between C02 (3) - E05 (2) 3. Wiring harness between C02 (4) - E05 (3) and between C02 (2) - E05 (1) short circuiting with wiring harness between C02 (5) - E05 (4) 4. Wiring harness in Items 2 and 3 short circuiting with ground

Condition when normal (voltage, current, resistance)			Action by controller when abnormality is detected	Problem that appears on machine when there is abnormality																
<table border="1"> <thead> <tr> <th>C03 (female)</th> <th>E06 (male)</th> <th>Resistance value</th> </tr> </thead> <tbody> <tr> <td>(7) - (4)</td> <td>(1) - (2)</td> <td>0.25 - 7kΩ</td> </tr> <tr> <td>(4) - (17)</td> <td>(2) - (3)</td> <td>0.25 - 7kΩ</td> </tr> <tr> <td>(7) - (17)</td> <td>-</td> <td>2 - 3kΩ</td> </tr> <tr> <td>-</td> <td>(1) - (3)</td> <td>4 - 6kΩ</td> </tr> <tr> <td>Between each pin and chassis</td> <td>-</td> <td>No continuity</td> </tr> </tbody> </table>	C03 (female)	E06 (male)	Resistance value	(7) - (4)	(1) - (2)	0.25 - 7kΩ	(4) - (17)	(2) - (3)	0.25 - 7kΩ	(7) - (17)	-	2 - 3kΩ	-	(1) - (3)	4 - 6kΩ	Between each pin and chassis	-	No continuity	<p>Maintains engine speed at position of fuel control dial immediately before abnormality occurred</p>	<ol style="list-style-type: none"> Does not become partial speed when set at MAX position Does not reach high idling when set at partial speed There are cases of hunting Lacks output (max. speed of engine is too low)
C03 (female)	E06 (male)	Resistance value																		
(7) - (4)	(1) - (2)	0.25 - 7kΩ																		
(4) - (17)	(2) - (3)	0.25 - 7kΩ																		
(7) - (17)	-	2 - 3kΩ																		
-	(1) - (3)	4 - 6kΩ																		
Between each pin and chassis	-	No continuity																		
<table border="1"> <thead> <tr> <th>E05 (male)</th> <th>C02 (female)</th> <th>Resistance value</th> </tr> </thead> <tbody> <tr> <td>(1) - (2)</td> <td>(2) - (3)</td> <td>0.25 - 7kΩ</td> </tr> <tr> <td>(3) - (4)</td> <td>(4) - (5)</td> <td>0.25 - 7kΩ</td> </tr> <tr> <td>(1) - (3)</td> <td>(2) - (4)</td> <td>No continuity</td> </tr> <tr> <td>(1) - (94)</td> <td>(2) - (5)</td> <td>No continuity</td> </tr> <tr> <td>Between pins (1), (2), (3), (4) and chassis</td> <td>Between pins (2), (3), (4), and (5) and chassis</td> <td>No continuity</td> </tr> </tbody> </table> <p>Motor drive current: Hold: 0.7 A Start: 0.84 A</p>	E05 (male)	C02 (female)	Resistance value	(1) - (2)	(2) - (3)	0.25 - 7kΩ	(3) - (4)	(4) - (5)	0.25 - 7kΩ	(1) - (3)	(2) - (4)	No continuity	(1) - (94)	(2) - (5)	No continuity	Between pins (1), (2), (3), (4) and chassis	Between pins (2), (3), (4), and (5) and chassis	No continuity	<p>Takes no particular action</p>	<ol style="list-style-type: none"> When there is a disconnection in both the A phase and B phase at the same time, the problem is the same as for a short circuit in the governor motor system When there is a disconnection in only one of A phase or B phase <ol style="list-style-type: none"> Engine does not stop Stops moving at position immediately before failure, so engine speed cannot be controlled There are cases of hunting
E05 (male)	C02 (female)	Resistance value																		
(1) - (2)	(2) - (3)	0.25 - 7kΩ																		
(3) - (4)	(4) - (5)	0.25 - 7kΩ																		
(1) - (3)	(2) - (4)	No continuity																		
(1) - (94)	(2) - (5)	No continuity																		
Between pins (1), (2), (3), (4) and chassis	Between pins (2), (3), (4), and (5) and chassis	No continuity																		
<table border="1"> <thead> <tr> <th>E05 (male)</th> <th>C02 (female)</th> <th>Resistance value</th> </tr> </thead> <tbody> <tr> <td>(1) - (2)</td> <td>(2) - (3)</td> <td>0.25 - 7kΩ</td> </tr> <tr> <td>(3) - (4)</td> <td>(4) - (5)</td> <td>0.25 - 7kΩ</td> </tr> <tr> <td>(1) - (3)</td> <td>(2) - (4)</td> <td>No continuity</td> </tr> <tr> <td>(1) - (4)</td> <td>(2) - (5)</td> <td>No continuity</td> </tr> <tr> <td>Between pins (1), (2), (3), (4) and chassis</td> <td>Between pins (2), (3), (4), and (5) and chassis</td> <td>No continuity</td> </tr> </tbody> </table> <p>Motor drive current: Hold: 0.7 A Start: 0.84 A</p>	E05 (male)	C02 (female)	Resistance value	(1) - (2)	(2) - (3)	0.25 - 7kΩ	(3) - (4)	(4) - (5)	0.25 - 7kΩ	(1) - (3)	(2) - (4)	No continuity	(1) - (4)	(2) - (5)	No continuity	Between pins (1), (2), (3), (4) and chassis	Between pins (2), (3), (4), and (5) and chassis	No continuity	<p>Sets motor drive current to 0</p>	<ol style="list-style-type: none"> If during operation <ol style="list-style-type: none"> Set to low idling Engine does not stop There are cases of hunting When stopped <ol style="list-style-type: none"> Engine starts, but stays at low idling Engine does not stop after starting There are cases of hunting
E05 (male)	C02 (female)	Resistance value																		
(1) - (2)	(2) - (3)	0.25 - 7kΩ																		
(3) - (4)	(4) - (5)	0.25 - 7kΩ																		
(1) - (3)	(2) - (4)	No continuity																		
(1) - (4)	(2) - (5)	No continuity																		
Between pins (1), (2), (3), (4) and chassis	Between pins (2), (3), (4), and (5) and chassis	No continuity																		

User code	Service code	Abnormal system	Nature of abnormality
-	E306	Abnormality in feedback potentiometer system	<ol style="list-style-type: none"> 1. Short circuit in wiring harness between C03 (7) - (14), (7) - (17), (14) - (17) 2. Short circuit in wiring harness between E04 (1) - (2), (1) - (3), (2) - (3) 3. Short circuit in wiring harness between E06 (1) - (2), (10) - (3), (2) - (3) 4. Short circuit in wiring harness between C03 (7) - (4), (4) - (17) 5. Disconnection in wiring harness between C03 (7) - E04 (1) 6. Disconnection in wiring harness between C03 (14) - E04 (2) 7. Disconnection in wiring harness between C03 (17) - E04 (3) 8. Defective governor motor potentiometer 9. Defective contact of C03, E04 connectors
-	E315	Abnormality (short circuit) in battery relay output system	<p>If excess current flows between C03 (1) and battery relay</p> <p>★ This occurs only when turning starting switch to OFF and stopping engine</p>
-	E316	Abnormality (step-out) in motor	<ol style="list-style-type: none"> 1. Defective adjustment of rod or scuffing of loose spring 2. Abnormality in governor motor 3. Abnormality in engine throttle • pump controller

Condition when normal (voltage, current, resistance)	Action by controller when abnormality is detected	Problem that appears on machine when there is abnormality																		
<table border="1" data-bbox="105 490 563 795"> <thead> <tr> <th>C03 (female)</th> <th>E04 (male)</th> <th>Resistance value</th> </tr> </thead> <tbody> <tr> <td>(7) - (14)</td> <td>(1) - (2)</td> <td>0.25 - 7kΩ</td> </tr> <tr> <td>(7) - (17)</td> <td>(2) - (3)</td> <td>0.25 - 7kΩ</td> </tr> <tr> <td>(14) - (17)</td> <td>-</td> <td>2 - 3kΩ</td> </tr> <tr> <td>-</td> <td>(1) - (3)</td> <td>4 - 6kΩ</td> </tr> <tr> <td>Between each pin and chassis</td> <td>-</td> <td>No continuity</td> </tr> </tbody> </table>	C03 (female)	E04 (male)	Resistance value	(7) - (14)	(1) - (2)	0.25 - 7kΩ	(7) - (17)	(2) - (3)	0.25 - 7kΩ	(14) - (17)	-	2 - 3kΩ	-	(1) - (3)	4 - 6kΩ	Between each pin and chassis	-	No continuity	<p>Calculates position of motor and carries out control from value of voltage immediately before abnormality occurred</p>	<p>1. Precision of engine speed control may be reduced. For example:</p> <ol style="list-style-type: none"> 1) Engine does not rise to high idling speed (a little too low) 2) Engine does not go down to low idling speed (a little too high) 3) Defective engine speed for autodeceleration or automatic warming-up 4) Engine may not stop <ul style="list-style-type: none"> ★ The governor motor moves in the direction to stop the engine, but the motor may not move completely to the position to stop the engine. 5) There are cases of hunting
C03 (female)	E04 (male)	Resistance value																		
(7) - (14)	(1) - (2)	0.25 - 7kΩ																		
(7) - (17)	(2) - (3)	0.25 - 7kΩ																		
(14) - (17)	-	2 - 3kΩ																		
-	(1) - (3)	4 - 6kΩ																		
Between each pin and chassis	-	No continuity																		
<p>Between C03 (1) and chassis: 20 - 30 V ★ Holds with the motor in the stop position for 2 - 2.5 sec, returns to the low idling position, the turns the battery relay OFF.</p>	<p>Sets battery relay drive current to 0</p>	<p>Engine does not stop</p>																		
<ol style="list-style-type: none"> 1. Linkage adjustment correct 2. Must move lightly when connector is removed 3. Normal 	<ol style="list-style-type: none"> 1. Displays when returning from high idling to low idling <ul style="list-style-type: none"> ★ Starts again (repeats step-out) 2. In some cases it may not display when returning from partial speed to low idling 	<p>Engine speed cannot be controlled (particularly at high idling), so there is hunting</p>																		

JUDGEMENT TABLE FOR ENGINE THROTTLE • PUMP GOVERNOR (GOVERNOR CONTROL SYSTEM) AND ENGINE RELATED PARTS

Failure mode		Abnormality in engine throttle - pump controller power source system	Engine throttle - pump controller, engine related parts (E3:XX system)						
			Self-diagnostic display						
			Abnormality in fuel control dial input value	Abnormality (disconnection) in motor drive system	Abnormality (short-circuit) in motor drive system	Abnormality in feedback potentiometer system	Abnormality (short-circuit) in battery relay output	Abnormality (step-out) in motor	
User code		E05							
Service code		308	317	318	306	315	316		
1	Engine does not start easily								
2	Engine does not start								
3	Engine speed stays at low idling and does not follow accelerator; or engine pickup is poor	●	●	●	●	●			
4	Engine stops during operation								
5	Engine rotation is irregular	When idling speed is irregular							
		When there is hunting		●	●	●	●	●	
6	Lack of output (engine high idling speed is too low)	●			●				
7	Auto-deceleration does not work								
8	Engine does not stop								
9	Warming-up operation is defective								
10	Exhaust gas is black								
11	Oil consumption is excessive, or exhaust gas is blue								
12	Oil becomes dirty prematurely								
13	Fuel consumption is excessive, or exhaust gas is blue								
14	Oil is mixed in coolant								
15	Engine oil pressure caution lamp lights up								
16	Oil level rises								
17	Coolant temperature rises too high (overheating)								
18	Abnormal noise is generated								
19	There is excessive vibration								
20	Engine speed does not change even when working mode is switched								
There is excessive vibration		E-1	E-2	E-3	E-4	E-5	E-6	E-7	
There is excessive vibration									

- : This shows item to check with monitoring or machine monitor
- : This shows applicable item for service code
- * : This shows item that needs only checking with monitor

X02CH167

Checking monitoring, check items							Machine monitor check item		Does starting motor turn?	Troubleshooting code if no service code display is given
Battery relay drive signal	No. 2 throttle command value	Fuel control dial command value	Governor motor potentiometer	Governor motor A phase current	Governor motor B phase current	Coolant temperature voltage	102°C or above	105°C or above		
Monitoring code										
35	16	30	31	33	34	41		108		
										S-1
									○	S-2
		✱	✱	✱	✱			○		S-3
										S-4
										E-9A), S-5
			✱							E-9A), S-5
	✱	✱						○		E-10, S-6
										E-3, E-4
										E-11
								○	○	E-3, E-4
										S-7
										S-8
										S-9
										S-10
										S-11
										S-12
										S-13
								○	○	S-14
										S-15
										S-16
	✱									E-3, E-4
E-12								M-13	M-13	E-8

X02CH168

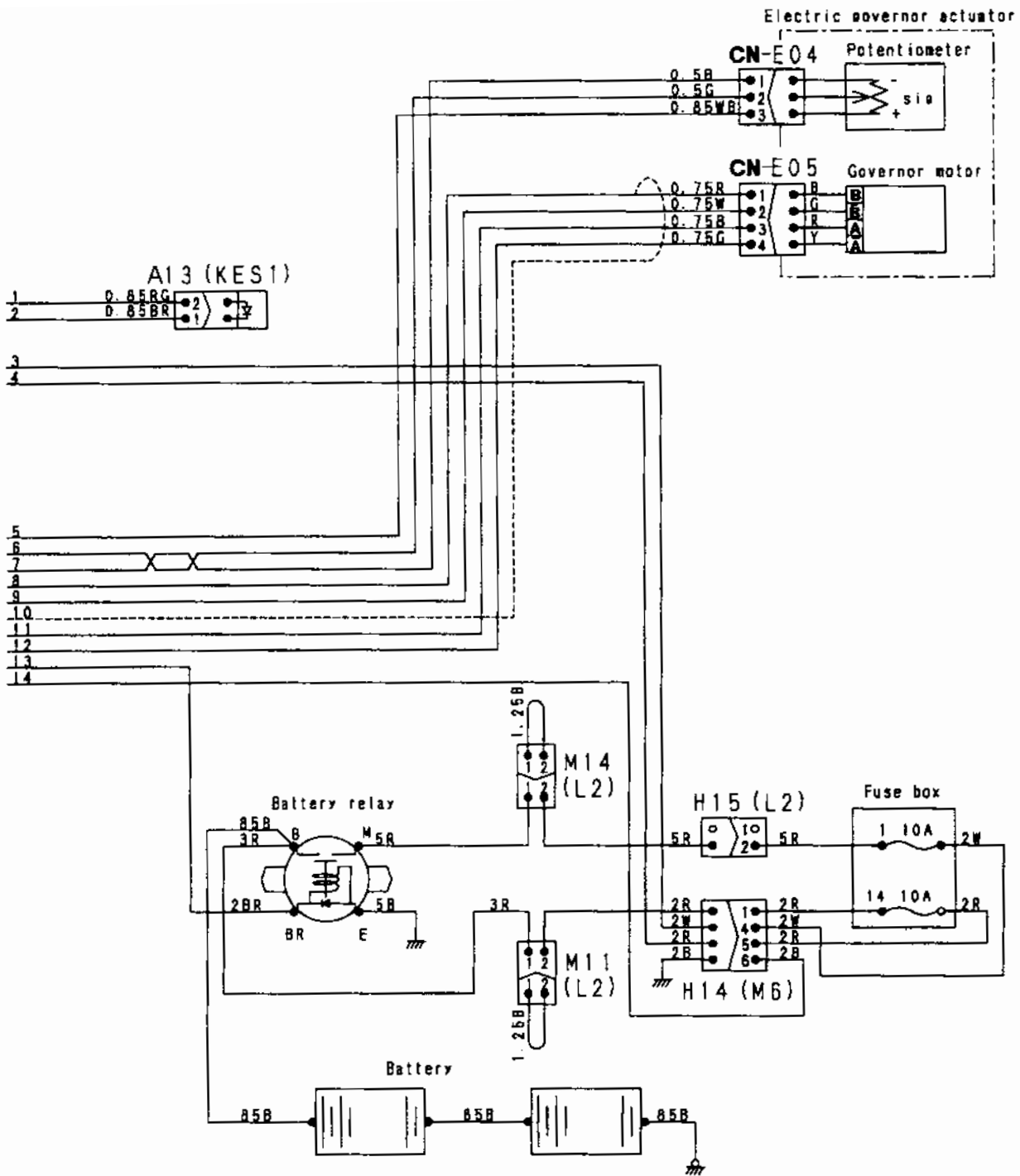

X08DD261

E-1 Abnormality in engine throttle • pump controller power source (controller LED is OFF)

- ★ This troubleshooting is carried out when there is still an abnormality, so when disconnecting the connector and inserting the T-adaptor, or when removing the T-adaptor and returning the connector to its original position, if the service code E is not displayed, the problem has been removed.
- ★ Check that fuse 1 is not blown.
- ★ Before carrying out troubleshooting, check that all related connectors are properly inserted.
- ★ Always connect any disconnected connectors before going on to the next step.
- ★ When the starting motor rotates correctly. (If the starting motor also does not rotate, go to E-8.)

		Cause	Remedy	
<p>1</p> <p>Is voltage between C01 (7) (6) and between C01 (12) normal?</p> <p>• Turn starting switch ON. • 20 - 30 V</p>	YES	Defective governor, pump controller	Replace	
	NO	2	<p>Defective contact, or disconnection in wiring harness between fuse 1 and C01 (female) (7) (13)</p> <p>Defective contact, or disconnection in wiring harness between fuse 1-H15 (2)-M14 (2) (1)-battery relay M</p>	<p>Repair or replace</p> <p>Repair or replace</p>
	NO	NO		

E-1 Related electric circuit diagram

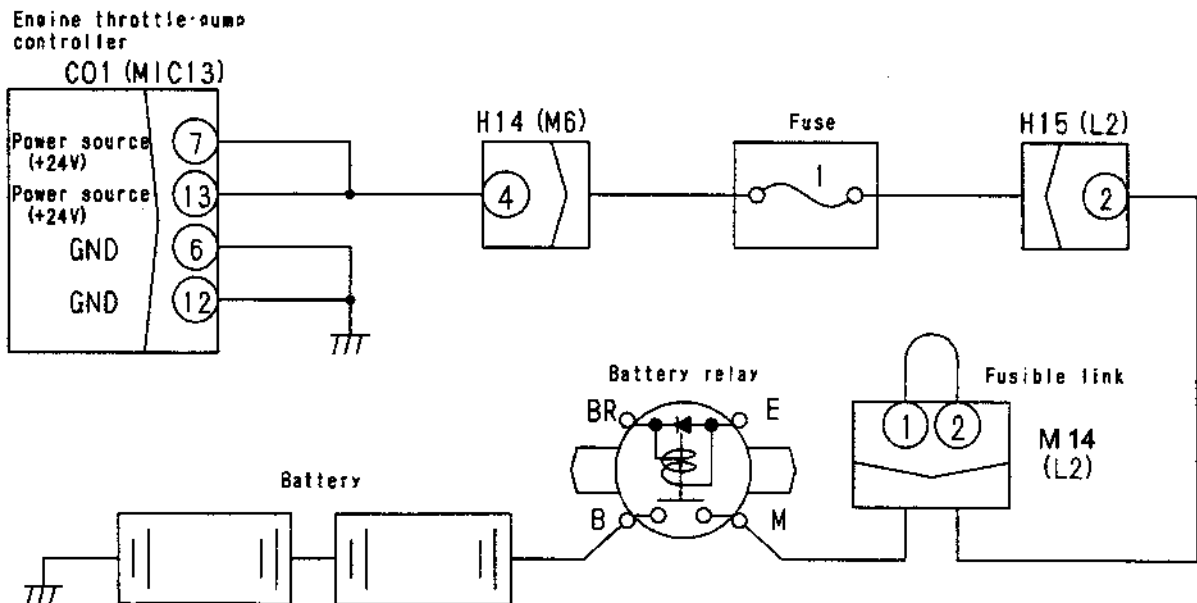

X08DD274

E-2 [E308] Abnormality in fuel control dial input value is displayed

- ★ This troubleshooting is carried out when there is still an abnormality, so when disconnecting the connector and inserting the T-adapter, or when removing the T-adapter and returning the connector to its original position, if the service code E is not displayed, the problem has been removed.
- ★ Before carrying out troubleshooting, check that all the related connectors are properly inserted.
- ★ Always connect any disconnected connectors before going on the next step.

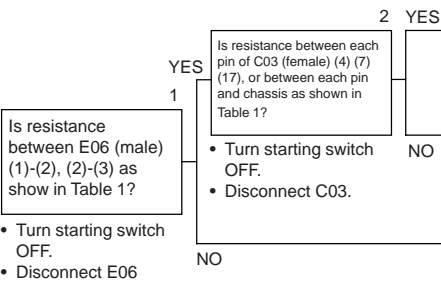

Cause	Remedy
Defective engine throttle, pump controller	Replace
Defective wiring harness in system with defective resistance	Replace
Defective fuel control dial	Replace

- ★ If E306 also occurs at the same time, check the wiring harness between C03 (female) (7) - E04 (female) (1) short circuiting with ground or contact with other parts of the wiring harness.

Table 1

C03 (female)	E04 (male)	Resistance value
(7) - (4)	(1) - (2)	0.25 - 7kΩ
(4) - (17)	(2) - (3)	0.25 - 7kΩ
(7) - (17)	-	2 - 3kΩ
-	(1) - (3)	4 - 6kΩ
Between each pin and chassis	-	No continuity

E-2 Related electric circuit diagram

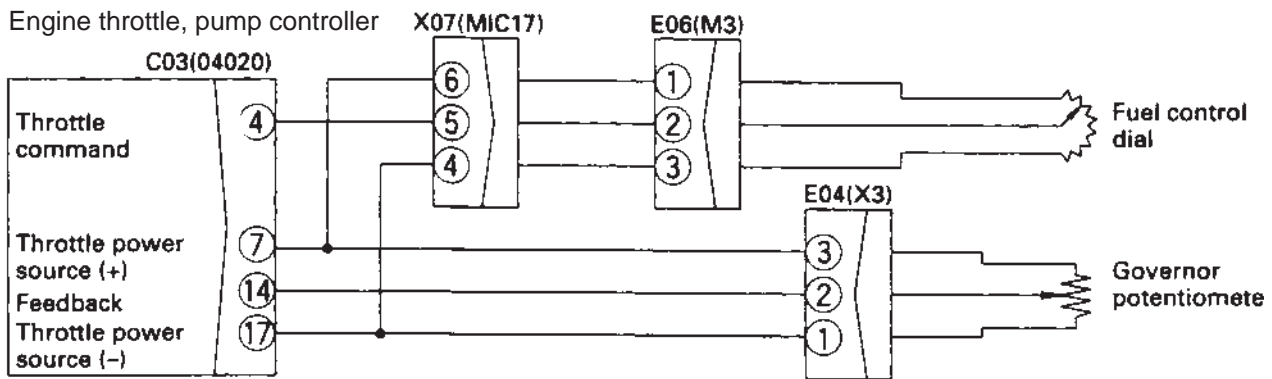

BKP00087

E-3 [E317] Abnormality (disconnection) in motor drive system is displayed

- ★ This troubleshooting is carried out when there is still an abnormality, so when disconnecting the connector and inserting the T-adapter, or when removing the T-adapter and returning the connector to its original position, if the service code E is not displayed, the problem has been removed.
- ★ During operation, if there is
 - 1) a simultaneous disconnection in A phase and B phase:
 - a. the engine will run at low idling
 - b. the engine will not stop
 - 2) a disconnection in either A phase or B phase, the engine speed will remain the same as before the abnormality occurred
- ★ If the problem occurs when the engine is stopped, the engine can be started, but it stays in low idling, or it will not stop after it is started.
- ⚠ Check with the engine stopped (push the fuel control lever of the fuel injection pump to the NO INJECTION position).
- ★ Before carrying out troubleshooting, check that all the related connectors are properly inserted.
- ★ Always connect any disconnected connectors before going on the next step.

	Cause	Remedy
<p>1 YES</p> <p>Is resistance between each pin of E05 (male), or between each pin and chassis as shown in Table 1?</p> <ul style="list-style-type: none"> • Turn starting switch OFF. • Disconnect E05 <p>NO</p> <p>2 YES</p> <p>Is resistance between each pin of C02 (female), or between each pin and chassis as shown in Table 1?</p> <ul style="list-style-type: none"> • Turn starting switch OFF. • Disconnect C02. <p>NO</p>	Defective engine throttle, pump controller	Replace
	Defective wiring harness in system with defective resistance	Replace
	Defective governor motor	Replace

Table 1

E05 (male)	C02 (female)	Resistance value
(1) - (2)	(2) - (3)	2.5 - 7.5 kΩ
(3) - (4)	(4) - (5)	2.5 - 7.5 kΩ

E-3 Related electric circuit diagram

Engine throttle pump controller



E-4 [E318] Abnormality (short circuit) in motor drive system is displayed

- ★ This troubleshooting is carried out when there is still an abnormality, so when disconnecting the connector and inserting the T-adapter, or when removing the T-adapter and returning the connector to its original position, if the service code E is not displayed, the problem has been removed.
- ★ During operation, if there is
 1. A simultaneous disconnection in A phase and B phase:
 - a. The engine will run at low idling
 - b. The engine will not stop
 2. A disconnection in either A phase or B phase, the engine speed will remain the same as before the abnormality occurred.
- ★ If the problem occurs when the engine is stopped, the engine can be started but it stays in low idling, or it will not stop after it is started.
- ⚠ Check with the engine stopped (push the fuel control lever of the fuel injection pump to the NO INJECTION position).
- ★ Before carrying out troubleshooting, check that all related connectors are properly inserted.
- ★ Always connect any disconnected connectors before going on to the next step.

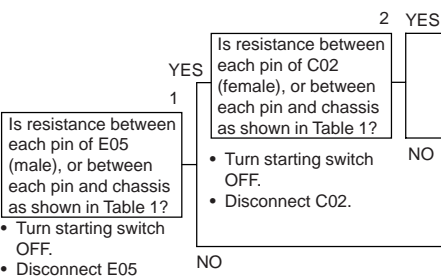

Cause	Remedy
Defective engine throttle, pump controller	Replace
Defective wiring harness in system with defective resistance	Replace
Defective governor motor	Replace

Table 1

E05 (male)	C02 (female)	Resistance value
(1) - (2)	(2) - (3)	2.5 - 7.5kΩ
(3) - (4)	(4) - (5)	2.5 - 7.5kΩ
(1) - (3)	(2) - (4)	No continuity
(1) - (4)	(2) - (5)	No continuity
Between chassis and pins (1) (2) (3) (4)	Between chassis and pins (2) (3) (4) (5)	No continuity

E-4 Related electric circuit diagram

Engine throttle pump controller

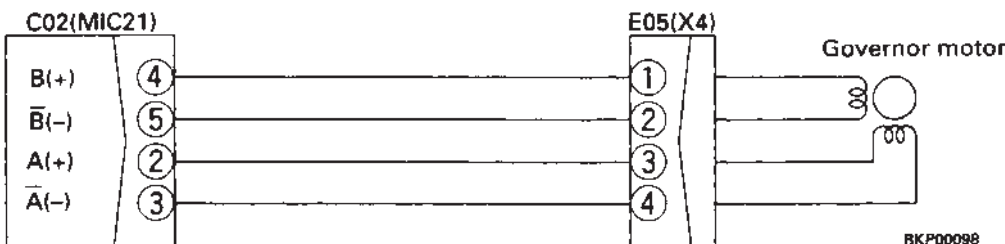

BKP00098

E-5 [E306] Abnormality in feedback potentiometer system is displayed

- ★ This troubleshooting is carried out when there is still an abnormality, so when disconnecting the connector and inserting the T-adapter, or when removing the T-adapter and returning the connector to its original position, if the service code E is not displayed, the problem has been removed.
- ★ Before carrying out troubleshooting, check that all related connectors are properly inserted.
- ★ Always connect any disconnected connectors before going on to the next step.

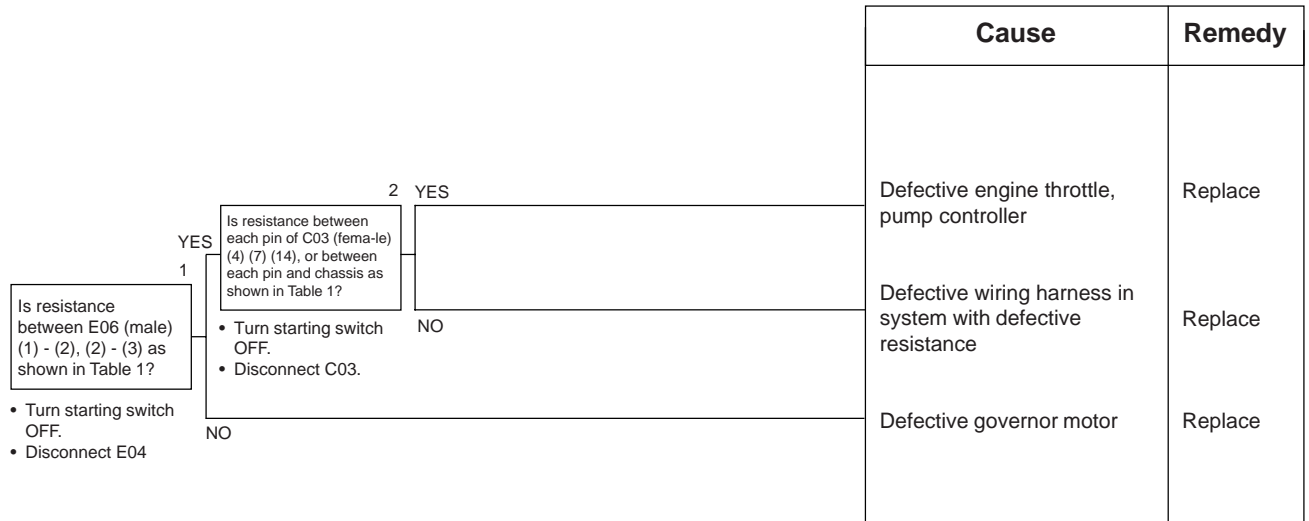

- ★ If E308 also occurs at the same time, check the wiring harness between C03 (female) (7) - X07 (6) - E06 (female) (1) short circuiting with ground or contact with other parts of the wiring harness.

Table 1

C03 (female)	E06 (male)	Resistance value
(7) - (4)	(1) - (2)	2.5 - 7kΩ
(14) - (17)	(2) - (3)	2.5 - 7kΩ
(7) - (17)	-	2 - 3kΩ
-	(1) - (3)	4 - 6kΩ
Between chassis and pins	-	No continuity

E-5 Related electric circuit diagram

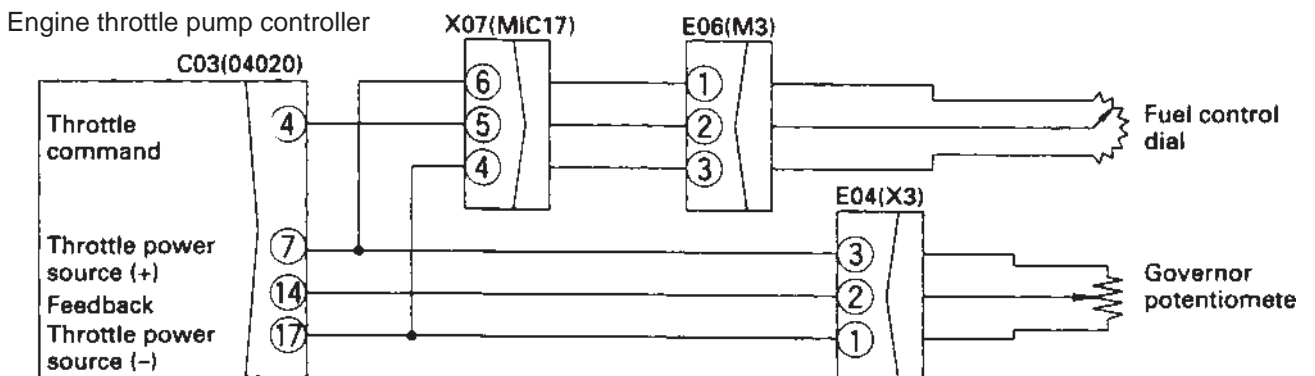

BKP00087

E-6 [E315] Abnormality (short circuit) in battery relay output system is displayed

- ★ This troubleshooting is carried out when there is still an abnormality, so when disconnecting the connector and inserting the T-adapter, or when removing the T-adapter and returning the connector to its original position, if the service code E is not displayed, the problem has been removed.
- ⚠ Check with the engine stopped (push the fuel control lever of the fuel injection pump to the NO INJECTION position).
- ★ Before carrying out troubleshooting, check that all related connectors are properly inserted.
- ★ Always connect any disconnected connectors before going on to the next step.
- ★ This only occurs when the engine is stopped and the starting switch is turned OFF.

	Cause	Remedy
<div style="display: flex; align-items: flex-start;"> <div style="margin-right: 20px;"> <p>1</p> <p>Is resistance between C01 (female) (1) and chassis normal?</p> <ul style="list-style-type: none"> • Between C01 (female) (1) and chassis: Approx. 110X • Turn starting switch OFF. • Disconnect C01. </div> <div style="margin-right: 20px;"> <p>2</p> <p>Is resistance between C01 (female) (1) and battery relay terminal BR, and between wiring harness and chassis normal?</p> <ul style="list-style-type: none"> • Between C01 (female) (1) and battery relay BR: Max 1X • Between wiring harness and chassis: Min. 1 MX • Turn starting switch OFF. • Disconnect C01 and battery relay BR. </div> </div>	Defective engine throttle, pump controller	Replace
	Defective battery relay	Replace
	<p>1) Contact between other wiring harnesses and wiring harness between C01 (female) (1)-H02 (9)-battery relay BR.</p> <p>2) When light is connected</p>	Replace

E-6 Related electric circuit diagram

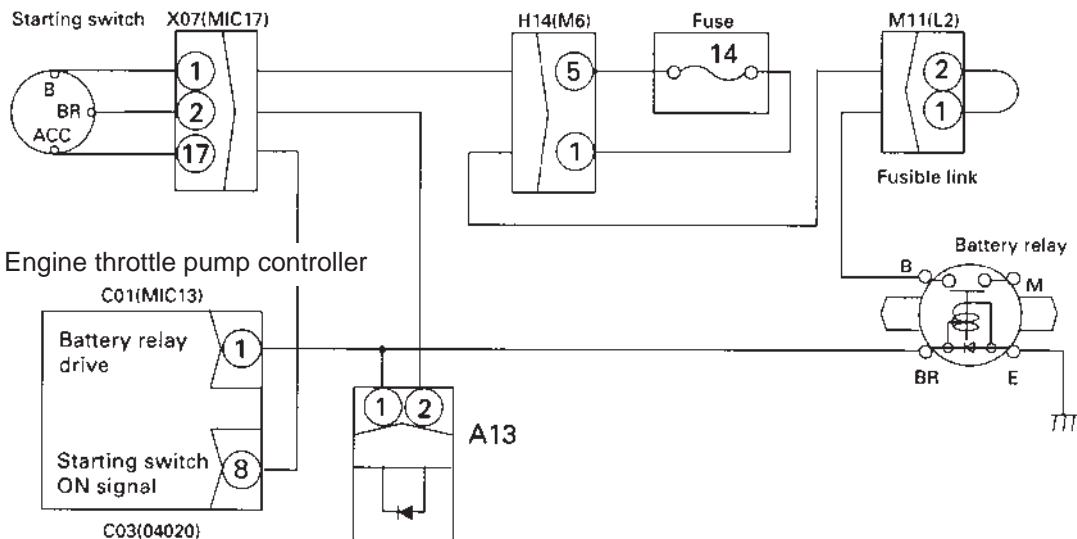

E-7 [E316] Abnormality (step-out) in motor is displayed

- ★ This troubleshooting is carried out when there is still an abnormality, so when disconnecting the connector and inserting the T-adapter, or when removing the T-adapter and returning the connector to its original position, if the service code E is not displayed, the problem has been removed.
- ★ If any other service code [E306] - [E318] has occurred at the same time, start troubleshooting from the code except code [E316].
- ★ Check that the fuse is normal.
- ★ Read the precautions given in TESTING AND ADJUSTING, "Adjusting travel of governor motor lever" before carrying out the troubleshooting.
- ★ Before carrying out troubleshooting, check that all related connectors are properly inserted.
- ★ Always connect any disconnected connectors before going on to the next step.

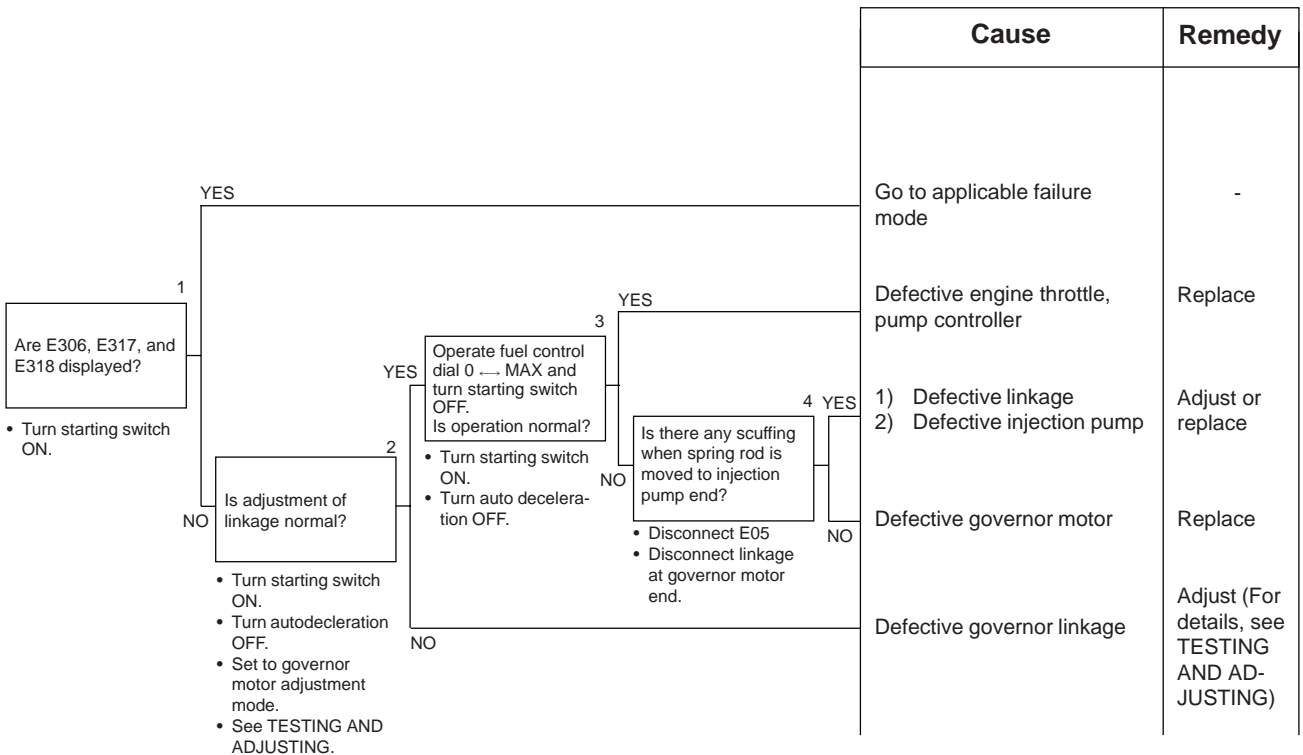

X02CH016

MEMORANDA

E-8 Engine does not start

- ★ When starting motor does not rotate.
- ★ Check that fuse No. 14 is not blown before starting troubleshooting.
- ★ Before carrying out troubleshooting, check that all the related connectors are properly inserted.
- ★ Always connect any disconnected connectors before going on the next step.

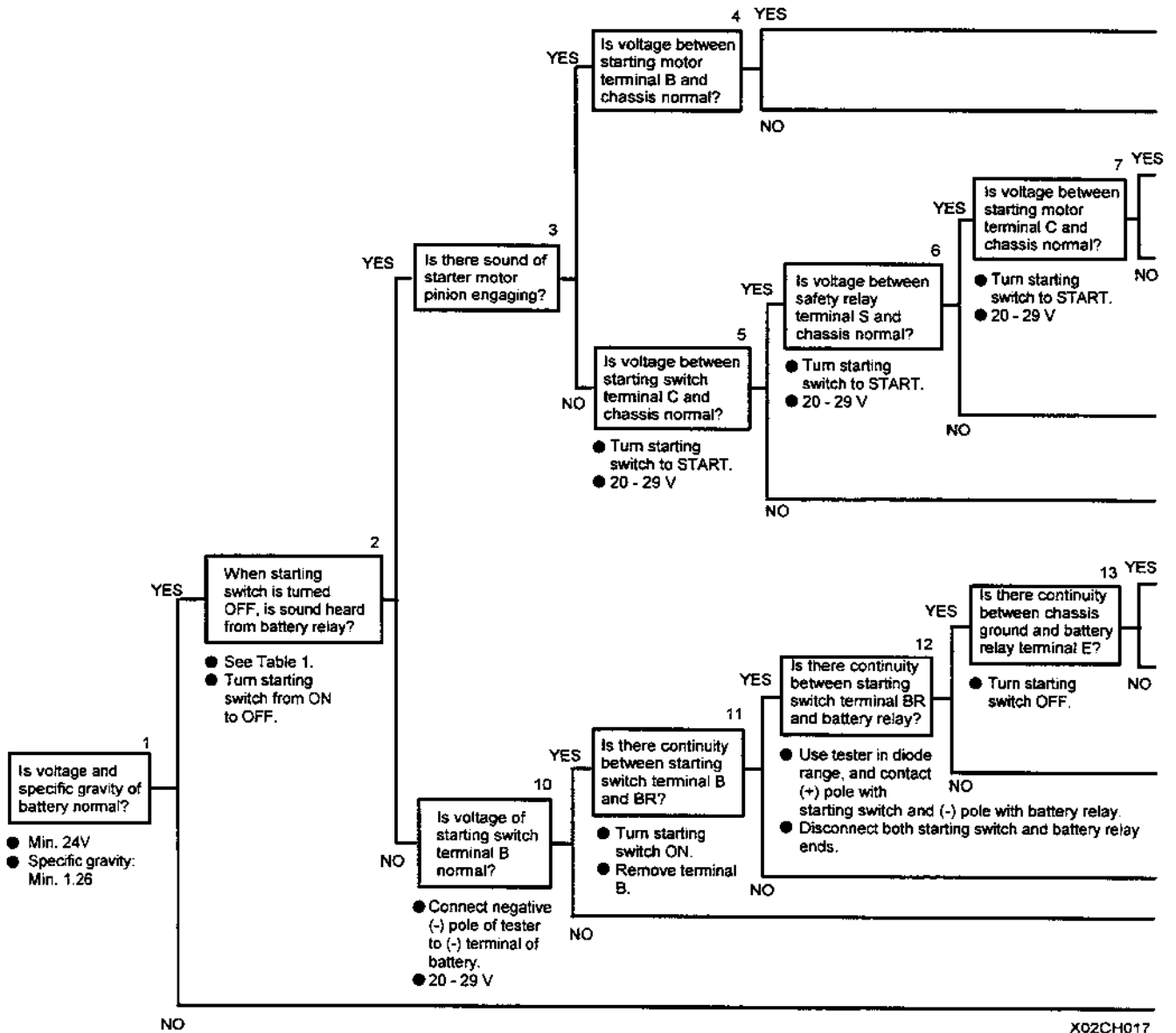

	Cause	Remedy
<p>14</p> <p>Is voltage between fuel shut-off connector E10 - B and C normal?</p> <p>YES</p> <p>15</p> <p>Does fuel shut-off lever move when starting switch is moved from ON to start?</p> <p>NO</p>	<p>Defective starting motor (starting motor proper)</p> <p>Defective fuel shut-off solenoid</p> <p>Defective wiring between safety relay and fuel shut-off solenoid</p>	<p>Repair or replace</p> <p>Repair or replace</p> <p>Repair or replace</p>
<p>8</p> <p>Is voltage between safety relay terminal C and chassis normal?</p> <p>● Turn starting switch to START.</p> <p>● 20 - 29 V</p> <p>NO</p> <p>9</p> <p>Is voltage between safety relay terminal R and chassis normal?</p> <p>● Turn starting switch ON.</p> <p>● Max. 13 V</p> <p>YES</p> <p>NO</p>	<p>Defective contact of wiring harness between battery (+) - battery relay B - battery relay M - starting motor terminal B (including battery relay)</p> <p>Defective starting motor (magnetic clutch)</p> <p>Defective contact or disconnection in wiring harness between safety relay terminal C - T13(1) - starting motor terminal C</p> <p>Defective safety relay</p> <p>Defective alternator, shorted D14 diode, or defective contact between Safety relay terminal R - M02 (2) - E08(1) - alternator terminal R or D14 (2)</p>	<p>Repair or replace</p> <p>Repair or replace</p> <p>Repair or replace</p> <p>Replace</p> <p>Repair or replace</p>
	<p>Defective contact or disconnection in wiring harness between X07 (female) (10) - M02 (1) - safety relay terminal S</p>	<p>Repair or replace</p>
	<p>Defective starting switch (between terminals B and C)</p>	<p>Replace</p>
	<p>Defective battery relay</p>	<p>Replace</p>
	<p>Defective contact of wiring harness between battery relay terminal E and revolving frame ground terminal</p>	<p>Repair or replace</p>
	<p>Defective contact, or disconnection in wiring harness between starting switch terminal BR - D13 - battery relay terminal BR (including diode)</p>	<p>Replace</p>
	<p>Defective starting switch (between B and BR)</p>	<p>Replace</p>
	<p>Defective contact or disconnection in wiring harness between battery terminal (+) - M11 - H14 (1),(5) - X07 (1) - starting switch terminal B (including fusible link)</p>	<p>Replace</p>
	<p>Lack of battery capacity</p>	<p>Charge or replace</p>

X02CH01B

E-8 Related electric circuit diagram

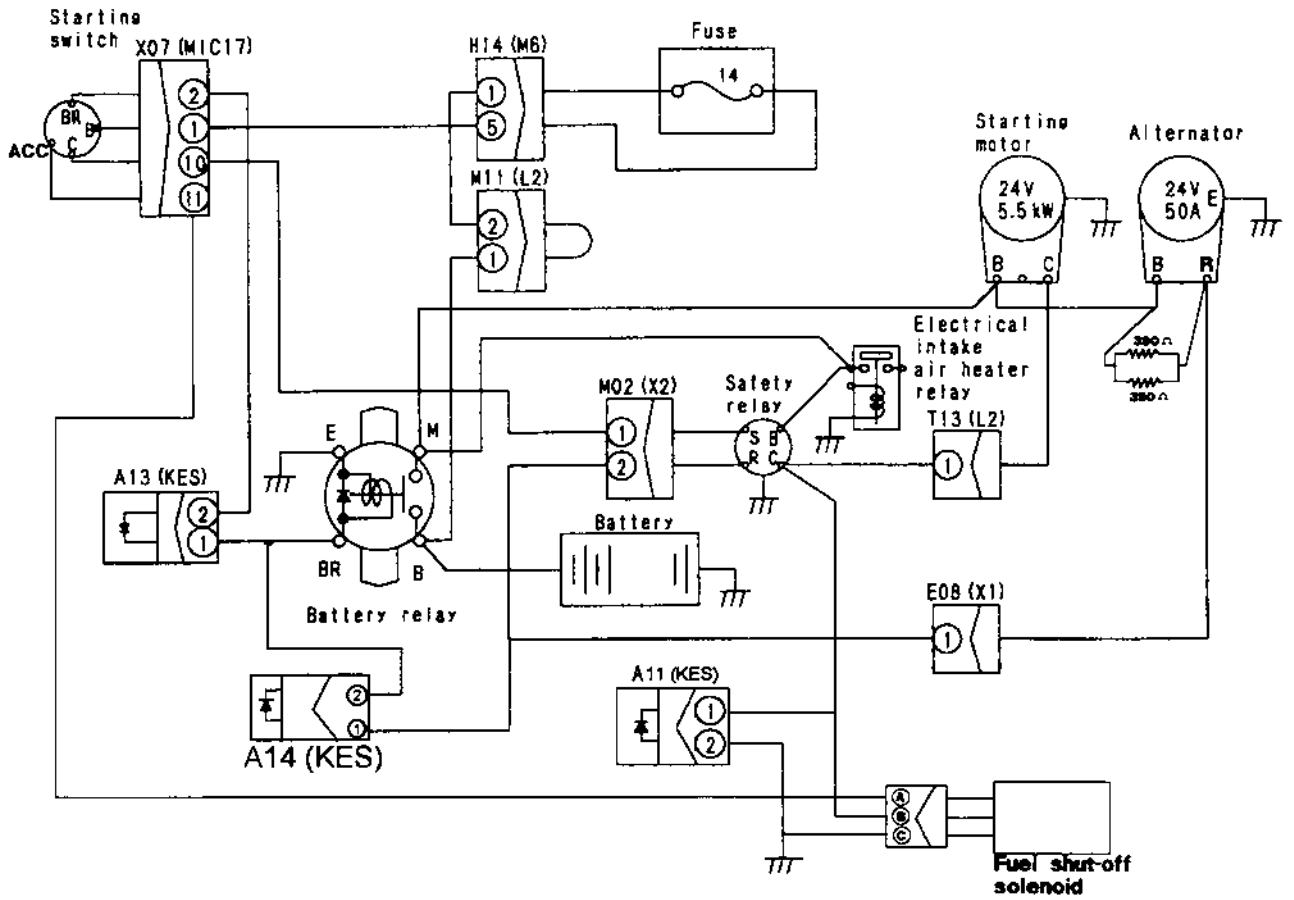

X08DD266

E-9 Engine speed is irregular

- ★ Before carrying out troubleshooting, check that all the related connectors are properly inserted.
- ★ Always connect any disconnected connectors before going on the next step.

a) Idling speed is irregular

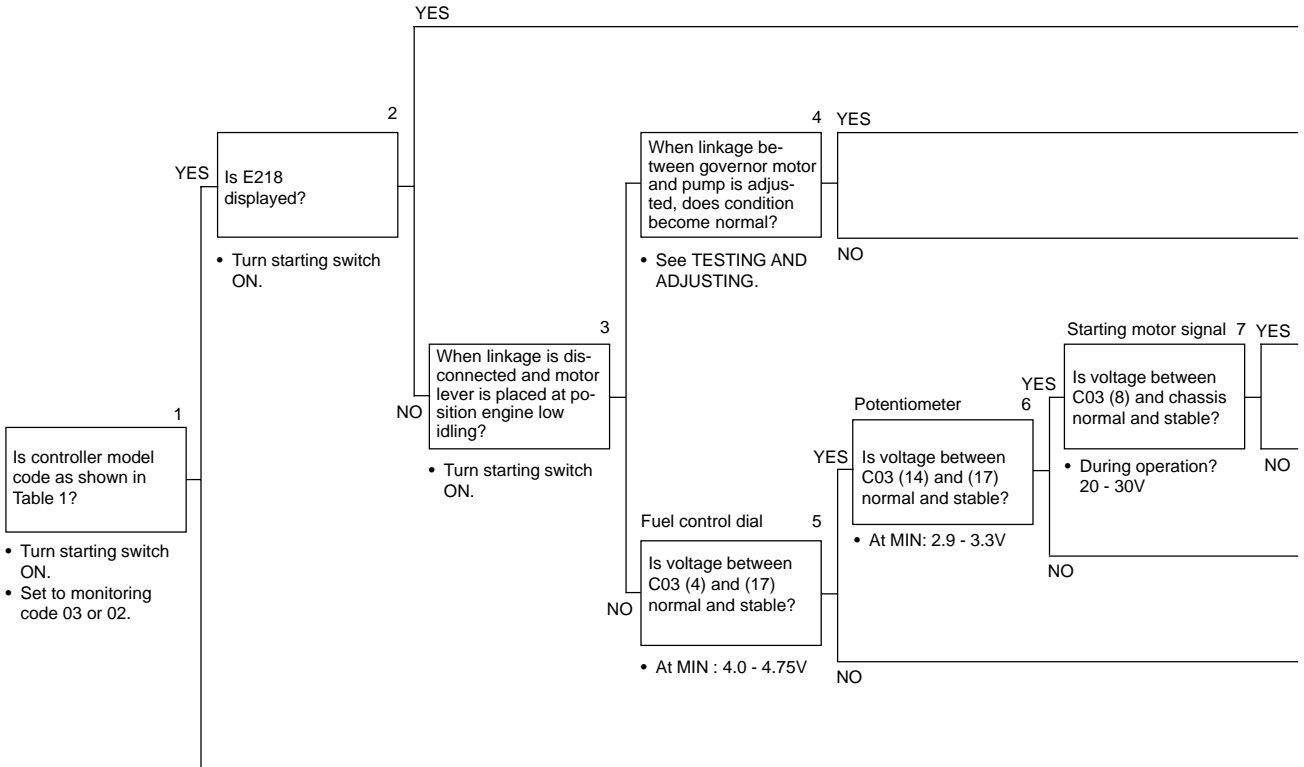

Table 1

Controller model code

- ★ The diagram shows monitoring code 03.

	Cause	Remedy
	See N mode	
	Defective adjustment of linkage	Adjust
	Defective injection pump	See S mode
	Defective governor motor	Replace
	Defective contract of wiring harness between starting switch ACC-X07 (17)-C03 (female) (8), or defective starting switch	Repair or replace
	See E-5	-
	See E-2	-
	See C-20	-

E-9 Related electric circuit diagram

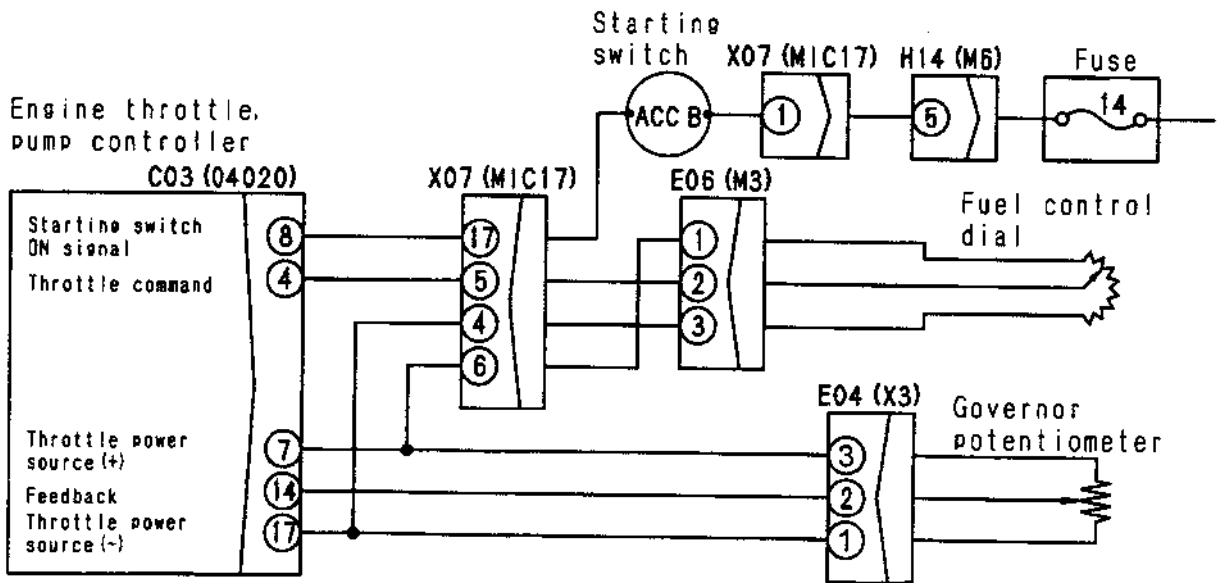

X08DD269

b) There is hunting

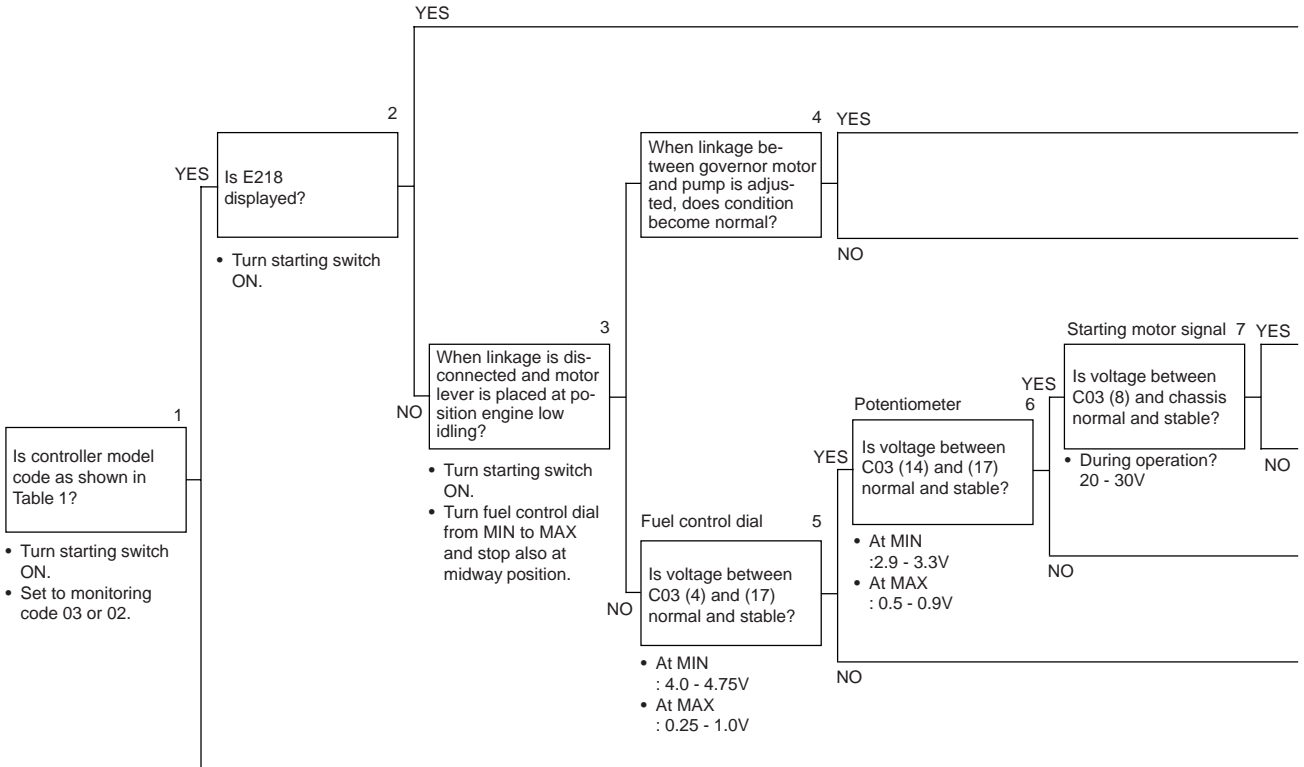

Table 1

Controller model code

★ The diagram shows monitoring code 03.

	Cause	Remedy
	See N mode	
	Defective adjustment of linkage	Adjust
	Defective injection pump	See S mode
	Defective governor motor	Replace
	Defective contact of wiring harness between starting switch ACC-X07 (17)-C03 (femal) (8), or defective starting switch	Repair or replace
	See E-5	-
	See E-2	-
	See C-20	-

E-9 Related electric circuit diagram

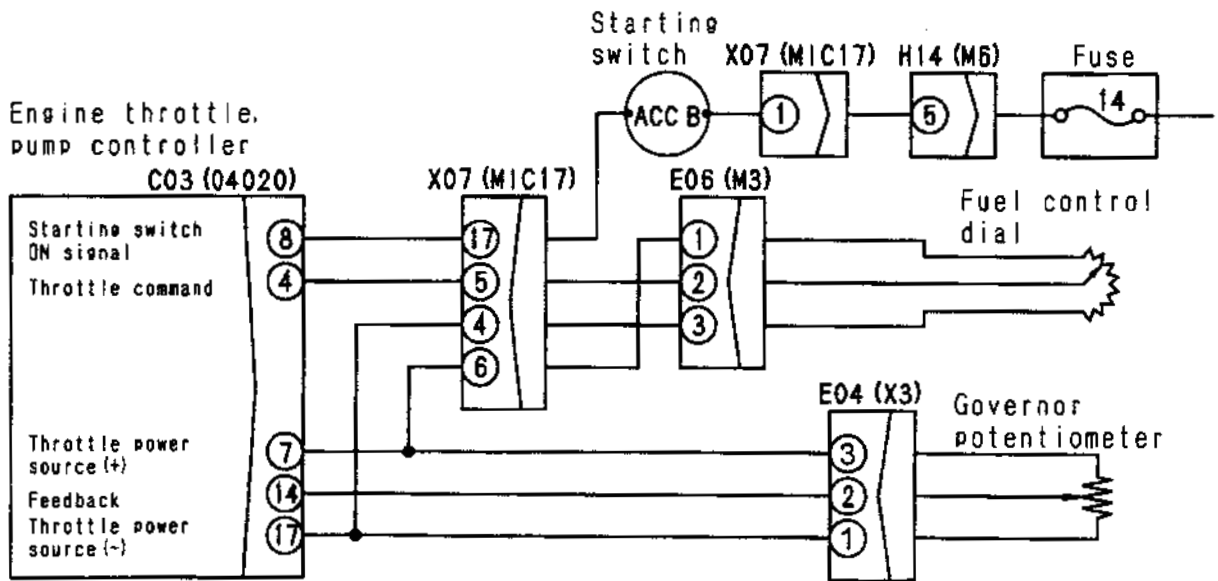

X08DD269

E-10 Lack of output (engine high idling speed is too low)

- ★ Before carrying out troubleshooting, check that all the related connectors are properly inserted.
- ★ Always connect any disconnected connectors before going on the next step.

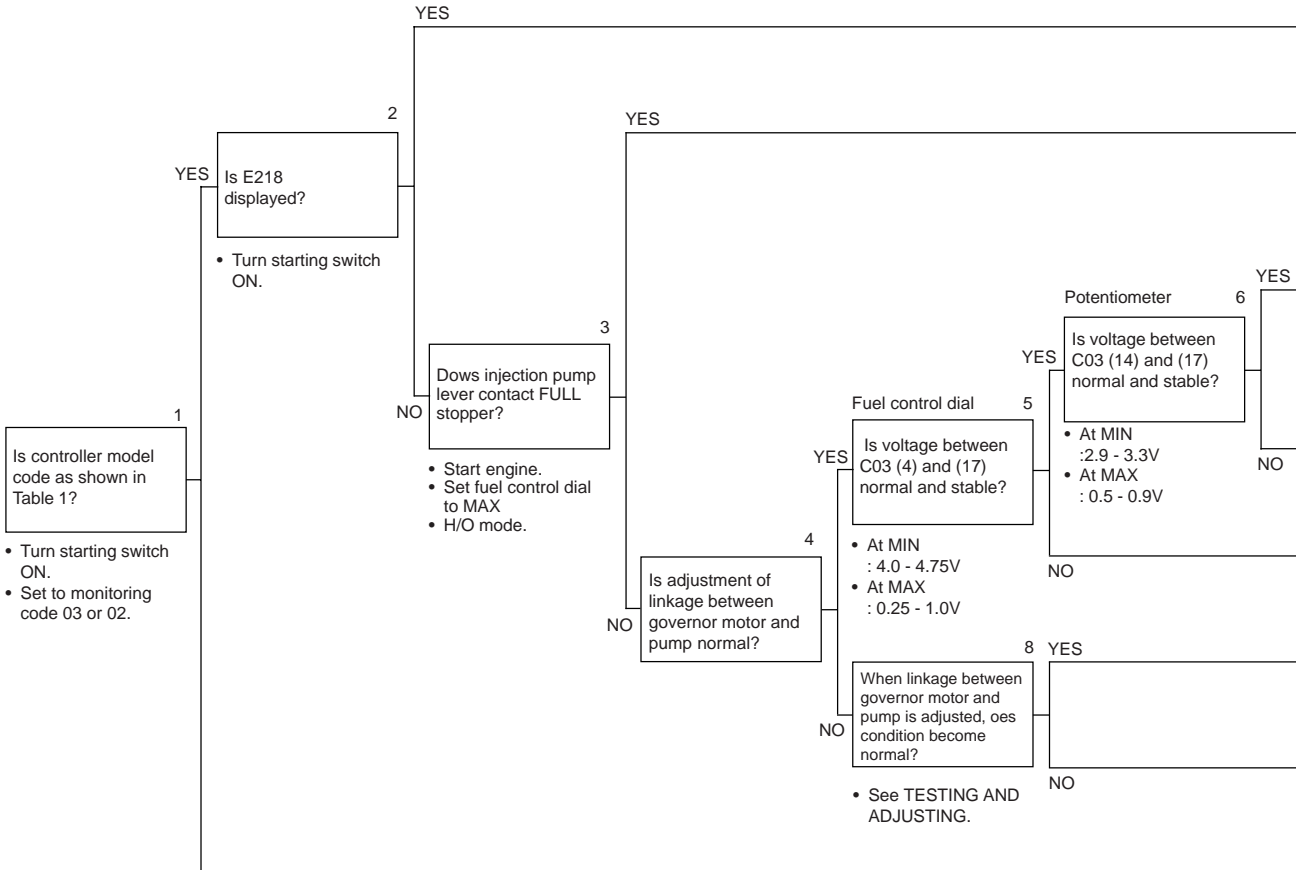

Table 1

Controller model code

- ★ The diagram shows monitoring code 03.

		Cause	Remedy
		See N mode	-
		Defective injection pump	See S mode
Starting motor signal 7 YES		Defective governor motor	Replace
Is voltage between C03 (8) and chassis normal and stable? • During operation? 20 - 30V		Defective contact of wiring harness between starting switch ACC - X07 (17) - C03 (female) (8), or defective starting switch	Repair or replace
NO		See E-5	
		See E-2	
		Defective adjustment of governor motor linkage	
		See S mode	Adjust
		See C-20	-

E-10 Related electric circuit diagram

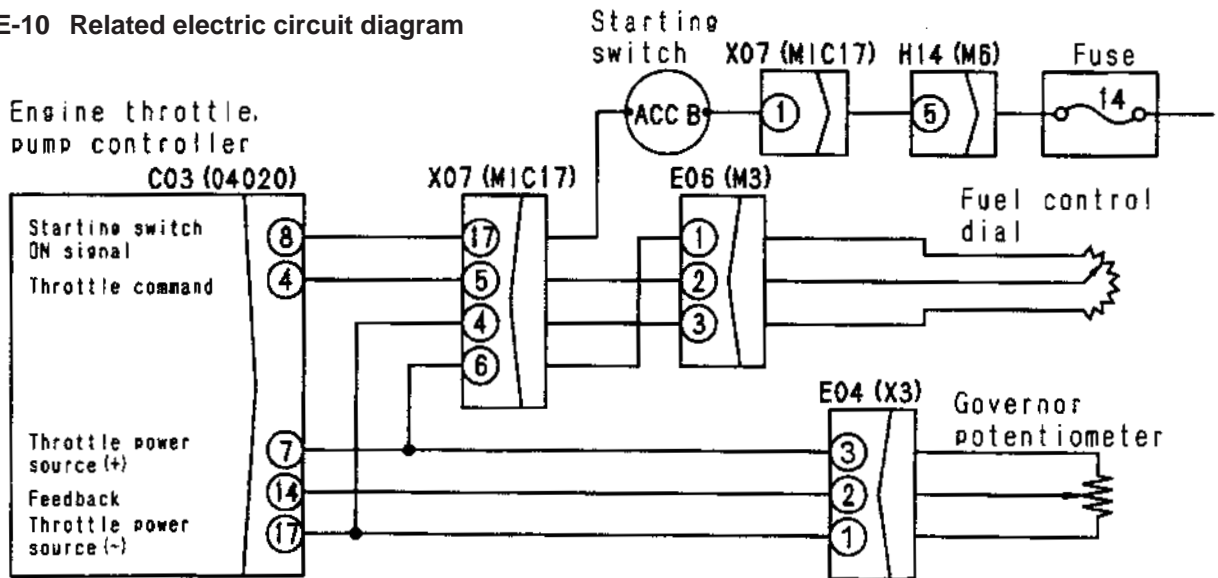

X08DD269

E-11 Engine does not stop

- ⚠ Check with the engine stopped (push the fuel control lever of the fuel injection pump to the NO INJECTION position).
- ★ Before carrying out troubleshooting, check that all the related connectors are properly inserted.
- ★ Always connect any disconnected connectors before going on the next step.
- ★ Read the precautions given in TESTING AND ADJUSTING, "Adjusting travel of governor motor lever" before carrying out the troubleshooting.

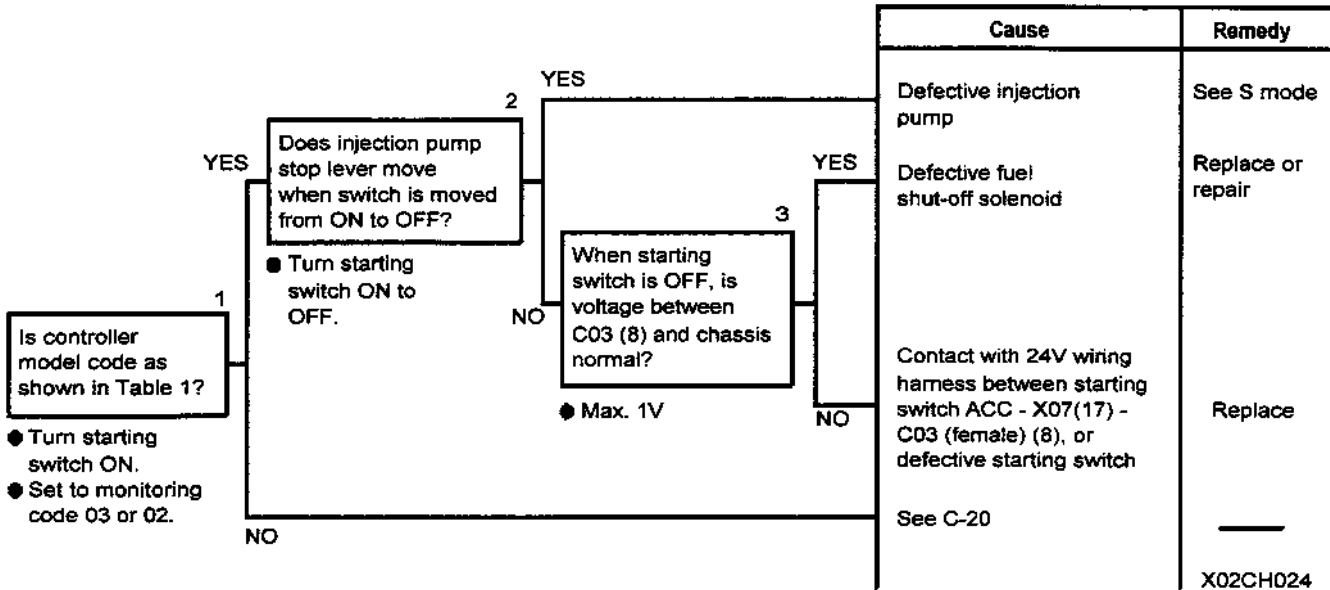

Table 1

Controller model code	
03	290
X06DD268	
03	200
X06DD267	

- ★ The diagram shows monitoring code 03.

E-11 Related electric circuit diagram

Engine throttle,
pump controller

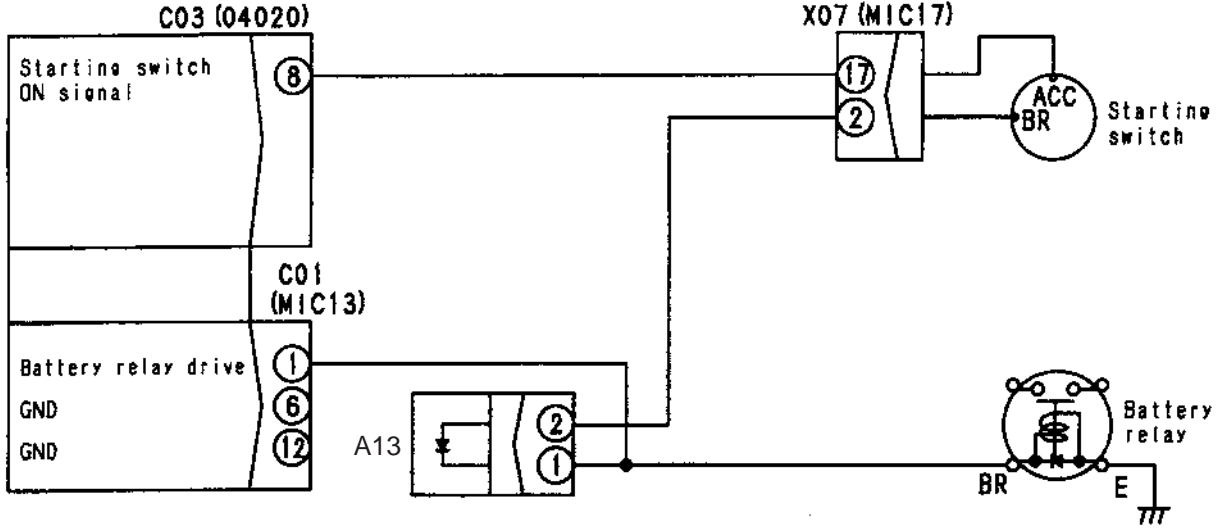

X08DD270

E-12 Defective operation of battery relay system (engine does not stop)

- ★ This only occurs when the engine is stopped and the starting switch is turned OFF.
- Check with the engine stopped (push the fuel control lever of the fuel injection pump to the NO INJECTION position).
- ⚠ Before carrying out troubleshooting, check that all the related connectors are properly inserted.
- ★ Always connect any disconnected connectors before going on the next step.

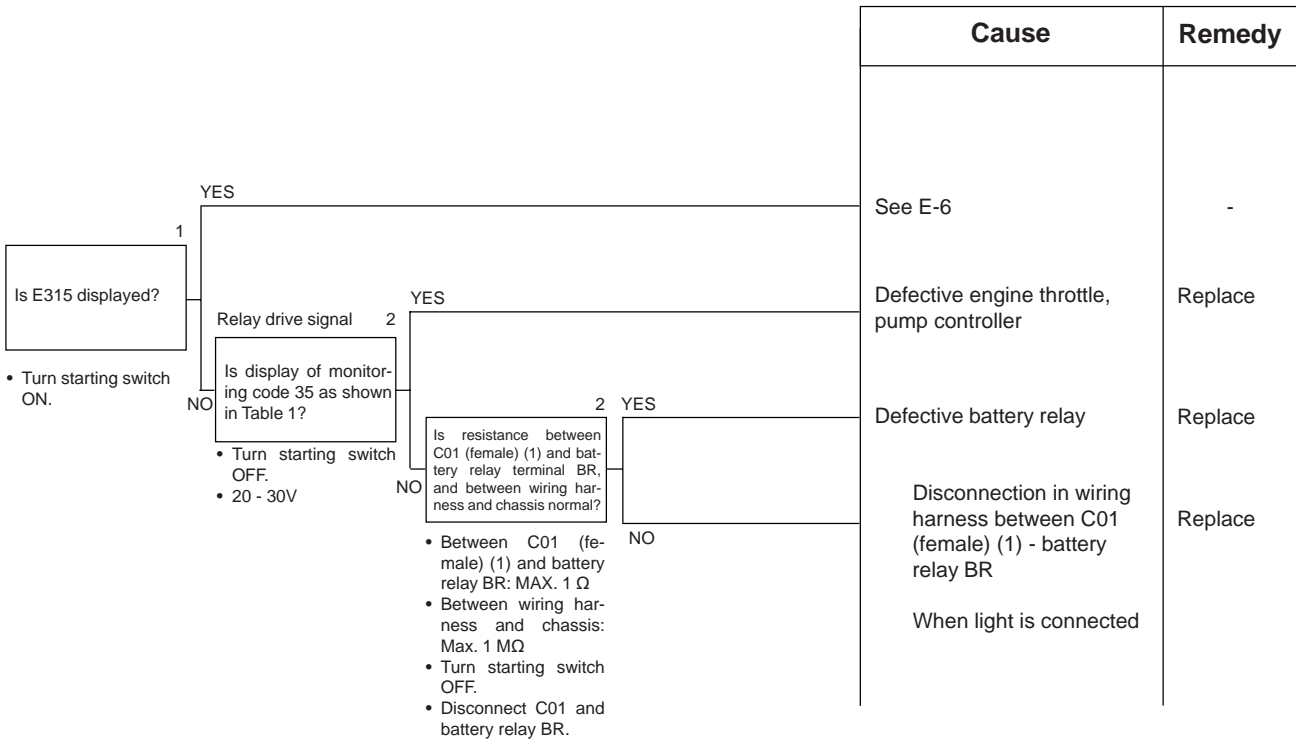
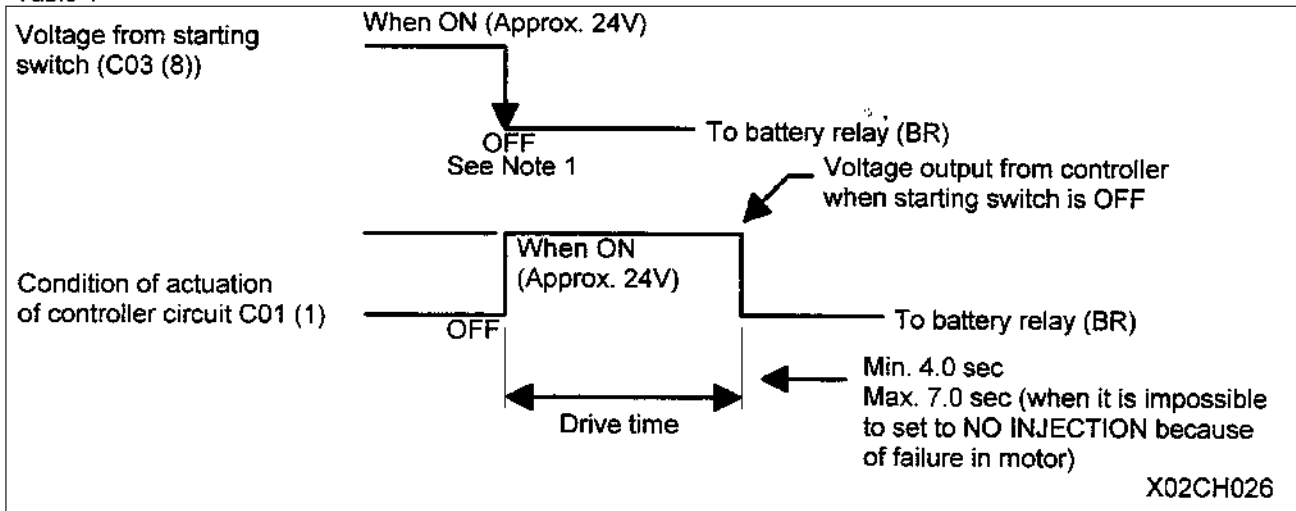
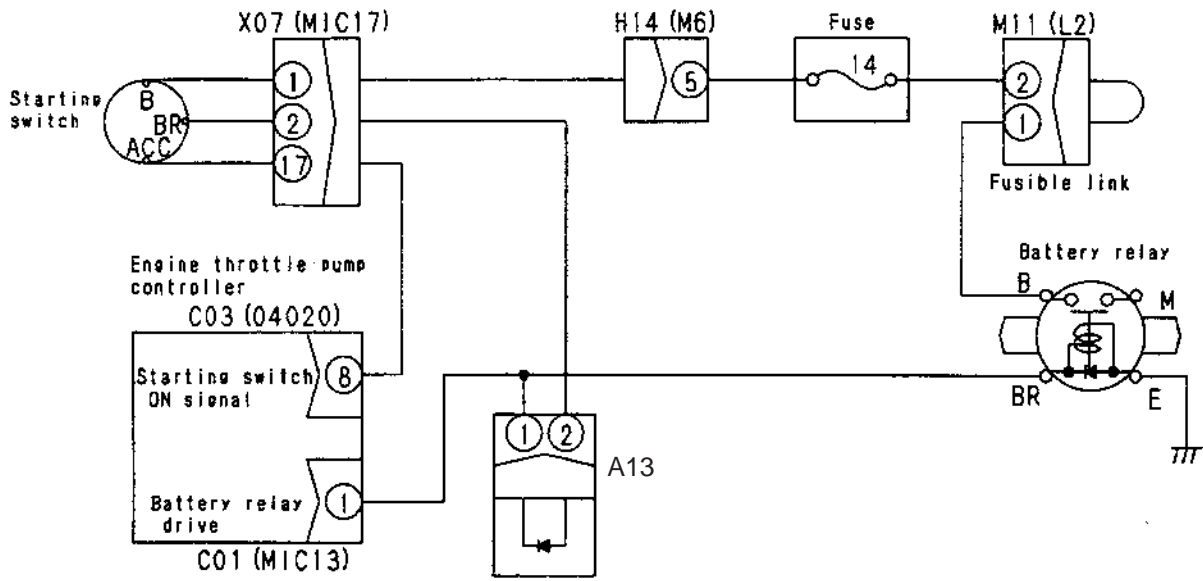

Table 1



Note 1: When the starting switch is ON, the controller end is OFF, but a voltage of approx. 20 - 30V is always from starting switch BR, so if the voltage is measured at C01 (1), there is a voltage of 20 - 30V.

E-12 Related electric circuit diagram



X08DD271

TROUBLESHOOTING OF ENGINE SYSTEM (S MODE)

METHOD OF USING TROUBLESHOOTING CHARTS

This troubleshooting chart is divided into three sections: questions, check items, and troubleshooting. The questions and check items are used to pinpoint high probability causes that can be located from the failure symptoms or simple inspection without using troubleshooting tools.

Next, troubleshooting tools or direct inspection are used to check the high probability causes to make the final confirmation.

Question

Sections (A) and (B) in the chart below corresponds to the items where the answers can be obtained from the user. The items in (B) are items that can be obtained from the user, depending on the user's level.

Check items

The serviceman carries out simple inspections to narrow down the causes. The items under (C) in the chart below correspond to this. The serviceman narrows down the causes from information (A) that he has obtained from the user and the results of (C) that he has obtained from his own inspection.

Troubleshooting

Troubleshooting is carried out in the order of probability, starting with the causes that have been marked as having the highest probability from information gained from (A) and (B).

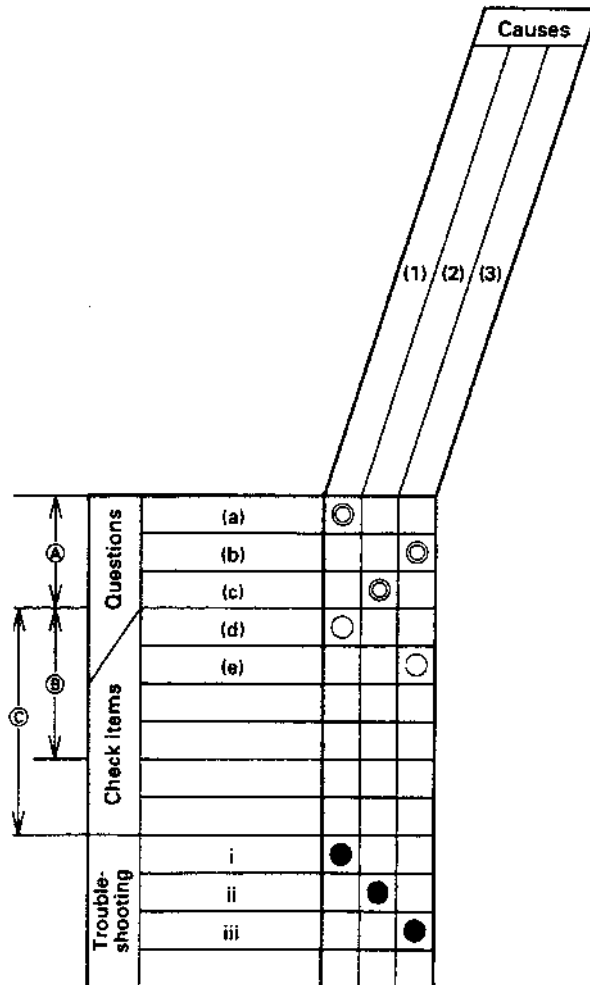

The basic method of using the troubleshooting chart is as follows. Items listed for Question and Check Items that have a relationship with the Cause items are marked with O, and of these, causes that have a high probability are marked with OO.

Check each of the Questions and Check items in turn, and not the O and OO in the chart for items where the problem appeared. The vertical column (Causes) that has the highest number of points is the most probable cause, so start troubleshooting for that item to make the final confirmation of the cause.

- * 1. For [Confirm recent repair history] in the Question section, ask the user, and mark the Cause column with a OE to use as reference for locating the cause of the failure. However, do not use this when making calculation to narrow down the causes.
- * 2. Use the OE in the Cause column as reference for [Degree of use (Operated for long period)] in the Questions section as reference. As a rule, do not use it when calculating the points for locating the cause, but it can be included in necessary to determine the order for troubleshooting.

		Causes						
		Seized turbocharger, interference	Clogged air cleaner element	Worn piston ring, cylinder	Clogged, seized injection nozzle	Improper injection timing	Defective injection pump (excessive injection)	
*1	Confirm recent repair history							
*2	Degree of use		△	△	△			
	Operated for long period							

- Example of troubleshooting when exhaust gas is black
 Let us assume that [Clogged air cleaner] is taken to be the cause of black exhaust gas. Three symptoms have causal relationship with this problem: [Exhaust gas slowly became black], [Power slowly weaker], and [Air cleaner clogging caution lamp flashes]. If we look from these three symptoms to find the causes, we find that there is a relationship with five causes. Let us explain here the method of using this causal relationship to pinpoint the most probable cause.

Legend

- : Possible causes (judging from Questions and check items)
- ◐ : Most probable causes (judging from Questions and Check Items)
- △ : Possible causes due to length of use (used for a long period)
- : Items to confirm the cause.

		Causes						
		Skewed turbocharger interference	Worn piston ring cylinder	Improper injector timing	Defective injector gmbly	Improper injector pump (excessive injection)	Crushed, clogged muffler	Defective injection pump (test, plunger seized)
Questions	Confirm recent repair history							
	Degree of use	Operated for long period	△					
	Color of exhaust gas	Suddenly became black	◐					
		Blue under light load	○					
	Engine oil must be added more frequently	○						
	Power was lost	Suddenly	○					
	Non-specified fuel has been used							
	Noise of interference is heard from around turbocharger	○						
	Blow-by gas is excessive		○					
	Engine pickup is poor and combustion is irregular	○						
Check items	When exhaust manifold is touched immediately after starting engine, temperature of some cylinders is low							
	Match marks on fuel injection pump are out of alignment			○				
	Seal on injection pump has come off			○				
	Clanging sound is heard from around cylinder head			○				
	Exhaust noise is abnormal	○						
	Muffler is crushed					○		
	Leakage of air between turbocharger and head, loose clamp							
Troubleshooting	When turbocharger is rotated by hand, it is found to be heavy	●						
	When air cleaner is inspected directly, it is found to be clogged	●						
	When compression pressure is measured, it is found to be low	●						
	Speed of some cylinders does not change when operating on reduced cylinders			●				
	Injection timing is found to be incorrect			●				
	Injection pump test shows that injection amount is incorrect				●			
	When valve clearance is checked directly it is found to be outside standard value				●			
	When muffler is removed, exhaust gas color returns to normal						●	
When control rack is pushed, it is found to be heavy or does not return							●	
	Remedy	Replace	Replace	Adjust	Adjust	Adjust	Replace	Replace

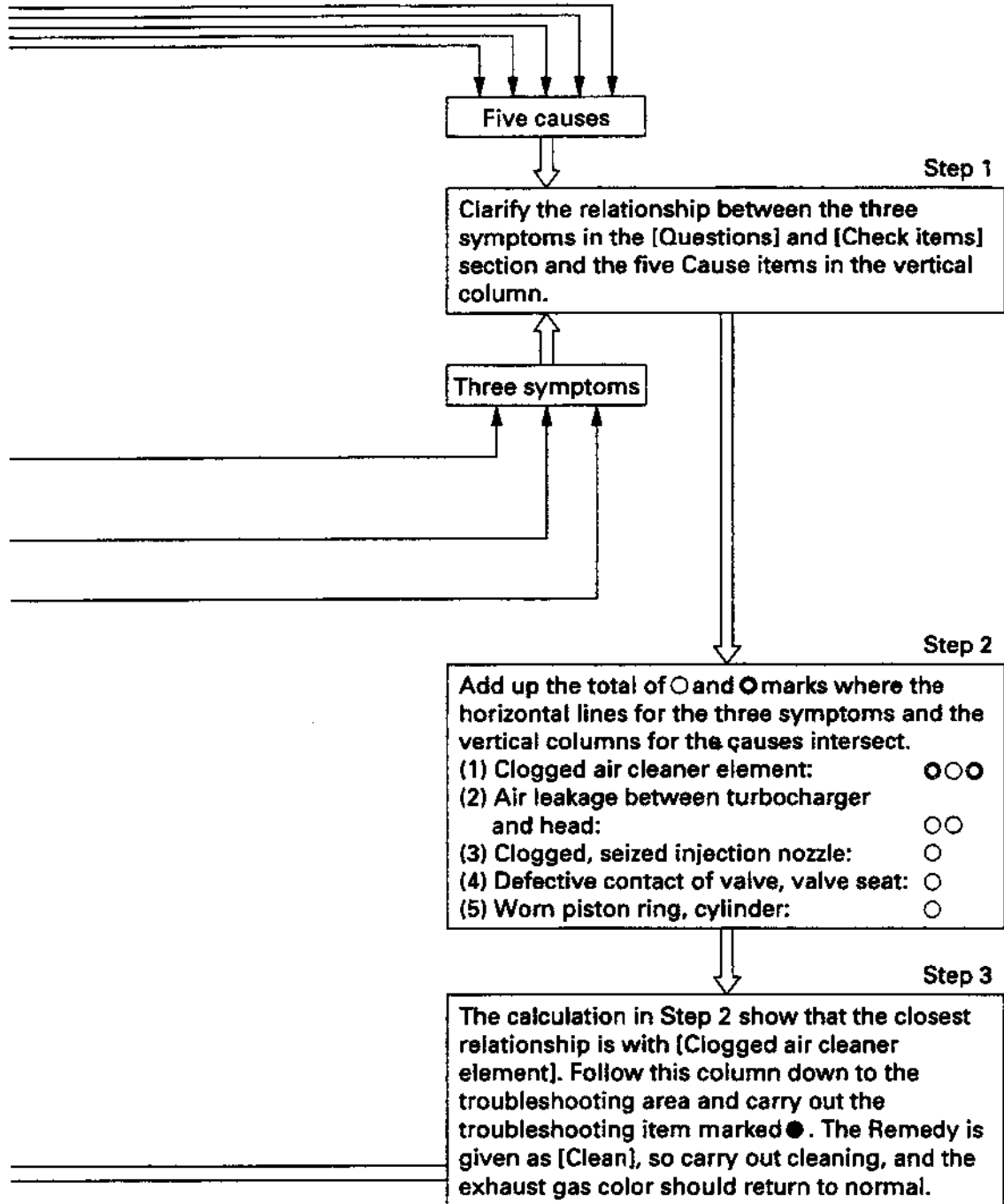

MEMORANDA

S-1 Starting performance is poor (starting always takes time)

- ★ Check that the monitor panel does not display any abnormality in the governor control system. General causes why exhaust smoke comes out but engine takes time to start.
 - Defective electrical system
 - Insufficient supply of fuel
 - Insufficient intake of air
 - Improper selection of fuel (At ambient temperature of 10°C or below, use ASTM D975 No. 1)
- ★ Battery charging rate

Charging rate					
	100%	90%	80%	75%	70%
Ambient temperature					
20°C	1.28	1.26	1.24	1.23	1.22
0°C	1.29	1.27	1.25	1.24	1.23
-10°C	1.30	1.28	1.26	1.25	1.24

- The specific gravity should exceed the value for the charging rate of 70% in the above table.
- In cold areas, the specific gravity must exceed the value for the charging rate of 75% in the above table.

Legend

- : Possible causes (judging from Questions and Check items)
- ⊕ : Most probable cause (judging from Questions and Check items)
- △ : Possible causes due to length of use (used for a long period)
- : Items to confirm the cause

Causes									
Worn piston ring, cylinder									
Defective contact of valve, valve seat									
Clogged air cleaner element									
Clogged fuel filter, strainer									
Clogged feed pump strainer									
Starting aid - Electrical intake air heater									
Defective alternator (including regulator)									
Defective or deteriorated battery									
Defective injection nozzle									
Defective injection timing									
Leakage, clogging, air in fuel piping									
Clogged air breather in fuel tank cap									

Questions	Degree of use of machine		Causes											
	Operated for long period	Gradually became worse	Worn piston ring, cylinder	Defective contact of valve, valve seat	Clogged air cleaner element	Clogged fuel filter, strainer	Clogged feed pump strainer	Starting aid - Electrical intake air heater	Defective alternator (including regulator)	Defective or deteriorated battery	Defective injection nozzle	Defective injection timing	Leakage, clogging, air in fuel piping	Clogged air breather in fuel tank cap
Confirm recent repair history														
Ease of starting	Operated for long period	Gradually became worse												
	Starts when warm													
Indicator lamp does not light up														
Engine oil must be added more frequently														
Replacement of filters has not been carried out according to Operation Manual														
Air cleaner clogging caution lamp flashes														
Non-specified fuel is being used														
Battery charge lamp is ON														
Starting motor cranks engine slowly														
When exhaust manifold is touched immediately after starting engine, temperature of some cylinders is low														
Engine does not pick up smoothly, and combustion is irregular														
Blow-by gas is excessive														
Match marks on fuel injection pump are out of alignment														
Mud is stuck to fuel tank cap														
When engine is cranked with starting motor														
1) Little fuel comes out even when injection pump sleeve nut is loosened														
2) Little fuel comes out even when fuel filter air bleed plug is loosened														
Leakage from fuel piping														
There is hunting from engine (rotation is irregular)														

Troubleshooting	Causes										Remedy			
	Worn piston ring, cylinder	Defective contact of valve, valve seat	Clogged air cleaner element	Clogged fuel filter, strainer	Clogged feed pump strainer	Starting aid - Electrical intake air heater	Defective alternator (including regulator)	Defective or deteriorated battery	Defective injection nozzle	Defective injection timing		Leakage, clogging, air in fuel piping	Clogged air breather in fuel tank cap	
When compression pressure is measured, it is low	●	●												
When air cleaner element is inspected, it is clogged			●											
When fuel filter, strainer are inspected, they are clogged				●										
When feed pump strainer is inspected, it is clogged					●									
Heater mount does not become warm						●								
Voltage between alternator terminal R and terminal E is not within 26 - 30V							●							
Either specific gravity of electrolyte or voltage of battery is low								●						
Speed does not change when operation of certain cylinders is stopped									●					
When check is made, injection timing is incorrect										●				
When control rack is pushed, it is found to be heavy or does not return (when blind cover at rear of pump is removed, it can be seen that plunger control sleeve does not move)											●			
When fuel cap is inspected directly, it is clogged												●		

X02CH031

S-2 Engine does not start

(1) Engine does not turn

General causes why engine does not turn

- Internal parts of engine seized
- ★ If internal parts of the engine are seized, carry out troubleshooting for "Engine stops during operation".
- Defective electrical system

		Causes							
		Defective or deteriorated battery	Defective starting motor	Broken ring gear	Defective safety relay or safety switch	Defective battery relay	Defective battery terminal connection	Defective starting switch	Defective wiring of starting circuit
Questions	Confirm recent repair history								
	Degree of use of machine	Operated for long period	△	△					
	Condition of horn when starting switch is turned ON	Horn sounds				○	○	◎	
		Horn does not sound or volume is low	◎						
	When starting switch is turned to START, pinion moves out, but	Makes grating noise		◎	◎				
		Soon disengages again		◎	◎				
		Makes rattling noise and does not turn						◎	
	When starting switch is turned to START, pinion does not move out						◎		
	When starting switch is turned to ON, there is no clicking sound					◎			◎
	Battery terminal is loose					◎			
When battery is checked, battery electrolyte is low	◎								
Troubleshooting	Specific gravity of electrolyte, voltage of battery is low	●							
	For the following conditions 1) - 4), turn the starting switch OFF, connect the cord and carry out troubleshooting at ON								
	1) When terminal B and terminal C of starting switch are connected, engine starts							●	
	2) When terminal B and terminal C of starting motor are connected, engine starts		●		●				
	3) When terminal B and terminal C of safety relay are connected, engine starts				●				
	4) There is not 24V between battery relay terminal M and terminal E					●			
When ring gear is inspected directly, tooth surface is chipped			●						
	Remedy	Replace	Replace	Replace	Replace	Replace	Replace	Replace	
									See E-8 mode ENGINE DOES NOT START
									See E-8 mode ENGINE DOES NOT START

X02CH032

(2) Engine turns but no exhaust smoke comes out (fuel is not being injected)

★ Check that the monitor panel does not display any abnormality in the governor control system.

General causes why engine turns but no exhaust smoke comes out

- Supply of fuel impossible
- Supply of fuel is extremely small
- Improper selection of fuel (particularly in winter)
- ★ For standard for fuel use, see FUEL, COOLANT and LUBRICANTS.

		Causes							
		Broken injection pump drive shaft, key	Defective injection pump (rack, plunger seized)	Seized, broken feed pump plston	Clogged fuel filter, strainer	Clogged feed pump strainer	Clogged, leaking fuel piping	Clogged air breather hole in fuel tank cap	Improper fuel used
Questions	Confirm recent repair history								
	Degree of use of machine	Operated for long period				△	△	△	
	Exhaust smoke suddenly stops coming out (when starting again)		◎	◎	◎				
	Replacement of filters has not been carried out according to Operation Manual				◎	◎			
	There is leakage from fuel piping						◎		
	Mud is stuck to fuel tank cap							◎	
	When fuel filter is drained, fuel does not come out								◎
	When engine is cranked with starting motor,								
Check items	1) Injection pump coupling does not turn		◎						
	2) No fuel comes out even when fuel filter air bleed plug is loosened		◎			○	○		○
	3) No fuel spurts out even when injection pipe sleeve nut is loosened		◎	◎	◎				
	Rust and water are found when fuel tank is drained					○	○		
Troubleshooting	Inspect injection pump directly		●						
	When control rack is pushed, it is heavy or does not return			●					
	Inspect feed pump directly				●				
	When fuel filter, strainer are inspected directly, they are clogged					●			●
	When feed pump strainer is inspected directly, it is clogged						●		
	When fuel cap is inspected directly, it is clogged							●	
	Remedy	Replace	Replace	Replace	Clean	Clean	Correct	Correct	Replace

X02CH033

(3) Exhaust smoke comes out but engine does not start (fuel is being injected)

General causes why exhaust smoke comes out but engine does not start

- Lack of rotating force due to defective electrical system
- Insufficient supply of fuel
- Insufficient intake of air
- Improper selection of fuel and oil

Causes										
Defective, broken valve system (valve, rocker lever, etc.)										
Defective injection pump (rack, plunger stuck)										
Worn piston ring, cylinder liner										
Clogged fuel filter, strainer										
Clogged feed pump strainer										
Clogged air cleaner element										
Electrical intake air heater - starting aid										
Defective or deteriorated battery										
Leakage, clogging, air in fuel system										
Clogged injection nozzle, defective spray										
Clogged air breather hole in fuel tank cap										
Improper fuel used										

Legend

- : Possible causes (judging from Questions and Check items)
- ⊙ : Most probable cause (judging from Questions and Check items)
- △ : Possible causes due to length of use (used for a long period)
- : Items to confirm the cause

		Causes													
		1	2	3	4	5	6	7	8	9	10	11			
Questions	Confirm recent repair history														
	Degree of use of machine														
	Operated for long period														
	Suddenly failed to start														
	When engine is cranked, abnormal noise is heard from around head														
	Engine oil must be added more frequently														
	Non-specified fuel is being used														
	Replacement of filters has not been carried out according to Operation Manual														
	Rust and water are found when fuel tank is drained														
	Air cleaner clogging caution lamp flashes														
Check items	Preheating indicator lamp does not light up														
	Starting motor cranks engine slowly														
	Mud is stuck to fuel tank cap														
	When fuel lever is placed at FULL position, it does not contact stopper														
	When engine is cranked with starting motor,														
	1) Little fuel comes out even when injection pump sleeve nut is loosened														
	2) No fuel comes out even when fuel filter air bleed plug is loosened														
	There is leakage from fuel piping														
	When exhaust manifold is touched immediately after starting engine, temperature of some cylinders is low														
	When fuel filter is drained, no fuel comes out														

		Causes													
		1	2	3	4	5	6	7	8	9	10	11			
Troubleshooting	Remove head cover and check directly														
	When control rack is pushed, it is heavy or does not return														
	When compression pressure is measured, it is low														
	When fuel filter, strainer are inspected directly, they are clogged														
	When feed pump strainer is inspected directly, it is clogged														
	When air cleaner element is inspected directly, it is clogged														
	Heater mount does not become warm														
	Either specific gravity of electrolyte or voltage of battery is low														
	When feed pump is operated, operation is too light or too heavy														
	When injection nozzle is tested independently, spray condition is poor														
	When fuel cap is inspected directly, it is clogged														
	Remedy	Replace	Replace	Replace	Clean	Clean	Clean	Replace	Replace	Correct	Clean	Clean	Replace		

X02CH034

S-3 Engine does not pick up smoothly (follow-up is poor)

★ Check that the monitor panel does not display any abnormality in the governor control system

General causes why engine does not pick up smoothly

- Insufficient intake of air
- Insufficient supply of fuel
- Improper condition of fuel injection
- Improper fuel used

		Causes										
		1	2	3	4	5	6	7	8	9	10	
Questions	Confirm recent repair history											
	Degree of use of machine	Operated for long period	△	△	△			△			△	
	Replacement of filters has not been carried out according to Operation Manual		⊙	⊙	⊙							
	Non-specified fuel is being used		⊙	⊙	⊙	⊙						
	Engine oil must be added more frequently						⊙					
	Rust and water are found when fuel tank is drained		⊙									
	Air cleaner clogging caution lamp flashes		⊙									
	Noises of interference is heard from around turbocharger							⊙				
	Engine pick-up suddenly became poor				○		⊙		○	○		
	Color of exhaust gas	Blue under light load					⊙					
		Black	⊙		⊙		⊙				○	
	Check items	Clanging sound is heard from around cylinder head							⊙			
		Mud is stuck to fuel tank cap								⊙		
		There is leakage from fuel piping									⊙	
High idling speed under no load is normal, but speed suddenly drops when load is applied			⊙	⊙								
There is hunting from engine (rotation is irregular)			○	⊙	○				○			
When exhaust manifold is touched immediately after starting engine, temperature of some cylinders is low					⊙	○						
Blow-by gas is excessive							⊙					
Troubleshooting		When air cleaner element is inspected directly, it is clogged	●									
		When fuel filter, strainer are inspected, they are clogged		●								
		When feed pump strainer is inspected directly, it is clogged			●							
	Speed does not change when operation of certain cylinders is stopped				●							
	When control rack is pushed, it is heavy or does not return					●						
	When compression pressure is measured, it is low						●			●		
	When turbocharger is rotated by hand, it is heavy							●				
	When valve clearance is checked, it is outside standard value								●			
	When fuel cap is inspected directly, it is clogged									●		
	When feed pump is operated, operation is too light or too heavy									●		
	Remedy	Clean	Clean	Clean	Correct	Replace	Replace	Replace	Adjust	Clean	Correct	Replace

X02CH035

S-5 Engine does not rotate smoothly (hunting)

★ Check that the monitor panel does not display any abnormality in the governor control system

General causes why engine does not rotate smoothly

- air in fuel system
- Defective governor mechanism
- Defective electric governor mechanism

★ If hunting does not occur when the rod between the governor motor and the injection pump is disconnected, troubleshoot by using the electrical system troubleshooting (E Mode)

Causes	
Defective operation of governor	
Defective adjustment of governor	
Defective operation of control rack	
Low idling speed is too low	
Clogged feed pump strainer	
Clogged fuel filter, strainer	
Clogged, air in circuit between fuel tank and feed pump	
Clogged, air in circuit between feed pump and nozzle	
Clogged air breather hole in fuel tank cap	

Legend

- : Possible causes (judging from Questions and Check items)
- ⊙ : Most probable cause (judging from Questions and Check items)
- △ : Possible causes due to length of use (used for a long period)
- : Items to confirm the cause

Questions	Confirm recent repair history										
	Degree of use of machine	Operated for long period					△	△			
	Condition of hunting	Occurs at a certain speed range	⊙	⊙	⊙	○					
		Occurs at low idling	○			⊙	○	○	○	○	
		Occurs even when speed is raised	○	○	○						○
Replacement of filters has not been carried out according to Operation Manual						⊙	⊙				
Rust and water are found when fuel tank is drained						○	○				
Check items	Leakage from fuel piping							⊙	⊙		
	When feed pump is operated										
	1) No response, light, return is quick							⊙	⊙		
	2) No response, light, return is normal							⊙			
	Engine speed rises too far		⊙	⊙							
	Engine is sometimes difficult to stop		⊙		⊙						
	Seal on injection pump has come off			⊙		⊙					
Troubleshooting	When governor lever is moved it is stiff		●		●						
	When injection pump is tested, governor is improperly adjusted			●							
	When control rack is pushed, it is heavy or does not return				●						
	When fuel cap is inspected directly, it is clogged					●				●	
	When feed pump strainer is inspected, it is clogged						●				
	When fuel filter, strainer are inspected, they are clogged							●			
Remedy		Adjust	Adjust	Adjust	Adjust	Clean	Clean	Correct	Correct	Clean	

X02CH037

S-6 Engine lacks output (no power)

★ Check that the monitor panel does not display any abnormality in the governor control system. Measure the engine speed and judge if the cause is in the engine or in the chassis.

General causes why engine lacks output

- Insufficient intake or air
- Insufficient supply of fuel
- Improper condition of fuel injection
- Improper fuel used (if non-specified fuel is used, output drops)
- Lack of output due to overheating
- ★ If there is overheating and insufficient output, carry out troubleshooting for overheating.

Causes											
Clogged air cleaner element	Seized turbocharger, interference	Worn piston ring, cylinder liner	Clogged fuel filter, strainer	Clogged feed pump strainer	Clogged injection nozzle, defective spray	Improper injection pump plunger	Defective valve clearance	Bent fuel control linkage and valve seal	Clogged, leaking fuel piping	Clogged air breather hole in fuel tank cap	Overheating

Legend

- : Possible causes (judging from Questions and Check items)
- ⊙ : Most probable cause (judging from Questions and Check items)
- △ : Possible causes due to length of use (used for a long period)
- : Items to confirm the cause

	Questions	Causes																				
		1	2	3	4	5	6	7	8	9	10	11										
	Confirm recent repair history																					
	Degree of use of machine	Operated for long period	△		△	△	△							△								
	Power was lost	Suddenly			⊙																	⊙
		Gradually			○	○	○	○	○					○								
	Engine oil must be added more frequently							⊙														
	Replacement of filters has not been carried out according to Operation Manual							⊙		⊙	⊙											
	Non-specified fuel is being used									⊙	⊙	⊙	⊙									
	Air cleaner clogging caution lamp flashes							⊙														
	Color of exhaust gas	Black						⊙	⊙													
		Blue under light load								⊙												
	Noise of interference is heard from around turbocharger							⊙														
	Blow-by gas is excessive								⊙													
	Engine pickup is poor and combustion is irregular							⊙					⊙						○	○		
	High idling speed under no load is normal, but speed suddenly drops when load is applied											⊙	⊙									○
	When exhaust manifold is touched immediately after starting engine, temperature of some cylinders is low													⊙	○							
	There is hunting from engine (rotation is irregular)											○	○							○	○	
	Clanging sound is heard from around cylinder head																					⊙
	High idling speed of engine is low													○						⊙		
	Leakage from fuel piping																					⊙
	Coolant temperature gauge is in red range																					⊙

	Troubleshooting	Causes																				
		1	2	3	4	5	6	7	8	9	10	11										
	When air cleaner element is inspected, it is clogged																					●
	When turbocharger is rotated by hand, it is heavy																					●
	When compression is measured, it is low																					●
	When fuel filter, strainer are inspected, they are clogged																					●
	When feed pump strainer is inspected, it is clogged																					●
	Speed does not change when operation of certain cylinders is stopped																					●
	When control rack is pushed, it is heavy or does not return																					●
	When valve clearance is checked, it is outside standard value																					●
	When lever is placed at FULL position, it does not contact stopper																					●
	When feed pump is operated, operation is too light or too heavy																					●
	When fuel cap is inspected, it is clogged																					●
	Remedy	Clean	Replace	Replace	Clean	Clean	Correct	Replace	Adjust	Replace	Adjust	Correct	Clean	—								

XQ2CH038

S-7 Exhaust smoke is black (incomplete combustion)

General causes why exhaust smoke is black

- Insufficient intake of air
- Improper condition of fuel injection
- Excessive injection of fuel

Causes	
Seized turbocharger, interference	
Clogged air cleaner element	
Worn piston ring, cylinder liner	
Clogged injection nozzle, defective spray	
Improper injection timing	
Defective injection pump	
Improper valve clearance (excessive injection)	
Crushed, clogged muffler	
Leakage of air between turbocharger and head	
Defective contact of valve and valve seat	
Defective injection pump (rack, plunger seized)	

Legend

- : Possible causes (judging from Questions and Check items)
- ⊙ : Most probable cause (judging from Questions and Check items)
- △ : Possible causes due to length of use (used for a long period)
- : Items to confirm the cause

		Seized turbocharger, interference	Clogged air cleaner element	Worn piston ring, cylinder liner	Clogged injection nozzle, defective spray	Improper injection timing	Defective injection pump	Improper valve clearance (excessive injection)	Crushed, clogged muffler	Leakage of air between turbocharger and head	Defective contact of valve and valve seat	Defective injection pump (rack, plunger seized)	
Questions	Confirm recent repair history												
	Degree of use of machine		△	△	△							△	
	Color of exhaust gas	Suddenly became black	⊙										○
		Gradually became black		⊙							○		
		Blue under light load			⊙								
	Engine oil must be added more frequently			⊙									
	Power was lost	Suddenly	⊙			○			○				○
		Gradually		○	○					○	○		
	Non-specified fuel being used				○							○	
	Noise of interference is heard from around turbocharger	⊙											
	Air cleaner clogging caution lamp flashes		⊙										
	Blow-by gas is excessive			⊙									
	Engine pickup is poor and combustion is irregular	○			⊙			○	○	○		○	
	Check items	When exhaust manifold is touched immediately after starting engine, temperature of some cylinders is low				⊙							○
		Match marks on fuel injection pump are out of alignment					⊙						
Seal on injection pump has come off							⊙						
Clanging sound is heard from around cylinder head								⊙					
Exhaust noise is abnormal		○			○				⊙				
Muffler is crushed									⊙				
Leakage of air between turbocharger and head, loose clamp										⊙			
Troubleshooting	When turbocharger is rotated by hand, it is heavy		●										
	When air cleaner is inspected, it is clogged		●										
	When compression pressure is measured, it is low			●								●	
	Speed does not change when operation of certain cylinders is stopped				●								
	When check is made, injection timing is incorrect					●							
	Injection pump test shows that injection amount is incorrect						●						
	When valve clearance is checked, it is outside standard value							●					
	When muffler is removed, exhaust color returns to normal								●				
	When control rack is pushed, it is heavy or does not return											●	
Remedy	Replace	Clean	Replace	Replace	Adjust	Adjust	Adjust	Replace	Correct	Replace	Replace		

X02CH039

S-8 Oil consumption is excessive (or exhaust smoke is blue)

★ Do not run the engine at idling for more than 20 minutes continuously. (Both low and high idling)

General causes why oil consumption is excessive

- Abnormal combustion of oil
- External leakage of oil
- Wear of lubrication system

		Causes												
		Broken piston ring	Worn piston ring, cylinder liner	Clogged breather or breather hose	Leakage from oil filter or oil cooler	Leakage from oil piping	Leakage from oil drain plug	Broken oil pan or cylinder head	Worn oil cooler	Worn seal at turbine end - Turbocharger	Worn seal at blower end - Turbocharger	Worn, broken rear seal, seal surface	Dust sucked in from intake system	Worn valve (stem, guide), broken seal
Questions	Confirm recent repair history													
	Degree of use of machine	Operated for long period		△						△	△			△
	Oil consumption suddenly increased		⊙						○					
	Engine oil must be added more frequently								○					
	Engine oil becomes contaminated quickly		○	⊙	○									
	Exhaust smoke is blue under light load		⊙	⊙										
	Amount of blow-by gas	Excessive	⊙	⊙							○			○
		None			⊙									
	Area around engine is dirty with oil			⊙	⊙	⊙	⊙							
	There is oil in engine coolant								⊙					
When exhaust pipe is removed, it is dirty with oil									⊙				○	
When turbocharger air supply pipe is removed, it is dirty with oil										⊙				
Oil level in PTO chamber rises											⊙			
Clamps for intake system are loose												⊙		
Troubleshooting	When compression pressure is measured, it is low	●	●											
	When breather element is inspected, it is clogged with dirty oil			●										
	There is external leakage of oil from engine				●	●	●	●						
	Pressure-tightness test of oil cooler shows leakage								●					
	Excessive play of turbocharger shaft									●	●			
	Inspect rear seal											●		
	When intake manifold is removed, dust is found inside												●	
	When intake manifold is removed, inside is dirty with oil													●
Remedy	Replace	Replace	Clean	Correct	Correct	Correct	Correct	Replace	Replace	Replace	Correct	Correct	Correct	

X02CH040

S-9 Oil becomes contaminated quickly

General causes why oil becomes contaminated quickly

- Intake of exhaust gas due to internal wear
- Clogging of lubrication passage
- Improper fuel
- Improper oil used
- Operation under excessive load

Causes	
Worn piston ring, cylinder liner	
Clogged breather, breather hose	
Clogged oil filter	
Worn valve, valve guide	
Clogged oil cooler	
Clogged turbocharger drain pipe	
Defective seal at turbocharger turbine end	
Defective safety valve	
Exhaust smoke is black	

Legend

- : Possible causes (judging from Questions and Check items)
- ⊙ : Most probable cause (judging from Questions and Check items)
- △ : Possible causes due to length of use (used for a long period)
- : Items to confirm the cause

		Worn piston ring, cylinder liner	Clogged breather, breather hose	Clogged oil filter	Worn valve, valve guide	Clogged oil cooler	Clogged turbocharger drain pipe	Defective seal at turbocharger turbine end	Defective safety valve	Exhaust smoke is black	
Questions	Confirm recent repair history										
	Degree of use of machine	Operated for long period	△					△			
	Engine oil must be added more frequently		⊙								
	Non-specified oil is being used			○							
	Color of exhaust gas	Blue under light load		⊙							
		Black									⊙
	Amount of blow-by gas	Excessive		⊙		○		○	○		
		None			⊙						
Check items	When oil filter is inspected, metal particles are found		○	⊙	○						
	When exhaust pipe is removed, inside is dirty with oil				⊙						
	Engine oil temperature rises quickly					⊙					
Troubleshooting	When compression pressure is measured, it is low		●			●					
	When breather element is inspected, the hose is broken or it is clogged with dirty oil		●								
	When oil filter is inspected, it is clogged			●							
	When oil cooler is inspected, it is clogged					●					
	Turbocharger drain tube is clogged						●				
	Excessive play of turbocharger shaft							●			
	When safety valve is inspected, spring is catching or broken								●		
Remedy		Replace	Clean	Replace	Replace	Clean	Clean	Replace	Replace	—	

Carry out troubleshooting for "Exhaust smoke is black"

X02CH041

S-10 Fuel consumption is excessive

General causes why fuel consumption is excessive

- Leakage of fuel
- Improper condition of fuel injection
- Excessive injection of fuel

Legend

- : Possible causes (judging from Questions and Check items)
- ⊙ : Most probable cause (judging from Questions and Check items)
- △ : Possible causes due to length of use (used for a long period)
- : Items to confirm the cause

Causes							
Defective injection pump (excessive injection)							
Defective nozzle holder spray							
Defective injection pump plunger							
External leakage from fuel piping							
Leakage of fuel inside head cover							
Defective oil seal inside feed pump							
Defective adjustment of fuel control linkage							

Questions	Confirm recent repair history									
	Degree of use of machine	Operated for long period		△	△					△
Condition of fuel consumption	More than for other machines of same model		⊙		○					
	Gradually increased			○	○					
	Suddenly increased						○	○		
Exhaust smoke color	Black		⊙	○		○				○
	White							○		
Check items	Seal on injection pump has come off		⊙							
	There is irregular combustion			⊙						
	When exhaust manifold is touched immediately after starting engine, temperature of some cylinders is low			⊙	○					
	Match mark on injection pump is misaligned					⊙				
	There is external leakage of fuel from engine						⊙			
	Engine oil level rises and smells of diesel fuel		○					⊙	⊙	
	Engine low idling speed is high		○							⊙

Troubleshooting	Remedy							
	Injection pump measurement shows that injection amount is excessive	●						
	Speed does not change when operation of certain cylinders is stopped		●					
	When control rack is pushed, it is heavy or does not return			●				
	When check is made, injection timing is incorrect				●			
	Remove head cover and inspect						●	
	Remove feed pump and inspect							●
When engine speed is measured, low idling speed is too high							●	

X02CH042

S-12 Oil pressure caution lamp lights up (drop in oil pressure)

- ★ Check that the monitor panel engine oil level lamp is not lighted up.
- ★ When the oil pressure sensor is normal (See M mode).

General causes why oil pressure lamp lights up

- Leakage, clogging, wear of lubrication system
- Defective oil pressure control
- Improper oil used (improper viscosity)
- Deterioration of oil due to overheating
- ★ For standard of engine oil selection, see FUEL, COOLANT AND LUBRICANTS.

		Causes											
		Clogged oil filter	Worn bearing, journal	Clogged strainer inside oil pan	Clogged, broken oil pipe inside oil pan	Broken suction pipe inside oil pan	Defective oil pump	Defective regulator valve	Defective main relief valve	Leaking, crushed hydraulic piping	Defective oil pressure sensor	Coolant, fuel in oil	
Questions	Confirm recent repair history												
	Degree of use of machine		△					△					
	Operated for long period		△										
	Replacement of filters has not been carried out according to Operation Manual	◎											
	Non-specified oil is being used	○	○										
	Check items	Condition when oil pressure lamp lights up	Lights up at low idling		◎					○			
			Lights up at low and high idling			◎	◎	◎	◎	○	○		
			Sometimes lights up							◎	◎	○	
		There is clogging, leakage from hydraulic piping (external)								◎			
		Metal particles are found when oil is drained		◎									
	Metal particles are stuck to oil filter element		◎			○							
	Oil is cloudy white or smells of diesel fuel										◎		
Troubleshooting	When oil filter is inspected, it is clogged		●	●									
	Remove oil pan and inspect			●	●	●							
	Oil pump rotation is heavy or there is play						●						
	There is catching of relief valve or regulator valve, spring or valve guide is broken							●	●				
	When oil pressure is measured, it is within standard value										●		
	Remedy	Clean	Clean	Clean	Clean	Correct	Replace	Adjust	Adjust	Correct	Replace	—	

Carry out troubleshooting for "Oil level (low)"

S-13 Oil level rises (coolant, fuel in oil)

★ If there is oil in the coolant, carry out troubleshooting for "Oil is in coolant".

General causes why oil level rises

- Coolant in oil
- Fuel in oil (Diluted, and smells of diesel fuel)
- Entry of oil from other components

		Causes											
		Broken oil cooler core, O-ring	Defective nozzle holder sleeve	Broken cylinder head, head gasket (precombustion chamber)	Clogged water pump breather hole, defective seal	Worn, damaged rear seal surface	Defective main pump seal	Leakage of fuel inside head cover	Defective part inside injection pump	Defective thermostat seal portion (flange type)	Damaged liner O-ring, holes made by pitting	Defective thermostat seat	Cracks inside cylinder block

- Legend
- : Possible causes (judging from Questions and Check items)
 - ◎ : Most probable cause (judging from Questions and Check items)
 - △ : Possible causes due to length of use (used for a long period)
 - : Items to confirm the cause

Questions	Confirm recent repair history												
	Degree of use of machine	Operated for long period											
	When engine is first started, drops of water come from muffler			◎	○								
	Exhaust smoke is white			◎				○		○	○		
	There is oil in radiator coolant		◎	○	○						○	○	
Check items	Leave radiator cap open. When engine is run at idling, an abnormal number of bubbles appear, or coolant spurts back				◎						○		
	Water pump breather hole is clogged with mud					◎							
	When water pump breather hole is cleaned, water comes out					◎							
	Oil level goes down in damper chamber						◎						
	Oil level goes down in hydraulic tank							◎					
	Engine oil smells of diesel fuel								◎	◎	◎		
	Fuel must be added more frequently								◎	◎	◎		

Troubleshooting	Pressure-tightness test of oil cooler shows there is leakage											●
	Pressure-tightness test of cylinder head shows there is leakage											●
	When compression pressure is measured, it is low											●
	Remove water pump and inspect											●
	Remove wear seal and inspect											●
	When main pump is removed, seal is found to be damaged											●
	Remove head cover and inspect											●
	Remove injection pump and inspect											●
	Defective contact of thermostat seal valve											●
	Remove oil pan and check											●
	Remedy		Replace	Replace	Replace	Replace	Correct	Replace	Correct	Replace	Replace	Replace

X02CH045

S-14 Coolant temperature becomes too high (overheating)

- ★ Check that the monitor panel coolant level caution lamp is not lit.
- ★ When the monitor panel coolant temperature gauge is normal, go to troubleshooting of machine monitor system (M mode).

General causes why coolant temperature becomes too high

- Lack of cooling air (deformation, damage of fan)
- Drop in heat dissipation efficiency
- Defective cooling circulation system
- ★ Carry out troubleshooting for chassis

Causes	
Broken water pump	
Clogged, crushed radiator fins	
Clogged radiator core	
Defective thermostat (does not open)	
Defective coolant temperature gauge	
Fan belt slipping, worn fan pulley	
Clogged, broken oil cooler	
Defective radiator pressure valve	
Broken head, head gasket	
Damaged liner O-ring, holes made by pitting	
External leakage from coolant piping	

Legend

- : Possible causes (judging from Questions and Check items)
- ⊙ : Most probable cause (judging from Questions and Check items)
- △ : Possible causes due to length of use (used for a long period)
- : Items to confirm the cause

Questions		Causes																				
Confirm recent repair history																						
Degree of use of machine		Operated for long period				△	△															
Condition of overheating		Suddenly overheated				⊙				○												
		Always tends to overheat				⊙	⊙	○		○												
Coolant temperature gauge		Rises quickly						⊙														
		Does not go down								⊙												
Check items		Fan belt whines under sudden load								⊙												
		Cloudy white oil is floating on coolant										⊙										
		Coolant flows out from overflow hose												⊙								
		Excessive air bubbles inside radiator, coolant spurts back													⊙							
		Engine oil level has risen, oil is cloudy white										○								⊙		
		There is play when fan pulley is rotated						⊙														
		Radiator shroud, inside of underground are clogged with dirt or mud						⊙														
		When light bulb is held behind radiator, no light passes through						⊙														
		Coolant is leaking because of cracks in hose or loose clamps																				⊙
		When belt tension is inspected, it is loose										⊙										
Troubleshooting		Temperature difference between top and bottom radiator tanks is excessive																		●		
		Temperature difference between top and bottom radiator tanks is slight																			●	
		When coolant filler port is inspected, core is clogged																			●	
		When function test is carried out on thermostat, it does not open even at cracking temperature																			●	
		When coolant temperature is measured, it is normal																			●	
		When oil cooler is inspected, it is clogged																			●	
		When measurement is made with radiator cap tester, set pressure is low																			●	
		When compression pressure is measured, it is low																			●	
		Remove oil pan and inspect																			●	
Remedy																						
		Replace	Correct	Correct	Replace	Replace	Correct	Replace	Replace	Replace	Replace	Replace	Replace	Correct, replace								

X02CH046

S-15 Abnormal noise is made

- ★ Judge if the noise is an internal noise or an external noise
- General causes why abnormal noise is made
 - Abnormality due to defective parts
 - Abnormal combustion
 - Air sucked in from intake system

Legend

- : Possible causes (judging from Questions and Check items)
- ⊙ : Most probable cause (judging from Questions and Check items)
- △ : Possible causes due to length of use (used for a long period)
- : Items to confirm the cause

		Causes											
		Excessive wear of piston ring, cylinder liner	Seized turbocharger, interference	Missing, seized bushing	Clogged, seized injection nozzle	Defective injection pump (rack, plunger seized)	Deformed fan, fan belt interference	Defective adjustment of valve clearance	Broken dynamic valve system	Improper gear train backlash (valve, rocker lever, etc.)	Leakage of air between turbocharger and head	Defect inside muffler (dividing board out of position)	
Questions	Confirm recent repair history												
	Degree of use of machine	Operated for long period	△										
	Condition of abnormal noise	Gradually occurred	○				○						
		Suddenly occurred		○	○				○				
	Non-specified fuel is being used				○	○							
	Engine oil must be added more frequently		⊙										
	Color of exhaust gas	Blue under light load	⊙					○			○		
		Black		⊙									
	Metal particles are found in oil filter		⊙		⊙								
	Blow-by gas is excessive		⊙										
Noise of interference is heard from around turbocharger			⊙										
Check items	Engine pickup is poor and combustion is abnormal				⊙								
	When exhaust manifold is touched immediately after starting engine, temperature of some cylinders is low				⊙	○							
	Seal on injection pump has come off						⊙						
	Abnormal noise is loud when accelerating engine				○	○	○	○	○	○			
	Clanging sound is heard from around cylinder head							⊙	⊙				
	Leakage of air between turbocharger and head, loose clamp										⊙		
	Vibrating noise is heard from around muffler											⊙	
	Troubleshooting	When compression pressure is measured, it is low		●									
		When turbocharger is rotated by hand, it is heavy			●								
		Remove gear cover and inspect				●					●		
Speed does not change when operation of certain cylinders is stopped					●								
When control rack is pushed, it is heavy or does not return						●							
Injection pump test shows that injection amount is incorrect						●							
Fan is deformed, belt is loose							●						
When valve clearance is checked, it is outside standard value								●					
Remove cylinder head cover and inspect									●				
When muffler is removed, abnormal noise disappears											●		
Remedy		Replace	Replace	Replace	Replace	Correct	Replace	Correct	Replace	Correct	Replace	Replace	

S-16 Vibration is excessive

★ If there is abnormal noise together with the vibration, carry out troubleshooting for “Abnormal noise is made”.

General causes why vibration is excessive

- Defective parts (abnormal wear, breakage)
- Improper alignment
- Abnormal combustion

Causes	
Worn connecting rod, main bearing	
Worn balancer, cam bushing	
Loose engine mounting bolts, broken cushion	
Broken part inside output shaft (damper)	
Improper gear train backlash	
Defective dynamic valve system (valve, rocker lever, etc.)	
Defective injection pump (excessive injection)	

Legend

- : Possible causes (judging from Questions and Check items)
- ⊙ : Most probable cause (judging from Questions and Check items)
- △ : Possible causes due to length of use (used for a long period)
- : Items to confirm the cause

Questions									
	Confirm recent repair history								
Degree of use of machine	Operated for long period		△	△	△				
Condition of vibration	Suddenly increased					○		○	
	Gradually increased		○	○	○				
Check items	Non-specified oil being used		⊙	○					
	Metal particles are found in oil filter		⊙	⊙					
	Metal particles are found when oil is drained		⊙	⊙					
	Oil pressure is low at low idling		○	○					
	Vibration occurs at mid-range speed				○	○			
	Vibration follows engine speed				○	○	○		
	Exhaust smoke is black							⊙	○
	Seal on injection pump has come off								⊙

Troubleshooting										
	Remove oil pan and inspect		●							
	Remove side cover and inspect			●						
	Inspect for loose engine mouting bolts and broken cushions				●					
	Inspect inside of output shaft (damper)					●				
	Remove front cover and inspect						●			
	Remove head cover and inspect							●		
Injection pump test shows that injection amount is incorrect								●		

Remedy									
Replace									
Replace									
Replace									
Replace									
Correct									
Replace									
Adjust									

X02CH048

TROUBLESHOOTING OF ENGINE THROTTLE • PUMP CONTROLLER (PUMP CONTROL SYSTEM) (C-MODE)

POINTS TO REMEMBER WHEN TROUBLESHOOTING PUMP CONTROLLER SYSTEM

1. Points to remember if abnormality returns to normal by itself
In the following case, there is a high probability that the same problem will occur again, so it is desirable to follow up this problem carefully.
 - a. If any abnormality returns to normal by itself, or
 - b. If the connector is disconnected and the T-adapter is inserted, or if the T-adapter is removed and the connector is returned to its original position when carrying out troubleshooting of the failure, and the service code is no longer displayed, or if the monitor display returns to normal.
 - c. After completing troubleshooting, always erase the user code from memory.

2. User code memory retention function
When displaying the abnormality code in memory and carrying out troubleshooting, note down the content of the display, then erase the display. After trying to re-enact the problem, carry out troubleshooting according to the failure code that is displayed.
(There are cases where mistaken operation or abnormalities that occur when the connector is disconnected are recorded by the memory retention function. Erasing the data in this way saves any wasted work).

ACTION TAKEN BY CONTROLLER WHEN ABNORMALITY OCCURS AND PROBLEMS ON MACHINE

User code	Service code	Abnormal system	Nature of abnormality
E02	E232	Short circuit in pump PC solenoid system	<ol style="list-style-type: none"> 1. Short circuit with ground, short circuit inside front pump PC solenoid 2. Short circuit with power source, short circuit with ground in wiring harness between controller C02 (8) and PC solenoid C13 (1) ((+ side) 3. Short circuit with power source in wiring harness between controller C02 (18) and PC solenoid C13 (2) ((- side) 4. Defective engine throttle • pump controller
	E233	Disconnection in pump PC solenoid system	<ol style="list-style-type: none"> 1. Disconnection, defective contact inside front pump PC solenoid 2. Disconnection, defective contact in wiring harness between controller C02 (8) and PC solenoid C13 (1) ((+ side) 3. Disconnection, defective contact, short circuit with ground in wiring harness between controller C02 (18) and PC solenoid C13 (2) ((- side) 4. Defective engine throttle • pump controller
E03	E203	Short circuit in swing holding brake solenoid system	<ol style="list-style-type: none"> 1. Short circuit with ground, short circuit inside swing holding brake solenoid 2. Short circuit with ground in wiring harness between controller C01 (3) and solenoid V04 (2) ((+ side) 3. Defective engine throttle • pump controller
	E213	Disconnection in swing holding brake solenoid system	<ol style="list-style-type: none"> 1. Disconnection, defective contact inside swing holding brake solenoid 2. Disconnection, defective contact, short circuit with power source in wiring harness between controller C01 (3) and solenoid V04 (2) ((+ side) 3. Disconnection, defective contact in wiring harness between solenoid V04 (1) and chassis ground((- side) 4. Defective engine throttle • pump controller

Condition when normal (voltage, current, resistance)	Action by controller when abnormality is detected	Problem that appears on machine when there is abnormality
<ul style="list-style-type: none"> Resistance of solenoid: 7 - 14 Ω 	<ol style="list-style-type: none"> Makes output to solenoid 0. Displays user code E02 on monitor panel. <p>★ If the abnormality is restored by the vibration of the machine, it resets the power source to restore to the proper condition. (However, the service code display does not go out).</p>	<ol style="list-style-type: none"> No current flows to the pump EPC solenoid. Therefore, when the load is large, there is a big drop in the engine speed which may result in the engine stalling.
<ul style="list-style-type: none"> Resistance of solenoid; 7 - 14 Ω Current: 1000mA (H/O mode, auto-deceleration ON, levers at neutral, fuel control dial at MAX.) 	<ol style="list-style-type: none"> The current stops flowing to the solenoid, so no particular action is taken. If there is a short circuit with the ground at the (-) end, the current (min. 1A) continues to flow to the solenoid. It displays user code E02 on the monitor panel. <p>★ If the abnormality is restored by the vibration of the machine, it resets the power source to restore to the proper condition. (However, the service code display does not go out.)</p>	<ol style="list-style-type: none"> In the case of 1, it is the same as E232. In the case of 2, the current (min. 1A) continues to flow to the front pump PC solenoid, so the output of the front pump PC valve increases and the overall speed becomes slower.
<ul style="list-style-type: none"> Resistance of solenoid: 20 - 60 Ω 	<ol style="list-style-type: none"> Makes output to PC solenoid 0. Displays user code E03 on monitor panel. <p>★ If the abnormality is restored by the vibration of the machine, it resets the power source to restore to the proper condition. (However, the service code display does not go out.)</p>	<p>When the swing is operated, the motor brake is not released, so the upper structure does not swing.</p>
<ul style="list-style-type: none"> Resistance of solenoid: 20 - 60 Ω 	<ol style="list-style-type: none"> The current stops flowing to the PC solenoid, so no particular action is taken. It displays user code E02 on the monitor panel. <p>★ If the abnormality is restored by the vibration of the machine, it resets the power source to restore to the proper condition. (However, the service code display does not go out.)</p>	<p>Same as display E203.</p>

User code	Service code	Abnormal system	Nature of abnormality
-	E204	Short circuit in pump merge/divider solenoid system	<ol style="list-style-type: none"> 1. Short circuit with ground, short circuit inside pump merge/divider solenoid. 2. Short circuit with ground in wiring harness between controller C01 (2) and solenoid V03 (2) ((+) side) 3. Defective engine throttle • pump controller
-	E205	Short circuit in 2-stage relief solenoid system	<ol style="list-style-type: none"> 1. Short circuit with ground, short circuit inside 2-stage relief solenoid. 2. Short circuit with ground in wiring harness between controller C01 (1) and solenoid V05 (2) ((+) side) 3. Defective engine throttle • pump controller
-	E206	Short circuit in travel speed solenoid system	<ol style="list-style-type: none"> 1. Short circuit with ground in wiring harness between controller C01 (9) and solenoid V06 ((+) side) 3. Defective engine throttle • pump controller
-	E207	Short circuit in active mode solenoid system	<ol style="list-style-type: none"> 1. Short circuit with ground, short circuit inside active mode solenoid 2. Short circuit with ground in wiring harness between controller C01(8) and solenoid V02 (2) ((+) side) 3. Defective engine throttle • pump controller.
-	E208	Disconnection in active mode solenoid system	<ol style="list-style-type: none"> 1. Defective contact, disconnection inside active mode solenoid 2. Defective contact, disconnection, contact with power source in wiring harness between controller C01 (8) and solenoid V02 (2) ((+) side) 3. Defective contact, disconnection in wiring harness between solenoid V02 (1) and chassis ground ((-) side) 4. Defective engine throttle • pump controller
-	E214	Disconnection in pump merge/divider solenoid system	<ol style="list-style-type: none"> 1. Disconnection, defective contact inside pump merge/divider solenoid 2. Disconnection, defective contact, short circuit with power source in wiring harness between controller C01(2) and solenoid V03 (2) ((+) side) 3. Disconnection, defective contact in wiring harness between solenoid V03 (2) and chassis ground ((-) side)
-	E215	Disconnection in 2-stage relief solenoid system	<ol style="list-style-type: none"> 1. Disconnection, defective contact inside 2-stage relief solenoid 2. Disconnection, defective contact, short circuit with power source in wiring harness between controller C01(10) and solenoid V05(2) ((+) side) 3. Disconnection, defective contact in wiring harness between solenoid V05 (1) and chassis ground ((-) side) 4. Defective engine throttle • pump controller

Condition when normal (voltage, current, resistance)	Action by controller when abnormality is detected	Problem that appears on machine when there is abnormality
<ul style="list-style-type: none"> Resistance of solenoid: 20 - 60 Ω 	<ol style="list-style-type: none"> Makes output to solenoid 0. <ul style="list-style-type: none"> If the abnormality is restored by the vibration of the machine, it resets the power source to restore to the proper condition. (However, the service code display does not go out.) 	<p>The pump merge/divider valve continues to merge the oil flow.</p> <ol style="list-style-type: none"> In the L/O modes, the work equipment and swing speeds become faster. The steering is difficult to turn.
<ul style="list-style-type: none"> Resistance of solenoid: 20 - 60 Ω 	<ol style="list-style-type: none"> Makes output to solenoid 0. <ul style="list-style-type: none"> If the abnormality is restored by the vibration of the machine, it resets the power source to restore to the proper condition. (However, the service code display does not go out.) 	<p>There is no power when traveling or when power max. function is used (relief pressure is not increased).</p>
<ul style="list-style-type: none"> Resistance of solenoid: 20 - 60 Ω 	<ol style="list-style-type: none"> Makes output to solenoid 0. <ul style="list-style-type: none"> If the abnormality is restored by the vibration of the machine, it resets the power source to restore to the proper condition. (However, the service code display does not go out.) 	<p>Even if the travel speed is switched, the travel speed does not change (travel motor swash plate angle MAX).</p>
<ul style="list-style-type: none"> Resistance of solenoid: 20 - 60 Ω 	<ol style="list-style-type: none"> The current stops flowing to the solenoid, so no particular action is taken. <ul style="list-style-type: none"> If the abnormality is restored by the vibration of the machine, it resets the power source to restore to the proper condition. (However, the service code display does not go out.) 	<p>In the standard mode (active mode OFF), the boom LOWER speed becomes faster.</p>
<ul style="list-style-type: none"> Resistance of solenoid: 20 - 60 Ω 	<ol style="list-style-type: none"> The current stops flowing to the solenoid, so no particular action is taken. <ul style="list-style-type: none"> If the abnormality is restored by the vibration of the machine, it resets the power source to restore to the proper condition. (However, the service code display does not go out.) 	<p>Same content as display for E208</p>
<ul style="list-style-type: none"> Resistance of solenoid: 20 - 60 Ω 	<ol style="list-style-type: none"> The current stops flowing to the solenoid, so no particular action is taken. <ul style="list-style-type: none"> If the abnormality is restored by the vibration of the machine, it resets the power source to restore to the proper condition. (However, the service code display does not go out.) 	<p>Same content as display for E204</p>
<ul style="list-style-type: none"> Resistance of solenoid: 20 - 60 Ω 	<ol style="list-style-type: none"> The current stops flowing to the solenoid, so no particular action is taken. <ul style="list-style-type: none"> If the abnormality is restored by the vibration of the machine, it resets the power source to restore to the proper condition. (However, the service code display does not go out.) 	<p>Same content as display for E205</p>

User code	Service code	Abnormal system	Nature of abnormality
-	E216	Disconnection in travel speed solenoid system	<ol style="list-style-type: none"> 1. Disconnection, defective contact inside travel speed solenoid 2. Disconnection, defective contact, short circuit with power source in wiring harness between controller C01 (9) and solenoid V06 (2) ((+) side) 3. Disconnection, defective contact in wiring harness between solenoid V06 (1) and chassis ground ((-) side) 4. Defective engine throttle • pump controller
-	E217	Model selection input error	<ol style="list-style-type: none"> 1. Disconnection, defective contact, short circuit with ground in model selection wiring harness C17 (5) (6) (7) (13) (14) 2. Defective engine throttle • pump controller
-	E218	Network response overtime error	<ol style="list-style-type: none"> 1. Disconnection, short circuit, short circuit with ground in network wiring harness 2. Defective engine throttle • pump controller
-	E222	Short circuit in LS-EPC solenoid system	<ol style="list-style-type: none"> 1. Short circuit with ground, short circuit inside LS-EPC solenoid 2. Short circuit with power source, short circuit with ground in wiring harness between controller C02 (7) and solenoid C10 (1) ((+) side) 3. Short circuit with power source in wiring harness between controller C02 (17) and solenoid C10 (2) ((-) side) 4. Defective engine throttle • pump controller
-	E223	Disconnection in LS-EPC solenoid system	<ol style="list-style-type: none"> 1. Disconnection, defective contact inside LS-EPC solenoid 2. Disconnection, defective contact inside wiring harness between controller C02 (7) and solenoid C10 (1) ((+) side) 3. Disconnection, defective contact, short circuit with ground in wiring harness between controller C02 (17) and solenoid C10 (2) ((-) side) 4. Defective engine throttle • pump controller
-	E224	Abnormality in front pump pressure sensor system	<ol style="list-style-type: none"> 1. Disconnection, defective contact, short circuit, short circuit with ground inside front pump pressure sensor. 2. Disconnection, defective contact, short circuit in wiring harness between controller C03 (6) and pressure sensor C08 (2) ((+) side) and between C03 (16) and C08 ((-) side) 3. Disconnection, defective contact, short circuit with power source, short circuit with ground in wiring harness between controller C03 (3) and pressure sensor C08 (3) (SIG side) 4. Defective engine throttle • pump controller

Condition when normal (voltage, current, resistance)	Action by controller when abnormality is detected	Problem that appears on machine when there is abnormality
<ul style="list-style-type: none"> Resistance of solenoid: 20 -60 	<ol style="list-style-type: none"> The current stops flowing to the solenoid, so no particular action is taken <p>★ If the abnormality is restored by the vibration of the machine, it resets the power source to restore the proper condition. (However, the service code display does not go out).</p>	<p>Same content as display for E206</p>
<ul style="list-style-type: none"> Between C17 (6) and chassis: Max 1 . Between C17 (5), (7), (13), (14) and chassis: No continuity 	<p>Detects abnormality in input</p> <ol style="list-style-type: none"> Retains data when starting switch is ON 	<ol style="list-style-type: none"> Engine stalls, or Work equipment, swing, travel speeds are all slow and there is no power
	<p>When communications are impossible with the monitor, control is carried out with the following settings:</p> <ol style="list-style-type: none"> Working mode: G/O Priority mode: OFF Travel speed: Lo Auto-deceleration: ON Power Max: ON (other are as usual) 	<ol style="list-style-type: none"> Even when travel is operated, the power max. function does not work The swift speed-down function does not work The auto-deceleration cannot be canceled The travel speed does not increase The priority mode has no effect The automatic mode has no effect
<ul style="list-style-type: none"> Resistance of solenoid: 7 - 14 	<ol style="list-style-type: none"> Makes output to LS-EPC solenoid 0. <p>★ If the abnormality is restored by vibration of the machine, it resets the power source to restore to the proper condition. (However, the service code display does not go out).</p>	<ol style="list-style-type: none"> The Mi and Lo travel speed is too fast In L/O and F/O modes, the work equipment and swing speed is too fast
<ul style="list-style-type: none"> Current: Approximately 900 mA (Levers at neutral, low idling) 	<ol style="list-style-type: none"> The current stops flowing to the LS-EPC solenoid, so no particular action is taken If there is a short circuit with the ground at the (-) end, the current (min 1A) continues to flow to the LS-EPC solenoid. <p>★ If the abnormality is restored by the vibration of the machine, it resets the power source to restore to the proper condition. (However, the service code display does not go out.)</p>	<ol style="list-style-type: none"> In the case of 1, it is the same as E222 In the case of 2, electric current (min 1A) continues to flow to the LS-EPC solenoid, so the work equipment, travel, and swing speeds are slow
<ul style="list-style-type: none"> Between C03 (3) and (16): 0.5 - 4.5 V Between C03 (6) and (16): 18 -28 V Between C03 (female) (3) and (16), (3) and chassis Resistance: No continuity (Disconnect connectors C03 and C08) 	<ol style="list-style-type: none"> Takes front pump pressure as 0 MPa (0kg/cm²) when actuating <p>★ If the abnormality is restored by the vibration of the machine, it resets the power source to restore to the proper condition. (However, the service code display does not go out).</p>	<p>The travel speed does not automatically shift (it does not change from Hi to Lo)</p> <p>★ If the button is operated manually, the panel display is switched</p>

User code	Service code	Abnormal system	Nature of abnormality
-	E225	Abnormality in rear pump pressure sensor system	<ol style="list-style-type: none"> 1. Disconnection, defective contact, short circuit, short circuit with ground inside rear pump pressure sensor 2. Disconnection, defective contact, short circuit in wiring harness between controller C03 (6) and pressure sensor C07 (2) ((+)side) 3. Disconnection, defective contact, short circuit with power source, short circuit with ground in wiring harness between controller C03 (13) and pressure sensor C07 (3) (SIG side) 4. Defective engine throttle • pump controller
-	E226	Abnormality in pressure sensor power source system	<ol style="list-style-type: none"> 1. Short circuit, short circuit with ground inside front pump pressure sensor or rear pump pressure sensor 2. Short circuit, short circuit with ground in wiring harness between controller C03 (6) and front pressure sensor C08 (2) or rear pressure sensor C07 (2) ((+)side) 3. Defective engine throttle • pump controller
-	E227	Abnormality in speed sensor system	<ol style="list-style-type: none"> 1. Disconnection, defective contact, short circuit inside engine speed sensor 2. Disconnection, defective contact, short circuit with ground in wiring harness between controller C16 (1) and speed sensor E07 (2) ((-) side) and between C16 (2) and E07 (1) (SIG side) 3. Defective engine throttle • pump controller

Condition when normal (voltage, current, resistance)	Action by controller when abnormality is detected	Problem that appears on machine when there is abnormality
<ul style="list-style-type: none"> • Between C03 (13) and (16): 0.5 - 4.5 V • Between C03 (6) and (16): 18 - 28 V • Between C03 (female) (13) and (16), (13) and chassis • Resistance: No continuity (Disconnect connectors C03 and C07) 	<p>1. Takes front pump pressure as 0 MPa (0 kg/cm²) when actuating</p> <p>★ If the abnormality is restored by the vibration of the machine, it resets the power source to restore to the proper condition. (However, the service code display does not go out).</p>	<p>The travel speed does not automatically shift (it does not change from Hi to Lo)</p> <p>★ If the button is operated manually, the panel display is switched.</p>
<ul style="list-style-type: none"> • Voltage between C03 (6) and (16): 18 -28 V 	<p>Takes front pump and rear pump pressure as 0 MPa (0 kg/cm²) when actuating</p>	<p>The travel speed does not automatically shift (it does not change from Hi to Lo)</p> <p>★ If the button is operated manually, the panel display is switched)</p>
<ul style="list-style-type: none"> • Resistance: 500 - 1000 W • Voltage (AC range): 0.5 - 3.0 V (engine started) 	<p>It functions in the equivalent of the G/O mode (the speed rises)</p>	<p>It operates about the same as G/O mode (prolix) (the power is slightly lower)</p>

★ If service code E218 (abnormality in network system) is displayed, go to troubleshooting for N mode.

Engine pump controller R2120 system				Check items in monitoring mode															Troubleshooting code if no service code is displayed							
Self-diagnostic display																										
Abnormality in front pump pressure sensor system				Pressure switch						Actuation of solenoid						Monitoring code										
Abnormality in rear pump pressure sensor system				(1) Swing	(2) Travel	(3) Boom LOWER	(4) Boom RAISE	(5) Arm IN	(6) Arm OUT	(1) Bucket CURL	(2) Bucket DUMP	(3) Swing lock switch	(5) Kerosene mode	(6) Knob switch	(2) Active mode	(3) Swing holding brake	(4) Pump merge/divider	(5) 2-stage relief		(6) Travel speed	Model code	Engine speed input	Front pump discharge pressure input	Rear pump discharge pressure input	Front pump TVC current output	Rear pump TVC current output
Abnormality in pressure sensor power source system				Bit pattern																						
Abnormality in engine speed sensor system				224	225	226	227	20			21	22	23			02	10	11	12	13	14	15				
			●								○								※	※	※	※	※	※		H-1
			●																	※			※	※		H-2
																										H-3
																										H-4
			●	○	○	○	○	○	○	○																H-5
						○	○									※						※	※			H-6
								○	○							※						※	※			H-7
										○	○											※	※			H-8
										○	○											※	※			H-9
																										H-10
								○		○														※		H-11
										○																H-12
																										H-13
																										H-14
																										H-15
																										H-16
																										H-17
																										H-18
																										H-19
																										H-20
																										H-21
																										H-22
																										H-23
																										H-24
																										H-25
																										H-26
																										H-27
																										H-28
																										H-29
																										H-30
																										H-31
C-17	C-18	C-19	C-20																							
				F-1	F-2	F-3	F-4	F-5	F-6	F-7	F-8	F-9	F-10	F-11												

※ : This shows item that needs only checking with monitoring
 ○ : This shows item to check with monitoring or machine monitor

X02CH050

ELECTICAL CIRCUIT DIAGRAM FOR C MODE AND F MODE

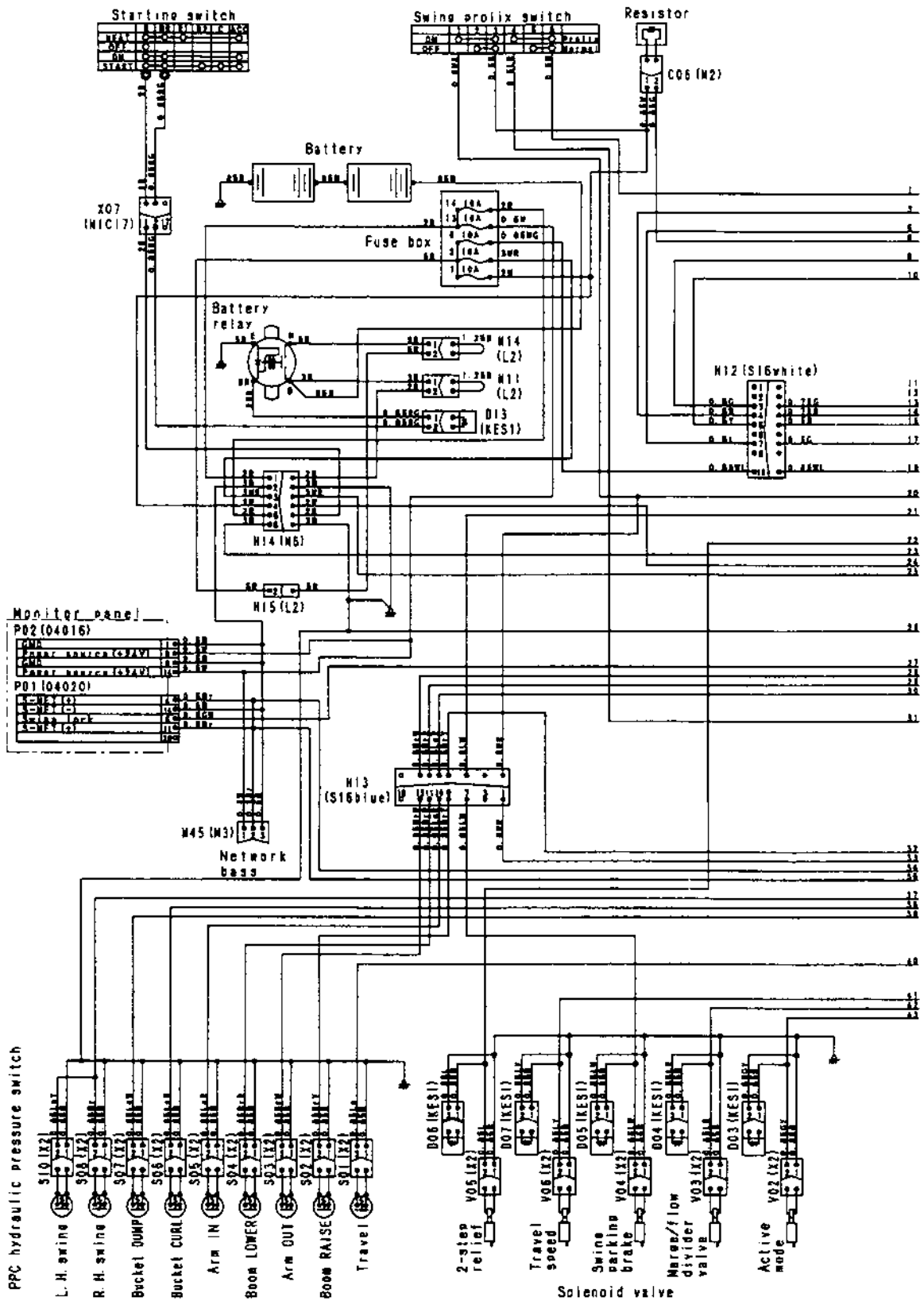

X08DD272

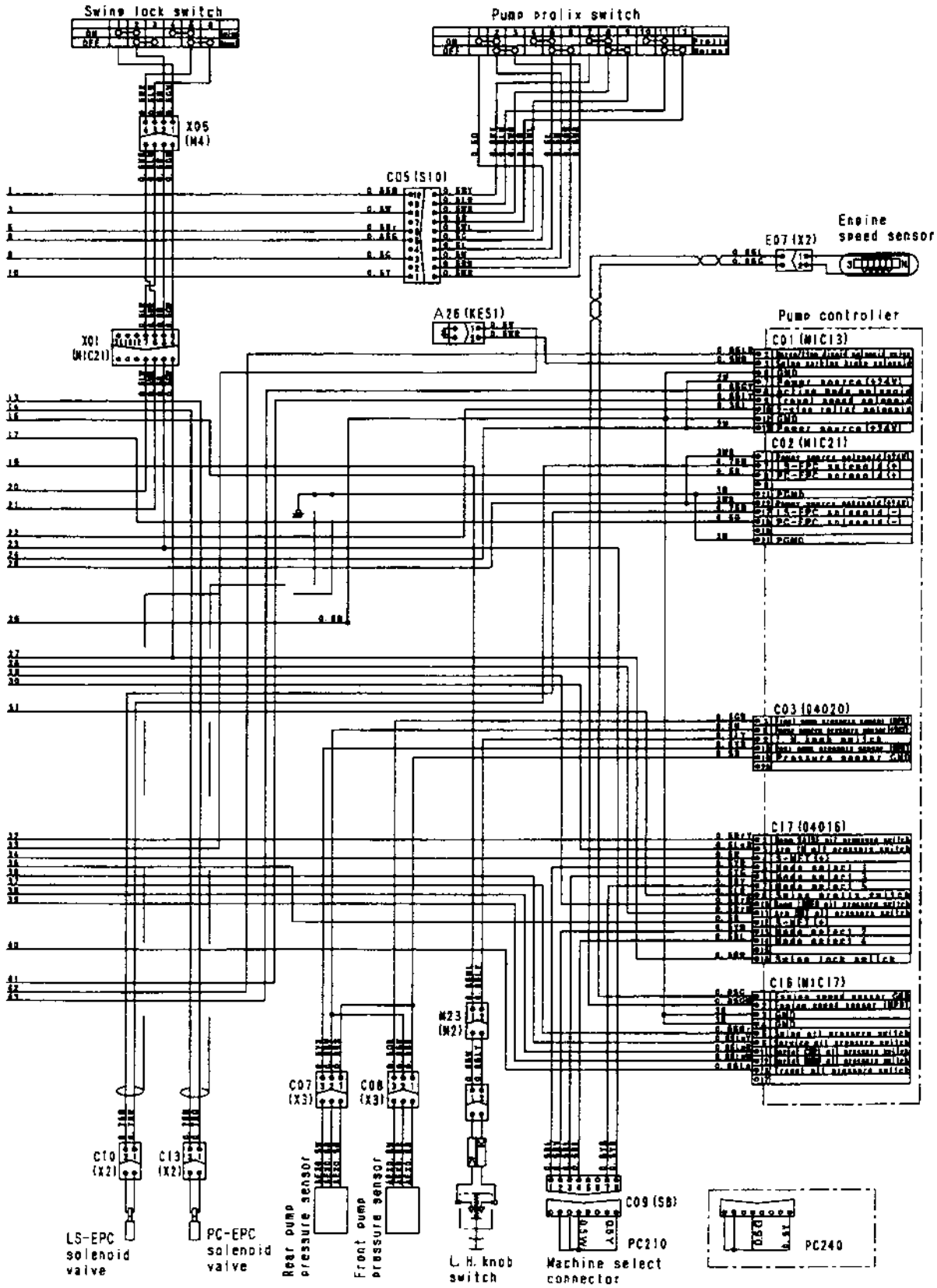

X08DD273

C-1 Abnormality in controller power source system (controller LED is OFF)

- ★ This troubleshooting is carried out when there is still an abnormality, so when disconnecting the connector and inserting the T-adapter, or when removing the T-adapter and returning the connector to its original position, if an E service code is not displayed, the problem has been removed.
- ★ Check that fuse 1 is not blown.
- ★ Before carrying out troubleshooting, check that all related connectors are properly inserted.
- ★ Always connect any disconnected connectors before going on the next step.
- ★ When the starting motor rotates normally. (If the starting motor also does not rotate, go to E-8).

		Cause	Remedy
<p>1</p> <p>Is voltage between C01 (7) (6) and between C01 (12) normal?</p> <p>• Turn starting switch ON. • 20 - 30 V</p>	YES	Defective engine throttle • pump controller	Replace
	2 YES	Defective contact, or disconnection in wiring harness between fuse 1 and C01 (female) (7) (13)	Repair or replace
	NO	Defective contact, or disconnection in wiring harness between fuse 1 - H15 (2) - M14 (2) (1) - battery relay M	Repair or replace

C-1 Related electric circuit diagram

Engine throttle pump controller

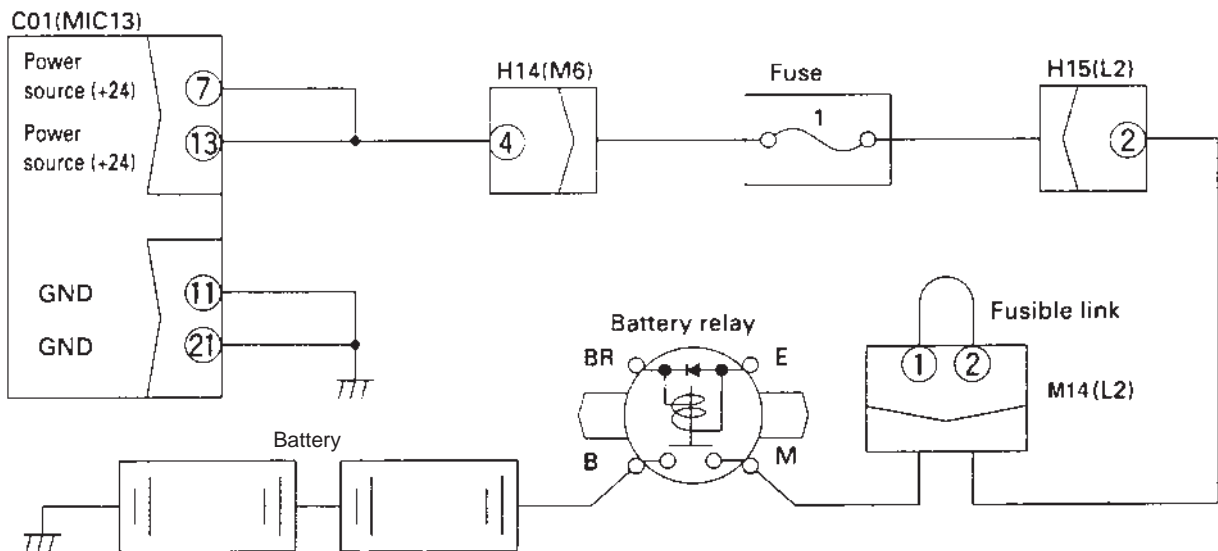

C-2 [E232] Short circuit in pump EPC solenoid system is displayed

- ★ This troubleshooting is carried out when there is still an abnormality, so when disconnection the connector and inserting the T-adapter, or when removing the T-adapter and returning the connector to its original position, if an E service code is not displayed, the problem has been removed.
- ★ If the starting switch is turned OFF after an abnormality occurs, turn the starting switch ON and check if an E service code is displayed. (If is not displayed, the problem had been removed).
- ★ Always turn the pump prolix switch OFF.
- ★ Before carrying out troubleshooting, check that all related connectors are properly inserted.
- ★ Always connect any disconnected connectors before going on the next step.

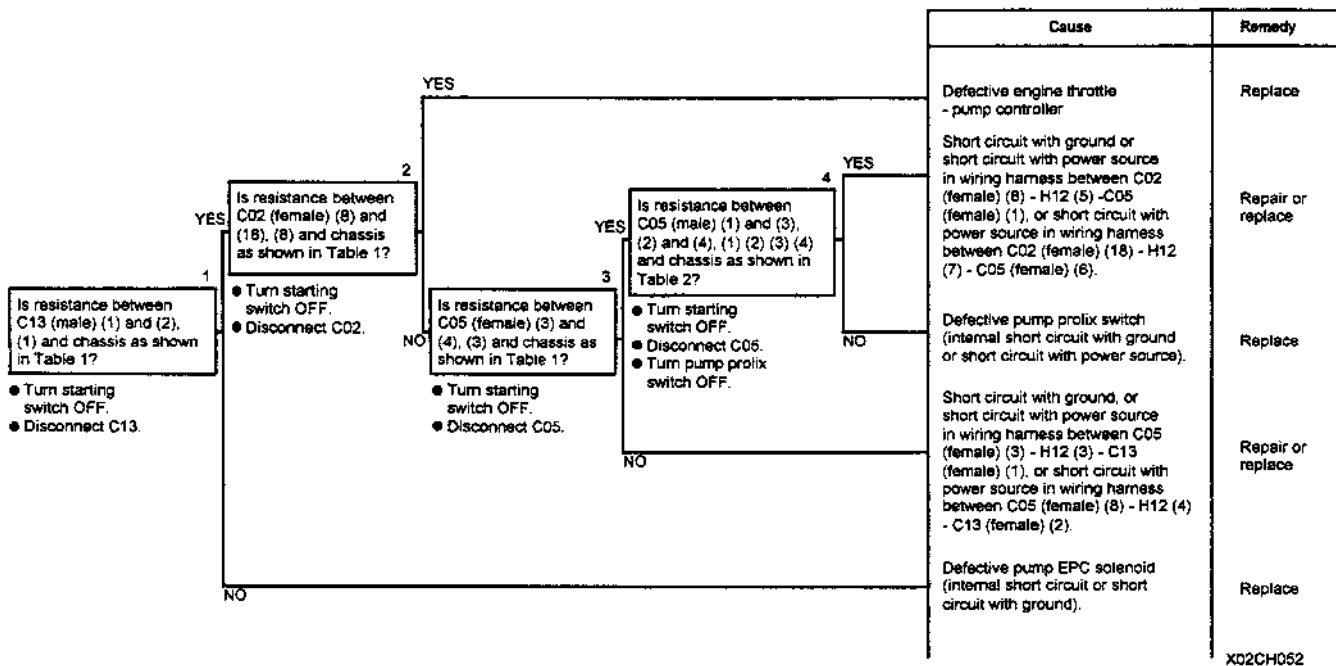

Table 1

Troubleshooting No 1	Troubleshooting No 2	Troubleshooting No 3	Resistance value
Between C13 (male) (1) - (2)	Between C02 (female) (8) - (18)	Between C05 (female) (3) - (4)	7 - 14 Ω
Between C13 (male) (1) - chassis	Between C02 (female) (8) - chassis	Between C05 (female) (3) - chassis	Min. 1 MΩ

Table 2

Troubleshooting No 4	Resistance value
Between C05 (male) (1) - (3),(2) - (4)	Max. 1 Ω
Between C05 (male) (1) (2) (3) (4) - chassis	Min. 1 MΩ

C-2 Related electric circuit diagram

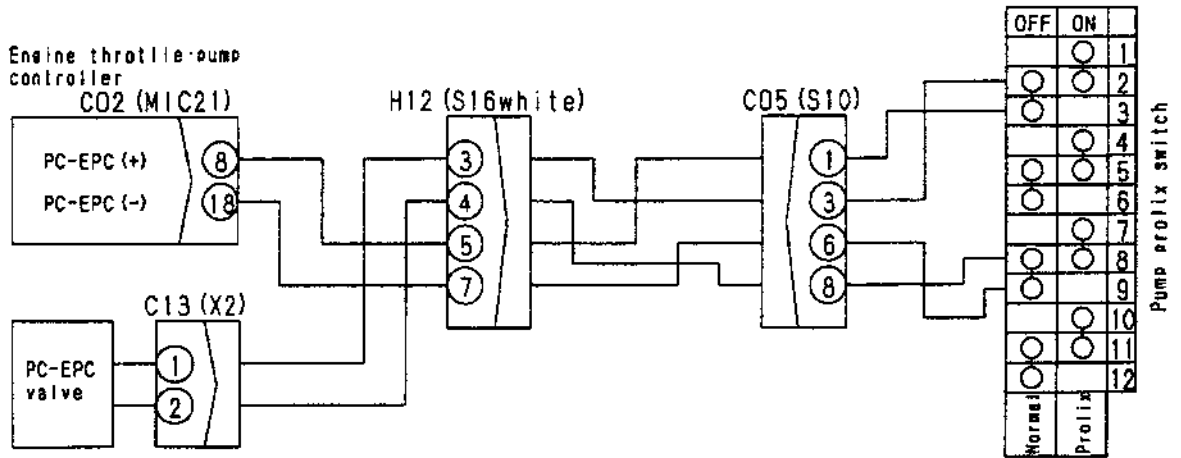

X08DD275

C-3 [E233] Disconnection in PC-EPC solenoid system is displayed

- ★ This troubleshooting is carried out when there is still an abnormality, so when disconnecting the connector and inserting the T-adaptor, or when removing the T-adaptor and returning the connector to its original position, if an E service code is not displayed, the problem has been removed.
If the starting switch is turned OFF after an abnormality occurs, turn the starting switch ON and check if an E service code is displayed. (If it is not displayed, the problem had been removed).
- ★ If there is a disconnection in the solenoid or wiring harness, no current flows to the solenoid. If the No. 2 pin of the solenoid is short circuiting with the ground, the current (approximately 1A) continues to flow to the solenoid.
- ★ Always turn the pump prolix switch OFF.
- ★ Before carrying out troubleshooting, check that all related connectors are properly inserted.
- ★ Always connect any disconnected connectors before going on the next step.

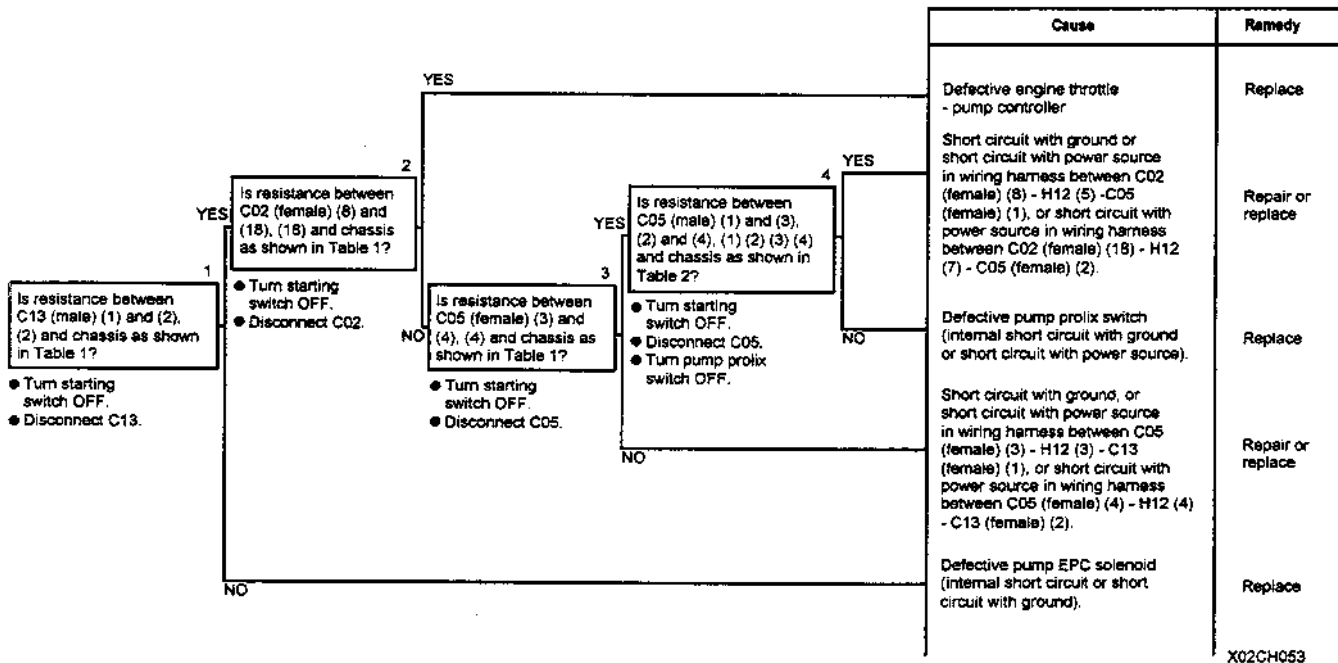

Table 1

Troubleshooting No 1	Troubleshooting No 2	Troubleshooting No 3	Resistance value
Between C13 (male) (1) - (2)	Between C02 (female) (8) - (18)	Between C05 (female) (3) - (4)	7 - 14 Ω
Between C13 (male) (2) - chassis	Between C02 (female) (18) - chassis	Between C05 (female) (4) - chassis	Min. 1 MΩ

Table 2

Troubleshooting No 4	Resistance value
Between C05 (male) (1) - (3), (2) - (4)	Max. 1 Ω
Between C05 (male) (1) (2) (3) (4) - chassis	Min. 1 MΩ

C-3 Related electric circuit diagram

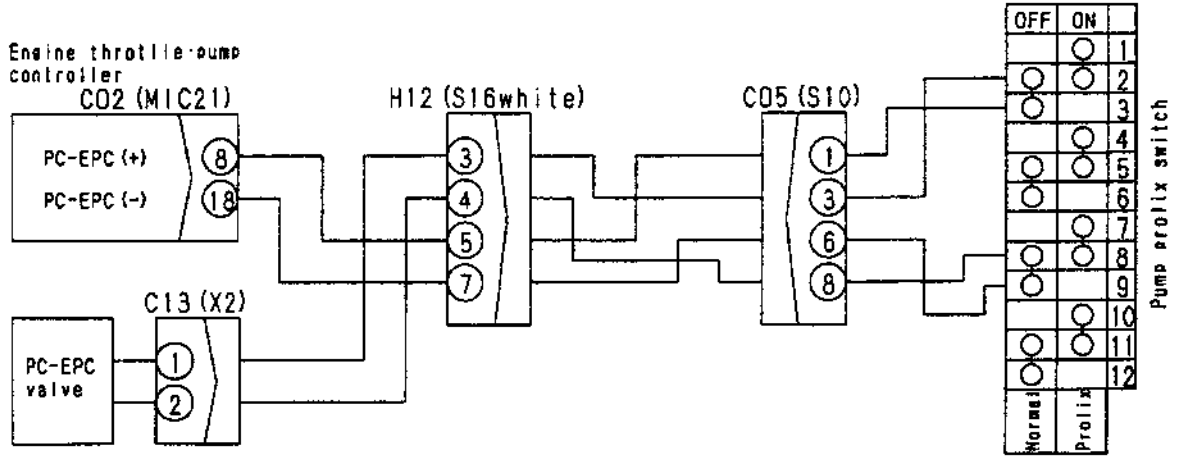

X08DD275

C-4 [213] Disconnection in swing holding brake solenoid system is displayed

- ★ This troubleshooting is carried out when there is still an abnormality, so when disconnecting the connector and inserting the T-adaptor, or when removing the T-adaptor and returning the connector to its original position, if an E service code is displayed. (If it is not displayed, the problem had been removed).
- ★ Before carrying out troubleshooting, check that all related connectors are properly inserted.
- ★ Always connect any disconnected connectors before going on the next step.

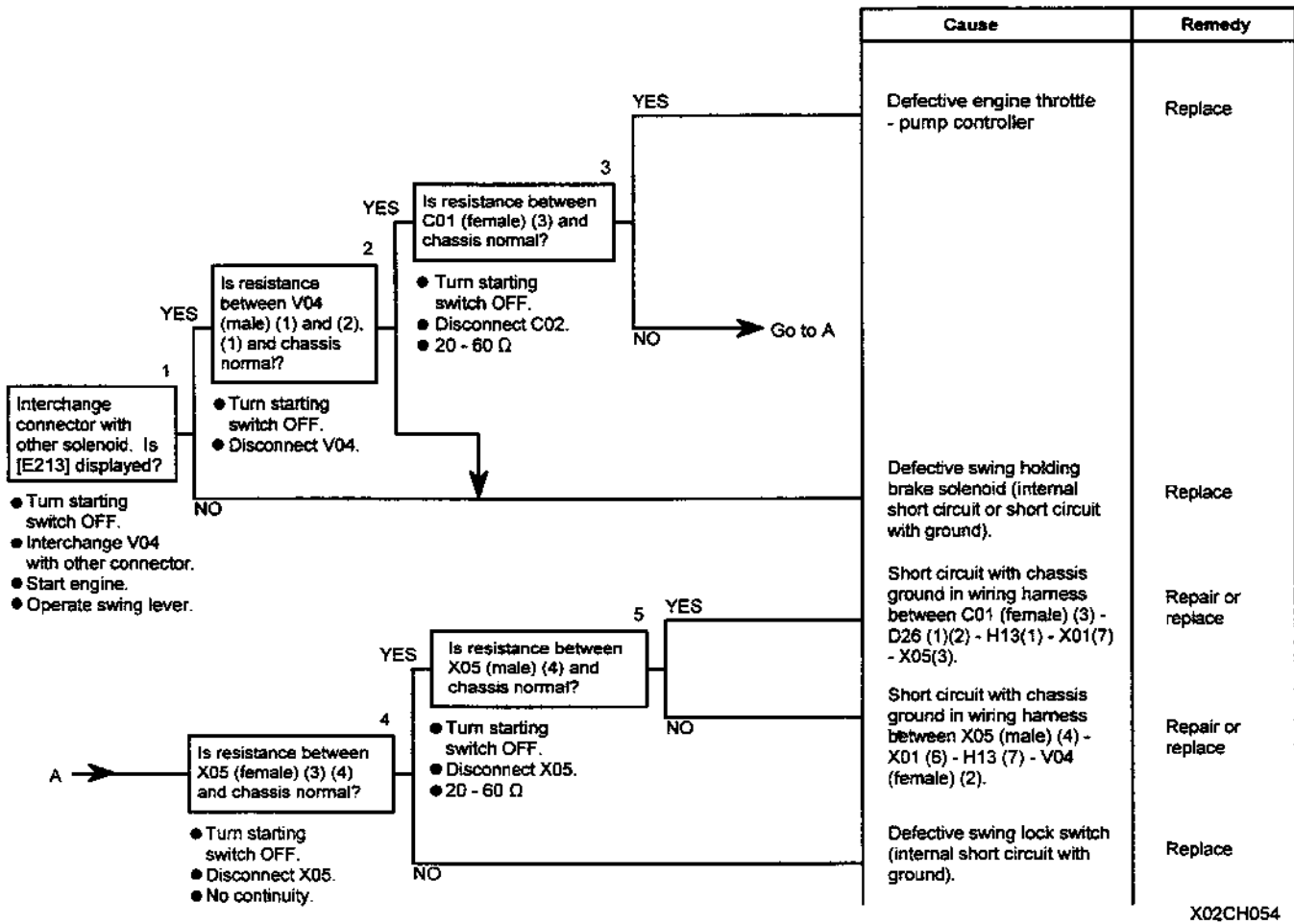
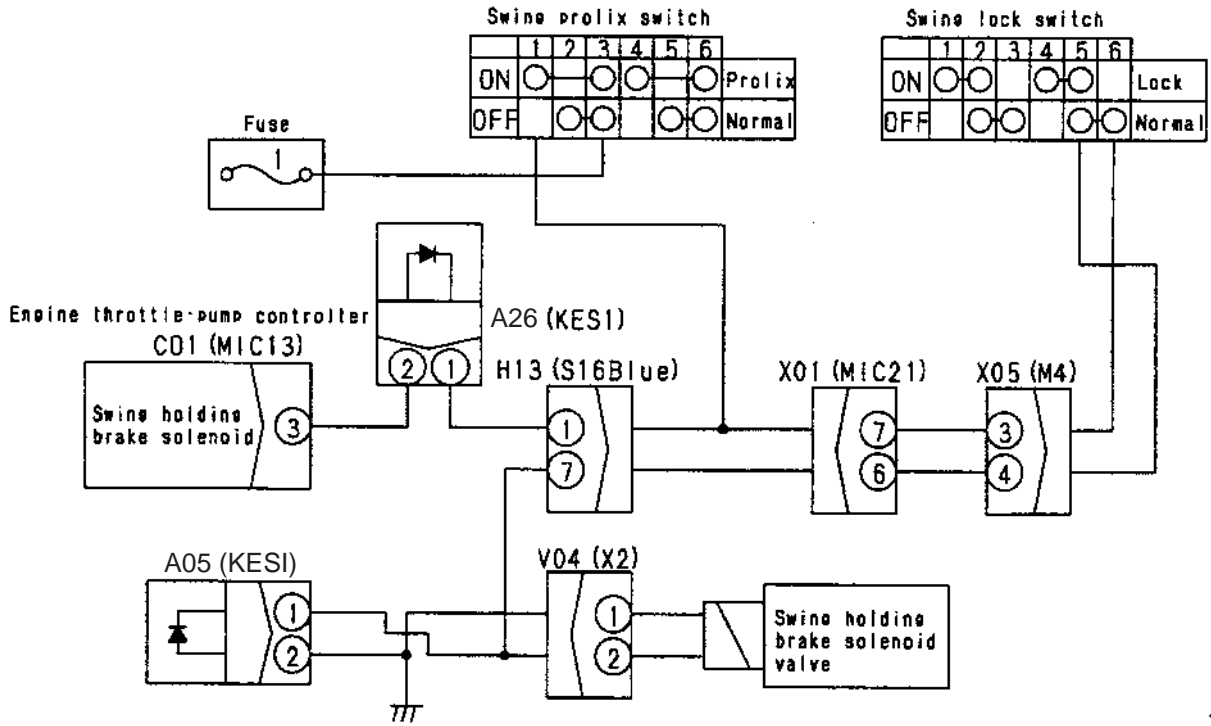

Table 1

Between V04 (male) (1) - (2)	20 -60
Between V04 (male) (2) - chassis	No continuity

C-4 Related electric circuit diagram



X08DD276

C-5 [E203] Short circuit in swing holding brake solenoid system is displayed

- ★ This troubleshooting is carried out when there is still an abnormality, so when disconnecting the connector and inserting the T-adaptor, or when removing the T-adaptor and returning the connector to its original position, if an E service code is not displayed, the problem has been removed.
- ★ If the starting switch is turned OFF after an abnormality occurs, turn the starting switch ON and check if an E service code is displayed. (If it is not displayed, the problem had been removed).
- ★ Always turn the swing lock prolix switch OFF, then turn the swing lock switch OFF before checking.
- ★ Before carrying out troubleshooting, check that all related connectors are properly inserted.
- ★ Always connect any disconnected connectors before going on the next step.

Note: When the swing prolix switch is operated, error [E203] is detected, but this is not a failure.

Note: If error [E203] is generated when the swing lock is operated, carry out troubleshooting F-9 for failure in the swing lock signal input system.

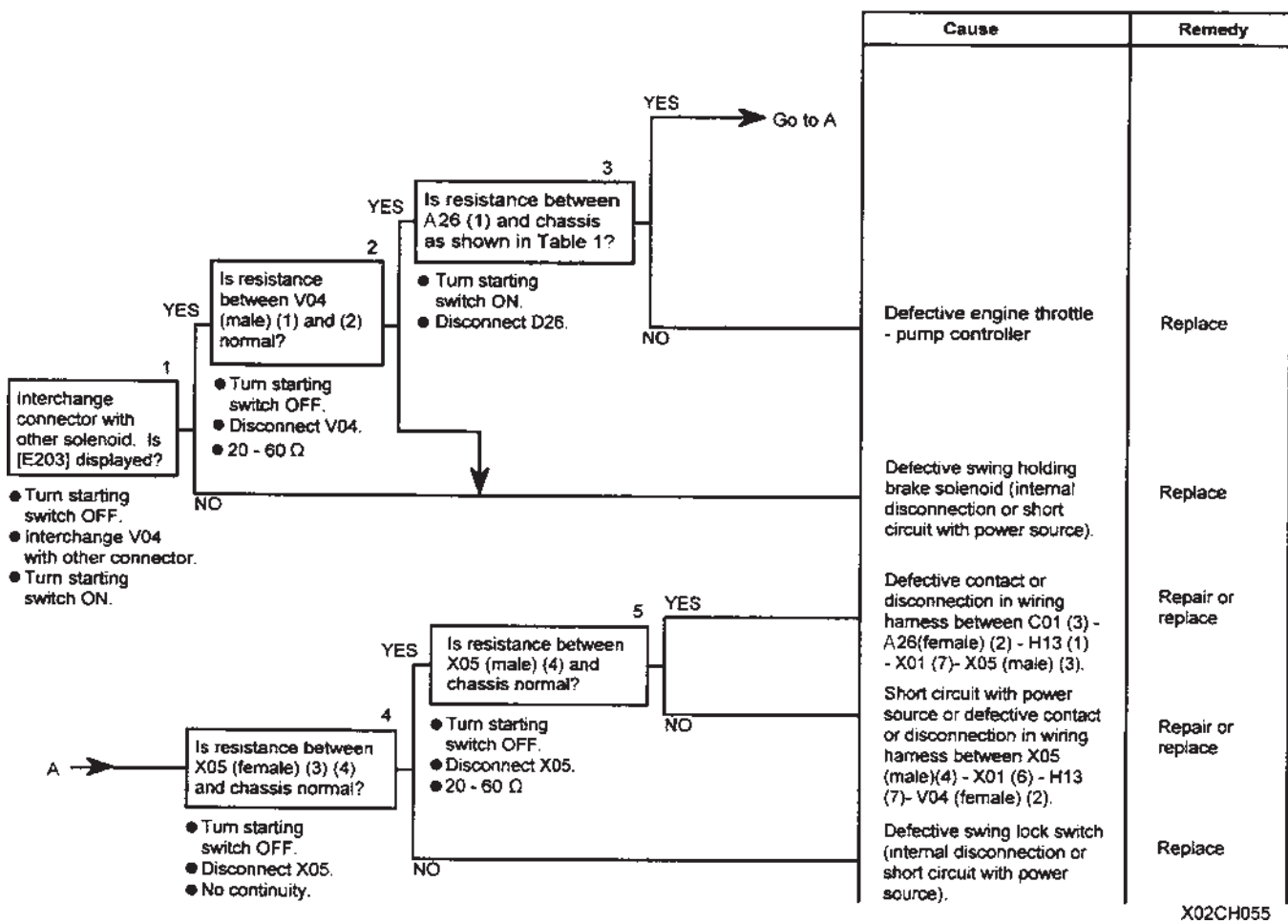
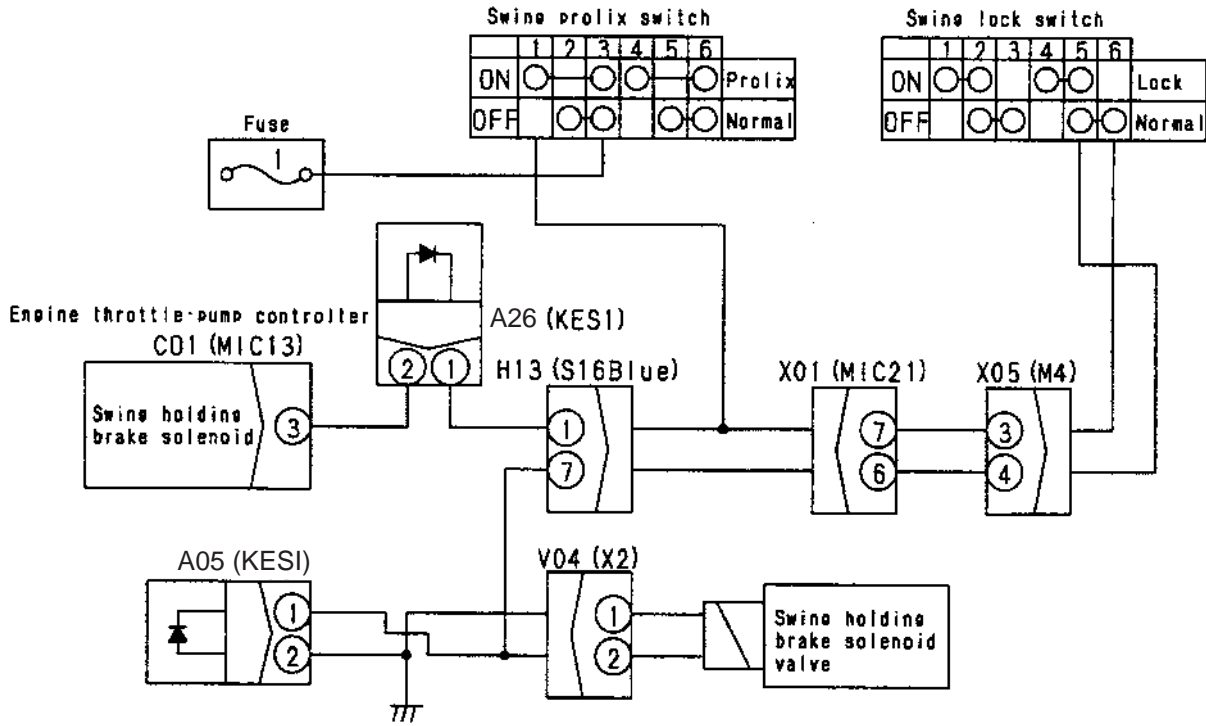

Table 1

Troubleshooting No. 3	Voltage	Measurement conditions
Between A26 (1) - chassis	0 - 10 V	4 - 5 sec after all levers placed at neutral
	20 -30 V	Swing or work equipment lever operated slightly (not enough to move swing or work equipment)

C-5 Related electric circuit diagram



X08DD276

C-6 [E204] Short circuit in pump merge/divider solenoid system is displayed

- ★ This troubleshooting is carried out when there is still an abnormality, so when disconnecting the connector and inserting the T-adapter, or when removing the T-adapter and returning the connector to its original position, if an E service code is not displayed, the problem has been removed.
- ★ If the starting switch is turned OFF after an abnormality occurs, turn the starting switch ON and check is an E
- ★ Before carrying out troubleshooting, check that all related connectors are properly inserted.
- ★ Always connect any disconnected connectors before going on the next step.

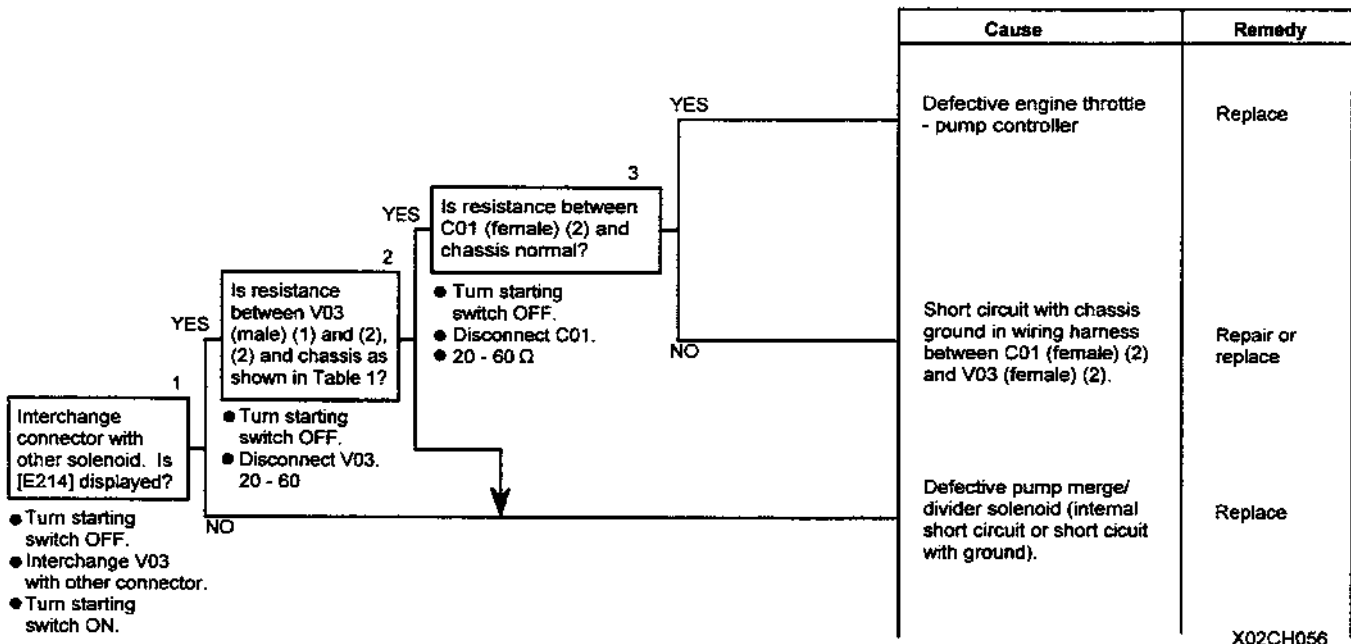
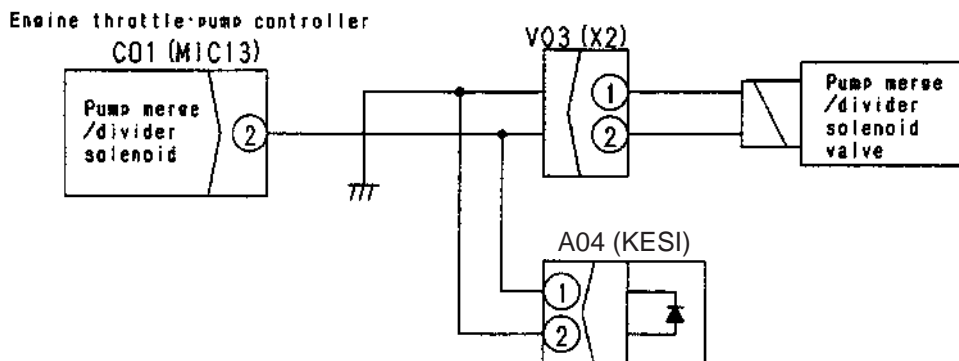

Table 1

Between V03 (male) (1) - (2)	20 - 60 Ω
Between V03 (male) (2) - chassis	No continuity

C-6 Related electric circuit diagram



X08DD277

C-7 [E214] Disconnection in pump merge/divider solenoid system is displayed

- ★ This troubleshooting is carried out when there is still an abnormality, so when disconnecting the connector and inserting the T-adaptor, or when removing the T-adaptor and returning the connector to its original position, if an E service code is not displayed. (If it is not displayed, the problem had been removed).
- ★ Before carrying out troubleshooting, check that all related connectors are properly inserted.
- ★ Always connect any disconnected connectors before going on the next step.

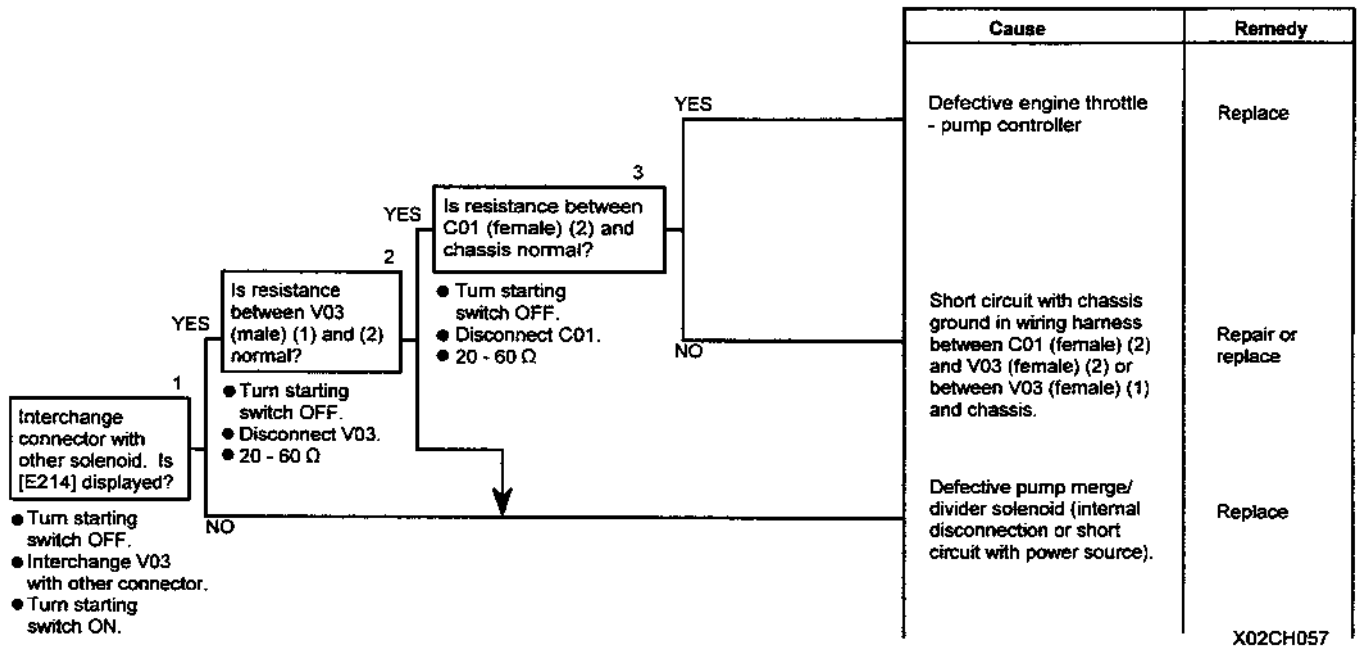

C-7 Related electric circuit diagram

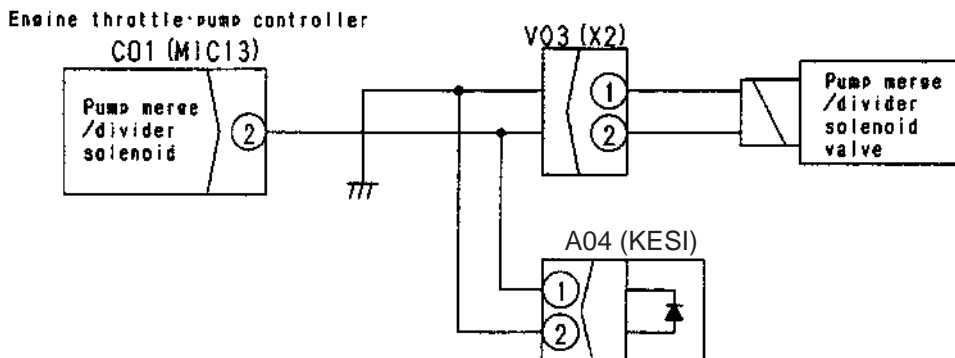

X08DD277

C-8 [E207] Short circuit in active mode solenoid system is displayed

- ★ This troubleshooting is carried out when there is still an abnormality, so when disconnecting the connector and inserting the T-adaptor, or when removing the T-adaptor and returning the connector to its original position, if an E service code is not displayed, the problem has been removed.
- ★ If the starting switch is turned OFF after an abnormality occurs, turn the starting switch ON and check is an E
- ★ Before carrying out troubleshooting, check that all related connectors are properly inserted.
- ★ Always connect any disconnected connectors before going on the next step.

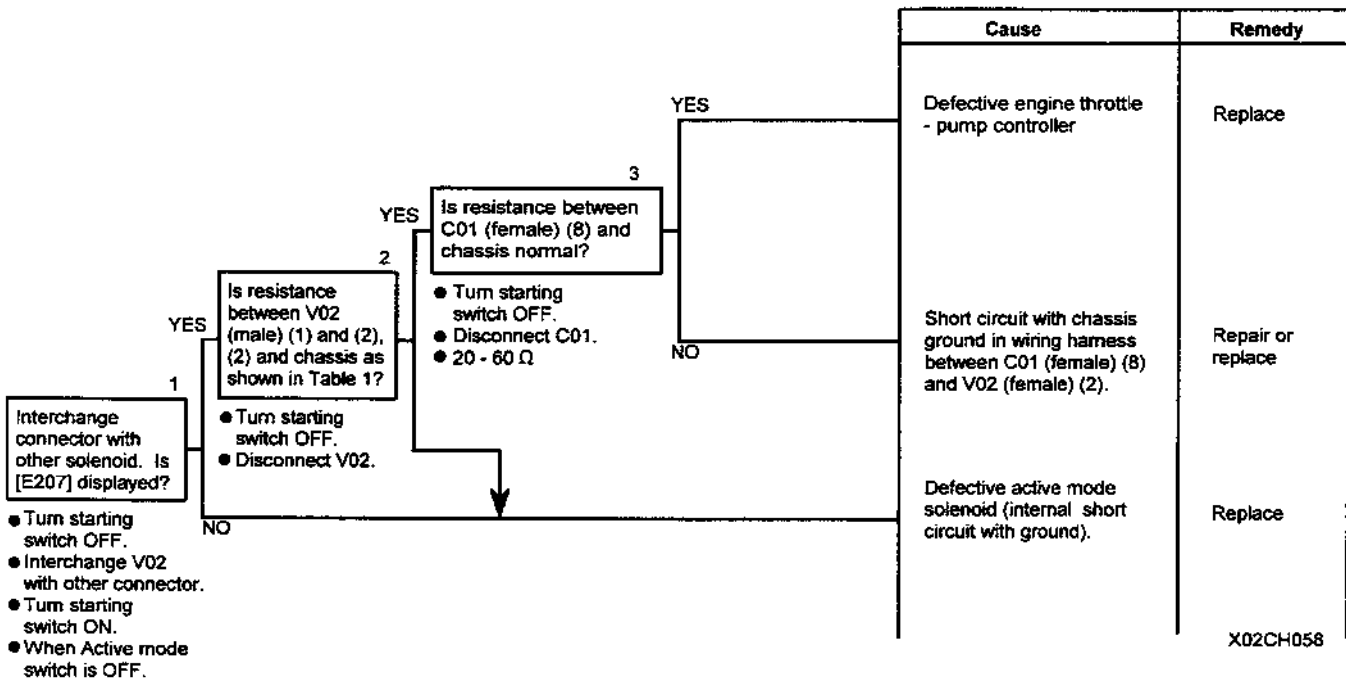
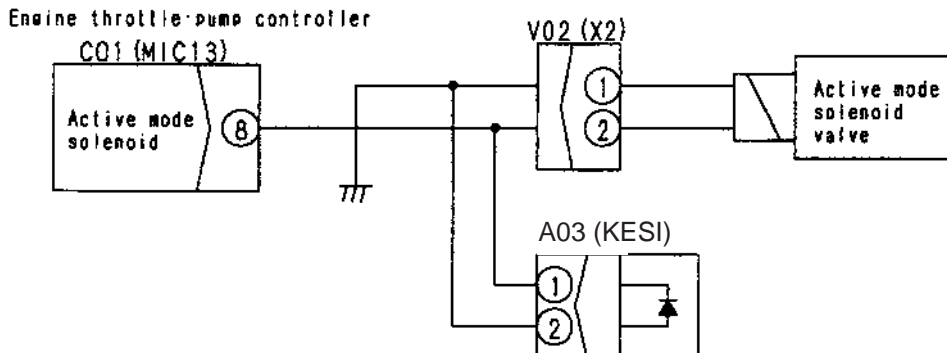

Table 1

Between V02 (male) (1) - (2)	20 - 60 Ω
Between V02 (male) (2) - chassis	No continuity

C-8 Related electric circuit diagram



X08DD278

C-9 [E208] Disconnection in active mode solenoid system is displayed

- ★ This troubleshooting is carried out when there is still an abnormality, so when disconnecting the connector and inserting the T-adaptor, or when removing the T-adaptor and returning the connector to its original position, if an E service code is not displayed, the problem has been removed.
- ★ If the starting switch is turned OFF after an abnormality occurs, turn the starting switch ON and check if an E service code is displayed. (If it is not displayed, the problem had been removed).
- ★ If the starting switch is turned OFF after an abnormality occurs, turn the starting switch ON and check if an E service code is displayed. (If it is not displayed, the problem had been removed).
- ★ Before carrying out troubleshooting, check that all related connectors are properly inserted.
- ★ Always connect any disconnected connectors before going on the next step.

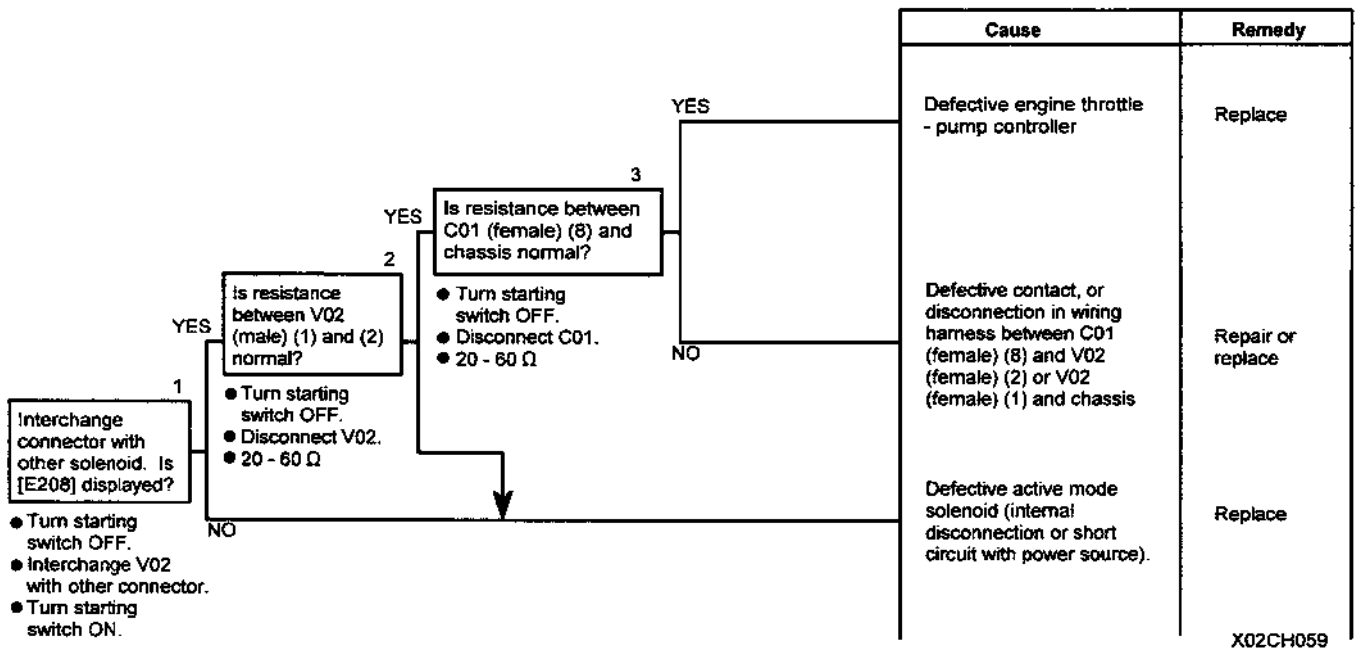

C-9 Related electric circuit diagram

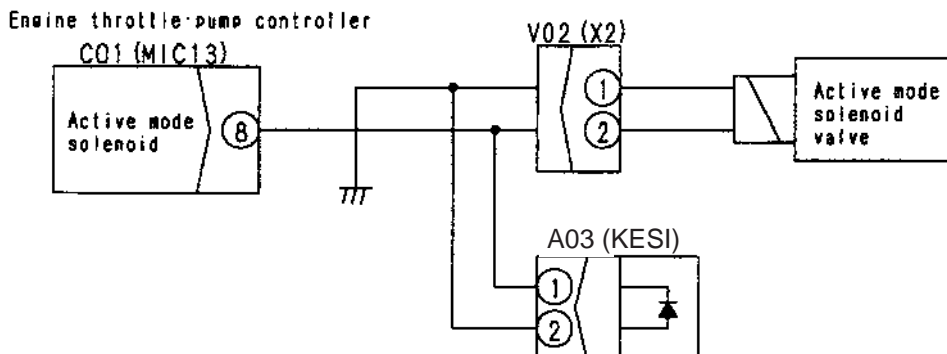

X08DD278

C-10 [E206] Short circuit in travel speed solenoid system is displayed

- ★ This troubleshooting is carried out when there is still an abnormality, so when disconnecting the connector and inserting the T-adapter, or when removing the T-adapter and returning the connector to its original position, if an E service code is not displayed, the problem has been removed.
- ★ If the starting switch is turned OFF after an abnormality occurs, turn the starting switch ON and check if an e service code is displayed. (If it is not displayed, the problem had been removed).
- ★ Before carrying out troubleshooting, check that all related connectors are properly inserted.
- ★ Always connect any disconnected connectors before going on the next step.

	Cause	Remedy
<div style="border: 1px solid black; padding: 5px; margin-bottom: 10px;"> Interchange connector with other solenoid. Is [E206] displayed? </div> <div style="margin-left: 20px;"> YES 1 </div> <div style="margin-left: 40px;"> Is resistance between V03 (male) (1) and (2), (2) and chassis as shown in Table 1? </div> <div style="margin-left: 60px;"> YES 2 </div> <div style="margin-left: 80px;"> Is resistance between C01 (female) (2) and chassis normal? </div> <div style="margin-left: 100px;"> YES 3 </div> <div style="margin-left: 120px;"> NO </div> <div style="margin-left: 140px;"> NO </div>	Defective engine throttle • pump controller Short circuit with chassis ground in wiring harness between C01 (female) (8) and V06 (female) (2) Defective pump merge/divider solenoid (internal short circuit or short circuit with ground)	Replace Repair or replace Replace

- Turn starting switch OFF.
- Interchange V06 with other connector.
- Start engine
- Travel speed switch at Hi or Mi.
- Operate the lever slightly but not enough to move the machine.

Table 1

Between V06 (male) (1) - (2)	20 - 60 Ω
Between V06 (male) (2) - chassis	Min. 1 MΩ

C-10 Related electric circuit diagram

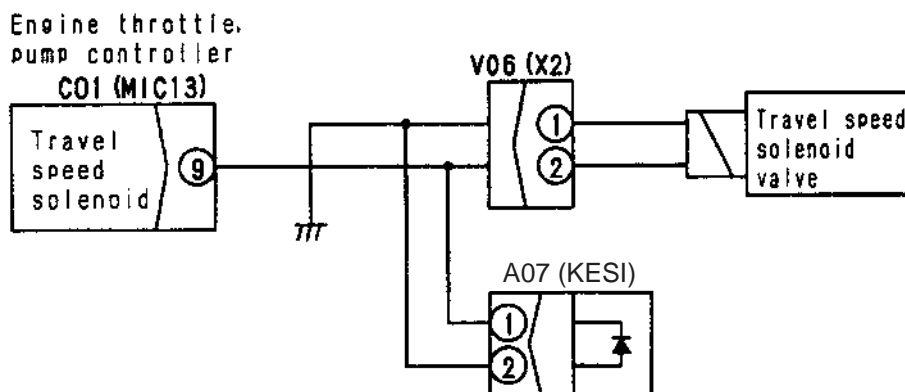

X08DD279

C-13 [E215] Disconnection in 2-stage relief solenoid system is displayed

- ★ This troubleshooting is carried out when there is still an abnormality, so when disconnecting the connector and inserting the T-adapter, or when removing the T-adapter and returning the connector to its original position, if an E service code is not displayed, the problem has been removed.
- ★ If the starting switch is turned OFF after an abnormality occurs, turn the starting switch ON and check if an E service is displayed. (If it is not displayed, the problem has been removed).
- ★ Before carrying out troubleshooting, check that all related connectors are properly inserted.
- ★ Always connect any disconnected connectors before going on the next step.

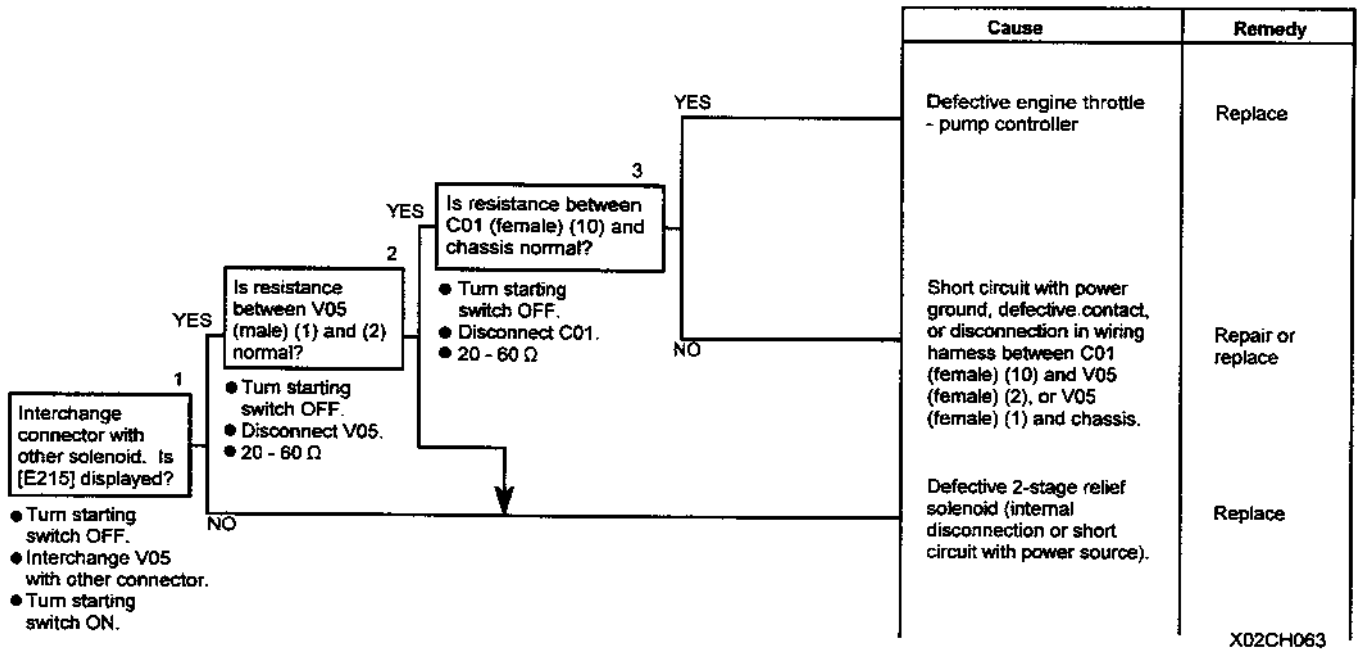

C-13 Related electric circuit diagram

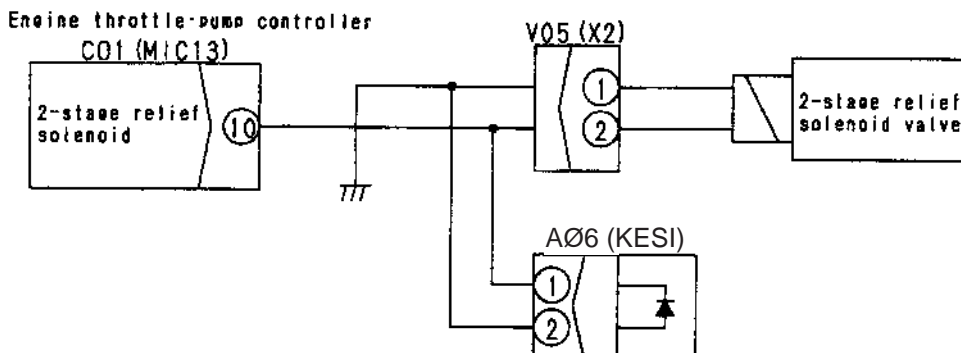

X08DD280

C-14 [E217] Model selection input error is displayed

- ★ This troubleshooting is carried out when there is still an abnormality, so when disconnecting the connector and inserting the T-adapter, or when removing the T-adapter and returning the connector to its original position, if an E service code is not displayed, the problem has been removed.
- ★ If the starting switch is turned OFF after an abnormality occurs, turn the starting switch ON and check if an E service code is displayed. (If it is not displayed, the problem had been removed).
- ★ Before carrying out troubleshooting, check that all related connectors are properly inserted.
- ★ Always connect any disconnected connectors before going on the next step.

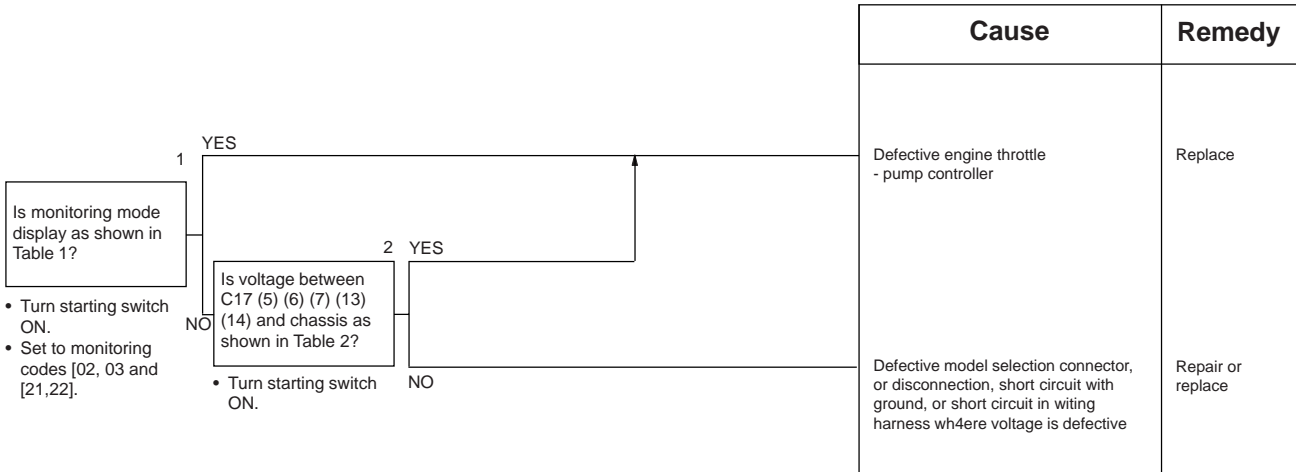

Table 1 Monitoring code display

Model code display	Model selection signal input display	
Monitoring codes 02, 03	Monitoring code 21	Monitoring code 22

- ★ The diagram shows monitoring code 03.
- ★ Check the bit pattern display marked with ←.

Table 2 Voltage of wiring harness

C17	Between (5) - chassis	Between (6) - chassis	Between (7) - chassis	Between (13) - chassis	Between (14) - chassis
Voltage	Max. 1 V	Max. 1 V	20 - 30 V	Max. 1 V	20 -30 V

C-14 Related electric circuit diagram

Engine throttle pump controller

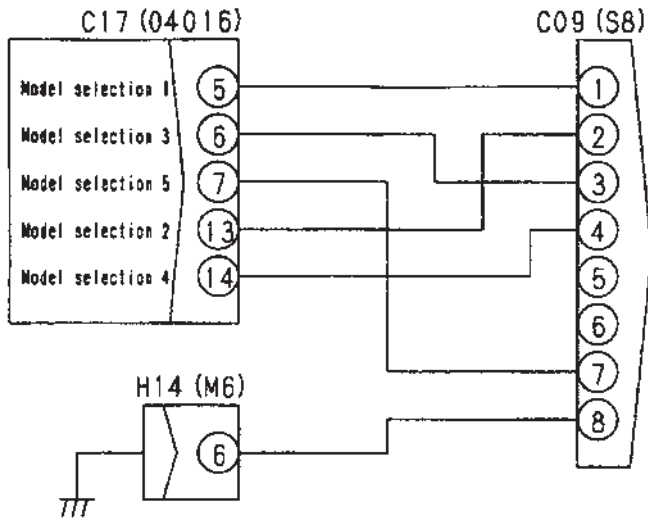

Model selection connector

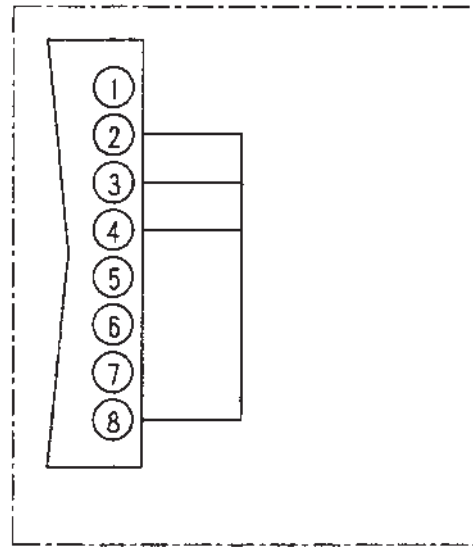

X08DD283

C-15 [E222] Short circuit in LS-EPC solenoid system is displayed

- ★ This troubleshooting is carried out when there is still an abnormality, so when disconnecting the connector and inserting the T-adapter, or when removing the T-adapter and returning the connector to its original position, if an E service code is not displayed, the problem has been removed.
- ★ If the starting switch is turned OFF after an abnormality occurs, turn the starting switch ON and check if an E service code is displayed. (If it is not displayed, the problem had been removed).
- ★ Before carrying out troubleshooting, check that all related connectors are properly inserted.
- ★ Always connect any disconnected connectors before going on the next step.

		Cause	Remedy
<p>Is resistance between C10 (male) (1) and (2), (1) and chassis as shown in Table 1?</p> <p>1</p> <p>YES</p>	<p>Is resistance between C02 (female) (7) and (17), (7) and chassis as shown in Table 1?</p> <p>2</p> <p>YES</p>	Defective engine throttle - pump controller	Replace
	<p>NO</p> <p>• Turn starting switch OFF.</p> <p>• Cisconnect C02</p>	<p>NO</p>	Short circuit with ground or short circuit with power source in wiring harness between C02 (female) (7) - C10 (female) (1), or short circuit with power source in wiring harness between C02 (female) (17) - C10 (female) (2)
<p>NO</p> <p>• Turn starting switch OFF.</p> <p>• Disconnect C10</p>		Defective LS-EPC solenoid (internal short circuit with ground or short circuit with power source)	Replace

Table 1

Troubleshooting No.1	Troubleshooting No. 2	Resistance value
Between C10 (male) (1) - (2)	Between C02 (female) (7) - (17)	7 - 14
Between C10 (male) (1) - chassis	Between C02 (female) (7) - chassis	No continuity

C-15 Related electric circuit diagram

Engine throttle pump controller

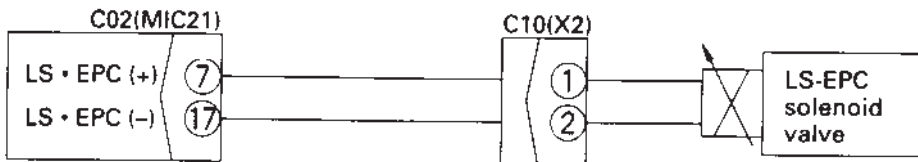

BKP00251

C-16 [E223] Disconnection in LS-EPC solenoid system is displayed

	Cause	Remedy
<p>Is resistance between C10 (male) (1) and (2), (2) and chassis as shown in Table 1?</p> <p>1 YES</p> <p>Is resistance between C02 (female) (7) and (17), (17) and chassis as shown in Table 1?</p> <p>2 YES</p> <p>• Turn starting switch OFF. • Disconnect C02.</p> <p>NO</p> <p>NO</p> <p>• Turn starting switch OFF. • Disconnect C10.</p>	<p>Defective engine throttle - pump controller</p> <p>Defect contact or short circuit with chassis ground in wiring harness between C02 (female) (7) and C10 (female) (1), or defective contact, short circuit with ground, or disconnection in wiring harness between C02 (female) (17) - C10 (female) (2)</p> <p>Defective LS-EPS solenoid (internal disconnection, defective contact, or short circuit with ground)</p>	<p>Replace</p> <p>Repair or replace</p> <p>Replace</p>

Table 1

Troubleshooting No.1	Troubleshooting No. 2	Resistance value
Between C10 (male) (1) - (2)	Between C02 (female) (7) - (17)	7 - 14
Between C10 (male) (1) - chassis	Between C02 (female) (7) - chassis	No continuity

C-16 Related electric circuit diagram

Engine throttle pump controller

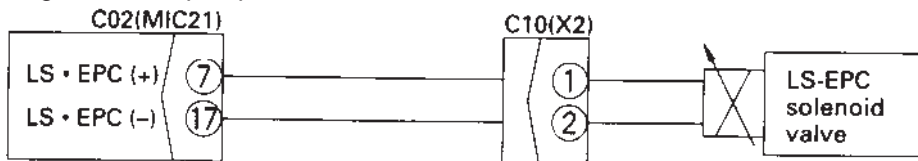

BKP00251

C-17 [E224] Abnormality in front pump pressure sensor system is displayed

- ★ This troubleshooting is carried out when there is still an abnormality, so when disconnecting the connector and inserting the T-adaptor, or when removing the T-adaptor and returning the connector to its original position, if an E service code is not displayed, the problem has been removed.
- ★ If the starting switch is turned OFF after an abnormality occurs, turn the starting switch ON and check is an E service code is displayed. (If it is not displayed, the problem had been removed).
- ★ Before carrying out troubleshooting, check that all related connectors are properly inserted.
- ★ Always connect any disconnected connectors before going on the next step.

	Cause	Remedy
<p style="text-align: center;">3 YES</p> <p style="text-align: center;">2 YES</p> <p style="text-align: center;">1 YES</p> <div style="border: 1px solid black; padding: 5px; margin-bottom: 5px;"> Interchange connector with rear pump pressure sensor. Is [E244] displayd? </div> <ul style="list-style-type: none"> • Turn starting switch OFF. • Interchange C07 with C08. • Engine at high idling. <p style="text-align: center;">NO</p> <div style="border: 1px solid black; padding: 5px; margin-bottom: 5px;"> Is voltage between C08 (2) and (1) normal? • Turn starting switch ON. • 18 - 28 V </div> <p style="text-align: center;">NO</p> <div style="border: 1px solid black; padding: 5px; margin-bottom: 5px;"> Is voltage between C03 (3) and (16) normal? • Engine at high idling • Operate repeatedly arm IN relief ↔ lever NEUTRAL. • 0.5 - 4.5 V </div> <p style="text-align: center;">NO</p> <div style="border: 1px solid black; padding: 5px;"> Is voltage between C08 (2) and chassis normal? • Disconnect C08. • Turn starting switch ON. • 18 - 28 V </div>	<p style="text-align: center;">3 YES</p> <p style="text-align: center;">4 YES</p> <p style="text-align: center;">NO</p> <p style="text-align: center;">NO</p>	<p style="text-align: center;">Replace</p> <p style="text-align: center;">Repair or replace</p> <p style="text-align: center;">Repair or replace</p> <p style="text-align: center;">Repair or replace</p> <p style="text-align: center;">Replace</p>

C-17 Related electric circuit diagram

Engine throttle pump controller

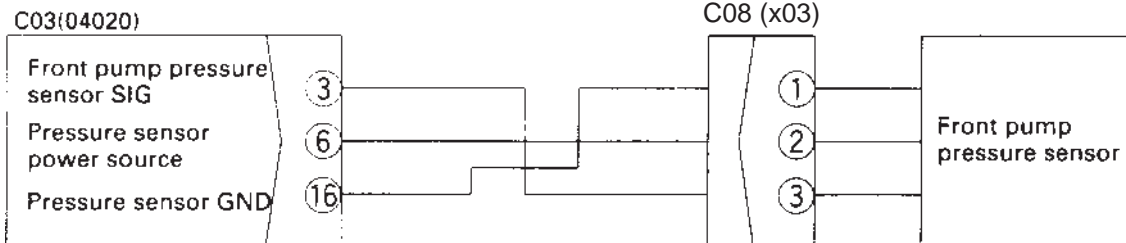

BKP00252

C-18 [E225] Abnormality in rear pump pressure sensor system is displayed

- ★ This troubleshooting is carried out when there is still an abnormality, so when disconnecting the connector and inserting the T-adaptor, or when removing the T-adaptor and returning the connector to its original position, if an E service code is not displayed, the problem has been removed.
- ★ If the starting switch is turned OFF after an abnormality occurs, turn the starting switch ON and check if an E service code is displayed. (If it is not displayed, the problem had been removed).
- ★ Before carrying out troubleshooting, check that all related connectors are properly inserted.
- ★ Always connect any disconnected connectors before going on the next step.

		Cause	Remedy
<p>1</p> <p>Interchange connector with front pump pressure sensor. Is [E225] displayed?</p> <ul style="list-style-type: none"> • Turn starting switch OFF. • Interchange C08 with C07. • Engine at high idling. <p>YES</p> <p>2</p> <p>Is voltage between C07 (2) and (1) normal?</p> <ul style="list-style-type: none"> • Turn starting switch ON. • 18 - 28 V <p>NO</p> <p>3</p> <p>Is voltage between C03 (3) and (16) normal?</p> <ul style="list-style-type: none"> • Engine at high idling • Operate repeatedly arm IN relief ←→ lever NEUTRAL. • 0.5 - 4.5 V <p>NO</p> <p>4</p> <p>Is voltage between C07 (2) and chassis normal?</p> <ul style="list-style-type: none"> • Disconnect C07. • Turn starting switch ON. • 18 - 28 V 	<p>YES</p> <p>NO</p> <p>YES</p> <p>NO</p>	<p>Defective engine throttle - pump controller</p> <p>Short circuit with power source, defective contact, or disconnection in wiring harness between C03 (female) (13) - C07 (female) (3)</p> <p>Short circuit with ground, defective contact, or disconnection in wiring harness between C03 (female) (16) and C07 (female) (1)</p> <p>Short circuit with ground, defective contact, or disconnection in wiring harness between C03 (female) (6) and C07 (female) (2)</p> <p>Defective rear pump pressure sensor (internal disconnection, defective contact, short circuit, or short circuit with ground)</p>	<p>Replace</p> <p>Repair or replace</p> <p>Repair or replace</p> <p>Repair or replace</p> <p>Replace</p>

C-18 Related electric circuit diagram

Engine throttle pump controller

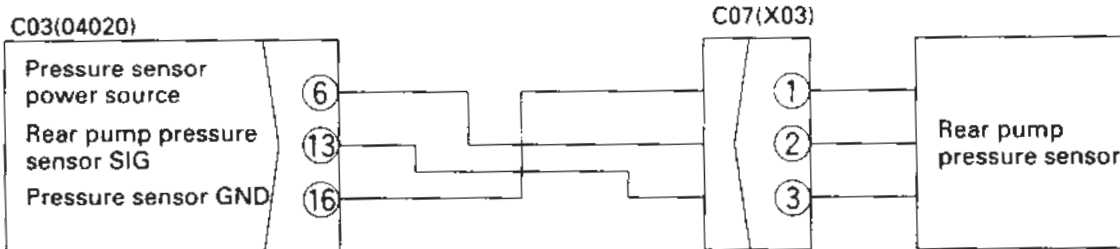

BK P00253

C-19 [E226] Abnormality in pressure sensor power source system is displayed

- ★ This troubleshooting is carried out when there is still an abnormality, so when disconnecting the connector and inserting the T-adaptor, or when removing the T-adaptor and returning the connector to its original position, if an E service code is not displayed, the problem has been removed.
- ★ If the starting switch is turned OFF after an abnormality occurs, turn the starting switch ON and check if an E service code is displayed. (If it is not displayed, the problem had been removed).
- ★ Before carrying out troubleshooting, check that all related connectors are properly inserted.
- ★ Always connect any disconnected connectors before going on the next step.

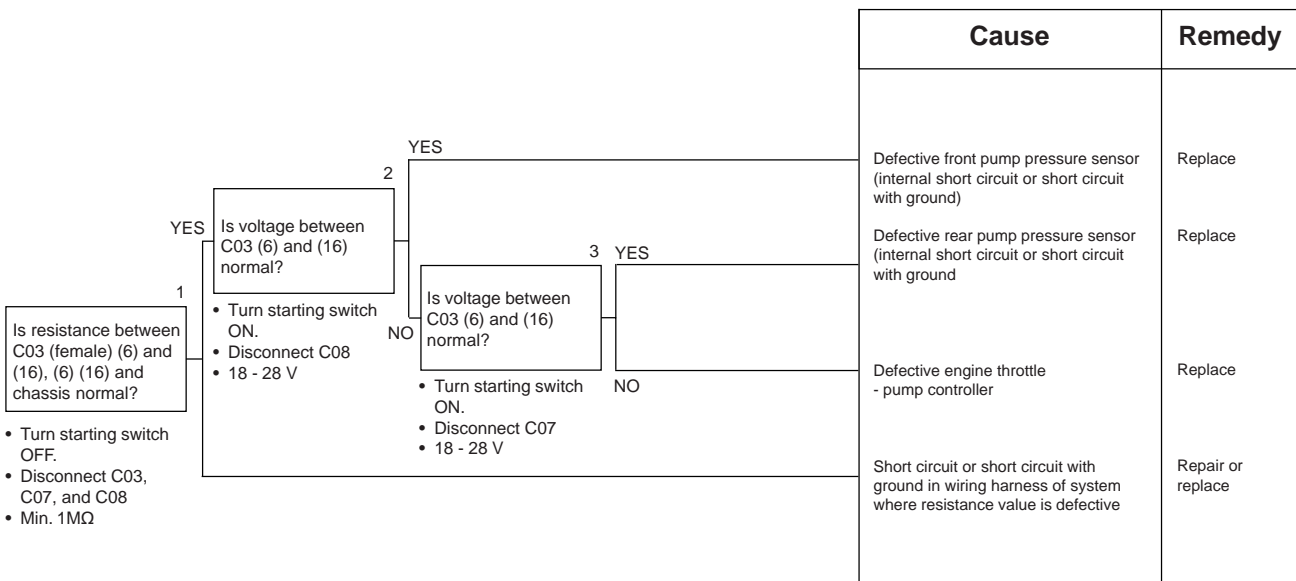

C-19 Related electric circuit diagram

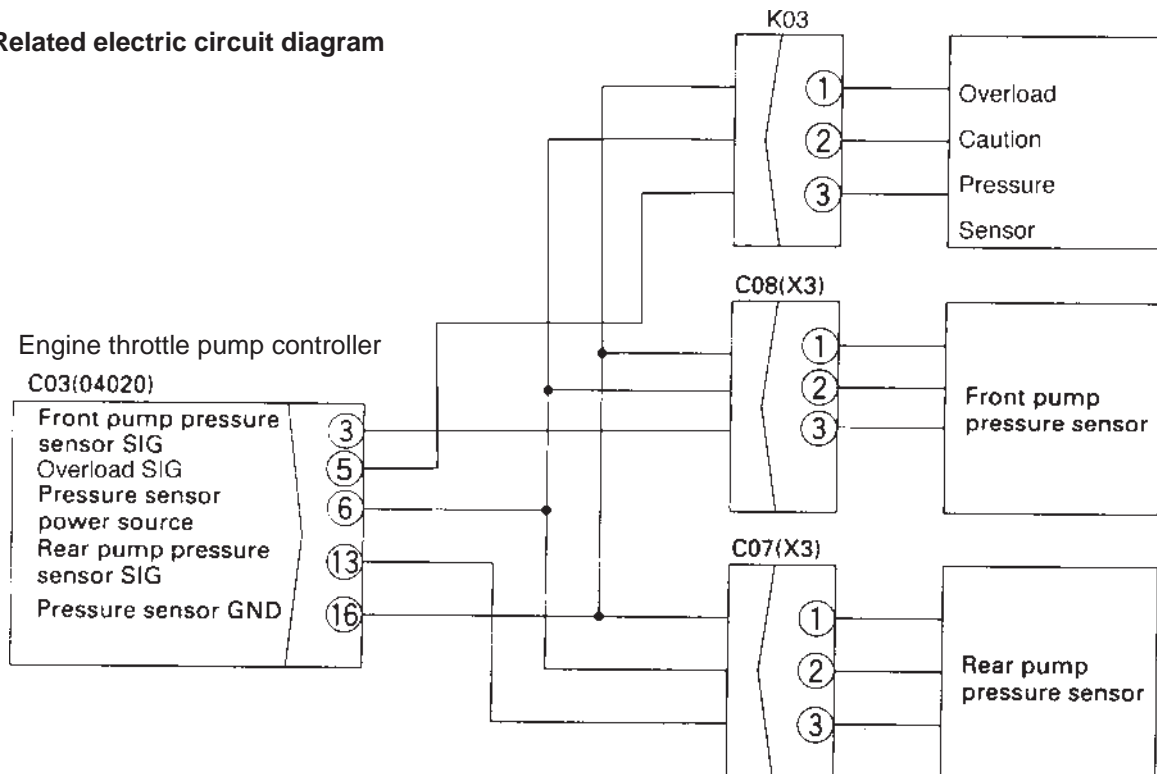

C-20 [E227] Abnormality in engine speed sensor system is displayed

- ★ This troubleshooting is carried out when there is still an abnormality, so when disconnecting the connector and inserting the T-adaptor, or when removing the T-adaptor and returning the connector to its original position, if an E service code is not displayed, the problem has been removed.
- ★ If the starting switch is turned OFF after an abnormality occurs, turn the starting switch ON and check if an E service code is displayed. (If it is not displayed, the problem had been removed).
- ★ Before carrying out troubleshooting, check that all related connectors are properly inserted.
- ★ Always connect any disconnected connectors before going on the next step.

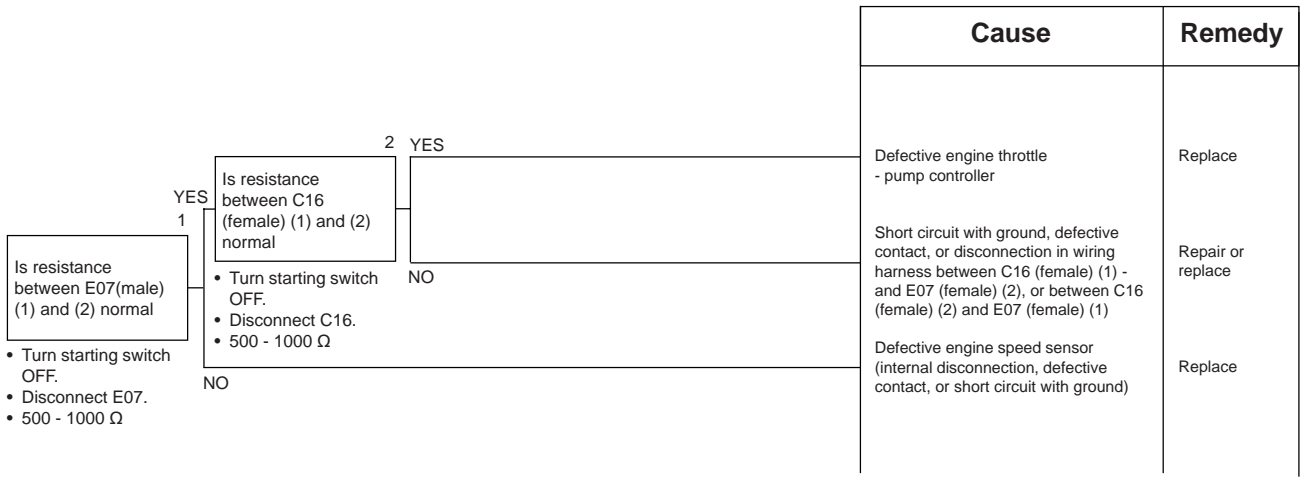

C-20 Related electric circuit diagram

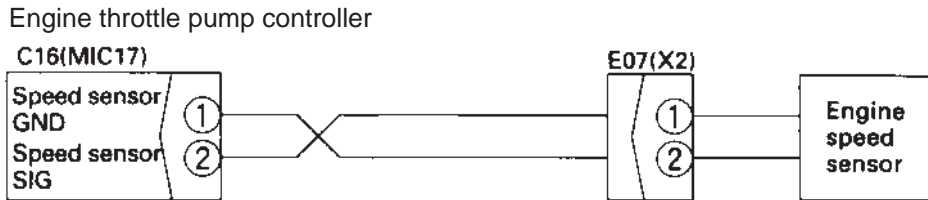

BKP00255

TROUBLESHOOTING OF ENGINE THROTTLE • PUMP CONTROLLER (INPUT SIGNAL SYSTEM) (F MODE)

F-1 Bit pattern 20 - (1) Swing oil pressure switch does not light up

★ This troubleshooting is carried out when there is still an abnormality, so when disconnecting the connector and inserting the T-adapter, or when removing the T-adapter and returning the connector to its original position, if an E service code is not displayed, the problem has been removed.

⚠ Turn swing lock switch ON before operating the swing lever.

★ If there is no display when the lever is operated on one side, the PPC shuttle valve is defective. (See H-5) (When measuring with the engine stopped, charge the accumulator first). *! Before carrying out troubleshooting, check that all related connectors are properly inserted.

★ Always connect any disconnected connectors before going on the next step.

	Cause	Remedy
<div style="display: flex; align-items: flex-start;"> <div style="margin-right: 20px;"> <p>1</p> <p>Is voltage between C16 (5) and chassis normal?</p> <ul style="list-style-type: none"> Start engine Swing lever at neutral : 20 - 30 V Swing lever operated : Max. 1V </div> <div> <p>YES</p> <hr/> <p>2</p> <p>Is resistance between S08 (male) (1) and (2) normal, and is circuit insulated from chassis?</p> <ul style="list-style-type: none"> Disconnect S08. Start engine. Swing lever at neutral : Min. 1MΩ Swing lever operated: Max. 1 Ω See Note 1. </div> <div style="margin-left: 20px;"> <p>NO</p> <hr/> <p>3</p> <p>Is resistance between C16 (female) (5) and S08 (female) (2) normal, and is circuit insulated from chassis?</p> <ul style="list-style-type: none"> Turn starting switch OFF. Disconnect C16 and S08. Between C16 and S08: Max. 1Ω Between wiring harness and chassis: No continuity </div> </div>	Defective engine throttle - pump controller	Replace
	Defective contact, or disconnection in wiring harness between S08 (female) (1) and chassis ground	Repair or replace
	Defective contact, short circuit with ground, or disconnection in wiring harness between C16 (female) (5) and S08 (female) (2)	Repair or replace
	Defective swing oil pressure switch (If the condition does not return to normal even when the switch is replaced, go to H-5.	Replace

Note 1: It is also possible to fit a short connector and judge the condition. In this case, check the voltage between C16 (5) and the chassis.

- If it is 20-30 V: go to YES
- If it is less than 1V: Go to NO

F-1 Related electric circuit diagram

Engine throttle pump controller

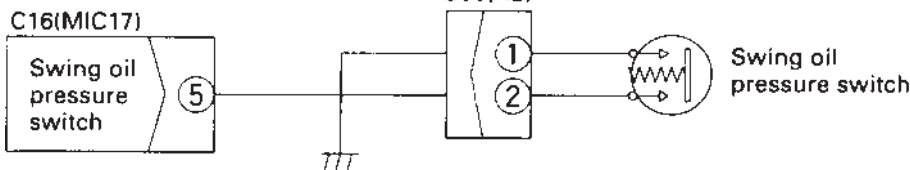

BKP00257

F-2 Bit pattern 20-(2) Travel oil pressure switch does not light up

★ This troubleshooting is carried out when there is still an abnormality, so when disconnecting the connector and inserting the T-adaptor, or when removing the T-adaptor and returning the connector to its original position, if an E service code is not displayed, the problem has been removed.

⚠ Turn swing lock switch ON before operating the swing lever.

- ★ If there is no display when the lever is operated on one side, the PPC shuttle valve is defective. (See H-5) (When measuring with the engine stopped, charge the accumulator first).
- ★ Before carrying out troubleshooting, check that all related connectors are properly inserted.
- ★ Always connect any disconnected connectors before going on the next step.

	Cause	Remedy
<p>1</p> <p>Is voltage between C16 (13) and chassis normal?</p> <ul style="list-style-type: none"> • Start engine • Swing lever at neutral : 20 - 30 V • Travel lever operated : Max. 1V <p>YES</p> <p>NO</p>	<p>Defective engine throttle - pump controller</p>	<p>Replace</p>
<p>2</p> <p>Is resistance between S01(male) (1) and (2) normal, and is circuit insulated from chassis?</p> <ul style="list-style-type: none"> • Disconnect S01. • Start engine. • Travel lever at neutral : Min. 1MΩ • Travel lever operated: Max. 1 Ω • See Note 1. <p>YES</p> <p>NO</p>	<p>Defective contact, or disconnection in wiring harness between S01(female) (1) and chassis ground</p>	<p>Repair or replace</p>
<p>3</p> <p>Is resistance between C16 (female) (13) and S01 (female) (2) normal, and is circuit insulated from chassis?</p> <ul style="list-style-type: none"> • Turn starting switch OFF. • Disconnect C16 and S01. • Between C16 and S01: Max. 1Ω • Between wiring harness and chassis: No continuity <p>YES</p> <p>NO</p>	<p>Defective contact, short circuit with ground, or disconnection in wiring harness between C16 (female) (13) and S01 (female) (2)</p>	<p>Repair or replace</p>
	<p>Defective swing oil pressure switch (If the condition does not return to normal even when the switch is replaced, go to H-5.</p>	<p>Replace</p>

Note 1: It is also possible to fit a short connector and judge the condition. In this case, check the voltage between C16 (13) and the chassis.

- If it is 20-30 V: go to YES
- If it is less than 1V: Go to NO

F-2 Related electric circuit diagram

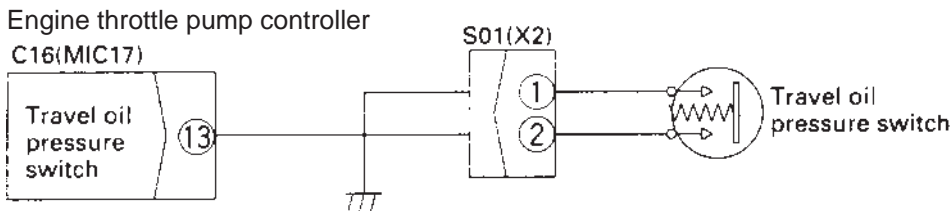

BK.P00258

F-3 Bit pattern 20-(3) Boom LOWER oil pressure switch does not light up

★ This troubleshooting is carried out when there is still an abnormality, so when disconnecting the connector and inserting the T-adaptor, or when removing the T-adaptor and returning the connector to its original position, if an E service code is not displayed, the problem has been removed.

⚠ When measuring with the engine running, operate the lever slightly and make sure that the work equipment does not move. (When measuring with the engine stopped, charge the accumulator first).

★ Before carrying out troubleshooting, check that all related connectors are properly inserted.

★ Always connect any disconnected connectors before going on the next step.

		Cause	Remedy		
<p>1</p> <p>Is voltage between C17 (10) and chassis normal?</p> <ul style="list-style-type: none"> Start engine Boom lever at neutral : 20 - 30 V Boom lever operated to LOWER: Max. 1V 	YES	Defective engine throttle - pump controller	Replace		
	NO	<p>2</p> <p>Is resistance between S04 (male) (1) and (2) normal, and is circuit insulated from chassis?</p> <ul style="list-style-type: none"> Disconnect S04. Start engine. Boom lever at neutral : Min. 1MΩ Boom lever operated to LOWER: Max. 1 Ω See Note 1. 	<p>3 YES</p> <p>Is resistance between C17 (female) (10) and S04 (female) (2) normal, and is circuit insulated from chassis?</p> <ul style="list-style-type: none"> Turn starting switch OFF. Disconnect C17 and S04. Between C17 and S04: Max. 1Ω Between wiring harness and chassis: No continuity 	<p>Defective contact, or disconnection in wiring harness between S04 (female) (1) and chassis ground</p> <p>Defective contact, short circuit with ground, or disconnection in wiring harness between C17 (female) (10) - H13 (11) - S04 (female) (2)</p>	<p>Repair or replace</p> <p>Repair or replace</p>
	NO	<p>3 NO</p> <p>Is resistance between C17 (female) (10) and S04 (female) (2) normal, and is circuit insulated from chassis?</p> <ul style="list-style-type: none"> Turn starting switch OFF. Disconnect C17 and S04. Between C17 and S04: Max. 1Ω Between wiring harness and chassis: No continuity 	Defective boom LOWER oil pressure switch (If the condition does not return to normal even when the switch is replaced, go to H-5).	Replace	

Note 1: It is also possible to fit a short connector and judge the condition. In this case, check the voltage between C17 (10) and the chassis.

- If it is 20-30 V: go to YES
- If it is less than 1V: Go to NO

F-3 Related electric circuit diagram

Engine throttle pump controller

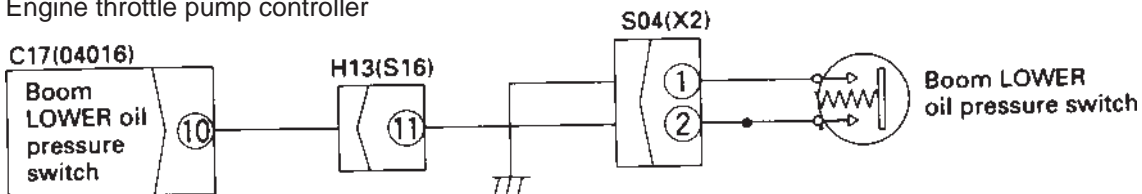

BK P00259

F-4 Bit pattern 20-(4) Boom RAISE oil pressure switch does not light up

- ★ This troubleshooting is carried out when there is still an abnormality, so when disconnecting the connector and inserting the T-adaptor, or when removing the T-adaptor and returning the connector to its original position, if an E service code is not displayed, the problem has been removed.
- ⚠ When measuring with the engine running, operate the lever slightly and make sure that the work equipment does not move. (When measuring with the engine stopped, charge the accumulator first).
- ★ Before carrying out troubleshooting, check that all related connectors are properly inserted.
- ★ Always connect any disconnected connectors before going on the next step.

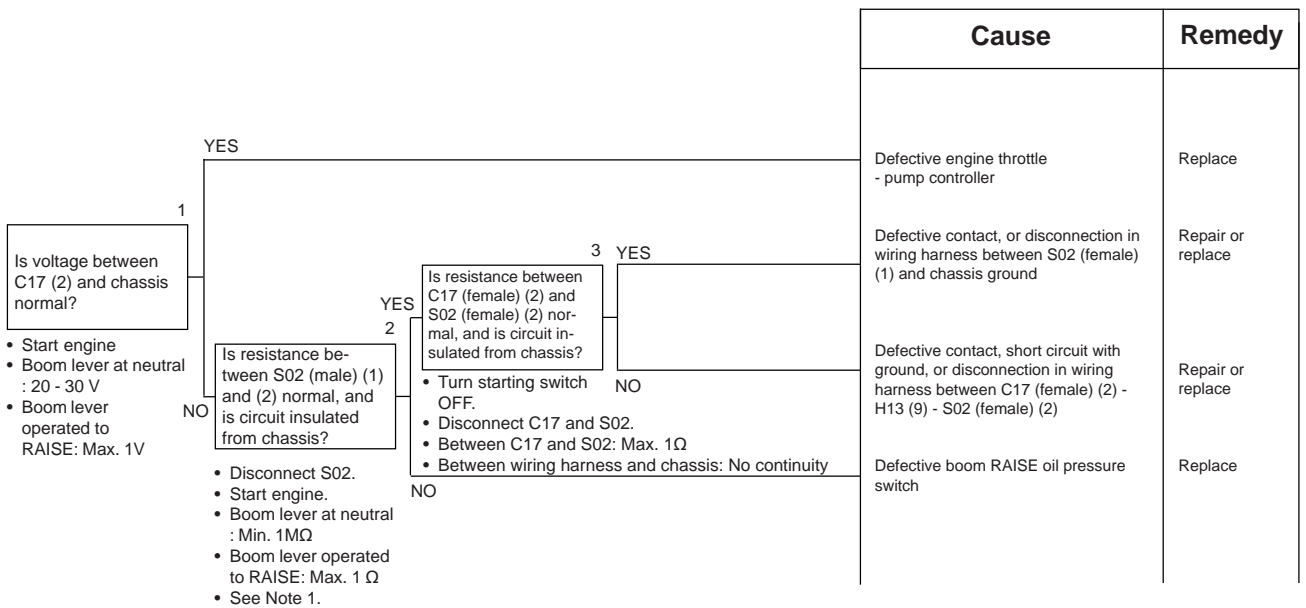

Note 1: It is also possible to fit a short connector and judge the condition. In this case, check the voltage between C17 (2) and the chassis.

- If it is 20-30 V: go to YES
- If it is less than 1V: Go to NO

F-4 Related electric circuit diagram

Engine throttle pump controller

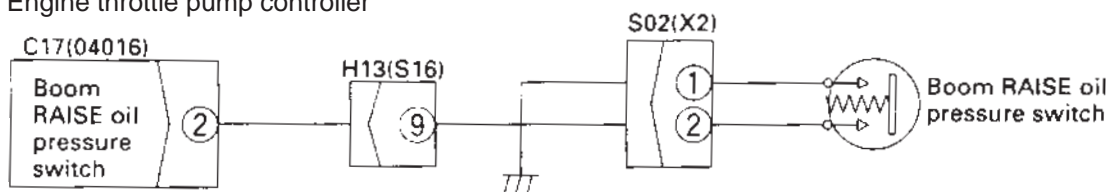

BKP00260

F-5 Bit pattern 20-(5) Arm IN oil pressure switch does not light up

- ★ This troubleshooting is carried out when there is still an abnormality, so when disconnecting the connector and inserting the T-adapter, or when removing the T-adapter and returning the connector to its original position, if an E service code is not displayed, the problem has been removed.
- ⚠ When measuring with the engine running, operate the lever slightly and make sure that the work equipment does not move. (When measuring with the engine stopped, charge the accumulator first).
- ★ Before carrying out troubleshooting, check that all related connectors are properly inserted.
- ★ Always connect any disconnected connectors before going on the next step.

		Cause	Remedy		
<p>1</p> <p>Is voltage between C17 (3) and chassis normal?</p> <ul style="list-style-type: none"> • Start engine • Arm lever at neutral : 20 - 30 V • Arm lever operated to IN: Max. 1V 	YES	Defective engine throttle - pump controller	Replace		
	NO	<p>2</p> <p>Is resistance between S05 (male) (1) and (2) normal, and is circuit insulated from chassis?</p> <ul style="list-style-type: none"> • Disconnect S05. • Start engine. • Arm lever at neutral : Min. 1MΩ • Arm lever operated to IN: Max. 1 Ω • See Note 1. 	<p>3 YES</p> <p>Is resistance between C17 (female) (3) and S05 (female) (2) normal, and is circuit insulated from chassis?</p> <ul style="list-style-type: none"> • Turn starting switch OFF. • Disconnect C17 and S05. • Between C17 and S05: Max. 1Ω • Between wiring harness and chassis: No continuity 	<p>Defective contact, or disconnection in wiring harness between S05 (female) (1) and chassis ground</p> <p>Defective contact, short circuit with ground, or disconnection in wiring harness between C17 (female) (3) - H13 (10) - S05 (female) (2)</p>	<p>Repair or replace</p> <p>Repair or replace</p>
	NO		Defective arm IN oil pressure switch	Replace	

Note 1: It is also possible to fit a short connector and judge the condition. In this case, check the voltage between C17 (3) and the chassis.

- If it is 20-30 V: go to YES
- If it is less than 1V: Go to NO

F-5 Related electric circuit diagram

Engine throttle pump controller

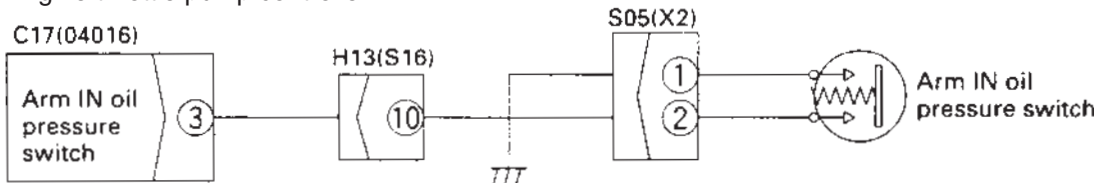

F-6 Bit pattern 20-(6) Arm OUT oil pressure switch does not light up

- ★ This troubleshooting is carried out when there is still an abnormality, so when disconnecting the connector and inserting the T-adapter, or when removing the T-adapter and returning the connector to its original position, if an E service code is not displayed, the problem has been removed.
- ⚠ When measuring with the engine running, operate the lever slightly and make sure that the work equipment does not move. (When measuring with the engine stopped, charge the accumulator first).
- ★ Before carrying out troubleshooting, check that all related connectors are properly inserted.
- ★ Always connect any disconnected connectors before going on the next step.

		Cause	Remedy	
<p>1</p> <p>Is voltage between C17 (11) and chassis normal?</p> <ul style="list-style-type: none"> • Start engine • Arm lever at neutral : 20 - 30 V • Arm lever operated to OUT: Max. 1V 	YES	Defective engine throttle - pump controller	Replace	
	NO	2	Is resistance between S03 (male) (1) and (2) normal, and is circuit insulated from chassis?	<ul style="list-style-type: none"> • Disconnect S03. • Start engine. • Arm lever at neutral : Min. 1MΩ • Arm lever operated to OUT: Max. 1 Ω • See Note 1.
	YES	3	Is resistance between C17 (female) (11) and S03 (female) (2) normal, and is circuit insulated from chassis?	
		NO	<ul style="list-style-type: none"> • Turn starting switch OFF. • Disconnect C17 and S03. • Between C17 and S03: Max. 1Ω • Between wiring harness and chassis: No continuity 	Defective contact, or disconnection in wiring harness between S03 (female) (1) and chassis ground Defective contact, short circuit with ground, or disconnection in wiring harness between C17 (female) (11) - H13 (12) - S03 (female) (2)
	NO		Defective arm OUT oil pressure switch	Replace

Note 1: It is also possible to fit a short connector and judge the condition. In this case, check the voltage between C17 (11) and the chassis.

- If it is 20-30 V: go to YES
- If it is less than 1V: Go to NO

F-6 Related electric circuit diagram

Engine throttle pump controller

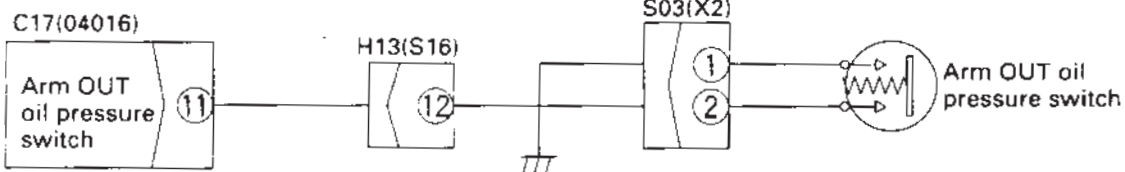

F-7 Bit pattern 21-(1) Bucket CURL oil pressure switch does not light up

★ This troubleshooting is carried out when there is still an abnormality, so when disconnecting the connector and inserting the T-adapter, or when removing the T-adapter and returning the connector to its original position, if an E service code is not displayed, the problem has been removed.

⚠ When measuring with the engine running, operate the lever slightly and make sure that the work equipment does not move. (When measuring with the engine stopped, charge the accumulator first).

★ Before carrying out troubleshooting, check that all related connectors are properly inserted.

★ Always connect any disconnected connectors before going on the next step.

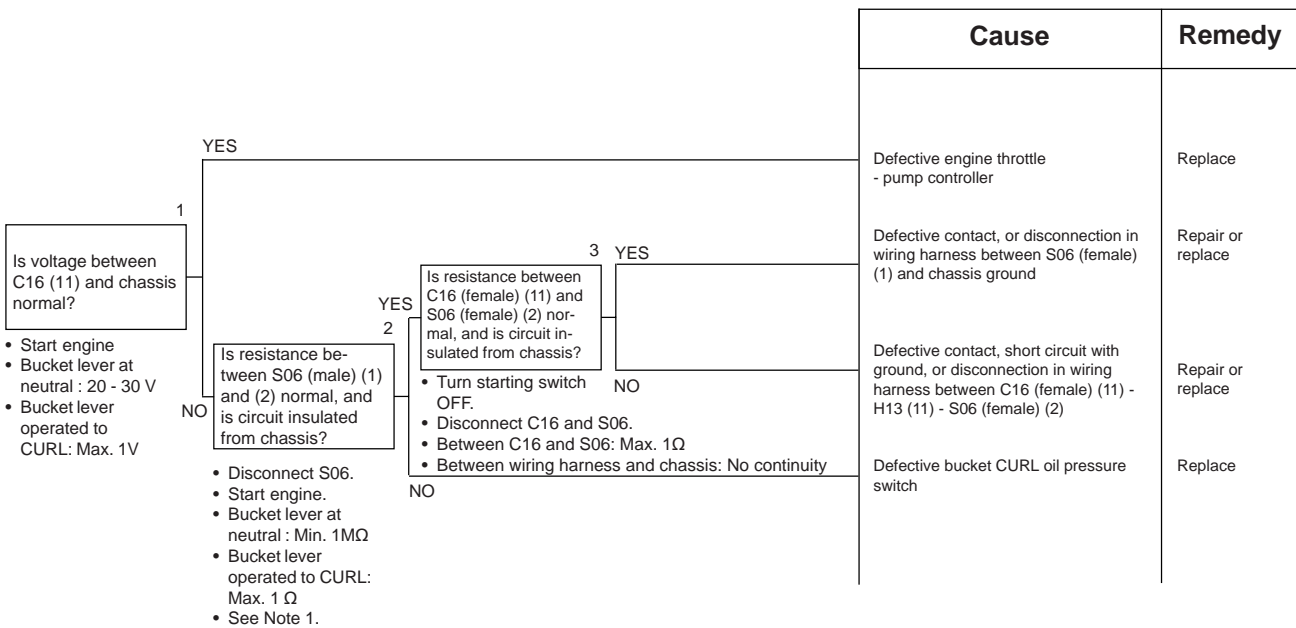

Note 1: It is also possible to fit a short connector and judge the condition. In this case, check the voltage between C16 (11) and the chassis.

- If it is 20-30 V: go to YES
- If it is less than 1V: Go to NO

F-7 Related electric circuit diagram

Engine throttle pump controller

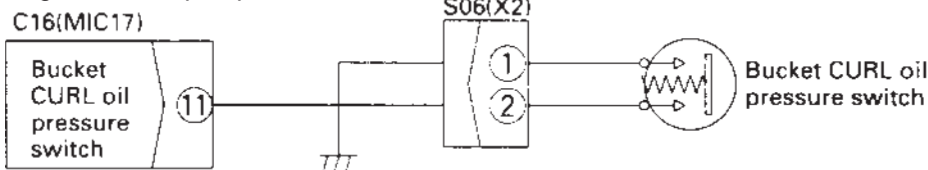

BKP00263

F-8 Bit pattern 21-(2) Bucket DUMP oil pressure switch does not light up

- ★ This troubleshooting is carried out when there is still an abnormality, so when disconnecting the connector and inserting the T-adaptor, or when removing the T-adaptor and returning the connector to its original position, if an E service code is not displayed, the problem has been removed.
- ⚠ When measuring with the engine running, operate the lever slightly and make sure that the work equipment does not move. (When measuring with the engine stopped, charge the accumulator first).
- ★ Before carrying out troubleshooting, check that all related connectors are properly inserted.
- ★ Always connect any disconnected connectors before going on the next step.

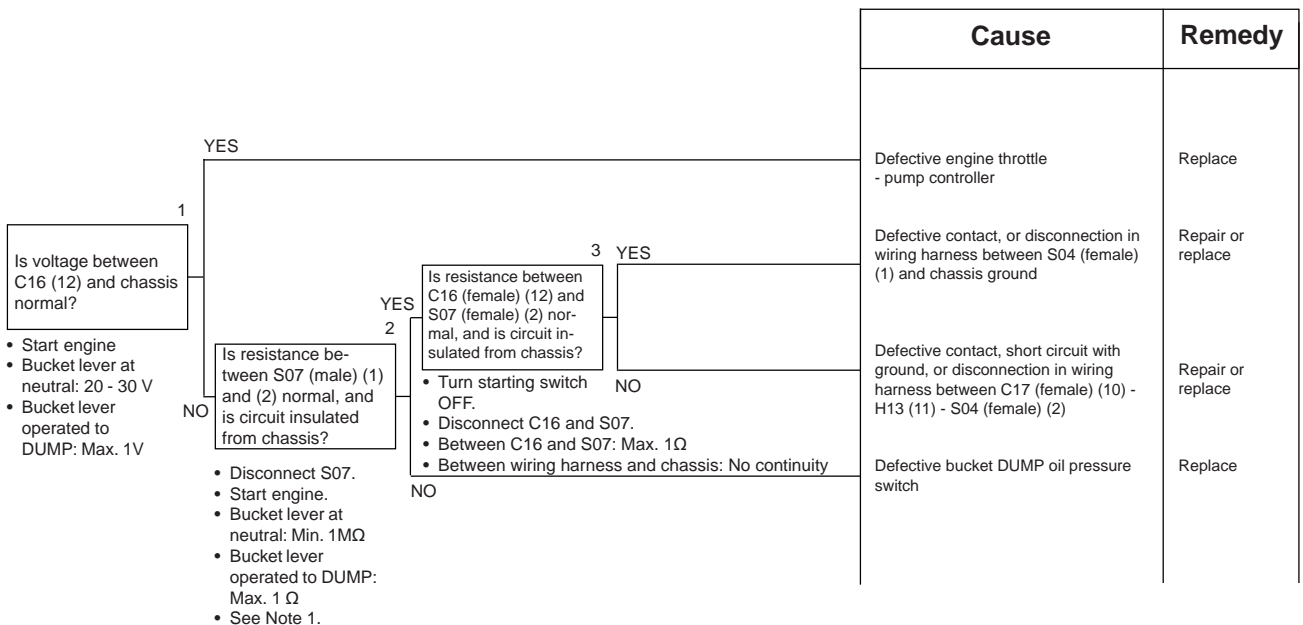

Note 1: It is also possible to fit a short connector and judge the condition. In this case, check the voltage between C16 (12) and the chassis.

- If it is 20-30 V: go to YES
- If it is less than 1V: Go to NO

F-8 Related electric circuit diagram

Engine throttle pump controller

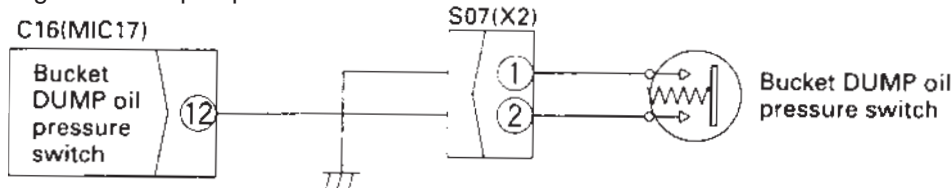

F-9 Bit pattern 21-(3) Swing lock switch does not light up

★ This troubleshooting is carried out when there is still an abnormality, so when disconnecting the connector and inserting the T-adaptor, or when removing the T-adaptor and returning the connector to its original position, if an E service code is not displayed, the problem has been removed.

⚠ When measuring with the engine running, operate the lever slightly and make sure that the work equipment does not move. (When measuring with the engine stopped, charge the accumulator first).

★ Before carrying out troubleshooting, check that all related connectors are properly inserted.

★ Always connect any disconnected connectors before going on the next step.

	Cause	Remedy
<div style="display: flex; justify-content: space-between;"> <div style="width: 45%;"> <p>1</p> <p>Is voltage between C17 (16) and chassis normal?</p> <ul style="list-style-type: none"> • Turn starting switch ON. • Swing lock switch ON: Max. 1V • OFF: 20 - 30V </div> <div style="width: 45%;"> <p>2</p> <p>Is resistance between X05 (female) (1) and (2) normal, and is circuit insulated from chassis?</p> <ul style="list-style-type: none"> • Turn starting switch OFF. • Disconnect X05 • Swing lock switch ON: Max. 1 Ω • OFF: Min 1 MΩ </div> </div> <div style="display: flex; justify-content: space-between; margin-top: 10px;"> <div style="width: 45%;"> <p>3</p> <p>Is resistance between C17 (female) (16) and X05 (female) (1) normal, and is circuit insulated from chassis?</p> <ul style="list-style-type: none"> • Turn starting switch OFF. • Disconnect C17 and X05. • Between C17 and X05: Max. 1Ω • Between wiring harness and chassis: No continuity </div> <div style="width: 45%;"> <p>4</p> <p>Is resistance between X05 (female) (1) and (2) normal, and is circuit insulated from chassis?</p> <ul style="list-style-type: none"> • Turn starting switch OFF. • Disconnect X05 • Swing lock switch ON: Max. 1 Ω • OFF: Min 1 MΩ </div> </div>	Defective engine throttle - pump controller	Replace
	Defective contact, short circuit with ground, or disconnection in wiring harness between X05 (female) (2) - X01 (5) - H14 (6) - chassis ground.	Repair or replace
	Defective contact, short circuit with ground, or disconnection in wiring harness between C17 (female) (16) - X01 (4) - X05 (male) (1)	Repair or replace
	Defective swing lock switch	Replace

F-9 Related electric circuit diagram

Engine throttle pump controller

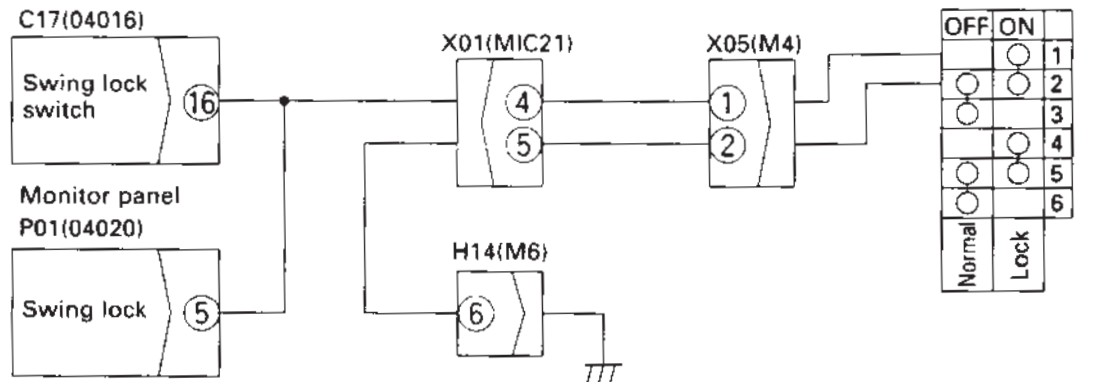

BKP00265

F-11 Bit pattern 22-(6) L.H. knob switch does not light up

- ★ This troubleshooting is carried out when there is still an abnormality, so when disconnecting the connector and inserting the T-adaptor, or when removing the T-adaptor and returning the connector to its original position, if an E service code is not displayed, the problem has been removed.
- ★ When fuse No. 5 is not blown.
- ★ Before carrying out troubleshooting, check that all related connectors are properly inserted.
- ★ Always connect any disconnected connectors before going on the next step.

	Cause	Remedy
<p>1</p> <p>Is voltage between C03 (9) and chassis normal?</p> <ul style="list-style-type: none"> • Turn starting switch ON. • Knob switch ON: 20 - 30V OFF: Max. 1V <p>YES</p> <p>2</p> <p>Is voltage between knob switch inlet terminal and chassis normal?</p> <ul style="list-style-type: none"> • Turn starting switch ON. • 20 - 30V <p>NO</p> <p>3</p> <p>Is resistance between terminals of knob switch normal?</p> <ul style="list-style-type: none"> • Turn starting switch OFF. • Disconnect switch terminal. • Knob switch ON: Max. 1 Ω OFF: No continuity <p>YES</p> <p>NO</p>	<p>Defective engine throttle - pump controller</p> <p>Defective contact, or disconnection in wiring harness between knob switch outlet - M23 (2) - M22 (2) C03 (female) (9)</p> <p>Defective L.H. knob switch</p> <p>Defective contact, or disconnection in wiring harness between fuse No. 5 - H12 (16) - M22 (1) - H23 (1) - knob switch inlet</p>	<p>Replace</p> <p>Repair wiring harness</p> <p>Replace</p> <p>Repair wiring harness</p>

F-11 Related electric circuit diagram

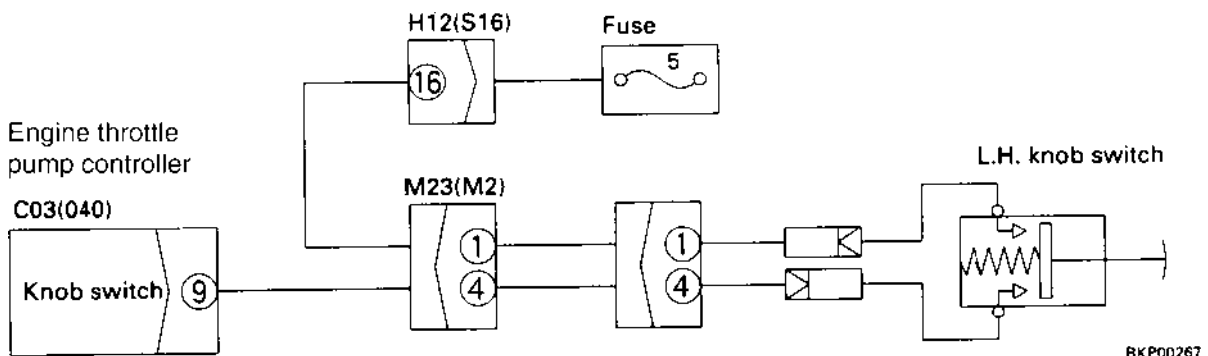

MEMORANDA

TROUBLESHOOTING OF HYDRAULIC AND MECHANICAL SYSTEM (H-MODE)

TABLE OF FAILURE MODES AND CAUSES FOR HYDRAULIC AND MECHANICAL SYSTEM

Failure mode		Parts causing failure								Self pressure reducing valve	Strainer	Damper
		Piston pump										
		F		R								
		PC valve	LS valve	Servo piston	Pump prooper	PC valve	LS valve	Servo piston	Pump proper			
All work equipment, travel, swing	Speeds of all work equipment, swing, travel are slow or lack power	▲	▲	▲	▲	▲	▲	▲	▲	○		
	There is excessive drop in engine speed, or engine stalls	○	○	○		○	○	○				
	No work equipment, travel, swing move				△				△	○		○
	Abnormal noise generated (around pump)				○				○		○	
	Auto-deceleration does not work											
	Fine control ability is poor or response is poor		○	○		○	○					
Work equipment	Boom is slow or lacks power											
	Arm is slow or lacks power											
	Bucket is slow or lacks power											
	Boom does not move											
	Arm does not move											
	Bucket does not move											
	Excessive hydraulic drift											
	Excessive time lag (engine at low idling)											
	Other equipment moves when single circuit is relieved											
	Lack of power when pressure rises											
	In L/O, F/O modes, work equipment speed is faster than specified speed		○				○					
	In compound operations, work equipment with larger load is slow											
Compound operations	In swing + boom (RAISE), boom is slow											
	In swing + arm, arm is slow											
	In swing + travel, travel speed drops excessively											
Travel system	Travel deviation											
	Travel speed is slow											
	Steering does not turn or lacks power											
	Travel speed does not switch or is faster than specified speed											
Swing system	Does not swing											
	Swing acceleration is poor or swing speed is slow											
	Excessive overrun when stopping swing											
	Excessive shock when stopping swing (one direction only)											
	Excessive abnormal noise when stopping swing											
	Excessive hydraulic drift of swing											
Swing speed is faster than specified swing speed		○										

In the failure modes, modes for compound operations are used when independent operations are normal
 ▲ When there is an abnormality for both front and rear

		Control valve																						
Spool	For front pump		For rear pump		Pressure compensation valve	Pump merge divider valve		Main circuit check valve	LS circuit check valve	LS shuttle valve	LS circuit throttle	Regeneration circuit		Safety-suction valve	Suction valve	Slow return valve for pump merge divider	PPC valve	Travel PPC shuttle	Safety lock valve	Swing PPC slow return valve	Swivel joint	Engine system	Troubleshooting code	
	Main relief valve	Unload valve	Main relief valve	Unload valve		For main	For LS					Boom	Arm											
	▲																							H-1
	▲																						○	H-2
	▲																							H-3
	▲																							H-4
																								H-5
																								H-6
																								H-7
																								H-8
																								H-9
																								H-10
																								H-11
																								H-12
																								H-13
																								H-14
																								H-15
																								H-16
																								H-17
																								H-18
																								H-19
																								H-20
																								H-21
																								H-22
																								H-23
																								H-24
																								H-25
																								H-26
																								H-27
																								H-28
																								H-29
																								H-30

X02CH083

Failure mode		Parts causing failure									
		Solenoid valve					Swing motor				
		PC-EPC	LS select	Pump merge-divider	2-stage relief	Travel speed select	Swing brake	Holding brake	Safety valve	Suction valve	Leakage, breakage inside body
All work equipment, travel, swing	Speeds of all work equipment, swing, travel are slow or lack power	○									
	There is excessive drop in engine speed, or engine stalls										
	No work equipment, travel, swing move										
	Abnormal noise generated (around pump)										
	Auto-deceleration does not work										
	Fine control ability is poor or response is poor	○									
Work equipment	Boom is slow or lacks power										
	Arm is slow or lacks power			○							
	Bucket is slow or lacks power			○							
	Boom does not move										
	Arm does not move										
	Bucket does not move										
	Excessive hydraulic drift										
	Excessive time lag (engine at low idling)	○									
	Other equipment moves when single circuit is relieved										
	Lack of power when pressure rises				○						
	In L/O, F/O modes, work equipment speed is faster than specified speed	○	○								
	Compound operations	In compound operations, work equipment with larger load is slow									
In swing + boom (RAISE), boom is slow			○								
In swing + travel, travel speed drops excessively											
Travel system	Travel deviation										
	Deviation excessive										
	Deviation is excessive when starting										
	Travel speed is slow	○									
Swing system	Steering does not turn or lacks power			○	○						
	Travel speed does not switch or is faster than set speed	○				○					
	Does not move (one side only)										
	Does not swing						○	○			○
									○		
Swing system	Swing acceleration is poor or swing speed is slow										○
									○	○	
	Excessive overrun when stopping swing								○		○
	Excessive shock when stopping swing (one direction only)										
	Excessive abnormal noise when stopping swing								○	○	
	Excessive hydraulic drift of swing								○	○	○
									○	○	
Swing speed is faster than specified swing speed	○	○									

- ★ In the failure modes, modes for compound operations are used when independent operations are normal
- ▲ When there is an abnormality for both front and rear

PUMP MERGE/DIVIDER LOGIC

Flow divided	Flow merged																								
Solenoid ON (excited)	Solenoid OFF (de-energized)																								
<ul style="list-style-type: none"> Breaker mode + service switch ON 																									
<ul style="list-style-type: none"> In L/O mode, except for Conditions 1), 2), or 3) <ol style="list-style-type: none"> Any of travel + (boom or arm or bucket or swing) operated independently Any of travel + (boom or arm or bucket or swing) operated simultaneously Swing + boom RAISE (hoist swing) 	<ul style="list-style-type: none"> In L/O mode, under Conditions 1), 2), 3) <ol style="list-style-type: none"> Any of travel + (boom or arm or bucket or swing) operated independently Any of travel + (boom or arm or bucket or swing) operated simultaneously Swing + boom RAISE (hoist swing) 																								
<ul style="list-style-type: none"> In other modes (breaker mode + service switch ON or any other mode except L/O mode) <table border="1" style="margin-left: 20px;"> <tr> <td> <ul style="list-style-type: none"> Independent operation of travel <table border="1" style="margin-left: 20px;"> <tr> <td> <ul style="list-style-type: none"> With travel OFF <table border="1" style="margin-left: 20px;"> <tr> <td> <ul style="list-style-type: none"> Swing lock switch OFF <table border="1" style="margin-left: 20px;"> <tr> <td> <ul style="list-style-type: none"> F/O mode + arm IN </td> <td style="text-align: center;">a</td> </tr> <tr> <td> <ul style="list-style-type: none"> Operation except operation a except in active mode (in standard mode) + swing OFF <table border="1" style="margin-left: 20px;"> <tr> <td> <ul style="list-style-type: none"> Arm OUT + service ON + pressure sensor (F pump pressure or R pump pressure) more than 19.6 MPa (200 kg/cm²) </td> <td style="text-align: center;">b</td> </tr> </table> </td> <td></td> </tr> </table> </td> <td></td> </tr> </table> </td> </tr> </table> </td> <td> <ul style="list-style-type: none"> In other modes (breaker mode + service switch ON or any other mode except L/O mode) <table border="1" style="margin-left: 20px;"> <tr> <td> <ul style="list-style-type: none"> Compound operation of travel (Travel + other work equipment) <table border="1" style="margin-left: 20px;"> <tr> <td> <ul style="list-style-type: none"> With travel OFF <table border="1" style="margin-left: 20px;"> <tr> <td> <ul style="list-style-type: none"> With swing lock switch ON </td> <td></td> </tr> <tr> <td> <ul style="list-style-type: none"> With swing lock switch OFF <table border="1" style="margin-left: 20px;"> <tr> <td> <ul style="list-style-type: none"> Except operation a on left, in active mode </td> <td></td> </tr> <tr> <td> <ul style="list-style-type: none"> Except operation a on left, and except in active mode <table border="1" style="margin-left: 20px;"> <tr> <td> <ul style="list-style-type: none"> With swing ON </td> <td></td> </tr> <tr> <td> <ul style="list-style-type: none"> With swing OFF except operation b on left </td> <td></td> </tr> </table> </td> <td></td> </tr> </table> </td> <td></td> </tr> </table> </td> </tr> </table> </td> </tr> </table></td></tr></table>	<ul style="list-style-type: none"> Independent operation of travel <table border="1" style="margin-left: 20px;"> <tr> <td> <ul style="list-style-type: none"> With travel OFF <table border="1" style="margin-left: 20px;"> <tr> <td> <ul style="list-style-type: none"> Swing lock switch OFF <table border="1" style="margin-left: 20px;"> <tr> <td> <ul style="list-style-type: none"> F/O mode + arm IN </td> <td style="text-align: center;">a</td> </tr> <tr> <td> <ul style="list-style-type: none"> Operation except operation a except in active mode (in standard mode) + swing OFF <table border="1" style="margin-left: 20px;"> <tr> <td> <ul style="list-style-type: none"> Arm OUT + service ON + pressure sensor (F pump pressure or R pump pressure) more than 19.6 MPa (200 kg/cm²) </td> <td style="text-align: center;">b</td> </tr> </table> </td> <td></td> </tr> </table> </td> <td></td> </tr> </table> </td> </tr> </table> 	<ul style="list-style-type: none"> With travel OFF <table border="1" style="margin-left: 20px;"> <tr> <td> <ul style="list-style-type: none"> Swing lock switch OFF <table border="1" style="margin-left: 20px;"> <tr> <td> <ul style="list-style-type: none"> F/O mode + arm IN </td> <td style="text-align: center;">a</td> </tr> <tr> <td> <ul style="list-style-type: none"> Operation except operation a except in active mode (in standard mode) + swing OFF <table border="1" style="margin-left: 20px;"> <tr> <td> <ul style="list-style-type: none"> Arm OUT + service ON + pressure sensor (F pump pressure or R pump pressure) more than 19.6 MPa (200 kg/cm²) </td> <td style="text-align: center;">b</td> </tr> </table> </td> <td></td> </tr> </table> </td> <td></td> </tr> </table> 	<ul style="list-style-type: none"> Swing lock switch OFF <table border="1" style="margin-left: 20px;"> <tr> <td> <ul style="list-style-type: none"> F/O mode + arm IN </td> <td style="text-align: center;">a</td> </tr> <tr> <td> <ul style="list-style-type: none"> Operation except operation a except in active mode (in standard mode) + swing OFF <table border="1" style="margin-left: 20px;"> <tr> <td> <ul style="list-style-type: none"> Arm OUT + service ON + pressure sensor (F pump pressure or R pump pressure) more than 19.6 MPa (200 kg/cm²) </td> <td style="text-align: center;">b</td> </tr> </table> </td> <td></td> </tr> </table> 	<ul style="list-style-type: none"> F/O mode + arm IN 	a	<ul style="list-style-type: none"> Operation except operation a except in active mode (in standard mode) + swing OFF <table border="1" style="margin-left: 20px;"> <tr> <td> <ul style="list-style-type: none"> Arm OUT + service ON + pressure sensor (F pump pressure or R pump pressure) more than 19.6 MPa (200 kg/cm²) </td> <td style="text-align: center;">b</td> </tr> </table> 	<ul style="list-style-type: none"> Arm OUT + service ON + pressure sensor (F pump pressure or R pump pressure) more than 19.6 MPa (200 kg/cm²) 	b			<ul style="list-style-type: none"> In other modes (breaker mode + service switch ON or any other mode except L/O mode) <table border="1" style="margin-left: 20px;"> <tr> <td> <ul style="list-style-type: none"> Compound operation of travel (Travel + other work equipment) <table border="1" style="margin-left: 20px;"> <tr> <td> <ul style="list-style-type: none"> With travel OFF <table border="1" style="margin-left: 20px;"> <tr> <td> <ul style="list-style-type: none"> With swing lock switch ON </td> <td></td> </tr> <tr> <td> <ul style="list-style-type: none"> With swing lock switch OFF <table border="1" style="margin-left: 20px;"> <tr> <td> <ul style="list-style-type: none"> Except operation a on left, in active mode </td> <td></td> </tr> <tr> <td> <ul style="list-style-type: none"> Except operation a on left, and except in active mode <table border="1" style="margin-left: 20px;"> <tr> <td> <ul style="list-style-type: none"> With swing ON </td> <td></td> </tr> <tr> <td> <ul style="list-style-type: none"> With swing OFF except operation b on left </td> <td></td> </tr> </table> </td> <td></td> </tr> </table> </td> <td></td> </tr> </table> </td> </tr> </table> </td> </tr> </table>	<ul style="list-style-type: none"> Compound operation of travel (Travel + other work equipment) <table border="1" style="margin-left: 20px;"> <tr> <td> <ul style="list-style-type: none"> With travel OFF <table border="1" style="margin-left: 20px;"> <tr> <td> <ul style="list-style-type: none"> With swing lock switch ON </td> <td></td> </tr> <tr> <td> <ul style="list-style-type: none"> With swing lock switch OFF <table border="1" style="margin-left: 20px;"> <tr> <td> <ul style="list-style-type: none"> Except operation a on left, in active mode </td> <td></td> </tr> <tr> <td> <ul style="list-style-type: none"> Except operation a on left, and except in active mode <table border="1" style="margin-left: 20px;"> <tr> <td> <ul style="list-style-type: none"> With swing ON </td> <td></td> </tr> <tr> <td> <ul style="list-style-type: none"> With swing OFF except operation b on left </td> <td></td> </tr> </table> </td> <td></td> </tr> </table> </td> <td></td> </tr> </table> </td> </tr> </table> 	<ul style="list-style-type: none"> With travel OFF <table border="1" style="margin-left: 20px;"> <tr> <td> <ul style="list-style-type: none"> With swing lock switch ON </td> <td></td> </tr> <tr> <td> <ul style="list-style-type: none"> With swing lock switch OFF <table border="1" style="margin-left: 20px;"> <tr> <td> <ul style="list-style-type: none"> Except operation a on left, in active mode </td> <td></td> </tr> <tr> <td> <ul style="list-style-type: none"> Except operation a on left, and except in active mode <table border="1" style="margin-left: 20px;"> <tr> <td> <ul style="list-style-type: none"> With swing ON </td> <td></td> </tr> <tr> <td> <ul style="list-style-type: none"> With swing OFF except operation b on left </td> <td></td> </tr> </table> </td> <td></td> </tr> </table> </td> <td></td> </tr> </table> 	<ul style="list-style-type: none"> With swing lock switch ON 		<ul style="list-style-type: none"> With swing lock switch OFF <table border="1" style="margin-left: 20px;"> <tr> <td> <ul style="list-style-type: none"> Except operation a on left, in active mode </td> <td></td> </tr> <tr> <td> <ul style="list-style-type: none"> Except operation a on left, and except in active mode <table border="1" style="margin-left: 20px;"> <tr> <td> <ul style="list-style-type: none"> With swing ON </td> <td></td> </tr> <tr> <td> <ul style="list-style-type: none"> With swing OFF except operation b on left </td> <td></td> </tr> </table> </td> <td></td> </tr> </table> 	<ul style="list-style-type: none"> Except operation a on left, in active mode 		<ul style="list-style-type: none"> Except operation a on left, and except in active mode <table border="1" style="margin-left: 20px;"> <tr> <td> <ul style="list-style-type: none"> With swing ON </td> <td></td> </tr> <tr> <td> <ul style="list-style-type: none"> With swing OFF except operation b on left </td> <td></td> </tr> </table> 	<ul style="list-style-type: none"> With swing ON 		<ul style="list-style-type: none"> With swing OFF except operation b on left 			
<ul style="list-style-type: none"> Independent operation of travel <table border="1" style="margin-left: 20px;"> <tr> <td> <ul style="list-style-type: none"> With travel OFF <table border="1" style="margin-left: 20px;"> <tr> <td> <ul style="list-style-type: none"> Swing lock switch OFF <table border="1" style="margin-left: 20px;"> <tr> <td> <ul style="list-style-type: none"> F/O mode + arm IN </td> <td style="text-align: center;">a</td> </tr> <tr> <td> <ul style="list-style-type: none"> Operation except operation a except in active mode (in standard mode) + swing OFF <table border="1" style="margin-left: 20px;"> <tr> <td> <ul style="list-style-type: none"> Arm OUT + service ON + pressure sensor (F pump pressure or R pump pressure) more than 19.6 MPa (200 kg/cm²) </td> <td style="text-align: center;">b</td> </tr> </table> </td> <td></td> </tr> </table> </td> <td></td> </tr> </table> </td> </tr> </table> 	<ul style="list-style-type: none"> With travel OFF <table border="1" style="margin-left: 20px;"> <tr> <td> <ul style="list-style-type: none"> Swing lock switch OFF <table border="1" style="margin-left: 20px;"> <tr> <td> <ul style="list-style-type: none"> F/O mode + arm IN </td> <td style="text-align: center;">a</td> </tr> <tr> <td> <ul style="list-style-type: none"> Operation except operation a except in active mode (in standard mode) + swing OFF <table border="1" style="margin-left: 20px;"> <tr> <td> <ul style="list-style-type: none"> Arm OUT + service ON + pressure sensor (F pump pressure or R pump pressure) more than 19.6 MPa (200 kg/cm²) </td> <td style="text-align: center;">b</td> </tr> </table> </td> <td></td> </tr> </table> </td> <td></td> </tr> </table> 	<ul style="list-style-type: none"> Swing lock switch OFF <table border="1" style="margin-left: 20px;"> <tr> <td> <ul style="list-style-type: none"> F/O mode + arm IN </td> <td style="text-align: center;">a</td> </tr> <tr> <td> <ul style="list-style-type: none"> Operation except operation a except in active mode (in standard mode) + swing OFF <table border="1" style="margin-left: 20px;"> <tr> <td> <ul style="list-style-type: none"> Arm OUT + service ON + pressure sensor (F pump pressure or R pump pressure) more than 19.6 MPa (200 kg/cm²) </td> <td style="text-align: center;">b</td> </tr> </table> </td> <td></td> </tr> </table> 	<ul style="list-style-type: none"> F/O mode + arm IN 	a	<ul style="list-style-type: none"> Operation except operation a except in active mode (in standard mode) + swing OFF <table border="1" style="margin-left: 20px;"> <tr> <td> <ul style="list-style-type: none"> Arm OUT + service ON + pressure sensor (F pump pressure or R pump pressure) more than 19.6 MPa (200 kg/cm²) </td> <td style="text-align: center;">b</td> </tr> </table> 	<ul style="list-style-type: none"> Arm OUT + service ON + pressure sensor (F pump pressure or R pump pressure) more than 19.6 MPa (200 kg/cm²) 	b			<ul style="list-style-type: none"> In other modes (breaker mode + service switch ON or any other mode except L/O mode) <table border="1" style="margin-left: 20px;"> <tr> <td> <ul style="list-style-type: none"> Compound operation of travel (Travel + other work equipment) <table border="1" style="margin-left: 20px;"> <tr> <td> <ul style="list-style-type: none"> With travel OFF <table border="1" style="margin-left: 20px;"> <tr> <td> <ul style="list-style-type: none"> With swing lock switch ON </td> <td></td> </tr> <tr> <td> <ul style="list-style-type: none"> With swing lock switch OFF <table border="1" style="margin-left: 20px;"> <tr> <td> <ul style="list-style-type: none"> Except operation a on left, in active mode </td> <td></td> </tr> <tr> <td> <ul style="list-style-type: none"> Except operation a on left, and except in active mode <table border="1" style="margin-left: 20px;"> <tr> <td> <ul style="list-style-type: none"> With swing ON </td> <td></td> </tr> <tr> <td> <ul style="list-style-type: none"> With swing OFF except operation b on left </td> <td></td> </tr> </table> </td> <td></td> </tr> </table> </td> <td></td> </tr> </table> </td> </tr> </table> </td> </tr> </table>	<ul style="list-style-type: none"> Compound operation of travel (Travel + other work equipment) <table border="1" style="margin-left: 20px;"> <tr> <td> <ul style="list-style-type: none"> With travel OFF <table border="1" style="margin-left: 20px;"> <tr> <td> <ul style="list-style-type: none"> With swing lock switch ON </td> <td></td> </tr> <tr> <td> <ul style="list-style-type: none"> With swing lock switch OFF <table border="1" style="margin-left: 20px;"> <tr> <td> <ul style="list-style-type: none"> Except operation a on left, in active mode </td> <td></td> </tr> <tr> <td> <ul style="list-style-type: none"> Except operation a on left, and except in active mode <table border="1" style="margin-left: 20px;"> <tr> <td> <ul style="list-style-type: none"> With swing ON </td> <td></td> </tr> <tr> <td> <ul style="list-style-type: none"> With swing OFF except operation b on left </td> <td></td> </tr> </table> </td> <td></td> </tr> </table> </td> <td></td> </tr> </table> </td> </tr> </table> 	<ul style="list-style-type: none"> With travel OFF <table border="1" style="margin-left: 20px;"> <tr> <td> <ul style="list-style-type: none"> With swing lock switch ON </td> <td></td> </tr> <tr> <td> <ul style="list-style-type: none"> With swing lock switch OFF <table border="1" style="margin-left: 20px;"> <tr> <td> <ul style="list-style-type: none"> Except operation a on left, in active mode </td> <td></td> </tr> <tr> <td> <ul style="list-style-type: none"> Except operation a on left, and except in active mode <table border="1" style="margin-left: 20px;"> <tr> <td> <ul style="list-style-type: none"> With swing ON </td> <td></td> </tr> <tr> <td> <ul style="list-style-type: none"> With swing OFF except operation b on left </td> <td></td> </tr> </table> </td> <td></td> </tr> </table> </td> <td></td> </tr> </table> 	<ul style="list-style-type: none"> With swing lock switch ON 		<ul style="list-style-type: none"> With swing lock switch OFF <table border="1" style="margin-left: 20px;"> <tr> <td> <ul style="list-style-type: none"> Except operation a on left, in active mode </td> <td></td> </tr> <tr> <td> <ul style="list-style-type: none"> Except operation a on left, and except in active mode <table border="1" style="margin-left: 20px;"> <tr> <td> <ul style="list-style-type: none"> With swing ON </td> <td></td> </tr> <tr> <td> <ul style="list-style-type: none"> With swing OFF except operation b on left </td> <td></td> </tr> </table> </td> <td></td> </tr> </table> 	<ul style="list-style-type: none"> Except operation a on left, in active mode 		<ul style="list-style-type: none"> Except operation a on left, and except in active mode <table border="1" style="margin-left: 20px;"> <tr> <td> <ul style="list-style-type: none"> With swing ON </td> <td></td> </tr> <tr> <td> <ul style="list-style-type: none"> With swing OFF except operation b on left </td> <td></td> </tr> </table> 	<ul style="list-style-type: none"> With swing ON 		<ul style="list-style-type: none"> With swing OFF except operation b on left 				
<ul style="list-style-type: none"> With travel OFF <table border="1" style="margin-left: 20px;"> <tr> <td> <ul style="list-style-type: none"> Swing lock switch OFF <table border="1" style="margin-left: 20px;"> <tr> <td> <ul style="list-style-type: none"> F/O mode + arm IN </td> <td style="text-align: center;">a</td> </tr> <tr> <td> <ul style="list-style-type: none"> Operation except operation a except in active mode (in standard mode) + swing OFF <table border="1" style="margin-left: 20px;"> <tr> <td> <ul style="list-style-type: none"> Arm OUT + service ON + pressure sensor (F pump pressure or R pump pressure) more than 19.6 MPa (200 kg/cm²) </td> <td style="text-align: center;">b</td> </tr> </table> </td> <td></td> </tr> </table> </td> <td></td> </tr> </table> 	<ul style="list-style-type: none"> Swing lock switch OFF <table border="1" style="margin-left: 20px;"> <tr> <td> <ul style="list-style-type: none"> F/O mode + arm IN </td> <td style="text-align: center;">a</td> </tr> <tr> <td> <ul style="list-style-type: none"> Operation except operation a except in active mode (in standard mode) + swing OFF <table border="1" style="margin-left: 20px;"> <tr> <td> <ul style="list-style-type: none"> Arm OUT + service ON + pressure sensor (F pump pressure or R pump pressure) more than 19.6 MPa (200 kg/cm²) </td> <td style="text-align: center;">b</td> </tr> </table> </td> <td></td> </tr> </table> 	<ul style="list-style-type: none"> F/O mode + arm IN 	a	<ul style="list-style-type: none"> Operation except operation a except in active mode (in standard mode) + swing OFF <table border="1" style="margin-left: 20px;"> <tr> <td> <ul style="list-style-type: none"> Arm OUT + service ON + pressure sensor (F pump pressure or R pump pressure) more than 19.6 MPa (200 kg/cm²) </td> <td style="text-align: center;">b</td> </tr> </table> 	<ul style="list-style-type: none"> Arm OUT + service ON + pressure sensor (F pump pressure or R pump pressure) more than 19.6 MPa (200 kg/cm²) 	b																			
<ul style="list-style-type: none"> Swing lock switch OFF <table border="1" style="margin-left: 20px;"> <tr> <td> <ul style="list-style-type: none"> F/O mode + arm IN </td> <td style="text-align: center;">a</td> </tr> <tr> <td> <ul style="list-style-type: none"> Operation except operation a except in active mode (in standard mode) + swing OFF <table border="1" style="margin-left: 20px;"> <tr> <td> <ul style="list-style-type: none"> Arm OUT + service ON + pressure sensor (F pump pressure or R pump pressure) more than 19.6 MPa (200 kg/cm²) </td> <td style="text-align: center;">b</td> </tr> </table> </td> <td></td> </tr> </table> 	<ul style="list-style-type: none"> F/O mode + arm IN 	a	<ul style="list-style-type: none"> Operation except operation a except in active mode (in standard mode) + swing OFF <table border="1" style="margin-left: 20px;"> <tr> <td> <ul style="list-style-type: none"> Arm OUT + service ON + pressure sensor (F pump pressure or R pump pressure) more than 19.6 MPa (200 kg/cm²) </td> <td style="text-align: center;">b</td> </tr> </table> 	<ul style="list-style-type: none"> Arm OUT + service ON + pressure sensor (F pump pressure or R pump pressure) more than 19.6 MPa (200 kg/cm²) 	b																				
<ul style="list-style-type: none"> F/O mode + arm IN 	a																								
<ul style="list-style-type: none"> Operation except operation a except in active mode (in standard mode) + swing OFF <table border="1" style="margin-left: 20px;"> <tr> <td> <ul style="list-style-type: none"> Arm OUT + service ON + pressure sensor (F pump pressure or R pump pressure) more than 19.6 MPa (200 kg/cm²) </td> <td style="text-align: center;">b</td> </tr> </table> 	<ul style="list-style-type: none"> Arm OUT + service ON + pressure sensor (F pump pressure or R pump pressure) more than 19.6 MPa (200 kg/cm²) 	b																							
<ul style="list-style-type: none"> Arm OUT + service ON + pressure sensor (F pump pressure or R pump pressure) more than 19.6 MPa (200 kg/cm²) 	b																								
<ul style="list-style-type: none"> Compound operation of travel (Travel + other work equipment) <table border="1" style="margin-left: 20px;"> <tr> <td> <ul style="list-style-type: none"> With travel OFF <table border="1" style="margin-left: 20px;"> <tr> <td> <ul style="list-style-type: none"> With swing lock switch ON </td> <td></td> </tr> <tr> <td> <ul style="list-style-type: none"> With swing lock switch OFF <table border="1" style="margin-left: 20px;"> <tr> <td> <ul style="list-style-type: none"> Except operation a on left, in active mode </td> <td></td> </tr> <tr> <td> <ul style="list-style-type: none"> Except operation a on left, and except in active mode <table border="1" style="margin-left: 20px;"> <tr> <td> <ul style="list-style-type: none"> With swing ON </td> <td></td> </tr> <tr> <td> <ul style="list-style-type: none"> With swing OFF except operation b on left </td> <td></td> </tr> </table> </td> <td></td> </tr> </table> </td> <td></td> </tr> </table> </td> </tr> </table> 	<ul style="list-style-type: none"> With travel OFF <table border="1" style="margin-left: 20px;"> <tr> <td> <ul style="list-style-type: none"> With swing lock switch ON </td> <td></td> </tr> <tr> <td> <ul style="list-style-type: none"> With swing lock switch OFF <table border="1" style="margin-left: 20px;"> <tr> <td> <ul style="list-style-type: none"> Except operation a on left, in active mode </td> <td></td> </tr> <tr> <td> <ul style="list-style-type: none"> Except operation a on left, and except in active mode <table border="1" style="margin-left: 20px;"> <tr> <td> <ul style="list-style-type: none"> With swing ON </td> <td></td> </tr> <tr> <td> <ul style="list-style-type: none"> With swing OFF except operation b on left </td> <td></td> </tr> </table> </td> <td></td> </tr> </table> </td> <td></td> </tr> </table> 	<ul style="list-style-type: none"> With swing lock switch ON 		<ul style="list-style-type: none"> With swing lock switch OFF <table border="1" style="margin-left: 20px;"> <tr> <td> <ul style="list-style-type: none"> Except operation a on left, in active mode </td> <td></td> </tr> <tr> <td> <ul style="list-style-type: none"> Except operation a on left, and except in active mode <table border="1" style="margin-left: 20px;"> <tr> <td> <ul style="list-style-type: none"> With swing ON </td> <td></td> </tr> <tr> <td> <ul style="list-style-type: none"> With swing OFF except operation b on left </td> <td></td> </tr> </table> </td> <td></td> </tr> </table> 	<ul style="list-style-type: none"> Except operation a on left, in active mode 		<ul style="list-style-type: none"> Except operation a on left, and except in active mode <table border="1" style="margin-left: 20px;"> <tr> <td> <ul style="list-style-type: none"> With swing ON </td> <td></td> </tr> <tr> <td> <ul style="list-style-type: none"> With swing OFF except operation b on left </td> <td></td> </tr> </table> 	<ul style="list-style-type: none"> With swing ON 		<ul style="list-style-type: none"> With swing OFF except operation b on left 															
<ul style="list-style-type: none"> With travel OFF <table border="1" style="margin-left: 20px;"> <tr> <td> <ul style="list-style-type: none"> With swing lock switch ON </td> <td></td> </tr> <tr> <td> <ul style="list-style-type: none"> With swing lock switch OFF <table border="1" style="margin-left: 20px;"> <tr> <td> <ul style="list-style-type: none"> Except operation a on left, in active mode </td> <td></td> </tr> <tr> <td> <ul style="list-style-type: none"> Except operation a on left, and except in active mode <table border="1" style="margin-left: 20px;"> <tr> <td> <ul style="list-style-type: none"> With swing ON </td> <td></td> </tr> <tr> <td> <ul style="list-style-type: none"> With swing OFF except operation b on left </td> <td></td> </tr> </table> </td> <td></td> </tr> </table> </td> <td></td> </tr> </table> 	<ul style="list-style-type: none"> With swing lock switch ON 		<ul style="list-style-type: none"> With swing lock switch OFF <table border="1" style="margin-left: 20px;"> <tr> <td> <ul style="list-style-type: none"> Except operation a on left, in active mode </td> <td></td> </tr> <tr> <td> <ul style="list-style-type: none"> Except operation a on left, and except in active mode <table border="1" style="margin-left: 20px;"> <tr> <td> <ul style="list-style-type: none"> With swing ON </td> <td></td> </tr> <tr> <td> <ul style="list-style-type: none"> With swing OFF except operation b on left </td> <td></td> </tr> </table> </td> <td></td> </tr> </table> 	<ul style="list-style-type: none"> Except operation a on left, in active mode 		<ul style="list-style-type: none"> Except operation a on left, and except in active mode <table border="1" style="margin-left: 20px;"> <tr> <td> <ul style="list-style-type: none"> With swing ON </td> <td></td> </tr> <tr> <td> <ul style="list-style-type: none"> With swing OFF except operation b on left </td> <td></td> </tr> </table> 	<ul style="list-style-type: none"> With swing ON 		<ul style="list-style-type: none"> With swing OFF except operation b on left 																
<ul style="list-style-type: none"> With swing lock switch ON 																									
<ul style="list-style-type: none"> With swing lock switch OFF <table border="1" style="margin-left: 20px;"> <tr> <td> <ul style="list-style-type: none"> Except operation a on left, in active mode </td> <td></td> </tr> <tr> <td> <ul style="list-style-type: none"> Except operation a on left, and except in active mode <table border="1" style="margin-left: 20px;"> <tr> <td> <ul style="list-style-type: none"> With swing ON </td> <td></td> </tr> <tr> <td> <ul style="list-style-type: none"> With swing OFF except operation b on left </td> <td></td> </tr> </table> </td> <td></td> </tr> </table> 	<ul style="list-style-type: none"> Except operation a on left, in active mode 		<ul style="list-style-type: none"> Except operation a on left, and except in active mode <table border="1" style="margin-left: 20px;"> <tr> <td> <ul style="list-style-type: none"> With swing ON </td> <td></td> </tr> <tr> <td> <ul style="list-style-type: none"> With swing OFF except operation b on left </td> <td></td> </tr> </table> 	<ul style="list-style-type: none"> With swing ON 		<ul style="list-style-type: none"> With swing OFF except operation b on left 																			
<ul style="list-style-type: none"> Except operation a on left, in active mode 																									
<ul style="list-style-type: none"> Except operation a on left, and except in active mode <table border="1" style="margin-left: 20px;"> <tr> <td> <ul style="list-style-type: none"> With swing ON </td> <td></td> </tr> <tr> <td> <ul style="list-style-type: none"> With swing OFF except operation b on left </td> <td></td> </tr> </table> 	<ul style="list-style-type: none"> With swing ON 		<ul style="list-style-type: none"> With swing OFF except operation b on left 																						
<ul style="list-style-type: none"> With swing ON 																									
<ul style="list-style-type: none"> With swing OFF except operation b on left 																									

★ The higher pressure of the F or R pumps is as follows:
 When pressure rises: 19.6 MPa (200 kg/cm²)
 When pressure goes down: 14.7 MPa (150 kg/cm²)

SOLENOID ACTUATION TABLE

Name of solenoid	ON (energized)	OFF (de-energized)
Swing holding brake	Brake released	Brake applied
Travel speed	Travel motor swash plate angle at MIN	Travel motor swash plate angle at MAX
Active mode	Standard mode (active mode OFF)	Active mode ON
Pump merge/divider valve	Divided flow	Merged flow
2-stage relief valve	Pressure rises	Pressure does not rise

H-1 Speeds of all work equipment, swing, travel are slow

- ★ Carry out troubleshooting in the H/O mode.
- ★ Check that no abnormal noise is being generated from the main pump before carrying out troubleshooting. (If there is any abnormal noise, carry out troubleshooting for H-4.)

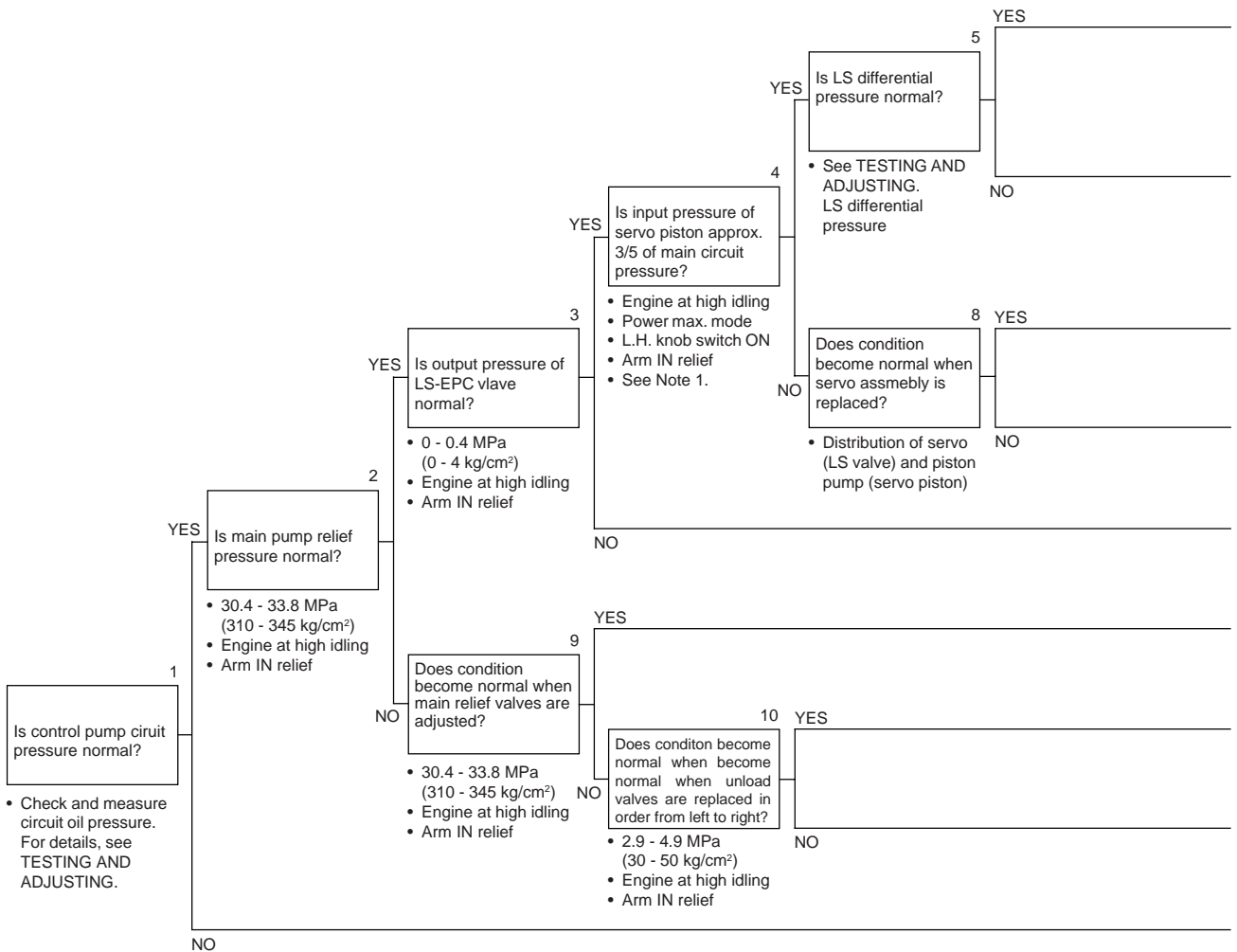

- ★ The PPC control circuit oil pressure is reduced by self-reducing pressure valve.

Note 1: Measuring servo piston inlet port pressure in Item No. 4

Measure the input pressure to the large diameter end of the servo piston when the arm is relieved in the power max. mode. (Approximately 17.6 MPa (180 kg/cm²)) Basically, the pressure at large diameter end is approximately 3/5 of the small diameter end. (For details, see TESTING AND ADJUSTING).

	Cause	Remedy
<p>6</p> <p>Does condition become normal when PC valve is adjusted?</p> <p>• See TESTING AND ADJUSTING.</p>		
<p>YES</p>	Defective adjustment of PC valve	Adjust
<p>NO</p> <p>7</p> <p>Does condition become normal when PC valve assembly is replaced?</p>		
<p>YES</p>	Defective PC valve servo assembly	Repair or replace
<p>NO</p>	Defective piston pump	Repair or replace
	Defective LS differential pressure	Adjust
	Defective LS valve assembly	Repair or replace
	Defective piston pump (servo piston)	Repair or replace
	Defective operation of LS-EPC solenoid valve	Replace
	Defective operation of main relief assembly (valve which becomes normal when adjusted)	Adjust
	Defective operation of unload valve (valve which becomes normal when replaced)	Replace
	Defective operation of main relief valve	Replace
	Defective self-pressure reducing valve	Repair or replace

H-2 There is excessive drop in engine speed, or engine stalls

- ★ Carry out troubleshooting in the H/O mode.
- ★ Check that the main relief pressure is normal.

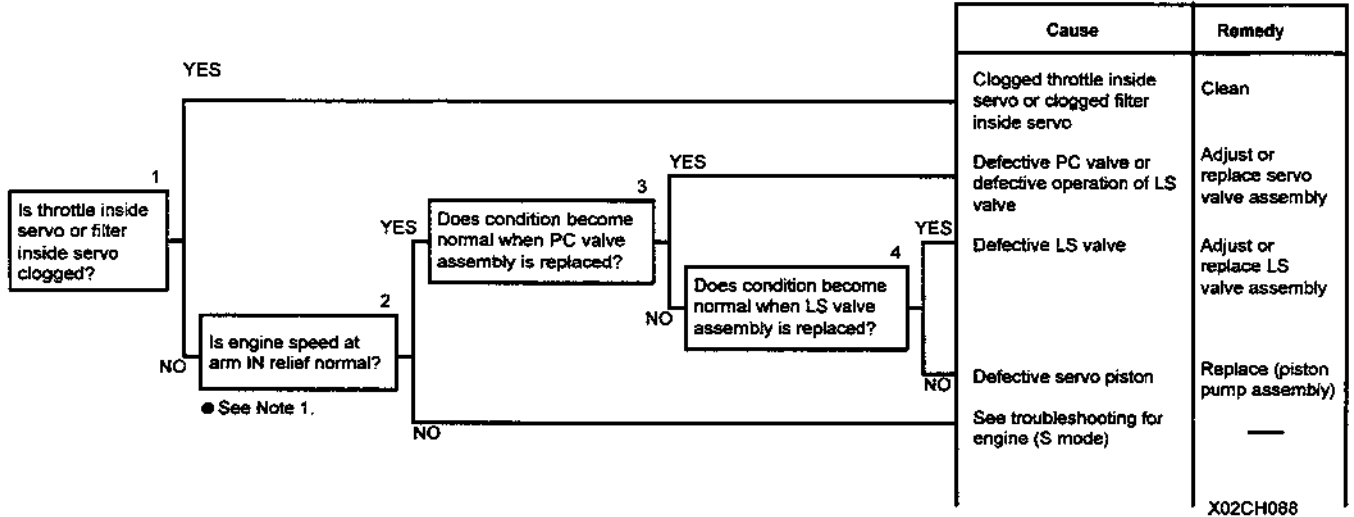

Note 1: Replace the servo valve assembly on the defective side with a new part, and if the engine speed is lower than the reference value below, carry out troubleshooting for S mode (engine).

- ★ Engine speed (reference) at arm IN relief when engine and pump are normal.

Engine speed at arm IN relief	Conditions
Min. 2,200 rpm	<ul style="list-style-type: none"> • Engine at high idling • Power max. mode • L.H. knob switch ON

H-3 No work equipment, travel, swing move

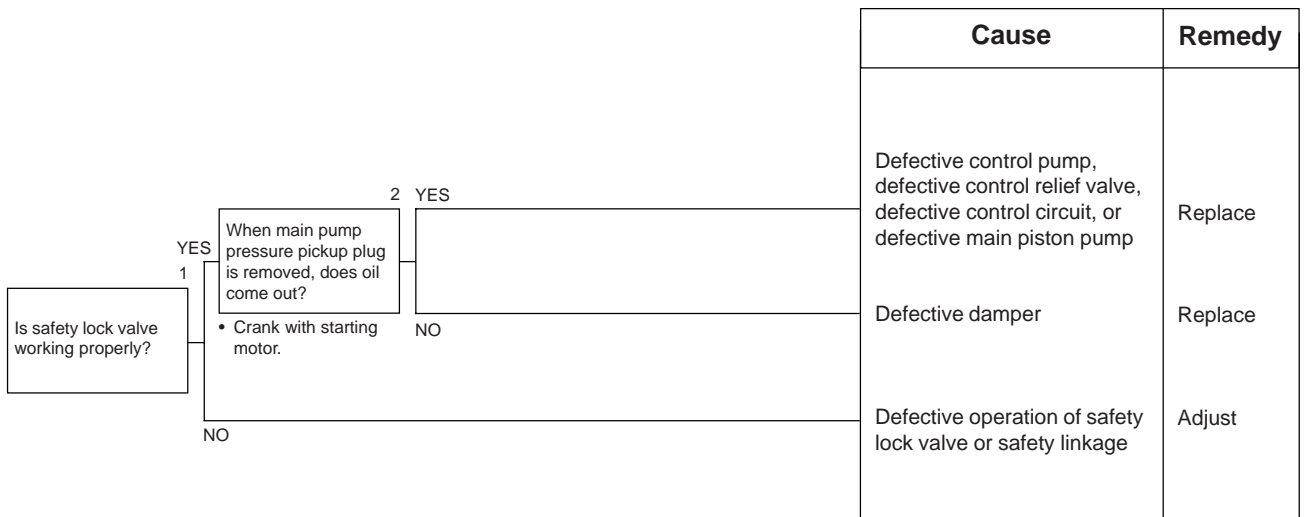

H-4 Abnormal noise generated (around pump)

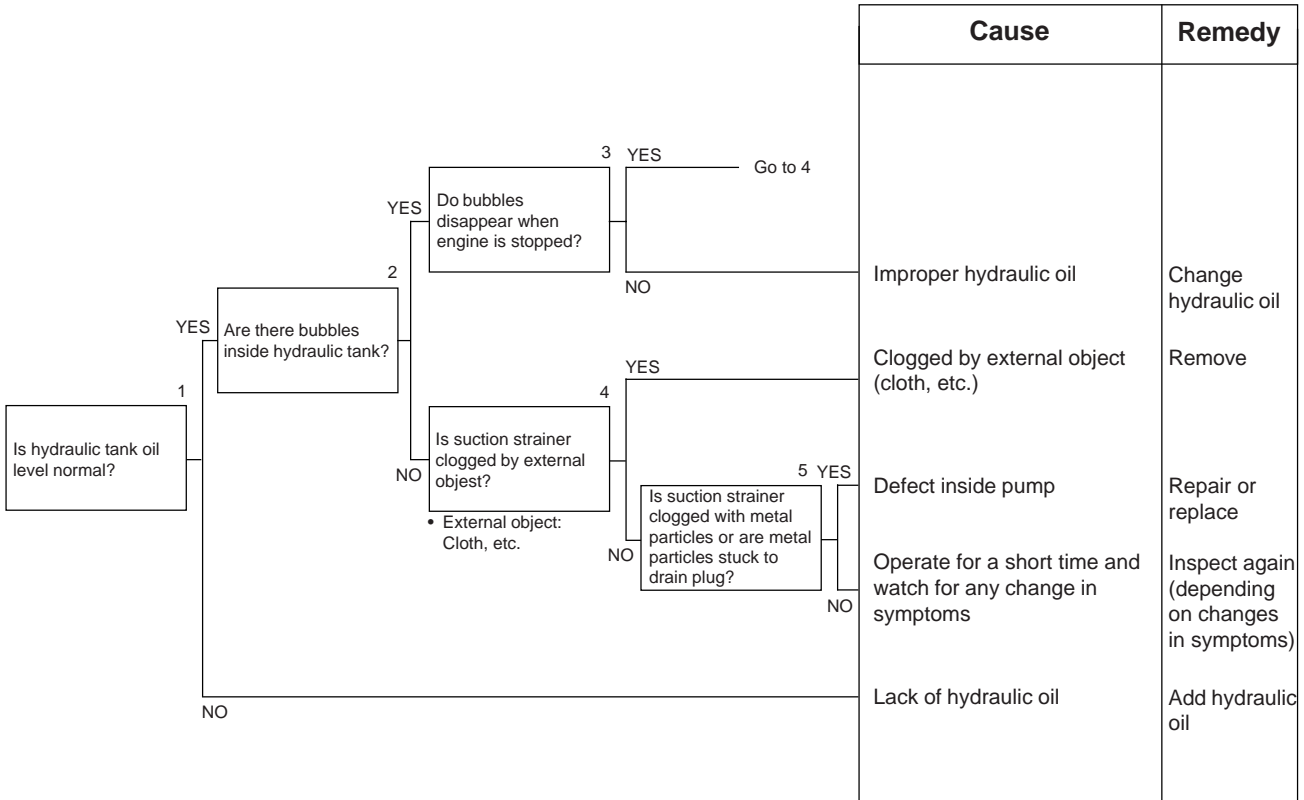

H-5 Auto-deceleration does not work (when PPC shuttle valve)

★ The control pressure for the travel and swing passes through the PPC shuttle valve and is supplied to the pressure switch.



H-6 Fine control ability is poor or response is poor

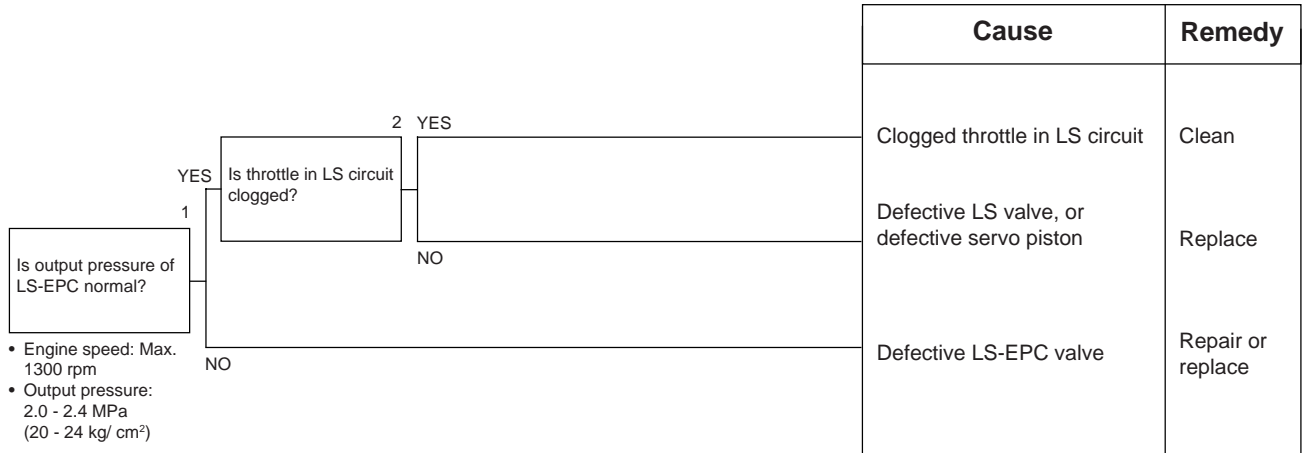

MEMORANDA

H-7 Boom is slow or lacks power

- ★ When travel and swing speeds are normal.
- ★ Carry out troubleshooting in the H/O mode.

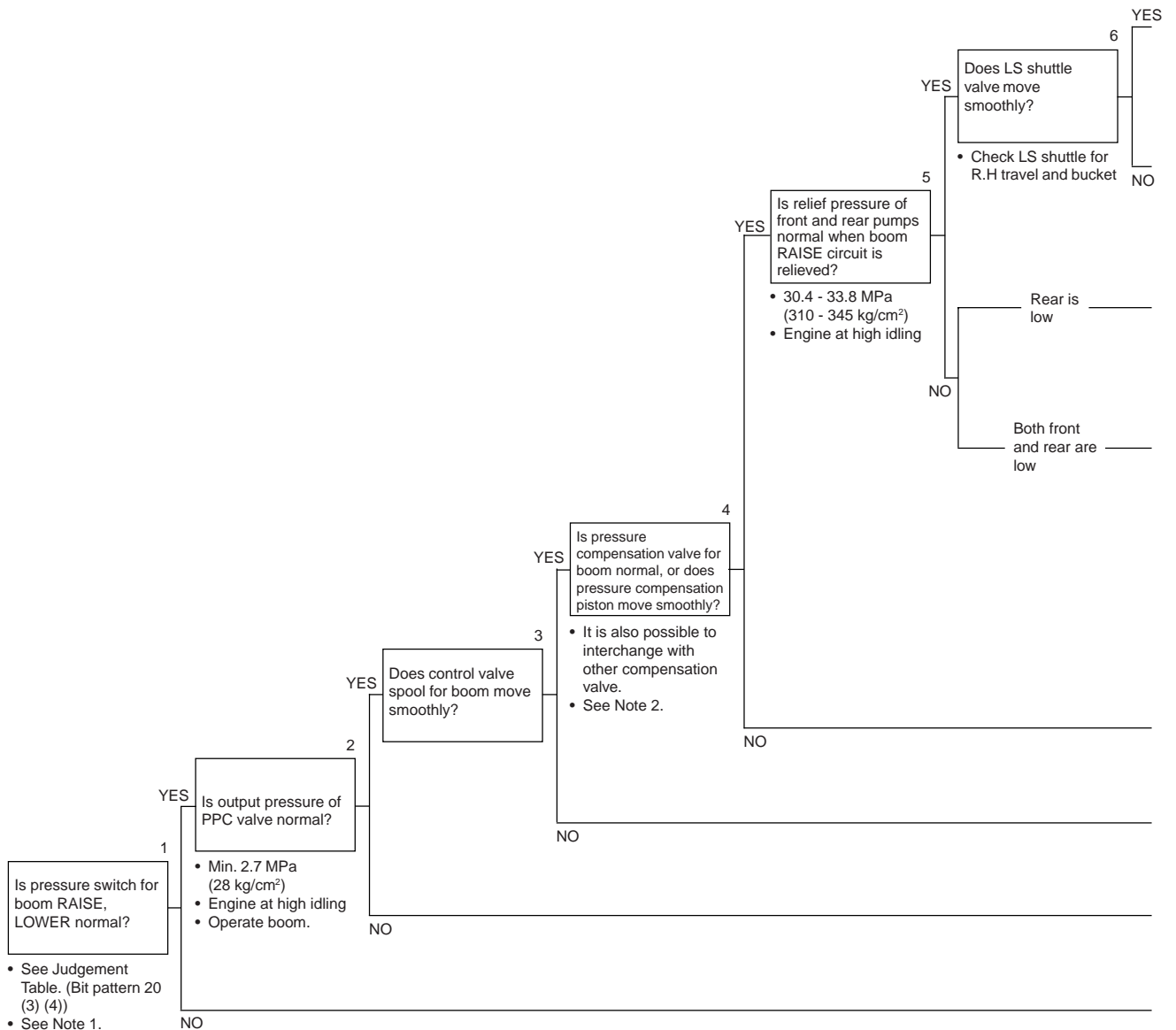

Note 1: If auto-deceleration is canceled when boom RAISE or boom LOWER is operated, system is normal.

Note 2: After inspection, do not forget to return the interchanged valves to the original position.

Note 3: 16.7 ± 1.5 MPa (170 ± 15 kg cm²).

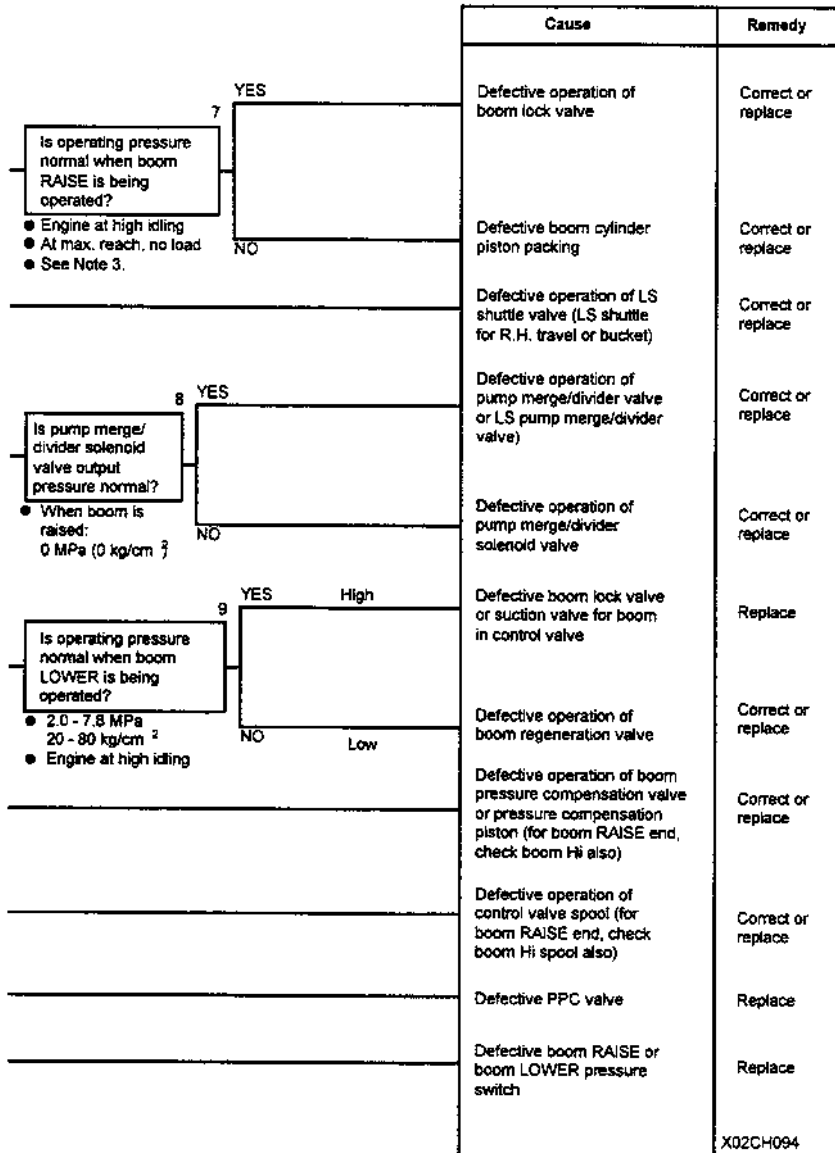

X02CH094

H-8 Arm is slow or lacks power

- ★ When travel and swing speeds are normal.
- ★ Carry out troubleshooting in the H/O mode.

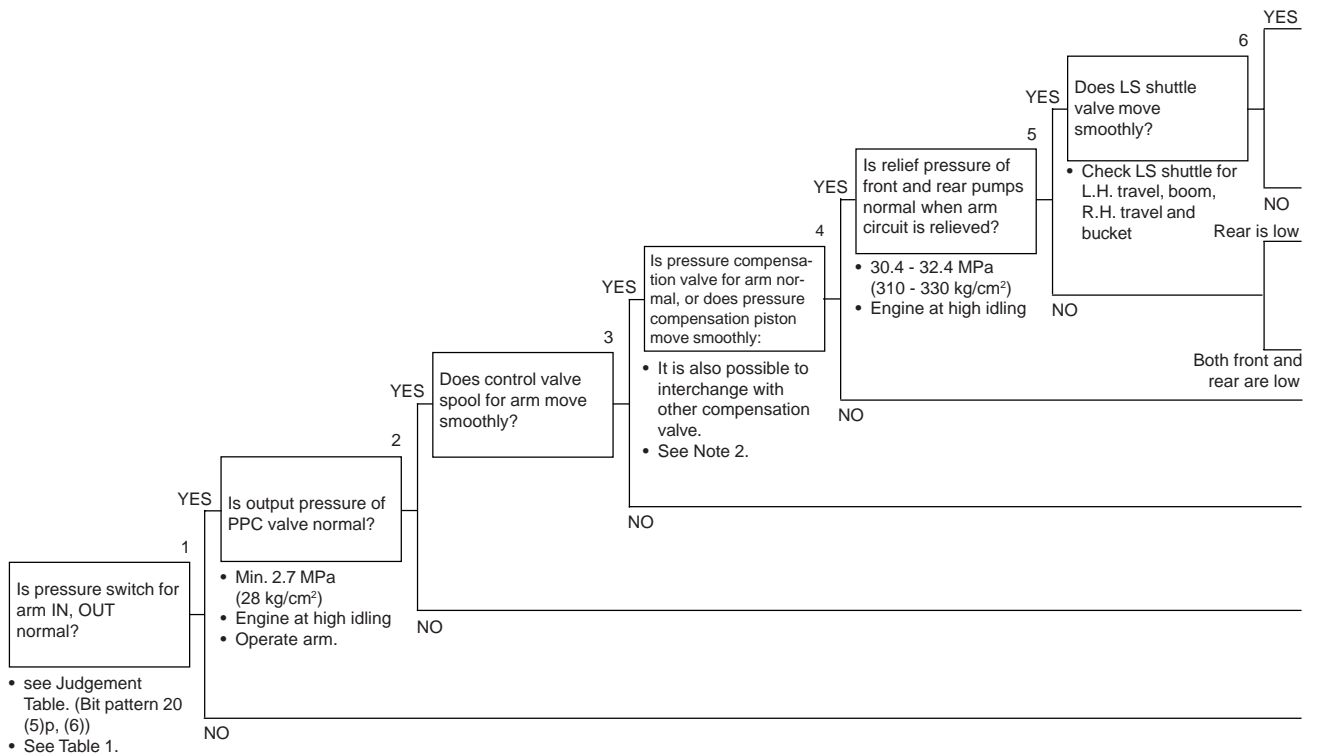

Note 1: If the auto-deceleration is canceled when arm IN or arm OUT is operated, the system is normal.

Note 2: After inspection, do not forget to return the interchanged valves to the original position.

		Cause	Remedy
7 Is leakage from arm cylinder normal? ● Engine at high idling ● Max. 20 cc/min	YES	Defective operation of arm regeneration circuit	Correct or replace
	NO	Defective arm cylinder piston packing	Correct or replace
8 Is pump merge/divider solenoid valve output pressure normal? ● When arm lever is operated:: 0 MPa (0 kg/cm ²) ● Engine at high idling	YES	Defective operation of LS shuttle valve (LS shuttle for L.H. travel, boom,R.H. travel or bucket)	Correct or replace
		Defective operation of pump merge/divider valve or LS pump merge/divider valve	Correct or replace
	NO	Defective operation of pump merge/divider solenoid valve	Correct or replace
		Defective operation of arm safety-suction valve	Correct or replace
		Defective operation of arm pressure compensation valve or pressure compensation piston (for arm Lo and arm Hi)	Correct or replace
		Defective operation of control valve spool	Correct or replace
		Defective PPC valve	Replace
		Defective arm IN or arm OUT pressure switch	Replace

X02CH096

H-9 Bucket is slow or lacks power

★ When travel and swing speeds are normal.

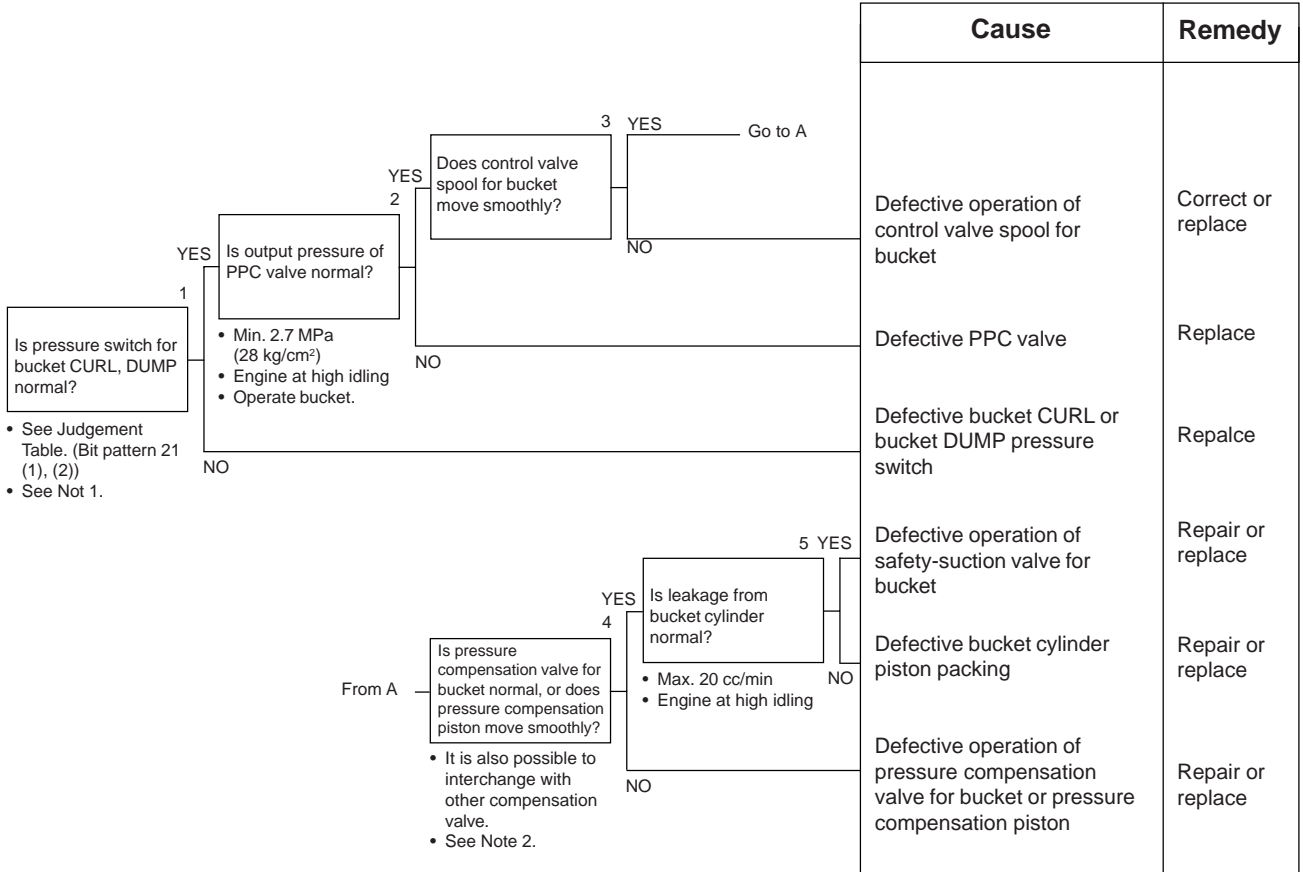

Note 1: If the auto-deceleration is canceled when bucket CURL or bucket DUMP is operated, the system is normal.

Note 2: After inspection, do not forget to return the interchanged valves to the original position.

H-10 Work equipment (boom, arm, bucket) does not move (but travel and swing are normal)

★ When boom, arm, and bucket are each operated independently.

<p>1 YES</p> <p>Is output pressure of PPC valve normal?</p> <ul style="list-style-type: none"> • Min. 2.7 MPa (28 kg/cm²) • Engine at high idling 		Defective control valve spool	Rreplace
	NO	Defective PPC valve	Correct or replace

H-11 Excessive hydraulic drift (boom, arm, bucket)

1) Excessive hydraulic drift of boom

<p>1 YES</p> <p>Does speed of downward movement become faster when lever is operated?</p> <ul style="list-style-type: none"> • See TESTING AND ADJUSTING. • It is also possible to measure leakage of cylinder. • Max. 20 cc/min • At relief and engine at high idling 		Defective hydraulic cylinder piston packing	Replace	
	NO	2 YES	Defective operation of safety-suction valve	Replace
	NO	NO	Defective operation of boom lock valve	Correct or replace

2) Excessive hydraulic drift of arm or bucket

Note 1: After inspection, do not forget to return the interchanged valves to the original position.

<p>1 YES</p> <p>Does speed of downward movement become faster when lever is operated?</p> <ul style="list-style-type: none"> • See TESTING AND ADJUSTING. • It is also possible to measure leakage of cylinder. • Max. 20 cc/min • At relief and engine at high idling 		Defective hydraulic cylinder piston packing	Replace		
	NO	2 YES	Defective operation of safety-suction valve	Replace	
	NO	NO	3 YES	Defective control valve spool	Replace
	NO	NO	Damaged slipper seal of pressure compensation valve, or defective operation of pressure compensation piston	Correct or replace	

- It is also possible to interchange with other compensation valve.
- See Note 1.

H-12 Excessive time lag (engine at low idling)

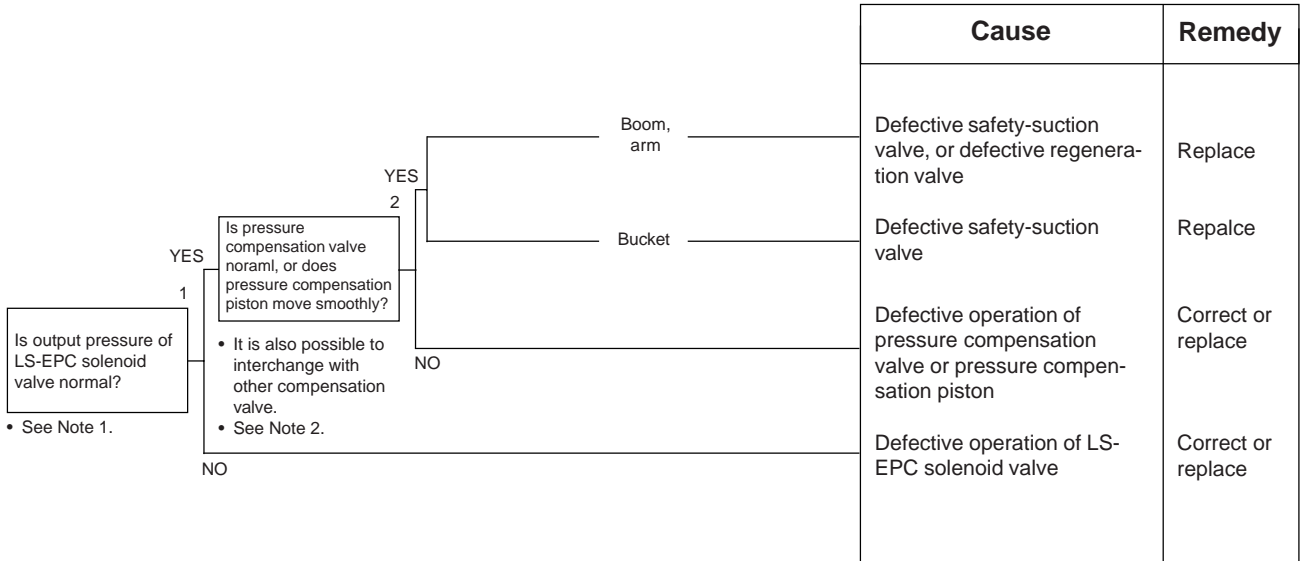

Note 1: Output pressure of LS-EPC solenoid

- 2.2 ± 0.2 MPa (22 ± 2 kg/cm²) is output from the LS-EPC solenoid when the engine is at low idling (approx. 1350 rpm or below) regardless of the working mode.

Note 2: After inspection, do not forget to return the interchanged valves to the original position.

H-13 Other equipment moves when single circuit is relieved

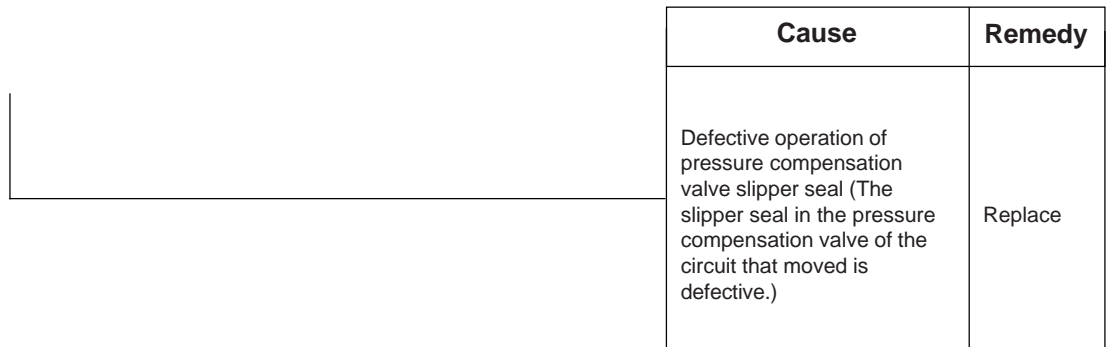

a)-2 When E114 is not displayed

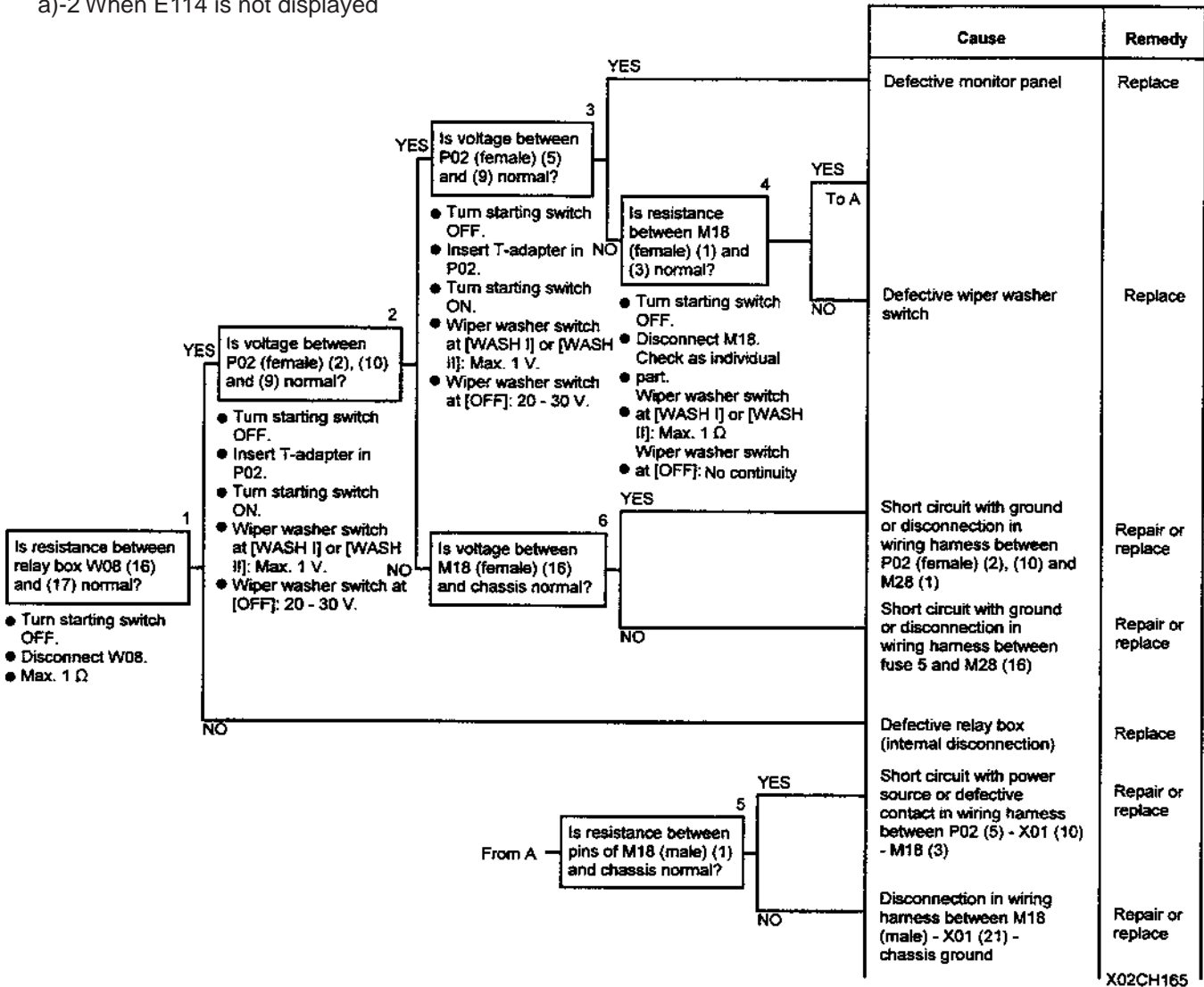

b) Switch is not being operated but washer is actuated

★ For this failure mode, E114 is not displayed

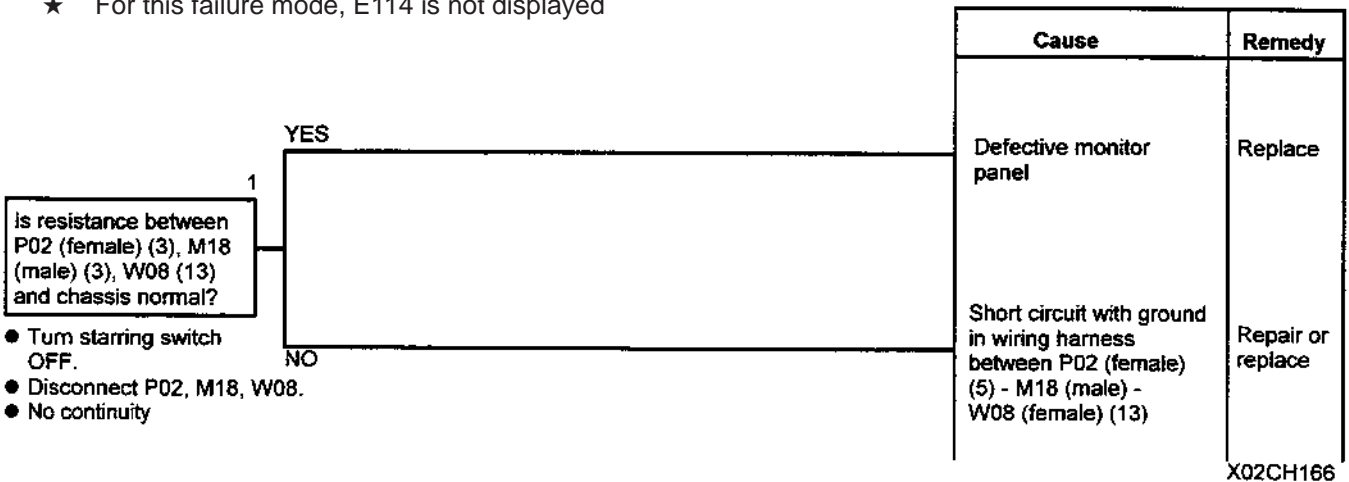

M-30 Related electric circuit diagram

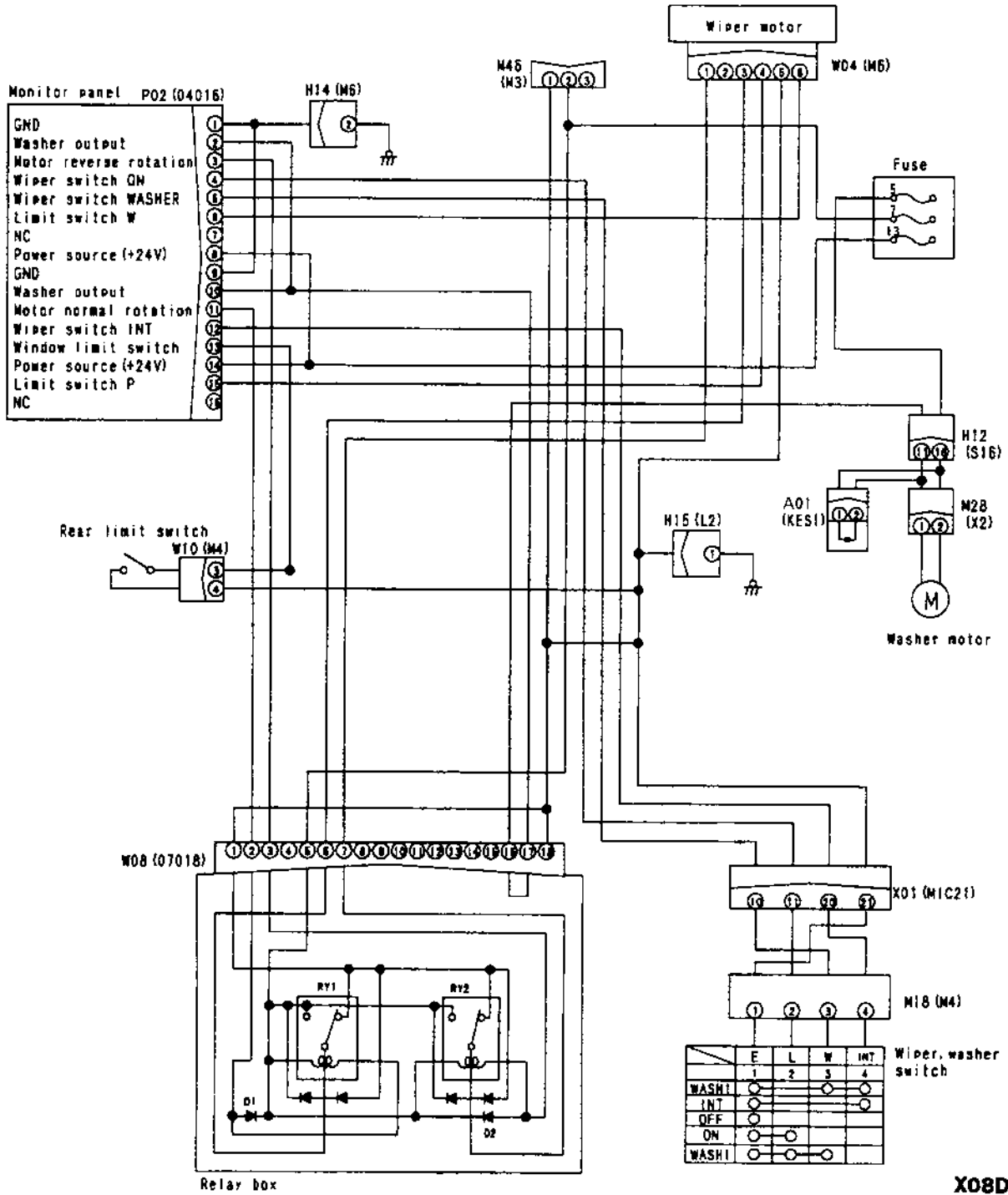

X08DD329

H-14 Lack of power when pressure rises

★ If condition is normal except when pressure rises.

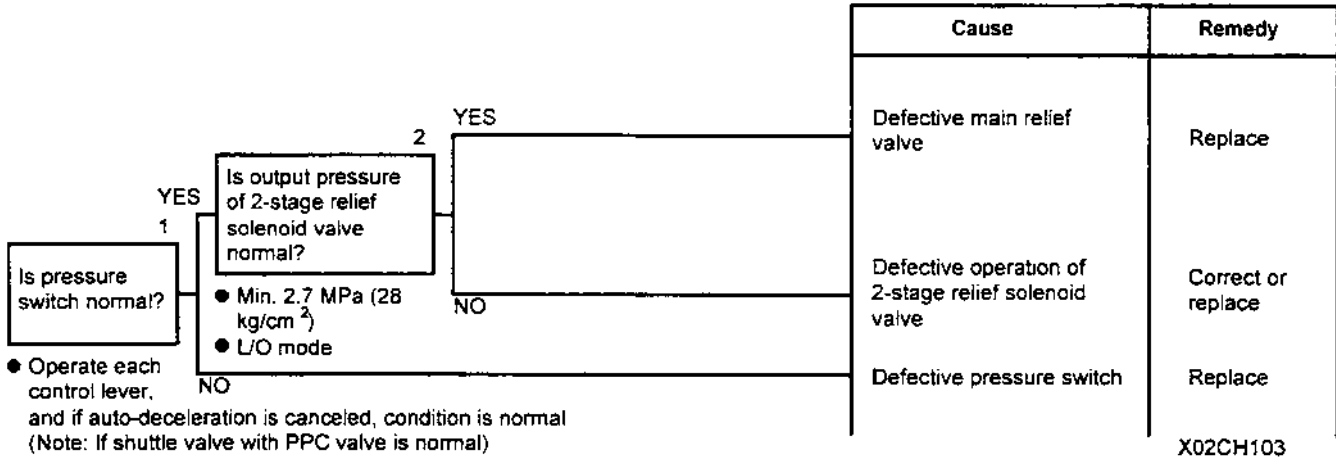

1

Is pressure switch normal?

2

Is output pressure of 2-stage relief solenoid valve normal?

- Min. 2.7 MPa (28 kg/cm²)
- L/O mode

● Operate each control lever, and if auto-deceleration is canceled, condition is normal (Note: If shuttle valve with PPC valve is normal)

H-15 In L/O, F/O modes, work equipment speed is faster than specified speed

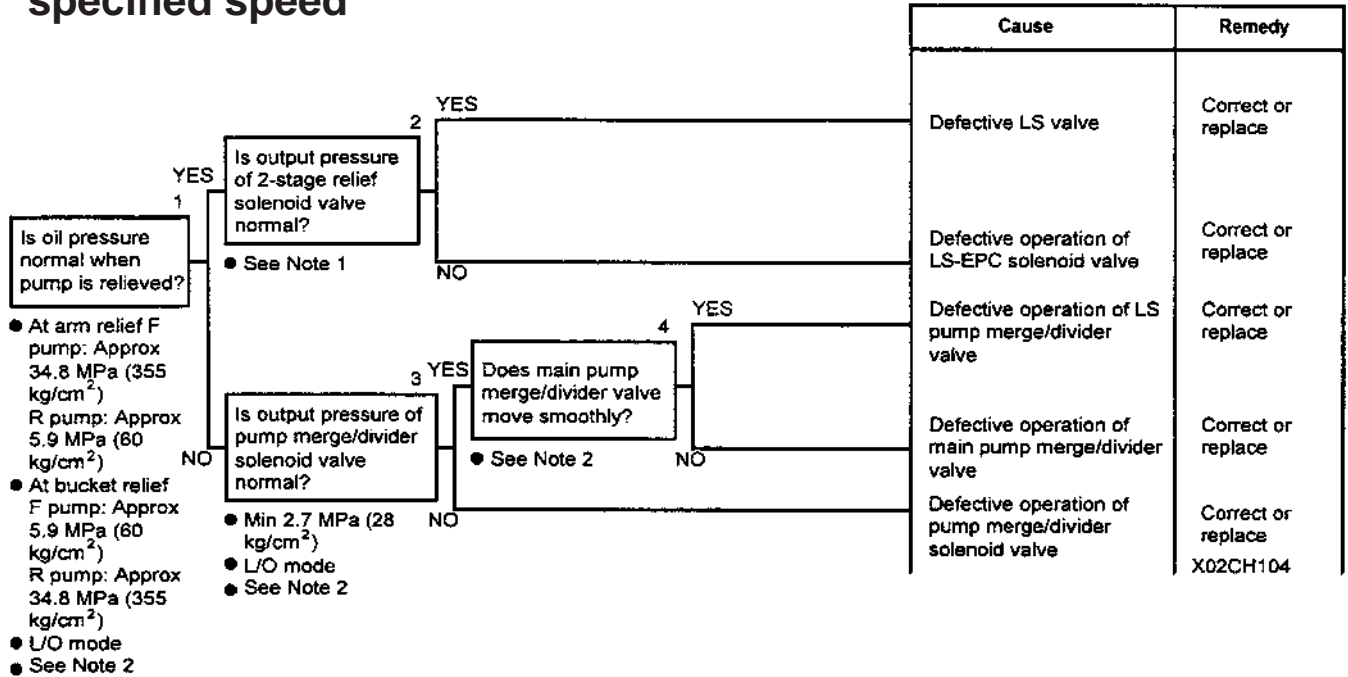

Note 1: Output pressure of LS-EPC solenoid (travel OFF): Approximately 1.3 MPa (13 kg/cm²) is output from the LS-EPC solenoid when the lever is operated in the L/O and F/O modes, regardless of the engine speed.

Note 2: Troubleshooting Items 3 and 4 apply only for the L/O mode.

H-16 In compound operations, work equipment with larger load is slow

Cause	Remedy
Defective operation of pressure compensation valve	Replace (replace pressure compensation valve on side where load is lower)

	Combination of compound operation	Side where load is larger
1	Boom RAISE + arm IN	Boom RAISE
2	Boom RAISE + arm OUT	Arm OUT
3	Boom RAISE + bucket CURL	Boom RAISE
4	Arm OUT + bucket CURL	Arm OUT
5	Boom LOWER + arm OUT	Arm OUT

H-17 In swing + boom RAISE, boom RAISE is slow

★ If swing and boom RAISE work normally when operated independently.

	Cause	Remedy
	Defective operation of LS select solenoid valve	Correct or replace

H-18 In swing + travel, travel speed drops excessively

★ If swing and travel work normally when operated independently

	Cause	Remedy
	Defective operation of LS shuttle valve (LS shuttle for L.H. travel or swing)	Correct or replace

H-19 Travel deviation

- ★ Carry out troubleshooting in the H/O mode.
- ★ When swing and work equipment speeds are normal.

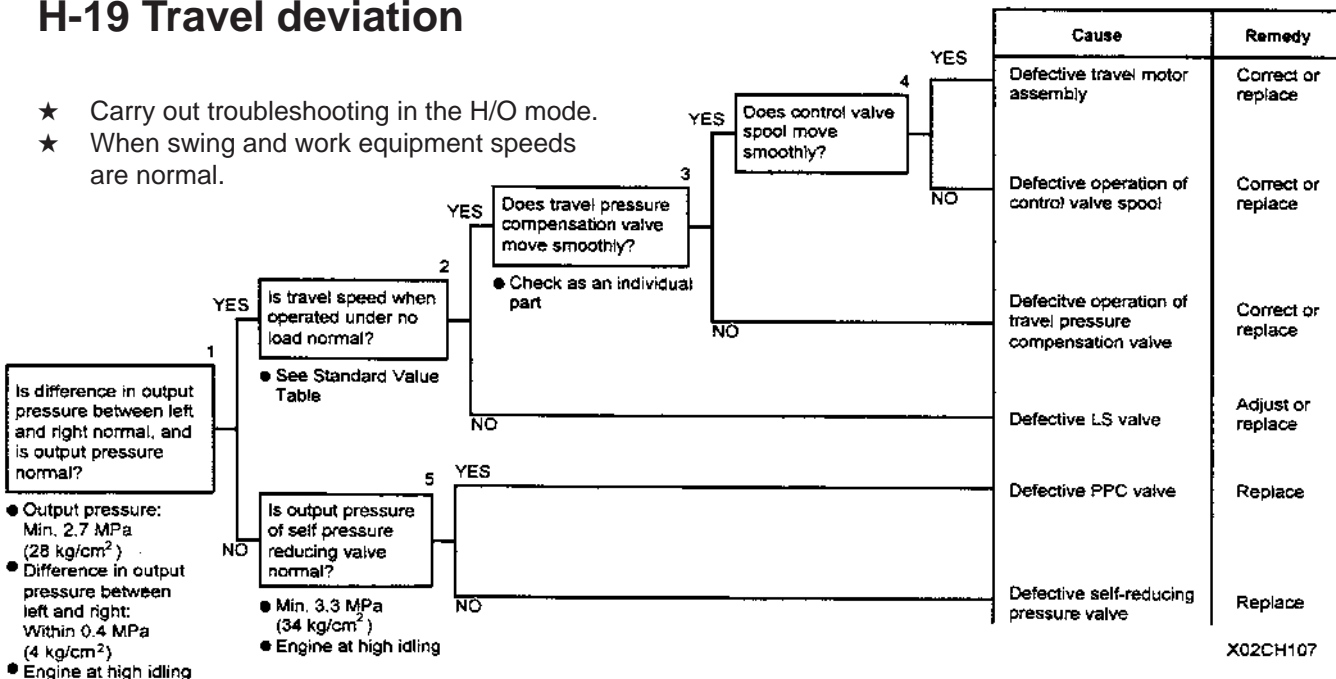

H-20 Travel speed is slow

- ★ Check that the spool of the travel PPC valve is moving the full stroke before carrying out troubleshooting.
- ★ Carry out troubleshooting in the H/O mode.
- ★ When the swing and work equipment speeds are normal.

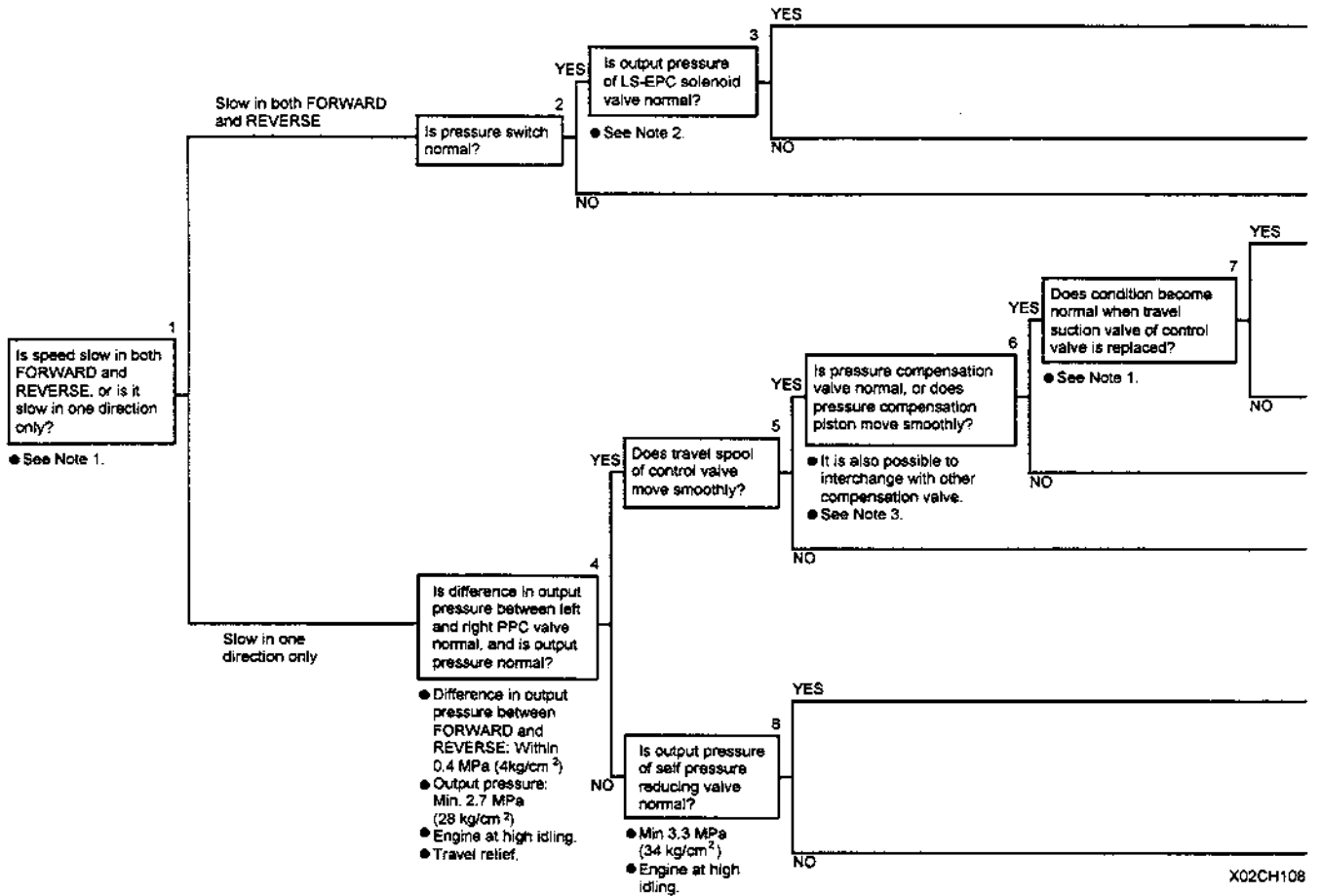

- Note1: Measure the travel speed when operated under no load or the specified time for 20m. (See Standard Value Table for Engine related parts).
 Measurement of travel motor speed when rotated under no load: Remove the connector of the LS-EPC solenoid, then measure the travel speed when rotated under no load: Remove the connector of the LS-EPC solenoid, then measure the travel speed in Hi and Lo.
- Note 2: Output pressure of LS-EPC solenoid: In H/O mode, 0.2 ± 0.2 MPa (2 ± 2 kg/cm²) is output regardless of the engine speed.
- Note 3: After inspection, do not forget to return the interchanged valves to the original position.

Cause	Remedy
Defective operation of LS shuttle valve (for bucket)	Correct or replace
Defective operation of LS-EPC solenoid valve	Correct or replace
Defective travel pressure switch	Replace
Defective operation of travel suction valve of control valve	Correct or replace
Defective travel motor assembly	Correct or replace
Defective pressure compensation valve, or defective operation of pressure compensation piston	Correct or replace
Defective operation of control valve travel spool	Correct or replace
Defective PPC valve	Replace
Defective self pressure reducing valve	Replace

X02CH109

H-21 Steering does not turn easily or lacks power

★ Carry out troubleshooting in the H/O mode.

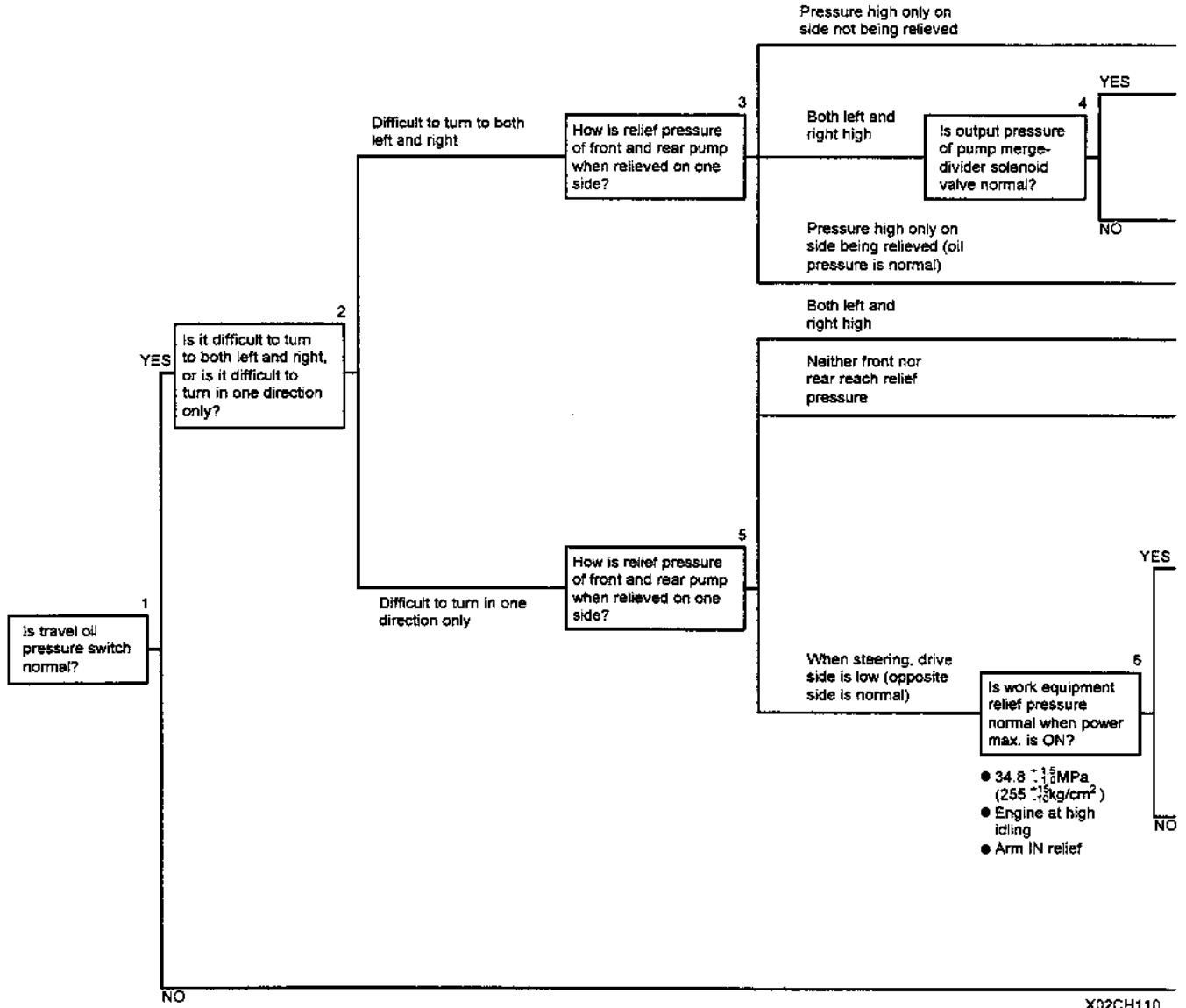

	Cause	Remedy
	Mistaken connection of LS pilot hose (F and R are connected in reverse)	Connect or correct
	Defective operation of main merge-divider valve or defective LS merge-divider valve	Repair or replace
	Defective operation of pump merge-divider solenoid valve	Repair or replace
	Defective operation of travel pressure compensation valve	Repair or replace
	Defective operation of LS circuit check valve	Repair or replace
	Defective operation of control valve main circuit check valve (remains open)	Repair or replace
<p>Does condition become normal when suction valve of control valve is interchanged?</p> <p>7</p> <p>YES</p> <p>NO</p> <p>◆ Interchange left and right spools</p> <p>Does not turn to left or right</p>	<p>Defective control valve suction valve</p>	Replace
	Defective travel motor check valve	Repair or replace
<p>Does bucket LS shuttle valve move smoothly?</p> <p>9</p> <p>YES</p> <p>NO</p> <p>Does not turn to left only</p>	<p>Defective travel motor safety valve</p> <p>See troubleshooting for H-14 Lack of power when pressure rises</p>	<p>Replace</p> <p>—</p>
	<p>Defective operation of LS shuttle valve for bucket</p> <p>Defective travel oil pressure switch</p>	<p>Repair or replace</p> <p>Replace</p>

H-22 Travel speed does not switch or is faster than specified speed

★ Carry out troubleshooting in the H/O mode

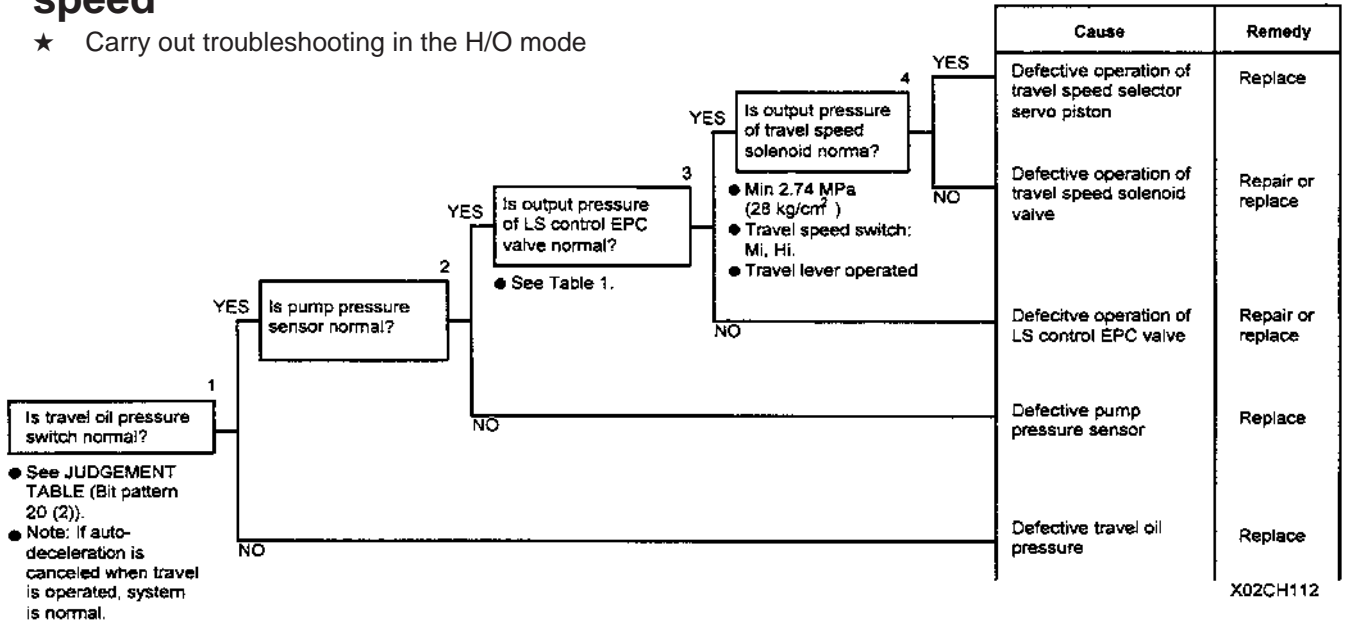
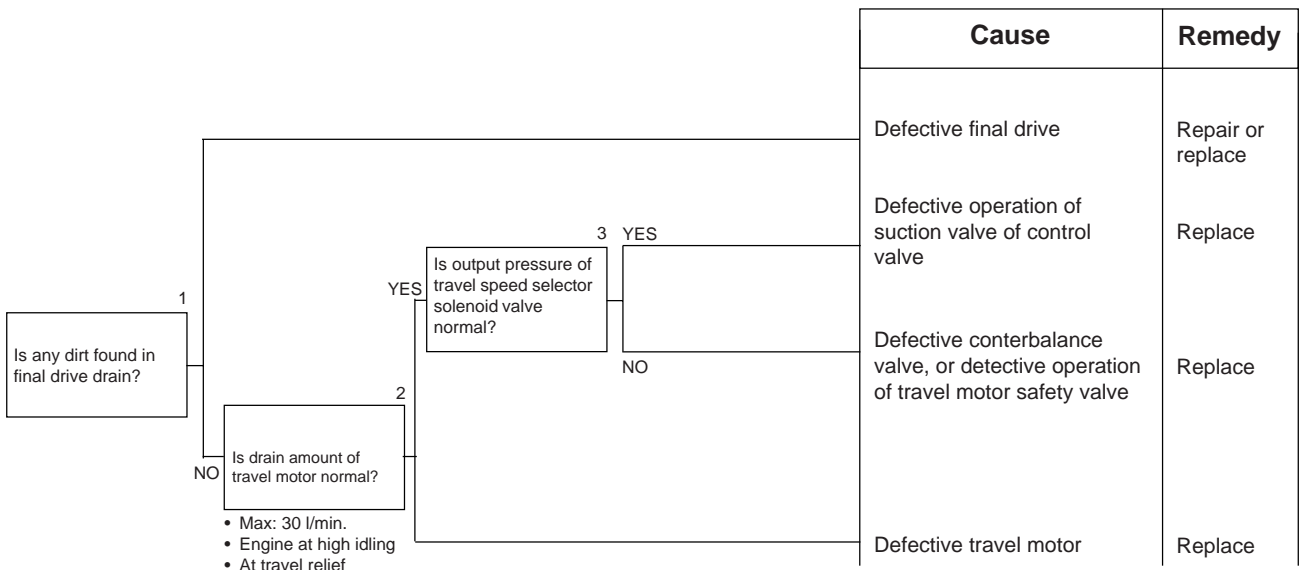

Table 1 Output pressure of LS control EPC valve

	Lo	Mi	Hi
PC290	1.9 ± 0.2 MPa (19 ± 2 kg/cm ²)	1.9 ± 0.2 MPa (19 ± 2 kg/cm ²)	0.2 ± 0.2 MPa / 3.0 ± 3.0 MPa (2 ± 2 kg/cm ²) / (30 ± 2 kg/cm ²)
Remarks	<ul style="list-style-type: none"> Engine at high idling Travel lever at Fine control position (auto-deceleration canceled) 		

H-23 Travel does not move (one side only)



H-24 Does not swing

a) Does not swing to either left or right

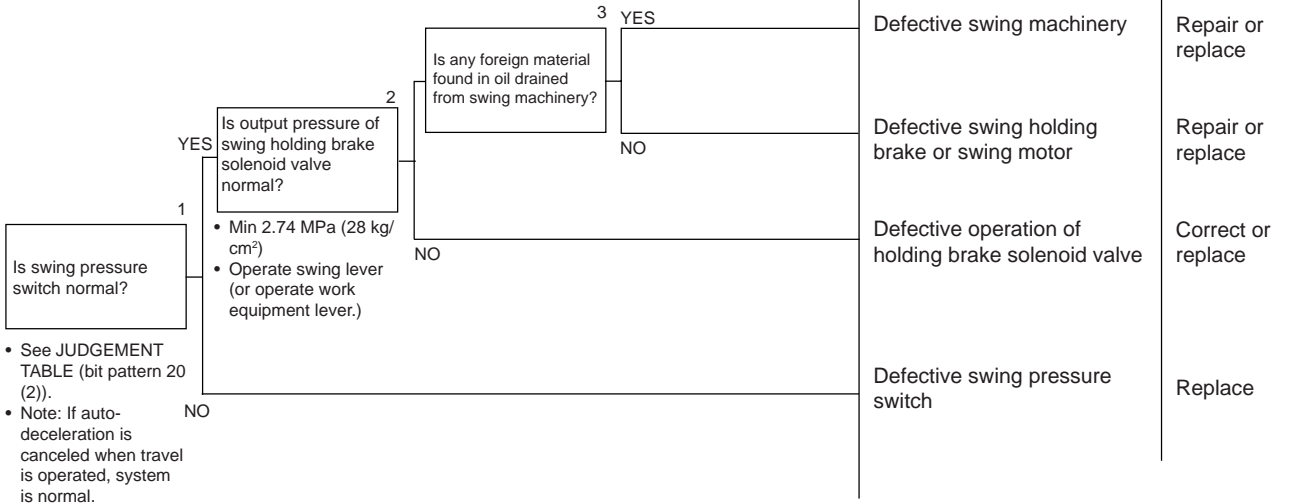

b) Does not swing in one direction

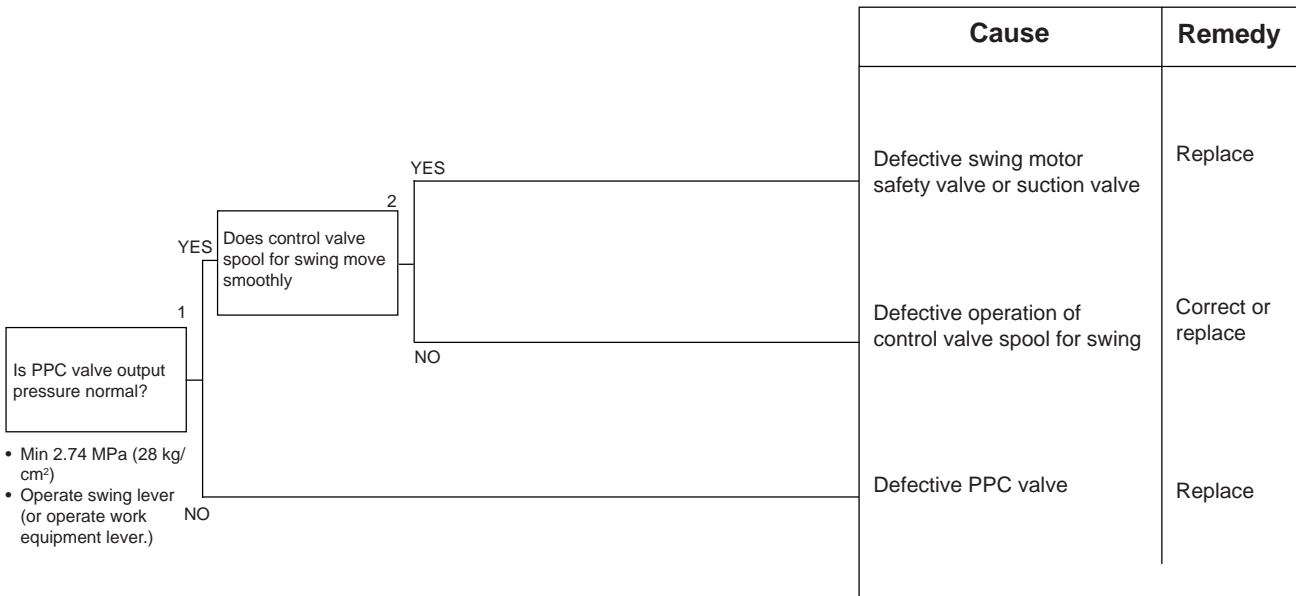

H-25 Swing acceleration is poor or swing speed is slow

- ★ Carry out troubleshooting in the H/O mode.
- ★ When individual operation of the work equipment is normal.

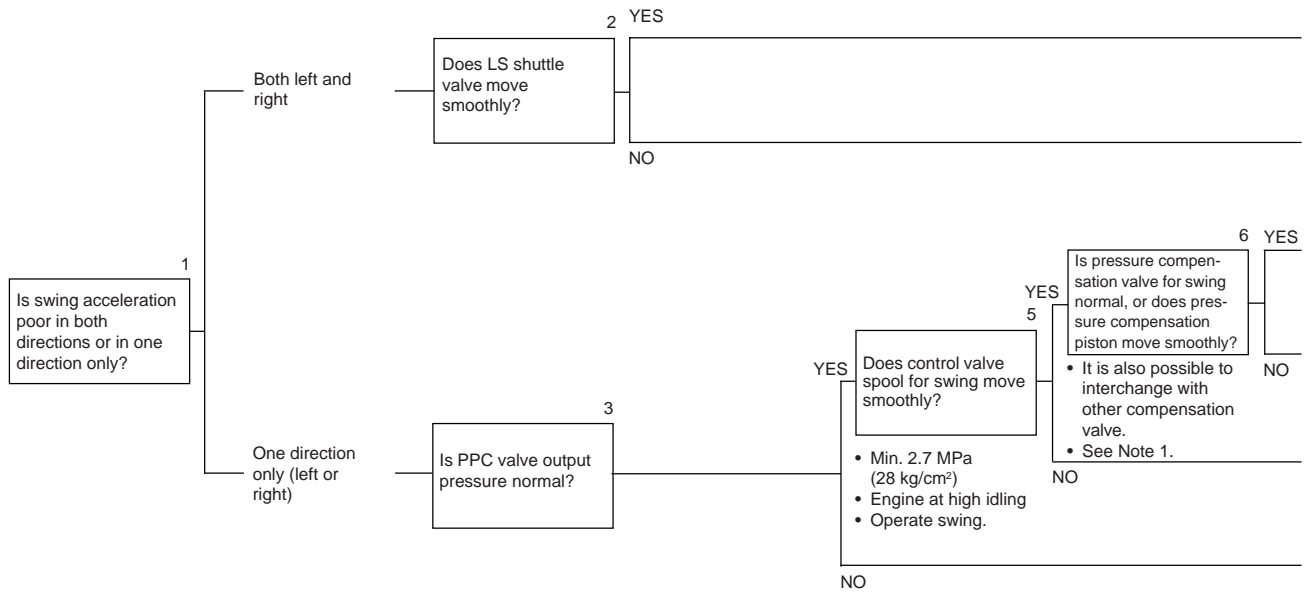

Note 1: After checking, always return the interchanged valves to their original positions.

	Cause	Remedy
	Defective swing motor assembly	Replace
	Defective operation of LS shuttle valve (all LS shuttles)	Correct or replace
	Defective operation of swing motor safety suction valve	Correct or replace
	Defective operation of pressure compensation valve or compensation piston	Correct or replace
	Defective operation of control valve swing pool	Correct or replace
	Defective PPC valve	Replace

H-26 Excessive overrun when stopping swing

a) One direction only

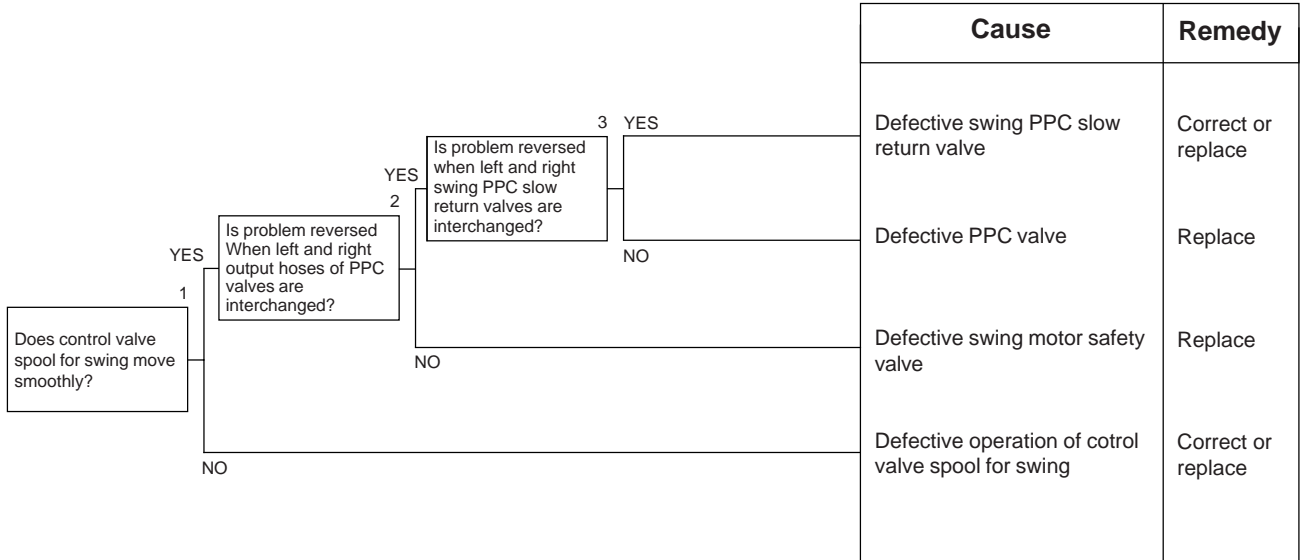

b) Both directions

Cause	Remedy
Defective swing motor	Repair or replace

H-27 Excessive shock when stopping swing (one direction only)

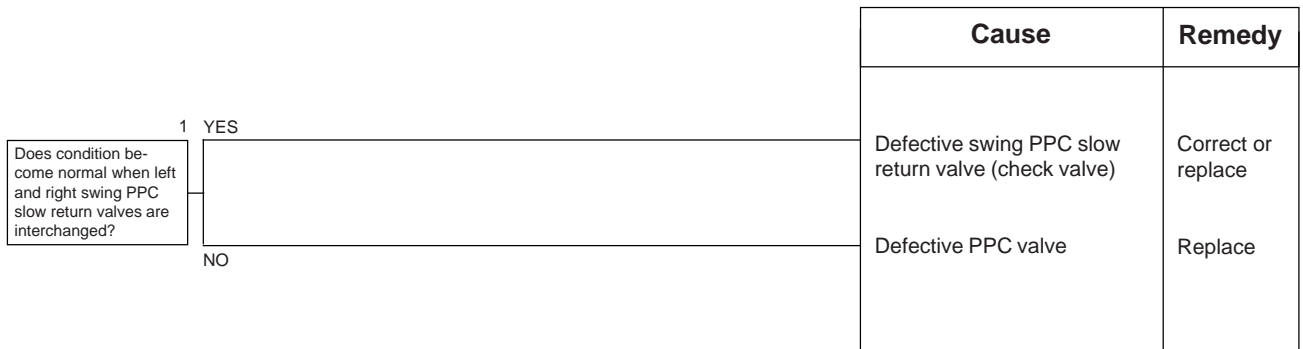

H-28 Excessive abnormal noise when stopping swing

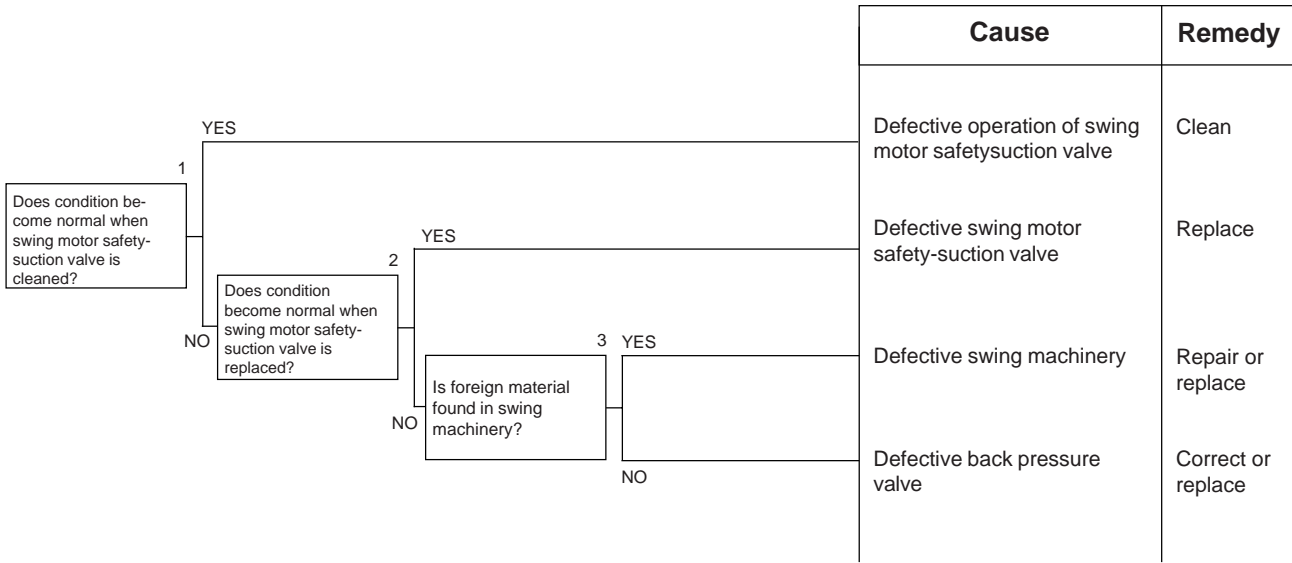

H-29 Excessive hydraulic drift of swing

a) When swing holding brake is released

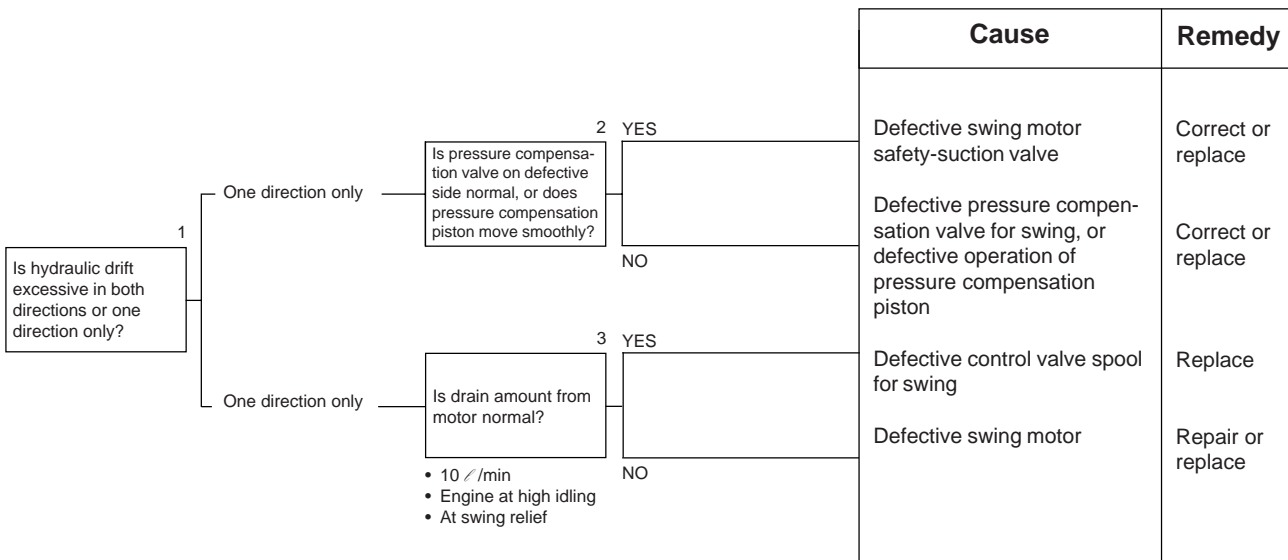

b) When swing holding brake is applied

	Cause	Remedy
1 YES Is output pressure of swing holding brake solenoid valve normal?	Defective operation of swing holding brake	Repair or replace
NO	Defective operation of swing holding brake solenoid valve	Correct or replace

H-30 Swing speed is faster than specified speed in L/O and F/O modes

★ Carry out troubleshooting in the H/O mode.

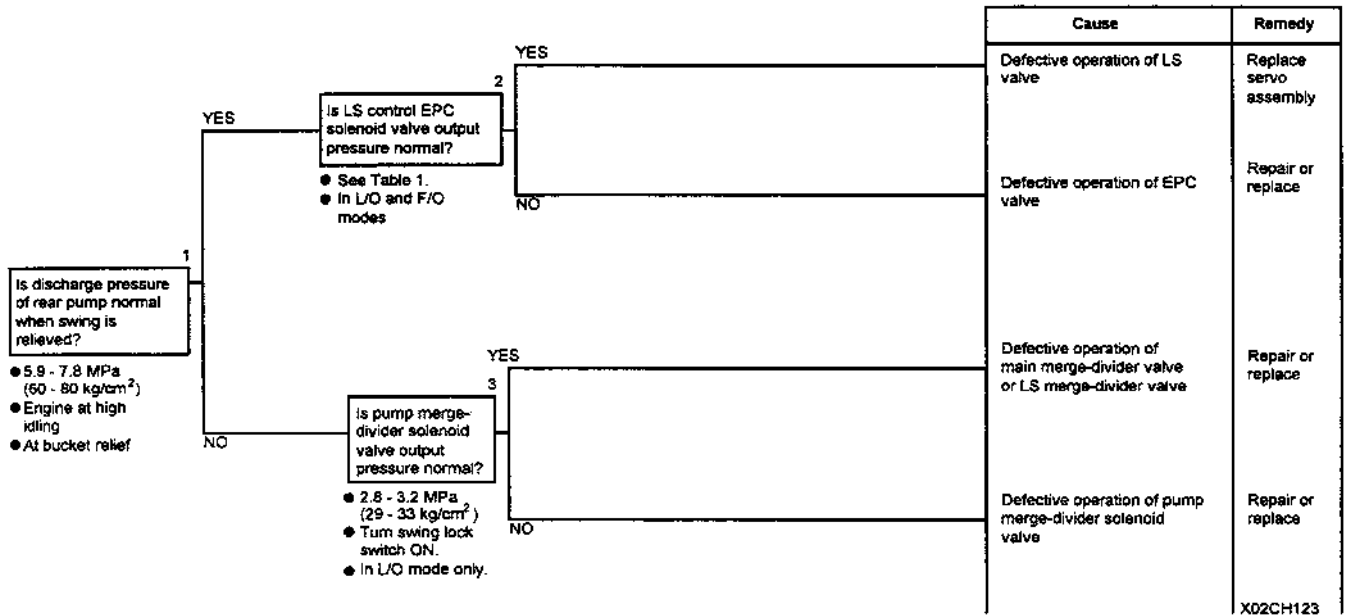

Table 1 Output pressure of LS control EPC valve

- Engine at high idling PC290-6K

H/O mode	G/O mode	F/O mode	L/O mode
3.0 ± 0.2 MPa (30 ± 2 kg/cm ²)	3.0 ± 0.2 MPa (30 ± 2 kg/cm ²)	3.0 ± 0.2 MPa (30 ± 2 kg/cm ²)	1.5 ± 0.2 MPa (15.5 ± 2.0 kg/cm ²)

TROUBLESHOOTING OF MACHINE MONITOR SYSTEM (M CODE)

ACTION TAKEN BY MONITOR PANEL WHEN ABNORMALITY OCCURS AND PROBLEMS ON MACHINE

User code	Service code	Abnormal system	Nature of abnormality
-	E101	Abnormality in error data	<ol style="list-style-type: none"> 1. Abnormality in internal memory 2. Excess voltage (more than 36V) has occurred 3. Low voltage (less than 12V) has occurred 4. Connector has separated
-	E102	Abnormality in clock data	<ol style="list-style-type: none"> 1. Abnormality in internal clock function 2. Excess voltage (more than 36V) has occurred 3. Low voltage (less than 12V) has occurred 4. Connector has separated
-	E103	Short circuit in buzzer output system	<ol style="list-style-type: none"> 1. Short circuit inside buzzer 2. Power line in contact with wiring harness between monitor (P01 (7) pin) and buzzer 3. Abnormality in monitor panel
-	E104	Air cleaner clogging detected is displayed	<ol style="list-style-type: none"> 1. Air cleaner clogging sensor has detected clogging
-	E108	Engine water temperature 105°C detected is displayed	<ol style="list-style-type: none"> 1. Coolant temperature gauge has detected water temperature of 105°C
-	E112	Short circuit in wiper motor drive normal rotation system	<ol style="list-style-type: none"> 1. Short circuit with ground, short circuit inside wiper motor 2. Short circuit with ground, short circuit inside relay box 3. Short circuit with ground, short circuit in wiring harness between monitor P02 (11) and relay box W08 (2), or between W08 (6) and wiper motor W04 (3)
-	E113	Short circuit in wiper motor drive reverse rotation system	<ol style="list-style-type: none"> 1. Short circuit with ground, short circuit inside wiper motor 2. Short circuit with ground, short circuit inside relay box 3. Short circuit with ground, short circuit in wiring harness between monitor P02 (3) and relay box W08 (3), or between W08 (7) and wiper motor W04 (1)
-	E114	Short circuit in window washer drive system.	<ol style="list-style-type: none"> 1. Short circuit inside washer monitor 2. Short circuit inside relay box 3. Short circuit with power source in wiring harness between monitor P02 (2) and relay box W08 (17), or between W08 (16) and M28 (1)

Condition when normal (voltage, current, resistance)	Action by controller when abnormality is detected	Problem that appears on machine when there is abnormality
<ul style="list-style-type: none"> When starting switch is turned ON, keep time switch pressed for 5 seconds to actuated clear function 	-	<ol style="list-style-type: none"> Service code cannot be cleared Time becomes 00:00
	-	<ol style="list-style-type: none"> Service code cannot be cleared Time becomes 00:00 Clock does not advance.
<ul style="list-style-type: none"> Voltage between P01 (7) - chassis Buzzer On: Max. 1V Buzzer OFF: 20 - 30V ★ When there is a disconnection, E103 is not displayed and the buzzer does not sound 	-	<ol style="list-style-type: none"> Buzzer does not sound
<ul style="list-style-type: none"> Resistance between P11 (male) - P12 (male): Min 1Ω (engine started) 	-	<ol style="list-style-type: none"> If abnormality detection continues, air cleaner clogging caution lamp flashes and buzzer sounds
<ul style="list-style-type: none"> Resistance between sensor terminal and chassis: Min. 1 MΩ (engine at mid-range speed or above) 	-	<ol style="list-style-type: none"> If abnormality detection continues, engine oil pressure caution lamp flashes and buzzer sounds
<ul style="list-style-type: none"> Resistance between P07 (1) - (2): Min. 3.156 Ω (engine started) 	-	<ol style="list-style-type: none"> If abnormality detection continues, coolant temperature caution lamp flashes and buzzer sounds If abnormality detection continues, engine speed is reduced to low idling
<ul style="list-style-type: none"> Voltage between W04 (3) and (5): Max. 3 V to 20 -30 V ★ Repeats in regular cycle 	<ol style="list-style-type: none"> Sets output to relay box to 0 	<ol style="list-style-type: none"> Operation of wiper stops
<ul style="list-style-type: none"> Voltage between W04 (3) and (5): Max. 3 V to 20 -30 V ★ Repeats in regular cycle 	Same as E112	Same as E112
<ul style="list-style-type: none"> Resistance of motor: 1.6 	<ol style="list-style-type: none"> Sets output to washer motor to 0 	<ol style="list-style-type: none"> Operation of window washer stops

ELECTRICAL CIRCUIT DIAGRAM FOR M MODE SYSTEM

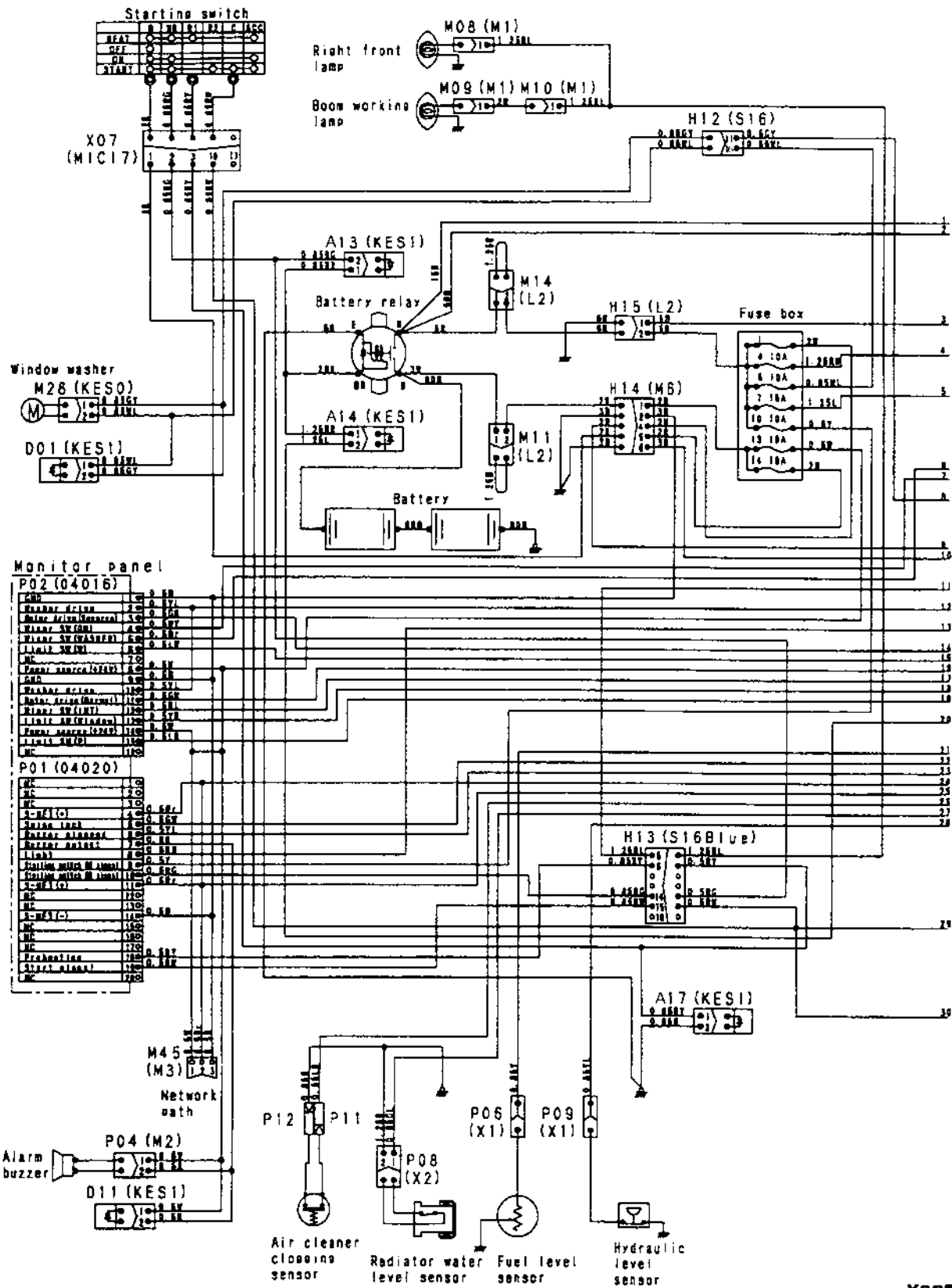

X08DD300

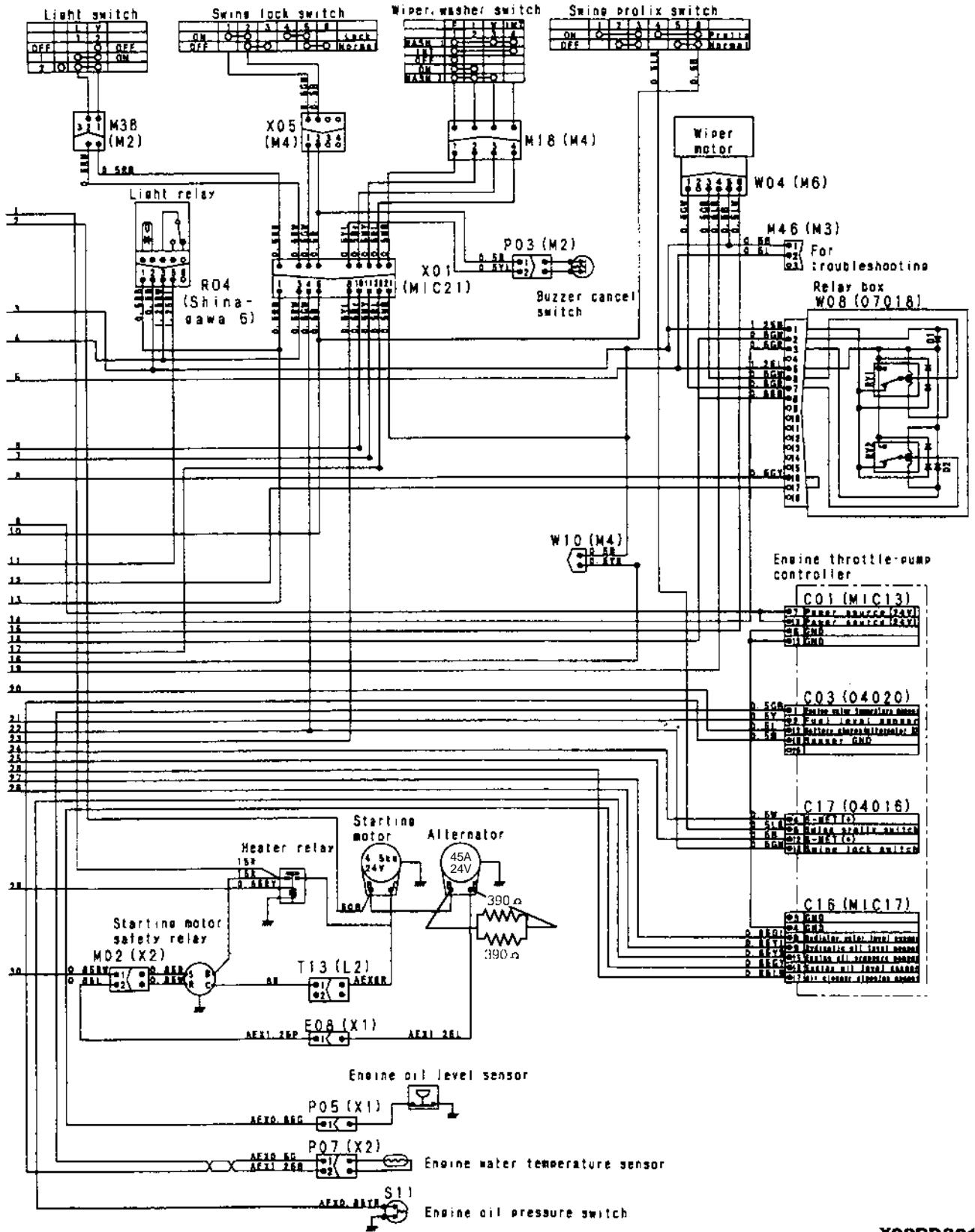

X08DD301

M-1 [E101] Abnormality in error data is displayed [E102] Error in clock data is displayed

- ★ This is not an abnormality. It occurs during troubleshooting when disconnecting and connecting connector P02 (for the monitor panel electrical system), fuse No. 13, connector M14, connector M11, battery relay terminal B, or the battery terminal. (When the monitor panel power source circuit is shut off with the starting switch turned OFF).
- ★ If the service code display appears again after the system has been reset, carry out troubleshooting as follows.

		Cause	Remedy
<p>Does service code display appear again after system has been reset?</p> <p>1 YES</p> <p>Is voltage between P02 (8) (14) and chassis normal?</p> <p>2 YES</p> <p>NO</p> <p>NO</p> <p>• Turn starting switch OFF. • 20 - 30V</p> <p>• After resetting system, carry out normal operations for a short time and watch the condition. (See Note 1.)</p>	YES	Defective monitor panel	Replace
	NO	Disconnection, defective contact, short circuit with ground in wiring harness between battery - battery relay B - M11 (1)(2) - H14 (1) - fuse No. 13 - P02 (female) (8) (14)	Repair or replace
	NO	Normal	-

Note 1: Resetting operation: Turn the starting switch OFF. Then keep the time switch at the back of the monitor panel depressed, switch the starting switch ON again, and keep the time switch depressed for 5 seconds to return the system to normal. (With this operation, all the service codes in the internal memory are erased-.

M-1 Related electric circuit diagram

Engine throttle, pump controller

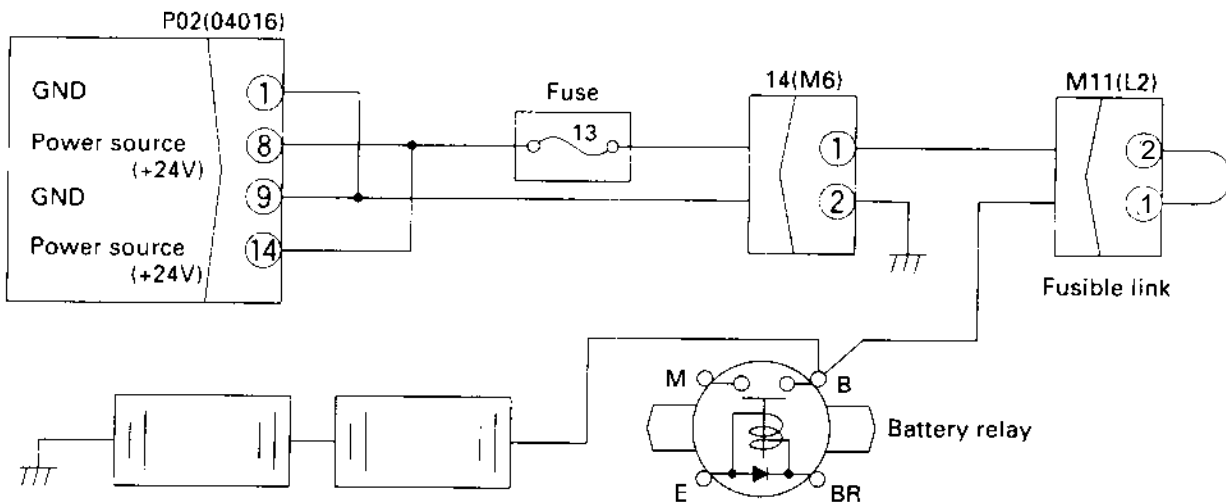

BKP00272

M-2 [E103] Short circuit in buzzer output or contact of 24V wiring harness with buzzer drive harness is displayed

- ★ If the starting switch is turned OFF after an abnormality occurs, turn the starting switch ON and check if an E service code is displayed. (If it is not displayed, the system has been reset.)
- ★ Before carrying out troubleshooting, check that all the related connectors are properly inserted.
- ★ Always connect any disconnected connectors before going on the next step.

	Cause	Remedy
<p style="text-align: center;">2 YES</p> <p style="text-align: center;">1 YES</p> <p>Is resistance between P04 (male) (1) - (2), (2) - chassis as shown in the table?</p> <ul style="list-style-type: none"> • Turn starting switch OFF. • Disconnect P04. 	<p>Defective monitor panel</p> <p>Short circuit with power source in wiring harness between P01 (female) (7) and P04 (female) (2) or short circuit in wiring harness between P04 (1) and (2)</p> <p>Defective buzzer</p>	<p>Replace</p> <p>Repair or replace</p> <p>Replace</p>
<p style="text-align: center;">2 NO</p> <p>Is voltage between P04 (2) and chassis normal?</p> <ul style="list-style-type: none"> • Turn starting switch ON. • Buzzer ON: Max. 1V • Buzzer OFF: 20 - 30V 		
<p style="text-align: center;">NO</p>		

Table

P04 (male)	Resistance value
Between (1) and (2)	200 - 300 Ω
Between (2) and chassis	Min. 1 MΩ

M-2 Related electric circuit diagram

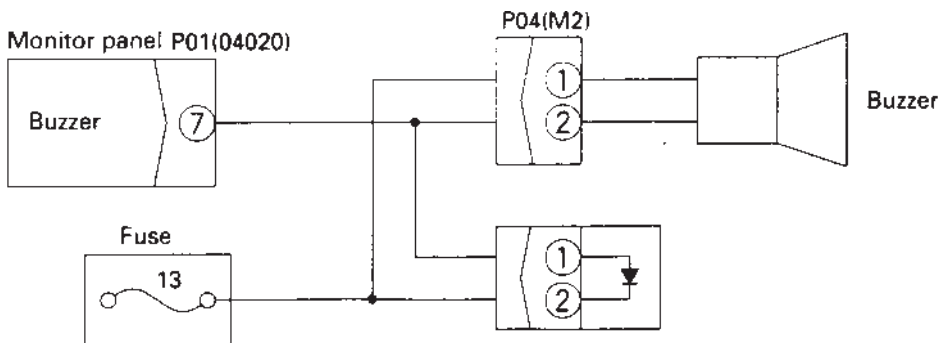

BKP00273

M-3 [E104] Air clogging detected is displayed

	Cause	Remedy
<p>1 YES</p> <p>Is air cleaner clogging caution lamp on monitor flashing?</p>	See M-13 f)	-
<p>2 YES</p> <p>Is "E" service code displayed?</p>	Defective monitor panel	Replace
<p>NO</p> <p>• Turn starting switch ON.</p>	Failure in engine system (See Note 1)	-

Note 1: The monitor panel display has returned to normal, but the air cleaner clogging sensor has detected symptoms of clogging in the past, so carry out troubleshooting of the engine to remove the problem

M-4 [E108] Engine coolant temperature 105°C detected is displayed

	Cause	Remedy
<p>1 YES</p> <p>Does coolant temperature gauge on monitor panel display red range and is caution lamp flashing?</p>	See M-12 d)	-
<p>2 YES</p> <p>Is "E" service code displayed?</p>	Defective monitor panel	Replace
<p>NO</p> <p>• Turn starting switch ON.</p>	Failure in engine system (See Note 1)	-

Note 1: The monitor panel display has returned to normal, but the coolant temperature sensor has detected symptoms of the coolant temperature reaching 105°C in the past, so carry out troubleshooting of the engine to remove the problem.

M-5 When starting switch is turned ON, none of the lamps on the monitor panel light up for 3 seconds

- ★ Check that fuses No. 10 and 13 are not blown.
- ★ Before carrying out troubleshooting, check that all the related connectors are properly inserted.
- ★ Always connect any disconnected connectors before going on the next step.

a) None of lamps on monitor panel light up

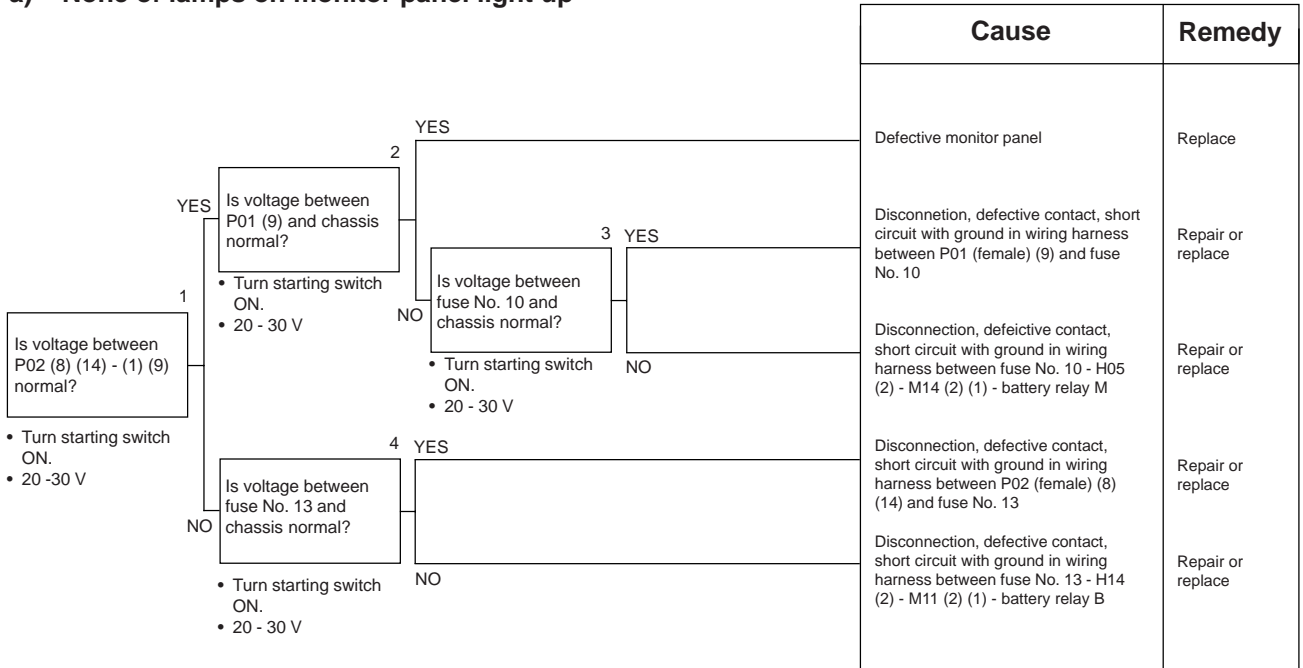

b) Some of lamps on monitor panel do not light up

	Cause	Remedy
	Defective monitor panel	Replace

M-5 a) Related electric circuit diagram

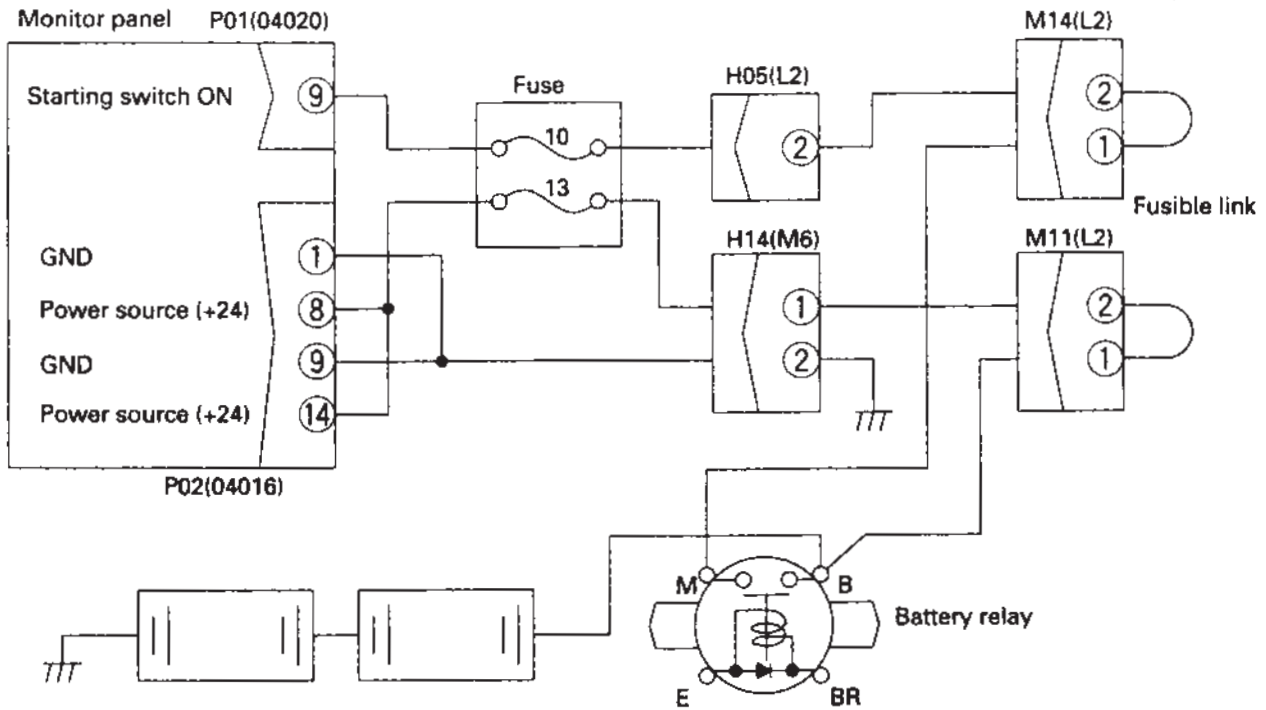

BKP00274

M-6 When starting switch is turned ON, monitor panel lamps all stay lit up and do not go out

	Cause	Remedy
	Defective monitor panel	Replace

M-7 When starting switch is turned ON, items lit up on monitor panel are different from actual machine (model)

★ Immediately after replacing the monitor panel, turn the starting switch OFF, then turn it On again and check

	Cause	Remedy
<p>1 YES</p> <p>Is display of monitoring code 01 as shown in table?</p>	Defective monitor panel	Replace
<p>NO</p> <ul style="list-style-type: none"> • Turn starting switch ON. • Set to monitoring code 01. 	Go to troubleshooting for C mode (See C-16)	-

Table 1

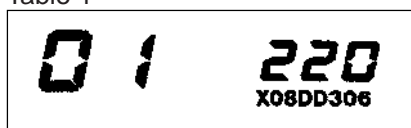

M-8 When starting switch is turned ON (engine stopped), basic check items flashes

- ★ Before carrying out troubleshooting, check that all the related connectors are properly inserted.
- ★ Always connect any disconnected connectors before going on the next step.

a) (coolant level) flashes

SAP00519

- ★ Check that the coolant is at the specified level before carrying out troubleshooting.

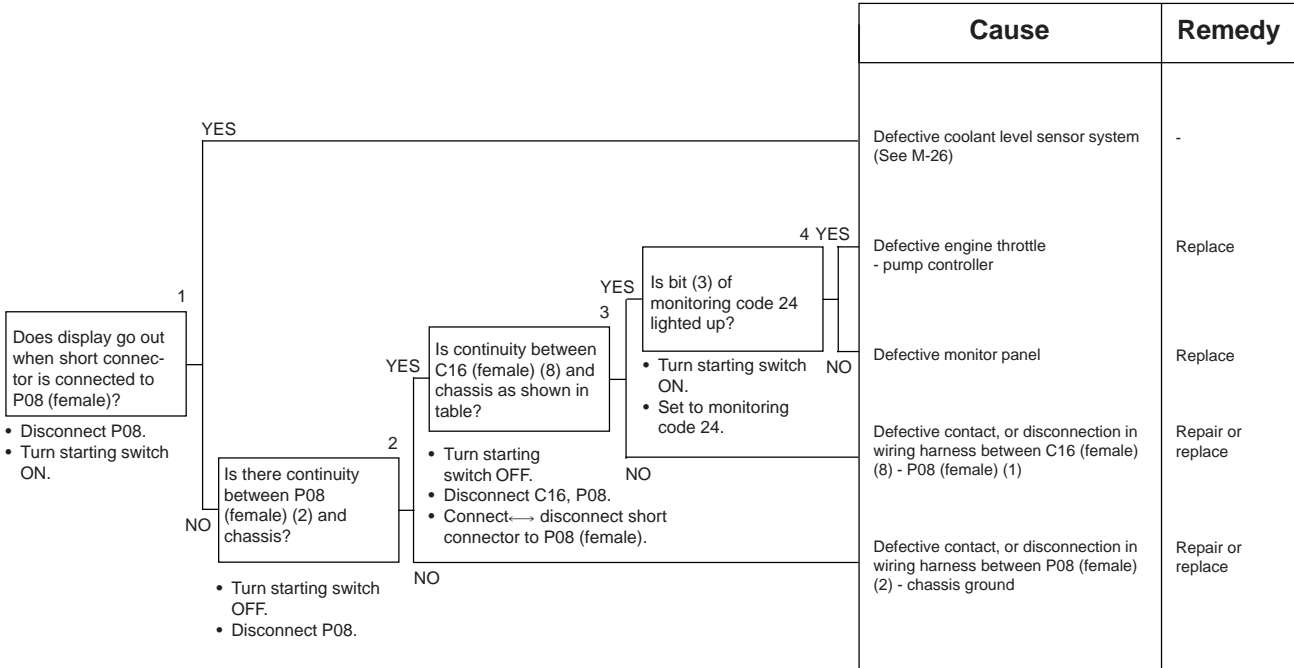
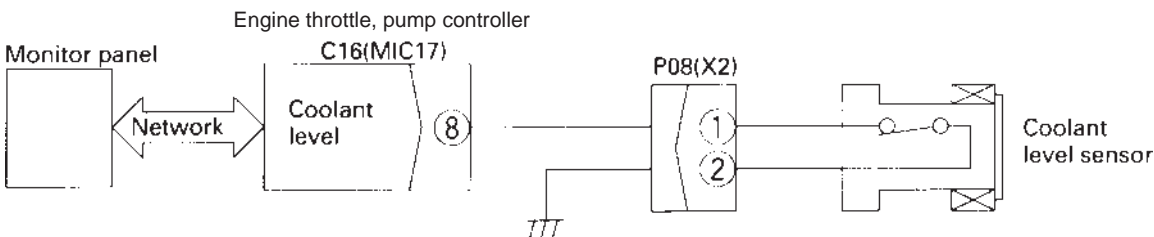

Table 1

Short connector	Continuity
Connected	Yes
Disconnected	No

M-9 a) Related electric circuit diagram



BKP00277

M-8 When starting switch is turned ON (engine stopped), basic check items flashes

- ★ Before carrying out troubleshooting, check that all the related connectors are properly inserted.
- ★ Always connect any disconnected connectors before going on the next step.

a) (coolant level) flashes

- ★ Check that the coolant is at the specified level before carrying out troubleshooting.

		Cause	Remedy	
<p>1 Does display go out when short connector is connected to P08 (female)?</p> <ul style="list-style-type: none"> • Disconnect P08. • Turn starting switch ON. 	YES	Defective coolant level sensor system (See M-26)	-	
	<p>2 Is there continuity between P08 (female) (2) and chassis?</p> <ul style="list-style-type: none"> • Turn starting switch OFF. • Disconnect P08. 	NO	Defective contact, or disconnection in wiring harness between P08 (female) (2) - chassis ground	Repair or replace
		YES	<p>3 Is continuity between C16 (female) (8) and chassis as shown in table?</p> <ul style="list-style-type: none"> • Turn starting switch OFF. • Disconnect C16, P08. • Connect → disconnect short connector to P08 (female). 	Defective engine throttle - pump controller
	NO	Defective monitor panel		Replace
	<p>4 Is bit (3) of monitoring code 24 lighted up?</p> <ul style="list-style-type: none"> • Turn starting switch ON. • Set to monitoring code 24. 	YES	Defective engine throttle - pump controller	Replace
NO		Defective contact, or disconnection in wiring harness between C16 (female) (8) - P08 (female) (1)	Repair or replace	

Table 1

Short connector	Continuity
Connected	Yes
Disconnected	No

M-9 a) Related electric circuit diagram

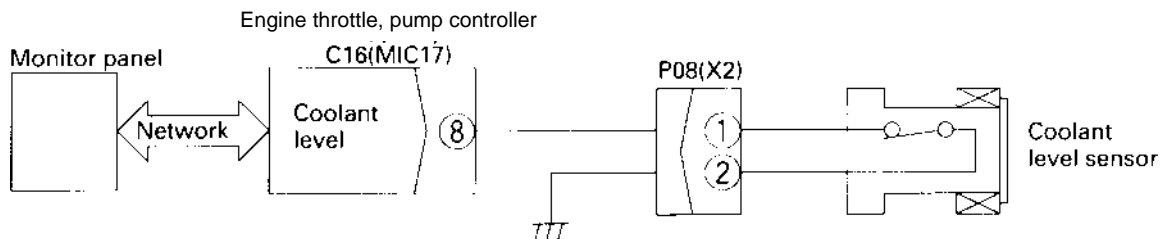

BKP00277

b)  (engine oil level) flashes

SAP:10523

★ Chek that the engine oil is at the specified level before carrying out troubleshooting.

		Cause	Remedy	
<p>1</p> <p>Does display go out when P05 (female) (1) is connected to chassis ground?</p> <ul style="list-style-type: none"> • Disconnect P05. • Turn starting switch ON. 	YES	Defective engine oil level sensor system (see M-27)	-	
	NO	2	Is continuity between C16 (female) (16) and chassis as shown in table?	
	YES	3	Is bit (4) of monitoring code 24 lighted up?	Replace
	NO		Defective monitor panel	Replace
			Defective contact, or disconnection in wiring harness between C16 (female) (16) - E08 (5) - P05 (female) (1)	Repair or replace

Table

Chassis ground	Continuity
Connected	Yes
Disconnected	No

M-8 b) Related electric circuit diagram

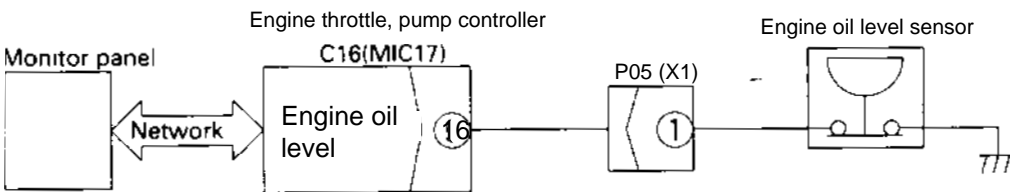

BKP00279

M-9 Preheating is not being used but (preheating monitor) lights up

SAP00528

- ★ Before carrying out troubleshooting, check that all the related connectors are properly inserted.
- ★ Always connect any disconnected connectors before going on the next step.

		Cause	Remedy		
<p>1</p> <p>Is voltage between starting switch terminal R1 and chassis normal?</p> <ul style="list-style-type: none"> • Disconnect terminal R1. • Turn starting switch ON. • Max. 1V 	YES	Defective monitor panel	Replace		
	2	Is voltage between P01 (18) and chassis normal?	NO	Short circuit with power source in wiring harness between starting switch R1 - X07 (3) - H13 (6) - P01 (female) (18)	Repair or replace
	NO		Defective starting switch	Replace	

M-9 Related electric circuit diagram

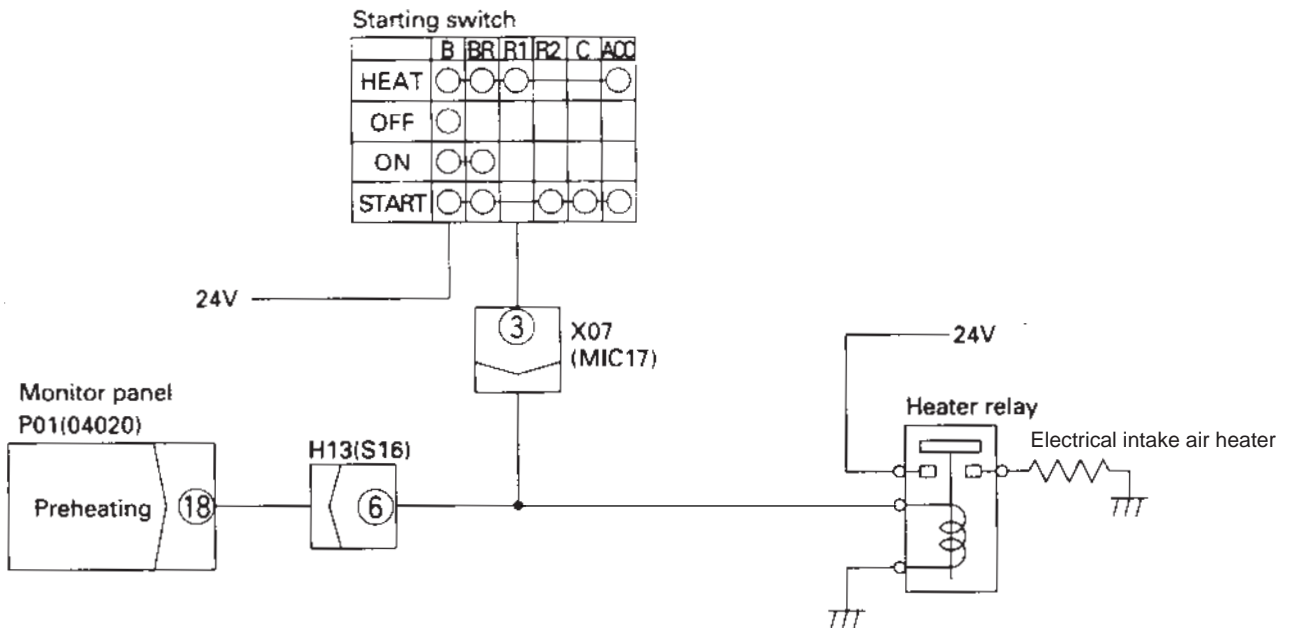

M-10 When starting switch is turned ON and engine is started, basic check items flash

- ★ Before carrying out troubleshooting, check that all the related connectors are properly inserted.
- ★ Always connect any disconnected connectors before going on the next step.
- ★ Check both the alternator system and the engine oil pressure system.

a) Alternator system

		Cause	Remedy
<p>Is voltage between alternator terminal R and chassis normal?</p> <p>• Start engine and run at mid-range or above</p> <p>• 20 -30V</p>	YES		
	NO		
	YES		
	NO		
	YES	Defective engine throttle - pump controller	Replace
	NO	Defective monitor panel	Replace
		Defective contact, or disconnection in wiring harness between alternator terminal R - E08 (2) - C03 (female) (12)	Repair or replace
		Defective alternator	Replace

M-10 a) Related electric circuit diagram

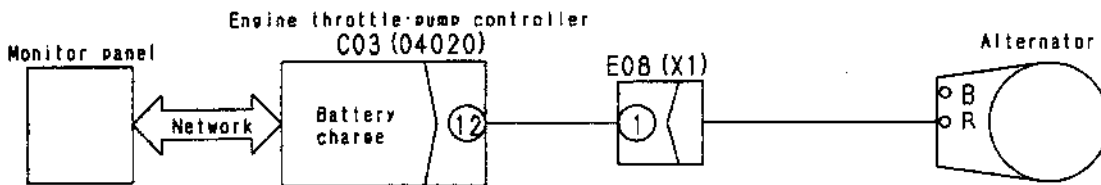

X08DD313

b) Engine oil pressure system

★ When engine oil pressure is normal

		Cause	Remedy	
<p>When engine is running at high idling and wiring harness of oil pressure sensor is removed, does display go out?</p> <p>• Engine at low idling</p>	1 YES	Defective oil pressure sensor (for low pressure)	Replace	
	NO	2 YES	Contact of chassis ground with wiring harness between C16 (female) (15) - E08 (8) - sensor	Repair or replace
	NO	3 YES	Defective engine throttle - pump controller	Replace
	NO	NO	Defective monitor panel	Replace

M-10 b) Related electric circuit diagram

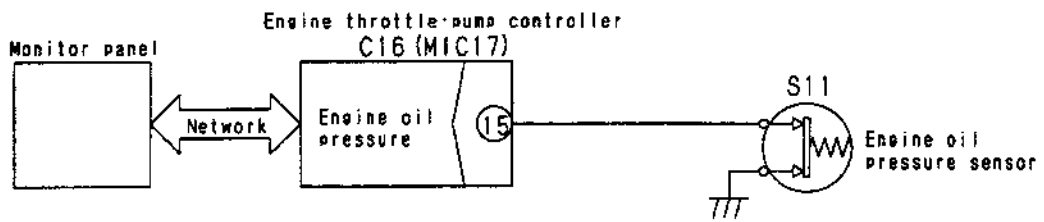

X08DD312

M-11 When starting switch is turned ON (engine stopped), caution items, emergency items flash (battery, engine oil pressure lamps do not light up)

- ★ Before carrying out troubleshooting, check that all the related connectors are properly inserted.
- ★ Always connect any disconnected connectors before going on the next step.
- ★ Check both the alternator system and the engine oil pressure system.

a) Alternator system

	Cause	Remedy
<p>3 YES</p> <p>Does monitoring code 43 show a value of greater than 100?</p> <ul style="list-style-type: none"> • Set engine and run at mid-range speed or above. • Set to monitoring code 43 	Defective engine throttle - pump controller	Replace
<p>2 YES</p> <p>Is voltage between C03 (female) (12) and chassis normal?</p> <ul style="list-style-type: none"> • Disconnect C03. • Turn starting switch ON. • Max. 1V 	Defective monitor panel	Replace
<p>1 YES</p> <p>Is voltage between alternator terminal R and chassis normal?</p> <ul style="list-style-type: none"> • Disconnect terminal R. • Turn starting switch ON. • Max. 1V 	Short circuit with power source in wiring harness between C03 (female) (12) - E08 (2) - alternator R	Repair or replace
<p>NO</p>	Defective alternator	Replace

M-11 a) Related electric circuit diagram

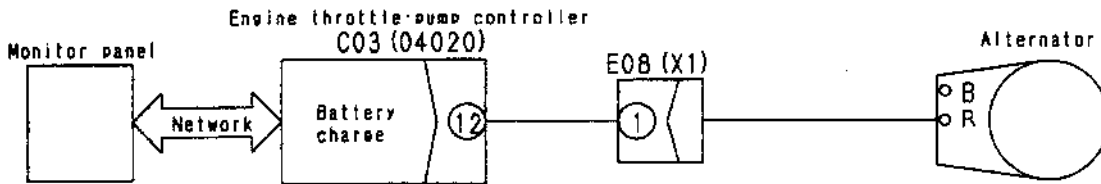

X08DD313

b) Engine oil pressure sensor system

★ When engine oil pressure is normal.

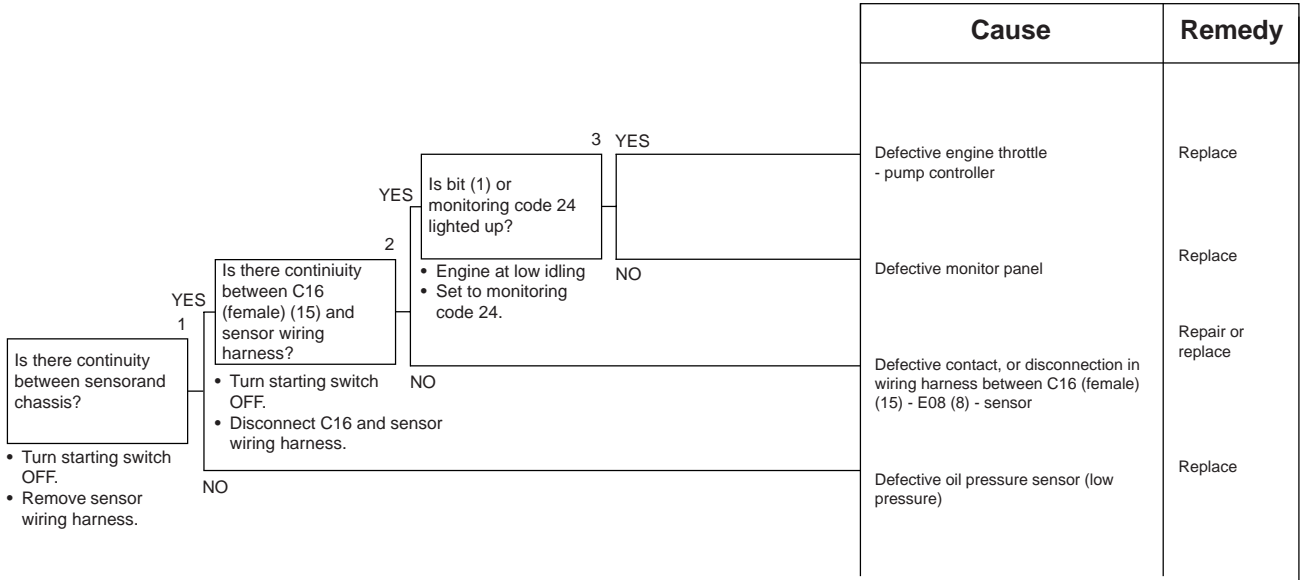

M-11 b) Related electric circuit diagram

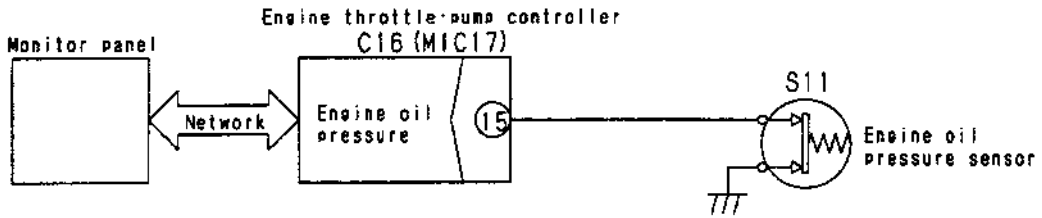

X08DD312

M-12 When starting switch is turned ON and engine is started, caution items, emergency items flash (then there is no abnormality in engine or items to check before troubleshooting)

- ★ Before carrying out troubleshooting, check that all the related connectors are properly inserted.
- ★ Always connect any disconnected connectors before going on the next step.

a)  (engine oil pressure) flashes

SAP00520

- ★ Check that the engine oil pressure is normal before carrying out troubleshooting.

Cause	Remedy
See M-11 b)	-

b)  (coolant level) flashes

SAP00519

- ★ Check that the coolant level is normal before carrying out troubleshooting.

Cause	Remedy
See M-9 a)	-

c)  (battery charge) flashes

SAP00522

Cause	Remedy
See M-11 a)	-

d)  (coolant temperature) flashes

SAP00527

- ★ Check that the coolant temperature is normal before carrying out troubleshooting

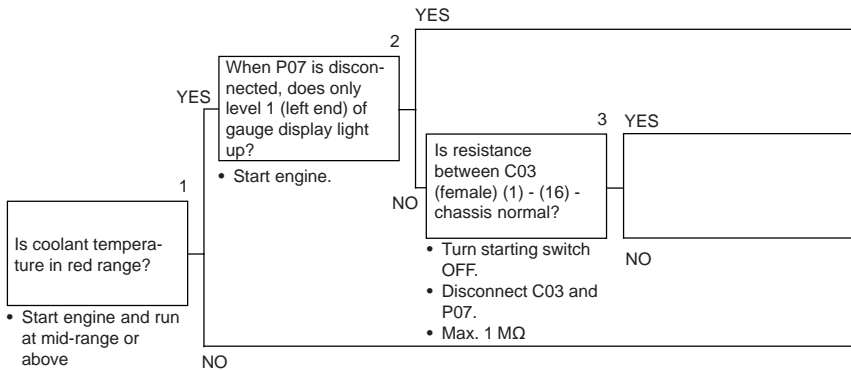

Cause	Remedy
Defective coolant temperature sensor system (see M-26)	-
Defective engine throttle - pump controller	Replace
Short circuit of wiring harness between, C03 (female) (1) and P07 (female) (1) and wiring harness between C03 (female) (16) and P07 (female) (2)	Repair or replace
Defective monitor panel	Replace

M-12 d) Related electric circuit diagram

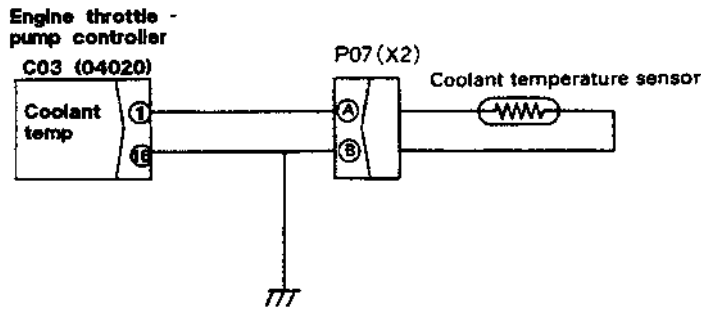

X08DD315

e)  (fuel) flashes

SAP00528

- ★ Check that there is fuel before carrying out troubleshooting.

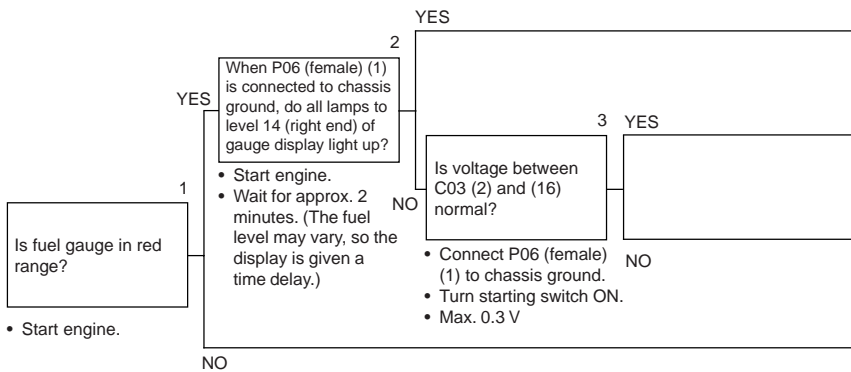

Cause	Remedy
Defective fuel level sensor system (see M-25)	-
Defective engine throttle - pump controller	Replace
Defective contact or disconnection in wiring harness between C03 (female) (2) and P06 (female) (1)	Repair or replace
Defective monitor panel	Replace

M-12 e) Related electric circuit diagram

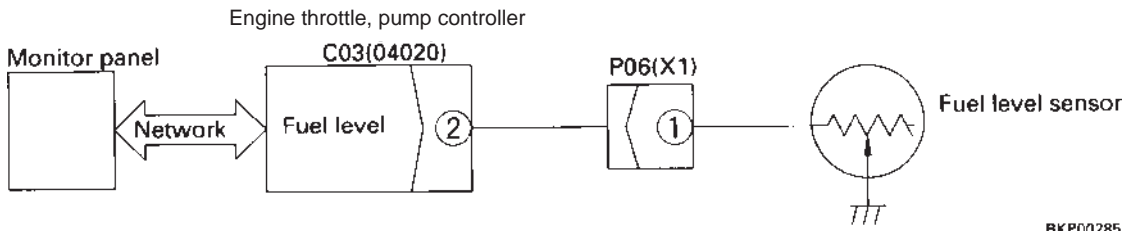

BKP00285

f)  (air cleaner clogging) flashes

★ Check that the air cleaner is not clogged before carrying out troubleshooting

		Cause	Remedy
<p>1 Does display go out when P11 (female) is connected to P12 (male)?</p> <p>• Start engine.</p>	YES	Defective air cleaner clogging sensor	Replace
	NO	Defective governor, pump controller	Replace
	NO	Defective monitor panel	Replace
	NO	Defective contact or disconnection in wiring harness between C16 (female) (17) and P11 (female)	Repair or replace
<p>2 Is there continuity between P12 (male) and chassis?</p> <p>• Turn starting switch OFF.</p> <p>• Disconnect P12</p>		Defective contact or disconnection in wiring harness between P12 (male) and chassis ground	Repair or replace
<p>3 Is continuity between C16 (female) (17) and chassis as shown in table?</p> <p>• Turn starting switch OFF.</p> <p>• Disconnect C16, P11 and P12.</p> <p>• Connect ↔ disconnect P11 (female) to P12 (male).</p>			
<p>4 Is bit (6) of monitoring code 24 lighted up?</p> <p>• Start engine</p> <p>• Set to monitoring code 24.</p>			

Table 1

C16 (female) (17) - chassis	P11 (female) and P12 (male) connected	P11 (female) and P12 (male) disconnected
	Continuity	No continuity

M-12 f) Related electric circuit diagram

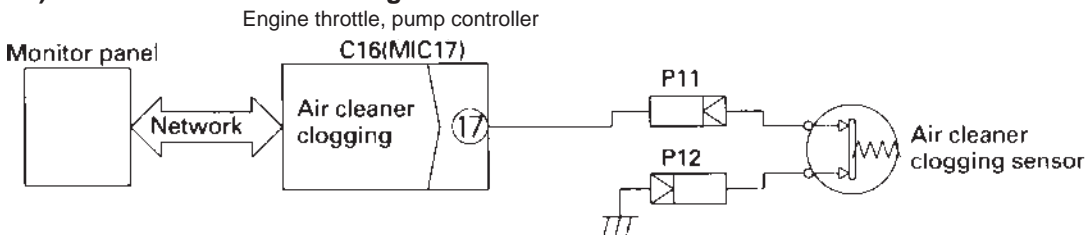

BKP00286

M-13 When starting switch is turned ON (engine stopped), buzzer does not sound for 1 second Caution item flashes but buzzer does not sound

- ★ Of the caution items, the buzzer will not sound even if there is an abnormality in the battery charge or fuel level.
- ★ Before carrying out troubleshooting, check that all the related connectors are properly inserted.
- ★ Always connect any disconnected connectors before going on the next step.

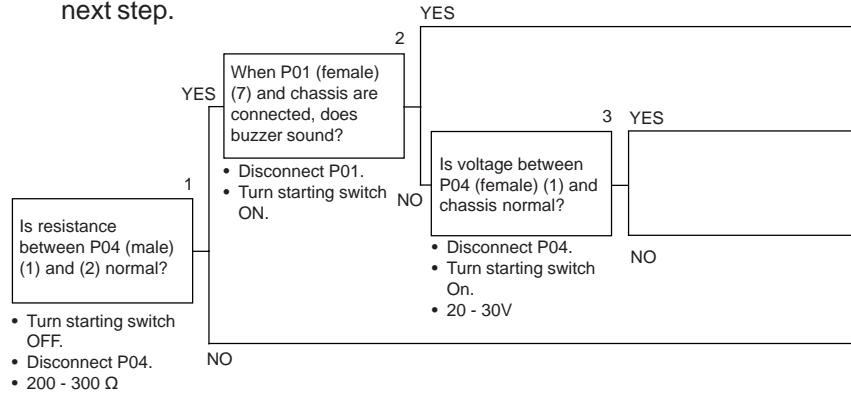

Cause	Remedy
Defective monitor panel	Replace
Defective contact or disconnection in wiring harness between P01 (female) (7) and P04 (female) (2).	Repair or replace
Disconnection, defective contact, short circuit with ground in wiring harness between P04 (female) (1) and fuse No. 13	Repair or replace
Defective buzzer	Replace

M-14 No abnormality is displayed on monitor but buzzer sounds

- ★ When buzzer sounds continuously. If the buzzer sounds intermittently, carry out troubleshooting for M-13.
- ★ Before carrying out troubleshooting, check that all the related connectors are properly inserted.
- ★ Always connect any disconnected connectors before going on the next step.

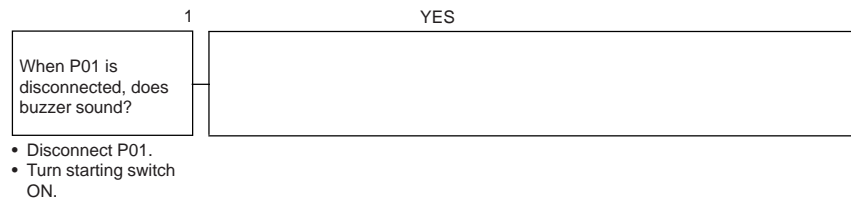

Cause	Remedy
Contact of chassis ground with wiring harness between P01 (female) (7) and P04 (female) (2), or defective buzzer	Repair or replace
Defective monitor panel	Replace

M-13, 14 Related electric circuit diagram

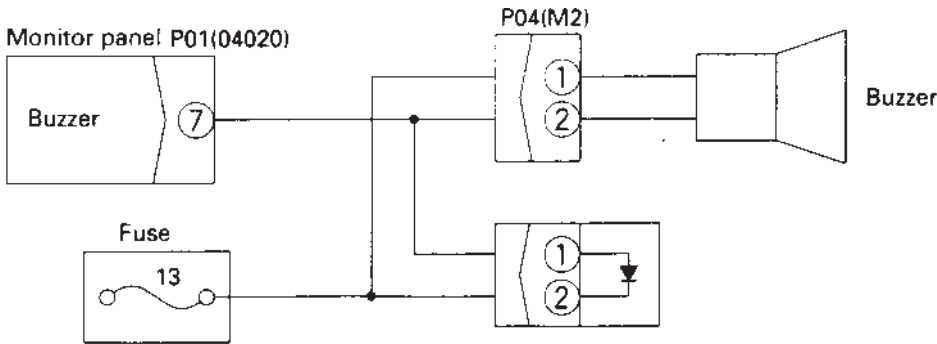

BKP00273

M-15 Night lighting on monitor panel does not light up (liquid crystal display is normal)

★ When the front lamp and working lamp light up normally.

	Cause	Remedy
<p>1 YES</p> <p>Is bulb blown, or is there defective contact?</p> <ul style="list-style-type: none"> Remove bulb. Check visually for blown bulb 	Blown bulb or defective contact of bulb	Replace bulb, or clean (defective contact)
<p>2 YES</p> <p>Does bit (3) of monitoring code 49 go out?</p> <ul style="list-style-type: none"> Turn starting switch ON. Set to monitoring code 49 	Defective monitor panel	Replace
<p>3 YES</p> <p>Is voltage between P01 (8) and (12) normal?</p> <ul style="list-style-type: none"> Turn starting switch ON. Turn light switch ON. 20 - 30V 	Defective contact, or disconnection in wiring harness between P01 (female) (8) - X01 (1) - M38 (female) (1)	Repair or replace
<p>NO</p> <p>NO</p> <p>NO</p>		

M-15 Related electric circuit diagram

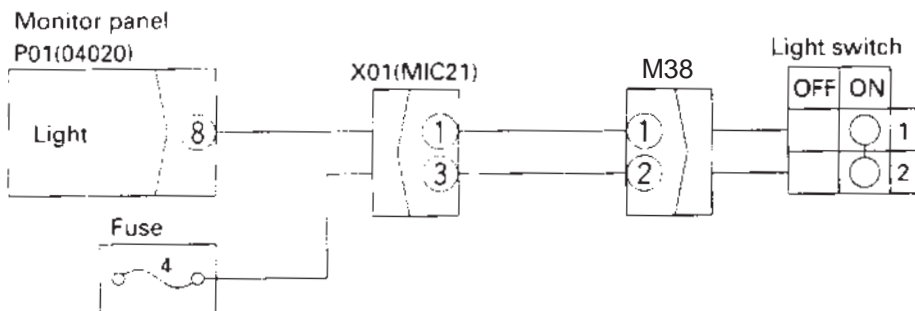

BKP00287

M-16 Coolant temperature gauge does not rise

- ★ If the coolant temperature actually does not rise, check the engine system.
- ★ Before carrying out troubleshooting, check that all the related connectors are properly inserted.
- ★ Always connect any disconnected connectors before going on the next step.

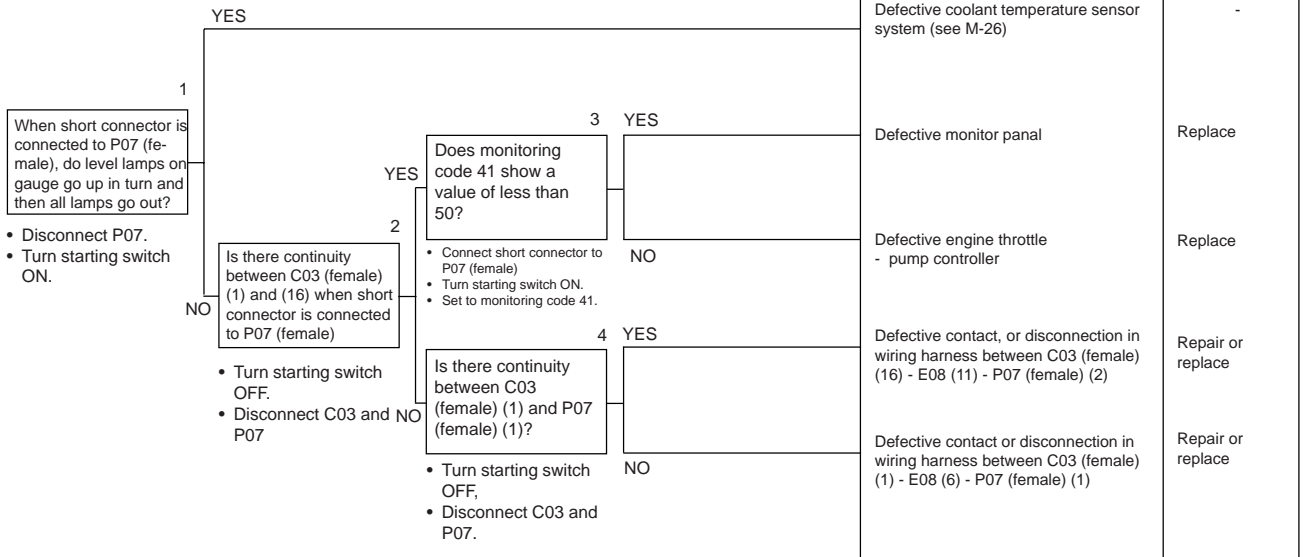

M-17 Coolant temperature gauge does not give any display (none of the gauge lamps light up during operation)

- ★ Before carrying out troubleshooting, check that all the relate connectors are properly inserted.
- ★ Always connect any disconnected connectors before going on the next step.

	Cause	Remedy
<p>1</p> <p>When P07 is disconnected, does coolant temperature gauge display appear?</p> <ul style="list-style-type: none"> • Disconnect P07. • Turn starting switch ON. <p>YES</p> <p>NO</p> <p>2</p> <p>Is there continuity between C03 (female) (1) and chassis?</p> <ul style="list-style-type: none"> • Turn starting switch OFF. • Disconnect C03, P07. <p>YES</p> <p>NO</p> <p>3</p> <p>Does monitoring code 41 show a value of less than 500?</p> <ul style="list-style-type: none"> • Turn starting switch ON. • Set to monitoring code 41 <p>YES</p> <p>NO</p>	<p>Defective coolant temperature sensor system (see M-26)</p> <p>Contact of chassis ground with wiring harness between C03 (female) (1) - E08 (6) - P07 (female) (1)</p> <p>Defective engine throttle - pump controller</p> <p>Defective montior panel</p>	<p>-</p> <p>Repair or replace</p> <p>Replace</p> <p>Replace</p>

M-16, 17 Related electric circuit diagram

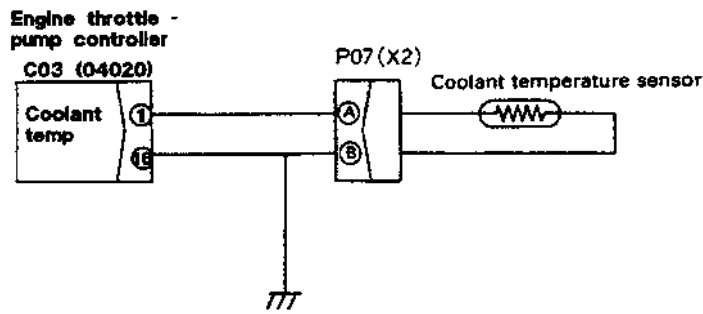

X08DD315

M-18 Fuel level gauge always displays FULL

- ★ Check if the tank is actually full before carrying out troubleshooting.
- ★ Before carrying out troubleshooting, check that all the related connectors are properly inserted.
- ★ Always connect any disconnected connectors before going on the next step.

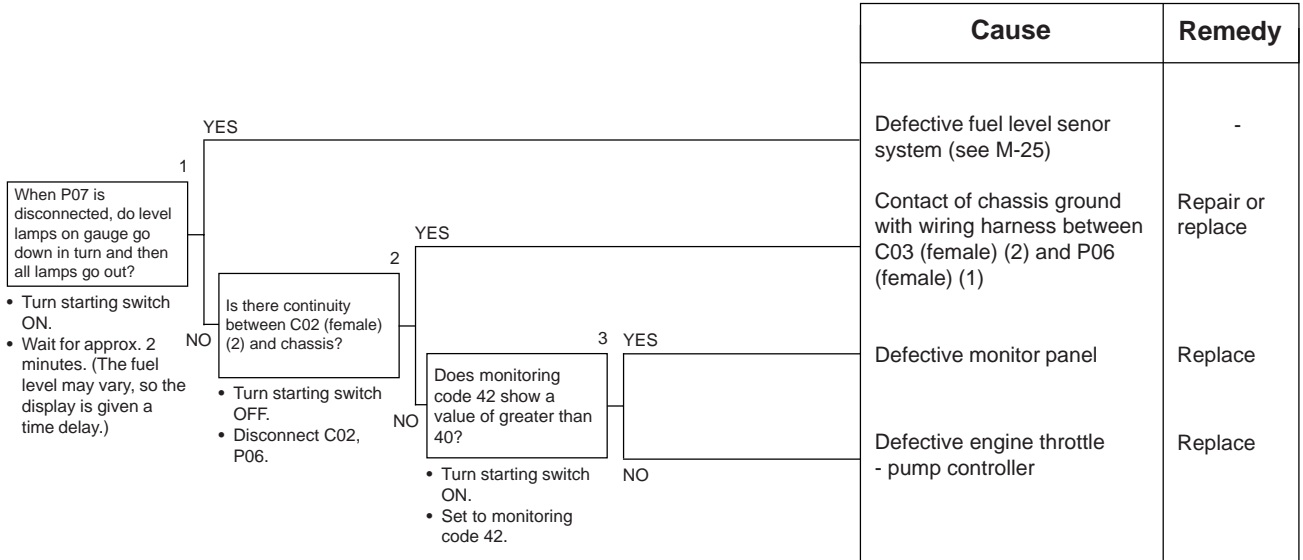

M-19 Fuel level gauge does not give display

- ★ Check that there is actually no fuel before carrying out troubleshooting
- ★ Before carrying out troubleshooting, check that all the related connectors are properly inserted.
- ★ Always connect any disconnected connectors before going on the next step.

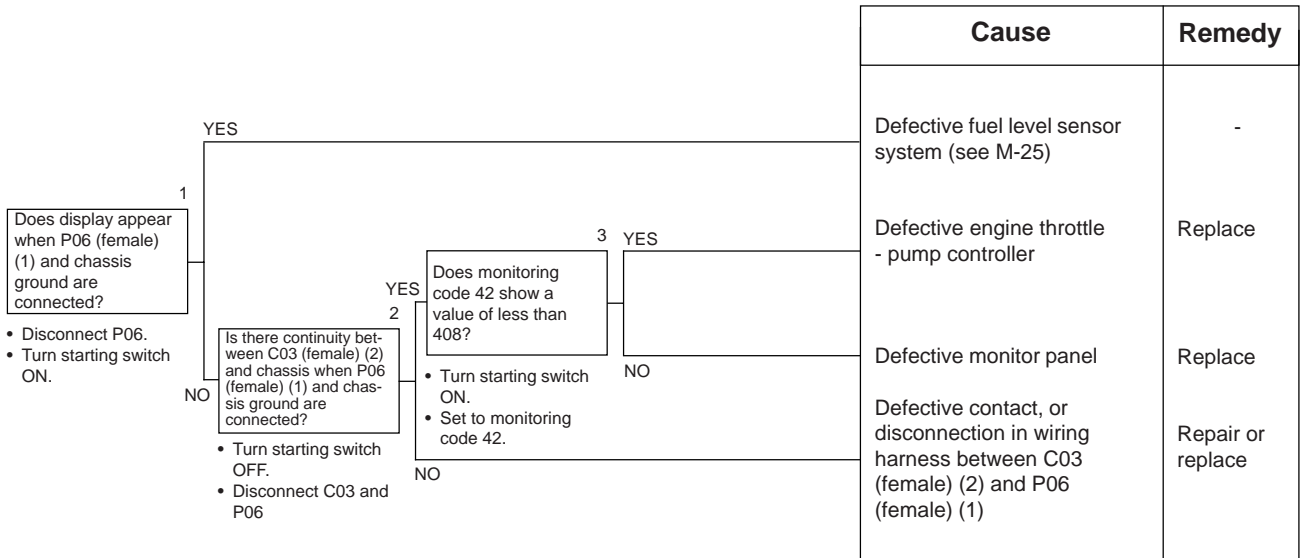

M-18, 19 Related electric circuit diagram

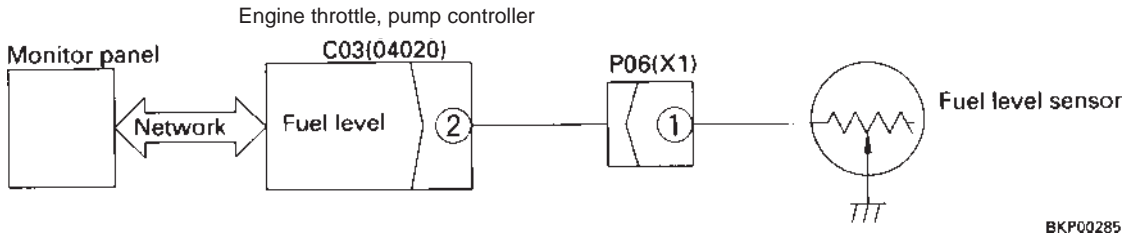

BKP00285

M-20 Swing lock switch is turned ON (LOCK) but (swing lock monitor) does not light up



- ★ Carry out this troubleshooting only if the swing lock is actually being actuated.
- ★ Before carrying out troubleshooting, check that all the related connectors are properly inserted.
- ★ Always connect any disconnected connectors before going on the next step.



• Turn starting switch ON.

Cause	Remedy
Defective monitor panel	Replace
Defective contact or disconnection in wiring harness between P01 (female) (5) - X01 (4) - X05 (male)	Repair or replace

M-20 Related electric circuit diagram

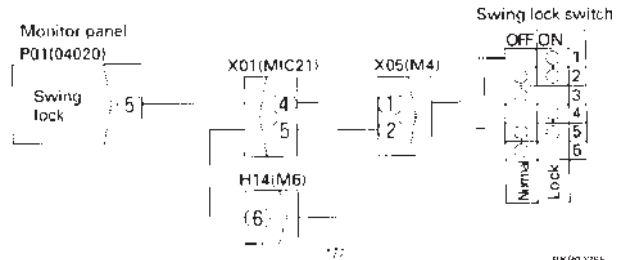

BKP00276

Table

Swing lock switch ON	Max. 1 V
Swing lock switch OFF	20 - 30 V

M-21 Swing prolix switch is turned ON (prolix), but (swing lock monitor) does not flash



- ★ Carry out this troubleshooting only if the swing prolix is actually being actuated.
- ★ Before carrying out troubleshooting, check that all the related connectors are properly inserted.
- ★ Always connect any disconnected connectors before going on the next step.

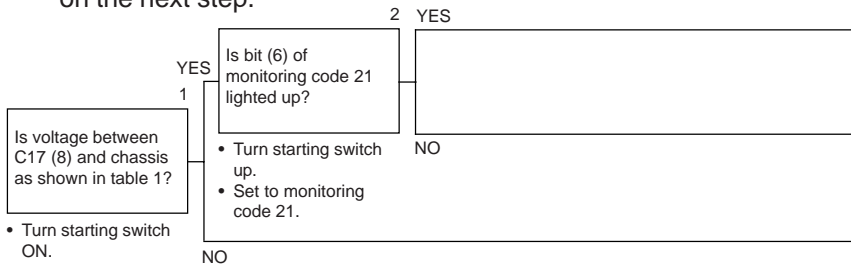

Cause	Remedy
Defective monitor panel	Replace
Defective contact or disconnection in wiring harness between C17 (female) (8) and prolix switch (4)	Repair or replace
Defective monitor panel	Replace

Table 1

Swing prolix switch ON	Max. 1 V
Swing prolix switch OFF	20 - 30 V

M-21 Related electric circuit diagram

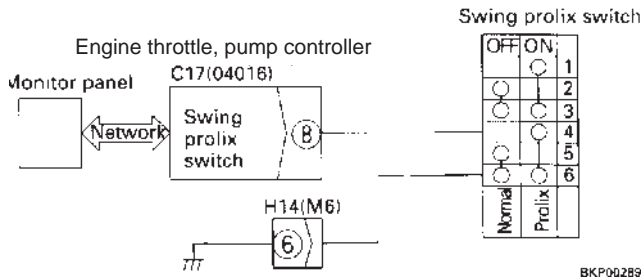

M-22 Service meter does not advance while engine is running

		Cause	Remedy
<p>1</p> <p>Does battery charge caution lamp flash?</p> <ul style="list-style-type: none"> Start engine and run at midrange or above. 	YES	See M-13 d)	-
	NO	<p>2</p> <p>Does monitoring code 43 show a value of greater than 100?</p> <ul style="list-style-type: none"> Start engine and run at mid-range or above. Set to monitoring code 43. 	Replace
YES	Defective engine throttle - pump controller		
	NO		

M-23 When starting switch is at OFF and time switch is pressed, time and service meter are not displayed

		Cause	Remedy
<p>2</p> <p>When starting switch is ON, is panel display normal?</p> <ul style="list-style-type: none"> Turn starting switch ON. 	YES	Defective monitor panel	Replace
	NO	See M-6	-

X02CH155

M-24 Defective fuel level sensor system

★ Remove the fuel level sensor when carrying out the troubleshooting

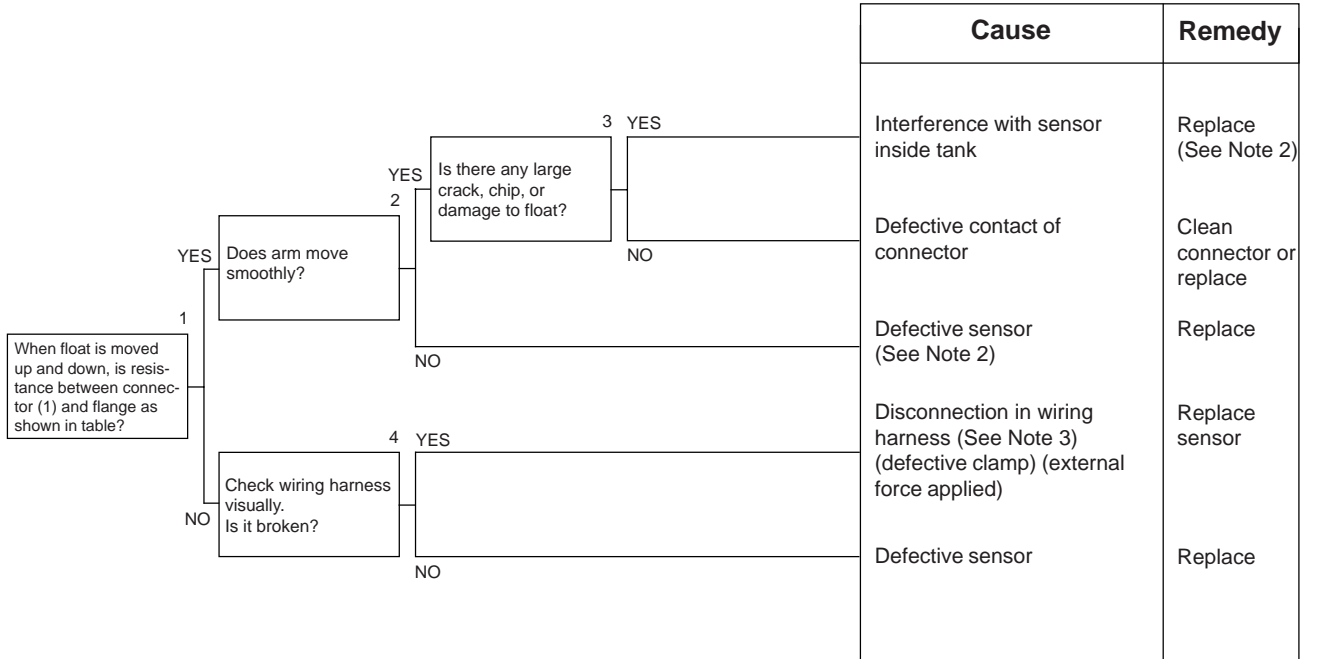

X02CH156

Table

Top (FULL) Stopper position	Approx. 12Ω or below
Bottom (EMPTY) stopper position	Approx. 85 - 110 Ω

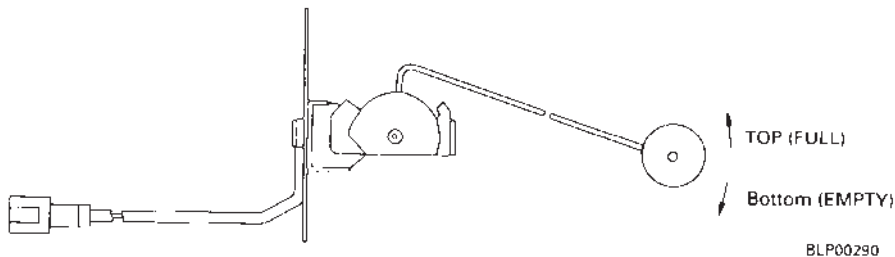

Note 1: Difference between fuel level and gauge display. For gauge display position 14 (Full), the amount of fuel is 78-100 %; and for display position 1 (EMPTY) it is below 14.5%. If the chassis is at an angle, the displayed amount of fuel will be different from the actual amount. Therefore, when checking, stop the machine at a horizontal place and wait for at least 2 minutes before checking the gauge. (The display is given a time delay so that the gauge can deal with sudden changes in the fuel level).

Note 2: There is the possibility of defective installation of interference with the sensor inside the tank, so be careful when installing.

Note 3: Check for vibration at the connector mount. If there is excessive vibration, take the appropriate action.

M-25 Defective coolant temperature sensor system

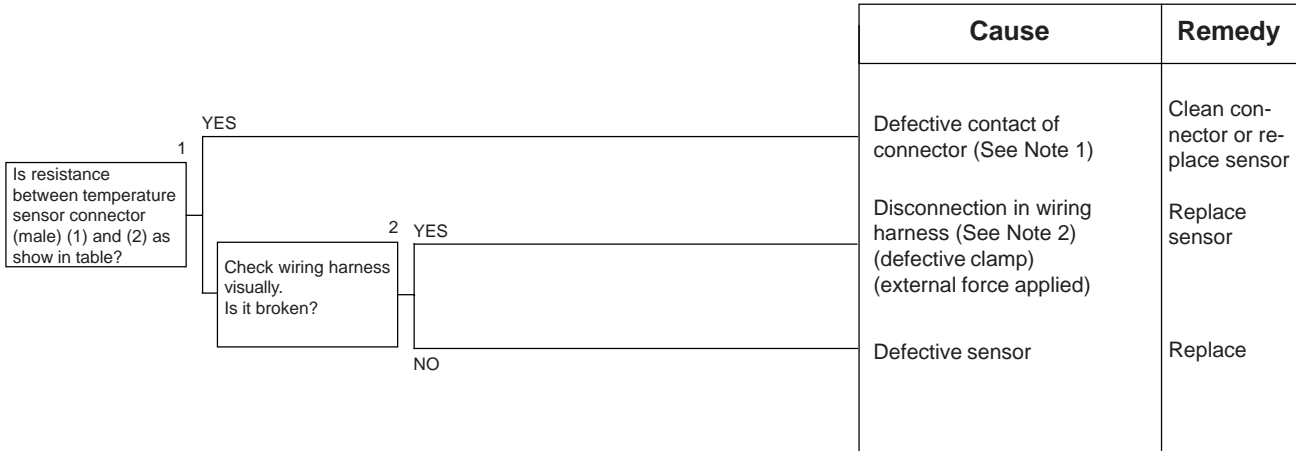

Table

Normal temperature (20°C)	Approx. 37 - 50 kΩ
100°C	Approx. 3.5 - 4.0 k

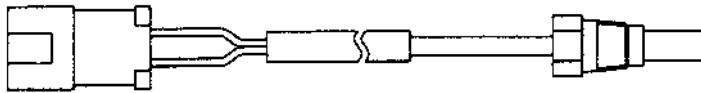

X08DD325

Note 1: If the problem occurs again, the connector (female) at the chassis end is probably defective, so check the connector and wiring harness at the chassis end.

Note 2: Check for vibration at the connector mount. If there is excessive vibration, take the appropriate action.

M-26 Defective engine oil sensor system

★ Remove the engine oil level sensor when carrying out troubleshooting.

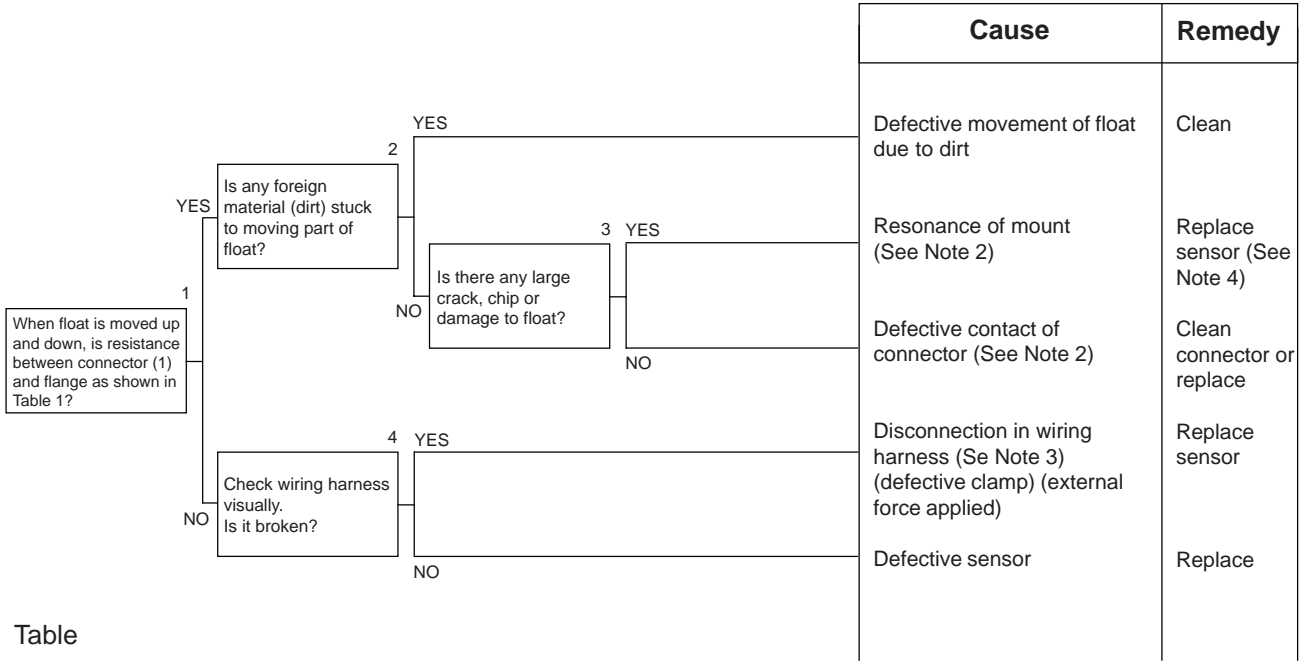

Table

Float UP	Max. 1 Ω
Float DOWN	Min. 1 MΩ

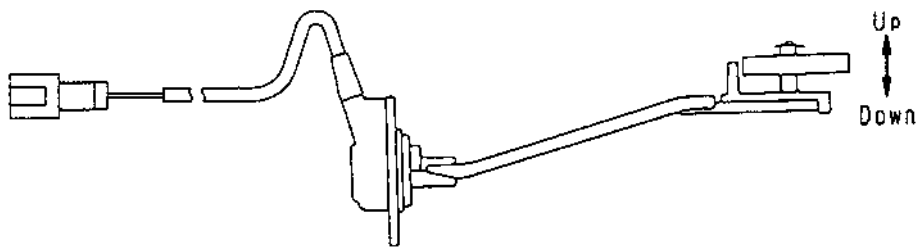

X08DD326

Note 1: Variations in oil level. The oil level may change according to the angle of the machine, the engine speed, or the temperature of the oil, so if there is any display, check the oil level again with the machine at a horizontal place.

Note 2: If the problem occurs again, the connector (female) at the chassis end is probably defective, so check the connector and wiring harness at the chassis end.

Note 3: Check for vibration at the connector mount. If there is excessive vibration, take the appropriate action.

Note 4: Defective installation is a possible cause, so be careful when installing. If the problem occurs again, check for any vibration of the mount, and if there is excessive vibration, take the appropriate action.

M-27 Defective coolant level sensor system

★ Remove the coolant level sensor when carrying out troubleshooting.

		Cause	Remedy
<p>When float is moved up and down, is resistance between connector (1) and (2) as shown in Table 1?</p> <p>1</p> <p>YES</p> <p>Is any foreign material (dirt) stuck to moving part of float?</p> <p>2</p> <p>NO</p> <p>Is there any large crack, chip or damage to float?</p> <p>3</p> <p>YES</p> <p>NO</p> <p>NO</p> <p>Check wiring harness visually. Is it broken?</p> <p>4</p> <p>YES</p> <p>NO</p>	Defective movement of float due to dirt	Clean	
	Resonance of mount (See Note 2)	Replace sensor (See Note 4)	
	Defective contact of connector (See Note 2)	Clean connector or replace	
	Disconnection in wiring harness (See Note 3) (defective clamp) (external force applied)	Replace sensor	
	Defective sensor	Replace	

Table

Float UP	Max. 1 Ω
Float DOWN	Min. 1 MΩ

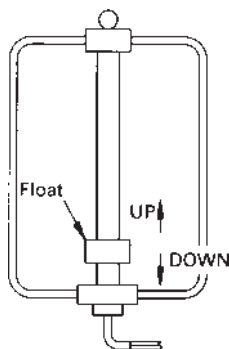

BLP00293

Note 1: Variations in coolant level. The coolant level may change according to the angle of the machine, or the swaying of the machine, so if there is any display, check the coolant again with the machine at a horizontal place.

Note 2: If the problem occurs again, the connector (female) at the chassis end is probably defective, so check the connector and wiring harness at the chassis end.

Note 3: Check for vibration at the connector mount. If there is excessive vibration, take the appropriate action.

Note 4: Defective installation is a possible cause, so be careful when installing. If the problem occurs again, check for any vibration of the mount, and if there is excessive vibration, take the appropriate action.

M-28 Defective hydraulic oil level sensor system

★ Remove the hydraulic oil level sensor when carrying out troubleshooting.

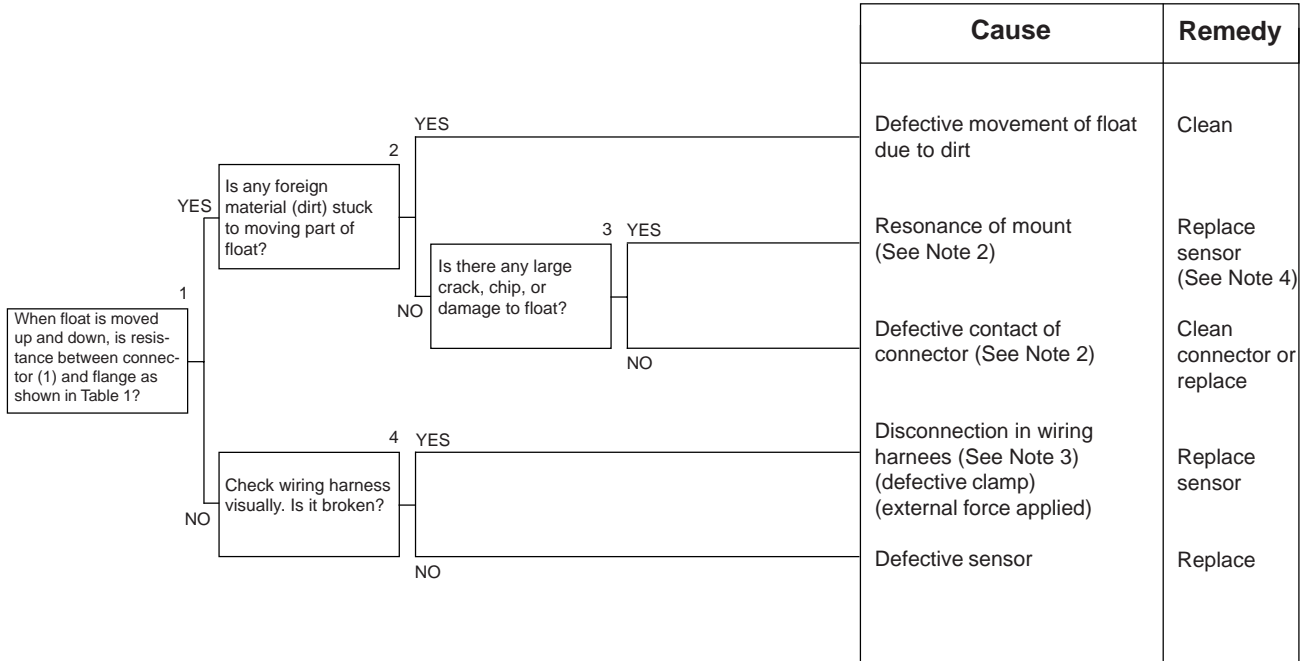

Table

Float UP	Max. 1 Ω
Float DOWN	Min. 1 MΩ

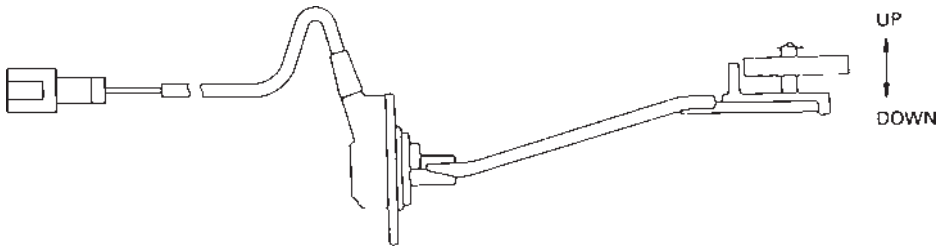

BLP00292

Note 1: Variations in hydraulic oil level. The hydraulic oil level may change according to the angle of the machine, or the swaying of the machine, so if there is any display, check the hydraulic oil level again with the machine at a horizontal place.

Note 2: If the problem occurs again, the connector (female) at the chassis end is probably defective, so check the connector and wiring harness at the chassis end.

Note 3: Check for vibration at the connector mount. If there is excessive vibration, take the appropriate action.

Note 4: Defective installation is a possible cause, so be careful when installing. If the problem occurs again, check for any vibration of the mount, and if there is excessive vibration, take the appropriate action.

	Cause	Remedy
_____	Defective wiper motor	Replace
_____	Defective relay box	Replace
_____	Defective contact or disconnection in wiring harness with defective resistance	Repair or replace
_____	Short circuit with power source in wiring harness between P02 (female) (3) and W08 (female) (3), or between P02 (female) (11) and W08 (female) (2)	Repair or replace
_____	Defective contact or disconnection in above wiring harness	Repair or replace
_____	Defective monitor panel	Replace
_____	Defective monitor panel	Replace
_____	Defective contact or disconnection in wiring harness with defective resistance	Repair or replace
_____	Defective wiper, washer switch	Replace
_____	Defective monitor panel	Replace
_____	Defective contact or disconnection in wiring harness between P02 (female) (13) and W10 (male) (3), or between P02 (female) (1) - H14 (2) - chassis, or between W10 (male) (4) - H15 (1) - chassis?	Repair or replace
_____	Defective rear limit switch, or front window is open	Inspect or replace

X02CH161

Table 1

Timing chart when wiper switch is at ON.

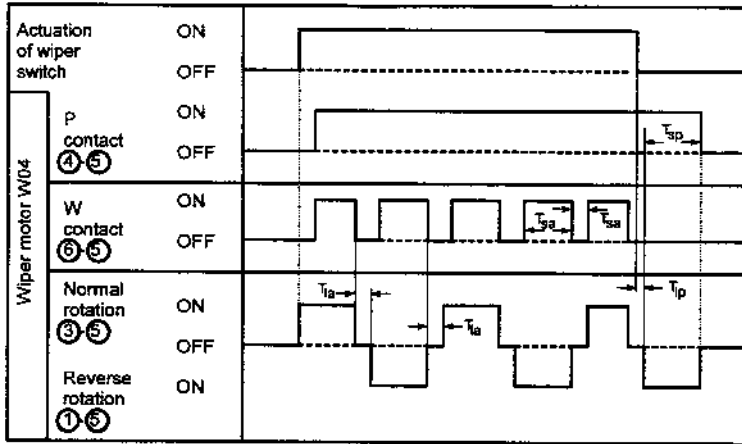

Item	Symbol	Set time
Length of pause until next actuation	T _{sp}	0.13 sec
Safety circuit during operation of wiper [safety function (1)]	T _{sa}	10 sec
Length of pause when stowing wiper blade	T _{lp}	1.5 sec
Safety circuit during stowing of wiper [safety function (2)]	T _{sp}	10 sec

Timing chart when wiper switch is at INT.

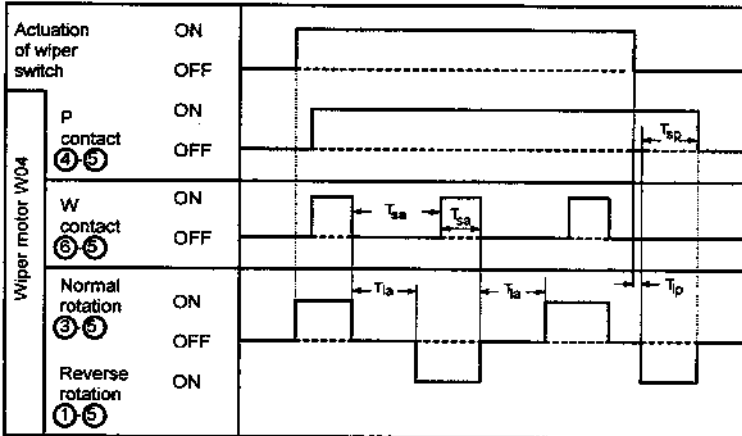

Item	Symbol	Set time
Length of pause until next actuation	T _{la}	4 sec
Safety circuit during operation of wiper [safety function (1)]	T _{sa}	10 sec
Length of pause when stowing wiper blade	T _{lp}	1.5 sec
Safety circuit during stowing of wiper [safety function (2)]	T _{sp}	10 sec

X02CH162

Table 2

	Resistance value
Between W04 (female) (1) and W08 (female) (7)	Max. 1
Between W04 (female) (3) and W08 (female) (6)	
Between W04 (female) (4) and P02 (female) (5)	
Between W04 (female) (5) and P02 (female) (1)	
Between W04 (female) (6) and P02 (female) (6)	
Between W04 (female) (1), (3), (4), (5), (6) and GND	
Between W08 (female) (2) and P02 (female) (11)	
Between W08 (female) (3) and P02 (female) (3)	Max. 1

Table 3

Wiper switch	M18 (female)	P02 (female)	Resistance
INT mode	Between (1) - (2)	Between (1) - (4)	No continuity
	Between (1) - (4)	Between (1) - (12)	Max. 1
	Between (2) - (4)	Between (4) - (12)	No continuity
OFF mode	Between (1) - (2)	Between (1) - (4)	No continuity
	Between (1) - (4)	Between (1) - (12)	
	Between (2) - (4)	Between (4) - (12)	
ON mode	Between (1) - (2)	Between (1) - (4)	Max. 1
	Between (1) - (4)	Between (1) - (12)	No continuity
	Between (2) - (4)	Between (4) - (12)	

b) Wiper switch is not being used but wiper is actuated

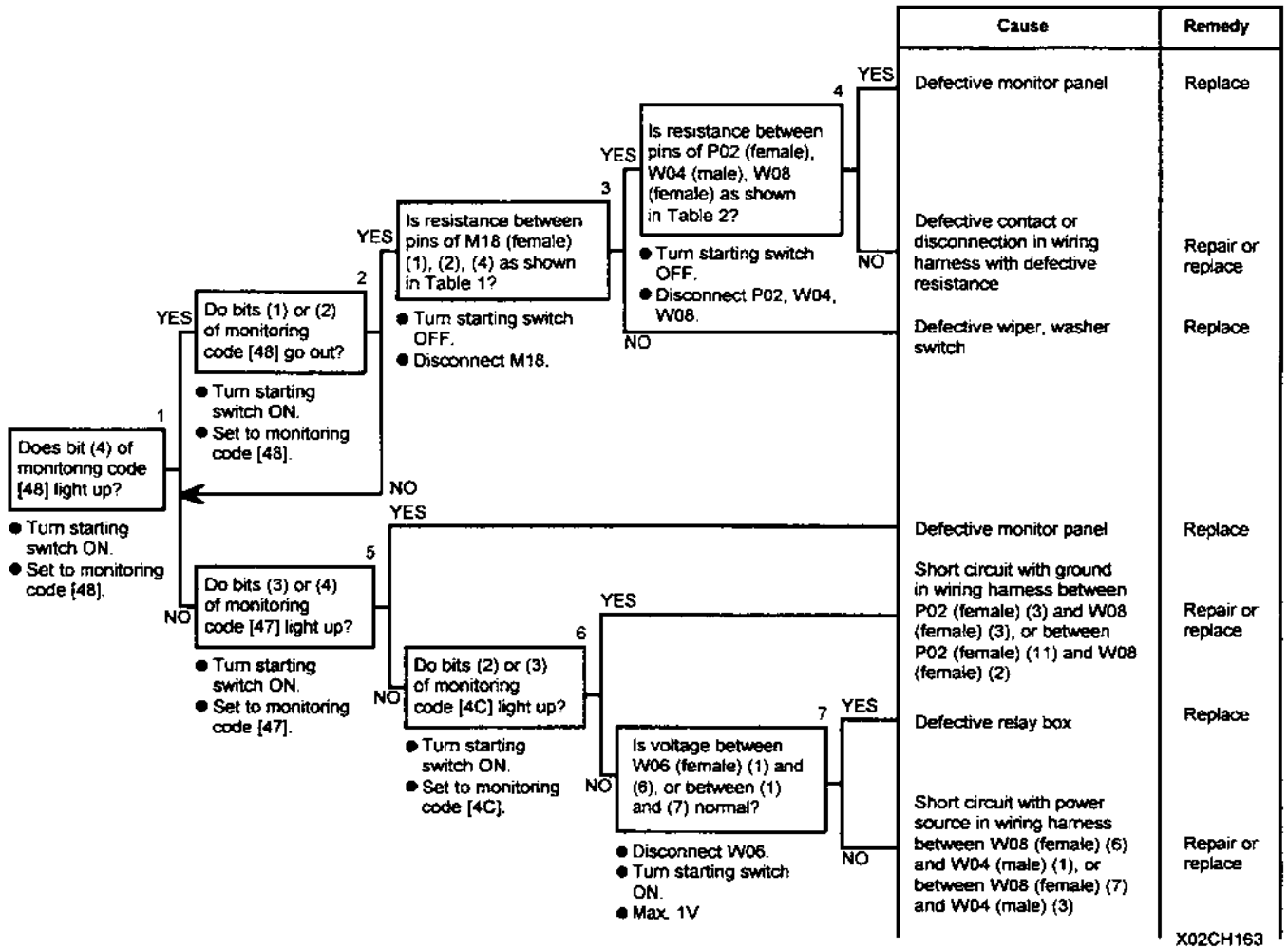

Table 2

	Resistance value
Between W04 (female) (1) and W08 (female) (7)	Max. 1
Between W04 (female) (3) and W08 (female) (6)	
Between W04 (female) (4) and P02 (female) (5)	
Between W04 (female) (5) and P02 (female) (1)	
Between W04 (female) (6) and P02 (female) (6)	
Between W04 (female) (1), (3), (4), (5), (6) and GND	No continuity
Between W08 (female) (2) and P02 (female) (11)	
Between W08 (female) (3) and P02 (female) (3)	Max. 1

Table 3

Wiper switch	M18 (female)	P02 (female)	Resistance
INT mode	Between (1) - (2)	Between (1) - (4)	No continuity
	Between (1) - (4)	Between (1) - (12)	Max. 1
	Between (2) - (4)	Between (4) - (12)	No continuity
OFF mode	Between (1) - (2)	Between (1) - (4)	No continuity
	Between (1) - (4)	Between (1) - (12)	
	Between (2) - (4)	Between (4) - (12)	
ON mode	Between (1) - (2)	Between (1) - (4)	Max. 1
	Between (1) - (4)	Between (1) - (12)	No continuity
	Between (2) - (4)	Between (4) - (12)	

M-29 Related electric circuit diagram

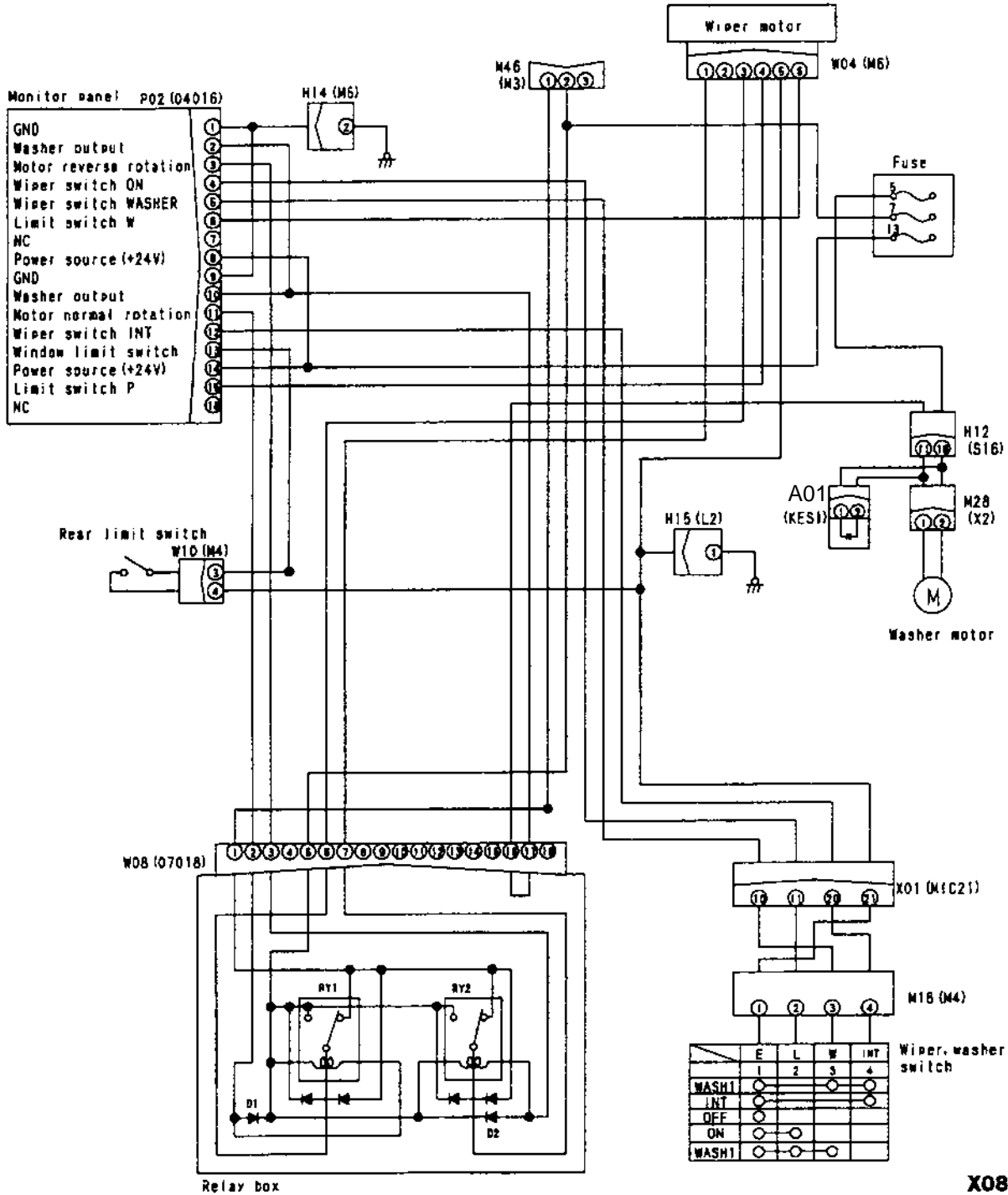

X08DD328

M-30 Washer motor does not work, or switch is not being used but washer motor is actuated

- ★ Before carrying out troubleshooting, check that all the related connectors are properly inserted.
- ★ Always connect any disconnected connectors before going on the next step.
- a) Washer motor does not work
- ★ Check that fuse 5 is normal.
- a)-1 When E114 is displayed

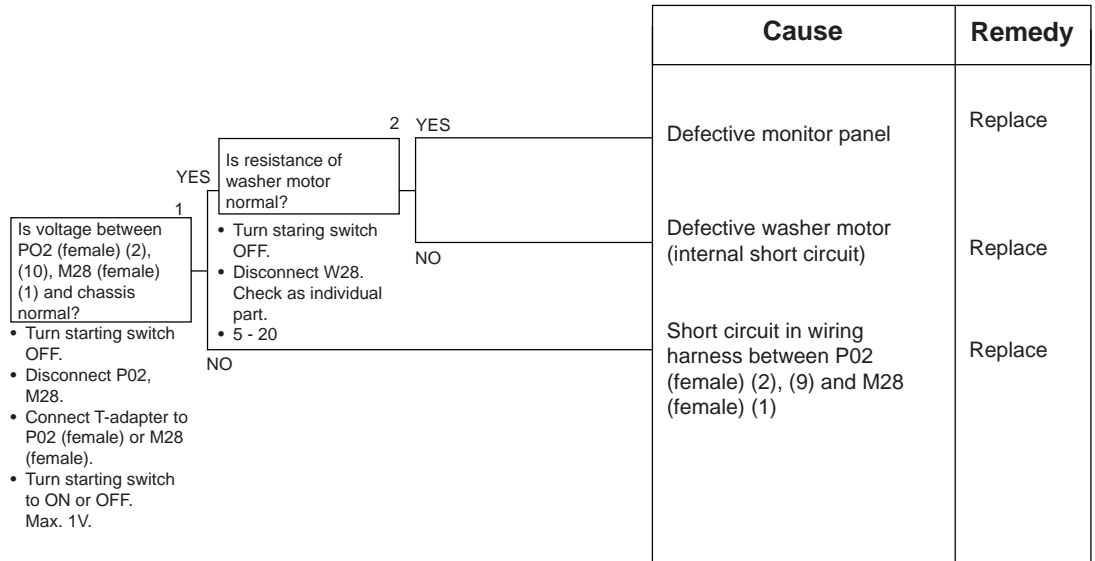

30 DISASSEMBLY AND ASSEMBLY

METHOD OF USING MANUAL	30-6
When removing or installing unit assemblies	30-6
General precautions	30-6
Listing of special tools	30-6
PRECAUTIONS WHEN CARRYING OUT OPERATION	30-7
Precautions when carrying out removal work	30-7
Precautions when carrying out installation work	30-8
Precautions when completing the operations	30-8
SPECIAL TOOL LIST	30-9
SKETCHES OF SPECIAL TOOLS	30-13
STARTING MOTOR	30-14
Removal	30-14
Installation	30-14
ALTERNATOR	30-15
Removal	30-15
Removal	30-15
FUEL INJECTION PUMP	30-16
Removal	30-16
Installation	30-18
WATER PUMP	30-19
Removal	30-19
Installation	30-20
NOZZLE HOLDER	30-21
Removal	30-21
Installation	30-21
TURBOCHARGER	30-22
Removal	30-22
Installation	30-22
THERMOSTAT	30-23
Removal	30-23
Installation	30-24
GOVERNOR MOTOR	30-25
Removal	30-25
Installation	30-25

CYLINDER HEAD ASSEMBLY	30-26
Removal	
PC290-6K	30-26
Installation	
PC290-6K	30-29
RADIATOR • HYDRAULIC OIL COOLER	30-30
Removal	30-30
Installation	30-31
ENGINE, MAIN PUMP	30-32
Removal	30-32
Installation	30-35
DAMPER	30-36
Removal	30-36
Installation	30-36
FUEL TANK	30-37
Removal	30-37
Installation	30-37
CENTER SWIVEL JOINT	30-38
Removal	30-38
Installation	30-39
Disassembly	30-40
Assembly	30-40
FINAL DRIVE	30-41
Removal	30-41
Installation	30-41
Disassembly	30-42
Assembly	30-45
SPROCKET	30-52
Removal	30-52
Installation	30-52
SWING MOTOR AND MACHINERY	30-53
Removal	30-53
Installation	30-54
Disassembly - Assembly	30-55
REVOLVING FRAME	30-63
Removal	30-63
Installation	30-64
SWING CIRCLE	30-65
Removal	30-65
Installation	30-65
IDLER • RECOIL SPRING	30-66
Removal	30-66
Installation	30-66

RECOIL SPRING	30-67
Disassembly	30-67
Assembly	30-68
IDLER	30-70
Disassembly	30-70
Assembly	30-71
TRACK ROLLER	30-73
Removal	30-73
Installation	30-73
Disassembly	30-74
Assembly	30-76
CARRIER ROLLER	30-77
Removal	30-77
Installation	30-77
Disassembly	30-78
Assembly	30-79
TRACK SHOE	30-82
Removal	30-82
Installation	30-82
HYDRAULIC TANK	30-83
Removal	30-83
Installation	30-84
MAIN PUMP	30-85
Removal	30-85
Installation	30-87
MAIN PUMP INPUT SHAFT OIL SEAL	30-88
Removal	30-88
Installation	30-88
CONTROL VALVE	30-89
Removal	30-89
Installation	30-91
Disassembly	30-92
Assembly	30-96
PUMP MERGE-DIVIDER VALVE	30-98
Disassembly	30-98
Assembly	30-98
MAIN RELIEF VALVE	30-99
Disassembly	30-99
Assembly	30-99
PC VALVE	30-100
Removal	30-100
Installation	30-100
LS VALVE	30-101
Removal	30-101
Installation	30-101

PC, LS-EPC VALVE	30-102
Removal	30-102
Installation	30-102
SOLENOID VALVE	30-103
Removal	30-103
Installation	30-103
WORK EQUIPMENT - SWING PPC VALVE	30-104
Removal	30-104
Installation	30-104
Disassembly	30-105
Assembly	30-106
TRAVEL PPC VALVE	30-107
Removal	30-107
Installation	30-107
Disassembly	30-108
Installation	30-108
BOOM CYLINDER	30-109
Removal	30-109
Installation	30-110
ARM CYLINDER	30-111
Removal	30-111
Installation	30-112
BUCKET CYLINDER	30-113
Removal	30-113
Installation	30-114
HYDRAULIC CYLINDER	30-115
Disassembly	30-115
Assembly	30-117
WORK EQUIPMENT	30-121
Removal	30-121
Installation	30-122
BUCKET	30-123
Removal	30-123
Installation	30-124
ARM	30-125
Removal	30-125
Installation	30-126
BUCKET-ARM	30-127
Removal	30-127
Installation	30-128
BOOM	30-129
Removal	30-129
Installation	30-130



OPERATOR'S CAB	30-131
Removal	30-132
Installation	30-133
COUNTERWEIGHT	30-134
Removal	30-134
Installation	30-134
ENGINE THROTTLE - PUMP CONTROLLER	30-135
Removal	30-135
Installation	30-135
MONITOR	30-136
Removal	30-136
Installation	30-136

METHOD OF USING MANUAL

When removing or installing unit assemblies

- ① When removing or installing a unit assembly, the order of work and techniques used are given for the removal operation; the order of work for the installation operation is not given.
- ② Any special techniques applying only to the installation procedure are marked * 1, and the same mark is placed after the relevant step in the removal procedure to indicate which step in the installation procedure it applies to.

(Example)

REMOVAL OF ○○○○ ASSEMBLY	Title of operation
	Precautions related to safety when carrying out the operation
1. XXXX (1)	Step in operation
★	Technique or important point to remember when removing XXXX (1).
2. △ △ △ △ (2):	* 1 Indicated that a technique is listed for use during installation
3. □□□□ assembly (3)	
	Quantity of oil or water drained
INSTALLATION OF ○○○○ ASSEMBLY	Title of operation
• Carry out installation in the reverse order to removal.	
* 1	Technique used during installation
★	Technique or important point to remember when installing △ △ △ △ (2).
• Adding water, oil	Step in operation
★	Point to remember when adding water or oil
	Quantity when filling with oil and water

General precautions when carrying out installation or removal (disassembly or assembly) of units are given together as PRECAUTIONS WHEN CARRYING OUT OPERATION, so be sure to follow these precautions when carrying out the operation.

Listing of special tools

For details of the description, part number, and quantity of any tools (A1, etc.) that appear in the operation procedure, see the SPECIAL TOOLS LIST given in this manual.

PRECAUTIONS WHEN CARRYING OUT OPERATION

[When carrying out removal or installation (disassembly or assembly) of units, be sure to follow the general precautions given below when carrying out the operation.]

Precautions when carrying out removal work

- If the coolant contains antifreeze, dispose of it correctly.
- After disconnecting hoses or tubes, cover them or fit blind plugs to prevent dirt or dust from entering.
- When draining oil, prepare a container of adequate size to catch the oil.
- Confirm the match marks showing the installation position, and make match marks in the necessary places before removal to prevent any mistake when assembling.
- To prevent any excessive force from being applied to the wiring, always hold the connectors when disconnecting the connectors.
- Fit wires and hoses with tags to show their installation position to prevent any mistakes when installing.
- Check the number and thickness of the shims, and keep in a safe place.
- When raising components, be sure to use lifting equipment of ample strength.
- When using forcing screws to remove any components, tighten the forcing screws alternately.
- Before removing any unit, clean the surrounding area and fit a cover to prevent any dust or dirt from entering after removal.

★ **Precautions when handling piping during disassembling**

Fit the following blind plugs into the piping after disconnecting it during disassembly operations.

1) Hoses and tubes using sleeve nuts

Nominal number	Plug (nut end)	Sleeve nut (elbow end) Use the two items below as a set
02	07376-50210	07221-20210 (Nut), 07222-00210 (Plug)
03	07376-50315	07221-20315 (Nut), 07222-00312 (Plug)
04	07376-50422	07221-20422 (Nut), 07222-00414 (Plug)
05	07376-50522	07221-20522 (Nut), 07222-00515 (Plug)
06	07376-50628	07221-20628 (Nut), 07222-00616 (Plug)
10	07376-51034	07221-21034 (Nut), 07222-01018 (Plug)
12	07376-51234	07221-21234 (Nut), 07222-01219 (Plug)

2) Split flange type hoses and tubes

Nominal number	Flange (hose end)	Sleeve head (tube end)	Split flange
04	07379-00400	07378-10400	07371-30400
05	07379-00500	07378-10500	07371-30500

3. If the part is not under hydraulic pressure, the following corks can be used.

Nominal number	Part Number	Dimensions		
		D	d	L
06	07049-00608	6	5	8
08	07049-00811	8	6.5	11
10	07049-01012	10	8.5	12
12	07049-01215	12	10	15
14	07049-01418	14	11.5	18
16	07049-01620	16	13.5	20
18	07049-01822	18	15	22
20	07049-02025	20	17	25
22	07049-02228	22	18.5	28
24	07049-02430	24	20	30
27	07049-02734	27	22.5	34

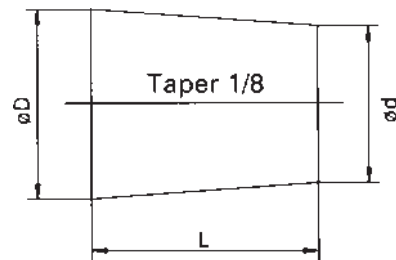

DEW00401

Precautions when carrying out installation work

- Tighten all bolts and nuts (sleeve nuts) to the specified (KES) torque.
- Install the hoses without twisting or interference.
- Replace all gaskets, O-rings, cotter pins, and lock plates with new parts.
- Bend the cotter pin or lock plate securely.
- When coating with adhesive, clean the part and remove all oil and grease, then coat the threaded portion with 2-3 drops of adhesive.
- When coating with gasket sealant, clean the surface and remove all oil and grease, check that there is no dirt or damage, then coat uniformly with gasket sealant.
- Clean all parts, and correct any damage, dents, burrs, or rust.
- Coat rotating parts and sliding parts with engine oil.
- When press fitting parts, coat the surface with anti-friction compound (LM-P).
- After fitting snap rings, check that the snap ring is fitted securely in the ring groove.
- When connecting wiring connectors, clean the connector to remove oil, dirt, or water, then connect securely.
- When using eyebolts, check that there is no deformation or deterioration, screw them fully, and align the direction of the hook.
- When tightening split flanges, tighten uniformly in turn to prevent excessive tightening on one side.
- ★ When operating the hydraulic cylinders for the first time after reassembling cylinders, pumps and other hydraulic equipment removed for repair, always bleed the air as follows:
 1. Start the engine and run at low idling.
 2. Operate the work equipment control lever to operate the hydraulic cylinder 4 -5 times, stopping 100 mm from end of its stroke.
 3. Next, operate the hydraulic cylinder 3 - 4 times to the end of its stroke.
 4. After doing this, run the engine at normal speed.
- ★ When using the machine for the first time after repair or long storage, follow the same procedure.

Precautions when completing the operations

- If the coolant has been drained, tighten the drain valve, and add coolant to the specified level. Run the engine to circulate the coolant through the system. Then check the coolant level again.
- If the hydraulic equipment has been removed and installed again, add engine oil to the specified level. Run the engine to circulate the oil through the system. Then check the oil level again.
- If the piping or hydraulic equipment, such as hydraulic cylinders, pumps, or motors, have been removed for repair, always bleed air from the system after reassembling the parts.
- ★ For details, see TESTING AND ADJUSTING, Bleeding air.
- Add the specified amount of grease (molybdenum disulphide grease) to the work equipment related parts.

SPECIAL TOOL LIST

- ★ Tools with part number 79○T-○○○-○○○○ cannot be supplied (they are items to be locally manufactured).
- ★ Necessity: ■: Cannot be substituted, should always be installed (used);
●: Extremely useful if available, can be substituted with commercially available part.
- ★ New/remodel: N: Tools with new part numbers, newly developed for this model.
R: Tools with upgraded part numbers, remodeled from items already available for other models.
- ★ Blank: Tools already available for other models, used without any modification.
- ★ Tools marked ○ in the Sketch column are tools introduced in special sketches (See SKETCHES OF SPECIAL TOOLS).

Component	Symbol	Part No.	Part name	Necessity	Q'ty	New/remodel	Sketch	Nature of work
Removal, installation of cylinderhead assembly. Removal, installation of fuel injection pump assembly	A	1	790-331-1110	Wrench	■	1		Tightening of cylinder head bolt
		2	795-799-1130	Gear	■	1		Barring
		3	795-799-1390	Puller	■	1		Removal of drive gear
		4	795-799-1170	Puller	■	1		Removal of nozzle holder
Removal, installation of nozzle holder assembly								
Engine, main pump assembly. Radiator, hydraulic cooler assembly. Control pump assembly. Main pump assembly. Removal, installation of servo valve assembly	B	796-460-1210	Oil stopper	■	1			
Disassembly of center swivel joint assembly	D	790-101-2501	Push-puller	●	1			
		790-101-2510	Block		1			
		790-101-2520	Screw		1			
		791-112-1180	Nut		1			
		790-101-2540	Washer		1			
		790-101-2630	Leg		2			
		790-101-2570	Plate		4			
		790-101-2560	Nut		2			
		790-101-2650	Adapter		2			
Disassembly, assembly of swing machinery	F	796-426-1120	Push tool	■	1			Press fitting of bearing

Component	Symbol	Part No.	Part name	Necessity	Q'ty	New/remodel	Sketch	Nature of work	
Disassembly, assembly of final drive assembly	G	1	796-627-1210	Wrench	■	1		Removal, installation of round nut	
		2	1	796T-627-1230	Push tool	■	1	○	Press fitting of bearing inner race
			2	790-101-2510	Block	■	1		
			3	792-104-3940	Bolt	■	2		
			4	10580-11613	Nut	■	2		
			5	790-101-2570	Washer	■	2		
			6	01643-31645	Washer	■	2		
			7	790-105-2100	Jack	■	1		
	8	790-101-1102	Pump	■	1				
		3	790-331-1110	Wrench	■	1		Tightening of final drive cover mounting bolt	
	4	791-580-1510	Installer	■	1		Installation of floating seal		
Removal, installation of recoil spring assembly	H	1	791-685-8005	Compressor (B)	■	1		Removal, press fitting of master pin	
					■	1			
			791-635-3160	Extension	■	1			
		790-101-1600	Cylinder (686 kN (70 ton))	■	1				
		790-101-1102	Pump	■	1				
	2	790-201-1500	Push tool kit	●	1		Installation of dust seal on recoil spring piston		
		790-201-1650	Plate		1				
		790-101-5021	Grip		1				
		01010-50816	Bolt		1				
Removal, installation of track shoe	I	791-646-3000	Remover and installer	■	1		Removal, press fitting of master pin		
		790-101-1300	Cylinder (980 kN (100 ton))	■	1				
		790-101-1102	Pump	■	1				
Assembly of idler assembly	J	1	796-570-1020	Installer	■	1	Installation of floating seal		
		2	791-601-1000	Oil pump	■	1	Charging with oil, checking for air leakage		

Component	Symbol	Part No.	Part name	Neces- sity	Q'ty	New/ remodel	Sketch	Nature of work	
Disassembly, assembly of track roller assembly	K	1	796-670-1010	Installer	■	1		Installation of floating seal	
		2	791-601-1000	Oil pump	●	1		Charging with oil, checking for air leakage	
Disassembly, assembly of carrier roller assembly	L	1	790-302-1500	Wrench kit	■	1		Removal, installation of nut	
			• 09003-05560	• Wrench	■	1			
		2	796-670-1020	Installer	■	1		Installation of floating seal	
		3	796T-630-1130	Push tool	■	1		O	Press fitting of ring
Disassembly, assembly of track roller assembly	M	1	796-670-1010	Installer	■	1		Installation of floating seal	
		2	791-601-1000	Oil pump	●	1		Charging with oil	
Replacement of pump shaft oil seal	N		791-463-1141	Push tool	■	1			
			790-201-2740	Spacer	■	1			
Disassembly, assembly of hydraulic cylinder	O	1	790-502-1003	Cylinder repair stand	●	1			
			790-101-1102	Pump	●	1			
		2	790-102-4300	Wrench assembly	■	1			Removal, installation of piston assembly
			790-102-4310	Pin	■	2			Replacement pin for wrench assembly
3	370-720-1000	Expander	●	1			Expansion of piston ring		

Component	Symbol	Part No.	Part name	Neces- sity	Q'ty	New/ remodel	Sketch	Nature of work	
Disassembly, assembly of hydraulic cylinder	O	4	796-720-1680 07281-01589	Ring Clamp	●	1 1		Arm and Boom	Installation of piston ring
			796-720-1670 07281-01279	Ring Clamp	●	1 1		Boom Bucket	
		5	790-201-1702 790-201-1841 790-101-5021 01010-50816	Push kit Push tool Grip Bolt	■	1 1 1 1		Boom Bucket	Press fitting of coiled bushing
			790-201-1702 790-201-1851 790-101-5021 01010-50816	Push kit Push tool Grip Bolt	■	1 1 1 1		Arm and Boom	
	6	790-201-1500 790-201-1650 790-101-5021 01010-50816	Push kit Push tool Grip Bolt	●	1 1 1 1		Boom Bucket	Installation of dust seal	
		790-201-1500 790-201-1660 790-101-5021 01010-50816	Push Kit Push tool Grip Bolt	●	1 1 1 1		Arm and Boom		
		790-201-1990 790-101-5021 01010-50816	Plate Grip Bolt	●	1 1 1		Arm		

Component	Symbol	Part No.	Part name	Neces- sity	Q'ty	New/ remodel	Sketch	Nature of work, remarks
Removal, installation or work, equipment assembly Boom assembly	P	796-900-1200	Remover Puller	■	1			Removal of boom foot pin
		790-101-4000	(490 kN (50 ton)) long	■	1			
		790-101-1102	Pump (294 kN (30 ton))	■	1			

SKETCHES OF SPECIAL TOOLS

Note: Komatsu cannot accept any responsibility for special tools manufactured according to these sketches.

L3 Push tool (Carrier roller assembly)

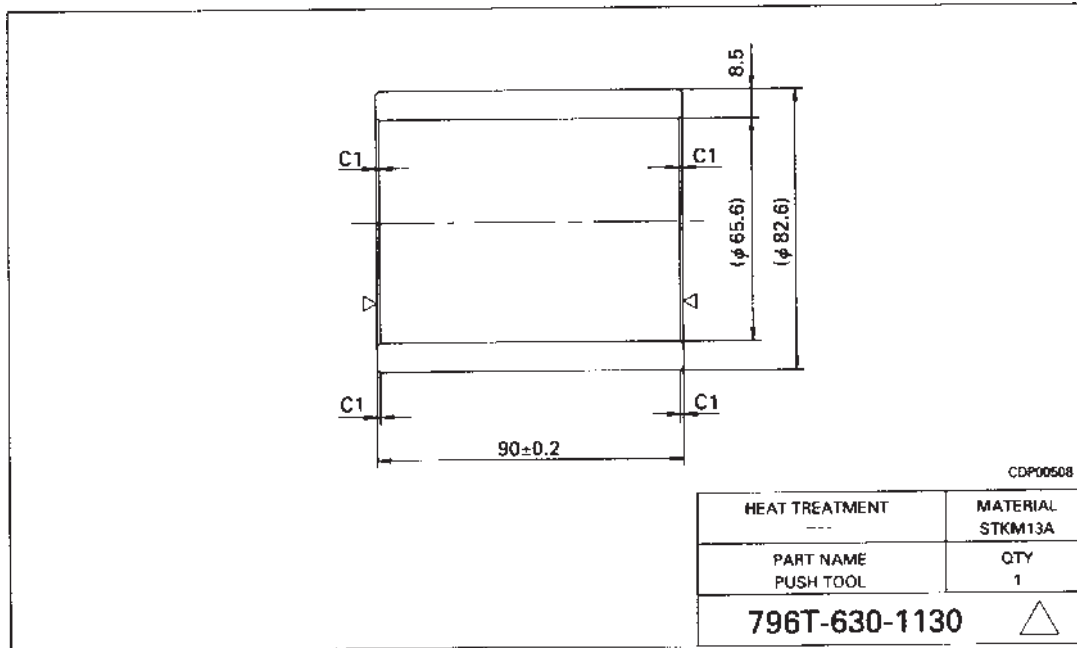

G2-1 Push tool

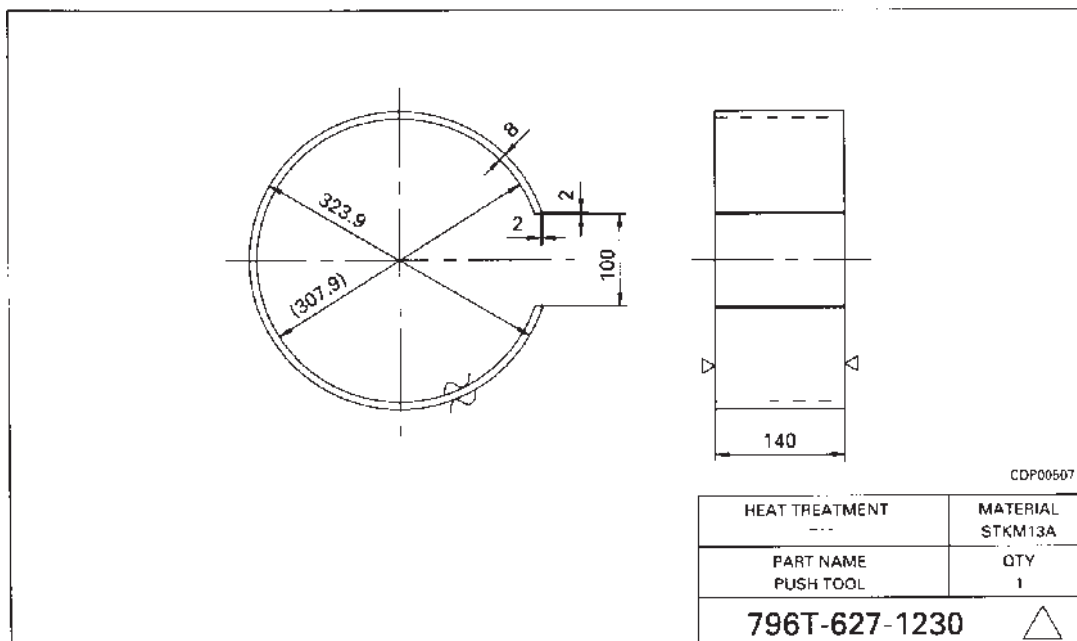

STARTING MOTOR

Removal

⚠ Disconnect the cable from the negative (-) terminal of the battery.

1. Open engine hood.
2. Disconnect 3 wires (1).

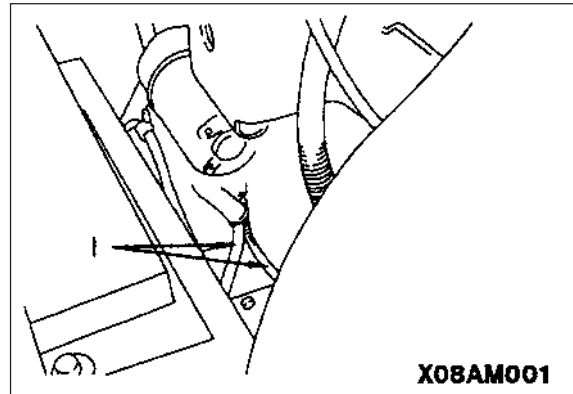

3. Remove 2 bolts (2) and mounting nut. * 1
4. Remove starting motor assembly (3). * 2

Installation

• Carry out installation in the reverse order to removal.

* 1

 Starting motor mounting bolt: 43 ± 6 Nm (4.38 ± 0.61 kgm)

* 2

 Both faces of starting motor gasket: Gasket sealant (LG-1)

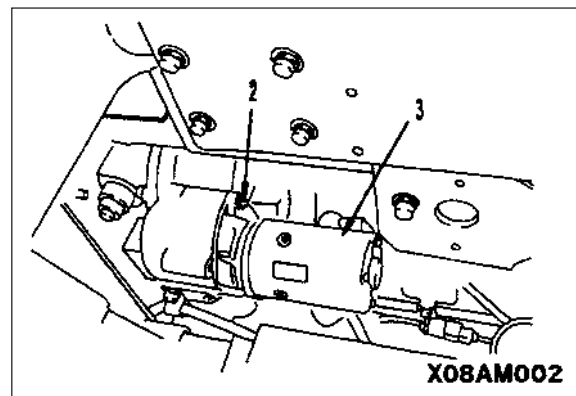

ALTERNATOR

Removal

⚠ Disconnect the cable from the negative (-) terminal of the battery.

1. Open engine hood.
2. Remove fan guard (1) and right fan guard mounting bracket (2).

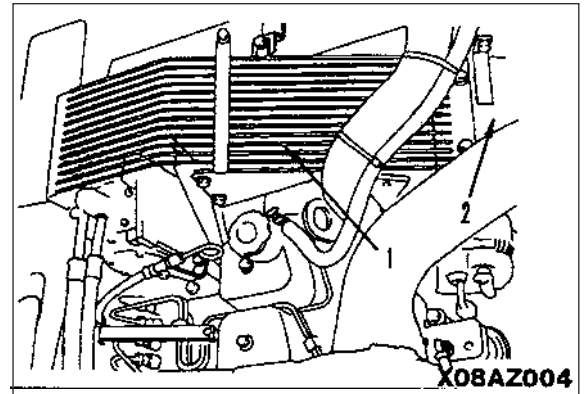

3. Disconnect wiring (3).

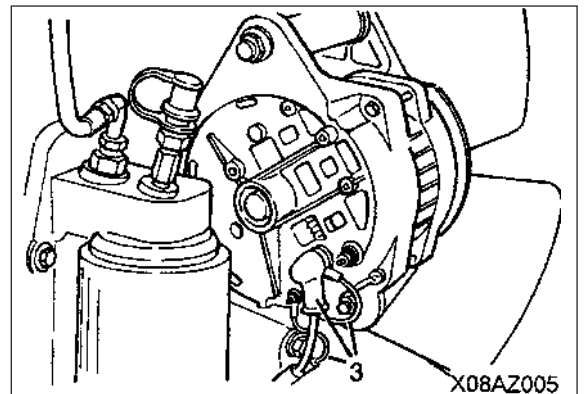

4. Using wrench ①, raise tensioner (6) and remove belt (7).

⚠ Be extremely careful not to get your fingers caught when removing the belt.

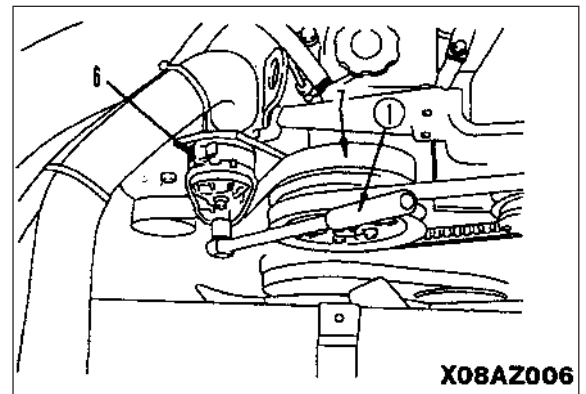

5. Remove alternator mounting bolts (8) and (9), then remove alternator assembly (10).

Removal

- Carry out installation in the reverse order to removal.

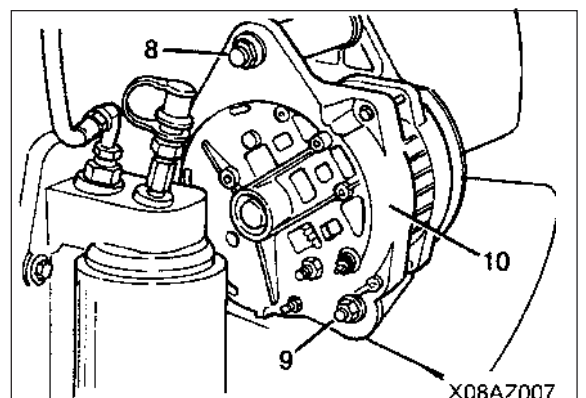

FUEL INJECTION PUMP

Removal

⚠ Disconnect the cable from the negative (-) terminal of the battery.

1. Open engine hood.
2. Remove cover (1) on top of condenser, then remove stay (2) at the counterweight.
3. Remove fan guard (3) and left bracket (4).

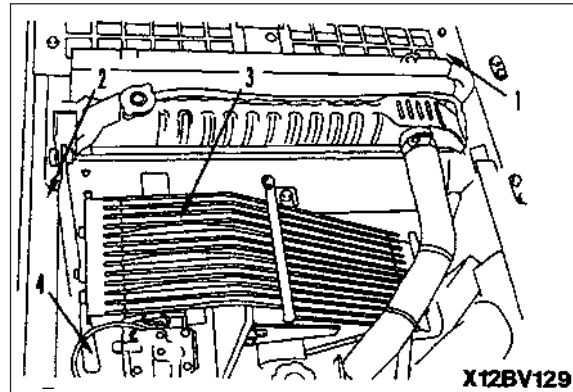

4. Disconnect coolant temperature sensor connector (5).
5. For machines with air conditioning, remove bracket (6) for compressor hose clamp.
- ★ Tighten together with the fuel inlet hose clamp.
6. Remove lock clips (8) (2 places) and lock bracket (7) of dipstick guide.

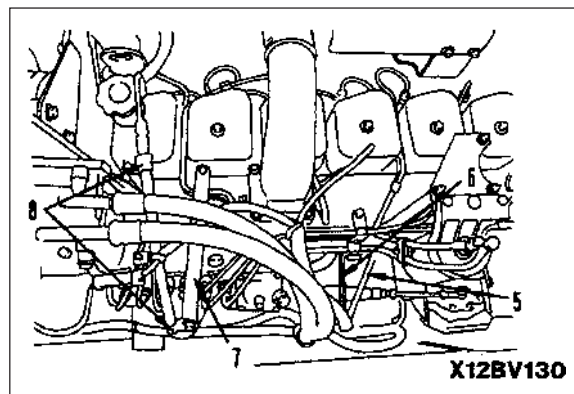

7. Disconnect governor motor rod (9) at governor end. 1
- ★ Rotate the shaft of the governor motor and do not stop it suddenly.
- ★ Always disconnect the guide motor connector before disconnecting the rod.

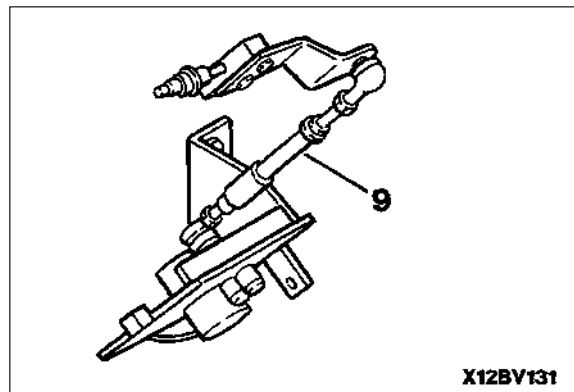

8. Disconnected the 6 delivery tubes (10). See engine 2 shop manual for details.
9. Disconnect the return fuel hose (11).
- ★ Fuel will flow out when the hose is disconnected, so plug hose to prevent the fuel from leaking.

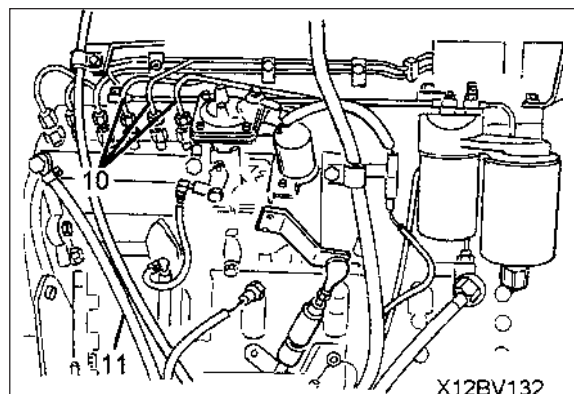

10. Disconnect tube (12) between fuel filter and fuel injection pump.
11. Remove lubrication tube (13).
12. Remove mounting bolt (14) of support bracket at bottom of fuel injection pump.

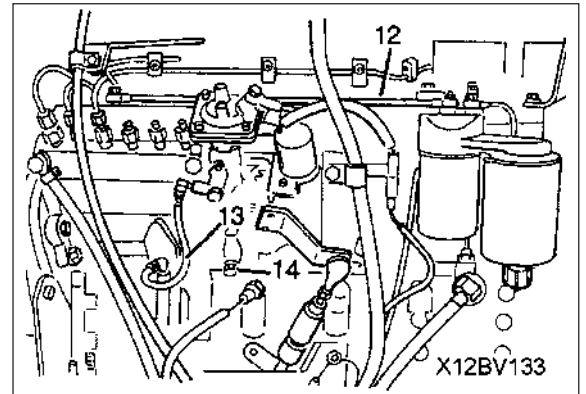

13. Using tool **A2**, rotate engine in normal direction, and push No. 1 cylinder compression top dead center positioning pin (15) into gear.
 - ★ Push the pin lightly against the gear and rotate the engine slowly.
 - ★ After determining the TDC position, check if the meshing of the timing pin has come out.

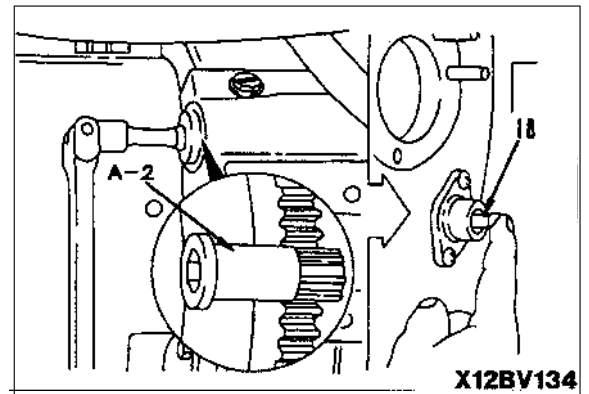

14. Remove 2 fan belts (16), then move fan tension "3 pulley (17) and adjustment bar (18) towards fan shaft.
 - ★ Loosen mounting bolt (19) of adjustment bolt bottom bracket (20), then loosen adjustment bolt (21).
15. Turn cap (22) and remove.

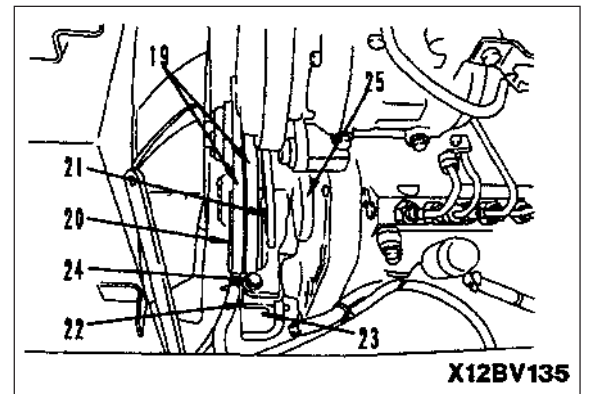

16. Remove fuel injection pump. For details, see engine shop manual.

Installation

- Carry out installation in the reverse order to removal.

 1

- ★ Adjust the governor lever. For details, see TESTING AND ADJUSTING, Adjusting governor motor lever stroke.

 2

-  **kgm** Delivery tube sleeve nut (10): 24 ± 4 Nm
(2.45 ± 0.41 kgm)

 3

- ★ Adjust the belt tension. For details, see TESTING AND ADJUSTING, Testing and adjusting the fan belt tension.
- Bleed air from fuel system.

WATER PUMP

Removal

1. Drain coolant.
2. Opening engine hood.
3. Remove fan guard (1), then remove left and right side covers (2) and (3) of fan guard mount.

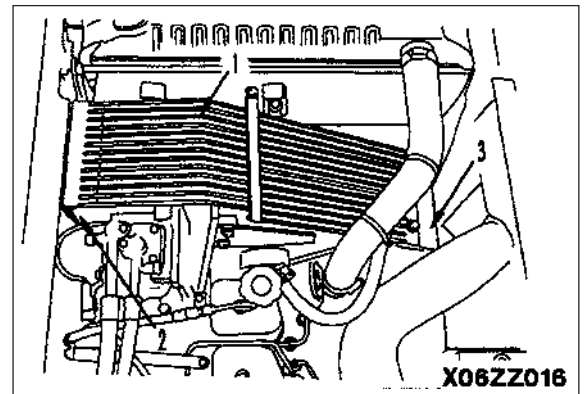

4. Using wrench 1*, raise tensioner (4), then remove belt (5).

⚠ Be extremely careful not to get your fingers caught when removing the belt.

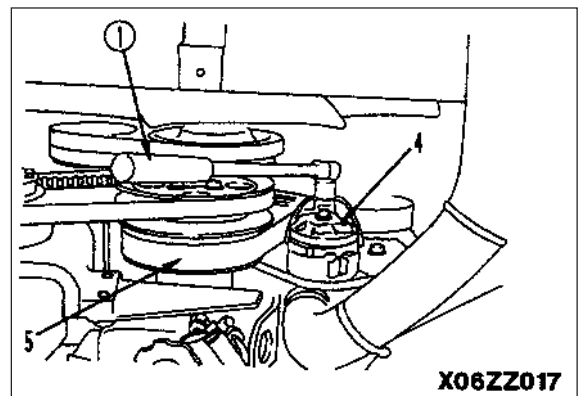

5. Loosen adjustment bar (7) of fan tension pulley (6),  1 then loosen fan belt (8).

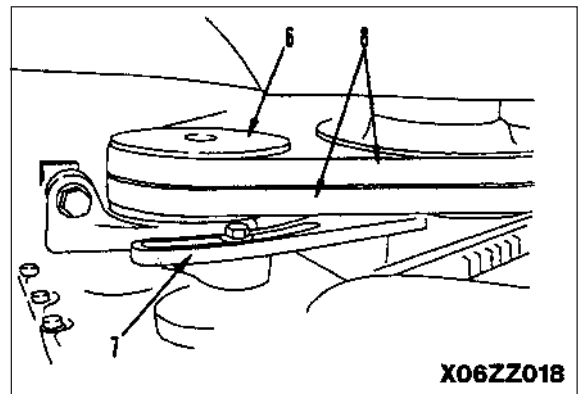

6. Loosen mounting bolt (11) of fan pulley (10) and fan shaft (9) 2 - 3 mm, then move towards radiator.

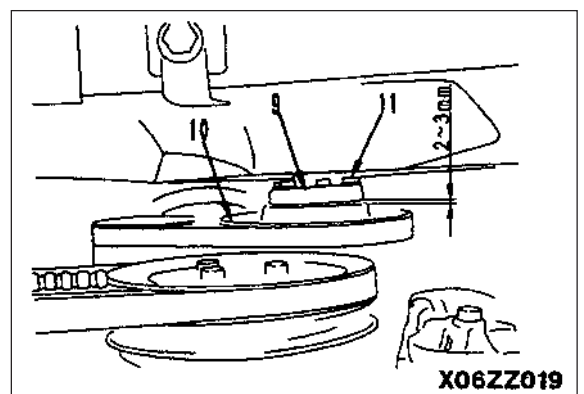

7. Remove water pump assembly (12).

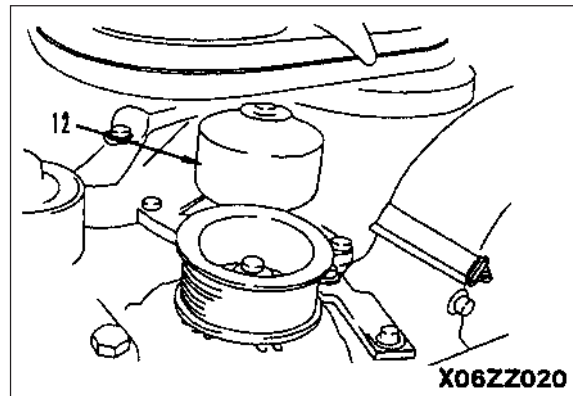

Installation



- Carry out installation in the reverse order to removal.

❖ 1

- ★ Adjust the belt tension. For details, see TESTING AND ADJUSTING, Testing and adjusting of fan belt tension.
- ★ Add coolant through the coolant filler to the specified level. Run the engine to circulate the coolant through the system. Then check the coolant level again.

NOZZLE HOLDER

Removal

1. Open engine hood.
2. Disconnect delivery tube (1) at nozzle holder assembly end. 
3. Remove spill tube (2). 

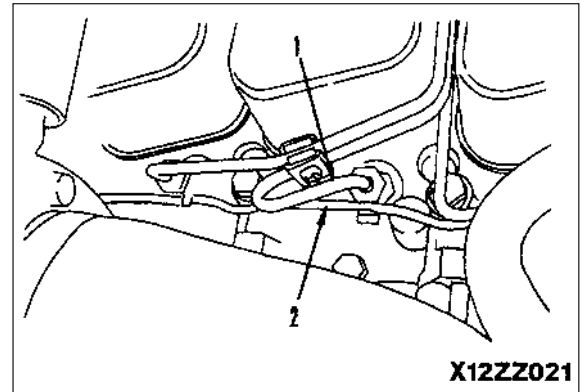



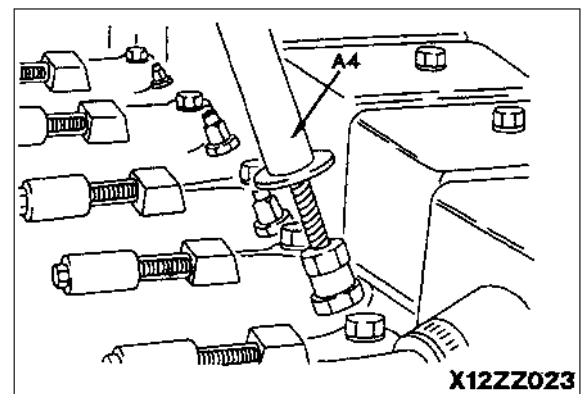
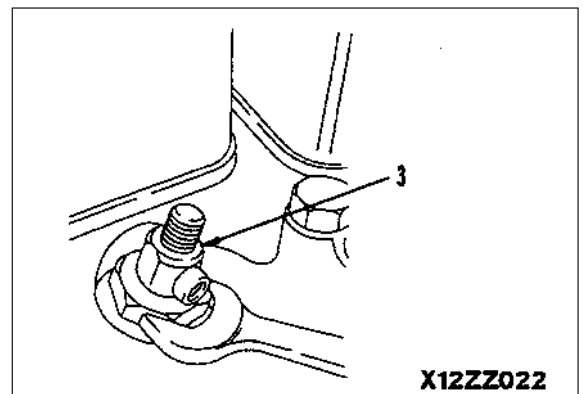

4. Remove nozzle holder assembly (3). 
- ★ If it is difficult to remove the nozzle holder assembly, use tool **A4** to remove it.
- ★ Be careful not to let dirt or dust get into the nozzle holder assembly mount.





Installation

- Carry out installation in the reverse order to removal.

  Delivery tube sleeve nut: 30 ± 5 Nm (3.06 ± 0.51 kgm)

  Joint bolt: 8 ± 2 Nm (0.81 ± 0.20 kgm)

  Nozzle holder assembly: 60 ± 5 Nm (6.12 ± 0.51 kgm)

 Nozzle holder assembly thread portion: Seizer prevention compound (Molycoat 1000)

- ★ When assembling the nozzle holder, clean the nozzle mount, and check that there is no dirt or dust inside the sleeve before assembling.

TURBOCHARGER

Removal

1. Open engine hood, and remove turbocharger shield (1).

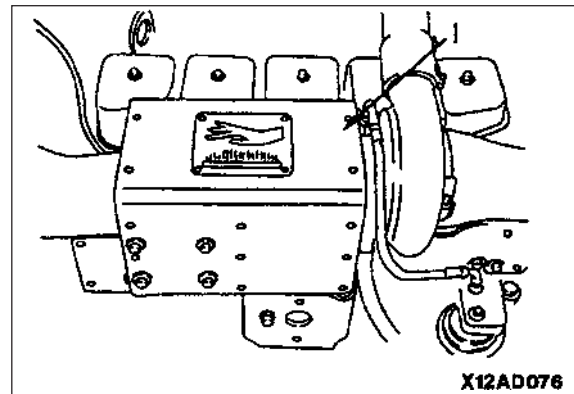

2. Remove turbocharger. See engine shop manual for details.

Installation

- Carry out installation in the reverse order to removal.

THERMOSTAT

Removal

1. Drain coolant.
2. Open engine hood, and remove fan guard (1) and right side guard mounting bracket (2).

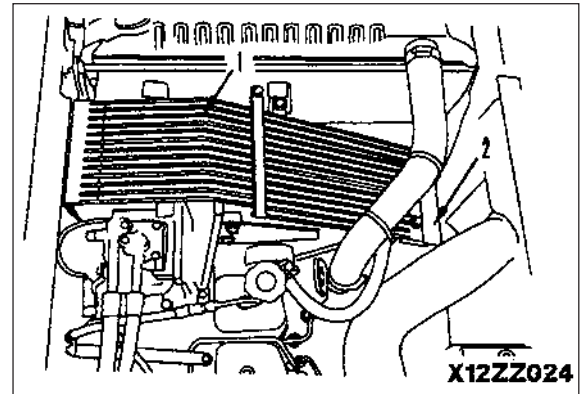

3. Using wrench 1*, raise tensioner (3), then remove fan belt (4).

⚠ Be extremely careful not to get your fingers caught when removing the belt.

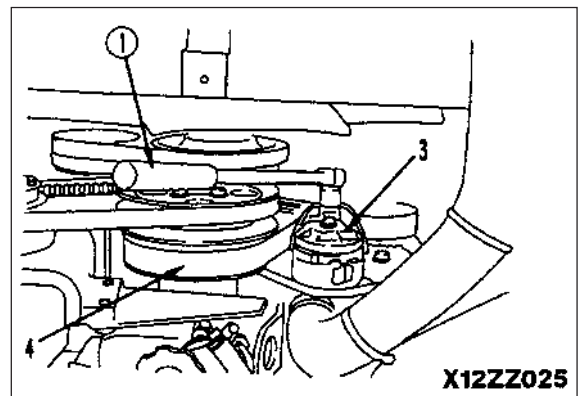

4. Remove alternator assembly top mounting bolt (5) from bracket, then alternator assembly (6) towards partition plate end.

★ Loosen the mounting bolts at the bottom of the alternator assembly.

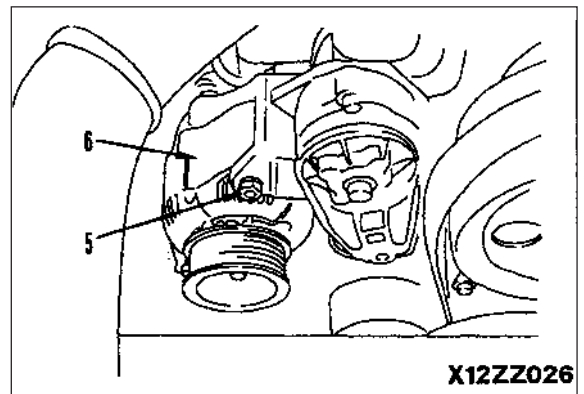

5. Disconnect radiator inlet hose (7) and aeration hose (8).
6. Remove alternator bracket (9).
7. Remove thermostat. For details, see engine shop manual.

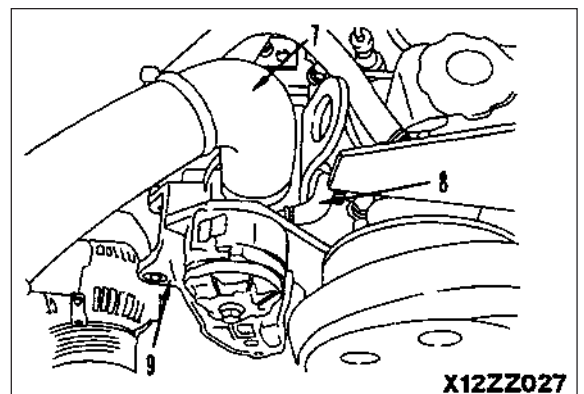

Installation

- Carry out installation in the reverse order to removal.

- ★ Add coolant through the coolant filter to the specified level. Run the engine to circulate the coolant through the system. Then check the coolant level again.

GOVERNOR MOTOR

Removal

⚠ Disconnect the cable from the negative (-) terminal of the battery.

1. Open engine hood.
2. Disconnect wiring (1).
- ★ Disconnect 2 connectors at the bottom of governor motor mounting bracket (2).
3. Remove motor rod (3).

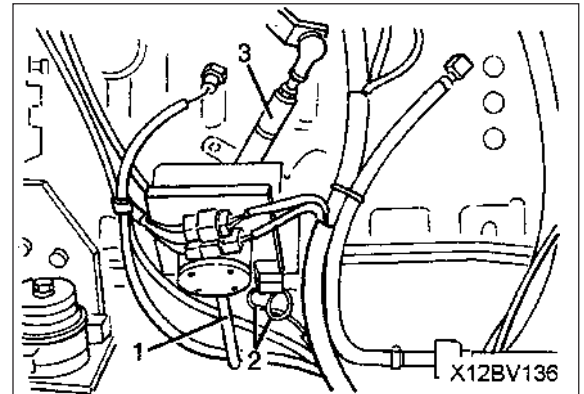

4. Remove governor motor assembly (4). * I
- ★ Rotate the shaft of the governor motor and do not stop it suddenly.

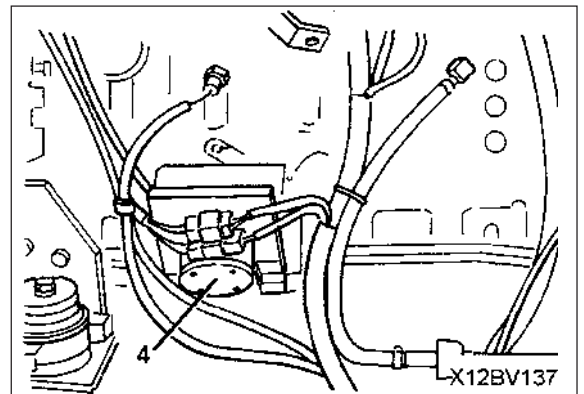

Installation

- Carry out installation in the reverse order to removal.

* I

- ★ Adjust the rod. For details, see TESTING AND ADJUSTING, Testing and adjusting of governor motor lever stroke.

CYLINDER HEAD ASSEMBLY

PC290-6K

Removal

 Disconnect the cable from the negative (-) terminal of the battery.

1. Drain coolant.
2. Open engine hood.
3. Remove fan guard (1), then remove left and right side covers (2) and (3) of fan guard mount.

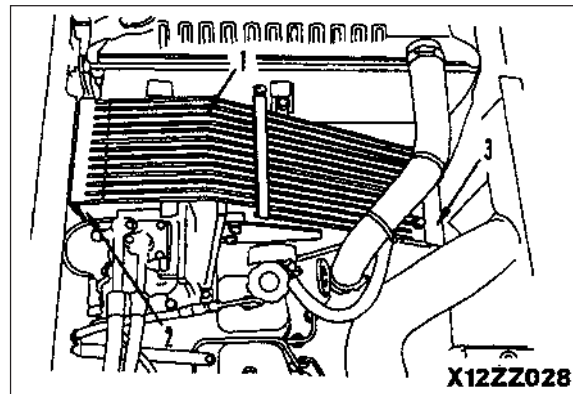

4. Loosen clamp of hose (4), then remove hose (4) and air connector portion (5) of aftercooler.
5. Disconnect tube (6) and hose (7).
6. Remove turbocharger assembly. For details, see REMOVAL OF TURBOCHARGER ASSEMBLY.

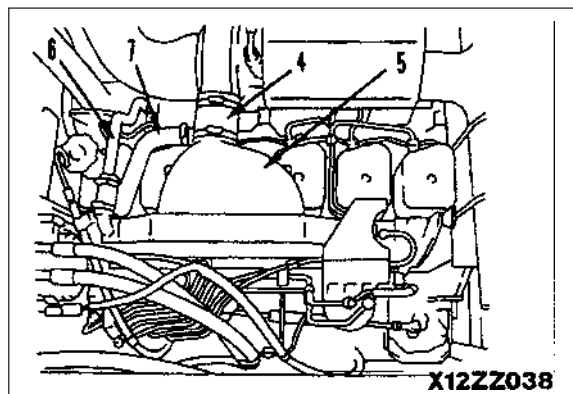

7. Remove exhaust manifold cover (8).

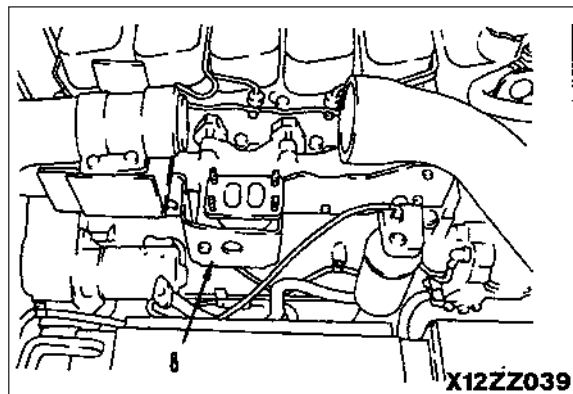

8. Remove turbocharger shield mounting bracket (9).
 - ★ In order to remove mounting bolt (10), do as follows.
 - a. Remove muffler drain pipe. (Main pump end)
 - b. Loosen muffler mounting U-bolt.
 - c. Rotate connector (11) at the muffler end up slightly to a position where it is possible to remove the mounting bolts.
9. Remove exhaust manifold (12).

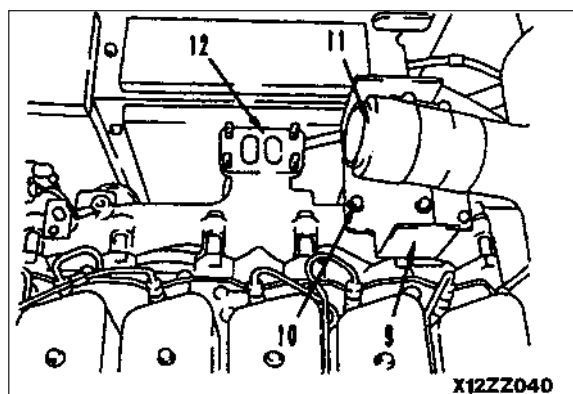

10. Disconnect electrical intake air heater wiring (13), coolant temperature sensor connector (14).

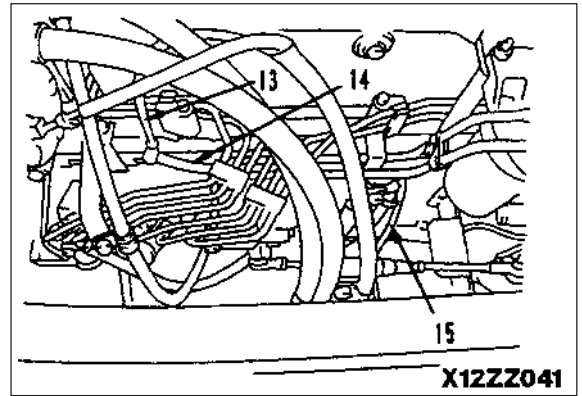

11. Remove mounting bracket (17) of intermediate clamp for wiring and air conditioner hose at engine end.
12. For machines equipped with air conditioners,  3 disconnect compressor connector (16). Remove air conditioner belt (18), then remove compressor assembly (19) together with bracket and move towards counterweight.
13. Remove mounting plate (21) and clamp (20) of dipstick guide.

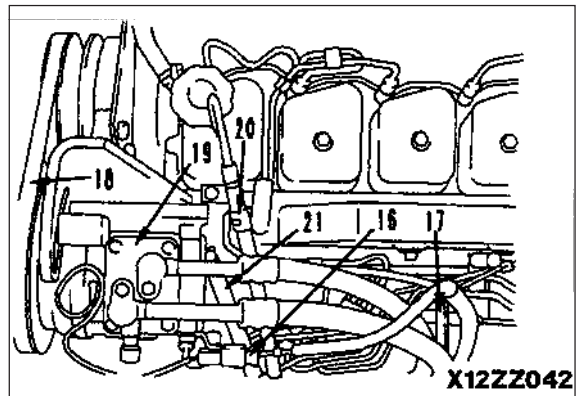

14. Disconnect radiator inlet hose (22), heater hose (23), and aeration hose (24).

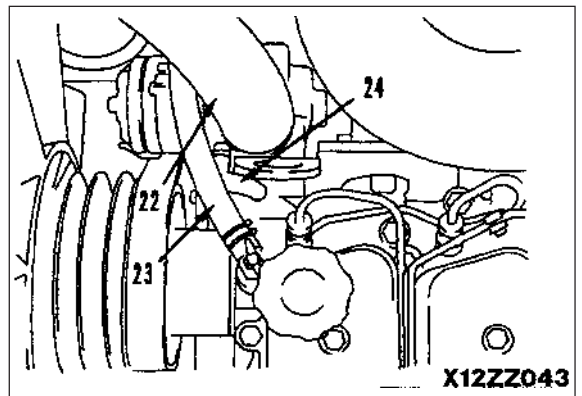

15. Using wrench 1*, raise tensioner (25), then remove belt (26).
-  Be extremely careful not to get your fingers caught when removing the belt.
- ★ For machines equipped with air conditioning, before removing belt, loosen 4 mounting bolts of air conditioner pulley (27).
16. For machines equipped with air conditioning, remove air conditioner

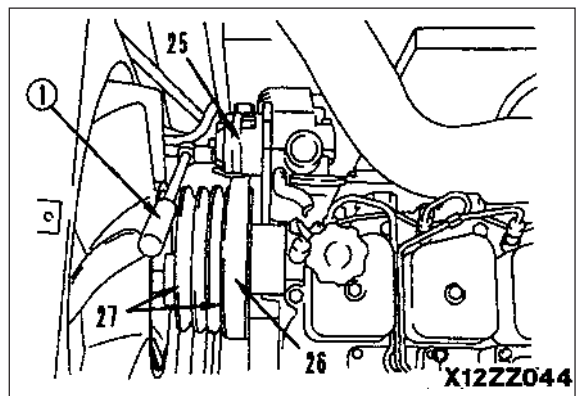

17. Remove alternator assembly top mounting bolt (28) from bracket, then move alternator assembly (29) towards partition plate.
- ★ Loosen the mounting bolts at the bottom of the alternator assembly.

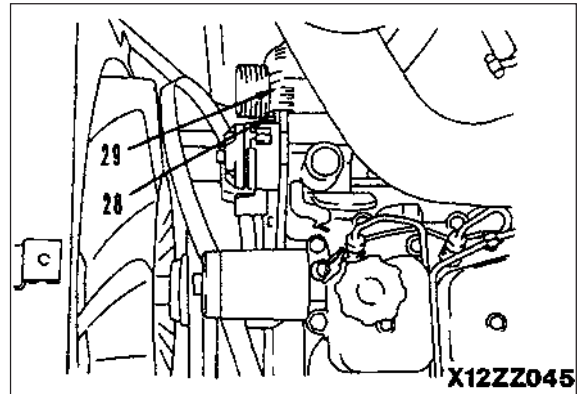

18. Remove alternator bracket (30), pulley hub (31) and  tensioner (25) together with bracket (32).
19. Remove fuel lines, remove fuel filter assembly, remove fuel nozzle holders. For details, see engine shop manual.
20. Remove aftercooler assembly. For details, see engine shop manual.
21. Remove head covers, remove rocker arm assemblies, remove push rods, and remove cylinder head. For details, see engine shop manual.

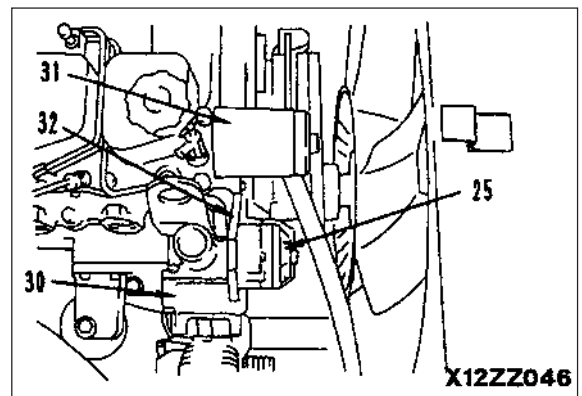

Installation PC210-6K/PC290-6K

- Carry out installation in the reverse order to removal.

✳ 1

 **kgm** Muffler mounting U-bolt: 12 ± 2.5 Nm (1.22 ± 0.26 kgm).

✳ 2

- ★ Tighten the mounting bolts in the order (1) - (12) shown in the diagram on the right.

 **kgm** Exhaust manifold mounting bolt: 43 ± 6 Nm (4.38 ± 0.61 kgm)

✳ 3

- ★ Adjust the belt tension. For details, see TESTING AND ADJUSTING, Testing and adjusting air conditioner belt tension.

✳ 4

 **kgm** Pulley hub mounting bolt: 33 ± 5 Nm (3.37 ± 0.51 kgm)

 **kgm** Tensioner bracket mounting bolt: 24 ± 4 Nm (2.45 ± 0.41 kgm)

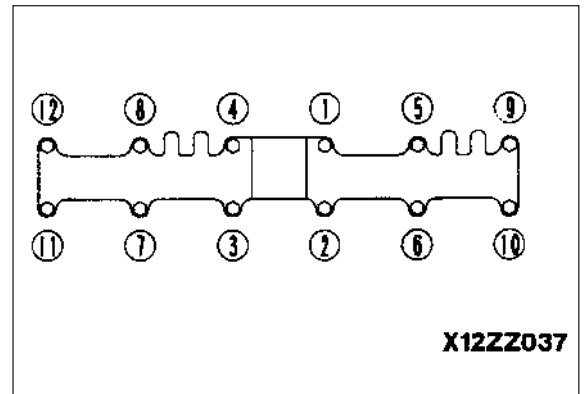

RADIATOR • HYDRAULIC OIL COOLER

Removal

 Lower the work equipment completely to the ground and stop the engine. Then loosen the oil filler cap slowly to release the pressure inside the hydraulic tank.

- Remove the hydraulic tank strainer, and using tool **B**, stop the oil.
- When not using tool **B**, remove the drain plug, and drain the oil from the hydraulic tank and inside the system.



Hydraulic tank: Approx. 170 l.

1. Drain engine coolant
2. Open engine hood, remove top cover (1) and tool box and undercover (2), then set oil container under chassis.
3. Remove undercover under radiator.
4. Disconnect connector of reservoir tank wiring (3) and hose (4), then hose (4), then remove reservoir tank (5).
5. Disconnect oil cooler hoses (6) and (7).

6. Remove fan guard (8).
7. Disconnect radiator upper hose (9).

 3

8. Remove clamps (11) (2 places) of heater hose (10).

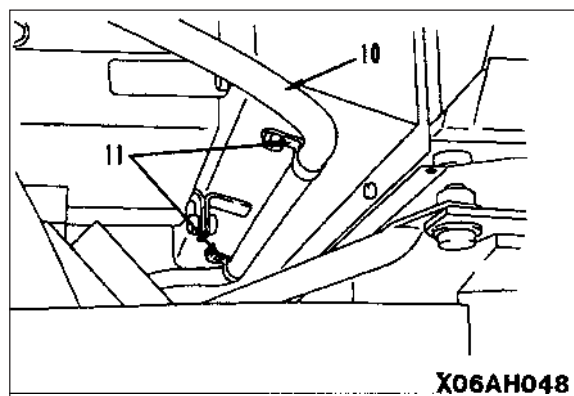
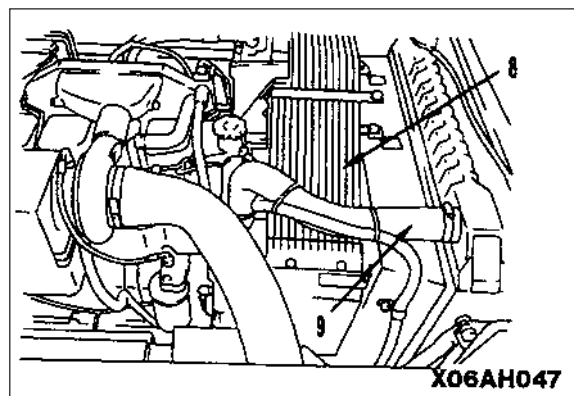
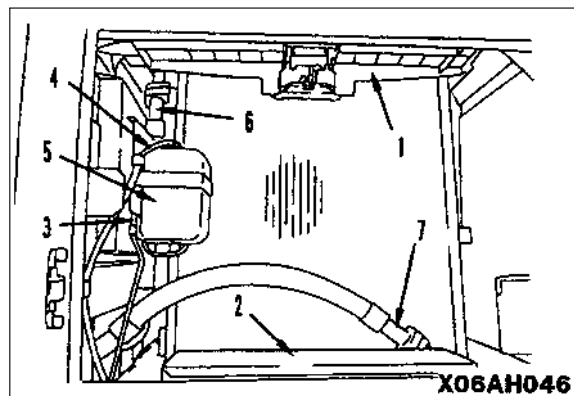
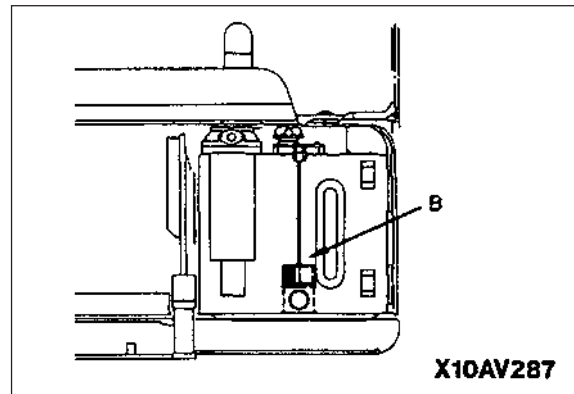

9. Disconnect radiator support rods (12) and (13).

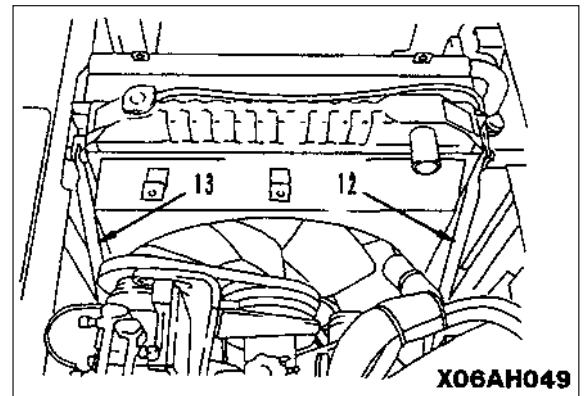

10. Disconnect radiator lower hose (14) and heater hose  (15), then remove intermediate clamp (16) of radiator lower hose.

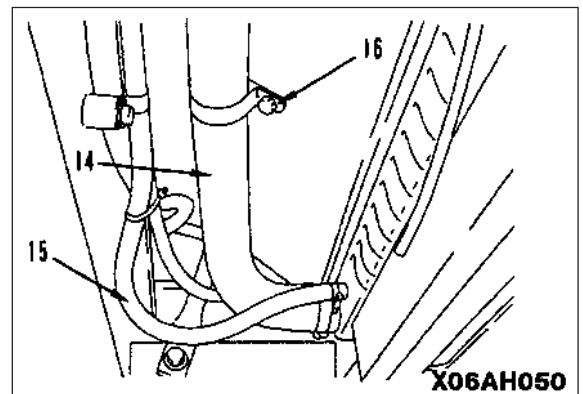

11. Sling radiator and hydraulic cooler assembly (17), remove bottom mounting bolts, then lift off radiator and hydraulic cooler assembly.

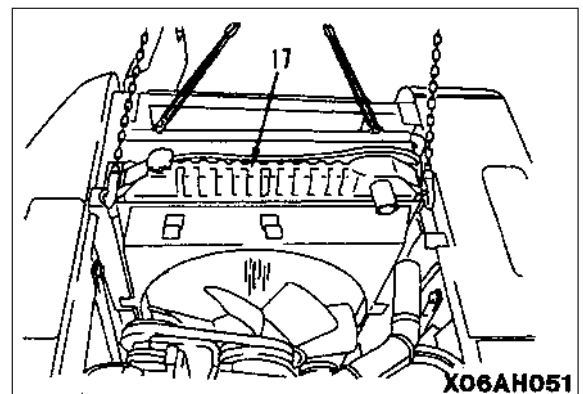

- ★ When raising the radiator and hydraulic cooler assembly, check the position carefully and do not let it hit the fan when removing it.

 Radiator, hydraulic cooler assembly: 147 kg



Installation

- Carry out installation in the reverse order to removal.

 1  2

 Radiator hose band clip: 8.83 ± 0.98 Nm (0.9 ± 0.1 kgm)

- Refilling with coolant
- ★ Add coolant through the water filler to the specified level. Run the engine to circulate the coolant through the system. Then check the coolant level again.
- Refilling with oil (hydraulic tank).
- ★ Add oil through the oil filler to the specified level. Run the engine to circulate the oil through the system. Then check the oil level again.

ENGINE, MAIN PUMP

Removal

- ⚠ Disconnect the cable from the negative (-) terminal of the battery.
- ⚠ Lower the work equipment completely to the ground and stop the engine. Then loosen the oil filler cap slowly to release the pressure inside the hydraulic tank.
- Remove the hydraulic tank strainer, and using tool **B**, stop the oil.
- When not using tool **B**, remove the drain plug, and drain the oil from the hydraulic tank and inside the system.



Hydraulic tank: Approx. 170 l.

- ★ Mark all the piping with tags to prevent mistakes in the mounting position when installing.
1. Drain coolant.
 2. Remove engine hood (1).

3. Remove main pump top cover (2).
 4. Remove right side cover (3) together with cover mounting frame (4).
- ★ Remove the cover at the bottom of the main pump and the cover at the bottom of the engine, and set a container under the main pump to catch the oil.

5. Remove connector (5) and (6) from under bracket and disconnect.

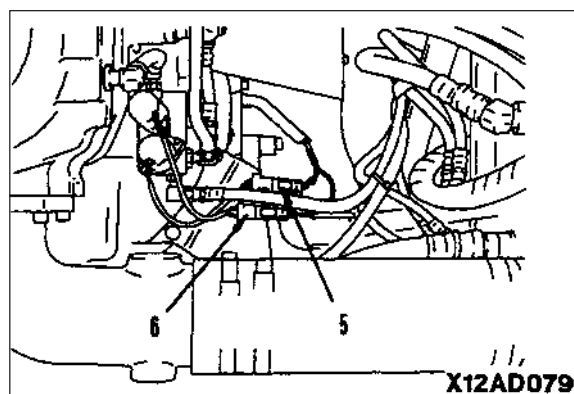
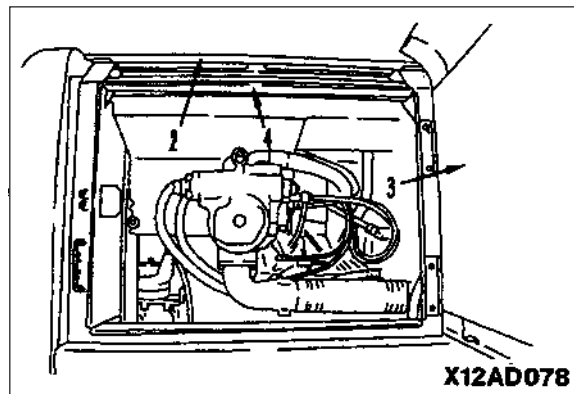
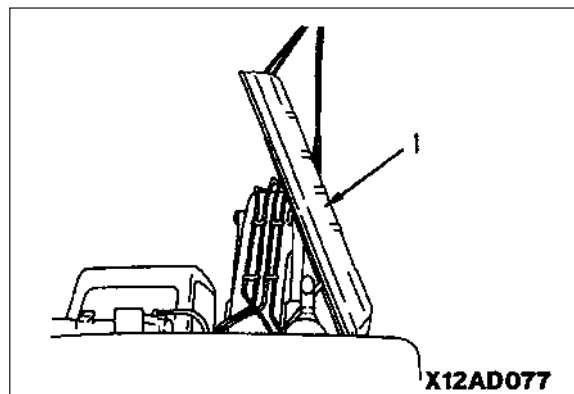
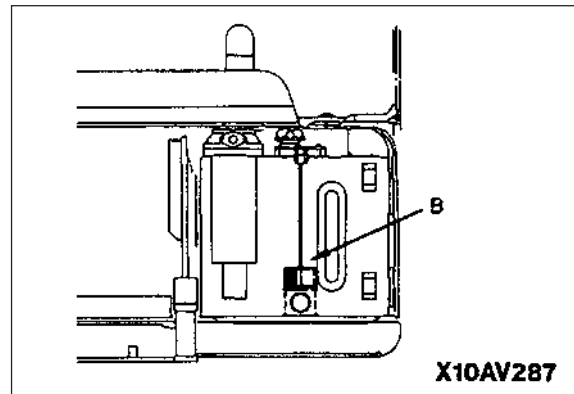

6. Disconnect front and rear pump discharge hoses (7) and (8), front and rear LS pressure hoses (9) and (10), and EPC basic pressure hose (11).
 - ★ Protect with the sleeve nut to prevent damage to the nipple or elbow taper seal portion.
7. Disconnect pump servo pressure hose (12) and pump drain hose (13).
 - ★ Protect with the sleeve nut to prevent damage to the nipple or elbow taper seal portion.
8. Disconnect suction tube (15) at pump end.
 - ★ Cover the suction tube port portion with plastic.

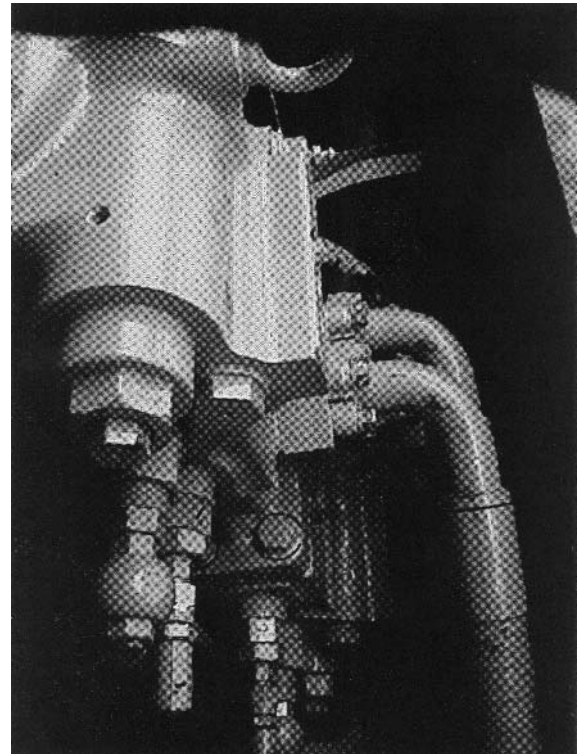

9. Remove engine partition plates (16), (17) and (18).

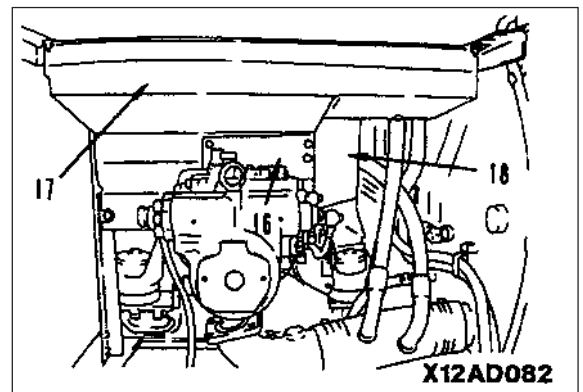

10. Remove bracket (19) at counterweight end.
11. Remove fan guard (20), then remove left and right side brackets (21) of fan guard mount. Photo shows delivery hose arrangement (Re sketch x 12AD020)

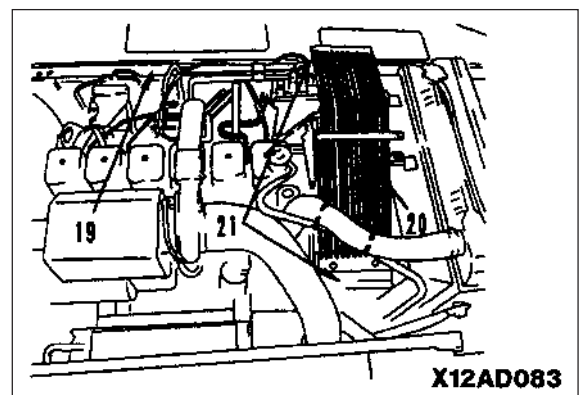

12. Disconnect oil level sensor connector (22) of oil pan, wiring (23) for oil pressure sensor, and ground connection (24)
13. Remove intermediate clamp (25) of heater hose.

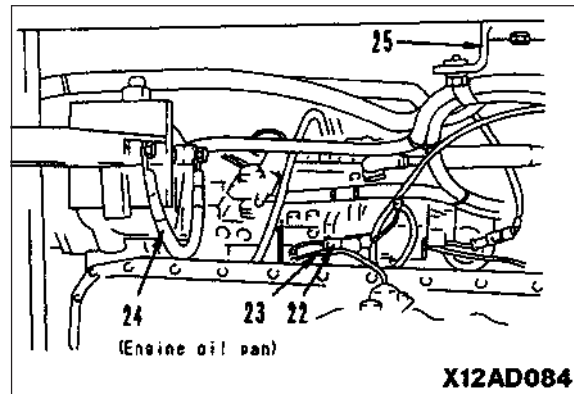

14. Disconnect governor motor connectors (26) (2 places) and speed sensor connector (27).

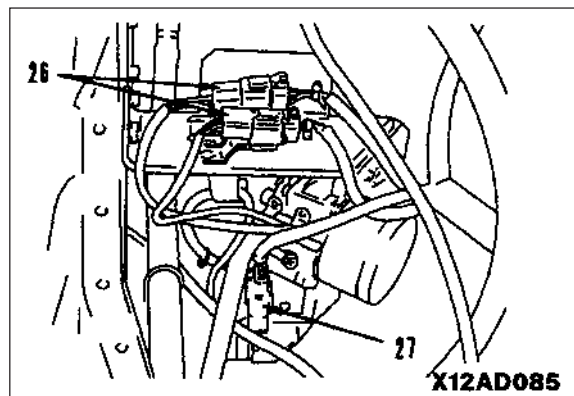

15. Disconnect starting motor wiring (28) and starting motor connectors (29) and (30), and remove from clamp.
16. Disconnect fuel supply hose and fuel return hose. For details, see engine shop manual.

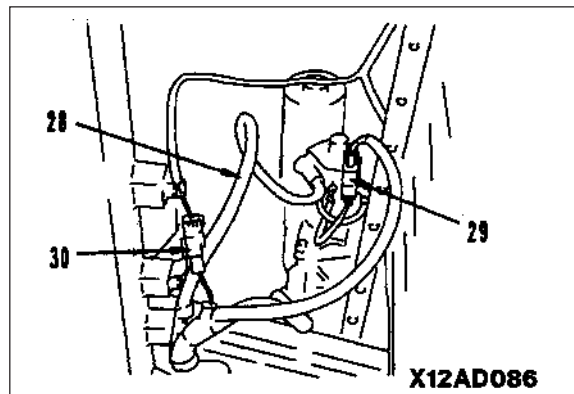

17. Disconnect electrical intake air heater wiring (34).
 18. For machines with air conditioning, disconnect air conditioner connector (35), remove compressor assembly (356). For details, see AIR CONDITIONER COMPRESSOR, Removal.
- ★ After removing the compressor assembly, put it on top of the counterweight.

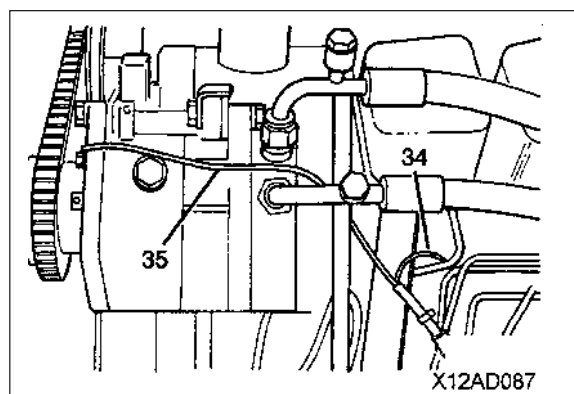

19. Remove fan (37) and move towards radiator.

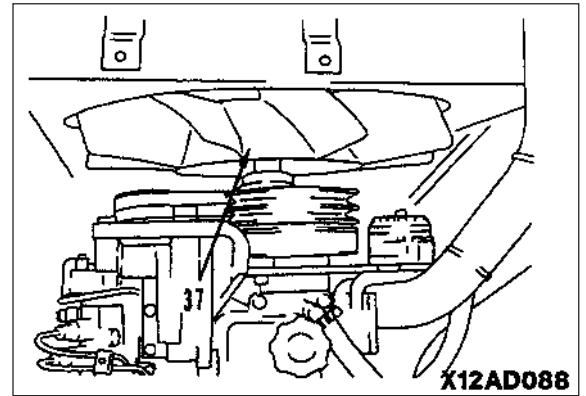

20. Remove radiator upper hose (38), radiator lower hose (39), heater hose (40), and air cleaner connector (41).

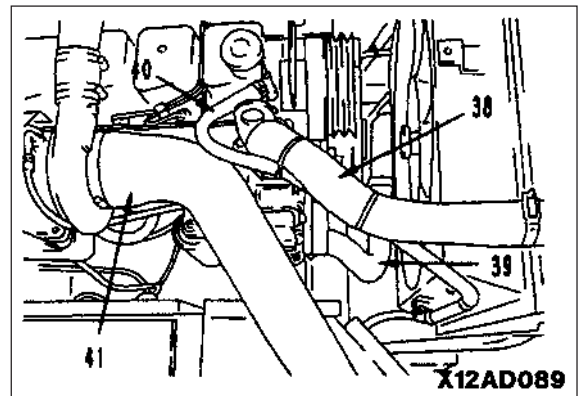

21. Remove engine mounting bolts, then raise engine  and main pump assembly (42) slowly and lift off.

★ When removing the engine and main pump assembly, check that all the wiring and piping has been disconnected.

 Engine, main pump assembly: 770 kg.

Installation

• Carry out installation in the reverse order to removal.

 Set the engine mounting rubber as shown in the diagram, then install the engine and main pump assembly.

 Engine mounting bolt: $227 \pm 32 \text{ Nm}$ ($28.3 \pm 3.3 \text{ kgm}$)

- Refilling with coolant.
- ★ Add coolant through the water filler to the specified level. Run the engine to circulate the coolant through the system. Then check the coolant level again.
- Refilling with oil (hydraulic tank)
- ★ Add oil through the oil filler to the specified level. Run the engine to circulate the oil through the system. Then check the oil level again.
- Bleeding air.
- ★ Bleed air from the main pump. For details, see TESTING AND ADJUSTING, Bleeding air.

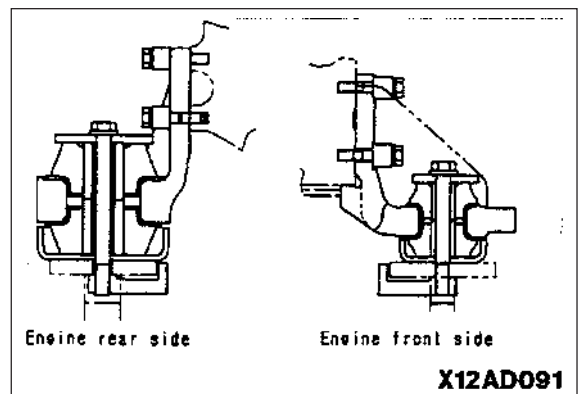
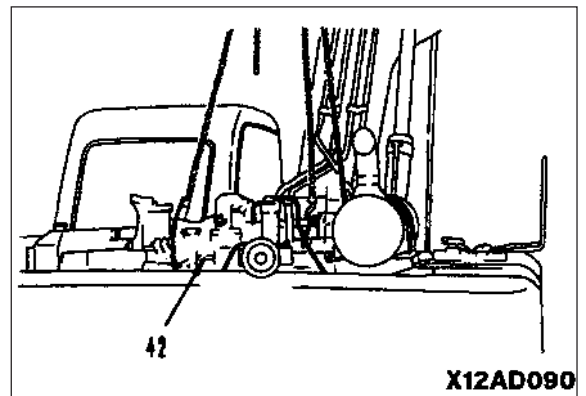

DAMPER

Removal

1. Remove main pump assembly. For details, see ENGINE, MAIN PUMP, Removal.
2. Remove damper assembly (1).

Installation

- Carry out installation in the reverse order to removal.

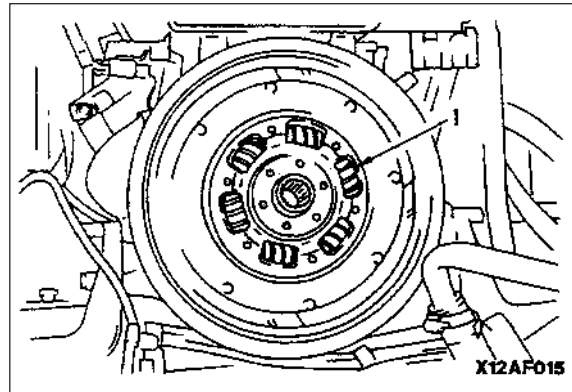

FUEL TANK

Removal

 Disconnect the cable from the negative (-) terminal of the battery.

- Loosen drain valve (1) of fuel tank and drain fuel.



Disconnect fuel supply hose (2) and return hose (3).

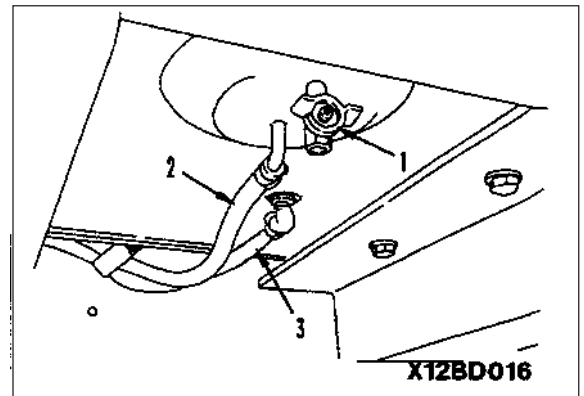

- Remove handrail (5), battery case (6), and cover (7).



Battery case: 28 kg

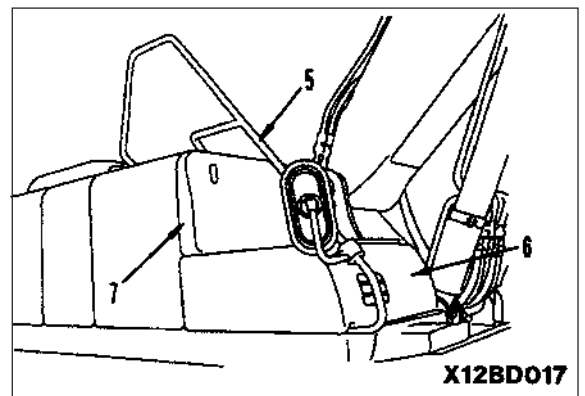

- Disconnect fuel sensor connector (8), then remove wiring from clamp.

- Sling fuel tank assembly (9), then remove mounting bolts and lift off fuel tank assembly (9).



Fuel tank assembly: 122 kg

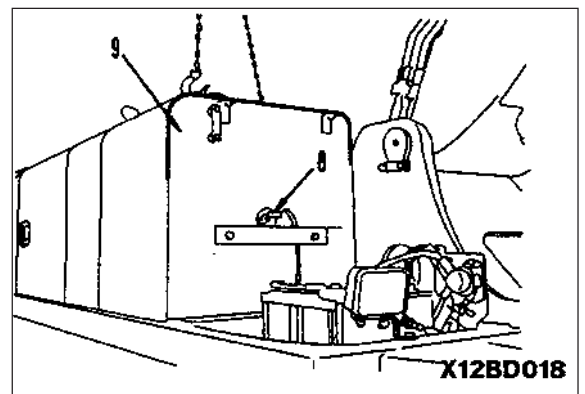

Installation

- Carry out installation in the reverse order to removal.



Fuel tank mounting bolt: 277 ± 32 Nm (28.3 ± 3.2 kgm)

- Add fuel.

CENTER SWIVEL JOINT

Removal

⚠ Release the remaining pressure in the hydraulic circuit. For details, see TESTING AND ADJUSTING, Releasing remaining pressure from hydraulic circuit.

★ Mark all the piping with tags to prevent mistakes in the mounting position when installing.

1. Disconnect hoses (1), (2), (3), and (4) and tubes (5) and (6), and remove filter and bracket assembly.

★ For machines equipped with additional attachment circuit.



Filter, bracket assembly: 95 kg

2. Disconnect hoses (7), (8), (9), and (10) between travel motor and swivel joint.

3. Remove elbow (11).

4. Disconnect drain hose (12).

5. Disconnect hoses (13) and (14) between control valve and swivel joint.

6. Disconnect travel speed selector hose (15).

7. Disconnect plate (16).

8. Remove center swivel joint assembly (17).



Center swivel joint assembly: 45 kg.

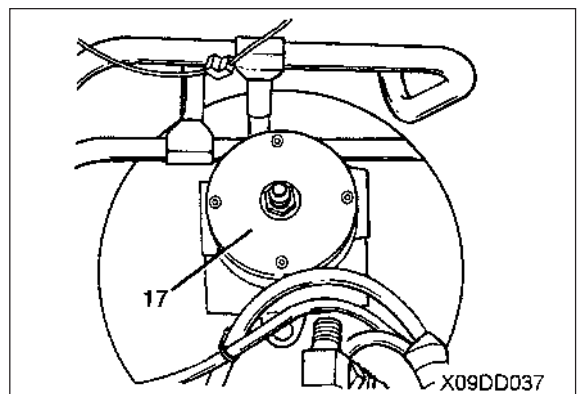
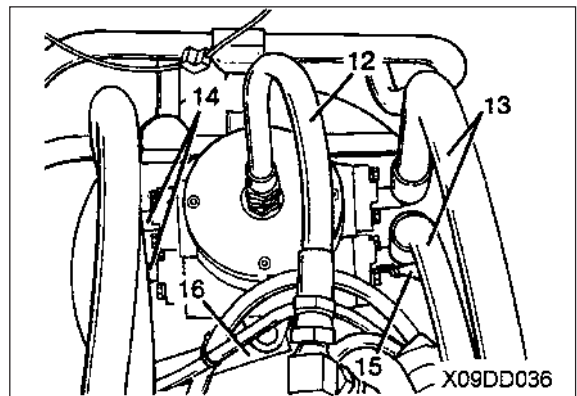
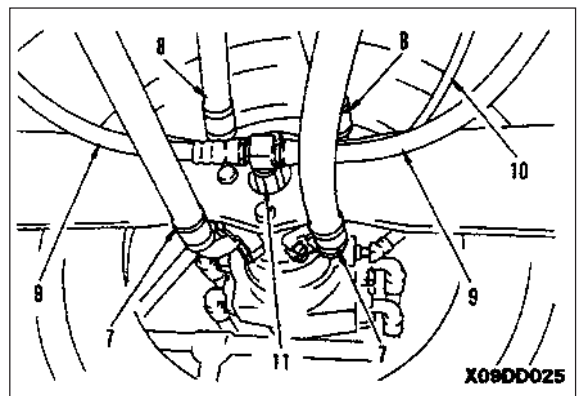
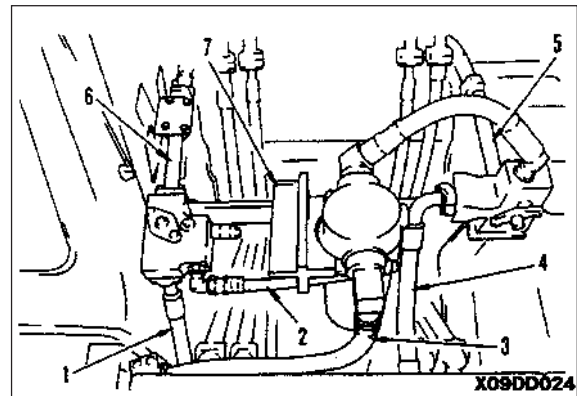

Installation

- Carry out installation in the reverse order to removal.



- ★ Assemble the center swivel as shown in the diagram to the right.
- Refilling with oil (hydraulic tank)
- ★ Add oil through the oil filler to the specified level. Run the engine to circulate the oil through the system. Then check the oil level again.
- Bleeding air.
- ★ Bleed the air from the travel motor. For details, see TESTING AND ADJUSTING, Bleeding air.

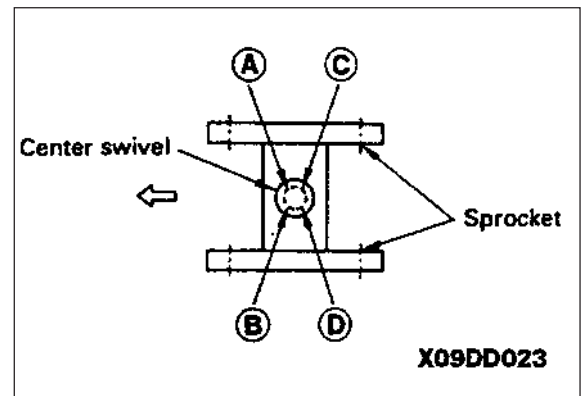

Disassembly

1. Remove cover mounting bolts (1) (4 places), cover (2) and O-ring (3).
 2. Remove thrust plate mounting bolts (4) (4 places), thrust plate (5) and O-rings (6) (4 places).
 3. Remove shaft (7) from housing (8).
 4. Remove seals (9) and (10) from housing (8).
- ★ Check all seals and O-rings for damage or wear and replace if necessary.

Assembly

1. Assemble seals (9) and (10) to housing (8).
2. Set shaft (7) on a block, then using push tool, tap housing (8) with a plastic hammer to install.

 Contact surface of housing, shaft: Grease (GS-LI)

- ★ When installing the shaft, be extremely careful not to damage the seals or O-rings.
3. Install O-rings (6) and thrust plate (5).
 4. Fit O-ring (3) and install cover (2).

 **kgm** Mounting bolt: 31.36 ± 2.94 Nm (3.2 ± 0.3 kgm)

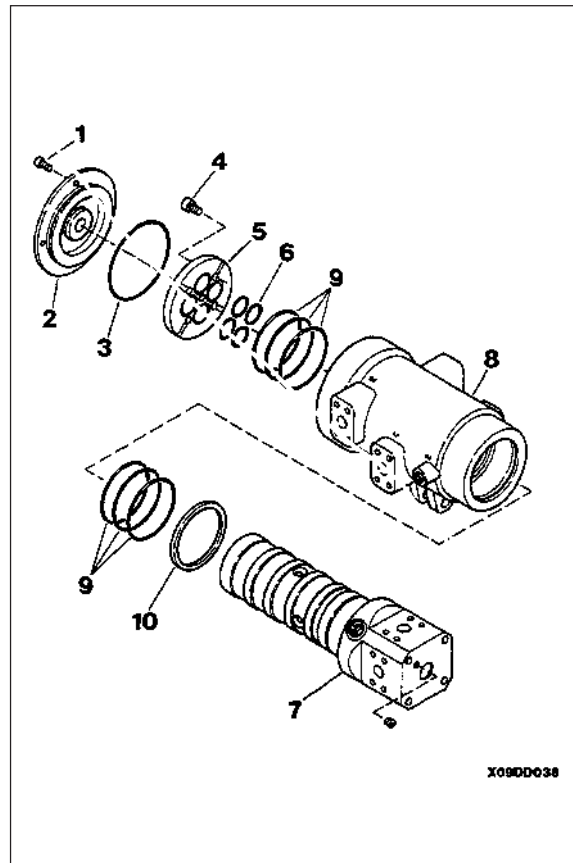

REMOVAL OF FINAL DRIVE ASSEMBLY

1. Remove the track shoe assembly.
For details, see REMOVAL OF TRACK SHOE ASSEMBLY.
2. Using work equipment, push up track frame and set block between track frame and link.
- ⚠ Loosen the oil filler cap slowly to release the pressure inside the hydraulic tank.
3. Remove sprocket.
For details, see REMOVAL OF SPROCKET.
4. Remove cover (1).
5. Disconnect drain hose (2).
★ Set a container to catch the oil, then disconnect the hose and install a blind plug.
6. Disconnect speed selector hose (3) and motor hoses (4) and (5).
7. Sling final drive assembly (6), and remove mounting bolts, then remove. ※ I

 Final drive assembly: **550 kg**

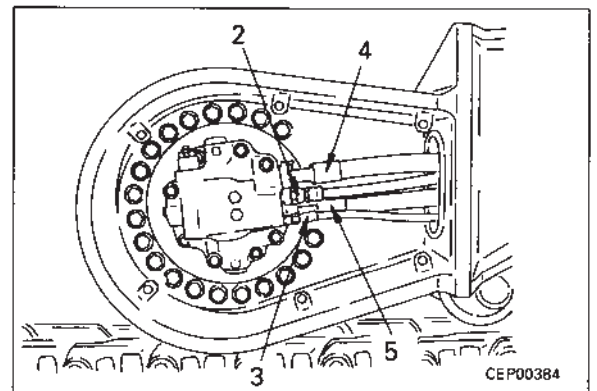
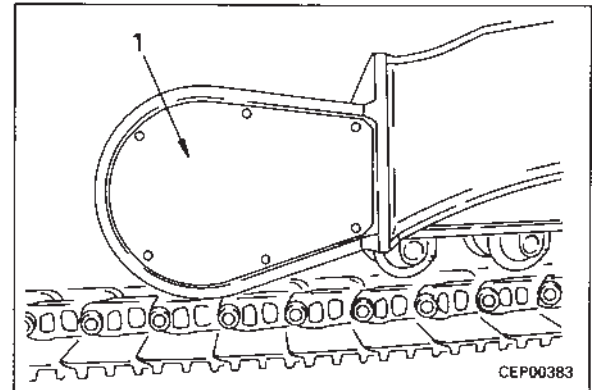

INSTALLATION OF FINAL DRIVE ASSEMBLY

- Carry out installation in the reverse order to removal.

※ I  Final drive mounting bolt: **549 ± 59 Nm**
(**56 ± 6 kgm**)

- **Refilling with oil (hydraulic tank)**
★ Add oil through the oil filler to the specified level.
Run the engine to circulate the oil through the system. Then check the oil level again.
- **Bleeding air**
★ Bleed the air from the travel motor (hydraulic tank).
For details, see TESTING AND ADJUSTING, Bleeding air.

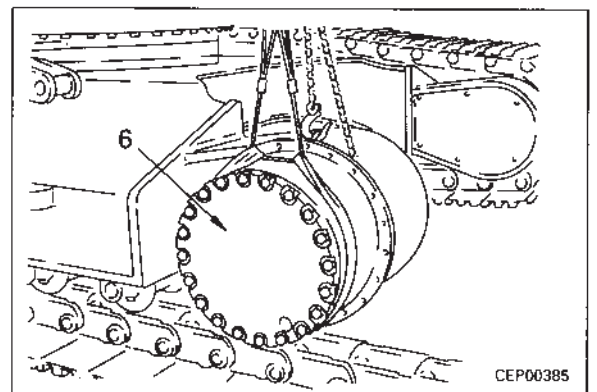

DISASSEMBLY OF FINAL DRIVE ASSEMBLY

1. Draining oil

Remove drain plug and drain oil from final drive case.



Final drive case: Approx. 10 ℓ

2. Cover

1) Remove mounting bolts, then use forcing screws ① to disconnect cover (1) from ring gear.

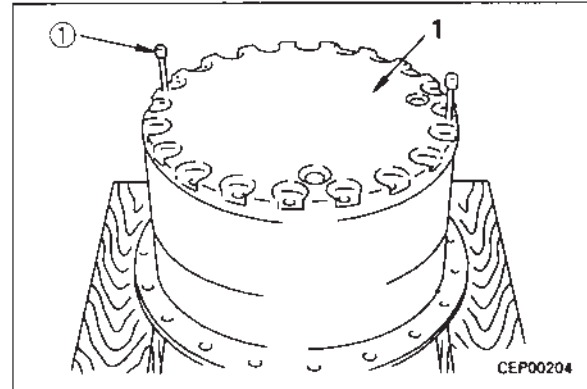

2) Use eyebolts ② to remove cover (1).

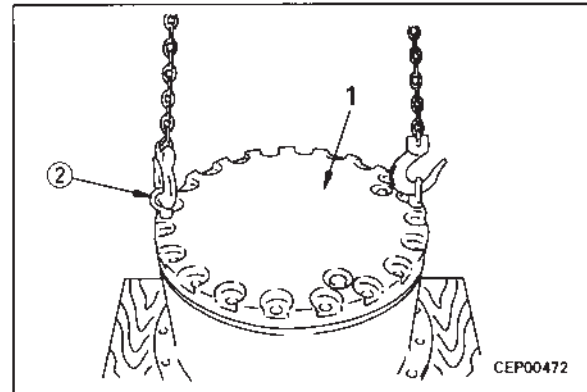

3. Spacer

Remove spacer (2).

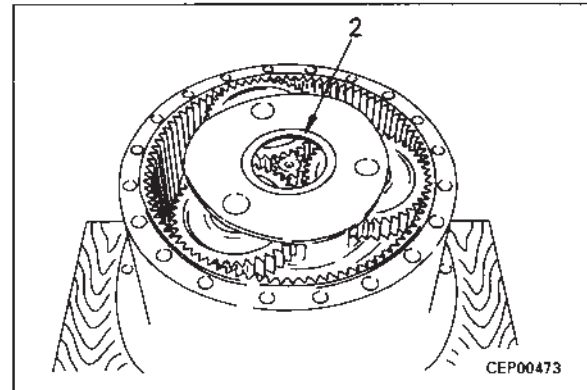

4. No. 1 carrier assembly

1) Remove No. 1 carrier assembly (3).

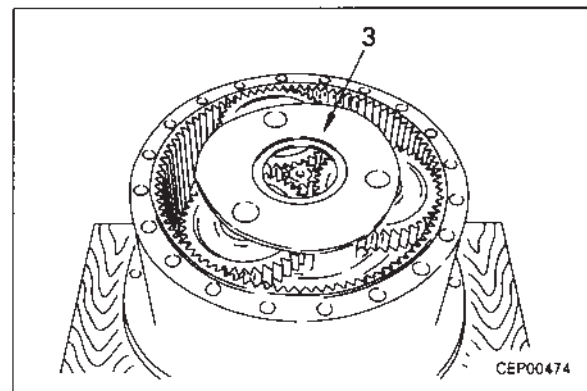

2) Disassemble No. 1 carrier assembly as follows.

- i) Push in pin (4), and knock out shaft (5) from carrier (6).
 - ★ After removing shaft (5), remove pin (4).
- ii) Remove thrust washer (7), gear (8), bearing (9), and thrust washer (10).

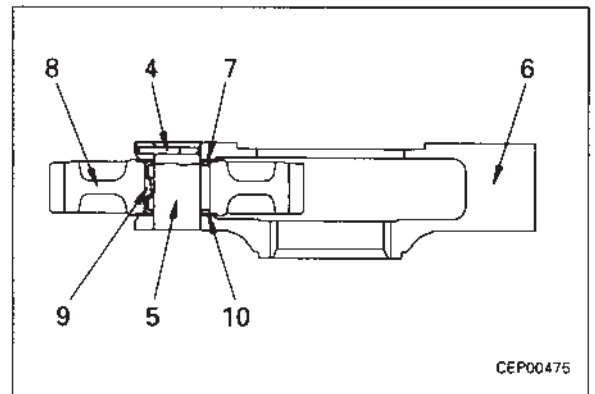

5. No. 1 sun gear shaft

Remove No. 1 sun gear shaft (11).

6. No. 2 sun gear

Remove No. 2 sun gear (12).

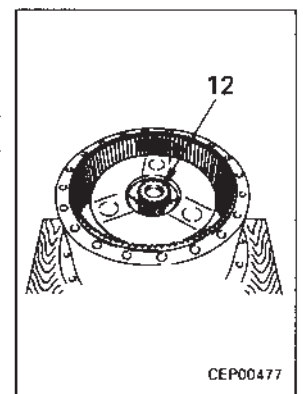
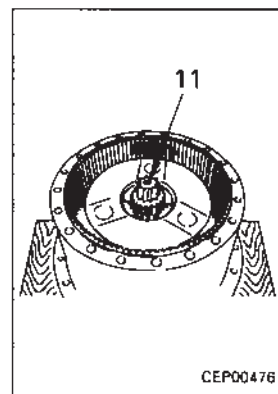

7. Thrust washer

Remove thrust washer (13).

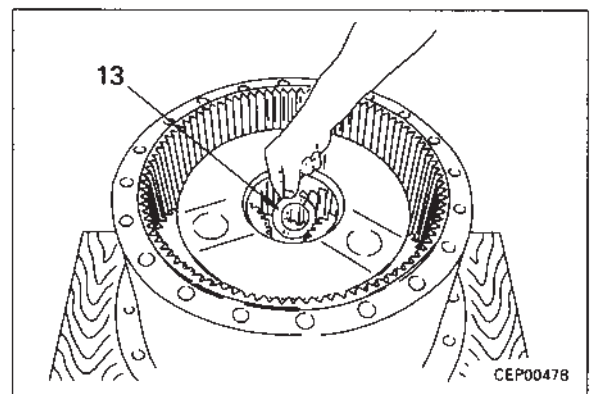

8. Ring gear

Using eyebolts (3), remove ring gear (14).

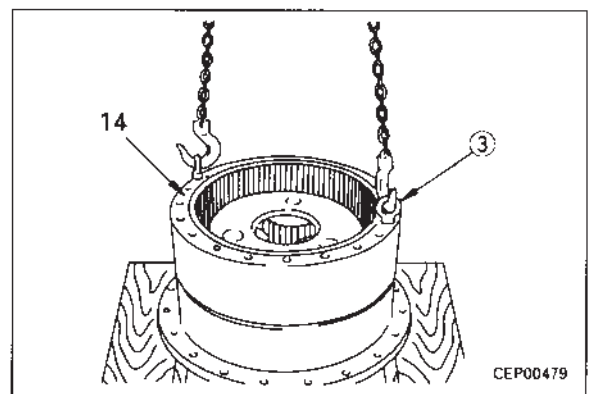

9. No. 2 carrier assembly.

- 1) Remove No. 2 carrier assembly (15).

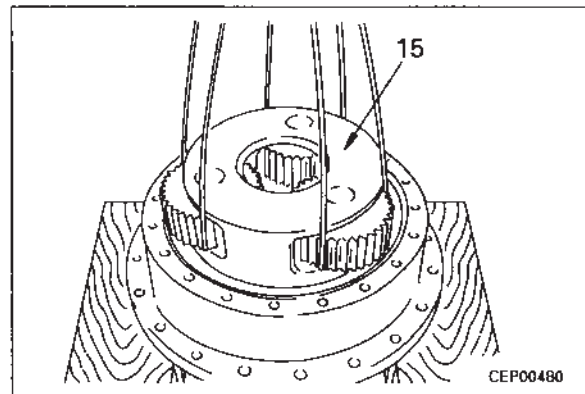

- 2) Disassemble No. 2 carrier assembly as follows.

- i) Push in pin (16) and pull out shaft (17) from carrier (18).
 - ★ After removing the shaft, remove pin (16).
- ii) Remove thrust washer (19), gear (20), bearing (21), and thrust washer (22).

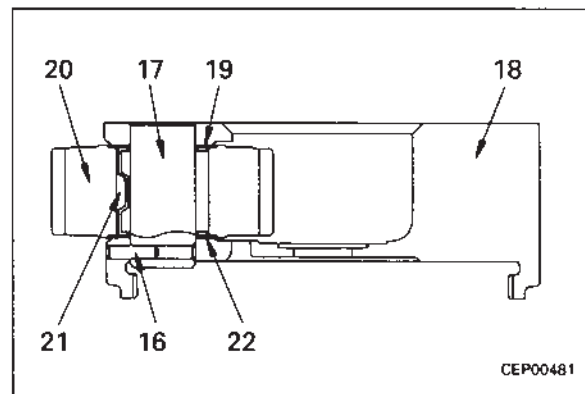
**10. Nut**

- 1) Remove lock plate (23).

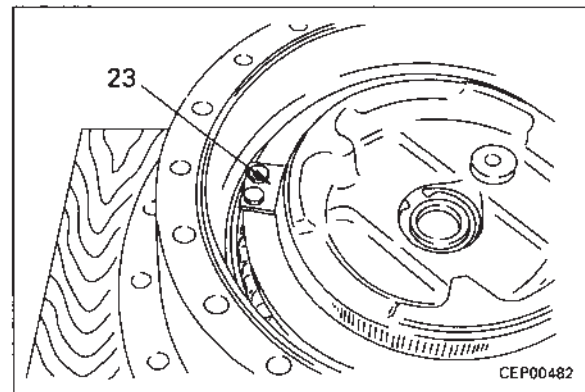

- 2) Using tool G1, remove nut (24).

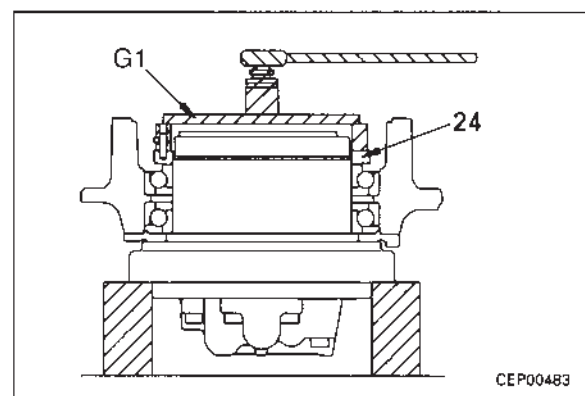

11. Hub assembly

- 1) Using eyebolts ④, remove hub assembly (25) from travel motor.

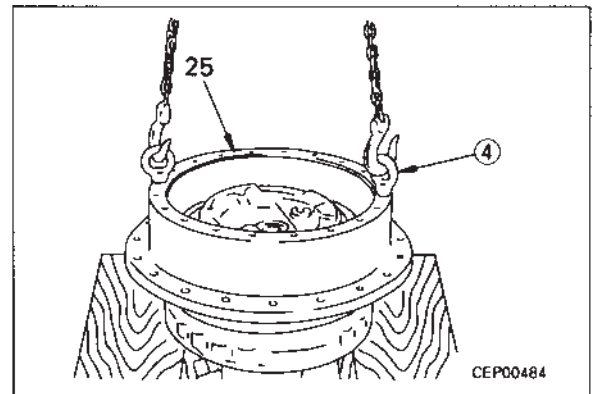

- 2) Disassemble hub assembly as follows.
 - i) Remove floating seal (26).

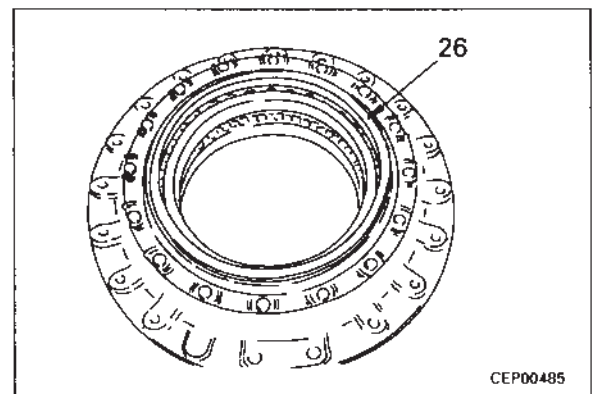

- ii) Remove bearings (27) and (28) from hub (29).

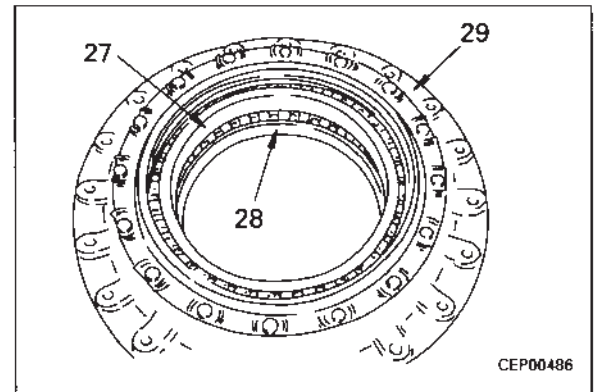

- 3) Remove floating seal (30) from travel motor (31).

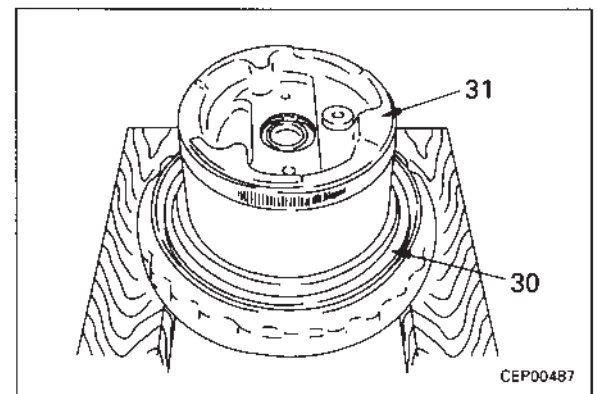

ASSEMBLY OF FINAL DRIVE ASSEMBLY

- ★ Clean all parts, and check for dirt or damage. Coat the sliding surfaces of all parts with engine oil before installing.

1. Hub assembly

- 1) Assemble hub assembly as follows.
 - i) Using push tool, press fit bearings (28) and (29) to hub.
 - ii) Using tool G4, install floating seal (26).
 - ★ Remove all oil and grease from the O-ring and O-ring contact surface, and dry the parts before installing the floating seal.
 - ★ After installing the floating seal, check that the angle of the floating seal is within 1 mm.
 - ★ After installing the floating seal, coat the sliding surface thinly with engine oil.

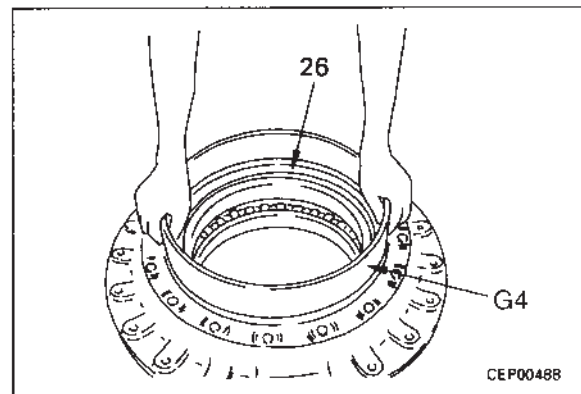
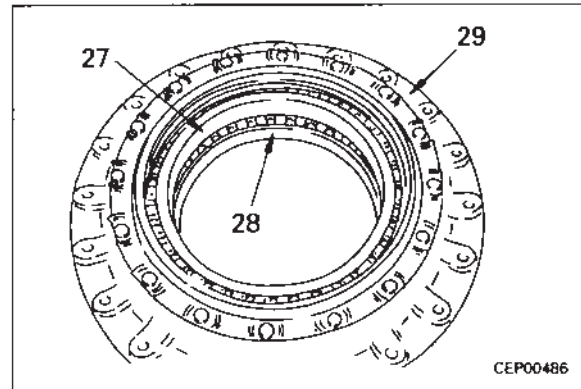

- 2) Using tool G4, install floating seal (30) to travel motor (31).
 - ★ The procedure for installation is the same as in Step 1)-ii) above.

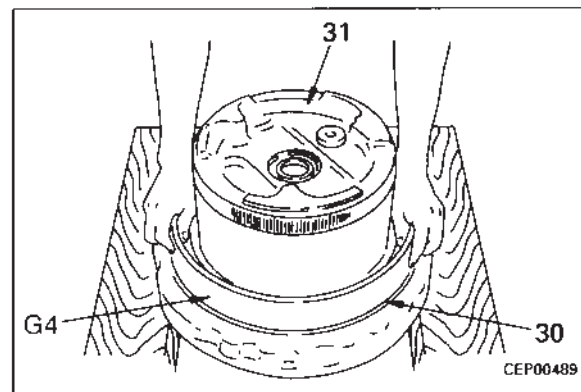

- 3) Using eyebolts ④, set hub assembly (25) to travel motor, then using push tool, tap to press fit bearing portion.

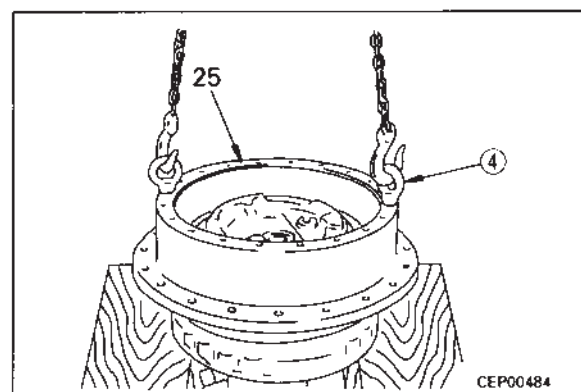

2. Nut

- 1) Using tool G2, push inner race portion of bearing (27).
- ★ Pushing force: 14.7 – 18.6 kN (1.5 – 1.9 ton)
- ★ Rotate the hub 2 – 3 times before applying the pushing force to the bearing inner race.

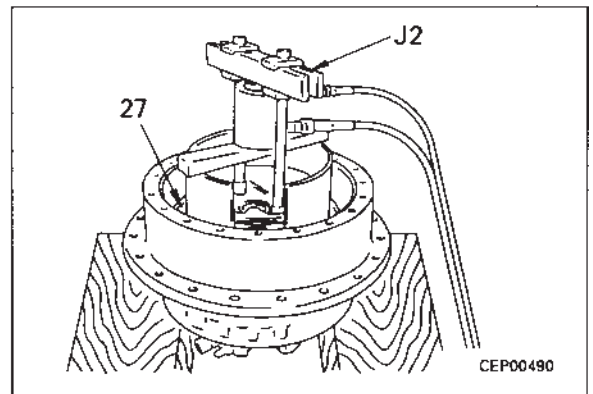

- 2) Measure dimension **a** in the condition in Step 1) above.

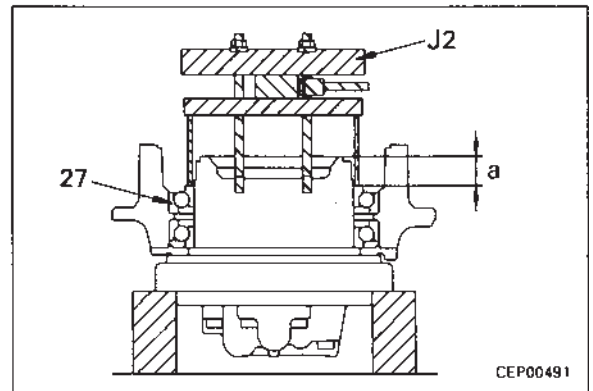

- 3) Measure thickness **b** of nut (24) as an individual part.
- 4) Calculate $a - b = c$
- 5) Using tool G1, tighten nut (24) until **c** portion dimension is as follows.
 c portion dimension = $c_{-0.1}^0$ mm

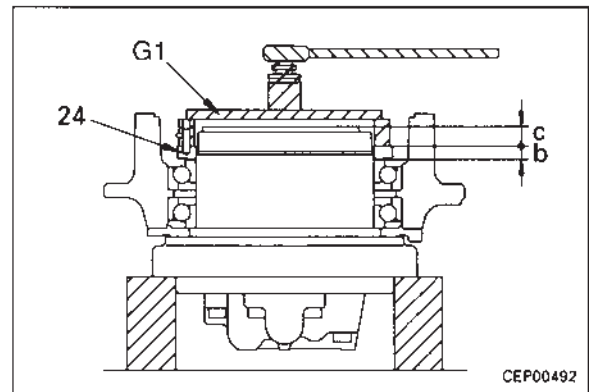

- 6) Using push-pull scale ⑤, measure tangential force in direction of rotation of hub in relation to motor case.
- ★ Tangential force: Max. 490 N (50 kg)
- ★ The tangential force is the maximum force when starting rotation.

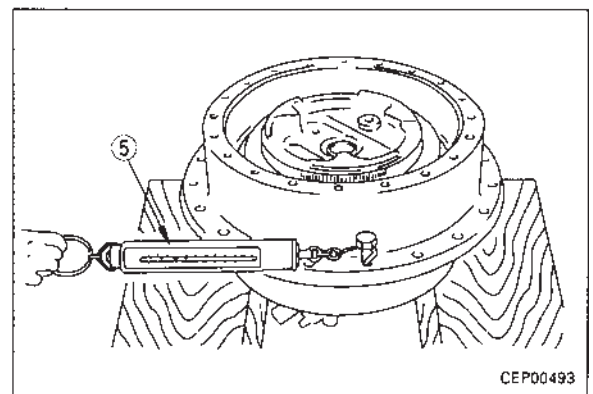

7) Install lock plate (23).

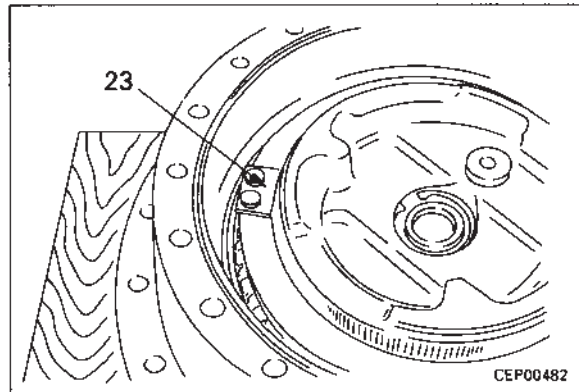

★ Install the lock plate as shown in the diagram on the right.

 Thread of mounting bolt:
Thread tightener (LT-2)

★ Do not coat the threaded portion of the nut with thread tightener (LT-2).

 Mounting bolt: **66.19 ± 7.35 Nm**
(6.75 ± 0.75 kgm)

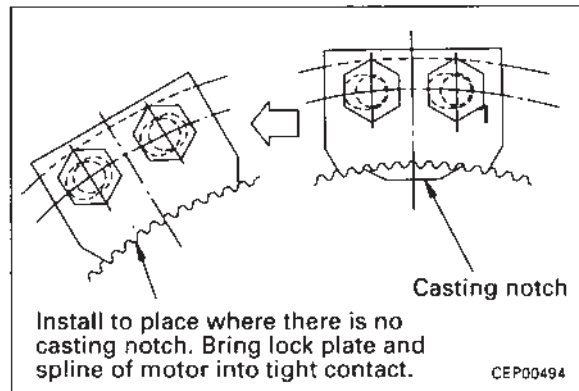

Install to place where there is no casting notch. Bring lock plate and spline of motor into tight contact.

3. No. 2 carrier assembly

1) Assemble No. 2 carrier assembly as follows.

★ There are the remains of the caulking when the pin is inserted at the end face of hole **h** at the side of the carrier, so remove the caulked metal from the inside diameter of the hole before starting to assemble.

i) Assemble bearing (21) to gear (20), fit top and bottom thrust washers (19) and (22), and set gear assembly in carrier (18).

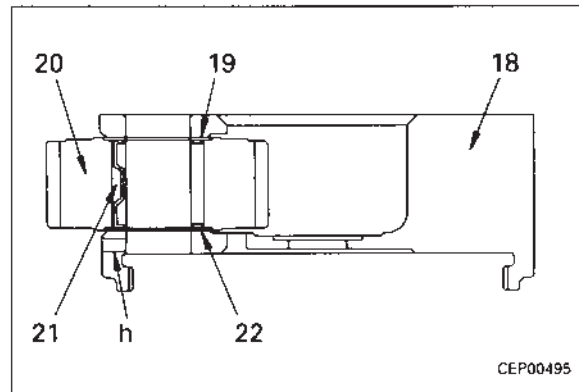

ii) Align with position of pin holes of shaft and carrier, then tap with a plastic hammer to install shaft (17).

★ When installing the shaft, rotate the planetary gear, and be careful not to damage the thrust washer.

iii) Insert pin (16).

★ After inserting the pin, caulk the pin portion of the carrier.

★ After assembling the carrier assembly, check that gear (20) rotates smoothly.

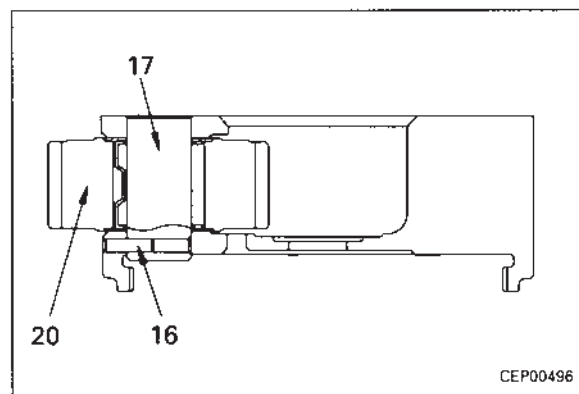

- 2) Install No. 2 carrier assembly (15).
 ★ Align the position so that the three tips of the gear shafts of carrier assembly (15) enter the three hollows in the end face of the motor case, then install.

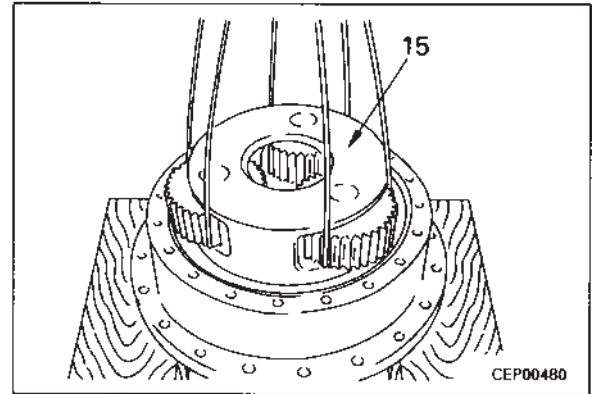

4. Ring gear

Fit O-ring to hub end, then using eyebolts ③, install ring gear (14).

- ★ Install so that the side with two grooves machined in the outside circumference of the ring gear is at the top (cover end).
- ★ Remove all grease and oil from the mating surface of the ring gear and hub.
- ★ Do not put any gasket sealant on the mating surface of the ring gear and hub under any circumstances.

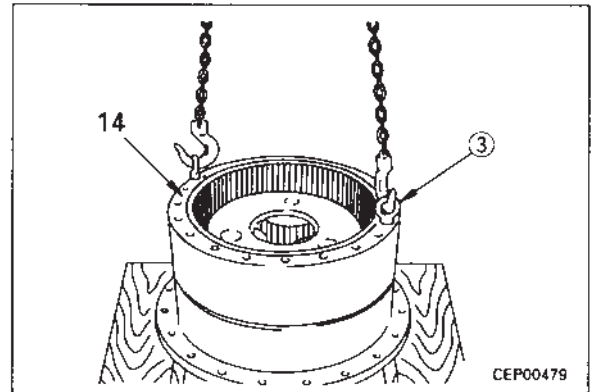

5. Thrust washer

Install thrust washer (13).

6. No. 2 sun gear

Install No. 2 sun gear (12).

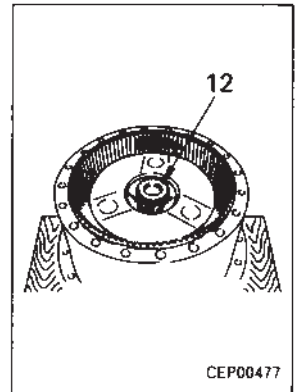
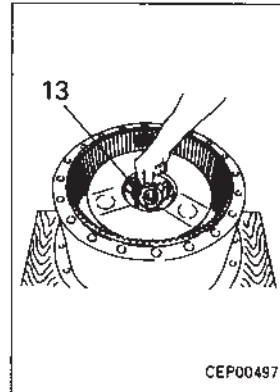

7. No. 1 carrier assembly

1) Assemble No. 1 carrier assembly as follows.

- ★ There are the remains of the caulking when the pin is inserted at the end face of hole **h** at the side of the carrier, so remove the caulked metal from the inside diameter of the hole before starting to assemble.
- i) Assemble bearing (9) to gear (8), fit top and bottom thrust washers (7) and (10) and set gear assembly to carrier (6).

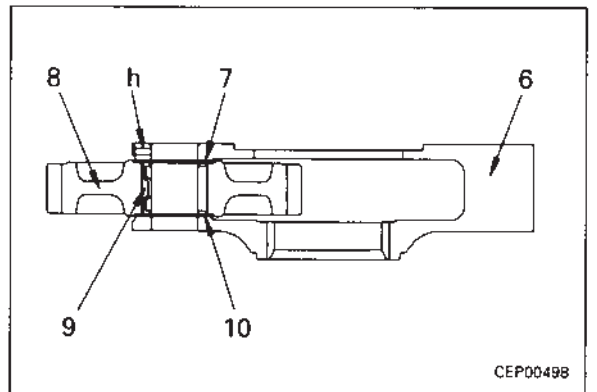

- ii) Align position of pin holes of shaft and carrier, then tap with a plastic hammer to install shaft (5).
 - ★ When installing the shaft, rotate the planetary gear, and be careful not to damage the thrust washer.
- iii) Insert pin (4).
 - ★ After inserting the pin, caulk the pin portion of the carrier.
 - ★ After assembling the carrier assembly, check that gear (8) rotates smoothly.

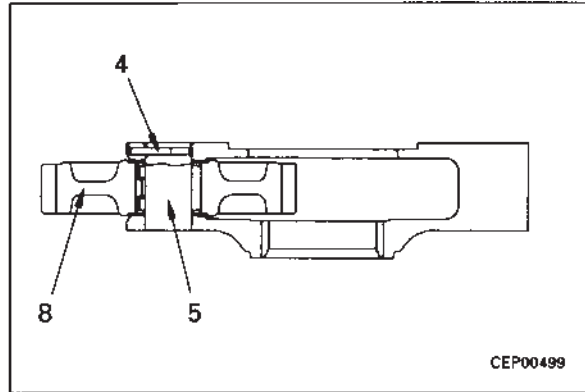

2) Install No. 1 carrier assembly (3).

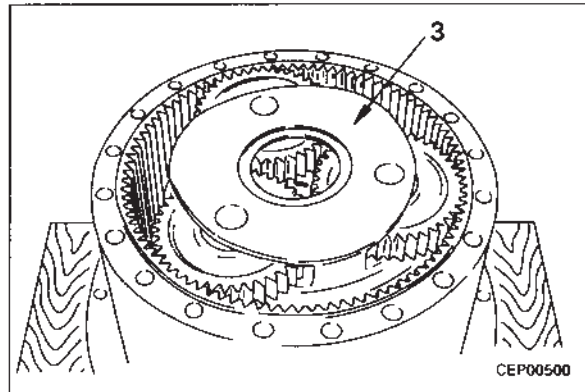

8. No. 1 sun gear shaft

Install No. 1 sun gear shaft (11).

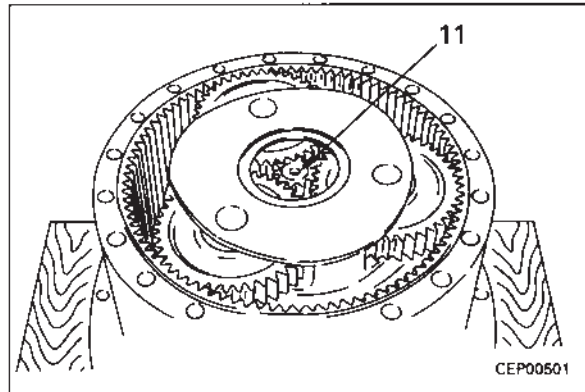

9. Spacer

Install spacer (2).

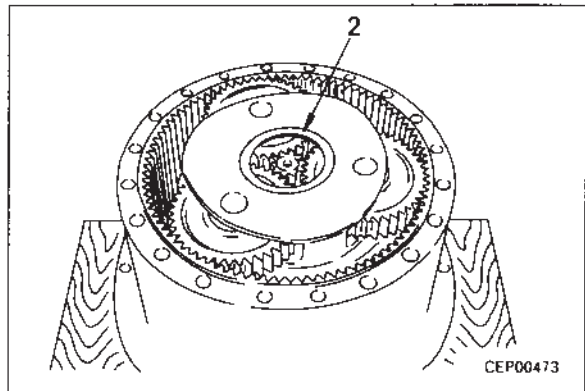

10. Cover

- 1) Using eyebolts ②, install cover (1).

 Mounting surface of cover:

Gasket sealant (LG-6)

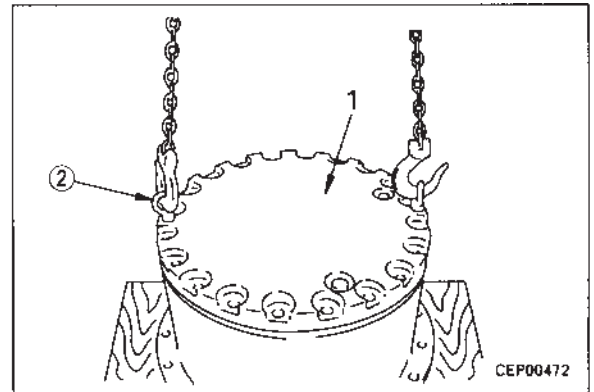

- 2) Using tool G3, tighten mounting bolts.

 Mounting bolt:

Initial torque: **98 Nm (10 kgm)**

Additional tightening angle:

115 - 125°

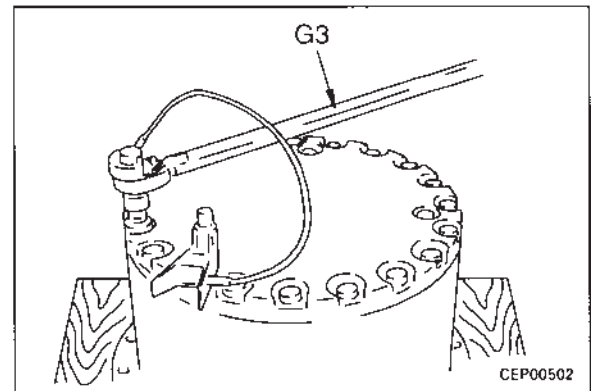
**11. Refilling with oil**

Tighten drain plug and add engine oil through oil filler.



Final drive case: Approx. **10 ℓ**

- ★ Carry out a final check of the oil level at the determined position after installing the final drive assembly to the chassis.

REMOVAL OF SPROCKET

1. Remove track shoe assembly.
For details, see REMOVAL OF TRACK SHOE ASSEMBLY.
2. Swing work equipment 90°, then push up chassis with work equipment and set block ① between track frame and track shoe.
3. Remove mounting bolts, then lift off sprocket (1). ※ I

kg Sprocket : 70 kg

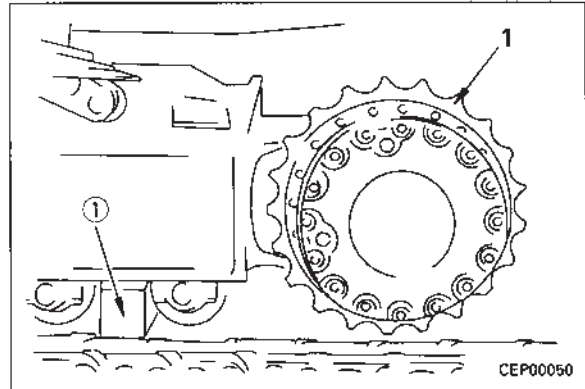

INSTALLATION OF SPROCKET

- Carry out installation in the reverse order to removal.

※ I

 Thread of sprocket mounting bolt:
Thread tightener (LT-2)

 kgm Sprocket mounting bolt:
637 ± 49 Nm (65 ± 5 kgm)

SWING MOTOR AND MACHINERY

Removal



Lower the work equipment completely to the ground and stop the engine. Loosen the oil filler cap slowly to release the pressure inside the hydraulic tank. Then set the safety lock lever to the LOCK position.

1. Remove hose clamps (1) and (2) (2 places each).
 2. Disconnect swing motor inlet and outlet hoses (3) and (4), and disconnect suction hose (5).
 3. Remove hose clamp (6).
 4. Disconnect drain hoses (7) and (8), then disconnect pilot hose (9).
 5. Remove 12 mounting bolts (10) at swing machinery , then lift off swing motor and swing machinery assembly (11).
- ★ When removing the swing motor and swing machinery assembly, be careful not to damage the hoses and lift off slowly.



Swing motor, swing machinery assembly: 225 kg

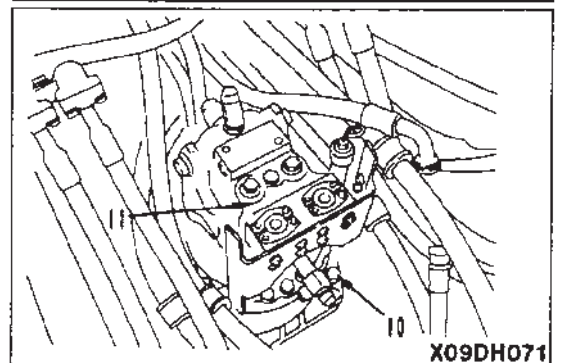
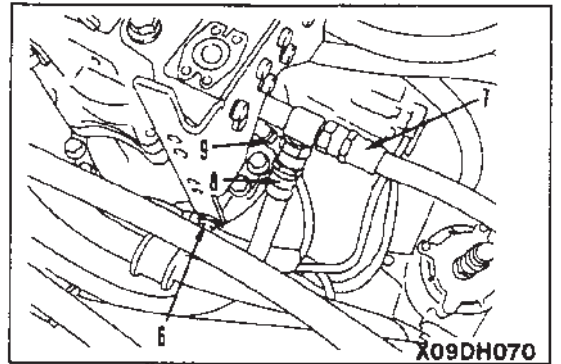
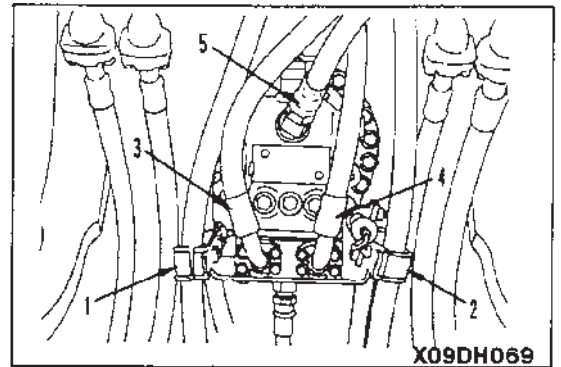

Installation

- Carry out installation in the reverse order to removal.



 Swing machinery mounting bolt: 549 ± 59 Nm (56 ± 6 kgm)

- Refilling with oil (hydraulic tank)
- ★ Add oil through the oil filler to the specified level. Run the engine to circulate the oil through the system. There check the oil level again.
- Bleeding air
- ★ Bleed the air from swing motor. For details, see TESTING AND ADJUSTING, Bleeding air.

Disassembly

1. Loosen drain plug and drain oil from swing machinery case.

 Swing machinery case : Approximately 5.5 ℓ.

2. Swing motor assembly
 - a. Set swing motor and swing machinery assembly to block ①.
 - b. Remove mounting bolts, then remove swing motor assembly (1).
3. Remove No. 1 thrust washer (2).

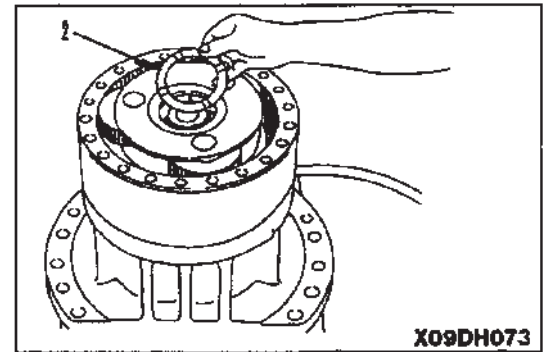
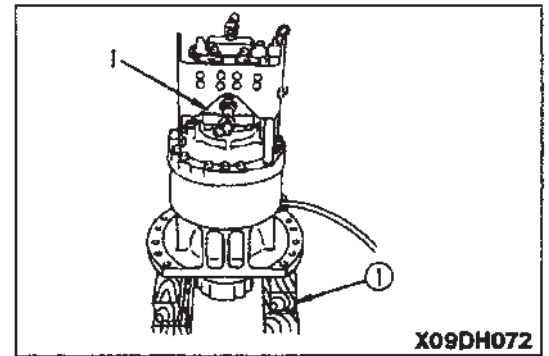

4. Remove No. 1 sun gear (3).

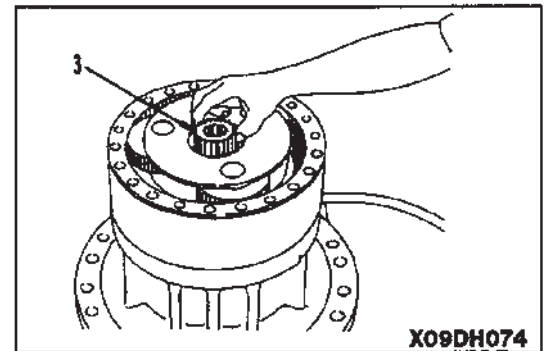

5. No. 1 carrier assembly
 - a. Remove No. 1 carrier assembly (4).

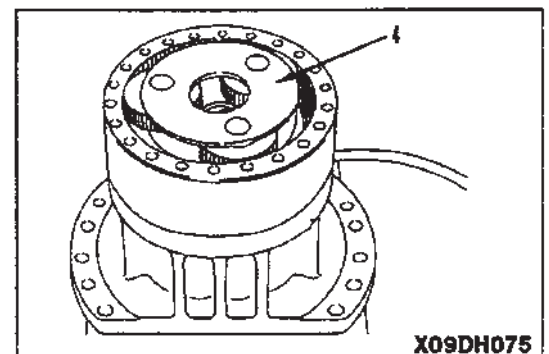

- b. Disassemble No. 1 carrier assembly as follows.
Loosen pin (5), and remove shaft (6), gear (7), bearing (8) and thrust washer (9).

★ After removing shaft (6), remove pin (5) from the shaft.

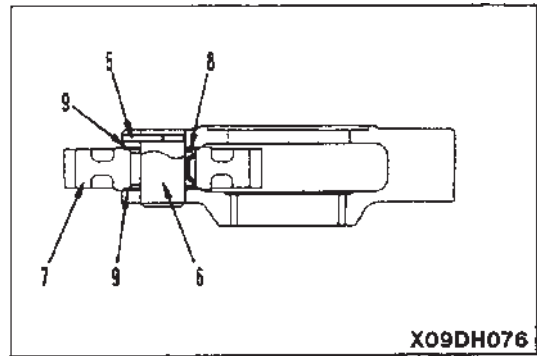

6. Remove ring gear (10).

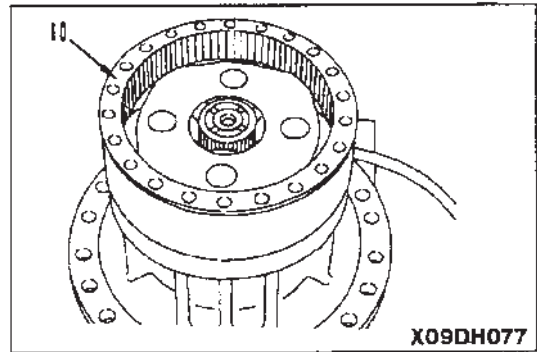

7. Remove No. 2 thrust washer (11).

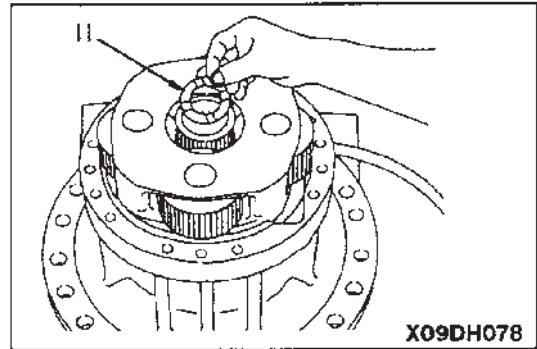

8. Remove No. 2 sun gear (12).

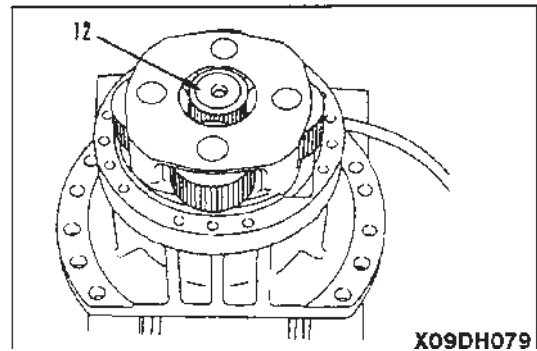

9. Remove holder mounting bolt (13).
10. No. 2 carrier assembly
 - a. Remove No. 1 carrier assembly (14).

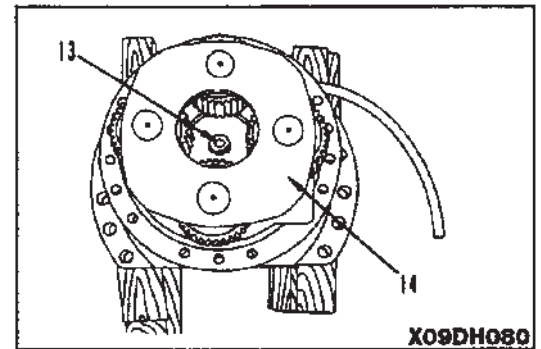

- b. Disassemble No. 2 carrier assembly as follows.
 - i. Push in pin (15), and knock shaft (16) out from carrier (17).
 - ★ After removing the shaft, remove pin (15).
 - ii. Remove thrust washer (18), gear (19), bearing (20), and thrust washer (21).
 - iii. Remove plate (22).

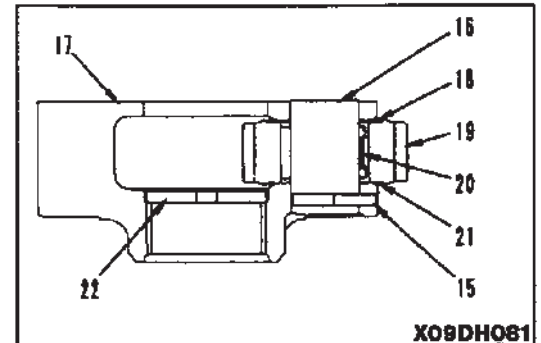

11. Shaft assembly
 - a. Remove mounting bolts (23).
 - b. Set shaft and case assembly to press, then using push tool ②, remove shaft assembly (24) from case assembly (25).

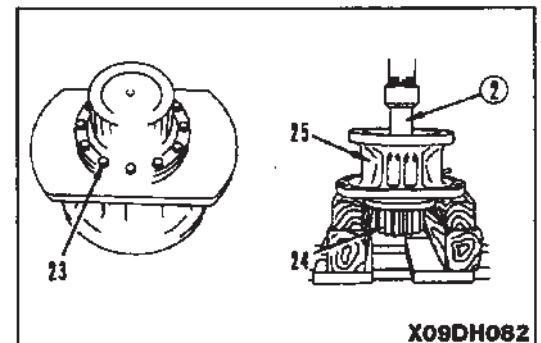

- c. Disassemble shaft assembly as follows.
 - i. Using push tool ③, remove cover assembly (26) and bearing (27) from shaft (28).
 - ii. Remove oil seal (29) from cover (30).

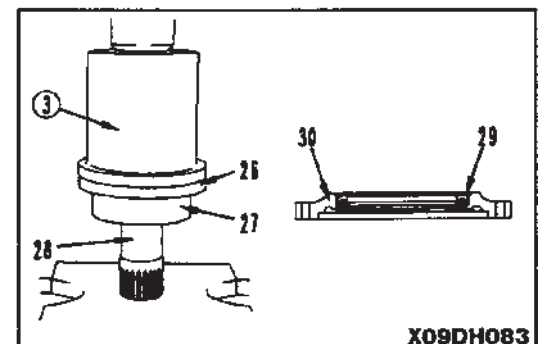

12 Using push tool, remove bearing (31) from case (32).

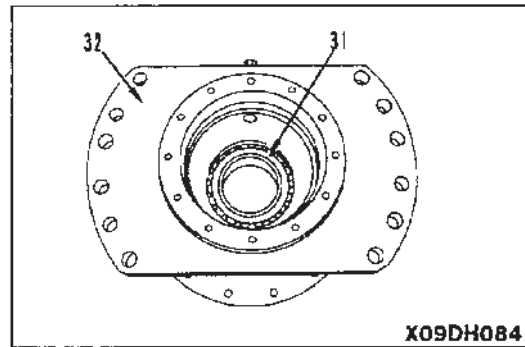

Assembly

★ Clean all parts and check for dirt or damage. Coat the sliding surfaces of all parts with engine oil before installing

1. Using push tool ④, press fit bearing (27) to case (32).

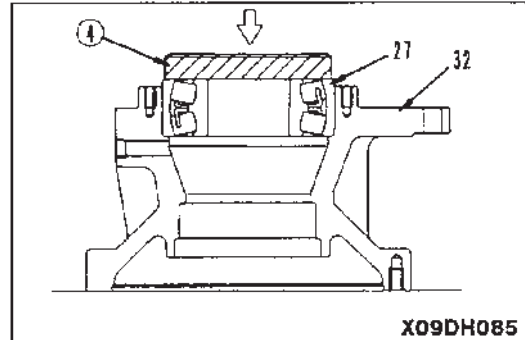

2. Cover assembly

a. Using push tool ⑤, press fit oil seal (29) to cover (30).

 Outside circumference of oil seal: Gasket sealant (LG-6)

★ Be careful not to let the gasket sealant (LG-6) get on the oil seal lip when press fitting

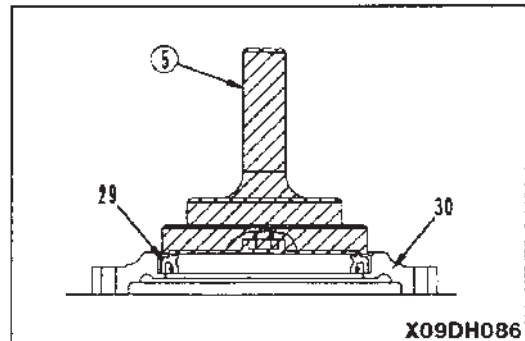

b. Fit cover assembly (26) to case (32), and tighten mounting bolts (23).

 Cover mounting surface: Gasket sealant (LG-6)

 Mounting bolt: 66.2 ± 7.4 Nm (6.75 ± 0.75 kgm)

 Lip of oil seal: Grease (G2-L1)

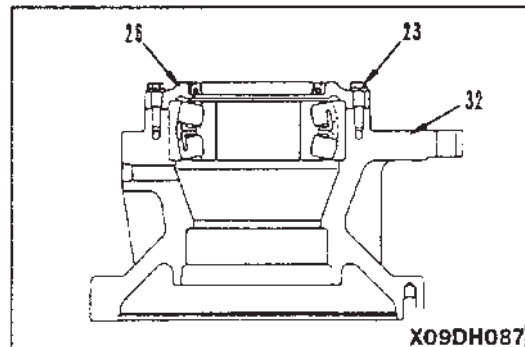

3. Set case assembly (25) to shaft (28), then using push tool ⑥, press fit bearing inner race portion.
- ★ When setting the case assembly to the shaft, be extremely careful not to damage the oil seal.

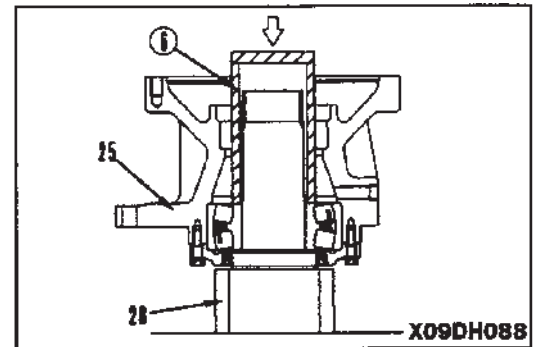

4. Using tool F, press fit bearing (31).
- ★ Press the bearing inner race and outer race at the same time when press fitting. Do not press only the inner race when press fitting.
- ★ After press fitting the bearing, check that the case rotates smoothly.

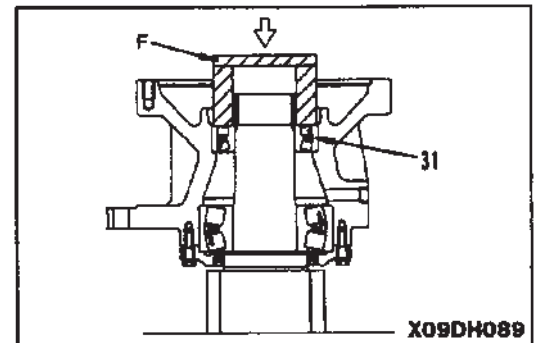

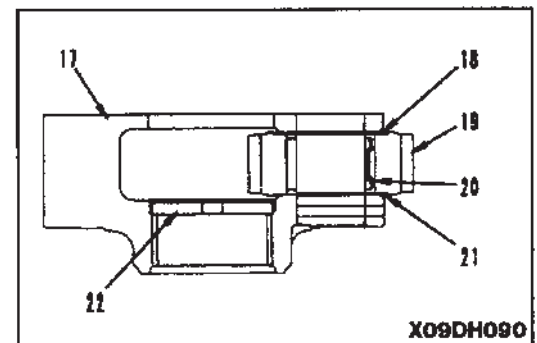

5. No. 2 carrier assembly
 - a. Assemble No.2 carrier assembly as follows.
 - ★ There are the remains of the caulking when the pin is inserted at the end face of hole h at the side of the carrier, so remove the caulked metal from the inside diameter of the hole before starting to assemble.
 - i. Assemble plate (22) to carrier (17).
 - ii. Assemble bearing (20) to gear (19), fit top and bottom thrust washers (18) and (21) and set gear assembly to carrier (17).

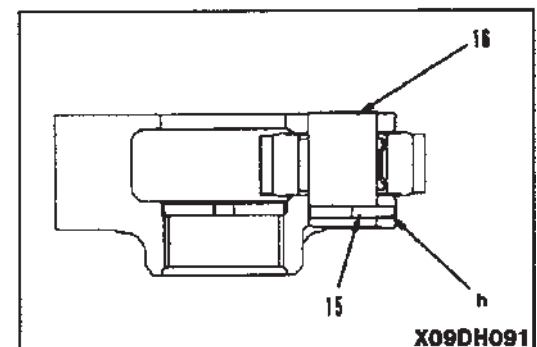

- iii. Align with position of pin holes of shaft and carrier, then tap with a plastic hammer to install shaft (16).
 - ★ When installing the shaft, rotate the planetary gear, and be careful not to damage the thrust washer.
 - iv. Insert pin (15).
 - ★ After inserting the pin, caulk the pin portion of the carrier.



- b. Install No. 2 carrier assembly (14).
- 6. Tighten bolt (13).
-  Mounting bolt: Thread tightener (LT-2)
-  Mounting bolt: 176.5 ± 19.6 Nm (18 ± 2.0 kgm)

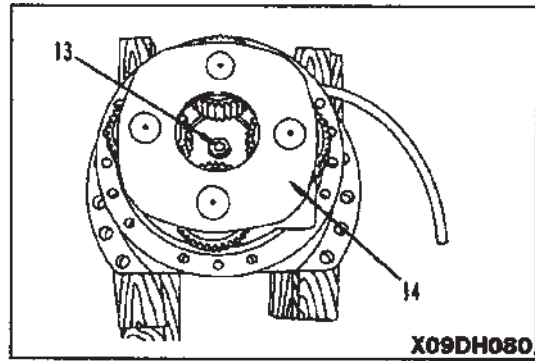

- 7. Install No. 2 sun gear (12).

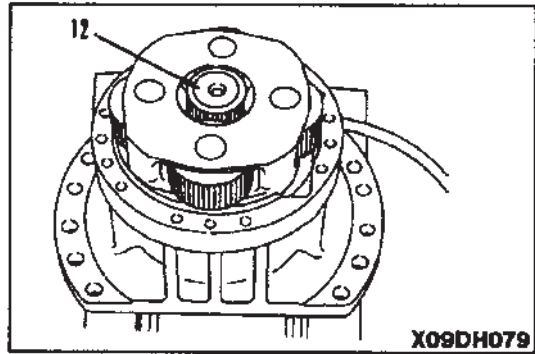

- 8. Install No. 2 thrust washer (11).

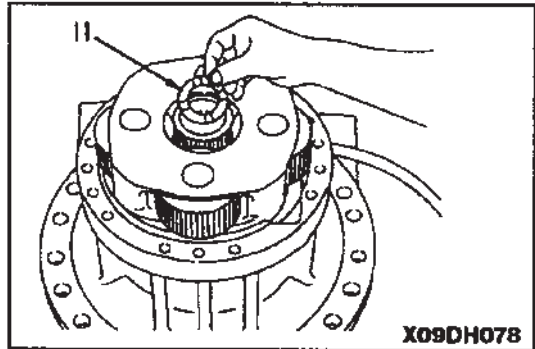

- 9. Instal ring gear (10).
-  Case side mounting surface: Gasket sealant (LG-6)

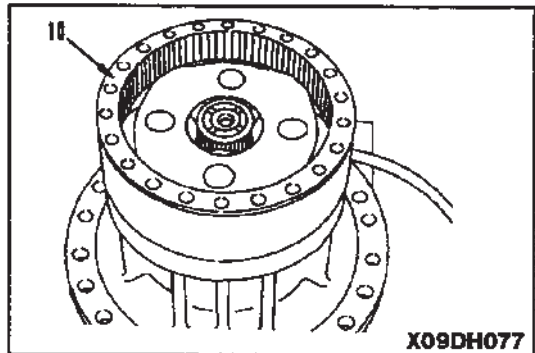

10. No. 1 carrier assembly

a. Assemble No. 1 carrier assembly as follows.

- ★ There are the remains of the caulking at the end face of the carrier side hole k made when inserting the pin, so remove the remains of the caulking on the inside diameter of the hole before starting assembly.

i. Assemble bearing (8) to gear (7), then fit top and bottom thrust washers (9) and set gear assembly to carrier.

ii. Align pin hole position of carrier and shaft, then tap with plastic hammer and install shaft (6).

- ★ Rotate the planet gear when installing the shaft, and be careful not to damage the thrust washer.

iii. Insert pin (5).

- ★ After inserting the pin, caulk the pin portion of the carrier.

iv. Install No. 1 carrier assembly (4).

11. Install No. 1 sun gear (3).

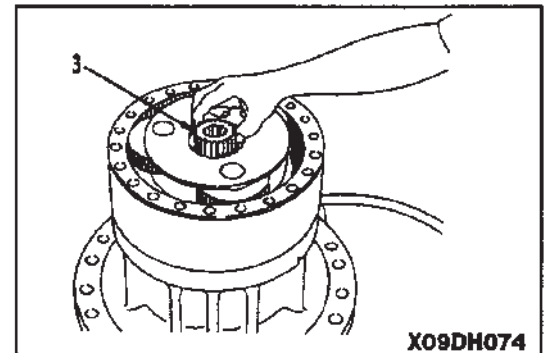
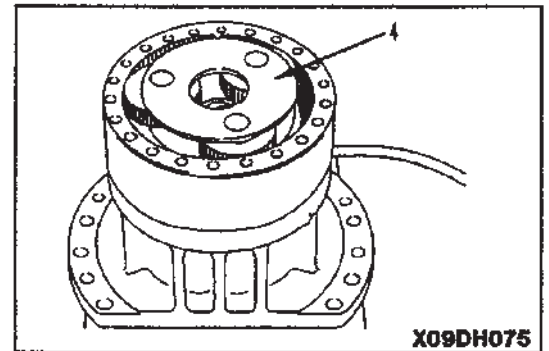
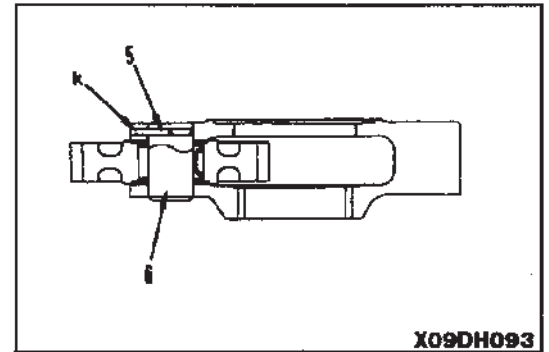
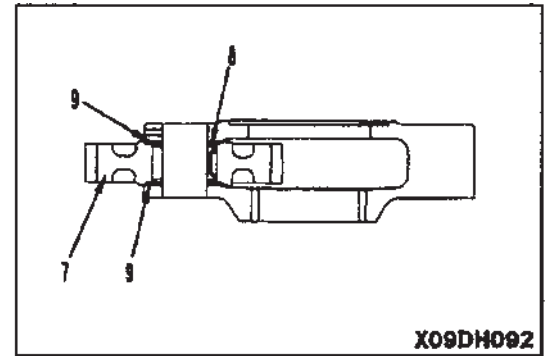

12. Install No. 1 thrust washer (2).

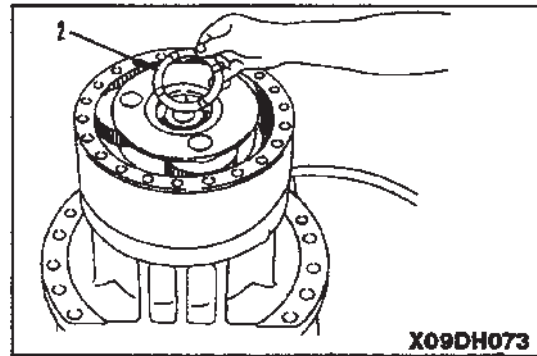

13. Install swing motor assembly (1).

 Ring gear side mounting surface: Gasket sealant (LG-6)

★ Coat the outside diameter of the hole only at the hole in the ring gear where there is a distinguishing protrusion on the case. (See the diagram on the right.)

 Mounting bolt: $176.5 \pm 19.6 \text{ Nm}$ ($18 \pm 2.0 \text{ kgm}$)

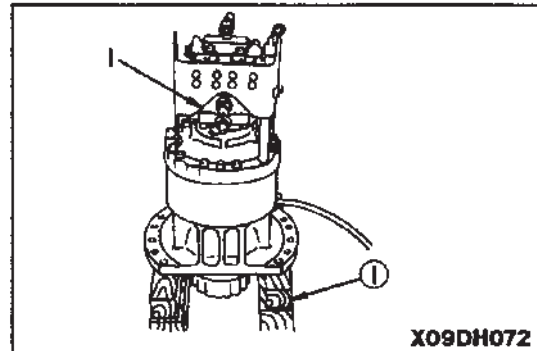

14. Tighten drain plug and add engine oil through oil filler to specified level.

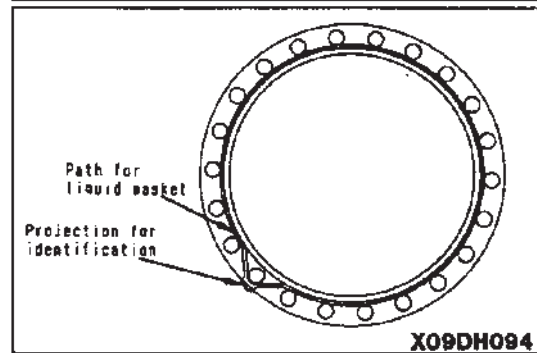



REVOLVING FRAME

Removal

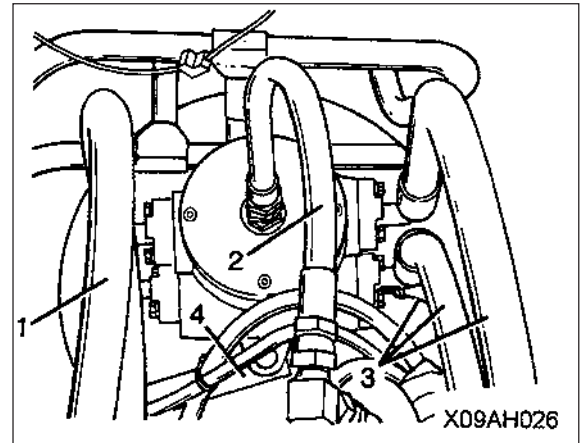
1. Remove 2 boom cylinder assemblies. For details, see BOOM CYLINDER ASSEMBLY, Removal.
2. Remove work equipment assembly. For details, see WORK EQUIPMENT, Removal.
3. Remove counterweight assembly. For details, see COUNTERWEIGHT, Removal.
4. Disconnect top mounting hoses (1), (2) and (3) of swivel joint assembly at swivel joint assembly end.
5. Remove stopper link (4).



6. Remove mounting bolts, then lift off revolving frame  assembly (5).
 - ★ Leave 2 bolts 1* each at the front and rear, use a lever block to adjust the balance of the revolving frame assembly to the front and rear, and left and right, then remove the remaining bolts, and lift off.

 When removing the revolving frame assembly, be careful not to hit the center swivel joint assembly.

 Revolving frame assembly: 6.300 kg.

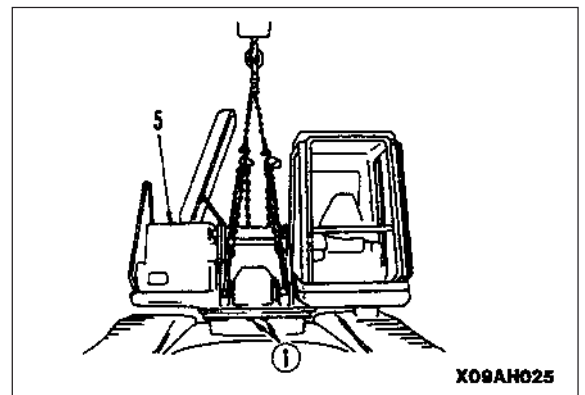

Installation

- Carry out installation in the reverse order to removal.



Mating surface of swing circle: Gasket sealant (LG-1)



Thread of revolving frame mounting bolt: Thread tightener (LT-2)



Revolving frame mounting bolt:

Mounting bolt		Mounting bolt Tightening torque
Size (mm)	Q'ty	Nm (kgm)
24 x 135	35	927 ± 103 (94.0 ± 10.5)

- Refilling with oil (hydraulic tank)
- ★ Add oil through the oil filler to the specified level. Run the engine to circulate the oil through the system. There check the oil level again.
- Bleeding air
- ★ Bleed the air from swing motor. For details, see TESTING AND ADJUSTING

REMOVAL OF SWING CIRCLE ASSEMBLY

1. Remove revolving frame assembly. For details, see REMOVAL OF REVOLVING FRAME ASSEMBLY.
2. Sling swing circle assembly (1) at three points, then remove mounting bolts, and lift off swing circle assembly.

 Swing circle assembly: **500 kg**

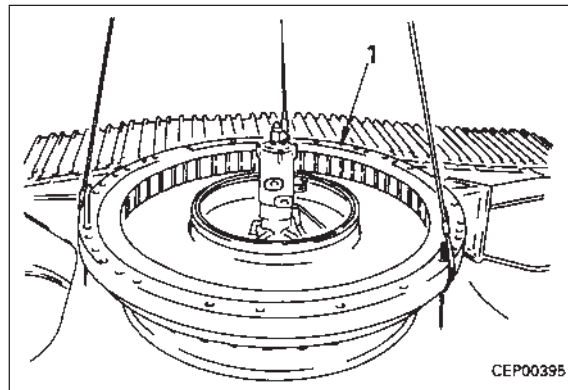

INSTALLATION OF SWING CIRCLE ASSEMBLY

- Carry out installation in the reverse order to removal.

 1

 Thread of swing circle mounting bolt:
Thread tightener (LT-2)

 Swing circle mounting bolt:
926.7 ± 103.0 Nm (94.5 ± 10.5 kgm)

- ★ Set the soft zone **S** mark on the inside ring of the inner race facing the right side of the machine as shown in the diagram, then install to the track frame.

 Swing circle: **Grease (G2-LI) 33 l**

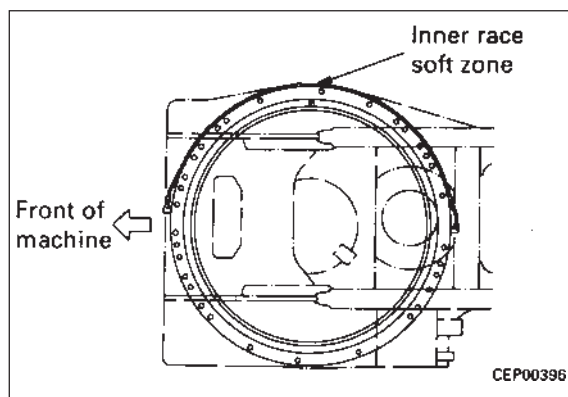

REMOVAL OF IDLER, RECOIL SPRING ASSEMBLY

1. Remove track shoe assembly.
For details, see REMOVAL OF TRACK SHOE ASSEMBLY.
★ Remove lubricator (1).

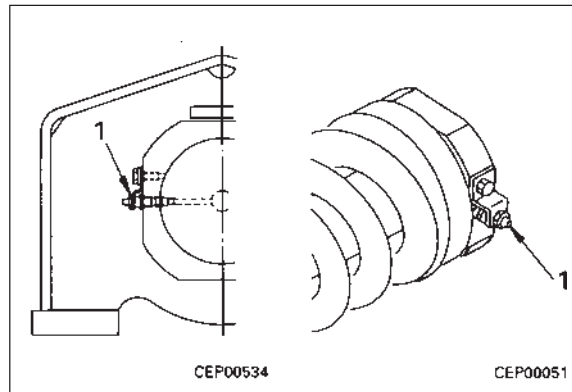

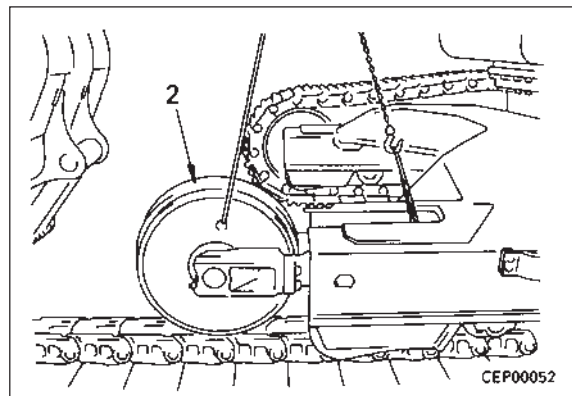

2. Sling idler and recoil spring assembly (2), and pull out to the front to remove.
★ Fit wire to the idler and spring of the idler and recoil spring assembly, and adjust the balance when removing.

 Idler, recoil spring assembly: **430 kg**



3. Disconnect recoil spring assembly (4) from idler assembly (3).

 Idler assembly: **170 kg**

 Recoil spring assembly: **260 kg**

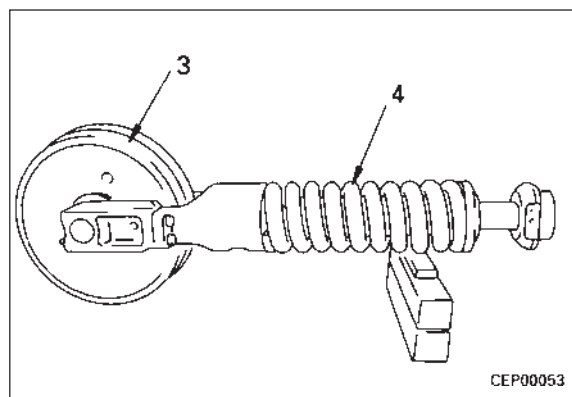

INSTALLATION OF IDLER, RECOIL SPRING ASSEMBLY

- Carry out installation in the reverse order to removal.

 I

- ★ When installing the idler assembly and recoil spring assembly, assemble so that the position of the greasing plug on the idler is on the outside for the right side of the machine and on the inside for the left side of the machine.

DISASSEMBLY OF RECOIL SPRING ASSEMBLY

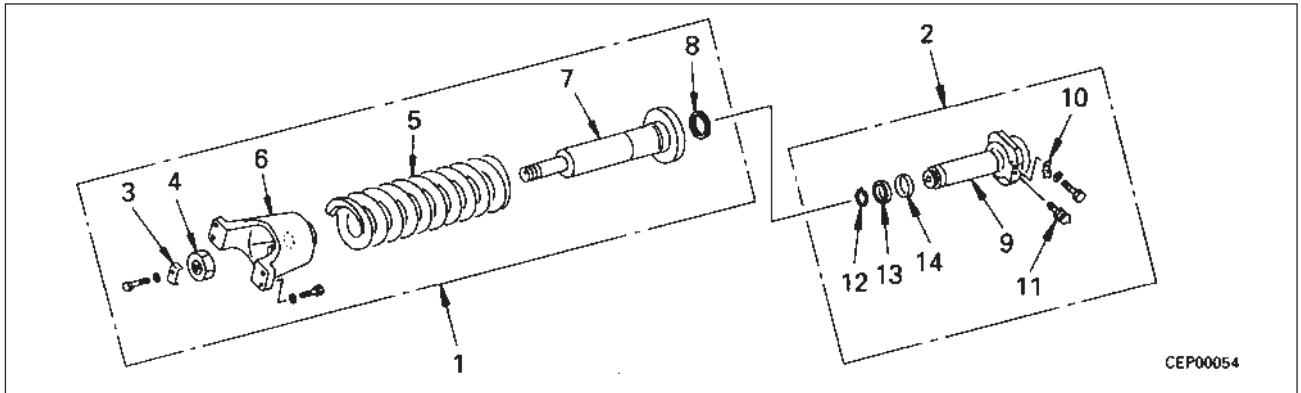

CEP00054

1. Remove piston assembly (2) from recoil spring assembly (1).

2. Disassembly of recoil spring assembly

- 1) Set tool to recoil spring assembly (1).

⚠ The recoil spring is under large installed load, so be sure to set the tool properly. Failure to do this is dangerous.

- ★ Installed load of spring:

173.3 kN (17,680 kg)

- 2) Apply hydraulic pressure slowly to compress spring, then remove lock plate (3), and remove nut (4).

- ★ Compress the spring to a point where the nut becomes loose.

- ★ Free length of spring: 795 mm

- 3) Remove yoke (6), cylinder (7), and dust seal (8) from spring (5).

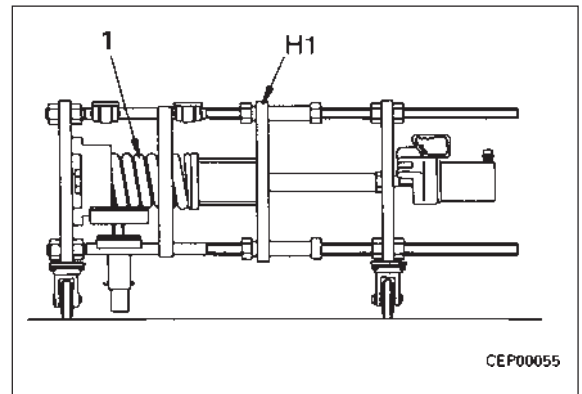

CEP00055

4. Disassembly of piston assembly

- 1) Remove lock plate (10) from piston (9), then remove valve (11).
- 2) Remove snap ring (12), then remove U-packing (13) and ring (14).

ASSEMBLY OF RECOIL SPRING ASSEMBLY

1. Assembly of piston assembly

- 1) Assemble ring (14) and U-packing (13) to piston (9), and secure with snap ring (12).
- 2) Tighten valve (11) temporarily, and secure with lock plate (10).

2. Assembly of recoil spring assembly

- 1) Using tool **H2**, assemble dust seal (8) to cylinder (7).
- 2) Assemble cylinder (7) and yoke (6) to spring (5), and set in tool H1.

 Sliding portion of cylinder:

Grease (G2-LI)

- 3) Apply hydraulic pressure slowly to compress spring, and tighten nut (4) so that installed length of spring is dimension "a", then secure with lock plate (3)
 - ★ Installed length "a" of spring: 648 mm
- 4) Remove recoil spring assembly (1) from tool **H1**.

3. Assemble piston assembly (2) to recoil spring assembly (1).

 Piston sliding portion and wear ring:

Grease (G2-LI)

- ★ Assemble the cylinder assembly so that the mounting position of the valve is 90° to the side.
- ★ Fill the inside of the cylinder with approx. 200 cc of grease (G2-LI), then bleed the air and check that grease comes out of the grease hole.

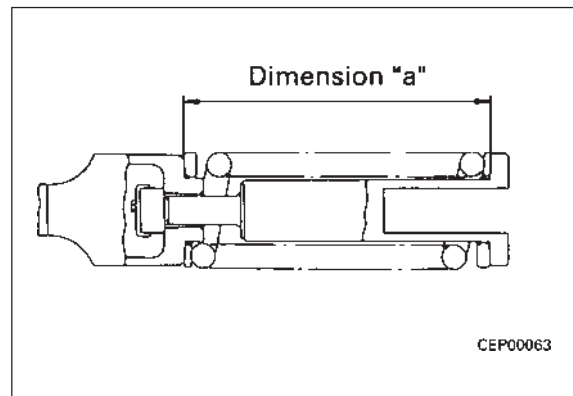
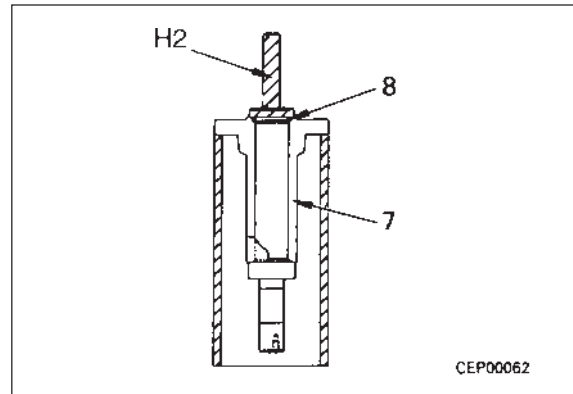

DISASSEMBLY OF IDLER ASSEMBLY

1. Remove pin (2), then remove support (3).
2. Remove floating seal (4) from support (3) and idler (5).
3. Pull out shaft and support assembly (6) from idler (5).
 - ★ It is filled with approx. 230 cc. of oil, so drain the oil at this point or lay a cloth to prevent the area from becoming dirty.

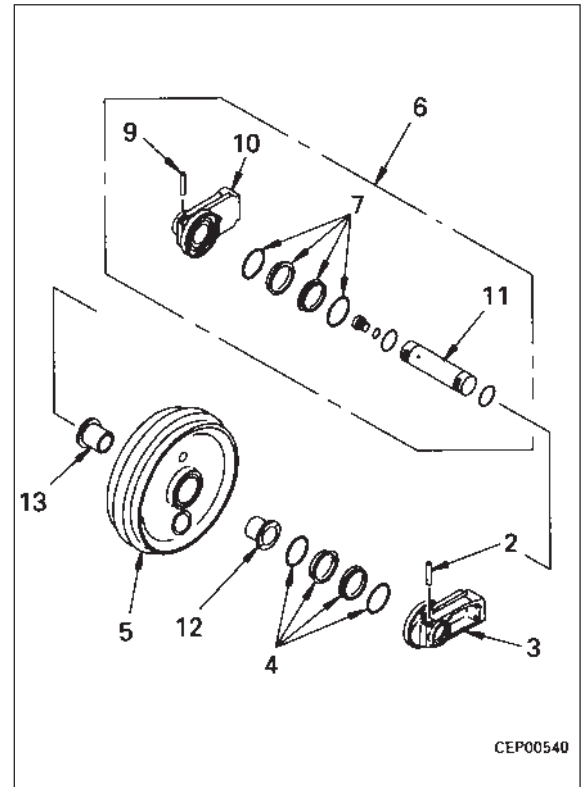

4. Remove floating seal (7) on opposite side from idler (5) and shaft and support assembly (6).

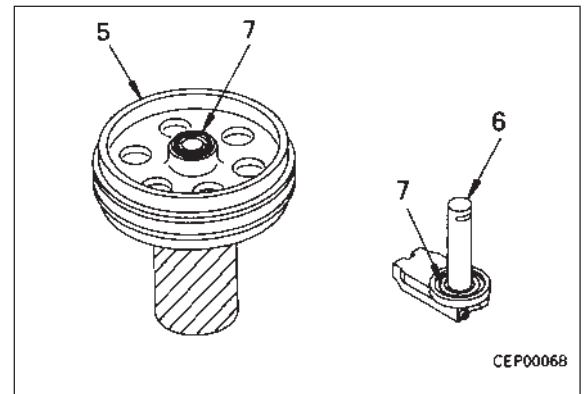

5. Remove pin (9), then remove support (10) from shaft (11).
6. Remove bushing (12) from idler (5).

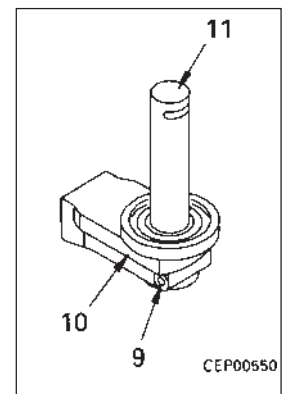
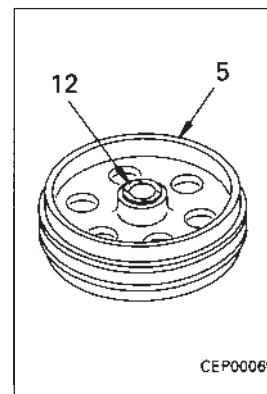

DISASSEMBLY OF IDLER ASSEMBLY

1. Remove pin (2), then remove support (3).
2. Remove floating seal (4) from support (3) and idler (5).
3. Pull out shaft and support assembly (6) from idler (5).
 - ★ It is filled with approx. 230 cc. of oil, so drain the oil at this point or lay a cloth to prevent the area from becoming dirty.

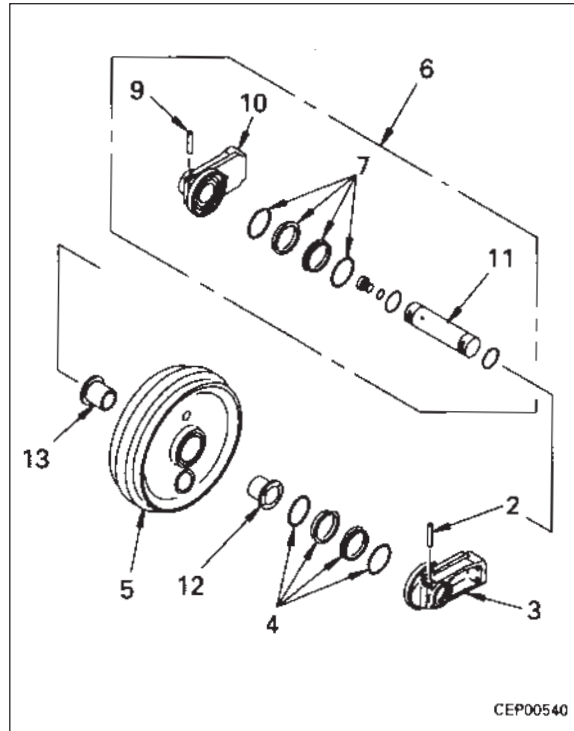

4. Remove floating seal (7) on opposite side from idler (5) and shaft and support assembly (6).

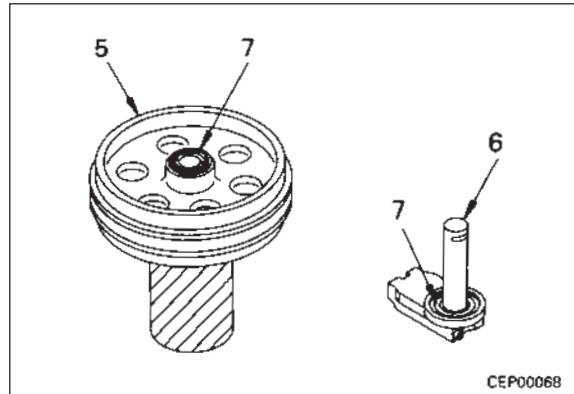

5. Remove pin (9), then remove support (10) from shaft (11).
6. Remove bushing (12) from idler (5).

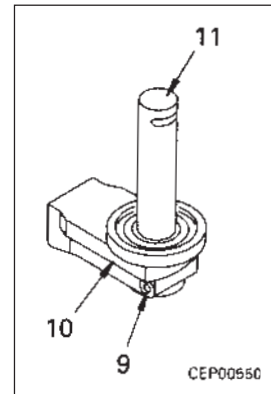
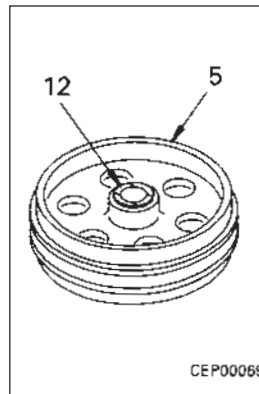

ASSEMBLY OF IDLER ASSEMBLY

1. Press fit bushing (12) to idler (5).
2. Fit O-ring and install support (10) to shaft (11), then install pin (9).
 - ★ After inserting the pin, caulk the pin portion of the support.
3. Using tool **J1**, install floating seal (7) to idler (5) and shaft and support assembly (6).
 - ★ Coat the sliding surface of the floating seal with oil, and be careful not to let any dirt or dust get stuck to it.
 - ★ Remove all grease and oil from the contact surface of the O-ring and the floating seal.

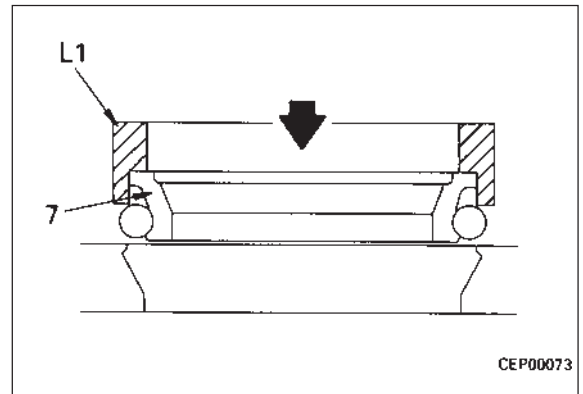
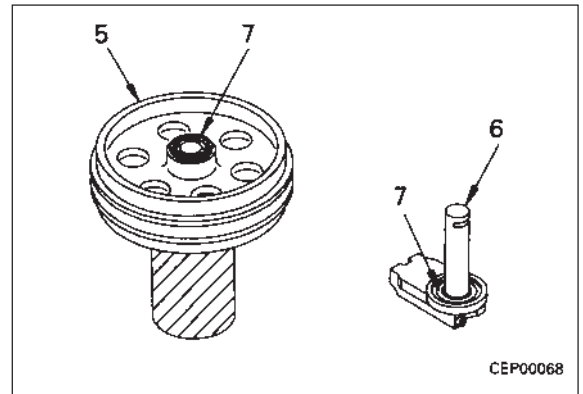
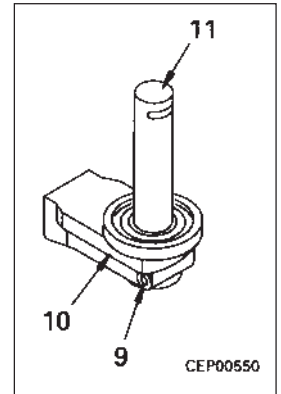
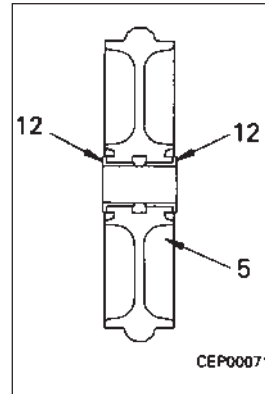

4. Assemble shaft and support assembly (6) to idler (5).

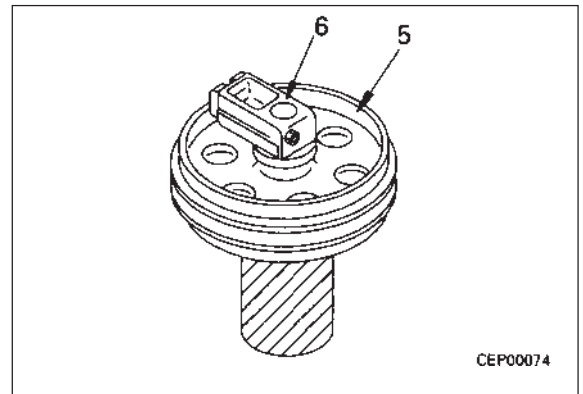

5. Using tool **J1** install floating seal (4) to idler (5) and support (3).
 - ★ Coat the sliding surface of the floating seal with oil, and be careful not to let any dirt or dust get stuck to it.
 - ★ Remove all grease and oil from the contact surface of the 0-ring and the floating seal.

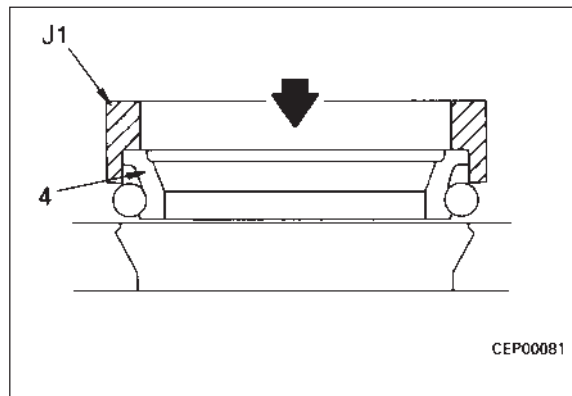
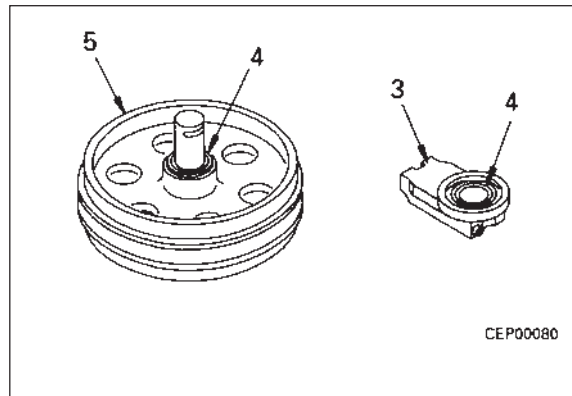

6. Install 0-ring, then assemble support (3) and install pin (2).
 - ★ After inserting the pin, caulk the pin portion of the support.

7. Add oil and tighten plug.

Oil: Approx. **230 cc** (E030-CD)

Plug: **152.0 ± 24.5 Nm (15.5 ± 2.5 kgm)**

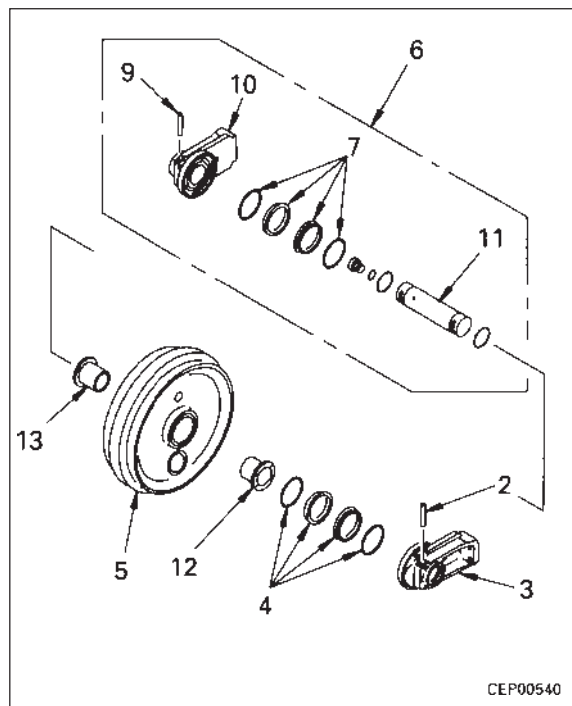

REMOVAL OF TRACK ROLLER ASSEMBLY

1. Lower work equipment to ground, then loosen lubricator (1), and relieve track tension. * 1

 The adjustment cylinder is under extremely high pressure, so never loosen the lubricator more than one turn. If the grease does not come out easily, move the machine backwards and forwards.

2. Remove mounting bolts of track roller guard (2), then swing work equipment 90°, jack up machine with work equipment, and remove track roller guard (2) towards outside of machine. * 2

 Track roller guard: **35 kg**

3. Lower chassis completely, remove mounting bolts of track roller assembly (3), then jack up machine with work equipment, and remove track roller assembly (3) to outside of machine. * 3

 Track roller assembly: **55 kg**

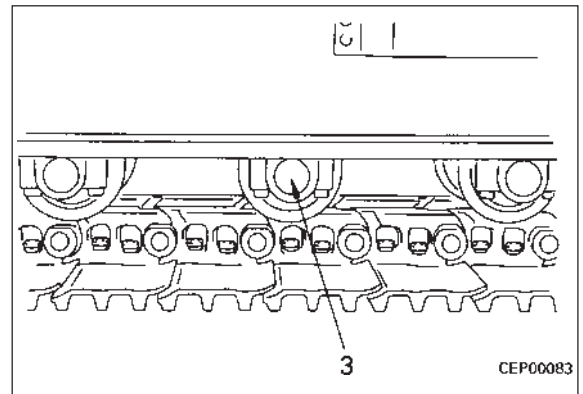
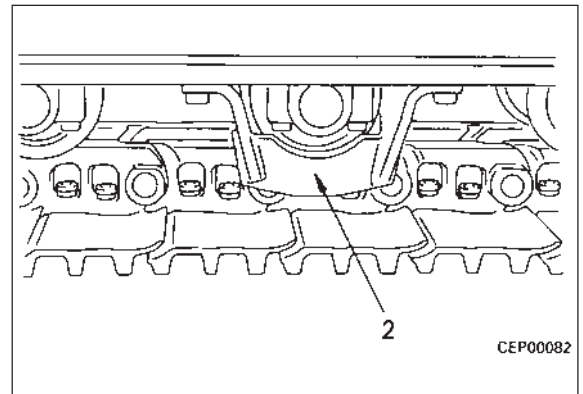
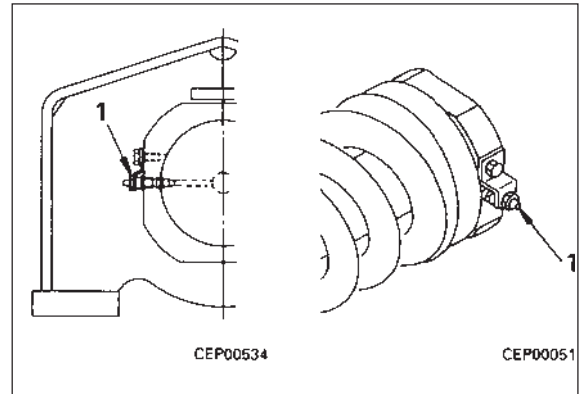

INSTALLATION OF TRACK ROLLER ASSEMBLY

- Carry out installation in the reverse order to removal.

* 1

★ Adjust the track tension. For details, see TESTING AND ADJUSTING, Testing and adjusting track tension.

* 2

 Roller guard mounting bolt:
Thread tightener (LT-2)

 Roller guard mounting bolt:
926.7 ± 103.0 Nm (94.5 ± 10.5 kgm)

* 3

 Track roller mounting bolt:
Thread tightener (LT-2)

 Track roller mounting bolt:
1st pass: **196.1 ± 19.6 Nm (20 ± 2 kgm)**
2nd pass:
Tighten an additional 105 ± 5°

DISASSEMBLY OF TRACK ROLLER ASSEMBLY

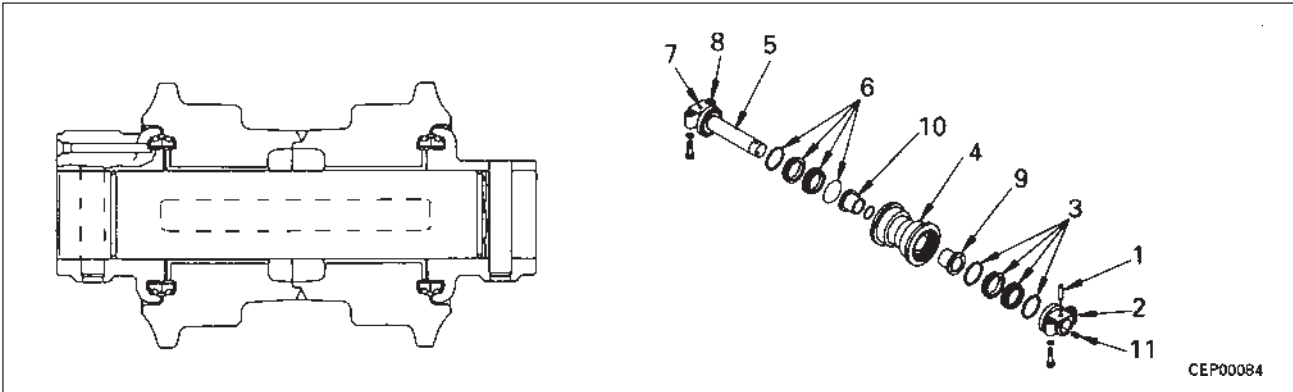

1. Remove pin (1), then remove collar (2).
2. Remove floating seal (3) from collar (2) and roller (4).
3. Pull out roller (4) from shaft (5).
 - ★ It is filled with 250 - 280 cc. of oil, so drain the oil at this point or lay a cloth to prevent the area from becoming dirty.

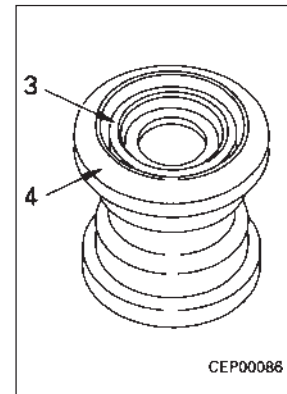
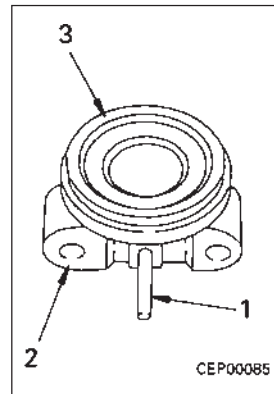

4. Remove floating seal (6) on opposite side from roller (4) and collar (8).

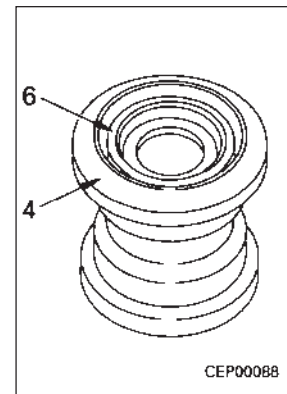
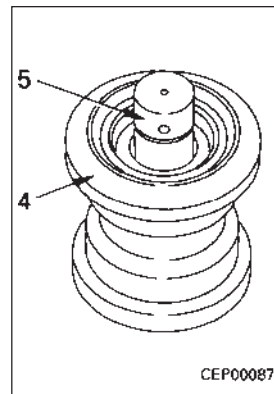

5. Remove pin (7), then remove collar (8) from shaft (5).
6. Remove bushings (9) and (10) from roller (4).

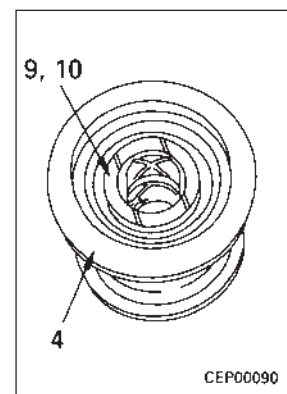
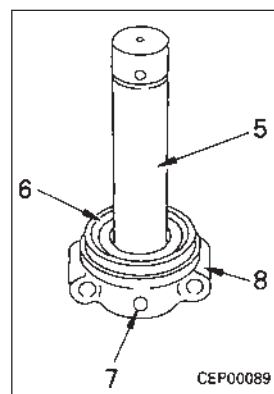

ASSEMBLY OF TRACK ROLLER ASSEMBLY

1. Using push tool ①, press fit bushings (9) and (10) to roller (4).
2. Assemble collar (8) to shaft (5), and install pin (7).
3. Using tool **M1**, install floating seal (6) to shaft (5).
 - ★ When assembling the floating seal, clean the contact surface of O-ring (6c) and floating seal (6a), remove all grease and oil, and dry it. Make sure that no dirt or dust sticks to the contact surface of the floating seal.
 - ★ After inserting the floating seal, check that the angle of the seal is less than 1 mm and that the protrusion of the seal is within a range of 5 - 7 mm.

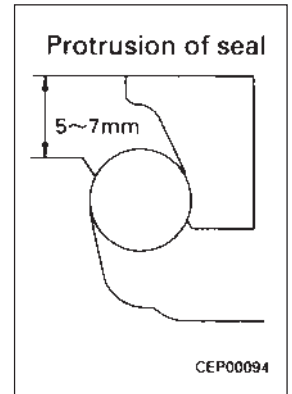
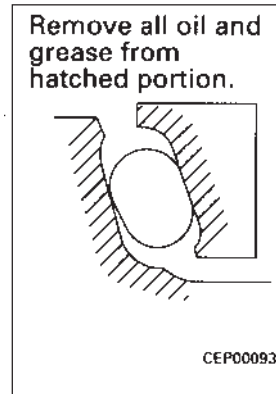
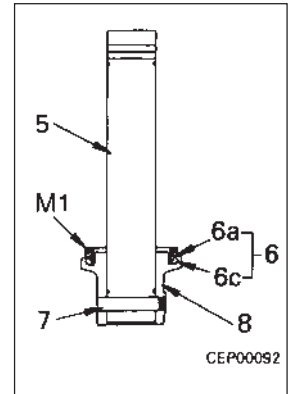
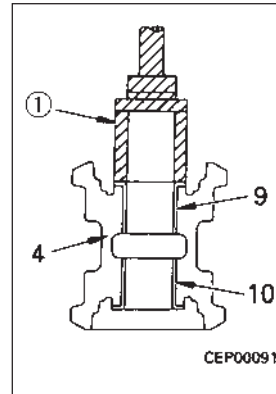

4. Using tool **M1**, install floating seals (6) and (3) to roller (4).
 - ★ For details of the precautions when installing floating seals (6b) and (6d), and (3b) and (3d), see the precautions marked ★ for Step 3.
5. Assemble shaft (5) to roller (4).

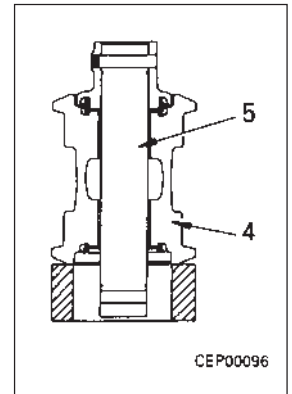
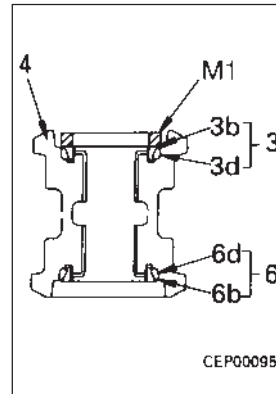

6. Turn over roller (4) and shaft (5) assembly.
7. Using tool **M1**, install floating seal (3) to collar (2).
 - ★ For details of the precautions when installing floating seals (3a) and (3c), see the precautions marked ★ for Step 3.

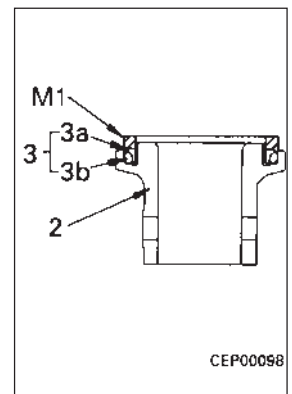
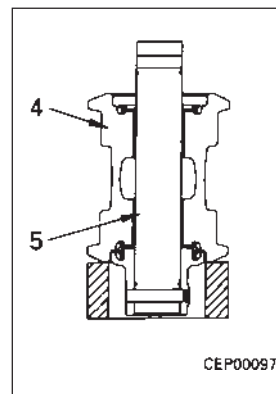

8. Assemble collar (2) to shaft (5), and install pin (1).

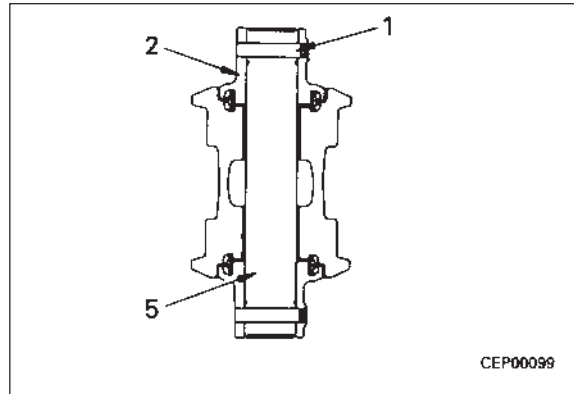

9. Using tool **M2** apply standard pressure to roller oil filler port, and check for leakage of air from seal.

- ★ Standard pressure: 0.1 MPa (1 kg/cm²)
- ★ Method of checking

The standard pressure shall be maintained for 10 seconds and the indicator of the gauge shall not go down.

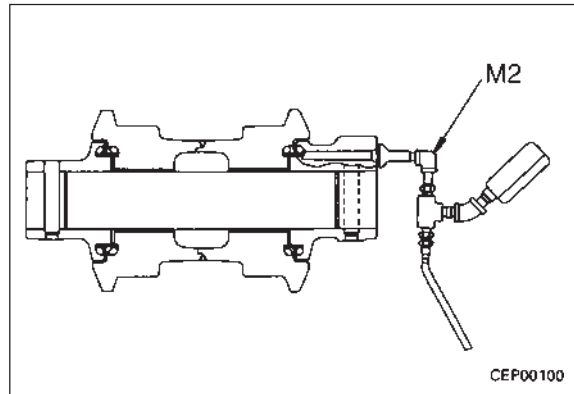

10. Using tool **M2** fill track roller assembly with oil, then tighten plug (11).

 Track roller oil: **250 - 280 cc (E030-CD)**

 Plug: **14.7 ± 4.9 Nm (1.5 ± 0.5 kgm)**

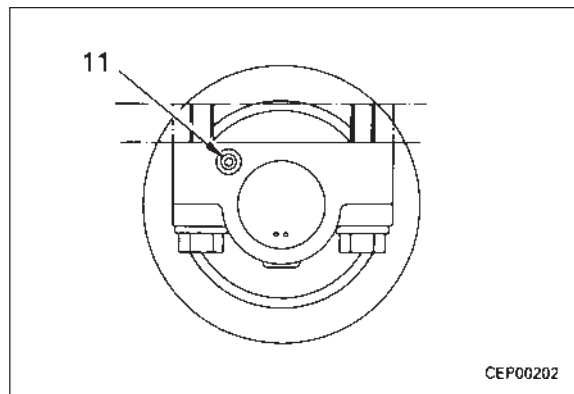
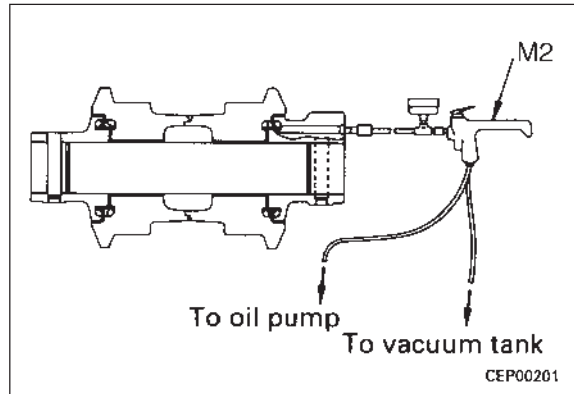

REMOVAL OF CARRIER ROLLER ASSEMBLY

1. Lower work equipment to ground, then loosen lubricator (1), and relieve track tension. * 1

 The adjustment cylinder is under extremely high pressure, so never loosen the lubricator more than one turn. If the grease does not come out, move the machine backwards and forwards.

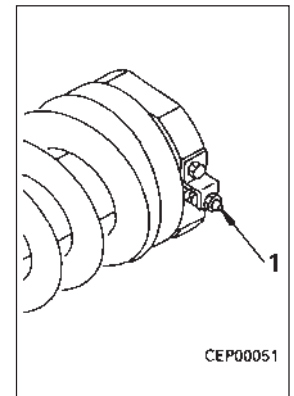
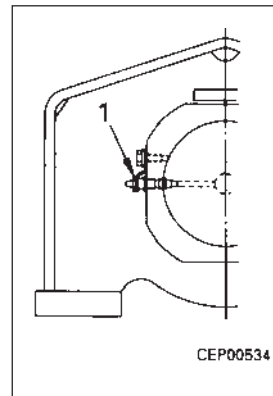

2. Using hydraulic jacks ① push up track to a position where carrier roller assembly can be removed, then remove carrier roller assembly (2). * 2

 Carrier roller assembly: **35 kg**

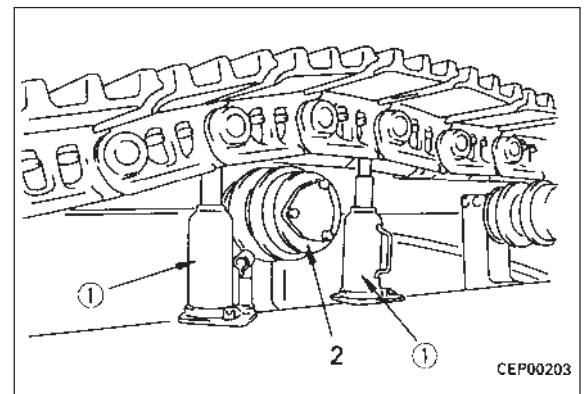

INSTALLATION OF CARRIER ROLLER ASSEMBLY

- Carry out installation in the reverse order to removal.

* 1

- ★ Adjust the track tension. For details, see TESTING AND ADJUSTING, Testing and adjusting track tension.

DISASSEMBLY OF CARRIER ROLLER ASSEMBLY

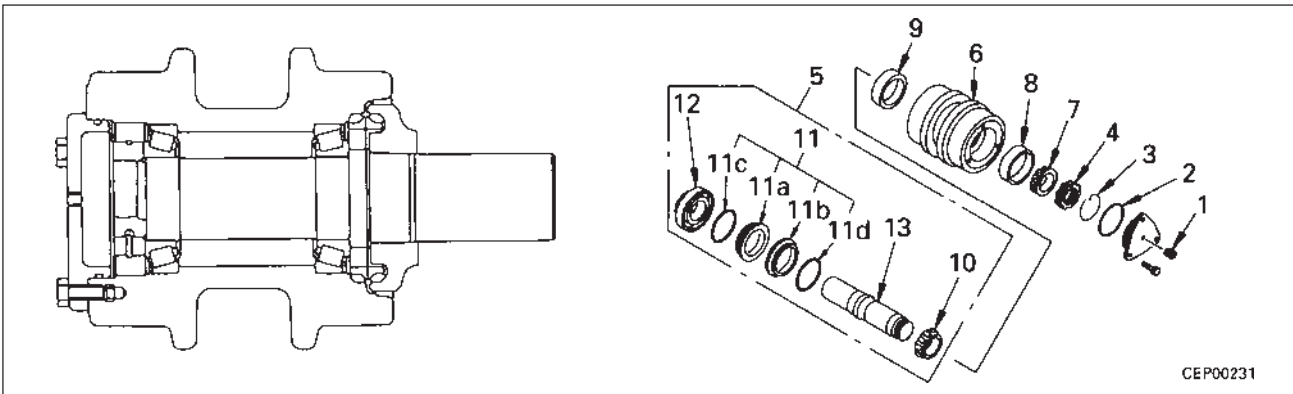

1. Remove plug (1) and drain oil.



Carrier roller assembly: **450-500 cc**

2. Set carrier roller assembly on stand ①.
3. Remove cover (2).
4. Remove ring (3).
5. Using tool L1, remove nut (4).
6. Using push tool ②, pull out shaft assembly (5) from roller (6) with press, then remove inner race (7).

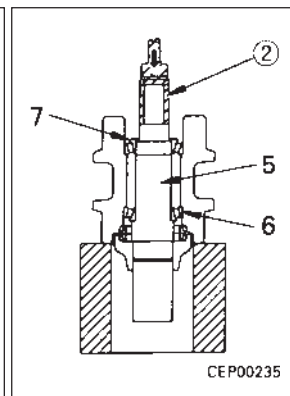
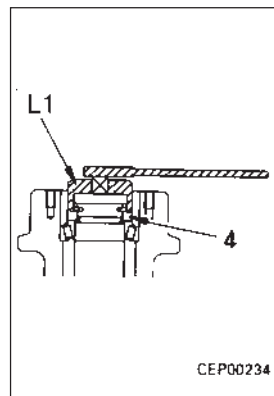
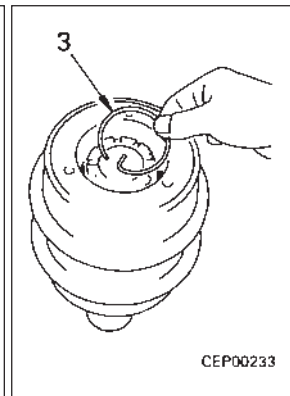
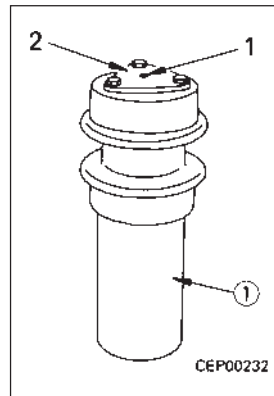

7. Remove outer races (8) and (9) from roller (6).
8. **Disassembly of shaft assembly.**
 - 1) Using puller ③, remove inner race (10).

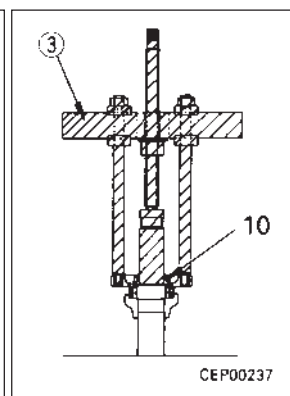
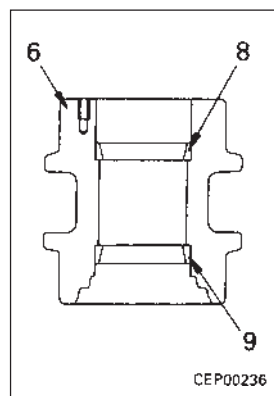

- 2) Remove floating seals (11).
- 3) Using push tool ④, remove collar (12) from shaft (13)

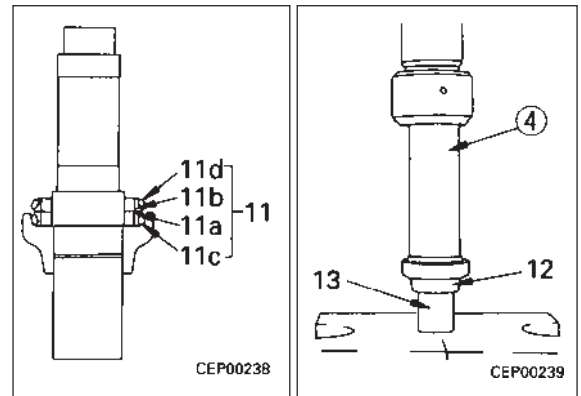

ASSEMBLY OF CARRIER ROLLER ASSEMBLY

1. Using push tool ⑤, press fit outer races (8) and (9) to roller (6).

2. Assembly of shaft assembly.

1) Using tool L3, press fit collar (12) to shaft (13).
★ When press fitting, be careful that there is no scuffing.

 Fitting portion of shaft:

Engine oil (E030-CD)

2) Using tool L2, assemble floating seals (11).

★ When assembling the floating seal, clean the contact surface of O-ring (11c) and floating seal (11a), remove all grease and oil, and dry it. Make sure that no dirt or dust sticks to the contact surface of the floating seal.

★ After inserting the floating seal, check that the angle of the seal is less than 1 mm and that the protrusion of the seal is within a range of 5 - 7 mm.

3) Assemble floating seals (11), then using push tool ⑥, press fit inner race (10).

★ For details of the precautions when installing floating seals (11b) and (11d), see the precautions marked ★ for Step 2).

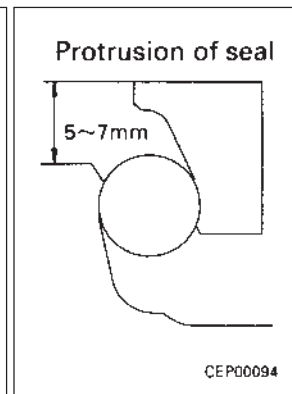
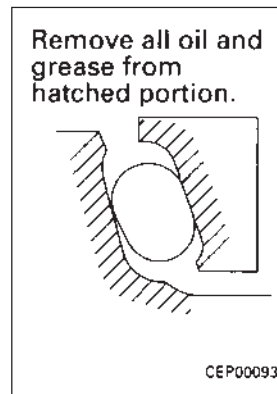
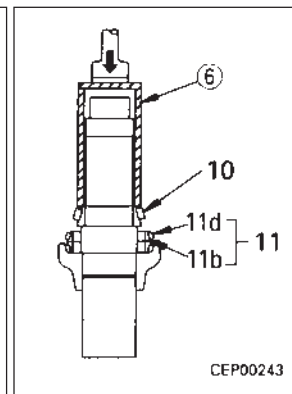
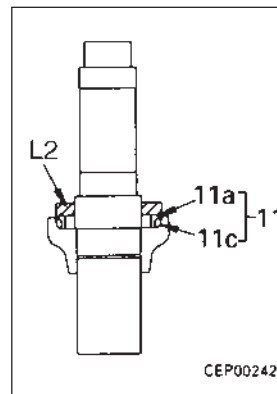
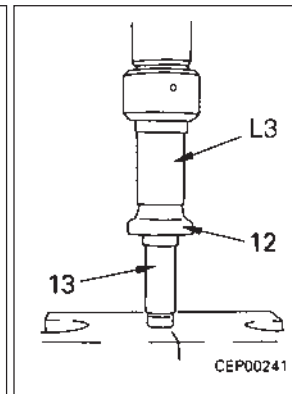
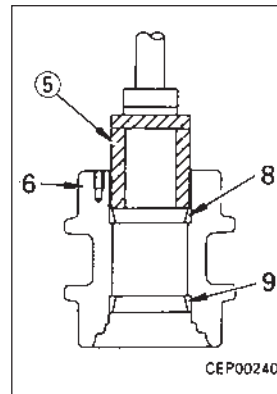

3. Assemble roller (6) to shaft assembly (5).

4. Using push tool 07, press fit inner race (7).

★ When press fitting the bearing, rotate the roller, and press fit to a point where the rotation becomes slightly heavier.

5. Using tool L1 tighten nut (4) to a point where drill hole in shaft is aligned with drill hole in nut.

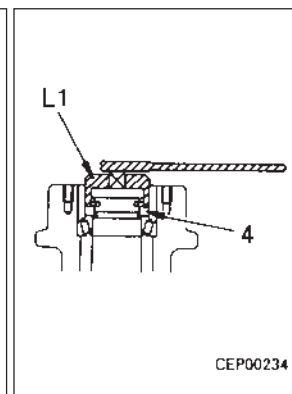
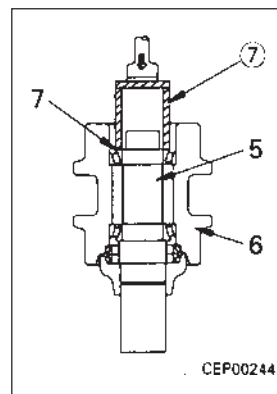

6. Install ring (3).
7. Using push-pull scale (8), check that roller rotates smoothly.

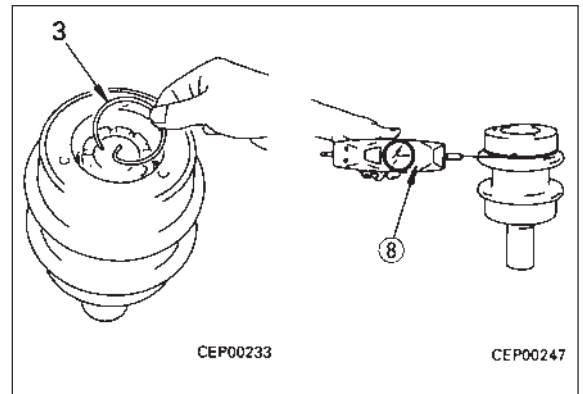

8. Fit O-ring and install cover (2).

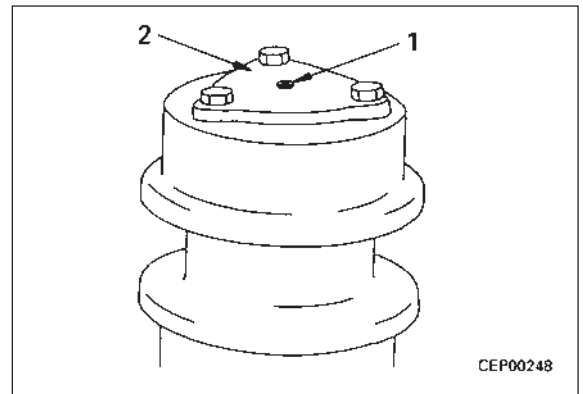

9. Using tool L4, apply standard pressure to roller oil filler port, and check for leakage of air from seal.
 - ★ Standard pressure: 0.1 MPa (1 kg/cm²)
 - ★ Method of checking The standard pressure shall be maintained for 10 seconds and the indicator of the gauge shall not go down.

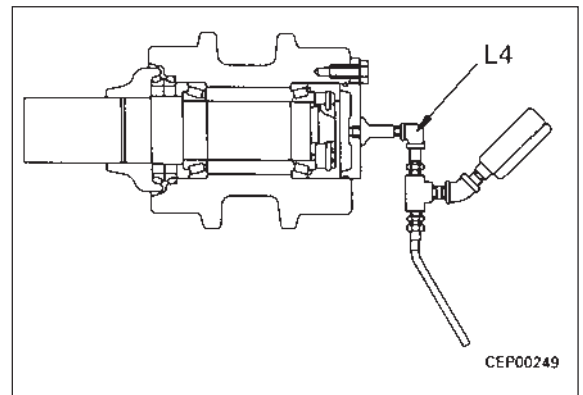

10. Using tool L4 fill carrier roller assembly with oil, then tighten plug (1).

 Carrier roller oil: **450 - 500 cc (E030-CD)**

 Plug: **14.7 + 4.9 Nm (1.5 + 0.5 kgm)**

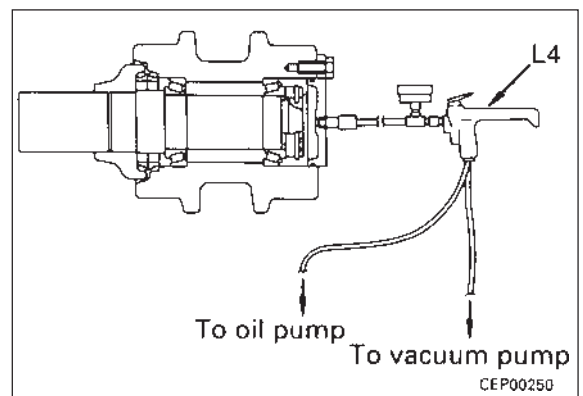

REMOVAL OF TRACK SHOE ASSEMBLY

1. Positioning track shoe

- ★ Stop the machine at a point where it is easy to set master pin removal tool **I** and where master pin is in the middle of the track frame, then loosen lubricator (1), and relieve the track tension. ※ 1

 The adjustment cylinder is under extremely high pressure, so never loosen the lubricator more than one turn. If the grease does not come out, move the machine backwards and forwards.

- 2. Using tool **I** pull out master pin (2). ※ 2

- 3. Lay out track as follows.

- 1) Move machine forward so that position of temporary pin is at front of idler, set block ① in position, then remove temporary pin ②, and remove dust seal. ※ 3
- 2) Drive machine in reverse to lay out track.

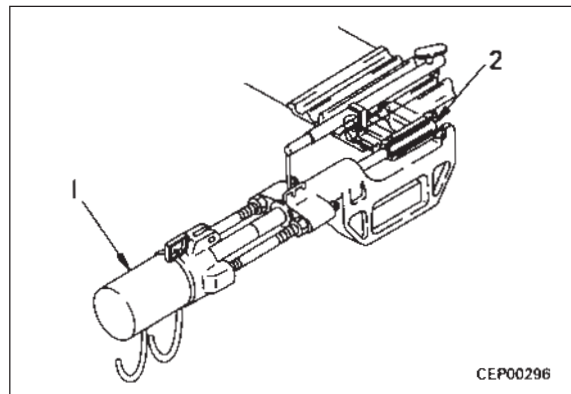
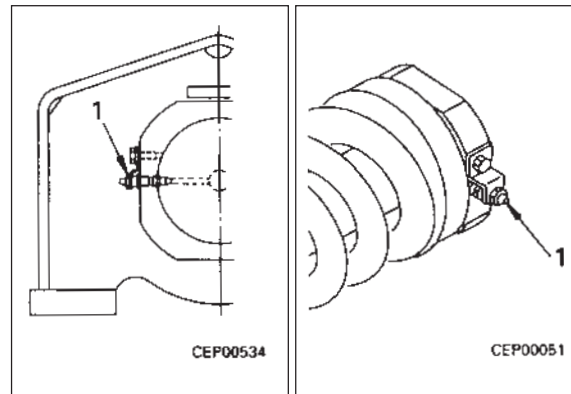

INSTALLATION OF TRACK SHOE ASSEMBLY

- Carry out installation in the reverse order to removal.

※ 1

Adjust the track tension.

For details, see TESTING AND ADJUSTING, Testing and adjusting track tension.

※ 2

- ★ Use tool **I** and press fit so that the protrusion of the master pin is dimension "a"
Protrusion "a" of master pin: 4.2 ± 2 mm

※ 3

 When assembling the dust seal, coat the bushing contact surface with grease (G2-LI).

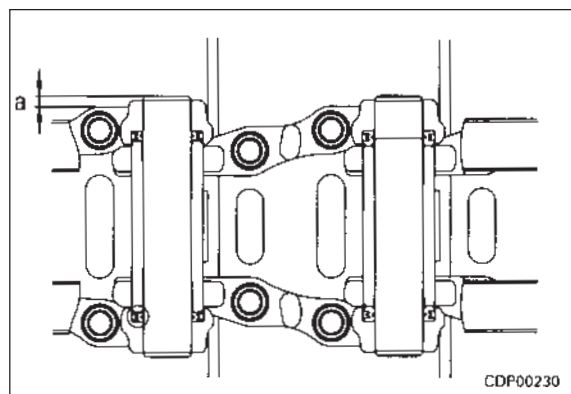
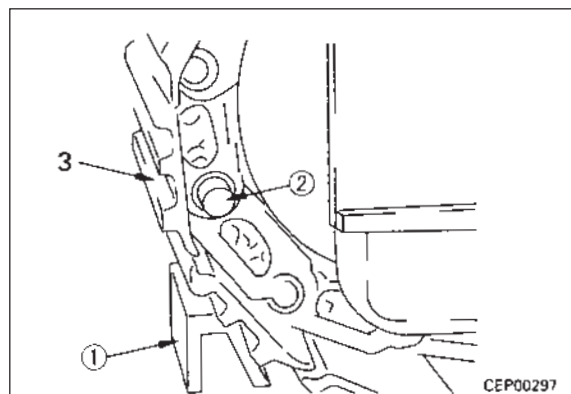

HYDRAULIC TANK

Removal

1. Drain oil from hydraulic tank. * 1
Hydraulic tank: Approximately 170 l.



2. Remove engine hood (1), pump top cover (2), and control valve top cover (3).
3. Remove right side cover (4) together with cover mounting frame (5).
4. Remove engine partition plates (6) and (7) and mounting bracket for partition plate on hydraulic tank side.
5. Disconnect hydraulic oil return tube (8).
6. Remove pump suction tube (9) together with joint hose (10).

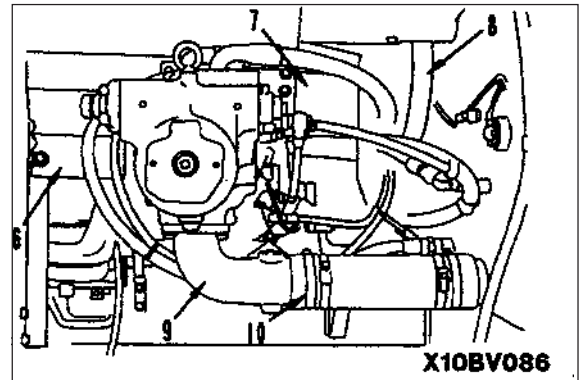
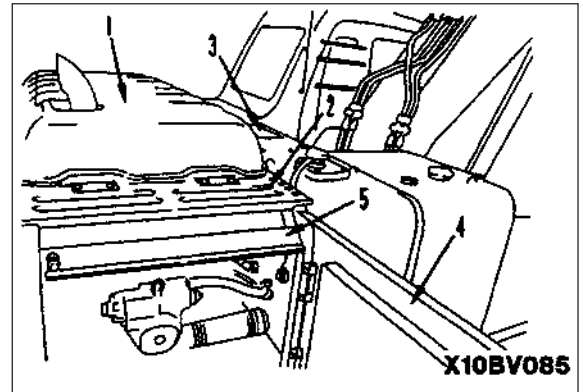

7. Disconnect oil level sensor connector (11) and remove LS pressure hose clamp (12).
8. Disconnect 7 hydraulic tank return hoses, fit tags to distinguish them.
 - ★ After disconnecting the hoses, fit tags to distinguish them.
 - ★ Protect with the sleeve nut to prevent damage to the nipple or elbow taper seal portion.

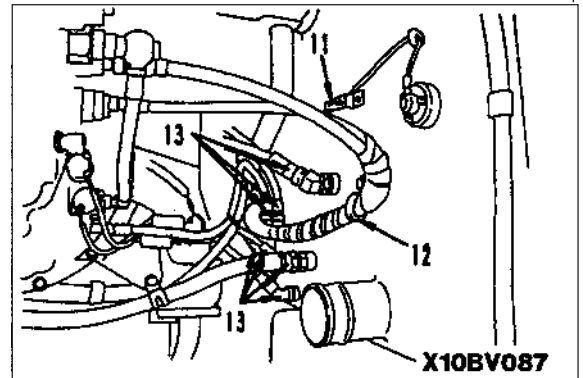

9. Sling hydraulic tank assembly (14), then remove mounting bolts, and lift off hydraulic tank assembly. * 3



Hydraulic tank assembly: 136 kg.

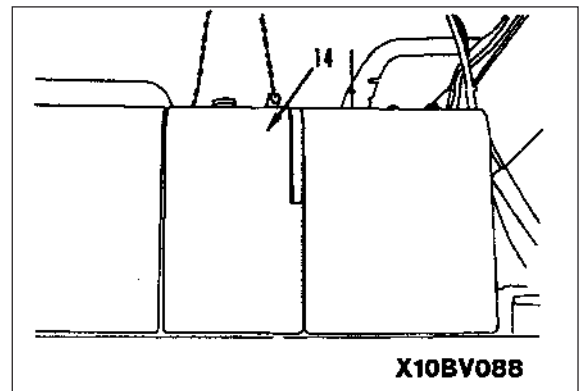

Installation

- Carry out installation in the reverse order to removal.

 1

Hydraulic tank drain plug: 68.5 ± 10 Nm (6.98 ± 1.01 kgm)

 2

Hydraulic tank mounting bolt: 277 ± 32 Nm (28.3 ± 3.2 kgm)

- Refilling with oil (hydraulic tank)
- ★ Add oil through the oil filter to the specified level. Run the engine to circulate the oil through the system . Then check the oil level again.



Hydraulic tank: Approximately 170 l.

- Bleeding air
- ★ Bleed the air. For details, see TESTING AND ADJUSTING, Bleeding air.

MAIN PUMP

Removal

- ⚠ Disconnect the cable from the negative (-) terminal of the battery.
- ⚠ Lower the work equipment completely to the ground and stop the engine. Then loosen the oil filler cap slowly to release the pressure inside the hydraulic tank.
- Remove the hydraulic tank strainer, and using tool **B**, stop the oil.
- When not using tool **B**, remove the drain plug, and drain the oil from the hydraulic tank and inside the system.



Hydraulic tank: Approx. 170 l.

- Drain oil from damper case.
1. Remove engine hood cover. (1)
 2. Remove main pump top cover. (2)
 3. Remove right side cover (3) together with cover mounting frame (4).

4. Remove connectors (5) and (6) from bracket and disconnect.

5. Disconnect Front and Rear pump discharge hoses (7) and (8), Front and Rear LS pressure hoses (9) and (10), and EPC basic pressure hose (11).

- ★ Protect with the sleeve nut to prevent damage to the nipple or elbow taper seal portion.

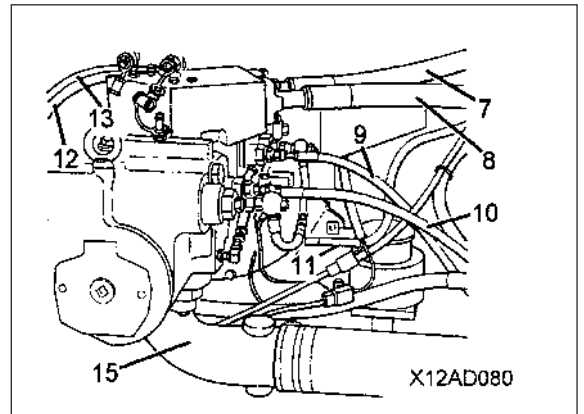
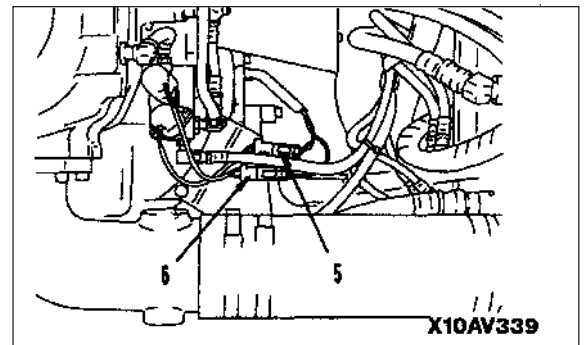
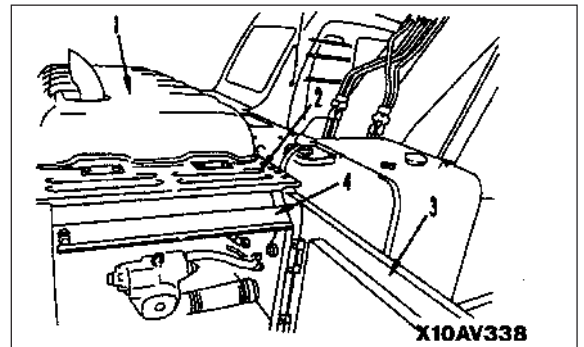
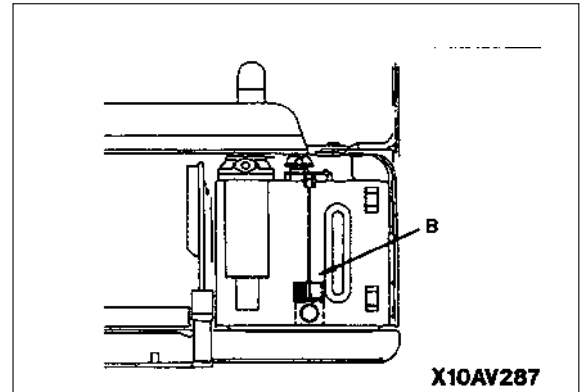

6. Disconnect pump servo pressure hose (12) and pump drain hose (13), and remove intermediate clamp (14) of hose.
 - ★ Protect with the sleeve nut to prevent damage to the nipple or elbow taper seal portion.
7. Disconnect suction tube (15) at pump end.
 - ★ Cover the suction tube port portion with plastic.

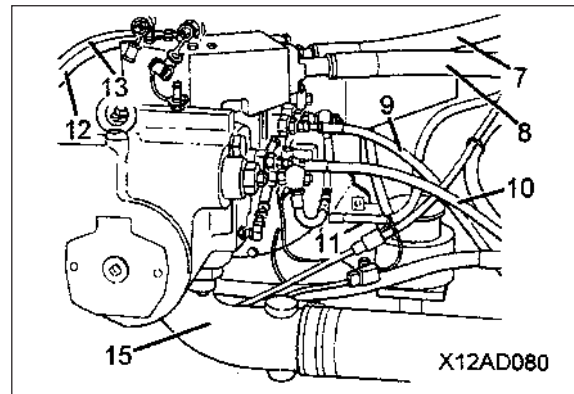

8. Remove engine partition plates (16), (17) and (18).

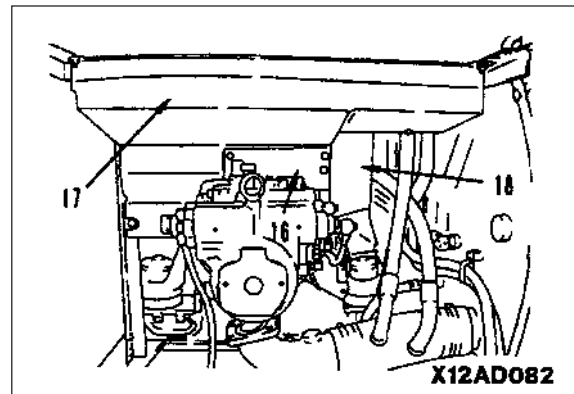

9. Remove muffler drain pipe (19) and clamp mounting bracket (20).

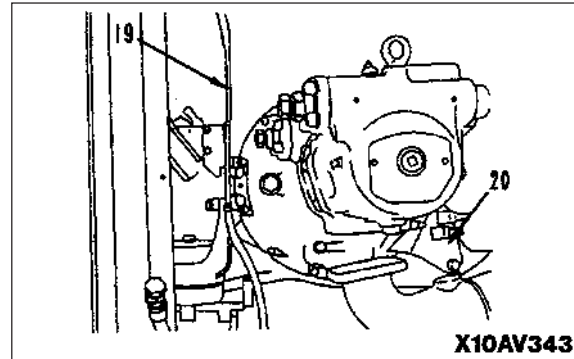

10. Remove main pump assembly as follows.
 - a. Leaving 2 - 3 mounting bolts, remove other mounting bolts.
 - b. Sling main pump assembly and install 2 guide bolts 1* on diametrically opposite sides.
 - c. Remove remaining mounting bolts, then pull out slowly until main pump assembly separates from spline shaft.
 - d. Lift off main pump assembly. * 1

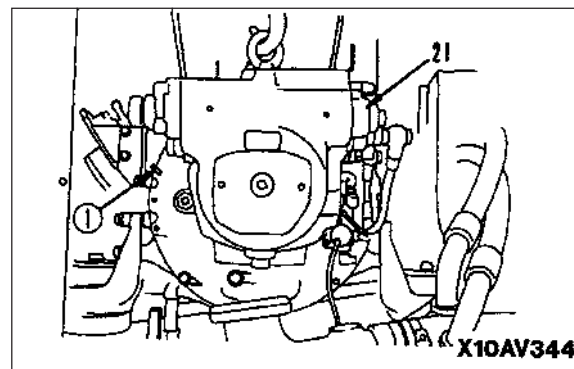

Main pump assembly: 150 kg

Installation

- Carry out installation in the reverse order to removal.



Involute spline of main pump: Anti-friction compound (LM-G)



Mating surface of main pump case: Gasket sealant (LG-6)

- Refilling with oil (damper)
- ★ Add engine oil through the oil filler to the specified level. Run the engine to circulate the oil through the system. Wait for at least 15 minutes, then check the oil level again.



Damper: Approximately 0.7 l.

- Refilling with oil (hydraulic tank)
- ★ Add oil through the oil filler to the specified level. Run the engine to circulate the oil through the system. Then check the oil level again.
- Bleeding air
- ★ Bleed the air. For details, see TESTING AND ADJUSTING, Bleeding air.

MAIN PUMP INPUT SHAFT OIL SEAL

Removal

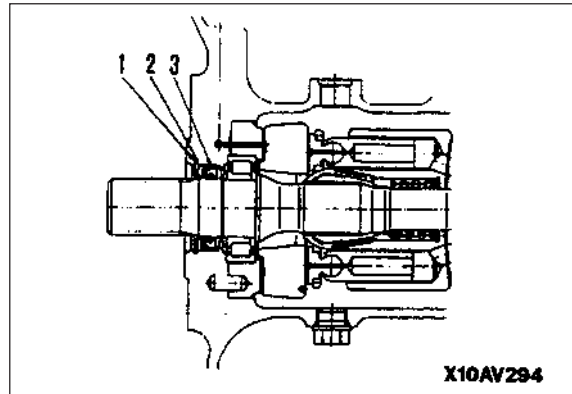

1. Remove main pump assembly. For details, see MAIN PUMP, Removal.
 2. Remove snap ring (1), then remove spacer (2). 
 3. Lever up oil seal (3) with a screwdriver to remove.
- ★ When removing the oil seal, be extremely careful not to damage the shaft.



Installation

- Carry out installation in the reverse order to removal.



-  Lip of seal: Grease (G2-L1)
 -  Coat the outside circumference of the oil seal with grease (G2-L1) thinly, then press fit.
- ★ Using tool **N**, press fit oil seal (3).

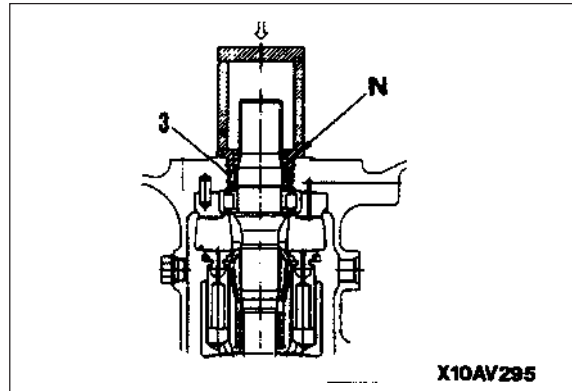

CONTROL VALVE

Removal

⚠ Run the engine at low idling, operate the cylinder to the end of its stroke without relieving the circuit, then lower the work equipment to the ground. For details, see TESTING AND ADJUSTING, Releasing pressure in hydraulic circuit. Stop the engine.

- Loosen the oil filler cap slowly to release the pressure inside the tank.
 - Operate the control levers several times to release the pressure in the accumulator.
 - Start the engine and run at low idling for approximately 5 seconds, then stop the engine and operate the control levers. Repeat the above operation several times to release the remaining pressure completely.
1. Open engine hood, and remove valve top cover (1) and air cleaner top cover (2).
 2. Remove partition plate covers (3) and (4) between engine and control valve, move partition plate cover (5) under intake hoses towards engine.

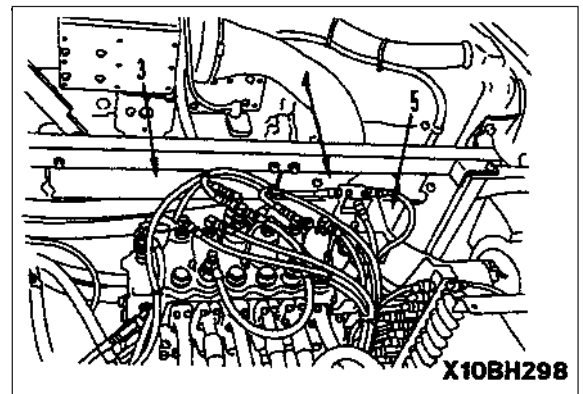
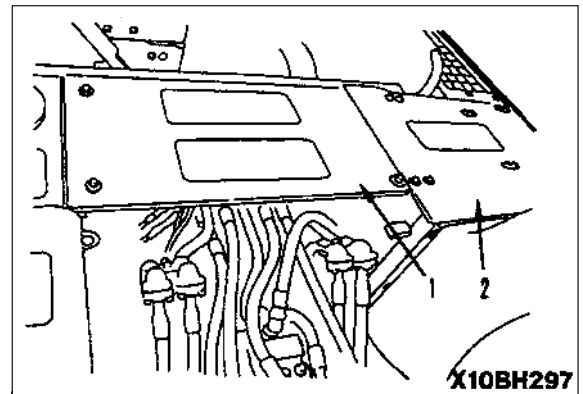

3. Disconnect 2 connectors (6) of pressure sensor and remove from holder.

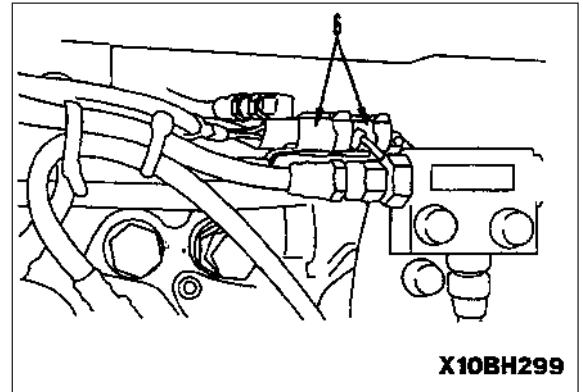

4. Disconnect pump discharge hoses (7) and (8), and remove hose clamp (9).
5. Remove self-reducing pressure valve (10).
- ★ The length of the mounting bolts is different. Left side mounting bolts (2 bolts): L=120 mm. Right side mounting bolts (2 bolts): L=125 mm.

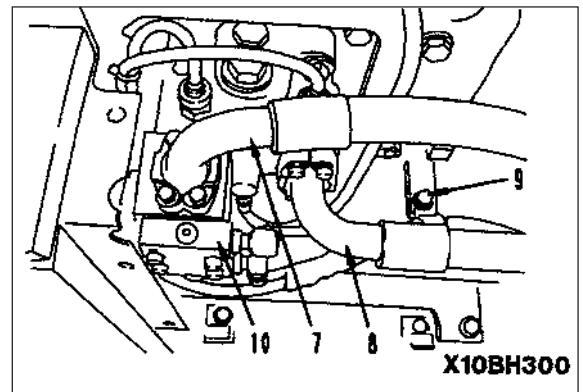

6. Disconnect 5 hoses (11) between control valve and relay block, hose (12) between control valve and timing valve, travel valve pilot hose (13), 2 boom valve pilot hoses (14), and 2 relief valve pilot hoses (15).
 - ★ After disconnecting the hoses, fit tags to distinguish them.
 - ★ Protect with the sleeve nut to prevent damage to the nipple or elbow taper seal portion.
7. Disconnect 2 travel valve junction hoses (16).
8. Disconnect 2 LS pressure pilot hoses (17).
 - ★ After disconnecting the hoses, fit tags to distinguish them.
9. Disconnect 4 hoses (20) between control valve and relay block, hose (21) between control valve and timing valve, travel valve junction hose (22), travel valve pilot hoses (23), and pilot hose (24) between arm and bucket.
 - ★ After disconnecting the hoses, fit tags to distinguish them.
 - ★ Protect with the sleeve nut to prevent damage to the nipple or elbow taper seal portion.
10. Disconnect 2 each of bucket valve tube (25), boom valve tube (26), and arm valve tube (27).
11. Disconnect 2 each of right hand travel valve hose (28), swing valve hose (29), and left travel valve hose (30).
12. Disconnect 2 LS select valve pilot hoses (31).

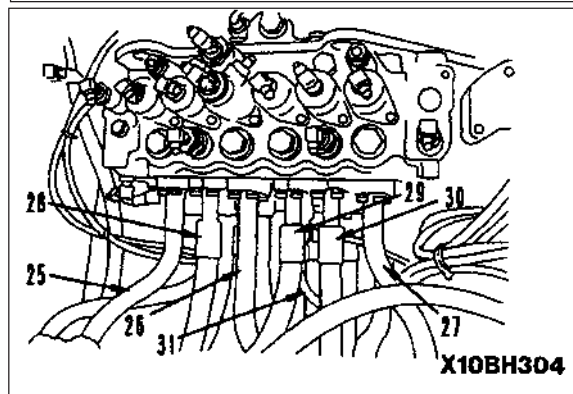
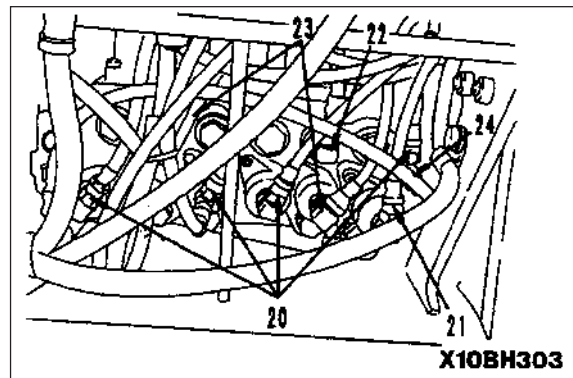
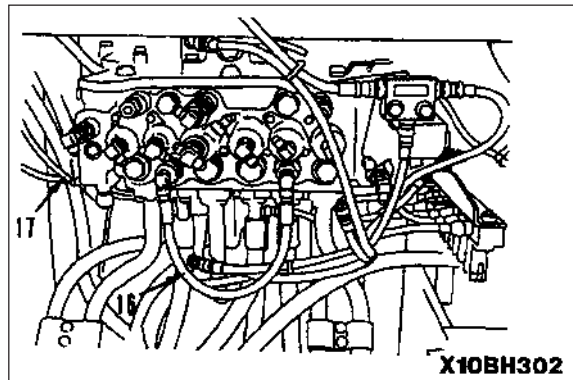
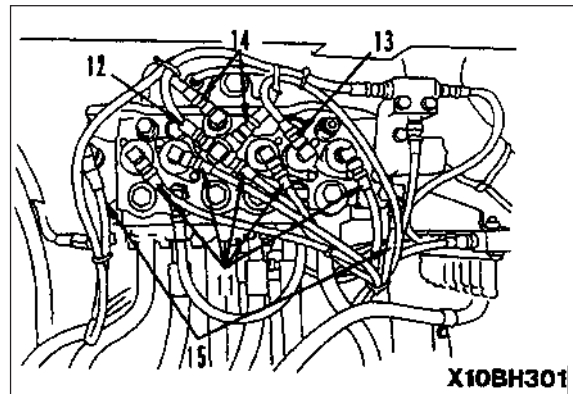

14. Sling control valve assembly (32), then remove mounting bolts, and lift off control valve assembly.



Control valve assembly: 170 kg

Installation

- Carry out installation in the reverse order to removal.
- Refilling with oil (hydraulic tank)
- ★ Add oil through the oil filler to the specified level. Run the engine to circulate the oil through the system. Then check the oil level again.
- Bleeding air
- ★ Bleed the air from the circuit between the valve and the hydraulic cylinder. For details, see TESTING AND ADJUSTING, Bleeding air.

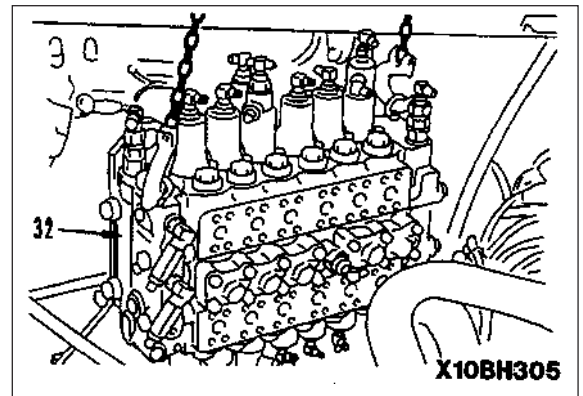

Disassembly

- ★ The set pressure of the safety valve cannot be adjusted when it is installed on the machine, so do not disassemble.
 - This section explains the procedure for the 6-spool valve.
1. Remove the main relief valve (2).
 2. Unload valves, safety suction valves, suction valves.
 - a. Remove unload valve (1) and (17).
 - b. Remove safety-suction valves (23), (22), (27), (18) and (20).
 - c. Remove suction valves (25), (24), (21), (26) and (19).
 3. Pressure compensation valves.
 - ★ Before removing any pressure compensation valve, check and mark its mounting position.
 - a. Remove bucket DUMP (8), R.H. travel REVERSE (7), boom RAISE (6), L.H. travel REVERSE (4), and arm OUT pressure compensation valve (3).
 - b. Remove bucket CURL (10), R.H. travel FORWARD (11), boom LOWER (12), left swing (13), L.H. travel FORWARD (14), and arm IN pressure compensation valve (15).
 - ★ After removing the pressure compensation valves, remove the check valves (35) from each pressure compensation valve mount.
 4. Remove LS select valve (38).
 5. LS Shuttle valves, pump merge/divider valve, boom regeneration valve.
 - a. Remove LS shuttle valves (79) and (81).
 - b. Remove pump merge/divider valve assembly (80), then remove boom regeneration spring (61) and boom regeneration valve (62).
 6. Remove covers (9) and (16).
 7. Arm control valve.
 - a. Remove case (70), then remove spring (74) and retainer (69).
 - b. Remove case (66), then remove spring (67) and retainer (78).
 - c. Remove spool assembly (68).
 8. Swing control valve
 - a. Remove case (40), then remove spring (39) and retainer (41).
 - b. Remove case (43), then remove spring (36) and retainer (42).
 - c. Remove spool assembly (37).
 - ★ Do not disassemble spool assembly (37).
 9. R.H. travel, L.H. travel control valves.
 - a. Remove case (47), then remove spring (46) and retainer (48).
 - b. Remove case (50), spring (44), and retainer (49).
 - c. Remove spool assembly (45).
 - ★ Do not disassemble spool assembly (45).
 10. Boom control valve
 - a. Remove case (57), then remove spring (55) and retainer (60).
 - b. Remove plug (58), then remove piston (59) and spring (56).
 - c. Remove case (64), then remove spring (53) and retainer (63).
 - d. Remove spool assembly (54).
 - ★ Do not disassemble spool assembly (54).
 11. Bucket control valve.
 - a. Remove case (30), then remove spring (31), and retainer (32).
 - b. Remove case (34), then remove spring (28) and retainer (33).
 - c. Remove spool assembly (29).
 - ★ Do not disassemble spool assembly (29).
 12. Remove plate (75), then remove arm regeneration spring (76) and arm regeneration valve (77).

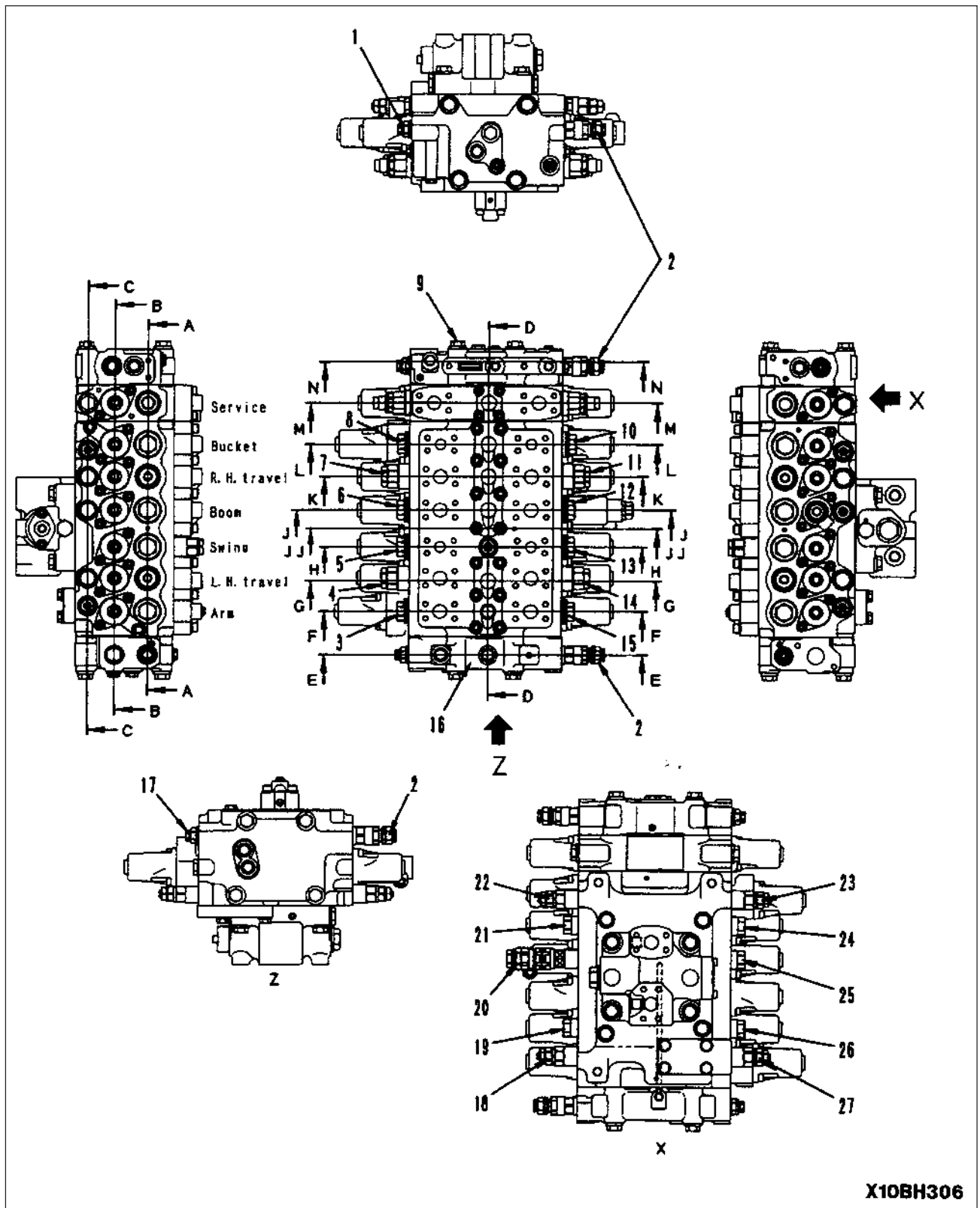

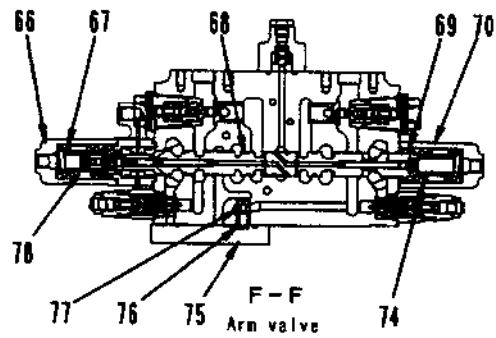
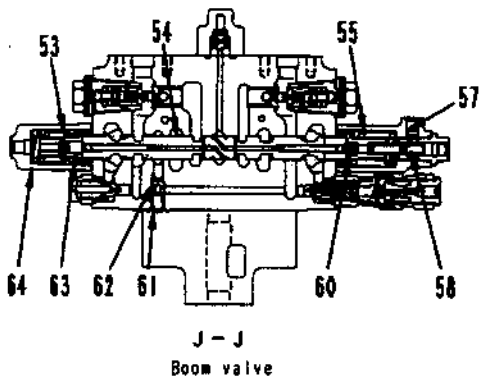
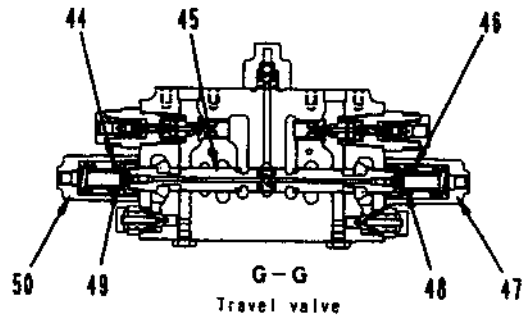
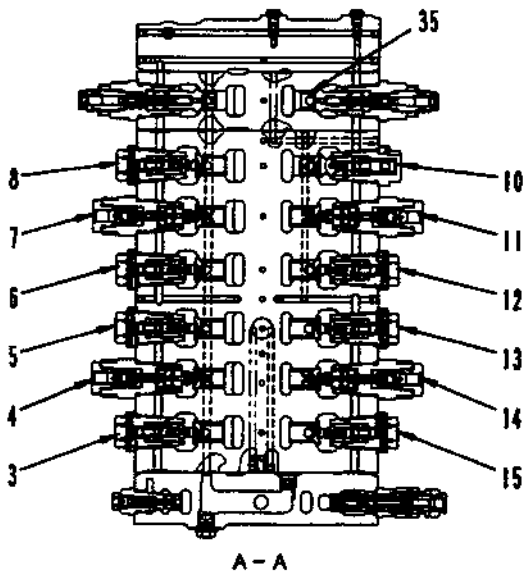
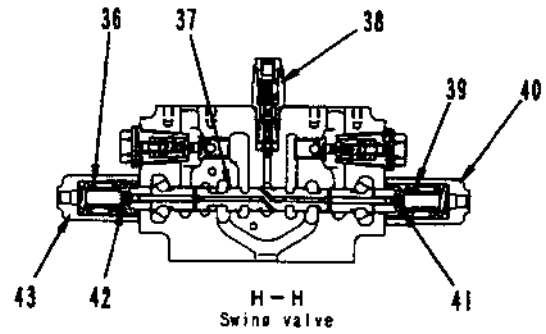
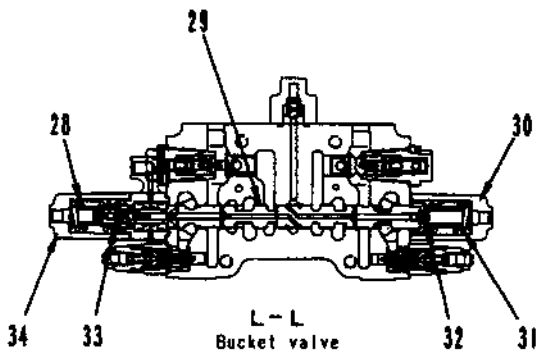

X10BH307

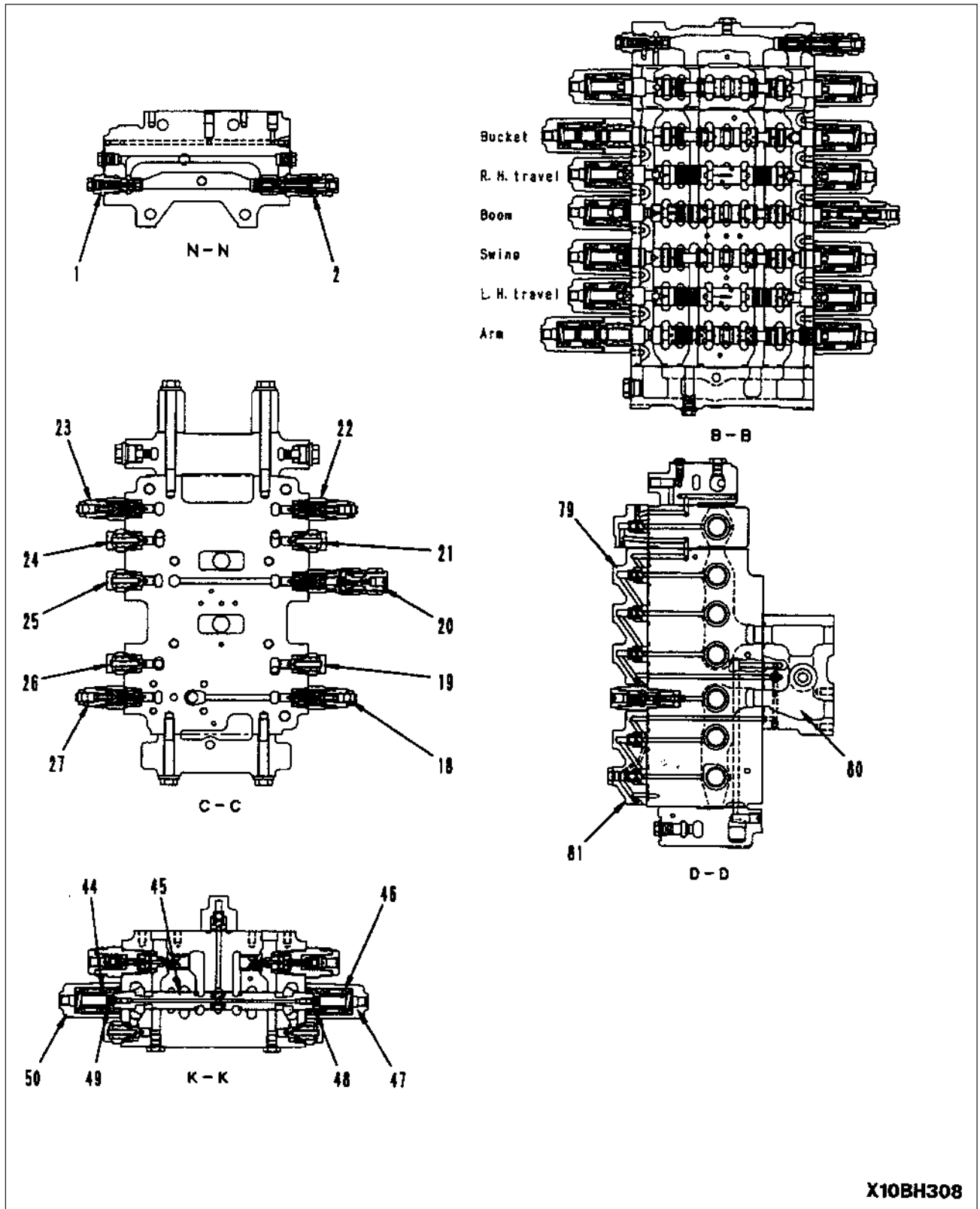



Assembly

- Coat the sliding surfaces of all parts with engine oil before installing.
- 1. Bucket control valve spool.
 - a. Assemble spool assembly (29) to valve body.
 - b. Assemble retainer (33) and spring (28), then fit O-ring to case (34) and install.

 **kgm** Case mounting bolt: 30.87 ± 3.43 Nm (3.15 ± 0.35 kgm)

 - c. Assemble retainer (32) and spring (31) to spool, then fit O-ring to case (30) and install.

 **kgm** Case mounting bolt: 30.87 ± 3.43 Nm (3.15 ± 0.35 kgm)
- 2. Boom control valve spool
 - a. Assemble spool assembly (54) to valve body.
 - b. Assemble retainer (63) and spring (53), then fit O-ring to case (64) and install.

 **kgm** Case mounting bolt: 30.87 ± 3.43 Nm (3.15 ± 0.35 kgm)

 - c. Assemble spring (56) and piston (59), then install plug (58).

 **kgm** Plug: 107.8 ± 14.7 Nm (11.0 ± 1.5 kgm)

 - d. Assemble retainer (60) and spring (55), then install case (57).

 **kgm** Case mounting bolt : 30.87 ± 3.43 Nm (3.15 ± 0.35 kgm)
- 3. R.H. travel, L.H. travel control valves.
 - a. Assemble spool assembly (45) to valve body.
 - b. Assemble retainer (49) and spring (44), then fit O-ring to case (50) and install.

 **kgm** Case mounting bolt : 30.87 ± 3.43 Nm (3.15 ± 0.35 kgm)

 - c. Assemble retainer (48) and spring (46) to spool, then fit O-ring to case (47) and install.

 **kgm** Case mounting bolt : 30.87 ± 3.43 Nm (3.15 ± 0.35 kgm)
- 4. Swing control valve spool.
 - a. Assemble spool assembly (37) to valve body.
 - b. Assemble retainer (42) and spring (36), then fit O-ring to case (43) and install.

 **kgm** Case mounting bolt : 30.87 ± 3.43 Nm (3.15 ± 0.35 kgm)

 - c. Assemble retainer (41) and spring (39), then fit O-ring to case (40) and install.

 **kgm** Case mounting bolt : 30.87 ± 3.43 Nm (3.15 ± 0.35 kgm)
- 5. Arm control valve.
 - a. Assemble spool assembly (68) to valve body.
 - b. Assemble retainer (78) and spring (67), then fit O-ring to case (66) and install.

 **kgm** Case mounting bolt : 30.87 ± 3.43 Nm (3.15 ± 0.35 kgm)

 - c. Assemble retainer (69) and spring (74), then fit O-ring to case (70) and install.

 **kgm** Case mounting bolt : 30.87 ± 3.43 Nm (3.15 ± 0.35 kgm)
- 6. Covers.
 - a. Fit O-ring to cover (16), then install.
 - b. Fit O-ring to cover (9), then install.

 Mating surface of covers (16), (9): Seal end 242 or equivalent.

★ Tighten the mounting bolts in the order shown in the diagram on the right.

 **kgm** Mounting bolt: 166.6 ± 9.8 Nm (17 ± 1 kgm)

7. LS shuttle valves, pump merge/divider valve, boom regeneration valve
 - a. Assemble boom regeneration valve (62) and spring (61) to valve body, then install pump merge/divider valve assembly (80).

★ Tighten the mounting bolts in the order shown in the diagram on the right.

 **kgm** Mounting bolt: 166.6 ± 9.8 Nm (17 ± 1 kgm)

- b. Install LS shuttle valves (81) and (79).

 **kgm** Mounting bolt: 66.17 ± 7.35 Nm (6.75 ± 0.75 kgm)

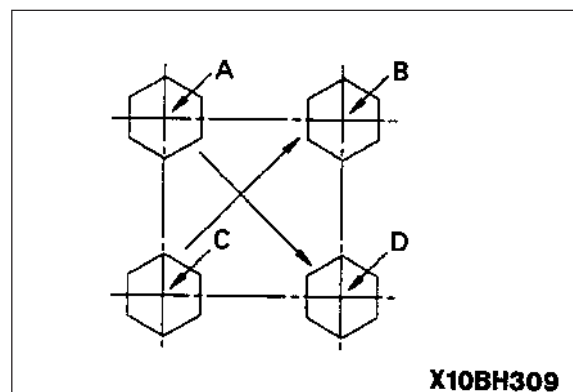

8. Install LS select valve (38).

 LS select valve: 127.4 ± 19.6 Nm (13 ± 2 kgm)

9. Pressure compensation valves

- Check the marks made on each pressure compensation valve during disassembly, and install in the correct position.
 - a. Before installing pressure compensation valves below, install check valves (35).
 - b. Fit O-ring, then install arm IN (15), L.H. travel FORWARD (14), left swing (13), boom LOWER (12), R.H. travel FORWARD (11), and bucket CURL pressure compensation valve (10).
 - c. Fit O-ring, then install arm OUT (3), L.H. travel REVERSE (4), right swing (5), boom RAISE (6), R.H. travel REVERSE (7), and bucket DUMP pressure compensation valve (8).

 Pressure compensation valve: 392 ± 19.6 Nm (40 ± 2 kgm)

10. Install arm regeneration valve (77) and spring (76), then install plate (75).

★ Tighten the mounting bolts in the order shown in the diagram on the right.

 Mounting bolt: 66.15 ± 7.35 Nm (6.75 ± 0.75 kgm)

11. Unload valves, safety-suction valves, suction valves

- a. Fit O-rings and install suction valves (19), (26), (21), (24) and (25).

 Suction valve: 147 ± 9.8 Nm (15 ± 1 kgm)

- b. Fit O-rings and install safety-suction valves (18), (27), (22) and (23).

 Safety-suction valve: 147 ± 9.8 Nm (15 ± 1 kgm)

- c. Fit O-rings and install unload valves (17) and (1).

 Unload valve assembly: 166.6 ± 9.8 Nm (17 ± 2 kgm)

12. Fit O-ring and install main relief valve assembly (2).

 Main relief valve: 53.9 ± 4.9 Nm (5.5 ± 0.5 kgm)

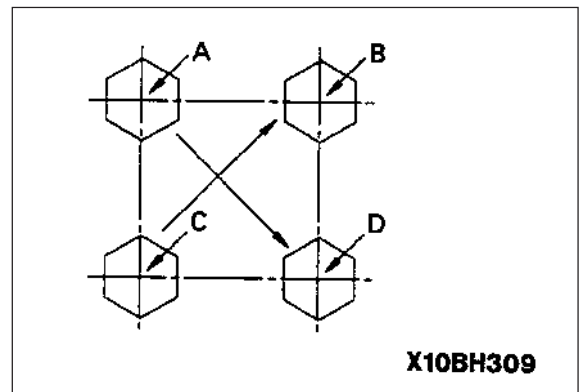

PUMP MERGE-DIVIDER VALVE

Disassembly

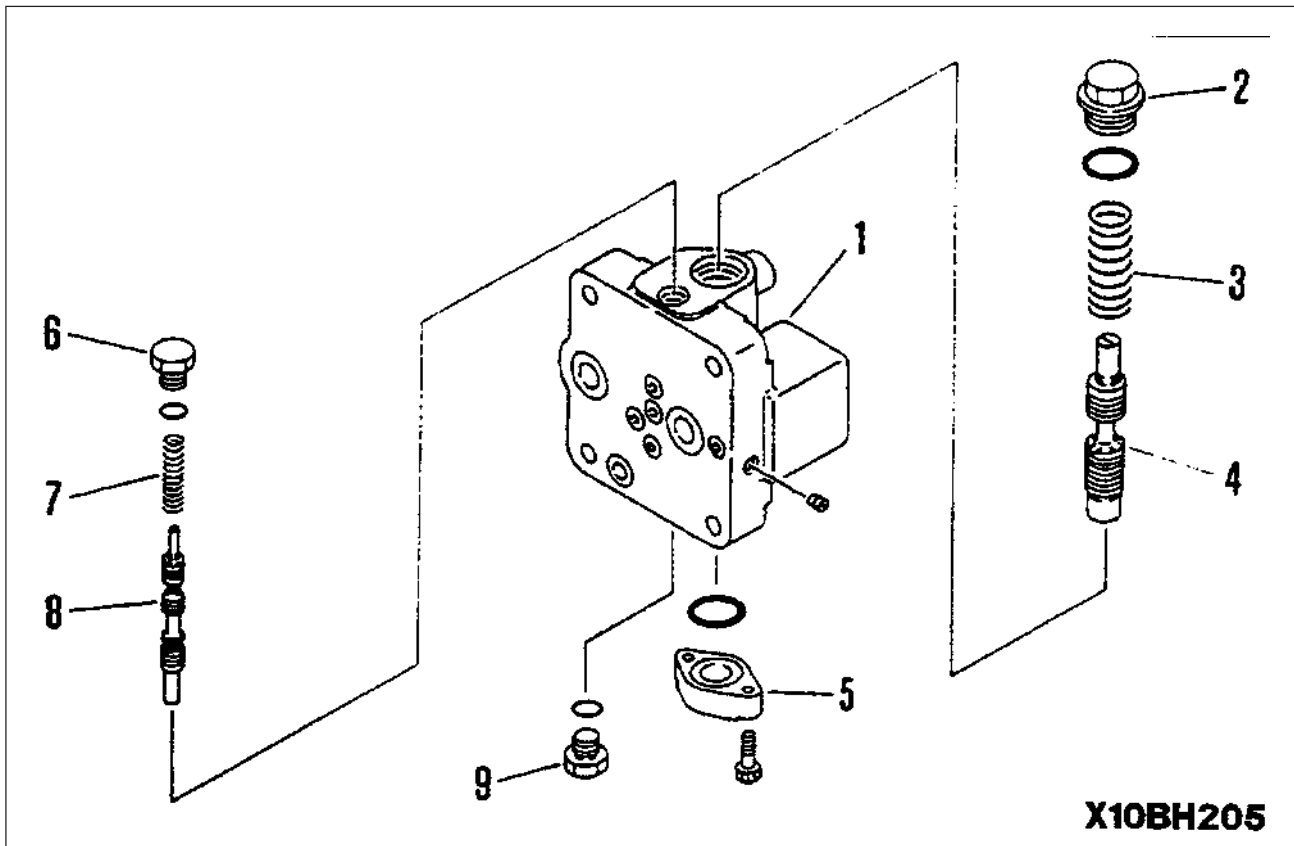

1. Remove plug (2) from valve body (1), then remove spring (3) and spool (4).
 2. Remove plate (5).
 3. Remove plug (6), then remove spring (7) and spool (8).
 4. Remove plug (9).
- ★ After disassembling, if there is any abnormality in body (1) or spools (4) or (8), replace the whole pump merge-divider valve assembly.

Assembly

- Before assembling, coat the sliding surface with engine oil.

1. Fit O-ring to plug (9) and install to valve body (1).

 **kgm** Plug (9): 39.2 ± 5.88 Nm (4.0 ± 0.6 kgm)

2. Assemble spool (8) and spring (7), then fit O-ring to plug (6) and install.

 **kgm** Plug (6): 39.2 ± 5.88 Nm (4.0 ± 0.6 kgm)

3. Fit O-ring to plate (5) and install to valve body.

4. Assemble spool (4) and spring (3), then fit O-ring to plug (2) and install.

 **kgm** Plug (2): 151.9 ± 24.5 Nm (15.5 ± 2.5 kgm)

MAIN RELIEF VALVE

Disassembly

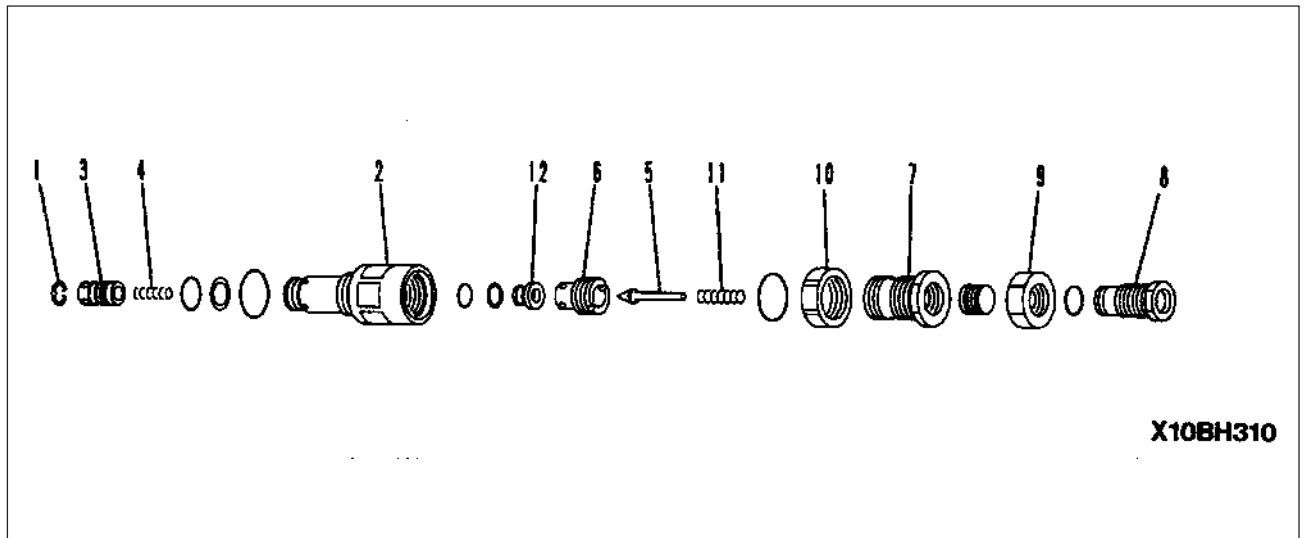

1. Loosen locknut (9), remove plug (8), then remove retainer (6).
2. Loosen locknut (10), then remove holder (7), spring (11), seat (12), and poppet (5).
3. Remove ring (1), then remove valve (3) and spring (4).
- ★ If any abnormality is found in any part after disassembly, replace the whole main relief valve assembly.

Assembly

- Coat the sliding surfaces with engine oil.
1. Assemble spring (4) and valve (3), then install ring (1).
 2. Install seat (12), poppet (5), spring (11), and holder (7), and secure in position with locknut (10).

 **kgm** Locknut: 53.9 ± 4.9 Nm (5.5 ± 0.5 kgm)

3. Fit retainer (6), then install plug (8) and secure in position with locknut (9).

 **kgm** Locknut: 39.7 ± 4.9 Nm (4.0 ± 0.5 kgm)

- ★ After installing main relief valve to control valve assembly, adjust pressure referring to TESTING AND ADJUSTING, testing and adjusting hydraulic pressure in work equipment, swing, travel circuit.

❖ 1

❖ 2

PC VALVE

Removal

- ⚠ Disconnect the cable from the negative (-) terminal of the battery.
- ⚠ Lower the work equipment completely to the ground and stop the engine. Then loosen the oil filler cap slowly to release the pressure inside the hydraulic tank.
- Remove the hydraulic tank strainer, and using tool **B**, stop the oil.
- When not using tool **B**, remove the drain plug, and drain the oil from the hydraulic tank and inside the system.



Hydraulic tank: Approx. 170 l.

- There are PC valve assemblies installed to both the front pump and the rear pump, but the procedure for removal is the same.

1. Remove nut (1), then remove hose assembly (2).

1

2. Install locknut ① 01582-11008

2

kgm Locknut: 100.5 ± 12.5 Nm (10.25 ± 1.25 kgm)

3. Turn nut (3) in direction of loosening, then tighten at locknut ① end.

★ Angle of turning for nut (3): Approximately 30° 3

4. Fit tool to width across flats (22 mm) of hexagonal portion of sleeve (4), then loosen and remove PC valve assembly (5).

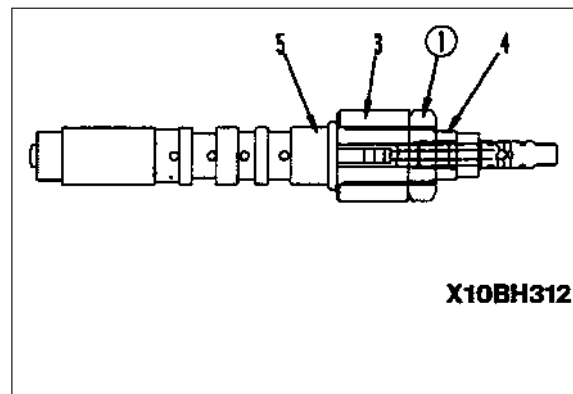
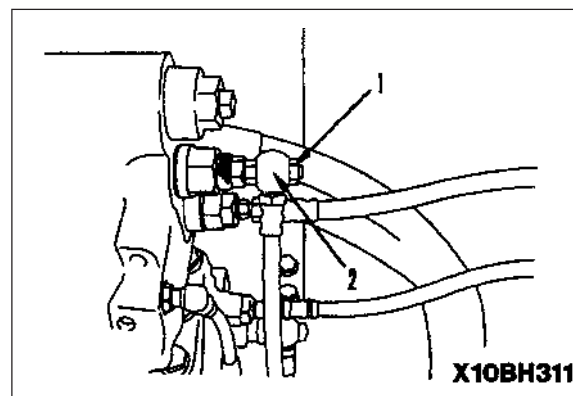
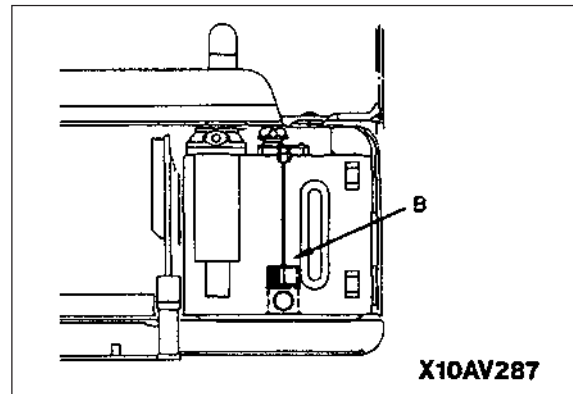

Installation

- Carry out installation in the reverse order to removal.

1

kgm Nut (2): 100.5 ± 12.5 Nm (10.25 ± 1.25 kgm)

2

★ After installing the PC valve assembly, remove locknut ①.

3

★ Adjust the PC valve assembly. For details, see TESTING AND ADJUSTING, testing and adjusting PC valve output pressure (servo piston inlet pressure).

kgm Nut (3): 100.5 ± 12.5 Nm (10.25 ± 1.25 kgm)

- Refilling with oil (hydraulic tank)

★ Add oil through the oil filler to the specified level. Run the engine to circulate the oil through the system. Then check the oil level again.

LS VALVE

Removal

Disconnect the cable from the negative (-) terminal of the battery.

Lower the work equipment completely to the ground and stop the engine. Then loosen the oil filler cap slowly to release the pressure inside the hydraulic tank.

- Remove the hydraulic tank strainer, and using tool **B**, stop the oil.
- When not using tool **B**, remove the drain plug, and drain the oil from the hydraulic tank and inside the system.



Hydraulic tank: Approx. 170 l.

- There are LS valve assemblies installed to both the front pump and the rear pump, but the procedure for removal is the same.
1. Disconnect hose (1).
 2. Fit tool to width across flats (30 mm) of  of hexagonal portion of sleeve, then loosen and remove LS valve assembly (2).

Installation

- Carry out installation in the reverse order to removal.



- ★ Adjust the LS valve assembly. For details, see TESTING and ADJUSTING, testing and adjusting LS valve output pressure (servo piston inlet pressure) and LS differential pressure.



Sleeve: 139.7 ± 12.3 Nm (14.75 ± 1.25 kgm)

- Refilling with oil (hydraulic tank)
- ★ Add oil through the oil filler to the specified level. Run the engine to circulate the oil through the system. Then check the oil level again.

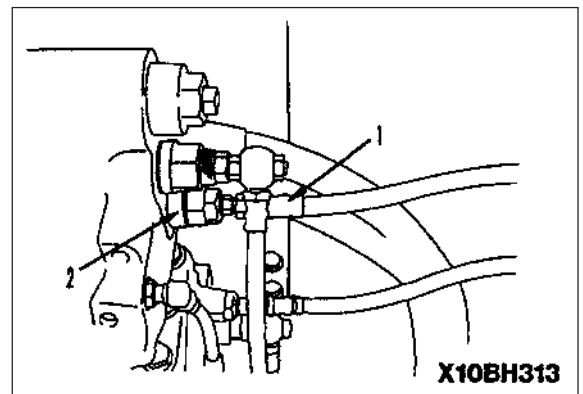
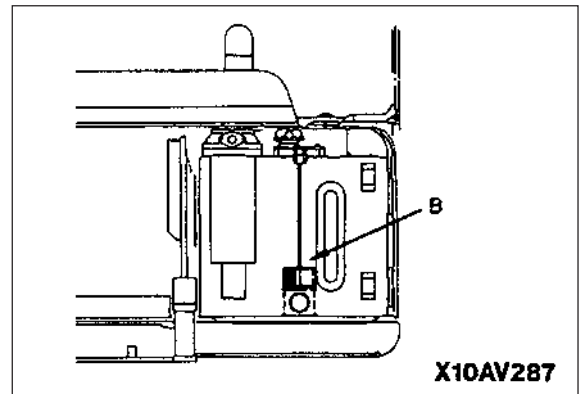

PC, LS-EPC VALVE

Removal

- ⚠ Disconnect the cable from the negative (-) terminal of the battery.
- ⚠ Lower the work equipment completely to the ground and stop the engine. Then loosen the oil filler cap slowly to release the pressure inside the hydraulic tank.
- 1. Remove the main pump bottom cover.
- 2. Disconnect wiring connectors (1) (2 places).
- ★ After disconnecting the connectors, fit tags to distinguish them.
- 3. Disconnect hoses (2) and (3). ※ 1
- 4. Remove PC-EPC valve assembly (4) and LS-EPC valve assembly (5). ※ 2

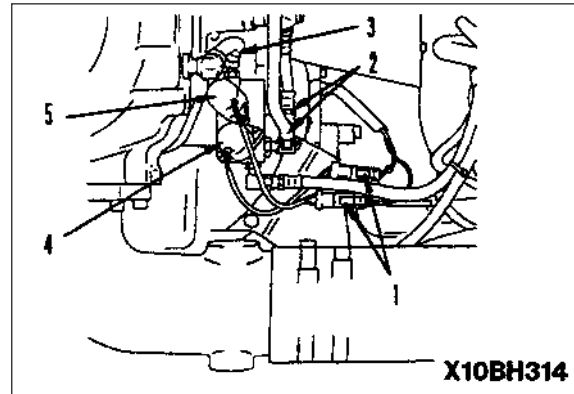

Installation

- Carry out installation in the reverse order to removal.

※ 1

 **kgm** Hose sleeve nut: 24.5 ± 4.9 Nm (2.5 ± 0.5 kgm)

※ 2

 **kgm** PC, LS-EPC valve assembly mounting bolt: 13.3 ± 1.5 Nm (1.35 ± 0.15 kgm)

SOLENOID VALVE

Removal

⚠ Disconnect the cable from the negative (-) terminal of the battery.

1. Remove 5 solenoid wiring connectors (1) from clip and disconnect.
 - ★ Mark the male and female ends of each connector with tags to prevent mistakes when connecting.

2. Disconnect 3 hoses (2) installed to the bottom of the valve.
 - ★ After disconnecting the hoses, fit tags to distinguish them.
3. Disconnect 7 hoses (3) installed to the top of the valve.
 - ★ After disconnecting the hoses, fit tags to distinguish them.
4. Remove mounting bolts, then remove solenoid valve assembly (4).

5. To remove individual solenoid valves, loosen  1 mounting bolt (5) and remove.

Installation

- Carry out installation in the reverse order to removal.

 1

 Bolt: $3.9 \pm 0.39 \text{ Nm}$ ($0.4 \pm 0.04 \text{ kgm}$)

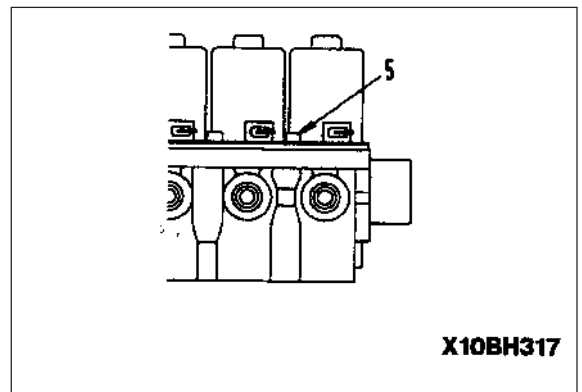
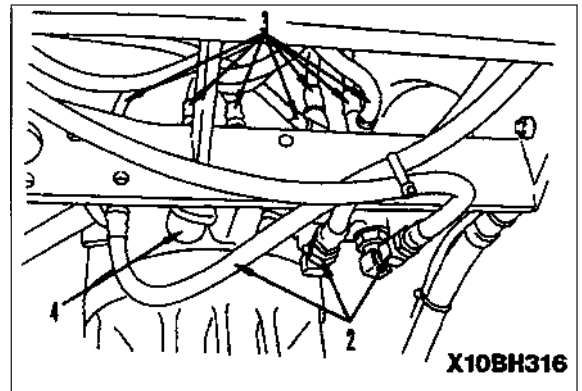
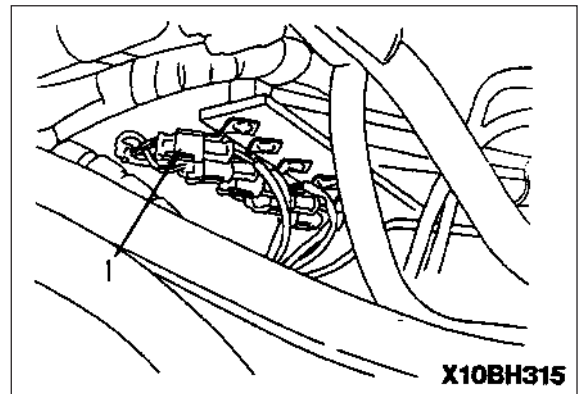

REMOVAL OF WORK EQUIPMENT • SWING PPC VALVE ASSEMBLY

⚠ Lower the work equipment completely to the ground and stop the engine. Then loosen the oil filler cap slowly to release the pressure inside the hydraulic tank.

1. Remove boot (1) from cover, raise boot, then remove lever (2).
 2. Remove mounting bolts.
 3. Disconnect hoses (4) + (5) x 6 + remove valve ass'y.
- ★ Mark the connecting position of the hoses before disconnecting.

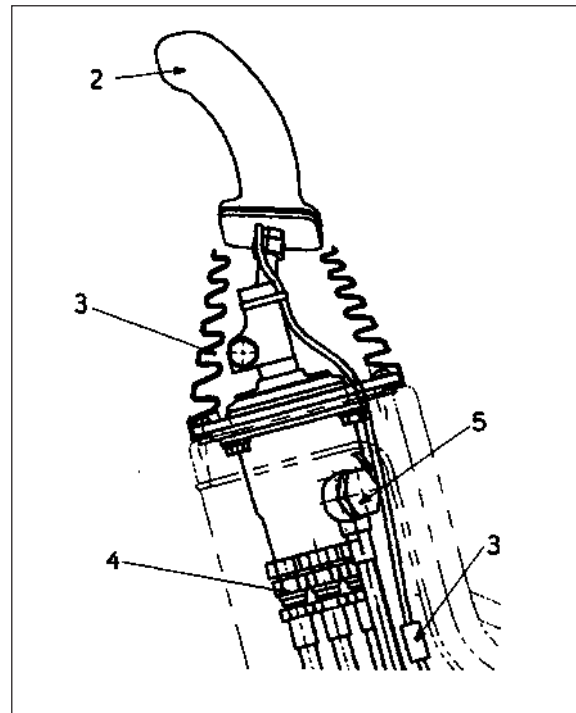

INSTALLATION OF WORK EQUIPMENT • SWING PPC VALVE ASSEMBLY

- Carry out installation in the reverse order to removal.

※ 1

 Hose mounting joint bolt: 29.4 ± 4.9 Nm (3.0 ± 0.5 kgm)

※ 2

 Hose mounting joint bolt: 39.2 ± 4.9 Nm (4.0 ± 0.5 kgm)

- ★ If there is excessive play in the control levers, adjust the PPC valve, for details, see TESTING AND ADJUSTING, Adjusting PPC valve.

Disassembly

1. Remove nut (1), then remove disc (2) and boot (3).
2. Remove bolts, then remove plate (5).
- ★ Do not remove joint (4) unless it is to be replaced.
3. Remove seal (6) and collar (7).
4. Pull out piston (8), and remove retainer (9), spring (10) and (11), and shim (12).
- ★ Spring (10) consists of a set of two types of spring with different installed loads, so check the mounting position (oil port) and mark with tags to prevent mistakes when installing.
5. Pull out valve (13) from body (14).

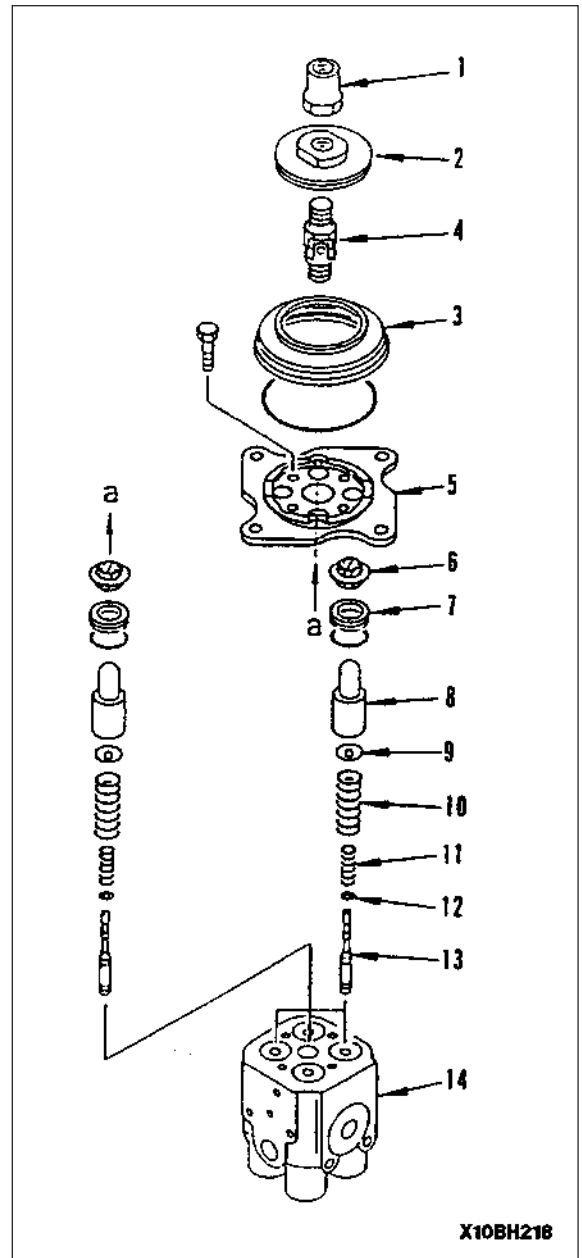

X10BH218

Assembly

1. Assemble valve (13) to body (14).
2. Assemble shim (12) and spring (11) to valve (13).
- ★ When assembling spring (11), set the end with the small coil diameter (inside diameter) at shim (12) end.
3. Assemble spring (10), retainer (9), and piston (8).
- ★ The number of loops in the coil for spring (10) is different for each of the hydraulic ports below, so be careful when installing.

Position of port	Free length of spring
P1, P2	44.4 mm
P3, P4	42.4 mm

- ★ The position of each port is marked on the bottom of the valve body.

 Piston: Grease (G2-L1)

- ★ When assembling piston (8), coat the outside of the piston and the inside of the hole in the body with grease.

4. Fit O-ring to collar (7) and assemble in body (14), then install seal (6).
5. Install plate (5).

 **kgm** Mounting bolt: 13.2 ± 1.5 Nm (1.35 ± 0.15 kgm)

6. Install joint (4).

 Sliding portion of joint: Grease (G2-L1)

 Female thread of body: Thread tightener (LT-2)

- ★ Coat two places on the female thread with one drop each of Loctite as shown in the diagram below.

 **kgm** Joint: 44.1 ± 4.9 Nm (4.5 ± 0.5 kgm)

- ★ Keep strictly to the tightening torque.

7. Assemble boot (3) and disc (2), and tighten with nut (1).

 Contact surface of piston and disc: Grease (G2-L1), 0.3 - 0.8 cc.

 **kgm** Nut: 112.7 ± 14.7 Nm (11.5 ± 1.5 kgm)

- ★ After assembling the disc, adjust the height of the disc. For details, see TESTING AND ADJUSTING, Adjusting PPC valve.

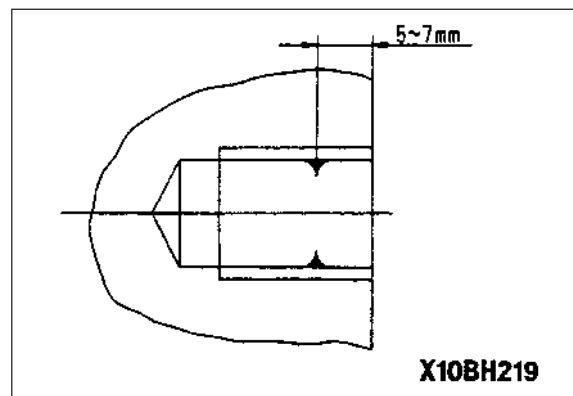

TRAVEL PPC VALVE

Removal

⚠ Lower the work equipment completely to the ground and stop the engine. Then loosen the oil filler cap slowly to release the pressure inside the hydraulic tank.

1. Remove floor mat.
2. Remove travel PPC valve bottom cover.
3. Remove pedals (1) and levers (2).

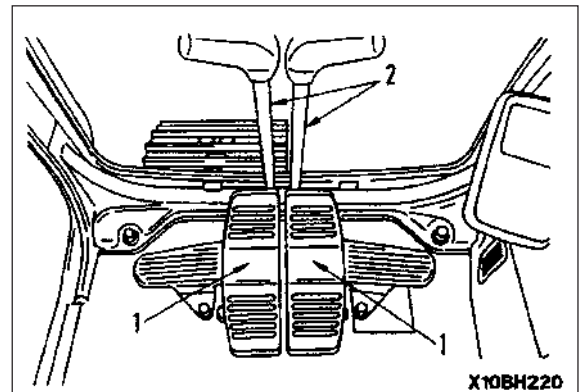

4. Remove cover (3).

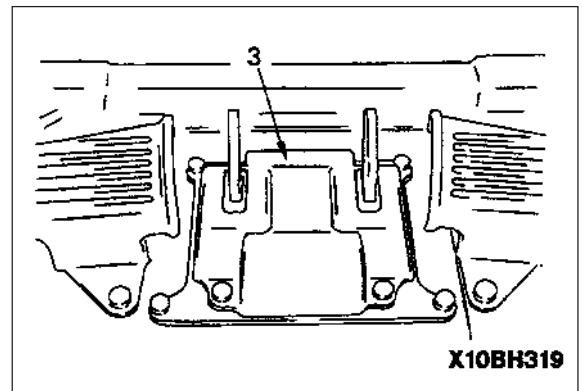

5. Remove covers (4), then remove springs (5).

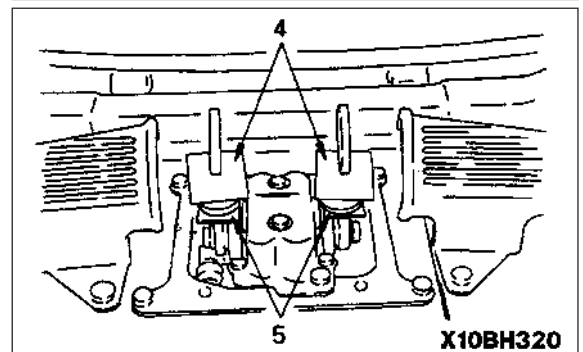

6. Disconnect 6 PPC hoses (7), then remove travel PPC valve assembly (8).

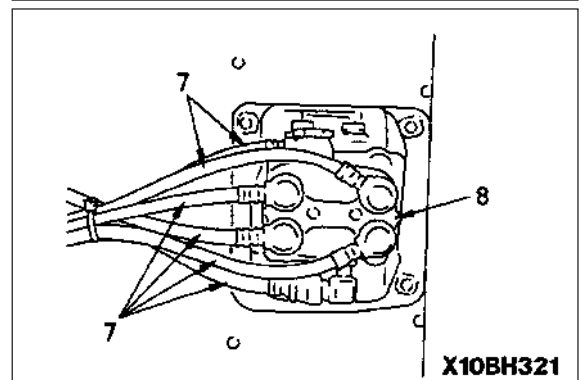

Installation

- Carry out installation in the reverse order to removal.



-  **kgm** Cover mounting bolt: 19.6 ± 2 Nm (2.0 ± 0.23 kgm)



-  **kgm** Hose mounting joint bolt (width across flats: 30 mm): 39.2 ± 4.9 Nm (4.0 ± 0.5 kgm)

-  **kgm** Hose mount elbow (width across flats: 22 mm): 34.3 ± 4.9 Nm ($3. \pm 0.5$ kgm)

-  **kgm** Hose mounting joint bolt (width across flats: 17 mm): 24.5 ± 4.9 Nm (2.5 ± 0.5 kgm)

Disassembly

1. Remove screws (1), then remove levers (2).
2. Remove mounting bolts (3), then remove case and shaft assembly (4).
3. Remove mounting bolts (5), then remove plate (6) and damper assembly (7) as one unit.
- ★ Check the thickness and mounting position of washer (18).
- ★ Never disassemble damper assembly (7).
4. Remove mounting bolts (8), then remove damper assembly (7) from plate (6).
5. Remove seal (9) and collar (10).
6. Pull out piston (11), and remove retainer (12), springs (13) and (14), and shims (15).
- ★ Check the number and thickness of shims (15) for each mounting position and keep in a safe place.
7. Pull out valve (16) from body (17).

Installation

1. Assemble valve (16) in body (17).
2. Assemble shim (15) and spring (14) to valve (16).
- ★ Assemble the same number and thickness of shim (15) as was removed during disassembly. Standard shim thickness: 0.3 mm.
- ★ Spring (14) is not symmetrical at the top and bottom, so assemble with the small coil diameter (inside diameter) at the shim end.
3. Assemble spring (13), retainer (12), and piston (11).

 Outside circumference of piston, body hole:
Grease (G2-L1).

4. Fit O-ring to collar (10) and assemble in body (17), then install seal (9).
5. Install damper assembly (7) to plate (6), then tighten mounting bolts (8).

 Mounting bolt: Thread tightener (LT-2)

 Mounting bolt: $4.41 \pm 0.49 \text{ Nm}$ ($0.45 \pm 0.05 \text{ kgm}$)

6. Install plate (6) and damper assembly (7) as one unit, then tighten mounting bolts (5).

★ Check the thickness of washer (18) and assemble in the position checked during disassembly.

 Mounting bolt: $30.87 \pm 3.43 \text{ Nm}$ ($3.15 \pm 0.35 \text{ kgm}$)

7. Install case and shaft assembly (4), then tighten mounting bolts (3).

★ Check that the out-of-parallel of shaft and damper assembly (7) of case and shaft assembly (4) is less than 0.5.

 Rocking portion of shaft, connection of lever and piston: Grease (G2-L1)

 Mounting bolt: $27.93 \pm 3.43 \text{ Nm}$ ($2.85 \pm 0.35 \text{ kgm}$)

8. Install levers (2), then tighten screws (1).

★ Adjust so that lever (2) can slightly move.

 Rocking portion of lever pin and plate: Grease (G2-L1).

 Screw: $8.82 \pm 0.98 \text{ Nm}$ ($0.9 \pm 0.1 \text{ kgm}$)

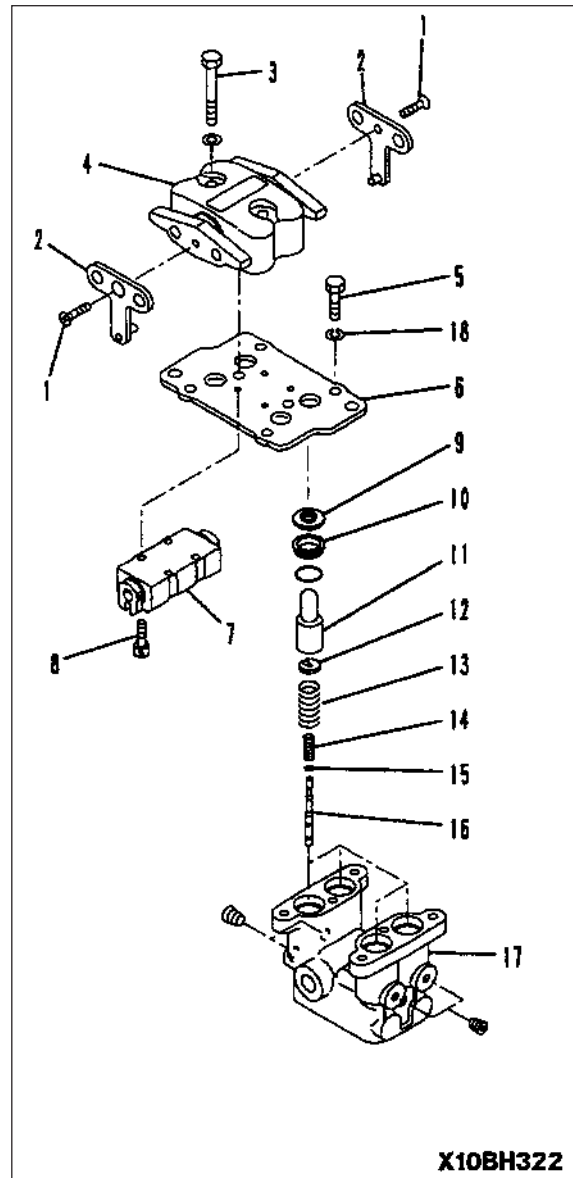

REMOVAL OF BOOM CYLINDER ASSEMBLY

! Extend the arm and bucket fully, lower the work equipment completely to the ground, and put the safety lock lever in the LOCK position.

1. Disconnect grease hose (1).
2. Sling boom cylinder assembly (2), and remove lock bolt (3). * 1
3. Remove plate, then remove head pin (4). * 2
 - ★ There are shims installed, so check the number and thickness, and keep in a safe place.
4. Start engine, and retract piston rod, then tie piston rod with wire to prevent it from coming out.
 - ★ Set stand ① under the cylinder assembly, and adjust the position for slinging.

! Release the remaining pressure in the hydraulic circuit. For details, see TESTING AND ADJUSTING, Releasing remaining pressure in hydraulic circuit.

5. Disconnect hoses (5).
6. Remove plate, then using forcing screws ②, remove bottom pin (6), and remove boom cylinder assembly (2). * 3
 - ★ There are shims installed, so check the number and thickness, and keep in a safe place.

 Boom cylinder assembly: 250 kg

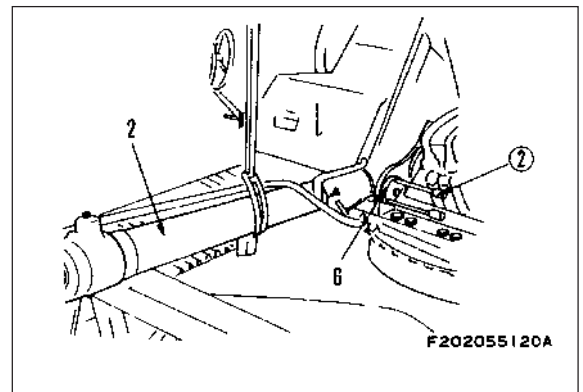
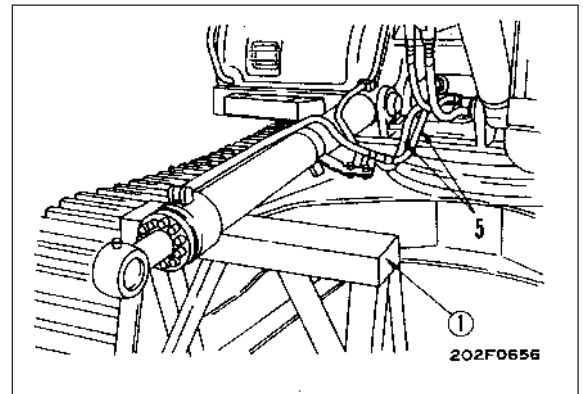
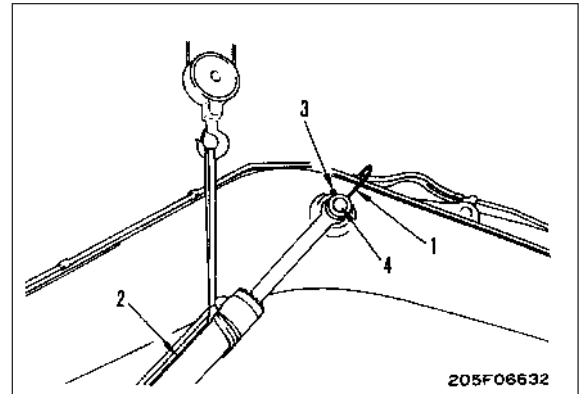

INSTALLATION OF BOOM CYLINDER ASSEMBLY

- Carry out installation in the reverse order to removal.

※ 1

- ★ When tightening the locknut, tighten so that the clearance between the plate and nut is 0.5 - 1.5 mm.

※ 2

 Inside surface of bushing when assembling pin: anti-friction compound (LM-P)

 Greasing after assembling pin:
Grease (LM-G)

- ⚠ When aligning the position of the pin hole, never insert your fingers in the pin hole.

- ★ Adjust the shim thickness so that the clearance between cylinder rod (7) and plate (8) is below 1 mm.

- ★ Standard shim thickness: 0.8 mm, 1.5 mm;

※ 3

 Inside surface of bushing when assembling pin: anti-friction compound (LM-P)

 Greasing after assembling pin:
Grease (LM-G)

- ⚠ When aligning the position of the pin hole, never insert your fingers in the pin hole.

- ★ Adjust the shim thickness so that the clearance between cylinder bottom (9) and bracket (10) is below 1 mm.

- ★ Standard shim thickness: 0.8 mm, 1.5 mm.

- Refilling with oil (hydraulic tank)
 - ★ Add oil through the oil filler to the specified level. Run the engine to circulate the oil through the system. Then check the oil level again.

- Bleeding air
 - ★ Bleed the air from the cylinder. For details, see TESTING AND ADJUSTING, Bleeding air from hydraulic cylinder.

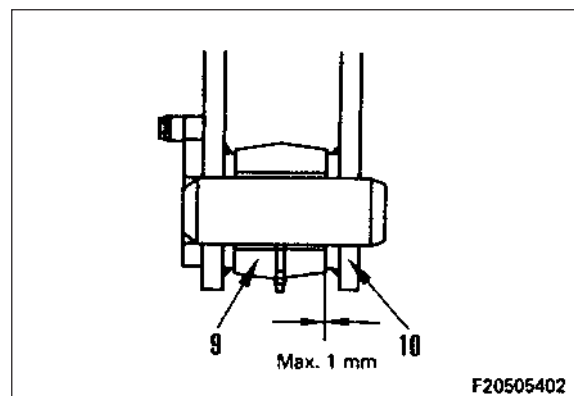
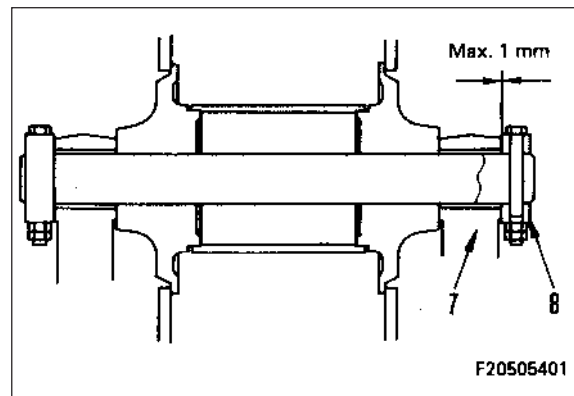
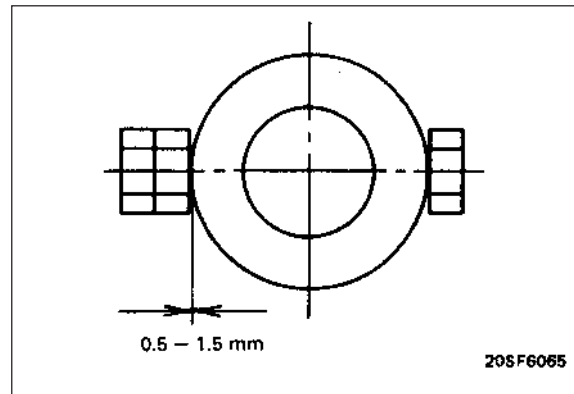

REMOVAL OF ARM CYLINDER ASSEMBLY

⚠ Extend the arm cylinder piston rod approx. 200 mm, lower the work equipment completely to the ground, then set the remaining safety lock lever to the LOCK position.

1. Set block ① between arm cylinder and boom.

2. Remove plate, then remove head pin (1). * 1

3. Start engine, and retract piston rod, then tie piston rod with wire to prevent it from coming out.

⚠ Release the remaining pressure in the hydraulic circuit. For details, see TESTING AND ADJUSTING, Releasing remaining pressure in hydraulic circuit.

4. Disconnect hoses (2).

5. Disconnect grease hose (3).

6. Raise arm cylinder assembly, remove plate, remove bottom pin (4), then remove arm cylinder assembly (5). * 2

★ There are shims installed, so check the number and thickness, and keep in a safe place.



Arm cylinder assembly: 345 kg

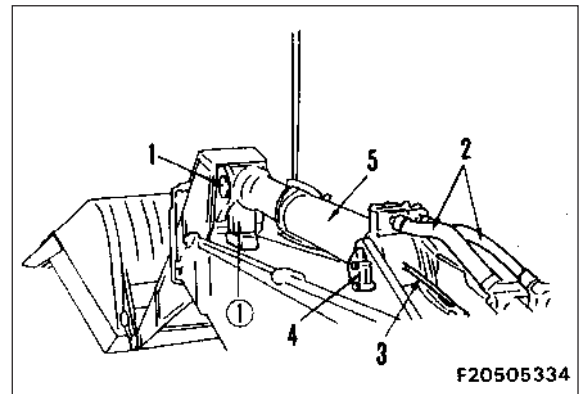



F20505334

INSTALLATION OF ARM CYLINDER ASSEMBLY

- Carry out installation in the reverse order to removal.

※ 1

 Inside surface of bushing when assembling pin: anti-friction compound (LM-P)

 Greasing after assembling pin:
Grease (LM-G)

 When aligning the position of the pin hole, never insert your fingers in the pin hole.

※ 2

 Inside surface of bushing when assembling pin: anti-friction compound (LM-P)

 Greasing after assembling pin:
Grease (LM-G)

 When aligning the position of the pin hole, never insert your fingers in the pin hole.

★ Adjust the shim thickness so that the clearance between cylinder bottom (6) and bracket (7) is below 1 mm.

★ Standard shim thickness: 0.8 mm, 1.5 mm.

- Refilling with oil (hydraulic tank)
 - ★ Add oil through the oil filler to the specified level. Run the engine to circulate the oil through the system. Then check the oil level again.
- Bleeding air
 - ★ Bleed the air from the cylinder. For details, see TESTING AND ADJUSTING, Bleeding air from hydraulic cylinder.

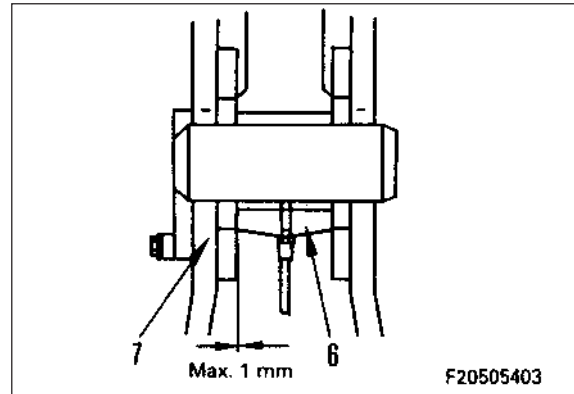

REMOVAL OF BUCKET CYLINDER ASSEMBLY

! Extend the bucket cylinder piston rod approx. 200 mm, lower the work equipment completely to the ground, then set the remaining safety lock lever to the LOCK position.





1. Set block ① between arm top.
 2. Set block ② between link and arm, and block ③ between bucket cylinder and arm.
 3. Remove lock bolt (1). * 1
 4. Remove plate, then remove head pin (2). * 2
 5. Start engine, and retract piston rod, then tie piston rod with wire to prevent it from coming out.
 - ★ Release the remaining pressure in the hydraulic circuit. For details, see TESTING AND ADJUSTING, Releasing remaining pressure in hydraulic circuit.
 6. Disconnect 2 hoses (3).
 7. Raise bucket cylinder assembly, remove plate, remove bottom pin (4), then remove bucket cylinder assembly (5). * 3
- * There are shims installed, so check the number and thickness, and keep in a safe place.

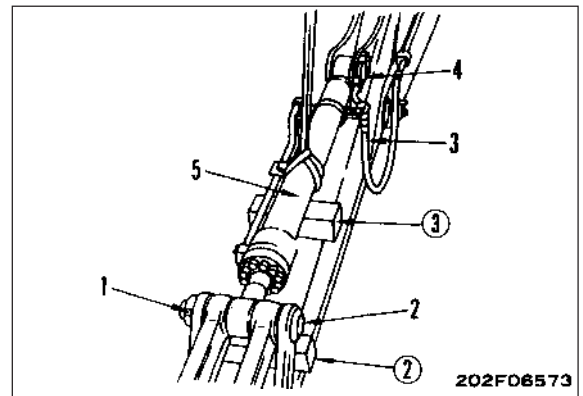
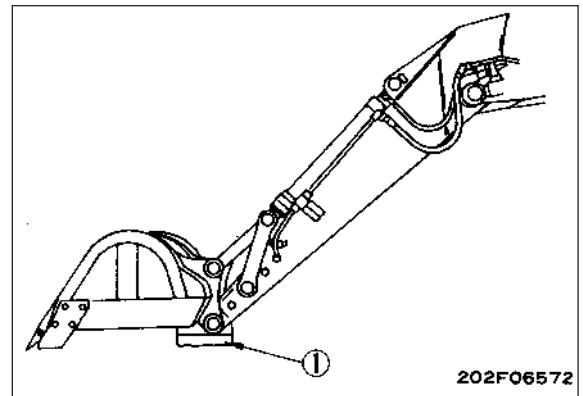

Bucket cylinder assembly: 215 kg



INSTALLATION OF BUCKET CYLINDER ASSEMBLY

- Carry out installation in the reverse order to removal.
 - ★ When tightening the locknut, tighten so that the clearance between the plate and nut is 0.5 - 1.5 mm.
-  Inside surface of bushing when assembling pin: anti-friction compound (LM-P)
-  Greasing after assembling pin: Grease (LM-G)
- ⚠ When aligning the position of the pin hole, never insert your fingers in the pin hole.
- ★ Adjust the shim thickness so that the clearance between cylinder bottom (6) and bracket (7) is below 1 mm.
 - ★ Standard shim thickness: 0.8 mm, 1.5 mm.
-  Inside surface of bushing when assembling pin: anti-friction compound (LM-P)
-  Greasing after assembling pin: Grease (LM-G)
- ⚠ When aligning the position of the pin hole, never insert your fingers in the pin hole.
- ★ Adjust the shim thickness so that the clearance between cylinder bottom (6) and bracket (7) is below 1 mm.
 - ★ Standard shim thickness: 0.8 mm, 1.5 mm.
- Refilling with oil (hydraulic tank)
 - ★ Add oil through the oil filler to the specified level. Run the engine to circulate the oil through the system. Then check the oil level again.
- Bleeding air
 - ★ Bleed the air from the cylinder. For details, see TESTING AND ADJUSTING, Bleeding air from hydraulic cylinder.

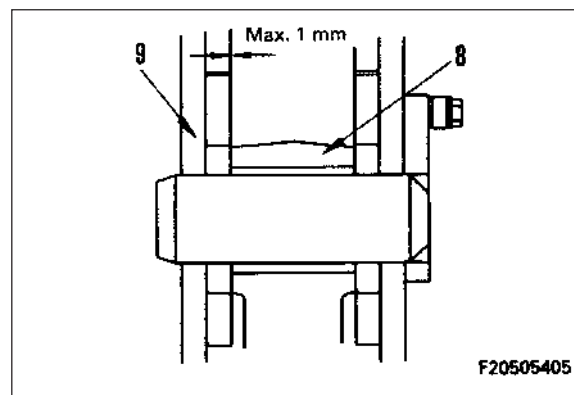
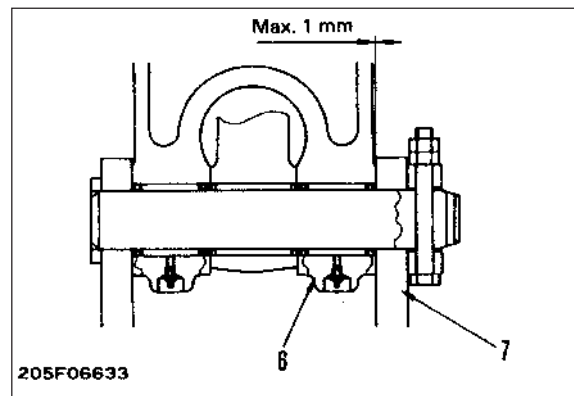
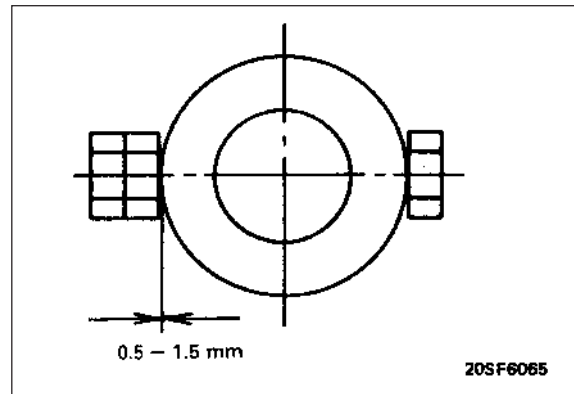

HYDRAULIC CYLINDER

Disassembly

1. Piston rod assembly
 - a. Remove piping from cylinder assembly.
 - b. Remove mounting bolts and disconnect head assembly (1).
 - c. Pull out piston rod assembly (2).
- ★ Place a container under the cylinder to catch the oil.

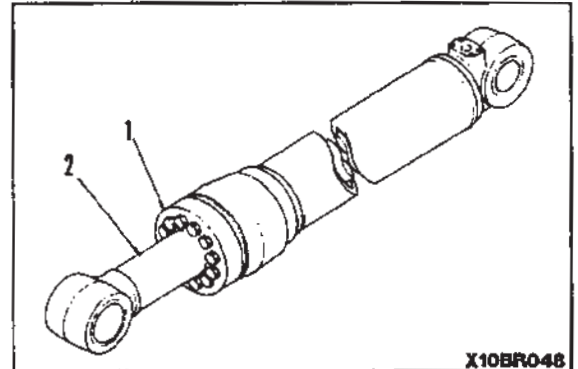

- d. Disassemble piston rod assembly as follows.
 - i. Set piston rod assembly (2) in tool O1.

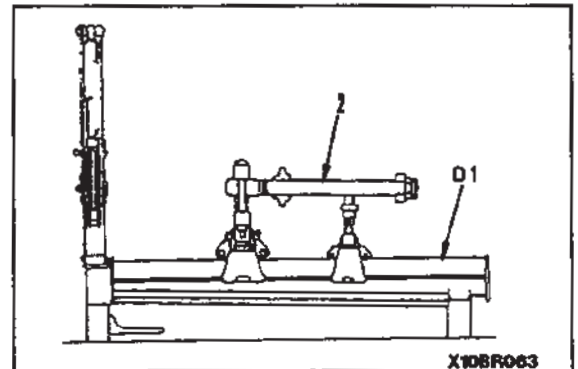

- ii. Remove stopper screw (3) of piston assembly.
- ★ Common screw size for boom, arm, and bucket cylinder: M12 X Pitch 1.75.

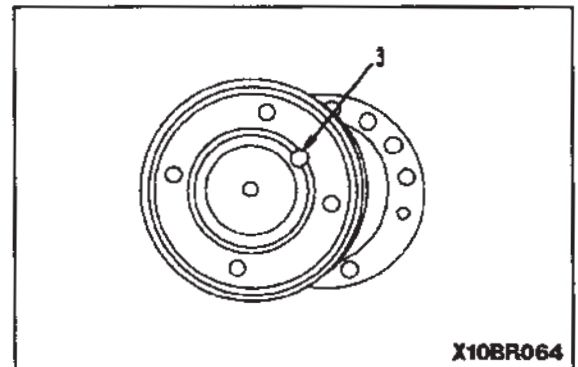

- ★ If the caulking of screw (3) is too strong and it cannot be removed, tighten the screw fully, then fit a tap to the thread and remove the screw.

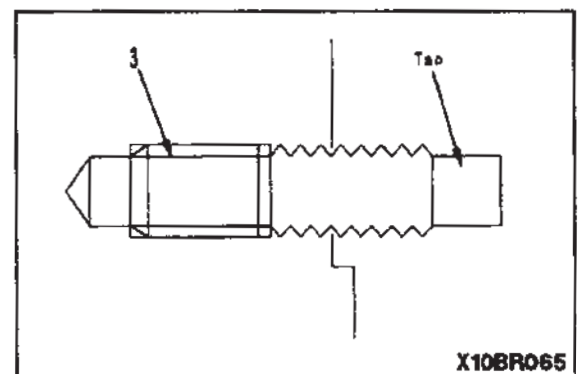

iii. Using tool **O2**, remove piston assembly (4).

★ When not using tool **O2**, use the drill holes ($\phi 10$, 4 places) and loosen the piston assembly.

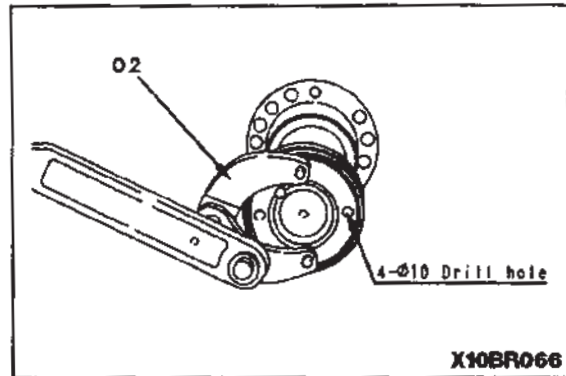

iv. Remove plunger (5).

★ Boom and arm cylinder only.

v. Remove collar (6).

★ Boom and arm cylinder only.

vi. Remove head assembly (7).

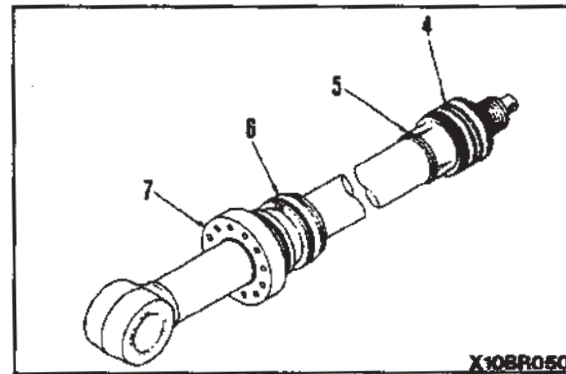

vii. Remove cap (8), and pull out 12 balls (9), then remove plunger (10).

★ Boom and arm cylinder only.

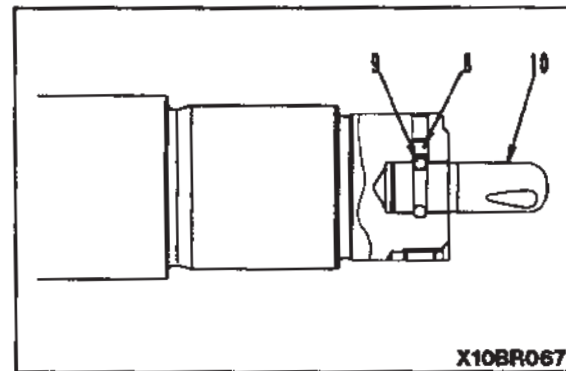

2. Disassembly of piston assembly.

a. Remove rings (11).

b. Remove wear rings (12).

c. Remove piston ring (13).

d. Remove O-ring and backup ring (14).

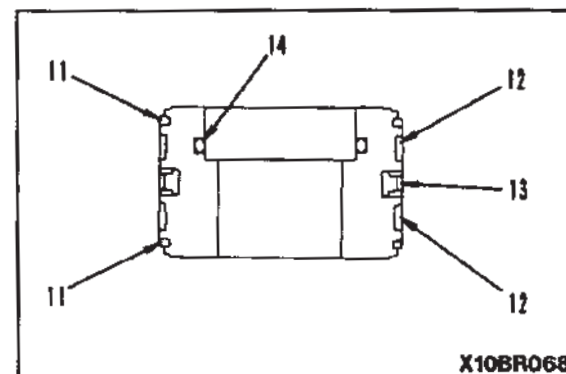

3. Disassembly of cylinder head assembly.
 - a. Remove O-ring and backup ring (15).
 - b. Remove snap ring (16), then remove dust seal (17).
 - c. Remove rod packing (18).
 - d. Remove buffer ring (19).
 - e. Remove bushing (20).

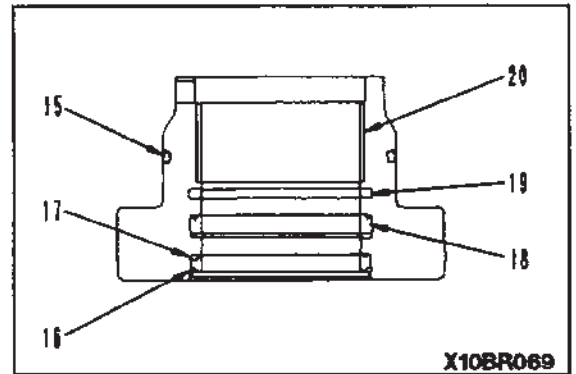

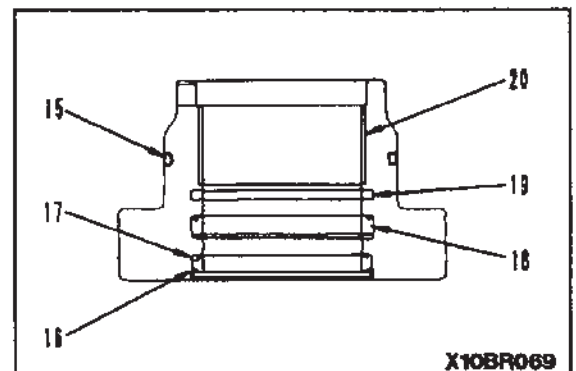
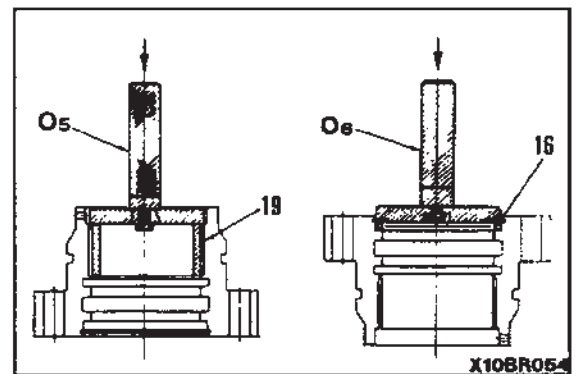

Assembly

- ★ Be careful not to damage the packings, dust seals, and O-rings.
 - ★ Do not try to force the backup ring into position. Warm it in warm water (50 - 60°C) before fitting it.
1. Assembly of head assembly.
 - a. Using tool O5, press fit bushing (20).
 - b. Assemble buffer ring (19).
 - c. Assemble rod packing (18).
 - d. Using tool O6, install dust seal (17), and secure with snap ring (16).
 - e. Install backup ring and O-ring (15).

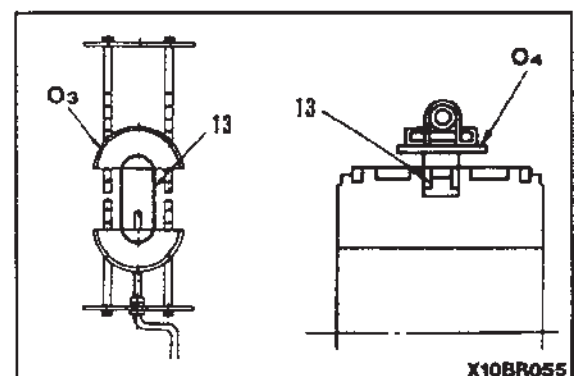

2. Assembly of piston assembly.
 - a. Using tool O3, expand piston ring (13).
 - ★ Set the piston ring on tool O3, and turn the handle 8 - 10 times to expand the ring.
 - b. Set tool O4 in position, and compress piston ring (13).



- c. Install backup ring and O-ring (14).
- d. Assemble wear ring (12).
- e. Assemble ring (11).
- ★ Be careful not to open the end gap of the ring too wide.
-  Ring groove: Grease (G2-L1)

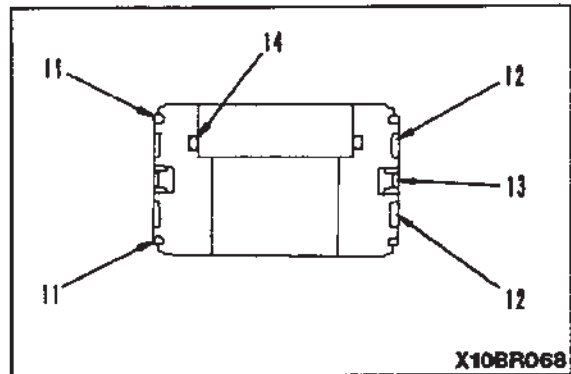

- 3. Piston rod assembly
 - a. Set piston rod assembly (2) in tool O1.

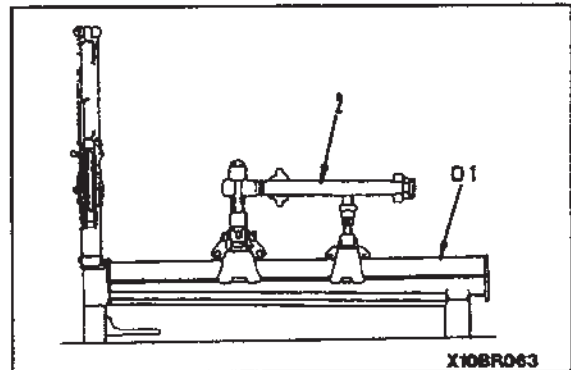

- b. Assemble head assembly (7).
- c. Fit O-ring and backup ring to collar (6), then assemble.
- ★ Boom and arm cylinder only.
- d. Assemble plunger (5).
- ★ Boom and arm cylinder only.
- ★ Check that there is a small amount of play at the tip of the plunger (arm cylinder only).

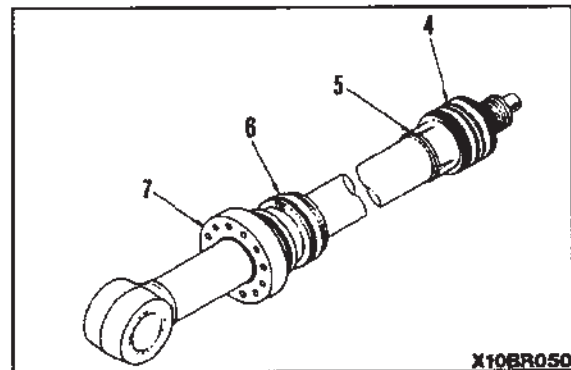

- e. Set cushion plunger (10) to piston rod, then assemble 12 balls (9) and secure with cap (8).
- ★ Arm cylinder only.

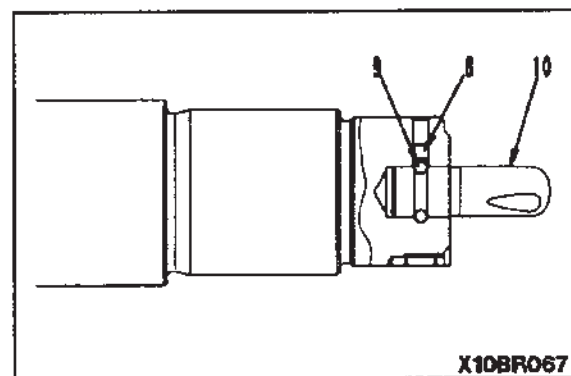

- f. Assemble piston assembly (4) as follows. When using rod and piston again:
 - ★ Wash thoroughly and remove all metal particles and dirt.
 - i. Screw in piston assembly (4), then use tool O2 to tighten piston assembly (2) so that position of screw thread hole matches.
 - ★ Remove all burrs and flashes with a file.
 - ii. Tighten screw (3).
-  Screw (3): $66.2 \pm 7.35 \text{ Nm}$ ($6.75 \pm 0.75 \text{ kgm}$)

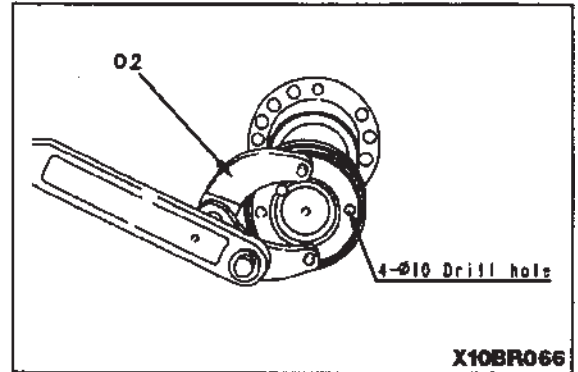

- iii. Caulk thread at 2 places with punch.

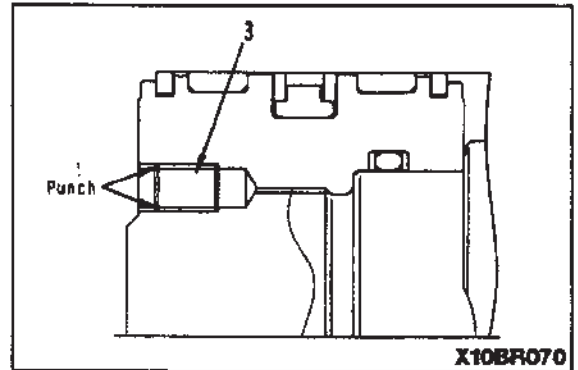

- g. When using a new part for either or both of rod or piston assembly (2).
 - ★ For the rod with bottom cushion, mark the cushion plug position on the end face of the rod (arm cylinder only).
 - i. Screw in until piston assembly (4) contacts end face of rod, then use tool O2 to tighten.
 -  Piston assembly (4): $294 \pm 29.4 \text{ Nm}$ ($30 \pm 3.0 \text{ kgm}$)
 - ★ After tightening the piston, check that there is play in plunger (5).
 - Boom and arm cylinder only.

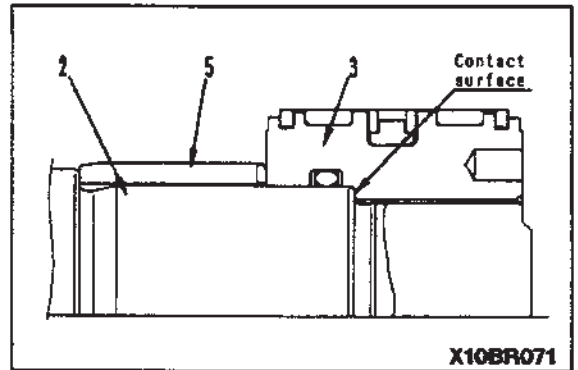

- ii. Machine one of the holes used to install screw (3).
 - ★ Align a drill horizontal with the V-groove of the thread of rod (2) and piston (4), then carry out machining.
 - ★ For the cylinder with bottom cushion (arm cylinder), avoid the cushion plug position when machining.
 - ★ Screw machining dimension (mm)

Drill diameter	Bottom hole depth	Tap used	Tap depth
10.3	27	12 X 1.75	20

- iii. After machining, wash thoroughly to remove all metal particles and dust.

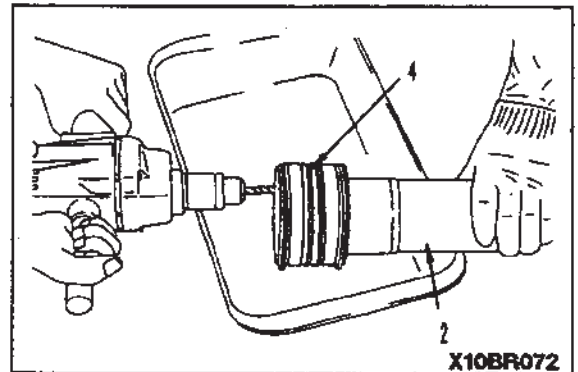

iv. Tighten screw (3)

-  Screw (3): $66.2 \pm 7.35 \text{ Nm}$ ($6.75 \pm 0.75 \text{ kgm}$)
- v. Caulk thread at 2 places with punch.

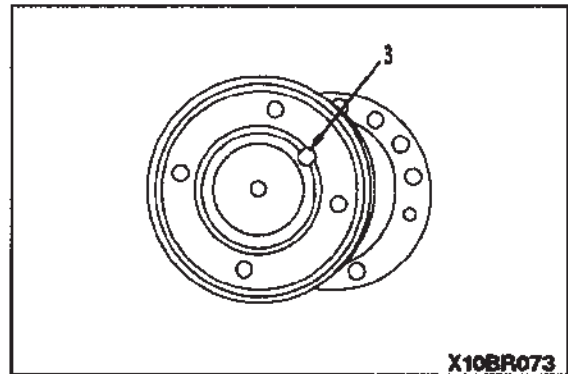

h. Assemble piston rod assembly (2).

-  Seal portion: Grease (G2-LI)

- ★ Set the end gap of the ring horizontal (at side position), align axial center of cylinder tube, then insert.
- ★ After inserting, check that the ring is not broken and has not come out, then push in fully.

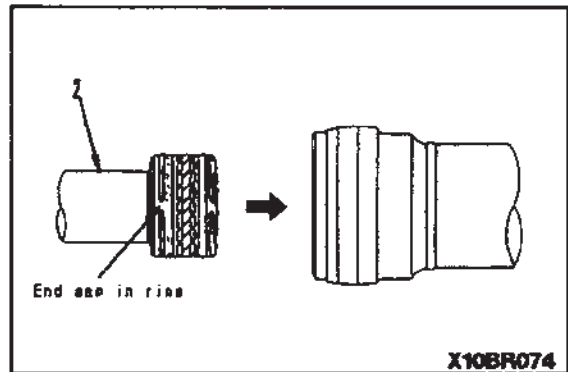

i. Tighten head assembly (1) with mounting bolts.

-  Mounting bolt:

Cylinder	Tightening torque
Bucket	$(38 \pm 5.5 \text{ kgm})$
Arm	$530 \pm 78.5 \text{ Nm}$ ($54 \pm 8 \text{ kgm}$)
Boom	$373 \pm 54 \text{ Nm}$

j. Install piping.

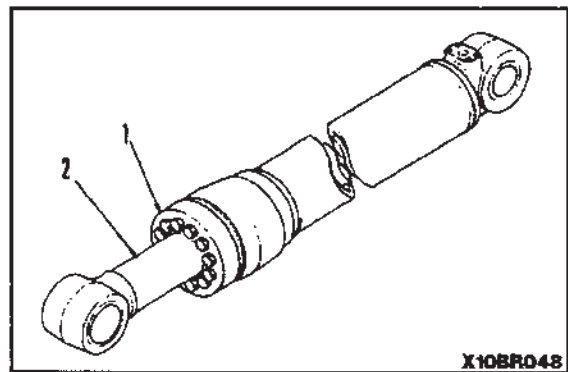

WORK EQUIPMENT

Removal

! Extend the arm bucket fully, lower the work equipment to the ground, and set the safety lock lever to the LOCK position.

1. Disconnect grease hose (1).
2. Sling boom cylinder assembly (2), and remove lock bolt (3).
3. Remove plate, then remove head pin (4).

* 1

* 2

★ There are shims installed, so check the number and thickness, and keep in a safe place.

4. Start engine, and retract piston rod, then tie piston rod with wire to prevent it from coming out, and lower it into block.

★ Disconnect the boom cylinder on the opposite side in the same way.

! Release the remaining pressure in the hydraulic circuit. For details, see TESTING AND ADJUSTING. Releasing remaining pressure in hydraulic circuit.

5. Disconnect hoses (5) and (6), and secure it to valve with rope.

★ Hoses (6) are for machines equipped with an additional attachment circuit.

6. Disconnect wiring connector (7) for working lamp.

7. Sling work equipment assembly, remove plate, then remove foot pin (8) using tool **P**, and remove work equipment assembly (9).

* 3

★ There are shims installed, so check the number and thickness, and keep in a safe place.



Work equipment assembly: 4882 kg

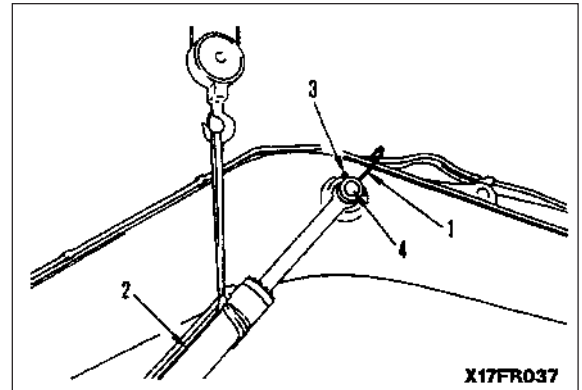

X17FR037

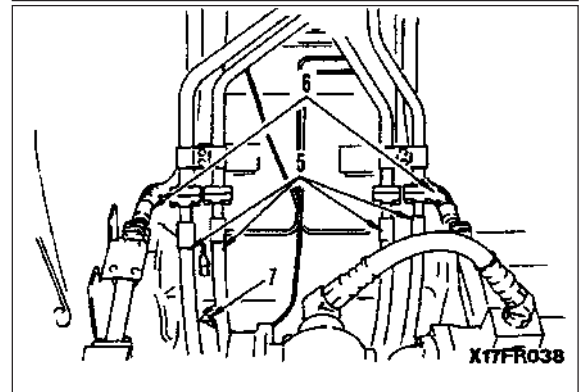

X17FR038

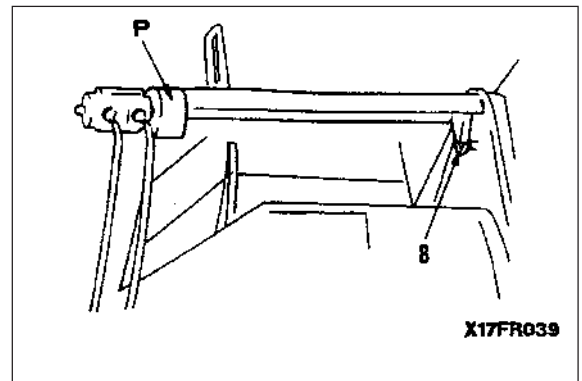

X17FR039

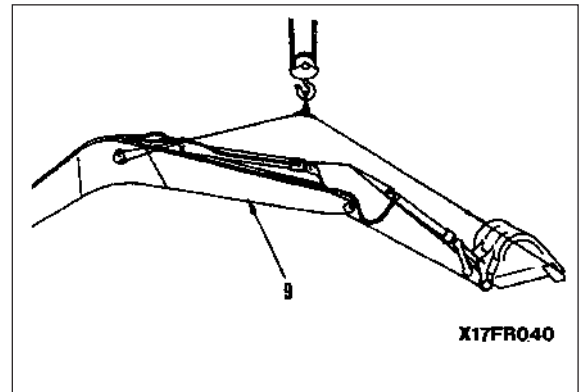

X17FR040



Installation

- Carry out installation in the reverse order to removal.

❖ 1

- ★ When tightening the locknut, tighten so that the clearance between the plate and nut is 0.5 - 1.5 mm.



❖ 2

-  Inside surface of bushing when assembling pin: anti-friction compound (LM-P)
-  Greasing after assembling pin: Grease (LM-G)

- ⚠ When aligning the position of the pin hole, never insert your fingers in the pin hole.

- ★ Adjust the shim thickness so that the clearance between cylinder rod (10) and plate (11) is below 1 mm.
- ★ Standard shim thickness: 0.8 mm, 1.5 mm.

❖ 3

-  Inside surface of bushing when assembling pin: anti-friction compound (LM-P)
-  Greasing after assembling pin: Grease (LM-G)

- ⚠ When aligning the position of the pin hole, never insert your fingers in the pin hole.

- ★ Adjust the shim thickness so that the clearance between boom (12) and bracket (13) is below 1 mm.
- ★ Standard shim thickness: 0.8 mm, 1.5 mm.

- Refilling with oil (hydraulic tank)
- ★ Add oil through the oil filler to the specified level. Run the engine to circulate the oil through the system. Then check the oil level again.

- Bleeding air
- ★ Bleed the air from the cylinder. For details, see TESTING AND ADJUSTING, Bleeding air from hydraulic cylinder.

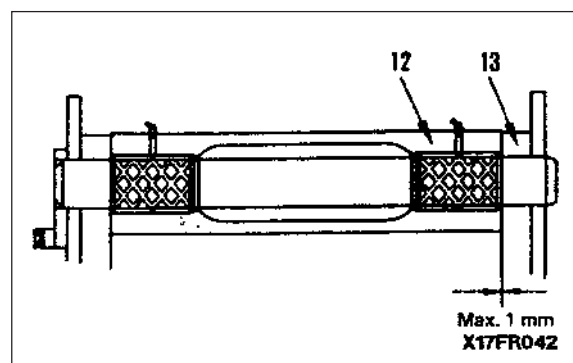
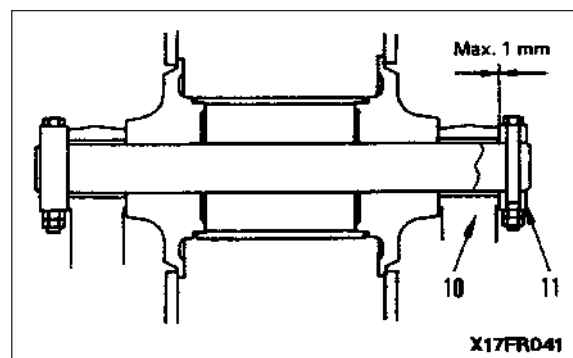
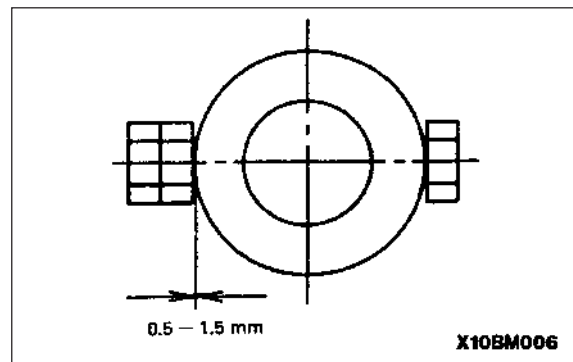

BUCKET

Removal

⚠ Set the back of the bucket facing down, lower the work equipment completely to the ground, and set the safety lock lever to the LOCK position.

1. Remove lock bolt (1). * 1

2. Remove connecting pin (2) between link and bucket. * 2

★ There are shims installed, so check the number and thickness, and keep in a safe place.

3. Start engine, and retract piston, rod, then tie the piston rod with wire to prevent it from coming out.

4. Remove lock bolt (3). * 3

5. Remove plate (4), then remove connecting pin (5) between arm and bucket. * 4

★ There are shims installed, so check the number and thickness, and keep in a safe place.

6. After raising work equipment, swing to disconnect bucket assembly (6).



Bucket assembly: 875 kg

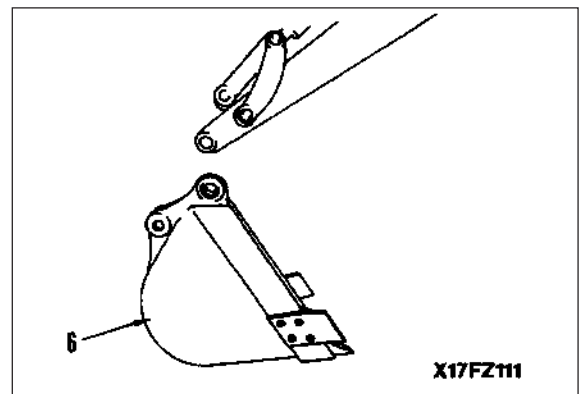
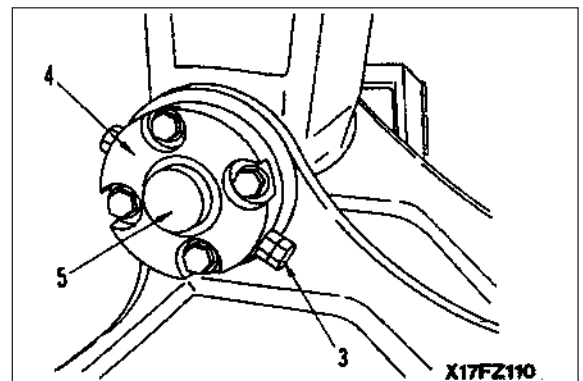
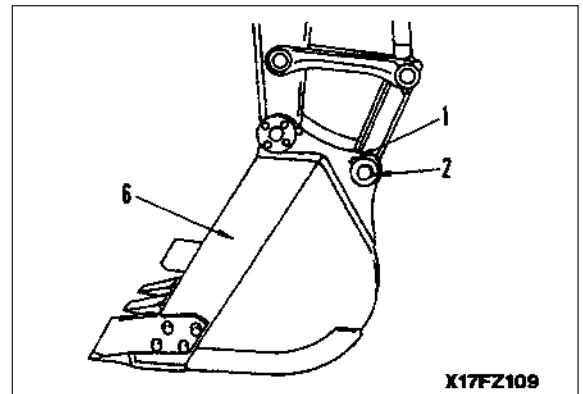

Installation

- Carry out installation in the reverse order to removal.

❖ 1 ❖ 3

- ★ When tightening the locknut, tighten so that the clearance between the plate and nut is 0.5 - 1.5 mm.

❖ 2

 Inside surface of bushing when assembling pin:
anti-friction compound (LM-P)

 Greasing after assembling pin:
Grease (LM-G)

 When aligning the position of the pin hole, never insert your fingers in the pin hole.

- ★ Adjust the shim thickness so that the clearance between bucket boss (7) and link (8) is below 1 mm.

- ★ Standard shim thickness: 0.8 mm, 1.5 mm.

❖ 4

 Inside surface of bushing when assembling pin:
anti-friction compound (LM-P)

 Greasing after assembling pin:
Grease (LM-G)

 When aligning the position of the pin hole, never insert your fingers in the pin hole.

- ★ Set the O-ring at the end face of the bucket boss securely.

- ★ Adjust the shim thickness so that the clearance between arm top (9) and spacer (10) is 0.5- 1.0 mm.

- ★ Standard shim thickness: 0.5 mm, 1.0 mm.

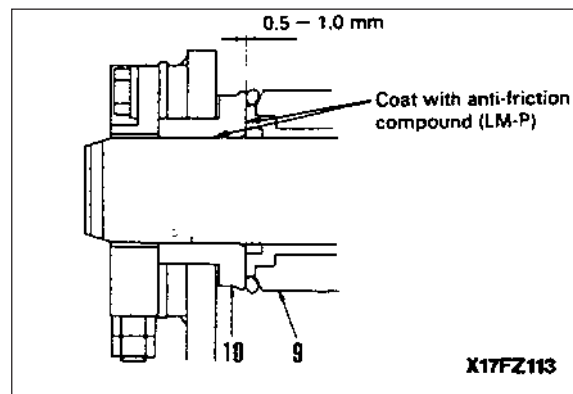
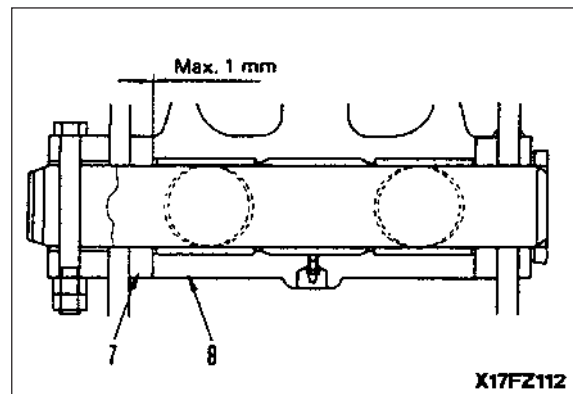
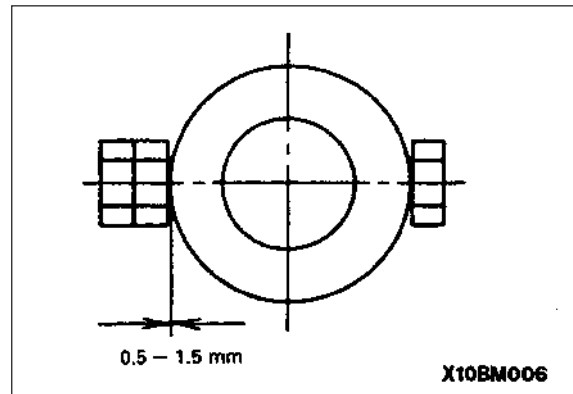

ARM

Removal

1. Remove bucket assembly. For details, see BUCKET, Removal.
2. Secure front link to arm with wire.
3. Pull in arm so that it is easy to remove pin at arm cylinder head, then lower arm and bucket cylinder assembly (1) on to block ①.

- ⚠ Set the safety lock lever to the LOCK position.
- 4. Set block ② between arm cylinder and boom.
- 5. Remove plate, then remove arm cylinder head pin.(2)

※ 1

6. Start engine, and retract piston rod, then tie piston rod with wire to prevent it from coming out.

- ⚠ Release the remaining pressure in the hydraulic circuit. For details, see TESTING AND ADJUSTING, Releasing remaining pressure in hydraulic circuit.

7. Disconnect 2 hoses (3) and 2 hoses (4).
- ★ Install blind plugs at the male end and in the disconnected hoses.
- ★ Hoses (4) are for machines equipped with an additional attachment circuit.
8. Remove plate, then remove connecting pin (5) between arm and boom.
- ★ There are shims installed, so check the number and thickness, and keep in a safe place.
9. After raising boom, swing to remove arm and bucket cylinder assembly (1).

※ 2



Arm, bucket cylinder assembly: 1330 kg

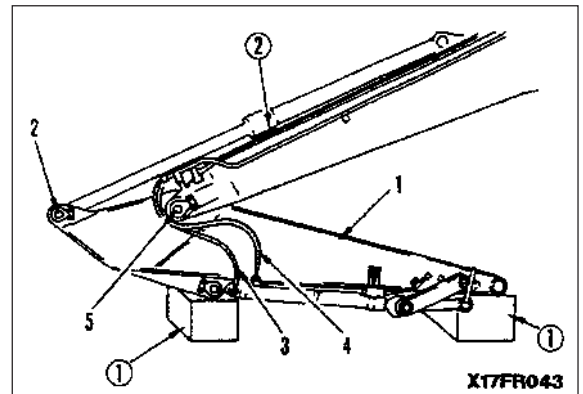

X17FR043

Installation

- Carry out installation in the reverse order to removal.

※ 1



Inside surface of bushing when assembling pin:
anti-friction compound (LM-P)



Greasing after assembling pin:
Grease (LM-G)



When aligning the position of the pin hole, never insert your fingers in the pin hole.

※ 2



Inside surface of bushing when assembling pin:
anti-friction compound (LM-P)



Greasing after assembling pin:
Grease (LM-G)



When aligning the position of the pin hole, never insert your fingers in the pin hole.

- ★ Adjust the shim thickness so that the clearance between boom top (6) and arm bottom (7) is below 1 mm.
- ★ Standard shim thickness: 0.8 mm.
- Refilling with oil (hydraulic tank)
- ★ Add oil through the oil filler to the specified level. Run the engine to circulate the oil through the system. Then check the oil level again.
- Bleeding air
- ★ Bleed the air from the cylinder. For details, see TESTING AND ADJUSTING, Bleeding air from hydraulic cylinder.

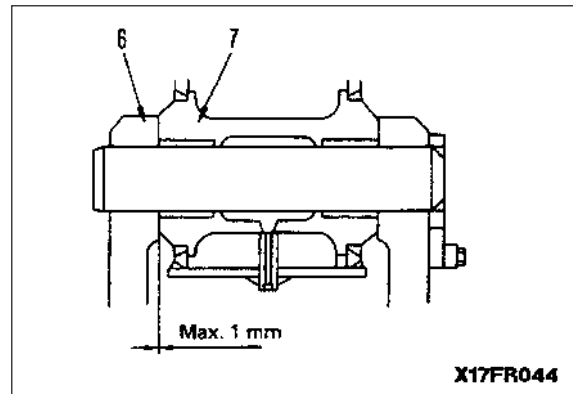

BUCKET - ARM

Removal

⚠ Extend the arm cylinder piston rod approx. 200 mm, lower the work equipment to the ground, and set the safety lock lever to the LOCK position.

1. Set block ① between arm cylinder and boom.
2. Remove plate, then remove arm cylinder head pin (1).
* 1
3. Start engine, and retract piston rod, then tie piston rod with wire to prevent it from coming out.

⚠ Release the remaining pressure in the hydraulic circuit. For details, see TESTING AND ADJUSTING. Releasing remaining pressure in hydraulic circuit.

4. Disconnect 2 hoses (2) and 2 hoses (3)
- ★ Install blind plugs at the male end in the disconnected hoses.
- ★ Hoses (3) are for machines equipped with an additional attachment circuit.
5. Raise bucket and arm assembly, remove plate, then
* 2 remove connecting pin (4) between arm and boom, and remove bucket and arm assembly (5).
- ★ There are shims installed, so check the number and thickness, and keep in a safe place.



Bucket, arm assembly: 2210 kg

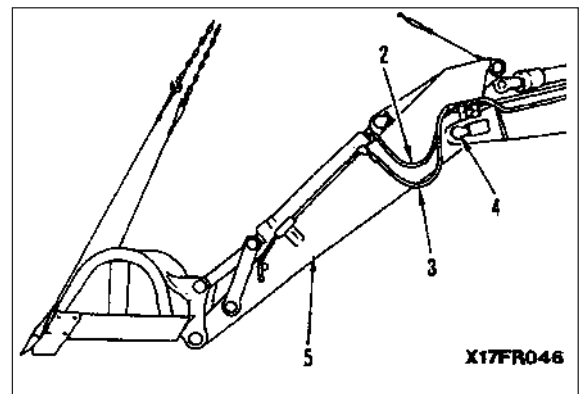
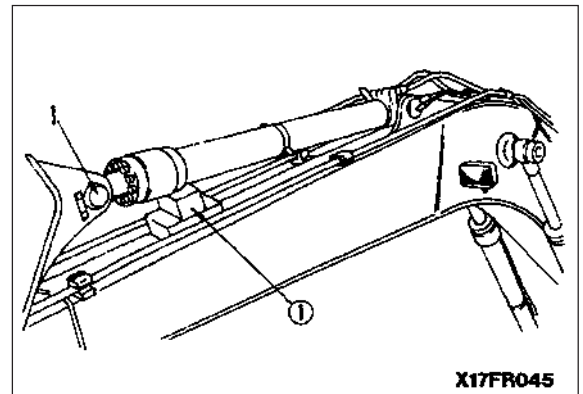

X17FR045

X17FR046

Installation

- Carry out installation in the reverse order to removal.

❖ 1



Inside surface of bushing when assembling pin:
anti-friction compound (LM-P)



Greasing after assembling pin:
Grease (LM-G)



When aligning the position of the pin hole, never insert your fingers in the pin hole.

❖ 2



Inside surface of bushing when assembling pin:
anti-friction compound (LM-P)



Greasing after assembling pin:
Grease (LM-G)



When aligning the position of the pin hole, never insert your fingers in the pin hole.

- ★ Adjust the shim thickness so that the clearance between boom top (6) and arm bottom (7) is below 1 mm.
- ★ Standard shim thickness: 0.8 mm.
- Refilling with oil (hydraulic tank)
- ★ Add oil through the oil filler to the specified level. Run the engine to circulate the oil through the system. Then check the oil level again.
- Bleeding air
- ★ Bleed the air from the cylinder. For details, see TESTING AND ADJUSTING, Bleeding air from hydraulic cylinder.

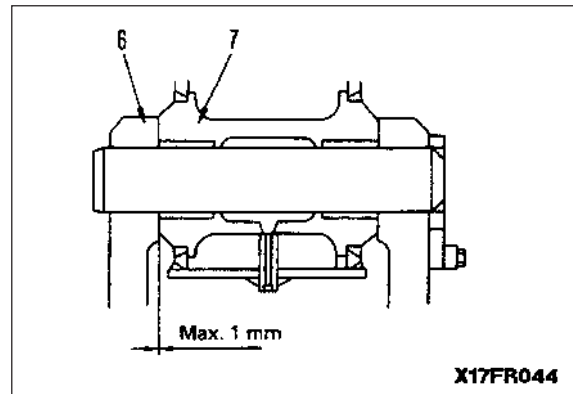

BOOM

Removal

1. Remove bucket and arm assembly. For details, see BUCKET- ARM, Removal.
2. Lower boom assembly completely to the ground and set safety lock lever to LOCK position.
3. Disconnect grease hose (1).
4. Sling boom cylinder assembly (2), and remove lock bolt (3).
5. Remove plate, then remove head pin (4). ✳ 1
5. Remove plate, then remove head pin (4). ✳ 2

- ★ There are shims installed, so check the number and thickness, and keep in a safe place.
- 6. Start engine, and retract piston rod, then tie piston rod with wire to prevent it from coming out, and lower it onto block.
- ★ Disconnect the boom cylinder on the opposite side in the same way.

⚠ Release the remaining pressure in the hydraulic circuit. For details, see TESTING AND ADJUSTING, Releasing remaining pressure in hydraulic circuit.

7. Disconnect hoses (5) and (6), and secure to valve with rope.
- ★ Hoses (6) are for machines equipped with an additional attachment circuit.
8. Disconnect wiring connector (7) for working lamp.
9. Raise boom assembly and remove plate, remove ✳ 3 foot pin (8) using tool **P**, then remove boom assembly (9).
- ★ There are shims installed, so check the number and thickness, and keep in a safe place.

kg Boom assembly: 2040 kg

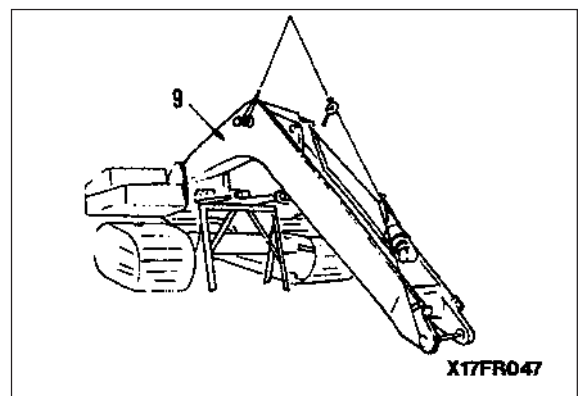
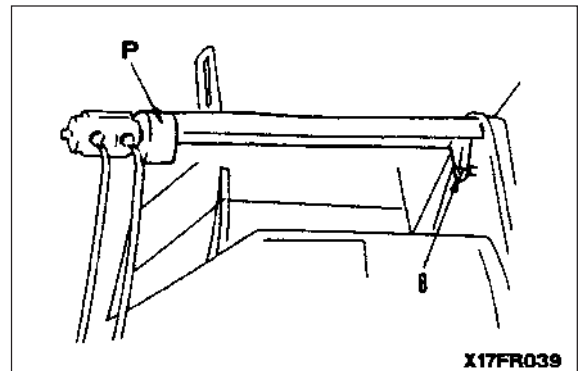
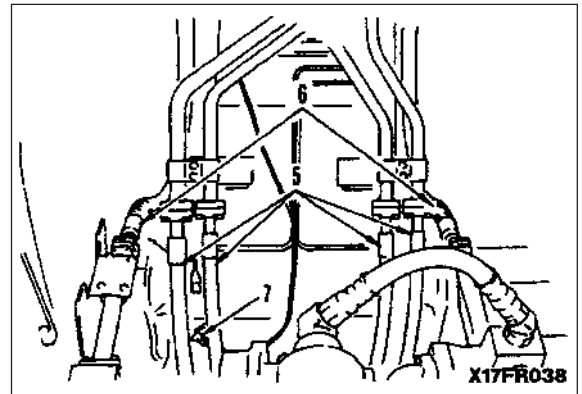
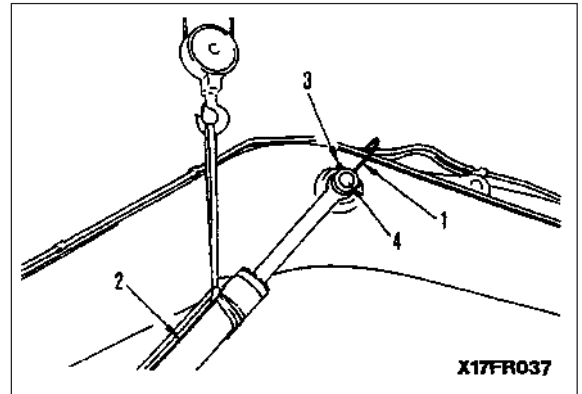



Installation

- Carry out installation in the reverse order to removal.

❖ 1

- ★ When tightening the locknut, tighten so that the clearance between the plate and nut is 0.5 mm - 1.5 mm.



❖ 2

-  Inside surface of bushing when assembling pin:
anti-friction compound (LM-P)
-  Greasing after assembling pin:
Grease (LM-G)

- ⚠ When aligning the position of the pin hole, never insert your fingers in the pin hole.

- ★ Adjust the shim thickness so that the clearance between cylinder rod (10) and plate (11) is below 1 mm.
- ★ Standard shim thickness: 0.8 mm, 1.5 mm.

❖ 3

-  Inside surface of bushing when assembling pin:
anti-friction compound (LM-P)
-  Greasing after assembling pin:
Grease (LM-G)

- ⚠ When aligning the position of the pin hole, never insert your fingers in the pin hole.

- ★ Adjust the shim thickness so that the clearance between boom (12) and bracket (13) is below 1 mm.
- ★ Standard shim thickness: 0.8 mm, 1.0 mm, 1.5 mm.
- Refilling with oil (hydraulic tank)
- ★ Add oil through the oil filler to the specified level. Run the engine to circulate the oil through the system. Then check the oil level again.
- Bleeding air
- ★ Bleed the air from the cylinder. For details, see TESTING AND ADJUSTING, Bleeding air from hydraulic cylinder.

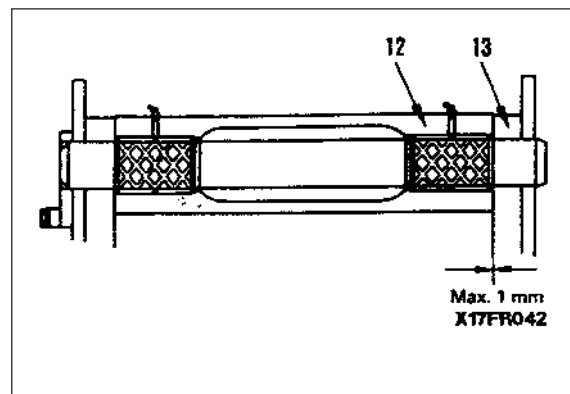
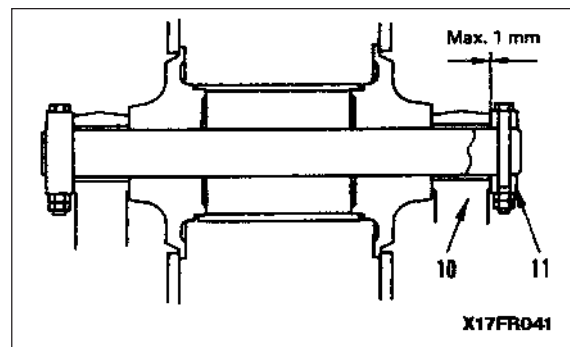
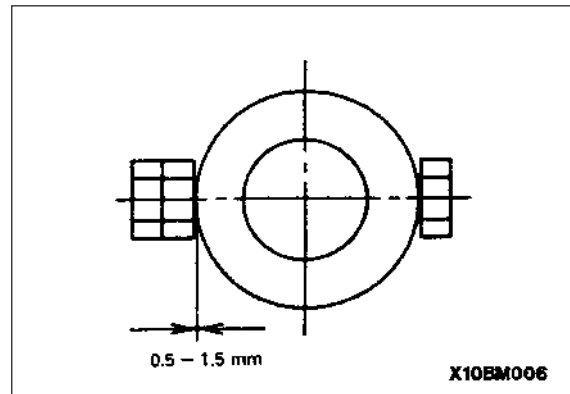

REMOVAL OF OPERATOR'S CAB ASSEMBLY

! Disconnect the cable from the negative (-) terminal of the battery.

1. Remove floor mat. (1)
2. Remove operator's seat assembly. (2)
(Disconnect heated seat connection is fitted).

 Operator's seat assembly: 40 kg.

3. Remove knob(3).
4. Remove 4 caps (4) and clip (5), then remove middle panel (6).
5. Remove bottom panel (7).
 - ★ The panel is held by a clip, so remove the clip when removing the panel and be careful not to damage it.

6. Disconnect washer hose (8).

7. Remove radio (11) if fitted (refer to radio operation manual).
 - ★ Remove plate (9), then remove cover (10).
8. Lift cover (10) away carefully to locate speaker harness connector. Disconnect and remove panel completely.

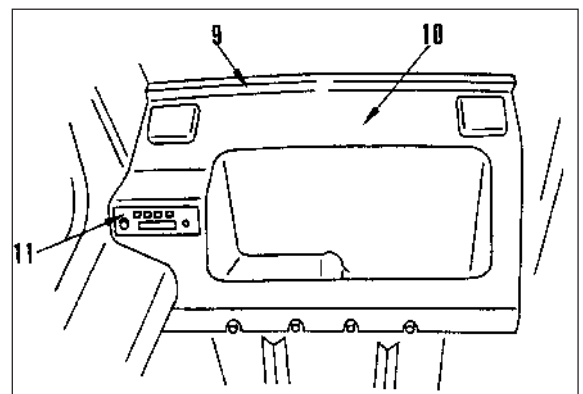
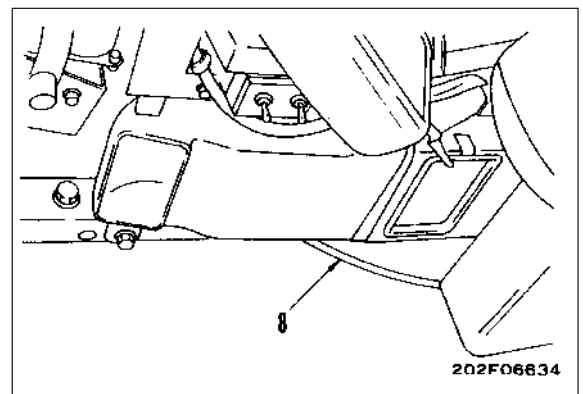
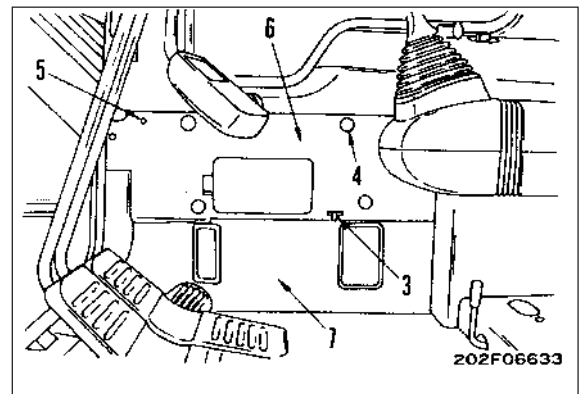
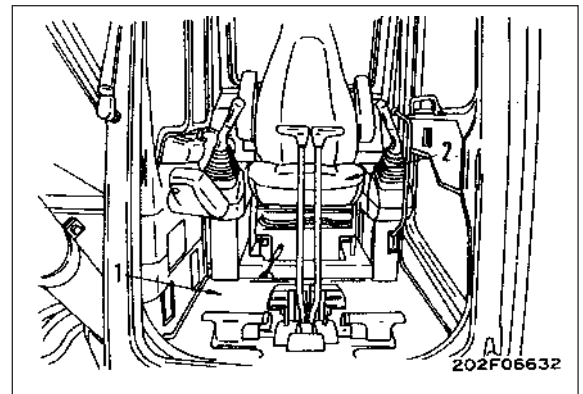

9. Remove divider board (13).
10. Remove heater duct of air conditioner ducts (14) and (15) if fitted.
11. Disconnect 13 connectors (12)
Panel: CN-X07 (mic17)
Controller: CN-C01 (mic13)
CN-C02 (mic21)
CN-C03 (040)
CN-C16 (mic17)
Wiring harness intermediate:
CN-H07
CN-H08
CN-H12
CN-H13
CN-H14
CN-H15
CN-G01
CN-K01 (if fitted)
12. Disconnect heater cables or air conditioner cables (16) if fitted.

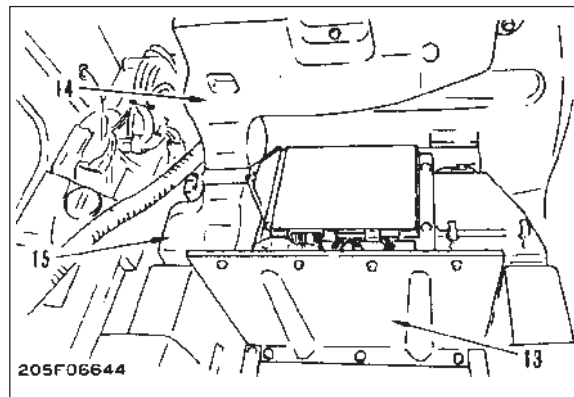
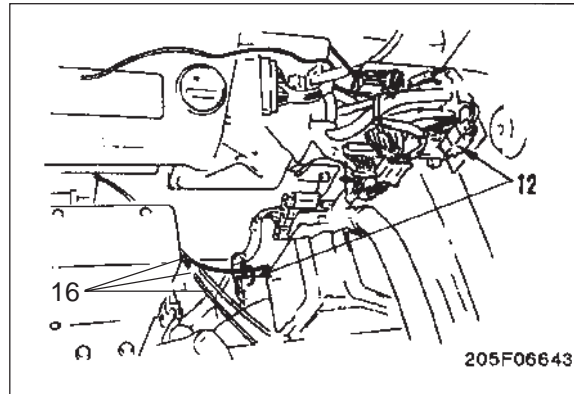

13. Remove 11 cab mounting bolts (marked x).

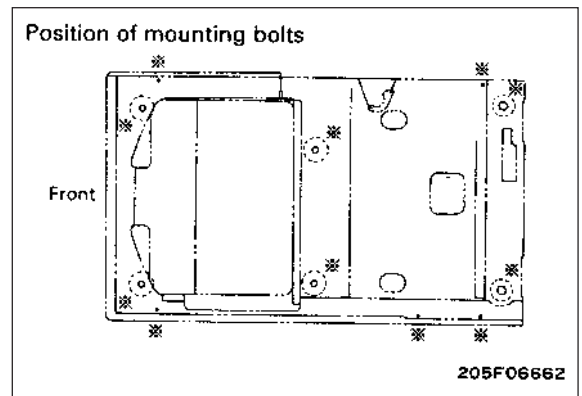

14. Using eyebolts ①, remove operator's cab assembly (17).



Operator's cab assembly: 300 kg

- ★ When raising the cab assembly, check that all the wiring has been disconnected, then lift off slowly and be careful not to hit any part.

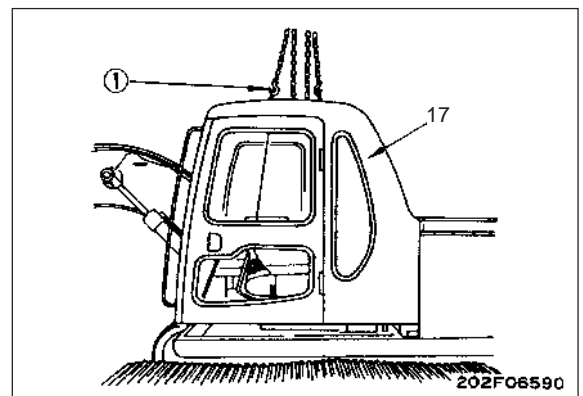

INSTALLATION OF OPERATOR'S CAB ASSEMBLY

- Carry out installation in the reverse order to removal.

COUNTERWEIGHT

Removal

1. Set eyebolts ① to counterweight assembly (1), and sling.
2. Remove mounting bolts (2) and (3). ※ 1
- ★ Be careful not to lose the shims when removing.
3. Lift off counterweight (1) horizontally with wire or chain block. ※ 2
- ★ Be careful not to hit the engine, radiator and cooler assembly.



Counterweight assembly: 5.800 kg

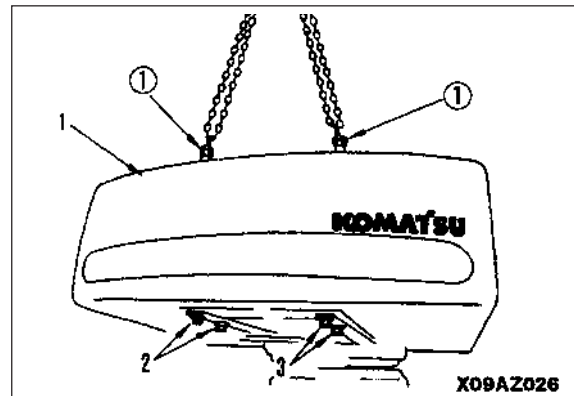

Installation

- Carry out installation in the reverse order to removal.

※ 1



Thread of counterweight mounting bolt: Thread tightener (LT-2)



Counterweight mounting bolt: 1.323 ± 147 Nm
(135 ± 15 kgm)

※ 2

- ★ Installing and adjusting counterweight
1. Sling counterweight with crane and set in position on frame.
 2. Push counterweight and install shim and mounting bolts (2) and (3), and adjust to following dimensions.
 - a. Clearance from revolving frame: 10 ± 5 mm (left and right)
 - b. Clearance from bodywork door: 10 ± 5 mm (left and right)
 - c. Stepped difference **b** from revolving frame in left-to-right direction: Max. 5 mm
 - d. Stepped difference **a** from bodywork door in left-to-right direction: 10 ± 4 mm
 - e. Stepped difference **c** from bodywork top cover in updown direction: Max. 5 mm

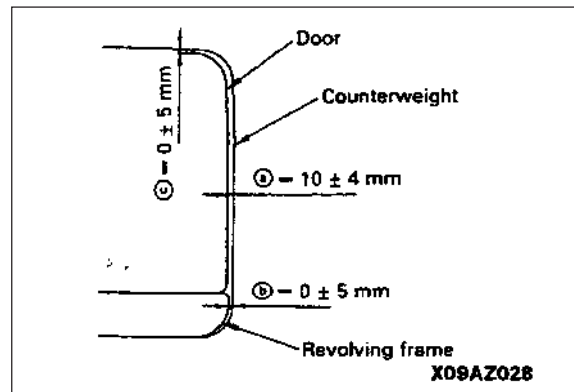

REMOVAL OF ENGINE THROTTLE CONTROLLER ASSEMBLY

⚠ Disconnect the cable from the negative (-) terminal of the battery.

1. Remove Radio (2) if fitted.
2. Remove plate (1), then remove cover (2), (3).
3. Lift cover (3) away carefully to locate speaker harness connector. Disconnect and remove panel completely.

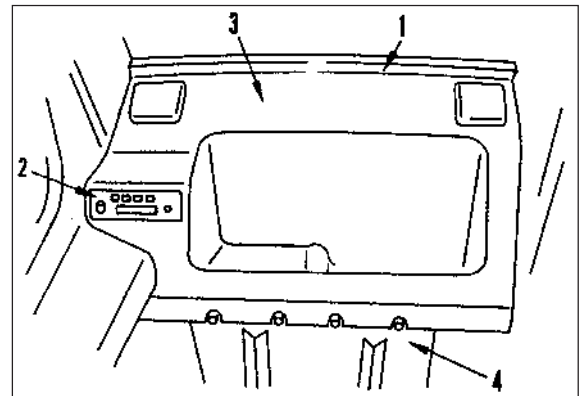

4. Remove divider board (5).
5. Remove 5 connectors (5).
6. Remove engine throttle and pump controller assembly (6).

Installation

- Carry out installation in the reverse order to removal. * I
- ★ Check the performance of the work equipment, travel, and swing. For details, see TESTING AND ADJUSTING.

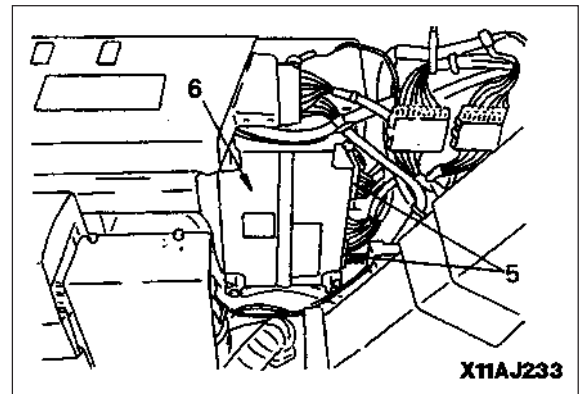

X11AJ233

MONITOR

Removal

⚠ Disconnect the cable from the negative (-) terminal of the battery.

1. Remove screws (1), then lift up monitor assembly (2).
2. Disconnect wiring connectors (3), then remove monitor assembly (2).

Installation

- Carry out installation in the reverse order to removal.
- Check the mode setting and display function. For details, see TESTING, ADJUSTING AND TROUBLESHOOTING.

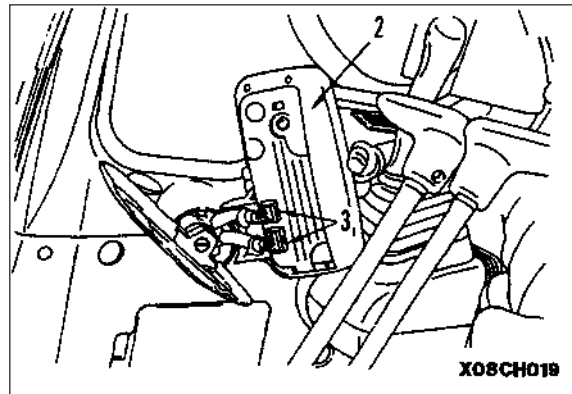
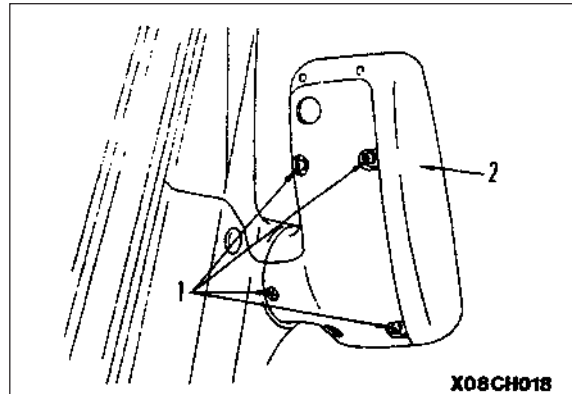

MEMORANDA

40 MAINTENANCE STANDARD

SWING MACHINERY	40-4
SWING CIRCLE	40-6
FINAL DRIVE	40-7
TRACK FRAME • RECOIL SPRING	40-9
IDLER	40-10
CARRIER ROLLER	40-12
TRACK ROLLER	40-13
TRACK SHOE	40-14
HYDRAULIC PUMP	40-16
CONTROL VALVE	40-17
VARIABLE PRESSURE COMPENSATION VALVE	40-23
SAFETY-SUCTION VALVE FOR SERVICE VALVE	40-24
SELF-REDUCING PRESSURE VALVE	40-25
SWING MOTOR	40-26
TRAVEL MOTOR	40-27
TRAVEL PPC VALVE	40-29
WORK EQUIPMENT • SWING PPC VALVE	40-28
EPC SOLENOID VALVE	40-31
CENTER SWIVEL JOINT	40-32

HYDRAULIC CYLINDER	40-33
PC290	
Boom cylinder	40-33
Arm cylinder	40-33
Bucket cylinder	40-33
WORK EQUIPMENT	40-35
DIMENSION OF WORK EQUIPMENT	40-37
Arm portion	40-37
PROPOSAL FOR MANUAL REVISION	40-41

MEMORANDA

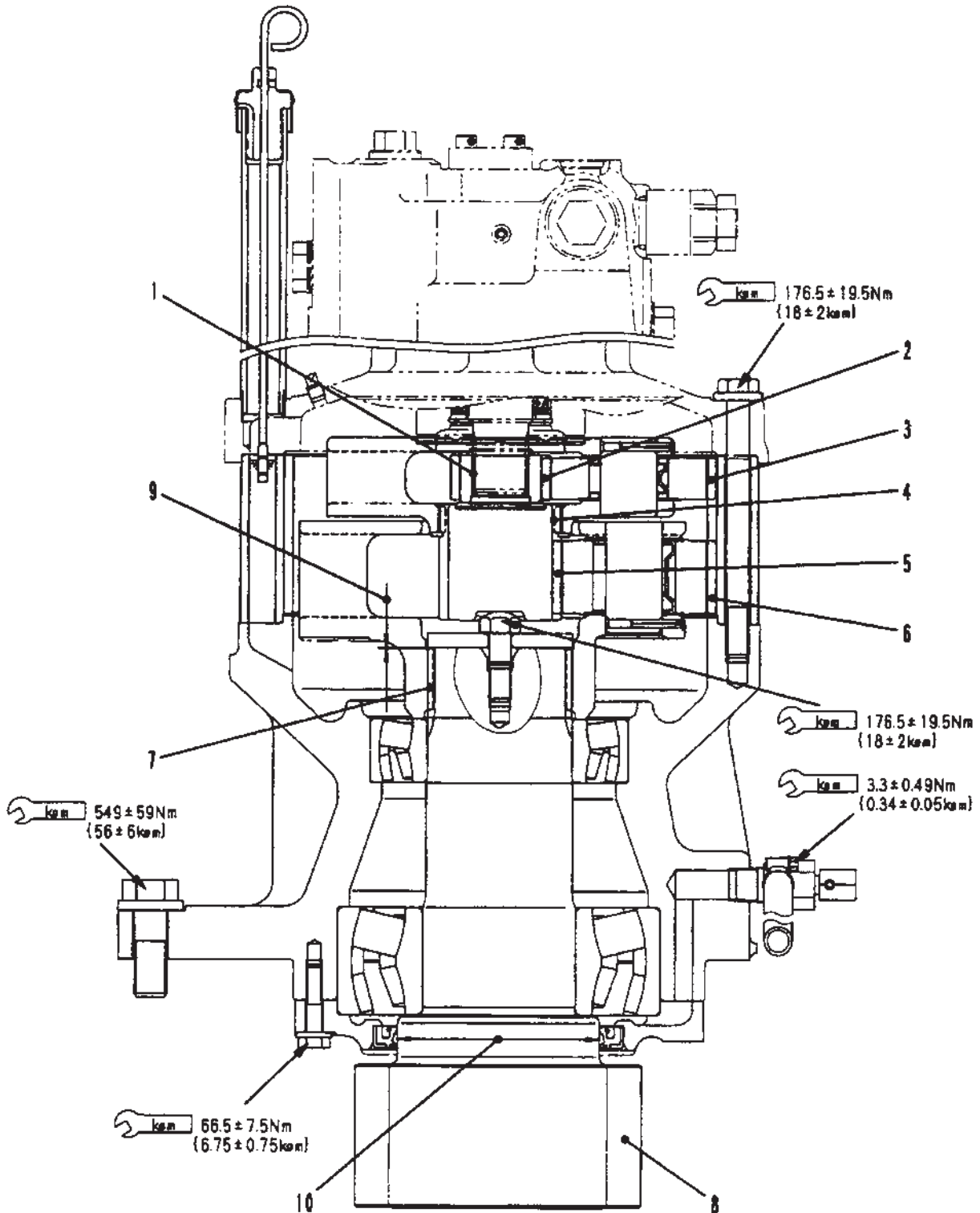

X09DH066

Unit: mm

No.	Check item	Criteria		Remedy
		Standard clearance	Clearance limit	
1	Backlash between swing motor shaft and No. 1 sun gear	0.18 - 0.29	-	Replace
2	Backlash between No. 1 sun gear and No. 1 planetary gear	0.15 - 0.47	1.00	
3	Backlash between No. 1 planetary gear and ring gear	0.17 - 0.55	1.10	
4	Backlash between No. 1 planetary carrier and No.2 sun gear	0.36 - 0.63	1.20	
5	Backlash between No. 2 sun gear and No. 2 planetary gear	0.14 - 0.44	0.90	
6	Backlash between No. 2 planetary gear and ring gear	0.16 - 0.51	1.00	
7	Backlash between No. 2 planetary carrier and swing pinion	0.09 - 0.20	-	
8	Backlash between swing pinion and swing circle	0.22 - 1.32	2.00	
9	Clearance between plate and planetary carrier	0.90 ± 0.22	-	
10	Wear of swing pinion surface contacting with oil seal	Standard size	Repair limit	Apply hard chrome plating, recondition, or replace
	Wear of swing pinion surface contacting with oil seal	125 ⁰ _{-0.100}	124.7	

SWING CIRCLE

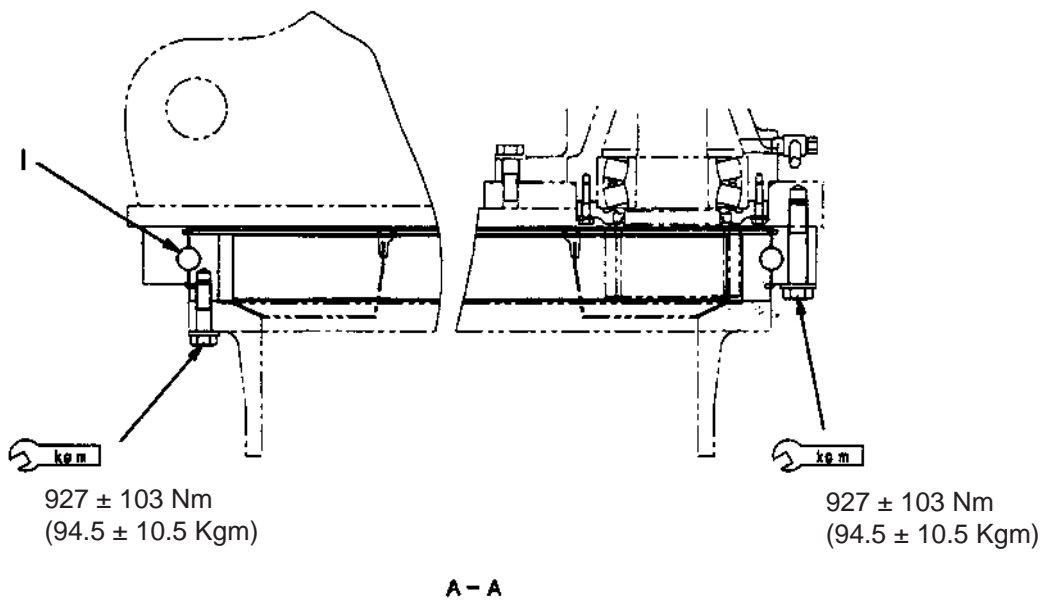
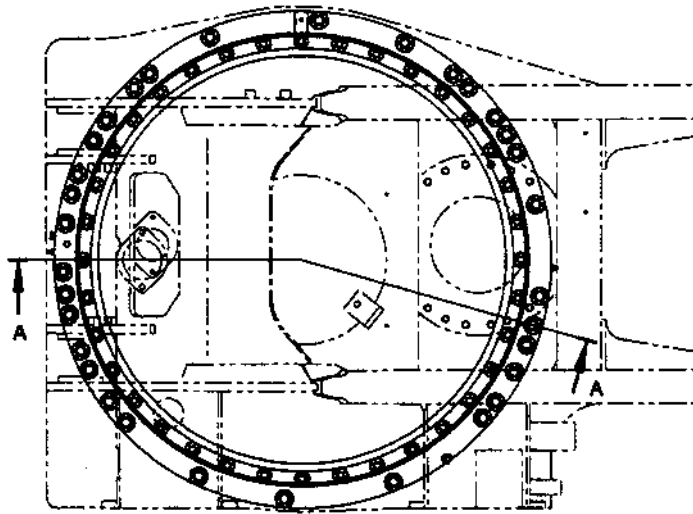

Unit: mm

No.	Check item	Criteria		Remedy
		Standard clearance	Clearance limit	
1	Axial clearance of bearing (when mounted on chassis)	0.5 - 1.6	3.2	Replace

FINAL DRIVE

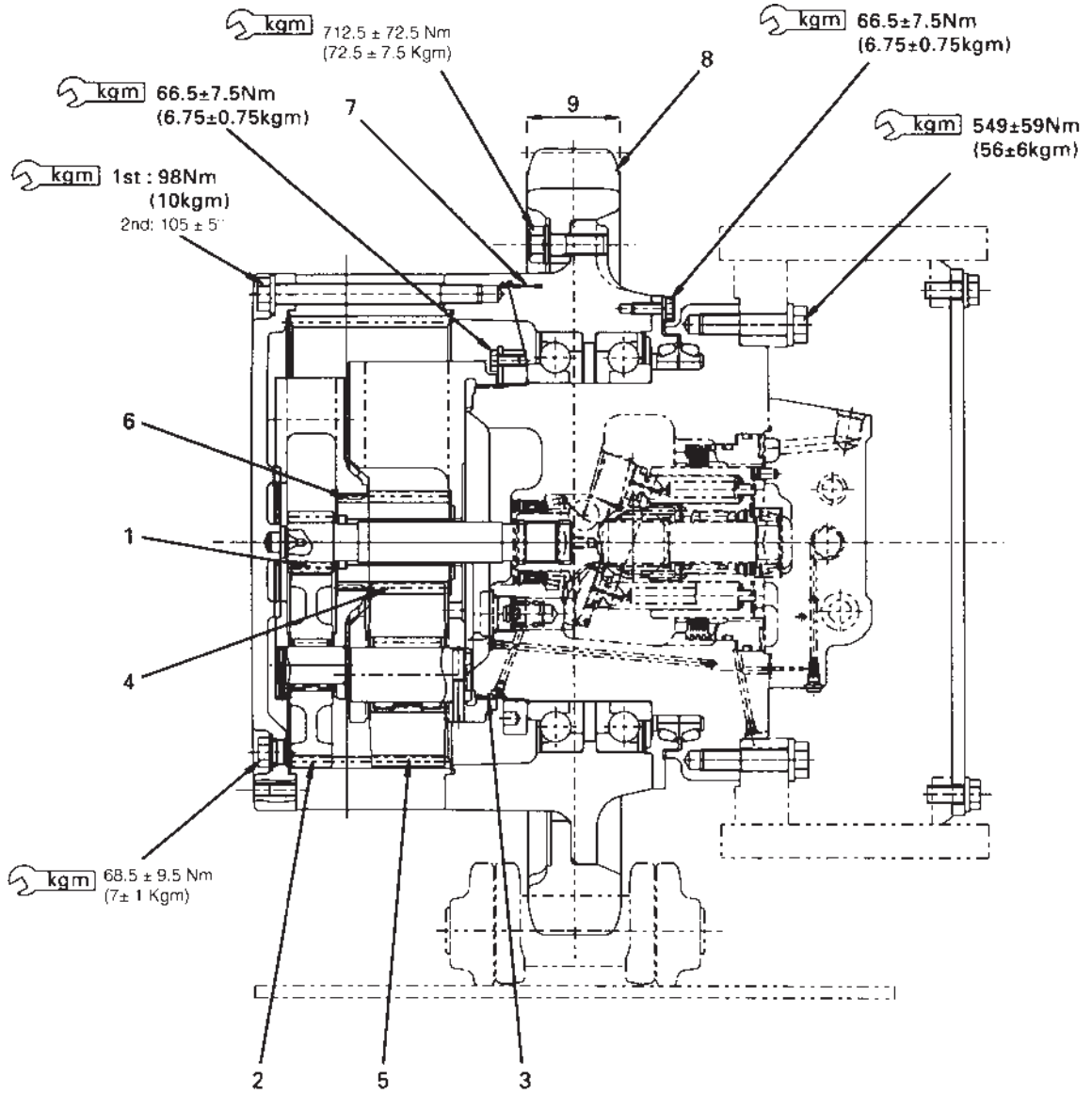

SAP00407

Unit: mm

No.	Check item	Criteria		Remedy
		Standard clearance	Clearance limit	
1	Backlash between No. 1 sun gear and No. 1 planetary gear	0.17 - 0.50	1.00	Replace
2	Backlash between No. 1 planetary gear and ring gear	0.21 - 0.64	1.10	
3	Backlash between No. 1 planetary carrier and motor	0.06 - 0.24	-	
4	Backlash between No. 2 sun gear and No. 2 planetary gear	0.17 - 0.52	1.00	
5	Backlash between No. 2 planetary gear and ring gear	0.217 - 0.64	1.10	
6	Backlash between No. 1 planetary carrier and No. 2 sun gear	0.38 - 0.78	1.00	
7	End play of sprocket shaft	0.10 - 0.15	-	
8	Wear of sprocket teeth	Repair limit: 6		
9	Sprocket tooth width	Standard size	Repair limit	Rebuild or replace
		87	84	

TRACK FRAME AND RECOIL SPRING

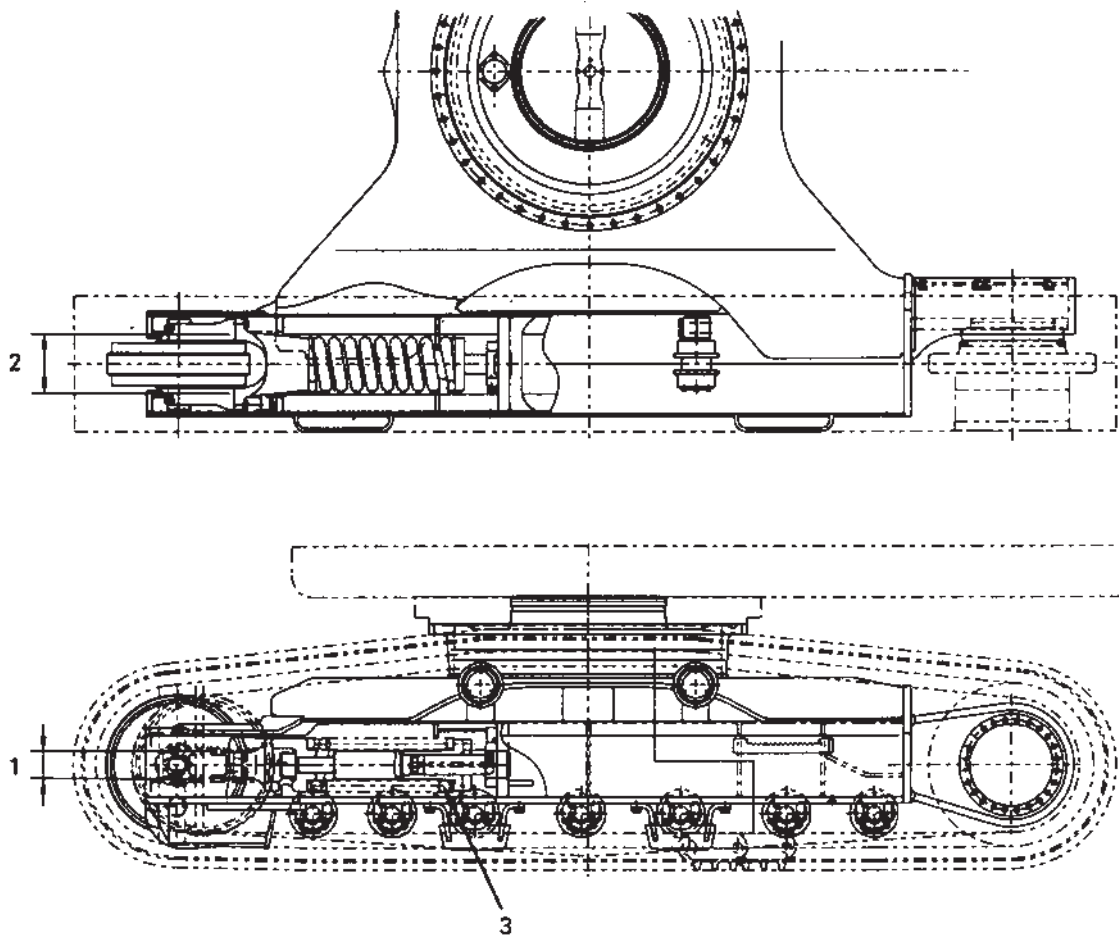

SAP00409

Unit: mm

No.	Check item	Criteria				Remedy
			Standard size	Tolerance	Repair limit	
1	Top-to-bottom width of idler guide	Track frame	123	+3 -1	127	Rebuild or replace
		Idler support	120	±0.5	118	
2	Left-to-right width of idler guide	Track frame	266	+4 -1	271	
		Idler support	261	-	259	
3	Recoil spring	Standard size		Tolerance	Repair limit	Replace
		Free length X OD	Installed length	Installed load	Installed load	
		820 x 243	669	185.2 kN (18885 kgf)	±9.5 kN (969 kgf) 148.8 kN (15137 kgf)	

IDLER

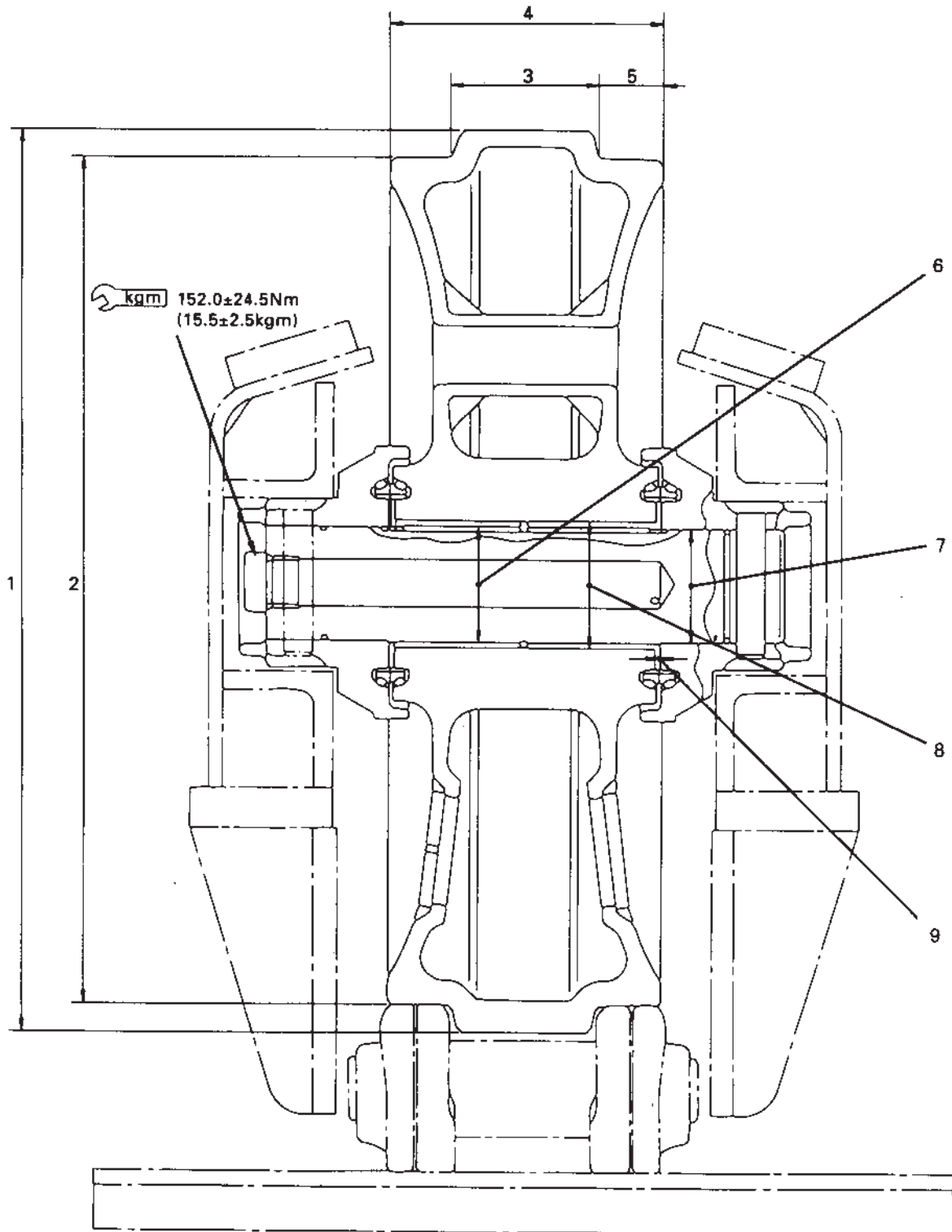

SBP00411

Unit: mm

No.	Check item	Criteria				Remedy	
		Standard size		Repair limit			
1	Outside diameter of protruding portion	630		—		Rebuild or replace	
2	Outside diameter of tread	590		578			
3	Width of protrusion	101		—			
4	Overall width	190		—			
5	Width of tread	44.5		50.5		Replace bushing	
6	Clearance between shaft and bushing	Standard size	Tolerance		Standard clearance		Clearance limit
			Shaft	Hole			
		80	-0.225 -0.325	+0.130 -0.010	0.215 – 0.455	1.5	
7	Clearance between shaft and support	80	-0.225 -0.290	-0.085 -0.195	0.03 – 0.205	—	Replace
8	Interference between idler and bushing	Standard size	Tolerance		Standard interference	Interference limit	
			Shaft	Hole			
		87.6	+0.087 +0.037	-0.042 -0.079	0.064 – 0.166	—	Replace bushing
9	Side clearance of idler (both sides)	Standard clearance		Clearance limit			
		0.68 – 1.22		2			

CARRIER ROLLER

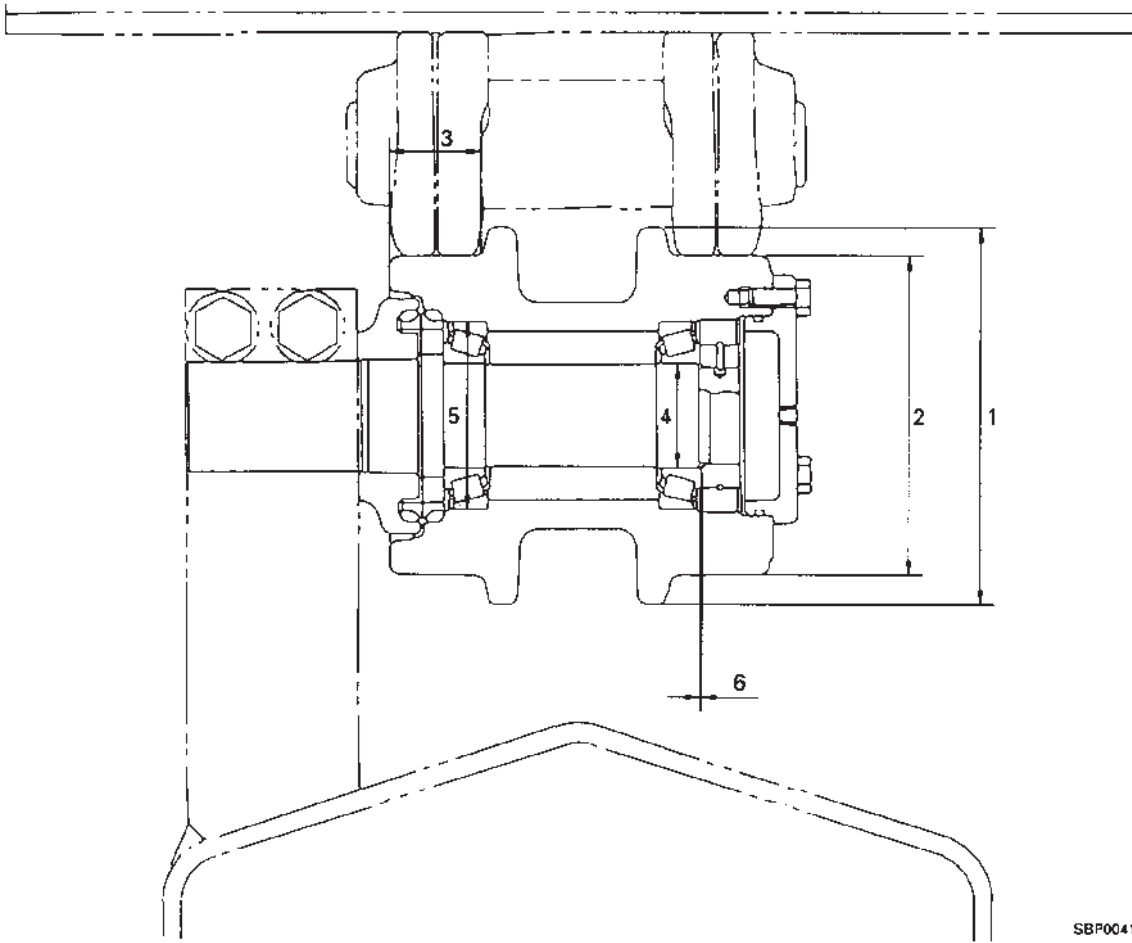

SBP00415

Unit: mm

No.	Check item	Criteria				Remedy	
		Standard size	Repair limit				
1	Outside diameter of flange (outside)	Standard size	Repair limit		Rebuild or replace		
		200	-				
2	Outside diameter of tread	168	158				
3	Width of tread	57	66				
4	Interference between shaft and bearing	Standard size	Tolerance		Standard interference	Interference limit	
			Shaft	Hole			
		55	+0.021 -0.002	0 -0.015	0.002 - 0.036	-	
5	Interference between roller and bearing	100	0 -0.015	-0.024 -0.059	0.009 - 0.059	-	Replace
6	Side clearance of roller	Standard size		Repair limit			
		0.01 - 0.22		-			

TRACK ROLLER

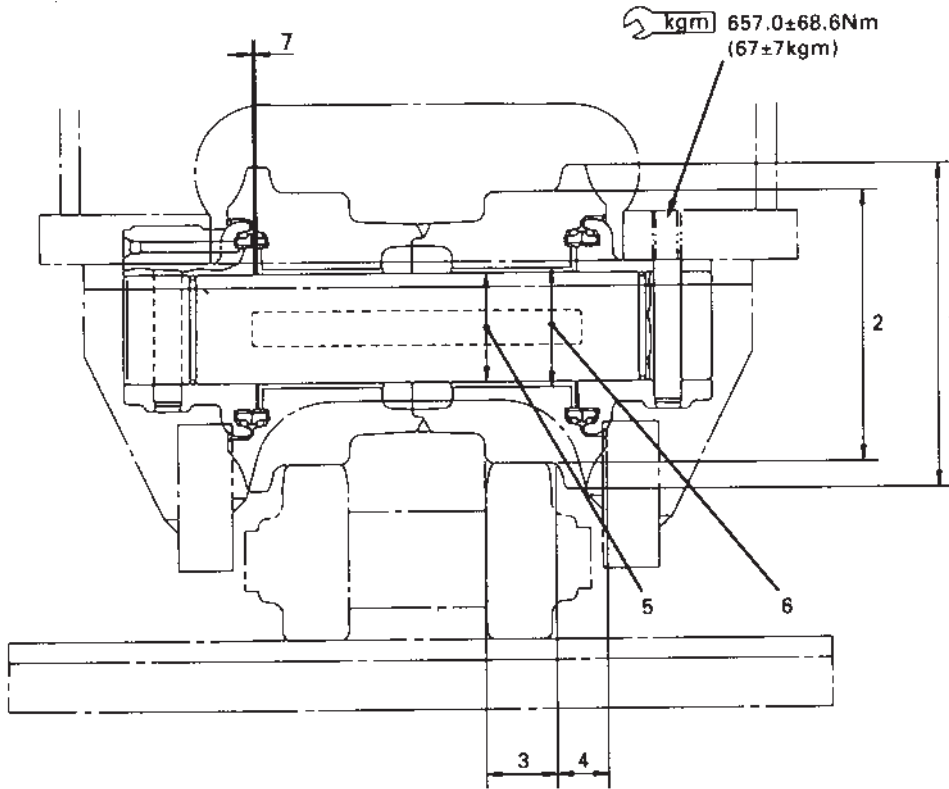

SBP00413

Unit: mm

No.	Check item	Criteria				Remedy
1	Outside diameter of flange (outside)	Standard size		Repair limit		Rebuild or replace
		216		-		
2	Outside diameter of tread	180		168		
3	Width of tread	49		55		
4	Width of flange	27		-		
5	Clearance between shaft and bushing	Standard size	Tolerance		Standard clearance	Clearance limit
			Shaft	Hole		
		65	- 0.250 - 0.315	+ 0.186 - 0.064	0.151 - 0.510	1.5
6	Interference between roller and bearing	Standard size	Tolerance		Standard interference	Interference limit
			Shaft	Hole		
		72	+ 0.108 + 0.008	- 0.006 - 0.036	0.014 - 0.144	-
7	Side clearance of idler (both sides)	Standard clearance		Clearance limit		Replace
		0.44 - 0.97		1.5		

TRACK SHOE

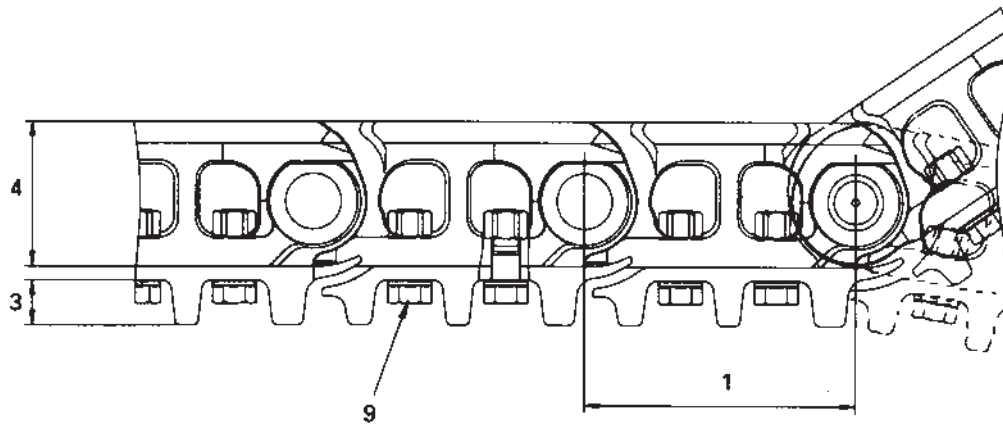
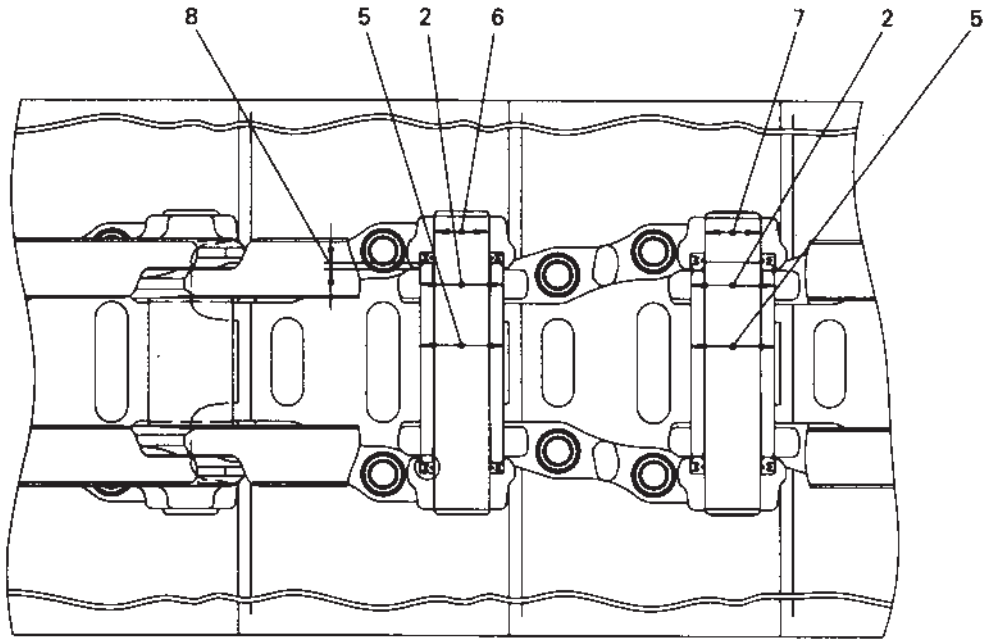

SDPC0416

Unit: mm

No.	Check item	Criteria				Remedy	
1	Link pitch	Standard size		Repair limit		Replace	
		216.3		219.3			
2	Outside diameter of bushing	66.9		61.9			
3	Height of grouser	36		24		Carry out lug welding or rebuild if it is possible within repairable limit	
4	Height of link	116		107			
5	Interference between bushing and link	Standard size	Tolerance		Standard interference	Interference limit	
			Shaft	Hole			
		66.5	+0.464 +0.424	+0.074 0	0.35 - 0.464	0.10	
6	Interference between regular pin and link	44.6 (Shaft) 44.35 (Hole)	+0.235 +0.085	+0.062 0	0.273 - 0.485	0.14	If it is lower than interference limit, replace with oversize
7	Interference between master pin and link	44.6 (Shaft) 44.35 (Hole)	+0.03 0	+0.062 0	0.188 - 0.28	0.14	
8	Protrusion of bushing	5.25 ± 0.3					
9	Tightening torque for shoe bolt	After tightening to initial torque: 196.1 ± 19.6 Nm (20 ± 2 kgm), tighten a further 120° ± 10°				Replace	

HYDRAULIC PUMP

HPV95 + 95

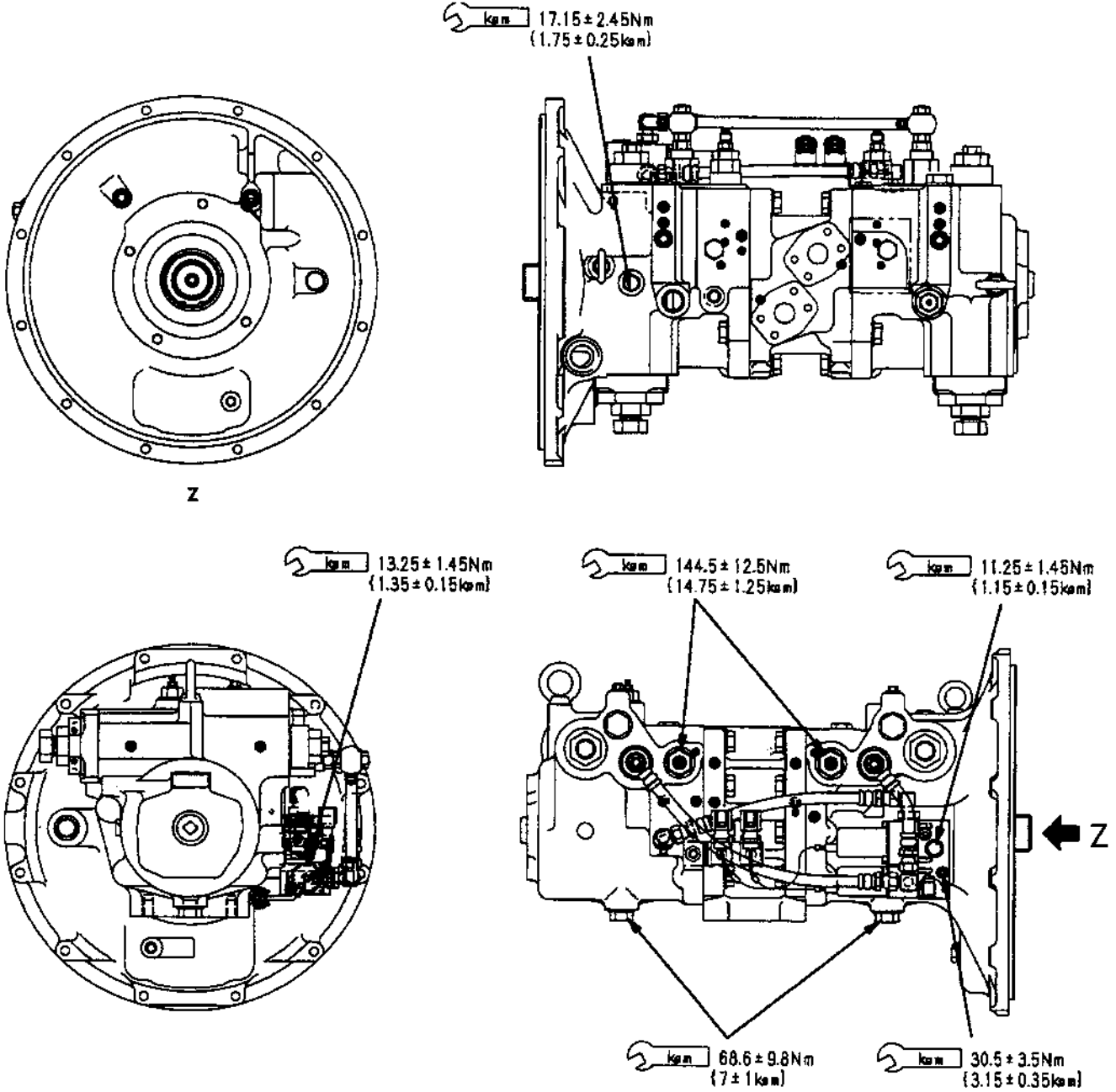

X10AV337

CONTROL VALVE

★ Figure shows 6-spool control valve with 3 option service valve.

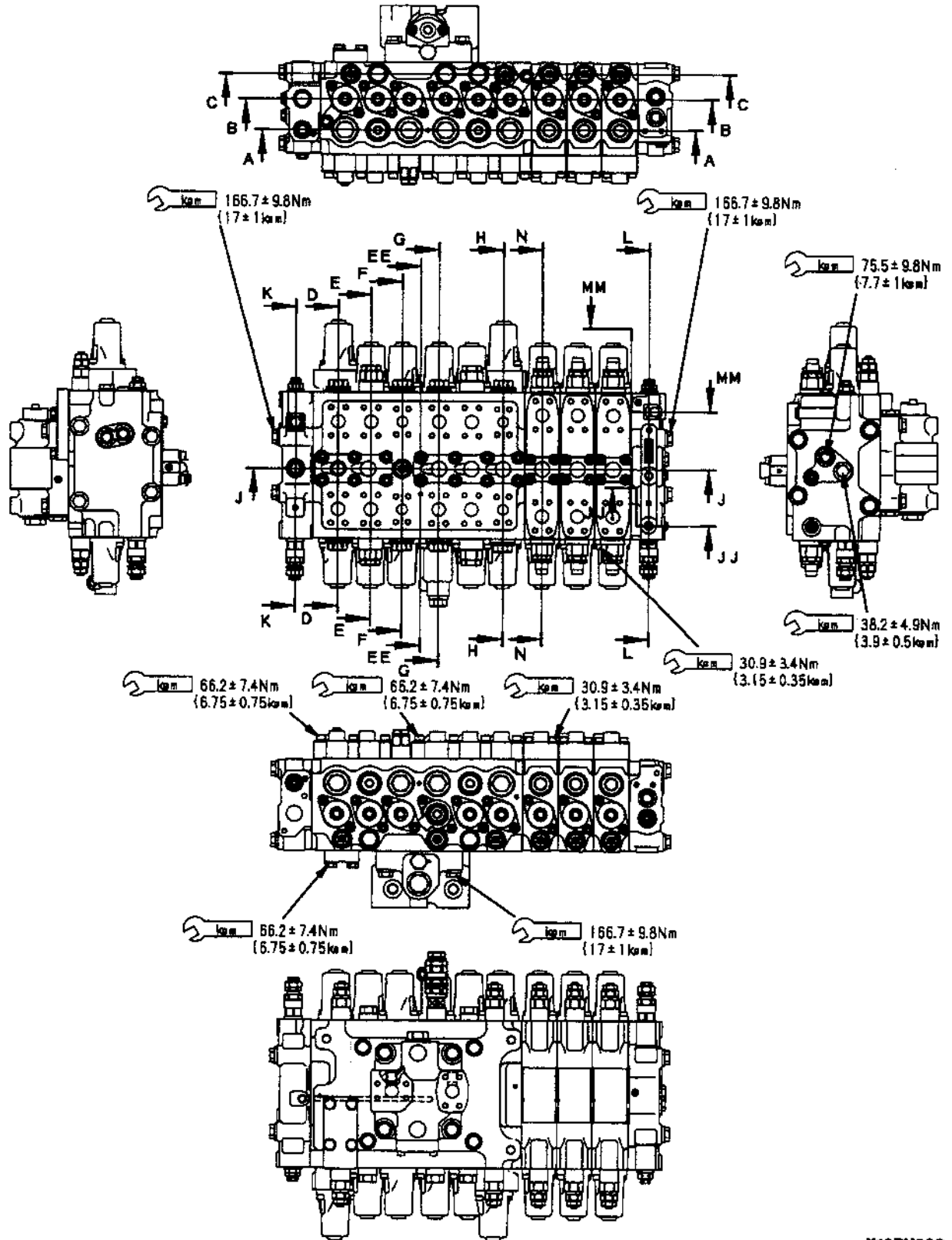

X10BH283

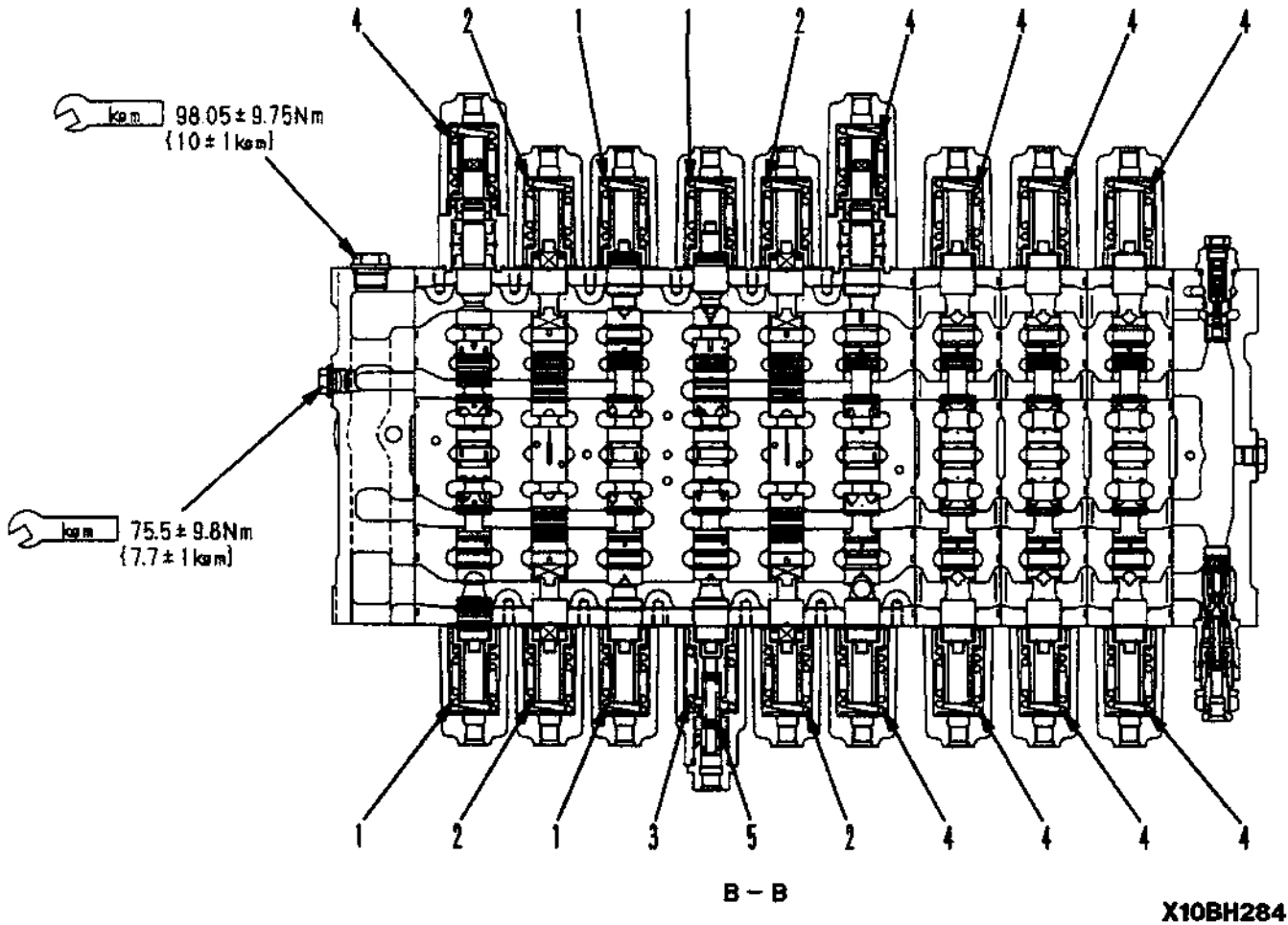

X10BH284

Unit: mm

No.	Check item	Criteria					Remedy
		Standard size			Repair limit		
		Free length X OD	Installed length	Installed load	Free length	Installed load	
1	Spool return spring	54.2 X 34.8	51.2	416.8 N (42.5 kg)	-	333.2 N (34 kg)	Replace spring if any damages or deformations are found.
2	Spool return spring	54.6 X 34.8	51.2	420.4 N (42.9 kg)	-	336.1 N (34.3 kg)	
3	Spool return spring	53.3 X 37.1	51.2	358.7 N (36.6 kg)	-	287.1 N (29.3 kg)	
4	Spool return spring	54.5 X 34.8	51.2	393.2 N (40.1 kg)	-	314.6 N (32.1 kg)	
5	Stroke selector spring	40 X 12.3	38.0	50.0 N (5.1 kg)	-	40.2 N (4.1 kg)	

When installing to valve, spring is free, so judge from test height

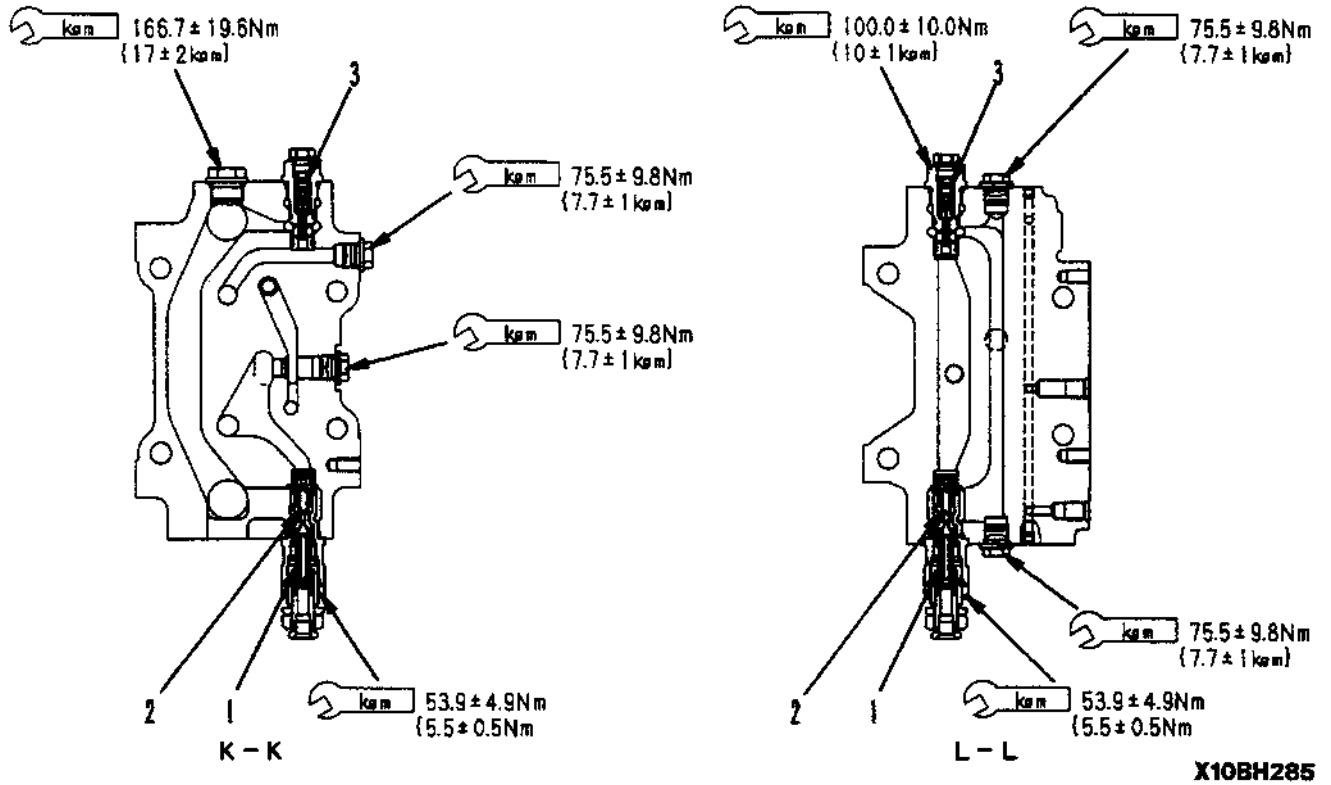

Unit: mm

No.	Check item	Criteria					Remedy
		Standard size			Repair limit		
1	Valve spring	Free length X OD	Installed length	Installed load	Free length	Installed load	Replace spring if any damages or deformations are found.
		23.2 X 7.2	19	41.2 N (4.2 kg)	-	33.4 N (3.4 kg)	
2	Relief spring	30.7 X 9.6	26.3	327.5 N (33.4 kg)	-	261.8 N (26.7 kg)	
3	Unload spring	35 x 10.4	26	83.4 N (8.5 kg)	-	66.7 N (6.8 kg)	

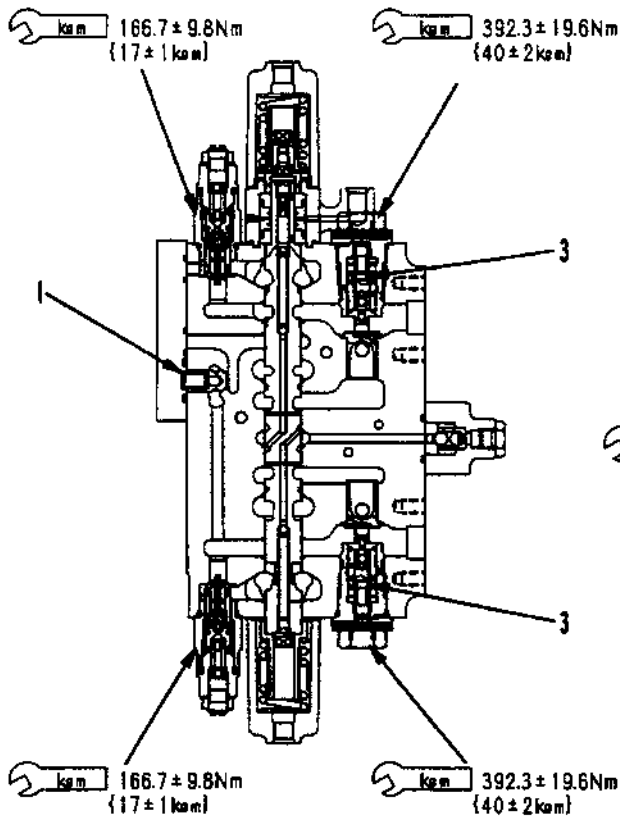

D - D

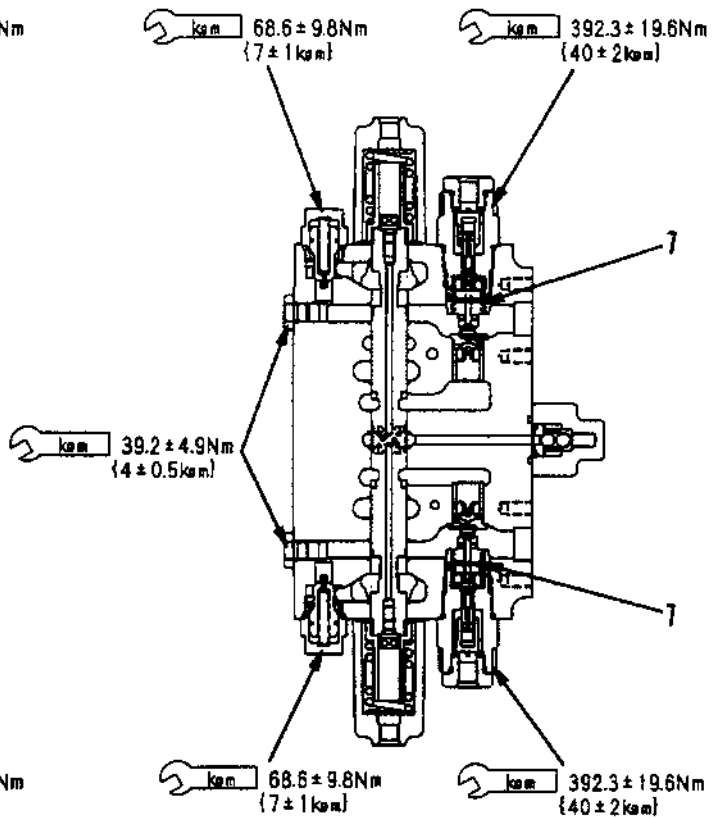

E - E

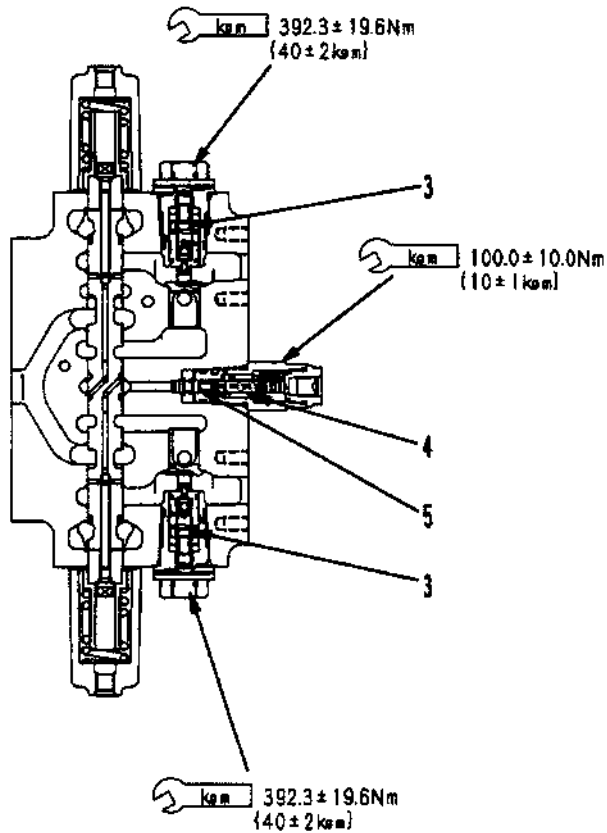

F - F

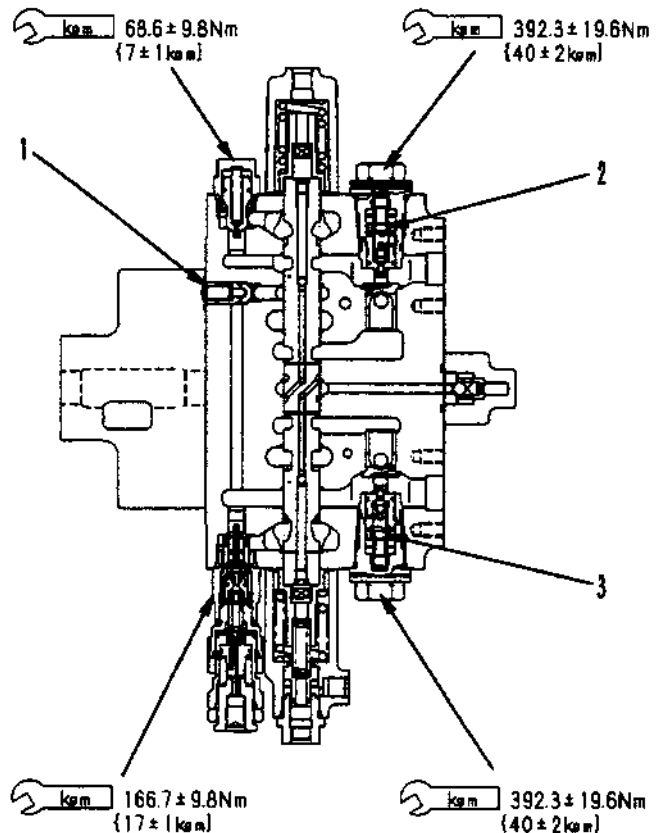

G - G

X10BH286

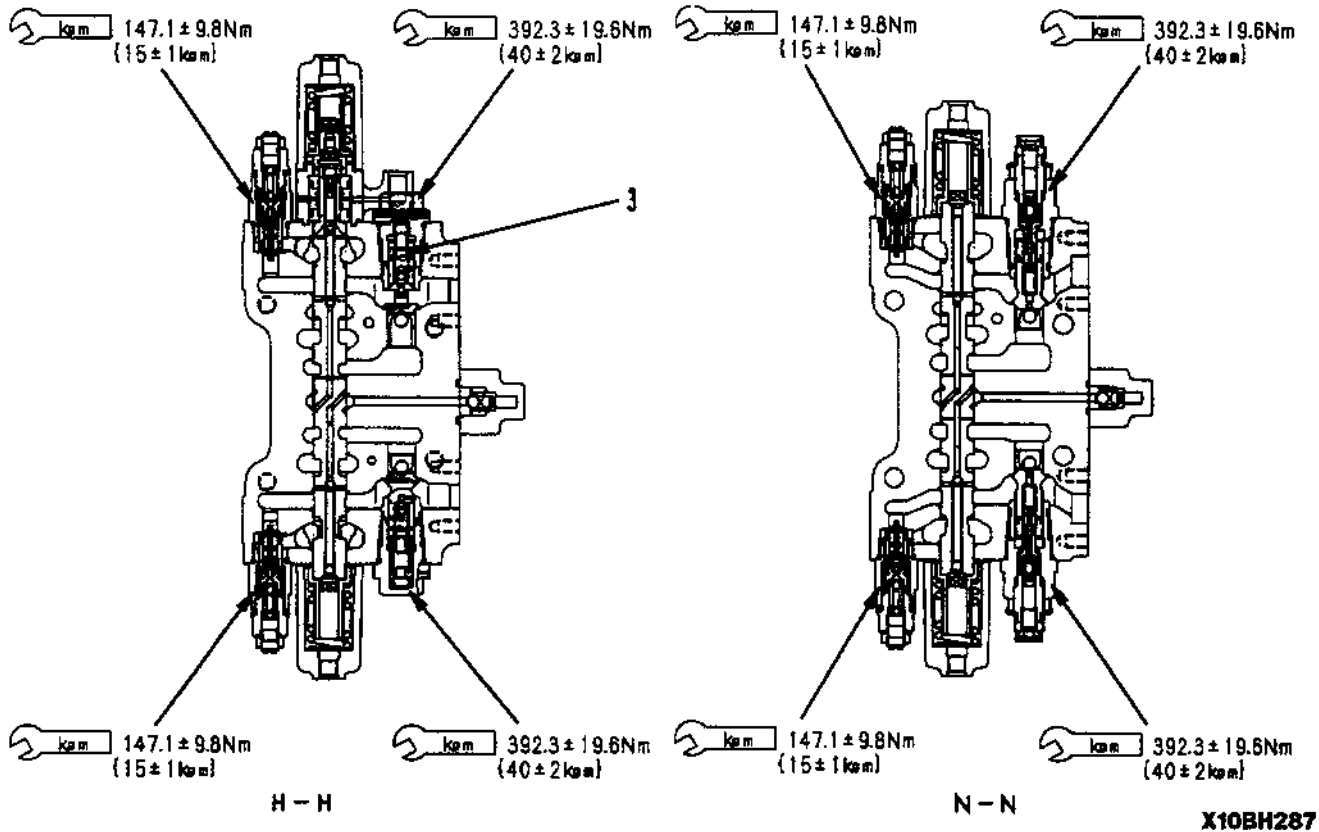

Unit: mm

No.	Check item	Criteria					Remedy
		Standard size			Repair limit		
1	Regeneration valve spring	Free length X OD	Installed length	Installed load	Free length	Installed load	Replace spring if any damages or deformations are found.
		31.5 X 10.3	19.5	5.9 N (0.6 kg)	-	4.4 N (0.45 kg)	
2	Piston return spring	36.9 X 11.1	28	29.4 N (3 kg)	-	23.5 N (2.4 kg)	
3	Piston return spring	41.1 X 10.8	28	17.6 N (1.8 kg)	-	13.7 N (1.4 kg)	
4	Load spring	30.4 X 16.7	27	428.3 N (43.7 kg)	-	343 N (35.0 kg)	
5	Check valve spring	13.6 X 5.5	10	2 N (0.2 kg)	-	1.5 N (.15 kg)	
6	Piston return spring	50.4 X 17	39	158.8 N (16.2 kg)	-	127.4 N (13 kg)	
7	Piston return spring	40.8 X 22.4	21	17.6 N (1.8 kg)	-	13.7 N (1.4 kg)	

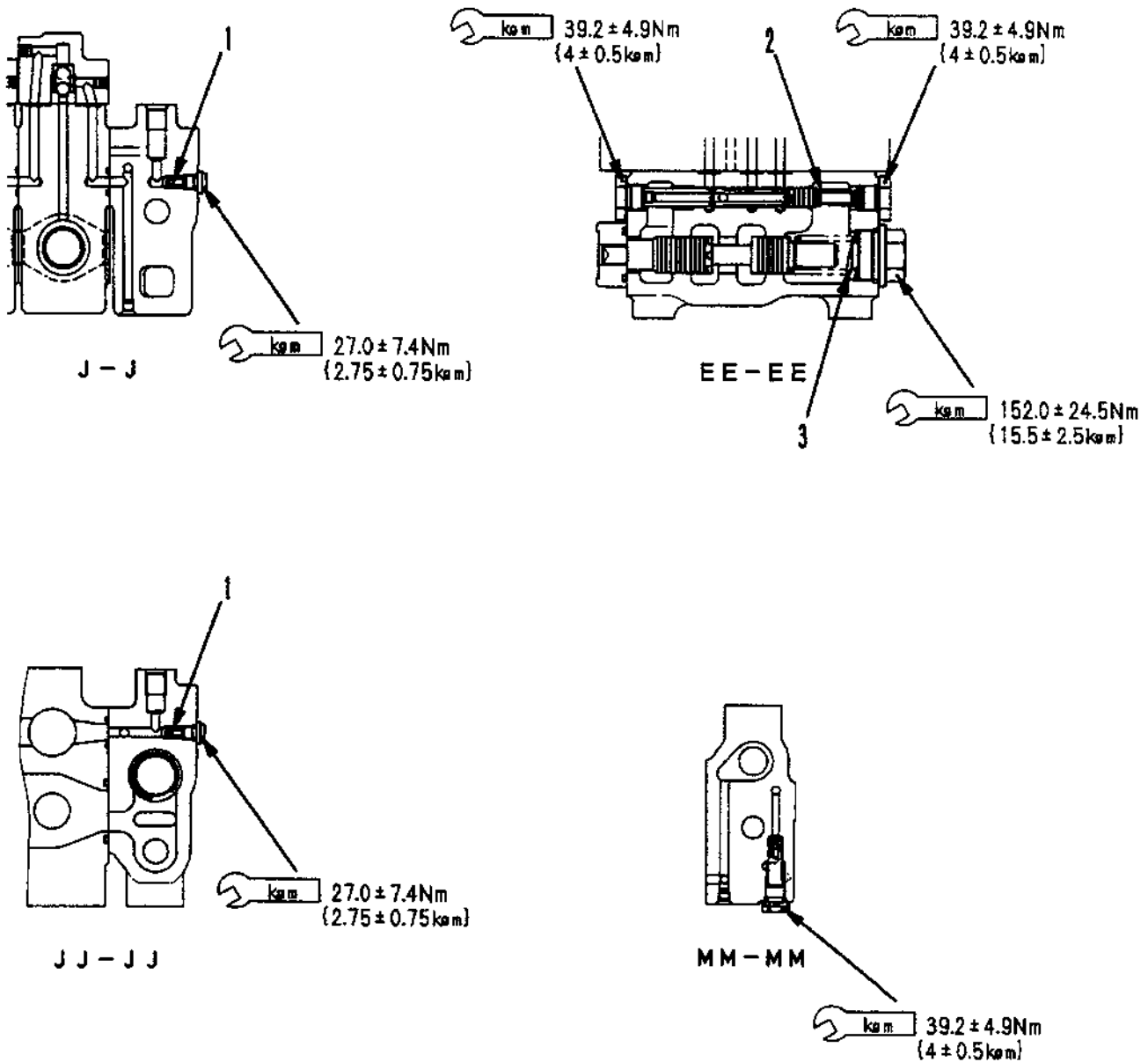

X10BH288

Unit: mm

No.	Check item	Criteria					Remedy
		Standard size			Repair limit		
1	Check valve spring	Free length X OD	Installed length	Installed load	Free length	Installed load	Replace spring if any damages or deformations are found.
		11.5 X 4.6	8.5	1.5 N (.15 kg)	-	1.2 N (0.12 kg)	
2	Spool return spring	65.5 X 27.2	50	167.6 N (17.1 kg)	-	134.3 N (13.7 kg)	
3	Spool return spring	13.6 X 5.5	10	2.0 N (0.2 kg)	-	1.5 N (0.15 kg)	

VARIABLE PRESSURE COMPENSATION VALVE

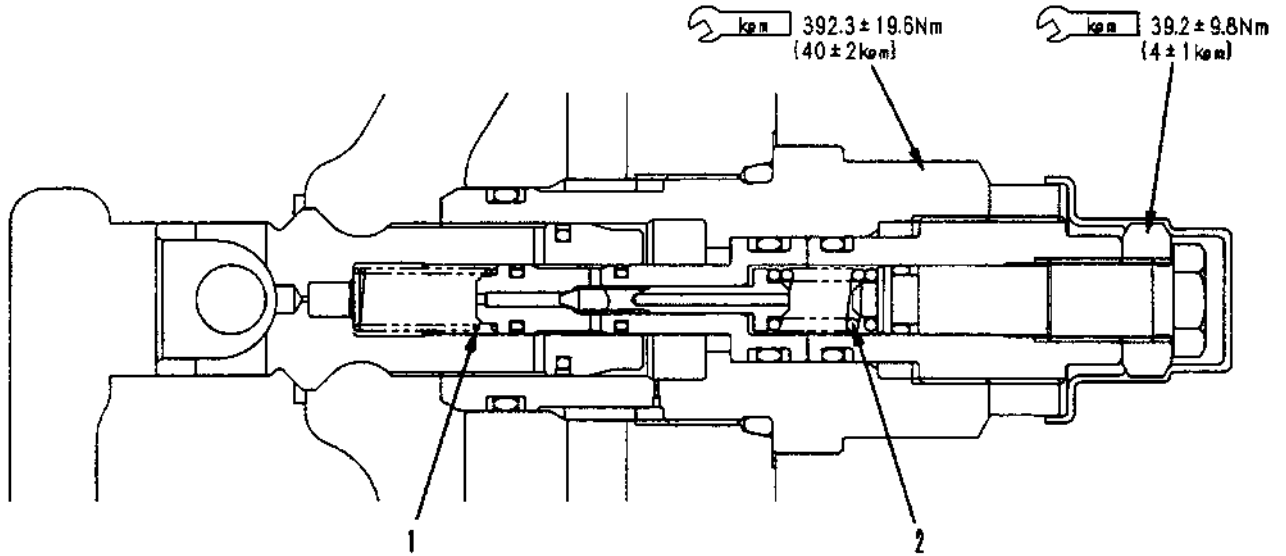

X10BH289

Unit: mm

No.	Check item	Criteria					Remedy
		Standard size			Repair limit		
1	Piston return spring	Free length X OD	Installed length	Installed load	Free length	Installed load	Replace spring if any damages or deformations are found.
		32.76 X 8.5	20.5	9.8 N (1.0 kg)	-	7.8 N (0.8 kg)	
2	Relief valve spring	17.1 X 9	15.5	74.5 N (7.6 kg)	-	59.8 N (6.1 kg)	

SAFETY-SUCTION VALVE FOR SERVICE VALVE

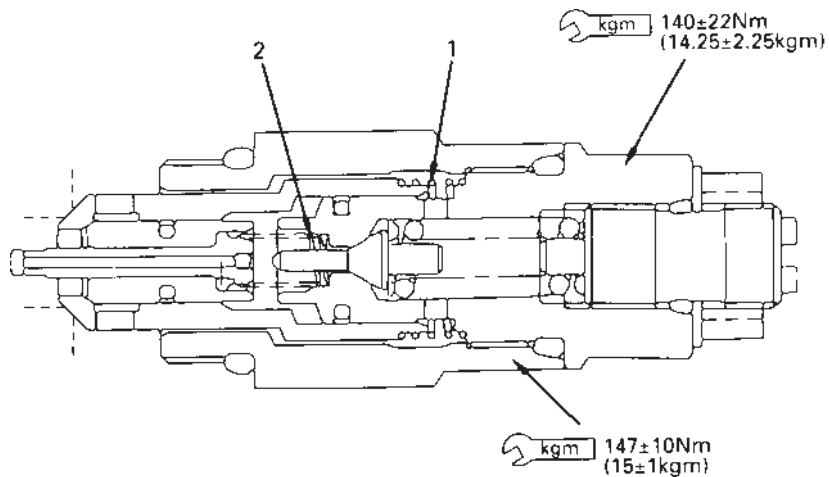

SBP00430

Unit: mm

No.	Check item	Criteria						Remedy
		Standard size			Repair limit			
1	Suction valve spring	Free length X OD	Installed length	Installed load	Free length	Installed load	Replace spring if any damages or deformations are found.	
		16.3 x 21.3	9.5	2.1 N (0.21 kg)	-	1.6 N (0.16 kg)		
2	Piston spring	20 x 7	14	2.1 N (0.21 kg)	-	1.6 N (0.16 kg)		

SELF-REDUCING PRESSURE VALVE

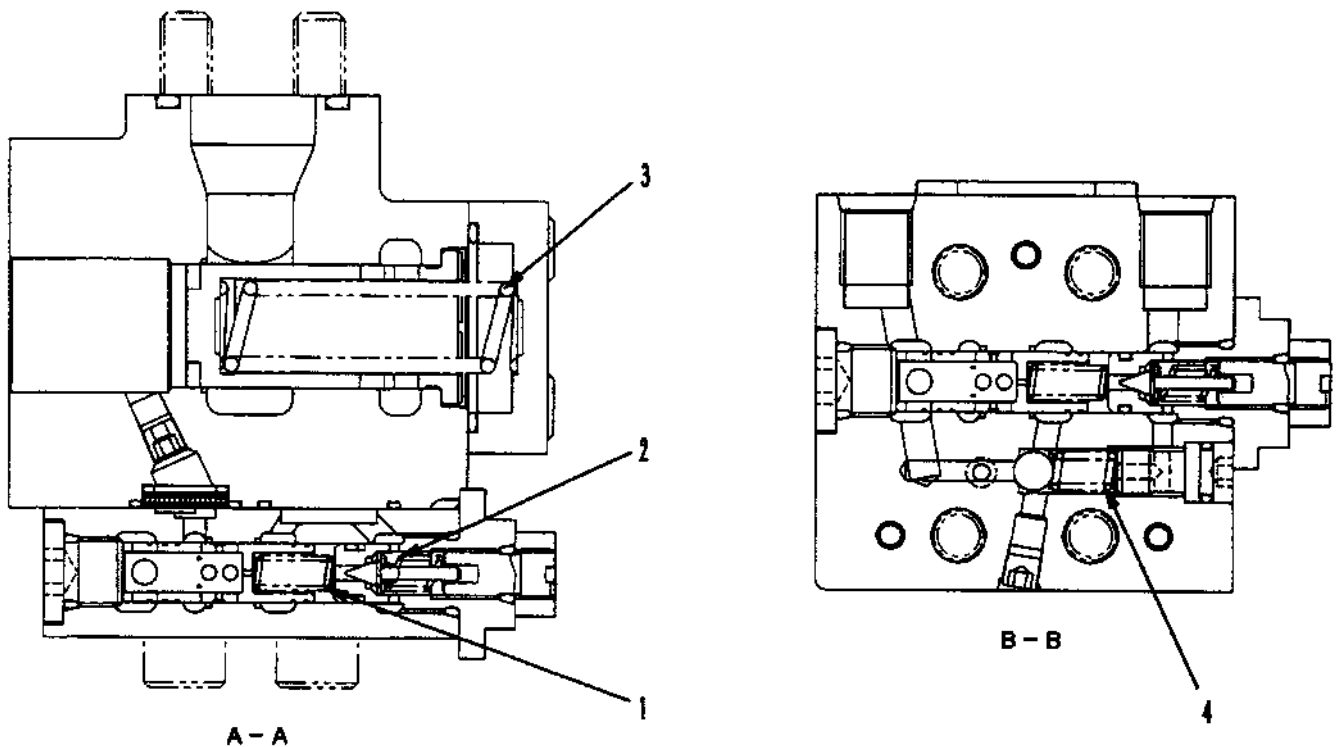

X10BH291

Unit: mm

No.	Check item	Criteria					Remedy
		Standard size			Repair limit		
		Free length X OD	Installed length	Installed load	Free length	Installed load	
1	Spring (reducing pressure valve, main)	19.2 X 7.2	16.1	19.6 N (2 kg)	-		Replace spring if any damages or deformations are found.
2	Spring (reducing pressure valve, pilot)	16.5 X 7.2	12.7	20.6 N (2.1 kg)	-		
3	Spring	71 X 18	59	199.8 N (20.4 kg)	-		
4	Spring (safety valve)	16.1 X 7.8	13.4	61.7 N (6.3 kg)	-		

SWING MOTOR

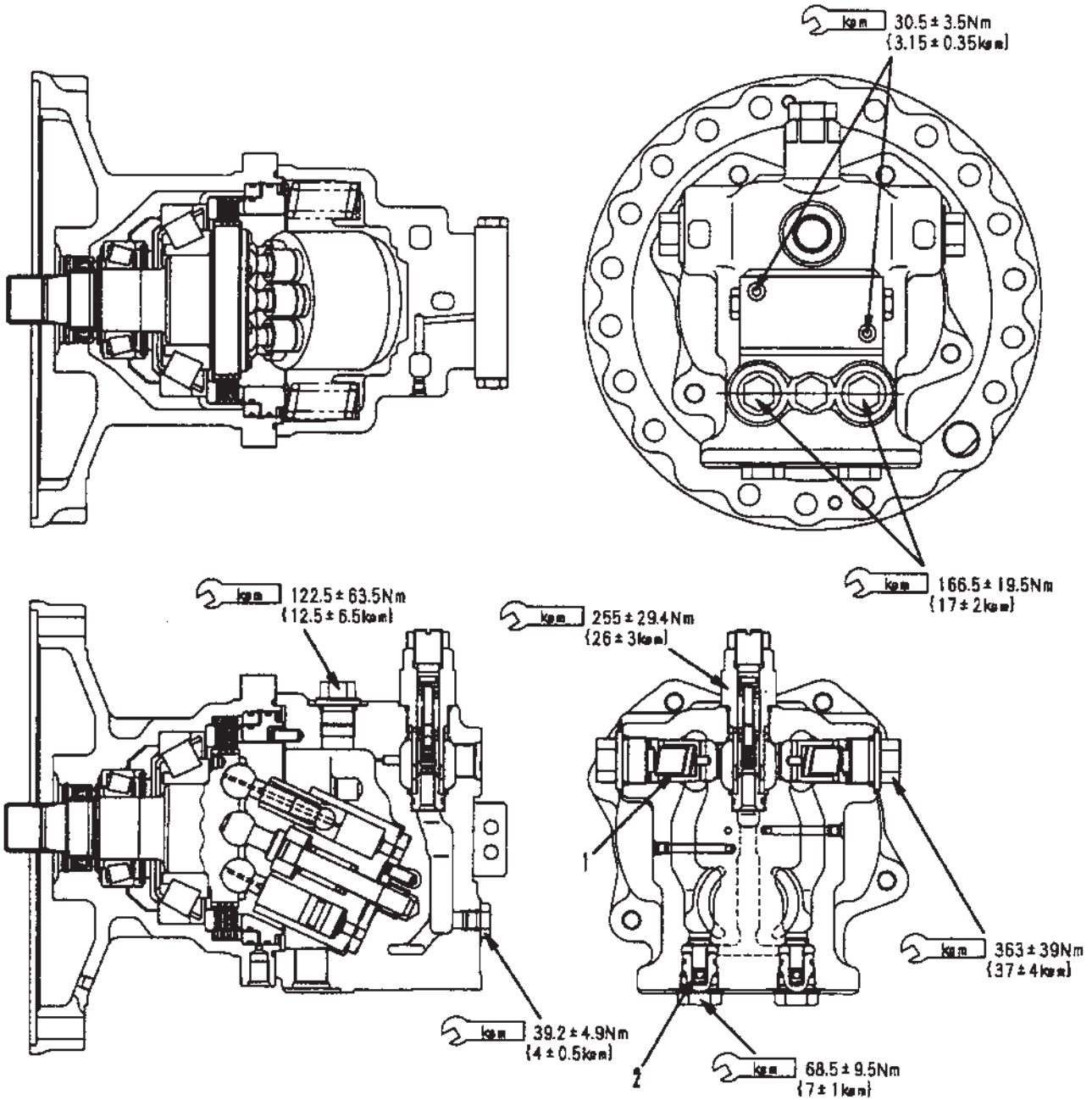

X09DH068
Unit: mm

No.	Check item	Criteria					Remedy
		Standard size			Repair limit		
1	Check valve spring	Free length X O.D.	Installed length	Installed load	Free length	Installed load	Replace spring if any damages or deformations are found.
		62.5 X 20.0	35.0	3.5 N (0.36 kg)	—	2.8 N (0.29 kg)	
2	Shuttle valve spring	16.4 X 8.9	11.5	13.7 N (1.4 kg)	—	10.8 N (1.1 kg)	

TRAVEL MOTOR

HMV160ADT-2

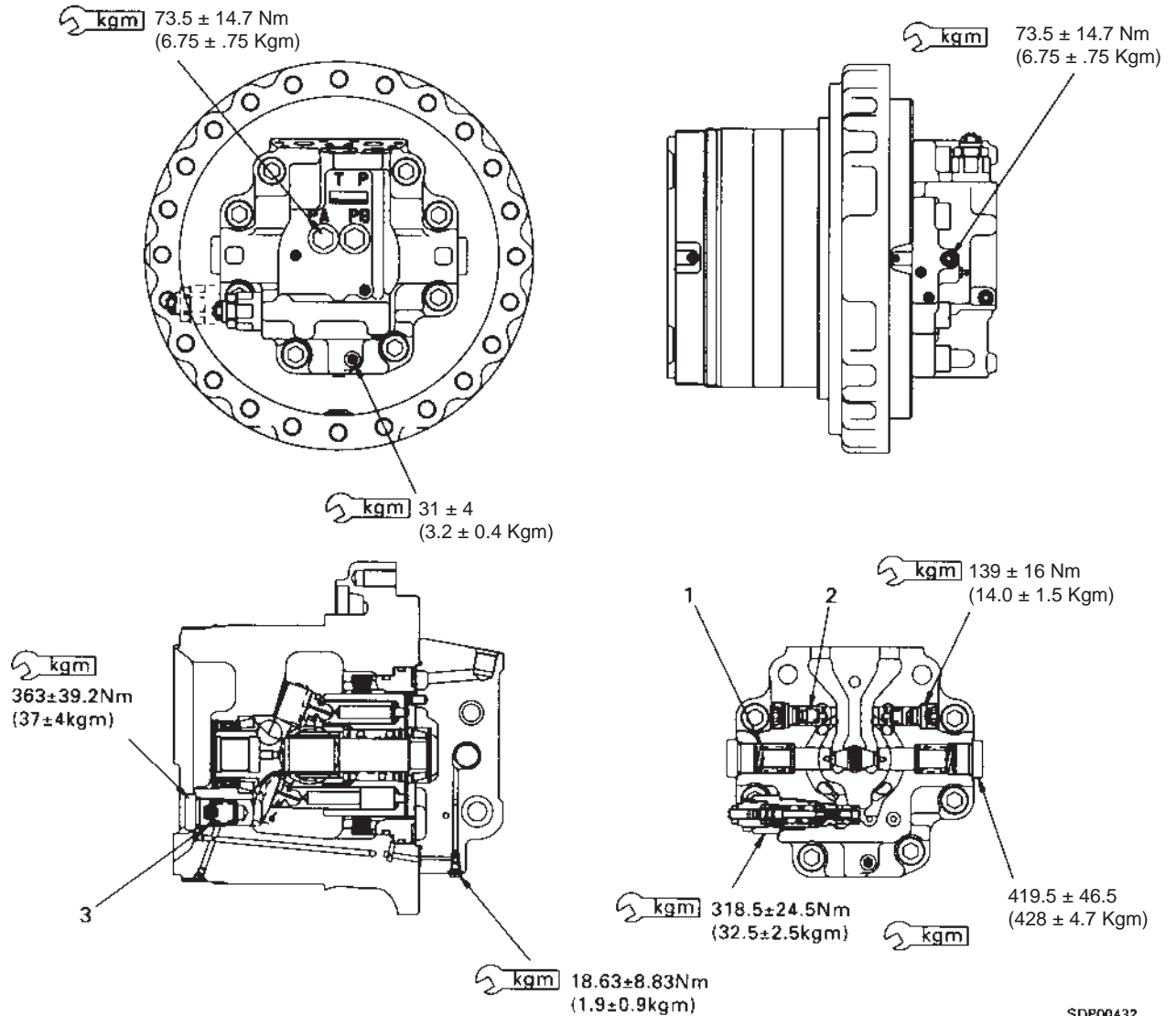

SDF00432

Unit: mm

No.	Check item	Criteria					Remedy
		Standard size			Repair limit		
1	Spool return spring	Free length X OD	Installed length	Installed load	Free length	Installed load	Replace spring if there is damage or deformation
		58.43 X 30.0	42.0	427 N (43.5 kg)	-	341.3 N (34.8 kg)	
2	Check valve spring	33.0 X 13.8	23.0	1.27 N (0.13 kg)	-	0.98 N (0.10 kg)	
3	Regulator piston spring	61.1 X 23.2	40.0	270.8 N (27.6 kg)	-	319.7 N (32.6 kg)	

WORK EQUIPMENT • SWING PPC VALVE

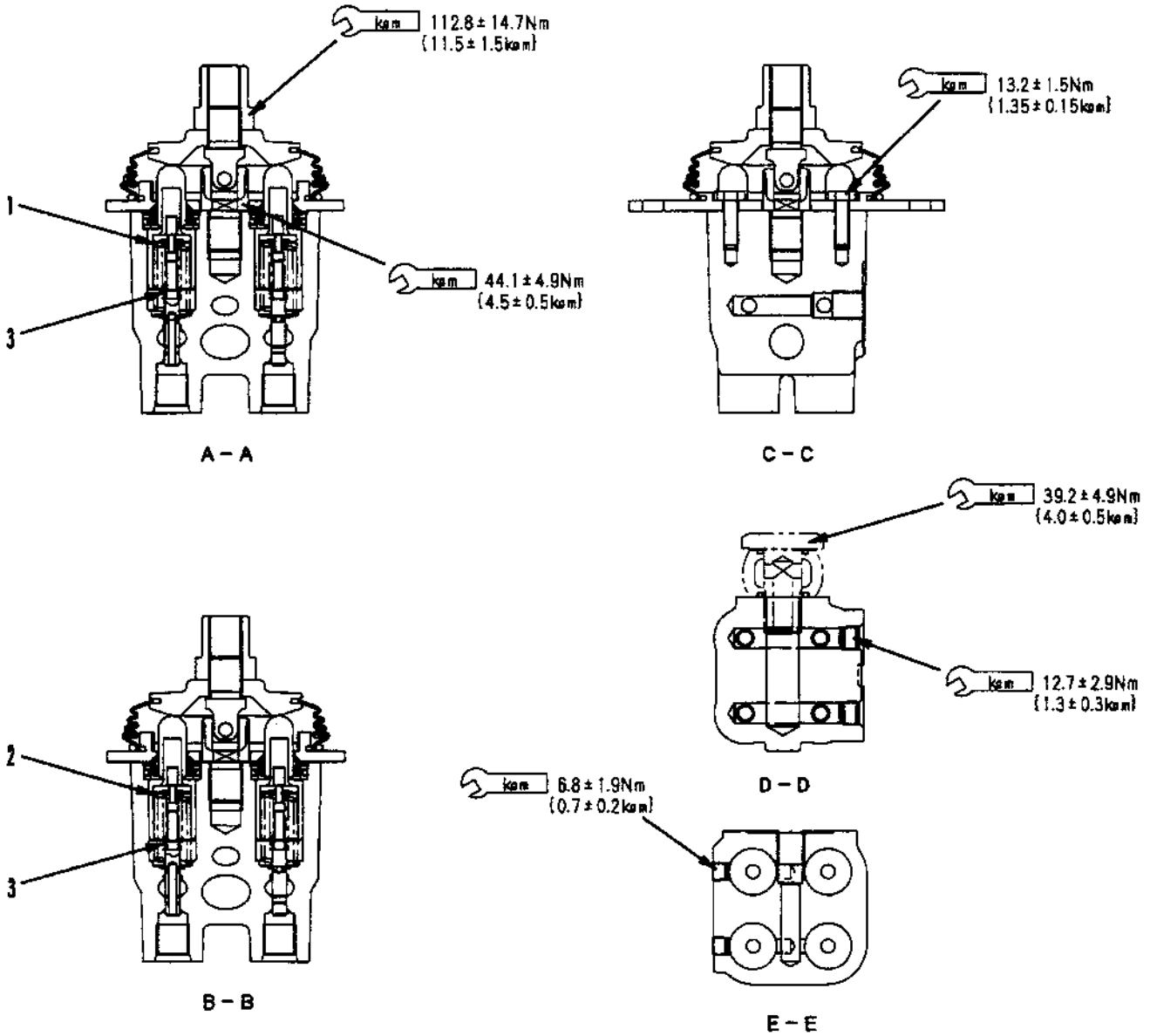

X10BH292

Unit: mm

No.	Check item	Criteria					Remedy
		Standard size			Repair limit		
		Free length X OD	Installed length	Installed load	Free length	Installed load	
1	Centering spring (for P3, P4)	42.4 X 15.5	34	17.6 N (1.8 kg)	-	13.7 N (1.4 kg)	Replace spring if any damages or deformations are found.
2	Centering spring (for P1, P2)	44.4 X 15.5	34	29.4 N (3.0 kg)	-	23.5 N (2.4 kg)	
3	Metering spring	26.5 X 8.2	24.9	16.7 N (1.7 kg)	-	13.7 N (1.4 kg)	

TRAVEL PPC VALVE

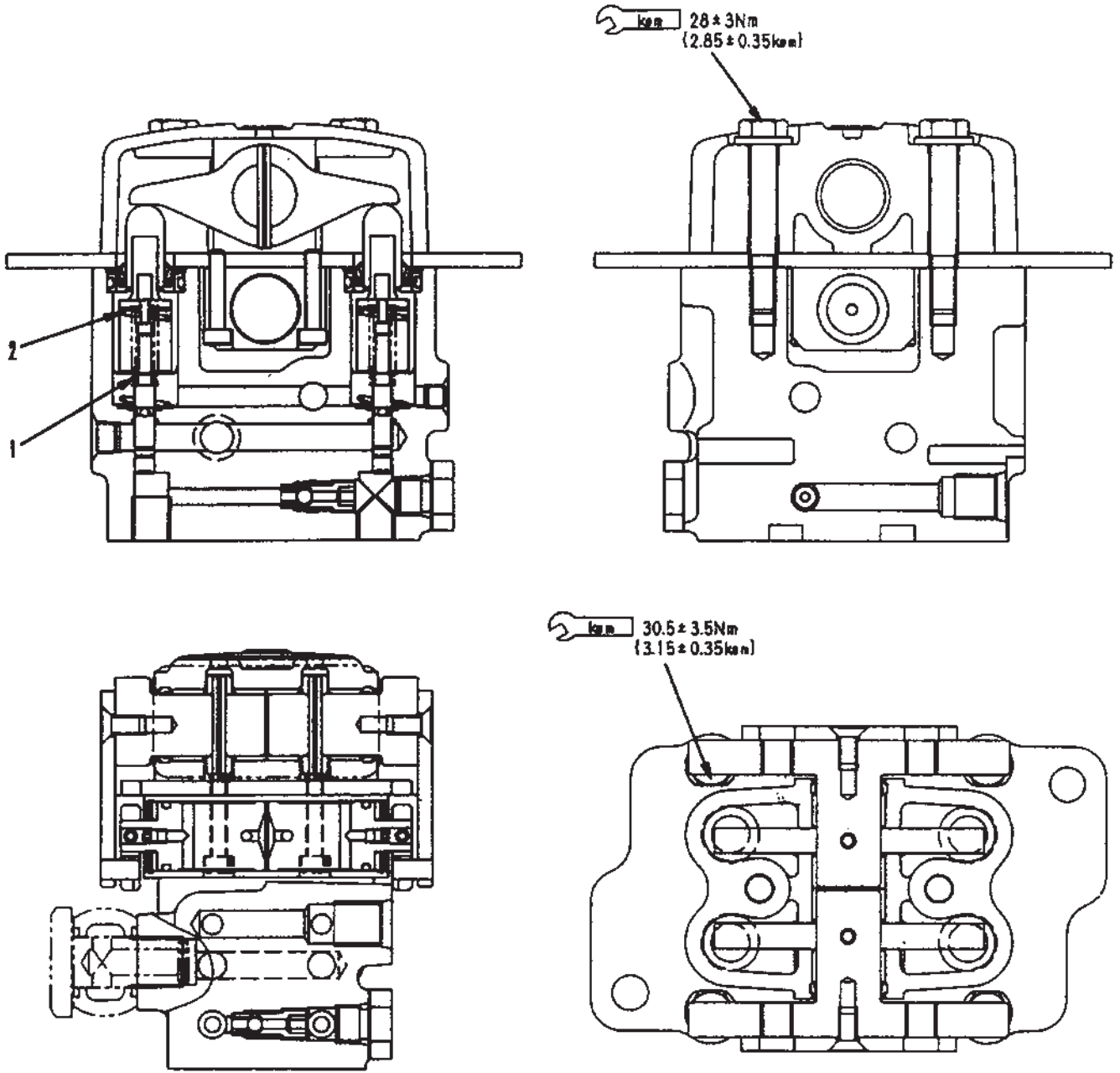

X10BH293

Unit: mm

No.	Check item	Criteria					Remedy	
		Standard size			Repair limit		Replace spring if any damages or deformations are found.	
		Free length X OD	Installed length	Installed load	Free length	Installed load		
1	Metering spring	26.5 x 8.15	24.7	16.7 N (1.7 kg)	-	13.7 N (1.4 kg)		
2	Centering spring	48.1 x 15.5	32.5	107.8 N (11 kg)	-	86.2 N (8.8 kg)		

SERVICE PPC VALVE

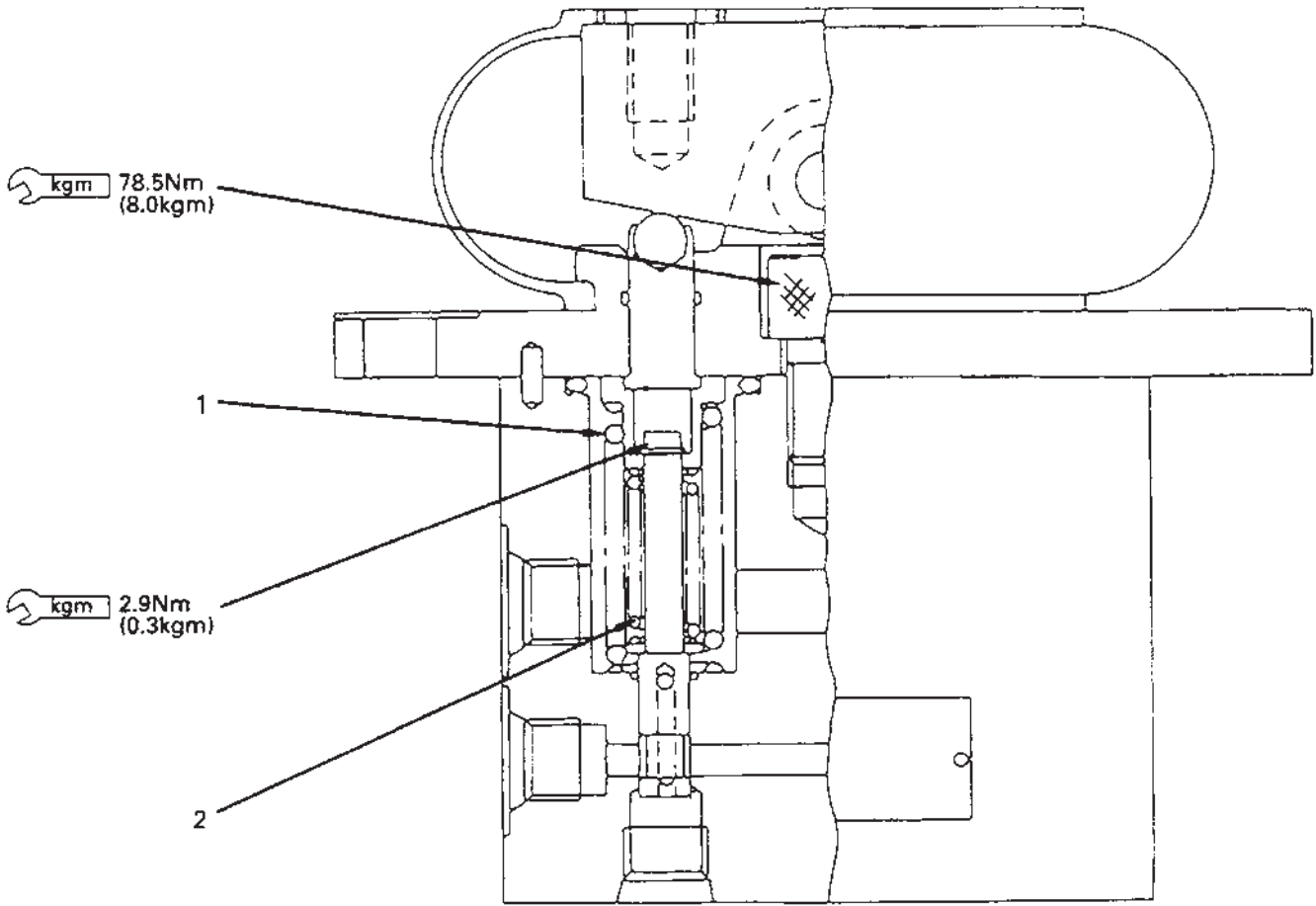

X10BH294

Unit: mm

No.	Check item	Criteria					Remedy
		Standard size			Repair limit		
1	Centering spring	Free length X O.D.	Installed length	Installed load	Free length	Installed load	Replace spring if any damages or deformation are found.
		64.8 X 16.6	40.5	46.1 N (4.7 kg)	—	44.1 N (4.5 kg)	
2	Metering spring	26.0 X 10.5	25.0	25.5 N (2.6 kg)	—	24.5 N (2.5 kg)	

EPC SOLENOID VALVE

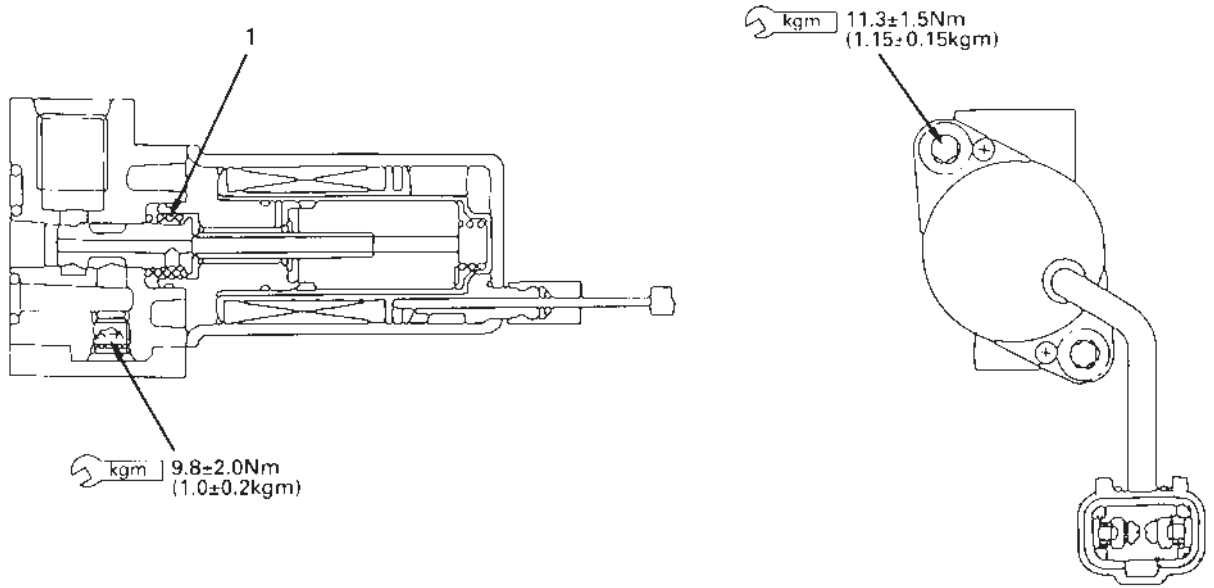

SBP00438

Unit: mm

No.	Check item	Criteria					Remedy
		Standard size			Repair limit		
1	Return spring	Free length X OD	Installed length	Installed load	Free length	Installed load	Replace EPC valve assem- bly if any damages or deformations are found.
		9.0 x 11.4	7.9	3.14 N (0.32 kg)	-	-	

CENTER SWIVEL JOINT

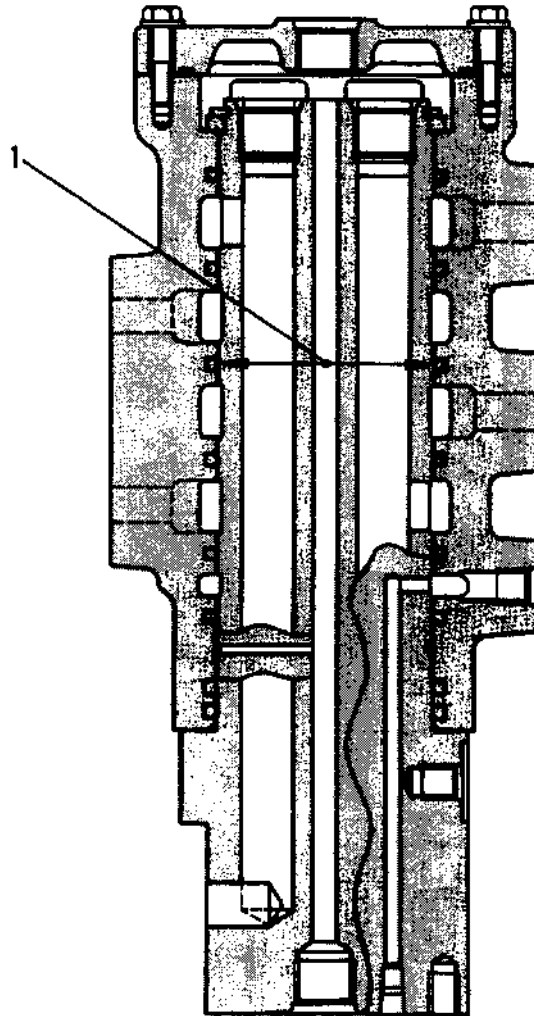

X10ZZ021

Unit: mm

No.	Check item	Criteria			Remedy
1	Clearance between rotor and shaft	Standard size			Replace
		Standard size	Standard clearance	Clearance limit	
		90	0.056 - 0.105	0.111	

HYDRAULIC CYLINDER

BOOM CYLINDER

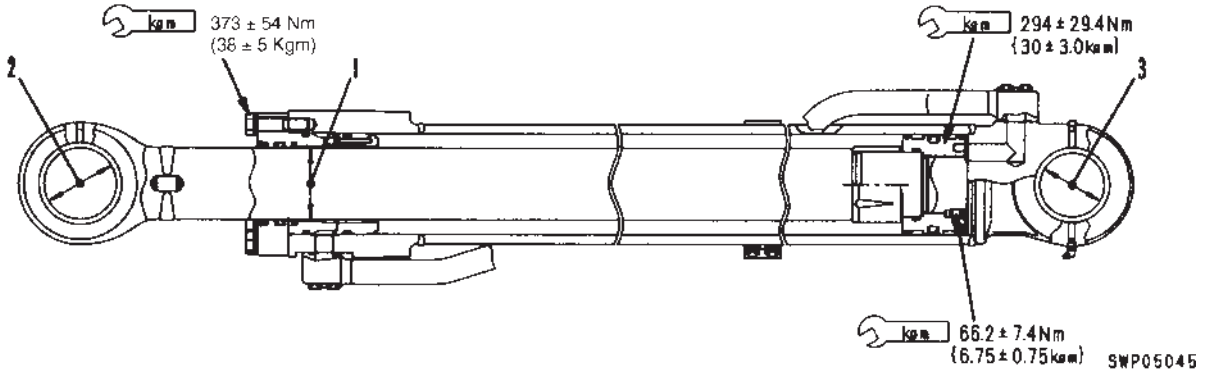

ARM CYLINDER

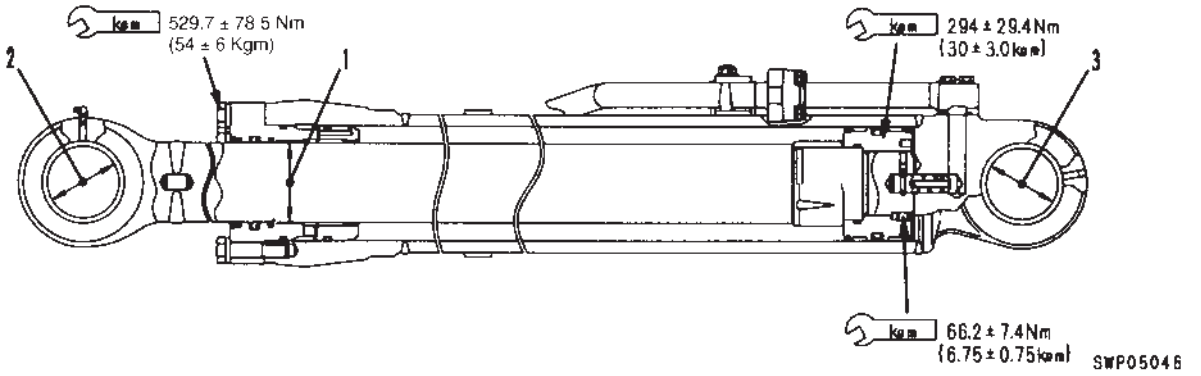

BUCKET CYLINDER

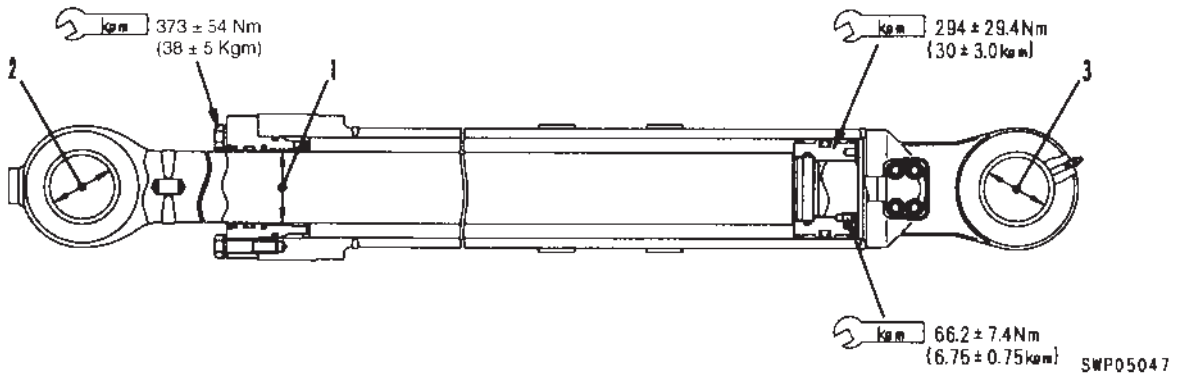

Unit: mm

No.	Check item	Criteria						Remedy
		Name of cylinder	Standard size	Tolerance		Standard clearance	Clearance limit Limit of bush size	
				Shaft	Hole			
1	Clearance between piston rod and bushing	Boom	100	-0.036 -0.090	+0.257 +0.047	0.083 - 0.347	0.447	Replace bushing
		Arm	110	-0.036 -0.090	+0.261 +0.047	0.083 - 0.351	0.451	
		Bucket	100	-0.036 -0.090	+0.251 +0.047	0.083 - 0.347	0.447	
2	Clearance between piston rod support pin and bushing	Boom	80	-0.030 -0.060	+0.211 +0.124	0.154 - 0.271	81.2	Replace pin, bushing
		Arm	80	-0.030 -0.076	+0.465 +0.387	0.417 - 0.541	82	
		Bucket	80	-0.030 -0.076	+0.457 +0.370	0.400 - 0.533	82	
3	Clearance between cylinder bottom support pin and bushing	Boom	80	-0.030 -0.060	+0.103 +0.041	0.071 - 0.163	81.2	Replace pin, bushing
		Arm	100	-0.036 -0.090	+0.457 +0.370	0.406 - 0.517	102	
		Bucket	80	-0.030 -0.076	+0.457 +0.370	0.400 - 0.533	82	

WORK EQUIPMENT

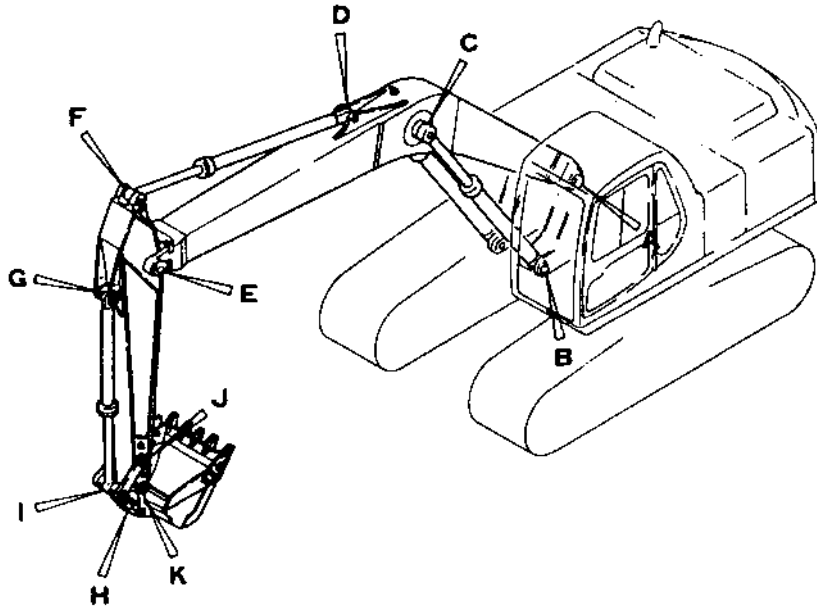

205F06282

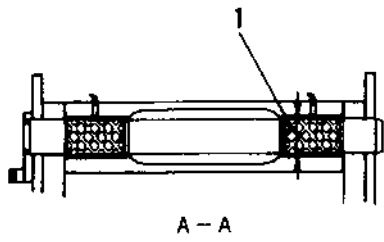

A-A

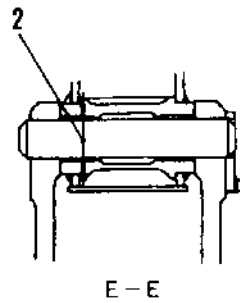

E-E

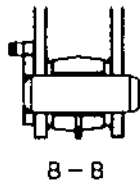

B-B

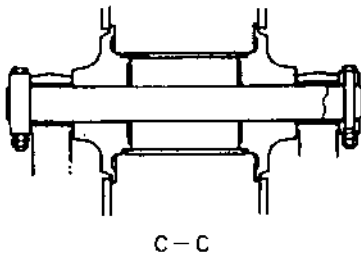

C-C

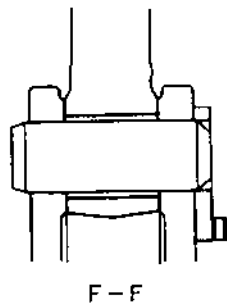

F-F

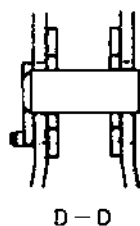

D-D

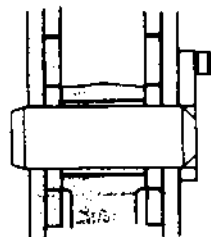

G-G

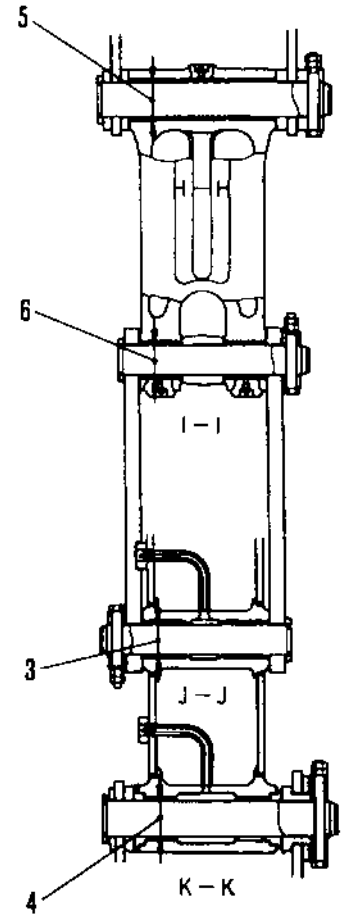

K-K

205F06283

K30001 ~ up

Unit: mm

No.	Check item	Criteria				Remedy
		Standard size	Tolerance		Standard clearance	
Shaft	Hole					
1	Clearance between connecting pin and bushing of revolving frame and boom	100	-0.036	+0.112	+0.097 +0.175	101.2
			-0.071	+0.49	+0.077 +0.174	
2	Clearance between connecting pin and bushing of boom and arm	90	-0.036 -0.071	+0.153 +0.097	0.133 - 0.224	91.2
3	Clearance between connecting pin and bushing of arm and link	80	-0.030 -0.076	+0.337 +0.273	0.303 - 0.413	82
4	Clearance between connecting pint and bushing of arm and bucket	80	-0.030 -0.076	+0.337 +0.273	0.303 - 0.413	82
5	Clearance between connecting pin and bushing of link and bucket	80	-0.030 -0.076	+0.337 +0.273	0.303 - 0.413	82
6	Clearance between connecting pin and bushing of link and link	80	-0.030 -0.076	+0.335 +0.275	0.303 - 0.411	82

Replace bush and pin

K34001 ~ up

Unit: mm

No.	Check item	Criteria				Remedy
		Standard size	Tolerance		Standard clearance	
Shaft	Hole					
1	Clearance between connecting pin and bushing of revolving frame and boom	100	-0.036	+0.114 +0.051	+0.087 +0.185	101.2
			-0.071	+0.103 +0.041	+0.077 +0.174	
2	Clearance between connecting pin and bushing of boom and arm	90	-0.036 -0.071	+0.153 +0.097	0.133 - 0.224	91.2
3	Clearance between connecting pin and bushing of arm and link	80	-0.030 -0.076	+0.335 +0.275	0.305 - 0.413	82
4	Clearance between connecting pint and bushing of arm and bucket	80	-0.030 -0.076	+0.337 +0.273	0.303 - 0.413	82
5	Clearance between connecting pin and bushing of link and bucket	80	-0.030 -0.076	+0.337 +0.273	0.303 - 0.413	82
6	Clearance between connecting pin and bushing of link and link	80	-0.030 -0.076	+0.335 +0.275	0.303 - 0.411	82

Replace bush and pin

Serial K34001 ~ up

Unit: mm

No.	Check item	Criteria					Remedy
		Standard size	Tolerance		Standard clearance	Clearance limit	
Shaft	Hole						
1	Clearance between connecting pin and bushing of revolving frame and boom	90 (PC210)	-0.036	+0.114 +0.051	+0.087 +0.185	91.2	Replace bush and pin
		100 (PC240)	-0.071	+0.103 +0.041	+0.077 +0.174	101.2	
2	Clearance between connecting pin and bushing of boom and arm	90	-0.036 -0.071	+0.114 +0.051	+0.087 +0.185	91.2	
3	Clearance between connecting pin and bushing of arm and link	70 (PC210)	-0.030	+0.335	0.305 - 0.411	72	
		80 (PC240)	-0.076	+0.275		82	
4	Clearance between connecting pint and bushing of arm and bucket	80	-0.030 -0.076	+0.337 +0.273	0.303 - 0.413	82	
5	Clearance between connecting pin and bushing of link and bucket	80	-0.030 -0.076	+0.337 +0.273	0.303 - 0.413	82	
6	Clearance between connecting pin and bushing of link and link	70 (PC210)	-0.030	+0.335	0.303 - 0.411	72	
		80 (PC210)	-0.076	+0.275		82	

DIMENSIONS OF WORK EQUIPMENT

1. ARM PORTION (3050 mm)

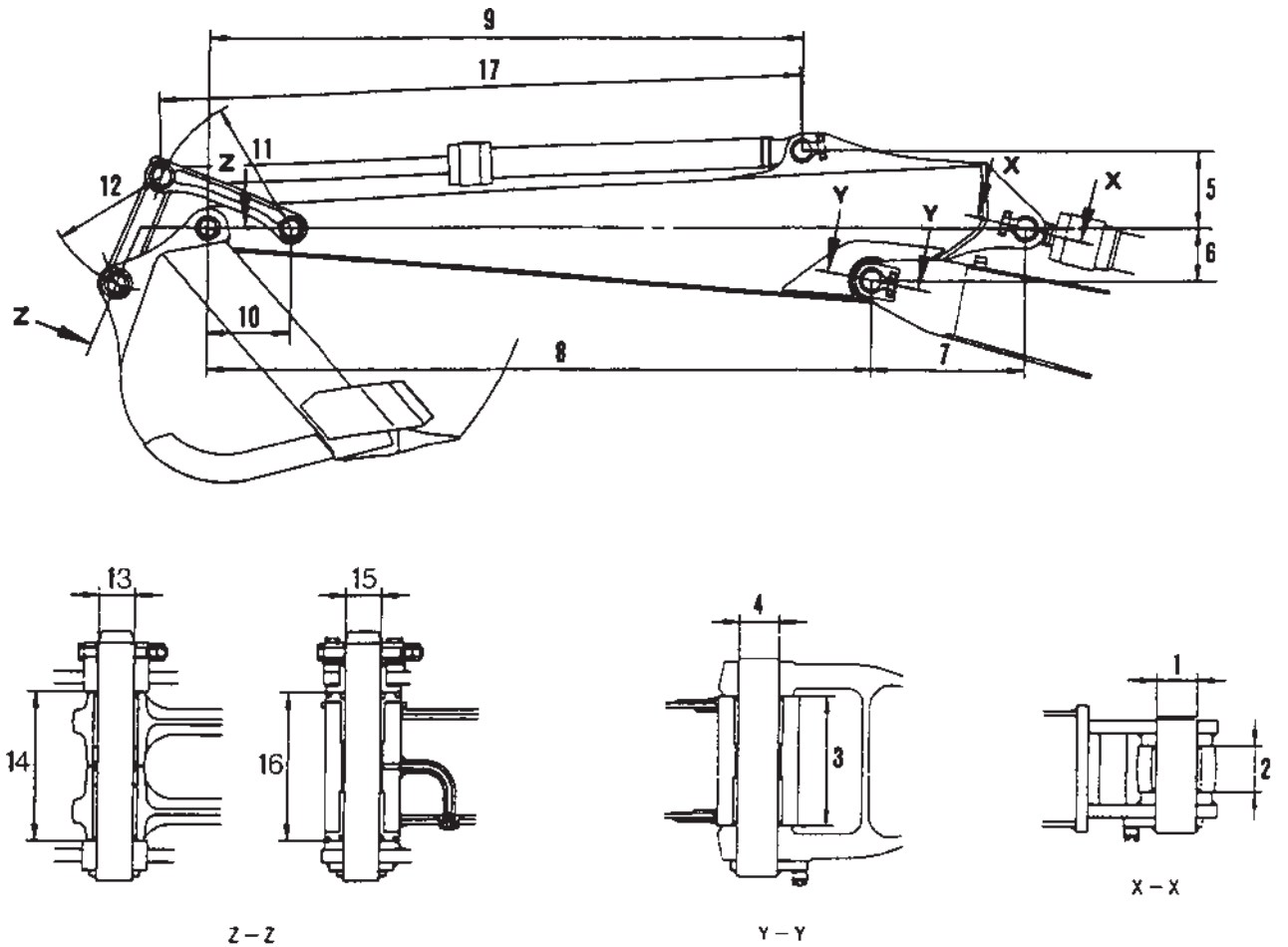

205F06284

No.	Check item		Remedy
1		$\varnothing 80 +0.1$ 0	
2		107.3 +1.5 0	
3		310 +0.5 0	
4		$\varnothing 90 -0.036$ -0.071	
5		406.0 ± 1	
6		200.0 ± 1	
7		920.0 ± 1	
8		3038	
9		2562.9 ± 1	
10		465 ± 1	
11		707 ± 0.2	
12		600 ± 0.5	
13		$\varnothing 80 + 0.2$ 0	
14		326.5 ± 1	
15		$\varnothing 80 + 0.1$ 0	
16	Arm width	311.0 +0 - 0.5	
	Bushing installed	325	
17	Min.	1648	
	Max.	2770	

Bucket portion

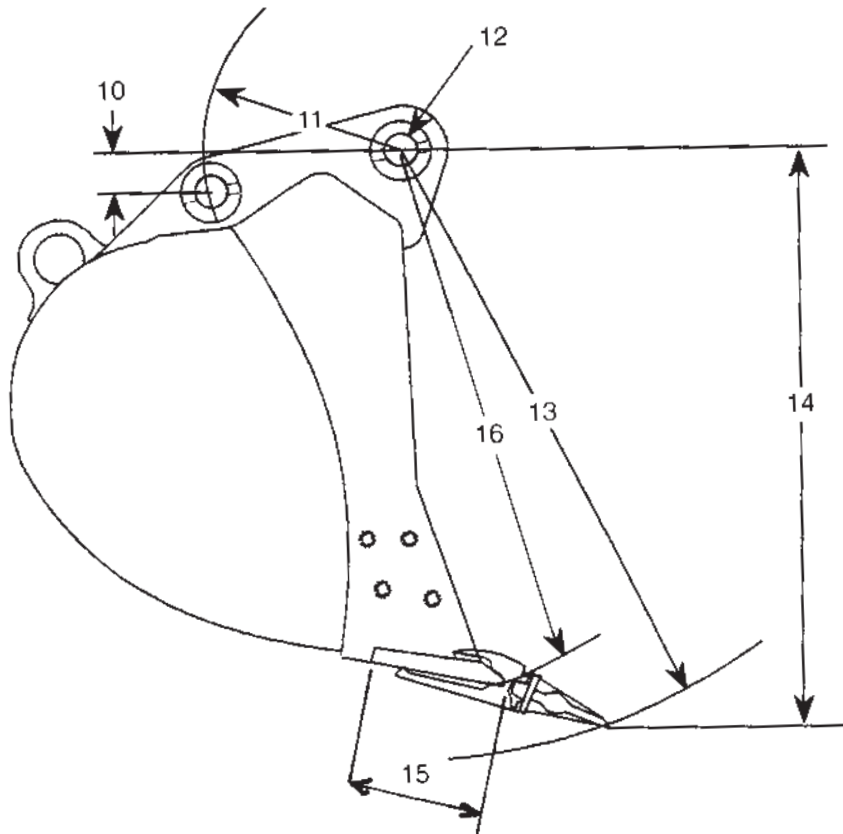
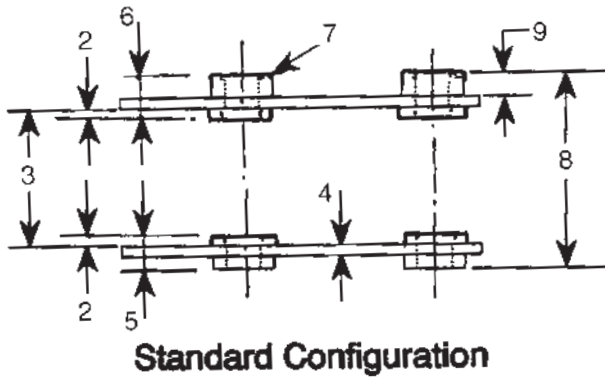

X17FZ047

Unit: mm

No.	Model	
1		326.5 ± 1
2		10
3		346.5 ± 1
4		35
5		59
6		105
7		Ø140
8		490.5 ± 1
9		60
10		251
11		520
12		Ø80
13		1562
14		1321
15		270
16		1400

Komatsu Europe International n.v.
 Mechelsesteenweg 586
 B-1800 Vilvoorde, Belgium
 Fax: 32 2 / 255 19 81

PROPOSAL FOR MANUAL REVISION

FOR INTERNAL USE ONLY – No. PMR

P R O P O S E R	NAME OF COMPANY:		LOCATION:	
			PHONE NO:	
	DEPARTMENT:		DATE:	
	NAME:			
MANUAL NAME:				
MANUAL NO:				
MACHINE MODEL: S/N IF APPLICABLE:				
PAGE NO:				
PROBLEM:				
Attach photo or sketch. If more space is needed, use another sheet.				
FOR INTERNAL USE ONLY				
CORRECTIVE ACTION:				

PFMR1 081696

STRUCTURE AND FUNCTION

FOLDOUT 1

Operation of CLSS system as a whole

When all work equipment is at neutral

- ★ The diagram shows the when all work equipment is at neutral
- ★ The valves and circuits that are not connected with the explanation of the operation of the CLSS hydraulic system have been omitted.

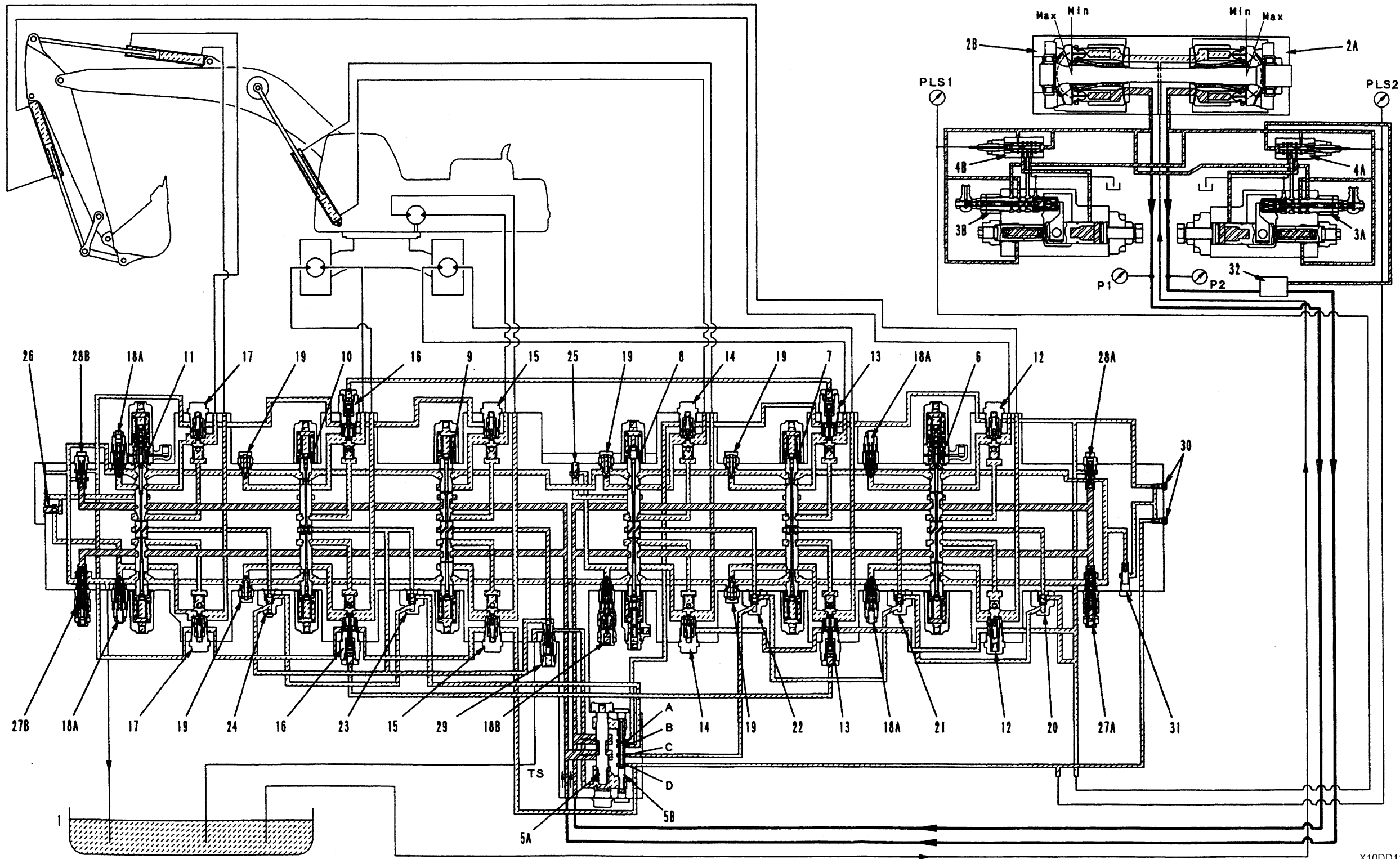

X10DD112

- Connection of ports when pump flow is merged. Connected ports: A - D, B - C.

STRUCTURE AND FUNCTION

Pump flow divided, one side actuated, other side neutral
★ The diagram shows the independant bucket DUMP operation with pump merge.

FOLDOUT 2

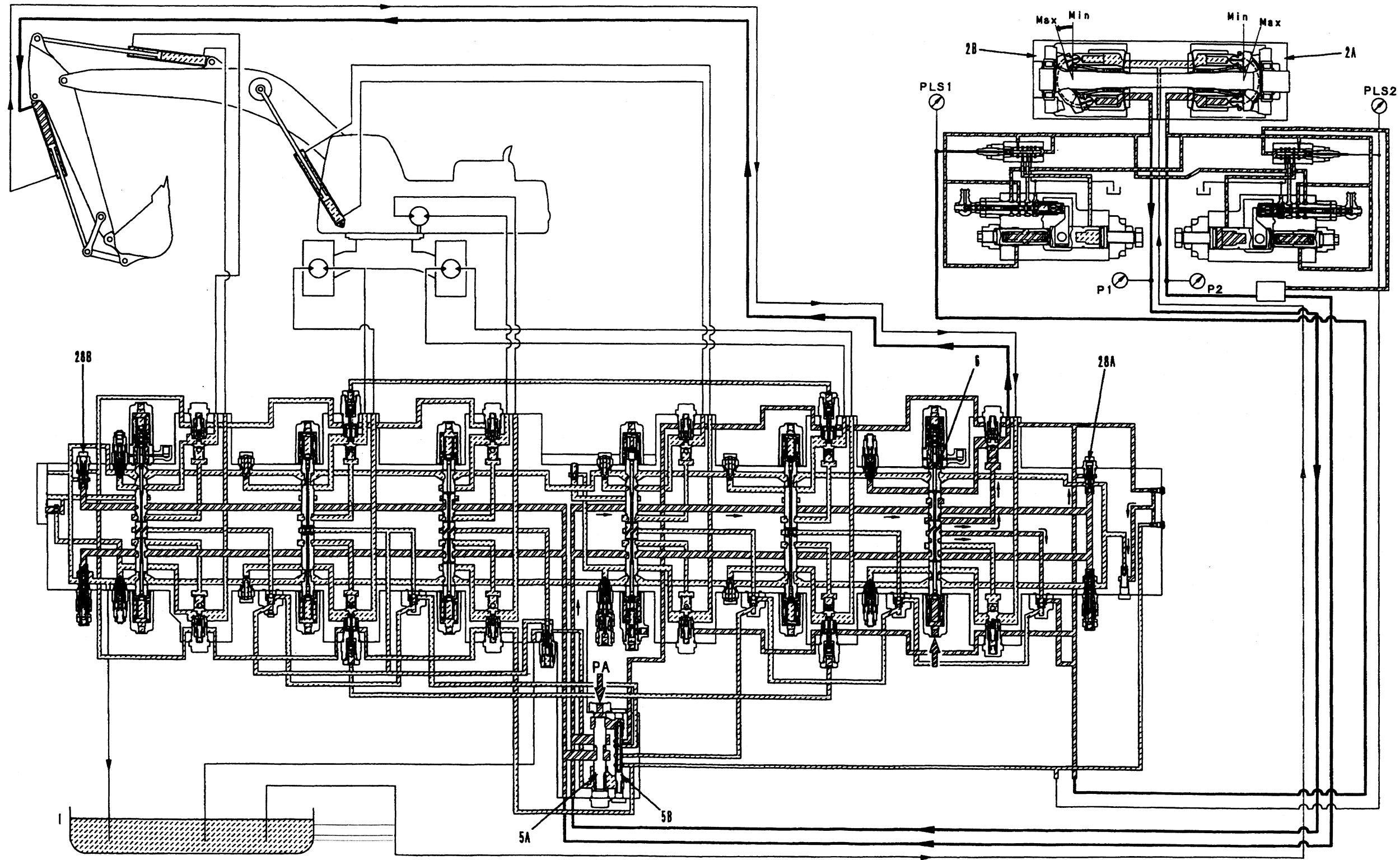

X10DD113

STRUCTURE AND FUNCTION

Pump flow merged, arm OUT, standard mode relief (cut-off control)

★ The diagram shows the arm DUMP and standard mode relief with the pump flow merged.

FOLDOUT 3

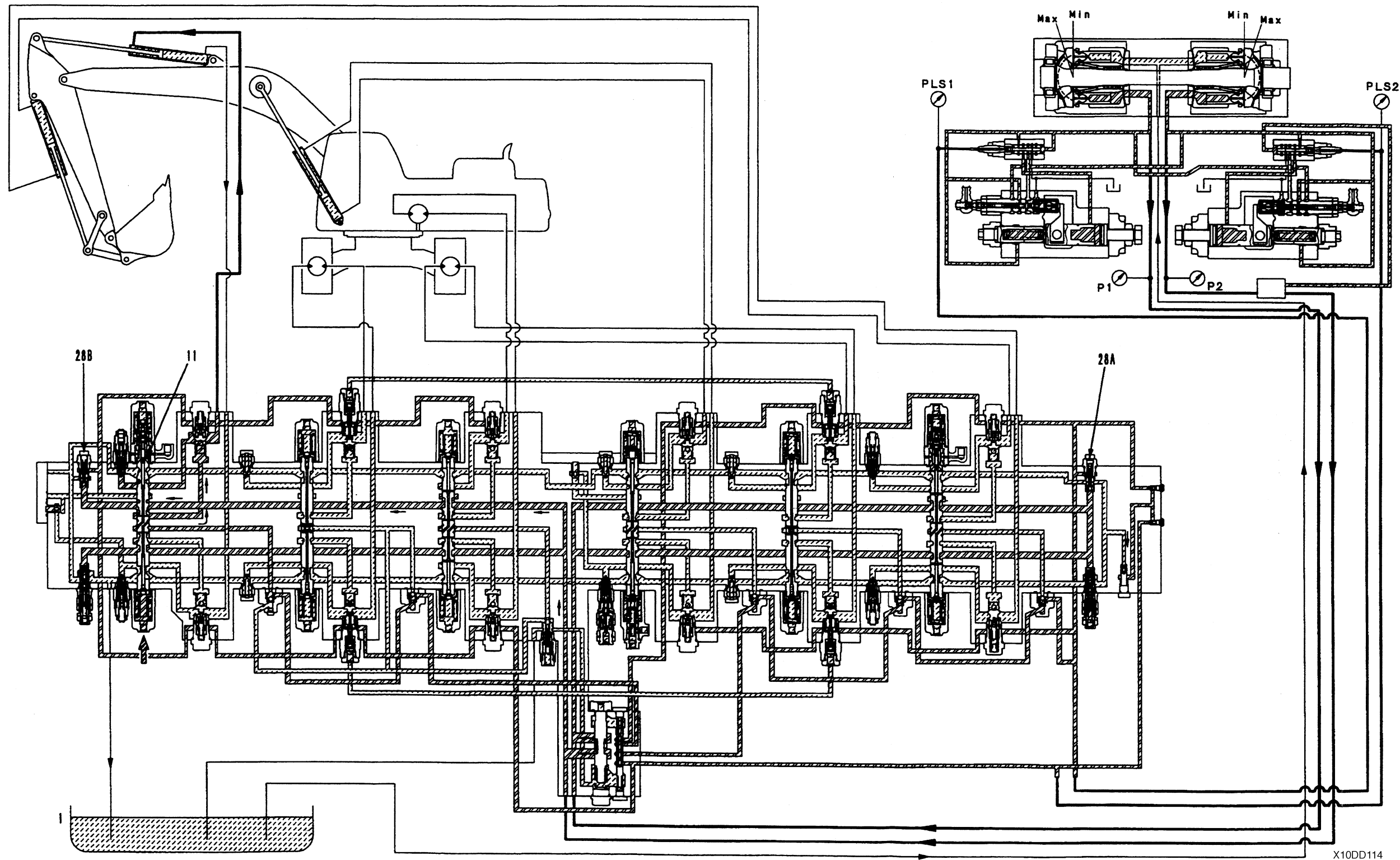

X10DD114

- Connection of ports when pump flow is merged. Connected ports: A - D, B-C.

STRUCTURE AND FUNCTION

Pump flow divided, bucket DUMP, power max. relief.

★ The diagram shows bucket DUMP, relief with the pump flow divided.

FOLDOUT 4

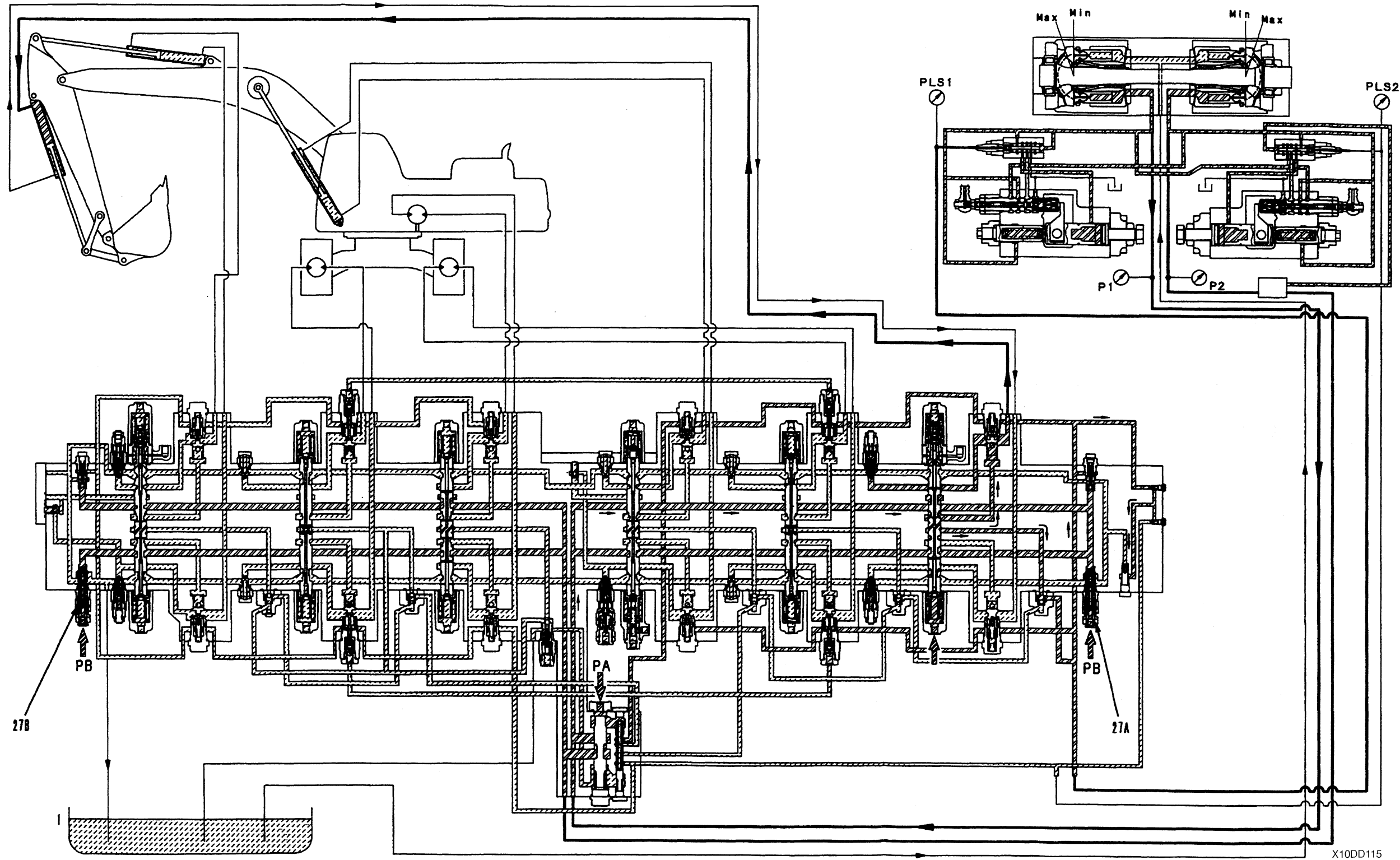

X10DD115

- Connection of ports when pump flow is divided. Connected ports: B - D Disconnected ports: A, C

STRUCTURE AND FUNCTION

Pump flow merged, boom RAISE

★ The diagram shows boom RAISE, with the pump flow merged.

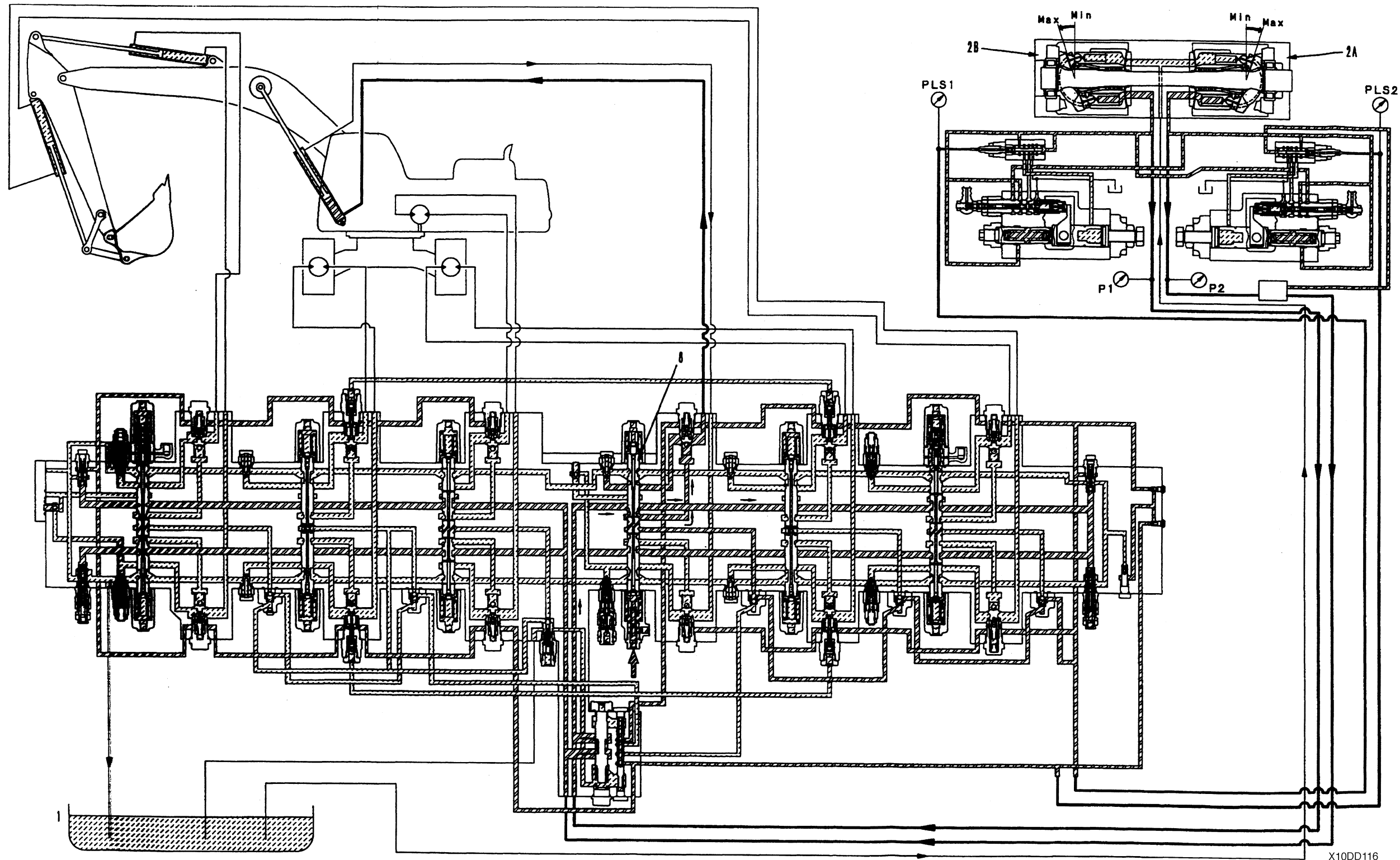

X10DD116

- Connection of ports when pump flow is merged. Connected ports: A-D, B-C

STRUCTURE AND FUNCTION

Pump flow merged, swing operated independently

★ The diagram shows the swing operated independently, with the pump flow divided.

FOLDOUT 6

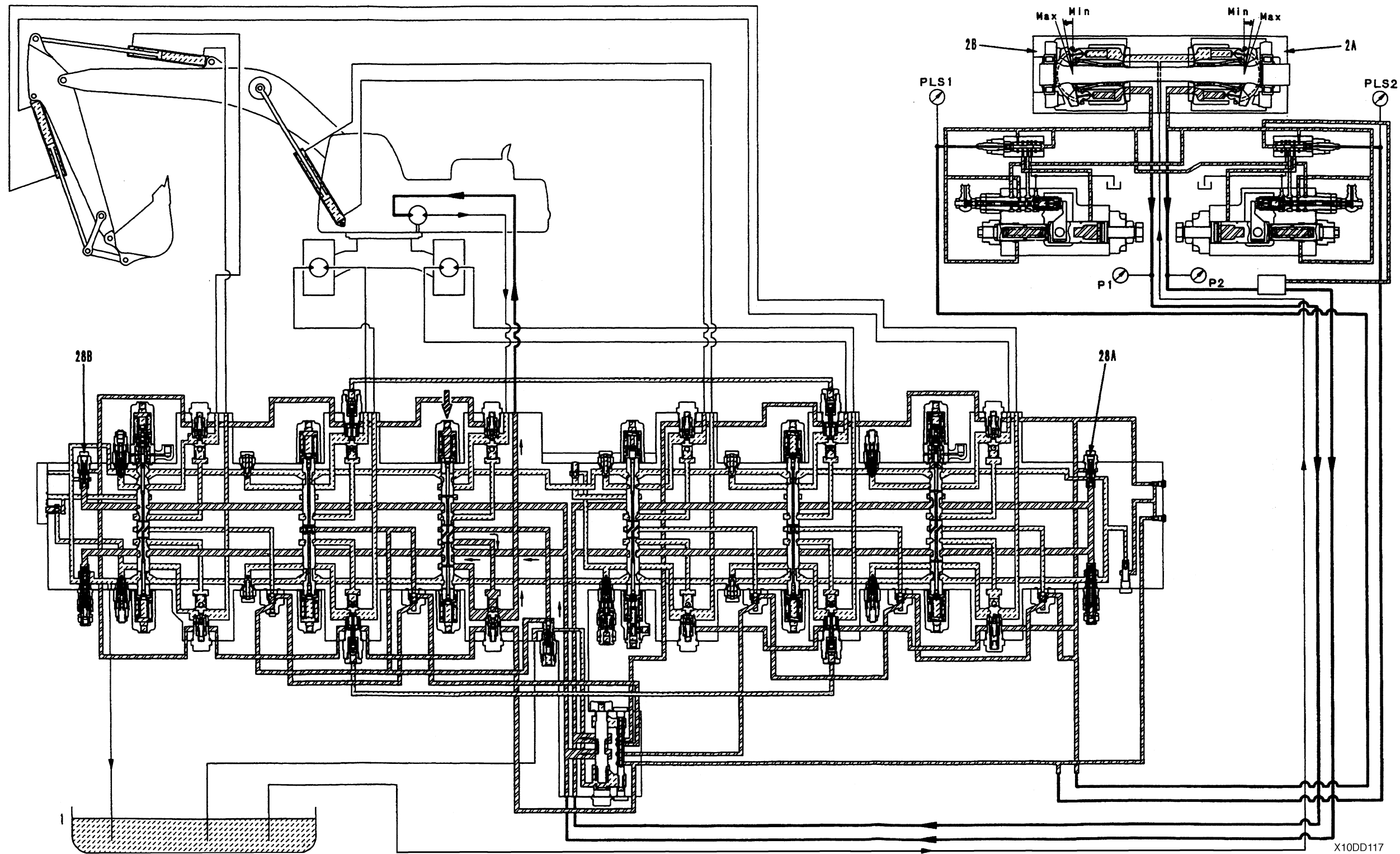

- Connection of ports when pump flow is divided. Connected ports: **B - D** Disconnected ports: **A, C**

STRUCTURE AND FUNCTION

Pump flow divided, travel operated independently

★ The diagram shows the travel operated independently with the pump flow divided.

FOLDOUT 7

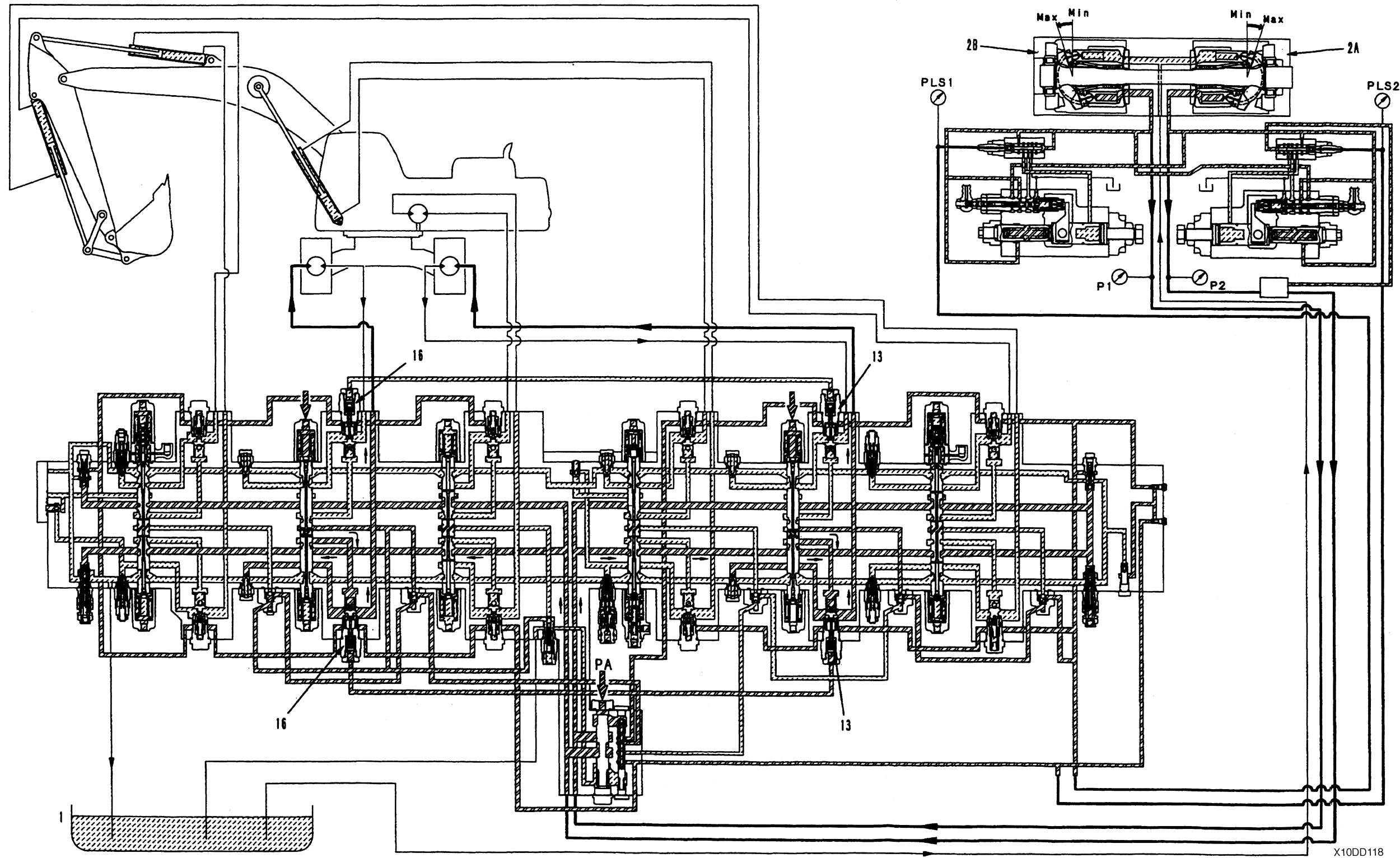

- Connection of ports when pump flow is divided. Connected ports: **B - D** Disconnected ports: **A, C**

STRUCTURE AND FUNCTION

Pump flow merged, compound operation

★ The diagram shows boom RAISE + arm IN with the pump flow merged.

FOLDOUT 8

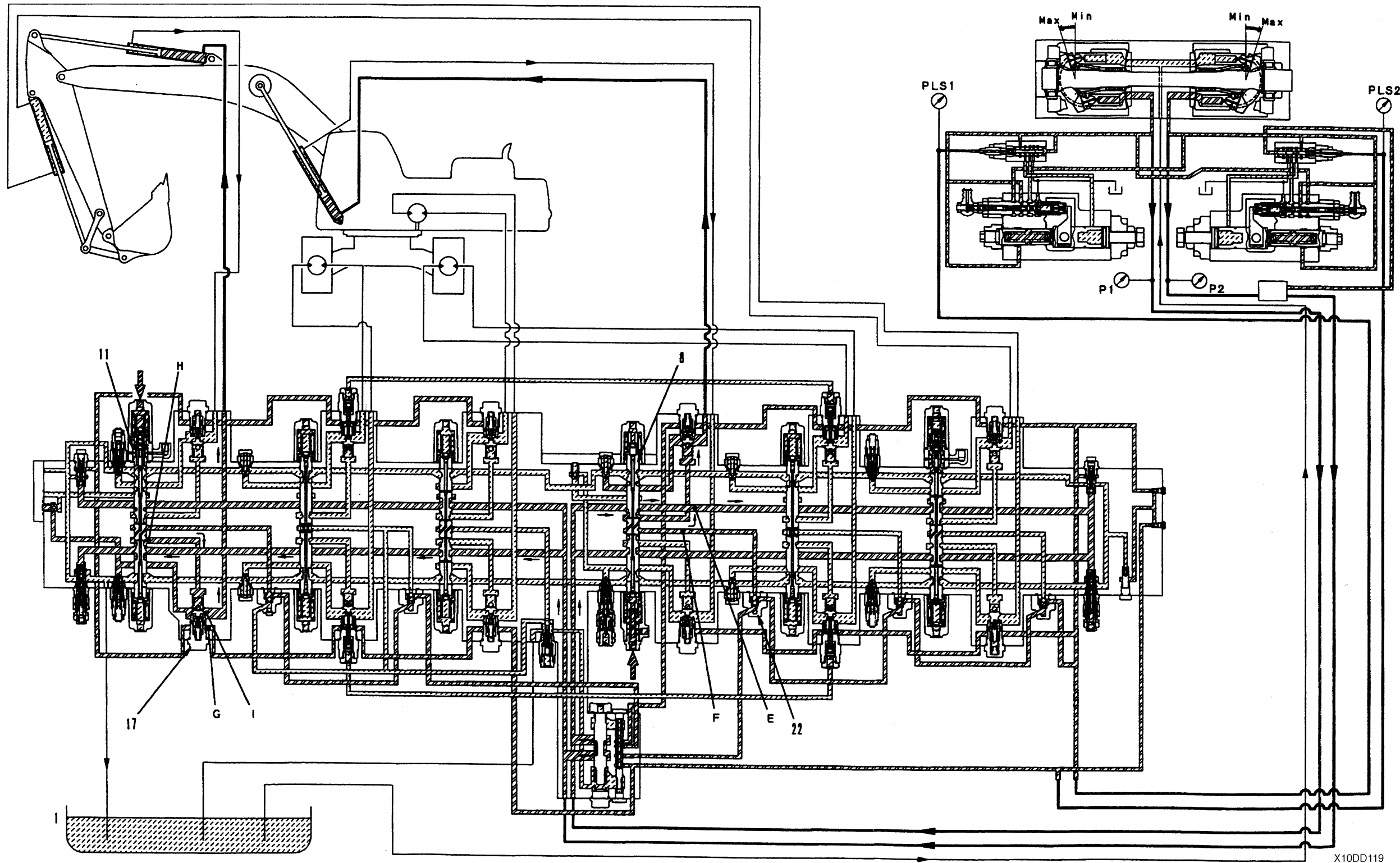

- Connection of ports when pump flow is merged. Connected ports: A - D, B - C.

Total system diagram

FOLDOUT 9

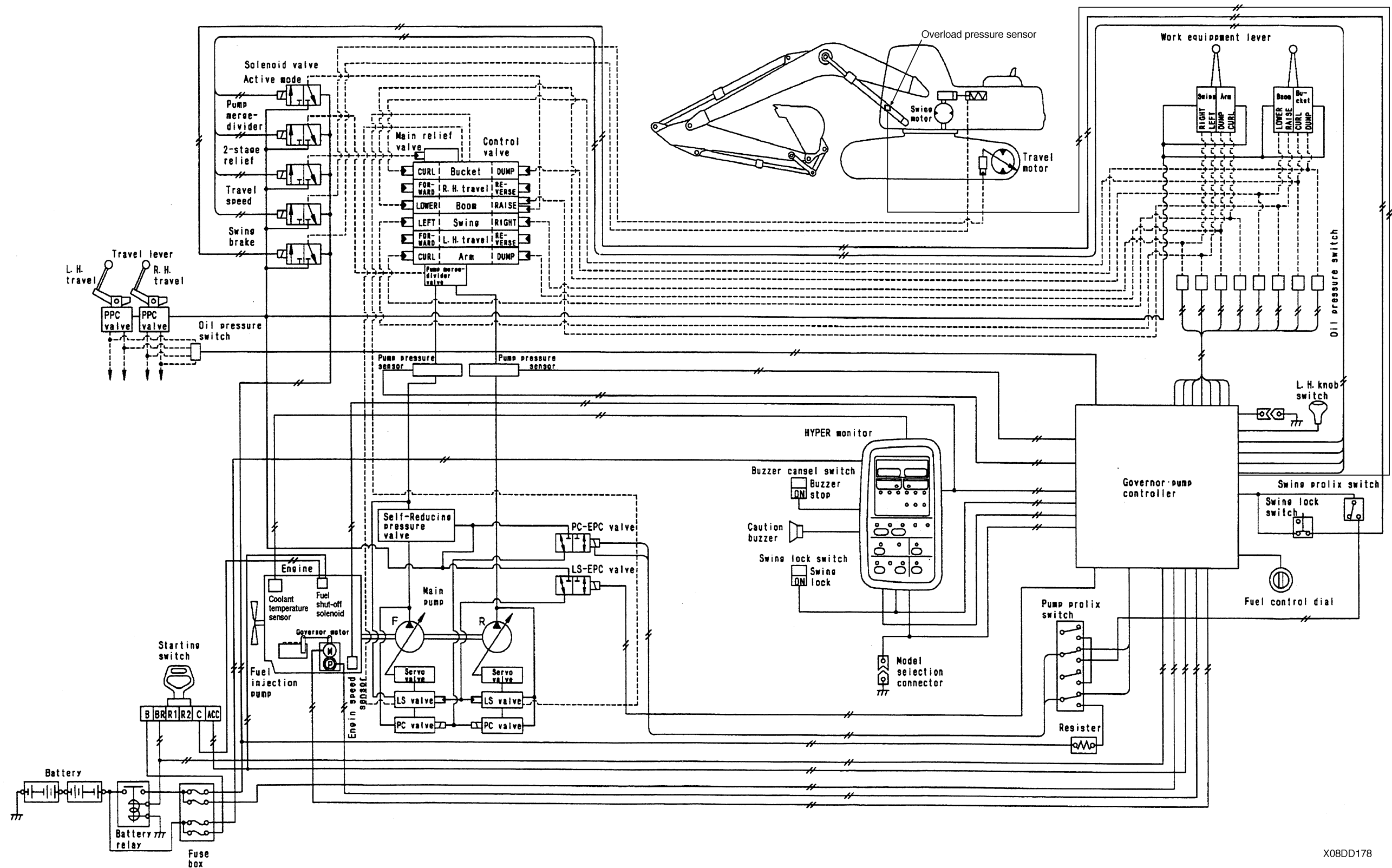

X08DD178

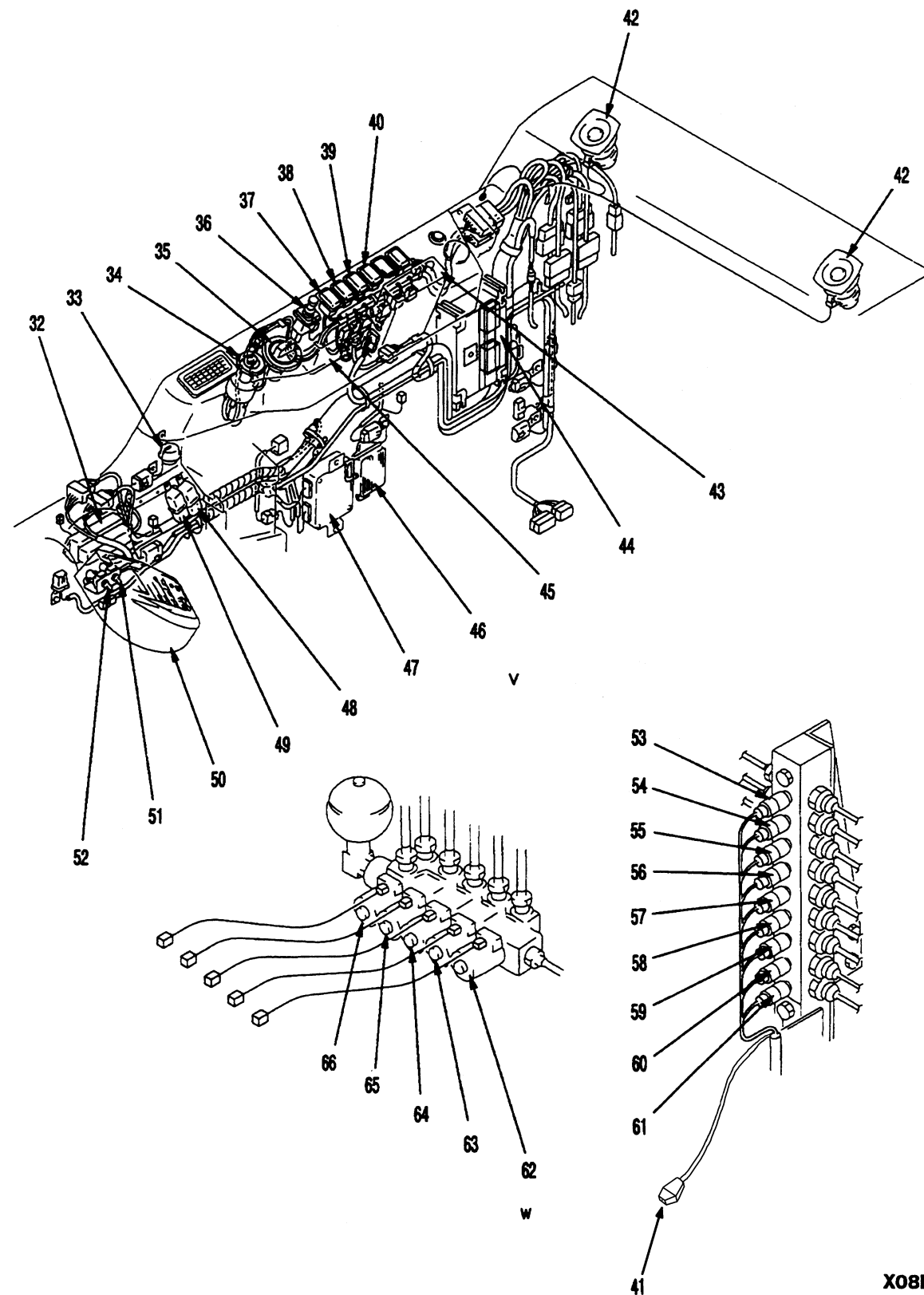

- | | |
|--|--|
| 1. Fuel level sensor | 39. Light switch |
| 2. Working lamp | 40. Buzzer cancel switch |
| 3. Hydraulic oil level sensor | 41. Clamshell rot/breaker solenoid valve |
| 4. LS control EPC valve | 42. Speaker |
| 5. PC control EPC valve | 43. Air conditioner control panel |
| 6. Engine speed sensor | 44. Governor pump controller |
| 7. Governor motor | 45. Radio |
| 8. Engine oil pressure sensor | 46. Prolix resistor |
| 9. Rear pump pressure sensor | 47. Wiper motor controller |
| 10. Front pump pressure sensor | 48. Light relay |
| 11. Air cleaner clogging sensor | 49. Light relay |
| 12. Radiator water level sensor | 50. Monitor panel |
| 13. Window washer motor | 51. Swing prolix switch |
| 14. Overload caution sensor | 52. Pump prolix switch |
| 15. Horn (high tone) | 53. Arm OUT oil pressure switch |
| 16. Horn (low tone) | 54. Arm IN oil pressure switch |
| 17. Battery relay | 55. Travel oil pressure switch |
| 18. Battery | 56. Right swing switch |
| 19. R.H. front lamp | 57. Bucket DUMP oil pressure switch |
| 20. Engine water temperature sensor | 58. Boom RAISE oil pressure switch |
| 21. Intake air heater | 59. Bucket CURL oil pressure switch |
| 22. Air conditioner compressor magnet clutch | 60. Left swing switch |
| 23. Engine oil level sensor | 61. Boom LOWER oil pressure switch |
| 24. Alternator | 62. Swing brake solenoid valve |
| 25. Starting motor | 63. Travel speed solenoid valve |
| 26. Wiper motor | 64. Merge/flow divider solenoid valve |
| 27. Horn switch | 65. 2-stage relief solenoid valve |
| 28. Room lamp | |
| 29. L.H. knob switch | |
| 30. Heater relay | |
| 31. Fuel shut-off solenoid | |
| 32. Fuse box | |
| 33. Alarm buzzer | |
| 34. Starting switch | |
| 35. Fuel control dial | |
| 36. Cigarette lighter | |
| 37. Swing lock switch | |
| 38. Wiper, washer switch | |

X08DD177

ELECTRICAL WIRING DIAGRAM

FOLDOUT 11

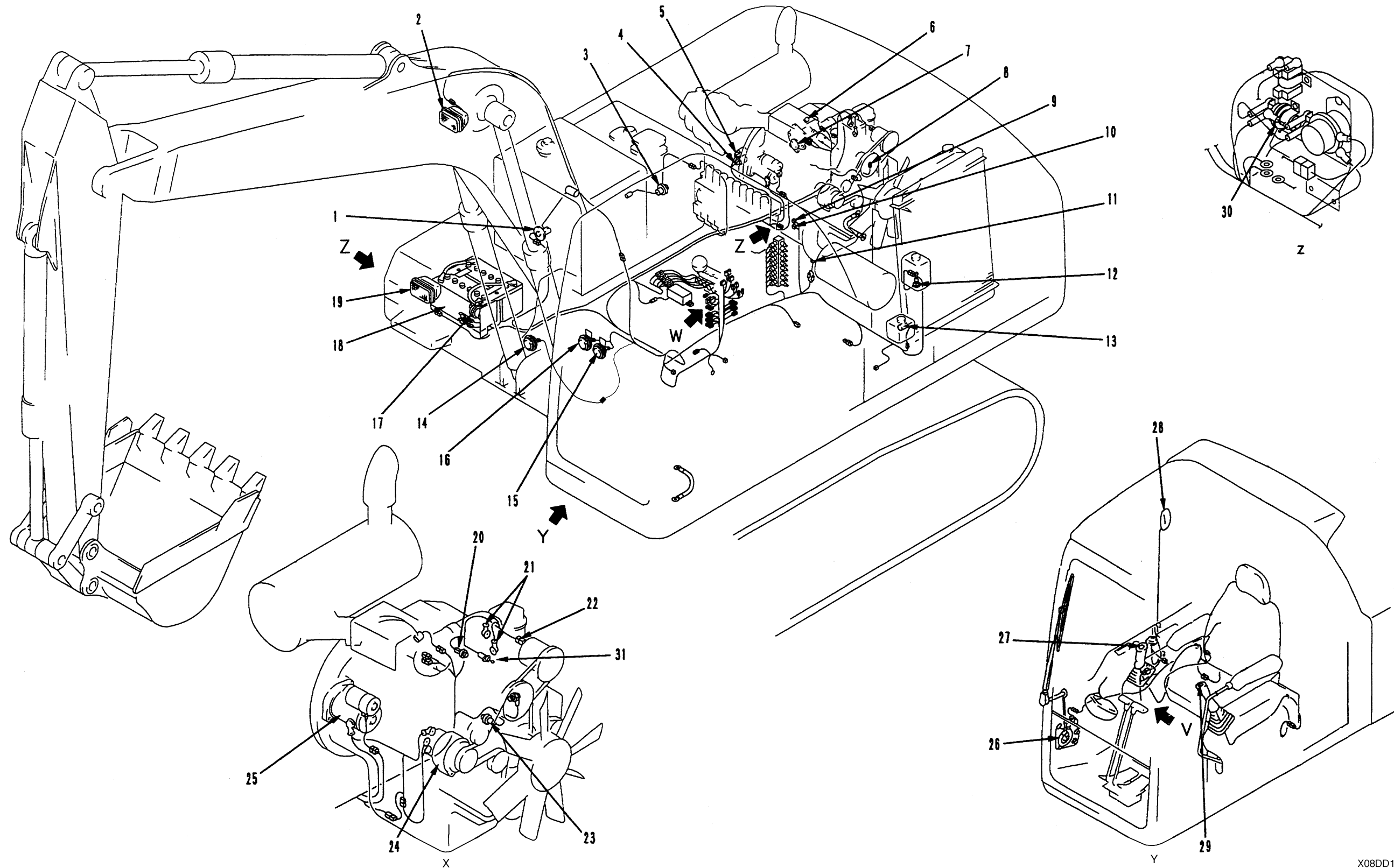

X08DD176

