

# **Mega 500-V (Tier II)**

Shop Manual

023-00054E

Serial Number 2001 and Up

Doosan reserves the right to improve our products in a continuing process to provide the best possible product to the market place. These improvements can be implemented at any time with no obligation to change materials on previously sold products. It is recommended that consumers periodically contact their distributors for recent documentation on purchased equipment.

This documentation may include attachments and optional equipment that is not available in your machine's package. Please call your distributor for additional items that you may require.

Illustrations used throughout this manual are used only as a representation of the actual piece of equipment, and may vary from the actual item.



# TABLE OF CONTENTS

## Safety

Wheel Loader Safety .....	S0103010K
---------------------------	-----------

## Specifications

Specifications for Mega 500-V (Tier II) .....	S0203075K
---	-----------

## General Maintenance

General Maintenance Procedures .....	S0302000
Standard Torques .....	S0309000

## Upper Structure

Counterweight.....	S0403040K
Fuel Transfer Pump.....	S0405500
Hydraulic Oil Tank .....	S0406040K

## Lower Structure and Chassis

Center Joint (Articulation Joint).....	S0502020K
--	-----------

## Engine and Drive Train

Axle (ZF AP-420R) .....	S0602170K
Air Conditioner .....	S0605050K
Transmission and Torque Converter (ZF 4WG-310).....	S0607080K
Transmission Error Codes (ZF) .....	S0607900C

## Hydraulics

Accumulator.....	S0703000
Cylinders.....	S0705010
Fan Drive Hydraulic Motor (Haldex) .....	S0707100K
Pump (Denison T67DB Series) .....	S0708465K

Brake Pedal Valve .....	S0709240K
Main Control Valve (Toshiba) .....	S0709455K
Pilot Control Valve .....	S0709476K
Flow Amplifier (Danfoss).....	S0709665K
Power Steering Unit.....	S0709730K
Restriction Valve.....	S0709750K
Hydraulic Schematic (Mega 500-V (Tier II)) .....	S0793065K

## **Electrical System**

Electrical System .....	S0802195K
Electrical Schematic (Mega 500-V (Tier II)).....	S0893065K

## **Attachments**

# SAFETY





# WHEEL LOADER SAFETY



## CAUTION!

Follow all safety recommendations and safe shop practices outlined in the front of this manual or those contained within this section.

Always use tools and equipment that is in good working order.

Use lifting and hoisting equipment capable of safely handling load.

Remember, that ultimately safety is your own personal responsibility.

MODEL	SERIAL NUMBER RANGE
Mega 200-V	1001 and Up
Mega 250-V	1001 and Up
Mega 300-V	1001 and Up
Mega 400-V	1001 and Up
Mega 500-V	1001 thru 2000
Mega 500-V (Tier II)	2001 and Up

# TABLE OF CONTENTS

To the Operator of a Doosan Wheel Loader ..... 3

General Safety Essentials ..... 6

Location of Safety Labels ..... 6

Unauthorized Modifications ..... 6

General Hazard Information ..... 7

Before Starting Engine ..... 15

Machine Operation ..... 18

Maintenance ..... 25

Battery ..... 33

Towing ..... 35

Shipping and Transportation ..... 36



# TO THE OPERATOR OF A DOOSAN WHEEL LOADER



**Unsafe use of the wheel loader could lead to serious injury or death. Operating procedures, maintenance and equipment practices or traveling or shipping methods that do not follow the safety guidelines on the following pages could cause serious, potentially fatal injuries or extensive damage to the machine or nearby property.**

Please respect the importance of taking responsibility for your own safety, and that other people who may be affected by your actions.

Safety information on the following pages is organized into the following topics.

1. "General Safety Essentials" on page 6.
2. "Location of Safety Labels" on page 6.
3. "Unauthorized Modifications" on page 6.
4. "General Hazard Information" on page 7.
5. "Before Starting Engine" on page 15.
6. "Machine Operation" on page 18.
7. "Maintenance" on page 25.
8. "Battery" on page 33.
9. "Towing" on page 35.
10. "Shipping and Transportation" on page 36.



## **WARNING!**

**Improper operation and maintenance of this machine can be hazardous and could result in serious injury or death.**

**Operator and maintenance personnel should read this manual thoroughly before beginning operation or maintenance.**

**Keep this manual in the storage compartment to the rear of the operator's seat, and have all personnel involved in working on the machine read the manual periodically.**

**Some actions involved in operation and maintenance of the machine can cause a serious accident, if they are not done in a manner described in this manual.**

**The procedures and precautions given in this manual apply only to intended uses of the machine.**

**If you use your machine for any unintended uses that are not specifically prohibited, you must be sure that it is safe for any others. In no event should you or others engage in prohibited uses or actions as described in this manual.**

**Daewoo delivers machines that comply with all applicable regulations and standards of the country to which it has been shipped. If this machine has been purchased in another country or purchased from someone in another country, it may lack certain safety devices and specifications that are necessary for use in your country. If there is any question about whether your product complies with the applicable standards and regulations of your country, consult Daewoo or your Daewoo distributor before operating the machine.**



## SAFETY ALERT SYMBOL



**Be Prepared - Get to Know All Operating and Safety Instructions**

**This is the Safety Alert Symbol. Wherever it appears - in this manual or on safety signs on the machine - you should be alert to potential for personal injury or accidents. Always observe safety precautions and follow recommended procedures.**

### LEARN SIGNAL WORDS USED WITH SAFETY ALERT SYMBOL

Words "**CAUTION**," "**WARNING**," and "**DANGER**" used throughout this manual and on labels on machine indicate hazards or unsafe practices. All three statements indicate that safety is involved. Observe precautions indicated whenever you see the Safety Alert "Triangle," no matter which signal word appears next to the "Exclamation Point" symbol.



### CAUTION!

**This word is used on safety messages and safety labels and indicates potential of a hazardous situation that, if not avoided, could result in minor or moderate injury. It may also be used to alert against a generally unsafe practice.**



### WARNING!

**This word is used on safety messages and safety labels and indicates potential of a hazardous situation that, if not avoided, could result in serious injury or death. It may also be used to alert against a highly unsafe practice.**



### DANGER!

**This word is used on safety messages and safety labels and indicates imminent hazard of a situation that, if not avoided, is very likely to cause death or extremely serious injury. It may also be used to alert against equipment that may explode or detonate if handled or treated carelessly.**

Safety precautions are described in SAFETY from page 6 on.

Daewoo cannot predict every circumstance that might involve a potential hazard in operation and maintenance. Therefore the safety messages in this manual and on the machine may not include all possible safety precautions. If any procedures or actions not specifically recommended or allowed in this manual are used, you must be sure that you and others can do such procedures and actions safely and without damaging the machine. If your unsure about the safety of some procedures, contact a DAEWOO distributor.

# GENERAL SAFETY ESSENTIALS

## ACCESSORY APPLICATIONS

This wheel loader has been designed primarily for moving earth with a bucket. For use as a grapple or for other object handling, contact Daewoo. Lifting-work applications are permitted in approved lift configuration, to rated capacity only, with no side-loading (unless prohibited by local regulation). Do not use machine for activities for which it was not intended. Do not use bucket for lifting work, unless lift slings are used in approved configuration.

## LOCATION OF SAFETY LABELS

Location of safety labels (decals) can vary from unit to unit. Refer to appropriate Operation and Maintenance Manual, and Parts Manual for your unit.

There are several specific warning signs on this machine. The exact location of hazards and the description of the hazards are reviewed in the appropriate Operation and Maintenance Manual.

Please become familiarized with all warning signs.

Make sure that all of the warning signs are legible. Clean the warning signs or replace the warning signs if you cannot read the words. Replace the illustrations if the illustrations are not visible. When you clean the warning signs, use a cloth, water and soap. Do not use solvent, gasoline, or other harsh chemicals to clean the safety signs. Solvents, gasoline, or other harsh chemicals could loosen the adhesive that secures the warning sign. Loose adhesive will allow the warning sign to fall off.

Replace any safety sign that is damaged, or missing. If a safety sign is attached to a part that is replaced, install a safety sign on the replacement part.

## UNAUTHORIZED MODIFICATIONS

Any modification made without authorization or written approval from Daewoo can create a safety hazard, for which the machine owner must be held responsible.

For safety's sake, replace all OEM parts with the correct authorized or genuine Daewoo part. For example, not taking the time to replace fasteners, bolts or nuts with the correct replacement parts could lead to a condition in which the safety of critical assemblies is dangerously compromised.

# GENERAL HAZARD INFORMATION

## SAFETY RULES

Only trained and authorized personnel can operate and maintain the machine.

Follow all safety rules, precautions and instructions when operating or performing maintenance on the machine.

Do not operate the machine if you are not feeling well, if you are taking medication that makes you feel sleepy, if you have been drinking, or if you are suffering from emotional problems. These problems will interfere with your sense of judgement in emergencies and may cause accidents.

When working with another operator or with a person on work site traffic duty, be sure that all personnel know the nature of the work and understand all hand signals that are to be used.

Always observe strictly any other rules related to safety.

## SAFETY FEATURES

Be sure that all guards and covers are installed in their proper position. Have guards and covers repaired immediately if damaged.

Be sure that you understand the method of use of safety features such as transmission lever neutral lock and the seat belt, and use them properly.

Never remove any safety features. Always keep them in good operating condition.

Failure to use safety features according to the instructions in the Operation and Maintenance Manual could result in serious bodily injury.

## INSIDE OPERATOR'S COMPARTMENT

When entering the operator's compartment, always remove all mud and oil from the soles of your shoes. If you operate the accelerator and brake pedals with mud or oil stuck to your shoes, your foot may slip and this may cause a serious accident.

Clean grease and dirt from pedals and controls. This contributes to safe operation. Cleaning also provides an opportunity to inspect equipment. Minor damage can be repaired or corrected before major problems result.

Keep cab floor and consoles free of tools and personal items.

After using the ashtray, make sure that any matches or cigarettes are properly extinguished, and be sure to close the ashtray. If the ashtray is left open, there is danger of fire.

Do not stick suction pads to the window glass. Suction pads act as a lens and may cause fire.

Do not leave lighters laying around the operator's compartment. If the temperature inside the operator's compartment becomes high, there is danger that the lighter may explode.

Do not use cellular telephones inside the operator's compartment when driving or operating the machine. There is danger that this may lead to an unexpected accident.

Never bring any dangerous objects such as flammable or explosive items into the operator's cab.

To ensure safety, do not use the radio or music headphones when operating the machine. There is danger that this may lead to a serious accident.

When operating the machine, do not put your hands or head out of the window.

When standing up from the operator's seat, always place transmission neutral lock lever in the "LOCK" position and set pilot cutoff switch to "O" (OFF) position. If you accidentally touch the work equipment levers when they are not locked, the machine may suddenly move and cause serious injury or damage.

When leaving the machine, lower the work equipment completely to the ground, set transmission neutral lock lever in the "LOCK" position, set pilot cutoff switch to "O" (OFF) position, "APPLY" parking brake, and shut down engine. Use the key to lock all the equipment. Always remove the key and take it with you.

## CLOTHING AND PERSONAL PROTECTIVE ITEMS

Contain long hair, and avoid loose clothing and jewelry. They can catch on controls or in protruding parts and cause serious injury or death.

Do not wear oily clothes. They are highly flammable.

Full eye protection, a hard hat, safety shoes and gloves may be required at the work site.

While working on the machine, never use inadequate tools. They could break or slip, causing injury, or they may not adequately perform intended functions.

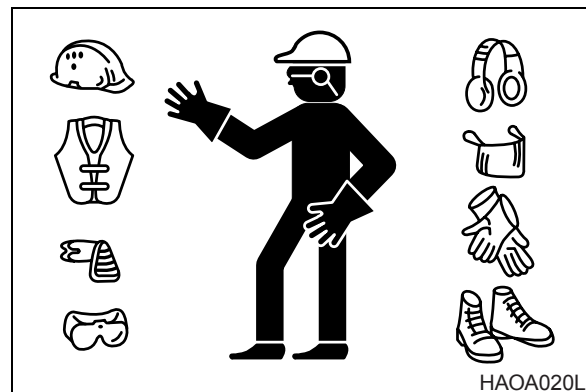

Figure 1

## BREATHING MASKS, EAR PROTECTION MAY BE REQUIRED

Do not forget that some risks to your health may not be immediately apparent. Exhaust gases and noise pollution may not be visible, but these hazards can cause disabling or permanent injuries.

**NOTE:** *Sound level in closed operator's cab is 75 dB(A). Additional information on machine sound and vibration levels can be found in Shop Manual.*

## ASBESTOS DUST HAZARD PREVENTION

Asbestos dust can be HAZARDOUS to your health if it is inhaled.

If you handle materials containing asbestos fibers, follow these guidelines as given below:

- Use an approved respirator.
- Never use compressed air for cleaning.
- Use water for cleaning to keep down the dust.
- Work on the machine or component with the wind at your back whenever possible.
- Always observe any rules and regulations related to the work site and working environment.

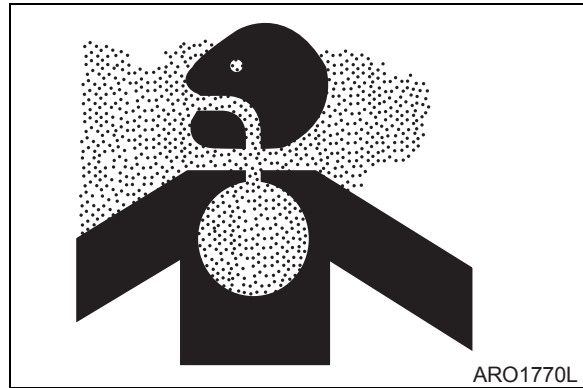

**Figure 2**

## MOUNTING AND DISMOUNTING

Before getting on or off the machine, if there is any oil, grease, or mud on the handrails, steps, or track shoes, wipe it off immediately. Always keep these parts clean. Repair any damage and tighten any loose bolts.

Never get on or off a moving machine. In particular, never get on or off a moving machine. These actions may lead to serious injury.

When getting on or off the machine, always face the machine, and maintain a three-point contact (both feet and one hand or one foot and both hands) with the handholds and steps to ensure that you support yourself securely.

Never hold any control levers when getting on or off the machine.

Never get up from operator's seat or leave operator's station and dismount machine if engine is running.

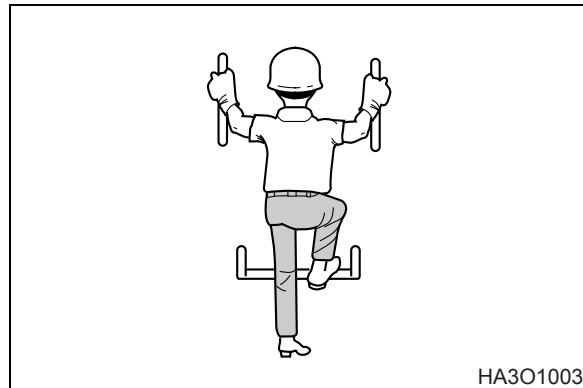

**Figure 3**

## FUEL, OIL AND HYDRAULIC FLUID FIRE HAZARDS

Fuel, oil and antifreeze will catch fire if it is brought close to a flame. Fuel is particularly flammable and can be hazardous.

Always strictly observe the following.

Add fuel, oil, antifreeze and hydraulic fluid to the machine only in a well-ventilated area. The machine must be parked with controls, lights and switches turned "OFF." The engine must be "OFF" and any flames, glowing embers, auxiliary heating units or spark-causing equipment must be doused, turned off and/or kept well clear of the machine.

Static electricity can produce dangerous sparks at the fuel filling nozzle. In very cold, dry weather or other conditions that could produce a static discharge, keep the tip of the fuel nozzle in constant contact with the neck of the fuel filling nozzle, to provide a ground.

Keep fuel and other fluid reservoir caps tight and do not start the engine until caps have been secured.



Figure 4

## PRECAUTIONS WHEN HANDLING FLUIDS AT HIGH TEMPERATURE

Immediately after operations are stopped, the coolant, engine oil, and hydraulic oil are at high temperature and the radiator and hydraulic tank are still under pressure. Attempting to remove the cap, drain the oil or coolant, or replace the filters may lead to serious burns. Always wait for the temperature to go down, and follow the specified procedures when carrying out these operations.

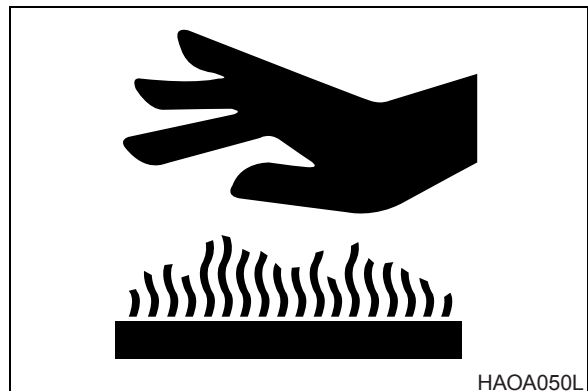

Figure 5

To prevent hot coolant from spurting out, stop the engine, wait for the coolant to cool, then loosen the cap slowly to relieve the pressure.

To prevent hot oil from spurting out, stop the engine, wait for the oil to cool, then loosen the cap slowly to relieve the pressure.

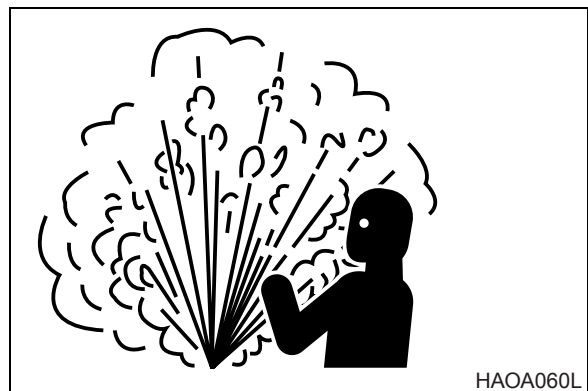

Figure 6



## INJURY FROM WORK EQUIPMENT

Do not enter or put your hand, arm or any other part of your body between movable parts, such as between the work equipment and cylinders, or between the machine and work equipment.

If the control levers are operated, the clearance between the machine and the work equipment will change and this may lead to serious damage or personal injury.

If going between movable parts is necessary, always position and secure the work equipment so that it cannot move.

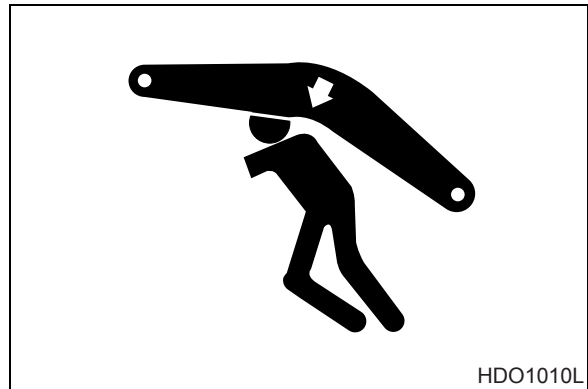

Figure 7

## FIRE EXTINGUISHER AND FIRST AID KIT

As a precaution if any injury or fire should occur, always do the following.

- Be sure that fire extinguishers have been provided and read the labels to ensure that you know how to use them. It is recommended that an appropriately sized (2.27 kg [5 lb] or larger) multipurpose "A/B/C" fire extinguisher be mounted in the cab. Check and service the fire extinguisher at regular intervals and make sure that all work site crew members are adequately trained in its use.
- Provide a first aid kit in the storage compartment and keep another at the work site. Check the kit periodically and make any additions if necessary.
- Know what to do in case of injury from fire.
- Keep emergency numbers for doctor, ambulance service, hospital and fire department near your telephone.

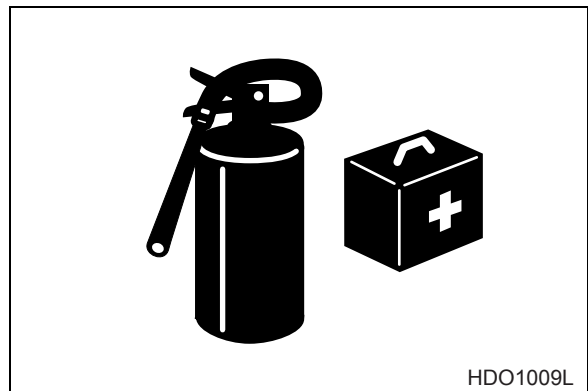

Figure 8

If the machine catches fire, it may lead to serious personal injury or death. If a fire occurs during operation, escape from the machine as follows;

- Turn the starter switch "OFF" and stop the engine.
- If there is time, use the fire extinguisher to extinguish as much of the fire as possible.
- Use the handrails and steps to escape from the machine.

The above is the basic method for escaping from the machine, but changing the method may be necessary according to the conditions, so carry out practice drills at the work site.

## PROTECTION FROM FALLING OR FLYING OBJECTS

On work sites where there is danger that falling objects or flying objects may hit the operator's cab select a guard to match the operating conditions to protect the operator.

Work in mines, tunnels, deep pits or on loose or wet surfaces could produce danger of falling rock, roll over or hazardous flying objects. Additional protection for operator's cab could be required in form of a FOPS/Falling Object Protective Structure and/or ROPS/Roll Over Protective Structure reinforcement system.

Any reinforcement system that is installed on machine must pass safety and certification standards and carry appropriate labeling and rating information. For example, most often added type of reinforcement system, FOPS, must meet or exceed Society of Automotive Engineers standard SAE J1356, "Performance Criteria for Falling Object Guards for Wheel loaders."

Never attempt to alter or modify any type of protective structure reinforcement system, by drilling holes, welding or remounting or relocating fasteners. Any serious impact or damage to system requires a complete integrity reevaluation. Reinstallation, recertification and/or replacement of system may be necessary.

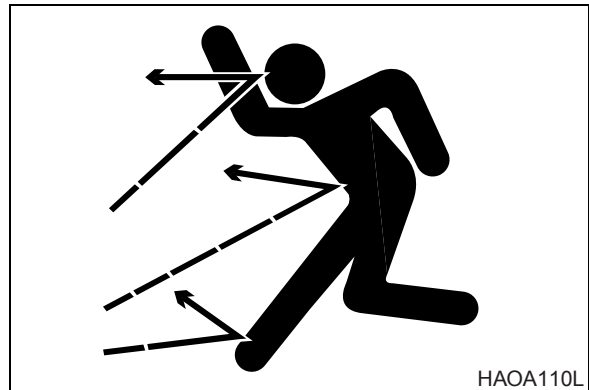

Figure 9



Figure 10

## INSTALL ADDITIONAL SAFETY EQUIPMENT IF CONDITIONS REQUIRE

Laminate glass protection for the front, side or rear windows may also be recommended depending upon particular site conditions.

Contact your Daewoo distributor for available safety guards and/or recommendations if there is any danger of getting hit by objects that could strike the operator's cab. Make sure that all other work site crew members are kept well away from wheel loader and safe from potential hazards.

## MAINTAIN STANDARD SAFETY EQUIPMENT IN GOOD CONDITION

Machinery guards and body panel covers must be in place at all times. Keep well clear of rotating parts. Pinch point hazards such as cooling fan and alternator drive belts could catch hair, jewelry or oversize or very loose clothing.

Safety labels must be replaced if they are damaged or become unreadable. Information on labels gives work crew members an important safety reminder. Part numbers for each decal and required mounting locations are shown on pages 1-2 through 1-4 of this section.

## ATTACHMENT PRECAUTIONS

Options kits are available through your dealer. Contact Daewoo for information on available one-way (single-acting) and two-way (double-acting) piping / valving / auxiliary control kits. Because Daewoo cannot anticipate, identify or test all attachments that owners may wish to install on their machines, please contact Daewoo for authorization and approval of attachments, and their compatibility with options kits.

## ACCUMULATOR

The pilot control system is equipped with an accumulator. For a brief period of time after the engine has been shut down, the accumulator will store a pressure charge that may enable hydraulic controls to be activated. Activation of any controls may enable the selected function to operate under force of gravity.

When performing maintenance on the pilot control system, the hydraulic pressure in the system must be released as describe in Operation and Maintenance Manual.

The accumulator is charged with high-pressure nitrogen gas, so it is extremely dangerous if it is handled in the wrong way. Always observe the following precautions;

- Do not drill or make any holes in the accumulator or expose it any flame, fire or heat source.
- Do not weld on the accumulator, or try attaching anything to it.
- When carrying out disassembly or maintenance of the accumulator, or when disposing of the accumulator, the charged gas must be properly released. Contact your Daewoo distributor.
- Wear safety goggles and protective gloves when working on an accumulator. Hydraulic oil under pressure can penetrate the skin and cause serious injuries.

## ENGINE VENTILATION

Engine exhaust gases can cause loss of judgment, loss of alertness, and loss of motor control. These gases can also cause unconsciousness, serious injury and fatal accidents.

Make sure of adequate ventilation before starting engine in any enclosed area.

You should also be aware of open windows, doors or ductwork into which exhaust may be carried, or blown by wind, exposing others to danger.

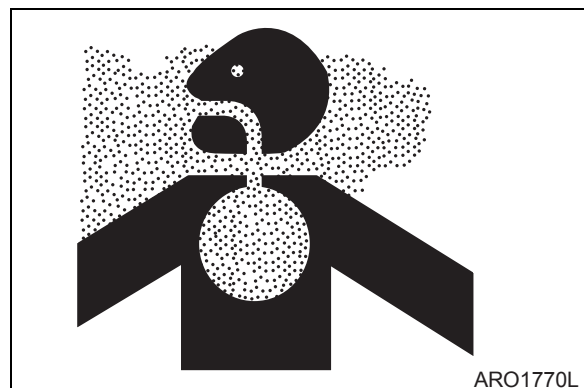

Figure 11

## WINDOW GLASS BREAKING TOOL

This loader is equipped with a glass breaking tool. It is on the lower right side of the cab beside the operator's seat. This tool can be used in case of an emergency situation which requires the breaking of glass to exit from the operator's cab. Grip the handle firmly and use the sharp point to break the glass.



**WARNING!**

**Protect your eyes when breaking the glass.**

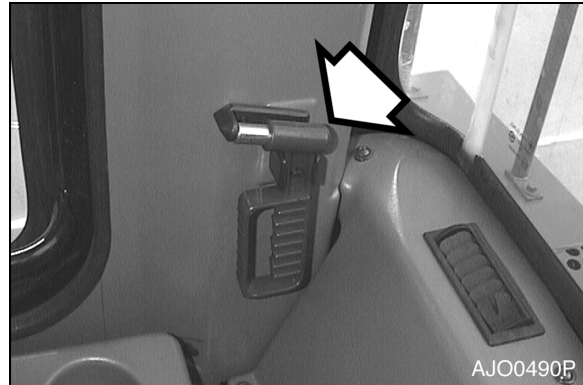

**Figure 12 RIGHT SIDE**

# BEFORE STARTING ENGINE

## WORK SITE PRECAUTIONS

Before starting operations, thoroughly check the area for any unusual conditions that could be dangerous.

Check the terrain and condition of the ground at the work site, and determine the best and safest method of operation.

Make the ground surface as hard and horizontal as possible before carrying out operations. If there is a lot of dust and sand on the work site, spray water before starting operations.

If you need to operate on a street, protect pedestrians and cars by designating a person for work site traffic duty or by erecting fences and posting "No Entry" signs around the work site.

Erect fences, post "No Entry" signs, and take other steps to prevent people from coming close to or entering the work site. If people come close to a moving machine, they may be hit or caught by the machine, and this may lead to serious personal injury or death.

Water lines, gas lines, phone lines and high-voltage electrical lines may be buried under the work site. Contact each utility and identify their locations. Be careful not to damage or cut any of these lines.

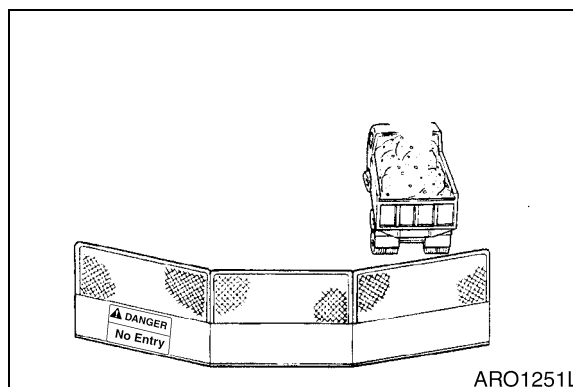

Figure 13

NEVER be in water that is in excess of the permissible water depth. Refer to "Operation Manual."

Any type of object in the vicinity of the boom could represent a potential hazard, or cause the operator to react suddenly and cause an accident. Use a spotter or signal person working near bridges, phone lines, work site scaffolds, or other obstructions.

Minimum levels of insurance coverage, work permits or certification, physical barriers around the work site or restricted hours of operation may be mandated by governing authorities. There may also be regulations, guidelines, standards or restrictions on equipment that may have to be followed for local requirements. There may also be regulations related to performing certain kinds of work. If there is any question about whether your machine and work site complies with the applicable standards and regulations contact your local authorities and agencies.

Avoid entering soft ground. It will be difficult for the machine to escape.

Avoid operating your machine too close to the edge of cliffs, overhangs, and deep ditches. The ground may be weak in such areas. If the ground should collapse, the machine could fall or tip over and this could result in serious injury or death.

Remember that the soil after heavy rain, blasting or after earthquakes, is weakened in these areas.

Earth laid on the ground and the soil near ditches is loose. It can collapse under the weight of vibration of your machine and cause your machine to tip over.

Install the head guard (FOPS) if working in areas where there is danger of falling rocks.

## CHECKS BEFORE STARTING ENGINE

Every day before starting the engine for the first time, carry out the following checks. If these checks are not carried out properly, there is danger of serious injury.

- Completely remove all wood chips, leaves, grass, paper and other flammable materials accumulated in the engine compartment and around the battery. They could cause a fire. Remove any dirt from the window glass, mirrors, handrails, and steps.
- Do not leave tools or spare parts laying around in the operator's compartment. The vibration of the machine when traveling or during operations may cause them to fall and damage or break the control levers or switches. They may also get caught in the gap of the control levers and cause the work equipment to malfunction or move dangerously. This may lead to unexpected accidents.
- Check the coolant level, fuel level, and hydraulic tank oil level, and check for clogged air cleaner and damage to the electrical wiring.
- Adjust the operator's seat to a position where it is easy to operate the machine, and check the seat belt and mounts for damage and wear.
- Check the operation of the gauges and the angle of the mirrors, and check that the safety lever is in "LOCKED" position.
- If any abnormalities are found in the above checks, carry out repairs immediately.

## ENGINE STARTING

- Walk around your machine before getting in operator's cab. Look for evidence of leaking fluid, loose fasteners, misaligned assemblies or any other indications of possible equipment hazard.
- All equipment covers and machinery safety guards must be in place, to protect against injury while machine is being operated.
- Look around work site area for potential hazards, or people or property that could be at risk while operation is in progress.
- NEVER start engine if there is any indication that maintenance or service work is in progress, or if a warning tag is attached to controls in cab.
- A machine that has not been used recently, or is being operated in extremely cold temperatures, could require a warm-up or maintenance service before start up.
- Check gauges and monitor displays for normal operation before starting engine. Listen for unusual noises and remain alert for other potentially hazardous conditions at start of work cycle.
- Check tire inflation and check tires for damage or uneven wear. Perform maintenance before operation.
- Do not short circuit the starting motor to start the engine. This is not only dangerous, but may also damage the machine.
- When starting the engine, sound the horn as an alert.
- Start and operate the machine only while seated.

## **BEFORE OPERATING MACHINE**

If checks are not carried out properly after starting the engine, it may result in a delay in discovering abnormalities in the machine, and this may lead to personal injury or damage to the machine.

Carry out the checks in an open area where there are no obstructions. Do not let anyone near the machine when carrying out the checks.

- Check the operating condition of the equipment, and the actuation of the bucket, boom, and travel systems.
- Check the machine for any abnormal noise, vibration, heat, smell, or abnormality with the gauges. Check also for leakage of air, oil, and fuel.
- If any abnormality is found, repair the problem immediately. If the machine is used without repairing the problems, it may lead to unexpected injury or failure.
- Clear all personnel from directly around machine and from the area.
- Clear all obstacles from the machine's path. Beware of hazards.
- Be sure that all windows are clean. Secure the doors and the windows in the open position or in the shut position.
- Adjust the rear view mirrors for best visibility close to the machine. Make sure that the horn, the travel alarm (if equipped), and all other warning devices are working properly.
- Fasten the seat belt securely.
- Warm up the engine and hydraulic oil before operating machine.
- Before moving the machine, check the position of undercarriage. The normal travel position is with idler wheels to the front under the cab and the drive sprockets to the rear. When the undercarriage is in the reversed position, the travel controls must be operated in opposite directions.

# MACHINE OPERATION

## IMPORTANT

If you need more information or have any questions or concerns about safe operating procedures or working the wheel loader correctly in a particular application or in the specific conditions of your individual operating environment, please consult your local Daewoo representative.

### OPERATE WHILE SEATED AT OPERATOR'S STATION ONLY

Never reach in through a window to work a control. Do not try to operate wheel loader unless you're in command position - seated at controls. You should stay alert and focused on your work at all times. Do not twist out of seat if job activity behind you (or to the side) requires your attention.

Use a spotter or signal person if you cannot see clearly and something is happening behind you.

Replace damaged safety labels and lost or damaged operator's manuals.

Do not let anyone operate machine unless they've been fully and completely trained, in safety and in operation of the machine.



Figure 14

### SEAT BELTS SHOULD BE USED AT ALL TIMES

Whenever engine is running, operator should be seated at the control station with seat belt properly engaged.



Figure 15

### MOVEMENT ALARMS

If wheel loader is equipped with an audible travel movement alarm, test alarm on a daily basis. Audible alarm should sound as soon as travel system is engaged.



## TRAVEL PRECAUTIONS

When traveling, wheel loader always keeps lights on; make sure that you are in compliance with all state and local regulations concerning warning flags and signs.

Never turn the starter switch to the "O" (OFF) position when traveling. It is dangerous if the engine stops when the machine is traveling. It will be impossible to operate the steering unless the unit is equipped with an emergency steering system.

Pilot control valve lever (joystick) should not be operated while traveling.

Lower work equipment so that it is 400 mm (16 in) above ground.

Never travel over obstacles or slopes that will cause machine to tilt severely. Travel around any slope or obstacle that causes 10 degrees tilt, or more.

Do not operate the steering suddenly. The work equipment may hit the ground and cause the machine to lose its balance, and this may damage the machine or structures in the area.

When traveling on rough ground, travel at low speed, and avoid sudden changes in direction.

Always keep to the permissible water depth.

When traveling over bridges or structures on private land, check first that the bridge or structure can withstand the weight of the machine. When traveling on public roads, check with the local authorities and follow their instructions.

## SLOPING TERRAIN REQUIRES CAUTION

Dig evenly around work site whenever possible, trying to gradually level any existing slope. If it's not possible to level area or avoid working on a slope, reducing size and cycling rate workload is recommended.

On sloping surfaces, use caution when positioning wheel loader before starting a work cycle. Stay alert for instability situations to avoid getting into them. For example, you should always avoid working bucket over downhill side of machine when parked perpendicular to slope. Avoid full extensions of bucket in a downhill direction. Lifting bucket too high, too close to machine, while wheel loader is turned uphill can also be hazardous.

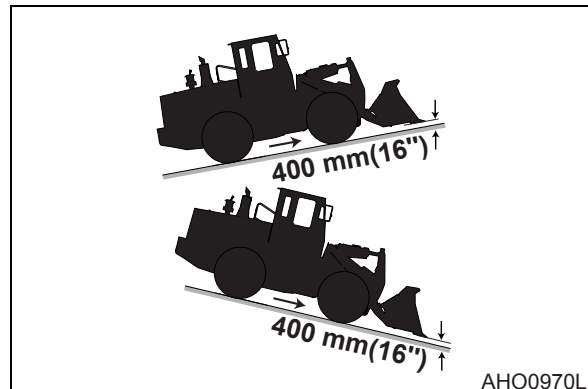

Figure 16

## AVOID HIGH-VOLTAGE CABLES

Serious injury or death can result from contact or proximity to high-voltage electric lines. The bucket does not have to make physical contact with power lines for current to be transmitted.

Use a spotter and hand signals to stay away from power lines not clearly visible to operator.

VOLTAGE	MINIMUM SAFE DISTANCE
6.6 kV	3 m (9' 10")
33.0 kV	4 m (13' 1")
66.0 kV	5 m (16' 5")
154.0 kV	8 m (26' 3")
275.0 kV	10 m (32' 10")

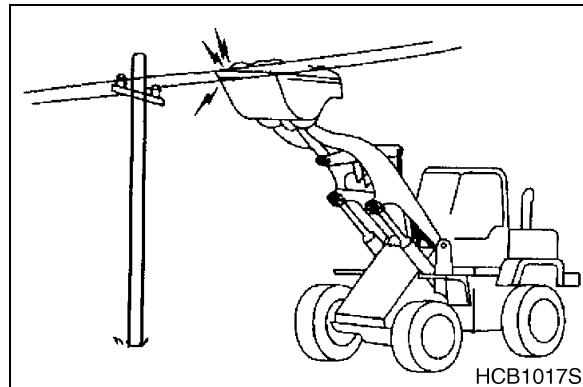

Figure 17

Use these minimum distances as a guideline only. Depending upon voltage in line and atmospheric conditions, strong current shocks can occur with boom or bucket as far away as 4 - 6 m (13 - 20 ft) from power line. Very high voltage and rainy weather could further decrease that safety margin.

**NOTE:** *Before starting any type of operation near power lines (either above ground or buried cable-type) you should always contact power utility directly and work out a safety plan with them.*

## BEFORE STARTING TO DIG, CONTACT AUTHORITIES

Below ground hazards also include natural gas lines, water mains, tunnels and buried foundations. Know what's underneath work site before starting to dig.

## BE AWARE OF HEIGHT OBSTACLES

Any type of object in vicinity of boom could represent a potential hazard, or cause operator to react suddenly and cause an accident. Use a spotter or signal person working near bridges, phone lines, work site scaffolds, or other obstructions.

## USE CARE ON LOOSE SUPPORT

Working heavy loads over loose, soft ground or uneven, broken terrain can cause dangerous side load conditions and possible tipover and injury. Travel without a load or balanced load may also be hazardous.

If temperatures are changing, be cautious of dark and wet patches when working or traveling over frozen ground. Stay away from ditches, overhangs and all other weak support surfaces. Halt work and install support mats or blocking if work is required in an area of poor support.

### USE SOLID SUPPORT BLOCKING

Never rely on lift jacks or other inadequate supports when work is being done. Block wheels fore and aft to prevent any movement.

### DIGGING BENEATH OVERHANGS

Digging beneath an overhang is dangerous. Overhang could collapse on top of operator and cause serious injury or death. Go on to another digging area before steep overhangs are formed. Know height and reach limits of wheel loader and plan ahead while working. Park wheel loader away from overhangs before work shutdown.



Figure 18

### DIGGING BENEATH WHEEL LOADER

Digging beneath wheel loader is dangerous. Earth beneath could collapse. This could cause wheel loader to tip, which could cause serious injury or death to operator. Working around deep pits, trenching or along high walls may require support blocks, especially after heavy rainfalls or during spring thaws.

### STAY ALERT FOR PEOPLE MOVING THROUGH WORK AREA

When loading a truck you should always know where the driver is.

Avoid loading over the cab of a truck even if the driver is in a safe spot. Someone else could have gone inside, for any number of reasons. Avoid working where unseen passersby might be.

Slow down work cycle and use slower travel speeds in congested or populated areas. Use a commonly understood signal so that other members of work crew can warn operator to slow or halt work in an impending hazardous situation.

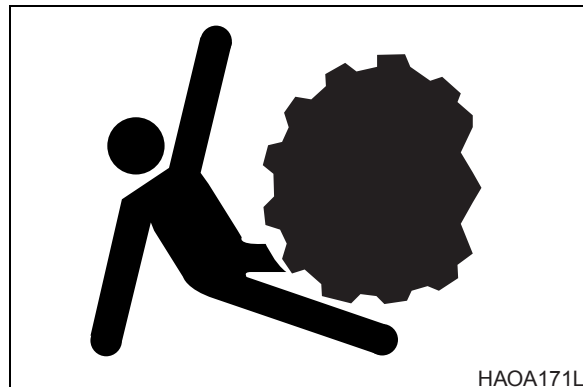

Figure 19

### BE AWARE OF AND CONFORM TO LOCAL REGULATIONS

Minimum levels of insurance coverage, work permits or certification, physical barriers around work-site or restricted hours of operation may be mandated by governing authorities. There may also be guidelines, standards or restrictions on equipment that may be used to perform certain kinds of work. Check and follow all local requirements, which may also be related to below ground hazards and power lines.

## NEVER USE ETHER STARTING AIDS

An electric-grid type manifold heater is used for cold starting. Glowing heater element can cause ether or other starting fluid to detonate, causing injury.

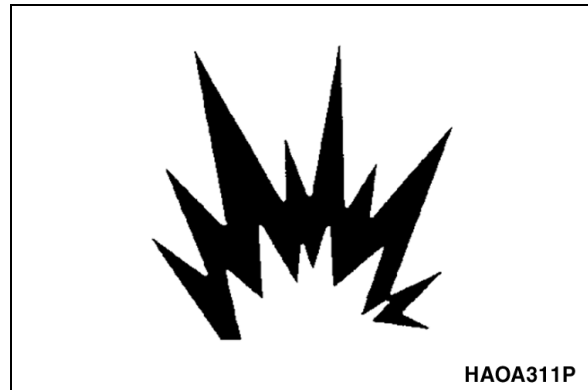

Figure 20

## OBSERVE GENERAL SAFETY RULES

Only trained and authorized personnel, with a good knowledge and awareness of safe procedures, may be allowed to operate or perform maintenance or service on wheel loader.

All personnel at work site should be aware of assigned individual responsibilities and tasks. Communication and hand signals used should be understood by everyone.

Terrain and soil conditions at job site, approaching traffic, weather-related hazards and any above or below ground obstacles or hazards should be observed and monitored by all work crew members.

## TAKE TIME TO PROVIDE GOOD VISIBILITY

Be careful not to go close to the edge of a cliff by mistake.

Use the machine only for its main purpose. Using it for other purposes will cause failures.

To ensure an ample view, do as follows:

- When working in dark areas, attach working lights and front lights to the machine. If necessary, set up lighting at the work site.
- Stop operations when the visibility is poor, such as in fog, mist, snow, and rain. Wait for the visibility to improve to a level which causes no problems for the operation.
- Keep dirt and dust off of windows and off lens surfaces of work lights. Stop working if lights, windows or mirrors need cleaning or adjustment.

To avoid hitting the work equipment, always do the following;

- When working in tunnels, on bridges, under electric wires, or when parking the machine or carrying out other operations in places with limited height, be extremely careful not to hit the bucket or other parts.
- To prevent collisions, operate the machine at a safe speed when working in confined spaces, indoors, or in crowded areas.
- Do not pass the bucket over the heads of workers or over the operator's compartment of dump truck.

### **KEEP "PINCH POINT" AREAS CLEAR - USE CAUTION IN REVERSE**

Use a signal person in high traffic areas and whenever operator's view is not clear, such as when traveling in reverse.

Anyone standing near wheels, or working assemblies of the attachment, is at risk of being caught between moving parts of machine.

Never allow anyone to ride on any part of machine or attachment, including any part of operator's cab.

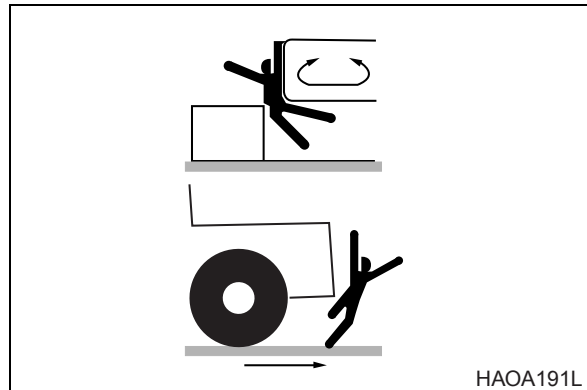

**Figure 21**

### **OPERATE CAREFULLY ON SNOW AND ICE AND IN VERY COLD TEMPERATURES**

In icy cold weather avoid sudden travel movements and stay away from even very slight slopes. Machine could skid off to one side very easily.

Snow accumulation could hide or obscure potential hazards. Use care while operating or while using machine to clear snow.

Warming up engine for a short period may be necessary, to avoid operating with sluggish or reduced working capacity. Jolting shocks and impact loads caused by bumping or bottoming boom or attachment are more likely to cause severe stress in very cold temperatures. Reducing work cycle rate and work load may be necessary.

When the temperature rises, frozen road surfaces become soft, so the machine travel becomes unstable.

In cold weather, do not touch metal surfaces with your bare hands. If you touch a metal surface in extremely cold weather, your skin may freeze to the metal surface.

### **PARKING MACHINE**

Avoid making sudden stops, or parking machine wherever it happens to be at the end of the work day. Plan ahead so that the wheel loader will be on a firm, level surface away from traffic and away from high walls, cliff edges and any area of potential water accumulation or runoff. If parking on inclines is unavoidable, block wheels to prevent movement. Lower bucket or other working attachment completely to ground, or to an overnight support saddle. There should be no possibility of unintended or accidental movement.

When parking on public roads, provide fences, signs, flags, or lights, and put up any other necessary signs to ensure that passing traffic can see the machine clearly, and park the machine so that the machine, flags, and fences do not obstruct traffic.

## SHUTDOWN CONTROL FUNCTIONS

After bucket has been lowered to overnight storage position, move all switches and controls to "OFF" position. Pull parking brake knob to "APPLIED" position. This will apply parking brake. Move pilot cutoff switch to "LOCK" position. This will disable pilot control valve lever (joystick). Move key in starter switch to "OFF" position, and remove key from switch.

Engage all lock-down security equipment that may have been installed on machine.

## IMPORTANT

**When hydraulic system maintenance or service work must be performed, be aware that accumulators in system store fluid under pressure after system has been shutdown. To release hydraulic pressure in accumulators, operate control with engine "OFF" until accumulator pressure is completely dissipated.**

## NEVER LET ANYONE RIDE ON ATTACHMENT

Never let anyone ride on any work attachment, such as the bucket, crusher, grapple, or clamshell (grab bucket). There is a danger of the person falling and suffering serious injury.



Figure 22

# MAINTENANCE

## USE WARNING TAG DURING SERVICE

Alert others that service or maintenance is being performed and tag operator's cab controls - and other machine areas if required - with a warning notice.

Warning tags for controls are available from Daewoo distributors; see Figure 23.

## CLEAN BEFORE INSPECTION OR MAINTENANCE

Clean the machine before carrying out inspection and maintenance. This prevents dirt from getting into the machine and also ensures safety during maintenance.

If inspection and maintenance are carried out when the machine is dirty, it will become more difficult to locate the problems, and also there is danger that you may get dirt or mud in your eyes or that you may slip and injure yourself.

When washing the machine, do the following;

- Wear shoes with non-slip soles to prevent yourself from slipping and falling on wet places.
- Wear safety glasses and protective clothing when washing the machine with high-pressure steam.
- Take action to prevent touching high-pressure water and cutting your skin or having mud fly into your eyes.
- Do not spray water directly on electrical components (sensors, connector) (1, Figure 24). If water gets into the electrical system, there is danger that it will cause defective operation and malfunction.



Figure 23

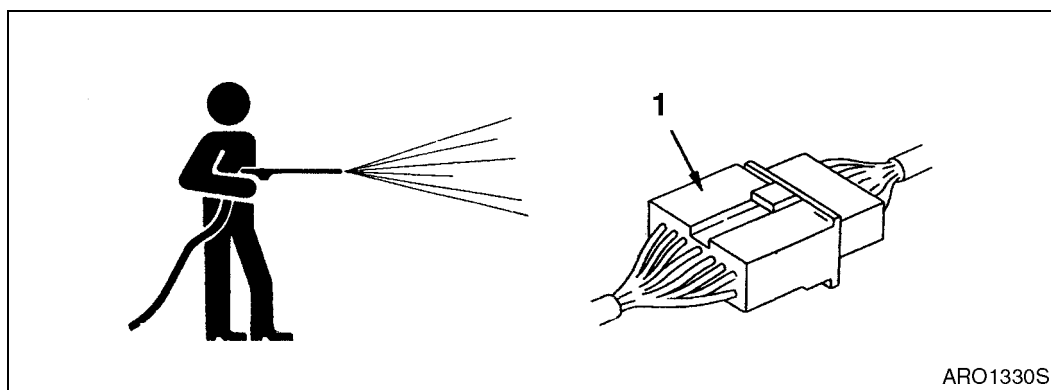
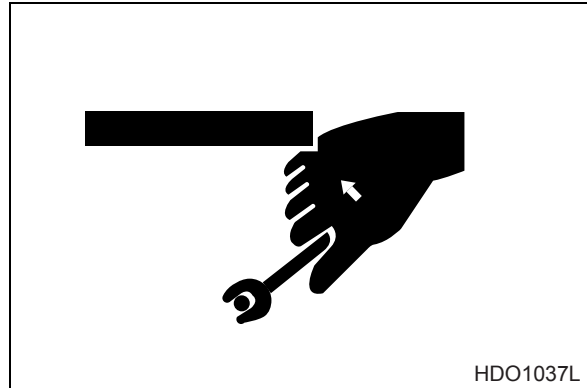

Figure 24

Pick up any tools or hammers that are laying in the work place, wipe up any grease or oil or any other slippery substances, and clean the area to make it possible to carry out the operation in safety. If the work place is left untidy, you may trip or slip and suffer injury.

## PROPER TOOLS

Use only tools suited to the task. Using damaged, low quality, faulty, or makeshift tools could cause personal injury. There is danger that pieces from, chisels with crushed heads, or hammers, may get into your eyes and cause blindness.



**Figure 25**

## USE OF LIGHTING

When checking fuel, oil, battery electrolyte, or window washing fluid, always use lighting with anti-explosion specifications. If such lighting equipment is not used, there is danger of explosion.

If work is carried out in dark places without using lighting, it may lead to injury, so always use proper lighting.

Even if the place is dark, never use a lighter or flame instead of lighting. There is danger of fire. There is also danger that the battery gas may catch fire and cause an explosion.

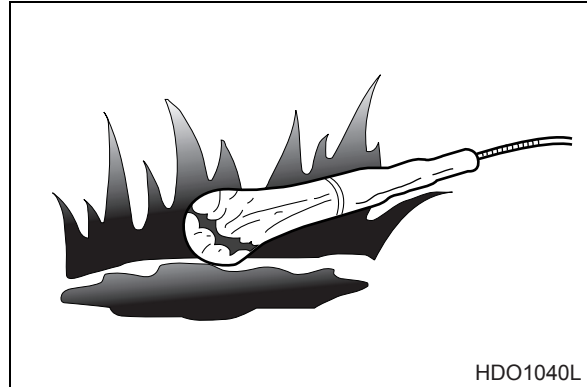

**Figure 26**

## FIRE PREVENTION AND EXPLOSION PREVENTION

All fuels, most lubricants and some coolant mixtures are flammable. Leaking fuel or fuel that is spilled onto hot surfaces or onto electrical components can cause a fire.

Store all fuels and all lubricants in properly marked containers and away from all unauthorized persons.

Store oily rags and other flammable material in a protective container.

Do not smoke while you refuel the machine or while you are in a refueling area.

Do not smoke in battery charging areas or in areas that contain flammable material.

Clean all electrical connections and tighten all electrical connections. Check the electrical wires daily for wires that are loose or frayed. Tighten all loose electrical wires before you operate the machine. Repair all frayed electrical wires before you operate the machine.

Remove all flammable materials before the flammable materials accumulate on the machine.

Do not weld on pipes or on tubes that contain flammable fluids. Do not flame cut on pipes or on tubes that contain flammable fluids. Before you weld on pipes or on tubes or before you flame cut on pipes or on tubes, clean the pipes or tubes thoroughly with a nonflammable solvent.



## BURN PREVENTION

When checking the radiator coolant level, stop the engine, let the engine and radiator cool down, then check the coolant recovery tank. If the coolant level in the coolant recovery tank is near the upper limit, there is enough coolant in the radiator.

Loosen the radiator cap gradually to release the internal pressure before removing the radiator cap.

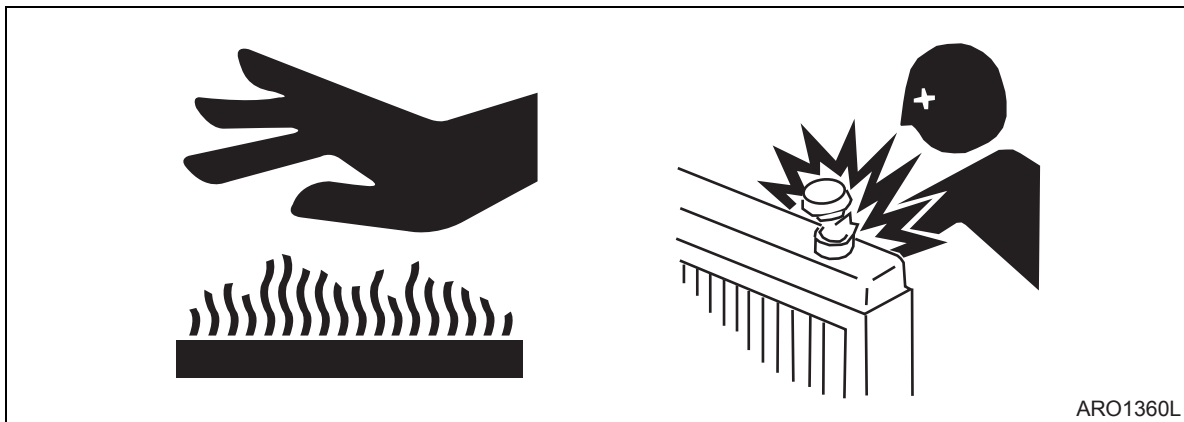

**Figure 27**

If the coolant level in the coolant recovery tank is below the lower limit, add coolant.

Cooling system conditioner contains alkali. Alkali can cause personal injury. Do not allow alkali to contact the skin, the eyes, or the mouth.

Allow cooling system components to cool before you drain the cooling system.

Hot oil and hot components can cause personal injury. Do not allow hot oil or hot components to contact the skin.

Remove the hydraulic tank filter plug only after the engine has been stopped. Make sure that the hydraulic tank filter plug is cool before you remove it with your bare hand. Remove the hydraulic tank filter plug slowly to relieve pressure.

Relieve all pressure in the hydraulic oil system, in the fuel system, or in the cooling system before you disconnect any lines, fittings, or related items.

Batteries give off flammable fumes that can explode.

Do not smoke while you are checking the battery electrolyte levels.

Electrolyte is an acid. Electrolyte can cause personal injury. Do not allow electrolyte to contact the skin or the eyes.

Always wear protective glasses when you work on batteries.

## WELDING REPAIRS

When carrying out welding repairs, carry out the welding in a properly equipped place. The welding should be performed by a qualified worker. During welding operations, there is the danger of, generation of gas, fire, or electric shock, so never let an unqualified worker do welding.

The qualified welder must do the following;

- To prevent explosion of the battery, disconnect the battery terminals and remove batteries.
- To prevent generation of gas, remove the paint from the location of the weld.
- If hydraulic equipment, piping or places close to them are heated, a flammable gas or mist will be generated and there is danger of it catching fire. To avoid this, never subject these places to heat.
- Do not weld on pipes or on tubes that contain flammable fluids. Do not flame cut on pipes or on tubes that contain flammable fluids. Before you weld on pipes or on tubes or before you flame cut on pipes or on tubes, clean the pipes or tubes thoroughly with a nonflammable solvent.
- If heat is applied directly to rubber hoses or piping under pressure, they may suddenly break so cover them with a fireproof covering.
- Wear protective clothing.
- Make sure there is good ventilation.
- Remove all flammable objects and provide a fire extinguisher.

## PRECAUTIONS FOR REMOVAL, INSTALLATION, AND STORAGE OF ATTACHMENTS

Before starting removal and installation of attachments, decide the team leader.

Do not allow anyone except the authorized workers close to the machine or attachment.

Place attachments that have been removed from the machine in a safe place so that they do not fall. Put up a fence around the attachments and take other measures to prevent unauthorized persons from entering.

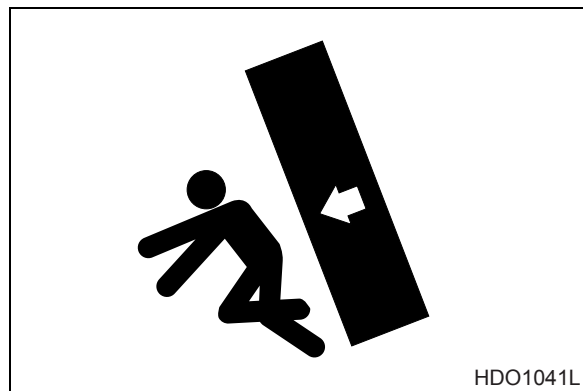

**Figure 28**

## **PRECAUTIONS WHEN WORKING ON MACHINE**

When carrying out maintenance operations on the machine, keep the area around your feet clean and tidy to prevent you from falling. Always do the following;

- Do not spill oil or grease.
- Do not leave tools laying about.
- Watch your step when walking.

Never jump down from the machine. When getting on or off the machine, use the steps and handrails, and maintain a three-point contact (both feet and one hand or both hands and one foot) to support yourself securely.

If the job requires it, wear protective clothing.

To prevent injury from slipping or falling, when working on the hood or covers, never use any part except the inspection passage fitted with non-slip pads.

## **LOCK INSPECTION COVERS**

When carrying out maintenance with the inspection cover open, lock the cover securely in position with the lock bar.

If maintenance work is carried out with the inspection cover open but not locked, there is danger that it may suddenly close and cause injury if there is a gust of wind.

## **CRUSHING PREVENTION AND CUTTING PREVENTION**

You should always have at least two people working together if the engine must be run during service. One person needs to remain in the operator's seat, ready to work the controls or stop the machine and shut off the engine.

Unless you are instructed otherwise, never attempt adjustments while the machine is moving or while the engine is running.

Stay clear of all rotating parts and moving parts.

Keep objects away from moving fan blades. The fan blades will throw objects and the fan blades can cut objects.

Do not use a wire rope cable that is kinked or flayed. Wear gloves when you handle a wire rope cable.

When you strike a retainer pin, the retainer pin might fly out. The loose retainer pin can injure personnel. Make sure that the area is clear of people when you strike a retainer pin. To avoid injury to your eyes, wear protective glasses when you strike a retainer pin.

## **DO NOT RUN ENGINE IF REPAIRS OR WORK ARE BEING PERFORMED ALONE**

You should always have at least two people working together if engine must be run during service. One person needs to remain in operator's seat, ready to work controls or stop machine and shut "OFF" engine.



**Figure 29**

## **ALWAYS USE ADEQUATE EQUIPMENT SUPPORTS AND BLOCKING**

Do not allow weight or equipment loads to remain suspended. Lower everything to ground before leaving operator's seat. Do not use hollow, cracked or unsteady, wobbling weight supports. Do not work under any equipment supported solely by a lift jack.

## **DO NOT WORK ON HOT ENGINES OR HOT COOLING OR HYDRAULIC SYSTEMS**

Wait for engine to cool off after normal operation. Park wheel loader on a firm, level surface and lower all equipment before shutting down and switching "OFF" controls. When engine lube oil, gearbox lubricant or other fluids require change, wait for fluid temperatures to decrease to a moderate level before removing drain plugs.

**NOTE:** *Oil will drain more quickly and completely if it is warm. Do not drain fluids at temperatures exceeding 95°C (203°F), however do not allow full cool-down.*

## **HYDRAULIC CYLINDER SEALS REQUIRE PERIODIC REPLACEMENT**

Check cylinder drift rate at regular intervals. Overhaul seal kits are available through Daewoo.

## **HIGH PRESSURE HYDRAULIC LINES CAN STORE A GREAT DEAL OF ENERGY**

Exposed hydraulic hoses on arm or boom could react with explosive force if struck by a falling rock, overhead obstacle or other job site hazard. Extra safety guards may be required. NEVER allow hoses to be hit, bent or interfered with during operation.

## PRECAUTIONS WITH HIGH PRESSURE LINE, TUBES AND HOSES

When inspecting or replacing high-pressure piping or hoses, check that the pressure has been released from the circuit. Failure to release the pressure may lead to serious injury. Always do the following;

- Wear protective glasses and leather gloves.
- Fluid leaks from hydraulic hoses or pressurized components can be difficult to see but pressurized oil has enough force to pierce the skin and cause serious injury. Always use a piece of wood or cardboard to check for suspected hydraulic leaks. Never use your hands or expose your fingers.
- Do not bend high pressure lines. Do not strike high pressure lines. Do not install lines, tubes or hoses that are bent or damaged.
- Make sure that all clamps, guards and heat shields are installed correctly to prevent vibration, rubbing against other parts, and excessive heat during operation.
  - If any of the following conditions are found, replace the part.
  - Damage or leakage from hose end.
  - Wear, damage, cutting of covering, or exposure of strengthening wire layer.
  - Cover portion is swollen in places.
  - There is twisting or crushing at movable parts of hose.
  - Foreign material is embedded in the covering.
  - Hose end is deformed.

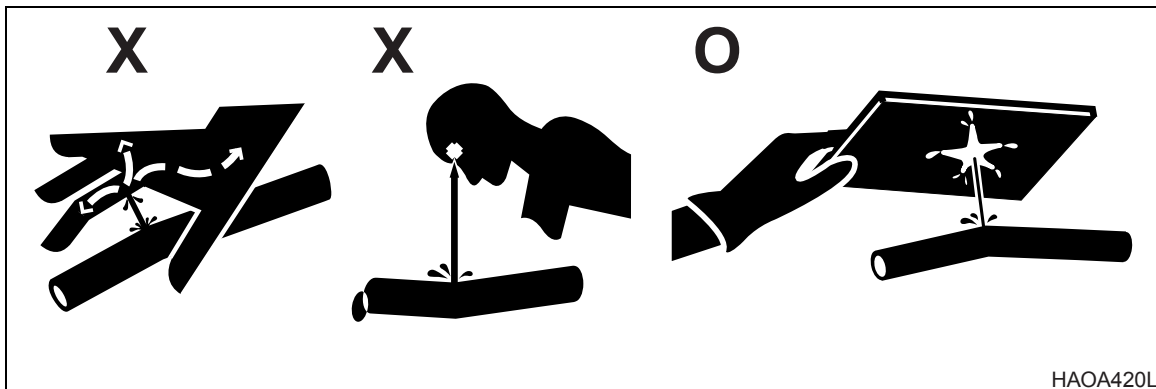

Figure 30

**OBTAIN IMMEDIATE MEDICAL ATTENTION IF PRESSURIZED OIL PIERCES SKIN.**

**! WARNING!**

**Failure to obtain prompt medical assistance could result in gangrene or other serious damage to tissue.**

## USE CORRECT REPLACEMENT FASTENERS TIGHTENED TO PROPER TORQUE

Refer to "General Maintenance" section of Shop Manual for information on tightening torques and recommended assembly compounds and always use correct part.

Poor or incorrect fastener connections can dangerously weaken assemblies.

## SAFETY-CRITICAL PARTS MUST BE REPLACED PERIODICALLY

Replace following fire-related components as soon as they begin to show any sign of wear, or at regular periodic intervals, whether or not deterioration is visible:

- Fuel system flexible hoses, the tank overflow drain hose and the fuel filler cap.
- Hydraulic system hoses, especially the pump outlet lines and front and rear pump branch hoses.
- Keep mounting brackets and hose and cable routing straps tight. Hose routing should have gradual bends.

## DISPOSE OF ALL PETROLEUM-BASED OILS AND FLUIDS PROPERLY

Physical contact with used motor oil may pose a health risk. Wipe oil from your hands promptly and wash off any remaining residue.

Used motor oil is an environmental contaminant and may only be disposed of at approved collection facilities. To prevent pollution of the environment, always do the following;

- Never dump waste oil in a sewer system, rivers, etc.
- Always put oil drained from your machine in containers. Never drain oil directly onto the ground.
- Obey appropriate laws and regulations when disposing of harmful materials such as oil, fuel, solvent, filters, and batteries.

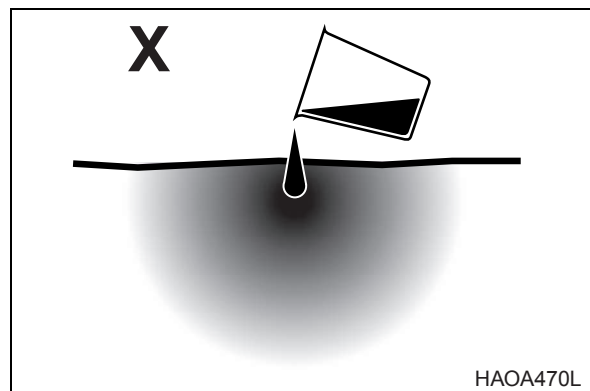

Figure 31

## CHECK TIRE PRESSURE AND CONDITION

Maintain tire pressure but do not over inflate. Inspect tires and wheels daily. When inflating tires, follow procedures in Maintenance Section, which include using an extension to allow you to avoid standing in front of or over a tire. Do not change a tire unless you have both experience and proper equipment.

# BATTERY

## BATTERY HAZARD PREVENTION

Battery electrolyte contains diluted sulfuric acid and batteries generate hydrogen gas. Hydrogen gas is highly explosive, and mistakes in handling them can cause serious injury or fire. To prevent problems, always do the following;

- Do not smoke or bring any flame near the battery.
- When working with batteries, ALWAYS wear safety glasses and rubber gloves.
- If you spill battery electrolyte on yourself or your clothes, immediately flush the area with water.
- If battery electrolyte gets into your eyes, flush them immediately with large quantities of water and see a doctor at once.
- If you accidentally drink battery electrolyte, drink a large quantity of water or milk, raw egg or vegetable oil. Call a doctor or poison prevention center immediately.
- When cleaning the top surface of the battery, wipe it with a clean, damp cloth. Never use gasoline, thinner, or any other organic solvent or detergent.
- Tighten the battery caps securely.
- Explosive battery gas can be set off by sparks from incidental contact or static discharge. Turn "OFF" all switches and engine when working on batteries. Keep battery terminals tight. Contact between a loose terminal and post can create an explosive spark.
- If the battery electrolyte is frozen, do not charge the battery or start the engine with power from another source. There is danger that the battery may catch fire.
- When charging the battery or starting with power from another source, let the battery electrolyte melt and check that there is no leakage of battery electrolyte before starting the operation.
- Always remove the battery from the machine before charging.

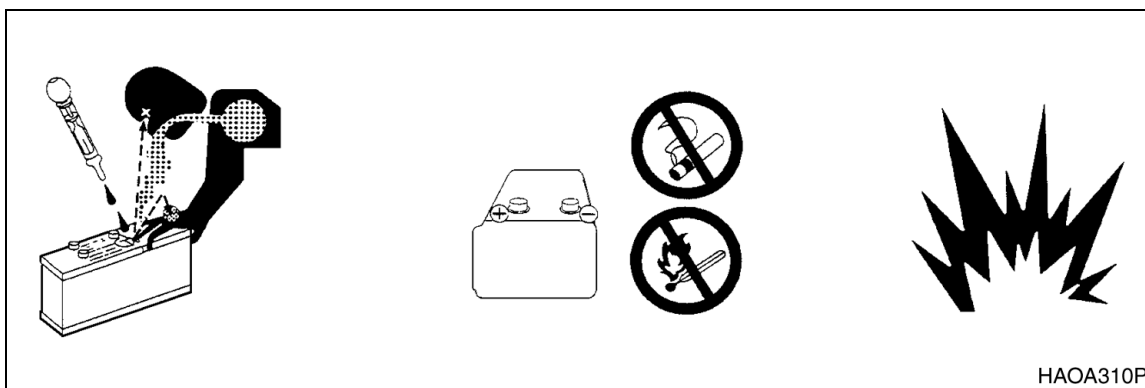

Figure 32

## DISCONNECT BATTERIES BEFORE ELECTRICAL SERVICE OR ELECTRICAL WELDING

Remove cable to negative terminal first when disconnecting cable. Connect positive terminal cables first when installing a battery.

## USE LOW HEAT PORTABLE LIGHTING

Hot surfaces on trouble lights or portable work lights can set off fuel or battery explosive gases.

## BOOST STARTING OR CHARGING ENGINE BATTERIES

If any mistake is made in the method of connecting the booster cables, it may cause an explosion or fire. Always do the following;

- Turn off all electrical equipment before connecting leads to the battery. This includes electrical switches on the battery charger or boost starting equipment.
- When boost-starting from another machine or vehicle do not allow the two machines to touch. Wear safety glasses or goggles while required battery connections are made.
- 24 volt battery units consisting of two series-connected twelve volt batteries have a cable connecting one positive terminal on one of the 12 volt batteries to a negative terminal on the other battery. Booster or charger cable connections must be made between the non-series-connected positive terminals and between the negative terminal of the booster battery and the metal frame of the machine being boosted or charged. Refer to the procedure and illustration in Operation and Maintenance Manual.
- Connect positive cable first when installing cables and disconnect the negative cable first when removing them. The final cable connection, at the metal frame of the machine being charged or boost-started, should be as far away from the batteries as possible.

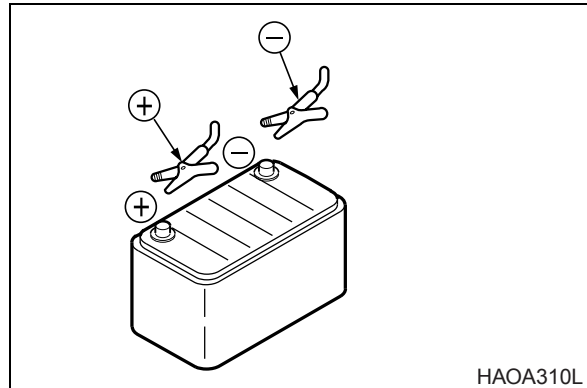

**Figure 33**



# TOWING

## PRECAUTIONS WHEN TOWING

If any mistake is made in the method of selecting or inspecting the towing wire or in the method of towing, it may lead to serious personal injury. Always do the following;

- Always use the method of towing given in this Operation and Maintenance Manual. Do not use any other method.
- Use leather gloves when handling the wire rope.
- When carrying out the preparation work for towing with two or more workers, determine the signals to use and follow these signals correctly.
- If the engine on the problem machine will not start or there is a failure in the brake system, always contact your Daewoo distributor.
- Never go between the towing machine and the towed machine during the towing operation.
- It is dangerous to carry out towing on slopes, so select a place where the slope is gradual. If there is no place where the slope is gradual, carry out operations to reduce the angle of the slope before starting the towing operation.
- When towing a problem machine, always use a wire rope with a sufficient towing capacity.
- Do not use a frayed, kinked rope or a rope with any loss of diameter.

# SHIPPING AND TRANSPORTATION

## OBEY STATE AND LOCAL OVER-THE-ROAD REGULATIONS

Check state and local restrictions regarding weight, width and length of a load before making any other preparation for transport.

Hauling vehicle, trailer and load must all be in compliance with local regulations governing intended shipping route.

Partial disassembly or tear-down of wheel loader may be necessary to meet travel restrictions or particular conditions at work site.

Refer to the section "Transportation" section of operation manual.

## SUMMARY OF SAFETY PRECAUTIONS FOR LIFTING

	<b>WARNING!</b>
<b>Improper lifting can allow load to shift and cause personal injury or damage to the machine</b>	

To make safe lifts, the following items must be evaluated by operator and work site crew.

- Condition of ground support.
- Wheel loader configuration and attachments.
- Weight, lifting height and lifting radius.
- Safe rigging of load.
- Proper handling of suspended load.

Taglines on opposite sides of load can be very helpful in keeping a suspended load secure, if they are anchored safely to control points on ground.

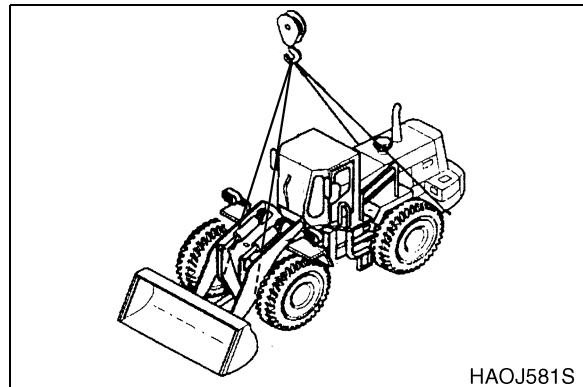

**Figure 34**

# SPECIFICATIONS





# SPECIFICATIONS FOR MEGA 500-V (TIER II)



## CAUTION!

Follow all safety recommendations and safe shop practices outlined in the front of this manual or those contained within this section.

Always use tools and equipment that is in good working order.

Use lifting and hoisting equipment capable of safely handling load.

Remember, that ultimately safety is your own personal responsibility.

MODEL	SERIAL NUMBER RANGE
Mega 500-V (Tier II)	2001 and Up

# TABLE OF CONTENTS

General Description.....	3
General Specifications .....	5
Engine Performance Curves .....	6
Working Range and Dimensions.....	8
Working Capacities .....	11
Bucket Capacity .....	11
Tipping Load .....	11
Material Weight .....	11
Approximate Weight of Workload Materials .....	11

# GENERAL DESCRIPTION

Figure 1 identifies the location of major machine components.

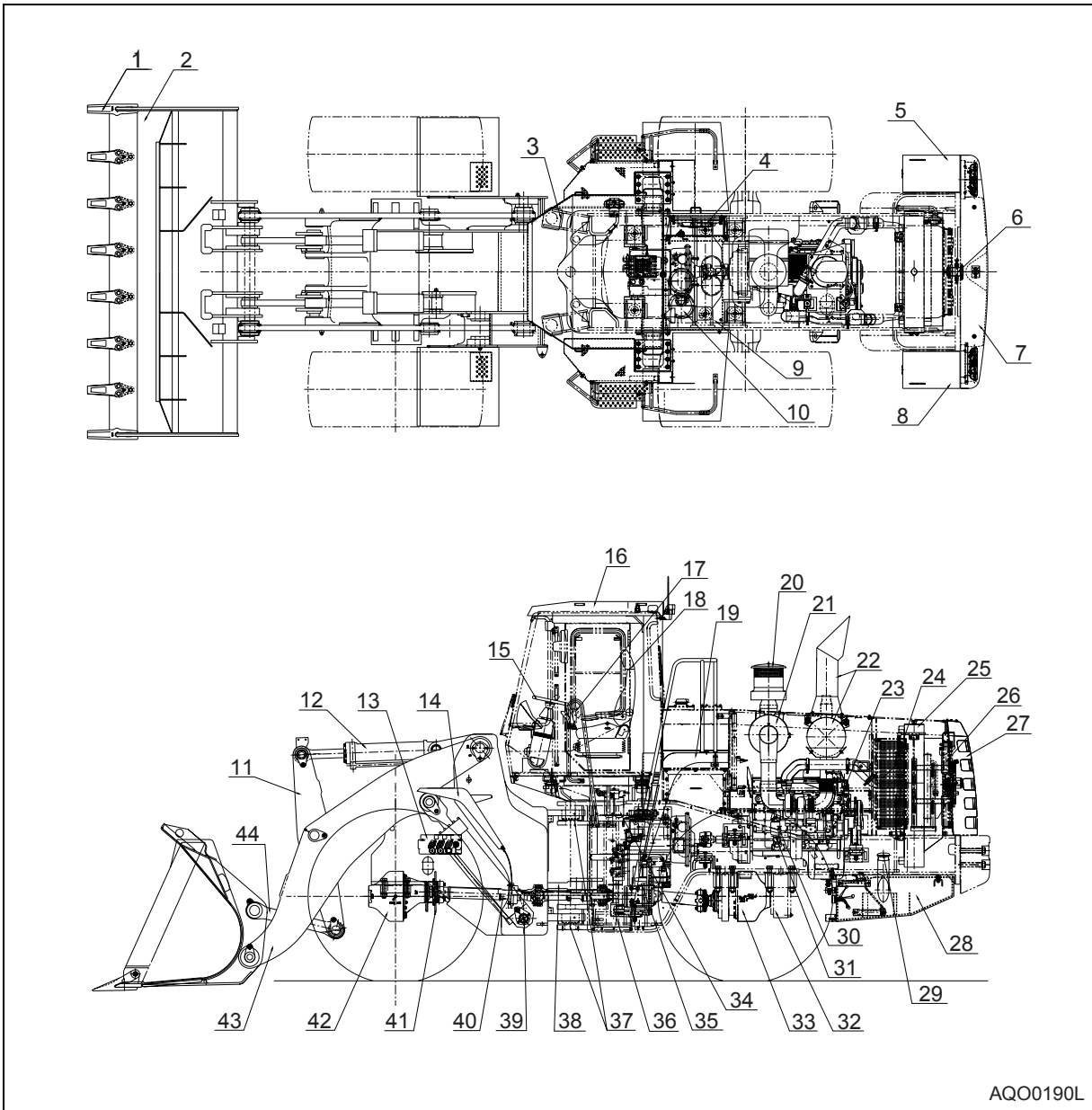

Figure 1

AQO0190L

1. BUCKET TOOTH
2. BUCKET
3. OPERATOR'S CAB
4. AIR CONDITIONING CONDENSER
5. BATTERY BOX (R.H.)
6. FAN MOTOR
7. COUNTERWEIGHT
8. BATTERY BOX (L.H.)
9. OIL TANK
10. FULL FLOW FILTER
11. TILT LEVER
12. BUCKET CYLINDER
13. CONTROL VALVE
14. FRONT WHEEL COVER
15. STEERING WHEEL
16. ROPS
17. WORK LEVER
18. SEAT
19. REAR WHEEL COVER
20. PRE-CLEANER
21. AIR CLEANER
22. MUFFLER
23. ENGINE
24. CAC COOLER
25. RADIATOR
26. FAN
27. GRILL
28. FUEL TANK
29. FUEL FILLER PIPE
30. ENGINE OIL LEVEL GAUGE
31. ENGINE OIL FILLER PIPE
32. REAR AXLE PIVOT
33. REAR AXLE
34. TRANSMISSION OIL FILTER
35. WHEEL CHOCK
36. TRANSMISSION
37. CENTER PIN
38. STEERING CYLINDER
39. BOOM CYLINDER
40. DRIVE SHAFT
41. PARKING BRAKE
42. FRONT AXLE
43. LOADER ARM
44. LINK



# GENERAL SPECIFICATIONS

MEGA 500 TIER II	
Item	Specification
Standard Bucket Capacity	4.8 m <sup>3</sup> (6.3 yd <sup>3</sup> )
Vehicle Weight (W/ROPS CANOPY)	28,800 (29,600) kg (63.493 (65.257) lb)
Engine	
Type	Cummins QSM11
Horsepower	340 ps (335 hp) @ 2,100 rpm
Max. Torque	174 kg•m (1,255 ft lb) @ 1,400 rpm
Transmission	
Full Automatic Power -Shift	Full Automatic Power Shift
Speeds	4 Forward, 3 Reverse
Brake Systems	
Travel Brakes	4 Wheel, Wet Disk
Parking Brake	SHAR, Dry Disc Type
Performance	
Travel Speed	7 – 35 km/h (4.35 - 21.75 MPH)
Steering Angle	± 40°
Min. Tire Turning Radius	6,140 mm (20' 2")
Safe Operating Load	8,640 kg (19,050 lb)
Max. Breakout Force	27,000 kg (59,520 lb)
Bucket Rise Time	6.5 Sec
Bucket Dump Time	1.3 Sec
Bucket Descent Time	3.4 Sec
Maximum Gradeability	30° (58%)

# ENGINE PERFORMANCE CURVES

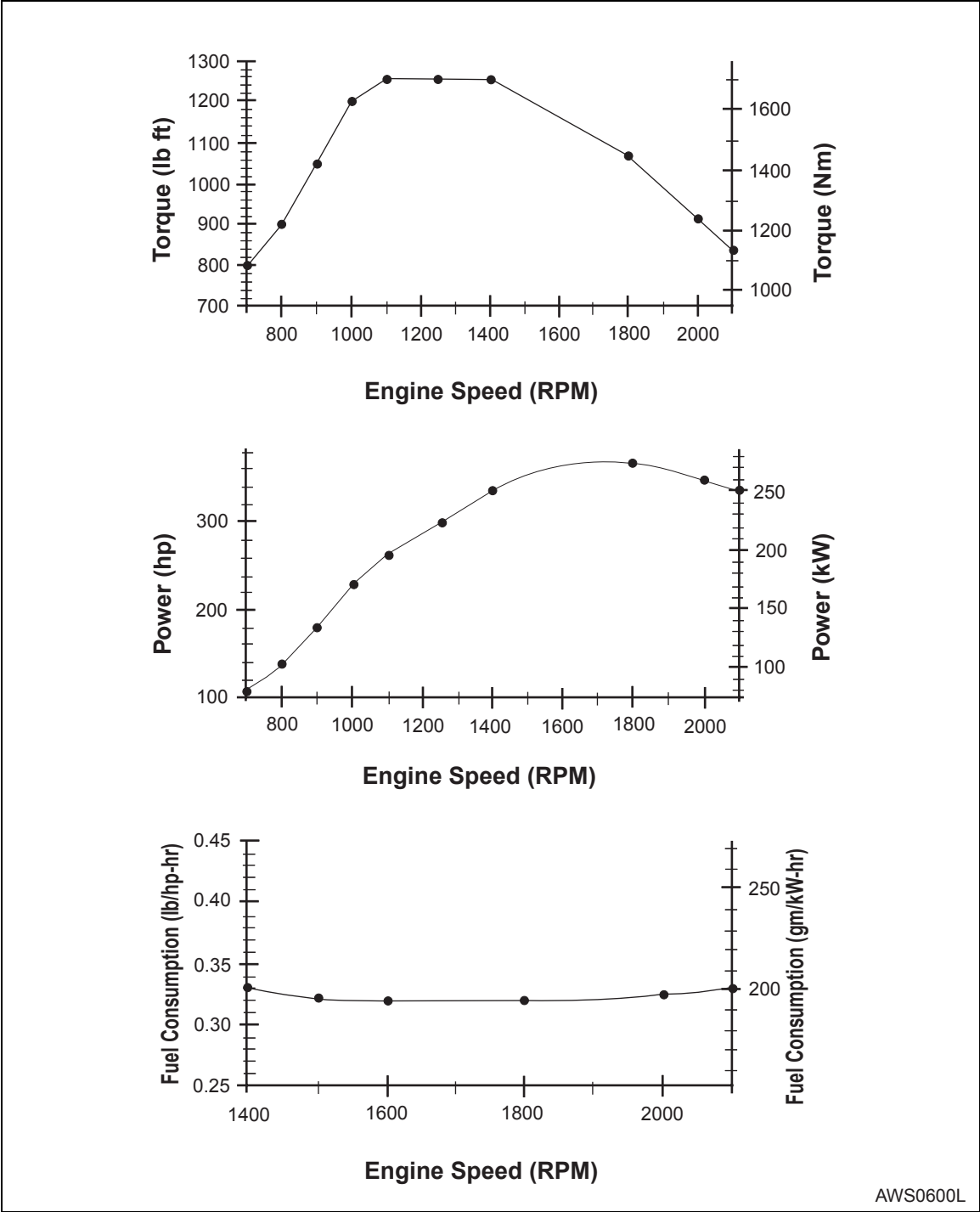

Figure 2

AWS0600L

Performance standard	SAE J1995
Power (Maximum / rpm)	340 ps @ 2,100 rpm (335 hp @ 2,100 rpm)
Maximum Torque	174 kg•m / 1,400 rpm (1,255 ft lb @ 1,400 rpm)
Fuel Consumption	153 g/ps•h (5.39 oz/hp•h)

**NOTE:** *Barometric Pressure: 760 mm (30") Mercury*

*Temperature: 20° C (68° F)*

*W/ Cooling Fan*

*Alternator: 24 V, 70 amp*

*Exhaust System: Complete, attached*

*Air Cleaner; Installed*

# WORKING RANGE AND DIMENSIONS

Figure 3, illustrates exterior machine dimensions and working range of machine when it is equipped with a standard bucket.

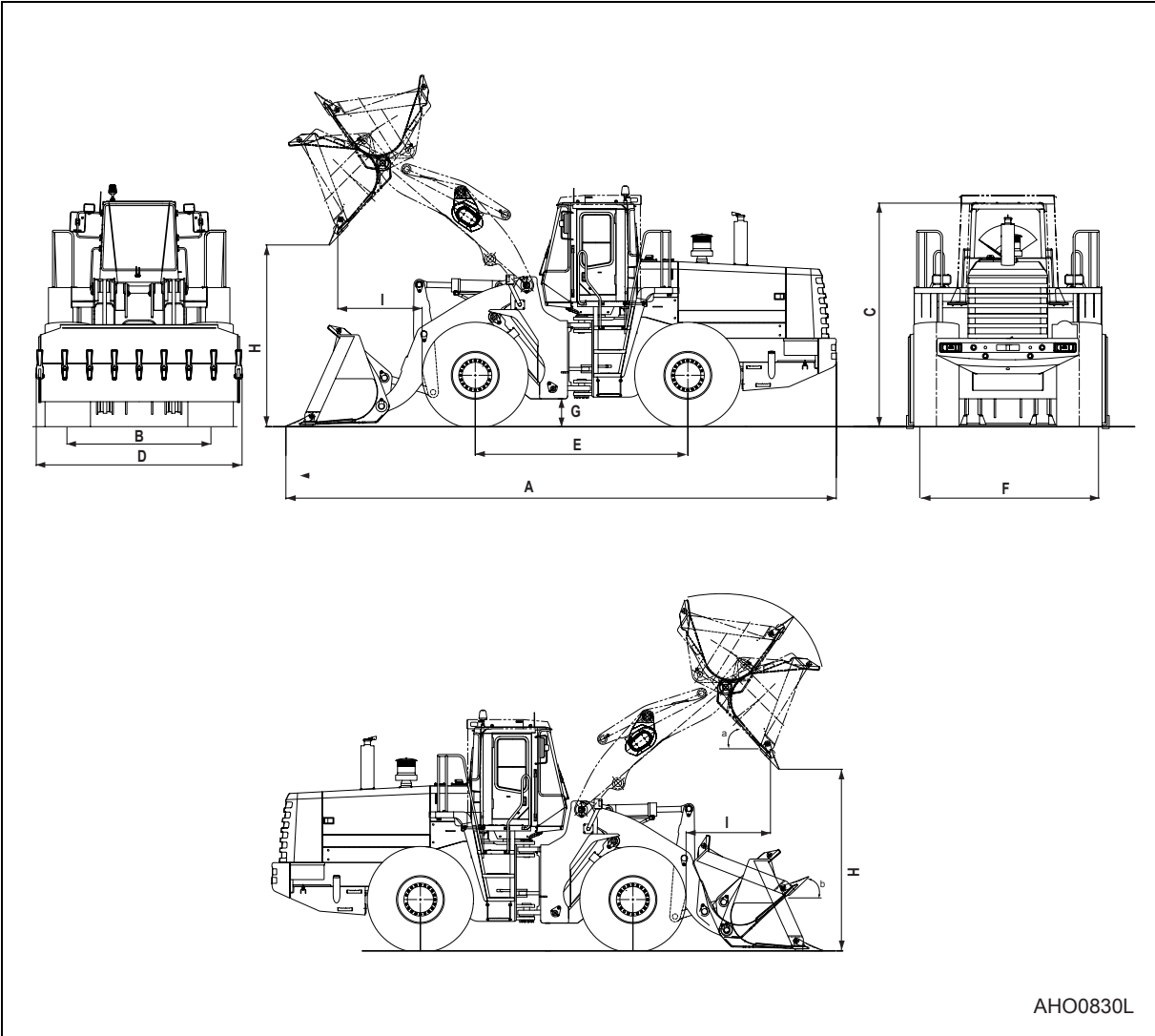

Figure 3

<b>Category</b>	<b>Dimension</b>
Overall Length (A)	9,320 mm (30' 7")
Overall Width, without bucket (B)	3,190 mm (10' 6")
Overall Height (C)	3,780 mm (12' 5")
Bucket Width (D)	3,480 mm (11' 5")
Wheel Base (E)	3,600 mm (11' 10")
Tread (F)	2,420 mm (7' 11")
Ground Clearance (G)	490 mm (1' 7")
Dump Height, to tooth (H)	3,080 mm (10' 1")
Dump Distance, to Bucket Edge (I)	1,380 mm (4' 6")
Dump Height to Bucket Pivot	4,470 mm (14' 8")
Bucket Angle, Raised (a)	47°
Bucket Angle (b), Lowered (at carry)	48°
Tire Size	29.5-25-22 PR(L3)

Figure 4 and Figure 5, illustrate working range when machine is equipped with optional Pallet or Log Fork.

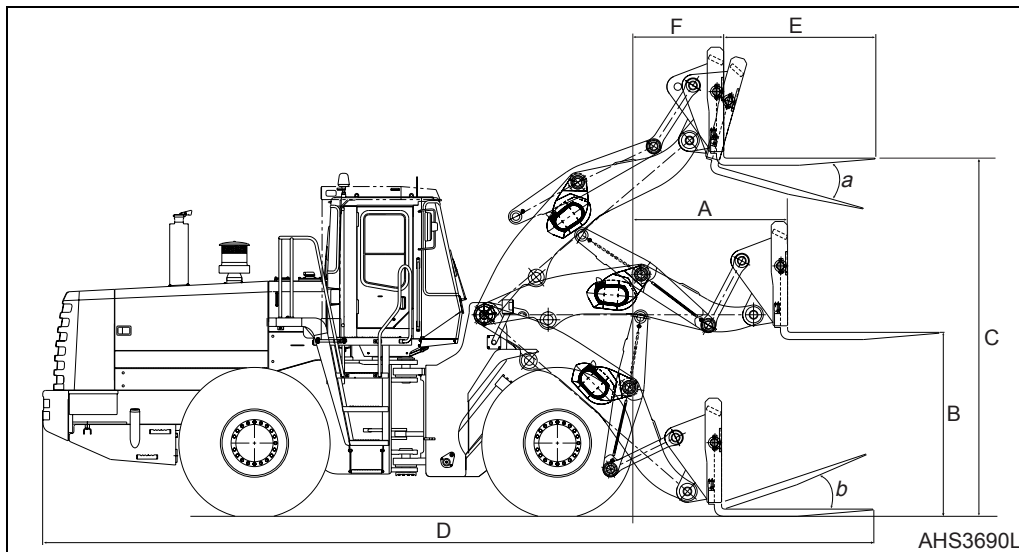

Figure 4

Reference Number	Dimension
A	1,785 mm (5' 10")
B	2,185 mm (7' 2")
C	4,260 mm (13' 12")
D	9,870 mm (32' 5")

Reference Number	Dimension
E	1,800 (5' 11")
F	1,025 (3' 4")
a	16°
b	22°

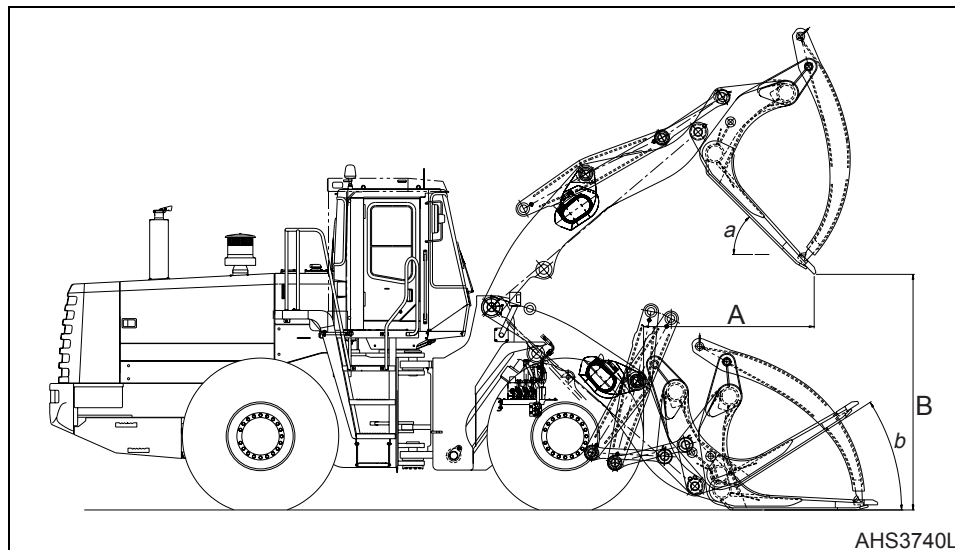

Figure 5

Reference Number	Dimension
A	2,016 mm (6' 7")
B	2,785 mm (9' 2")

Reference Number	Dimension
a	45°
b	33°

# WORKING CAPACITIES

## BUCKET CAPACITY

Standard toothed bucket has a capacity of 4.8 m<sup>3</sup> (6.3 yd<sup>3</sup>). An optional bucket equipped with a cutting edge and no teeth has a capacity of 4.8 m<sup>3</sup> (6.3 yd<sup>3</sup>).

## TIPPING LOAD

Static Tipping Load with bucket in Over Front position is 22,000 kg (48,500 lb). With bucket in Fully Turned position, Static Tipping Load is 19,000 kg (41,890 lb).

# MATERIAL WEIGHT

The data below describes weight of a cubic meter (cubic yard) of many types of workload materials.

## APPROXIMATE WEIGHT OF WORKLOAD MATERIALS

MATERIAL	LOW WEIGHT OR DENSITY 1,100 KG/M <sup>3</sup> (1,850 LB/YD <sup>3</sup> ), OR LESS	MEDIUM WEIGHT OR DENSITY 1,600 KG/M <sup>3</sup> (2,700 LB/YD <sup>3</sup> ), OR LESS	HIGH WEIGHT OR DENSITY 2,000 KG/M <sup>3</sup> (3,370 LB/YD <sup>3</sup> ), OR LESS
Charcoal	401 kg/m <sup>3</sup> (695 lb/yd <sup>3</sup> )	-----	-----
Coke, blast furnace size	433 kg/m <sup>3</sup> (729 lb/yd <sup>3</sup> )	-----	-----
Coke, foundry size	449 kg/m <sup>3</sup> (756 lb/yd <sup>3</sup> )	-----	-----
Coal, bituminous slack, piled	801 kg/m <sup>3</sup> (1,350 lb/yd <sup>3</sup> )	-----	-----
Coal, bituminous r. of m., piled	881 kg/m <sup>3</sup> (1,485 lb/yd <sup>3</sup> )	-----	-----
Coal, anthracite	897 kg/m <sup>3</sup> (1,512 lb/yd <sup>3</sup> )	-----	-----
Clay, DRY, in broken lumps	1,009 kg/m <sup>3</sup> (1,701 lb/yd <sup>3</sup> )	-----	-----
Clay, DAMP, natural bed	-----	1,746 kg/m <sup>3</sup> (2,943 lb/yd <sup>3</sup> )	-----

<b>MATERIAL</b>	<b>LOW WEIGHT OR DENSITY 1,100 KG/M<sup>3</sup> (1,850 LB/YD<sup>3</sup>), OR LESS</b>	<b>MEDIUM WEIGHT OR DENSITY 1,600 KG/M<sup>3</sup> (2,700 LB/YD<sup>3</sup>), OR LESS</b>	<b>HIGH WEIGHT OR DENSITY 2,000 KG/M<sup>3</sup> (3,370 LB/YD<sup>3</sup>), OR LESS</b>
Cement, Portland, DRY granular	-----	1,506 kg/m <sup>3</sup> (2,583 lb/yd <sup>3</sup> )	-----
Cement, Portland, DRY clinkers	-----	1,362 kg/m <sup>3</sup> (2,295 lb/yd <sup>3</sup> )	-----
Dolomite, crushed	-----	1,522 kg/m <sup>3</sup> (2,565 lb/yd <sup>3</sup> )	-----
Earth, loamy, DRY, loose	-----	1,202 kg/m <sup>3</sup> (2,025 lb/yd <sup>3</sup> )	-----
Earth, DRY, packed	-----	1,522 kg/m <sup>3</sup> (2,565 lb/yd <sup>3</sup> )	-----
Earth, WET, muddy	-----	-----	1,762 kg/m <sup>3</sup> (2,970 lb/yd <sup>3</sup> )
Gypsum, calcined, (heated, powder)	961 kg/m <sup>3</sup> (1,620 lb/yd <sup>3</sup> )	-----	-----
Gypsum, crushed to 3 inch size	-----	1,522 kg/m <sup>3</sup> (2,565 lb/yd <sup>3</sup> )	-----
Gravel, DRY, packed fragments	-----	-----	1,810 kg/m <sup>3</sup> (3,051 lb/yd <sup>3</sup> )
Gravel, WET, packed fragments	-----	-----	1,922 kg/m <sup>3</sup> (3,240 lb/yd <sup>3</sup> )
Limestone, graded above 2	-----	1,282 kg/m <sup>3</sup> (2,160 lb/yd <sup>3</sup> )	-----
Limestone, graded 1-1/2 or 2	-----	1,362 kg/m <sup>3</sup> (2,295 lb/yd <sup>3</sup> )	-----
Limestone, crushed	-----	1,522 kg/m <sup>3</sup> (2,565 lb/yd <sup>3</sup> )	-----
Limestone, fine	-----	-----	1,602 kg/m <sup>3</sup> (2,705 lb/yd <sup>3</sup> )
Phosphate, rock	-----	1,282 kg/m <sup>3</sup> (2,160 lb/yd <sup>3</sup> )	-----



<b>MATERIAL</b>	<b>LOW WEIGHT OR DENSITY 1,100 KG/M<sup>3</sup> (1,850 LB/YD<sup>3</sup>), OR LESS</b>	<b>MEDIUM WEIGHT OR DENSITY 1,600 KG/M<sup>3</sup> (2,700 LB/YD<sup>3</sup>), OR LESS</b>	<b>HIGH WEIGHT OR DENSITY 2,000 KG/M<sup>3</sup> (3,370 LB/YD<sup>3</sup>), OR LESS</b>
Salt	929 kg/m <sup>3</sup> (1,566 lb/yd <sup>3</sup> )	-----	-----
Snow, light density	529 kg/m <sup>3</sup> (891 lb/yd <sup>3</sup> )	-----	-----
Sand, DRY, loose	-----	1,522 kg/m <sup>3</sup> (2,565 lb/yd <sup>3</sup> )	-----
Sand, WET, packed	-----	-----	1,922 kg/m <sup>3</sup> (3,240 lb/yd <sup>3</sup> )
Shale, broken	-----	1,362 kg/m <sup>3</sup> (2,295 lb/yd <sup>3</sup> )	-----
Sulphur, broken	529 kg/m <sup>3</sup> (1,620 lb/yd <sup>3</sup> )	-----	-----

## IMPORTANT

**Weights are approximations of estimated average volume and mass. Exposure to rain, snow or ground water; settling or compaction due to overhead weight and chemical or industrial processing or changes due to thermal or chemical transformations could all increase value of weights listed in table.**

