

690E LC Excavator Repair

TECHNICAL MANUAL 690E LC Excavator Repair

TM1509 02JUL98 (ENGLISH)

For complete service information also see:

690E LC Excavator	
Operation and Tests	TM1508
6068 Engine (Serial No. —559602)	CTM8
6068 Engine (Serial No. 559603—)	CTM104
Alternators and Starting Motors.....	CTM77

**Worldwide Construction
And Forestry Division**
LITHO IN U.S.A.

Introduction

Foreword

This manual is written for an experienced technician. Essential tools required in performing certain service work are identified in this manual and are recommended for use.

Live with safety: Read the safety messages in the introduction of this manual and the cautions presented throughout the text of the manual.

 This is the safety-alert symbol. When you see this symbol on the machine or in this manual, be alert to the potential for personal injury.

Technical manuals are divided in two parts: repair and operation and tests. Repair sections tell how to repair the components. Operation and tests sections help you identify the majority of routine failures quickly.

Information is organized in groups for the various components requiring service instruction. At the beginning of each group are summary listings of all applicable essential tools, service equipment and tools, other materials needed to do the job, service parts kits, specifications, wear tolerances, and torque values.

Technical Manuals are concise guides for specific machines. They are on-the-job guides containing only the vital information needed for diagnosis, analysis, testing, and repair.

Fundamental service information is available from other sources covering basic theory of operation, fundamentals of troubleshooting, general maintenance, and basic type of failures and their causes.

DX, TMIFC -19-22MAY92-1/1

Introduction

Help!! Help!! Help!! Help!!

We need your help to continually improve our technical publications. Please FAX or mail your comments, ideas and improvements.

SEND TO: John Deere Dubuque Works
P.O. Box 538
Attn: Publications Supervisor, Dept. 303
Dubuque, Iowa 52004-0538

FAX NUMBER: 319-589-5800

Ideas, Comments (Please State Page Number): _____

OVERALL, how would you rate the quality of "ALL" Manuals provided to you? (Check one)

1 Poor 2 3 Fair 4 5 Good 6 7 Very Good 8 9 Excellent 10

Company Name _____
Address _____
Phone _____
FAX No. _____
Dealer Acct. No. _____

THANK YOU!

Introduction

Contents

SECTION 00—General Information

- Group 0001—Safety
- Group 0002—General Specifications
- Group 0003—Torque Values
- Group 0004—Fuels And Lubricants

SECTION 01—Tracks

- Group 0130—Track System

SECTION 02—Axles And Suspension Systems

- Group 0250—Axle Shaft, Bearings, And Reduction Gears
- Group 0260—Hydraulic System

SECTION 04—Engine

- Group 0400—Removal And Installation

SECTION 05—Engine Auxiliary System

- Group 0505—Cold Weather Starting Aids
- Group 0510—Cooling System
- Group 0515—Speed Controls
- Group 0520—Intake System
- Group 0530—External Exhaust Systems
- Group 0560—External Fuel Supply Systems

SECTION 07—Dampener Drive (Flex Coupling)

- Group 0752—Elements

SECTION 16—Electrical System

- Group 1671—Batteries, Support, And Cables
- Group 1672—Alternator, Regulator, And Charging Wiring
- Group 1673—Lighting System
- Group 1674—Wiring Harness And Switches
- Group 1675—System Controls
- Group 1676—Instruments And Indicators

SECTION 17—Frame Or Supporting Structure

- Group 1740—Frame Installation
- Group 1749—Chassis Weights

SECTION 18—Operator's Station

- Group 1800—Removal And Installation

- Group 1810—Operator Enclosure
- Group 1821—Seat
- Group 1830—Heating And Air Conditioning

SECTION 20—Safety And Convenience

- Group 2004—Horn And Warning Devices

SECTION 33—Excavator

- Group 3302—Bucket
- Group 3340—Frames
- Group 3360—Hydraulic System

SECTION 43—Swing Or Pivoting System

- Group 4311—Brakes
- Group 4350—Mechanical Drive Elements
- Group 4360—Hydraulic System

SECTION 99—Dealer Fabricated Tools

- Group 9900—Dealer Fabricated Tools

All information, illustrations and specifications in this manual are based on the latest information available at the time of publication. The right is reserved to make changes at any time without notice.

COPYRIGHT © 1997
DEERE & COMPANY
Moline, Illinois
All rights reserved
A John Deere ILLUSTRATION® Manual
Previous Editions
Copyright © 1992, 1995

Contents

00

01

02

04

05

07

16

17

18

20

Contents

33

43

99

INDX

Contents

33

43

99

INDX

Section 00

General Information

Contents

	Page		Page
Group 0001—Safety	00-0001-1	Mixing of Lubricants	00-0004-9
Group 0002—General Specifications			
690E LC	00-0002-1		
690E LC Long Front Specifications	00-0002-3		
690E LC And 690E LC Long Front Drain And Refill Capacities	00-0002-4		
Group 0003—Torque Values			
Unified Inch Bolt and Cap Screw Torque Values	00-0003-1		
Metric Bolt and Cap Screw Torque Values	00-0003-2		
Additional Metric Cap Screw Torque Values	00-0003-3		
Service Recommendations for O-Ring Boss Fittings	00-0003-4		
Service Recommendations for Flat Face O-Ring Seal Fittings	00-0003-6		
Service Recommendations for 37° Flare and 30° Cone Seat Connectors	00-0003-7		
Service Recommendations For Flared Connections—Straight or Tapered Threads	00-0003-8		
Service Recommendations For Inch Series Four Bolt Flange Fittings	00-0003-9		
Service Recommendations for Metric Series Four Bolt Flange Fitting	00-0003-10		
Group 0004—Fuels And Lubricants			
Diesel Fuel	00-0004-1		
Do Not Use Galvanized Containers	00-0004-1		
Storing Fuel	00-0004-2		
Low Sulfur Diesel Fuel Conditioner	00-0004-2		
Fuel Tank	00-0004-3		
Diesel Engine Oil	00-0004-4		
Hydraulic Oil	00-0004-5		
Propel Gearbox Oil	00-0004-6		
Track Roller, Front Idler, And Carrier Roller Oil	00-0004-6		
Track Adjuster, Working Tool Pivot, Swing Bearing, And Swing Bearing Gear Grease	00-0004-7		
Oil Filters	00-0004-7		
Lubricant Storage	00-0004-8		
Alternative and Synthetic Lubricants	00-0004-8		

Contents

00

Follow Safe Procedures

Unsafe work practices are dangerous. Understand service procedure before doing work; do not attempt shortcuts.



TS231 -19-07OCT88

TX,05,FF1611 -19-14JUN90-1/1

Prepare for Emergencies

Be prepared if a fire starts.

Keep a first aid kit and fire extinguisher handy.

Keep emergency numbers for doctors, ambulance service, hospital, and fire department near your telephone.

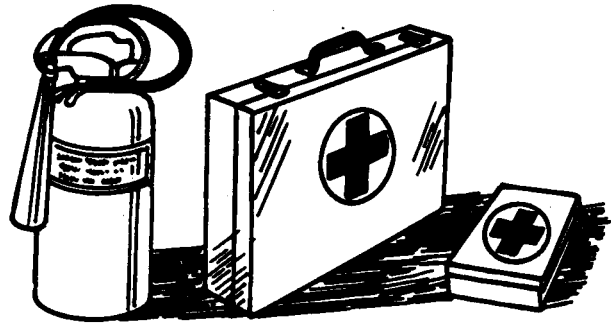

TS291 -UN-23AUG88

DX,FIRE2 -19-03MAR93-1/1

Prevent Acid Burns

Sulfuric acid in battery electrolyte is poisonous. It is strong enough to burn skin, eat holes in clothing, and cause blindness if splashed into eyes.

Avoid the hazard by:

1. Filling batteries in a well-ventilated area.
2. Wearing eye protection and rubber gloves.
3. Avoiding breathing fumes when electrolyte is added.
4. Avoiding spilling or dripping electrolyte.
5. Use proper jump start procedure.

If you spill acid on yourself:

1. Flush your skin with water.
2. Apply baking soda or lime to help neutralize the acid.
3. Flush your eyes with water for 15—30 minutes. Get medical attention immediately.

If acid is swallowed:

1. Do not induce vomiting.
2. Drink large amounts of water or milk, but do not exceed 2 L (2 quarts).
3. Get medical attention immediately.

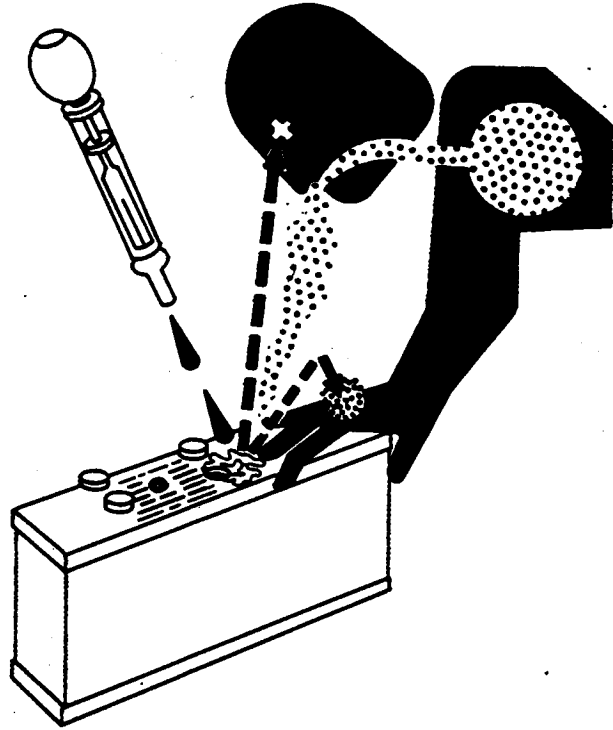

TS203 -UN-23AUG88

DX,POISON -19-21APR93-1/1

Handle Chemical Products Safely

Direct exposure to hazardous chemicals can cause serious injury. Potentially hazardous chemicals used with John Deere equipment include such items as lubricants, coolants, paints, and adhesives.

A Material Safety Data Sheet (MSDS) provides specific details on chemical products: physical and health hazards, safety procedures, and emergency response techniques.

Check the MSDS before you start any job using a hazardous chemical. That way you will know exactly what the risks are and how to do the job safely. Then follow procedures and recommended equipment.

(See your John Deere dealer for MSDS's on chemical products used with John Deere equipment.)



TS1132 -UN-26NOV90

DX,MSDS,NA -19-03MAR93-1/1

Handle Fluids Safely—Avoid Fires

Handle fuel with care; it is highly flammable. Do not refuel the machine while smoking or when near open flame or sparks. Always stop engine before refueling machine. Fill fuel tank outdoors.



TS202 -UN-23AUG88

TX,05,FF1622 -19-14JUN90-1/2

Store flammable fluids away from fire hazards. Do not incinerate or puncture pressurized containers.

Make sure machine is clean of trash, grease, and debris.

Do not store oily rags; they can ignite and burn spontaneously.



TS227 -UN-23AUG88

TX,05,FF1622 -19-14JUN90-2/2

Safety

Avoid High-Pressure Fluids

Escaping fluid under pressure can penetrate the skin causing serious injury.

Avoid the hazard by relieving pressure before disconnecting hydraulic or other lines. Tighten all connections before applying pressure.

Search for leaks with a piece of cardboard. Protect hands and body from high pressure fluids.

If an accident occurs, see a doctor immediately. Any fluid injected into the skin must be surgically removed within a few hours or gangrene may result. Doctors unfamiliar with this type of injury should reference a knowledgeable medical source. Such information is available from Deere & Company Medical Department in Moline, Illinois, U.S.A.

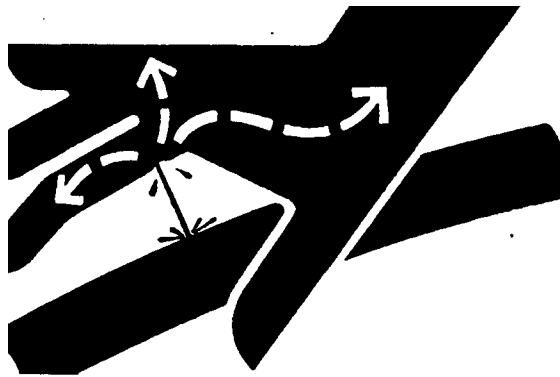

X9811 -UN-23AUG88

DX,FLUID -19-03MAR93-1/1

Warn Others of Service Work

Unexpected machine movement can cause serious injury.

Before performing any work on the machine, attach a "Do Not Operate" tag on the right control lever.

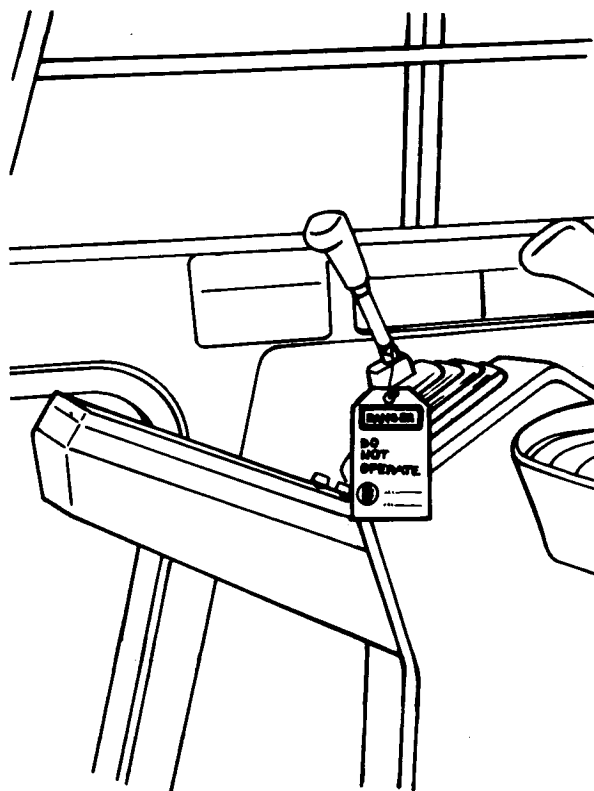

T7273AP -UN-08JUN90

TX,05,RR,566 -19-23JUL91-1/1

Safety

Support Machine Properly

Always lower the attachment or implement to the ground before you work on the machine. If you must work on a lifted machine or attachment, securely support the machine or attachment. If left in a raised position, hydraulically supported devices can settle or leak down.

Do not support the machine on cinder blocks, hollow tiles, or props that may crumble under continuous load. Do not work under a machine that is supported solely by a jack. Follow recommended procedures in this manual.

When implements or attachments are used with a tractor, always follow safety precautions listed in the implement operator's manual.

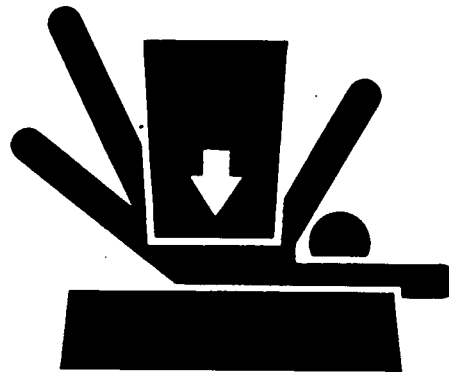

TS229 -JUN-23AUG88

00
0001
5

DX,LOWER -19-17FEB99-1/1

Operate Only from Operator's Seat

Avoid possible injury or machine damage. Do not start engine by shorting across starter terminals.

NEVER start engine while standing on ground. Start engine only from operator's seat.

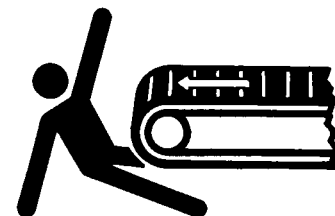

T6607AO -JUN-18OCT88

TX,05,FF1615 -19-14JUN90-1/1

Park Machine Safely

Before working on the machine:

- Park machine on a level surface.
- Lower bucket to the ground.
- Turn auto-idle switch off.
- Run engine in light duty "L" mode without load for 2 minutes.
- Set power mode to low idle "I" and turn key switch to OFF to stop engine. Remove key from switch.
- Pull pilot control shut-off lever to locked position.
- Allow engine to cool.

CED,OUTX782,582 -19-18AUG99-1/1

Safety

Stay Clear of Moving Parts

Entanglements in moving parts can cause serious injury.

To prevent accidents, use care when working around rotating parts.

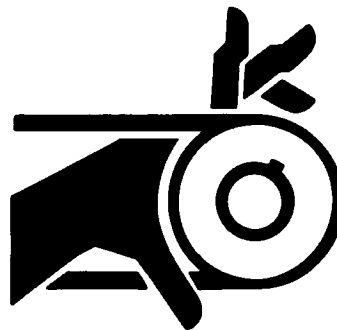

T7273AS -UN-08JUN90

TX,05,RR,572 -19-12JUN90-1/1

Avoid Power Lines

Serious injury or death can result from contact with electric lines.

Never move any part of the machine or load closer to electric line than 3 m (10 ft) plus twice the line insulator length.



T7273AD -UN-08JUN90

TX,05,RR,594 -19-12JUN90-1/1

Use Handholds and Steps

Falling is one of the major causes of personal injury.

When you get on and off the machine, always maintain a three point contact with the steps and handrails and face the machine. Do not use any controls as handholds.

Never jump on or off the machine. Never mount or dismount a moving machine.

Be careful of slippery conditions on platforms, steps, and handrails when leaving the machine.



T6981AN -UN-15JUN89

TX,05,DH832 -19-16MAR92-1/1

Safety

00
0001
7

Keep Riders Off Machine

Only allow the operator on the machine. Keep riders off.

Riders on machine are subject to injury such as being struck by foreign objects and being thrown off the machine. Riders also obstruct the operator's view resulting in the machine being operated in an unsafe manner.

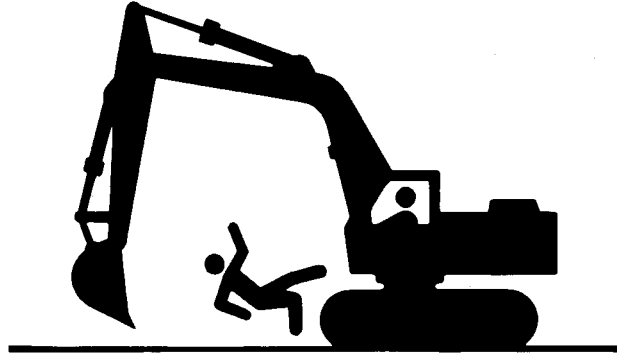

T7273AH -UN-08JUN90

TX.05.RR.560 -19-05OCT90-1/1

Move and Operate Machine Safely

Bystanders can be run over. Know the location of bystanders before moving, swinging, or operating the machine.

Always keep the travel alarm in working condition. It warns people when the machine starts to move.

Use a signal person when moving, swinging, or operating the machine in congested areas. Coordinate hand signals before starting the machine.

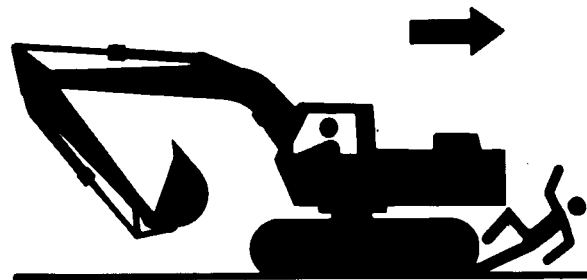

T7273AL -UN-08JUN90

TX.05.FF1806 -19-05OCT90-1/1

Wear Protective Clothing

Wear close fitting clothing and safety equipment appropriate to the job.

Operating equipment safely requires the full attention of the operator. Do not wear radio or music headphones while operating machine.

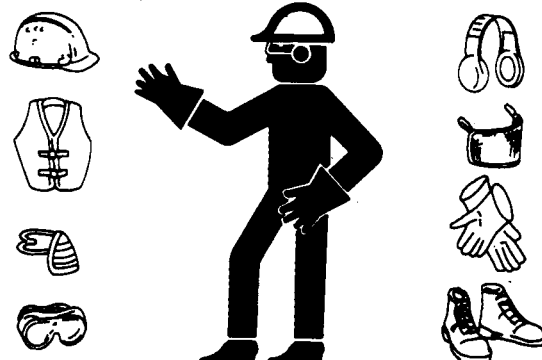

TS206 -UN-23AUG88

DX,WEAR2 -19-03MAR93-1/1

Safety

00
0001
8

Protect Against Flying Debris

Guard against injury from flying pieces of metal or debris; wear goggles or safety glasses.

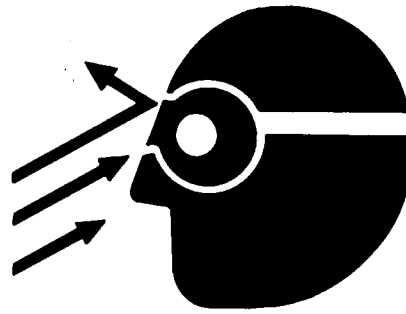

T6642DK -UN-18OCT88

TX,05,FF1613 -19-14JUN90-1/1

Protect Against Noise

Prolonged exposure to loud noise can cause impairment or loss of hearing.

Wear a suitable hearing protective device such as earmuffs or earplugs to protect against objectionable or uncomfortable loud noises.



TS207 -UN-23AUG88

DX,NOISE -19-03MAR93-1/1

Illuminate Work Area Safely

Illuminate your work area adequately but safely. Use a portable safety light for working inside or under the machine. Make sure the bulb is enclosed by a wire cage. The hot filament of an accidentally broken bulb can ignite spilled fuel or oil.

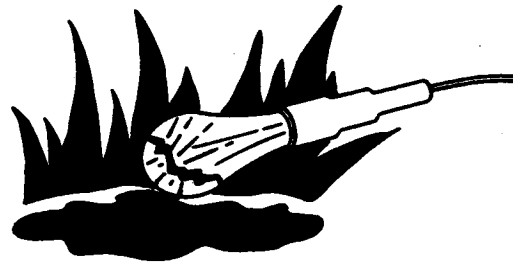

TS223 -UN-23AUG88

DX,LIGHT -19-04JUN90-1/1

Service Machines Safely

Tie long hair behind your head. Do not wear a necktie, scarf, loose clothing, or necklace when you work near machine tools or moving parts. If these items were to get caught, severe injury could result.

Remove rings and other jewelry to prevent electrical shorts and entanglement in moving parts.

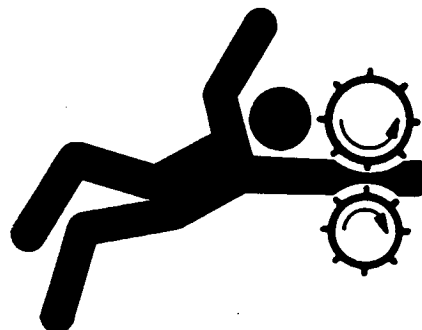

TS228 -UN-23AUG88

DX,LOOSE -19-04JUN90-1/1

Remove Paint Before Welding or Heating

Avoid potentially toxic fumes and dust.

Hazardous fumes can be generated when paint is heated by welding, soldering, or using a torch.

Do all work outside or in a well ventilated area. Dispose of paint and solvent properly.

Remove paint before welding or heating:

- If you sand or grind paint, avoid breathing the dust. Wear an approved respirator.
- If you use solvent or paint stripper, remove stripper with soap and water before welding. Remove solvent or paint stripper containers and other flammable material from area. Allow fumes to disperse at least 15 minutes before welding or heating.

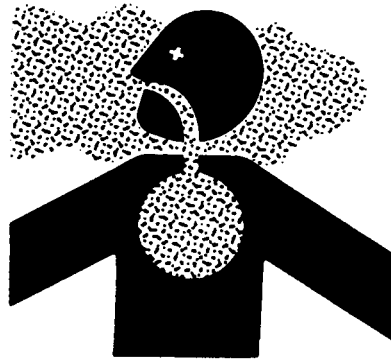

TS220 -UN-23AUG88

DX,PAINT -19-03MAR93-1/1

Avoid Heating Near Pressurized Fluid Lines

Flammable spray can be generated by heating near pressurized fluid lines, resulting in severe burns to yourself and bystanders. Do not heat by welding, soldering, or using a torch near pressurized fluid lines or other flammable materials. Pressurized lines can be accidentally cut when heat goes beyond the immediate flame area.



TS953 -UN-15MAY90

DX,TORCH -19-03MAR93-1/1

Beware of Exhaust Fumes

Prevent asphyxiation. Engine exhaust fumes can cause sickness or death.

If you must operate in a building, be positive there is adequate ventilation. Either use an exhaust pipe extension to remove the exhaust fumes or open doors and windows to bring enough outside air into the area.



T6468AO -UN-18OCT88

02T,05,J9 -19-07JAN91-1/1

Safety

Use Proper Lifting Equipment

Lifting heavy components incorrectly can cause severe injury or machine damage.

Follow recommended procedure for removal and installation of components in the manual.

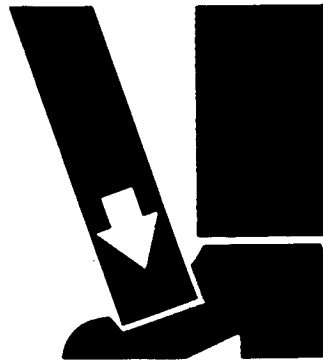

TS226 -UN-23AUG88

DX,LIFT -19-04JUN90-1/1

Service Cooling System Safely

Explosive release of fluids from pressurized cooling system can cause serious burns.

Shut off engine. Only remove filler cap when cool enough to touch with bare hands. Slowly loosen cap to first stop to relieve pressure before removing completely.

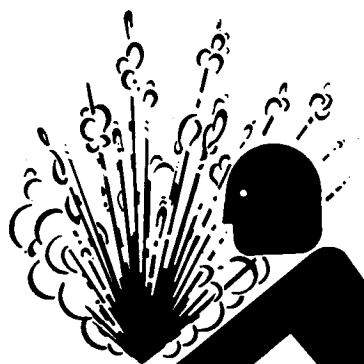

TS281 -UN-23AUG88

DX,RCAP -19-04JUN90-1/1

Dispose of Waste Properly

Improperly disposing of waste can threaten the environment and ecology. Potentially harmful waste used with John Deere equipment include such items as oil, fuel, coolant, brake fluid, filters, and batteries.

Use leakproof containers when draining fluids. Do not use food or beverage containers that may mislead someone into drinking from them.

Do not pour waste onto the ground, down a drain, or into any water source.

Air conditioning refrigerants escaping into the air can damage the Earth's atmosphere. Government regulations may require a certified air conditioning service center to recover and recycle used air conditioning refrigerants.

Inquire on the proper way to recycle or dispose of waste from your local environmental or recycling center, or from your John Deere dealer.

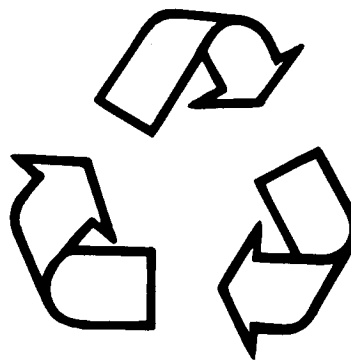

TS1133 -UN-26NOV90

DX,DRAIN -19-03MAR93-1/1

Work in a Clean Area

Before starting a job, clean the work area. Remove objects that may be a safety hazard to the mechanic or bystanders.

TX,05,FF1624 -19-14JUN90-1/1

Use Tools Properly

Use tools appropriate to the work. Makeshift tools, parts, and procedures can create safety hazards.

Use power tools only to loosen threaded tools and fasteners.

For loosening and tightening hardware, use the correct size tools. **DO NOT** use U.S. measurement tools on metric fasteners. Avoid bodily injury caused by slipping wrenches.

Use only recommended replacement parts. (See Parts Catalog.)



TS779 -UN-08NOV89

TX,05,FF1614 -19-14JUN90-1/1

Replace Safety Signs

Replace missing or damaged safety signs. See the machine operator's manual for correct safety sign placement.



TS201 -UN-23AUG88

DX,SIGNS1 -19-04JUN90-1/1

Safety

00
0001
12

Live With Safety

Before returning machine to customer, make sure machine is functioning properly, especially the safety systems. Install all guards and shields.



TS231 -19-07OCT88

DX.LIVE -19-25SEP92-1/1

690E LC

00
0002
1

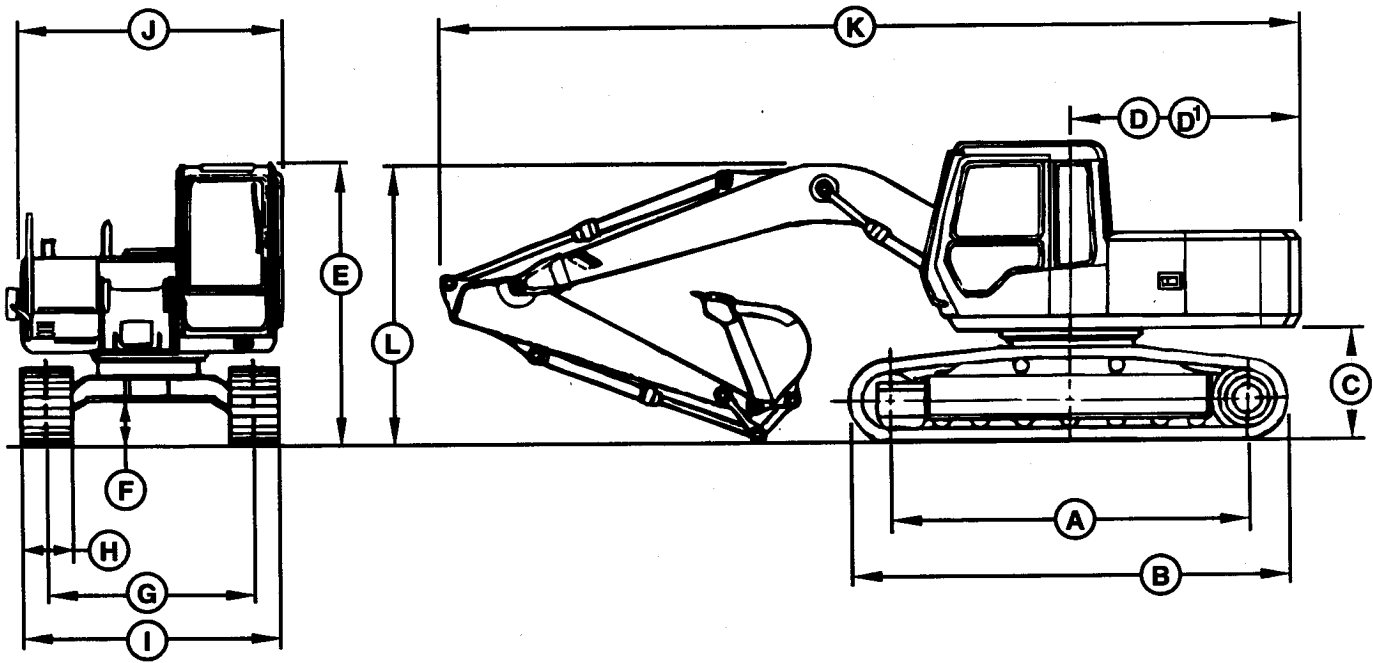

T7527DQ -UN-27APR93

Continued on next page

TX,115,FF2461 -19-21AUG97-1/2

General Specifications

NOTE: Specifications and design subject to change without notice. Wherever applicable,

specifications are in accordance with PCSA and SAE standards.

A	3607 mm (11 ft 10 in.)
B	4445 mm (14 ft 7 in.)
C	1090 mm (3 ft 7 in.)
D	2630 mm (8 ft 8 in.)
D ¹ Swing Radius	2740 mm (9 ft 0 in.)
E	2910 mm (9 ft 6 in.)
F	455 mm (1 ft 6 in.)
G	2380 mm (7 ft 10 in.)
H	650 mm (26 in.) or 750 mm (30 in.) or 800 mm (32 in.)
I With 2380 mm (7 ft 10 in.) undercarriage and With 650 mm (26 in.) shoes With 750 mm (30 in.) shoes With 800 mm (32 in.) shoes	3030 mm (9 ft 11 in.) 3130 mm (10 ft 3 in.) 3180 mm (10 ft 5 in.)
J	2780 mm (9 ft 1 in.)
K With 2200 mm (7 ft 3 in.) arm With 2900 mm (9 ft 6 in.) arm	9480 mm (31 ft 1 in.) 9410 mm (30 ft 10 in.)
L With 2200 mm (7 ft 3 in.) arm	2910 mm (9 ft 6 in.)
With 2900 mm (9 ft 6 in.) arm	2910 mm (9 ft 6 in.)

TX,115,FF2461 -19-21AUG97-2/2

General Specifications

690E LC Long Front Specifications

00
0002
3

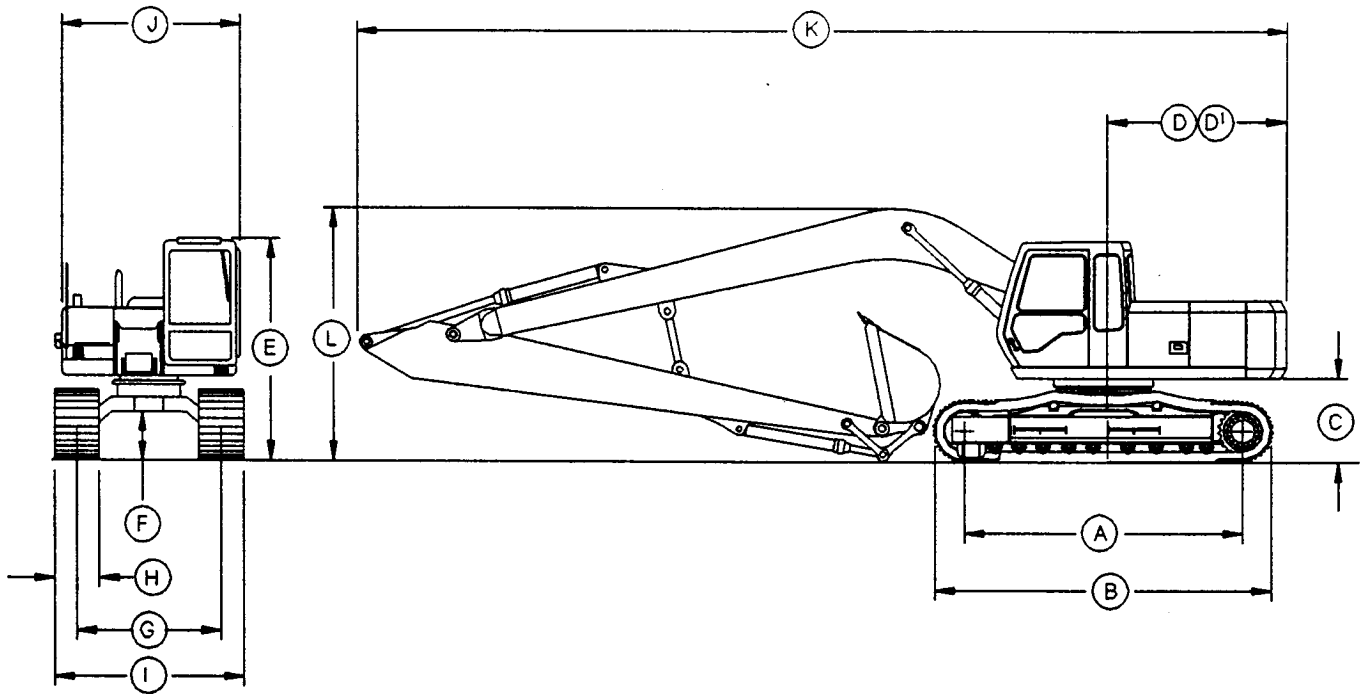

T7961AE -UN-02APR93

Continued on next page

TX,115,FF3345 -19-11JAN95-1/2

General Specifications

NOTE: Specifications and design subject to change without notice. Wherever applicable, specifications are in accordance with PCSA and SAE Standards. Except where otherwise noted these specifications are based on a unit

equipped with 379 kg (835 lb) bucket, 800 mm (32 in.) track shoes, 4.45 m (14 ft 7 in.) undercarriage, full fuel tank, 80 kg (175 lb) operator, and standard equipment.

A	3.66 m (12 ft 0 in.)
B	4.45 m (14 ft 7 in.)
C	1.09 m (3 ft 7 in.)
D	2.63 m (8 ft 8 in.)
D ¹ Tailswing Radius	2.74 m (9 ft 0 in.)
E	2.84 m (9 ft 4 in.)
F	455 mm (1 ft 6 in.)
G	2.38 m (7 ft 10 in.)
H	800 mm (32 in.)
I	3.18 m (10 ft 5 in.)
J	2.77 m (9 ft 1 in.)
K	11.86 m (38 ft 11 in.)
L	3.15 m (10 ft 4 in.)
With 100 mm (4 in.) block under bucket linkage pivot ^a	3.25 m (10 ft 8 in.)

^aLubrication lines at boom cylinder rod ends may extend 100 mm (4 in.) over maximum machine height. If necessary, lines can be tied down to meet height requirements.

TX,115,FF3345 -19-11JAN95-2/2

690E LC And 690E LC Long Front Drain And Refill Capacities

	Metric	English
Fuel tank (Serial No. —536413)	322 L	85 gal
Fuel tank (Serial No. 536414—)	303 L	80 gal
Cooling system (Serial No. —559602)	34 L	9 gal
Cooling system (Serial No. 559603—)	41.5 L	11 gal
Engine lubrication, including filter	19 L	20 qt
Hydraulic tank	148 L	39 gal
Swing gear	21.8 kg	48 lb
Propel gearbox (each)	3.9 L	4.1 qt

TX,115,FF2463 -19-21AUG97-1/1

Unified Inch Bolt and Cap Screw Torque Values

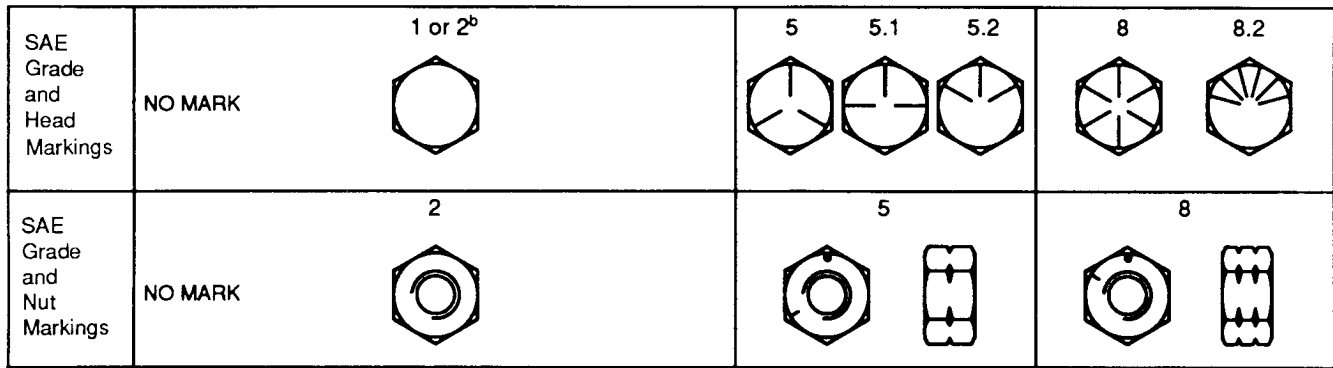

Size	Grade 1				Grade 2 ^b				Grade 5, 5.1, or 5.2				Grade 8 or 8.2			
	Lubricated ^a		Dry ^a		Lubricated ^a		Dry ^a		Lubricated ^a		Dry ^a		Lubricated ^a		Dry ^a	
	N-m	lb-ft	N-m	lb-ft	N-m	lb-ft	N-m	lb-ft	N-m	lb-ft	N-m	lb-ft	N-m	lb-ft	N-m	lb-ft
1/4	3.7	2.8	4.7	3.5	6	4.5	7.5	5.5	9.5	7	12	9	13.5	10	17	12.5
5/16	7.7	5.5	10	7	12	9	15	11	20	15	25	18	28	21	35	26
3/8	14	10	17	13	22	16	27	20	35	26	44	33	50	36	63	46
7/16	22	16	28	20	35	26	44	32	55	41	70	52	80	58	100	75
1/2	33	25	42	31	53	39	67	50	85	63	110	80	120	90	150	115
9/16	48	36	60	45	75	56	95	70	125	90	155	115	175	130	225	160
5/8	67	50	85	62	105	78	135	100	170	125	215	160	240	175	300	225
3/4	120	87	150	110	190	140	240	175	300	225	375	280	425	310	550	400
7/8	190	140	240	175	190	140	240	175	490	360	625	450	700	500	875	650
1	290	210	360	270	290	210	360	270	725	540	925	675	1050	750	1300	975
1-1/8	400	300	510	375	400	300	510	375	900	675	1150	850	1450	1075	1850	1350
1-1/4	570	425	725	530	570	425	725	530	1300	950	1650	1200	2050	1500	2600	1950
1-3/8	750	550	950	700	750	550	950	700	1700	1250	2150	1550	2700	2000	3400	2550
1-1/2	1000	725	1250	925	990	725	1250	930	2250	1650	2850	2100	3600	2650	4550	3350

DO NOT use these values if a different torque value or tightening procedure is given for a specific application. Torque values listed are for general use only. Check tightness of fasteners periodically.

Shear bolts are designed to fail under predetermined loads. Always replace shear bolts with identical grade.

^a "Lubricated" means coated with a lubricant such as engine oil, or fasteners with phosphate and oil coatings. "Dry" means plain or zinc plated without any lubrication.

^b Grade 2 applies for hex cap screws (not hex bolts) up to 152 mm (6-in.) long. Grade 1 applies for hex cap screws over 152 mm (6-in.) long, and for all other types of bolts and screws of any length.

Fasteners should be replaced with the same or higher grade. If higher grade fasteners are used, these should only be tightened to the strength of the original.

Make sure fasteners threads are clean and that you properly start thread engagement. This will prevent them from failing when tightening.

Tighten plastic insert or crimped steel-type lock nuts to approximately 50 percent of the dry torque shown in the chart, applied to the nut, not to the bolt head. Tighten toothed or serrated-type lock nuts to the full torque value.

TS1656 -19-02APR97

Torque Values

Metric Bolt and Cap Screw Torque Values

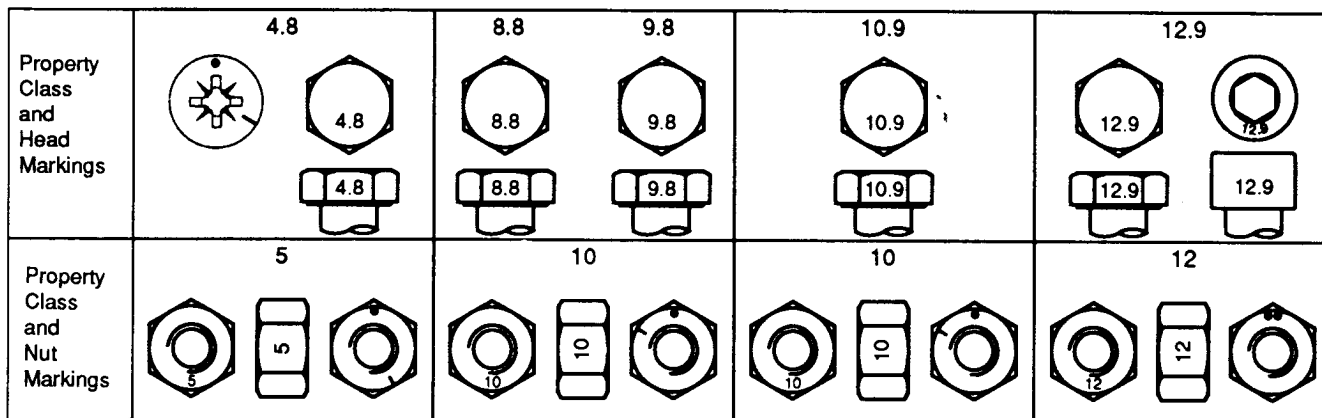

Size	Class 4.8				Class 8.8 or 9.8				Class 10.9				Class 12.9			
	Lubricated ^a		Dry ^a		Lubricated ^a		Dry ^a		Lubricated ^a		Dry ^a		Lubricated ^a		Dry ^a	
	N-m	lb-ft	N-m	lb-ft	N-m	lb-ft	N-m	lb-ft	N-m	lb-ft	N-m	lb-ft	N-m	lb-ft	N-m	lb-ft
M6	4.8	3.5	6	4.5	9	6.5	11	8.5	13	9.5	17	12	15	11.5	19	14.5
M8	12	8.5	15	11	22	16	28	20	32	24	40	30	37	28	47	35
M10	23	17	29	21	43	32	55	40	63	47	80	60	75	55	95	70
M12	40	29	50	37	75	55	95	70	110	80	140	105	130	95	165	120
M14	63	47	80	60	120	88	150	110	175	130	225	165	205	150	260	190
M16	100	73	125	92	190	140	240	175	275	200	350	255	320	240	400	300
M18	135	100	175	125	260	195	330	250	375	275	475	350	440	325	560	410
M20	190	140	240	180	375	275	475	350	530	400	675	500	625	460	800	580
M22	260	190	330	250	510	375	650	475	725	540	925	675	850	625	1075	800
M24	330	250	425	310	650	475	825	600	925	675	1150	850	1075	800	1350	1000
M27	490	360	625	450	950	700	1200	875	1350	1000	1700	1250	1600	1150	2000	1500
M30	675	490	850	625	1300	950	1650	1200	1850	1350	2300	1700	2150	1600	2700	2000
M33	900	675	1150	850	1750	1300	2200	1650	2500	1850	3150	2350	2900	2150	3700	2750
M36	1150	850	1450	1075	2250	1650	2850	2100	3200	2350	4050	3000	3750	2750	4750	3500

DO NOT use these values if a different torque value or tightening procedure is given for a specific application. Torque values listed are for general use only. Check tightness of fasteners periodically.

Shear bolts are designed to fail under predetermined loads. Always replace shear bolts with identical property class.

Fasteners should be replaced with the same or higher property class. If higher property class fasteners are used, these should only be tightened to the strength of the original.

^a "Lubricated" means coated with a lubricant such as engine oil, or fasteners with phosphate and oil coatings. "Dry" means plain or zinc plated without any lubrication.

Make sure fasteners threads are clean and that you properly start thread engagement. This will prevent them from failing when tightening.

Tighten plastic insert or crimped steel-type lock nuts to approximately 50 percent of the dry torque shown in the chart, applied to the nut, not to the bolt head. Tighten toothed or serrated-type lock nuts to the full torque value.

Torque Values

Additional Metric Cap Screw Torque Values

⚠ CAUTION: Use only metric tools on metric hardware. Other tools may not fit properly. They may slip and cause injury.

Check tightness of cap screws periodically. Torque values listed are for general use only. Do not use these values if a different torque value or tightening procedure is listed for a specific application.

T6873AA



Shear bolts are designed to fail under predetermined loads. Always replace shear bolts with identical grade.

T6873AB



Fasteners should be replaced with the same or higher grade. If higher grade fasteners are used, these should only be tightened to the strength of the original.

Make sure fastener threads are clean and you properly start thread engagement. This will prevent them from failing when tightening.

Tighten cap screws having lock nuts to approximately 50 percent of amount shown in chart.

T6873AC



T6873AA -UN-18OCT88

T6873AB -UN-18OCT88

T6873AC -UN-18OCT88

00
0003
3

Continued on next page

04T,90,M170 -19-01AUG94-1/2

Torque Values

METRIC CAP SCREW TORQUE VALUES^a

Nominal Dia	T-Bolt		H-Bolt		M-Bolt	
	lb-ft	N•m	lb-ft	N•m	lb-ft	N•m
8	29	21	20	15	10	7
10	63	46	45	33	20	15
12	108	80	88	65	34	25
14	176	130	137	101	54	40
16	265	195	206	152	78	58
18	392	289	294	217	118	87
20	539	398	392	289	167	125
22	735	542	539	398	216	159
24	931	687	686	506	274	202
27	1372	1012	1029	759	392	289
30	1911	1410	1421	1049	539	398
33	2548	1890	1911	1410	735	542
36	3136	2314	2401	1772	931	687

^aTorque tolerance is $\pm 10\%$.

04T,90,M170 -19-01AUG94-2/2

Service Recommendations for O-Ring Boss Fittings

Straight Fitting

1. Inspect O-ring boss seat for dirt or defects.
2. Lubricate O-ring with petroleum jelly. Place electrical tape over threads to protect O-ring. Slide O-ring over tape and into O-ring groove of fitting. Remove tape.
3. Tighten fitting to torque value shown on chart.

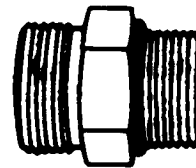

T6243AE -UN-18OCT88

Continued on next page

04T,90,K66 -19-19MAR96-1/2

Torque Values

00
0003
5

Angle Fitting

1. Back-off lock nut (A) and back-up washer (B) completely to head-end (C) of fitting.
2. Turn fitting into threaded boss until back-up washer contacts face of boss.
3. Turn fitting head-end counterclockwise to proper index (maximum of one turn).

NOTE: Do not allow hoses to twist when tightening fittings.

4. Hold fitting head-end with a wrench and tighten locknut and back-up washer to proper torque value.

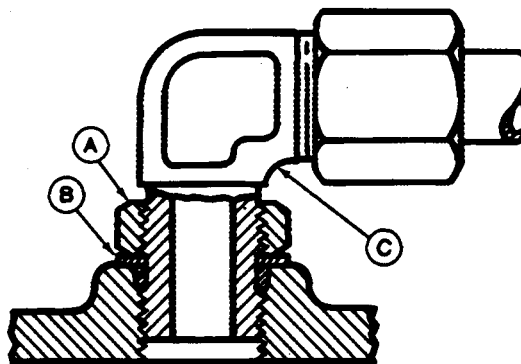

T6520AB -UN-18OCT88

STRAIGHT FITTING OR SPECIAL NUT TORQUE CHART

Thread Size	N•m	lb-ft
3/8-24 UNF	8	6
7/16-20 UNF	12	9
1/2-20 UNF	16	12
9/16-18 UNF	24	18
3/4-16 UNF	46	34
7/8-14 UNF	62	46
1-1/16-12 UN	102	75
1-3/16-12 UN	122	90
1-5/16-12 UN	142	105
1-5/8-12 UN	190	140
1-7/8-12 UN	217	160

NOTE: Torque tolerance is ± 10%.

04T,90,K66 -19-19MAR96-2/2

Torque Values

**Service Recommendations for Flat Face
O-Ring Seal Fittings**

1. Inspect the fitting sealing surfaces. They must be free of dirt or defects.
2. Inspect the O-ring. It must be free of damage or defects.
3. Lubricate O-rings and install into groove using petroleum jelly to hold in place.
4. Push O-ring into the groove with plenty of petroleum jelly so O-ring is not displaced during assembly.
5. Index angle fittings and tighten by hand pressing joint together to insure O-ring remains in place.
6. Tighten fitting or nut to torque value shown on the chart per dash size stamped on the fitting. Do not allow hoses to twist when tightening fittings.

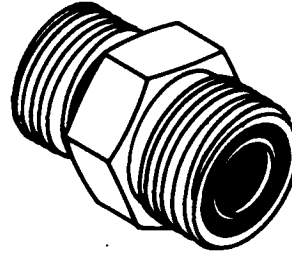

T6243AD -UN-18OCT88

FLAT FACE O-RING SEAL FITTING TORQUE

Nominal Tube O.D.		Dash Size	Thread Size in.	Swivel Nut		Bulkhead Nut	
mm	in.			N•m	lb-ft	N•m	lb-ft
6.35	0.250	-4	9/16-18	16	12	5.0	3.5
9.52	0.375	-6	11/16-16	24	18	9.0	6.5
12.70	0.500	-8	13/16-16	50	37	17.0	12.5
15.88	0.625	-10	1-14	69	51	17.0	12.5
19.05	0.750	-12	1 3/16-12	102	75	17.0	12.5
22.22	0.875	-14	1 3/16-12	102	75	17.0	12.5
25.40	1.000	-16	1 7/16-12	142	105	17.0	12.5
31.75	1.250	-20	1 11/16-12	190	140	17.0	12.5
38.10	1.500	-24	2-12	217	160	17.0	12.5

NOTE: Torque tolerance is +15 -20%.

04T,90,K67 -19-01AUG94-1/1

Torque Values

00
0003
7**Service Recommendations for 37° Flare and 30° Cone Seat Connectors**

1. Inspect flare and flare seat. They must be free of dirt or obvious defects.
2. Defects in tube flare cannot be repaired. Overtightening a defective flared fitting will not stop leaks.
3. Align tube with fitting before attempting to start nut.
4. Lubricate male threads with hydraulic fluid or petroleum jelly.
5. Index angle fittings and tighten by hand.
6. Tighten fitting or nut to torque value shown on torque chart. Do not allow hoses to twist when tightening fittings.

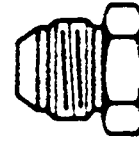

T6234AC -JUN-18OCT88

STRAIGHT FITTING OR SPECIAL NUT TORQUE CHART

Thread Size	N•m	lb-ft
3/8 - 24 UNF	8	6
7/16 - 20 UNF	12	9
1/2 - 20 UNF	16	12
9/16 - 18 UNF	24	18
3/4 - 16 UNF	46	34
7/8 - 14 UNF	62	46
1-1/16 - 12 UN	102	75
1-3/16 - 12 UN	122	90
1-5/16 - 12 UN	142	105
1-5/8 - 12	190	140
1-7/8 - 12 UN	217	160

NOTE: Torque tolerance is $\pm 10\%$.

04T,90,C96 -19-21JAN92-1/1

Service Recommendations For Flared Connections—Straight or Tapered Threads

1. Inspect flare and flare seat. They must be free of dirt or obvious defects.
2. Defects in the tube flare cannot be repaired. Overtightening a defective flared fitting will not stop leaks.
3. Align the tube with the fitting before attempting to start the nut.
4. Lubricate the male threads with hydraulic fluid or petroleum jelly.
5. Index angle fittings and tighten by hand.
6. Tighten fitting or nut to torque value shown on the chart. Do not allow hoses to twist when tightening fittings.

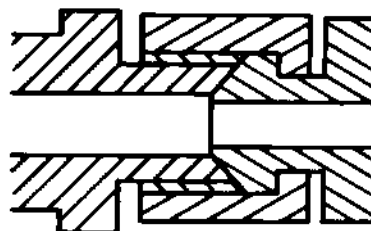

T6873AE

Straight Thread

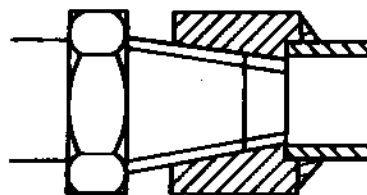

T6873AD

Tapered Thread

TORQUE CHART ^a

Thread Size	Straight Thread ^b		Tapered Thread	
	N•m	lb-ft	N•m	lb-ft
1/8	15	11		
1/4	20	15	45	33
3/8	29	21	69	51
1/2	49	36	93	69
3/4	69	51	176	130
1	157	116	343	253
1-1/2	196	145	539	398
2	255	188	588	434

^aTorque tolerance is ±10%.

^bWith seat face.

NOTE: If female thread is cast iron (control valves, brake valves motors, etc.), torque must be reduced approximately 10%.

T6873AE -UN-18OCT88

T6873AD -UN-18OCT88

Service Recommendations For Inch Series Four Bolt Flange Fittings

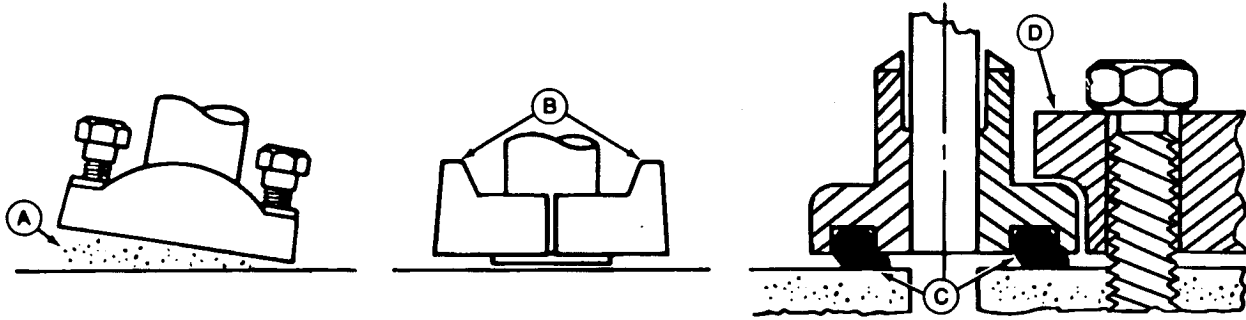

A—Sealing Surface

B—Split Flange

C—Pinched O-Ring

D—Single Piece Flange

1. Clean sealing surfaces (A). Inspect. Scratches cause leaks. Roughness causes seal wear. Out-of-flat causes seal extrusion. If defects cannot be polished out, replace component.
2. Install O-ring (and backup washer if required) into groove using petroleum jelly to hold it in place.
3. Split flange: Loosely assemble split flange (B) halves. Make sure split is centrally located and perpendicular to port. Hand tighten cap screws to hold parts in place. Do not pinch O-ring (C).
4. Single piece flange (D): Place hydraulic line in center of flange and install cap screws. Flange must be centrally located on port. Hand tighten cap screws to hold flange in place. Do not pinch O-ring.
5. Tighten one cap screw, then tighten the diagonally opposite cap screw. Tighten two remaining cap screws. Tighten all cap screws as specified in the chart below.

DO NOT use air wrenches. DO NOT tighten one cap screw fully before tightening the others. DO NOT over tighten.

TORQUE CHART					
Nominal Flange Size	Cap Screw Size	N•m		lb-ft	
		Min	Max	Min	Max
1/2	5/16-18 UNC	20	31	15	23
3/4	3/8-16 UNC	28	54	21	40
1	3/8-16 UNC	37	54	27	40
1-1/4	7/16-14 UNC	47	85	35	63
1-1/2	1/2-13 UNC	62	131	46	97
2	1/2-13 UNC	73	131	54	97
2-1/2	1/2-13 UNC	107	131	79	97
3	5/8-11 UNC	158	264	117	195
3-1/2	5/8-11 UNC	158	264	117	195
4	5/8-11 UNC	158	264	117	195
5	5/8-11 UNC	158	264	117	195

T6890BB -JUN-01MAR90

00
0003
10
Service Recommendations for Metric Series Four Bolt Flange Fitting

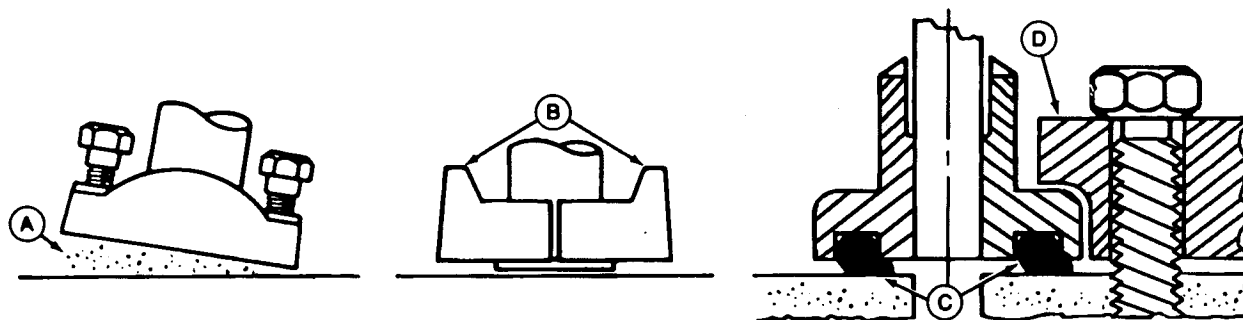

A—Sealing Surface

B—Split Flange

C—Pinched O-Ring

D—Single Piece Flange

1. Clean sealing surfaces (A). Inspect. Scratches cause leaks. Roughness causes seal wear. Out-of-flat causes seal extrusion. If defects cannot be polished out, replace component.
2. Install the correct O-ring (and backup washer if required) into groove using petroleum jelly to hold it in place.
3. Split flange: Loosely assemble split flange (B) halves. Make sure split is centrally located and perpendicular to the port. Hand tighten cap screws to hold parts in place. Do not pinch O-ring (C).
4. Single piece flange (D): Place hydraulic line in center of flange and install four cap screws. Flange must be centrally located on port. Hand tighten cap screws to hold flange in place. Do not pinch O-ring.
5. After components are properly positioned and cap screws are hand tightened, tighten one cap screw,

then tighten the diagonally opposite cap screw. Tighten two remaining cap screws. Tighten all cap screws as specified in the chart below.

DO NOT use air wrenches. DO NOT tighten one cap screw fully before tightening the others. DO NOT over tighten.

TORQUE CHART ^a		
Thread ^b	N•m	lb-ft
M6	12	9
M8	30	22
M10	57	42
M12	95	70
M14	157	116
M16	217	160
M18	334	246
M20	421	318

^aTolerance ± 10%. The torques given are enough for the given size connection with the recommended working pressure. Increasing cap screw torque beyond these amounts will result in flange and cap screw bending and connection failures.

^bMetric standard thread.

T6890BB -UN-01MAR90

04T,90,K175 -19-05JAN96-1/1

Diesel Fuel

Consult your local fuel distributor for properties of the diesel fuel available in your area.

In general, diesel fuels are blended to satisfy the low temperature requirements of the geographical area in which they are marketed.

Diesel fuels specified to EN 590 or ASTM D975 are recommended.

In all cases, the fuel shall meet the following properties:

Cetane number of 40 minimum. Cetane number greater than 50 is preferred, especially for temperatures below -20°C (-4°F) or elevations above 1500 m (5,000 ft).

Cold Filter Plugging Point (CFPP) below the expected low temperature OR **Cloud Point** at least 5°C (9°F) below the expected low temperature.

Fuel lubricity should pass a minimum of 3100 gram load level as measured by the BOCLE scuffing test.

Sulfur content:

- Sulfur content should not exceed 0.5%. Sulfur content less than 0.05% is preferred.
- If diesel fuel with sulfur content greater than 0.5% sulfur content is used, reduce the service interval for engine oil and filter by 50%.
- DO NOT use diesel fuel with sulfur content greater than 1.0%.

Bio-diesel fuels may be used ONLY if the fuel properties meet DIN 51606 or equivalent specification.

DO NOT mix used engine oil or any other type of lubricant with diesel fuel.

TX,45,JC1132 -19-22MAY96-1/1

Do Not Use Galvanized Containers

IMPORTANT: Diesel fuel stored in galvanized containers reacts with zinc coating on the container to form zinc flakes. If fuel contains water, a zinc gel will also form. The gel and flakes will quickly plug fuel filters and damage fuel injectors and fuel pumps.

DO NOT USE a galvanized container to store diesel fuel.

Store fuel in:

- plastic containers.
- aluminum containers.
- specially coated steel containers made for diesel fuel.

DO NOT USE brass-coated containers: brass is an alloy of copper and zinc.

MX,FLBT,C -19-04JUN90-1/1

Storing Fuel

If there is a very slow turnover of fuel in the fuel tank or supply tank, it may be necessary to add a fuel conditioner to prevent water condensation. Contact your authorized dealer for proper service or maintenance recommendations.

DX,FUEL -19-03MAR93-1/1

Low Sulfur Diesel Fuel Conditioner

When possible, use existing fuel formulations for engines used off-highway. This fuel will not require any additives to provide good performance and engine reliability. However, many local fuel distributors will not carry both low and regular sulfur diesel fuels.

If the local fuel distributor will supply only low sulfur fuel, order and use John Deere PREMIUM DIESEL FUEL CONDITIONER. It provides lubricating properties along with other useful benefits, such as cetane improver, anti-oxidant, fuel stabilizer, corrosion inhibitor and others. John Deere PREMIUM DIESEL FUEL CONDITIONER is specifically for use with low sulfur fuels. Nearly all other diesel fuel conditioners only improve cold weather flow and stabilize long-term fuel storage. They do not contain the lubrication additives needed by rotary fuel injection pumps.

TX,45,DH3124 -19-20OCT93-1/1

Fuel Tank



CAUTION: Handle fuel carefully. If the engine is hot or running, do not fill the fuel tank. Do not smoke while you fill fuel tank or work on fuel system.

To avoid condensation, fill the fuel tank at the end of each day's operation.

Allow for fuel expansion. Fill tank to no more than 38 mm (1.5 in.) below fuel filler neck.

Capacity is 303 L (80 gal).

TX,45,FF2359 -19-12MAY93-1/1

00
0004
4

Diesel Engine Oil

AIR TEMPERATURE RANGE												
Fahrenheit (F)	-67	-40	-22	-4	.14	32	50	68	86	104	122	
Celsius (C)	-55	-40	-30	-20	-10	0	10	20	30	40	50	
								SAE 40				
							SAE 30					
						SAE 15W-40						
						SAE 10W-40						
					SAE 5W-30							
		SAE 0W-30 (ARTIC OIL)										

T101239 -19-22MAY96

Use oil viscosity based on the expected air temperature range during the period between oil changes.

John Deere PLUS-50™ engine oil is preferred.

If John Deere PLUS-50™ engine oil and a John Deere oil filter are used, the service interval for oil and filter changes may be extended by 50 hours.

John Deere TORQ-GARD SUPREME® oil is also recommended.

Other oils may be used if they meet one or more of the following:

- John Deere UNI-GARD™
- API Service Classification CG-4
- API Service Classification CF-4
- API Service Classification CE
- CCMC Specification D5 and Mercedes Benz MB228.3
- CCMC Specification D4 and Mercedes Benz MB228.1

Multi-viscosity diesel engine oils are preferred.

If diesel fuel with sulfur content greater than 0.5% is used, reduce the service interval by 50%.

*PLUS-50 is a trademark of Deere & Company.
TORQ-GARD SUPREME is a registered trademark of Deere & Company.
UNI-GARD is a trademark of Deere & Company.*

Hydraulic Oil

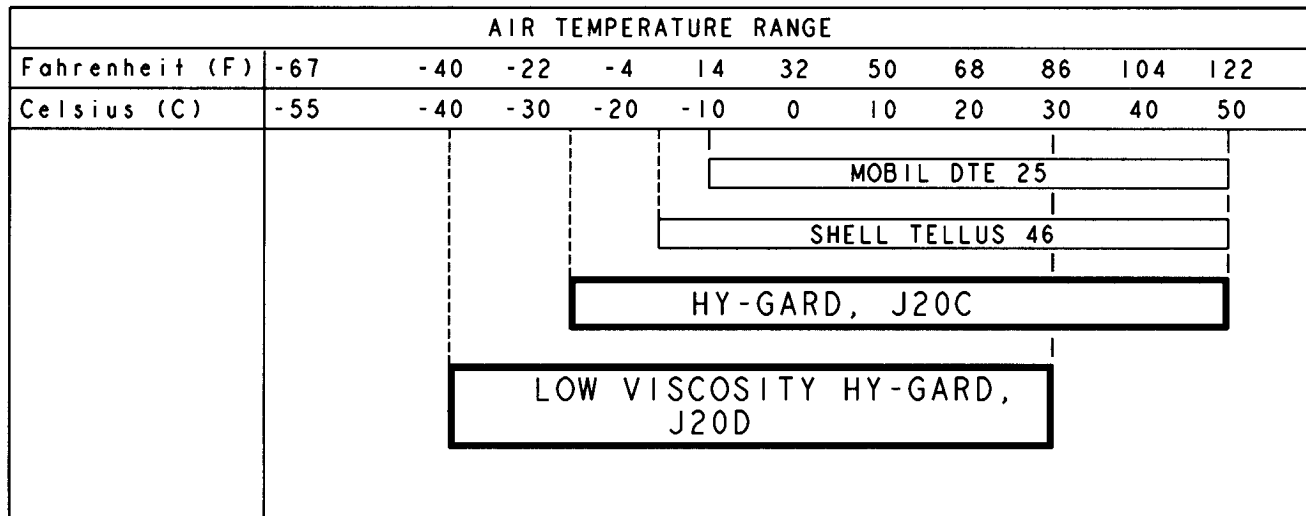

T8508AD -19-27JUN95

Depending upon the expected air temperature range between oil changes, use oil viscosity shown on the temperature chart above.

The following oils may be used.

- John Deere HY-GARD® Transmission and Hydraulic Oils.
- You may also use other oils meeting John Deere Standard J20C or J20D.

Manufacturer	Oil
Mobil	DTE 25
Shell	Tellus 46
Caltex Oil	Rando Oil HD46
Texaco Inc.	Rando Oil HD46
Chevron U.S.A. Inc.	Chevron AW46
Esso Standard Oil	NUTO H46

HY-GARD is a registered trademark of Deere & Company.

TX,45,DH3705 -19-30JUN95-1/1

Propel Gearbox Oil

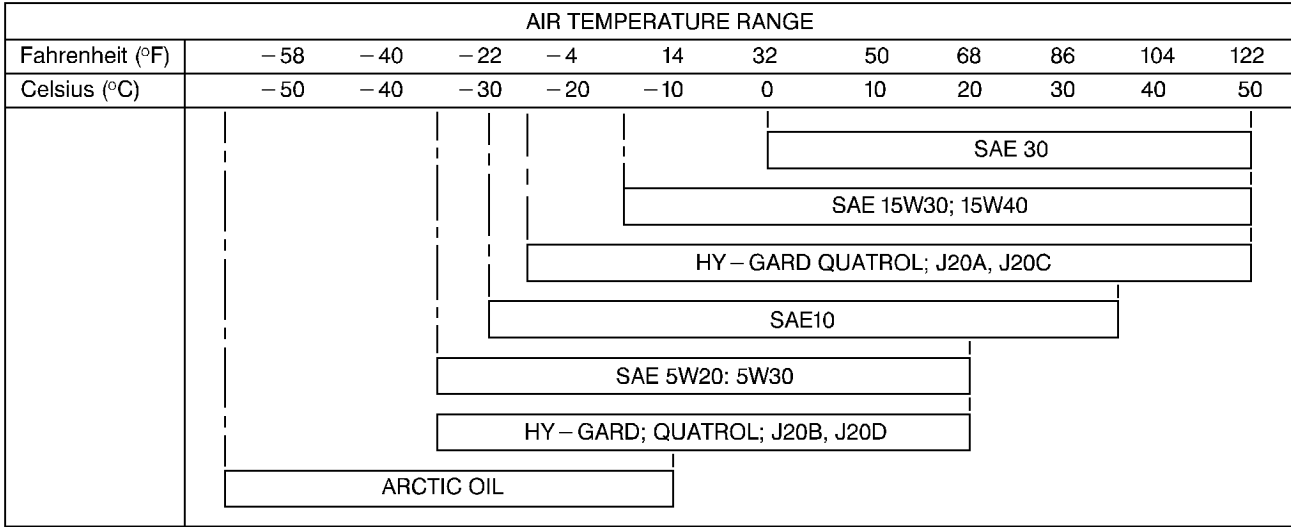

T110205

Depending upon the expected air temperature range between oil changes, use oil viscosity shown on the temperature chart above.

The following oils are recommended:

- Oil meeting John Deere Standard J20A or J20C
- John Deere API GL-5 Gear Oil
- Oil meeting API Service GL-5 (MIL-L-2105B or MIL-L-2105C)
- Oil meeting MIL-L-10324A may be used as arctic oil.

T110205 -19-25JUN97

TX,45,DT5027 -19-09JUN97-1/1

Track Roller, Front Idler, And Carrier Roller Oil

Use SAE 30 oil meeting API Service GL-5 (MIL-L-2105B or MIL-L-2105C).

TX,45,DH5142 -19-09AUG96-1/1

Track Adjuster, Working Tool Pivot, Swing Bearing, And Swing Bearing Gear Grease

		AIR TEMPERATURE RANGE									
Fahrenheit (°F)	-67	-40	-22	-4	14	32	50	68	86	104	122
Celsius (°C)	-55	-40	-30	-20	-10	0	10	20	30	40	50
		NLGI NO. 2									
		GREASE-GARD									
		JOHN DEERE MOLY HIGH TEMP. EP									
		JOHN DEERE HIGH TEMP. /EP									
		NLGI NO. 1									
		NLGI NO. 0									
		ARTIC GREASE									

T8358A1 ©

T8358A1 -19-27MAR95

Use grease based on NLGI consistency numbers and the expected air temperature range during the service interval.

- John Deere HIGH TEMPERATURE EP GREASE
- John Deere GREASE-GARD®

The following greases are preferred:

- John Deere MOLY HIGH TEMPERATURE EP GREASE

Other greases may be used if they meet NLGI Performance Classification GC-LB.

GREASE-GARD is a registered trademark of Deere & Company.

TX,45,DH5078 -19-01JUL96-1/1

Oil Filters

Filtration of oils is critical to proper operation and lubrication.

Always change filters regularly as specified in this manual.

Use filters meeting John Deere performance specifications.

DX,FILT -19-18MAR96-1/1

*Fuels And Lubricants*00
0004
8**Lubricant Storage**

Your equipment can operate at top efficiency only when clean lubricants are used.

Use clean containers to handle all lubricants.

Whenever possible, store lubricants and containers in an area protected from dust, moisture, and other contamination. Store containers on their side to avoid water and dirt accumulation.

Make certain that all containers are properly marked to identify their contents.

Properly dispose of all old containers and any residual lubricant they may contain.

DX,LUBST -19-18MAR96-1/1

Alternative and Synthetic Lubricants

Conditions in certain geographical areas may require lubricant recommendations different from those printed in this manual.

Some John Deere brand coolants and lubricants may not be available in your location.

Consult your John Deere dealer to obtain information and recommendations.

Synthetic lubricants may be used if they meet the performance requirements as shown in this manual.

The temperature limits and service intervals shown in this manual apply to both conventional and synthetic oils.

Re—refined base stock products may be used if the finished lubricant meets the performance requirements.

DX,ALTER -19-18MAR96-1/1

Mixing of Lubricants

In general, avoid mixing different brands or types of oil. Oil manufacturers blend additives in their oils to meet certain specifications and performance requirements.

Consult your John Deere dealer to obtain specific information and recommendations.

Mixing different oils can interfere with the proper functioning of these additives and degrade lubricant performance.

DX,LUBMIX -19-18MAR96-1/1

Fuels And Lubricants

00
0004
10

Section 01

Tracks

01

Contents

	Page
Group 0130—Track System	
Service Equipment And Tools	01-0130-1
Other Material	01-0130-3
Specifications	01-0130-4
Track Guide	
Remove and Install	01-0130-6
Lower Track Roller	
Measure Wear	01-0130-8
Remove and Install	01-0130-9
Disassemble and Assemble.	01-0130-11
Test for Oil Leakage	01-0130-15
Metal Face Seals	
Inspect.	01-0130-16
Upper Track Roller	
Measure Wear	01-0130-17
Remove and Install	01-0130-18
Disassemble and Assemble.	01-0130-19
Track Shoe	
Measure Grouser Wear	01-0130-22
Remove and Install	01-0130-23
Track Chain	
Measure Wear	01-0130-24
Measure Track Chain Bushing Wear	01-0130-25
Measure Track Chain Pitch.	01-0130-26
Track Chain	
Remove	01-0130-27
Install.	01-0130-29
Disassemble and Assemble.	01-0130-30
Disassemble and Assemble to Replace	
Broken Part	01-0130-30
Track Sag	
Measure and Adjust.	01-0130-32
Sprocket	
Remove and Install	01-0130-34
Front Idler	
Measure Wear	01-0130-36
Remove and Install	01-0130-37
Disassemble	01-0130-39
Assemble.	01-0130-40
Test for Oil Leakage	01-0130-42
Track Adjuster Cylinder and Recoil Spring	
Remove and Install	01-0130-43
Recoil Spring	
Disassemble and Assemble.	01-0130-44
Track Adjuster Cylinder	
Disassemble and Assemble.	01-0130-47

Contents

01

Service Equipment And Tools

NOTE: Order tools from the U.S. SERVICE-GARD™ Catalog or from the European Microfiche Tool Catalog (MTC). Some tools may be available from a local supplier.

SERVICE-GARD is a trademark of Deere & Company.

TX,0130,AB436 -19-12APR95-1/3

17-1/2 and 30 Ton Puller Set

Used to remove brackets and bushings from track roller and front idler.

Disk Driver Set

Used to install bushings into track roller and front idler.

Rubber Stopper/Leak Detector Kit Hoses 0—400 kPa (0—4 bar)(0—60 psi) Gauge Snubber (Needle) Valve Air Pressure Regulator D05361ST

Used to test track rollers and front idlers for leakage.

445 kN (50 Ton) or 890 kN (100 Ton) Master Pin Pusher

Used to remove and install master pin in track chain.

Depth Gauge Caliper Tape Measure¹

Used to measure undercarriage components for wear.

¹Tools are available in JT05518 or JT05523 Undercarriage Inspection Service Tool Kit.

Continued on next page

TX,0130,AB436 -19-12APR95-2/3

Track System

Track Recoil Spring Disassembly and Assembly
Tool¹. ST4920

Used to compress recoil spring in track adjuster repair.

Track Recoil Spring Disassembly And Assembly Guard
Tool¹. DFT1087

Used with ST4920 Track Recoil Spring Disassembly And
Assembly Tool.

Spacer¹. DFT1111

Used to install between top plate and recoil spring retainer
plate to allow access to spring pin in nut.

Spacer¹. DFT1110

Used to install on bottom plate to apply force to spring
flange on cylinder.

¹Fabricated tool, dealer made. (See Section 99 for instruction to make
tool.)

01
0130
2

Track System

Other Material

Number	Name	Use
PT569 (U.S.)	John Deere NEVER-SEEZ® Lubricant	Apply to spring pin, bracket bore, and end of shaft for track roller and front idler.
T43512 (U.S.) TY9473 (Canadian) 242 (LOCTITE®)	Thread Lock and Sealer (Medium Strength) Products	To be applied to threads of plug for upper track roller and front idler.
TY9370 (U.S.) TY9477 (Canadian) 242 (LOCTITE®)	Thread Lock and Sealer (Medium Strength) Products	To be applied to threads of plug for upper track roller and front idler.
T43513 or TY9371 (U.S.)	John Deere Thread Lock and Sealer (High Strength)	Apply to threads of cap screws for sprocket.
TY6305 (U.S.) TY9485 (Canadian) 764 (LOCTITE®)	Clean and Cure Primer Products	Used to clean and cure surface prior to application of adhesives and sealants.

01
0130
3

NEVER-SEEZ is a registered trademark of the Emhart Chemical Group.
LOCTITE is a registered trademark of Loctite Corp.

TX,0130,AB437 -19-21AUG97-1/1

Track System

Specifications

Item	Measurement	Specification
Track Guide-to-Undercarriage Cap Screw	Torque	325 N•m (240 lb-ft)
Lower Track Roller:		
Roller Tread	New Diameter Minimum Used Diameter	150 mm (5.91 in.) 135 mm (5.31 in.)
Roller Weight	Approximate Weight	34 kg (75 lb)
Roller-to-Frame Cap Screw	Torque	325 N•m (240 lb-ft)
Leakage Test	Pressure	110 ± 28 kPa (1.1 ± 0.3 bar) (16 ± 4 psi) for a minimum of 30 seconds
Upper Track Roller:		
Roller Tread	New Diameter Minimum Used Diameter	120 mm (4.70 in.) 108 mm (4.25 in.)
Roller-to-Undercarriage Mount Cap Screw	Torque	272 N•m (200 lb-ft)
Thrust Washer-to-Axle Cap Screw	Torque	42 N•m (31 lb-ft)
Cover-to-Roller Cap Screw	Torque	72 N•m (55 lb-ft)
Track Shoe:		
Grouser	New Height Minimum Used Height	25.5 mm (1.00 in.) 11 mm (0.43 in.)
800 mm (31 in.) Shoe	Approximate Weight	23 kg (50 lb)
Shoe-to-Link Cap Screw	Torque	298 N•m (220 lb-ft) plus 1/2 (180°) turn
Track Chain:		
Link	New Height Minimum Used Height	106 mm (4.17 in.) 98 mm (3.86 in.)

Continued on next page

TX,0130,AB438 -19-12APR95-1/2

Track System

Item	Measurement	Specification
Bushing	New OD	58.7 mm (2.31 in.)
	Minimum Used OD	54.5 mm (2.15 in.)
Pitch	New Length	760 mm (29.92 in.)
	Maximum Used Length	773 mm (30.43 in.)
Track Chain	Approximate Weight	1600 kg (3530 lb)
Shoe-to-Link Cap Screw	Torque (New)	298 N•m (220 lb-ft) plus 1/2 (180°) turn
Track Sag	Distance	305—325 mm (12.0—12.75 in.)
Sprocket:		
Weight	Approximate Weight	34 kg (75 lb)
Sprocket-to-Gearbox Cap Screw	Torque	540 N•m (400 lb-ft)
Front Idler:		
Center Flange	New Height	19 mm (0.75 in.)
	Maximum Used Height	25 mm (0.98 in.)
Weight	Approximate Weight	300 kg (660 lb)
Yoke-to-Idler Bracket Cap Screw	Torque	90 N•m (65 lb-ft)
Leakage Test	Pressure	110 ± 28 kPa (1.1 ± 0.3 bar) (16 ± 4 psi) for a minimum of 30 seconds
Track Adjuster Cylinder and Recoil Spring-to-Yoke Cap Screw	Torque	90 N•m (65 lb-ft)

TX,0130,AB438 -19-12APR95-2/2

01
0130
5

Track System

Remove And Install Track Guide

1. Swing upperstructure 90° and lower bucket to raise track off ground. Keep angle between boom and arm 90°—110° and position round side of bucket on ground.

Place support stands under the undercarriage.

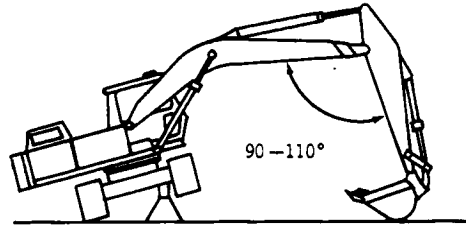

T6876FG -UN-06DEC88

TX,0130,AB440 -19-21FEB92-1/3

CAUTION: Grease in track adjusting cylinder is under extreme pressure. DO NOT remove lubrication fittings to release track tension.

2. Loosen track by loosening valve (C) at access hole (A) to release grease pressure. Grease will escape from grease relief passage (D).

- A—Access Hole
- B—Lubrication Fitting
- C—Valve
- D—Grease Relief Fitting

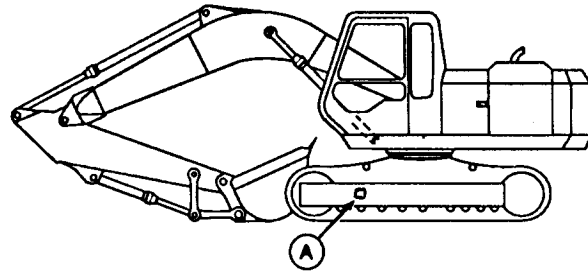

T7584AC -UN-29JUL91

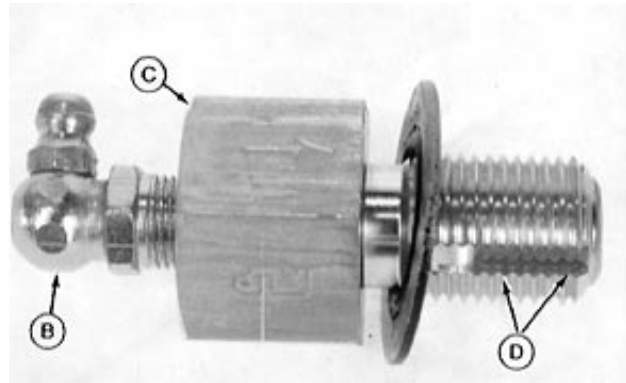

T7584AD -UN-29JUL91

Continued on next page

TX,0130,AB440 -19-21FEB92-2/3

01
0130
6

Track System

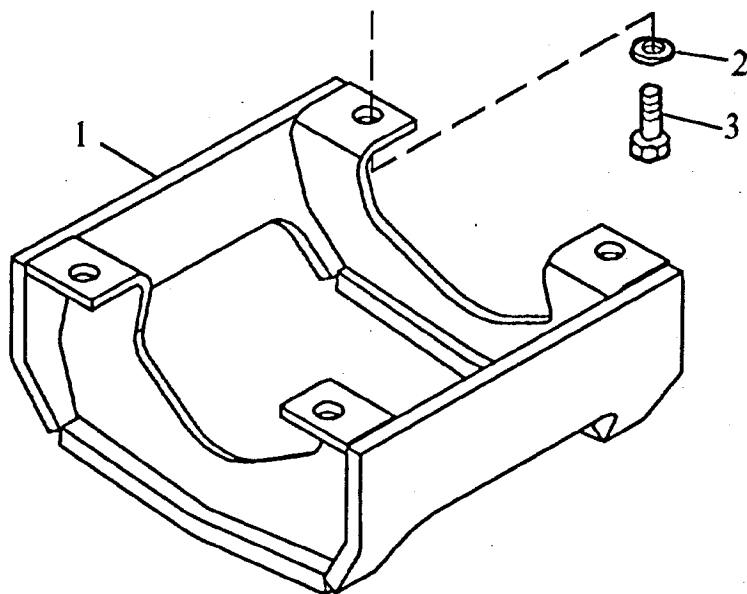

TP32961

TP32961 -UN-01JAN94

01
0130
7

3. Remove cap screws (3) and washers (2) to remove track guide (1) from undercarriage.
4. Install track guide so it is centered. Install washers and cap screws. Tighten cap screws to 325 N•m (240 lb-ft).

Specification

Track Guide-to-Undercarriage
Cap Screw—Torque 325 N•m (240 lb-ft)

5. Adjust track sag. (See Measure and Adjust Track Sag procedure in this group.)

TX,0130,AB440 -19-21FEB92-3/3

Track System

Measure Lower Track Roller Wear

SPECIFICATIONS	
Roller Tread (Minimum Used) Diameter	135 mm (5.31 in.)
Roller Tread (New) Diameter	150 mm (5.91 in.)

SERVICE EQUIPMENT AND TOOLS
JT05518 or JT05523 Undercarriage Inspection Service Tool Kit

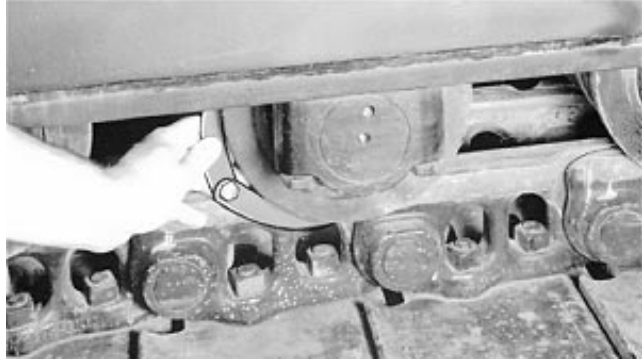

T87973 -UN-08NOV88

Minimum used is the maximum allowable wear for rebuilding roller tread.

Specification

Roller Tread (Minimum Used)—Diameter 135 mm (5.31 in.)

Under some conditions roller wear can be uneven. If wear is uneven, rollers may be interchanged to even out the wear.

Measure roller tread diameter using a caliper such as the JT05519 Special Roller Caliper from JT05518 or JT05523 Undercarriage Inspection Service Tool Kit.

Specification

Roller Tread (New)—Diameter 150 mm (5.91 in.)
 Roller Tread (Minimum Used)—Diameter 135 mm (5.31 in.)

NOTE: See Undercarriage Appraisal Manual SP-326 for additional information.

TX,902015,VV301 -19-21FEB92-1/1

01
0130
8

Track System

Remove And Install Lower Track Roller



CAUTION: Grease in track adjusting cylinder is under extreme pressure. **DO NOT** remove lubrication fittings to release track tension.

1. Loosen track by loosening valve (C) at access hole (A) to release grease pressure. Grease will escape from grease relief passage (D).

A—Access Hole
B—Lubrication Fitting
C—Valve
D—Grease Relief Passage

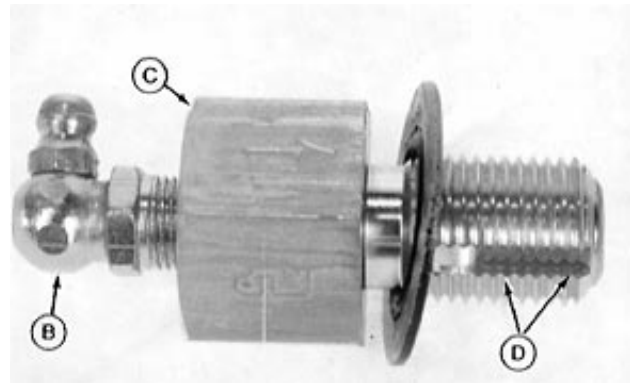
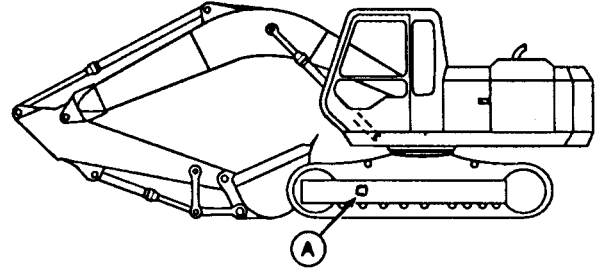

T7584AC -UN-29JUL91

T7584AD -UN-29JUL91

01
0130
9

Continued on next page

TX,0130,AB545 -19-21FEB92-1/2

Track System

2. Remove four cap screws and washers for each roller to be removed.
3. Lift side of machine just high enough to permit roller removal.

⚠ CAUTION: To prevent accidental lowering of machine, put wooden blocks between frame and track.

4. Put wooden blocks between frame and track to prevent accidental lowering of machine.

⚠ CAUTION: The approximate weight of lower track roller is 34 kg (75 lb).

Specification

Roller—Approximate Weight 34 kg (75 lb)

5. Remove roller.
6. Repair or replace parts. (See procedure in this group.)
7. Install roller on track chain with flat surface of brackets toward frame.
8. Carefully lower machine just enough so cap screws can be installed through bracket and into frame.
9. Tighten cap screws to 325 N•m (240 lb-ft).

Specification

Roller-to-Frame Cap Screws—
Torque 325 N•m (240 lb-ft)

After tightening cap screws, roller must turn freely by hand.

10. Adjust track sag. (See Measure and Adjust Track Sag procedure in this group.)

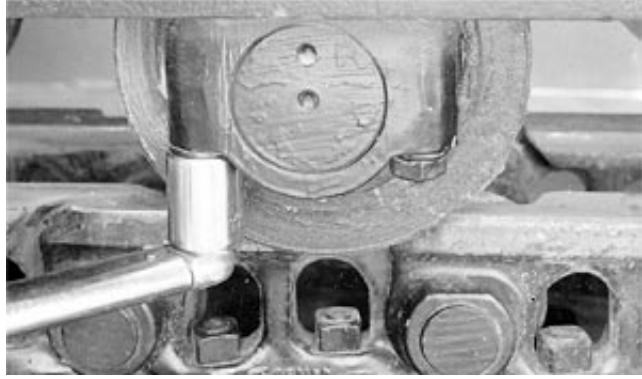

T82858 -UN-08NOV88

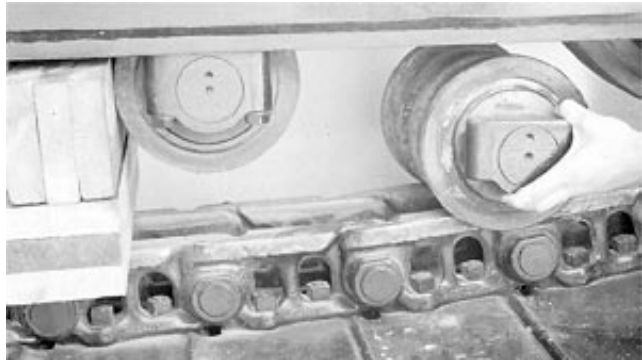

T82857 -UN-08NOV88

TX,0130,AB545 -19-21FEB92-2/2

01
0130
10

Track System

Disassemble And Assemble Lower Track Roller

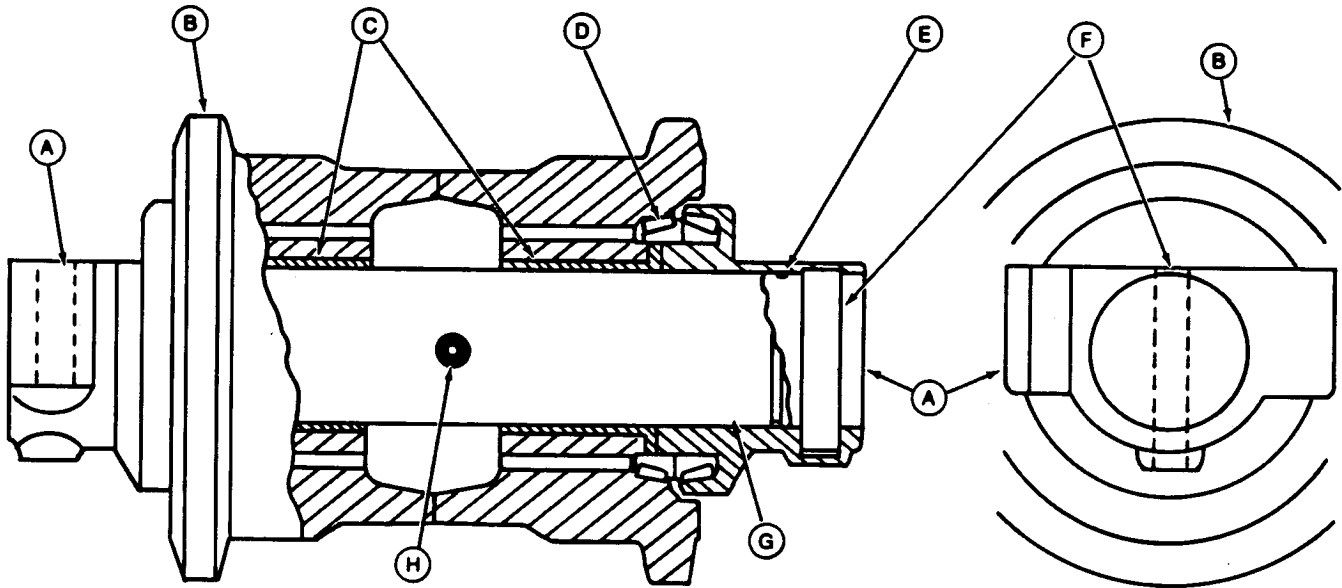

01
0130
11

T7681BB -UN-03FEB92

1. Remove plug (H) and drain oil.
2. Remove spring pin (F) from each support (A).

- A—Support (2 used)
- B—Roller with Bushings
- C—Bushing (2 used)
- D—Metal Face Seal (2 used)
- E—O-Ring (2 used)
- F—Spring Pin (2 used)
- G—Shaft
- H—Plug with O-ring

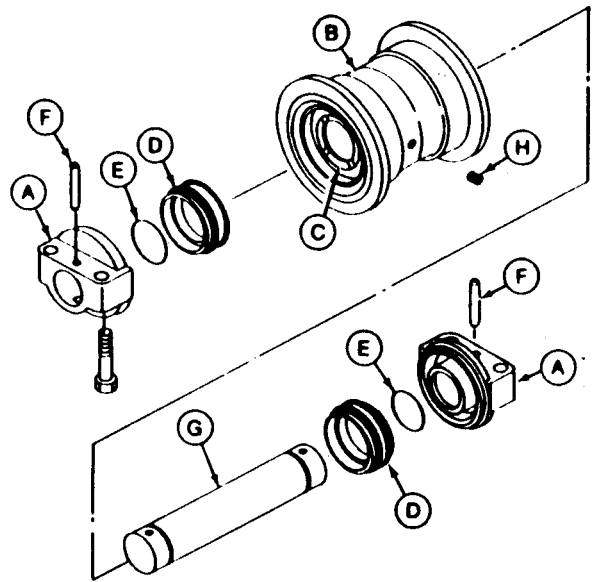

T7681BC -UN-03FEB92

Continued on next page

TX,0130,AB445 -19-21FEB92-1/6

Track System

3. Remove support (C) using puller (A) and adapters (B) from 17-1/2 and 30 ton puller set.

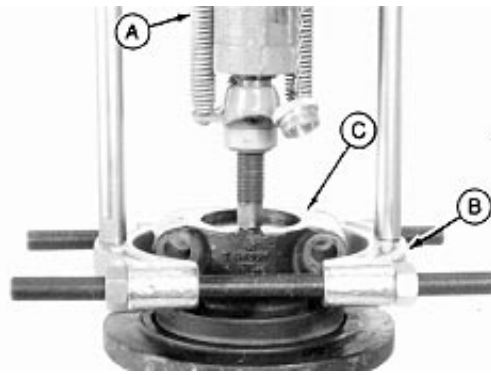

T82836 -UN-08NOV/88

TX,0130,AB445 -19-21FEB92-2/6

IMPORTANT: Metal face seals can be reused if they are not worn or damaged. Keep seals together as a set because of wear patterns on seal ring faces.

4. Remove metal face seal (D) from support (A) and roller (B).
5. Remove second support (A) from shaft (G).
6. Remove metal face seal (D) from support (A) and roller (B) and keep halves together.
7. Remove O-rings (E) from shaft (G).
8. Inspect the bushings for scoring or excessive wear. Also inspect the shaft.

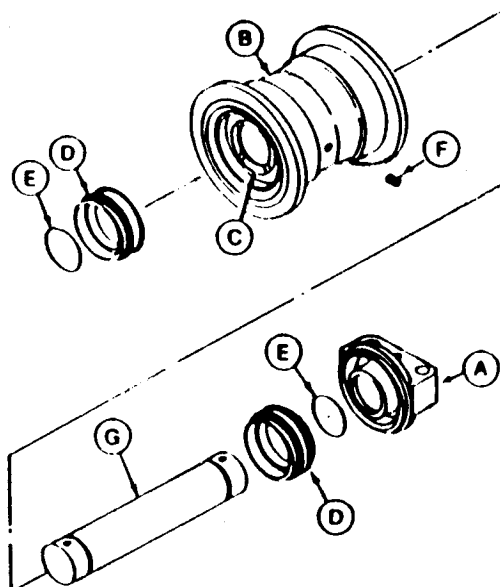

T7681FU -UN-23FEB92

- A—Support
- B—Roller with Bushings
- C—Bushing (2 used)
- D—Metal Face Seal (2 used)
- E—O-Ring (2 used)
- F—Plug with O-Ring
- G—Shaft

Continued on next page

TX,0130,AB445 -19-21FEB92-3/6

Track System

NOTE: Only remove bushings if replacement is necessary.

9. Remove bushing using a 2-jaw puller and adapters from 17-1/2 and 30 ton puller set.
10. Repair or replace parts.
11. Inspect metal face seals. (See procedure in this group.)

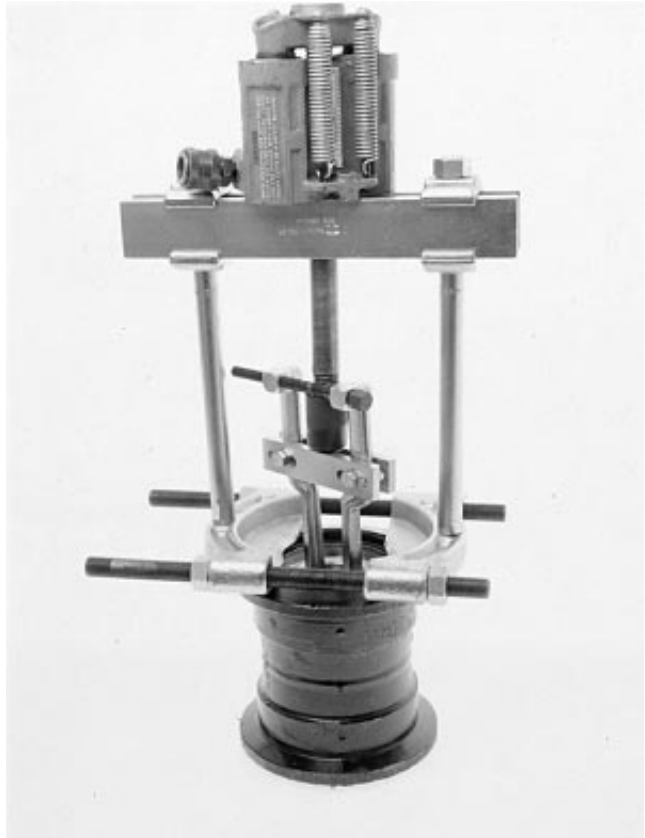
01
0130
13

T6920AB -UN-25OCT88

Continued on next page

TX,0130,AB445 -19-21FEB92-4/6

Track System

12. Install O-rings (E) on shaft (G).
13. Apply a thin layer of NEVER-SEEZ® lubricant (or an equivalent) on shaft from O-ring groove to each end and to the bore in each support.
14. Install shaft (G) in one support (A). Install one spring pin (F) even with flat on support.

IMPORTANT: Metal face seal rubber rings and seal surfaces in supports must be clean, dry and oil free so rubber seals will not slip when roller is turning.

15. Thoroughly clean support surfaces and rubber rings of metal face seals using volatile, non-petroleum base solvent and lint-free tissues.
16. Install half of metal face seal (D) on shaft and into support (A) seat. Apply a thin film of oil to seal ring face.
17. Install other half of seal in clean seat area of roller (B). Apply a thin film of oil to seal ring face.
18. Install roller on shaft (G), then install half of second metal face seal in clean roller seat. Apply a thin film of oil to seal ring face.
19. Install other half of second metal face seal (D) in clean seat on support, then install support (A) on shaft. Apply a thin film of oil to seal ring face.
20. Install spring pin (F) with NEVER-SEEZ® Lubricant or an equivalent in bore of support (A) and shaft (G).

A slight press is necessary to overcome the light "spring action" of the metal face seal rubber rings.

21. Fill roller with recommended lubricant. Capacity is 0.38 L (13 oz). (See Track Roller and Idler Oil in Group 0004.)
22. Apply thread lock and sealer (medium strength) to oil in plug (H) and install in roller.

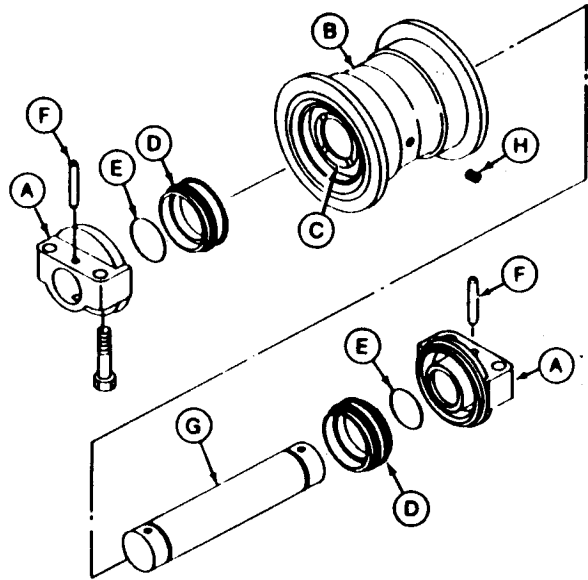

- A—Support (2 used)
 B—Roller with Bushings
 C—Bushing (2 used)
 D—Metal Face Seal (2 used)
 E—O-Ring (2 used)
 F—Spring Pin
 G—Shaft
 H—Plug with O-Ring

T7681BC -UN-03FEB92

Track System

23. Turn roller 10 turns and check for oil leakage.

TX,0130,AB445 -19-21FEB92-6/6

01
0130
15

Test Lower Track Roller For Oil Leakage

SPECIFICATIONS

Leakage Test Pressure	110 ± 28 kPa (1.1 ± 0.3 bar) (16 ± 4 psi)
-----------------------	---

SERVICE EQUIPMENT AND TOOLS

D05361ST Rubber Stopper/Leak Detector Kit Hoses 0—400 kPa (0—4 bar)(0—60 psi) Gauge Snubber (Needle) Valve Air Pressure Regulator

1. Hold the shaft and turn shell several turns to seat metal face seals.
2. Remove the plug.
3. Install parts (A—F) as shown. Plug, barbed adapter and connector are from a leak detector kit such as the D05361ST Rubber Stopper/Leak Detector Kit.
4. Holding plug so it is not pushed out, slowly pressurize oil cavity to 110 ± 28 kPa (1.1 ± 0.3 bar) (16 ± 4 psi) using air.

Specification

Leakage Test—Pressure..... 110 ± 28 kPa (1.1 ± 0.3 bar) (16 ± 4 psi)

5. Close valve and wait for a minimum of 30 seconds. Check for oil leakage. Check gauge to see if air pressure has decreased.
6. If there is leakage, disassemble roller and replace parts as necessary.

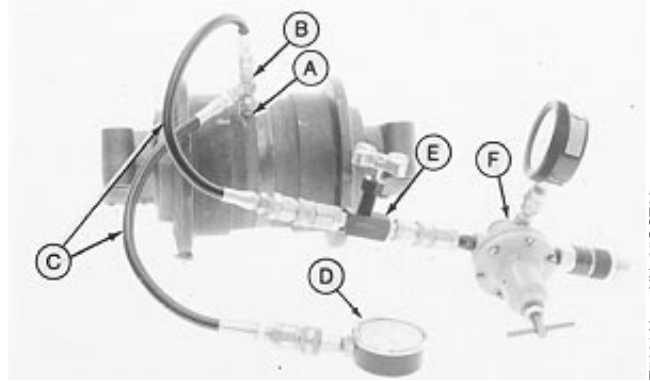

- A—Plug, Barbed Adapter and Connector
- B—JT03001 Tee Fitting 7/16-20M 37° x 7/16-20F 37° SW x 7/16-20M 37°
- C—Hose (2 used)
- D—Pressure Gauge
- E—Snubber (Needle) Valve
- F—Air Pressure Regulator

T5921AL -JUN-25OCT88

TX,0130,AB500 -19-21FEB92-1/1

Track System

Inspect Metal Face Seals

1. Inspect for the following conditions to determine if seals can be reused:

- a. The narrow, highly polished sealing area (E) must be in the outer half of seal ring face (D).
- b. Sealing area must be uniform and concentric with the ID and OD of seal ring (A).
- c. Sealing area must not be chipped, nicked, or scratched.

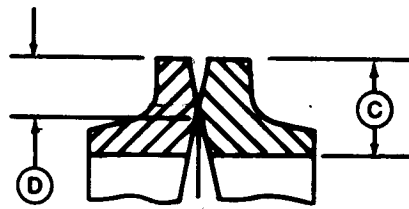
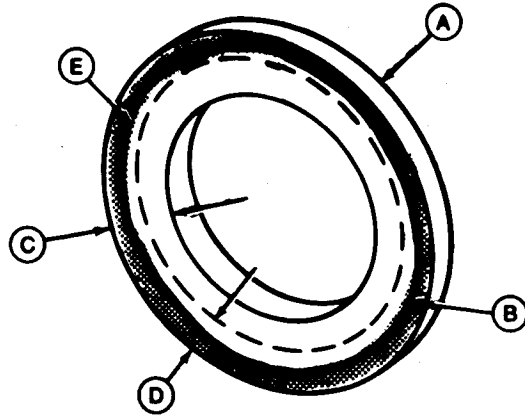

- A—Seal Ring
- B—Worn Area (shaded area)
- C—Seal Ring Face
- D—Outer Half of Seal Ring Face
- E—Sealing Area (dark line)

T85079 -UN-24AUG93

T47,0130,5939HQ -19-25AUG93-1/3

2. Illustration shows examples of worn seal rings (A).

I—Sealing area (D) is in inner half of seal ring face (C).

II—Sealing area (D) not concentric with ID and OD of seal ring.

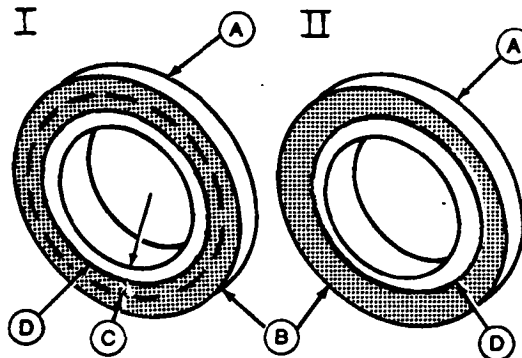

- A—Seal Ring
- B—Worn area (shaded area)
- C—Inner Half of Seal Ring Face
- D—Sealing Area (dark line)

T85080 -UN-05DEC96

Continued on next page

T47,0130,5939HQ -19-25AUG93-2/3

01
0130
16

Track System

3. Clean reusable seals by removing all foreign material from seal rings, except seal face (A), using a scraper or a stiff bristled fiber brush.
4. Wash seal rings and O-rings using a volatile, non-petroleum base solvent to remove all oil. Thoroughly dry parts using a lint-free tissue.

Apply a thin film of oil to seal ring face. Put face of seal rings together and hold using tape.

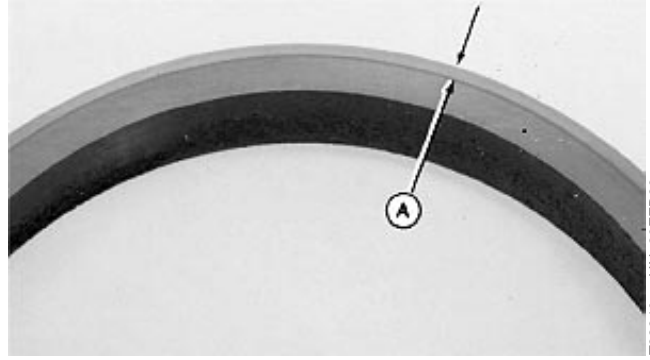

01
0130
17

T82840 -UN-23FEB89

T47.0130.5939HQ -19-25AUG93-3/3

Measure Upper Track Roller Wear

SPECIFICATIONS	
Roller Tread (Minimum Used) Diameter	108 mm (4.25 in.)
Roller Tread (New) Diameter	120 mm (4.70 in.)

SERVICE EQUIPMENT AND TOOLS
JT05518 or JT05523 Undercarriage Inspection Service Tool Kit



Minimum used is the maximum allowable wear for rebuilding wear surface.

Specification

Roller Tread (Minimum Used)—
Diameter 108 mm (4.25 in.)

Measure roller tread diameter using a caliper such as the JT05519 Special Roller Caliper From JT05518 or JT05523 Undercarriage Inspection Service Tool Kit.

Specification

Roller Tread (New)—Diameter..... 120 mm (4.70 in.)
Roller Tread (Minimum Used)—
Diameter 108 mm (4.25 in.)

NOTE: See SP-326 Undercarriage Appraisal Manual for additional information.

T6813AQ -UN-29JAN98

TX,0130,GG238 -19-21FEB92-1/1

Track System

Remove And Install Upper Track Roller

1. Raise track just enough to allow carrier roller removal.

CAUTION: Support track to prevent accidental lowering of track.

2. Install wooden blocks between track links and frame.
3. Remove cap screws to remove carrier roller.
4. Install carrier roller. Tighten cap screws to 272 N•m (200 lb-ft).

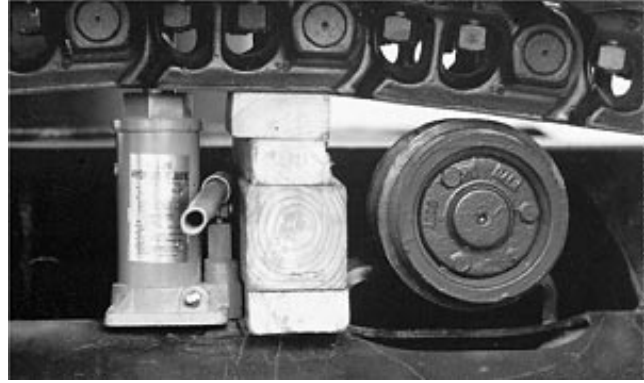

T6557DJ -UN-25OCT88

Specification

Roller-to-Undercarriage Mount
 Cap Screw—Torque..... 272 N•m (200 lb-ft)

5. Remove blocking.

TX,0130,AB448 -19-12APR95-1/1

01
 0130
 18

Track System

Disassemble And Assemble Upper Track Roller

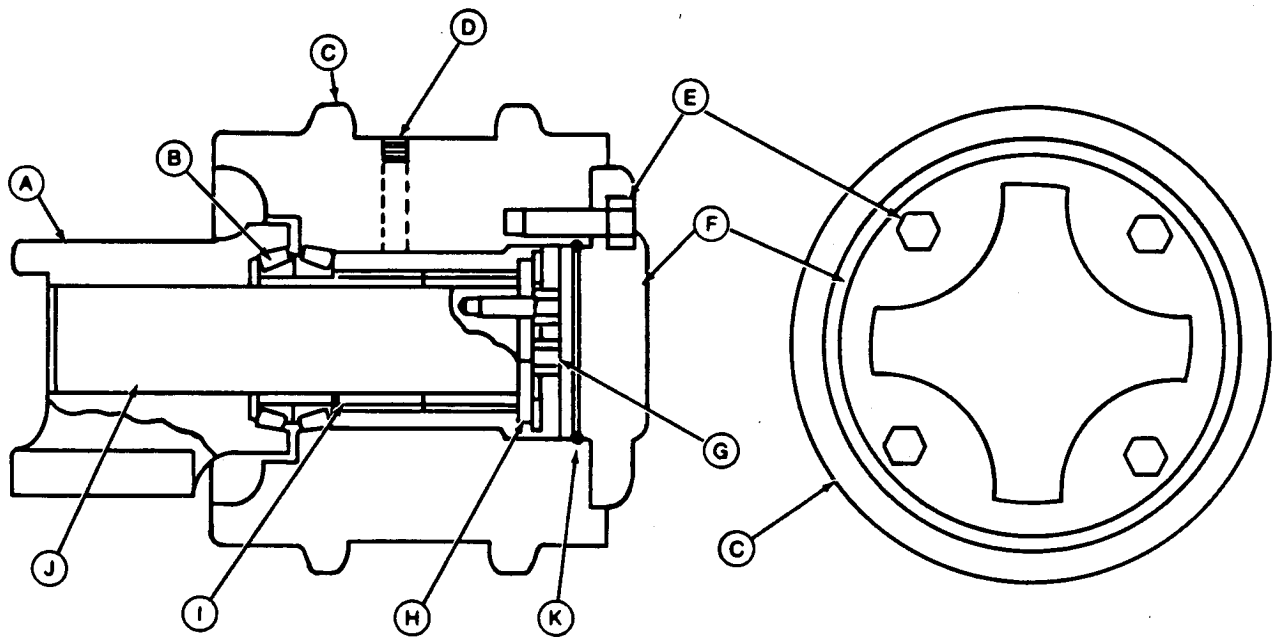

A—Support with Shaft
 B—Metal Face Seal
 C—Roller

D—Pipe Plug
 E—Cap Screw (4 used)
 F—Cover

G—Cap Screw (2 used)
 H—Thrust Washer
 I—Bushing (2 used)

J—Shaft
 K—O-Ring

Continued on next page

TX,0130,AB449 -19-21FEB92-1/4

01
 0130
 19

T7681BE -UN-03FEB92

Track System

1. Remove pipe plug (I) to drain oil.
2. Remove cap screws (G), then lightly pry cover (F) from roller (C). Remove O-ring (E) from cover.
3. Remove cap screws (H) and thrust washer (D).
4. Remove roller (C) from shaft.

IMPORTANT: Metal face seals can be reused if they are not worn or damaged. Keep seals together as a set because of wear pattern on seal ring faces.

5. Remove metal face seal (B) and rubber ring (A) from roller and support (K).
6. Keep seal rings (B and A) together as a set (J).
7. Inspect metal face seal. (See procedure in this group.)

IMPORTANT: Rubber rings and seat surfaces for rubber rings must be clean, dry, and oil free so rubber rings do not slip when roller is turning.

8. Thoroughly clean the roller and seat surfaces in roller, support and seal rings using volatile, non-petroleum base solvent and lint-free tissues.

- A—Seal Rubber Ring
- B—Seal Ring (2 used)
- C—Roller with Bushings
- D—Thrust Washer
- E—O-Ring
- F—Cover
- G—Cap Screw (4 used)
- H—Cap Screw (2 used)
- I—Pipe Plug
- J—Metal Face Seal
- K—Support with Shaft

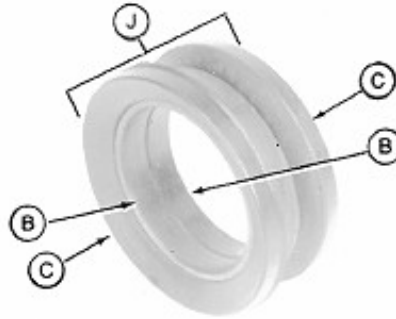

T7681BF -JUN-16JAN92

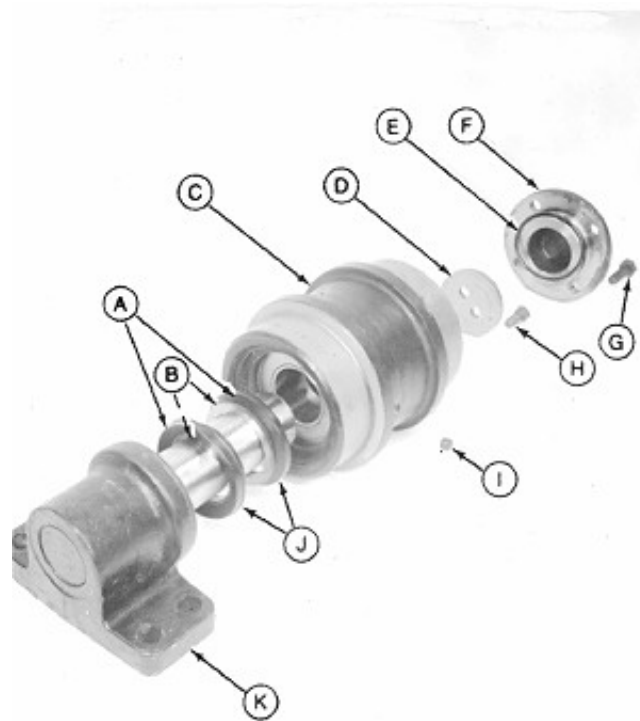

T7681BG -JUN-16JAN92

Continued on next page

TX,0130,AB449 -19-21FEB92-2/4

Track System

9. Install half of metal face seal with rubber ring (A) in seat (B) of support (C) and roller.
10. Wipe any finger prints and foreign material off seal ring face using a lint-free tissue.
11. Apply a thin film of oil on each seal ring face. DO NOT apply any oil on rubber rings.

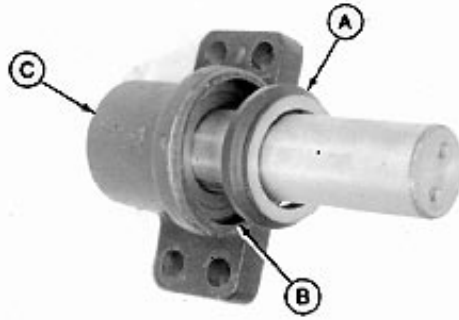

TX,0130,AB449 -19-21FEB92-3/4

T7681BH -UN-16JAN92

01
0130
21

12. Install roller (A) on shaft.
13. With roller washer seat (B) up, apply a thin layer of oil on thrust washer. Install thrust washer (E) and cap screws. Tighten cap screws to 42 N•m (31 lb-ft).

Specification

Thrust Washer-to-Axle Cap Screw—Torque..... 42 N•m (31 lb-ft)

14. Install O-ring on cover. Install cover. Tighten cap screws to 72 N•m (55 lb-ft).

Specification

Cover-to-Roller Cap Screw—Torque 72 N•m (55 lb-ft)

15. Fill roller with oil. Capacity is 0.23 L (7.5 oz.). (See Track Roller and Idler Oil in Group 0004.)
16. Clean plug using cure and clean primer. Apply thread lock and sealer (medium strength). Install plug.
17. Turn roller 10 revolutions and check for oil leakage.

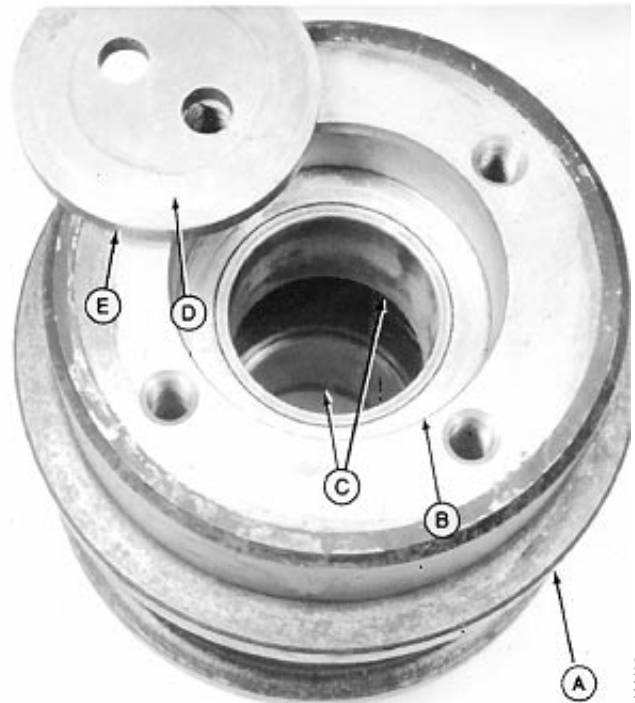

- A—Roller
- B—Roller Thrust Washer Seat
- C—Bushings
- D—Thrust Washer Face
- E—Thrust Washer

TX,0130,AB449 -19-21FEB92-4/4

T7681BJ -UN-16JAN92

Track System

Measure Track Shoe Grouser Wear

SPECIFICATIONS	
Grouser (Minimum Used) Height	11.0 mm (0.43 in.)
Grouser (New) Height	25.5 mm (1.00 in.)

SERVICE EQUIPMENT AND TOOLS	
JT05518 or JT05523 Undercarriage Inspection Service Tool Kit	

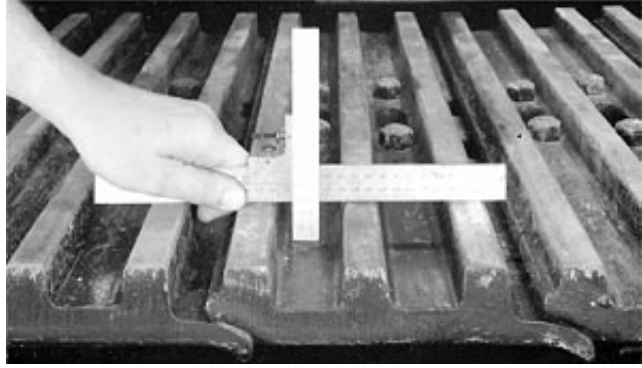

T82859 -JN-08NOV/88

Minimum used is the maximum allowable wear for rebuilding grouser bars with weld.

Specification

Grouser (Minimum Used)—Height..... 11.0 mm (0.43 in.)

Measure grouser height of several track shoes to find an average using a depth gauge such as the JT05521 200 mm Ruler, JT05534 Right Angle Attachment, and D05231ST 300 mm Ruler from JT05518 or JT05523 Undercarriage Inspection Service Tool Kit.

Specification

Grouser (New)—Height..... 25.5 mm (1.00 in.)
 Grouser (Minimum Used)—Height..... 11.0 mm (0.43 in.)

NOTE: See Undercarriage Appraisal Manual SP-326 for additional information.

TX,902015,VV303 -19-04MAY95-1/1

01
0130
22

Track System

Remove And Install Track Shoes

CAUTION: The approximate weight of 800 mm (31 in.) shoe is 23 kg (50 lb).

Specification

800 mm (31 in.) Shoe—Weight..... 23 kg (50 lb)

1. Remove four nuts and cap screws to remove shoe.
2. Before installing shoes, clean paint, dirt and debris from mounting surfaces of shoes and links.
3. Apply oil to cap screw threads and bearing surface on head before installing cap screws.
4. Install nuts so rounded corners (A) are against links and not the chamfered edge (B).
5. Starting at any cap screw, tighten cap screws in sequence shown, to 298 N•m (220 lb-ft) plus 1/2 (180°) turn.

Specification

Shoe-to-Link Cap Screws—
Torque 298 N•m (220 lb-ft) plus 1/2 (180°) turn



T82861 -UN-08NOV88



T82862 -UN-08NOV88

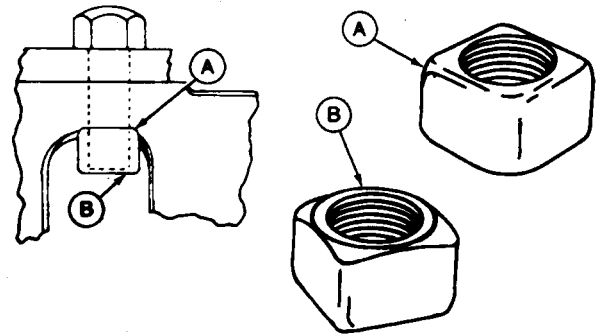

T6794AM -UN-23FEB89

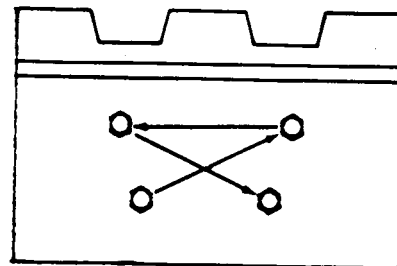

T6352AH -UN-23FEB89

01
0130
23

Track System

Measure Track Chain Link Wear

SPECIFICATIONS	
Link (Minimum Used) Height	98.0 mm (3.86 in.)
Link (New) Height	106.0 mm (4.17 in.)

SERVICE EQUIPMENT AND TOOLS	
JT05518 or JT05523 Undercarriage Inspection Service Tool Kit	

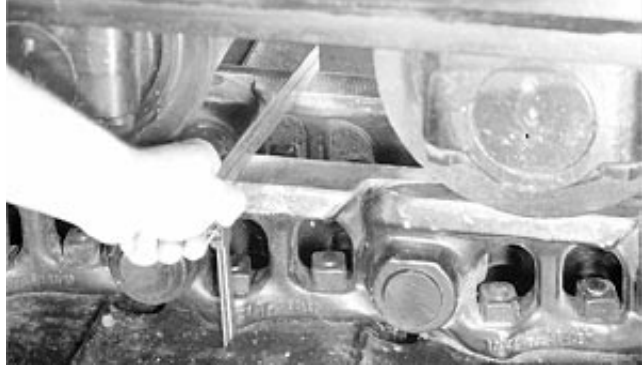

T82864 -UN-08NOV88

Minimum used is the maximum allowable wear for rebuilding links.

Specification

Link (Minimum Used)—Height 98.0 mm (3.86 in.)

Measure height of several links to find an average using a depth gauge such as the JT05521 200 mm Ruler, JT05534 Right Angle Attachment, and D05231ST 300 mm Ruler from JT05518 or JT05523 Undercarriage Inspection Service Tool Kit.

Specification

Link (New)—Height 106.0 mm (4.17 in.)
 Link (Minimum Used)—Height 98.0 mm (3.86 in.)

NOTE: See Undercarriage Appraisal Manual SP-326 for additional information.

TX,902015,VV300 -19-25FEB92-1/1

01
0130
24

Track System

Measure Track Chain Bushing Wear

SPECIFICATIONS	
Bushing (Minimum Used) OD	54.40 mm (2.15 in.)
Bushing (New) OD	58.70 mm (2.31 in.)

SERVICE EQUIPMENT AND TOOLS
JT05518 or JT05523 Undercarriage Inspection Service Tool Kit



01
 0130
 25
 T82865 -UN-08NOV88

Minimum used is the maximum allowable wear for turning pins and bushings.

Specification

Bushing (Minimum Used)—OD..... 54.40 mm (2.15 in.)

Measure bushing outer diameter at the two worn places using a caliper such as the D17524C1 100 mm Caliper from JT05518 or JT05523 Undercarriage Inspection Service Tool Kit.

Specification

Bushing (New)—OD 58.70 mm (2.31 in.)
 Bushing (Minimum Used)—OD..... 54.40 mm (2.15 in.)

NOTE: See Undercarriage Appraisal Manual SP-326 for additional information.

TX,902015,VV299 -19-25FEB92-1/1

Track System

Measure Track Chain Pitch

SPECIFICATIONS	
Track (Maximum Used) Pitch	773 mm (30.43 in.)
Track (New) Pitch	760 mm (29.92 in.)

SERVICE EQUIPMENT AND TOOLS	
JT05518 or JT05523 Undercarriage Inspection Service Tool Kit	

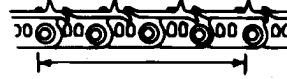

Maximum used is the maximum allowable wear for turning pins and bushings.

Specification

Track (Maximum Used)—Pitch 773 mm (30.43 in.)

1. Remove slack by putting a wooden block between sprocket and chain, then slowly move machine in reverse to tighten chain.
2. Measure pitch across several four link sections (A), except section on either side of master pin, to find average chain wear.

Specification

Track (Maximum Used)—Pitch 773 mm (30.43 in.)
 Track (New)—Pitch 760 mm (29.92 in.)

Use a tape measure such as the JT05520 Metric Tape from JT05518 or JT05523 Undercarriage Inspection Service Tool Kit.

NOTE: See Undercarriage Appraisal Manual SP-326 for additional information.

T6813AL -UN-29JAN98

01
0130
26

Track System

Remove Track Chain



CAUTION: Grease in track adjusting cylinder is under extreme pressure. **DO NOT** remove lubrication fittings to release track tension.

1. Loosen track by loosening valve (C) at access hole (A) to release grease pressure. Grease will escape from grease relief passage (D).

A—Access Hole
B—Lubrication Fitting
C—Valve
D—Grease Relief Fitting

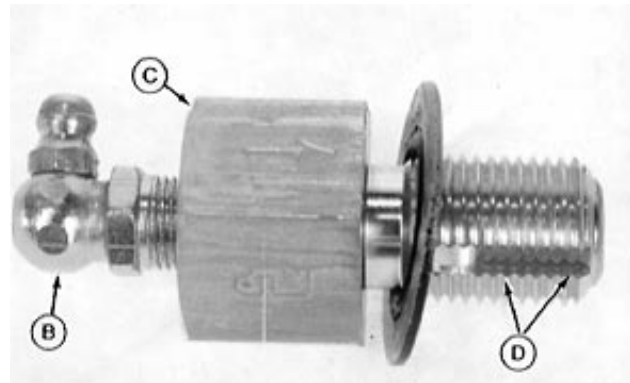
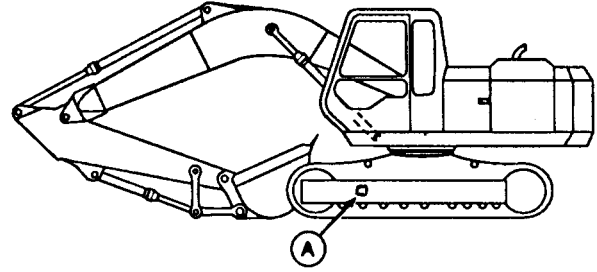
01
0130
27

T7584AC -UN-29JUL91

T7584AD -UN-29JUL91

TX,0130,AB552 -19-21FEB92-1/3

2. Move the track chain so master pin (identified by drill point in end of pin) is over idler.
3. Remove the track shoe on each side of pin.



Continued on next page

TX,0130,AB552 -19-21FEB92-2/3

T5922AS -UN-25OCT88

Track System

4. Remove master pin (B) from chain using a 445 kN (50 ton) or 890 kN (100 ton) master pin pusher and tools (A, C—E).
5. Put a wooden block under track so it does not fall when forcing pin is removed.
6. Remove spacer and disk springs from counterbore in each link.
7. Lift side of machine just enough so bottom of sprocket clears chain.

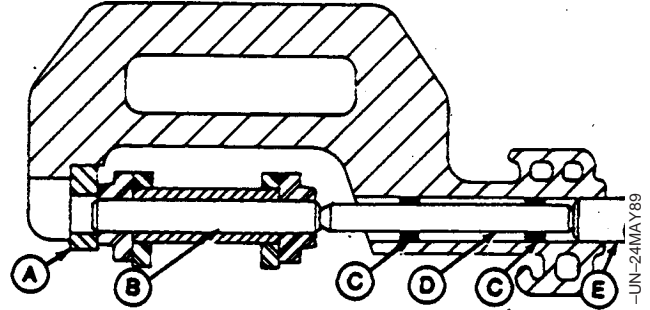

T5805AJ -UN-24MAY89

⚠ CAUTION: Approximate weight of chain with 800 mm (31 in.) shoes is 1600 kg (3530 lb).

Specification

Track Chain—Approximate Weight..... 1600 kg (3530 lb)

8. Slowly turn sprocket in reverse direction to remove track.

- A—Aligning Adapter
- B—Master Pin
- C—Aligning Bushing (2 used)
- D—Forcing Pin
- E—Rear Forcing Pin

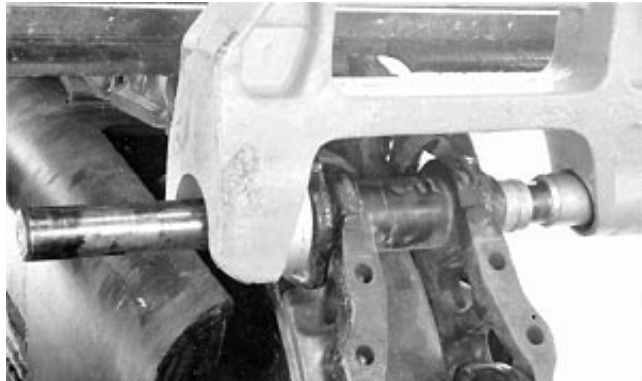

T82690 -UN-08NOV88

TX,0130,AB552 -19-21FEB92-3/3

01
0130
28

Track System

Install Track Chain

1. Install track chain so section on ground has the pin boss on links toward rear of machine.
2. Put end of chain on the sprocket, then slowly turn sprocket in forward direction to pull chain across top of frame to the front idler.
3. Install a spacer and disk springs into counterbore of each link.
4. Pull ends of chain together. Install guide pin (D) to align bores and hold chain together so master pin (C) can be installed using master pin pusher.
5. Clean mounting surfaces in shoes and links.
6. Apply oil to cap screw threads and bearing surface on head.
7. Install nuts so rounded corners are against links.

Starting at any cap screw, tighten cap screws, in sequence shown, to 298 N•m (220 lb-ft) plus 1/2 (180°) turn.

Specification

Shoe-to-Link Cap Screw—Torque
 (New) 298 N•m (220 lb-ft) plus 1/2 (180°) turn

8. Adjust track sag. (See Measure and Adjust Track Sag procedure in this group.)

- A—Rear Forcing Pin
- B—Aligning Bushing (2 used)
- C—Master Pin
- D—Guide Pin
- E—Aligning Adapter



T5914AA -UN-25OCT88

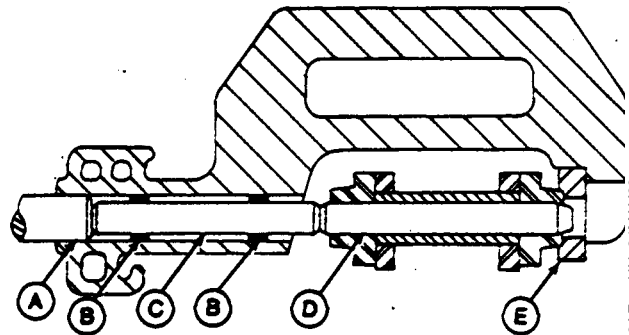

T5808AF -UN-24MAY89

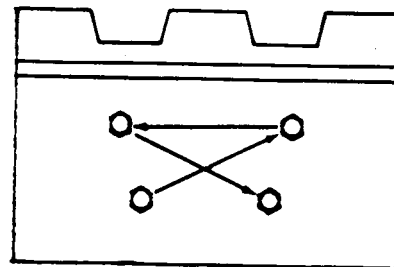

T6352AH -UN-23FEB89

TX,0130,AB454 -19-12APR95-1/1

01
0130
29

Track System

Disassemble And Assemble Track Chain

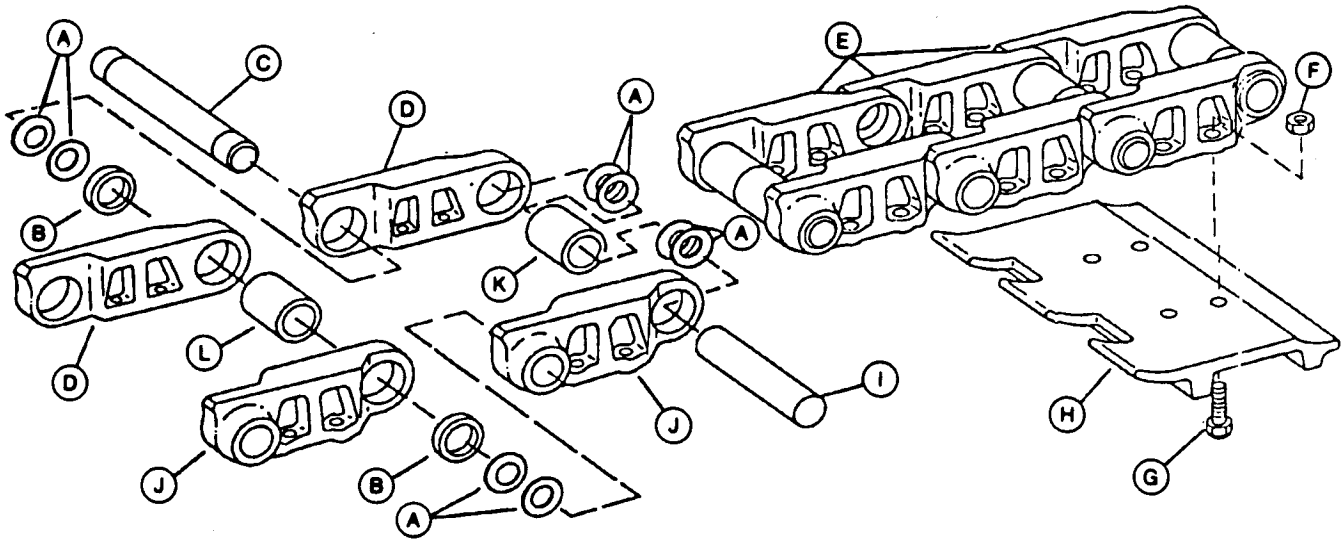

- | | | | |
|-----------------------------|------------------------|----------------------------------|------------------------------|
| A—Disk Spring (196 used) | E—Track Chain | H—Track Shoe (Grouser) (49 used) | J—Right Track Link (49 used) |
| B—Spacer (2 used) | F—Nut (196 used) | I—Pin (48 used) | K—Bushing (48 used) |
| C—Master Pin | G—Cap Screw (196 used) | | L—Master Bushing |
| D—Left Track Link (49 used) | | | |

NOTE: Wear on pins and bushings does not extend over the entire surface. Turning pins and bushings is determined by amount of wear. (See Measure Track Chain Bushing Wear and Measure Track Chain Pitch Wear in this group.)

See your track press manufacturer's operator manual to disassemble and assemble track chain.

TX,0130,AB455 -19-12APR95-1/1

Disassemble And Assemble Track Chain To Replace Broken Part

NOTE: It is not necessary to completely disassemble a chain to replace a broken part. If a track press is available, refer to the operator's manual. If a track press is not available, do the following procedure.

1. Remove track shoe from broken link assembly. Remove the track. (See procedure in this group.)

Continued on next page

0130,CC10 -19-24SEP91-1/5

T7681BK -JUN-16-JAN92

01
0130
30

Track System

IMPORTANT: When making cuts using cutting torch, be careful not to cut or gouge good parts.

- Cut links, bushing, and pin at points (A) to remove broken link (B).

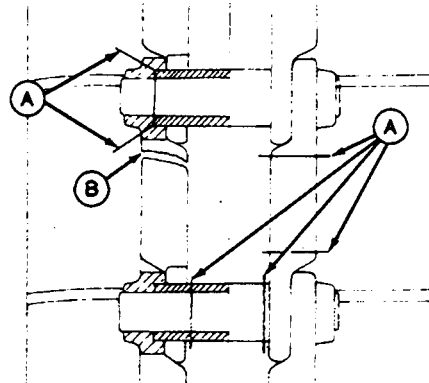

0130,CC10 -19-24SEP91-2/5

T5821AG -UN-26OCT88

01
0130
31

- Grind the ends of bushing (A) even with links to make it into a master bushing.

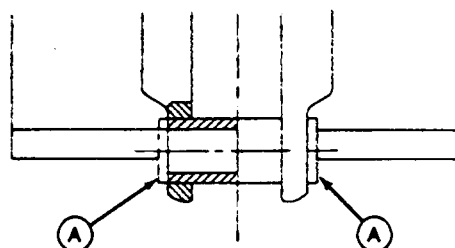

0130,CC10 -19-24SEP91-3/5

T5821AH -UN-26OCT88

- Burn holes through center of pin stubs (A).
- Hold a heavy hammer (B) against the link while pin stub is being driven out.

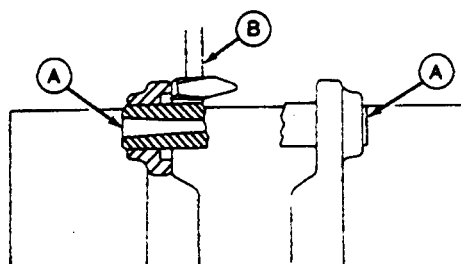

Continued on next page

0130,CC10 -19-24SEP91-4/5

T5821AI -UN-26OCT88

Track System

NOTE: When new parts are ordered, have dealer assemble the new links and master bushing.

6. Install links (C and E) on master bushing (D). Check cap screw hole spacing using a track shoe.
7. Install spacers (B) into counterbore of links.
8. Install link assembly. Install the master pins (A).

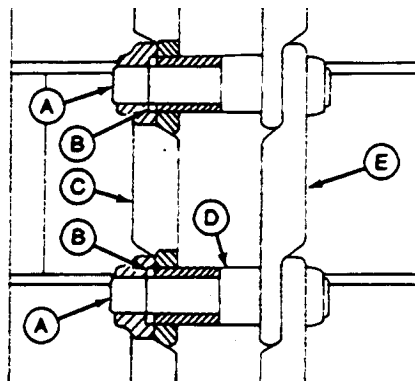

T5821AJ -UN-24MAY89

- A—Master Pin
- B—Spacer
- C—Right Link
- D—Master Bushing
- E—Left Link

0130,CC10 -19-24SEP91-5/5

Measure And Adjust Track Sag

SPECIFICATIONS	
Middle Roller Track Sag	305—325 mm (12.0—12.75 in.)
Grease Gun Capacity	68 950 kPa (690 bar) (10,000 psi)

1. Swing upperstructure 90° and lower bucket to raise track off ground.

TX,0130,AB555 -19-12APR95-1/4

2. Keep the angle (A) between boom and arm 90—100° and position the bucket's round side on the ground.

CAUTION: Prevent possible injury from unexpected machine movement. Place blocks under machine frame to support machine while measuring track sag.

3. Place blocks under machine frame to support machine.
4. Rotate track in forward two full rotations and then reverse two full rotations.

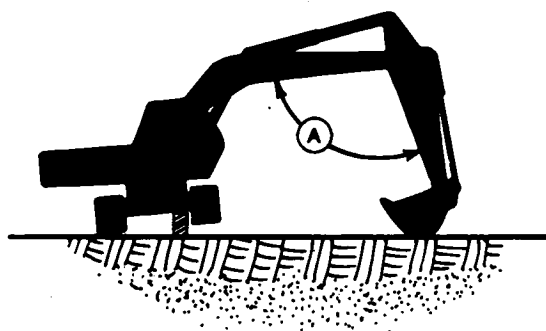

T6879AT -UN-06DEC88

Continued on next page

TX,0130,AB555 -19-12APR95-2/4

Track System

5. Measure distance (A) at middle track roller from bottom of track frame to top surface of track shoe.

Specification

Middle Roller—Track Sag 305—325 mm (12.0—12.75 in.)

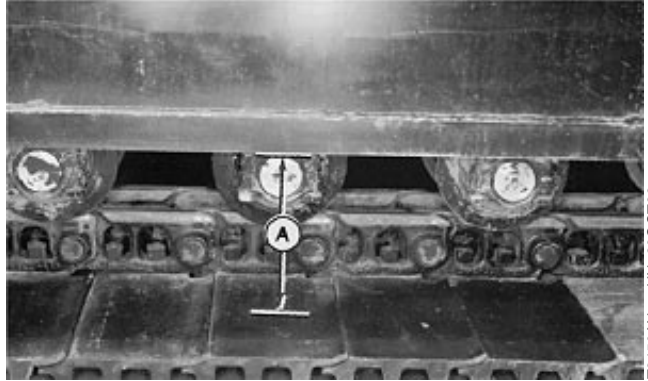

TX,0130,AB555 -19-12APR95-3/4

01
0130
33

T6450AN -UN-26OCT88

CAUTION: High pressure grease in track adjuster cylinder. Do not remove grease fitting or valve to release grease.

6. To decrease track sag, add multi-purpose grease to track adjuster cylinder through grease fitting (A) using a grease gun with a maximum capacity of 68 950 kPa (690 bar) (10,000 psi).

Specification

Grease Gun—Capacity 68 950 kPa (690 bar) (10,000 psi)

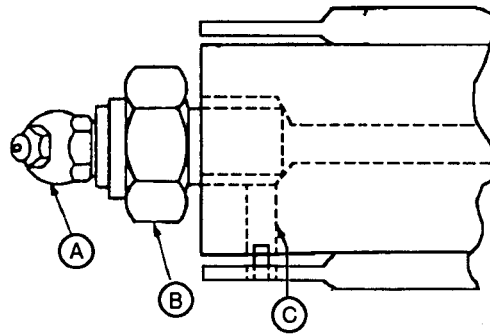

T7396DZ -UN-28NOV90

To increase track sag, loosen valve (B) one turn to release grease from track adjuster cylinder through hole (C) in rod. Tighten valve when track sag is correct.

NOTE: If piston in track adjuster cylinder does not move, remove the cylinder to make repairs.

TX,0130,AB555 -19-12APR95-4/4

Track System

Remove And Install Sprocket

IMPORTANT: Sprocket must be replaced when the tooth tips become excessively rounded, worn, or chipped to prevent excessive wear to chain. If machine is driven in one direction a majority of the time, wear will be on one side of teeth. To extend the service life, change the sprockets from one side of machine to the other.

1. Disconnect and remove track chain from sprocket.
(See procedure in this group.)
2. Lift side of machine so sprocket teeth clear chain. Put shop stands under the frame.

Continued on next page

TX,0130,AB456 -19-21FEB92-1/2

01
0130
34

Track System

CAUTION: The approximate weight of sprocket is 34 kg (75 lb).

Specification

Sprocket—Approximate Weight 34 kg (75 lb)

3. Remove cap screws and washers (A) to remove sprocket.
4. Clean cap screws using clean and cure primer. Thoroughly clean the mounting surfaces and tapped holes of all paint, oil, grease, dirt, and debris.
5. Apply thread lock and sealer (high strength) to threads of cap screws. Install sprocket, cap screws and washers. Tighten cap screws to 540 N•m (400 lb-ft).

Specification

Sprocket-to-Gearbox Cap
Screws—Torque 540 N•m (400 lb-ft)

6. Install track chain. (See procedure in this group.)
7. Adjust track sag. (See procedure in this group.)

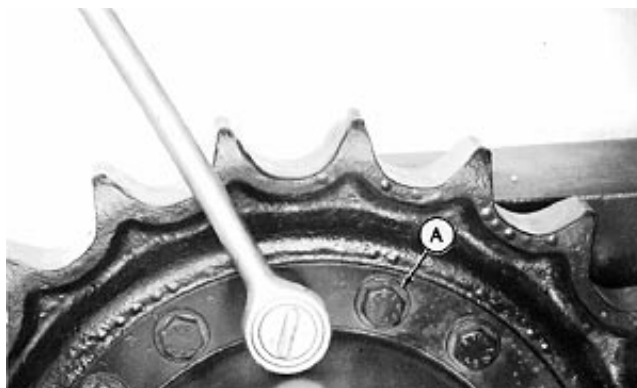

T7681BL -UN-16JAN92

01
0130
35

TX,0130,AB456 -19-21FEB92-2/2

Track System

Measure Front Idler Wear

SPECIFICATIONS	
Flange (Maximum Used) Height	25 mm (0.980 in.)
Flange (New) Height	19 mm (0.750 in.)

SERVICE EQUIPMENT AND TOOLS	
JT05518 or JT05523 Undercarriage Inspection Service Tool Kit	



T87972 -JUN-08NOV88

Maximum used is the maximum allowable height of flange for rebuilding wear surface.

Specification

Flange (Maximum Used)—Height..... 25 mm (0.980 in.)

Measure height of flange using a depth gauge such as the JT05521 200 mm Ruler, JT05534 Right Angle Attachment, and D05231ST 300 mm Ruler from JT05518 or JT05523 Undercarriage Inspection Service Tool Kit.

Specification

Flange (New)—Height..... 19 mm (0.750 in.)
 Flange (Maximum)—Height..... 25 mm (0.980 in.)

NOTE: See SP-326 Undercarriage Appraisal Manual for additional information.

TX,0130,GG237 -19-21FEB92-1/1

01
0130
36

Track System

Remove And Install Front Idler

1. Disconnect track chain (A). (See procedure in this group.)

CAUTION: The approximate weight of front idler and spring is 300 kg (660 lb).

Specification

Front Idler—Approximate Weight..... 300 kg (660 lb)

2. Remove idler, track adjuster cylinder, and recoil spring as an assembly from frame (B).

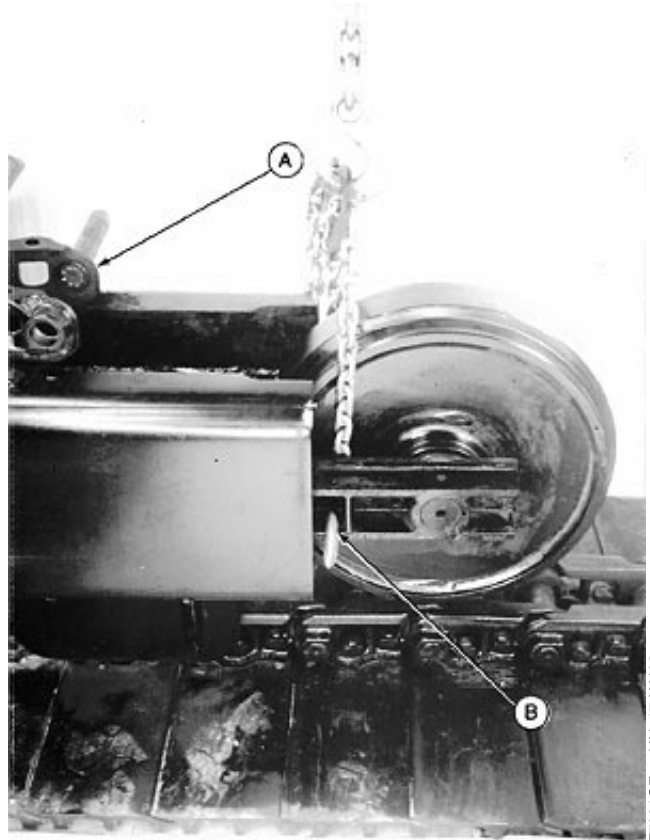

01
0130
37

T7681CF -UN-17JAN92

Continued on next page

TX,0130,AB497 -19-21FEB92-1/2

Track System

3. Remove cap screws and washers (B) to remove idler from yoke.
4. Repair or replace as necessary. (See procedure in this group.)
5. Install yoke to idler bracket. Tighten cap screws to 90 N•m (65 lb-ft).

Specification

Yoke-to-Idler Bracket Cap
Screw—Torque..... 90 N•m (65 lb-ft)

6. Clean the slides so brackets slide freely in frame.

NOTE: *The centerline of recoil spring and track adjuster cylinder are offset 9 mm (0.35 in.) from centerline of idler shaft.*

7. Install idler in frame so centerline of recoil spring and track adjuster cylinder is above centerline of idler shaft. Part number on yoke will be on top.

The flats on cylinder piston must be installed vertically to fit between bars welded to bulkhead in frame.

8. Connect the track chain.
9. Adjust track sag. (See procedure in this group.)

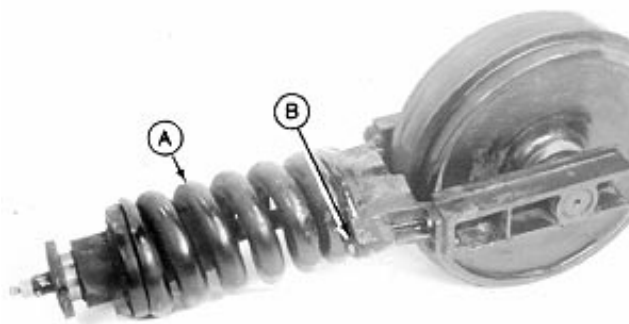

T7681BN -UN-16JAN92

TX,0130,AB497 -19-21FEB92-2/2

Track System

Disassemble Front Idler

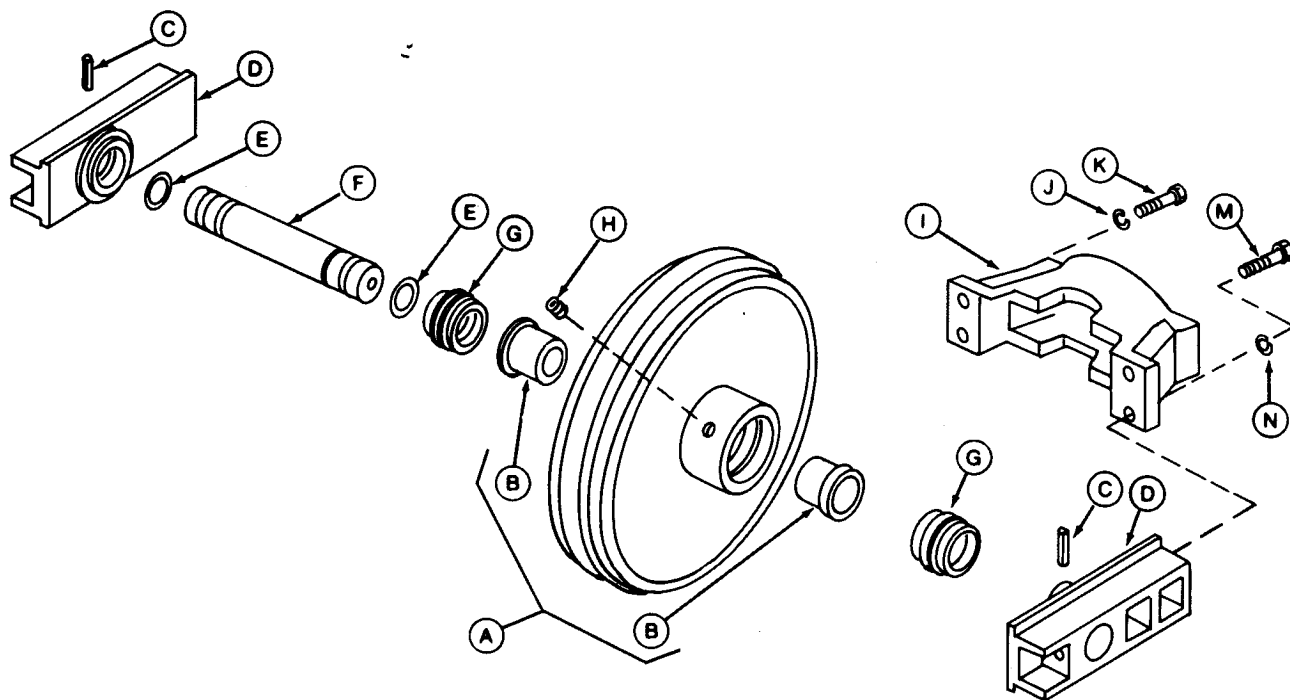

A—Idler
B—Bushing (2 used)
C—Spring Pin
D—Support

E—O-Ring
F—Shaft
G—Metal Face Seal

H—Pipe Plug
I—Yoke
J—Lock Washer (2 used)

K—Cap Screw (2 used)
M—Cap Screw (4 used)
N—Lock Washer (4 used)

1. Remove pipe plug (H) using a 6 mm hex wrench to drain oil.
2. Remove spring pins (C) to remove the supports (D).

IMPORTANT: Metal face seals can be reused if they are not worn or damaged. A used seal must be kept together as a set because of wear pattern on seal face.

3. Remove the metal face seal rings and rubber rings (G) from supports (D) and idler (A). Keep seal rings as matched sets with seal faces together to protect the surfaces. (See Inspect Metal Face Seals in this group.)

4. Remove O-rings (E) from shaft.
5. Remove shaft (F).
6. Inspect the bushings (B) for scoring or excessive wear. Also inspect the shaft.

NOTE: Remove bushings only if replacement is necessary.

7. Remove bushings using a 2-jaw puller and adapters from 17-1/2 and 30 ton puller set.

01
0130
39

T7681B0 -UN-03FEB92

TX,0130,AB459 -19-21FEB92-1/1

Track System

Assemble Front Idler

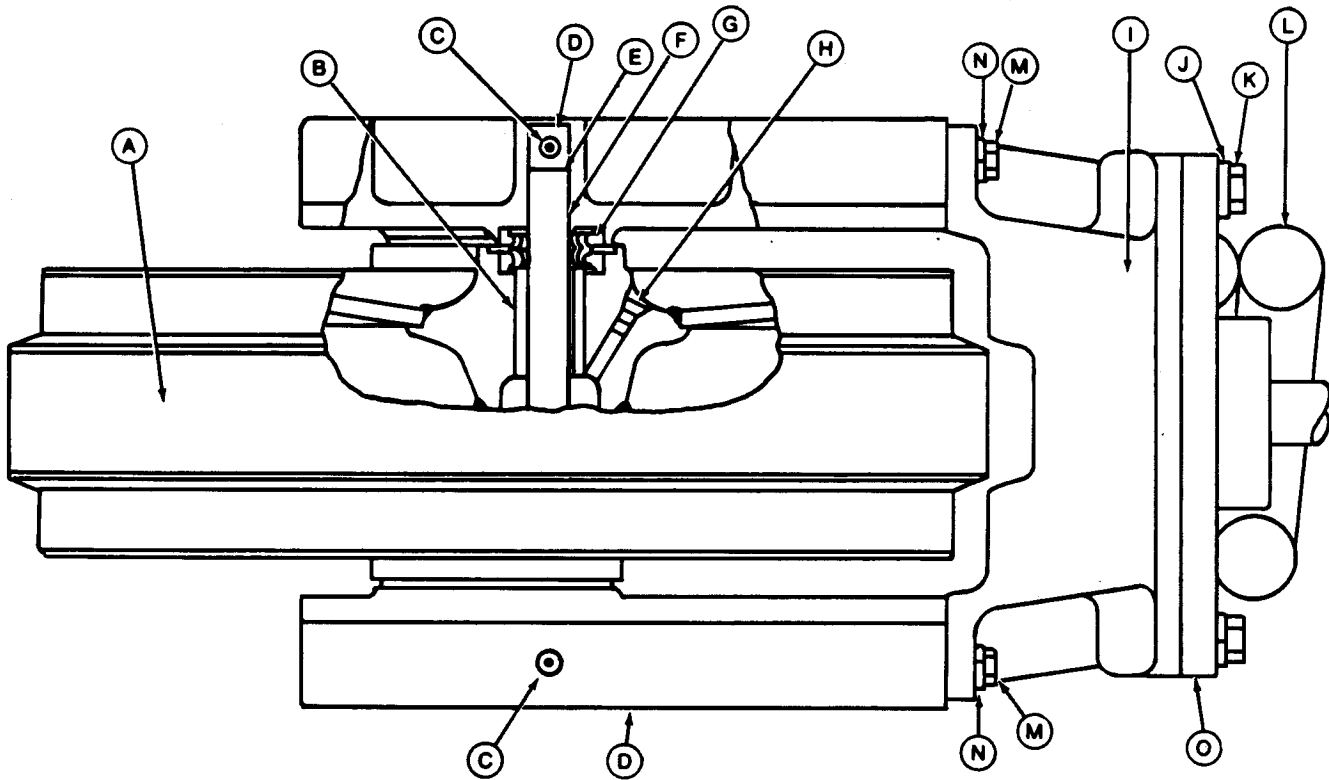

- | | | | |
|-----------------------|-------------------|------------------------|------------------------|
| A—Idler | E—O-Ring (2 used) | I—Yoke | M—Cap Screw (4 used) |
| B—Bushing (2 used) | F—Shaft | J—Lock Washer (2 used) | N—Lock Washer (4 used) |
| C—Spring Pin (2 used) | G—Metal Face Seal | K—Cap Screw (2 used) | O—Spring Plate |
| D—Support | H—Pipe Plug | | |

1. Push bushing (B) into idler (A) so flange is tight against idler.
2. Install O-ring (E) on support (D).
3. Apply a thin layer of John Deere NEVER-SEEZ® Lubricant or an equivalent to end of shaft from the O-ring outward, to bore in support, and to spring pin.
4. Install shaft (F) in support (D).
5. Install spring pin (C).

IMPORTANT: Rubber rings and seat surfaces for rubber rings must be clean, dry, and oil free so rubber rings do not slip when idler is turning.

6. Thoroughly clean the rubber rings and seat surfaces in idler, brackets, and seal rings using volatile, non-petroleum base solvent and lint-free tissues.
7. Install metal face seal (G) in support (D), and other half in idler (A).

NEVER-SEEZ is a registered trademark of the Emhart Chemical Group.

Continued on next page

TX,0130,AB461 -19-12APR95-1/2

Track System

8. Wipe any finger prints and foreign material off seal ring face using a lint-free tissue.
9. Apply a thin film of oil on each seal ring face. DO NOT apply any oil on rubber rings.
10. Install idler (A) on shaft.
11. Install metal face seal (G) in idler (A) and other half in second support (D).
12. Install second support (D) on shaft (F).
13. Install spring pin (C).
14. Install track adjuster cylinder and recoil spring (I—L). (See procedure in this group.)
15. Fill idler with recommended oil. Capacity is 0.33 L (11.3 oz). (See Track Roller and Idler Oil in Group 0004.)
16. Clean plug using clean and cure primer. Apply thread lock and sealer (medium strength). Install plug.

01
0130
41

TX,0130,AB461 -19-12APR95-2/2

Track System

Test Front Idler For Oil Leakage

SPECIFICATIONS

Front Idler Leakage Test Pressure	110 ± 28 kPa (1.1 ± 0.3 bar) (16 ± 4 psi) for a minimum of 30 seconds
-----------------------------------	---

SERVICE EQUIPMENT AND TOOLS

D05361ST Rubber Stopper/Leak Detector Kit Hoses 0—400 kPa (0—4 bar)(0—60 psi) Gauge Snubber (Needle) Valve Air Pressure Regulator

OTHER MATERIAL

T43512 U.S. Thread Lock and Sealer (Medium Strength) Products

TY9473 Canadian Thread Lock and Sealer (Medium Strength) Products

242 LOCTITE® Thread Lock and Sealer (Medium Strength) Products

TY9477 Canadian Thread Lock and Sealer (Medium Strength) Products

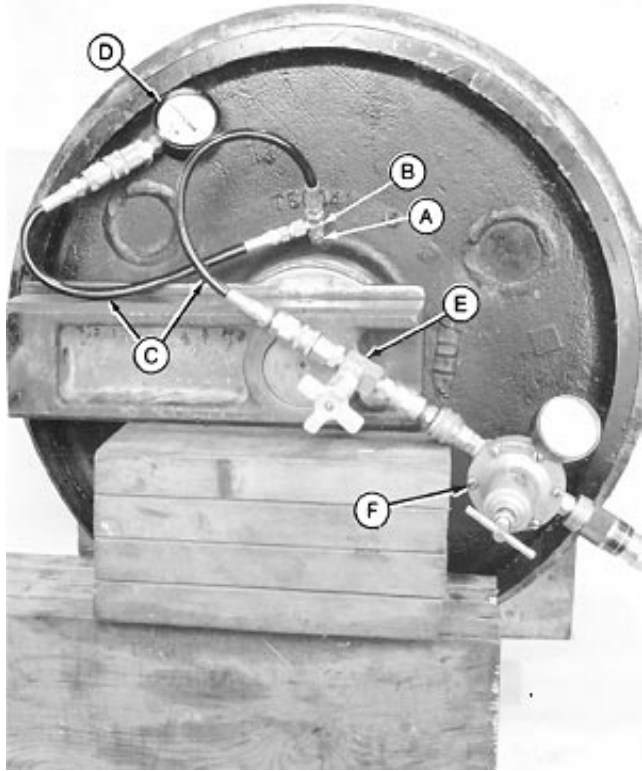

T82933 -UN-08NOV/88

- A—Plug, Barbed Adapter and Connector
- B—JT03001 Tee Fitting 7/16-20 M 37° x 7/16-20 F 37° SW x 7/16-20 M 37°
- C—Hose
- D—Pressure Gauge
- E—Snubber (Needle) Valve
- F—Air Pressure Regulator

1. Turn the shaft several turns to seat metal face seals.
2. Remove the plug.
3. Install parts (A—F) as shown. Plug, barbed adapter, and connector are from a leak detector kit such as the D05361ST Rubber Stopper/Leak Detector Kit.
4. Holding plug so it is not pushed out, slowly pressurize oil cavity to 110 ± 28 kPa (1.1 ± 0.3 bar) (16 ± 4 psi) using air.

Specification

Front Idler Leakage Test—	
Pressure	110 ± 28 kPa (1.1 ± 0.3 bar) (16 ± 4 psi) for a minimum of 30 seconds

5. Close valve and wait for a minimum of 30 seconds to check for oil leakage. Check gauge to see if air pressure has decreased.
6. If there is external leakage, disassemble idler and replace parts as necessary.

01
0130
42

Track System

7. Check oil level in idler. If the oil level is down and there is no external leakage, check for a leak from oil cavity to interior of idler.
8. Apply thread lock and sealer (medium strength) to threads of plug. Install and tighten plug.

01
0130
43

TX,0130,AB556 -19-21FEB92-2/2

Remove And Install Track Adjuster Cylinder And Recoil Spring

1. Remove track and front idler wheel. (See procedures in this group.)

TX,0130,AB463 -19-26FEB92-1/2

2. Remove cap screws (B) to remove idler and yoke from track adjuster cylinder and recoil spring (A).
3. Inspect and repair as necessary.
4. Install track adjuster cylinder and recoil spring to yoke.
5. Tighten cap screws to 90 N•m (65 lb-ft).

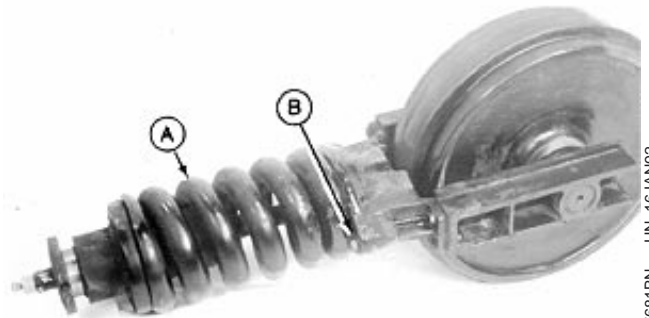

T7681BN -JUN-16JAN92

Specification

Track Adjuster Cylinder and Recoil Spring-to-Yoke Cap Screw—Torque.....	90 N•m (65 lb-ft)
---	-------------------

TX,0130,AB463 -19-26FEB92-2/2

Disassemble And Assemble Recoil Spring



CAUTION: Spring or rod may break if dropped while handling, transporting or disassembling. Nicks or weld craters in spring and rod assembly can cause stress concentration resulting in a weak spot that may result in immediate or eventual failure creating a risk of personal injury. Put a heavy protective covering around spring assembly when handling, transporting, or disassembling.

A compression tool must be used for disassembly and assembly because of the extreme preload on spring.

1. Place a 18-t (20-ton) hydraulic jack on bottom of ST4920 Track Recoil Spring Disassembly and Assembly Tool (A). (See Section 99 for instruction to make tool.)
2. Remove nuts (B) and top plate (C).
3. Remove lubrication fitting and check valve from piston.

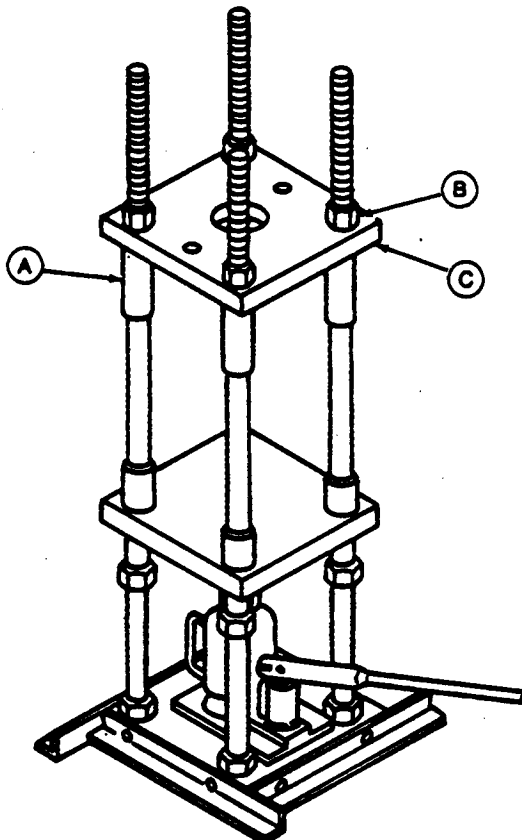

T657DY -UN-25OCT88

Continued on next page

TX,0130,GG268 -19-14FEB92-1/3

Track System



CAUTION: Approximate weight of track adjuster cylinder and recoil spring is 73 kg (160 lb).

4. Put track adjuster cylinder and recoil spring (F) in tool using a hoist and lifting strap. Piston end fits into DFT1110 Spacer (A) on bottom plate. (See Section 99 for instruction to make tool.)
5. Install DFT1087 Track Recoil Spring Disassembly and Assembly Guard Tool (B). (See Section 99 for instruction to make tool.)
6. Install two DFT1111 Spacers (C). (See Section 99 for instruction to make tool.)
7. Install top plate with the smallest opening to allow access to nut (D).
8. Extend jack ram so there is enough travel to release the spring to an approximate free length of 391 mm (15.4 in.).
9. Tighten nuts so top plate is tight against spacers. Check that nut is centered in opening in top plate.
10. Operate jack to compress spring until spring pin (E) is just above the spring retainer plate.
11. Remove spring pin using a roll pin punch and hammer. Remove nut.
12. Lower jack to release spring force.
13. Replace parts as necessary.
14. Install cylinder on spacer. Install spring and plate.
15. Install guard tool and spacers.
16. Install top plate and nuts.
17. Operate jack to compress spring.
18. Install nut so pin hole is aligned with hole in rod. Install spring pin so ends are even with flats on nut.
19. Release jack. Remove nuts and top plate to remove track adjuster cylinder and recoil spring.

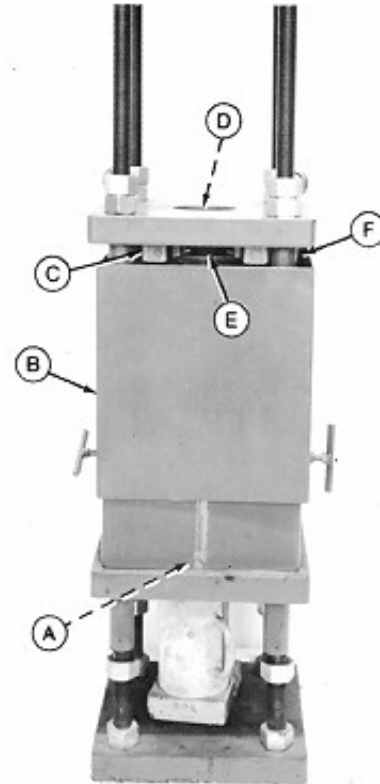

- A—DFT1110 Spacer
 B—DFT1087 Track Recoil Spring Disassembly and Assembly Guard Tool
 C—DFT1111 Spacer (2 used)
 D—Nut
 E—Spring Pin
 F—Track Adjuster Cylinder and Recoil Spring

01
0130
45

T7711AC -UN-23FEB92

Continued on next page

TX,0130,GG268 -19-14FEB92-2/3

Track System

20. Install track adjuster cylinder and recoil spring. (See procedure in this group.)

TX,0130,GG268 -19-14FEB92-3/3

01
0130
46

Track System

Disassemble And Assemble Track Adjuster Cylinder

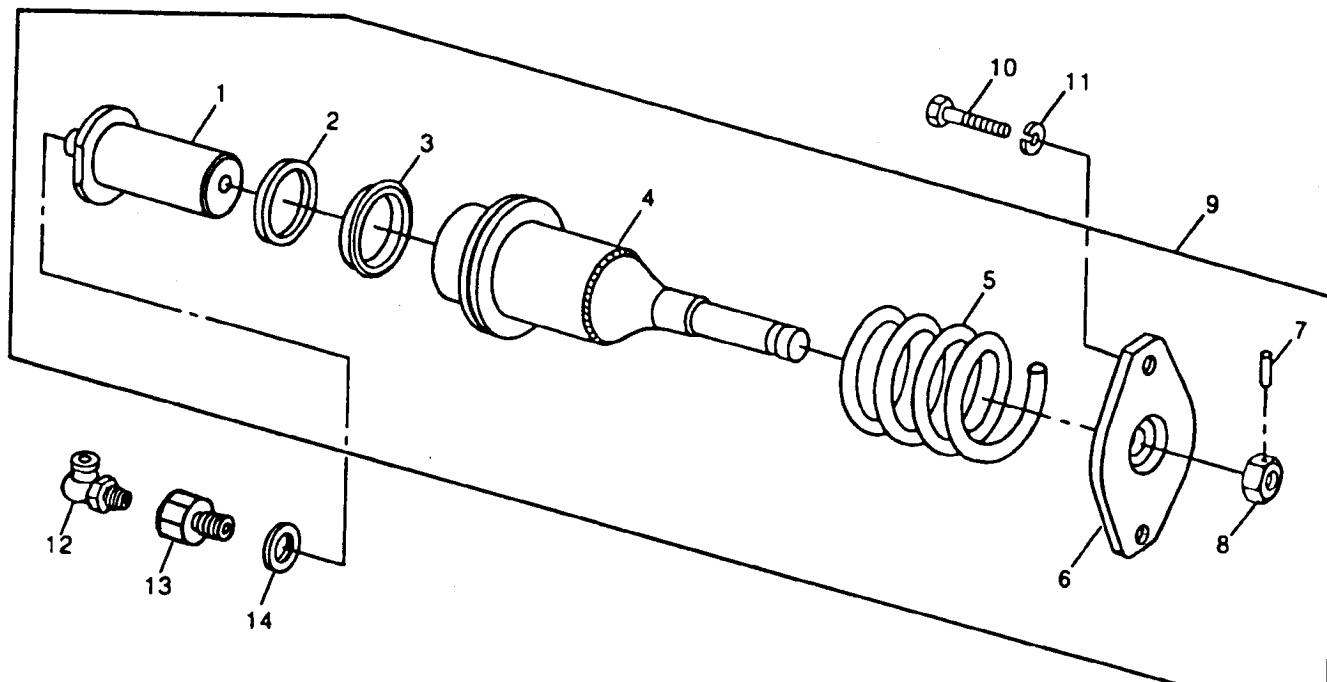

1—Piston
2—Wiper Seal
3—Seal
4—Cylinder

5—Recoil Spring
6—Retainer Plate
7—Spring Pin
8—Nut

9—Track Adjuster Cylinder
and Recoil Spring
10—Cap Screw (2 used)
11—Lock Washer (2 used)

12—Lubrication Fitting
13—Check Valve
14—Washer Seal



CAUTION: Spring or rod may break if dropped while handling, transporting or disassembling. Nicks or weld craters in spring and rod assembly can cause stress concentration resulting in a weak spot that may result in immediate or eventual failure creating a risk of personal injury. Put a heavy protective covering around spring assembly when handling, transporting, or disassembling.

A compression tool must be used for disassembly and assembly because of the extreme preload on spring.

NOTE: It is not necessary to remove the recoil spring (5) to replace the seals (2 and 3) in cylinder (4). The recoil spring is removed using the ST4920 Track Recoil Spring Disassembly and Assembly Tool. (See procedure in this group.)

1. Install seal (3) with lips towards closed end of cylinder (4).
2. Install wiper seal (2) with lip towards open end of cylinder.
3. Apply thread lock and sealer (high strength) to thread of lubrication fitting (12).

01
0130
47

T7711AF -UN-23FEB92

TX,0130,GG270 -19-14FEB92-1/1

Track System

01
0130
48

Section 02

Axles And Suspension Systems

Contents

	Page		Page
Group 0250—Axle Shaft, Bearings, And Reduction Gears			
Special Or Essential Tools	02-0250-1	Propel Hydraulic Lines	
Service Equipment And Tools	02-0250-1	Remove and Install	02-0260-32
Other Material	02-0250-3	Rotary Manifold	
Specifications	02-0250-4	Remove and Install	02-0260-33
Towing Machine	02-0250-4	Disassemble and Assemble	02-0260-38
Propel Gearbox and Brake Elements		Air Test	02-0260-39
Replace	02-0250-6	Propel Speed Change Solenoid Valve	
Propel Gearbox and Brake		Remove and Install	02-0260-40
Remove and Install	02-0250-8	Disassemble and Assemble	02-0260-43
Propel Gearbox			
Disassemble	02-0250-15		
Metal Face Seals			
Inspect	02-0250-22		
Propel Gearbox			
Assemble	02-0250-24		
Propel Gearbox and Brake			
Assemble Replacement Housing and			
Bearing Assembly	02-0250-32		
Group 0260—Hydraulic System			
Service Equipment And Tools	02-0260-1		
Other Material	02-0260-2		
Specifications	02-0260-3		
Propel Motor			
Remove and Install	02-0260-3		
Start-Up Procedure	02-0260-6		
Disassemble	02-0260-8		
Valve Housing and Cover			
Disassemble	02-0260-14		
Propel Motor			
Assemble	02-0260-16		
Counterbalance Valve			
Remove and Install	02-0260-24		
Disassemble and Assemble	02-0260-25		
Supply Shuttle Valve			
Remove and Install	02-0260-26		
Crossover Relief Valve			
Remove and Install	02-0260-28		
Shuttle Valve			
Remove and Install	02-0260-30		
Low Speed Selector Valve			
Remove and Install	02-0260-31		
Brake Release Pressure Reducing Valve			
Remove and Install	02-0260-32		

Contents

02

Axle Shaft, Bearings, And Reduction Gears

Special Or Essential Tools

T7681FR -UN-18FEB92

NOTE: Order tools according to information given in the U.S. SERVICE-GARD™ Catalog or in the European Microfiche Tool Catalog (MTC).

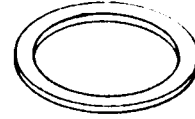

SERVICE-GARD is a trademark of Deere & Company.

DX,TOOLS -19-20JUL95-1/3

02
0250
1

Seal Installer-Final Drive. JDG733A

Used to install metal face seals in propel gearbox.

DX,TOOLS -19-20JUL95-2/3

To install metal face seals in propel gearbox.

DX,TOOLS -19-20JUL95-3/3

Service Equipment And Tools

NOTE: Order tools from the U.S. SERVICE-GARD™ Catalog or from the European Microfiche Tool Catalog (MTC). Some tools may be available from a local supplier.

SERVICE-GARD is a trademark of Deere & Company.

,02,15 -19-19JUN96-1/7

17-1/2 and 30 Ton Puller Set

Used to remove bearing cups and cones.

,02,15 -19-19JUN96-2/7

Metric Disk and Driver Set

Used to remove and install bearing cones, cups, and seals.

Continued on next page

,02,15 -19-19JUN96-3/7

Axle Shaft, Bearings, And Reduction Gears

Lifting BracketJT01748

Used to remove propel gearbox.

.02,15 -19-19JUN96-4/7

Planetary Gear Shaft Removal Tool¹ DFT1096

Used to remove planet gear shafts from third planetary carrier.

¹Fabricated tool, dealer made. (See Section 99 for instructions to make tools.)

.02,15 -19-19JUN96-5/7

Bearing Pilot Tool¹. DFT1094

Used to keep loose needle bearings in planet gear.

¹Fabricated tool, dealer made. (See Section 99 for instructions to make tools.)

.02,15 -19-19JUN96-6/7

Planetary Gear Assembly Tool¹ DFT1095

Used to install planet gears with needle bearing on gear shaft.

¹Fabricated tool, dealer made. (See Section 99 for instructions to make tools.)

.02,15 -19-19JUN96-7/7

02
0250
2

Axle Shaft, Bearings, And Reduction Gears

Other Material

Number	Name	Use
TY6305 (U.S.) TY9485 (Canadian) 764 (LOCTITE®)	Clean and Cure Primer Products	Used to clean and cure surfaces prior to application of adhesives and sealants.
T43513 (U.S.) TY9474 (Canadian) 271 (LOCTITE®)	Thread Lock and Sealer (High Strength) Products	Used to apply to threads of sprocket-to-housing cap screws.
T43512 (U.S.) TY9473 (Canadian) 242 (LOCTITE®)	Thread Lock and Sealer (Medium Strength) Products	Used to apply to threads of third planet carrier-to-support hub cap screws.
TY9375 (U.S.) TY9480 (Canadian) 592 (LOCTITE®)	Pipe Sealant TEFLON®Products	Used to apply to threads of plugs in gearbox cover.

02
0250
3

LOCTITE is a registered trademark of Loctite Corp.
TEFLON is a registered trademark of the DuPont Company.

TX,0250,DW340 -19-22NOV94-1/1

Axle Shaft, Bearings, And Reduction Gears

Specifications

Item	Measurement	Specification
Propel Gearbox and Brake: Cover-to-Gearbox Cap Screw	Torque	75 N•m (55 lb-ft)
Plug-to-Cover	Torque	65 N•m (45 lb-ft)
Propel Motor	Approximate Weight	64 kg (141 lb)
Sprocket-to-Housing Cap Screw	Torque	540 N•m (400 lb-ft)
Frame-to-Gearbox Cap Screw	Torque	540 N•m (400 lb-ft)
Propel Motor-to-Gearbox Cap Screw	Torque	75 N•m (55 lb-ft)
Supply Shuttle Valve-to-Propel Motor Cap Screw	Torque	75 N•m (55 lb-ft)
Counterbalance Valve-to-Supply Shuttle Valve Cap Screw	Torque	75 N•m (55 lb-ft)
Sprocket	Approximate weight	84 kg (184 lb)
Third Planetary Carrier-to-Hub Cap Screw	Torque	540 N•m (400 lb-ft)
Planet Carrier Cover-to-Housing Cap Screw	Torque	75 N•m (55 lb-ft)

TX,0250,DW584 -19-12APR95-1/1

Towing Machine



CAUTION: Prevent possible injury from unexpected machine movement. Block both tracks when disconnecting propel gearboxes. When propel gearboxes are disconnected, machine has no brakes and can move. The machine will roll free on a slope or while being towed.

1. Block tracks.
2. Drain oil from each propel gearbox. Approximate capacity is 3.9 L (4.1 qt).
3. Remove cover from each gearbox.

Continued on next page

TX,0250,AB304 -19-21FEB92-1/4

Axle Shaft, Bearings, And Reduction Gears

- 4. Remove sun gear (A) from each gearbox.
- 5. Install cover. Fill gearbox with oil.

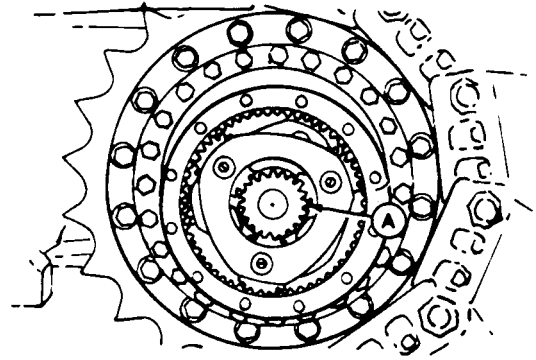

TX,0250,AB304 -19-21FEB92-2/4

T6879EG -JUN-06DEC88

02
0250
5

- 6. Attach a tow line to frame loop (A).
- 7. Remove cover. Install sun gear.

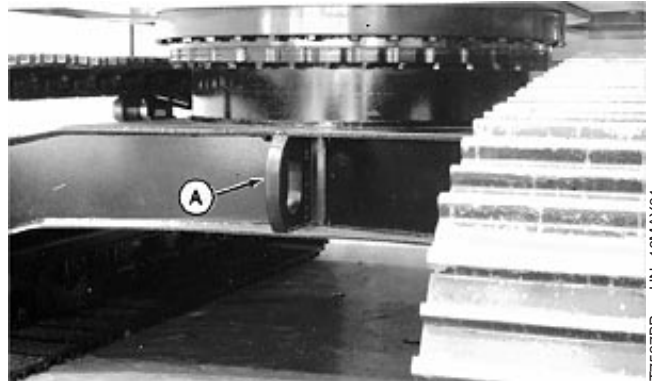

Front Tow Loop Shown

T7527BP -JUN-16MAY91

Continued on next page

TX,0250,AB304 -19-21FEB92-3/4

Axle Shaft, Bearings, And Reduction Gears

8. Install cover with a hole (A) at the 12 o'clock position and a hole (B) just above the horizontal centerline. Tighten cap screws to 75 N•m (55 lb-ft).

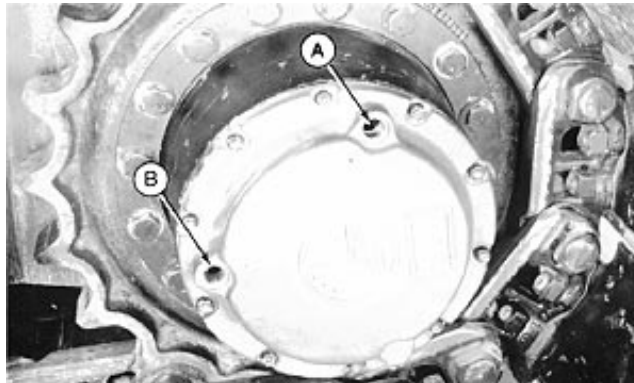

T7626AG -UN-27NOV91

Specification

Propel Gearbox and
 Brake:Cover-to-Gearbox Cap
 Screw—Torque..... 75 N•m (55 lb-ft)

9. Fill gearbox with oil through top hole (A) until oil flows out of hole (B). (See Propel Gearbox Oil in Group 0004.)

10. Apply pipe sealant to thread of plugs. Tighten plugs to 65 N•m (45 lb-ft).

Specification

Plug-to-Cover—Torque..... 65 N•m (45 lb-ft)

TX,0250,AB304 -19-21FEB92-4/4

Replace Propel Gearbox Brake Elements

1. Remove propel motor. (See procedure in Group 0260.)

NOTE: Propel gearbox does not have to be removed to perform this procedure.

2. Remove two propel gearbox mounting cap screws opposite each other.
3. Install pusher.
4. Tighten pusher to compress brake piston springs.

Continued on next page

TX,0250,DW445 -19-22NOV94-1/4

02
 0250
 6

Axle Shaft, Bearings, And Reduction Gears

- 5. Remove snap ring (A).
- 6. Loosen pusher slowly to release spring pressure. Remove pusher.

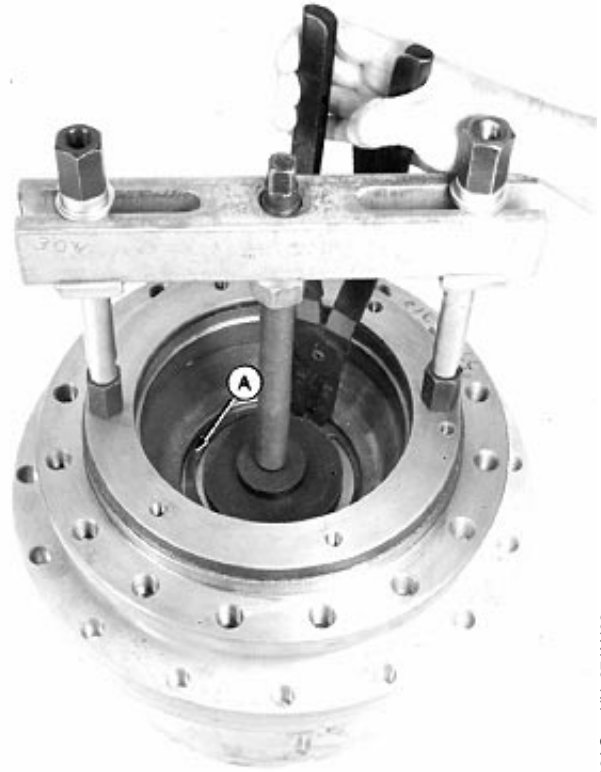

Propel Gearbox Removed For Clarity

02
0250
7

T7392AG -UN-27JAN92

TX,0250,DW445 -19-22NOV94-2/4

- 7. Remove retaining disk (C).

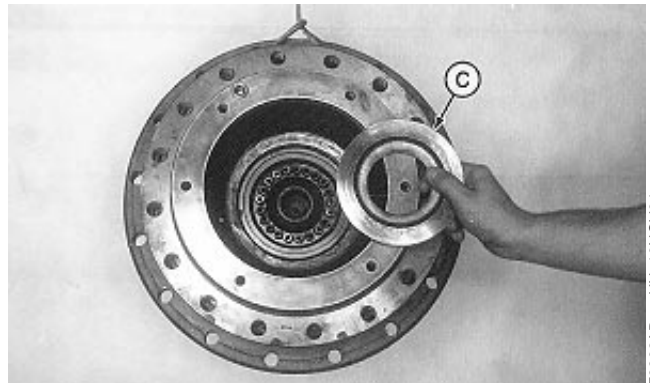

Continued on next page

TX,0250,DW445 -19-22NOV94-3/4

T8362AB -UN-16NOV94

Axle Shaft, Bearings, And Reduction Gears

8. Remove brake piston springs (B).
9. Apply low air pressure to brake port (A). Remove piston (C).
10. Remove spacer (D).
11. Remove rings (E) and brake disks (F).
12. Replace parts as necessary.
13. Install rings and brake disks in an alternating pattern.
14. Install spacer, piston, and springs.
15. Install retaining ring and compress with pusher.
16. Install snap ring.
17. Install propel gearbox mounting cap screws.
18. Install propel motor. (See procedure in this group.)

- A—Brake Port
- B—Piston Spring (21 used)
- C—Piston
- D—Spacer
- E—Ring (6 used)
- F—Brake Disk (7 used)

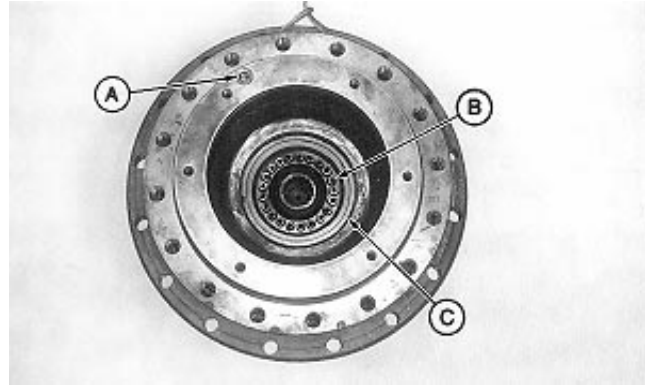

T8362AC -UN-16NOV94

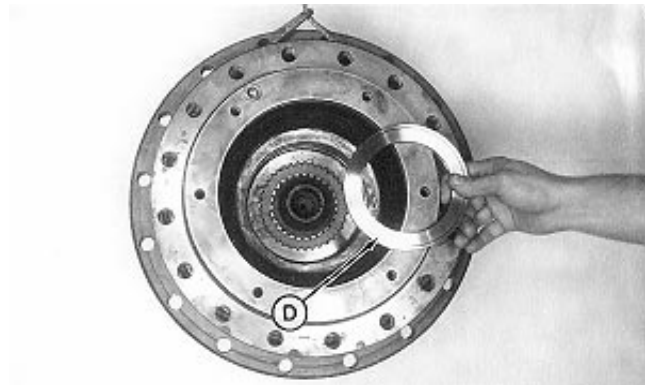

T8362AD -UN-16NOV94

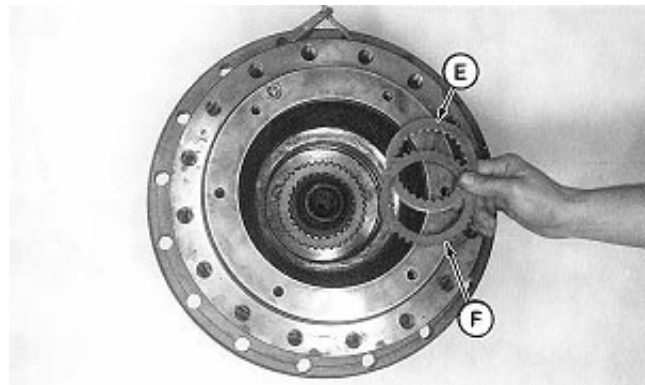

T8362AE -UN-16NOV94

TX,0250,DW445 -19-22NOV94-4/4

Remove And Install Propel Gearbox And Brake

1. Disconnect track. (See Remove and Install Track Chain, Group 0130.)
2. Drain oil from gearbox.

Continued on next page

TX,0250,AB507 -19-21FEB92-1/13

Axle Shaft, Bearings, And Reduction Gears

3. Swing upperstructure 90° and lower bucket to raise machine just enough so sprocket will clear chain. Keep angle between boom and arm 90—110° and position round side of bucket on ground. Put a support stand under the undercarriage.

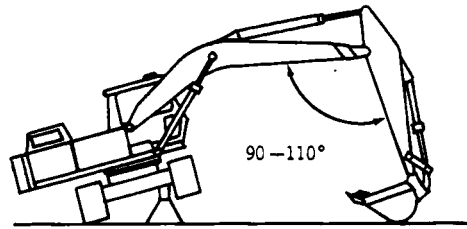

T6876FG -UN-06DEC88

02
0250
9

TX,0250,AB507 -19-21FEB92-2/13

- ⚠ CAUTION: Hydraulic reservoir is pressurized. Loosen fill cap to release pressure.**

4. Loosen fill cap (A) to release air pressure in the reservoir.

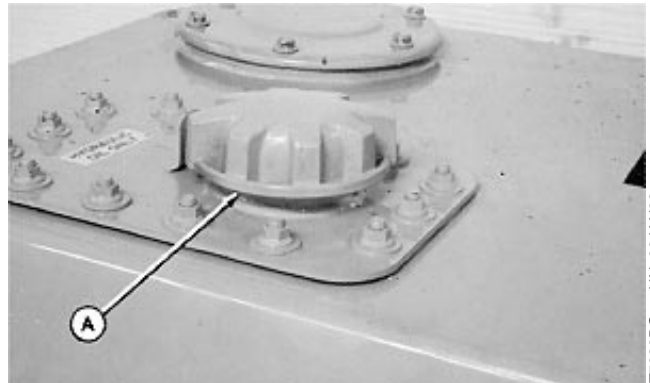

T7626DG -UN-06JAN92

TX,0250,AB507 -19-21FEB92-3/13

5. Remove cap screws (B). Remove propel motor cover (C).

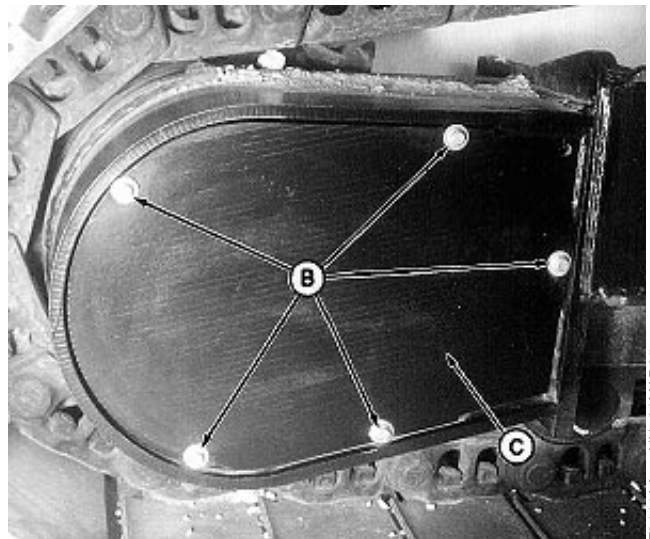

T8444AA -UN-31MAR95

Continued on next page

TX,0250,AB507 -19-21FEB92-4/13

! **CAUTION:** Escaping fluid under pressure can penetrate the skin causing serious injury. Avoid the hazard by relieving pressure before disconnecting hydraulic or other lines. Tighten all connections before applying pressure. Search for leaks with a piece of cardboard. Protect hands and body from high pressure fluids.

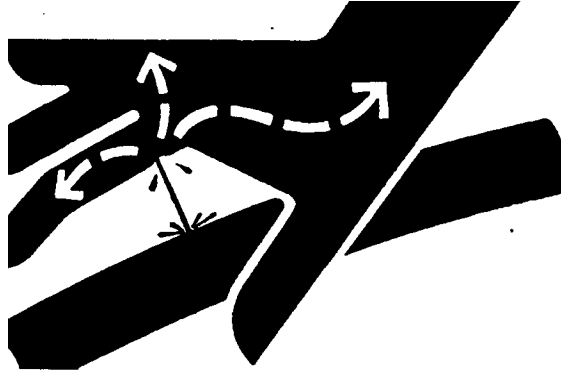

If an accident occurs, see a doctor immediately. Any fluid injected into the skin must be surgically removed within a few hours or gangrene may result. Doctors unfamiliar with this type of injury may call the Deere & Company Medical Department in Moline, Illinois, or other knowledgeable medical source.

6. Disconnect lines (A—C, G and H).
7. Remove counterbalance valve (I) and supply shuttle valve (F).

- A—Drain Port-to-Rotary Manifold Return Line
- B—Propel Speed Change Port-to-Rotary Manifold "P1" Port Line
- C—Propel Brake Release Port-to-Gearbox Line
- D—Cap Screw (6 used)
- E—Cap Screws (6 used)
- F—Supply Shuttle Valve
- G—"A" Port-to-Rotary Manifold "2" or "4" Port Line
- H—"B" Port-to-Rotary Manifold "1" or "3" Port Line
- I—Counterbalance Valve
- J—Cap Screw (6 used)

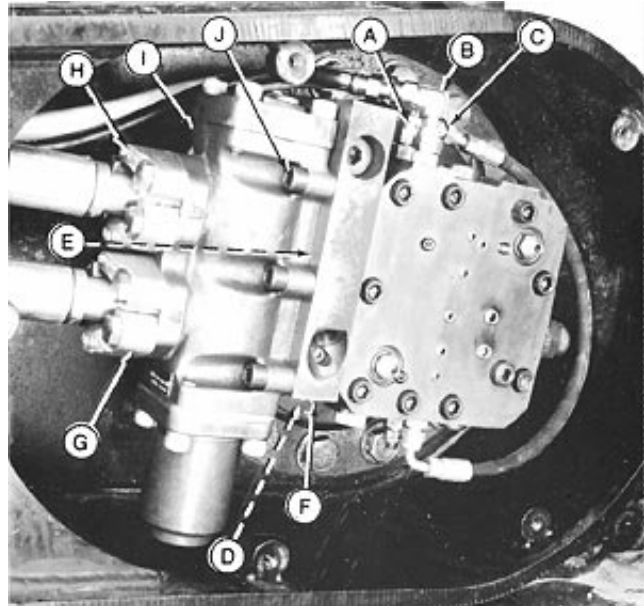

Right Side

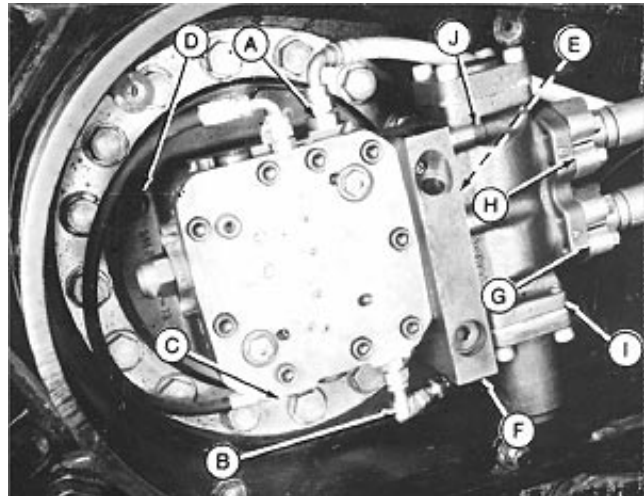

Left Side

X9811 -UN-23AUG88

T7681FB -UN-05FEB92

T7681FC -UN-05FEB92

02
0250
10

Axle Shaft, Bearings, And Reduction Gears



CAUTION: The approximate weight of propel motor is 64 kg (141 lb).

Specification

Propel Motor—Weight 64 kg (141 lb)

8. Attach motor to a hoist using a lifting strap. Remove cap screws (A) to remove propel motor.
9. Loosen, but do not remove, cap screws (D).

- A—Cap Screw (6 used)
- B—Right Gearbox Brake Port at 12:30 O'clock Position
- C—Propel Motor
- D—Cap Screw (16 used)

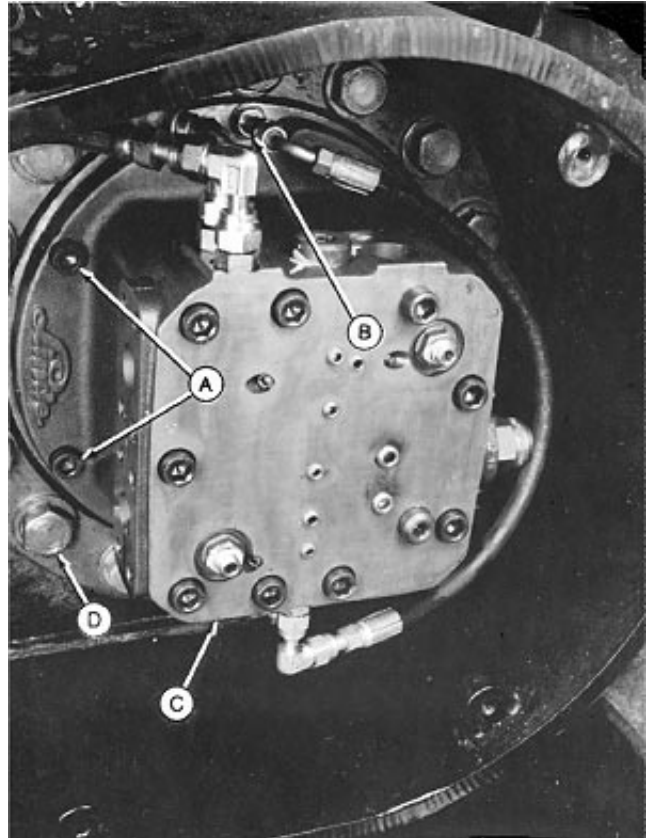

T7628DI -JUN-06JAN92

TX,0250,AB507 -19-21FEB92-6/13

02
0250
11

10. Remove a cap screw (A). Install a lifting bracket (B) such as JT01748 Lifting Bracket. Loosen remaining cap screws if sprocket is to be removed.

NOTE: Follow Steps 11—15, if the gearbox is going to be disassembled, to loosen third planet cap screws.

11. Remove cover (C).

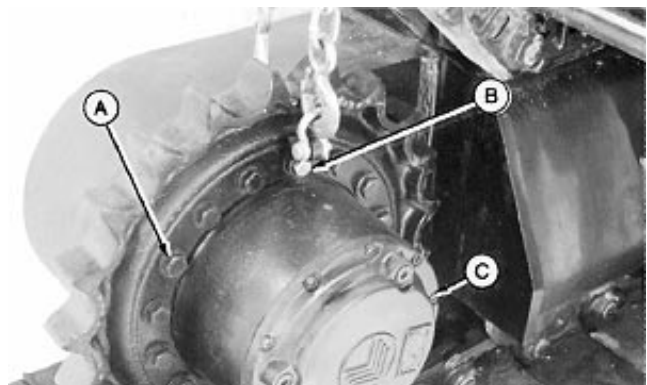

T7628DJ -JUN-06JAN92

Continued on next page

TX,0250,AB507 -19-21FEB92-7/13

Axle Shaft, Bearings, And Reduction Gears

! CAUTION: Gears may turn. Keep fingers away from planet gears.

12. Remove input shaft (first planet sun gear) (A).

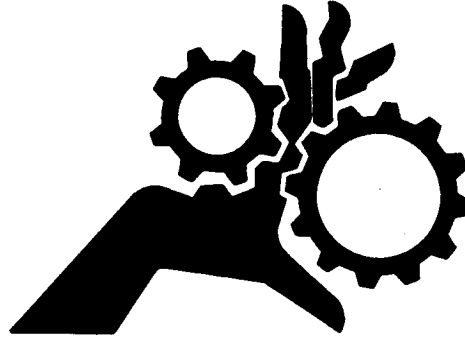

T6639GK -UN-19OCT88

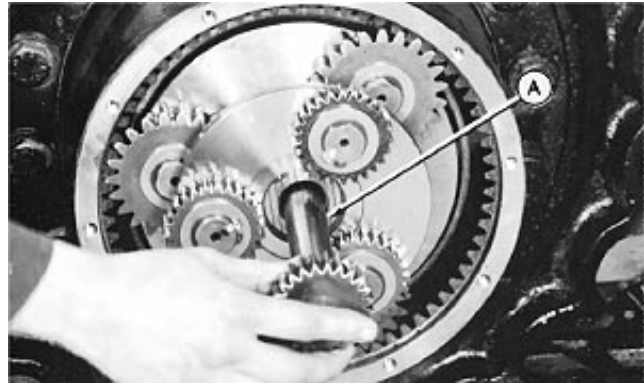

T7626DH -UN-06JAN92

TX,0250,AB507 -19-21FEB92-8/13

13. Remove first planet carrier (A).

14. Remove second planet sun gear (B).

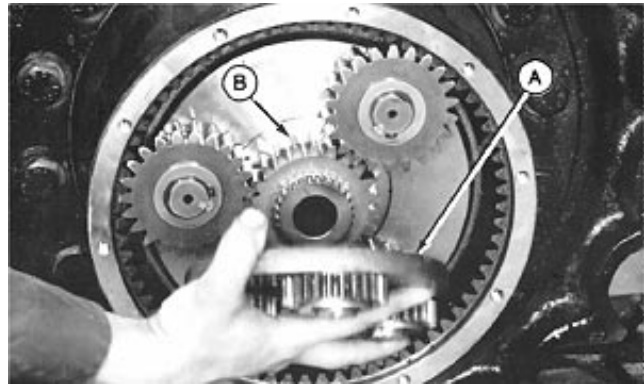

T7626DK -UN-06JAN92

TX,0250,AB507 -19-21FEB92-9/13

15. Remove second planet carrier (A) and third planet sun gear (B).

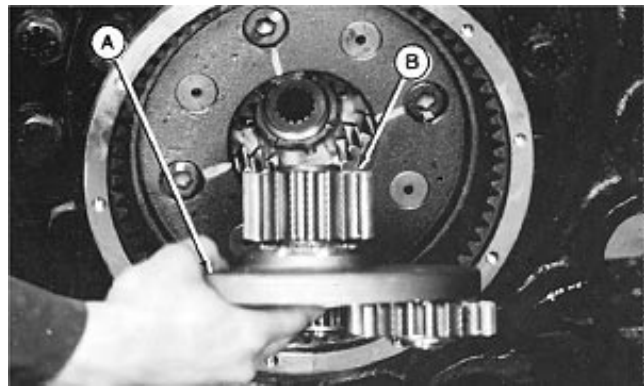

T7626DM -UN-06JAN92

Continued on next page

TX,0250,AB507 -19-21FEB92-10/13

Axle Shaft, Bearings, And Reduction Gears

16. Loosen, but do not remove, cap screws (A).

NOTE: Thread lock and sealer (medium strength) is used on threads of cap screws.

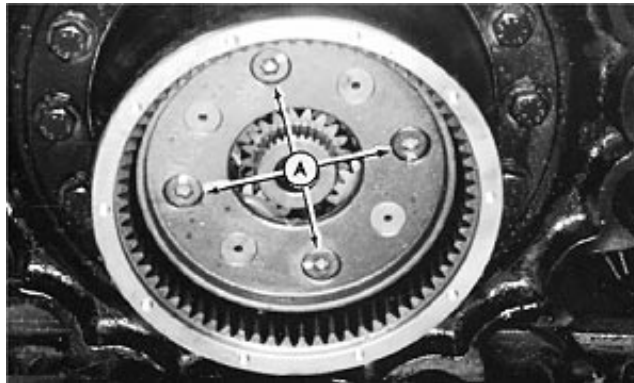

T7626BK -UN-06JAN92

TX,0250,AB507 -19-21FEB92-11/13

02
0250
13

CAUTION: The approximate weight of gearbox and sprocket is 232 kg (578 lb).

- 17. Remove cap screws (D) to remove gearbox and sprocket as an assembly.
- 18. Make repairs as necessary. (See procedure in this group.)
- 19. Install right gearbox with brake port at the 12:30 o'clock position. Install left gearbox with brake port at the 5:30 o'clock position.
- 20. Tighten cap screws to 540 N•m (400 lb-ft).

Specification

Sprocket-to-Housing Cap Screw—Torque..... 540 N•m (400 lb-ft)

- 21. Install sprocket. Clean threads of cap screws using clean and cure primer. Apply thread lock and sealer (high strength) to threads of cap screws. Tighten cap screws to 540 N•m (400 lb-ft).

Specification

Frame-to-Gearbox Cap Screw—Torque 540 N•m (400 lb-ft)

- 22. Install O-ring. Install propel motor. Tighten cap screws to 75 N•m (55 lb-ft).

Specification

Propel Motor-to-Gearbox Cap Screw—Torque..... 75 N•m (55 lb-ft)

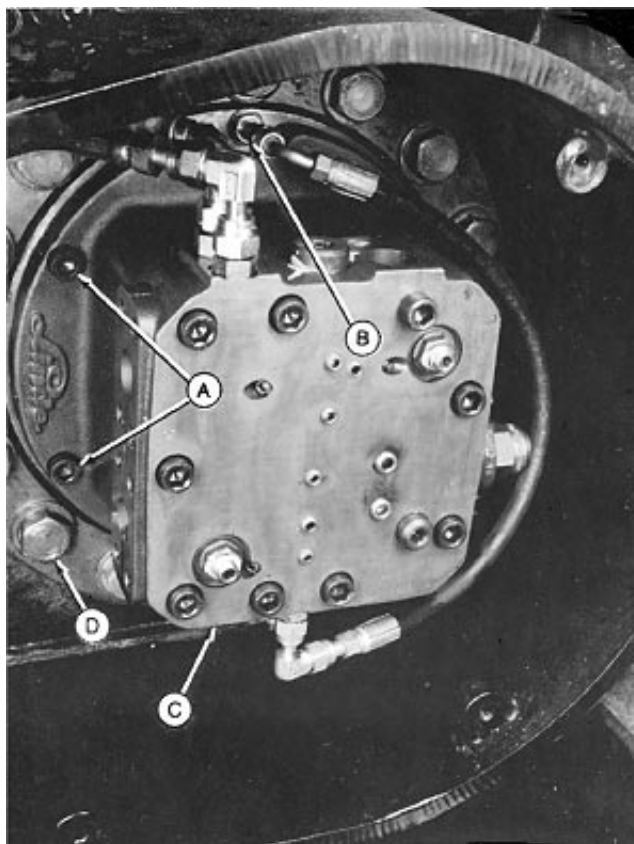

T7626D1 -UN-06JAN92

- A—Cap Screw (6 used)
- B—Right Gearbox Brake Port at 12:30 O'clock Position
- C—Propel Motor
- D—Cap Screw (16 used)

Continued on next page

TX,0250,AB507 -19-21FEB92-12/13

Axle Shaft, Bearings, And Reduction Gears

23. Install supply shuttle valve (F) so the side with one plug is towards gearbox. Install counterbalance valve (I). Tighten cap screws to 75 N•m (55 lb-ft).

Specification

Counterbalance Valve-to-Supply
 Shuttle Valve Cap Screw—
 Torque 75 N•m (55 lb-ft)

24. Connect lines (A—C, G, and H).

25. Install cover.

- A—Drain Port-to-Rotary Manifold Return Line
- B—Propel Speed Change Port-to-Rotary Manifold "P1" Port Line
- C—Propel Brake Release Port-to-Gearbox Line
- D—Cap Screw (6 used)
- E—Cap Screws (6 used)
- F—Supply Shuttle Valve
- G—"A" Port-to-Rotary Manifold "2" or "4" Port Line
- H—"B" Port-to-Rotary Manifold "1" or "3" Port Line
- I—Counterbalance Valve
- J—Cap Screw (6 used)

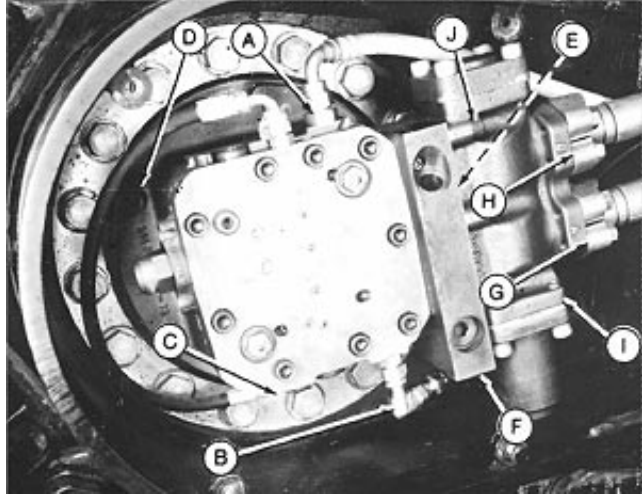

Left Side

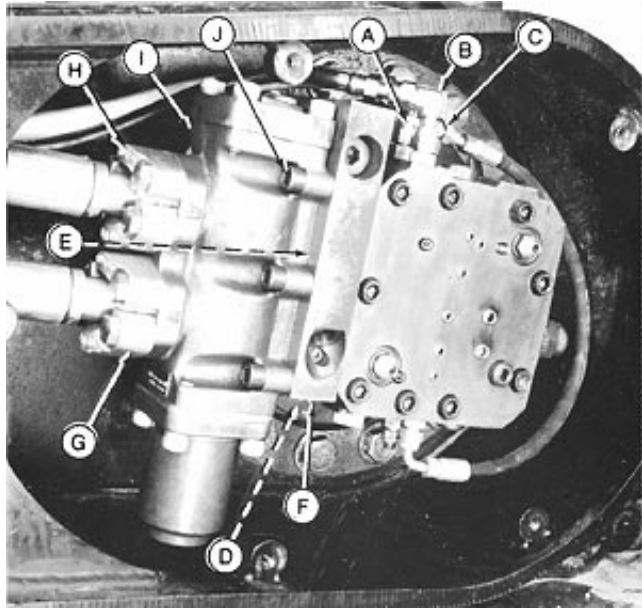

Right Side

T7681FC -UN-05FEB92

T7681FB -UN-05FEB92

TX,0250,AB507 -19-21FEB92-13/13

02
0250
14

Axle Shaft, Bearings, And Reduction Gears

Disassemble Propel Gearbox

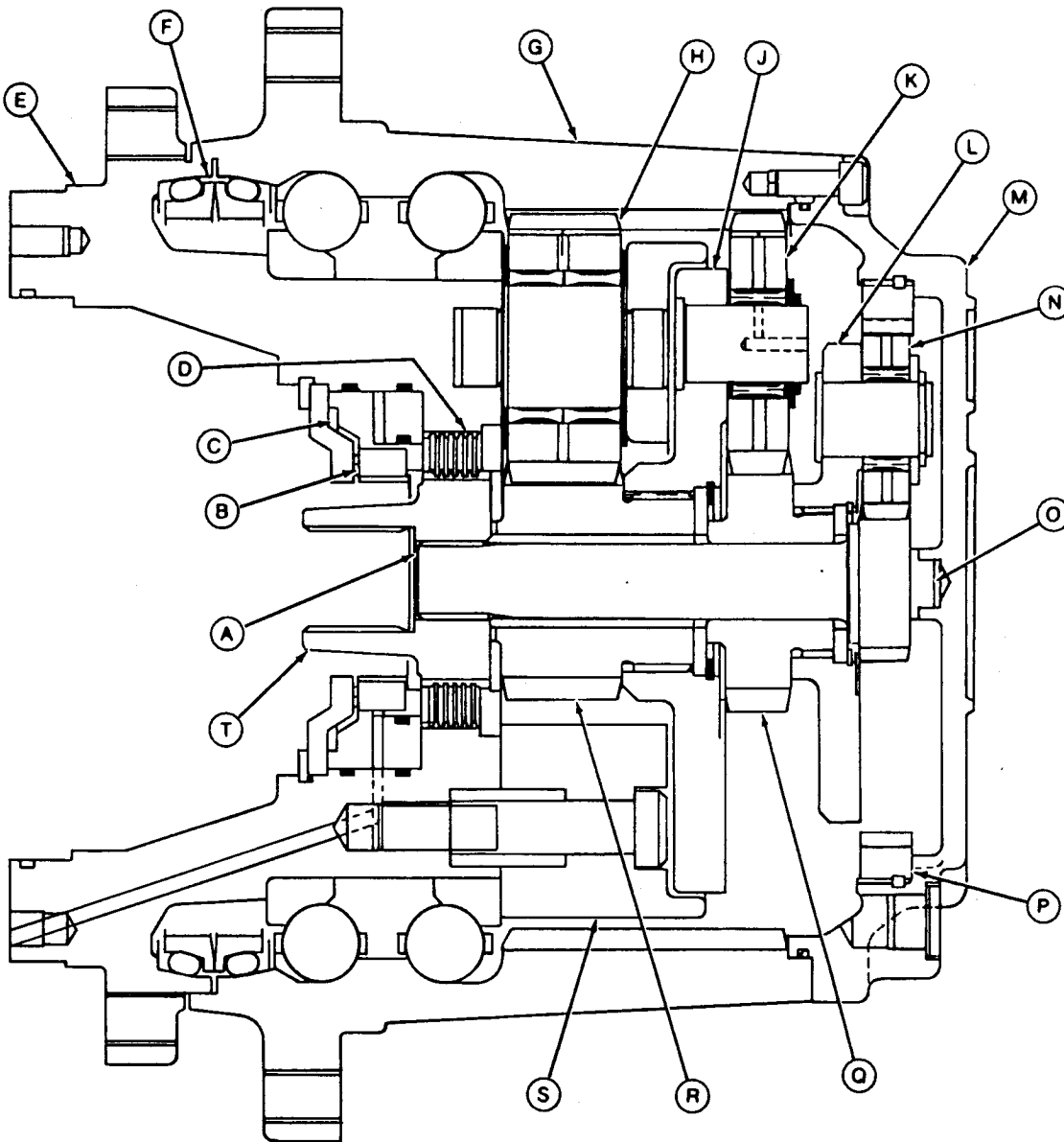

A—First Planet Sun Gear
(Input Shaft)
B—Spring (21 used)
C—Brake Piston
D—Brake Disk (7 used) and
Plate (6 used)

E—Support Hub
F—Metal Face Seal
G—Housing
H—Third Planet Gear (4 used)
J—Second Planet Carrier
K—Second Planet Gear (3
used)

L—First Planet Carrier
M—Cover
N—First Planet Gear (3 used)
O—Thrust Bushing
P—First Planet Ring Gear

Q—Second Planet Sun Gear
R—Third Planet Sun Gear
S—Third Planet Carrier
T—Brake Hub

Continued on next page

TX,0250,DW582 -19-12APR95-1/15

02
0250
15

T7681EZ -JUN-24,JAN92

Axle Shaft, Bearings, And Reduction Gears

CAUTION: The approximate weight of sprocket is 84 kg (184 lb).

- 1. Remove cap screws. Remove sprocket.

Specification

Sprocket—Approximate Weight..... 84 kg (184 lb)

TX,0250,DW582 -19-12APR95-2/15

- 2. Remove cap screws (A). Remove cover (B).



T7375AW -UN-27JAN92

TX,0250,DW582 -19-12APR95-3/15

CAUTION: Gears may turn. Keep fingers away from planet gears.

- 3. Remove first planet sun gear (input shaft) (A).
- 4. Remove first planet carrier (B).

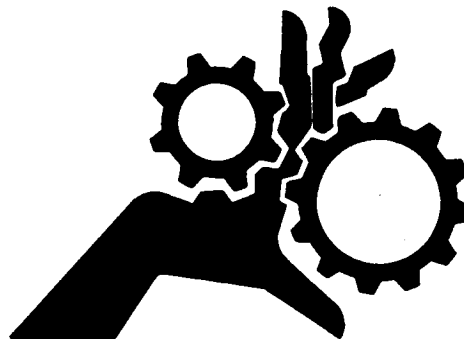

T6639GK -UN-19OCT88



T7375BF -UN-27JAN92

Continued on next page

TX,0250,DW582 -19-12APR95-4/15

Axle Shaft, Bearings, And Reduction Gears

5. Remove second planet sun gear (A) and second planet carrier (B).



T7375BE -UN-27JAN92

TX,0250,DW582 -19-12APR95-5/15

02
0250
17

6. Remove third planet sun gear (B).

7. Remove cap screws (A).

NOTE: Thread lock and sealer (medium strength) is used on threads of cap screws.

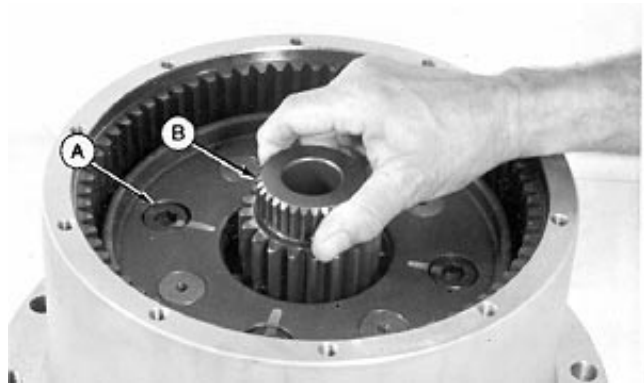

T7375BD -UN-27JAN92

TX,0250,DW582 -19-12APR95-6/15

8. Remove third planet carrier (B) using a puller (A) and adapter (C).

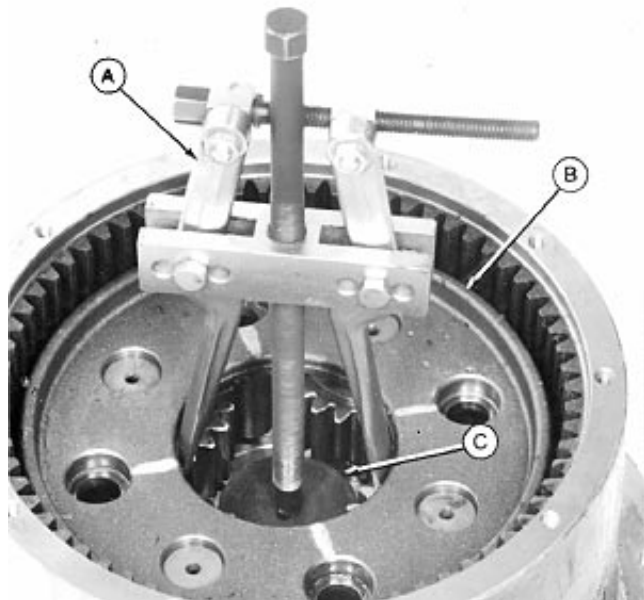

T7626BY -UN-06DEC91

Continued on next page

TX,0250,DW582 -19-12APR95-7/15

Axle Shaft, Bearings, And Reduction Gears

- Remove third planet gears (A) using DFT1095 Planet Gear Assembly Tool and DFT1094 Bearing Pilot Tool to keep needle bearing in place. Slide knife edge of tool under lower washer and put bearing pilot tool on shaft. (See Section 99 for Instruction to make tools.)

NOTE: If third planet carrier and gears are being replaced also remove the shafts using the DFT1096 Planet Gear Shaft Removal Tool.

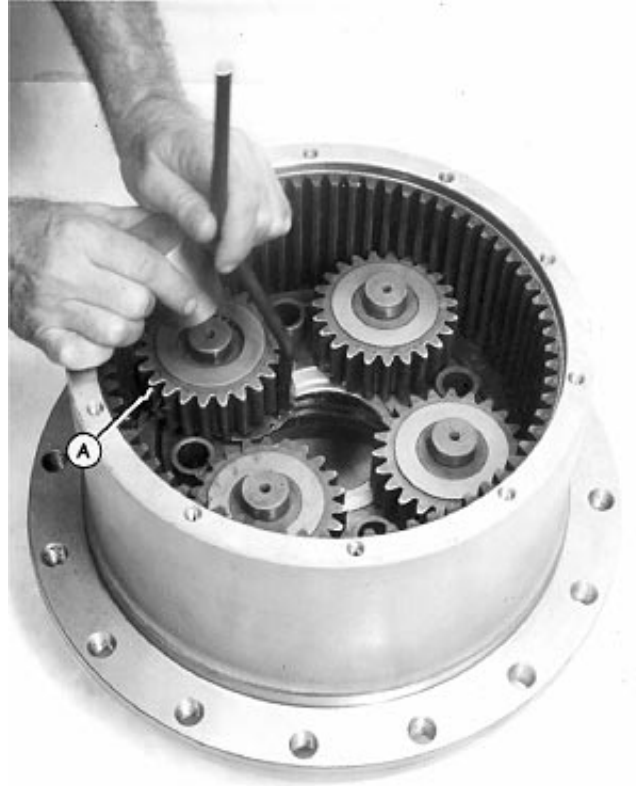

T7401AH -UN-27JAN92

TX,0250,DW582 -19-12APR95-8/15

- Remove spacer (A).

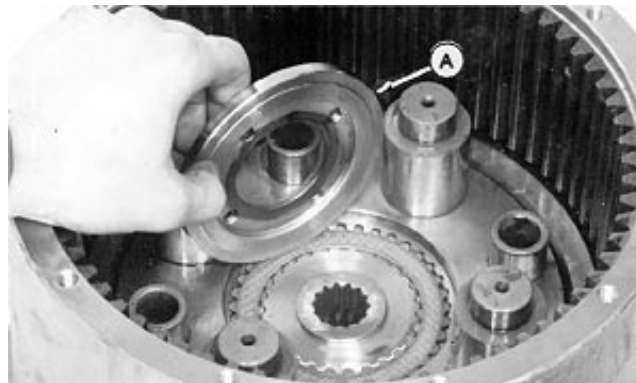

T7626CA -UN-06DEC91

Continued on next page

TX,0250,DW582 -19-12APR95-9/15

02
0250
18

Axle Shaft, Bearings, And Reduction Gears

11. Remove disks (A), plates (B) and brake hub (C).

- A—Disk (7 used)
- B—Plate (6 used)
- C—Brake Hub

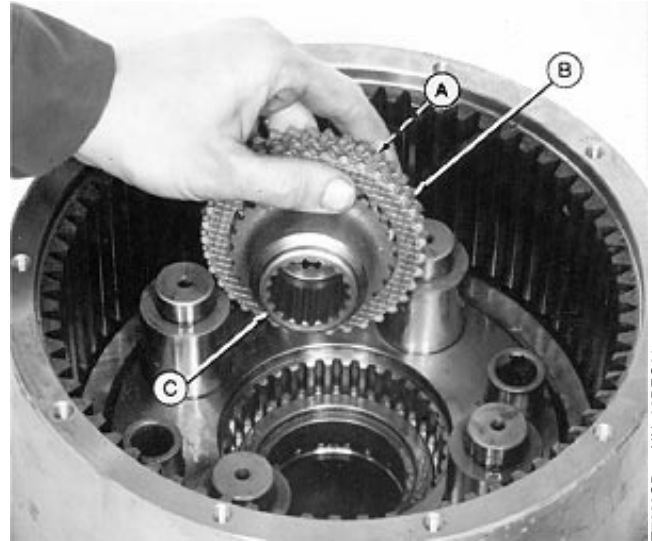

T7626CB -UN-06DEC91

02
0250
19

TX,0250,DW582 -19-12APR95-10/15

12. Pull housing (A) off support hub (D) using a hydraulic ram (B), pullers, and attachments (C).

NOTE: Ball bearings are loosely held by a cage and can fall out when housing is removed.

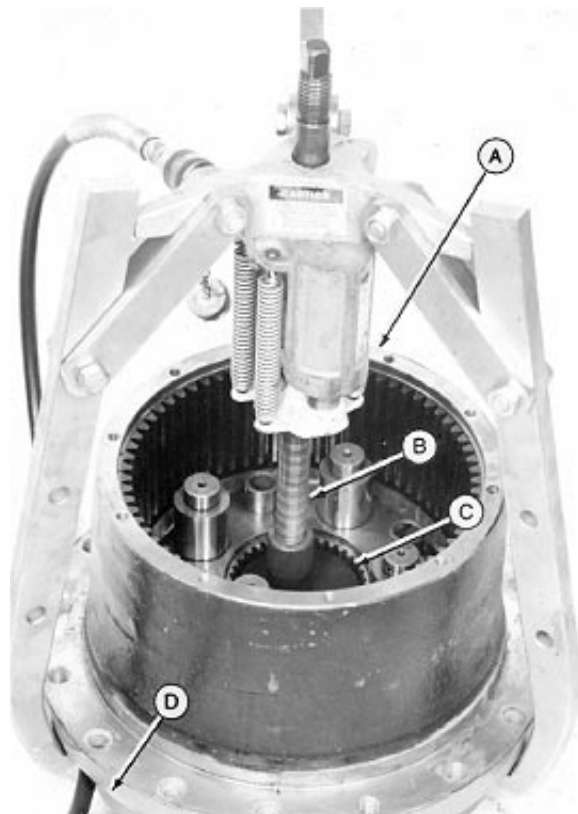

T7626BX -UN-06DEC91

Continued on next page

TX,0250,DW582 -19-12APR95-11/15

Axle Shaft, Bearings, And Reduction Gears

CAUTION: Use a lifting device for heavy components.

13. Remove housing (B) using lifting brackets (A) such as JT01748 Lifting Bracket and a hoist.

14. Remove ball bearings (C).

IMPORTANT: Metal face seals can be reused if they are not worn or damaged. A used seal must be kept together as a set because of wear patterns on seal ring face.

15. Remove metal face seal ring and O-ring from housing. Keep seal rings together as a matched set with metal faces together to protect surfaces.

16. Inspect metal face seal. (See procedure in this group.) For seals that are reused, put a piece of cardboard between seal rings to protect seal ring face.



T7396AE -UN-27JAN92

TX,0250,DW582 -19-12APR95-12/15

17. Remove other metal face seal ring (A) and O-ring (B) from hub (C).

Remove bearing race only if replacement is necessary.

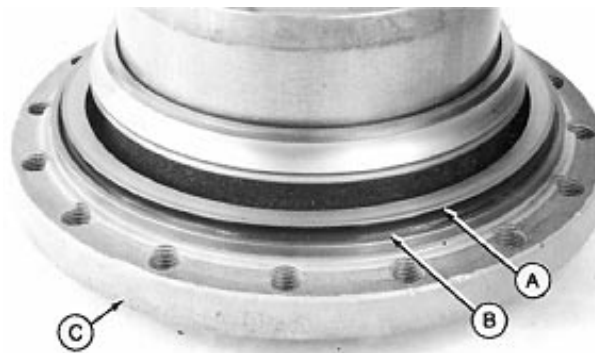

T7397CF -UN-27JAN92

Continued on next page

TX,0250,DW582 -19-12APR95-13/15

Axle Shaft, Bearings, And Reduction Gears

18. Compress brake springs using a puller and attachments.
19. Remove snap ring (A). Slowly release spring force.

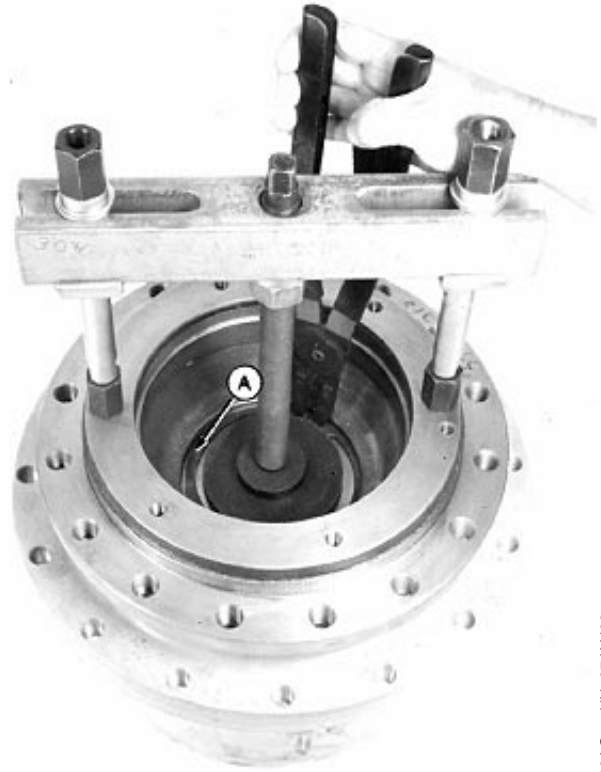

02
0250
21

T7392AG -UN-27JAN92

TX,0250,DW582 -19-12APR95-14/15

20. Remove disk (A), springs (C), piston (D) and spacer (B).
21. Remove O-rings from hub and spacer.

- A—Disk
- B—Spacer
- C—Spring (21 used)
- D—Piston

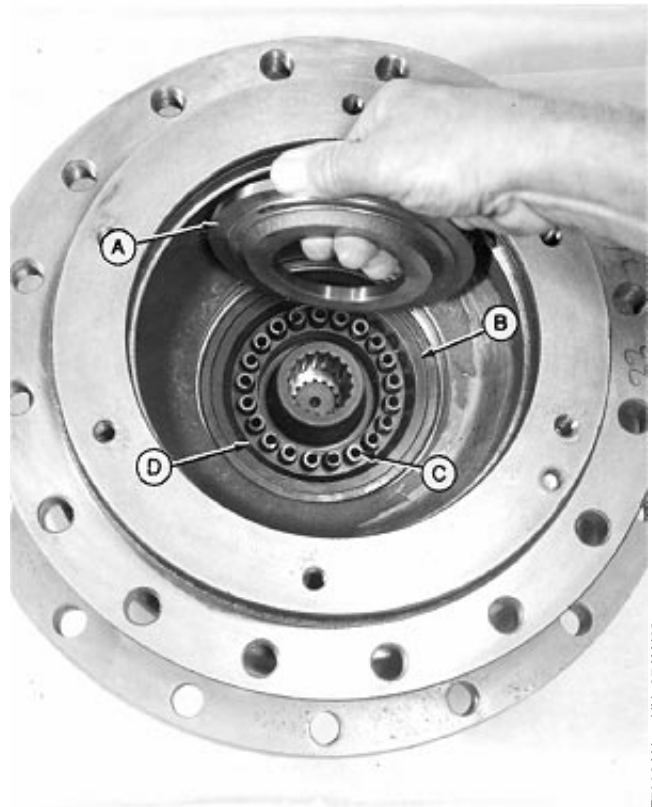

T7392AH -UN-27JAN92

TX,0250,DW582 -19-12APR95-15/15

Inspect Metal Face Seals

1. Inspect for the following conditions to determine if seals can be reused.
 - a. The narrow, highly polished sealing area (E) must be in the outer half of seal ring face (D).
 - b. Sealing area must be uniform and concentric with the ID and OD of seal ring (A).
 - c. Sealing area must not be chipped, nicked, or scratched.

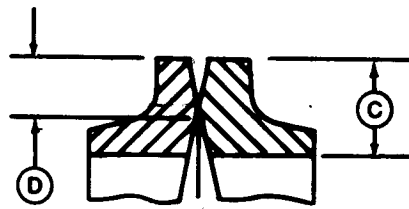
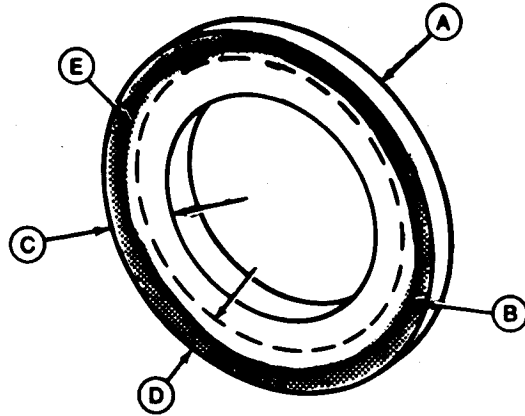

- A—Seal Ring
- B—Worn Area (shaded area)
- C—Seal Ring Face
- D—Outer Half of Seal Ring Face
- E—Sealing Area (dark line)

T85079 -UN-24AUG93

TX,0250,AA3036 -19-11NOV94-1/3

2. Illustration shows examples of worn seal rings (A).
 - I-Sealing area (D) is in inner half of seal ring face (C).
 - II-Sealing area (D) not concentric with ID and OD of seal ring.

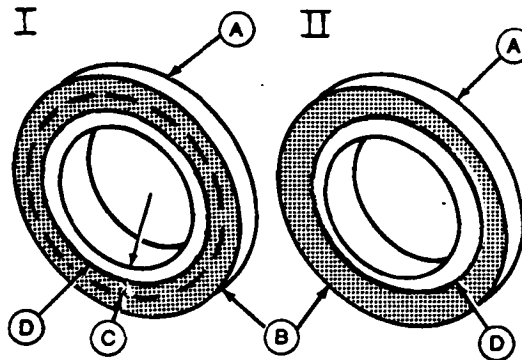

- A—Seal Ring
- B—Worn Area (shaded area)
- C—Inner Half of Seal Ring Face
- D—Sealing Area (dark line)

T85080 -UN-05DEC96

Continued on next page

TX,0250,AA3036 -19-11NOV94-2/3

02
0250
22

Axle Shaft, Bearings, And Reduction Gears

3. Clean seals to be reused by removing all foreign material from seal rings, except seal face (A), using a scraper or a stiff bristled fiber brush.
 4. Wash seal rings and O-rings using a volatile, non-petroleum base solvent to remove all oil. Thoroughly dry parts using a lint-free tissue.
- Apply a thin film of oil to seal ring face.

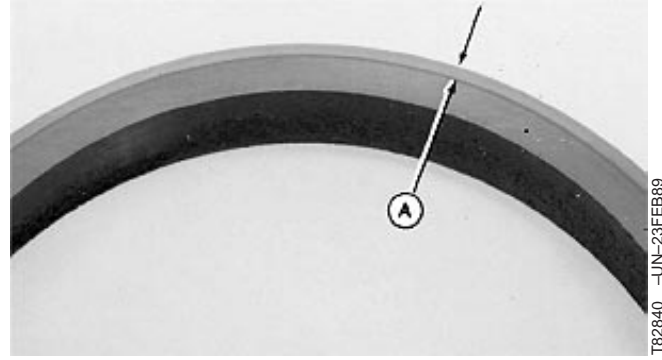

TX,0250,AA3036 -19-11NOV94-3/3

02
0250
23

Assemble Propel Gearbox

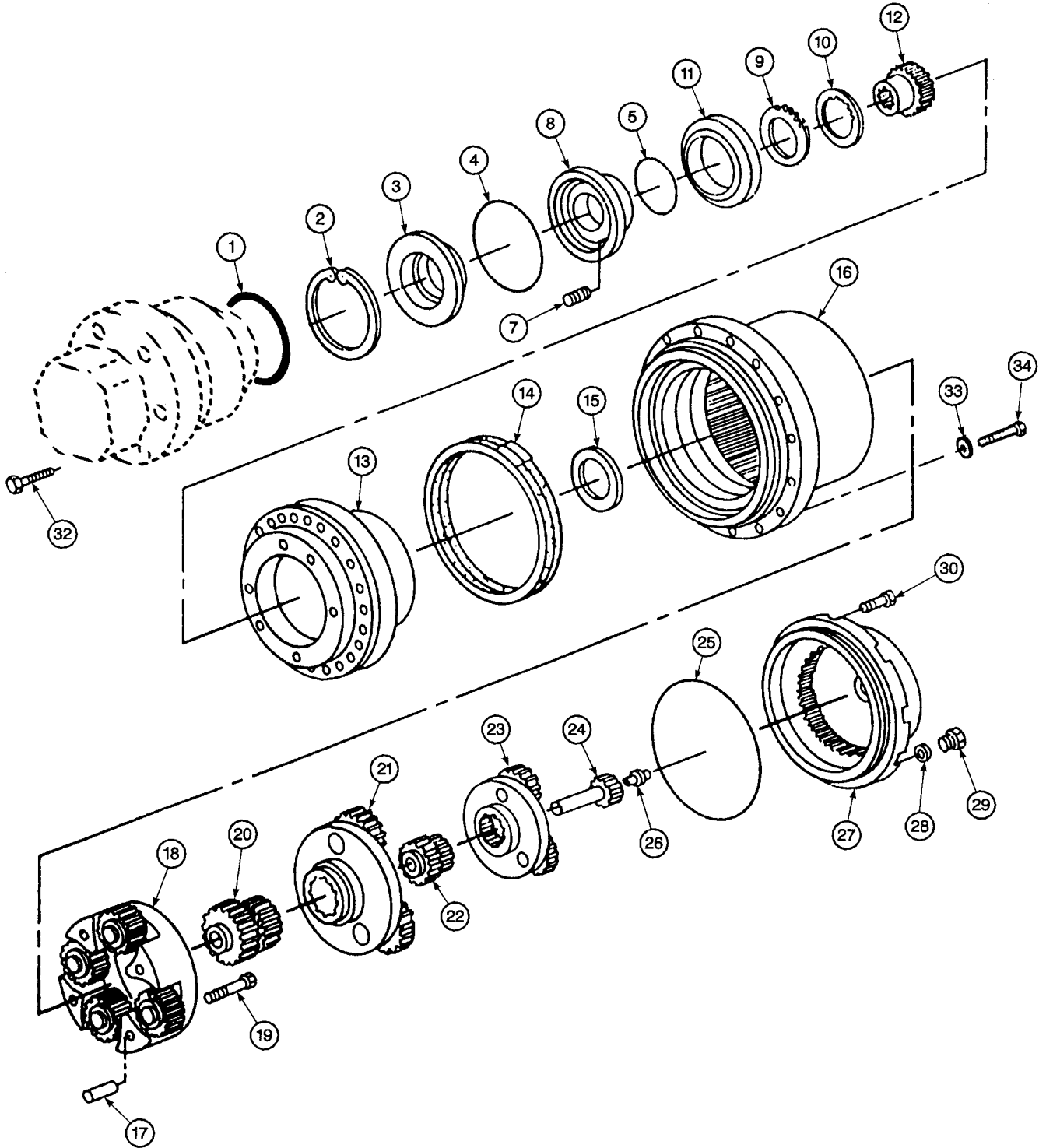

T8364AA CV

T8364AA -UN-28NOV94

Continued on next page

TX.0250.DX266 -19-11NOV94-1/14

Axle Shaft, Bearings, And Reduction Gears

- | | | | |
|--------------------|---------------------------------------|--|-------------------------|
| 1—O-Ring | 11—Spacer | 19—Cap Screw | 26—Thrust Bushing |
| 2—Snap Ring | 12—Brake Hub | 20—Third Planet Sun Gear | 27—Cover with Ring Gear |
| 3—Retainer Disk | 13—Support Hub | 21—Second Planet | 28—Aluminum Washer |
| 4—O-Ring (2 used) | 14—Metal Face Seal | 22—Second Planet Sun Gear | 29—Drain Plug |
| 5—O-Ring | 15—Spacer | 23—First Planet | 30—Cap Screw (10 used) |
| 7—Spring (21 used) | 16—Housing with Bearing and Ring Gear | 24—First Planet Sun Gear (Input Shaft) | 32—Cap Screw (6 used) |
| 8—Piston | 17—Bushing | 25—O-Ring | 33—Washer (16 used) |
| 9—Disk (7 used) | 18—Third Planet | | 34—Cap Screw (16 used) |
| 10—Plate (6 used) | | | |

- | | |
|---|--|
| 1. Install two new O-rings (4) in the hub (13). | 5. Install springs (7) in piston. |
| 2. Install new O-ring (5) in the spacer (11). | 6. Install retainer disk (3). |
| 3. Install spacer (11) on piston (8). | 7. Compress spring. Install snap ring (2). |
| 4. Install piston and spacer in hub. | 8. Install new hub-to-propel motor O-ring (1). |

Continued on next page

TX,0250,DX266 -19-11NOV94-2/14

02
0250
25

Axle Shaft, Bearings, And Reduction Gears

NOTE: Housing and ball bearings are serviced as an assembly. See Assemble Replacement Housing and Bearing Assembly in this group for assembly instruction.

9. Install ball bearings and cages (B). Apply ample amounts of petroleum jelly to bearings to help hold them in place.

IMPORTANT: O-ring and seat surfaces for O-ring must be clean, dry, and oil free so O-ring does not slip in housing.

10. Thoroughly clean O-ring and seat surfaces in housing, hub, and seal rings using volatile, non-petroleum base solvent and lint-free tissues.

NOTE: A volatile, non-petroleum base solvent or talcum powder must be used as a lubricant. Solvent must not damage the O-ring or leave an oil residue.

11. Install metal face seal using JDG733A Seal Installer.

Apply equal pressure to seal installer. Seal must "pop" down into place so O-ring is tight against seal bore and seal ring is installed squarely.

12. Wipe finger prints and foreign material off seal ring face using clean oil and lint-free tissues.
13. Apply a thin film of clean oil on each seal ring face.

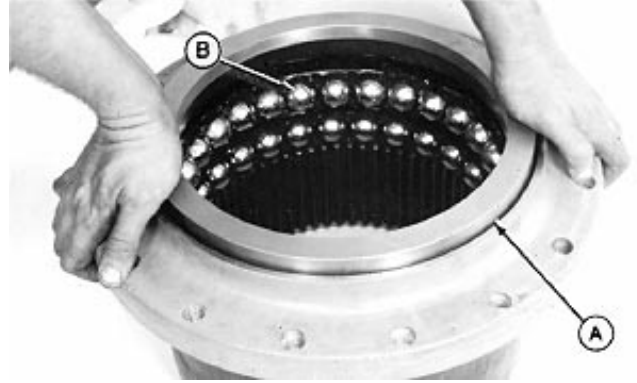

T7626DO -UN-06JAN92

Continued on next page

TX,0250,DX266 -19-11NOV94-3/14

Axle Shaft, Bearings, And Reduction Gears

14. Carefully turn housing over and support it so that seal ring face does not contact any surface.
15. Hold upper and lower bearings in position in the race using light weight monofilament line wrapped around the cage and cap screws. Also, install lifting brackets so that housing can be lifted and installed on hub.

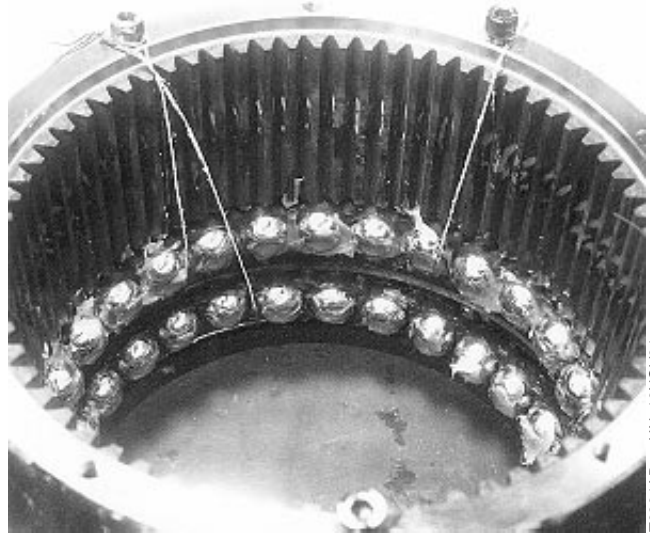

02
0250
27

TX,0250,DX266 -19-11NOV94-4/14

16. From underneath, install adapter plate and threaded rod (A) up through hub.
17. Install housing on hub.
18. Install 3-jaw pullers on housing. Tighten nut (C) to pull housing and hub together just enough so bearing race can be installed.

NOTE: Definite resistance to tightening will be felt when housing and hub are together.

19. Install bearing race.
20. Push bearing race on hub using a second 3-jaw puller, washer, and nut (B).
21. Remove pullers, attachments, and rod.
22. Remove monofilament line and cap screws (D).

- A—Steel Threaded Rod
- B—Nut and Large Washer
- C—Nut and Large Washer
- D—Monofilament Line and Cap Screws

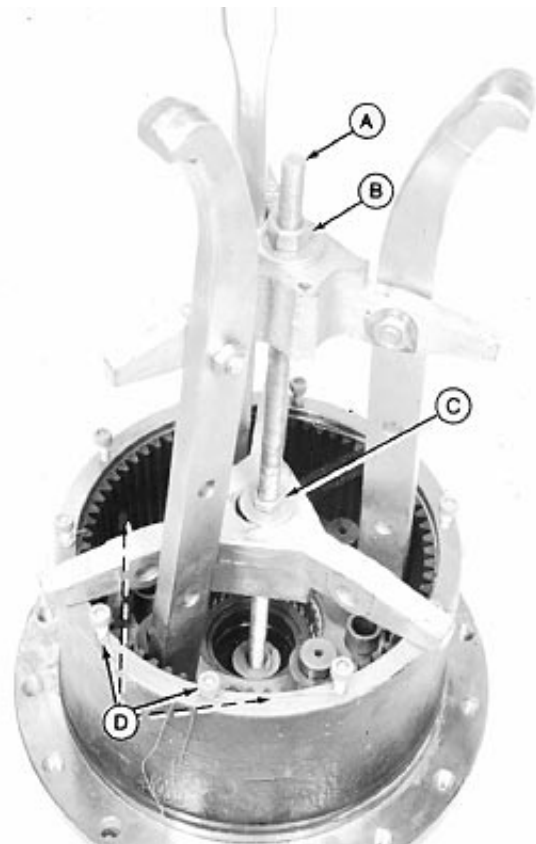

T7626DR -UN-06JAN92

Continued on next page

TX,0250,DX266 -19-11NOV94-5/14

Axle Shaft, Bearings, And Reduction Gears

23. Install brake hub (C).

24. Starting with disk (B), alternately install seven disks and six plates (A).

To get the last disk to engage splines in hub, apply hydraulic pressure to brake port to move piston down.

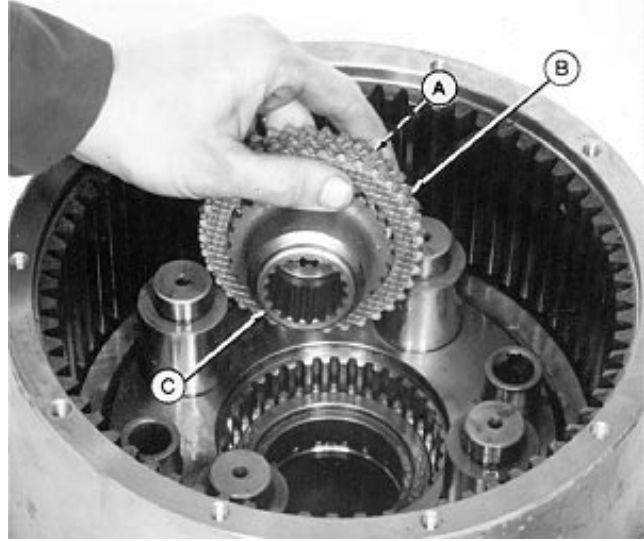

T7626CB -UN-06DEC91

TX,0250,DX266 -19-11NOV94-6/14

25. Install spacer (A).

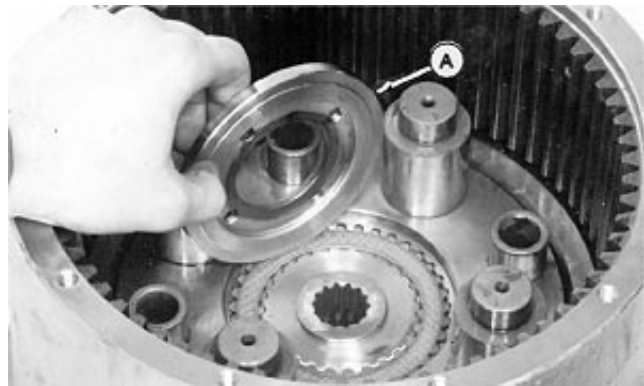

T7626CA -UN-06DEC91

Continued on next page

TX,0250,DX266 -19-11NOV94-7/14

Axle Shaft, Bearings, And Reduction Gears

26. Install the third planet gears (A) using DFT1095 Planet Gear Assembly Tool and DFT1094 Bearing Pilot Tool. (See Section 99 for instruction to make tools.)

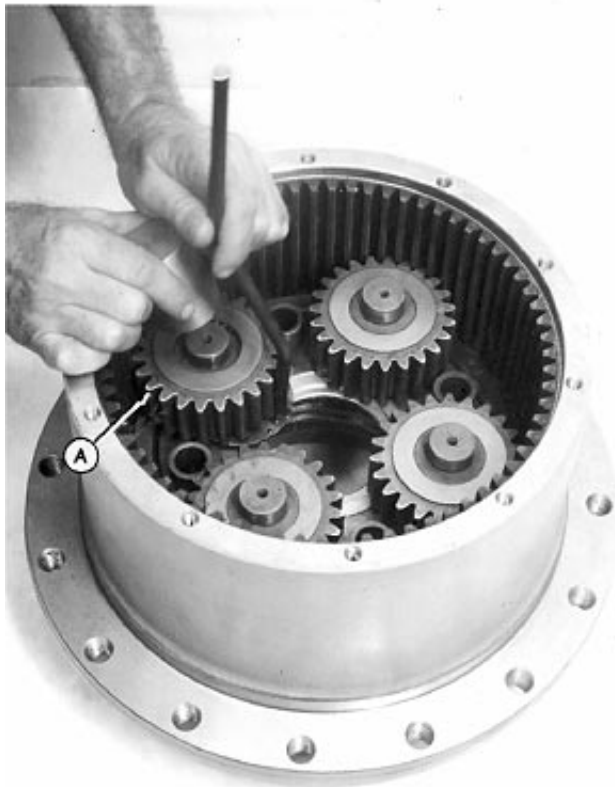

T7401AH -UN-27JAN92

TX,0250,DX266 -19-11NOV94-8/14

02
0250
29

27. Install third planetary carrier (A) on gear shafts (B).
28. Pull carrier down on shafts and bushing using cap screws and washers.
29. Clean cap screw threads using clean and cure primer. Apply thread lock and sealer (medium strength) to threads.
30. Tighten cap screws to 540 N•m (400 lb-ft).

Specification

Cap Screws—Torque 540 N•m (400 lb-ft)

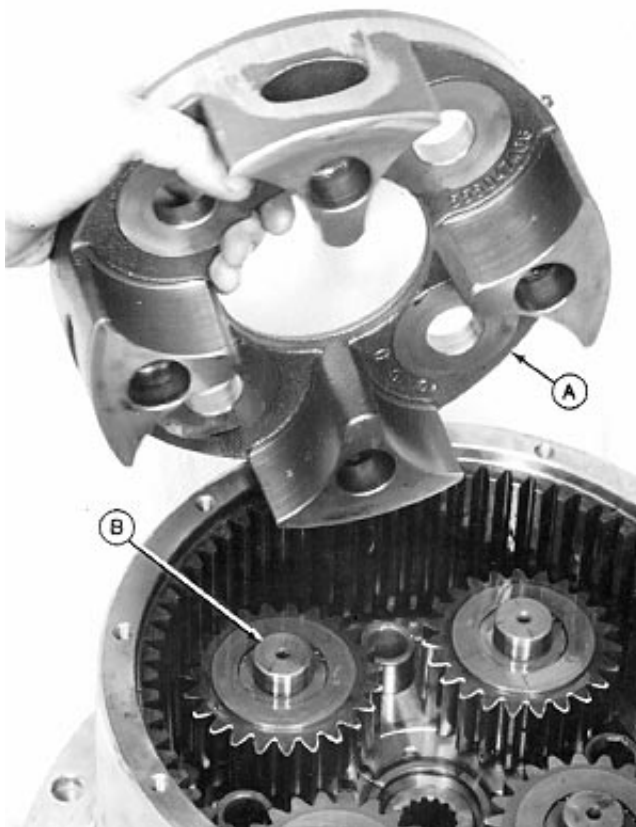

T7626BZ -UN-06DEC91

Continued on next page

TX,0250,DX266 -19-11NOV94-9/14

Axle Shaft, Bearings, And Reduction Gears

31. Install third planet sun gear (B) in carrier (A).

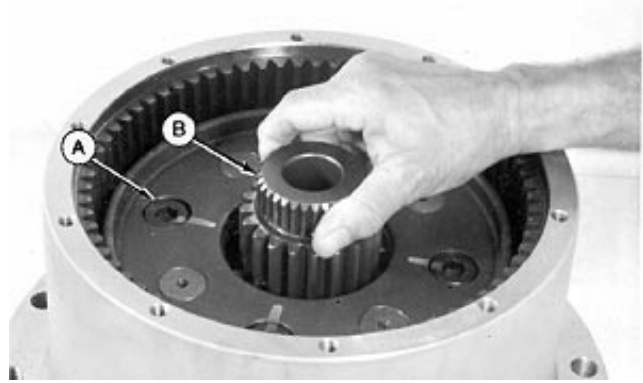

T7375BD -UN-27JAN92

TX,0250,DX266 -19-11NOV94-10/14

32. Install second planet carrier (B).

33. Install second planet sun gear (A).



T7375BE -UN-27JAN92

TX,0250,DX266 -19-11NOV94-11/14

34. Install first planet carrier (A).



T7375BA -UN-27JAN92

Continued on next page

TX,0250,DX266 -19-11NOV94-12/14

Axle Shaft, Bearings, And Reduction Gears

35. Install first planet sun gear (input shaft) (A).



T7375BF -JUN-27JAN92

TX,0250,DX266 -19-11NOV94-13/14

02
0250
31

36. Install O-ring (A) in groove on cover (B).

37. Install cover on housing. Tighten cap screws to 75 N•m (55 lb-ft).

Specification

Planet Carrier Cover-to-Housing
Cap Screw—Torque 75 N•m (55 lb-ft)



T7375BC -JUN-31JUL96

TX,0250,DX266 -19-11NOV94-14/14

Assemble Replacement Housing And Bearing Assembly

NOTE: Do not remove shipping tube. Shipping tube is used to hold bearings in place during shipping and installation on support hub.

1. Install threaded rod (K), adapter (J) and nut (E).

Install housing so it is centered over hub (I).

CAUTION: Use a lifting device on heavy components.

2. Install steel tube (D) on inner race.
3. Install 3-jaw puller (G) on threaded rod (K) and steel tube (D).
4. Install washer (F) and nut (E).
5. Tighten nut to pull housing and bearing assembly down onto hub.

Check to be sure bearings are being pulled down on the hub squarely.

6. Remove tools and shipping tube.
7. See Assemble Propel Gearbox in this group for remainder of assembly.

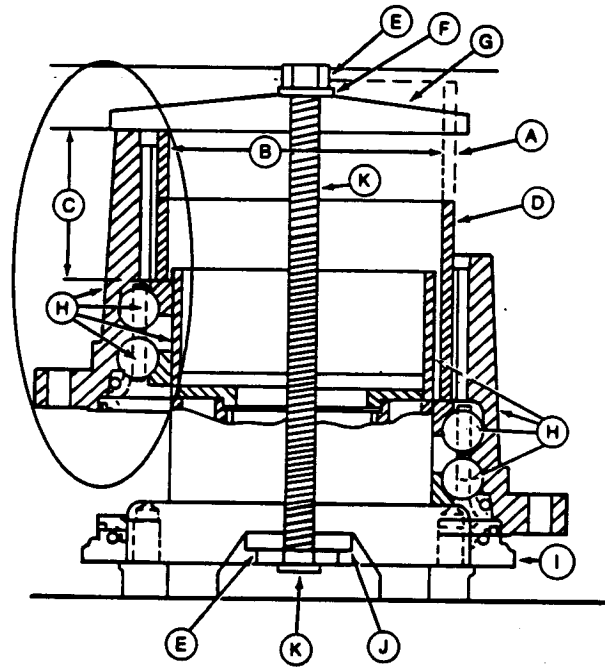

- A—256 mm (10 in.) OD
- B—243 mm (9.5 in.) ID
- C—134 mm (5.25 in.)
- D—Steel Tube
- E—Nut
- F—Washer
- G—3-Jaw Puller
- H—Housing, Bearing and Shipping Tube
- I—Hub
- J—Adapter
- K—Threaded Rod—510 mm (20 in.) Length

T7626DT -UN-10JAN92

TX,0250,AB150 -19-21FEB92-1/1

Service Equipment And Tools

NOTE: Order tools from the U.S. SERVICE-GARD™ Catalog or from the European Microfiche Tool Catalog (MTC). Some tools may be available from a local supplier.

SERVICE-GARD is a trademark of Deere & Company.

TX,0260,DW595 -19-12APR95-1/4

02
0260
1

Pump Workbench Support¹ DF1039

Used to hold propel motor housing.

Pump Rotary Group¹ DF1040

Used to hold rotary group.

Spool Holding Fixture¹ DFT1077

Used to hold counterbalance valve piston.

¹*Fabricated tool, dealer made. (See Section 99 for instructions to make tools.)*

TX,0260,DW595 -19-12APR95-2/4

Rotary Manifold Lifting Tool¹ DFT1157

Used to remove and install rotor manifold.

¹*Fabricated tool, dealer made. (See Section 99 for instructions to make tools.)*

Continued on next page

TX,0260,DW595 -19-12APR95-3/4

Hydraulic System

17-1/2 and 30 Ton Puller Set

Used to remove and install bearings.

Push-Puller (Mechanical) D01200AA

Used to align ports on rotary manifold to existing lines.

Service Wrench D05242ST

Used to align ports on rotary manifold to existing lines.

Plug38H1147

Used to plug propel motor drain line.

Air Test Plug JDG185

Used to seal port during pressure test.

TX,0260,DW595 -19-12APR95-4/4

Other Material

Number	Name	Use
T43512 (U.S.) TY9473 (Canadian) 242 (LOCTITE®)	Thread Lock and Sealer (Medium Strength) Products	Used to apply to threads of cap screws for valve housing and cover.
TY6305 (U.S.) TY9485 (Canadian) 764 (LOCTITE®)	Clean and Cure Primer Products	Used to clean and cure surfaces prior to application of adhesives and sealants.
T43514 (U.S.) TY9475 (Canadian) 277 (LOCTITE®)	Plastic Gasket Products	Used to provide a gasket-type seal between surfaces.
TY9374 (U.S.) TY9481 (Canadian) 592 (LOCTITE®)	Pipe Sealant TEFLON®Products	Used to apply to threads of plugs in propel motor.

LOCTITE is a registered trademark of Loctite Corp.
TEFLON is a registered trademark of the DuPont Company.

TX,0260,AB161 -19-22NOV94-1/1

Hydraulic System

02
0260
3

Specifications

Item	Measurement	Specification
Propel Motor:		
Propel Motor-to-Gearbox Cap Screw	Torque	135 N•m (100 lb-ft)
Cover-to-Housing Cap Screw	Torque	80 N•m (60 lb-ft)
Cylinder Block-to-Valve Plate	Clearance	0.20—0.40 mm (0.008—0.016 in.)
Drive Shaft	End play	0.10—0.30 mm (0.004—0.012 in.)
Valve Housing and Cover Cap Screw	Torque	120 N•m (90 lb-ft)

Item	Measurement	Specification
Counterbalance Valve Cap Screw	Torque	75 N•m (55 lb-ft)
Crossover Relief Valve Cap Nut	Torque	120 N•m (90 lb-ft)
Low Speed Selector Plug	Torque	80 N•m (60 lb-ft)

Item	Measurement	Specification
Rotary Manifold:		
Manifold Housing-to-Uppercarriage Cap Screw	Torque	98 N•m (65 lb-ft)
Cover and Strap Cap Screw	Torque	40 N•m (30 lb-ft)
Retaining Cap Screw	Torque	49 N•m (36 lb-ft)

TX,0260,DW590 -19-12APR95-1/1

Remove And Install Propel Motor

CAUTION: Hydraulic reservoir is pressurized. Loosen fill cap to release pressure.

- Loosen reservoir fill cap (A) to relieve air pressure. Drain oil from propel gearbox. Approximate capacity is 3.9 L (4.1 qt).

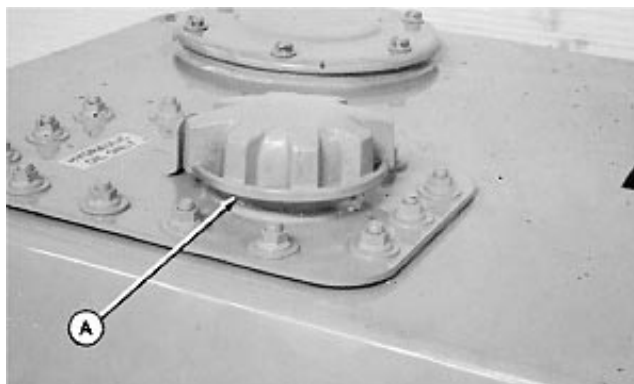

T7626DG -UN-06JAN92

Continued on next page

TX,0260,DW586 -19-12APR95-1/4

Hydraulic System

2. Remove cap screws (B). Remove propel motor cover (C).

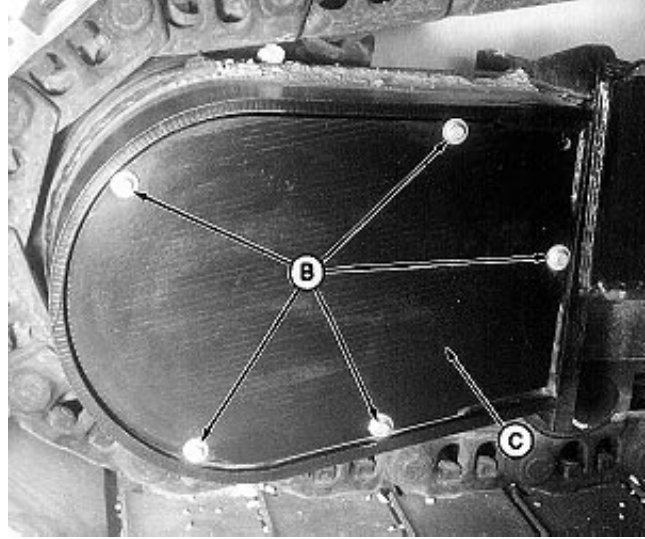

Early Machine Shown

Continued on next page

TX,0260,DW586 -19-12APR95-2/4

02
0260
4

Hydraulic System

CAUTION: To avoid injury from escaping fluid under pressure, stop engine and relieve the pressure in the system before disconnecting or connecting hydraulic or other lines. Tighten all connections before applying pressure.

3. Disconnect lines (A—C, G and H). Remove cap screws (J) to remove counterbalance valve (I).
4. Remove six cap screws to remove supply shuttle valve (F).

CAUTION: Approximate weight of propel motor assembly is 64 kg (141 lb).

5. Attach motor to a hoist using a lifting strap. Remove cap screws (D).
6. Remove motor.
7. Install motor.
8. Install cap screws and tighten to 135 N•m (100 lb-ft).

Specification

Propel Motor-to-Gearbox Cap Screw—Torque..... 135 N•m (100 lb-ft)

9. Connect lines.
10. Tighten reservoir filler cap.
11. Perform Propel Motor Start-Up Procedure. (See procedure in this group.)

- A—Drain Port-to-Rotary Manifold Return Line
- B—Propel Speed Change Port-to-Rotary Manifold "P1" Line
- C—Propel Brake Release Port-to-Gearbox Line
- D—Cap Screw (6 used)
- E—Supply Shuttle Valve Cap Screws (6 used)
- F—Supply Shuttle Valve
- G—"A" Port-to-Rotary Manifold "2" or "4" Port Line
- H—"B" Port-to-Rotary Manifold "1" or "3" Port Line
- I—Counterbalance Valve
- J—Cap Screw (6 used)

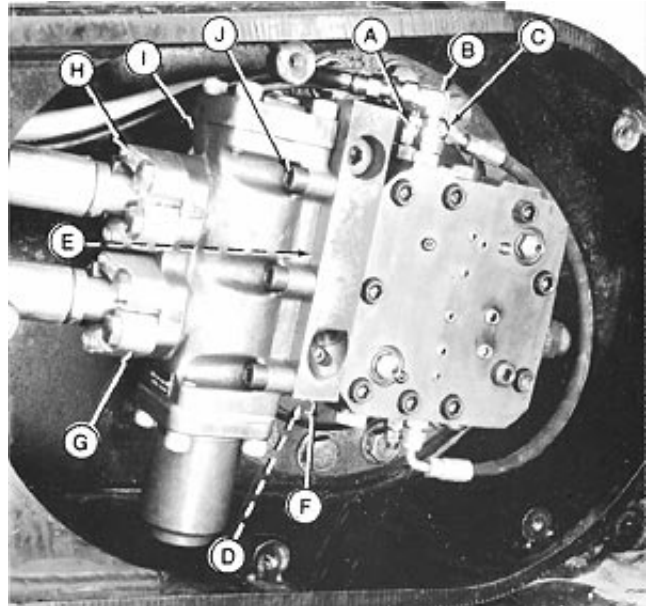
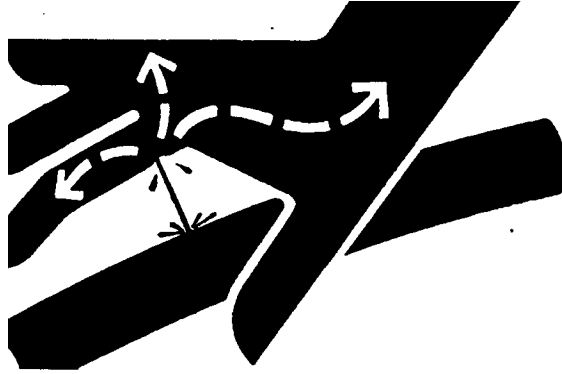

Right Side

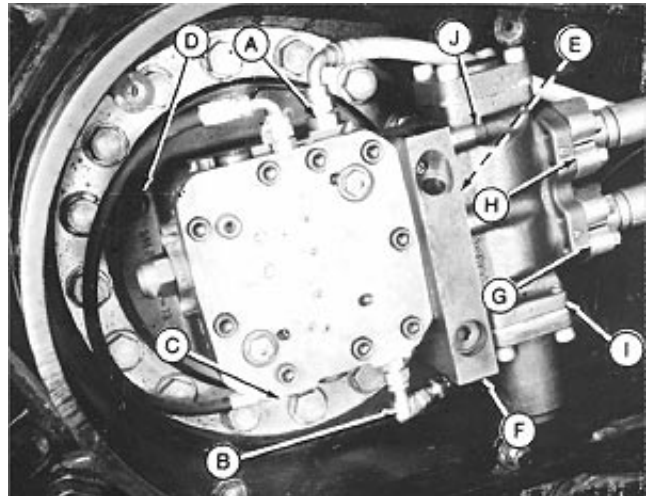

Left Side

X9811 -UN-23AUG88

02
0260
5

T7681FB -UN-05FEB92

T7681FC -UN-05FEB92

Continued on next page

TX,0260,DW586 -19-12APR95-3/4

Hydraulic System

12. Install cover.

TX,0260,DW586 -19-12APR95-4/4

Propel Motor Start-Up Procedure

IMPORTANT: Propel motor will be damaged if not filled with oil before operating propel function. Procedure must be performed whenever a new propel motor is installed or whenever oil has been drained from the motor.

1. Disconnect propel motor drain line (A). Install plug in line to minimize loss of oil.
2. To let air escape, loosen the valve body for propel brake reducing valve on the left side or the plug for low speed selector valve on the right side one turn. Valves are next to the drain hose connection. Do not turn the lock nut or adjusting screw for the propel brake reducing valve.
3. Fill motor with oil through drain port. Add oil until level is to the top of drain port. (See Propel Gearbox Oil in Fuels and Lubricants group.)
4. Tighten valve body or plug.
5. Connect line.
6. Run each propel motor with track off the ground for 3 track revolutions to remove air from the propel circuit.

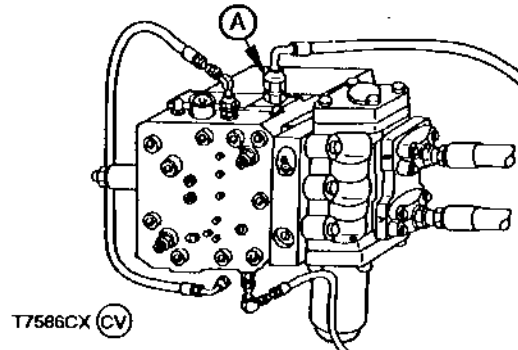

T7586CX -JUN-19AUG91

TX,902025,GG192 -19-17JAN95-1/1

Hydraulic System

02
0260
7

Disassemble Propel Motor

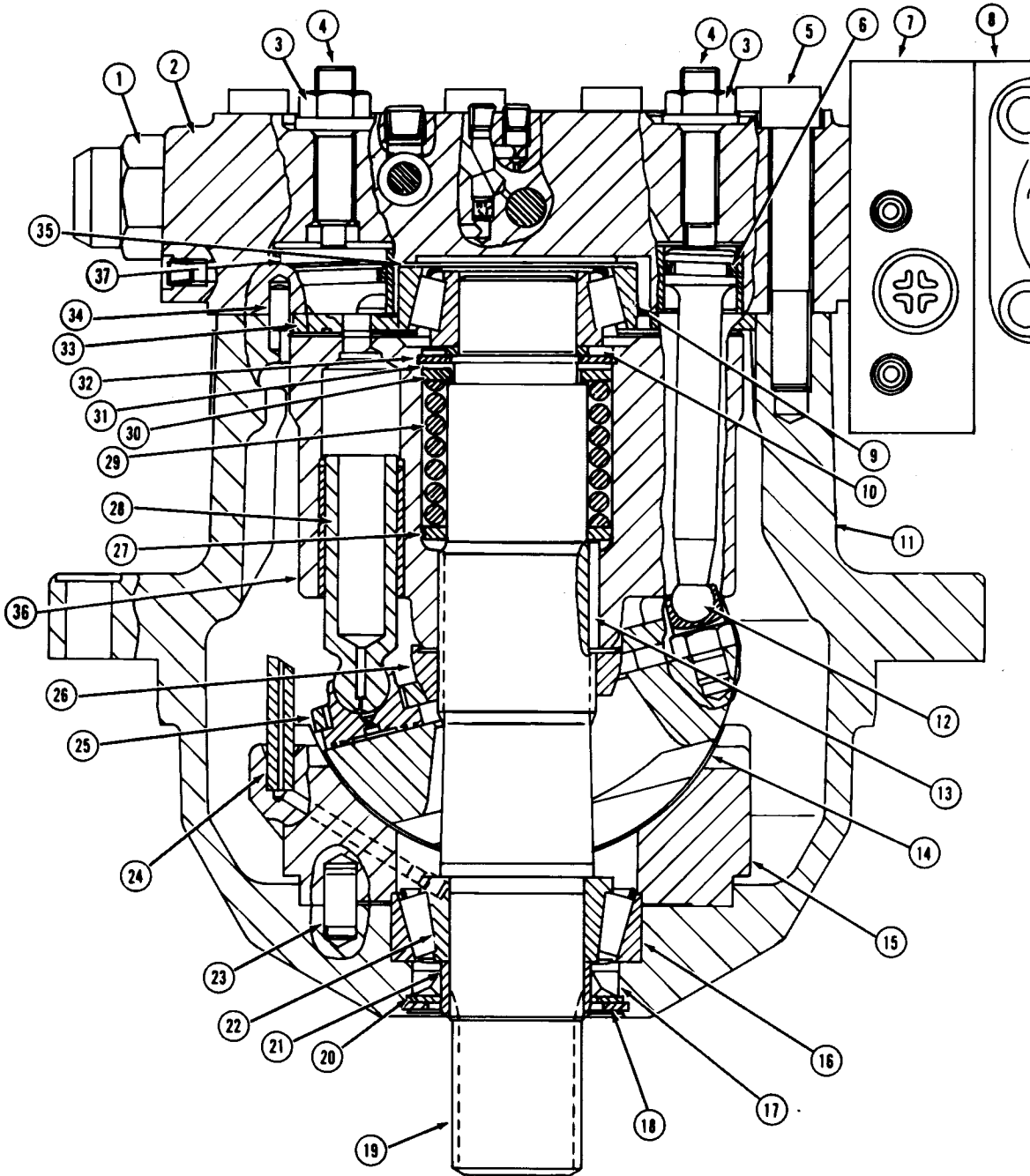

Legend For Propel Motor

Continued on next page

TX,0260,AB165 -19-25FEB92-1/11

T7681FD -UN-05FEB92

02
0260
8

Hydraulic System

- | | | | |
|-----------------------------------|--------------------------------|-------------------|--------------------------------|
| 1—Crossover Relief Valve | 10—Bearing Cone | 19—Drive Shaft | 29—Spring |
| 2—Valve Housing and Cover | 11—Motor Housing | 20—Washer | 30—Washer |
| 3—Seal Nut (do not remove) | 12—Minimum Displacement Piston | 21—Bushing | 31—Shim (as required) |
| 4—Adjusting Screw (do not remove) | 13—Needle Bearing (3 used) | 22—Bearing Cone | 32—Snap Ring |
| 5—Cap Screw (9 used) | 14—Swashplate | 23—Dowel Pin | 33—Valve Plate |
| 6—Piston Ring | 15—Cradle (Bearing Shell) | 24—Oil Tube | 34—Dowel Pin |
| 7—Supply Shuttle Valve | 16—Bearing Cup | 25—Retainer Plate | 35—Shim |
| 8—Counterbalance Valve | 17—Oil Seal | 26—Ball Guide | 36—Cylinder Block |
| 9—Bearing Cup | 18—Snap Ring | 27—Washer | 37—Maximum Displacement Piston |

TX,0260,AB165 -19-25FEB92-2/11

02
0260
9

1. Remove bottom plug (H) to drain motor. Approximate capacity is 2 L (34 oz).
2. Set motor (J) in DF1039 Pump Workbench Support (I). (See Section 99 for instructions to make tool.)

IMPORTANT: Do not remove, nor change settings of adjusters (B and E). This is a factory adjustment and the adjusters are sealed to maintain it. The brake reducing valve adjustment screw (G) is also sealed.

3. Remove cap screws (C). Remove valve housing and cover (D) from motor housing (J).

NOTE: Drain port fitting (K) and drain plug (H) swap positions for right and left motors. On right motor shown, brake port fitting (F) is down. On left side motor, fitting is up.

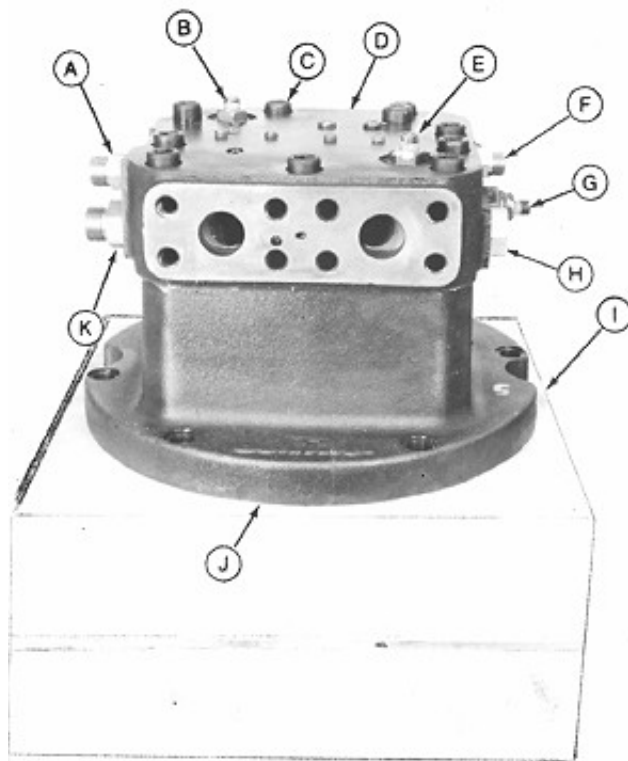

- A—Speed Change Port Fitting
- B—Minimum Displacement Adjuster
- C—Cap Screw (9 used)
- D—Valve Housing and Cover
- E—Maximum Displacement Adjuster
- F—Propel Brake Port Fitting
- G—Propel Brake Pressure Reducing Valve Adjustment Screw
- H—Drain Plug
- I—DF1039 Pump Workbench Support
- J—Motor Housing
- K—Drain Port Fitting

T7681FE -UN-05FEB92

Continued on next page

TX,0260,AB165 -19-25FEB92-3/11

Hydraulic System

4. Note location of dowel pin (D) in valve housing and cover (B), notch (C) in valve plate (A) and hole in motor housing (E) for assembly.

- A—Valve Plate
- B—Valve Housing and Cover
- C—Notch in Plate
- D—Dowel Pin
- E—Motor Housing

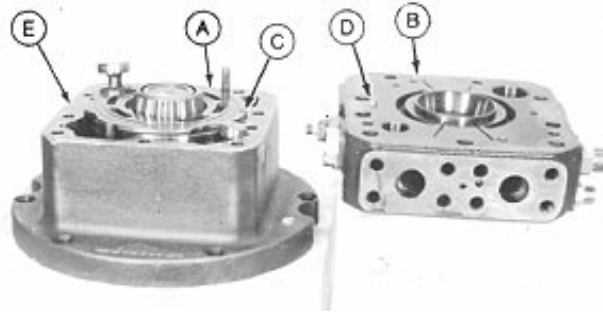

T7681FF -UN-05FEB92

TX,0260,AB165 -19-25FEB92-4/11

5. Remove oil tubes (B).
6. Use pistons (D) to lift rotating group (A) out of housing (C).
7. Set rotating group in DF1040 Pump Rotate Group Workbench Support. (See Section 99 for instructions to make tool.)

- A—Rotating Group
- B—Oil Tube (2 used)
- C—Motor Housing
- D—Minimum Displacement Piston Maximum Displacement Piston

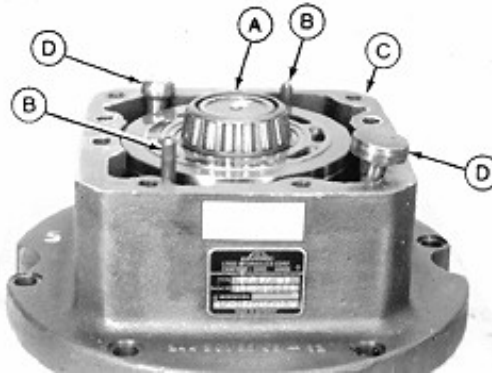

T7626AS -UN-27NOV91

Continued on next page

TX,0260,AB165 -19-25FEB92-5/11

Hydraulic System

8. Put cardboard (C) on cylinder block to protect surface.
9. Break roller cage (D) to remove rollers.
10. Remove bearing inner race (A) and spacer (B) using a bearing puller.

A—Inner Race
 B—Spacer
 C—Cardboard
 D—Roller Cage



TX,0260,AB165 -19-25FEB92-6/11

02
 0260
 11

T7626CP -UN-06/JAN92

IMPORTANT: Do not scratch, nick, or damage lapped surfaces of cylinder block.

11. Put cardboard (B) and workbench support (C) on cylinder block. Turn over to remove shaft and swash plate (A).

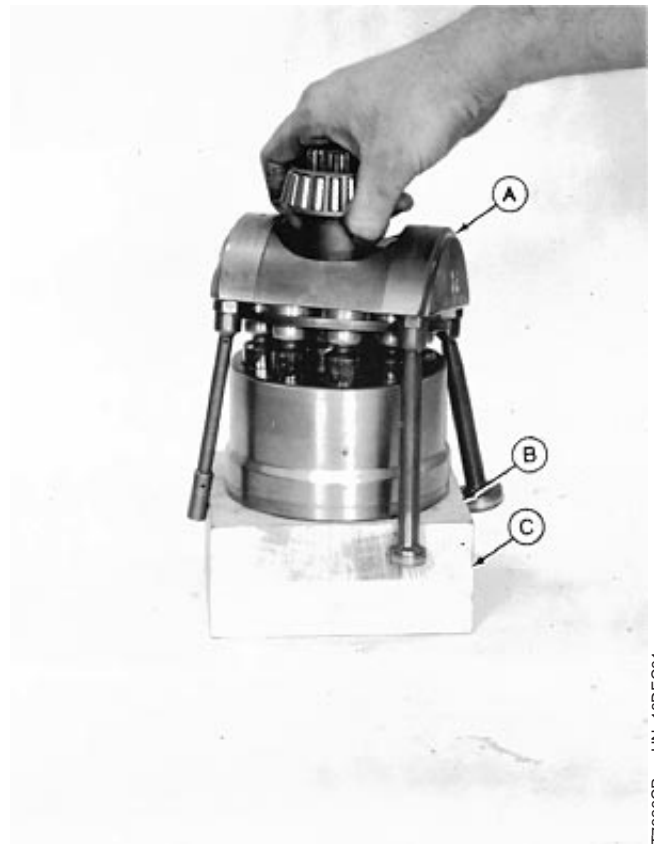

Continued on next page

TX,0260,AB165 -19-25FEB92-7/11

T7626CR -UN-18/DEC91

Hydraulic System

12. Remove the three loose needle bearings (E).

13. Remove driveshaft.

- A—Swash Plate
- B—Piston (9 used)
- C—Retainer Plate
- D—Ball Guide
- E—Needle Bearing (3 used)
- F—Cylinder Block
- G—Minimum Displacement Piston Maximum Displacement Piston
- H—Shim

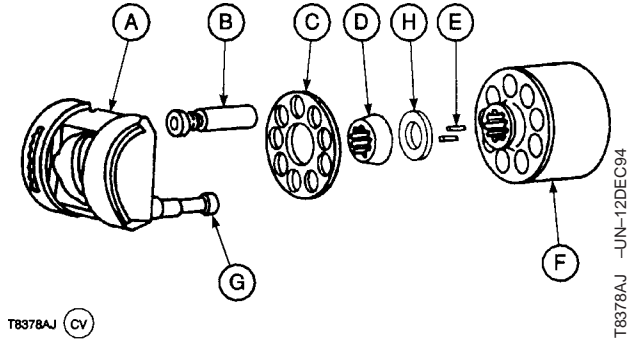

T8378AJ -UN-12DEC94

TX,0260,AB165 -19-25FEB92-8/11

14. Place cylinder block (A) on press. Compress spring (B) and washer (C) enough to remove snap ring (D).

15. Slowly release pressure on spring until it is fully extended.

- A—Cylinder Block
- B—Spring
- C—Washer
- D—Snap Ring

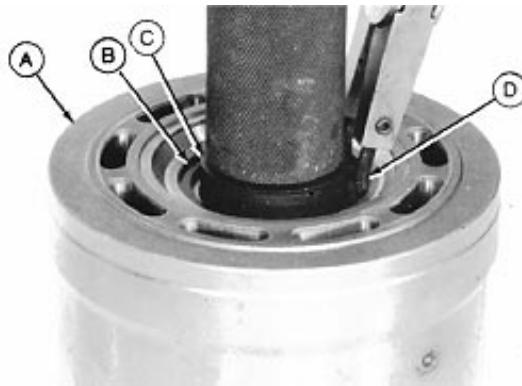

T7626AV -UN-27NOV91

TX,0260,AB165 -19-25FEB92-9/11

16. Remove parts (B—F) from cylinder block (A).

- A—Cylinder Block
- B—Washer
- C—Spring
- D—Washer
- E—Shims (as required)
- F—Snap Ring

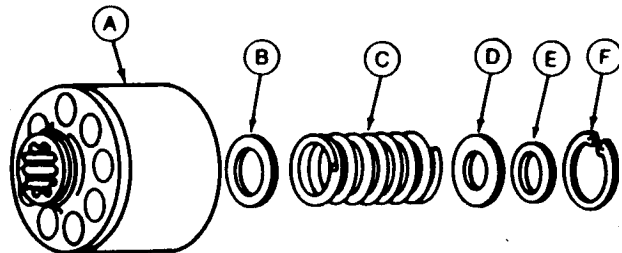

T7626BI -UN-10JAN92

Continued on next page

TX,0260,AB165 -19-25FEB92-10/11

Hydraulic System

17. Remove bushing (B) from drive shaft (E), and bearing cone (D). Cone is a press fit.
18. Remove bearing cup (C) from motor housing (A). Cup is a press fit.

- A—Motor Housing
- B—Bushing
- C—Bearing Cup
- D—Bearing Cone
- E—Drive Shaft

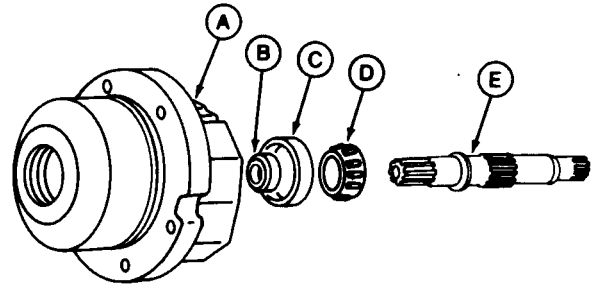

T7626BJ -UN-10JAN92

02
0260
13

TX,0260,AB165 -19-25FEB92-11/11

Hydraulic System

Disassemble Valve Housing And Cover

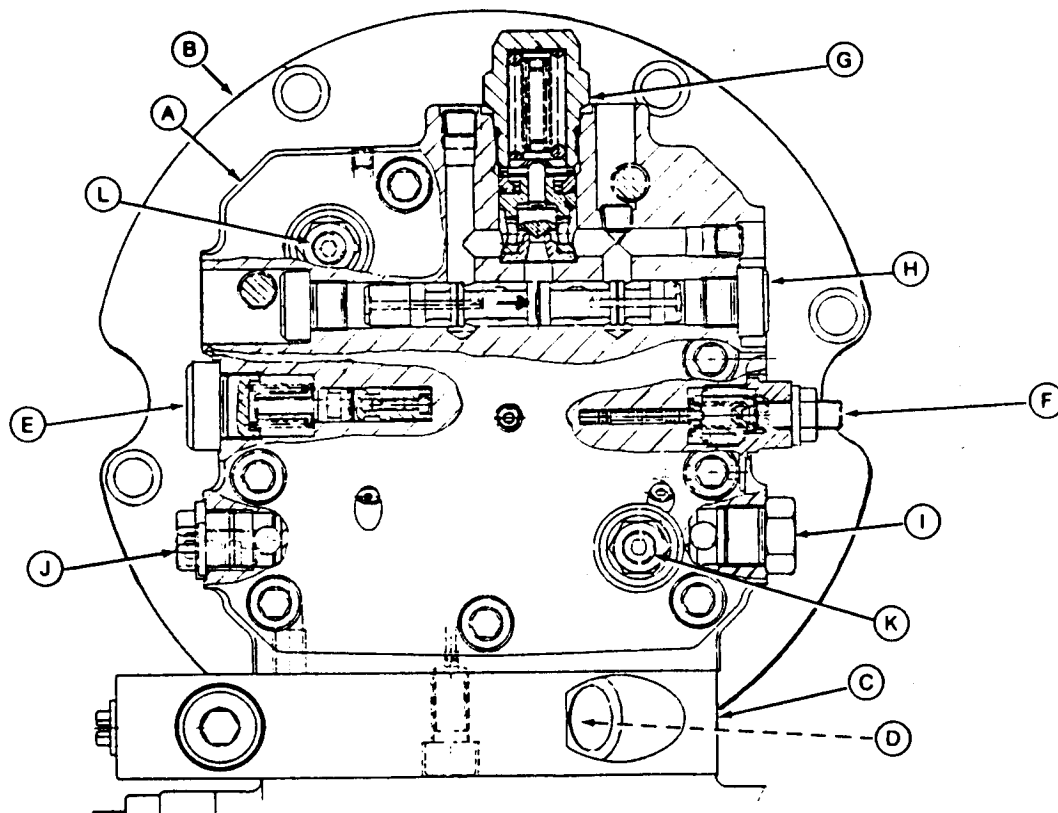

A—Valve Housing and Cover
 B—Motor Housing
 C—Shuttle Valve Block
 D—Shuttle Valve
 E—Low Speed Selector Valve

F—Brake Release Pressure Reducing Valve
 G—Crossover Relief Valve
 H—Shuttle Valve

I—Drain Plug (Right Motor) Drain Port (Left Motor)
 J—Drain Plug (Left Motor) Drain Port (Right Motor)

K—Maximum Displacement Adjusting Screw
 L—Minimum Displacement Adjusting Screw

IMPORTANT: DO NOT remove, nor change settings of minimum or maximum displacement adjusting screws (K and L). This is a factory setting and the screws are sealed to maintain it.

See individual valves in this group for service procedures.

Continued on next page

TX,0260,AB522 -19-22FEB92-1/5

T7681FL -UN-05FEB92

Hydraulic System

Note the location of the propel speed change orifice (A), flushing orifice (B), and the edge filter and pressure reducing valve orifice (C) for the right and left propel motors.

- A—Propel Speed Change Orifice
- B—Flushing Orifice (Long Type)
- C—Edge Filter and Pressure Reducing Valve Orifice

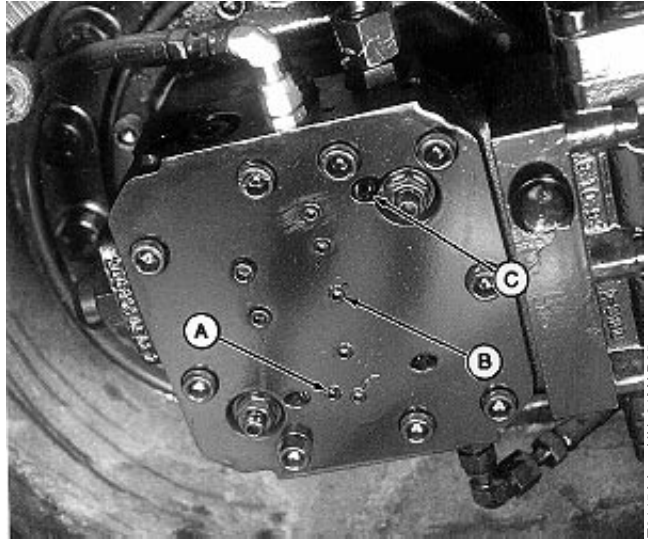

Left Side

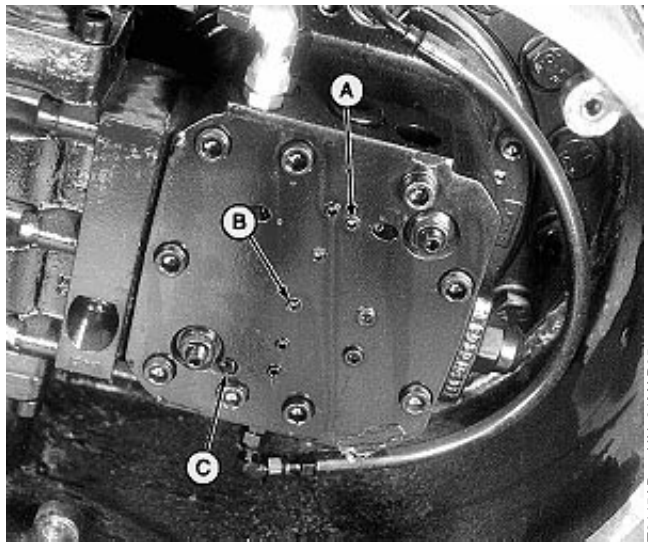

Right Side

T8445AA -UN-31MAR95

02
0260
15

TX,0260,AB522 -19-22FEB92-2/5

Edge Filter And Orifice

Remove parts (A—C). Inspect and replace as necessary, then install.

Note the orientation of edge filter (B) to aid in assembly.

- A—Orifice
- B—Edge Filter
- C—Plug

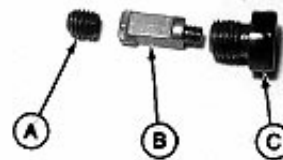

T8447AD -UN-31MAR95

Continued on next page

TX,0260,AB522 -19-22FEB92-3/5

Hydraulic System

Flushing Orifice

Remove parts (A and B). Inspect and replace as necessary. Apply pipe sealant to plug and install.

- A—Orifice
- B—Plug

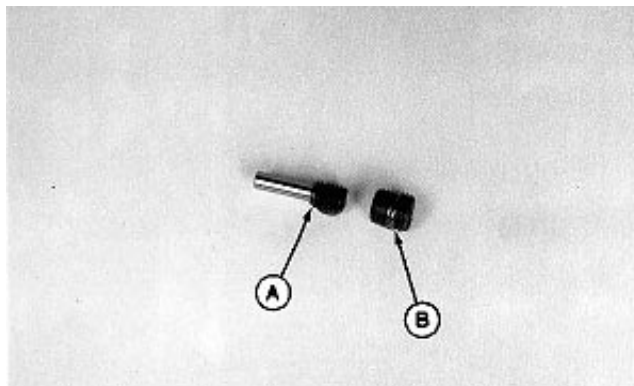

T8447AE -UN-31MAR95

TX,0260,AB522 -19-22FEB92-4/5

Propel Speed Change Orifice

Remove parts (A and B). Inspect and replace as necessary. Apply pipe sealant to plug and install.

- A—Orifice
- B—Plug

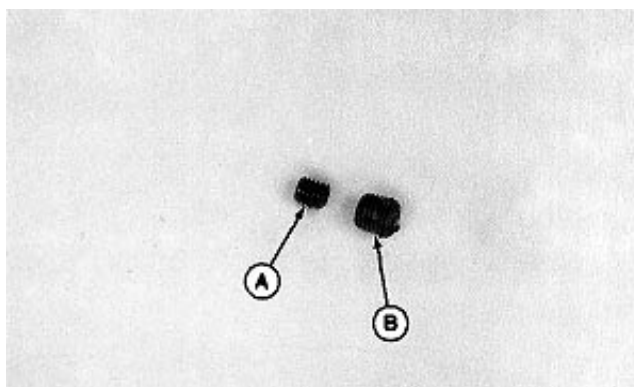

T8447AF -UN-31MAR95

TX,0260,AB522 -19-22FEB92-5/5

Assemble Propel Motor

1. Apply clean hydraulic oil to parts during assembly.

TX,0260,AB524 -19-22FEB92-1/13

2. Install bearing cup (B) in motor housing (A) using a driver (C). Cup is a press fit. Push cup to bottom of bore.

- A—Motor Housing
- B—Bearing Cup
- C—Driver
- D—Dowel Pin

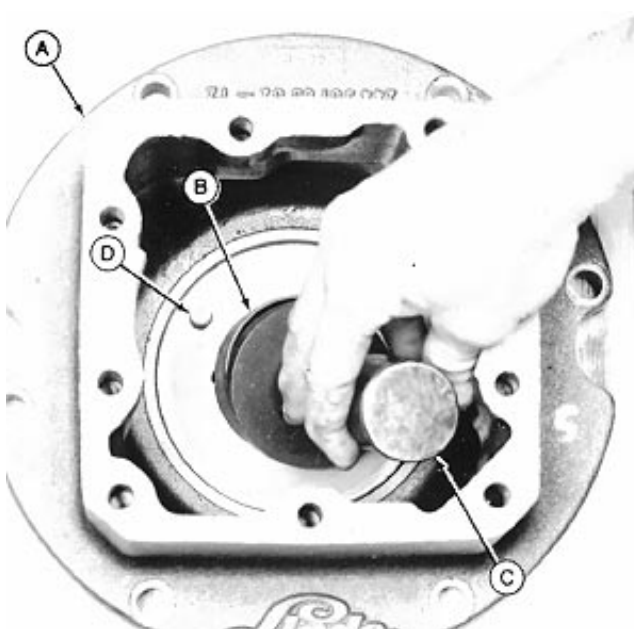

T7626BC -UN-27NOV91

Continued on next page

TX,0260,AB524 -19-22FEB92-2/13

Hydraulic System

3. Install bearing cones (D and I) on drive shaft (A).

Install bushing (J) so tapered end is toward spline end of shaft.

4. Install bearing cup (H) and original shims (F) in valve housing and cover (G). Cup is a press fit.

5. Install cover on housing. Tighten cap screws to 80 N•m (60 lb-ft).

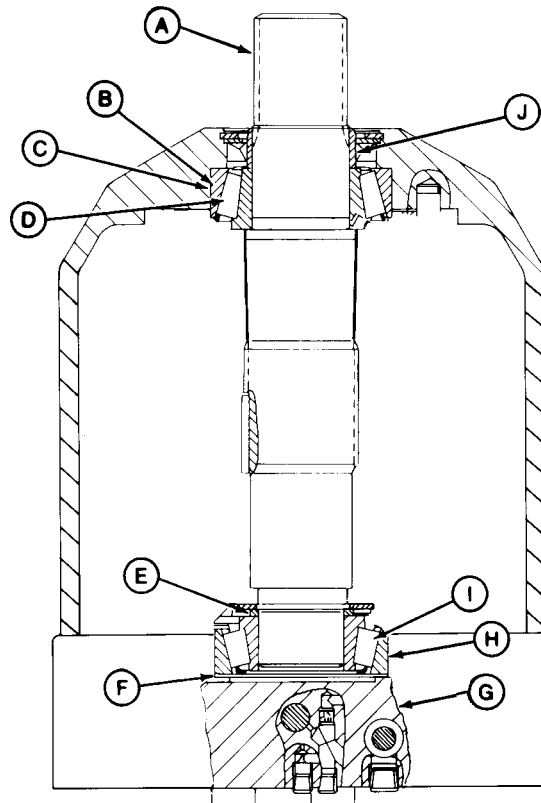

Specification

cover-to-Housing Cap Screws—

Torque 80 N•m (60 lb-ft)

- A—Drive Shaft
- B—Housing
- C—Bearing Cup
- D—Bearing Cone
- E—Washer
- F—Shim
- G—Valve Housing and Cover
- H—Bearing Cup
- I—Bearing Cone
- J—Bushing

02
0260
17

T8445AE -UN-31MAR95

Continued on next page

TX,0260,AB524 -19-22FEB92-3/13

Hydraulic System

6. Fasten lifting bracket (B) to drive shaft (F) using an M12 cap screw (C).
7. Check end play using a dial indicator (D).
8. Add or remove shims to get an end play of 0.10—0.30 mm (0.004—0.012 in.).

Specification

Drive Shaft—End Play 0.10—0.30 mm (0.004—0.012 in.)

9. Remove valve housing and cover.
10. Remove bearing cup.
11. Carefully pull bearing cone from cover end of drive shaft.

- A—Motor Housing
- B—Lifting Bracket
- C—M12 Cap Screw
- D—Dial Indicator
- E—End Play
- F—Drive Shaft

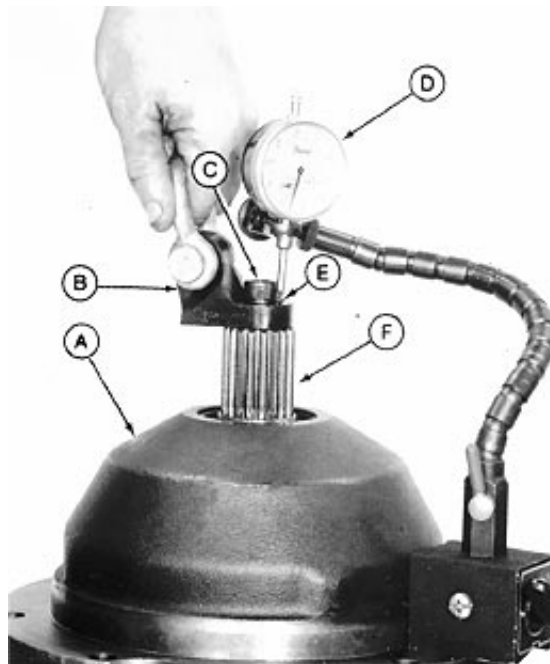

T7626AX -JUN-27NOV91

TX,0260,AB524 -19-22FEB92-4/13

12. Before assembly of the complete motor, the "lift off limitation" must be measured, if any parts (A—E) has been replaced.

- A—Drive Shaft
- B—Bearing
- C—Cradle (Bearing Shell)
- D—Swash Plate
- E—Cylinder

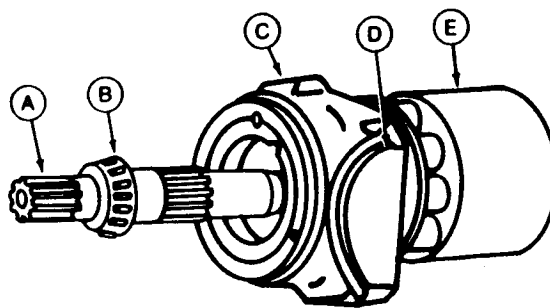

T7626BM -JUN-10/JAN92

Continued on next page

TX,0260,AB524 -19-22FEB92-5/13

Hydraulic System

13. Temporarily, install parts (C—K) into motor housing (A). Make cylinder (K) and motor housing as square (L) as possible so end of cylinder block and housing are parallel (B).

NOTE: Neither shims nor spring is installed at this time.

- A—Motor Housing
- B—Parallel
- C—Snap Ring
- D—Washer
- E—Ball Guide
- F—Swash Plate
- G—Cradle (Bearing Shell)
- H—Bearing Cone
- I—Drive Shaft
- J—Bearing Cup
- K—Cylinder Block
- L—Square A and K

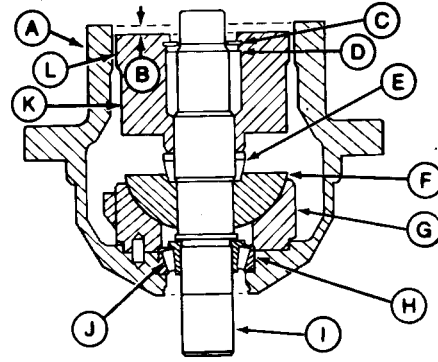

T7626BN -JUN-10JAN92

02
0260
19

Continued on next page

TX,0260,AB524 -19-22FEB92-6/13

Hydraulic System

14. Measure distance from machined surface (D) to end of cylinder block using a depth micrometer. Measure at several places to get a consistent reading.
15. Install valve plate (F) on valve housing and cover (E).
16. Measure distance from top of valve plate to machined surface on cover at several places to get a consistent reading. Record dimension.

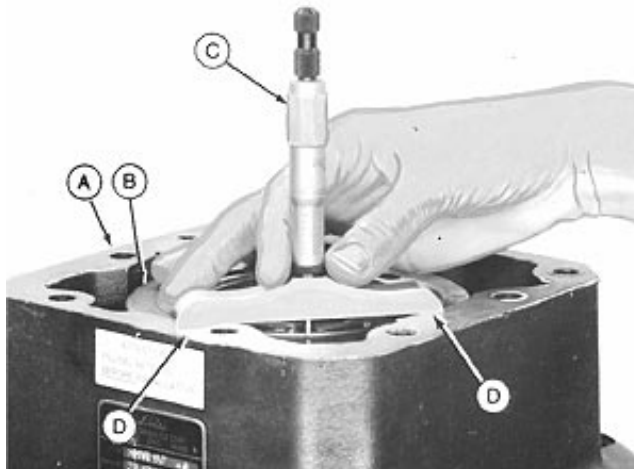

T7626AY -UN-27NOV91

Example: Step 14	Dimension	3.20 mm (0.125 in.)
Minus Step 16	Dimension	2.50 mm (0.100 in.)
	Difference	0.70 mm (0.025 in.)
Tolerance		0.20—0.40 mm (0.008—0.016 in.)
Shim Pack Thickness		0.30 mm (0.012 in.)

17. Install shims (H) between ball guide (G) and needle bearing (I). Remove all parts from motor housing, except bearing cone and cradle.

- A—Motor Housing
- B—Cylinder Block
- C—Depth Micrometer
- D—Machined Surface
- E—Valve Housing and Cover
- F—Valve Plate
- G—Ball Guide
- H—Shim (As required)
- I—Needle Bearing (3 used)
- J—Cylinder Block

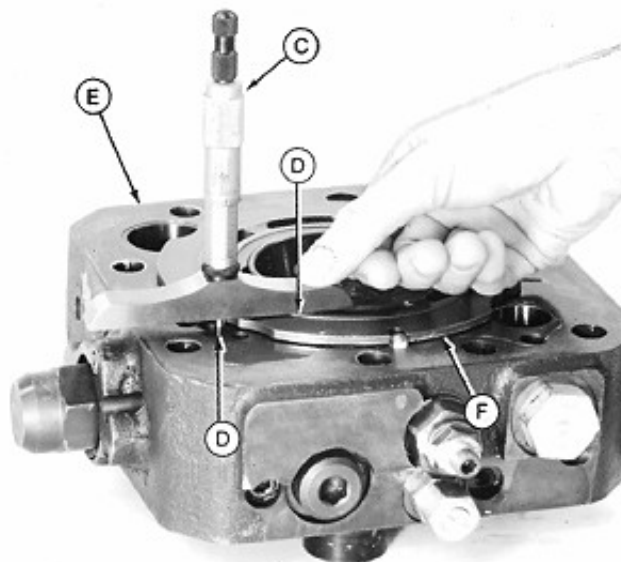

T7626AZ -UN-27NOV91

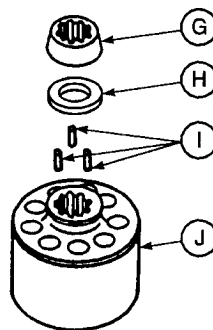

T8378AL CV

T8378AL -UN-10DEC94

Continued on next page

TX,0260,AB524 -19-22FEB92-7/13

Hydraulic System

18. Install oil seal (D) with lip to inside of housing until seal bottoms on shoulder (A).

NOTE: If suitable seal sleeve and driver are available, install seal after installing drive shaft.

19. Install washer (B) and snap ring (C).

- A—Shoulder
- B—Washer
- C—Snap Ring
- D—Oil Seal

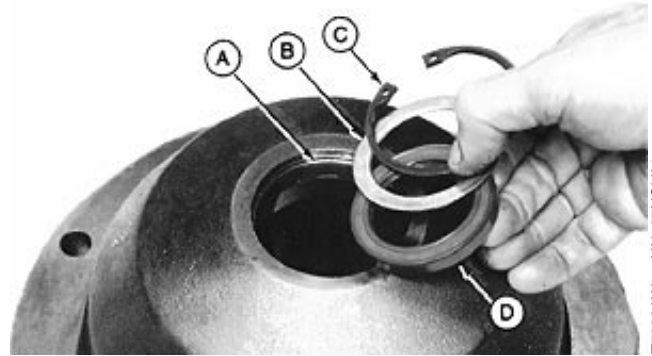

T7626AW -UN-27NOV91

02
0260
21

TX,0260,AB524 -19-22FEB92-8/13

20. Install parts (A—N).

Install shims (O) as determined in steps 12—16.

21. Heat bearing cone to 200°C (300°F) in oven.

- A—Drive Shaft
- B—Swash Plate
- C—Piston (9 used)
- D—Retainer Plate
- E—Ball Guide
- F—Needle Bearing (3 used)
- G—Cylinder Block
- H—Washer
- I—Spring
- J—Washer
- K—Washer
- L—Snap Ring
- M—Washer
- N—Bearing Cone
- O—Shim (As required)

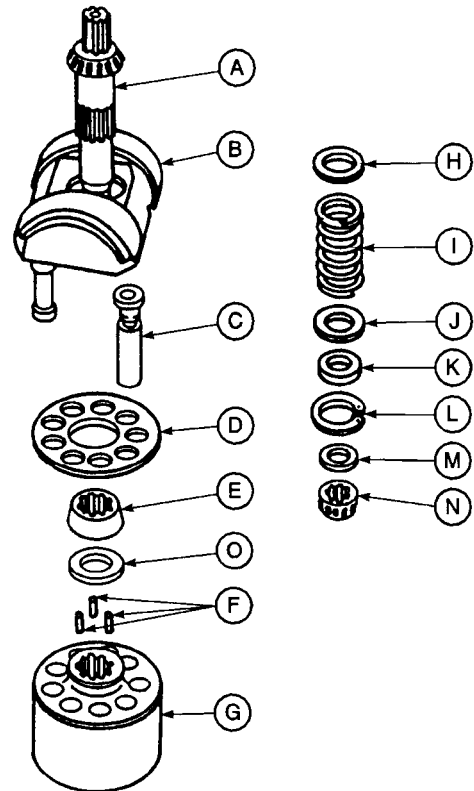

T837BAK CV

T837BAK -UN-10DEC94

Continued on next page

TX,0260,AB524 -19-22FEB92-9/13

Hydraulic System

22. Install washer (C) on drive shaft (D).

CAUTION: Plan a safe handling procedure to avoid burns.

23. Install heated bearing cone on drive shaft.

- A—Piston
- B—Rotating Group
- C—Washer
- D—Drive Shaft



T7626AN -UN-27NOV91

TX,0260,AB524 -19-22FEB92-10/13

IMPORTANT: Protect front seal from damage as assembly is lowered into housing.

24. Install rotating group into motor housing (D) while carefully guiding drive shaft through the oil seal.

NOTE: Larger piston (minimum displacement) goes toward I.D. tag side of motor housing.

- A—Piston
- B—Bearing Cone
- C—Minimum Displacement Piston
- D—Motor Housing

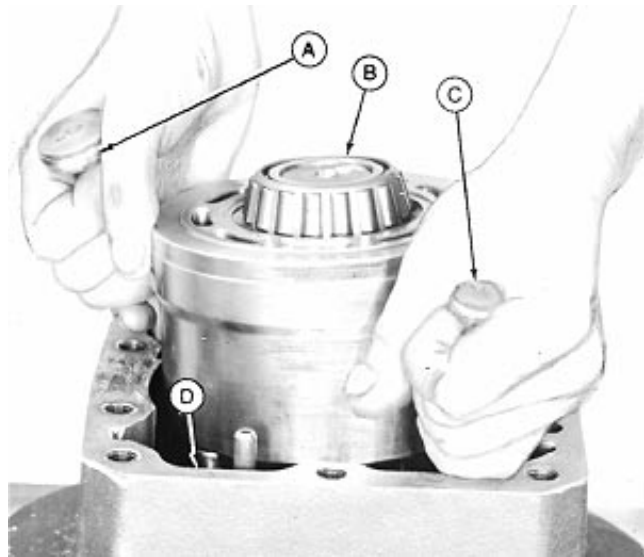

T7626AL -UN-27NOV91

Continued on next page

TX,0260,AB524 -19-22FEB92-11/13

Hydraulic System

- 25. Install oil tubes (F).
- 26. Install valve plate (B) with notch (E) to align with hole in motor housing (D).
- 27. Apply oil to pistons (A and C).

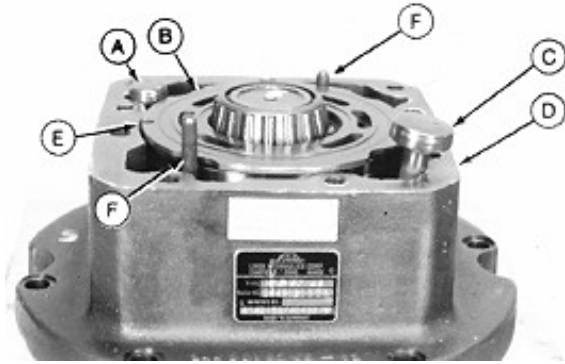

- A—Maximum Displacement Piston
- B—Valve Plate
- C—Minimum Displacement Piston
- D—Motor Housing
- E—Notch
- F—Oil Tube (2 used)

T7626AP -UN-27NOV91

02
0260
23

TX,0260,AB524 -19-22FEB92-12/13

- 28. Apply plastic gasket to machine surface (E) on motor housing (A).
- 29. Install valve housing and cover (B) so dowel pin (D) is aligned with notch in valve plate (C) and hole in housing.
- 30. Work pistons and oil tubes into ports. Install cap screws and tighten to 120 N•m (89 lb-ft).

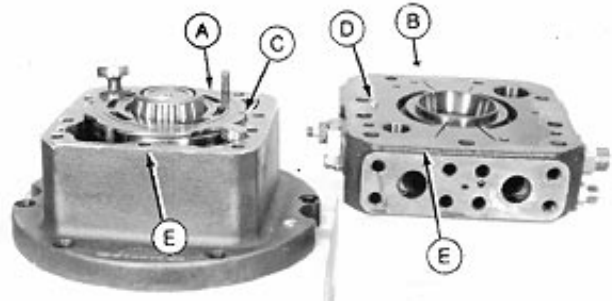

- A—Motor Housing
- B—Valve Housing and Cover
- C—Valve Plate
- D—Dowel Pin
- E—Machine Surface

T7626AK -UN-27NOV91

Specification

Valve Housing and Cover Cap
Screw—Torque..... 120 N•m (89 lb-ft)

- 31. Fill motor with 2 L (34 oz) of hydraulic fluid.

NOTE: If proper seal sleeve and driver are available to clear drive shaft, oil seal, washer and snap ring can be installed at this time.

- 32. Install counterbalance and supply shuttle valves.

TX,0260,AB524 -19-22FEB92-13/13

Remove And Install Counterbalance Valve

! CAUTION: Hydraulic reservoir is pressurized. Loosen fill cap to release pressure.

1. Loosen fill cap to release reservoir air pressure.
2. Remove propel motor cover.

! CAUTION: Escaping fluid under pressure can penetrate the skin causing serious injury. Avoid the hazard by relieving pressure before disconnecting hydraulic or other lines. Tighten all connections before applying pressure. Search for leaks with a piece of cardboard. Protect hands and body from high pressure fluids.

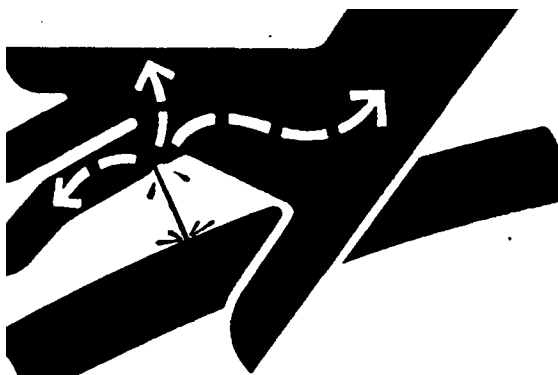

X9811 -UN-23AUG88

If an accident occurs, see a doctor immediately. Any fluid injected into the skin must be surgically removed within a few hours or gangrene may result. Doctors unfamiliar with this type of injury may call the Deere & Company Medical Department in Moline, Illinois, or other knowledgeable medical source.

3. Disconnect lines (A and B).
4. Remove cap screws (C) to remove counterbalance valve.
5. Install counterbalance valve. Tighten cap screws to 75 N•m (55 lb-ft).

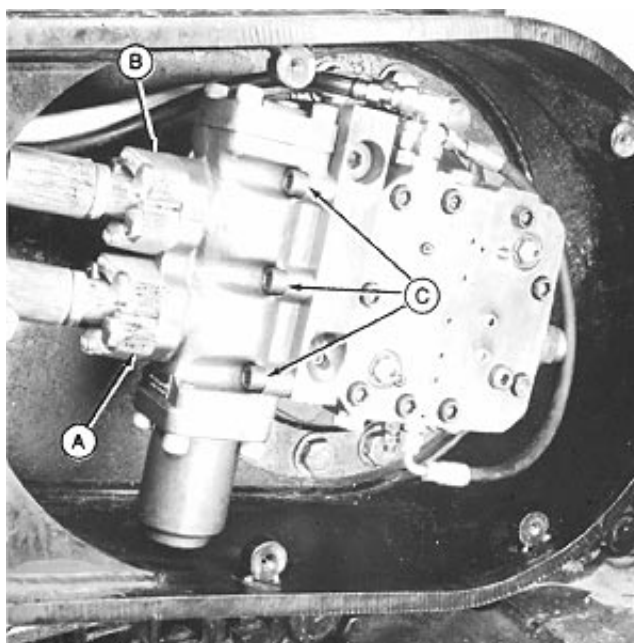

T7681FM -UN-06FEB92

Specification

Counterbalance Valve Cap
Screw—Torque..... 75 N•m (55 lb-ft)

6. Install O-rings. Connect lines.
7. Install motor compartment cover.

Hydraulic System

Disassemble And Assemble Counterbalance Valve

1. Replace O-rings (B and C).
2. Remove cap screws (D) to remove cover from counterbalance valve (A).

- A—Counterbalance Valve
- B—O-Ring (2 used)
- C—O-Ring (2 used)
- D—Cap Screw (8 used)

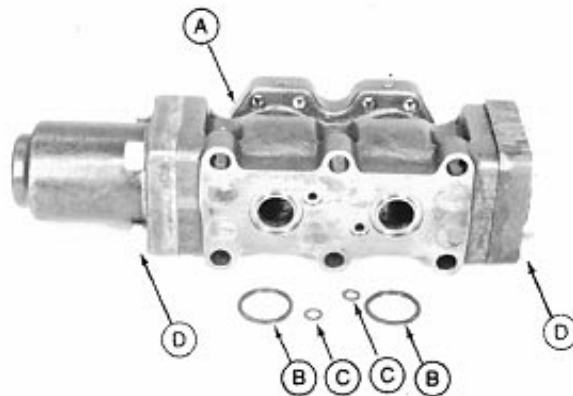

T7626BE -UN-27NOV91

02
0260
25

TX,0260,AB198 -19-22FEB92-1/4

3. Remove covers (A and D) and O-rings (B).
4. Remove piston (E) from valve housing (C).
5. Piston can be partially disassembled for cleaning and inspection purposes only. Piston is replaced as one component.
6. Place piston in DFT1077 Spool Holding Fixture and clamp tool in vise. (See Section 99 for instructions to make tool.)

- A—Cover
- B—O-Ring (2 used)
- C—Valve Housing
- D—Cover
- E—Piston

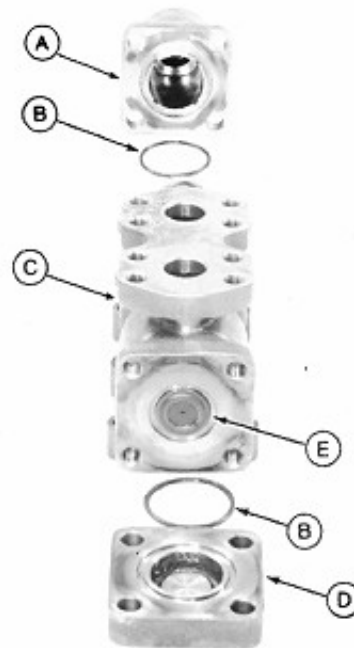

T7626BF -UN-27NOV91

Continued on next page

TX,0260,AB198 -19-22FEB92-2/4

Hydraulic System

7. Use one wrench in flat area to hold piston (G) while removing screw (A).
8. Remove parts (B—E).
9. Clean and inspect. Apply oil to piston.
10. Install balls (H) and pins (I).
11. Assemble parts (B—E) on piston. Install screw (A).

- A—Screw
- B—Seat
- C—Spring
- D—Washer
- E—Seat
- F—Spool
- G—Piston
- H—Ball
- I—Pin

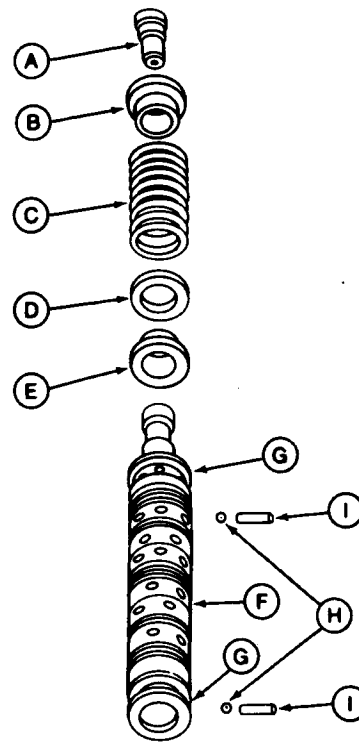

T7626BG -UN-27NOV91

TX,0260,AB198 -19-22FEB92-3/4

12. Install piston in housing with spring toward "A" port (A).
13. Install flat cap (C) on port "B" (B) side of housing.

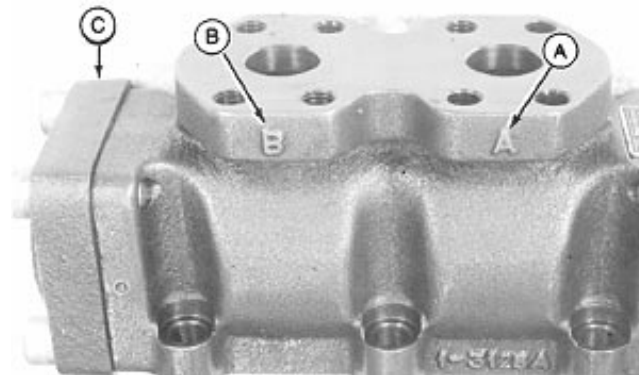

T7681FN -UN-05FEB92

TX,0260,AB198 -19-22FEB92-4/4

Remove And Install Supply Shuttle Valve

CAUTION: Hydraulic reservoir is pressurized. Loosen fill cap to release pressure.

1. Loosen reservoir fill cap to release air pressure in reservoir.
2. Remove cover.

Continued on next page

TX,0260,AB530 -19-22FEB92-1/2

Hydraulic System



CAUTION: Escaping fluid under pressure can penetrate the skin causing serious injury. Avoid the hazard by relieving pressure before disconnecting hydraulic or other lines. Tighten all connections before applying pressure. Search for leaks with a piece of cardboard. Protect hands and body from high pressure fluids.

If an accident occurs, see a doctor immediately. Any fluid injected into the skin must be surgically removed within a few hours or gangrene may result. Doctors unfamiliar with this type of injury may call the Deere & Company Medical Department in Moline, Illinois, or other knowledgeable medical source.

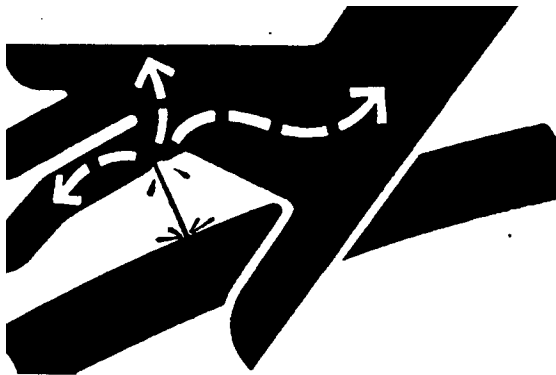

3. Remove parts (B—H) from supply shuttle valve plate (A).
4. Clean, inspect, and replace parts as necessary.
5. Install parts (B—H) in valve plate (A).

A—Valve Plate
 B—O-Ring (2 used)
 C—Sleeve
 D—Seat (2 used)
 E—Plug
 F—Backup Ring
 G—O-Ring
 H—Shuttle Ball

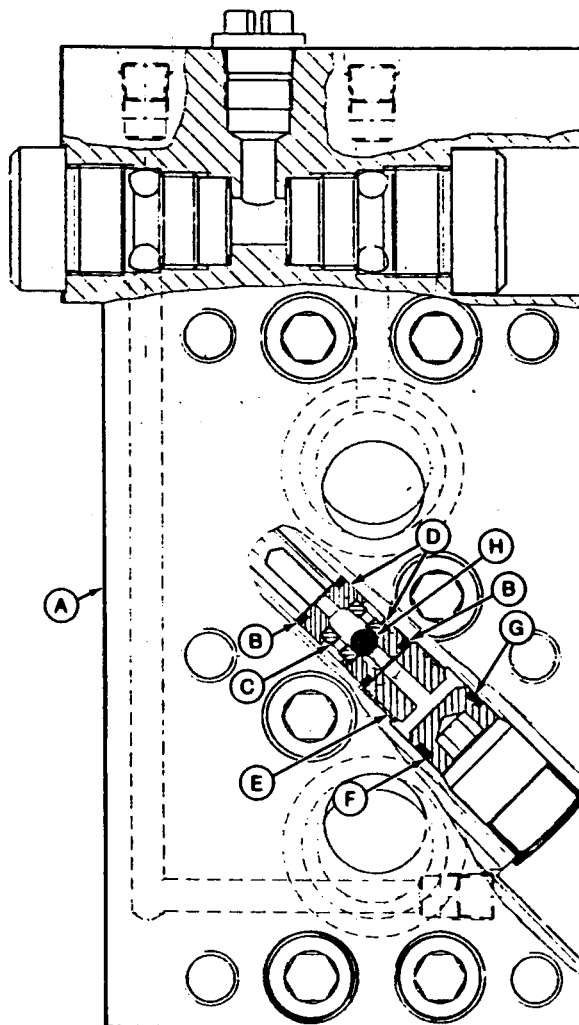

X9811 -UN-23AUG88

02
0260
27

T7681FP -UN-05FEB92

TX.0260,AB530 -19-22FEB92-2/2

Hydraulic System

Remove And Install Crossover Relief Valve



**CAUTION: Hydraulic reservoir is pressurized.
Loosen fill cap to release pressure.**

1. Loosen reservoir fill cap to release air pressure in reservoir.
2. Remove cover.

Continued on next page

TX,0260,AB531 -19-22FEB92-1/2

02
0260
28

Hydraulic System



CAUTION: Escaping fluid under pressure can penetrate the skin causing serious injury. Avoid the hazard by relieving pressure before disconnecting hydraulic or other lines. Tighten all connections before applying pressure. Search for leaks with a piece of cardboard. Protect hands and body from high pressure fluids.

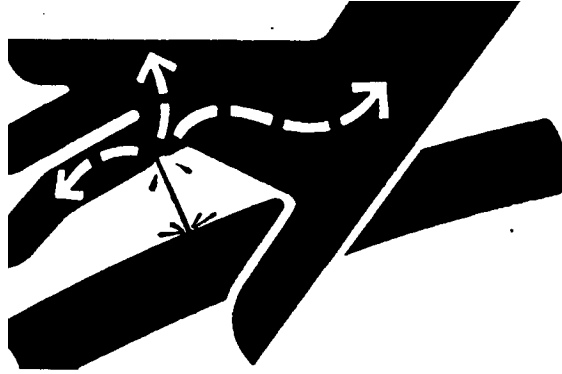

If an accident occurs, see a doctor immediately. Any fluid injected into the skin must be surgically removed within a few hours or gangrene may result. Doctors unfamiliar with this type of injury may call the Deere & Company Medical Department in Moline, Illinois, or other knowledgeable medical source.

3. Remove parts (A—J) from valve housing and cover (K).
4. Clean, inspect and replace parts as necessary.
5. Install parts (A—J) in cover (K). Tighten to 120 N•m (90 lb-ft).

Specification

Crossover Relief Valve Cap
 Nut—Torque 120 N•m (90 lb-ft)

6. Install frame cover.

- A—Cap Nut
- B—O-Ring
- C—Small Spring Seat
- D—Large Spring
- E—Small Spring
- F—Large Spring Seat
- G—Metal Ring
- H—O-Ring
- I—Valve
- J—Poppet
- K—Valve Housing and Cover

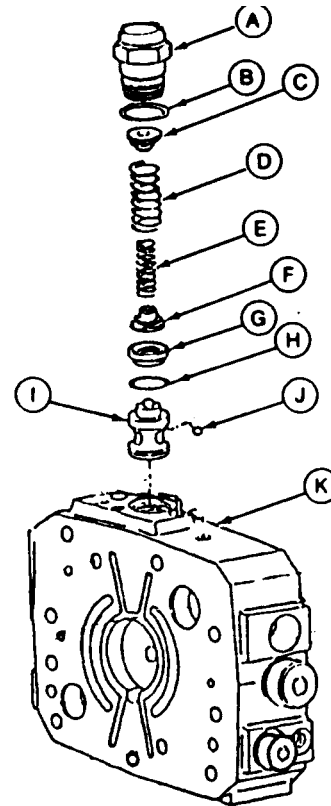

X9811 -UN-23AUG88

02
0260
29

T7681FH -UN-05FEB92

TX,0260,AB531 -19-22FEB92-2/2

Hydraulic System

Remove And Install Shuttle Valve

⚠ CAUTION: Hydraulic reservoir is pressurized. Loosen fill cap to release pressure.

1. Loosen reservoir fill cap to release air pressure in reservoir.
2. Remove cover.

3. Remove parts (A—C) from valve housing and cover (D).
4. Clean, inspect and replace as necessary.
5. Install parts in cover.

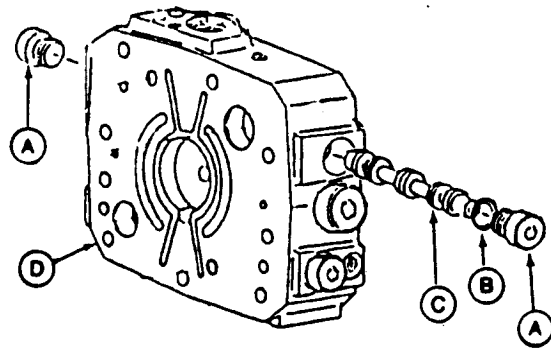

T7681FG -UN-05FEB92

TX,0260,AB532 -19-22FEB92-2/2

Remove And Install Low Speed Selector Valve

CAUTION: Hydraulic reservoir is pressurized. Loosen fill cap to release pressure.

1. Loosen reservoir fill cap to release air pressure in reservoir.
2. Remove propel motor cover.

CAUTION: Escaping fluid under pressure can penetrate the skin causing serious injury. Avoid the hazard by relieving pressure before disconnecting hydraulic or other lines. Tighten all connections before applying pressure. Search for leaks with a piece of cardboard. Protect hands and body from high pressure fluids.

If an accident occurs, see a doctor immediately. Any fluid injected into the skin must be surgically removed within a few hours or gangrene may result. Doctors unfamiliar with this type of injury may call the Deere & Company Medical Department in Moline, Illinois, or other knowledgeable medical source.

3. Remove parts (A—H) from valve housing and cover (I).
4. Clean, inspect and replace parts as necessary.
5. Install parts (A—H) in cover (I). Tighten plug (A) to 80 N•m (60 lb-ft).

Specification

Low Speed Selector Plug—
Torque 80 N•m (60 lb-ft)

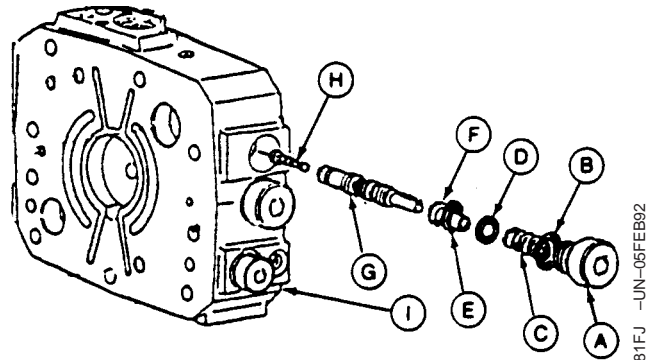

- A—Plug
- B—O-Ring
- C—Spring
- D—Washer
- E—Shims
- F—Guide
- G—Valve Piston
- H—Poppet
- I—Valve Housing and Cover

02
0260
31

Hydraulic System

Remove And Install Brake Release Pressure Reducing Valve

CAUTION: Hydraulic reservoir is pressurized. Loosen fill cap to release pressure.

1. Loosen reservoir fill cap to release air pressure in reservoir.
2. Remove propel motor cover.
3. Remove parts (A—G) from valve housing and cover (H).
4. Clean, inspect and replace as necessary.

NOTE: Do not separate nut and screw (G), this is a factory setting.

5. Install parts (A—G) in cover.

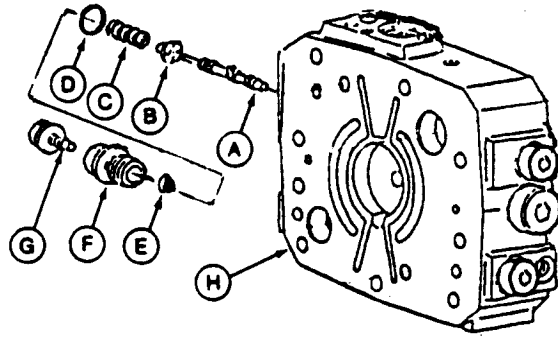

- A—Valve
- B—Seat
- C—Spring
- D—O-Ring
- E—Seat
- F—Plug
- G—Nut and Screw
- H—Valve Housing and Cover

T7681FK -UN-05FEB92

TX,0260,AB535 -19-12APR95-1/1

Remove And Install Propel Hydraulic Lines

CAUTION: Hydraulic reservoir is pressurized. Loosen fill cap to release pressure.

Loosen reservoir fill cap (A) to release air pressure in reservoir.

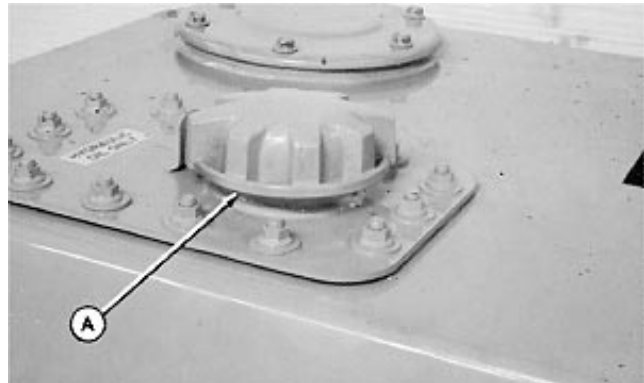

Continued on next page

TX,0260,AB203 -19-22FEB92-1/2

T7626DG -UN-06JAN92

Hydraulic System

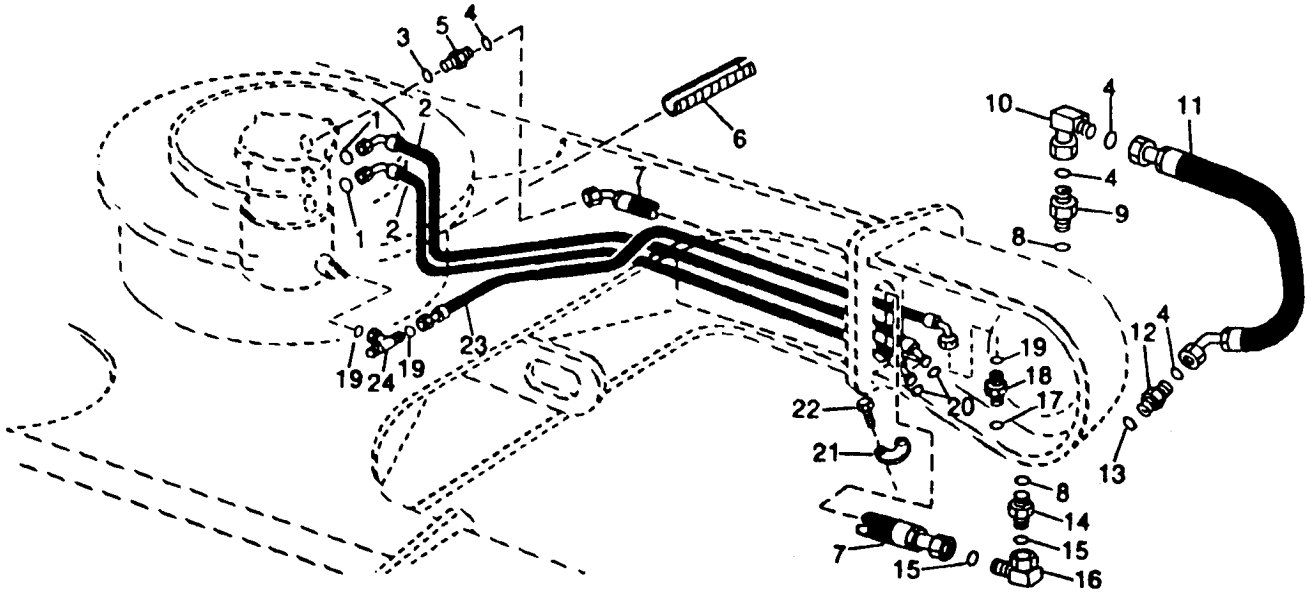

02
0260
33

T7626DV -UN-06JAN92

- | | | | |
|------------------|-------------------|------------------|-------------------|
| 1—O-Ring | 7—Hydraulic Hose | 13—O-Ring | 19—O-Ring |
| 2—Hydraulic Hose | 8—O-Ring | 14—Adapter | 20—O-Ring |
| 3—O-Ring | 9—Adapter | 15—O-Ring | 21—Flange Fitting |
| 4—O-Ring | 10—Elbow Fitting | 16—Elbow Fitting | 22—Cap Screw |
| 5—Adapter | 11—Hydraulic Hose | 17—O-Ring | 23—Hydraulic Hose |
| 6—Conduit | 12—Fitting | 18—Adapter | 24—Tee Fitting |

CAUTION: Escaping fluid under pressure can penetrate the skin causing serious injury. Avoid the hazard by relieving pressure before disconnecting hydraulic or other lines. Tighten all connections before applying pressure. Search for leaks with a piece of cardboard. Protect hands and body from high pressure fluids.

If an accident occurs, see a doctor immediately. Any fluid injected into the skin must be surgically removed within a few hours or gangrene may result. Doctors unfamiliar with this type of injury may call the Deere & Company Medical Department in Moline, Illinois, or other knowledgeable medical source.

TX,0260,AB203 -19-22FEB92-2/2

Remove And Install Rotary Manifold

CAUTION: Hydraulic reservoir is pressurized. Loosen fill cap to release pressure.

- Loosen reservoir fill cap (A) to release air pressure.

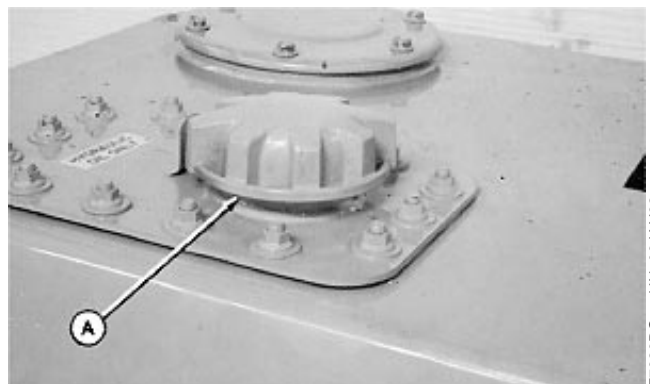

T7626DG -UN-06JAN92

Continued on next page

TX,0260,AB207 -19-22FEB92-1/5

Hydraulic System

! **CAUTION:** Escaping fluid under pressure can penetrate the skin causing serious injury. Avoid the hazard by relieving pressure before disconnecting hydraulic or other lines. Tighten all connections before applying pressure. Search for leaks with a piece of cardboard. Protect hands and boy from high pressure fluids.

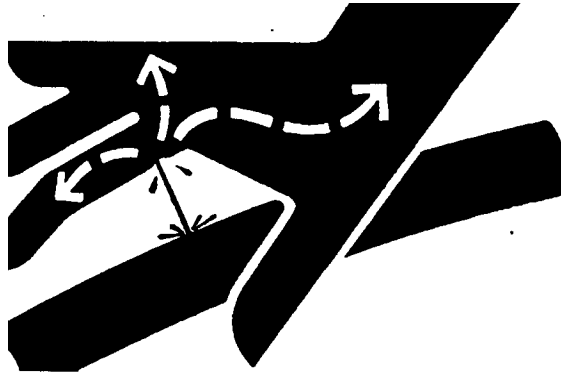

If an accident occurs, see a doctor immediately. Any fluid injected into the skin must be surgically removed within a few hours or gangrene may result. Doctors unfamiliar with this type of injury may call the Deere & Company Medical Department in Moline, Illinois, or other knowledgeable medical source.

2. Disconnect lines (A—F).
3. Remove cap screws (H) and strap (I).
4. Remove cover (G).

! **CAUTION:** The approximate weight of rotary manifold is 38 kg (84 lb).

5. Attach rotary manifold to a hoist using a lifting strap and two rotary manifold lifting tools. (See Section 99 for instruction to make tool.)

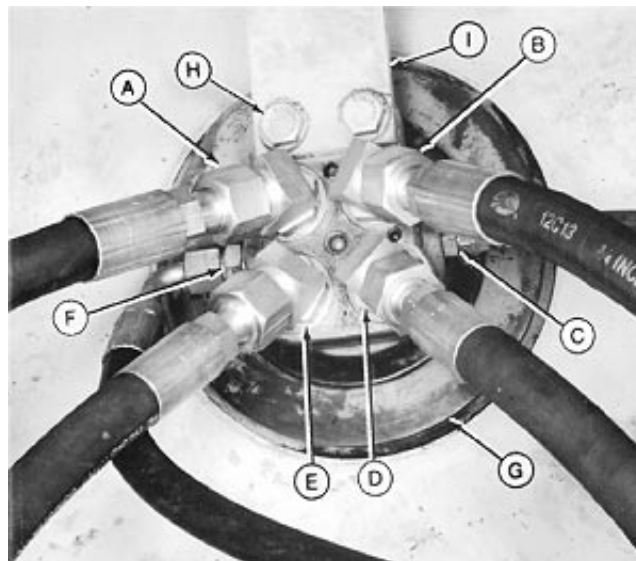

- A—Port 3-to-Left Propel Section Port B
- B—Port 1-to-Right Propel Section Port A
- C—Speed Change Port P1-to-Dual Solenoid Block Port A
- D—Port 2-to-Right Propel Section Port B
- E—Port 4-to-Left Propel Section Port A
- F—Port D-to-Reservoir
- G—Cover
- H—Cap Screw (2 used)
- I—Strap

X9811 -UN-23AUG88

T7626CC -UN-06DEC91

Continued on next page

TX,0260,AB207 -19-22FEB92-2/5

Hydraulic System

6. Disconnect lines (A—H).
7. Remove cap screws (I). Lower rotary manifold.
8. Replace parts as necessary.

IMPORTANT: Turn manifold body as necessary so that ports match with correct hoses.

9. Raise manifold into position and install cap screws (I). Tighten to 98 N•m (65 lb-ft).

Specification

Manifold	
Housing-to-Uppercarriage Cap	
Screw—Torque.....	98 N•m (65 lb-ft)

10. Connect lines (A—H).

- A—Rotary Manifold Left Top Port-to-Left Propel Motor Bottom Port Line
- B—Rotary Manifold Middle Left Port-to-Left Propel Motor Top Front Port Line
- C—Rotary Manifold Bottom Left Port-to-Left Propel Motor Bottom Front Port Line
- D—Rotary Manifold Bottom Port-to-Left Propel Motor Top Port Line
- E—Rotary Manifold Bottom Port-to-Right Propel Motor Top Port Line
- F—Rotary Manifold Bottom Right Port-to-Right Propel Motor Bottom Front Port Line
- G—Rotary Manifold Right Top Port-to-Right Propel Motor Top Port Line
- H—Rotary Manifold Middle Right Port-to-Right Propel Motor Top Front Port Line
- I—Cap Screw (4 used)

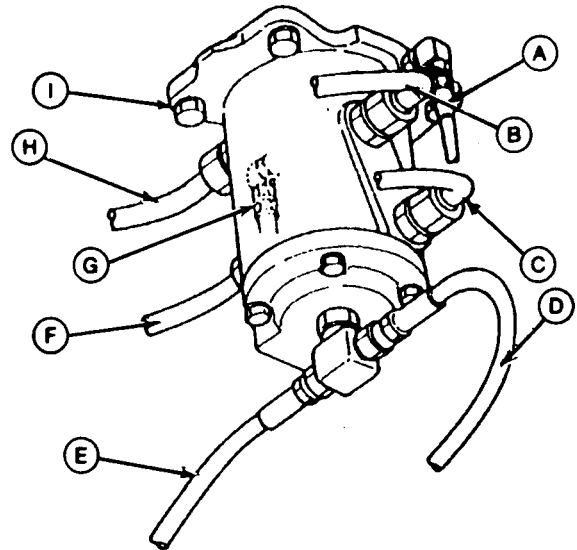

02
0260
35

T7626DW -JUN-06JAN92

Continued on next page

TX.0260,AB207 -19-22FEB92-3/5

Hydraulic System

11. Remove lifting device, and install cover (G) and strap (I). Tighten cap screws (H) to 40 N•m (30 lb-ft).

Specification

Cover and Strap Cap Screw—

Torque 40 N•m (30 lb-ft)

12. Connect lines (A—F). If ports on rotary manifold do not align with existing lines, lower rotary manifold and perform steps 13—18.

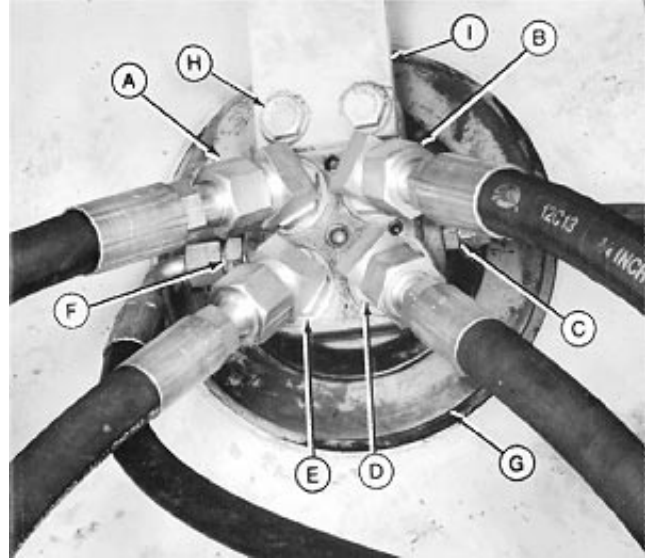

T7626CC -UN-06DEC91

- A—Port 3-to-Left Propel Section Port B
- B—Port 1-to-Right Propel Section Port A
- C—Speed Change Port P1-to-Dual Solenoid Block Port A
- D—Port 2-to-Right Propel Section Port B
- E—Port 4-to-Left Propel Section Port A
- F—Port D-to-Reservoir
- G—Cover
- H—Cap Screw (2 used)
- I—Strap

Continued on next page

TX,0260,AB207 -19-22FEB92-4/5

02
0260
36

Hydraulic System

13. Install cap screws (O) in spindle. Clamp cap screws in a vise.
14. Install cap screw (N), washer (J), and nut (K) in a mechanical push-puller such as the D01200AA Push-Puller (Mechanical). Install push-puller on rotary manifold using cap screws (L). Use an extra thin service wrench (I) such as the D05242ST Service Wrench to prevent cap screw (N) from turning.
15. Rotate manifold three times using nut (K) and a torque wrench. Torque for first rotation is 373 N•m (275 lb-ft). Torque for second rotation is 237 N•m (175 lb-ft). Torque for third rotation is 170 N•m (125 lb-ft).
16. Raise rotary manifold into position. Tighten mounting cap screws to 98 N•m (65 lb-ft).
17. Remove lifting device. Install strap. Tighten strap mounting cap screw to 40 N•m (30 lb-ft).

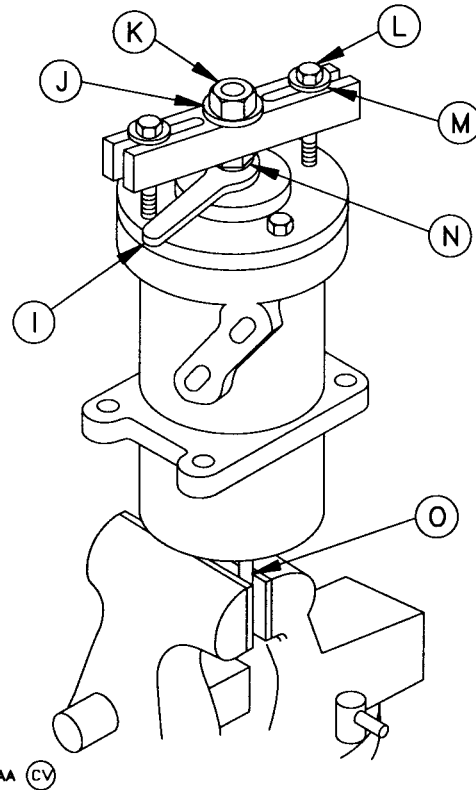

Specification

Cover and Strap Cap Screw—
 Torque 40 N•m (30 lb-ft)

18. Connect lines.

- I—Service Wrench
- J—Washer
- K—Nut
- L—Cap Screw (2 used)
- M—Washer (2 used)
- N—Cap Screw
- O—Cap Screw (2 used)

02
0260
37

T8313AA -UN-20SEP94

TX,0260,AB207 -19-22FEB92-5/5

Hydraulic System

Disassemble And Assemble Rotary Manifold

- A—Spindle
- B—Seal Dust
- C—O-Ring
- D—Bushing
- E—Oil Seal Ring (6 used)
- F—Housing
- G—Washer
- H—Snap Ring
- I—O-Ring
- J—Cover
- K—Cap Screw

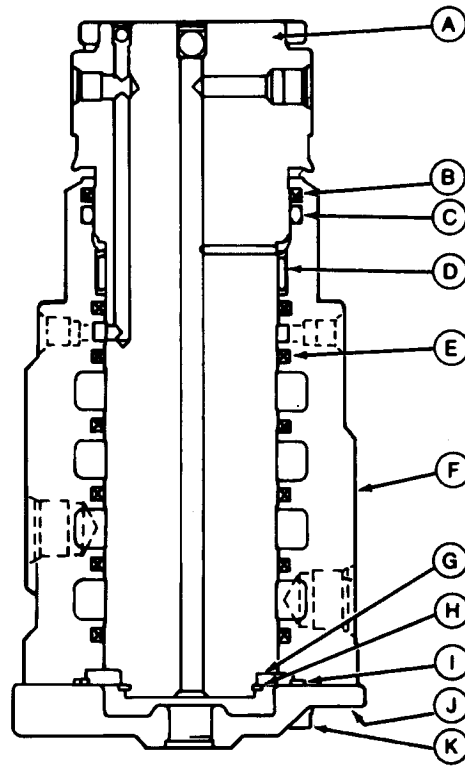

T7626DX -UN-09JAN92

Continued on next page

TX,0260,AB214 -19-22FEB92-1/2

02
0260
38

Hydraulic System

1. Mark spindle (A), housing (F) and cover (J) to aid in assembly.
2. Remove cap screws (K), washers (L) and cover (J) Inspect O-ring (I) and replace if necessary.
3. Remove snap ring (H) and ring (G).
4. Carefully, remove spindle assembly (A—E) from housing (F).
5. Remove plugs in spindle to clean ports. Install plugs.
6. Remove O-ring (C), seal (B), rings (E) and bushing (D) from housing (F).
7. Inspect and repair as necessary. Keep hydraulic oil on all disassembled parts.
8. Install bushing (D), O-ring (C) and seal (B) in housing (F).
9. Install oil seal rings (E) into housing (F).
10. Install spindle (A) in housing (F) so that match marks align.
11. Install ring (G) and snap ring (H).
12. Install O-ring (I) and cover (J) with washers (L) and cap screws (K). Tighten to 49 N•m (36 lb-ft).

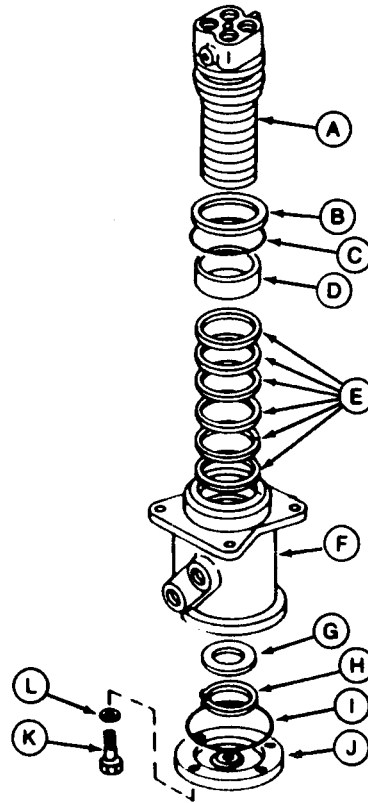

- A—Spindle
- B—Oil Seal
- C—O-Ring
- D—Bushing
- E—Oil Seal Ring (6 used)
- F—Housing
- G—Ring
- H—Snap Ring
- I—O-Ring
- J—Cover
- K—Cap Screw (4 used)
- L—Lock Washer (4 used)

Specification

Retaining Cap Screw—Torque 49 N•m (36 lb-ft)

02
0260
39

T7626DY -UN-09JAN92

TX,0260,AB214 -19-22FEB92-2/2

Rotary Manifold Air Test

1. Install a plug in one port.
2. Apply air pressure using JDG185 Air Test Plug and shop air pressure through the other port in that passage.
3. Listen for air leaks at ports on either side of pressurized port.



T6557JB -UN-01NOV88

TX,0260,AB216 -19-22FEB92-1/1

Hydraulic System

Remove And Install Propel Speed Change Solenoid Valve

⚠ CAUTION: Hydraulic reservoir is pressurized. Loosen fill cap to release air pressure.

1. Loosen reservoir fill cap (A) to release air pressure.

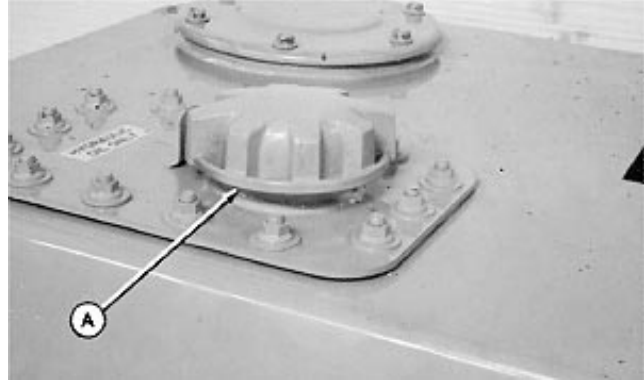

T7626DG -UN-06JAN92

Continued on next page

TX.02.DY2918 -19-21AUG97-1/3

02
0260
40

Hydraulic System

2. Remove nut (A), plate (B), and cover (C).

- A—Nut
- B—Plate
- C—Cover
- D—Solenoid
- E—Connector

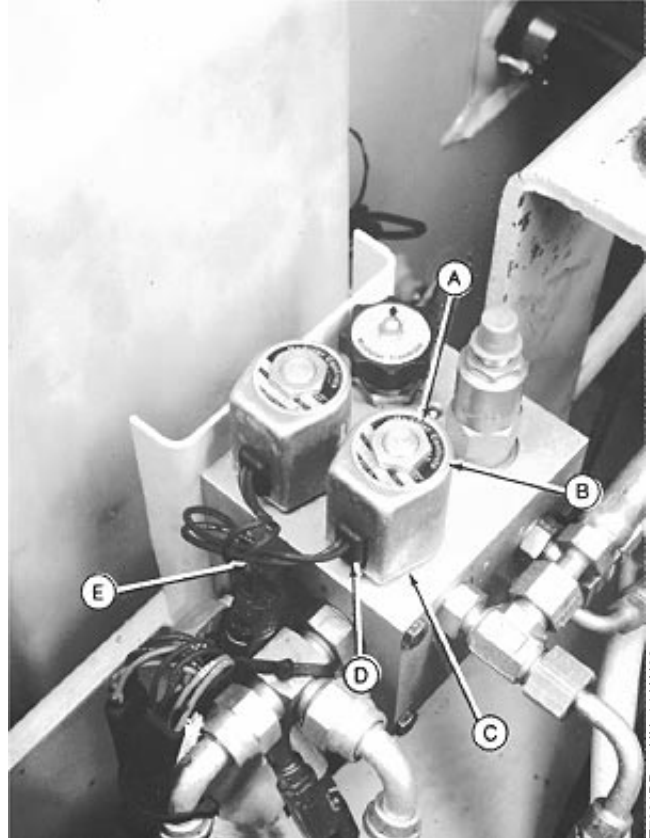

02
0260
41

T7681BR -UN-14JAN92

(Serial No. —556935)

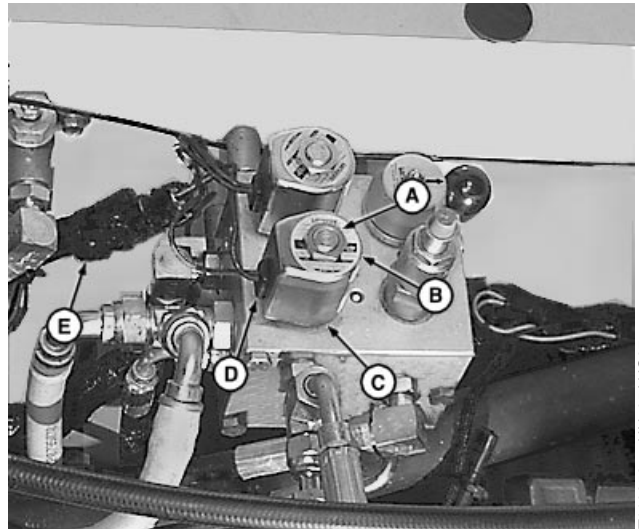

T110252 -UN-05AUG97

(Serial No. 556936—)

Continued on next page

TX,02,DY2918 -19-21AUG97-2/3

Hydraulic System



CAUTION: Escaping fluid under pressure can penetrate the skin causing serious injury. Avoid the hazard by relieving pressure before disconnecting hydraulic or other lines. Tighten all connections before applying pressure. Search for leaks with a piece of cardboard. Protect hands and body from high pressure fluids.

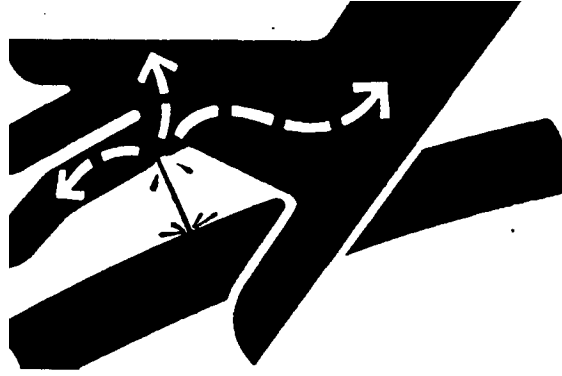

If an accident occurs, see a doctor immediately. Any fluid injected into the skin must be surgically removed within a few hours or gangrene may result. Doctors unfamiliar with this type of injury may call the Deere & Company Medical Department in Moline, Illinois, or other knowledgeable medical source.

3. Disconnect connector (E), and remove solenoid (D).
4. Remove valve.
5. Inspect, repair, and test valve. (See procedure in group 9020-25.)
6. Install valve.
7. Install and connect solenoid.
8. Tighten reservoir fill cap.

X9811 -UN-23AUG88

TX,02,DY2918 -19-21AUG97-3/3

Hydraulic System

Disassemble And Assemble Propel Speed Change Solenoid Valve

Replace O-rings (G and H) and backup rings (I).

- A—Nut
- B—Plate
- C—Cover
- D—Coil
- E—Washer
- F—Valve Spool
- G—O-Ring (2 used)
- H—O-Ring (2 used)
- I—Backup Ring (2 used)

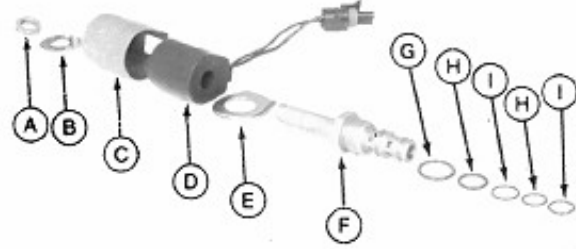

T7681BS -JUN-14JAN92

02
0260
43

TX,0260,AB316 -19-22FEB92-1/1

Hydraulic System

02
0260
44

Section 04 Engine

Contents

	Page		Page
Group 0400—Removal And Installation			
6068 John Deere Engine—Use CTM8	04-0400-1	Intake Manifold Tube (SN -559602)	
6068 John Deere Engine—Use CTM104.	04-0400-1	Remove and Install	04-0400-55
Special Or Essential Tools	04-0400-1	Intake Manifold Tube (SN 559603-)	
Service Equipment And Tools	04-0400-5	Remove and Install	04-0400-56
Other Material	04-0400-6	Exhaust Manifold (SN -559602)	
Specifications	04-0400-7	Remove and Install	04-0400-57
Engine (SN -559602)		Exhaust Manifold (SN 559603-)	
Remove and Install	04-0400-9	Remove and Install	04-0400-59
Engine (SN 559603-)		Turbocharger (SN -559602)	
Remove and Install	04-0400-16	Remove and Install	04-0400-61
Oil Pan		Turbocharger (SN 559603-)	
Remove and Install	04-0400-25	Remove and Install	04-0400-63
Fuel Injection Nozzles		Oil Cooler (SN -559602)	
Remove and Install	04-0400-26	Remove and Install	04-0400-64
Injection Nozzle Bores		Oil Cooler (SN 559603-)	
Clean	04-0400-29	Remove and Install	04-0400-65
DB4 Fuel Injection Pump (SN -559602)		Engine Valve Lash (Clearance) (SN -559602)	
Remove	04-0400-29	Check and Adjust	04-0400-66
Install	04-0400-32	Engine Valve Lash (Clearance) (SN 559603-)	
DB4 Fuel Injection Pump (SN 559603-)		Check and Adjust	04-0400-68
Remove and Install	04-0400-35	Starter (SN -559602)	
JT07158 TIME TRAC Installation	04-0400-36	Remove and Install	04-0400-71
Fuel Filter (SN -559602)		Starter (SN 559603-)	
Change	04-0400-37	Remove and Install	04-0400-72
Final Fuel Filter (SN 559603-)			
Change	04-0400-37		
Primary Fuel Filter/Water Separator (SN 559603-)			
Change	04-0400-38		
Fuel Transfer Pump (SN -559602)			
Remove and Install	04-0400-40		
Fuel Transfer Pump (SN 559603-)			
Remove and Install	04-0400-41		
Fuel System (SN -559602)			
Bleed	04-0400-42		
Fuel System (SN 559603-)			
Bleed	04-0400-42		
Water Pump (SN -559602)			
Remove and Install	04-0400-43		
Water Pump (SN 559603-)			
Remove and Install	04-0400-47		
Thermostat (SN -559602)			
Remove and Install	04-0400-51		
Thermostat (SN 559603-)			
Remove and Install	04-0400-53		

Contents

04

6068 John Deere Engine—Use CTM8

For additional engine information, the component technical manual (CTM) is also required.

Use the CTM in conjunction with this machine manual.



M44215 -UN-07SEP88

TX,9010,SS494 -19-04OCT90-1/1

6068 John Deere Engine—Use CTM104

For additional engine information, the component technical manual (CTM) is also required.

Use the CTM in conjunction with this machine manual.



M44215 -UN-07SEP88

TX,04,DY2913 -19-21AUG97-1/1

04
0400
1

Special Or Essential Tools

RG4950 -UN-23AUG88

NOTE: Order tools according to information given in the U.S. SERVICE-GARD™ Catalog or in the European Microfiche Tool Catalog (MTC).



SERVICE-GARD is a trademark of Deere & Company.

TX,04,DY2912 -19-21AUG97-1/24

Flywheel Turning Tool JDE81-1

Used on machines (Serial No. —559602), rotate engine flywheel. Use with JDE81-4.

TX,04,DY2912 -19-21AUG97-2/24

On machines (Serial No. —559602), rotate engine flywheel. Use with JDE81-4.

Continued on next page

TX,04,DY2912 -19-21AUG97-3/24

Removal And Installation

RG7056 -UN-17JUN05

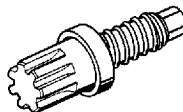

TX,04,DY2912 -19-21AUG97-4/24

Flywheel Turning Tool JDG820

Used on machines (Serial No. 559603—), rotate engine flywheel. Use with JDE81-4.

TX,04,DY2912 -19-21AUG97-5/24

On machines (Serial No. 559603—), rotate engine flywheel. Use with JDE81-4.

TX,04,DY2912 -19-21AUG97-6/24

T6585NP -UN-18OCT88



TX,04,DY2912 -19-21AUG97-7/24

Timing Pin JDE81-4

Used to lock engine at TDC.

TX,04,DY2912 -19-21AUG97-8/24

To lock engine at TDC.

TX,04,DY2912 -19-21AUG97-9/24

RW18149 -UN-09APR90

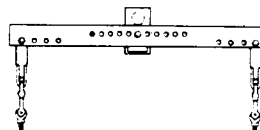

TX,04,DY2912 -19-21AUG97-10/24

Lifting Sling JDG23

Used to remove and install engine

TX,04,DY2912 -19-21AUG97-11/24

Continued on next page

04
0400
2

Removal And Installation

Remove and install engine
TX,04,DY2912 -19-21AUG97-12/24

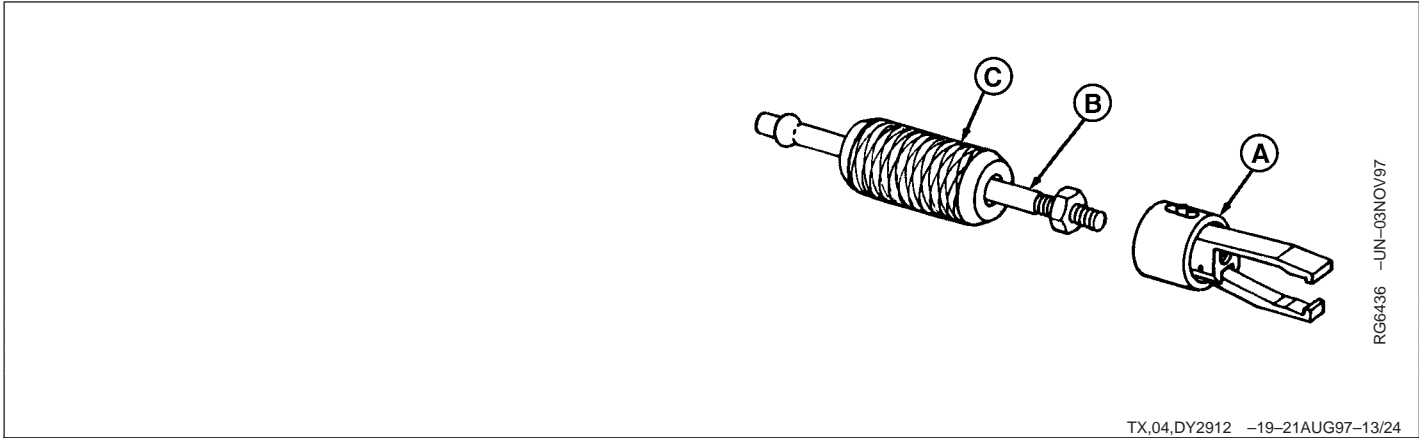

TX,04,DY2912 -19-21AUG97-13/24

04
0400
3

Nozzle Puller JDE28B
Used to remove injection nozzles.
TX,04,DY2912 -19-21AUG97-14/24

To remove injection nozzles.
TX,04,DY2912 -19-21AUG97-15/24

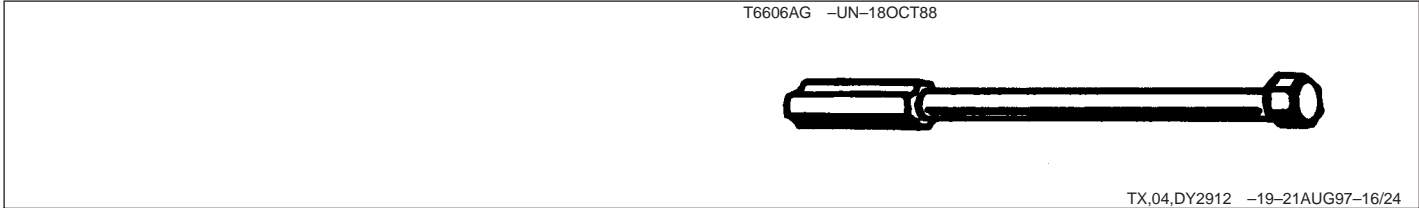

TX,04,DY2912 -19-21AUG97-16/24

Nozzle Bore Cleaning Tool JDE39
Used to clean carbon and other foreign matter from
nozzle bore in cylinder head.
TX,04,DY2912 -19-21AUG97-17/24

Used to clean carbon and other foreign matter from
nozzle bore in cylinder head.

Continued on next page

TX,04,DY2912 -19-21AUG97-18/24

Removal And Installation

T6585PV -UN-18OCT88



TX,04,DY2912 -19-21AUG97-19/24

Carbon Seal Installer JD258

Used to install new carbon seal over nozzle tip.

TX,04,DY2912 -19-21AUG97-20/24

To install new carbon seal over nozzle tip.

TX,04,DY2912 -19-21AUG97-21/24

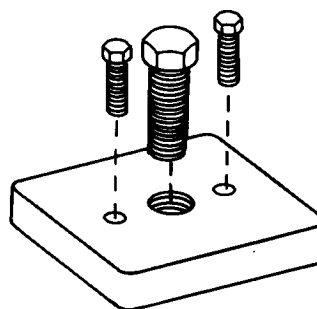

RG6032 -UN-13JAN92

TX,04,DY2912 -19-21AUG97-22/24

Infection Pump Drive Gear Puller JDG670A

Used to remove Stanadyne DB4 injection pump drive gear from tapered shaft.

TX,04,DY2912 -19-21AUG97-23/24

To remove Stanadyne DB4 injection pump drive gear from tapered shaft.

TX,04,DY2912 -19-21AUG97-24/24

04
0400
4

Removal And Installation

Service Equipment And Tools

NOTE: Order tools from the U.S. SERVICE-GARD™ Catalog or from the European Microfiche Tool Catalog (MTC). Some tools may be available from a local supplier.

SERVICE-GARD is a trademark of Deere & Company.

TX,0260,DW596 -19-12APR96-1/3

Lifting Bracket JT01748

Used to support main hydraulic pump.

Special Crowsfoot JDF22

Used to disconnect fuel pressure lines.

04
0400
5

TX,0260,DW596 -19-12APR96-2/3

TIME TRAC® JT01758

Used to time fuel injection pump to engine.

TIME TRAC is a registered trademark of the Stanadyne Automotive Corp.

TX,0260,DW596 -19-12APR96-3/3

Removal And Installation

Other Material

Number	Name	Use
TY15130 (U.S.)	John Deere Form-In-Place Gasket	Apply to ends of gaskets under oil pan gasket.
AT66866 (U.S.)	Solvent	To clean tapered surfaces of shaft and gear for DB4 Fuel Injection Pump
PT569 (U.S.)	John Deere NEVER-SEEZ® Lubricant	Apply to exhaust manifold cap screw threads.
TY6304 (U.S.) TY9484 (Canadian) 515 (LOCTITE®)	Flexible Sealant Products	Used to apply to oil pan rail.
T43512 (U.S.) TY9473 (Canadian) 242 (LOCTITE®)	Thread Lock and Sealer (Medium Strength) Products	Used to apply to cap screw threads and gasket of fuel transfer pump.

NEVER-SEEZ is a registered trademark of the Emhart Chemical Group.

LOCTITE is a registered trademark of Loctite Corp.

TX,04,DY2919 -19-21AUG97-1/1

Removal And Installation

Specifications

Item	Measurement	Specification
Flywheel (Serial No. —559602):		
Cover-to-Housing Cap Screw	Torque	50 N•m (35 lb-ft)
Flywheel (Serial No. 559603—):		
Cover-to-Housing Cap Screw	Torque	75 N•m (55 lb-ft)
Engine (Serial No. —559602):		
Bracket-to-Flywheel Housing Cap Screw	Torque	150 N•m (115 lb-ft)
Bracket-to-Cylinder Block Cap Screw	Torque	215 N•m (160 lb-ft)
Isolator-to-Frame Cap Screw	Torque	675 N•m (500 lb-ft)
Fan Blade-to-Shroud	Approximate Clearance	7 mm (0.27 in.)
Fan Shroud Cap Screw	Torque	40 N•m (30 lb-ft)
Fan Guard Cap Screw	Torque	16.2 N•m (12 lb-ft)
Engine (Serial No. 559603—):		
Fan Mounting Cap Screws	Torque	70 N•m (52 lb-ft)
Fan Shroud Cap Screws	Torque	40.5 N•m (30 lb-ft)
Fan Guard Cap Screws	Torque	16.2 N•m (12 lb-ft)
Front Engine Mounting Cap Screws	Torque	346 N•m (255 lb-ft)
Rear Engine Mounting Cap Screws	Torque	142 N•m (105 lb-ft)
Engine-to-Frame Mounting Cap Screws	Torque	678 N•m (500 lb-ft)

04
0400
7

Continued on next page

TX,04,DY2911 -19-20AUG97-1/3

Removal And Installation

Item	Measurement	Specification
Oil Pan Mounting Cap Screws	Torque	35 N•m (26 lb-ft)
Item	Measurement	Specification
Injection Nozzle:		
Connector Nut	Torque	27 N•m (20 lb-ft)
Nozzle Hold Down Cap Screw	Torque	27 N•m (20 lb-ft)
Injection Pump:		
Drive Gear Nut	Torque	197 N•m (145 lb-ft)
Attaching Nut	Torque	25 N•m (18 lb-ft)
Item	Measurement	Specification
Fuel Transfer Pump Cap Screw	Torque	30 N•m (22 lb-ft)
Item	Measurement	Specification
Thermostat (Serial No. —559602):		
Begin Operating	Temperature	79—83°C (175—182°F)
Full Open	Temperature	94°C (202°F)
Cover Cap Screw	Torque	27 N•m (20 lb-ft)
Thermostat (Serial No. 559603—):		
Thermostat Cover Cap Screws	Torque	70 N•m (52 lb-ft)
Item	Measurement	Specification
Exhaust Manifold-to-Engine Mounting Cap Screw (Serial No. —559602)	Torque	47 N•m (35 lb-ft)
Exhaust Manifold-to-Engine Mounting Cap Screw (Serial No. 559603—)	Torque	70 N•m (52 lb-ft)
Water Pump Pulley Cap Screws	Torque	16 N•m (12 lb-ft)
Water Pump Cap Screws	Torque	16 N•m (12 lb-ft)

Continued on next page

TX,04,DY2911 -19-20AUG97-2/3

Removal And Installation

Item	Measurement	Specification
Water Pump Inlet Elbow Cap Screws	Torque	35 N•m (26 lb-ft)
Turbocharger (Serial No. —559602) Turbocharger-to-Manifold Cap Screw	Torque	47 N•m (35 lb-ft)
Turbocharger (Serial No. 559603—) Turbocharger Cap Screws	Torque	70 N•m (52 lb-ft)
Rocker Arm Cap Screw	Torque	10.8 N•m (96 lb-in.)
Item	Measurement	Specification
Starter:		
Cable Nut at Starter	Torque	30.5 N•m (270 lb-in.)
Item	Measurement	Specification
Ground Cable Nut at Battery	Torque	9.0 N•m (82 lb-in.)

04
0400
9

TX,04,DY2911 -19-20AUG97-3/3

Remove And Install Engine (Serial No. — 559602)

1. Disconnect negative battery cable and close fuel shut-off valve.

Continued on next page

TX,04,DY2884 -19-20AUG97-1/12

Removal And Installation



CAUTION: Explosive release of fluids from pressurized cooling system can cause serious burns.

Shut off engine. Only remove filler cap when cool enough to touch with bare hands. Slowly loosen cap to first stop to relieve pressure before removing completely.

2. Drain coolant. Approximate radiator capacity is 34 L (9 gal).

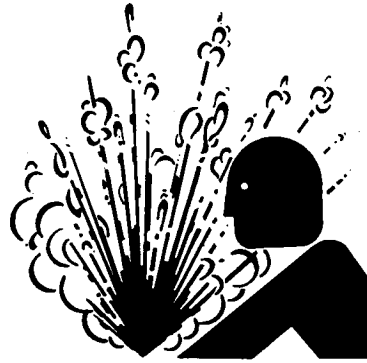

TS281 -UN-23AUG88

TX,04,DY2884 -19-20AUG97-2/12

3. Remove air intake hose (A).
4. Remove upper radiator hose (B) and lower radiator hose (F).
5. Remove eight cap screws to remove upper and lower fan guards (D).
6. Remove six cap screws to remove fan (C).
7. Remove eight cap screws to remove shroud (E).

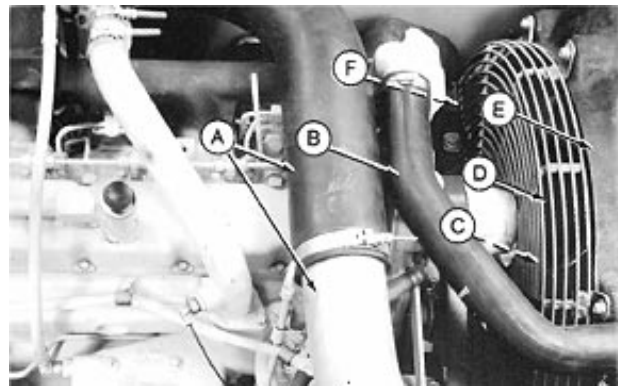

T7626CV -UN-18DEC91

A—Air Intake Hose
 B—Upper Radiator Hose
 C—Fan
 D—Fan Guard
 E—Fan Shroud
 F—Lower Radiator Hose

Continued on next page

TX,04,DY2884 -19-20AUG97-3/12

Removal And Installation

8. Remove clamp (A).
9. Remove three small clamps from rear of muffler bracket.
10. Remove cap screws (B and D).
11. Remove bracket (C) and muffler.

- A—Clamp
- B—Cap Screw (2 used)
- C—Muffler Bracket
- D—Cap Screw (2 used)

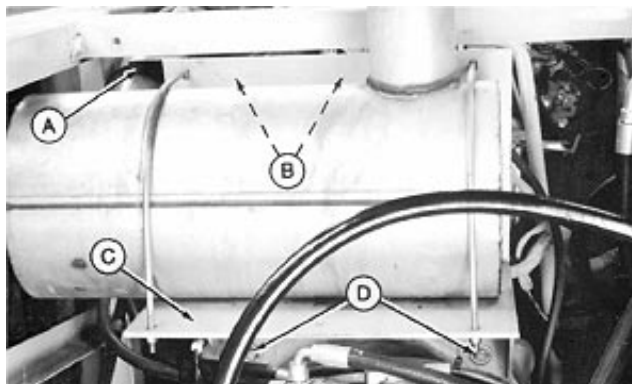

T7626CW -UN-18DEC91

04
0400
11

TX,04,DY2884 -19-20AUG97-4/12

12. Disconnect wiring harness (A).
- NOTE: Engine wiring harness can be removed with engine. Disconnect harness bulkhead connector at firewall.*
13. Disconnect fuel line (B) and start aid line (C).
 14. Disconnect heater hose (D).
 15. Remove two cap screws (E) to remove air conditioning compressor (F).
 16. Disconnect battery cables (G and H).
 17. Disconnect ground strap (I).

- A—Main Wire Harness
- B—Fuel Line
- C—Start Aid Line
- D—Heater-to-Water Pump Hose
- E—Cap Screw (2 used)
- F—Air Conditioning Compressor
- G—Negative Battery Cable
- H—Positive Battery Cable
- I—Ground Strap

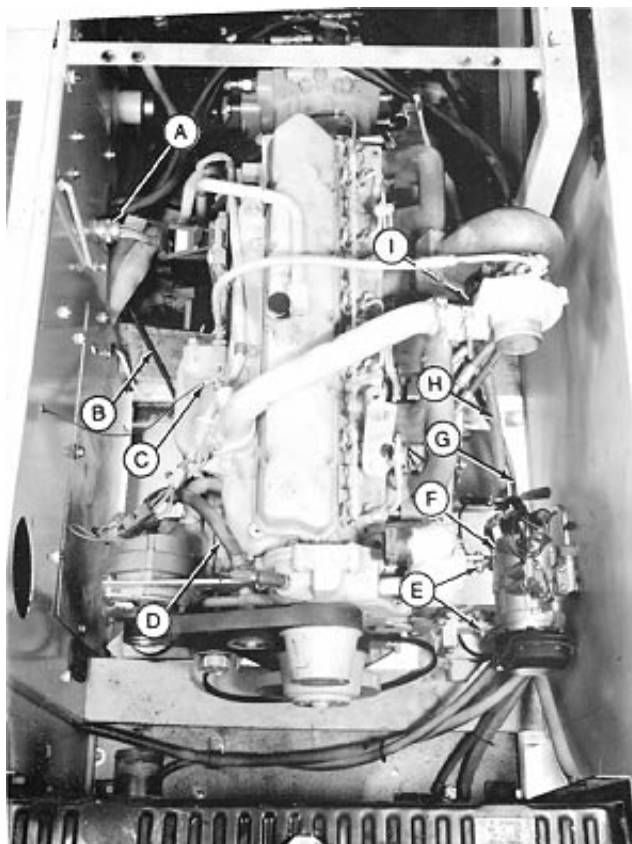

T7626CX -UN-18DEC91

Continued on next page

TX,04,DY2884 -19-20AUG97-5/12

Removal And Installation



CAUTION: Escaping fluid under pressure can penetrate the skin causing serious injury. Avoid the hazard by relieving pressure before disconnecting hydraulic or other lines. Tighten all connections before applying pressure. Search for leaks with a piece of cardboard. Protect hands and body from high pressure fluids.

If an accident occurs, see a doctor immediately. Any fluid injected into the skin must be surgically removed within a few hours or gangrene may result. Doctors unfamiliar with this type of injury may call the Deere & Company Medical Department in Moline, Illinois, or other knowledgeable medical source.

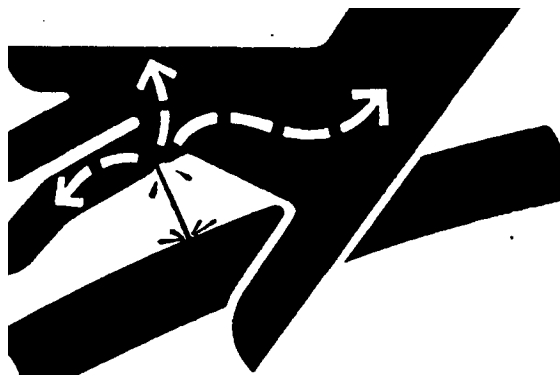

X9811 -UN-23AUG88

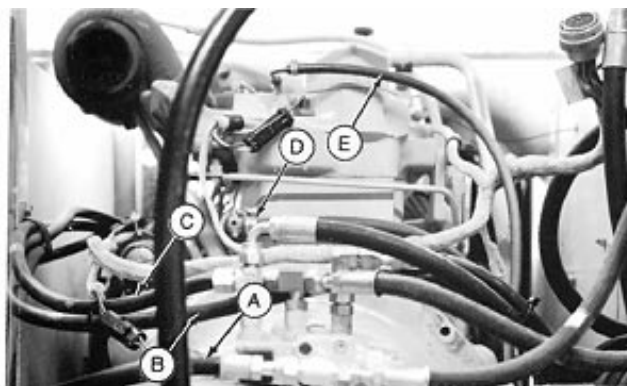

T7626CY -UN-18DEC91

18. Disconnect lines (A—C).
19. Disconnect fuel return line (E).
20. Disconnect heater hose (D).

A—Pump Displacement Valve-to-Engine Speed Control Actuator Line
 B—Reservoir-to-Engine Speed Control Actuator Line
 C—Load Sense Valve-to-Engine Speed Control Actuator Line
 D—Heater-to-Cylinder Block Hose
 E—Fuel Return Line

Continued on next page

TX,04,DY2884 -19-20AUG97-6/12

Removal And Installation

⚠ CAUTION: The approximate weight of main hydraulic pump is 125 kg (276 lb).

21. Support hydraulic pump (C) using a lifting bracket (B) such as JT01748 and a hoist.

⚠ CAUTION: The approximate weight of engine is 630 kg (1400 lb).

The recommended method for lifting the engine is using the JDG23 Lifting Sling. The lifting force must be at 90° at the lifting points.

22. Connect engine to a hoist using the JDG23 Lifting Sling.
23. Remove flywheel cover-to-engine housing cap screws.
24. Remove four isolator mount-to-frame cap screws.
25. To remove engine, lift fan end so oil pan will clear frame crossbar and move engine away from hydraulic pump.
26. Repair or replace engine as necessary. (See procedures in CTM8.)

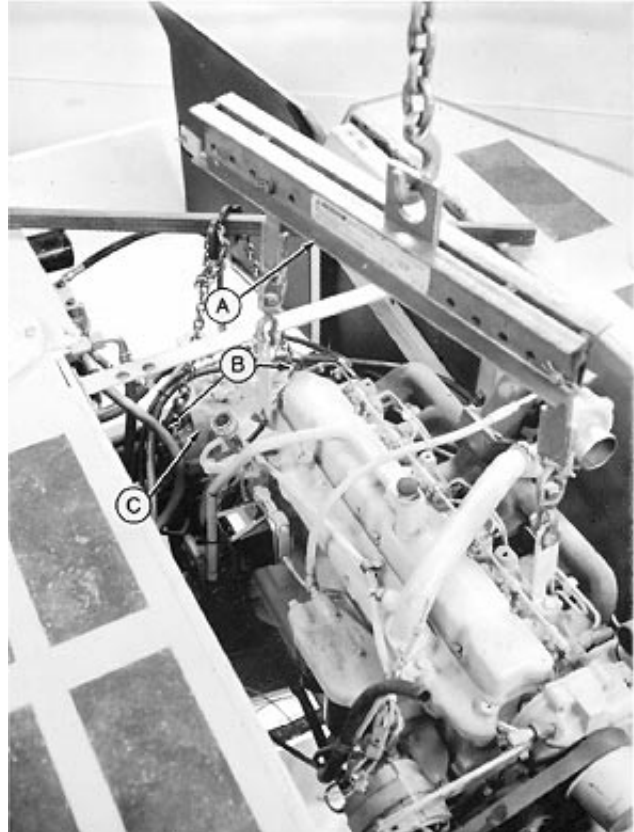

04
0400
13

T7626CZ -UN-18DEC91

Continued on next page

TX,04,DY2884 -19-20AUG97-7/12

Removal And Installation

27. Install engine. As engine is installed, align absorber (A) with hub and adapters (B).

28. Install pump mount cover-to-flywheel housing cap screws. Tighten cap screws to 50 N•m (35 lb-ft).

Specification

Cover-To-Flywheel Housing Cap
Screws—Torque 50 N•m (35 lb-ft)

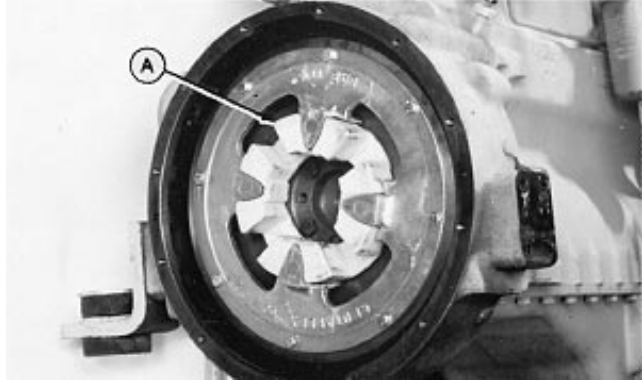

T6439SZ -UN-13FEB90

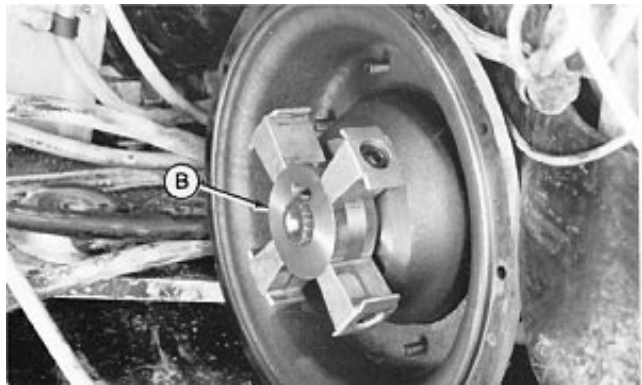

T6439TA -UN-13FEB90

TX,04,DY2884 -19-20AUG97-8/12

29. Install engine mounts. Install lower isolator (D) in bracket (C) using water as a lubricant. Install upper isolator (B), special washer (A), cap screw and nut.

Specification

Bracket-to-Flywheel Housing 1/2 in. Cap Screw—Torque 150 N•m (115 lb-ft)
Bracket-to-Engine Block 5/8 in. Cap Screw—Torque 215 N•m (160 lb-ft)
Isolator-to-Frame M20 Cap Screw and Nut—Torque 675 N•m (500 lb-ft)

- A—Special Washer
- B—Upper Isolator
- C—Bracket
- D—Lower Isolator

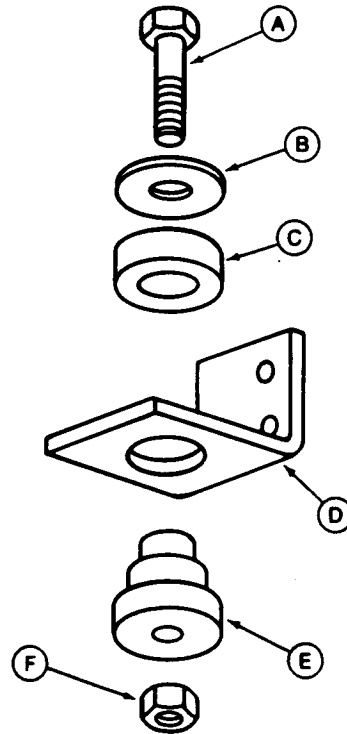

T7681FV -UN-24FEB92

Continued on next page

TX,04,DY2884 -19-20AUG97-9/12

04
0400
14

Removal And Installation

- 30. Connect hose (D).
- 31. Connect lines (A—C and E).

- A—Pump Displacement Valve-to-Engine Speed Control Actuator Line
- B—Reservoir-to-Engine Speed Control Actuator Line
- C—Load Sense Valve-to-Engine Speed Control Actuator Line
- D—Heater-to-Engine Block Hose
- E—Fuel Return Line

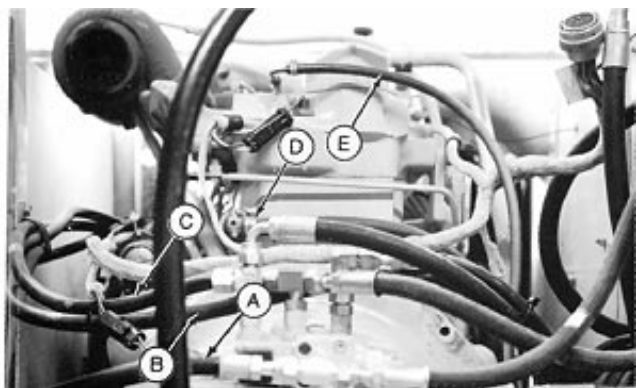

T7626CY -UN-18DEC91

04
0400
15

TX,04,DY2884 -19-20AUG97-10/12

- 32. Connect battery cables (G and H) and ground strap (I).
- 33. Install air conditioning compressor (F) and tighten cap screws (E).
- 34. Connect heater hose (D).
- 35. Connect lines (B and C).
- 36. Connect wiring harness (A).

- A—Main Wire Harness
- B—Fuel Line
- C—Start Aid Line
- D—Heater-to-Water Pump Hose
- E—Cap Screw (2 used)
- F—Air Conditioning Compressor
- G—Negative Battery Cable
- H—Positive Battery Cable
- I—Ground Strap

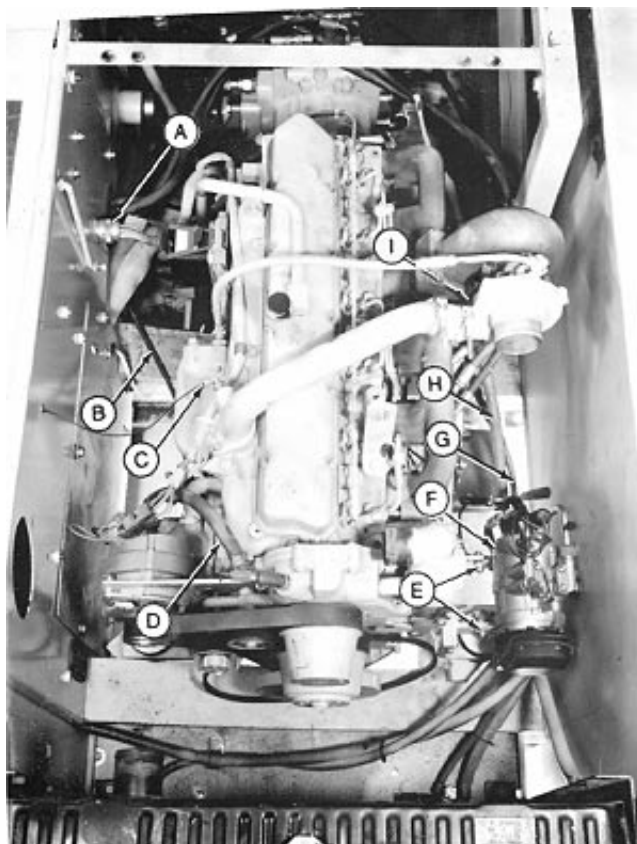

T7626CX -UN-18DEC91

Continued on next page

TX,04,DY2884 -19-20AUG97-11/12

Removal And Installation

- 37. Install muffler bracket (C) and muffler.
- 38. Install cap screws (B and D).
- 39. Install clamp (A).
- 40. Install inlet tube and tighten exhaust clamp (A).
- 41. Install fan shroud, fan, upper, and lower fan guard.

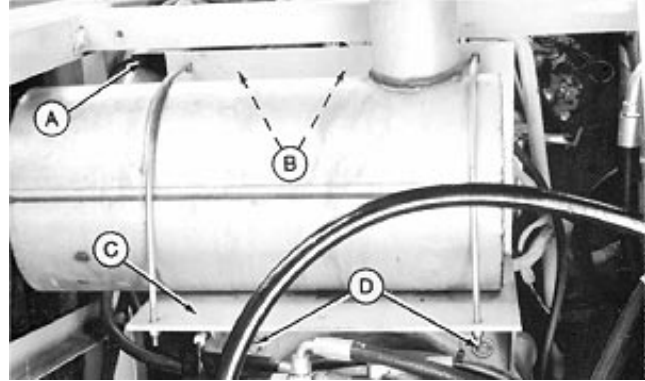

Install fan shroud so there is approximately 7 mm (0.27 in.) clearance between blades and shroud.

Specification

Fan Blade-to-Shroud—Clearance 7 mm (0.27 in.)

- A—Clamp
- B—Cap Screw (2 used)
- C—Muffler Bracket
- D—Cap Screw (2 used)

Tighten fan shroud cap screws to 40 N•m (30 lb-ft).

Specification

Fan Shroud Cap Screw—Torque..... 40 N•m (30 lb-ft)

Tighten fan guard cap screws to 16.2 N•m (12 lb-ft).

Specification

Fan Guard Cap Screw—Torque 16.2 N•m (12 lb-ft)

- 42. Install upper and lower radiator hoses.
- 43. Fill radiator and reservoir to proper level.
- 44. Bleed fuel system. (See procedure in this group.)
- 45. Adjust speed control linkage. (See procedure in Group 0515.)

TX,04,DY2884 -19-20AUG97-12/12

Remove And Install Engine (Serial No. 559603—)

- 1. Disconnect negative battery cable and close fuel shut-off valve.

Continued on next page

TX,04,DT5057 -19-12JUN97-1/12

04
0400
16

Removal And Installation



CAUTION: Explosive release of fluids from pressurized cooling system can cause serious burns.

Shut off engine. Only remove filler cap when cool enough to touch with bare hands. Slowly loosen cap to first stop to relieve pressure before removing completely.

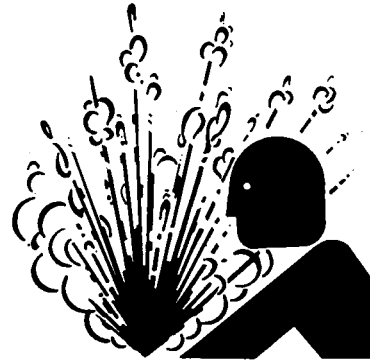

TTS281 -JUN-23AUG88

2. Drain coolant. Approximate radiator capacity is 41.5 L (11 gal).
3. Remove engine hood.
4. Remove top muffler access panel and crossbar assembly.

04
0400
17

TX,04,DT5057 -19-12JUN97-2/12

5. Loosen clamp (A)

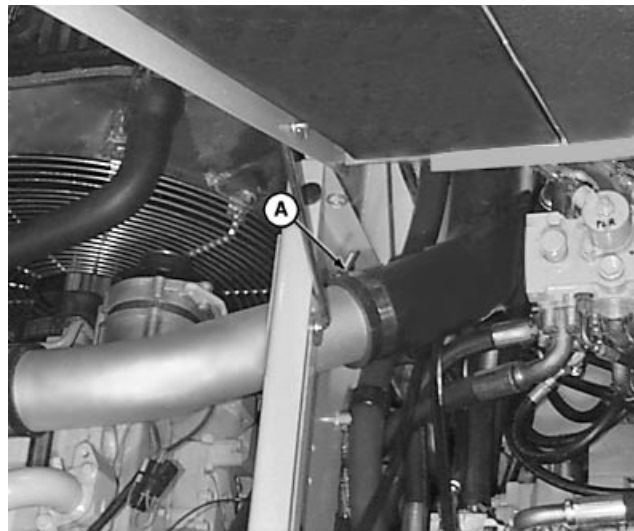

T109976 -JUN-05AUG97

Continued on next page

TX,04,DT5057 -19-12JUN97-3/12

Removal And Installation

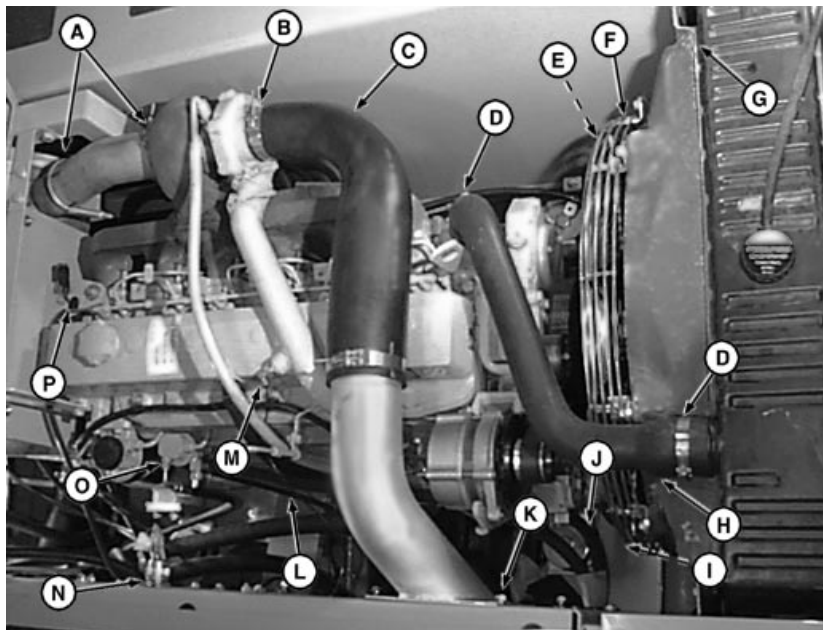

T1109977 -UN-05AUG97

A—Clamp (2 used)
 B—Clamp
 C—Air Intake Hose
 D—Clamp (2 usesd)
 E—Fan

F—Fan Guard
 G—Fan Shroud
 H—Upper Radiator Hose
 I—Lower Radiator Hose

J—Heater-to-Water Pump Hose
 K—Cap Screw (2 used)
 L—Heater-to-Engine Block
 Hose

M—Start Aid Line
 N—Wire Harness
 O—Fuel Line
 P—Fuel Return Line

6. Remove cap screws (K). Loosen clamp (B). Remove air intake hose assembly (C).
7. Loosen clamps (D). Remove upper radiator hose (H).
8. Loosen clamps and remove lower radiator hose (I).
9. Remove eight cap screws to remove fan guard (F).
10. Remove eight cap screws from fan shroud. Move shroud toward engine.
11. Remove four cap screws to remove fan (E) and spacer.
12. Remove fan shroud (G).
13. Disconnect heater lines (J and L). Label lines to aid in installation.

14. Disconnect fuel line (O).
15. Disconnect start aid line (M).
16. Disconnect fuel return line (P).
17. Disconnect wiring harness (N).

NOTE: Engine wiring harness can be removed with engine. Disconnect harness bulkhead connector at firewall.

18. Remove electrical harness clamps from muffler bracket.
19. Remove clamp (A). Remove muffler. (See procedure in Group 0530.)
20. Remove pressure regulator valve solenoid connector.

Continued on next page

TX,04,DT5057 -19-12JUN97-4/12

Removal And Installation

21. Disconnect battery cables (A and C).
22. Disconnect ground strap (B).

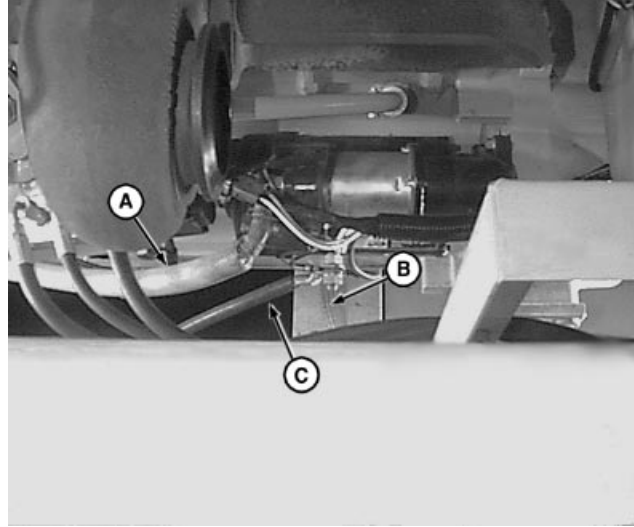

T110036 -JUN-05AUG97

04
0400
19

Continued on next page

TX,04,DT5057 -19-12JUN97-5/12

Removal And Installation

! **CAUTION:** Escaping fluid under pressure can penetrate the skin causing serious injury. Avoid the hazard by relieving pressure before disconnecting hydraulic or other lines. Tighten all connections before applying pressure. Search for leaks with a piece of cardboard. Protect hands and body from high pressure fluids.

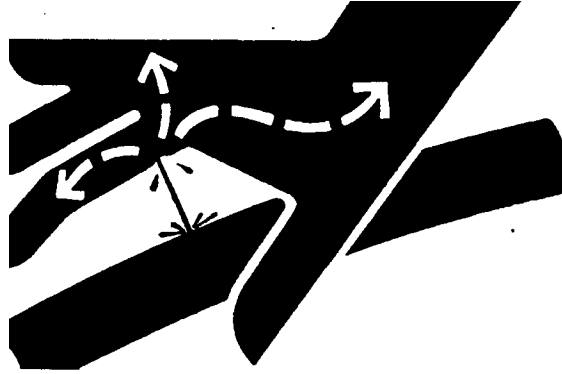

If an accident occurs, see a doctor immediately. Any fluid injected into the skin must be surgically removed within a few hours or gangrene may result. Doctors unfamiliar with this type of injury may call the Deere & Company Medical Department in Moline, Illinois, or other knowledgeable medical source.

23. Disconnect lines (A—C). Label lines to aid in assembly.

! **CAUTION:** Use adequate lifting device for heavy components.

24. Support hydraulic pump using a lifting bracket such as JT01748 and a hoist.

25. Remove main hydraulic pump-to-flywheel cover mounting cap screws.

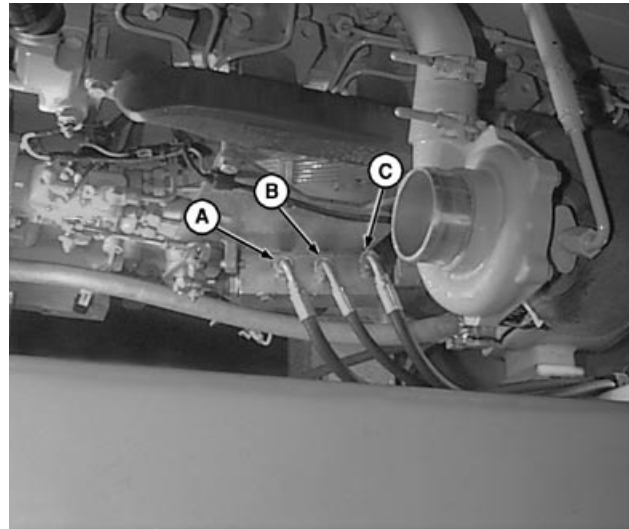

Heat Shield Removed For Clarity

- A—Engine Speed Control Actuator T Port-to-Hydraulic Tank
- B—Engine Speed Control Actuator A Port-to-Dual Solenoid Valve E Port Line
- C—Engine Speed Control Actuator PST Port-to-Hydraulic Filter Outlet Port Line

X9811 -UN-23AUG88

T110041 -UN-05AUG97

Continued on next page

TX,04,DT5057 -19-12JUN97-6/12

Removal And Installation

CAUTION: The approximate weight of engine is 685 kg (1450 lb).

NOTE: If engine does not have lifting straps they can be procured through service parts. Use an engine lifting sling (as shown), which is the **ONLY APPROVED** method for lifting the engine.

26. Connect engine to hoist using JDG23 Lifting Sling.
27. Remove cap screws. Swing front mounts away from engine for clearance.
28. Slide engine forward to disengage pump drive and remove engine.
29. Repair or replace engine as necessary. (See procedures in CTM104.)

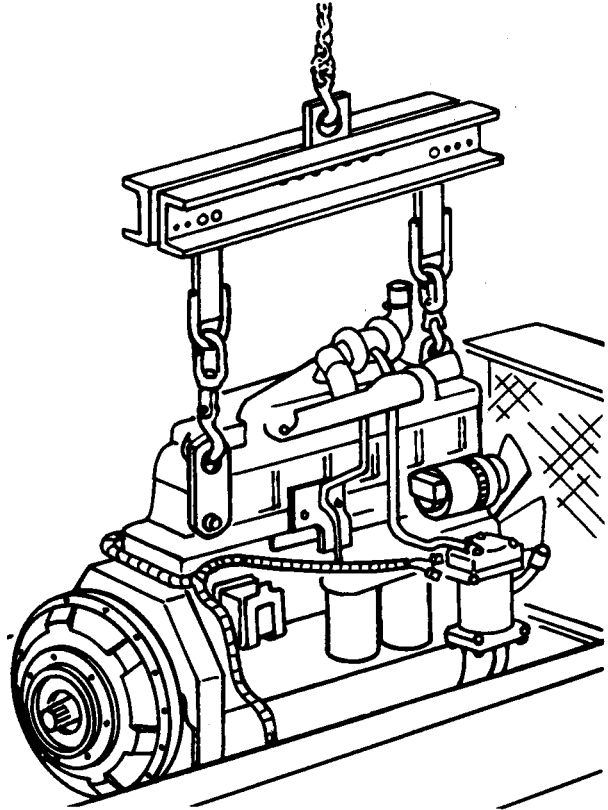

04
0400
21

T6683FQ -UN-18OCT88

TX,04,DT5057 -19-12JUN97-7/12

30. Install engine. As engine is installed, align flex-coupling (A) with hub assembly (B).
31. Install main hydraulic pump mount-to-flywheel cover mounting cap screws. Tighten to 75 N•m (55 lb-ft).
32. Install engine mounting cap screws.

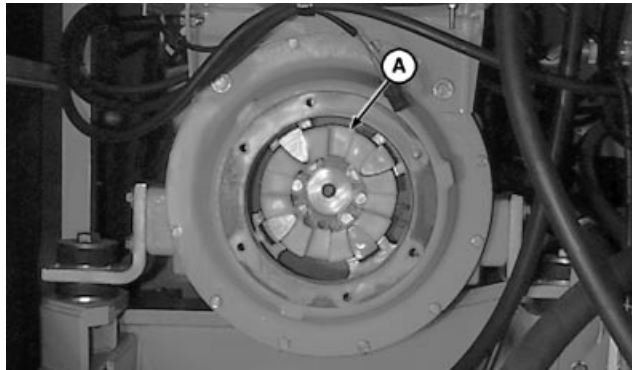

T110068 -UN-05AUG97

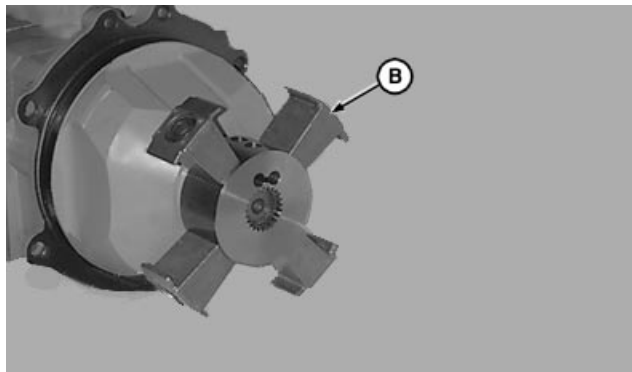

T110069 -UN-05AUG97

Continued on next page

TX,04,DT5057 -19-12JUN97-8/12

Removal And Installation

33. Connect lines (A—C).

- A—Engine Speed Control Actuator T Port-to-Hydraulic Tank
- B—Engine Speed Control Actuator A Port-to-Dual Solenoid Valve E Port Line
- C—Engine Speed Control Actuator PST Port-to-Hydraulic Filter Outlet Port Line

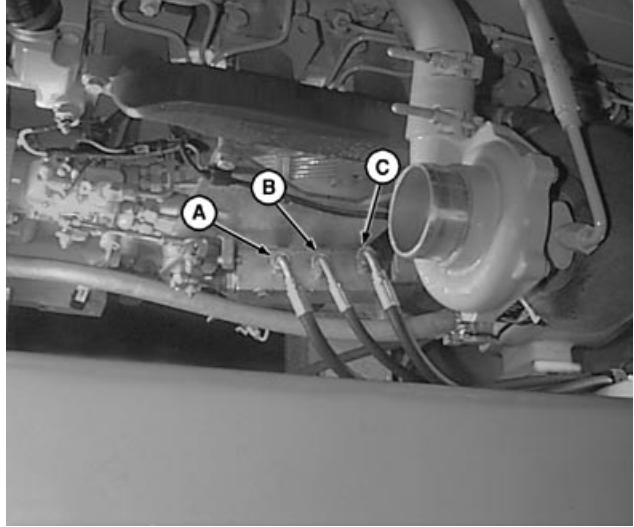

T110041 -UN-05AUG97

Heat Shield Removed For Clarity

TX,04,DT5057 -19-12JUN97-9/12

34. Connect battery cables (A and C).

35. Connect ground strap (B).

36. Install muffler. (See procedure in Group 0530.)

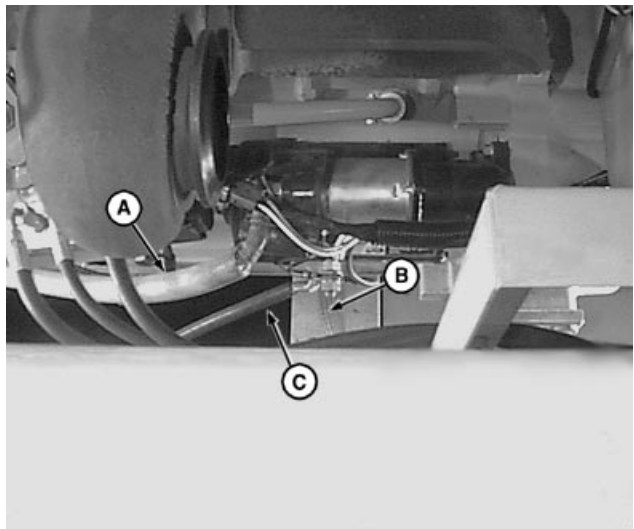

T110036 -UN-05AUG97

Continued on next page

TX,04,DT5057 -19-12JUN97-10/12

Removal And Installation

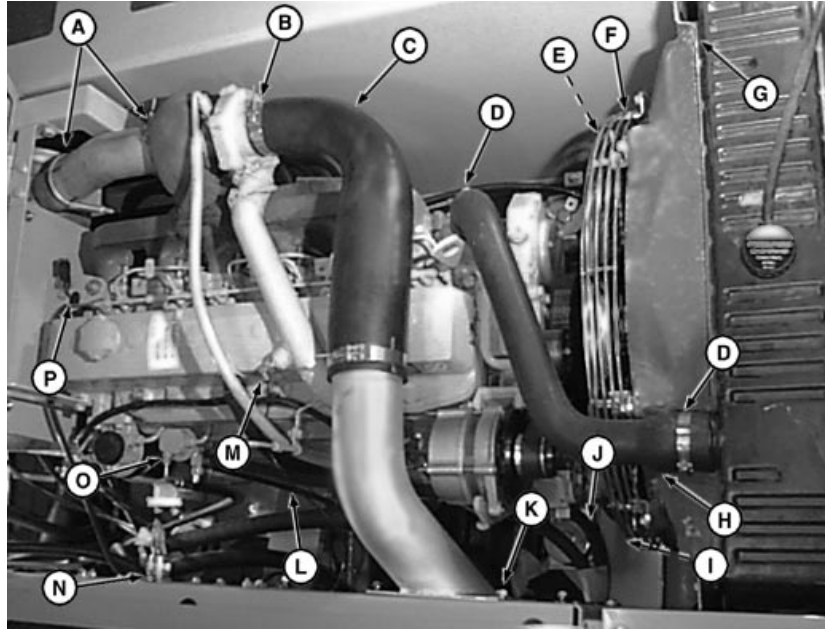

T109977 -UN-05AUG97

04
0400
23

- | | | | |
|-------------------|-----------------------|-----------------------------|--------------------|
| A—Clamp (2 used) | F—Fan Guard | J—Heater-to-Water Pump Hose | M—Start Aid Line |
| B—Clamp | G—Fan Shroud | K—Cap Screw (2 used) | N—Wire Harness |
| C—Air Intake Hose | H—Upper Radiator Hose | L—Heater-to-Engine Block | O—Fuel Line |
| D—Clamp (2 used) | I—Lower Radiator Hose | Hose | P—Fuel Return Line |
| E—Fan | | | |

- 37. Install clamp (A).
- 38. Connect wiring harness (N).
- 39. Connect fuel return line (P).
- 40. Connect start aid line (M).
- 41. Connect fuel line (O).
- 42. Connect heater hoses (J and L).
- 43. Install fan shroud (G).
- 44. Install fan (E) and spacer. Tighten fan cap screws to 70 N•m (52 lb-ft)

Specification

Fan Mounting Cap Screws—
Torque..... 70 N•m (52 lb-ft)

- 45. Install fan shroud cap screws. Tighten fan shroud cap screws to 40.5 N•m (30 lb-ft).

Specification

Fan Shroud Cap Screws—
Torque..... 40.5 N•m (30 lb-ft).

- 46. Install fan guard (F). Tighten fan guard cap screws to 16.2 N•m (12 lb-ft).

Specification

Fan Guard Cap Screws—
Torque..... 16.2 N•m (12 lb-ft).

- 47. Install lower radiator hose (I) and clamps.
- 48. Install upper radiator hose (H) and clamp (D).
- 49. Install air intake hose (C). Tighten clamp (B). Install cap screws (K).

Continued on next page

TX,04,DT5057 -19-12JUN97-11/12

Removal And Installation

50. Tighten clamp (A).
51. Install top muffler access panel and crossbar assembly.
52. Install engine hood.
53. Fill coolant. Approximate capacity is 41.5 L (11 gal).
54. Open fuel shut off valve and connect negative battery cable.
55. Bleed fuel system. (See procedure in this group.)
56. Adjust speed control linkage. (See procedure on Group 0515.)

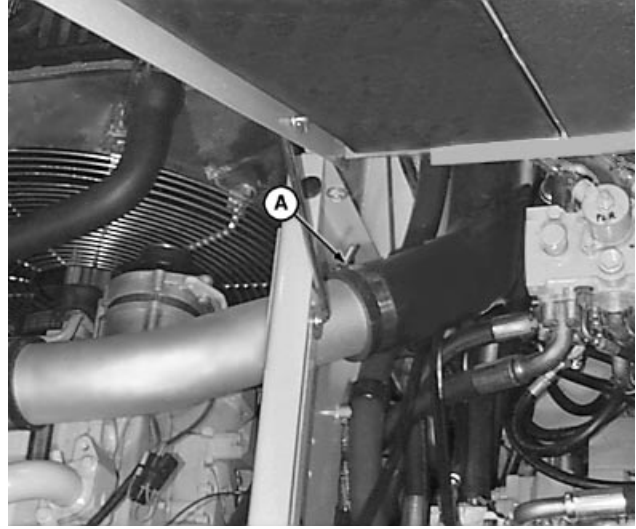

T109976 -UN-05AUG97

TX,04,DT5057 -19-12JUN97-12/12

Removal And Installation

Remove And Install Oil Pan

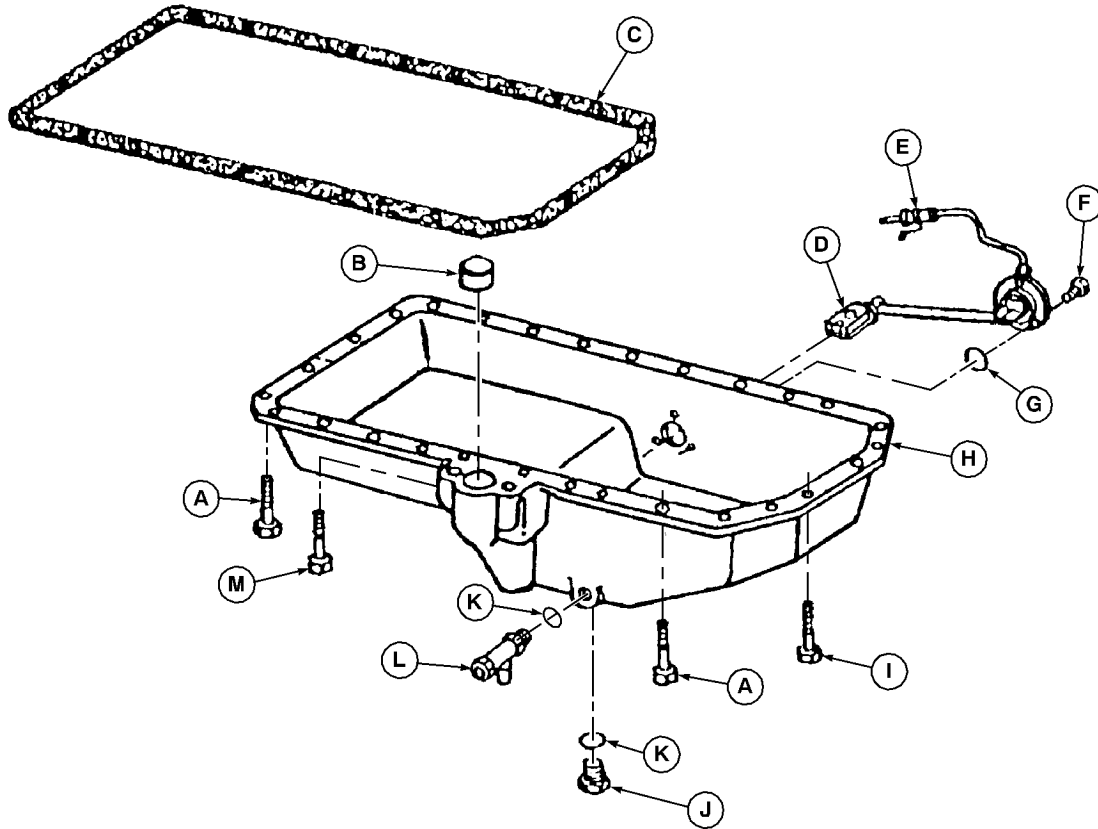

T110092

04
0400
25
T110092 -UN-05AUG97

- | | | | |
|-----------------------|------------------------|----------------------|----------------------|
| A—Cap Screw (26 used) | E—Electrical Connector | H—Oil Pan | K—O-Ring (2 used) |
| B—Cap | F—Cap Screw (3 used) | I—Cap Screw (6 used) | L—Drain Valve |
| C—Gasket | G—O-Ring | J—Plug | M—Cap Screw (4 used) |
| D—Sensor | | | |

1. Drain engine oil. Approximate capacity is 19 L (5 gal) including filter.

NOTE: Engine must be removed to remove oil pan.

2. Remove engine. (See procedure in this group.)
3. Remove cap screws (A, I and M). Remove oil pan (H).
4. Remove all gasket material from oil pan and cylinder block.
5. Apply Flexible Form-In-Place Gasket on oil pan rail where flywheel housing, front plate, and timing gear cover attach to cylinder block.

6. Position oil pan (H) on cylinder block.
7. Install cap screws (A, I and M). Tighten to 35 N•m (26 lb-ft).

Specification

Oil Pan Mounting Cap
Screws—Torque 35 N•m (26 lb-ft).

Start at right rear corner and proceed counterclockwise.

8. Install engine. (See procedure in this group.)
9. Add engine oil. (See Engine Oil, Group 0004.) Approximate capacity is 19 L (5 gal) including filter.

TX,04,DY2914 -19-21AUG97-1/1

Removal And Installation

Remove And Install Fuel Injection Nozzles

IMPORTANT: To avoid twisting lines, use a wrench to hold the injection nozzle connector while loosening the line fitting.

1. Remove fuel leak-off line (A).
2. Remove cap screw (B) to remove hold-down clamp (D) and spacer (C).

A—Leak-Off Line
 B—Cap Screw
 C—Spacer
 D—Hold-Down Clamp
 E—Fuel Injection Nozzle
 F—Fuel Injection Line Nut

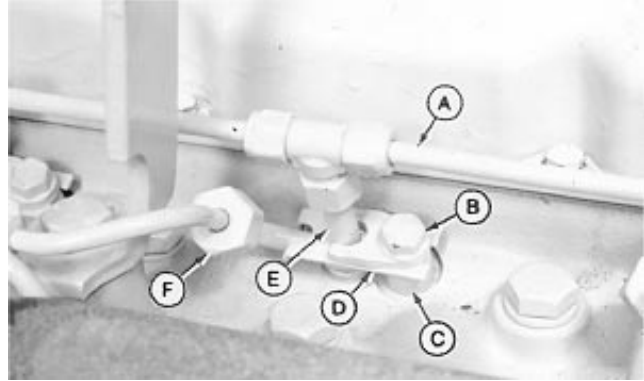

T7041BO -UN-19SEP89

TX,0400,BA151 -19-25SEP91-1/8

3. Loosen injection nozzles connections using two wrenches. Install cap on nozzle inlet.



T79458 -UN-01NOV88

TX,0400,BA151 -19-25SEP91-2/8

IMPORTANT: DO NOT use a screwdriver or pry bars to remove injection nozzles.

4. Pull injection nozzle from cylinder head. If nozzle cannot be easily removed, use JDE38 Nozzle Puller.



T82100 -UN-09NOV88

Continued on next page

TX,0400,BA151 -19-25SEP91-3/8

Removal And Installation

IMPORTANT: DO NOT scrape or otherwise damage the TEFLON® coating on the nozzle body above the carbon seal groove. This coating will become discolored during normal service, but this is not harmful. **DO NOT** use a motor-driven brush to clean the nozzle body.

5. Remove carbon seal (A) and seal washer (B) from nozzle.

IMPORTANT: DO NOT attempt to test nozzles unless the proper service tools are available. For injection nozzle repair, have an authorized diesel injection service station perform the work or refer to the engine component technical manual.

6. Clean the exterior of nozzle by soaking in clean solvent or diesel fuel. Then clean the spray tip using a brass wire brush.

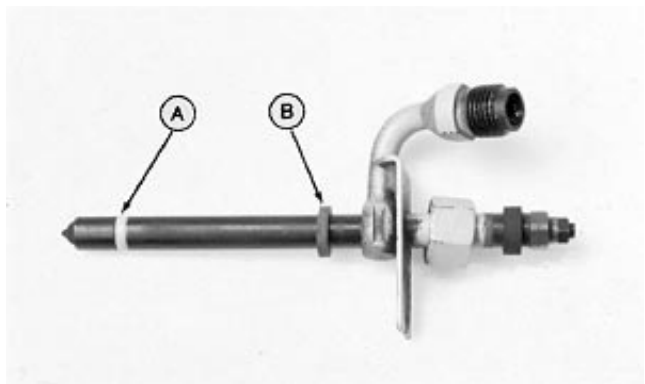

T6451AJ -UN-18OCT88

04
0400
27

TEFLON is a registered trademark of the DuPont Company.

TX,0400,BA151 -19-25SEP91-4/8

7. Remove parts (A—E). Replace grommets and sleeves if necessary.

- A—Leak-Off Cap
- B—Grommet
- C—Nut
- D—Rubber Sleeve
- E—Special Nut

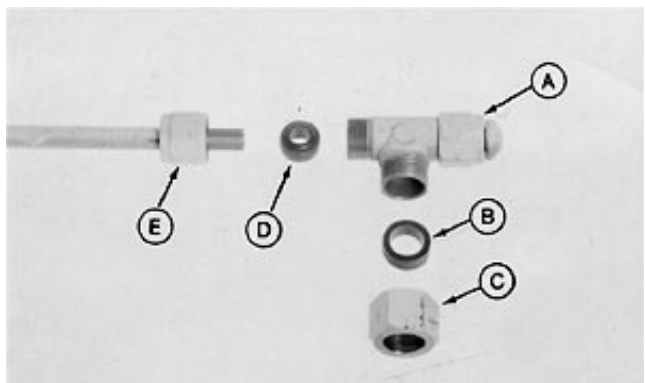

T94607 -UN-01NOV88

TX,0400,BA151 -19-25SEP91-5/8

8. Install a new upper seal washer (B).

9. Install JD258 (16477) Pilot (A) over nozzle tip. Install a new carbon seal (C) over pilot.

10. Help slide the carbon seal into place in its groove using a new seal washer (B).

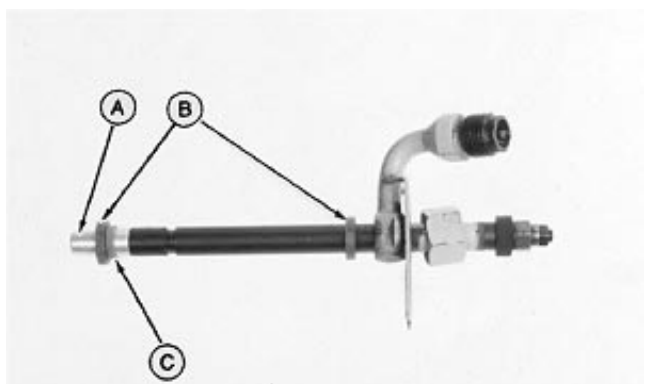

T6451AK -UN-18OCT88

Continued on next page

TX,0400,BA151 -19-25SEP91-6/8

Removal And Installation

11. Clean the cylinder head nozzle bore using JDE39 Nozzle Bore Cleaning Tool.
12. Clean debris from nozzle bore.



T82101 -UN-01NOV88

TX,0400,BA151 -19-25SEP91-7/8

13. Install nozzle (E) in nozzle bore using a twisting motion.
14. Install spacer (C), clamp (D), and cap screw (B). Tighten cap screw to 27 N•m (20 lb-ft).

Specification

Injection Nozzle Connector Nut—
Torque 27 N•m (20 lb-ft)

15. Connect lines (A and F) to injection nozzle. Tighten injection line nut (F) to 27 N•m (20 lb-ft) using two wrenches.

Specification

Nozzle Hold Down Cap Screw—
Torque 27 N•m (20 lb-ft)

16. Tighten all line clamps.
17. Bleed the fuel system. (See procedure in this group.)

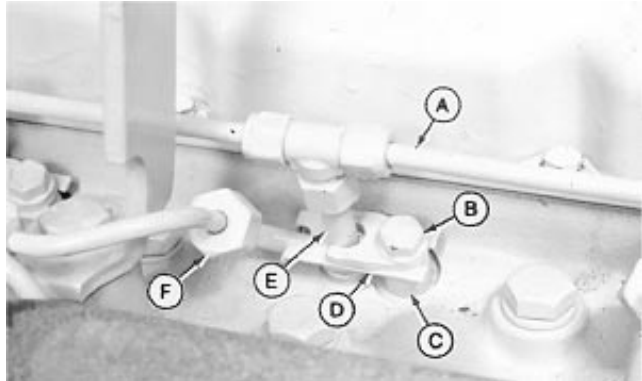

T7041B0 -UN-19SEP89

- A—Leak-Off Line
- B—Cap Screw
- C—Spacer
- D—Hold-Down Clamp
- E—Fuel Injection Nozzle
- F—Fuel Injection Line Nut

TX,0400,BA151 -19-25SEP91-8/8

04
0400
28

Removal And Installation

Clean Injection Nozzle Bores

IMPORTANT: To keep cleaning tool from getting dull, always turn the tool clockwise through the bore, even when removing.

1. Clean cylinder head nozzle bore using the JDE39 Nozzle Bore Cleaning Tool.

CAUTION: Reduce compressed air to less than 210 kPa (2 bar) (30 psi) when using for cleaning purposes. Clear area of bystanders, guard against flying chips, and wear personal protection equipment including eye protection.

2. Remove debris from nozzle bore using compressed air.



T82101 -UN-01NOV88

TX,0400,GG266 -19-07FEB92-1/1

04
0400
29**Removing DB4 Fuel Injection Pump (Serial No. —559602)**

The Stanadyne DB4 Fuel Injection Pump requires a gear puller to remove the gear from the tapered shaft.

The gear puller (A) and cap screws (B and C) can be ordered from your John Deere dealer by ordering Kit No. JDG670A, DB4 Drive Gear Puller. The kit includes the following parts:

- One DB4 Drive Gear Puller Plate
- One Cap Screw (1/2—13 UNC x 1.25)
- Two Cap Screws (6 mm—1 x 40)

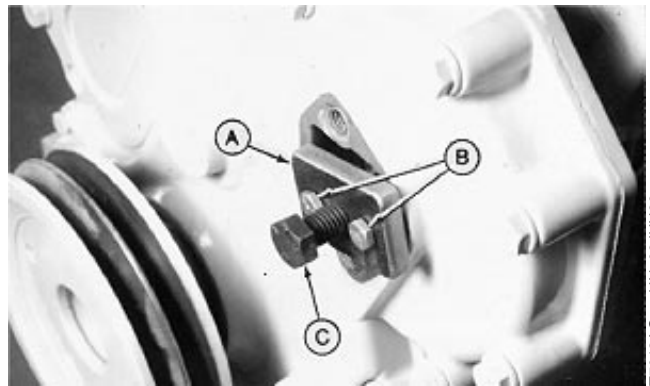

T7042A0 -UN-08JUN89

- A—DB4 Drive Gear Puller
B—Two Cap Screw (6 mm - 1 x 40)
C—Cap Screw (1/2 - 13 UNC x 1.25)

Continued on next page

TX,04,DY2885 -19-20AUG97-1/6

Removal And Installation

The DB4 Drive Gear Puller Kit now can be used on Stanadyne's DB4 and DB2 Injection Pumps. Earlier pumps displayed the metal plate (A) attached to the fuel injection pump's mounting flange.

1. Park machine on a level surface.
2. Lower bucket to the ground.
3. Turn auto-idle switch off.

IMPORTANT: Turbocharger may be damaged if engine is not properly shut down.

4. Run engine in light duty "L" mode without load for 2 minutes.
5. Set power mode to low idle "I" and turn key switch to OFF to stop engine. Remove key from switch.
6. Attach a "Do Not Operate" tag on the right control lever.
7. Pull pilot control shut-off lever to locked position.

IMPORTANT: Never steam clean or pour cold water on fuel injection pump while the pump is running or while it is warm. Doing so may cause seizure of pump.

8. Clean the fuel injection pump, lines, and area around the pump with cleaning solvent or a steam cleaner.
9. Disconnect shut-off connector.
10. Disconnect engine speed control rod at injection pump lever. (See Operator's Manual.)



Continued on next page

TX,04,DY2885 -19-20AUG97-2/6

Removal And Installation

11. Disconnect fuel supply line (B).
12. Disconnect return line (A).
13. Disconnect fuel pressure lines (C) using JDF-22 wrench.
14. Plug and cap all openings in pump.

A—Return Line
 B—Fuel Supply Line
 C—Fuel Pressure Line

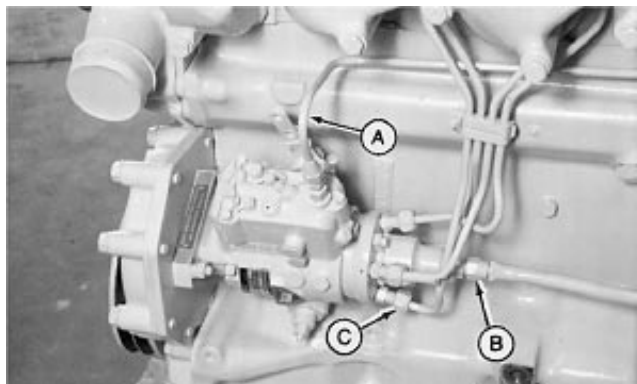

Four Cylinder Engine Shown

T7042AL -UN-08JUN89

04
0400
31

TX,04,DY2885 -19-20AUG97-3/6

15. Remove plug (A). Install JDE-81-1 Flywheel Turning Tool.
16. Remove cap screw (B). Install JDE-81-4 Timing Pin.
17. While holding timing pin in place, rotate crankshaft until timing pin goes into flywheel hole.

NOTE: The injection pump can be removed without engine No. 1 piston at TDC, however, maintaining piston No. 1 at TDC will ease installation of injection pump.

18. Remove pump hex nuts.

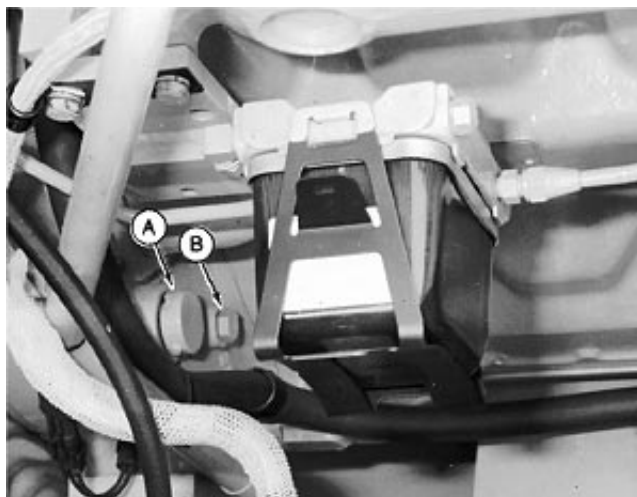

T7527BD -UN-08MAY91

TX,04,DY2885 -19-20AUG97-4/6

NOTE: Do not drop nut or washer inside engine front cover when removing them from shaft.

19. Remove engine front cover. Remove shaft nut (A) and washer (B).

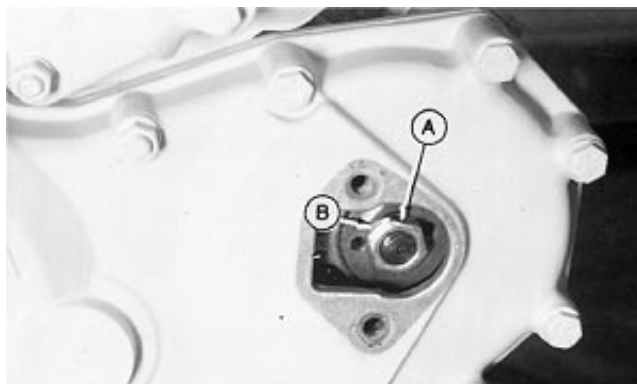

T7042AM -UN-08JUN89

Continued on next page

TX,04,DY2885 -19-20AUG97-5/6

Removal And Installation

20. With plate (B) tight against engine front, turn cap screw (A) in forcing drive shaft and pump out.

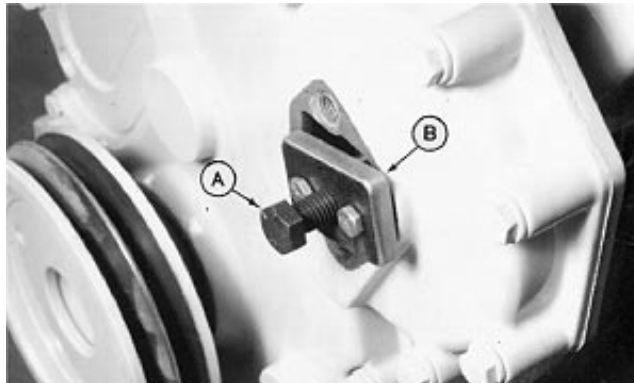

T7078AB -UN-08JUN89

TX,04,DY2885 -19-20AUG97-6/6

Installing DB4 Fuel Injection Pump (Serial No. —559602)

1. Tapered surfaces of shaft and gear must be clean and dry for assembly. Clean tapered surfaces of shaft and gear using AT66866 solvent.

2. Install pump by aligning drive shaft key with gear key slot. Align timing mark on pump flange (B) with timing mark on cylinder block front plate (A).
3. Install pump attaching nuts finger tight.

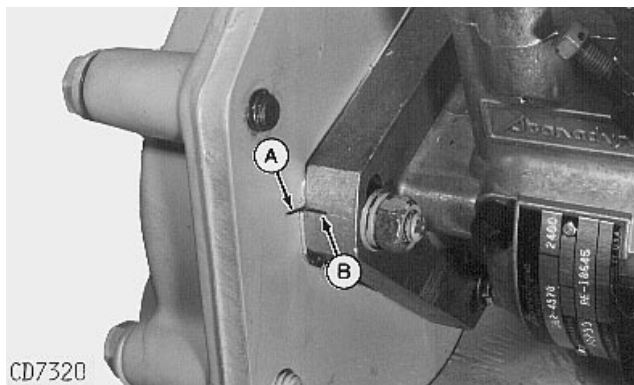

CD7320

CD7320 -UN-23MAY95

Continued on next page

TX,04,DY2886 -19-20AUG97-2/7

Removal And Installation

4. Install washer (B) and nut (A) on drive shaft and tighten to 197 N•m (145 lb-ft).

Specification

Drive Gear Nut—Torque 197 N•m (145 lb-ft)

5. Remove timing pin and flywheel turning tool.

6. Tighten pump attaching hex nuts to 25 N•m (18 lb-ft).

Specification

Attaching Nut—Torque 25 N•m (18 lb-ft)

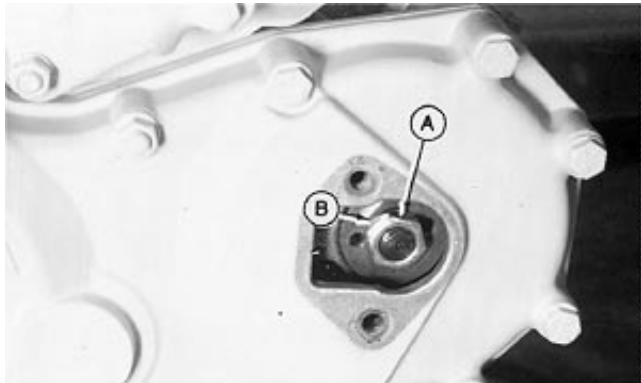

T7042AM -UN-08JUN89

04
0400
33

TX,04,DY2886 -19-20AUG97-3/7

IMPORTANT: When tightening fuel pressure lines at fuel injection pump, be sure not to turn fuel injection pump fittings. Turning these fittings may cause internal pump damage.

7. Tighten fuel pressure lines (C) at pump using JDF-22 Wrench to 27 N•m (20 lb-ft).
8. Install fuel shut-off connector, speed control rod (A), fuel supply line (D), and fuel return line (B).

Check speed control linkage adjustment. (See procedure in Group 0515.)

NOTE: For optimum performance after installation, the injection pump timing should be checked using JT07158 TIME TRAC® Kit.

- A—Speed Control Rod
- B—Fuel Return Line
- C—Fuel Pressure Line
- D—Fuel Supply Line
- E—Timing Window Cover

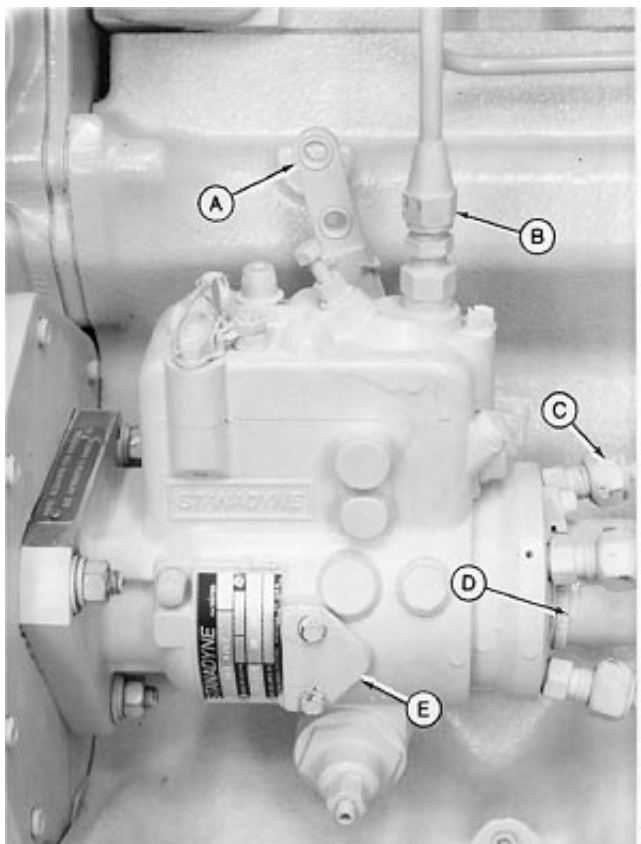

T7042AT -UN-08JUN89

TIME TRAC is a registered trademark of the Stanadyne Automotive Corp.

Continued on next page

TX,04,DY2886 -19-20AUG97-4/7

Removal And Installation

9. Check drain screw (C) to be sure it is tight.
10. Loosen fuel filter bleed screw (A).
11. Operate primer lever (B) until only fuel flows out of bleed screw. Tighten screw.

NOTE: If there is no fuel flow, push primer lever toward engine; turn crankshaft using starting motor to reposition camshaft.

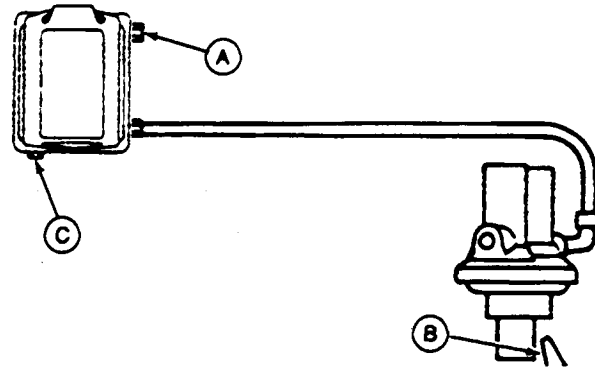

T6201A02 -UN-01NOV88

TX,04,DY2886 -19-20AUG97-5/7

12. Loosen fuel supply line (A) connection.
13. To purge air from filter to injection pump line, continue to operate primer lever several times or operate primer lever until only fuel flows out of connection. Tighten connection.

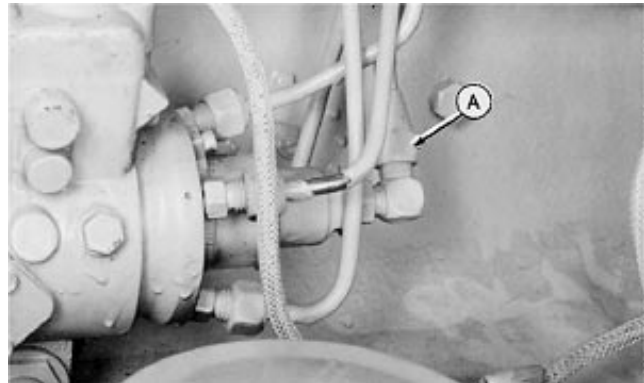

T6683DM -UN-18OCT88

Continued on next page

TX,04,DY2886 -19-20AUG97-6/7

Removal And Installation



CAUTION: Escaping fluid under pressure can penetrate the skin causing serious injury. Avoid the hazard by relieving pressure before disconnecting hydraulic or other lines. Tighten all connections before applying pressure. Search for leaks with a piece of cardboard. Protect hands and body from high pressure fluids.

If an accident occurs, see a doctor immediately. Any fluid injected into the skin must be surgically removed within a few hours or gangrene may result. Doctors unfamiliar with this type of injury should reference a knowledgeable medical source. Such information is available from Deere & Company Medical Department in Moline, Illinois, U.S.A.



T92924 -JUN-01NOV88

14. To purge air from injection lines, loosen pump-to-nozzle connections at ALL nozzles using two wrenches. Cover connections with shop towels.
15. Set engine speed at light duty "L" mode. Crank engine until a small amount of fuel leaks from injection lines.
16. Tighten injection line connections.
17. Start engine.

04
0400
35

TX,04,DY2886 -19-20AUG97-7/7

Remove And Install DB4 Fuel Injection Pump (Serial No. 559603—)

Refer to Component Technical Manual (CTM-104) for procedures on removal and installation of fuel injection pump.

TX,04,DT5058 -19-17JUN97-1/1

Removal And Installation

JT07158 TIME TRAC® Installation

Remove paint and clean injection line for installation of clamp-on transducer (E).

IMPORTANT: Install clamp-on transducer as close as possible to fuel injection nozzle.

- A—SOI Sensor
- B—Transducer Clamp
- C—Ground
- D—Meter Connection
- E—Clamp-On Transducer
- F—Injection Line
- G—Ground
- H—Meter Connection
- I—Adapter
- J—Magnetic Probe
- K—Meter Connection

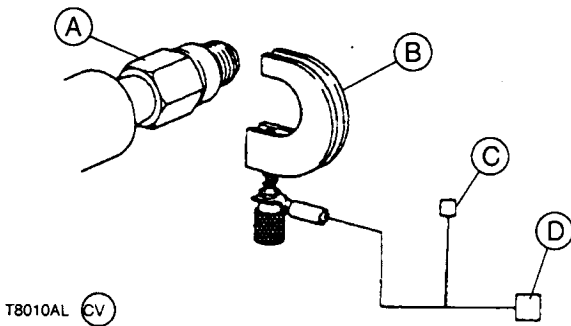

T8010AL -UN-18MAY93

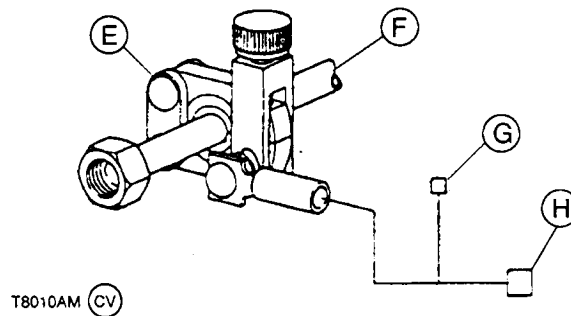

T8010AM -UN-20MAY93

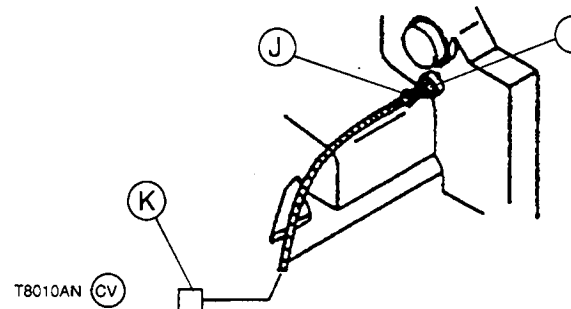

T8010AN -UN-18MAY93

TIME TRAC is a registered trademark of the Stanadyne Automotive Corp.

TX,TIMETRAC,300 -19-20JUN95-1/1

04
0400
36

Removal And Installation

Change Fuel Filter (Serial No. —559602)

1. Remove retainer spring (A) to remove filter (C). Push on outer tab (B) while pulling up on center tab to disengage inner tab from notch in filter base (D).
2. Clean filter base.
3. Install new filter and retainer spring.

- A—Spring
- B—Tab
- C—Filter
- D—Base

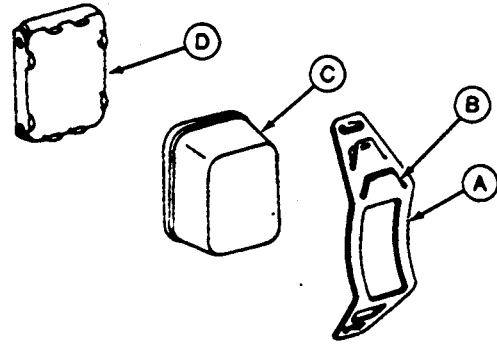

T6201A02 -UN-18OCT88

04
0400
37

TX,04,DY2915 -19-21AUG97-1/2

4. Check drain screw (C) to be sure it is tight.

CAUTION: Prevent possible injury from flying glass. This filter must not be pressurized over 210 kPa (2.0 bar) (30 psi) as glass may shatter.

5. Loosen bleed screw (A). Operate primer lever (B) until fuel flow from bleed screw is free of bubbles.

NOTE: If there is no fuel flow, push primer lever toward engine. Turn crankshaft using starter motor to reposition camshaft. Repeat Step 5.

6. Tighten bleed screw.
7. Push primer lever toward engine as far as possible.

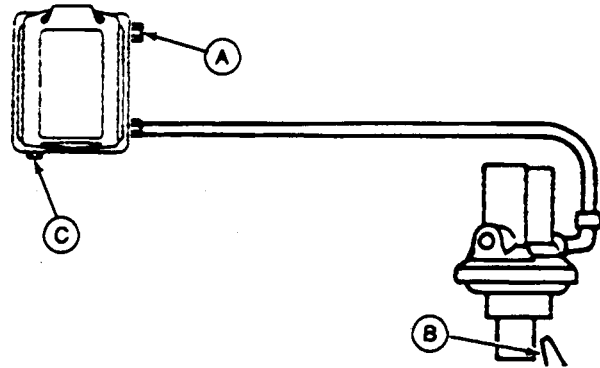

T6201A02 -UN-01NOV88

TX,04,DY2915 -19-21AUG97-2/2

Change Final Fuel Filter (Serial No. 559603—)

1. Close fuel shut off valve at fuel tank.

Continued on next page

TX,04,DY2916 -19-21AUG97-1/2

Removal And Installation

NOTE: Lifting up on retaining ring (A) as it is rotated helps to get it past the raised locators.

2. Thoroughly clean final fuel filter assembly and surrounding area, if not previously done.
3. Connect a drain line to filter drain adapter and drain all fuel from filter into a container. Dispose of waste properly.
4. Firmly grasp the retaining ring and rotate it counterclockwise 1/4 turn. Remove ring with filter element (B).
5. Inspect filter mounting base for cleanliness. Clean as required.

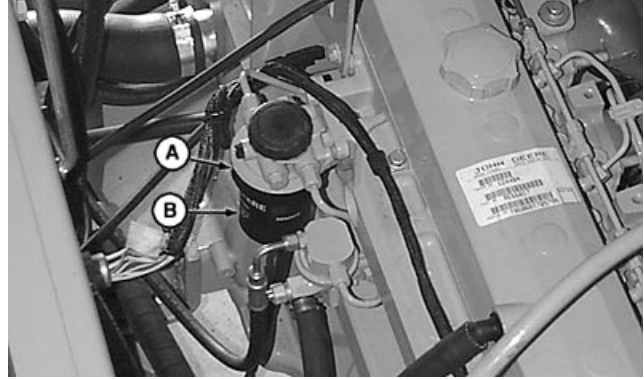

T109306 -UN-02JUN97

NOTE: The filter must be indexed properly and the key on canister must be oriented in slot of mounting base for correct installation.

6. Thoroughly inspect filter base seal ring. Replace as needed.
7. Install new filter onto mounting base and position element using a slight rocking motion. Be sure element is properly indexed on mounting base.
8. Install retaining ring onto mounting base and tighten about 1/3 turn until ring “snaps” into the detent. DO NOT overtighten the retaining ring.
9. Bleed fuel system. (See procedure in this group.)

TX,04,DY2916 -19-21AUG97-2/2

Change Primary Fuel Filter/Water Separator (Serial No. 559603—)

1. Close fuel shut-off valve at fuel tank.

Continued on next page

TX,04,DY2920 -19-21AUG97-1/2

Removal And Installation

NOTE: Lifting up on retaining ring (A) as it is rotated helps to get it past the raised locators.

2. Thoroughly clean primary fuel filter/water separator assembly and surrounding area, if not previously done.
3. Connect a drain line to filter drain adapter and drain all fuel from filter into a container. Dispose of waste properly.
4. Firmly grasp the retaining ring and rotate it counterclockwise 1/4 turn. Remove ring with filter element (B).
5. Inspect filter mounting base for cleanliness. Clean as required.

Remove water separator bowl. Drain and clean separator bowl. Dry with compressed air.

Install water separator bowl onto new filter element. Tighten securely.

NOTE: The filter must be indexed properly and the key on canister must be oriented in slot of mounting base for correct installation.

6. Thoroughly inspect filter base seal ring. Replace as needed.
7. Install new filter onto mounting base and position element using a slight rocking motion. Be sure element is properly indexed on mounting base.
8. Install retaining ring onto mounting base and tighten about 1/3 turn until ring “snaps” into the detent. DO NOT overtighten the retaining ring.
9. Bleed fuel system. (See procedure in this group.)

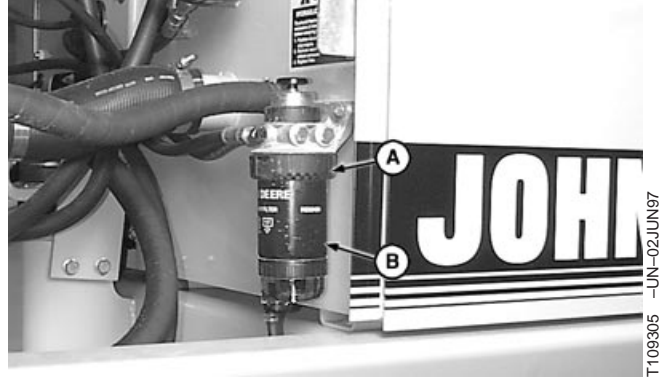

04
0400
39

TX,04,DY2920 -19-21AUG97-2/2

Removal And Installation

**Remove And Install Fuel Transfer Pump
(Serial No. —559602)**

1. Disconnect fuel lines (A and B). Close all openings using caps and plugs.
2. Remove cap screws (C) to remove pump.

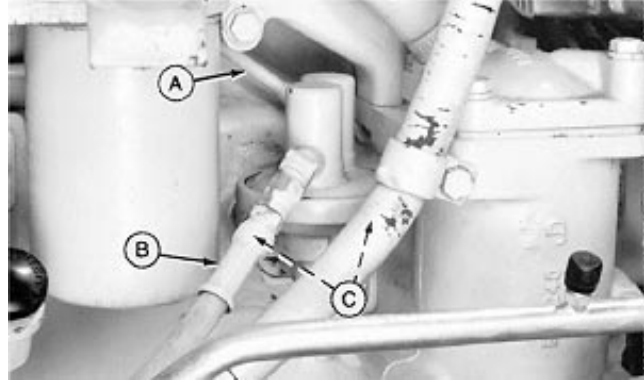

T6439SQ -UN-13FEB90

TX,04,DY2888 -19-20AUG97-1/2

3. Push against fuel pump rocker arm to remove and install primer lever (4).

If primer lever shaft is worn, install a new lever. Be sure O-ring (3) is on primer lever shaft.

Apply thread lock and sealer (medium strength) to gasket (1). Also, apply to cap screw threads and fuel line fittings threads.

4. Install a new gasket (1) and packing (2). Install the fuel transfer pump.
5. Install cap screws. Tighten cap screws to 30 N•m (22 lb-ft).

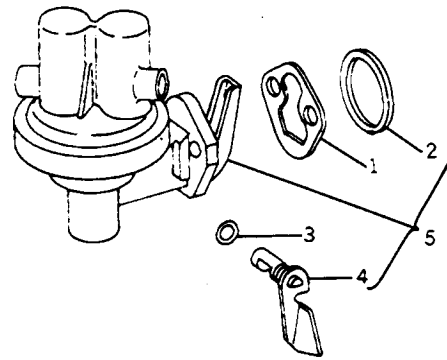

- 1—Gasket
- 2—Packing
- 3—O-Ring
- 4—Primer Lever
- 5—Fuel Pump Kit

T6065AM -UN-20OCT88

Specification

Fuel Transfer Pump Cap Screw—
Torque 30 N•m (22 lb-ft)

IMPORTANT: To avoid breaking fitting or pump, use two wrenches, one on the fitting and one on the connector.

6. Connect fuel lines.

TX,04,DY2888 -19-20AUG97-2/2

04
0400
40

Remove And Install Fuel Transfer Pump (Serial No. 559603—)

1. Disconnect fuel lines (A and C) and cap connections on fuel supply pump and fuel lines.
2. Remove cap screws (B). Remove fuel transfer pump.

NOTE: The fuel transfer pump is driven by a push rod that rides on an eccentric camshaft lobe. The cylinder head must be removed to remove push rod.

3. Cover opening on cylinder block to prevent dirt from entering the engine.
4. Inspect face of pump lever for wear. If lever face is worn, flat, or concave, replace pump.

IMPORTANT: Apply Thread Lock and Sealer (medium strength) to threads of supply pump mounting screws and fuel line fittings when installing supply pump. DO NOT allow sealant to get into fuel system

5. Install fuel transfer pump with pumping lever resting on top of push rod using a new O-ring. Tighten cap screws to 30 N•m (22 lb-ft).

Specification

Fuel Transfer Pump Cap Screw—

Torque 30 N•m (22 lb-ft)

IMPORTANT: ALWAYS use a backup wrench when installing fittings or fuel lines onto transfer pump to avoid damage to fittings.

6. Connect fuel lines and tighten securely.
7. Bleed fuel system. (See procedure in this group.)

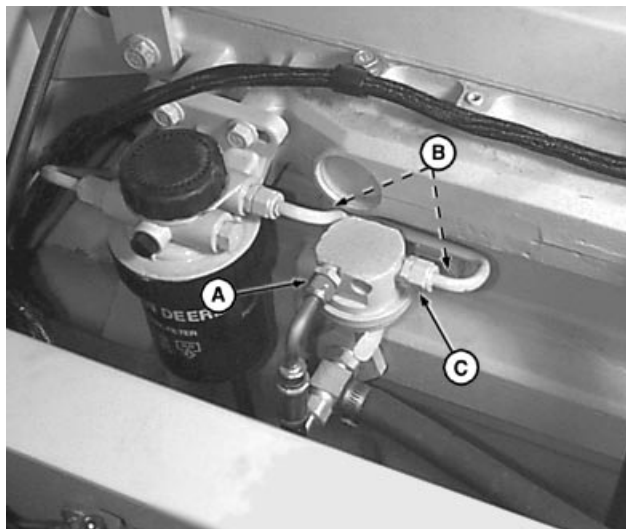

T110118 -JUN-05AUG97

04
0400
41

TX,04,DT5074 -19-03JUL97-1/1

Removal And Installation

Bleed Fuel System (Serial No. —559602)

1. Check drain screw (C) to be sure it is tight.
2. Loosen fuel filter bleed screw (A).
3. Operate primer lever (B) until only fuel, no air, flows out of bleed screw. Tighten screw.

NOTE: If there is no fuel flow, push primer lever toward engine and turn crankshaft using starting motor to reposition camshaft.

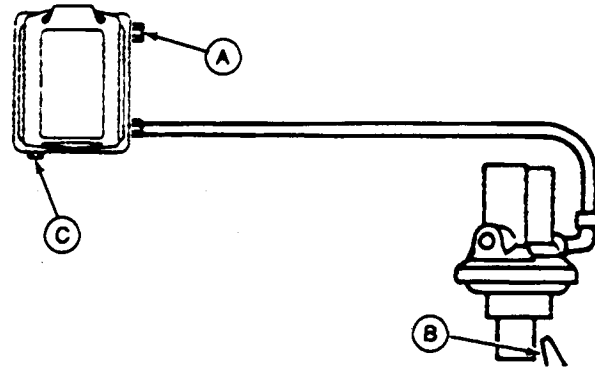

T6201A02 -UN-01NOV88

TX,04,DY2889 -19-20AUG97-1/1

Bleed Fuel System (Serial No. 559603—)

1. Open bleed screws (A) on final fuel filter and on primary fuel filter/water separator.
2. Pump primary fuel filter/water separator primer (B) until fuel fills separator bowl and fuel escapes from water separator bleed screw.
3. Tighten water separator bleed screw.
4. Pump primary fuel filter/water separator primer (B) until fuel escapes from final fuel filter bleed screw.
5. Tighten final fuel filter bleed screw.

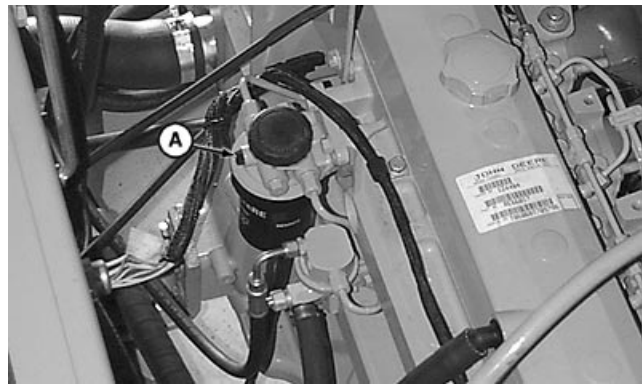

T109314 -UN-02JUN97

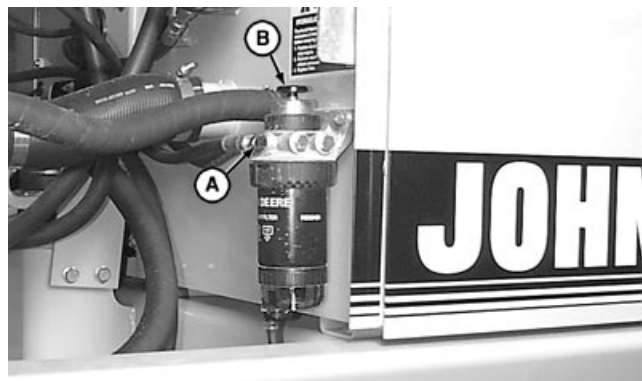

T109315 -UN-02JUN97

TX,04,DY2922 -19-21AUG97-1/1

Remove And Install Water Pump (Serial No. —559602)



CAUTION: Explosive release of fluids from pressurized cooling system can cause serious burns.

Shut off engine. Only remove filler cap when cool enough to touch with bare hands. Slowly loosen cap to first stop to relieve pressure before removing completely.

1. Drain coolant from radiator and engine. Approximate capacity is 34 L (36 qt).

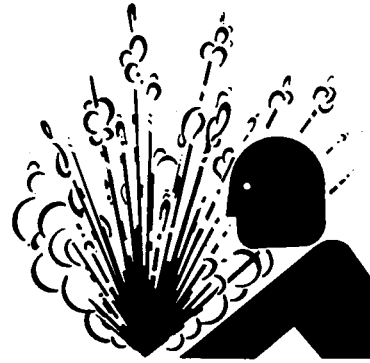

TTS281 —JUN-23AUG88

04
0400
43

TX,04,DY2890 —19-20AUG97-1/8

2. Disconnect upper radiator hose (C).
3. Remove cap screws (A) to remove upper and lower fan guards (B and D).

A—Cap Screw (8 used)
B—Upper Fan Guard
C—Upper Radiator Hose
D—Lower Fan Guard

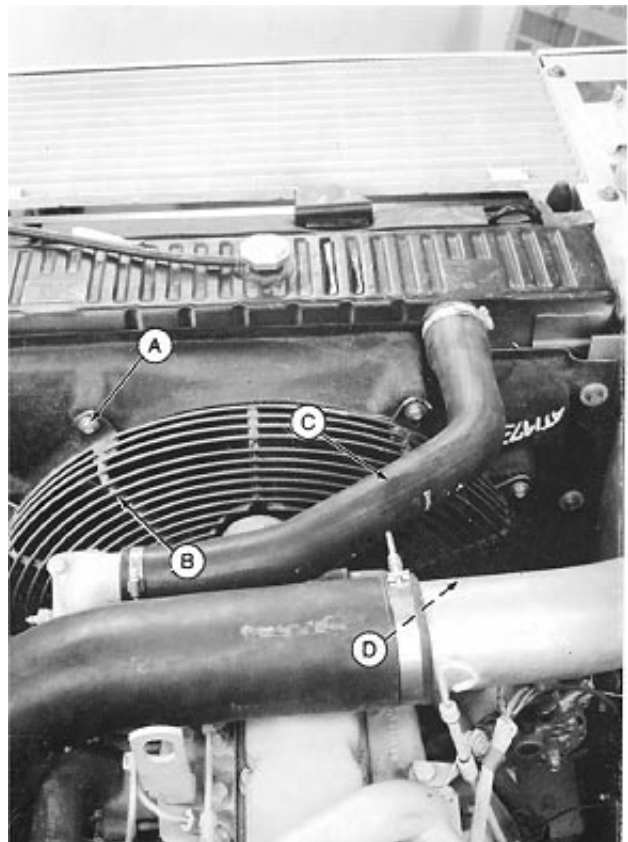

T7681AO —JUN-13JAN92

Continued on next page

TX,04,DY2890 —19-20AUG97-2/8

Removal And Installation

- Place the drive of a 1/2 in. drive ratchet in square hole (A). Turn ratchet counterclockwise to pull tension adjuster assembly (B) away from belt while removing belt.

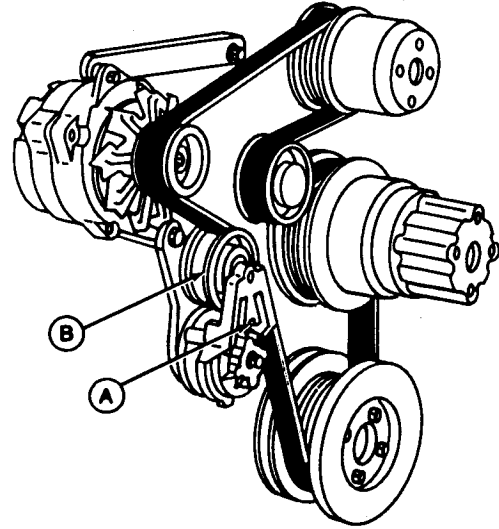

T7405BG -UN-15NOV90

TX,04,DY2890 -19-20AUG97-3/8

- Remove cap screws to remove fan and hub.

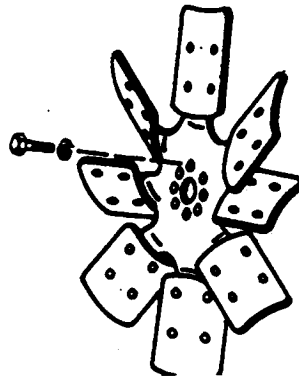

RG4797 -UN-14DEC88

Continued on next page

TX,04,DY2890 -19-20AUG97-4/8

Removal And Installation

6. Disconnect oil cooler line (D), upper, and lower radiator hoses.
7. Remove thermostat housing (B) to remove bypass tube.
8. Remove cap screws (A), nut, and lock washer (C) to remove water pump and gasket.

Inspect parts for wear or damage. Replace as necessary.

9. Install gasket, water pump, bypass tube, thermostat housing, and hoses.

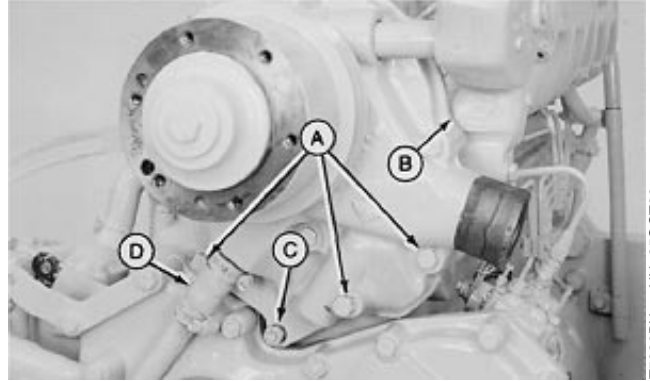

T5820BX -JUN-25OCT88

04
0400
45

TX,04,DY2890 -19-20AUG97-5/8

10. Install cap screws to fan and hub.
11. Install serpentine belt. Tension is automatically adjusted.

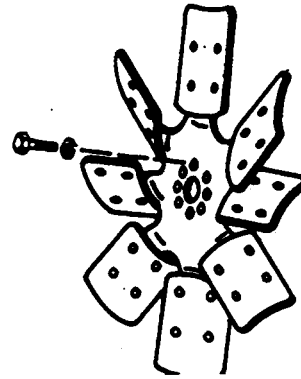

RG4797 -JUN-14DEC88

Continued on next page

TX,04,DY2890 -19-20AUG97-6/8

Removal And Installation

12. Place the drive of a 1/2 in. drive ratchet in square hole (A). Turn ratchet clockwise to place tension adjuster assembly (B) against belt.
13. Remove ratchet.

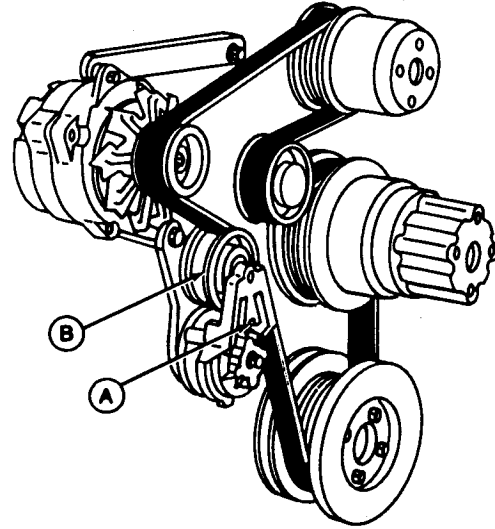

T7405BG -UN-15NOV90

TX,04,DY2890 -19-20AUG97-7/8

14. Install upper and lower fan guards (B and D) and cap screws (A).
15. Connect upper radiator hose (C).
16. Fill cooling system and check for leaks.

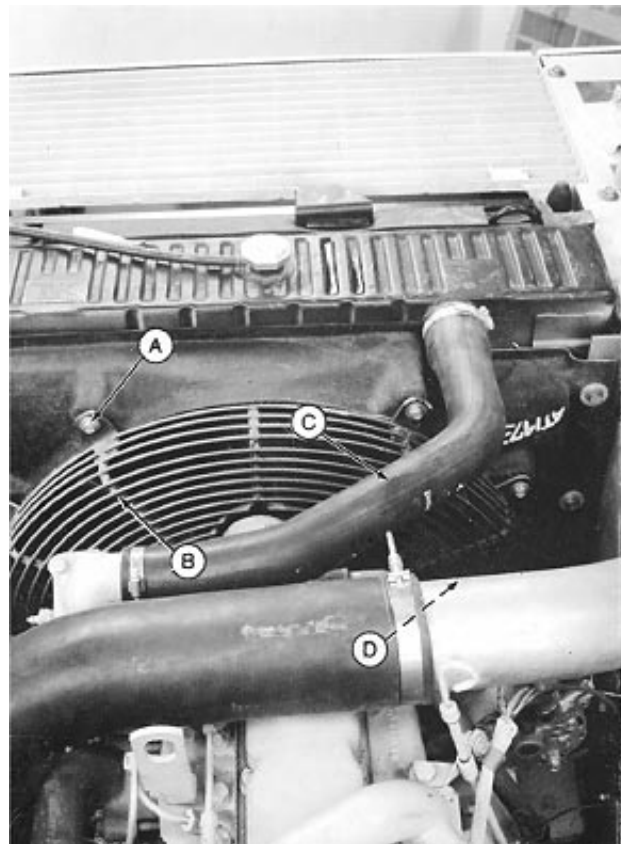

T7681AO -UN-13JAN92

TX,04,DY2890 -19-20AUG97-8/8

Remove And Install Water Pump (Serial No. 559603—)

CAUTION: Explosive release of fluids from pressurized cooling system can cause serious burns.

Shut off engine. Only remove filler cap when cool enough to touch with bare hands. Slowly loosen cap to first stop to relieve pressure before removing completely.



TTS281 -UN-23AUG88

1. Drain coolant from radiator and engine. Approximate capacity is 41.5 L (11 gal)

04
0400
47

TX,04,DT5075 -19-03JUL97-1/10

2. Remove upper radiator hose (E).
3. Remove lower radiator hose (F).
4. Remove cap screws (A). Remove fan guard (D).
5. Remove cap screws (B). Move fan shroud toward engine.
6. Remove four cap screws to remove fan (H) and fan hub (G).
7. Remove fan shroud (C).

A—Cap Screw (8 used)
B—Cap Screw (8 used)
C—Fan Shroud
D—Fan Guard
E—Upper Radiator Hose
F—Lower radiator Hose
G—Fan Hub
H—Fan

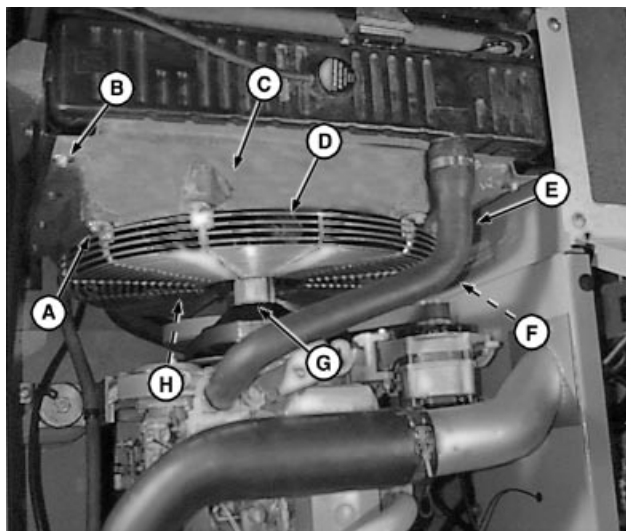

T110120 -UN-05AUG97

Continued on next page

TX,04,DT5075 -19-03JUL97-2/10

Removal And Installation

8. Place 15 mm, 1/2 in. drive socket on cap screw (A). Turn ratchet counterclockwise to pull tension adjuster assembly (B) away from belt while removing belt.

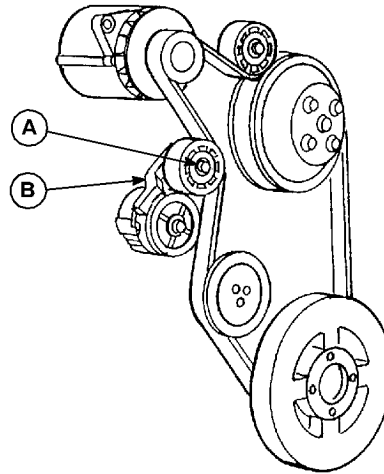

T109285

T109285 -UN-02JUN97

TX,04,DT5075 -19-03JUL97-3/10

9. Remove clamp and thermostat housing-to-water pump tube (A).

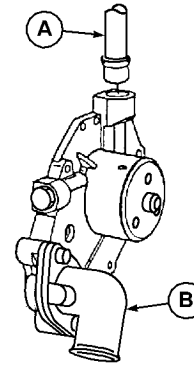

T110135

T110135 -UN-05AUG97

TX,04,DT5075 -19-03JUL97-4/10

10. Remove two cap screws (C). Remove water pump inlet elbow (B).

11. Remove eight cap screws (D).

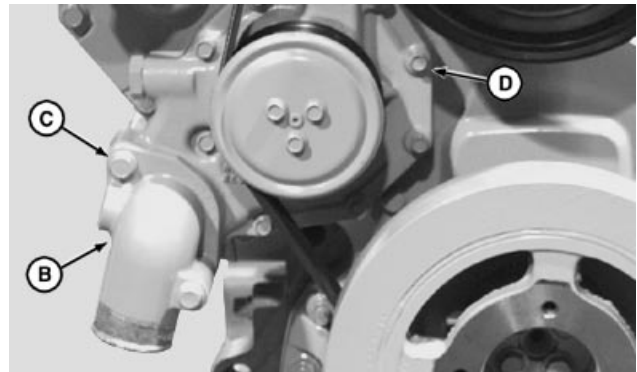

T110122 -UN-05AUG97

Continued on next page

TX,04,DT5075 -19-03JUL97-5/10

Removal And Installation

- 12. Remove water pump (F).
- 13. Remove pulley (E) from water pump.
- 14. Repair or replace as necessary.

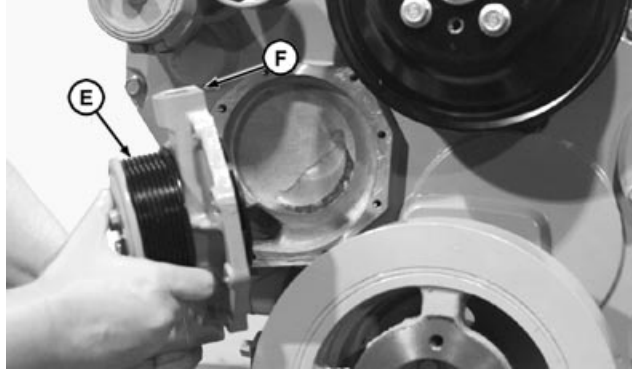

T110123 -UN-05AUG97

TX,04,DT5075 -19-03JUL97-6/10

- 15. Install pulley (A) onto water pump (B). Tighten cap screws to 16 N•m (12 lb-ft).

Specification

Water Pump Pulley Cap
Screws—Torque..... 16 N•m (12 lb-ft)

- 16. Clean gasket surface.
- 17. Install water pump (B) onto timing gear cover.

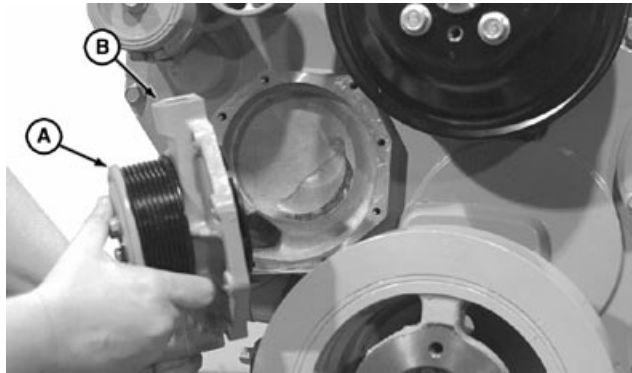

T110139 -UN-05AUG97

TX,04,DT5075 -19-03JUL97-7/10

04
0400
49

- 18. Install eight cap screws (E). Tighten cap screws to 16 N•m (12 lb-ft).

Specification

Water Pump Cap Screws—
Torque 16 N•m (12 lb-ft)

- 19. Install thermostat housing-to-water pump tube.
- 20. Install water pump inlet elbow (C) using new O-ring.
- 21. Tighten cap screws (D) to 35 N•m (26 lb-ft).

Specification

Water Pump Inlet Elbow Cap
Screws—Torque..... 35 N•m (26 lb-ft)

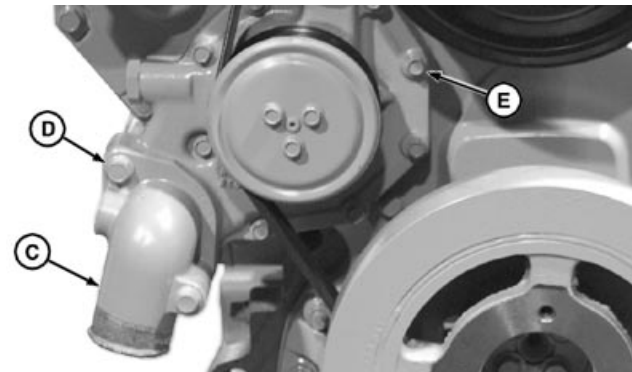

T110140 -UN-05AUG97

Continued on next page

TX,04,DT5075 -19-03JUL97-8/10

Removal And Installation

22. Place 15 mm, 1/2 in. drive socket on cap screw (A). Turn ratchet counterclockwise to pull tension adjuster assembly (B) away while installing belt.
23. Slowly turn ratchet clockwise to place tension adjuster assembly against belt. Tension is automatically adjusted.

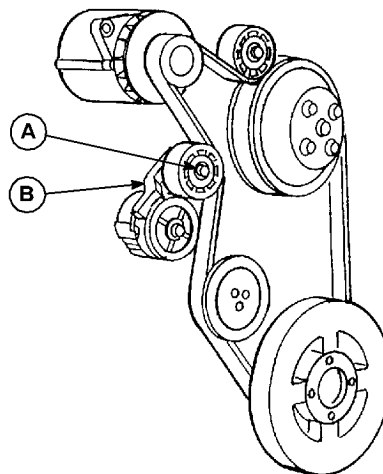

T109285

T109285 -UN-02JUN97

TX,04,DT5075 -19-03JUL97-9/10

24. Install fan shroud (C). Move fan shroud towards engine.
25. Install fan hub (G) and fan (H). Tighten cap screws to 70 N•m (52 lb-ft).

Specification

Turbocharger (Serial No. —
559602Turbocharger Cap
Screws—Torque..... 70 N•m (52 lb-ft)

26. Install fan shroud (C). Install cap screws (B). Tighten cap screws to 40.5 N•m (30 lb-ft).
27. Install fan guard (D). Install cap screws (A). Tighten cap screws to 16.2 N•m (12 lb-ft).
28. Install lower radiator hose (F).
29. Install upper radiator hose (E).
30. Fill cooling system. Approximate capacity is 41.5 L (11 gal).

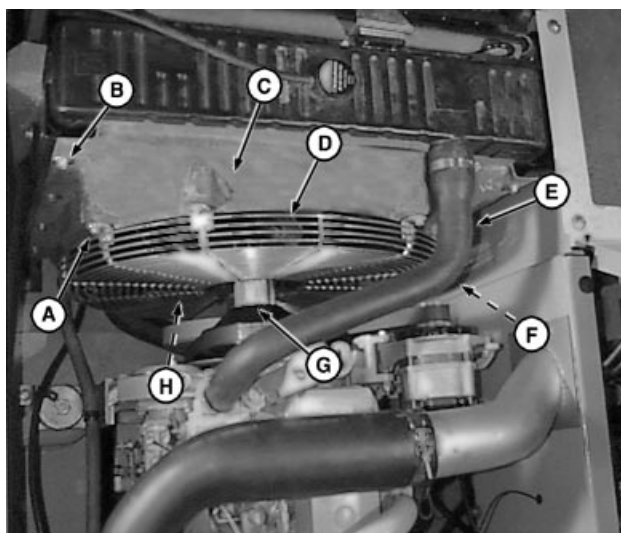

- A—Cap Screw (8 used)
- B—Cap Screw (8 used)
- C—Fan Shroud
- D—Fan Guard
- E—Upper Radiator Hose
- F—Lower radiator Hose
- G—Fan Hub
- H—Fan

T110120 -UN-05AUG97

TX,04,DT5075 -19-03JUL97-10/10

Remove And Install Thermostat (Serial No. — 559602)



CAUTION: Explosive release of fluids from pressurized cooling system can cause serious burns.

Shut off engine. Only remove filler cap when cool enough to touch with bare hands. Slowly loosen cap to first stop to relieve pressure before removing completely.

1. Drain coolant from radiator until level is below thermostat housing.

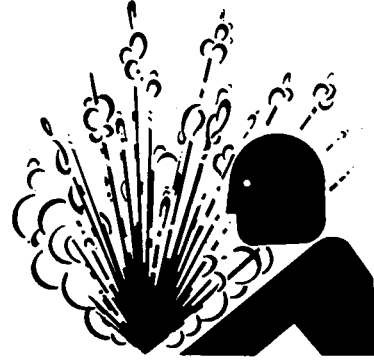

TSS281 -JUN-23AUG88

04
0400
51

Continued on next page

TX,04,DY2891 -19-20AUG97-1/2

Removal And Installation

2. Remove cover (A) and thermostat (B).
3. Clean gasket (C) from cover and housing.
4. If there is no visible damage, heat thermostat in water to check opening temperature.

Specification

82° C (180° F) Thermostat—
 Begin Opening—Temperature..... 79—83° C (175—182° F)
 82° C (180° F) Thermostat—Full
 Open—Temperature..... 94° C (202° F)

5. Install thermostat so flow arrow is toward the radiator.
6. Install gasket (C) and cover (A).
7. Install cover cap screws. Tighten cap screws to 27 N•m (20 lb-ft).

Specification

Cover Cap Screw—Torque 27 N•m (20 lb-ft)

8. Connect hoses.
9. Fill cooling system and check for leaks.

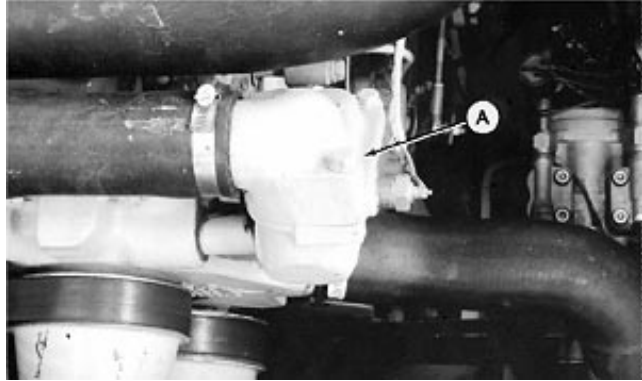

T7681FW -UN-23FEB92

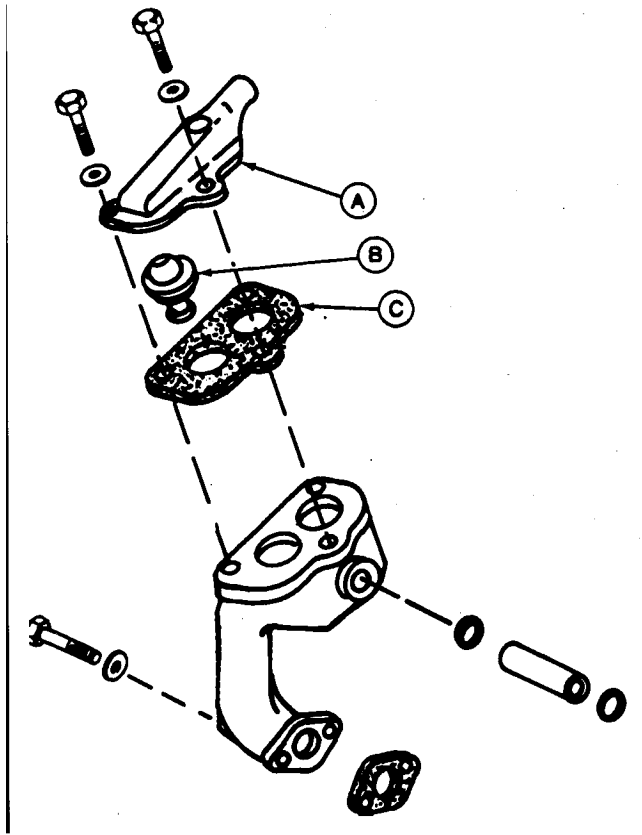

T6439TB -UN-18OCT88

TX.04.DY2891 -19-20AUG97-2/2

04
0400
52

Remove And Install Thermostat (Serial No. 559603—)

CAUTION: Explosive release of fluids from pressurized cooling system can cause serious burns.

Shut off engine. Only remove filler cap when cool enough to touch with bare hands. Slowly loosen cap to first stop to relieve pressure before removing completely.



TSS281 -JUN-23AUG88

1. Drain coolant from radiator until level is below thermostat housing.
2. Remove upper radiator hose.

04
0400
53

Continued on next page

TX,04,DT5076 -19-03JUL97-1/5

Removal And Installation

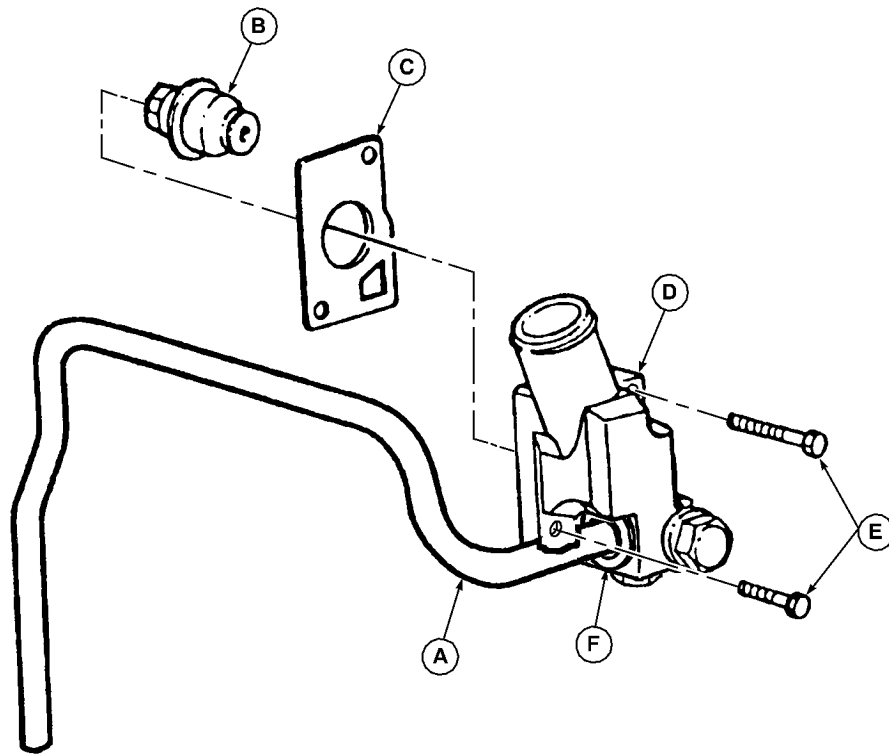

T110151

T110151 -UN-05AUG97

- | | | | |
|---------------------------------------|--------------|----------------------|--------|
| A—Thermostat Cover-to-Water Pump Tube | B—Thermostat | D—Cover | F—Seal |
| | C—Gasket | E—Cap Screw (2 used) | |

3. Remove thermostat cover-to-water pump tube (A) and seal (F).
4. Remove cap screws (E). Remove cover (D).
5. Remove thermostat (B).
6. Remove and discard gasket (C).
7. Replace as necessary.
8. Clean gasket mating surfaces.

TX,04,DT5076 -19-03JUL97-2/5

9. Using guide studs (B) to keep gasket in place, install gasket (A).
10. Using a screwdriver to hold thermostat in place, install thermostat (C).

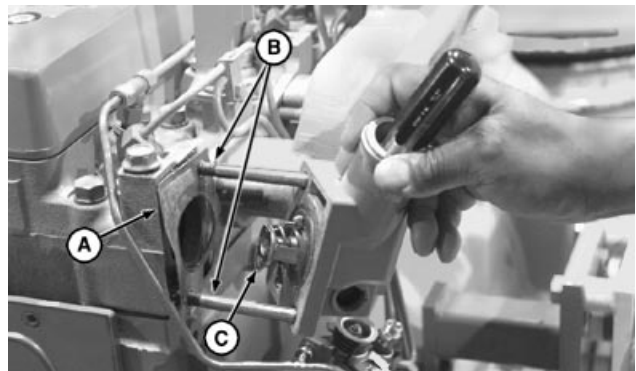

T110150 -UN-05AUG97

Continued on next page

TX,04,DT5076 -19-03JUL97-3/5

Removal And Installation

11. Install two cap screws (D). Tighten to 70 N•m (52 lb-ft).

Specification

Thermostat Cover Cap Screws—
Torque 70 N•m (52 lb-ft)

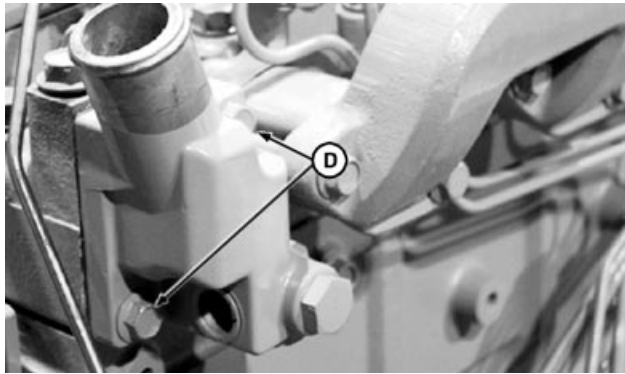

T110149 -UN-05AUG97

TX,04,DT5076 -19-03JUL97-4/5

12. Install thermostat cover-to-water pump tube (A).
13. Install upper radiator hose.
14. Fill cooling system.



T110148 -UN-05AUG97

TX,04,DT5076 -19-03JUL97-5/5

04
0400
55

**Remove And Install Intake Manifold Tube
(Serial No. —559602)**

1. Remove cold weather start aid line (D).
2. Loosen clamps (C).
3. Remove cap screws (B).
4. Remove intake manifold.
5. Install new gaskets (A).
6. Install intake manifold.
7. Install and tighten cap screw (B).
8. Tighten clamps (C) until hose starts to deform around clamp.
9. Install cold weather start aid line.

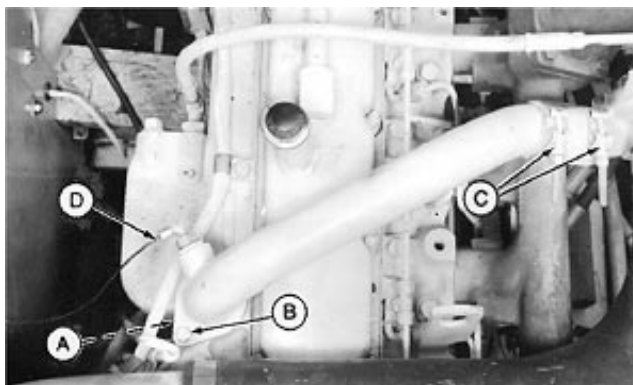

T7681FA -UN-23JAN92

- A—Gasket
- B—Cap Screw (2 used)
- C—Clamp (2 used)
- D—Cold Weather Start Aid Line

TX,04,DY2892 -19-20AUG97-1/1

Removal And Installation

**Remove And Install Intake Manifold Tube
(Serial No. 559603—)**

1. Remove start aid line (B).
2. Loosen clamps (C).
3. Remove cap screws (A).
4. Remove intake manifold.
5. Install new gasket (D).
6. Install intake manifold
7. Install cap screws (A).
8. Tighten clamps (C) until hose starts to deform around clamp.
9. Install start aid line (B).

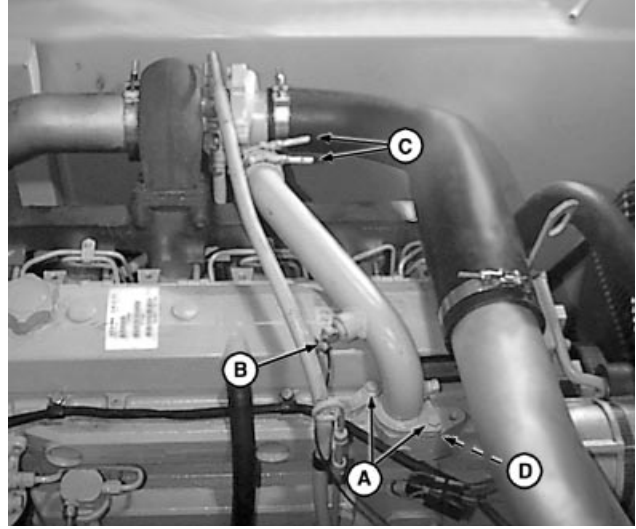

A—Cap Screw (2 used)
B—Start Aid Line
C—Clamp (2 used)
D—Gasket

TX,04,DT5077 -19-03JUL97-1/1

Removal And Installation

Remove And Install Exhaust Manifold (Serial No. —559602)

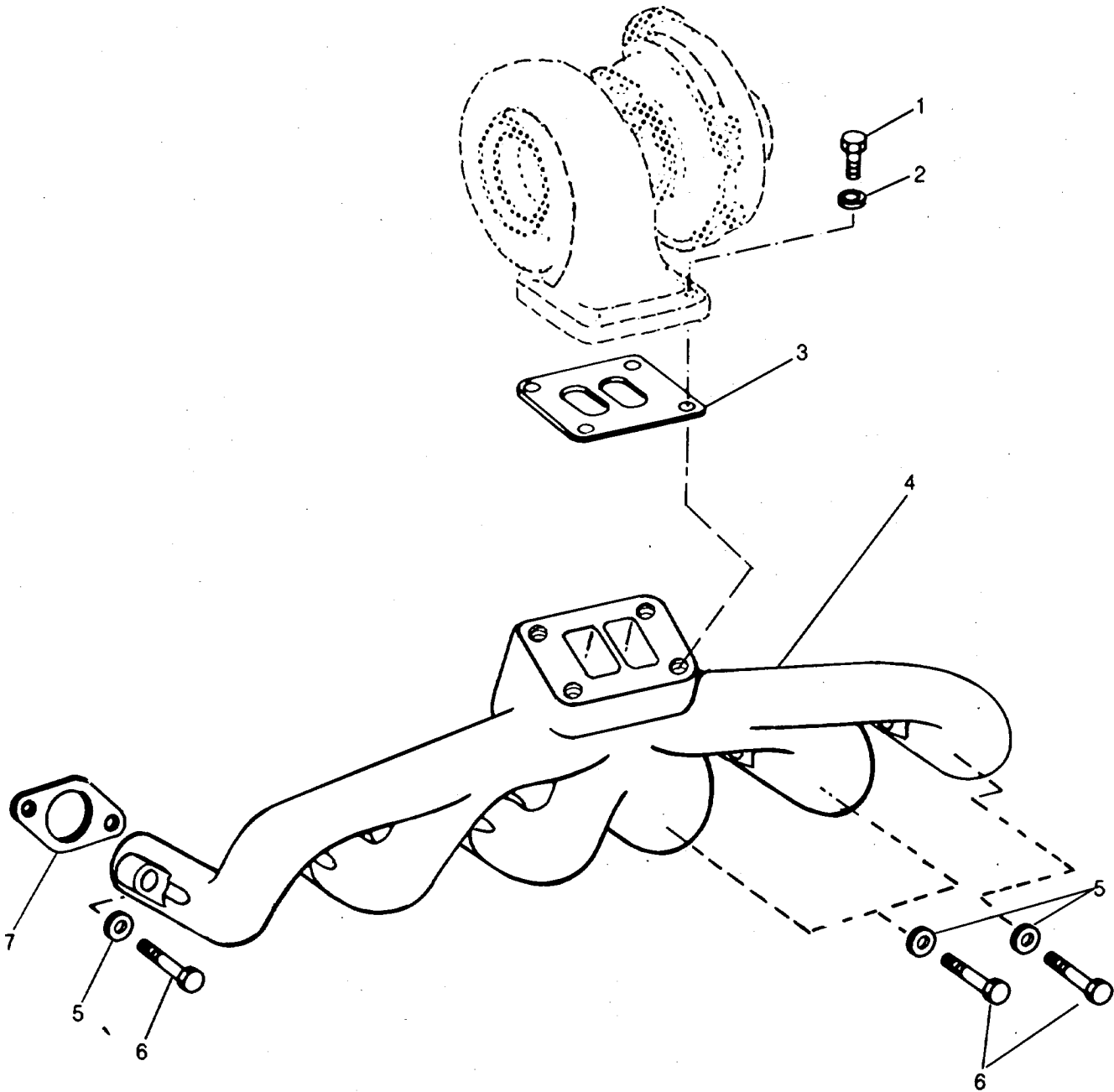

TP41202

TP41202 -UN-01JAN94

1—Cap Screw (4 used)
2—Washer (4 used)

3—Gasket
4—Exhaust Manifold

5—Washer (12 used)
6—Cap Screw (12 used)

7—Gasket (6 used)

1. Remove turbocharger. (See procedure in this group.)
2. Remove cap screws (6) and washers (5) to remove exhaust manifold (4).

3. Remove all residue and gasket material from surfaces.
4. Thoroughly clean passages in exhaust manifold, elbow, and pipe.

Continued on next page

TX,04,DY2893 -19-20AUG97-1/2

Removal And Installation

5. Inspect exhaust manifold. Replace parts as necessary. (lb-ft).

6. Install new gaskets (7 and 3). Install manifold.

7. Apply NEVER-SEEZ® lubricant or an equivalent to cap screws (6). Tighten cap screws to 47 N•m (35

Specification

Exhaust Manifold-to-Engine
Mounting Cap Screw—Torque 47 N•m (35 lb-ft)

NEVER-SEEZ is a registered trademark of the Emhart Chemical Group.

TX,04.DY2893 -19-20AUG97-2/2

04
0400
58

Remove And Install Exhaust Manifold (Serial No. 559603—)

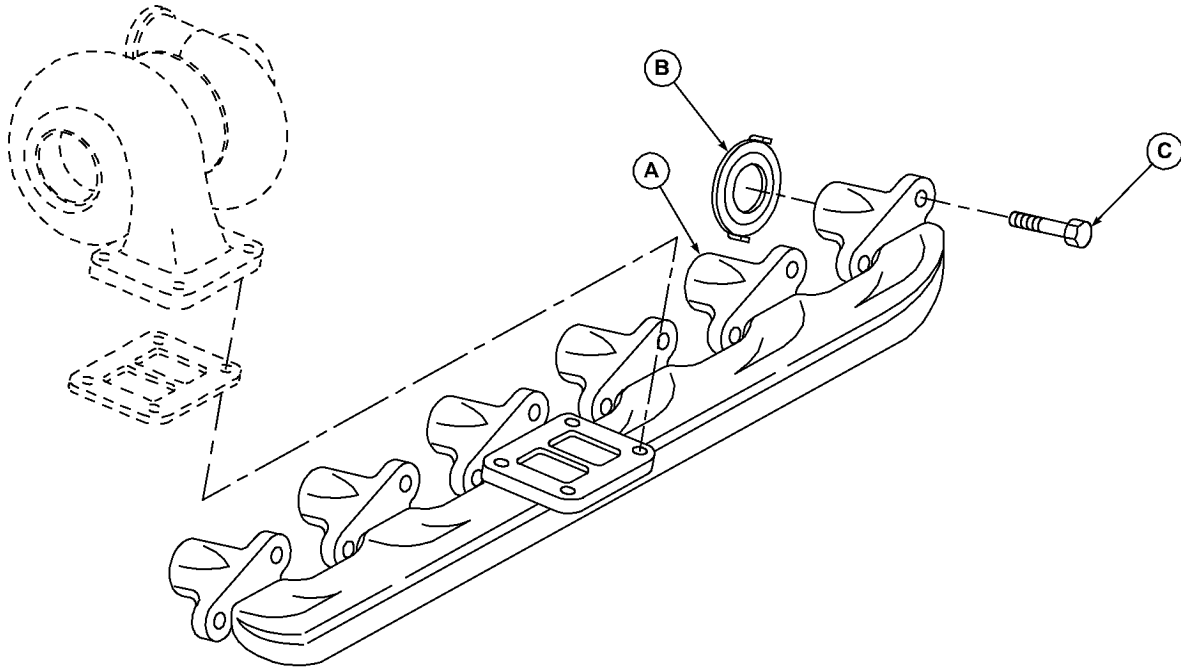

T110158



CAUTION: Allow exhaust system to cool before removal.

1. Remove turbocharger. (See procedure in this group.)

NOTE: Use guide studs when removing and installing exhaust manifold.

2. Remove twelve cap screws (C). Remove exhaust manifold (A).
3. Remove six gaskets (B).
4. Inspect exhaust manifold and stainless steel gaskets.
5. Thoroughly clean passages in exhaust manifold.

6. Inspect exhaust manifold for cracks or damage. Inspect mounting surfaces for burrs or other defects that might prevent gaskets from sealing properly. Replaces parts as necessary.

7. Install gaskets (B).

8. Install manifold (A).

NOTE: Tighten cap screws on No. 3 and No. 4 cylinders first.

9. Apply NEVER-SEEZ® lubricant to twelve cap screws (C). Tighten cap screws to 70 N•m (52 lb-ft).

Specification

Exhaust Manifold-to-Engine
 Mounting Cap Screw—Torque 70 N•m (52 lb-ft)

NEVER-SEEZ is a registered trademark of the Emhart Chemical Group.

Continued on next page

TX,04,DT5078 -19-03JUL97-1/2

Removal And Installation

10. Install turbocharger. (See procedure in this group.)

TX,04,DT5078 -19-03JUL97-2/2

04
0400
60

Removal And Installation

Remove And Install Turbocharger (Serial No. —559602)

CAUTION: Allow exhaust system to cool before removal.

Thoroughly clean exterior of turbocharger and surrounding area to prevent entry of dirt into the air intake system during removal.

1. Remove air intake hose (F) and exhaust adapter (D).
2. Loosen clamps to remove air inlet hose (A).
3. Disconnect lines (C and E).
4. Remove cap screws and nuts (B) and remove turbocharger and gasket.
5. Cap and plug all openings.
6. Inspect parts. Repair or replace as necessary.
7. Install gasket, turbocharger and cap screws. Do not tighten cap screws.
8. Put a small amount of engine oil in oil inlet line. Connect lines.
9. Rotate compressor housing to align with air inlet hose (A). Tighten hose clamps until hose deforms around clamp band.
10. Tighten cap screws (B) to 47 N•m (35 lb-ft).

Specification

Turbocharger (—559602) Turbocharger-to-Manifold
 Cap Screw—Torque 47 N•m (35 lb-ft)

11. Connect hose (F). Tighten clamp until hose deforms around clamp band.
12. Tighten U-bolts until muffler just starts to crush against support.

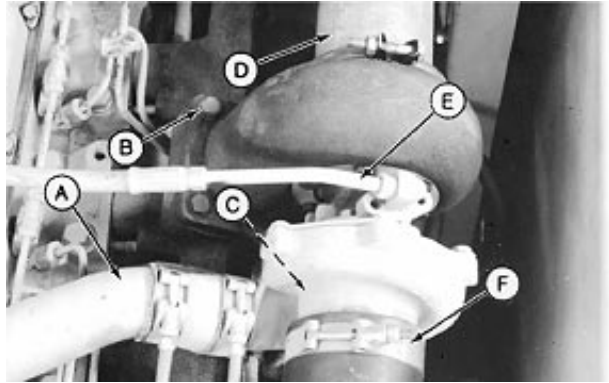

A—Air Inlet Hose
 B—Turbocharger-to-Exhaust Manifold Cap Screw (4 used)
 C—Oil Return Line
 D—Exhaust Adapter
 E—Oil Inlet Line
 F—Air Cleaner-to-Turbocharger Hose

T7681FX -JUN-23FEB92

04
 0400
 61

Continued on next page

TX,04,DY2894 -19-20AUG97-1/2

Removal And Installation

**IMPORTANT: Be sure oil is present at turbocharger.
Operating engine without oil at
turbocharger can damage turbocharger.**

13. Disconnect fuel shutoff wiring connector from injection pump. Turn engine using starter until engine oil pressure gauge registers pressure.
14. Connect wiring lead to injection pump. Start engine and run at slow idle. Check all connections for leaks.

TX,04,DY2894 -19-20AUG97-2/2

04
0400
62

Removal And Installation

Remove And Install Turbocharger (Serial No. 559603—)

CAUTION: After operating engine, allow exhaust system to cool before removing turbocharger.

Thoroughly clean exterior of turbocharger and surrounding area to prevent entry of dirt into the air intake system during removal.

1. Loosen clamp (D). Remove air intake hose (E).
2. Loosen clamp (B).
3. Loosen clamp (F) from intake manifold tube (G).
4. Remove cap screws (I) from oil return line (H).
5. Disconnect line (C).
6. Remove cap screws (A). Remove turbocharger and gasket.
7. Cap and plug all openings.
8. Inspect parts. Repair or replace as necessary.
9. Using a new gasket, install turbocharger. Tighten cap screws (A) to 70 N•m (52 lb-ft).

Specification

Turbocharger (—
559603) Turbocharger-to-Manifold
Cap Screw—Torque 70 N•m (52 lb-ft)

10. Connect line (C).
11. Install cap screws (I) on oil return line (H).
12. Tighten clamps (F) on intake manifold tube (G).
13. Tighten clamp (B).
14. Install air intake hose (E). Tighten clamp (D).

IMPORTANT: Be sure oil is present at turbocharger.
Operating engine without oil at
turbocharger can damage turbocharger.

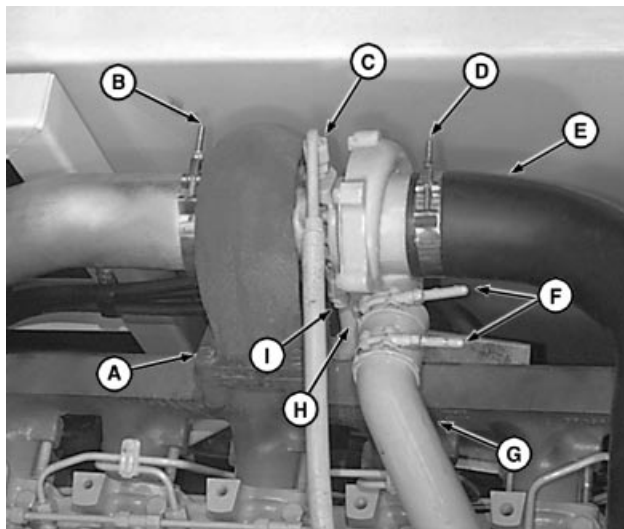

A—Cap Screw (4 used)
B—Clamp
C—Oil Inlet Line
D—Clamp
E—Air Intake Hose
F—Clamp
G—Intake Manifold Tube
H—Oil Return Line
I—Cap Screws (2 used)

T110159 -JUN-05AUG97

04
0400
63

Remove And Install Oil Cooler (Serial No. — 559602)

CAUTION: Explosive release of fluids from pressurized cooling system can cause serious burns.

Shut off engine. Only remove filler cap when cool enough to touch with bare hands. Slowly loosen cap to first stop to relieve pressure before removing completely.



TS281 -UN-23AUG88

1. Drain coolant. Radiator capacity is approximately 34 L (36 qt).

TX,04,DY2895 -19-20AUG97-1/2

2. Disconnect lines (A and B).
3. Remove cap screws (C) to remove filter base.
4. Remove cap screws (D) to remove oil cooler.
5. Clean gasket material from cylinder block, filter base, and oil cooler housing.
6. Be sure O-ring is installed on pressure regulating valve in engine block.
7. Install new gaskets. Install oil cooler, filter base, and cap screws. Tighten cap screws for oil cooler first, then filter base.
8. Connect lines. Fill radiator with coolant.



T6439SR -UN-13FEB90

A—Coolant Hoses
 B—Turbocharger Lube Line
 C—Filter Base Cap Screw (3 used)
 D—Oil Cooler Cap Screw (4 used)

TX,04,DY2895 -19-20AUG97-2/2

Remove And Install Oil Cooler (Serial No. 559603—)

CAUTION: Explosive release of fluids from pressurized cooling system can cause serious burns.

Shut off engine. Only remove filler cap when cool enough to touch with hands. Slowly loosen cap.



1. Remove oil cooler drain plug (I) and drain coolant.
2. Remove oil filter (A).
3. Disconnect line (B).
4. Remove cap screws (L).
5. Remove oil filter base (C).
6. Remove cap screws (H).
7. Remove elbow adapter (G).
8. Remove housing (J). Remove oil cooler (E).
9. Clean gasket mating surfaces.

NOTE: Make sure gasket is properly aligned with cap screw holes.

10. Install oil cooler (E).
11. Install gasket (K) on housing (J) aligning cap screw holes.
12. Install housing (J).
13. Install gaskets (D and F) aligning cap screw holes.
14. Apply thread lock and sealer (medium strength) to threads of cap screws (H and L).
15. Install elbow adapter (G) and cap screws (H). Tighten cap screws to 35 N•m (26 lb-ft).

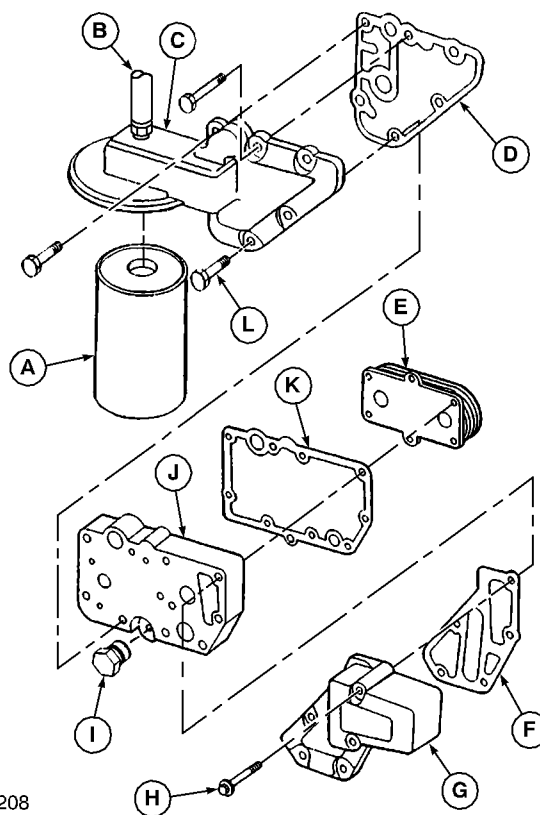

T110208

- A—Oil Filter
- B—Oil Filter Outlet-to-Turbocharger Inlet Port Line
- C—Oil Filter Base
- D—Gasket
- E—Oil Cooler
- F—Gasket
- G—Elbow Adapter
- H—Cap Screw (5 used)
- I—Plug
- J—Housing
- K—Gasket
- L—Cap Screw (7 used)
- K—Gasket

TTS281 -JUN-23AUG88

04
0400
65

T110208 -JUN-05AUG97

Removal And Installation

Specification

Water Pump Inlet Elbow Cap
Screws—Torque..... 35 N•m (26 lb-ft)

- 16. Connect line (B).
- 17. Install oil filter (A).
- 18. Install oil cooler drain plug (I).
- 19. Fill cooling system.

TX,04,DT5080 -19-03JUL97-2/2

Check And Adjust Engine Valve Lash (Clearance) (Serial No. —559602)

04
0400
66

SPECIFICATIONS

Rocker Arm Cap Screw Torque	10.8 N•m (96 lb-in.)
-----------------------------	----------------------

ESSENTIAL TOOLS

JDE81-1 Flywheel Turning Tool
JDE81-4 Timing Pin

OTHER MATERIAL

AT66866 U.S. Solvent

- 1. Disconnect crankcase ventilation tube from rocker arm cover. Clean tube with solvent or diesel fuel. Check that O-ring in rocker arm cover is in good condition.
- 2. Remove rocker arm cover.

Continued on next page

TX,04,DY2917 -19-21AUG97-1/3

Removal And Installation

3. Remove plug (A). Install JDE-81-1 Flywheel Turning Tool. Remove cap screw (B). Install JDE-81-4 Timing Pin.
4. Turn flywheel until timing pin goes into hole in flywheel.
5. To determine which cylinder is at top dead center (TDC), try to move both pushrods at number one cylinder. If both are not loose, pull timing pin out of flywheel, rotate flywheel 360°, and insert timing pin. If both pushrods are loose, the piston is at TDC on the compression stroke.



T7527BD -JUN-08MAY91

04
0400
67

TX,04,DY2917 -19-21AUG97-2/3

6. Measure and adjust valve clearance, first with number one piston at TDC and then with number six at TDC. To change piston position, pull timing pin out of flywheel, rotate flywheel 360°, and insert timing pin.

NOTE: Valve clearance can be adjusted whether engine is hot or cold.

7. Clean cylinder head and rocker arm cover mating surfaces.
8. Install rocker arm cover gasket. Do not use sealant on the gasket.
9. Install rocker arm cover. Tighten screws to 10.8 N•m (96 lb-in.).

Specification

Rocker Arm Cap Screw—Torque 10.8 N•m (96 lb-in.)

Do not over tighten cap screws.

10. Remove turning tool and timing pin.
11. Install parts. Center muffler to turbocharger inlet tube before fastening muffler into place.

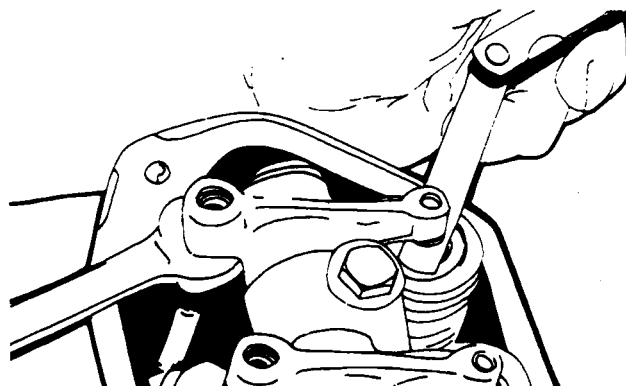

T6119AI -JUN-13MAR89

TX,04,DY2917 -19-21AUG97-3/3

Removal And Installation

**Check And Adjust Engine Valve Lash
(Clearance) (Serial No. 559603—)**

SPECIFICATIONS	
Exhaust Valves (E) Clearance	0.45 mm (0.018 in.)
Intake Valves (I) Clearance	0.35 mm (0.014 in.)
Rocker Arm Cap Screw Torque	10.8 N•m (96 lb-in.)

ESSENTIAL TOOLS	
JDG820 Flywheel Turning Tool	
JDE81-4 Timing Pin	

OTHER MATERIAL	
AT66866 U.S. Solvent	

! **CAUTION: Prevent accidental starting of engine while performing valve adjustments. Always disconnect NEGATIVE (—) battery terminal.**

IMPORTANT: Valve clearance MUST BE checked and adjusted with engine COLD.

1. Remove rocker arm cover and engine crankcase ventilation tube. Clean tube with solvent or diesel fuel. Check that O-ring in rocker arm cover is in good condition.

Continued on next page

TX,85,DY5045 -19-22MAY97-1/4

Removal And Installation

IMPORTANT: Visually inspect contact surfaces of valve tips and rocker arm wear pads. Check all parts for excessive wear, breakage, or cracks. Replace parts that show visible damage.

Rocker arms that exhibit excessive valve clearance should be inspected more thoroughly to identify damaged parts.



T109309 -UN-02JUN97

2. Remove cap from holes (A and B). Install JDG820 Flywheel Turning Tool in hole (A). Install JDE-81—4 Timing Pin in hole (B).
3. Using engine rotation tool, rotate engine flywheel in running direction (clockwise viewed from front) until No. 1 cylinder is at TDC Compression stroke. Timing pin will go into hole (B).

If No. 1 cylinder rocker arms are loose, the engine is at No. 1 TDC Compression. If No. 1 cylinder rocker arms are not loose, rotate engine one full revolution (360°) to No. 1 TDC Compression

To change piston position, remove timing pin and rotate flywheel.

4. Check and adjust valve clearance to specifications as directed in the following steps.

Specification

Exhaust Valves (E)—Clearance.....	0.45 mm (0.018 in.)
Intake Valves (I)—Clearance	0.35 mm (0.014 in.)

04
0400
69

TX,85,DY5045 -19-22MAY97-2/4

5. Loosen jam nut (A) and adjust clearance with a screwdriver, as shown.

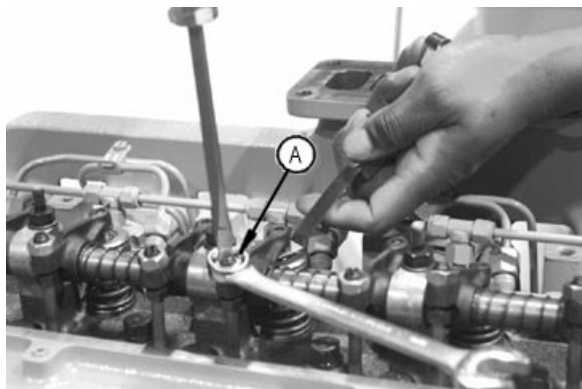

RG7409 -UN-06AUG96

Continued on next page

TX,85,DY5045 -19-22MAY97-3/4

Removal And Installation

6. Adjust No. 1, 3 and 5 exhaust valves and No. 1, 2 and 4 intake valves.
7. Tighten jam nut to 27 N•m (20 lb-ft) after adjustment.
8. Rotate engine 360° and repeat steps 7 and 8 for the remaining intake and exhaust valves (B).
9. Clean cylinder head and rocker arm cover mating surfaces.
10. Install rocker arm cover gasket. Do not use sealant on the gasket.
11. Install rocker arm cover. Tighten screws to 10.8 N•m (96 lb-in.). Do not over tighten cap screws.

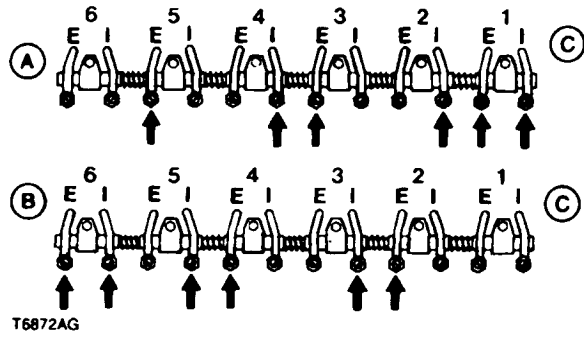

A—No. 1 TDC Compression Stroke
 B—No. 6 Compression Stroke
 C—Fan End of Engine

T6872AG -JUN-18MAY94

Specification

Rocker Arm Cap Screw—Torque 10.8 N•m (96 lb-in.)

12. Remove turning tool and timing pin.
13. Install cap.

TX,85,DY5045 -19-22MAY97-4/4

04
 0400
 70

Removal And Installation

Remove And Install Starter (Serial No. — 559602)

1. Disconnect ground cable (—) from battery.
2. Disconnect wiring leads (C—E).
3. Disconnect negative cable (A) and positive cable (B).
4. Remove cap screws (G) to remove starting motor.
5. Inspect parts. Replace as necessary.
6. Install starter cap screws.
7. Connect wiring leads (C—E).
8. Connect positive and negative cables at starter. Tighten nuts to 30.5 N•m (270 lb-in.).

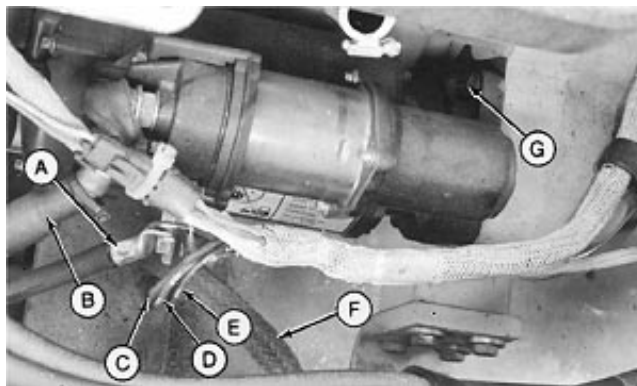

T7681FY -JUN-23FEB92

- A—Negative (—) Battery Cable
- B—Positive (+) Battery Cable
- C—Black Wiring Lead
- D—Red Wiring Lead
- E—Red Wiring Lead
- F—Negative Ground Strap
- G—Cap Screw (3 used)

Specification

Starter Cable Nut—Torque..... 30.5 N•m (270 lb-in.)

9. Connect ground cable at battery. Tighten nut to 9.0 N•m (82 lb-in.).

Specification

Ground Cable Nut at Battery—
Torque 9.0 N•m (82 lb-in.)

04
0400
71

TX,04,DY2897 -19-20AUG97-1/1

Removal And Installation

Remove And Install Starter (Serial No. 559603—)

1. Disconnect ground cable (—) from battery.
2. Disconnect negative cable (I).
3. Disconnect wiring leads (E, G, and H).
4. Disconnect ground strap (F).
5. Disconnect positive cable (A).
6. Disconnect wiring leads (B and C).

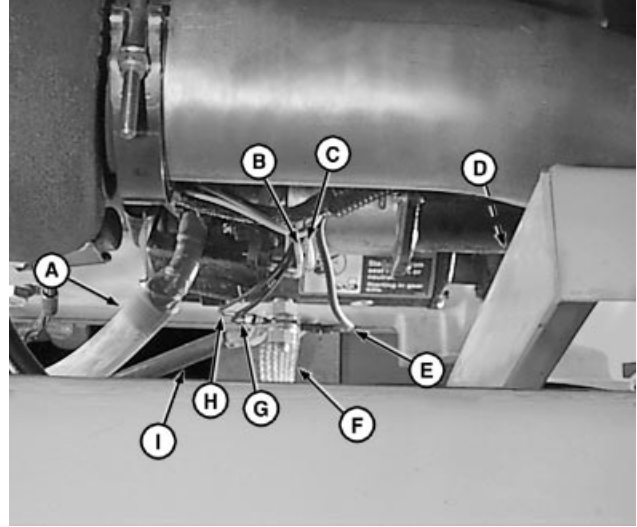

T110224 -UN-05AUG97

CAUTION: The approximate weight of starting motor is 23 kg (50 lb).

7. Remove cap screws (D). Remove starting motor.
8. Make repairs as necessary. (See procedure in CTM77.)
9. Install starting motor.
10. Install cap screws (D). Tighten to 47 N•m (35 lb-ft).
11. Connect wiring leads (B and C).
12. Connect positive cable (A).
13. Connect ground strap (F).
14. Connect wiring leads (E, G and H).
15. Connect negative cable (I).
16. Connect ground cable (—) from battery.

A—Positive (+) Battery Cable
 B—Wiring Lead (E01 WHT)
 C—Wiring Lead (E01 WHT)
 D—Cap Screw (3 used)
 E—Wiring Lead (G02 BLK)
 F—Ground Strap—Braided
 G—Wiring Lead (G03 BLK)
 H—Wiring Lead (G04 BLK)
 I—Negative (—) Battery Cable

TX,04,DT5081 -19-03JUL97-1/1

Section 05

Engine Auxiliary System

Contents

	Page	Page
Group 0505—Cold Weather Starting Aids		
Other Material	05-0505-1	
Specifications	05-0505-1	
Starting Aid Solenoid and Nozzle		
Remove and Install	05-0505-2	
Engine Coolant Heater		
Remove and Install	05-0505-2	
Group 0510—Cooling System		
Specifications	05-0510-1	
Fan, Guards, and Shroud (SN -559602)		
Remove and Install	05-0510-2	
Fan, Guards, and Shroud (SN 559603-)		
Remove and Install	05-0510-4	
Radiator		
Remove and Install	05-0510-6	
Serpentine Belt (SN -559602)		
Inspect.	05-0510-9	
Serpentine Belt (SN 559603-)		
Inspect.	05-0510-10	
Group 0515—Speed Controls		
Specifications	05-0515-1	
Speed Control Linkage		
Remove and Install	05-0515-2	
Adjust	05-0515-3	
Group 0520—Intake System		
Special Or Essential Tools	05-0520-1	
Service Equipment And Tools	05-0520-1	
Specifications	05-0520-2	
Air Cleaner		
Remove and Install	05-0520-3	
Air Intake System		
Leakage Test.	05-0520-4	
Group 0530—External Exhaust Systems		
Muffler		
Remove and Install	05-0530-1	
Group 0560—External Fuel Supply Systems		
Specifications	05-0560-1	
Other Material	05-0560-1	
Fuel Tank		
Remove and Install	05-0560-2	
Water Separator (SN -559602)		
Remove and Install	05-0560-4	
Primary Fuel Filter (Water Separator) (SN 559603-)		
Remove and Install	05-0560-5	
Water Separator Filter Element (SN -559602)		
Replace	05-0560-5	
Primary Fuel Filter (Water Separator) (SN 559603-)		
Disassemble and Assemble.	05-0560-6	

05

Contents

05

Group 0505 Cold Weather Starting Aids

Other Material

Number	Name	Use
T43513 (U.S.) TY9474 (Canadian) 271 (LOCTITE®)	Thread Lock and Sealer (High Strength) Products	Apply to threads of nozzle holder.

LOCTITE is a registered trademark of Loctite Corp.

0505,AA1 -19-25AUG97-1/1

Specifications

Item	Measurement	Specification
Engine Coolant Heater Element Nut	Torque	34 N•m (25 lb-ft)

08T,0505,J1 -19-07NOV94-1/1

05
0505
1

Cold Weather Starting Aids

Remove And Install Starting Aid Solenoid And Nozzle

IMPORTANT: Nozzle must be secure in holder to prevent engine damage from dust. Do not overtighten or nozzle may break.

Carefully tighten nozzle (B) in nozzle holder (A).

Apply thread lock and sealer (high strength) to male threads of nozzle holder.

Install nozzle holder so arrow on hex flat points toward center of air inlet.

IMPORTANT: To avoid drawing dust into engine, always keep a starting fluid can in position or canister installed with closed end against valve.

When a can is not installed, turn canister so closed end is installed tight against valve in solenoid.

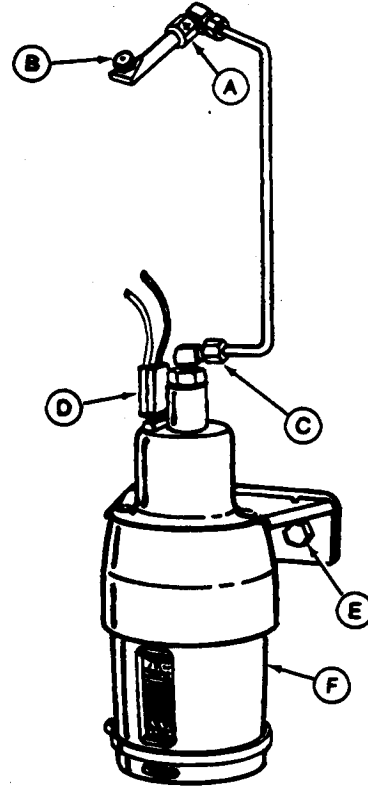

T6422AE -UN-21OCT88

- A—Nozzle Holder
- B—Nozzle
- C—Starting Aid Tube
- D—Wire Harness
- E—Cap Screws
- F—Canister

08T,0505,J2 -19-13MAR92-1/1

Remove And Install Engine Coolant Heater

CAUTION: Coolant may be hot. Wait until radiator is cool to the touch before draining radiator.

1. Drain cooling system. Approximate capacity is 15 L (14 qt).

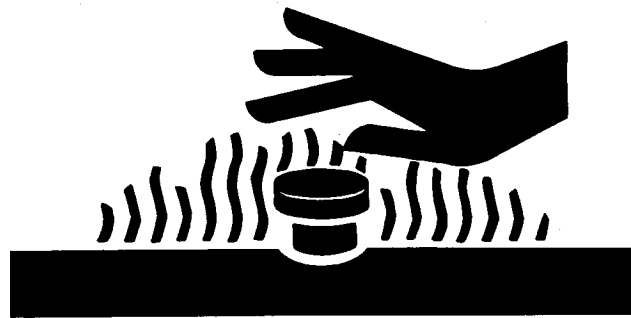

T6642EK -UN-01NOV88

Continued on next page

TX,0505,BA169 -19-25SEP91-1/2

05
0505
2

Cold Weather Starting Aids

2. Remove wiring lead (A).
3. Loosen nut (C) and pull heater element from block.

CAUTION: Do not plug coolant heater into electrical power unless heating element is immersed in coolant. Sheath could burst and result in personal injury.

Use a heavy-duty grounded cord to connect coolant heater to electrical power.

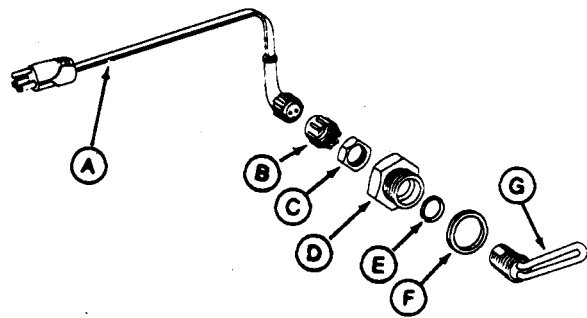

T6427AC -JUN-21OCT88

- A—Wiring Lead
- B—Cap
- C—Nut
- D—Adapter
- E—Gasket
- F—O-Ring
- G—Heater Element

4. Repair or replace parts as necessary.
5. Install heater element (G) through adapter (D) and install nut (C), but do not tighten.
6. Install heater into cylinder block with element pointing to rear.
7. Tighten adapter.
8. Turn element clockwise, then counterclockwise, until element contacts casting. Move element to the center position.
9. Hold element using wrench and tighten nut to 34 N•m (25 lb-ft).

Specification

Engine Coolant Heater Element
 Nut—Torque 34 N•m (25 lb-ft)

05
0505
3

Cold Weather Starting Aids

05
0505
4

Specifications

Item	Measurement	Specification
Fan, Guards, And Shroud:		
Fan-to-Pulley Cap Screw (Serial No. —559602)	Torque	47 N•m (35 lb-ft)
Fan-to-Pulley Cap Screw (Serial No. 559603—)	Torque	70 N•m (52 lb-ft)
Fan-to-Shroud	Clearance (Approximate)	7 mm (0.27 in.)
Fan Guard-to-Shroud Cap Screw	Torque	16.2 N•m (141.2 lb-in.)
Shroud-to-Radiator Support Cap Screw	Torque	40 N•m (30 lb-ft)

05
0510
1

TX,05,DY2923 -19-25AUG97-1/1

Cooling System

Remove And Install Fan, Guards, And Shroud (Serial No. —559602)

⚠ CAUTION: Explosive release of fluids from pressurized cooling system can cause serious burns.

Shut off engine. Only remove filler cap when cool enough to touch with bare hands. Slowly loosen cap to first stop to relieve pressure before removing completely.

1. Drain engine coolant until level is below upper radiator hose (C).
2. Disconnect upper radiator hose.
3. Remove cap screws (A) to remove upper and lower fan guards (B and D).

A—Cap Screw (8 used)
B—Upper Fan Guard
C—Upper Radiator Hose
D—Lower Fan Guard



TS281 -JUN-23AUG88

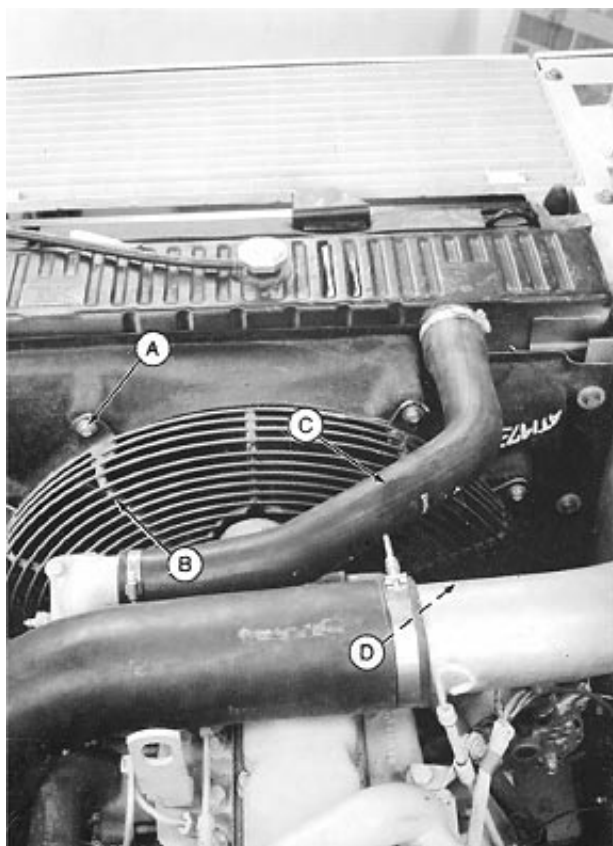

T7681AO -UN-13JAN92

TX.05.DY2924 -19-25AUG97-1/5

4. Remove cap screws to remove fan and hub.

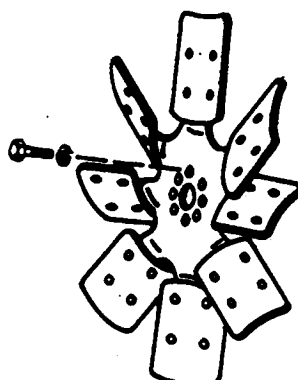

RG4797 -UN-14DEC88

Continued on next page

TX.05.DY2924 -19-25AUG97-2/5

Cooling System

5. Remove cap screws (A) and washers (B). Pull top of fan shroud (C) towards engine and lift from unit.

6. Inspect parts. Replace or repair as necessary.

7. Install fan shroud. Tighten cap screws to 40 N•m (30 lb-ft).

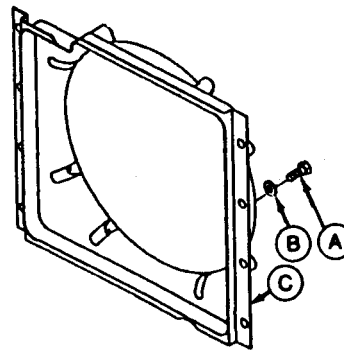

Specification

Fan-to-Pulley Cap Screw (559603)—Torque..... 40 N•m (30 lb-ft)

TX,05,DY2924 -19-25AUG97-3/5

T7681AP -JUN-13JAN92

8. Install fan. Tighten fan-to-pulley cap screws to 47 N•m (35 lb-ft).

Specification

Fan-to-Pulley Cap Screw (—559602)—Torque..... 47 N•m (35 lb-ft)

9. Adjust shroud so fan is centered in shroud with approximately 7 mm (0.27 in.) clearance between fan blades and shroud.

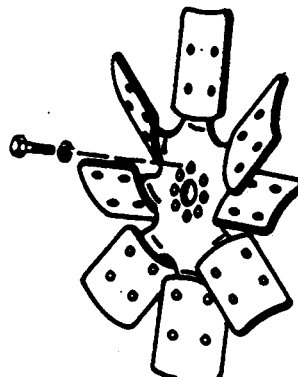

Specification

Fan-to-Shroud—Clearance..... 7 mm (0.27 in.)

Continued on next page

TX,05,DY2924 -19-25AUG97-4/5

RG4797 -JUN-14DEC88

05
0510
3

Cooling System

10. Install fan guards (B and D). Tighten cap screws (A) to 16.2 N•m (141.6 lb-in.).

Specification

Fan Guard-to-Shroud Cap
Screw—Torque..... 16.2 N•m (141.6 lb-in.)

11. Install upper radiator hose (C).
12. Fill radiator and reservoir to proper level.

- A—Cap Screw (8 used)
- B—Upper Fan Guard
- C—Upper Radiator Hose
- D—Lower Fan Guard

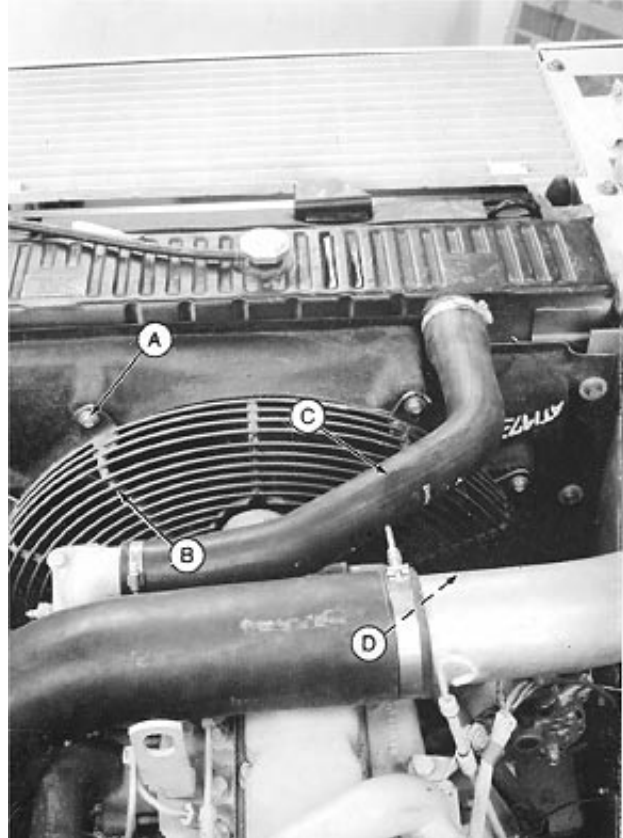

T7681AO -UN-13JAN92

TX,05,DY2924 -19-25AUG97-5/5

Remove And Install Fan, Guards, And Shroud (Serial No. 559603—)

CAUTION: Explosive release of fluids from pressurized cooling system can cause serious burns.

Shut off engine. Only remove filler cap when cool enough to touch with bare hands. Slowly loosen cap to first stop to relieve pressure before removing completely.

1. Drain coolant from radiator and engine. Approximate capacity is 41.5 L (11 gal).

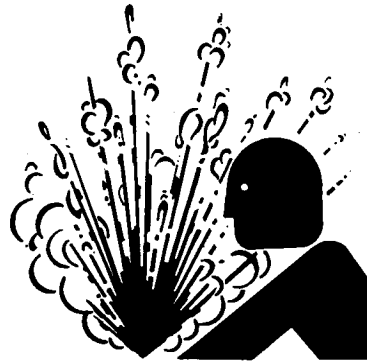

TS281 -UN-23AUG88

Continued on next page

TX,05,DT5069 -19-25JUN97-1/2

05
0510
4

Cooling System

2. Remove upper radiator hose (E).
3. Remove lower radiator hose (F).
4. Remove cap screws (A). Remove fan guard (D).
5. Remove cap screws (B). Move fan shroud toward engine.
6. Remove four cap screws to remove fan (H) and fan hub (G).
7. Remove fan shroud (C).
8. Inspect parts. Repair or replace as necessary.
9. Install fan shroud (C). Move fan shroud toward engine.
10. Install fan hub (G) and fan (H). Tighten cap screws to 70 N•m (52 lb-ft).

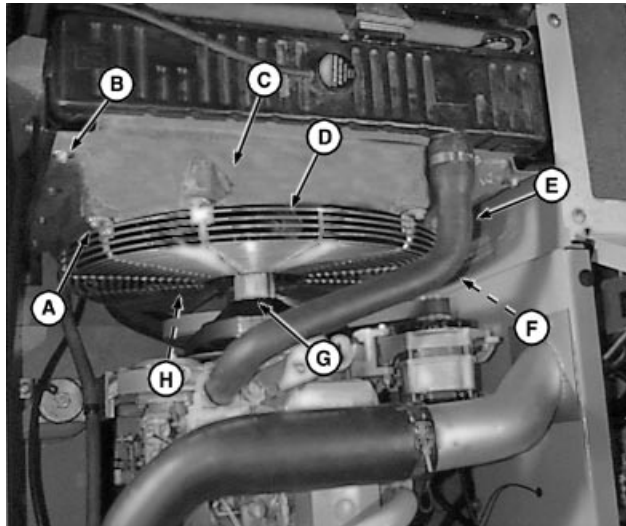

- A—Cap Screw (8 used)
- B—Cap Screw (8 used)
- C—Fan Shroud
- D—Fan Guard
- E—Upper Radiator Hose
- F—Lower radiator Hose
- G—Fan Hub
- H—Fan

Specification

Fan-to-Pulley Cap Screw (—5596020)—Torque..... 70 N•m (52 lb-ft)

11. Install fan shroud (C). Install cap screws (B). Tighten cap screws to 40 N•m (30 lb-ft).

Specification

Shroud-to-Radiator Support Cap Screw—Torque..... 40 N•m (30 lb-ft)

12. Install fan guard (D). Install cap screws (A). Tighten cap screws to 16.2 N•m (141.6 lb-in.).

Specification

Fan Guard-to-Shroud Cap Screw—Torque..... 16.2 N•m (141.6 lb-in.)

13. Install lower radiator hose (F).
14. Install upper radiator hose (E).
15. Fill cooling system. Approximate capacity is 41.5 L (11 gal).

05
0510
5

Cooling System

Remove And Install Radiator



CAUTION: Explosive release of fluids from pressurized cooling system can cause serious burns.

Shut off engine. Only remove filler cap when cool enough to touch with bare hands. Slowly loosen cap to first stop to relieve pressure before removing completely.

1. Drain coolant from radiator. On machines (Serial No. —559602) approximate capacity is 29 L (31 qt). On machines (Serial No. 559603—) approximate capacity is 41.5 L (11 gal)
2. Remove fan, guards and fan shroud. (See procedure in this group.)

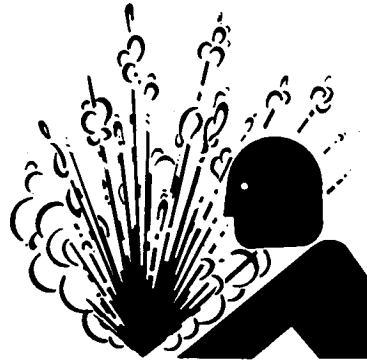

TS281 -JUN-23AUG88

Continued on next page

TX,05,DY2925 -19-25AUG97-1/3

Cooling System

05
0510
7

Cooling System

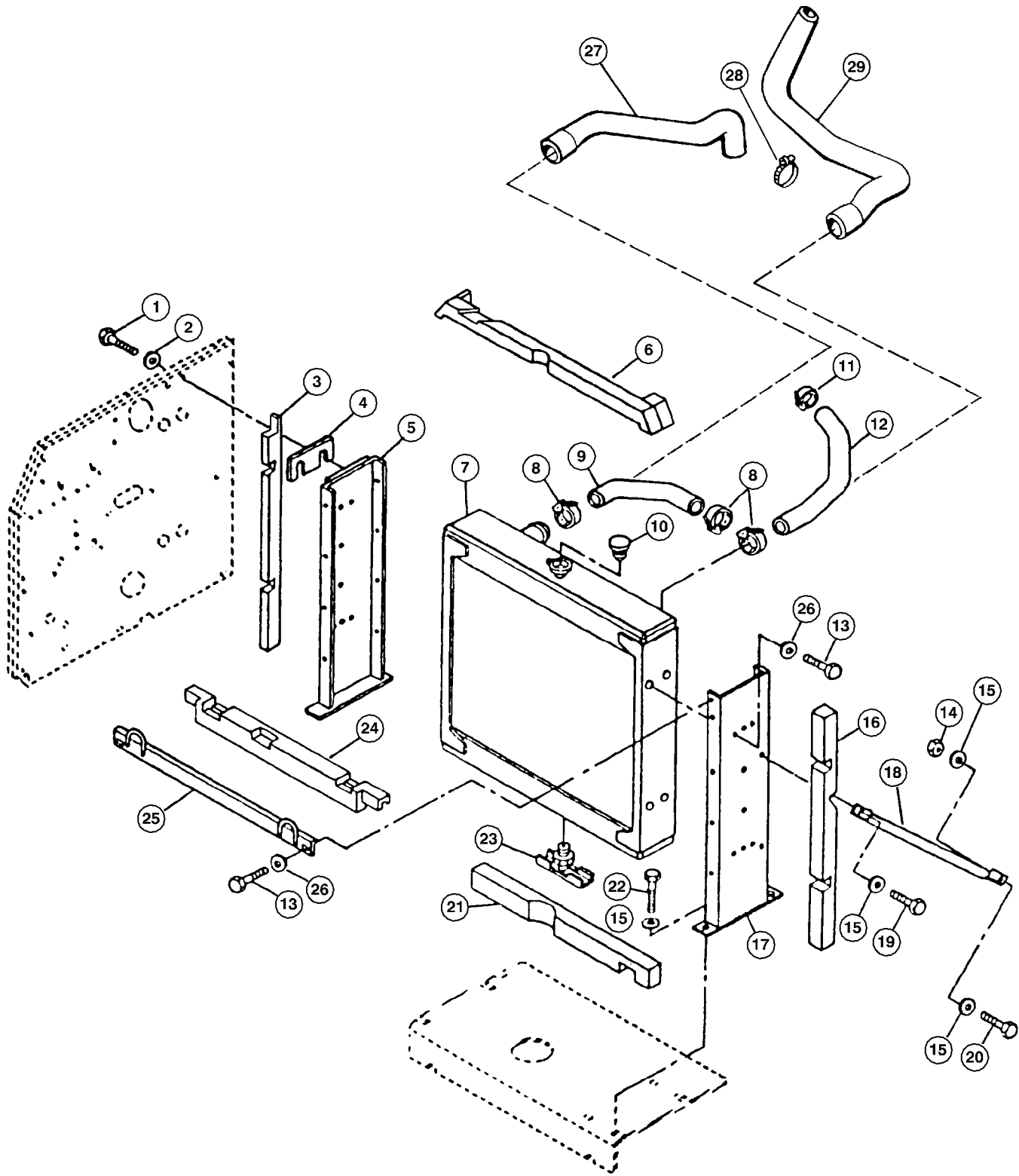

05
0510
8

T110255

Continued on next page

TX.05.DY2925 -19-25AUG97-2/3

T110255 -UN-05AUG97

Cooling System

- | | | | |
|----------------------|------------------------------|-----------------------|-------------------------------|
| 1—Cap Screw (2 used) | 9—Hose (Serial No. —559602) | 15—Washer (7 used) | 23—Drain Valve |
| 2—Washer (2 used) | 10—Filler Cap | 16—Isolator | 24—Isolator |
| 3—Isolator | 11—Clamp | 17—Support | 25—Angle |
| 4—Shim (4 used) | 12—Hose (Serial No. —559602) | 18—Support | 26—Washer (10 used) |
| 5—Support | 13—Cap Screw (10 used) | 19—Cap Screw | 27—Hose (Serial No. 559603—) |
| 6—Isolator | 14—Lock Nut | 20—Cap Screw | 28—Clamp (Serial No. 559603—) |
| 7—Radiator | | 21—Isolator | 29—Hose (Serial No. 559603—) |
| 8—Clamp (3 used) | | 22—Cap Screw (4 used) | |

CAUTION: Approximate weight of radiator is 41 kg (91 lb).

- Install shims (4) (as required) to take up gap between radiator support (5) and isolator (3).

TX,05,DY2925 -19-25AUG97-3/3

Inspect Serpentine Belt (Serial No. —559602)

- Check belt for wear, especially for cracks at the bottom of grooves and for frayed edges.
- If necessary, replace belt.

05
0510
9

TX,05,DY2899 -19-20AUG97-1/2

- Place the drive of a 1/2 in. drive ratchet in square hole (A). Turn ratchet counterclockwise to pull tension adjuster assembly (B) away from belt, releasing belt tension.
- Hold tension adjuster assembly away from belt while removing old belt and installing new belt.
- Slowly turn ratchet clockwise to place tension adjuster assembly against new belt. Tension is automatically adjusted.
- Remove ratchet from assembly.

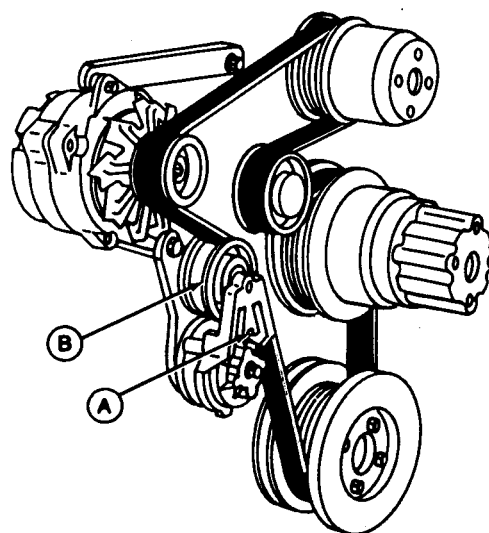

T7405BG -UN-15NOV90

TX,05,DY2899 -19-20AUG97-2/2

Cooling System

Inspect Serpentine Belt (Serial No. 559603—)

1. Check belt for wear, especially for cracks at the bottom of grooves and for frayed edges.
2. If necessary, replace belt.

TX,55,DT5037 -19-09JUN97-1/2

3. Place 15 mm, 1/2 in. drive socket on cap screw (A). Turn ratchet counterclockwise to pull tension adjuster assembly (B) away from belt, releasing belt tension.
4. Hold tension adjuster assembly away from belt while removing old belt and installing new belt.
5. Slowly turn ratchet clockwise to place tension adjuster assembly against new belt. Tension is automatically adjusted.
6. Remove ratchet from assembly.

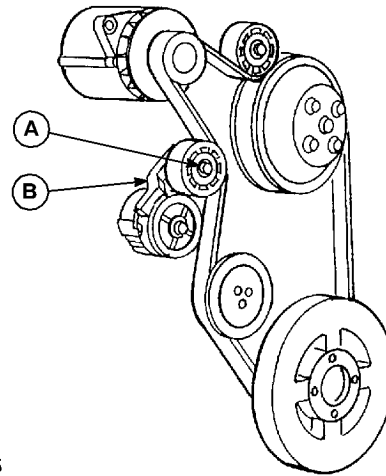

T109285

T109285 -JUN-02JUN97

TX,55,DT5037 -19-09JUN97-2/2

Specifications

Item	Measurement	Specification
Speed Control Linkage:		
Thread Clearance Between Spring Retainer Cap Screw End and Nut	Distance	5—10 mm (1/8—1/4 in.)

TX.0515,AB297 -19-17FEB92-1/1

05
0515
1

Speed Controls

Remove And Install Speed Control Linkage

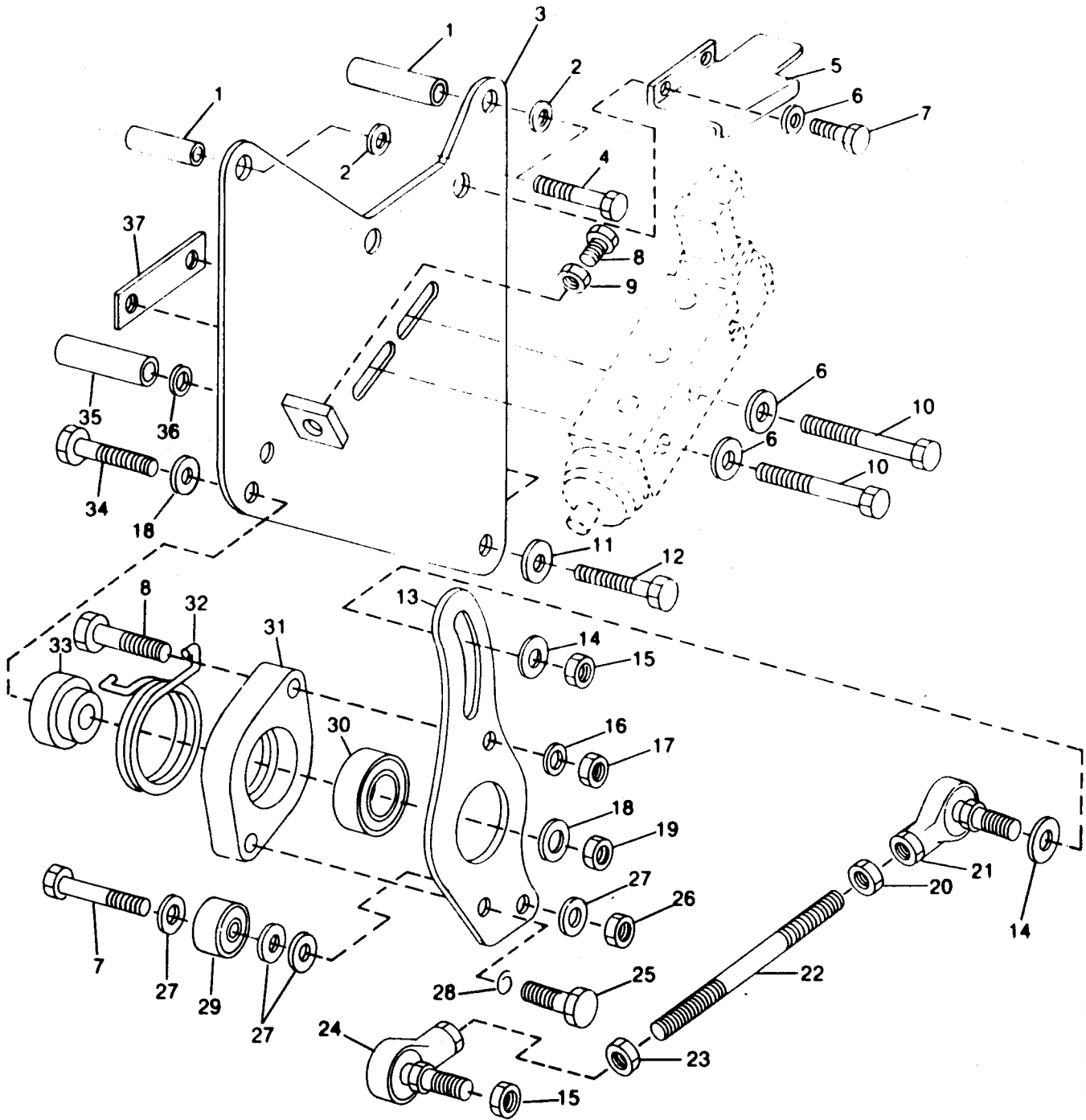

Continued on next page

TX,0515,AB157 -19-17FEB92-1/2

T7681BA -UN-13, JAN92

05
0515
2

Speed Controls

- | | | | |
|-----------------------|----------------------|--------------------|-----------------|
| 1—Bushing (2 used) | 11—Washer | 20—Nut | 29—Ball Bearing |
| 2—Washer (2 used) | 12—Cap Screw | 21—Ball Joint | 30—Ball Bearing |
| 3—Plate | 13—Link | 22—Stud | 31—Retainer |
| 4—Cap Screw (2 used) | 14—Washer (2 used) | 23—Nut | 32—Spring |
| 5—Cover | 15—Lock Nut (2 used) | 24—Ball Joint | 33—Spacer |
| 6—Washer (4 used) | 16—Washer | 25—Screw | 34—Cap Screw |
| 7—Cap Screw (3 used) | 17—Lock Nut | 26—Lock Nut | 35—Bushing |
| 8—Cap Screw (2 used) | 18—Washer (2 used) | 27—Washer (4 used) | 36—Washer |
| 9—Nut | 19—Lock Nut | 28—Lock Washer | 37—Strap |
| 10—Cap Screw (2 used) | | | |

Leave 5—10 mm (1/8—1/4 in.) of threads exposed on cap screw (8).

Adjust speed control linkage. (See procedure in this group.)

Speed Control Linkage:—Specification

Thread Clearance Between
Spring Retainer Cap Screw
End and Nut—Distance..... 5—10 mm (1/8—1/4 in.)

TX,0515,AB157 -19-17FEB92-2/2

Adjust Engine Speed Control Linkage

05
0515
3

SPECIFICATIONS

System Controller—"Engine Rpm Correct" Indicator ON Low Idle Range	820—880 rpm
System Controller—"Engine Rpm Correct" Indicator ON High Idle Stop Screw (G) Range	2175—2225 rpm
Indicator Blinking—Engine RPM Low RPM	0—800 rpm
Indicator on Steadily—Engine RPM Low RPM	800—820 rpm
Indicator Blinking—Engine RPM High RPM	900 rpm or greater
Indicator on Steadily—Engine RPM High RPM	880—900 rpm
System Controller—"Engine RPM Correct" and "Engine RPM High" indicators Blinking Together High Idle Range	2250—2300 rpm

SERVICE EQUIPMENT AND TOOLS

Tachometer

Continued on next page

TX,05,DY2926 -19-25AUG97-1/4

Speed Controls

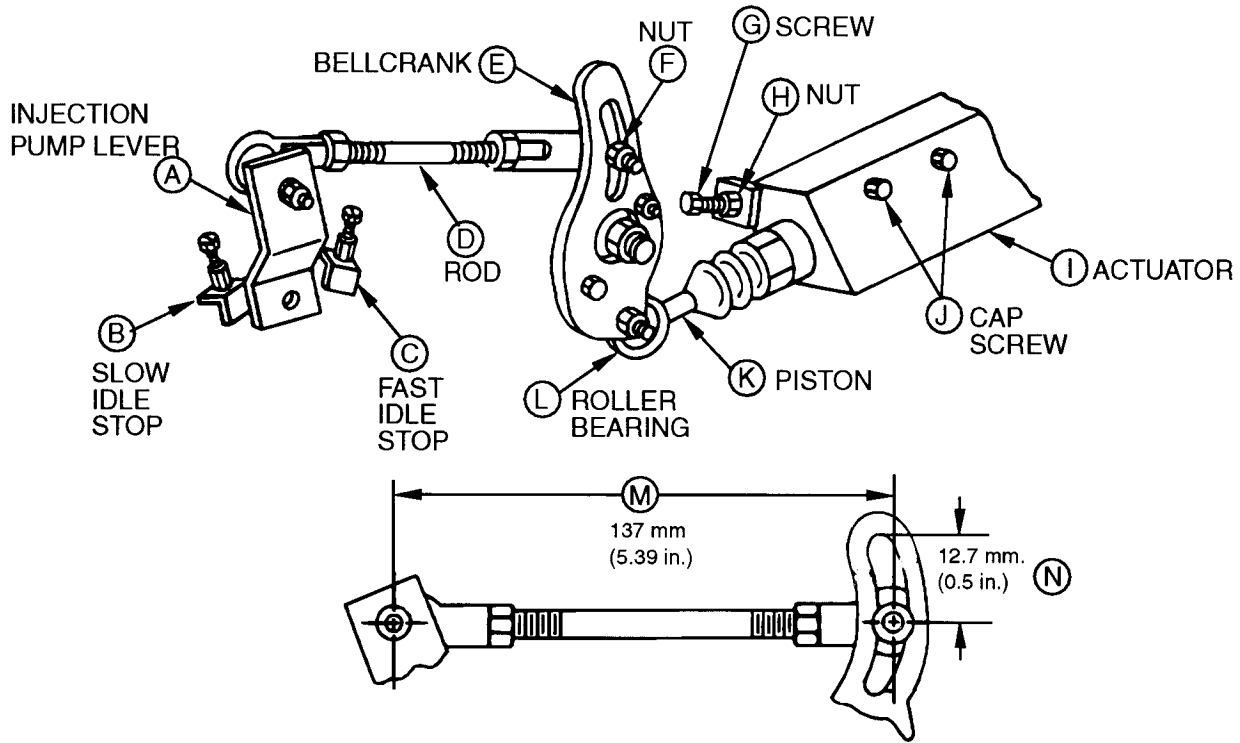

© ENGINE SPEED CONTROL LINKAGE ADJUSTMENT

T8419AB (CV)

T8419AB -19-28FEB95

PUSH 2 - LOW IDLE ADJUST MODE

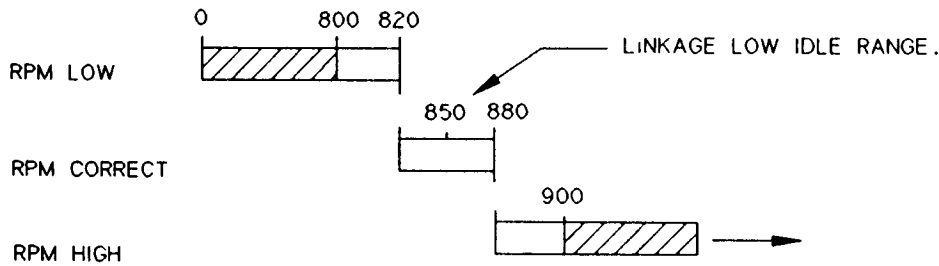

PUSH 3 AND 4 - HIGH IDLE ADJUST MODE

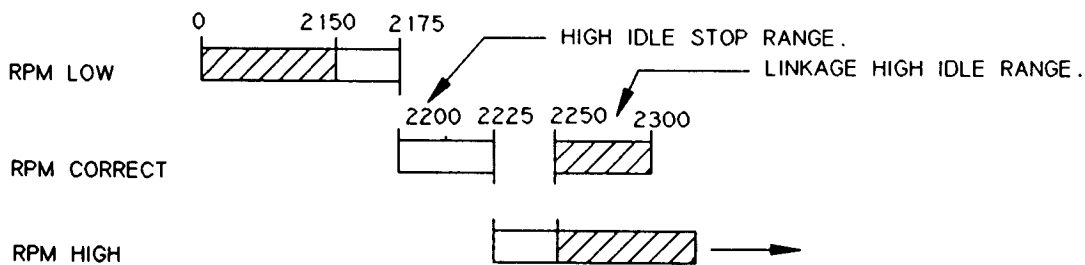

-LIGHT "BLINKING" -LIGHT "ON"

T7577AD (CV)

Ⓟ SYSTEM CONTROLLER ENGINE SPEED INDICATOR LIGHTS

T7577AD -19-29JUL91

Continued on next page

TX.05.DY2926 -19-25AUG97-2/4

Speed Controls

1. Connect tachometer.
2. Start engine and run until it is at normal operating temperature.
3. Before leaving the cab, pull pilot control shut-off lever to locked position. Do not leave machine unattended while engine is running.
4. Loosen cap screws (J). Do not remove cap screws. Move actuator (I) away from roller bearing (L).
5. Loosen nut (H). Turn cap screw (G) in.

Specification

System Controller—"Engine Rpm Correct" Indicator ON—High Idle Stop Screw (G)
 Range 2175—2225 rpm

6. Hold injection pump lever (A) against slow idle stop (B). Slow idle must be 850 ± 30 rpm.

Specification

System Controller—"Engine Rpm Correct" Indicator ON—Low Idle Range..... 820—880 rpm

- Hold injection pump lever against fast idle stop (C). Fast idle must be 2275 ± 25 rpm.

Specification

System Controller—"Engine RPM Correct" and "Engine RPM High" indicators Blinking Together—High Idle Range..... 2250—2300 rpm

If these speeds are not correct, see your authorized dealer.

NOTE: Rod (D) has left-hand and right-hand threads.

7. Measure rod (D) from center of balljoint to center of balljoint. Rod length must be approximately 137 mm (5.39 in.) (M), so that the bellcrank slot forms a arc around injection pump lever balljoint, when lever is against slow idle stop. Loosen nuts and turn rod to adjust length, if necessary. Tighten nuts.

8. Position rod so nut (F) is approximately 12.7 mm (0.5 in.) (N) from top of bellcrank (E) slot. Tighten nut (F).
9. Inside the cab, remove four cap screws and the fuse box cover to remove the rear console cover.
10. Push system controller switch (Q) twice. Engine speed will decrease. Actuator piston (K) will be fully retracted.
11. Hold injection pump lever against slow idle stop and move actuator until piston contacts roller bearing (L). Tighten cap screws (J).

NOTE: If "Engine RPM Correct" and "Engine RPM Low" or "Engine RPM High" indicators are blinking erratically, the engine linkage adjustment is close to specification.

12. Watch system controller indicators. "Adjust Mode" (green), "Pump Solenoid Valve Current," and "Low Idle" indicators must be on.

In addition, one of the following indicators will be on.

- If "Engine RPM Correct" indicator is on, go to next step.
- If "Engine RPM Low" indicator is on, loosen rod (D) nuts and turn rod to shorten its length.

Specification

Indicator Blinking—Engine RPM
 Low—RPM..... 0—800 rpm
 Indicator on Steadily—Engine
 RPM Low—RPM..... 800—820 rpm

- If "Engine RPM High" indicator is on, loosen rod (D) nuts and turn rod to lengthen it.

05
0515
5

Speed Controls

Specification

Indicator Blinking—Engine RPM	
High—RPM.....	900 rpm or greater
Indicator on Steadily—Engine	
RPM High—RPM.....	880—900 rpm

13. Push system controller switch the third time. Engine speed will increase. Actuator piston will be fully extended.

“Adjust Mode” (green) “Pump Solenoid Valve Current,” and “High Idle” indicators must be on.

14. Loosen nut (F). While holding injection pump lever against fast idle stop, adjust position of nut (F) in bellcrank slot until roller bearing (L) contacts actuator piston (K).

15. Check system controller indicators.

- If both “Engine RPM Correct” and “Engine RPM High” indicators are BLINKING TOGETHER, go to next step. (Linkage is adjusted to high idle range of 2250—2300 rpm.)

Specification

System Controller—“Engine RPM Correct” and “Engine RPM High” indicators Blinking Together—High Idle Range.....	2250—2300 rpm
--	---------------

- If “Engine RPM High” indicator is on steadily (2225—2350 rpm) OR
If “Engine RPM Correct” indicator is on steadily (2200—2250) OR
If “Engine RPM Low” indicator is blinking or on steadily (0—2175 rpm),
THEN raise nut (F) in bellcrank slot.
- If “Engine RPM High” indicator is blinking (2350 rpm or greater), lower nut (F) in bellcrank slot

16. Push system controller switch a fourth time. The system controller will maintain engine speed at 2200 rpm.

“Adjust Mode” (green) “Pump Solenoid Valve Current,” “High Idle Stop,” and “Engine RPM Correct” indicators must be on. If any of these indicators are not on, see your authorized dealer.

17. Turn screw (G) out until it contacts bellcrank (E). Tighten nut (H).

18. Push system controller switch a fifth time to return system controller to normal operation mode. All indicators should go out.

TX,05,DY2926 -19-25AUG97-4/4

05
0515
6

T6606AJ -UN-23AUG88

Special Or Essential Tools

NOTE: Order tools according to information given in the U.S. SERVICE-GARD™ Catalog or in the European Microfiche Tool Catalog (MTC).

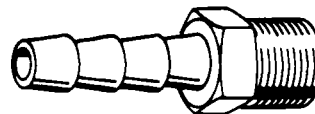

SERVICE-GARD is a trademark of Deere & Company.

53T,JDG51 -19-12FEB90-1/3

Inlet Air Adapter JDG51

Used for intake manifold pressure test.

53T,JDG51 -19-12FEB90-2/3

Used for intake manifold pressure test.

05
0520
1

53T,JDG51 -19-12FEB90-3/3

Service Equipment And Tools

NOTE: Order tools from the U.S. SERVICE-GARD™ Catalog. Some tools may be available from a local supplier.

SERVICE-GARD is a trademark of Deere & Company.

TX,0520,CC1 -19-07JUL87-1/2

Air Pressure Regulator 1/4 in. Plastic Hose

Used to pressurize air intake system to check for leaks.

TX,0520,CC1 -19-07JUL87-2/2

*Intake System***Specifications**

Item	Measurement	Specification
Air Cleaner		
Inside Center of Radius of U-Bolt to Baffle	Distance	307 mm (12.08 in.)
Air Intake System Test	Air Pressure	14—21 kPa (0.14—0.21 bar) (2—3 psi)

TX,0520,AB505 -19-17FEB92-1/1

Intake System

Remove And Install Air Cleaner

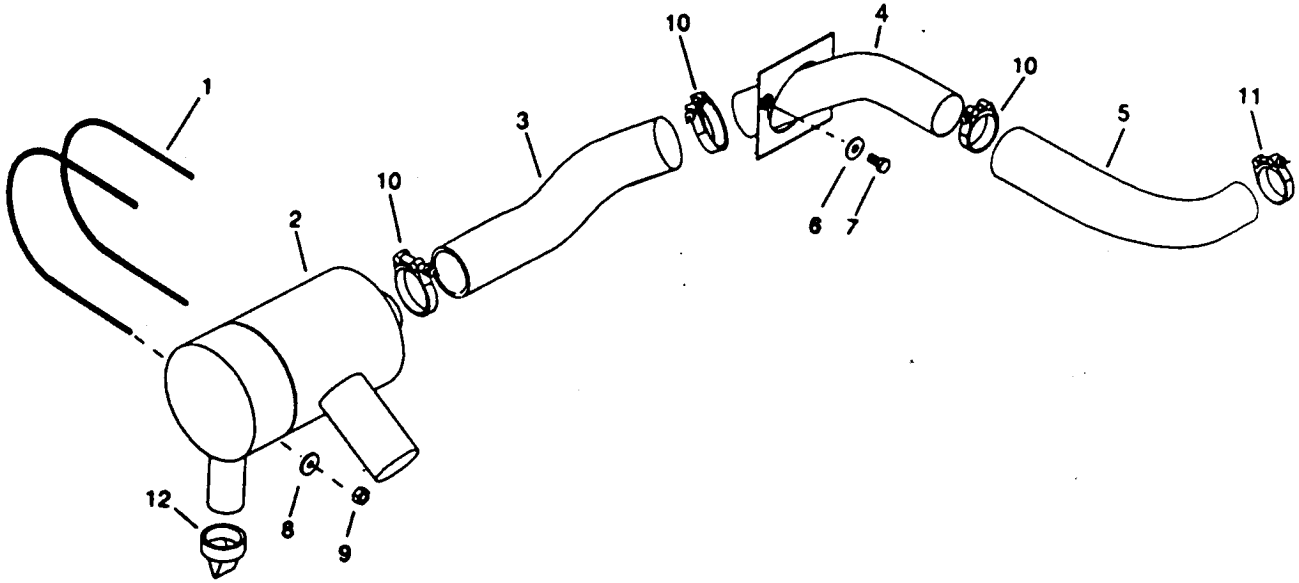

- | | | | |
|-------------------|-------------------|----------------------|-------------------|
| 1—U-Bolt (2 used) | 4—Hose | 7—Cap Screw (2 used) | 10—Clamp (3 used) |
| 2—Air Cleaner | 5—Hose | 8—Washer (8 used) | 11—Clamp |
| 3—Hose | 6—Washer (2 used) | 9—Lock Nut (8 used) | 12—Unloader Valve |

Before tightening, be sure air cleaner inlet tube is not contacting left side baffle.

keep air cleaner from rotating or rattling after assembly.

Install first lock nut (9), nylon insert end first, so the distance measured from the inside center of radius to baffle is 307 mm (12.08 in.).

Install air cleaner so unloader valve is at the 6 o'clock position.

Air Cleaner—Specification

Inside Center of Radius of
U-Bolt to Baffle—Distance..... 307 mm (12.08 in.)

Tighten clamps (10) until hoses (3 and 5) deforms around clamp band.

Be careful not to overtighten lock nuts which will crush the outside of the air cleaner body. Tighten only to

TX,0520,AB158 -19-17FEB92-1/1

05
0520
3
T7681AB -UN-10JAN92

Intake System

Air Intake System Leakage Test

SPECIFICATIONS	
Air Intake System Test Air Pressure	14—21 kPa (0.14—0.21 bar) (2—3 psi)

ESSENTIAL TOOLS
JDG51 Inlet Air Adapter

SERVICE EQUIPMENT AND TOOLS
Air Pressure Regulator 1/4 in. Plastic Hose



T5906AP -UN-23FEB89

1. Remove air cleaner cover and primary filter element.
2. Put large plastic bag inside and over end of element. Install element and cover.

0520,CC4 -19-25SEP91-1/2

3. Remove fitting for start aid nozzle from intake manifold and install JDG-51 Inlet Air Adapter (A).
4. Connect air pressure regulator to adapter using hose and fitting.

IMPORTANT: DO NOT start unit when turning crankshaft slightly to close intake valves; plastic bag could be sucked into engine.

5. Pressurize air intake system to 14—21 kPa (0.14—0.21 bar) (2—3 psi).

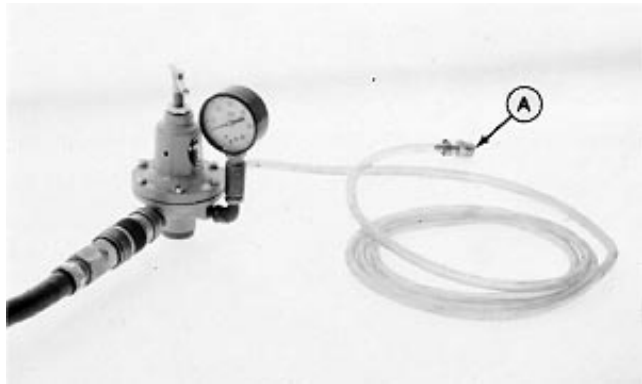

T6089AR -UN-25OCT88

Air Cleaner—Specification

Air Intake System Test—Air Pressure	14—21 kPa (0.14—0.21 bar) (2—3 psi)
---	-------------------------------------

If intake system cannot be pressurized, turn crankshaft slightly to close intake valves.

6. Spray soap solution over all connections from the air cleaner to turbocharger and air intake manifold to check for leaks. Correct all leaks.

0520,CC4 -19-25SEP91-2/2

05
0520
4

Remove And Install Muffler

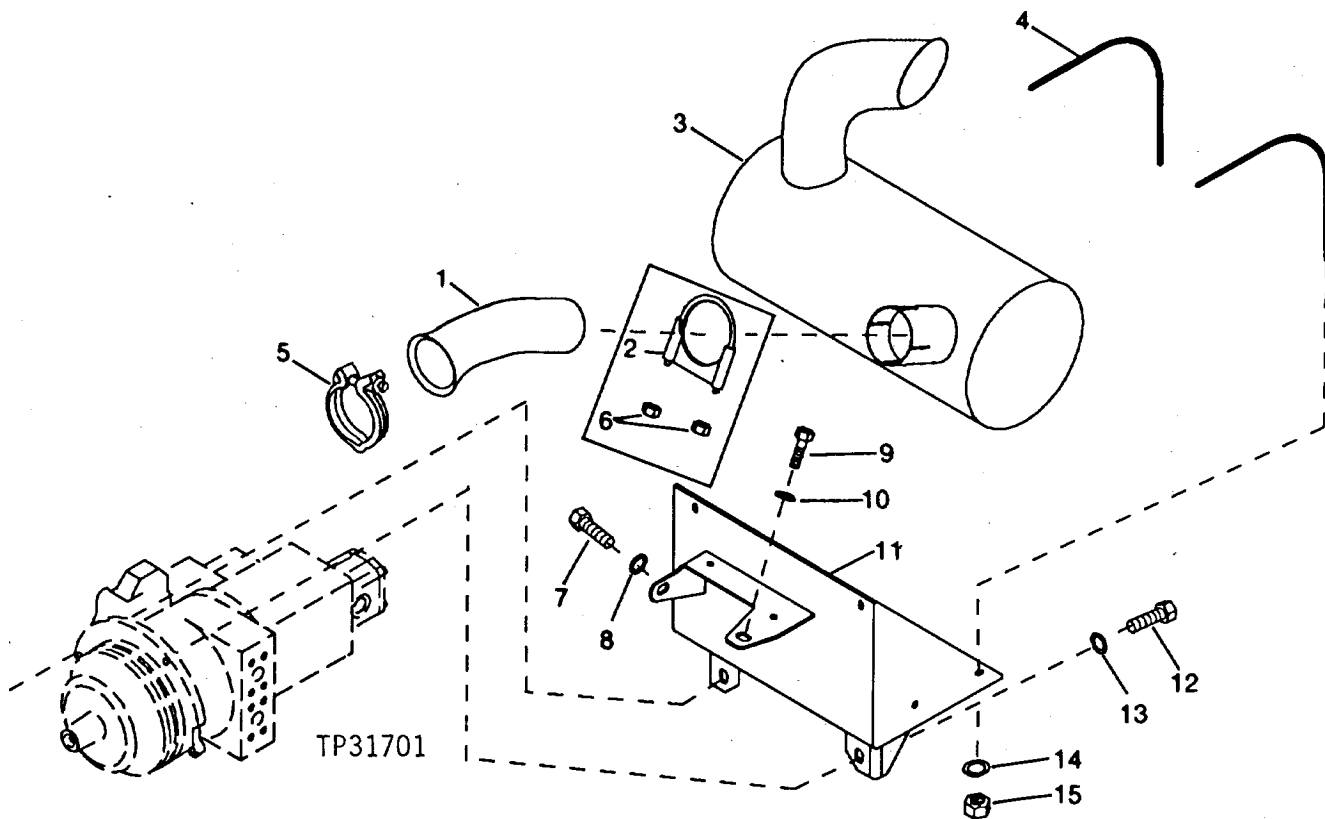

- | | | | |
|----------------------|----------------|-----------------------|----------------------|
| 1—Inlet Tube | 5—Clamp | 9—Cap Screw | 13—Washer (2 used) |
| 2—Clamp | 6—Nut (2 used) | 10—Washer | 14—Washer (4 used) |
| 3—Muffler | 7—Cap Screw | 11—Support | 15—Lock Nut (4 used) |
| 4—Hook Bolt (2 used) | 8—Washer | 12—Cap Screw (2 used) | |

CAUTION: Do not attempt removal until muffler is cool to the touch.

Tighten hook bolts (4) until muffler just starts to crush against support.

Tighten clamp (2) so as to deform muffler inlet tube (1).

TP31701 -JUN-01JAN94

05
0530
1

External Exhaust Systems

05
0530
2

Group 0560 External Fuel Supply Systems

Specifications

Item	Measurement	Specification
Fuel Tank		
Clamp-to-Fuel Tank Cap Screw	Torque	8.5 N•m (75 lb-in.)
Sender and Gasket-to-Tank Screw	Torque	4.5 N•m (40 lb-in.)

TX,0560,AB293 -19-12APR95-1/1

Other Material

Number	Name	Use
T43512 (U.S.) TY9473 (Canadian) 242 (LOCTITE®)	Thread Lock and Sealer (Medium Strength) Products	Used to apply to sender and gasket-to-tank screw.
TY6304 (U.S.) TY9484 (Canadian) 515 (LOCTITE®)	Flexible Sealant	Used to apply tank filter and drain valve.

05
0560
1

LOCTITE is a registered trademark of Loctite Corp.

TX,05,DY2927 -19-25AUG97-1/1

External Fuel Supply Systems

Remove And Install Fuel Tank

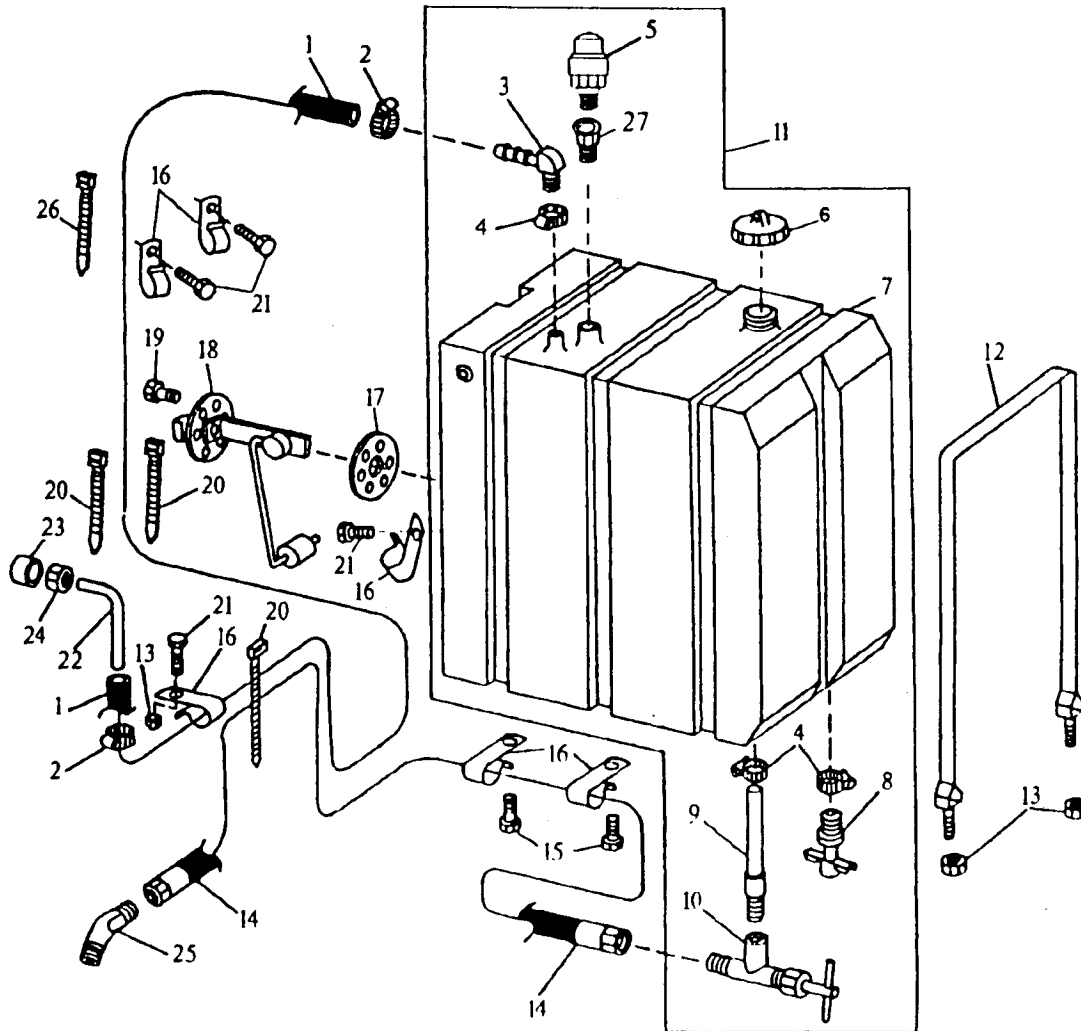

(Serial No. —542359)

- | | | | |
|------------------|------------------------|-----------------------|-----------------------|
| 1—Hose | 8—Drain Valve | 15—Cap Screw (2 used) | 21—Cap Screw (4 used) |
| 2—Clamp (2 used) | 9—Filter | 16—Clamp (6 used) | 22—Line |
| 3—Elbow Fitting | 10—Shut-Off Valve | 17—Gasket | 23—Packing |
| 4—Clamp (3 used) | 11—Fuel Tank, Complete | 18—Sender | 24—Tube Nut |
| 5—Breather | 12—Strap (2 used) | 19—Screw (5 used) | 25—Elbow Fitting |
| 6—Filler Cap | 13—Lock Nut (5 used) | 20—Tie Band (3 used) | 26—Tie Band |
| 7—Fuel Tank | 14—Hose | | |

Continued on next page

TX,05,DY2928 -19-25AUG97-1/3

05
0560
2

External Fuel Supply Systems

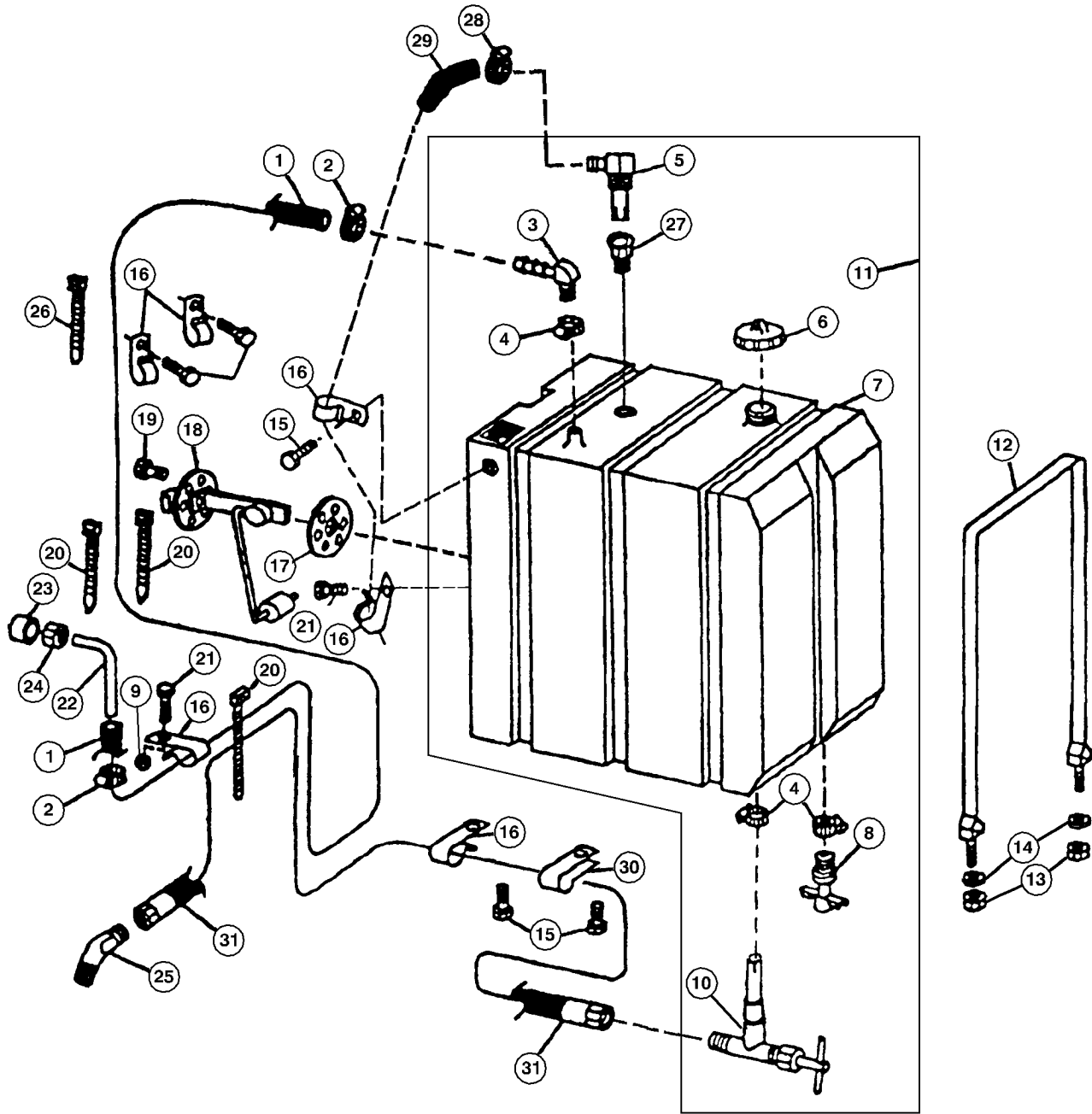

T110268

(Serial No. 542360—)

- | | | | |
|------------------|------------------------|-----------------------|------------------|
| 1—Hose | 9—Lock Nut | 17—Gasket | 25—Elbow Fitting |
| 2—Clamp (2 used) | 10—Shut-Off Valve | 18—Sender | 26—Tie Band |
| 3—Elbow Fitting | 11—Fuel Tank, Complete | 19—Screw (5 used) | 27—Pipe Bushing |
| 4—Clamp (3 used) | 12—Strap | 20—Tie Band (3 used) | 28—Clamp |
| 5—Vent | 13—Lock Nut (4 used) | 21—Cap Screw (7 used) | 29—Hose |
| 6—Filler | 14—Washer (2 used) | 22—Line | 30—Clamp |
| 7—Fuel Tank | 15—Cap Screw (3 used) | 23—Packing | 31—Hose |
| 8—Drain Valve | 16—Clamp (7 used) | 24—Tube Nut | |

Continued on next page

TX,05,DY2928 -19-25AUG97-2/3

External Fuel Supply Systems

NOTE: Fuel tank must be drained before removing hydraulic reservoir. Reservoir wall provides fuel tank support.

Drain fuel from tank. On machines (Serial No. — 542359) approximate capacity is 322 L (85 gal). On machines (Serial No. 542360—) approximate capacity is 303 L (80 gal).

Remove hydraulic reservoir. (See procedure in Group 3360.)

Tighten cap screws (15) to 8.5 N•m (75 lb-in.).

Fuel Tank—Specification

Clamp-to-Fuel Tank Cap
Screw—Torque 8.5 N•m (75 lb-in.)

Apply thread lock and sealer (medium strength) to threads of screw (19). Install ground eyelet under screw head at the 5 o'clock position. Tighten screw to 4.5 N•m (40 lb-in.).

Fuel Tank—Specification

Sender and Gasket-to-Tank
Screw—Torque 4.5 N•m (40 lb-in.)

Apply flexible sealant to that part of filter (9) on machines (Serial No. —542359) and drain valve (8) that is held in the tank by the hose clamps (4).

Fill fuel tank with proper fuel. (See Fuel Specifications in Group 0004.)

TX,05,DY2928 -19-25AUG97-3/3

Remove And Install Water Separator (Serial No. —559602)

Bleed fuel system. (See procedure in Group 0400.)

- A—Water Separator-to-Fuel Transfer Pump Line
- B—Fuel Tank-to-Water Separator Line
- C—Cap Screw (2 used)
- D—Drain Line

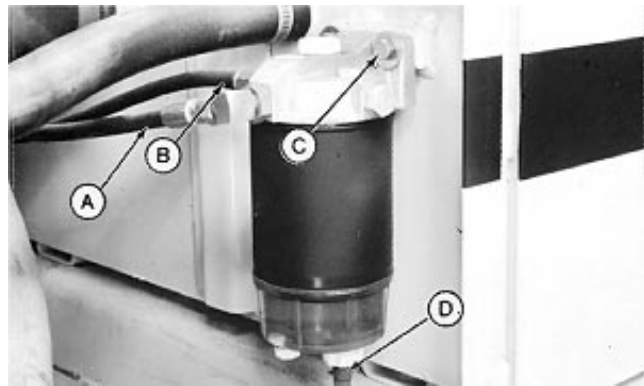

T7626DA -UN-05JAN92

TX,05,DY2929 -19-25AUG97-1/1

05
0560
4

External Fuel Supply Systems

Remove And Install Primary Fuel Filter (Water Separator) (Serial No. 559603—)

1. Close fuel shut-off valve at fuel tank.
2. Drain all fuel from filter into a container. Dispose of waste properly.
3. Disconnect lines (A—C).
4. Remove cap screws (D). Remove fuel filter.
5. Replace parts as necessary.
6. Install filter.
7. Install cap screws (D).
8. Connect lines (A—C).
9. Open fuel shut-off valve.
10. Bleed fuel system. (See procedure in Group 0400.)

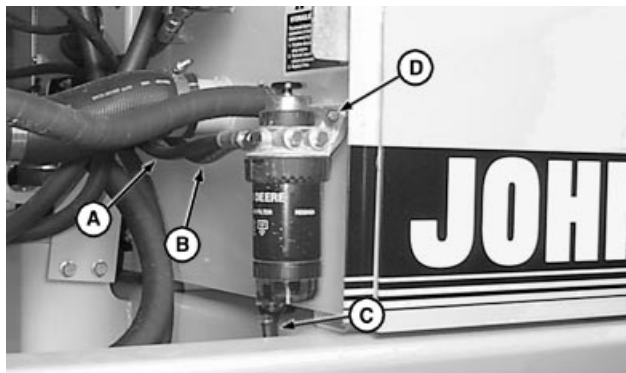

A—Fuel Filter Outlet Port-to-Transfer Pump Inlet Port Line
 B—Fuel Pump Inlet Port-to-Fuel Tank Outlet Port Line
 C—Drain Line
 D—Cap Screw (2 used)

T110271 -UN-05AUG97

TX,05,DT5070 -19-26JUN97-1/1

05
0560
5

Replace Water Separator Filter Element (Serial No. —559602)

1. Open plunger (A).
2. Place container on track under hose from drain plug (E). Open plug and drain fuel from filter into container. Dispose of waste properly. Close plunger.
3. Turn separator bowl (D) counterclockwise to remove from filter assembly (C).
4. Turn filter assembly counterclockwise to remove from separator base (B).
5. Fill water separator filter with fuel.
6. Install new filter assembly to separator base.
7. Install separator bowl to filter assembly.
8. Bleed fuel system. (See procedure in Group 0400.)

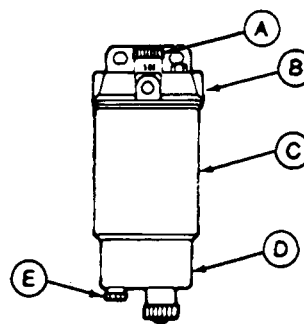

A—Plunger
 B—Base
 C—Filter Assembly
 D—Separator Bowl
 E—Drain Plug

T6105BG1 -UN-18OCT88

TX,05,DY2930 -19-25AUG97-1/1

External Fuel Supply Systems

Disassemble And Assemble Primary Fuel Filter (Water Separator) (Serial No. 559603—)

1. Remove parts (A—D).
2. Remove locking ring (E). Remove filter element (F).
3. Remove parts (G—P).
4. Inspect and replace parts as necessary.
5. Install parts (G—P).
6. Install filter element and locking ring.
7. Install parts (A—D).

- A—Drain Plug
- B—Packing
- C—Cap Screw
- D—Sediment Bowl
- E—Locking Ring
- F—Filter Element
- G—Filter
- H—Bleed Screw
- I—Packing
- J—Plug (2 used)
- K—Diaphragm
- L—Spring Seat
- M—Spring
- N—Spring Cover
- O—Pump Knob
- P—Locking Ring

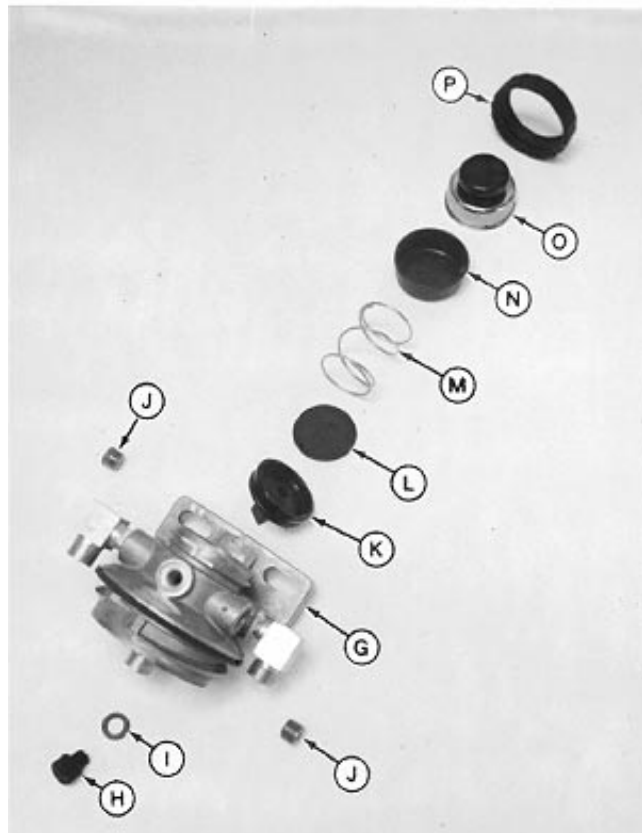
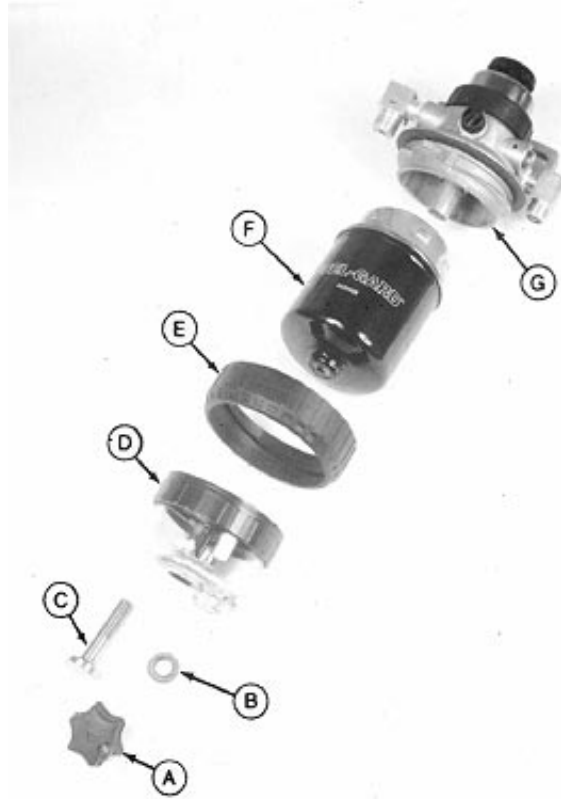

T7751HR -UN-22OCT92

T7751HS -UN-22OCT92

TX,05,DY5182 -19-31MAR97-1/1

05
0560
6

Section 07 Dampener Drive (Flex Coupling)

Contents

Page

Group 0752—Elements

Specifications	07-0752-1
Dampener Drive (Flex Coupler) (SN -559602)	
Remove and Install	07-0752-2
Dampener Drive (Flex Coupler) (SN 559603-)	
Remove and Install	07-0752-4

Contents

07

Specifications

Item	Measurement	Specification
Dampener Drive		
Drive Hub-to-Pump Housing	Clearance	3 ± 1 mm (0.12 ± 0.04 in.)
Arm-to-Hub Socket Head Screw	Torque	220 N•m (160 lb-ft)
Hub Set Screw	Torque	120 N•m (90 lb-ft)
Drive Flange-to-Flywheel Cap Screw	Torque	50 N•m (35 lb-ft)
Pump Mount Cover-to-Flywheel Housing Cap Screw (Serial No. — 559602)	Torque	50 N•m (35 lb-ft)
Pump Mount Cover-to-Flywheel Housing Cap Screw (Serial No. 559603—)	Torque	75 N•m (55 lb-ft)

TX,07,DY2931 -19-25AUG97-1/1

07
0752
1

Remove And Install Dampener Drive (Flex Coupler) (Serial No. —559602)

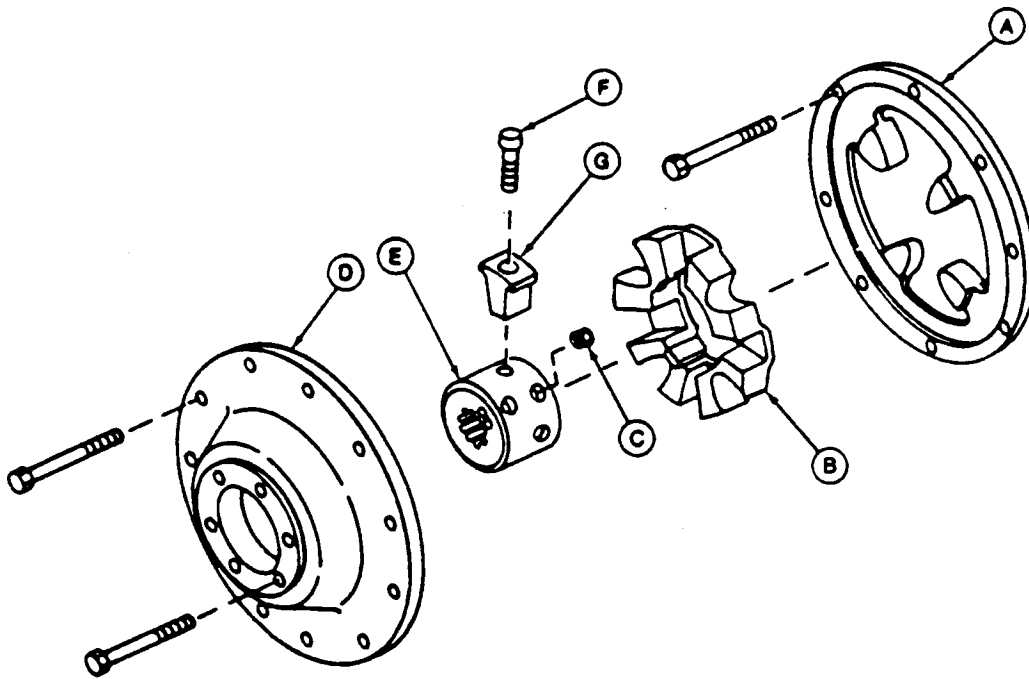

(Serial No. —559602)

- | | | | |
|-----------------|----------------------|------------------------------|----------------|
| A—Drive Flange | C—Set Screw (2 used) | E—Hub | G—Arm (4 used) |
| B—Drive Element | D—Cover | F—Socket Head Screw (4 used) | |

1. Remove hydraulic pump. (See procedure in Group 3360.)
2. Remove cover (D) and lower baffle.
3. Remove drive element (B) and flange (A).
4. Remove set screws (C) to remove hub (E) and arms (G) from pump.

NOTE: *If original hub is installed, the set screws have distorted the center spline, making for a tight fit on pump shaft.*

5. Install drive hub assembly with end of hub even with arms away from pump. Push drive hub on pump shaft 3 ± 1 mm (0.12 ± 0.04 in.) from pump housing.

Specification

Drive Hub-to-Pump Housing—	
Clearance.....	3 ± 1 mm (0.12 ± 0.04 in.)

Tighten set screws.

Specification

Arm-to-Hub Socket Head	
Screw (F)—Torque	220 N•m (160 lb-ft)
Hub Set Screw (C)—Torque	120 N•m (90 lb-ft)
Drive Flange-to-Flywheel Cap	
Screw—Torque	50 N•m (35 lb-ft)
Pump Mount Cover-to-Flywheel	
Housing Cap Screw—Torque.....	50 N•m (35 lb-ft)

6. Install drive flange on flywheel.
7. Install cover, spacers, lower baffle, and cap screws.

Continued on next page

TX,07,DY2932 -19-25AUG97-1/2

Elements

8. Install hydraulic pump.

TX,07,DY2932 -19-25AUG97-2/2

07
0752
3

Remove And Install Dampener Drive (Flex Coupler) (Serial No. 559603—)

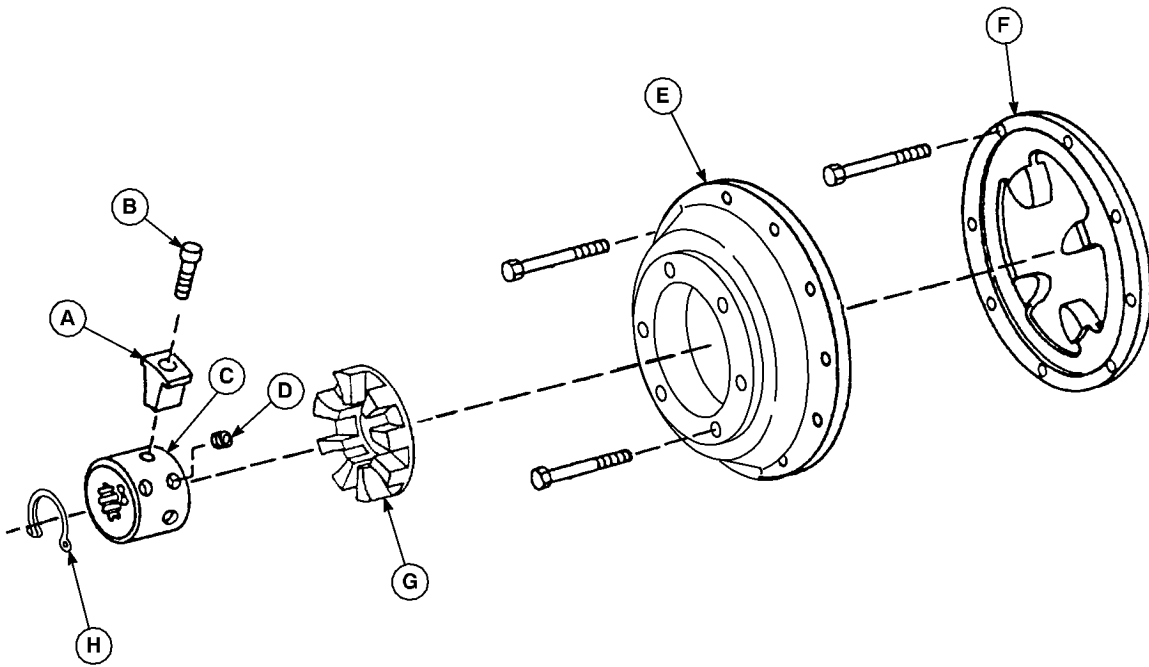

T110274

(Serial No. 559603—)

- | | | | |
|----------------------|----------------------|----------------|------------------|
| A—Arm (4 used) | C—Hub | E—Cover | G—Drive Element |
| B—Cap Screw (4 used) | D—Set Screw (2 used) | F—Drive Flange | H—Retaining Clip |

1. Remove hydraulic pump. (See procedure in Group 3360.)
2. Remove retaining clip (H) and set screws (D). Remove hub assembly from hydraulic pump shaft.
3. Remove cap screws (B). Remove arms (A) from hub (C).
4. Remove drive element (G).
5. Remove cap screws. Remove cover (E).
6. Remove cap screws. Remove drive flange (F).
7. Install drive flange (F).
8. Install cover (E).
9. Install drive element (G).
10. Install arms (A) and cap screws (B) on hub (C).
11. Install hub assembly on hydraulic pump shaft 3 ± 1 mm (0.12 ± 0.04 in.) from pump.

Specification

Drive Hub-to-Pump Housing—
 Clearance..... 3 ± 1 mm (0.12 ± 0.04 in.)

Continued on next page

TX,07,DT5082 -19-03JUL97-1/2

Elements

NOTE: *If original hub is installed, the set screws have distorted the center spline, making for a tight fit on pump shaft.*

12. Install drive hub assembly with end of hub even with arms away from pump. Push drive hub on pump shaft 3 ± 1 mm (0.12 ± 0.04 in.) from pump housing.

Specification

Drive Hub-to-Pump Housing—
Clearance..... 3 ± 1 mm (0.12 ± 0.04 in.)

Tighten set screws.

Specification

Arm-to-Hub Socket Head
Screw (F)—Torque 220 N•m (160 lb-ft)

Hub Set Screw (C)—Torque 120 N•m (90 lb-ft)
Drive Flange-to-Flywheel Cap
Screw—Torque 50 N•m (35 lb-ft)
Pump Mount Cover-to-Flywheel
Housing Cap Screw—Torque..... 75 N•m (55 lb-ft)

13. Install set screws (D) and retaining clip (H).

14. Install cover, spacers, lower baffle, and cap screws.

15. Install hydraulic pump.

TX,07,DT5082 -19-03JUL97-2/2

07
0752
5

Elements

07
0752
6

Section 16 Electrical System

Contents

	Page		Page
Group 1671—Batteries, Support, And Cables			
Service Equipment And Tools	16-1671-1		
Specifications	16-1671-2		
Handle Batteries Safely	16-1671-3		
Procedure For Testing Batteries	16-1671-4		
Check Battery Electrolyte Specific Gravity	16-1671-5		
Check Battery Electrolyte Level And Terminals	16-1671-6		
Booster Batteries			
24-Volt System	16-1671-8		
Batteries			
Charge	16-1671-10		
Remove and Install	16-1671-11		
Adding 12-Volt Accessories	16-1671-12		
Group 1672—Alternator, Regulator, And Charging Wiring			
Alternators And Starting Motors—Use			
CTM77	16-1672-1		
Specifications	16-1672-1		
Alternator			
Remove and Install (SN -541822)	16-1672-2		
Remove and Install (SN 541823-)	16-1672-3		
Remove and Install (SN 559603-)	16-1672-4		
Group 1673—Lighting System			
Halogen Bulbs			
Replacing	16-1673-1		
Work Light			
Adjustment	16-1673-2		
Fuses			
Replacing	16-1673-3		
Specifications	16-1673-4		
Color Codes	16-1673-5		
Group 1674—Wiring Harness And Switches			
Special Or Essential Tools	16-1674-1		
Vehicle Electrical Component			
Identification	16-1674-3		
Engine Electrical Component			
Identification	16-1674-5		
Cab Electrical Component Identification	16-1674-6		
Starter Switch			
Remove and Install	16-1674-7		
		Radio, Propel Alarm Cancel, and Start Aid Switches	
		Remove and Install	16-1674-8
		Monitor Buzzer and Air Conditioner Switch	
		Remove and Install	16-1674-10
		DEUTSCH Connectors	
		Replace	16-1674-10
		DEUTSCH Contact	
		Install	16-1674-12
		WEATHER PACK Connector	
		Replace	16-1674-13
		WEATHER PACK Contact	
		Install	16-1674-14
		Remove Connector Body From Blade	
		Terminals	16-1674-15
		Group 1675—System Controls	
		Welding On Machine	16-1675-1
		System Controller	
		Remove and Install	16-1675-2
		Monitor Controller	
		Remove and Install	16-1675-3
		Group 1676—Instruments And Indicators	
		Monitor Panel	
		Replace Bulbs	16-1676-1
		Remove and Install	16-1676-1
		Switch Panel 1	
		Remove and Install	16-1676-3
		Hour Meter, Coolant Temperature and Fuel Level Gauges	16-1676-4
		Switch Panel 2	
		Replace Bulb	16-1676-5
		Remove and Install	16-1676-6

Contents

Service Equipment And Tools

*NOTE: Order tools from the U.S. SERVICE-GARD™
Catalog or from the European Microfiche Tool
Catalog (MTC). Some tools may be available from
a local supplier.*

SERVICE-GARD is a trademark of Deere & Company.

TX,1671,DU175 -19-11JUL92-1/4

Battery Post/Clamp Cleaner JT05838

Used to clean corrosion off battery posts and clamps.

TX,1671,DU175 -19-11JUL92-2/4

Coolant/Battery Tester JT05460

Used to check battery electrolyte specific gravity.

TX,1671,DU175 -19-11JUL92-3/4

Battery Load Tester JT05832

Used to check battery capacity.

TX,1671,DU175 -19-11JUL92-4/4

16
1671
1

*Batteries, Support, And Cables***Specifications**

Item	Measurement	Specification
Battery	BCI Group	31
	Cold Cranking Amps—18°C (0°F)	625 amps
	Reserve Capacity, Minutes at 25 Amps and 27°C (80°F)	160 minutes
	Voltage	12 volts
	BCI Group	4D
	Cold Cranking Amps 18°C (0°F)	1000 amps
	Reserve Capacity, Minutes at 25 Amps and 27°C (80°F)	320 minutes
Cable Clamp Nuts	Voltage	12 volts
	Torque	9 N•m (82 lb-in.)
System	Voltage	24 volts

TX,1671,AB41 -19-12APR95-1/1

Handle Batteries Safely



CAUTION: An explosive gas is produced while batteries are in use or being charged. Keep flames or sparks away from the battery area. Make sure the batteries are charged in a well ventilated area.

Never lay a metal object on top of a battery as a short circuit can result.



TS204 -JUN-23AUG88

Battery acid is harmful on contact with skin or fabrics. If acid spills, follow these first aid tips:

1. Immediately remove any clothing on which acid spills.
2. If acid contacts the skin, rinse the affected area with running water for 10 to 15 minutes.
3. If acid comes into contact with the eyes, flood the eyes with running water for 15 to 30 minutes. See a doctor at once. Never use any medication or eye drops unless prescribed by the doctor.
4. To neutralize acid spilled on the floor, use one of the following mixtures: 0.5 kg (1 lb) of baking soda in 4 L (1 gal) of water, or 0.4 L (1 pt) of household ammonia in 4 L (1 gal) of water.
5. Acid from the batteries can also damage the paint and metal surfaces of the machine. Avoid over filling the battery cells.

16
1671
3

TX,1671,DV1300 -19-29MAR93-1/1

Procedure For Testing Batteries

SERVICE EQUIPMENT AND TOOLS

JT05838 Battery Post/Clamp Cleaner
JT05460 Coolant/Battery Tester
JT05832 Battery Load Tester

Visual Check

1. Check for damage such as cracked or broken case and electrolyte leakage.

If damage is seen, replace battery.

2. Check electrolyte level. (See procedure in this group.)

If low, add distilled water to specified level and charge battery.

3. Check terminals for corrosion.

If corroded, clean using a wire brush or battery post cleaner such as JT05838 Battery Post/Clamp Cleaner.

4. Check posts for looseness.

If posts are loose, replace battery.

Hydrometer Test

1. Check specific gravity with a hydrometer or battery tester such as JT05460 Coolant/Battery Tester.
2. Record specific gravity reading for each cell.

If high and low readings vary LESS than 0.050 and average specific gravity is between 1.225 and 1.280, battery is fully charged, go to LOAD TEST.

If high and low readings vary LESS than 0.050 and average specific gravity is LESS than 1.225, charge battery and repeat test. If average specific gravity is still LESS than 1.225, replace both batteries.

If high and low readings vary MORE than 0.050, charge battery and repeat test. If high and low readings still vary MORE than 0.050, replace both batteries.

Load Test

1. Check battery capacity with a load tester such as JT05832 Battery Load Tester. Follow tester manufacturer's instructions for proper load test procedures.
2. If one battery fails load test, replace both batteries.

Checking Electrolyte Specific Gravity

CAUTION: Battery gas can explode. Keep sparks and flames away from batteries. Use a flashlight to check battery electrolyte level.

Never check battery charge by placing a metal object across the posts. Use a voltmeter or hydrometer.

Always remove grounded (-) battery clamp first and replace it last.

Sulfuric acid in battery electrolyte is poisonous. It is strong enough to burn skin, eat holes in clothing, and cause blindness if splashed into eyes.

Avoid the hazard by:

1. Filling batteries in a well-ventilated area.
2. Wearing eye protection and rubber gloves.
3. Avoiding breathing fumes when electrolyte is added.
4. Avoiding spilling or dripping electrolyte.
5. Use proper jump start procedure.

If you spill acid on yourself:

1. Flush your skin with water.
2. Apply baking soda or lime to help neutralize the acid.
3. Flush your eyes with water for 15—30 minutes. Get medical attention immediately.

If acid is swallowed:

1. Do not induce vomiting.
2. Drink large amounts of water or milk, but do not exceed 1.9 L (2 quarts).
3. Get medical attention immediately.

Check the specific gravity of electrolyte in each battery cell using a battery and coolant tester such as JT05460 Battery/Coolant Tester.

Follow directions included with the tester.

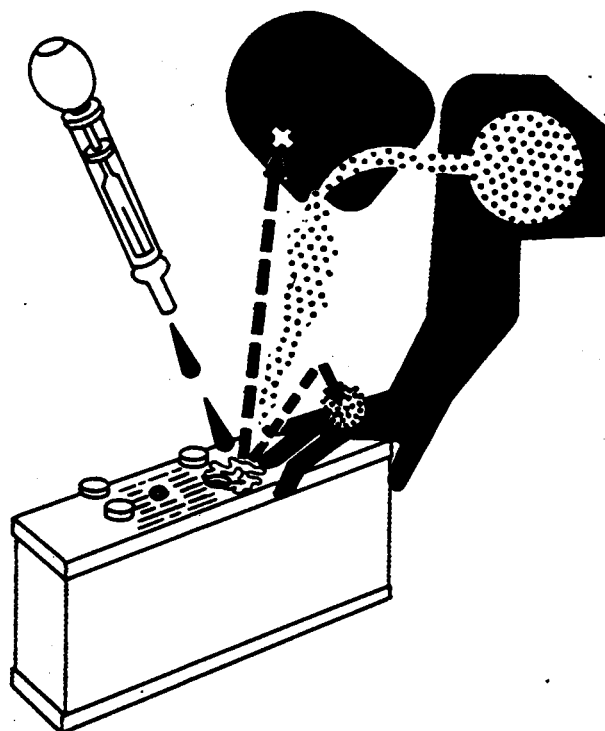

TS204 -UN-23AUG88

TS203 -UN-23AUG88

T85402 -UN-10NOV88

16
1671
5

Batteries, Support, And Cables

A fully charged battery will have a corrected specific gravity reading of 1.260. If the reading is below 1.200, charge the battery.

NOTE: In tropical areas, use 1.225 for the full charge reading. In cold areas, use 1.280 for the full-charge reading.

TX,1671,J7 -19-21SEP94-2/2

Check Battery Electrolyte Level And Terminals

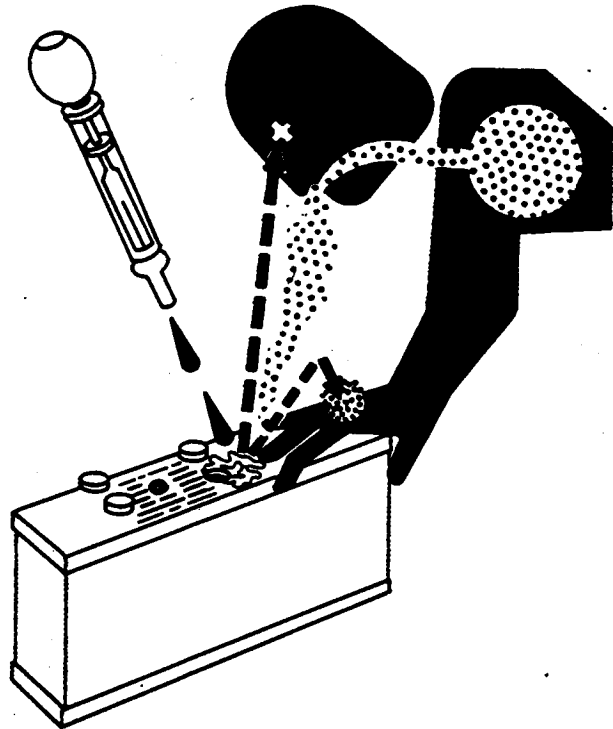

TS203 -UN-23AUG88

Continued on next page

TX,FF,141 -19-29MAY91-1/4

16
1671
6



CAUTION: Battery gas can explode. Keep sparks and flames away from batteries. Use a flashlight to check battery electrolyte level.

Never check battery charge by placing a metal object across the posts. Use a voltmeter or hydrometer.

Always remove grounded (-) battery clamp first and replace it last.

Sulfuric acid in battery electrolyte is poisonous. It is strong enough to burn skin, eat holes in clothing, and cause blindness if splashed into eyes.

Avoid the hazard by:

1. Filling batteries in a well-ventilated area.
2. Wearing eye protection and rubber gloves.
3. Avoiding breathing fumes when electrolyte is added.
4. Avoiding spilling or dripping electrolyte.
5. Use proper jump start procedure.

If you spill acid on yourself:

1. Flush your skin with water.
2. Apply baking soda or lime to help neutralize the acid.
3. Flush your eyes with water for 10—15 minutes. Get medical attention immediately.

If acid is swallowed:

1. Drink large amounts of water or milk.
2. Then drink milk of magnesia, beaten eggs, or vegetable oil.
3. Get medical attention immediately.

IMPORTANT: During freezing weather, batteries must be charged after water is added to prevent battery freezing. Charge battery using a battery charger or by running the engine.

1. Remove hold-down clamps.

Batteries, Support, And Cables

2. Remove battery covers.

TX,FF,141 -19-29MAY91-3/4

3. Fill each cell to within specified range with distilled water. DO NOT overfill.

- A—Battery Post
- B—Fill Tube
- C—Electrolyte Level Range

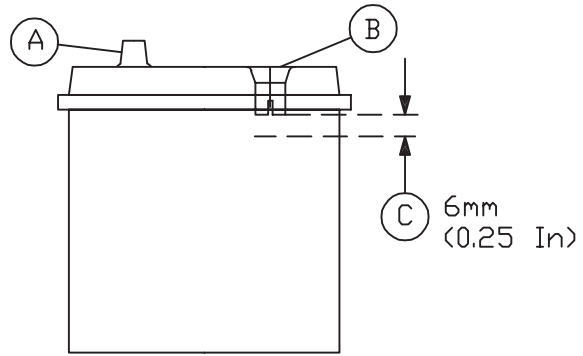

Single Level Fill Tube Application

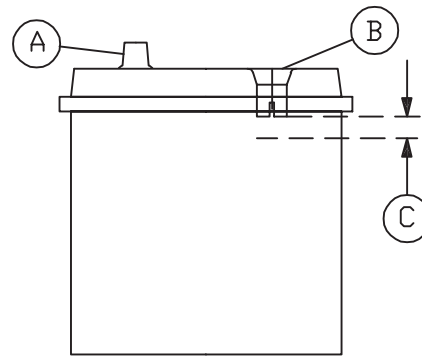

Dual Level Fill Tube Application

T6996DB -UN-09SEP03

T6996DA -UN-09SEP03

TX,FF,141 -19-29MAY91-4/4

Using Booster Batteries—24-Volt System

1. Turn key switch to OFF.

Continued on next page

TX,1671,GG110 -19-25SEP91-1/3



CAUTION: Battery gas can explode. Keep sparks and flames away from batteries. Use a flashlight to check battery electrolyte level.

Never check battery charge by placing a metal object across the posts. Use a voltmeter or hydrometer.

Always remove grounded (-) battery clamp first and replace it last.



TS204 -UN-23AUG88

IMPORTANT: Machine electrical system is 24-volt negative (-) ground. Use only 24-volt booster batteries.

2. Connect booster batteries (B) to machine batteries (A) making the last connection at machine frame, away from batteries.

Rock the clamps to make sure they make good contact.

When possible, use equipment with a switch in the cable that connects booster batteries to machine batteries.

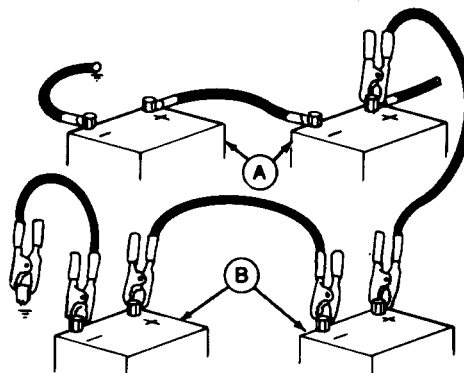

Two Battery Application

T7233JUN -UN-21MAY90

TX,1671,GG110 -19-25SEP91-2/3

16
1671
9

CAUTION: Avoid possible injury or death from machinery runaway.

Do not start engine by shorting across starter terminals. Machine will start in gear if normal circuitry is bypassed.

NEVER start engine while standing on ground. Start engine only from operator's seat, with transmission in neutral or park.



TS177 -UN-11JAN89

Start engine while seated on operator's seat.

After engine starts, disconnect clamp at machine frame first and then disconnect remaining clamps.

TX,1671,GG110 -19-25SEP91-3/3

Charge Battery



CAUTION: Battery gas can explode. Keep sparks and flames away from batteries. Use a flashlight to check battery electrolyte level.

Never check battery charge by placing a metal object across the posts. Use a voltmeter or hydrometer.

Always remove grounded (-) battery clamp first and replace it last.

IMPORTANT: When charging a battery in unit, all cables must be disconnected to avoid damaging electrical components if battery charger cables are inadvertently connected to battery wrong.

NOTE: Follow manufacturer's instructions to use battery charger as a booster to start engine.

1. Disconnect all battery cables starting at the negative (-) ground cable.
2. Turn charger off before connecting or disconnecting it.
3. Charge battery following manufacturer's instructions for your battery charger.
4. After battery is charged, connect the cables doing the negative (-) ground cable last.



TS204 -UN-23AUG88

16
1671
10

TX,1671,DV2638 -19-10MAY94-1/1

Remove And Install Batteries

1. Remove battery cover.
2. Disconnect ground cables (C and E).
3. Disconnect positive cables (B and D).
4. Remove battery hold-down clamp (A).
5. Remove batteries.
6. Check cables and clamps for wear or corrosion. Make sure batteries are fully charged.

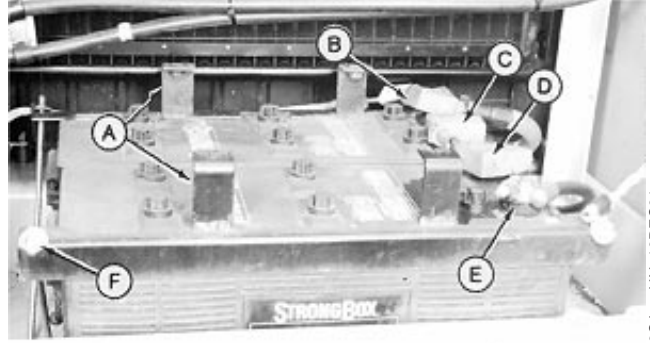

T7626CJ -UN-16DEC91

- A—Battery Hold-Down Clamp
- B—Positive Cable
- C—Negative Cable
- D—Positive Cable
- E—Negative Cable
- F—Lock Nut (4 used)

IMPORTANT: If one battery in a 24-volt system has failed but the other is still good, replace the failed battery with one of the same type. For example, replace a failed maintenance-free battery with a new maintenance-free battery. Different types of batteries may have different rates of charge. This difference could overload one of the batteries and cause it to fail.

7. Install batteries.

Specification

Battery—BCI Group.....	31
Cold Cranking Amps—18°C (0°F)	625 amps
Reserve Capacity, Minutes at 25 Amps and 27°C (80°F).....	160 minutes
Voltage.....	12 volts
BCI Group	4D
Cold Cranking Amps 18°C (0°F).....	1000 amps
Reserve Capacity, Minutes at 25 Amps and 27°C (80°F).....	320 minutes
Voltage.....	12 volts

8. Clean battery posts and cables.
9. Install battery hold-down clamp.
10. Connect positive cables and then negative cables.
Tighten nuts to 9 N•m (82 lb-in.).

Specification

Cable Clamp Nuts—Torque	9 N•m (82 lb-in.)
-------------------------------	-------------------

Continued on next page

TX,1671,AB42 -19-12APR95-1/2

16
1671
11

Batteries, Support, And Cables

11. Install cover.

TX,1671,AB42 -19-12APR95-2/2

Adding 12-Volt Battery Accessories

IMPORTANT: This unit has a 24-volt electrical system. Installing 12-volt accessories without addition of 24-volt-to-12-volt converter may cause battery failure. See your John Deere dealer.

When possible, use 24-volt accessories.

Specification	
System—Voltage	24 volts

If 12-volt accessories are added, use a 24-volt-to-12-volt converter. Converters are available from your John Deere dealer (see the Industrial Equipment Attachment Guide) or electronic retail stores. This converter may be wired into the ACC terminal of the ignition switch (see drawing).

Converter capacity requirements depend on the load of the accessories installed. Follow electronic dealer and manufacturer's recommendations to determine the capacity of the converter required and its installation requirements.

DO NOT connect an accessory to one battery. Connecting a 12-volt accessory to one battery will cause one battery to overcharge, and the other battery to undercharge, causing battery failure.

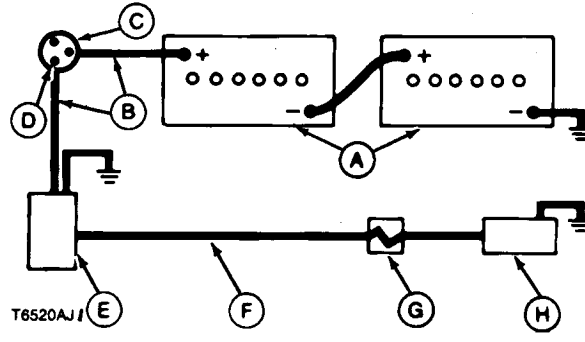

- A—Battery
- B—24 Volts
- C—Ignition Switch
- D—ACC Terminal
- E—Converter
- F—12 Volts
- G—In-Line Fuse
- H—12-Volt Accessory

T6520AJ1 -UN-18OCT88

TX,1671,AB301 -19-13JAN92-1/1

16
1671
12

Group 1672

Alternator, Regulator, And Charging Wiring

Alternators And Starting Motors—Use CTM77

For complete repair information, the Component Technical Manual (CTM) is also required.

Use the CTM in conjunction with this machine manual.



TS225 -JUN-17JAN89

TX,1672.DV2829 -19-30JUN94-1/1

Specifications

Item	Measurement	Specification
Alternator		
Pulley-to-Shaft Nut (Serial No. —541822)	Torque	61 N•m (45 lb-ft)
Housing-to-Bracket Cap Screw (Serial No. 541823—559602)	Torque	27 N•m (239 lb-in.)
Power Terminal Nut (Serial No. 541823—559602)	Torque	25 N•m (221 lb-in.)
Excitation Terminal Nut (Serial No. 541823—559602)	Torque	2 N•m (18 lb-in.)
Housing-to-Bracket Cap Screw and Nut (Serial No. 541823—559602)	Torque	47 N•m (35 lb-ft)
Housing-to-Bracket Cap Screw and Nut (Serial No. 559603—)	Torque	43 N•m (32 lb-ft)
Bracket Cap Screw (Serial No. 559603—)	Torque	22 N•m (195 lb-in.)

 16
1672
1

TX,16,DY2933 -19-25AUG97-1/1

Remove And Install Alternator (Serial No. — 541822)

IMPORTANT: Disconnect battery ground cable to prevent accidental grounding of alternator wiring leads.

1. Disconnect battery ground cable.
2. Disconnect wiring leads (D—G).
3. Place the drive of a 1/2 in. drive ratchet in square hole (C). Turn ratchet counterclockwise to pull tension adjuster assembly away from the belt. Remove belt.
4. Remove cap screw and nut (B) and cap screw and washer (A).
5. Make repairs as necessary. (See procedure in CTM77.)
6. Tighten pulley-to-shaft nut to 61 N•m (45 lb-ft).

Specification

Pulley-To-Shaft Nut (—541822)—
Torque 61 N•m (45 lb-ft)

7. Install alternator. Install lower cap screw (B) so nut is toward fan belt.
8. Install belt. Slowly turn ratchet clockwise to place tensioner assembly against belt. Tension is automatically adjusted.
9. Tighten cap screw (A) and cap screw and nut (B).
10. Connect wiring leads.

A—Cap Screw and Washer
B—Cap Screw and Lock Nut
C—Square Hole
D—1B Red Wiring Lead
E—Black Wiring Lead
F—1E Red Wiring Lead
G—Purple Wiring Lead

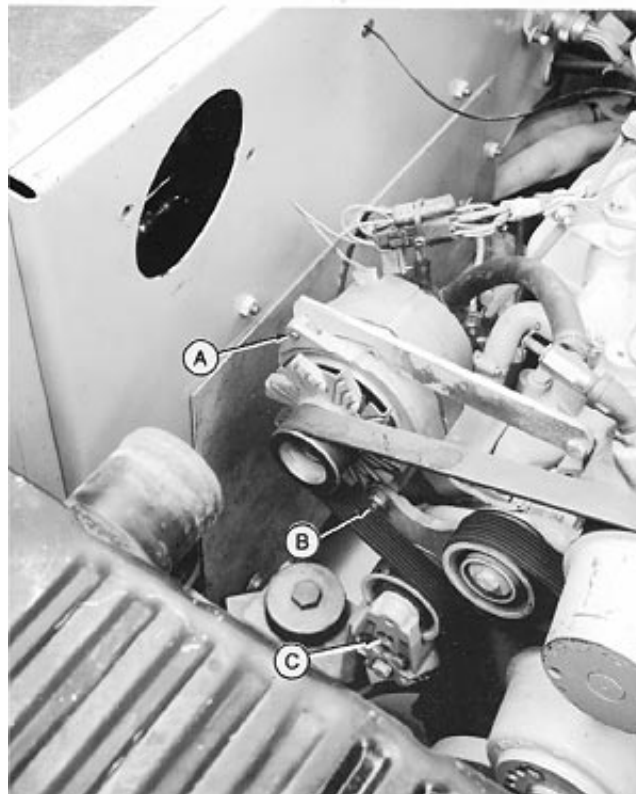

Components Removed For Clarity

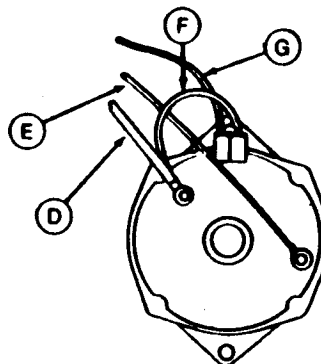

T7626CE -UN-16DEC91

T7626CF -UN-16DEC91

Remove And Install Alternator (Serial No. 541823—559602)

IMPORTANT: Always disconnect negative (-) battery cables before removing alternator or a short circuit could result.

1. Place the drive of a 1/2 in. drive ratchet into square hole (A). Turn ratchet counterclockwise to pull tension adjuster assembly (B) away from belt releasing belt tension. Remove belt from alternator pulley.
2. Disconnect wiring leads (D—F).
3. Remove cap screw and lock washer (H). Remove wiring lead (G).
4. Remove cap screw and nut (C) to remove alternator.
5. Make repairs as necessary. (See procedure in CTM77.)
6. Install alternator. Install lower cap screw and nut (C) so head of cap screw is toward belt.
7. Install cap screw and lock washer (H) and wiring lead (G).
8. Tighten cap screw (H) to 27 N•m (239 lb-in.) and cap screw and nut (C) to 47 N•m (35 lb-ft).

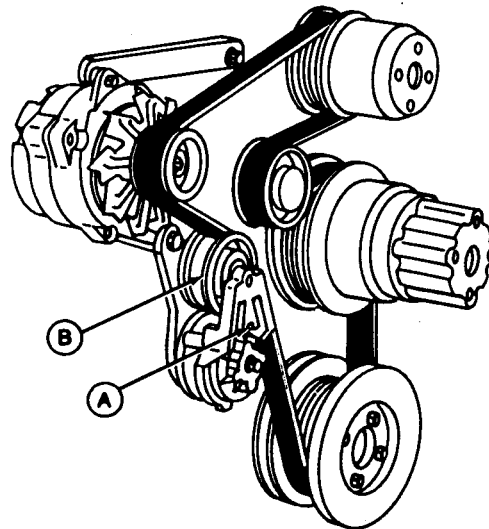

T7405BG -UN-15NOV90

Specification

Housing-to-Bracket Cap Screw (541823—559602)—Torque.....	27 N•m (239 lb-in.)
Housing-to-Bracket Cap Screw and Nut (541823—559602)—Torque	47 N•m (35 lb-ft.)

9. Connect wiring leads (D—F). Tighten power terminal nut to 25 N•m (221 lb-in.).

Specification

Power Terminal Nut (541823—559602)—Torque.....	25 N•m (221 lb-in.)
--	---------------------

Tighten excitation terminal nut to 2 N•m (18 lb-in.).

Specification

Excitation Terminal Nut (541823—559602)—Torque.....	2 N•m (18 lb-in.)
---	-------------------

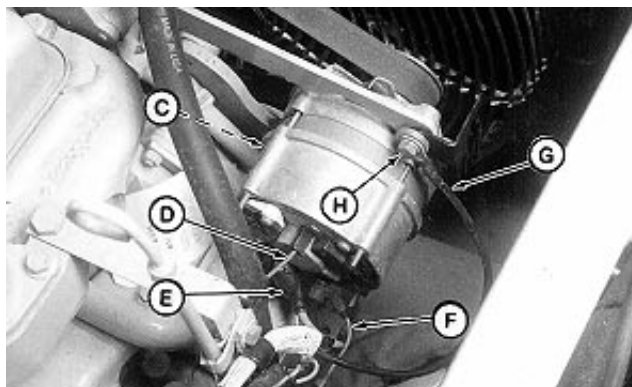

Components Removed For Clarity

- A—Square Hole
- B—Tension Adjuster Assembly
- C—Cap Screw and Nut
- D—Purple Wiring Lead (M01)
- E—Red Wiring Leads (B03, B03A)
- F—Red Wiring Lead (B03A)
- G—Black Wiring Lead (G02)
- H—Cap Screw and Lock Washer

T8449AA -UN-31MAR95

16
1672
3

Alternator, Regulator, And Charging Wiring

10. Slowly turn ratchet clockwise to place tension adjuster assembly against belt. Install belt. Tension is automatically adjusted.
11. Remove ratchet from assembly.

TX,16,DY2903 -19-20AUG97-2/2

Remove And Install Alternator (Serial No. 559603—)

IMPORTANT: Always disconnect negative (-) battery cables before removing alternator or a short circuit could result.

1. Disconnect negative battery cable.

TX,16,DT5071 -19-27JUN97-1/4

2. Place 15 mm, 1/2 in. drive socket on cap screw (A). Turn ratchet counterclockwise to pull tension adjuster assembly (B) away from belt, releasing belt tension. Remove belt from alternator pulley.

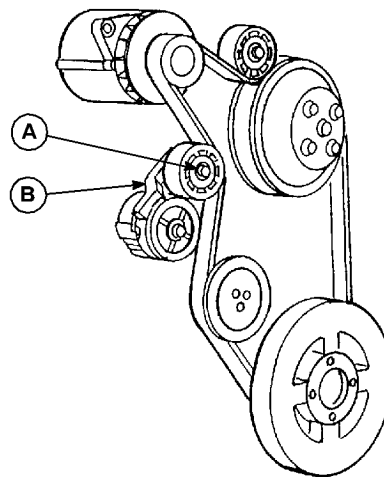

T109285

T109285 -JUN-02JUN97

Continued on next page

TX,16,DT5071 -19-27JUN97-2/4

Alternator, Regulator, And Charging Wiring

3. Disconnect wiring lead (C).
4. Disconnect electrical connector (G).
5. Remove cap screw and lockwasher (E). Remove wiring lead (F).
6. Remove nut and cap screw (D). Remove alternator.
7. Make repairs as necessary. (See procedure in CTM 77.)
8. Install alternator. Install nut and cap screw (D). Tighten to 43 N•m (32 lb-ft).

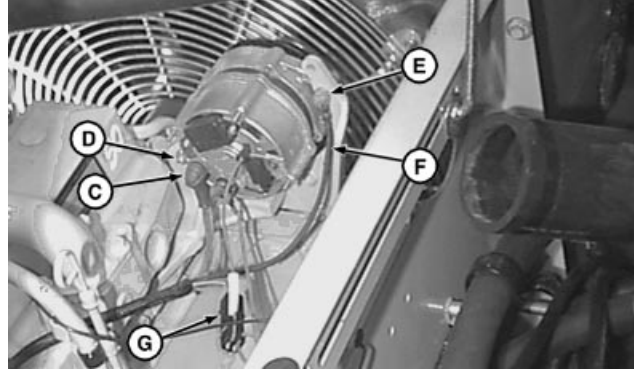

Components Removed For Clarity

- A—Cap Screw
- B—Adjuster Assembly
- C—Red Wiring Lead (B03)
- D—Nut and Cap Screw
- E—Cap Screw and Lockwasher
- F—Black Wiring Lead (G02)
- G—Electrical Connector

Specification

Housing-to-Bracket Cap Screw and Nut (559603)—Torque..... 43 N•m (32 lb-ft)

9. Install wiring lead (F). Install cap screw and lockwasher (A). Tighten to 22 N•m (195 lb-in.).

Specification

Bracket Cap Screw (559603)—Torque 22 N•m (195 lb-in.)

10. Connect electrical connector (G).
11. Connect wiring lead (C).

TX.16.DT5071 -19-27JUN97-3/4

16
1672
5

12. Place 15 mm, 1/2 in. drive socket on cap screw (A). Turn ratchet counterclockwise to pull tension adjuster assembly (B) away. Install belt. Slowly turn ratchet clockwise to place tension adjuster assembly against belt. Tension is automatically adjusted.

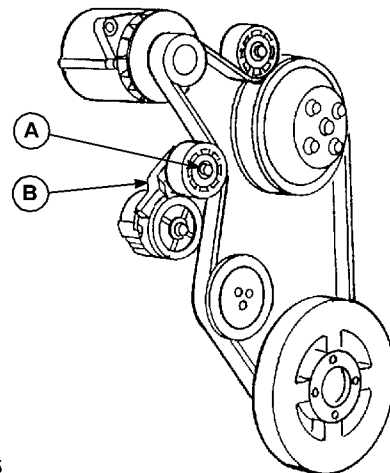

T109285

T109285 -UN-02JUN97

TX.16.DT5071 -19-27JUN97-4/4

Alternator, Regulator, And Charging Wiring

16
1672
6

Replacing Halogen Bulbs

IMPORTANT: To get the correct lighting pattern, lens must be installed so the word "TOP" is on top when lamp is installed on machine. Bezel must be installed so wider section is on top when lamp is installed.

1. Before disassembling, take notice of how bezel and lens are installed with respect to mounting stud.



T5894AG1 -JUN-17APR89

TX,16,DT5083 -19-03JUL97-1/4

2. Remove two screws (A).
3. Remove bezel (B) and lens (C).

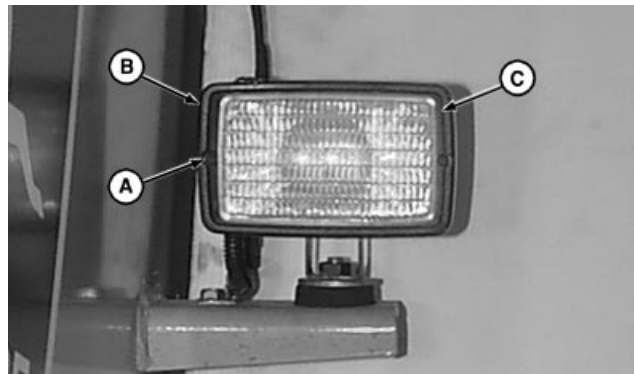

T110292 -JUN-05AUG97

TX,16,DT5083 -19-03JUL97-2/4

4. Disconnect wiring lead (B) and electrical connector (A).

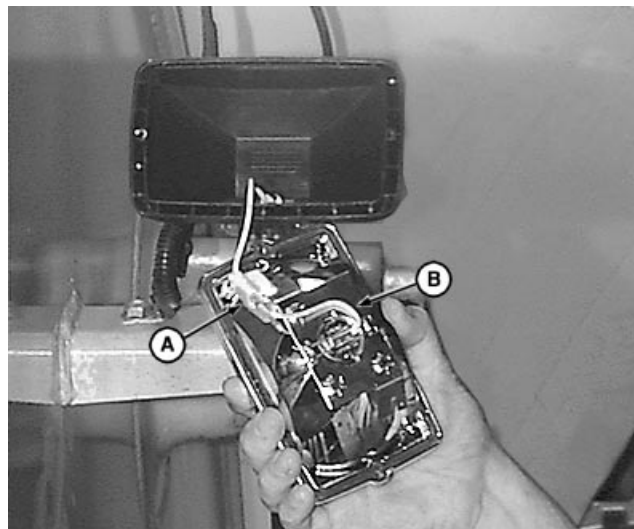

T110293 -JUN-05AUG97

Continued on next page

TX,16,DT5083 -19-03JUL97-3/4

Lighting System

IMPORTANT: Do not touch the halogen bulb with bare hands. Oil and moisture may cause premature bulb failure. If bulb glass is touched, clean using a soft, oil-free cloth and alcohol.

5. Remove retaining clip (A). Remove bulb (B).
6. Replace as necessary.
7. Install bulb. Install retaining clip.
8. Connect electrical connector and wiring lead.
9. Install lens and bezel.

NOTE: Do not overtighten screws as screws may strip out plastic.

10. Tighten screws.

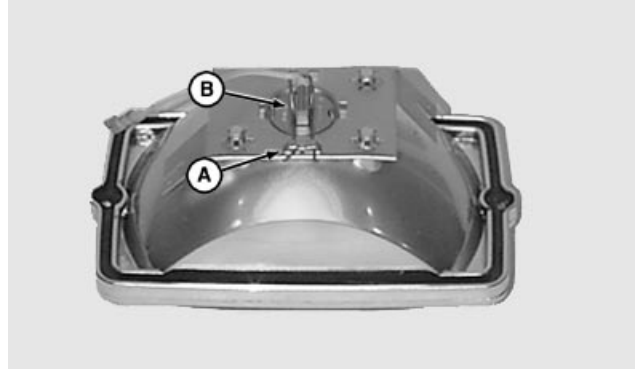

T110294 -UN-05AUG97

TX,16,DT5083 -19-03JUL97-4/4

Work Light Adjustment

1. Loosen nut and adjust work light to desired position.

IMPORTANT: Mounting isolators will become ridged when cap screw is over tightened. Vibrations will pass through isolators, causing premature failure of halogen bulbs.

2. Tighten cap screw just enough to keep work light from moving.

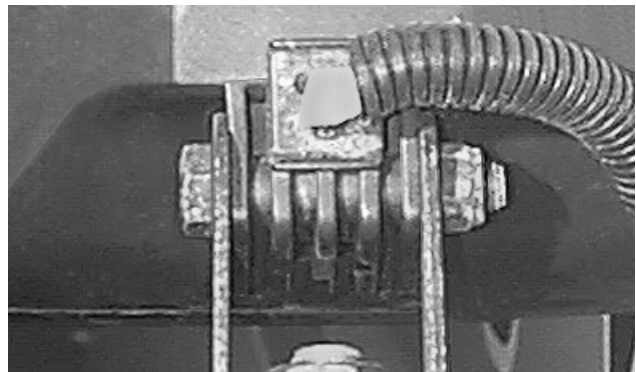

T110295 -UN-05AUG97

T52,1673,C12 -19-18FEB86-1/1

Lighting System

Replacing Fuses

Fuse box (A) is located behind the right control lever console, next to heater/air conditioner control panel (C). Fuse location/specification decal (B) is attached to fuse box cover.

Remove fuse box cover (D) by lifting upward. Spare fuses (E) are located on underside of cover.

- A—Fuse Box
- B—Decal
- C—Heater Control Panel
- D—Fuse Box Cover
- E—Spare Fuses

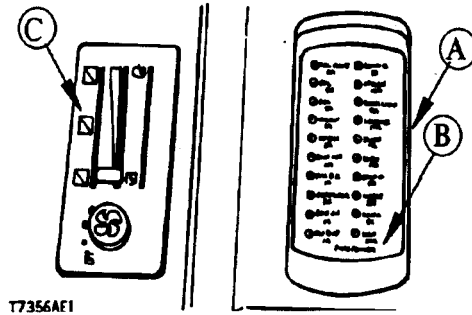

T7356AF1

T7356AE1 -UN-06SEP90

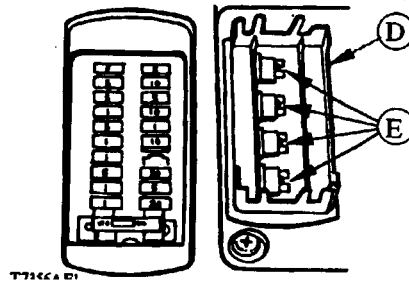

T7356AF1

T7356AF1 -UN-06SEP90

TX,901505,RP328 -19-24MAY91-1/1

Lighting System

Fuse Specifications

IMPORTANT: Install fuse with correct amperage rating to prevent electrical system damage from overload.

Fuse block is located behind the operators seat under a fuse block cover.

- F1—1 Amp Back up
- F2—1 Amp System Controller
- F3—5 Amp Standby Relay
- F4—Not Used
- F5—5 Amp Power Boost, Propel Speed Change Solenoid, Swing Brake, Propel Alarm, Inj. Pump, System Controller
- F6—10 Amp Monitor, Monitor Controller, Switch Panel 1, Switch Panel 2, A/C Switch and Blower Relay
- F7—Not Used
- F8—5 Amp Alternator Relay
- F9—Not Used
- F10—Not Used
- F11—20 Amp Work Lights
- F12—5 Amp Wiper/Washer
- F13—20 Amp Blower and Air Cond. Clutch
- F14—Not Used
- F15—10 Amp Horn and Alternator
- F16—Not Used
- F17—10 Amp Lighter
- F18—5 Amp Cab Interior Light
- F19—10 Amp Circulation Fan
- F20—20 Amp Start Aid
- F21—1 Amp Battery Relay Fuse (Located in-line with battery relay)

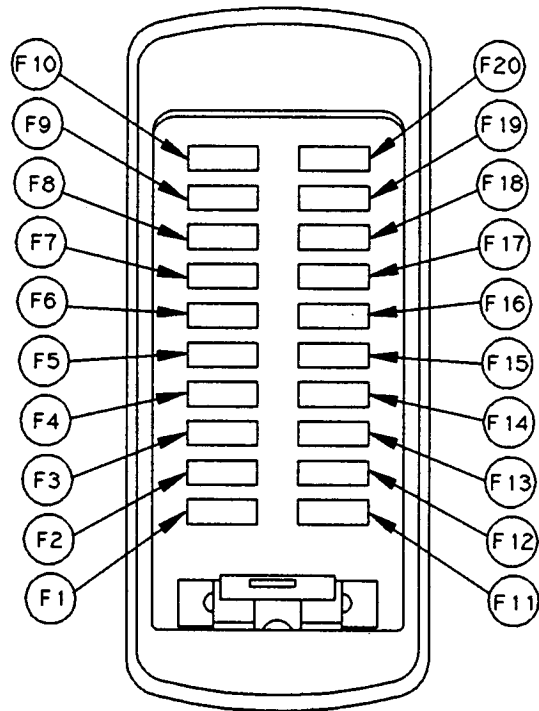

T7713AJ (CV)

T7713AJ -UN-06MAR92

TX,901505,RP549 -19-29JUN93-1/1

*Lighting System***Fuse (Blade-Type) Color Codes**

Amperage Rating	Color
1	Black
3	Violet
4	Pink
5	Tan
7-1/2	Brown
10	Red
15	Light Blue
20	Yellow
25	Natural (White)
30	Light Green

04T,90,J22 -19-28SEP92-1/1

16
1673
5

Lighting System

16
1673
6

Group 1674 Wiring Harness And Switches

Special Or Essential Tools

TS446 -UN-22JUN89

NOTE: Order tools according to information given in the U.S. SERVICE-GARD™ Catalog or in the European Microfiche Tool Catalog (MTC).



SERVICE-GARD is a trademark of Deere & Company.

DX,TOOLS -19-20JUL95-1/9

Electrical Repair Tool Kit JDG155

Used to repair and installation of wires into electrical connectors.

DX,TOOLS -19-20JUL95-2/9

Repair and installation of wires into electrical connectors.

DX,TOOLS -19-20JUL95-3/9

TS447 -UN-22JUN89

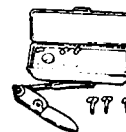

DX,TOOLS -19-20JUL95-4/9

DEUTSCH¹Electrical Repair Tool Kit JDG359

Used to repair DEUTSCH™ electrical connector bodies.

DEUTSCH is a trademark of the Deutsch Co.

¹*DEUTSCH is a trademark of the Deutsch Co.™*

DX,TOOLS -19-20JUL95-5/9

Repair DEUTSCH™ electrical connector bodies.

DEUTSCH is a trademark of the Deutsch Co.

Continued on next page

DX,TOOLS -19-20JUL95-6/9

Wiring Harness And Switches

T6606AC -UN-23AUG88

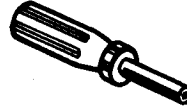

DX,TOOLS -19-20JUL95-7/9

WEATHER PACK¹Extraction Tool. JDG364

Used to remove contacts from WEATHER PACKTM electrical connectors.

WEATHER PACK is a trademark of Packard Electric.

¹WEATHER PACK is a trademark of Packard Electric.TM

DX,TOOLS -19-20JUL95-8/9

Used to remove contacts from WEATHER PACKTM electrical connectors.

WEATHER PACK is a trademark of Packard Electric.

DX,TOOLS -19-20JUL95-9/9

16
1674
2

Wiring Harness And Switches

Vehicle Electrical Component Identification

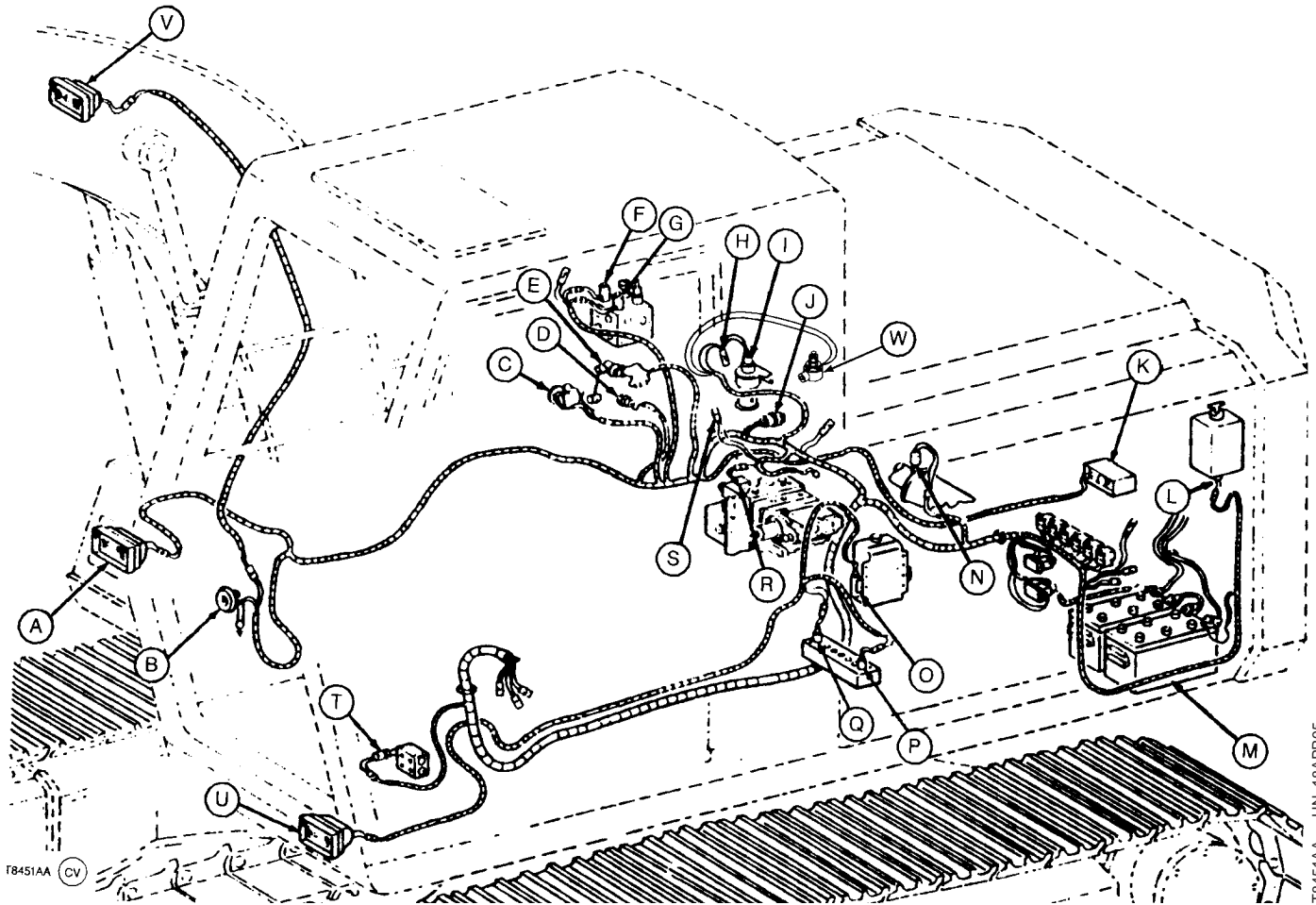

- A—Right Drive Light (E3)
- B—Horn (B7)
- C—Fuel Gauge Sender (B2)
- D—Hydraulic Oil Temperature Switch (B16)
- E—Hydraulic Oil Level Switch (B11)
- F—Swing Brake Release Solenoid (Y4)
- G—Propel Speed Change Solenoid (Y8)

- H—Start Aid Solenoid Diode (V2)
- I—Start Aid Solenoid (Y3)
- J—Vehicle Harness-to-Engine Harness Connector (X2)
- K—Propel Alarm (B15)
- L—Coolant Level Switch (B10)
- M—Batteries (G1 and G2)
- N—Air Cleaner Restriction Switch (B3)

- O—Windshield Washer Pump Motor (M4)
- P—Swing Pilot Pressure Switch (B6)
- Q—Auto Idle Pressure Switch (B14)
- R—Power Boost Solenoid (Y7)
- S—Power Boost Solenoid Diode (V4)

- T—Propel Pilot Pressure Transducer (B17)
- U—Left Drive Light (E1)
- V—Boom Work Light (E2)
- W—Hydraulic Filter Restriction Indicator Pressure Switch (S27) (Serial No. 538551—)

T8451AA -JUN-18APR95

16
1674
3

Continued on next page

TX,1674,AB342 -19-12APR95-1/2

Wiring Harness And Switches

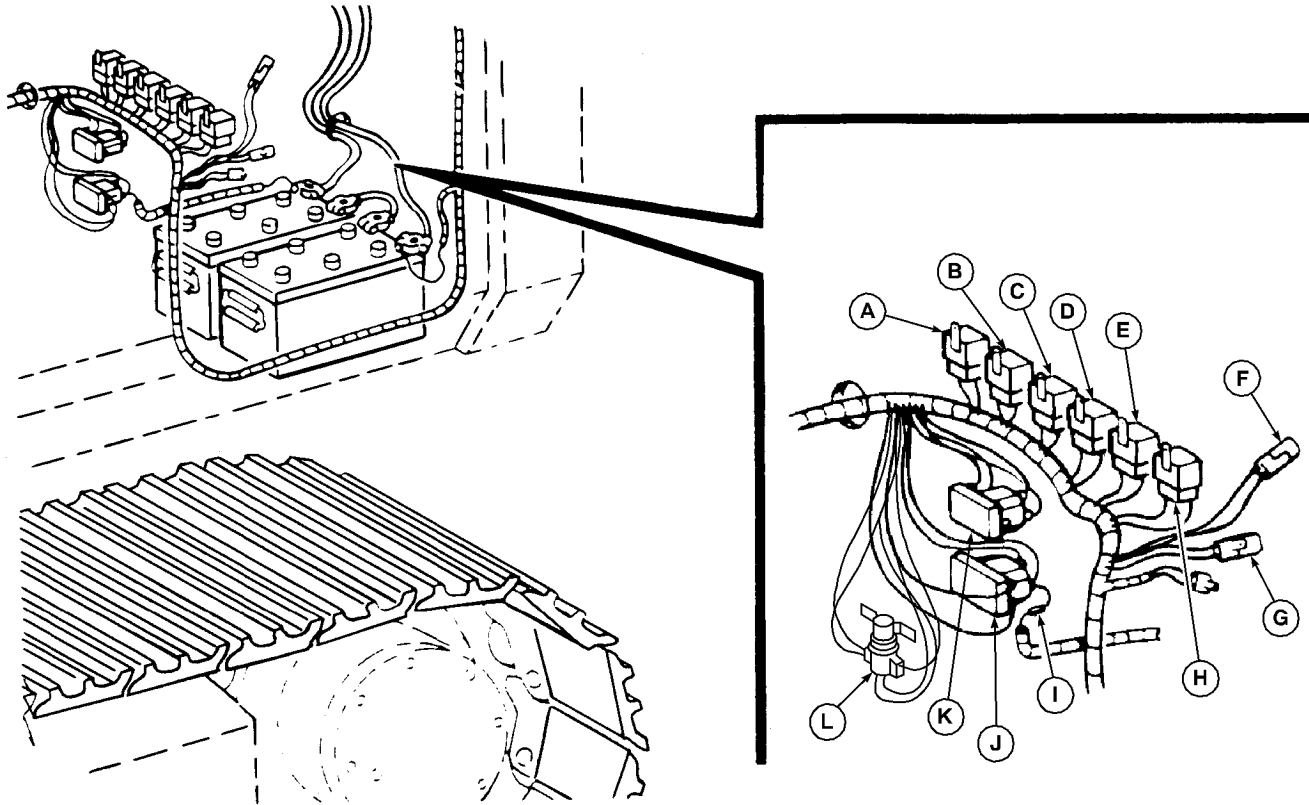

T110319

T110319 -UN-05AUG97

- | | | | |
|--|---|--|---|
| <p>A—Alternator Relay (K3) (2 PUR, 2 BLK, RED Wire Leads)</p> <p>B—Propel Alarm Relay (K13) (2 RED, 2 PUR, BLK Wire Leads)</p> <p>C—Propel Speed Change Relay (K12) (4 RED, GRN, BLU Wire Leads)</p> | <p>D—Power Boost Relay (K14) (2 GRN, 4 RED Wire Leads)</p> <p>E—Swing Brake Release Relay (K15) (3 GRN, 2 RED Wire Leads)</p> <p>F—Start Relay Diode (V9) (WHT, BLK Wire Leads)</p> <p>G—Battery Relay Diode (V3) (2 TAN, BLK Wire Leads)</p> | <p>H—Swing Brake Delay Relay (K17) (2 GRN, 2 RED Wire Leads)</p> <p>I—Battery Relay Fuse (F21) (2 Tan Wire Leads)</p> <p>J—Battery Relay (K1) (3 RED, BLK, TAN Wire Leads)</p> | <p>K—Start Relay (K2) (2 WHT, BLK Wire Leads) (Serial No. —549955)</p> <p>L—Start Relay (K2) (3 WHT, RED, BLK, Wire Leads) (Serial No. 549956—)</p> |
|--|---|--|---|

NOTE: The identification letters and numbers shown in parenthesis are those used on the operation and tests wiring diagrams and schematics.

TX,1674,AB342 -19-12APR95-2/2

16
1674
4

Wiring Harness And Switches

Engine Electrical Component Identification

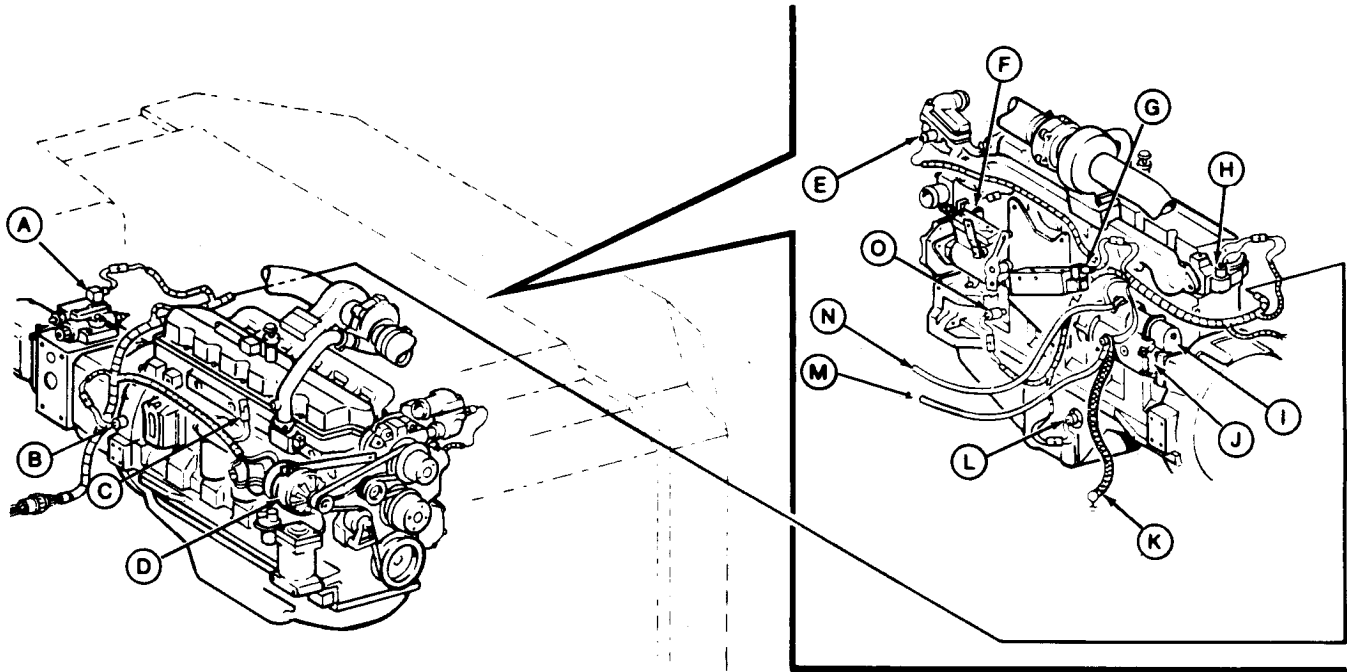

A—Pump Displacement Solenoid (Y6)
 B—Engine Speed Sensor (B13)
 C—Alternator Diode (V1)
 D—Alternator (G3) DELCO (Serial No. —541822) BOSCH (Serial No. 541823—)

E—Coolant Gauge Sender (B1)
 F—Fuel Shutoff Solenoid (Y2)
 G—Engine Speed Actuator Solenoid (Y5)
 H—Engine Overheat Switch (B5)

I—Starter Solenoid (Y1)
 J—Starter (M3)
 K—Engine-to-Frame Ground Connection (W2)
 L—Engine Oil Level Switch (B9)

M—Engine-to-Battery Ground Cable (W1)
 N—Battery-to-Engine Power Cable
 O—Engine Oil Pressure Switch (B4)

T7681CB -UN-23JAN92

TX,1674,AB344 -19-12APR95-1/1

16
 1674
 5

Cab Electrical Component Identification

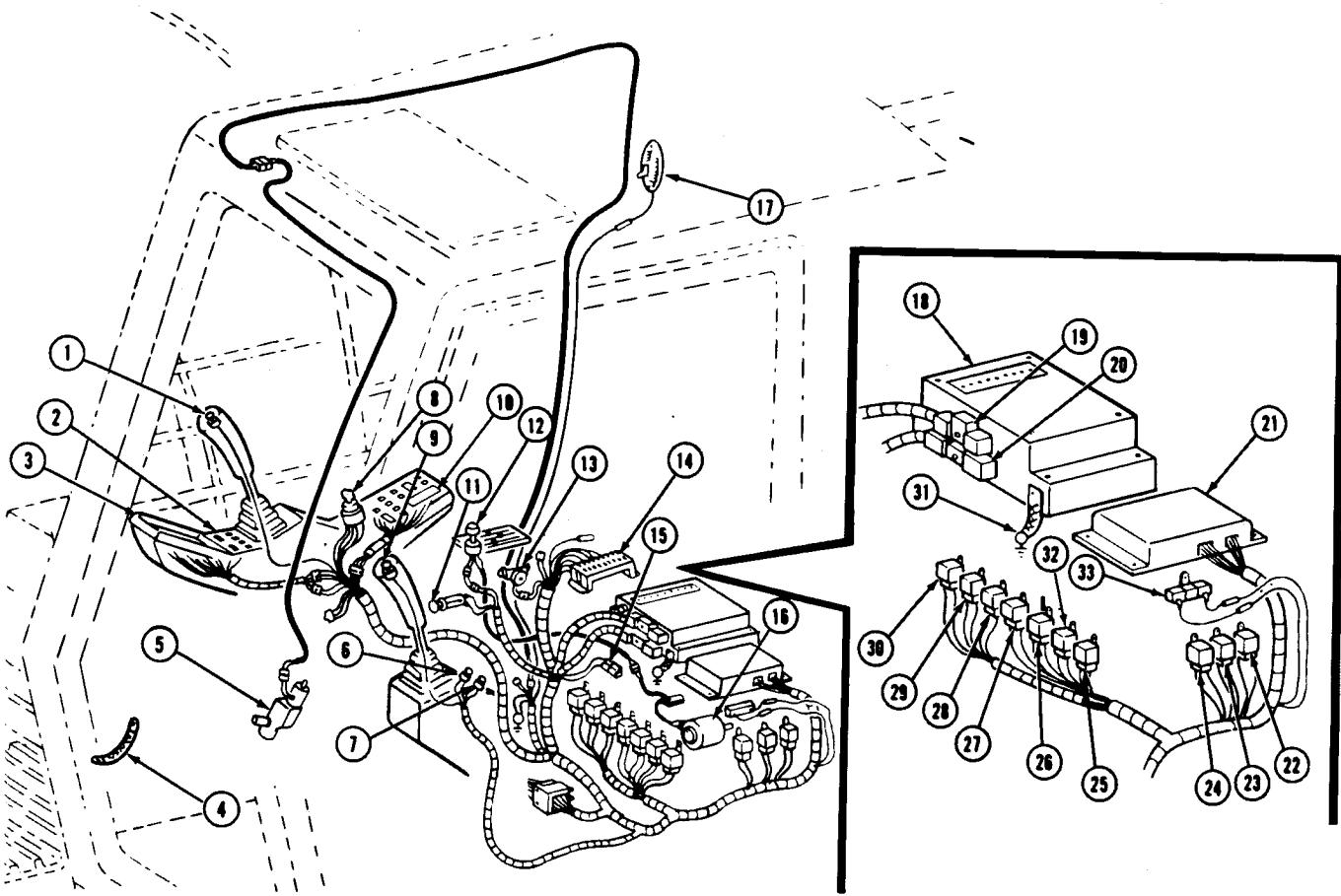

- 1—Power Boost Switch (S9)
- 2—Switch Panel 1 (N4)
- 3—Monitor (N3)
- 4—Cab to Frame Ground (W3)
(4 used)
- 5—Windshield Wiper Motor (M2)
- 6—Propel Alarm Cancel Switch (S25)
- 7—Start Aid Switch (S4)
- 8—Key Switch (S3)
- 9—Horn Switch (S5)
- 10—Switch Panel 2 (N5)
- 11—Cigar Lighter (R1)

- 12—Blower Fan Switch (S6)
- 13—Monitor Buzzer (B8)
- 14—Fuse Box
- 15—Key Switch Diode (V10)
- 16—Blower Fan Motor (M1)
- 17—Dome Light (E4)
- 18—System Controller (N1)
- 19—System Controller Connector (X8)
- 20—System Controller Connector (X9)
- 21—Monitor Controller (N2)
- 22—Start Aid Relay (K4)
(RED/BLU, BLK/ WHT, RED/BLK Wire Leads)

- 23—Safety Relay (K5) (RED, YEL/GRN, YEL/WHT, BLK Wire Leads)
- 24—Standby Relay (K18)
(BLK/WHT, PUR, BLU/ORG Wire Leads)
- 25—Work Light Relay (K8)
(RED/WHT, 2 RED/GRN, BRN Wire Leads)
- 26—Windshield Washer Relay (K10) (BLU/YEL, YEL/BLK, BLU Wire Leads)
- 27—Horn Relay (K7) (2 RED/WHT, BLK, PUR Wire Leads)

- 28—Load Dump Relay (K6)
(BLU/WHT, TAN, 2 RED Wire Leads)
- 29—(Not Used)
- 30—Windshield Wiper Relay (K11) (YEL/WHT, BLU/YEL, YEL, BLK, BLU Wire Leads)
- 31—System Controller Ground Cable (W4)
- 32—Drive Light Relay (K9)
- 33—(Not Used)

16
1674
6

T7681CD -UN-23/JAN92

Wiring Harness And Switches

Remove And Install Starter Switch

1. Disconnect battery ground cable.
2. Remove cover (G).
3. Remove cover (D).
4. Remove four cap screws from under control lever boot (A).
5. Turn cover (B) for access. Remove cap screws (C).
6. Loosen nut (E).
7. Disconnect wiring harness (F).

- A—Control Lever Boot
- B—Control Lever Cover
- C—Cap Screw (3 used)
- D—Cover
- E—Nut
- F—Wiring Harness Connector
- G—Cover

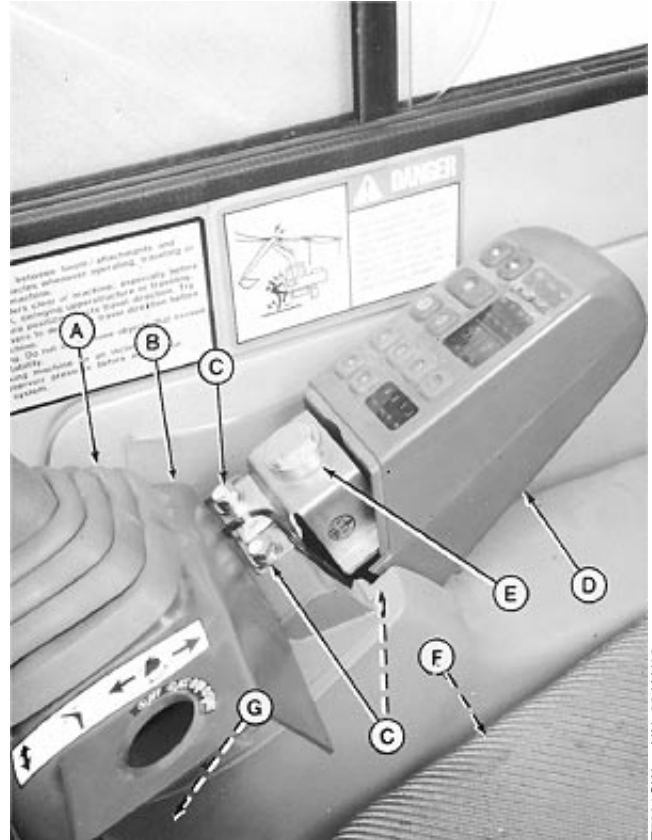

T7681CW -JUN-22JAN92

TX,1676,AB328 -19-20FEB92-1/2

16
1674
7

8. Connect wiring harness to connector (D).
9. Install switch (C) and spring washer (B) through bracket and install nut (A).
10. Install covers and shroud.
11. Connect battery ground cable.

- A—Nut
- B—Spring Washer
- C—Start Switch
- D—Connector

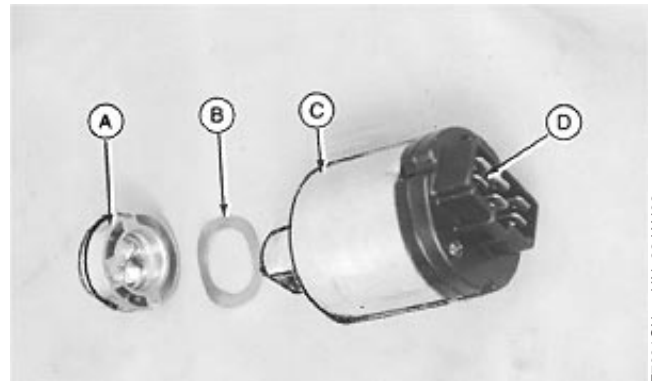

T7681CX -JUN-22JAN92

TX,1676,AB328 -19-20FEB92-2/2

Wiring Harness And Switches

Remove And Install Radio, Propel Alarm Cancel Switch, And Start Aid Switch

1. Disconnect battery ground cable.

TX,1676,AB333 -19-20FEB92-1/4

2. Remove screws (B) and cover (A).

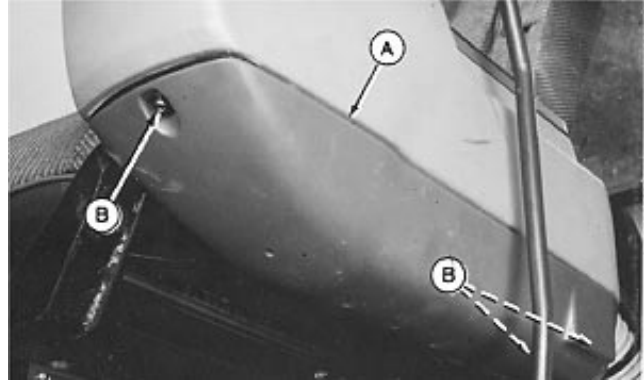

T7681DA -UN-22JAN92

TX,1676,AB333 -19-20FEB92-2/4

3. Remove parts (A—F and G).

- A—Screw (4 used)
- B—Cover
- C—Nut
- D—Propel Alarm Cancel Switch
- E—Radio
- F—Screw
- G—Panel
- H—Start Aid Switch

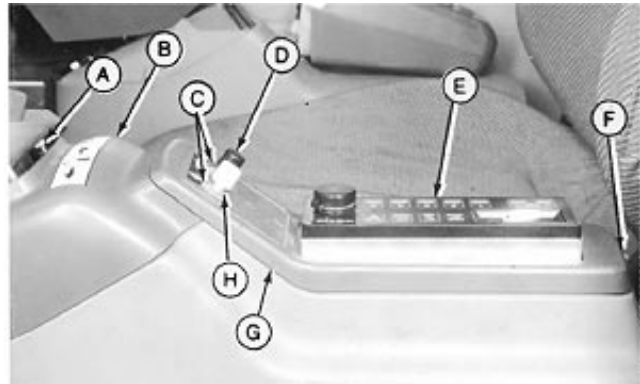

T7681DB -UN-22JAN92

Continued on next page

TX,1676,AB333 -19-20FEB92-3/4

16
1674
8

Wiring Harness And Switches

4. Remove screws (C).
5. Disconnect antenna lead (F) and wiring harness connectors (D, G and H).
6. Remove switches (A—B) and radio (E).
7. Repair or replace as necessary.
8. Install radio, switches, antenna lead and wiring harness connectors.
9. Install covers.
10. Connect battery ground cable.

- A—Propel Alarm Switch
- B—Start Aid Switch
- C—Screw (4 used)
- D—Wiring Harness
- E—Radio
- F—Antenna Lead
- G—Start Aid Wiring Harness Connector
- H—Propel Alarm Cancel Wiring Harness Connector

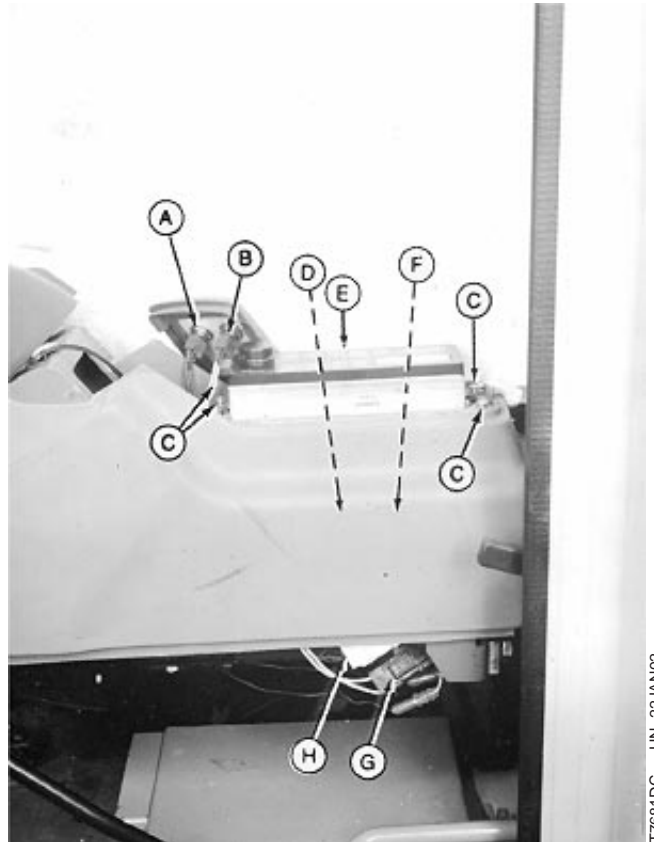

T7681DC -UN-22JAN92

TX,1676,AB333 -19-20FEB92-4/4

16
1674
9

Remove And Install Monitor Buzzer And Air Conditioner Switch

1. Disconnect battery ground cable.
2. Remove rear panel.
3. Disconnect wiring harness connectors (E—G).
4. Remove parts (A—D and H).
5. Repair or replace parts as necessary.
6. Install rear panel and connect battery ground cable.

A—Air Conditioner On/Off Knob
 B—Air Conditioner Control Knob
 C—Cap Screw (2 used)
 D—Screw (2 used)
 E—Buzzer Wiring Harness Connector
 F—A/C Wire Harness Connector
 G—A/C Wire Harness Connector
 H—Buzzer
 I—Nut
 J—Air Conditioning Dual Function Switch

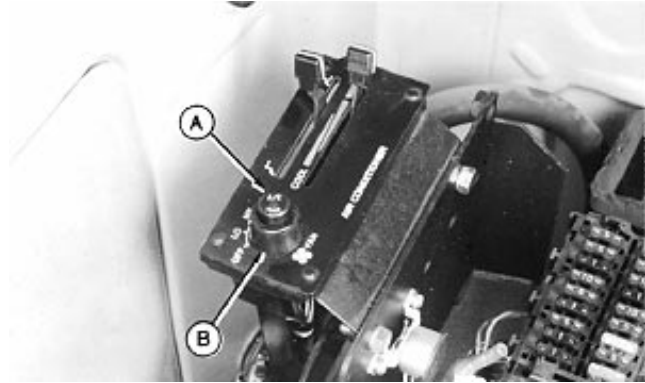

T7681DE -UN-22JAN92

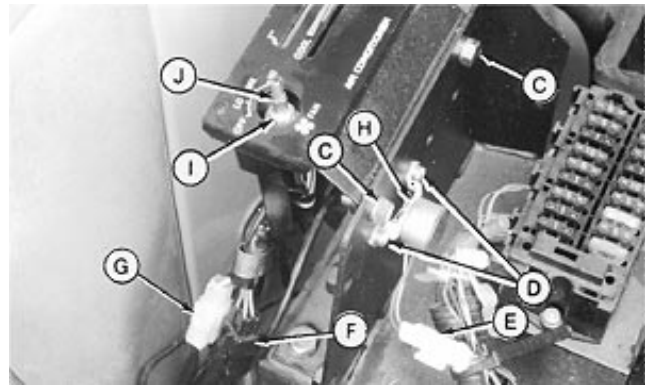

T7681DF -UN-22JAN92

TX,1676,AB338 -19-20FEB92-1/1

Replace DEUTSCH™ Connectors

1. Select correct size extractor tool for size of wire to be removed:
 - JDG361 Extractor Tool for 12 to 14 gauge wire.
 - JDG362 Extractor Tool for 16 to 18 gauge wire.
 - JDG363 Extractor Tool for 20 gauge wire.

DEUTSCH is a trademark of the Deutsch Co.

Continued on next page

DX,ECONN,J -19-03NOV94-1/3

Wiring Harness And Switches

2. Start correct size extractor tool over wire at handle (A).
3. Slide extractor tool rearward along wire until tool tip snaps onto wire.

IMPORTANT: Do NOT twist tool when inserting in connector.

4. Slide extractor tool along wire into connector body until it is positioned over terminal contact.
5. Pull wire out of connector body, using extractor tool.

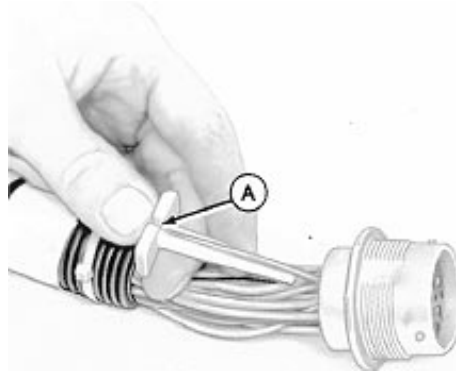

TS0124 -JUN-23AUG88

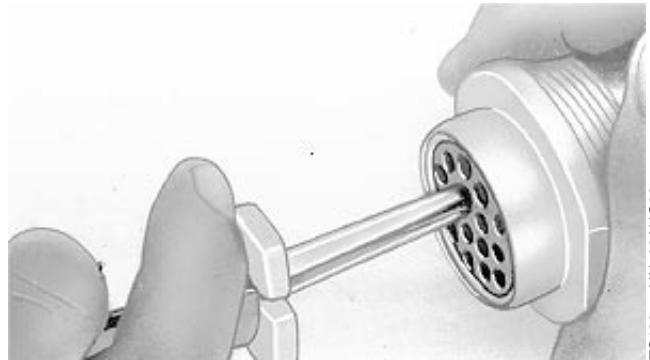

TS120 -JUN-23AUG88

DX,ECONN,J -19-03NOV94-2/3

IMPORTANT: Install contact in proper location using correct size grommet.

6. Push contact straight into connector body until positive stop is felt.
7. Pull on wire slightly to be certain contact is locked in place.
8. Transfer remaining wires to correct terminal in new connector.

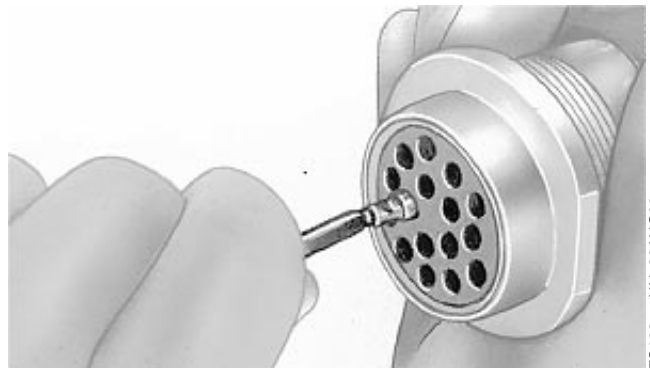

TS122 -JUN-23AUG88

16
1674
11

DX,ECONN,J -19-03NOV94-3/3

Wiring Harness And Switches

Install DEUTSCH™ Contact

1. Strip 6 mm (1/4 in.) insulation from wire.
2. Adjust selector (A) on JDG360 Crimper for correct wire size.
3. Loosen lock nut (B) and turn adjusting screw (C) in until it stops.

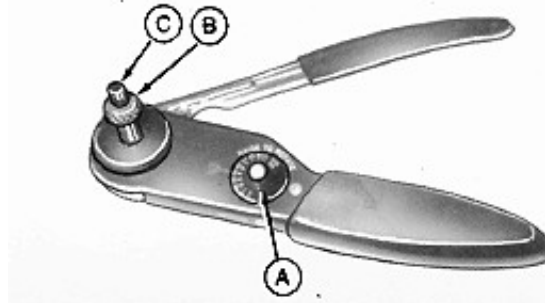

TS117 -UN-23AUG88

DEUTSCH is a trademark of the Deutsch Co.

DX,ECONN,W -19-04JUN90-1/4

IMPORTANT: Select proper size contact “sleeve” or “pin” to fit connector body.

4. Insert contact (A) and turn adjusting screw (D) until contact is flush with cover (B).
5. Tighten lock nut (C).

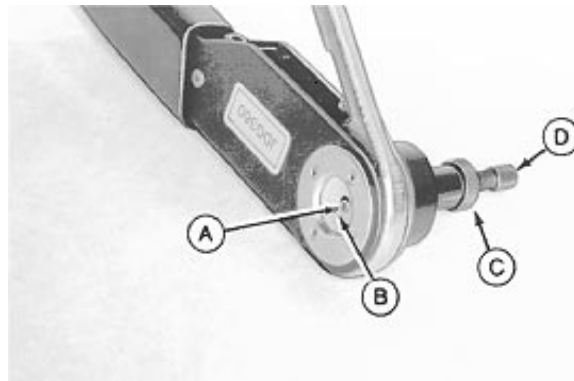

TS0134 -UN-23AUG88

DX,ECONN,W -19-04JUN90-2/4

IMPORTANT: Contact must remain centered between indentors while crimping.

6. Insert wire in contact and crimp until handle touches stop.
7. Release handle and remove contact.



TS118 -UN-23AUG88

DX,ECONN,W -19-04JUN90-3/4

IMPORTANT: If all wire strands are not crimped into contact, cut off wire at contact and repeat contact installation procedures.

NOTE: Readjust crimping tool for each crimping procedure.

8. Inspect contact to be certain all wires are in crimped barrel.

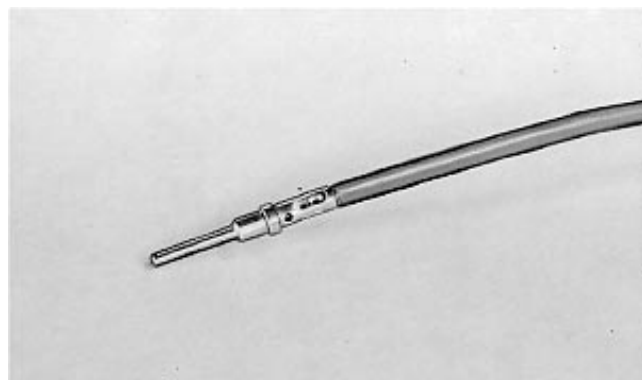

TS0135 -UN-23AUG88

DX,ECONN,W -19-04JUN90-4/4

Replace WEATHER PACK™ Connector

IMPORTANT: Identify wire color locations with connector terminal letters.

1. Open connector body.

WEATHER PACK is a trademark of Packard Electric.

DX,ECONN,O -19-03NOV94-1/3

2. Insert JDG364 Extraction Tool over terminal contact in connector body.
3. Hold extractor tool fully seated and pull wire from connector body.

NOTE: If terminal cannot be removed, insert wire or nail through extractor tool handle and push terminal contact from connector.



TS0128 -UN-23AUG88

DX,ECONN,O -19-03NOV94-2/3

IMPORTANT: Carefully spread contact lances to assure good seating on connector body.

NOTE: Connector bodies are "keyed" for proper contact mating. Be sure contacts are in proper alignment.

4. Push contact into new connector body until fully seated.
5. Pull on wire slightly to be certain contact is locked in place.
6. Transfer remaining wires to correct terminal in new connector.
7. Close connector body.

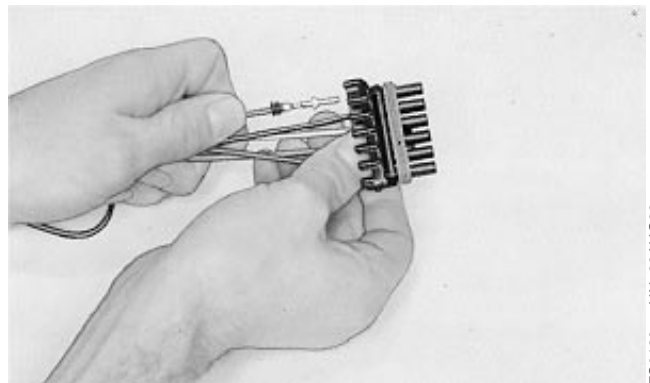

TS0130 -UN-23AUG88

DX,ECONN,O -19-03NOV94-3/3

16
1674
13

Wiring Harness And Switches

Install WEATHER PACK™ Contact

NOTE: Cable seals are color coded for three sizes of wire:

- Green—18 to 20 gauge wire
- Gray—14 to 16 gauge wire
- Blue—10 to 12 gauge wire

1. Slip correct size cable seal on wire.
2. Strip insulation from wire to expose 6 mm (1/4 in.) and align cable seal with edge of insulation.



TS0136 -JUN-23AUG88

WEATHER PACK is a trademark of Packard Electric.

DX,ECONN,AA -19-04JUN90-1/3

NOTE: Contacts have numbered identification for two sizes of wire:

- #15 for 14 to 16 gauge wire
- #19 for 18 to 20 gauge wire

3. Put proper size contact on wire and crimp in place with a “W” type crimp, using JDG783 Terminal Applicator.
4. Secure cable seal to contact as shown, using JDG783 Terminal Applicator.

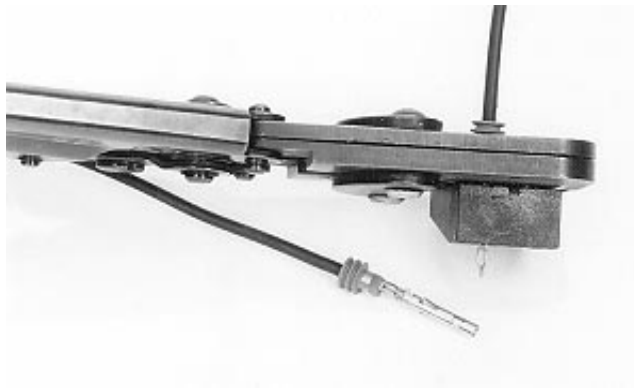

TS1623 -JUN-02NOV94

IMPORTANT: Proper contact installation for “sleeve” (A) and “pin” (B) is shown.

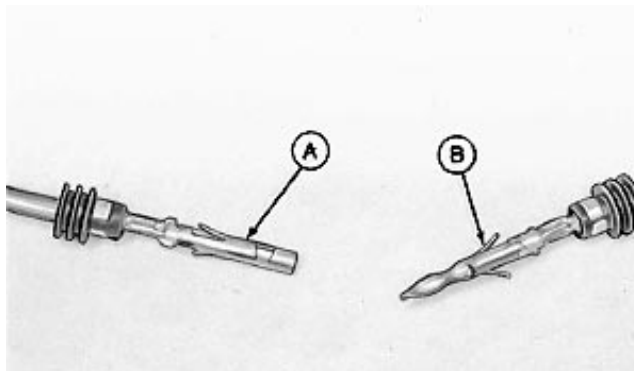

TS0139 -JUN-02DEC88

DX,ECONN,AA -19-04JUN90-3/3

16
1674
14

Remove Connector Body From Blade Terminals

1. Depress locking tang (A) on terminal, using a small screw driver. Slide connector body off.
2. Be sure to bend locking tang back to its original position (B) before installing connector body.

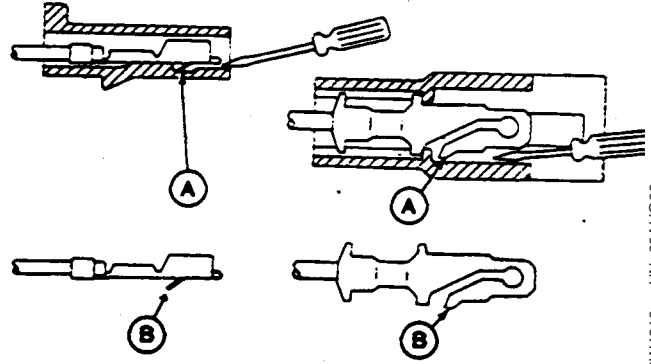

RW4218 -UN-23AUG88

DX,ECONN.V1 -19-02NOV94-1/1

Wiring Harness And Switches

16
1674
16

Welding On Machine

IMPORTANT: Electrical current traveling from the welder through the machine electrical system may damage the machine electrical system, including battery and system controller. Disconnect battery ground cable and system controller electrical connectors before welding on the machine.

Before welding on the machine, follow the steps listed below to protect the machine electrical system.

1. Disconnect the battery ground and positive cables.
2. Disconnect the system controller electrical connectors (E and F).
 - a. Inside the cab, remove four cap screws (C) and the fuse box cover (D) to remove the rear console cover.
 - b. Loosen cap screws (B) on upper connector (E) and lower connector (F) to remove connectors.

NOTE: When connector is firmly seated in the receptacle, the red torque indicator pin (A) is level with the surface of connector.

- A—Red Torque Indicator Pin
 B—Connector Cap Screw
 C—Console Cover Cap Screw
 D—Fuse Box Cover
 E—System Controller Upper Connector
 F—System Controller Lower Connector

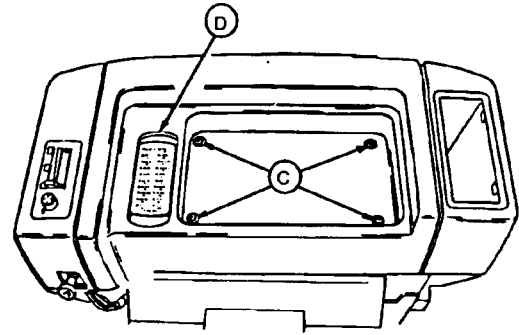

T7509A1 -UN-05SEP91

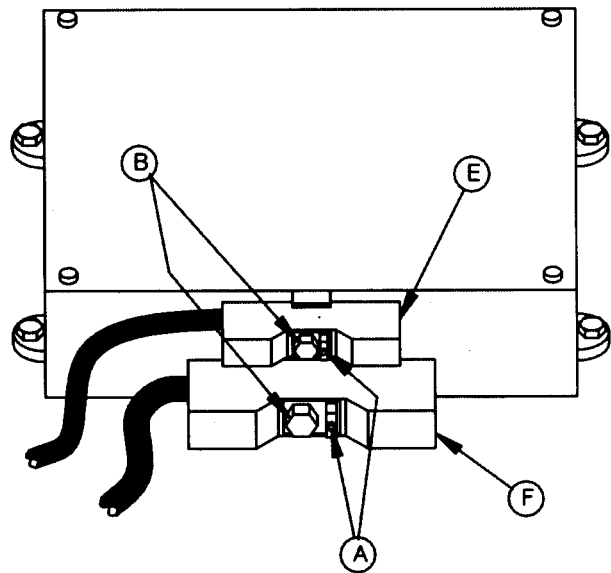

T8005AY (CV)

T8005AY -UN-10MAY93

16
1675
1

TX,1675,GG265 -19-12MAY93-1/1

System Controls

Remove And Install System Controller

IMPORTANT: If a system controller problem is indicated, the real problem may be poor connector pin contact. Before replacing system controller, remove and install both system controller connectors. Check machine operation.

1. Disconnect battery ground cable.
 2. Move seat forward.
 3. Remove access cover.
 4. Disconnect ground strap (C).
 5. Remove cap screws (E) and disconnect cable connectors.
 6. Remove cap screws (B) and remove system controller (A).
 7. Install system controller.
 8. Push connectors into system controller while turning cap screws (E).
- Tighten cap screws until red torque indicator pin (D) extends outward indicating correct torque.
9. Connect ground cable.

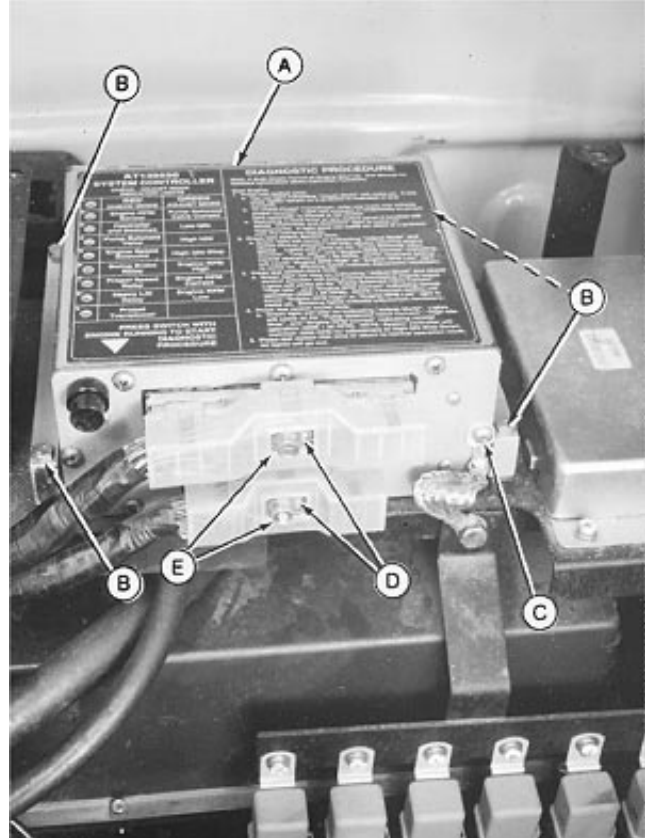

- A—System Controller
 B—Cap Screw (4 used)
 C—Ground Strap
 D—Red Torque Indicator Pin (2 used)
 E—Cap Screw (2 used)

T7681CG -UN-17JAN92

TX,1675,AB319 -19-12APR95-1/1

System Controls

Remove And Install Monitor Controller

1. Disconnect battery ground cable.
2. Move seat forward and remove access cover.
3. Disconnect wiring harness connectors (C).
4. Remove screws (B) and monitor controller (A).
5. Install monitor controller and connect wiring harnesses.
6. Install cover and connect battery cable.

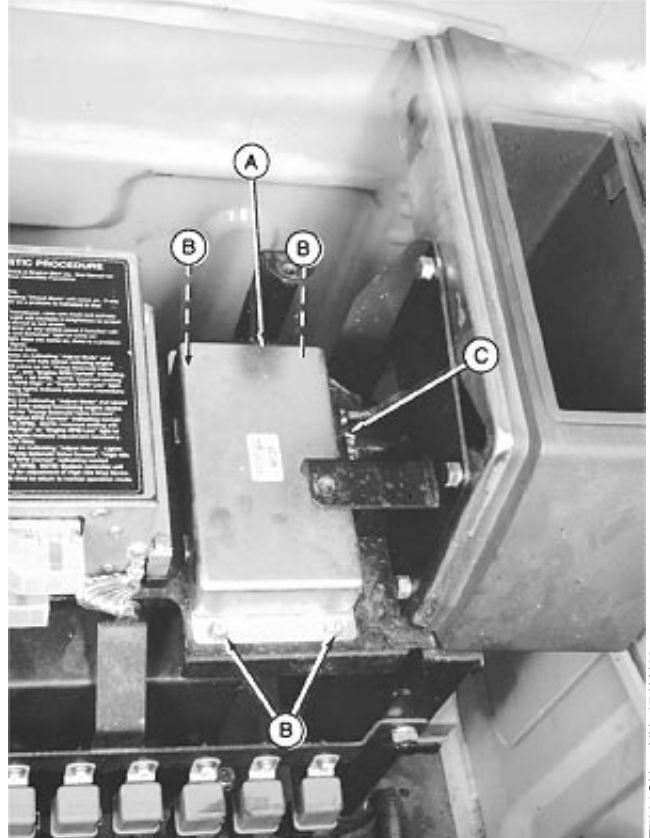

T7681CH -UN-17JAN92

TX,1675,DW618 -19-12APR95-1/1

16
1675
3

System Controls

16
1675
4

Group 1676 Instruments And Indicators

Replace Monitor Panel Bulbs

1. Remove monitor panel lower cover.
2. Pull socket (B) out of panel housing (A).
3. Replace bulb (C).
4. Push socket into housing.

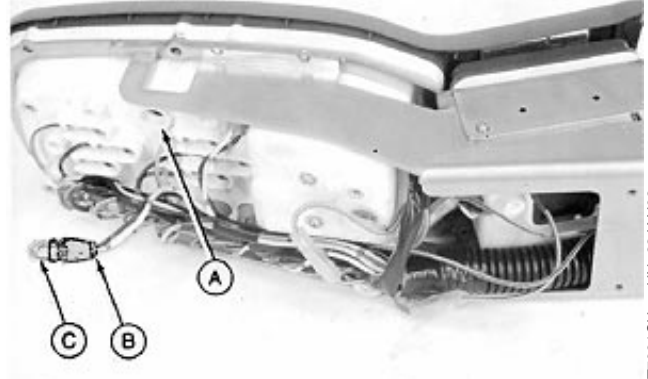

T7681CU -UN-22JAN92

TX,1676,AB326 -19-08JUN92-1/1

Remove And Install Monitor Panel

1. Disconnect battery ground cable.
2. Remove bottom cover from under right hand console.

TX,1676,AB321 -19-20FEB92-1/4

3. Remove screws (B). Remove lower cover (A).

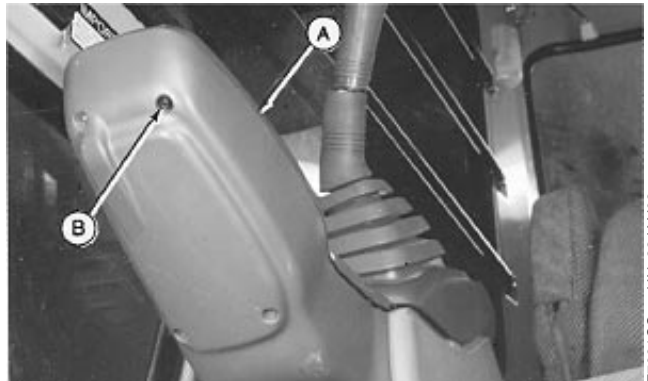

T7681CO -UN-22JAN92

Continued on next page

TX,1676,AB321 -19-20FEB92-2/4

16
1676
1

Instruments And Indicators

4. Remove screws. Turn control lever cover and boot (A) for access to cap screws (C).
5. Remove cap screws (C).
6. Remove screws (B).
7. Remove monitor panel.

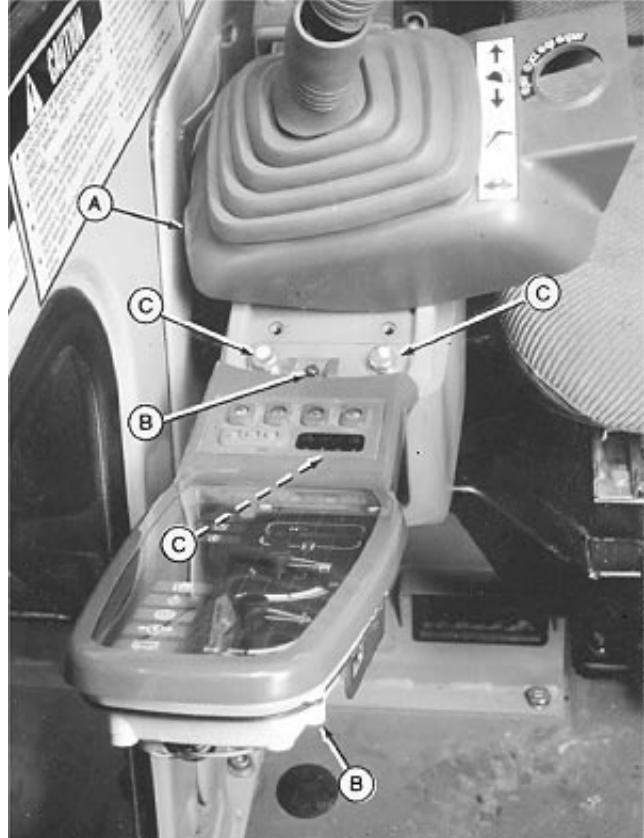

T7681CP -UN-22JAN92

TX,1676,AB321 -19-20FEB92-3/4

8. Disconnect wiring harness connectors (B—D).
9. Install panel on bracket using screws (A).
10. Install bracket using cap screws (E).
11. Connect wiring harness connectors.
12. Install covers and boot.
13. Connect battery ground cable.

- A—Screw (5 used)
- B—Wiring Harness Connector
- C—Wiring Harness Connector
- D—Wiring Harness Connector
- E—Cap Screw (3 used)

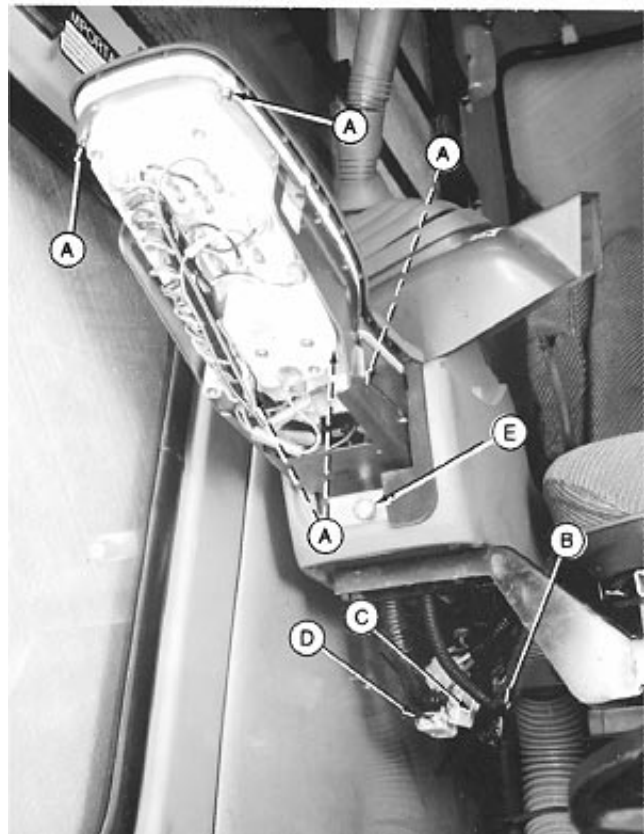

T7681CP -UN-22JAN92

TX,1676,AB321 -19-20FEB92-4/4

Remove And Install Switch Panel 1

1. Disconnect battery ground cable.
2. Remove cover under console.
3. Remove screws and turn right hand control lever boot and cover.
4. Remove monitor panel lower cover.
5. Remove screws holding bracket and housing (A).
6. Disconnect wiring harness connector (B).
7. Remove screws (C) and switch panel 1 (D).
8. Connect wiring harness and install switch.
9. Install panel and cover.
10. Install boot and covers.
11. Connect battery ground cable.

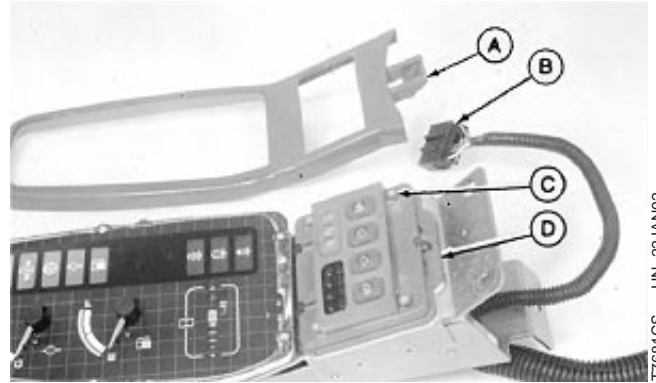

T7681CS -UN-22JAN92

- A—Housing**
B—Wiring Harness Connector
C—Screw (4 used)
D—Switch Panel 1

TX,1676,DW620 -19-12APR95-1/1

Remove And Install Hour Meter, Coolant Temperature And Fuel Level Gauges

1. Remove monitor panel.

IMPORTANT: Needles must not be removed because gauges are calibrated to the instrument panel. Instrument panel and gauges are serviced as an assembly.

2. Disconnect wires from coolant temperature gauge (B) and fuel level gauge (C).
3. Remove screws to remove housing (A) from housing (G).
4. Remove screws (D) and lift instrument panel (H) from housing.
5. Remove screws (E) and hour meter (F).
6. Repair or replace parts as required.
7. Install hour meter.
8. Install instrument panel and housing.
9. Install monitor panel on bracket.

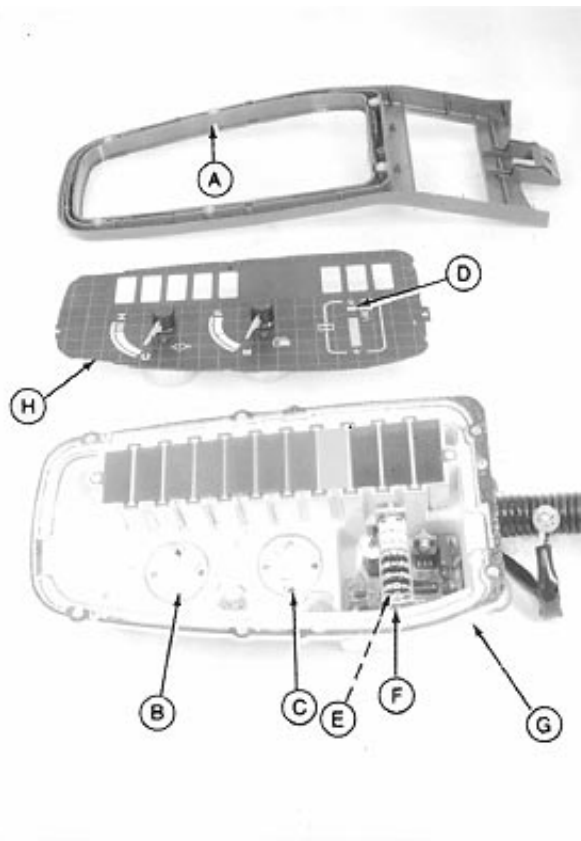

- A—Housing
 B—Coolant Temperature Gauge
 C—Fuel Level Gauge Seat
 D—Screw (2 used)
 E—Screw (2 used)
 F—Hour Meter
 G—Monitor Panel Housing
 H—Instrument Panel

T7681CT -UN-22JAN92

Continued on next page

TX,1676,AB538 -19-11JUL92-1/2

Instruments And Indicators

10. Connect wire leads (C—F).
11. Install bracket on right hand console.
12. Install boot, covers and connect battery cable.

- A—Fuel Gauge
- B—Coolant Temperature Gauge
- C—Black Ground Wire Lead
- D—Red/Yellow Wire Lead
- E—Brown Wire Lead
- F—Red/Green Wire Lead

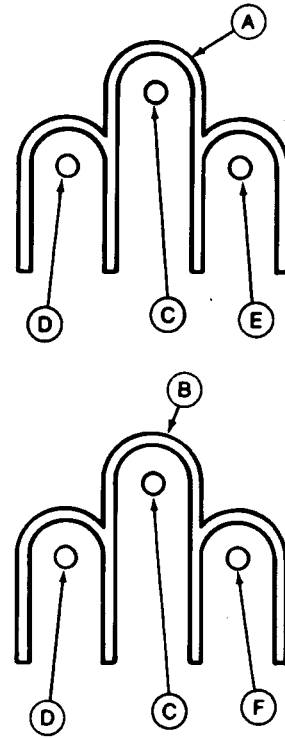

TX,1676,AB538 -19-11JUL92-2/2

T7681FS -UN-20FEB92

Replace Switch Panel 2 Bulb

1. Remove cover.
2. Pull on socket (B) to remove socket and bulb (C).
3. Replace bulb and install socket in housing (A). Install cover.



TX,1676,AB330 -19-08JUN92-1/1

T7681CY -UN-22JAN92

16
1676
5

Instruments And Indicators

Remove And Install Switch Panel 2

1. Disconnect battery ground cable.
2. Remove cover (G).
3. Remove cover (D).
4. Remove four cap screws from under control lever boot (A).
5. Turn cover (B) for access. Remove cap screws (C).
6. Remove bracket and switch as an assembly.
7. Disconnect wiring harness.

A—Control Lever Boot
 B—Control Lever Cover
 C—Cap Screw (3 used)
 D—Cover
 E—Starter Switch Nut
 F—Wiring Harness Connector
 G—Cover

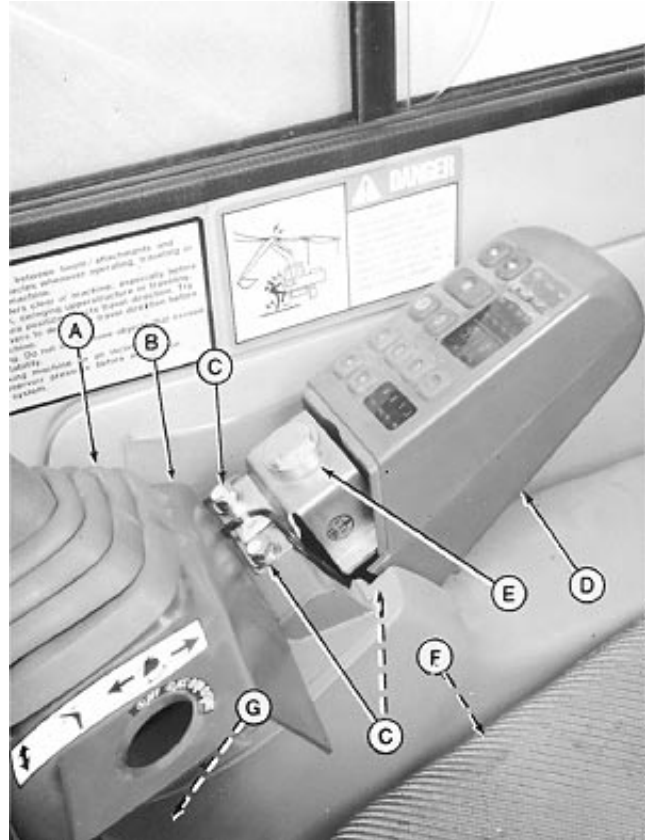

T7681CW -JUN-22JAN92

Continued on next page

TX,1676,AB331 -19-08JUN92-1/2

Instruments And Indicators

8. Remove panel (C) and clamp (F). Disconnect harness and bulb sockets (A).
9. Do not disassemble switch panel. Replace as a unit. Install wiring harness through the bracket (E) and install switch panel 2 (B).
10. Connect wiring harnesses connector (D). Then install bracket on console.
11. Install covers.
12. Connect battery ground cable.

- A—Lamp Sockets
- B—Switch Panel 2
- C—Panel
- D—Wiring Harness Connector
- E—Bracket
- F—Clamp

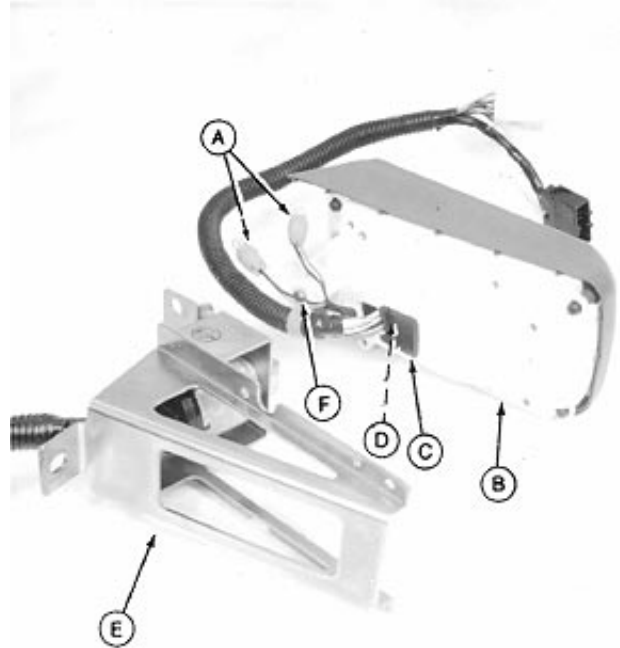

T7681CZ -UN-22JAN92

TX,1676,AB331 -19-08JUN92-2/2

16
1676
8

Section 17

Frame Or Supporting Structure

Contents

Page

Group 1740—Frame Installation

Specifications17-1740-1
Welding Repair Of Major Structure17-1740-2

Group 1749—Chassis Weights

Service Equipment And Tools17-1749-1
Specifications17-1749-1
Other Material17-1749-2
Counterweight
Remove and Install17-1749-3

Contents

Specifications

Item	Measurement	Specification
Weld Metal	Tensile Strength	482.6 mPa (70,000 psi)
	Yield Strength	413.7 mPa (60,000 psi)
	Elongation	22%
Structural Assemblies	Preheat Temperature	38°C (100°F)
Ground Engaging Tools	Preheat Temperature	177°C (350°F)

TX,1740,AB45 -19-06JAN92-1/1

Welding Repair Of Major Structure



CAUTION: Avoid potentially toxic fumes and dust. Hazardous fumes can be generated when paint is heated by welding, soldering, or using a torch. Do all work outside or in a well ventilated area. Dispose of paint and solvent properly.

If you sand or grind paint, avoid breathing the dust. Wear an approved respirator. If you use solvent or paint stripper, remove stripper with soap and water before welding. Remove solvent or paint stripper containers and other flammable material from area. Allow fumes to disperse at least 15 minutes before welding or heating.



TS220 -JUN-23AUG88

Remove paint before welding or heating.

IMPORTANT: Disconnect battery ground strap or turn battery disconnect switch to "OFF".

Have only a qualified welder do this job. Connect welder ground clamp close to each weld area so electrical current does not pass through any bearings.

Remove or protect all parts that can be damaged by heat or weld splatter.

Use one of the following weld processes:

- AWS-E-7018 covered electrode with shielded metal arc welding (SMAW) process
- AWS-ER-70S-3 wire electrode with gas metal arc welding (GMAW) process
- AWS-E70T-1 or E71T-1 wire electrode with flux core arc welding (FCAW) process.

Preheat area to be repaired to allow better weld penetration.

Specification

Weld Metal—Tensile Strength.....	482.6 mPa (70,000 psi)
Yield Strength.....	413.7 mPa (60,000 psi)
Elongation.....	22%

Continued on next page

TX,1740,WW1219 -19-02JUN93-1/2

17
1740
2

Frame Installation

To repair weld metal failure, remove failed weld metal using arc or grinding equipment. Thoroughly clean area to be welded. Preheat structural assemblies to a minimum of 38°C (100°F).

Specification

Structural Assemblies—Preheat

Temperature 38°C (100°F)

Preheat ground engaging tools (cutting edges, skid shoes, and teeth shanks) to 177°C (350°F).

Specification

Ground Engaging Tools—Preheat

Temperature 177°C (350°F)

To repair base metal failure remove enough material to allow weld to penetrate to the bottom of crack. Preheat structural assemblies to a minimum of 38°C (100°F).

Specification

Structural Assemblies—Preheat

Temperature 38°C (100°F)

Preheat ground engaging tools (cutting edges, skid shoes, and teeth shanks) to 177°C (350°F).

Specification

Ground Engaging Tools—Preheat

Temperature 177°C (350°F)

TX,1740,WW1219 -19-02JUN93-2/2

Frame Installation

17
1740
4

Service Equipment And Tools

NOTE: Order tools from the U.S. SERVICE-GARD™ Catalog or from the European Microfiche Tool Catalog (MTC). Some tools may be available from a local supplier.

SERVICE-GARD is a trademark of Deere & Company.

TX,1749,VV387 -19-12APR95-1/2

M30-3.5 Metric Lifting Eyebolt (with shoulder) such as
Metric Lifting Eyebolt JT05555

Used to remove and install counterweight.

Spreader Bar

Used to remove and install counterweight.

TX,1749,VV387 -19-12APR95-2/2

Specifications

Item	Measurement	Specification
Counterweight		
Standard	Approximate Weight	3768 kg (8,300 lb)
Optional	Approximate Weight	4627 kg (10,200 lb)
Counterweight-to-Edge of Service Door Gap	Distance	10 ± 3 mm (0.394 ± 0.12 in.)
Frame-to-Counterweight Cap Screw	Torque	1170 N•m (860 lb-ft)

TX,17,DY2934 -19-25AUG97-1/1

17
1749
1

Chassis Weights

Other Material

Number	Name	Use
T43512 (U.S.) TY9473 (Canadian) 242 (LOCTITE®)	Thread Lock and Sealer (Medium Strength) Products	Used to apply to threads of counterweight cap screws.

LOCTITE is a registered trademark of Loctite Corp.

TX,1749,DW622 -19-04MAY95-1/1

17
1749
2

Chassis Weights

Remove And Install Counterweight

1. Park machine on a level surface.
2. Remove cap screws from threaded holes on top of counterweight (C).
3. Install M30-3.5 eyebolts (B) such as JT05555 Metric Lifting Eyebolts.

CAUTION: The approximate weight of counterweight is 3768 kg (8,300 lb) (Standard) and 4627 kg (10,200 lb) (Optional).

Counterweight—Specification

Standard—Approximate Weight	3768 kg (8,300 lb)
Optional—Approximate Weight	4627 kg (10,200 lb)

4. Use a spreader bar (A) to obtain vertical lift from the eyebolts.
5. Connect counterweight to a hoist.
6. Remove cap screws (E), lock washers (D) and bushings (F). Remove counterweight.
7. Install counterweights so gap (I) between counterweight and edge of service door (H) is 10 ± 3 mm (0.394 ± 0.12 in.).

Counterweight—Specification

Counterweight-to-Edge of Service Door Gap—Distance	10 ± 3 mm (0.394 ± 0.12 in.)
--	---------------------------------------

Use shims (G) to obtain specification to allow service doors to open and close freely.

8. Apply thread lock and sealer (medium strength) to threads of cap screws (E). Tighten cap screws to 1170 N•m (860 lb-ft).

Counterweight—Specification

Frame-to-Counterweight Cap Screw—Torque	1170 N•m (860 lb-ft)
---	----------------------

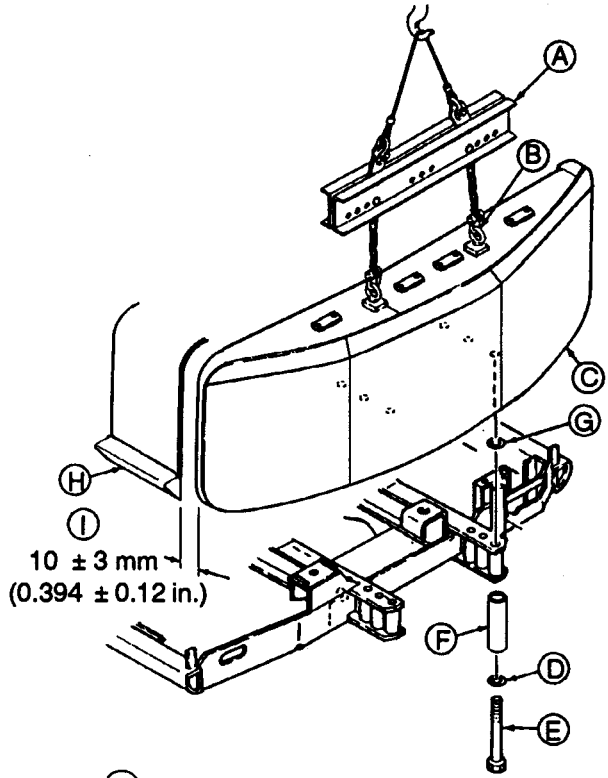

T7604AG (CV)

- A—Spreader Bar
- B—Eyebolt (2 used)
- C—Counterweight
- D—Washer (6 used)
- E—Cap Screw (6 used)
- F—Bushing (6 used)
- G—Shim (As required)
- H—Service Door
- I— 10 ± 3 mm (0.394 ± 0.12 in.)

T7604AG -UN-17SEP91

Chassis Weights

17
1749
4

Section 18

Operator's Station

Contents

Page	Page
Group 1800—Removal And Installation	
Specifications	18-1800-1
Cab	
Remove and Install	18-1800-1
Group 1810—Operator Enclosure	
Service Equipment And Tools	18-1810-1
Other Material	18-1810-1
Windowpane and Molding, Two Piece	
Remove and Install	18-1810-1
Windowpane and Molding, One Piece	
Remove and Install	18-1810-2
Sliding Windows	
Remove and Install	18-1810-3
Windowpane Dimensions	18-1810-4
Group 1821—Seat	
Seat (SN -538404)	
Remove and Install	18-1821-1
Seat (SN 538405-)	
Remove and Install	18-1821-2
Seat (SN 537781-538404)	
Disassemble and Assemble	18-1821-3
Seat (SN 538405-549976)	
Disassemble and Assemble	18-1821-4
Seat (SN 549977-)	
Disassemble and Assemble	18-1821-5
Seat Stand (SN -547853)	
Disassemble and Assemble	18-1821-6
Seat Stand (SN 547854-)	
Disassemble and Assemble	18-1821-8
Group 1830—Heating And Air Conditioning	
Special Or Essential Tools	18-1830-1
Service Equipment And Tools	18-1830-2
Other Material	18-1830-3
Specifications	18-1830-4
Blower Motor	
Remove and Install	18-1830-5
Heater Core and Blower Motor Relay	
Remove and Install	18-1830-6
Heater Control	
Remove and Install	18-1830-7
Refrigerant (R-12) Cautions (SN -541550)	18-1830-8
Compressor Oil (SN -541550)	
Check and Add	18-1830-9
Air Conditioning Gauge Set (SN -541550)	
Installation Procedure	18-1830-10
Refrigerant Recovery (SN -541550)	18-1830-11
Evacuate the System (SN -541550)	18-1830-12
Charge the System (SN -541550)	18-1830-14
Add Refrigerant (SN -541550)	18-1830-16
Compressor (SN -541550)	
Inspect Vee Belt, Check and Adjust	
Tension	18-1830-17
Remove and Install	18-1830-18
Volumetric Efficiency Test-R12	18-1830-19
Shaft Seal Leak Test	18-1830-20
Disassemble and Inspect	18-1830-22
Inspect Clutch Pulley, Bearing and	
Hub	18-1830-26
Replace Clutch Pulley Bearing	18-1830-26
Replace Shaft Seal Seat	18-1830-27
Assemble	18-1830-28
Leak Testing	18-1830-31
Refrigerant Hoses and Tubing Inspection (SN	
-541550)	18-1830-31
Condenser (SN -541550)	
Remove and Install	18-1830-32
Receiver/Dryer (SN -541550)	
Remove and Install	18-1830-33
Expansion Valve (SN -541550)	
Remove and Install	18-1830-33
Bench Test and Adjustment	18-1830-34
Evaporator (SN -541550)	
Remove and Install	18-1830-35
Low and High Pressure Switches (SN	
-541550)	
Remove and Install	18-1830-36
Thermostat Switch, Air Conditioner and	
Compressor Relay (SN -541550)	
Remove and Install	18-1830-37
Air Conditioning Switch (SN -541550)	
Remove and Install	18-1830-38

Contents

[Empty table area]

Specifications

Item	Measurement	Specification
Cab		
Cab	Approximate Weight	230 kg (507 lb)
Cab and Platform-to-Frame Cap Screw	Torque	320 N•m (235 lb-ft)
Cab-to-Platform Cap Screw	Torque	50 N•m (35 lb-ft)

TX,1800,AB270 -19-09JUN92-1/1

Remove And Install Cab

NOTE: Seat and propel control hand levers are removed for clarity of illustration. The seat and control levers do not have to be removed in order to remove cab.

1. Remove floor mat.

Continued on next page

TX,18,DW5012 -19-18JUL97-1/20

Removal And Installation

2. Remove nut, washer and cap screw (A) from each corner.
3. Remove four cap screws (B).
4. Remove cover (C).



T7681AI -UN-09JAN92

Earlier Machine Shown

TX,18,DW5012 -19-18JUL97-2/20

5. Remove four cap screws from each cover (A).
6. Remove cover.

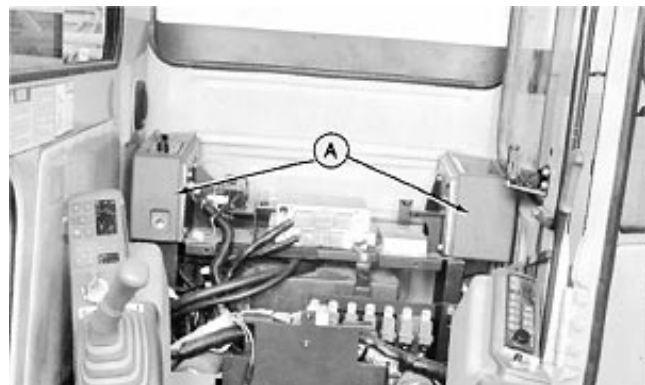

T7681AJ -UN-09JAN92

Continued on next page

TX,18,DW5012 -19-18JUL97-3/20

18
1800
2

Removal And Installation

7. Disconnect windshield wiper, dome light, and cab ground connector (A).
8. Disconnect radio antenna connector (B).



T7681AT -UN-13JAN92

TX,18,DW5012 -19-18JUL97-4/20

9. Disconnect and cap heater hoses (A and B).

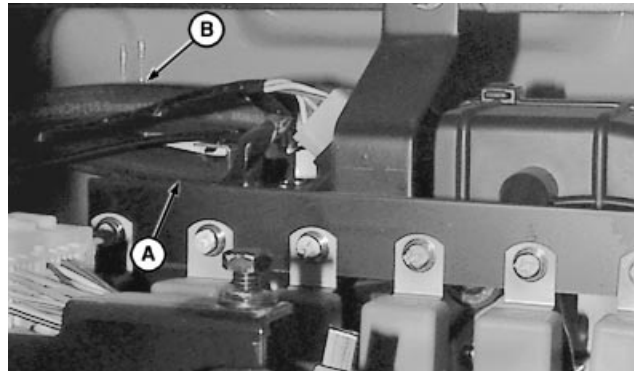

T109799 -UN-05AUG97

TX,18,DW5012 -19-18JUL97-5/20

10. Remove screws and disconnect electrical connector (B). Remove grommet and move harness (A) through access hole.

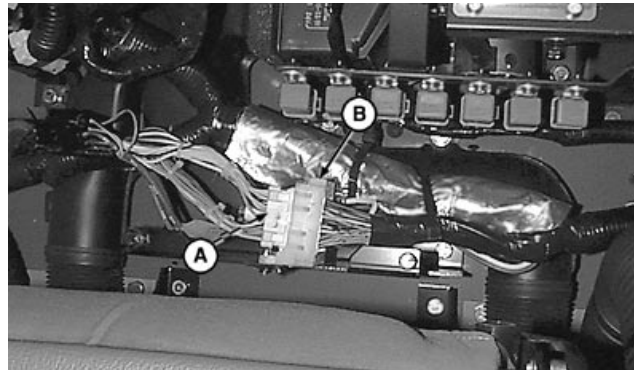

T109478 -UN-06AUG97

Continued on next page

TX,18,DW5012 -19-18JUL97-6/20

Removal And Installation

11. Disconnect lines (A and B). Label lines to aid in installation.
12. Disconnect lines (C—F and H). Label lines to aid in installation.
13. Disconnect electrical connector (G).

- A—Pilot Shut-Off Valve-to-Reservoir Line
 B—Pilot Shut-Off Valve-to-Dual Solenoid Block P Port Tee Fitting Line
 C—Propel Pilot Check Valve Upper Left Port-to-Propel Right Forward Port Line
 D—Propel Pilot Check Valve Upper Right Port-to-Propel Left Forward Port Line
 E—Propel Pilot Check Valve Tee Fitting-to-Boom, Swing, and Arm Control Valve Manifold Z2 Port Line
 F—Propel Pilot Check Valve Bottom Right Port-to-Propel Left Reverse Port Line
 G—Electrical Connector
 H—Propel Pilot Check Valve Bottom Left Port-to-Propel Right Reverse Port Line

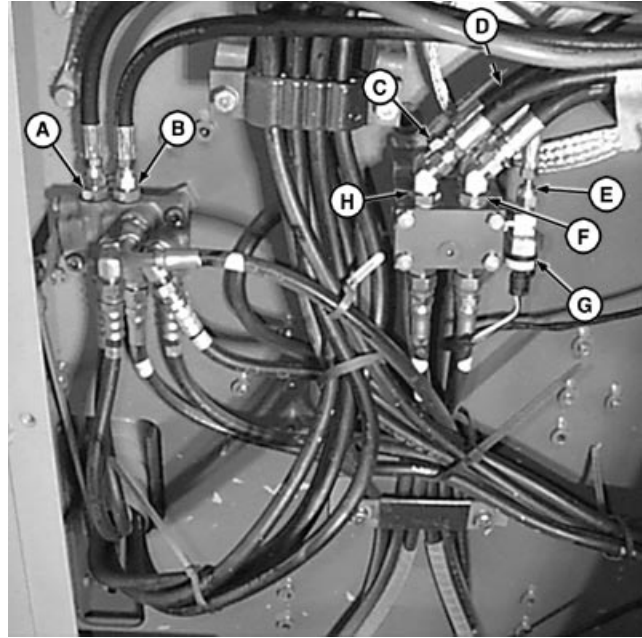

T109476 -LUN-06AUG97

Continued on next page

TX,18,DW5012 -19-18JUL97-7/20

Removal And Installation

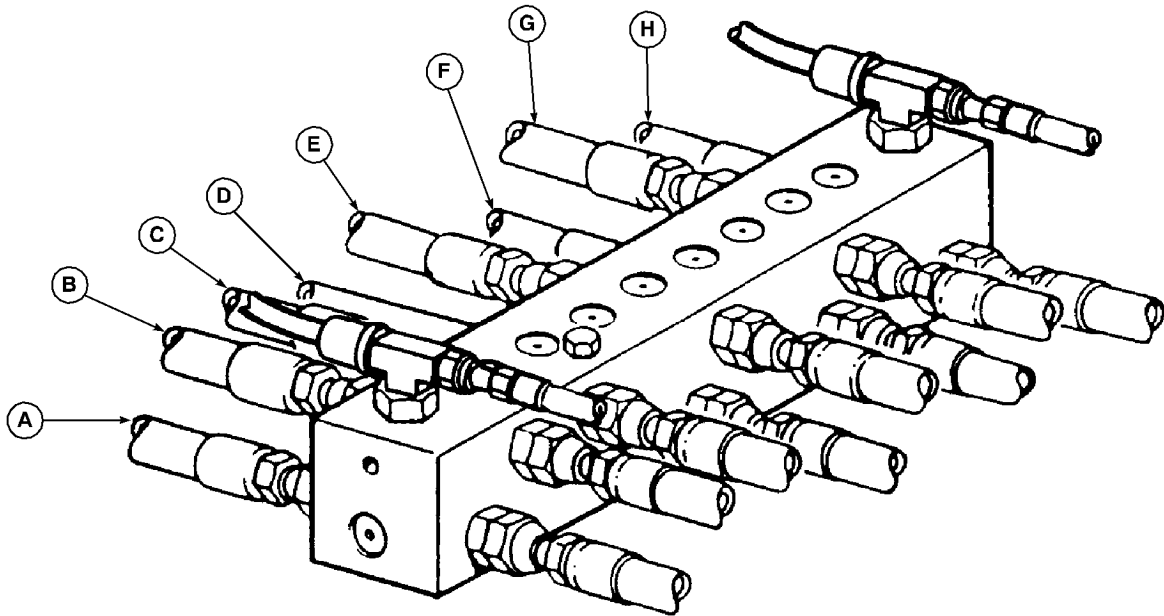

T110543

- | | | | |
|--|--|---|---|
| A —Left Pilot Controller Port
1-to-Dig Pilot Check Valve
E2 Port Line | C —Left Pilot Controller Port
3-to-Dig Pilot Check Valve
F2 Port Line | E —Right Pilot Controller Port
1-to-Dig Pilot Check Valve
I2 Port Line | G —Right Pilot Controller Port
3-to-Dig Pilot Check Valve
J2 Port Line |
| B —Left Pilot Controller Port
2-to-Dig Pilot Check Valve
H2 Port Line | D —Left Pilot Controller Port
4-to-Dig Pilot Check Valve
G2 Port Line | F —Right Pilot Controller Port
2-to-Dig Pilot Check Valve
K2 Port Line | H —Right Pilot Controller Port
4-to-Dig Pilot Check Valve
L2 Port Line |

14. Disconnect lines (A—H). Label lines to aid in installation.

TX,18,DW5012 -19-18JUL97-8/20

T110543 -UN-05AUG97

15. Remove electrical connector (A) and ground straps (B).

- A**—Left Drive Light Electrical Connector
- B**—Ground Strap (4 used)



Continued on next page

TX,18,DW5012 -19-18JUL97-9/20

T109477 -UN-06AUG97

18
1800
5

Removal And Installation

16. Disconnect lubrication line (A).

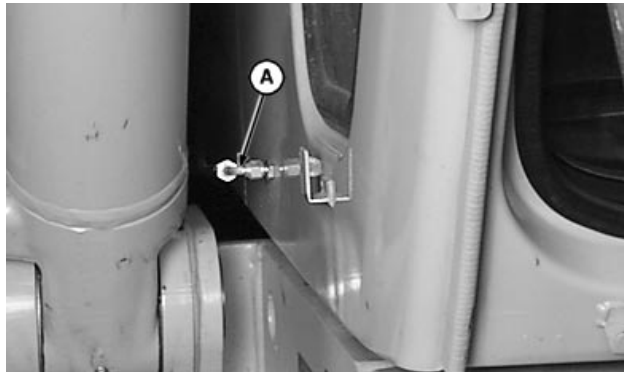

T109480 -JUN-06AUG97

TX,18,DW5012 -19-18JUL97-10/20

CAUTION: The approximate weight of cab is 230 kg (507 lb).

Cab—Specification

Cab—Approximate Weight..... 230 kg (507 lb)

- 17. Connect cab to hoist using lifting straps. Slowly lift cab from platform. Move cab slightly forward to clear propel pedals.
- 18. Lift each corner of platform and inspect isolators for wear.



T6878GN -JUN-15MAR89

Continued on next page

TX,18,DW5012 -19-18JUL97-11/20

Removal And Installation

19. Install top half of isolators (D) and washers (C) into main frame using soap and water as a lubricant.
20. Lower cab on platform. Keep lines and wires from under cab.
21. Install cap screws (A), washers (B), bottom half of isolators, washers (E), and nuts (F).
22. Tighten cap screws to 320 N•m (235 lb-ft).

Cab—Specification

Cab and Platform-to-Frame Cap

Screw—Torque..... 320 N•m (235 lb-ft)

23. Tighten cab-to-platform cap screws to 50 N•m (35 lb-ft).

Cab—Specification

Cab-to-Platform Cap Screw—

Torque 50 N•m (35 lb-ft)

- A—Cap Screw (4 used)
- B—Washer (4 used)
- C—Washer (4 used)
- D—Isolator (4 used)
- E—Washer (4 used)
- F—Nut (4 used)

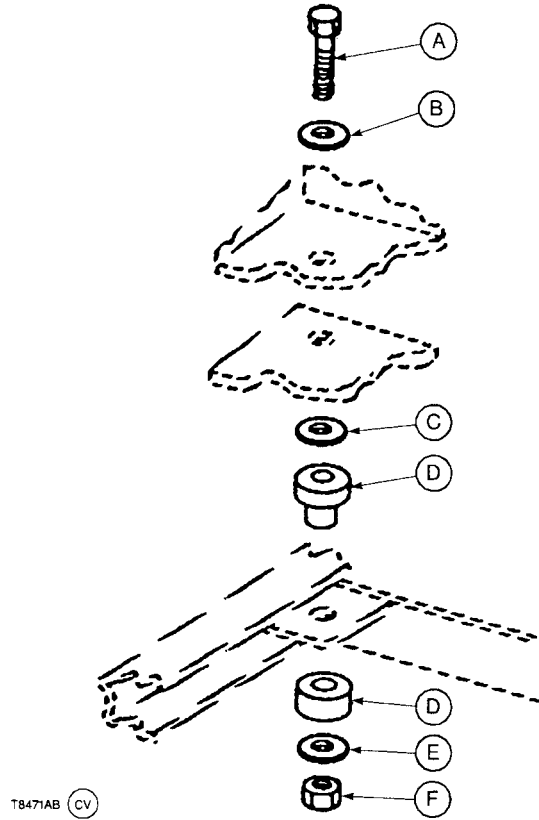

T8471AB -UN-28APR95

TX,18,DW5012 -19-18JUL97-12/20

24. Install electrical connector (A) and ground strap (B).

- A—Left Drive Light Electrical Connector
- B—Ground Strap (4 used)

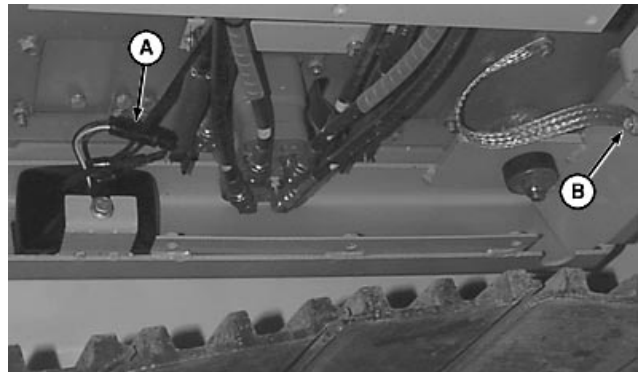

T109477 -UN-06AUG97

Continued on next page

TX,18,DW5012 -19-18JUL97-13/20

Removal And Installation

25. Connect lubrication line (A).

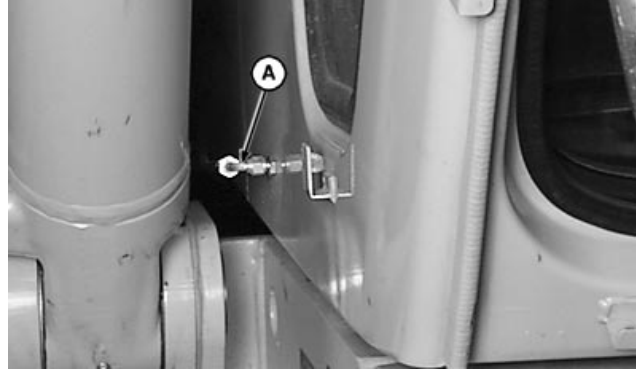

T1109480 -UN-06AUG97

TX,18,DW5012 -19-18JUL97-14/20

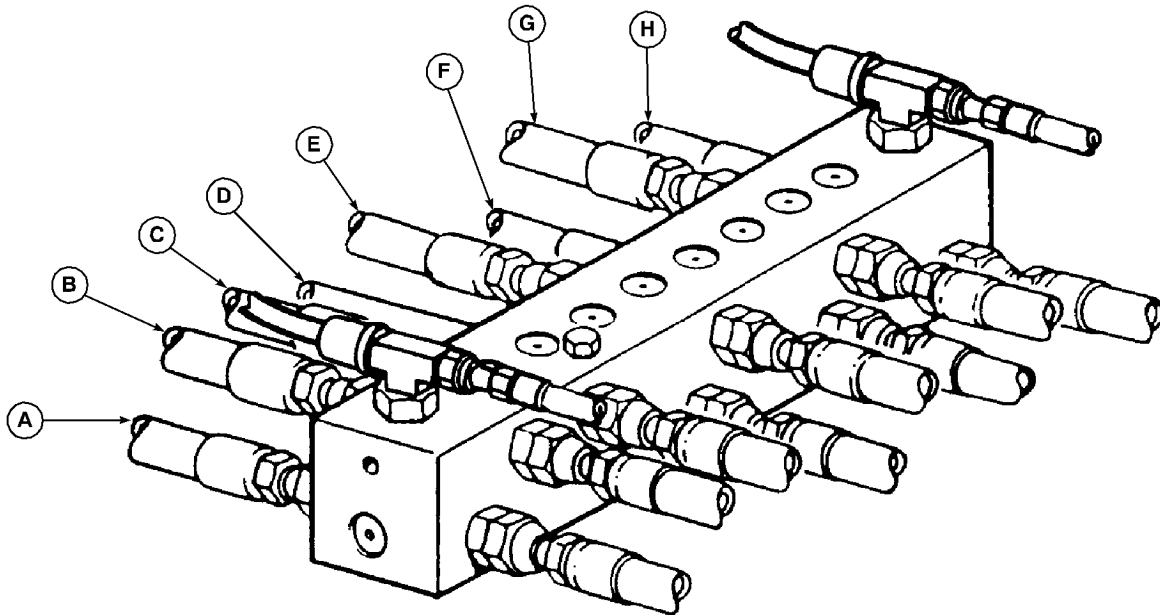

T110543

T110543 -UN-05AUG97

- A—Left Pilot Controller Port
1-to-Dig Pilot Check Valve
E2 Port Line
- B—Left Pilot Controller Port
2-to-Dig Pilot Check Valve
H2 Port Line

- C—Left Pilot Controller Port
3-to-Dig Pilot Check Valve
F2 Port Line
- D—Left Pilot Controller Port
4-to-Dig Pilot Check Valve
G2 Port Line

- E—Right Pilot Controller Port
1-to-Dig Pilot Check Valve
I2 Port Line
- F—Right Pilot Controller Port
2-to-Dig Pilot Check Valve
K2 Port Line

- G—Right Pilot Controller Port
3-to-Dig Pilot Check Valve
J2 Port Line
- H—Right Pilot Controller Port
4-to-Dig Pilot Check Valve
L2 Port Line

26. Connect lines (A—H).

Continued on next page

TX,18,DW5012 -19-18JUL97-15/20

18
1800
8

Removal And Installation

27. Connect lines (A and B). Label lines to aid in assembly.
28. Connect lines (C—F and H). Label lines to aid in assembly.
29. Connect electrical connector (G).

- A—Pilot Shut-Off Valve-to-Reservoir Line
- B—Pilot Shut-Off Valve-to-Dual Solenoid Block P Port Tee Fitting Line
- C—Propel Pilot Check Valve Upper Left Port-to-Propel Right Forward Port Line
- D—Propel Pilot Check Valve Upper Right Port-to-Propel Left Forward Port Line
- E—Propel Pilot Check Valve Tee Fitting-to-Boom, Swing, and Arm Control Valve Manifold Z2 Port Line
- F—Propel Pilot Check Valve Bottom Right Port-to-Propel Left Reverse Port Line
- G—Electrical Connector
- H—Propel Pilot Check Valve Bottom Left Port-to-Propel Right Reverse Port Line

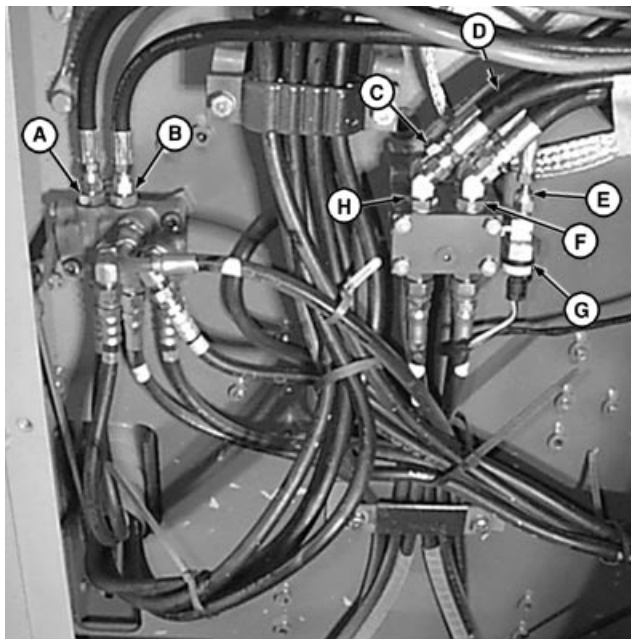

T109476 -UN-06AUG97

TX,18,DW5012 -19-18JUL97-16/20

30. Install grommet and move harness (A) through access hole. Install screws and connect electrical connector (B).

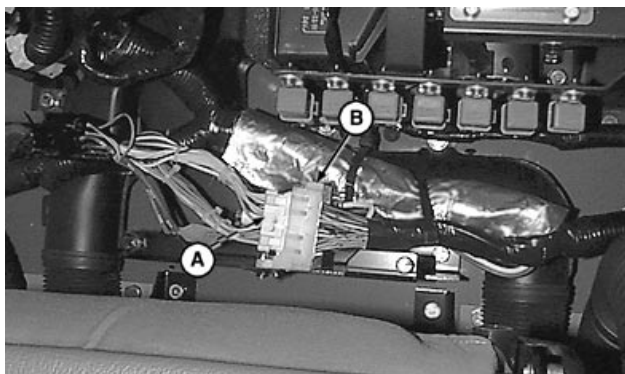

T109478 -UN-06AUG97

TX,18,DW5012 -19-18JUL97-17/20

31. Connect heater hoses (A and B).

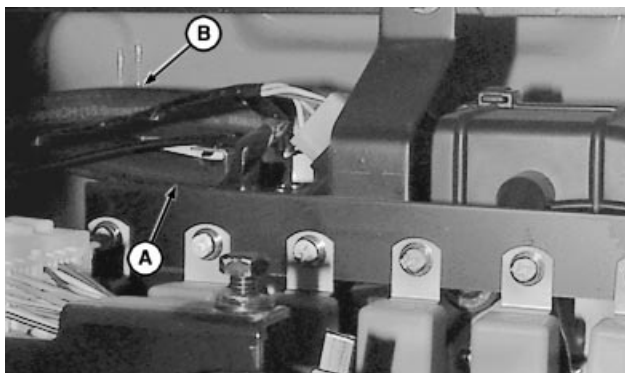

T108799 -UN-05AUG97

18
1800
9

Continued on next page

TX,18,DW5012 -19-18JUL97-18/20

Removal And Installation

32. Connect windshield wiper, dome light, and cab ground connector (A).

33. Connect radio antenna connector (B).

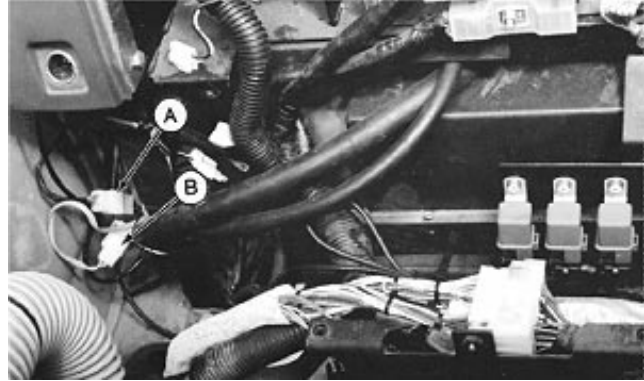

T7681AT -UN-13JAN92

TX,18,DW5012 -19-18JUL97-19/20

34. Install covers (A).

35. Install floor mat.

36. Install seat, if removed.

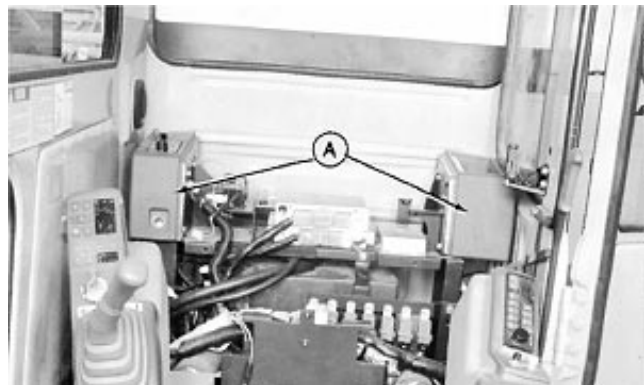

T7681AJ -UN-09JAN92

TX,18,DW5012 -19-18JUL97-20/20

Service Equipment And Tools

NOTE: Order tools from the U.S. SERVICE-GARD™ Catalog or from the European Microfiche Tool Catalog (MTC). Some tools may be available from a local supplier.

SERVICE-GARD is a trademark of Deere & Company.

1810,CC1 -19-26JUN87-1/3

Insert Tool

Used to remove and install windowpane and two-piece molding.

1810,CC1 -19-26JUN87-2/3

Weatherstrip Installing Tool

Used to install locking strip in two-piece molding.

1810,CC1 -19-26JUN87-3/3

Other Material

Number	Name	Use
TY21517 (U.S.)	Instant Gel Adhesive	Apply to frame channel of molding.
AR54749 (U.S.)	Soap Lubricant	Apply to molding.

TX,1810,AB280 -19-20APR92-1/1

Remove And Install Windowpane And Two Piece Molding

1. Remove locking strip (A) from molding using insert tool.

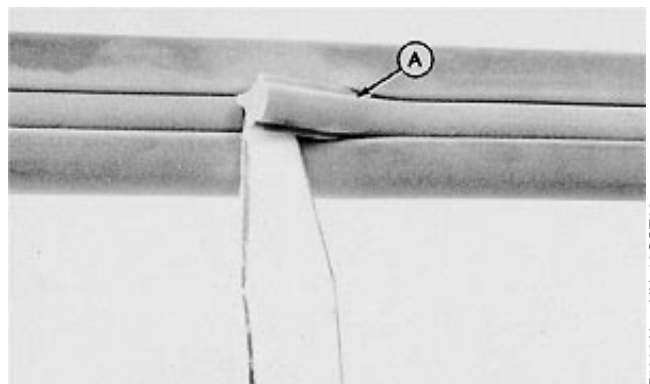

T5903AI -JUN-19OCT88

Continued on next page

1810,CC3 -19-25SEP91-1/4

18
1810
1

Operator Enclosure

IMPORTANT: Use extreme care to avoid damaging the windowpane.

2. Carefully push out windowpane from molding.
3. Inspect molding for damage; replace if necessary



T5903AJ -UN-19OCT88

1810.CC3 -19-25SEP91-2/4

4. Put instant gel adhesive in frame channel of molding (B). Install molding.
5. Install windowpane using insert tool (A) and a soap lubricant.

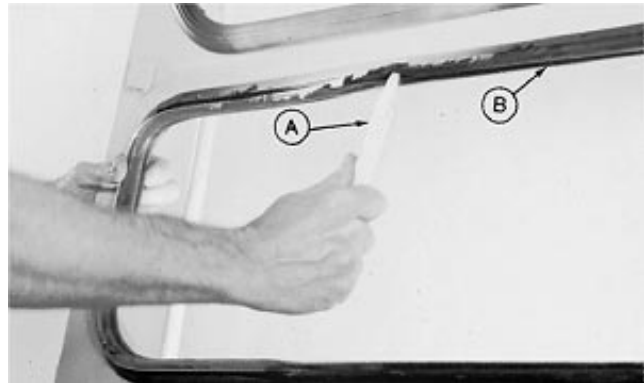

T5903AK -UN-19OCT88

1810.CC3 -19-25SEP91-3/4

6. Install locking strip (A) using Weatherstrip installing tool (B).

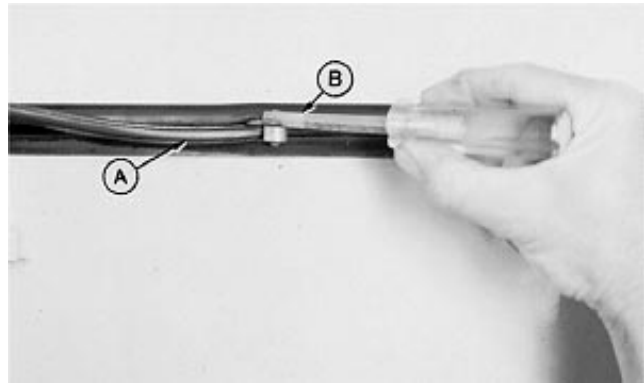

T5903AL -UN-19OCT88

1810.CC3 -19-25SEP91-4/4

Remove And Install Windowpane And One Piece Molding

1. Lift inside of molding over cab frame and carefully push windowpane and molding out.
2. Remove molding from windowpane; replace if necessary.



T6439XE -UN-19OCT88

Continued on next page

1810.CC6 -19-03OCT95-1/2

Operator Enclosure

3. Install molding on windowpane. Put drain notches (A) at bottom and towards outside of windowpane.
4. Install windowpane and molding. Lift inside of molding over cab frame.



T6439XD -UN-19OCT88

1810.CC6 -19-03OCT95-2/2

Remove And Install Sliding Windows

1. Pull molding (D) from inside of window.
2. Cut the adhesive (E) between cab flange and window frame (B) using a putty knife.

IMPORTANT: Use extreme care to avoid damaging frame and windowpane. Remove window using two people; one to push window out, the other to keep window from falling.

3. Carefully push window frame from cab.
4. Lift frame slightly at the top-center to remove and install windowpanes.
5. Apply instant gel adhesive to cab flange.
6. Install windows and frame with spacers (C) at the bottom and two on each end of frame.
7. Install three spacers (A) at top of frame.

Push window frame tight against cab flange. Use water for a lubricant.

8. Install molding (D) around window and cab flange.

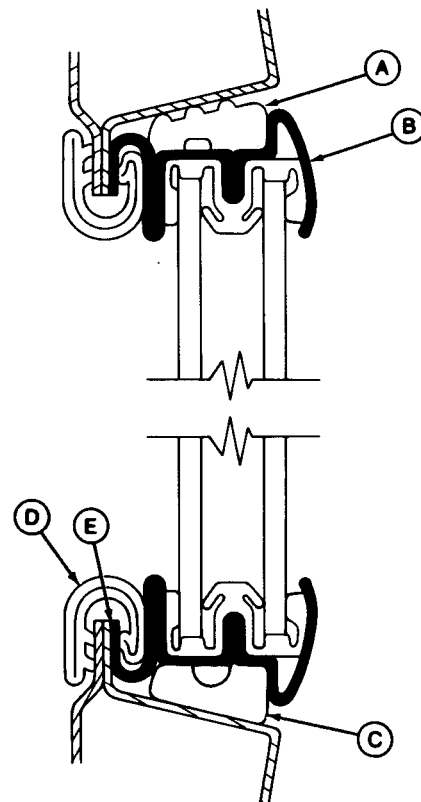

- A—Top Spacer (3 used)
- B—Window Frame
- C—Bottom and Side Spacer
- D—Molding
- E—Adhesive

T6439TD -UN-05DEC89

1810.AA29 -19-20APR92-1/1

18
1810
3

Operator Enclosure

Windowpane Dimensions

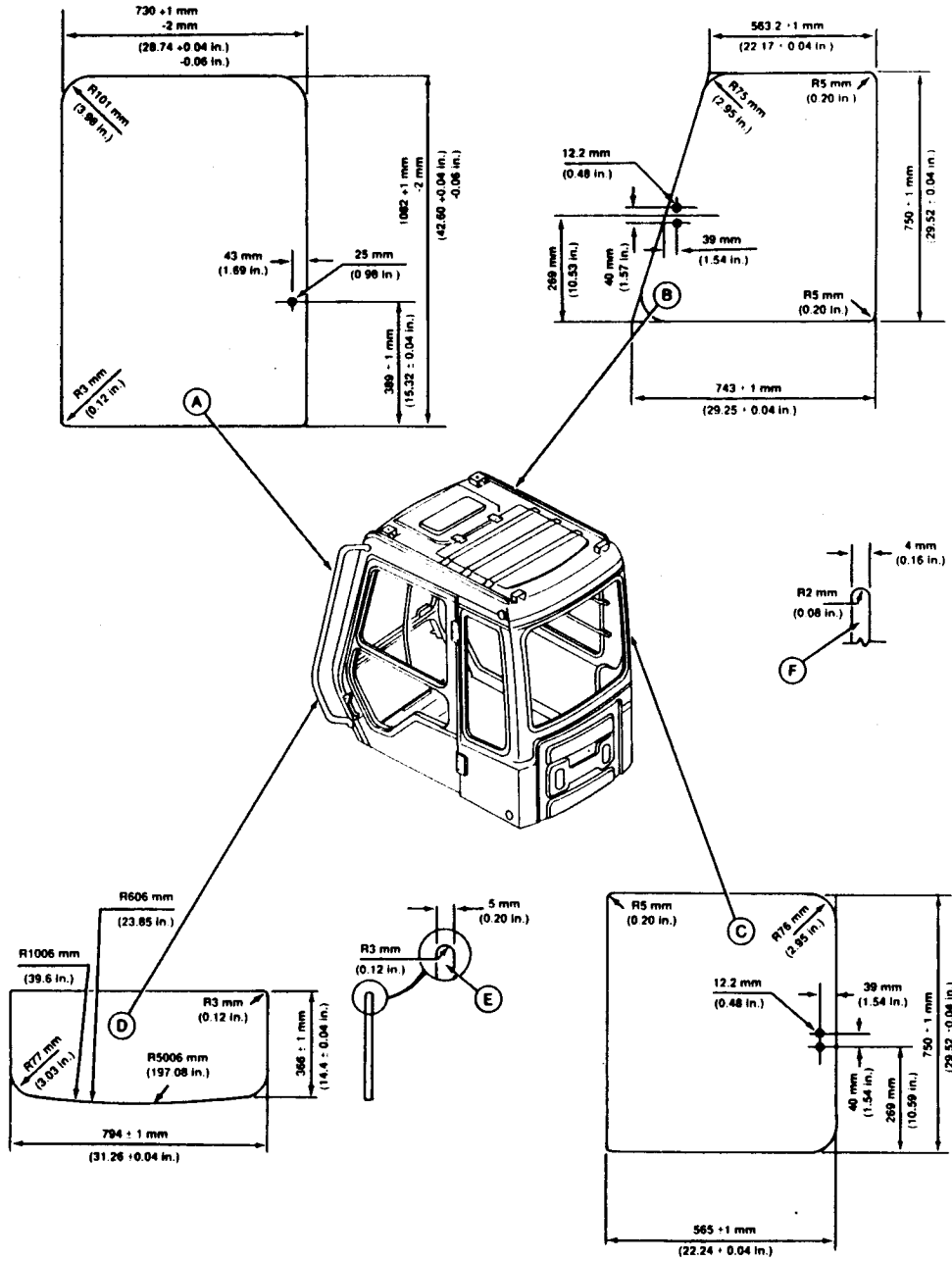

- A—Upper Front Windowpane C—Right Rear Windowpane
- B—Right Front Windowpane D—Lower Front Windowpane
- E—Thickness of Lower Front Windowpane
- F—Thickness of All Other Windowpanes

Install upper front windowpane so bottom edge rests securely against rubber bumpers. Adjust rubber bumpers if necessary.

Continued on next page

TX,1810,AB281 -19-14SEP94-1/2

Operator Enclosure

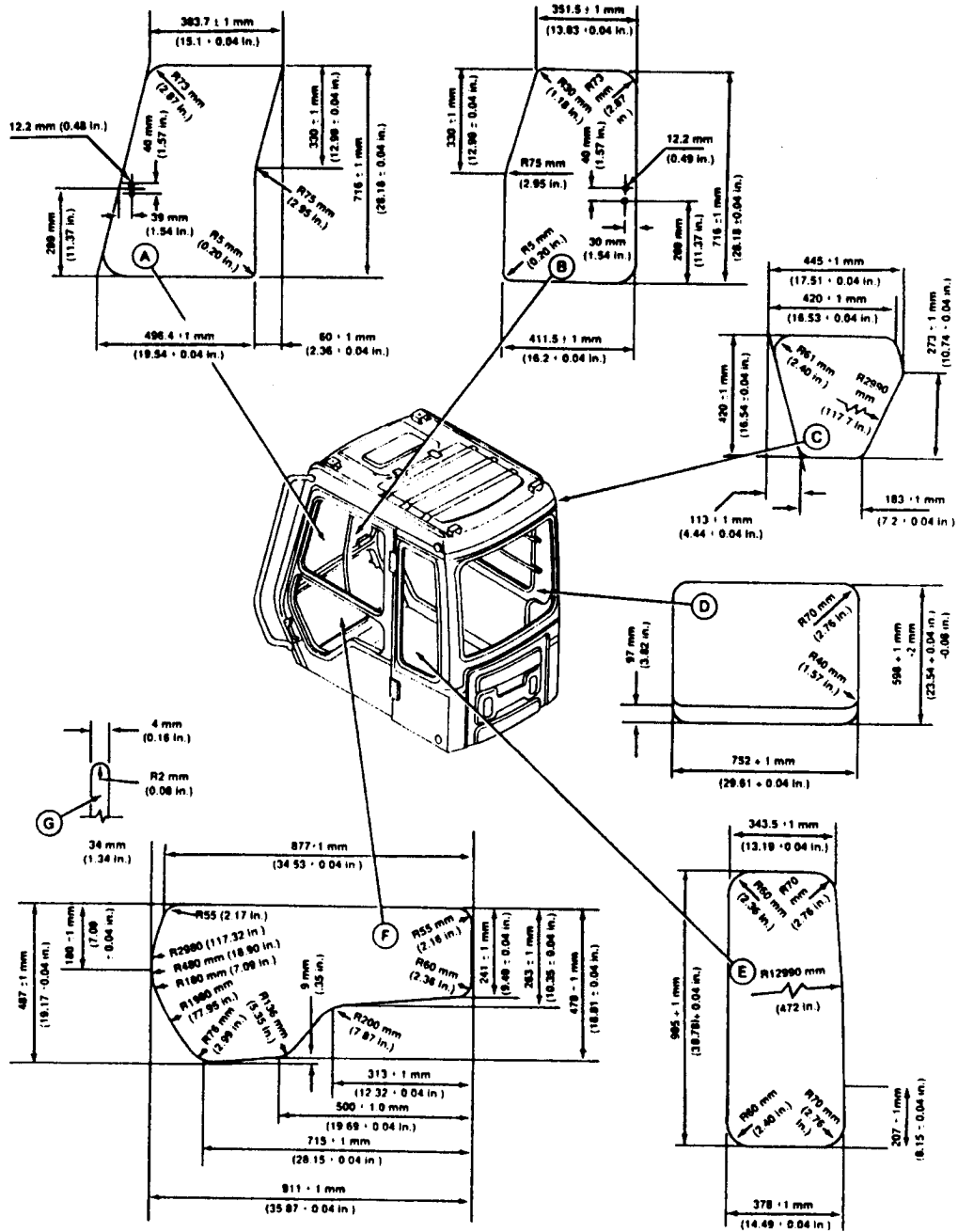

T8316AC (CV)

A—Upper Front Door Windowpane
B—Upper Rear Door Windowpane

C—Right Lower Windowpane
D—Rear Windowpane

E—Left Rear Windowpane
F—Lower Door Windowpane

G—Thickness of Windowpane

T8316AC -UN-21SEP94

18
1810
5

Operator Enclosure

18
1810
6

Remove And Install Seat (Serial No. — 538404)

1. Remove cap screws (A) to remove cover (B).
2. Remove the front two cap screws (D).

Tip console up for access to the rear two cap screws.
Lay console on cover behind seat.
3. Remove cap screws (C) from seat base.

⚠ CAUTION: Approximate weight of seat is 34 kg (75 lb).

4. Remove seat.
5. Inspect parts for wear.
6. Install seat.
7. Install cap screws (C).
8. Install consoles and cap screws (D).
9. Install cover (B) and cap screws (A).

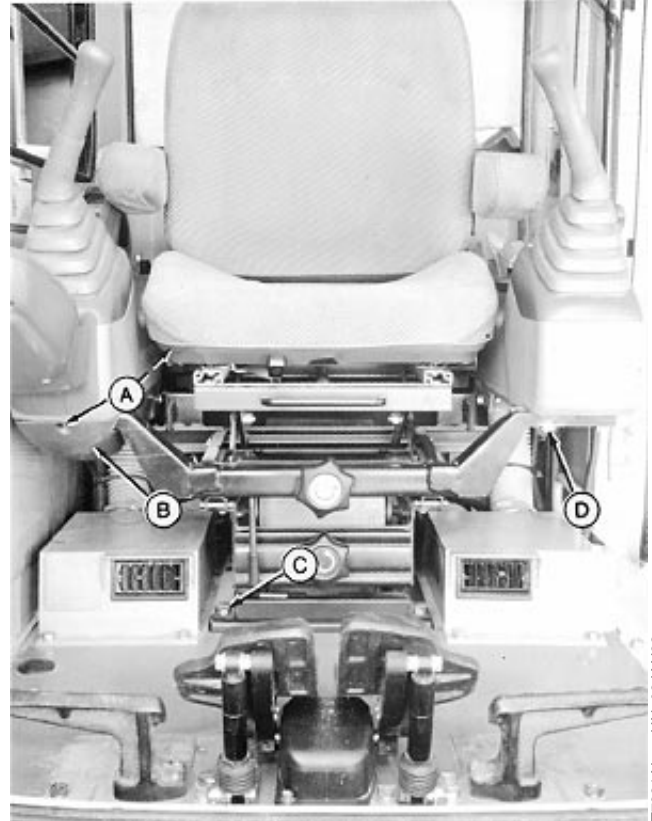

A—Cap Screw (3 used)
B—Cover
C—Cap Screw (4 used)
D—Cap Screw (4 used)

TX,18,DW5013 -19-18JUL97-1/1

Seat

Remove And Install Seat (Serial No. 538405—)

1. Remove cap screws (A) and nut (B).
2. Move left and right consoles (C).
3. Remove cap screws (D) from seat base.

⚠ CAUTION: Approximate weight of seat is 34 kg (75 lb).

4. Remove seat.
5. Inspect parts for wear. Replace as necessary.
6. Install seat.
7. Install cap screws (D).
8. Install left and right consoles (C). Tighten cap screws (A) and nut (B).

A—Cap Screw (4 used)
 B—Nut (4 used)
 C—Console (2 used)
 D—Cap Screw (4 used)

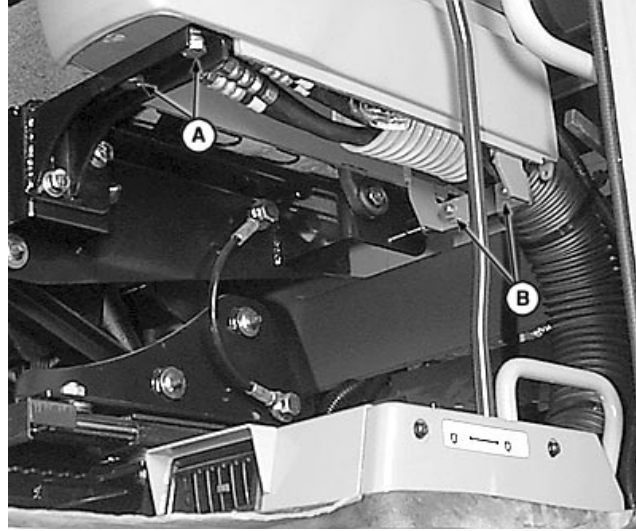

T111086 -UN-12AUG97

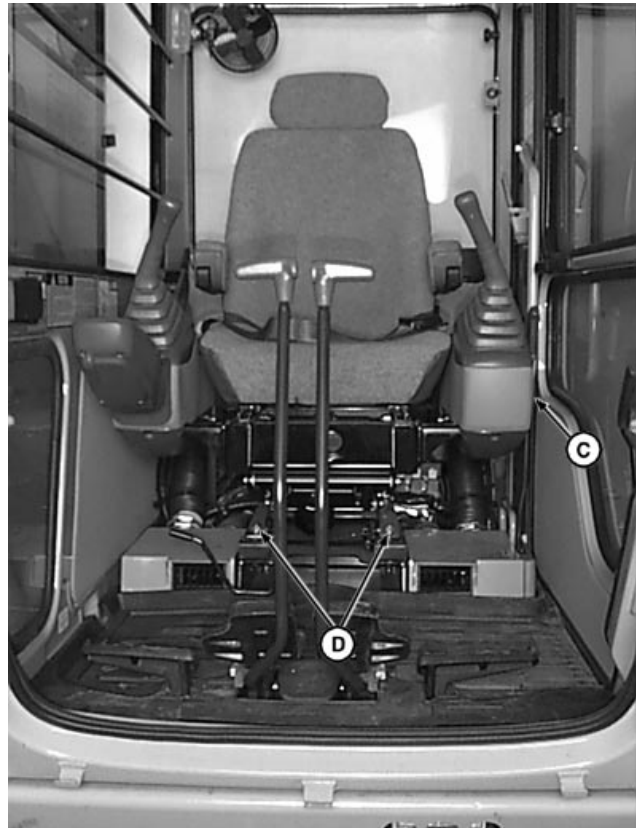

T109481 -UN-12AUG97

TX,18,DW5014 -19-18JUL97-1/1

Seat

Disassemble And Assemble Seat (Serial No. 537781—538404)

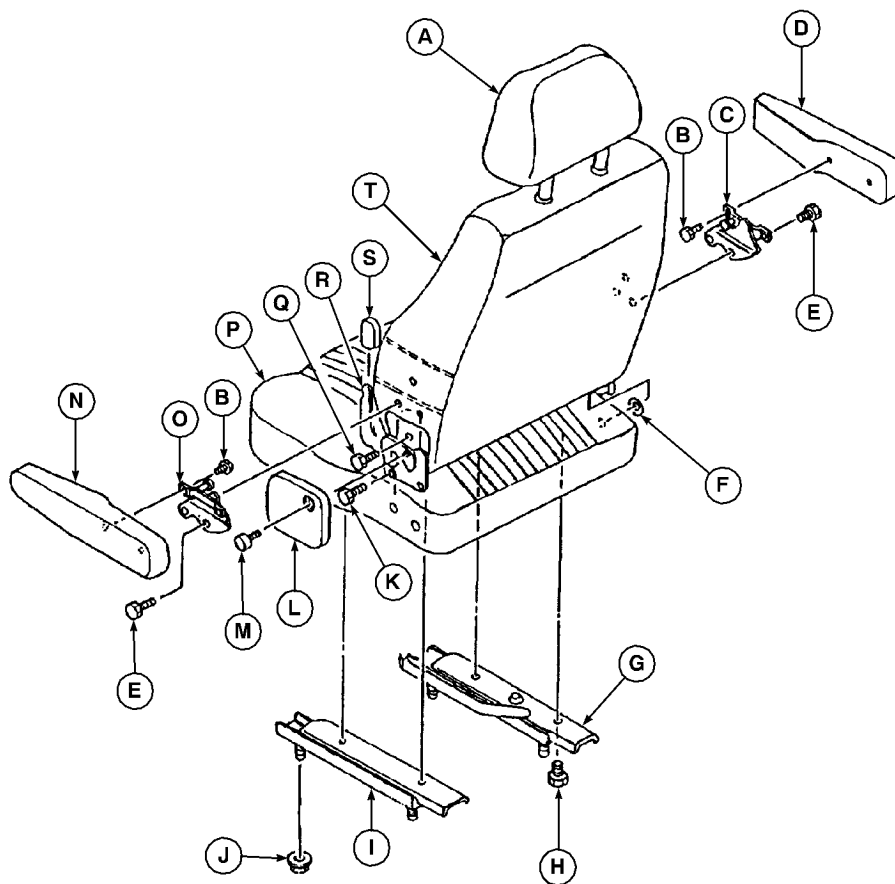

T109449

- | | | | |
|----------------------|----------------------|----------------------|----------------------|
| A—Head Restraint | F—Washer | K—Cap Screw (2 used) | P—Cushion |
| B—Cap Screw (2 used) | G—Slideset | L—Cover | Q—Cap Screw (2 used) |
| C—Link | H—Cap Screw (4 used) | M—Cap Screw | R—Lever |
| D—Armrest | I—Slideset | N—Armrest | S—Grip |
| E—Cap Screw (2 used) | J—Nut (4 used) | O—Link | T—Seat Back |

TX,18,DW5015 -19-18JUL97-1/1

T109449 -JUN-05AUG97

Seat

Disassemble And Assemble Seat (Serial No. 538405—549976)

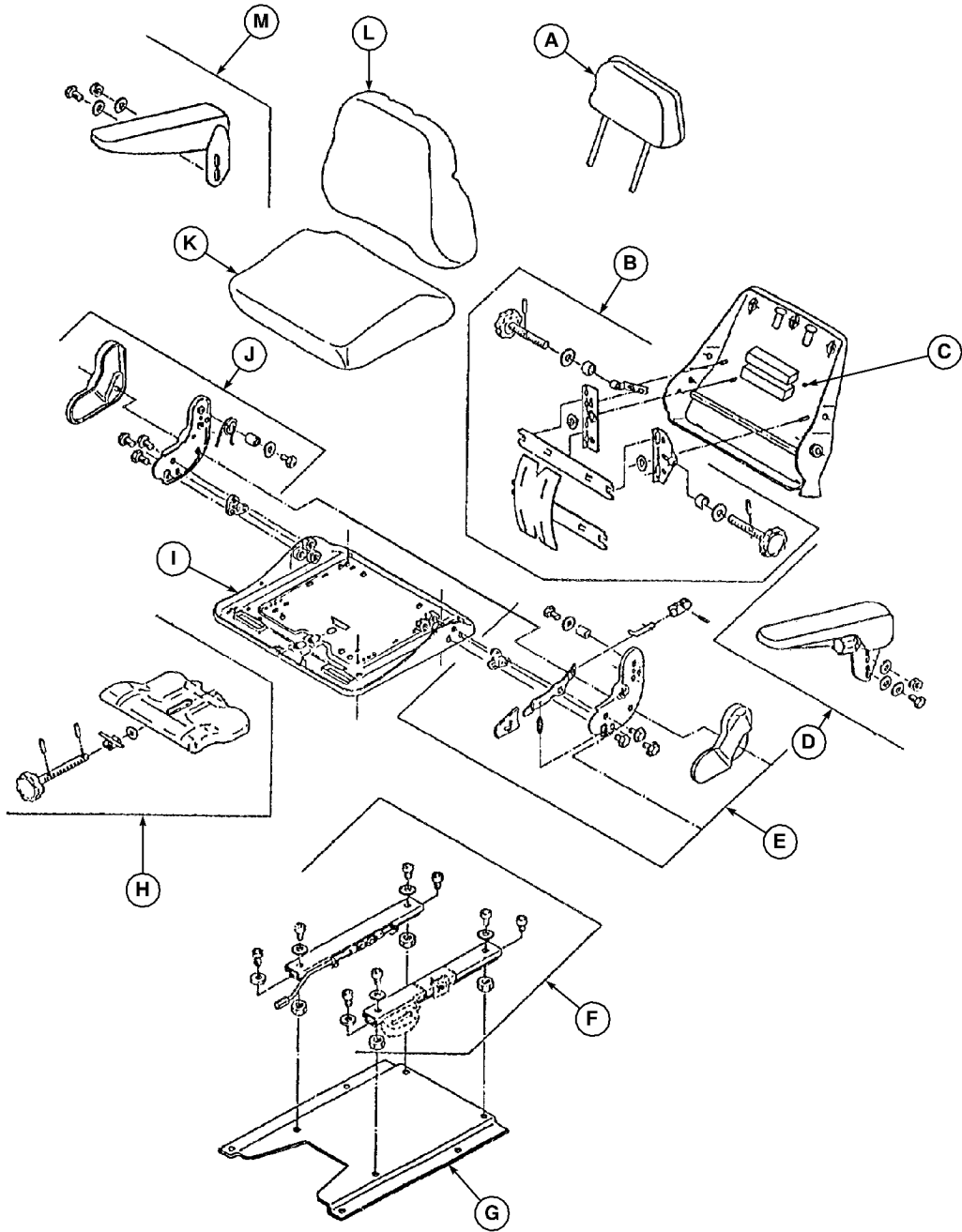

- | | | | |
|------------------|------------|------------|---------------------|
| A—Head Restraint | E—Adjuster | H—Adjuster | K—Cushion |
| B—Support | F—Frame | I—Pan | L—Seat Back Cushion |
| C—Seat Back | G—Plate | J—Bracket | M—Armrest |
| D—Armrest | | | |

18
1821
4

T109450

T109450 -UN-05AUG97

Seat

Disassemble And Assemble Seat (Serial No. 549977—)

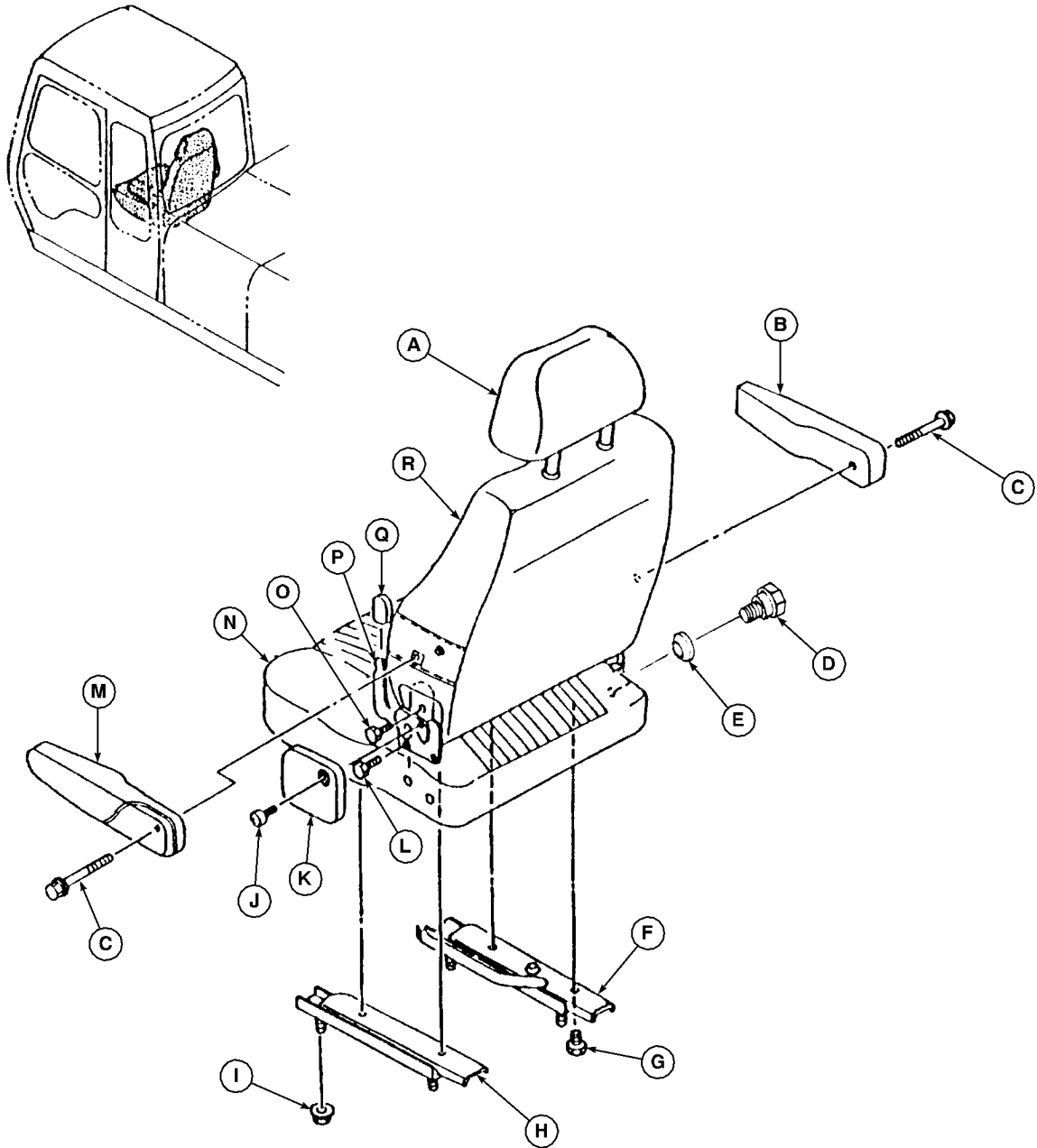

T109454

- | | | | |
|----------------------|----------------------|----------------------|----------------------|
| A—Head Restraint | F—Slideset | K—Cover | O—Cap Screw (2 used) |
| B—Armrest | G—Cap Screw (4 used) | L—Cap Screw (2 used) | P—Lever |
| C—Cap Screw (2 used) | H—Slideset | M—Armrest | Q—Grip |
| D—Cap Screw | I—Nut (4 used) | N—Cushion | R—Seat Back |
| E—Bushing | J—Cap Screw | | |

T109454 -UN-05AUG97

18
1821
5

TX,18,DT5086 -19-15JUL97-1/1

Seat

Disassemble And Assemble Seat Stand (Serial No. —547853)

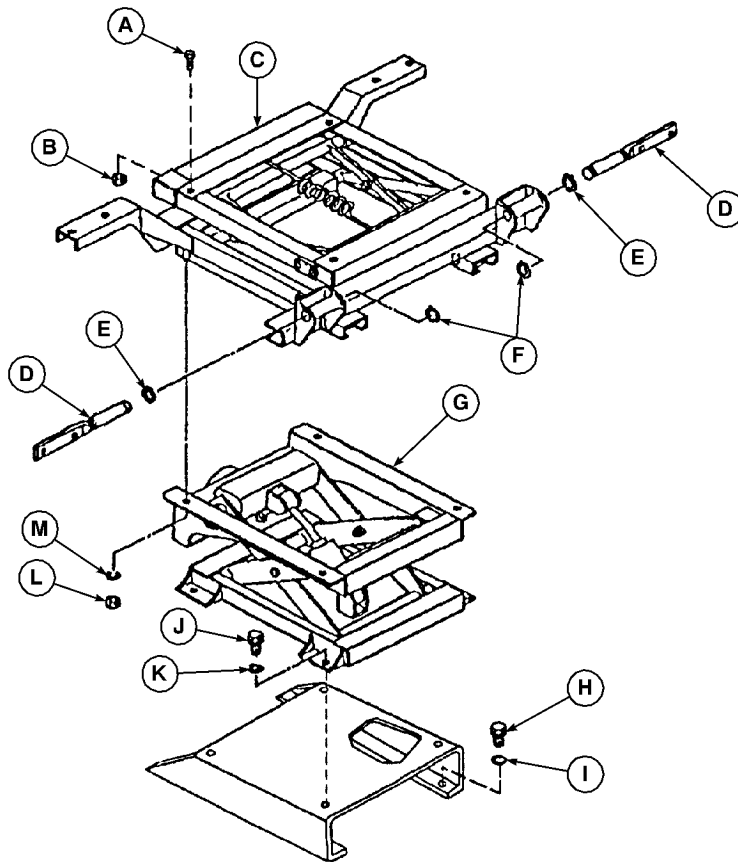
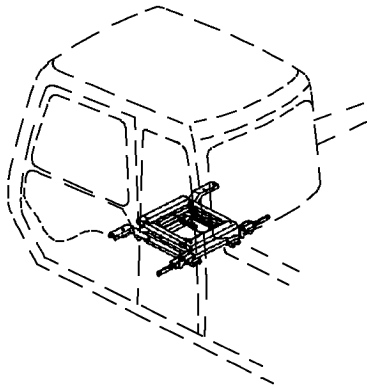

T109451

A—Cap Screw (4 used)
 B—Nut (4 used)
 C—Stand
 D—Pin

E—Washer (2 used)
 F—Washer (2 used)
 G—Seat Suspension

H—Cap Screw (4 used)
 I—Washer (4 used)
 J—Cap Screw (4 used)

K—Washer (4 used)
 L—Nut (4 used)
 M—Washer (4 used)

T109451 -UN-05AUG97

18
1821
6

Seat

18
1821
7

Seat

Disassemble And Assemble Seat Stand (Serial No. 547854—)

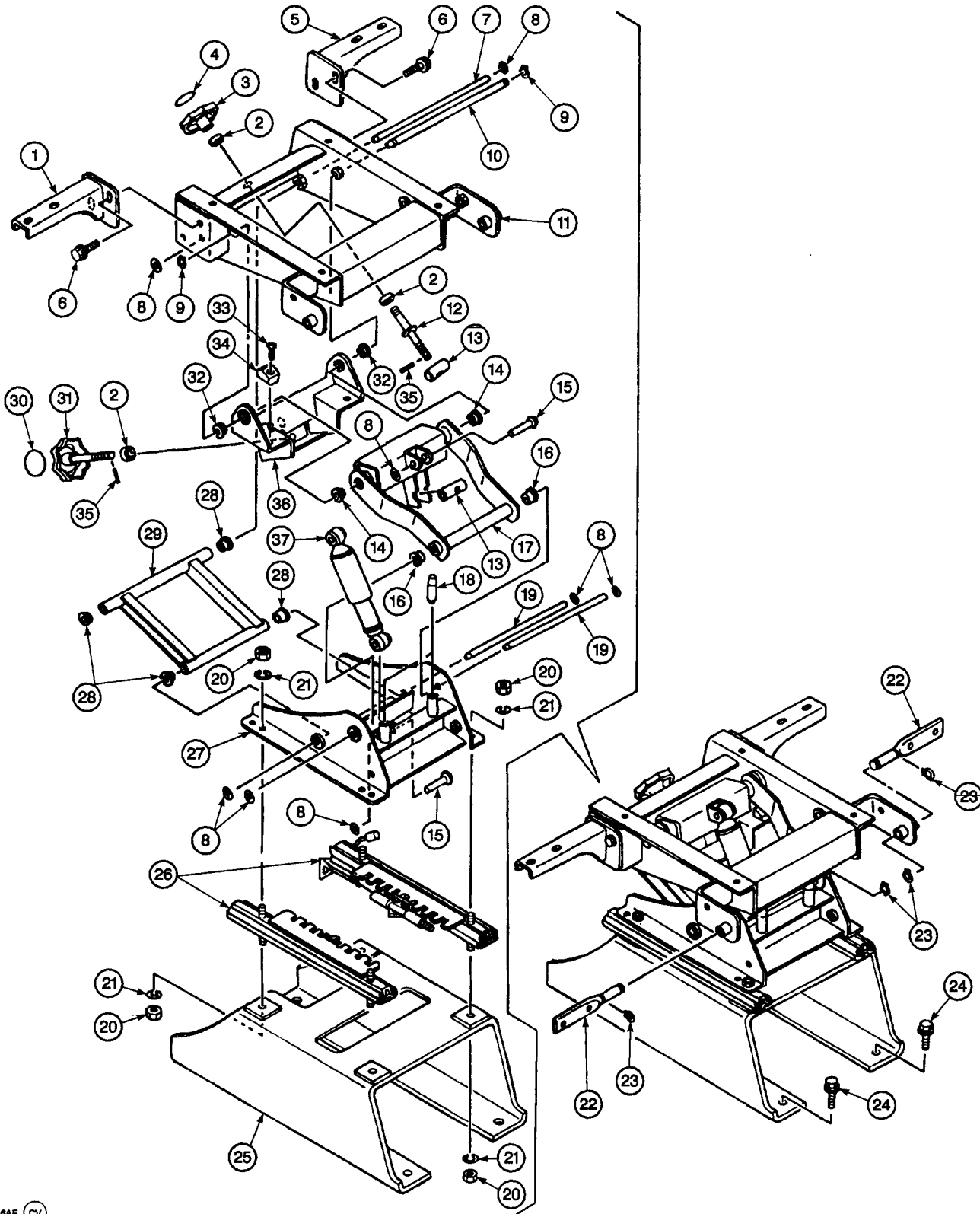

18
1821
8

T8316AF CV

T8316AF -UN-21SEP94

Continued on next page

TX.1821,DW267 -19-12APR95-1/2

Seat

1—Bracket	11—Stand	20—Nut (8 used)	29—Link
2—Bearing (3 used)	12—Rod	21—Washer (8 used)	30—Seal
3—Knob	13—Pin (2 used)	22—Pin (2 used)	31—Knob
4—Nameplate	14—Bushing (2 used)	23—Retaining Ring (4 used)	32—Bushing (2 used)
5—Bracket	15—Rivet (2 used)	24—Cap Screw (4 used)	33—Cap Screw (2 used)
6—Cap Screw (4 used)	16—Bushing (2 used)	25—Bracket	34—Rubber Stopper (2 used)
7—Shaft	17—Link	26—Slider	35—Spring Pin (2 used)
8—Retaining Ring (8 used)	18—Rubber Stopper (2 used)	27—Suspension	36—Bracket
9—Retaining Ring (2 used)	19—Shaft (2 used)	28—Bushing (4 used)	37—Dampener
10—Pin			

TX,1821,DW267 -19-12APR95-2/2

Seat

18
1821
10

Group 1830 Heating And Air Conditioning

Special Or Essential Tools

NOTE: Order tools according to information given in the U.S. SERVICE-GARD™ Catalog or in the European Microfiche Tool Catalog (MTC).

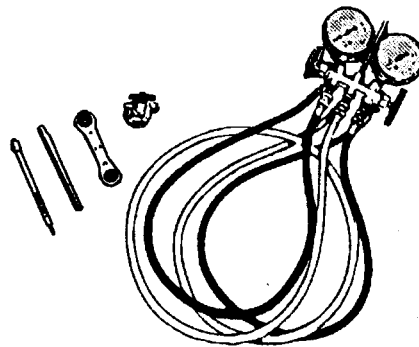

T7541AD -JUN-29MAY91

SERVICE-GARD is a trademark of Deere & Company.

DX,TOOLS -19-20JUL95-1/9

Air Conditioning Test Equipment Kit (Serial No. — 541550) D18018KD

Used to test air conditioning.

DX,TOOLS -19-20JUL95-2/9

Used to test air conditioning.

DX,TOOLS -19-20JUL95-3/9

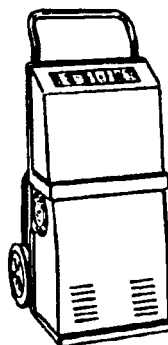

T7630AX -JUN-20MAY91

DX,TOOLS -19-20JUL95-4/9

Air Conditioning Recovery and Recycling System (Serial No. —541550) JT02020 or JT02021

Used to recover and recycle refrigerant from system.

DX,TOOLS -19-20JUL95-5/9

Used to recover and recycle refrigerant from system.

18
1830
1

Continued on next page

DX,TOOLS -19-20JUL95-6/9

Heating And Air Conditioning

R40105 -UN-23AUG88



DX,TOOLS -19-20JUL95-7/9

Compressor Seal and Clutch Repair Kit (Serial No. — 541550) JDG215

Remove and install air conditioning seal and clutch components on air conditioning compressor.

DX,TOOLS -19-20JUL95-8/9

Remove and install air conditioning seal and clutch components on air conditioning compressor

DX,TOOLS -19-20JUL95-9/9

Service Equipment And Tools

NOTE: Order tools from the U.S. SERVICE-GARD™ Catalog or from the European Microfiche Tool Catalog (MTC). Some tools may be available from a local supplier.

SERVICE-GARD is a trademark of Deere & Company.

TX,1830,DX357 -19-14APR95-1/9

Refrigerant Recovery System JT02022

Used to recover refrigerant from system.

TX,1830,DX357 -19-14APR95-2/9

Vacuum Pump D05267ST

Used to evacuate air conditioning system.

Continued on next page

TX,1830,DX357 -19-14APR95-3/9

18
1830
2

Heating And Air Conditioning

Charging Cylinder D05271ST

Used to add refrigerant R-12 to air conditioning system.

TX,1830,DX357 -19-14APR95-4/9

Belt Tension Gauge

Used to check compressor belt tension.

TX,1830,DX357 -19-14APR95-5/9

Air Conditioning Service Fitting Kit JT05419

Used to perform volumetric efficiency test.

TX,1830,DX357 -19-14APR95-6/9

Air Conditioning Gauge Set

Used to service air conditioning system.

TX,1830,DX357 -19-14APR95-7/9

Bench Mounted Holding Fixture D01006AA

Used to hold compressor during repair.

TX,1830,DX357 -19-14APR95-8/9

Volt-Ohm-Amp Multimeter

Used to test thermostat switch.

TX,1830,DX357 -19-14APR95-9/9

Other Material

Number	Name	Use
TY6334 (U.S.)	Refrigerant 12	To charge air conditioning system.
R49856 (U.S.)	Compressor Oil	To lubricate compressor.

TX,1830,DX358 -19-14APR95-1/1

18
1830
3

Heating And Air Conditioning

Specifications

Item	Measurement	Specification
(Serial No. —541550):		
Condenser	Oil Quantity	59 mL (2 oz)
Evaporator	Oil Quantity	118 mL (4 oz)
Receiver/Dryer	Oil Quantity	15 mL (1/2 oz)
Complete Air Conditioning System	Oil Quantity	326 mL (11 oz)
Air Conditioning System Refrigerant	Refrigerant Quantity	2.3 kg (5.00 lb)
Compressor:		
Clutch Hub-to-Pulley	Clearance	0.53—0.91 mm (0.021—0.036 in.)
Clutch Coil	Current Draw at 24 Volts, 20°C (68°F)	2.8—3.5 amps
	Resistance at 20°C (68°F)	2.8—4.5 ohms
Suction Line	Torque	31 N•m (23 lb-ft)
Discharge Line	Torque	22 N•m (16 lb-ft)
Hub Retaining Nut	Torque	16 N•m (12 lb-ft)
Front Head Cap Screw	Torque	26 N•m (19 lb-ft)
Adjusting Strap Cap Screw	Torque	27 N•m (20 lb-ft)
Belt Tension	Deflection	13 mm at 100 N (0.5 in. at 23 lb force)

Heating And Air Conditioning

Remove And Install Blower Motor

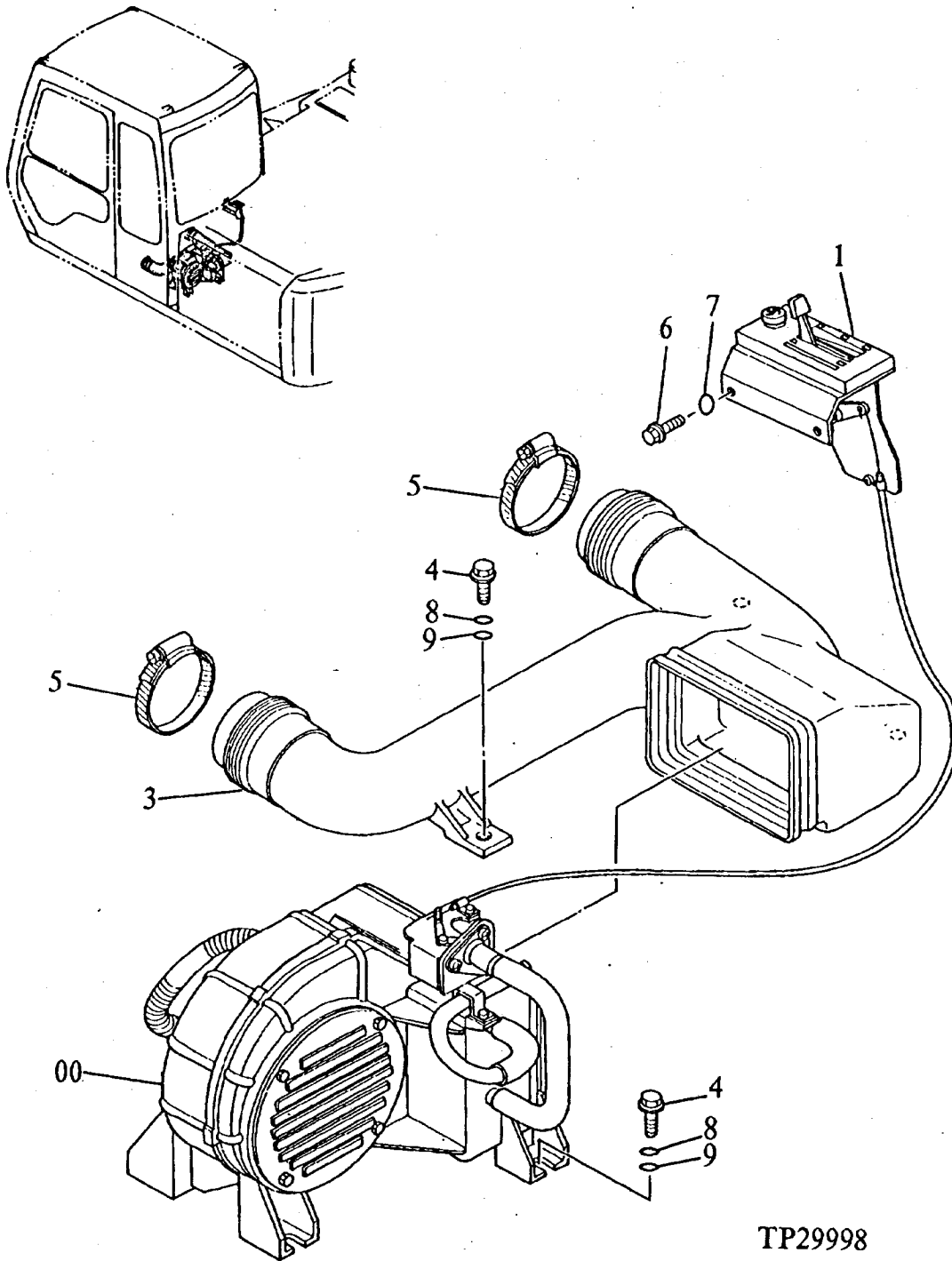

00—Heater Assembly
1—Control (Serial No. —001462)

3—Air Duct
4—Cap Screw (7 used)
5—Clamp (2 used)

6—Screw (2 used)
7—Lock Washer (2 used)

8—Lock Washer (7 used)
9—Washer (7 used)

TP29998

TP29998 -UN-01.JAN94

18
1830
5

Remove And Install Heater Core And Blower Motor Relay

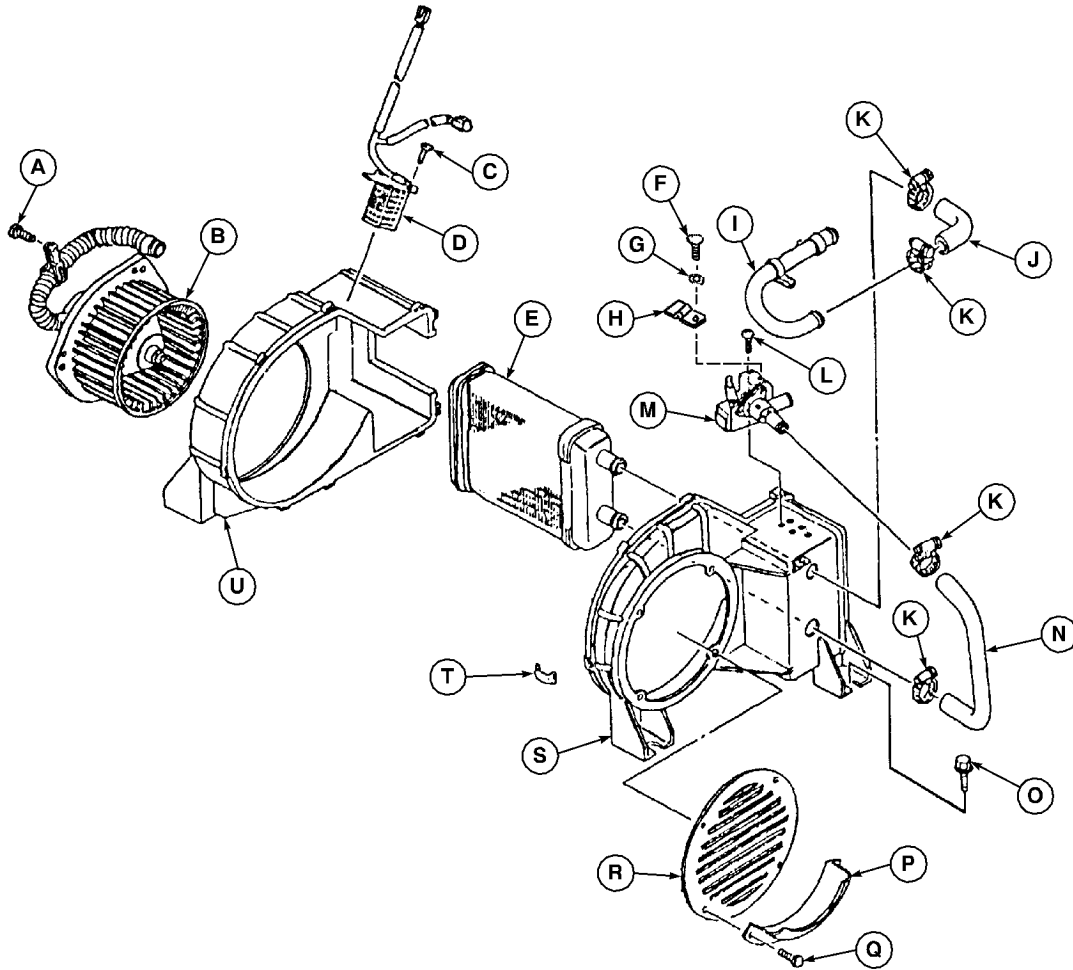

T109457

T109457 -UN-05AUG97

- | | | | |
|----------------------|------------------|----------------------|----------------------|
| A—Cap Screw (3 used) | G—Washer | L—Cap Screw (3 used) | Q—Cap Screw (4 used) |
| B—Blower Motor | H—Clamp | M—Valve | R—Cover |
| C—Cap Screw (2 used) | I—Hose | N—Hose | S—Housing Cover |
| D—Relay | J—Hose | O—Cap Screw (4 used) | T—Clip (9 used) |
| E—Core | K—Clamp (4 used) | P—Cover | U—Housing Cover |
| F—Cap Screw (3 used) | | | |

1. Disconnect electrical connectors.
2. Remove cap screws (C). Remove relay (D).
3. Inspect relay. Replace as necessary.
4. Install relay (D).

TX,18,DW5010 -19-18JUL97-1/1

Remove And Install Heater Control

1. Remove knobs (A and B).
2. Remove clamps (C). Remove panel (I).
3. Remove nut (J).
4. Remove parts (D—G) and remove bracket (H).
5. Repair or replace as necessary.
6. Install bracket (H).
7. Install parts (D—G, I, J and A—C).

- A—Knob
- B—Knob
- C—Clamp (4 used)
- D—Control Cable
- E—Clamp
- F—Cap Screw
- G—Switch
- H—Controller
- I—Panel
- J—Nut

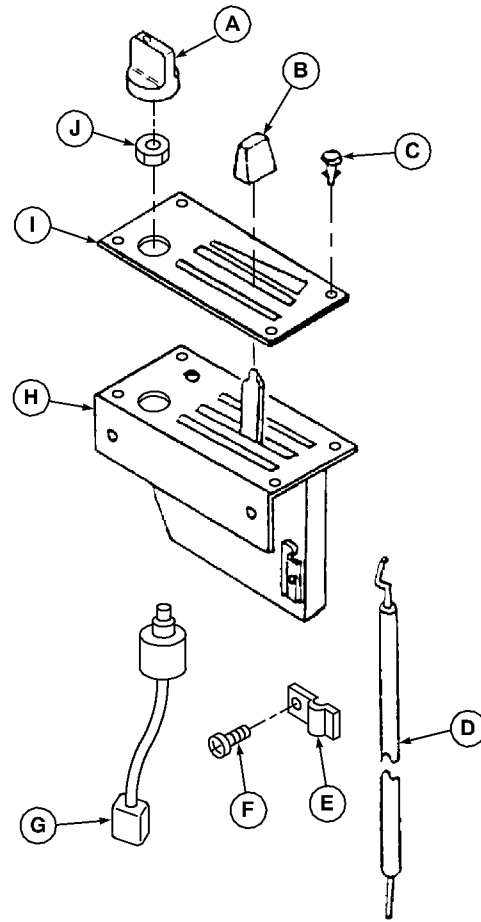

T109740

T109740 -UN-05AUG97

TX,18,DW5010 -19-18JUL97-1/1

Refrigerant (R-12) Cautions (Serial No. —541550)

CAUTION: DO NOT allow liquid refrigerant (R-12) to contact eye or skin. Liquid refrigerant (R-12) will freeze eye or skin on contact. Wear goggles, gloves and protective clothing.

If liquid refrigerant (R-12) contacts eye or skin, **DO NOT** rub the area. Splash large amounts of **COOL** water on affected area. Go to a physician or hospital immediately for treatment.

DO NOT allow refrigerant (R-12) to contact open flames or very hot surfaces such as electric welding arc, electric heating element and lighted smoking materials. Refrigerant (R-12), exposed to high temperature, forms phosgene gas.

Inhaling toxic phosgene gas may result in serious illness or death. Phosgene gas has

an odor like new mown hay or green corn. If you inhale phosgene gas, go to a physician or hospital immediately for treatment.

DO NOT heat refrigerant (R-12) over 52°C (125°F) in a closed container. Heated refrigerant (R-12) will develop high pressure which can burst the container.

Keep refrigerant (R-12) containers away from heat sources. Store refrigerant (R-12) in a cool place.

DO NOT handle damp refrigerant (R-12) container with your bare hands. Skin may freeze to container. Wear gloves.

If skin freezes to container, pour **COOL** water over container to free the skin. Go to a physician or hospital immediately for treatment.

TX,1830,DX359 -19-14APR95-1/1

Check And Add Compressor Oil (Serial No. —541550)

IMPORTANT: The compressor takes a special 525 viscosity oil that has “special additives” which give better compressor life.

If complete system was flushed to remove contamination, the full charge of oil 326 mL (11 fl oz) must be added to the system.

1. Remove compressor. Drain oil from suction port and record amount of oil.
2. If 90—240 mL (3—8 fl oz) was drained from original compressor, add 180 mL (6 fl oz) of new oil back into compressor.
3. If more than 240 mL (8 fl oz) was drained from original compressor, add 180 mL (6 fl oz) of new oil back into compressor. Replace receiver/dryer to remove excess oil from system.
4. If less than 90 mL (3 fl oz) was drained from original compressor, flush all components of system. Replace receiver/dryer and add 330 mL (11 fl oz) of new oil back into system.

Specification

Complete Air Conditioning
System—Oil Quantity 326 mL (11 oz)

5. When installing a compressor that has been disassembled and reassembled with no oil charge,

add an extra 30 mL (1 fl oz) to amounts specified in steps 2, 3 or 4.

6. When installing a new or remanufactured compressor, drain oil. Replace with new oil per steps 2, 3 or 4.
7. If components of system were drained and flushed, add 330 mL (11 fl oz) to compressor.

Specification

Complete Air Conditioning
System—Oil Quantity 326 mL (11 oz)

8. After adding proper amount of oil, rotate compressor shaft four or five times to insure proper lubrication of compressor seal.

IMPORTANT: DO NOT add any more oil than necessary or maximum cooling will be reduced.

9. When servicing individual components, determine oil charge needed using following chart:

Component	Oil Charge
Condenser	30 mL (1 fl oz)
Evaporator	60 mL (2 fl oz)
Receiver/Dryer	10 mL (0.4 fl oz)

TX,1830,DX360 -19-14APR95-1/1

Air Conditioning Gauge Set Installation Procedure (Serial No. —541550)

ESSENTIAL TOOLS
D18018KD Air Conditioning Test Equipment Kit (Serial No. —541550)
JT02020 or JT02021 Air Conditioning Recovery and Recycling System (Serial No. —541550)
JT02022 Refrigerant Recovery System

SERVICE EQUIPMENT AND TOOLS
Air Conditioning Gauge Set

CAUTION: Do not remove high pressure relief valve (D). Air conditioning system will discharge rapidly causing possible injury.

1. Remove cap from low-side test port.
2. Close both valves on air conditioning gauge set.
3. Remove high pressure switch (A) and connect red hose (B).
4. Connect blue hose (C) to low-side test port.
5. Connect yellow hose to Recovery System or a Refrigerant Recovery/Recycling System.

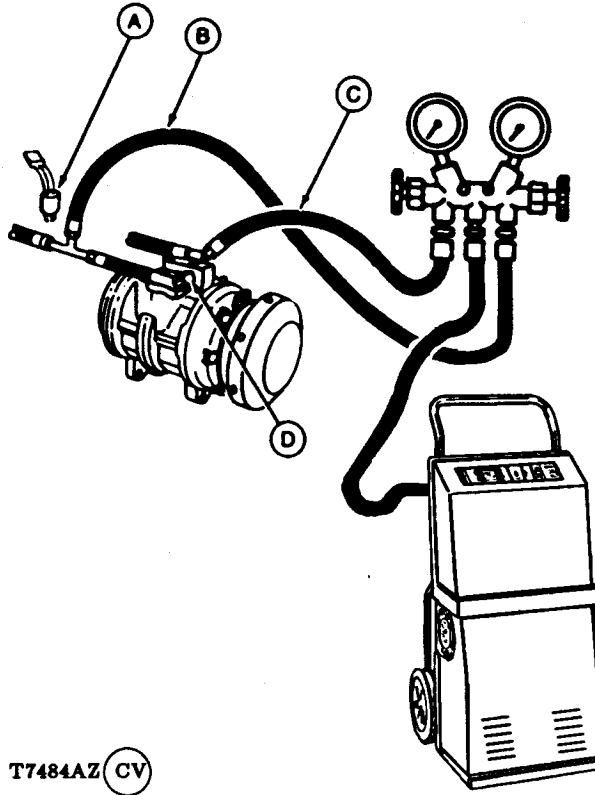

T7484AZ (CV)

- A—High Pressure Switch
- B—Red Hose
- C—Blue Hose
- D—High Pressure Relief Valve

T7484AZ -UN-04APR91

TX,1830,DX361 -19-14APR95-1/1

**Refrigerant Recovery
(Serial No. —541550)**

ESSENTIAL TOOLS

D18018KD Air Conditioning Test Equipment Kit (Serial No. —541550)
JT02020 or JT02021 Air Conditioning Recovery and Recycling System (Serial No. —541550)
JT02022 Refrigerant Recovery System

SERVICE EQUIPMENT AND TOOLS

Air Conditioning Gauge Set

NOTE: Run the air conditioning system for 3 minutes to help in the recovery process. Turn air conditioning system off before proceeding with recovery steps.

1. Connect air conditioning gauge set. (See installation procedure in this group.)
2. Connect yellow hose (C) to a Refrigerant Recovery System or a Refrigerant Recovery/Recycling System.

- A—Red Hose
- B—Blue Hose
- C—Yellow Hose

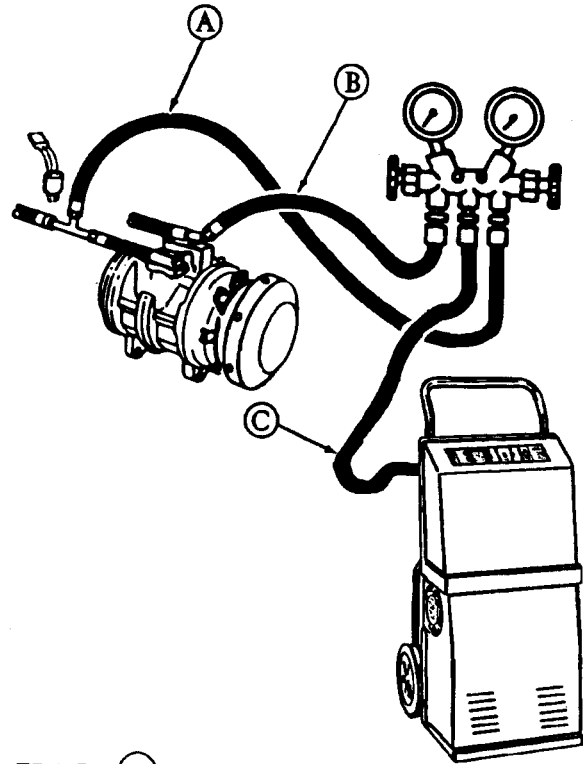

T7484BC (CV)

T7484BC -UN-08APR91

TX,1830,DX362 -19-14APR95-1/1

Evacuate The System (Serial No. —541550)

ESSENTIAL TOOLS

D18018KD Air Conditioning Test Equipment Kit (Serial No. —541550)

SERVICE EQUIPMENT AND TOOLS

Air Conditioning Gauge Set

D05267ST Vacuum Pump

IMPORTANT: DO NOT run compressor while evacuating.

1. Connect air conditioning gauge set. (See installation procedure in this group.)
2. Connect yellow hose of gauge set to a vacuum pump.
3. Start vacuum pump.
4. Open low-side and high-side valves.

NOTE: The vacuum specifications listed are for sea level conditions. Subtract 3.4 kPa (34 mbar) (1 in. Hg) from 98 kPa (980 mbar) (29 in. Hg) for each 300 m (1000 ft) elevation above sea level.

5. Evacuate system until low-side gauge registers 98 kPa (980 mbar) (29 in. Hg) vacuum.

If 98 kPa (980 mbar) (29 in. Hg) vacuum cannot be obtained in 15 minutes, test the system for leaks. (See Leak Testing, 9031-25). Correct any leaks.

6. When vacuum is 98 kPa (980 mbar) (29 in. Hg), close low-side and high-side valves. Turn vacuum pump off.
7. If vacuum decreases more than 3.4 kPa (34 mbar) (1 in. Hg) in 5 minutes, there is a leak in system.
8. Repair leak.
9. Start vacuum pump.
10. Open low-side and high-side valves.
11. Evacuate system for 30 minutes after 98 kPa (980 mbar) (29 in. Hg) vacuum is reached.

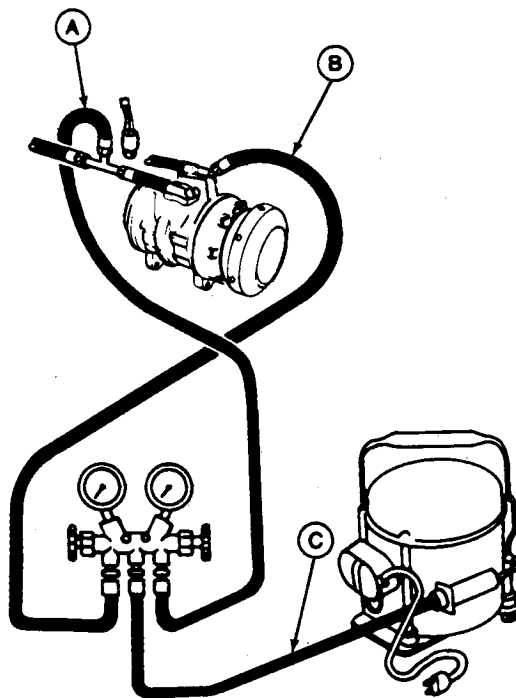

A—Red Hose
B—Blue Hose
C—Yellow Hose

T6597BD -UN-25OCT88

Continued on next page

TX,1830,DX363 -19-14APR95-1/2

Heating And Air Conditioning

12. Close low-side and high-side valves. Stop vacuum pump.
13. Charge the system. (See procedure in this group.)

TX,1830,DX363 -19-14APR95-2/2

18
1830
13

Heating And Air Conditioning

**Charge The System
(Serial No. —541550)**

SPECIFICATIONS	
Air Conditioning System	2.3 kg (5 lb)
Refrigerant Refrigerant Quantity	

ESSENTIAL TOOLS
D18018KD Air Conditioning Test Equipment Kit (Serial No. —541550)

SERVICE EQUIPMENT AND TOOLS
Air Conditioning Gauge Set
D05271ST Charging Cylinder

OTHER MATERIAL
TY6334 U.S. Refrigerant 12

IMPORTANT: DO NOT run compressor while charging the system if using a charging cylinder.

1. Connect air conditioning gauge set. (See installation procedure in this group.)
2. Connect gauge set yellow hose to charge cylinder "HI" valve or container of R-12. If using container of R-12, invert container so valve is on bottom.
3. Open valve completely on charging cylinder of R-12 container.
4. If using a charging cylinder, add 2.3 kg (5 lb) of R-12 through high-side valve.

Specification

Air Conditioning System	
Refrigerant—Refrigerant Quantity	2.3 kg (5 lb)

Close high-side valve.

5. If using containers of R-12, open high-side valve until pressure stops rising. Close valve.
6. Open low-side valve until pressure stops rising.
7. Start engine and run at 1/2 speed.

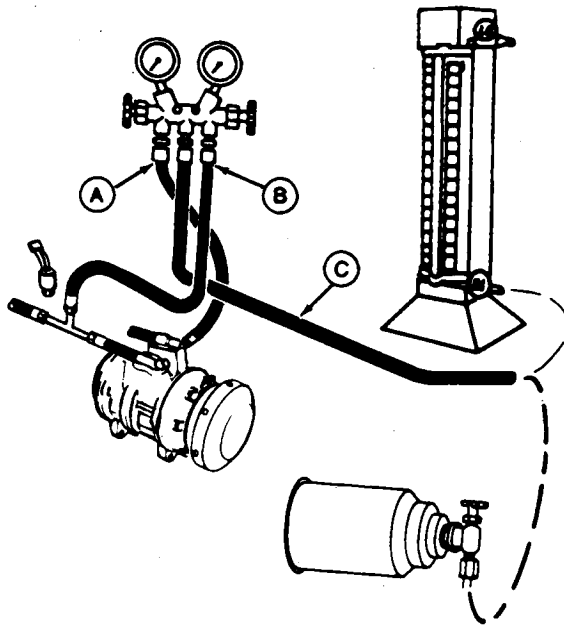

A—Red Hose
B—Blue Hose
C—Yellow Hose

T6597BE -UN-25OCT88

Continued on next page

TX,1830,DX364 -19-14APR95-1/2

18
1830
14

Heating And Air Conditioning

IMPORTANT: Regulate low-side valve to keep low-side pressure reading below 275 kPa (2.8 bar) (40 psi) when charging system. This will assure refrigerant enters system as a vapor. Too much liquid entering the compressor can damage internal parts.

TX,1830,DX364 -19-14APR95-2/2

18
1830
15

Add Refrigerant To The System (Serial No. —541550)

ESSENTIAL TOOLS

D18018KD Air Conditioning Test Equipment Kit (Serial No. —541550)

SERVICE EQUIPMENT AND TOOLS

Air Conditioning Gauge Set

OTHER MATERIAL

TY6334 U.S. Refrigerant 12

1. Connect air conditioning gauge set. (See installation procedure in this group.)
2. Connect yellow hose to a container of R-12.
3. Loosen yellow hose fitting at gauge set. Open valve on refrigerant container for a few seconds to purge air from hose. Tighten fitting.
4. Open valve on refrigerant container. Invert container.
5. Start engine and run at approximately 2000 rpm.

IMPORTANT: Be sure that refrigerant enters system only as a vapor. Too much liquid entering the compressor can damage internal parts. Regulate the valve on the container or low-side valve so that the low-side reading will not exceed 275 kPa (2.8 bar) (40 psi). This will assure that refrigerant in the hose has vaporized before entering the compressor.

6. Open low-side valve just enough to keep pressure less than 275 kPa (2.8 bar) (40 psi).
7. Add refrigerant until bubbles disappear from sight glass.
8. Weigh container of R-12.
9. Add an additional 0.23 kg (0.5 lb) of refrigerant.

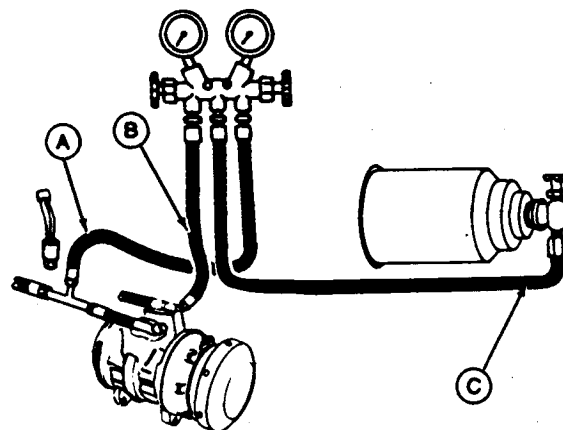

A—Red Hose
B—Blue Hose
C—Yellow Hose

T6597BB -UN-25OCT88

Heating And Air Conditioning

Inspect Vee Belt, Check And Adjust Tension—Air Conditioned Machines Only (Serial No. —541550)

SPECIFICATIONS	
Belt Tension Deflection	13 mm at 100 N (0.5 in. at 23 lb force)
Adjusting Strap Cap Screw Torque	27 N•m (20 lb-ft)

SERVICE EQUIPMENT AND TOOLS
Belt Tension Gauge

TX,1830,DX366 -19-14APR95-1/2

SPECIFICATIONS	
Belt Tension Deflection	13 mm at 100 N (0.5 in. at 23 lb force)
Adjusting Strap Cap Screw Torque	27 N•m (20 lb-ft)

SERVICE EQUIPMENT AND TOOLS
Belt Tension Gauge

1. Check belt regularly for wear. Replace if necessary.
2. Check belt tension.
3. If deflection is not within specifications, loosen compressor mounting cap screws.

Specification

Belt Tension—Deflection 13 mm at 100 N (0.5 in. at 23 lb force)

4. Apply force to FRONT compressor housing only (near the belt) until tension is correct.
5. Tighten cap screws to 27 N•m (20 lb-ft).

Specification

Adjusting Strap Cap Screw—
Torque 27 N•m (20 lb-ft)

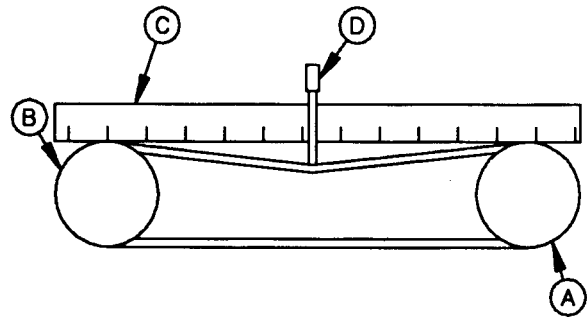

T7527DV (CV)

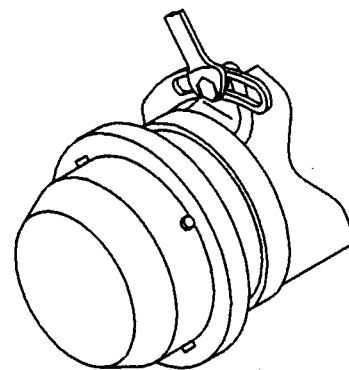

- A—Compressor Pulley
- B—Crankshaft Pulley
- C—Straight Edge
- D—Belt Deflection Gauge

T7527DV -JUN-16JUL91

T7527DW -JUN-16JUL91

18
1830
17

TX,1830,DX366 -19-14APR95-2/2

Remove And Install Compressor (Serial No. —541550)

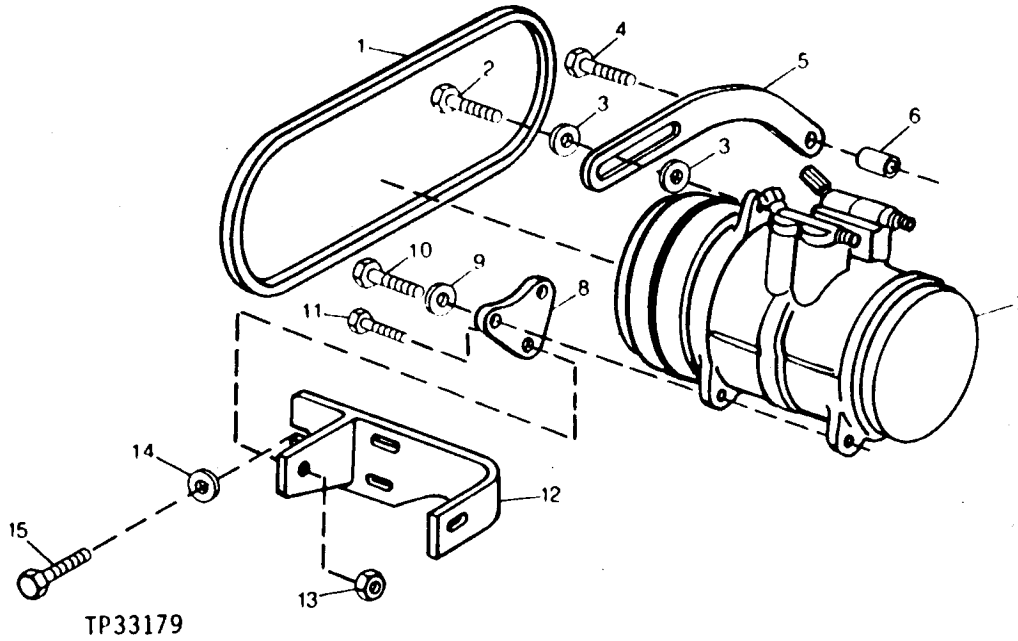

- | | | | |
|-------------------|--------------------|-----------------------|-----------------------|
| 1—Belt | 5—Housing | 9—Washer (4 used) | 13—Lock Nut (2 used) |
| 2—Cap Screw | 6—Bushing | 10—Cap Screw (4 used) | 14—Washer (3 used) |
| 3—Washer (2 used) | 7—Compressor | 11—Screw (2 used) | 15—Cap Screw (3 used) |
| 4—Cap Screw | 8—Bracket (2 used) | 12—Bracket | |

1. Recover refrigerant from the system. (See procedure in this group.)
2. Disconnect wiring lead, suction, and discharge lines.
3. Repair or replace compressor. (See procedure in this group.)
4. Tighten suction line to 31 N•m (23 lb-ft).

Specification

Suction Line—Torque..... 31 N•m (23 lb-ft)

Tighten discharge line to 22 N•m (16 lb-ft).

Specification

Discharge Line—Torque..... 22 N•m (16 lb-ft)

IMPORTANT: Never overtighten belt. Overtightening may cause belt cord damage and excessive load on bearings.

5. Adjust belt tension. (See procedure in this group.)
6. Install a new receiver/dryer.
7. Evacuate and charge the system. (See procedures in this group.)

TP33179 -UN-21JAN92

Volumetric Efficiency Test—R12 (Serial No. —541550)

SERVICE EQUIPMENT AND TOOLS
JT05419 Air Conditioning Service Fitting Kit

OTHER MATERIAL
R49856 U.S. Compressor Oil

1. Drain compressor oil from low side port.
2. If compressor has not been disassembled and internal parts are wet, add 120—150 mL (4—5 oz.) refrigerant oil. If compressor has been disassembled and internal parts are dry, add 150—180 mL (5—6 oz.) refrigerant oil. Add oil through suction port.
3. Stand compressor on each end, then slowly roll for 30 seconds.
4. Mount compressor in a vise and remove dust cover.
5. Remove large caps from both suction and discharge ports, and install JT03195 and JT03182 service fittings from JT05419 Air Conditioning Service Fitting Kit.

Continued on next page

TX,1830,DX367 -19-14APR95-1/2

Heating And Air Conditioning

6. Connect low pressure (left-hand) hose (A) from gauge set to JT03195 fitting. Leave suction port open. Open low pressure valve on manifold.

NOTE: Low pressure gauge is connected to discharge adapter so that pressure reading can be more easily read.

7. Use a speed handle (D) and 12 mm socket to quickly rotate compressor shaft five times.

8. Close low pressure gauge valve and use the speed handle to rotate compressor shaft exactly 20 times in exactly 20 seconds. Read and record pressure on gauge.

9. If pressure read is 370 kPa (3.70 bar) (55 psi) or greater, compressor is serviceable. Check for shaft seal leakage.

10. If pressure is less than 370 kPa (3.70 bar) (55 psi), disassemble the compressor and check the following:

- a. Front and rear head gaskets.
- b. Front and rear suction reed valves.
- c. Front and rear valve plates.
- d. Scored cylinder walls.

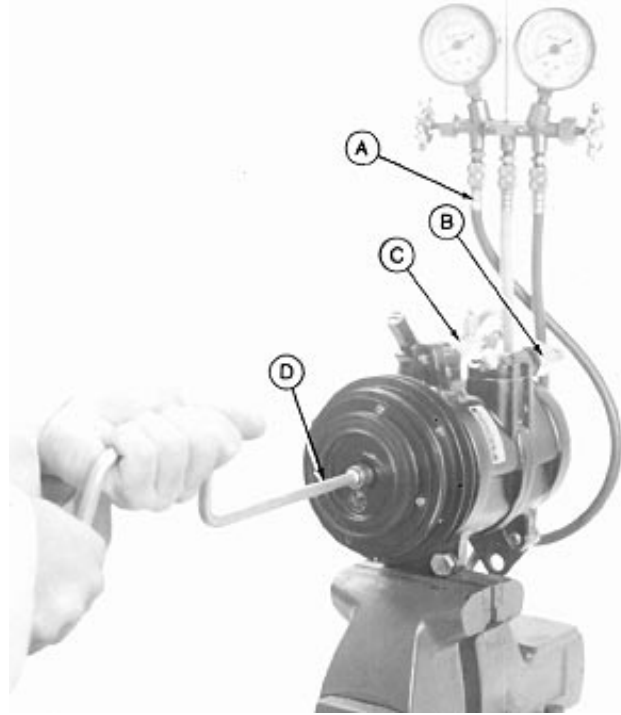

A—Low Pressure Hose
 B—JT03182 Fitting
 C—JT03195 Fitting
 D—Speed Handle

RW3651 -UN-23JAN89

TX,1830,DX367 -19-14APR95-2/2

**Make Shaft Seal Leak Test
 (Serial No. —541550)**

SERVICE EQUIPMENT AND TOOLS

JT05419 Air Conditioning Service Fitting Kit

OTHER MATERIAL

TY6334 U.S. Refrigerant 12

Continued on next page

TX,1830,DX368 -19-14APR95-1/2

18
 1830
 20

Heating And Air Conditioning

NOTE: It is normal for the compressor shaft seal to seep oil at the wick on lower front of compressor. If leakage exceeds 1 pound of refrigerant per year and no other leak is found, replace the shaft seal.

1. Remove large cap from discharge port and install JT03195 (B) and JT03182 (C) service fittings from JT05419 Air Conditioning Service Fitting Kit. Remove small cap from suction manifold, and install low pressure hose from gauge set.
2. Install high pressure hose from gauge set to JT03182 fitting (C).
3. Connect a 397 g (14 oz.) can of R-12 refrigerant (A) to center hose of gauge set. Open both valves on gauge set and pressurize compressor.
4. Use an electronic leak detector to check for leaks from shaft seal and front and rear heads.
5. If there is any leakage, replace shaft seal and end plate gaskets.
6. Bleed pressure from compressor and repair or reinstall on unit.

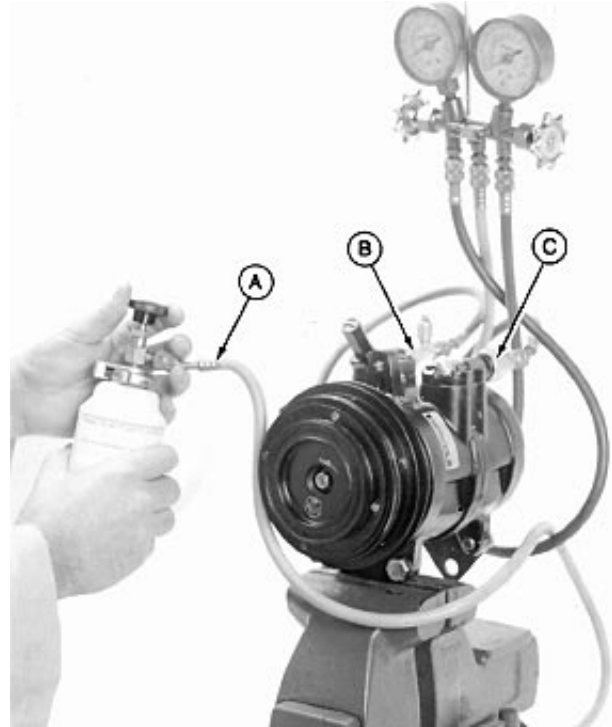

RW3653 -UN-23JAN89

TX,1830,DX368 -19-14APR95-2/2

Disassemble And Inspect Compressor (Serial No. —541550)

1. Mount holding fixture in a bench vise and support compressor on holding fixture.

NOTE: Mounting fixture can be made with two pieces of flat stock and two lengths of threaded rod.

Weld one piece of stock perpendicular to the other, drill two holes and install threaded rod as shown.

Compressor can also be mounted in pivoting D01006AA Bench Holding Fixture or similar holding device.



RW3654 -UN-23JAN89

TX,1830,DX369 -19-14APR95-1/16

2. Remove six dust cover cap screws (A) and remove cover.

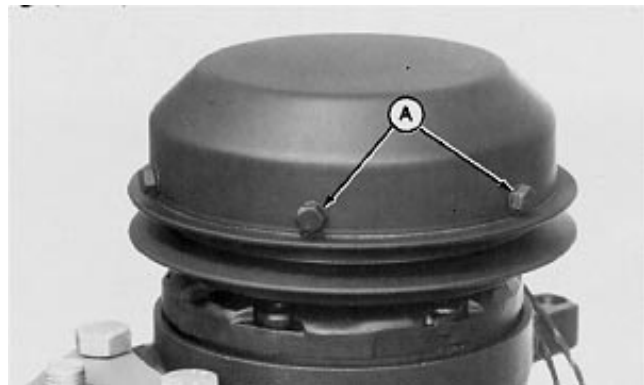

RW3655 -UN-23JAN89

TX,1830,DX369 -19-14APR95-2/16

3. Hold clutch hub with JDG217 Holding Tool (A), and remove clutch hub retaining nut from shaft.

NOTE: If clutch drive plate slips on hub, drill a 1/4 in. hole through flanges of drive plate and hub. Insert a punch to hold clutch hub for removal of hub retaining nut.



RW3656 -UN-23JAN89

Continued on next page

TX,1830,DX369 -19-14APR95-3/16

Heating And Air Conditioning

4. Screw lower portion (A) of JDG216 Clutch Hub Puller into hub.
5. Install forcing screw (B). Hold hub using JDG217 Holding Tool and tighten forcing screw until hub can be removed.

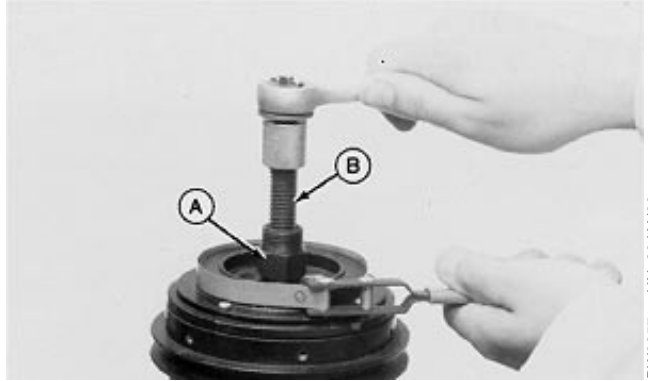

RW3657 -UN-23JAN89

TX,1830,DX369 -19-14APR95-4/16

6. Remove shims (A) from shaft and note quantity. Save shims for reinstallation.
7. Remove and discard snap ring (B) and shaft key (C).

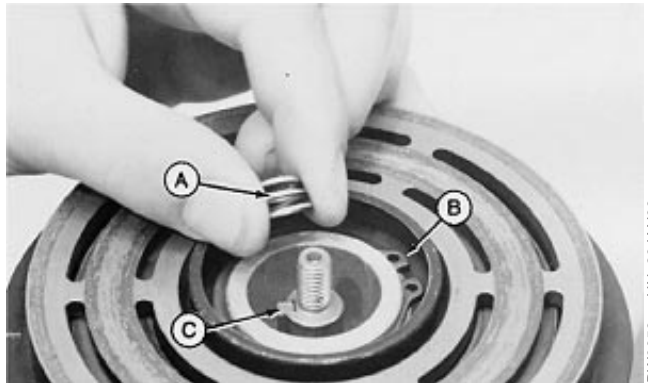

RW3658 -UN-23JAN89

TX,1830,DX369 -19-14APR95-5/16

8. Install JDG220 Driver (A) and use a suitable three jaw puller as shown to remove clutch pulley.

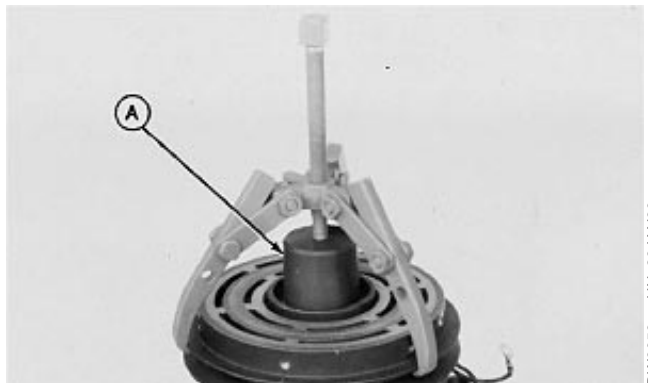

RW3659 -UN-23JAN89

TX,1830,DX369 -19-14APR95-6/16

9. Remove snap ring (A) and disconnect clutch field coil wire from compressor body. Remove clutch and field coil.

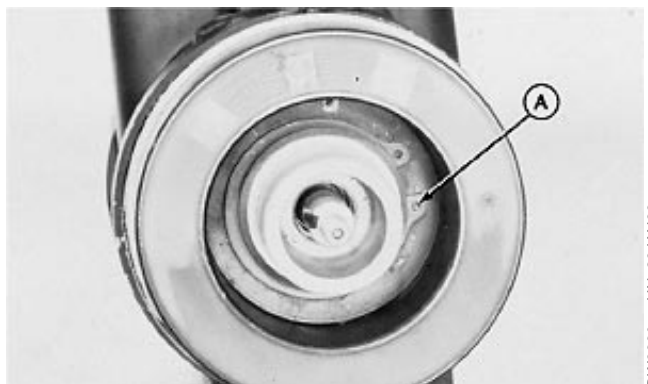

RW3660 -UN-23JAN89

Continued on next page

TX,1830,DX369 -19-14APR95-7/16

18
1830
23

Heating And Air Conditioning

10. Remove six head through-bolts using JDG226 Hex Head Adapter (A).

IMPORTANT: Do not remove through-bolts unless suction and discharge manifolds are in place and tight.

11. Carefully pry head from body using a screw driver. Pry only slightly around the circumference of the head. Repeat this procedure until head is removed.

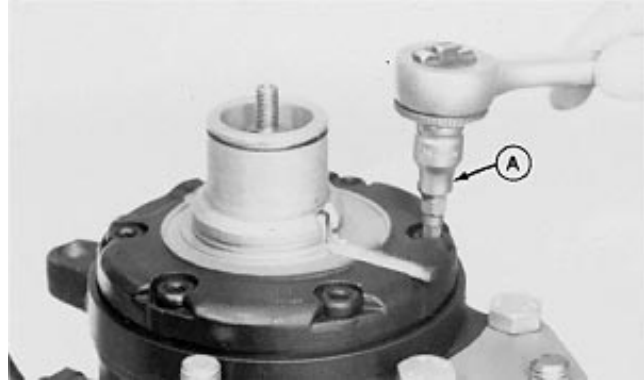

RW3661 -UN-23JAN89

TX,1830,DX369 -19-14APR95-8/16

12. Remove and discard shaft seal (A).

13. Use two screw drivers to remove discharge valve plate (B).

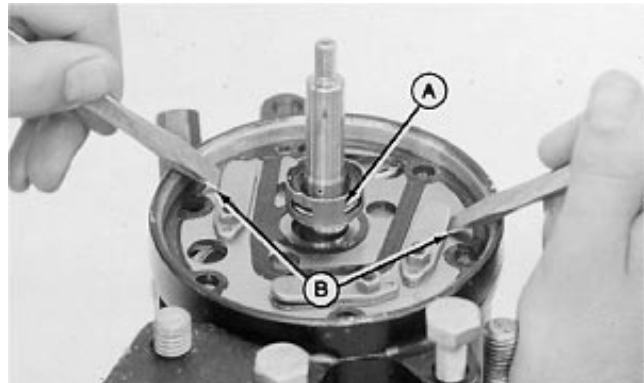

RW10908 -UN-07DEC88

TX,1830,DX369 -19-14APR95-9/16

14. If shaft seal and valve plate remain with compressor head, carefully separate inlet reed valve (A) from valve plate (C). Do not lose locating dowel pin (B).

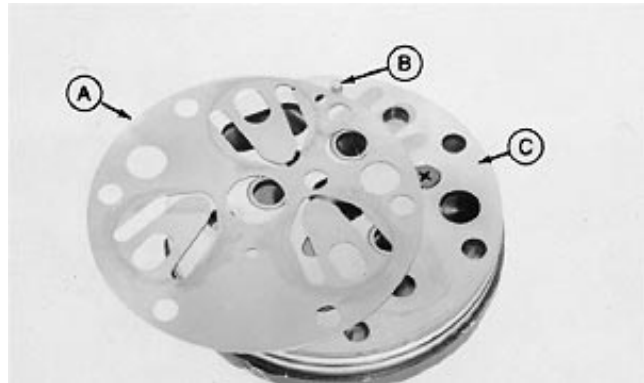

RW10000 -UN-07DEC88

TX,1830,DX369 -19-14APR95-10/16

15. Inspect valve plate side of inlet reed valves for a complete circular wear pattern (A).

16. If wear pattern has any voids in it, replace reed valve.

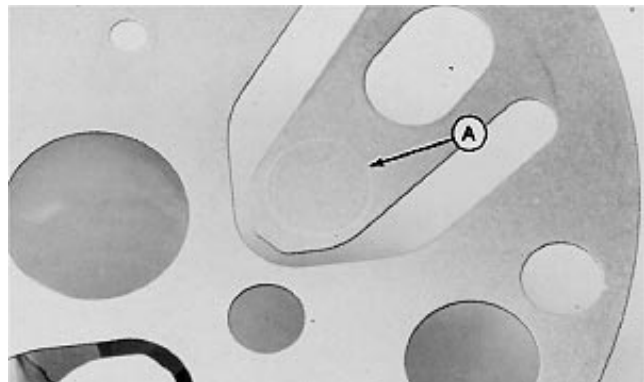

RW3665 -UN-23JAN89

Continued on next page

TX,1830,DX369 -19-14APR95-11/16

18
1830
24

Heating And Air Conditioning

17. Install JDG227 Puller (A) and carefully pull valve plate (B) from head (C).

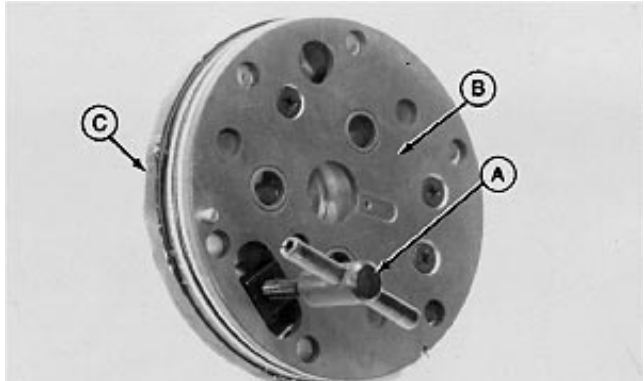

RW3663 -UN-23JAN89

TX,1830,DX369 -19-14APR95-12/16

18. Inspect discharge valve plate for general condition. Valves (A) should have slight pressure against valve plate.
19. Hold valve plate up to light and verify that valve is against its seat. If condition is doubtful, replace valve plate.

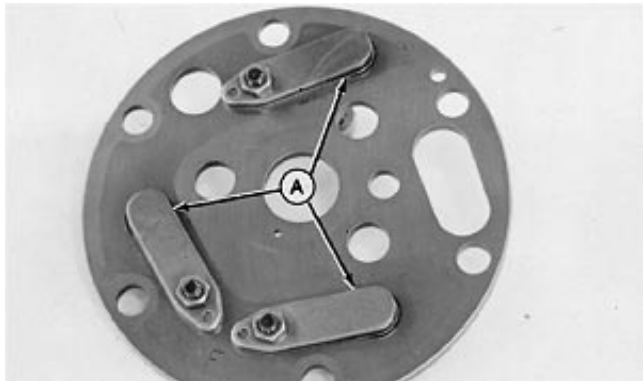

RW10001 -UN-07DEC88

TX,1830,DX369 -19-14APR95-13/16

20. Inspect cylinders for scoring or excessive wear. If cylinders are scored or damaged, replace compressor.

NOTE: Some cylinder scuffing (light scratches) is normal.



RW3667 -UN-23JAN89

TX,1830,DX369 -19-14APR95-14/16

21. Turn compressor over and remove rear head by prying on the small tabs cast into the head. Pry lightly around circumference of head.



RW3668 -UN-23JAN89

Continued on next page

TX,1830,DX369 -19-14APR95-15/16

18
1830
25

Heating And Air Conditioning

22. Separate reed valve (A) from valve plate (B). Inspect the three valves (C) for complete circular wear pattern. If wear pattern has any voids in it, replace reed valve.

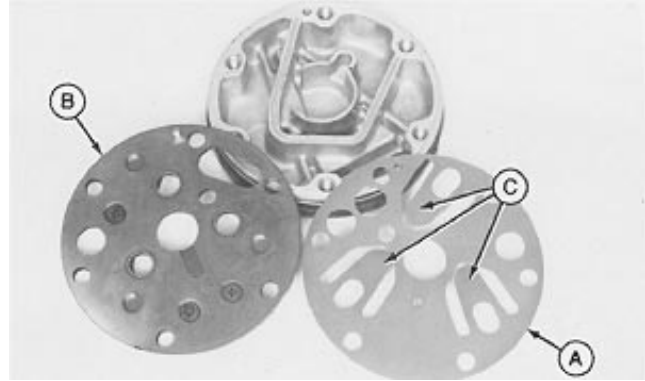

RW3669 -UN-23JAN89

TX,1830,DX369 -19-14APR95-16/16

Clutch Pulley, Bearing And Hub Inspection

1. Inspect surfaces of clutch pulley (A) and clutch hub (B). If pulley is more than 0.3 mm (0.012 in.) from flat, replace pulley and clutch hub.
2. Rotate bearing in pulley. If bearing is rough or has evidence of loss of lube, replace bearing.
3. Clean up as necessary.

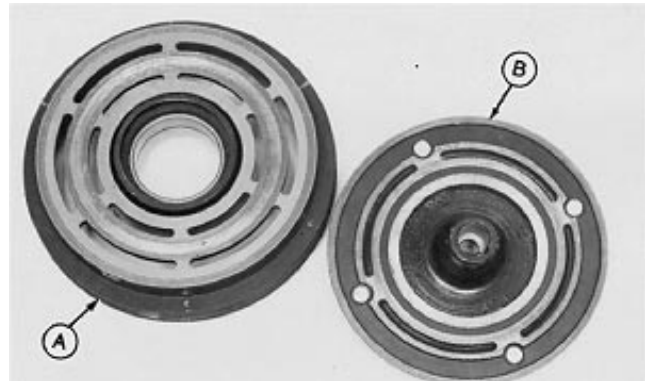

RW3677 -UN-23JAN89

U90,090005,AKX1 -19-28JUN90-1/1

Replacing Clutch Pulley Bearing

1. Remove retaining ring (A) from pulley bore.

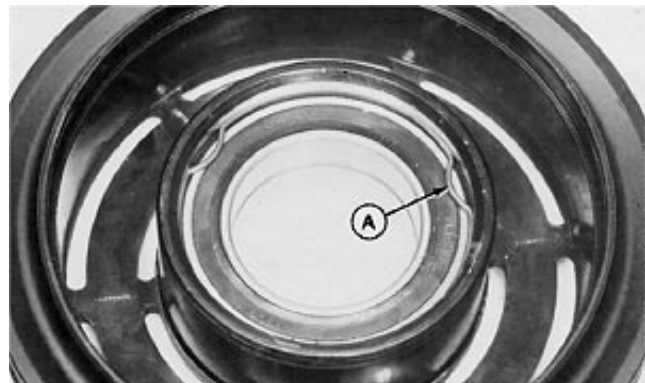

RW3670 -UN-23JAN89

U90,090005,ADX1 -19-28JUN90-1/4

2. Support pulley on JDG223 Receiving Cup (A). Use JDG221 Driver (B) and JDG220 Driver (C) to press bearing from pulley.

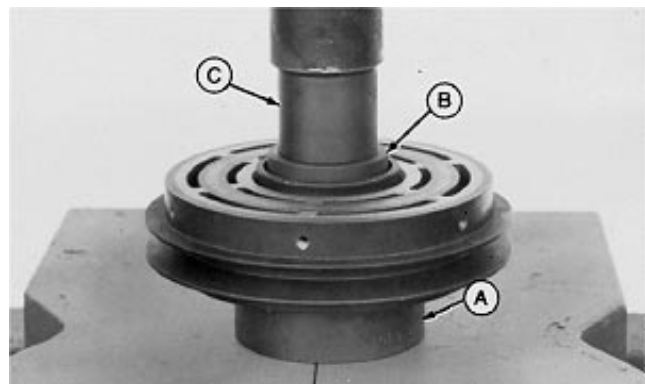

RW3671 -UN-23JAN89

Continued on next page

U90,090005,ADX1 -19-28JUN90-2/4

18
1830
26

Heating And Air Conditioning

3. Before installing new bearing, be sure to place dust shield into pulley. Install as shown with lip edge facing up.



RW3672 -UN-23JAN89

U90,090005,ADX1 -19-28JUN90-3/4

4. Support pulley on JDG225 Support (A). Be sure dust shield seats in support tool and set bearing in place.
5. Use JDG221 Driver (B) and JDG220 Driver (C) to press bearing in until it bottoms on dust shield.
6. Install bearing retaining ring.



RW3673 -UN-23JAN89

U90,090005,ADX1 -19-28JUN90-4/4

Replace Shaft Seal Seat

1. Support front head on press and use JDG228 Driver to press seat from head.



RW3674 -UN-23JAN89

U90,090005,AHX1 -19-08OCT90-1/3

2. Lubricate the new O-ring (A) on the seal seat (B) with a small amount of clean refrigerant oil.
3. Place seat in bore with grooved surface of seat facing up as shown.

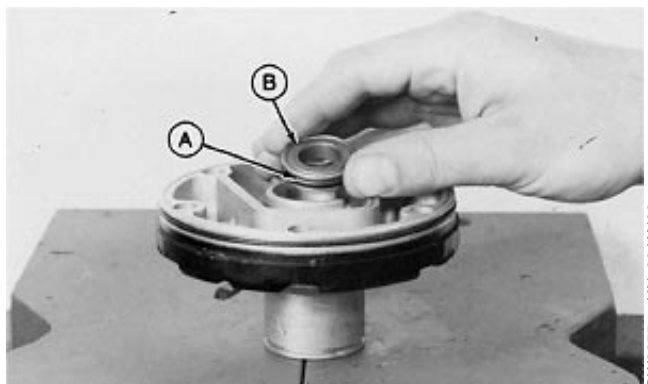

RW3675 -UN-23JAN89

Continued on next page

U90,090005,AHX1 -19-08OCT90-2/3

18
1830
27

Heating And Air Conditioning

4. Press seal seat in using JDG229 Driver until it bottoms in bore.



RW3676 -UN-23JAN89

U90,090005,AHX1 -19-08OCT90-3/3

Assemble Compressor (Serial No. —541550)

1. Remove gaskets from both front and rear heads. Be sure all gasket material is removed. Wash all parts in clean solvent before assembly.
2. Place suction reed valve against compressor side of rear head. Install locating dowel pin to assure that reed valve and valve plate are properly indexed. Set in place in compressor.
3. Carefully install new head gasket. Be sure it is properly in place.
4. Carefully install rear head. Be sure locating dowel pin is in position in head. Lightly tap head into place.
5. Turn compressor over and install suction reed and valve plate. Install new head gasket.

Continued on next page

TX,1830,DX370 -19-14APR95-1/6

Heating And Air Conditioning

6. Be sure to install new shaft seal (A) as shown. Be sure slotted rear side of seal engages with flats on compressor shaft.

IMPORTANT: This is a two piece seal. Be sure they are properly installed or breakage will occur during assembly of front head.

7. Place front head on compressor. Be sure to align head with dowel pin. Use the six cap screws to draw the head down **EVENLY**, then tighten to 26 N•m (19 lb-ft).

Specification

Front Head Cap Screw—Torque 26 N•m (19 lb-ft)

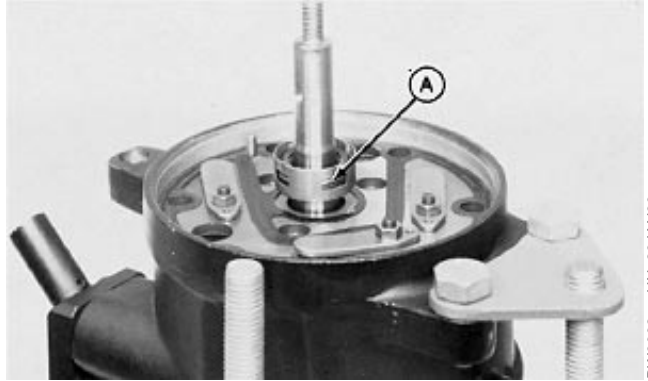

RW3662 -JUN-23JAN89

TX,1830,DX370 -19-14APR95-2/6

8. Place new shaft key in key way. Position JDG219 Key Driver (A) over key. Be sure slotted area of driver (B) fits in place over key.
9. Use a small hammer to tap key in until it bottoms in key way groove.

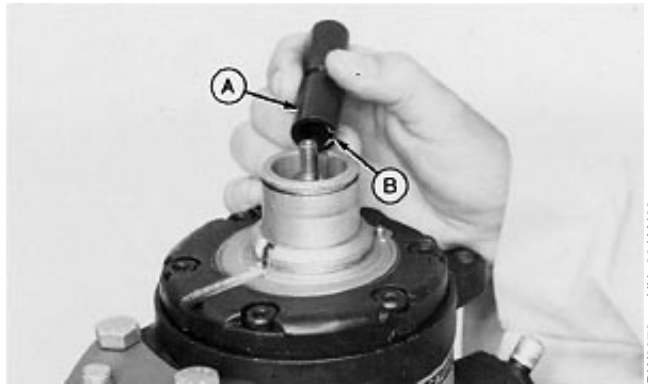

RW3678 -JUN-23JAN89

TX,1830,DX370 -19-14APR95-3/6

10. Position clutch coil over head. Be sure to position it properly over roll pin (B). Install snap ring (A). Install with rounded edge facing upward.
11. Connect clutch coil wire to ground screw on compressor.
12. Set clutch pulley in place over coil. Slight tap may be needed to properly position pulley on shaft.

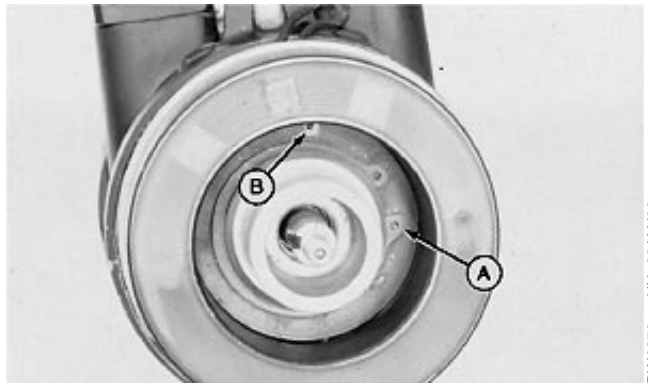

RW3679 -JUN-23JAN89

Continued on next page

TX,1830,DX370 -19-14APR95-4/6

18
1830
29

Heating And Air Conditioning

13. Install new snap ring (A) with rounded edge of snap ring facing upward. Install removed shims (B) on front head.
14. Place clutch hub over compressor shaft. Be sure hub key way is aligned with key.
15. Tighten pulling nut until clutch hub is pulled tight against shims on compressor shaft shoulder.

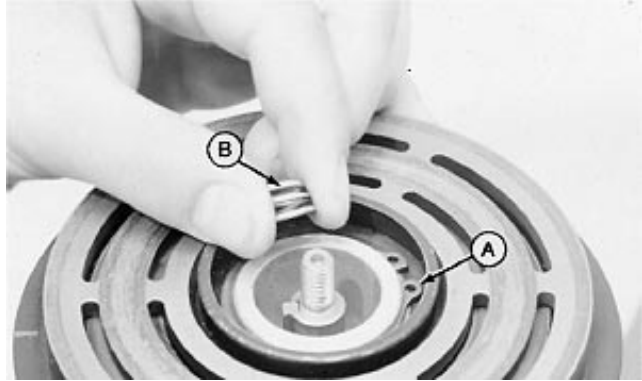

RW3684 -UN-23JAN89

TX,1830,DX370 -19-14APR95-5/6

16. Use a feeler gauge to check pulley-to-hub clearance. Check clearance in three equally spaced locations around the hub.
17. Rotate the pulley one-half turn (180°) and again check the clearance in three equally spaced locations.
18. Correct clearance is 0.53—0.91 mm (0.021—0.036 in.).

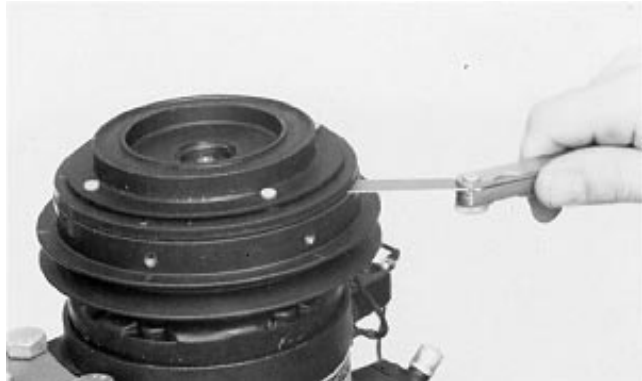

RW3682 -UN-23JAN89

Specification

Pulley-To-Clutch Hub—Clearance 0.53—0.91 mm (0.021—0.036 in.)

Add or remove shims as necessary to obtain proper clearance.

19. After correct pulley-to-hub clearance is obtained, torque clutch hub to 16 N•m (12 lb-ft).

Specification

Hub Retaining Nut—Torque 16 N•m (12 lb-ft)

TX,1830,DX370 -19-14APR95-6/6

Leak Testing (Serial No. —541550)

1. Inspect all lines, fittings, and components for oily or dusty spots. When refrigerant leaks from system, a small amount of oil is carried out with it.
2. A soap and water solution can be sprayed on components in system to form bubbles at source of leak.
3. If a leak detector is used, move leak detector probe under hoses and around connections at a rate of 25 mm (1 in.) per second. Refrigerant R-12 is heavier than air so it will normally be under leak.
4. Some Freon manufacturers add dye to Freon to aid in leak detection.

TX,1830,DX371 -19-14APR95-1/1

Refrigerant Hoses And Tubing Inspection (Serial No. —541550)

When a component is disconnected from the system, special care should be given to inspecting hoses and tubing for moisture, grease, dirt, rust, or other foreign material. If such contamination is present in hoses, tubing, or fittings and cannot be removed by cleaning, then replace parts.

Fittings that have grease or dirt on them should be wiped clean with a cloth dampened with alcohol. Chlorinated solvents (such as trichloroethylene) are contaminants, and must not be used for cleaning.

To assist in making leak-proof joints, use a small amount of clean 525 viscosity refrigerant oil on all

hose and tube connections. Dip O-rings in 525 oil before assembling.

IMPORTANT: Hose used for air conditioning systems contains special barriers in its walls to prevent migration of refrigerant gas.

DO NOT use hydraulic hoses as replacement hoses in the air conditioning system. Use ONLY certified hose meeting SAE J51b requirements.

TX,1830,DX372 -19-14APR95-1/1

18
1830
31

Remove And Install Condenser (Serial No. —541550)

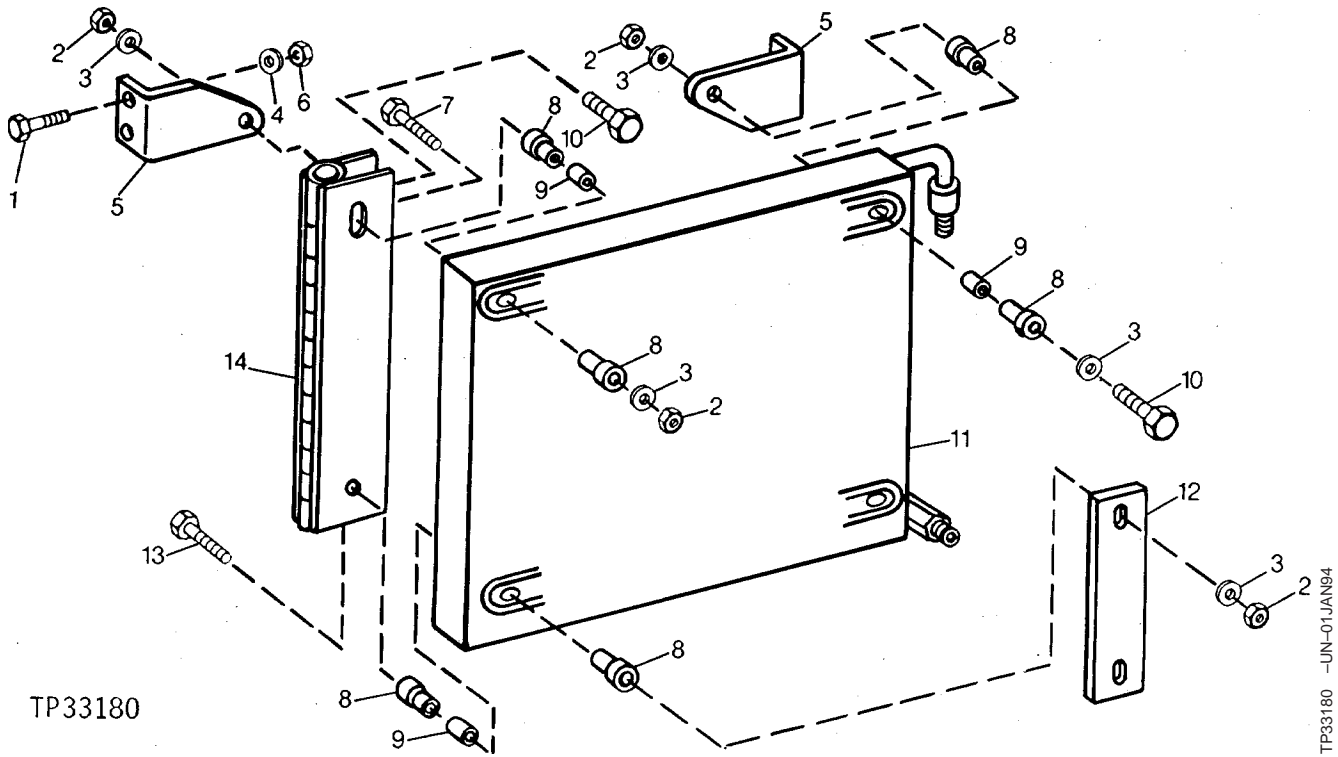

TP33180

TP33180 -JUN-01JAN94

- | | | | |
|---------------------|-------------------------|--------------------|--------------|
| 1—Screw (8 used) | 5—Bracket (2 used) | 9—Bushing (4 used) | 12—Strap |
| 2—Lock Nut (4 used) | 6—Lock Nut (8 used) | 10—Screw (2 used) | 13—Cap Screw |
| 3—Washer (6 used) | 7—Cap Screw | 11—Condenser | 14—Hinge |
| 4—Washer (8 used) | 8—Rubber Mount (8 used) | | |

1. Recover refrigerant from the system. (See procedure in this group.)
2. Evacuate and charge the system. (See procedures in this group.)

TX,1830,DY071 -19-20APR95-1/1

Heating And Air Conditioning

Remove And Install Receiver/Dryer (Serial No. —541550)

1. Recover refrigerant from system. (See procedure in this group.)
2. Evacuate and charge the system. (See procedure in this group.)

- 1—Receiver/Dryer
- 2—Lock Nut (2 used)
- 3—Washer (2 used)
- 4—Spacer (2 used)
- 5—Clip (2 used)
- 6—Cap Screw (2 used)

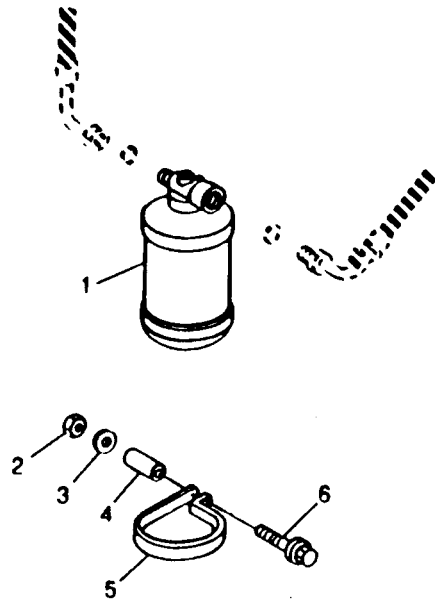

TX,1830,DY072 -19-20APR95-1/1

TP33181 -UN-21JAN92

Remove And Install Expansion Valve (Serial No. —541550)

1. Recover refrigerant from system. (See procedure in this group.)
2. Remove seat.
3. Disconnect line (A) and tube (B).
4. Remove expansion valve.
5. Install expansion valve.
6. Connect tube (B) and line (A).
7. Attach sensing bulb (C) to evaporator outlet with clip.
8. Evacuate and charge the system. (See procedures in this group.)
9. Install seat.

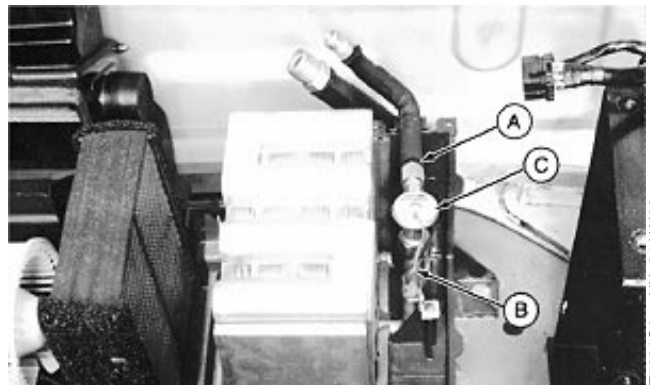

T7681CJ -UN-21JAN92

18
1830
33

TX,1830,DY073 -19-20APR95-1/1

Expansion Valve Bench Test And Adjustment (Serial No. —541550)

SERVICE EQUIPMENT AND TOOLS

Air Conditioning Gauge Set

TX,1830,DX373 -19-14APR95-1/3

1. Connect expansion valve to air conditioning gauge set using fittings (A—C).
2. Connect yellow hose to an air supply.
3. Close low-side valve and open high-side valve.
4. Adjust pressure on high-side valve to 570 kPa (5.2 bar) (75 psi) using a pressure regulator or by adjusting high-side valve.
5. Hold sensing bulb in hand until pressure on low-side gauge stops increasing. Pressure must be 280—380 kPa (2.8—3.8 bar) (40—55 psi).
6. Put sensing bulb in a container of ice water until pressure on low-side gauge stops decreasing. Pressure must be 140—170 kPa (1.4—1.7 bar) (20—25 psi).

A—JT03184 Tee Fitting With 0.020 in. Orifice Cap
 B—JT03183 Fitting
 C—JT03195 Tee Fitting

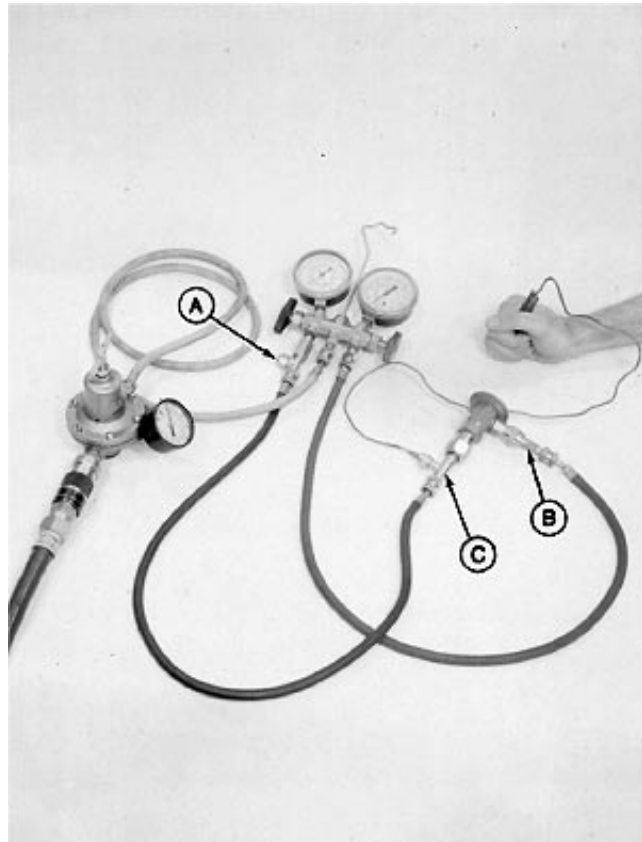

T84070 -UN-06DEC88

Continued on next page

TX,1830,DX373 -19-14APR95-2/3

Heating And Air Conditioning

- If pressures are not correct, turn adjusting screw clockwise to decrease pressure or counterclockwise to increase pressure. One turn will change pressure approximately 20 kPa (0.2 bar) (3 psi).

If pressure cannot be adjusted to specifications, install a new valve.

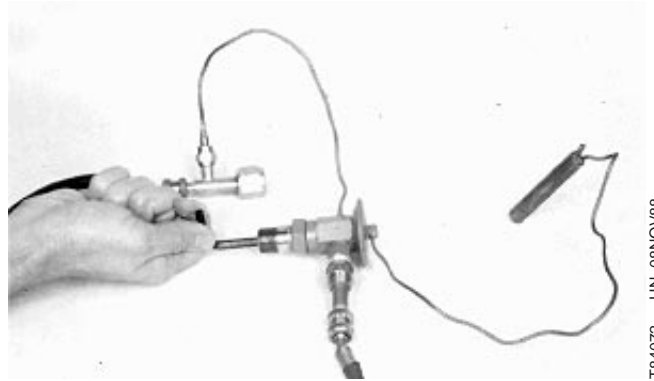

T84072 -UN-08NOV88

TX,1830,DX373 -19-14APR95-3/3

Remove And Install Evaporator (Serial No. — 541550)

- Recover refrigerant from system. (See procedure in this group.)
- Remove seat. (See procedure in Group 1821.)
- Remove screws (C) to remove top cover (A).
- Remove air conditioner cover (B).
- Remove tube (E) from evaporator (D).
- Remove evaporator.
- Inspect parts. Replace as necessary.
- Install evaporator and connect tube.
- Check and add compressor oil. (See procedure in this group.)
- Evacuate and charge the system. (See procedures in this group.)
- Install air conditioning cover and top cover.
- Install seat. (See procedure in Group 1821.)



T7681CK -UN-21JAN92



T7681CL -UN-21JAN92

- A—Top Cover
- B—Air Conditioner Cover
- C—Screw (4 used)
- D—Evaporator
- E—Tube

18
1830
35

TX,1830,DY074 -19-20APR95-1/1

Remove And Install Low And High Pressure Switches (Serial No. —541550)

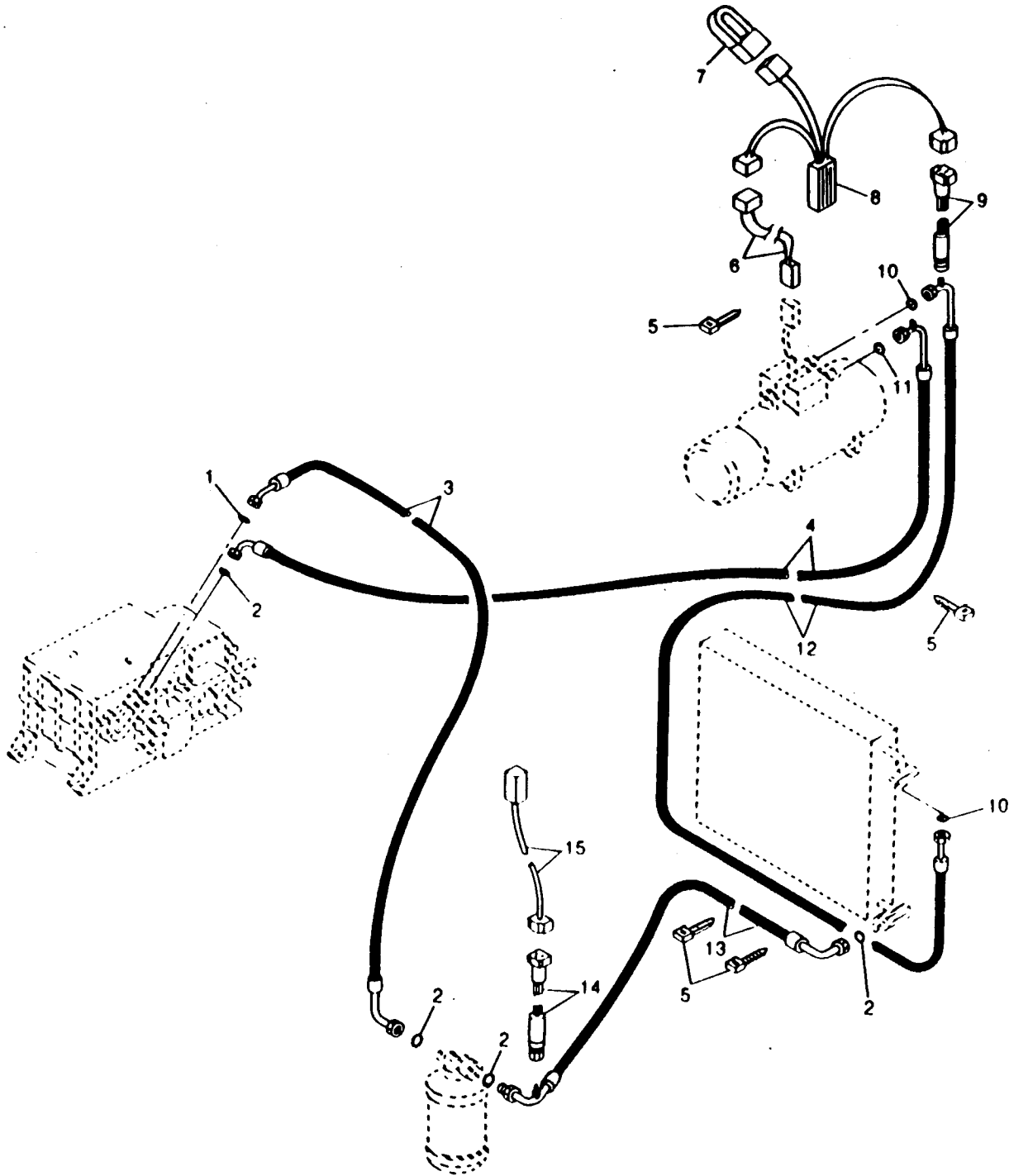

- | | | | |
|--|------------------------|---------------------------------|--|
| 1—O-Ring | 5—Tie Band | 10—O-Ring (2 used) | 13—Condenser-to-Receiver
Dryer Hose |
| 2—O-Ring (4 used) | 6—Connector | 11—O-Ring | 14—Low Pressure Switch |
| 3—Evaporator-to-Receiver
Dryer Hose | 7—Diode | 12— | 15—Connector |
| 4—Evaporator-to-Compressor
Hose | 8—Connector | Compressor-to-Condenser
Hose | |
| | 9—High Pressure Switch | | |

T7681CM -JUN-21,JAN92

TX,1830,DY075 -19-20APR95-1/1

Heating And Air Conditioning

Remove And Install Thermostat Switch, Air Conditioner Relay, And Compressor Relay (Serial No. —541550)

- A—Thermostat Switch
- B—Air Conditioner Relay (Blue/Black, Blue/White, Red/White, and Blue/Green Wire Leads)
- C—Compressor Relay (Blue/White, Blue/Red, Red/White, and Red/Black Wire Leads)

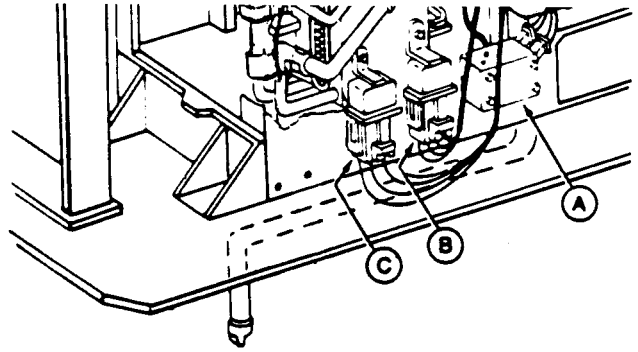

T7681CN -JUN-21JAN92

TX,1830,DY076 -19-20APR95-1/1

Remove And Install Air Conditioning Switch (Serial No. —541550)

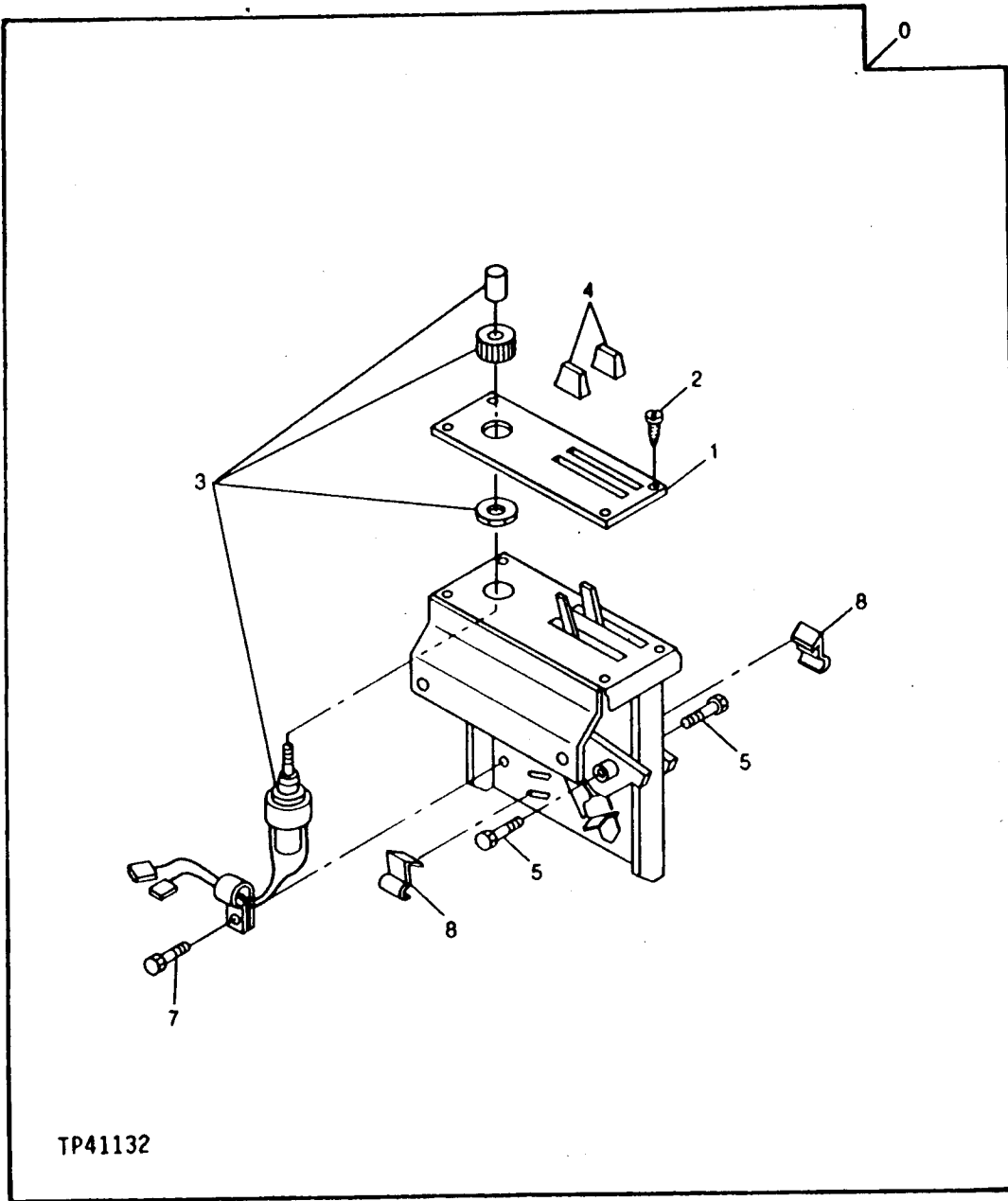

TP41132

0—Control
1—Plate

2—Clamp (4 used)
3—Switch

4—Knob (2 used)
5—Bolt (2 used)

7—Screw
8—Clamp (2 used)

18
1830
38

TP41132 -UN-21JAN92

Section 20 Safety And Convenience

Contents

Page

Group 2004—Horn And Warning Devices

Propel Alarm

Remove and Install20-2004-1

Changing Travel Alarm Volume.20-2004-1

Contents

[Empty content area for the table of contents]

Group 2004 Horn And Warning Devices

Remove And Install Propel Alarm

1. Disconnect battery ground cable.
2. Disconnect wire lead (A).
3. On earlier machines, remove four nuts (C) to remove propel alarm (B).
4. On later machines, remove two cap screws (C) to remove propel alarm (B).
5. Inspect alarm. Replace as necessary.
6. On earlier machines, install alarm (B) and four nuts (C).
7. On later machines, install propel alarm (B) and two cap screws (C).
8. Connect wire lead (A).
9. Connect battery ground cable.

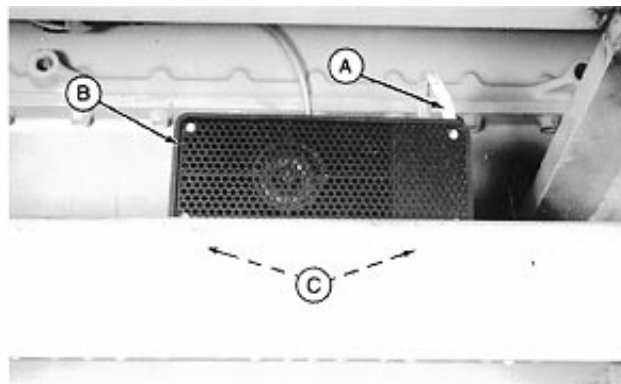

Earlier Machine Shown

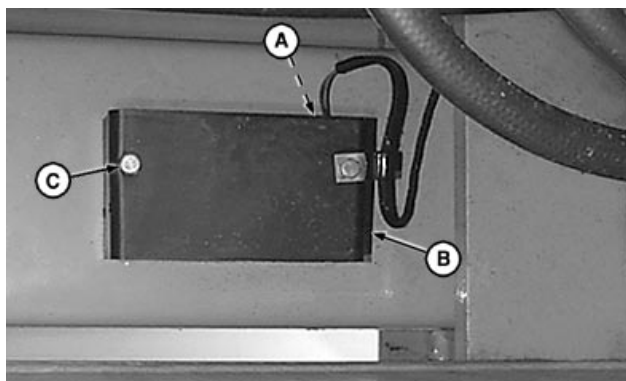

Later Machine Shown

TX,20,DY2939 -19-25AUG97-1/1

Changing Travel Alarm Volume

IMPORTANT: It may be necessary to adjust travel alarm volume to meet local regulations.

NOTE: Alarm removed from machine for clarity of photograph.

Move switch (A) to adjust volume of travel alarm. The alarm can be set at "HIGH," "MED" (medium), or "LOW" volume.

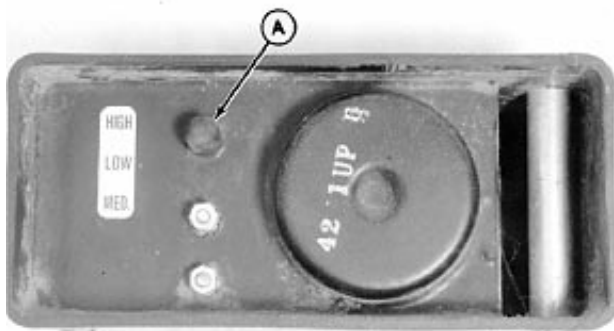

TX,90,FF2487 -19-13AUG91-1/1

Horn And Warning Devices

20
2004
2

Section 33 Excavator

Contents

	Page		Page
Group 3302—Bucket			
Specifications	33-3302-1	Hydraulic Pump (SN -559602)	
Bucket Tooth Tip-Heavy-Duty Bucket		Assemble.	33-3360-41
Replacing.	33-3302-1	Hydraulic Pump (SN 559603-)	
Tooth Shank		Disassemble and Assemble.	33-3360-52
Remove and Install	33-3302-2	Pump Displacement Solenoid Valve (SN	
Bucket and Linkage (SN -538759)		-559602)	
Remove and Install	33-3302-5	Remove and Install	33-3360-52
Bucket and Linkage (SN 538760-)		Pump Displacement Solenoid Valve (SN	
Remove and Install	33-3302-7	559603-)	
Bucket and Linkage		Remove and Install	33-3360-53
Adjust	33-3302-8	Pump Displacement Solenoid Valve (SN	
Cutting Edge		-559602)	
Replace Welded	33-3302-10	Disassemble and Assemble.	33-3360-54
Repair Cracked	33-3302-10	Pump Displacement Solenoid Valve (SN	
		559603-)	
		Disassemble and Assemble.	33-3360-55
Group 3340—Frames			
Specifications	33-3340-1	Load Sense Valve (SN -559602)	
Other Material	33-3340-1	Remove and Install	33-3360-56
Arm		Load Sense Valve (SN 559603-)	
Remove and Install	33-3340-2	Remove and Install	33-3360-57
Boom		Load Sense Valve (SN -559602)	
Remove and Install	33-3340-4	Disassemble and Assemble.	33-3360-58
Bushings and Seals		Load Sense Valve (SN 559603-)	
Remove and Install	33-3340-7	Disassemble and Assemble.	33-3360-59
		Pilot Pump	
		Remove and Install	33-3360-60
		Disassemble and Assemble.	33-3360-60
Group 3360—Hydraulic System			
Special Or Essential Tools	33-3360-1	Pilot Filter	
Service Equipment And Tools	33-3360-2	Remove and Install	33-3360-62
Other Material	33-3360-4	Hydraulic Oil Filter	
Specifications	33-3360-5	Inspect.	33-3360-63
Lower Boom With Engine Stopped	33-3360-13	Pilot Shut-Off Valve	
Raise Boom With Engine Stopped	33-3360-15	Remove and Install	33-3360-64
Swing Upperstructure With Engine		Disassemble and Assemble.	33-3360-65
Stopped.	33-3360-18	Linkage Adjustment	33-3360-66
Hydraulic Oil Cleanup Procedure	33-3360-21	Dig Function Pilot Controller	
Hydraulic Pump (SN -559602)		Remove and Install	33-3360-68
Remove and Install	33-3360-23	Disassemble and Assemble.	33-3360-70
Hydraulic Pump (SN 559603-)		Propel Pilot Controller (SN -547853)	
Remove and Install	33-3360-25	Remove and Install	33-3360-72
Hydraulic Pump		Propel Pilot Controller (SN -547854)	
Start-Up Procedure	33-3360-28	Remove and Install	33-3360-73
Hydraulic Pump (SN -559602)		Propel Pilot Controller	
Disassemble	33-3360-30	Disassemble and Assemble.	33-3360-76
Hydraulic Pump			
Inspect.	33-3360-38		

Continued on next page

Contents

	Page		Page
Dig Pilot Check Valve Block (SN 543990-559935)		Power Boost Solenoid Valve (SN 556936-)	
Remove and Install	33-3360-81	Remove and Install	33-3360-119
Dig Pilot Check Valve Block (SN 559936-)		Circuit Relief and Anti-Cavitation Valves (SN -556935)	
Remove and Install	33-3360-82	Remove and Install	33-3360-120
Propel Pilot Check Valve Block		Bucket Circuit Relief and Anti-Cavitation Valves (SN 556936-)	
Remove and Install	33-3360-83	Remove and Install	33-3360-121
Disassemble and Assemble	33-3360-85	Boom, Arm, and Bucket Valve Section (SN -556935)	
Hydraulic Control Valve (SN -556935)		Disassemble and Assemble	33-3360-122
Remove and Install	33-3360-86	Swing Valve Section	
Boom, Arm, and Swing Control Valve Manifold (SN 556936-)		Disassemble and Assemble	33-3360-127
Remove and Install	33-3360-97	Propel Valve Section (SN -556935)	
Return Manifold (SN 556936-)		Disassemble and Assemble	33-3360-132
Remove and Install	33-3360-106	Boom, Arm, and Swing Control Valve (SN 556936-)	
Oil Cooler Bypass Valve (SN 556936-)		Disassemble and Assemble	33-3360-136
Remove and Install	33-3360-107	Make-Up Valve (SN -556935)	
Arm Cylinder Restrictor (SN 546276-556935)		Remove and Install	33-3360-136
Remove and Install	33-3360-107	Propel Circuit Make-Up Valve (SN 556936-)	
Arm and Boom Cylinder Restrictors (SN 556936-)		Remove and Install	33-3360-137
Remove and Install	33-3360-109	Auxiliary Valve Section (SN -556935)	
Anti-Cavitation Back Pressure Check Valve (SN -556935)		Disassemble and Assemble	33-3360-137
Remove and Install	33-3360-109	Monoblock Control Valve (SN 556936-)	
Anti-Cavitation Back Pressure Check Valve (SN 556936-)		Remove and Install	33-3360-138
Remove and Install	33-3360-110	Monoblock Control Valve Manifold (SN 556936-)	
Combined Function Shuttle Valve (SN -556935)		Disassemble and Assemble	33-3360-142
Remove and Install	33-3360-112	Safety Relief Valve (SN 556936-)	
Combined Function Shuttle Valve (SN 556936-)		Remove and Install	33-3360-143
Remove and Install	33-3360-112	Disassemble and Assemble	33-3360-144
Disassemble and Assemble	33-3360-113	Boom Regenerative Valve (SN 545157-556935)	
Pressure Control Manifold (SN -556935)		Remove and Install	33-3360-145
Remove and Install	33-3360-114	Disassemble and Assemble	33-3360-146
Load Sense System Relief Valve (SN -556935)		Arm Regenerative Valve (SN 546277-556935)	
Disassemble and Assemble	33-3360-114	Remove and Install	33-3360-147
Load Sense System Relief Valve (SN 556936-)		Disassemble and Assemble	33-3360-148
Remove and Install	33-3360-115	Arm Regenerative Poppet Valve (SN 556936-)	
Disassemble and Assemble	33-3360-116	Remove and Install	33-3360-149
Safety Valve (SN -556935)		Arm Regenerative Valve (SN 556936-)	
Disassemble and Assemble	33-3360-117	Disassemble and Assemble	33-3360-150
Pilot Pressure Regulating Valve (SN -556935)		Stop Cushion Valve	
Disassemble and Assemble	33-3360-117	Remove and Install	33-3360-151
Pilot Pressure Regulating Valve (SN 556936-)		Swing Stop Cushion Valve (SN 546277-)	
Remove and Install	33-3360-118	Disassemble and Assemble	33-3360-152
Disassemble and Assemble	33-3360-118	Swing Torque Control Valve (SN -556935)	
Power Boost Solenoid Valve (SN -556935)		Remove and Install	33-3360-153
Remove and Install	33-3360-119		

Continued on next page

Contents

33

	Page
Swing Torque Control Valve (SN 556936-)	
Remove and Install	33-3360-154
Swing Torque Control Valve (SN -546276)	
Disassemble and Assemble.	33-3360-155
Swing Torque Control Valve (SN 556936-)	
Disassemble and Assemble.	33-3360-156
Boom and Arm Anti-Drift Valve (SN -556935)	
Remove and Install	33-3360-156
Boom and Arm Anti Drift Valve (SN 556936-)	
Remove and Install	33-3360-159
Boom and Arm Anti Drift Valve	
Disassemble and Assemble.	33-3360-161
Dual Solenoid Block (SN -538538)	
Remove and Install	33-3360-162
Dual Solenoid Block (SN 538539-)	
Remove and Install	33-3360-163
Dual Solenoid Valve Block (SN 538539-)	
Disassemble and Assemble.	33-3360-164
Engine Speed Control Actuator	
Remove and Install	33-3360-165
Disassemble and Assemble.	33-3360-166
Boom Cylinder	
Remove and Install	33-3360-167
Arm Cylinder	
Remove and Install	33-3360-169
Bucket Cylinder	
Remove and Install	33-3360-171
Hydraulic Cylinder Bleed Procedure	33-3360-173
Bucket, Arm, and Boom Cylinders	
Disassemble	33-3360-174
Assemble.	33-3360-179
Hydraulic Oil Cooler	
Remove and Install	33-3360-186
Change Hydraulic Return Filter	33-3360-187
Reservoir	
Remove and Install	33-3360-190
Disassemble and Assemble.	33-3360-194

Contents

33

Specifications

Item	Measurement	Specification
Tooth Shank	Preheat Temperature	204—316°C (400—600°F)
	Fillet Weld	12.7 mm (0.5 in.)
	Distance From Edge	25 ± 6 mm (0.98 ± 0.24 in.)

Arm-to-Arm Link	Clearance	1.5 mm (0.06 in.)
Bucket Linkage	Clearance	0.5 mm (0.020 in.)

Item	Measurement	Specification
Bucket Linkage		
Nut	Torque	205 N•m (150 lb-ft)

TX,3302,DX374 -19-14APR95-1/1

Replacing Bucket Tooth Tip—Heavy-Duty
Bucket

- Clean tooth (A) and tooth tip (B).
- Insert lock removal tool under U-shaped pin (C).

CAUTION: Avoid possible injury. Pin may fly after it is released from tooth tip. Keep a firm grip on pin to prevent injury.

- Remove pin.
- Turn tooth tip counterclockwise and pull it towards you to remove.
- Clean tooth shank.
- Replace U-shaped pin at same time you replace tooth tip.
- Insert tooth tip on shank turning tip clockwise.
- Install U-shaped pin. Side of pin marked "FRONT" (D) must face tooth tip. Make sure pin is firmly engaged over tooth tip.

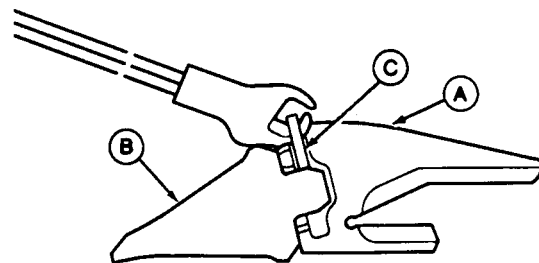

T6879EE

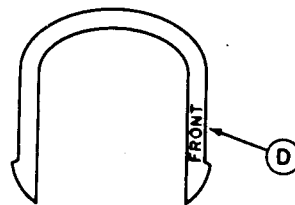

A—Tooth
B—Tooth Tip
C—Pin
D—"Front" Mark

T6879EE -JUN-06DEC88

T7527DO -JUN-27JUN91

04T,90,K273 -19-28JAN92-1/1

Bucket

Remove And Install Tooth Shank

1. Being careful not to cut into cutting edge, remove weld using a cutting torch or air arc equipment to remove shank.
2. Grind all surfaces smooth.



T92509 -UN-31OCT88



T92510 -UN-31OCT88

Continued on next page

TX,3302,CC13 -19-21NOV88-1/4

33
3302
2

Bucket

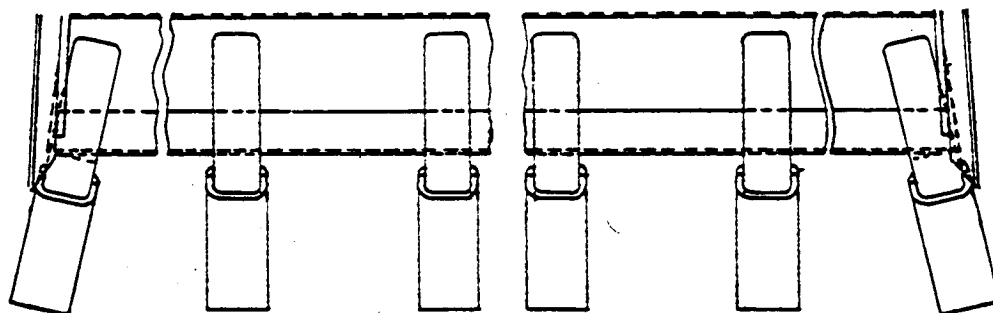
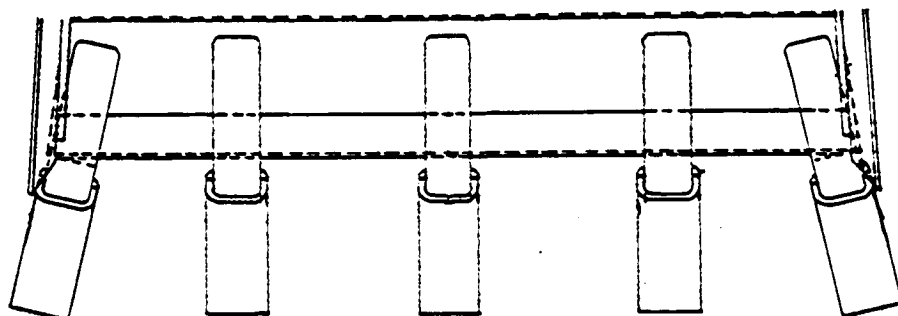
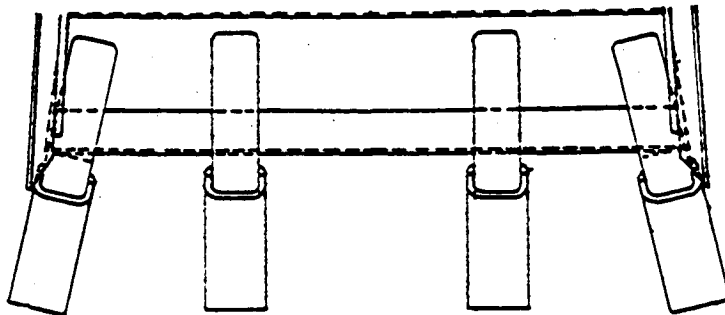
33
3302
3

T5985AQ -JUN-31OCT89

IMPORTANT: Good welds are important. Have only a qualified welder do the welding. Before welding, clean all dirt and paint from weld area. Connect the welder ground clamp close to each weld area, so electrical current does not pass through any bearings or bushings.

3. Before welding shank, remove the stop so rubber pin lock is not damaged by the heat.

4. Install shank into corner so it is tight against the bevel edge and side of bucket.

Install center shanks so they are tight against bevel edge and spaced equally across width of bucket.

5. Tack weld at the top rear center to hold it in position.

Continued on next page

TX,3302,CC13 -19-21NOV88-2/4

Bucket

33
3302
4

Use E7018 electrodes for welding or Lincoln Electric Co. gasless flux core process electrode type NS3M. 3/32 or 1/8 in. rod may be used.

Specification

Tooth Shank—Preheat
Temperature 204—316°C (400—600°F)

- 6. Preheat shank and cutting edge to 204—316°C (400—600°F).

Check temperature using a temperature stick to be sure correct temperature is obtained.

TX.3302.CC13 -19-21NOV88-3/4

IMPORTANT: All weld beads must be continuous starting at rear center, around the corner and along the side for a good strong weld joint. DO NOT start or stop welding at a corner.

- 7. Weld shank to cutting edge using 12.7 mm (0.5 in.) fillet weld (1).

Specification

Tooth Shank—Fillet Weld 12.7 mm (0.5 in.)

Starting at the rear center of shank, weld a continuous bead across end, around the corner, and along the side stopping 25 ± 6 mm (0.98 ± 0.24 in.) from edge of cutting edge.

Specification

Tooth Shank—Distance From
Edge 25 ± 6 mm (0.98 ± 0.24 in.)

Alternating from side to side, make as many passes as necessary to get the specified bead size.

- 8. Allow the weld area to cool slowly at room temperature.

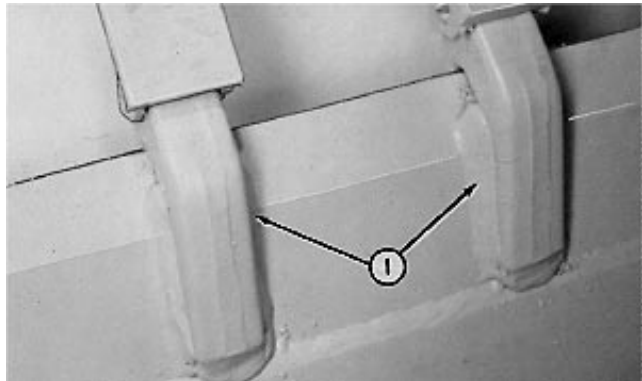

T82798 -JUN-31OCT88

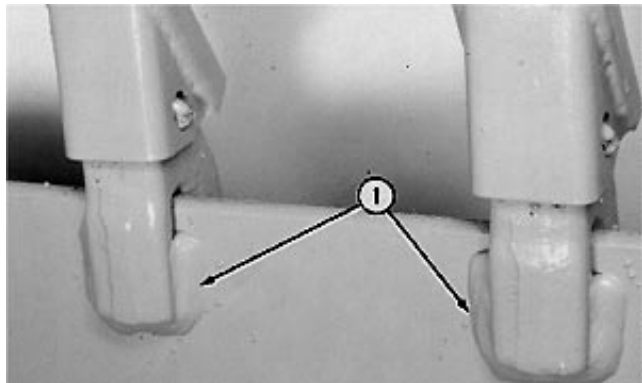

T82799 -JUN-31OCT88

TX.3302.CC13 -19-21NOV88-4/4

Remove And Install Bucket And Linkage (Serial No. —538759)

1. Lower bucket to the ground.

CAUTION: Approximate weight range of buckets is 560—845 kg (1245—1860 lb). Bucket link is 92 kg (205 lb) and arm link is 19 kg (42 lb).

2. Remove snap rings (A) and cross pins (B).
3. Slide O-rings (C) onto boss of links.
4. Remove pins (D and E) to remove bucket.

CAUTION: Approximate weight of bucket cylinder is 142 kg (312 lb).

5. Remove snap rings and cross pins to remove pins (F and G) and parts (H—J).
6. Inspect seals and bushings in bucket links, replace as necessary.

IMPORTANT: To prevent the seizure and galling of new or cleaned pins and bushings, apply grease to pins and bushings before assembly. Grease may not flow to all points of pin and bushing at the initial lubrication causing metal-to-metal contact. After assembly, lubricate pivot joint until grease escapes from joint. Then lubricate every 4 hours for the next 20 hours, then daily for the next 30 to 100 hours, and then at the regular maintenance intervals.

7. Apply grease to contact surfaces of pins and bushings.
8. Install links, bucket and pins. Turn snap rings so they are over cross pins.
9. Install washers (shims) between arm and each arm link to obtain a maximum clearance of 1.5 mm (0.06 in.).
10. Adjust bucket linkage. (See procedure in this group.)

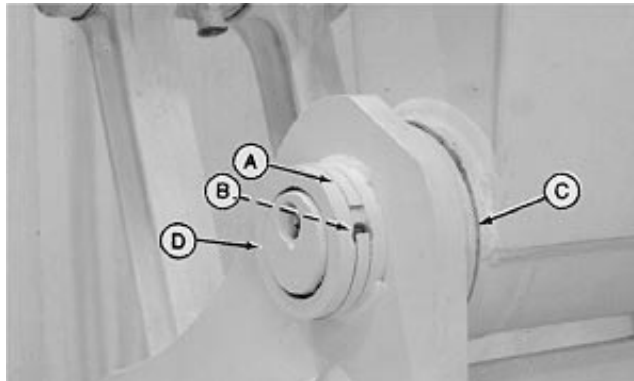

T6450CF -JUN-31OCT88

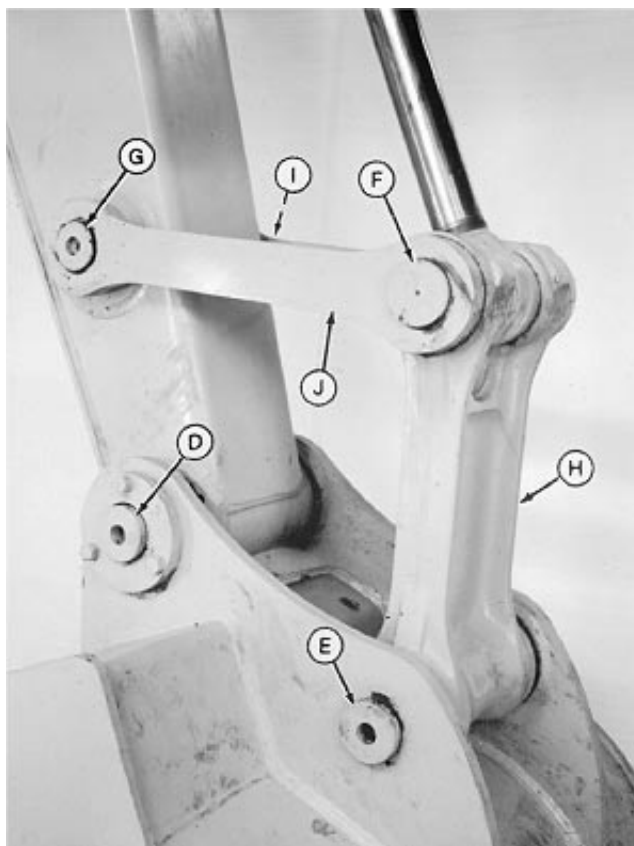

T7626CD -JUN-18DEC91

A—Snap Ring (2 used)
 B—Cross Pin (2 used)
 C—O-Ring (2 used)
 D—Pin
 E—Pin
 F—Pin
 G—Pin
 H—Bucket Link
 I—Left Arm Link and Washers
 J—Right Arm Link

Bucket

11. Adjust arm cylinder restrictor if bucket or attachment weight is changed. (See procedure in Group 9025-20.)

TX,3302,DY078 -19-04MAY95-2/2

33
3302
6

Remove And Install Bucket And Linkage (Serial No. 538760—)

1. Lower bucket to ground.

CAUTION: Approximate weight range of buckets is 560—845 kg (1245—1860 lb).

Bucket link is 92 kg (205 lb) and arm link is 19 kg (42 lb).

2. Slide O-rings onto bosses on bucket. Remove parts (B, E, F, G, and H). Remove bucket.

CAUTION: Approximate weight of bucket cylinder is 142 kg (312 lb).

3. Support bucket cylinder using wooden blocks.
4. Remove parts (B, C, D, I and J). Remove bucket link (L) and arm links (A and K).
5. Replace parts as necessary. Inspect seals and bushings in bucket link (L). (See Remove and Install Bushings and Seals in Group 3340.)

IMPORTANT: To prevent the seizure and galling of new or cleaned pins and bushings, Apply grease to pins and bushings before assembly. Grease may not flow to all points of pin and bushing at the initial lubrication causing metal-to-metal contact. After assembly, lubricate pivot joint until grease escapes from joint. Then lubricate every 4 hours for the next 20 hours, then daily for the next 30 to 100 hours, and then at the regular maintenance interval.

6. Apply grease to contact surfaces of pins (C and G) and bushings. Install links, bucket, and pins. Install washers (shims) under left arm link to obtain minimum clearance.

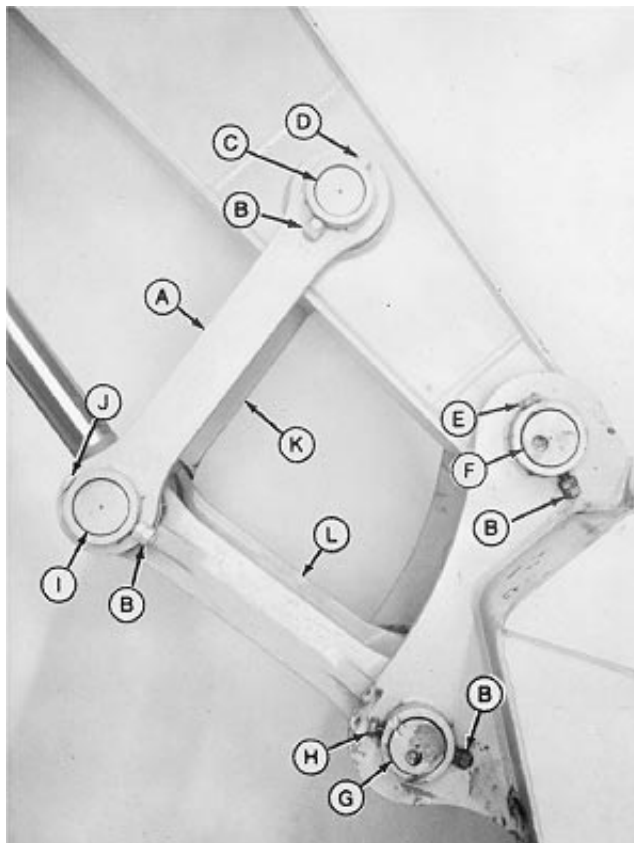

- A—Left Arm Link and Washers
- B—Nut (8 used)
- C—Pin
- D—Cap Screw
- E—Cap Screw
- F—Pin
- G—Pin
- H—Cap Screw
- I—Pin
- J—Cap Screw
- K—Right Arm Link
- L—Bucket Link

T7966EN -UN-04MAY93

Bucket

7. Install cap screws (D, E, H and J) and nuts (B).
Tighten nuts against each other, not the retainer, to 205 N•m (150 lb-ft).

Specification

Bucket LinkageNut—Torque 205 N•m (150 lb-ft)

Cap screws must be free to turn.

8. Adjust bucket to arm clearance. (See Adjust Bucket Linkage in this group.)
9. Lubricate pivot joints. (See Grease in Group 0004.)
10. Adjust arm cylinder restrictor if bucket attachment weight changes. (See procedure in Group 9025-20.)

TX,3302,DX375 -19-14APR95-2/2

Adjust Bucket Linkage

SPECIFICATIONS

SPECIFICATIONS	
Bucket Linkage Clearance	0.5 mm (0.020 in.)

Continued on next page

TX,3302,GG202 -19-23JUN94-1/2

Bucket

33
3302
9

1. Slide O-ring out of the way.
2. Measure the clearance (D) between the bushing (B) and arm.

Adjust the clearance as close to but not less than 0.5 mm (0.020 in.).

Specification

Bucket Linkage—Clearance 0.5 mm (0.020 in.)

3. Remove plate (F).

NOTE: Alternate buckets may have different adjustment procedures.

4. Remove shims (E) as needed to allow the bushing to move in to adjust the clearance and take up excessive play.
5. Install plate and tighten cap screws.
6. Slide O-ring back into position.

- A—Bucket
- B—Bushing
- C—Pin
- D—Clearance
- E—Shim (as required)
- F—Plate



T95775 -UN-10NOV88

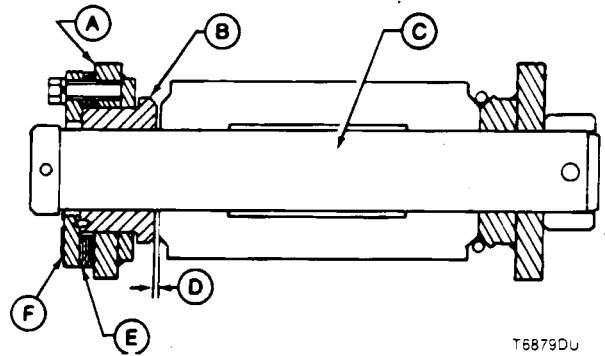

T6879DU -UN-06DEC88



T95788 -UN-10NOV88

TX,3302,GG202 -19-23JUN94-2/2

*Bucket***Replace Welded Bucket Cutting Edges**

1. Perform welding in an environment with a minimum ambient temperature of 10°C (50°F).
 2. Clean all joints to be welded of all foreign matter such as dirt, rust, mill scale, oil, etc. with grinders and/or solvents.
 3. Use dry AWS-E7018 low hydrogen electrodes or either of the following equivalent low hydrogen wire feed electrodes: gas metal arc welding (CO₂ or argon CO₂) AWS-E70S6 or flux cored arc welding AWS-E70T1.
 4. Preheat parts to be welded (both tack and final welds) to minimum of 204°C (400°F). PREHEAT TEMPERATURE MUST BE THROUGHOUT THE ENTIRE THICKNESS OF THE PARTS JOINED AND AT LEAST 51 mm (2 in.) BACK FROM THE JOINT. Maintain preheat throughout the entire welding operation. Tempilstiks should be used if possible.
 5. Tack weld preheated plates starting at center of bucket and working toward the outside ends.
 6. Final weld preheated plates starting at the center of the front edge of the bucket backing plate and working toward the outside ends.
- Repeat this operation at back edge of loader blade.
- Tack welds may be incorporated into the final weld, providing they have been made with electrodes that meet the requirements of the final welds and no cracking has occurred in the weld metal. Tack welds not meeting these requirements must be completely removed by grinding or air arc gouging just prior to making the final weld in that area.
7. Do not remove bucket from welding environment until weld metal temperature has dropped to the ambient temperature. Do not force cooling rate of weld metal.

TX,3302,AB35 -19-09JAN92-1/1

Repair Cracked Cutting Edge

1. If cutting edge has any cracks, clean the area to find end of crack.
2. Drill a small hole at end of crack to prevent spreading.
3. Grind V-grooves along crack on top and bottom of cutting edge.
4. Preheat the cracked area to approximately 149—260°C (300—500°F).
5. Fill the V-grooves with weld. Use E7018 electrodes. Extend the weld approximately 13 mm (1/2 in.) beyond end of crack.

TX,3302,AB36 -19-09JAN92-1/1

Specifications

Item	Measurement	Specification
Arm		
Short	Approximate Weight	710 kg (1570 lb)
Standard	Approximate Weight	770 kg (1700 lb)
Arm-to-Boom	Clearance	1.5 mm (0.06 in.)
Boom		
With Cylinder	Approximate Weight	1800 kg (4480 lb)
Cylinder	Approximate Weight	189 kg (418 lb)
Clearance Between Boom and Frame	Maximum Clearance	1.5 mm (0.06 in.)
Shield and Clamp-to-Boom Cap Screw	Torque	104 N•m (77 lb-ft)
Pin Retaining Nut	Torque	136 N•m (100 lb-ft)
Clamp-to-Boom Cap Screw	Torque	156 N•m (115 lb-ft)

TX,3340,AB3 -19-14APR95-1/1

Other Material

Number	Name	Use
TY6304 (U.S.) TY9484 (Canadian) 515 (LOCTITE®)	Flexible Sealant	Used to apply between bushing and spacer in arm-to-bucket joint to prevent grease from escaping between the spacer and casting.

LOCTITE is a registered trademark of Loctite Corp.

TX,3340,DX376 -19-04MAY95-1/1

Remove And Install Arm

1. Remove bucket. (See procedure in Group 3302.)
Remove linkage only if necessary for working on arm.
2. Retract the arm cylinder.
3. Put a floor stand under end of boom so load is on boom, not the arm cylinder.
4. Remove the bucket cylinder. (See procedure in Group 3360.)

TX,33,DY2940 -19-25AUG97-1/3

CAUTION: Approximate weight of short arm is 710 kg (1570 lb) and standard arm is 770 kg (1700 lb).

5. Connect arm to a hoist.

Specification

Short Arm—Approximate Weight	710 kg (1570 lb)
Standard Arm—Approximate Weight.....	770 kg (1700 lb)

Bucket end of arm is the heavy end when connected as shown.

6. Place a wooden block between arm cylinder and boom to keep cylinder off the lines.
7. On earlier machines, remove parts (A—F) to remove arm.

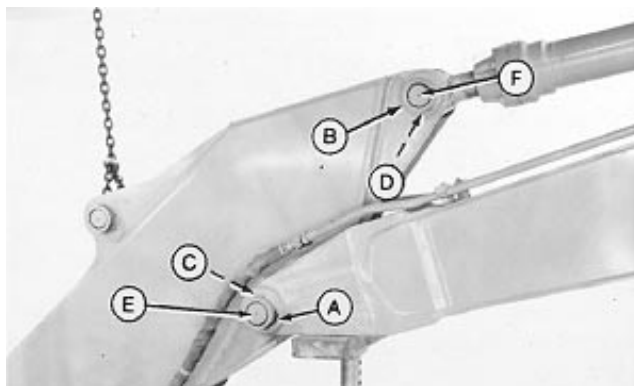

T6641DC -UN-26MAR90

Earlier Machine Shown

- A—Snap Ring
- B—Snap Ring
- C—Retaining Pin
- D—Retaining Pin
- E—Arm-to-Boom Pin
- F—Arm-to-Arm Cylinder Pin

Continued on next page

TX,33,DY2940 -19-25AUG97-2/3

Frames

8. On later machines, disconnect hydraulic lines at (A and B).
9. Remove parts (C—F) to remove arm.
10. On earlier machines, install arm and parts (A—F).
11. On later machines, install parts (C—F).

Add or remove shims equally on each side of arm to obtain maximum clearance between arm and boom of 1.5 mm (0.06 in.).

Specification

Arm-to-Boom—Clearance 1.5 mm (0.06 in.)

12. On later machines, connect hydraulic lines at (A and B).
13. Install bucket cylinder, bucket, and linkage.
14. Apply grease to all lubrication fittings. Check hydraulic reservoir oil level. Add oil if necessary.

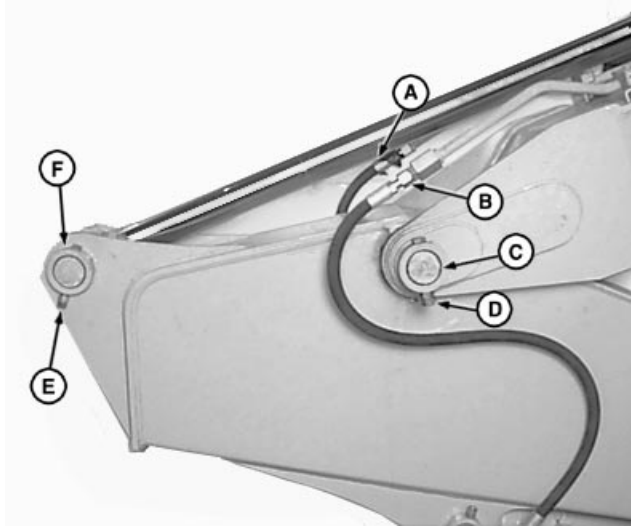

Later Machine Shown

- A—To Bucket Head End
- B—To Bucket Rod End
- C—Retaining Pin
- D—Nut (4 used)
- E—Cap Screw (2 used)
- F—Retaining Pin

TX,33,DY2940 -19-25AUG97-3/3

33
3340
3

T109484 -JUN-06AUG97

Remove And Install Boom

1. Remove bucket and arm. (See procedure in Group 3302 and this group.)
2. Lower boom to the ground.



CAUTION: Escaping fluid under pressure can penetrate the skin causing serious injury. Avoid the hazard by relieving pressure before disconnecting hydraulic or other lines. Tighten all connections before applying pressure. Search for leaks with a piece of cardboard. Protect hands and body from high pressure fluids.

If an accident occurs, see a doctor immediately. Any fluid injected into the skin must be surgically removed within a few hours or gangrene may result. Doctors unfamiliar with this type of injury may call the Deere & Company Medical Department in Moline, Illinois, or other knowledgeable medical source.

3. Release pressure in dig function circuits. (See procedure in Group 3360.)

Continued on next page

TX,3340,DY056 -19-04MAY95-1/3

Frames

33
3340
5

4. Remove cap screws (F). Remove shield.
5. Disconnect lines and wiring harness (A).
6. On later machines, disconnect lubrication lines

CAUTION: The approximate weight of boom cylinder is 189 kg (416 lb).

7. Disconnect rod end of boom cylinders and lower them to the ground.

CAUTION: Approximate weight of boom, with arm cylinder and lines, is 1800 kg (4480 lb).

8. Connect boom to a hoist.

Specification

Cylinder—Approximate Weight	189 kg (416 lb)
Boom with Cylinder—	
Approximate Weight	1800 kg (4480 lb)

Use a protective covering to prevent damage to pin if a chain is used.

With arm cylinder installed, arm end of boom is the heavy end. When arm cylinder is removed, frame end of boom is the heavy end.

9. On early machines, remove snap ring (B) and pin (C).
On later machines, remove cap screw (H) and nuts (I).
10. Remove pin (D) using a slide hammer puller and adapter. Remove shims (E). Note the shim locations to aid assembly.
11. Remove boom. Put blocks under frame end to protect lubrication fittings and lines.
12. Remove arm cylinder. (See procedure in Group 3360.)
13. Remove hydraulic line clamps. Remove hydraulic lines.
14. Install arm cylinder.

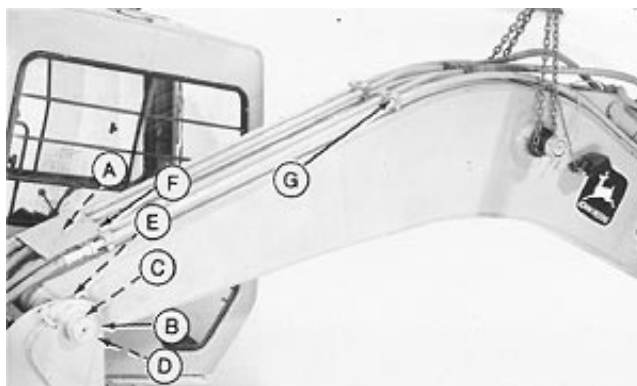

(Serial No. —538759)

T8641DE —UN-26MAR90

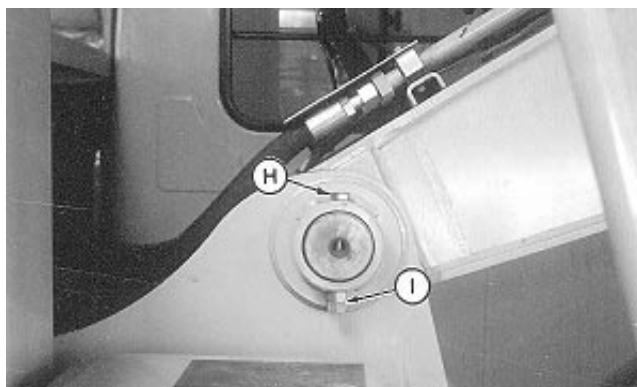

(Serial No. 538760—)

T8455AJ —UN-04MAR95

- A—Wiring Harness
- B—Snap Ring
- C—Pin
- D—Pin
- E—Shims (As required)
- F—Cap Screw (2 used)
- G—Cap Screw (8 used)
- H—Cap Screw
- I—Nut (2 used)

Continued on next page

TX,3340,DY056 —19-04MAY95-2/3

Frames

15. Install hydraulic lines and clamps. Tighten cap screws (G) to 156 N•m (115 lb-ft).

Specification

Clamp-to-Boom Cap Screw—
Torque 156 N•m (115 lb-ft)

16. On early machines, install boom and parts (B—E). On later machines, install boom and parts (D, E, H and I). Torque nut, not retaining nut, to 136 N•m (100 lb-ft).

Specification

Pin Retaining Nut—Torque 136 N•m (100 lb-ft)

17. Add or remove shims (E) equally on each side of boom to obtain maximum clearance between boom and frame of 1.5 mm (0.06 in.).

Specification

Boom and Frame—Maximum
Clearance 1.5 mm (0.06 in.)

18. Connect rod end of boom cylinders. Install retaining rings with chamfer side towards end of pin.

19. Connect lines and wiring harness (A).

20. On later machines, connect lubrication lines.

21. Install shield. Tighten cap screws (F) to 104 N•m (77 lb-ft).

Specification

Shield and Clamp-to-Boom Cap
Screw—Torque 104 N•m (77 lb-ft)

22. Install arm and bucket.

23. Apply grease to all lubrication fittings. Check hydraulic reservoir oil level. Add oil if necessary. (See Hydraulic Oil in Group 0004.)

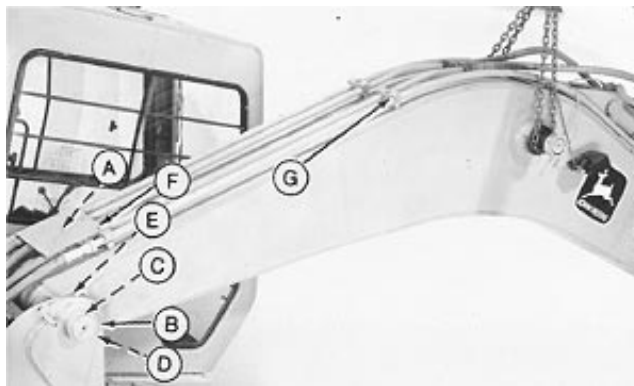

(Serial No. —538759)

T6641DE -UN-26MAR90

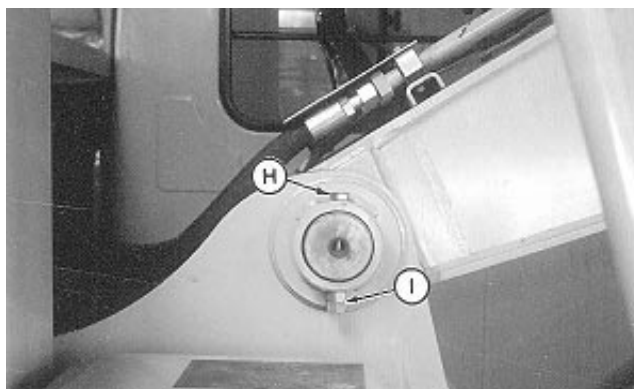

(Serial No. 538760—)

T8455AJ -UN-04MAR95

- A—Wiring Harness
- B—Snap Ring
- C—Pin
- D—Pin
- E—Shims (As required)
- F—Cap Screw (2 used)
- G—Cap Screw (8 used)
- H—Cap Screw
- I—Nut (2 used)

TX,3340,DY056 -19-04MAY95-3/3

33
3340
6

Remove And Install Bushings And Seals

NOTE: Bushing can also be removed by welding three to five weld beads on the inside of bushing. Bushing will shrink enough to permit removal using a hammer.

1. Remove and install bushings and dust seals using bushing, bearing, and seal driver set.
2. Install bushings with lubrication hole in alignment with lubrication passage in pivot.
3. Apply flexible sealant between end of bushings and spacer in arm-to-bucket joint to prevent grease from escaping between spacer and casting.
4. Install bushings to thickness of seal (H).
5. Install seals with lip toward outside of component.

- A—Hydraulic Ram
- B1—Pipe-Minimum I.D. to Clear Bushing O.D.
- B2—Pipe-Maximum O.D.
- B3—Pipe-Length of Bushing
- C—Bushing
- D—Disks
- E—Bushing Stop (Disk)
- F—Pilot (Disk)
- G—Ram Stop (Disk)
- H—Thickness of Seal

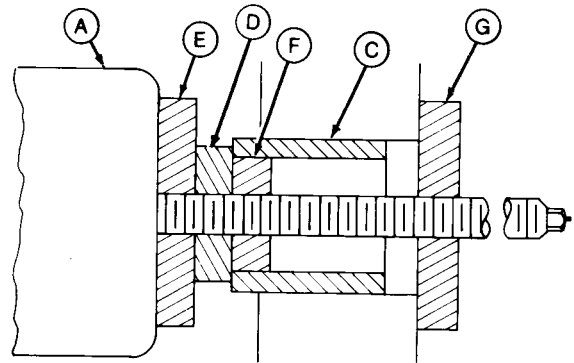
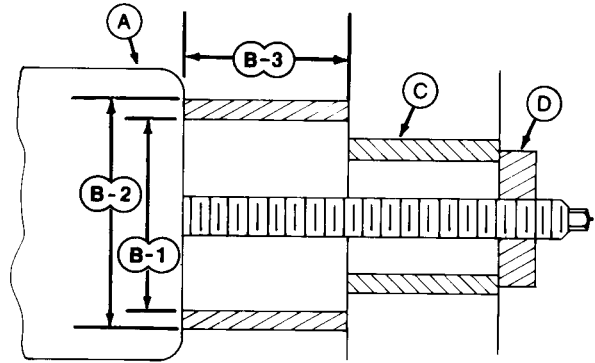

T95237 -UN-01NOV88

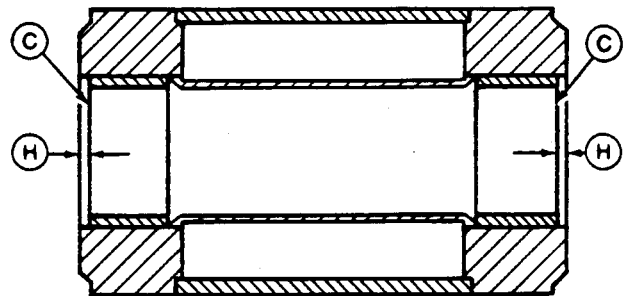

T6641CW -UN-31OCT88

TX,3340,DX377 -19-14APR95-1/1

Frames

33
3340
8

Special Or Essential Tools

NOTE: Order tools according to information given in the U.S. SERVICE-GARD™ Catalog or in the European Microfiche Tool Catalog (MTC).

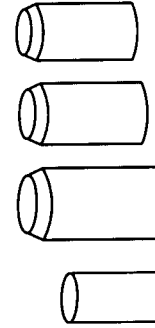

T8407AE ©

T8407AE -19-01FEB95

SERVICE-GARD is a trademark of Deere & Company.

JDG799 -19-04MAY95-1/7

Seal Protector Kit JDG799

Use to protect seals during the installation of rod guide on rod.

JDG799 -19-04MAY95-2/7

Bucket Seal Protector JDG800

Use to protect seals during the installation of rod guide on rod.

JDG799 -19-04MAY95-3/7

Boom Seal Protector JDG801

Use to protect seals during the installation of rod guide on rod.

JDG799 -19-04MAY95-4/7

Arm Seal Protector JDG802

Use to protect seals during the installation of rod guide on rod.

JDG799 -19-04MAY95-5/7

Spacer Sleeve (for smaller bucket rod) JDG803

Use to protect seals during the installation of rod guide on rod.

JDG799 -19-04MAY95-6/7

Use to protect seals during the installation of rod guide on rod.

JDG799 -19-04MAY95-7/7

Hydraulic System

Service Equipment And Tools

NOTE: Order tools from the U.S. SERVICE-GARD™ Catalog or from the European Microfiche Tool Catalog (MTC). Some tools may be available from a local supplier.

SERVICE-GARD is a trademark of Deere & Company.

TX,3360,AB427 -19-04MAY95-1/13

Pump Workbench Support¹ DF1039

Used to hold main pump while disassembling and assembling.

Pump Rotate Group Workbench Support¹. DF1040

Used to hold pump rotating group while disassembling and assembling.

Spool Holding Fixture¹ DFT1108

Used to hold spool while disassembling and assembling.

Spool Holding Fixture¹ DFT1077

Used to hold swing valve spool while disassembling and assembling.

¹Fabricated tool, dealer made. (See Section 99 for instructions to make tool.)

TX,3360,AB427 -19-04MAY95-2/13

17-1/2 and 30 Ton Puller Set

Used to remove pump bearings.

TX,3360,AB427 -19-04MAY95-3/13

Bushing, Bearing and Seal Driver Set

Used to remove and install seals and bushings.

Continued on next page

TX,3360,AB427 -19-04MAY95-4/13

Hydraulic System

Lifting BracketJT01748

Used to remove and install main hydraulic pump.

TX,3360,AB427 -19-04MAY95-5/13

33
3360
3

Polishing TableJT05425

Used to remove move nicks and scratches in pump cylinder block.

TX,3360,AB427 -19-04MAY95-6/13

Hydraulic Cylinder Repair StandJT30043

Used to repair hydraulic cylinders.

TX,3360,AB427 -19-04MAY95-7/13

Chain Wrench

Used around piston nut, for installing the hydraulic cylinder rod guide to the rod.

TX,3360,AB427 -19-04MAY95-8/13

PusherJDG843-3

Used to install seals and wear rings on bucket, arm, and boom cylinder pistons.

TX,3360,AB427 -19-04MAY95-9/13

InstallerJDG841

Used to install seals and wear rings on bucket, arm, and boom cylinder pistons.

TX,3360,AB427 -19-04MAY95-10/13

InstallerJDG918

Used to install seals and wear rings on bucket, arm, and boom cylinder pistons.

TX,3360,AB427 -19-04MAY95-11/13

InstallerJDG917

Used to install seals and wear rings on bucket, arm, and boom cylinder pistons.

Continued on next page

TX,3360,AB427 -19-04MAY95-12/13

Hydraulic System

Portable Filter Caddy

Used to clean hydraulic oil after a component failure.

TX,3360,AB427 -19-04MAY95-13/13

Other Material

Number	Name	Use
PT569 (U.S.)	NEVER-SEEZ® Lubricant	Apply to splines of pilot pump coupler.
TY9375 (U.S.) TY9480 (Canadian) 592 (LOCTITE®)	Pipe Sealant with TEFLON®	Used to apply to mating surfaces of pump and to threads of all fittings in reservoir.
T43512 (U.S.) TY9473 (Canadian) 242 (LOCTITE®)	Thread Lock and Sealer (Medium Strength) Products	Used to apply to threads of plug in control valve spool. Pilot controller U-joint, and threads of cylinder piston nut.
TY15969 (U.S.) TY9479 (Canadian) 635 (LOCTITE®)	Retaining Compound	Used to apply to threads of feedback plugs and piston rods and I.D. of pump seal collar.

NEVER-SEEZ is a registered trademark of the Emhart Chemical Group.

LOCTITE is a registered trademark of Loctite Corp.

TEFLON is a registered trademark of the DuPont Company.

TX,33,DW5017 -19-21JUL97-1/1

Hydraulic System

33
3360
5**Specifications**

Item	Measurement	Specification
Pump Drive:		
Hub-to-Pump Case	Clearance	3 ± 1 mm (0.12 ± 0.04 in.)
Set Screw	Torque	122 N•m (90 lb-ft)
Pump (Serial No. —559602):		
Pump-to-Flywheel Cap Screw	Torque	87 N•m (64 lb-ft)
Cylinder Block Bronze Material	Minimum Thickness	0.9 mm (0.035 in.)
Feedback Rod End Piston	Torque	30 N•m (22 lb-ft)
Front Pump-to-Rear Pump Stud	Torque	60 N•m (44 lb-ft)
Stud-to-Housing Nut	Torque	110 N•m (81 lb-ft)
Rear Pump Shaft	End Play	0.10—0.30 mm (0.004—0.012 in.)
Pilot Pump-to-Hydraulic Pump Cap Screw	Torque	110 N•m (81 lb-ft)
Suction Flange-to-Pump Valve Block Inner Cap Screw	Torque	32 N•m (24 lb-ft)
Suction Flange-to-Pump Valve Block Outer Cap Screw	Torque	46 N•m (34 lb-ft)
Pump (Serial No. 559603—):		
Pump-to-Flywheel Cap Screw	Torque	87 N•m (64 lb-ft)
Pilot Pump-to-Hydraulic Pump Cap Screw	Torque	46 N•m (34 lb-ft)
Pilot Pump-to-Hydraulic Pump Cap Screw	Torque	46 N•m (34 lb-ft)
Pump Displacement Solenoid Valve (Serial No. —559602):		
Mounting Cap Screw	Torque	10 N•m (90 lb-in.)

Continued on next page

TX,33,DW5016 -19-21JUL97-1/8

Hydraulic System

Item	Measurement	Specification
Solenoid-to-Valve Housing Cap Screw	Torque	2.7 N•m (24 lb-in.)
Bottom Plug	Torque	47 N•m (35 lb-ft)
Spool Retaining Plug	Torque	72 N•m (53 lb-ft)
Retaining Nut	Torque	31 N•m (23 lb-ft)

Item	Measurement	Specification
Load Sense Valve Cap Screw (Serial No. —559602)	Torque	32 N•m (24 lb-ft)

Item	Measurement	Specification
Pump Displacement Solenoid Valve (Serial No. 559603—):		
Cap Screw	Torque	23 N•m (17 lb-ft)
Solenoid-to-Valve Housing Cap Screw	Torque	2.7 N•m (24 lb-in.)

Load Sense Valve (Serial No. —559602):		
Left Side Plug	Torque	12 N•m (106 lb-in.)
Spool Valve Retaining Plug	Torque	122 N•m (90 lb-ft)
Test Port Plug	Torque	47 N•m (25 lb-ft)
Adjusting Screw Plug	Torque	93 N•m (69 lb-ft)
Adjusting Screw Retaining Nut	Torque	31 N•m (23 lb-ft)

Load Sense Valve (Serial No. 559603—):		
Mounting Cap Screw	Torque	23 N•m (17 lb-ft)
Retaining Plug	Torque	23 N•m (17 lb-ft)

Continued on next page

TX,33,DW5016 -19-21JUL97-2/8

Hydraulic System

Item	Measurement	Specification
Pilot Shut-Off Valve Linkage	Clearance Between Lever and Cap Screw	1.5 ± 0.5 mm (0.06 ± 0.02 in.)
Item		
Measurement		
Specification		
Dig Pilot Controller:		
Dig Function Pilot Controller Attaching Cap Screw	Torque	9 N•m (85 lb-in.)
Cap Screw Through Plate-to-Housing	Torque	49 N•m (36 lb-ft)
U-Joint Through Plate-to-Housing	Torque	24 N•m (18 lb-ft)
Coupling-to-Cam	Clearance	0—0.2 mm (0—0.008 in.)
Coupling	Torque	78 N•m (58 lb-ft)
Propel Controller:		
Attaching Cap Screw	Torque	49 N•m (36 lb-ft)
Lever Bracket Mounting Cap Screw (Serial No. 547584—)	Torque	88 N•m (65 lb-ft)
Valve Piston Plug	Torque	49 N•m (36 lb-ft)
Control Valve (Serial No. 546276—556935):		
Mounting Cap Screw	Torque	75 N•m (55 lb-ft)
Bucket Valve-to-Manifold	Torque	86 N•m (63 lb-ft)
Left Propel Valve-to-Manifold	Torque	49 N•m (36 lb-ft)
Arm Valve-to-Manifold	Torque	86 N•m (63 lb-ft)
Boom Valve-to-Manifold	Torque	86 N•m (63 lb-ft)
Arm Cylinder Restrictor Jam Nut (Serial No. 546276—556435)	Torque	60 N•m (44 lb-ft)
Safety Relief Valve Plug (Serial No. —556935)	Torque	80 N•m (59 lb-ft)

33
3360
7

Continued on next page

TX,33,DW5016 -19-21JUL97-3/8

Hydraulic System

Item	Measurement	Specification
Power Boost Solenoid Valve (Serial No. —556935) Cap Screw	Torque	120 N•m (88 lb-ft)
Boom, Swing, Arm Control Valve Manifold: (Serial No. 556936—):		
Mounting Cap Screw	Torque	75 N•m (55 lb-ft)
Boom Valve-to-Manifold	Torque	86 N•m (63 lb-ft)
Bucket Valve-to-Manifold	Torque	86 N•m (63 lb-ft)
Left Propel Valve-to-Manifold	Torque	49 N•m (36 lb-ft)
Arm Valve-to-Manifold	Torque	86 N•m (63 lb-ft)
Right Propel Valve-to-Manifold	Torque	49 N•m (36 lb-ft)
Return Manifold Mounting Cap Screws	Torque	55 N•m (40 lb-ft)
Boom and Arm Cylinder Restrictor Nut (Serial No. 556936—)	Torque	170 N•m (44 lb-ft)
Anti-Cavitation Back Pressure Check Valve Plug (Serial No. 556936—)	Torque	80 N•m (59 lb-ft)
Combined Function Shuttle Valve Plug (Serial No. 556936—)	Torque	20 N•m (54 lb-in.)
Load Sense Relief Valve Plug (Serial No. 556936—)	Torque	90—150 N•m (66—110 lb-ft)

Item	Measurement	Specification
Swing Valve-to-Manifold	Torque	49 N•m (36 lb-ft)

Item	Measurement	Specification
Boom Regenerative Valve (Serial No. —556935):		
Mounting Cap Screw	Torque	86 N•m (63 lb-ft)

Continued on next page

TX,33,DW5016 -19-21JUL97-4/8

Hydraulic System

33
3360
9

Item	Measurement	Specification
Pressure Control Manifold (Serial No. —556935):		
Mounting Cap Screw	Torque	120 N•m (88 lb-ft)
Circuit Relief and Anti-Cavitation Valve (Serial No. —556935)	Torque	80 N•m (59 lb-ft)
Item	Measurement	Specification
Pilot Pressure Regulating Valve (Serial No. 556936—)	Torque	30—35 N•m (22—26 lb-ft)
Item	Measurement	Specification
Power Boost Solenoid Valve (Serial No. 556936—):		
Nut	Torque	8 N•m (71 lb-in.)
Valve	Torque	50—55 N•m (36—40 lb-ft)
Item	Measurement	Specification
Valve Plug	Torque	100 N•m (74 lb-ft)
Item	Measurement	Specification
Boom, Swing, And Arm Valve Sections (Serial No. 556936—):		
Pilot Cap Relief Valve	Torque	6 N•m (55 lb-in.)
Balance Valve Plug	Torque	10 N•m (90 lb-in.)
Spool Plug	Torque	100 N•m (75 lb-ft)
Valve Cover-to-Housing Cap Screw	Torque	25 N•m (18 lb-ft)
Spool Stop Screw Nut	Torque	60 N•m (45 lb-ft)
Swing Valve Section:		
Pilot Check Valve	Torque	9 N•m (80 lb-in.)

Continued on next page

TX,33,DW5016 -19-21JUL97-5/8

Hydraulic System

Item	Measurement	Specification
Pilot Cap Relief Valve	Torque	6 N•m (55 lb-in.)
Swing Valve Plug	Torque	60 N•m (45 lb-ft)
Valve Cover-to-Housing Cap Screw	Torque	25 N•m (18 lb-ft)
Spool Stop Screw Nut	Torque	60 N•m (45 lb-ft)
Monoblock Control Valve Manifold (Serial No. 556936—):		
Mounting Cap Screws	Torque	75 N•m (55 lb-ft)
Bucket Circuit Relief and Anti-Cavitation Valve Plug (Serial No. 556936—)	Torque	80 N•m (59 lb-ft)
Propel Circuit Make-Up Valve Plug (Serial No. 556936—)	Torque	80 N•m (59 lb-ft)
Safety Relief Valve Plug (Serial No. 556936—)	Torque	120—150 N•m (88—110 lb-ft)
Propel Valve Section:		
Pilot Check Valve	Torque	9 N•m (80 lb-in.)
Spool Plug	Torque	60 N•m (45 lb-ft)
Valve Cover-to-Housing Cap Screw	Torque	25 N•m (18 lb-ft)
Spool Stop Screw Nut	Torque	60 N•m (45 lb-ft)
Bucket Valve-to-Manifold	Torque	86 N•m (63 lb-ft)
Left Propel Valve-to-Manifold	Torque	49 N•m (36 lb-ft)
Right Propel Valve-to-Manifold	Torque	49 N•m (36 lb-ft)
Spool Plug	Torque	75 N•m (55 lb-ft)
Cover-to-Housing Cap Screw	Torque	9.5 N•m (84 lb-in.)

Continued on next page

TX,33,DW5016 -19-21JUL97-6/8

Hydraulic System

Item	Measurement	Specification
Arm Regenerative Valve (Serial No. —556935):		
Mounting Cap Screw	Torque	80 N•m (59 lb-ft)
Spool Plug	Torque	75 N•m (55 lb-ft)
Cover-to-Housing Cap Screw	Torque	9.5 N•m (84 lb-in.)
Jam Nut	Torque	80 N•m (59 lb-ft)
Arm Regenerative Poppet Valve (Serial No. 556936—)		
	Torque	9.5 N•m (84 lb-in.)
Swing Stop Cushion Valve:		
Mounting Cap Screw	Torque	32 N•m (24 lb-ft)
Swing Torque Control Valve (Serial No. —556935):		
Valve-to-Manifold Cap Screw	Torque	49 N•m (36 lb-ft)
Spool Plug	Torque	47 N•m (35 lb-ft)
Adjusting Screw Jam Nut	Torque	10 N•m (88 lb-in.)
Swing Torque Control Valve (Serial No. 556936—)	Torque	86 N•m (63 lb-ft)
Boom And Arm Anti-Drift Valve (Serial No. —556935):		
Mounting Cap Screw	Torque	95 N•m (70 lb-ft)
Valve Plug	Torque	100 N•m (74 lb-ft)
Face Side Plug	Torque	20 N•m (177 lb-in.)

33
3360
11

Continued on next page

TX,33,DW5016 -19-21JUL97-7/8

Hydraulic System

Item	Measurement	Specification
33 3360 12 Boom And Arm Anti-Drift Valve (Serial No. 556936—):		
Mounting Cap Screw	Torque	95 N•m (70 lb-ft)
Bucket Cylinder:		
Piston Nut (M62 x 2)	Torque	4740 N•m (3485 lb-ft)
Piston Nut (M52 x 2)	Torque	4260 N•m (3130 lb-ft)
Rod Guide Cap Screw	Torque	558 N•m (410 lb-ft)
Arm Cylinder:		
Piston Nut	Torque	7560 N•m (5560 lb-ft)
Rod Guide Cap Screw	Torque	972 N•m (715 lb-ft)
Cushion Cap Screw	Torque	972 N•m (715 lb-ft)
Boom Cylinder:		
Piston Nut	Torque	6080 N•m (4470 lb-ft)
Rod Guide Cap Screw	Torque	558 N•m (410 lb-ft)
Item	Measurement	Specification
Hydraulic Return Filter Cover Cap Screw	Torque	49 N•m (36 lb-ft)

TX,33,DW5016 -19-21JUL97-8/8

Lower Boom With Engine Stopped

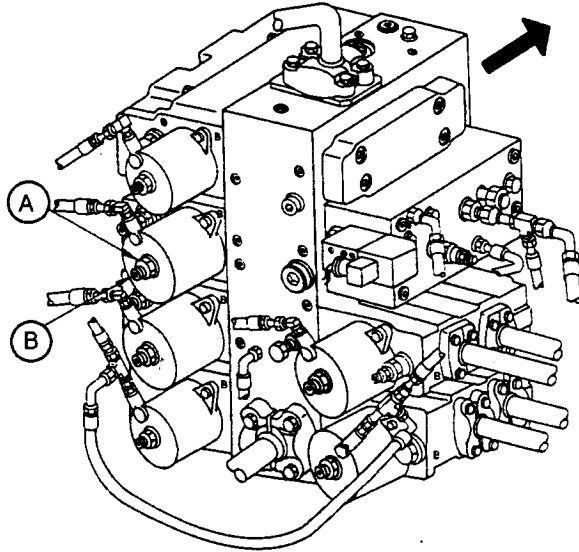

T7699AO (CV)

(Serial No. —556935)

T7699AO —UN-23FEB92

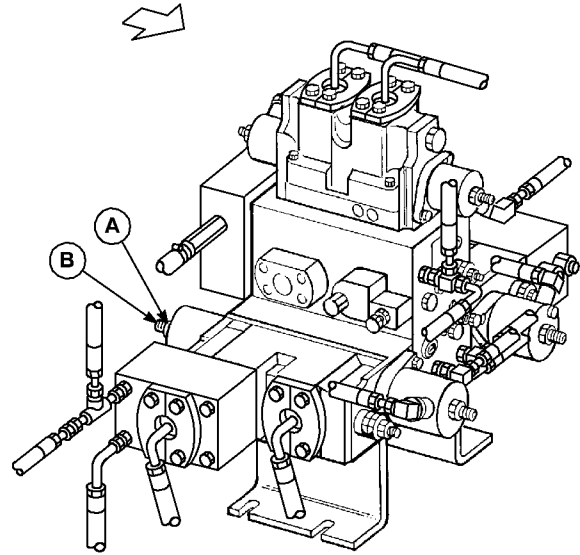

T109446

(Serial No. 556936—)

T109446 —UN-02JUN97

With engine stopped, boom cannot be lowered by using pilot control valve. The control valve spool must be moved manually.

CAUTION: Clear all persons from the area when lowering the boom with the engine stopped.

NOTE: For machines with an anti-drift valve (D), the relief valve (C) must be loosened 1/4 turn to make a passage through the valve for oil to flow from the cylinders to the control valve.

1. For machines with anti-drift valve, loosen relief valve (C) in anti-drift valve housing (E) 1/4 turn.
2. Hold spool stop screw (B), located at the rear of main control valve, and loosen lock nut (A) until it is held on by only one or two threads.

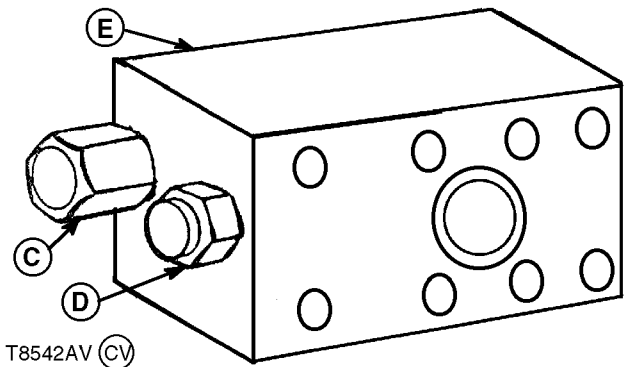

T8542AV (CV)

T8542AV —UN-12OCT95

- A—Spool Stop Screw
- B—Lock Nut
- C—Relief Valve
- D—Anti-Drift Valve
- E—Anti-Drift Valve Housing

Continued on next page

TX,33,DY2941 —19-26AUG97-1/2

Hydraulic System

- 33
3360
14
3. Counting the number of turns, turn the spool stop screw in (clockwise) until screw contacts spool (increased resistance).
 4. Turn screw an additional one or two turns until boom begins to lower.
 5. Record the total number of turns screw was turned in.
 6. Lower bucket to the ground.



CAUTION: Spool stop screw must be returned to its original position after boom has been lowered to avoid unexpected boom movement (lowering) when engine is started. Also, function speed is affected if spool stop screw is not returned to its original position.

7. Turn spool stop screw out the number of turns recorded in Step 5 to return it to its original position. Tighten lock nut.
8. For machines with anti-drift valve (D), tighten relief valve (C) in anti-drift valve housing (E).

TX,33,DY2941 -19-26AUG97-2/2

Raise Boom With Engine Stopped

With the engine stopped, boom cannot be raised using pilot control valve. The control valve boom spool must be moved manually.

CAUTION: Clear all persons from the area when raising the boom with the engine stopped.

1. Hold spool stop screw (B) in front of boom section, and loosen lock nut (A) until it is held on by only one or two threads.
2. While counting the number of revolutions, turn the spool stop screw in until screw contacts spool (increased resistance).
3. Turn spool stop screw an additional 4—6 turns to move spool enough to allow boom to be raised.

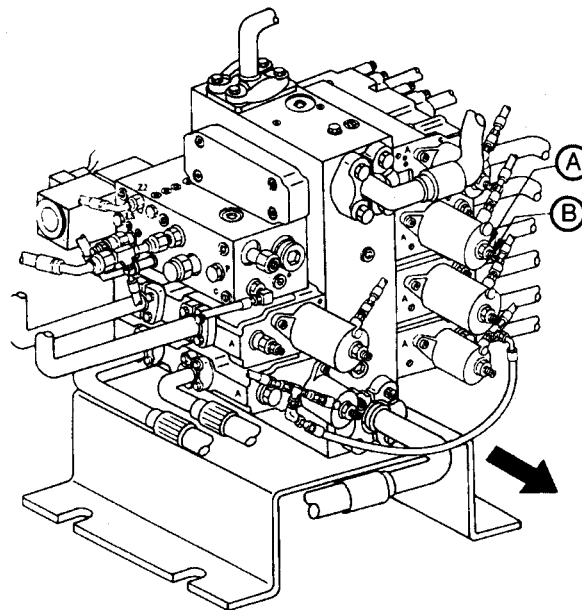

T8048AC (CV)

(Serial No. —556935)

T8048AC —UN—17JUL93

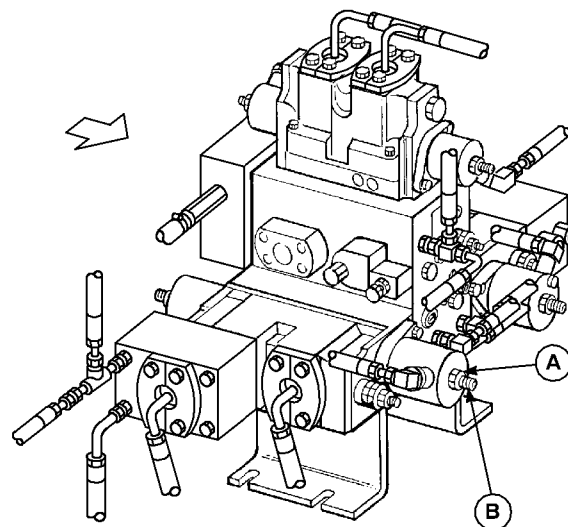

T109283

(Serial No. 556936—)

T109283 —UN—02JUN97

Continued on next page

TX,33,DY2942 —19—26AUG97—1/3

Hydraulic System

4. Attach an external lifting device to the guide link-to-bucket pin (C).
5. Lift the bucket to ground level.

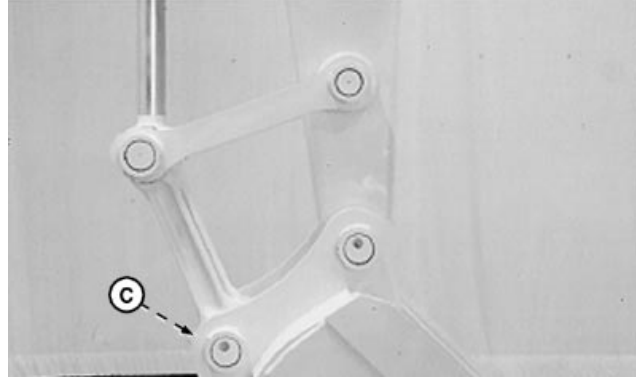

T109187 -JUN-02JUN97

! **CAUTION: Boom cylinder must be blocked to maintain boom position. Boom cylinder will not contain enough oil to hold the boom in position hydraulically.**

6. Block the boom cylinder.

Continued on next page

TX,33,DY2942 -19-26AUG97-2/3

33
3360
16

Hydraulic System



CAUTION: Return spool stop screw and lock nut to original position after boom has been raised to avoid unexpected boom movement (raising) when engine is started.

7. While counting the number of turns, return spool stop screw to original position. Tighten lock nut (A). Function speed is affected if spool stop screw is not returned to its original position.

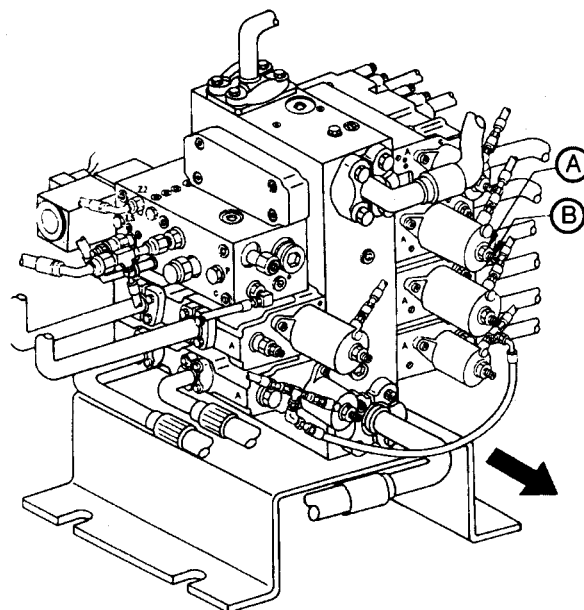

T8048AC (CV)

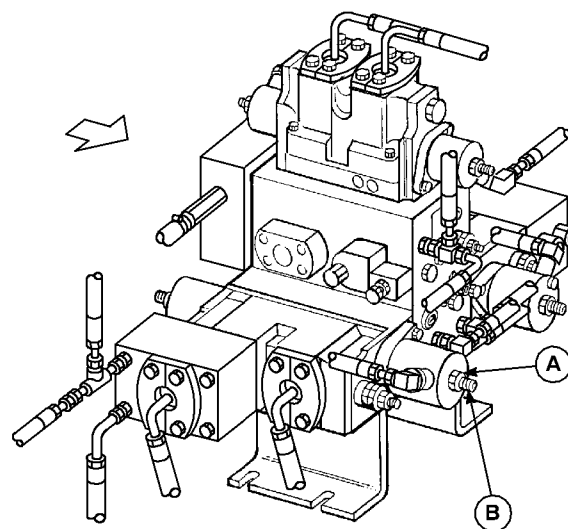

T109283

33
3360
17

T8048AC -UN-17JUL93

T109283 -UN-02JUN97

TX,33,DY2942 -19-26AUG97-3/3

Hydraulic System

Swing Upperstructure With Engine Stopped

With engine stopped, upperstructure cannot be swung using pilot control valve. The control valve swing spool must be moved manually.

To swing upperstructure to the left, use rear cap on main control valve as shown. Loosen lock nut (A). Turn spool stop screw (B) clockwise.

To swing upperstructure to the right, use front cap on main control valve.

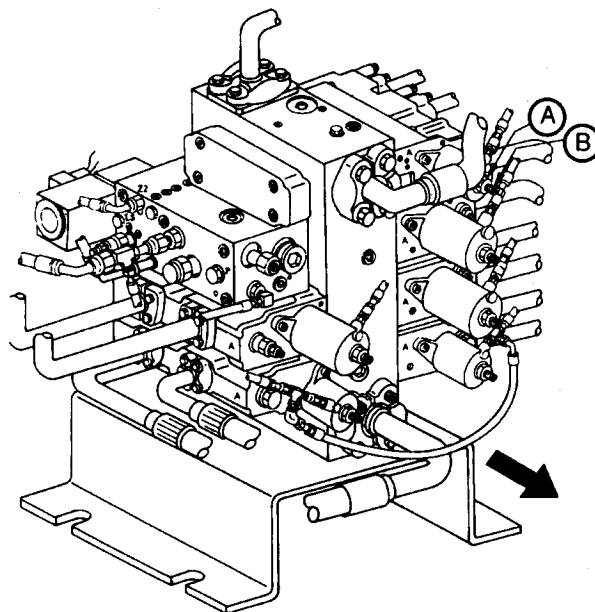

T8048AD (CV)

Front Pilot Cap (Serial No. —556935)

T8048AD -UN-17JUL93

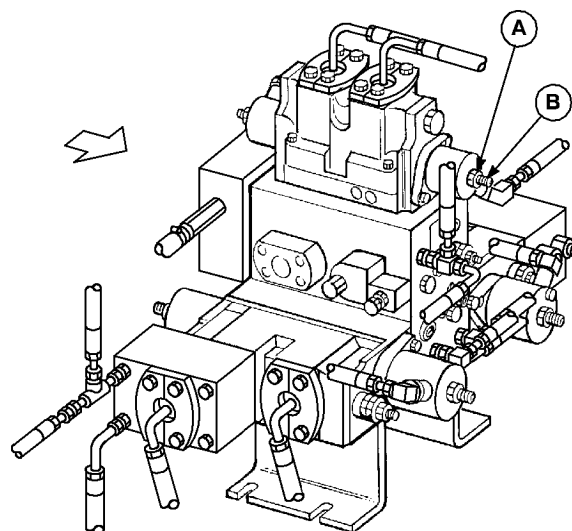

T109448

Front Pilot Cap (Serial No. 556936—)

T109448 -UN-02JUN97

Continued on next page

TX.35,DT5026 -19-09JUN97-1/3

Hydraulic System

33
3360
19

1. Holding spool stop screw (B), loosen lock nut (A) until it is held on by only one or two threads.
2. Counting the number of turns, turn spool stop screw (B) clockwise until the screw contacts spool (increased resistance).
3. Turn spool stop screw an additional 4—6 turns to move spool sufficiently to swing upperstructure.
4. Disconnect swing brake release hose and plug the hose.

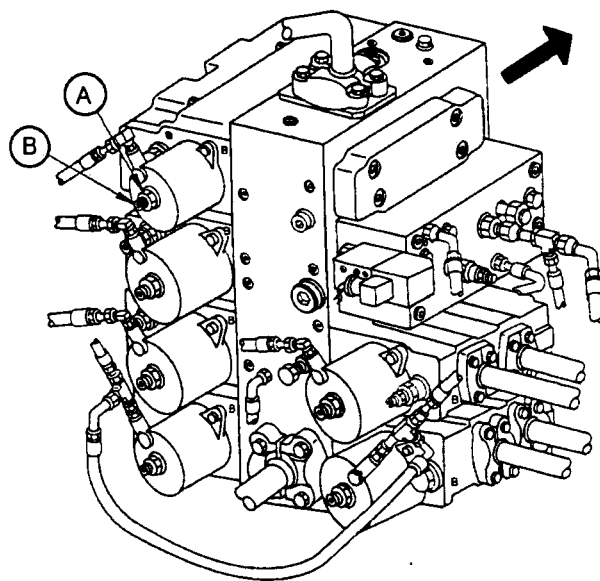

T7699AR CV

Rear Pilot Cap (Serial No. —556935)

T7699AR —UN-23FEB92

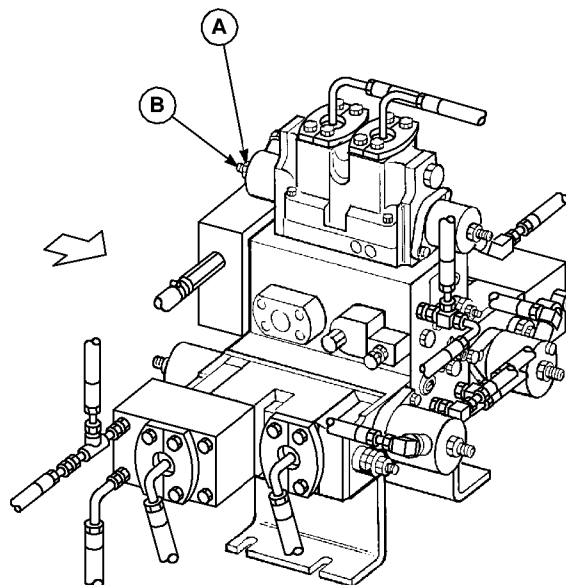

T109447

Rear Pilot Cap (Serial No. 556936—)

T109447 —UN-02JUN97

Continued on next page

TX.35.DT5026 —19-09JUN97-2/3

Hydraulic System

5. Attach an external pressure source to brake release fitting (A).

! **CAUTION: Prevent possible injury from unexpected machine movement. Clear all persons from the area when swinging the upperstructure with the engine stopped.**

6. Apply pressure of 1380—3450 kPa (13.8—34.5 bar) (200—500 psi) to swing brake release fitting to release swing brake.

7. With external source, lift and swing boom away from excavation.

8. When unit is in desired position, release pressure from swing brake to apply brake.

9. Disconnect pressure source.

10. Connect swing brake release hose to brake release fitting.

! **CAUTION: Prevent possible injury from unexpected swing movement when engine is started. Return center screw and jam nut to original position after swinging the upperstructure.**

11. Counting number of turns, return spool stop screw to original position to reset function speed. Tighten nut.

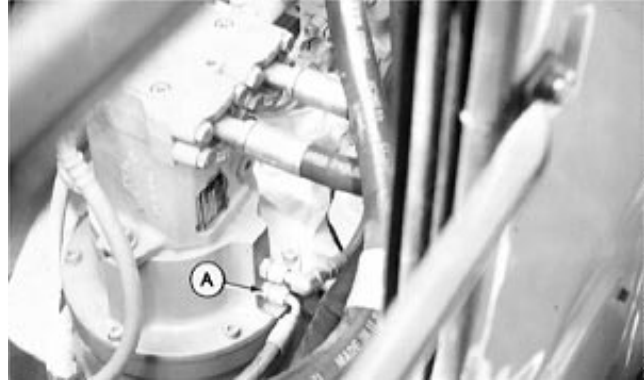

Earlier Machine Shown

T7581AC -UN-29JUL91

TX,35,DT5026 -19-09JUN97-3/3

Hydraulic System

33
3360
21

Hydraulic Oil Cleanup Procedure Using Portable Filter Caddy

SPECIFICATIONS	
Reservoir (Serial No. — 556935) Capacity	148 L (39 gal)
Reservoir (Serial No. 556936—) Capacity	151 L (40 gal)
System (Serial No. —556935) Capacity	265 L (70 gal)
System (Serial No. 556936—) Capacity	218 L (58 gal)
Reservoir (Serial No. — 556935) Approximate Filtering Time	13 minutes
Reservoir (Serial No. 556936—) Approximate Filtering Time	13.35 minutes
System (Serial No. —556935) Approximate Filtering Time	42 minutes
System (Serial No. 556936—) Approximate Filtering Time	34.35 minutes

ESSENTIAL TOOLS
JT03291 (3/4 M NPT x 3/4 M NPT) Elbow

SERVICE EQUIPMENT AND TOOLS
Portable Filter Caddy
Two 3658 mm (12 ft) x 3/4 in. I.D. 100R1
Hoses with 3/4 M NPT Ends
Quick Disconnect Fittings
Discharge Wand

Procedure is used to clean contamination from the hydraulic system after a hydraulic component failure. The Hydraulic Oil Cleanup Procedure Using Clean-Up Filter can also be used or used as a follow-up to the filter caddy to ensure a complete cleanup of contamination. (See procedure in this group.)

The hydraulic system return filter can be cut apart and inspected for indications of contamination.

1. Install a new return filter element.

IMPORTANT: The minimum ID of connector must be 1/2 in. to prevent cavitation of filter caddy pump.

NOTE: For a failure that creates a lot of debris, drain the reservoir. Remove access cover from reservoir. Connect filter caddy suction line to drain port. Add a minimum of 19 L (5 gal) of oil to reservoir. Wash out the reservoir using the filter caddy. Check and clean the suction lines to the main hydraulic pump and pilot pump.

2. To minimize oil loss, pull a vacuum in reservoir using a vacuum pump. Connect filter caddy suction line to quick disconnect fitting. Check to be sure debris has not closed drain port.
3. Put filter caddy discharge wand into reservoir filler hole so end is as far away from drain port as possible to obtain a thorough cleaning of oil.
4. Start the filter caddy. Check to be sure oil is flowing through the filters.

Operate filter caddy until all the oil in reservoir has been circulated through the filter a minimum of four times.

Leave filter caddy operating for the next step.

NOTE: Filtering time for reservoir is 0.089 minute x number of liters (0.33 minutes x number of gallons).

5. Start the engine and run it at fast idle.

IMPORTANT: For the most effective results, cleaning procedure must start with the smallest capacity circuit then proceed to the next largest capacity circuit.

6. Starting with the smallest capacity circuit, operate each functions through a complete cycle.

Specification

Reservoir (Serial No. — 556935)—Capacity	148 L (39 gal)
Reservoir (Serial No. 556936—)—Capacity	151 L (40 gal)

Hydraulic System

Specification

System (Serial No. —556935)—Capacity.....	265 L (70 gal)
System (Serial No. 556936—)—Capacity	218 L (58 gal)

Repeat procedure until the total system capacity has circulated through filter caddy seven times. Each function must go through a minimum of three complete cycles for a thorough cleaning of oil.

Specification

Reservoir (Serial No. — 556935)—Approximate Filtering Time	13 minutes
Reservoir (Serial No. 556936—)—Approximate Filtering Time.....	13.35 minutes
System (Serial No. — 556935)—Approximate Filtering Time	42 minutes
System (Serial No. 556936—)—Approximate Filtering Time.....	34.35 minutes

NOTE: Filtering time for complete hydraulic system is 0.158 minute x number of liters (0.6 minutes x number of gallons). Filtering time for machines with auxiliary hydraulic circuits must be increased because system capacity is larger.

7. Stop the engine. Remove the filter caddy.
8. Install new return filter elements.
9. Check oil level in hydraulic oil tank, add oil if necessary. (See Hydraulic Oil in Fuels and Lubricants group.)

TX,33,DY2943 -19-26AUG97-2/2

Hydraulic System

33
3360
23**Remove And Install Hydraulic Pump (Serial No. —559602)**

1. Loosen reservoir fill cap to release air pressure from reservoir.
2. Drain reservoir. Approximate capacity is 148 L (39 gal).
3. Remove pump regulator housing (A).
4. Disconnect lines (B—H).

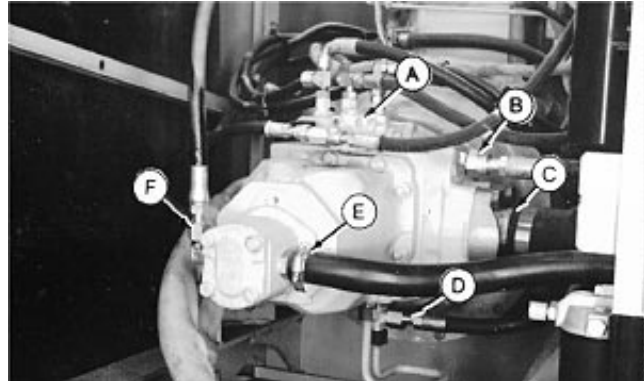

T7626CG -UN-18DEC91

⚠ CAUTION: The approximate weight of hydraulic pump is 125 kg (276 lb).

5. Remove pump.
6. Repair or replace pump as necessary.

- A—Pump Regulator Housing
 B—Drain Port-to-Reservoir
 C—Inlet Port-to-Reservoir
 D—Drain Port-to-Reservoir
 E—Inlet Port-to-Reservoir
 F—Outlet Port-to-Pilot Filter
 G—Outlet Port-to-Control Valve Upper Port
 H—Outlet Port-to-Control Valve Lower Port

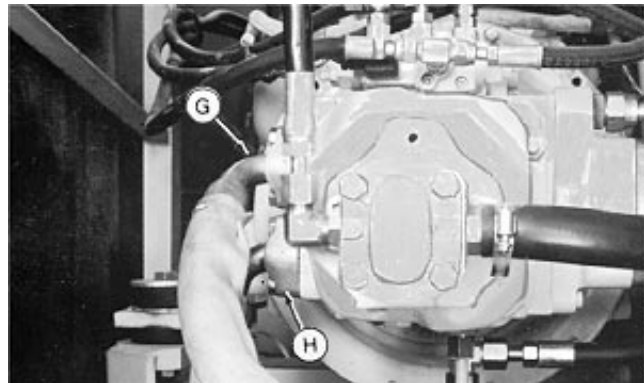

T7626CH -UN-18DEC91

Hydraulic Pump And Pilot Pump Line

Continued on next page

TX,33,DY2944 -19-26AUG97-1/3

Hydraulic System

7. Remove set screws (A) to remove drive hub assembly.

8. Install drive hub assembly with end of hub even with arms away from pump. Push drive hub on pump shaft 3 ± 1 mm (0.12 ± 0.04 in.) from pump housing.

Specification

Hub-to-Pump Case—Clearance..... 3 ± 1 mm (0.12 ± 0.04 in.)

Tighten set screws to 122 N•m (90 lb-ft).

Specification

Set Screw—Torque 122 N•m (90 lb-ft)

9. Install drive element on hub assembly.

10. Align drive element with drive flange on flywheel.

11. Install pump. Tighten cap screws to 87 N•m (64 lb-ft).

Specification

Pump-to-Flywheel Cap Screw—
Torque 87 N•m (64 lb-ft)

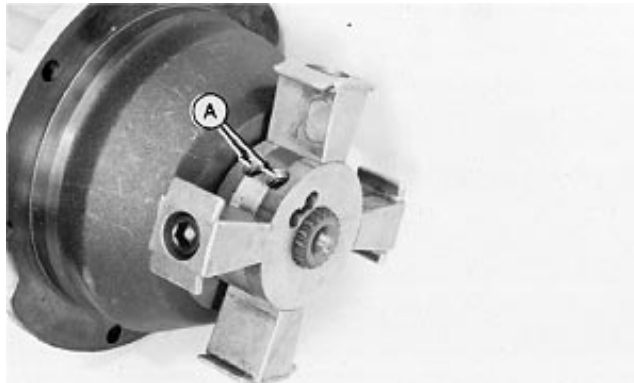

T6439YL -UN-22MAR90

TX,33,DY2944 -19-26AUG97-2/3

IMPORTANT: Original pump-to-control valve hoses are made to a specific length to control hydraulic pump noise. Replace hoses with the same lengths as the original.

12. Connect lines (B—H).

13. Check that O-rings are installed. Install pump regulator housing (A).

14. Do hydraulic pump start-up procedure. (See procedure in this group.)

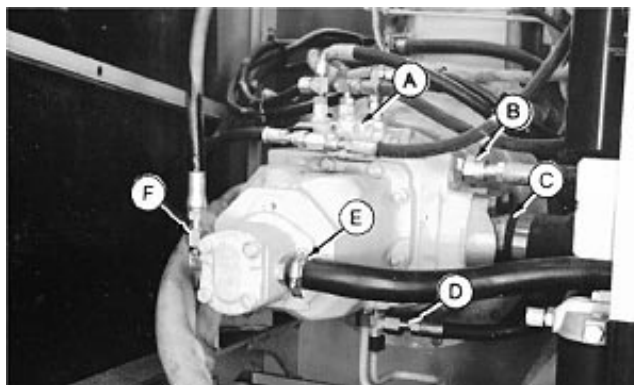

T7626CG -UN-18DEC91

- A—Pump Regulator Housing
- B—Drain Port-to-Reservoir
- C—Inlet Port-to-Reservoir
- D—Drain Port-to-Reservoir
- E—Inlet Port-to-Reservoir
- F—Outlet Port-to-Pilot Filter
- G—Outlet Port-to-Control Valve Upper Port
- H—Outlet Port-to-Control Valve Lower Port

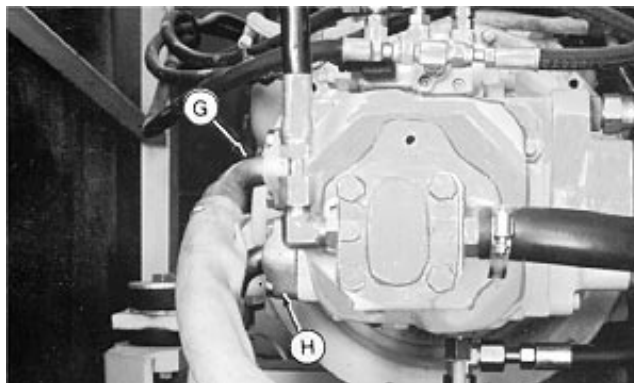

T7626CH -UN-18DEC91

TX,33,DY2944 -19-26AUG97-3/3

Hydraulic System

33
3360
25**Remove And Install Hydraulic Pump (Serial No. 559603—)**

1. Loosen reservoir fill cap to release air pressure from reservoir.
2. Drain reservoir. Approximate capacity is 150 L (40 gal).

TX,33,DY2945 -19-26AUG97-1/5

3. Disconnect lines (A, B and E—K)
4. Disconnect electrical connector (C).

- A—Pump Regulator LS Port-to-Main Control Valve Bottom Tee Port Line
- B—Pump Regulator Right Port-to-Dual Solenoid Valve Manifold "D" Port-to-Reservoir Line
- C—Electrical Connector
- D—Cap Screw (6 used)
- E—Pump Inlet Port-to-Reservoir Line
- F—Pilot Pump Inlet Port-to-Reservoir Line
- G—Pump Rear Drain Port-to-Reservoir Line
- H—Pump Front Drain Port-to-Reservoir Line
- I—Pilot Pump Outlet Port-to-Pilot Filter Forward Port Line
- J—Pump Bottom Rear Port-to-Monoblock Rear Inlet Port Line
- K—Pump Top Rear Port-to-Boom, Arm, Swing Bottom Tee Port Line

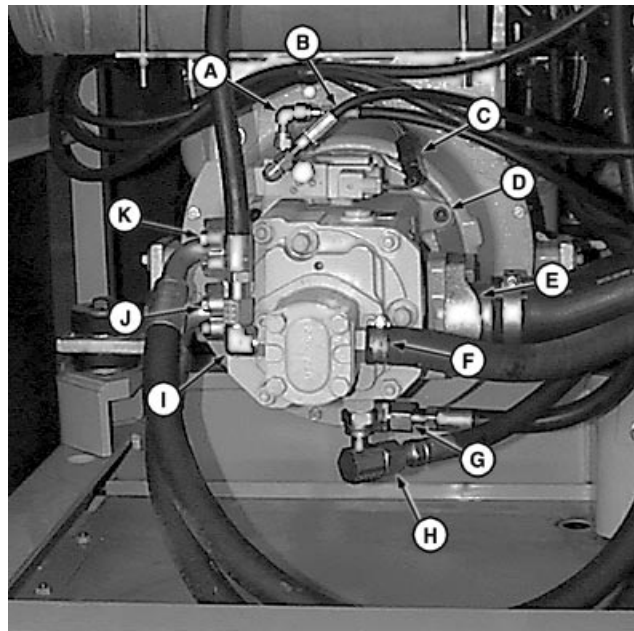

T109709 -UN-05AUG97

Hydraulic Pump And Pilot Pump Line

Continued on next page

TX,33,DY2945 -19-26AUG97-2/5

Hydraulic System

5. Connect JT01748 lifting brackets (C), and strap (B) to pump. Attach to shop hoist (A).

NOTE: Remove clamps to lines (E and K) and fitting to line (G) in order to remove pump mounting cap screws

6. Remove cap screws (D).

CAUTION: The approximate weight of hydraulic pump is 88 kg (194 lb).

7. Remove pump.

NOTE: Do not disassemble the hydraulic pump. The pump is serviced as an assembly and has a core value as a complete assembly.

8. Replace pump as necessary.

9. Install pump, aligning drive hub with drive element and flange on flywheel. Tighten cap screws to 87 N•m (64 lb-ft).

Specification

Pump-to-flywheel Cap Screw—
Torque 87 N•m (64 lb-ft)

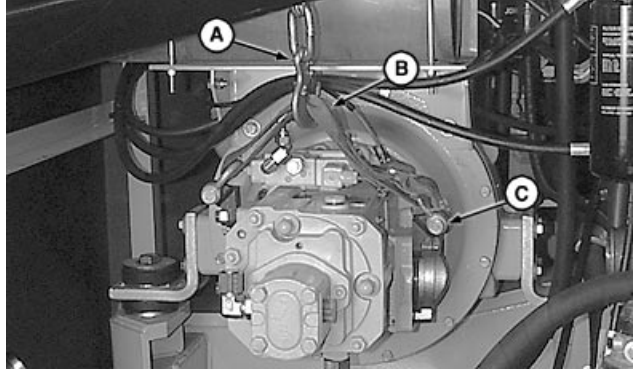

T109711 -UN-05AUG97

TX,33,DY2945 -19-26AUG97-3/5

10. Remove straps (B) and lifting brackets (C).

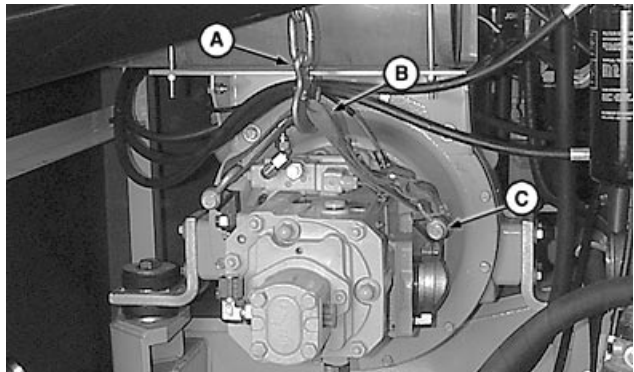

T109711 -UN-05AUG97

Continued on next page

TX,33,DY2945 -19-26AUG97-4/5

Hydraulic System

IMPORTANT: Original pump-to-control valve hoses are made to a specific length to control hydraulic pump noise. Replace hoses with the same lengths as the original.

11. Install clamps and fittings removed and connect lines (A, B and E—K).
12. Connect electrical connector (C).
13. Fill reservoir. Approximate capacity is 151 L (40 gal).
14. Do hydraulic pump start-up procedure. (See procedure in this group.)

- A—Pump Regulator LS Port-to-Main Control Valve Bottom Tee Port Line
- B—Pump Regulator Right Port-to-Dual Solenoid Valve Manifold "D" Port-to-Reservoir Line
- C—Electrical Connector
- D—Cap Screw (6 used)
- E—Pump Inlet Port-to-Reservoir Line
- F—Pilot Pump Inlet Port-to-Reservoir Line
- G—Pump Rear Drain Port-to-Reservoir Line
- H—Pump Front Drain Port-to-Reservoir Line
- I—Pilot Pump Outlet Port-to-Pilot Filter Forward Port Line
- J—Pump Bottom Rear Port-to-Monoblock Rear Inlet Port Line
- K—Pump Top Rear Port-to-Boom, Arm, Swing Bottom Tee Port Line

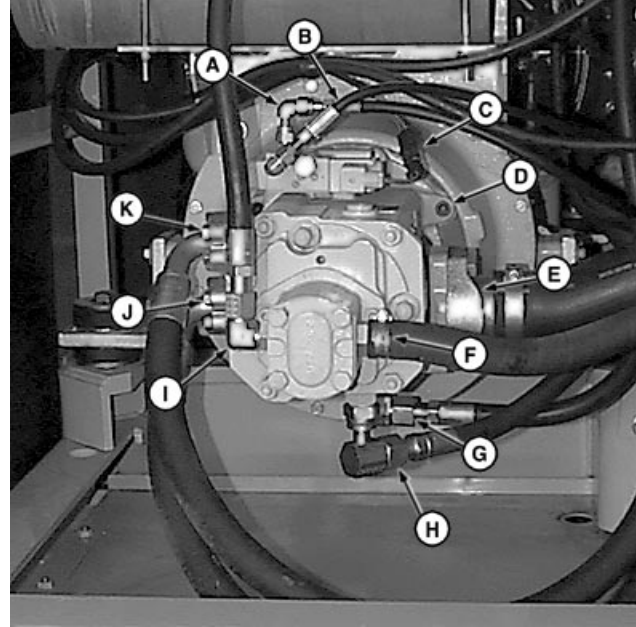

Hydraulic Pump And Pilot Pump Line

T1109709 -UN-05AUG97

33
3360
27

TX,33,DY2945 -19-26AUG97-5/5

Hydraulic Pump Start-Up Procedure

IMPORTANT: Pump will be damaged if not filled with oil before starting engine. Procedure must be done whenever a new pump is installed or whenever oil has been drained from the pump or reservoir.

Procedure is to ensure the pump is filled with oil and air is bled from suction side of pump to prevent cavitation.

1. Fill reservoir so oil level is at center line of sight tube.

TX,33,DY2946 -19-26AUG97-1/3

2. On machines (Serial No. —559602) remove plug (A) from bleed port. On machines (Serial No. 559603—) remove plugs (A and B).

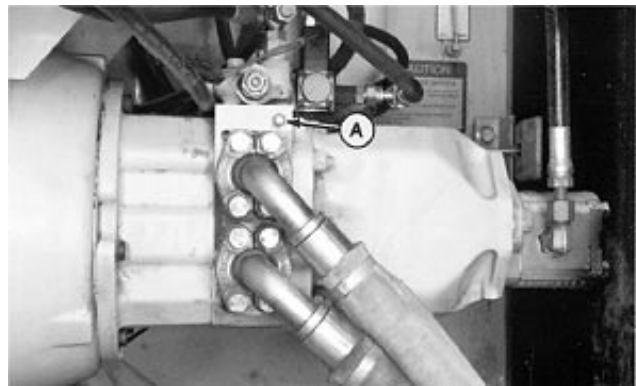

(Serial No. —559602)

T7527DX -UN-15JUL91

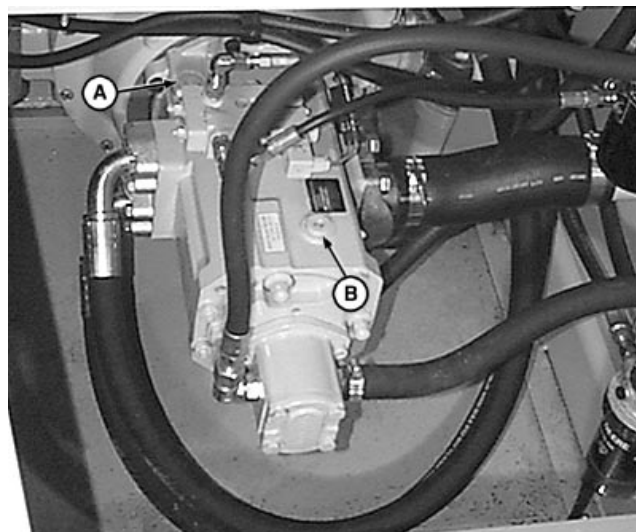

(Serial No. 559603—)

T108313 -UN-02JUN97

Continued on next page

TX,33,DY2946 -19-26AUG97-2/3

Hydraulic System

3. On machines (Serial No. —559602) disconnect drain hose (B). Add oil to pump case through the drain port until oil flows from bleed port.
4. On machines (Serial No. 559603—) add oil to pump case through plugs (A and B).
5. Install plugs.
6. On machines (Serial No. —559602) connect hose.
7. Check oil level after operating machine for several minutes.

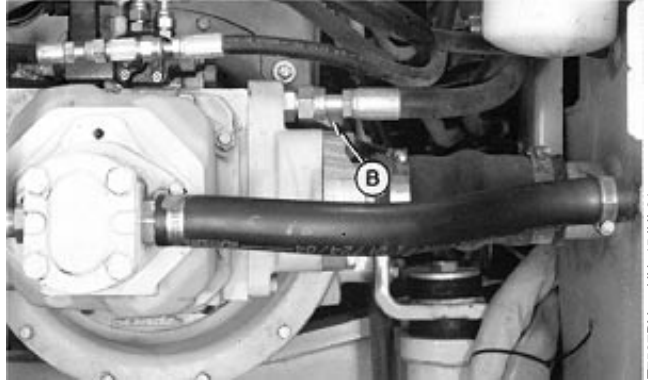

T7527DY -UN-15JUL91

33
3360
29

TX,33,DY2946 -19-26AUG97-3/3

Hydraulic System

Disassemble Hydraulic Pump (Serial No. —559602)

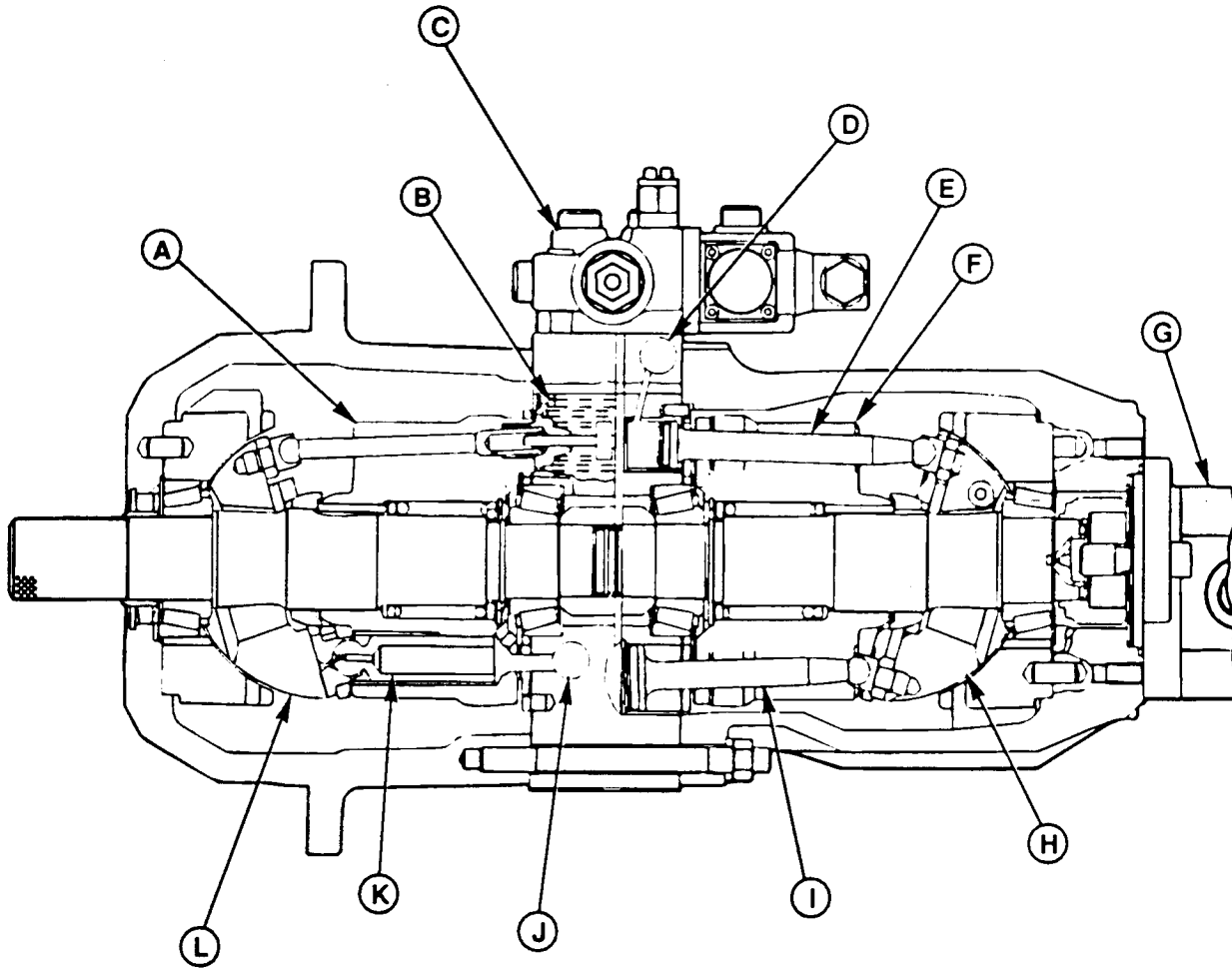

- | | | | |
|---------------------|--------------------------|------------------------|--------------------------|
| A—Cylinder Block | D—Pump Discharge Passage | G—Pilot Pump | J—Pump Discharge Passage |
| B—Feedback Spring | E—Small Control Piston | H—Swash Plate | K—Pistons |
| C—Regulator Housing | F—Cylinder Block | I—Large Control Piston | L—Swash Plate |

Continued on next page

TX,33,DY2905 -19-20AUG97-1/17

T7626CK -UN-18DEC91

Hydraulic System

33
3360
31

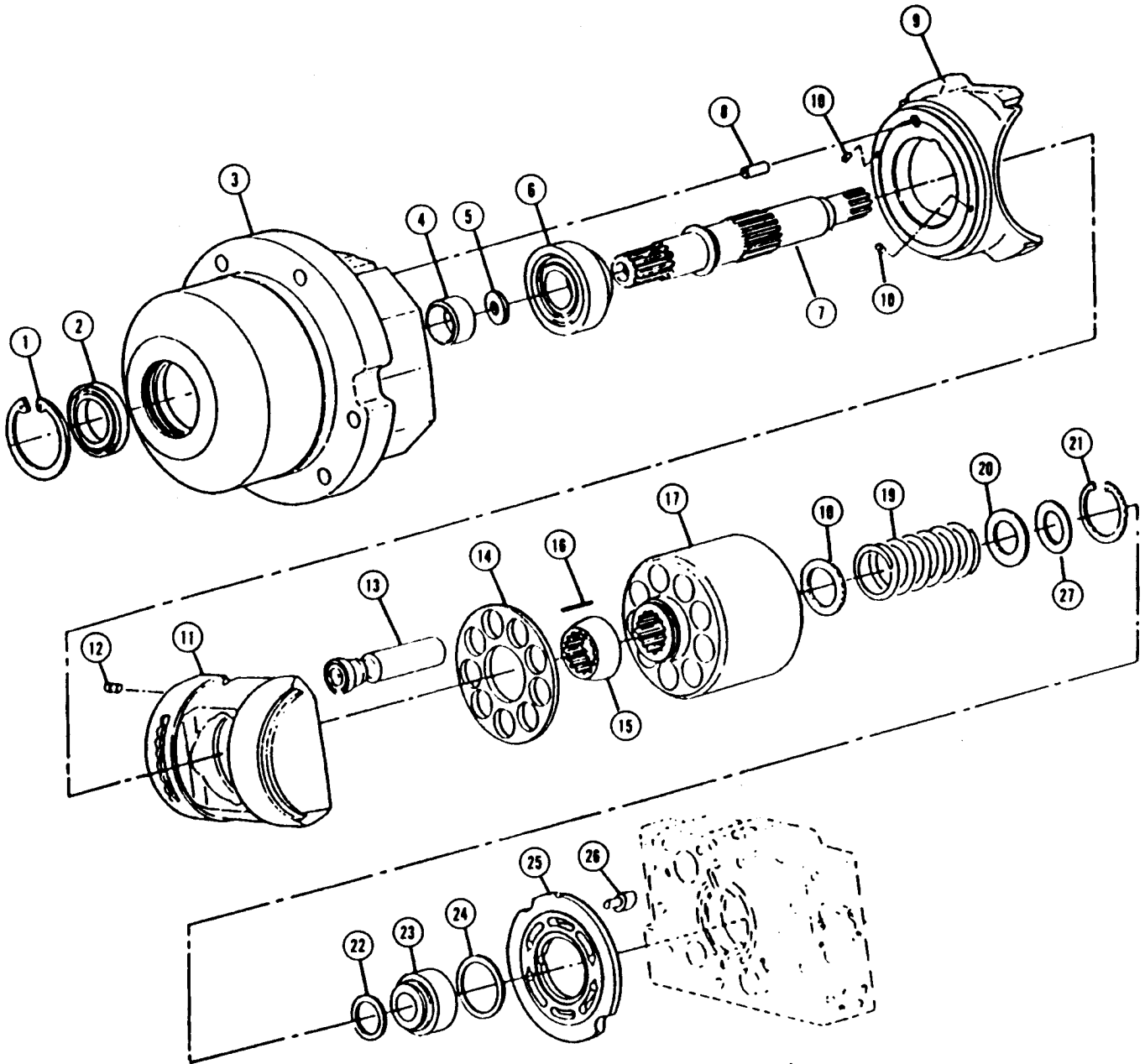

Front Hydraulic Pump

- | | | | |
|-------------|--------------------|-------------------|-------------------|
| 1—Snap Ring | 8—Dowel Pin | 15—Ball Guide | 22—Washer |
| 2—Seal | 9—Cradle | 16—Pin (3 used) | 23—Roller Bearing |
| 3—Housing | 10—Plug (2 used) | 17—Cylinder Block | 24—Shim |
| 4—Bushing | 11—Swash Plate | 18—Washer | 25—Valve Plate |
| 5—Washer | 12—Plug | 19—Spring | 26—Pin |
| 6—Bearing | 13—Piston (9 used) | 20—Washer | 27—Washer |
| 7—Shaft | 14—Retainer Plate | 21—Snap Ring | |

T7626CL -JUN-18DEC91

Continued on next page

TX,33,DY2905 -19-20AUG97-2/17

Hydraulic System

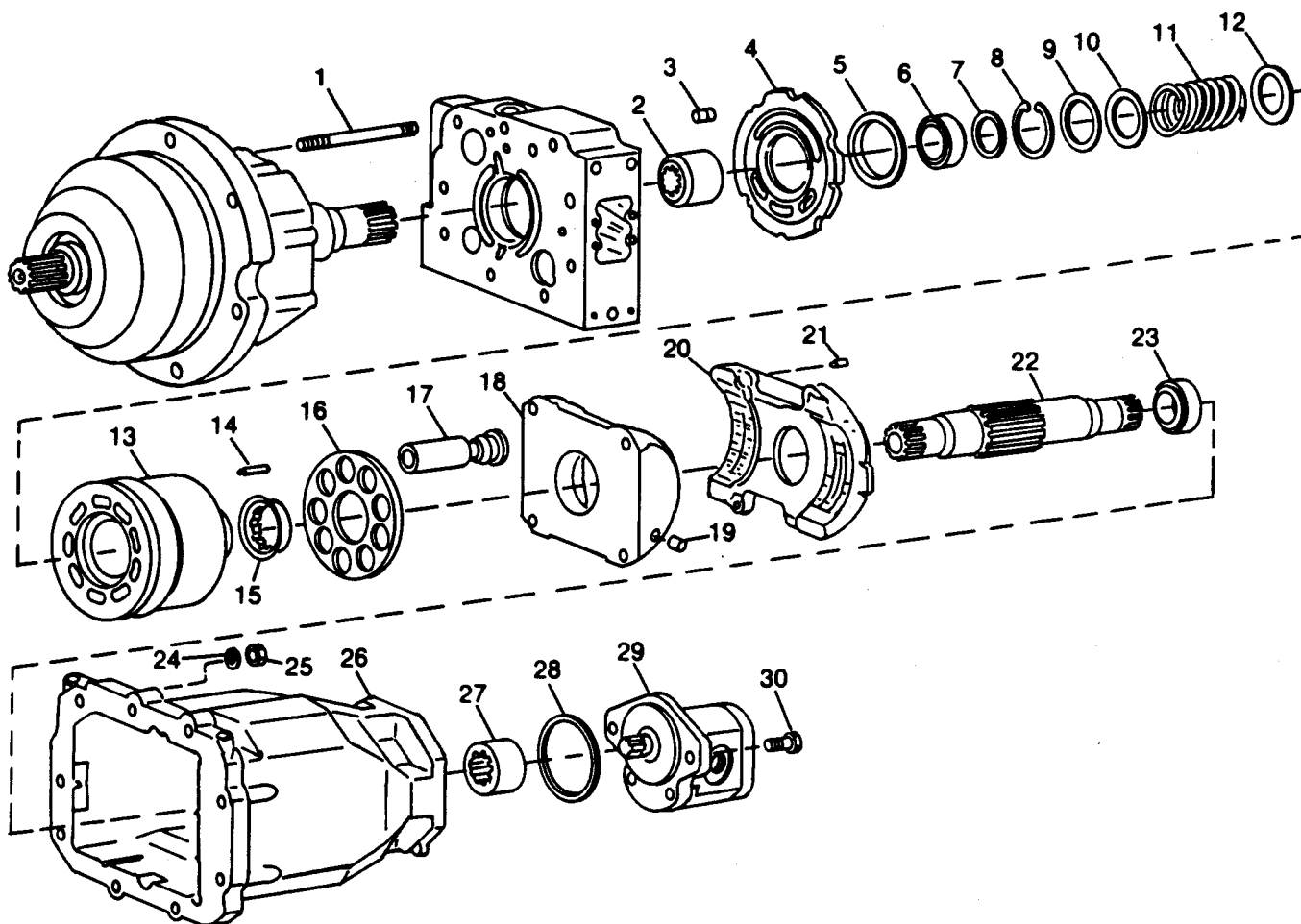

Rear Hydraulic Pump

- | | | | |
|------------------|----------------------------|--------------------|-----------------------|
| 1—Stud (9 used) | 9—Shim | 17—Piston (9 used) | 24—Washer (9 used) |
| 2—Coupling | 10—Washer | 18—Swash Plate | 25—Nut (9 used) |
| 3—Pin | 11—Spring | 19—Plug | 26—Housing |
| 4—Valve Plate | 12—Washer | 20—Cradle | 27—Coupling |
| 5—Shim | 13—Cylinder Block | 21—Pin | 28—O-Ring |
| 6—Roller Bearing | 14—Needle Bearing (3 used) | 22—Shaft | 29—Pilot Pump |
| 7—Washer | 15—Ball Guide | 23—Bearing | 30—Cap Screw (2 used) |
| 8—Snap Ring | 16—Retainer Plate | | |

T7626CM -UN-18DEC91

Continued on next page

TX,33,DY2905 -19-20AUG97-3/17

Hydraulic System

1. Remove pilot pump (A).

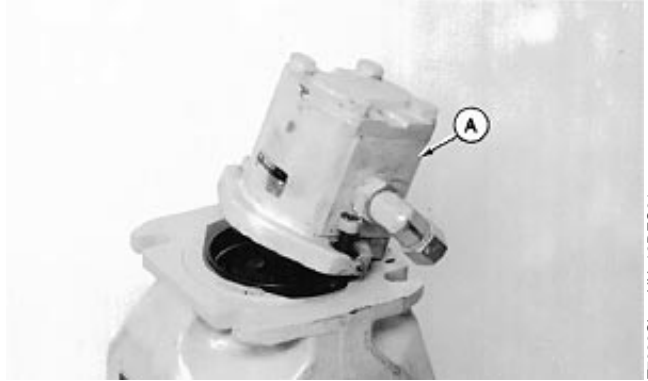

TX,33,DY2905 -19-20AUG97-4/17

33
3360
33

T7626CI -UN-18DEC91

2. Put pump in DF1039 Pump Workbench Support (A).
(See Section 99 for instructions to make tool.)

IMPORTANT: Keep parts for each pump together. The rotating components in each pump are a matched set. Mixing of components can change wear patterns, shortening the life of pumps. Protect lapped surfaces of valve plate and cylinder block from scratches or damage.

3. Remove rear pump (B). Cylinder block and piston assembly will not stay in housing as pump is removed.

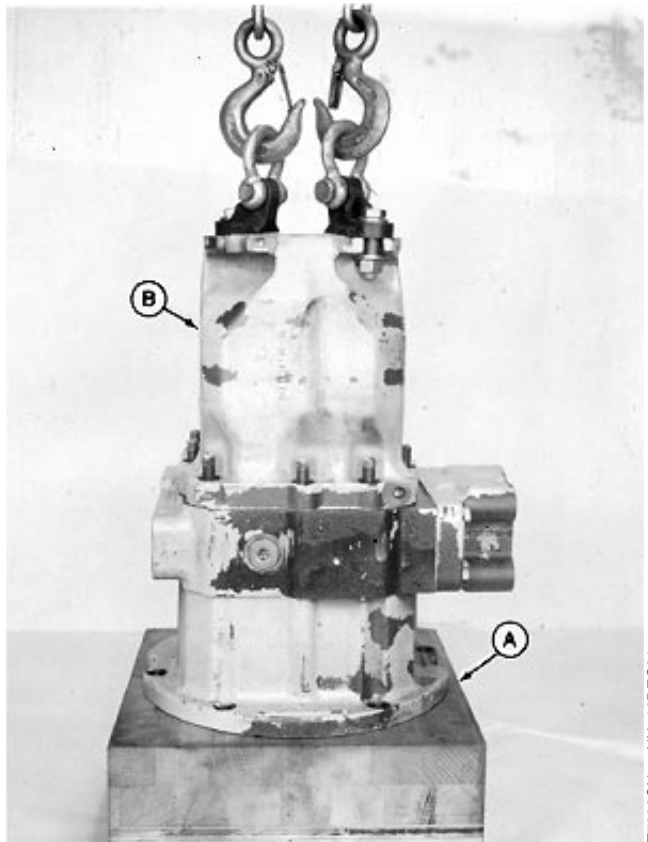

TX,33,DY2905 -19-20AUG97-5/17

T7626CN -UN-18DEC91

IMPORTANT: Do not scratch, nick, or damaged lapped surfaces of valve block.

4. Remove valve block (A). Front pump remains on workbench support (B).

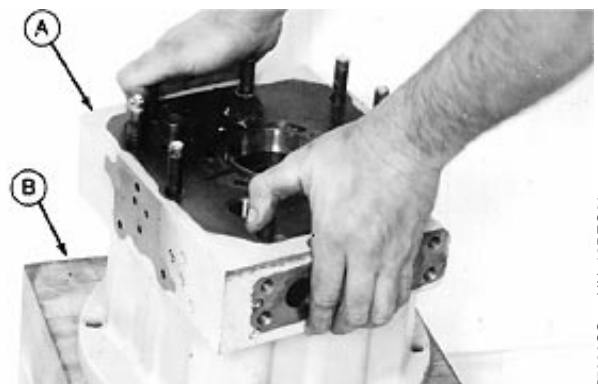

Continued on next page

TX,33,DY2905 -19-20AUG97-6/17

T7626CO -UN-18DEC91

Hydraulic System

- If inner bearing is to be replaced, remove bearing cup and shim pack (A) using a two-jaw puller.

Repeat step for opposite bearing cup if inner bearing for other pump is to be replaced.

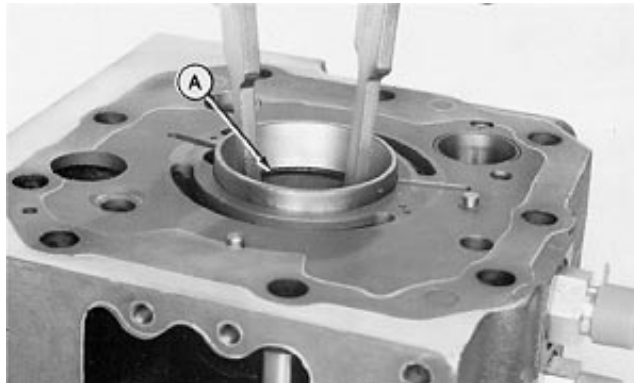

T6439VS -UN-22MAR90

TX,33,DY2905 -19-20AUG97-7/17

- Compress plates (A) in center housing.
- Remove snap ring (B) and slowly release pressure on plates.
- Remove parts.

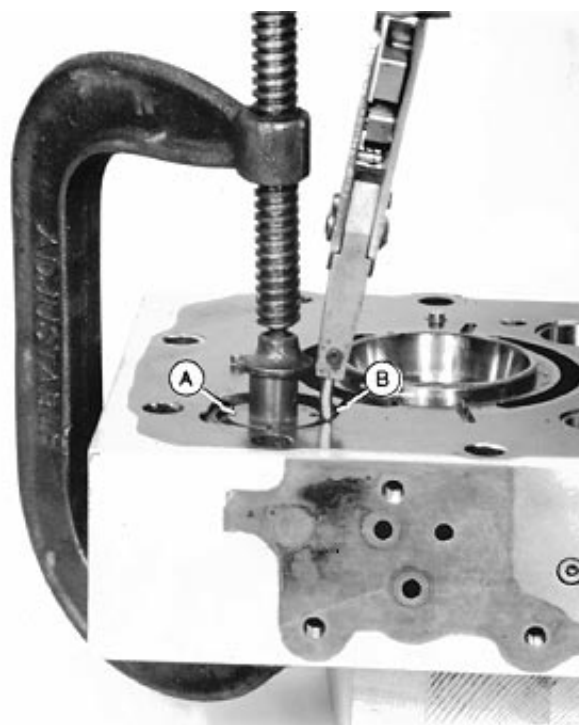

T7626CT -UN-18DEC91

TX,33,DY2905 -19-20AUG97-8/17

- Inspect parts and replace as necessary.

- A—Snap Ring (2 used)
- B—Plate (2 used)
- C—Spring (2 used)
- D—Spring
- E—Spring
- F—Plate

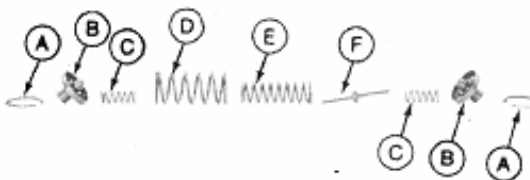

T7626CU -UN-18DEC91

Continued on next page

TX,33,DY2905 -19-20AUG97-9/17

Hydraulic System

- Remove cylinder block, pistons, and swashplate as an assembly.

IMPORTANT: Do not scratch, nick, or damage lapped surfaces of cylinder block.

- Put front pump cylinder block and piston assembly into DF1040 Pump Rotate Group Workbench Support. (See Section 99 for instructions to make tool.)



33
3360
35

T6439UX -UN-22MAR90

TX,33,DY2905 -19-20AUG97-10/17

NOTE: Disassembly of cylinder block and piston assembly for rear and front pump is similar.

- Put cardboard (C) on cylinder block to protect surface.
- Break roller cage (D) to remove rollers.
- Remove bearing inner race (A) and spacer (B) using a bearing puller.

- A—Inner Race
- B—Spacer
- C—Cardboard
- D—Roller Cage



T7626CP -UN-06JAN92

Continued on next page

TX,33,DY2905 -19-20AUG97-11/17

Hydraulic System

IMPORTANT: Do not scratch, nick, or damage lapped surfaces of cylinder block.

15. Put cardboard (B) and workbench support (C) on cylinder block. Turn over to remove shaft and swash plate (A).

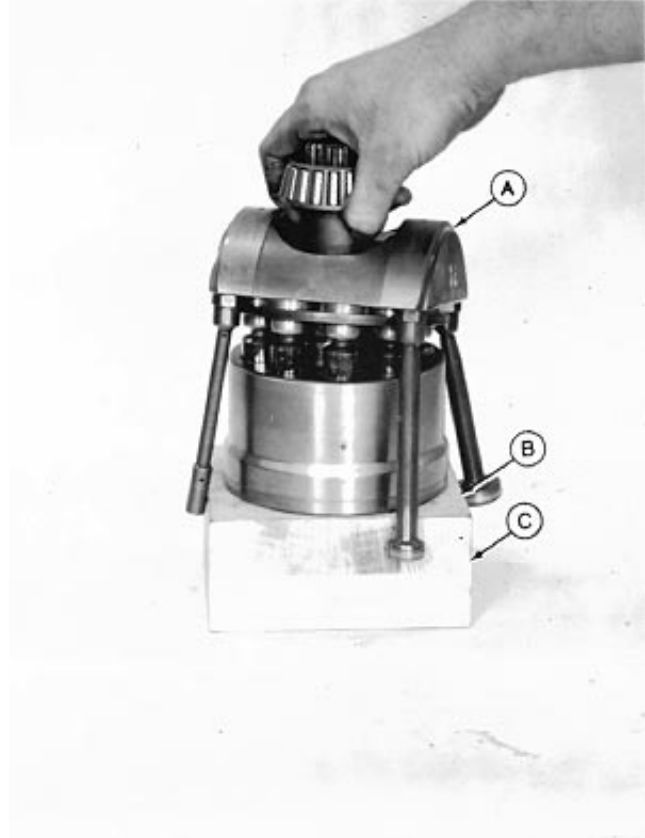

T7626CR -UN-18DEC91

TX,33,DY2905 -19-20AUG97-12/17

16. Remove bearing cone (A), spacer (B), and seal collar (C) from front pump using a press and bearing puller.

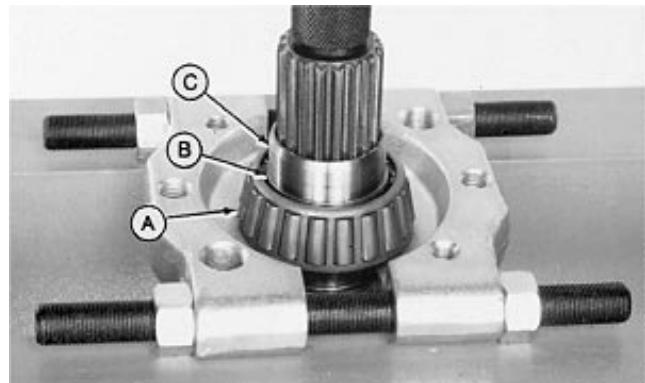

TG439VD -UN-22MAR90

Continued on next page

TX,33,DY2905 -19-20AUG97-13/17

Hydraulic System

17. Lift retainer plate (A) to remove pistons (B).

18. Remove ball guide (C) and pins (D).

- A—Retainer Plate
- B—Piston (9 used)
- C—Ball Guide
- D—Pin (3 used)

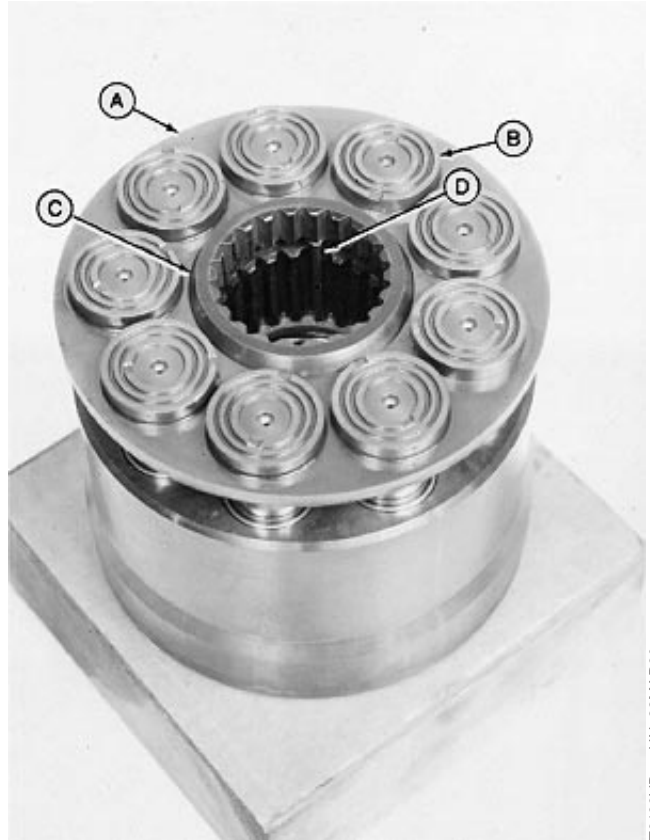

33
3360
37

T6439VB -UN-22MAR90

TX,33,DY2905 -19-20AUG97-14/17

19. Push washer (B) down using a 46 mm disk and a press. Remove snap ring (A) to remove washer (B), spring (C), and washer (D).

- A—Snap Ring
- B—Small ID Washer
- C—Spring
- D—Large ID Washer



T6439VC -UN-22MAR90

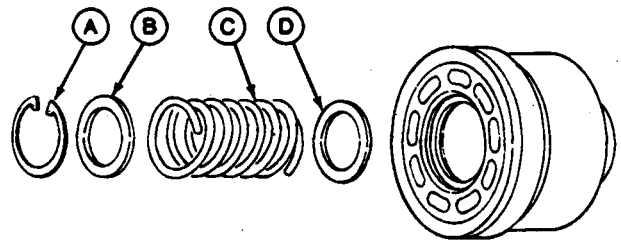

T6439UR -UN-01NOV88

Continued on next page

TX,33,DY2905 -19-20AUG97-15/17

Hydraulic System

NOTE: Bearing cup is a slip-fit in cradle.

20. Remove cradle and bearing cup (B).

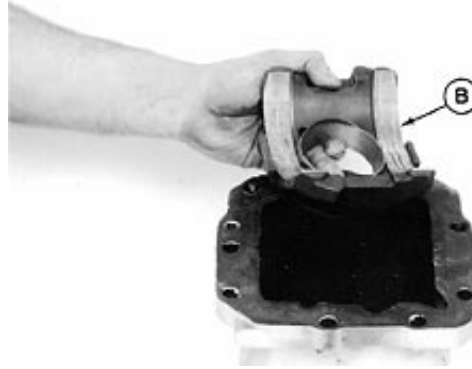

TX,33,DY2905 -19-20AUG97-16/17

T7681FT -UN-23FEB92

21. Remove snap ring to remove seal (A).

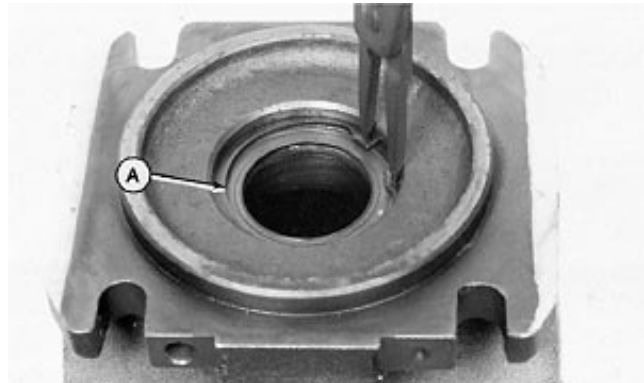

TX,33,DY2905 -19-20AUG97-17/17

T6439VF -UN-22MAR90

Inspect Hydraulic Pump



CAUTION: Reduce compressed air to less than 210 kPa (2 bar) (30 psi) when using for cleaning purposes. Clear area of bystanders, guard against flying chips, and wear personal protection equipment including eye protection.

IMPORTANT: Use only diesel fuel to clean pump parts. DO NOT use solvents, they can damage internal components.

Be careful when handling parts with lapped surfaces. DO NOT scratch or damage surfaces.

1. Wash all parts in diesel fuel and dry using compressed air.

Continued on next page

TX,33,DY2947 -19-26AUG97-1/6

Hydraulic System

33
3360
39

2. Inspect pistons (A) for scoring or wear. Check piston-to-slipper ball joint for looseness. Check for equal wear between all slippers (B).

Inspect lapped surfaces of slippers, valve plate (D), and cylinder block (C) for scratches or wear.

Replace pump if necessary.

- A—Piston
- B—Slipper
- C—Cylinder Block
- D—Valve Plate



T6439YQ -UN-22MAR90

Earlier Machine Shown

TX,33,DY2947 -19-26AUG97-2/6

3. Inspect thickness (A) of bronze material on cylinder block. Cylinder block can be resurfaced to remove scratches from lapped surfaces if minimum thickness is maintained.

Specification

Cylinder Block Bronze Material—
Minimum Thickness..... 0.9 mm (0.035 in.)



T6439YP -UN-16APR90

Continued on next page

TX,33,DY2947 -19-26AUG97-3/6

Hydraulic System

- 33
3360
40
4. Resurface cylinder block using JT05425 Polishing Table or an equivalent surface and 4/0 emery paper. Wet polishing paper using diesel fuel.
 5. Put the part on polishing table. Move the part in a figure 8 pattern. Normally it is not necessary to make more than 10 complete figure 8 patterns.

Turn the part 90° and do Step 3 again if necessary.
 6. Wash parts in diesel fuel. Dry the parts.



T83352 -UN-08MAR90

TX,33,DY2947 -19-26AUG97-4/6

7. Inspect swash plate (B) for wear or scratches. Replace pump if swash plate is worn or damaged.
8. Inspect ball joint of feedback rod (A), small (C), and large (D) pistons. If replacement is necessary, ball joint may require heating to loosen retaining compound.

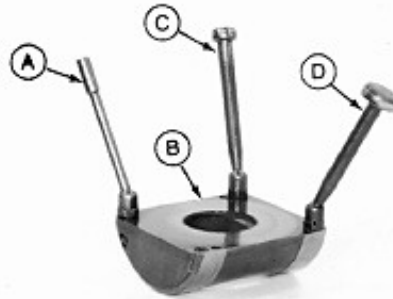

T7626CS -UN-18DEC91

TX,33,DY2947 -19-26AUG97-5/6

9. Inspect piston rings for wear or scratches. Replace if necessary.
10. Install new piston ring with sealing area (A) toward stem of piston.

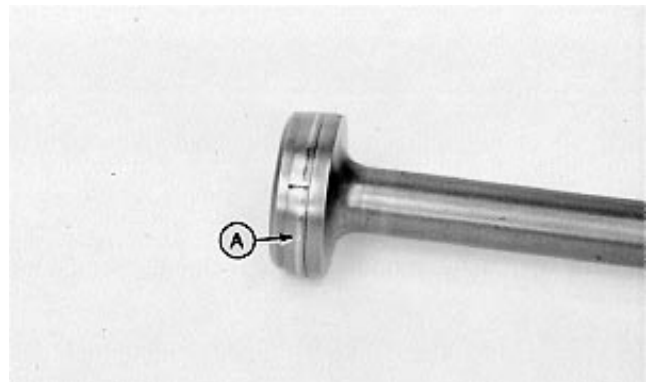

T6439VI -UN-22MAR90

TX,33,DY2947 -19-26AUG97-6/6

Hydraulic System

33
3360
41

Assemble Hydraulic Pump (Serial No. — 559602)

1. Install new O-rings and seals.
2. Apply clean hydraulic oil to all internal parts.
3. Apply retaining compound to inside surface of seal collar.

TX,33,DY2949 -19-26AUG97-1/21

4. Press bearing (A), spacer (B), and seal collar (C) on shaft of front pump.

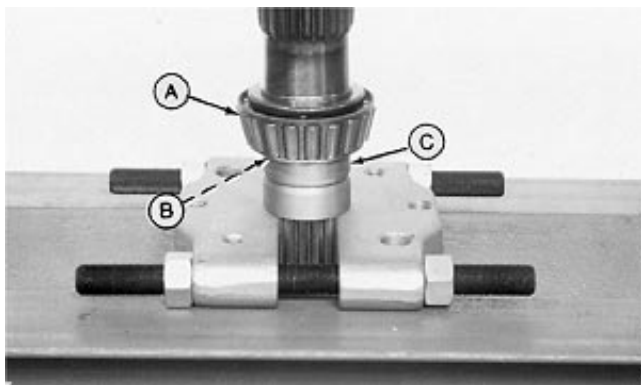

T6439VK -UN-22MAR90

TX,33,DY2949 -19-26AUG97-2/21

5. Install washer (D), spring (C), and washer (B). Push washer down using a 46 mm disk and press. Install snap ring (A).

IMPORTANT: Protect lapped surface of cylinder block using a clean piece of cardboard.

6. Put cylinder block on cardboard and workbench support with lapped surface down.

- A—Snap Ring
- B—Small ID Washer
- C—Spring
- D—Large ID Washer

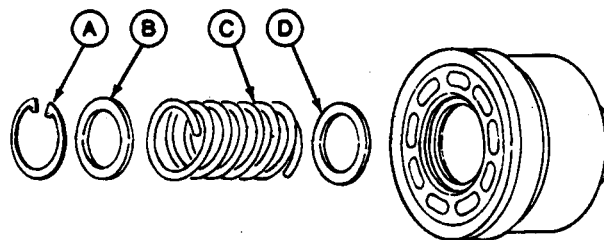

T6439UR -UN-01NOV88



T6439VC -UN-22MAR90

Continued on next page

TX,33,DY2949 -19-26AUG97-3/21

Hydraulic System

7. Apply petroleum jelly to pins (D). Install pins and ball guide (C) and align splines.

8. Install pistons (B) and retainer plate (A).

- A—Retainer Plate
- B—Pistons (9 used)
- C—Ball Guide
- D—Pin (3 used)

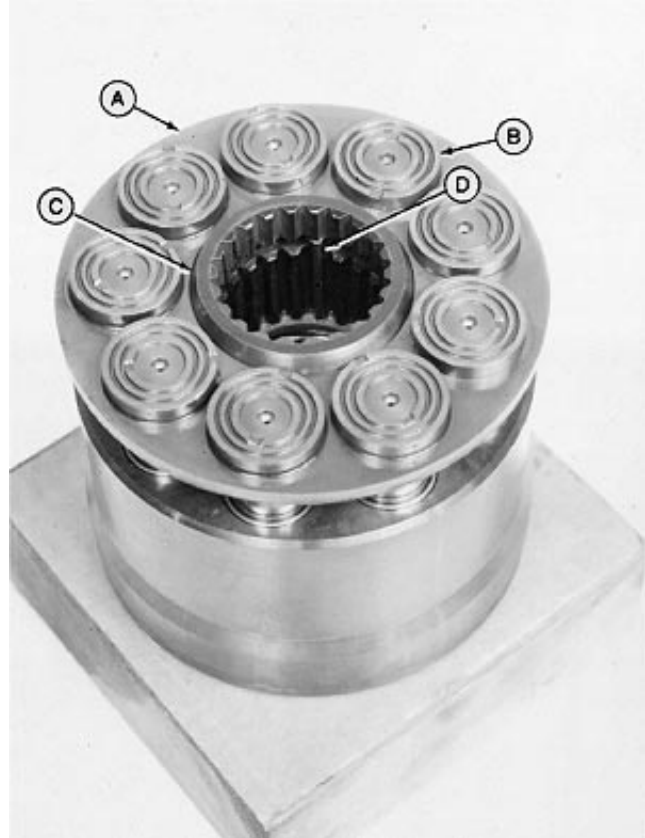

T6439VB -UN-22MAR90

Continued on next page

TX,33,DY2949 -19-26AUG97-4/21

Hydraulic System

33
3360
43

9. Apply retaining compound to threads of feedback rod, small, and large pistons (B). Install and tighten rod and pistons to 30 N•m (22 lb-ft).

Specification

Feedback Rod End Piston—
Torque 30 N•m (22 lb-ft)

10. Install swashplate (A) and pump shaft using care not to move three pins in cylinder block.

Carefully turn cylinder block over and install end of shaft in workbench support (C).

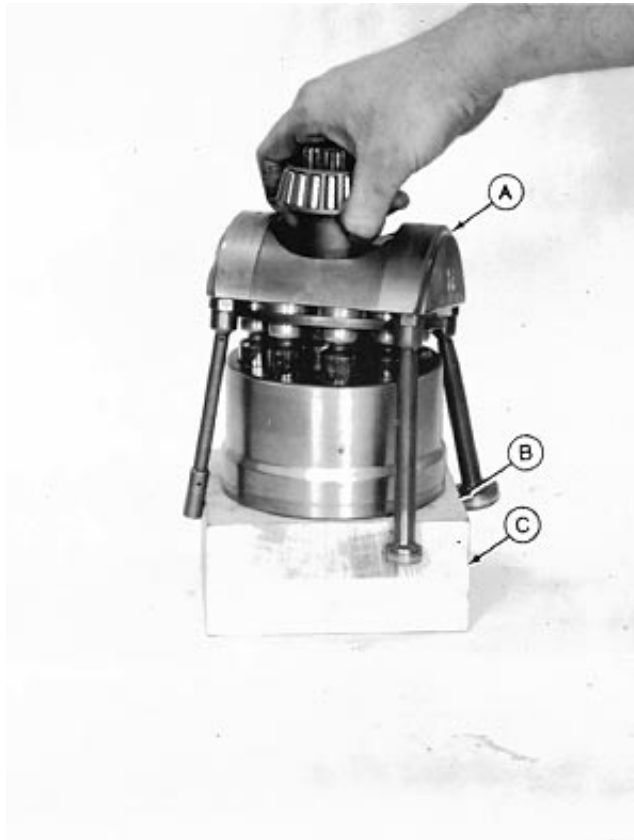

T7626CR -UN-18DEC91

Front Pump Components Shown

TX,33,DY2949 -19-26AUG97-5/21

11. Install spacer (A).



T6439VJ -UN-22MAR90

Continued on next page

TX,33,DY2949 -19-26AUG97-6/21

Hydraulic System

! CAUTION: DO NOT heat oil over 182°C (360°F). Oil fumes or oil can ignite above 193°C (380°F). Use a thermometer. DO NOT allow a flame or heating element to come in direct contact with the oil. Heat the oil in a well-ventilated area.

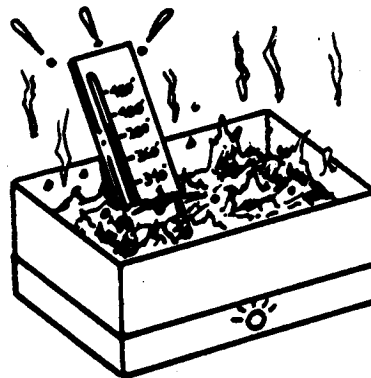

12. Heat new bearing cone to approximately 93°C (200°F) and install on shaft.

TX,33,DY2949 -19-26AUG97-7/21

T81191 -UN-23FEB89

13. Install snap ring (A).

14. Push seal into housing tight against snap ring using 45 and 62 mm disks. Put petroleum jelly on seal lips.

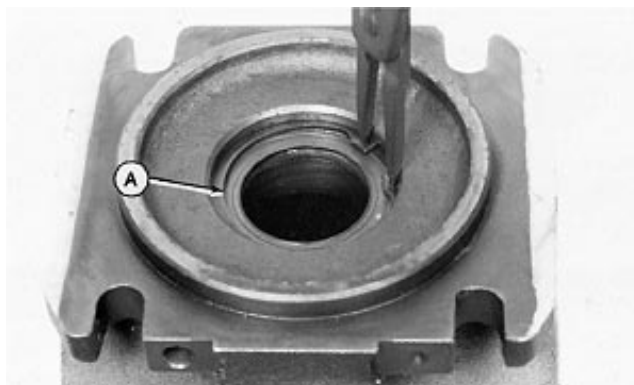

TX,33,DY2949 -19-26AUG97-8/21

T6439VF -UN-22MAR90

NOTE: Bearing cup is a slip-fit in cradle.

15. Install bearing cup (A) and cradle (B).

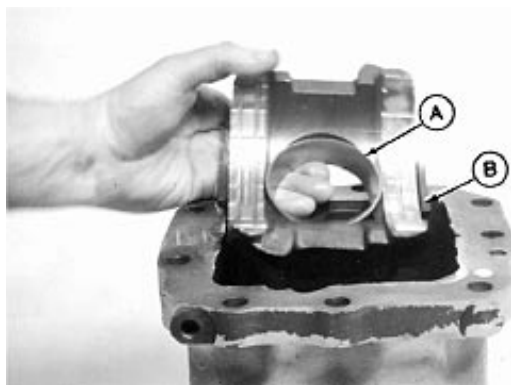

TX,33,DY2949 -19-26AUG97-9/21

T7681EU -UN-27JAN92

16. Put pump housing horizontal. Install cylinder block assembly in housing and carefully guide shaft through seal.

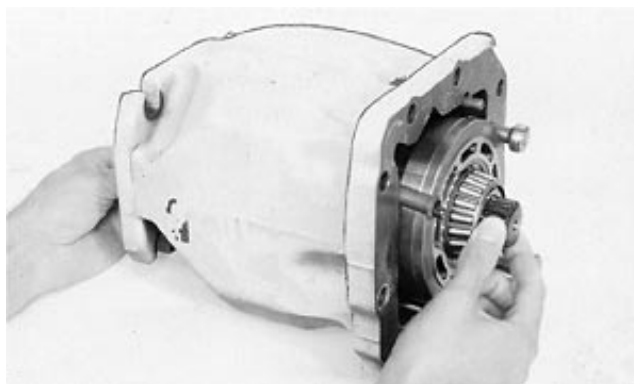

TX,33,DY2949 -19-26AUG97-10/21

T6439VL -UN-22MAR90

Continued on next page

Hydraulic System

33
3360
45

17. Install and tighten studs (A) to 60 N•m (44 lb-ft).

Specification

Front Pump-to-Rear Pump Stud—
Torque 60 N•m (44 lb-ft)

IMPORTANT: Front pump valve plate is marked “R” for right, as viewed from suction side of pumps.

18. Install valve plate (B) marked “R”, on front pump cylinder block with lapped surfaces toward each other.

Put the two small holes in valve plate towards the bottom of pump and align notches (C) on the suction side of the pump.

NOTE: Splined coupling is not installed at this time. Pump shaft end play is checked before coupling is installed.

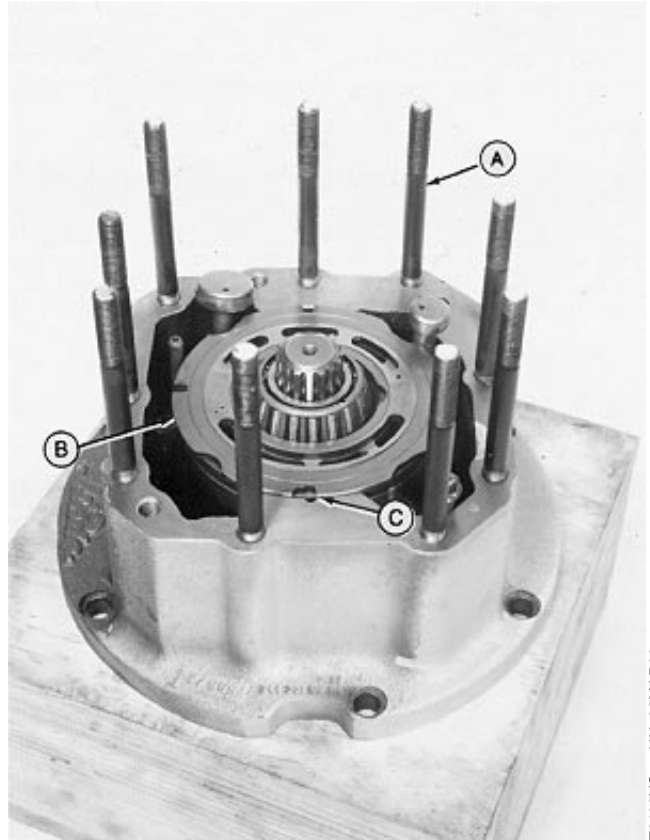

T6439YS -UN-22MAR90

TX,33,DY2949 -19-26AUG97-11/21

19. Carefully install valve block (A). As valve block is lowered, align studs (B), pistons (D), and feedback rod with bores as valve block.

Make sure locator pins fit into notches of valve plate (C). When parts are aligned properly, there is approximately 1.5 mm (1/16 in.) gap between pump housing and valve block.

- A—Valve Block
- B—Stud (9 used)
- C—Valve Plate
- D—Small and Large Piston

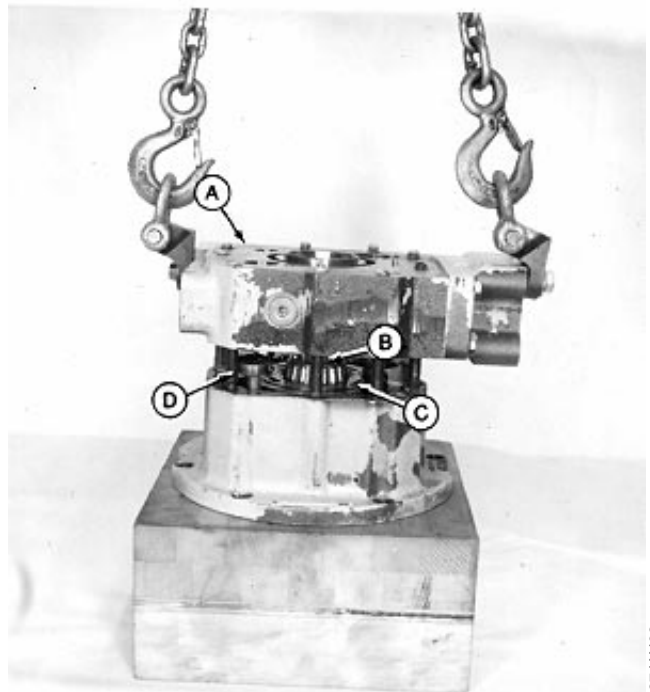

T7681EX -UN-27JAN92

Continued on next page

TX,33,DY2949 -19-26AUG97-12/21

Hydraulic System

IMPORTANT: Rear pump valve plate is marked “L” for left, as viewed from suction side of pumps.

20. Apply petroleum jelly to lapped side of valve plate (A) marked “L”. Install valve plate on rear pump cylinder block with lapped surfaces toward each other.

Put the two small holes in valve plate towards the bottom of pump and align notches (B) on the suction side of pump.

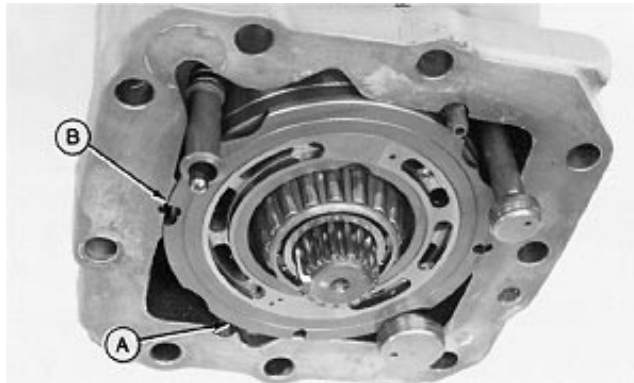

T6439YT -UN-22MAR90

TX,33,DY2949 -19-26AUG97-13/21

IMPORTANT: Make sure cradle remains on locator pin when rear pump is picked up or pump will not align properly with valve block.

21. Carefully install rear pump (B). As pump is lowered, align pistons, feedback rod, and oil tube with bores in valve block.

Make sure locator pins fit into notches of valve plate. When parts are aligned properly, there is approximately 1.5 mm (1/16 in.) gap between pump housing and valve block.

22. Install washers and nuts (A). Tighten nuts to 110 N•m (81 lb-ft).

Specification

Stud-to-Housing Nut—Torque..... 110 N•m (81 lb-ft)

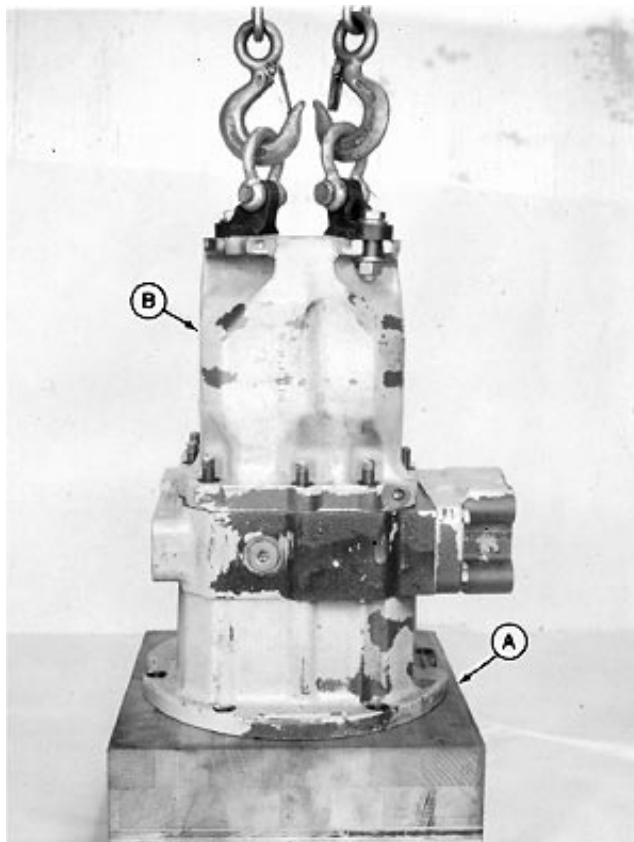

T7626CN -UN-18DEC91

Continued on next page

TX,33,DY2949 -19-26AUG97-14/21

Hydraulic System

- Turn rear pump shaft several times. Install dial indicator and lift pump to check shaft end play.

Specification

Rear Pump Shaft—End Play..... 0.10—0.30 mm (0.004—0.012 in.)

Add or subtract shims from shim pack in valve block to obtain proper end play.

- Install a M12-1.75 eyebolt in shaft of front pump and repeat Step 23 for front pump.
- Remove nuts and washers to remove rear pump, valve plates, and valve block.



33
3360
47

T6439YV -UN-22MAR90

TX,33,DY2949 -19-26AUG97-15/21

IMPORTANT: Pumps are phased to each other to reduce pressure spikes and noise.

- Use splined coupler (C), hose clamp, and tie band (A) to make a pump phasing tool.

Align tie band with any root (B) of a spline. Tighten hose clamp to keep band square with root.



T6439VN -UN-22MAR90

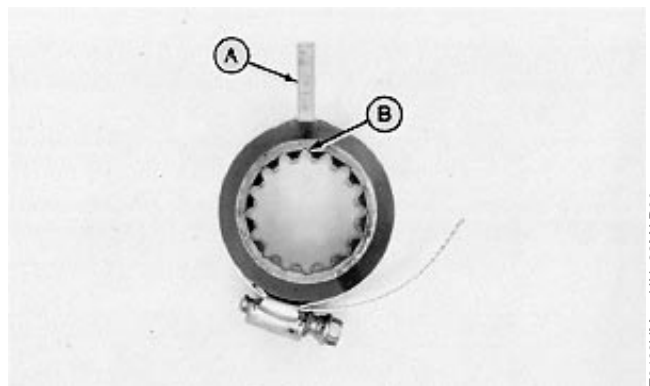

T6439VM -UN-22MAR90

Continued on next page

TX,33,DY2949 -19-26AUG97-16/21

Hydraulic System

27. Check to make sure pistons (A and B) and feedback rods (C), and are positioned correctly as shown.

28. Keep putting coupler and tie band on front pump shaft until the BEST position is located where tie band is centered between two cylinder ports.

Turn shaft and coupler to align tie band, BEST position of cylinder block, and notch (D), on suction side of pump.

29. Mark rear pump shaft. Align using tie band until BEST position is located where tie band is centered over a cylinder port.

Turn shaft and coupler to align tie band, BEST position of cylinder block, and notch (D), on suction side of pump.

IMPORTANT: Keep lapped surface of cylinder block clean and free from scratches.

30. Put a mark on shafts, coupler, and housings to indicate alignment position.

Remove clamp and tie band from coupler.

- A—Large Piston
- B—Small Piston
- C—Feedback Rod
- D—Suction-Side Locator Notch

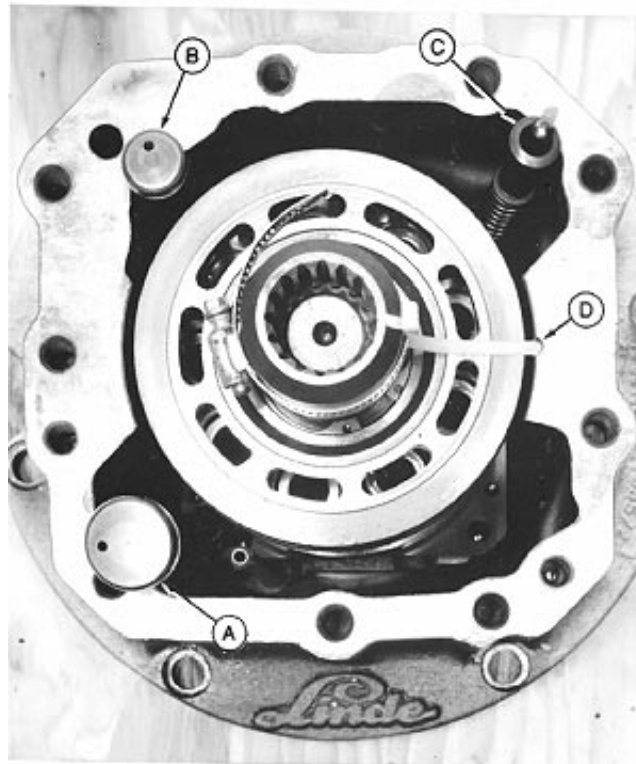

T7704AG -UN-10FEB92

Front Pump

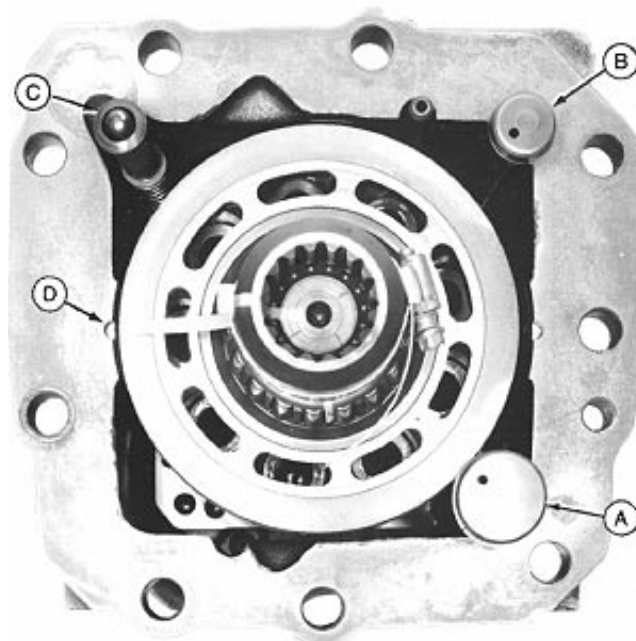

T7704AH -UN-10FEB92

Rear Pump

Continued on next page

TX,33,DY2949 -19-26AUG97-17/21

Hydraulic System

31. Install coupler (B) on front pump shaft; align marks.
32. Install valve plate (C) marked "R", on cylinder block with lapped surfaces toward each other. Put two small holes in valve plate towards bottom of pump and align notches on suction side of pump.
33. Apply a thin, even layer of pipe sealant with TEFLON® to mating surface of front pump housing.
34. Carefully install valve block (A). As valve block is lowered, align studs (D), pistons and feedback rod, with bores in valve block.

Make sure locator pins fit into notches of valve plate. When parts are aligned properly, there is approximately 1.5 mm (1/16 in.) gap between pump housing and valve block.

- A—Valve Block
- B—Coupler
- C—Valve Plate
- D—Stud (9 used)

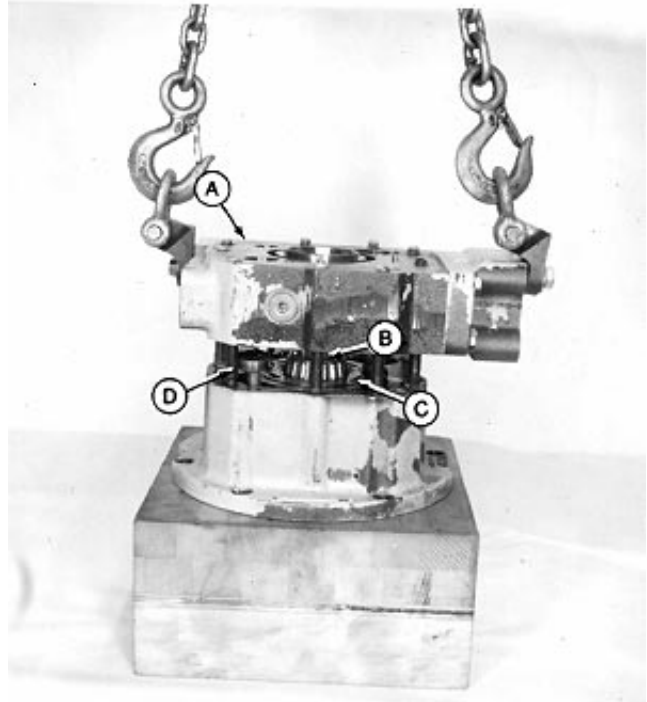

T7681EX -UN-27JAN92

33
3360
49

TEFLON is a registered trademark of the DuPont Company.

Continued on next page

TX,33,DY2949 -19-26AUG97-18/21

Hydraulic System

35. Apply petroleum jelly to lapped side of valve plate (A) marked "L". Install valve plate on rear pump cylinder block with lapped surfaces toward each other.

Put the two small holes in valve plate towards the bottom of pump and align notches (B) on the suction side of pump.

36. Apply a thin, even layer of pipe sealant with TEFLON® to mating surface of rear pump housing.

IMPORTANT: Make sure cradle remains on locator pin when rear pump is picked up or pump will not align properly with valve block.

37. Carefully install rear pump. As pump is lowered, align pistons and feedback rod with bores in valve block.

Make sure locator pins fit into notches of valve plate. When parts are aligned properly, there is approximately 1.5 mm (1/16 in.) gap between pump housing and valve block.

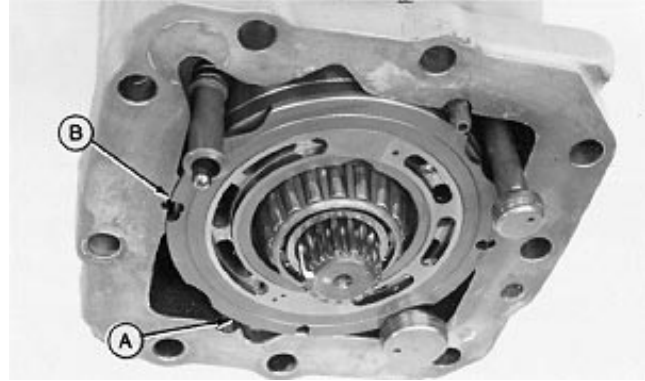

T6439YT -UN-22MAR90

TEFLON is a registered trademark of the DuPont Company.

Continued on next page

TX,33,DY2949 -19-26AUG97-19/21

Hydraulic System

33
3360
51

38. Install washers and nuts (A). Tighten nuts to 110 N•m (81 lb-ft).

Specification

Pilot Pump-to-Hydraulic Pump
Cap Screws—Torque 110 N•m (81 lb-ft)

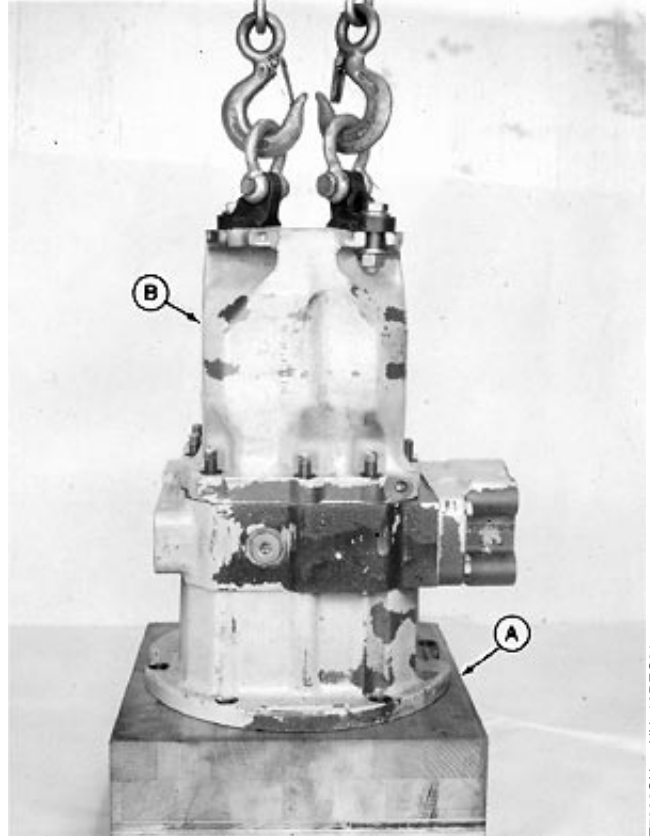

T7626CN -UN-18DEC91

TX,33,DY2949 -19-26AUG97-20/21

39. Apply a thin, even layer of pipe sealant with TEFLON® to mating surface of suction flange (C).

40. Install cap screws (A and B).

Specification

Suction Flange-to-Pump Valve
Block Inner Cap Screw—Torque 32 N•m (24 lb-ft)
Suction Flange-to-Pump Valve
Block Outer Cap Screw—Torque..... 46 N•m (34 lb-ft)

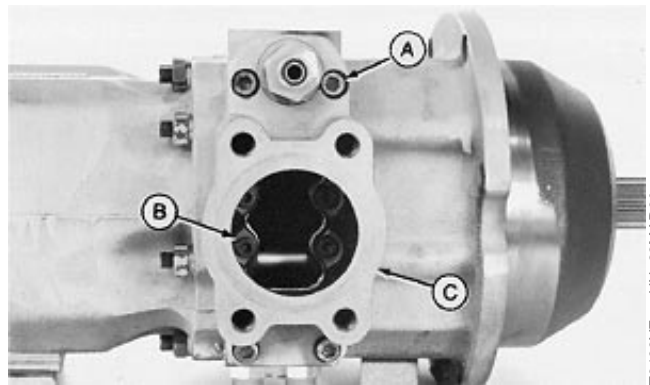

T6439YE -UN-22MAR90

TEFLON is a registered trademark of the DuPont Company.

TX,33,DY2949 -19-26AUG97-21/21

Hydraulic System

**Disassemble And Assemble Hydraulic Pump
(Serial No. 559603—)**

NOTE: Do not disassemble the hydraulic pump. The pump is serviced as an assembly and has a core valve as a complete assembly.

TX,33,DY2948 -19-26AUG97-1/1

**Remove And Install Pump Displacement
Solenoid Valve (Serial No. —559602)**

1. Disconnect wiring harness.

TX,33,DY2907 -19-20AUG97-1/2

2. Remove cap screws. Remove valve (A).
3. Repair or replace as necessary.
4. Install O-rings.
5. Tighten cap screws to 10 N•m (90 lb-in.).

Specification

Mounting Cap Screw—Torque..... 10 N•m (90 lb-in.)

6. Connect wiring harness.

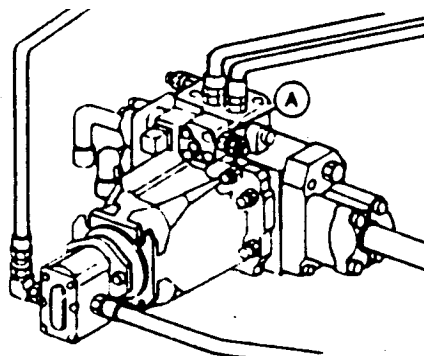

T7681EP -JUN-27JAN92

TX,33,DY2907 -19-20AUG97-2/2

Remove And Install Pump Displacement Solenoid Valve (Serial No. 559603—)

1. Disconnect lines (A and C).
2. Disconnect electrical connector (E).
3. If necessary, remove cap screws (B) and remove pressure regulator valve.
4. Remove cap screws (D). Remove solenoid (F).
5. Remove cap screws (H). Remove cover (G).
6. Repair or replace as necessary.
7. Install new O-rings.
8. Install parts (D, F, G and H).
9. Install pressure regulator and tighten cap screws (B) to 23 N•m (17 lb-ft).

Specification

Cap Screw—Torque 23 N•m (17 lb-ft)

10. Connect lines (A and C).
11. Connect electrical connector (E).

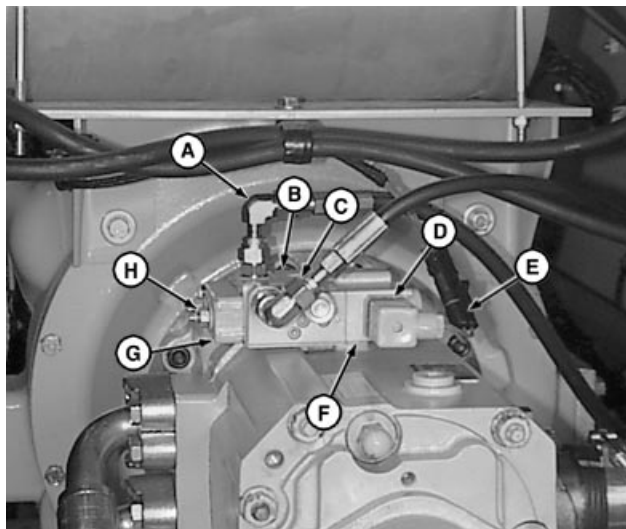

- A—Pump Regulator LS Port-to-Main Control Valve Bottom Tee Port Line
 B—Socket Head Cap Screw (3 used)
 C—Pump Regulator Right Port-to-Dual Solenoid Valve Manifold "D" Port Reservoir
 D—Socket Head Cap Screw (4 used)
 E—Electrical Connector
 F—Solenoid
 G—Cover
 H—Socket Head Cap Screw (4 used)

Disassemble And Assemble Pump Displacement Solenoid Valve (Serial No. — 559602)

1. Inspect parts (1—18) and replace as necessary.
2. Install new O-rings (4, 5, and 15).

Specification

Solenoid-to-Valve Housing Cap	
Screw—Torque.....	2.7 N•m (24 lb-in.)
Mounting Cap Screw—Torque.....	10 N•m (90 lb-in.)
Bottom Plug—Torque.....	47 N•m (35 lb-ft)
Spool Retaining Plug—Torque.....	72 N•m (53 lb-ft)
Retaining Nut—Torque.....	31 N•m (23 lb-ft)

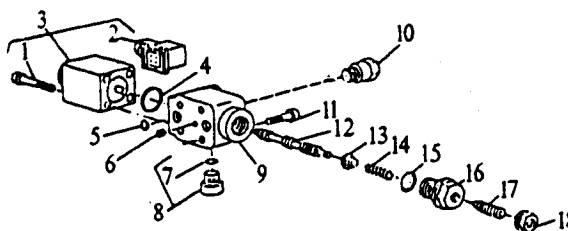

- 1—Cap Screw (4 used)
- 2—Connector
- 3—Solenoid
- 4—O-Ring
- 5—O-Ring (6 used)
- 6—Plug
- 7—Seal
- 8—Plug
- 9—Housing
- 10—Adapter (3 used)
- 11—Cap Screw (4 used)
- 12—Piston
- 13—Retainer
- 14—Spring
- 15—O-Ring
- 16—Plug
- 17—Pin
- 18—Nut (2 used)

T7681AC -JUN-08JAN92

TX,33,DY2908 -19-20AUG97-1/1

Disassemble And Assemble Pump Displacement Solenoid Valve (Serial No. 559603—)

1. Inspect parts (A—Q) and replace as necessary.
2. Install new O-rings.

Specification

Solenoid-to-valve Housing Cap	
Screw—Torque.....	2.7 N•m (24 lb-in.)
Cap Screw—Torque.....	23 N•m (17 lb-ft)

- A—Socket Head Cap Screw (4 used)
- B—Nut (2 used)
- C—Sleeve (2 used)
- D—Cover
- E—O-Ring (2 used)
- F—Adjusting Screw (2 used)
- G—Ring (2 used)
- H—O-Ring (2 used)
- I—Retainer (2 used)
- J—Spring
- K—Piston
- L—Housing
- M—O-Ring
- N—Connector
- O—Seal
- P—Socket Head Cap Screw (4 used)
- Q—Solenoid

T109729

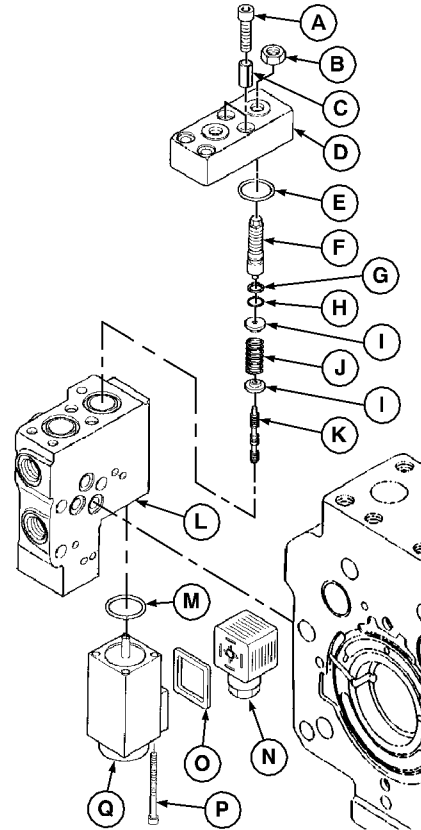

T109729 -UN-05AUG97

TX,33,DY2950 -19-26AUG97-1/1

Hydraulic System

Remove And Install Load Sense Valve (Serial No. —559602)

1. Loosen reservoir fill cap to release air pressure from reservoir.
2. Drain reservoir. Approximate capacity is 148 L (39 gal).
3. Remove pump displacement solenoid (E). It is not necessary to disconnect electrical connector or oil line.
4. Disconnect lines (B—D).
5. Remove load sense valve (A).
6. Repair or replace valve as necessary.
7. Install valve. Tighten cap screws to 32 N•m (24 lb-ft).

Specification

Load Sense Valve Cap Screw (—
559602)—Torque..... 32 N•m (24 lb-ft)

8. Connect lines.
9. Install pump displacement solenoid.
10. Fill reservoir.
11. Do Hydraulic Pump Start-Up Procedure. (See procedure in this group.)

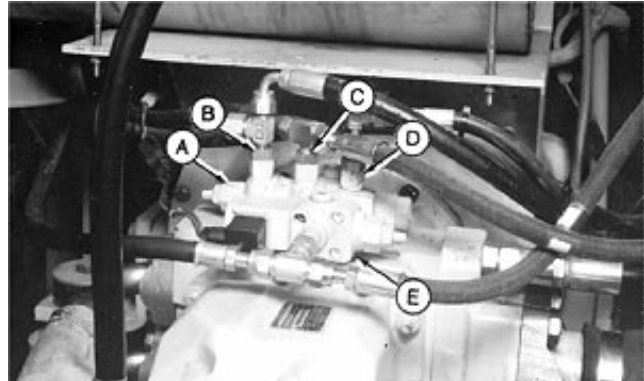

A—Load Sense Valve
 B—LS Port-to-Pressure Control Manifold Line
 C—T Port-to-Reservoir and Engine Speed Control Actuator Line
 D—X Port-to-Dual Solenoid Valve Block Line
 E—Pump Displacement Solenoid

T7681ES -JUN-27JAN92

TX,33,DY2951 -19-26AUG97-1/1

Hydraulic System

Remove And Install Load Sense Valve (Serial No. 559603—)

1. Loosen reservoir fill cap to release air pressure from reservoir.
2. Drain reservoir. Approximate capacity is 151 L (40 gal).
3. Disconnect lines (A and B).
4. Disconnect electrical connector (D).
5. Remove cap screws (C) and remove load sense valve.
6. Repair or replace valve as necessary.
7. Install valve. Tighten cap screws to 23 N•m (17 lb-ft).

Specification

Cap Screw—Torque 23 N•m (17 lb-ft)

8. Connect lines (A and B).
9. Connect electrical connector (D)
10. Fill reservoir.
11. Do Hydraulic Pump Start-Up Procedure. (See procedure in this group.)

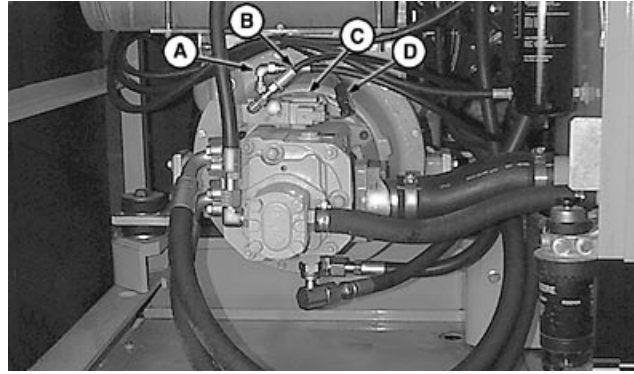

- A—Pump Regulator LS Port-to-Main Control Valve Bottom Tee Port Line
 B—Pump Regulator Right Port-to-Dual Solenoid Valve Manifold "D" Port Reservoir
 C—Socket Head Cap Screw (3 used)
 D—Electrical Connector

33
3360
57

T1109726 -UN-05AUG97

TX,3360,AB346 -19-17FEB92-1/1

Disassemble And Assemble Load Sense Valve (Serial No. —559602)

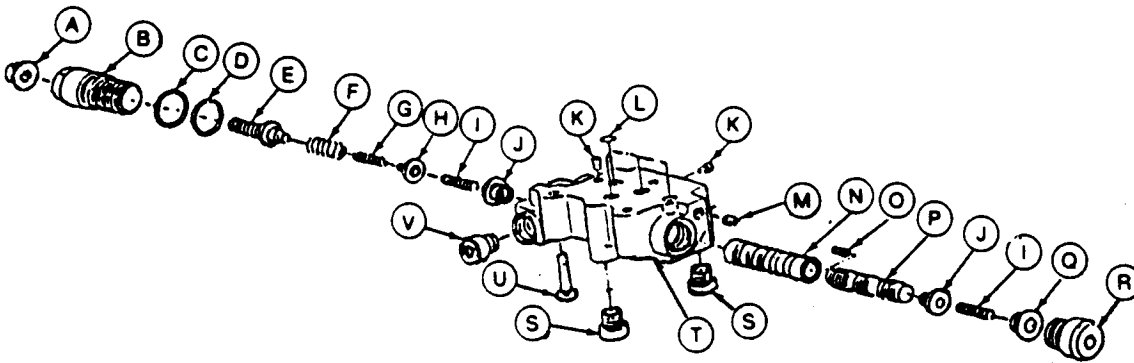

- | | | | |
|------------------------|--------------------|-----------|----------------------|
| A—Nut | G—Spring | M—Plug | R—Plug |
| B—Adjusting Screw Plug | H—Retainer | N—Sleeve | S—Plug (2 used) |
| C—Backup Ring | I—Piston (2 used) | O—Pin | T—Housing |
| D—O-Ring | J—Bushing (2 used) | P—Guide | U—Cap Screw (3 used) |
| E—Adjusting Screw | K—Stop (2 used) | Q—Bushing | V—Plug |
| F—Spring | L—O-Ring (4 used) | | |

1. Disassemble parts (A—V).
2. Inspect parts and replace as necessary.
3. Install parts.

Test Port Plug—Torque.....	47 N•m (35 lb-ft)
Adjusting Screw Plug—Torque.....	93 N•m (69 lb-ft)
Adjusting Screw Retaining	
Nut—Torque	31 N•m (23 lb-ft)

IMPORTANT: The plug (R) must be tightened first to seat parts in housing correctly.

	Specification
Left Side Plug—Torque	12 N•m (106 lb-in.)
Spool Valve Retaining Plug—Torque.....	122 N•m (90 lb-ft)

Tighten plug (R) first and then the adjusting screw plug (B).

T7681ER -JUN-27JAN92

Disassemble And Assemble Load Sense Valve (Serial No. 559603—)

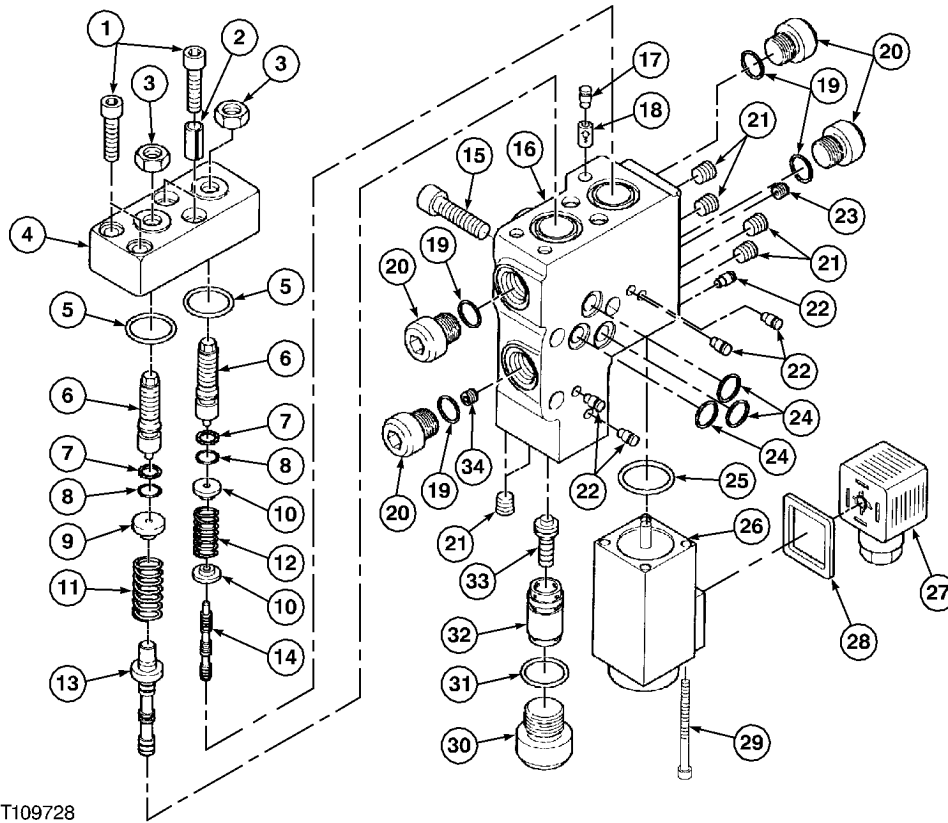

T109728

T109728 -UN-05AUG97

- | | | | |
|-------------------|-------------------------------|--------------------|-------------------|
| 1—Screw (4 used) | 10—Plate (2 used) | 18—Check Valve | 27—Plug |
| 2—Sleeve (2 used) | 11—Compression Spring | 19—O-Ring (4 used) | 28—Seal |
| 3—Nut (2 used) | 12—Compression Spring | 20—Plug (4 used) | 29—Screw (4 used) |
| 4—Cover | 13—Guide | 21—Plug (6 used) | 30—Plug |
| 5—O-Ring (2 used) | 14—Piston | 22—Plug (5 used) | 31—O-Ring |
| 6—Bolt (2 used) | 15—Socket Head Screw (3 used) | 23—Orifice | 32—Bushing |
| 7—Ring (2 used) | 16—Housing | 24—O-Ring (3 used) | 33—Piston |
| 8—O-Ring (2 used) | 17—Plug | 25—O-Ring | 34—Pin |
| 9—Plate | | 26—Solenoid | |

1. Disassemble parts (1—34).
2. Inspect parts and replace as necessary.
3. Install parts.

Specification

Solenoid-to-Valve Housing Cap
 Screw—Torque 2.7 N•m (24 lb-in.)
 Plug (30)—Torque 23 N•m (17 lb-ft)

Hydraulic System

Remove And Install Pilot Pump

1. Loosen reservoir fill cap to release air pressure from reservoir.
2. Drain reservoir. Approximate capacity is 148 L (39 gal).
3. Disconnect lines (A and B).
4. Remove pump (C) and coupler.
5. Repair or replace pump as necessary.
6. Install O-ring.
7. Install coupler and pump.
8. Connect lines (A and B).
9. Do hydraulic pump start-up procedure. (See procedure in this group.)

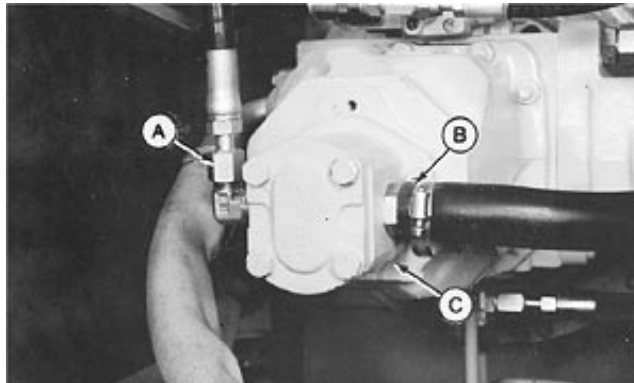

Earlier Machine Shown

T7626DC -UN-09JAN92

TX,33,DY2952 -19-26AUG97-1/1

Disassemble And Assemble Pilot Pump

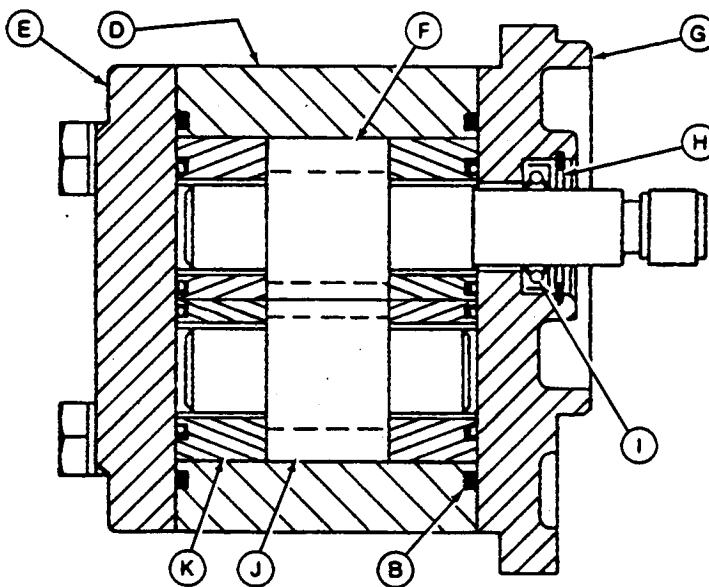
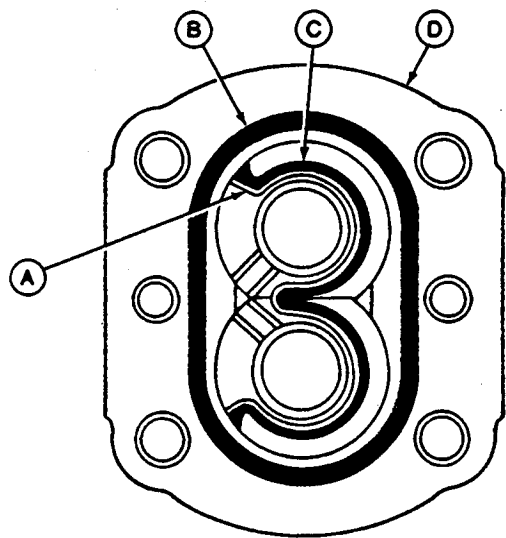

A—Backup Retainer (2 used)
B—Packing (2 used)
C—Seal (2 used)

D—Housing
E—Cover
F—Drive Gear

G—Cover
H—Snap Ring
I—Seal

J—Driven Gear
K—Bushing (4 used)

T6439UO -UN-04NOV88

Continued on next page

TX,3360,AB262 -19-17FEB92-1/5

Hydraulic System

1. Remove cap screws (A) and separate parts (B—D).

- A—Cap Screw (4 used)
- B—Cover
- C—Housing
- D—Cover

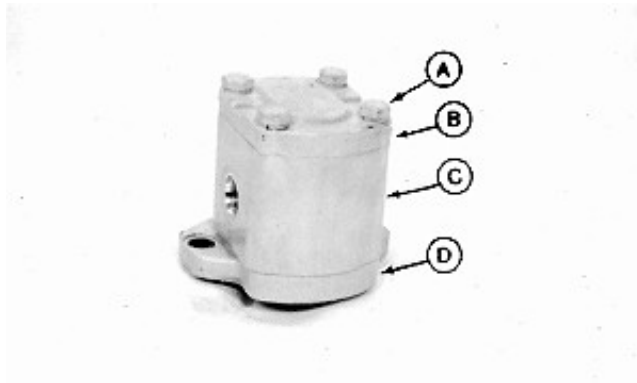

TX,3360,AB262 -19-17FEB92-2/5

T7626DD -UN-09JAN92

33
3360
61

2. Remove snap ring (A) and seal (B).

3. Install new seal. Install seal so lip (spring side) is towards inside of housing.

Install snap ring.



TX,3360,AB262 -19-17FEB92-3/5

T7626DE -UN-09JAN92

4. Disassemble and inspect parts (A—G).

5. Check bushings (C). If inside diameter and surface toward gear are rough or worn, replace pump.

6. Check gear teeth (A and G), gear shaft, and inside pump housing (B). If rough or worn, replace pump.

IMPORTANT: Apply clean hydraulic oil to all parts. Premature pump failure can result if pump is assembled dry.

7. Apply clean hydraulic oil to all parts.

8. Assemble parts (A—G).

- A—Drive Gear
- B—Housing
- C—Bushing (4 used)
- D—Seal (2 used)
- E—Backup Retainer (2 used)
- F—Packing (2 used)
- G—Driven Gear

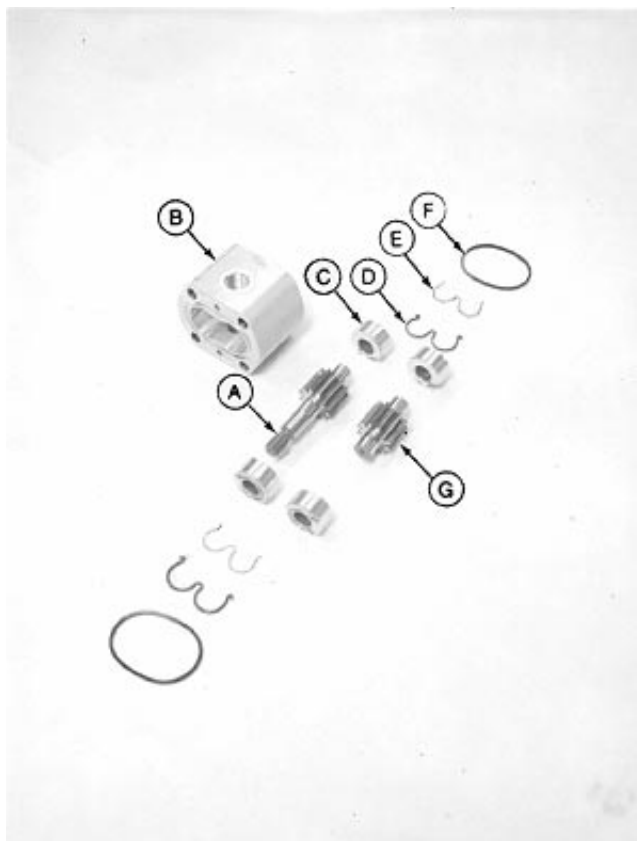

Continued on next page

TX,3360,AB262 -19-17FEB92-4/5

T7626DF -UN-09JAN92

Hydraulic System

9. Make sure grooves (A) on seal side are toward suction side, larger hole (B), of pump housing.

10. Install backup retainer (D) in groove of seal (C).

11. Apply petroleum jelly on seal lips.

12. Install covers and cap screws.

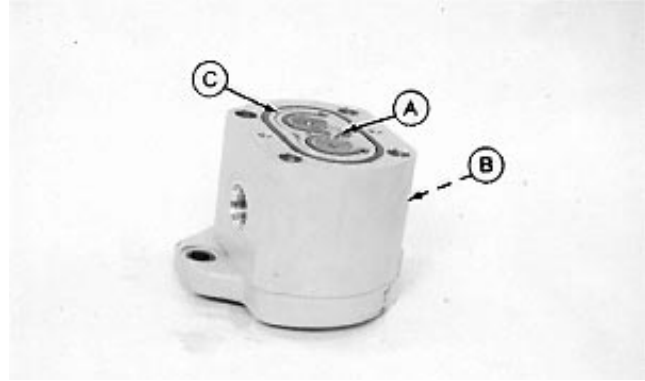

T7681AE -UN-09JAN92

- A—Bushing Grooves
- B—Suction Side-Larger Hole
- C—Seal (2 used)
- D—Backup Retainer (2 used)

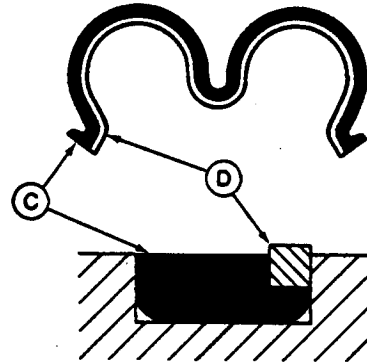

T6439UP -UN-18OCT88

TX,3360,AB262 -19-17FEB92-5/5

Remove And Install Pilot Filter

- A—Pilot Filter-to-Pressure Control Manifold Line
- B—Pilot Filter-to-Pump Displacement Valve Line
- C—Pilot Filter-to-Pilot Pump Outlet Line
- D—Pilot Filter



T7681AF -UN-09JAN92

TX,3360,AB267 -19-17FEB92-1/1

Hydraulic System

Hydraulic Oil Filter Inspection Procedure

Pour oil out of filter to inspect for water contamination.

Use an oil filter cutting tool to cut top off filter.

Remove element and inspect for metal particles and debris in bottom of filter can.

Excessive amounts of brass and steel particles can indicate a failed hydraulic pump or a pump failure in process.

A rubber type of material can indicate cylinder packing failure.

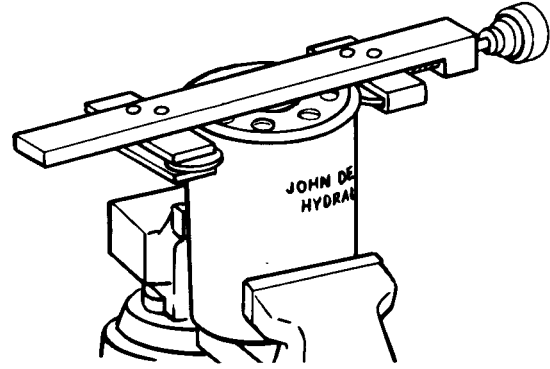

33
3360
63

IT4633 -JUN-19JAN90

902525,F4A -19-18JUL94-1/1

Hydraulic System

Remove And Install Pilot Shut-Off Valve

1. Disconnect control linkage (H).
2. Release pressure in hydraulic reservoir. Unlock hydraulic tank fill cap. Slowly turn cap to release air pressure.
3. Disconnect lines (A—G and I).
4. Remove valve.
5. Repair or replace valve as necessary.
6. Install valve.
7. Connect lines.
8. Connect control linkage. Check adjustment. (See procedure in this group.)

A—Valve-to-Reservoir line
 B—Valve-to-Propel Pilot Controller Line
 C—Valve-to-Right Pilot Controller Line (P Port)
 D—Valve-to-Right Pilot Controller Line (T Port)
 E—Valve-to-Propel Pilot Controller Line
 F—Valve-to-Left Pilot Controller (P Port)
 G—Valve-to-Left Pilot Controller (T Port)
 H—Control Linkage
 I—Valve-to-Load Sense Valve (Serial No. —556935) Dual Solenoid Valve (P Port) (Serial No. 556936—)

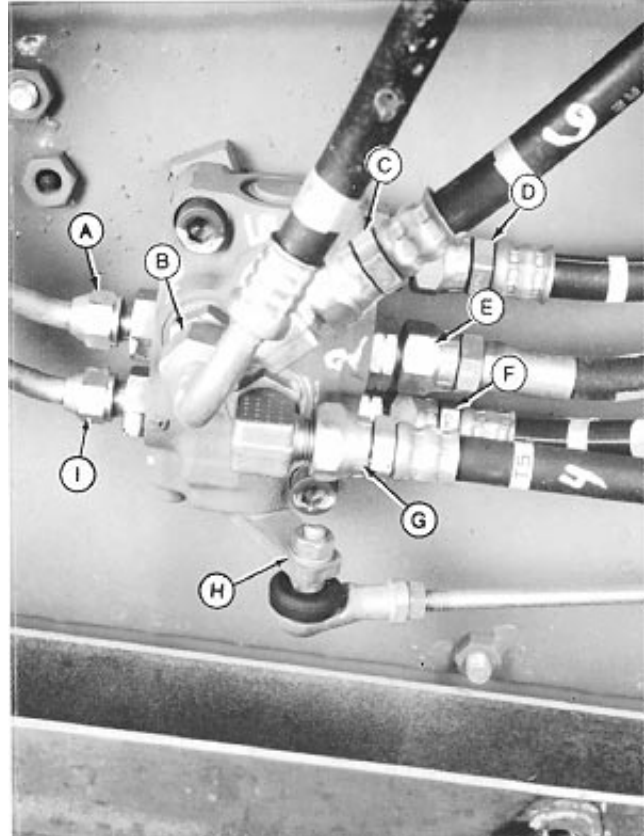

T7681AU -UN-13/JAN92

TX,33,DY2953 -19-26AUG97-1/1

Disassemble And Assemble Pilot Shut-Off Valve

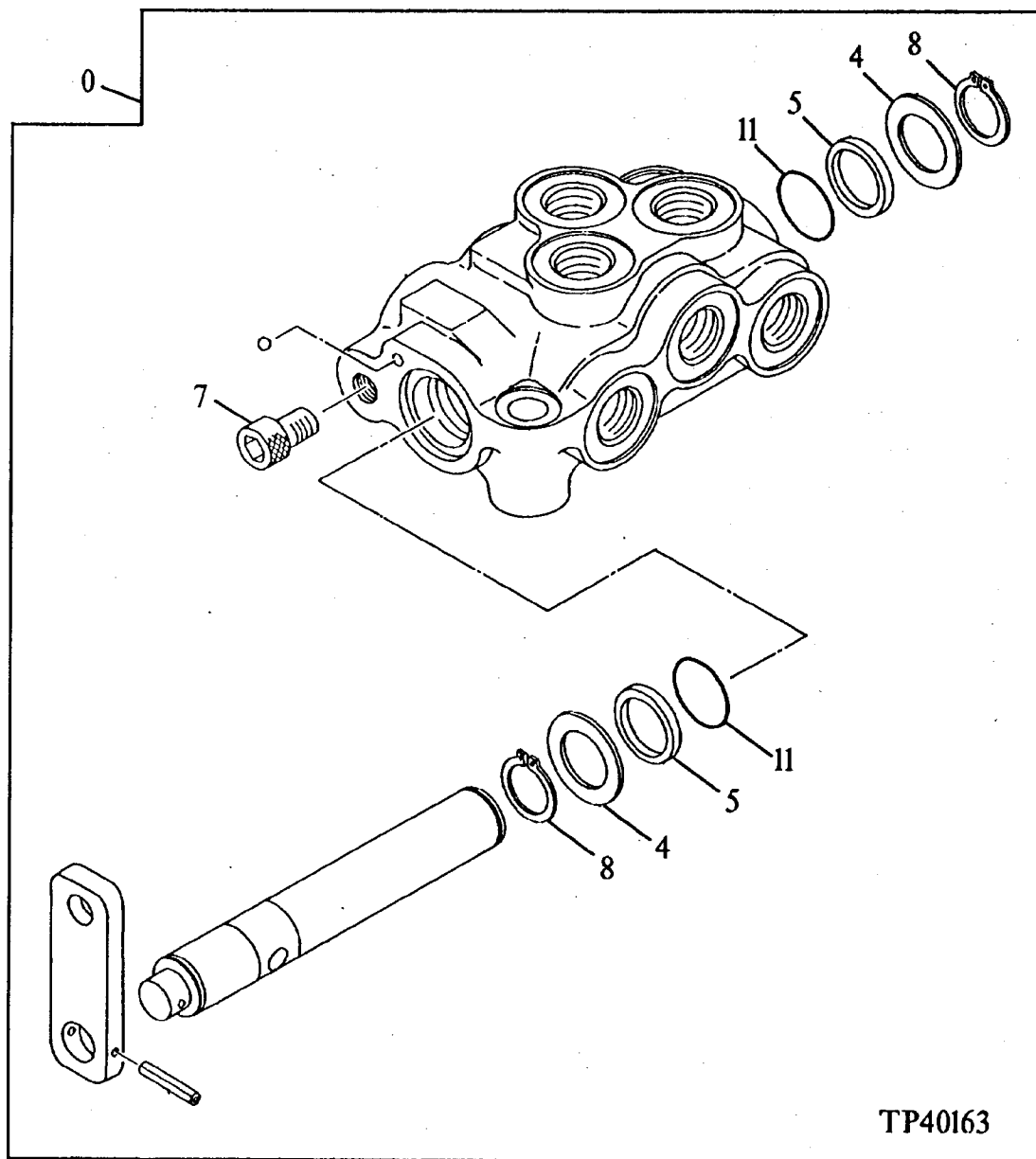

TP40163 -UN-01.JAN94

- 0—Valve
- 4—Washer (2 used)
- 5—Back-Up Ring (2 used)
- 7—Cap Screw
- 8—Snap Ring (2 used)
- 11—Packing (2 used)

1. Remove parts (4—11).
2. Inspect and replace as necessary.
3. Install parts.

TX,3360,AB349 -19-30SEP94-1/1

Hydraulic System

Pilot Shut-Off Valve Linkage Adjustment

SPECIFICATIONS

Pilot Shut-Off Valve Linkage Clearance Between Lever and Cap Screw	1.5 ± 0.5 mm (0.06 ± 0.02 in.)
--	--------------------------------

Continued on next page

TX,902520,UU735 -19-30SEP94-1/2

33
3360
66

Hydraulic System

33
3360
67

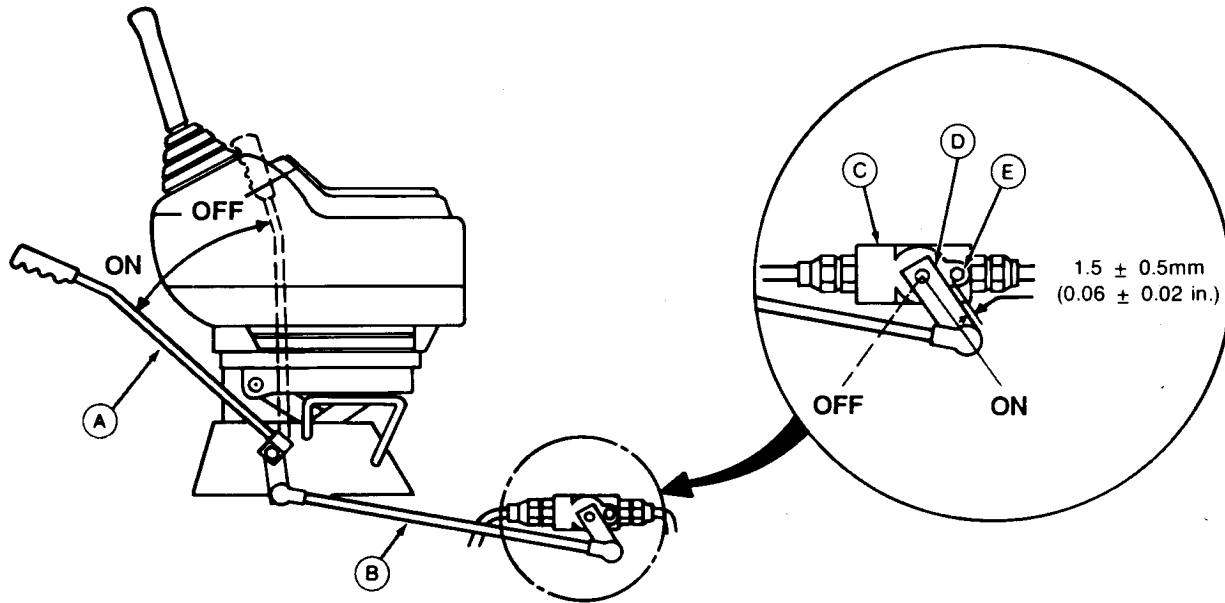

T7660AL

A—Shut-Off Lever
B—Rod

C—Shut-Off Valve

D—Lever

E—Cap Screw

1. Stop engine.
2. Remove cover from left console (beside seat) in operator's station.
3. Remove cover underneath operator's station. (If equipped).
4. Push pilot shut-off lever (A) forward to the ON position. Adjust ball joints on rod (B) ends to specified clearance between lever (D) and cap screw (E).



CAUTION: Machine may move if adjustment is incorrect. Prior to checking shut-off lever adjustment, make sure the area around machine is clear.

5. Check adjustment by pulling shut-off lever (A) up to the OFF position. Start engine and set engine speed at low idle. Move pilot control levers. Hydraulic functions must NOT operate. If functions move, repeat adjustment procedure.

Specification

Pilot Shut-Off Valve Linkage—
Clearance Between Lever and
Cap Screw 1.5 ± 0.5 mm (0.06 ± 0.02 in.)

T7660AL -19-06DEC91

Hydraulic System

Remove And Install Dig Function Pilot Controller

1. Release pressure in hydraulic reservoir. Unlock hydraulic tank fill cap. Slowly turn cap to release air pressure.
2. Remove lower console cover.
3. Remove lever (B).
4. Remove four cap screws and lower valve (A).
5. Disconnect lines. (See following for line locations.) (John Deere pattern shown.)
6. Repair or replace controller as necessary.
7. Connect lines.
8. Install valve. Tighten cap screw to 9 N•m (85 lb-in.)

Specification

Dig Function Pilot Controller
 Attaching Cap Screw—Torque..... 9 N•m (85 lb-in.)

9. Install lever.
10. Install cover.

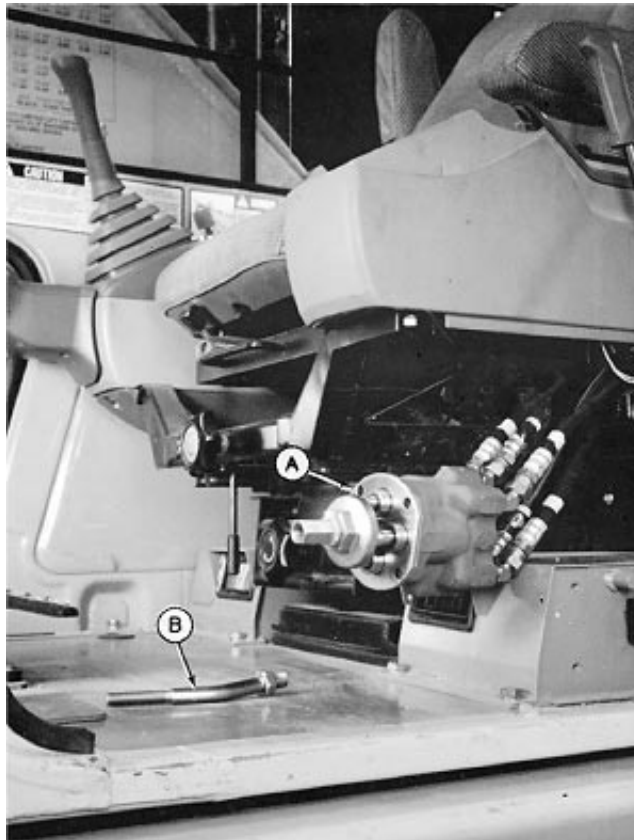

T7681AV -UN-13JAN92

Continued on next page

TX,3360,AB350 -19-20APR95-1/3

Hydraulic System

- P—To Pilot Shut-Off Valve P Port
- 1—To Swing Right of Dig Pilot Check Valve Block (E2 Port)
- 2—To Boom Lower of Dig Pilot Check Valve Block H2 Port
- 3—To Swing Left of Dig Pilot Check Valve Block F2 Port
- 4—To Boom Raise of Dig Pilot Check Valve Block G2 Port
- T—To Pilot Shut-Off Valve T Port

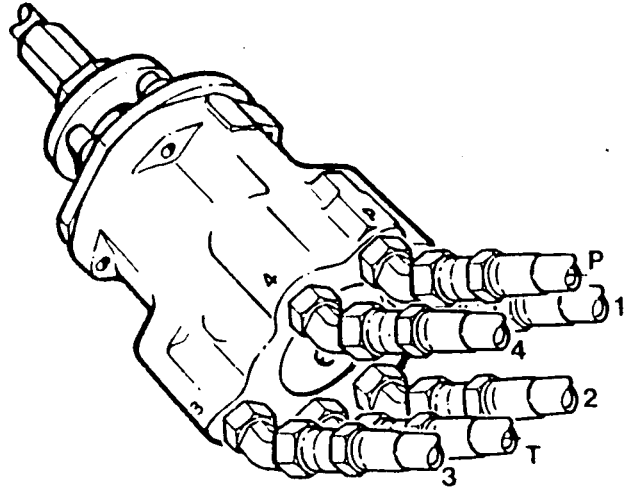

Left Pilot Controller

33
3360
69

T7681AW -UN-13JAN92

Continued on next page

TX,3360,AB350 -19-20APR95-2/3

Hydraulic System

- T—To Pilot Shut-off Valve T Port
- 1—To Bucket Curl of Dig Pilot Check Valve Block I2 Port
- 2—To Arm in of Dig Pilot Check Valve Block K2 Port
- 3—To Bucket Dump of Dig Pilot Check Valve Block J2 Port
- 4—To Arm out of Dig Pilot Check Valve Block L2 Port
- P—To Pilot Shut-Off Valve P Port

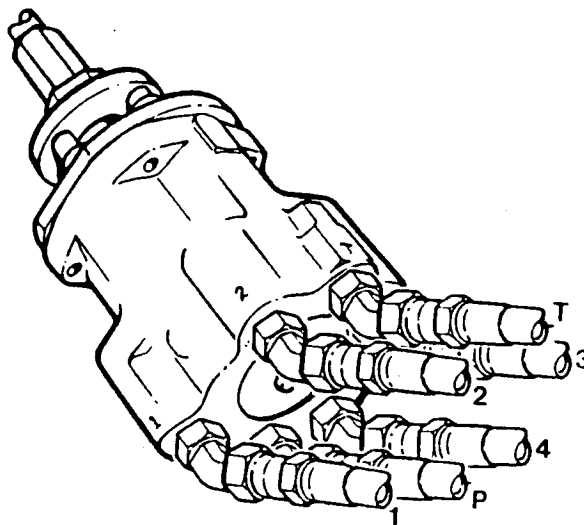

Right Pilot Controller

T7681AX -UN-13JAN92

TX,3360,AB350 -19-20APR95-3/3

Disassemble And Assemble Dig Function Pilot Controller

1. Remove coupling (D), cam (C), and U-joint (B), from controller (A).

- A—Pilot Controller
- B—U-Joint
- C—Cam
- D—Coupling



Continued on next page

TX,3360,AB353 -19-17FEB92-1/2

T7681AY -UN-13JAN92

Hydraulic System

33
3360
71

2. Remove parts (I—S). Note that plate (D) is under a small amount of spring pressure.
3. Be sure parts removed from ports are identified so they will be installed in the same ports.
4. Pistons (M) must be removed first and installed last.
5. Replace parts as necessary.
6. Install parts.
7. Apply multi-purpose grease to seals on cap and pusher (E and F).
8. Tighten cap screw (I) to 49 N•m (36 lb-ft).

Guides (H and G) are different.

Specification

Cap Screw Through
Plate-to-Housing—Torque..... 49 N•m (36 lb-ft)

9. Apply thread lock and sealer (medium strength) to U-joint (C) and install. Tighten to 24 N•m (18 lb-ft).

Specification

U-Joint Through
Plate-to-Housing—Torque..... 24 N•m (18 lb-ft)

10. Apply multi-purpose grease to cam (B) and install.

11. Install coupling (A) so there is 0—0.2 mm (0—0.008 in.) clearance between cam and pushers.

Specification

Coupling-to-Cam—Clearance..... 0—0.2 mm (0—0.008 in.)

Tighten to 78 N•m (58 lb-ft). Hold cam to prevent U-joint from being tightened.

Specification

Coupling—Torque..... 78 N•m (58 lb-ft)

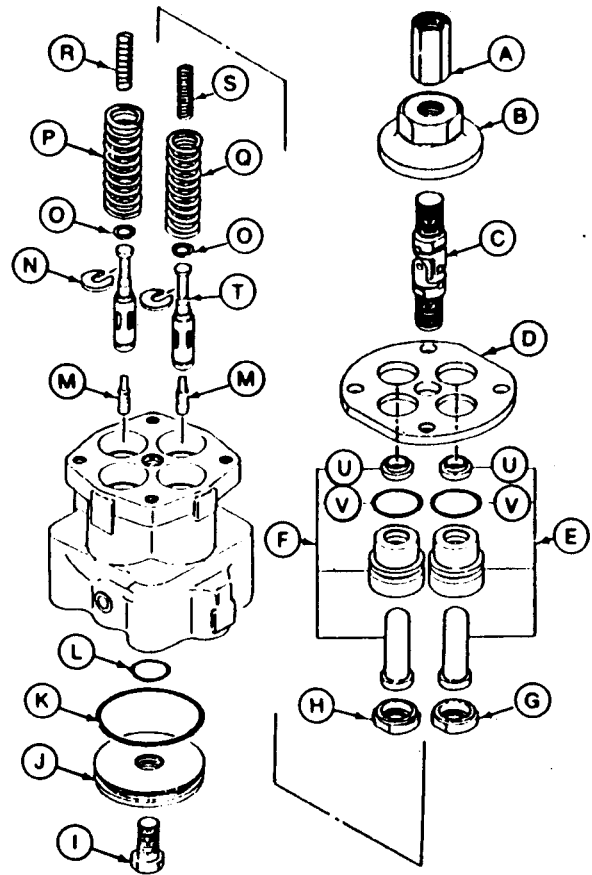

- A—Coupling
- B—Cam
- C—U-Joint
- D—Plate
- E—Cap and Pusher (2 used)
- F—Cap and Pusher (2 used)
- G—Guide (2 used)
- H—Guide (2 used)
- I—Cap Screw
- J—Plate
- K—Packing
- L—Seal
- M—Piston (4 used)
- N—Spacer (4 used)
- O—Shim (2 used)
- P—Spring (2 used)
- Q—Spring (2 used)
- R—Spring (2 used)
- S—Spring (2 used)
- T—Spool (4 used)
- U—Cap (4 used)
- V—O-Ring (4 used)

T7681AZ -JUN-23JAN92

Remove And Install Propel Pilot Controller (Serial No. —547853)

1. Release pressure in hydraulic reservoir. Unlock hydraulic tank fill cap. Slowly turn cap to release air pressure.
2. Disconnect lines (A—F).

- A—Pilot Shut-Off Valve-to-Controller Line
- B—Controller-to-Pilot Shut-Off Valve Line
- C—Controller-to-Propel Pilot Check Valve Block Line
- D—Controller-to-Propel Pilot Check Valve Block Line
- E—Controller-to-Propel Pilot Check Valve Block Line
- F—Controller-to-Propel Pilot Check Valve Block Line

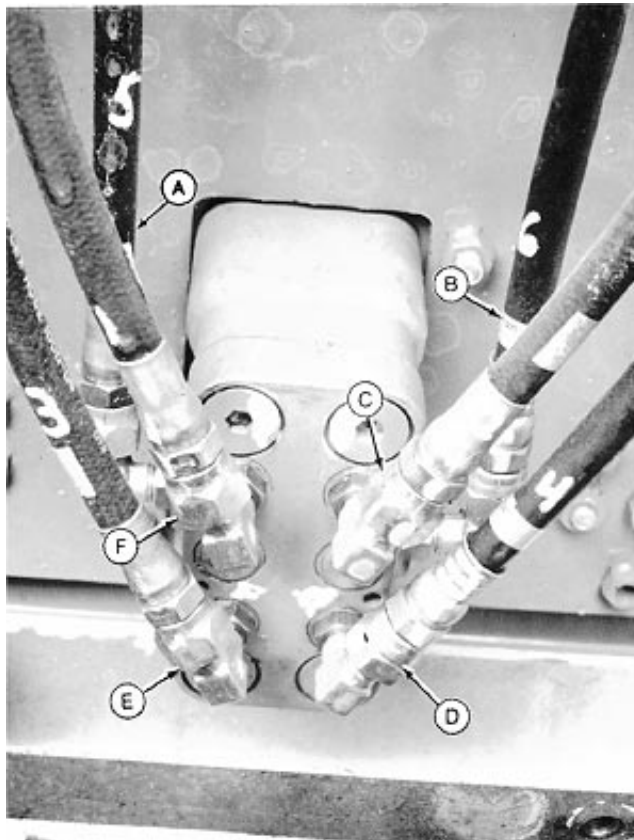

T7681BT -UN-16JAN92

TX,33,DY2954 -19-26AUG97-1/2

3. Disconnect dampeners (A).
4. Remove two cap screws (B).
5. Remove levers, pedals, and valve as an assembly.
6. Repair or replace valve as necessary.
7. Install valve. Tighten cap screws to 49 N•m (36 lb-ft).

Specification

Attaching Cap Screw—Torque..... 49 N•m (36 lb-ft)

IMPORTANT: Washers on dampener pivots must be free to turn so pedals can return to neutral freely when released.

8. Tighten cap screws through dampeners pivots just enough so the washers are free to turn after nuts are tightened against pedal.

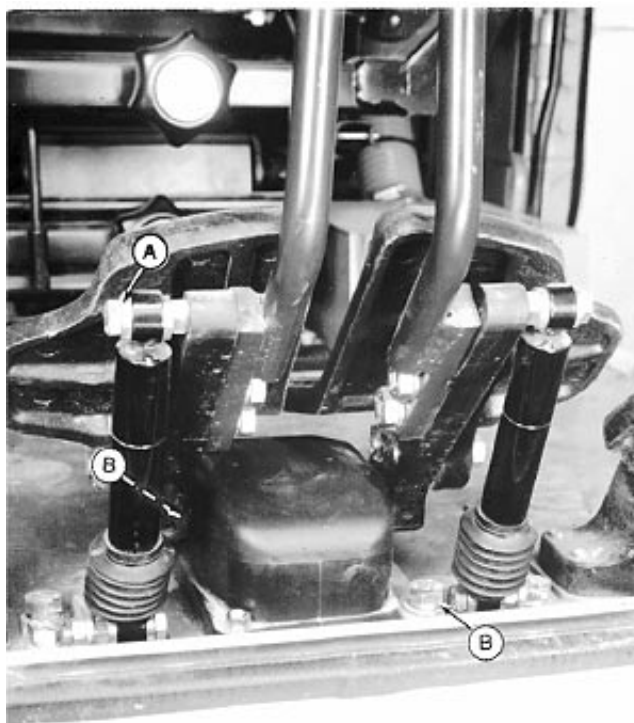

T7681BU -UN-16JAN92

TX,33,DY2954 -19-26AUG97-2/2

Remove And Install Propel Pilot Controller (Serial No. 547854—)

1. Release pressure in hydraulic reservoir. Unlock hydraulic tank fill cap. Slowly turn cap to release air pressure.
2. Disconnect lines (A—F).

A—Pilot Shut-Off Valve-to-Controller Line
 B—Controller-to-Pilot Shut-Off Valve Line
 C—Controller-to-Propel Pilot Check Valve Block Line
 D—Controller-to-Propel Pilot Check Valve Block Line
 E—Controller-to-Propel Pilot Check Valve Block Line
 F—Controller-to-Propel Pilot Check Valve Block Line

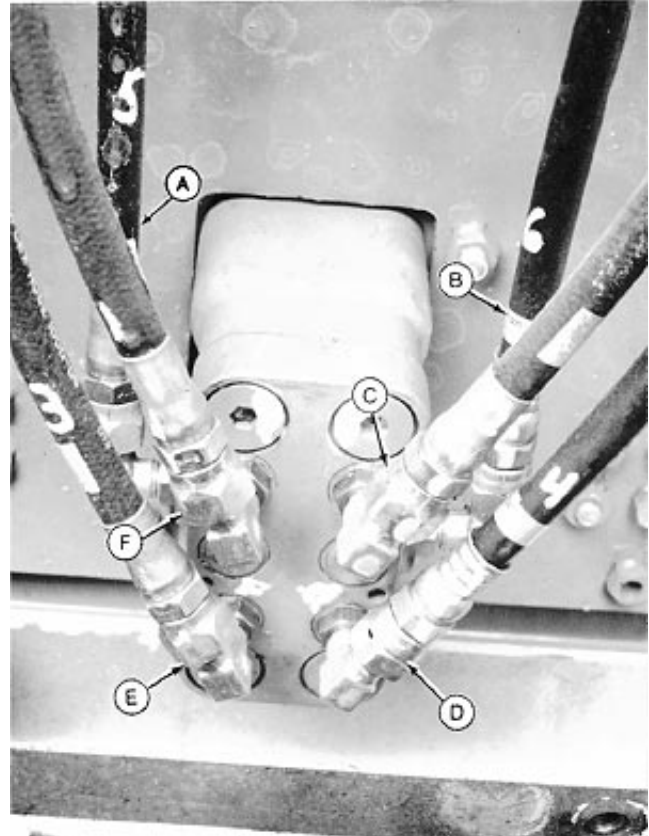

Continued on next page

TX,33,DY2955 -19-26AUG97-1/2

33
3360
73

T7681BT -UN-16JAN92

Hydraulic System

3. Remove two cap screws (A).
4. Remove inner and outer spring pins at (B). Remove bracket (C).
5. Remove levers and pedals. Move dampener brackets aside.
6. Remove cap screws (D). Remove valve as an assembly.
7. Repair or replace valve as necessary.
8. Install valve. Tighten cap screws (D) to 49 N•m (36 lb-ft).

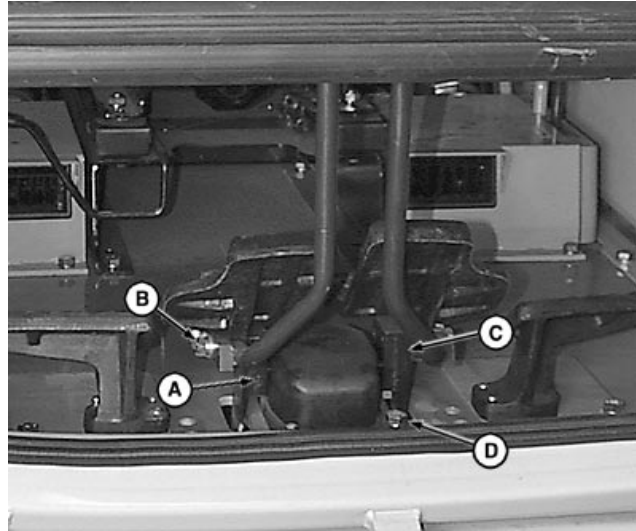

T109490 -UN-05AUG97

Specification

Attaching Cap Screw—Torque..... 49 N•m (36 lb-ft)

9. Install levers and pedals. Install bracket (C).
10. Install dampener brackets. Install spring pins at (B).
11. Tighten cap screws (A) to 88 N•m (65 lb-ft).

Specification

Lever Bracket Mounting Cap
Screw (547584—)—Torque..... 88 N•m (65 lb-ft)

12. After propel pilot controller is installed, check the operation of all functions to be sure they operate correctly.

TX,33,DY2955 -19-26AUG97-2/2

Hydraulic System

33
3360
75

Disassemble And Assemble Propel Pilot Controller

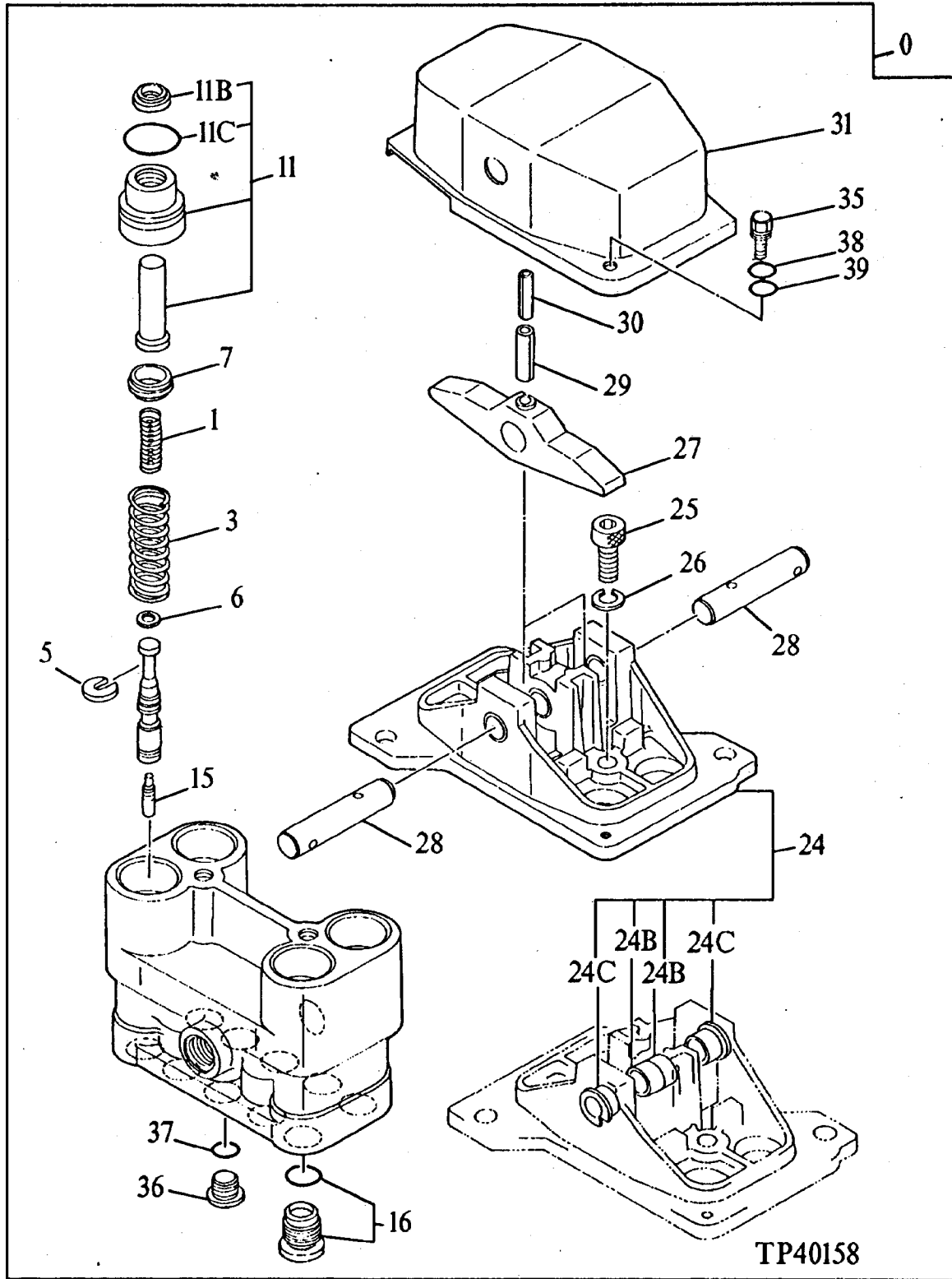

TP40158 -UN-01JAN94

Continued on next page

TX.33.DY2956 -19-26AUG97-1/7

Hydraulic System

0—Valve	11B—Seal	25—Cap Screw (2 used)	31—Cover
1—Spring (4 used)	11C—O-Ring	26—Lock Washer (2 used)	35—Cap Screw (2 used)
3—Spring (4 used)	15—Piston (4 used)	27—Cam (2 used)	36—Plug (2 used)
5—Spacer (Retainer) (4 used)	16—Plug (4 used)	28—Pin (2 used)	37—Packing (2 used)
6—Shim (20 used)	24—Holder	29—Spring Pin (2 used)	38—Lock Washer (2 used)
7—Guide (4 used)	24B—Bushing (2 used)	30—Spring Pin (2 used)	39—Washer (2 used)
11—Cap and Pusher (4 used)	24C—Bushing (2 used)		

1. Remove pedals.
2. Remove propel pilot controller. (See procedure in this group.)

Continued on next page

TX,33,DY2956 -19-26AUG97-2/7

33
3360
77

Hydraulic System

3. Remove cover (B).

- A—Lever (2 used)
- B—Valve
- C—Cover
- D—Inner Spring Pin (2 used)
- E—Outer Spring Pin (2 used)
- F—Bracket (2 used)

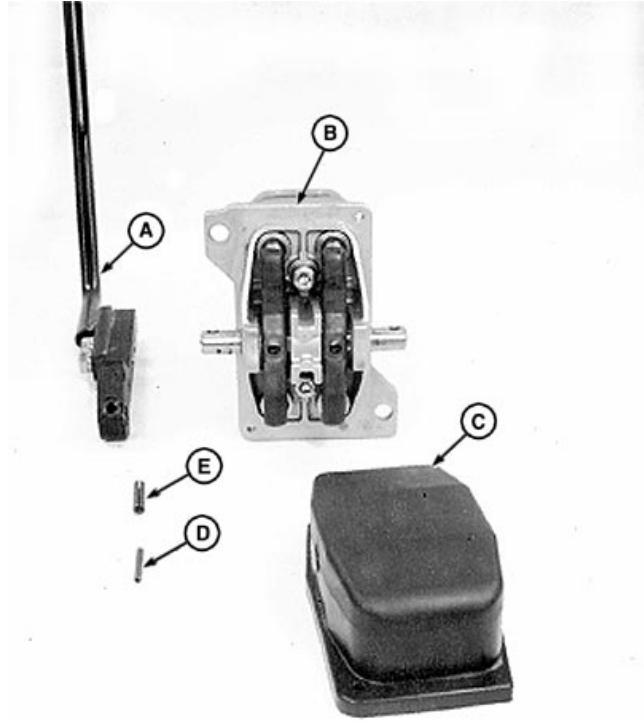

(Serial No. —547853)

T110464 -UN-05AUG97

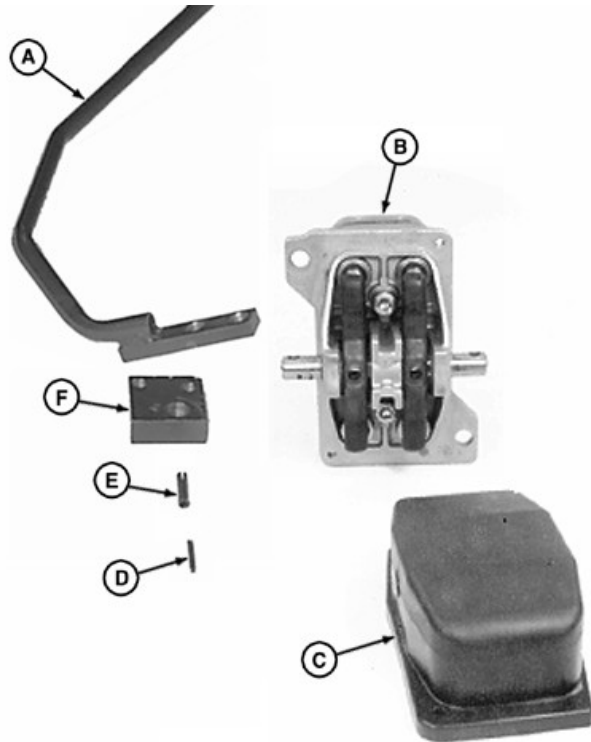

(Serial No. 547854—)

T109489 -UN-06AUG97

Continued on next page

TX,33,DY2956 -19-26AUG97-3/7

33
3360
78

Hydraulic System

33
3360
79

4. Remove plug (A), O-ring (C), and piston (B).

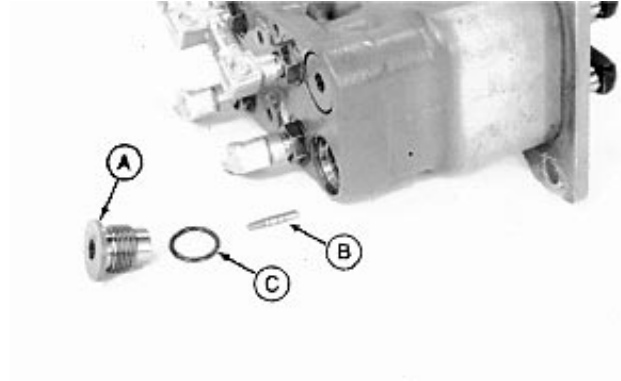

T7681BW -UN-16JAN92

TX,33,DY2956 -19-26AUG97-4/7

5. Remove parts (A—I).

6. Inspect parts and replace as necessary. Inspect housing bores for wear and scoring. Replace complete assembly if housing is scored or damaged.

7. Install parts.

Install spacer (E) and guide (B) with spring seat against springs (A and D).

- A—Spring
- B—Guide
- C—Piston
- D—Spring
- E—Spacer (Retainer)
- F—Pusher
- G—O-Ring
- H—Cap
- I—Seal



T7681BX -UN-16JAN92

TX,33,DY2956 -19-26AUG97-5/7

8. Install piston (B), O-ring (C), and plug (A). Tighten plug (A) to 49 N•m (36 lb-ft).

Specification

Valve Piston Plug—Torque 49 N•m (36 lb-ft)

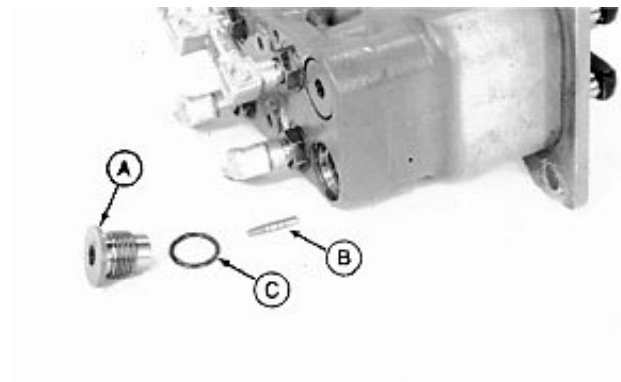

T7681BW -UN-16JAN92

Continued on next page

TX,33,DY2956 -19-26AUG97-6/7

Hydraulic System

9. Install cover (B).

10. Install propel pilot controller. (See procedure in this group.)

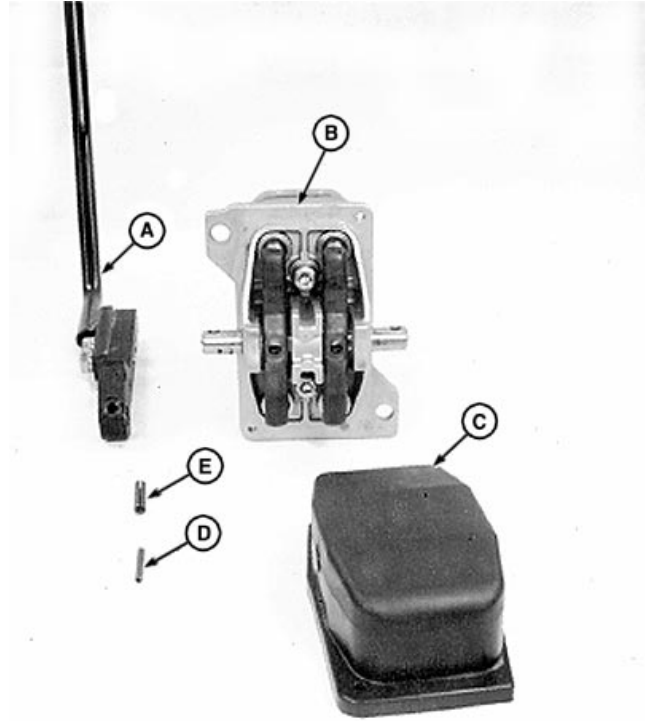

(Serial No. —547853)

T110464 -UN-05AUG97

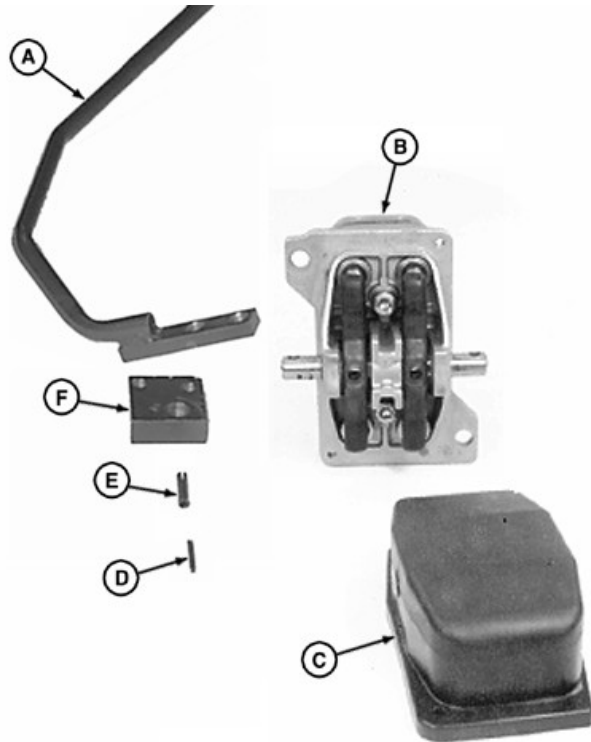

(Serial No. 547854—)

T109489 -UN-06AUG97

TX,33,DY2956 -19-26AUG97-717

Remove And Install Dig Pilot Check Valve Block (Serial No. 543990—559935)

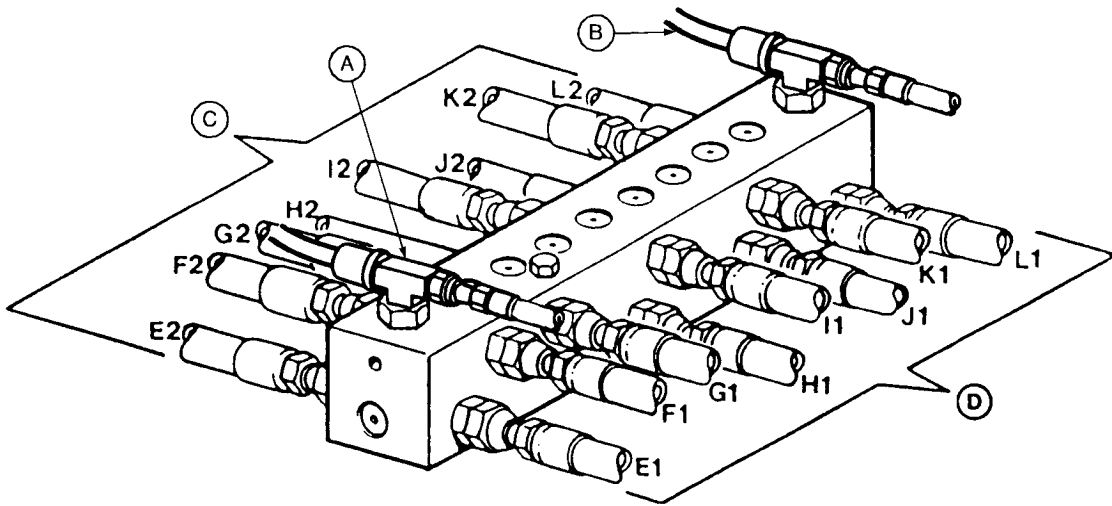

T8448AB (CV)

T8448AB -JUN-11APR95

- | | | | |
|-------------------------------------|----------------|----------------|----------------|
| A—Swing Brake Release Switch | E1—Swing Right | H1—Boom Lower | J2—Bucket Dump |
| B—Auto Idle Switch | E2—Swing Right | H2—Boom Lower | K1—Arm In |
| C—Lines From Dig Pilot Controllers | F1—Swing Left | I1—Bucket Curl | K2—Arm In |
| D—Lines to Control Valve Pilot Caps | F2—Swing Left | I2—Bucket Curl | L1—Arm Out |
| | G1—Boom Raise | J1—Bucket Dump | L2—Arm Out |
| | G2—Boom Raise | | |

1. Release pressure in hydraulic reservoir. Unlock hydraulic tank fill cap. Slowly turn cap to release air pressure.
2. Disconnect swing brake release switch wiring lead (A) and auto idle switch wiring lead (B).

must be surgically removed within a few hours or gangrene may result. Doctors unfamiliar with this type of injury should reference a knowledgeable medical source. Such information is available from Deere & Company Medical Department in Moline, Illinois, U.S.A.

CAUTION: Escaping fluid under pressure can penetrate the skin causing serious injury. Avoid the hazard by relieving pressure before disconnecting hydraulic or other lines. Tighten all connections before applying pressure. Search for leaks with a piece of cardboard. Protect hands and body from high pressure fluids.

If an accident occurs, see a doctor immediately. Any fluid injected into the skin

3. Disconnect lines.
4. Remove valve block.
5. Replace valve block as necessary.
6. Install valve block.
7. Connect lines. Connect wiring leads.

Hydraulic System

Remove And Install Dig Pilot Check Valve Block (Serial No. 559936—)

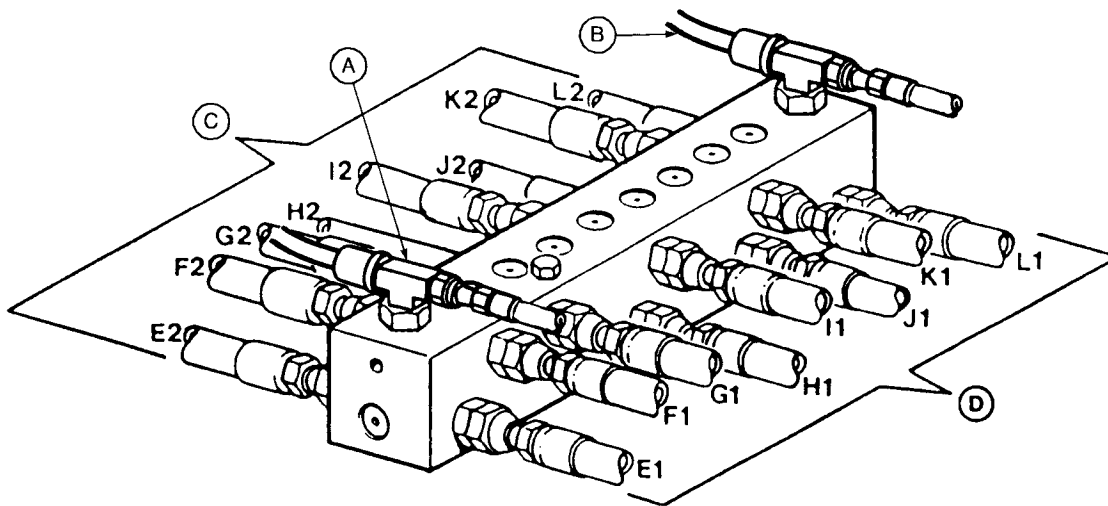

T8448AB (CV)

T8448AB -JUN-11APR95

A—Swing Brake Release Switch	F1—Swing Valve Left Rear Pilot Cap	I1—Bucket Curl Valve top Pilot Cap	K2—Boom Raise Valve-to-Right Pilot Controller
B—Auto Idle Switch	F2—Swing Left-to-Left Pilot Controller	I2—Bucket Curl Valve-to-Right Pilot Controller	L1—Boom Lower Valve Front Pilot Cap
C—Lines From Dig Pilot Controllers	G1—Arm Valve In Rear Pilot Cap	J1—Bucket Dump Valve Bottom Pilot Cap	L2—Boom Lower Valve-to-Right Pilot Controller
D—Lines to Boom, Arm, Swing Control Valve Pilot Caps	G2—Arm Valve In-to-Right Pilot Controller	J2—Bucket Dump Valve-to-Right Pilot Controller	
E1—Swing Valve Right Front Pilot Cap	H1—Arm Valve Out Front Pilot Cap	K1—Boom Raise Valve Rear Pilot Cap	
E2—Swing Right-to-Left Pilot Controller	H2—Arm Valve Out-to-Right Pilot Controller		

1. Release pressure in hydraulic reservoir. Unlock hydraulic tank fill cap. Slowly turn cap to release air pressure.
2. Disconnect swing brake release switch wiring lead (A) and auto idle switch wiring lead (B).

CAUTION: Escaping fluid under pressure can penetrate the skin causing serious injury. Avoid the hazard by relieving pressure before disconnecting hydraulic or other lines. Tighten all connections before applying pressure. Search for leaks with a piece of cardboard. Protect hands and body from high pressure fluids.

If an accident occurs, see a doctor immediately. Any fluid injected into the skin must be surgically removed within a few hours or gangrene may result. Doctors unfamiliar with this type of injury should reference a knowledgeable medical source. Such information is available from Deere & Company Medical Department in Moline, Illinois, U.S.A.

3. Disconnect lines.
4. Remove valve block.
5. Replace valve block as necessary.

Continued on next page

TX,33,DY2958 -19-26AUG97-1/2

Hydraulic System

6. Install valve block.

7. Connect lines. Connect wiring leads.

33
3360
83

TX,33,DY2958 -19-26AUG97-2/2

Remove And Install Propel Pilot Check Valve Block

1. Release pressure in hydraulic reservoir. Unlock hydraulic tank fill cap. Slowly turn cap to release air pressure.

TX,33,DY2959 -19-26AUG97-1/3

2. Disconnect wiring harness (H).

- A—Right Forward Control Line
- B—Right Reverse Control Line
- C—Right Reverse Control Line
- D—Right Forward Control Line
- E—Left Reverse Control Line
- F—Left Forward Control Line
- G—From Pressure Control Manifold Line (Serial No. —556935)
- G—From Boom, Arm, Swing, Control Valve Z2 Port Line (Serial No. 556936—)
- H—Electrical Harness
- I—Left Reverse Control Line
- J—Left Forward Control Line

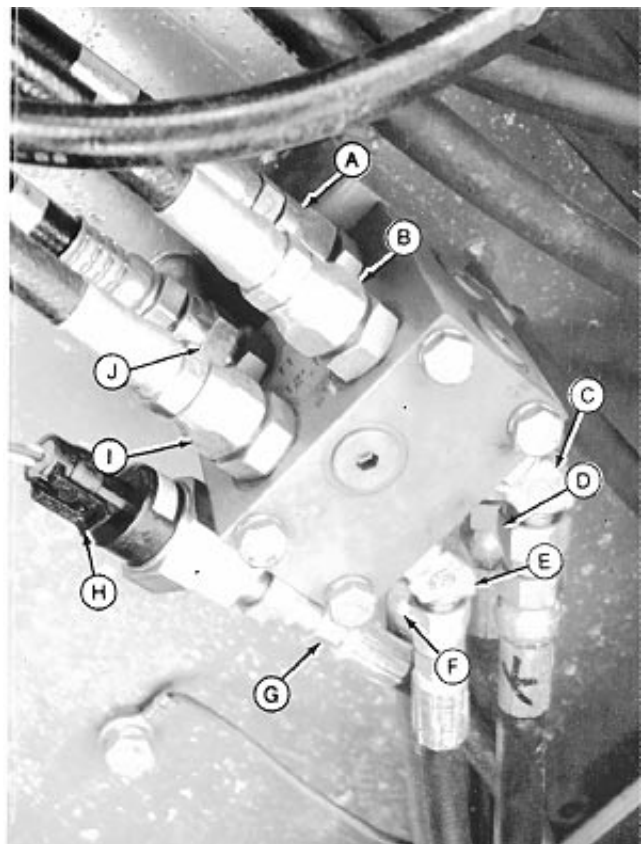

T7681BZ -UN-16JAN92

Continued on next page

TX,33,DY2959 -19-26AUG97-2/3

Hydraulic System



CAUTION: Escaping fluid under pressure can penetrate the skin causing serious injury. Avoid the hazard by relieving pressure before disconnecting hydraulic or other lines. Tighten all connections before applying pressure. Search for leaks with a piece of cardboard. Protect hands and body from high pressure fluids.

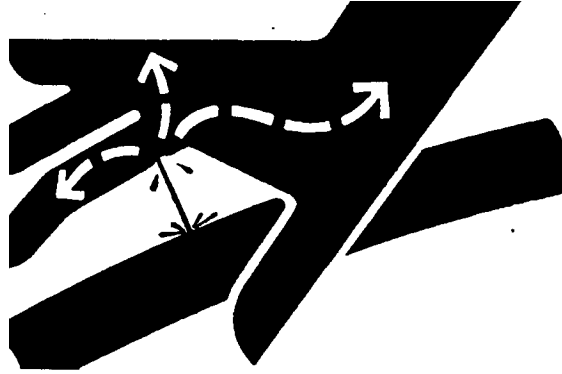

If an accident occurs, see a doctor immediately. Any fluid injected into the skin must be surgically removed within a few hours or gangrene may result. Doctors unfamiliar with this type of injury may call the Deere & Company Medical Department in Moline, Illinois, or other knowledgeable medical source.

3. Disconnect lines (A—G and I—J).
4. Remove valve block.
5. Repair or replace valve block as necessary.
6. Install valve block.
7. Connect lines.
8. Connect wiring harness.

X9811 -UN-23AUG88

TX,33,DY2959 -19-26AUG97-3/3

Disassemble And Assemble Propel Pilot Check Valve Block

33
3360
85

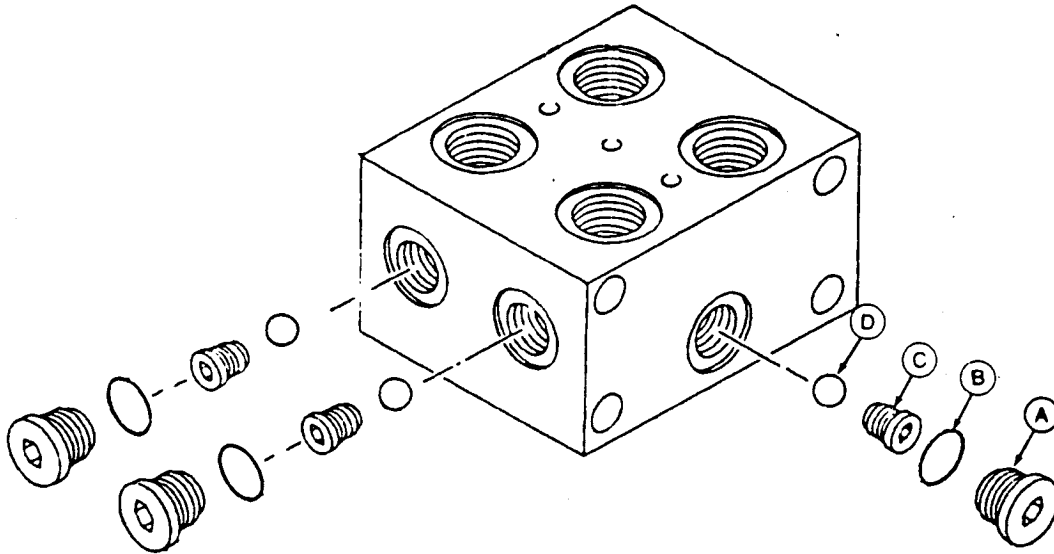

A—Plug (3 used)

B—O-Ring (3 used)

C—Ball Seat (3 used)

D—Ball (3 used)

1. Remove plugs (A).
2. Remove ball seats (C) and balls (D).
3. Inspect parts and replace as necessary.
4. Install parts and new O-rings (B).

T7681CA -UN-16/JAN92

TX,3360,AB368 -19-17FEB92-1/1

Hydraulic System

**Remove And Install Hydraulic Control Valve
(Serial No. —556935)**

NOTE: Valve sections can be removed with the control valve in the machine.

1. Lower equipment to ground.
2. Release pressure in hydraulic reservoir. Unlock hydraulic tank fill cap. Slowly turn cap to release air pressure.
3. Drain reservoir. Approximate capacity is 148 L (39 gal).

Continued on next page

TX,33,DY2960 -19-26AUG97-1/14

Hydraulic System



CAUTION: Escaping fluid under pressure can penetrate the skin causing serious injury. Avoid the hazard by relieving pressure before disconnecting hydraulic or other lines. Tighten all connections before applying pressure. Search for leaks with a piece of cardboard. Protect hands and body from high pressure fluids.

If an accident occurs, see a doctor immediately. Any fluid injected into the skin must be surgically removed within a few hours or gangrene may result. Doctors unfamiliar with this type of injury may call the Deere & Company Medical Department in Moline, Illinois, or other knowledgeable medical source.

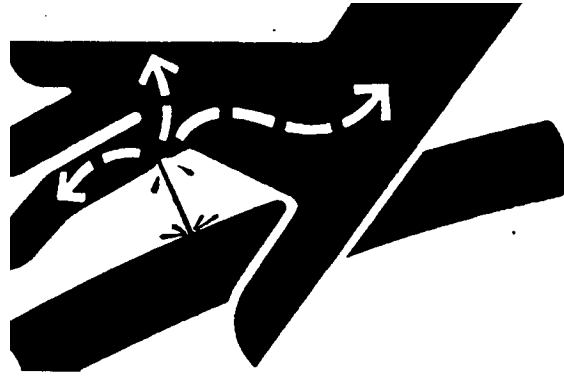
33
3360
87

X9811 -UN-23AUG88

4. Disconnect lines (B, D, E and G).
5. Remove clamps (C and F).
6. Remove plate (A).

A—Plate
 B—Control Valve-to-Bucket Cylinder Piston End Line
 C—Clamp
 D—Control Valve-to-Arm Cylinder Piston End Line
 E—Control Valve-to-Arm Cylinder Rod End Line
 F—Clamp
 G—Control Valve-to-Bucket Cylinder Rod End Line

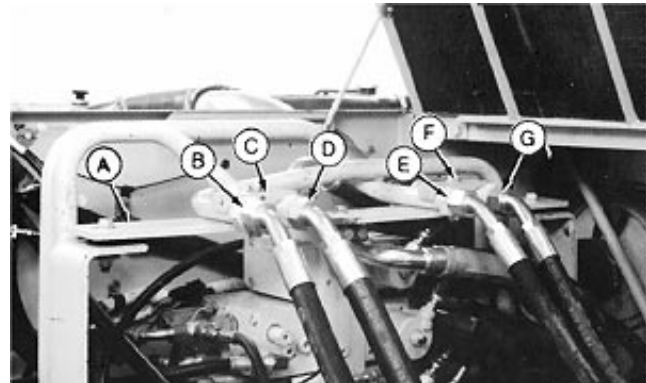

T7681DG -UN-22JAN92

Continued on next page

TX,33,DY2960 -19-26AUG97-2/14

Hydraulic System

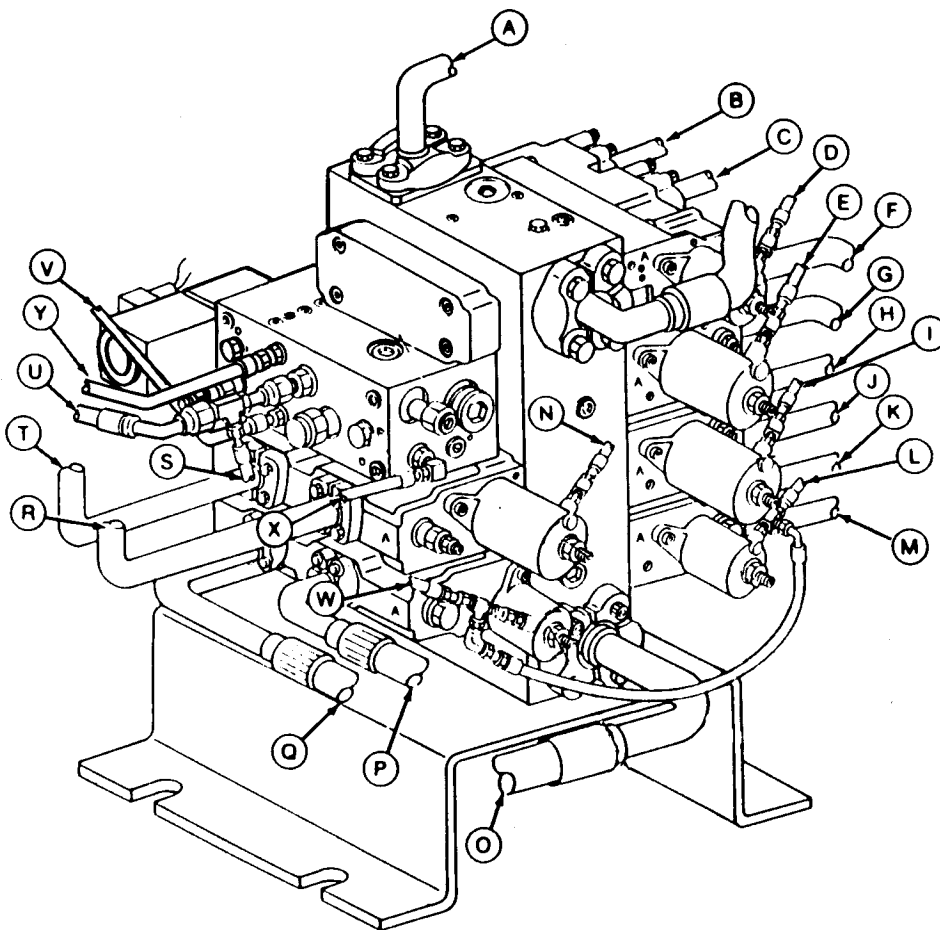

(Serial No. —543989)

- | | | | |
|--|--|--|---|
| A—To Oil Cooler Line | H—Line to Bucket Cylinder
Piston End | N—Line to Dig Pilot Check
Valve Block K2 Port | U—Line to Pilot Filter |
| B—To Swing Motor Line | I—Line to Dig Pilot Check
Valve Block I1 Port | O—Line to Reservoir | V—Line to Swing Motor |
| C—To Swing Motor Line | J—Line to Bucket Cylinder
Rod End | P—Line to Rotary Manifold | W—Line to Propel Pilot Check
Valve Block |
| D—Line to Dig Pilot Check
Valve Block F2 Port | K—Line to Left Propel Reverse | Q—Line to Rotary Manifold | X—Line to Dual Solenoid
Block |
| E—Line to Dig Pilot Check
Valve Block G2 Port | L—Line to Propel Pilot
Controller | R—Line to Arm Cylinder
Piston End | Y—Pressure Control Manifold
Line (Z2 Port) |
| F—Line to Boom Cylinder Rod
End | M—Line to Left Propel
Forward | S—Line to Dual Solenoid
Block | |
| G—Line to Boom Cylinder
Piston End | | T—Line to Arm Cylinder Rod
End | |

7. Disconnect lines (A—X).

T7681DH -JUN-22JAN92

Continued on next page

TX,33,DY2960 -19-26AUG97-3/14

Hydraulic System

33
3360
89

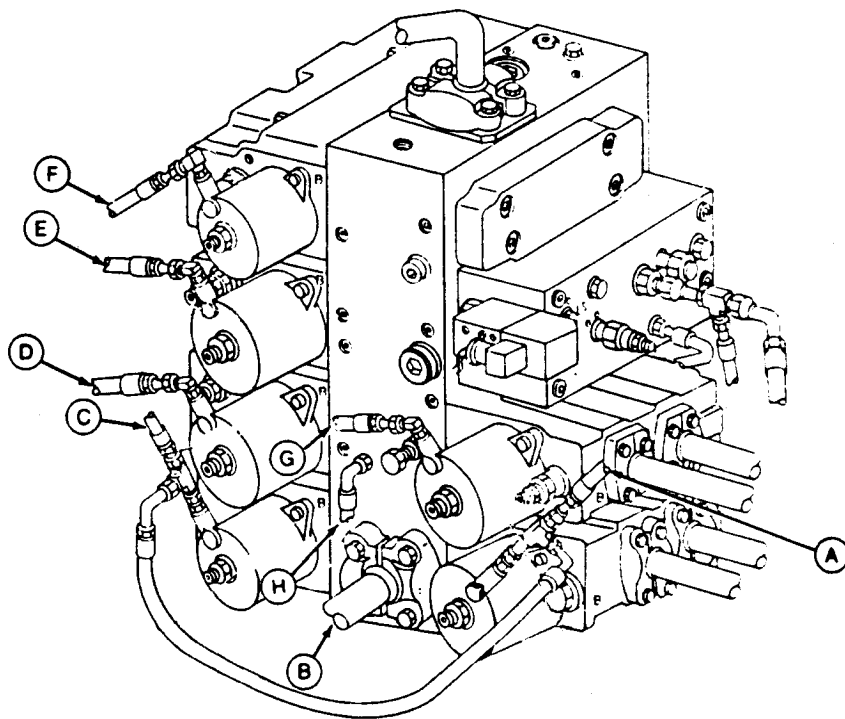

(Serial No. —543989)

A—Line-to-Right Propel Reverse
B—Line From Hydraulic Pump
C—Line-to-Left Propel Reverse

D—Line-to-Dig Pilot Check Valve J1 Port
E—Line-to-Dig Pilot Check Valve L1 Port

F—Line-to-Dig Pilot Check Valve E1 Port
G—Line-to-Dig Pilot Check Valve H1 Port

H—Line-to-Swing Gearbox

8. Disconnect lines (A—H).

T7681DI —JUN-22-JAN92

Continued on next page

TX,33,DY2960 —19-26AUG97-4/14

Hydraulic System

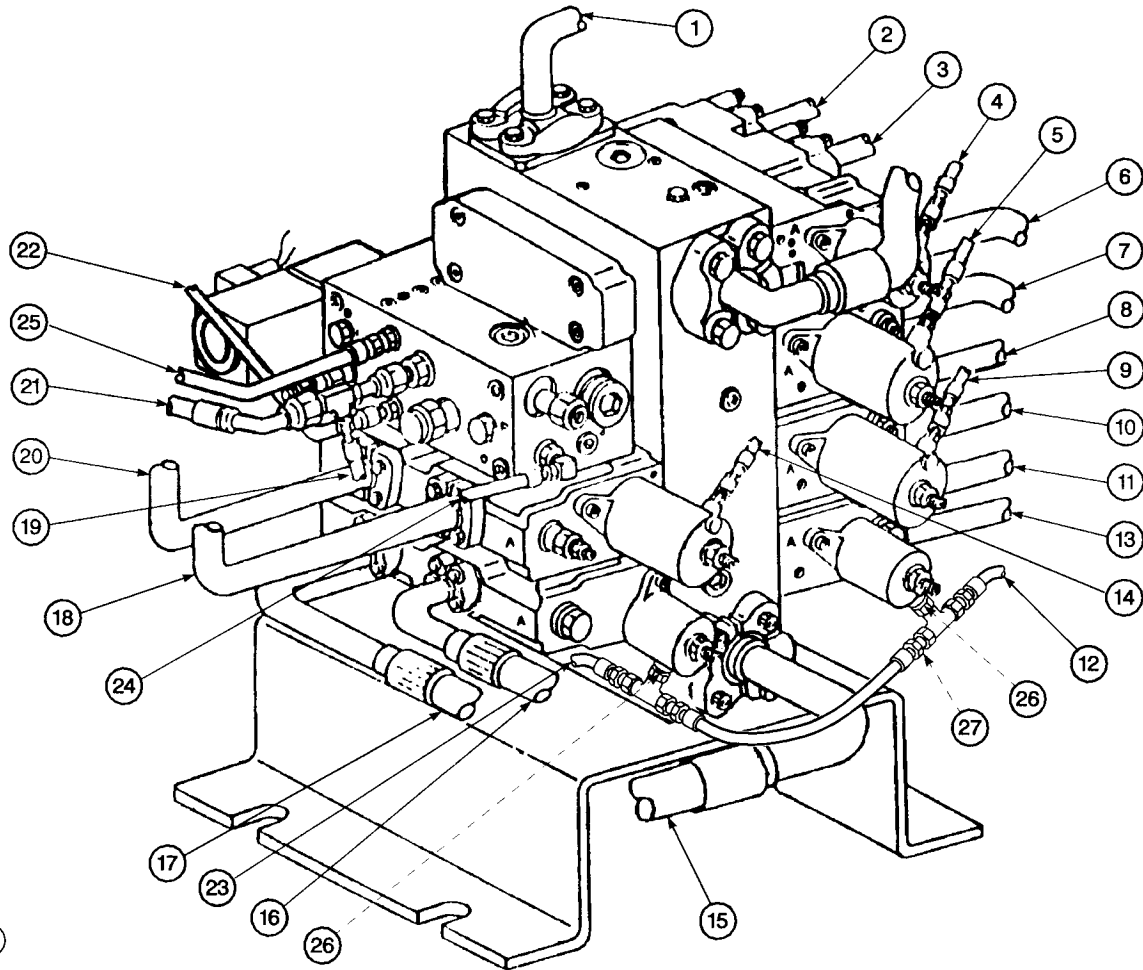

T8448AD CV

(Serial No. 543990—556935)

- | | | | |
|--|--|---|--|
| 1—To Oil Cooler Line | 8—Line-to-Bucket Cylinder
Piston End | 14—Line-to-Dig Pilot Check
Valve Block K2 Port | 21—Line-to-Pilot Filter |
| 2—To Swing Motor Line | 9—Line-to-Dig Pilot Check
Valve Block I1 Port | 15—Line-to-Reservoir | 22—Line-to-Swing Motor |
| 3—To Swing Motor Line | 10—Line-to-Bucket Cylinder
Rod End | 16—Line-to-Rotary Manifold | 23—Line-to-Propel Pilot Check
Valve Block |
| 4—Line-to-Dig Pilot Check
Valve Block F2 Port | 11—Line-to-Left Propel
Reverse | 17—Line-to-Rotary Manifold
Piston End | 24—Line-to-Dual Solenoid
Block |
| 5—Line-to-Dig Pilot Check
Valve Block G2 Port | 12—Line-to-Propel Pilot
Controller | 18—Line-to-Arm Cylinder
Rod End | 25—Pressure Control Manifold
Line (Z2 Port) |
| 6—Line-to-Boom Cylinder Rod
End | 13—Line-to-Left Propel
Forward | 19—Line-to-Dual Solenoid
Block | 26—Orifice (2 used) |
| 7—Line-to-Boom Cylinder
Piston End | | 20—Line-to-Arm Cylinder Rod
End | 27—Orifice |

9. Disconnect lines (1—24).

NOTE: The T-fittings for hydraulic lines (23 and 12) contain orifices (26 and 27). The orifices will fall out when hoses are removed.

T8448AD -JUN-11APR95

Continued on next page

TX,33,DY2960 -19-26AUG97-5/14

Hydraulic System

33
3360
91

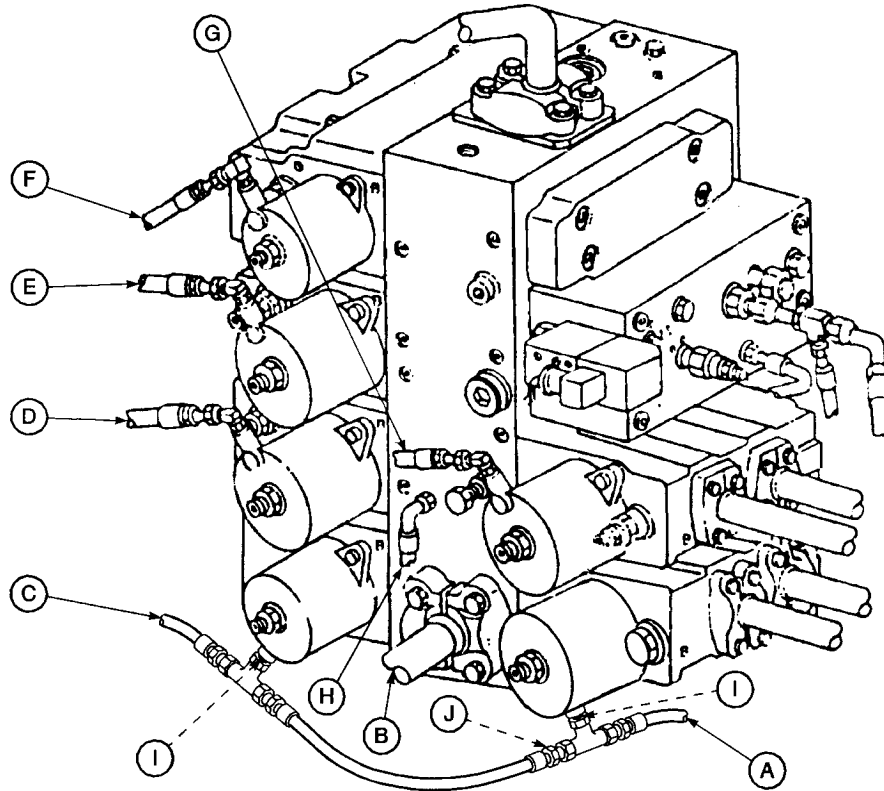

T8448AC (CV)

(Serial No. 543990—556935)

- | | | | |
|--------------------------------|---|---|-------------------------|
| A—Line-to-Right Propel Reverse | D—Line-to-Dig Pilot Check Valve J1 Port | F—Line-to-Dig Pilot Check Valve E1 Port | H—Line-to-Swing Gearbox |
| B—Line From Hydraulic Pump | E—Line-to-Dig Pilot Check Valve L1 Port | G—Line-to-Dig Pilot Check Valve H1 Port | I—Orifice (2 used) |
| C—Line-to-Left Propel Reverse | | | J—Orifice |

10. Disconnect lines (A—H).

NOTE: The T-fittings for hydraulic lines (A and C) contain orifices (I and J). The orifices will fall out when hoses are removed.

TX,33,DY2960 -19-26AUG97-6/14

CAUTION: Approximate weight of control valve is 159 kg (350 lb).

11. Remove cap screws (A).
12. Remove valve.

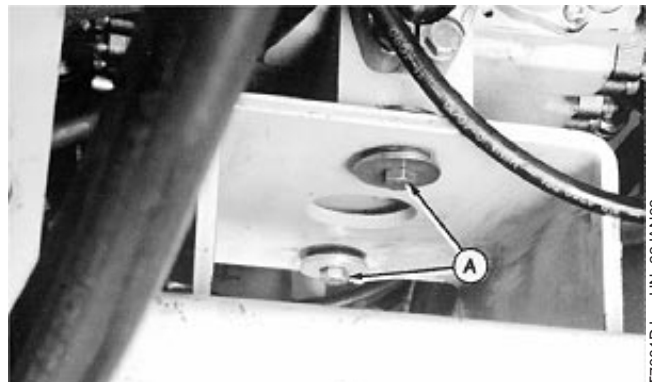

Continued on next page

TX,33,DY2960 -19-26AUG97-7/14

T7681DU -UN-22JAN92

Hydraulic System

13. Remove valve sections and pressure control manifold (B—H) from control valve manifold (A).

14. Repair or replace valve sections and manifold as necessary.

15. Install valve sections.

Specification

Swing Valve-to-Manifold—Torque.....	49 N•m (36 lb-ft)
Boom Valve-to-Manifold—Torque	86 N•m (63 lb-ft)
Bucket Valve-to-Manifold— Torque	86 N•m (63 lb-ft)
Left Propel Valve-to-Manifold— Torque	49 N•m (36 lb-ft)
Arm Valve-to-Manifold—Torque	86 N•m (63 lb-ft)
Right Propel Valve-to-Manifold— Torque	49 N•m (36 lb-ft)

16. Install valve.

- A—Manifold
- B—Swing Valve
- C—Boom Valve
- D—Bucket Valve
- E—Left Propel Valve
- F—Right Propel Valve
- G—Arm Valve
- H—Pressure Control Manifold

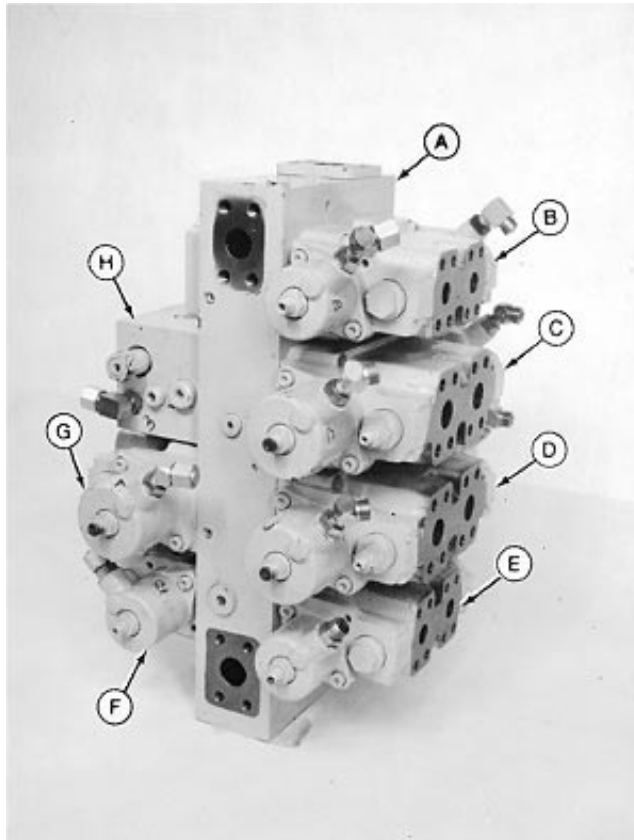

T7681DK -UN-22JAN92

TX,33,DY2960 -19-26AUG97-8/14

17. Install cap screws (A) and tighten to 75 N•m (55 lb-ft).

Specification

Mounting Cap Screws—Torque	75 N•m (55 lb-ft)
----------------------------------	-------------------

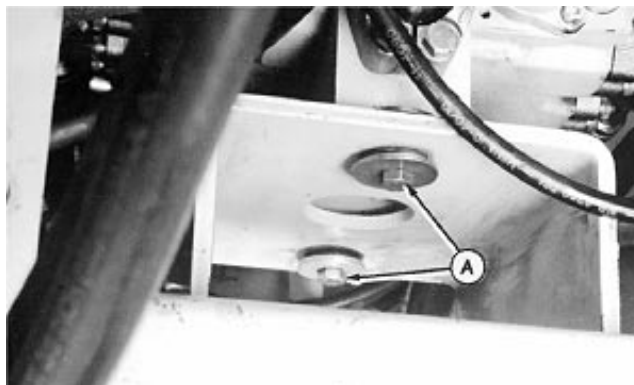

T7681DJ -UN-22JAN92

Continued on next page

TX,33,DY2960 -19-26AUG97-9/14

Hydraulic System

33
3360
93

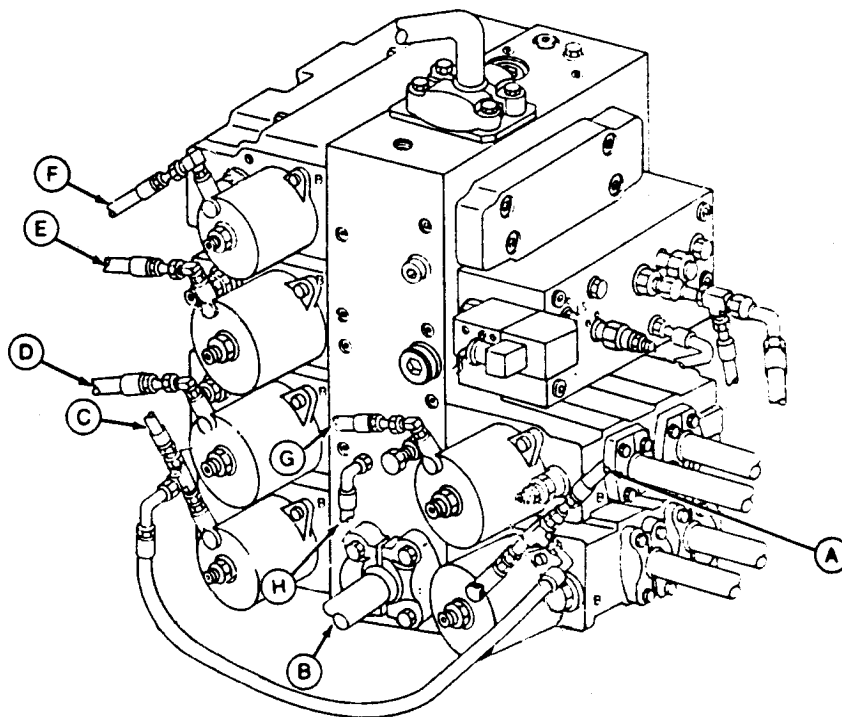

(Serial No. —543989)

A—Line-to-Right Propel Reverse
B—Line From Hydraulic Pump
C—Line-to-Left Propel Reverse

D—Line-to-Dig Pilot Check Valve J1 Port
E—Line-to-Dig Pilot Check Valve L1 Port

F—Line-to-Dig Pilot Check Valve E1 Port
G—Line-to-Dig Pilot Check Valve H1 Port

H—Line-to-Swing Gearbox

18. Connect lines (A—H).

T7681DI —JUN-22-JAN92

Continued on next page

TX,33,DY2960 —19-26AUG97-10/14

Hydraulic System

33
3360
94

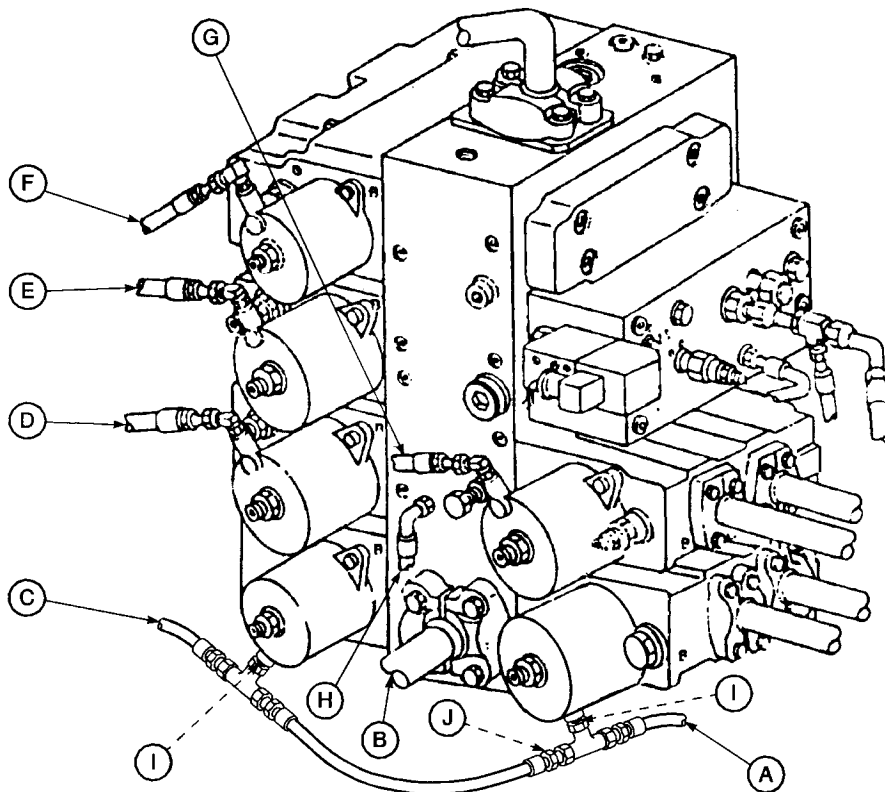

T8448AC (CV)

(Serial No. 543990—556935)

A—Line-to-Right Propel Reverse
B—Line From Hydraulic Pump
C—Line-to-Left Propel Reverse

D—Line-to-Dig Pilot Check Valve J1 Port
E—Line-to-Dig Pilot Check Valve L1 Port

F—Line-to-Dig Pilot Check Valve E1 Port
G—Line-to-Dig Pilot Check Valve H1 Port

H—Line-to-Swing Gearbox
I—Orifice (2 used)
J—Orifice

19. Connect lines (A—H).

T8448AC -UN-11APR95

Continued on next page

TX,33,DY2960 -19-26AUG97-11/14

Hydraulic System

33
3360
95

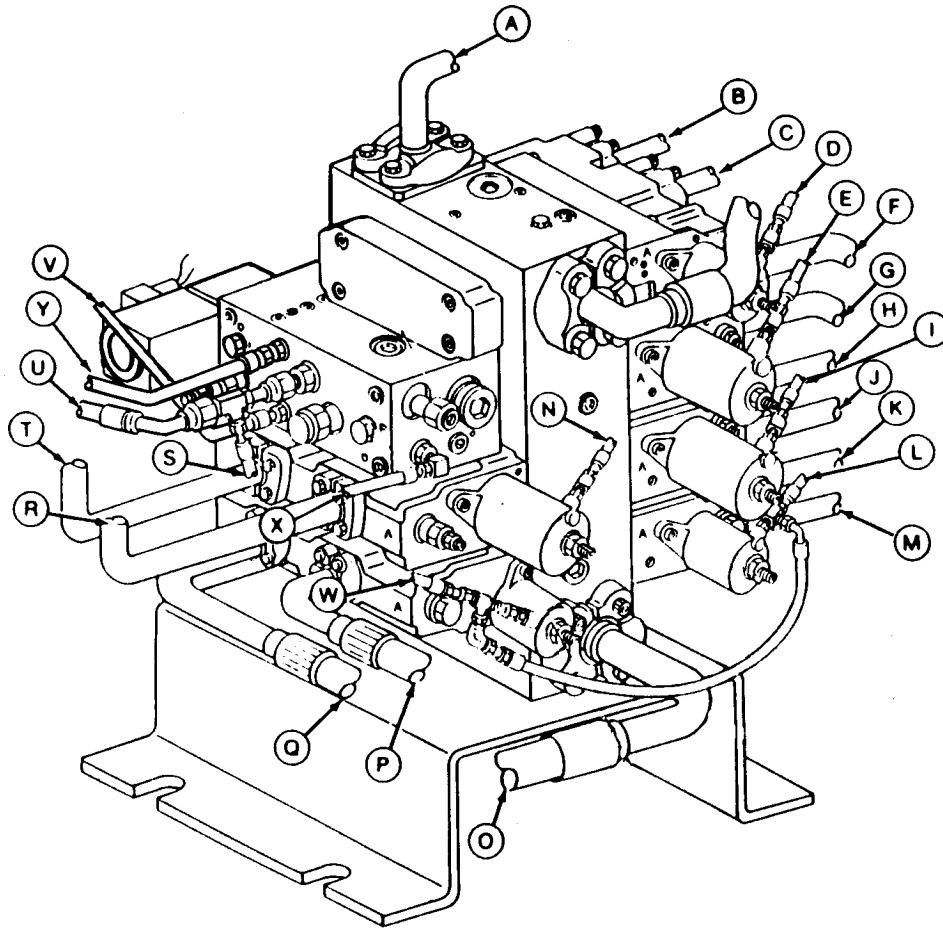

(Serial No. —543989)

- | | | | |
|---|---|---|---|
| A—To Oil Cooler Line | H—Line-to-Bucket Cylinder
Piston End | N—Line-to-Dig Pilot Check
Valve Block (K2) | U—Line-to-Pilot Filter |
| B—To Swing Motor Line | I—Line-to-Dig Pilot Check
Valve Block (I1) | O—Line-to-Reservoir | V—Line-to-Swing Motor |
| C—To Swing Motor Line | J—Line-to-Bucket Cylinder
Rod End | P—Line-to-Rotary Manifold | W—Line-to-Propel Pilot Check
Valve Block |
| D—Line-to-Dig Pilot Check
Valve block (F2) | K—Line-to-Left Propel Reverse
Piston End | Q—Line-to-Rotary Manifold | X—Line-to-Dual Solenoid
Block |
| E—Line-to-Dig Pilot Check
Valve Block (G2) | L—Line-to-Propel Pilot
Controller | R—Line-to-Arm Cylinder
Piston End | Y—Pressure Control Manifold
Line (Z2 Port) |
| F—Line-to-Boom Cylinder Rod
End | M—Line-to-Left Propel
Forward | S—Line-to-Dual Solenoid
Block | |
| G—Line-to-Boom Cylinder
Piston End | | T—Line-to-Arm Cylinder Rod
End | |

20. Connect lines (A—X).

T7681DH -JUN-22/JAN92

Continued on next page

TX.33,DY2960 -19-26AUG97-12/14

Hydraulic System

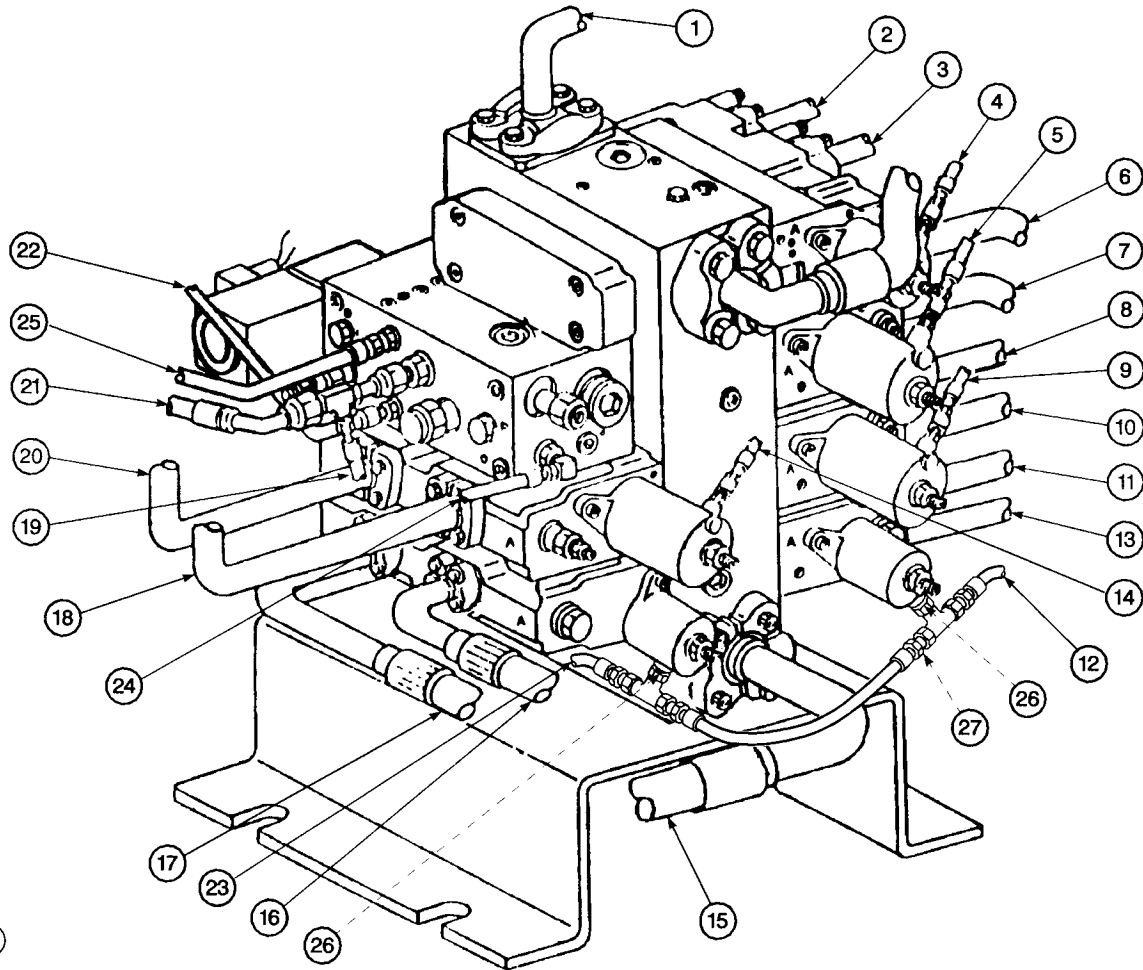

T8448AD CV

(Serial No. 543990—559935)

- | | | | |
|---|---|--|--|
| 1—To Oil Cooler Line | 8—Line-to-Bucket Cylinder
Piston End | 14—Line-to-Dig Pilot Check
Valve Block (K2) | 21—Line-to-Pilot Filter |
| 2—To Swing Motor Line | 9—Line-to-Dig Pilot Check
Valve Block (I1) | 15—Line-to-Reservoir | 22—Line-to-Swing Motor |
| 3—To Swing Motor Line | 10—Line-to-Bucket Cylinder
Rod End | 16—Line-to-Rotary Manifold | 23—Line-to-Propel Pilot Check
Valve Block |
| 4—Line-to-Dig Pilot Check
Valve Block (F2) | 11—Line-to-Left Propel
Reverse | 17—Line-to-Rotary Manifold | 24—Line-to-Dual Solenoid
Block |
| 5—Line-to-Dig Pilot Check
Valve Block (G2) | 12—Line-to-Propel Pilot
Controller | 18—Line-to-Arm Cylinder
Piston End | 25—Pressure Control Manifold
Line (Z2 Port) |
| 6—Line-to-Boom Cylinder Rod
End | 13—Line-to-Left Propel
Forward | 19—Line-to-Dual Solenoid
Block | 26—Orifice (2 used) |
| 7—Line-to-Boom Cylinder
Piston End | | 20—Line-to-Arm Cylinder Rod
End | 27—Orifice |

21. Connect lines (1—24).

Continued on next page

TX,33,DY2960 -19-26AUG97-13/14

T8448AD -JUN-11APR95

Hydraulic System

22. Install plate (A).
23. Install clamps (C and F).
24. Connect lines (B, D, E and G).
25. Fill reservoir. Approximate capacity is 148 L (39 gal).

- A—Plate
- B—Control Valve-to-Bucket Cylinder Piston End Line
- C—Clamp
- D—Control Valve-to-Arm Cylinder Piston End Line
- E—Control Valve-to-Arm Cylinder Rod End Line
- F—Clamp
- G—Control Valve-to-Bucket Cylinder Rod End Line

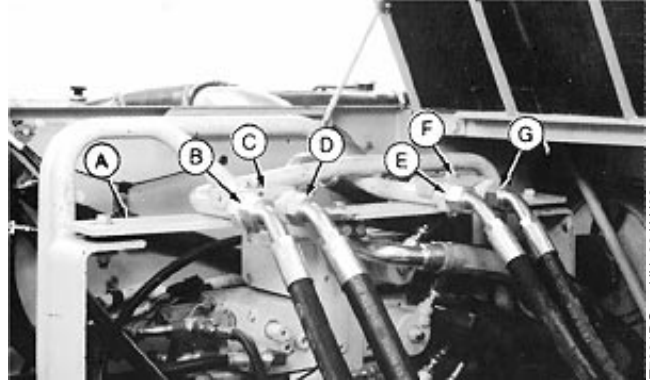
33
3360
97

T7681DG -UN-22JAN92

TX,33,DY2960 -19-26AUG97-14/14

Remove And Install Boom, Arm, And Swing Control Valve Manifold (Serial No. 556936—)

NOTE: Valve sections can be removed with the control valve in the machine.

1. Lower equipment to ground.
2. Release pressure in hydraulic reservoir. Unlock hydraulic tank fill cap. Slowly turn cap to release air pressure.
3. Drain reservoir. Approximate capacity is 151 L (40 gal).

Continued on next page

TX,33,DY2961 -19-26AUG97-1/11

Hydraulic System



CAUTION: Escaping fluid under pressure can penetrate the skin causing serious injury. Avoid the hazard by relieving pressure before disconnecting hydraulic or other lines. Tighten all connections before applying pressure. Search for leaks with a piece of cardboard. Protect hands and body from high pressure fluids.

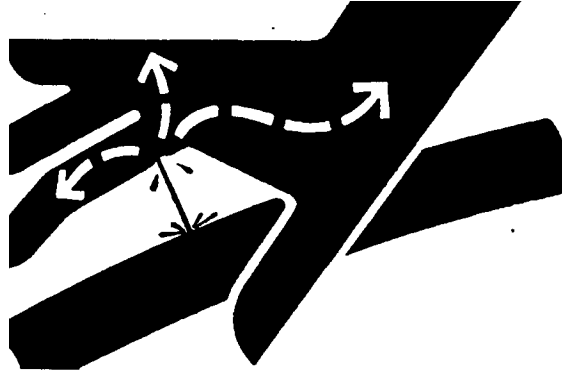

If an accident occurs, see a doctor immediately. Any fluid injected into the skin must be surgically removed within a few hours or gangrene may result. Doctors unfamiliar with this type of injury may call the Deere & Company Medical Department in Moline, Illinois, or other knowledgeable medical source.

IMPORTANT: For machines with an anti-drift valve, the relief valve must be loosened 1/4 turn to make a passage through the valve for high pressure oil to flow from cylinders to the control valve.

4. Loosen relief valve 1/4 turn on anti-drift valve, if equipped.

X9811 -UN-23AUG88

Continued on next page

TX,33,DY2961 -19-26AUG97-2/11

Hydraulic System

5. Disconnect electrical connector (D).
6. Disconnect lines (A—C and E—O). Label lines to aid in installation.

- A—Main Control Valve Boom Raise Anti-Drift Valve Y Port-to-Hydraulic Tank Line
- B—Main Control Valve Boom Raise Anti-Drift Valve Y Port-to-Arm Raise Anti-Drift Valve Y Port Line
- C—Main Control Valve Return Manifold RES Port-to-Hydraulic Tank Line
- D—Electrical Connector
- E—Main Control Valve Swing Valve Left Rear Pilot Cap-to-Dig Shuttle Valve F1 Port Line
- F—Main Control Valve Swing Section A Port-to-Swing Motor Left Front Port Line
- G—Main Control Valve Swing Section B Port-to-Swing Motor Right Front Port Line
- H—Main Control Valve Swing Valve Right Front Pilot Cap-to-Dig Shuttle Valve E1 Port Line
- I—Main Control Valve P2 Port-to-Dual Solenoid Valve P Port Line
- J—Main Control Manifold P2 Port-to-Hydraulic Outlet Port Line
- K—Main Control Valve Boom Lower Front Pilot Cap Port-to-Main Control Valve Boom Raise Anti-Drift Valve X Port Line
- L—Main Control Valve Boom Lower Front Pilot Cap Port-to-Dig Shuttle Valve L1 Port Line
- M—Main Control Valve Boom Lower B Port-to-Boom Cylinder Rod End Port Line
- N—Main Control Valve Boom Raise Anti-Drift Valve A Port-to-Boom Cylinder Head End Port Line
- O—Main Control Valve Boom Raise Anti-Drift Valve X Port-to-Main Control Valve Boom Lower Front Pilot Cap Port Line

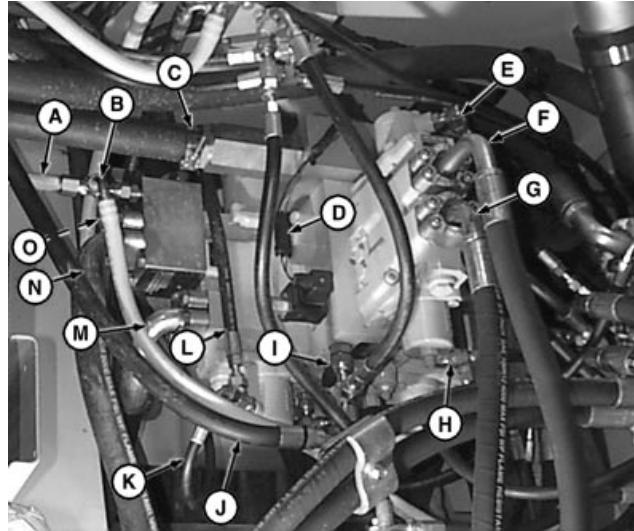

T109755 -UN-22AUG97

33
3360
99

Continued on next page

TX,33,DY2961 -19-26AUG97-3/11

Hydraulic System

7. Disconnect lines (A—D). Label lines to aid in installation.

- A—Main Control Valve Manifold LSA Port-to-Monoblock Control Valve LSA Port Line
- B—Main Control Valve Manifold Z2 Port-to-Dig Shuttle Valve S1 Port Line
- C—Main Control Valve Manifold Z1 Port-to-Propel Pilot Check Valve Line
- D—Main Control Valve Manifold Bottom Forward Port-to-Monoblock Control Valve LS Port Line

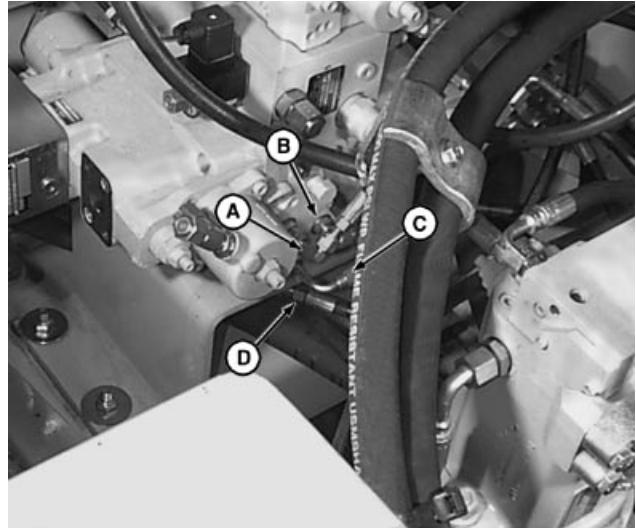

Rear View Of Control Valve Manifold

TX,33,DY2961 -19-26AUG97-4/11

8. Disconnect lines (A—E). Label lines to aid in installation.

- A—Main Control Valve Arm Lower A Port-to-Arm Cylinder Head End Port Line
- B—Main Control Valve Arm Raise Anti-Drift Valve B Port-to-Arm Cylinder Rod End Port Line
- C—Main Control Valve Arm Raise Anti-Drift Valve Y Port-to-Boom Raise Anti-Drift Valve Y Port Line
- D—Main Control Valve Arm Raise Anti-Drift Valve X Port-to-Main Control Valve Arm Raise Front Pilot Cap Port Line
- E—Main Control Valve Arm Raise Front Pilot Cap-to-Dig Shuttle Valve H1 Port Line

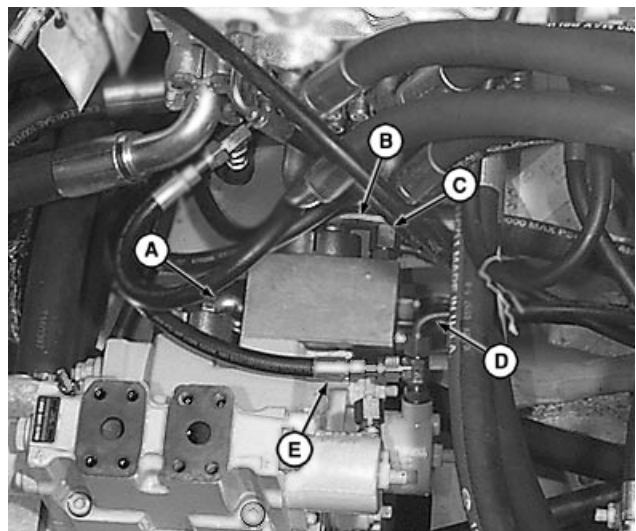

Continued on next page

TX,33,DY2961 -19-26AUG97-5/11

Hydraulic System

9. Disconnect lines (A—F and I). Label lines to aid in installation.

CAUTION: Use proper lifting device when removing heavy components.

10. Remove cap screws (G) and washers (H). Remove valve.

- A—Main Control Valve Arm Lower Rear Pilot Cap-to-Dig Shuttle Valve C1 Port Line
- B—Main Control Valve Return Manifold Left Side Port-to-Oil Cooler Bottom Port Line
- C—Main Control Manifold Rear S2 Port-to-Monoblock Control Valve Bottom Rear Port Line
- D—Main Control Valve Boom Raise Rear Pilot Cap-to-Dig Shuttle Valve K1 Port Line
- E—Main Control Valve Bottom Middle Port-to-Main Hydraulic Pump Top Rear Port Line
- F—Main Control Valve Forward Bottom Port-to-Main Hydraulic Pump Regulator LS Port Line
- G—Cap Screw (3 used)
- H—Washer (3 used)
- I—Main Control Valve Manifold Rear Bottom Port-to-Monoblock Control Valve Left Rear Port Line

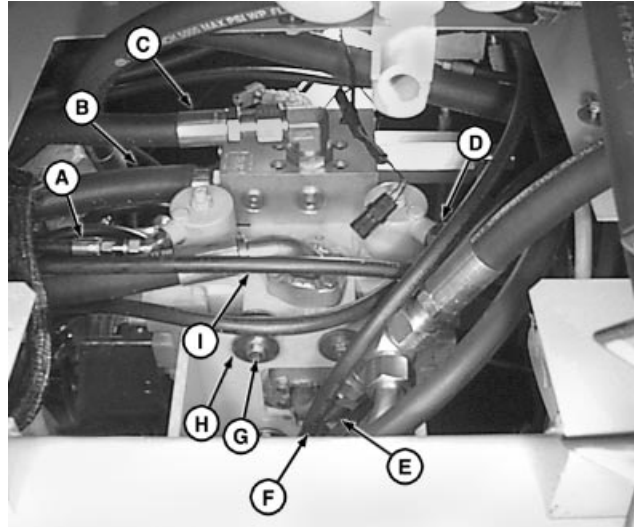

Bottom View Of Control Valve Manifold

33
3360
101

T109758 -JUN-05AUG97

Continued on next page

TX,33,DY2961 -19-26AUG97-6/11

Hydraulic System

11. Remove valve sections (A, B and D) from manifold (C).

12. Repair or replace as necessary.

13. Install valve sections.

Specification

Boom Valve-to-Manifold—Torque	86 N•m (63 lb-ft)
Swing Valve-to-Manifold—Torque	49 N•m (36 lb-ft)
Arm Valve-to-Manifold—Torque	86 N•m (63 lb-ft)

NOTE: Inspect isolators for wear or cracks. Replace as necessary.

14. Install valve.

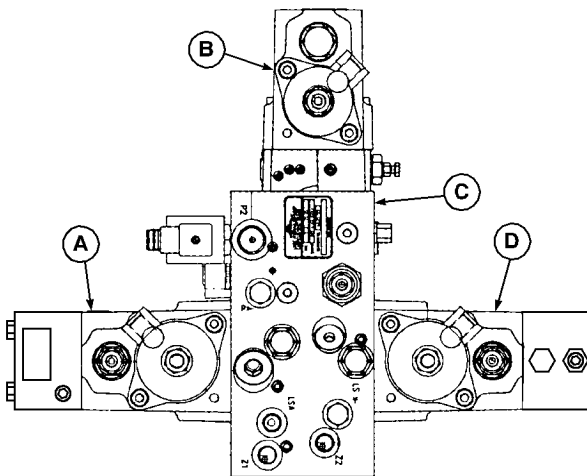

T109773

Continued on next page

TX,33,DY2961 -19-26AUG97-7/11

T109773 -JUN-06AUG97

Hydraulic System

33
3360
103

15. Install cap screws (G) and washers (H). Tighten to 75 N•m (55 lb-ft).

Specification

Mounting Cap Screw—Torque..... 75 N•m (55 lb-ft)

16. Connect lines (A—F and I).

- A—Main Control Valve Arm Lower Rear Pilot Cap-to-Dig Shuttle Valve C1 Port Line
- B—Main Control Valve Return Manifold Left Side Port-to-Oil Cooler Bottom Port Line
- C—Main Control Manifold Rear S2 Port-to-Monoblock Control Valve Bottom Rear Port Line
- D—Main Control Valve Boom Raise Rear Pilot Cap-to-Dig Shuttle Valve K1 Port Line
- E—Main Control Valve Bottom Middle Port-to-Main Hydraulic Pump Top Rear Port Line
- F—Main Control Valve Forward Bottom Port-to-Main Hydraulic Pump Regulator LS Port Line
- G—Cap Screw (3 used)
- H—Washer (3 used)
- I—Main Control Valve Manifold Rear Bottom Port-to-Monoblock Control Valve Left Rear Port Line

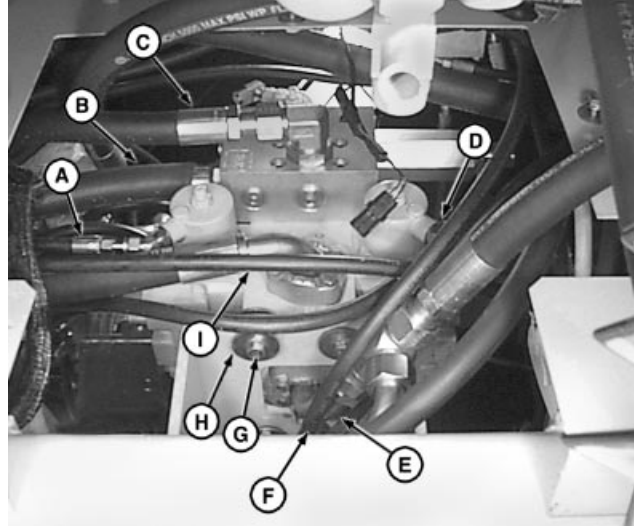

Bottom View Of Control Valve Manifold

T109758 -UN-05AUG97

TX,33,DY2961 -19-26AUG97-8/11

17. Connect lines (A—E).

- A—Main Control Valve Arm Lower A Port-to-Arm Cylinder Head End Port Line
- B—Main Control Valve Arm Raise Anti-Drift Valve B Port-to-Arm Cylinder Rod End Port Line
- C—Main Control Valve Arm Raise Anti-Drift Valve Y Port-to-Boom Raise Anti-Drift Valve Y Port Line
- D—Main Control Valve Arm Raise Anti-Drift Valve X Port-to-Main Control Valve Arm Raise Front Pilot Cap Port Line
- E—Main Control Valve Arm Raise Front Pilot Cap-to-Dig Shuttle Valve H1 Port Line

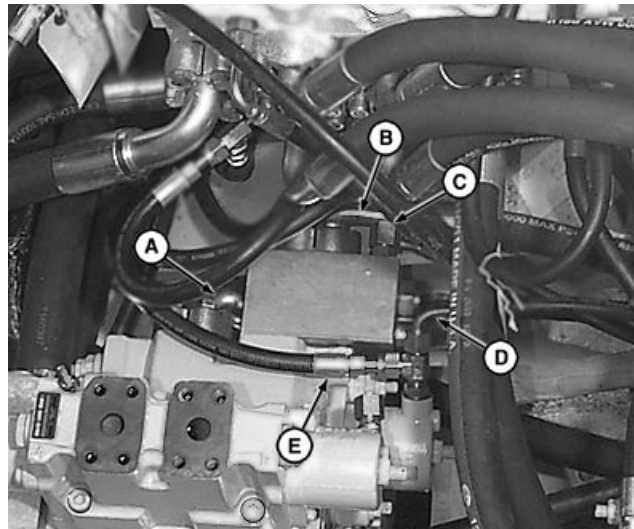

T109757 -UN-05AUG97

Continued on next page

TX,33,DY2961 -19-26AUG97-9/11

Hydraulic System

18. Connect Lines (A—D).

- A—Main Control Valve Manifold LSA
Port-to-Monoblock Control Valve LAS Port Line
- B—Main Control Valve Manifold Z2 Port-to-Dig Shuttle
Valve S1 Port Line
- C—Main Control Valve Manifold Z1 Port-to-Propel
Pilot Check Valve Line
- D—Main Control Valve Manifold Bottom Forward
Port-to-Monoblock Control Valve LS Port Line

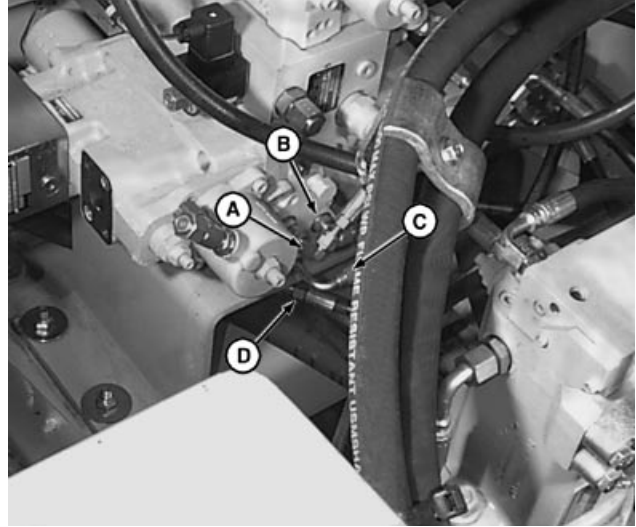

Front View Control Valve Manifold

T109756 -UN-05AUG97

Continued on next page

TX,33,DY2961 -19-26AUG97-10/11

Hydraulic System

19. Connect lines (A—C and E—O).
20. Connect electrical connector (D).
21. Fill reservoir. Approximate capacity is 151 L (40 gal).

- A—Main Control Valve Boom Raise Anti-Drift Valve Y Port-to-Hydraulic Tank Line
- B—Main Control Valve Boom Raise Anti-Drift Valve Y Port-to-Arm Raise Anti-Drift Valve Y Port Line
- C—Main Control Valve Return Manifold RES Port-to-Hydraulic Tank Line
- D—Electrical Connector
- E—Main Control Valve Swing Valve Left Rear Pilot Cap-to-Dig Shuttle Valve F1 Port Line
- F—Main Control Valve Swing Section A Port-to-Swing Motor Left Front Port Line
- G—Main Control Valve Swing Section B Port-to-Swing Motor Right Front Port Line
- H—Main Control Valve Swing Valve Right Front Pilot Cap-to-Dig Shuttle Valve E1 Port Line
- I—Main Control Valve P2 Port-to-Dual Solenoid Valve P Port Line
- J—Main Control Manifold P2 Port-to-Hydraulic Outlet Port Line
- K—Main Control Valve Boom Lower Front Pilot Cap Port-to-Main Control Valve Boom Raise Anti-Drift Valve X Port Line
- L—Main Control Valve Boom Lower Front Pilot Cap Port-to-Dig Shuttle Valve L1 Port Line
- M—Main Control Valve Boom Lower B Port-to-Boom Cylinder Rod End Port Line
- N—Main Control Valve Boom Raise Anti-Drift Valve A Port-to-Boom Cylinder Head End Port Line
- O—Main Control Valve Boom Raise Anti-Drift Valve X Port-to-Main Control Valve Boom Lower Front Pilot Cap Port Line

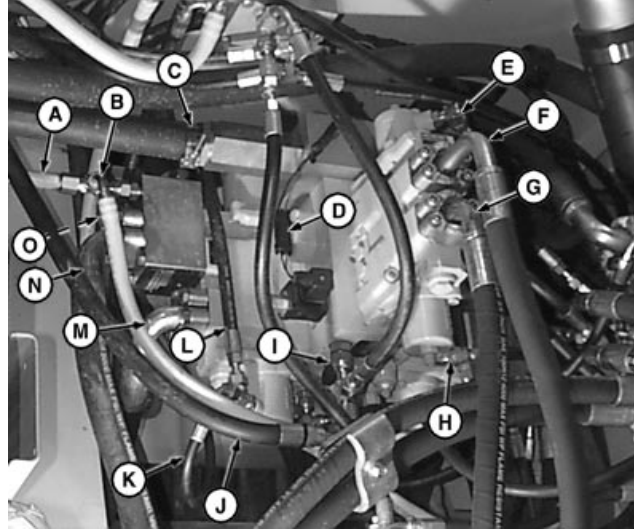

33
3360
105

T109755 -UN-22AUG97

TX,33,DY2961 -19-26AUG97-11/11

Remove And Install Return Manifold (Serial No. 556936—)

1. Lower all equipment to ground.

CAUTION: To avoid injury from escaping fluid under pressure, stop engine and relieve the pressure in the system before disconnecting or connecting hydraulic or other lines. Tighten all connections before applying pressure.

2. Release pressure in hydraulic reservoir. Loosen hydraulic fill cap. Slowly turn cap to release pressure.
3. Drain reservoir. Approximate capacity is 151 L (40 gal).
4. Disconnect lines (A, B and E)
5. Remove cap screw (C). Remove valve (D).
6. Repair or replace as necessary.
7. Install valve.
8. Install cap screw. Tighten to 55 N•m (40 lb-ft).

Specification

Return Manifold Mounting Cap
Screw—Torque..... 55 N•m (40 lb-ft)

9. Connect lines.
10. Fill reservoir. Approximate capacity is 151 L (40 gal).

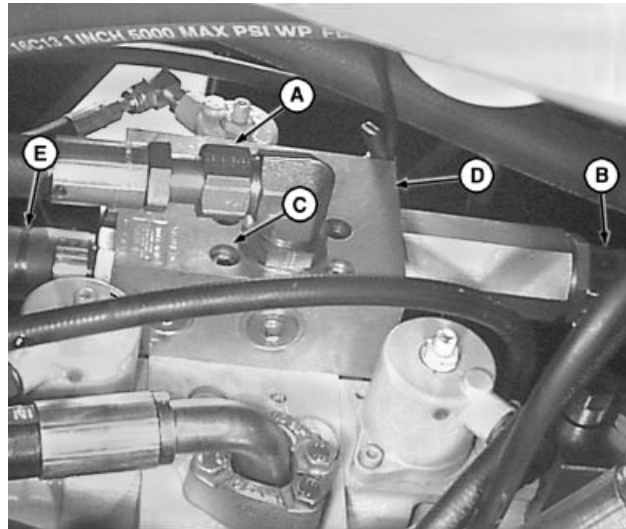

Rear View Control Valve Manifold

- A—Main Control Valve Return Manifold Rear Port-to-Monoblock Control Valve Bottom Rear T Port Line
- B—Main Control Valve Return Manifold RES Port-to-Hydraulic Tank
- C—Cap Screw (4 used)
- D—Return Manifold
- E—Main Control Valve Return Manifold Left Side Port-to-Oil Cooler Bottom Port Line

TX,33,DT5054 -19-10JUN97-1/1

Hydraulic System

33
3360
107**Remove And Install Oil Cooler Bypass Valve
(Serial No. 556936—)**

1. Lower all equipment to ground.

CAUTION: To avoid injury from escaping fluid under pressure, stop engine and relieve the pressure in the system before disconnecting or connecting hydraulic or other lines. Tighten all connections before applying pressure.

2. Release pressure in hydraulic reservoir. Loosen hydraulic fill cap. Slowly turn cap to release pressure.
3. Drain reservoir. Approximate capacity is 151 L (40 gal).

TX,33,DY2963 -19-26AUG97-1/2

4. Remove hose (B).
5. Remove relief valve (A). Replace as necessary.
6. Inspect O-ring for wear or damage. Replace as necessary.
7. Install relief valve.
8. Install hose.
9. Fill reservoir. Approximate capacity is 151 L (40 gal).

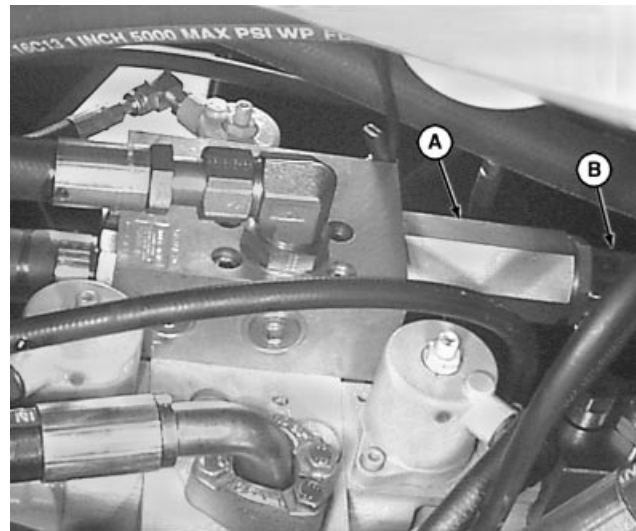

TX,33,DY2963 -19-26AUG97-2/2

**Remove And Install Arm Cylinder Restrictor
(Serial No. 546276—556935)**

NOTE: Restrictor can be removed with control valve in machine.

1. Release pressure in hydraulic reservoir. Loosen hydraulic tank fill cap. Slowly turn cap to release air pressure.

Continued on next page

TX,33,DY2964 -19-26AUG97-1/2

Hydraulic System

2. Remove arm cylinder restrictor and lock nut (A) from control valve manifold.
3. Inspect for wear or damage. Replace as necessary.
4. Install restrictor. Tighten nut to 60 N•m (44 lb-ft).

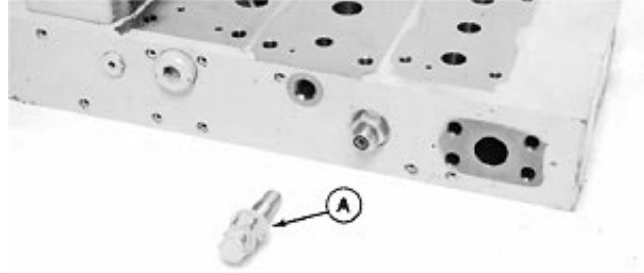

(Serial No. —546276)

Specification

Arm Cylinder Restrictor Jam Nut
 (—556935) Cap Screw—Torque..... 60 N•m (44 lb-ft)

5. Adjust restrictor. (See procedure in Group 9025-20.)

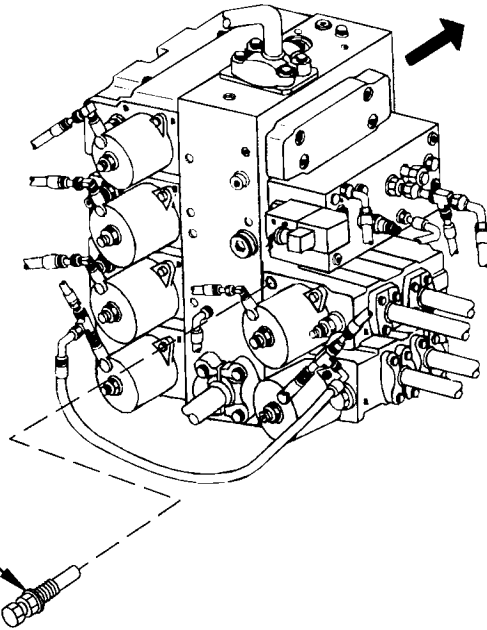

T8448AE (CV)

(Serial No. 546277—556935)

TX.33.DY2964 -19-26AUG97-2/2

T7681DL -UN-22JAN92

T8448AE -UN-11APR95

33
3360
108

Hydraulic System

Remove And Install Arm And Boom Cylinder Restrictors (Serial No. 556936—)

NOTE: Restrictor can be removed with control valve in machine.

1. Release pressure in hydraulic reservoir. Loosen hydraulic tank fill cap. Slowly turn cap to release air pressure.
2. Remove boom cylinder restrictor and lock nut (A) from control valve manifold.
3. Remove arm cylinder restrictor and lock nut (B) from control valve manifold.
4. Inspect for wear or damage. Replace as necessary.
5. Install restrictor. Tighten nut to 60 N•m (44 lb-ft).

Specification

Arm Cylinder Restrictor Jam Nut
(—556935) Cap Screw—Torque..... 60 N•m (44 lb-ft)

6. Adjust restrictor. (See procedure in Group 9025-20.)

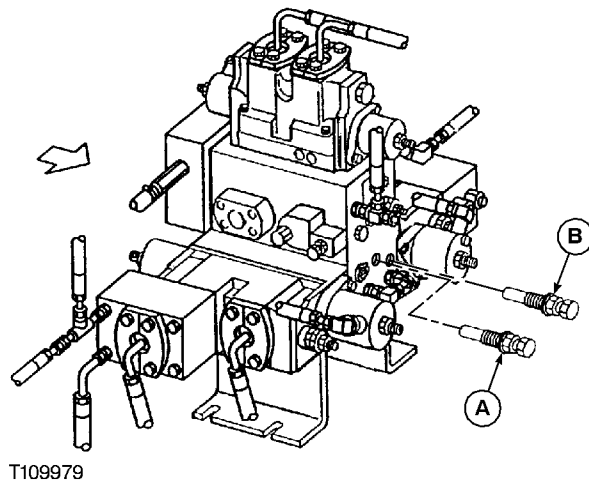

T109979 -UN-05AUG97

33
3360
109

TX,33,DY2965 -19-26AUG97-1/1

Remove And Install Anti-Cavitation Back Pressure Check Valve (Serial No. —556935)

NOTE: Valve can be removed with control valve in machine.

1. Release pressure in hydraulic reservoir. Unlock hydraulic tank fill cap. Slowly turn cap to release air pressure.
2. Disconnect oil line.

Continued on next page

TX,33,DY2966 -19-26AUG97-1/2

Hydraulic System

3. Remove parts (A—D) from top of control valve manifold (E).
4. Inspect parts. Replace as necessary.
5. Install parts.
6. Connect oil line.

A—Cap
 B—O-Ring
 C—Spring
 D—Valve
 E—Control Valve Manifold

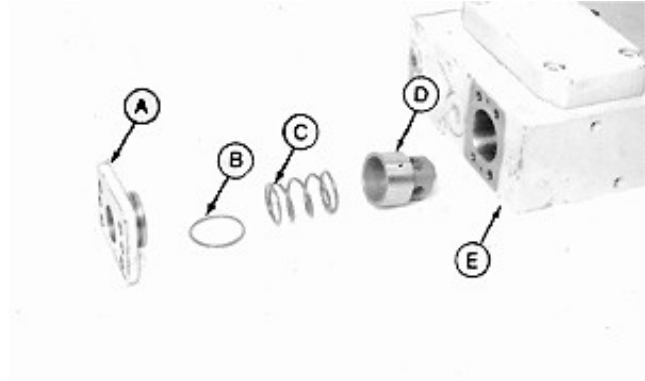

T7681DM -UN-27JAN92

TX,33,DY2966 -19-26AUG97-2/2

Remove And Install Anti-Cavitation Back Pressure Check Valve (Serial No. 556936—)

1. Lower all equipment to ground.



CAUTION: To avoid injury from escaping fluid under pressure, stop engine and relieve the pressure in the system before disconnecting or connecting hydraulic or other lines. Tighten all connections before applying pressure.

2. Release pressure in hydraulic reservoir. Loosen hydraulic fill cap. Slowly turn cap to release pressure.
3. Drain reservoir. Approximate capacity is 151 L (40 gal).

Continued on next page

TX,33,DT5020 -19-09JUN97-1/3

Hydraulic System

33
3360
111

4. Remove valve (A).

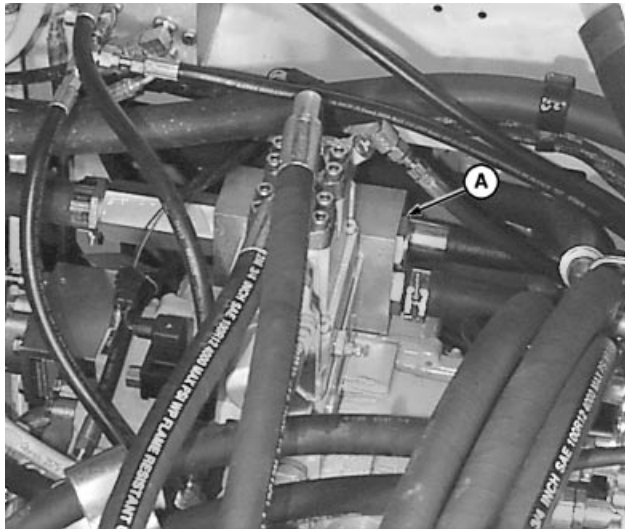

T109801 -UN-05AUG97

TX,33,DT5020 -19-09JUN97-2/3

5. Inspect O-rings (B and C) and backup ring (D).
Replace as necessary.

6. Install valve. Tighten to 80 N•m (59 lb-ft).

Specification

Safety Relief Valve Plug (—
556935)—Torque..... 80 N•m (59 lb-ft)

7. Fill reservoir. Approximate capacity is 151 L (40 gal).

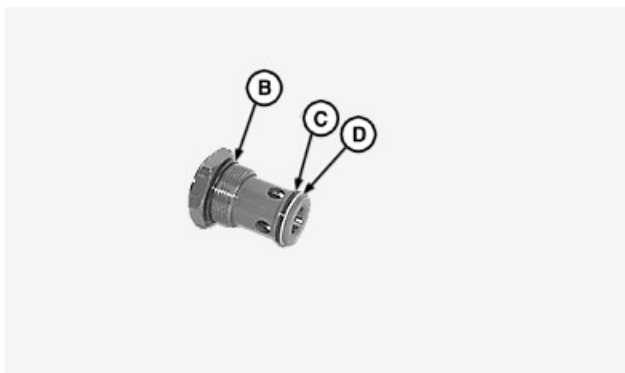

T109802 -UN-05AUG97

TX,33,DT5020 -19-09JUN97-3/3

Remove And Install Combined Function Shuttle Valve (Serial No. —556935)

1. Remove pressure control manifold (A). (See procedure in this group.)
2. Remove parts (B—G). Replace as necessary.
3. Install parts.
4. Install manifold. (See procedure in this group.)

- A—Manifold
- B—Spool
- C—Spring Seat
- D—Spring
- E—Spring Retainer
- F—O-Ring
- G—Plug

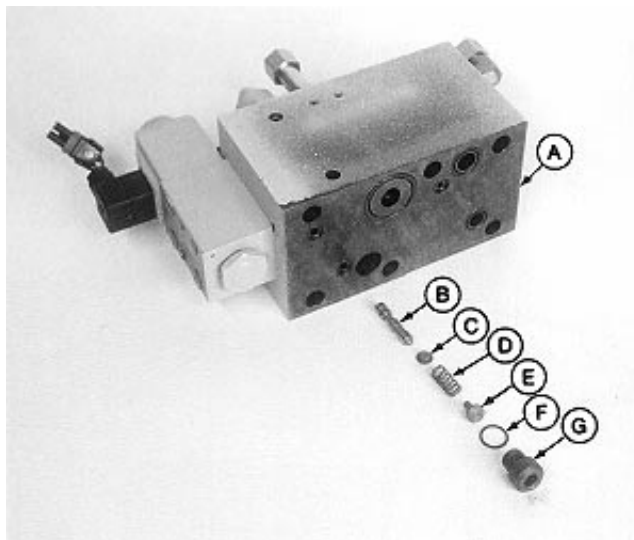

T8455AK -UN-04MAR95

TX,3360,AB383 -19-20APR95-1/1

Remove And Install Combined Function Shuttle Valve (Serial No. 556936—)

NOTE: It may be necessary to remove boom valve section in order to remove valve access plugs and valves.

1. Remove plugs (A and B).
2. Carefully push from plug (A) side to remove valve parts. Inspect and replace as necessary.
3. Remove plug (C). Remove valve parts. Replace as necessary.
4. Install parts. Tighten plugs (A—C) to 20 N•m (54 lb-in.).

Specification

Combined Function Shuttle Valve
 Plug (556936—)—Torque 20 N•m (54 lb-in.)

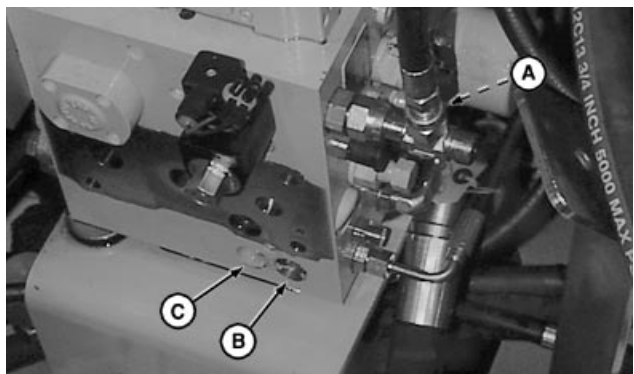

T110214 -UN-05AUG97

TX,33,DY2967 -19-26AUG97-1/1

Hydraulic System

Disassemble And Assemble Combined Function Shuttle Valve (Serial No. 556936—)

- Carefully remove parts (B—E and G—K). Replace as necessary.
- Install parts (B—E and G—K). Tighten plugs (A, F and L) to 20 N•m (54 lb-in.).

Specification

Combined Function Shuttle Valve
 Plug (556936—)—Torque 20 N•m (54 lb-in.)

- A—Plug
- B—O-Ring
- C—Spring Retainer
- D—Spring
- E—Ball
- F—Plug
- G—Spring Retainer
- H—Spring
- I—Spring Seat
- J—Spool
- K—O-Ring
- L—Plug

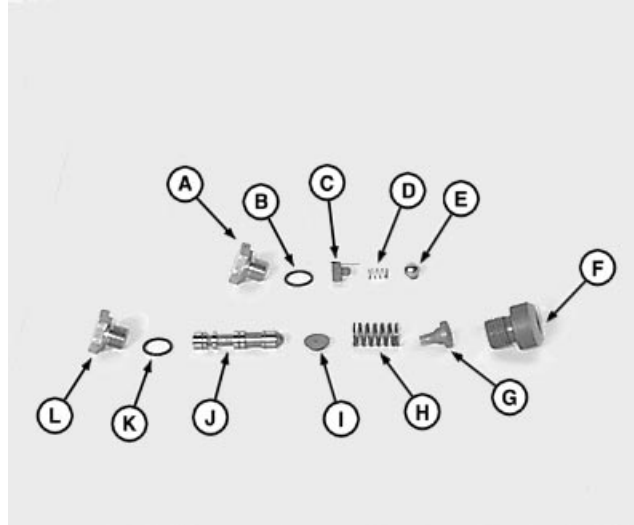

T110213 -JUN-05AUG97

33
 3360
 113

TX,3360,AB383 -19-20APR95-1/1

Hydraulic System

Remove And Install Pressure Control Manifold (Serial No. —556935)

1. Release pressure in hydraulic reservoir. Unlock hydraulic tank fill cap. Slowly turn cap to release air pressure.
2. Drain hydraulic reservoir. Approximate capacity is 148 L (39 gal).
3. Disconnect lines (A, B and D).
4. Remove manifold (E).
5. Repair or replace manifold as necessary. Note that valves in manifold are covered in other areas in this group.
6. Install manifold. Tighten cap screws to 120 N•m (88 lb-ft).

Specification

Mounting Cap Screw—Torque..... 120 N•m (88 lb-ft)

7. Connect lines.
8. Fill reservoir.

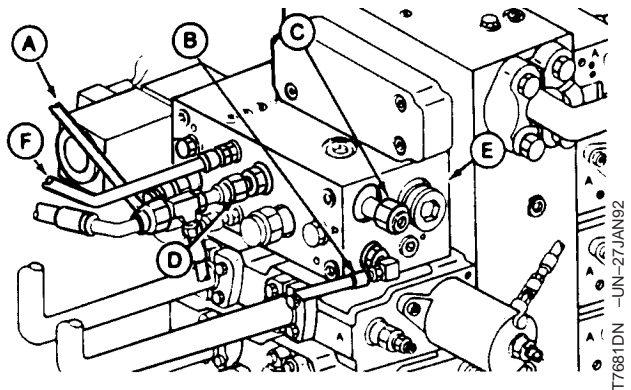

- A—Line From Propel Pilot Check Valve Block
 B—Load Sense-to-Pump Regulator Line
 C—Pilot Pressure Regulating Valve
 D—Pilot Filter and Dual Solenoid Block Line
 E—Pressure Control Manifold
 F—Pressure Control Manifold Line (Z2 Port)

TX,33,DY2968 —19-26AUG97-1/1

Disassemble And Assemble Load Sense System Relief Valve (Serial No. —556935)

NOTE: It is not necessary to remove pressure control manifold. Manifold removed for clarity of photograph.

1. Release pressure in hydraulic reservoir. Unlock hydraulic tank fill cap. Slowly turn cap to release air pressure.

Continued on next page

TX,33,DY2969 —19-26AUG97-1/2

Hydraulic System

33
3360
115

2. Remove parts (B—L). Measure distance of adjustment screw (L) to body (J) for proper assembly.
3. Inspect parts and replace as necessary.
4. Install new O-rings and backup ring.
5. Adjust valve. (See procedure in Group 9025-25.)

- A—Pressure Control Manifold
- B—O-Ring
- C—Poppet
- D—Backup Ring
- E—O-Ring
- F—Ring
- G—Retainer
- H—Spring
- I—Retainer
- J—Body
- K—Nut
- L—Adjustment Screw

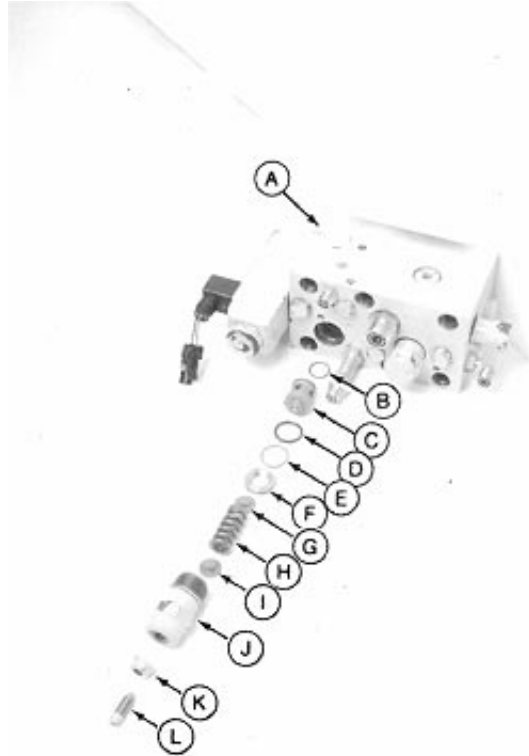

T7681DR -UN-27JAN92

TX,33,DY2969 -19-26AUG97-2/2

Remove And Install Load Sense System Relief Valve (Serial No. 556936—)

1. Release pressure in hydraulic reservoir. Unlock hydraulic tank fill cap. Slowly turn cap to release air pressure.
2. To gain access to relief valve, disconnect and tag hydraulic line (A).
3. Remove valve (B).
4. Replace parts as necessary.
5. Install valve. Tighten to 90—150 N•m (66—110 lb-ft).

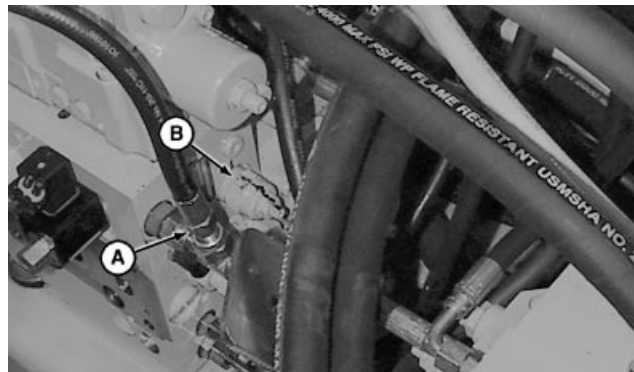

T110211 -UN-05AUG97

Specification

Load Sense Relief Valve Plug (556936—)—Torque..... 90—150 N•m (66—110 lb-ft)

6. Connect hydraulic line (A).
7. Adjust valve. (See procedure in Group 9025-25.)

TX,33,DY2970 -19-26AUG97-1/1

Hydraulic System

Disassemble And Assemble Load Sense System Relief Valve (Serial No. 556936—)

1. Release pressure in hydraulic reservoir. Unlock hydraulic tank fill cap. Slowly turn cap to release air pressure.

TX,33,DY2971 -19-26AUG97-1/2

2. Remove parts (A—H). Measure distance of adjustment screw (F) to body (D) to aid in assembly.
3. Inspect parts and replace as necessary.
4. Install new O-rings and seal.
5. Adjust valve. (See procedure in Group 9025-25.)

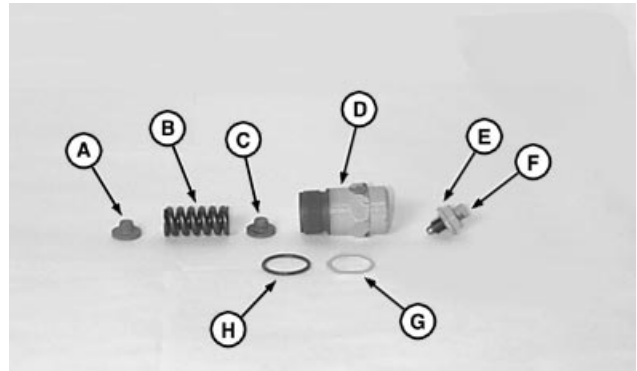

T110212 -UN-05AUG97

- A—Retainer (2 used)
- B—Spring
- C—Retainer
- D—Valve Body
- E—Nut
- F—Adjustment Screw
- G—Seal
- H—O-Ring

TX,33,DY2971 -19-26AUG97-2/2

Disassemble And Assemble Safety Valve (Serial No. —556935)

NOTE: It is not necessary to remove pressure control Manifold. Manifold removed for clarity of photograph.

1. Release pressure in hydraulic reservoir. Unlock hydraulic tank fill cap. Slowly turn cap to release air pressure.
2. Remove parts (A—E and G and H).
3. Inspect parts and replace as necessary.
4. Install parts. Tighten plug (A) to 80 N•m (59 lb-ft).

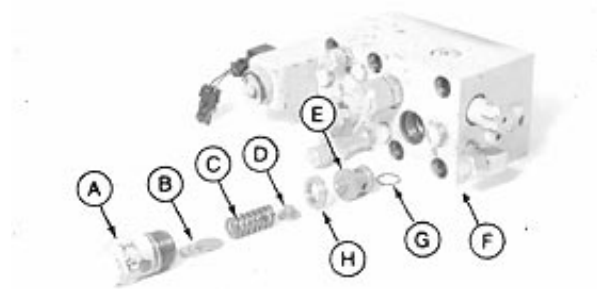

- A—Plug
- B—Shim (as required)
- C—Spring
- D—Keeper
- E—Valve
- F—Pressure Control Manifold
- G—O-Ring
- H—Insert

Specification

Circuit Relief and Anti-Cavitation
Valve (—556935)—Torque..... 80 N•m (59 lb-ft)

5. Adjust valve. (See procedure in Group 9025-25.)

TX,33,DY2972 -19-26AUG97-1/1

T7681DS -JUN-27JAN92

Disassemble And Assemble Pilot Pressure Regulating Valve (Serial No. —556935)

NOTE: It is not necessary to remove Pressure Control Manifold. Manifold removed for clarity of photograph.

1. Remove valve (D) from pressure control manifold (E).
2. Remove parts (A—C, F and G). Replace as necessary.
3. Install parts.
4. Adjust valve. (See procedure in Group 9025-25.)

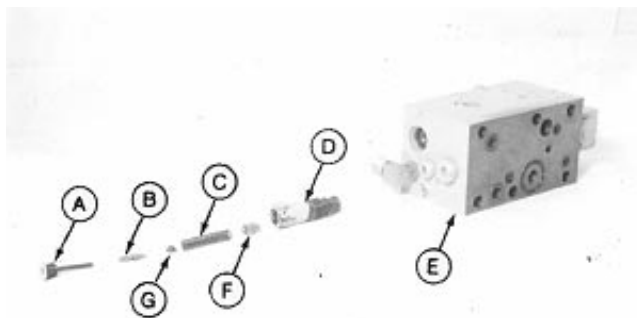

- A—Pin
- B—Shim (as required)
- C—Spring
- D—Valve
- E—Housing
- F—Piston
- G—Guide

TX,33,DY2973 -19-26AUG97-1/1

T7681DT -JUN-27JAN92

Hydraulic System

Remove And Install Pilot Pressure Regulating Valve (Serial No. 556936—)

1. Release pressure in hydraulic reservoir. Unlock hydraulic tank fill cap. Slowly turn cap to release air pressure.
2. Loosen locknut (A). Remove valve (B).
3. Replace parts as necessary.
4. Install valve. Tighten locknut (A) to 30—35 N•m (22—26 lb-ft).

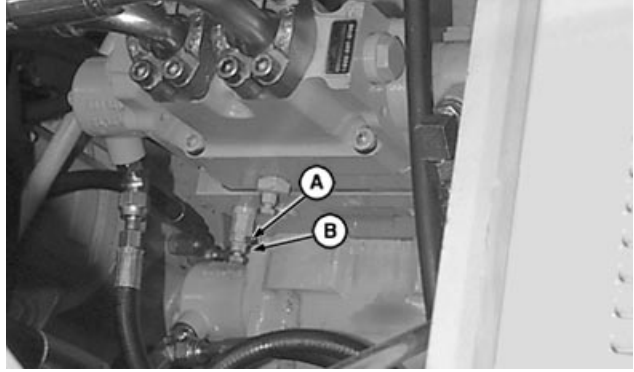

T110697 -UN-05AUG97

Specification

Pilot Pressure Regulating Valve
 (556936—)—Torque..... 30—35 N•m (22—26 lb-ft)

5. Adjust valve. (See procedure in Group 9025-25.)

TX,33,DY2974 -19-26AUG97-1/1

Disassemble And Assemble Pilot Pressure Regulating Valve (Serial No. 556936—)

1. Remove parts (A—J). Replace as necessary.
2. Install valve.
3. Adjust valve. (See procedure in Group 9025-25.)

- A—Valve Sleeve
- B—O-Ring
- C—O-Ring
- D—Valve
- E—Spring
- F—Retainer
- G—O-Ring
- H—Plug
- I—Nut
- J—Adjustment Screw

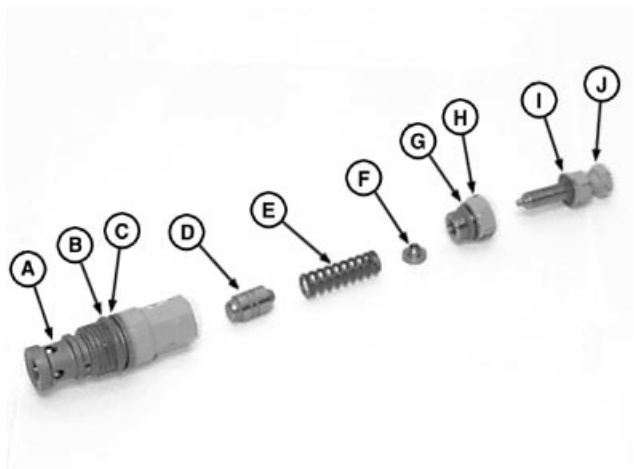

T110215 -UN-05AUG97

TX,33,DY2975 -19-26AUG97-1/1

Hydraulic System

Remove And Install Power Boost Solenoid Valve (Serial No. —556935)

NOTE: It is not necessary to remove pressure control manifold to remove solenoid valve. This was done for clarity of photograph.

1. Release pressure in hydraulic reservoir. Unlock hydraulic tank fill cap. Slowly turn cap to release air pressure.
2. Disconnect wiring lead.

TX,33,DY2976 -19-26AUG97-1/2

33
3360
119

3. Remove valve (A). Valve must be replaced as a complete assembly.
4. Install valve. Tighten cap screws to 120 N•m (88 lb-ft).
5. Connect wiring lead.

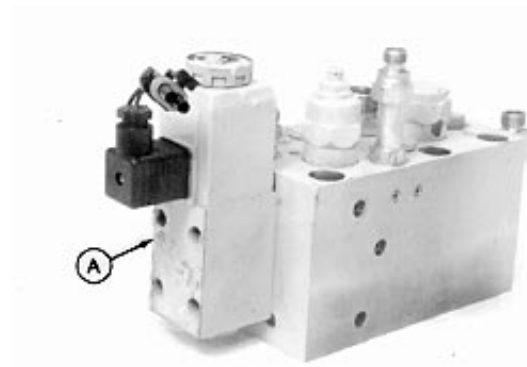

T7681DU -UN-27JAN92

TX,33,DY2976 -19-26AUG97-2/2

Remove And Install Power Boost Solenoid Valve (Serial No. 556936—)

NOTE: It is not necessary to remove boom control valve section. This was done for clarity of photograph.

1. Release pressure in hydraulic reservoir. Unlock hydraulic tank fill cap. Slowly turn cap to release air pressure.

Continued on next page

TX,33,DY2977 -19-26AUG97-1/2

Hydraulic System

2. Disconnect wiring lead.
3. Remove nut (A). Remove solenoid (B).
4. Remove valve. Valve must be replaced as a complete assembly.
5. Replace O-rings and seals. Install valve. Tighten valve to 50—55 N•m (36—40 lb-ft).

Specification

Power Boost Solenoid Valve—

Torque 50—55 N•m (36—40 lb-ft)

6. Install solenoid (B), tighten nut (A) to 8 N•m (71 lb-in.).

Specification

Solenoid Nut—Torque 8 N•m (71 lb-in.)

7. Connect wiring lead.

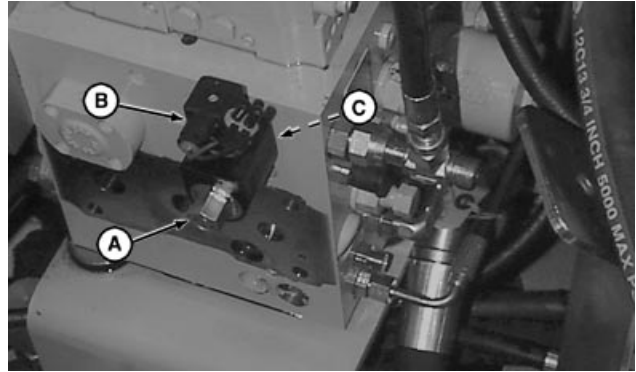

T110216 -UN-05AUG97

TX,33,DY2977 -19-26AUG97-2/2

Remove And Install Circuit Relief And Anti-Cavitation Valves (Serial No. —556935)

NOTE: It is not necessary to remove valve sections to remove valves. Valve section removed for clarity of photograph.

Circuit relief and anti-cavitation valves are used in boom, arm, and bucket valve sections.

1. Release pressure in hydraulic reservoir. Unlock hydraulic tank fill cap. Slowly turn cap to release air pressure.

Continued on next page

TX,33,DY2978 -19-26AUG97-1/2

Hydraulic System

2. Remove valve. Valve cannot be repaired. It must be replaced. Install new O-ring (A).

3. Install valve. Tighten to 80 N•m (59 lb-ft).

Specification

Circuit Relief and Anti-Cavitation
 Valve (—556935)—Torque..... 80 N•m (59 lb-ft)

4. Adjust valve. (See procedure in Group 9025-25.)



33
3360
121

T7681DV -UN-27JAN92

TX,33,DY2978 -19-26AUG97-2/2

Remove And Install Bucket Circuit Relief And Anti-Cavitation Valves (Serial No. 556936—)

NOTE: Circuit relief and anti-cavitation valves used in bucket valve section are located in the monoblock control valve manifold.

1. Release pressure in hydraulic reservoir. Unlock hydraulic tank fill cap. Slowly turn cap to release air pressure.

TX,33,DY2983 -19-27AUG97-1/2

2. Remove valve (C). Valve cannot be repaired. It must be replaced. Install new O-rings (A and B).

3. Install valve. Tighten to 80 N•m (59 lb-ft).

Specification

Circuit Relief and Anti-Cavitation
 Valve (—556935)—Torque..... 80 N•m (59 lb-ft)

4. Adjust valve. (See procedure in Group 9025-25.)

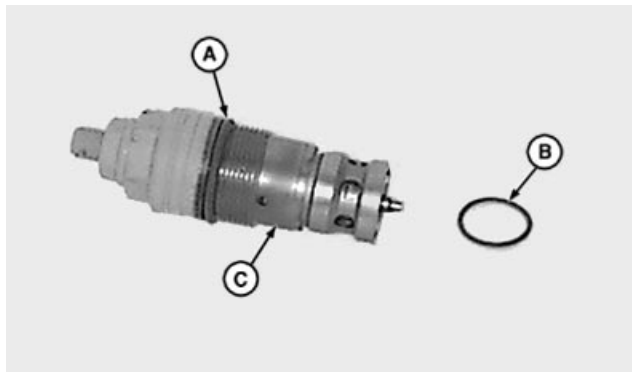

T110700 -UN-05AUG97

TX,33,DY2983 -19-27AUG97-2/2

Hydraulic System

Disassemble And Assemble Boom, Arm, And Bucket Valve Section (Serial No. —556935)

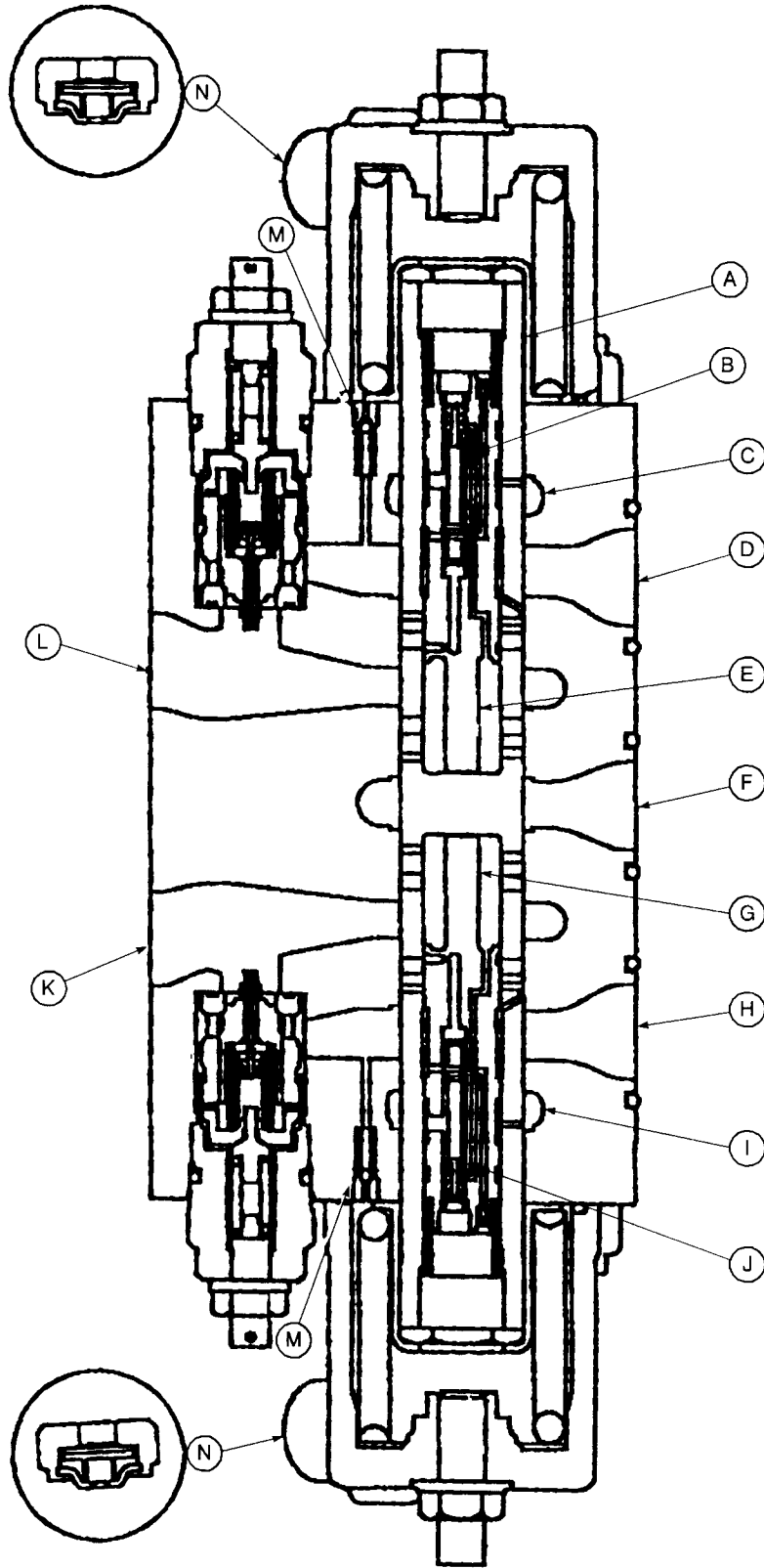

T844BAF (CV)

T844BAF -UN-11APR95

Continued on next page

TX,33,DY2979 -19-26AUG97-1/8

Hydraulic System

33
3360
123

- | | | | |
|----------------------|------------------|----------------------|---|
| A—Spool | E—Balance Valve | I—Load Sense Passage | M—Pilot Cap Relief Valve (Air Bleed Valve) (2 used) |
| B—Shuttle Valve | F—Pump Supply | J—Shuttle Valve | N—Pilot Check Valve |
| C—Load Sense Passage | G—Balance Valve | K—Work Port | |
| D—Return Passage | H—Return Passage | L—Work Port | |

Tighten pilot cap relief valves (M) to 6 N•m (55 lb-in.).

Specification

Pilot Cap Relief Valve—Torque..... 6 N•m (55 lb-in.)

TX,33,DY2979 -19-26AUG97-2/8

NOTE: Pilot check valve is used only on boom valves.

1. Remove parts (A—J) from both ends of valve.

IMPORTANT: Spool and valve section is a matched set. Spool is fitted to a bore and must be installed with the same end towards the same end of housing.

2. Inspect spool and bore for scratches, gouges, or excessive wear. Minor surface damage may be removed using crocus cloth. If badly damaged, replace valve section.

3. Check spring (C).

IMPORTANT: Disassemble spool only for cleaning. Replacement parts are not available.

4. Install spool in DFT1108 Spool Holding Fixture. (See Section 99 for instruction to make tool.) Clamp in vise.

- A—O-Ring
- B—Shim (as required)
- C—Spring
- D—Cap
- E—Housing
- F—Spool
- G—Cover
- H—Cap Screw (2 used)
- I—Nut
- J—Spool Stop Screw

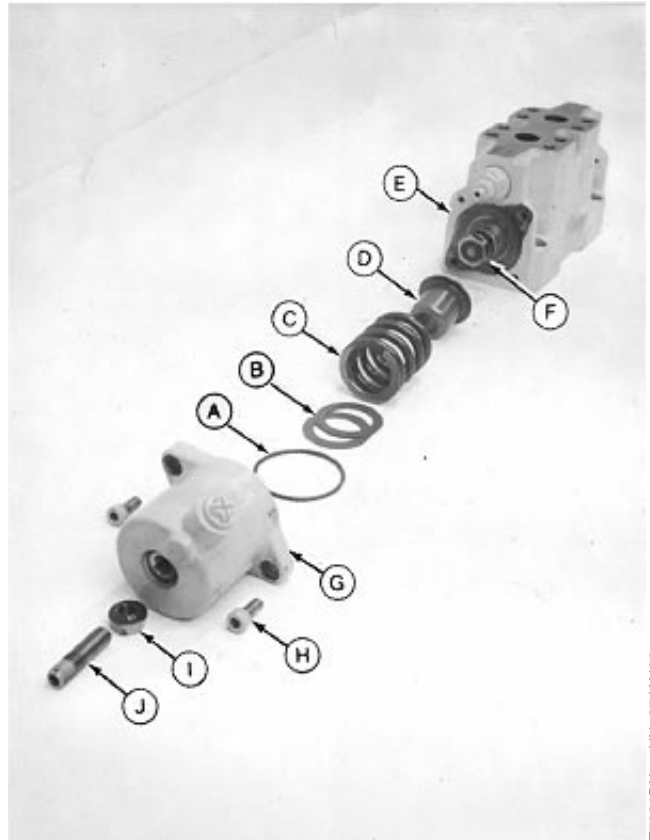

T7681DX -JUN-27JAN92

Continued on next page

TX,33,DY2979 -19-26AUG97-3/8

Hydraulic System

5. Remove plugs (A) from each end of spool.

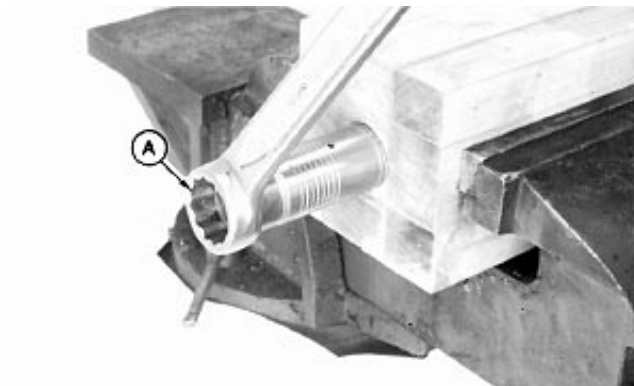

T7681DY -UN-27JAN92

TX,33,DY2979 -19-26AUG97-4/8

6. Remove springs (B) and balance valves (C).

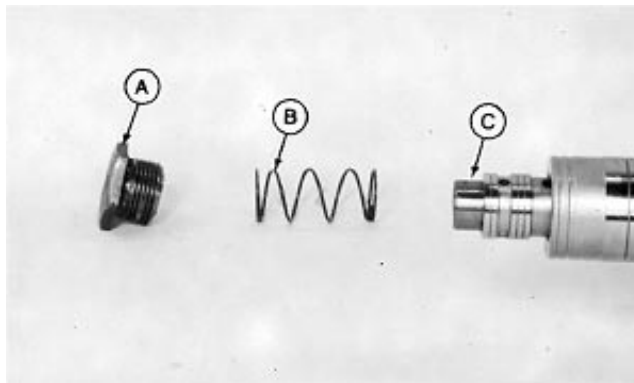

T7681DZ -UN-27JAN92

TX,33,DY2979 -19-26AUG97-5/8

7. Remove plug (A) and shuttle valve (B) from balance valve (C). Hold the balance valve in a vise by the stem end. Clean parts.

Apply thread lock and sealer (medium strength) to threads of plug.

Tighten plug to 10 N•m (90 lb-in.).

Specification

Balance Valve Plug—Torque 10 N•m (90 lb-in.)

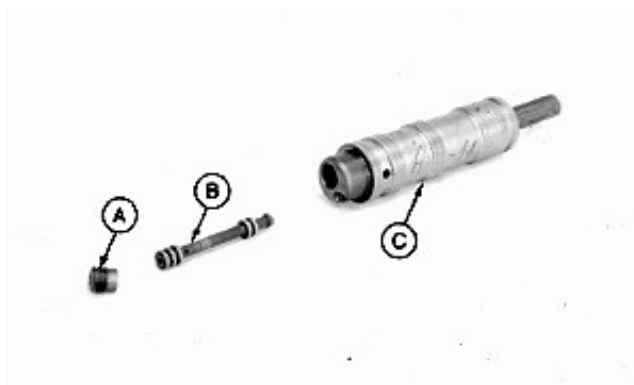

T7681EA -UN-27JAN92

Continued on next page

TX,33,DY2979 -19-26AUG97-6/8

Hydraulic System

8. Apply thread lock and sealer (medium strength) to threads of plug (A).

9. Install valve (C), spring (B), and plug (A).

Tighten plug to 100 N•m (75 lb-ft).

Specification

Spool Plug—Torque 100 N•m (75 lb-ft)

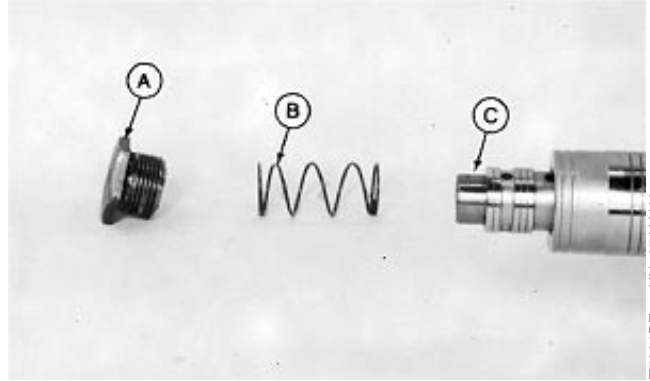

33
3360
125

T7681DZ -UN-27JAN92

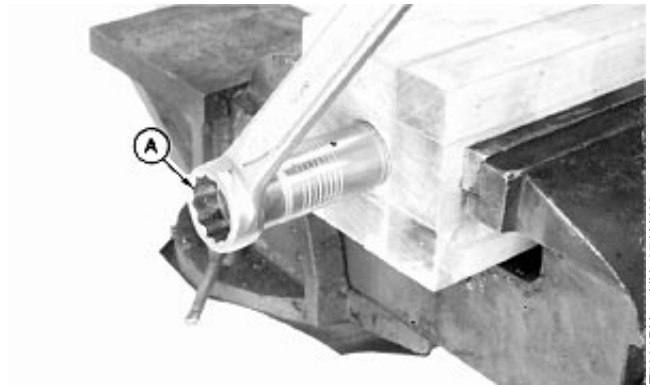

T7681DY -UN-27JAN92

Continued on next page

TX,33,DY2979 -19-26AUG97-7/8

Hydraulic System

10. Install parts (A—J).

Install spool so end with extra groove is towards “B” end of valve section.

NOTE: Letters “A” and “B” are cast on ends of valve section.

11. Tighten cap screws (H) to 25 N•m (18 lb-ft).

Specification

Valve cover-to-Housing Cap
Screw—Torque..... 25 N•m (18 lb-ft)

12. Adjust spool stop screws (J). (See procedure in this group.) Tighten nut (I) to 60 N•m (45 lb-ft).

Specification

Spool Stop Screw Nut—Torque..... 60 N•m (45 lb-ft)

- A—O-Ring
- B—Shim (as required)
- C—Spring
- D—Cap
- E—Housing
- F—Spool
- G—Cover
- H—Cap Screw (2 used)
- I—Nut
- J—Spool Stop Screw

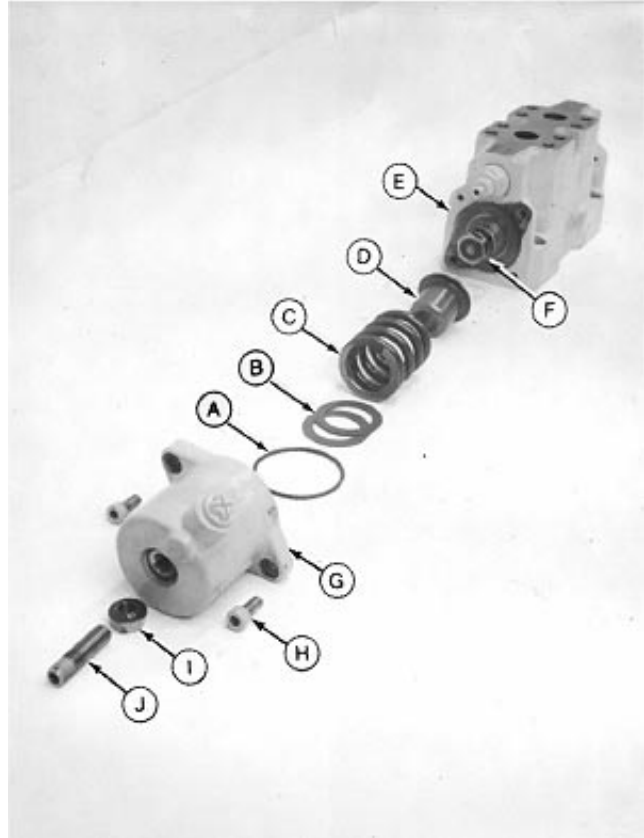

T7681DX -UN-27JAN92

TX,33,DY2979 -19-26AUG97-8/8

Disassemble And Assemble Swing Valve Section

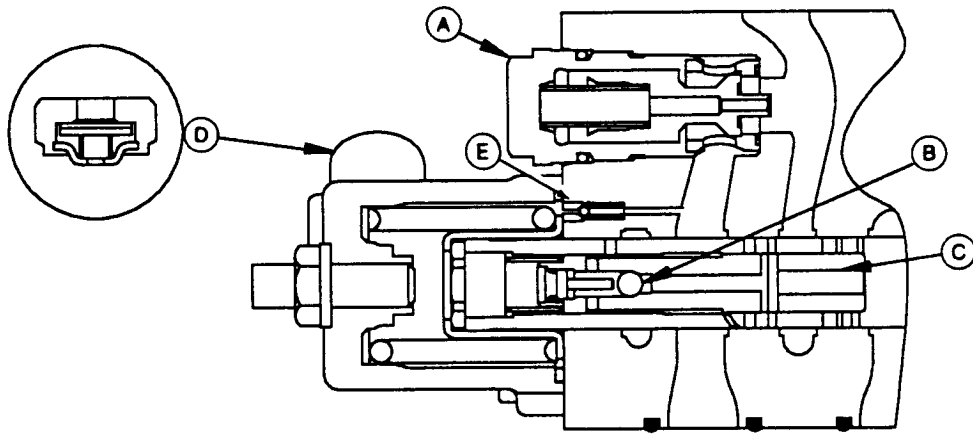

A—Make-Up Valve
B—Ball

C—Balance Valve

D—Pilot Check Valve

E—Pilot Cap Relief Valve (Air Bleed Valve)

Tighten pilot check valve (D) to 9 N•m (80 lb-in.).

Tighten pilot cap relief valve (E) to 6 N•m (55 lb-in.).

Specification

Pilot Check Valve—Torque 9 N•m (80 lb-in.)

Specification

Pilot Cap Relief Valve—Torque..... 6 N•m (55 lb-in.)

Continued on next page

TX,3360,AB397 -19-20APR95-1/6

T7681EC -UN-27JAN92

Hydraulic System

1. Remove parts (A—J) from both ends of valve.

IMPORTANT: Spool and valve section is a matched set. Spool is fitted to a bore and must be installed with same end towards the same end of housing.

2. Inspect spool and bore for scratches, gouges, or excessive wear. Minor surface damage may be removed using crocus cloth. If badly damaged, replace valve section.

3. Check spring (C).

IMPORTANT: Disassemble spool only for cleaning. Replacement parts are not available.

4. Install spool in DFT1077 Spool Holding Fixture. (See Section 99 for instruction to make tool.) Clamp in vise.

- A—O-Ring
- B—Shim (as required)
- C—Spring
- D—Cap
- E—Housing
- F—Spool
- G—Cover
- H—Cap Screw (2 used)
- I—Nut
- J—Spool Stop Screw

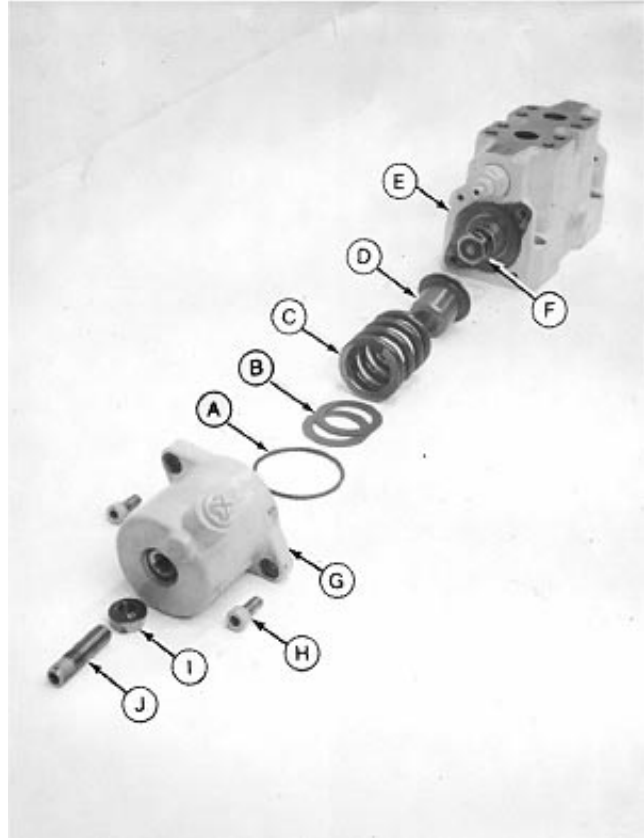

T7681DX -UN-27JAN92

Continued on next page

TX,3360,AB397 -19-20APR95-2/6

Hydraulic System

5. Remove plugs (A) from each end of spool.
6. Remove springs (B) and balance valves (C).

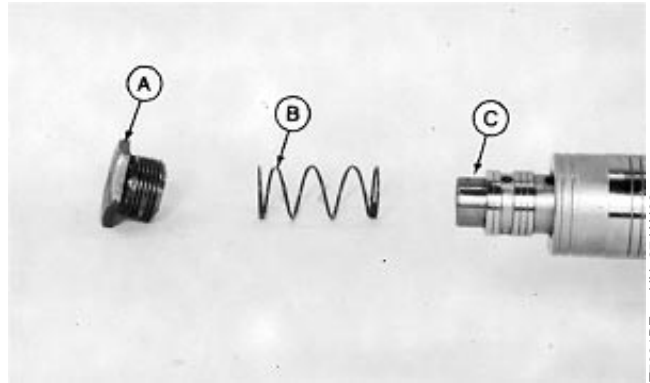
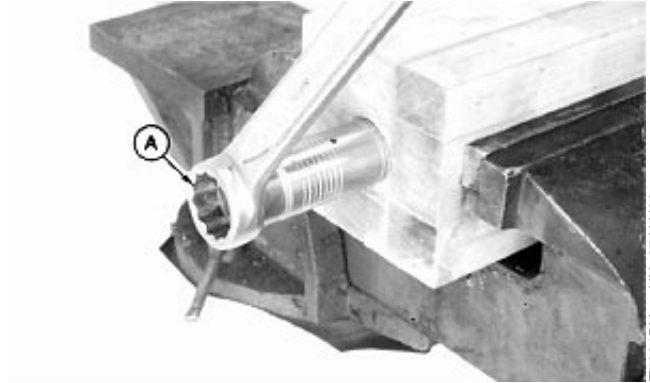

TX,3360,AB397 -19-20APR95-3/6

7. Remove plug (C) and ball (B) from balance valve (A). Hold the balance valve in a vise by the stem end. Clean parts.

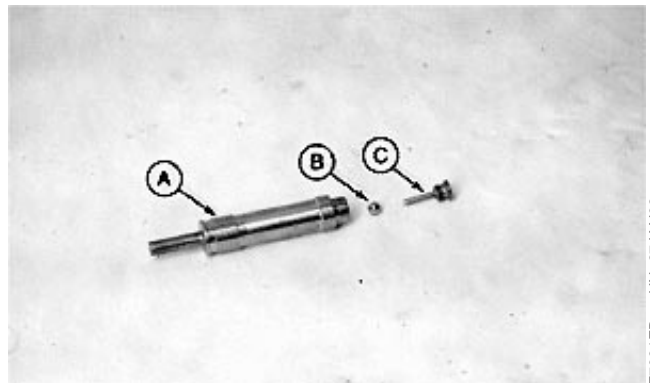

Continued on next page

TX,3360,AB397 -19-20APR95-4/6

Hydraulic System

8. Apply thread lock and sealer (medium strength) to threads of plug (A).

9. Install valve (C), spring (B), and plug (A).

Tighten plug to 60 N•m (45 lb-ft).

Specification

Spool Stop Screw Nut—Torque..... 60 N•m (45 lb-ft)

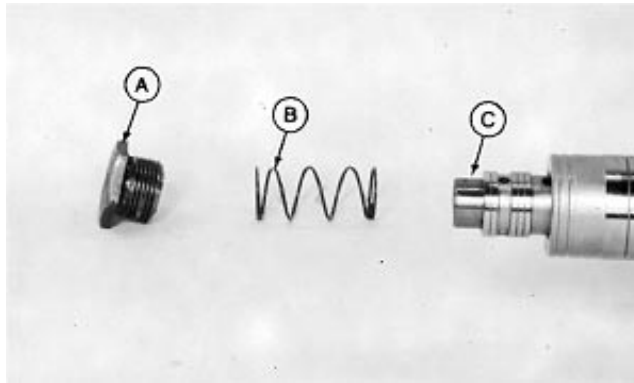

T7681DZ -UN-27JAN92

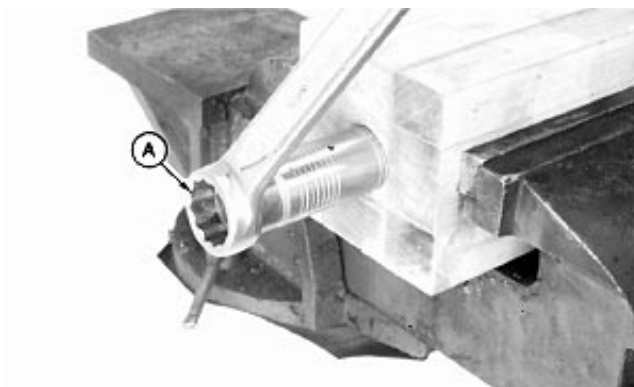

T7681DY -UN-27JAN92

Continued on next page

TX,3360,AB397 -19-20APR95-5/6

33
3360
130

Hydraulic System

33
3360
131

10. Install parts (A—J).

Install spool so end with extra groove is towards “B” end of valve section.

NOTE: Letters “A” and “B” are cast on ends of valve section.

11. Tighten cap screws (H) to 25 N•m (18 lb-ft).

Specification

Valve Cover-to-Housing Cap

Screw—Torque..... 25 N•m (18 lb-ft)

12. Adjust spool stop screws (J). (See procedure in this group.) Tighten nut (I) to 60 N•m (45 lb-ft).

Specification

Valve Cover-to-Housing Cap

Screw—Torque..... 60 N•m (45 lb-ft)

- A—O-Ring
- B—Shim (as required)
- C—Spring
- D—Cap
- E—Housing
- F—Spool
- G—Cover
- H—Cap Screw (2 used)
- I—Nut
- J—Spool Stop Screw

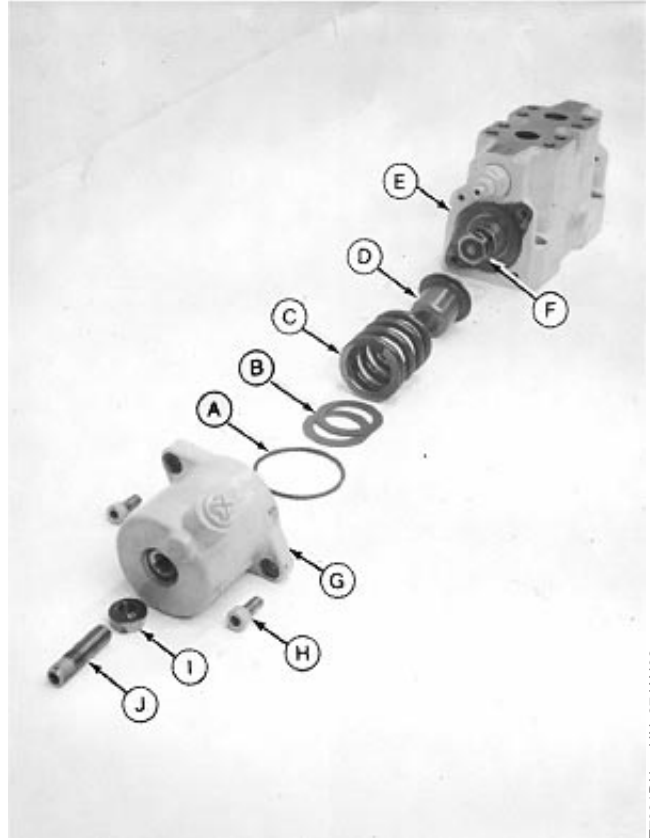

T7681DX -UN-27JAN92

TX,3360,AB397 -19-20APR95-6/6

Hydraulic System

Disassemble And Assemble Propel Valve Section (Serial No. —556935)

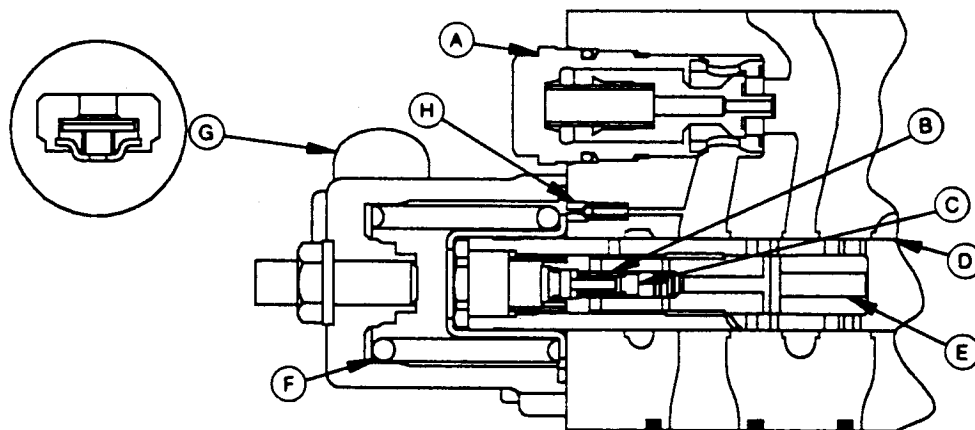

A—Make-Up Valve
B—Spring
C—Poppet

D—Spool
E—Balance Valve
F—Spring

G—Pilot Check Valve (2 used)
(Serial No. —543989)

H—Pilot Cap Relief Valve (Air
Bleed Valve) (2 used)

Tighten pilot check valve (G) to 9 N•m (80 lb-in.).

Tighten pilot cap relief valve (H) to 6 N•m (55 lb-in.).

Specification

Pilot Check Valve—Torque 9 N•m (80 lb-in.)

Specification

Pilot Cap Relief Valve—Torque..... 6 N•m (55 lb-in.)

Continued on next page

TX,33,DY2980 -19-26AUG97-1/6

T7681ED -UN-27JAN92

Hydraulic System

NOTE: On machines (Serial No. 543990—556936), pilot check valves have been changed to plate type orifices. Install between fitting and T-fitting for hose to pilot controller.

1. Remove parts (A—J) from both ends of valve.

IMPORTANT: Spool and valve is a matched set. Spool is fitted to a bore and must be installed with same end towards the same end of housing.

2. Inspect spool and bore for scratches, gouges, or excessive wear. Minor surface damage may be removed using crocus cloth. If badly damaged, replace valve section.

3. Check spring (C).

IMPORTANT: Disassemble spool only for cleaning. Replacement parts are not available.

4. Install spool in DFT1077 Spool Holding Fixture. (See Section 99 for instruction to make tool.) Clamp in vise.

- A—O-Ring
- B—Shim (as required)
- C—Spring
- D—Cap
- E—Housing
- F—Spool
- G—Cover
- H—Cap Screw (2 used)
- I—Nut
- J—Spool Stop Screw

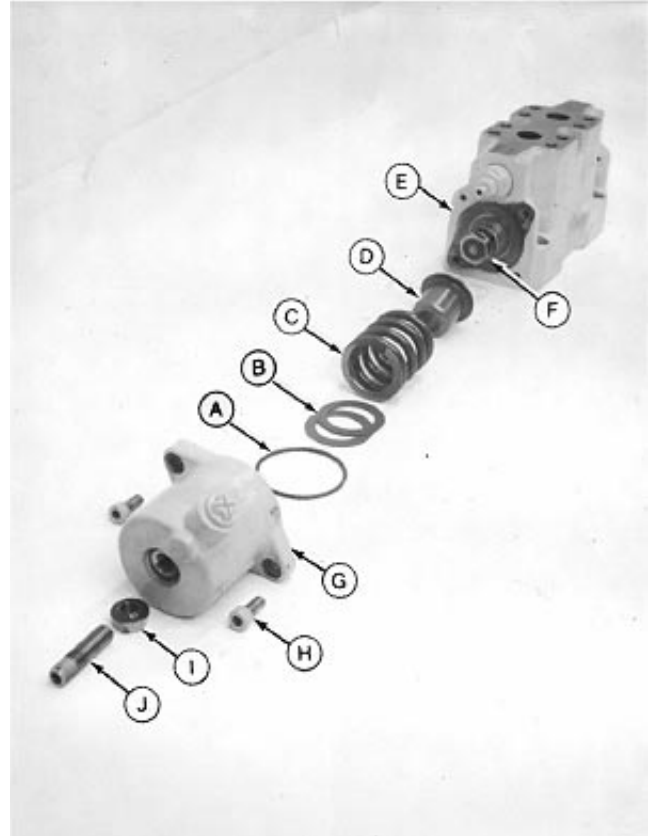

33
3360
133

T7681DX -UN-27JAN92

Continued on next page

TX,33,DY2980 -19-26AUG97-2/6

Hydraulic System

5. Remove plugs (A) from each end of spool.
6. Remove springs (B) and balance valves (C).

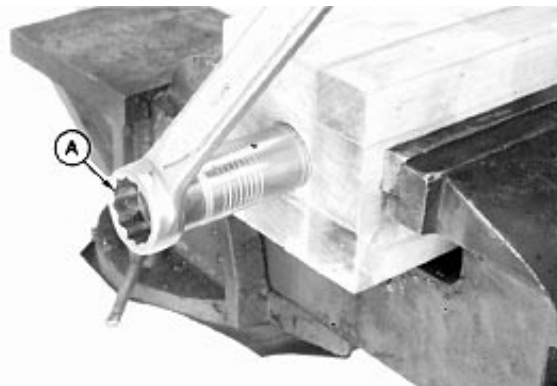

T7681DY -UN-27JAN92

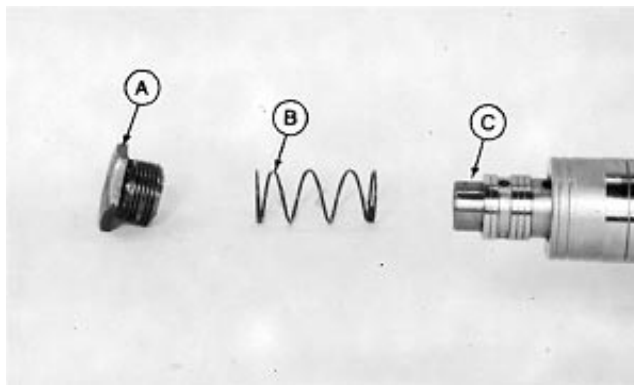

T7681DZ -UN-27JAN92

TX,33,DY2980 -19-26AUG97-3/6

7. Disassemble parts (A—F). Hold the balance valve in a vise by the stem end.
8. Clean parts and install.
9. Apply thread lock and sealer (medium strength) to threads of plug. Tighten plug (E) to 10 N•m (90 lb-in.).

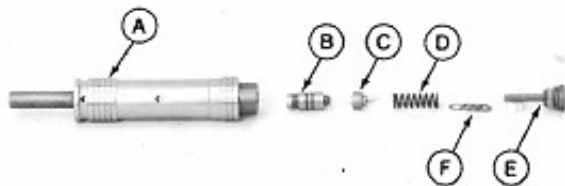

T7681EE -UN-27JAN92

Specification

Balance Valve Plug—Torque 10 N•m (90 lb-in.)

- A—Balance Valve
- B—Poppet
- C—Retainer
- D—Spring
- E—Plug
- F—Shims

Continued on next page

TX,33,DY2980 -19-26AUG97-4/6

Hydraulic System

33
3360
135

10. Apply thread lock and sealer (medium strength) to threads of plug (A).

11. Install valve (C), spring (B), and plug (A).

Tighten plug to 60 N•m (45 lb-ft).

Specification

Spool Plug—Torque 60 N•m (45 lb-ft)

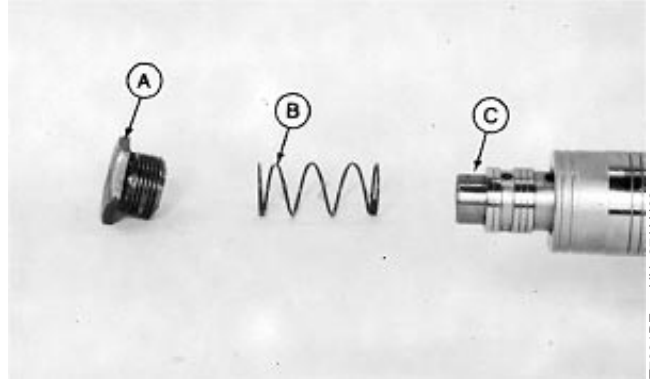

T7681DZ -UN-27JAN92

TX,33,DY2980 -19-26AUG97-5/6

12. Install parts (A—J).

Install spool so end with extra groove is towards “B” end of valve section.

NOTE: Letters “A” and “B” are cast on ends of valve section.

13. Tighten cap screws (H) to 25 N•m (18 lb-ft).

Specification

Valve Cover-to-Housing Cap Screw—Torque 25 N•m (18 lb-ft)

14. Adjust spool stop screws (J). (See procedure in this group.) Tighten nut (I) to 60 N•m (45 lb-ft).

Specification

Spool Stop Screw Nut—Torque 60 N•m (45 lb-ft)

- A—O-Ring
- B—Shim (as required)
- C—Spring
- D—Cap
- E—Housing
- F—Spool
- G—Cover
- H—Cap Screw (2 used)
- I—Nut
- J—Spool Stop Screw

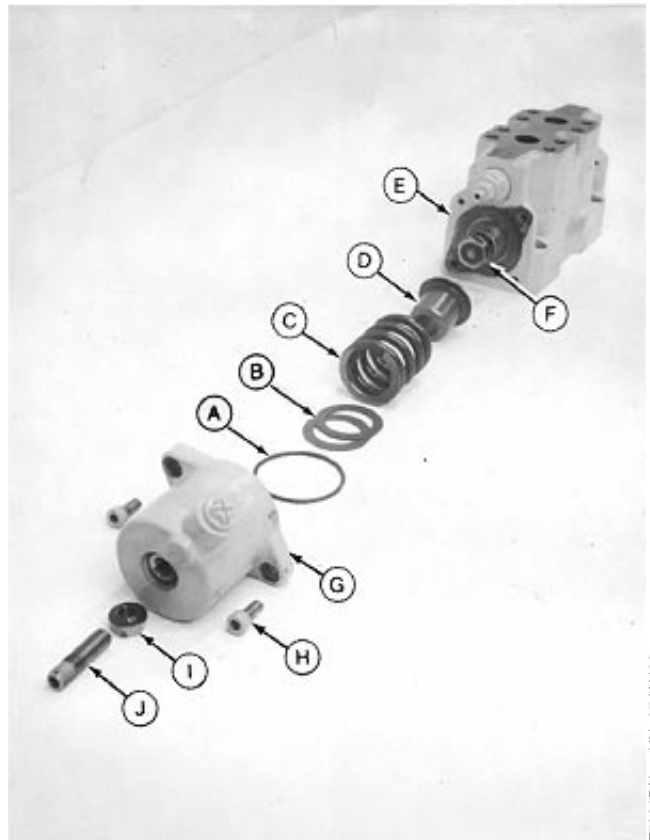

T7681DX -UN-27JAN92

TX,33,DY2980 -19-26AUG97-6/6

Disassemble And Assemble Boom, Arm, And Swing Control Valve (Serial No. 556936—)

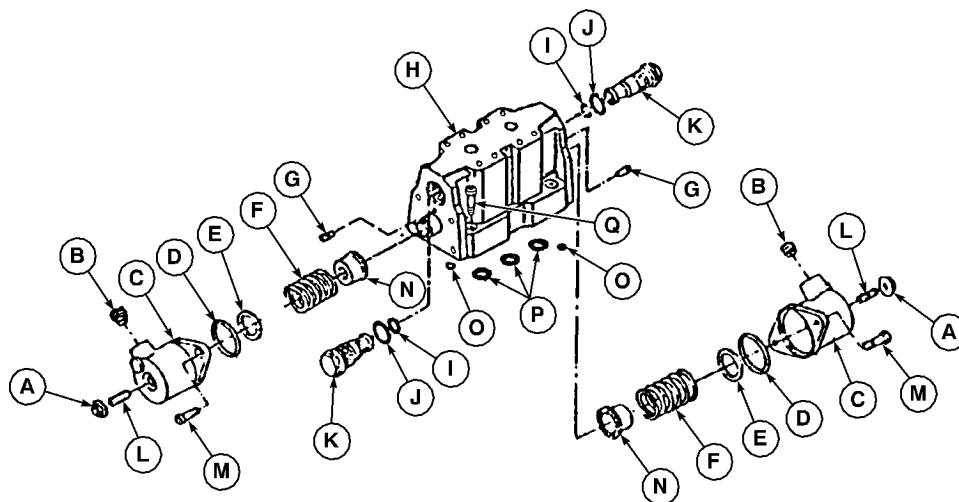

T109788

Valve Shown Removed From Manifold

- | | | | |
|----------------------|-----------------------------------|-----------------------------|----------------------|
| A—Nut (2 used) | F—Spring (2 used) | J—O-Ring (2 used) | N—Cap (2 used) |
| B—Fitting (2 used) | G—Pilot Cap Relief Valve (2 used) | K—Check Valve (2 used) | O—O-Ring (2 used) |
| C—Cover (2 used) | H—Housing | L—Spool Stop Screw (2 used) | P—O-Ring (3 used) |
| D—O-Ring (2 used) | I—O-Ring (2 used) | M—Cap Screw (4 used) | Q—Cap Screw (4 used) |
| E—Shim (as required) | | | |

T109788 -UN-05AUG97

TX,33,DY2962 -19-26AUG97-1/1

Remove And Install Make-Up Valve (Serial No. —556935)

Make-up valve cannot be repaired. It must be replaced as a complete assembly. Valve cannot be disassembled and assembled.

Continued on next page

TX,33,DY2981 -19-26AUG97-1/2

Hydraulic System

Inspect O-ring (A) and valve (B). Replace as necessary.

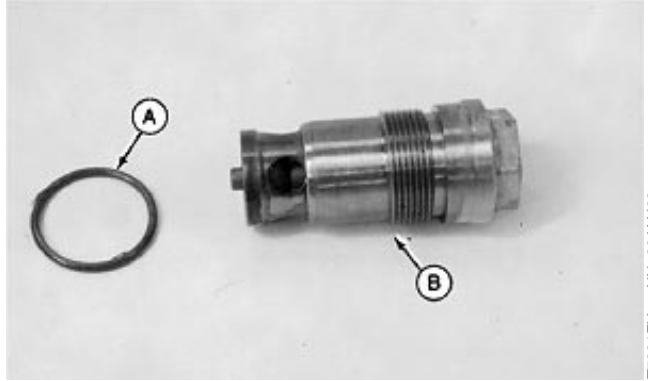

33
3360
137

T7681EY -UN-23JAN92

TX,33,DY2981 -19-26AUG97-2/2

Remove And Install Propel Circuit Make-Up Valve (Serial No. 556936—)

NOTE: Propel circuit make-up valves used in propel valve section are located in the monoblock control valve manifold.

1. Make-up valve cannot be repaired. It must be replaced as a complete assembly. Valve cannot be disassembled and assembled.
2. Inspect O-rings (A and B) and valve (C). Replace as necessary.
3. Tighten valve (C) to 80 N•m (59 lb-ft).

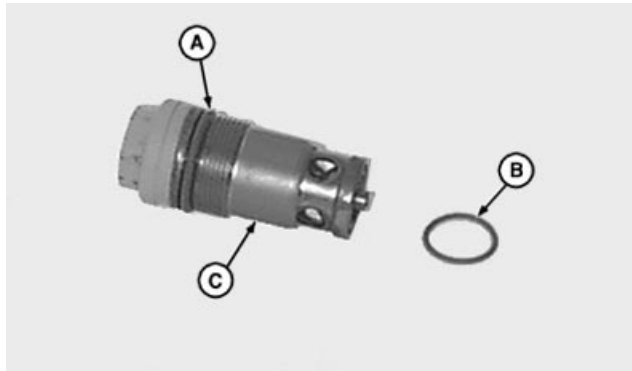

T110699 -UN-05AUG97

Specification

Propel Circuit Make-Up Valve
Plug (556936—)—Torque 80 N•m (59 lb-ft)

TX,33,DY2984 -19-27AUG97-1/1

Disassemble And Assemble Auxiliary Valve Section (Serial No. —556935)

For a section with a motor spool, see propel valve section for repair.

For a section with a cylinder spool, see boom valve section for repair.

TX,33,DY2982 -19-26AUG97-1/1

Hydraulic System

**Remove And Install Monoblock Control Valve
(Serial No. 556936—)**

NOTE: Left propel, right propel, and bucket valve sections are incorporated into the monoblock control configuration.

1. Lower equipment to ground.
2. Release pressure in hydraulic reservoir. Loosen hydraulic tank fill cap. Slowly turn cap to release air pressure.
3. Drain reservoir. Approximate capacity is 151 L (40 gal).

Continued on next page

TX,33,DW5002 -19-16JUL97-1/6

Hydraulic System



CAUTION: To avoid injury from escaping fluid under pressure, stop engine and relieve the pressure in the system before disconnecting or connecting hydraulic or other lines. Tighten all connections before applying pressure.

NOTE: Hydraulic lines A, B, O, and P contain orifices. Use caution when disconnecting lines.

4. Disconnect and cap hydraulic lines (A—D), then (E—H); and remove flanges. Label lines to aid in installation.

- A—Propel Left Reverse Return Loop
T-Fitting-to-Propel Pilot Check Valve Block
Bottom Right Port Line
- B—Propel Right Reverse Return Loop
T-Fitting-to-Propel Pilot Check Valve Block
Bottom Left Port Line
- C—Bucket Curl Valve Pilot Cap Port-to-Dig Pilot
Check Valve I1 Port Line
- D—Monoblock Control Valve LSA Port-to-Boom, Arm,
Swing Main Control Valve LSA Port Line
- E—Left Propel Valve A Port-to-Rotary Manifold #1
Port Line
- F—Right Propel Valve A Port-to-Rotary Manifold #3
Port Line
- G—Left Propel Valve B Port-to-Rotary Manifold #2
Port Line
- H—Right Propel Valve B Port-to-Rotary Manifold #4
Port Line
- I—Monoblock Control Valve LS Port-to-Boom, Arm,
Swing Main Control Valve Bottom Forward
T-Fitting Port Line
- J—Monoblock Control Valve Pressure Port-to-Boom,
Arm, Swing Main Control Valve Bottom Rear Port
Line
- K—Bucket Valve-to-Cylinder Rod End Port Line
- L—Monoblock Control Valve Bottom Forward
Port-to-Swing Motor U Port Line
- M—Bucket Valve-to-Cylinder Head End Port Line
- N—Bucket Dump Valve Bottom Pilot Cap-to-Dig Pilot
Check Valve J1 Port Line
- O—Right Forward Propel Pilot End Cap-to-Dig Pilot
Check Valve I1 Port Line
- P—Left Forward Propel Pilot End Cap-to-Dig Pilot
Check Valve J1 Port Line
- Q—Monoblock Control Valve Rear Feed Port-to-Main
Hydraulic Pump Top Rear Port Line
- R—Monoblock Control Valve Bottom Rear
Port-to-Return Manifold Rear Left Port Line

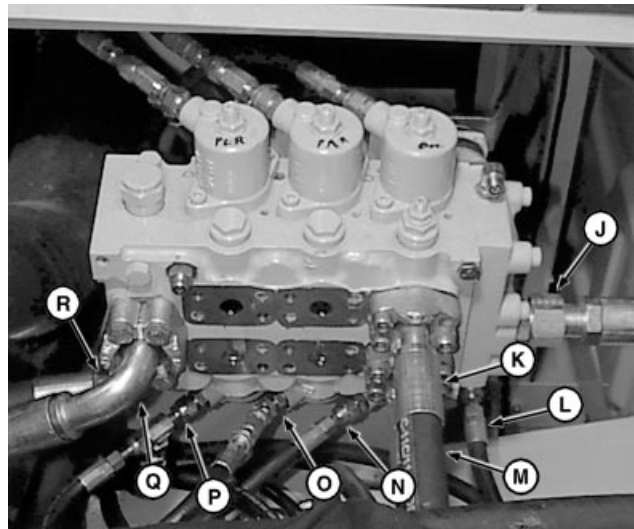
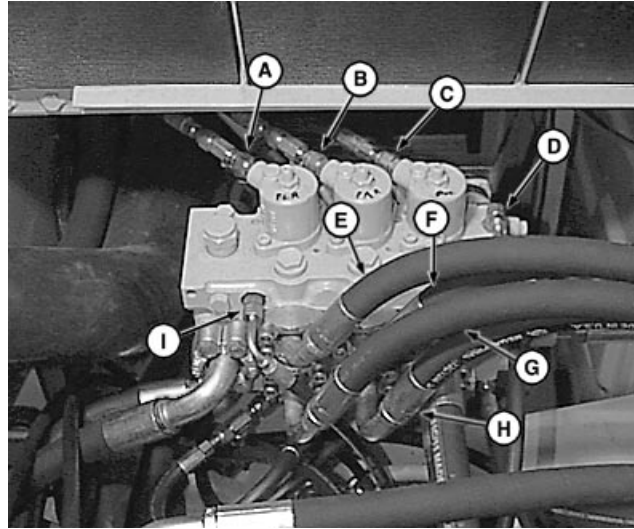

Hydraulic Lines Removed For Clarity

33
3360
139

T110436 -UN-05AUG97

T110435 -UN-05AUG97

Hydraulic System

5. Disconnect and cap hydraulic lines (I—R). Label lines to aid in installation.

TX,33,DW5002 -19-16JUL97-3/6

6. Remove and plug hydraulic line (B).

CAUTION: Use suitable lifting device for heavy components.

7. Remove cap screws (A). Remove monoblock.
8. Repair or replace parts as necessary.
9. Install new O-rings.

- A—Cap Screw (3 used)
- B—Monoblock Control Valve Right Rear
Port-to-Boom, Arm, Swing Main Control Valve
Right Rear Port Line

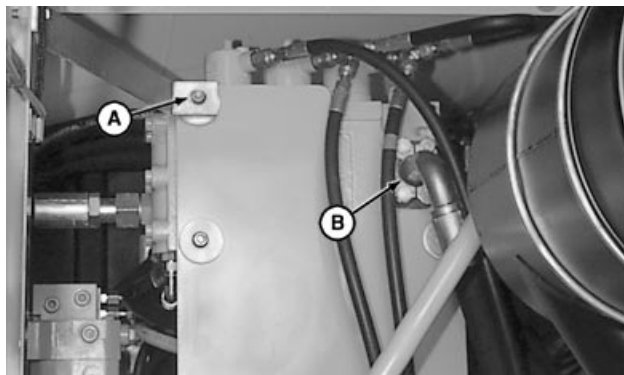

T110437 -UN-05AUG97

TX,33,DW5002 -19-16JUL97-4/6

10. Install monoblock control valve. Tighten mounting cap screws (A) to 75 N•m (55 lb-ft).

Specification

Mounting Cap Screws—Torque 75 N•m (55 lb-ft)

11. Install hydraulic line (B).

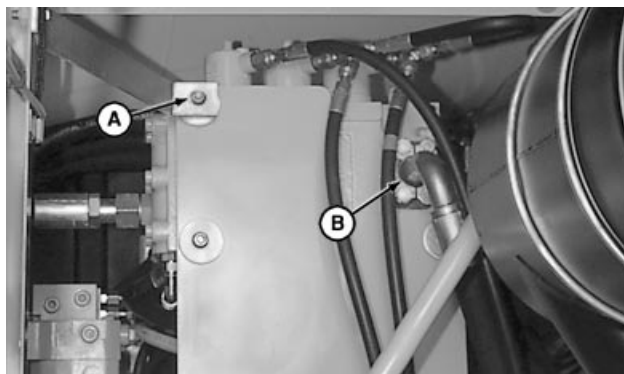

T110437 -UN-05AUG97

Continued on next page

TX,33,DW5002 -19-16JUL97-5/6

Hydraulic System

12. Connect hydraulic lines (J—R), then (A—I) and install flanges.
13. Fill reservoir. Approximate capacity is 151 L (40 gal).
(See Hydraulic Oil in Group 0004.)

Specification

Reservoir—Capacity..... 151 L (40 gal)

- A—Propel Left Reverse Return Loop
T-Fitting-to-Propel Pilot Check Valve Block
Bottom Right Port Line
- B—Propel Right Reverse Return Loop
T-Fitting-to-Propel Pilot Check Valve Block
Bottom Left Port Line
- C—Bucket Curl Valve Pilot Cap Port-to-Dig Pilot
Check Valve I1 Port Line
- D—Monoblock Control Valve LSA Port-to-Boom, Arm,
Swing Main Control Valve LSA Port Line
- E—Left Propel Valve A Port-to-Rotary Manifold #1
Port Line
- F—Right Propel Valve A Port-to-Rotary Manifold #3
Port Line
- G—Left Propel Valve B Port-to-Rotary Manifold #2
Port Line
- H—Right Propel Valve B Port-to-Rotary Manifold #4
Port Line
- I—Monoblock Control Valve LS Port-to-Boom, Arm,
Swing Main Control Valve Bottom Forward
T-Fitting Port Line
- J—Monoblock Control Valve Pressure Port-to-Boom,
Arm, Swing Main Control Valve Bottom Rear Port
Line
- K—Bucket Curl Valve-to-Cylinder Rod End Port Line
- L—Monoblock Control Valve Bottom Forward
Port-to-Swing Motor U Port Line
- M—Bucket Dump Valve-to-Cylinder Head End Port
Line
- N—Bucket Dump Valve Bottom Pilot Cap-to-Dig Pilot
Check Valve J1 Port Line
- O—Right Forward Propel Pilot End Cap-to-Dig Pilot
Check Valve I1 Port Line
- P—Left Forward Propel Pilot End Cap-to-Dig Pilot
Check Valve J1 Port Line
- Q—Monoblock Control Valve Rear Feed Port-to-Main
Hydraulic Pump Top Rear Port Line
- R—Monoblock Control Valve Bottom Rear
Port-to-Return Manifold Rear left Port Line

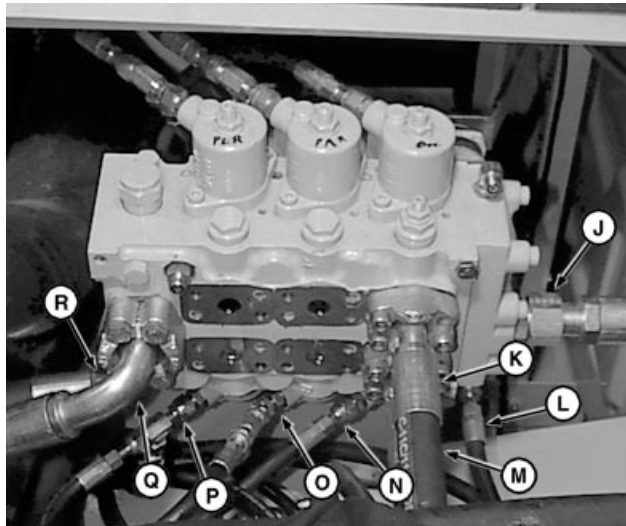

T110435 -UN-05AUG97

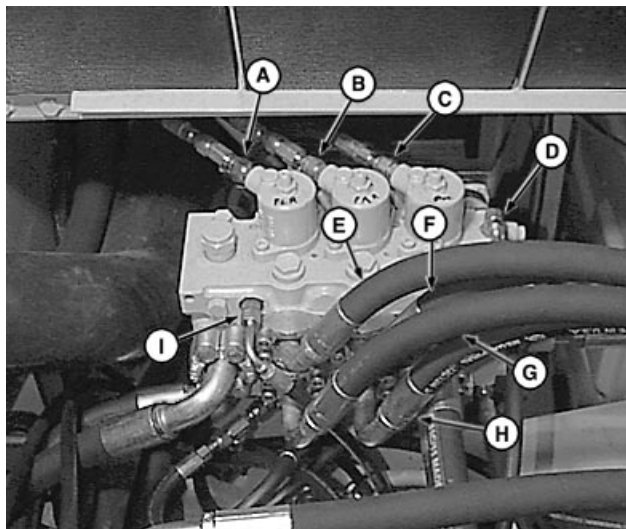

T110436 -UN-05AUG97

Hydraulic System

Disassemble And Assemble Monoblock Control Valve Manifold (Serial No. 556936—)

33
3360
142

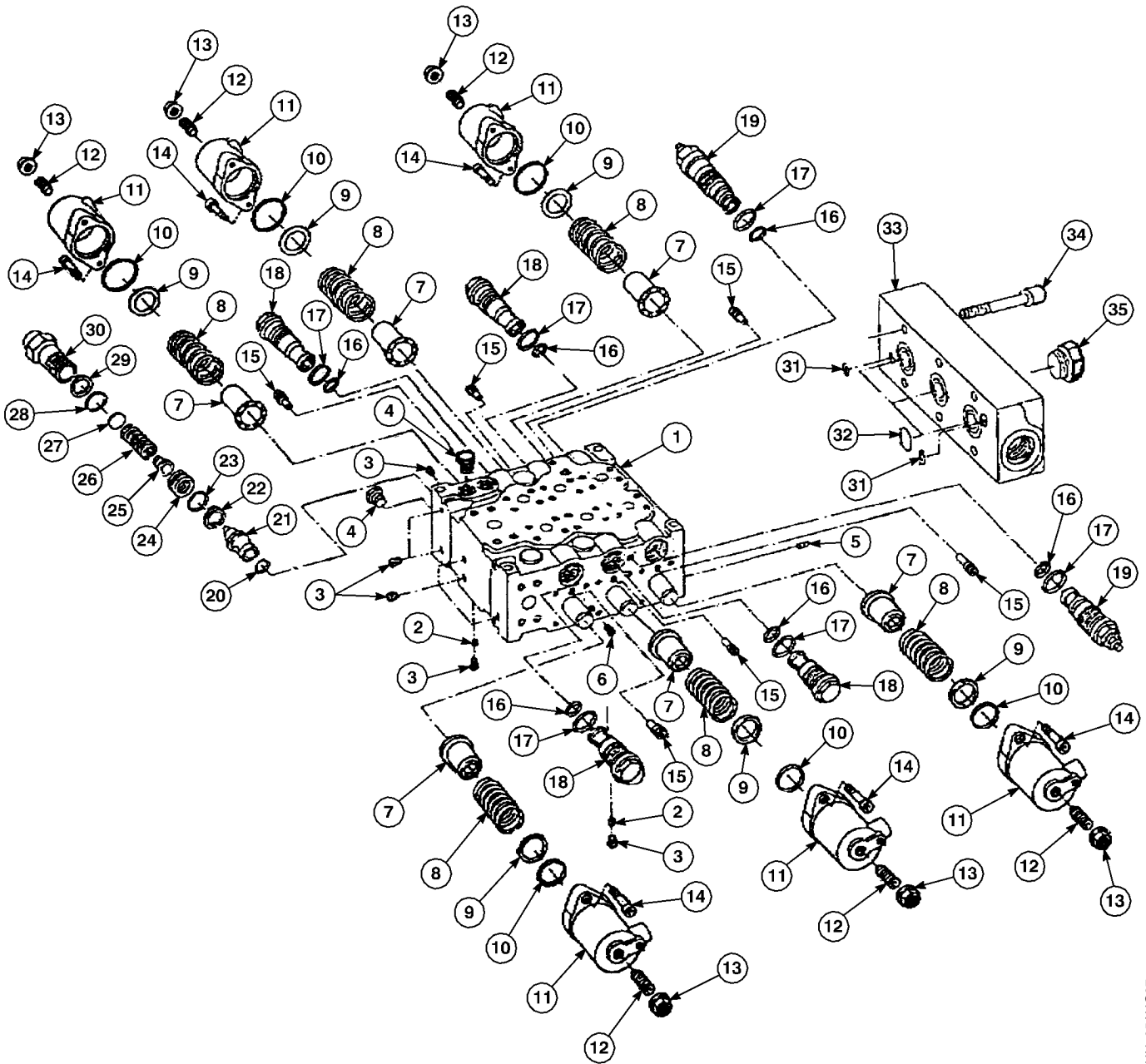

T110432

T110432 -UN-05AUG97

Continued on next page

TX,33,DW5018 -19-22JUL97-1/2

Hydraulic System

33
3360
143

- | | | | |
|----------------------|------------------------------------|-----------------------|-----------------------------------|
| 1—Housing Block | 11—Cushion Cover (6 used) | 19—Valve (2 used) | 28—O-Ring |
| 2—Plug (2 used) | 12—Screw (6 used) | 20—O-Ring | 29—Back-up Ring |
| 3—Pipe Plug (6 used) | 13—Nut (6 used) | 21—Relief Valve | 30—Safety Valve |
| 4—Plug (2 used) | 14—Socket Head Cap Screw (12 used) | 22—Back-up Ring | 31—O-Ring (2 used) |
| 5—Plug | 15—Valve (6 used) | 23—O-Ring | 32—O-Ring (3 used) |
| 6—Plug | 16—O-Ring (6 used) | 24—Ring | 33—End Plate |
| 7—Cap (6 used) | 17—O-Ring (6 used) | 25—Cap | 34—Socket Head Cap Screw (6 used) |
| 8—Spring (6 used) | 18—Check Valve (4 used) | 26—Spring | 35—Plug |
| 9—Shim (as required) | | 27—Shim (as required) | |
| 10—Nut | | | |

1. Remove parts (1—35) from both ends of valve.
2. Replace parts as necessary. Replace O-rings.
3. Tighten nuts (13) to 60 N•m (44 lb-ft). Tighten cap screws (14) to 25 N•m (221 lb-in.).
4. Tighten nuts (18 and 19) to 80 N•m (59 lb-ft). Tighten valve (30) to 120—150 N•m (88—92 lb-ft).

Specification

Safety Relief Valve Plug
(556936—)—Torque..... 120—150 N•m (88—92 lb-ft)

5. Tighten cap screws (34) to 25 N•m (221 lb-in.).

TX,33,DW5018 -19-22JUL97-2/2

Remove And Install Safety Relief Valve (Serial No. 556936—)

1. Release pressure in hydraulic reservoir. Unlock hydraulic tank fill cap. Slowly turn cap to release air pressure.
2. Remove valve (A).
3. Replace parts as necessary. Replace O-rings.
4. Install valve. Tighten valve (A) to 120—150 N•m (88—92 lb-ft).

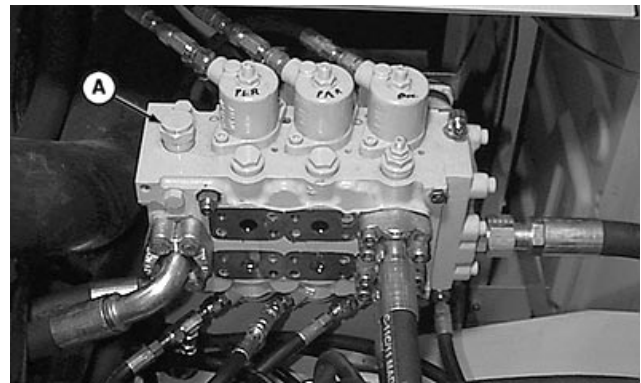

Lines Removed For Clarity

T110744 -UN-05AUG97

Specification

Safety Relief Valve Plug
(556936—)—Torque..... 120—150 N•m (88—92 lb-ft)

5. Adjust valve. (See procedure in Group 9025-25.)

TX,33,DW5023 -19-23JUL97-1/1

Hydraulic System

Disassemble And Assemble Safety Relief Valve (Serial No. 556936—)

1. Release pressure in hydraulic reservoir. Unlock hydraulic tank fill cap. Slowly turn cap to release air pressure.
2. Remove parts (A—H).
3. Inspect parts and replace as necessary.
4. Install parts. Tighten plug (A) to 120—150 N•m (88—92 lb-ft).

Specification

Safety Relief Valve Plug
(556936—)—Torque..... 120—150 N•m (88—92 lb-ft)

5. Adjust valve. (See procedure in Group 9025-25.)

- A—Plug**
B—Back-Up Ring
C—O-Ring
D—Shim (as required)
E—Spring
F—Cap
G—Ring
H—O-Ring
I—Back-Up Ring
J—Relief Valve
K—O-Ring

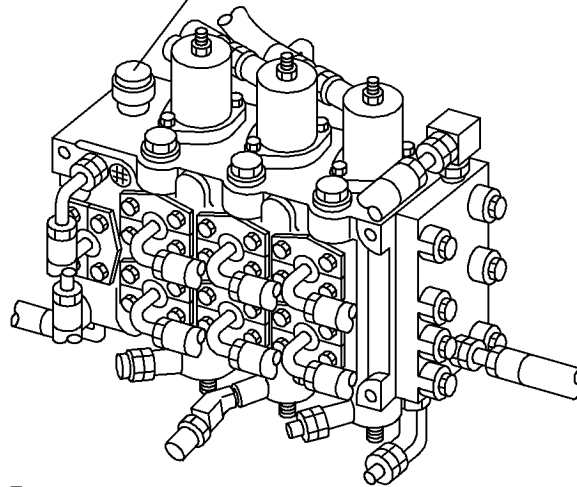
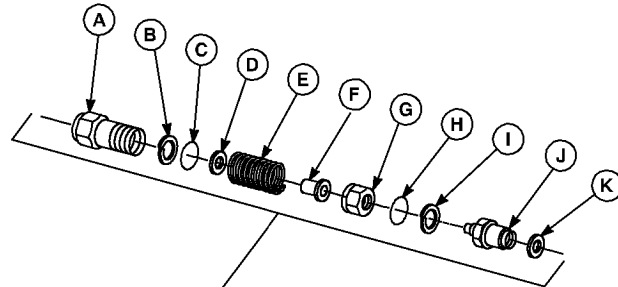

T110743

T110743 -UN-06AUG97

TX,33,DW5022 -19-23JUL97-1/1

Hydraulic System

Remove And Install Boom Regenerative Valve (Serial No. 545157—556935)

1. Lower equipment to ground.
2. Release pressure in hydraulic reservoir. Loosen hydraulic tank fill cap. Slowly turn cap to release air pressure.
3. Drain reservoir. Approximate capacity is 148 L (39 gal).

CAUTION: To avoid injury from escaping fluid under pressure, stop engine and relieve the pressure in the system before disconnecting or connecting hydraulic or other lines. Tighten all connections before applying pressure.

4. Remove hydraulic lines (A, B, C and E).
5. Remove cap screws (I and F) and flanges (J and K). Remove hydraulic lines (D and G).
6. Remove cap screws (H). Remove boom valve (M) and boom regenerative valve (L).
7. Replace parts as necessary.
8. Install new O-rings.
9. Install boom regenerative valve and boom valve. Tighten mounting cap screws to 86 N•m (63 lb-ft).
10. Install hydraulic lines.
11. Fill reservoir. (See Hydraulic Oil in Group 0004.)

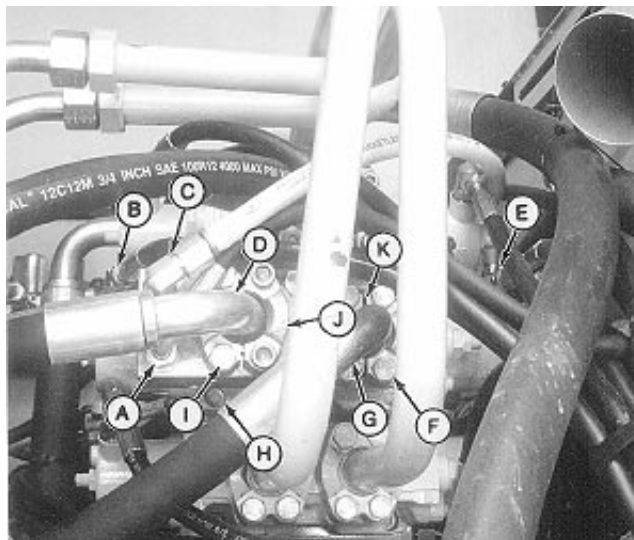

Components Removed For Clarity

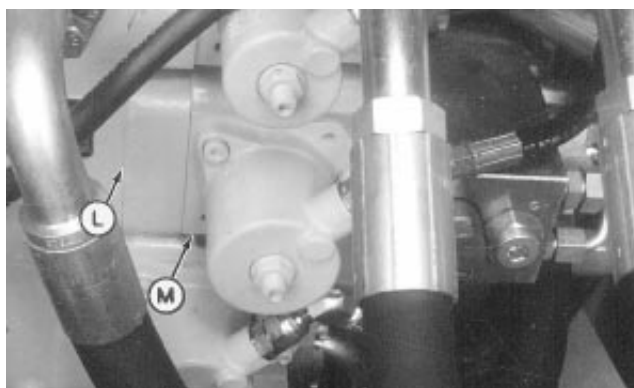

- A—Boom Lower Valve B Port-to-Boom Anti-Drift Valve X Port Line
 B—Boom Raise Valve A Port-to-Dig Pilot Check Valve Block K1 Port Line
 C—Boom Anti-Drift Valve Y Port-to-Hydraulic Reservoir
 D—Boom Anti-Drift Valve Port-to-Boom Cylinders Rod End Port Line
 E—Boom Lower Valve B Port-to-Dig Pilot Check Valve Block L1 Port Line
 F—Cap Screw (4 used)
 G—Boom Valve B Port-to-Boom Cylinders Head End Port Line
 H—Cap Screw (4 used)
 I—Cap Screw (4 used)
 J—Flange (2 used)
 K—Flange (2 used)
 L—Boom Regenerative Valve
 M—Boom Valve

33
3360
145

T8455AL -UN-04MAR95

T8472AA -UN-28APR95

TX,33,DW5019 -19-22JUL97-1/1

Disassemble And Assemble Boom Regenerative Valve (Serial No. 545157—556935)

1. Remove parts (B—D).
2. Replace parts as necessary.
3. Install new O-rings.
4. Align marking (A) on boom valve section with (A) on boom regenerative valve.

A—A Cast On Housing
 B—O-Ring (2 used)
 C—O-Ring (3 used)
 D—Orifice

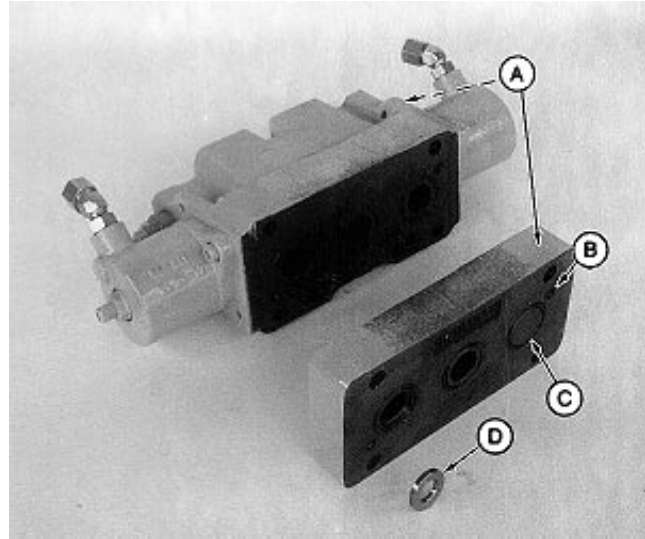

T8455AN -UN-10APR95

TX,33,DY2985 -19-27AUG97-1/1

Hydraulic System

Remove And Install Arm Regenerative Valve (Serial No. 546277—556935)

1. Lower equipment to ground.
2. Release pressure in hydraulic reservoir. Loosen hydraulic tank fill cap. Slowly turn cap to release pressure.
3. Drain reservoir. Approximate capacity is 148 L (39 gal).

CAUTION: To avoid injury from escaping fluid under pressure, stop engine and relieve the pressure in the system before disconnecting or connecting hydraulic or other lines. Tighten all connections before applying pressure.

4. Remove cap screws (A). Remove clamp (B).
5. Remove cap screws (C). Remove bracket (D).
6. Disconnect line (E) and T-fitting (G).
7. Remove cap screws (F). Slide arm valve section (I) to one side. Remove arm regenerative valve (H).
8. Replace parts as necessary.
9. Install arm regenerative valve (H) and arm valve section (I). Tighten cap screws (F) to 80 N•m (59 lb-ft).

Specification

Mounting Cap Screw—Torque..... 80 N•m (59 lb-ft)

10. Connect line (E) and T-fitting (G).
11. Install bracket (D) and clamps (B).

- A—Cap Screw (2 used)
- B—Clamp (2 used)
- C—Cap Screw (3 used)
- D—Bracket
- E—Dig Pilot Check Valve L1 Port-to-Arm Out B Port Line
- F—Cap Screw (4 used)
- G—Dig Pilot Check Valve K1 Port-to-Arm In A Port Line
- H—Arm Regenerative Valve
- I—Arm Valve Section

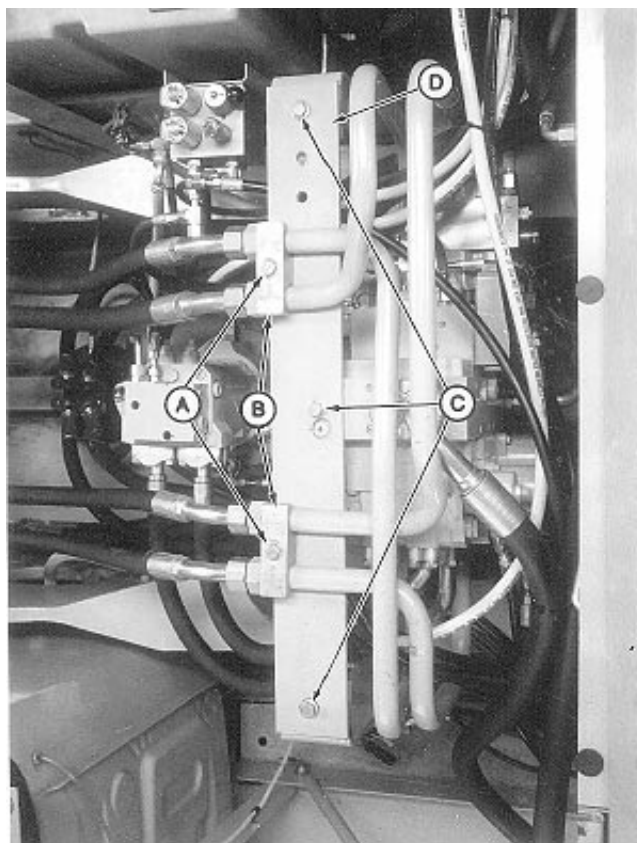

T8455AA -UN-04MAR95

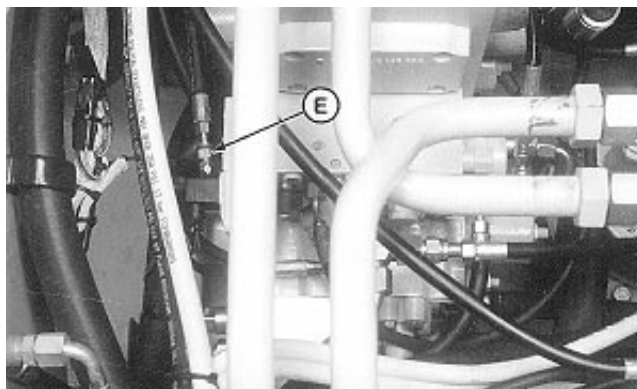

T8455AB -UN-04MAR95

Right Side Of Control Manifold

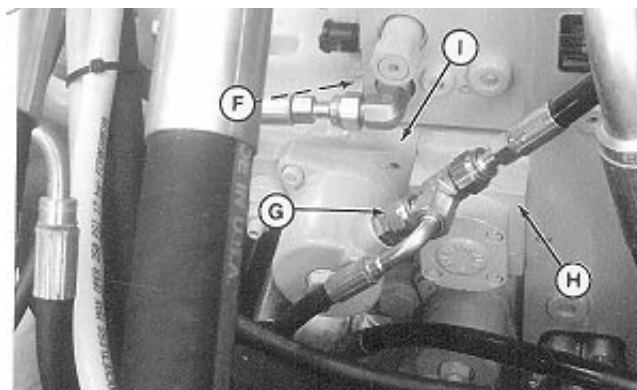

T8455AC -UN-04MAR95

TX,33,DY2986 -19-27AUG97-1/1

Disassemble And Assemble Arm Regenerative Valve (Serial No. 546277—556935)

1. Measure dimension (M) to aid in assembly.
2. Tighten plug (L) to 75 N•m (55 lb-ft).

Specification

Spool Plug—Torque 75 N•m (55 lb-ft)

3. Tighten cap screws (G) to 9.5 N•m (84 lb-in.).

Specification

Cover-to-Housing Cap Screw—
Torque 9.5 N•m (84 lb-in.)

4. Tighten jam nut (B) to 80 N•m (59 lb-ft).

Specification

Jam Nut—Torque 80 N•m (59 lb-ft)

- A—Arm Cylinder Restrictor
- B—Jam Nut
- C—Housing
- D—Poppet
- E—Spring
- F—Cover
- G—Cap Screw (4 used)
- H—O-Ring
- I—O-Ring (3 used)
- J—O-Ring
- K—O-Ring
- L—Plug
- M—Dimension

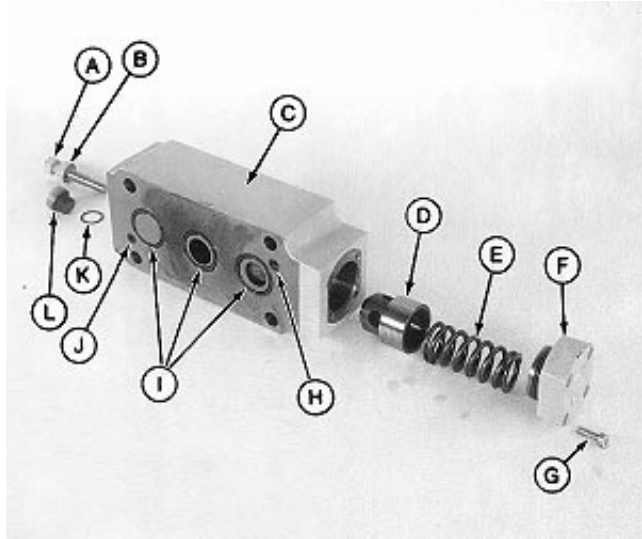

T8455AE -UN-04MAR95

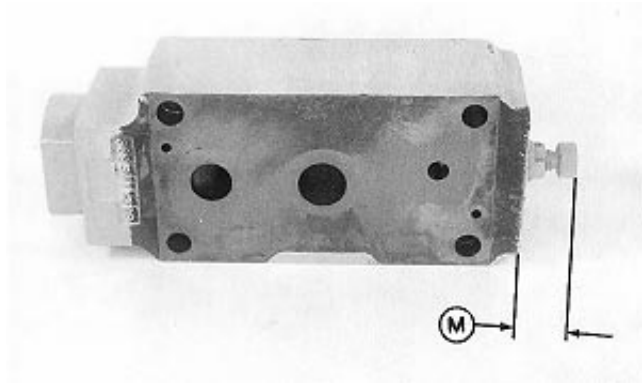

T8455AF -UN-04MAR95

Hydraulic System

Remove And Install Arm Regenerative Poppet Valve (Serial No. 556936—)

1. Lower equipment to ground.
2. Release pressure in hydraulic reservoir. Loosen hydraulic tank fill cap. Slowly turn cap to release pressure.
3. Drain reservoir. Approximate capacity is 151 L (40 gal).

IMPORTANT: The spring loaded cap retains the poppet that must be removed. The retaining screws are not long enough to relax all of the spring tension. Installation may be difficult.

4. Remove two opposing cap screws at (A).
5. Install two 6 x 75 mm threaded rod stock with washers and cap screws at (A).
6. Remove remaining cap screws at (A).
7. Carefully remove the two cap screws to relieve spring tension.
8. Remove threaded rod stock and washers.
9. Remove regenerative arm valve cover (B), spring and poppet sections.
10. Remove arm valve sections.
11. Replace parts as necessary. Replace O-ring.
12. Install arm regenerative valve sections.
13. Install valve cover (B) and two cap screws at (A).
14. Install two 6 x 75 mm threaded rod stock and washers and cap screws.
15. Remove threaded rod stock and washers.
16. Install remaining cap screws at (A). Tighten cap screws to 9.5 N•m (84 lb-in.).

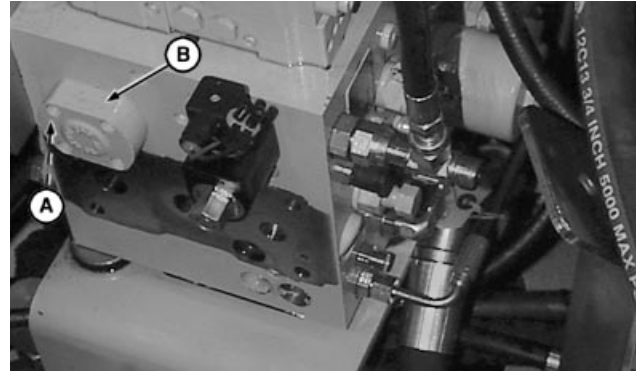

Boom Valve Section Removed For Clarity

33
3360
149

T110218 -UN-05AUG97

Continued on next page

TX,33,DW5003 -19-16JUL97-1/2

Hydraulic System

Specification

Cover-to-Housing Cap Screw—
Torque 9.5 N•m (84 lb-in.)

TX,33,DW5003 -19-16JUL97-2/2

Disassemble And Assemble Arm Regenerative Valve (Serial No. 556936—)

1. Remove arm regenerative valve parts.
2. Replace parts as necessary. Replace O-ring.
3. Tighten cap screws to 9.5 N•m (84 lb-in.).

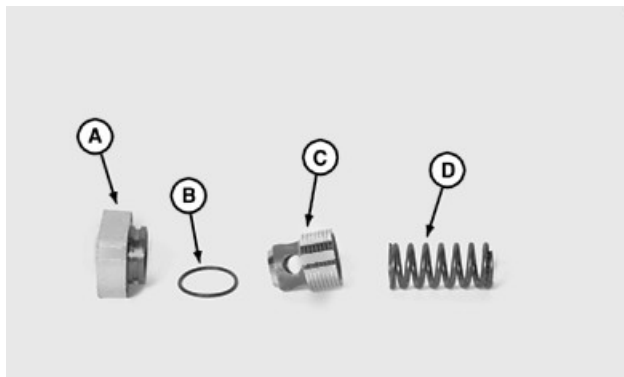

T110219 -UN-05AUG97

Specification

Cover-to-Housing Cap Screw—
Torque 9.5 N•m (84 lb-in.)

- A—Cover
- B—Poppet
- C—Spring
- D—O-Ring

TX,33,DW5004 -19-16JUL97-1/1

Hydraulic System

Remove And Install Swing Stop Cushion Valve

1. Lower equipment to ground.
2. Release pressure in hydraulic reservoir. Loosen hydraulic tank fill cap. Slowly turn cap to release air pressure.

CAUTION: To avoid injury from escaping fluid under pressure, stop engine and relieve the pressure in the system before disconnecting or connecting hydraulic or other lines. Tighten all connections before applying pressure.

3. Remove hydraulic lines (A and B).
4. Remove cap screws (D). Remove manifold (C).
5. Replace parts as necessary.
6. Install manifold. Torque cap screws to 32 N•m (24 lb-ft).

Specification

Mounting Cap Screw—Torque..... 32 N•m (24 lb-ft)

7. Install hydraulic lines.

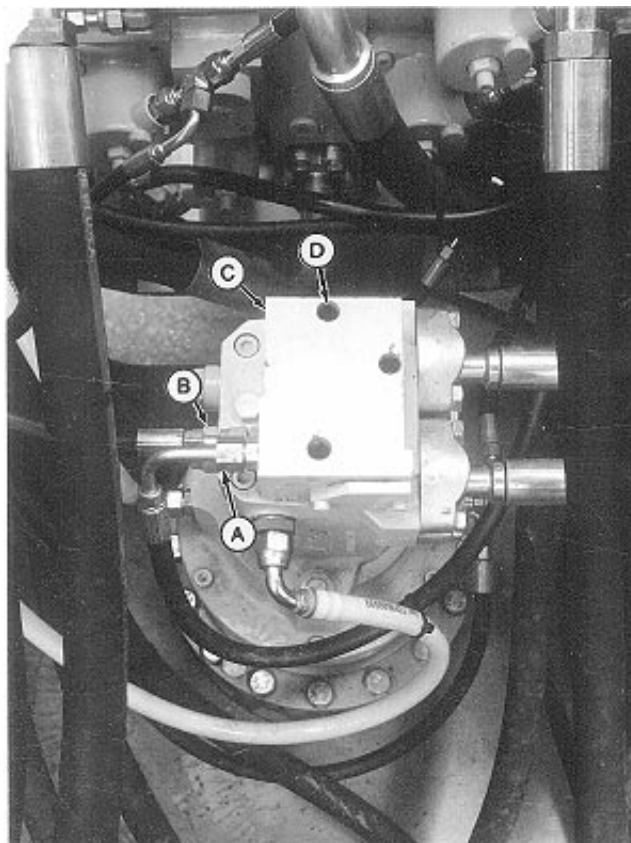

Earlier Machine Shown

A—Dig Pilot Check Valve Block S1 Port-to-Swing Stop Cushion Valve PST Port Line (Serial No. 546277—556935)

Dig Pilot Check Valve Block Signal Switch Port-to-Swing Stop Cushion Valve PST Port Line (Serial No. 556936—)

B—Swing Stop Cushion Valve PZUL Port-to-Dual Solenoid Block T Port Line (Serial No. 546277—556935)

Swing Stop Cushion Valve PZUL Port-to-Dual Solenoid Block P Port Line (Serial No. 556936—)

C—Manifold

D—Cap Screw (3 used)

33
3360
151

T8455AO -UN-04MAR95

TX,33,DY2991 -19-27AUG97-1/1

Hydraulic System

Disassemble And Assemble Swing Stop Cushion Valve (Serial No. 546277—)

1. Remove parts (A—C and E—K) from housing (D).
2. Replace parts as necessary.
3. Install parts (A—C and E—K).

A—Plug
 B—Spring
 C—Pilot Pressure Spool
 D—Housing
 E—Spring
 F—Cushion Valve Spool
 G—O-Ring
 H—Cap Screw (2 used)
 I—Cover
 J—O-Ring (4 used)
 K—Plug

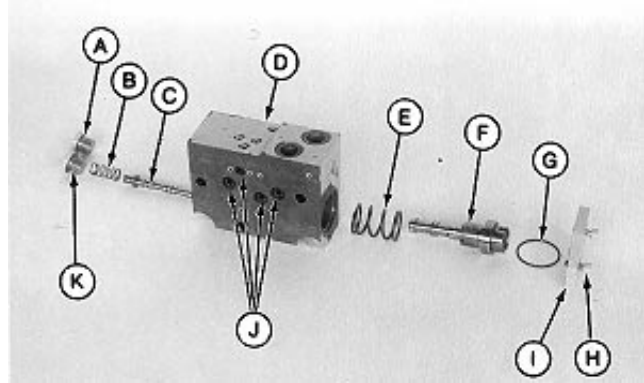

TX,3360,DW601 -19-20APR95-1/1

Remove And Install Swing Torque Control Valve (Serial No. —556935)

1. Lower equipment to ground.
2. Release pressure in hydraulic reservoir. Loosen hydraulic tank fill cap. Slowly turn cap to release pressure.
3. Drain reservoir. Approximate capacity is 148 L (39 gal).

CAUTION: To avoid injury from escaping fluid under pressure, stop engine and relieve the pressure in the system before disconnecting or connecting hydraulic or other lines. Tighten all connections before applying pressure.

4. Remove cap screws (A). Remove clamps (B). Remove cap screws (C) and bracket (D).
5. Remove cap screws (F). Slide swing valve (G) to one side. Remove swing torque control valve (E).
6. Replace parts as necessary.
7. Install swing torque control valve (E) and swing valve (G).
8. Install cap screws (F). Tighten to 49 N•m (36 lb-ft).

Specification

Valve-to-Manifold Cap Screw—
Torque 49 N•m (36 lb-ft)

9. Install bracket (D) and clamps (B).

- A—Cap Screw (2 used)
- B—Clamp (2 used)
- C—Cap Screw (3 used)
- D—Bracket
- E—Swing Torque Control Valve
- F—Cap Screw (4 used)
- G—Swing Valve

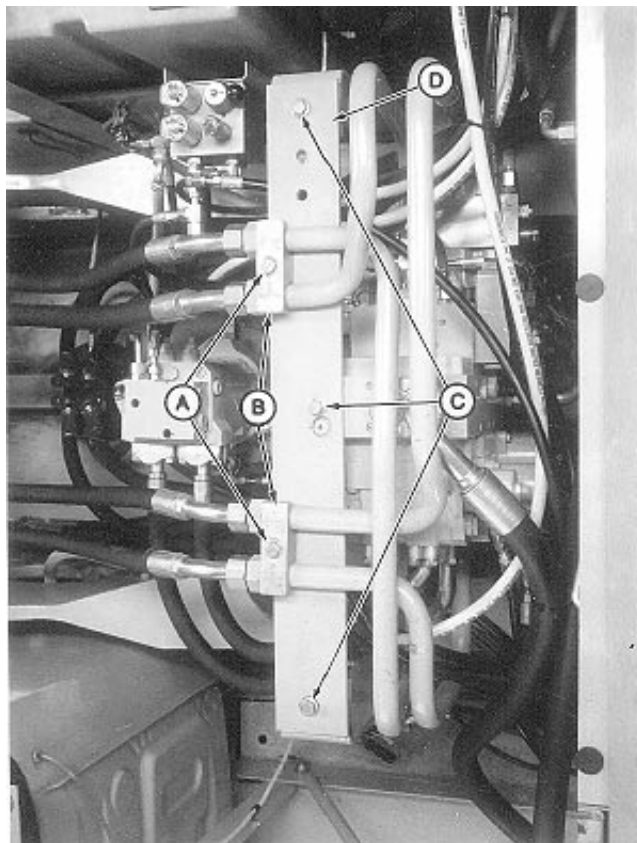

T8455AA -UN-04MAR95

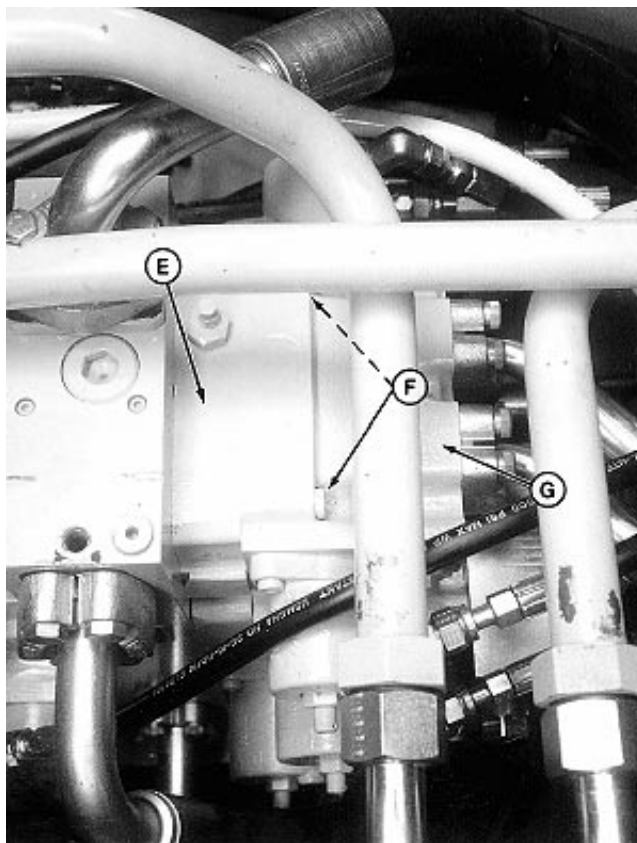

T8455AD -UN-10APR95

TX,33,DY2992 -19-27AUG97-1/1

Hydraulic System

Remove And Install Swing Torque Control Valve (Serial No. 556936—)

1. Lower all equipment to ground.
2. Release pressure in hydraulic reservoir. Loosen hydraulic fill cap. Slowly turn cap to release pressure.
3. Drain reservoir. Approximate capacity is 151 L (40 gal).



CAUTION: To avoid injury from escaping fluid under pressure, stop engine and relieve the pressure in the system before disconnecting or connecting hydraulic or other lines. Tighten all connections before applying pressure.

4. Remove four cap screws (A).
5. Move swing valve (B) to one side.
6. Remove swing torque control valve (C).
7. Replace parts as necessary.
8. Install swing torque control valve.
9. Install swing valve.
10. Install cap screws. Tighten to 86 N•m (63 lb-ft).

Specification

Swing Torque control Valve
(556936—)—Torque..... 86 N•m (63 lb-ft)

11. Fill reservoir. Approximate capacity is 151 L (40 gal).

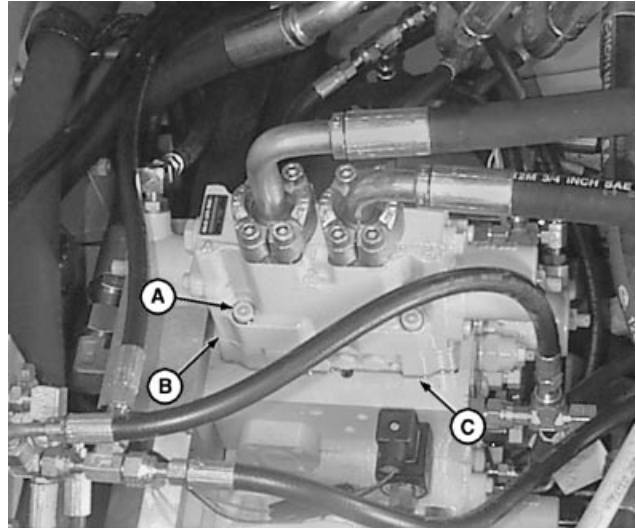

T109792 -UN-05AUG97

TX,33,DY2993 -19-27AUG97-1/1

**Disassemble And Assemble Swing Torque Control Valve
(Serial No. —546276)**

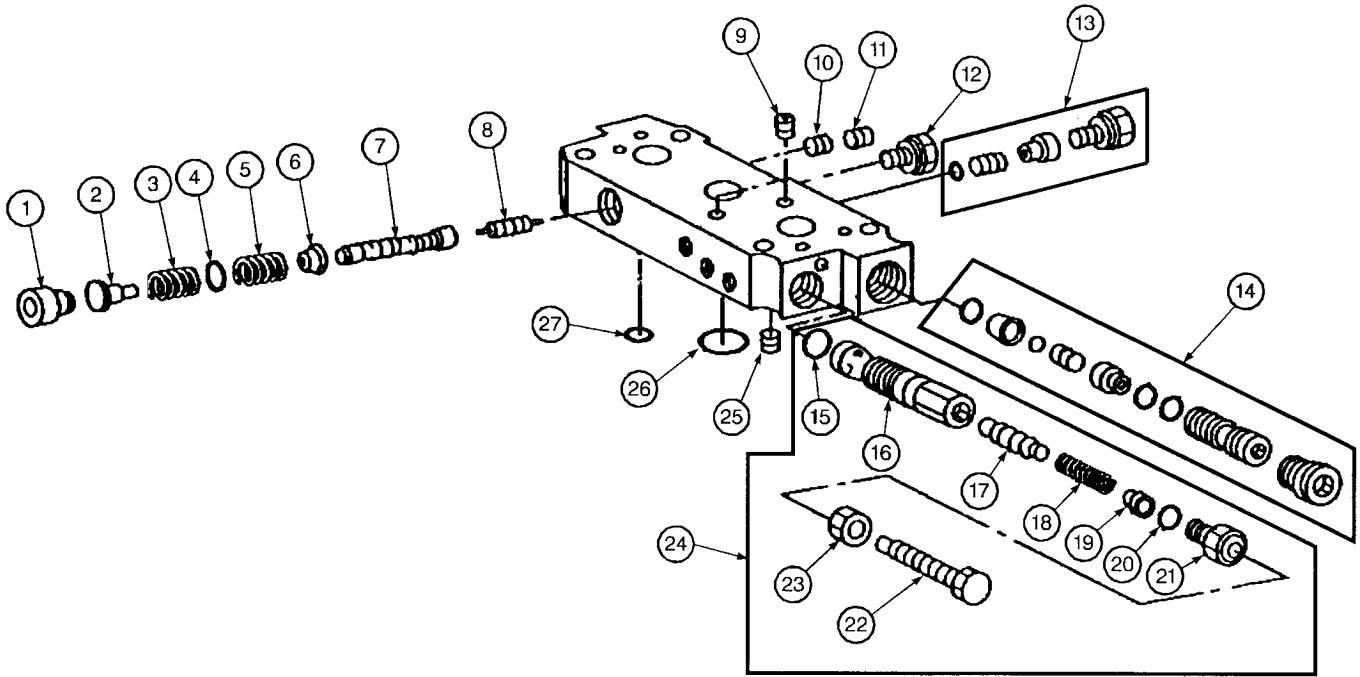

T8455AG (CV)

T8455AG -UN-18APR95

- | | | | |
|---------------|------------------|-------------|--------------------|
| 1—Plug | 8—Shuttle Spool | 15—O-Ring | 22—Screw |
| 2—Spring Seat | 9—Plug | 16—Sleeve | 23—Nut |
| 3—Spring | 10—Orifice | 17—Piston | 24—Relief Valve |
| 4—Shim | 11—Plug | 18—Spring | 25—Plug |
| 5—Spring | 12—Plug | 19—Retainer | 26—O-Ring (3 used) |
| 6—Spring Seat | 13—Check Valve | 20—O-Ring | 27—O-Ring (2 used) |
| 7—Spool | 14—Shuttle Valve | 21—Plug | |

TX,3360,DW602 -19-27AUG97-1/1

Hydraulic System

Disassemble And Assemble Swing Torque Control Valve (Serial No. 546277—)

1. Take dimension (A) and record for assembly.
2. Tighten plug (D) to 47 N•m (35 lb-ft).

Specification

Spool Plug—Torque 47 N•m (35 lb-ft)

3. Set adjusting screw to dimension (A). Tighten nut to 10 N•m (88 lb-in.).

Specification

Adjusting Screw Jam Nut—
Torque 10 N•m (88 lb-in.)

- A—Dimension
- B—Adjusting Screw and Nut
- C—Pin
- D—Plug
- E—O-Ring
- F—Spring Guide
- G—Spring
- H—O-Ring (3 used)
- I—O-Ring (2 used)
- J—Plug
- K—O-Ring
- L—Spring Guide
- M—Spring
- N—Ball
- O—O-Ring
- P—Plug
- Q—Plug
- R—Orifice
- S—Piston
- T—Pressure Regulating Valve Spool
- U—Spring Guide

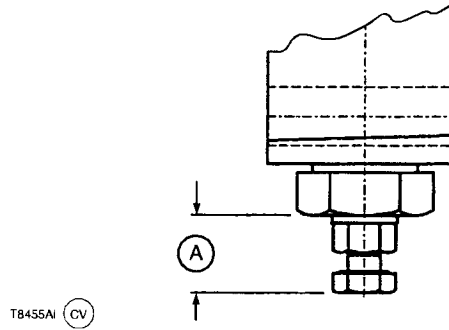

T8455A1 (CV)

T8455A1 -UN-18APR95

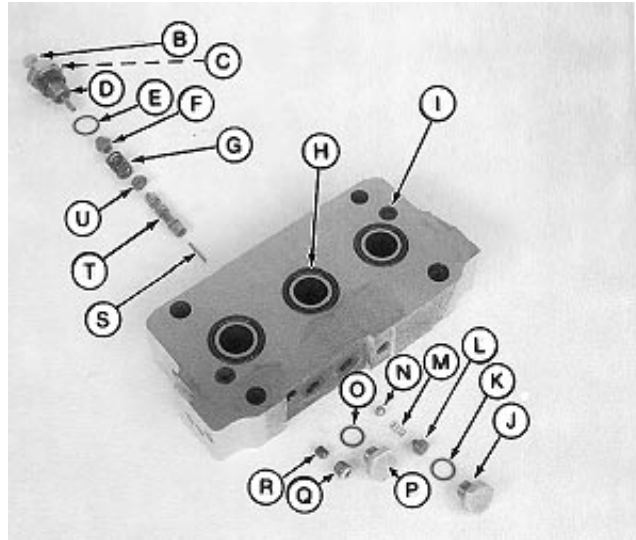

T8455AH -UN-04MAR95

TX,33,DY2994 -19-27AUG97-1/1

Remove And Install Boom And Arm Anti-Drift Valve (Serial No. —556935)

1. Lower equipment to ground.
2. Release pressure in hydraulic reservoir. Loosen hydraulic tank fill cap. Slowly turn cap to release air pressure.

Continued on next page

TX,33,DW5021 -19-22JUL97-1/4

Hydraulic System

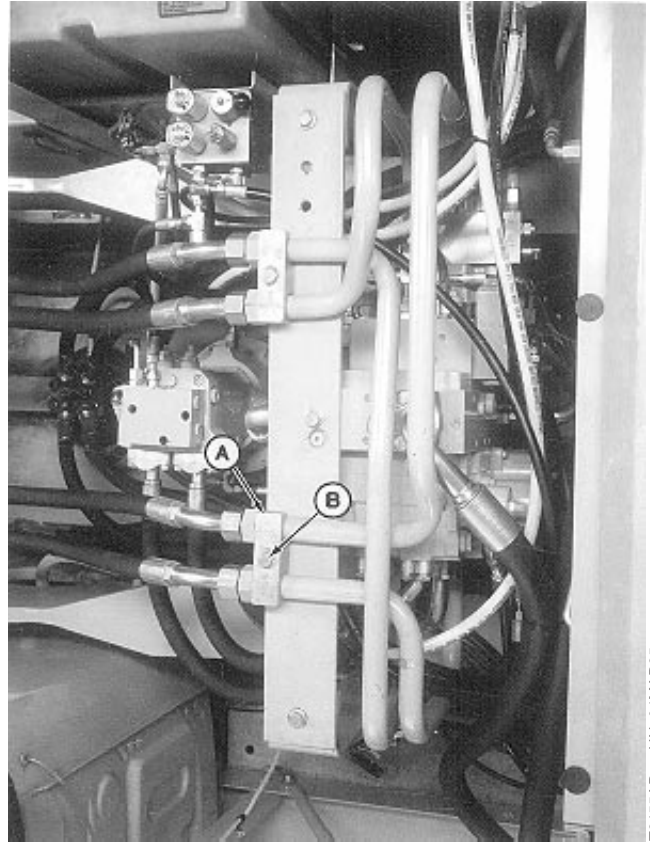

33
3360
157

T8455AP -UN-04MAR95

Continued on next page

TX,33,DW5021 -19-22JUL97-2/4

Hydraulic System



CAUTION: To avoid injury from escaping fluid under pressure, stop engine and relieve the pressure in the system before disconnecting or connecting hydraulic or other lines. Tighten all connections before applying pressure.

IMPORTANT: For machines with an anti-drift valve, the relief valve must be loosened 1/4 turn to make a passage through the valve for high pressure oil to flow from cylinders to the control valve.

NOTE: When removing arm anti-drift valve, it is necessary to remove cap screw (B) and clamp (A).

3. Remove hydraulic lines (A, B, G, L and M).
4. Remove cap screws (F and J) and flanges (D and H). Remove hydraulic lines (C and K).
5. Remove cap screws (E and I). Remove valve housings.
6. Replace parts as necessary.
7. Install valve housings. Torque mounting cap screws to 95 N•m (70 lb-ft).

- A—Boom Lower Valve B Port-to-Boom Anti-Drift Valve X Port Line
 B—Boom Anti-Drift Valve Y Port-to-Hydraulic Reservoir Port Line
 C—Boom Anti-Drift Valve Port-to-Boom Cylinders Rod End Port Line
 D—Flange (2 used)
 E—Cap Screw (2 used)
 F—Cap Screw (4 used)
 G—Boom Valve B Port-to-Boom Cylinders Head End Port Line
 H—Flange
 I—Cap Screw (2 used)
 J—Cap Screw (4 used)
 K—Arm Anti-Drift Valve Port-to-Arm Cylinder Rod End Port Line
 L—Arm Raise Valve A Port-to-Arm Anti-Drift Valve X Port Line
 M—Arm Anti-Drift Valve Y Port-to-Hydraulic Reservoir Port Line

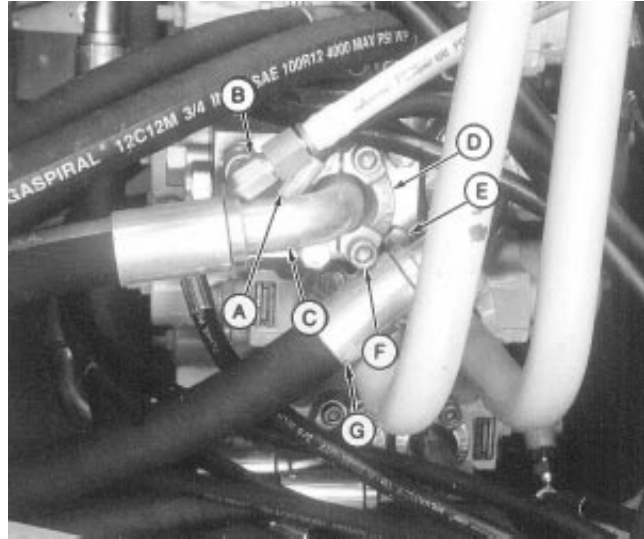

Boom Anti-Drift Valve Shown

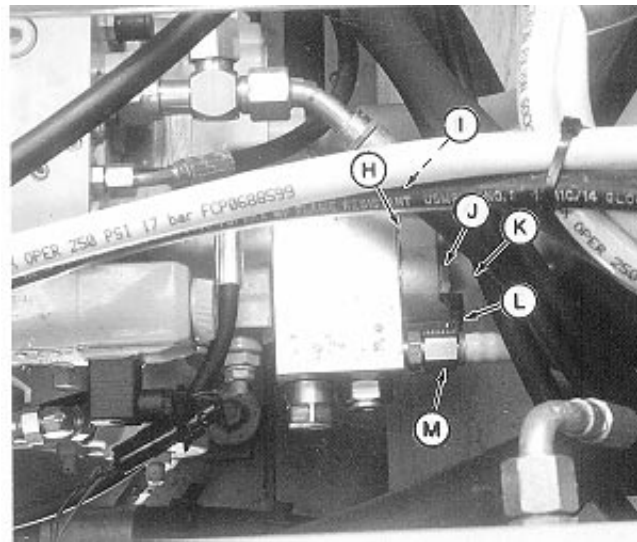

Arm Anti-Drift Valve Shown

Hydraulic System

Specification

Mounting Cap Screw—Torque..... 95 N•m (70 lb-ft)

- 8. Install hydraulic lines.
- 9. Install clamp.

33
3360
159

TX,33,DW5021 -19-22JUL97-4/4

Remove And Install Boom And Arm Anti-Drift Valve (Serial No. 556936—)

- 1. Lower equipment to ground.
- 2. Release pressure in hydraulic reservoir. Loosen hydraulic tank fill cap. Slowly turn cap to release air pressure.

Continued on next page

TX,33,DW5005 -19-16JUL97-1/2

Hydraulic System

CAUTION: To avoid injury from escaping fluid under pressure, stop engine and relieve the pressure in the system before disconnecting or connecting hydraulic or other lines. Tighten all connections before applying pressure.

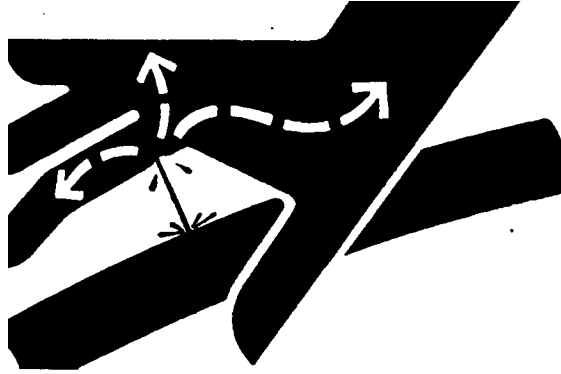

IMPORTANT: For machines with an anti-drift valve, the relief valve must be loosened 1/4 turn to make a passage through the valve for high pressure oil to flow from cylinders to the control valve.

3. Remove hydraulic lines (A, B, D, F, G and H) and flanges. Label lines to aid in installation.
4. Remove cap screws (C and E). Remove valve housings.
5. Replace parts as necessary.
6. Install valve housings. Torque mounting cap screws (C and E) to 95 N•m (70 lb-ft).

Specification

Mounting Cap Screw—Torque..... 95 N•m (70 lb-ft)

7. Install hydraulic lines (A, B, D, F, G and H) and flanges.

- A—Boom Anti-Drift Valve Y Port-to-Hydraulic Reservoir Port Line
- B—Boom Anti-Drift Valve A Port-to-Boom Cylinders Rod End Port Line
- C—Cap Screw (2 used)
- D—Boom Anti-Drift Valve X Port-to-Boom Lower Pilot Cap Port Line
- E—Cap Screw (2 used)
- F—Arm Anti-Drift Valve B Port-to-Arm Cylinder Rod End Port Line
- G—Arm Anti-Drift Valve Y Port-to-Boom Anti-Drift Valve Hydraulic Reservoir T-Fitting Port Line
- H—Arm Anti-Drift Valve X Port-to-Arm Raise Valve Pilot Port Line

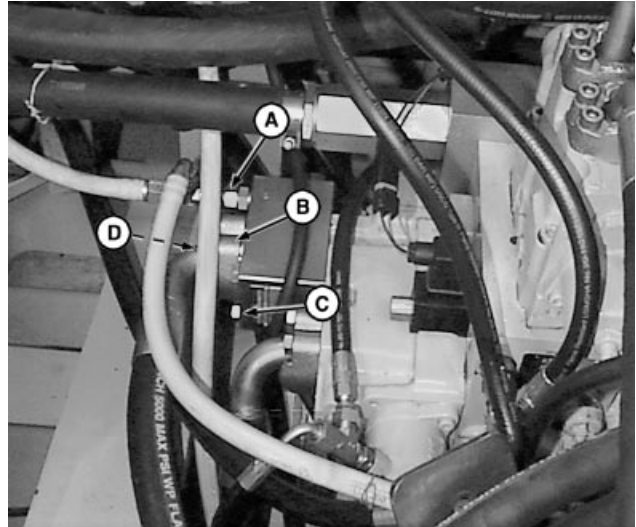

Boom Anti-Drift Valve

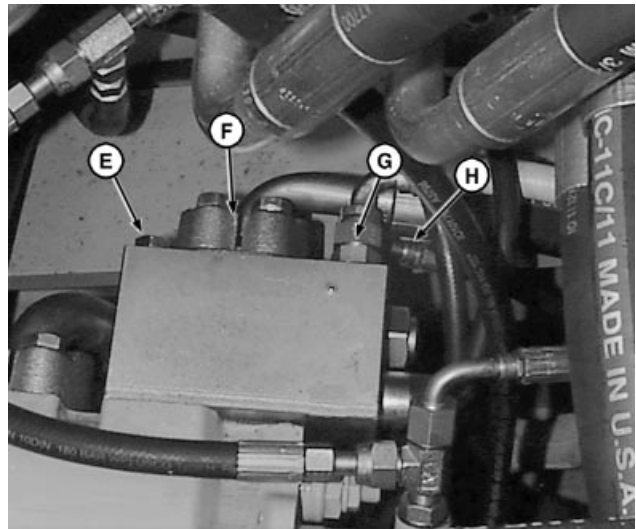

Arm Anti-Drift Valve Shown

TX,33,DW5005 -19-16JUL97-2/2

X9811 -UN-23AUG88

T110220 -UN-05AUG97

T110221 -UN-05AUG97

Disassemble And Assemble Boom And Arm Anti-Drift Valve

1. Remove parts (A—V).
2. Inspect for dirty, worn, or damaged parts. Replace parts as necessary.
3. Install new O-rings and back-up rings.
4. Instal parts (A—V). Tighten plugs (F and M) to 100 N•m (74 lb-ft).

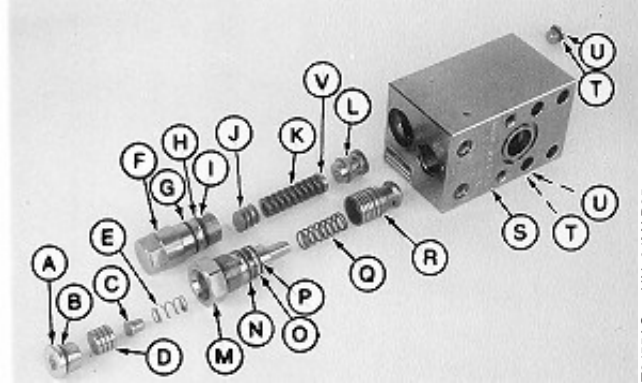

33
3360
161

TB455AS -UN-04MAR95

Specification

Valve Plug—Torque 100 N•m (74 lb-ft)

Tighten plugs (U) to 20 N•m (177 lb-in.).

Specification

Face Side Plug—Torque..... 20 N•m (177 lb-in.)

- A—Plug
- B—O-Ring
- C—Piston
- D—Piston
- E—Spring
- F—Plug
- G—O-Ring
- H—Back-Up Ring
- I—O-Ring
- J—Shim (As required)
- K—Spring
- L—Valve Seat
- M—Plug
- N—O-Ring
- O—Back-Up Ring
- P—O-Ring
- Q—Spring
- R—Poppet
- S—Housing
- T—O-Ring (2 used)
- U—Plug (2 used)
- V—Guide

TX,3360,DX388 -19-04MAY95-1/1

Remove And Install Dual Solenoid Block (Serial No. —538538)

1. Disconnect wiring leads from solenoids (A and B).
2. Release pressure in hydraulic reservoir. Unlock hydraulic tank fill cap. Slowly turn cap to release air pressure.
3. Disconnect oil lines (E—L).
4. Remove valve from reservoir.
5. Repair or replace valve components as necessary.
6. Install valve.
7. Connect oil lines.
8. Connect wiring leads.
9. Do Manual Bypass Pressure Reducing Valve Test and Adjustment. (See procedure in Group 9025-25.)

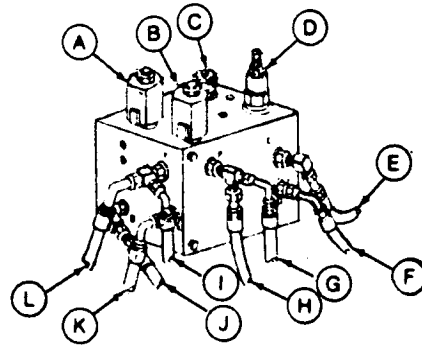

- A—Swing Brake Release Solenoid
- B—Propel Speed Change Solenoid
- C—System Controller Manual Bypass Valve
- D—Manual Bypass Pressure Reducing Valve
- E—Line to Engine Speed Control Actuator
- F—Line to Pump Regulator
- G—Line to Control Valve
- H—Line to Dig Pilot Check Valve Block
- I—Line to Reservoir
- J—Line to Swing Brake
- K—Line to Rotary Manifold
- L—Line to Swing Motor

T7681EF —UN—27JAN92

TX,33,DW5006 —19—16JUL97—1/1

Hydraulic System

**Remove And Install Dual Solenoid Block
(Serial No. 538539—)**

1. Release pressure in hydraulic reservoir. Unlock hydraulic tank fill cap. Slowly turn cap to release air pressure.
2. Disconnect electrical connectors (I).
3. Disconnect hydraulic lines (B—H).
4. Remove cap screws (A) and spacers (J). Remove valve.
5. Repair or replace valve components as necessary.
6. Install valve. Tighten cap screws.
7. Connect hydraulic lines (B—H).
8. Connect electrical connectors at (I).
9. Do Manual Bypass Pressure Reducing Valve Test and Adjustment. (See procedure in Group 9025-25.)

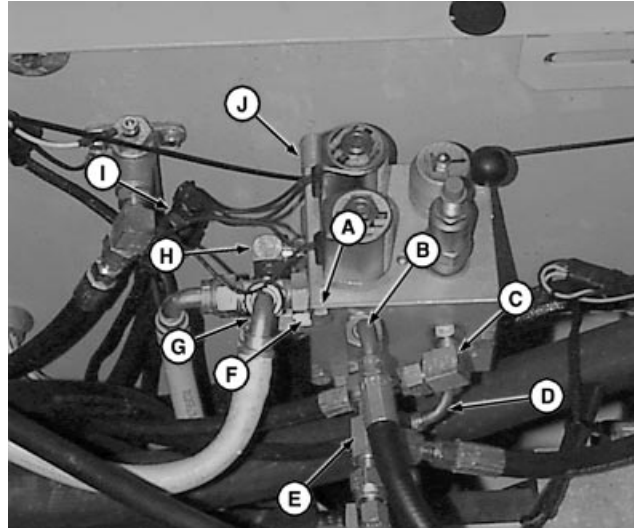

- A—Cap Screw (3 used)
- B—Dual Solenoid Valve P Port T-Fitting-to-Boom, Arm, Swing Control Valve Manifold P2 Port Line
- C—Dual Solenoid Valve E Port-to-Engine Speed Control Actuator Center Port Line
- D—Dual Solenoid Valve D Port-to-Main Hydraulic Pump Pressure Regulator X1 Port Line
- E—Dual Solenoid Valve P Port T-Fitting-to-Swing Cushion PZUL Port Line
- F—Dual Solenoid Valve A Port-to-Rotary Manifold P1 Port Line
- G—Dual Solenoid Valve T Port-to-Reservoir
- H—Dual Solenoid Valve T Port-to-Swing Valve Z Port Line
- I—Electrical Connector (3 used)
- J—Spacer (3 used)

33
3360
163

T110222 -UN-05AUG97

TX,33,DW5007 -19-16JUL97-1/1

Disassemble And Assemble Dual Solenoid Valve Block (Serial No. 538539—)

33
3360
164

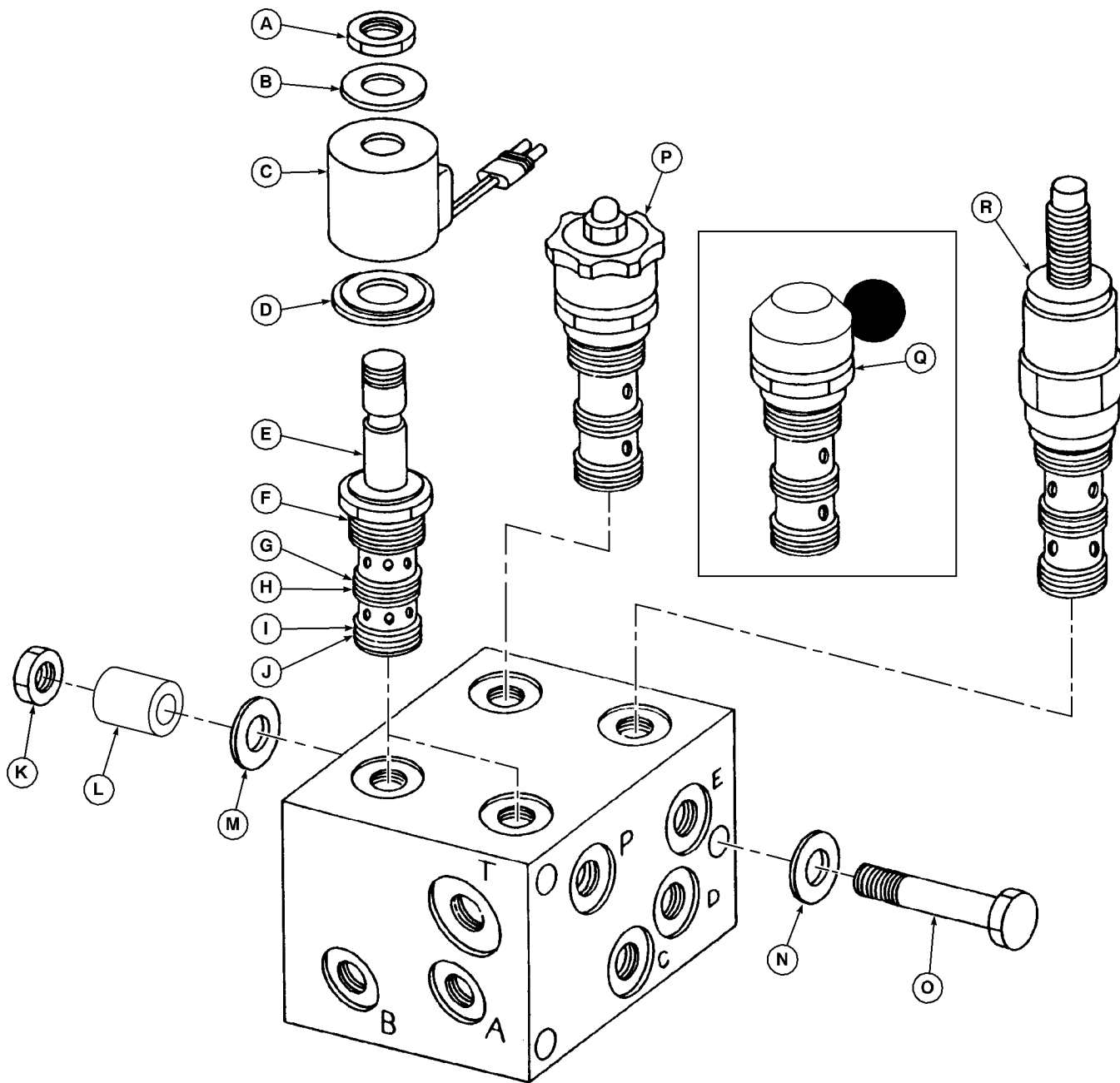

T110223

- A—Nut
- B—Washer (2 used)
- C—Coil (2 used)
- D—Plate (2 used)
- E—Solenoid Valve (2 used)
- F—O-Ring

- G—O-Ring
- H—Backup Ring
- I—O-Ring
- J—Backup Ring
- K—Lock Nut (3 used)

- L—Spacer (3 used) (Serial No. 538539—)
- M—Washer (3 used)
- N—Washer (3 used)
- O—Cap Screw (3 used)

- P—Controller Valve (Serial No.—538538)
- Q—Manual Bypass Valve (Serial No. 538539—)
- R—Regulator Valve

T110223 -UN-05AUG97

Hydraulic System

33
3360
165**Remove And Install Engine Speed Control Actuator**

1. Release pressure in hydraulic reservoir. Unlock hydraulic tank fill cap. Slowly turn cap to release air pressure.

TX,3360,AB413 -19-17FEB92-1/2

2. Disconnect lines (A—C).
3. Remove actuator.
4. Repair or replace actuator as necessary.
5. Install actuator.
6. Connect lines.

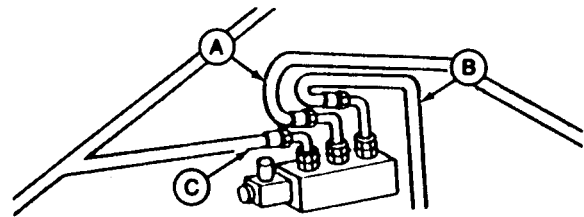

A—Line to Dual Solenoid Block
B—Line to Reservoir
C—Line to Pilot Filter

T7681EG -UN-27JAN92

TX,3360,AB413 -19-17FEB92-2/2

Disassemble And Assemble Engine Speed Control Actuator

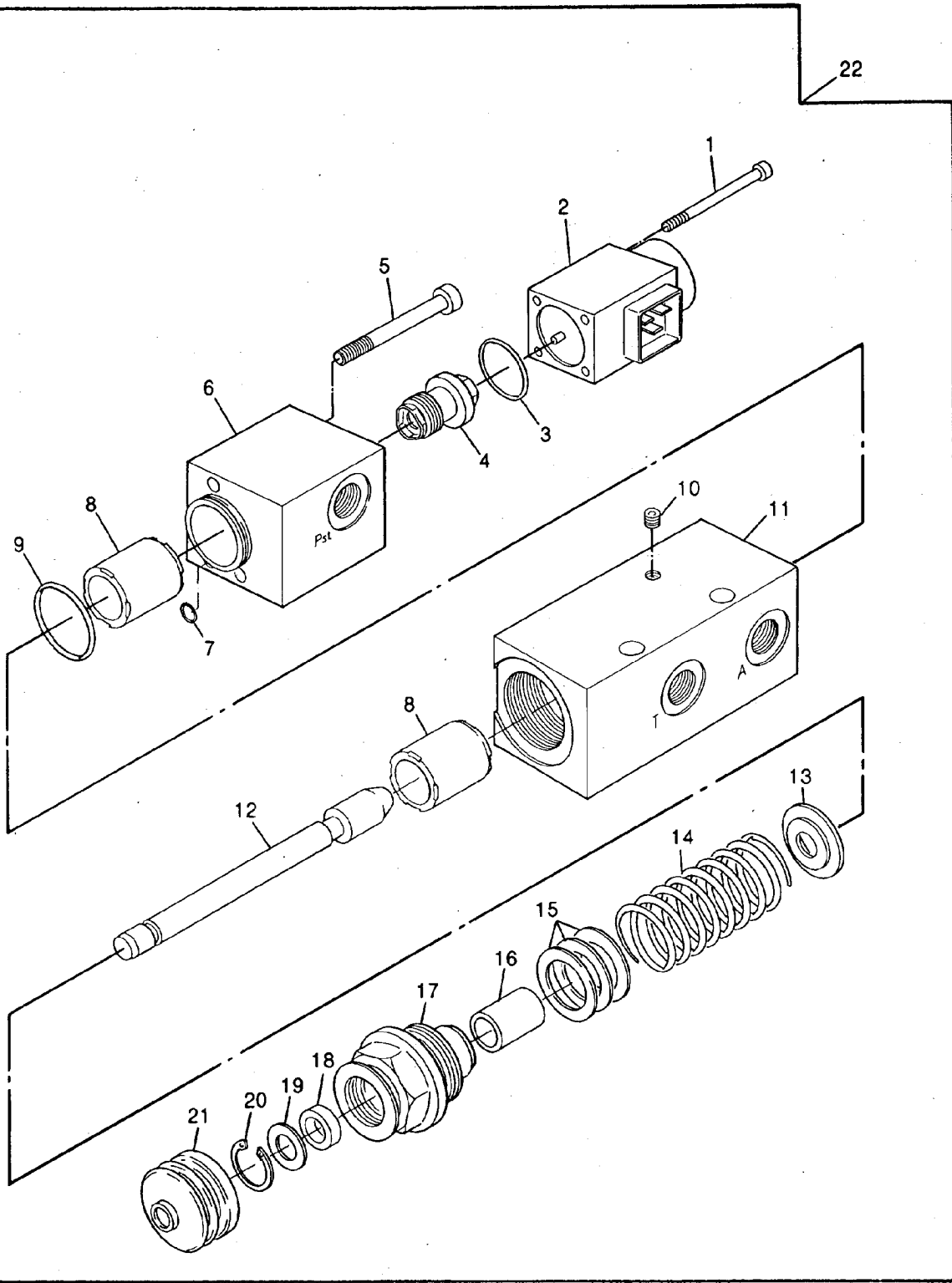

TP33094

T111078 -UN-12AUG97

Continued on next page

TX,3360,AB414 -19-17FEB92-1/2

Hydraulic System

1—Cap Screw (4 used)	7—O-Ring	13—Plate	18—Ring
2—Solenoid	8—Holder	14—Spring	19—Washer
3—O-Ring	9—O-Ring	15—Shim (as required)	20—Snap Ring
4—Plug	10—Set Screw	16—Sleeve	21—Boot
5—Cap Screw (2 used)	11—Housing	17—Screw	22—Actuator
6—Block	12—Rod		

33
3360
167

1. Remove parts (1—21).
2. Inspect parts and replace as necessary.

TX,3360,AB414 -19-17FEB92-2/2

Remove And Install Boom Cylinder

1. Retract arm cylinder.
2. Put a floor stand under end of boom so load is not on boom cylinders. Lower bucket to ground.
3. Release pressure in reservoir. Unlock hydraulic tank fill cap. Slowly turn cap to release air pressure.

Continued on next page

TX,33,DY2995 -19-27AUG97-1/2

Hydraulic System

! **CAUTION:** Escaping fluid under pressure can penetrate the skin causing serious injury. Avoid the hazard by relieving pressure before disconnecting hydraulic or other lines. Tighten all connections before applying pressure. Search for leaks with a piece of cardboard. Protect hands and body from high pressure fluids.

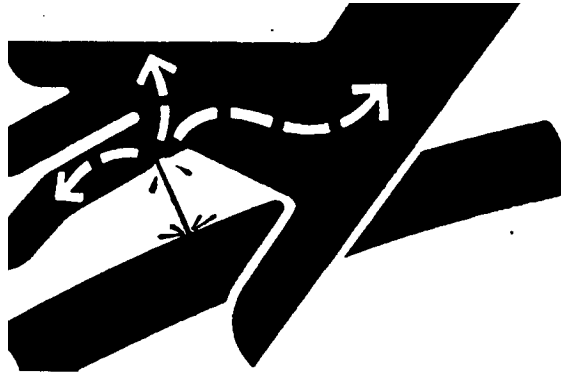

If an accident occurs, see a doctor immediately. Any fluid injected into the skin must be surgically removed within a few hours or gangrene may result. Doctors unfamiliar with this type of injury may call the Deere & Company Medical Department in Moline, Illinois, or other knowledgeable medical source.

4. Disconnect lines (B—E and G).
5. Remove pins (F) from both ends of cylinder. Note shim locations to aid installation.

! **CAUTION:** The approximate weight of boom cylinder is 189 kg (416 lb).

6. Remove cylinder. Keep shims for use at installation.
7. Repair or replace cylinder as necessary.
8. Install cylinder. Install or remove shims at the head and rod end to limit play to 1.5 mm (0.06 in.) or less.
9. Connect lines. Bleed air from cylinder. (See procedure in this group.)

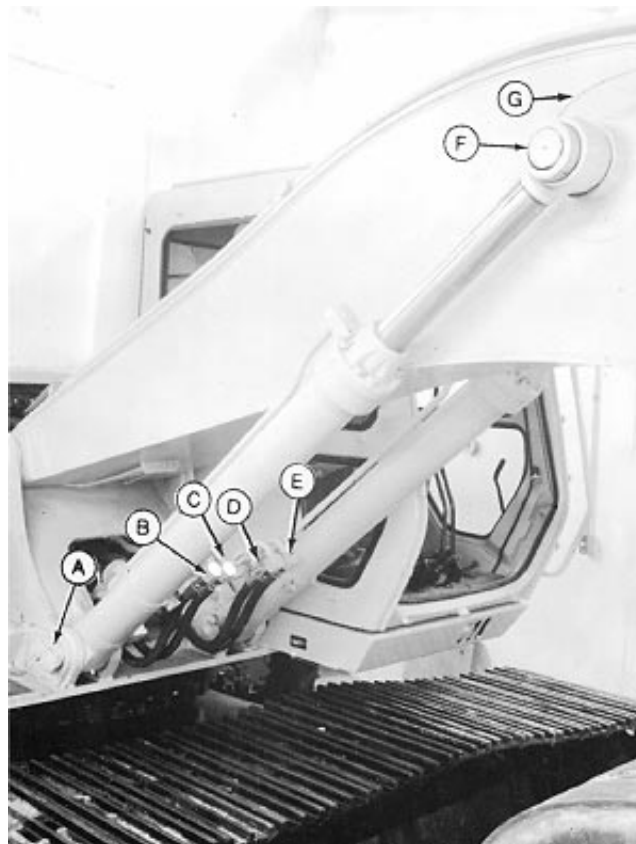

A—Pin
 B—Line to Right Cylinder Piston End
 C—Line to Right Cylinder Rod End
 D—Line to Left Cylinder Rod End
 E—Line to Left Cylinder Piston End
 F—Pin (2 used)
 G—Lubrication Line

X9811 -UN-23AUG88

T7681EH -UN-27JAN92

TX,33,DY2995 -19-27AUG97-2/2

Hydraulic System

Remove And Install Arm Cylinder

1. Retract cylinder.
2. Place a floor stand under end of boom so load is on boom, not arm cylinder, when boom is lowered, lower bucket to ground.
3. Release pressure in hydraulic reservoir. Unlock hydraulic tank fill cap. Slowly turn cap to release air pressure.

33
3360
169

Continued on next page

TX,33,DY2996 -19-27AUG97-1/2

Hydraulic System

! **CAUTION:** Escaping fluid under pressure can penetrate the skin causing serious injury. Avoid the hazard by relieving pressure before disconnecting hydraulic or other lines. Tighten all connections before applying pressure. Search for leaks with a piece of cardboard. Protect hands and body from high pressure fluids.

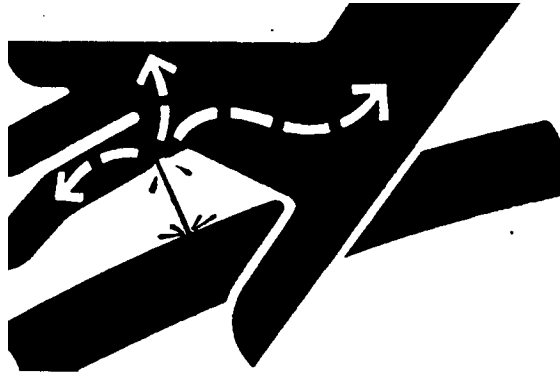

If an accident occurs, see a doctor immediately. Any fluid injected into the skin must be surgically removed within a few hours or gangrene may result. Doctors unfamiliar with this type of injury may call the Deere & Company Medical Department in Moline, Illinois, or other knowledgeable medical source.

4. Disconnect lines (A and B).
5. On later machines disconnect lubrication lines.

! **CAUTION:** The approximate weight of arm cylinder is 296 kg (652 lb).

6. Remove pins (C) from both ends of cylinder. Note shim locations to aid assembly.
7. Remove cylinder.
8. Repair or replace cylinder as necessary.
9. Install cylinder.
10. Install or remove shims at the head and rod end to limit play to 1.5 mm (0.06 in.) or less.
11. Connect lines. Bleed air from cylinder. (See procedure in this group.)
12. On later machines connect lubrication lines
13. Operate cylinder through several cycles. Check reservoir level. Add oil as necessary.

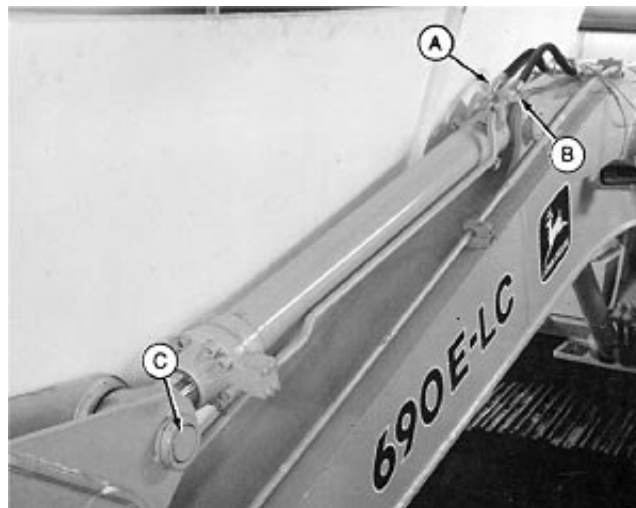

Earlier Machine Shown

A—Line to Piston End of Cylinder
 B—Line to Rod End of Cylinder
 C—Pin (2 used)

X9811 -UN-23AUG88

T7681EI -UN-27JAN92

Hydraulic System

Remove And Install Bucket Cylinder

1. Retract arm and bucket cylinders.
2. Place a floor stand under end of arm so load is on arm cylinder, not on bucket cylinder when boom is lowered. Lower bucket to ground.
3. Release pressure in hydraulic reservoir. Unlock hydraulic tank fill cap. Slowly turn cap to release air pressure.

33
3360
171

Continued on next page

TX,33,DY2997 -19-27AUG97-1/2

Hydraulic System

! **CAUTION:** Escaping fluid under pressure can penetrate the skin causing serious injury. Avoid the hazard by relieving pressure before disconnecting hydraulic or other lines. Tighten all connections before applying pressure. Search for leaks with a piece of cardboard. Protect hands and body from high pressure fluids.

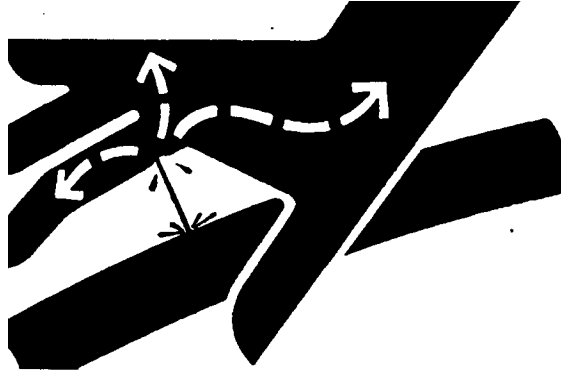

If an accident occurs, see a doctor immediately. Any fluid injected into the skin must be surgically removed within a few hours or gangrene may result. Doctors unfamiliar with this type of injury may call the Deere & Company Medical Department in Moline, Illinois, or other knowledgeable medical source.

4. Disconnect lines (A and C).

! **CAUTION:** The approximate weight of bucket cylinder is 142 kg (312 lb.)

5. Remove pins (B and D). Note location of shims to aid assembly. Remove cylinder.
6. Repair or replace cylinder as necessary.
7. Install cylinder. Check for 1.5 mm (0.06 in.) or less play at both ends of cylinder. Add or remove shims as necessary.
8. Connect lines. Bleed air from cylinder. (See procedure in this group.)
9. Operate cylinder through several cycles. Check reservoir oil level. Add oil as necessary.

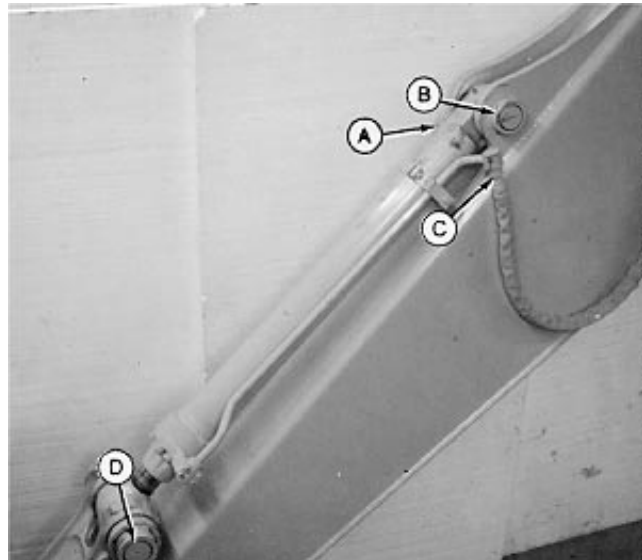

Earlier Machine Shown

A—Line to Cylinder Piston End
 B—Pin
 C—Line to Cylinder Rod End
 D—Pin

X9811 -UN-23AUG88

T7681EJ -UN-27JAN92

TX,33,DY2997 -19-27AUG97-2/2

Hydraulic Cylinder Bleed Procedure

IMPORTANT: Trapped air in the hydraulic system can damage the cap seals and rings on cylinder piston or hydraulic pump components.

When positioning machine to bleed cylinders, avoid moving cylinders suddenly or quickly to prevent burning seals.

NOTE: Bleed air at initial start-up, whenever major repairs or maintenance (oil change) is done on hydraulic system or when machine has been in storage for a period of time.

1. Run engine at slow idle.
2. Slowly operate functions to move the cylinder to the most horizontal position possible.
3. Slowly extend and retract cylinder several times to approximately 100 mm (4 in.) from end of stroke.
4. Operate cylinder several times to full stroke.

3360,NN280 -19-19OCT94-1/1

Hydraulic System

Disassemble Bucket, Arm, And Boom Cylinders

CAUTION: The approximate weight of cylinders are:

Bucket Cylinder..... 142 kg (312 lb)

Arm Cylinder..... 296 kg (652 lb)

Boom Cylinder..... 189 kg (416 lb)

NOTE: Procedures are the same for all cylinders except as noted; Arm cylinder shown.

1. Fasten rod end of cylinder to JT30043 Hydraulic Cylinder Repair Stand.

TX,3360,VV389 -19-25NOV91-1/10

2. Remove rod guide cap screws (A) and disconnect rod end line (B).

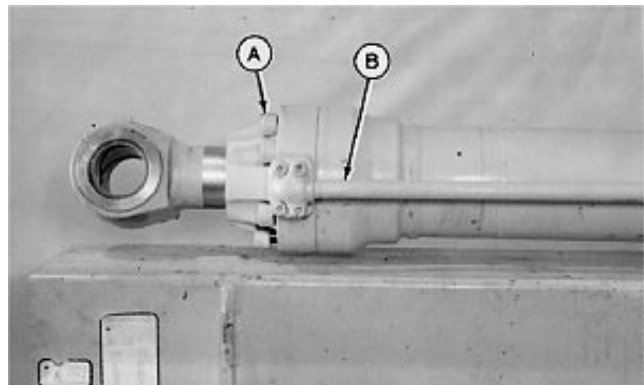

T6557HI -UN-27OCT88

TX,3360,VV389 -19-25NOV91-2/10

3. Pull rod with rod guide out of cylinder housing. Remove rod assembly using lift straps and a hoist. Move rod guide (A) as required to balance the rod.

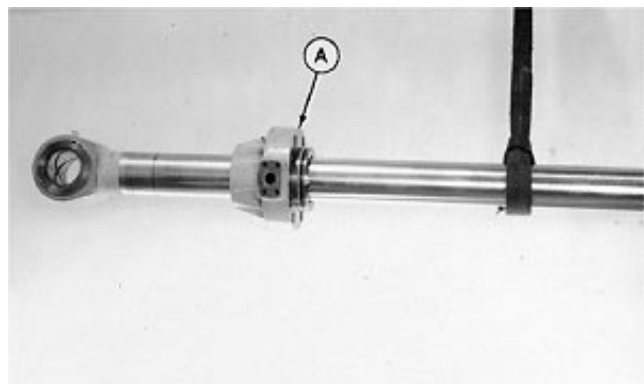

T6557HJ -UN-27OCT88

Continued on next page

TX,3360,VV389 -19-25NOV91-3/10

Hydraulic System

4. Install head end of rod in housing (B) and install inside JT30043 Hydraulic Cylinder Repair Stand.

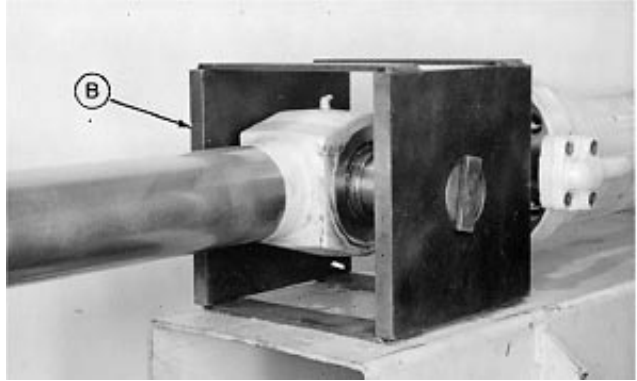

33
3360
175

T6557HK -UN-27OCT88

TX,3360,VV389 -19-25NOV91-4/10

5. Install wrench on the piston nut (A) with the setscrew at the bottom.

IMPORTANT: Damage to piston nut flats can result from tightening setscrew. Use a steel spacer between nut and setscrew before tightening.

6. To protect nut from possible damage from setscrew, install a 38 x 51 x 6.4 mm (1.5 x 2.0 x 0.25 in.) piece of steel flat stock (A) between nut and setscrew.

7. Tighten setscrew.

Bucket Cylinder—Specification

Piston Nut—M62 x 2—Torque	4740 N•m (3485 lb-ft)
Piston Nut—M52 x 2—Torque	4260 N•m (3130 lb-ft)
Rod Guide Cap Screws—Torque	558 N•m (410 lb-ft)

Arm Cylinder—Specification

Piston Nut—Torque	7560 N•m (5560 lb-ft)
Rod Guide Cap Screws—Torque	972 N•m (715 lb-ft)
Cushion Cap Screw—Torque.....	972 N•m (715 lb-ft)

Boom Cylinder—Specification

Piston Nut—Torque	6080 N•m (4470 lb-ft)
Rod Guide Cap Screws—Torque	558 N•m (410 lb-ft)

8. Remove nut.



T6685XJ -UN-27OCT88

Continued on next page

TX,3360,VV389 -19-25NOV91-5/10

Hydraulic System

9. Remove parts (A—F) from rod (I).

10. Remove O-ring (G).

- A—Cap Screw (Arm cylinder only)
- B—Washer (Arm cylinder only)
- C—Cushion (Arm cylinder only)
- D—Nut
- E—Piston
- F—Cushion
- G—O-Ring
- H—Rod Guide
- I—Cylinder Rod

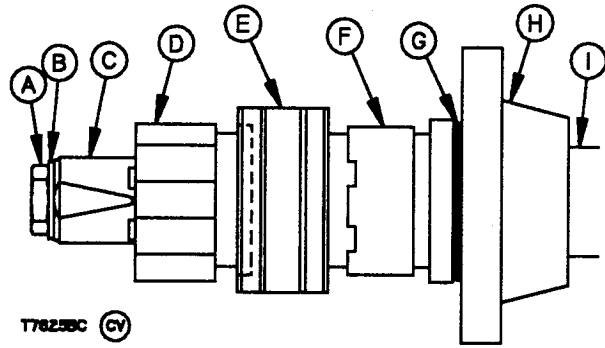

T7625BC -UN-22OCT91

TX,3360,VV389 -19-25NOV91-6/10

11. Remove parts (A—E) from the piston (F).

12. Remove rod guide from rod.

- A—Wiper Ring (2 used)
- B—Seal Expander
- C—Cap Seal
- D—Backup Ring (2 used)
- E—Wear Ring (2 used)
- F—Piston



T7625BE -UN-22OCT91

Continued on next page

TX,3360,VV389 -19-25NOV91-7/10

Hydraulic System

13. Remove O-ring (A).

Remove retaining ring (B) from rod guide if bearing (C) replacement is necessary.

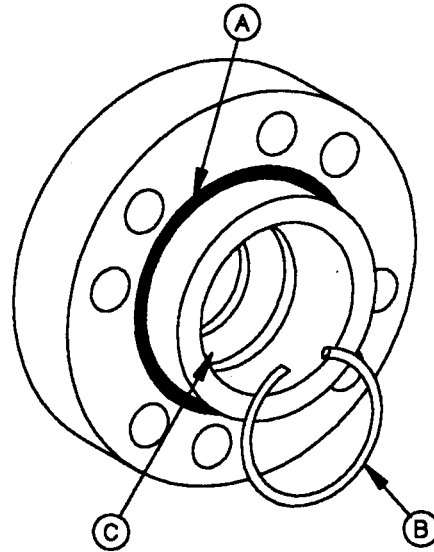

T7626AA (CV)

Continued on next page

TX,3360,VV389 -19-25NOV91-8/10

33
3360
177

T7626AA -UN-22OCT91

Hydraulic System

33
3360
178

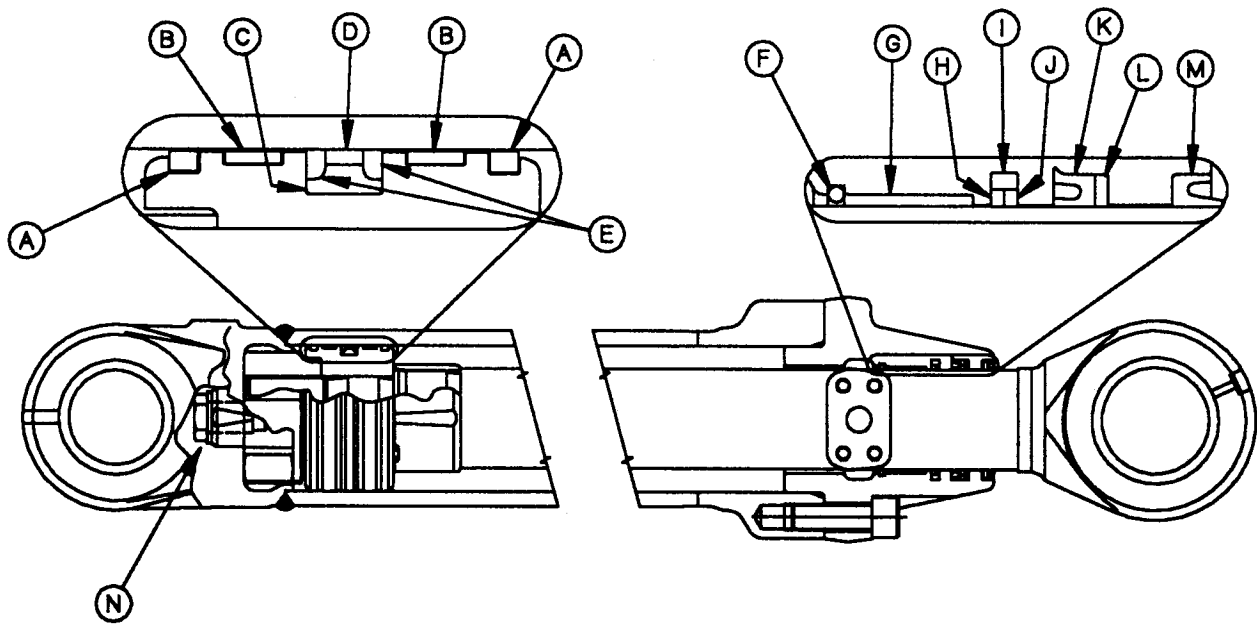

T7623AC (C)

- | | | | |
|-----------------------|------------------------|----------------------|---------------------------------|
| A—Wiper Ring (2 used) | E—Backup Ring (2 used) | I—Ribbed Rubber Ring | M—Wiper seal |
| B—Wear ring (2 used) | F—Retaining ring | J—Plain Ring | N—Cap Screw (Arm Cylinder Only) |
| C—Expander | G—Bearing | K—U-cup seal | |
| D—Cap Seal | H—Notched Ring | L—Backup Ring | |

14. Remove remaining parts (H—M).

TX.3360,VV389 -19-25NOV91-9/10

15. Inspect rod and head end bushings (B) and seals (A) for damage; replace if necessary.

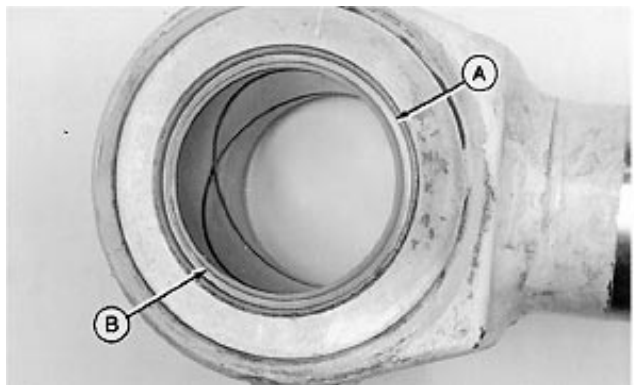

TX.3360,VV389 -19-25NOV91-10/10

T7623AC -UN-24OCT91

T6557HR -UN-27OCT88

Hydraulic System

Assemble Bucket, Arm And Boom Cylinders

NOTE: Use a cylinder repair kit when assembling cylinder.

1. Press bushing (B) into both rod or head ends of cylinder until it is centered in bore.
2. Install seals (A) tight against bushing with seal lip outward.

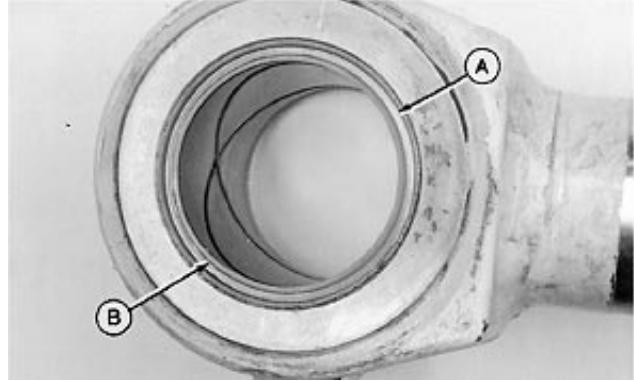

TX,3360,VV392 -19-25NOV91-1/10

33
3360
179

T6557HR -UN-27OCT88

IMPORTANT: DO NOT use a hammer to install bearing into rod guide.

3. Using a disk driving set and a hydraulic press, push bearing (C) to bottom of bore in rod guide.
4. Install retaining ring (B) and O-ring (A).

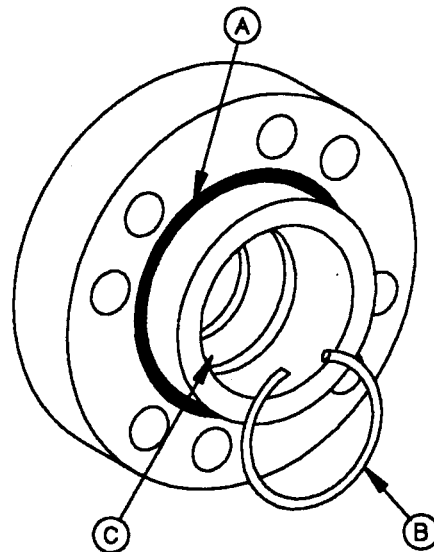

T7828AA (C)

Continued on next page

TX,3360,VV392 -19-25NOV91-2/10

T7626AA -UN-22OCT91

Hydraulic System

5. Install seals by using bending method (K). DO NOT twist seals. Install seal (I) with ribbed side toward bearing (B).
6. Install ring (D) with the notched side (C) towards bearing (B).
7. Install backup ring (E).
8. Install parts (F—H)

- A—Retaining Ring
- B—Bearing
- C—Notch Side
- D—Notched Ring
- E—Ring
- F—U-Cup Seal
- G—Backup Ring
- H—Wiper Seal
- I—Ribbed Rubber Seal
- J—Rod Guide
- K—Seal Installation

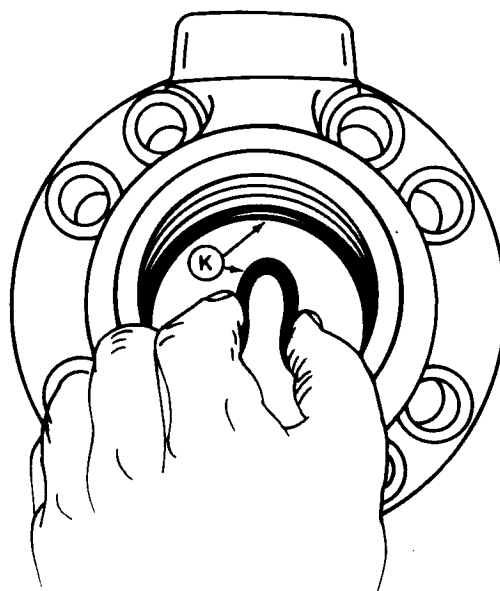

T7963AK

T7963AK -UN-01APR93

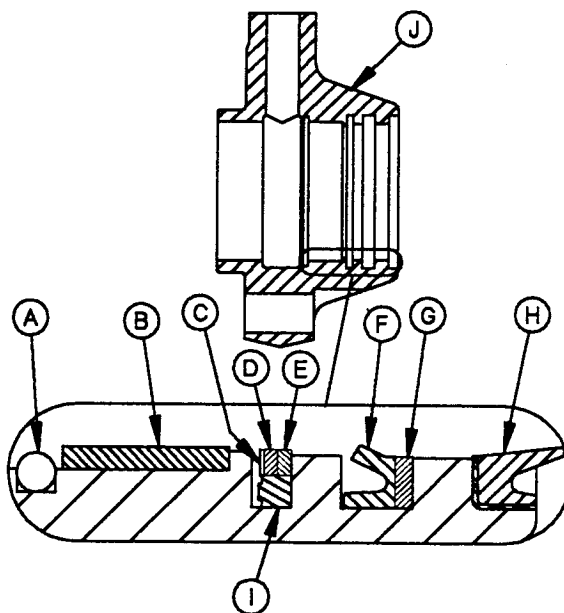

T7623AF (CV)

T7623AF -UN-22OCT91

Continued on next page

TX.3360.VV392 -19-25NOV91-3/10

33
3360
180

Hydraulic System

IMPORTANT: To prevent shoulder (E) on rod from damaging notched rod guide seal during rod guide installation, seal protectors (A) from the JDG799 Seal Protector Kit are required.

9. Install beveled end (B) of seal protector into rod guide.
10. Push seal protector into rod guide until approximately 13 mm (0.5 in.) (C) is left exposed.
11. Install the rod guide with seal protector installed, onto the rod.

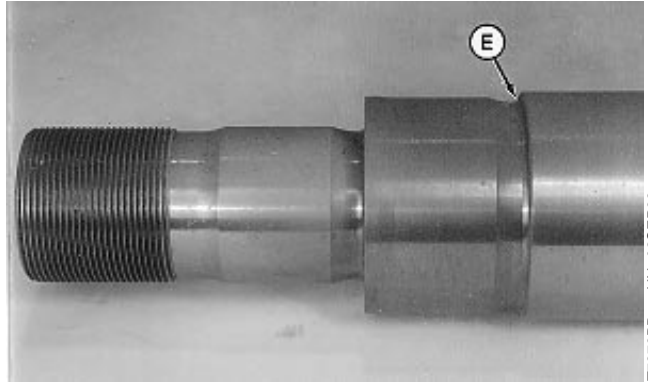

33
3360
181

T7979BB -UN-02SEP93

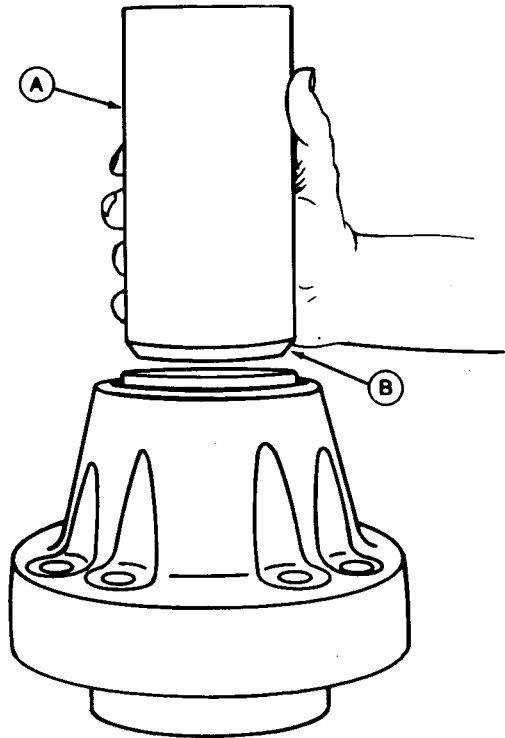

T7963AL

T7963AL -UN-01APR93

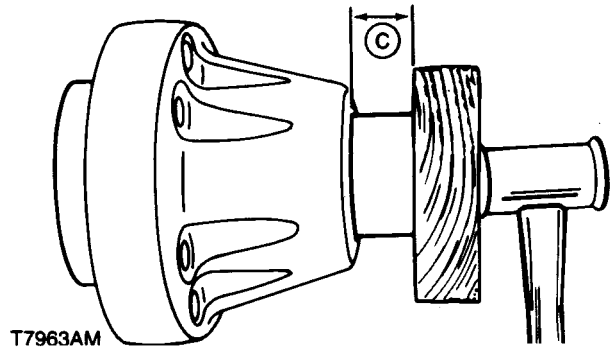

T7963AM

T7963AM -UN-01APR93

Continued on next page

TX,3360,VV392 -19-25NOV91-4/10

Hydraulic System

12. Position the end of seal protector approximately 38 mm (1.5 in.) (D) from the shoulder (E) on rod.

Using one quick smooth motion, slide the rod guide along the rod until the seal protector impacts the shoulder and the rod guide slides onto the rod.

IMPORTANT: If gray seal shavings are found on seal protector at the shoulder on the rod, the notched ring in rod guide has been damaged and must be replaced. There must be no gray seal shavings found after rod guide is installed.

13. Inspect seal protector at the rod shoulder for any gray seal shavings. If shavings are found, remove rod guide and replace the notched ring. Install the rod guide using procedure above.
14. Remove the seal protector.
15. Install the rod guide outer O-ring.

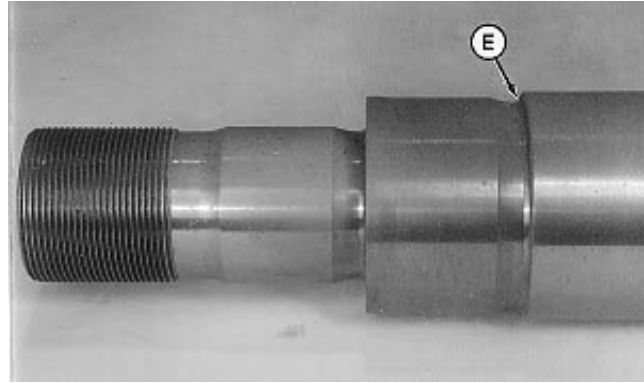

T7979BB -UN-02SEP93

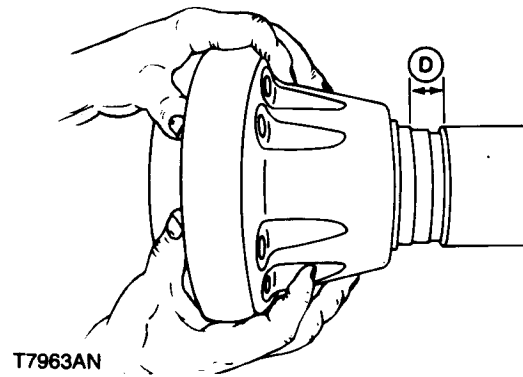

T7963AN -UN-01APR93

Continued on next page

TX,3360,VV392 -19-25NOV91-5/10

Hydraulic System

16. Install seal expander (C) into middle groove of piston.
17. Install wear ring (D) in groove below so cap seal does not go into that groove if pushed too far.
18. Install the correct size installer for each piston:
JDG841 Installer for bucket piston, JDG918 Installer for arm piston, JDG917 Installer for boom piston.

Apply clean oil to installer.

19. Push cap seal (B) down installer and into middle groove over seal expander (C) using JDG843-3 Pusher (A).
20. Check cap seal. Seal must fit tight against seal expander and not turn. If seal can be turned, it has been stretched too much and can be damaged during installation into cylinder barrel.
21. If necessary, shrink cap seal to its original size using a ring compressor or a plastic tie band and hose clamp.

When using a ring compressor, put a piece of shim stock between cap seal and compressor at joint so it does not damage seal.

When using a plastic tie band and hose clamp, grind a taper on one end of tie band. Install tie band with taper against cap seal. Before tightening hose clamp, check to be sure tie band is under hose clamp all around piston.

A—JDG843-3 Pusher JDG841 Installer For Bucket
Piston JDG918 Installer For Arm Piston JDG917
Installer For Boom Piston

B—Cap Seal
C—Seal Expander
D—Wear Ring

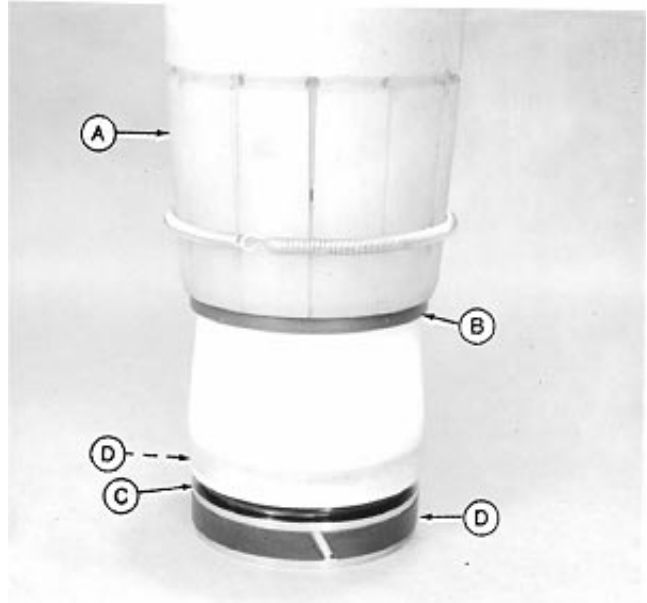

33
3360
183

T7964AQ -UN-18MAR93

T6396AC -UN-27OCT88

Continued on next page

TX,3360,VV392 -19-25NOV91-6/10

Hydraulic System

22. Install backup rings (D) with rounded edge towards radius on seal expander.
23. Install the wear rings (E) and wiper rings (A).
24. Turn the rings so the slits are approximately 90 degrees from each other.

- A—Wiper Ring (2 used)
- B—Seal Expander
- C—Cap Seal
- D—Backup Ring (2 used)
- E—Wear Ring (2 used)
- F—Piston



T7625BE -UN-22OCT91

TX,3360,VV392 -19-25NOV91-7/10

25. Install cushion (F) and piston (E).
26. Apply thread lock and sealer (medium strength) to threads on nut (D).
27. Tighten cap screw (A) to 972 N•m (715 lb-ft).

Specification

Rod Guide Cap Screw—Torque 972 N•m (715 lb-ft)

28. Install cylinder wrench on the piston nut with the setscrew at the bottom.

- A—Cap Screw (Arm cylinder only)
- B—Washer (Arm cylinder only)
- C—Cushion (Arm cylinder only)
- D—Nut
- E—Piston
- F—Cushion
- G—O-Ring
- H—Rod Guide
- I—Cylinder Rod

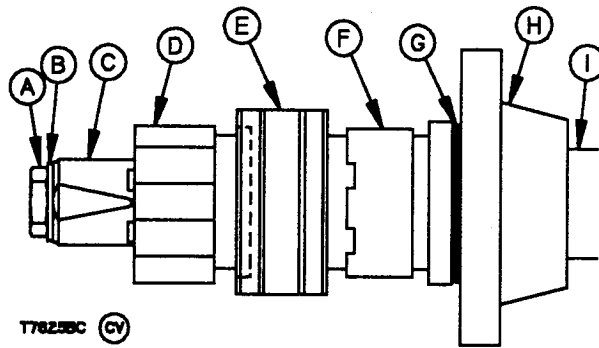

T7625BC (CV)

T7625BC -UN-22OCT91

Continued on next page

TX,3360,VV392 -19-25NOV91-8/10

Hydraulic System

33
3360
185

29. To protect nut from damage, insert a 38 x 51 x 6.4 mm (1.5 x 2.0 x 0.25 in.) piece of steel flat stock (A) between nut and setscrew.

Bucket Cylinder—Specification

Piston Nut—M62 x 2—Torque 4740 N•m (3485 lb-ft)
Piston Nut—M52 x 2—Torque 4260 N•m (3130 lb-ft)

Arm Cylinder—Specification

Piston Nut—Torque 7560 N•m (5560 lb-ft)
Cushion Cap Screw—Torque 972 N•m (715 lb-ft)

Boom Cylinder—Specification

Piston Nut—Torque 6080 N•m (4470 lb-ft)

30. Tighten nut.

31. Attach a hoist to rod using lifting straps. Carefully install rod in cylinder barrel. Do not damage piston seals.

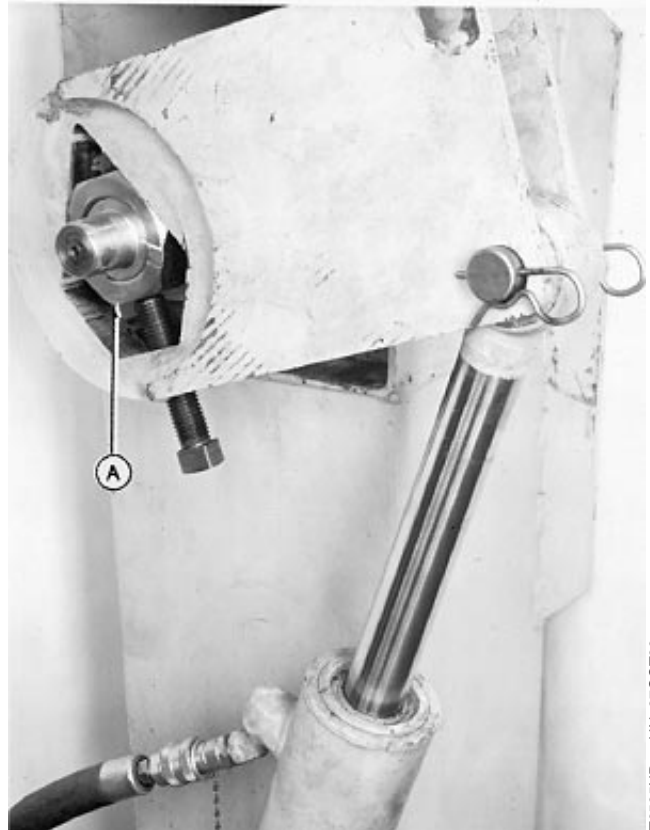

T6585XP -UN-27OCT88

TX,3360,VV392 -19-25NOV91-9/10

32. Install and tighten cap screws (A) to specification.

Bucket And Boom Cylinder—Specification

Rod Guide Cap Screw—Torque 558 N•m (410 lb-ft)

Arm Cylinder—Specification

Rod Guide Cap Screw—Torque 972 N•m (715 lb-ft)

33. Connect lines (B) to cylinder. Tighten cap screws.

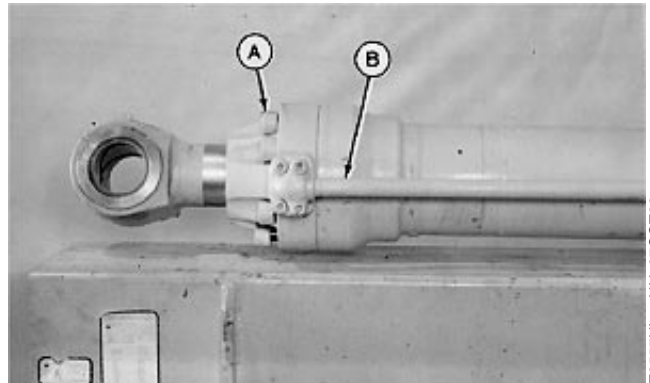

T6557HI -UN-27OCT88

TX,3360,VV392 -19-25NOV91-10/10

Hydraulic System

Remove And Install Hydraulic Oil Cooler

1. Release pressure in hydraulic reservoir. Unlock hydraulic tank fill cap. Slowly turn cap to release air pressure.
2. Drain reservoir. Approximate capacity is 148 L (39 gal).
3. Remove air conditioning condenser, if installed. It is not necessary to disconnect lines.
4. Remove grille over top of cooler and radiator.
5. Disconnect hoses (A and C).

⚠ CAUTION: Use suitable lifting device for heavy components.

6. Remove cap screws (B) from both sides of cooler.
7. Remove cooler.
8. If replacing radiator, remove engine hood latch.
9. Repair or replace cooler as necessary.
10. Install cooler.
11. Connect oil lines.
12. Install air conditioning condenser.
13. Install grille.
14. Fill reservoir.

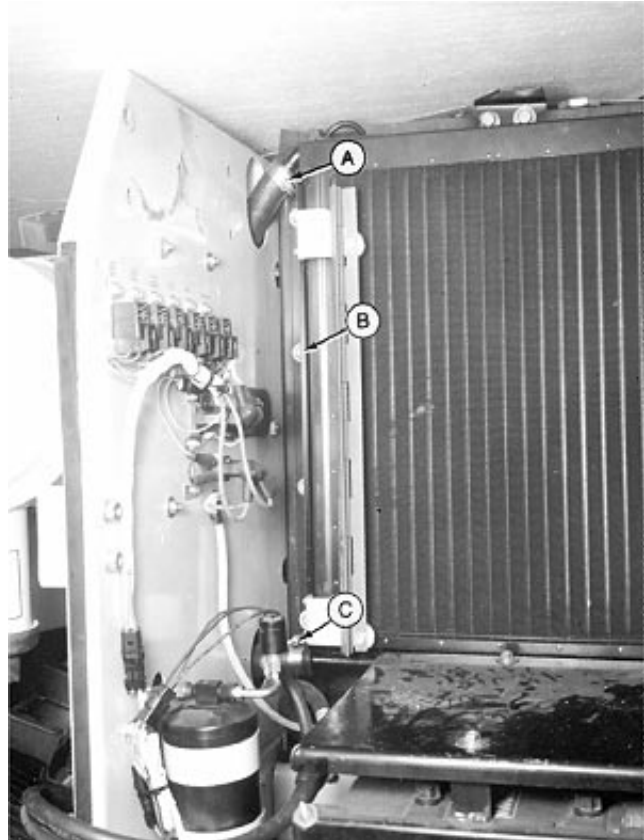

A—Radiator Inlet Hose
B—Cap Screw (10 used)
C—Radiator Outlet Hose

T7681EK -UN-27JAN92

TX,3360,AB420 -19-22FEB92-1/1

Change Hydraulic Return Filter

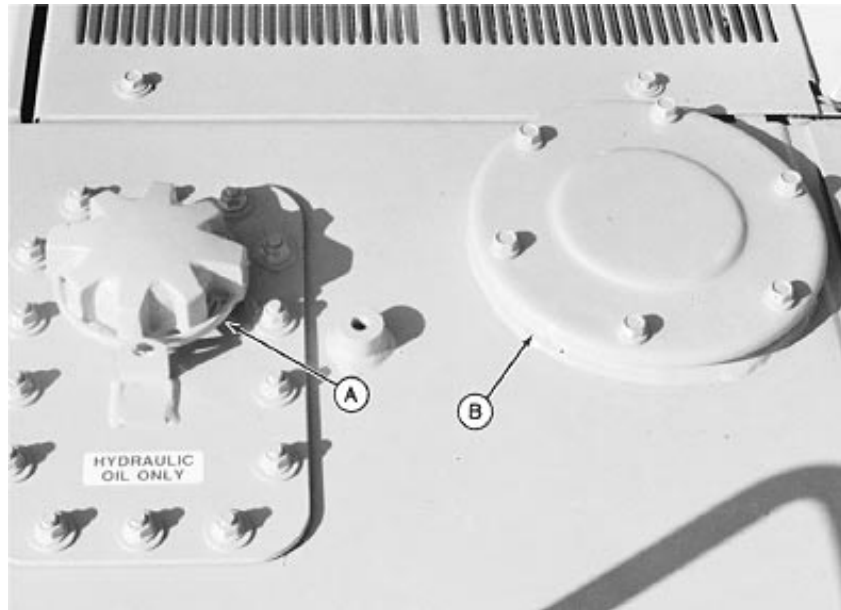

CAUTION: High pressure release of oil from pressurized system can cause serious burns or penetrating injury. The hydraulic tank is pressurized. Turn fill cap slowly. Release all pressure before removing cap.

1. Turn fill cap (A) slowly. Release all pressure before removing cap.

NOTE: There is spring tension under cover. Hold down cover when removing last two cap screws.

2. Loosen and remove cap screws on hydraulic tank filter cover (B).

Hold down filter cover against light spring load when removing the last two cap screws. Remove cover.

Continued on next page

TX,80,FF2370 -19-13AUG91-1/2

Hydraulic System

3. Remove spring (D), valve (E), and element (F).

NOTE: Remove element and inspect for metal particles and debris in bottom of filter case. Excessive amounts of brass and steel particles can indicate a failed hydraulic pump, motor, valve, or a failure in process. A rubber type of material can indicate cylinder packing failure.

4. Discard element and O-ring (C).

CAUTION: Prevent possible injury from flying chips if compressed air is more than 210 kPa (2 bar) (30 psi). Reduce compressed air to less than 210 kPa (2 bar) (30 psi) when using for cleaning purposes. Clear area of bystanders, guard against flying chips, and wear personal protection equipment including eye protection.

5. Install filter, valve, and spring in tank.

6. Install O-ring.

7. Install cover and tighten cap screws.

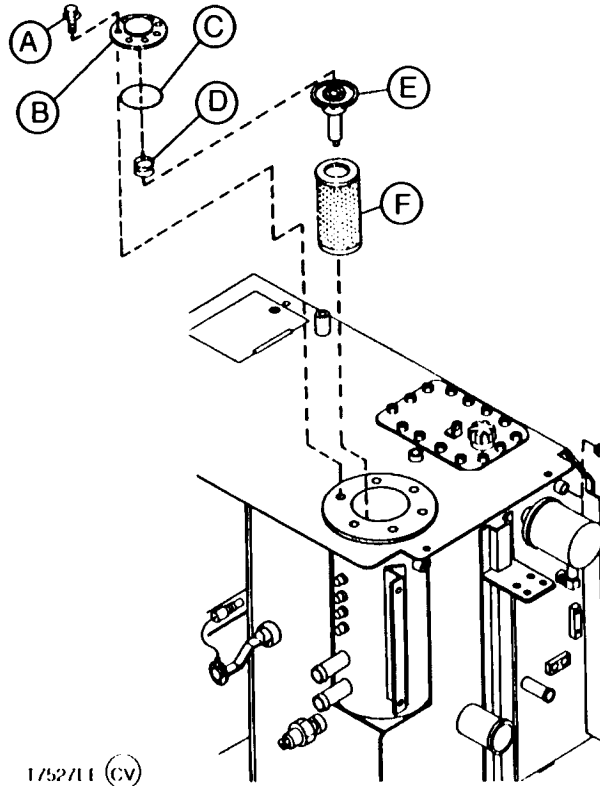

1752711 (C)

- A—Cap Screw
- B—Cover
- C—O-Ring
- D—Spring
- E—Valve
- F—Element

Specification

Hydraulic Return Filter Cover Cap

Screw—Torque..... 49 N•m (36 lb-ft)

T7527EE -UN-01AUG91

TX,80,FF2370 -19-13AUG91-2/2

Hydraulic System

33
3360
189

Hydraulic System

Remove And Install Reservoir

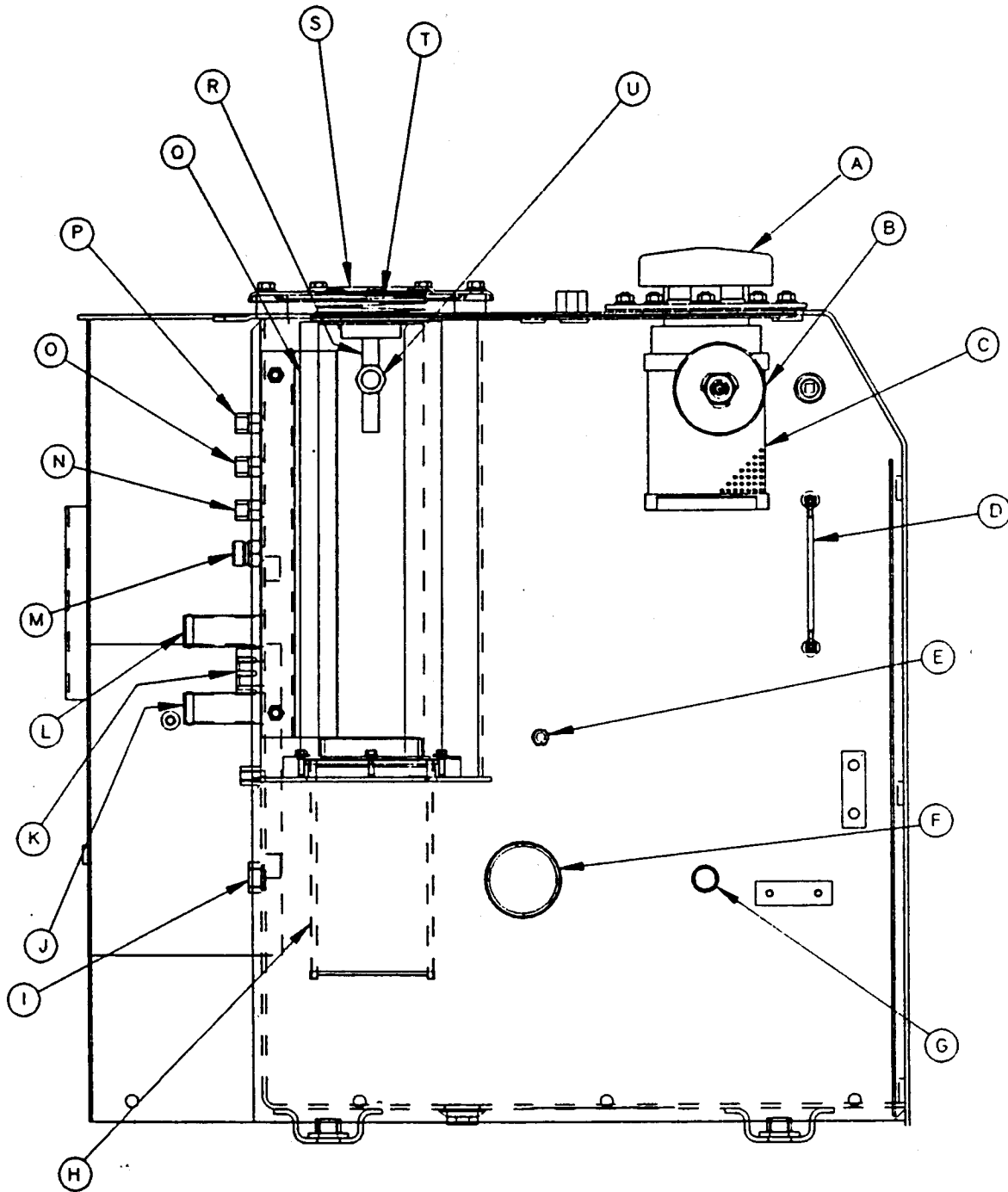

T7661EM -JUN-27JAN92

Continued on next page

TX,33,DY2998 -19-27AUG97-1/3

Hydraulic System

A—Cap	F—To Hydraulic Pumps	L—From Oil Cooler	Q—Return Filter
B—Breather Filter	G—To Pilot Pump	M—From Dual Solenoid Block	R—Filter Bypass Valve
C—Inlet Screen	H—Diffuser Screen	N—From Rotary Manifold	S—Cover
D—Sight Tube	I—Oil Temperature Switch	O—From Swing Gearbox	T—Spring
E—From Pump Regulator and Engine Speed Control Actuator	J—From Control Valve (T1) K—Oil Level Sender	P—From Pilot Shut-Off Valve	U—From Hydraulic Pumps

33
3360
191

NOTE: Walls of reservoir provide support for the fuel tank walls. Fuel tank must be drained before removing reservoir.

1. Drain fuel tank. Approximate capacity is 303 L (80 gal).
2. Release pressure in hydraulic reservoir. Unlock hydraulic tank fill cap. Slowly turn cap to release air pressure.
3. Drain reservoir. Approximate capacity is 148 L (39 gal) for machines (Serial No. —538062), and 151 L (40 gal) for machines (Serial No. 538063—).



CAUTION: Use suitable lifting device for heavy components.

4. Remove tool box.
5. Remove dual solenoid block from reservoir.
6. Remove pilot filter assembly from reservoir.
7. Disconnect electrical wiring leads.
8. Disconnect lines (E, F, G, J, L, M, N, O, P and U).

Continued on next page

TX,33,DY2998 -19-27AUG97-2/3

Hydraulic System

9. Remove four cap screws (A).
10. Remove four cap screws (B) from bottom of reservoir.

! **CAUTION: Use suitable lifting device for heavy components.**

11. Remove reservoir.
12. Repair or replace reservoir as necessary.
13. Install reservoir.
14. Connect oil lines.
15. Connect electrical wiring leads.
16. Install pilot filter assembly.
17. Install dual solenoid block.
18. Install tool box.
19. Fill reservoir. (See Hydraulic Oil in Group 0004.)
20. Fill fuel tank.



T7681EN -UN-27JAN92

TX,33,DY2998 -19-27AUG97-3/3

Hydraulic System

33
3360
193

Disassemble And Assemble Reservoir

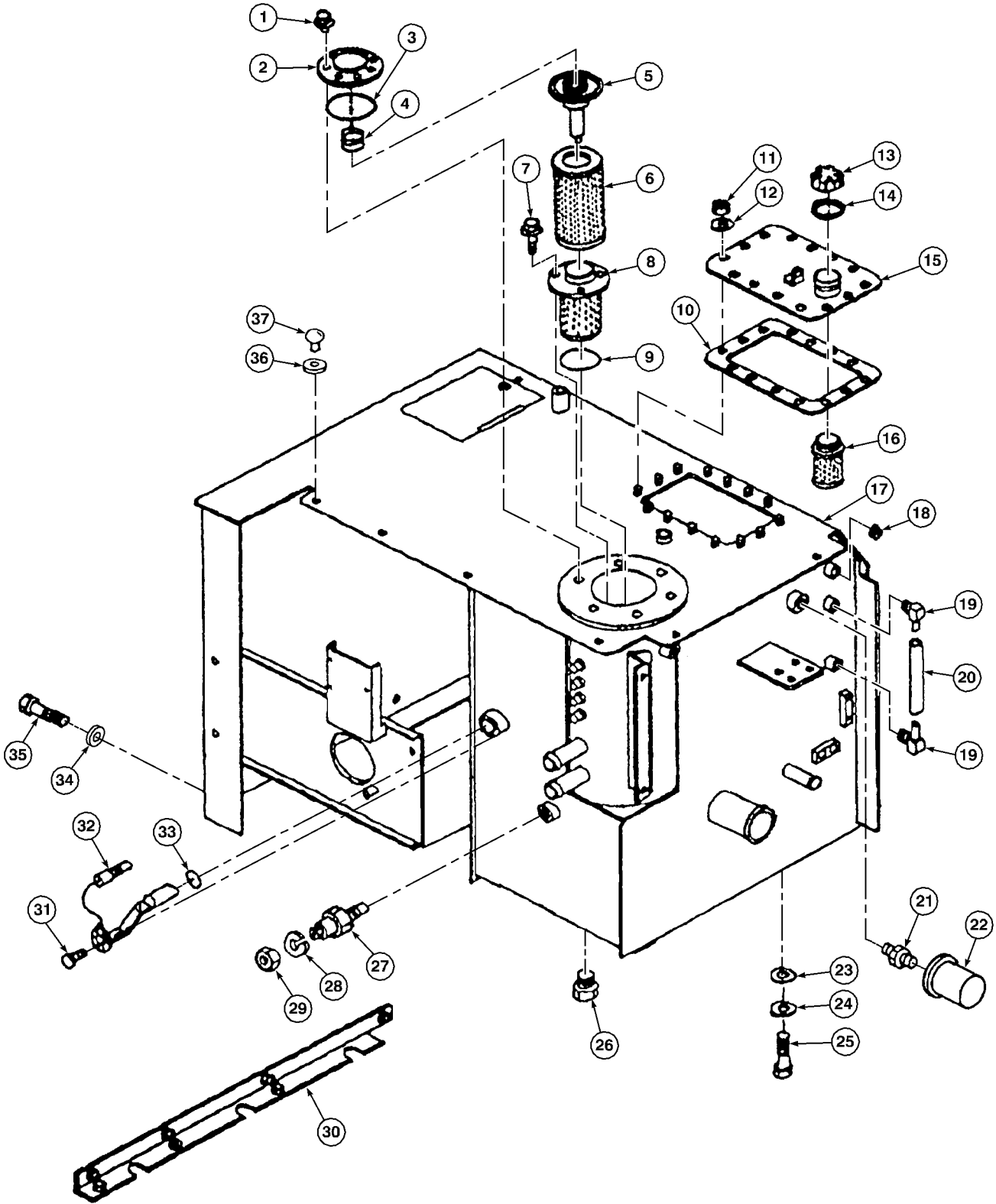

33
3360
194

T110725

T110725 -JUN-05AUG97

Continued on next page

TX,33,DW5009 -19-17JUL97-1/2

Hydraulic System

1—Screw (6 used)	12—Washer (14 used) (Serial No. 538063—)	22—Filter	31—Cap Screw (7 used)
2—Cover	13—Cap	23—Washer (as required)	32—Cap Screw (3 used)
3—O-Ring	14—Gasket	24—Washer (4 used)	33—Sensor
4—Spring	15—Cover	25—Cap Screw (4 used)	34—O-Ring
5—Valve	16—Screen	26—Fitting	35—Washer (7 used)
6—Filter Element	17—Reservoir	27—Switch	36—Cap Screw (7 used)
7—Screw (3 used)	18—Plug	28—Lock Washer (Serial No. 538063—)	37—Washer (4 used) (Serial No. 538063—)
8—Filter	19—Union Fitting (2 used)	29—Nut (Serial No. 538063—)	38—Bumper (4 used) (Serial No. 538063—)
9—O-Ring	20—Tube	30—Angle	
10—Gasket	21—Relief Valve		
11—Nut (14 used)			

Replace parts as necessary.

TX,33,DW5009 -19-17JUL97-2/2

33
3360
195

Hydraulic System

33
3360
196

Section 43

Swing Or Pivoting System

Contents

	Page
Group 4311—Brakes	
Service Equipment Tools	43-4311-1
Specifications	43-4311-1
Swing Brake	
Remove and Install	43-4311-2
Disassemble and Assemble	43-4311-3
Group 4350—Mechanical Drive Elements	
Service Equipment And Tools	43-4350-1
Other Material	43-4350-3
Specifications	43-4350-4
Swing Gearbox	
Remove and Install	43-4350-5
Start-Up Procedure	43-4350-7
Disassemble and Assemble	43-4350-8
Upperstructure	
Remove	43-4350-14
Install	43-4350-20
Swing Bearing	
Remove and Install	43-4350-23
Install Upper Seal	43-4350-24
Install Lower Seal	43-4350-26
Group 4360—Hydraulic System	
Service Equipment And Tools	43-4360-1
Other Material	43-4360-2
Specifications	43-4360-2
Swing Motor (SN -556935)	
Remove and Install	43-4360-3
Swing Motor (SN 556936-)	
Remove and Install	43-4360-5
Swing Motor	
Start-Up Procedure	43-4360-7
Remove and Install Seal	43-4360-8
Disassemble and Assemble	43-4360-9
Crossover Relief Valve	
Remove and Install	43-4360-18

Contents

43

Service Equipment Tools

*NOTE: Order tools from the U.S. SERVICE-GARD™
Catalog or from the European Microfiche Tool*

*Catalog (MTC). Some tools may be available
from a local supplier.*

SERVICE-GARD is a trademark of Deere & Company.

TX,4311,AB6 -19-08JAN92-1/4

17-1/2 and 30-Ton Puller Set

Used to remove brake piston and disk holder.

TX,4311,AB6 -19-08JAN92-2/4

Two M6-1 x 89 mm threaded rods with nuts and washers

Used to compress swing brake springs.

TX,4311,AB6 -19-08JAN92-3/4

Disk Holding Tool¹. DF1052

Used to hold brake disks together for assembly.

¹*Fabricated tool, dealer made. (See Section 99 for instructions to make tool.)*

TX,4311,AB6 -19-08JAN92-4/4

Specifications

Item	Measurement	Specification
Swing Brake Cap Screws	Torque	49 N•m (36 lb-ft)

TX,4311,AB7 -19-08JAN92-1/1

Brakes

Remove And Install Swing Brake

1. Remove swing motor. (See procedure in Group 4360.)

TX,4311,AB8 -19-08JAN92-1/2

2. Disconnect lines (A—C).

3. Remove brake and gear.

4. Repair or replace brake as necessary.

5. Install brake and gear. Tighten cap screws to 49 N•m (36 lb-ft).

Specification

Swing Brake Cap Screws—
Torque 49 N•m (36 lb-ft)

6. Connect lines.

7. Install swing motor. (See procedure in Group 4360.)

8. Do swing gearbox start-up procedure. (See procedure in Group 4350.)

Do swing motor start-up procedure. (See procedure in Group 4360.)

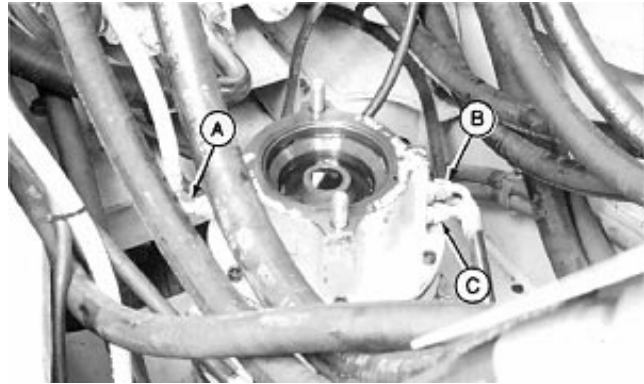

T7626BS -UN-06DEC91

- A—Swing Brake-to-Reservoir Line
- B—Swing Brake-to-Main Hydraulic Control Valve Line
- C—Swing Brake-to-Dual Solenoid Block Line

TX,4311,AB8 -19-08JAN92-2/2

43
4311
2

Brakes

Disassemble And Assemble Swing Brake

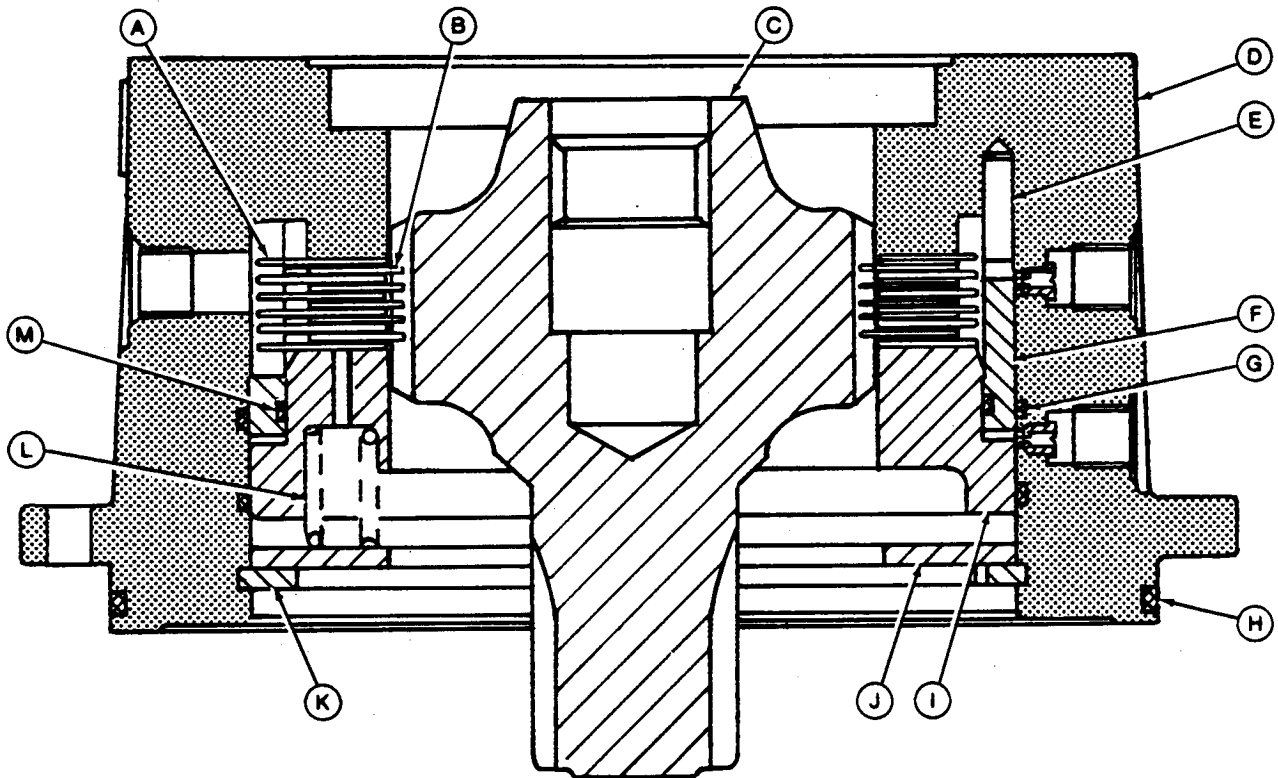

- | | | | |
|----------------------------|-----------------------|-------------------|--------------------|
| A—Separator Plate (6 used) | E—Spring Pin (6 used) | H—O-Ring | K—Snap Ring |
| B—Disk (5 used) | F—Disk Holder | I—Brake Piston | L—Spring (12 used) |
| C—Sun Gear | G—O-Ring (2 used) | J—Spring Retainer | M—O-Ring |
| D—Housing | | | |

TX.4311,AB9 -19-08JAN92-1/11

1. Remove O-ring (A).
2. Compress springs (D) using two M6-1 x 89 mm threaded rods, nuts, and washers.
Remove snap ring (B).
3. Release spring pressure to remove spring retainer (C) and springs.
Inspect springs for wear or damage.

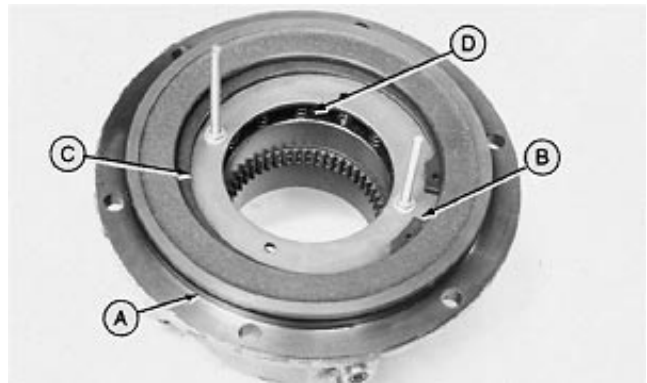

- | |
|--------------------|
| A—O-Ring |
| B—Snap Ring |
| C—Spring Retainer |
| D—Spring (12 used) |

Continued on next page

TX.4311,AB9 -19-08JAN92-2/11

Brakes

4. Remove brake piston using puller bar, M6-1 x 89 mm threaded rods, nuts, and washers.



T6439ZM -UN-22MAR90

TX,4311,AB9 -19-08JAN92-3/11

5. Remove O-rings (A and B).
6. Remove disk holder (C) using a two-jaw puller and slide hammer.
7. Remove separator plates (D) and disks (E).

A—O-Ring
 B—O-Ring
 C—Disk Holder
 D—Separator Plate (6 used)
 E—Disks (5 used)

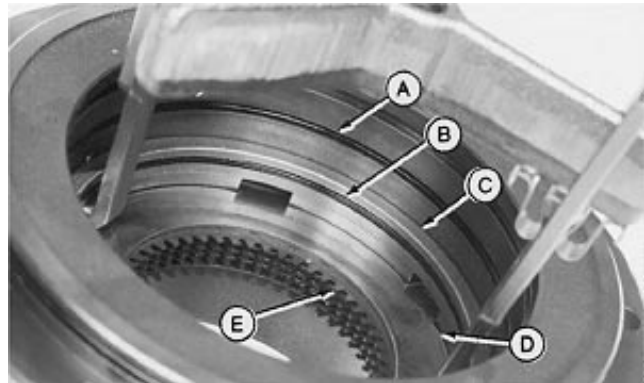

T6439ZN -UN-22MAR90

TX,4311,AB9 -19-08JAN92-4/11

8. Inspect O-ring (A) and swing pins (B), replace as necessary.

Keep split of spring pin towards center of housing.

9. Apply clean hydraulic oil to all internal parts.

When installing new disks, soak the disks in clean hydraulic oil for 1 hour.

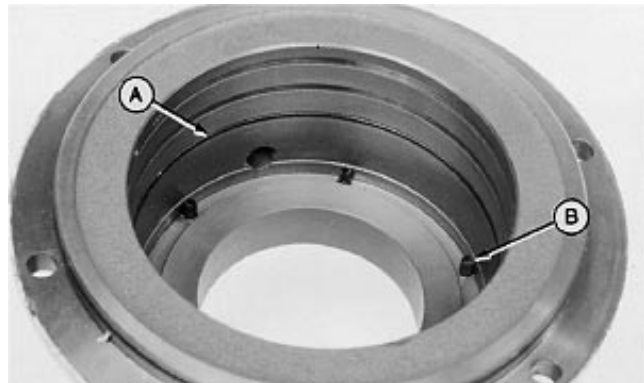

T6439ZO -UN-22MAR90

Continued on next page

TX,4311,AB9 -19-08JAN92-5/11

Brakes

10. Install O-ring (A), separator plates (B), and disks (C) in disk holder (D).

A—O-Ring
 B—Separator Plate (6 used)
 C—Disk (5 used)
 D—Disk Holder

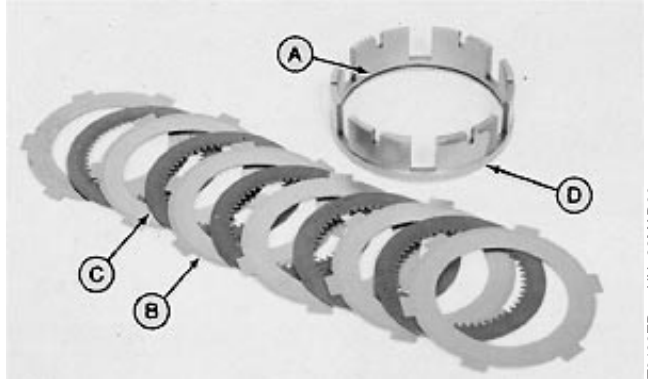

T6439ZP -UN-22MAR90

TX,4311,AB9 -19-08JAN92-6/11

43
 4311
 5

11. Install DF1052 Disk Holding Tool (A). (See Section 99 for instructions to make tool.)

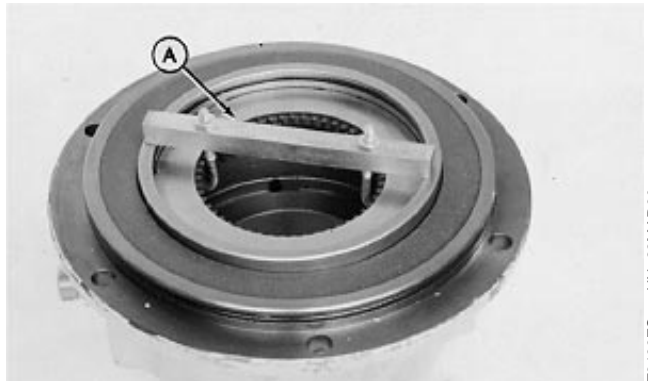

T6439ZQ -UN-22MAR90

TX,4311,AB9 -19-08JAN92-7/11

12. Install disk holder in housing. Align slots (B) in holder with spring pins (C). Push disk holder to bottom of bore.

13. Remove disk holding tool.

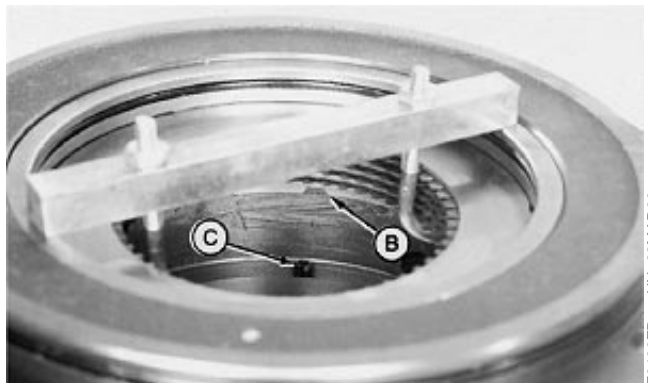

T6439ZR -UN-22MAR90

TX,4311,AB9 -19-08JAN92-8/11

14. Install O-ring (A) and brake piston. Do not push piston tight against separator plate at this time.

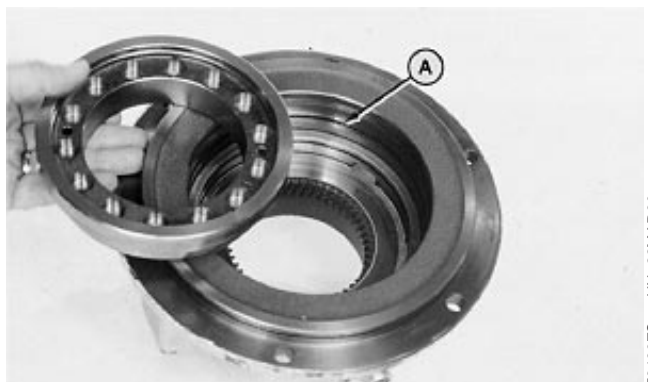

T6439ZS -UN-22MAR90

Continued on next page

TX,4311,AB9 -19-08JAN92-9/11

Brakes

15. Install gear (A) to align teeth of disks with spline on gear.
16. Push piston (B) tight against separator plates while gear is still in position.

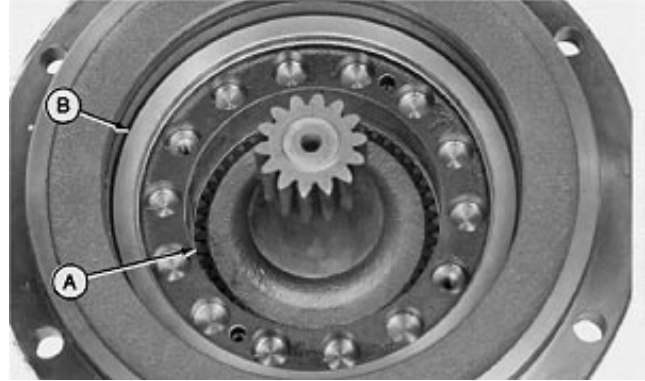

T6439ZT -UN-22MAR90

TX,4311,AB9 -19-08JAN92-10/11

17. Install springs (D) and spring retainer (C).
18. Compress springs using 6 mm threaded rods, nuts, and washers.
19. Install snap ring (B). Remove threaded rods.

IMPORTANT: A new O-ring must be used to prevent leakage. A used O-ring has taken a set and may not seal if reused.

20. Install a new O-ring (A).

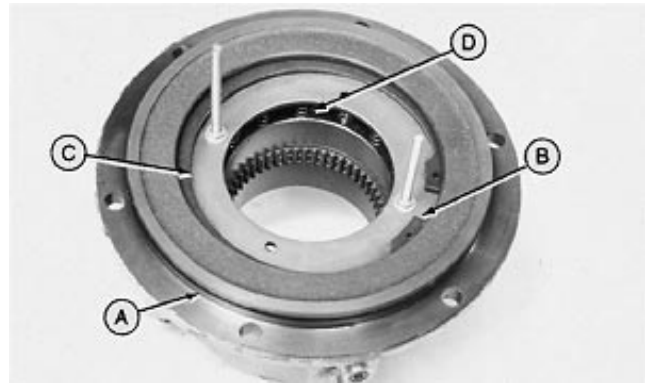

T6439ZL -UN-22MAR90

- A—O-Ring
- B—Snap Ring
- C—Spring Retainer
- D—Spring (12 used)

TX,4311,AB9 -19-08JAN92-11/11

Service Equipment And Tools

NOTE: Order tools from the U.S. SERVICE-GARD™ Catalog or from the European Microfiche Tool Catalog (MTC). Some tools may be available from a local supplier.

SERVICE-GARD is a trademark of Deere & Company.

TX,4350,AB37 -19-20APR95-1/9

17-1/2 and 30 Ton Puller Set

Used to remove bearings.

TX,4350,AB37 -19-20APR95-2/9

Spring Scale

Used measure rolling torque of swing drive.

TX,4350,AB37 -19-20APR95-3/9

Lifting Brackets JT01748

Used with hoist to remove and install swing gearbox.

TX,4350,AB37 -19-20APR95-4/9

Swing Gearbox Pinion Holding Fixture¹ DFT1074

Used to hold swing motor pinion.

¹Fabricated tool, dealer made. (See Section 99 for instructions to make tools.)

Continued on next page

TX,4350,AB37 -19-20APR95-5/9

Mechanical Drive Elements

Swing Gearbox Nut Spanner Wrench¹ DF1054

Used to remove special staked gearbox nut.

¹Fabricated tool, dealer made. (See Section 99 for instructions to make tools.)

TX,4350,AB37 -19-20APR95-6/9

Barrel Support¹ DFT1089

Use two under counterweight with bridge planks and two under main frame and corner of cab with wide flange beam to support upperstructure.

¹Fabricated tool, dealer made. (See Section 99 for instructions to make tools.)

TX,4350,AB37 -19-20APR95-7/9

Wide Flange Beam¹

Used to support upperstructure.

¹Fabricated tool, dealer made. (See Section 99 for instructions to make tools.)

TX,4350,AB37 -19-20APR95-8/9

Bridge Planks¹

Used to support upperstructure.

¹Fabricated tool, dealer made. (See Section 99 for instructions to make tools.)

TX,4350,AB37 -19-20APR95-9/9

43
4350
2

Mechanical Drive Elements

Other Material

Number	Name	Use
	Lithium Grease	To lubricate swing gearbox bearings and metal seal.
	Multi-Purpose EP Grease	To lubricate swing bearing.
	General Purpose Grease	To lubricate threads of swing bearing to undercarriage cap screws.
	SCOTCH-GRIP® Plastic Adhesive	To bond upper and lower seal to swing bearing.
T43512 (U.S.) TY9473 (Canadian) 242 (LOCTITE®)	Thread Lock and Sealer (Medium Strength) Products	Used to apply to threads of cap screws for valve housing and cover.
TY6305 (U.S.) TY9485 (Canadian) 764 (LOCTITE®)	Clean and Cure Primer Products	Used to clean surfaces prior to application of adhesives and sealants.

43
4350
3

SCOTCH-GRIP is a registered trademark of the 3M Company.
LOCTITE is a registered trademark of Loctite Corp.

TX,43,DY2988 -19-27AUG97-1/1

Mechanical Drive Elements

Specifications

Item	Measurement	Specification
Swing Gearbox:		
Gearbox-to-Frame Cap Screw	Torque	190 N•m (140 lb-ft)
Bearing-to-Pinion Shaft Special Nut	Torque	2000 N•m (1475 lb-ft)
Bearing Adjustment	Rolling Drag Torque of Shaft Turning Force of Housing at Smallest Diameter	22—29 N•m (16—21 lb-ft) 245—320 N (55—72 lb force)
Housing-to-Ring Gear Cap Screw	Torque	55 N•m (40 lb-ft)
Swing Bearing:		
Undercarriage-to-Swing Bearing Cap Screw	Torque	530 N•m (390 lb-ft)
Upperstructure Removal And Installation:		
Floor to Bottom of Main Frame	Height	1270 mm (50 in.)
Swing Bearing-to-Upperstructure Cap Screw	Torque	620 N•m (460 lb-ft)
Rotary Manifold-to-Undercarriage Cap Screw	Torque	98 N•m (65 lb-ft)

TX,4350,AB289 -19-16NOV94-1/1

Remove And Install Swing Gearbox

NOTE: Swing motor and swing brake may be removed as one unit.

Swing motor, brake, and gearbox may be removed as one unit also, but for ease of lifting, motor and brake are removed.

1. Release pressure in hydraulic reservoir. Unlock hydraulic tank fill cap. Slowly turn cap to release air pressure. Remove cap.
2. Remove swing motor. (See procedure in Group 4360.)
3. Remove swing brake. (See procedure in Group 4311.)

Continued on next page

TX,4350,AB10 -19-20APR95-1/2

43
4350
5

CAUTION: Approximate weight of swing gearbox is 91 kg (200 lb).

- Remove cap screws (E). Remove swing gearbox (A) using lifting brackets (D) and a hoist.

Use cap screws (B) to separate gearbox from spacer (C).

- Repair or replace gearbox as necessary.
- Install gearbox.
- Install one washer on 13 cap screws not located over swing bearing.
- Install three cap screws over swing bearing hand tight. Determine number of washers that will fit between head of cap screws and spacer. Add one washer.
- Tighten cap screws to 190 N•m (140 lb-ft).

Specification

Gearbox-to-Frame Cap Screw—
Torque 190 N•m (140 lb-ft)

- Install swing brake. (See procedure in Group 4311.)
- Install swing motor. (See procedure in Group 4360.)
- Do swing gearbox start-up procedure. (See procedure in this group.)

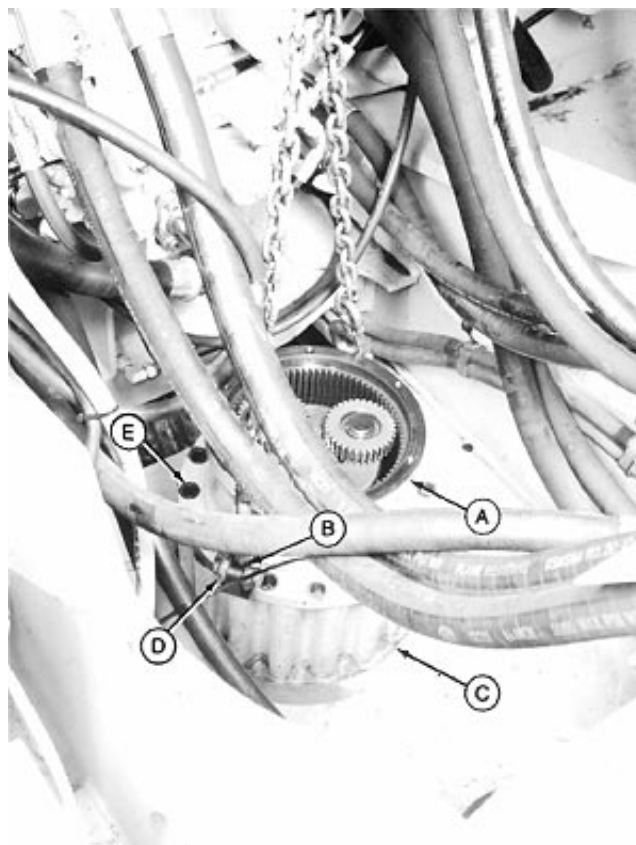

A—Swing Gearbox
B—Cap Screw (2 used)
C—Spacer
D—Lifting Bracket (2 used)
E—Cap Screw (16 used)

T7626BT -UN-06DEC91

TX,4350,AB10 -19-20APR95-2/2

43
4350
6

Swing Brake And Gearbox Start-Up Procedure

IMPORTANT: Failure to fill swing gearbox and brake with oil before operating swing function may result in damage. Procedure must be performed whenever a new swing gearbox or brake is installed or oil has been drained from the gearbox and swing brake.

Procedure is to ensure the swing gearbox and brake are filled and there is a flow of oil for lubrication and cooling before operating the swing function.

Start engine and run for 4—5 minutes before operating swing function to ensure swing gearbox and brake are filled and there is a flow of oil for lubrication and cooling.

TX,902525,GG163 -19-21AUG91-1/1

43
4350
7

Disassemble And Assemble Swing Gearbox

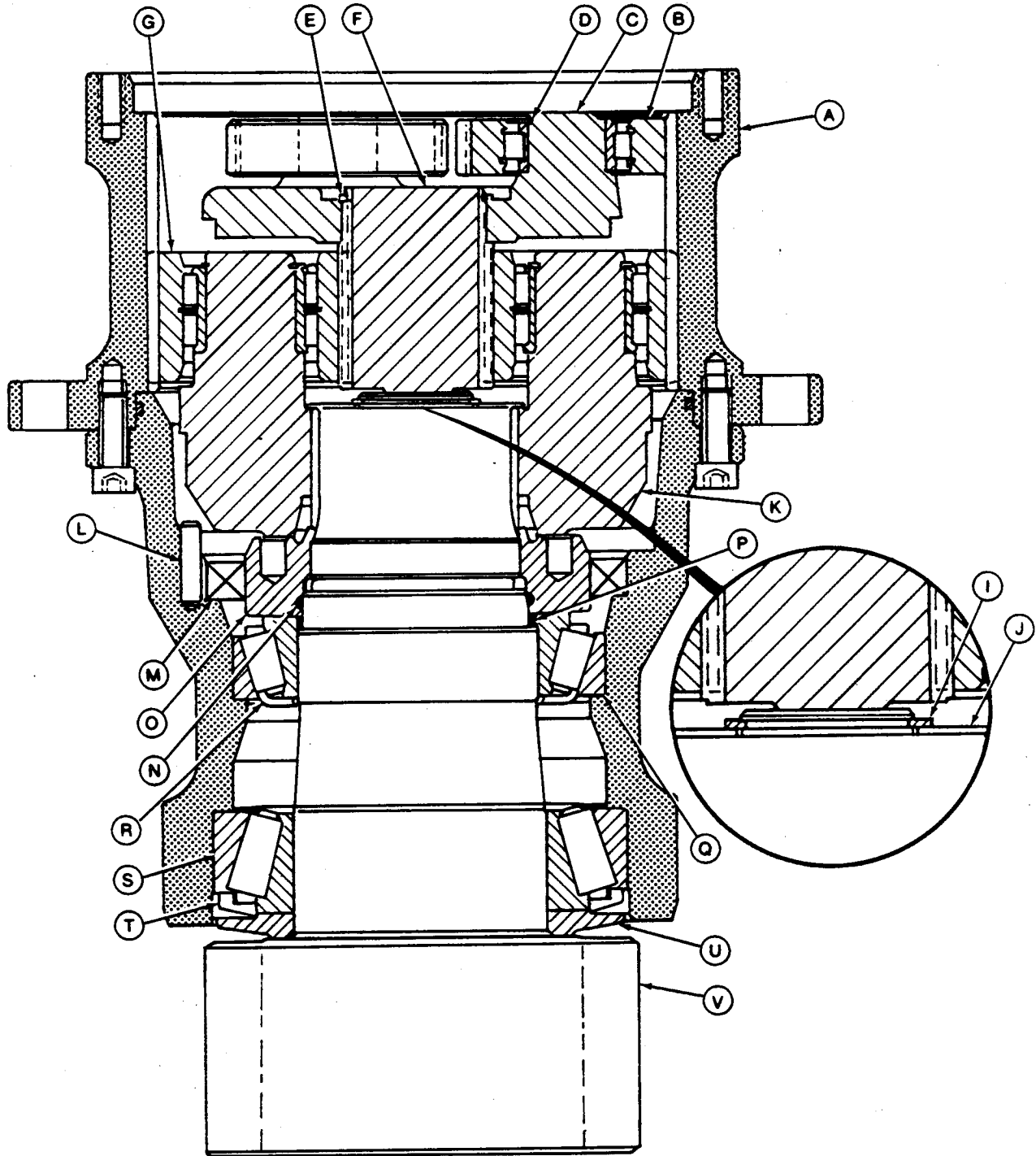

Cross Section Of Swing Gearbox

T6439ZX -JUN-07NOV88

Continued on next page

TX,43,DY2989 -19-27AUG97-1/13

Mechanical Drive Elements

- | | | | |
|--|---|-------------------------|--------------------|
| A—Ring Gear | F—Second Sun Gear | K—Second Planet Carrier | Q—Upper Bearing |
| B—First Planet Gear and Bearing (3 used) | G—Second Planet Gear and Bearing (3 used) | L—Magnet | R—Upper Metal Seal |
| C—First Planet Carrier | H—Snap Ring (3 used) | M—Seal | S—Lower Bearing |
| D—Snap Ring (3 used) | I—Snap Ring | N—O-Ring | T—Lower Metal Seal |
| E—Snap Ring | J—Washer | O—Special Nut | U—Cover |
| | | P—Spacer Ring | V—Pinion Shaft |

TX,43,DY2989 -19-27AUG97-2/13

43
4350
9

1. Remove first planet carrier assembly.



T6641AM -JUN-26MAR90

TX,43,DY2989 -19-27AUG97-3/13

NOTE: Second sun gear snap ring can be removed from sun gear without removing planet gears.

2. Remove snap ring (E). Remove second sun gear (C).
3. Remove snap ring (A).

NOTE: Planet gear is outer race of bearing. Bearing and planet gear must be replaced as one piece.

4. Remove planet gear (B) using a two-jaw puller.
5. Install planet gear using a piece of pipe and a press. Push on inner race of bearing.
6. Install second sun gear and snap rings.

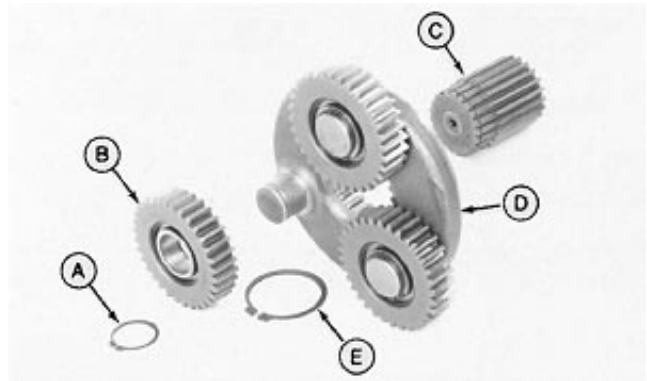

T6641AN -JUN-20MAR90

- A—Snap Ring (3 used)
 B—First Planet Gear (3 used)
 C—Second Sun Gear
 D—First Planet Carrier
 E—Snap Ring

Continued on next page

TX,43,DY2989 -19-27AUG97-4/13

Mechanical Drive Elements

- Attach ring gear (A) to a hoist. Remove socket head screws (B). Remove ring gear.

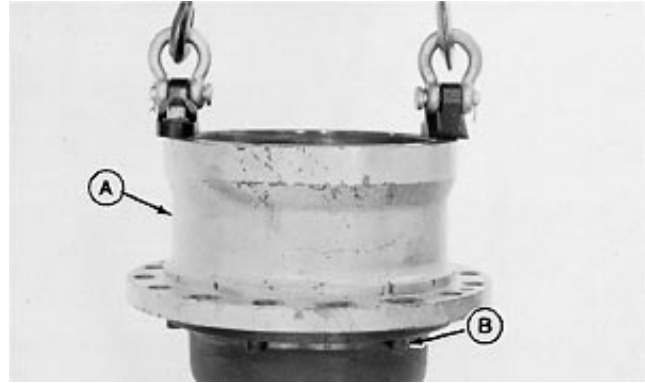

T6641AQ -UN-20MAR90

TX,43,DY2989 -19-27AUG97-5/13

- Remove snap ring and second planet carrier assembly.



T6641AP -UN-20MAR90

TX,43,DY2989 -19-27AUG97-6/13

- Remove snap ring (B).

NOTE: Planet gear is outer race of bearing. Bearing and planet gear must be replaced as one piece.

- Remove planet gear (C) using a two-jaw puller.
- Replace washer (D) and O-ring (A) as necessary.
- Install planet gear using a piece of pipe and a press. Push on inner race of bearing.

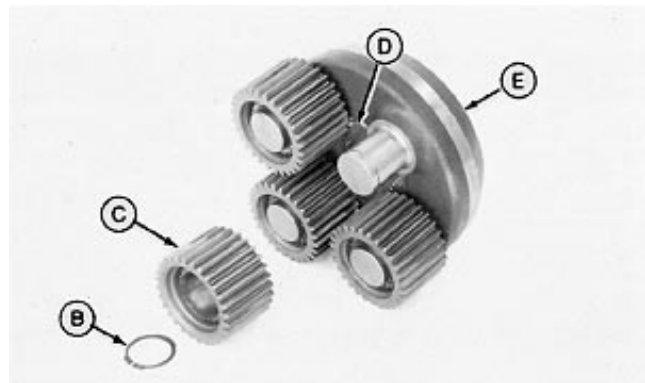

T6641AQ -UN-20MAR90

- A—O-Ring
- B—Snap Ring (4 used)
- C—Second Planet Gear (4 used)
- D—Washer
- E—Second Planet Carrier

Continued on next page

TX,43,DY2989 -19-27AUG97-7/13

Mechanical Drive Elements

13. Install and clean magnet (A).

NOTE: Special nut is staked in five positions (B).

14. Hold pinion shaft using DFT1074 Swing Gearbox Pinion Holding Fixture. Remove special nut (C) using DF1054 Swing Gearbox Nut Spanner Wrench (E). (See Section 99 for instructions to make tools.)

15. Remove oil seal (D).

- A—Magnet
- B—Staking—5 Places
- C—Special Nut
- D—Oil Seal
- E—DF1054 Spanner Wrench

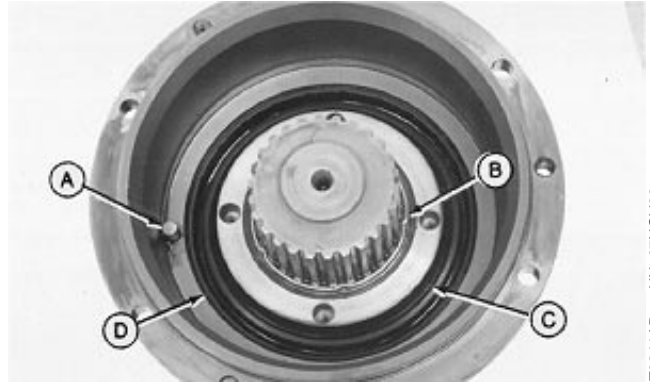

T6641AR -UN-07NOV88

43
4350
11



T7628BU -UN-06DEC91

Continued on next page

TX,43,DY2989 -19-27AUG97-8/13

Mechanical Drive Elements

**IMPORTANT: Spacer is ground to a close tolerance.
Use care in handling.**

16. Remove spacer (D).
17. Remove pinion shaft (N).
18. Remove lower bearing cone (K), metal seal (L), and cover (M).
19. Replace parts as necessary.
20. Install cover with tapered side towards gear.
21. Install lower metal seal with outer edge towards bearing. Fill seal with lithium grease.
22. Heat bearing cone in a bearing heating oven to approximately 93°C (200°F). Install cone on pinion shaft. Fill cone with lithium grease.
23. Install housing on pinion shaft.
24. Fill upper bearing cone and metal seal with lithium grease. Install seal with inner edge towards bearing.
25. Install bearing cone.
26. Install spacer with points towards spline.
27. Install O-ring (C) in special nut. Install and tighten nut to 2000 N•m (1475 lb-ft).

Specification

Bearing-to-Pinion Shaft Special
Nut—Torque 2000 N•m (1475 lb-ft)

- A—Oil Seal
- B—Special Nut
- C—O-Ring
- D—Spacer
- E—Bearing Cone and Cup
- F—Metal Seal
- G—O-Ring
- H—Magnet
- I—Housing
- J—Cap Screw (6 used)
- K—Bearing Cone and Cup
- L—Metal Seal
- M—Cover
- N—Pinion Shaft

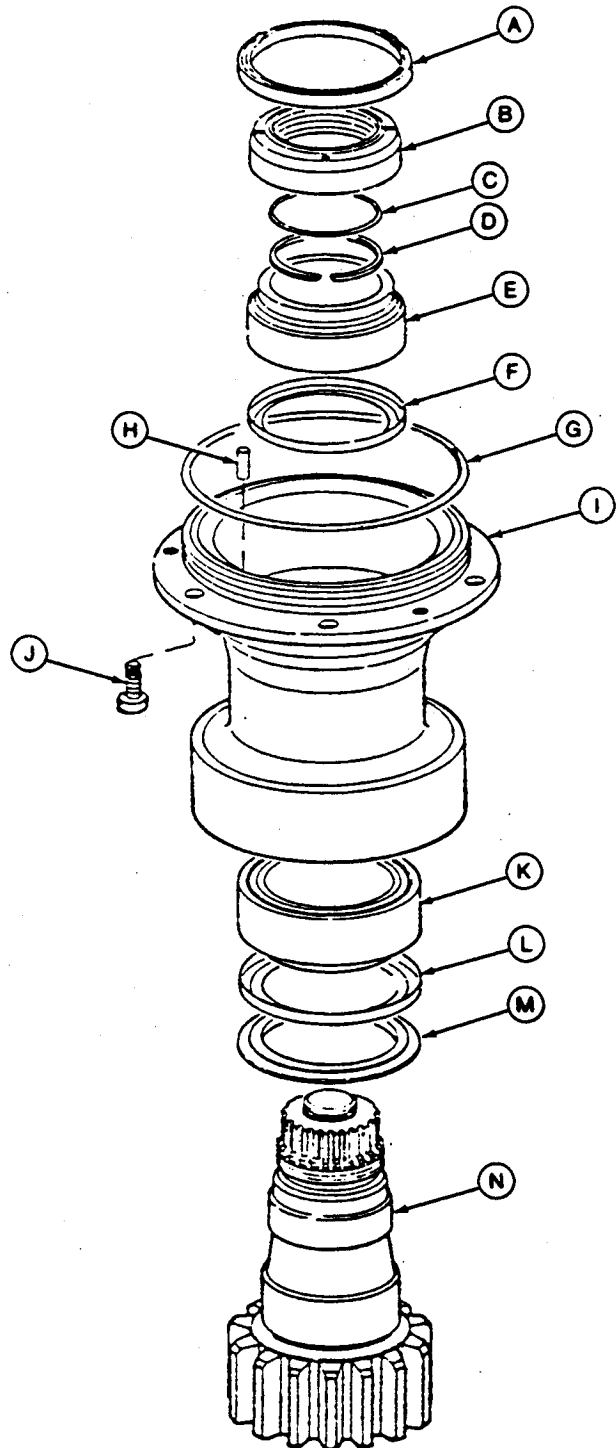

Continued on next page

TX,43,DY2989 -19-27AUG97-9/13

T6439ZW -UN-07NOV88

43
4350
12

Mechanical Drive Elements

43
4350
13

28. Check that rolling drag torque on shaft is 22—29 N•m (16—21 lb-ft) or force to turn housing with a cord wrapped around smallest diameter of housing is 245—320 N (55—72 lb force).

Specification

Bearing Adjustment—Torque 22—29 N•m (16—21 lb-ft)
Turning Force Housing at
Smallest Diameter—Torque 245—320 N (55—72 lb force).

NOTE: As necessary, grind spacer to increase bearing load. Remove spacer and install four lead balls into cavity. Tighten nut until rolling drag torque on shaft or force to turn housing is to specifications given. Have spacer ground so thickness is 0.02—0.05 mm (0.001—0.002 in.) greater than measurement of balls.

TX,43,DY2989 -19-27AUG97-10/13

29. Apply lithium grease to seal (D). Install seal using a piece of pipe and a press.
30. Stake special nut (C) to spline at five locations (B) around shaft.
31. Inspect and clean magnet (A).
32. Install second planet carrier assembly.

- A—Magnet
- B—Staking—5 Places
- C—Special Nut
- D—Oil Seal

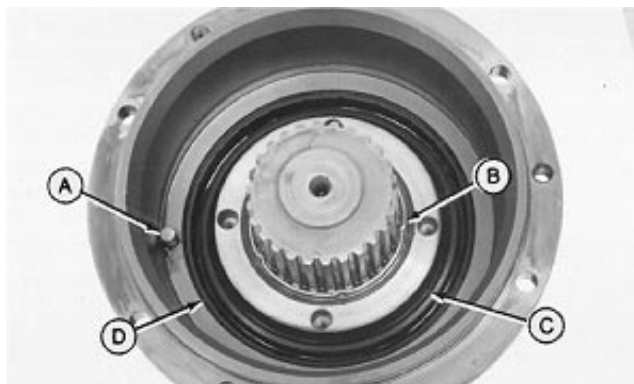

T6641AR -UN-07NOV88

TX,43,DY2989 -19-27AUG97-11/13

IMPORTANT: Replace O-ring. O-ring should not be reused as it had taken a set from prior use.

33. Install snap ring and O-ring (A).

NOTE: Allow thread lock and sealer to cure before operating the machine.

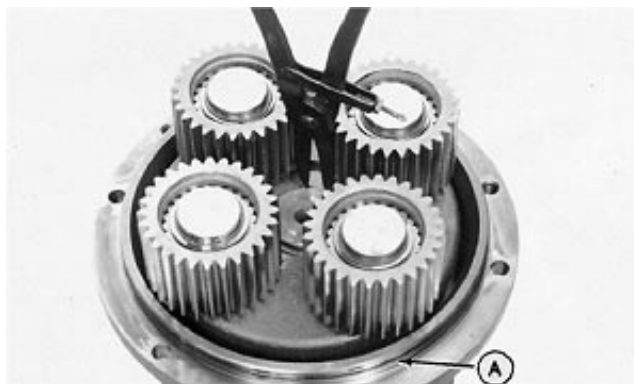

T6641AP -UN-20MAR90

Continued on next page

TX,43,DY2989 -19-27AUG97-12/13

Mechanical Drive Elements

- 34. Clean threads of screws (B) using clean and cure primer. Apply Thread Lock and Sealer (medium strength) to threads of screws.
- 35. Install ring gear (A) and screws (B). Tighten screws to 55 N•m (40 lb-ft).

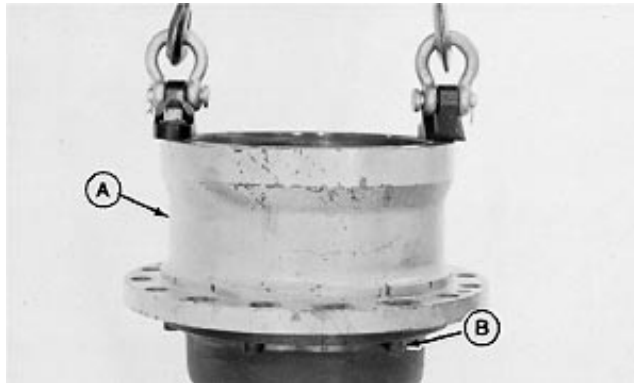

T6641AO -UN-20MAR90

Specification

Gousing-to-Ring Gear Cap
 Screw—Torque..... 55 N•m (40 lb-ft)

- 36. Install first planet carrier assembly.

TX,43,DY2989 -19-27AUG97-13/13

Remove Upperstructure

NOTE: Procedure requires two technicians. The cement floor must be a minimum of 102 mm (4 in.) thick. Area must be large enough so the upperstructure can be turned 180° with the angle between boom and arm at 90—100° and the tracks laid out flat on the floor.

- 1. Clean the machine thoroughly.

CAUTION: Keep the angle between boom and arm at 90—100° to prevent machine from sliding backwards.

- 2. Park machine with boom to the left side (cab side towards sprocket) of undercarriage.
- 3. Disconnect tracks and lay out flat on the floor to the sprocket end of undercarriage. (See procedure in Group 0130.)

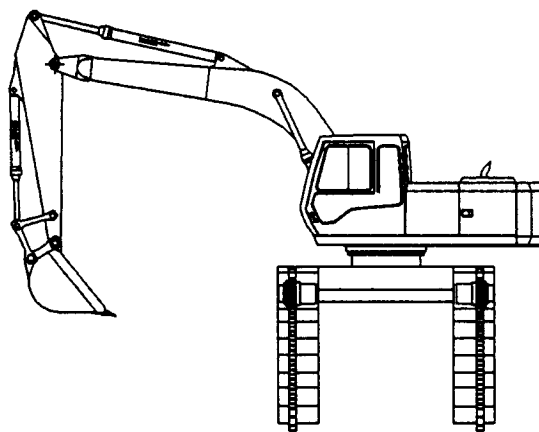

T77 12AG CV

T7712AG -UN-24FEB92

Continued on next page

TX,4350,GG273 -19-18FEB92-1/7

Mechanical Drive Elements

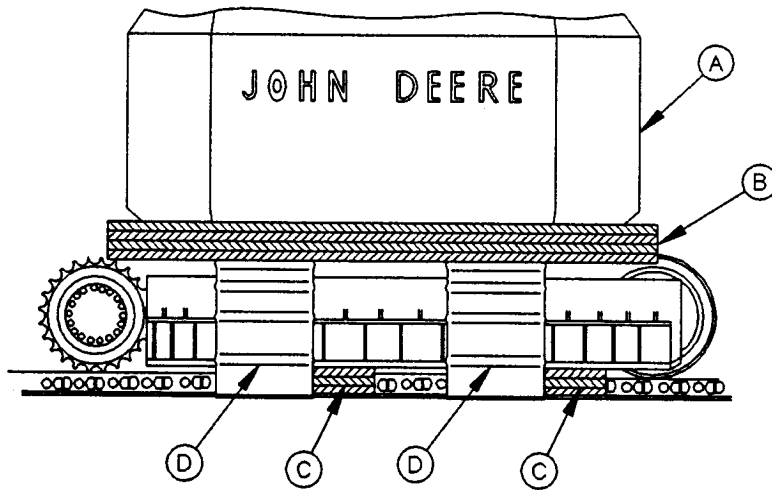

T7640BA (CV)

NOTE: To make removal of swing bearing-to-main frame cap screws easier after machine is raised into position, loosen the cap screws one turn at this time.

4. Turn upperstructure and raise the right side of machine using boom down function. Put hardwood blocks (C), approximately 180 mm (7 in.), between lower track rollers and track chain.
5. Turn upperstructure back to the left side so center of cab is over the left rear upper track roller next to sprocket. This position will allow the beam used to support the boom end to be installed under the upperstructure as far as possible.

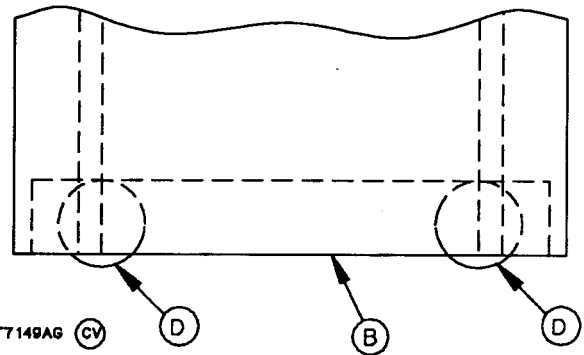

T7149AG (CV)

- A—Counterweight
- B—Bridge Plank (as required)
- C—Hardwood Block (2 used)
- D—DFT1089 Barrel Support (2 used)

CAUTION: The approximate weight of DFT1089 Barrel Supports is 545 kg (1200 lb).

The approximate weight of machine without the tracks is 17 670 kg (38,920 lb).

6. Put two DFT1089 Barrel Supports (D) under the counterweight (A) so they are centered on the main frame. (See Section 99 for instructions to make barrel supports.)

43
4350
15

T7640BA -UN-24FEB92

T7149AG -UN-05OCT89

Mechanical Drive Elements

To provide enough clearance, use bridge planks (B) to raise the height of supports and planks to 1270 mm (50 in.).

Specification

Floor To Bottom of Main Frame—

Height 1270 mm (50 in.)

Do not exceed a maximum height of 1320 mm (52 in.).



CAUTION: Keep the angle between boom and arm at 90—100° to prevent machine from sliding backwards.

7. Slowly raise left side, using boom down function, until machine is level.

Continued on next page

TX,4350,GG273 -19-18FEB92-3/7

43
4350
16

Mechanical Drive Elements

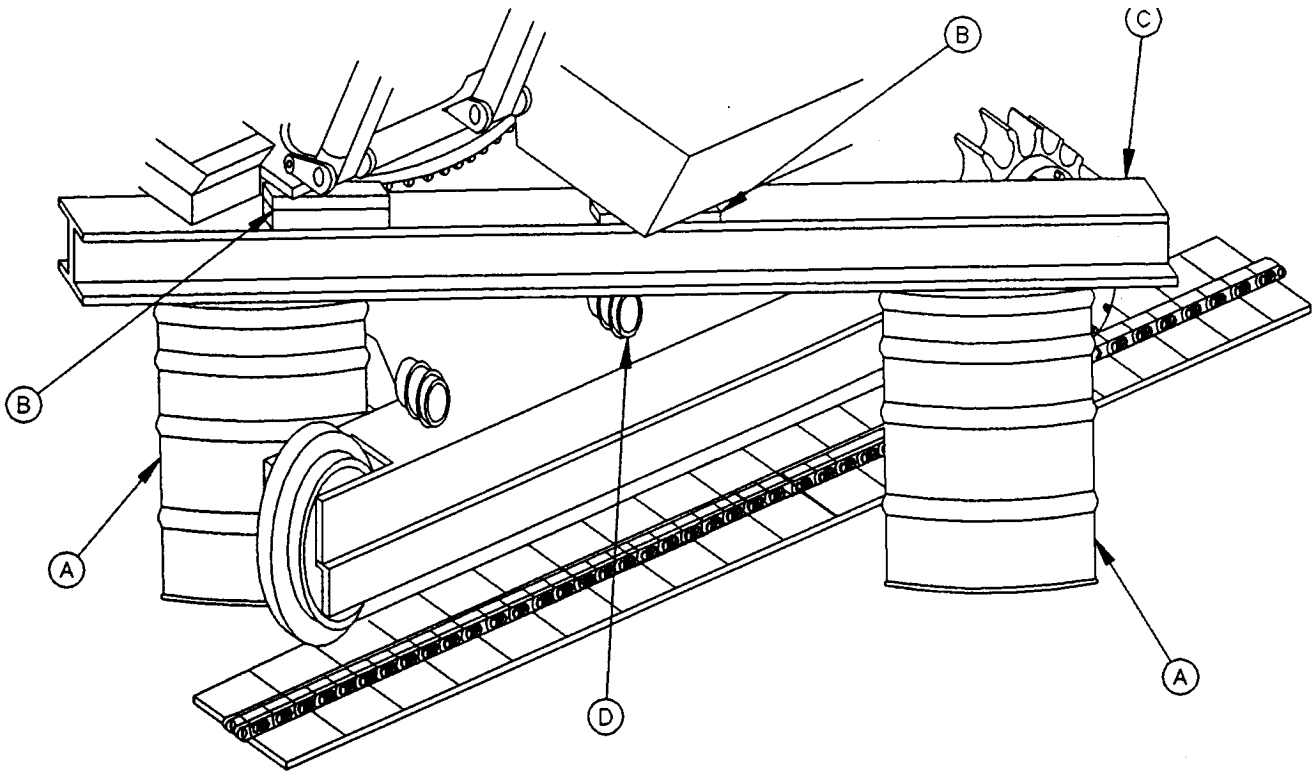

T7712AH (CV)

A—DFT1089 Barrel Supports (2 used)

B—Hardwood Blocks (Use as required)

C—3.7 m (12 ft) Length of W8 x 28 lb Wide Flange Beam

D—Upper Track Roller

8. Put two DFT1089 Barrel Supports (A) and a 3.7 m (12 ft) length of W8 x 28 lb Wide Flange Beam (C) under main frame at right boom cylinder and right corner of cab.

Remove the upper track roller (D) if additional clearance is needed.

For maximum support, the barrel supports must be positioned so the beam is under the main frame and corner of cab as far as possible.

Install hardwood blocks (B) as needed to make up for any unevenness.

9. Lower machine so main frame and corner of cab is on the beam.

10. Check that bottom of main frame is 1270 mm (50 in.) off the floor and level.

Specification

Floor To Bottom of Main Frame—Height..... 1270 mm (50 in.)

Do not exceed a maximum height of 1320 mm (52 in.).

Continued on next page

TX,4350,GG273 -19-18FEB92-4/7

43
4350
17

T7712AH -UN-24FEB92

Mechanical Drive Elements

11. Install a 13 mm (1/2 in.) chain around boom cylinder head end boss on frame and rod end boss on boom. Tighten chain just enough to remove the slack using a chain binder.

12. Disconnect the battery negative cables.

! **CAUTION: Reservoir is pressurized. Loosen fill cap to release air pressure.**

13. Loosen reservoir fill cap to release air pressure.

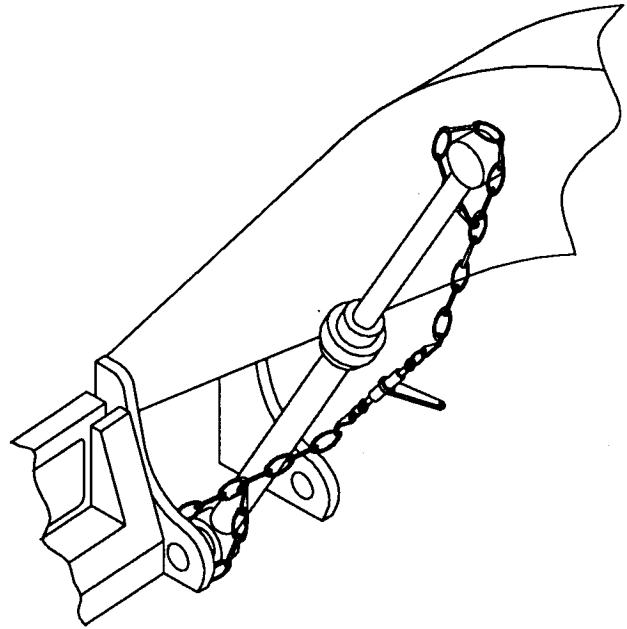

T7149AJ (CV)

Continued on next page

TX,4350,GG273 -19-18FEB92-5/7

T7149AJ -UN-05OCT89

! **CAUTION:** Escaping fluid under pressure can penetrate the skin causing serious injury. Avoid the hazard by relieving pressure before disconnecting hydraulic or other lines. Tighten all connections before applying pressure. Search for leaks with a piece of cardboard. Protect hands and body from high pressure fluids.

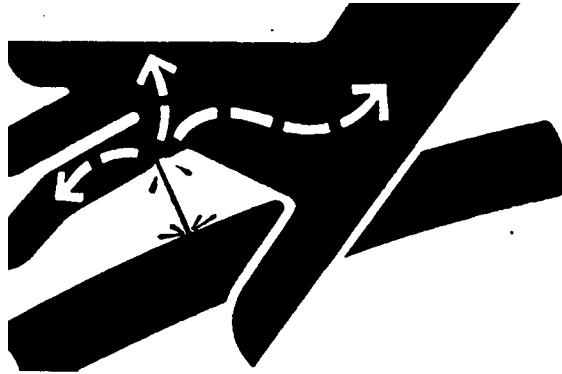

If an accident occurs, see a doctor immediately. Any fluid injected into the skin must be surgically removed within a few hours or gangrene may result. Doctors unfamiliar with this type of injury should reference a knowledgeable medical source. Such information is available from Deere & Company Medical Department in Moline, Illinois, U.S.A.

14. Disconnect lines (A—F).
15. Remove cap screws (H). Remove strap (I).
16. Remove cover (G).

! **CAUTION:** The approximate weight of rotary manifold is 38 kg (84 lb).

17. Remove two rotary manifold-to-undercarriage cap screws. Install two M12 x 152 mm cap screws. Remove the remaining cap screws to lower manifold onto heads of longer cap screws.

! **CAUTION:** The approximate weight of undercarriage is 4300 kg (9500 lb).

18. Put an 18-t (20-ton) service jack under each end of undercarriage.

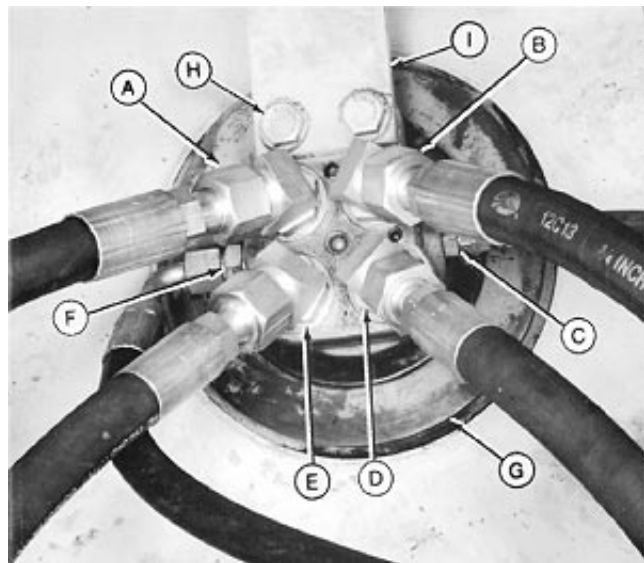

A—Port 3-to-Left Propel Section B Port Line
 B—Port 1-to-Right Propel Section A Port Line
 C—P1 Port-to-Dual Solenoid Block A Port Line
 D—Port 2-to-Right Propel Section B Port Line
 E—Port 4-to-Left Propel Section A Port Line
 F—Drain Port-to-Reservoir Line
 G—Cover
 H—Cap Screw (2 used)
 I—Strap

X9811 -UN-23AUG88

43
4350
19

T7626CC -UN-06DEC91

Continued on next page

TX,4350,GG273 -19-18FEB92-6/7

Mechanical Drive Elements

19. Remove cap screws (B) from swing bearing (A).
20. Slowly lower undercarriage onto track chain.
21. Lift sprocket end of undercarriage so sprocket clears track chain.
22. Pull undercarriage out from under the upperstructure.
23. Remove swing bearing. (See procedure in this group.)

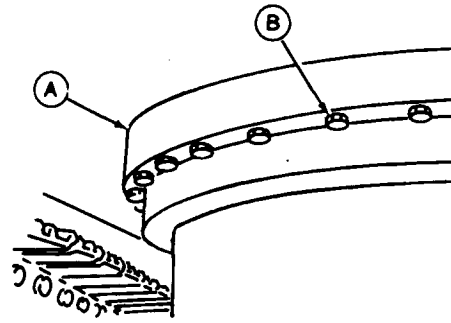

T6626JK -UN-06DEC88

TX,4350,GG273 -19-18FEB92-7/7

Install Upperstructure

1. Push undercarriage under upperstructure.
2. Install guide pins to help align holes in swing bearing (A) with holes in main frame.
3. Raise undercarriage into position using two 18-t (20-ton) service jacks. It may be necessary to turn swing bearing inner race to align teeth with teeth on swing motor pinion shaft.
4. Install cap screws and washers (B). Tighten cap screws to 620 N•m (460 lb-ft).

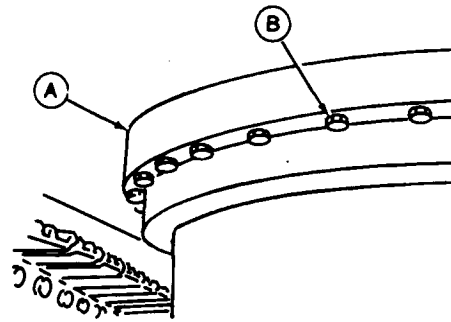

T6626JK -UN-06DEC88

Specification

Swing Bearing-to-Upperstructure
 Cap Screw—Torque 620 N•m (460 lb-ft)

If all cap screws are not accessible, tighten them after machine has been lowered and supports have been removed.

5. Raise rotary manifold into position and install cap screws. Tighten cap screws to 98 N•m (65 lb-ft).

Specification

Rotary Manifold-to-Undercarriage
 Cap Screw—Torque 98 N•m (65 lb-ft)

Continued on next page

TX,4350,GG280 -19-20APR95-1/3

Mechanical Drive Elements

6. Install cover (G).
7. Install strap (I). Install cap screws (H).
8. Connect lines (A—F).
9. Connect battery negative cable.
10. Remove chain from boom cylinder.

- A—Port 3-to-Left Propel Section B Port Line
- B—Port 1-to-Right Propel Section A Port Line
- C—P1 Port-to-Dual Solenoid Block A Port Line
- D—Port 2-to-Right Propel Section B Port Line
- E—Port 4-to-Left Propel Section A Port Line
- F—Drain Port-to-Reservoir Line
- G—Cover
- H—Cap Screw (2 used)
- I—Strap

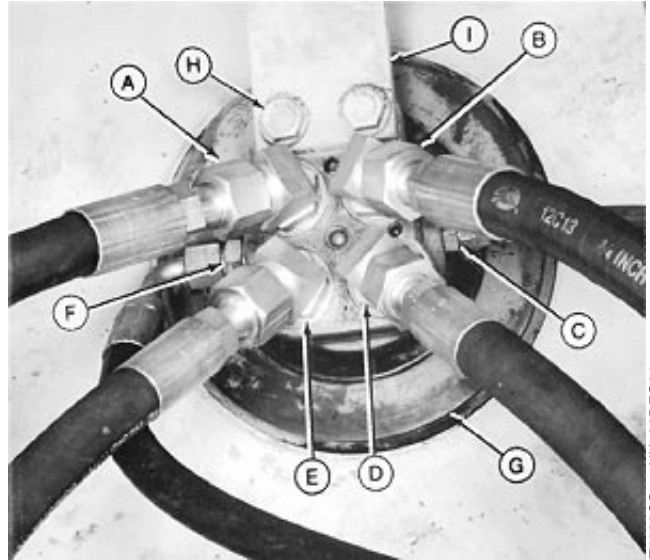

T7626CC -UN-06DEC91

43
4350
21

Continued on next page

TX,4350,GG280 -19-20APR95-2/3

Mechanical Drive Elements

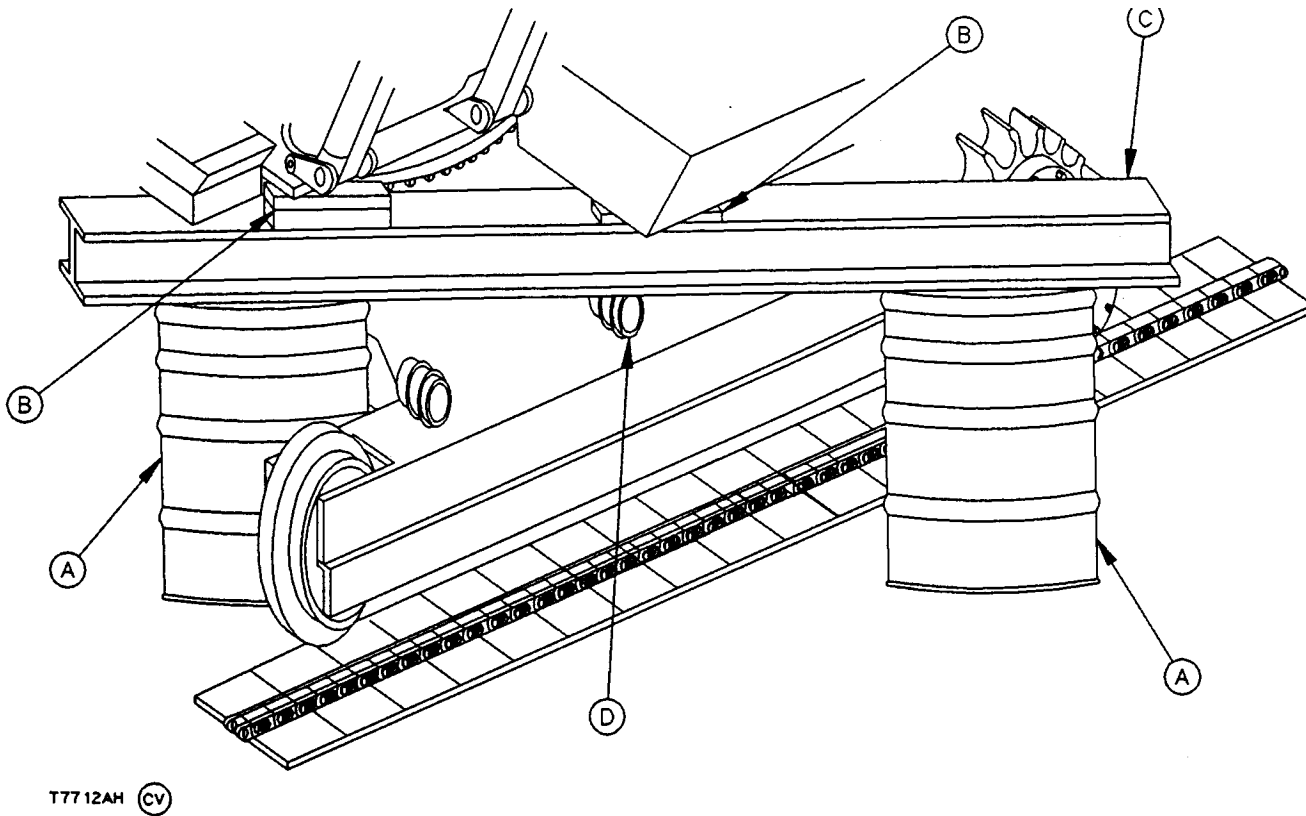

A—Barrel Support

B—Hardwood Block

C—Wide Flange Beam

D—Upper Track Roller

11. Raise machine just enough to remove the hardwood blocks (B), wide flange beam (C), and barrel supports (A).
12. Lower machine so lower track rollers and front idler are on the track chain.
13. Remove bridge planks and barrel supports from other side.
14. Turn upperstructure to the other side and raise machine just enough to remove hardwood blocks between roller and track chain.
15. Lower machine so lower track rollers and front idler are on the track chain.
16. Tighten any of the swing bearing-to-main frame cap screws that could not be tightened.
17. Install the upper track roller (D).
18. Install track chains.
19. Adjust and measure track sag. (See procedure in Group 0130.)

TX,4350,GG280 -19-20APR95-3/3

Remove And Install Swing Bearing

1. Remove upperstructure. (See procedure in this group.)



CAUTION: Approximate weight of swing bearing is 230 kg (510 lb).

2. Connect bearing to a hoist using lifting brackets such as JT01748 Lifting Brackets.
3. Remove cap screws and washers. Remove bearing.
4. Replace upper and lower seals as necessary. (See procedure in this group.)
5. Clean mating surfaces of swing bearing, upperstructure, and undercarriage.

43
4350
23

Continued on next page

TX,4350,GG267 -19-20APR95-1/2

Mechanical Drive Elements

NOTE: The letter stamped on the face of inner race and the loading plug in outer race are the starting and stopping point for the hardening process. The letter and loading plug are installed to the left side of machine so the grease fittings are located in the correct position.

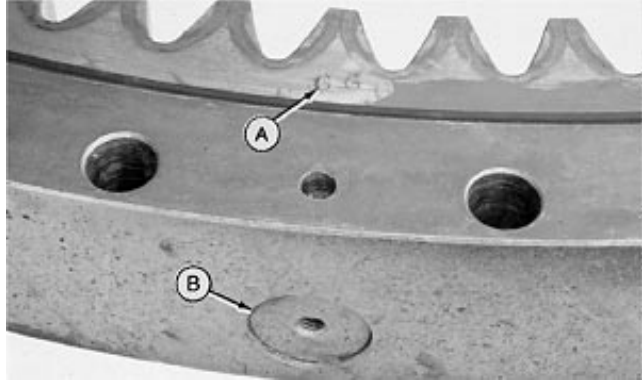

T5925AA -UN-11APR90

The paint on a few of the teeth have no significance for the installation of swing bearing on this machine.

6. Install swing bearing on undercarriage so the letter (A) and bearing loading plug (B) are to the left side of machine.
7. Lubricate cap screws with general purpose grease. Install cap screws and washers and tighten to 530 N•m (390 lb-ft).

Specification

Undercarriage-to-Swing Bearing
 Cap Screw—Torque..... 530 N•m (390 lb-ft)

8. Apply multi-purpose EP grease to teeth of swing bearing and pinion shaft. (See Grease in Group 0004.)

TX,4350,GG267 -19-20APR95-2/2

Install Swing Bearing Upper Seal

1. Remove upperstructure. (See procedure in this group.)

Continued on next page

TX,4350,GG283 -19-30MAR93-1/2

43
 4350
 24

Mechanical Drive Elements

2. Remove old seal (A).
3. Scrape old adhesive from seal groove.

Thoroughly clean seal groove and new seal using clean and cure primer.
4. Apply instant gel adhesive sparingly to seal groove.
5. Install seal with lip against outer bearing race.

Start about 76 mm (3 in.) from end of seal using a blunt instrument to force seal into groove. Push seal in direction of portion already installed to avoid stretching seal.

6. Before bringing ends of seal together, cut off excess length.
7. Apply adhesive to both ends of seal. Push ends into seal groove making sure they come together.

IMPORTANT: To avoid pulling seal out of groove, adhesive must cure for at least 24 hours before using swing function

8. Let adhesive cure for at least 24 hours before using swing function.

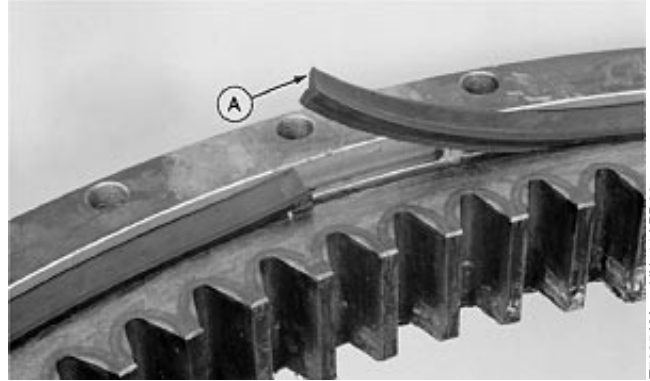

T5925AM -UN-11APR90

43
4350
25

TX,4350,GG283 -19-30MAR93-2/2

Install Swing Bearing Lower Seal

NOTE: Part of swing bearing shown cut away to show lower seal in groove.

1. Remove old seal (A).
2. Scrape old adhesive from seal groove (B).

Thoroughly clean seal groove and new seal using clean and cure primer.

3. Apply instant gel adhesive sparingly to seal groove.
4. Install seal with seal lip against outer race.

Start about 76 mm (3 in.) from end of seal using a blunt instrument to force seal into groove. Push seal in direction of portion already installed to avoid stretching seal.

5. Before bringing ends of seal together, cut off excess length.
6. Apply adhesive to both ends of seal. Push ends into seal groove making sure they come together.

IMPORTANT: To avoid pulling seal out of groove, adhesive must cure for at least 24 hours before using swing function

7. Let adhesive cure for at least 24 hours before using swing function.

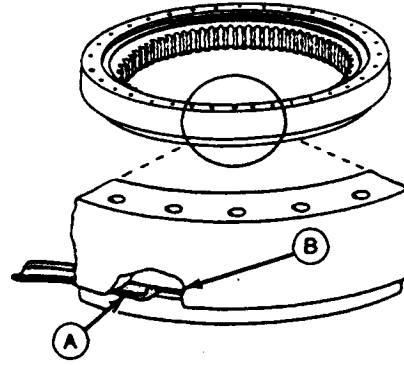

T5936BA -UN-17MAY89

TX,4350,GG284 -19-30MAR93-1/1

Service Equipment And Tools

NOTE: Order tools from the U.S. SERVICE-GARD™ Catalog or from the European Microfiche Tool Catalog (MTC). Some tools may be available from a local supplier.

SERVICE-GARD is a trademark of Deere & Company.

TX,4360,AB291 -19-20APR95-1/3

M10-1.5 Cap Screw

Used to remove swing motor seal.

68 mm Disk

Used to remove swing motor seal.

17-1/2 Ton Puller Set

Used to remove upper swing bearing cup.

Polishing Table JT05425

Used to remove nicks and scratches from cylinder block.

M10-1.5 Lifting Eyebolt

Used to lift swing motor when checking shaft end play.

TX,4360,AB291 -19-20APR95-2/3

Pump Rotate Group Workbench Support¹. DF1040

Used to hold swing motor and rotating group.

¹Fabricated tool; dealer made. (See Section 99 for instructions to make tool.)

TX,4360,AB291 -19-20APR95-3/3

Hydraulic System

Other Material

Number	Name	Use
TY15969 (U.S.) TY9479 (Canadian) 635 (LOCTITE®)	Retaining Compound (High Strength)	Used to apply to inside surface of swing motor seal collar.
TY9375 (U.S.) TY9480 (Canadian) 592 (LOCTITE®)	Pipe Sealant with TEFLON®	Used to apply to pump-to-pump housing mating surface.

LOCTITE is a registered trademark of Loctite Corp.
TEFLON is a registered trademark of the DuPont Company.

TX,43,DY2990 -19-27AUG97-1/1

Specifications

Item	Measurement	Specification
Swing Motor:		
Swing Motor-to-Swing Brake Nut	Torque	195 N•m (144 lb-ft)
Line-to-Swing Motor Socket Head Cap Screw	Torque	86 N•m (63 lb-ft)
Valve Housing-to-Motor Housing Socket Head Screw	Torque	69 N•m (51 lb-ft)
Swing Stop Cushion Valve	Torque	32 N•m (24 lb-ft)
Shaft	End Play	0.02—0.35 mm (0.001—0.014 in.)

4360,CC3 -19-20APR95-1/1

Hydraulic System

Remove And Install Swing Motor (Serial No. —556935)

CAUTION: Escaping fluid under pressure can penetrate the skin causing serious injury. Avoid the hazard by relieving pressure before disconnecting hydraulic or other lines. Tighten all connections before applying pressure. Search for leaks with a piece of cardboard. Protect hands and body from high pressure fluids.

If an accident occurs, see a doctor immediately. Any fluid injected into the skin must be surgically removed within a few hours or gangrene may result. Doctors unfamiliar with this type of injury may call the Deere & Company Medical Department in Moline, Illinois, or other knowledgeable medical source.

1. Loosen reservoir fill cap to release air pressure from reservoir.

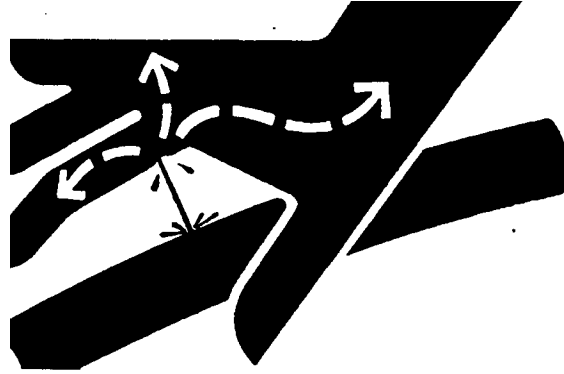

X9811 -UN-23AUG88

43
4360
3

Continued on next page

TX,43,DW5020 -19-22JUL97-1/2

Hydraulic System

2. Disconnect lines (A—C, F and G).
3. Remove swing motor.
4. Repair or replace motor as necessary.

IMPORTANT: Replace O-ring. O-ring should not be reused as it has taken a set from prior use.

5. Replace O-ring (E).
6. Install swing motor, washers, and nuts. Tighten nuts to 195 N•m (144 lb-ft).

Specification

Swing Motor-to-Swing Brake
Nut—Torque 195 N•m (144 lb-ft)

7. Tighten line-to-swing motor socket head screws to 86 N•m (63 lb-ft).

Specification

Line-To-Swing Motor Socket
Head Screw—Torque 86 N•m (63 lb-ft)

8. Do Swing Motor Start-Up Procedure. (See procedure in this group.)

- A—Swing Valve Section A Port-to-Swing Motor Swing Right Rear Port Line
- B—Swing Valve Section B Port-to-Swing Motor Swing Left Front Port Line
- C—Swing Motor Front Drain Port-to-Return Manifold P Port Line
- D—Nut (2 used)
- E—O-Ring
- F—Swing Stop Cushion Valve PZUL Port-to-Dual Solenoid Block T Port Line
- G—Dig Pilot Check Valve Block Top Left Port-to-Swing Stop Cushion Valve PST Port Line

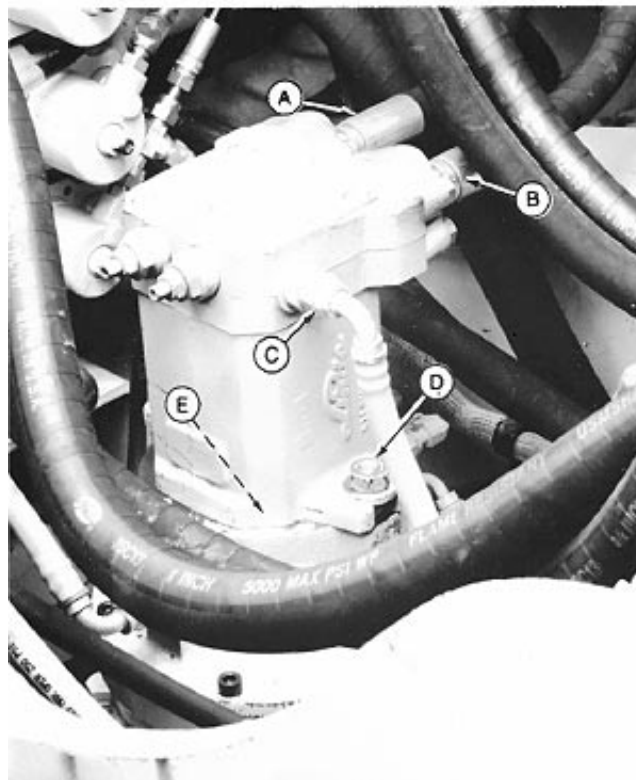

Early Machine Shown

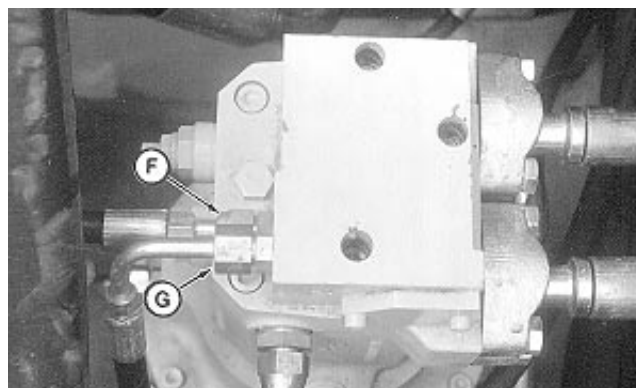

T7626EV -UN-06DEC91

T8455AT -UN-04MAR95

TX,43,DW5020 -19-22JUL97-2/2

Hydraulic System

Remove And Install Swing Motor (Serial No. 556936—)

CAUTION: Escaping fluid under pressure can penetrate the skin causing serious injury. Avoid the hazard by relieving pressure before disconnecting hydraulic or other lines. Tighten all connections before applying pressure. Search for leaks with a piece of cardboard. Protect hands and body from high pressure fluids.

If an accident occurs, see a doctor immediately. Any fluid injected into the skin must be surgically removed within a few hours or gangrene may result. Doctors unfamiliar with this type of injury may call the Deere & Company Medical Department in Moline Illinois, or other knowledgeable medical source.

1. Lower all equipment to ground.
2. Loosen reservoir fill cap to release air pressure from reservoir.

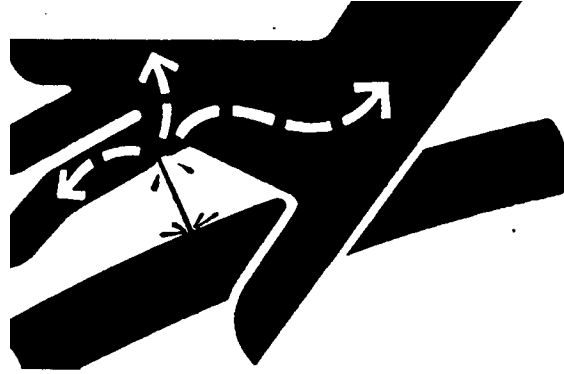

X9811 -UN-23AUG88

43
4360
5

Continued on next page

TX,04,DT5072 -19-02JUL97-1/2

Hydraulic System

3. Disconnect lines (A—D and F).
4. Remove nut and washer (E). Remove swing motor.
5. Repair or replace motor as necessary.

IMPORTANT: Replace O-ring. O-ring should not be reused as it has taken a set from prior use.

6. Replace O-ring.
7. Install swing motor. Install washers and nuts (E). Tighten nuts to 195 N•m (144 lb-ft).

Specification

Swing Motor-to-Swing Brake
 Nut—Torque 195 N•m (144 lb-ft)

8. Connect lines (A—D and F).
9. Tighten flange fitting cap screws to 86 N•m (63 lb-ft).

Specification

Line-To-Swing Motor Socket
 Head Screw—Torque 86 N•m (63 lb-ft)

10. Do Swing Motor Start-Up Procedure. (See procedure in this group.)

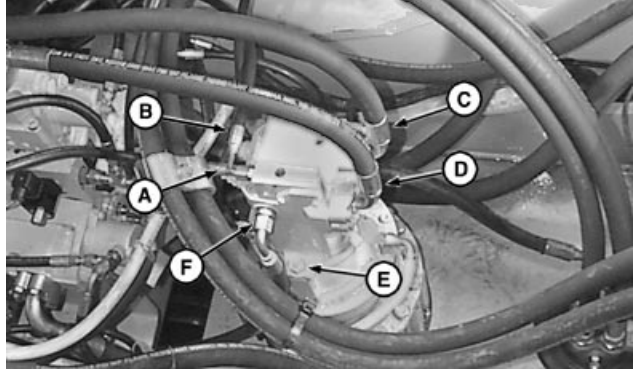

- A—Swing Motor PZUL Port-to-Dual Solenoid Valve P Port Line
- B—Swing Motor PST Port-to-Dig Shuttle Valve Top Left Switch Signal Port Line
- C—Swing Motor Left Front Port Line-to-Main Control Valve Swing Section A Port Line
- D—Swing Motor Right Front Port Line-to-Main Control Valve Swing Section B Port Line
- E—Nut and Washer (2 used)
- F—Swing Motor Right Side Port-to-Hydraulic Tank Line

TX,04,DT5072 -19-02JUL97-2/2

43
 4360
 6

Hydraulic System

Swing Motor Start-Up Procedure

IMPORTANT: Motor will be damaged if not filled with oil before operating swing function. Procedure must be performed whenever a new motor is installed or oil has been drained from the motor.

Procedure is to ensure the motor is filled with oil.

1. Disconnect swing motor drain line (A).
2. Open the bleed screw located between the crossover relief valves.
3. Fill motor with hydraulic oil through drain port (B) until oil reaches the level of drain port.
4. Connect drain line.
5. Close bleed screw.

T7225AU

CV

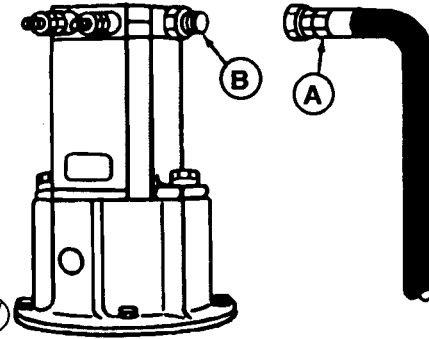

T7225AU -UN-10MAR90

43
4360
7

TX,902525,GG162 -19-21AUG91-1/1

Remove And Install Swing Motor Seal

1. Install disk (B) and cap screw (A) on swing motor shaft.
2. Remove snap ring (C) and plug from port (D).

CAUTION: Reduce compressed air to less than 210 kPa (2 bar) (30 psi). Clear area of bystanders, guard against flying chips, and wear personal protection equipment including eye protection.

3. Apply 210 kPa (2 bar) (30 psi) maximum compressed air to port to remove seal retainer (E), O-ring (F), and seal (G).
4. Install new O-ring and seal in seal retainer. Push seal to bottom of bore.
5. Apply petroleum jelly to O-ring. Install seal retainer in swing motor using a piece of pipe and seal driver.

IMPORTANT: Install same snap ring as removed or snap ring of same thickness as original snap ring. Motor shaft end play is determined by snap ring thickness.

6. Install original snap ring.

A—M10-1.5 Cap Screw
 B—68 mm (2.5 in.) Disk
 C—Snap Ring
 D—Motor Port
 E—Seal Retainer
 F—O-Ring
 G—Seal

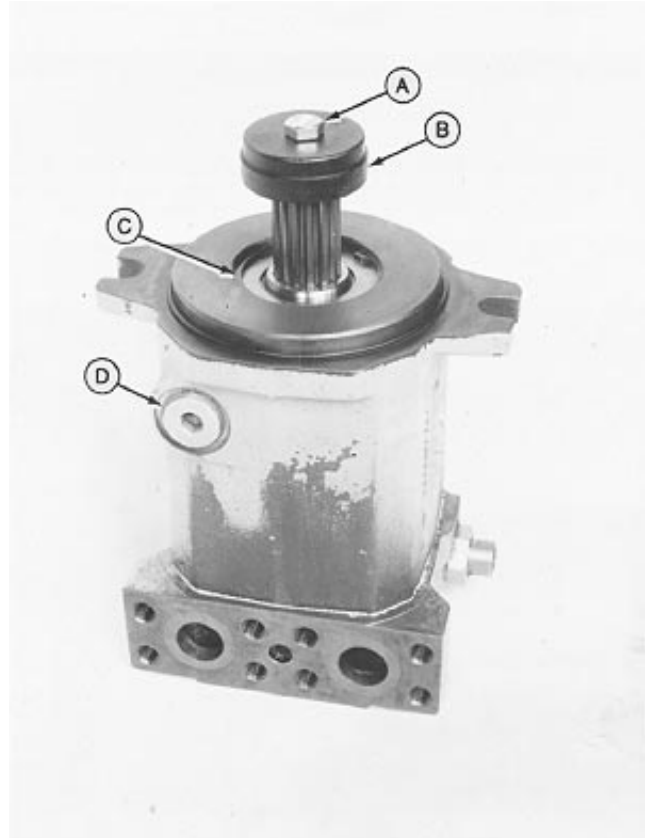

T6641EM -UN-26MAR90

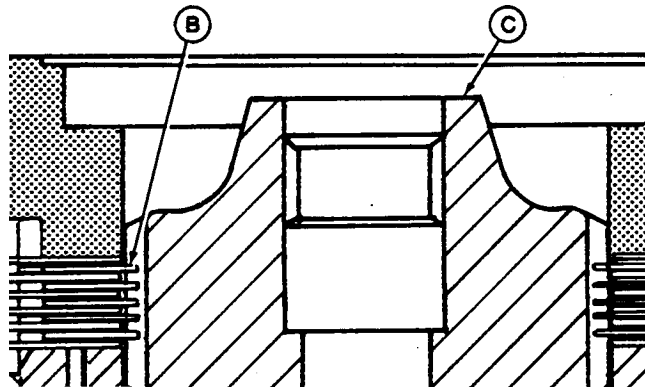

T6439ZV -UN-01NOV88

4360,CC7 -19-11SEP87-1/1

Hydraulic System

Disassemble And Assemble Swing Motor

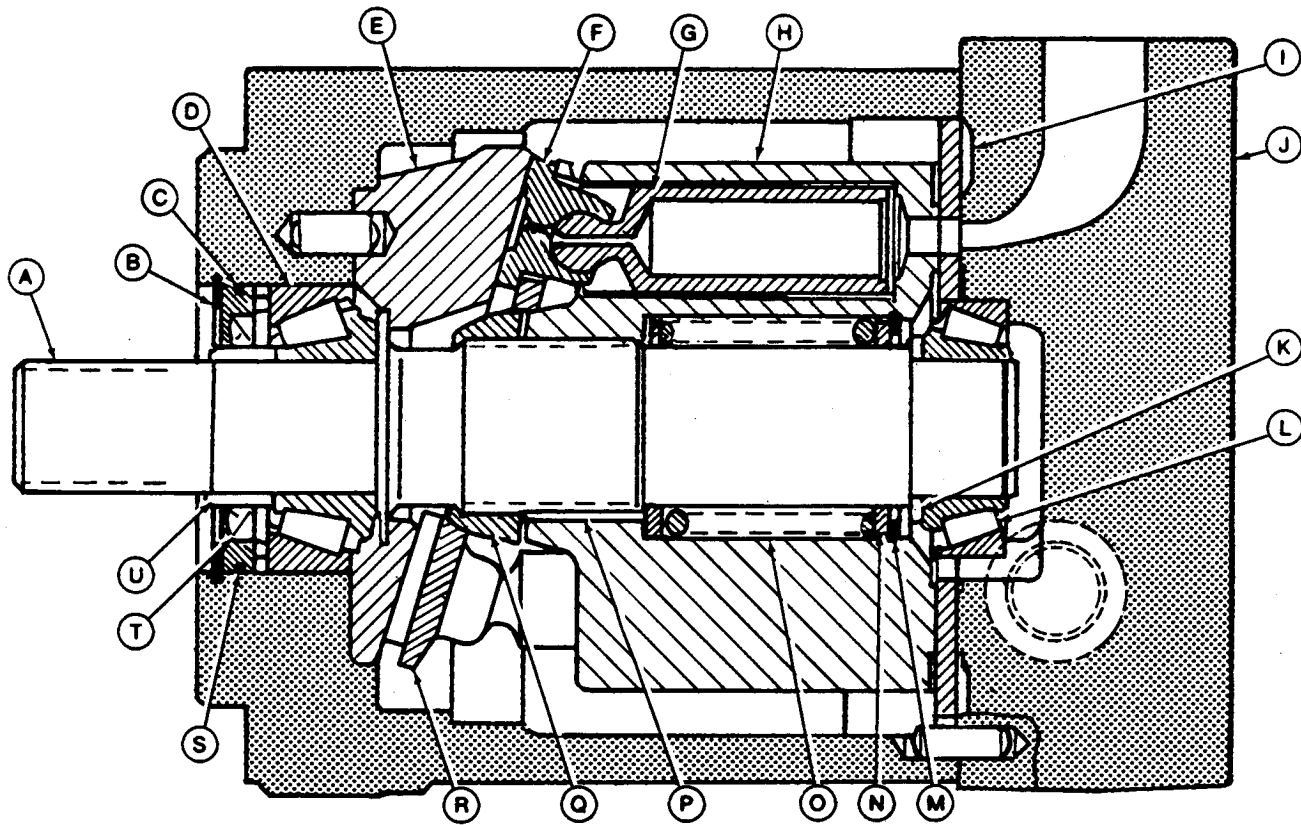

- | | | | |
|-----------------|-----------------------|-------------------|------------------|
| A—Shaft | G—Piston | L—Upper Bearing | Q—Ball Guide |
| B—Snap Ring | H—Cylinder Block | M—Snap Ring | R—Retainer Plate |
| C—Seal Retainer | I—Valve Plate | N—Washer (2 used) | S—O-Ring |
| D—Lower Bearing | J—Valve Plate Housing | O—Spring | T—Seal |
| E—Swash Plate | K—Spacer | P—Pin (3 used) | U—Seal Collar |
| F—Slipper | | | |

Continued on next page

TX,4360,AB40 -19-08JAN92-1/20

T6439ZU -UN-01NOV88

43
4360
9

Hydraulic System

IMPORTANT: Protect lapped surfaces of valve plate and cylinder block from scratches or damage.

1. For swing motor with swing stop cushion, remove valve. Remove socket head screws to remove valve plate housing (A) and valve plate (B).
2. Remove upper bearing cup (C) using a 2-jaw puller and slide hammer.
3. Lift cylinder block and swash plate assembly from housing.

IMPORTANT: DO NOT scratch, nick, or damage lapped surfaces of cylinder block.

NOTE: Upper bearing has to be destroyed to disassemble rotating group of pump.

4. Put pump shaft into wood support. (See Section 99 for instructions to make tool.)

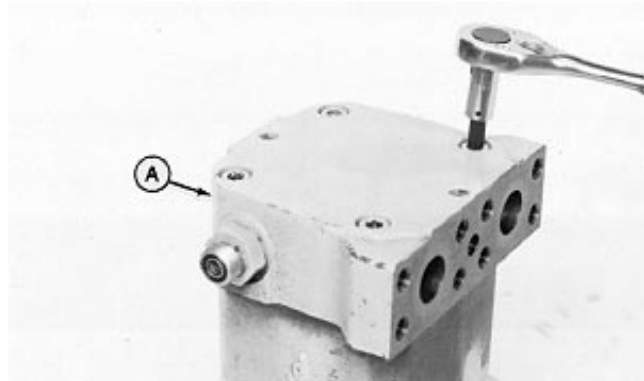

Early Machine Shown

T6641EO -UN-26MAR90

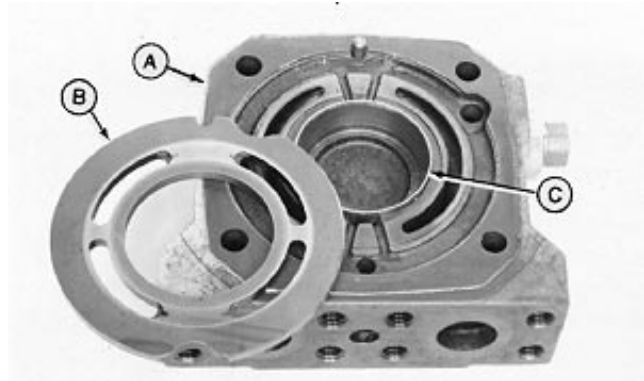

T6641EP -UN-26MAR90

TX,4360,AB40 -19-08JAN92-2/20

5. Put a piece of cardboard (A) on cylinder block to protect sealing surface. Break roller cage (B) to remove rollers.
6. Remove bearing inner race (C) and spacer (D) using a bearing puller.

- A—Cardboard
- B—Roller Cage
- C—Inner Race
- D—Spacer

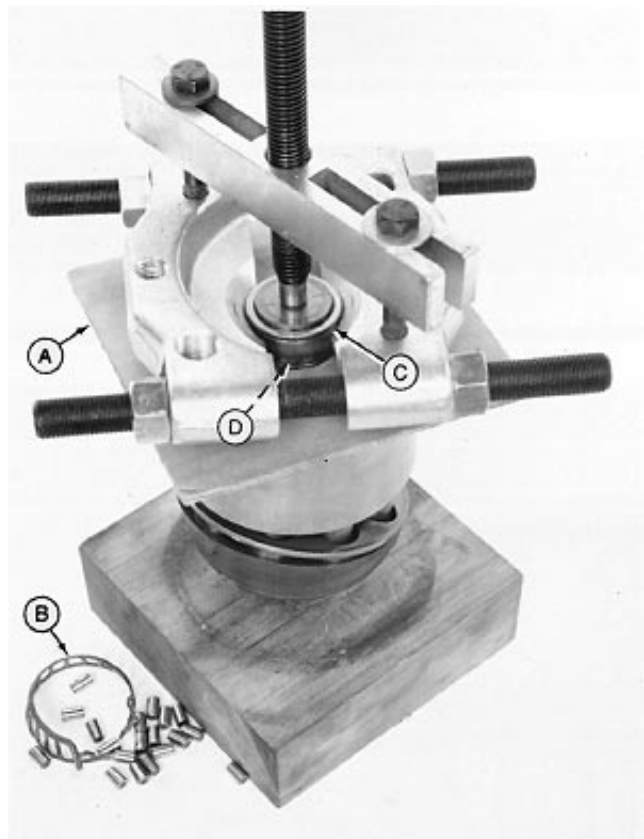

T6641EQ -UN-20MAR90

Continued on next page

TX,4360,AB40 -19-08JAN92-3/20

Hydraulic System

IMPORTANT: DO NOT scratch, nick, or damage lapped surfaces of cylinder block.

7. Put a piece of cardboard (A) and wood support (B) on cylinder block. Turn rotating group and wood support over to remove shaft, swash plate (C), retainer plate (D), and pistons (E).

- A—Cardboard
- B—Wood Support
- C—Swash Plate
- D—Retainer Plate
- E—Piston (9 used)

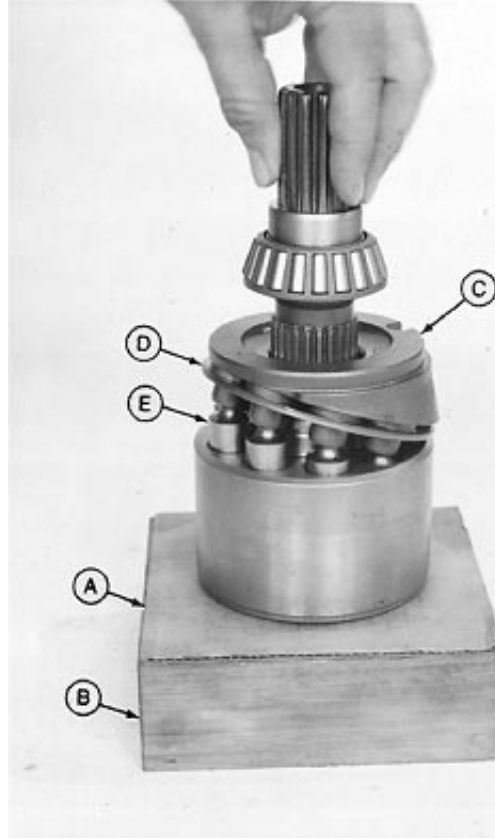

43
4360
11

T6641ER -UN-20MAR90

TX,4360,AB40 -19-08JAN92-4/20

8. Remove bearing cone (A) and seal collar (B). Bearing cone is a press fit.

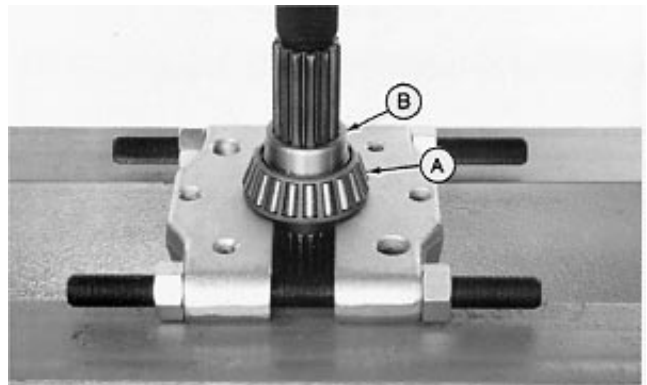

T6641ES -UN-22MAR90

TX,4360,AB40 -19-08JAN92-5/20

9. Remove ball guide (A) and pins (B).

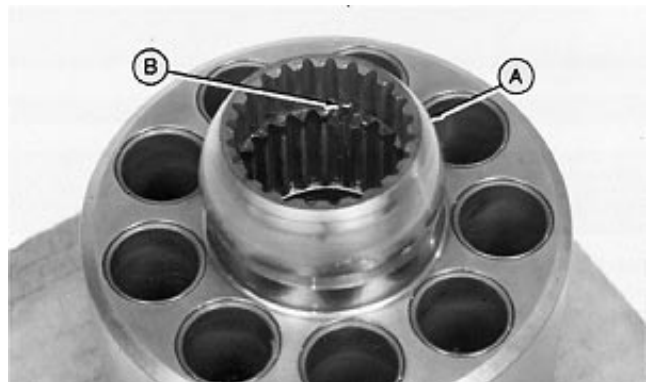

T6641ET -UN-22MAR90

Continued on next page

TX,4360,AB40 -19-08JAN92-6/20

Hydraulic System

10. Push washer (B) down using a disk and a press. Remove snap ring (A), washer (B), spring (C), and washer (D).

Specification

New Spring—Free Length (approximate)..... 73.3 mm (2.89 in.)

- A—Snap Ring
- B—Washer
- C—Spring
- D—Washer



T6439VC -UN-22MAR90

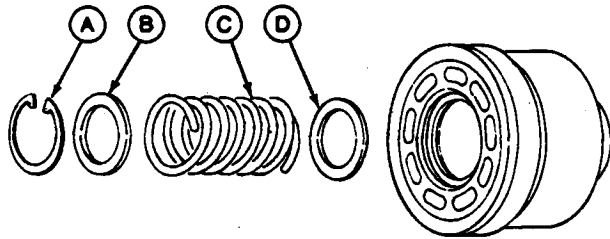

T6439UR -UN-01NOV88

TX,4360,AB40 -19-08JAN92-7/20

11. Remove snap ring (A).

Remove seal retainer (B), O-ring (C), seal (D), and lower bearing cup (E) using a 68 mm disk.

CAUTION: Reduce compressed air to less than 210 kPa (2 bar) (30 psi) when using for cleaning purposes. Clear area of bystanders, guard against flying chips, and wear personal protection equipment including eye protection.

IMPORTANT: Use only diesel fuel to clean pump parts. DO NOT use solvents, they can damage internal components.

Be careful when handling parts with lapped surfaces. DO NOT scratch or damage surfaces.

12. Wash all parts in diesel fuel and dry using compressed air.

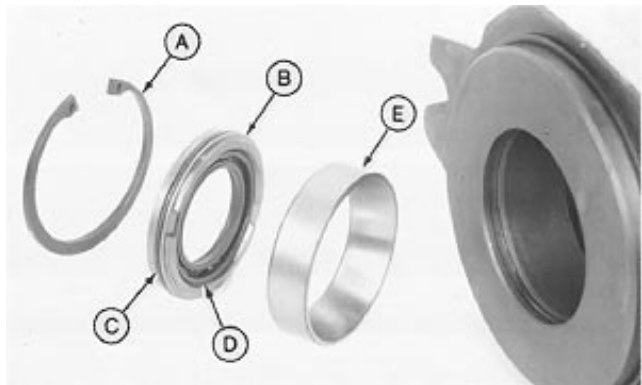

T6641EU -UN-22MAR90

- A—Snap Ring
- B—Seal Retainer
- C—O-Ring
- D—Seal
- E—Bearing Cup

Continued on next page

TX,4360,AB40 -19-08JAN92-8/20

Hydraulic System

13. Inspect pistons (C) for scoring or wear. Check piston-to-slipper ball joint for looseness. Check for equal wear between all slippers (A).

Inspect lapped surfaces of slippers, valve plate, and cylinder block (D) for scratches and wear.

Valve plate is surface hardened and cannot be polished. Replace plate if damaged or worn.

Minor scratches on cylinder block can be removed using JT05425 Polishing Table or an equivalent surface and 4/0 emery paper. Wet polishing paper using diesel fuel.

Inspect swash plate (B) for wear or damage; replace if necessary.

NOTE: *The face of slippers are made with a concave surface. Minor scratches can not be removed using a polishing table.*

14. Apply clean hydraulic oil to all internal parts.

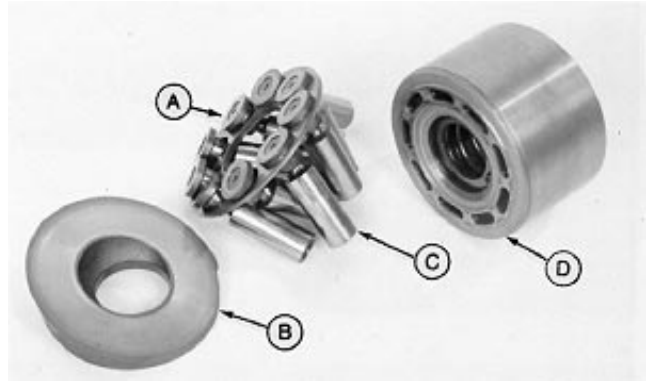

A—Slipper
B—Swash Plate
C—Piston (9 used)
D—Cylinder Block

T6641EW -UN-22MAR90

43
4360
13

TX,4360,AB40 -19-08JAN92-9/20

15. Apply retaining compound to inside surface of seal collar (A).

Install seal collar so chamfered end is toward input end of shaft. Push bearing (B) and seal collar on shaft using a press and a bearing puller until bearing is tight against shoulder.

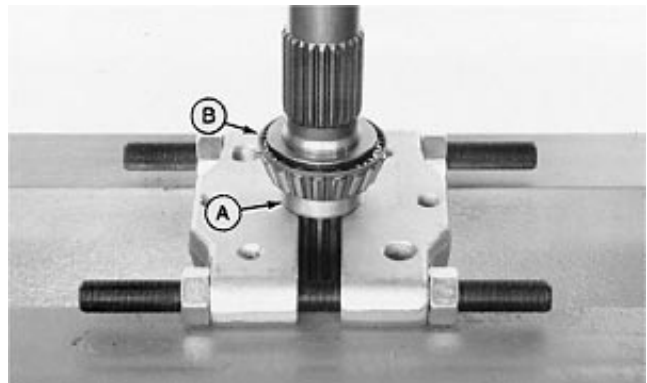

Continued on next page

TX,4360,AB40 -19-08JAN92-10/20

T6641EW -UN-22MAR90

Hydraulic System

16. Install parts (B—D). Push washer (B) down using a press and disk. Install snap ring (A).

- A—Snap Ring
- B—Washer
- C—Spring
- D—Washer

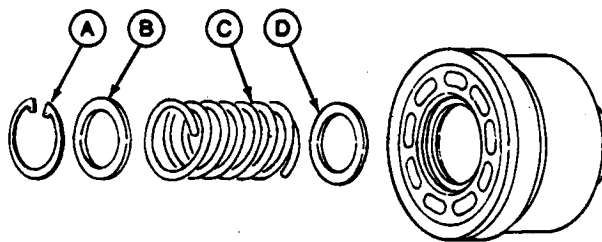

T6439UR -UN-01NOV88



T6439VC -UN-22MAR90

TX,4360,AB40 -19-08JAN92-11/20

17. Push seal (D) in seal retainer (B) to bottom of bore.

Apply petroleum jelly to O-ring (C). Install bearing cup (E), seal retainer (C), O-ring, and snap ring (A) in motor housing.

IMPORTANT: Protect lapped surface of cylinder block using a clean piece of cardboard.

18. Put cylinder block on cardboard and wood block with lapped surface down.

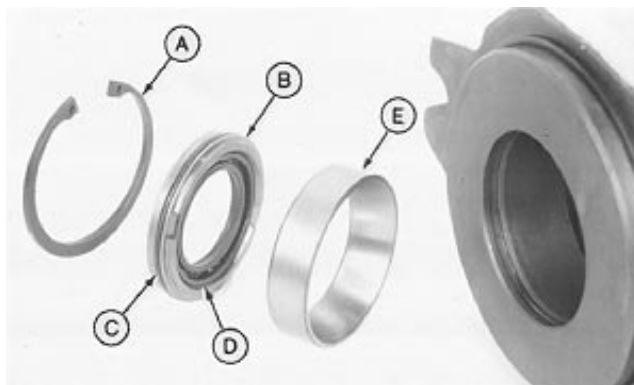

T6641EU -UN-22MAR90

- A—Snap Ring
- B—Seal Retainer
- C—O-Ring
- D—Seal
- E—Bearing Cup

Continued on next page

TX,4360,AB40 -19-08JAN92-12/20

Hydraulic System

19. Apply petroleum jelly to pins (B). Install pins and ball guide (A) and align splines.

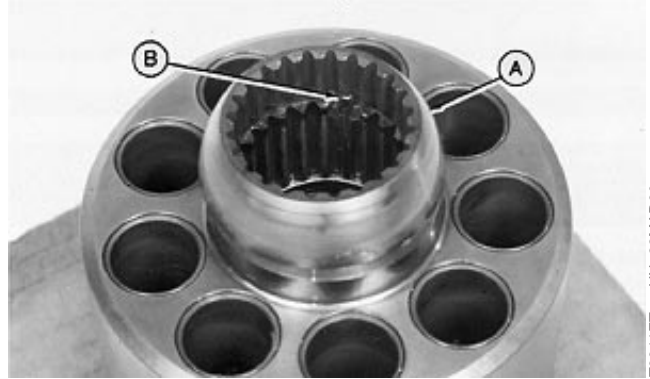

T6641ET -JUN-22MAR90

43
4360
15

TX,4360,AB40 -19-08JAN92-13/20

20. Install parts (C—E).

Install motor shaft using care not to move three pins in cylinder block.

- A—Cardboard
- B—Wood Support
- C—Swash Plate
- D—Retainer Plate
- E—Piston (9 used)



T6641ER -JUN-20MAR90

Continued on next page

TX,4360,AB40 -19-08JAN92-14/20

Hydraulic System

21. Put motor housing in horizontal position with locator pin (A) on bottom.

Carefully install rotating group in housing and carefully guide shaft through seal. Align locator pin with notch in swash plate.



T6641EX -UN-22MAR90

22. Turn motor vertical and put on wood block.



T6641EY -UN-22MAR90

TX,4360,AB40 -19-08JAN92-15/20

Install spacer (A).

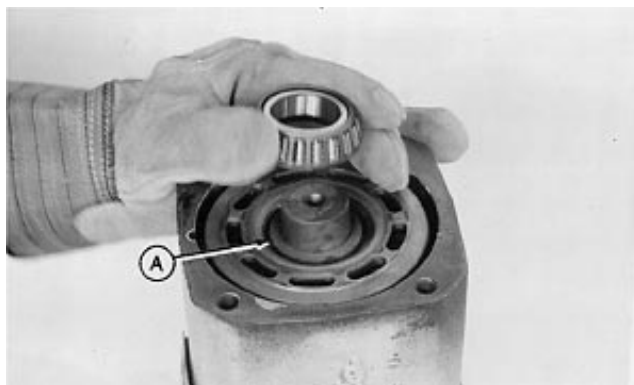

T6641EZ -UN-22MAR90

TX,4360,AB40 -19-08JAN92-16/20

! CAUTION: DO NOT heat oil over 182°C (360°F). Oil fumes or oil can ignite above 193°C (380°F). Use a thermometer. DO NOT allow a flame or heating element to come in direct contact with the oil. Heat the oil in a well-ventilated area.

23. Heat new bearing cone to approximately 93°C (200°F) and install on shaft.

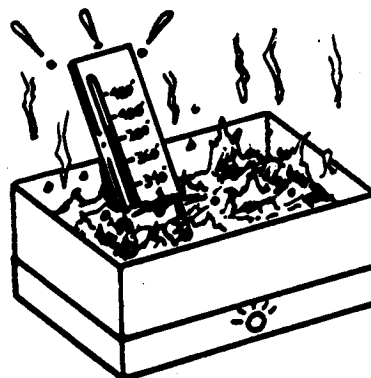

T81191 -UN-23FEB89

Continued on next page

TX,4360,AB40 -19-08JAN92-17/20

Hydraulic System

24. Push new bearing cup (C) to bottom of bore. Bearing cup is a press fit.
25. Apply petroleum jelly to valve plate (B) on side opposite sliding lapped surface.

Install valve plate on housing (A) with lapped surface up.
26. Apply a thin, even layer of pipe sealant with TEFLON® to mating surface of swing motor.
27. Carefully install valve plate and housing on swing motor. Install and tighten socket head screws to 69 N•m (51 lb-ft).

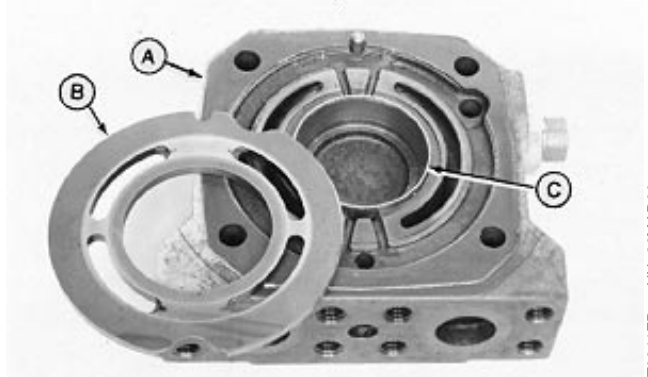

T6641EP -UN-26MAR90

43
4360
17

Specification

Valve Housing-to-Motor Housing
Socket Head Screw—Torque..... 69 N•m (51 lb-ft)

For swing motor with swing stop cushion valve, install valve. Tighten cap screws to 32 N•m (24 lb-ft).

Specification

Swing Stop Cushion Valve—
Torque 32 N•m (24 lb-ft)

TEFLON is a registered trademark of the Du Pont Company.

TX,4360,AB40 -19-08JAN92-18/20

28. Turn swing motor shaft several times. Make sure seal retainer (B) is pushed tight against bearing (C).
29. Install M10-1.5 eyebolt in motor shaft and attach to hoist.

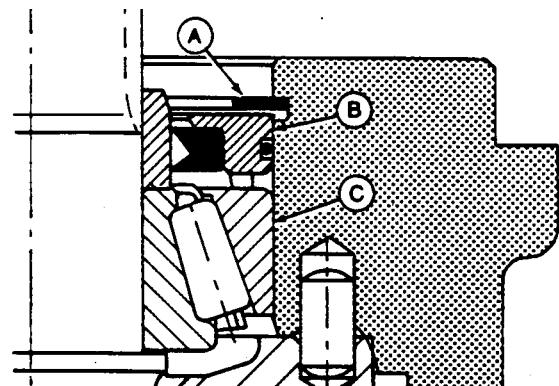

T6641FB -UN-03NOV88

Continued on next page

TX,4360,AB40 -19-08JAN92-19/20

Hydraulic System

Install dial indicator. Lift motor to check shaft end play. Lifting motor pulls bearing and seal retainer tight against snap ring (A).

Specification

Shaft—End Play 0.02—0.35 mm (0.001—0.014 in.)

Replace snap ring with another snap ring of different thickness to obtain proper end play.

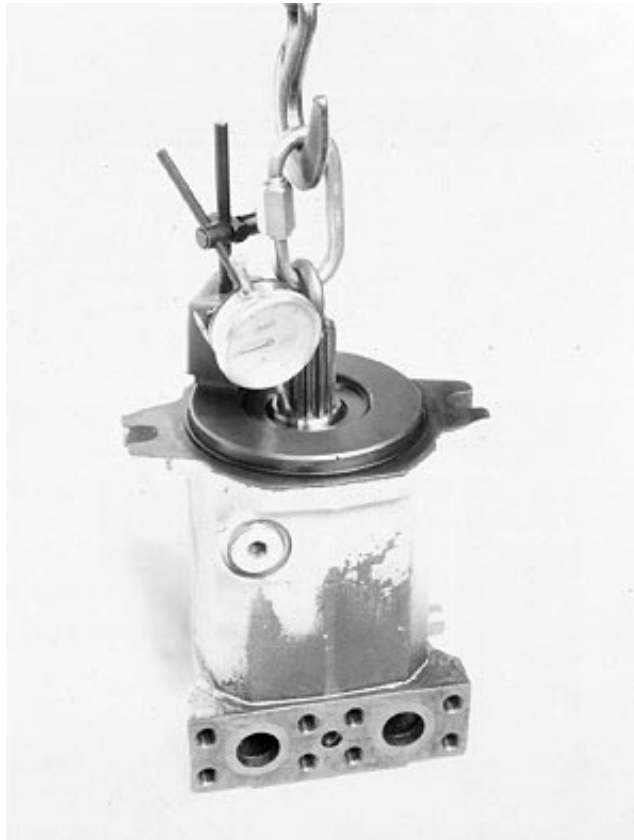

TX,4360,AB40 -19-08JAN92-20/20

Remove And Install Crossover Relief Valve

Crossover valve cannot be repaired. Valve cannot be disassembled and reassembled. It must be replaced as a complete assembly.

Inspect O-ring (A) and valve (B). Replace as necessary.

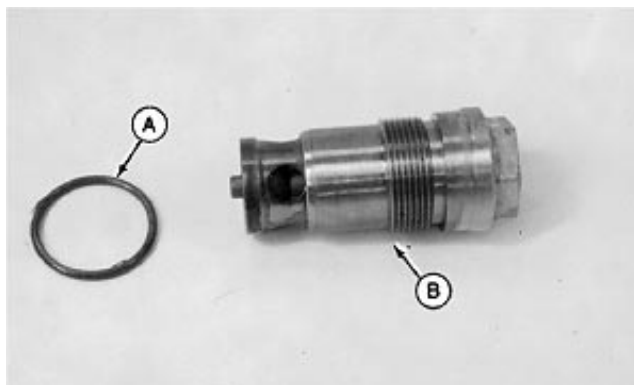

TX,4360,AB430 -19-26FEB92-1/1

43
4360
18

Section 99

Dealer Fabricated Tools

Contents

	Page
Group 9900—Dealer Fabricated Tools	
ST4920 Track Recoil Spring Disassembly And Assembly Tool	99-9900-1
DFT1087 Track Recoil Spring Disassembly And Assembly Guard Tool	99-9900-5
DFT1111 Spacer	99-9900-6
DFT1110 Spacer	99-9900-7
DFT1094 Bearing Pilot Tool	99-9900-8
DFT1095 Planetary Gear Assembly Tool	99-9900-9
DFT1096 Planetary Gear Shaft Removal Tool	99-9900-10
Rotary Manifold Lifting Tool	99-9900-11
DF1039 Pump Workbench Support	99-9900-11
DF1040 Pump Rotate Group Workbench Support	99-9900-12
DF1052 Disk Holder Tool	99-9900-13
JT38009 Guide Pin	99-9900-14
DFT1089 Barrel Support	99-9900-15
DFT1077 Spool Holding Fixture	99-9900-16
DFT1108 Spool Holding Fixture	99-9900-16
DF1054 Swing Gearbox Nut Spanner Wrench	99-9900-17
DFT1074 Swing Gearbox Pinion Holder Fixture	99-9900-18

Contents

**ST4920 Track Recoil Spring Disassembly
And Assembly Tool**

NOTE: It is recommended that DFT1087 Track Recoil Spring Disassembly and Assembly Guard Tool be used with track recoil spring disassembly and assembly tool.

Dimensions given are metric.

Tool is the same as used on other machines except the holder (C). For each track adjuster use the holder with the correct size hole for the nut on that track adjuster.

Track Recoil Spring Disassembly and Assembly Tool (compression tool) is used with hydraulic jack to compress recoil spring in track adjuster repair.

Material required:

- 1020 HR Steel for Holder (C), Supporting Plate (E), Base Plate (F), and Base (G).
- "D" Grade (SAE Grade 5) for Eyebolts (D), Nuts (A), and Cap Screws (H).
- "F" Grade (SAE Grade 8) for Studs (B)

Print Numbers:

- A-ST4050 Nut
- B-ST4045 Bolt
- C-ST4035 Holder (Plate)
 - -ST4036 Holder (Plate)
 - -ST4037 Holder (Plate)
- D-ST4047 Eyebolt
- E-ST4040 Supporting Base
- F-ST4042 Base Plate
- G-ST4041 Base
- H-ST4046 Cap Screw
- I-ST4049 Lock Washer

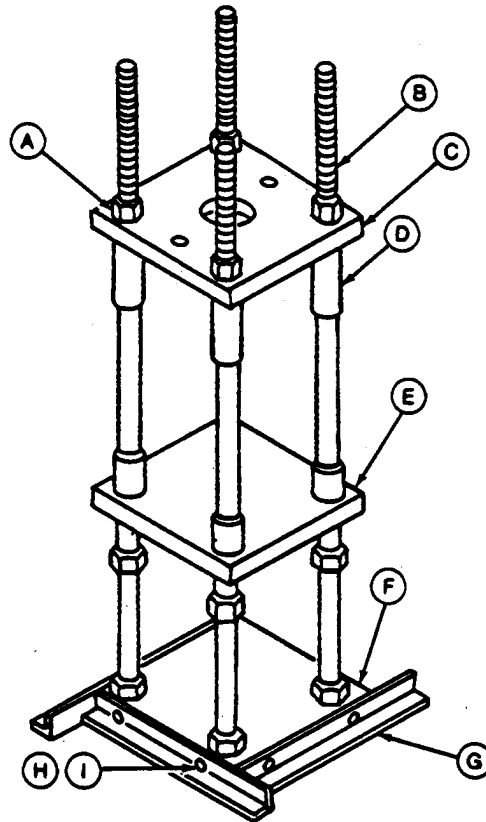

- A—Nut (12 used)
- B—Stud (4 used)
- C—Holder
- D—Eyebolt (2 used)
- E—Supporting Plate
- F—Base Plate
- G—Base (4 used)
- H—Cap Screw (8 used)
- I—Lock Washer (8 used)

99
9900
1

T6585UY -UN-24MAR98

Continued on next page

TX,9900,AA3574 -19-20FEB92-1/4

Dealer Fabricated Tools

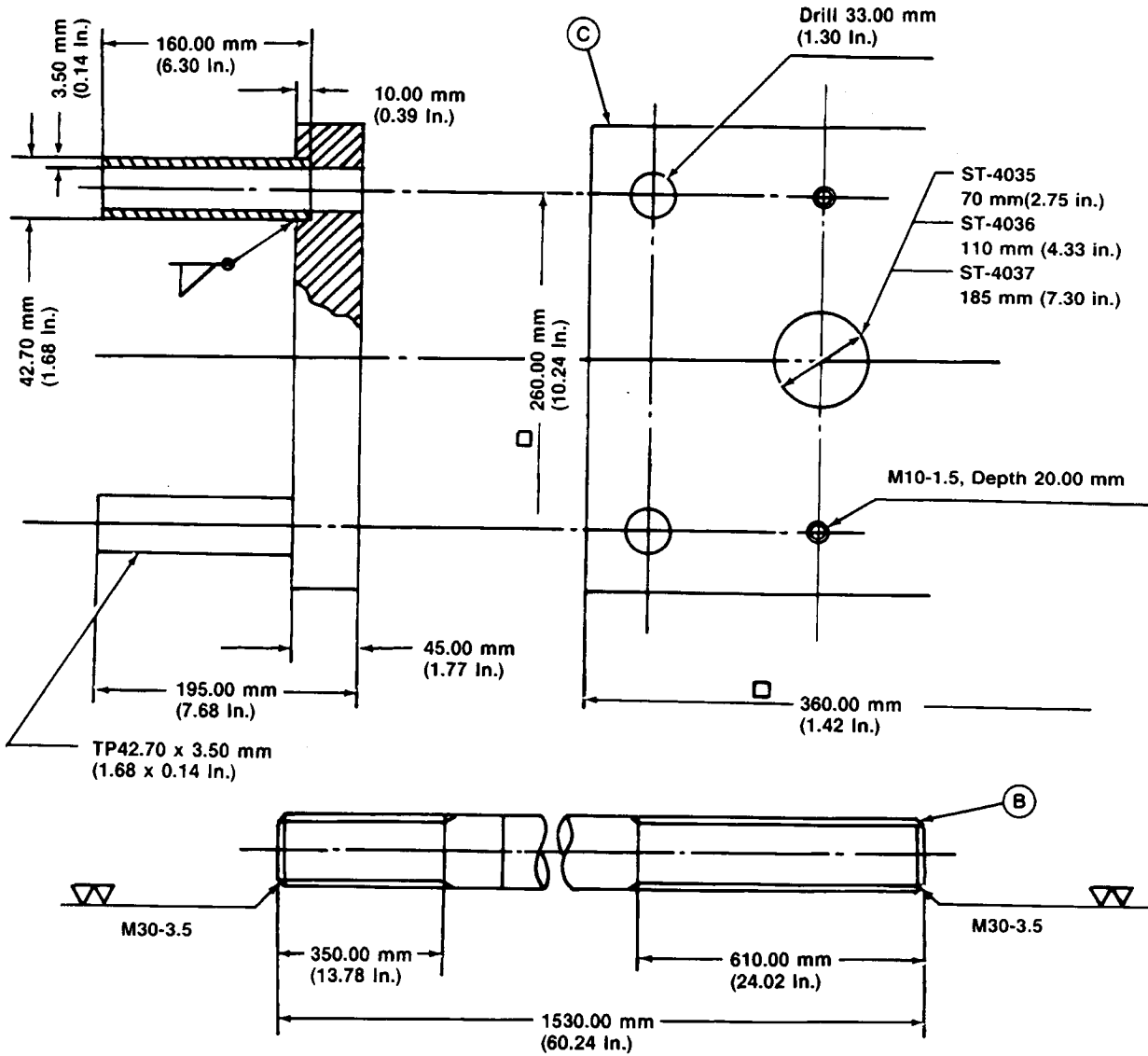

99
9900
2

T7029CI -UN-06JUL89

Continued on next page

TX,9900,AA3574 -19-20FEB92-2/4

Dealer Fabricated Tools

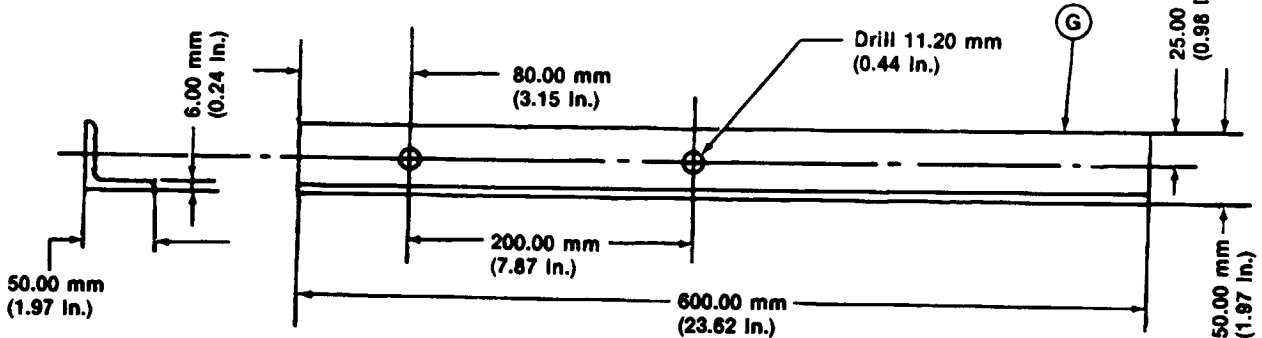
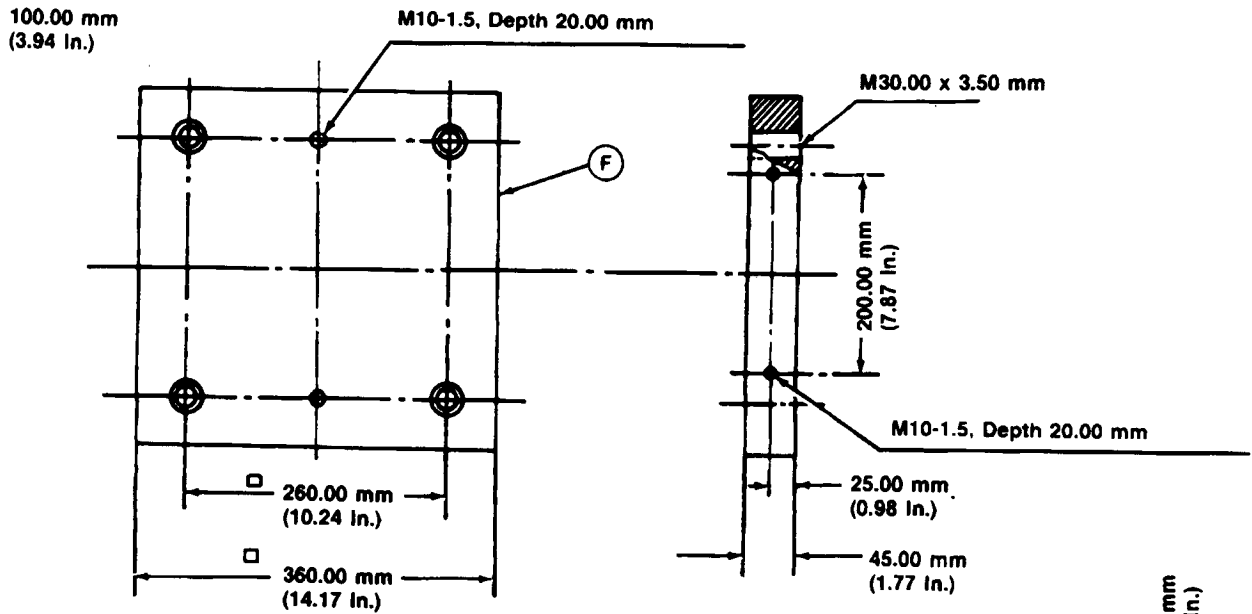
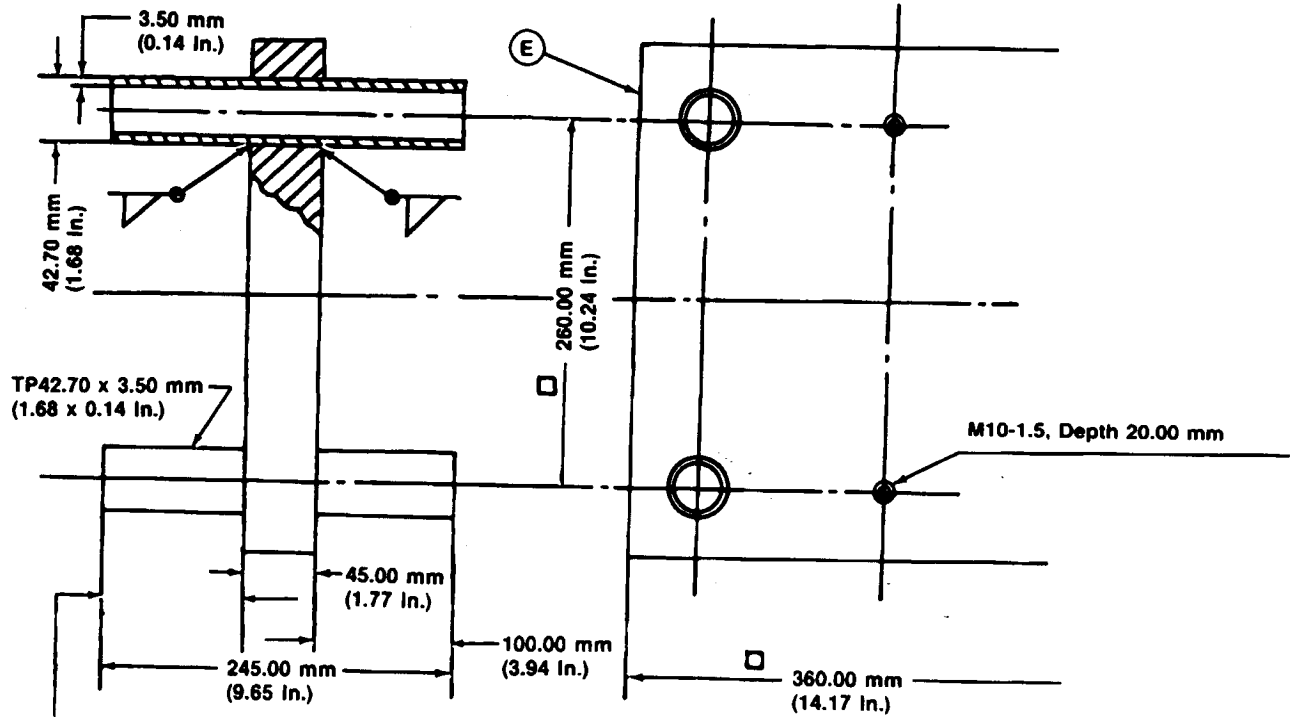

99
9900
3

Continued on next page

TX,9900,AA3574 -19-20FEB92-3/4

T7029CH -UN-06/JUL89

Dealer Fabricated Tools

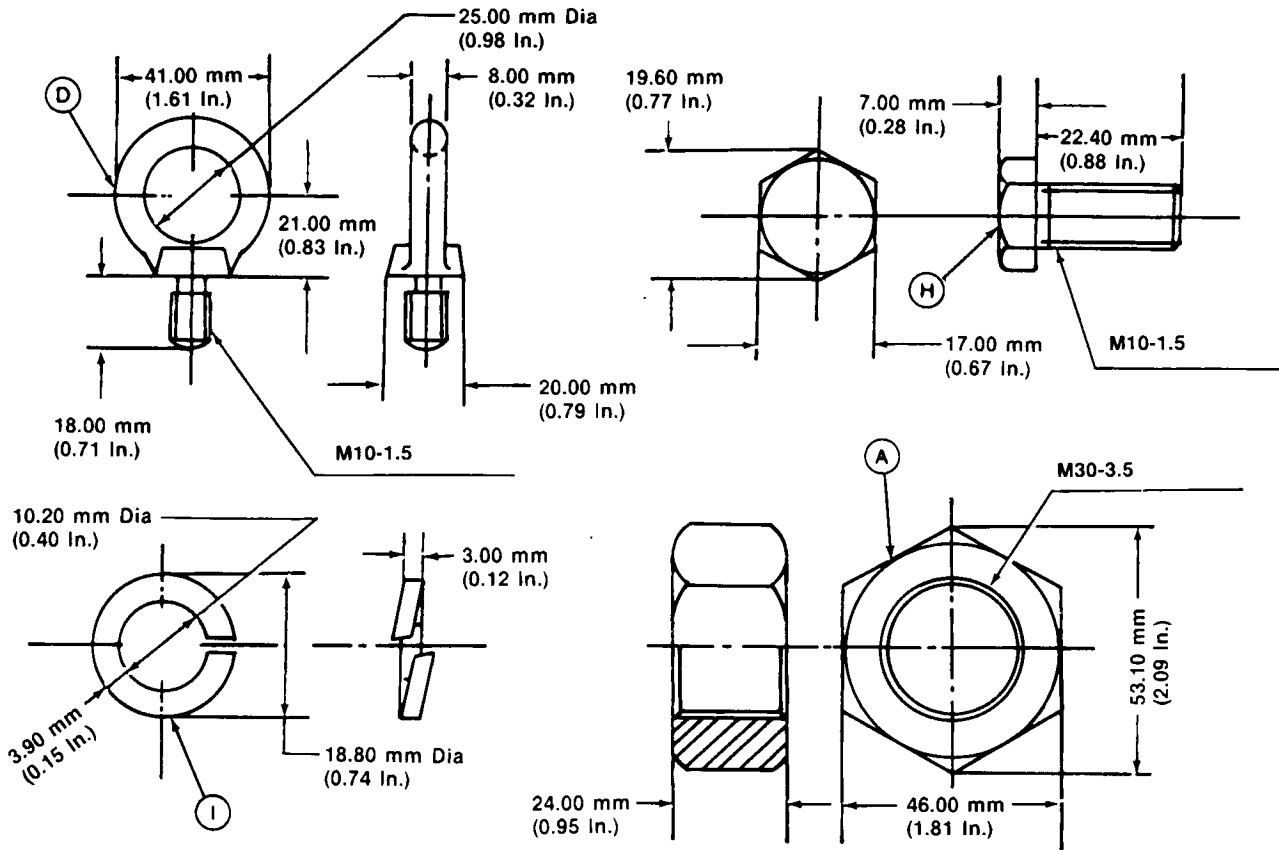

99
9900
4

T7029CG -UN-06JUL89

TX,9900,AA3574 -19-20FEB92-4/4

DFT1087 Track Recoil Spring Disassembly And Assembly Guard Tool

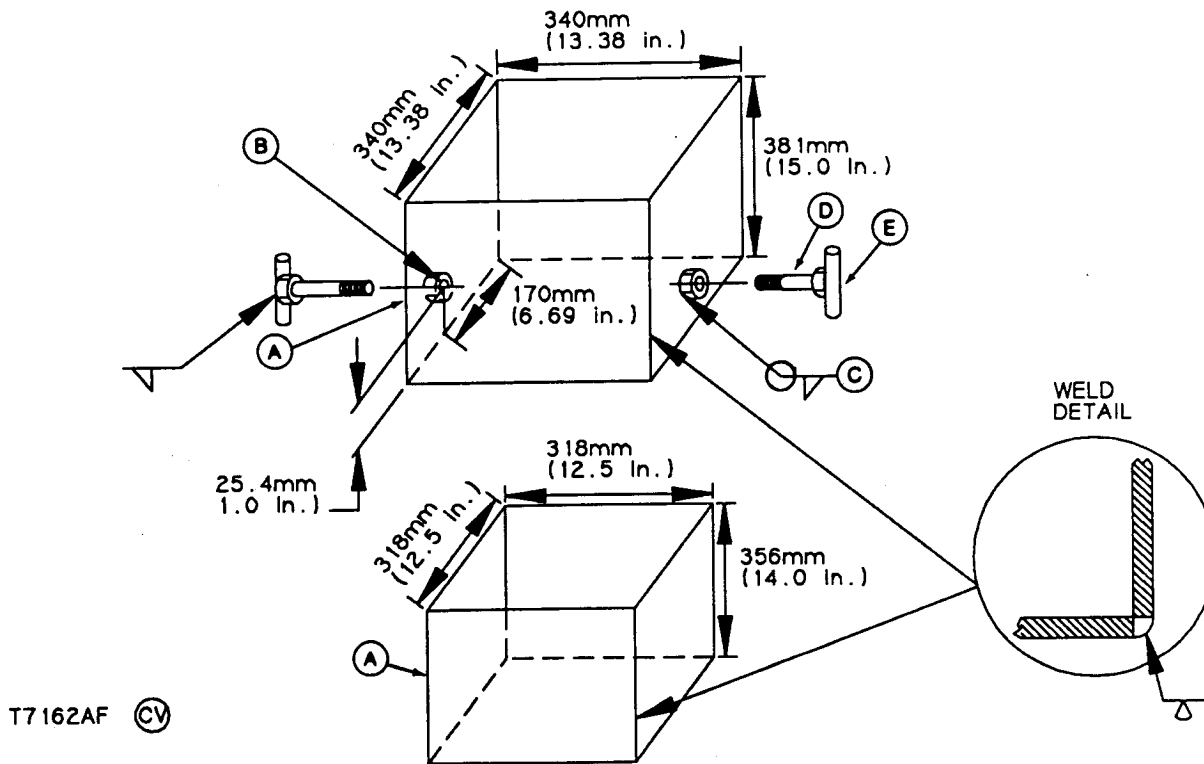

T7162AF ©

A—3/16 in. 1020 CR Steel Plate C—1/2 in. Nut (2 used)
 B—9/16 in. Hole (2 places)

D—1/2 x 2 in. Cap Screw (2 used)

E—1/2 x 3 in. Steel Round Stock (2 used)

Track Disassembly and Assembly Guard Tool is used with ST4920 Track Recoil Spring Disassembly and Assembly Tool.

- 3/16 in. 1020 CR Steel Plate (A)
- 1/2 in. Nut (C) (2 used)
- 1/2 x 2 in. Cap Screw (D) (2 used)
- 1/2 x 3 in. Steel Round Stock (E) (2 used)

Material required:

99
9900
5

T7162AF -UN-17OCT89

TX.9900,BA499 -19-24SEP91-1/1

Dealer Fabricated Tools

DFT1111 Spacer

Spacers are used with ST4920 Track Recoil Spring Disassembly and Assembly Tool. Spacers are installed between the top plate and recoil spring retainer plate to allow access to spring pin in nut.

Material required:

31.75 x 31.75 x 335 mm (1.25 x 1.25 x 13.20 in.) Bar
Stock (2 used)

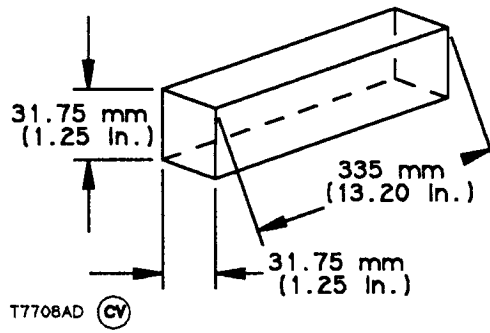

TX,9900,GG271 -19-22NOV94-1/1

DFT1110 Spacer

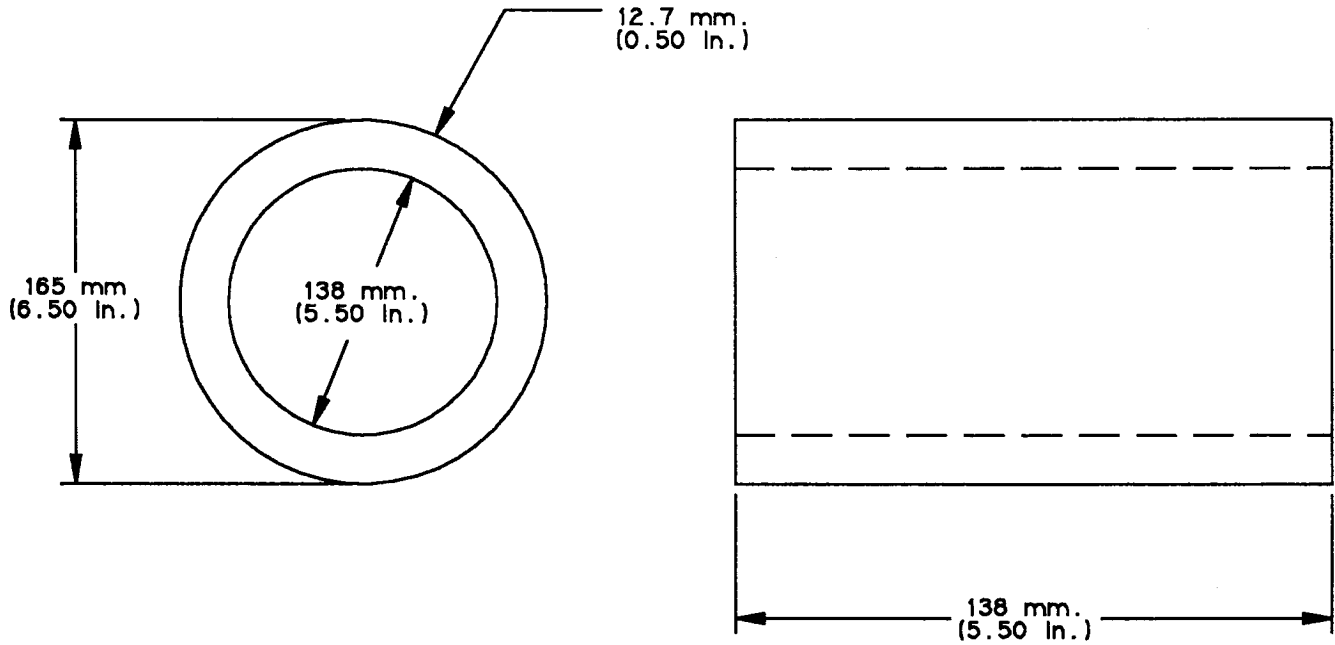

T7708AC (CV)

99
9900
7

T7708AC -UN-23FEB92

Spacer is used with ST4920 Track Recoil Spring Disassembly and Assembly Tool. Spacer is installed on the bottom plate so force is applied to spring flange on cylinder and not to the piston.

Material Required:

165 x 138 x 138 mm (6.50 x 5.50 x 5.50 in.) Heavy Wall Steel Pipe

Cut the ends of spacer so they are parallel to each other.

DFT1094 Bearing Pilot Tool

Bearing Pilot Tool is use with the DFT1095 Planetary Gear Assembly Tool to hold the roller bearings in the third planet gear while installing on the shaft.

Drill holes for 3 x 16 mm metric spring pin (D) to 3 mm or drill holes for 1/8 x 1/2 in. spring pin (D) to 0.125 in.

Drill pilot hole (C) in round bar stock (A) so it is centered.

Grind a chamfer (B) on the end to remove sharp edge.

Material required:

- 59 x 46 mm (2.32 x 1.812 in.) Round Bar Stock (A)
- 3 x 16 mm Metric Spring Pin (such as 34M7085 Metric Spring Pin) (D) or 1/8 x 1/2 Spring Pin (such as 34H243 Spring Pin) (D)

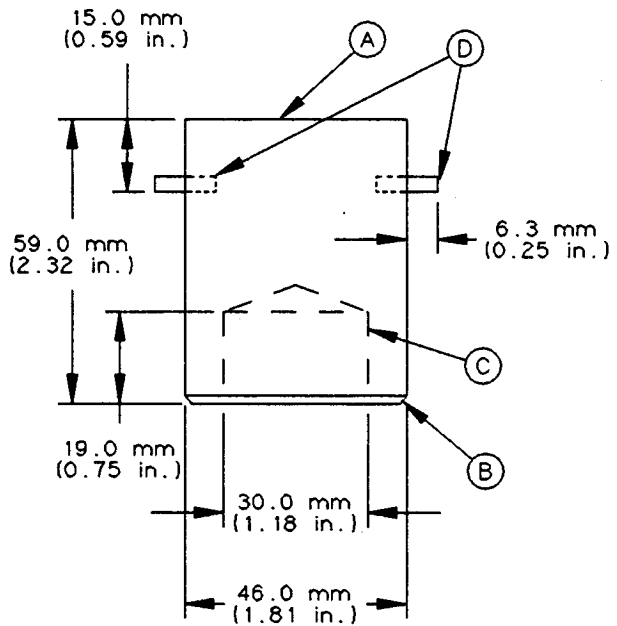

T7383AK (CV)

T7383AK -UN-15OCT91

TX,9900,GG209 -19-03OCT91-1/1

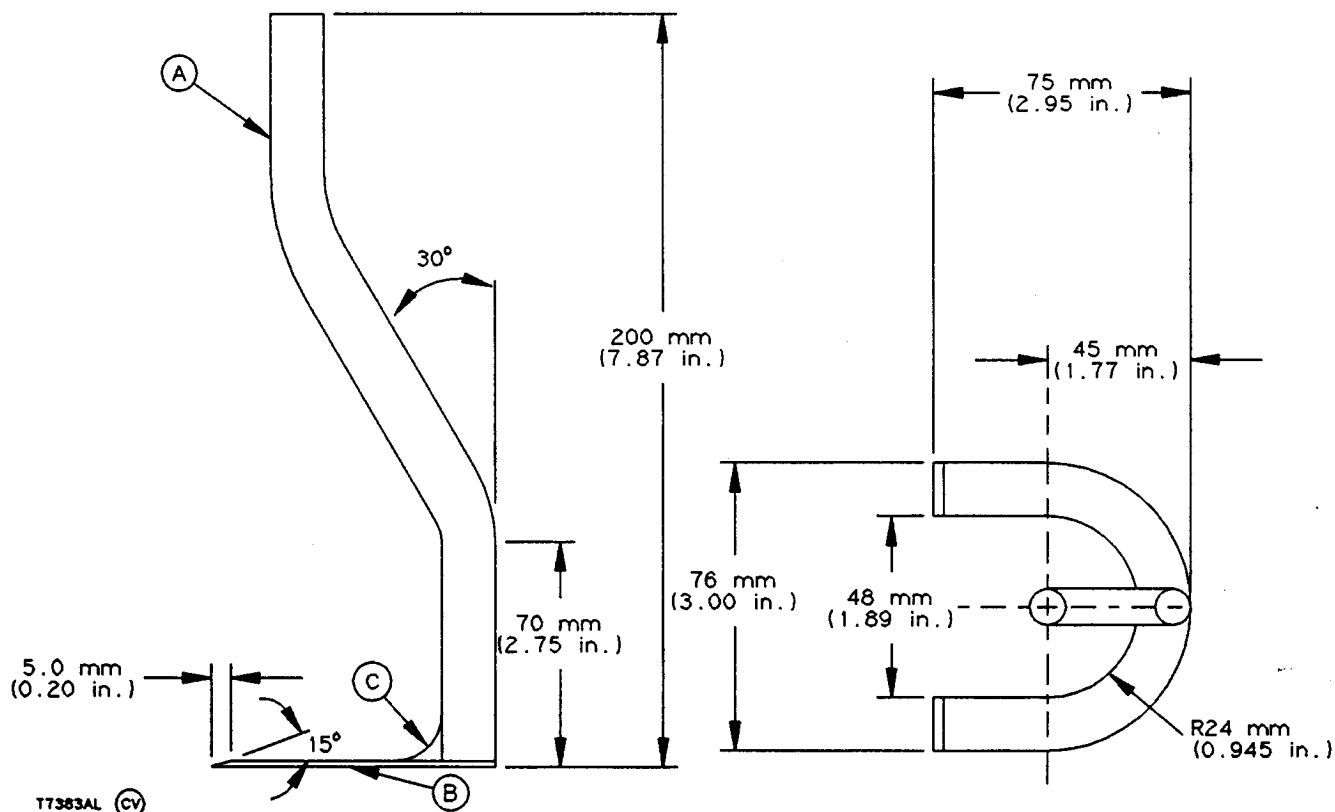
DFT1095 Planetary Gear Assembly Tool

Planetary Gear Assembly Tool is used with the DFT1094 Bearing Pilot Tool to hold the roller bearings in the third planet gear while installing on the shaft.

Tack weld (C) rod (A) to sheet metal (B).

Material required:

- 10 x 200 mm (0.375 x 7.87 in.) Rod (A)
- 76 x 76 mm (3 x 3 in.) 16 Gauge Sheet Metal (B)

TX.9900.GG210 -19-03OCT91-1/1

DFT1096 Planetary Gear Shaft Removal Tool

Planetary Gear Shaft Removal Tool is use with a 2-jaw puller and a slide hammer puller to remove shafts for third planet in the propel gearbox.

Drill a 10 mm (0.375 in.) hole (F) through the steel tabs (D).

Cut steel tube (A) the full length using a 2.54 mm (0.100 in.) saw cut (E).

Install a length of 46 mm (1-13/16 in.) round bar stock or pipe into the steel tube before welding on tabs to prevent warping.

Weld tabs (B and D) centered on steel tube using 10 mm (0.375 in.) bevel groove weld.

Material required:

- 60 x 46 x 45 mm Steel Tube (A) or 2.375 x 1.810 x 1.750 in. Steel Tube (A)
- 19 x 19 x 25 mm Steel Tab (B) or 0.750 x 0.750 x 1.00 in. Steel Tab (B)
- 19 x 19 x 13 mm Steel Tab (D) (2 used) or 0.750 x 0.750 x 0.500 in. Steel Tab (D) (2 used)
- M8-1.25 x 50 mm Grade 10.9 Cap Screw and M8-1.25 Grade 10 Nut or 5/16-18 x 2 in. SAE Grade 8 Cap Screw and 5/16-18 in. SAE Grade 8 Nut

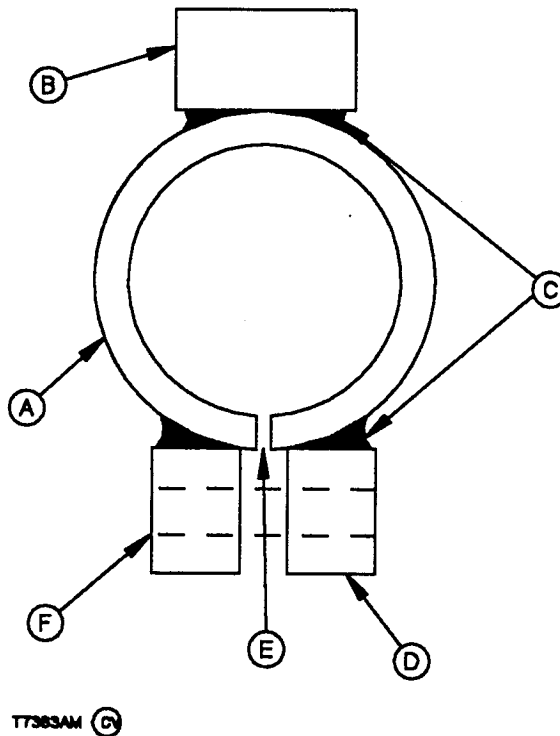

- T7383AM (C)
- A—Steel Tube
 - B—Steel Tab
 - C—Bevel Groove Weld
 - D—Steel Tab (2 used)
 - E—Saw Cut
 - F—Hole For Cap Screw

T7383AM -UN-06JAN92

TX,9900,GG263 -19-06JAN92-1/1

Dealer Fabricated Tools

Rotary Manifold Lifting Tool

Tool is used to remove and install rotary manifold.

Drill and tap disk in fitting cap to M8-1.25 mm threads (A).

Material required:

- 38H1416 Cap (—12)
- JT05548 8-mm Metric Lifting Eyebolt

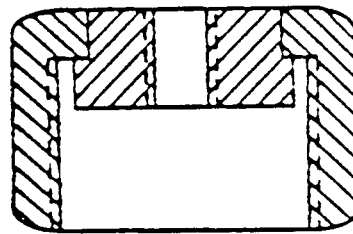
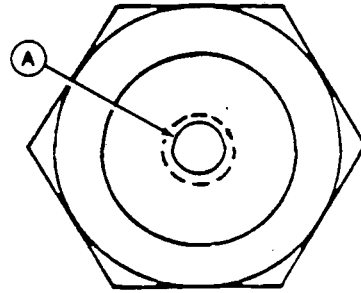

99
9900
11

T6641DO -UN-24OCT88

9900,CC4 -19-24SEP91-1/1

DF1039 Pump Workbench Support

Support is used to hold hydraulic pump while disassembling and assembling.

Material required:

Wood

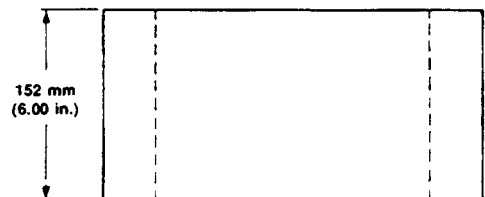
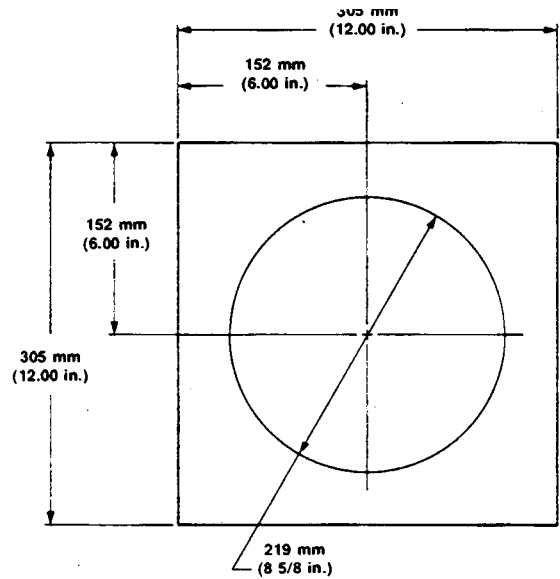

T6439VQ -UN-24OCT88

9900,CC1 -19-24SEP91-1/1

Dealer Fabricated Tools

DF1040 Pump Rotate Group Workbench Support

Support is used to hold pump rotating group while disassembling and assembling.

Material required:

Wood

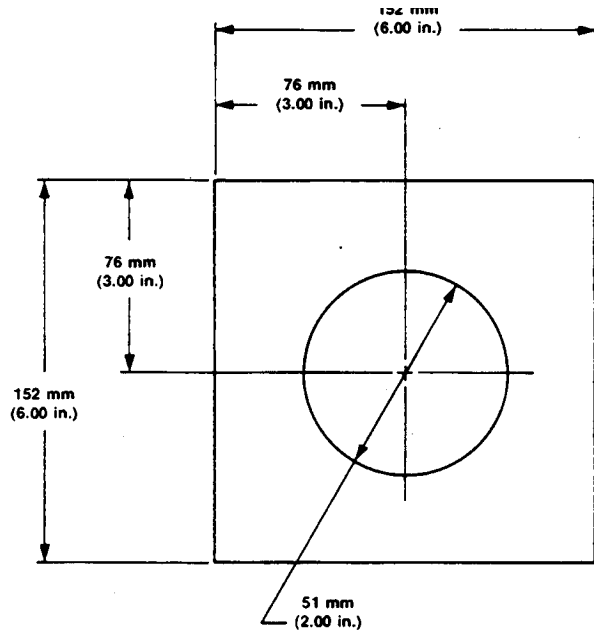

T6439YX -UN-24OCT88

9900,CC2 -19-24SEP91-1/1

99
9900
12

DF1052 Disk Holder Tool

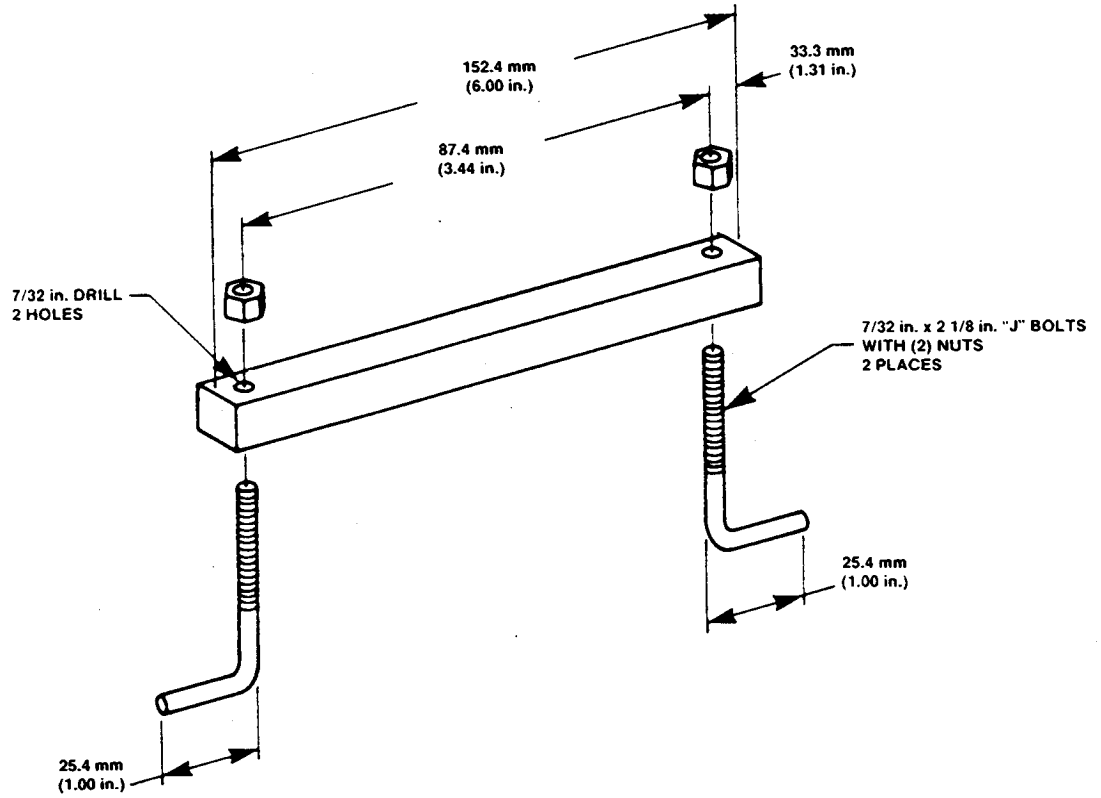

Tool is used to hold swing brake disks and separator plate together while installing in brake housing.

Bend J-bolts to dimension shown.

Material required:

- 1/2 in. Square Steel Bar Stock
- 7/32 x 2-1/8 in. J-Bolt with Nut (2 used)

99
9900
13

T6641DP -19-21MAR89

9900,CC5 -19-24SEP91-1/1

JT38009 Guide Pin

Guide pin is used to align cap screw holes in swing bearing and upperstructure.

Remove threads for distance (B) and grind taper on same end.

Material required:

- 3/4-10 UNC x 9 in. Long Threaded Rod
- 3/4-10 UNC Nut

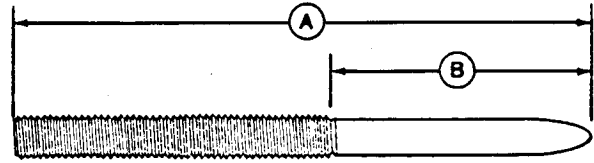

T6641EK -UN-24OCT88

A—230 mm (9 in.)
B—100 mm (4 in.)

9900,CC7 -19-24SEP91-1/1

DFT1089 Barrel Support

Barrel supports are used to support the upperstructure when removing the undercarriage.

Material required:

CAUTION: Cutting tops off barrels that contained flammable or explosive material can cause serious injury or death.

- Clean metal 55 gal barrels of equal height with lids removed. (Must be 34.5—35.5 in. height x 24 in. wide.)
- 1/2 x 4 x 24 in. 1020 CR Plate
- 1/2 x 4 x 12 in. 1020 CR Plate
- One empty 3 lb coffee can or equivalent
- Highway Cement (9 bag mix). Mix extra dry to aid curing time.

Insert hook assembly into barrel before cement is set. Hold assembly in position, using a steel plate or wire, until cement begins to cure.

Level off cement with top of barrels.

Cement must cure for a minimum of ten days.

The approximate weight of each barrel support is 545 kg (1200 lb). The approximate support capacity of each barrel support is 385 560 kg (850,000 lb).

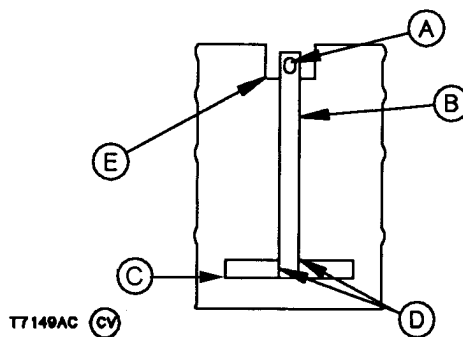

- A—2 x 4 in. Slotted Hole, Recessed
- B—1/2 x 4 x 24 in. 1020 CR Plate
- C—1/2 x 4 x 12 in. 1020 CR Plate
- D—1/4 in. Fillet Weld
- E—One empty 3 lb coffee can or equivalent

T7149AC -JUN-08JAN97

99
9900
15

TX,9900,AA3912 -19-24SEP91-1/1

DFT1077 Spool Holding Fixture

Spool Holding Fixture is used to hold valve spools to prevent damage when disassembling and assembling.

Material required:

4 x 4 x 6 in. Hardwood

- A—Cut Here
- B—25.4 mm (1.00 in.) Hole
- C—51 mm (2 in.)
- D—102 mm (4 in.)
- E—153 mm (6 in.)

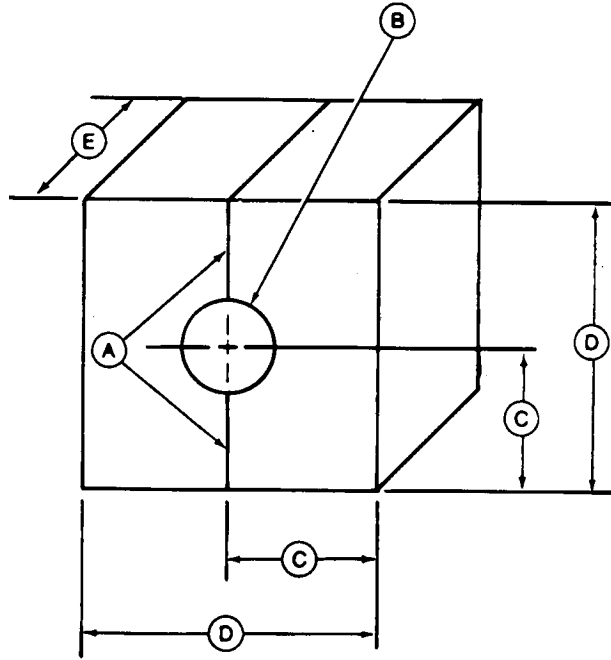

T7084BK -UN-06JUL89

TX,9900,AA3572 -19-26SEP91-1/1

DFT1108 Spool Holding Fixture

Spool Holding Fixture is used to hold valve spools to prevent damage when disassembling and assembling.

Material required:

4 x 4 x 6 in. Hardwood

- A—Cut Here
- B—32.0 mm (1.25 in.) Hole
- C—51 mm (2 in.)
- D—102 mm (4 in.)
- E—153 mm (6 in.)

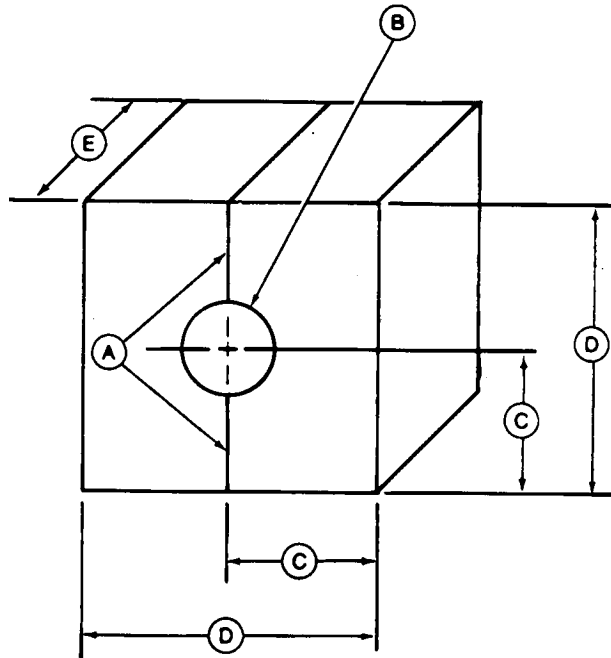

T7084BK -UN-06JUL89

TX,9900,GG206 -19-26SEP91-1/1

DF1054 Swing Gearbox Nut Spanner Wrench

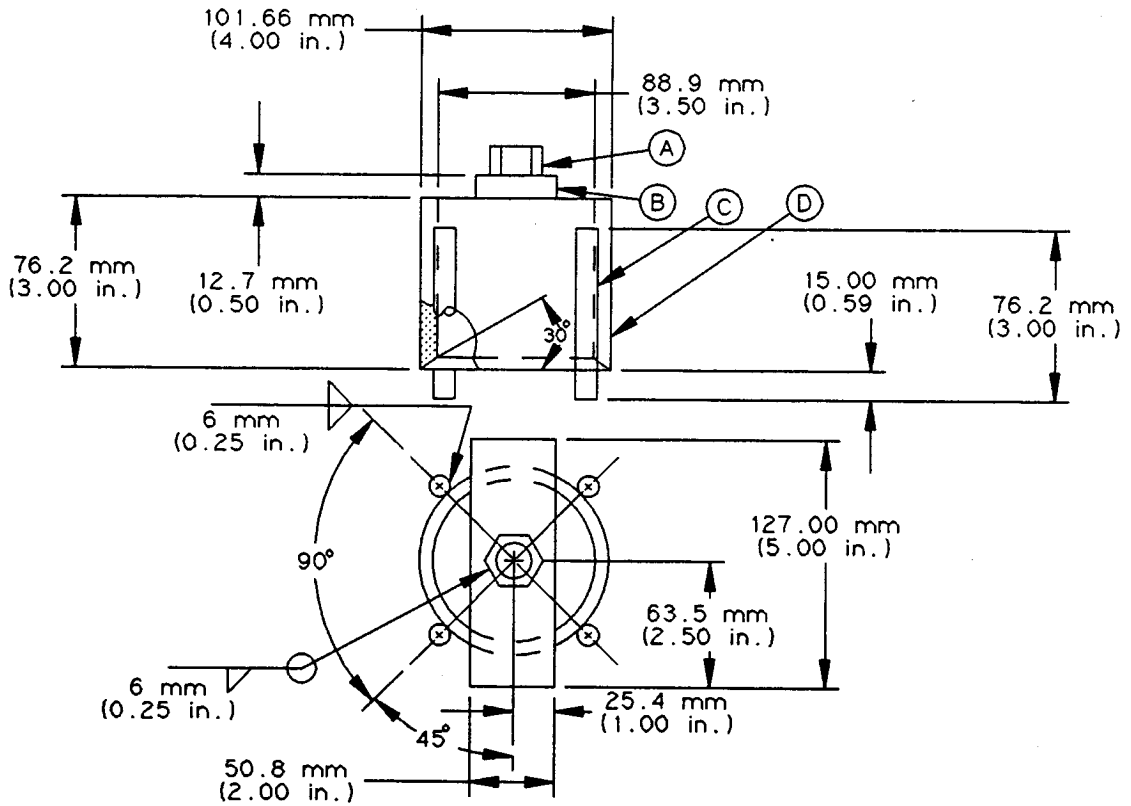

T7623AA (CV)

Swing Gearbox Nut Spanner Wrench is used to loosen and tighten the special nut in swing gearbox.

Material required:

- 3/4 in. Nut (A)

- 127.0 x 50.8 x 12.7 mm (5 x 2 x 0.5 in.) Flat Bar Stock (B)
- 7/16 x 3 in. Rod (C) (4 used)
- 101.6 x 88.9 x 76.2 mm (4 x 3.5 x 3 in.) Pipe (D)

99
9900
17

T7623AA -UN-15OCT19

TX,9900,GG207 -19-30SEP91-1/1

DFT1074 Swing Gearbox Pinion Holder Fixture

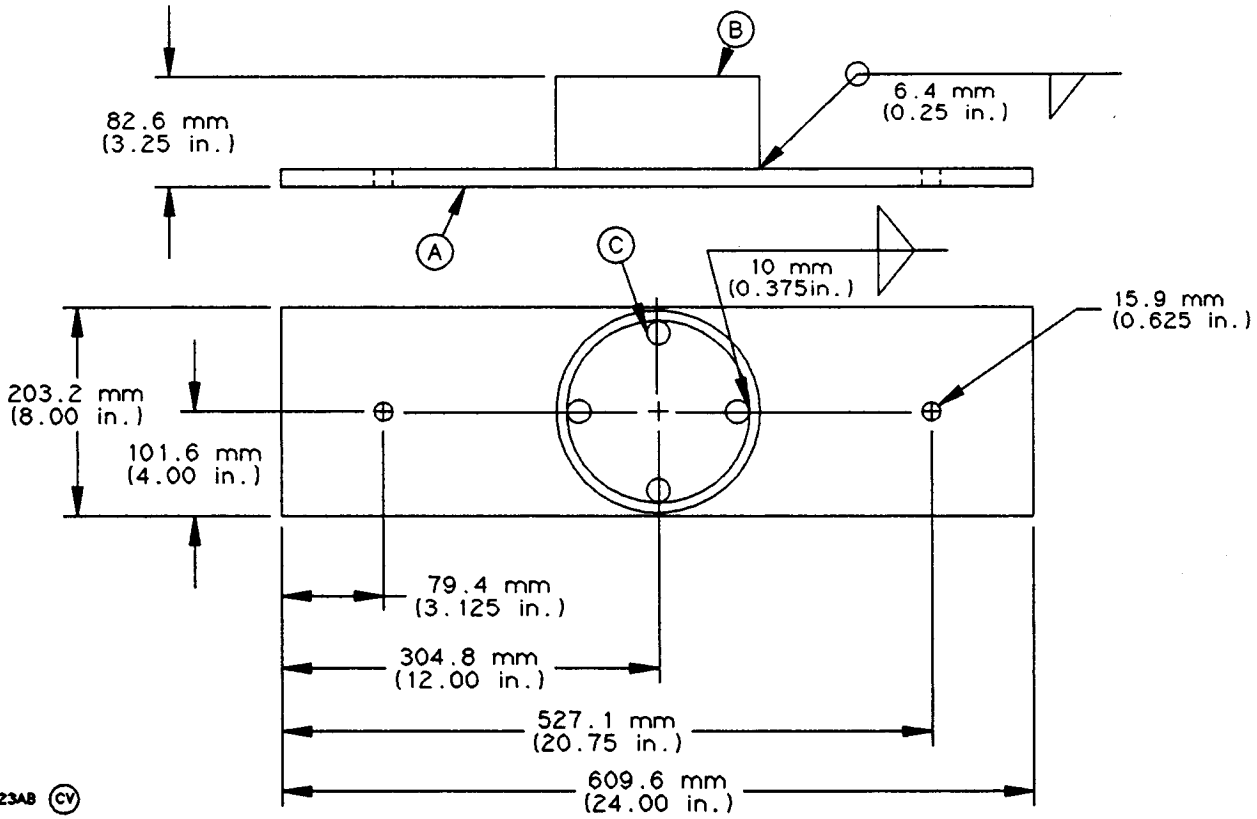

Swing Gearbox Pinion Holder Fixture is used to hold the pinion so special nut can be loosen or tighten.

Use the pinion as a template to locate the rods in the pipe.

The distance dimension given for the 5/8 in. holes is the distance between the mud holes over three track shoes so fixture can be fasten to the track.

Material required:

- 609.6 x 203.2 x 6.35 mm (24 x 8 x 0.250 in.) Flat Steel Plate (A)
- 177.8 mm ID x 9.5 mm min wall (7 in. ID x 0.375 in. min wall) Pipe (B)
- 3/4 x 3 in. Rod (C) (4 used)

Index

	Page		Page
A			
Adjustment		Charge	16-1671-10
Travel alarm volume	20-2004-1	Electrolyte level.	16-1671-6
Air cleaner		Electrolyte specific gravity	16-1671-5
Remove and install	05-0520-3	Handle safely	16-1671-3
Air conditioner relay		Remove and install	16-1671-11
Remove and install	18-1830-37	Terminal	16-1671-6
Air conditioner switch		Testing	16-1671-4
Remove and install	16-1674-10	Using booster-24-volt	16-1671-8
Air conditioning gauge set (SN -541550)		Battery explosion	16-1671-8, 16-1671-10
Installation.	18-1830-10	Bleed fuel system (SN -559602).	04-0400-42
Air conditioning switch (SN -541550)		Bleed fuel system (SN 559603-).	04-0400-42
Remove and install	18-1830-38	Blower motor	
Air intake system		Remove and install	18-1830-5
Leakage test.	05-0520-4	Boom	
Alternator (SN -541822)		Install bushings and seals.	33-3340-7
Remove and install	16-1672-2	Lower with engine stopped	33-3360-13
Alternator (SN 541823-559602)		Raise with engine stopped	33-3360-15
Remove and install	16-1672-3	Remove and install	33-3340-4
Alternator (SN 559603-)		Boom and arm anti drift valve	
Remove and install	16-1672-4	Disassemble and assemble	33-3360-161
Anti-cavitation back pressure check valve (SN -556935)		Boom and arm anti drift valve (SN 556936-)	
Remove and install	33-3360-109	Remove and install	33-3360-159
Anti-cavitation back pressure check valve (SN 556936-)		Boom and arm anti-drift valve (SN -556935)	
Remove and install	33-3360-110	Remove and install	33-3360-156
Arm		Boom cylinder	
Install bushings and seals.	33-3340-7	Assemble	33-3360-179
Remove and install	33-3340-2	Disassemble	33-3360-174
Arm and boom cylinder restrictors (SN 556936-)		Remove and install	33-3360-167
Remove and install	33-3360-109	Boom regenerative valve (SN 545157-556935)	
Arm cylinder		Disassemble and assemble	33-3360-146
Assemble	33-3360-179	Remove and install	33-3360-145
Disassemble	33-3360-174	Boom, arm and swing control valve (SN 556936-)	
Remove and install	33-3360-169	Disassemble and assemble	33-3360-136
Arm cylinder restrictor (SN 546276-556935)		Boom, arm and swing manifold valve (SN 556936-)	
Remove and install	33-3360-107	Remove and install	33-3360-97
Arm regenerative poppet valve (SN 556936-)		Boom, arm, and bucket valve section (SN -556935)	
Remove and install	33-3360-149	Disassemble and assemble	33-3360-122
Arm regenerative valve (SN 546277-556935)		Brake elements, propel gearbox	
Disassemble and assemble	33-3360-148	Replace	02-0250-6
Remove and install	33-3360-147	Brake release pressure reducing valve	
Arm regenerative valve (SN 556936-)		Remove and install	02-0260-32
Disassemble and assemble	33-3360-150	Bucket	
Assemble Compressor (SN -541550)	18-1830-28	Install bushings and seals.	33-3340-7
Auxiliary valve section (SN -556935)		Repair cracked cutting edge	33-3302-10
Disassemble and assemble	33-3360-137	Replace welded cutting edges	33-3302-10
B			
Battery		Tooth	33-3302-1
Adding 12-V accessories	16-1671-12	Bucket and linkage (SN -538759)	
		Remove and install	33-3302-5
		Bucket and linkage (SN 538760-)	
		Remove and install	33-3302-7
		Bucket circuit relief and anti-cavitation valve (SN 556936-)	
		Remove and install	33-3360-121

Index

	Page		Page
Bucket cylinder		Counterweight	
Assemble	33-3360-179	Remove and install	17-1749-3
Disassemble	33-3360-174	Crossover relief valve	
Remove and install	33-3360-171	Remove and install	02-0260-28, 43-4360-18
Bucket linkage		Cutting edge	
Adjust	33-3302-8	Repair cracked	33-3302-10
Bucket tooth tip (heavy-duty)		Replace welded	33-3302-10
Replacing	33-3302-1	Cylinder	
Bulbs		Bucket, arm, and boom	33-3360-179
Monitor panel, replace	16-1676-1	Bucket, arm, and boom,	
Bushing wear, track chain		disassemble	33-3360-174
Measure	01-0130-25	Install bushings and seals	33-3340-7
		Cylinder restrictors, arm and boom (SN 556936-)	
		Remove and install	33-3360-109
		Cylinder, arm	
		Remove and install	33-3360-169
		Cylinder, boom	
		Remove and install	33-3360-167
		Cylinder, bucket	
		Remove and install	33-3360-171
		Cylinder, hydraulic	
		Bleed procedure	33-3360-173
		D	
		Dampener drive (flex coupler) (SN -559602)	
		Remove and install	07-0752-2
		Dampener drive (flex coupler) (SN 559603-)	
		Remove and install	07-0752-4
		DB4 fuel injection pump (SN -559602)	
		Install	04-0400-32
		Remove	04-0400-29
		DB4 fuel injection pump (SN 559603-)	
		Remove and install	04-0400-35
		Dealer fabricated tools	
		DFT1074 swing gearbox pinion	
		holder	99-9900-18
		DFT1077 spool holding fixture	99-9900-16
		DFT1087 track recoil spring guard	99-9900-5
		DFT1089 barrel support	99-9900-15
		DFT1094 bearing pilot tool	99-9900-8
		DFT1095 planet gear assembly tool	99-9900-9
		DFT1096 planet gear shaft removal	99-9900-10
		DFT1108 spool holding fixture	99-9900-16
		DFT1110 spacer	99-9900-7
		DFT1111 spacer	99-9900-6
		DF1039 pump workbench support	99-9900-11
		DF1040 pump rotate group support	99-9900-12
		DF1052 disk holder	99-9900-13
		DF1054 swing gearbox nut spanner	99-9900-17
		JT38009 guide pin	99-9900-14

C

Cab	
Remove and install	18-1800-1
Cab electrical component identification	16-1674-6
Capacities	00-0002-4
Carrier roller oil specification	00-0004-6
Charge the system (SN -541550)	18-1830-14
Circuit relief and anti-cavitation valves (SN -556935)	
Remove and install	33-3360-120
Cleanup procedure	
Hydraulic oil	33-3360-21
Clutch pulley bearing	
Replace	18-1830-26
Clutch pulley, bearing and hub	
Inspect	18-1830-26
Combined function shuttle valve (SN -556935)	
Remove and install	33-3360-112
Combined function shuttle valve (SN 556936-)	
Disassemble and assemble	33-3360-113
Remove and install	33-3360-112
Compressor oil (SN -541550)	
Check and add	18-1830-9
Compressor relay	
Remove and install	18-1830-37
Compressor (SN -541550)	
Assemble	18-1830-28
Disassemble and inspect	18-1830-22
Remove and install	18-1830-18
Condenser (SN -541550)	
Remove install	18-1830-32
Coolant heater, engine	
Remove and install	05-0505-2
Coolant temperature gauge	
Remove and install	16-1676-4
Counterbalance valve	
Disassemble and assemble	02-0260-25
Remove and install	02-0260-24

Index

	Page		Page
Rotary manifold lifting	99-9900-11	Exhaust manifold (SN 559603-)	
ST4920 track recoil spring assembly.	99-9900-1	Remove and install	04-0400-59
Diesel engine oil.	00-0004-4	Expansion valve (SN -541550)	
Diesel fuel	00-0004-1	Bench test and adjustment	18-1830-34
Diesel fuel conditioner		Remove and Install	18-1830-33
Low sulfur	00-0004-2		
Dig function controller		F	
Remove and install	33-3360-68	Fan, guards and shroud (SN -559602)	
Dig function pilot controller		Remove and install	05-0510-2
Disassemble and assemble	33-3360-70	Fan, guards and shroud (SN 559603-)	
Dig pilot check valve block (SN 543990-559935)		Remove and install	05-0510-4
Remove and install	33-3360-81	Filter	
Dig pilot check valve block (SN 559936-)		Hydraulic return.	33-3360-187
Remove and install	33-3360-82	Inspection procedure, hydraulic oil	33-3360-63
Dual solenoid block (SN 538539-)		Filter element, water separator (SN -559602)	
Remove and install	33-3360-163	Replace	05-0560-5
Dual solenoid valve block (SN -538538)		Filter (SN -559602)	
Remove and install	33-3360-162	Fuel	04-0400-37
Dual solenoid valve block (SN 538539-)		Filter, primary fuel (water separator) (SN 559603-)	
Disassemble and assemble	33-3360-164	Disassemble and assemble	05-0560-6
E		Final fuel filter (SN 559603-)	
Electrical		Change	04-0400-37
Fuse specifications	16-1673-4	Flex coupler, dampener drive (SN -559602)	
Electrolyte specific gravity		Remove and install	07-0752-2
Checking.	16-1671-5	Frame	
Engine coolant heater		Repair	17-1740-2
Remove and install	05-0505-2	Front idler	
Engine electrical component		Assemble	01-0130-40
identification	16-1674-5	Disassemble	01-0130-39
Engine oil		Oil specification.	00-0004-6
Diesel	00-0004-4	Remove and install	01-0130-37
Engine (SN -559602)		Test for oil leakage	01-0130-42
Remove and install	04-0400-9	Front idler wear	
Engine (SN 559603-)		Measure	01-0130-36
Remove and install	04-0400-16	Fuel	
Engine speed control actuator		Diesel	00-0004-1
Disassemble and assemble	33-3360-166	Storage	00-0004-2
Remove and install	33-3360-165	Tank	00-0004-3
Engine speed control linkage		Fuel filter (SN -559602)	
Adjust	05-0515-3	Change	04-0400-37
Engine valve lash (clearance) (SN -559602)		Fuel filter, primary (water separator) (SN 559603-)	
Check and adjust	04-0400-66	Disassemble and assemble	05-0560-6
Engine valve lash (clearance) (SN 559603-)		Fuel injection nozzles	
Check and adjust	04-0400-68	Remove and install	04-0400-26
Evacuate the system (SN -541550)	18-1830-12	Fuel level gauge	
Evaporator (SN -541550)		Remove and install	16-1676-4
Remove and install	18-1830-35	Fuel system (SN -559602)	
Exhaust manifold (SN -559602)		Bleed	04-0400-42
Remove and install	04-0400-57	Fuel system (SN 559603-)	
		Bleed	04-0400-42

Index

	Page		Page
Fuel tank00-0004-3	Hydraulic oil cooler	
Remove and install05-0560-2	Remove and install33-3360-186
Fuel transfer pump (SN -559602)		Hydraulic pump	
Remove and install04-0400-40	Inspect33-3360-38
Fuel transfer pump (SN 559603-)		Start-up procedure33-3360-28
Remove and install04-0400-41	Hydraulic pump (SN -559602)	
Fuse		Assemble33-3360-41
Color codes16-1673-5	Disassemble33-3360-30
Replacing16-1673-3	Remove and install33-3360-23
Specification16-1673-4	Hydraulic Pump (SN -559603)	
		Disassemble and Assemble33-3360-52
		Hydraulic pump (SN 559603-)	
		Remove and install33-3360-25
G			
Gauge			
Coolant temperature16-1676-4	I	
Fuel level16-1676-4	Idler wear, front	
Hour meter16-1676-4	Measure01-0130-36
Grease		Idler, front	
Specification00-0004-7	Assemble01-0130-40
Grouser wear, track shoe		Disassemble01-0130-39
Measure01-0130-22	Remove and install01-0130-37
		Test for oil leakage01-0130-42
		Inch torque values00-0003-1
H		Injection nozzle bores	
Halogen bulbs		Clean04-0400-29
Replacing16-1673-1	Intake manifold tube (SN -559602)	
Heater control		Remove and install04-0400-55
Remove and install18-1830-7	Intake manifold tube (SN 559603-)	
Heater core and blower motor relay		Remove and install04-0400-56
Remove and install18-1830-6		
Hour meter		J	
Remove and install16-1676-4	JT07158 TIME TRAC	
Hydraulic		Installation04-0400-36
Fittings, 30° cone seat.00-0003-7		
Fittings, 37° flare00-0003-7	L	
Oil00-0004-5	Leak testing (SN -541550)18-1830-31
Return filter change.33-3360-187	Linkage and bucket (SN 538760-)	
Hydraulic control valve (SN -556935)		Remove and install33-3302-7
Remove and install33-3360-86	Load sense system relief valve (SN -556935)	
Hydraulic cylinder		Disassemble and assemble33-3360-114
Bleed procedure33-3360-173	Remove and install33-3360-115
Hydraulic fitting		Load sense system relief valve (SN 556936-)	
Flared connections00-0003-8	Disassemble and assemble33-3360-116
Hydraulic lines, propel		Load sense valve (SN -559602)	
Remove and install02-0260-32	Disassemble and assemble33-3360-58
Hydraulic oil			
Cleanup procedure33-3360-21		
Hydraulic oil cleanup procedure			
Using portable filter caddy.33-3360-21		

Index

Page	Page
Remove and install33-3360-56	O
Load sense valve (SN 559603-)	
Disassemble and assemble33-3360-59	O-ring boss fittings00-0003-4
Remove and install33-3360-57	Oil
Low and high pressure switches (SN -541550)	Specification carrier roller00-0004-6
Remove and install18-1830-36	Specification front idler00-0004-6
Low speed selector valve	Specification hydraulic.00-0004-5
Remove and install02-0260-31	Specification propel gearbox00-0004-6
Low sulfur diesel fuel conditioner00-0004-2	Specification track roller00-0004-6
Lower boom with engine stopped33-3360-13	Oil cooler bypass valve (SN 556936-)
Lower track roller	Remove and install33-3360-107
Disassemble and assemble01-0130-11	Oil cooler hydraulic
Remove and install01-0130-9	Remove and install33-3360-186
Test for oil leakage01-0130-15	Oil cooler (SN -559602)
Lower track roller wear	Remove and install04-0400-64
Measure01-0130-8	Oil cooler (SN 559603-)
Lubricant	Remove and install04-0400-65
Mixing00-0004-9	Oil filter
Storage.00-0004-8	Inspection procedure, hydraulic.33-3360-63
	Oil filters00-0004-7
M	Oil pan
Machine, towing02-0250-4	Remove and install04-0400-25
Make-up valve (SN -556935)	
Remove and install33-3360-136	P
Manifold, return (SN 556936-)	Pilot filter
Remove and install33-3360-106	Remove and install33-3360-62
Metal face seals	Pilot pressure regulating valve (SN -556935)
Inspect01-0130-16, 02-0250-22	Disassemble and assemble33-3360-117
Mixing lubricants.00-0004-9	Pilot pressure regulating valve (SN 556936-)
Monitor buzzer switch	Disassemble and assemble33-3360-118
Remove and install16-1674-10	Remove and install33-3360-118
Monitor controller	Pilot pump
Remove and install16-1675-3	Disassemble and assemble33-3360-60
Monitor panel	Remove and install33-3360-60
Bulbs, replace.16-1676-1	Pilot shut-off valve
Remove and install16-1676-1	Disassemble and assemble33-3360-65
Monoblock control valve manifold (SN 556936-)	Linkage adjustment.33-3360-66
Disassemble and assemble33-3360-142	Remove and install33-3360-64
Monoblock control valve (SN 556936-)	Power boost solenoid valve (SN -556935)
Remove and install33-3360-138	Remove and install33-3360-119
Muffler	Power boost solenoid valve (SN 556936-)
Remove and install05-0530-1	Remove and install33-3360-119
	Pressure control manifold (SN -556935)
N	Remove and install33-3360-114
Nozzles, fuel injection	Primary fuel filter (water separator) (SN 559603-)
Remove and install04-0400-26	Remove and install05-0560-5
	Primary fuel filter/water separator (SN 559603-)
	Change.04-0400-38
	Propel
	Gearbox oil specification00-0004-6

Index

	Page		Page
Propel alarm		Remove and install	33-3360-23
Remove and install	20-2004-1	Pump, hydraulic (SN 559603-)	
Propel circuit make-up valve (SN 556936-)		Remove and install	33-3360-25
Remove and install	33-3360-137		
Propel gearbox			
Assemble	02-0250-24	R	
Assemble replacement housing and		Radiator	
bearing	02-0250-32	Remove and install	05-0510-6
Disassemble	02-0250-15	Radio, propel alarm cancel, and start aid switches	
Propel gearbox and brake		Remove and install	16-1674-8
Remove and install	02-0250-8	Raise boom with engine stopped	33-3360-15
Propel gearbox brake elements		Receiver/dryer (SN -541550)	
Replace	02-0250-6	Remove and install	18-1830-33
Propel hydraulic lines		Recoil spring	
Remove and install	02-0260-32	Disassemble and assemble	01-0130-44
Propel motor		Remove and install	01-0130-43
Assemble	02-0260-16	Refrigerant hoses and tubing (SN -541550)	
Disassemble	02-0260-8	Inspection	18-1830-31
Remove and install	02-0260-3	Refrigerant (R-12) (SN -541550)	
Start-up procedure	02-0260-6	Cautions	18-1830-8
Propel pilot check valve block		Refrigerant recovery (SN -541550)	18-1830-11
Disassemble and assemble	33-3360-85	Refrigerant (SN -541550)	
Remove and install	33-3360-83	Add	18-1830-16
Propel pilot controller		Reservoir	
Disassemble and assemble	33-3360-76	Disassemble and assemble	33-3360-194
Propel pilot controller (SN -547853)		Remove and install	33-3360-190
Remove and install	33-3360-72	Restrictor, arm cylinder (SN 546276-556935)	
Propel pilot controller (SN -547854)		Remove and install	33-3360-107
Remove and install	33-3360-73	Return manifold (SN 556936-)	
Propel speed change solenoid valve		Remove and install	33-3360-106
Disassemble and assemble	02-0260-43	Roller wear, lower track	
Propel valve section (SN -556935)		Measure	01-0130-8
Disassemble and assemble	33-3360-132	Roller wear, upper track	
Pump displacement solenoid valve (SN -559602)		Measure	01-0130-17
Disassemble and assemble	33-3360-54	Roller, lower track	
Remove and install	33-3360-52	Disassemble and assemble	01-0130-11
Pump displacement solenoid valve (SN 559603-)		Remove and install	01-0130-9
Disassemble and assemble	33-3360-55	Test for oil leakage	01-0130-15
Remove and install	33-3360-53	Roller, upper track	
Pump (SN -559602), DB4 fuel injection		Disassemble and assemble	01-0130-19
Install	04-0400-32	Remove and install	01-0130-18
Remove	04-0400-29	Rotary manifold	
Pump (SN 559603-), DB4 fuel injection		Air test	02-0260-39
Remove and install	04-0400-35	Disassemble and assemble	02-0260-38
Pump, fuel transfer (SN -559602)		Remove and install	02-0260-33
Remove and install	04-0400-40		
Pump, fuel transfer (SN 559603-)		S	
Remove and install	04-0400-41	Safety relief valve (SN 556936-)	
Pump, hydraulic		Disassemble and assemble	33-3360-144
Start-up procedure	33-3360-28		
Pump, hydraulic (SN -559602)			
Assemble	33-3360-41		
Disassemble	33-3360-30		

Index

Page	Page		
Remove and install	33-3360-143	Starter (SN -559602)	
Safety valve (SN -556935)		Remove and install	04-0400-71
Disassemble and assemble	33-3360-117	Starter (SN 559603-)	
Seals, metal face		Remove and install	04-0400-72
Inspect	01-0130-16	Starter switch	
Seat (SN -538404)		Remove and install	16-1674-7
Remove and install	18-1821-1	Starting aid solenoid and nozzle	
Seat (SN 537781-538404)		Remove and install	05-0505-2
Disassemble and assemble	18-1821-3	Storing lubricants	00-0004-8
Seat (SN 538405-)		Supply shuttle valve	
Remove and install	18-1821-2	Remove and install	02-0260-26
Seat (SN 538405-549976)		Swing bearing	
Disassemble and assemble	18-1821-4	Remove and install	43-4350-23
Seat (SN 549977-)		Upper seal, install	43-4350-24
Disassemble and assemble	18-1821-5	Swing bearing lower seal	
Seat stand (SN -547853)		Install	43-4350-26
Disassemble and assemble	18-1821-6	Swing brake	
Seat stand (SN 547854-)		Disassemble and assemble	43-4311-3
Disassemble and assemble	18-1821-8	Remove and install	43-4311-2
Serpentine belt (SN -559602)		Swing brake and gearbox	
Inspect	05-0510-9	Start-up procedure	43-4350-7
Serpentine belt (SN 559603-)		Swing gearbox	
Inspect	05-0510-10	Disassemble and assemble	43-4350-8
Shaft seal leak test (SN -541550).	18-1830-20	Remove and install	43-4350-5
Shaft Seal Seat		Swing motor	
Replace	18-1830-27	Disassemble and assemble	43-4360-9
Shuttle valve		Start-up procedure	43-4360-7
Remove and install	02-0260-30	Swing motor seal	
Sliding windows		Remove and install	43-4360-8
Remove and install	18-1810-3	Swing motor (SN -556935)	
Solenoid and nozzle, starting aid		Remove and install	43-4360-3
Remove and install	05-0505-2	Swing motor (SN 556936-)	
Specific gravity, electrolyte	16-1671-5	Remove and install	43-4360-5
Specification		Swing stop cushion valve	
Carrier roller oil	00-0004-6	Remove and install	33-3360-151
Front idler oil	00-0004-6	Swing stop cushion valve (SN 546277-)	
Fuse	16-1673-4	Disassemble and assemble	33-3360-152
Grease	00-0004-7	Swing torque control valve (SN -546276)	
Hydraulic oil	00-0004-5	Disassemble and assemble	33-3360-155
Propel gearbox oil	00-0004-6	Swing torque control valve (SN -556935)	
Track roller oil	00-0004-6	Remove and install	33-3360-153
Specifications		Swing torque control valve (SN 556936-)	
690E LC	00-0002-1	Disassemble and assemble	33-3360-156
690E LC long front	00-0002-3	Remove and install	33-3360-154
Speed control linkage		Swing upperstructure with engine	
Remove and install	05-0515-2	stopped	33-3360-18
Sprocket		Swing valve section	
Remove and install	01-0130-34	Disassemble and assemble	33-3360-127
Start-up procedure		Switch panel 1	
Hydraulic pump	33-3360-28	Remove and install	16-1676-3
Propel motor	02-0260-6	Switch panel 2	
Swing brake and gearbox	43-4350-7	Remove and install	16-1676-6
		Replace bulb	16-1676-5

Index

	Page		Page
System controller		Track adjuster cylinder and recoil spring	
Remove and install	16-1675-2	Remove and install	01-0130-43
		Track chain	
T		Disassemble and assemble	01-0130-30
Thermostat (SN -559602)		Install	01-0130-29
Remove and install	04-0400-51	Measure pitch	01-0130-26
Thermostat (SN 559603-)		Remove	01-0130-27
Remove and install	04-0400-53	Replace broken part	01-0130-30
Thermostat switch		Track chain bushing wear	
Remove and install	18-1830-37	Measure	01-0130-25
Tools, dealer fabricated		Track chain link wear	
DFT1074 swing gearbox pinion		Measure	01-0130-24
holder	99-9900-18	Track guide	
DFT1077 spool holding fixture	99-9900-16	Remove and install	01-0130-6
DFT1087 track recoil spring guard	99-9900-5	Track roller wear, lower	
DFT1089 barrel support	99-9900-15	Measure	01-0130-8
DFT1094 bearing pilot tool	99-9900-8	Track roller wear, upper	
DFT1095 planet gear assembly tool	99-9900-9	Measure	01-0130-17
DFT1096 planet gear shaft removal	99-9900-10	Track roller, lower	
DFT1108 spool holding fixture	99-9900-16	Disassemble and assemble	01-0130-11
DFT1110 spacer	99-9900-7	Remove and install	01-0130-9
DFT1111 spacer	99-9900-6	Test for oil leakage	01-0130-15
DF1039 pump workbench support	99-9900-11	Track roller, upper	
DF1040 pump rotate group support	99-9900-12	Disassemble and assemble	01-0130-19
DF1052 disk holder	99-9900-13	Remove and install	01-0130-18
DF1054 swing gearbox nut spanner	99-9900-17	Track sag	
JT38009 guide pin	99-9900-14	Measure and adjust	01-0130-32
Rotary manifold lifting	99-9900-11	Track shoe	
ST4920 track recoil spring assembly	99-9900-1	Remove and install	01-0130-23
Tooth shank		Track shoe grouser wear	
Remove and install	33-3302-2	Measure	01-0130-22
Torque value		Travel alarm	
Flared connections	00-0003-8	Volume adjustment	20-2004-1
Flat face O-ring seal fitting	00-0003-6	Turbocharger (SN -559602)	
Inch SAE four bolt flange fitting	00-0003-9	Remove and install	04-0400-61
Metric cap screw	00-0003-3	Turbocharger (SN 559603-)	
Metric four bolt flange fitting	00-0003-10	Remove and install	04-0400-63
O-Ring boss fitting	00-0003-4		
30° cone seat hydraulic fittings	00-0003-7	U	
37° flare hydraulic fittings	00-0003-7	Upper track roller	
Torque values		Disassemble and assemble	01-0130-19
Inch	00-0003-1	Remove and install	01-0130-18
Metric	00-0003-2	Upper track roller wear	
Towing machine	02-0250-4	Measure	01-0130-17
Track		Upperstructure	
Roller oil specification	00-0004-6	Install	43-4350-20
Track adjuster cylinder		Remove	43-4350-14
Disassemble and assemble	01-0130-47		
Remove and install	01-0130-43	V	
		Valve	
		Pilot shut-off linkage adjustment	33-3360-66

Index

Page	Page		
Propel speed change solenoid	02-0260-40	Valve, crossover relief	
Valve housing and cover		Remove and install	02-0260-28
Disassemble	02-0260-14	Valve, expansion (SN -541550)	
Valve manifold, boom, arm, and swing (SN 556936-)		Bench test and adjustment	18-1830-34
Remove and install	33-3360-97	Remove and install	18-1830-33
Valve manifold, monoblock control (SN 556936-)		Valve, hydraulic control (SN -556935)	
Disassemble and assemble	33-3360-142	Remove and install	33-3360-86
Valve section, auxiliary (SN -556935)		Valve, load sense (SN -559602)	
Disassemble and assemble	33-3360-137	Disassemble and assemble	33-3360-58
Valve section, boom, arm, and bucket (SN -556935)		Remove and install	33-3360-56
Disassemble and assemble	33-3360-122	Valve, load sense (SN 559603-)	
Valve section, propel (SN -556935)		Disassemble and assemble	33-3360-59
Disassemble and assemble	33-3360-132	Remove and install	33-3360-57
Valve section, Swing		Valve, load sense system relief (SN -556935)	
Disassemble and assemble	33-3360-127	Disassemble and assemble	33-3360-114
Valve, anti-cavitation back pressure check (SN -556935)		Remove and install	33-3360-115
Remove and install	33-3360-109	Valve, load sense system relief (SN 556936-)	
Valve, anti-cavitation back pressure check (SN 556936-)		Disassemble and assemble	33-3360-116
Remove and install	33-3360-110	Valve, low speed selector	
Valve, arm regenerative poppet (SN 556936-)		Remove and install	02-0260-31
Remove and install	33-3360-149	Valve, make-up (SN -556935)	
Valve, arm regenerative (SN 546277-556935)		Remove and install	33-3360-136
Disassemble and assemble	33-3360-148	Valve, monoblock control (SN 556936-)	
Remove and install	33-3360-147	Remove and install	33-3360-138
Valve, arm regenerative (SN 556936-)		Valve, oil cooler bypass (SN 556936-)	
Disassemble and assemble	33-3360-150	Remove and install	33-3360-107
Valve, boom and arm anti drift		Valve, pilot pressure regulating (SN -556935)	
Disassemble and assemble	33-3360-161	Disassemble and assemble	33-3360-117
Valve, boom and arm anti drift (SN 556936-)		Remove and install	33-3360-118
Remove and install	33-3360-159	Valve, pilot shut-off	
Valve, boom and arm anti-drift (SN -556935)		Disassemble and assemble	33-3360-65
Remove and install	33-3360-156	Remove and install	33-3360-64
Valve, boom regenerative (SN 545157-556935)		Valve, power boost solenoid (SN -556935)	
Disassemble and assemble	33-3360-146	Remove and install	33-3360-119
Remove and install	33-3360-145	Valve, power boost solenoid (SN 556936-)	
Valve, brake release pressure reducing		Remove and install	33-3360-119
Remove and install	02-0260-32	Valve, propel circuit make-up (SN 556936-)	
Valve, bucket circuit relief and anti-cavitation (SN 556936-)		Remove and install	33-3360-137
Remove and install	33-3360-121	Valve, propel speed change solenoid	
Valve, circuit relief and anti-cavitation (SN -556935)		Disassemble and assemble	02-0260-43
Remove and install	33-3360-120	Valve, pump displacement solenoid (SN -559602)	
Valve, combined function shuttle (SN -556935)		Disassemble and assemble	33-3360-54
Remove and install	33-3360-112	Remove and install	33-3360-52
Valve, combined function shuttle (SN 556936-)		Valve, pump displacement solenoid (SN 559603-)	
Disassemble and assemble	33-3360-113	Disassemble and assemble	33-3360-55
Remove and install	33-3360-112	Remove and install	33-3360-53
Valve, counterbalance		Valve, safety relief (SN 556936-)	
Disassemble and assemble	02-0260-25	Disassemble and assemble	33-3360-144
Remove and install	02-0260-24	Remove and install	33-3360-143
		Valve, safety (SN -556935)	
		Disassemble and assemble	33-3360-117

Index

	Page
Valve, shuttle	
Remove and install	02-0260-30
Valve, supply shuttle	
Remove and install	02-0260-26
Valve, swing stop cushion	
Remove and install	33-3360-151
Valve, swing stop cushion (SN 546277-)	
Disassemble and assemble	33-3360-152
Valve, swing torque control (SN -546276)	
Disassemble and assemble	33-3360-155
Valve, swing torque control (SN -556935)	
Remove and install	33-3360-153
Valve, swing torque control (SN 556936-)	
Disassemble and assemble	33-3360-156
Remove and install	33-3360-154
Vee belt tension (SN -541550)	
Inspect, check and adjust	18-1830-17
Vehicle electrical component	
identification	16-1674-3
Volumetric efficiency test-R12 (SN	
-541550)	18-1830-19

W

Water pump (SN -559602)	
Remove and install	04-0400-43
Water pump (SN 559603-)	
Remove and install	04-0400-47
Water separator filter element (SN -559602)	
Replace	05-0560-5
Water separator (SN -559602)	
Remove and install	05-0560-4
Water separator, primary fuel filter (SN 559603-)	
Disassemble and assemble	05-0560-6
Remove and install	05-0560-5
Welding on machine	16-1675-1
Welding specifications	17-1740-2
Windowpane	
Dimensions	18-1810-4
Windowpane and molding, one piece	
Remove and install	18-1810-2
Windowpane and molding, two piece	
Remove and install	18-1810-1
Windowpane dimensions	18-1810-4
Windows, sliding	
Remove and install	18-1810-3
Work light	
Adjustment	16-1673-2