

Disassembly and Assembly

1104D Industrial Engine

NH1 (Engine)
NJ1 (Engine)

Important Safety Information

Most accidents that involve product operation, maintenance and repair are caused by failure to observe basic safety rules or precautions. An accident can often be avoided by recognizing potentially hazardous situations before an accident occurs. A person must be alert to potential hazards. This person should also have the necessary training, skills and tools to perform these functions properly.

Improper operation, lubrication, maintenance or repair of this product can be dangerous and could result in injury or death.

Do not operate or perform any lubrication, maintenance or repair on this product, until you have read and understood the operation, lubrication, maintenance and repair information.

Safety precautions and warnings are provided in this manual and on the product. If these hazard warnings are not heeded, bodily injury or death could occur to you or to other persons.

The hazards are identified by the "Safety Alert Symbol" and followed by a "Signal Word" such as "DANGER", "WARNING" or "CAUTION". The Safety Alert "WARNING" label is shown below.



The meaning of this safety alert symbol is as follows:

Attention! Become Alert! Your Safety is Involved.

The message that appears under the warning explains the hazard and can be either written or pictorially presented.

Operations that may cause product damage are identified by "NOTICE" labels on the product and in this publication.

Perkins cannot anticipate every possible circumstance that might involve a potential hazard. The warnings in this publication and on the product are, therefore, not all inclusive. If a tool, procedure, work method or operating technique that is not specifically recommended by Perkins is used, you must satisfy yourself that it is safe for you and for others. You should also ensure that the product will not be damaged or be made unsafe by the operation, lubrication, maintenance or repair procedures that you choose.

The information, specifications, and illustrations in this publication are on the basis of information that was available at the time that the publication was written. The specifications, torques, pressures, measurements, adjustments, illustrations, and other items can change at any time. These changes can affect the service that is given to the product. Obtain the complete and most current information before you start any job. Perkins dealers or Perkins distributors have the most current information available.



When replacement parts are required for this product Perkins recommends using Perkins replacement parts.

Failure to heed this warning can lead to premature failures, product damage, personal injury or death.

Table of Contents

Disassembly and Assembly Section

Fuel Priming Pump - Remove and Install (Electric Fuel Priming Pump)	5	Housing (Front) - Install	83
Fuel Priming Pump - Remove and Install (Manual Priming Pump)	6	Accessory Drive - Remove and Install	85
Fuel Filter Base - Remove and Install (Secondary Fuel Filter)	8	Crankcase Breather - Remove and Install (Filtered Breather)	87
Fuel Transfer Pump - Remove	9	Crankcase Breather - Remove and Install (Unfiltered Breather)	88
Fuel Transfer Pump - Install	11	Valve Mechanism Cover - Remove and Install	88
Fuel Injection Lines - Remove	13	Valve Mechanism Cover Base - Remove and Install	90
Fuel Injection Lines - Install	14	Rocker Shaft and Pushrod - Remove	92
Fuel Manifold (Rail) - Remove and Install	16	Rocker Shaft - Disassemble	93
Fuel Injection Pump - Remove	18	Rocker Shaft - Assemble	94
Fuel Injection Pump - Install	21	Rocker Shaft and Pushrod - Install	95
Fuel Injection Pump Gear - Remove	24	Cylinder Head - Remove	97
Fuel Injection Pump Gear - Install	26	Cylinder Head - Install	100
Electronic Unit Injector - Remove	27	Lifter Group - Remove and Install	104
Electronic Unit Injector - Install	31	Camshaft - Remove and Install	105
Turbocharger - Remove	36	Camshaft Gear - Remove and Install	106
Turbocharger - Install	37	Camshaft Bearings - Remove and Install	109
Wastegate Solenoid - Remove and Install	38	Engine Oil Pan - Remove and Install (Aluminum and Pressed Steel Oil Pans)	110
Exhaust Manifold - Remove and Install	39	Engine Oil Pan - Remove and Install (Cast Iron Oil Pan)	113
Exhaust Elbow - Remove and Install	41	Balancer - Remove	116
Inlet and Exhaust Valve Springs - Remove and Install	42	Balancer - Install	118
Inlet and Exhaust Valves - Remove and Install	45	Piston Cooling Jets - Remove and Install	120
Engine Oil Filter Base - Remove and Install	48	Pistons and Connecting Rods - Remove	121
Engine Oil Cooler - Remove	49	Pistons and Connecting Rods - Disassemble	122
Engine Oil Cooler - Install	50	Pistons and Connecting Rods - Assemble	124
Engine Oil Relief Valve - Remove and Install (Engines with a Balancer Unit)	51	Pistons and Connecting Rods - Install	126
Engine Oil Relief Valve - Remove and Install (Engines Without a Balancer Unit)	53	Connecting Rod Bearings - Remove (Connecting rods in position)	128
Engine Oil Pump - Remove and Install (Engines Without a Balancer Unit)	54	Connecting Rod Bearings - Install (Connecting rods in position)	129
Water Pump - Remove	56	Crankshaft Main Bearings - Remove and Install (Crankshaft in position)	130
Water Pump - Install	57	Crankshaft - Remove	135
Water Temperature Regulator - Remove and Install	58	Crankshaft - Install	137
Flywheel - Remove	60	Crankshaft Timing Ring - Remove and Install	140
Flywheel - Install	61	Crankshaft Gear - Remove and Install	141
Crankshaft Pulley - Remove and Install (Engines With an Automatic Belt Tensioner)	62	Bearing Clearance - Check	142
Crankshaft Pulley - Remove and Install (Engines Without an Automatic Belt Tensioner)	63	Crankshaft Position Sensor - Remove and Install	143
Crankshaft Rear Seal - Remove	64	Coolant Temperature Sensor - Remove and Install	144
Crankshaft Rear Seal - Install	65	Engine Oil Pressure Sensor - Remove and Install	145
Crankshaft Wear Sleeve (Rear) - Remove and Install	66	Position Sensor (Fuel Injection Pump) - Remove and Install	147
Flywheel Housing - Remove and Install	67	Fuel Pressure Sensor - Remove and Install	148
Crankshaft Front Seal - Remove and Install	69	Boost Pressure Sensor - Remove and Install	149
Crankshaft Wear Sleeve (Front) - Remove and Install	70	Inlet Air Temperature Sensor - Remove and Install	150
Front Cover - Remove and Install	72	Glow Plugs - Remove and Install	151
Gear Group (Front) - Remove and Install	73	V-Belts - Remove and Install (Engines Without an Automatic Belt Tensioner)	152
Idler Gear - Remove	76	Alternator Belt - Remove and Install (Engines With an Automatic Belt Tensioner)	153
Idler Gear - Install	79	Fan - Remove and Install	154
Housing (Front) - Remove	81	Fan Drive - Remove and Install	155
		Electronic Control Module - Remove and Install ..	156
		ECM Mounting Bracket - Remove and Install	158

Alternator - Remove (Engines Without an Automatic Belt Tensioner) 159
Alternator - Remove (Engines With an Automatic Belt Tensioner) 160
Alternator - Install (Engines Without an Automatic Belt Tensioner) 161
Alternator - Install (Engines With an Automatic Belt Tensioner) 161
Electric Starting Motor - Remove and Install 162
Air Compressor - Remove and Install 163
Vacuum Pump - Remove and Install 167

Index Section

Index 169

Disassembly and Assembly Section

i02583374

Fuel Priming Pump - Remove and Install (Electric Fuel Priming Pump)

Removal Procedure

NOTICE

Ensure that all adjustments and repairs that are carried out to the fuel system are performed by authorised personnel that have the correct training.

Before beginning ANY work on the fuel system, refer to Operation and Maintenance Manual, “General Hazard Information and High Pressure Fuel Lines” for safety information.

Refer to Systems Operation, Testing and Adjusting Manual, “Cleanliness of Fuel System Components” for detailed information on the standards of cleanliness that must be observed during ALL work on the fuel system.

NOTICE

Care must be taken to ensure that fluids are contained during performance of inspection, maintenance, testing, adjusting and repair of the product. Be prepared to collect the fluid with suitable containers before opening any compartment or disassembling any component containing fluids.

Dispose of all fluids according to local regulations and mandates.

Note: Put identification marks on all hoses, on all hose assemblies, on wires and on all tube assemblies for installation purposes. Plug all hose assemblies and tube assemblies. This helps to prevent fluid loss and this helps to keep contaminants from entering the system.

1. Isolate the fuel supply.
2. Isolate the electrical supply.

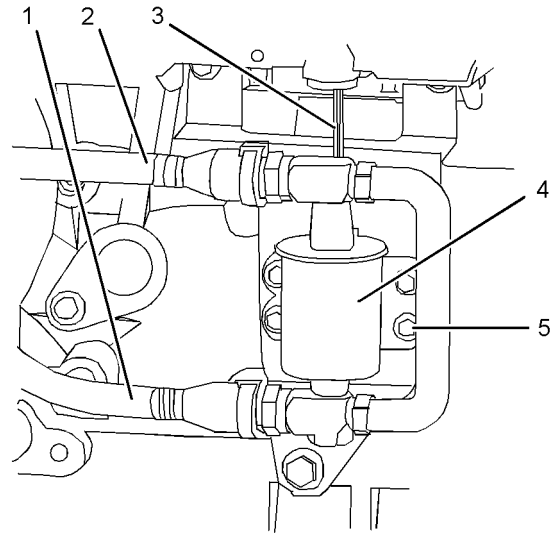

Illustration 1

g01269003

Typical example

3. Disconnect harness assembly (3) from electric priming pump (4).
4. Disconnect plastic tube assemblies (1) and (2).

Note: If the tube assemblies have quick fit connections, ensure that the connections are clean before the tube assemblies are plugged.

5. Remove bolts (5) from electric priming pump (4).
6. Remove electric priming pump (4) from the mounting bracket.

Installation Procedure

NOTICE

Ensure that all adjustments and repairs that are carried out to the fuel system are performed by authorised personnel that have the correct training.

Before beginning ANY work on the fuel system, refer to Operation and Maintenance Manual, “General Hazard Information and High Pressure Fuel Lines” for safety information.

Refer to Systems Operation, Testing and Adjusting Manual, “Cleanliness of Fuel System Components” for detailed information on the standards of cleanliness that must be observed during ALL work on the fuel system.

1. Ensure that the electric priming pump is clean and free from wear or damage. If necessary, replace the electric priming pump.

i02583376

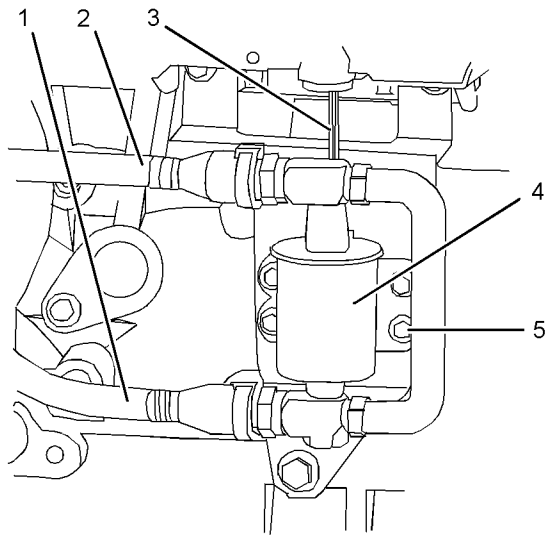

Illustration 2 g01269003

Typical example

2. Position electric priming pump (4) on the mounting bracket. Install bolts (5) to the electric priming pump.
 3. Tighten bolts (5) to a torque of 9 N·m (79 lb in).
 4. Connect plastic tube assemblies (1) and (2) to electric priming pump (4).
- Note:** If the tube assemblies have quick fit connections, ensure that the connections are clean before the tube assemblies are connected.
5. Connect harness assembly (3) to electric priming pump (4).
 6. Restore the electrical supply.
 7. Restore the fuel supply.
 8. Remove the air from the fuel system. Refer to Operation and Maintenance Manual, “Fuel System - Prime”.

Fuel Priming Pump - Remove and Install (Manual Priming Pump)

Removal Procedure

NOTICE

Ensure that all adjustments and repairs that are carried out to the fuel system are performed by authorised personnel that have the correct training.

Before beginning ANY work on the fuel system, refer to Operation and Maintenance Manual, “General Hazard Information and High Pressure Fuel Lines” for safety information.

Refer to Systems Operation, Testing and Adjusting Manual, “Cleanliness of Fuel System Components” for detailed information on the standards of cleanliness that must be observed during ALL work on the fuel system.

NOTICE

Care must be taken to ensure that fluids are contained during performance of inspection, maintenance, testing, adjusting and repair of the product. Be prepared to collect the fluid with suitable containers before opening any compartment or disassembling any component containing fluids.

Dispose of all fluids according to local regulations and mandates.

Note: Put identification marks on all hoses, on all hose assemblies, on wires and on all tube assemblies for installation purposes. Plug all hose assemblies and tube assemblies. This helps to prevent fluid loss and this helps to keep contaminants from entering the system.

1. Isolate the fuel supply.
2. Drain primary filter (7). Refer to Operation and Maintenance Manual, “Fuel System Primary Filter (Water Separator) Element - Replace”.

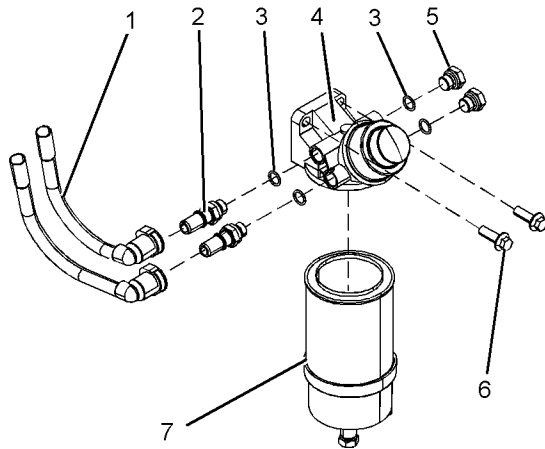

Illustration 3

g01269012

Typical example

3. Disconnect plastic tube assemblies (1).

Note: If the tube assemblies have quick fit connections, ensure that the connections are clean before the tube assemblies are plugged.

4. Remove primary filter (7) from fuel priming pump (4). Refer to Operation and Maintenance Manual, "Fuel System Primary Filter (Water Separator) Element - Replace".
5. Remove bolts (6) from fuel priming pump (4). Remove fuel priming pump (4) from the mounting bracket.
6. If necessary, follow Steps 6.a through 6.c in order to disassemble the fuel priming pump.
 - a. Remove connectors (2) from fuel priming pump (4).
 - b. Remove plugs (5) from fuel priming pump (4).
 - c. Remove O-ring seals (3) from connectors (2) and plugs (5).

Installation Procedure

NOTICE

Ensure that all adjustments and repairs that are carried out to the fuel system are performed by authorised personnel that have the correct training.

Before beginning ANY work on the fuel system, refer to Operation and Maintenance Manual, "General Hazard Information and High Pressure Fuel Lines" for safety information.

Refer to Systems Operation, Testing and Adjusting Manual, "Cleanliness of Fuel System Components" for detailed information on the standards of cleanliness that must be observed during ALL work on the fuel system.

1. Ensure that the fuel priming pump is clean and free from wear or damage. If necessary, replace the fuel priming pump.

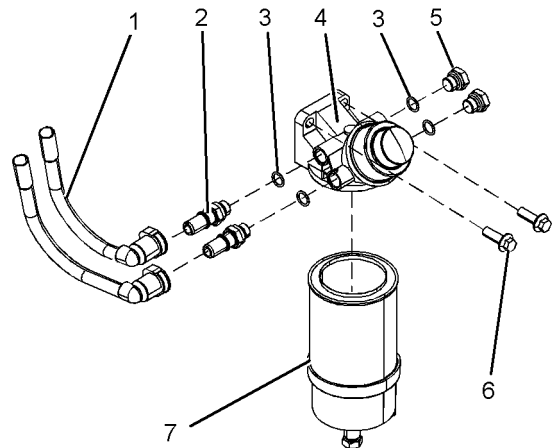

Illustration 4

g01269012

Typical example

2. If necessary, follow Steps 2.a through 2.d in order to assemble the fuel priming pump (4).
 - a. Install new O-ring seals (3) to connectors (2) and plugs (5).
 - b. Install connectors (2) to the fuel priming pump (4).
 - c. Install plugs (5) to fuel priming pump (4).
 - d. Tighten the plugs and the connectors to a torque of 20 N·m (14 lb ft).

3. Position fuel priming pump (4) on the mounting bracket. Install bolts (6) to the fuel priming pump . Tighten the bolts to a torque of 44 N·m (32 lb ft).
4. Connect plastic tube assemblies (1) to connectors (2).

Note: If the tube assemblies have quick fit connections, ensure that the connections are clean before the tube assemblies are connected.

5. Install a new primary filter (7) to fuel priming pump (4). Refer to Operation and Maintenance Manual, “Fuel System Primary Filter (Water Separator) Element - Replace”.
6. Restore the fuel supply.
7. Remove the air from the fuel system. Refer to Operation and Maintenance Manual, “Fuel System - Prime”.

i02583399

Fuel Filter Base - Remove and Install (Secondary Fuel Filter)

Removal Procedure

Table 1

Required Tools			
Tool	Part Number	Part Description	Qty
A	-	Strap Wrench	1

NOTICE

Ensure that all adjustments and repairs that are carried out to the fuel system are performed by authorised personnel that have the correct training.

Before beginning ANY work on the fuel system, refer to Operation and Maintenance Manual, “General Hazard Information and High Pressure Fuel Lines” for safety information.

Refer to Systems Operation, Testing and Adjusting Manual, “Cleanliness of Fuel System Components” for detailed information on the standards of cleanliness that must be observed during ALL work on the fuel system.

NOTICE

Care must be taken to ensure that fluids are contained during performance of inspection, maintenance, testing, adjusting and repair of the product. Be prepared to collect the fluid with suitable containers before opening any compartment or disassembling any component containing fluids.

Dispose of all fluids according to local regulations and mandates.

Note: Put identification marks on all hoses, on all hose assemblies, on wires and on all tube assemblies for installation purposes. Plug all hose assemblies and tube assemblies. This helps to prevent fluid loss and this helps to keep contaminants from entering the system.

1. Isolate the fuel supply.
2. If necessary, remove the boost pressure sensor. Refer to Disassembly and Assembly, “Boost Pressure Sensor - Remove and Install”.

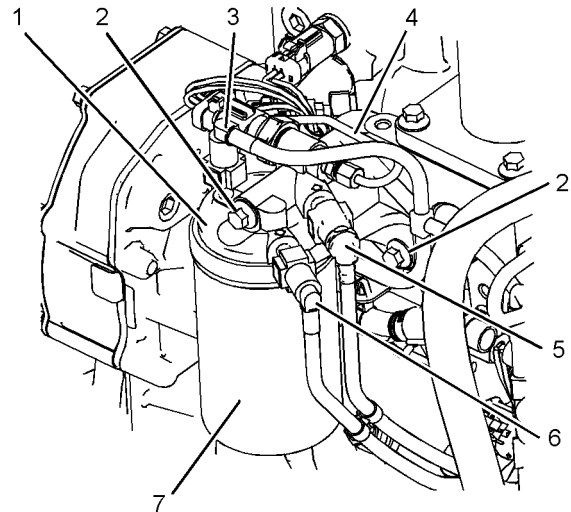

Illustration 5

g01247416

Typical example

3. Disconnect plastic tube assemblies (3), (5) and (6) from fuel filter base (1).

Note: If the tube assemblies have quick fit connections, ensure that the connections are clean before the tube assemblies are plugged.

4. Remove tube assembly (4), if equipped.
5. Use Tooling (A) in order to remove fuel filter (7). Refer to Operation and Maintenance Manual, “Fuel System Secondary Filter - Replace”.

- Remove bolts (2) from fuel filter base (1). Remove the fuel filter base from the cylinder head.

Note: Do not attempt to disassemble the fuel filter base.

Installation Procedure

NOTICE

Ensure that all adjustments and repairs that are carried out to the fuel system are performed by authorised personnel that have the correct training.

Before beginning ANY work on the fuel system, refer to Operation and Maintenance Manual, "General Hazard Information and High Pressure Fuel Lines" for safety information.

Refer to Systems Operation, Testing and Adjusting Manual, "Cleanliness of Fuel System Components" for detailed information on the standards of cleanliness that must be observed during ALL work on the fuel system.

- Ensure that the fuel filter base is clean and free from damage. If necessary, replace the complete fuel filter base assembly.

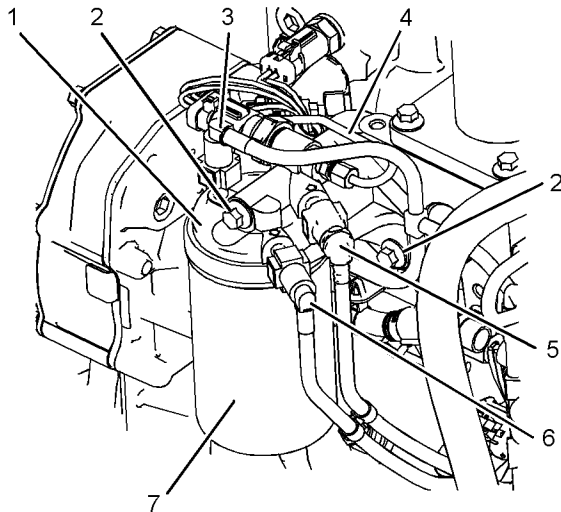

Illustration 6
Typical example

g01247416

- Position fuel filter base (1) onto the cylinder head. Install bolts (2). Tighten the bolts to a torque of 22 N·m (16 lb ft).
- Install a new fuel filter (7) to fuel filter base (1). Refer to Operation and Maintenance Manual, "Fuel System Secondary Filter - Replace" for the correct procedure.

- If necessary, install the boost pressure sensor. Refer to Disassembly and Assembly, "Boost Pressure Sensor - Remove and Install".
- Install tube assembly (4), if equipped. Tighten the nuts to a torque of 9 N·m (80 lb in).

NOTICE

Ensure that the plastic tube assemblies are installed in the original positions. Failure to connect the plastic tube assemblies to the correct ports will allow contamination to enter the fuel system. Contaminated fuel will cause serious damage to the engine.

- Connect plastic tube assemblies (3), (5) and (6) to fuel filter base (1).

Note: If the tube assemblies have quick fit connections, ensure that the connections are clean before the tube assemblies are connected.

- Restore the fuel supply.
- Remove the air from the fuel system. Refer to Operation and Maintenance Manual, "Fuel System - Prime".

i02583377

Fuel Transfer Pump - Remove

Removal Procedure

Start By:

- Remove the mounting bracket for the electronic control module. Refer to Disassembly and Assembly, "ECM Mounting Bracket - Remove and Install".

NOTICE

Ensure that all adjustments and repairs that are carried out to the fuel system are performed by authorised personnel that have the correct training.

Before beginning ANY work on the fuel system, refer to Operation and Maintenance Manual, "General Hazard Information and High Pressure Fuel Lines" for safety information.

Refer to Systems Operation, Testing and Adjusting Manual, "Cleanliness of Fuel System Components" for detailed information on the standards of cleanliness that must be observed during ALL work on the fuel system.

NOTICE

Care must be taken to ensure that fluids are contained during performance of inspection, maintenance, testing, adjusting and repair of the product. Be prepared to collect the fluid with suitable containers before opening any compartment or disassembling any component containing fluids.

Dispose of all fluids according to local regulations and mandates.

Note: Put identification marks on all hoses, on all hose assemblies, on wires and on all tube assemblies for installation purposes. Plug all hose assemblies and tube assemblies. This helps to prevent fluid loss and this helps to keep contaminants from entering the system.

1. Isolate the fuel supply.
2. If necessary, disconnect the hose for the crankcase breather from the clip that secures the hose to the engine oil pan. Position the hose away from the fuel transfer pump.

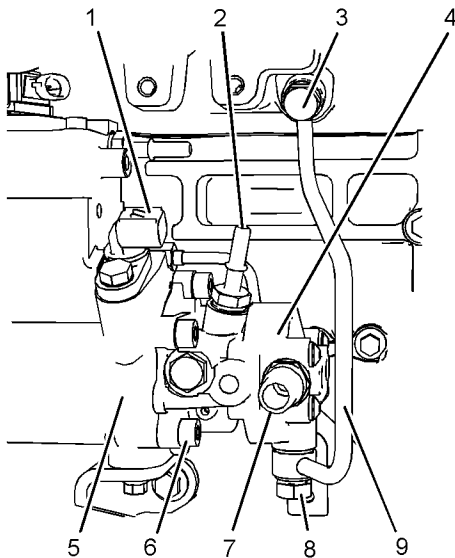

Illustration 7
Typical example

3. If necessary, disconnect the harness assembly from position sensor (1). Refer to Disassembly and Assembly, "Position Sensor (Fuel Injection Pump) - Remove and Install". Position the harness assembly away from the fuel transfer pump.

Note: If the tube assembly has quick fit connections, ensure that the connections are clean before the tube assembly is plugged.

4. Disconnect the plastic tube assembly from inlet connection (7) on the fuel transfer pump.

Note: If the tube assembly has quick fit connections, ensure that the connections are clean before the tube assembly is plugged.

5. Remove the plastic tube assembly from outlet connection (2).
6. Remove outlet connection (2) from fuel transfer pump (4). Plug the open port in the fuel transfer pump immediately with a new plug. Remove the O-ring seal from the connection.

If necessary, remove the inlet connection (7) from fuel transfer pump (4). Plug the open port in the fuel transfer pump immediately with a new plug. Remove the O-ring seal from the connection.

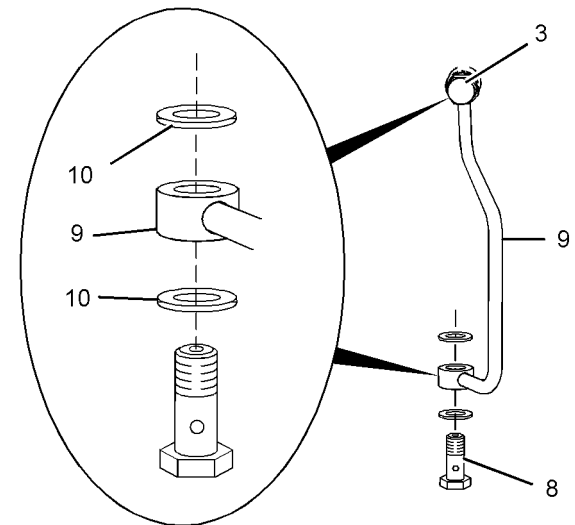

Illustration 8
g01256540

7. Loosen banjo bolts (3) and (8). Remove tube assembly (9) for the fuel return from the cylinder head to the fuel transfer pump.

Note: Disconnect the tube assembly at the fuel transfer pump first in order to drain the fuel from the cylinder head.

8. Remove banjo bolt (3) and sealing washers (10) from tube assembly (9). Remove banjo bolt (8) and sealing washers (10) from tube assembly (9).
9. Use an allen wrench with a ball end in order to remove allen head screws (6) that secure fuel transfer pump (4) to fuel injection pump (5).

i02583378

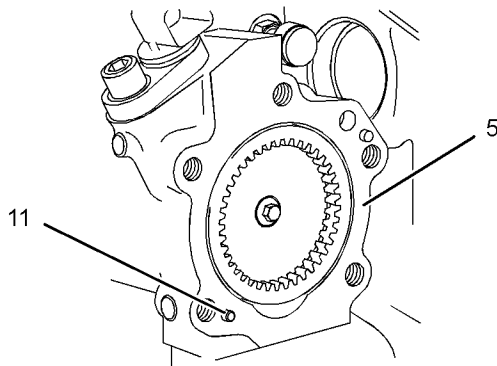

Illustration 9

g01254881

10. Remove the fuel transfer pump from fuel injection pump (5).

Note: Do not remove dowels (11) from the fuel injection pump.

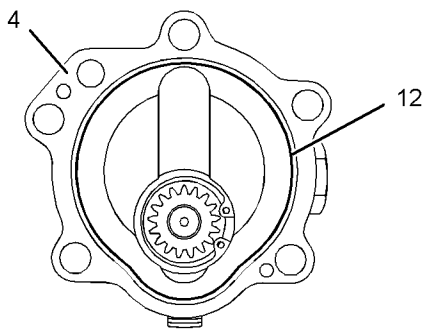

Illustration 10

g01254883

11. Remove O-ring seal (12) from fuel transfer pump (4).

Fuel Transfer Pump - Install

Installation Procedure

NOTICE

Ensure that all adjustments and repairs that are carried out to the fuel system are performed by authorised personnel that have the correct training.

Before beginning ANY work on the fuel system, refer to Operation and Maintenance Manual, "General Hazard Information and High Pressure Fuel Lines" for safety information.

Refer to Systems Operation, Testing and Adjusting Manual, "Cleanliness of Fuel System Components" for detailed information on the standards of cleanliness that must be observed during ALL work on the fuel system.

1. Ensure that the mating surfaces of the fuel injection pump and the fuel transfer pump are clean and free from damage. Replace any components that are damaged.

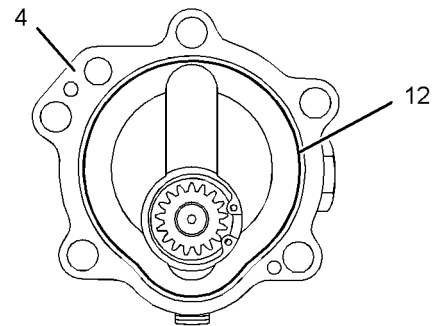

Illustration 11

g01254883

2. Install a new O-ring seal (12) to fuel transfer pump (4).

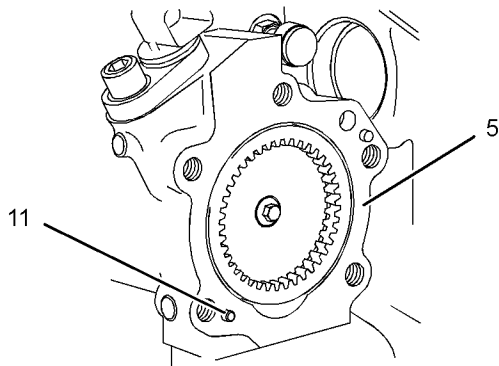

Illustration 12

g01254881

3. Align fuel transfer pump (4) with dowels (11) in fuel injection pump (5). Install the fuel transfer pump to the fuel injection pump.

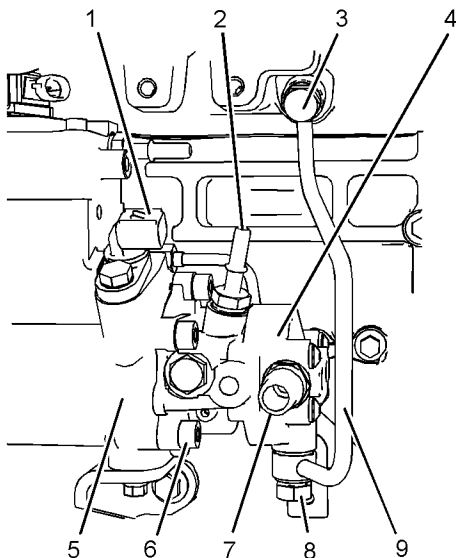

Illustration 13

g01247425

4. Use an allen wrench with a ball end to install allen head screws (6). Tighten the allen head screws to a torque of 30 N·m (22 lb ft).
5. Install a new O-ring seal to outlet connection (2). Install outlet connection (2) to fuel transfer pump (4). Tighten the connection to torque of 15 N·m (11 lb ft).

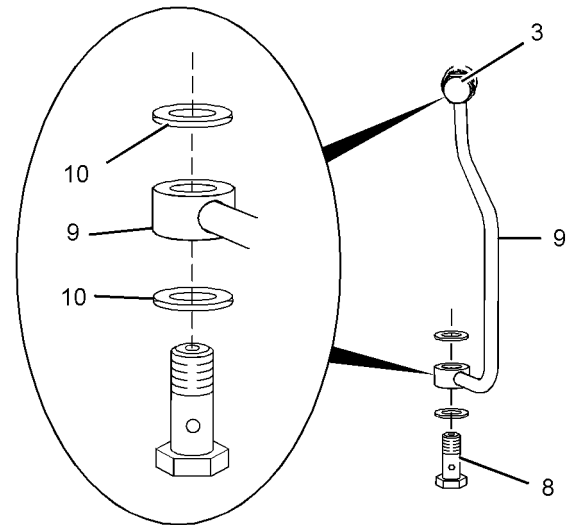

Illustration 14

g01256540

6. Install banjo bolt (8) and new sealing washers (10) to tube assembly (9). Install banjo bolt (3) and new sealing washers (10) to tube assembly (9).
 7. Install tube assembly (9) for the fuel return to fuel transfer pump (4) and to the cylinder head. Tighten banjo bolts (3) and (8) to a torque of 22 N·m (16 lb ft).
 8. If necessary, install a new O-ring seal to inlet connection (7). Install inlet connection (7) to fuel transfer pump (4). Tighten the connection to torque of 15 N·m (11 lb ft).
- Note:** If the tube assembly has quick fit connections, ensure that the connections are clean before the tube assembly is connected.
9. Install the plastic tube assembly to outlet connection (2) on the fuel transfer pump.
 10. Install the plastic tube assembly to inlet connection (7) on the fuel transfer pump.
 11. If necessary, connect the harness assembly to position sensor (1). Refer to Disassembly and Assembly, "Position Sensor (Fuel Injection Pump) - Remove and Install".
 12. If necessary, connect the hose for the crankcase breather to the clip that secures the hose to the engine oil pan.
 13. Install the mounting bracket for the electronic control module. Refer to Disassembly and Assembly, "ECM Mounting Bracket - Remove and Install".

14. Install the electronic control module. Refer to Disassembly and Assembly, "Electronic Control Module - Remove and Install".
15. Restore the fuel supply.
16. Remove the air from the fuel system. Refer to Operation and Maintenance Manual, "Fuel System - Prime".

i02583423

Fuel Injection Lines - Remove

Removal Procedure

Table 2

Required Tools			
Tool	Part Number	Part Name	Qty
A	U5MK1124	Cap Kit	1

WARNING

Contact with high pressure fuel may cause fluid penetration and burn hazards. High pressure fuel spray may cause a fire hazard. Failure to follow these inspection, maintenance and service instructions may cause personal injury or death.

NOTICE

Ensure that all adjustments and repairs that are carried out to the fuel system are performed by authorised personnel that have the correct training.

Before beginning ANY work on the fuel system, refer to Operation and Maintenance Manual, "General Hazard Information and High Pressure Fuel Lines" for safety information.

Refer to Systems Operation, Testing and Adjusting Manual, "Cleanliness of Fuel System Components" for detailed information on the standards of cleanliness that must be observed during ALL work on the fuel system.

NOTICE

Care must be taken to ensure that fluids are contained during performance of inspection, maintenance, testing, adjusting and repair of the product. Be prepared to collect the fluid with suitable containers before opening any compartment or disassembling any component containing fluids.

Dispose of all fluids according to local regulations and mandates.

Note: Put identification marks on all hoses, on all hose assemblies, on wires and on all tube assemblies for installation purposes. Plug all hose assemblies and tube assemblies. This helps to prevent fluid loss and this helps to keep contaminants from entering the system.

1. Isolate the fuel supply.
2. Isolate the electrical supply.

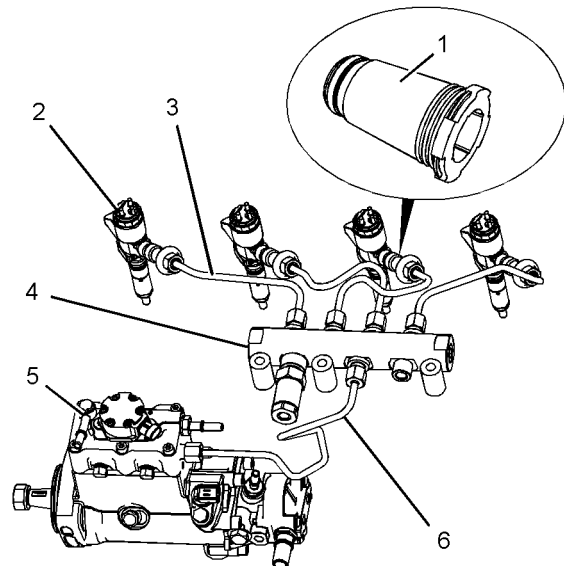

Illustration 15

g01245087

Typical example

3. Disconnect fuel injection line (3) from electronic unit injector (2).
4. Disconnect fuel injection line (3) from fuel manifold (4).
5. Remove fuel injection line (3). Discard the fuel injection line.
6. Plug the open port in fuel manifold (4) immediately. Use Tooling (A) in order to plug the open port.
7. Remove seal (1) from electronic unit injector (2) and from the base of the valve mechanism cover.

i02583440

8. Plug the open port in electronic unit injector (2) immediately. Use Tooling (A) in order to plug the open port.
9. Repeat Steps 3 through 8 in order to remove the remaining fuel injection lines from the electronic unit injectors.
10. If necessary, remove the crankcase breather. Refer to Disassembly and Assembly, "Crankcase Breather - Remove".
11. Remove the electronic control module. Refer to disassembly and Assembly, "Electronic Control Module - Remove and Install".

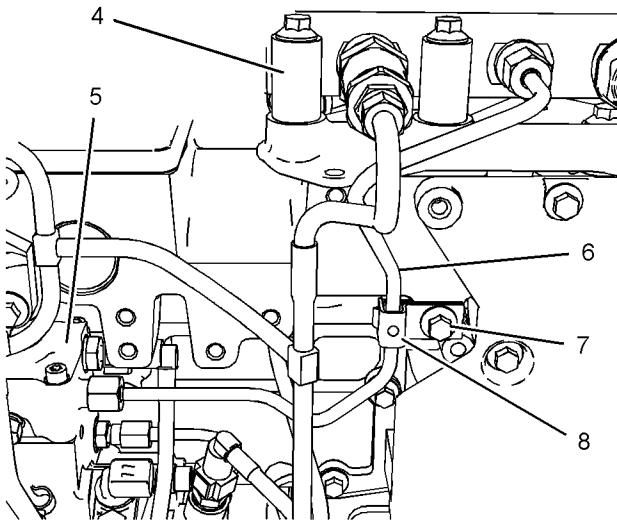

Illustration 16

g01254886

Typical example

12. Remove bolt (7) from clip (8).
13. Disconnect fuel injection line (6) from fuel injection pump (5).
14. Disconnect fuel injection line (6) from fuel manifold (4).
15. Remove fuel injection line (6). Discard the fuel injection line. Plug all open ports immediately. Use Tooling (A) in order to plug the open ports in the fuel manifold and in the fuel injection pump.

Fuel Injection Lines - Install

Installation Procedure

Table 3

Required Tools			
Tool	Part Number	Part Name	Qty
A	27610294	Injector Pipe Nut Tool	1

NOTICE

Ensure that all adjustments and repairs that are carried out to the fuel system are performed by authorised personnel that have the correct training.

Before beginning ANY work on the fuel system, refer to Operation and Maintenance Manual, "General Hazard Information and High Pressure Fuel Lines" for safety information.

Refer to Systems Operation, Testing and Adjusting Manual, "Cleanliness of Fuel System Components" for detailed information on the standards of cleanliness that must be observed during ALL work on the fuel system.

Note: The following procedure should be adopted in order to install the fuel injection lines when the electronic unit injectors or the fuel manifold have not been removed. If the electronic unit injectors or the fuel manifold have been removed, refer to Disassembly and Assembly, "Electronic Unit Injector - Install" and Disassembly and Assembly, "Fuel Manifold - Install" for more information.

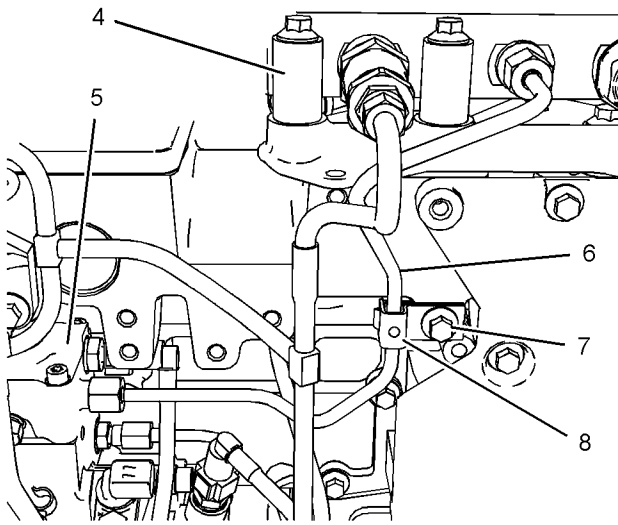

Illustration 17

g01254886

Typical example

1. Remove the caps from the port in fuel injection pump (5) and from the appropriate port in fuel manifold (4). Remove the caps from the new fuel injection line (6).
2. Loosely connect the nuts at both ends of fuel injection line (6), to fuel manifold (4) and to fuel injection pump (5). Ensure that the ends of the fuel injection line are correctly seated in the fuel injection pump and in the fuel manifold.
3. Use Tooling (A) to tighten the nuts on fuel injection line (6) to a torque of 30 N·m (22 lb ft).
4. Install bolt (7) to clip (8). Tighten bolt (7) to a torque of 22 N·m (16 lb ft).

Ensure that fuel injection line does not contact any other engine component.

5. Install the electronic control module. Refer to Disassembly and Assembly, "Electronic Control Module - Remove and Install".
6. If necessary, install the crankcase breather. Refer to Disassembly and Assembly, "Crankcase Breather - Install".

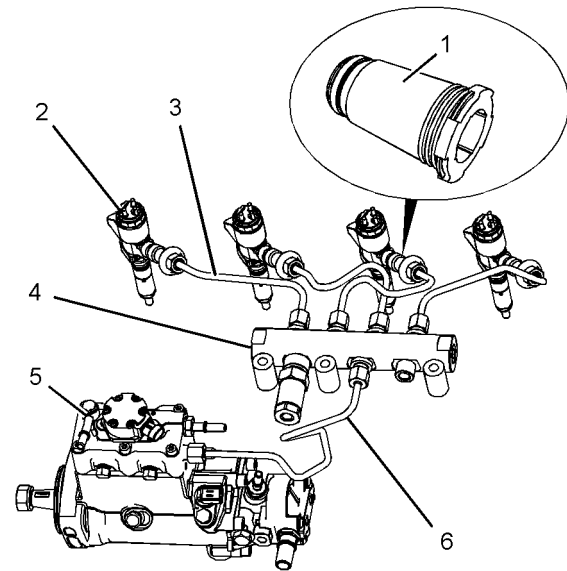

Illustration 18

g01245087

Typical example

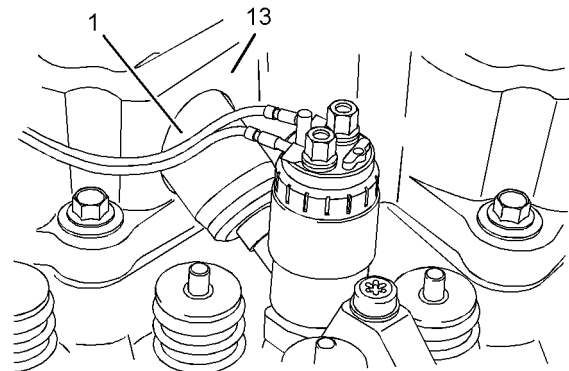

Illustration 19

g01271377

Typical example

7. Install a new seal (1) to electronic unit injector (2) and to valve mechanism cover base (13).

Note: Ensure that the flange on the seal is flush with the valve mechanism cover base.

8. Remove the caps from the new fuel injection line (3).

Note: Ensure that a dust seal is installed to the fuel injection line. Install the fuel injection line for number one cylinder first. Install the fuel injection lines in numerical order.

9. Remove the caps from electronic unit injector (2) and from the appropriate port in fuel manifold (4).

10. Loosely connect the nuts at both ends of fuel injection line (3), to electronic unit injector (2) and to the appropriate port in fuel manifold (4). Ensure that the ends of the fuel injection line are correctly seated in the electronic unit injector and in the fuel manifold.
 11. Use Tooling (A) to tighten the nuts on fuel injection line (3) to a torque of 30 N·m (22 lb ft). Ensure that the dust seal is seated correctly against seal (1).
 12. Follow Steps 7 through 11 in order to install the remaining fuel injection lines.
- Note:** Ensure that fuel injection lines do not contact any other engine component.
13. Restore the fuel supply.
 14. Restore the electrical supply.
 15. Remove the air from the fuel system. Refer to the Operations and Maintenance Manual, "Fuel System - Prime".

i02583756

Fuel Manifold (Rail) - Remove and Install

Removal Procedure

Start By:

- a. Remove the fuel injection lines. Refer to Disassembly and Assembly, "Fuel Injection Lines - Remove".

WARNING

Contact with high pressure fuel may cause fluid penetration and burn hazards. High pressure fuel spray may cause a fire hazard. Failure to follow these inspection, maintenance and service instructions may cause personal injury or death.

NOTICE

Ensure that all adjustments and repairs that are carried out to the fuel system are performed by authorised personnel that have the correct training.

Before beginning ANY work on the fuel system, refer to Operation and Maintenance Manual, "General Hazard Information and High Pressure Fuel Lines" for safety information.

Refer to Systems Operation, Testing and Adjusting Manual, "Cleanliness of Fuel System Components" for detailed information on the standards of cleanliness that must be observed during ALL work on the fuel system.

NOTICE

Care must be taken to ensure that fluids are contained during performance of inspection, maintenance, testing, adjusting and repair of the product. Be prepared to collect the fluid with suitable containers before opening any compartment or disassembling any component containing fluids.

Dispose of all fluids according to local regulations and mandates.

Note: Put identification marks on all hoses, on all hose assemblies, on wires and on all tube assemblies for installation purposes. Plug all hose assemblies and tube assemblies. This helps to prevent fluid loss and this helps to keep contaminants from entering the system.

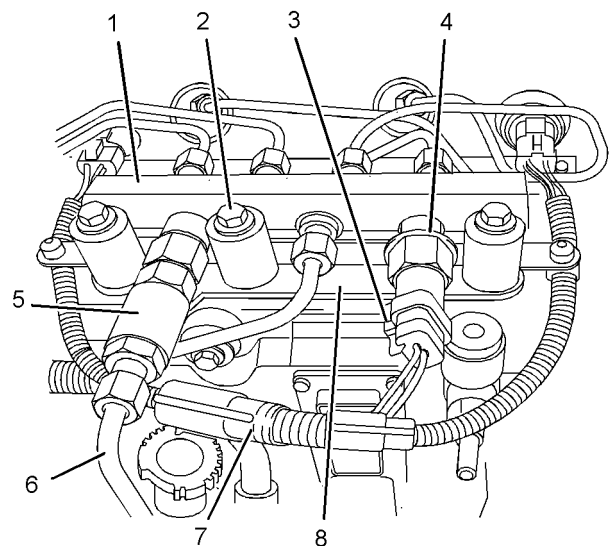

Illustration 20

g01243702

The fuel manifold is shown with fuel injection lines in position.

1. If necessary, remove fuel pressure sensor (4). Refer to Disassembly and Assembly, "Fuel Pressure Sensor - Remove and Install".
2. If fuel pressure sensor (4) does not require removal, slide locking tab (3) into the unlocked position. Disconnect the plug on harness assembly (7) from fuel pressure sensor (4).
3. Disconnect tube assembly (6) from the fuel pressure relief valve (5). Immediately cap the open port in the pressure relief valve with a new cap. Immediately plug the open end of the tube assembly with a new plug.

Note: Do not remove the fuel pressure relief valve from the fuel manifold.

4. Remove bolts (2) from fuel manifold (1). Note the position of any brackets that are secured by the bolts.
5. Remove fuel manifold (1) from mounting bracket (8).
6. If necessary, remove the bolts and remove mounting bracket (8).

Installation Procedure

Table 4

Required Tools			
Tool	Part Number	Part Name	Qty
A	27610294	Injector Pipe Nut Tool	1

NOTICE

Ensure that all adjustments and repairs that are carried out to the fuel system are performed by authorised personnel that have the correct training.

Before beginning ANY work on the fuel system, refer to Operation and Maintenance Manual, "General Hazard Information and High Pressure Fuel Lines" for safety information.

Refer to Systems Operation, Testing and Adjusting Manual, "Cleanliness of Fuel System Components" for detailed information on the standards of cleanliness that must be observed during ALL work on the fuel system.

1. Ensure that all ports on the fuel manifold are capped. Ensure that the fuel manifold is externally clean and free from damage.

Note: Do not install a fuel manifold that has not been capped. All caps must be left in place until the fuel injection lines or the fuel pressure sensor are installed.

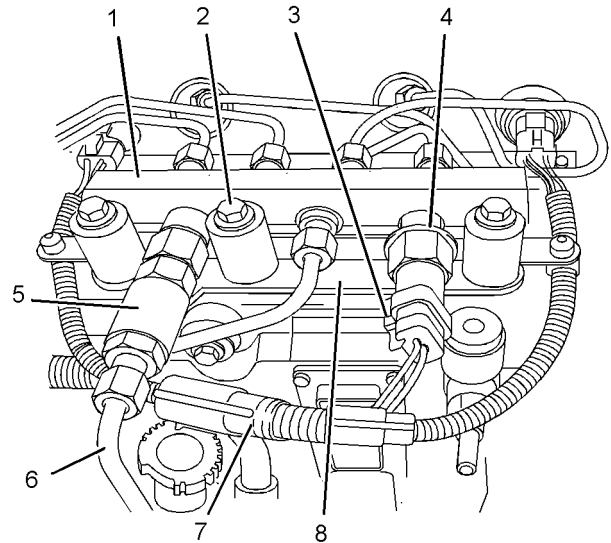

Illustration 21

g01243702

The fuel manifold is shown with fuel injection lines in position.

2. If necessary, install mounting bracket (8) and install the bolts. Tighten the bolts to a torque of 22 N·m (16 lb ft).
3. Position fuel manifold (1) onto mounting bracket (8). Install bolts (2) to the fuel manifold finger tight. Ensure that any brackets that are secured by bolts (2) are installed in the correct position.
4. Loosely install a new set of fuel injection lines. Refer to Disassembly and Assembly, "Fuel Injection Lines - Install" for more information.
5. Tighten bolts (2) to a torque of 22 N·m (16 lb ft).
6. Use Tooling (A) to tighten the nuts on the fuel injection lines to a torque of 30 N·m (22 lb ft). Refer to Disassembly and Assembly, "Fuel Injection Lines - Install" for more information.
7. Remove the plug from tube assembly (6). Remove the cap from the appropriate port in fuel manifold (1). Connect tube assembly (6) to the fuel pressure relief valve (5).
8. If fuel pressure sensor (4) was removed from fuel manifold (1), install a new sealing washer and install the fuel pressure sensor. Refer to Disassembly and Assembly, "Fuel Pressure Sensor - Remove and Install" for more information.

If fuel pressure sensor (4) was not removed from fuel manifold (1), connect the plug on harness assembly (7) to fuel pressure sensor (4). Slide locking tab (3) into the locked position.

9. Remove the air from the fuel system. Refer to Operation and Maintenance Manual, "Fuel System - Prime" for more information.

i02590384

Fuel Injection Pump - Remove

Removal Procedure

Table 5

Required Tools			
Tool	Part Number	Part Name	Qty
A ¹	21825576	Crankshaft Turning Tool	1
A ²	27610291	Barring Device Housing	1
	27610289	Gear	1
B	27610212	Camshaft Timing Pin	1
C	27610211	Crankshaft Timing Pin	1
D	U5MK1124	Cap Kit	1

Start By:

- a. Remove the electronic control module. Refer to Disassembly and Assembly, "Electronic Control Module - Remove and Install".
- b. Remove the front cover. Refer to Disassembly and Assembly, "Front Cover - Remove and Install".

Note: Either Tooling (A) can be used. Use the Tooling that is most suitable.

WARNING

Contact with high pressure fuel may cause fluid penetration and burn hazards. High pressure fuel spray may cause a fire hazard. Failure to follow these inspection, maintenance and service instructions may cause personal injury or death.

NOTICE

Ensure that all adjustments and repairs that are carried out to the fuel system are performed by authorised personnel that have the correct training.

Before beginning ANY work on the fuel system, refer to Operation and Maintenance Manual, "General Hazard Information and High Pressure Fuel Lines" for safety information.

Refer to Systems Operation, Testing and Adjusting Manual, "Cleanliness of Fuel System Components" for detailed information on the standards of cleanliness that must be observed during ALL work on the fuel system.

NOTICE

Care must be taken to ensure that fluids are contained during performance of inspection, maintenance, testing, adjusting and repair of the product. Be prepared to collect the fluid with suitable containers before opening any compartment or disassembling any component containing fluids.

Dispose of all fluids according to local regulations and mandates.

Note: Put identification marks on all hoses, on all hose assemblies, on wires and on all tube assemblies for installation purposes. Plug all hose assemblies and tube assemblies. This helps to prevent fluid loss and this helps to keep contaminants from entering the system.

1. Isolate the fuel supply.
2. Isolate the electrical supply.
3. If necessary, remove the fuel filter base. Refer to Disassembly and Assembly, "Fuel Filter Base - Remove and Install".
4. If necessary, remove the fuel priming pump. Refer to Disassembly and Assembly, "Fuel Priming Pump - Remove".
5. If necessary, remove the crankcase breather. Refer to Disassembly and Assembly, "Crankcase Breather - Remove".
6. Use Tooling (A) in order to rotate the crankshaft so that number one piston is at the top center position on the compression stroke. Refer to Systems Operation, Testing and Adjusting, "Finding Top Centre Position for No.1 Piston".

7. Use Tooling (B) in order to lock the camshaft in the correct position. Use Tooling (C) in order to lock the crankshaft in the correct position. Refer to Disassembly and Assembly, "Gear Group (Front) - Remove" for the correct procedure.
8. Remove the backlash from the fuel pump gear. Lock the fuel injection pump in the correct position and remove the fuel pump gear. Refer to Disassembly and Assembly, "Fuel Pump Gear - Remove and Install" for the correct procedure.

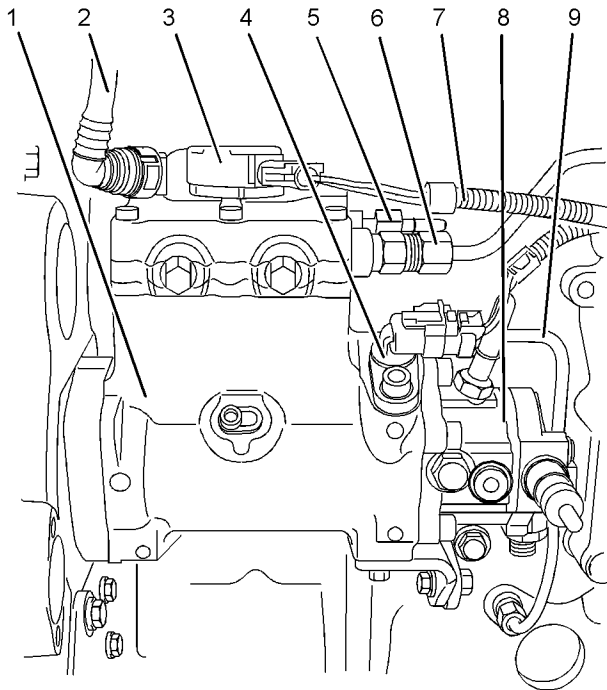

Illustration 22
Typical example

g01263061

9. Disconnect plastic tube assembly (2) from fuel injection pump (1).
10. Disconnect harness assembly (7) from solenoid (3). Slide the locking tab into the unlocked position and disconnect harness assembly (7) from position sensor (4). If necessary, cut the cable ties that secure the harness assembly.

Note: The harness assembly should be positioned in order to avoid an obstruction to the fuel injection pump.

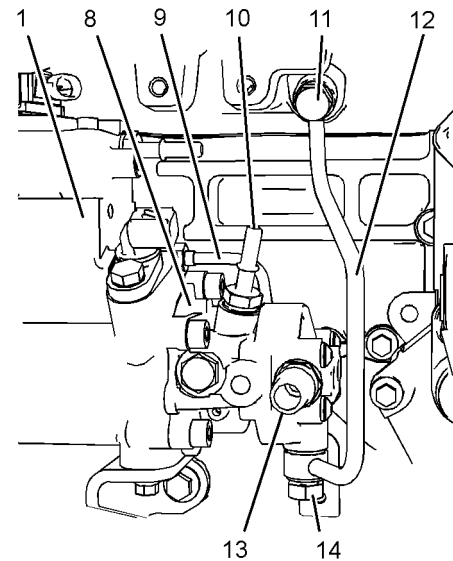

Illustration 23
Typical example

g01256934

11. Remove the plastic tube assembly from inlet connection (13) on fuel transfer pump (8).
12. Remove the plastic tube assembly from outlet connection (10) on fuel transfer pump (8).
13. Remove the plastic tube assembly from connection (5) on fuel injection pump (1).

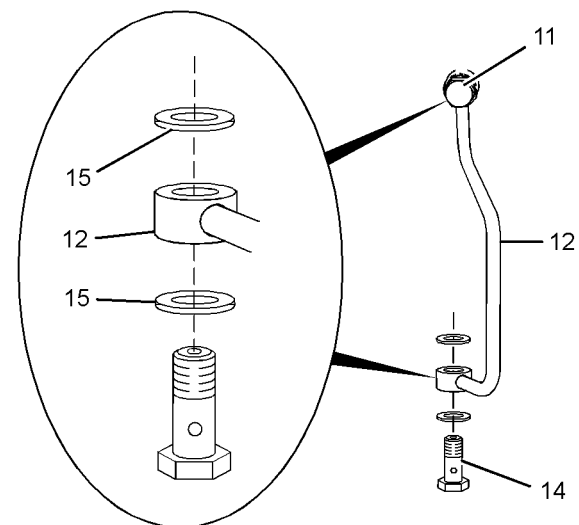

Illustration 24

g01256937

14. Remove tube assembly (12) for the fuel return from the cylinder head to the fuel transfer pump.

Note: Disconnect the tube assembly at the fuel transfer pump first in order to drain the fuel from the cylinder head.

15. Remove banjo bolt (11) and sealing washers (15) from tube assembly (12). Remove banjo bolt (14) and sealing washers (15) from tube assembly (12).

16. Plug or cap all open ports and tube assemblies immediately with new plugs or caps.

Note: If the tube assemblies have quick fit connections, ensure that the connections are clean before the tube assemblies are plugged.

17. Remove fuel injection line (6). Refer to Disassembly and Assembly, "Fuel Injection Lines - Remove". Plug all open ports in the fuel injection pump and in the fuel manifold with new plugs immediately. Discard the fuel injection line.

18. Remove tube assembly (9) for the engine oil supply to the fuel injection pump (1). Remove the banjo bolt and the sealing washers from tube assembly (9).

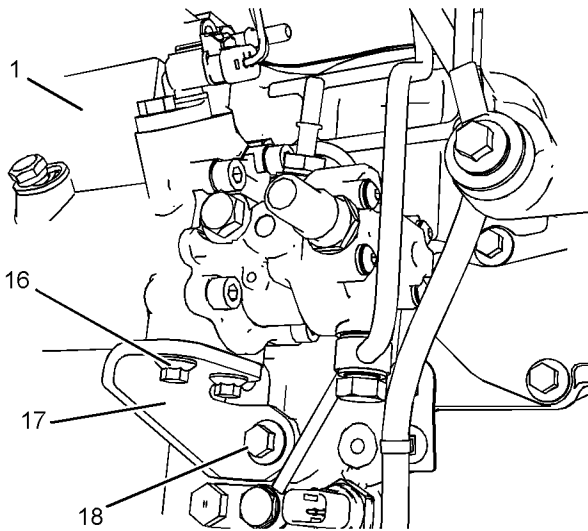

Illustration 25
Typical example

g01247430

19. Remove bolt (18). Remove bolts (16) and remove support bracket (17) from fuel injection pump (1).

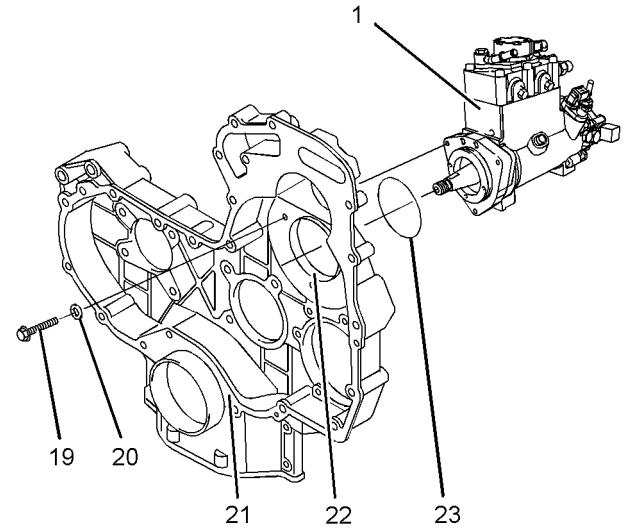

Illustration 26

g01254901

Typical example

20. Remove bolts (19) and sealing washers (20).

Note: The fuel injection pump should be supported by hand as the bolts are removed.

21. Carefully remove fuel injection pump (1) from front housing (21). Ensure that bore (22) in the front housing is not damaged as the fuel injection pump is removed.

22. Remove O-ring seal (23) from fuel injection pump (1).

23. If necessary, remove position sensor (4) from fuel injection pump (1). Refer to Disassembly and Assembly, "Position Sensor (Fuel Injection Pump) - Remove and Install".

24. If necessary, remove fuel transfer pump (8) from fuel injection pump (1). Refer to Disassembly and Assembly, "Fuel Transfer Pump - Remove".

i02590409

Fuel Injection Pump - Install

Installation Procedure

Table 6

Required Tools			
Tool	Part Number	Part Description	Qty
A ¹	21825576	Crankshaft Turning Tool	1
A ²	27610291	Barring Device Housing	1
	27610289	Gear	1
B	27610212	Camshaft Timing Pin	1
C	27610211	Crankshaft Timing Pin	1
E	27610302	Fuel Injection Pump Timing Tool	1
F	21820221	POWERPART Rubber Grease	-

Note: Either Tooling (A) can be used. Use the Tooling that is most suitable.

NOTICE

Ensure that all adjustments and repairs that are carried out to the fuel system are performed by authorised personnel that have the correct training.

Before beginning ANY work on the fuel system, refer to Operation and Maintenance Manual, "General Hazard Information and High Pressure Fuel Lines" for safety information.

Refer to Systems Operation, Testing and Adjusting Manual, "Cleanliness of Fuel System Components" for detailed information on the standards of cleanliness that must be observed during ALL work on the fuel system.

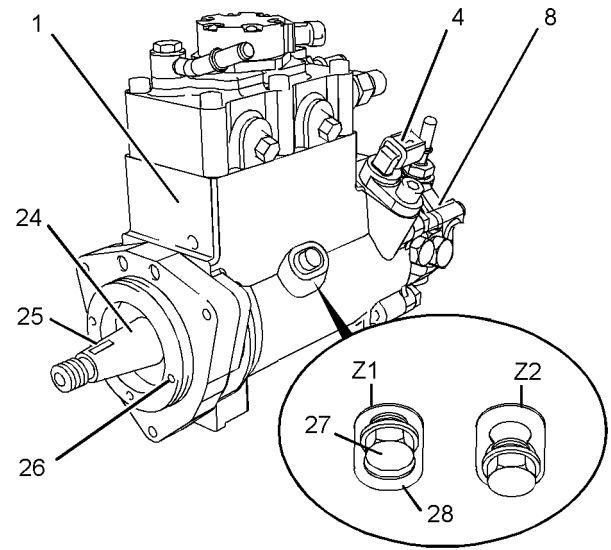

Illustration 27

g01254907

1. If the fuel injection pump was previously disassembled, follow Steps 1.a and 1.b in order to assemble the fuel injection pump.

- a. Install fuel transfer pump (8) to fuel injection pump (1). Refer to Disassembly and Assembly, "Fuel Transfer Pump - Install".
- b. Install position sensor (4) to fuel injection pump (1). Refer to Disassembly and Assembly, "Position Sensor (Fuel Injection Pump) - Remove and Install".

Note: A new fuel injection pump assembly includes the fuel transfer pump and the position sensor.

2. To check the fuel injection pump timing, follow Steps 2.a and 2.b.

- a. Position Tooling (E) onto shaft (24) of the fuel injection pump. Align the lever of Tooling (E) with key slot (25). Engage the lever into the key slot.
- b. Insert the locking pin of Tooling (E) into hole (26) in fuel injection pump.

If the locking pin can be inserted into the hole, the fuel injection pump timing is correct.

If the locking pin cannot be inserted into the hole, the fuel injection pump timing is not correct.

Note: There should be no resistance when the locking pin is inserted.

3. If the fuel injection pump timing has been lost follow Steps 3.a through 3.e in order to reset the fuel injection pump timing.

- a. If necessary, loosen locking screw (27) on the fuel injection pump. Slide spacer (28) into position (Z1). Tighten locking screw (27) to a torque of 9 N·m (80 lb in). This will prevent the locking screw from tightening against shaft (24).

The fuel injection pump is now unlocked.

- b. Position Tooling (E) onto shaft (24) of the fuel injection pump. Align the lever of Tooling (E) with key slot (25) in the fuel injection pump. Engage the lever into the key slot.
- c. Use the lever of Tooling (E) to rotate shaft (24) until the pin of Tooling (E) can be engaged into hole (26). Engage the pin of Tooling (E) into the hole.
- d. Loosen locking screw (27) in the fuel injection pump. Slide spacer (28) into position (Z2). Tighten locking screw (27) against the shaft of the fuel injection pump to a torque of 9 N·m (80 lb in).

The fuel injection pump is now correctly timed and locked.

- e. Remove tooling (E).

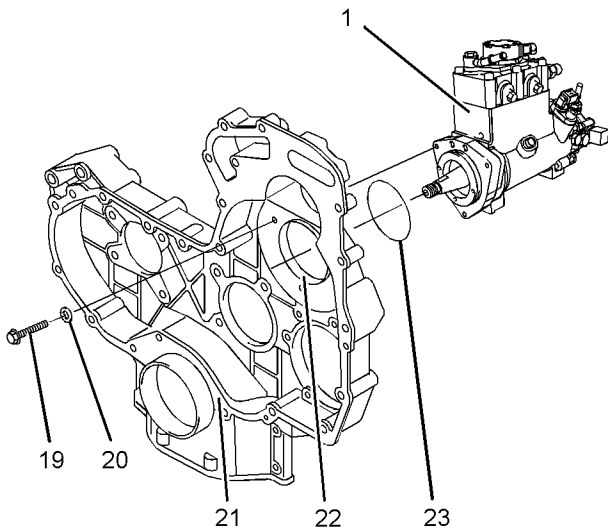

Illustration 28

g01254901

4. Inspect bore (22) in front housing (21) for damage. If the bore is damaged, replace the front housing. Refer to Disassembly and Assembly, "Housing (Front) - Remove" and Disassembly and Assembly, "Housing (Front) - Install".
5. Use Tooling (F) to lubricate a new O-ring seal (23). Install the O-ring seal onto fuel injection pump (1).

6. Align the holes in fuel injection pump (1) with the holes in front housing (21). Carefully install the fuel injection pump to the front housing.

Note: The fuel injection pump should be supported by hand until the bolts are installed.

7. Install bolts (19) and new sealing washers (20). Tighten the bolts to a torque of 25 N·m (18 lb ft).
8. If necessary, use Tooling (A) in order to rotate the crankshaft so that number one piston is at top dead center on the compression stroke. Refer to Systems Operation, Testing and Adjusting, "Finding Top Centre Position for No.1 Piston".
9. Use Tooling (B) in order to lock the camshaft in the correct position. Use Tooling (C) in order to lock the crankshaft in the correct position. Refer to Disassembly and Assembly, "Gear Group (Front) - Remove" for the correct procedure.
10. Install the fuel injection pump gear to the fuel injection pump. Refer to Disassembly and Assembly, "Fuel Injection Pump Gear - Install" and refer to Disassembly and Assembly, "Gear Group (Front) - Install".

Note: Ensure that spacer (28) on the fuel injection pump is in the unlocked position (Z1) after the installation of fuel injection pump gear is completed. Refer to Illustration 27.

11. Install the front cover. Refer to Disassembly and Assembly, "Front Cover - Remove and Install".

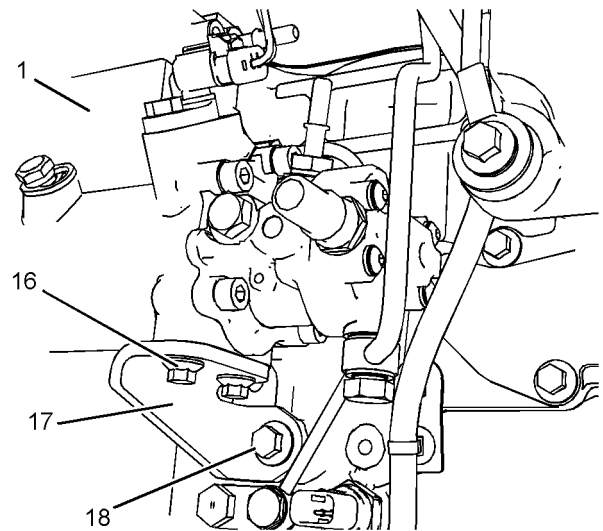

Illustration 29

Typical example

g01247430

12. Position support bracket (17) against fuel injection pump (1). Install bolts (16) finger tight.

13. Install bolt (18) finger tight.

14. Tighten bolt (18) to a torque of 44 N·m (32.5 lb ft). Tighten bolts (16) to a torque of 22 N·m (16 lb ft).

Note: Ensure that the fuel injection pump is not stressed as the bolts for the bracket are tightened.

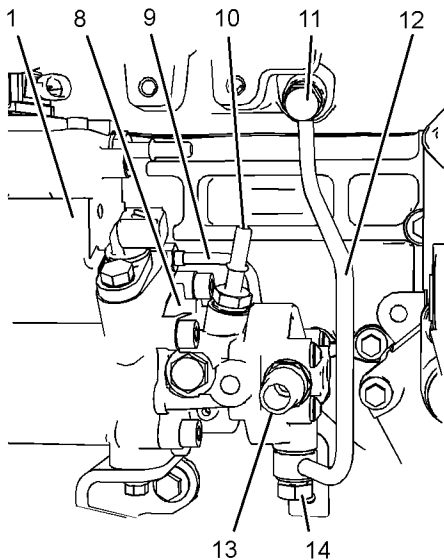

Illustration 30

g01256934

Typical example

15. Remove the appropriate plugs and caps in order to install tube assembly (9) for the engine oil supply to the fuel injection pump. Install the banjo bolt and new sealing washers to tube assembly (9). Install tube assembly (9) to the fuel injection pump and to the cylinder head. Tighten the banjo bolt to a torque of 15 N·m (11 lb ft). Tighten the nut to a torque of 15 N·m (11 lb ft).

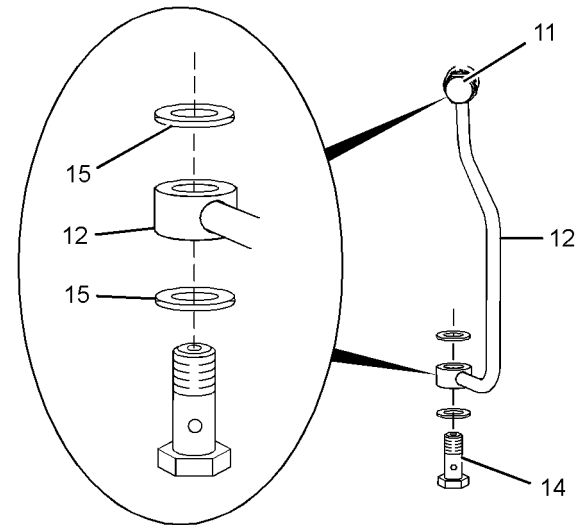

Illustration 31

g01256937

16. Install banjo bolt (11) and new sealing washers (15) to tube assembly (12). Install banjo bolt (14) and new sealing washers (15) to tube assembly (12).

17. Install tube assembly (12) for the fuel return from the cylinder head to the fuel transfer pump. Tighten both banjo bolts (11) finger tight.

18. Tighten banjo bolts (11) and (14) to a torque of 22 N·m (16 lb ft).

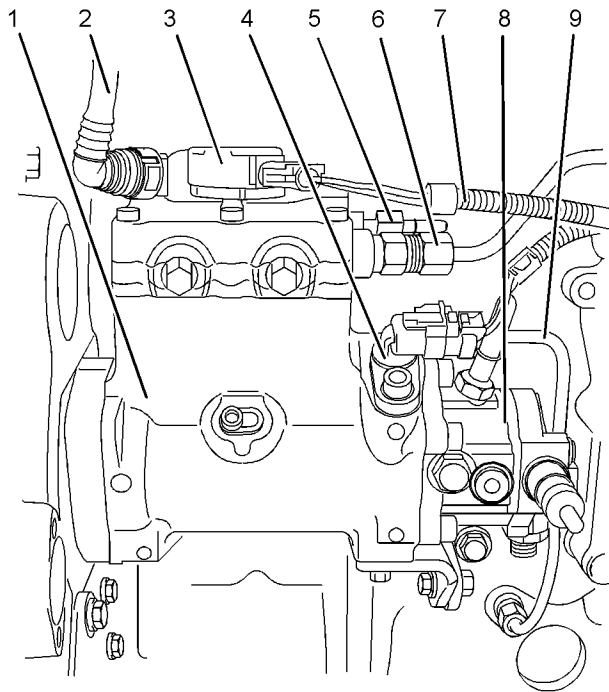

Illustration 32

g01263061

Typical example

19. Remove the appropriate caps in order to install the fuel injection line (6). Install a new fuel injection line (6) to the fuel injection pump and to the fuel manifold. Refer to Disassembly and Assembly, "Fuel Injection Lines - Install".

20. Remove the plugs and caps from the remaining ports and tube assemblies.

Note: If the tube assemblies have quick fit connections, ensure that the connections are clean before the tube assemblies are installed.

21. Install the plastic tube assembly to connection (5) on the fuel injection pump.

22. Install the plastic tube assembly to outlet connection (10) on the fuel transfer pump. Refer to Illustration 30.

23. Install the plastic tube assembly to inlet connection (13) on the fuel transfer pump. Refer to Illustration 30.

24. Connect harness assembly (7) to solenoid (3) on the fuel injection pump. Connect harness assembly (7) to position sensor (4) on the fuel injection pump. Slide the locking tab into the locked position. Secure the harness assembly with new cable ties.

25. Install plastic tube assembly (2) to the fuel injection pump.

26. Install the electronic control module. Refer to Disassembly and Assembly, "Electronic Control Module - Remove and Install".

27. If necessary, install the fuel filter base. Refer to Disassembly and Assembly, "Fuel Filter Base - Remove and Install".

28. If necessary, install the fuel priming pump. Refer to Disassembly and Assembly, "Fuel Priming Pump - Remove and Install".

29. Turn the fuel supply to the ON position.

30. Turn the battery disconnect switch to the ON position.

31. Remove the air from the fuel system. Refer to Operation and Maintenance Manual, "Fuel System - Prime" for more information.

i02590469

Fuel Injection Pump Gear - Remove

Removal Procedure

Table 7

Required Tools			
Tool	Part Number	Part Name	Qty
A ¹	21825576	Crankshaft Turning Tool	1
A ²	27610291	Barring Device Housing	1
	27610289	Gear	1
B	27610212	Camshaft Timing Pin	1
C	27610211	Crankshaft Timing Pin	1
D	-	Puller (Two Leg)	1

Start By:

a. Remove the front cover. Refer to Disassembly and Assembly, "Front Cover - Remove and Install".

Note: Either Tooling (A) can be used. Use the Tooling that is most suitable.

NOTICE

Keep all parts clean from contaminants.

Contaminants may cause rapid wear and shortened component life.

NOTICE

Care must be taken to ensure that fluids are contained during performance of inspection, maintenance, testing, adjusting and repair of the product. Be prepared to collect the fluid with suitable containers before opening any compartment or disassembling any component containing fluids.

Dispose of all fluids according to local regulations and mandates.

Note: Care must be taken in order to ensure that the fuel injection pump timing is not lost during the removal of the fuel pump gear. Carefully follow the procedure in order to remove the fuel pump gear.

1. Use Tooling (A) in order to rotate the crankshaft so that number one piston is at the top center position on the compression stroke. Refer to Systems Operation, Testing and Adjusting, "Finding Top Centre Position for No.1 Piston".

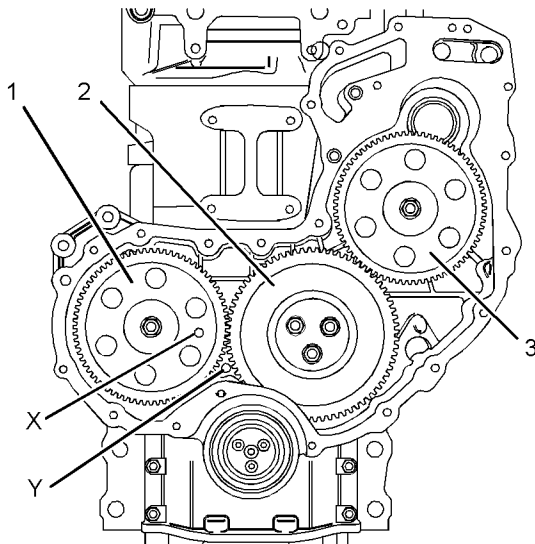

Illustration 33

g01247433

Typical example

2. Install Tooling (B) through hole (X) in camshaft gear (1) into the front housing. Use Tooling (B) in order to lock the camshaft in the correct position.
3. Install Tooling (C) into hole (Y) in the front housing. Use Tooling (C) in order to lock the crankshaft in the correct position.

Note: Do not use excessive force to install Tooling (C). Do not use Tooling (C) to hold the crankshaft during repairs.

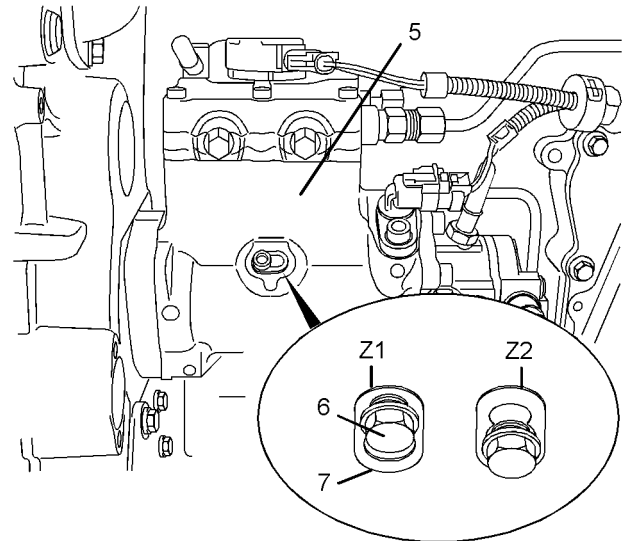

Illustration 34

g01247434

Typical example

4. Apply sufficient pressure to fuel injection pump gear (3) in a counterclockwise direction in order to remove the backlash. Lock fuel injection pump (5) in this position.

In order to lock the fuel injection pump (5), loosen locking screw (6) in the fuel injection pump. Slide spacer (7) into position (Z2). Tighten locking screw (6) against the shaft of the fuel injection pump to a torque of 9 N·m (80 lb in).

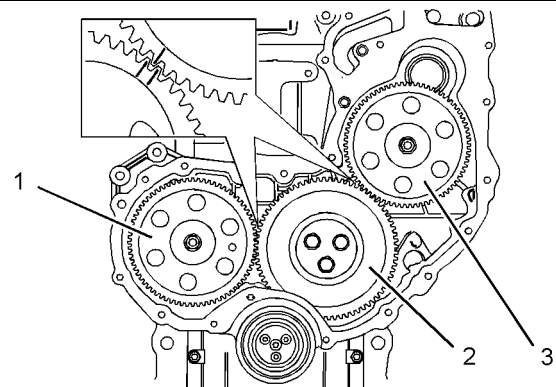

Illustration 35

g01247435

Alignment of timing marks

5. Mark gears (1), (2) and (3) in order to show alignment. Refer to Illustration 35.

Note: Identification will ensure that the gears can be installed in the original alignment.

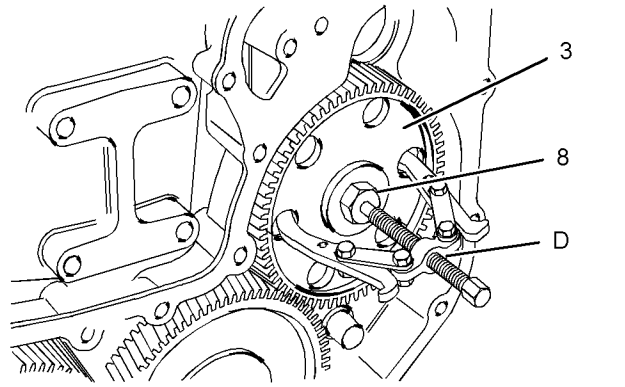

Illustration 36

g01247436

6. Loosen nut (8) on fuel pump gear (3).
7. Install Tooling (D) through two opposite holes in fuel pump gear (3). Tighten Tooling (D) until the fuel pump gear is released.
8. Remove Tooling (D) from fuel pump gear (3).
9. Remove nut (8) and the washer from fuel pump gear (3). Remove the fuel pump gear.

i02585395

Fuel Injection Pump Gear - Install

Installation Procedure

Table 8

Required Tools			
Tool	Part Number	Part Name	Qty
B	27610212	Camshaft Timing Pin	1
C	27610211	Crankshaft Timing Pin	1
E	21825617	Dial Indicator Group	1
	-	Finger Clock	1

NOTICE

Keep all parts clean from contaminants.

Contaminants may cause rapid wear and shortened component life.

Note: The fuel injection pump must remain locked until the procedure instructs you to unlock the fuel injection pump.

1. Ensure that number one piston is at the top center position on the compression stroke. Refer to the Systems Operation, Testing and Adjusting, "Finding Top Center Position for No. 1 Piston".

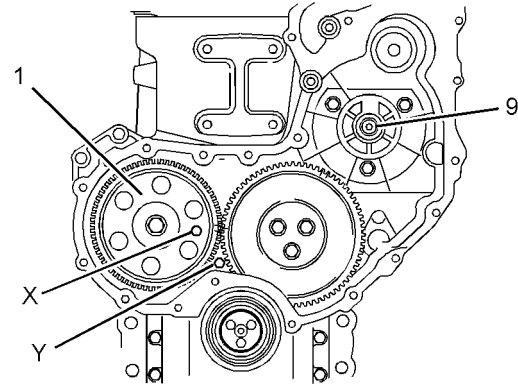

Illustration 37

g01247475

Typical example

2. Ensure that Tooling (C) is installed in hole (Y) in the front housing. Use Tooling (C) in order to lock the crankshaft in the correct position.
3. Ensure that Tooling (B) is installed into hole (X) in camshaft gear (1).
4. Ensure that shaft (9) on the fuel injection pump is clean, dry and free from damage.
5. Ensure that the fuel injection pump is locked in the correct position. Refer to Disassembly and Assembly, "Fuel Injection Pump - Install".
6. Ensure that the fuel pump gear is clean, dry and free from wear or damage. If necessary, replace the fuel pump gear.

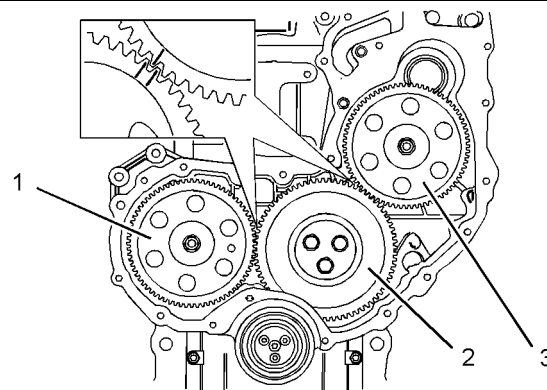

Illustration 38

g01247435

Alignment of timing marks

7. Install fuel pump gear (3) to shaft (9) of the fuel injection pump. Ensure that the timing marks on gears (2) and (3) are in alignment and that the mesh of the gears is correct.

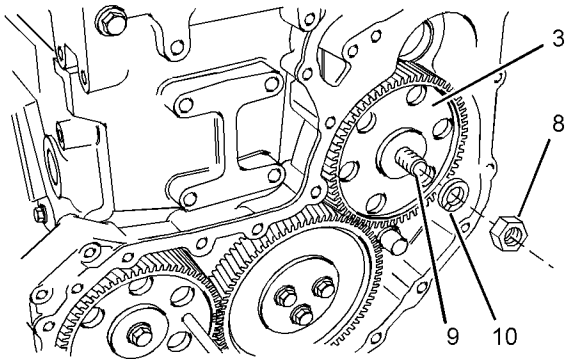

Illustration 39
Typical example

g01247478

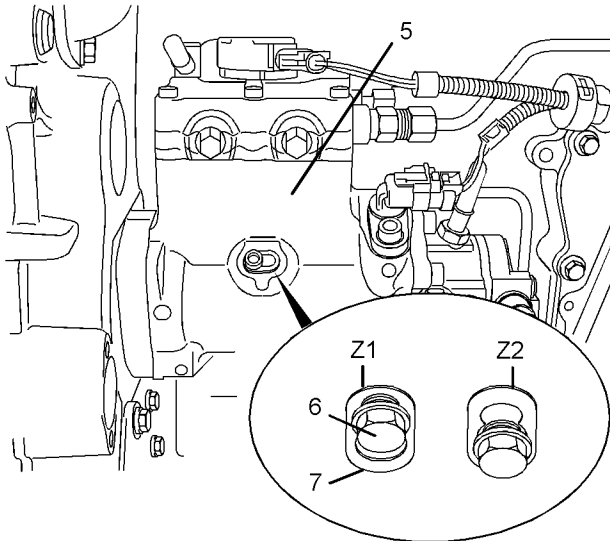

Illustration 40
Typical

g01247434

8. Install a new spring washer (10) and install nut (8) to shaft (9) of the fuel injection pump. Apply sufficient pressure to the fuel injection pump gear (3) in a counterclockwise direction in order to remove the backlash. Tighten nut (8) to a torque of 25 N·m (18 lb ft). Unlock the fuel injection pump (5).

In order to unlock the fuel injection pump, loosen locking screw (6) on the fuel injection pump. Slide spacer (7) into position (Z1). Tighten the locking screw against the spacer to a torque of 9 N·m (80 lb in). This will prevent the locking screw from tightening against the shaft of the fuel injection pump.

9. Remove Tooling (B) and (C).
10. Tighten nut (8) to a torque of 90 N·m (66.4 lb ft).

11. Use Tooling (E) to measure the backlash of gears (2) and (3). Ensure that the backlash for the gears is within specified values. Refer to Specifications, "Gear Group (Front)" for further information.

12. Lubricate the teeth of the gears with clean engine oil.

End By:

- a. Install the front cover. Refer to Disassembly and Assembly, "Front Cover - Remove and Install".

i02590481

Electronic Unit Injector - Remove

Removal Procedure

Table 9

Required Tools			
Tool	Part Number	Part Description	Qty
A ¹	21825576	Crankshaft Turning Tool	1
A ²	27610291	Barring Device Housing	1
	27610289	Gear	1
B	27610307	T40 Torx Socket	1
C	27610288	Pry Bar	1

Start By:

- a. Remove the valve mechanism cover. Refer to Disassembly and Assembly, "Valve Mechanism Cover - Remove and Install".

Note: Either Tooling (A) can be used. Use the Tooling that is most suitable.

WARNING

Contact with high pressure fuel may cause fluid penetration and burn hazards. High pressure fuel spray may cause a fire hazard. Failure to follow these inspection, maintenance and service instructions may cause personal injury or death.

NOTICE

Ensure that all adjustments and repairs that are carried out to the fuel system are performed by authorised personnel that have the correct training.

Before beginning ANY work on the fuel system, refer to Operation and Maintenance Manual, "General Hazard Information and High Pressure Fuel Lines" for safety information.

Refer to Systems Operation, Testing and Adjusting Manual, "Cleanliness of Fuel System Components" for detailed information on the standards of cleanliness that must be observed during ALL work on the fuel system.

NOTICE

Care must be taken to ensure that fluids are contained during performance of inspection, maintenance, testing, adjusting and repair of the product. Be prepared to collect the fluid with suitable containers before opening any compartment or disassembling any component containing fluids.

Dispose of all fluids according to local regulations and mandates.

NOTICE

Use a deep socket in order to remove the electrical connections from the electronic unit injectors. Use of incorrect tooling will result in damage to the electronic unit injectors.

Note: Put identification marks on all hoses, on all hose assemblies, on wires and on all tube assemblies for installation purposes. Plug all hose assemblies and tube assemblies. This helps to prevent fluid loss and this helps to keep contaminants from entering the system.

1. Isolate the fuel supply to the engine.
2. Isolate the electrical supply to the engine.

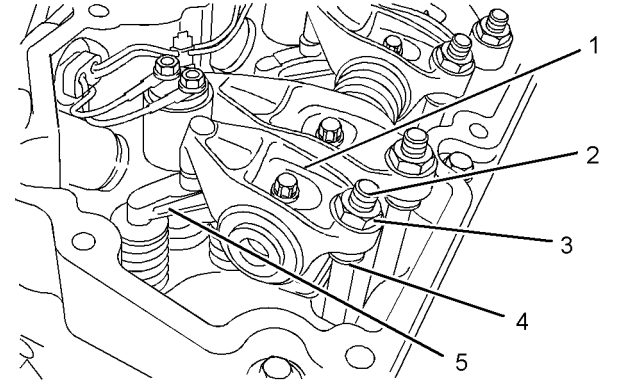

Illustration 41
Typical example

g01269378

3. Use Tooling (A) in order to rotate the crankshaft until rocker arms (1) for the appropriate cylinder are in the correct position in order to adjust the valve lash. Refer to Systems Operation, Testing and Adjusting, "Engine Valve Lash - Inspect/Adjust".
4. Follow Steps 4.a through 4.c in order to gain access to the electronic unit injector.
 - a. Loosen nuts (3) for the appropriate cylinder. Unscrew adjusters (2) for the appropriate cylinder until pushrods (4) can be withdrawn from the balls of the adjusters.
 - b. Withdraw the cups of pushrods (4) from the balls of adjusters (2).
 - c. Make a temporary mark on valve bridges (5) in order to show the location and orientation. Remove the valve bridges from the cylinder head.

Note: Identification will ensure that the valve bridges can be reinstalled in the original location and the original orientation. Do not interchange the location or the orientation of used valve bridges.

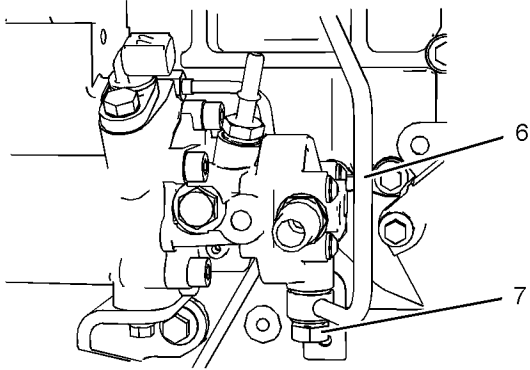

Illustration 42

g01247489

Typical example

5. Loosen banjo bolt (7) sufficiently in order to allow the fuel to drain from tube assembly (6).

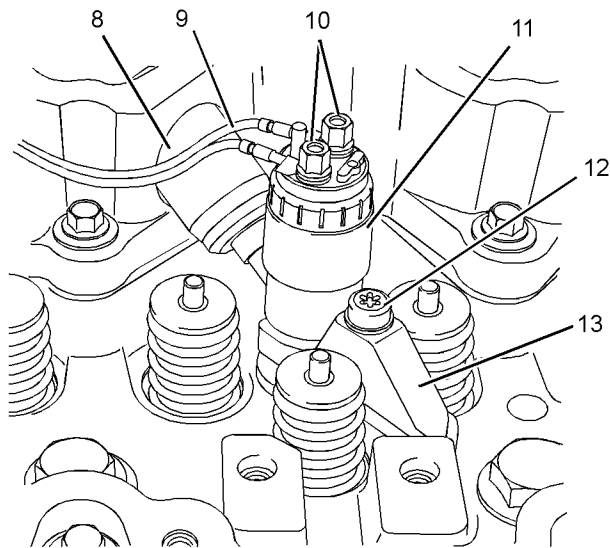

Illustration 43

g01255699

The rocker shaft is not shown for clarity.

6. Remove the fuel injection line and remove seal (8) from the appropriate electronic unit injector (11). Refer to Disassembly and Assembly, "Fuel Injection Lines - Remove".

Note: Cap all open ports immediately with new caps.

7. Use a deep socket to remove connections (10) from electronic unit injector (11).
8. Slide rocker arms (1) to one side in order to gain access to torx screw (12). Use Tooling (B) in order to remove the torx screw from clamp (13). Discard the torx screw.

9. Place a temporary identification mark on the electronic unit injector. The electronic unit injector must be reinstalled in the original location in the cylinder head.

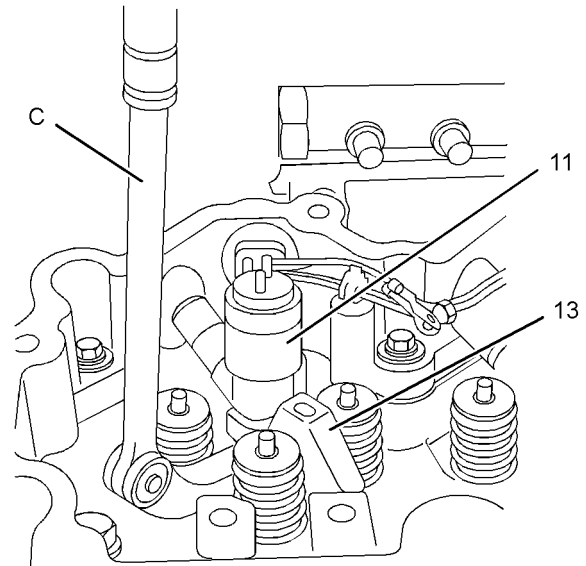

Illustration 44

g01255700

The rocker shaft is not shown for clarity.

10. Use Tooling (C) to pry beneath clamp (13) and free electronic unit injector (11) from the cylinder head.

11. Remove electronic unit injector (11) and clamp (13) from the cylinder head.

Note: Always handle electronic unit injectors with care.

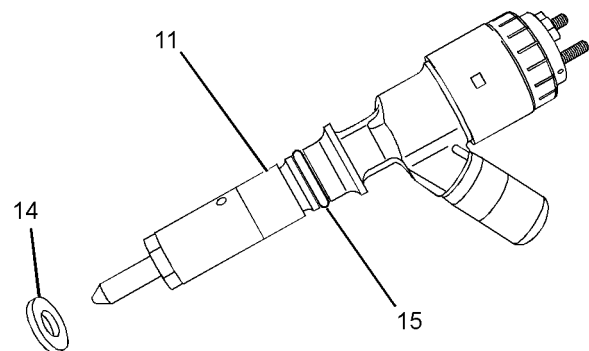

Illustration 45

g01255701

Typical example

12. Remove sealing washer (14). Remove O-ring seal (15) from the electronic unit injector.

Alternative Removal Procedure

Table 10

Required Tools			
Tool	Part Number	Part Description	Qty
B	27610307	T40 Torx Socket	1
C	27610288	Pry Bar	1

Start By:

- a. Remove the rocker shaft assembly. Refer to Disassembly and Assembly, "Rocker Shaft - Remove".
- b. Remove the fuel injection lines. Refer to Disassembly and Assembly, "Fuel Injection Lines - Remove".

Note: This is an optional procedure to remove the electronic unit injectors. The method should ONLY be used when all electronic unit injectors are removed and when the engine is removed from the application.

WARNING

Contact with high pressure fuel may cause fluid penetration and burn hazards. High pressure fuel spray may cause a fire hazard. Failure to follow these inspection, maintenance and service instructions may cause personal injury or death.

NOTICE

Ensure that all adjustments and repairs that are carried out to the fuel system are performed by authorised personnel that have the correct training.

Before beginning ANY work on the fuel system, refer to Operation and Maintenance Manual, "General Hazard Information and High Pressure Fuel Lines" for safety information.

Refer to Systems Operation, Testing and Adjusting Manual, "Cleanliness of Fuel System Components" for detailed information on the standards of cleanliness that must be observed during ALL work on the fuel system.

NOTICE

Care must be taken to ensure that fluids are contained during performance of inspection, maintenance, testing, adjusting and repair of the product. Be prepared to collect the fluid with suitable containers before opening any compartment or disassembling any component containing fluids.

Dispose of all fluids according to local regulations and mandates.

NOTICE

Use a deep socket in order to remove the electrical connections from the electronic unit injectors. Use of incorrect tooling will result in damage to the electronic unit injectors.

Note: Put identification marks on all hoses, on all hose assemblies, on wires and on all tube assemblies for installation purposes. Plug all hose assemblies and tube assemblies. This helps to prevent fluid loss and this helps to keep contaminants from entering the system.

1. Isolate the fuel supply to the engine.
2. Isolate the electrical supply to the engine.

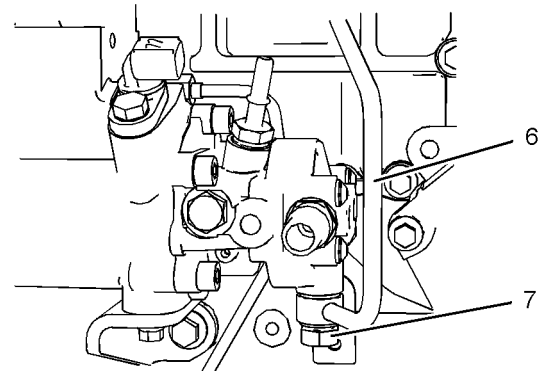

Illustration 46

g01247489

Typical example

3. Loosen banjo bolt (7) sufficiently in order to allow the fuel to drain from tube assembly (6).

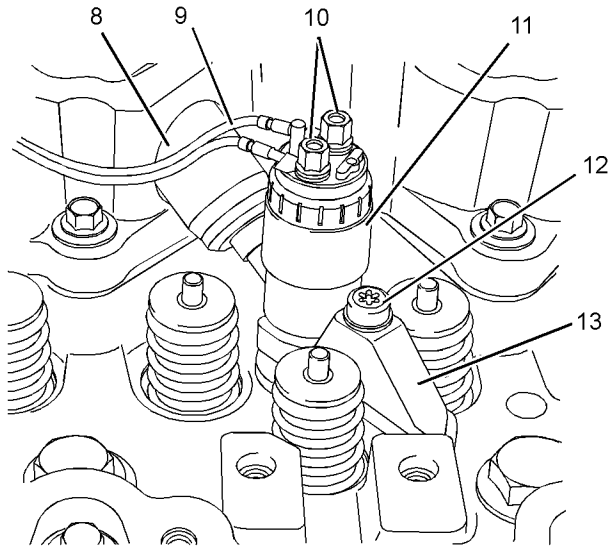

Illustration 47

g01255699

4. Place a temporary identification mark on connections (10) for harness assembly (9).
5. Use a deep socket to remove connections (10) from electronic unit injector (11).
6. Use Tooling (B) in order to remove torx screw (12) from clamp (13). Discard the torx screw.
7. Place a temporary identification mark on the electronic unit injector. The electronic unit injector must be reinstalled in the original location in the cylinder head.

9. Remove electronic unit injector (11) and clamp (13) from the cylinder head.

Note: Always handle electronic unit injectors with care.

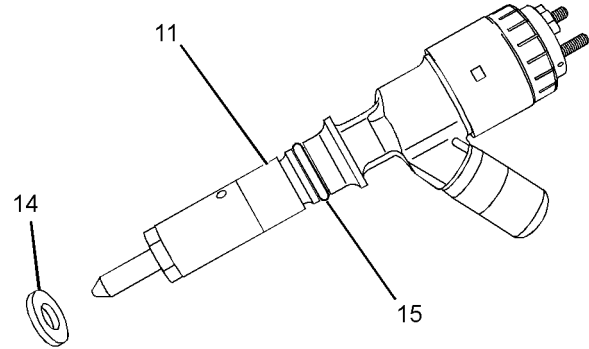

Illustration 49

g01255701

Typical example

10. Remove sealing washer (14). Remove O-ring seal (15) from the electronic unit injector.
11. Repeat Steps 4 through 11 in order to remove the remaining electronic unit injectors.

i02585456

Electronic Unit Injector - Install

Installation Procedure

Table 11

Required Tools			
Tool	Part Number	Part Description	Qty
B	27610307	T40 Torx Socket	1
D	GE50028	Vacuum Pump	1
	GE50030	Tube 7.9 mm (0.31 inch) OD	1
E	27610294	Injector Pipe Nut Tool	1
F	27610296	Torque Wrench	1

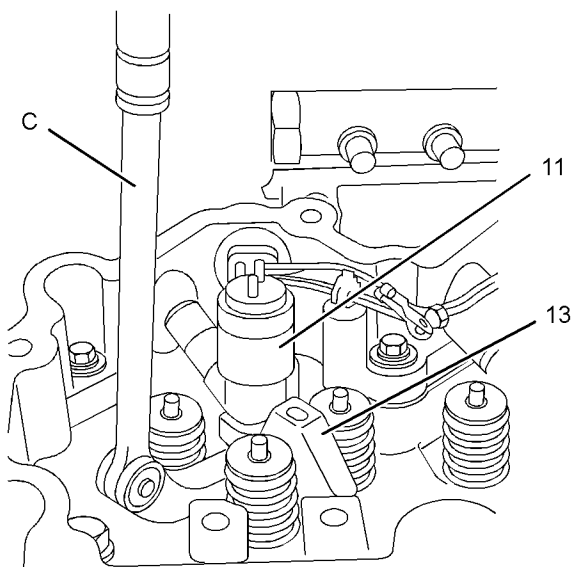

Illustration 48

g01255700

8. Use Tooling (C) to pry beneath clamp (13) and free electronic unit injector (11) from the cylinder head.

NOTICE

Ensure that all adjustments and repairs that are carried out to the fuel system are performed by authorised personnel that have the correct training.

Before beginning ANY work on the fuel system, refer to Operation and Maintenance Manual, "General Hazard Information and High Pressure Fuel Lines" for safety information.

Refer to Systems Operation, Testing and Adjusting Manual, "Cleanliness of Fuel System Components" for detailed information on the standards of cleanliness that must be observed during ALL work on the fuel system.

NOTICE

Care must be taken to ensure that fluids are contained during performance of inspection, maintenance, testing, adjusting and repair of the product. Be prepared to collect the fluid with suitable containers before opening any compartment or disassembling any component containing fluids.

Dispose of all fluids according to local regulations and mandates.

NOTICE

Use a deep socket in order to remove the electrical connections from the electronic unit injectors. Use of incorrect tooling will result in damage to the electronic unit injectors.

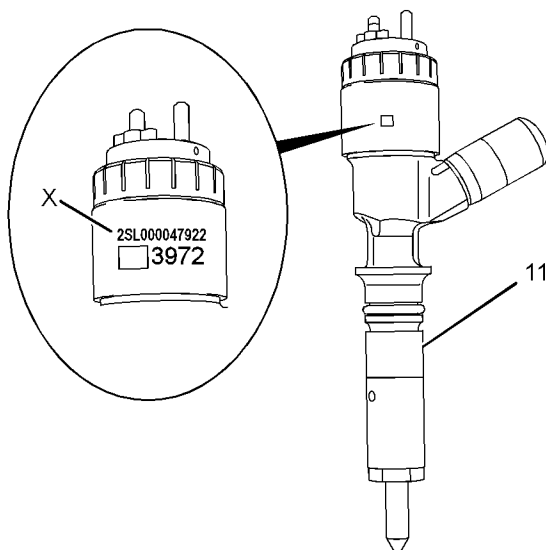

Illustration 50

g01255702

Typical calibration code

1. If a replacement electronic unit injector is installed, the correct injector trim file must be programmed into the electronic control module. Refer to Troubleshooting, "Injector Trim File" for more information. The code that is required to obtain the injector trim file is located at position (X).

Note: Record code (X) before the electronic unit injector is installed.

2. Use Tooling (D) in order to remove any fuel from the cylinder.

Note: Evacuate as much fuel as possible from the cylinder before installing the electronic unit injector.

3. Ensure that the fuel inlet port of the electronic unit injector is capped. Ensure that the electronic unit injector is clean.

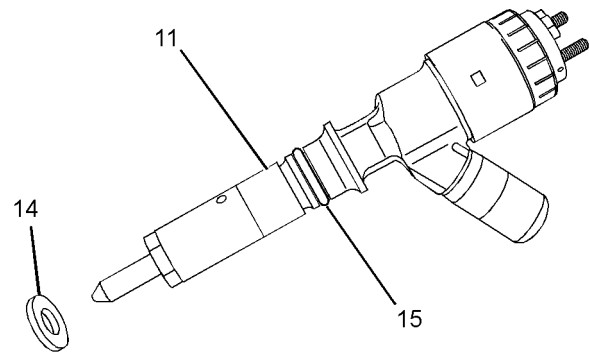

Illustration 51

g01255701

4. Install a new O-ring seal (15) to electronic unit injector (11).

Note: Do not lubricate the O-ring seal.

5. Ensure that the seat for the electronic unit injector in the cylinder head is clean and free from damage. Position a new sealing washer (14) onto the seat for the electronic unit injector in the cylinder head.

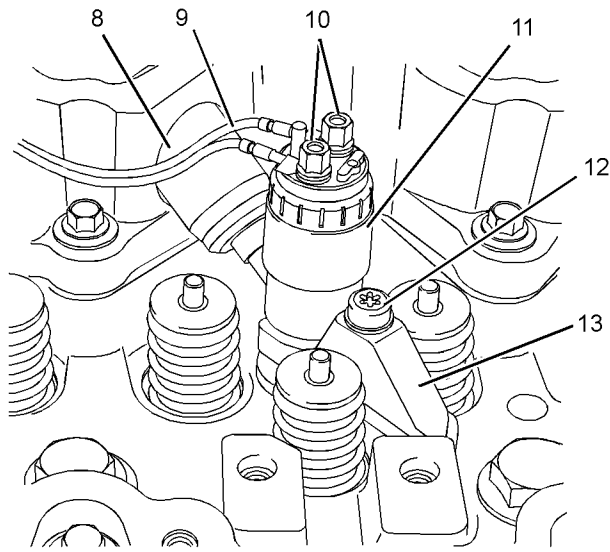

Illustration 52

g01255699

The rocker shaft is not shown for clarity.

6. Position clamp (13) between the rocker arm and the valve springs. Align electronic unit injector (11) to the bore for the electronic unit injector in the cylinder head. Install the clamp to the electronic unit injector. Ensure that the electronic unit injector is pushed firmly against the seat in the cylinder head.
7. Install a new torx screw (12) to clamp (13). Tighten the torx screw finger tight.
8. Remove the cap from electronic unit injector (11). Install a new seal (8) to electronic unit injector (11) and to the valve mechanism cover base. Ensure that the flange on the seal is flush with the valve mechanism cover base.
9. Remove the plugs from the new fuel injection line. Loosely install the fuel injection line. Refer to Disassembly and Assembly, "Fuel Injection Lines - Install".

Note: Ensure that the ends of the fuel injection line are seated in the electronic unit injector and the fuel manifold. Tighten the nuts finger tight.

10. Use Tooling (B) to tighten torx screw (12) to a torque of 27 N·m (20 lb ft).
11. Use Tooling (E) to tighten the fuel injection line to a torque of 30 N·m (22 lb ft). Refer to Disassembly and Assembly, "Fuel Injection Lines - Install".

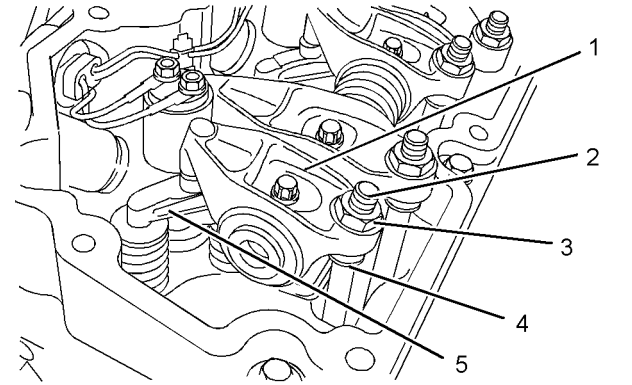

Illustration 53

g01263415

Typical example

12. Install valve bridges (5) to the cylinder head.

Note: Ensure that used valve bridges are reinstalled in the original location and the original orientation. Do not interchange the location or the orientation of used valve bridges.

13. Ensure that the bottoms of the pushrods are seated in the cups of the valve lifters. Locate the balls of adjusters (2) into the cups of pushrods (4). Adjust the valve lash. Refer to Systems Operation, Testing and Adjusting, "Engine Valve Lash - Inspect/Adjust".
14. Use a deep socket to install harness assembly (9) to electronic unit injector (11). Use Tooling (F) to tighten connections (10) to a torque of 2.4 N·m (21 lb in).

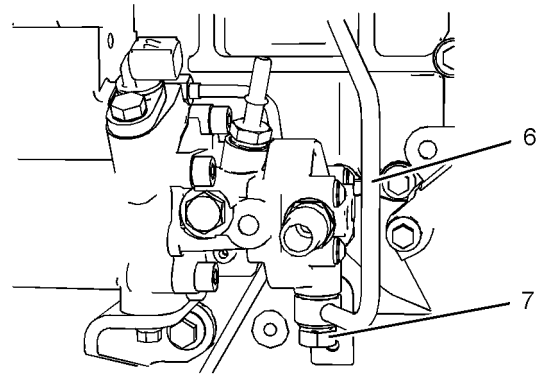

Illustration 54

g01247489

Typical example

15. Tighten banjo bolt (7) for tube assembly (6). Tighten the banjo bolt to a torque of 22 N·m (16 lb ft).
16. Install the valve mechanism cover. Refer to Disassembly and Assembly, "Valve Mechanism Cover - Remove and Install".
17. Restore the fuel supply to the engine.

18. Restore the electrical supply to the engine.
19. Remove the air from the fuel system. Refer to Operation and Maintenance Manual, "Fuel System - Prime" for more information.

Alternative Installation Procedure

Table 12

Required Tools			
Tool	Part Number	Part Description	Qty
B	27610307	T40 Torx Socket	1
D	GE50028	Vacuum Pump	1
	GE50030	Tube 7.9 mm (0.31 inch) OD	1
E	27610294	Injector Pipe Nut Tool	1
F	27610296	Torque Wrench	1

Note: This is an optional procedure to install the electronic unit injectors. The method should ONLY be used when all electronic unit injectors are installed and when the engine is removed from the application.

NOTICE

Ensure that all adjustments and repairs that are carried out to the fuel system are performed by authorised personnel that have the correct training.

Before beginning ANY work on the fuel system, refer to Operation and Maintenance Manual, "General Hazard Information and High Pressure Fuel Lines" for safety information.

Refer to Systems Operation, Testing and Adjusting Manual, "Cleanliness of Fuel System Components" for detailed information on the standards of cleanliness that must be observed during ALL work on the fuel system.

NOTICE

Care must be taken to ensure that fluids are contained during performance of inspection, maintenance, testing, adjusting and repair of the product. Be prepared to collect the fluid with suitable containers before opening any compartment or disassembling any component containing fluids.

Dispose of all fluids according to local regulations and mandates.

NOTICE

Use a deep socket in order to remove the electrical connections from the electronic unit injectors. Use of incorrect tooling will result in damage to the electronic unit injectors.

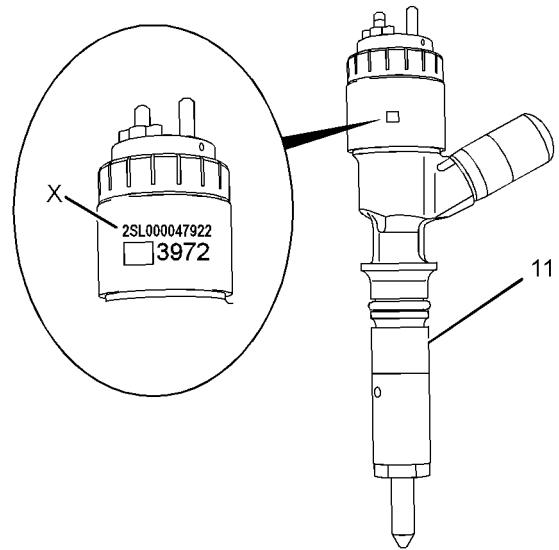

Illustration 55
Typical calibration code

g01255702

1. If a replacement electronic unit injector is installed, the correct injector trim file must be programmed into the electronic control module. Refer to Troubleshooting, "Injector Trim File" for more information. The code that is required to obtain the injector trim file is located at position (X).

Note: Record code (X) before the electronic unit injector is installed.

2. Use Tooling (D) to remove any fuel from the cylinder.

Note: Evacuate as much fuel as possible from the cylinder before installing the electronic unit injector.

3. Ensure that the fuel inlet port of the electronic unit injector is capped. Ensure that the electronic unit injector is clean.

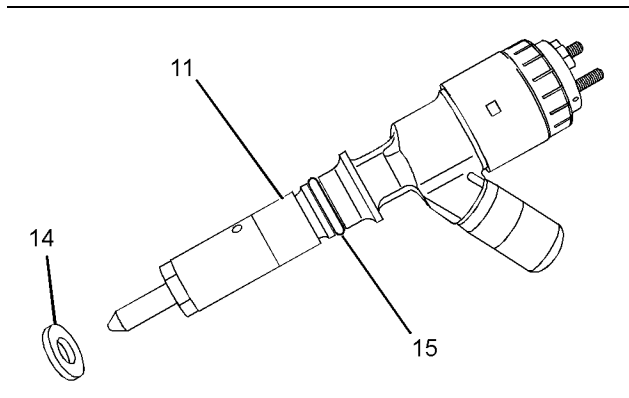

Illustration 56

g01255701

4. Install a new O-ring seal (15) to electronic unit injector (11).

Note: Do not lubricate the O-ring seal.

5. Ensure that the seat for the electronic unit injector in the cylinder head is clean and free from damage. Position a new sealing washer (14) on the seat for the electronic unit injector in the cylinder head.

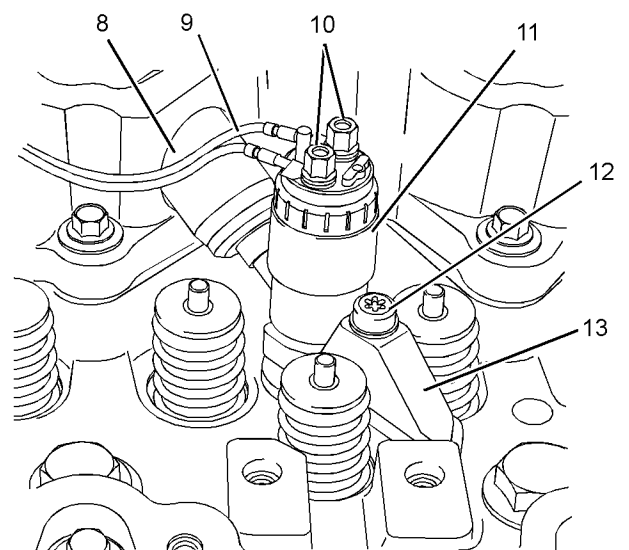

Illustration 57

g01255699

6. Install clamp (13) to electronic unit injector (11). Install the electronic unit injector assembly into the original location in the cylinder head.

Note: Ensure that the electronic unit injector is pushed firmly against the seat in the cylinder head. Install the electronic unit injector for number one cylinder first. Install the electronic unit injectors in numerical order.

7. Install a new torx screw (12) to clamp (13). Tighten the torx screw finger tight.

8. Remove the cap from electronic unit injector (11). Install a new seal (8) to electronic unit injector (11) and to the valve mechanism cover base. Ensure that the flange on the seal is flush with the valve mechanism cover base.

9. Remove the plugs from the new fuel injection line. Loosely install the fuel injection line. Refer to Disassembly and Assembly, "Fuel Injection Lines - Install".

Note: Ensure that the ends of the fuel injection line are seated in the electronic unit injector and the fuel manifold. Tighten the nuts finger tight.

10. Use Tooling (B) to tighten torx screw (12) to a torque of 27 N·m (20 lb ft).

11. Use Tooling (E) to tighten the fuel injection line to a torque of 30 N·m (22 lb ft). Refer to Disassembly and Assembly, "Fuel Injection Lines - Install".

12. Repeat Steps 2 through 11 in order to install the remaining electronic unit injectors.

13. Use a deep socket to install harness assemblies (9) to electronic unit injectors (11). Use Tooling (F) to tighten connections (10) to a torque of 2.4 N·m (21 lb in).

14. Install the rocker shaft assembly. Refer to Disassembly and Assembly, "Rocker Shaft - Install".

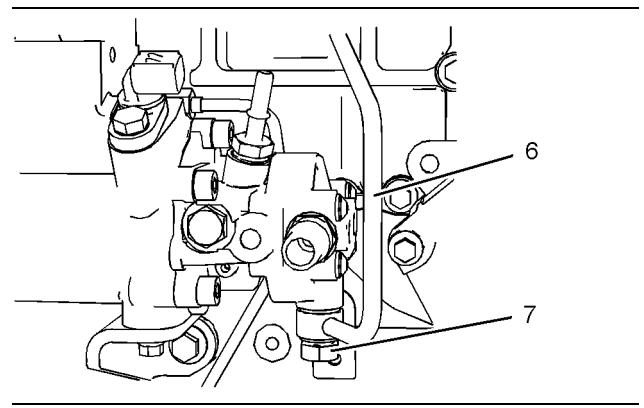

Illustration 58

g01247489

Typical example

15. Tighten banjo bolt (7) for tube assembly (6). Tighten the banjo bolt to a torque of 22 N·m (16 lb ft).

16. Restore the fuel supply to the engine.

17. Restore the electrical supply to the engine.

18. Remove the air from the fuel system. Refer to Operation and Maintenance Manual, "Fuel System - Prime" for more information.

i02585942

Turbocharger - Remove

Removal Procedure

NOTICE

Keep all parts clean from contaminants.

Contaminants may cause rapid wear and shortened component life.

NOTICE

Care must be taken to ensure that fluids are contained during performance of inspection, maintenance, testing, adjusting and repair of the product. Be prepared to collect the fluid with suitable containers before opening any compartment or disassembling any component containing fluids.

Dispose of all fluids according to local regulations and mandates.

Note: Plug and cap all open ports and tube assemblies.

1. If the turbocharger is equipped with an exhaust elbow, remove the exhaust elbow. Refer to Disassembly and Assembly, "Exhaust Elbow - Remove and Install".
2. Loosen the hose clamp and disconnect the air inlet hose from the turbocharger.
3. Loosen the hose clamp and disconnect the air outlet hose from the turbocharger. If the engine is equipped with an air pipe, remove the air pipe and remove the gasket from the cylinder head.
4. If the valve mechanism cover is equipped with a heat shield, remove the heat shield.

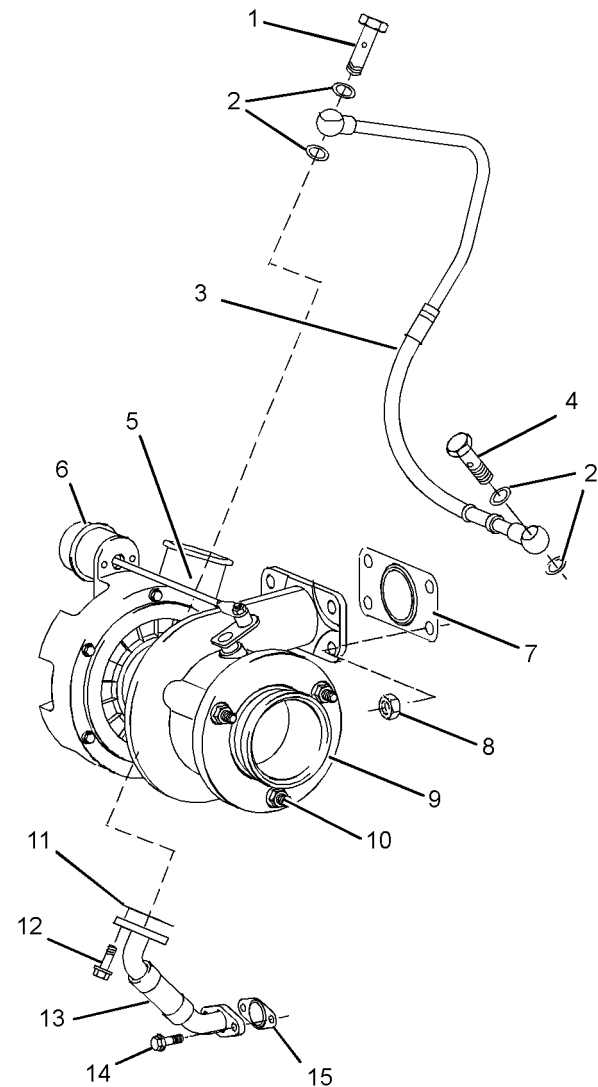

Illustration 59

g01264131

Typical example

5. If the turbocharger is equipped with an adapter (9), Remove nuts (10) and remove adapter (9) from turbocharger (5).

6. Remove banjo bolt (1) and disconnect tube assembly (3) from turbocharger (5). Remove sealing washers (2) from tube assembly (3).

If necessary, remove tube assembly (3) from the tube assembly for actuator (6). Tube assembly (3) is secured to the tube assembly for the actuator by clips.

7. Disconnect the hose from the actuator (6).

8. Remove banjo bolt (4) and remove tube assembly (3) from the cylinder block. Remove sealing washers (2) from tube assembly (3).
9. Remove bolts (12). Disconnect tube assembly (13) from turbocharger (5). Remove joint (11).

If necessary, remove bolts (14) and remove tube assembly (13) from the cylinder block. Remove joint (15).

If tube assembly (13) is secured with tube clips, loosen the fasteners for the tube clips. If the engine has a top mounted turbocharger, the exhaust manifold must be removed in order to remove tube assembly (13). Refer to Disassembly and Assembly, "Exhaust Manifold - Remove and Install".

10. Remove nuts (8) and remove turbocharger (5).

Note: Do not use the actuator rod to lift the turbocharger.

11. Remove gasket (7).

12. If necessary, remove the studs from the exhaust manifold.

i02590550

Turbocharger - Install

Installation Procedure

Table 13

Required Tools			
Tool	Part Number	Part Description	Qty
A	21820117	POWERPART Threadlock and Nutlock	1

NOTICE

Keep all parts clean from contaminants.

Contaminants may cause rapid wear and shortened component life.

1. Ensure that the turbocharger is clean and free from damage. Inspect the turbocharger for wear. Refer to Systems Operation, Testing and Adjusting, "Turbocharger - Inspect" for more information. If the turbocharger is worn, the complete turbocharger must be replaced.

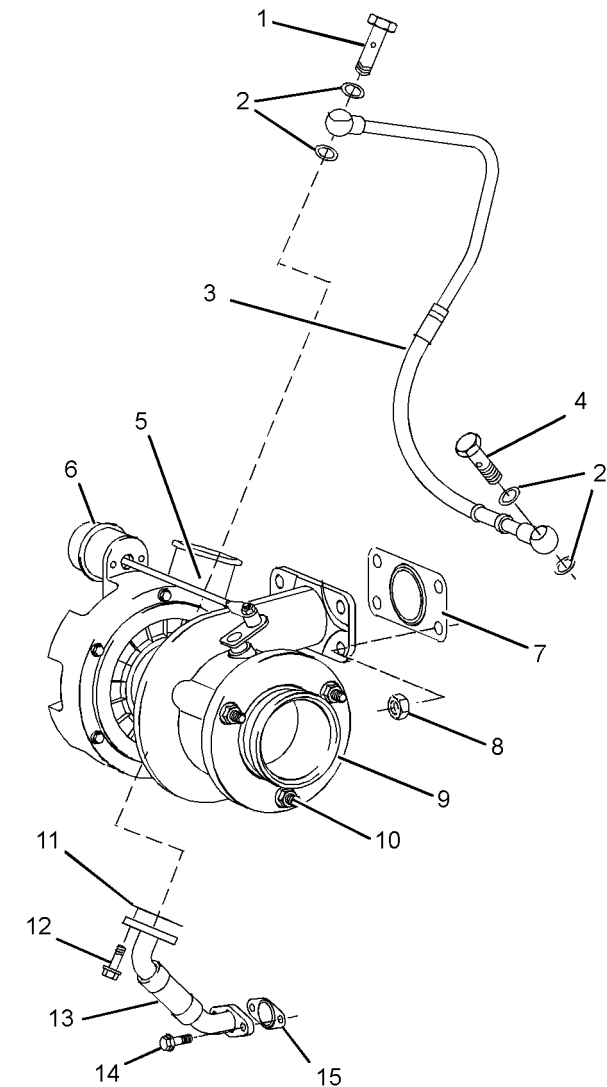

Illustration 60

g01264131

Typical example

2. Test the actuator (6) for correct operation. Refer to Systems Operation, Testing and Adjusting, "Turbocharger - Inspect". If the actuator is damaged or the actuator does not operate within the specified limits, the complete turbocharger must be replaced.
3. Clean the mating surfaces of the exhaust manifold. If necessary, install the studs to the exhaust manifold. Tighten the studs to a torque of 18 N·m (13 lb ft).
4. Install a new gasket (7) to the exhaust manifold.
5. Position turbocharger (5) onto the exhaust manifold and install nuts (8). Tighten the nuts to a torque of 47 N·m (35 lb ft).

Note: Do not use the actuator rod to lift the turbocharger.

6. Position a new joint (11) and tube assembly (13) onto turbocharger (5). Install bolts (12) finger tight.
7. Position a new joint (15) onto the cylinder block. Install bolts (14) finger tight.
8. Tighten bolts (12) to a torque of 22 N·m (16 lb ft). Tighten bolts (14) to a torque of 22 N·m (16 lb ft).

If tube assembly (13) is secured with tube clips, tighten the fasteners for the tube clips to a torque of 44 N·m (32 lb ft).
9. Lubricate the bearings of turbocharger (5) with clean engine oil through the oil inlet port. Rotate the shaft of the turbocharger in order to distribute the lubricant.
10. Position tube assembly (3) onto turbocharger (5). Install new washers (2) and banjo bolt (1) to tube assembly (3). Tighten the banjo bolt finger tight.
11. Install new washers (2) and banjo bolt (4) onto tube assembly (3). Connect the tube assembly to the cylinder block. Tighten the banjo bolt finger tight.
12. Tighten banjo bolts (1) and (4) to a torque of 18 N·m (13 lb ft).

Note: Ensure that the tube assembly does not come into contact with any other engine components.

13. Connect the hose to actuator (6). If necessary, secure tube assembly (3) to the tube assembly for actuator (6). Tube assembly (3) is secured to the tube assembly for the actuator by clips.
14. If the turbocharger has an adapter (9), position the adapter onto the turbocharger. Install nuts (10) finger tight.
15. If the turbocharger has an exhaust elbow, install the exhaust elbow. Refer to Disassembly and Assembly, "Exhaust Elbow - Remove and Install".
16. If the turbocharger has an adapter (9), tighten the three nuts (10) progressively. Tighten the nuts to a torque of 22 N·m (16 lb ft).

Note: Ensure that the adapter is square with the mating face of the turbocharger.

17. Connect the air outlet hose to turbocharger (5).

If the engine has an air pipe, install the air pipe and install the joint to the cylinder head. Apply Tooling (A) to the fasteners for the air pipe. Tighten the fasteners to a torque of 22 N·m (16 lb ft).

Tighten the hose clamps to a torque of 5 N·m (44 lb in).

Note: If the air outlet hose has a reflective heat shield, ensure that the reflective heat shield is installed toward the engine.

18. Connect the air inlet hose to turbocharger (5).
19. If the valve mechanism cover has a heat shield, install the heat shield. Tighten the fasteners for the heat shield to a torque of 9 N·m (80 lb in).

i02585944

Wastegate Solenoid - Remove and Install

Removal Procedure

Note: Put identification marks on all hoses, on all hose assemblies, on wires and on all tube assemblies for installation purposes. Plug all hose assemblies and tube assemblies. This helps to keep contaminants from entering the system.

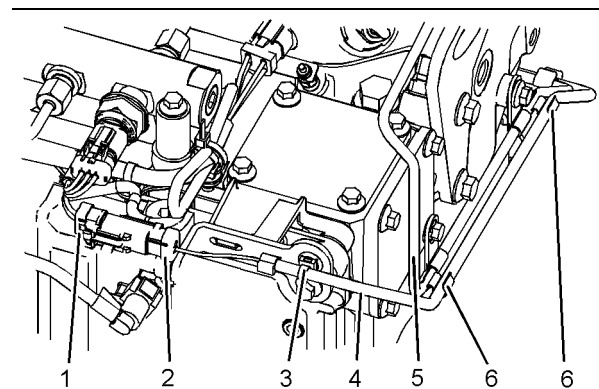

Illustration 61
Typical example

g01247498

1. Follow Steps 1.a through 1.d in order to disconnect the harness assembly for the wastegate solenoid.
 - a. Slide locking tab (1) into the unlocked position.
 - b. Disconnect plug (2) from the engine wiring harness.
 - c. Cut cable tie (3).

- d. Remove harness assembly (4) from tube assembly (5). The harness assembly is secured to the tube assembly by plastic clips (6).

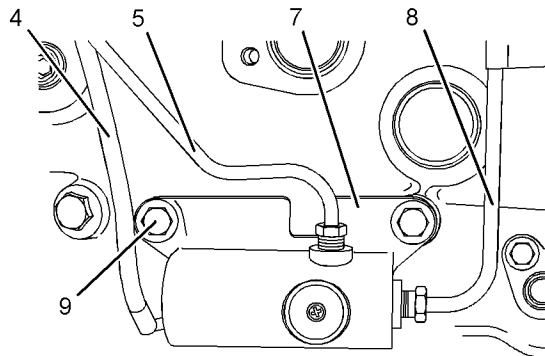

Illustration 62

g01247569

Typical example

2. Disconnect tube assembly (5) from wastegate solenoid (7).
3. Disconnect tube assembly (8) from wastegate solenoid (7). Remove tube assembly (8) from the tube assembly for the oil feed for the turbocharger. Tube assembly (8) is secured to the tube assembly for the oil feed for the turbocharger by spring clips.

Note: Tube assembly (8) must be loose in order to release the tube assembly from the wastegate solenoid.

4. Remove the two bolts (9) and remove wastegate solenoid (7) from the cylinder block.
5. Remove bolts (9) and remove wastegate solenoid (7) from the cylinder block.

Installation Procedure

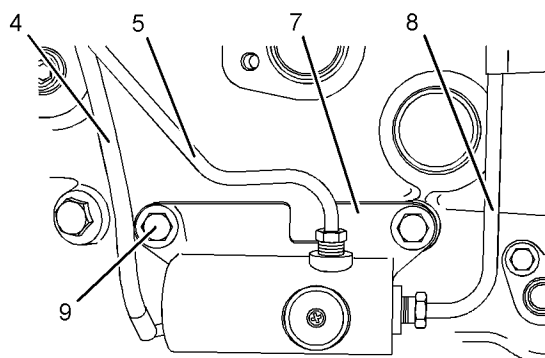

Illustration 63

g01247569

Typical example

1. Loosely install wastegate solenoid (7) to tube assembly (5).

2. Loosely install tube assembly (8) to wastegate solenoid (7).
3. Install bolts (9). Tighten bolts (9) to a torque of 22 N·m (16 lb ft).
4. Tighten tube assemblies (5) and (8) to a torque of 18 N·m (13 lb ft).
5. Secure tube assembly (8) to the tube assembly for the oil feed for the turbocharger. Tube assembly (8) is secured by spring clips.

Note: Ensure that the tube assemblies do not contact any other engine component.

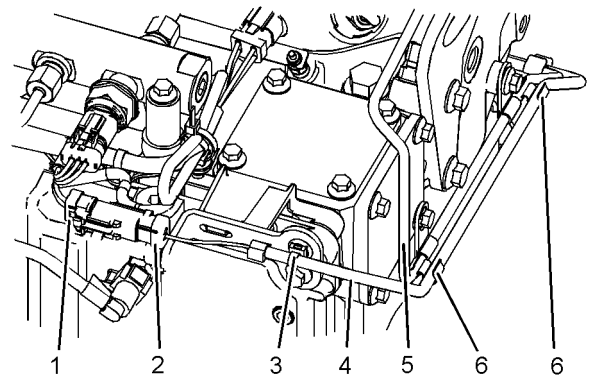

Illustration 64

g01247498

Typical example

6. Follow Steps 6 through 6.d in order to connect the wire lead for the wastegate solenoid.
 - a. Install harness assembly (4) to tube assembly (5). The harness assembly is secured to the tube assembly by plastic clips (6).
 - b. Connect plug (2) to the engine harness assembly.
 - c. Slide locking tab (1) into the locked position.
 - d. Install a new cable tie (3).

i02585962

Exhaust Manifold - Remove and Install

Removal Procedure

Start By:

- a. Remove the turbocharger. Refer to Disassembly and Assembly, "Turbocharger - Remove".

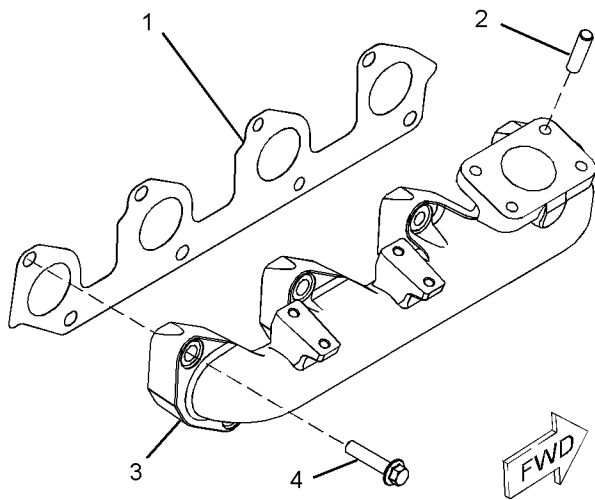

Illustration 65
Typical example
g01245092

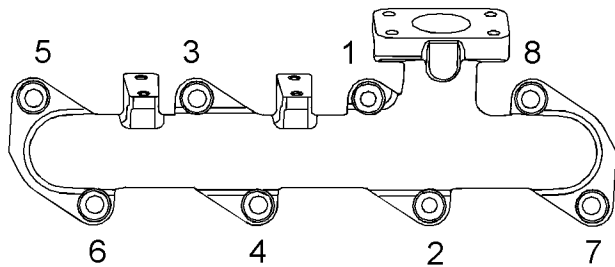

Illustration 66
Tightening sequence for the exhaust manifold
g01264513

1. Loosen bolts (4) in reverse numerical order to the sequence that is shown in Illustration 66.

Note: This will help prevent distortion of the exhaust manifold.

2. Remove bolts (4) from exhaust manifold (3).

Note: Support the manifold as the bolts are removed.

3. Remove exhaust manifold (3).
4. Remove exhaust manifold gasket (1).
5. If necessary, remove studs (2) from exhaust manifold (3).

Installation Procedure

Table 14

Required Tools			
Tool	Part Number	Part Description	Qty
A	-	Guide Stud (M10 by 100 mm)	2

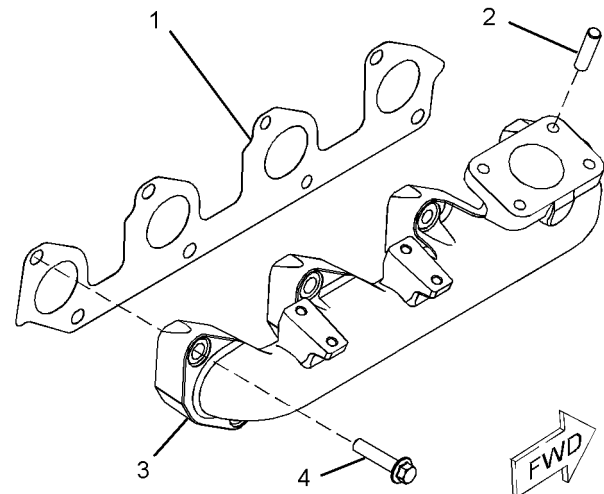

Illustration 67
Typical example
g01245092

1. Ensure that the exhaust manifold is clean and free from damage. If necessary, replace the exhaust manifold. Clean the joint face of the cylinder head.
2. If necessary, install studs (2) to exhaust manifold (3). Tighten the studs to a torque of 18 N·m (13 lb ft).

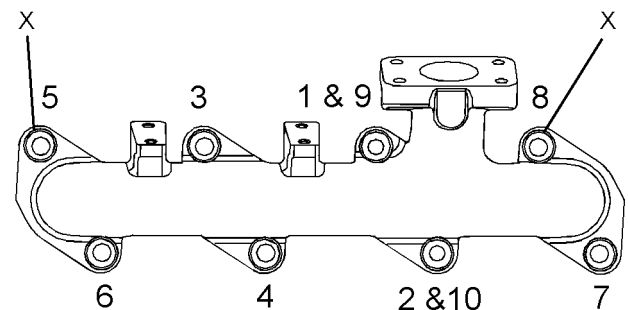

Illustration 68
Tightening sequence for the exhaust manifold
g01245093

3. Install Tooling (A) to the cylinder head in positions (X). Refer to Illustration 68.

- Position a new exhaust manifold gasket (1) onto Tooling (A).

Note: Ensure that the exhaust manifold gasket is correctly oriented.

- Align exhaust manifold (3) with Tooling (A). Install the exhaust manifold to the cylinder head.

Note: If the engine has a top mounted turbocharger, the tube assembly for the oil drain from the turbocharger must be connected to the cylinder block before the exhaust manifold is installed.

- Install new bolts (4) finger tight.
- Remove Tooling (A). Install the remaining bolts (4) finger tight.
- Tighten bolts (4) to a torque of 33 N·m (24 lb ft) in the sequence that is shown in Illustration 68.

End By:

- Install the turbocharger. Refer to Disassembly and Assembly, "Turbocharger - Install".

i02585967

Exhaust Elbow - Remove and Install

Removal Procedure

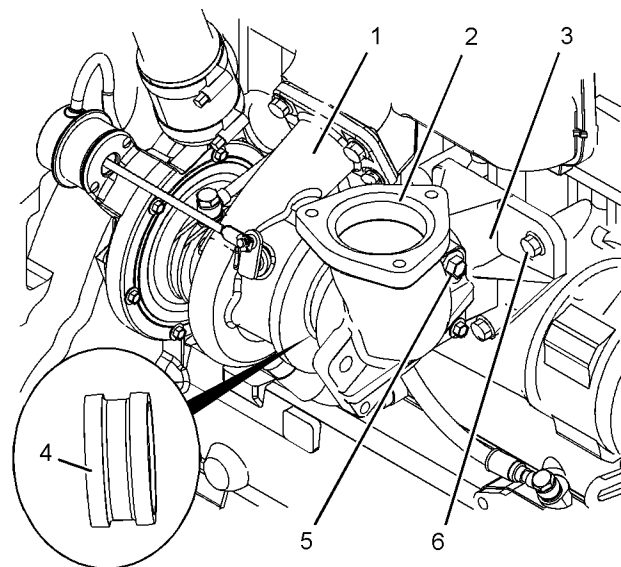

Illustration 69

g01261613

Typical example

- Remove bolts (5) and remove exhaust elbow (2) from turbocharger (1). Note the orientation of the exhaust elbow.
- Remove coupling (4) that connects exhaust elbow (2) to turbocharger (1).
- If necessary, remove bolts (6) and remove support bracket (3) from the cylinder block.

Installation Procedure

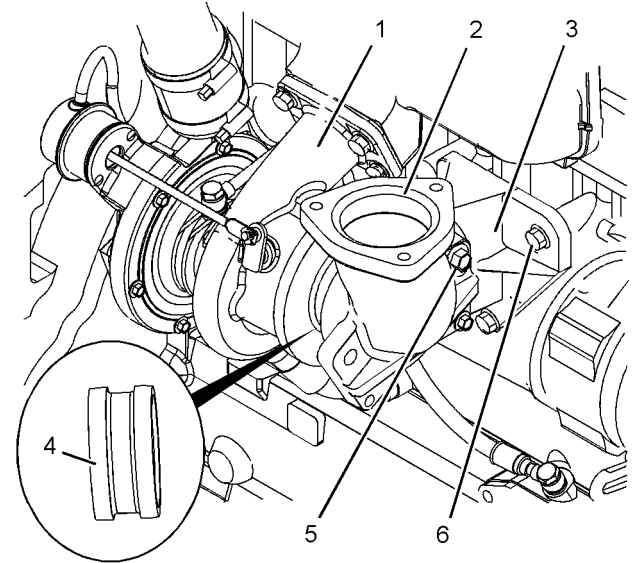

Illustration 70

g01261613

Typical example

- Ensure that the exhaust elbow, the coupling and the outlet of the turbocharger are free from damage. Replace any components that are damaged.
- Install coupling (4) to exhaust elbow (2).
- Align coupling (4) to the outlet of turbocharger (1) and install the assembly of the exhaust elbow.
- If necessary, install support bracket (3) to the cylinder block and install bolts (6). Tighten the bolts to a torque of 44 N·m (33 lb ft).
- Install bolts (5) finger tight.
- Ensure that coupling (4) is fully engaged into the outlet of the turbocharger (1). Ensure that the gap between the turbocharger and the exhaust elbow is evenly spaced.
- Tighten bolts (5) to a torque of 44 N·m (33 lb ft).

i02590671

Inlet and Exhaust Valve Springs - Remove and Install

Removal Procedure

Table 15

Required Tools			
Tool	Part Number	Part Description	Qty
A	-	Circlip Pliers	1
B	21825739	Valve Spring Compressor	1
	27610235	Adapter	1
	27610295	Head	1
C ¹	21825576	Crankshaft Turning Tool	1
C ²	27610291	Barring Device Housing	1
	27610289	Gear	1

Start By:

- a. Remove the rocker shaft assembly. Refer to Disassembly and Assembly, "Rocker Shaft and Pushrod - Remove".

Note: Either Tooling (C) can be used. Use the Tooling that is most suitable.

NOTICE

Keep all parts clean from contaminants.

Contaminants may cause rapid wear and shortened component life.

Note: The following procedure should be adopted in order to remove the valve springs when the cylinder head is installed to the engine. Refer to Disassembly and Assembly, "Inlet and Exhaust Valves - Remove and Install" for the procedure to remove the valve springs from a cylinder head that has been removed from the engine.

Note: Ensure that the appropriate piston is at the top center position before the valve spring is removed. Failure to ensure that the piston is at the top center position may allow the valve to drop into the cylinder bore.

WARNING

Personal injury can result from being struck by parts propelled by a released spring force.

Make sure to wear all necessary protective equipment.

Follow the recommended procedure and use all recommended tooling to release the spring force.

NOTICE

Plug the apertures for the push rods in the cylinder head in order to prevent the entry of loose parts into the engine.

NOTICE

Use a deep socket in order to remove the electrical connections from the electronic unit injectors. Use of incorrect tooling will result in damage to the electronic unit injectors.

1. Isolate the electrical supply to the engine.

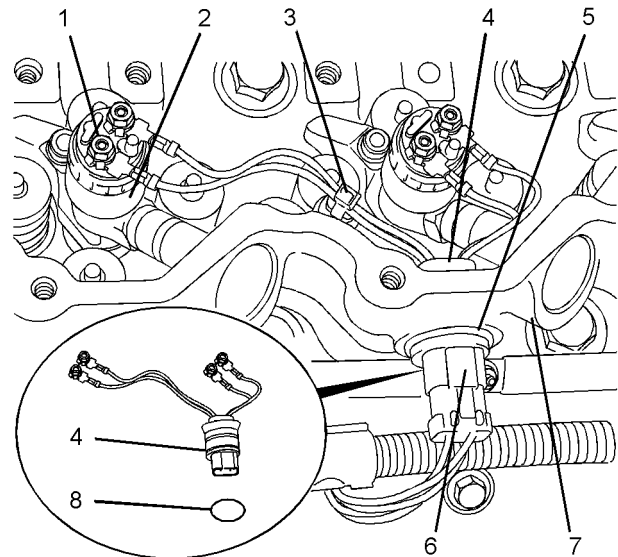

Illustration 71

g01269383

Typical example

2. Follow Steps 2.a through 2.h in order to remove the harness assemblies for the electronic unit injectors.
 - a. Place a temporary identification mark on connections (1).
 - b. Use a deep socket to remove connections (1) from electronic unit injectors (2).

- c. Cut cable tie (3).
- d. Disconnect plug (6) from harness assembly (4).
- e. Use Tooling (A) to remove circlip (5).
- f. From the outside of the valve mechanism cover base (7), push harness assembly (4) inward. Withdraw the harness assembly from the valve mechanism cover base.
- g. Remove O-ring seal (8) from harness assembly (4).
- h. Repeat Steps 2.a through 2.g in order to remove the remaining harness assembly.

Note: Do not use excessive force to turn the crankshaft. The use of force can result in bent valve stems.

- d. Continue to rotate the crankshaft and gradually release the pressure on Tooling (B) until the piston is at the top center position. The valve is now held in a position that allows the valve spring to be safely removed.

Note: Valve springs must be replaced in pairs for the inlet valve or the exhaust valve of each cylinder. If all valve springs require replacement the procedure can be carried out on two cylinders at the same time. The procedure can be carried out on the following pairs of cylinders. 1 with 4 and 2 with 3. Ensure that all of the valve springs are installed before changing from one pair of cylinders to another pair of cylinders.

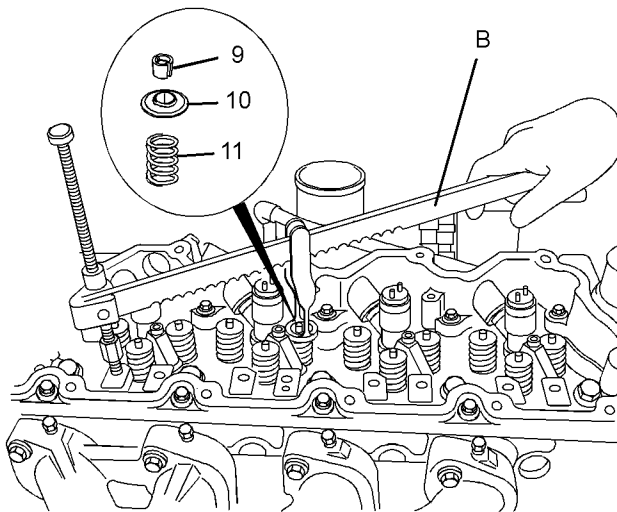

Illustration 72
Typical example

g01243732

NOTICE

Do not turn the crankshaft while the valve springs are removed.

- 4. Apply sufficient pressure to Tooling (B) in order to allow removal of the valve keepers (9).

Note: Do not compress the spring so that the valve spring retainer (10) touches the valve stem seal .

Remove valve keepers (9).

- 5. Slowly release the pressure on Tooling (B).
- 6. Remove valve spring retainer (10) and remove valve spring (11).
- 7. If necessary, remove the valve stem seals.
- 8. Repeat Steps 4 through 7 in order to remove the remaining valve springs from the appropriate cylinder.
- 9. Remove Tooling (B).

NOTICE

Ensure that the valve spring is compressed squarely or damage to the valve stem may occur.

- 3. Follow Steps 3.a through 3.d in order to position the appropriate piston at top dead center.
 - a. Install Tooling (B) in position on the cylinder head in order to compress a valve spring for the appropriate piston.
 - b. Use Tooling (B) in order to compress valve spring (11) and open the valve slightly.
- Note:** Do not compress the spring so that the valve spring retainer (10) touches the valve stem seal (not shown).
- c. Use Tooling (C) in order to rotate the crankshaft carefully, until the piston touches the valve.

Installation Procedure

Table 16

Required Tools			
Tool	Part Number	Part Description	Qty
A	-	Circlip Pliers	1
B	21825739	Valve Spring Compressor	1
	27610235	Adapter	1
	27610295	Head	1
C ¹	21825576	Crankshaft Turning Tool	1
C ²	27610291	Barring Device Housing	1
	27610289	Gear	1
D	21820221	POWERPART Rubber Grease	1
E	27610296	Torque Wrench	1

Note: Either Tooling (C) can be used. Use the Tooling that is most suitable.

NOTICE

Keep all parts clean from contaminants.

Contaminants may cause rapid wear and shortened component life.

NOTICE

Do not turn the crankshaft while the valve springs are removed.

NOTICE

Plug the apertures for the push rods in the cylinder head in order to prevent the entry of loose parts into the engine.

NOTICE

Use a deep socket in order to remove the electrical connections from the electronic unit injectors. Use of incorrect tooling will result in damage to the electronic unit injectors.

1. Inspect the valve springs for the correct length. Refer to Specifications, "Cylinder Head Valves".

2. If necessary, install a new valve stem seal onto the valve guide.

Note: The outer face of the valve guide must be clean and dry before installing the valve stem seal.

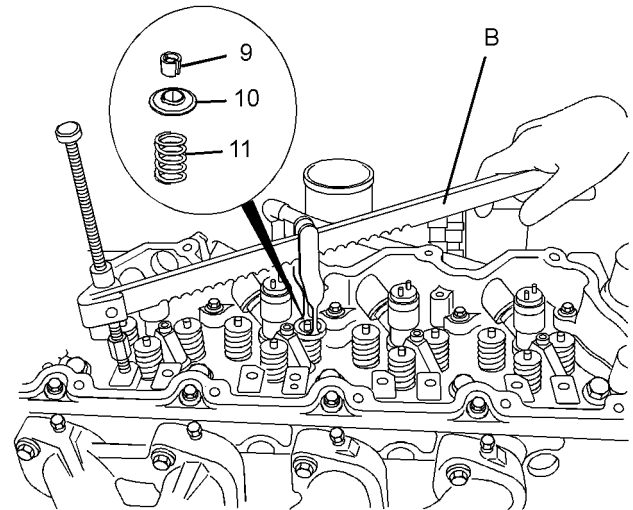

Illustration 73

g01243732

Typical example

3. Install valve spring (11) onto the cylinder head. Position valve spring retainer (10) onto valve spring (11).

WARNING

Improper assembly of parts that are spring loaded can cause bodily injury.

To prevent possible injury, follow the established assembly procedure and wear protective equipment.

NOTICE

Ensure that the valve spring is compressed squarely or damage to the valve stem may occur.

4. Install Tooling (B) in the appropriate position on the cylinder head in order to compress the valve spring.

5. Apply sufficient pressure to Tooling (B) in order to install valve keepers (9).

Note: Do not compress the spring so that the valve spring retainer (10) touches the valve stem seal.

Install the valve spring keepers.

6. Carefully release the pressure on Tooling (B).

Note: Ensure that the valve keepers are correctly seated.

7. Repeat steps 2 to 6 for the remaining valves.

! WARNING

The valve spring keepers can be thrown from the valve when the valve spring compressor is released. Ensure that the valve spring keepers are properly installed on the valve stem. To help prevent personal injury, keep away from the front of the valve spring keepers and valve springs during the installation of the valves.

8. Remove the Tooling (B).

Note: Valve springs must be replaced in pairs for the inlet valve or the exhaust valve of each cylinder. If all valve springs require replacement the procedure can be carried out on two cylinders at the same time. The procedure can be carried out on the following pairs of cylinders. 1 with 4 and 2 with 3. Ensure that all of the valve springs are installed before changing from one pair of cylinders to another pair of cylinders.

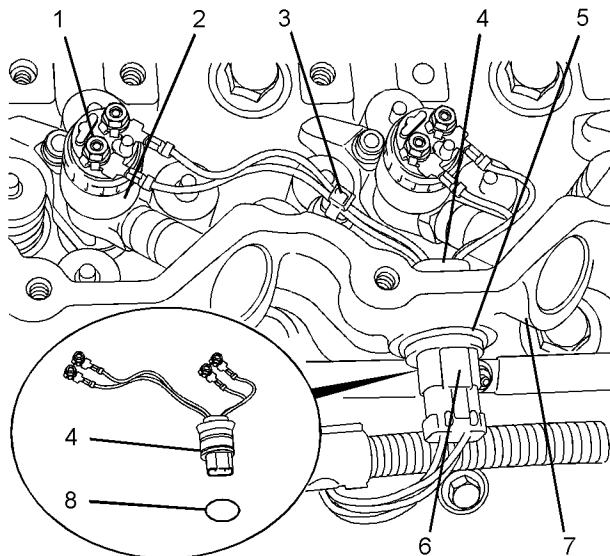

Illustration 74

g01269383

Typical example

9. Follow Steps 9.a through 9.g in order to install the harness assemblies for the electronic unit injectors.
- Ensure that harness assembly (4) and the bore in the valve mechanism cover base (7) are clean and free from damage.
 - Use Tooling (D) to lubricate a new O-ring seal. Install the new O-ring seal (8) onto harness assembly (4).
 - From the inside of the valve mechanism cover base (7), push harness assembly (4) into the valve mechanism cover base.

- Use Tooling (A) to install the circlip (5).
- Connect plug (6) to harness assembly (4).
- Use a deep socket to install connections (1) to the electronic unit injectors (2). Use Tooling (E) to tighten the connections to a torque of 2.5 N·m (22 lb in).
- Install a new cable tie (3).

Note: Ensure that the cable ties conform to the Perkins specification.

- Repeat Steps 9.a through 9.g for the remaining harness assemblies.

10. Restore the electrical supply to the engine.

End By:

- Install the rocker shaft assembly. Refer to Disassembly and Assembly, "Rocker Shaft and Pushrod - Install".

i02585973

Inlet and Exhaust Valves - Remove and Install

Removal Procedure

Table 17

Required Tools			
Tool	Part Number	Part Description	Qty
A	21825666	Valve Spring Compressor	1
	27610235	Adapter	1
	27610295	Head	1

Start By:

- Remove the cylinder head. Refer to Disassembly and Assembly, "Cylinder Head - Remove".

NOTICE

Keep all parts clean from contaminants.

Contaminants may cause rapid wear and shortened component life.

- Clean the bottom face of the cylinder head. Check the depth of the valves below the face of the cylinder head before the valve springs are removed. Refer to Specifications, "Cylinder Head Valves" for the correct dimensions.

- Place a temporary identification mark on the heads of the valves in order to identify the correct position. Inlet valves have a recess in the center of the head.

Note: Do not stamp the heads of the valve. Stamping or punching the heads of the valves could cause the valves to fracture.

- Use a suitable lifting device to position the cylinder head with the valve springs upward. The weight of the cylinder head is approximately 56 kg (125 lb).

Note: Ensure that the cylinder head is kept on a clean, soft surface in order to prevent damage to the machined face.

⚠ WARNING

Personal injury can result from being struck by parts propelled by a released spring force.

Make sure to wear all necessary protective equipment.

Follow the recommended procedure and use all recommended tooling to release the spring force.

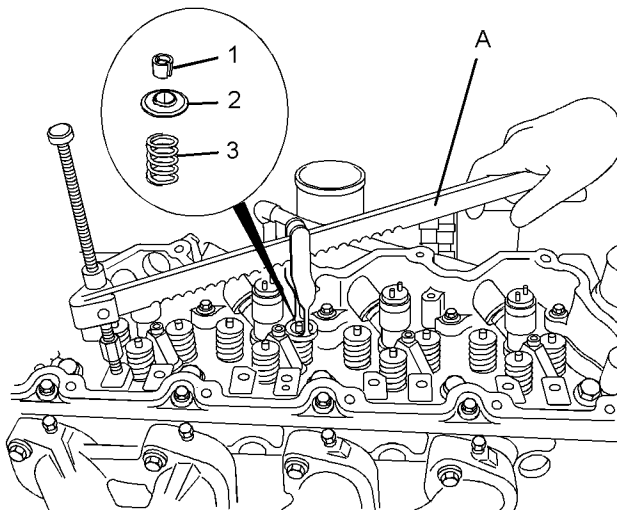

Illustration 75
Typical example

- Install Tooling (A) in position on the cylinder head in order to compress the appropriate valve spring.

NOTICE

Ensure that the valve spring is compressed squarely or damage to the valve stem may occur.

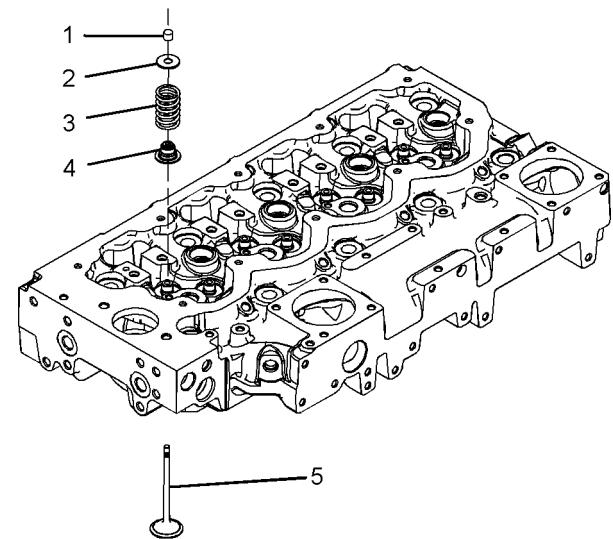

Illustration 76 g01245105

- Apply sufficient pressure to Tooling (A) in order to remove valve keepers (1).

Note: Do not compress the spring so that valve spring retainer (2) touches valve stem seal (4).

- Slowly release the pressure on Tooling (A).
- Remove valve spring retainer (2). Remove valve spring (3).
- Repeat Steps 4 to 7 for the remaining valves.
- Remove Tooling (A).
- Remove valve stem seals (4).
- Use a suitable lifting device to carefully turn over the cylinder head.
- Remove valves (5).

Installation Procedure

Table 18

Required Tools			
Tool	Part Number	Part Description	Qty
A	21825666	Valve Spring Compressor	1
	27610235	Adapter	1
	27610295	Head	1

NOTICE

Keep all parts clean from contaminants.

Contaminants may cause rapid wear and shortened component life.

1. Clean all components of the cylinder head assembly. Ensure that all ports, all coolant passages and all lubrication passages in the cylinder head are free from debris. Follow Steps 1.a through 1.e in order to inspect the components of the cylinder head assembly. Replace any components that are worn or damaged.
 - a. Inspect the cylinder head for wear and for damage. Refer to Systems Operation, Testing and Adjusting, "Cylinder Head Inspect".
 - b. Inspect the valve seats for wear and for damage. Refer to Specifications, "Cylinder Head Valves" for further information.
 - c. Inspect the valve guides for wear and for damage. Refer to Specifications, "Cylinder Head Valves" and Systems Operation, Testing and Adjusting, "Valve Guide - Inspect" for further information.
 - d. Inspect the valves for wear and for damage. Refer to Specifications, "Cylinder Head Valves".
 - e. Inspect the valve springs for damage and for the correct length. Refer to Specifications, "Cylinder Head Valves".

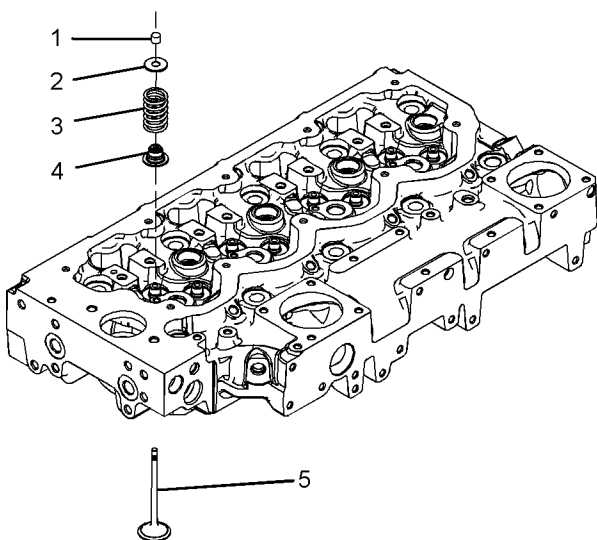

Illustration 77

g01245105

2. Lubricate the stems of valves (5) with clean engine oil. Install valves (5) in the appropriate positions in the cylinder head. Check the depth of the valves below the face of the cylinder head. Refer to Systems Operation, Testing and Adjusting, "Valve Depth - Inspect" for more information.

3. Use a suitable lifting device to carefully turn over the cylinder head. The weight of the cylinder head is approximately 56 kg (125 lb).

Note: Ensure that all of the valves remain in place.

4. Install new valve stem seals (4) onto each of the valve guides.

Note: The outer face of the valve guides must be clean and dry before installing the valve stem seals.

5. Install valve spring (3) onto the cylinder head. Position valve spring retainer (2) onto valve spring (3).

 **WARNING**

Personal injury can result from being struck by parts propelled by a released spring force.

Make sure to wear all necessary protective equipment.

Follow the recommended procedure and use all recommended tooling to release the spring force.

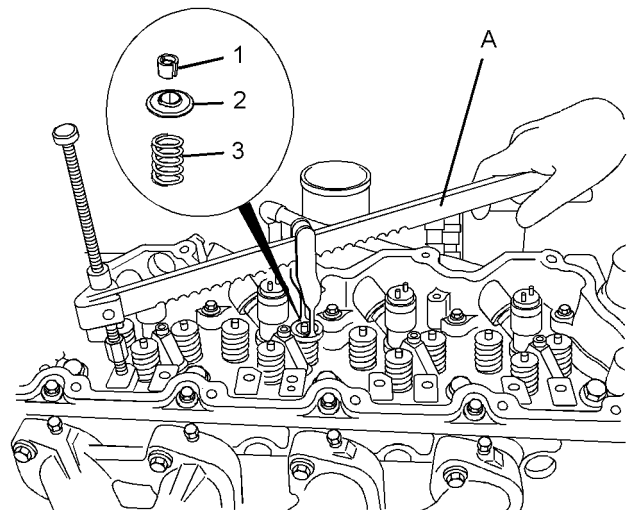

Illustration 78

g01257370

Typical example

6. Install Tooling (A) in the appropriate position on the cylinder head in order to compress the valve spring (3).

NOTICE

Ensure that the valve spring is compressed squarely or damage to the valve stem may occur.

7. Apply sufficient pressure to Tooling (A) in order to install valve keepers (1).

Note: Do not compress the spring so that valve spring retainer (2) touches valve stem seal (4).

WARNING

The valve spring keepers can be thrown from the valve when the valve spring compressor is released. Ensure that the valve spring keepers are properly installed on the valve stem. To help prevent personal injury, keep away from the front of the valve spring keepers and valve springs during the installation of the valves.

8. Carefully release the pressure on Tooling (A).
9. Repeat Steps 5 to 8 for the remaining valves.
10. Remove Tooling (A) from the cylinder head.
11. Use a suitable lifting device to position the cylinder head on a support. Ensure that the heads of the valves are not obstructed. Gently strike the top of the valves with a soft hammer in order to ensure that valve keepers (1) are properly installed.

End By:

- a. Install the cylinder head. Refer to Disassembly and Assembly, "Cylinder Head - Install".

i02585988

Engine Oil Filter Base - Remove and Install

Removal Procedure

Table 19

Required Tools			
Tool	Part Number	Part Description	Qty
A	-	Strap Wrench	1

Note: The oil filter may be installed vertically or the oil filter may be installed horizontally.

NOTICE

Keep all parts clean from contaminants.

Contaminants may cause rapid wear and shortened component life.

NOTICE

Care must be taken to ensure that fluids are contained during performance of inspection, maintenance, testing, adjusting, and repair of the product. Be prepared to collect the fluid with suitable containers before opening any compartment or disassembling any component containing fluids.

Dispose of all fluids according to local regulations and mandates.

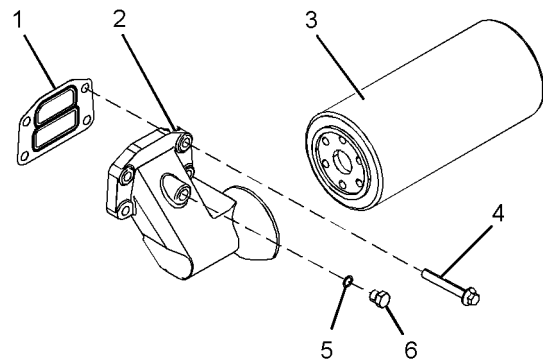

Illustration 79

g01254186

Typical example

1. Use Tooling (A) to remove engine oil filter (3). Refer to Disassembly and Assembly, "Engine Oil and Filter - Change".
2. If the engine oil pressure sensor is located in the engine oil filter base, remove the engine oil pressure sensor. Refer to Operation and Maintenance Manual, "Engine Oil Pressure Sensor - Remove and Install".
3. Remove bolts (4) and remove engine oil filter base (2).
4. Remove joint (1).
5. If the engine oil filter base has a spacer plate, remove the spacer plate and remove the joint.
6. If necessary, remove plug (6) from engine oil filter base (2). Remove O-ring seal (5) from the plug.

i02585998

Installation Procedure

Table 20

Required Tools			
Tool	Part Number	Part Description	Qty
A	21820117	POWERPART Threadlock and Nutlock	1

NOTICE

Keep all parts clean from contaminants.

Contaminants may cause rapid wear and shortened component life.

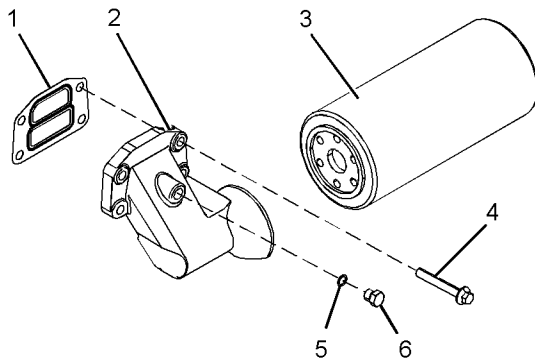

Illustration 80

g01254186

Typical example

1. Ensure that the engine oil filter base is clean. Clean the mating surfaces of the cylinder block.
2. If necessary, install a new O-ring seal (5) to plug (6). Install plug (6) to engine oil filter base (2). Tighten the plug to a torque of 12 N·m (106 lb in).
3. Install bolts (4) to engine oil filter base (2).
4. Install a new joint (1) onto bolts (4). If the engine oil filter base has a spacer plate, install the spacer plate and a new joint onto the bolts.
5. Apply Tooling (A) to the threads of the bolts. Install the assembly of the engine oil filter base to the cylinder block.
6. Tighten bolts (4) to a torque of 22 N·m (16 lb ft).
7. If the engine oil pressure sensor is located in the engine oil filter base, install the engine oil pressure sensor. Refer to Operation and Maintenance Manual, "Engine Oil Pressure Sensor - Remove and Install".
8. Install a new engine oil filter (3). If necessary, fill the engine oil pan to the correct level that is indicated on the oil level gauge. Refer to Operation and Maintenance Manual, "Engine Oil Level - Check".

Engine Oil Cooler - Remove

Removal Procedure

Start By:

- a. Remove the bracket for the Electronic Control Module. Refer to Disassembly and Assembly, "ECM Mounting Bracket - Remove and Install".

NOTICE

Ensure that all adjustments and repairs that are carried out to the fuel system are performed by authorised personnel that have the correct training.

Before beginning ANY work on the fuel system, refer to Operation and Maintenance Manual, "General Hazard Information and High Pressure Fuel Lines" for safety information.

Refer to Systems Operation, Testing and Adjusting Manual, "Cleanliness of Fuel System Components" for detailed information on the standards of cleanliness that must be observed during ALL work on the fuel system.

NOTICE

Keep all parts clean from contaminants.

Contaminants may cause rapid wear and shortened component life.

NOTICE

Care must be taken to ensure that fluids are contained during performance of inspection, maintenance, testing, adjusting and repair of the product. Be prepared to collect the fluid with suitable containers before opening any compartment or disassembling any component containing fluids.

Dispose of all fluids according to local regulations and mandates.

1. Drain the coolant from the cooling system into a suitable container. Refer to Operation and Maintenance Manual, "Cooling System Coolant - Drain" for the correct procedure.
2. Drain the engine lubricating oil into a suitable container. Refer to Operation and Maintenance Manual, "Engine Oil and Filter - Change" for the correct procedure.

3. If necessary, remove the electric starting motor. Refer to Disassembly and Assembly, "Electric Starting Motor - Remove and Install".
4. Position the engine wiring harness away from the assembly of oil cooler (1). If necessary, cut the cable tie.

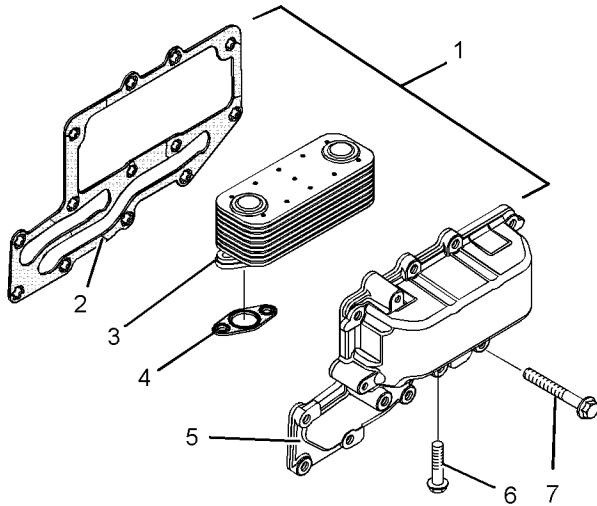

Illustration 81
Typical example

g01254472

Note: Bolts of different lengths are installed. Note the correct position of the bolts. Note the position of any brackets that are secured by the bolts. Do not remove bolts (6) at this time.

6. Remove the assembly of oil cooler (1) from the cylinder block.
7. Remove joint (2).
8. Follow Steps 8.a through 8.c in order to disassemble the engine oil cooler.
 - a. Remove bolts (6).
 - b. Remove cooler matrix (3) from housing (5).
 - c. Remove joints (4).

i02586025

Engine Oil Cooler - Install

Installation Procedure

NOTICE

Keep all parts clean from contaminants.

Contaminants may cause rapid wear and shortened component life.

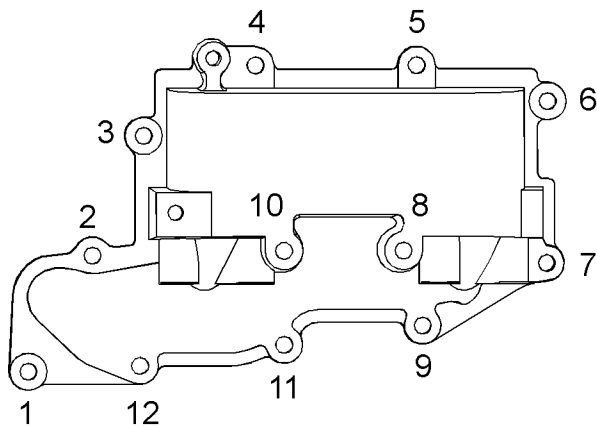

Illustration 82

g01254473

Tightening sequence for the engine oil cooler

5. Loosen bolts (7) in reverse numerical order to the sequence that is shown in Illustration 82. Remove bolts (7). Support the assembly of engine oil cooler (1) as the bolts are removed.

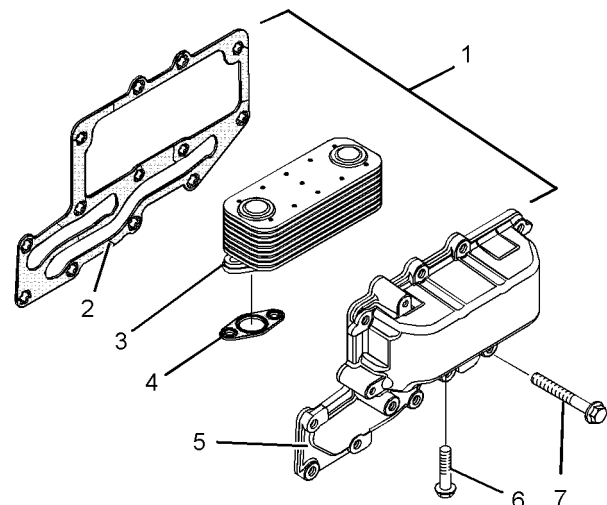

Illustration 83

g01254472

Typical example

1. Follow Steps 1.a through 1.c in order to assemble the engine oil cooler.

- a. Ensure that cooler matrix (3) is clean and free from damage. Ensure that housing (5) is clean and free from damage. Replace any damaged components.
 - b. Position new joints (4) onto housing (5). Install cooler matrix (3).
 - c. Install bolts (6) finger tight.
2. Clean the joint surface of the cylinder block.
 3. Install bolts (7).

Note: The bolts are different lengths. Ensure that the different bolts are installed in the correct location. Ensure that any brackets that are secured by the bolts are installed in the correct location.

4. Install a new joint (2) to the assembly of oil cooler (1). Push bolts (7) through the holes in the joint.

Note: The holes in the joint have serrations that hold the bolts captive.

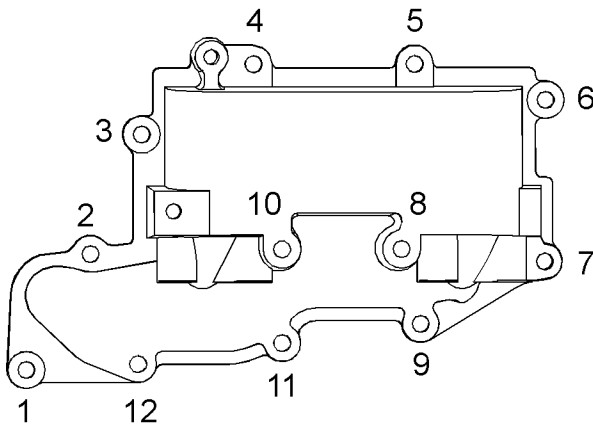

Illustration 84

g01254473

Tightening sequence for the engine oil cooler

5. Install the assembly of oil cooler (1) to the cylinder block. Tighten bolts (7) to a torque of 22 N·m (16 lb ft). Tighten the bolts in the sequence that is shown in Illustration 84.

Tighten bolts (6) to a torque of 22 N·m (16 lb ft). Refer to Illustration 83.

6. Place the engine wiring harness in the correct position. If necessary, install a new cable tie.
7. If necessary, Install the electric starting motor. Refer to Disassembly and Assembly, "Electric Starting Motor - Remove and Install".

8. Fill the cooling system to the correct level. Refer to Operation and Maintenance Manual, "Cooling System Coolant - Fill" for the correct procedure.
9. Fill the engine oil pan to the correct level. Refer to Operation and Maintenance Manual, "Engine Oil Filter - Change" for the correct procedure.

End By:

- a. Install the bracket for the Electronic Control Module. Refer to Disassembly and Assembly, "ECM Bracket - Remove".

102586067

Engine Oil Relief Valve - Remove and Install (Engines with a Balancer Unit)

Removal Procedure

Table 21

Required Tools			
Tool	Part Number	Part Description	Qty
A	-	Telescopic Magnet	1

Start By:

- a. Remove the engine oil pan. Refer to Disassembly and Assembly, "Engine Oil Pan - Remove and Install".

NOTICE

Keep all parts clean from contaminants.

Contaminants may cause rapid wear and shortened component life.

WARNING

Personal injury can result from being struck by parts propelled by a released spring force.

Make sure to wear all necessary protective equipment.

Follow the recommended procedure and use all recommended tooling to release the spring force.

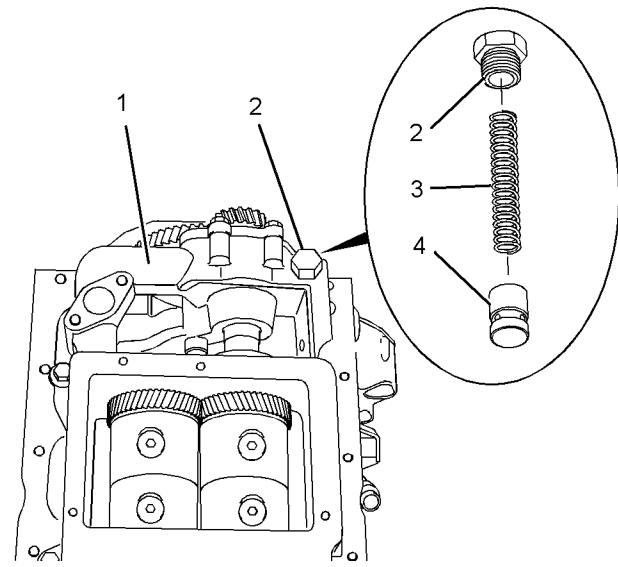

Illustration 85
Typical example g01265618

1. Loosen cap (2). Carefully remove the cap from balancer (1).

Note: The spring force will be released when the cap is removed.

2. Remove spring (3) from the bore for the relief valve in balancer (1).
3. Use Tooling (A) in order to remove plunger (4) from the bore for the relief valve in balancer (1).

Installation Procedure

Table 22

Required Tools			
Tool	Part Number	Part Description	Qty
B	-	Loctite 577	1

NOTICE

Keep all parts clean from contaminants.

Contaminants may cause rapid wear and shortened component life.

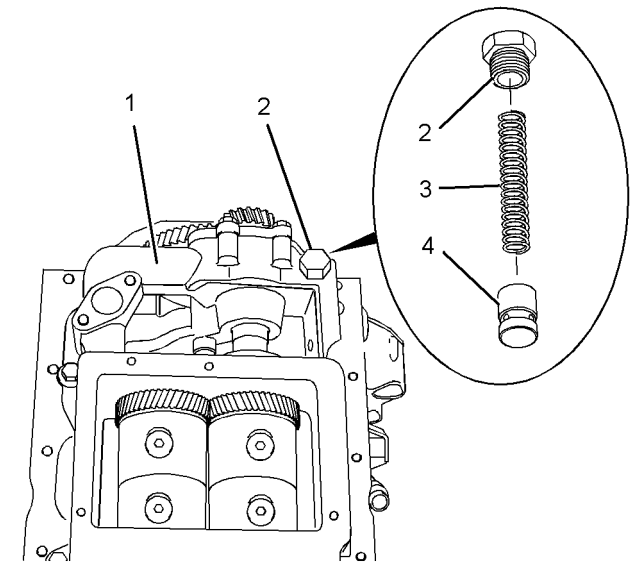

Illustration 86
Typical example g01265618

1. Ensure that all components are clean and free from wear or damage. If necessary, replace any components that are worn or damaged. If the bore for the relief valve in balancer (1) is worn or damaged, the complete assembly of the balancer must be replaced.

WARNING

Improper assembly of parts that are spring loaded can cause bodily injury.

To prevent possible injury, follow the established assembly procedure and wear protective equipment.

2. Lubricate plunger (4) with clean engine oil. Install plunger (4) and spring (3) into the bore for the relief valve in balancer (1).

Note: The plunger must slide freely in the bore for the relief valve.

3. Apply Tooling (B) to the threads of cap (2). Install cap (2) to balancer (1). Tighten the cap to a torque of 21 N·m (15.5 lb ft).

Note: Ensure that the spring is properly located inside the plunger and the cap. Ensure that Tooling (B) does not contaminate the bore for the relief valve in balancer (1).

End By:

- a. Install the engine oil pan. Refer to Disassembly and Assembly, "Engine Oil Pan - Remove and Install".

i02586039

Engine Oil Relief Valve - Remove and Install (Engines Without a Balancer Unit)

Removal Procedure

Start By:

- a. Remove the engine oil pan. Refer to Disassembly and Assembly, "Engine Oil Pan - Remove and Install".

NOTICE

Keep all parts clean from contaminants.

Contaminants may cause rapid wear and shortened component life.

WARNING

Personal injury can result from being struck by parts propelled by a released spring force.

Make sure to wear all necessary protective equipment.

Follow the recommended procedure and use all recommended tooling to release the spring force.

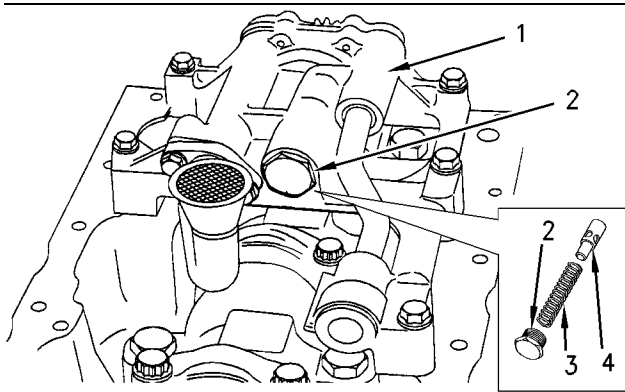

Illustration 87

g00959674

Typical example

1. Loosen cap (2). Carefully remove cap (2) from the housing of engine oil pump (1).

Note: The spring force will be released when the cap is removed.

2. Remove spring (3) from the bore for the relief valve in the housing of engine oil pump (1).
3. Use long nose pliers to remove plunger (4) from the bore for the relief valve in the housing of engine oil pump (1).

Installation Procedure

Table 23

Required Tools			
Tool	Part Number	Part Description	Qty
A	-	Loctite 640	1

NOTICE

Keep all parts clean from contaminants.

Contaminants may cause rapid wear and shortened component life.

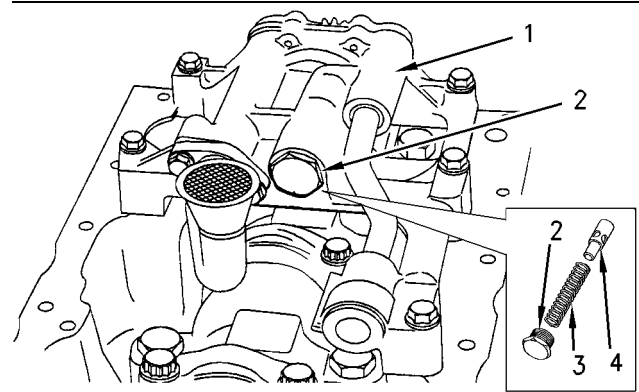

Illustration 88

g00959674

Typical example

1. Ensure that all components are clean and free from wear or damage. If necessary, replace any components that are worn or damaged. If the bore for the relief valve in the housing of engine oil pump (1) is worn or damaged, the complete assembly of the engine oil pump must be replaced.

WARNING

Improper assembly of parts that are spring loaded can cause bodily injury.

To prevent possible injury, follow the established assembly procedure and wear protective equipment.

2. Lubricate plunger (4) with clean engine oil. Use long nose pliers to install plunger (4) and spring (3) into the bore for the relief valve in the housing of engine oil pump (1).

Note: The plunger must slide freely in the bore for the relief valve.

3. Apply Tooling (A) to the threads of cap (2). Install cap (2) to engine oil pump (1). Tighten the cap to a torque of 35 N·m (26 lb ft).

Note: Ensure that the spring is properly located inside the plunger and the cap. Ensure that Tooling (A) does not contaminate the bore for the relief valve in the housing of the engine oil pump.

End By:

- a. Install the engine oil pan. Refer to Disassembly and Assembly, "Engine Oil Pan - Remove and Install".

i02590322

Engine Oil Pump - Remove and Install (Engines Without a Balancer Unit)

Removal Procedure

Start By:

- a. Remove the engine oil pan. Refer to Disassembly and Assembly, "Engine Oil Pan - Remove and Install".

Note: This procedure is for the removal of the engine oil pump on engines that are not equipped with a balancer. Refer to Disassembly and Assembly, "Balancer Group - Remove" for information on the removal of the engine oil pump for engines that are equipped with a balancer.

NOTICE

Keep all parts clean from contaminants.

Contaminants may cause rapid wear and shortened component life.

NOTICE

Care must be taken to ensure that fluids are contained during performance of inspection, maintenance, testing, adjusting and repair of the product. Be prepared to collect the fluid with suitable containers before opening any compartment or disassembling any component containing fluids.

Dispose of all fluids according to local regulations and mandates.

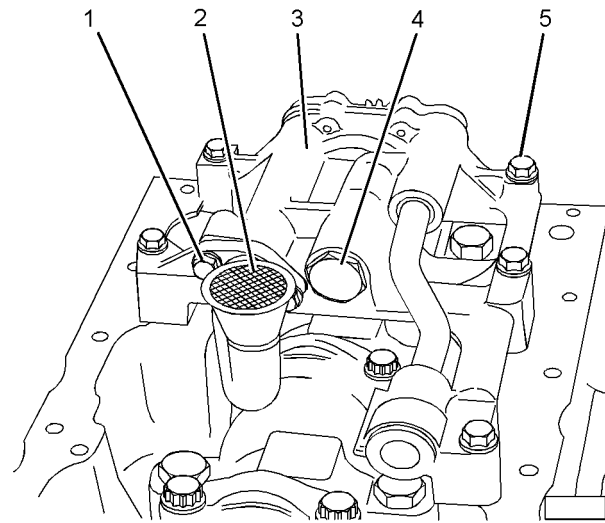

Illustration 89

g01255703

Typical example

1. Remove bolts (1) and suction pipe (2).
2. Remove the joint from the suction pipe.
3. Remove bolts (5). Remove the assembly of the engine oil pump (3) from the cylinder block.
4. If necessary, remove pressure relief valve (4) from the housing of engine oil pump (3). Refer to Disassembly and Assembly, "Engine Oil Relief Valve - Remove and Install".

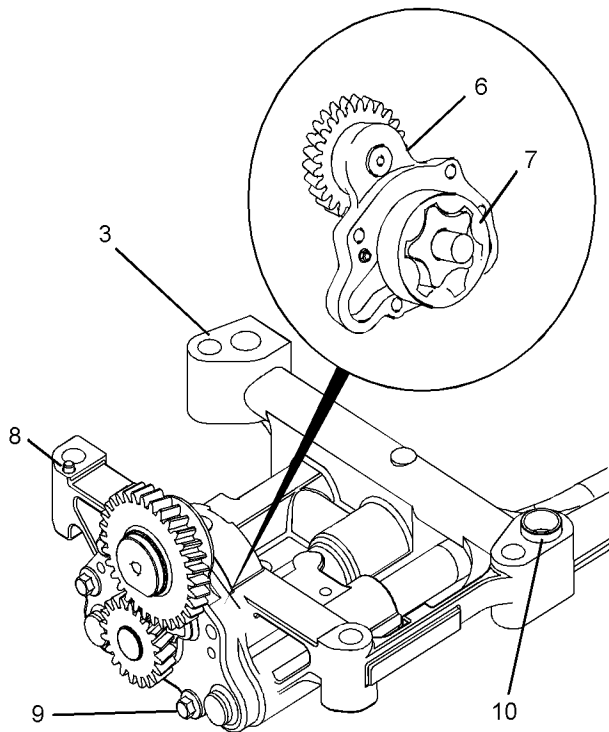

Illustration 90

g01255705

Typical example

5. If necessary, remove bolts (9) and front cover assembly (6). Remove outer rotor (7) from the housing of engine oil pump (3).

Note: Do not remove dowels (8) and (10) from the housing of the engine oil pump unless the dowels are damaged.

Installation Procedure

Table 24

Required Tools			
Tool	Part Number	Part Name	Qty
A	21825617	Dial Indicator Group	1
	-	Finger Clock	1

Note: This procedure is for the installation of the engine oil pump on engines that are not equipped with a balancer. Refer to Disassembly and Assembly, "Balancer Group - Install" for information on the installation of the engine oil pump for engines that are equipped with a balancer.

NOTICE

Keep all parts clean from contaminants.

Contaminants may cause rapid wear and shortened component life.

NOTICE

If any of the parts on the engine oil pump are worn or damaged, the entire pump must be replaced.

1. Ensure that all components of the engine oil pump are clean and free from wear or damage. Check the clearance between the outer rotor of the oil pump and the oil pump body. Check the clearance between the outer rotor and the inner rotor. Check the end play of the rotor. Refer to the Systems Operation, Testing and Adjusting, "Engine Oil Pump - Inspect". Replace the complete assembly of the engine oil pump if any of the components are worn or damaged.

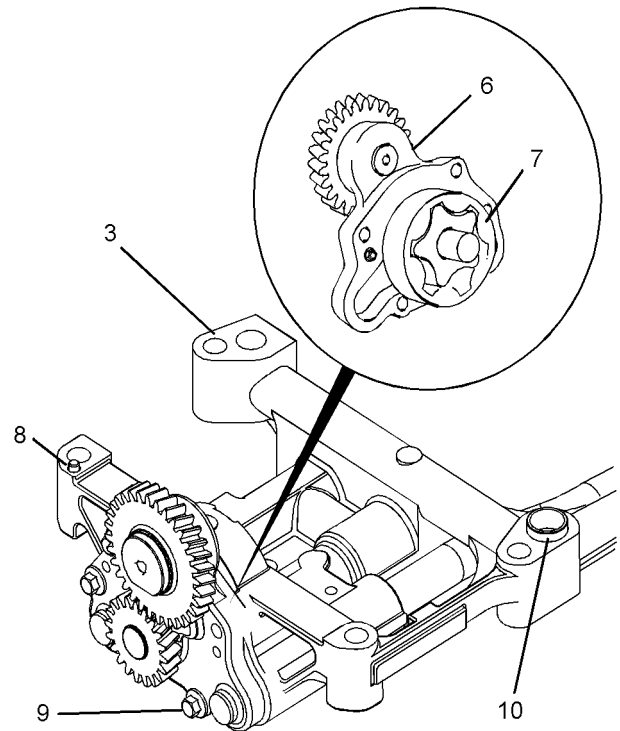

Illustration 91

g01255705

2. If necessary, lubricate the internal components of the assembly of the engine oil pump with clean engine oil. Install outer rotor (7) and front cover (6) to the housing of engine oil pump (3). Install bolts (9). Tighten the bolts to a torque of 9.5 N·m (84 lb in).

i02586341

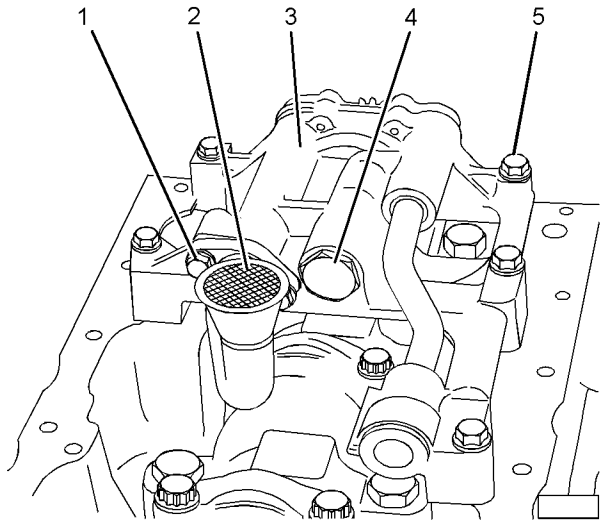

Illustration 92

g01255703

3. If necessary, install pressure relief valve (4). Refer to Disassembly and Assembly, "Engine Oil Relief Valve - Remove and Install" for further information.

4. Ensure that dowels (8) and (10) are correctly located in the housing of engine oil pump (3). Position the assembly of the engine oil pump onto the cylinder block.

Note: Ensure that the dowels in the housing of the engine oil pump are aligned with the holes in the cylinder block.

5. Install bolts (5). Tighten the bolts to a torque of 44 N·m (32 lb ft).

6. Install suction pipe (2) and a new joint to the assembly of the engine oil pump.

7. Install bolts (1). Tighten the bolts to a torque to 22 N·m (16 lb ft).

8. Use Tooling (A) in order to check the backlash between the idler gear of the oil pump and the crankshaft gear. Refer to Specifications, "Gear Group - Front" for further information.

End By:

a. Install the engine oil pan. Refer to Disassembly and Assembly, "Engine Oil Pan - Remove and Install".

Water Pump - Remove

Removal Procedure

Start By:

a. Remove the fan and the fan pulley. Refer to Disassembly and Assembly, "Fan - Remove and Install".

NOTICE

Keep all parts clean from contaminants.

Contaminants may cause rapid wear and shortened component life.

NOTICE

Care must be taken to ensure that fluids are contained during performance of inspection, maintenance, testing, adjusting and repair of the product. Be prepared to collect the fluid with suitable containers before opening any compartment or disassembling any component containing fluids.

Dispose of all fluids according to local regulations and mandates.

1. Drain the coolant from the cooling system into a suitable container for storage or disposal. Refer to Operation and Maintenance Manual, "Cooling System Coolant - Drain" for the correct procedure.

2. Loosen the hose clamps and remove the hose from the water pump inlet.

i02586360

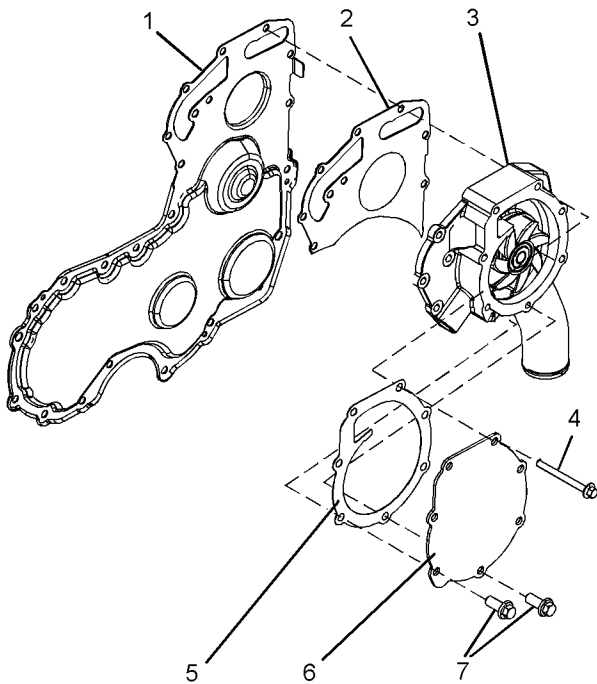

Illustration 93

g01263054

Typical example

3. Remove bolts (4). The bolts are different lengths. Note the positions of the different bolts.

Note: Do not remove bolts (7) at this time.

4. Remove water pump (3) from front cover (1).

Note: If necessary, tap the water pump with a soft hammer in order to loosen the water pump.

5. Remove joint (2).

6. If necessary, remove cover (6) from the water pump. Follow Steps 6.a through 6.c in order to remove the cover.

- a. Remove bolts (7).
- b. Remove cover (6).
- c. Remove joint (5).

Water Pump - Install

Installation Procedure

Table 25

Required Tools			
Tool	Part Number	Part Description	Qty
A	-	Guide Stud (M8 by 80 mm)	2

NOTICE

Keep all parts clean from contaminants.

Contaminants may cause rapid wear and shortened component life.

1. Ensure that the water pump is clean and free from wear or damage. If necessary, replace the water pump.

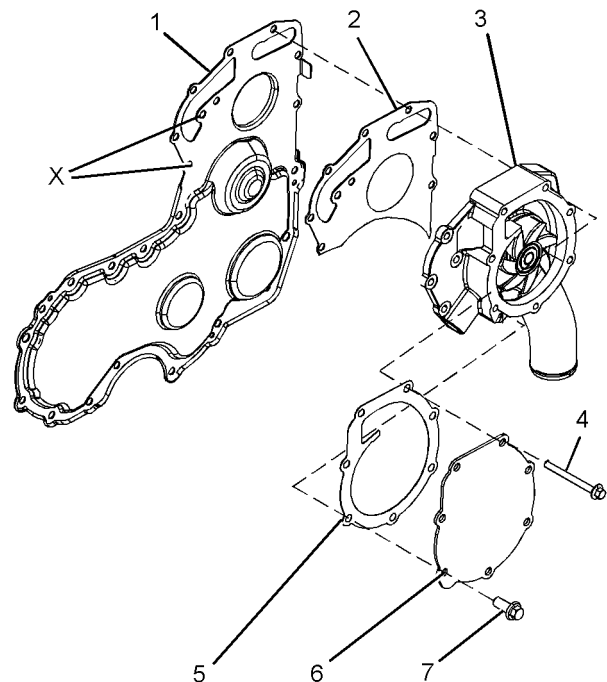

Illustration 94

g01269391

Typical example

2. If necessary, install cover (6) to water pump (3). Follow Steps 2.a through 2.d in order to install the cover.

- a. Clean the mating surface of cover (6).

- b. Position a new joint (5) onto water pump (3).
 - c. Install cover (6) to water pump (3).
 - d. Install bolts (7) to the cover (6). Tighten the bolts finger tight.
3. Clean the mating surface of front cover (1).

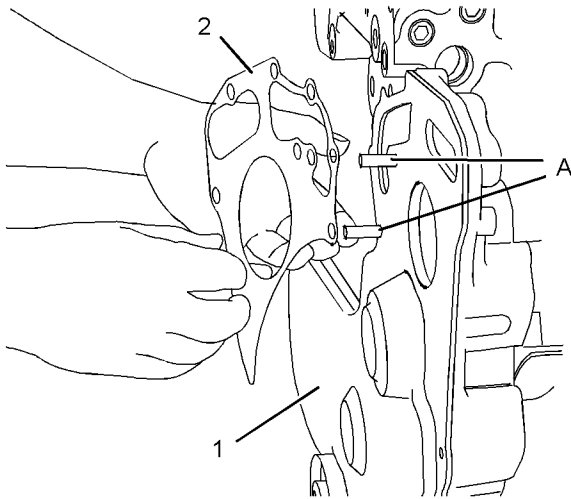

Illustration 95 g01269392

- 4. Install Tooling (A) in position (X).
 - 5. Use Tooling (A) in order to align a new joint (2) to front cover (1). Install the joint to the front cover.
 - 6. Align water pump (3) with Tooling (A). Install the water pump to front cover (1).
- Note:** Ensure that the gear of the water pump and the gear of the fuel injection pump mesh.
- 7. Install bolts (4). Refer to Illustration 94. Tighten the bolts finger tight.
- Note:** Ensure that bolts of different lengths are installed in the correct positions.
- 8. Remove Tooling (A) and install remaining bolts (4) finger tight.

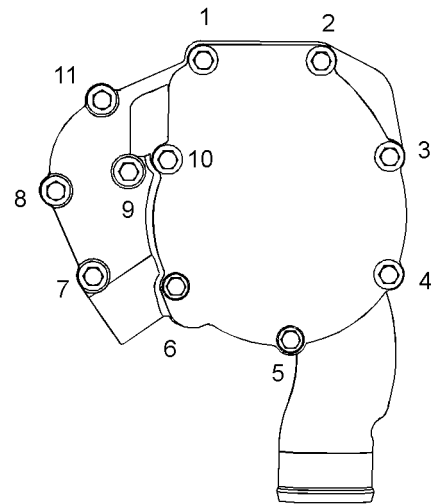

Illustration 96 g01269393

Tightening sequence for the water pump

- 9. Tighten bolts (4) and bolts (7) to a torque of 22 N·m (16 lb ft). Refer to Illustration 94. Tighten the bolts in the sequence that is shown in Illustration 96.
- 10. Install the hose to the water pump inlet. Tighten the hose clamps.
- 11. Fill the cooling system with coolant. Refer to the Operation and Maintenance Manual, "Cooling System Coolant - Fill" for the correct procedure.

End By:

- a. Install the fan and the fan pulley. Refer to Disassembly and Assembly, "Fan - Remove and Install".

i02586781

Water Temperature Regulator - Remove and Install

Removal Procedure

NOTICE

Keep all parts clean from contaminants.

Contaminants may cause rapid wear and shortened component life.

NOTICE

Care must be taken to ensure that fluids are contained during performance of inspection, maintenance, testing, adjusting and repair of the product. Be prepared to collect the fluid with suitable containers before opening any compartment or disassembling any component containing fluids.

Dispose of all fluids according to local regulations and mandates.

1. Drain the coolant from the cooling system to a level below the water temperature regulator, into a suitable container for storage or for disposal. Refer to Operation and Maintenance Manual, "Cooling System Coolant - Drain" for the correct draining procedure.
2. Loosen the hose clamps from the upper radiator hose and disconnect the upper radiator hose from water temperature regulator housing (2).

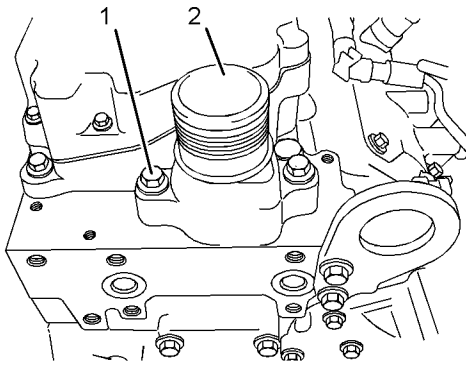

Illustration 97

g01269478

Typical example

3. Remove bolts (1) from water temperature regulator housing (2).
4. Remove water temperature regulator housing (2) from the cylinder head.

Note: Note the orientation of the water temperature regulator housing.

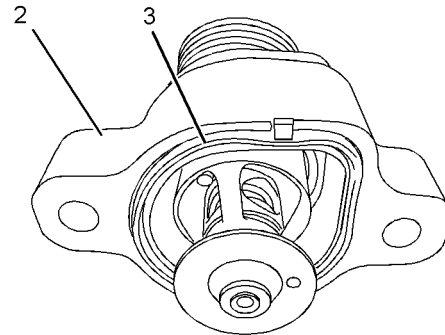

Illustration 98

g01269481

Typical example

5. Remove O-ring seal (3) from water temperature regulator housing (2).

Installation Procedure**NOTICE**

Keep all parts clean from contaminants.

Contaminants may cause rapid wear and shortened component life.

1. Ensure that all components of the water temperature regulator housing (2) are clean and free of wear or damage. Check the water temperature regulator for correct operation. Refer to Systems Operation, Testing and Adjusting, "Water Temperature Regulator - Test" for the procedure to test the water temperature regulator. If any components of the water temperature regulator housing are worn or damaged, the complete assembly must be replaced.

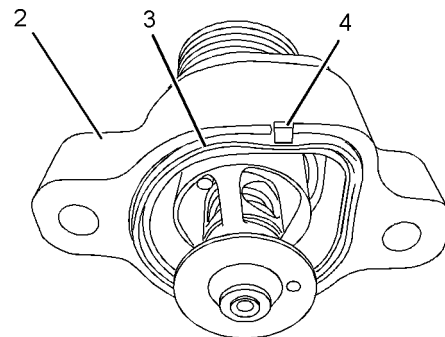

Illustration 99

g01263044

Typical example

2. If the original water temperature regulator housing is installed, position a new O-ring seal (3) into the groove in the water temperature regulator housing (2). Ensure that locating tab (4) is correctly seated in water temperature regulator housing (2).

A new water temperature regulator housing is supplied with a new O-ring seal.

3. Install water temperature regulator housing (2) to the cylinder head.

Note: Ensure the correct orientation of the water temperature regulator housing.

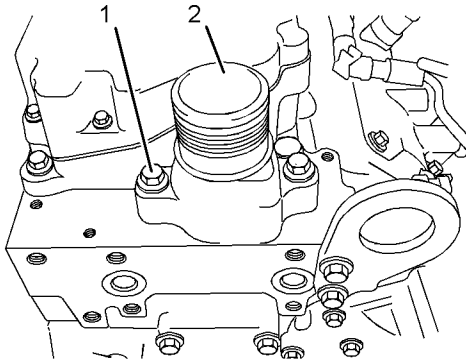

Illustration 100
Typical example
g01269478

4. Install bolts (1). Tighten the bolts to a torque of 44 N·m (32.5 lb ft).
5. Connect the upper radiator hose and tighten the hose clamps.
6. Fill the cooling system to the correct level. Refer to Operation and Maintenance Manual, "Cooling System Coolant - Check" and Operation and Maintenance Manual, "Cooling System Coolant - Fill" for the correct filling procedure.

i02586782

Flywheel - Remove

Removal Procedure

Table 26

Required Tools			
Tool	Part Number	Part Description	Qty
A	-	Guide Stud (1/2 inch - UNF by 4 inch)	2

Start By:

- a. Remove the electric starting motor. Refer to Disassembly and Assembly, "Electric Starting Motor - Remove and Install".

NOTICE

Keep all parts clean from contaminants.

Contaminants may cause rapid wear and shortened component life.

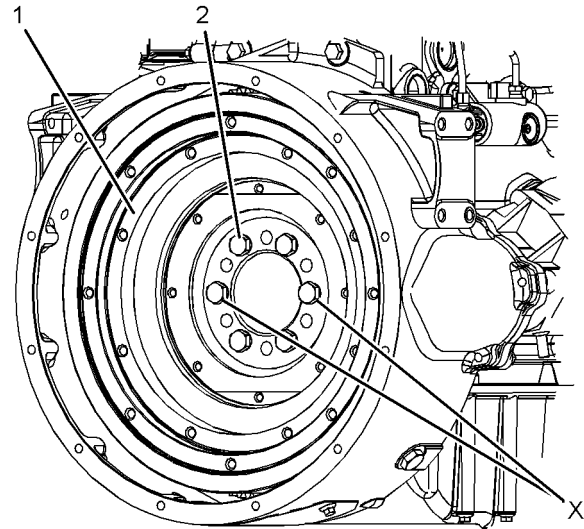

Illustration 101
Typical example
g01245126

1. Remove two bolts from positions (X) on flywheel (1).
2. Install Tooling (A) to positions (X) on flywheel (1).
3. Attach a suitable lifting device to flywheel (1). Support the weight of the flywheel. The weight of the flywheel is approximately 71 kg (155 lb).
4. Remove remaining bolts (2).
5. Use the lifting device in order to remove the flywheel from the engine.

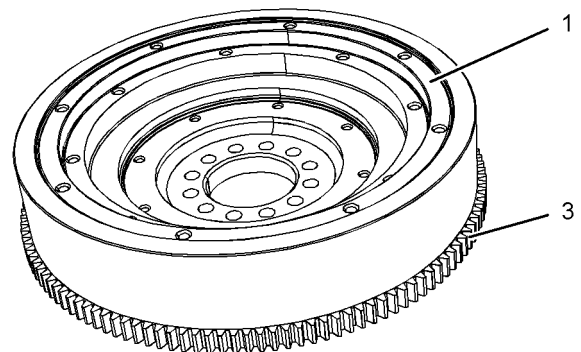

Illustration 102
Typical example
g01245152

6. Inspect flywheel (1) and ring gear (3) for wear or damage. Replace any components that are worn or damaged.
7. To remove the flywheel ring gear, follow Steps 7.a and 7.b.
 - a. Place the flywheel assembly on a suitable support.

Note: Identify the orientation of the teeth on the flywheel ring gear.

- b. Use a hammer and a punch in order to remove ring gear (3) from flywheel (1).

i02586783

Flywheel - Install

Installation Procedure

Table 27

Required Tools			
Tool	Part Number	Part Description	Qty
A	-	Guide Stud (1/2 inch - 20 UNF by 4 inch)	2

NOTICE

Keep all parts clean from contaminants.

Contaminants may cause rapid wear and shortened component life.

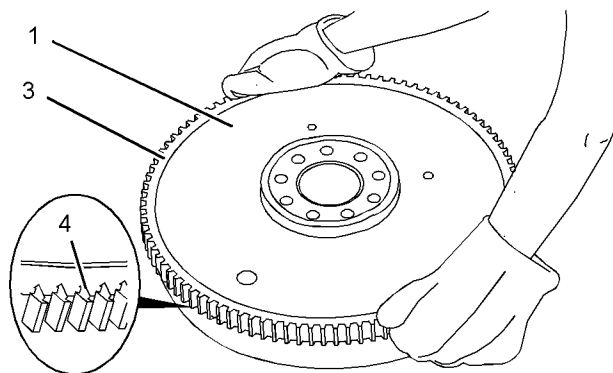

Illustration 103

Typical example

g01245153



WARNING

Always wear protective gloves when handling parts that have been heated.

1. If the flywheel ring gear was removed, follow Steps 1.a through 1.c in order to install a new ring gear to the flywheel.

- a. Identify the orientation of teeth (4) on the new ring gear (4).

Note: The chamfered side of the ring gear teeth must face toward the starting motor when the flywheel is installed. This will ensure the correct engagement of the starting motor.

- b. Heat flywheel ring gear (3) in an oven to a maximum temperature of 250 °C (482 °F) prior to installation.

Note: Do not use a torch to heat the ring gear.

- c. Ensure that the orientation of ring gear (3) is correct and quickly install the ring gear onto flywheel (1).

2. Inspect the crankshaft rear seal for leaks. If there are any oil leaks, replace the crankshaft rear seal. Refer to Disassembly and Assembly, "Crankshaft Rear Seal - Remove".

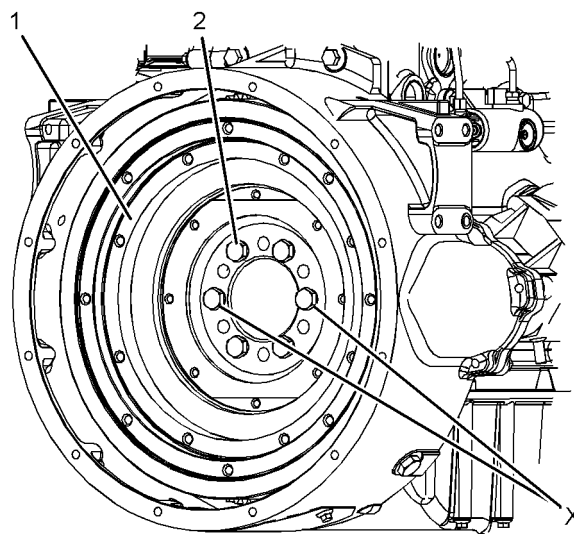

Illustration 104

Typical example

g01245126

3. Install a suitable lifting device to flywheel (1). The weight of the flywheel is approximately 71 kg (155 lb).
4. Install Tooling (A) to positions (X) on the crankshaft.
5. Use the lifting device in order to position flywheel (1) onto Tooling (A).
6. Install bolts (2) to flywheel (1) finger tight.

7. Remove Tooling (A) and install remaining bolts (2) to the flywheel (1).
8. Remove the lifting device from flywheel (1).
9. Use a suitable tool to prevent the flywheel from rotating. Tighten bolts (2) to a torque of 120 N·m (88 lb ft).
10. Check the run out of the flywheel. Refer to Specifications, "Flywheel" for further information.

End By:

- a. Install the electric starting motor. Refer to Disassembly and Assembly, "Electric Starting Motor - Remove and Install".

i02586784

Crankshaft Pulley - Remove and Install (Engines With an Automatic Belt Tensioner)

Removal Procedure**Start By:**

- a. Remove the Alternator belt. Refer to Disassembly and Assembly, "Alternator Belt - Remove and Install".

NOTICE

Keep all parts clean from contaminants.

Contaminants may cause rapid wear and shortened component life.

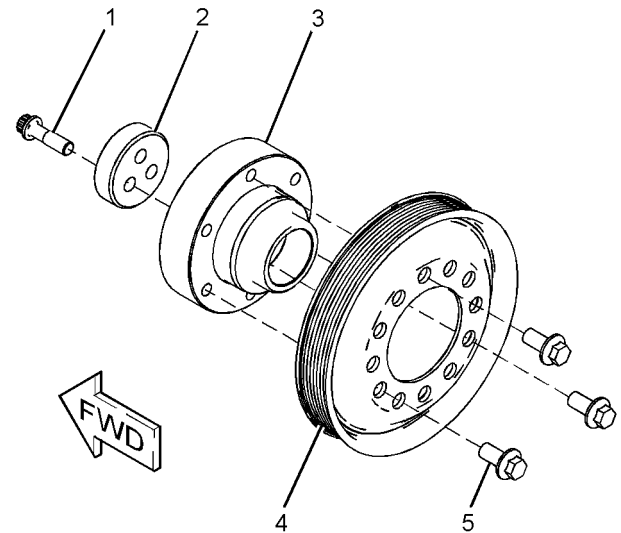

Illustration 105

g01249049

1. Use a suitable tool in order to prevent the crankshaft from rotating. Remove bolts (1).
2. Remove thrust block (2).
3. Carefully remove the assembly of the crankshaft pulley from the crankshaft.
4. Follow Steps 4.a through 4.b in order to disassemble the crankshaft pulley.
 - a. Remove bolts (5).
 - b. Remove crankshaft pulley (4) from crankshaft adapter (3).

Installation Procedure**NOTICE**

Keep all parts clean from contaminants.

Contaminants may cause rapid wear and shortened component life.

1. Ensure that the crankshaft adapter, the pulley and the thrust block are clean and free from damage. Replace any components that are damaged. It is possible to reclaim a crankshaft adapter with a worn seal surface by installing a wear sleeve. Refer to Disassembly and Assembly, "Crankshaft Wear Sleeve (Front) - Remove and Install".

i02586787

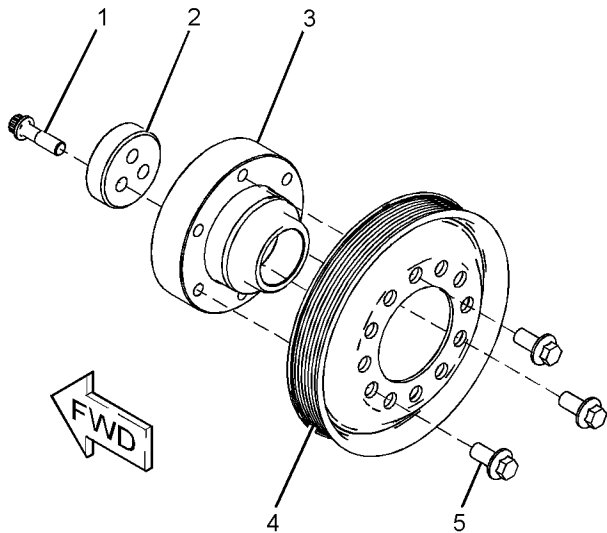

Illustration 106

g01249049

2. If necessary, follow Steps 2.a through 2.b in order to assemble the crankshaft pulley.
 - a. Install crankshaft pulley (4) to crankshaft adapter (3).
 - b. Install bolts (5) to the assembly of the crankshaft pulley, and the crankshaft adapter. The bolts should be evenly spaced.
 - c. Tighten the bolts to a torque of 78 N·m (58 lb ft).
3. Ensure that the front of the crankshaft is clean and free from damage. Install the assembly of the crankshaft pulley to the crankshaft.
4. Align the holes in the thrust block with the holes in the crankshaft. Install thrust block (2) to the assembly of the crankshaft pulley.
5. Install bolts (1) to thrust block (2).
6. Use a suitable tool in order to prevent the crankshaft from rotating. Tighten the bolts to a torque of 115 N·m (85 lb ft).
7. Repeat Step 6 two more times in order to ensure correct torque.

End By:

- a. Install the alternator belt. Refer to Disassembly and Assembly, "Alternator Belt - Remove and Install".

Crankshaft Pulley - Remove and Install (Engines Without an Automatic Belt Tensioner)

Removal Procedure

Start By:

- a. Remove the V-Belts. Refer to Disassembly and Assembly, "V-Belts - Remove and Install".

NOTICE

Keep all parts clean from contaminants.

Contaminants may cause rapid wear and shortened component life.

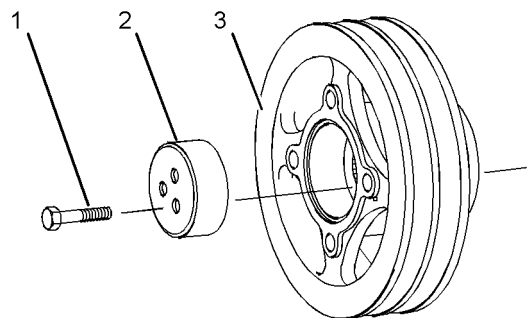

Illustration 107

g01255707

1. Use a suitable tool in order to prevent the crankshaft from rotating. Remove bolts (1).
2. Remove thrust block (2).
3. Carefully remove crankshaft pulley (3) from the crankshaft.

Installation Procedure

i02586790

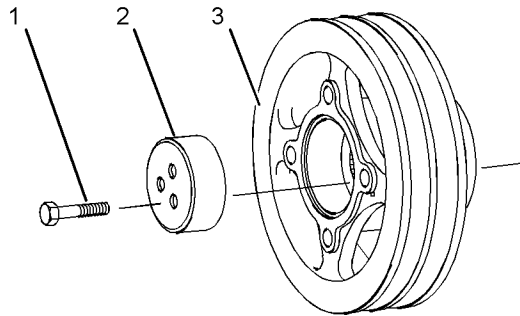

Illustration 108

g01255707

1. Ensure that the crankshaft pulley and the thrust block are clean and free from damage. Replace any components that are damaged. It is possible to reclaim a crankshaft pulley with a worn seal surface by installing a wear sleeve. Refer to Disassembly and Assembly, "Crankshaft Wear Sleeve (Front) - Remove and Install".
2. Ensure that the front of the crankshaft is clean and free from damage. Install crankshaft pulley (3) to the crankshaft.
3. Align the holes in the thrust block with the holes in the crankshaft. Install thrust block (2) to the crankshaft pulley.
4. Install bolts (1) to thrust block (2).
5. Use a suitable tool in order to prevent the crankshaft from rotating. Tighten bolts (1) to a torque of 115 N·m (85 lb ft).
6. Repeat Step 5 two more times in order to ensure correct torque.

End By:

- a. Install the V-Belts. Refer to Disassembly and Assembly, "V-Belts - Remove and Install".

Crankshaft Rear Seal - Remove

Removal Procedure

Table 28

Required Tools			
Tool	Part Number	Part Description	Qty
A	-	E12 Torx Socket	1

Start By:

- a. Remove the flywheel. Refer to Disassembly and Assembly, "Flywheel - Remove".

NOTICE

Keep all parts clean from contaminants.

Contaminants may cause rapid wear and shortened component life.

NOTICE

Care must be taken to ensure that fluids are contained during performance of inspection, maintenance, testing, adjusting and repair of the product. Be prepared to collect the fluid with suitable containers before opening any compartment or disassembling any component containing fluids.

Dispose of all fluids according to local regulations and mandates.

Note: The crankshaft rear seal and the housing are manufactured as a one-piece assembly. The assembly is not serviceable. If the crankshaft rear seal is removed, the assembly must be replaced.

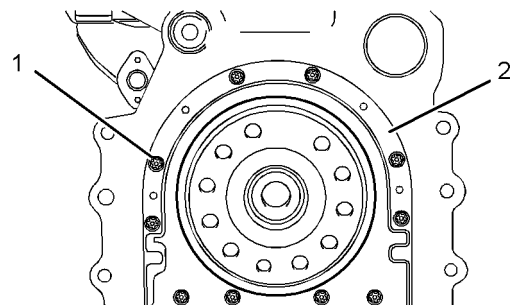

Illustration 109

g01269512

Typical example

1. Use Tooling (A) in order to remove torx screws (1) from crankshaft rear seal (2).
2. Remove crankshaft rear seal (2) from the cylinder block. Discard the crankshaft rear seal.

i02586792

Crankshaft Rear Seal - Install

Installation Procedure

Table 29

Required Tools			
Tool	Part Number	Part Description	Qty
A	-	E12 Torx Socket	1
B	27610306	Alignment Tool	1

Note: The crankshaft rear seal and the housing are manufactured as a one-piece assembly.

NOTICE

Keep all parts clean from contaminants.

Contaminants may cause rapid wear and shortened component life.

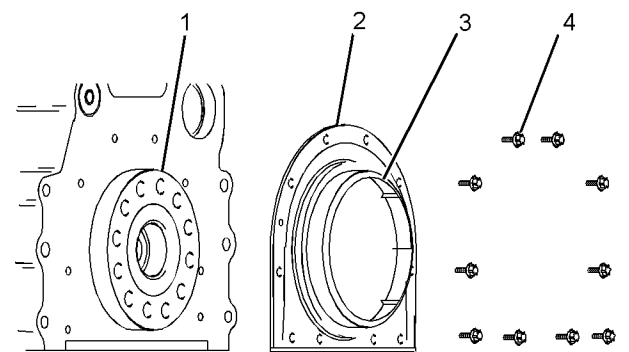

Illustration 110

g01258105

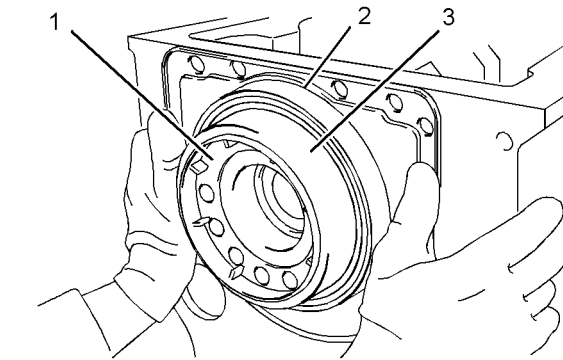

Illustration 111

g01255709

Typical example

1. Ensure that crankshaft flange (1) is clean, dry and free from damage. It is possible to reclaim a crankshaft flange that has a worn seal surface, or a damaged seal surface by installing a wear sleeve. Refer to Disassembly and Assembly, "Crankshaft Wear Sleeve (Rear) - Remove and Install" for more information.
2. Ensure that the mating surface of the cylinder block and the bridge piece are clean and dry.
3. A new crankshaft rear seal is supplied with a plastic sleeve (3). Ensure that the plastic sleeve is squarely installed within crankshaft rear seal (2).

Note: The plastic sleeve is included in order to protect the lip of the seal as the seal is pushed over the crankshaft flange.

Note: Do not lubricate the crankshaft rear seal or the crankshaft flange. The crankshaft rear seal must be installed dry.

4. Align plastic sleeve (3) with crankshaft flange (1). Ensure that the plastic sleeve is engaged onto the crankshaft flange. Push new crankshaft rear seal (2) squarely onto the crankshaft flange.

During this process, the plastic sleeve will be forced out of the crankshaft rear seal. Discard the plastic sleeve.

5. Align the two molded locators on crankshaft rear seal (2) with the holes in the cylinder block. Ensure that the crankshaft rear seal is seated against the cylinder block.

i02586793

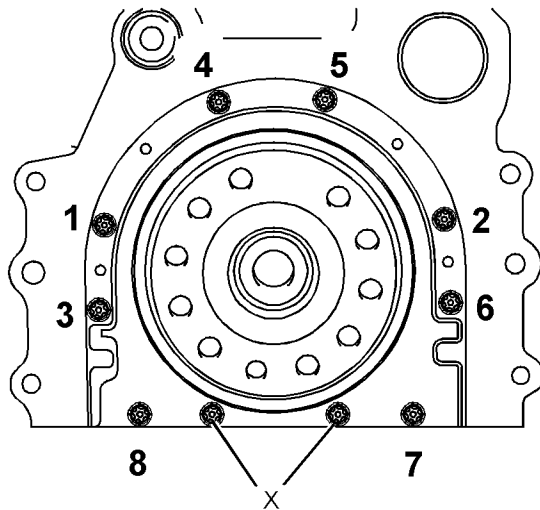

Illustration 112 g01258357

Tightening sequence for the crankshaft rear seal

6. Install torx screws (4) finger tight.

Note: Do not install torx screws to positions (X) at this stage.

7. Install Tooling (B) to crankshaft rear seal (2) and to crankshaft flange (1).

8. Use Tooling (A) in order to tighten torx screws (4) to a torque of 22 N·m (16 lb ft). Tighten torx screws (4) in the sequence that is shown in Illustration 112.

9. Remove the Tooling (B).

10. Install the remaining torx screws (4) to positions (X). Use Tooling (A) in order to tighten the torx screws to a torque of 22 N·m (16 lb ft). Refer to Illustration 112.

End By:

a. Install the flywheel. Refer to Disassembly and Assembly, "Flywheel - Install".

Crankshaft Wear Sleeve (Rear) - Remove and Install

Removal Procedure

Start By:

a. Remove the crankshaft rear seal. Refer to Disassembly and Assembly, "Crankshaft Rear Seal - Remove".

NOTICE

Keep all parts clean from contaminants.

Contaminants may cause rapid wear and shortened component life.

Note: Wear sleeves are used to reclaim worn seal surfaces or damaged seal surfaces. Wear sleeves are not original equipment.

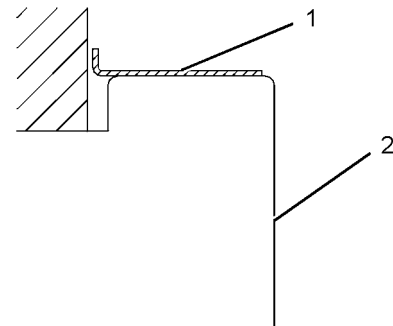

Illustration 113 g01266598

Sectional view of the crankshaft and of the wear sleeve

1. Use a sharp tool to score a deep line across crankshaft wear sleeve (1).

Note: Take care to avoid damaging the crankshaft.

2. Insert a thin blade between crankshaft wear sleeve (1) and crankshaft (2) below the scored line. The crankshaft wear sleeve will separate along the line.

3. Remove crankshaft wear sleeve (1) from crankshaft (2). Discard the crankshaft wear sleeve.

Installation Procedure

Table 30

Required Tools		
Tool	Part Number	Part Description
A	21820518	POWERPART Liquid Gasket

NOTICE

Keep all parts clean from contaminants.

Contaminants may cause rapid wear and shortened component life.

1. Ensure that the crankshaft is thoroughly clean and dry. Remove any areas of raised damage.

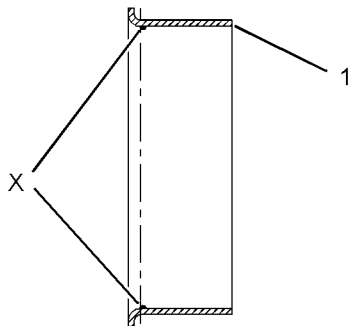

Illustration 114

g01269521

Sectional view of the wear sleeve

2. Apply a small continuous bead of Tooling (A) to the inner surface of crankshaft wear sleeve (1) at position X. Apply the bead of Tooling (A) 5.00 mm (0.2 inch) from the flange end of the crankshaft wear sleeve.

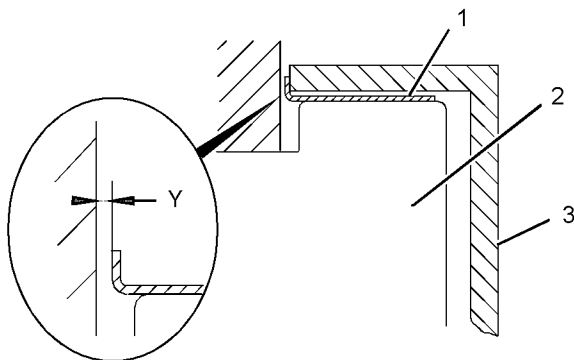

Illustration 115

g01266582

Sectional view of the crankshaft, the wear sleeve and the installation tool

3. Align crankshaft wear sleeve (1) with crankshaft (2). Position installation tool (3) that is provided with the crankshaft wear sleeve over the crankshaft. Use a hammer to drive the crankshaft wear sleeve onto the crankshaft. Ensure that the flange of the crankshaft wear sleeve is 0.40 to 0.60 mm (0.017 to 0.024 inch) from the cylinder block.

Note: Measure distance (Y) between the flange of crankshaft wear sleeve (1) and the cylinder block in two places that are 180 degrees from each other.

4. Remove installation tool (3).
5. Ensure that the crankshaft wear sleeve has no rough edges.

End By:

- a. Install a new crankshaft rear seal. Refer to Disassembly and Assembly, "Crankshaft Rear Seal - Install".

i02586796

Flywheel Housing - Remove and Install

Removal Procedure

Start By:

- a. Remove the flywheel. Refer to Disassembly and Assembly, "Flywheel - Remove".

NOTICE

Keep all parts clean from contaminants.

Contaminants may cause rapid wear and shortened component life.

1. Install a suitable lifting device to the flywheel housing in order to support the flywheel housing. The weight of the flywheel housing is approximately 30 kg (66 lb).

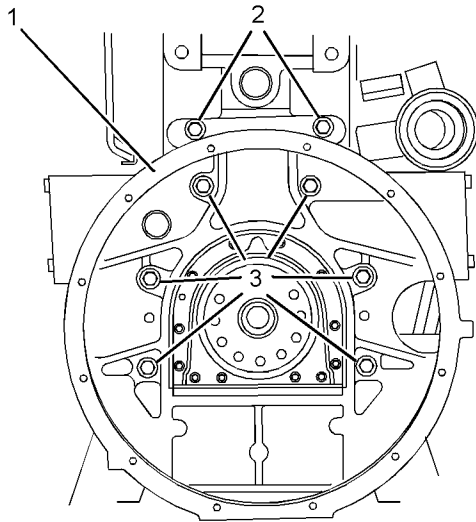

Illustration 116
Typical example g01244050

2. Remove bolts (2) and (3) from flywheel housing (1).
3. Use the lifting device in order to remove flywheel housing (1) from the cylinder block.

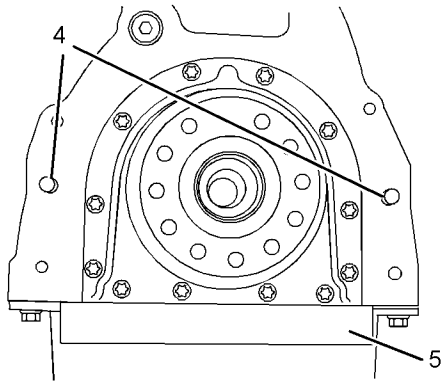

Illustration 117
Typical example g01244051

4. If the engine has an aluminum oil pan, remove dust seal (5).
5. If necessary, remove dowels (4) from the cylinder block.

Installation Procedure

Table 31

Required Tools			
Tool	Part Number	Part Description	Qty
A	-	Guide Stud (M10 by 100 mm)	2
B	21825617	Dial Indicator Group	1

NOTICE

Keep all parts clean from contaminants.

Contaminants may cause rapid wear and shortened component life.

1. Ensure that the flywheel housing is clean and free from damage. If necessary, replace the flywheel housing.

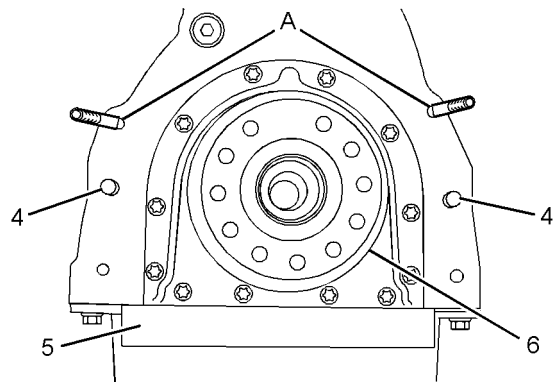

Illustration 118
Typical example g01244056

2. Inspect crankshaft rear seal (6) for leaks. If there are any oil leaks, replace the crankshaft rear seal. Refer to Disassembly and Assembly, "Crankshaft Rear Seal - Remove" and refer to Disassembly and Assembly, "Crankshaft Rear Seal - Install".
3. Clean the rear face of the cylinder block. If necessary, install dowels (4) to the cylinder block.
4. Install Tooling (A) to the cylinder block.
5. Install dust seal (5).

i02586797

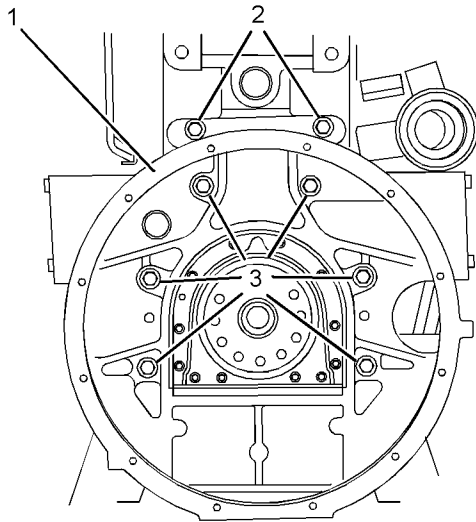

Illustration 119

g01244050

Typical example

6. Install a suitable lifting device to the flywheel housing. The weight of the flywheel housing is approximately 30 kg (66 lb).
7. Use the lifting device to align flywheel housing (1) with Tooling (A). Install the flywheel housing to the cylinder block.
8. Install the bolts (2) and (3) finger tight.
9. Remove Tooling (A). Install the remaining bolts (3).
10. Tighten bolts (3) to a torque of 63 N·m (46 lb ft).
11. Tighten bolts (2) to a torque of 75 N·m (55 lb ft).
12. Use Tooling (B) to check the alignment of the flywheel housing with the crankshaft. Refer to Systems Operation, Testing and Adjusting, "Flywheel Housing - Inspect".

End By:

- a. Install the flywheel. Refer to Disassembly and Assembly, "Flywheel - Install".

Crankshaft Front Seal - Remove and Install

Removal Procedure

Table 32

Required Tools			
Tool	Part Number	Part Description	Qty
A	27610230	Puller	1

Start By:

- a. Remove the crankshaft pulley. Refer to Disassembly and Assembly, "Crankshaft Pulley - Remove and Install".

NOTICE

Keep all parts clean from contaminants.

Contaminants may cause rapid wear and shortened component life.

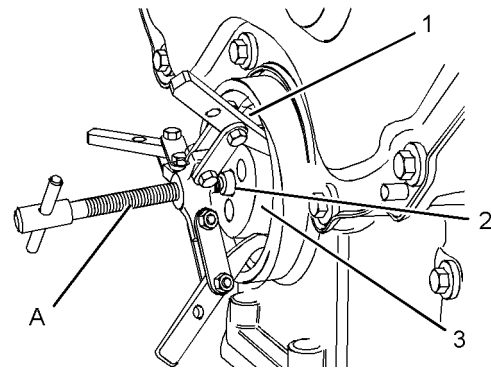

Illustration 120

g01266942

1. Install the legs of Tooling (A) behind crankshaft front seal (1). Install a suitable spacer (2) between Tooling (A) and crankshaft (3). Use Tooling (A) in order to pull the crankshaft front seal out of the front housing.

Note: Do not damage the bore for the crankshaft front seal in the front housing.

Installation Procedure

i02586798

Table 33

Required Tools			
Tool	Part Number	Part Description	Qty
B	21825577	Threaded Bar	1
	21825580	Anchor Plate	1
	21825579	Sleeve	1
	21825578	Pressure Plate	1
	21825581	Adapter	1

NOTICE

Keep all parts clean from contaminants.

Contaminants may cause rapid wear and shortened component life.

1. Ensure that the bore for the crankshaft front seal in the front housing is clean and free from damage.

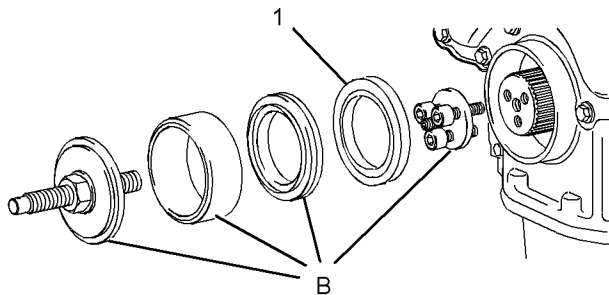

Illustration 121

g01266453

Typical example

2. Assemble Tooling (B).
3. Align a new crankshaft front seal (1) to the front housing.
4. Use Tooling (B) to install crankshaft front seal (1). Ensure that the front face of the seal is installed to a depth of 9 ± 0.2 mm (0.354 ± 0.008 inch) into the front housing.
5. Remove Tooling (B) from the crankshaft.

End By:

- a. Install the crankshaft pulley. Refer to Disassembly and Assembly, "Crankshaft Pulley - Remove and Install".

Crankshaft Wear Sleeve (Front) - Remove and Install

Removal Procedure

Start By:

- a. Remove the crankshaft pulley. Refer to Disassembly and Assembly, "Crankshaft Pulley - Remove and Install".
- b. Remove the crankshaft front seal. Refer to Disassembly and Assembly, "Crankshaft Front Seal - Remove and Install".

NOTICE

Keep all parts clean from contaminants.

Contaminants may cause rapid wear and shortened component life.

Note: Wear sleeves are used to reclaim worn seal surfaces. Wear sleeves are not original equipment. A new crankshaft front seal must be installed when a new wear sleeve is installed.

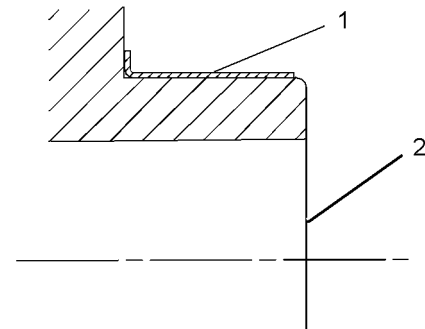

Illustration 122

g01269535

Sectional view of the crankshaft pulley and the wear sleeve

1. Use a sharp tool to score a deep line across wear sleeve (1).

Note: Take care to avoid damaging to the crankshaft pulley.

2. Insert a thin blade between wear sleeve (1) and crankshaft pulley (2) below the scored line. The wear sleeve will separate along the line.
3. Remove wear sleeve (1) from crankshaft pulley (2).

Installation Procedure

Table 34

Required Tools		
Tool	Part Number	Part Description
A	21820518	POWERPART Liquid Gasket

NOTICE

Keep all parts clean from contaminants.

Contaminants may cause rapid wear and shortened component life.

1. Ensure that the crankshaft pulley is thoroughly clean and dry. Remove any areas of raised damage.

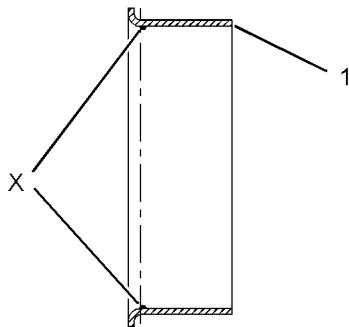

Illustration 123

g01269521

Sectional view of the wear sleeve

2. Apply a small continuous bead of Tooling (A) to the inner surface of wear sleeve (1) at position X. Apply the bead of Tooling (A) 5.00 mm (0.2 inch) from the flange end of the wear sleeve.

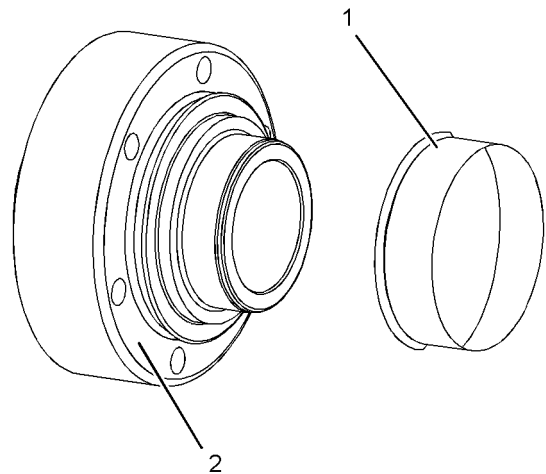

Illustration 124

g01258423

Typical example

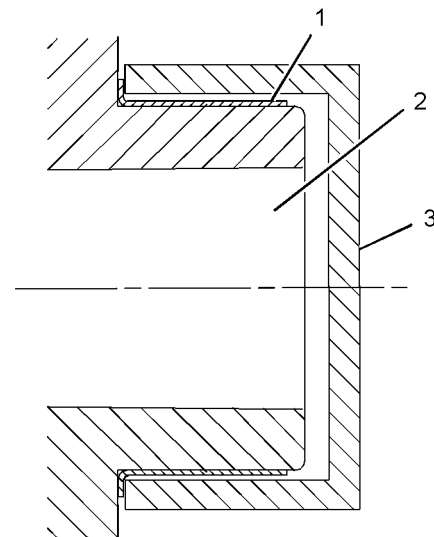

Illustration 125

g01258430

Sectional view of the crankshaft pulley, the wear sleeve and the installation tool

3. Align wear sleeve (1) with crankshaft pulley (2). Use installation tool (3) that is provided with the wear sleeve and use a suitable press in order to install wear sleeve (1) onto crankshaft pulley (2).

Note: Ensure that the wear sleeve is installed squarely against the shoulder of the crankshaft pulley.

4. Remove installation tool (3) from wear sleeve (1).
5. Ensure that wear sleeve (1) has no rough edges.

End By:

- a. Install a new crankshaft front seal. Refer to Disassembly and Assembly, "Crankshaft Front Seal - Remove and Install".
- b. Install the crankshaft pulley. Refer to Disassembly and Assembly, "Crankshaft Pulley - Remove and Install".

i02586802

Front Cover - Remove and Install

Removal Procedure

Start By:

- a. If the engine is equipped with a fan, remove the fan. Refer to Disassembly and Assembly, "Fan - Remove and Install".
- b. Remove the water pump. Refer to Disassembly and Assembly, "Water Pump - Remove".

NOTICE

Care must be taken to ensure that fluids are contained during performance of inspection, maintenance, testing, adjusting and repair of the product. Be prepared to collect the fluid with suitable containers before opening any compartment or disassembling any component containing fluids.

Dispose of all fluids according to local regulations and mandates.

NOTICE

Keep all parts clean from contaminants.

Contaminants may cause rapid wear and shortened component life.

Note: In order to remove the front cover, it is not necessary to remove the crankshaft pulley or the alternator.

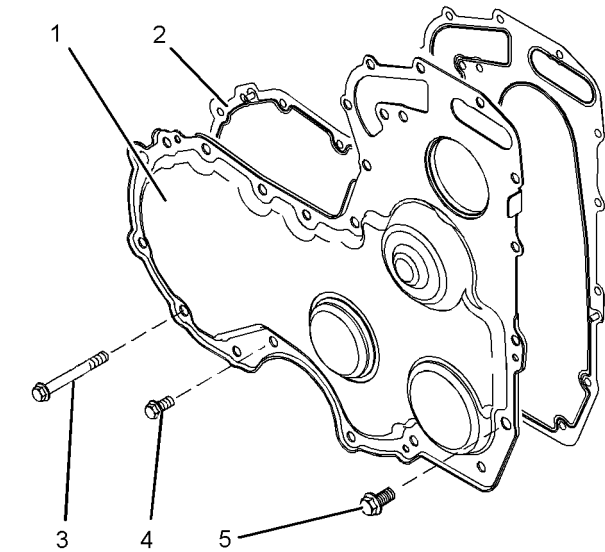

Illustration 126

g01258462

Typical example

1. Remove bolts (3), (4) and (5). Identify the positions of the different bolts.
2. Remove front cover (1) from the front housing.
3. Remove joint (2) from front cover (1).

Installation Procedure

Table 35

Required Tools			
Tool	Part Number	Part Name	Qty
A	-	Guide Stud (M8 by 80 mm)	2

NOTICE

Keep all parts clean from contaminants.

Contaminants may cause rapid wear and shortened component life.

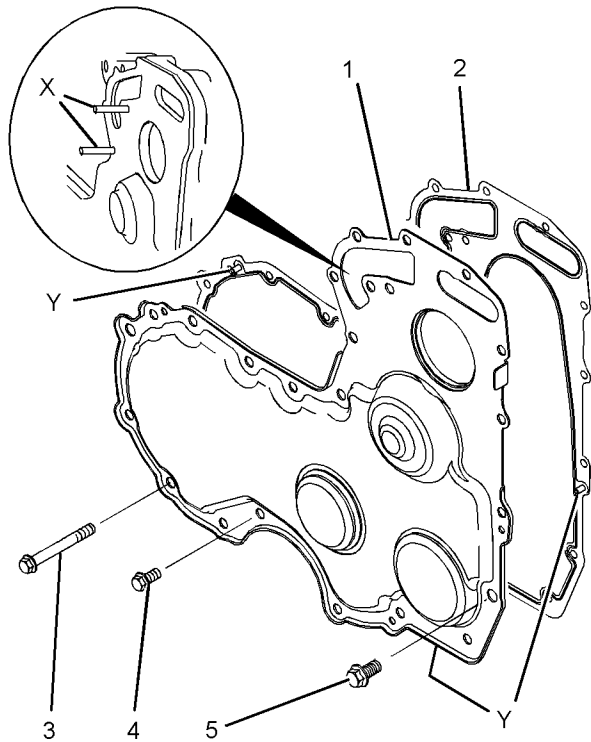

Illustration 127

g01269923

Typical example

1. Thoroughly clean the mating surface of the front housing.
2. If the original front cover is installed, follow Steps 2.a and 2.b in order to install the joint.
 - a. Thoroughly clean the front cover.
 - b. Install a new joint (2) to front cover (1). Engage locators (Y) into the holes in the front cover.
3. Install Tooling (A) into holes (X) in the front housing.
4. Use Tooling (A) in order to position the front cover assembly onto the front housing.
5. Install bolts (3), (4) and (5) finger tight. Ensure that the different bolts are installed in the correct positions.
6. Loosely install the water pump assembly and remove Tooling (A). Refer to Disassembly and Assembly, "Water Pump - Install" for the correct procedure.
7. Tighten bolts (3), (4) and (5) to a torque of 22 N·m (16 lb ft).
8. Tighten the bolts for the water pump to a torque of 22 N·m (16 lb ft).

End By:

- a. If the engine is equipped with a fan, install the fan. Refer to Disassembly and Assembly, "Fan - Remove and Install".

i02591045

Gear Group (Front) - Remove and Install**Removal Procedure**

Table 36

Required Tools			
Tool	Part Number	Part Name	Qty
A ¹	21825576	Crankshaft Turning Tool	1
A ²	27610291	Barring Device Housing	1
	27610289	Gear	1
B	27610212	Camshaft Timing Pin	1
C	27610211	Crankshaft Timing Pin	1

Start By:

- a. If the engine is equipped with an air compressor, remove the air compressor. Refer to Disassembly and Assembly, "Air Compressor - Remove and Install".
- b. If the engine is equipped with a vacuum pump, remove the vacuum pump. Refer to Disassembly and Assembly, "Vacuum Pump - Remove and Install".
- c. If the engine is equipped with an accessory drive, remove the accessory drive. Refer to Disassembly and Assembly, "Accessory Drive - Remove and Install".
- d. Remove the front cover. Refer to Disassembly and Assembly, "Front Cover - Remove and Install".
- e. Remove the valve mechanism cover. Refer to Disassembly and Assembly, "Valve Mechanism Cover - Remove and Install".

Note: Either Tooling (A) can be used. Use the Tooling that is most suitable.

NOTICE

Keep all parts clean from contaminants.

Contaminants may cause rapid wear and shortened component life.

NOTICE

Care must be taken to ensure that fluids are contained during performance of inspection, maintenance, testing, adjusting and repair of the product. Be prepared to collect the fluid with suitable containers before opening any compartment or disassembling any component containing fluids.

Dispose of all fluids according to local regulations and mandates.

Note: Care must be taken in order to ensure that the fuel injection pump timing is not lost during the removal of the front gear group. Carefully follow the procedure in order to remove the gear group.

1. Use Tooling (A) in order to rotate the crankshaft so that number one piston is at the top center position on the compression stroke. Refer to Systems Operation, Testing and Adjusting, "Finding Top Centre Position for No.1 Piston".

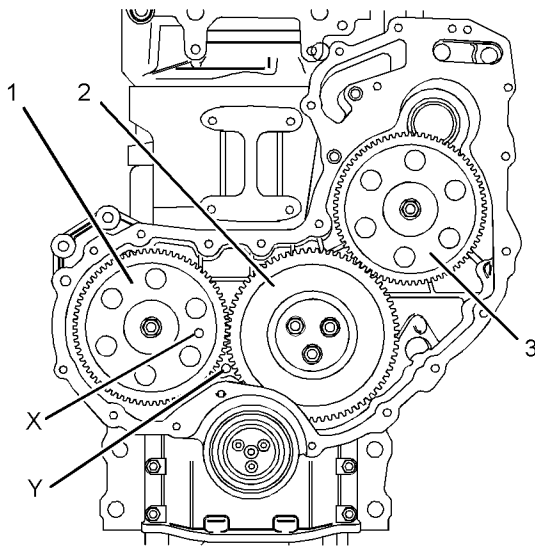

Illustration 128

g01247433

Typical example

2. Install Tooling (B) through hole (X) in camshaft gear (1) into the front housing. Use Tooling (B) in order to lock the camshaft in the correct position. Install Tooling (C) into hole (Y) in the front housing. Use Tooling (C) in order to lock the crankshaft in the correct position. Refer to Systems Operation, Testing and Adjusting, "Finding Top Centre Position for No.1 Piston".

Note: Do not use excessive force to install Tooling (C). Do not use Tooling (C) to hold the crankshaft during repairs.

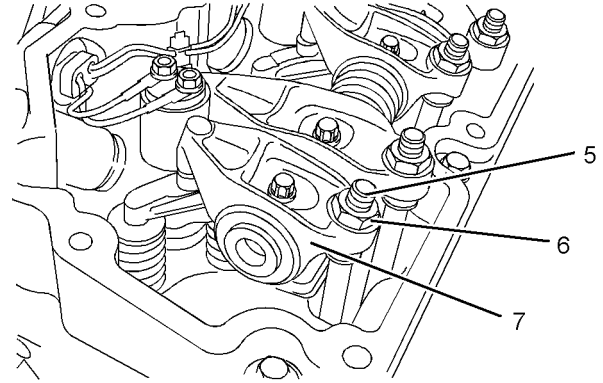

Illustration 129

g01269925

3. Loosen nuts (6) on all rocker arms (7). Unscrew adjusters (5) on all rocker arms (7) until all valves are fully closed.

Note: Failure to ensure that ALL adjusters are fully unscrewed can result in contact between the valves and pistons.

4. Apply sufficient pressure to fuel injection pump gear (3) in a counterclockwise direction in order to remove the backlash. Lock the fuel injection pump in this position. Refer to Disassembly and Assembly, "Fuel Pump Gear - Remove" for the correct procedure.

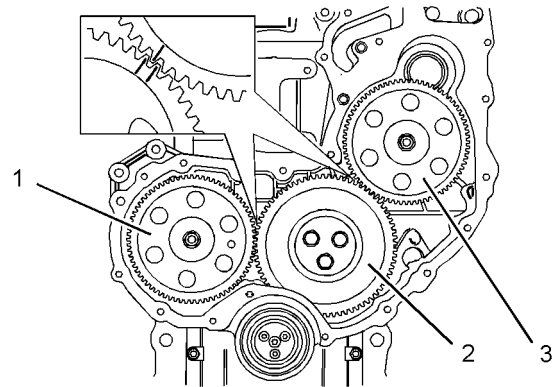

Illustration 130

g01247435

Typical example

5. Mark gears (1), (2) and (3) in order to show alignment. Refer to Illustration 130.

Note: Identification will ensure that the gears can be installed in the original alignment.

6. Remove fuel pump gear (3). Refer to Disassembly and Assembly, "Fuel Pump Gear - Remove" for the correct procedure.

7. Remove camshaft gear (1). Refer to Disassembly and Assembly, "Camshaft Gear - Remove and Install".
8. Remove idler gear (2). Refer to Disassembly and Assembly, "Idler Gear - Remove and Install".

Installation Procedure

Table 37

Required Tools			
Tool	Part Number	Part Name	Qty
B	27610212	Camshaft Timing Pin	1
C	27610286	Crankshaft Timing Pin	1
D	21825617	Dial Indicator Group	1
	-	Finger Clock	1

NOTICE

Keep all parts clean from contaminants.

Contaminants may cause rapid wear and shortened component life.

Note: The fuel injection pump must remain locked until the procedure instructs you to unlock the fuel injection pump.

1. Ensure that number one piston is at the top center position on the compression stroke. Refer to the Systems Operation, Testing and Adjusting, "Finding Top Center Position for No. 1 Piston".

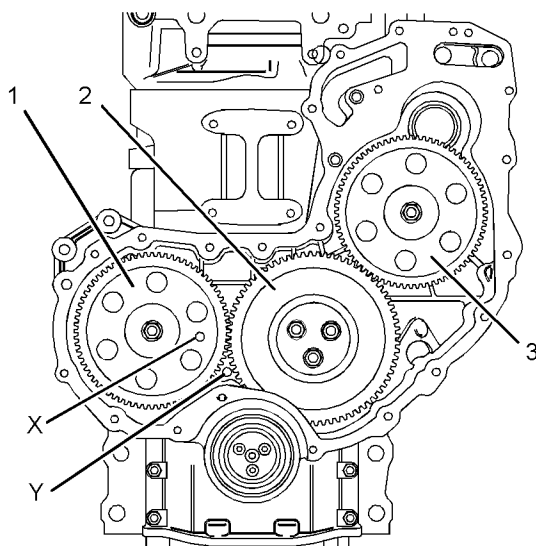

Illustration 131
Typical example

g01247433

2. If necessary, install Tooling (C) into hole (Y) in the front housing. Use Tooling (C) in order to lock the crankshaft in the correct position. Refer to Systems Operation, Testing and Adjusting, "Finding Top Centre Position for No.1 Piston".

Note: Do not use excessive force to install Tooling (C). Do not use Tooling (C) to hold the crankshaft during repairs.

3. Ensure that all of the components of the front gear group are clean and free from wear or damage. If necessary, replace any components that are worn or damaged.

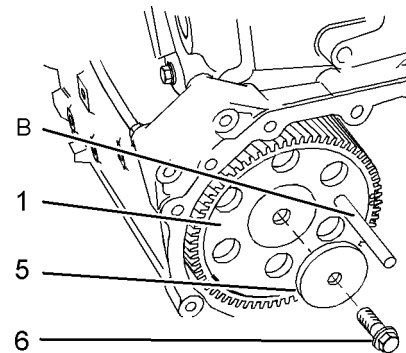

Illustration 132

g01269928

Typical example

4. Install camshaft gear (1). Loosely install bolt (6) and washer (5). Refer to Disassembly and Assembly, "Camshaft Gear - Remove and Install" for more information.
5. Install Tooling (B) through hole (X) in camshaft gear (1) into the front housing.

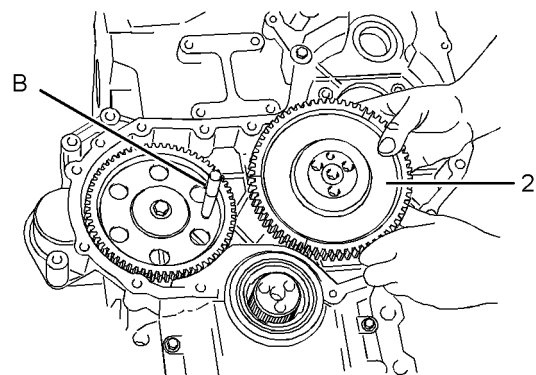

Illustration 133

g01269927

Typical example

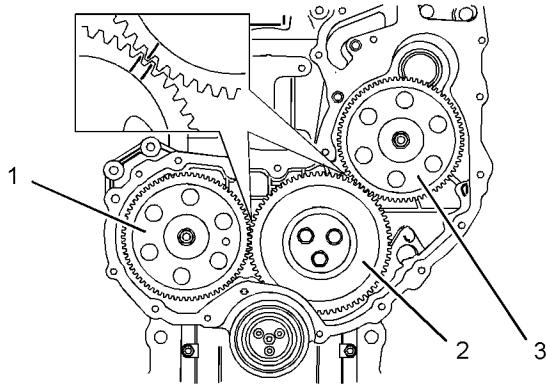

Illustration 134

g01247435

Alignment of timing marks

6. Install idler gear (2). Ensure that the timing marks on gears (1) and (2) are in alignment and that the mesh of the gears is correct. Refer to Disassembly and Assembly, "Idler Gear - Remove and Install". Check the end play of the idler gear. Refer to Specifications, "Gear Group (Front)" and refer to Disassembly and Assembly, "Idler Gear - Remove and Install" for further information.

7. Remove Tooling (B) and (C). Tighten the bolt (6) for the camshaft gear to a torque of 95 N·m (70 lb ft). Check the end play of the camshaft gear. Refer to Specifications, "Camshaft" for more information.

Install Tooling (B) through hole (X) in camshaft gear (1) into the front housing and install Tooling (C) into hole (Y) in the front housing.

8. Ensure that the fuel injection pump is locked in the correct position. Refer to Disassembly and Assembly, "Fuel Injection Pump - Install".

9. Install fuel injection pump gear (3). Refer to Disassembly and Assembly, "Fuel Injection Pump Gear - Install" for the correct procedure. Ensure that timing marks on gears (2) and (3) are in alignment. See Illustration 134. Ensure that the mesh of the gears is correct.

10. Remove Tooling (B) and (C).

11. Use Tooling (D) in order to measure the backlash for the gears (1), (2) and (3). Ensure that the backlash for the gears is within specified values. Refer to Specifications, "Gear Group (Front)" for further information.

12. Lubricate each gear with clean engine oil.

13. Adjust the engine valve lash. Refer to Systems Operation, Testing and Adjusting, "Engine Valve Lash - Inspect/Adjust".

End By:

- a. Install the front cover. Refer to Disassembly and Assembly, "Front Cover - Remove and Install".
- b. Install the valve mechanism cover. Refer to Disassembly and Assembly, "Valve Mechanism Cover - Remove and Install".
- c. If the engine is equipped with an air compressor, install the air compressor. Refer to Disassembly and Assembly, "Air Compressor - Remove and Install".
- d. If the engine is equipped with a vacuum pump, install the vacuum pump. Refer to Disassembly and Assembly, "Vacuum Pump - Remove and Install".
- e. If the engine is equipped with an accessory drive, install the accessory drive. Refer to Disassembly and Assembly, "Accessory Drive - Remove and Install".

i02586822

Idler Gear - Remove

Removal Procedure (Standard Idler Gear)

Table 38

Required Tools			
Tool	Part Number	Part Name	Qty
A	27610212	Camshaft Timing Pin	1
B	27610211	Crankshaft Timing Pin	1

Start By:

- a. If the engine is equipped with an air compressor, remove the air compressor. Refer to Disassembly and Assembly, "Air Compressor - Remove and Install".
- b. If the engine is equipped with a vacuum pump, remove the vacuum pump. Refer to Disassembly and Assembly, "Vacuum Pump - Remove and Install".
- c. If the engine is equipped with an accessory drive, remove the accessory drive. Refer to Disassembly and Assembly, "Accessory Drive - Remove and Install".

- d. Remove the fuel injection pump gear. Refer to Disassembly and Assembly, "Fuel Pump Gear - Remove".
- e. Remove the valve mechanism cover. Refer to Disassembly and Assembly, "Valve Mechanism Cover - Remove and Install".

Note: Care must be taken in order to ensure that the fuel injection pump timing is not lost during the removal of the fuel pump gear. Carefully follow the procedure in order to remove the fuel pump gear.

NOTICE

Keep all parts clean from contaminants.

Contaminants may cause rapid wear and shortened component life.

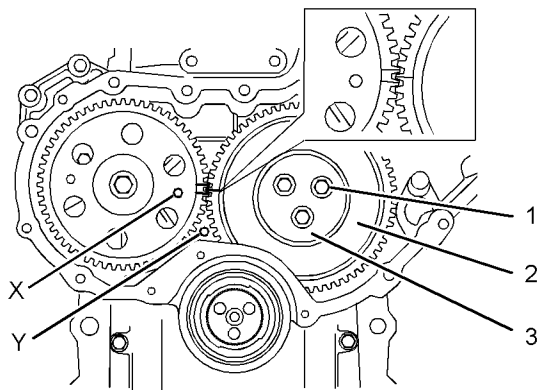

Illustration 135
Alignment of timing marks
g01249059

- 1. Ensure that Tooling (A) is installed into hole (X) in the camshaft gear. Use Tooling (A) in order to lock the camshaft in the correct position.

Note: Ensure that the gears are marked in order to show alignment. Refer to Illustration 135.

- 2. Ensure that Tooling (B) is installed in hole (Y) in the front housing. Use Tooling (B) in order to lock the crankshaft in the correct position.

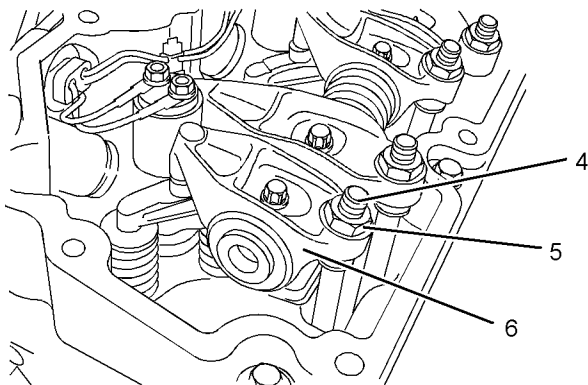

Illustration 136
g01269929

- 3. Loosen nuts (5) on all rocker arms (6). Unscrew adjusters (4) on all rocker arms (6) until all valves are fully closed.

Note: Failure to ensure that ALL adjusters are fully unscrewed can result in contact between the valves and pistons.

- 4. Mark plate (3) in order to show orientation. Refer to Illustration 135.

Note: Identification will ensure that the plate can be installed in the original orientation.

- 5. Remove bolts (1). Refer to Illustration 135.

- 6. Remove plate (3).

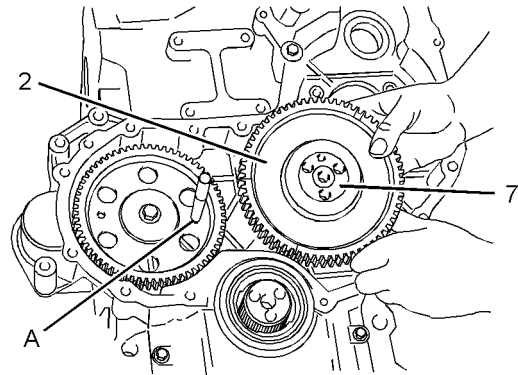

Illustration 137
Typical example
g01269930

- 7. Remove the assembly of idler gear (2) and hub (7) from the recess in the front housing.

Note: The idler gear must be tilted during removal.

- 8. Remove hub (7) from idler gear (2).

Removal Procedure (Heavy-Duty Idler Gear)

Table 39

Required Tools			
Tool	Part Number	Part Name	Qty
A	27610212	Camshaft Timing Pin	1
B	27610211	Crankshaft Timing Pin	1

Start By:

- a. If the engine is equipped with an air compressor, remove the air compressor. Refer to Disassembly and Assembly, "Air Compressor - Remove and Install".

- b. If the engine is equipped with a vacuum pump, remove the vacuum pump. Refer to Disassembly and Assembly, "Vacuum Pump - Remove and Install".
- c. If the engine is equipped with an accessory drive, remove the accessory drive. Refer to Disassembly and Assembly, "Accessory Drive - Remove and Install".
- d. Remove the fuel injection pump gear. Refer to Disassembly and Assembly, "Fuel Pump Gear - Remove".
- e. Remove the valve mechanism cover. Refer to Disassembly and Assembly, "Valve Mechanism Cover - Remove and Install".

Note: Care must be taken in order to ensure that the fuel injection pump timing is not lost during the removal of the fuel pump gear. Carefully follow the procedure in order to remove the fuel pump gear.

NOTICE

Keep all parts clean from contaminants.

Contaminants may cause rapid wear and shortened component life.

Note: The assembly of heavy-duty idler gear is not serviceable. Do not disassemble the heavy-duty idler gear.

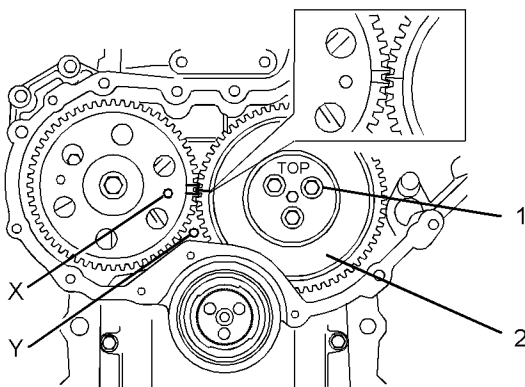

Illustration 138

g01269931

Alignment of timing marks

1. Ensure that Tooling (A) is installed into hole (X) in the camshaft gear. Use Tooling (A) in order to lock the camshaft in the correct position.

Note: Ensure that the gears are marked in order to show alignment. Refer to Illustration 138.

2. Ensure that Tooling (B) is installed in hole (Y) in the front housing. Use Tooling (B) in order to lock the crankshaft in the correct position.

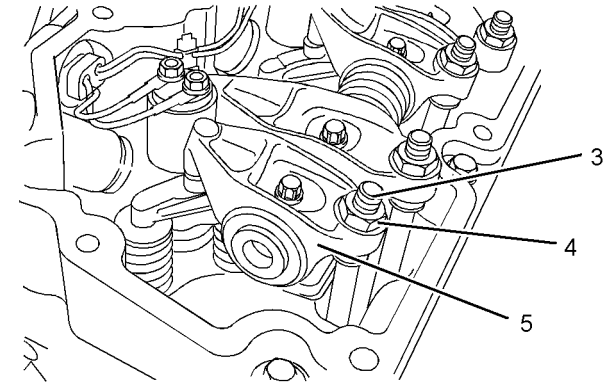

Illustration 139

g01269932

3. Loosen nuts (4) on all rocker arms (5). Unscrew adjusters (3) on all rocker arms (5) until all valves are fully closed.

Note: Failure to ensure that ALL adjusters are fully unscrewed can result in contact between the valves and pistons.

4. Remove bolts (1) from the assembly of idler gear (2). Refer to Illustration 138.

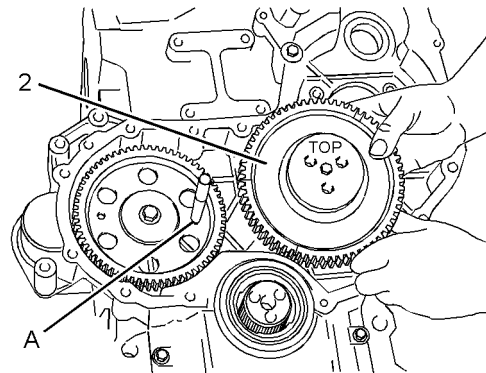

Illustration 140

g01269933

Typical example

5. Remove the assembly of idler gear (2) from the recess in the front housing.

Note: The idler gear must be tilted during removal.

i02586870

Idler Gear - Install

Installation Procedure (Standard Idler Gear)

Table 40

Required Tools			
Tool	Part Number	Part Name	Qty
A	27610212	Camshaft Timing Pin	1
B	27610211	Crankshaft Timing Pin	1
C	21825617	Dial Indicator Group	1
	-	Finger Clock	1

NOTICE

Keep all parts clean from contaminants.

Contaminants may cause rapid wear and shortened component life.

1. Ensure that number one piston is at the top center position on the compression stroke. Refer to the Systems Operation, Testing and Adjusting, "Finding Top Center Position for No. 1 Piston".

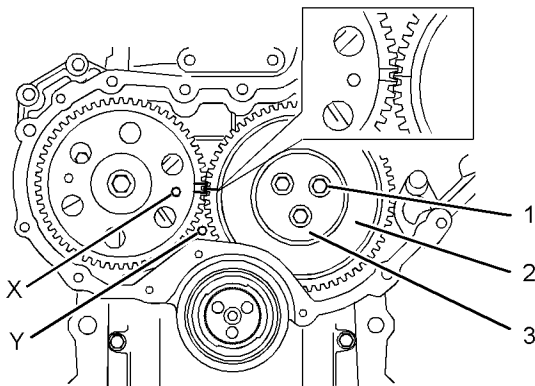

Illustration 141

g01249059

Alignment of timing marks

2. Ensure that Tooling (A) is installed into hole (X) in camshaft gear (1).
3. Ensure that Tooling (B) is installed in hole (Y) in the front housing. Use Tooling (B) in order to lock the crankshaft in the correct position. Refer to Systems Operation, Testing and Adjusting, "Finding Top Centre Position for No.1 Piston".

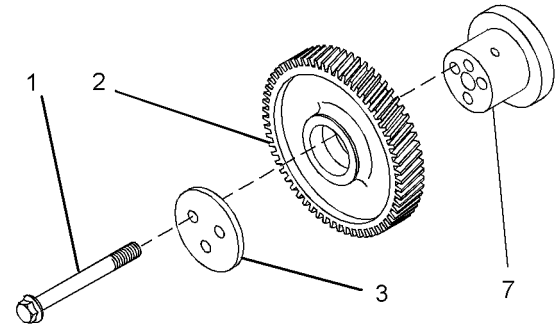

Illustration 142

g01269934

4. Clean idler gear (2) and inspect the idler gear for wear or damage. Refer to Specifications, "Gear Group (Front)" for more information. If necessary, replace the idler gear.
5. Clean hub (7) and inspect the hub for wear or damage. Refer to Specifications, "Gear Group (Front)" for more information. If necessary, replace the hub.
6. Lubricate hub (7) with clean engine oil. Slide the hub into idler gear (2). Ensure that the timing marks are toward the front of the idler gear.

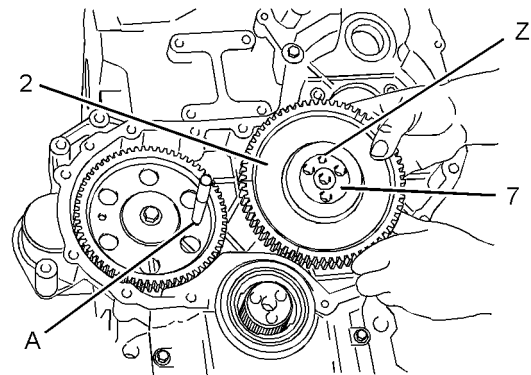

Illustration 143

g01269935

Typical example

7. Align the timing mark on idler gear (2) with the timing mark on the camshaft gear. Refer to the Illustration 141. Install the assembly of idler gear (2) and hub (7) into the recess in the timing case. Ensure that oil hole (Z) is to the top of the hub.

Note: The idler gear must be tilted during installation. Ensure that the holes in the hub are aligned with the holes in the cylinder block.

8. Clean plate (3) and inspect the plate for wear or damage. If necessary, replace the plate.

9. Lubricate plate (3) with clean engine oil. A used plate should be installed in the original orientation. If a new plate is installed, ensure that the holes in plate (3) are aligned with the holes in hub (7). Install plate (3) to hub (7).

10. Install bolts (1). Tighten bolts (1) to a torque of 44 N·m (32 lb ft).

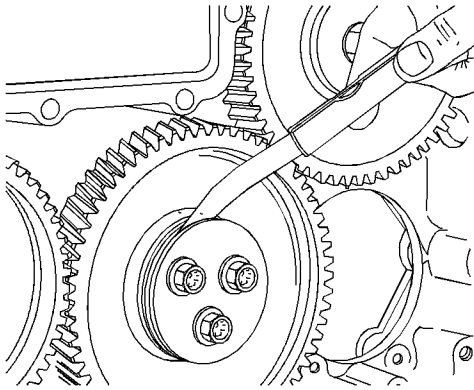

Illustration 144 g01269936
Checking end play by using a set of feeler gauge's

11. Use a set of feeler gauge's in order to check the end play of the idler gear. Refer to Specifications, "Gear Group (Front)" for more information.
12. Use Tooling (C) in order to check the backlash between the idler gear and the camshaft gear. Refer to Specifications, "Gear Group (Front)" for more information.
13. Use Tooling (C) in order to check the backlash between the idler gear and the crankshaft gear. Refer to Specifications, "Gear Group (Front)" for more information.

14. Lightly lubricate all of the gears with clean engine oil.

End By:

- a. Install the fuel injection pump gear. Refer to Disassembly and Assembly, "Fuel Pump Gear - Install".
- b. If the engine is equipped with an air compressor, install the air compressor. Refer to Disassembly and Assembly, "Air Compressor - Remove and Install".
- c. If the engine is equipped with a vacuum pump, install the vacuum pump. Refer to Disassembly and Assembly, "Vacuum Pump - Remove and Install".

- d. If the engine is equipped with an accessory drive, install the accessory drive. Refer to Disassembly and Assembly, "Accessory Drive - Remove and Install".

Installation Procedure (Heavy-Duty Idler Gear)

Table 41

Required Tools			
Tool	Part Number	Part Name	Qty
A	27610212	Camshaft Timing Pin	1
B	27610211	Crankshaft Timing Pin	1
C	21825617	Dial Indicator Group	1
	-	Finger Clock	1

NOTICE

Keep all parts clean from contaminants.

Contaminants may cause rapid wear and shortened component life.

1. Ensure that number one piston is at the top center position on the compression stroke. Refer to Systems Operation, Testing and Adjusting, "Finding Top Center Position for No. 1 Piston".

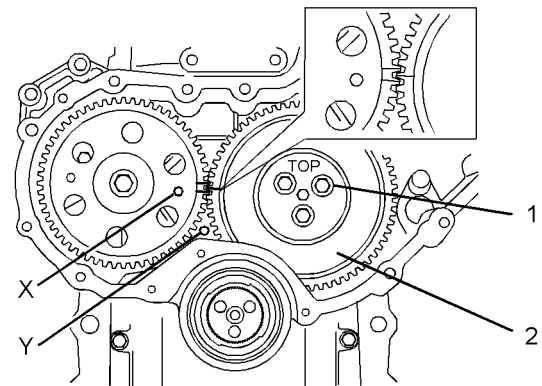

Illustration 145 g01269931
Alignment of timing marks

2. Ensure that Tooling (A) is installed into hole (X) in the camshaft gear.
3. Ensure that Tooling (B) is installed in hole (Y) in the cylinder block. Use Tooling (B) in order to lock the crankshaft in the correct position. Refer to Systems Operation, Testing and Adjusting, "Finding Top Centre Position for No.1 Piston".

4. Clean the assembly of idler gear (2) and inspect the assembly of the idler gear for wear or damage. Refer to Specifications, "Gear Group (Front)" for more information. If necessary, replace the assembly of the idler gear.
5. Lubricate the bearings in the assembly of idler gear (2) with clean engine oil.

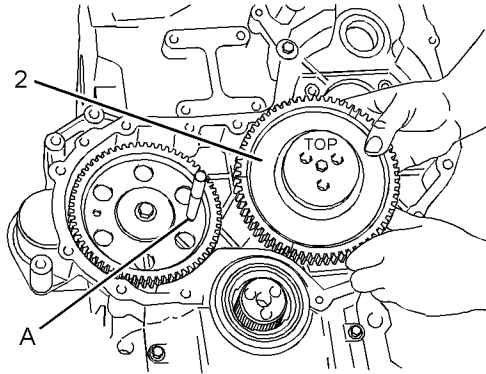

Illustration 146

g01269933

6. Align the timing mark on idler gear (2) with the timing mark on the camshaft gear. Refer to Illustration 145. Install the assembly of idler gear (2) into the recess in the timing case. Ensure that the identification mark TOP is upward.

Note: The idler gear must be tilted during installation. Ensure that the holes in assembly of the idler gear are aligned with the holes in the cylinder block.

7. Install bolts (1). Tighten bolts (1) to a torque of 44 N·m (32 lb ft).

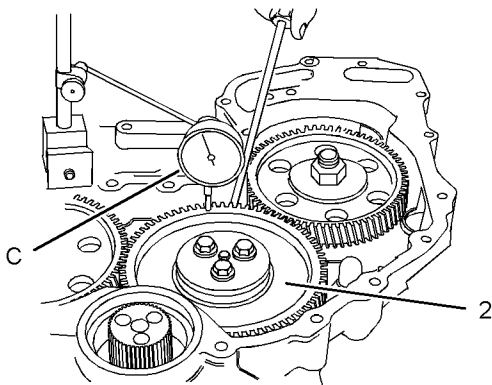

Illustration 147

g01269937

Checking end play by using a dial indicator group

8. Use Tooling (C) in order to check the end play of the idler gear. Refer to Specifications, "Gear Group (Front)" for more information.
9. Use Tooling (C) in order to check the backlash between the idler gear and the camshaft gear. Refer to Specifications, "Gear Group (Front)" for more information.

10. Use Tooling (C) in order to check the backlash between the idler gear and the crankshaft gear. Refer to Specifications, "Gear Group (Front)" for more information.

11. Lightly lubricate all of the gears with clean engine oil.

End By:

- a. Install the fuel injection pump gear. Refer to Disassembly and Assembly, "Fuel Pump Gear - Install".
- b. If the engine is equipped with an air compressor, install the air compressor. Refer to Disassembly and Assembly, "Air Compressor - Remove and Install".
- c. If the engine is equipped with a vacuum pump, install the vacuum pump. Refer to Disassembly and Assembly, "Vacuum Pump - Remove and Install".
- d. If the engine is equipped with an accessory drive, install the accessory drive. Refer to Disassembly and Assembly, "Accessory Drive - Remove and Install".

i02586916

Housing (Front) - Remove

Removal Procedure

Start By:

- a. Remove the fan. Refer to Disassembly and Assembly, "Fan - Remove and Install".
- b. Remove the alternator. Refer to Disassembly and Assembly, "Alternator - Remove".
- c. Remove the crankshaft pulley. Refer to Disassembly and Assembly, "Crankshaft Pulley - Remove and Install".
- d. Remove the engine oil pan. Refer to Disassembly and Assembly, "Engine Oil Pan - Remove and Install".
- e. Remove the timing gears. Refer to Disassembly and Assembly, "Gear Group (Front) - Remove and Install".
- f. Remove the fuel injection pump. Refer to Disassembly and Assembly, "Fuel Injection Pump - Remove".

NOTICE

Keep all parts clean from contaminants.

Contaminants may cause rapid wear and shortened component life.

NOTICE

Care must be taken to ensure that fluids are contained during performance of inspection, maintenance, testing, adjusting and repair of the product. Be prepared to collect the fluid with suitable containers before opening any compartment or disassembling any component containing fluids.

Dispose of all fluids according to local regulations and mandates.

1. Ensure that the coolant is drained into a suitable container for storage or disposal. Refer to Operation and Maintenance Manual, "Cooling System Coolant - Drain" for the correct procedure.

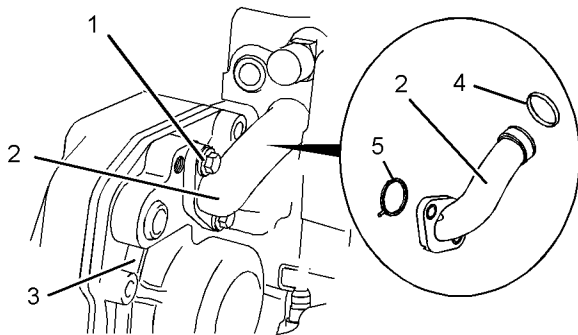

Illustration 148
Typical example

2. Remove bolts (1) that secure bypass tube (2) to front housing (3). Note the position of any brackets that are secured by the bolts. Remove bypass tube (2). Remove O-ring seals (4) and (5) from bypass tube (2).

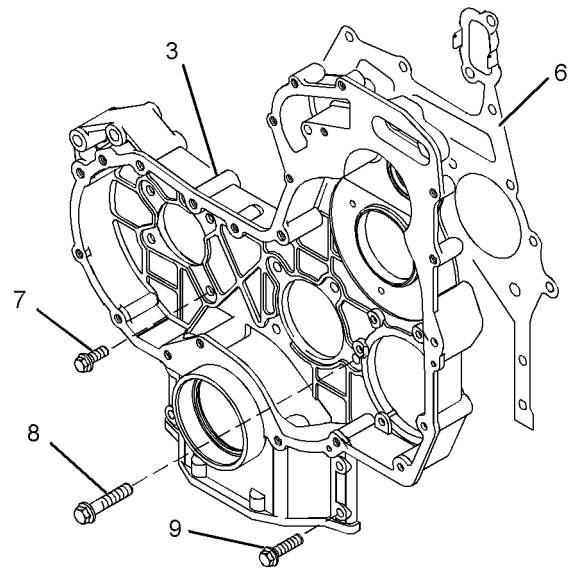

Illustration 149
Typical example

3. Remove bolts (7), (8) and (9) from front housing (3).

Note: The bolts are three different lengths. Note the positions of the different bolts.

4. Remove front housing (3) from the cylinder block.
5. Remove joint (6).

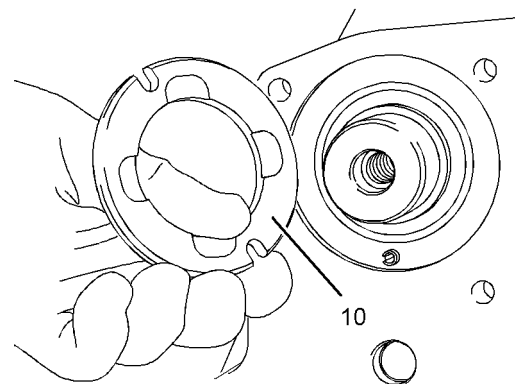

Illustration 150
Typical example

6. Remove thrust washer (10) from the cylinder block.

i02588314

Housing (Front) - Install

Installation Procedure

Table 42

Required Tools			
Tool	Part Number	Part Description	Qty
A	21820117	POWERPART Threadlock and Nutlock	1
B	-	Guide Stud (M8 by 80 mm)	2
C	27610216	Alignment Tool	1
	-	Bolts (M10 by 50 mm)	3
D	-	Straight Edge	1
E	21820221	POWERPART Rubber Grease	1

NOTICE

Keep all parts clean from contaminants.

Contaminants may cause rapid wear and shortened component life.

1. Ensure that the front housing is clean and free from damage. If necessary, replace the front housing.

If necessary, install blanking plugs to a new front housing. Use Tooling (A) to seal all D-plugs.
2. Check the condition of the crankshaft front seal. If the front seal is damaged, remove the front seal from the front housing.
3. Clean all the mating surfaces of the cylinder block.

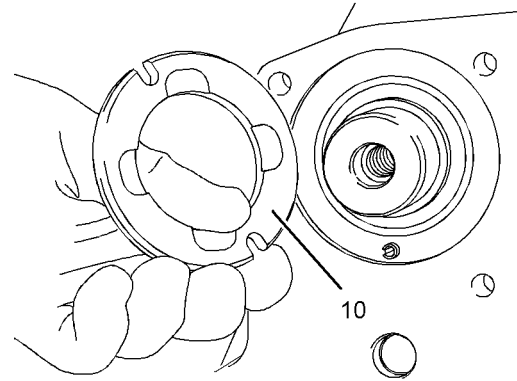

Illustration 151

g01265293

Typical example

4. Install thrust washer (10) into the recess in the cylinder block. Refer to Disassembly and Assembly, "Camshaft - Install" for more information.

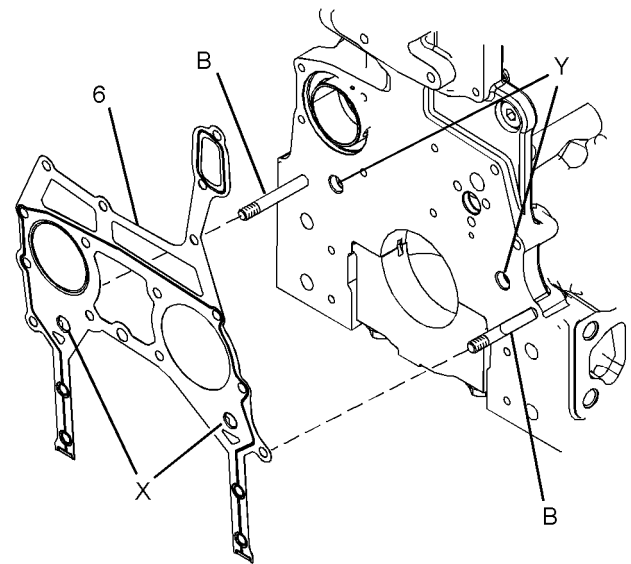

Illustration 152

g01269946

Typical example

5. Install Tooling (B) to the cylinder block. Refer to Illustration 152.
6. Install Tooling (C) to the cylinder block.
7. Align a new joint (6) with Tooling (B). Install the joint to the cylinder block.

Note: Ensure that tabs (X) on the joint are engaged in holes (Y) in the cylinder block.

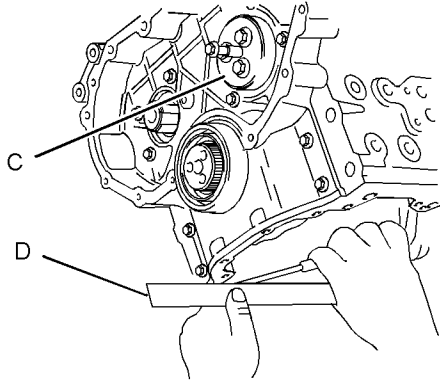

Illustration 153
Typical example
g01269947

8. Install the front housing over Tooling (B) and over Tooling (C) onto the cylinder block.

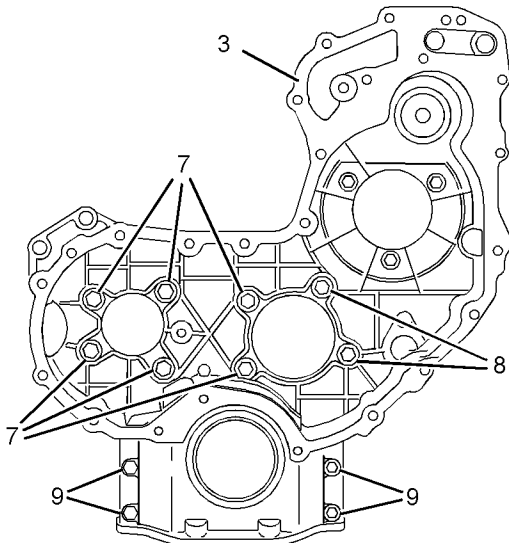

Illustration 154
g01269948
(7) M8 by 20 mm
(8) M8 by 35 mm
(9) M8 by 25 mm

9. Install bolts (9) to front housing (3) finger tight.

10. Remove Tooling (B).

11. Loosely install bolts (7) and (8). Refer to Illustration 154 for the correct position of the bolts.

12. Align the bottom face of front housing (3) to the lower machined face of the cylinder block. Use a Tooling (D) and a feeler gauge in order to check the alignment between the front housing and the cylinder block. Refer to Illustration 153. Refer to Specifications, "Front Housing and Covers" for further information.

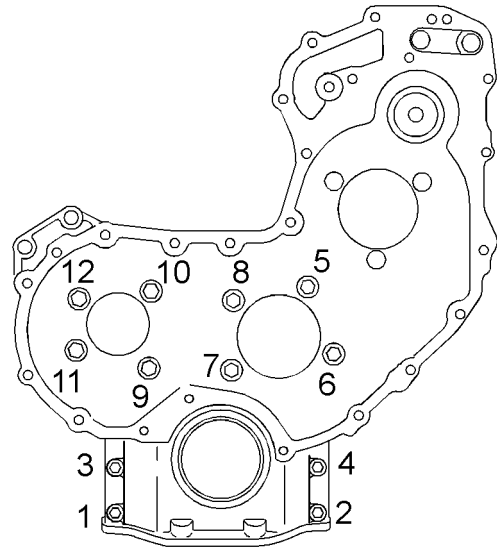

Illustration 155
Tightening sequence for the front housing
g01269949

13. Tighten bolts (6), (7) and (8) to a torque of 28 N·m (20 lb ft). Tighten the bolts in the sequence that is shown in Illustration 155.

Note: Ensure that the housing and the cylinder block are correctly aligned.

14. Remove Tooling (C) from the cylinder block.

15. If necessary, install a new crankshaft front seal. Refer to Disassembly and Assembly, "Crankshaft Front Seal - Remove and Install".

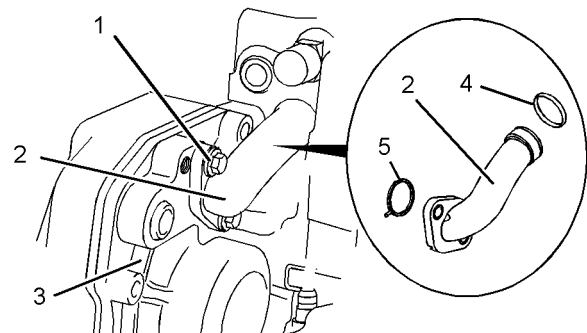

Illustration 156
Typical example
g01265269

16. Install new O-ring seals (4) and (5) to bypass tube (1). Use Tooling (E) in order to lubricate O-ring seal (5). Install bypass tube (2) to the cylinder head. Install bolts (1). Ensure that any brackets that are secured by the bolts are installed in the correct location. Tighten the bolts to a torque of 22 N·m (16 lb ft).

17. Fill the cooling system with coolant. Refer to Operation and Maintenance Manual, "Cooling System Coolant - Fill" for the correct procedure.

End By:

- a. Install the fuel injection pump. Refer to Disassembly and Assembly, "Fuel Injection Pump - Install".
- b. Install the timing gears. Refer to Disassembly and Assembly, "Gear Group (Front) - Install".
- c. Install the engine oil pan. Refer to Disassembly and Assembly, "Engine Oil Pan - Remove and Install".
- d. Install the crankshaft pulley. Refer to Disassembly and Assembly, "Crankshaft Pulley - Remove and Install".
- e. Install the alternator. Refer to Disassembly and Assembly, "Alternator - Install".
- f. Install the fan. Refer to Disassembly and Assembly, "Fan - Remove and Install".

i02588315

Accessory Drive - Remove and Install

Removal Procedure

Table 43

Required Tools			
Tool	Part Number	Part Description	Qty
A	-	Bearing Puller	1
	-	Puller	1
	-	Crossblock	1
	-	Puller Leg	2

NOTICE

Keep all parts clean from contaminants.

Contaminants may cause rapid wear and shortened component life.

NOTICE

Care must be taken to ensure that fluids are contained during performance of inspection, maintenance, testing, adjusting and repair of the product. Be prepared to collect the fluid with suitable containers before opening any compartment or disassembling any component containing fluids.

Dispose of all fluids according to local regulations and mandates.

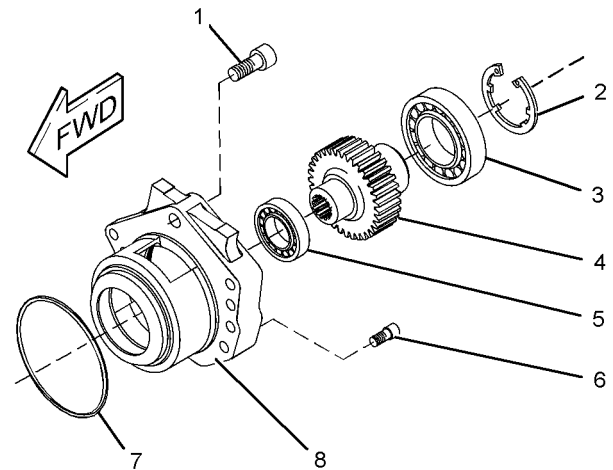

Illustration 157

g01269954

Typical example

1. Remove allen head screw (1) from accessory drive housing (8). Remove allen head screws (6) from accessory drive housing (8).
2. Remove accessory drive housing (8) from the front housing.
3. If necessary, follow Steps 3.a through 3.c in order to disassemble the accessory drive.
 - a. Remove circlip (2) from accessory drive housing (8).
 - b. Place accessory drive housing (8) onto a suitable support. Press the assembly of gear (4) and bearings (3) and (5) out of accessory drive housing (8). Use a Tooling (A) in order to remove bearings (3) and (5) from gear (4).
 - c. Remove O-ring seal (7) from accessory drive housing (8).

Installation Procedure

Table 44

Required Tools			
Tool	Part Number	Part Description	Qty
B	21820603	POWERPART Retainer	-
C	21820221	POWERPART Rubber Grease	1
D	21820117	POWERPART Threadlock and Nutlock	1

NOTICE

Keep all parts clean from contaminants.

Contaminants may cause rapid wear and shortened component life.

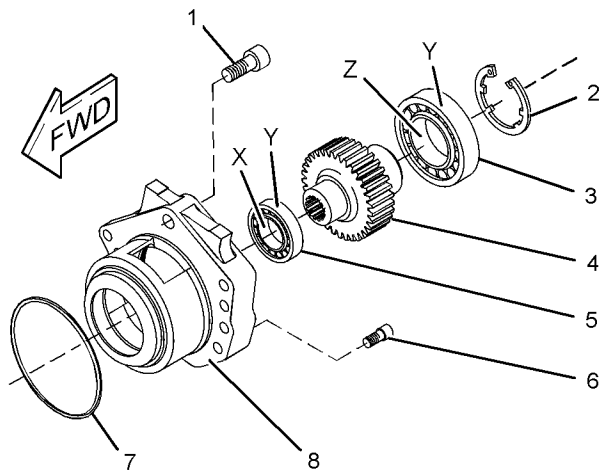

Illustration 158

g01264852

Typical example

1. If necessary, follow Steps 1.a through 1.e in order to assemble the accessory drive.
 - a. Inspect the condition of the teeth and the splines of gear (4) for wear or damage. Inspect bearings (3) and (5), circlip (2), and the front housing for wear or damage. Replace any components that are worn or damaged.
 - b. Apply a small continuous bead of Tooling (B) to inner surface (X) of bearing (5). Place the gear shaft on a suitable support. Press on the inner race of bearing (5) until the bearing (5) is against the shoulder of gear (4). Remove any excess sealant.

- c. Apply a small continuous bead of Tooling (B) to inner surface (Z) of bearing (3). Place the inner race of bearing (3) onto a suitable support. Press the shaft of gear (4) into bearing (3) until the shoulder of the gear is against the bearing. Remove any excess sealant.
 - d. Apply a small continuous bead of Tooling (B) to outer surface (Y) of bearings (3) and (5). Place accessory drive housing (8) on a suitable support. Press the assembly of the gear into the accessory drive housing. Ensure that bearing (5) is against the front face of the recess in accessory drive housing (8). Remove any excess sealant.
 - e. Install circlip (2) into the groove in accessory drive housing (8). Ensure that circlip (2) is correctly positioned in the groove.
2. Lightly lubricate a new O-ring seal (7) with Tooling (C). Install the O-ring seal into the groove in accessory drive housing (8).
3. Inspect the bore in the front housing for damage. If necessary, replace the front housing. Refer to Disassembly and Assembly, "Housing (Front) - Remove" and Disassembly and Assembly, "Housing (Front) - Install".
4. Lightly lubricate bearing (3), bearing (5), and gear (4) with clean engine lubricating oil. Install the assembly of the accessory drive to the front housing. Ensure that the flange on the accessory drive housing is flush with the front housing.
5. Apply Tooling (D) to allen head screws (1) and (6). Install allen head screws (1) and (6) to the accessory drive housing (8). Tighten the allen head screws to a torque of 22 N·m (16 lb ft).
6. Ensure that there is tactile backlash between the idler gear and the accessory drive gear.

i02588318

Crankcase Breather - Remove and Install (Filtered Breather)

Removal Procedure

NOTICE

Care must be taken to ensure that fluids are contained during performance of inspection, maintenance, testing, adjusting, and repair of the product. Be prepared to collect the fluid with suitable containers before opening any compartment or disassembling any component containing fluids.

Dispose of all fluids according to local regulations and mandates.

NOTICE

Keep all parts clean from contaminants.

Contaminants may cause rapid wear and shortened component life.

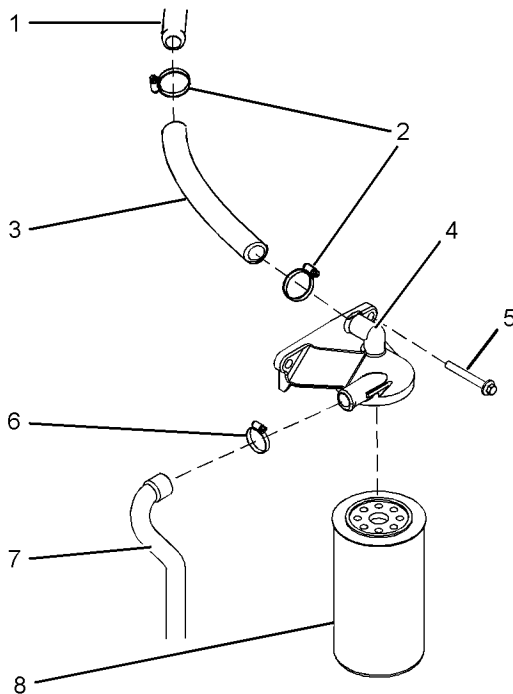

Illustration 159
Typical example

1. Remove canister (8). Refer to Operation and Maintenance Manual, "Crankcase Breather (Canister) - Replace".

2. Loosen clamp (6) and remove hose (7).
3. Release spring clamps (2) in order to remove hose (3). Remove the hose from connection (1) on the valve mechanism cover and from filter base (4).
4. Remove bolts (5) and remove filter base (4).

Note: If a spacer is installed between the filter base and the engine, remove the spacer.

Installation Procedure

NOTICE

Keep all parts clean from contaminants.

Contaminants may cause rapid wear and shortened component life.

1. Ensure that all components of the crankcase breather are clean and free from damage. Replace any components that are damaged.

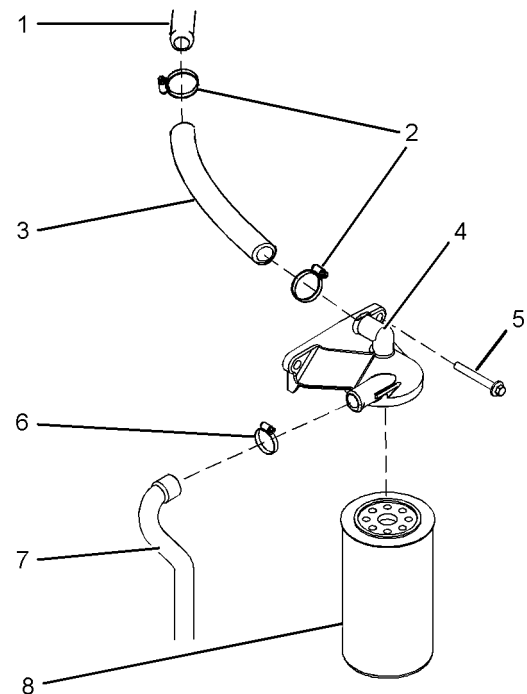

Illustration 160
Typical example

g01293387

2. Install bolts (5) to filter base (4).

Note: If spacers are installed, position the spacers over the bolts.

3. Install the assembly of the filter base to the engine.
4. Tighten bolts (5) to a torque of 22 N·m (16 lb ft).

5. Install spring clamps (2) to hose (3). Install hose (3) to connection (1) and to filter base (4).

Note: Ensure that the spring clamps are correctly positioned in order to secure the hose.

6. Install clamp (6) to hose (7). Install hose (7) to filter base (4). Tighten the clamp.
7. Install a new canister (8) to filter base (4). Refer to Operation and Maintenance Manual, "Crankcase Breather (Canister) - Replace".

i02588317

Crankcase Breather - Remove and Install (Unfiltered Breather)

Removal Procedure

NOTICE

Keep all parts clean from contaminants.

Contaminants may cause rapid wear and shortened component life.

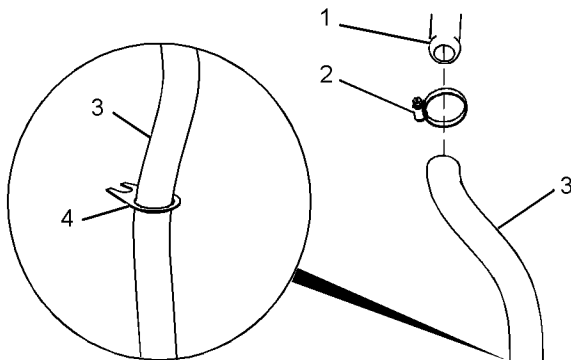

Illustration 161

g01249095

Typical example

1. Loosen clamp (2) and remove hose (3) from connection (1) on the valve mechanism cover. Withdraw hose (3) from clip (4) and remove the hose.

Installation Procedure

NOTICE

Keep all parts clean from contaminants.

Contaminants may cause rapid wear and shortened component life.

1. Ensure that all components of the crankcase breather are clean and free from damage. Replace any components that are damaged.

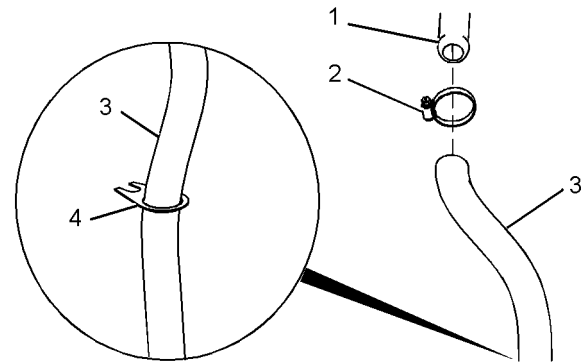

Illustration 162

g01249095

Typical example

2. Connect hose (3) to connection (1) on the valve mechanism cover. Tighten clamp (2). Install hose (3) into clip (4).

i02588319

Valve Mechanism Cover - Remove and Install

Removal Procedure

Start By:

- a. Disconnect the crankcase breather or remove the crankcase breather. Refer to Disassembly and Assembly, "Crankcase Breather - Remove".

NOTICE

Keep all parts clean from contaminants.

Contaminants may cause rapid wear and shortened component life.

1. If the valve mechanism cover is equipped with a heat shield, remove the heat shield.

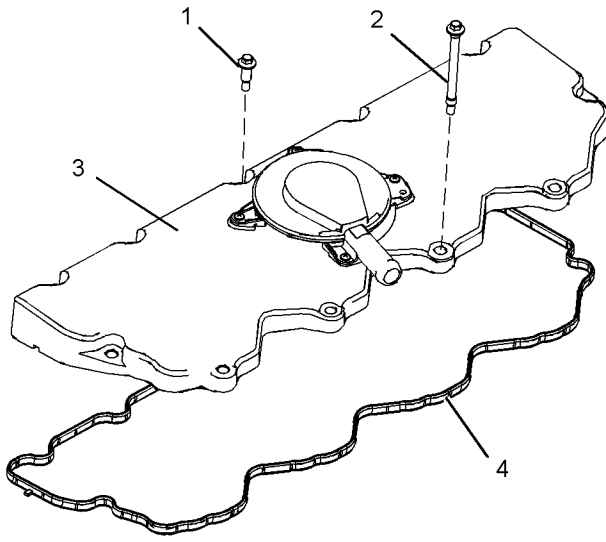

Illustration 163
Typical example g01245161

2. Remove bolts (1) and (2) from valve mechanism cover (3).
3. Remove valve mechanism cover (3) from the valve mechanism cover base.
4. Remove joint (4) from valve mechanism cover (3).

Installation Procedure

NOTICE

Keep all parts clean from contaminants.

Contaminants may cause rapid wear and shortened component life.

1. Thoroughly clean the valve mechanism cover.
Clean the mating surfaces of the valve mechanism cover base.

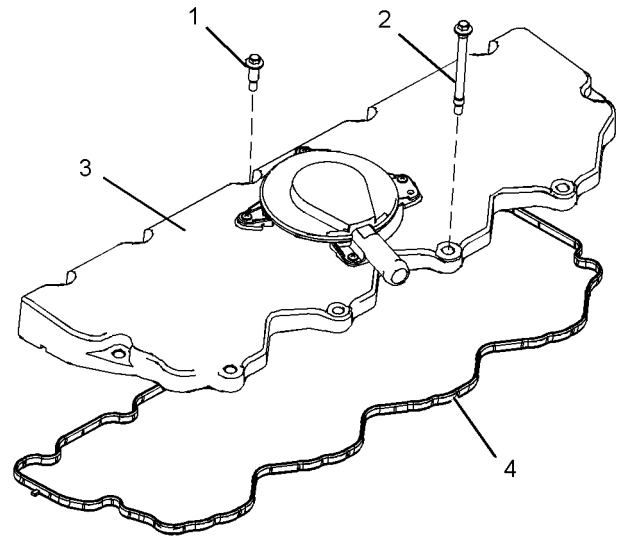

Illustration 164
Typical example g01245161

2. Install a new joint (4) to valve mechanism cover (3).

Note: Ensure that the joint is fully seated into the groove of the valve mechanism cover.

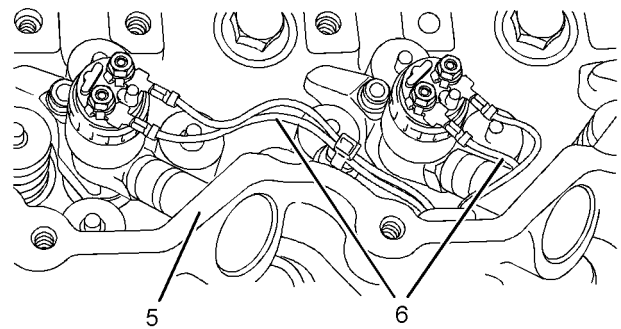

Illustration 165
Typical example g01269961

3. Ensure that harness assemblies (6) are not in contact with the rocker arms or in contact with the valve mechanism cover base. Position valve mechanism cover (3) onto valve mechanism cover base (5). Ensure that harness assemblies (6) are not trapped during the assembly procedure. Install bolts (1) and (2).

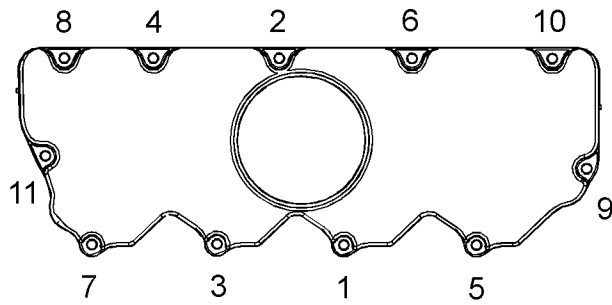

Illustration 166 g01245162

Tightening sequence for the valve mechanism cover

4. Tighten bolts (1) and (2) in the numerical sequence that is shown in Illustration 166. Tighten the bolts to a torque of 6 N·m (53 lb in).
5. If the valve mechanism cover is equipped with a heat shield, install the heat shield. Tighten the bolts to a torque of 9 N·m (79 lb in).

End By:

- a. Connect the crankcase breather or install the crankcase breather. Refer to Disassembly and Assembly, "Crankcase Breather - Install".

i02588321

Valve Mechanism Cover Base - Remove and Install

Removal Procedure

Table 45

Required Tools			
Tool	Part Number	Part Description	Qty
A	-	Circlip Pliers	1

Start By:

- a. Remove the valve mechanism cover. Refer to Disassembly and Assembly, "Valve Mechanism Cover - Remove and Install".
- b. Remove the fuel injection lines. Refer to Disassembly and Assembly, "Fuel Injection Lines - Remove".

NOTICE

Keep all parts clean from contaminants.

Contaminants may cause rapid wear and shortened component life.

NOTICE

Use a deep socket in order to remove the electrical connections from the electronic unit injectors. Use of incorrect tooling will result in damage to the electronic unit injectors.

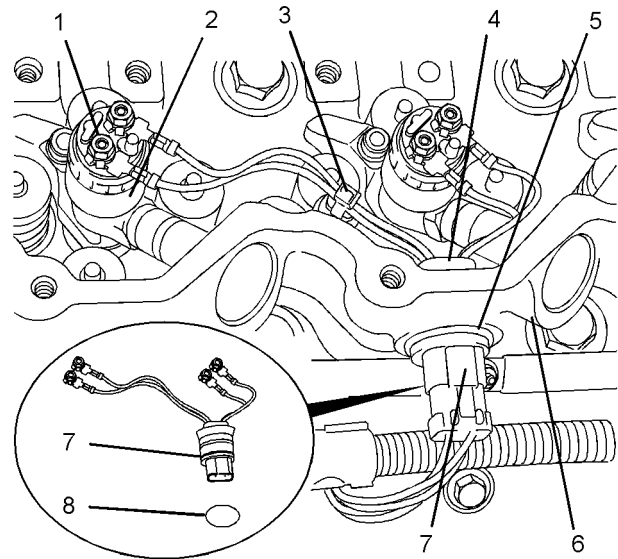

Illustration 167

g01269979

Typical example

1. Make a temporary identification mark on connections (1).
2. Use a deep socket to remove connections (1) from electronic unit injectors (2).
3. Disconnect plugs (7) from harness assemblies (4).
4. If necessary, follow Steps 4.a through 4.e in order to remove harness assemblies (4) from valve mechanism cover base (6).
 - a. Cut cable ties (3).
 - b. Use Tooling (A) to remove circlip (5).
 - c. From the outside of valve mechanism cover base (6), push harness assembly (4) inward. Withdraw the harness assembly from valve mechanism cover base (6).
 - d. Remove O-ring seal (8) from harness assembly (4).

- e. Repeat Steps 4.a through 4.d in order to remove the remaining harness assembly.

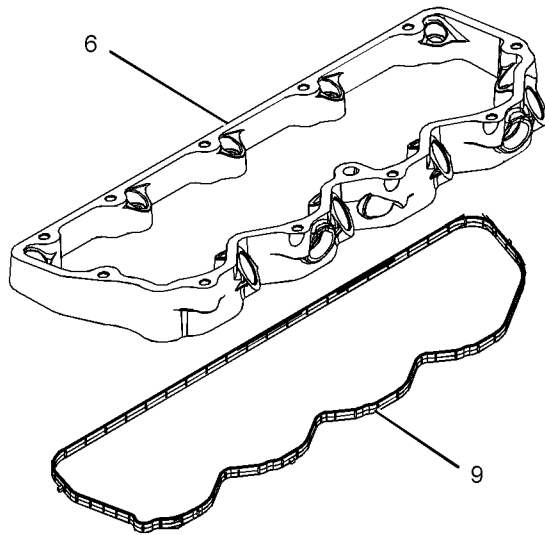

Illustration 168

g01245186

Typical example

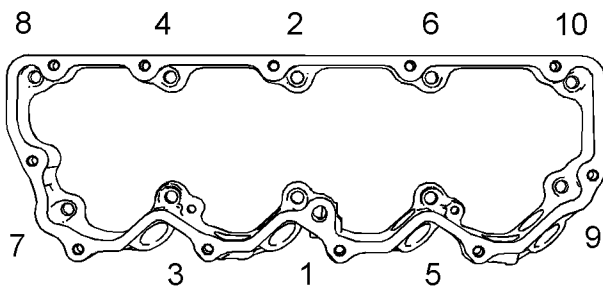

Illustration 169

g01245190

Tightening sequence for the valve mechanism cover base

5. Gradually loosen the captive bolts that secure the valve mechanism cover base in reverse numerical order. Refer to Illustration 169. This will help prevent distortion of the valve mechanism cover base.

Note: The captive bolts cannot be removed from the valve mechanism cover base.

6. Remove valve mechanism cover base (6) from the cylinder head.
7. Remove seal (9) from valve mechanism cover base (6).

Installation Procedure

Table 46

Required Tools			
Tool	Part Number	Part Description	Qty
A	-	Circlip Pliers	1
B	21820221	POWERPART Rubber Grease	1
C	27610296	Torque wrench	1

NOTICE

Keep all parts clean from contaminants.

Contaminants may cause rapid wear and shortened component life.

NOTICE

Use a deep socket in order to remove the electrical connections from the electronic unit injectors. Use of incorrect tooling will result in damage to the electronic unit injectors.

1. Clean the valve mechanism cover base. Ensure that the mating surfaces are free from damage.

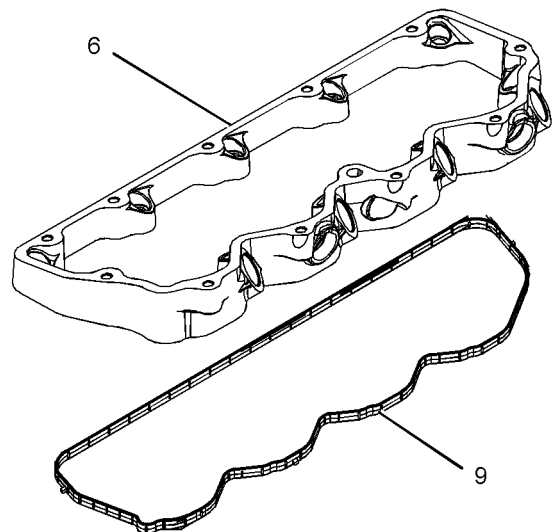

Illustration 170

g01245186

Typical example

2. Install seal (9) to valve mechanism cover base (6). Ensure that the seal is seated correctly in the groove in the valve mechanism cover base.

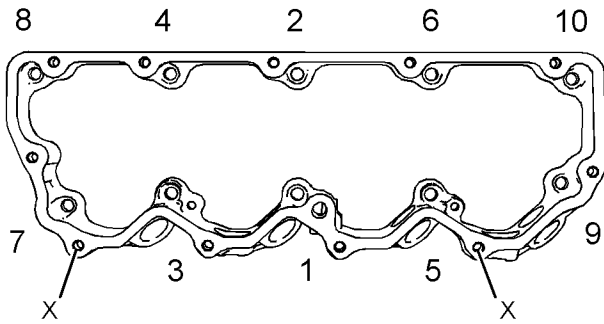

Illustration 171
Tightening sequence for the valve mechanism cover base

3. Position valve mechanism cover base (6) on the cylinder head. Temporarily install two long bolts from the valve mechanism cover in positions (X).

Note: The long bolts must be installed in order to align the valve mechanism cover base.

4. Gradually tighten the captive bolts that secure the valve mechanism cover base to a torque of 9 N·m (79 lb in) in the sequence that is shown in Illustration 171.

5. Remove the bolts from positions (X).

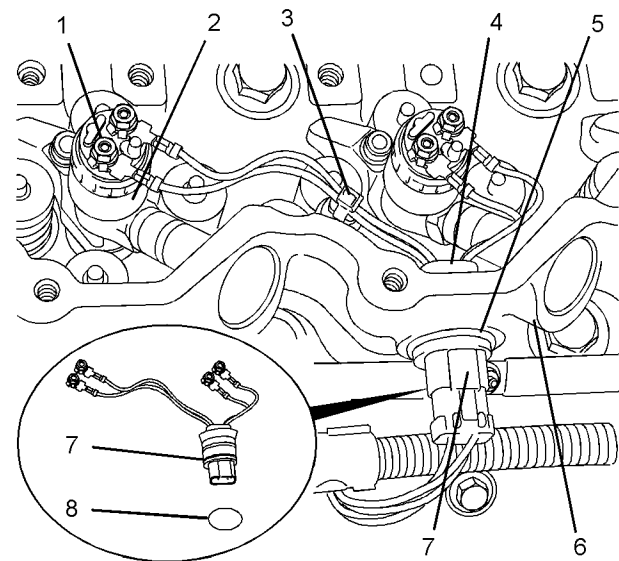

Illustration 172
Typical example

6. If necessary, install the harness assemblies for the electronic unit injectors. Follow Steps 6.a through 6.e in order to install the harness assemblies to the electronic unit injectors.

a. Ensure that harness assembly (4) and the bore in valve mechanism cover base (6) are clean and free from damage. Replace any damaged components.

b. Use Tooling (B) to lubricate a new O-ring seal (8). Install O-ring seal (8) onto harness assembly (4).

c. From the inside of valve mechanism cover base (6), push harness assembly (4) into the valve mechanism cover base.

d. Use Tooling (A) to install circlip (5).

e. Repeat Steps 6.a through 8 for the remaining harness assembly.

7. Use a deep socket to connect harness (4) to electronic unit injectors (2). Use Tooling (C) to tighten connectors (1) to a torque of 2.4 N·m (21 lb in).

8. If necessary, install new cable ties (3) to harness assemblies (4).

Note: Ensure that the cable ties conform to the Perkins specification.

9. Connect plugs (7) to harness assemblies (4).

End By:

a. Install new fuel injection lines. Refer to Disassembly and Assembly, "Fuel Injection Lines - Install".

b. Install the valve mechanism cover. Refer to Disassembly and Assembly, "Valve Mechanism Cover - Remove and Install".

i02588323

Rocker Shaft and Pushrod - Remove

Removal Procedure

Table 47

Required Tools			
Tool	Part Number	Part Description	Qty
A	-	E12 Torx Socket	1

Start By:

- a. Remove the valve mechanism cover. Refer to Disassembly and Assembly, "Valve Mechanism Cover - Remove and Install".

NOTICE

Keep all parts clean from contaminants.

Contaminants may cause rapid wear and shortened component life.

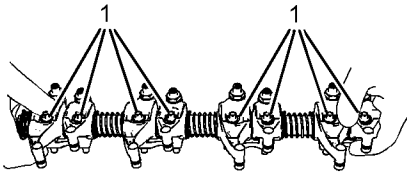

Illustration 173

g01244058

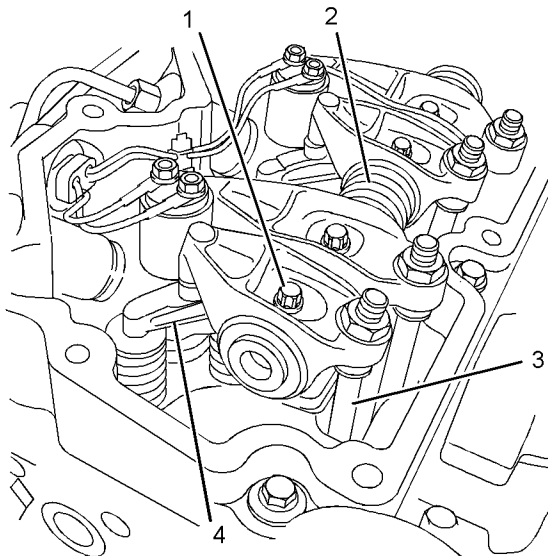

Illustration 174

g01270001

Typical example

1. Use Tooling (A) to progressively loosen torx screws (1). Begin at the ends of the rocker shaft assembly and work toward the center.

Note: To avoid distortion of the rocker shaft assembly, each torx screw should be loosened by a quarter of a turn at one time. Repeat the procedure until all torx screws are loosened.

2. Remove torx screws (1) from rocker shaft assembly (2).
3. Remove rocker shaft assembly (2) from the cylinder head.

4. Make a temporary mark on pushrods (3) in order to show the location. Remove the pushrods from the cylinder head.

Note: Identification will ensure that the pushrods can be reinstalled in the original positions. Do not interchange the positions of used pushrods.

5. Make a temporary mark on valve bridges (4) in order to show the location and the orientation. Remove the valve bridges from the cylinder head.

Note: Identification will ensure that the valve bridges can be reinstalled in the original location and the original orientation. Do not interchange the location or the orientation of used valve bridges.

i02590313

Rocker Shaft - Disassemble

Disassembly Procedure

Start By:

- a. Remove the rocker shaft assembly. Refer to Disassembly and Assembly, "Rocker Shaft and Pushrod - Remove".

NOTICE

Keep all parts clean from contaminants.

Contaminants may cause rapid wear and shortened component life.

WARNING

Personal injury can result from being struck by parts propelled by a released spring force.

Make sure to wear all necessary protective equipment.

Follow the recommended procedure and use all recommended tooling to release the spring force.

1. Make an identification mark on each rocker arm assembly in order to show the location.

Note: The components must be reinstalled in the original location. Do not interchange components.

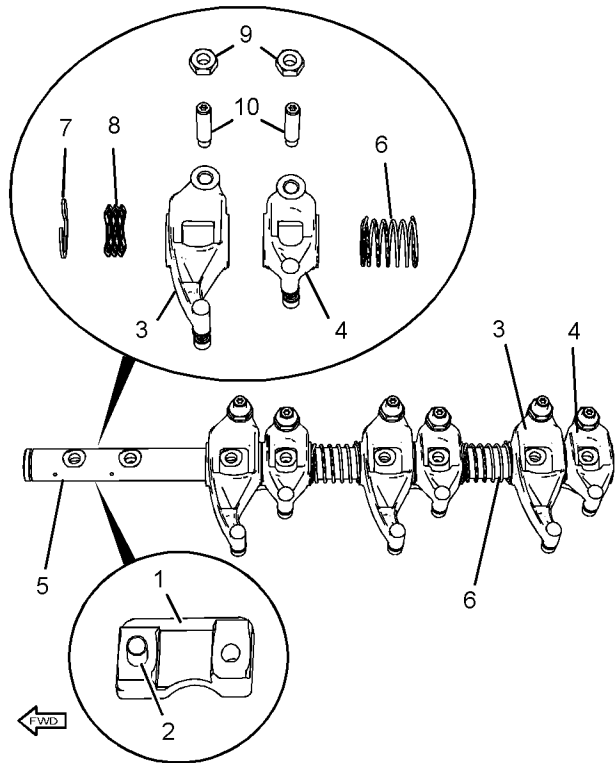

Illustration 175
Typical example

g01244059

2. Remove pedestals (1) from rocker shaft (5). Do not remove dowels (2) from the pedestals.
3. Remove rocker arm assembly (4) for the exhaust valve from rocker shaft (5). Remove rocker arm assembly (3) for the inlet valve from rocker shaft (5). Begin at the rear of the rocker shaft assembly.

Note: The rocker arm assembly for the inlet valve is longer than the rocker arm assembly for the exhaust valve.

4. Remove spring (6) from rocker shaft (5).
5. Repeat Steps 3 and 4 in order to remove the remaining rocker arms from rocker shaft (5).

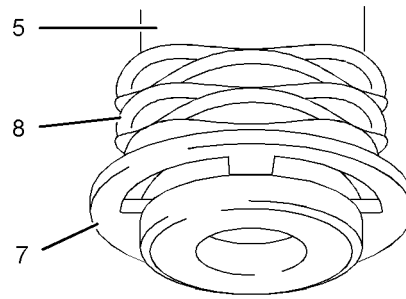

Illustration 176

g01270008

6. If necessary, remove retaining clip (7) and remove spring (8) from the front end of rocker shaft (5).
7. If necessary, remove nuts (9) and adjusters (10) from the rocker arms. Make a temporary identification mark on each adjuster in order to show the location.

Note: The components must be reinstalled in the original location. Do not interchange components.

i02588326

Rocker Shaft - Assemble

Assembly Procedure

NOTICE

Keep all parts clean from contaminants.

Contaminants may cause rapid wear and shortened component life.

1. Ensure that all components are clean and free from wear or damage. Refer to Specifications, "Rocker Shaft" for more information. If necessary, replace any components that are worn or damaged.

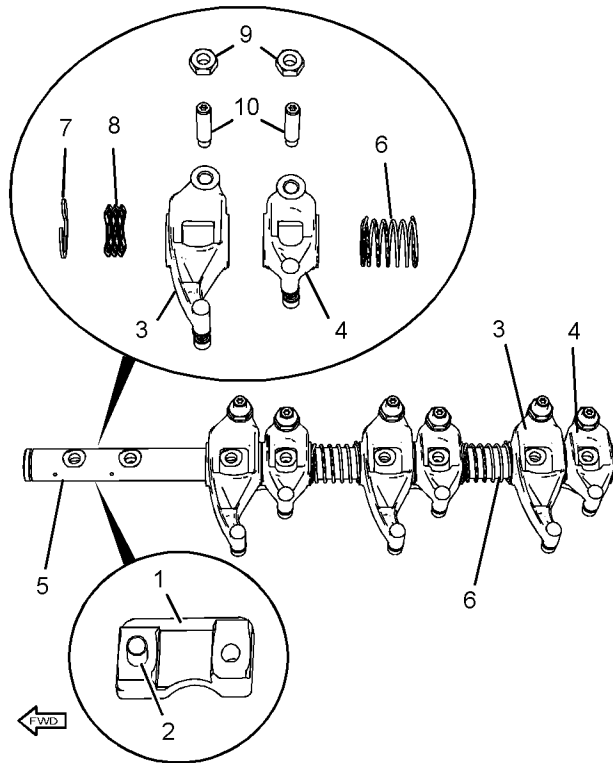

Illustration 177

g01244059

Typical example

2. If necessary, install nuts (9) and adjusters (10) to rocker arm assemblies (3) and (4). If the original adjusters are reused, ensure that the adjusters are installed in the original positions.

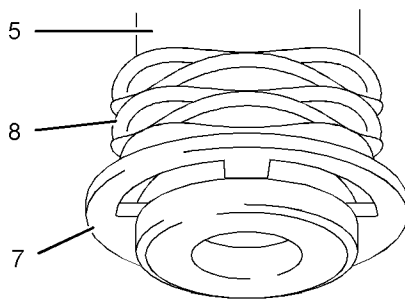

Illustration 178

g01270008

3. Install retaining clip (7) and spring (8) to the front end of rocker shaft (5).
4. Lubricate the bores of rocker arm assemblies (3) and (4) and rocker shaft (5) with clean engine oil.

5. Place the rocker shaft in the inverted position with the counterbores for the holes downward. Install rocker arm assembly (3) for number 1 cylinder inlet valves to the rocker shaft. Install rocker arm assembly (4) for number 1 cylinder exhaust valves to rocker shaft (5).

Note: The rocker arms for the inlet valves are longer than the rocker arms for the exhaust valves. Install rocker arms in the inverted position. Used components should be installed in the original location.

6. Ensure that dowel (2) is correctly seated in pedestal (1). Align the dowel with the appropriate hole in rocker shaft (5). Install the pedestal to the rocker shaft.

WARNING

Improper assembly of parts that are spring loaded can cause bodily injury.

To prevent possible injury, follow the established assembly procedure and wear protective equipment.

7. Install spring (6) to rocker shaft (5).
8. Repeat Steps 5 to 7 in order to assemble the remaining components to rocker shaft (5).

End By:

- a. Install the rocker shaft assembly. Refer to Disassembly and Assembly, "Rocker Shaft and Pushrod - Install".

i02588327

Rocker Shaft and Pushrod - Install

Installation Procedure

Table 48

Required Tools			
Tool	Part Number	Part Description	Qty
A	-	E12 Torx Socket	1
B	27610298	Angled Feeler Gauges	1

NOTICE

Keep all parts clean from contaminants.

Contaminants may cause rapid wear and shortened component life.

1. Clean the valve bridges. Inspect the valve bridges for wear or damage. Replace any valve bridges that are worn or damaged.

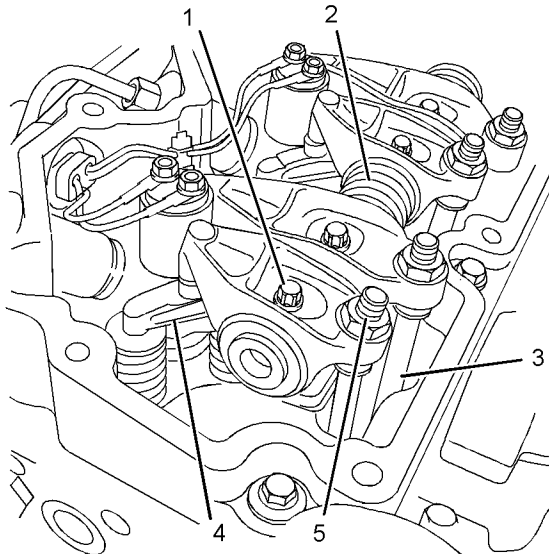

Illustration 179
Typical example
g01270054

2. Lubricate valve bridges (4) with clean engine oil. Install the valve bridges to the cylinder head.

Note: Install used valve bridges in the original location and in the original orientation. Ensure that the valve bridges are correctly seated on the valves. New valve bridges may be installed in either orientation.

3. Clean the pushrods. Inspect the pushrods for wear or damage. Replace any pushrods that are worn or damaged.
4. Apply clean engine lubricating oil to both ends of pushrods (3). Install the pushrods to the engine with the cup upward.

Note: Ensure that the pushrods are installed in the original location and that the ball end of each pushrod is correctly seated in the valve lifters.

5. Ensure that the rocker shaft assembly is clean and free from wear or damage.

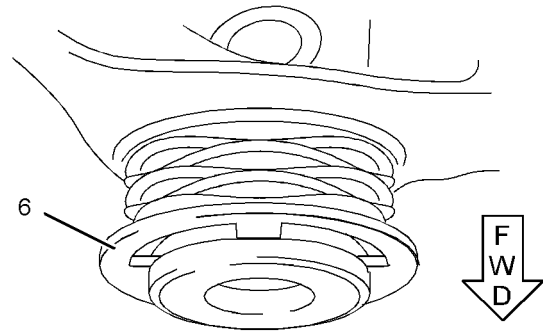

Illustration 180
g01270057

6. Position rocker shaft assembly (2) onto the cylinder head. The retaining clip (6) should face the front of the engine.

Note: Ensure that adjustment screws (5) are properly seated in the ends of pushrods (3).

7. Install torx screws (1) to the rocker shaft assembly.
8. Install torx screws (1) finger tight. Use Tooling (A) to progressively tighten torx screws (1). Begin at the center of the rocker shaft assembly and work toward the ends.

Note: To avoid distortion of the rocker shaft assembly, each torx screw should be tightened by a quarter of a turn at one time. Repeat the procedure until all torx screws are tightened.

Tighten torx screws (1) to a torque of 35 N·m (26 lb ft).

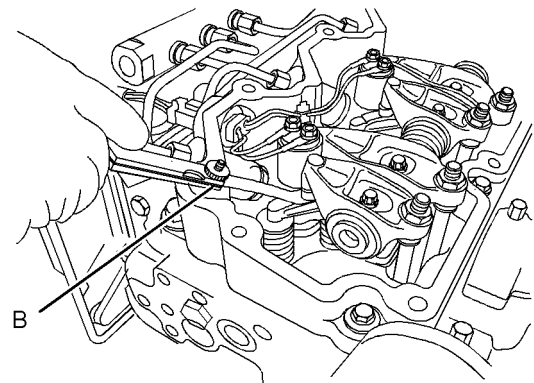

Illustration 181
Typical example
g01259267

9. Use Tooling (B) in order to check the valve lash. Refer to Systems Operation, Testing and Adjusting, "Engine Valve Lash - Inspect/Adjust". If necessary, adjust the valve lash. Refer to Systems Operation, Testing and Adjusting, "Engine Valve Lash - Inspect/Adjust" for the correct procedure.

End By:

- a. Install the valve mechanism cover. Refer to Disassembly and Assembly, "Valve Mechanism Cover - Remove and Install".

i02588329

Cylinder Head - Remove

Removal Procedure

Start By:

- a. Remove the exhaust manifold. Refer to Disassembly and Assembly, "Exhaust Manifold - Remove and Install".
- b. Remove the fuel manifold. Refer to Disassembly and Assembly, "Fuel Manifold (Rail) - Remove and Install".
- c. Remove the mounting bracket for the electronic control module. Refer to Disassembly and Assembly, "ECM Mounting Bracket- Remove and Install".
- d. Remove the electronic unit injectors. Refer to Disassembly and Assembly, "Electronic Unit Injector - Remove".
- e. Remove the valve mechanism cover base. Refer to Disassembly and Assembly, "Valve Mechanism Cover Base - Remove".
- f. Remove the glow plugs. Refer to Disassembly and Assembly, "Glow Plugs - Remove and Install".

NOTICE

Keep all parts clean from contaminants.

Contaminants may cause rapid wear and shortened component life.

NOTICE

Care must be taken to ensure that fluids are contained during performance of inspection, maintenance, testing, adjusting and repair of the product. Be prepared to collect the fluid with suitable containers before opening any compartment or disassembling any component containing fluids.

Dispose of all fluids according to local regulations and mandates.

Note: Put identification marks on all hoses, on all hose assemblies, on wires and on all tube assemblies for installation purposes. Plug all hose assemblies and tube assemblies. This helps to prevent fluid loss and this helps to keep contaminants from entering the system.

1. If the alternator bracket is mounted on the cylinder head, remove the alternator. Refer to Disassembly and Assembly, "Alternator - Remove".
2. If the fuel priming pump and the primary fuel filter are mounted on the cylinder head, remove the fuel priming pump and the primary fuel filter. Refer to Disassembly and Assembly, "Fuel Priming Pump - Remove and Install".
3. Drain the coolant from the cooling system into a suitable container for storage or for disposal. Refer to Operation and Maintenance Manual, "Cooling System Coolant - Change" for the correct draining procedure.

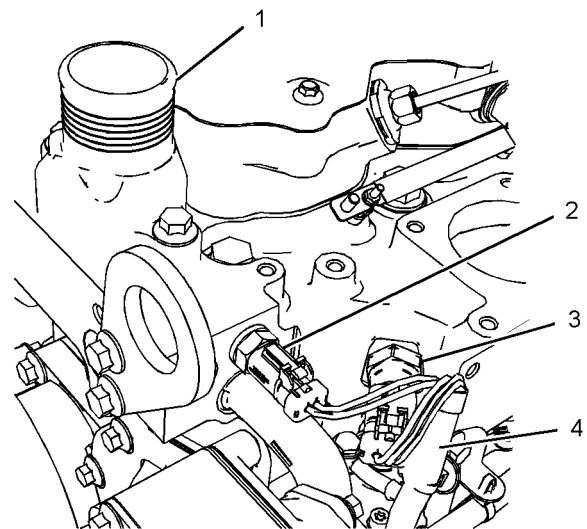

Illustration 182

g01245537

Typical example

4. Disconnect the upper radiator hose from water temperature regulator housing (1).

5. If necessary, remove the air hose from the inlet connection.
6. Follow Steps 6.a and 6.b in order to disconnect harness assembly (4) from coolant temperature sensor (2).
 - a. Slide the locking tab into the unlocked position.
 - b. Disconnect harness assembly (4) from coolant temperature sensor (2).
7. If necessary, follow Steps 7.a and 7.b in order to disconnect harness assembly (4) from boost pressure sensor (3).
 - a. Slide the locking tab into the unlocked position.
 - b. Disconnect harness assembly (4) from boost pressure sensor (3).

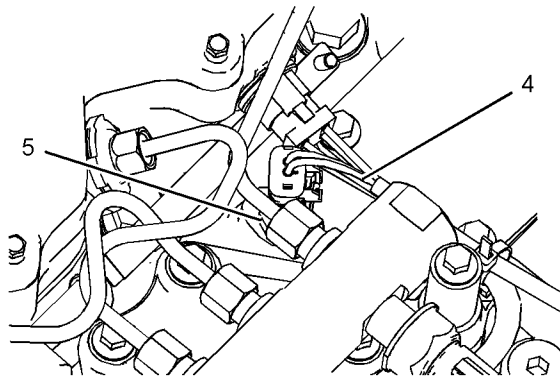

Illustration 183

g01249835

Typical example

8. Follow Steps 8.a and 8.b in order to disconnect harness assembly (4) from inlet air temperature sensor (5).
 - a. Slide the locking tab into the unlocked position.
 - b. Disconnect harness assembly (4) from inlet air temperature sensor (5).
9. Remove all cable ties that secure harness assembly (4) to the cylinder head. The harness assembly should be positioned in order to avoid causing an obstruction during the removal of the cylinder head.

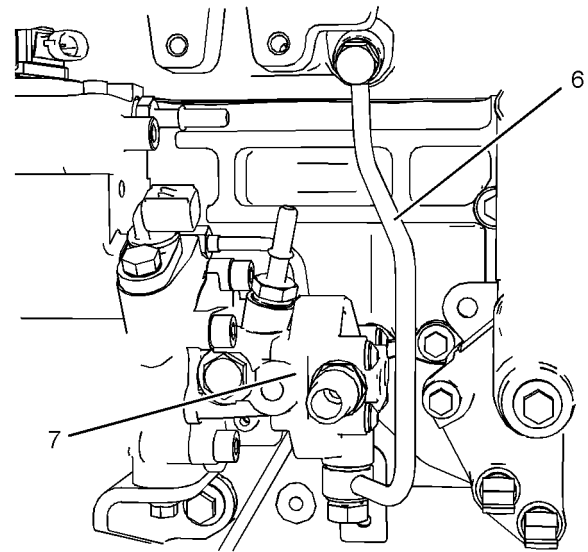

Illustration 184

g01249474

Typical example

10. Remove tube assembly (6) from the cylinder head and from transfer pump (7).

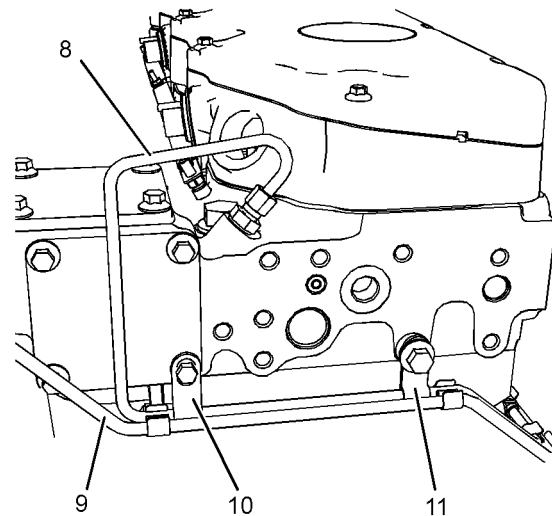

Illustration 185

g01249479

Typical example

11. If the engine is equipped with a wastegate solenoid, remove harness assembly (9) from tube assembly (8). Remove the fasteners for tube clips (10) and (11). Remove tube assembly (8) from the wastegate solenoid and from the cylinder head.

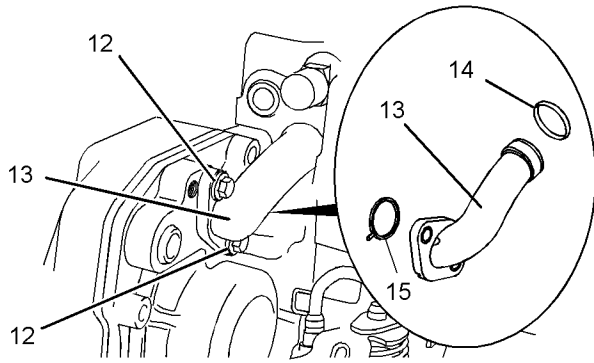

Illustration 186
Typical example
g01249836

12. Remove bolts (12). Note the position of any brackets that are secured by the bolts. Remove bypass tube (13) from the cylinder head. Remove O-ring seals (14) and (15) from the bypass tube.

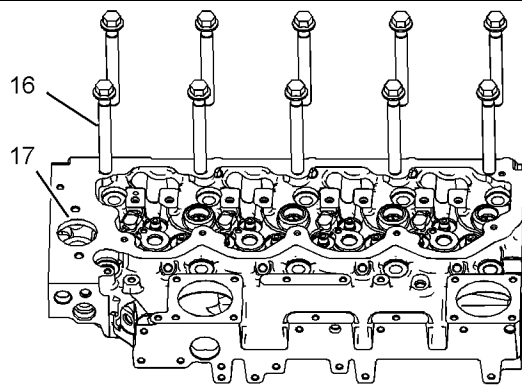

Illustration 187
g01245538

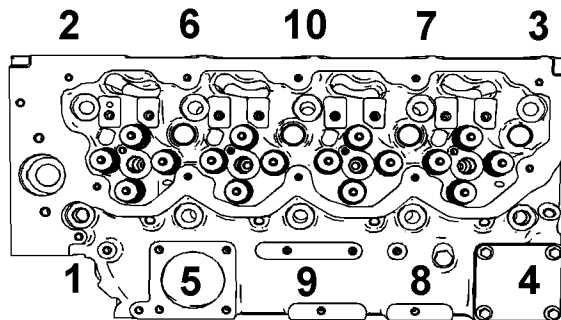

Illustration 188
Sequence for tightening the bolts for the cylinder head
g01250785

13. Gradually loosen bolts (16) in the reverse numerical order to the sequence that is shown in Illustration 188.

Note: Follow the correct sequence in order to help prevent distortion of the cylinder head.

14. Remove bolts (16) from cylinder head (17).

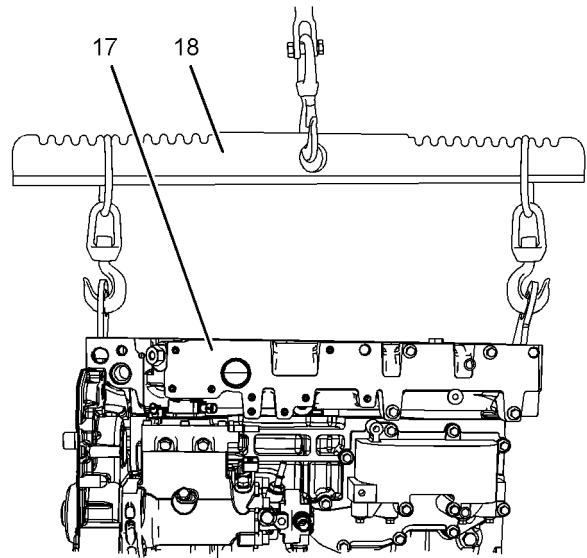

Illustration 189
Typical example
g01245540

15. Attach a suitable lifting device (18) to cylinder head (17). Support the weight of the cylinder head. The weight of the cylinder head is approximately 56 kg (124 lb).

Note: It is advisable to use a spreader bar during the lifting operation in order to distribute the weight of the cylinder head .

16. Use lifting device (18) to carefully lift cylinder head (17) off the cylinder block.

Note: Do not use a lever to separate the cylinder head from the cylinder block. Take care not to damage the machined surfaces of the cylinder head during the removal procedure.

NOTICE

Place the cylinder head on a surface that will not scratch the face of the cylinder head.

i02588330

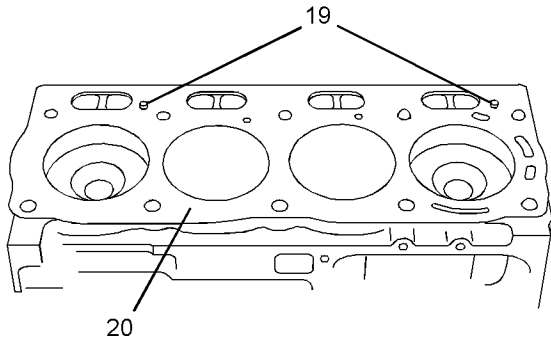

Illustration 190 g01244060

Typical example

17. Remove cylinder head gasket (20).
18. Note the position of dowels (19) in the cylinder block. Do not remove the dowels unless the dowels are damaged.

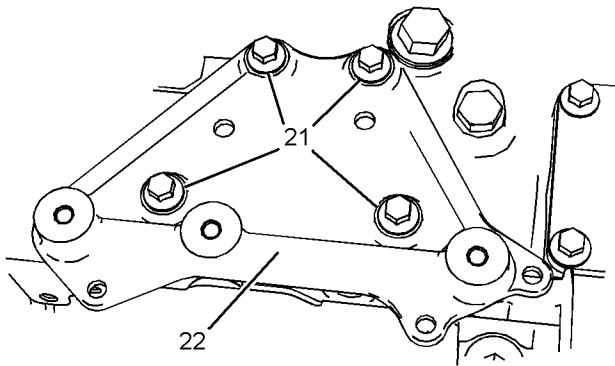

Illustration 191 g01266027

Typical example

19. If necessary, remove screws (21) and remove mounting bracket (22) from the cylinder head.
20. If necessary, remove the water temperature regulator from the cylinder head. Refer to Disassembly and Assembly, "Water Temperature Regulator - Remove and Install".
21. If necessary, remove the electronic sensors from the cylinder head. Refer to Disassembly and Assembly, "Coolant Temperature Sensor - Remove and Install". Refer to Disassembly and Assembly, "Air Temperature Sensor - Remove and Install". Refer to Disassembly and Assembly, "Boost Pressure Sensor - Remove and Install".

Cylinder Head - Install

Installation Procedure

Table 49

Required Tools			
Tool	Part Number	Part Description	Qty
A	-	Guide Stud (M16 by 115mm)	2
B	-	Straight Edge	1
C	21825607	Angle gauge	1
D	21820221	POWERPART Rubber Grease	1

NOTICE

Keep all parts clean from contaminants.

Contaminants may cause rapid wear and shortened component life.

1. Thoroughly clean the mating surfaces of the cylinder head and the cylinder block. Do not damage the mating surfaces of the cylinder head or the cylinder block. Ensure that no debris enters the cylinder bores, the coolant passages, or the lubricant passages.
2. Inspect the mating surface of the cylinder head for distortion. Refer to Specifications, "Cylinder Head" for more information. If the mating surface of the cylinder head is distorted beyond maximum permitted limits, replace the cylinder head.

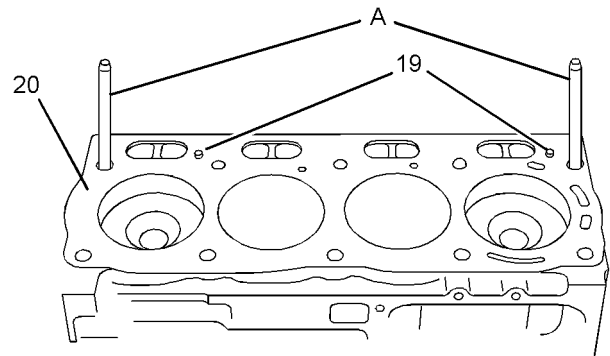

Illustration 192

g01244064

3. Inspect dowels (19) for damage. If necessary, replace the dowels in the cylinder block.

4. Install Tooling (A) to the cylinder block. Refer to Illustration 192.
5. Align cylinder head gasket (20) with Tooling (A) and with dowels (19). Install the cylinder head gasket onto the cylinder block.

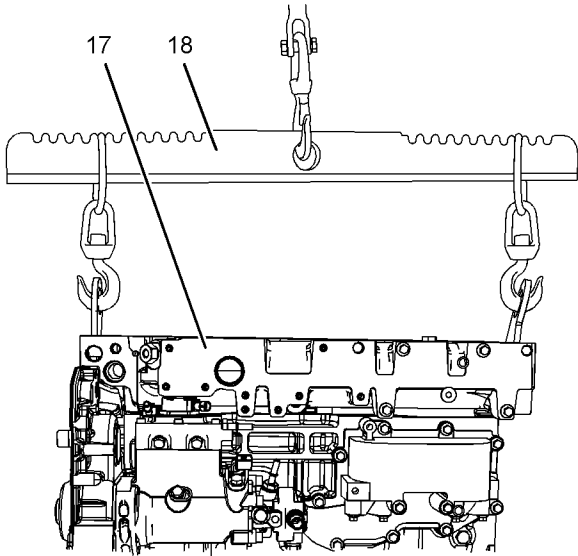

Illustration 193

g01245540

Typical example

6. Use a suitable lifting device (18) to lift the cylinder head. The weight of the cylinder head is approximately 56 kg (124 lb).

Note: It is advisable to use a spreader bar during the lifting operation in order to distribute the weight of the cylinder head.

7. Use Tooling (A) to align cylinder head (17) with the cylinder block. Install the cylinder head to the cylinder block.

Note: Ensure that the cylinder head is correctly positioned onto dowels (19).

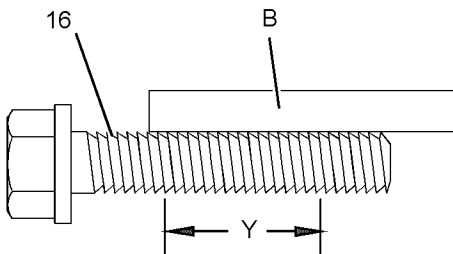

Illustration 194

g01250784

8. Clean bolts (16). Follow Steps 8.a and 8.b for the procedure to inspect the bolts.
 - a. Check the length of the bolts.
 - b. Use Tooling (B) in order to check the threads of the bolts. Refer to Illustration 194. Replace any bolts that show visual reduction in the diameter of the thread over length (Y).
9. Lubricate the threads and the shoulder of bolts (16) with clean engine oil.
10. Remove Tooling (A).

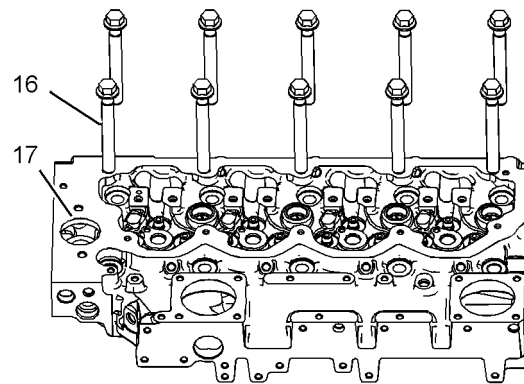

Illustration 195

g01245538

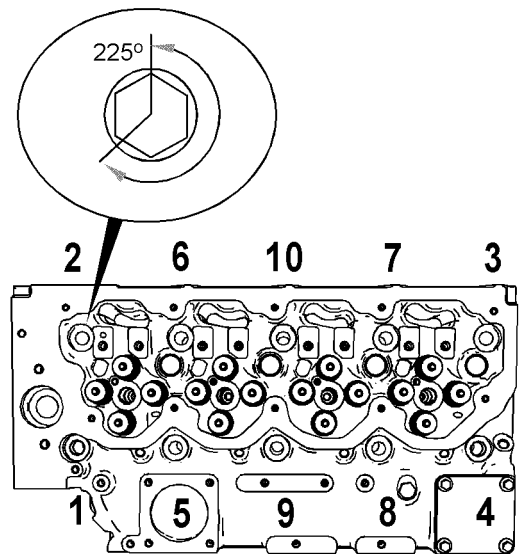

Illustration 196

g01245620

Sequence for tightening the bolts for the cylinder head

11. Install bolts (16) to cylinder head (17).
12. Tighten bolts (16) to a torque of 50 N·m (37 lb ft) in the sequence that is shown in Illustration 196.
13. Tighten bolts (16) to a torque of 100 N·m (74 lb ft) in the sequence that is shown in Illustration 196.

14. Use Tooling (C) to turn bolts (16) through an additional 225 degrees. Turn bolts (16) in the sequence that is shown in Illustration 196.

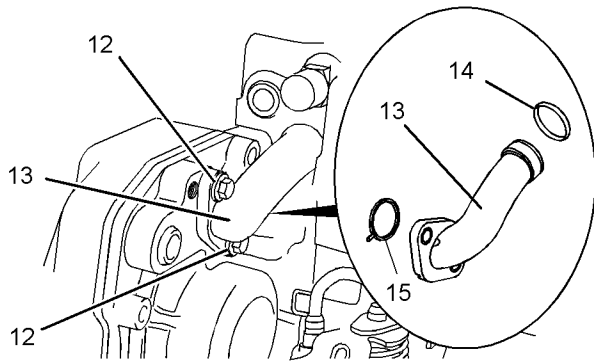

Illustration 197

g01249836

Typical example

15. Install new O-ring seals (14) and (15) to bypass tube (13). Use Tooling (D) in order to lubricate O-ring seal (14). Install the bypass tube to the cylinder head. Install bolts (12). Ensure that any brackets that are secured by the bolts are installed in the correct position. Tighten the bolts to a torque of 22 N·m (16 lb ft).

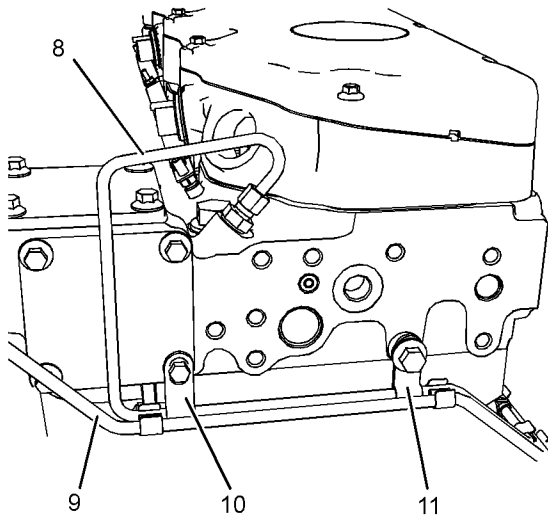

Illustration 198

g01249479

Typical example

16. If the engine is equipped with a wastegate solenoid, install tube assembly (9) to the wastegate solenoid and to the cylinder head. Install the fasteners for tube clips (10) and (11). Tighten M8 fasteners to a torque of 22 N·m (16 lb ft), tighten M10 fasteners to a torque of 44 N·m (32 lb ft). Secure harness assembly (9) to tube assembly (8).

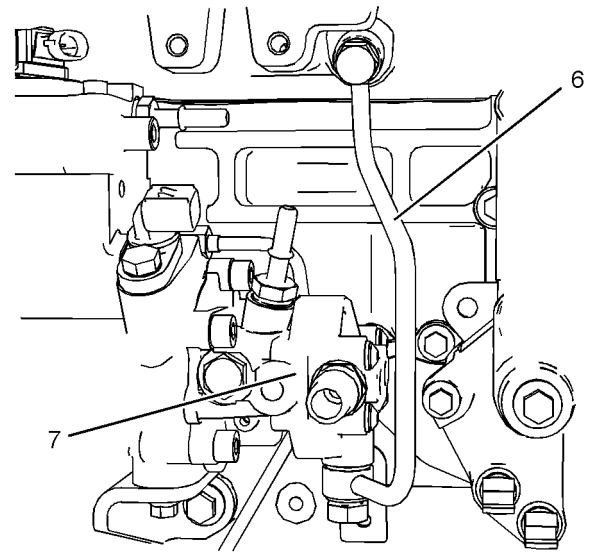

Illustration 199

g01249474

Typical example

17. Follow Steps 17.a through 17.c in order to install tube assembly (6) for the fuel return.

- a. Install the banjo bolts and new sealing washers to tube assembly (6).
- b. Install tube assembly (6) to the cylinder head and to transfer pump (7).
- c. Tighten the banjo bolts to a torque of 22 N·m (16 lb ft).

18. If necessary, install the electronic sensors to the cylinder head. Refer to Disassembly and Assembly, "Coolant Temperature Sensor - Remove and Install". Refer to Disassembly and Assembly, "Air Temperature Sensor - Remove and Install". Refer to Disassembly and Assembly, "Boost Pressure Sensor - Remove and Install".

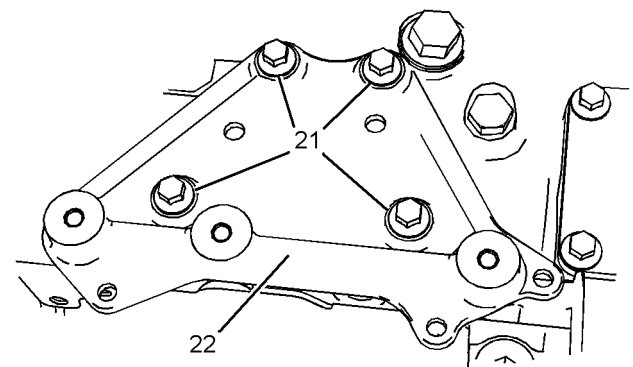

Illustration 200

g01266027

Typical example

19. If necessary, install mounting bracket (22) and install screws (21) to the cylinder head. Tighten the screws to a torque of 22 N·m (16 lb ft).

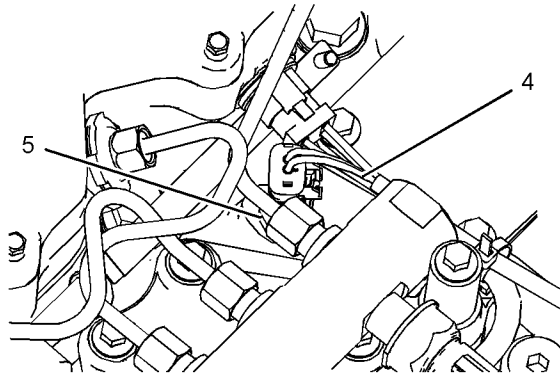

Illustration 201

g01249835

Typical example

20. Follow Steps 20.a and 20.b in order to connect harness assembly (4) to inlet air temperature sensor (5).

- a. Connect harness assembly (4) to inlet air temperature sensor (5).
- b. Slide the locking tab into the locked position.

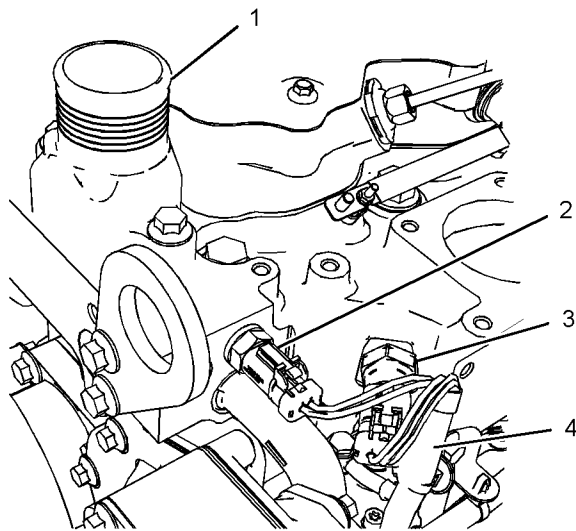

Illustration 202

g01245537

Typical example

21. Follow Steps 21.a and 21.b in order to connect harness assembly (4) to boost pressure sensor (3).

- a. Connect harness assembly (4) to boost pressure sensor (3).
- b. Slide the locking tab into the locked position.

22. Follow Steps 22.a and 22.b in order to connect harness assembly (4) to coolant temperature sensor (2).

- a. Connect harness assembly (4) to coolant temperature sensor (2).
- b. Slide the locking tab into the locked position.

23. Use new cable ties in order to secure the harness assembly to the cylinder head. Ensure that the harness assembly is not strained.

Note: Ensure that the harness assembly is clear of other engine components.

24. If necessary, install water temperature regulator housing (1) to the cylinder head. Refer to Disassembly and Assembly, "Water Temperature Regulator Housing - Remove and Install".

25. Install the mounting bracket for the electronic control module. Refer to Disassembly and Assembly, "ECM Mounting Bracket - Remove and Install".

26. Install the glow plugs. Refer to Disassembly and Assembly, "Glow Plugs - Remove and Install".

27. Install the valve mechanism cover base. Refer to Disassembly and Assembly, "Valve Mechanism Cover Base - Install".

28. Install the electronic unit injectors. Refer to Disassembly and Assembly, "Electronic Unit Injector - Remove".

29. Install the fuel manifold. Refer to Disassembly and Assembly, "Fuel Manifold - Remove and Install".

30. Install the exhaust manifold. Refer to Disassembly and Assembly, "Exhaust Manifold - Remove and Install".

31. If necessary, install the fuel filter base and the secondary fuel filter. Refer to Disassembly and Assembly, "Fuel Filter Base - Remove and Install".

32. If necessary, install the fuel priming pump and the primary fuel filter. Refer to Disassembly and Assembly, "Fuel Priming Pump - Remove and Install".

33. If the alternator bracket is mounted on the cylinder head, install the alternator. Refer to Disassembly and Assembly, "Alternator - Install".

34. If necessary, install the air hose to the inlet connection.

35. Connect the upper radiator hose to water temperature regulator housing (1).

36. Fill the cooling system with coolant. Refer to Operation and Maintenance Manual, "Cooling System Coolant - Change" for the correct filling procedure.

37. If necessary, fill the engine oil pan to the correct level that is indicated on the engine oil level gauge. Refer to Operation and Maintenance Manual, "Engine Oil Level - Check".

i02588331

Lifter Group - Remove and Install

Removal Procedure

Table 50

Required Tools			
Tool	Part Number	Part Description	Qty
A	21825576	Crankshaft Turning Tool	1
B	-	Telescopic Magnet	1

Start By:

- a. If the engine is equipped with a balancer, remove the balancer. Refer to Disassembly and Assembly, "Balancer - Remove". If the engine is not equipped with a balancer, remove the engine oil pump. Refer to Disassembly and Assembly, "Engine Oil Pump - Remove".
- b. Remove the camshaft. Refer to Disassembly and Assembly, "Camshaft - Remove and Install".

NOTICE

Keep all parts clean from contaminants.

Contaminants may cause rapid wear and shortened component life.

1. If the crankshaft is installed, use Tooling (A) to rotate the crankshaft in order to gain access to lifters (1).

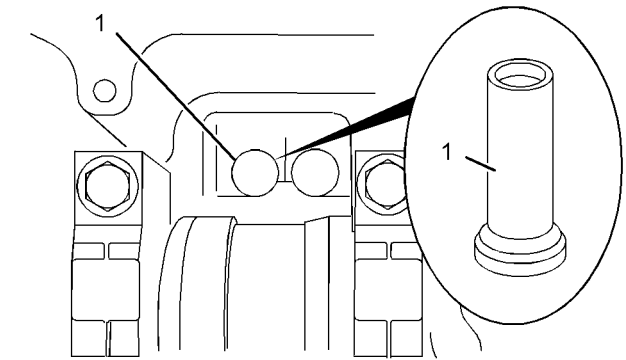

Illustration 203

g01266042

Typical example

2. Use Tooling (B) in order to remove lifters (1).

Note: Place a temporary identification mark on each lifter in order to identify the correct location.

3. Repeat Steps 1 and 2 in order to remove the remaining lifters.

Installation Procedure

Table 51

Required Tools			
Tool	Part Number	Part Description	Qty
A	21825576	Crankshaft Turning Tool	1
B	-	Telescopic Magnet	1

NOTICE

Keep all parts clean from contaminants.

Contaminants may cause rapid wear and shortened component life.

NOTICE

It is strongly recommended that all lifters should be replaced when a new camshaft is installed.

1. Clean the lifters. Follow Steps 1.a through 1.c in order to inspect the lifters. Replace lifters that are worn or damaged.
 - a. Inspect the seat of the pushrod in the lifter for visual wear or damage.
 - b. Inspect the shank of the lifter for wear or damage. Refer to Specifications, "Lifter Group" for more information.

- c. Inspect the face of the lifter that runs on the camshaft for visual wear or damage.
2. If the crankshaft is installed, use Tooling (A) to rotate the crankshaft. Rotate the crankshaft to access to the cylinder block in order to install lifters (1).
 3. Lubricate lifters (1) with clean engine oil.

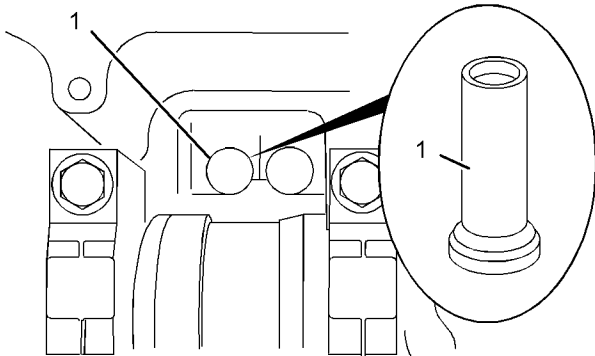

Illustration 204

g01266042

Typical example

4. Use Tooling (B) to install lifters (1) to the cylinder block. Ensure that used lifters are installed in the correct location.

Note: The lifters should be free to rotate.

5. Repeat Steps 1 and 4 in order to install the remaining lifters.

End By:

- a. Install the camshaft. Refer to Disassembly and Assembly, "Camshaft - Remove and Install".
- b. If the engine is equipped with a balancer, install the balancer. Refer to Disassembly and Assembly, "Balancer - Install". If the engine is not equipped with a balancer, install the engine oil pump. Refer to Disassembly and Assembly, "Engine Oil Pump - Install".

i02588358

Camshaft - Remove and Install

Removal Procedure

Start By:

- a. Remove the rockershaft and pushrods. Refer to Disassembly and Assembly, "Rocker shaft and Pushrod - Remove".

- b. Remove the front housing. Refer to Disassembly and Assembly, "Housing (Front) - Remove".

NOTICE

Keep all parts clean from contaminants.

Contaminants may cause rapid wear and shortened component life.

1. The engine should be mounted on a suitable stand and placed in the inverted position.

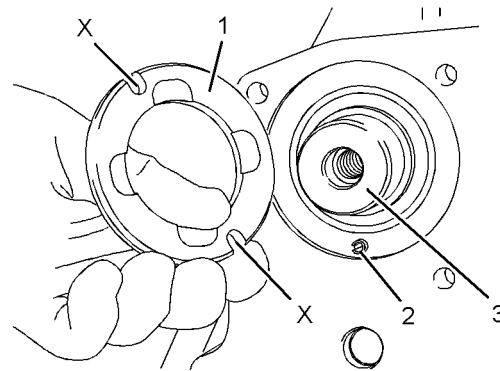

Illustration 205

g01266056

Typical example

2. Remove thrust washer (1) from the cylinder block. Do not remove dowel (2) from the cylinder block unless the dowel is damaged.

Note: The thrust washer can have one or two slots (X).

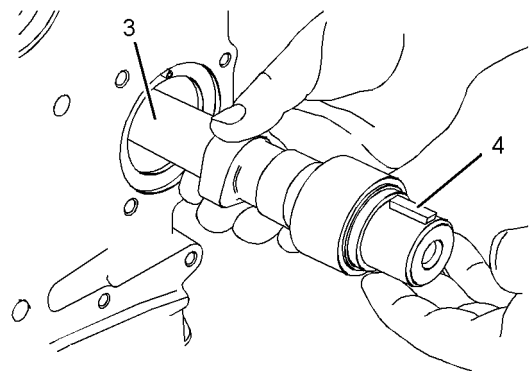

Illustration 206

g01266057

NOTICE

Do not damage the lobes or the bearings when the camshaft is removed or installed.

3. Carefully remove camshaft (3) from the cylinder block.
4. Do not remove key (4) from camshaft (3) unless the key is damaged.

Installation Procedure

NOTICE

Keep all parts clean from contaminants.

Contaminants may cause rapid wear and shortened component life.

1. Clean the camshaft and the thrust washer. Inspect the camshaft and the thrust washer for wear and for damage. Refer to Specifications, "Camshaft" for more information. Replace any components that are worn or damaged.
2. Clean the camshaft bearing in the cylinder block. Inspect the camshaft bearing for wear and for damage. Refer to Specifications, "Camshaft Bearings" for more information. If necessary, replace the camshaft bearing. Refer to Disassembly and Assembly, "Camshaft Bearing - Remove and Install".

NOTICE

It is strongly recommended that all lifters should be replaced when a new camshaft is installed.

3. Inspect the lifters for wear and for damage. Refer to Specifications, "Lifter Group" for more information. Replace any worn lifters or any damaged lifters. Refer to Disassembly and Assembly, "Lifter Group - Remove and install".

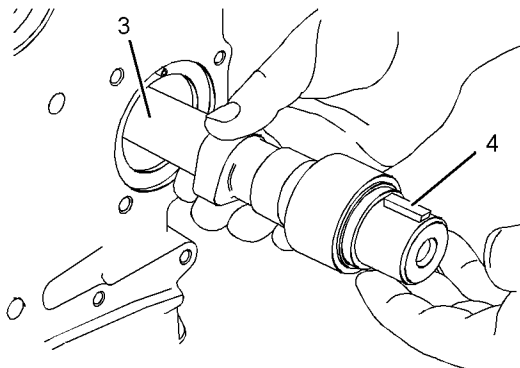

Illustration 207

g01266057

4. If necessary, install a new key (4) to camshaft (3).
5. Lubricate the bearing surfaces of camshaft (3) and lubricate the lobes of the camshaft with clean engine oil.

NOTICE

Do not damage the lobes or the bearings when the camshaft is removed or installed.

6. Carefully install camshaft (3) into the cylinder block.

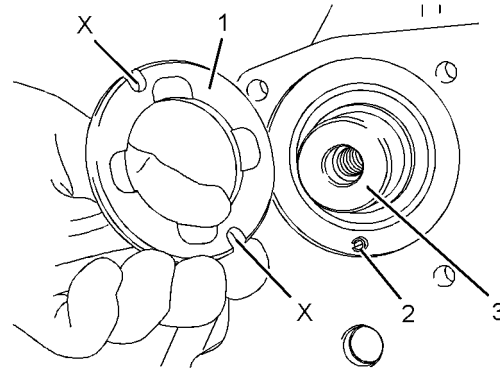

Illustration 208

g01266056

Typical example

7. Lubricate the thrust washer with clean engine oil. Align slot (X) in thrust washer (1) with dowel (2) in the cylinder block. Install thrust washer (1) into the recess in the cylinder block.

Note: The thrust washer can have one or two slots.

End By:

- a. Install the front housing. Refer to Disassembly and Assembly, "Housing (Front) - Install".
- b. Install the rockershaft and pushrods. Refer to Disassembly and Assembly, "Rocker shaft and Pushrod - Install".

i02590360

Camshaft Gear - Remove and Install

Removal Procedure

Table 52

Required Tools			
Tool	Part Number	Part Name	Qty
A ¹	21825576	Crankshaft Turning Tool	1
A ²	27610291	Barring Device Housing	1
	27610289	Gear	1
B	27610212	Camshaft Timing Pin	1
C	27610211	Crankshaft Timing Pin	1

Start By:

- a. Remove the valve mechanism cover. Refer to Disassembly and Assembly, "Valve Mechanism Cover - Remove and Install".
- b. Remove the front cover. Refer to Disassembly and Assembly, "Front Cover - Remove and Install".

Note: Either Tooling (A) can be used. Use the Tooling that is most suitable.

NOTICE

Keep all parts clean from contaminants.

Contaminants may cause rapid wear and shortened component life.

NOTICE

Care must be taken to ensure that fluids are contained during performance of inspection, maintenance, testing, adjusting and repair of the product. Be prepared to collect the fluid with suitable containers before opening any compartment or disassembling any component containing fluids.

Dispose of all fluids according to local regulations and mandates.

1. Use Tooling (A) in order to rotate the crankshaft so that number one piston is at the top center position on the compression stroke. Refer to Systems Operation, Testing and Adjusting, "Finding Top Centre Position for No.1 Piston".

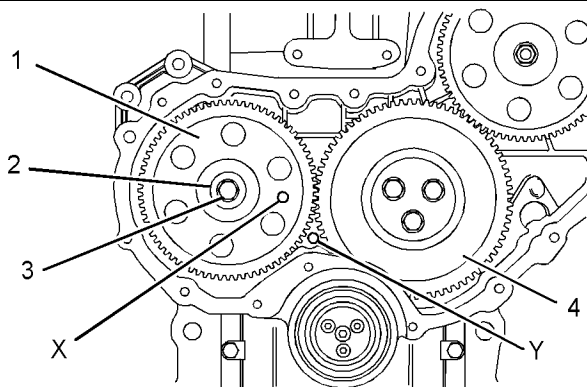

Illustration 209

g01255712

Typical example

2. Install Tooling (B) through hole (X) in camshaft gear (1) into the front housing. Use Tooling (B) in order to lock the camshaft in the correct position.
3. Install Tooling (C) into hole (Y) in the front housing. Use Tooling (C) in order to lock the crankshaft in the correct position.

Note: Do not use excessive force to install Tooling (C). Do not use Tooling (C) to hold the crankshaft during repairs.

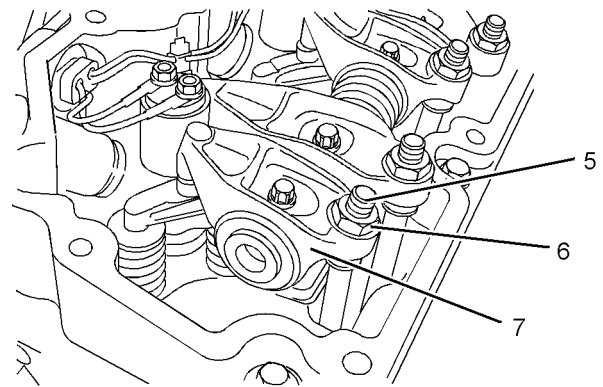

Illustration 210

g01270430

Typical example

4. Loosen nuts (6) on ALL rocker arms (7). Unscrew adjusters (5) on all rocker arms (7) until all valves are fully closed.

Note: Failure to ensure that all adjusters are fully unscrewed can result in contact between the valves and pistons.

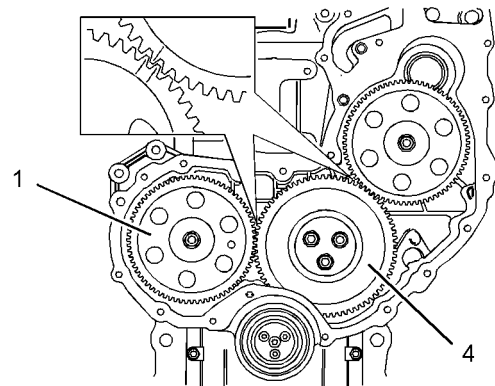

Illustration 211

g01255715

Alignment of timing marks

5. Mark gears (1) and (4) in order to show alignment. Refer to Illustration 211.

Note: Identification will ensure that the gears can be installed in the original alignment.

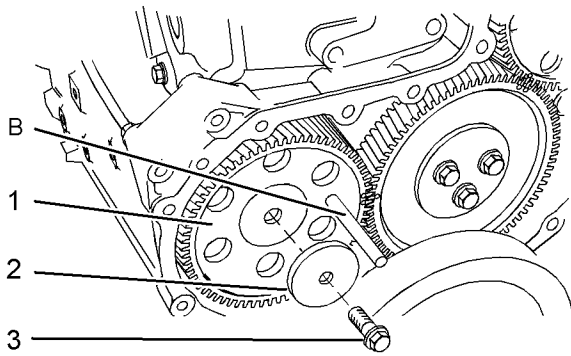

Illustration 212 g01270432
Typical example

6. Remove Tooling (B) and Tooling (C). Remove bolt (3) and washer (2) from camshaft gear (1).
7. Remove camshaft gear (1) from the camshaft.

Note: If the camshaft gear is a tight fit on the nose of the camshaft, use a prybar in order to remove the camshaft gear.

8. If necessary, remove the key from the nose of the camshaft.

Installation Procedure

Table 53

Required Tools			
Tool	Part Number	Part Name	Qty
B	27610212	Camshaft Timing Pin	1
C	27610211	Crankshaft Timing Pin	1
D	21825617	Dial Indicator Group	1
	-	Finger Clock	1

NOTICE

Keep all parts clean from contaminants.

Contaminants may cause rapid wear and shortened component life.

1. Ensure that number one piston is at the top center position on the compression stroke. Refer to the Systems Operation, Testing and Adjusting, "Finding Top Center Position for No. 1 Piston".

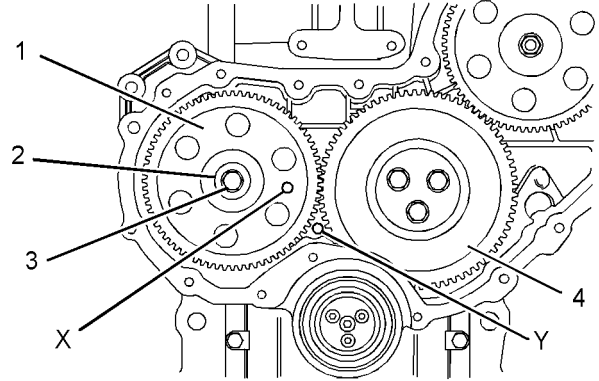

Illustration 213 g01255712
Typical example

2. Install Tooling (C) into hole (Y) in the cylinder block. Use Tooling (C) in order to lock the crankshaft in the correct position. Refer to Systems Operation, Testing and Adjusting, "Finding Top Centre Position for No.1 Piston".
3. Ensure that the camshaft gear and the key are clean and free from wear or damage.
4. If necessary, install the key into the nose of the camshaft.

Note: Ensure that the key is squarely seated.

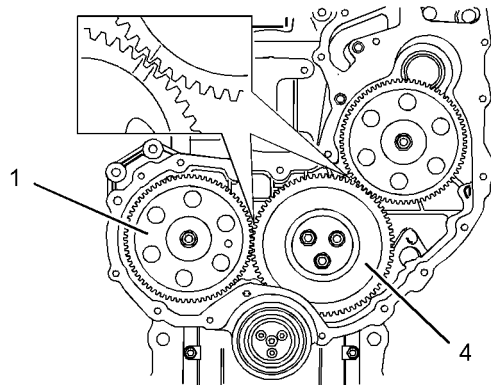

Illustration 214 g01255715
Alignment of timing marks

5. Align the keyway in camshaft gear (1) with the key in the camshaft. Install the camshaft gear onto the camshaft. Ensure that the timing marks on gears (1) and (8) are in alignment and that the mesh of the gears is correct. Refer to Illustration 214.

i02588511

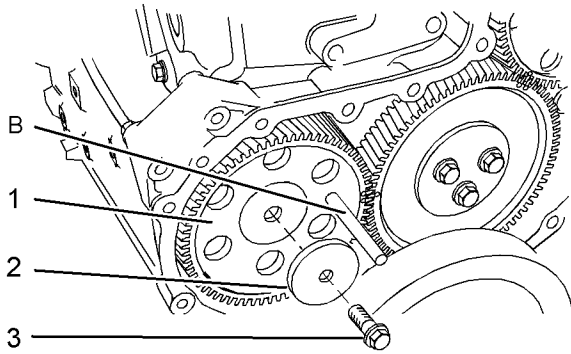

Illustration 215

g01270432

Typical example

6. Install Tooling (B) through hole (X) in the camshaft gear into the front housing. Install washer (2) and bolt (3) to camshaft gear (1).
7. Remove Tooling (B) and (C).
8. Tighten bolt (3) to a torque of 95 N·m (70 lb ft).
9. Use Tooling (D) to check the backlash for gears (1) and (8). Ensure that the backlash for the gears is within specified values. Refer to the Specifications, "Gear Group (Front)" for further information.
10. Use Tooling (D) to check the end play for camshaft gear (1). Ensure that the end play is within specified values. Refer to the Specifications, "Camshaft" for further information.
11. Lubricate the teeth of the gears with clean engine oil.
12. Adjust the valve lash. Refer to Systems Operation, Testing and Adjusting, "Engine Valve Lash - Inspect/Adjust".

End By:

- a. Install the front cover. Refer to Disassembly and Assembly, "Front Cover - Remove and Install".
- b. Install the valve mechanism cover. Refer to Disassembly and Assembly, "Valve Mechanism Cover - Remove and Install".

Camshaft Bearings - Remove and Install

Removal Procedure

Table 54

Required Tools			
Tool	Part Number	Part Description	Qty
A	27610271	Bearing Puller Group	1

Start By:

- a. If the engine is equipped with a balancer, remove the balancer. Refer to Disassembly and Assembly, "Balancer - Remove". If the engine is not equipped with a balancer, remove the engine oil pump. Refer to Disassembly and Assembly, "Engine Oil Pump - Remove".
- b. Remove the camshaft. Refer to Disassembly and Assembly, "Camshaft - Remove and Install".

NOTICE

Keep all parts clean from contaminants.

Contaminants may cause rapid wear and shortened component life.

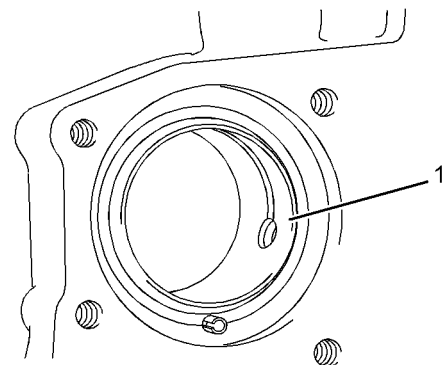

Illustration 216

g01270437

1. Inspect camshaft bearing (1). Refer to Specifications, "Camshaft Bearings" for more information.
2. If camshaft bearing (1) is worn or damaged use Tooling (A) in order to remove the camshaft bearing from the cylinder block.

Note: Remove the camshaft bearing from the front of the cylinder block.

Installation Procedure

Table 55

Required Tools			
Tool	Part Number	Part Description	Qty
A	27610271	Bearing Puller Group	1

NOTICE

Keep all parts clean from contaminants.

Contaminants may cause rapid wear and shortened component life.

1. Clean the bearing housing in the cylinder block. Ensure that the oil holes in the bearing housing are free from debris.

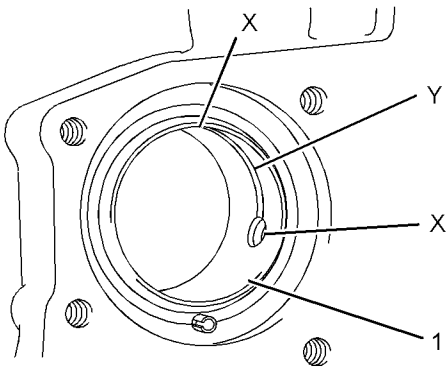

Illustration 217

g01266512

2. Lubricate the bearing housing in the cylinder block with clean engine oil.
3. Accurately align the two oil holes (X) in camshaft bearing (1) with the two oil holes in the cylinder block.

Note: The groove (Y) in the camshaft bearing must be to the top of the cylinder block.

4. Use Tooling (A) in order to install camshaft bearing (1) into the cylinder block. Install the camshaft bearing so that the front edge of the bearing is flush with the face of the recess in the cylinder block.

Note: Ensure that all oil holes are correctly aligned. If the oils are not correctly aligned, the camshaft bearing should be removed.

End By:

- a. Install the camshaft. Refer to Disassembly and Assembly, "Camshaft - Remove and Install".

- b. If the engine is equipped with a balancer, install the balancer. Refer to Disassembly and Assembly, "Balancer - Install". If the engine is not equipped with a balancer, install the engine oil pump. Refer to Disassembly and Assembly, "Engine Oil Pump - Install".

i02588515

Engine Oil Pan - Remove and Install (Aluminum and Pressed Steel Oil Pans)

Removal Procedure

NOTICE

Keep all parts clean from contaminants.

Contaminants may cause rapid wear and shortened component life.

NOTICE

Care must be taken to ensure that fluids are contained during performance of inspection, maintenance, testing, adjusting and repair of the product. Be prepared to collect the fluid with suitable containers before opening any compartment or disassembling any component containing fluids.

Dispose of all fluids according to local regulations and mandates.

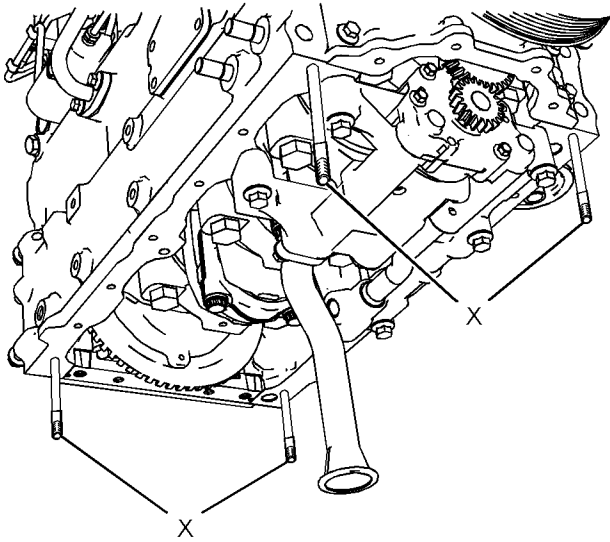

Illustration 220
Typical example
g01251768

2. Install Tooling (A) to positions (X) in the cylinder block.
3. Ensure that the engine oil pan is clean and free from damage.

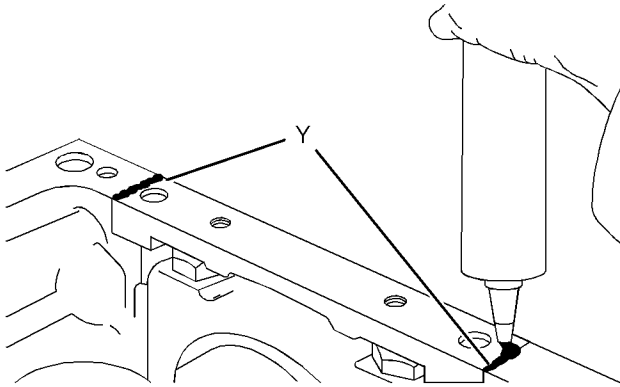

Illustration 221
Typical example
g01251763

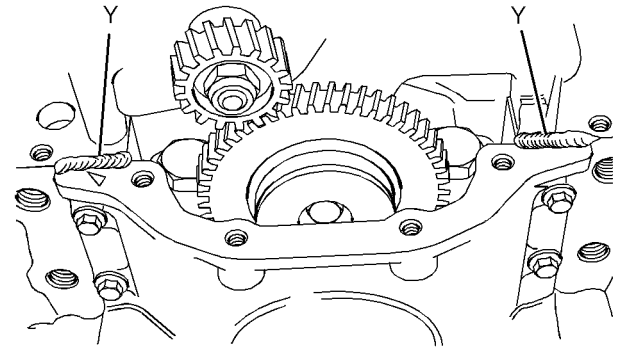

Illustration 222
Typical example
g01251766

4. Apply a bead of Tooling (B) to positions (Y) on the cylinder block.

Note: If the bridge piece for the cylinder block has just been installed, the engine oil pan must be installed before Tooling (B) has cured.

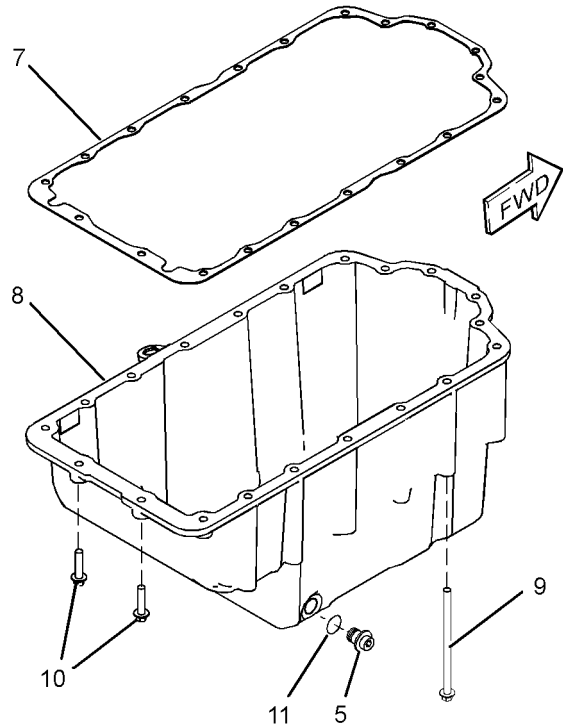

Illustration 223
Typical example
g01251767

5. Position a new joint (7) onto engine oil pan (8).

i02588533

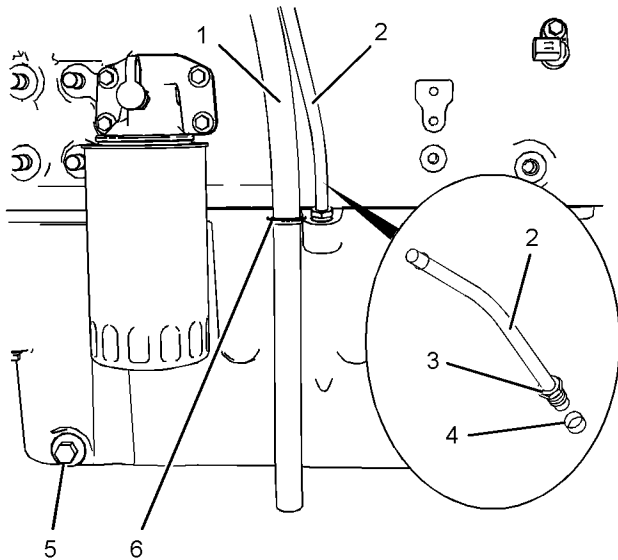

Illustration 224

g01251772

Typical example

6. Align the assembly of the engine oil pan with Tooling (A). Install the assembly of the engine oil pan to the cylinder block. Install the clip (6), that secures the breather hose (1) in the correct position.
 7. Install bolts (9). Tighten the bolts finger tight.
 8. Remove Tooling (A).
 9. Apply Tooling (C) to bolts (10). Install bolts (10) and the remaining bolts (9).
 10. Tighten bolts (10) and (10) to a torque of 22 N·m (16 lb ft).
 11. Install a new O-ring seal (11) to drain plug (5). Install the drain plug to engine oil pan (8). Tighten the oil drain plug to a torque of 34 N·m (25 lb ft).
 12. If necessary, follow Steps 12.a through 12.c in order to install the assembly of the dipstick tube.
 - a. Install a new seal (4) to tube assembly (2).
 - b. Apply Tooling (C) to nut (3). Install the tube assembly to the engine oil pan.
- Note:** Ensure that the orientation of the tube assembly is correct.
- c. Tighten nut (3) to a torque of 18 N·m (13 lb ft). Install the dipstick .

13. Fill the engine oil pan to the correct level. Refer to Operation and Maintenance Manual, "Oil Filter Change" for the procedure.

Engine Oil Pan - Remove and Install (Cast Iron Oil Pan)

Removal Procedure

Note: In order to remove a cast iron oil pan, the engine must be removed from the machine. Ensure that the engine lubricating oil is drained. Refer to Operation and Maintenance Manual, "Engine Oil and Filter - Change" for the correct procedure.

NOTICE

Keep all parts clean from contaminants.

Contaminants may cause rapid wear and shortened component life.

NOTICE

Care must be taken to ensure that fluids are contained during performance of inspection, maintenance, testing, adjusting and repair of the product. Be prepared to collect the fluid with suitable containers before opening any compartment or disassembling any component containing fluids.

Dispose of all fluids according to local regulations and mandates.

1. The engine should be mounted in a suitable stand and placed in the inverted position.

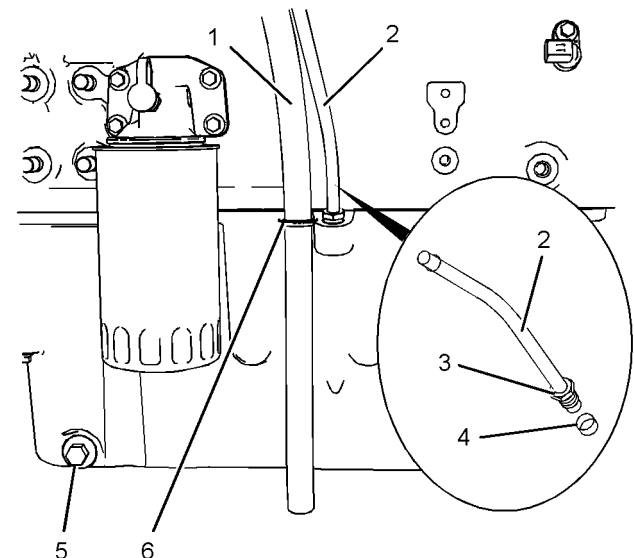

Illustration 225

g01251772

Typical example

- Disconnect breather hose (1) from clip (6). Position the breather hose away from the engine oil pan.

Note: Identify the position and orientation of the tube assembly before removal.

- Remove the assembly of dipstick tube. Loosen nut (3) and remove tube assembly (2). Remove seal (4) from the tube assembly.

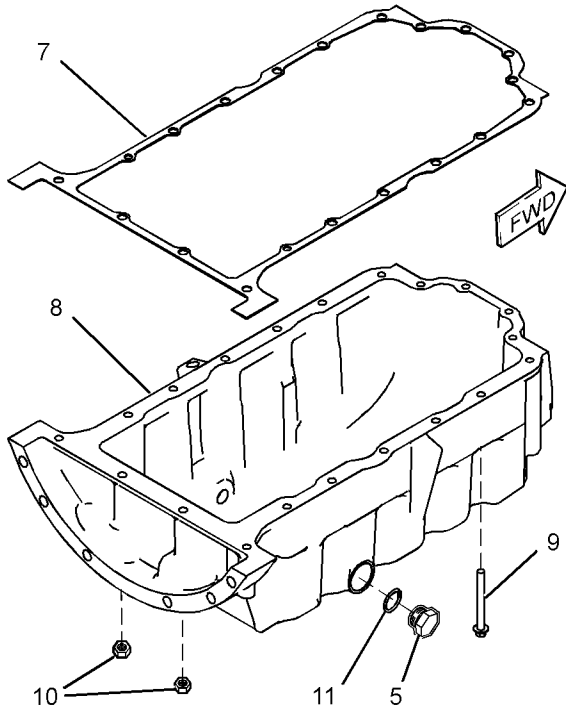

Illustration 226

g01251978

Typical example

- Mark the position of clip (6) that secures the breather hose. Refer to Illustration 225. Loosen the bolt that secures the clip and remove the clip.

- Remove nuts (10) and bolts (9).

Note: The bolts are different lengths. Note the position of the different bolts.

- Attach a suitable lifting device to engine oil pan (8). Support the weight of the engine oil pan. The weight of the engine oil pan is approximately 41 kg (90 lb).

- Use the lifting device to remove engine oil pan (8) from the cylinder block.

- Remove joint (7) from the cylinder block.

- If necessary, remove drain plug (5). Remove O-ring seal (11) from oil drain plug (5).

Installation Procedure

Table 57

Required Tools			
Tool	Part Number	Part Description	Qty
A	21826038	POWERPART Silicon Rubber Sealant	-
B	21820117	POWERPART Threadlock and Nutlock	-
C	-	Straight Edge	1

Note: In order to install a cast iron oil pan, the engine must be removed from the machine.

NOTICE

Keep all parts clean from contaminants.

Contaminants may cause rapid wear and shortened component life.

- Ensure that the joint face of the cylinder block is clean and free from damage. Inspect the studs in the cylinder block for damage. If necessary, replace the studs.
- Ensure that the engine oil pan is clean and free from damage.

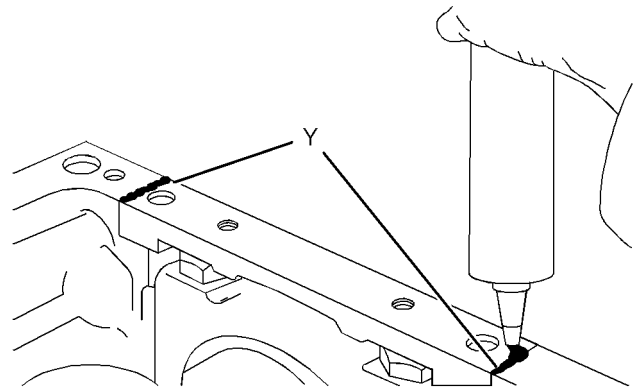

Illustration 227

g01251763

Typical example

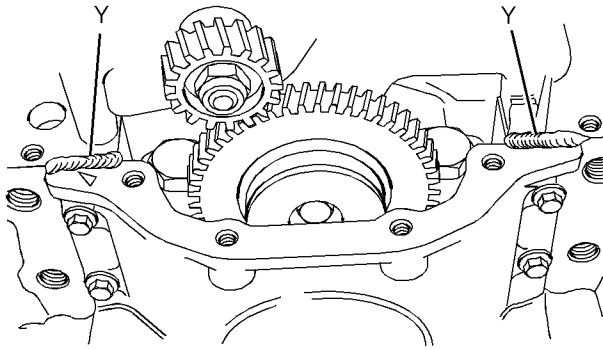

Illustration 228

g01251766

Typical example

3. Apply a bead of Tooling (A) to positions (Y) on the cylinder block.

Note: If the bridge piece for the cylinder block has just been installed, the engine oil pan must be installed before Tooling (A) has cured.

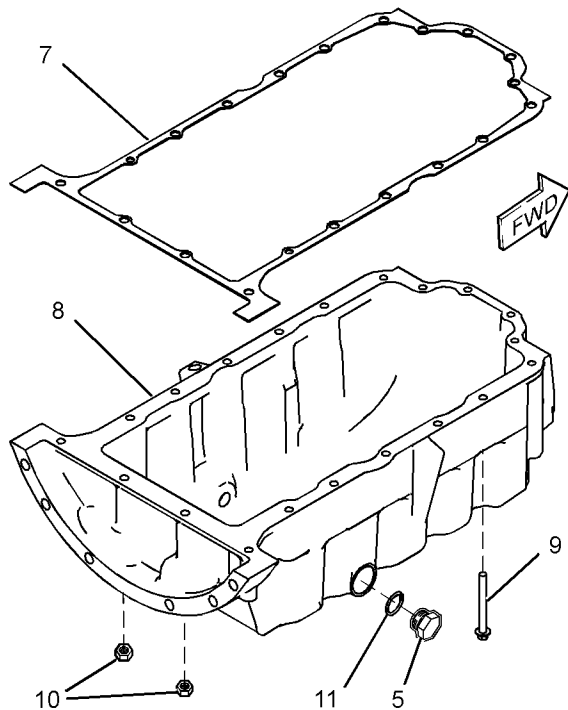

Illustration 229

g01251978

Typical example

4. Align a new joint (7) with the studs in the cylinder block. Install the joint to the cylinder block.
5. Attach a suitable lifting device to engine oil pan (8). The weight of the engine oil pan is approximately 41 kg (90 lb).

6. Use the lifting device to align engine oil pan (8) with the studs in the cylinder block. Install the engine oil pan to the cylinder block. Remove the lifting device from the engine oil pan.

7. Install bolts (9) and nuts (10) finger tight. Install the clip (6), that secures the breather hose in the correct position.

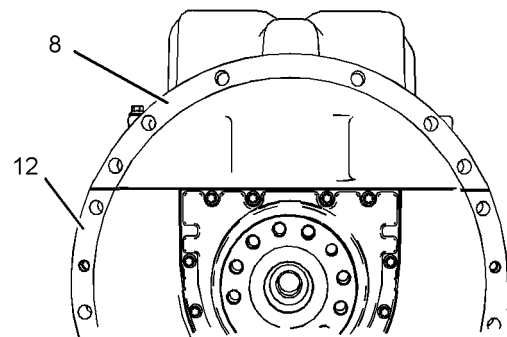

Illustration 230

g01251982

Typical example

8. Align the rear face of engine oil pan (8) to the rear face of cylinder block (12). Use Tooling (C) and a feeler gauge in order to check the alignment between the engine oil pan and the cylinder block.

9. Tighten bolts (9) and nuts (10) to a torque of 22 N·m (16 lb ft).

10. If necessary, install a new O-ring seal (11) to drain plug (5). Install drain plug (5) to engine oil pan (8). Tighten the drain plug to a torque of 34 N·m (25 lb ft).

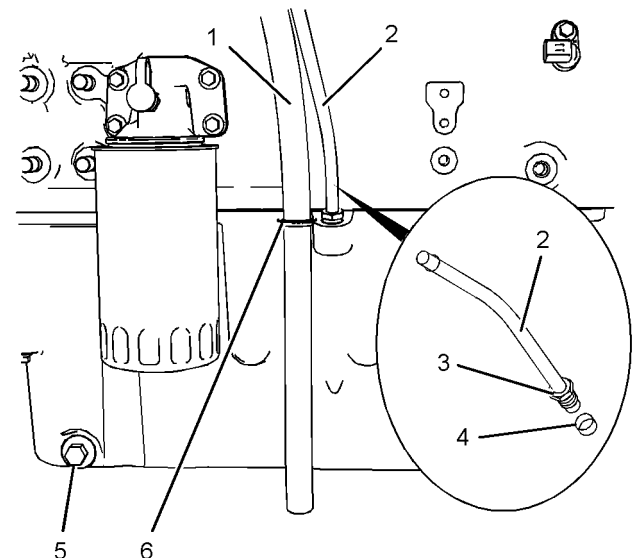

Illustration 231

g01251772

Typical example

11. Follow Steps 11.a through 11.c in order to install the assembly of the dipstick tube.

- a. Install a new seal (4) to tube assembly (2).
- b. Apply Tooling (B) to nut (3). Install the tube assembly to the engine oil pan.

Note: Ensure that the orientation of the tube assembly is correct.

- c. Tighten the nut to a torque of 18 N·m (13 lb ft). Install the dipstick.

12. Install breather hose (1) to clip (6) that secures the hose to the engine oil pan.

Note: After the engine has been installed, ensure that the engine oil pan is filled with lubricating oil to the correct level. Refer to Operation and Maintenance Manual, "Oil Filter Change" for the correct procedure.

i02589157

Balancer - Remove

Removal Procedure

Table 58

Required Tools			
Tool	Part Number	Part Name	Qty
A	21825576	Crankshaft Turning Tool	1
B	27610211	Crankshaft Timing Pin	1
C	27610225	Timing Pin (Balancer)	1
D	-	Puller (Two Leg)	1

Start By:

- a. Remove the engine oil pan. Refer to Disassembly and Assembly, "Engine Oil Pan - Remove and Install".
- b. Remove the front cover. Refer to Disassembly and Assembly, "Front Cover - Remove and Install".

Note: In order to remove the balancer, the engine must be removed from the machine. The engine should be mounted in a suitable stand and placed in the inverted position.

NOTICE

Keep all parts clean from contaminants.

Contaminants may cause rapid wear and shortened component life.

NOTICE

Care must be taken to ensure that fluids are contained during performance of inspection, maintenance, testing, adjusting and repair of the product. Be prepared to collect the fluid with suitable containers before opening any compartment or disassembling any component containing fluids.

Dispose of all fluids according to local regulations and mandates.

- 1. Use Tooling (A) in order to rotate the crankshaft so that number one piston is at the top center position.

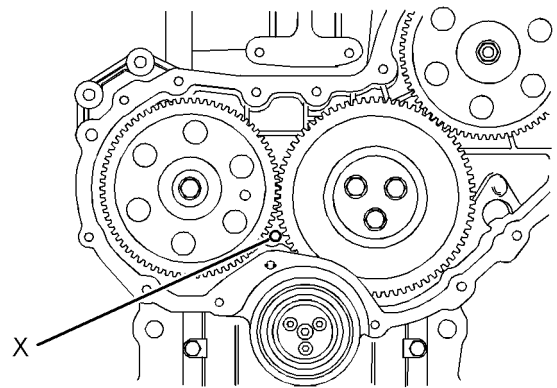

Illustration 232

g01259627

Typical example

- 2. Install Tooling (B) through hole (X) in the front housing. Use Tooling (B) in order to lock the crankshaft in the correct position.

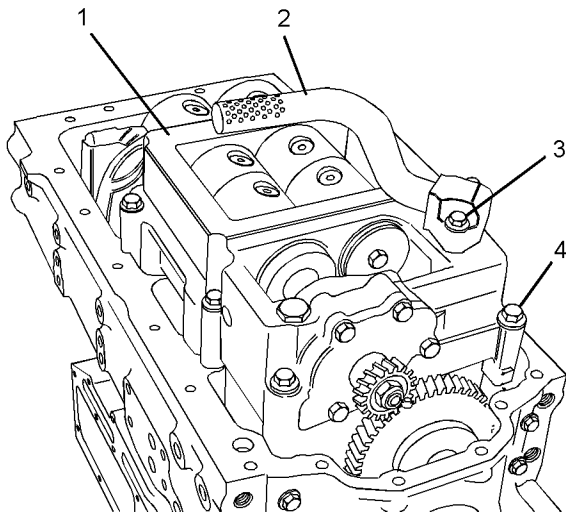

Illustration 233

g01259635

Typical example

3. Remove bolts (3) and suction pipe (2).
4. Remove the joint from the suction pipe.

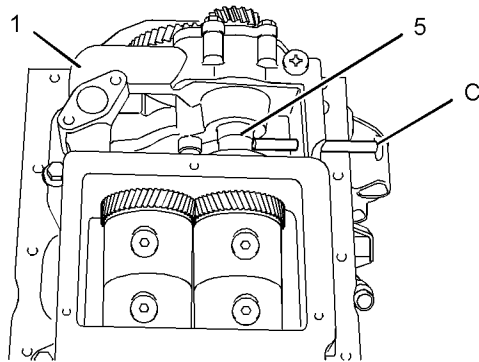

Illustration 234

g01252310

Typical example

5. Install Tooling (C) into balancer (1). Ensure that Tooling (C) is engaged into the hole in drive shaft (5).
6. Attach a suitable lifting device to balancer (1). Support the weight of the balancer. The balancer weighs approximately 23 kg (51 lb).
7. Remove bolts (4). Use the lifting device to remove the balancer.

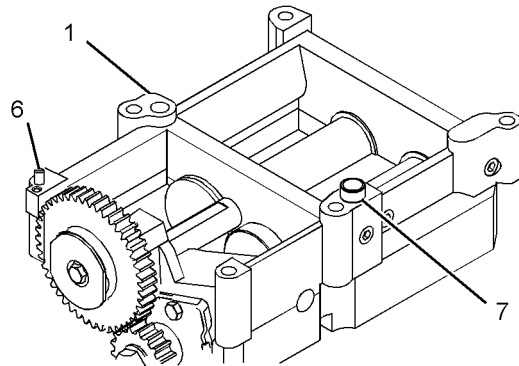

Illustration 235

g01259636

8. Do not remove dowels (6) and (7) unless the dowels are damaged.

Note: The balancer unit is not a serviceable item. The engine oil pump and the engine oil relief valve are the only serviceable parts of the balancer.

Disassembly Procedure

1. Remove the engine oil relief valve. Refer to Disassembly and Assembly, "Engine Oil Relief Valve - Remove and Install".

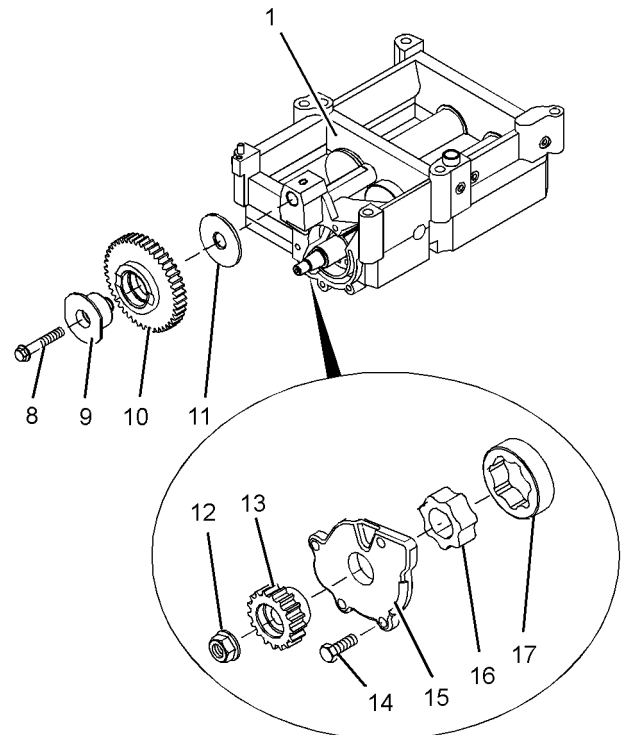

Illustration 236

g01252311

2. Remove bolt (8) and hub (9). Remove idler gear (10) and thrust washer (11).

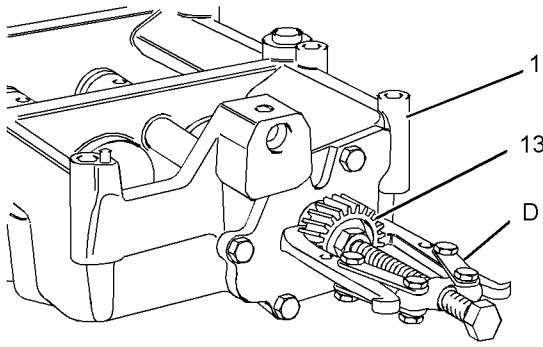

Illustration 237

g01259631

3. Remove nut (12). Use Tooling (D) in order to remove gear (13) from the shaft of the oil pump.

Note: Do not use a timing pin to lock the balancer in order to loosen nut (12).

4. Remove bolts (14) and remove front cover (15).

5. Remove outer rotor (17) and remove inner rotor (16).

Note: Mark the direction of rotation of the rotors.

i02589159

Balancer - Install

Assembly Procedure

Table 59

Required Tools			
Tool	Part Number	Part Description	Qty
E	21820117	POWERPART Threadlock and Nutlock	1

NOTICE

Keep all parts clean from contaminants.

Contaminants may cause rapid wear and shortened component life.

1. Ensure that all components of the engine oil pump are clean and free from wear or damage.

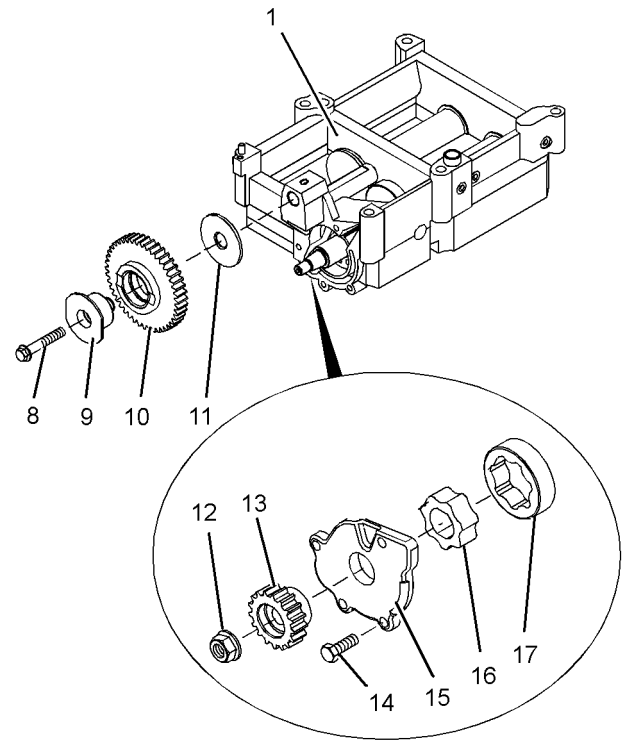

Illustration 238

g01252311

Typical example

2. Install inner rotor (16) and install outer rotor (17). Used rotors should be installed in the original direction of rotation. Check the clearance between the outer rotor and the body of the oil pump. Check the clearance between the inner rotor and the outer rotor. Check the end play of the rotor assembly. Refer to Specifications, "Engine Oil Pump" for more information.

3. Lubricate the assembly of the oil pump with clean engine oil. Install front cover (15). Install bolts (14). Tighten the bolts to a torque of 26 N·m (19 lb ft).

4. Ensure that the shaft of the oil pump is clean and dry. Position gear (13) onto the shaft. Install nut (12). Tighten the nut to a torque of 95 N·m (70 lb ft).

Note: Do not use a timing pin to lock the balancer in order to tighten nut (12).

5. Lubricate hub (9), thrust washer (11) and the bush of idler gear (10) with clean engine oil. Install hub (9) and thrust washer (11) to idler gear (10).

Note: Ensure the correct orientation of the idler gear.

6. Install the assembly of the idler gear to balancer (1).

7. Ensure that the threads of bolt (8) are clean and dry. Apply Tooling (E) to the threads of the bolt. Install bolt (8). Tighten the bolt to a torque of 26 N·m (19 lb ft).
8. Check the end play of idler gear (10). Refer to Specifications, "Engine Oil Pump".
9. Install the engine oil relief valve . Refer to Disassembly and Assembly, "Engine Oil Relief Valve - Remove and Install" for further information.

Installation Procedure

Table 60

Required Tools			
Tool	Part Number	Part Description	Qty
B	27610211	Crankshaft Timing Pin	1
C	27610225	Timing Pin (Balancer)	1
F	21825617	Dial Indicator Group	1
	-	Finger Clock	1
G	-	Guide Studs (M10 by 75 mm)	1

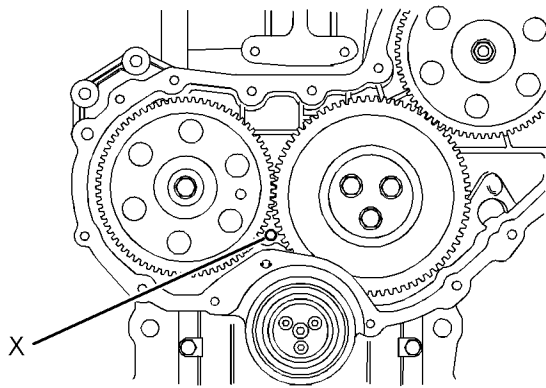

Illustration 239

g01259627

1. Ensure that No. 1 piston is at the top center position and that Tooling (B) is installed to position (X) in the front housing.
2. Clean the mating surfaces of the cylinder block.

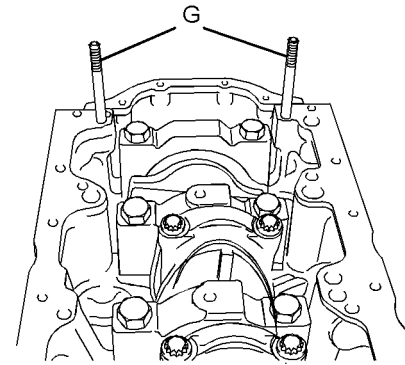

Illustration 240

g01252312

3. Install Tooling (G) to the cylinder block.

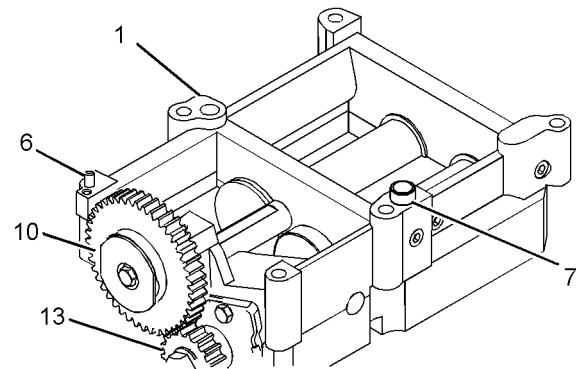

Illustration 241

g01260306

4. Ensure that dowels (6) and (7) are seated in the housing of balancer (1).

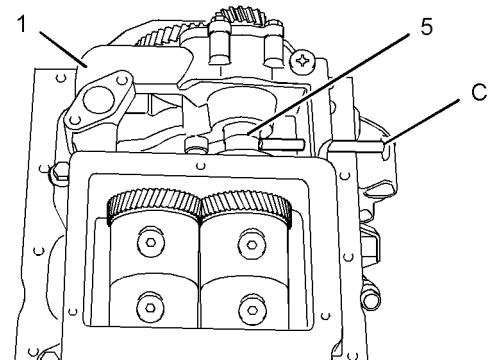

Illustration 242

g01252310

5. Install Tooling (C) to balancer (1). Ensure that Tooling (C) is engaged into shaft (5).
6. Attach a suitable lifting device to the balancer. The balancer weighs approximately 23 kg (51 lb).

i02591050

7. Use the lifting device to align balancer (1) with Tooling (G). Install the balancer to the cylinder block. Ensure that dowels (6) and (7) are aligned with the holes in the cylinder block. Ensure that gear (10) and the crankshaft gear mesh. Remove the lifting device.

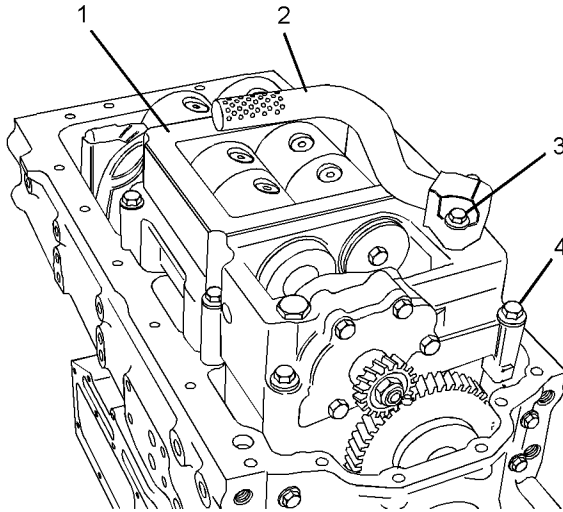

Illustration 243

g01259635

8. Install bolts (4) to balancer (1) finger tight.
9. Remove the Tooling (G) and install remaining bolts (4). Tighten the bolts to a torque of 54 N·m (40 lb ft).
10. Remove the Tooling (B) and (C).
11. Install suction pipe (2) and a new joint to balancer (1).
12. Install bolts (3). Tighten the bolts to a torque to 22 N·m (16 lb ft).
13. Use Tooling (F) in order to check the backlash between gears (10) and (13). Refer to Illustration 241. Refer to Specifications, "Engine Oil Pump".
14. Use Tooling (F) in order to check the backlash between gear (10) and the crankshaft gear. Refer to Specifications, "Gear Group - Front" for further information.

End By:

- a. Install the engine oil pan. Refer to Disassembly and Assembly, "Engine Oil Pan - Remove and Install".
- b. Install the front cover. Refer to Disassembly and Assembly, "Front Cover - Remove and Install".

Piston Cooling Jets - Remove and Install

Removal Procedure

Table 61

Required Tools			
Tool	Part Number	Part Description	Qty
A ¹	21825576	Crankshaft Turning Tool	1
A ²	27610291	Barring Device Housing	1
	27610289	Gear	1

Start By:

- a. If the engine is equipped with a balancer, remove the balancer. Refer to Disassembly and Assembly, "Balancer - Remove". If the engine is not equipped with a balancer, remove the engine oil pump. Refer to Disassembly and Assembly, "Engine Oil Pump - Remove".

Note: Either Tooling (A) can be used. Use the Tooling that is most suitable.

NOTICE

Keep all parts clean from contaminants.

Contaminants may cause rapid wear and shortened component life.

1. If the crankshaft is installed, use Tooling (A) to rotate the crankshaft in order to gain access to the appropriate piston cooling jet.

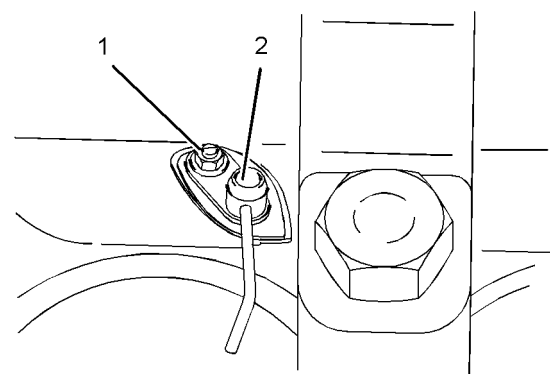

Illustration 244

g01265615

Typical example

- Remove bolt (1) and piston cooling jet (2) from the cylinder block.
- Repeat Steps 1 and 2 for the remaining piston cooling jets.

Installation Procedure

Table 62

Required Tools			
Tool	Part Number	Part Description	Qty
A ¹	21825576	Crankshaft Turning Tool	1
A ²	27610291	Barring Device Housing	1
	27610289	Gear	1

Note: Either Tooling (A) can be used. Use the Tooling that is most suitable.

NOTICE

Keep all parts clean from contaminants.

Contaminants may cause rapid wear and shortened component life.

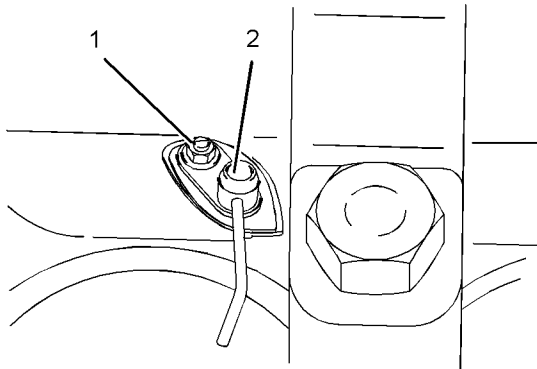

Illustration 245

g01265615

- Clean the piston cooling jets and inspect the piston cooling jets for damage. Ensure that the valve is free to move within each piston cooling jet. Replace any damaged piston cooling jets.
- If the crankshaft is installed, use Tooling (A) to rotate the crankshaft in order to access the mounting flange for the piston cooling jet.
- Position piston cooling jet (2) in the cylinder block. Install bolt (1). Tighten the bolt to a torque of 9 N·m (80 lb in).
- Repeat Steps 2 through 3 for the remaining piston cooling jets.

- If the cylinder head has been removed, It is possible to check the alignment of the piston cooling jets. Refer to Specifications, "Piston Cooling Jet Alignment" for more information.

Note: It is not possible to check the alignment of the piston cooling jets with the cylinder head in position.

End By:

- If the engine is equipped with a balancer, install the balancer. Refer to Disassembly and Assembly, "Balancer - Install". If the engine is not equipped with a balancer, install the engine oil pump. Refer to Disassembly and Assembly, "Engine Oil Pump - Install".

i02591051

Pistons and Connecting Rods - Remove

Removal Procedure

Table 63

Required Tools			
Tool	Part Number	Part Description	Qty
A ¹	21825576	Crankshaft Turning Tool	1
A ²	27610291	Barring Device Housing	1
	27610289	Gear	1
B	27610274	Ridge Reamer	1

Start By:

- Remove the cylinder head. Refer to Disassembly and Assembly , "Cylinder Head - Remove".
- If the engine is equipped with a balancer, remove the balancer. Refer to Disassembly and Assembly, "Balancer - Remove". If the engine is not equipped with a balancer, remove the engine oil pump. Refer to Disassembly and Assembly, "Engine Oil Pump - Remove".
- Remove the piston cooling jets. Refer to Disassembly and Assembly , "Piston Cooling Jets - Remove and Install".

Note: Either Tooling (A) can be used. Use the Tooling that is most suitable.

NOTICE

Keep all parts clean from contaminants.

Contaminants may cause rapid wear and shortened component life.

1. Use Tooling (A) to rotate the crankshaft until the crank pin is at the bottom center position.
2. Use Tooling (B) to remove the carbon ridge from the top inside surface of the cylinder bore.

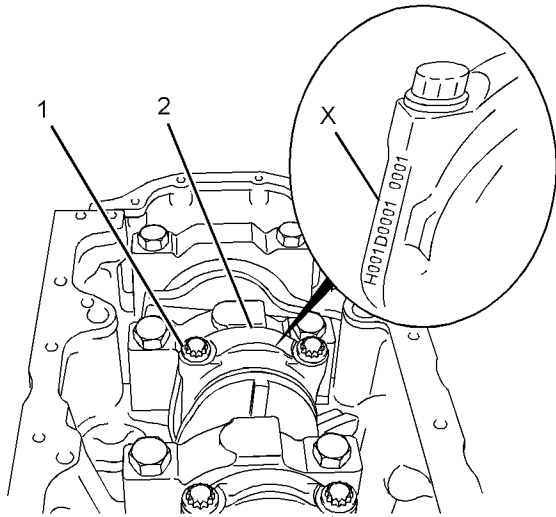

Illustration 246

g01252442

3. The connecting rod and the connecting rod cap should have an etched number (X) on the side. The number on the connecting rod and the connecting rod cap must match. Ensure that the connecting rod and connecting rod cap (2) are marked for the correct location. If necessary, make a temporary mark on the connecting rod and the connecting rod cap in order to identify the cylinder number.

Note: Do not stamp the connecting rod assembly. Stamping or punching the connecting rod assembly could cause the connecting rod to fracture.

4. Remove bolts (1) and remove connecting rod cap (2) from the connecting rod.

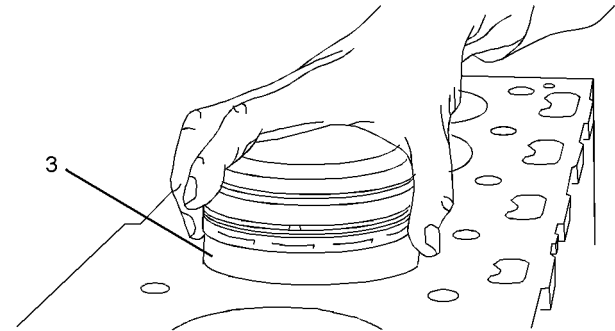

Illustration 247

g01244066

Typical example

5. Carefully push piston (3) and the connecting rod assembly out of the cylinder bore. Lift the piston out of the top of the cylinder block.

Note: Do not push on the fracture split surfaces of the connecting rod as damage may result.

6. Temporarily install connecting rod cap (2) and bolts (1) to the connecting rod when the assembly is out of the engine. Tighten bolts (1) to a torque of 20 N·m (14 lb ft).

Note: Fracture split connecting rods should not be left without the connecting rod caps installed. Ensure that the etched number on connecting rod cap matches the etched number on connecting rod. Ensure the correct orientation of the connecting rod cap.

7. Repeat Steps 1 through 5 for the remaining pistons and connecting rods.

i02591124

Pistons and Connecting Rods - Disassemble

Disassembly Procedure

Table 64

Required Tools			
Tool	Part Number	Part Description	Qty
A	-	Circlip Pliers	1
B	-	Piston Ring Expander	1

Start By:

- a. Remove the pistons and the connecting rods.
Refer to Disassembly and Assembly, "Piston and Connecting Rods - Remove".

NOTICE

Keep all parts clean from contaminants.

Contaminants may cause rapid wear and shortened component life.

1. Make a temporary mark on the components of the piston and connecting rod assembly. This will ensure that the components of each piston and connecting rod assembly can be reinstalled in the original cylinder. Mark the underside of the piston on the front pin boss. Do not interchange components.

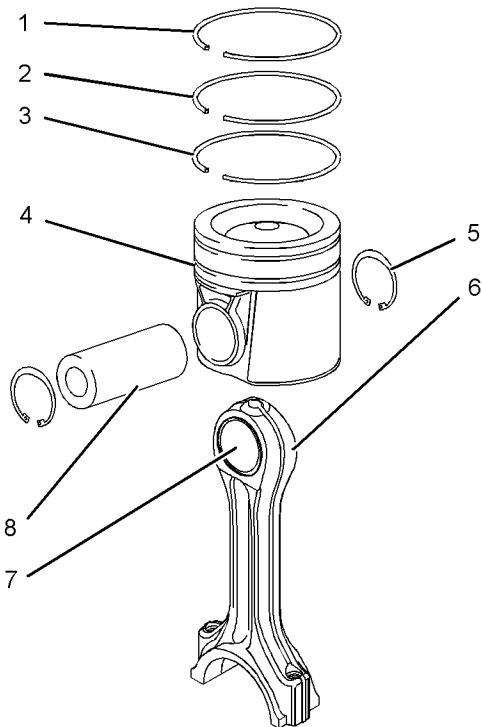

Illustration 248

g01244067

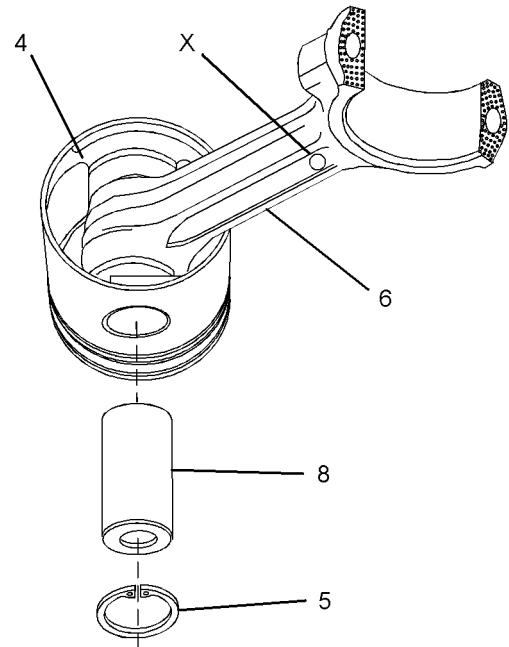

Illustration 249

g01253091

Typical example

2. Place the piston and connecting rod assembly on a suitable surface with the connecting rod upward. Use Tooling (A) in order to remove circlips (5).

Note: The forged marks (X) identify the front of the connecting rod assembly. The forged marks should be used for the purposes of orientation.

3. Remove piston pin (8) and connecting rod (6) from piston (4).

Note: If the piston pin cannot be removed by hand, heat the piston to a temperature of 45 ± 5 °C (113 ± 9 °F). Do not use a torch to heat the piston. Note the orientation of the connecting rod and the piston.

4. Place the piston on a suitable surface with the crown upward. Use Tooling (B) in order to remove compression rings (1) and (2), and oil control ring (3) from piston (4).

Note: Identify the position and orientation of compression rings (1) and (2), and oil control ring (3).

i02589163

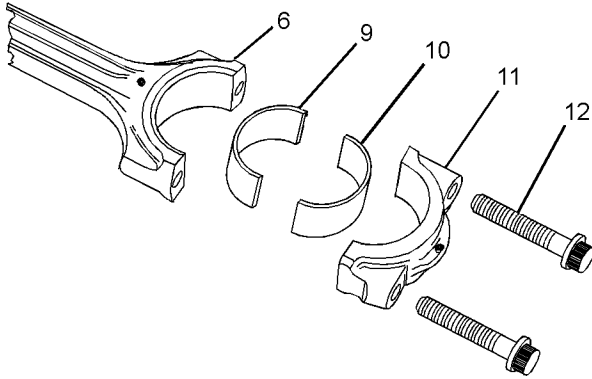

Illustration 250

g01244068

- Remove bolts (12) and connecting rod cap (11) from connecting rod (6). Discard the bolts.

Note: Fracture split connecting rods should not be left without the connecting rod caps installed. After the disassembly procedure for the piston and connecting rod is completed, carry out the assembly procedure and the installation procedure as soon as possible. Refer to Disassembly and Assembly, "Piston and Connecting Rods - Assemble" and Disassembly and Assembly, "Piston and Connecting Rods - Install".

- Remove the lower half of connecting rod bearing (10) from connecting rod cap (11). Remove the upper half of connecting rod bearing (9) from connecting rod (6). Keep the connecting rod bearings together.

NOTICE

Removal of the piston pin bushing in the connecting rod must be carried out by personnel with the correct training. Also special machinery is required. For more information refer to your authorized Perkins distributor.

- Inspect the connecting rod for wear or damage. If necessary, replace connecting rod (6) or replace bush (7) for the piston pin.

Note: If the connecting rod or the bush for the piston pin are replaced, first identify the height grade of the connecting rod. Refer to Specifications, "Connecting Rods".

- Repeat Steps 5 through 7 in order to disassemble the remaining pistons and connecting rods.

Pistons and Connecting Rods - Assemble

Assembly Procedure

Table 65

Required Tools			
Tool	Part Number	Part Description	Qty
A	-	Circlip Pliers	1
B	-	Piston Ring Expander	1

NOTICE

Keep all parts clean from contaminants.

Contaminants may cause rapid wear and shortened component life.

- Ensure that all components are clean and free from wear or damage. If necessary, replace any components that are worn or damaged.
- If the original piston is assembled, follow Steps 2.a through 2.e in order to install the piston rings.
 - Position the spring for oil control ring (3) into the oil ring groove in piston (4). The central wire must be located inside the end of the spring.

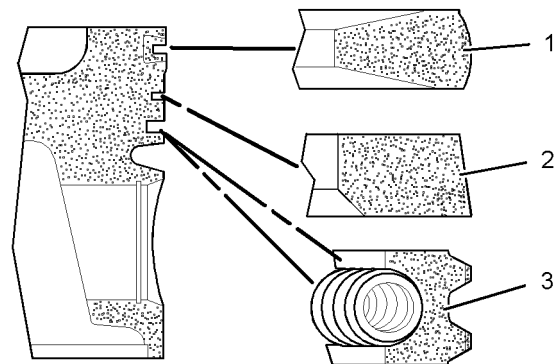

Illustration 251

g01155119

- Use Tooling (B) to install oil control ring (3) over the spring.

Note: Ensure that the central wire is 180 degrees from the ring gap.

- c. Use Tooling (B) to install intermediate compression ring (2) into the second groove in piston (4). The word "TOP" must be upward. The chamfer on the inner face must be downward.
- d. Use Tooling (B) to install top compression ring (1) into the top groove in piston (4). The word "TOP" must be upward.
- e. Position the piston ring gaps at 120 degrees away from each other.

Note: A new piston assembly is supplied with new piston rings.

NOTICE

Removal of the piston pin bushing in the connecting rod must be carried out by personnel with the correct training. Also special machinery is required. For more information refer to your authorized Perkins distributor.

3. If the connecting rod assembly or the bush for the piston pin have been replaced, ensure that the height grade of the connecting rod is correct. Refer to Specifications, "Connecting Rods" for further information.

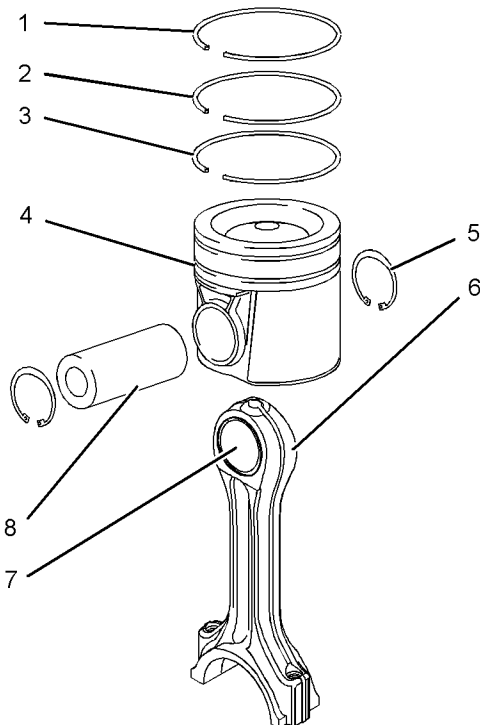

Illustration 252

g01244067

4. Lubricate bush (7) and lubricate the bore for the piston pin in piston (4) with clean engine oil.

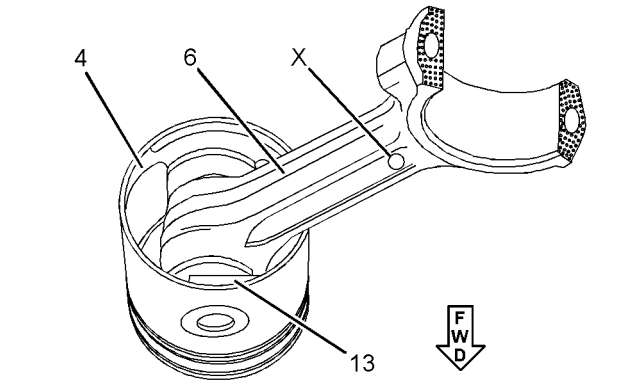

Illustration 253

g01244172

5. Place the piston on a suitable surface with the crown downward. Install connecting rod (6) and piston pin (8) to piston (4). Ensure that square boss (13) on the piston, and forged mark (X) on the connecting rod are in the correct position. See illustration 253.

Note: If the piston pin cannot be installed by hand, heat the piston to a temperature of $45^{\circ} \pm 5^{\circ}\text{C}$ ($113^{\circ} \pm 9^{\circ}\text{F}$).

6. Use Tooling (A) in order to install circlips (5) to the piston pin bore in piston (4).

Note: Ensure that the circlips are seated in the grooves in the piston.

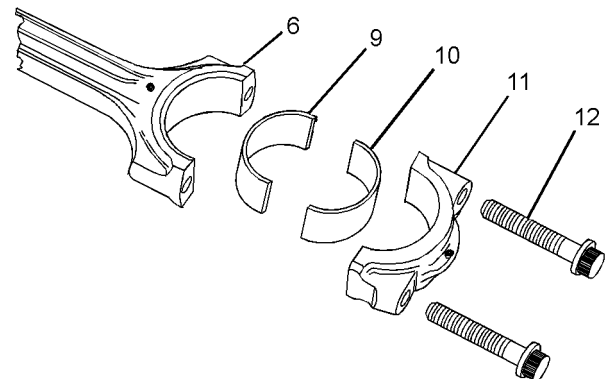

Illustration 254

g01244068

i02591052

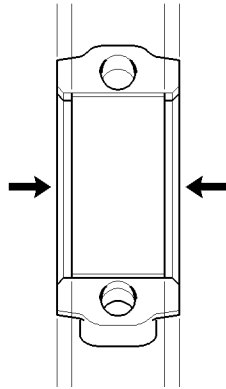

Illustration 255 g01001160
Aligning the connecting rod bearing in the center of the connecting rod

7. Install the upper half of connecting rod bearing (9) to connecting rod (6). Ensure that the connecting rod bearing is centralized in the connecting rod. Refer to Illustration 255.

Note: New connecting rod bearings are supplied with an alignment tool. If new connecting rod bearings are installed, use the tool to align the connecting rod bearing in the connecting rod.

8. Install the lower half of connecting rod bearing (10) to connecting rod cap (11). Ensure that the connecting rod bearing is centralized in the connecting rod cap. Refer to Illustration 255.

Note: New connecting rod bearings are supplied with an alignment tool. If new connecting rod bearings are installed, use the tool to align the connecting rod bearing in the connecting rod cap.

9. Repeat Steps 2 through 8 for the remaining piston and connecting rod assemblies.

Note: Fracture split connecting rods should not be left without the connecting rod caps installed. After the assembly procedure for the piston and connecting rod is completed, carry out the installation procedure as soon as possible. Refer to Disassembly and Assembly, "Piston and Connecting Rods - Install".

End By:

a. Install the pistons and the connecting rods. Refer to Disassembly and Assembly, "Piston and Connecting Rods - Install".

Pistons and Connecting Rods - Install

Installation Procedure

Table 66

Required Tools			
Tool	Part Number	Part Description	Qty
A ¹	21825576	Crankshaft Turning Tool	1
A ²	27610291	Barring Device Housing	1
	27610289	Gear	1
B	21825491	Piston Ring Compressor	1
C	21825607	Angle gauge	1

Note: Either Tooling (A) can be used. Use the Tooling that is most suitable.

NOTICE

Keep all parts clean from contaminants.

Contaminants may cause rapid wear and shortened component life.

NOTICE

Discard all used connecting rod bolts.

1. If the connecting rod caps were temporarily installed, remove the connecting rod caps. If necessary, thoroughly clean all of the components.

2. Apply clean engine oil to the cylinder bore, to the piston rings, to the outer surface of the piston and to the connecting rod bearings.

Note: Install the connecting rod bearings dry when clearance checks are performed. Refer to Disassembly and Assembly, "Bearing Clearance - Check". Apply clean engine oil to the connecting rod bearings during final assembly.

3. Use Tooling (A) to rotate the crankshaft until the crankshaft pin is at the bottom center position. Lubricate the crankshaft pin with clean engine oil.

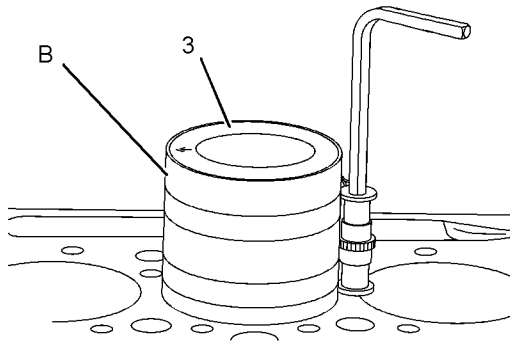

Illustration 256

g01253096

Typical example

4. Ensure that the gaps for the piston rings are at 120 degrees away from each other. Install Tooling (B) onto piston (3).

Note: Ensure that Tooling (B) is installed correctly and that the piston can easily slide from the tool. Ensure that the piston and the connecting rod assembly are installed in the correct cylinder. The arrow on the top of the piston must be toward the front of the engine.

5. Carefully push the piston and the connecting rod assembly into the cylinder bore and onto the crankshaft pin.

Note: Do not damage the finished surface of the crankshaft pin.

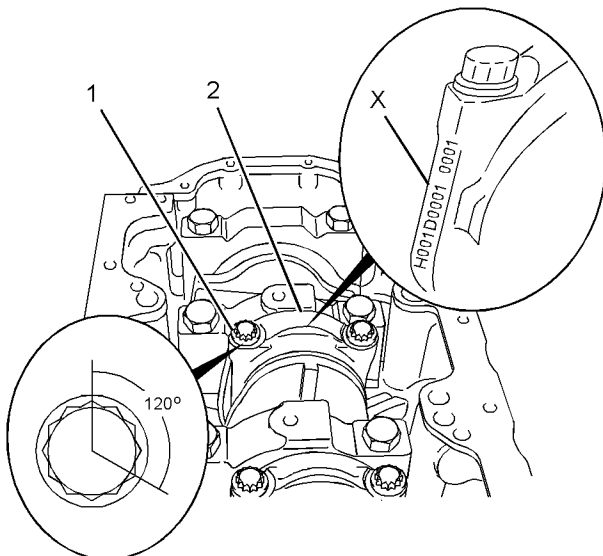

Illustration 257

g01253095

Typical example

6. Install connecting rod cap (2) onto the connecting rod.

Note: Ensure that etched number (X) on the connecting rod cap matches the etched number on the connecting rod. Ensure the correct orientation of connecting rod cap (2).

7. Install new bolts (1) to the connecting rod. Tighten the bolts evenly to a torque of 18 N·m (13 lb ft).
8. Tighten the bolts evenly to a torque of 70 N·m (52 lb ft).
9. Use Tooling (B) to turn the bolts through an additional 120 degrees.
10. Ensure that the installed connecting rod assembly has tactile side play. Carefully rotate the crankshaft in order to ensure that there is no binding.
11. Repeat Steps 2 through 10 in order to install the remaining pistons and connecting rods.

Note: If all pistons and connecting rods require replacement the procedure can be carried out on two cylinders at the same time. The procedure can be carried out on the following pairs of cylinders. 1 with 4 and 2 with 3. **Ensure that both pairs of the pistons and connecting rods are installed before changing from one pair of cylinders to another pair of cylinders..**

12. Check the height of the pistons above the top face of the cylinder block. Refer to Systems Operation, Testing and Adjusting, "Piston Height - Inspect" for the correct procedure.

End By:

- a. Install the piston cooling jets. Refer to Disassembly and Assembly, "Piston Cooling Jets - Remove and Install".
- b. If the engine is equipped with a balancer, install the balancer. Refer to Disassembly and Assembly, "Balancer - Install". If the engine is not equipped with a balancer, install the engine oil pump. Refer to Disassembly and Assembly, "Engine Oil Pump - Install".
- c. Install the cylinder head. Refer to Disassembly and Assembly, "Cylinder Head - Install".

i02591096

Connecting Rod Bearings - Remove (Connecting rods in position)

Removal Procedure

Table 67

Required Tools			
Tool	Part Number	Part Description	Qty
A ¹	21825576	Crankshaft Turning Tool	1
A ²	27610291	Barring Device Housing	1
	27610289	Gear	1

Start By:

- a. If the engine is equipped with a balancer, remove the balancer. Refer to Disassembly and Assembly, "Balancer - Remove". If the engine is not equipped with a balancer, remove the engine oil pump. Refer to Disassembly and Assembly, "Engine Oil Pump - Remove".

Note: Either Tooling (A) can be used. Use the Tooling that is most suitable.

NOTICE

Keep all parts clean from contaminants.

Contaminants may cause rapid wear and shortened component life.

NOTICE

Discard all used connecting rod bolts.

Note: If all connecting rod bearings require replacement the procedure can be carried out on two cylinders at the same time. The procedure can be carried out on the following pairs of cylinders. 1 with 4 and 2 with 3. **Ensure that both pairs of the connecting rod bearings are installed before changing from one pair of cylinders to another pair of cylinders.** Refer to Disassembly and Assembly, "Connecting Rod Bearings - Install".

1. Use Tooling (A) to rotate the crankshaft until the crank pin is at the bottom center position.

If necessary, remove the glow plugs. Refer to Disassembly and Assembly, "Glow Plugs - Remove and Install".

Note: Removal of the glow plugs aids removal of the connecting rod bearings. It is not essential.

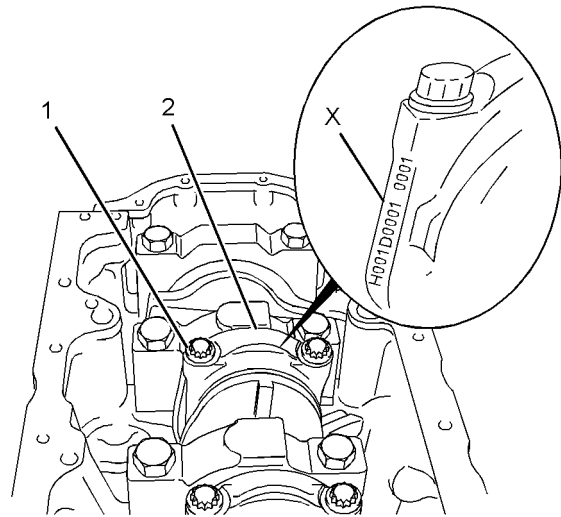

Illustration 258

g01252442

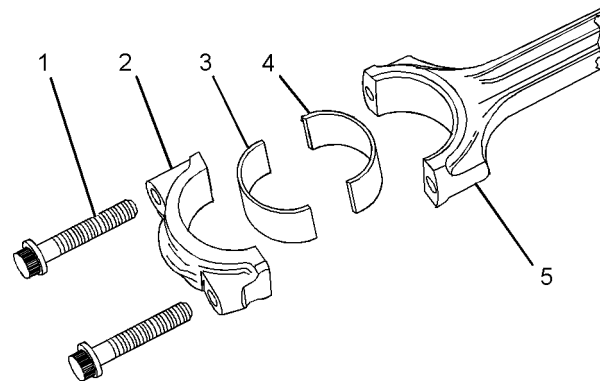

Illustration 259

g01253101

2. The connecting rod and the connecting rod cap should have an etched number (X) on the side. The number on the connecting rod and the connecting rod cap must match. If necessary, make a temporary mark on connecting rod (5) and connecting rod cap (2) in order to identify the cylinder number.

Note: Do not punch identification marks onto fracture split connecting rods. Do not stamp identification marks onto fracture split connecting rods.

3. Remove bolts (1) and connecting rod cap (2) from connecting rod (5). Discard the bolts.
4. Remove the lower half of connecting rod bearing (3) from connecting rod cap (2). Keep the connecting rod bearing and the connecting rod cap together.

5. Carefully push the piston and connecting rod assembly into the cylinder bore until connecting rod (5) is clear of the crankshaft. Remove the upper half of connecting rod bearing (4) from connecting rod (5). Keep the bearings together.

Note: Do not push on the fracture split surfaces of the connecting rod as damage may result. Do not allow the connecting rod to contact the piston cooling jet.

Fracture split connecting rods should not be left without the connecting rod caps installed. After the removal procedure for the connecting rod bearings is complete, carry out the installation procedure as soon as possible. Refer to Disassembly and Assembly, "Connecting Rod Bearings - Install".

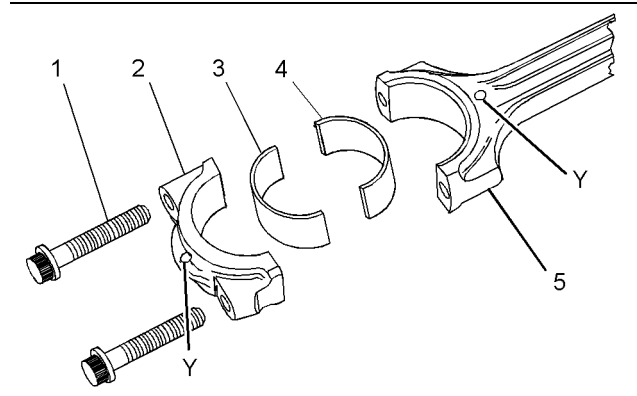

Illustration 260

g01260354

i02591123

Connecting Rod Bearings - Install (Connecting rods in position)

Installation Procedure

Table 68

Required Tools			
Tool	Part Number	Part Description	Qty
A ¹	21825576	Crankshaft Turning Tool	1
A ²	27610291	Barring Device Housing	1
	27610289	Gear	1
B	21825607	Angle Gauge	1

Note: Either Tooling (A) can be used. Use the Tooling that is most suitable.

NOTICE

Keep all parts clean from contaminants.

Contaminants may cause rapid wear and shortened component life.

NOTICE

Discard all used connecting rod bolts.

1. Inspect the pins of the crankshaft for damage. If the crankshaft is damaged, replace the crankshaft or recondition the crankshaft. Refer to Disassembly and Assembly, "Crankshaft - Remove" and Disassembly and Assembly, "Crankshaft - Install". Ensure that the connecting rod bearings are clean and free from wear or damage. If necessary, replace the connecting rod bearings.

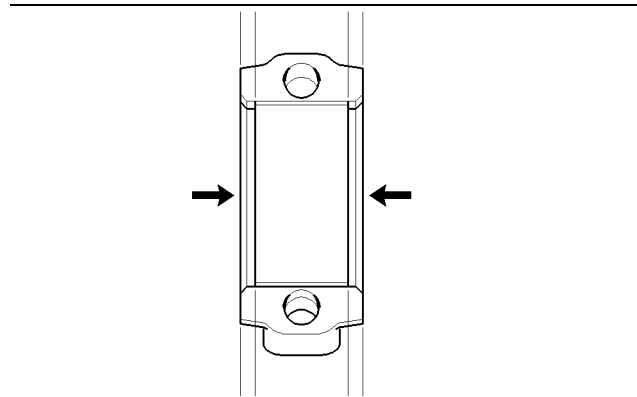

Illustration 261

g01001160

Aligning the bearing in the center of the connecting rod

Note: New connecting rod bearings are supplied with an alignment tool. If new bearings are installed, use the tool to align the bearing in the connecting rod.

2. Install the upper half of connecting rod bearing (4) to connecting rod (5). Ensure that the bearing is centralized in the connecting rod. Refer to Illustration 261.

The ends of the bearing must be centered in the connecting rod. The ends of the bearing must be equally positioned in relation to the mating faces of the connecting rod.

3. Clean the connecting rod cap. Install lower connecting rod bearing (3) to connecting rod cap (2). Ensure that the connecting rod bearing is centralized in the connecting rod cap. Refer to Illustration 261.

The ends of the lower connecting rod bearing must be centered in the connecting rod cap. The ends of the lower connecting rod bearing must be equally positioned in relation to the mating faces of the connecting rod cap.

4. Lubricate upper connecting rod bearing (4) with clean engine oil.

5. If necessary, use Tooling (A) in order to rotate the crankshaft until the crankshaft pin is at the bottom dead center position.

6. Carefully pull connecting rod (5) against the crankshaft pin.

Note: Do not allow the connecting rod to contact the piston cooling jet.

7. Lubricate the pin of the crankshaft and lubricate lower connecting rod bearing (3) with clean engine oil.

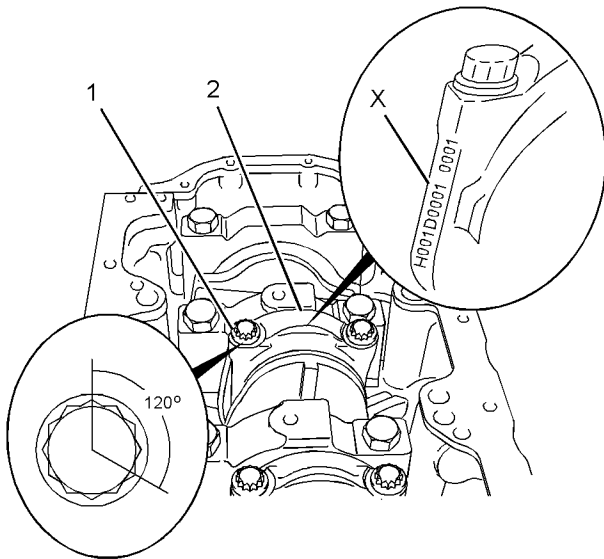

Illustration 262

g01260355

8. Install connecting rod cap (2) to connecting rod (5).

Note: Ensure that etched number (X) on connecting rod cap (2) matches etched number (X) on connecting rod (5). Ensure the correct orientation of the connecting rod cap. The forged marks (Y) on the connecting rod and the connecting rod cap should be on the same side. Refer to Illustration 260.

9. Install new bolts (1). Tighten the bolts evenly to a torque of 18 N·m (13 lb ft).

Note: Do not reuse the old bolts in order to secure the connecting rod cap.

10. Tighten the bolts evenly to a torque of 70 N·m (52 lb ft).

11. Use Tooling (B) to turn the bolts through an additional 120 degrees.

12. Ensure that the installed connecting rod assembly has tactile side play. Carefully rotate the crankshaft in order to ensure that there is no binding.

13. Repeat Steps 2 through 12 for the remaining connecting rod bearings.

Note: If all connecting rod bearings require replacement the procedure can be carried out on two cylinders at the same time. The procedure can be carried out on the following pairs of cylinders. 1 with 4 and 2 with 3. **Ensure that both pairs of the connecting rod bearings are installed before changing from one pair of cylinders to another pair of cylinders..**

14. If the glow plugs were removed, install the glow plugs. Refer to Disassembly and Assembly, "Glow Plugs - Install".

End By:

a. If the engine is equipped with a balancer, install the balancer. Refer to Disassembly and Assembly, "Balancer - Install". If the engine is not equipped with a balancer, install the engine oil pump. Refer to Disassembly and Assembly, "Engine Oil Pump - Install".

i02591100

Crankshaft Main Bearings - Remove and Install (Crankshaft in position)

Removal Procedure

Table 69

Required Tools			
Tool	Part Number	Part Description	Qty
A ¹	21825576	Crankshaft Turning Tool	1
A ²	27610291	Barring Device Housing	1
	27610289	Gear	1

Start By:

a. If the engine is equipped with a balancer, remove the balancer. Refer to Disassembly and Assembly, "Balancer - Remove". If the engine is not equipped with a balancer, remove the engine oil pump. Refer to Disassembly and Assembly, "Engine Oil Pump - Remove".

b. Remove the crankshaft rear seal. Refer to Disassembly and Assembly, "Crankshaft Rear Seal - Remove".

Note: Either Tooling (A) can be used. Use the Tooling that is most suitable.

NOTICE

This procedure must only be used to remove and install the main bearing shells with the crankshaft in position.

The removal procedure and the installation procedure must be completed for each pair of main bearing shells before the next pair of main bearing shells are removed.

NOTICE

Keep all parts clean from contaminants.

Contaminants may cause rapid wear and shortened component life.

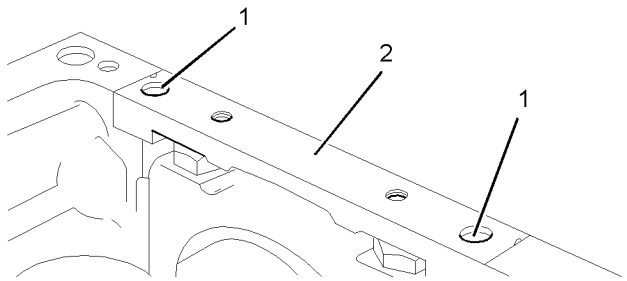

Illustration 263

g01253717

Typical example

1. Remove allen head screws (1). Remove bridge piece (2).
2. Ensure that the main bearing cap is marked for the correct location and orientation.

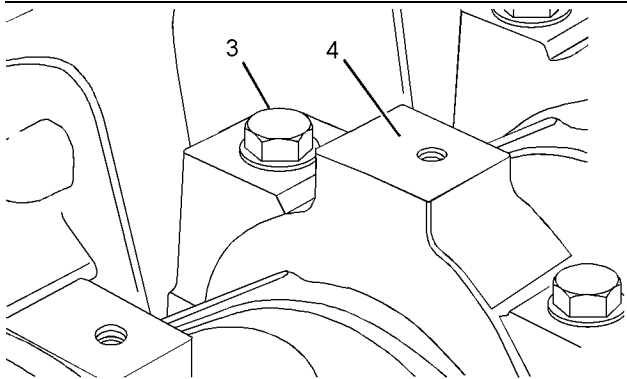

Illustration 264

g01253719

Typical example

3. Remove bolts (3). Remove main bearing cap (4) from the cylinder block.

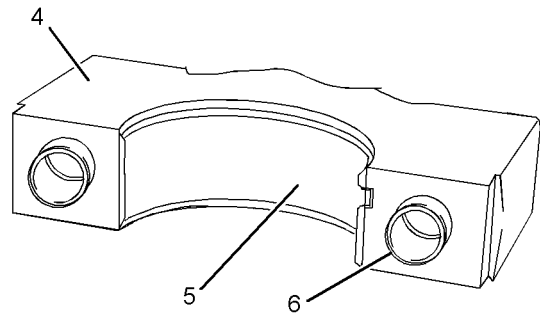

Illustration 265

g01253146

Typical example

4. Remove lower main bearing (5) from main bearing cap (4). Keep the main bearing and the main bearing cap together. Take care not to displace dowels (6).

Note: The lower main bearing is a plain bearing that has no oil holes. The dowels may remain in the main bearing cap or in the cylinder block.

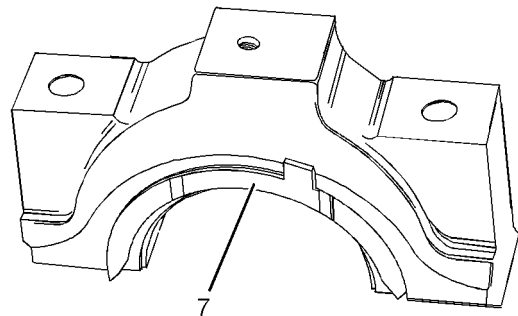

Illustration 266

g01253137

Typical example

5. For number three main bearing cap, remove thrust washers (7).

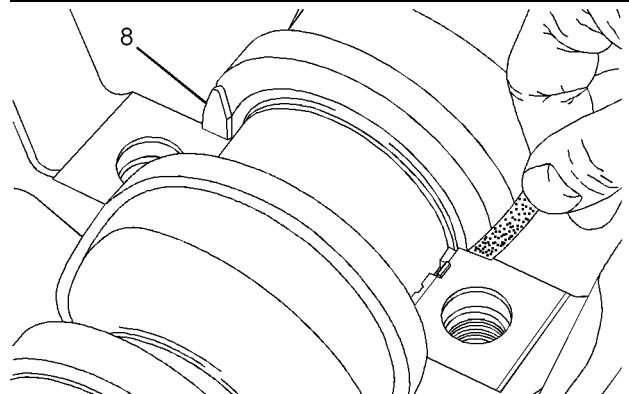

Illustration 267

g01253142

Typical example

6. For number three main bearing, remove thrust washers (8) from the cylinder block. In order to remove the thrust washers, push the crankshaft toward the front of the engine or push the crankshaft toward the rear of the engine. Use Tooling (A) in order to rotate the crankshaft. If necessary, use a suitable tool to free the thrust washers.

Note: Do not damage the machined surfaces of the crankshaft during removal of the thrust washers.

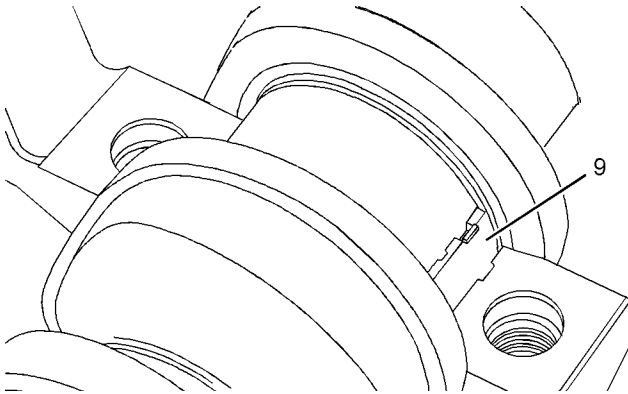

Illustration 268

g01253145

7. Push out upper main bearing (9) with a suitable tool from the side opposite the locating tab. Carefully rotate the crankshaft while you push on the bearing. Remove upper main bearing (9) from the cylinder block. Keep the bearings together.

Note: Do not damage the machined surfaces of the crankshaft during removal of the upper main bearing. The upper main bearing has a groove and two oil holes.

Installation Procedure

Table 70

Required Tools			
Tool	Part Number	Part Description	Qty
B	21825617	Dial Indicator Group	1
C	-	Straight Edge	1
D	-	5 mm Allen Socket	1
E	21826038	POWERPART Silicon Rubber Sealant	-

NOTICE

This procedure must only be used to remove and install the main bearing shells with the crankshaft in position.

The removal procedure and the installation procedure must be completed for each pair of main bearing shells before the next pair of main bearing shells are removed.

NOTICE

Keep all parts clean from contaminants.

Contaminants may cause rapid wear and shortened component life.

1. Ensure that the main bearings are clean and free from wear or damage. If necessary, replace the main bearings.
2. Clean the journals of the crankshaft. Inspect the journals of the crankshaft for damage. If necessary, replace the crankshaft or recondition the crankshaft.

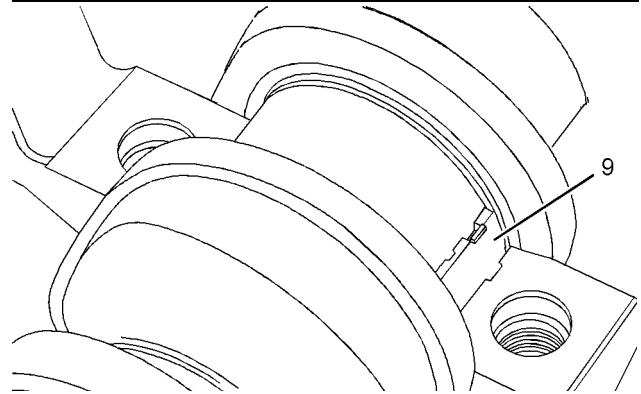

Illustration 269

g01253145

Typical example

3. Lubricate the crankshaft journal and the upper main bearing (9) with clean engine oil. Slide the upper main bearing (9) into position between the crankshaft journal and the cylinder block. Ensure that the locating tab for the upper main bearing is correctly seated in the slot in the cylinder block.

Note: The upper main bearing has a groove and two oil holes.

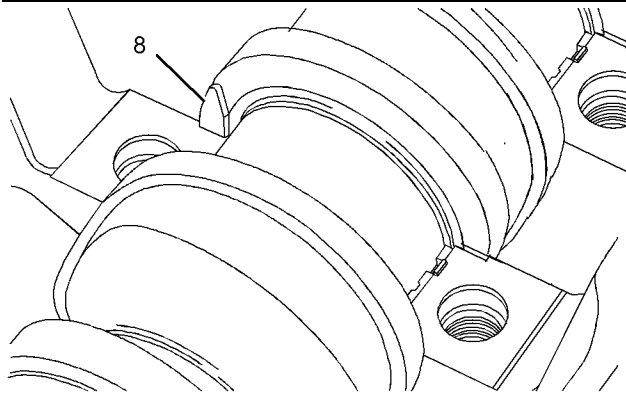

Illustration 270

g01261200

Typical example

4. For number three main bearing, ensure that thrust washers (8) are clean and free from wear or damage. If necessary, replace the thrust washers. Lubricate thrust washers (8) with clean engine oil. Slide the thrust washers into position between the crankshaft and the cylinder block. The grooves in the thrust washers must be located against the crankshaft.

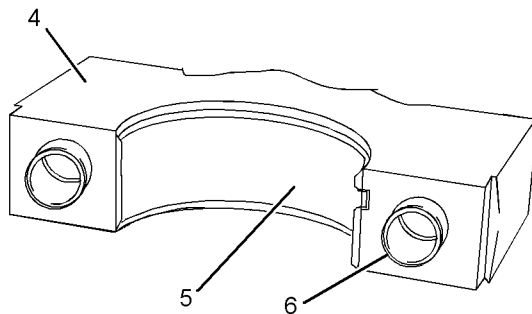

Illustration 271

g01253146

Typical example

5. Install lower main bearing (5) into main bearing cap (4). Ensure that the locating tab for the lower main bearing is correctly seated into the slot in the bearing cap.

Note: The lower main bearing is a plain bearing that has no oil holes.

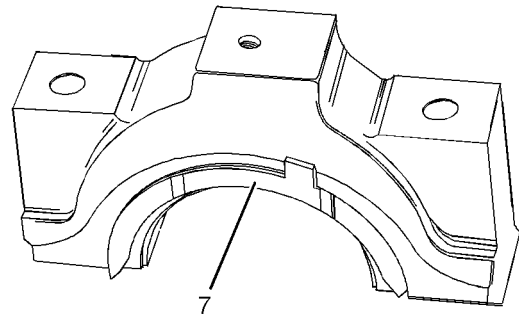

Illustration 272

g01253137

Typical example

6. For number three main bearing cap, ensure that thrust washers (7) are clean and free from wear or damage. If necessary, replace the thrust washers. Lubricate thrust washers (7) with clean engine oil. Place the thrust washers into position on the main bearing cap. Ensure that the locating tab is correctly seated in the main bearing cap.

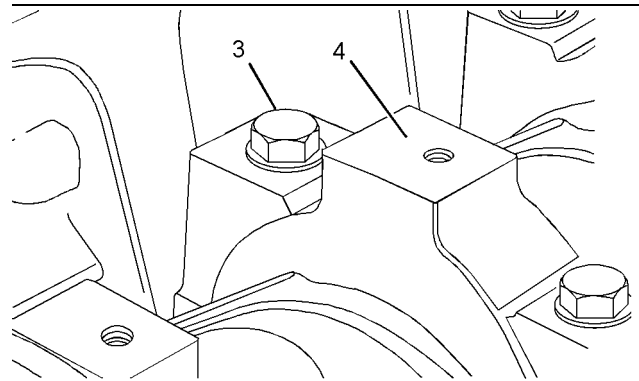

Illustration 273

g01253719

Typical example

7. Lubricate the crankshaft journal and the lower main bearing with clean engine oil. Install main bearing cap (4) to the cylinder block.

Note: Ensure the correct orientation of the main bearing cap. The locating tab for the upper and the lower bearing should be on the same side of the engine.

8. Lubricate the threads of bolts (3) with clean engine oil. Lubricate the underside of the heads of the bolts with clean engine oil.

9. Install bolts (3) to main bearing cap (4). Evenly tighten the bolts in order to pull cap (5) into position. Ensure that the cap is correctly seated.

Note: Do not tap the main bearing cap into position as the bearing may be dislodged.

10. Tighten bolts (3) to a torque of 245 N·m (180 lb ft).

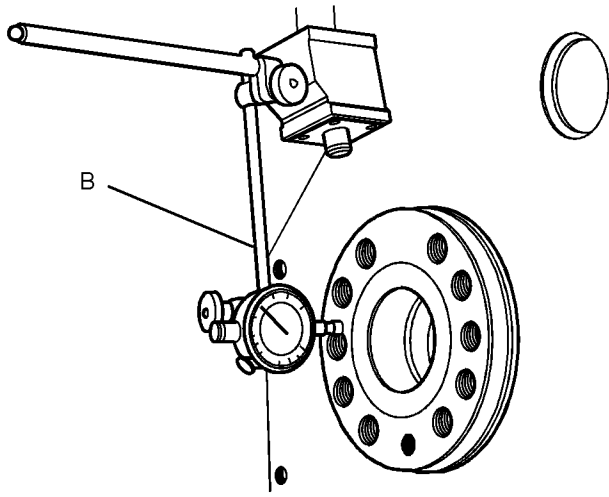

Illustration 274

g01253186

Typical example

11. Check the crankshaft end play. Push the crankshaft toward the front of the engine. Install Tooling (B) to the cylinder block and the rear face of the crankshaft. Push the crankshaft toward the rear of the engine. Use Tooling (B) to measure the crankshaft end play. The permissible crankshaft end play is 0.17 mm (0.007 inch) to 0.41 mm (0.016 inch).

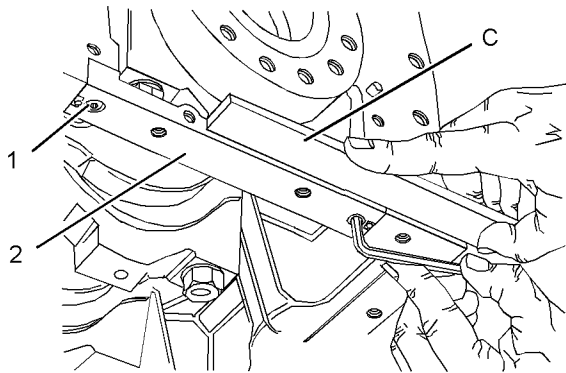

Illustration 275

g01253836

Typical example

12. Follow Steps 12.a through 12.d in order to install the bridge piece.

- a. Ensure that the recess in the cylinder block and the bridge piece are clean, dry and free from old sealant.
- b. Install bridge piece (2) and allen head screws (1). Tighten the allen head screws finger tight.

c. Use Tooling (C) in order to align the rear face of the bridge piece with the rear face of the cylinder block.

d. Use Tooling (D) to tighten allen head screws (1) to a torque of 16 N·m (12 lb ft).

13. Install the crankshaft rear seal. Refer to Disassembly and Assembly, "Crankshaft Rear Seal - Install".

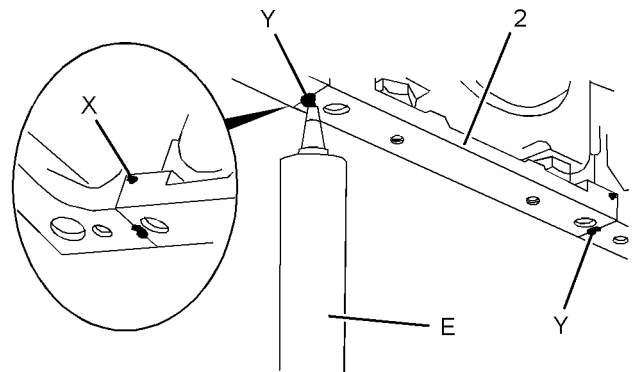

Illustration 276

g01261208

Typical example

14. Apply Tooling (E) to cavities (Y) in bridge piece (2). Continue to apply Tooling (E) until sealant extrudes from cavities (X).

Note: If the oil pan will not be installed immediately, ensure that the joint face of the bridge piece and the cylinder block are left free of sealant.

End By:

- a. If the engine is equipped with a balancer, install the balancer. Refer to Disassembly and Assembly, "Balancer - Install". If the engine is not equipped with a balancer, install the engine oil pump. Refer to Disassembly and Assembly, "Engine Oil Pump - Install".

i02589166

Crankshaft - Remove

Removal Procedure

Table 71

Required Tools			
Tool	Part Number	Part Description	Qty
A	-	Lifting Strap	1

Start By:

- a. Remove the rocker shaft and pushrods. Refer to Disassembly and Assembly, "Rocker Shaft and Pushrod - Remove".
- b. Remove the front housing. Refer to Disassembly and Assembly, "Housing (Front) - Remove".
- c. Remove the crankshaft rear seal. Refer to Disassembly and Assembly, "Crankshaft Rear Seal - Remove".
- d. If the engine is equipped with a balancer, remove the balancer. Refer to Disassembly and Assembly, "Balancer - Remove". If the engine is not equipped with a balancer, remove the engine oil pump. Refer to Disassembly and Assembly, "Engine Oil Pump - Remove".

NOTICE

If the crankshaft has been reground or if the crankshaft has been replaced, the height of the piston above the cylinder block must be inspected. It is necessary to remove the cylinder head in order to inspect the height of the piston above the cylinder block.

NOTICE

Keep all parts clean from contaminants.

Contaminants may cause rapid wear and shortened component life.

1. The engine should be mounted on a suitable stand and placed in the inverted position.
2. If necessary, remove the cylinder head. Refer to Disassembly and Assembly, "Cylinder Head - Remove". Remove the pistons and connecting rods. Refer to Disassembly and Assembly, "Pistons and Connecting Rods - Remove".

If the cylinder head, the pistons and the connecting rods have not been removed, remove the connecting rod caps. Refer to Disassembly and Assembly, "Connecting Rod Bearings - Remove".

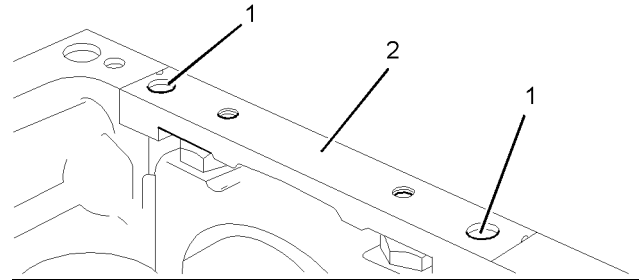

Illustration 277

g01253717

Typical example

3. Remove allen head screws (1). Remove bridge piece (2).
4. Ensure that the main bearing caps are marked for the location and orientation.

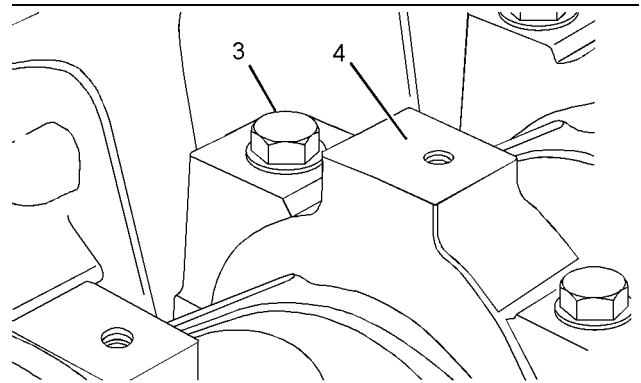

Illustration 278

g01253719

Typical example

5. Remove bolts (3) and main bearing caps (4) from the cylinder block.

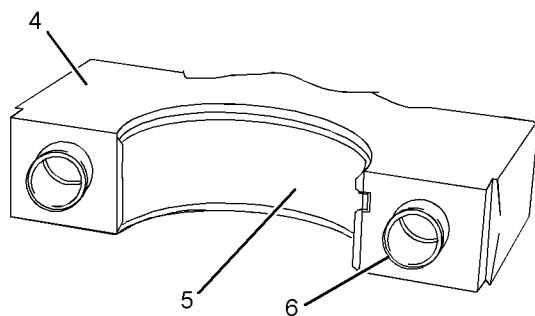

Illustration 279

g01253146

Typical example

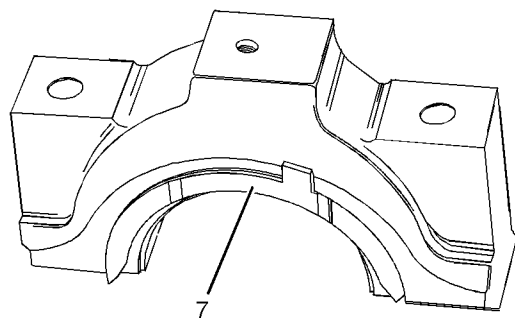

Illustration 280

g01253137

Typical example

6. Remove lower main bearings (5) from main bearing caps (4). Take care not to displace dowels (6). For number three main bearing cap, remove thrust washers (7). Keep the lower main bearings and the thrust washers with the respective main bearing caps.

Note: The lower main bearings are plain bearings that have no oil holes. The dowels may remain in the main bearing cap or in the cylinder block.

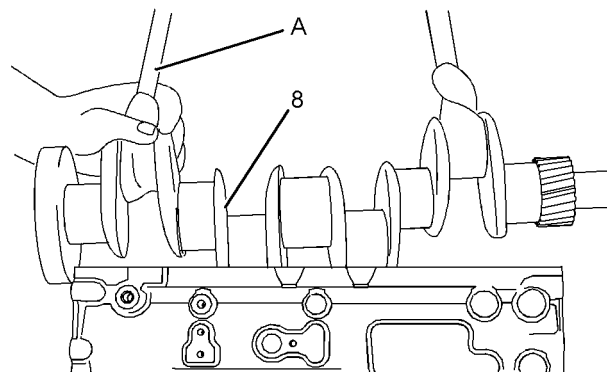

Illustration 281

g01254099

Typical example

7. Attach Tooling (A) and a suitable lifting device to crankshaft (8). Carefully lift the crankshaft out of the cylinder block. The weight of the crankshaft is approximately 30 kg (66 lb).

Note: Do not damage any of the finished surfaces on the crankshaft. When the crankshaft is removed from the engine, the crankshaft must be supported on a suitable stand in order to prevent damage to the crankshaft timing ring.

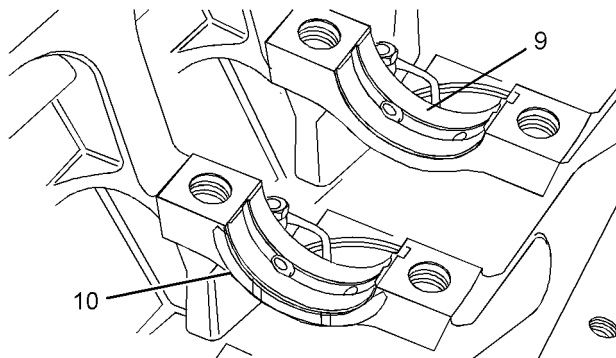

Illustration 282

g01254104

Typical example

8. Remove upper main bearings (9) from the cylinder block. Keep the upper main bearings with the respective main bearing caps.

Note: The upper main bearings have a groove and two oil holes.

9. Remove thrust washers (10) from number three main bearing in the cylinder block.

10. If necessary, remove the crankshaft timing ring. Refer to Disassembly and Assembly, "Crankshaft Timing Ring - Remove and Install".

11. If necessary, remove the crankshaft gear. Refer to Disassembly and Assembly, "Crankshaft Gear - Remove and Install".

i02589167

Crankshaft - Install

Installation Procedure

Table 72

Required Tools			
Tool	Part Number	Part Description	Qty
A	-	Lifting Strap	1
B	21825617	Dial Indicator Group	1
C	-	Straight Edge	1
D	-	5 mm Allen Socket	1
E	21826038	POWERPART Silicon Rubber Sealant	-

NOTICE

Keep all parts clean from contaminants.

Contaminants may cause rapid wear and shortened component life.

NOTICE

If the crankshaft has been reground or if the crankshaft has been replaced, the height of the piston above the cylinder block must be inspected. It is necessary to remove the cylinder head in order to inspect the height of the piston above the cylinder block.

1. Clean the crankshaft and inspect the crankshaft for wear or damage. Refer to Specifications, "Crankshaft" for more information. If necessary, replace the crankshaft or recondition the crankshaft.
2. If necessary, install the crankshaft gear. Refer to Disassembly and Assembly, "Crankshaft Gear - Remove and Install".
3. If necessary, install a new crankshaft timing ring. Refer to Disassembly and Assembly, "Crankshaft Timing Ring - Remove and Install".

Note: The engine should be mounted on a suitable stand and placed in the inverted position.

4. Ensure that the parent bores for the crankshaft bearings in the cylinder block are clean. Ensure that the threads for the bearing bolts in the cylinder block are clean and free from damage.

5. Clean the crankshaft bearings and the thrust washers. Inspect the bearings and the thrust washers for wear or damage. If necessary, replace the bearings and the thrust washers.

Note: If the crankshaft bearings are replaced, check whether oversize bearings were previously installed. If the thrust washers are replaced, check whether oversize thrust washers were previously installed.

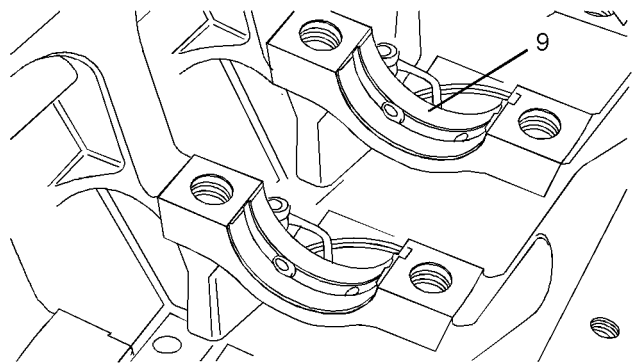

Illustration 283

g01253240

Typical example

6. Install upper bearings(9) to the cylinder block. Ensure that the locating tabs for the upper bearings are seated in the slots in the cylinder block.

Note: The upper bearings have a groove and two oil holes.

7. Lubricate upper bearings (9) with clean engine oil.

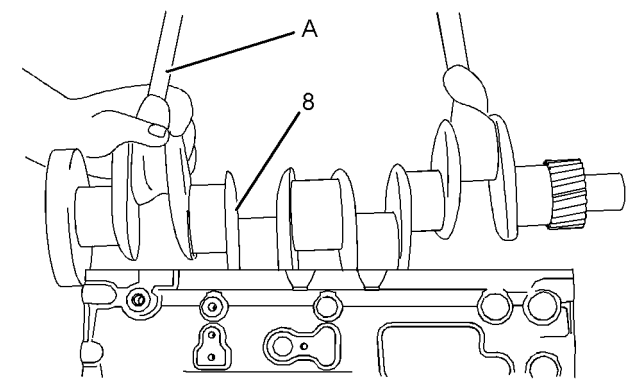

Illustration 284

g01254099

Typical example

8. Attach Tooling (A) and a suitable lifting device to crankshaft (8). Carefully lift the crankshaft into the cylinder block. The weight of the crankshaft is approximately 30 kg (66 lb). Remove Tooling (A).

Note: Do not damage any of the finished surfaces on the crankshaft. Do not damage the bearing.

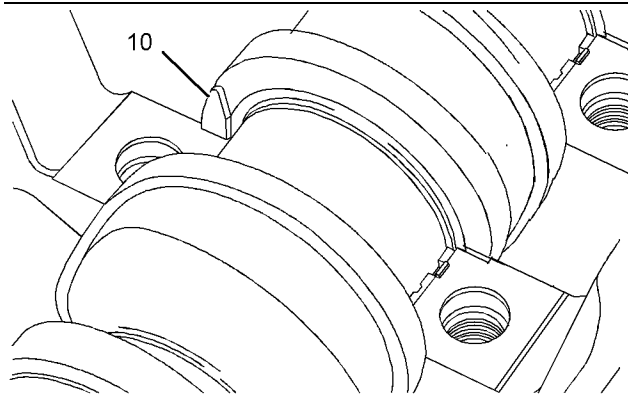

Illustration 285

g01254100

Typical example

9. For number three bearing, ensure that thrust washers (10) are clean and free from wear or damage. If necessary, replace the thrust washers. Lubricate thrust washers (10) with clean engine oil. Slide the thrust washers into position between the crankshaft and the cylinder block.

Note: The grooves in the thrust washers must be located against the crankshaft.

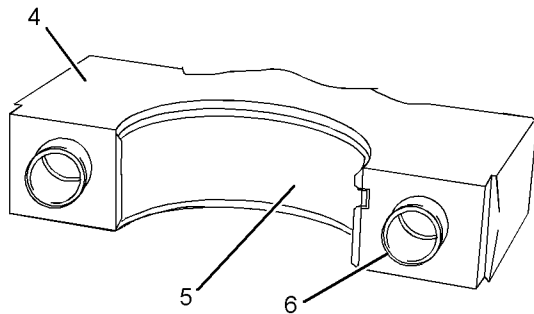

Illustration 286

g01253146

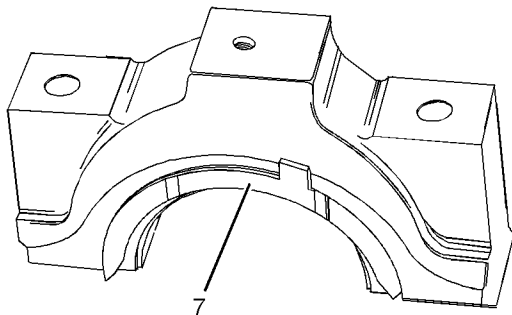

Illustration 287

g01253137

10. Install lower bearings (5) into bearing caps (4). Ensure that the locating tabs for the lower bearings are correctly seated into the slots in the bearing caps. For number three bearing cap, ensure that thrust washers (7) are clean and free from wear or damage. If necessary, replace both the thrust washers. Lubricate thrust washers (7) with clean engine oil. Place the thrust washers into position on the bearing cap. Ensure that the locating tab is correctly seated in the bearing cap.

Note: The lower bearing is a plain bearing that has no oil holes.

11. Lubricate lower bearings (5) and lubricate the journals of crankshaft (8) with clean engine oil. Install bearing caps (4) to the cylinder block.

Note: Ensure the correct location and orientation of the bearing caps. The locating tabs for the upper and the lower bearings should be on the same side of the engine.

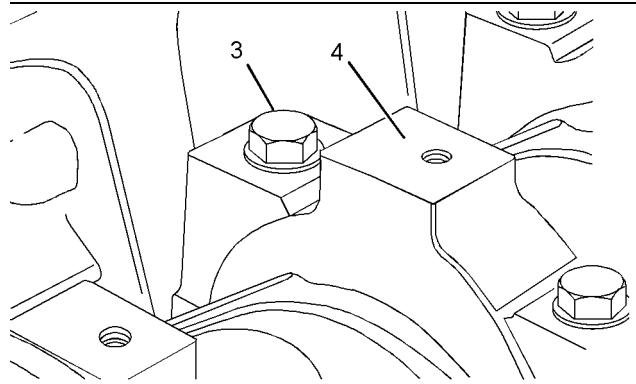

Illustration 288

g01253719

12. Lubricate the threads of bolts (3) with clean engine oil. Lubricate the underside of the heads of the bolts with clean engine oil.
13. Install bolts (3) to bearing caps (4). Evenly tighten the bolts in order to pull the caps into position. Ensure that the caps are correctly seated.
- Note:** Do not tap the bearing caps into position as the bearing may be dislodged.
14. Tighten bolts (3) to a torque of 245 N·m (180 lb ft).
15. Rotate the crankshaft in order to ensure that there is no binding.

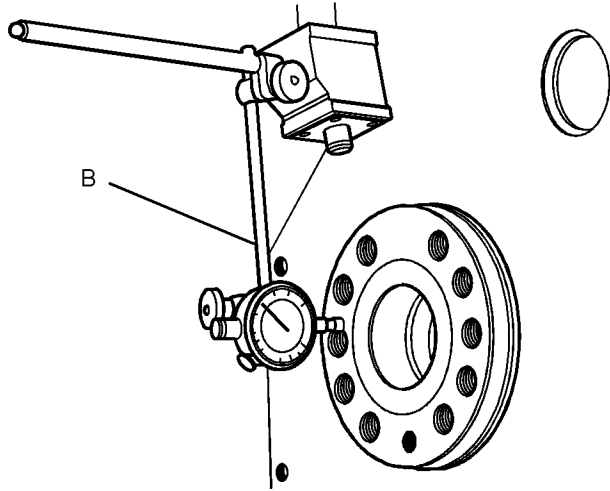

Illustration 289

g01253186

Typical example

16. Check the crankshaft end play. Push the crankshaft toward the front of the engine. Install Tooling (B) to the cylinder block and the rear face of the crankshaft. Push the crankshaft toward the rear of the engine. Use Tooling (B) to measure the crankshaft end play. The permissible crankshaft end play is 0.17 mm (0.007 inch) to 0.41 mm (0.016 inch).

17. If the crankshaft has been replaced or the crankshaft has been reconditioned, inspect the height of the piston above the cylinder block. Refer to Systems Operation, Testing and Adjusting, "Piston Height - Inspect" for more information.

If the crankshaft has not been replaced or the crankshaft has not been reconditioned, install the connecting rod caps. Refer to Disassembly and Assembly, "Connecting Rod Bearings - Install".

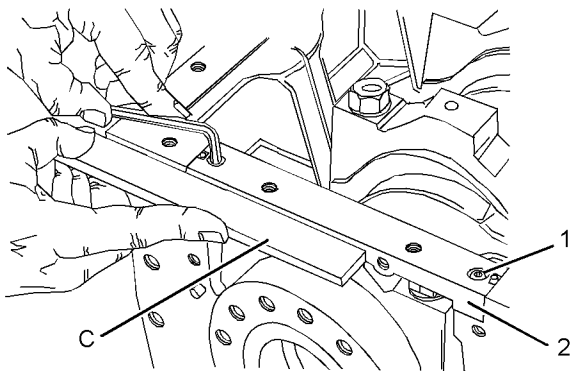

Illustration 290

g01254102

Typical example

18. Follow Steps 18.a through 18.d in order to install the bridge piece.

- a. Ensure that the cylinder block and the bridge piece are clean, dry and free from old sealant.
- b. Install bridge piece. (2) and allen head screws (1). Tighten the allen head screws finger tight.
- c. Use Tooling (C) in order to align the rear face of the bridge piece with the rear face of the cylinder block.
- d. Use Tooling (D) in order to tighten the allen head screws to a torque of 16 N·m (12 lb ft).

19. Install the crankshaft rear seal. Refer to Disassembly and Assembly, "Crankshaft Rear Seal - Install".

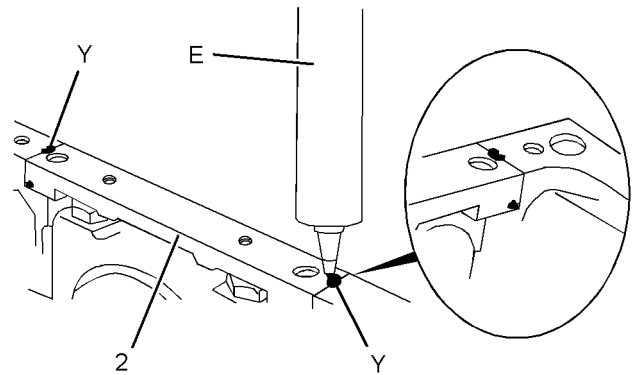

Illustration 291

g01261164

Typical example

20. Apply Tooling (E) to cavities (Y) in the bridge piece (2). Continue to apply Tooling (E) until sealant extrudes from cavities (X).

Note: If the oil pan will not be installed immediately, ensure that the joint face of the bridge piece and the cylinder block are left free of sealant.

End By:

- a. If necessary, install the pistons and connecting rods. Refer to Disassembly and Assembly, "Pistons and Connecting Rods - Install".
- b. If the engine has a balancer, install the balancer. Refer to Disassembly and Assembly, "Balancer - Install". If the engine does not have a balancer, install the engine oil pump. Refer to Disassembly and Assembly, "Engine Oil Pump - Install".
- c. Install the front housing. Refer to Disassembly and Assembly, "Housing (Front) - Install".
- d. If necessary, install the cylinder head. Refer to Disassembly and Assembly, "Cylinder Head - Install".

- e. Install the rockershaft and pushrods. Refer to Disassembly and Assembly, "Rockershaft and Push Rods - Install".

i02589168

Crankshaft Timing Ring - Remove and Install

Removal Procedure

Start By:

- a. Remove the crankshaft. Refer to Disassembly and Assembly, "Crankshaft - Remove".

NOTICE

Keep all parts clean from contaminants.

Contaminants may cause rapid wear and shortened component life.

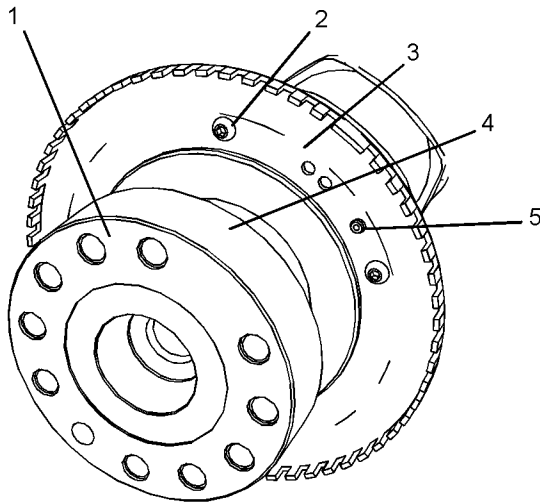

Illustration 292

g01254108

1. Support crankshaft (1) on a suitable stand.
2. Remove allen head screws (2) from crankshaft timing ring (3). Do not reuse the allen head screws.
3. Carefully remove crankshaft timing ring (3) from crankshaft (1). Do not reuse the crankshaft timing ring.

Note: Ensure that seal surface (4) of the crankshaft is not damaged when the crankshaft timing ring is removed.

Note: Do not remove dowel (5) from crankshaft (1) unless the dowel is damaged.

Installation Procedure

Table 73

Required Tools			
Tool	Part Number	Part Description	Qty
A	-	4 mm Allen Socket	1

NOTICE

Keep all parts clean from contaminants.

Contaminants may cause rapid wear and shortened component life.

1. Support crankshaft (1) on a suitable stand.
2. Ensure that the flange for the crankshaft timing ring on the crankshaft is clean and free from damage.

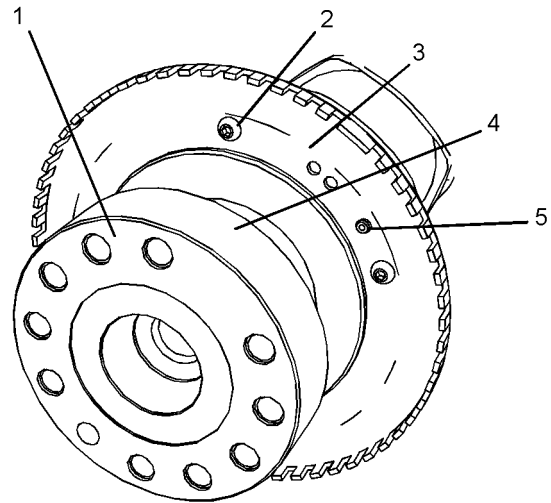

Illustration 293

g01254108

3. If dowel (5) was removed, install a new dowel to crankshaft (1).
4. Position crankshaft timing ring (3) onto the crankshaft with the teeth toward rear seal surface (4). Align the hole in crankshaft timing ring (3) with dowel (5). Carefully install crankshaft timing ring (3) to crankshaft (1).

Note: Ensure that seal surface (4) on the crankshaft is not damaged when the crankshaft timing ring is installed.

5. Use Tooling (A) to install new allen head screws (2). Tighten the allen head screws to a torque of 9 N·m (80 lb in).

End By:

- a. Install the crankshaft. Refer to Disassembly and Assembly, "Crankshaft - Install".

i02589170

Crankshaft Gear - Remove and Install

Removal Procedure

Table 74

Required Tools			
Tool	Part Number	Part Description	Qty
A	-	Bearing Puller	1
	-	Puller	1
	-	Crossblock	1
	-	Puller Leg	2

Start By:

- a. Remove the front housing. Refer to Disassembly and Assembly, "Housing (Front) - Remove".
- b. If the engine is equipped with a balancer, remove the balancer. Refer to Disassembly and Assembly, "Balancer - Remove". If the engine is not equipped with a balancer, remove the engine oil pump. Refer to Disassembly and Assembly, "Engine Oil Pump - Remove".

NOTICE

Keep all parts clean from contaminants.

Contaminants may cause rapid wear and shortened component life.

Note: The crankshaft gear may be a sliding fit on the crankshaft or an interference fit on the crankshaft.

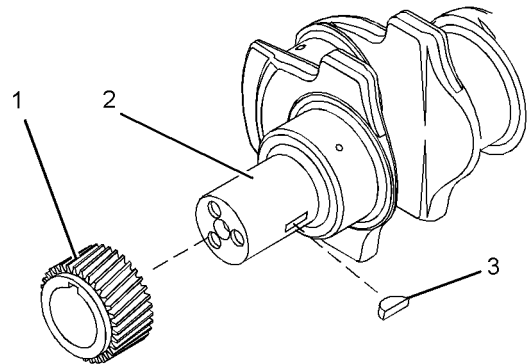

Illustration 294

g01270547

Typical example

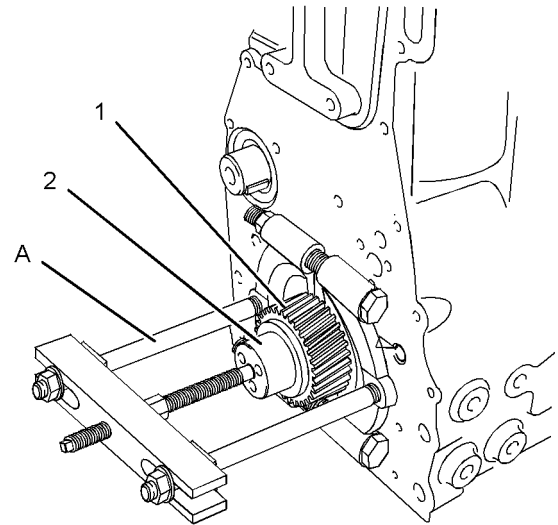

Illustration 295

g01270549

Typical example

1. If the crankshaft gear is a sliding fit on the crankshaft, remove crankshaft gear (1) from crankshaft (2).

If the crankshaft gear is an interference fit on the crankshaft, use Tooling (A) in order to remove crankshaft gear (1) from crankshaft (2).

2. If necessary, remove key (3) from crankshaft (2).

Note: Do not remove the key from the crankshaft unless the key is damaged.

Installation Procedure

NOTICE

Keep all parts clean from contaminants.

Contaminants may cause rapid wear and shortened component life.

i02347769

1. Ensure that all components are clean and free from wear or damage. If necessary, replace any components that are worn or damaged.

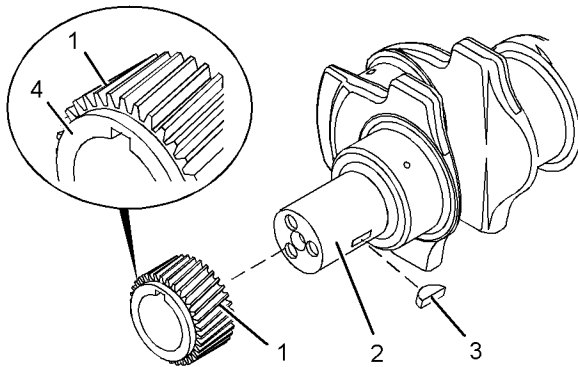

Illustration 296

g01270552

Typical example

2. If necessary, install a new key (3) to crankshaft (2).

Note: The crankshaft gear may be a sliding fit on the crankshaft or an interference fit on the crankshaft.

⚠ WARNING

Hot parts or hot components can cause burns or personal injury. Do not allow hot parts or components to contact your skin. Use protective clothing or protective equipment to protect your skin.

3. If the crankshaft gear is a sliding fit on the crankshaft, align the keyway in crankshaft gear (1) with key (3) in the crankshaft. Install crankshaft gear (1) to crankshaft (2).

If the crankshaft gear is an interference fit on the crankshaft, heat crankshaft gear (1) in an oven to $150^{\circ} \pm 50^{\circ}\text{C}$ ($302^{\circ} \pm 90^{\circ}\text{F}$). Align the keyway in crankshaft gear (1) with key (3) in the crankshaft. Install crankshaft gear (1) to crankshaft (2).

Ensure that shoulder (4) on crankshaft gear (1) is toward the front of the engine.

End By:

- a. Install the front housing. Refer to Disassembly and Assembly Manual, "Housing (Front) - Install".
- b. If the engine is equipped with a balancer, install the balancer. Refer to Disassembly and Assembly, "Balancer - Install". If the engine is not equipped with a balancer, install the engine oil pump. Refer to Disassembly and Assembly, "Engine Oil Pump - Install".

Bearing Clearance - Check

Measurement Procedure

Table 75

Required Tools	
Description	Qty
Plastigauge (Green) 0.025 to 0.076 mm (0.001 to 0.003 inch)	1
Plastigauge (Red) 0.051 to 0.152 mm (0.002 to 0.006 inch)	1
Plastigauge (Blue) 0.102 to 0.229 mm (0.004 to 0.009 inch)	1
Plastic Gauge (Yellow) 0.230 to 0.510 mm (0.009 to 0.020 inch)	1

NOTICE

Keep all parts clean from contaminants.

Contaminants may cause rapid wear and shortened component life.

Note: Perkins does not recommend the checking of the actual clearances of the bearing shells particularly on small engines. This is because of the possibility of obtaining inaccurate results and of damaging the bearing shell or the journal surfaces. Each Perkins bearing shell is quality checked for specific wall thickness. However, if the technician still wants to measure the clearance of the bearing shell, the use of Plastigauge is an acceptable method. Plastigauge is less accurate on journals with small diameters if clearances are less than 0.10 mm (0.004 inch).

Note: The bearing clearance for the crankshaft should be within specifications if the crankshaft journals and the crankshaft pins were checked before installing the crankshaft and the correct bearing shells are installed. No further checks should be necessary.

NOTICE

Lead wire, shim stock or a dial bore gauge can damage the bearing surfaces.

The technician must be very careful to use Plastigauge correctly. The following points must be observed:

- Ensure that the backs of the bearing shells and the bores of the bearing shells are clean and dry.
- If the bearing shells have locating tabs ensure that the locating tabs are properly seated in the tab grooves.
- The crankshaft must be clean and free of oil at the contact points of the Plastigauge.

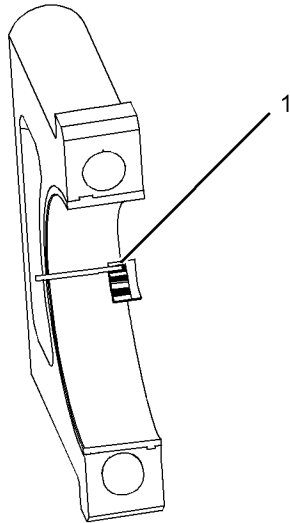

Illustration 297

g01010832

Typical example

1. Place a piece of the Plastigauge (1) onto the crown of the bearing shell that is in the cap.

Note: Do not allow the Plastigauge (1) to extend over the edge of the bearing shell.

2. Use the correct torque-turn specifications in order to install the bearing cap. Do not use an impact wrench. Be careful not to dislodge the bearing shell when the cap is installed.

Note: Do not turn the crankshaft when the Plastigauge (1) is installed.

3. Carefully remove the bearing cap, but do not remove the Plastigauge (1). Measure the width of the Plastigauge (1) while the Plastigauge is in the bearing cap or on the crankshaft journal. Refer to the Illustration 297.
4. Remove all of the Plastigauge (1) before you install the bearing cap.

Note: When Plastigauge is used, the readings can sometimes be unclear. For example, all parts of the Plastigauge are not the same width. Measure the major width in order to ensure that the parts are within the specification range. Refer to the Specifications Manual, "Connecting Rod Bearing Journal" and refer to the Specifications Manual, "Main Bearing Journal" for the correct clearances.

i02589173

Crankshaft Position Sensor - Remove and Install

Removal Procedure

NOTICE

Keep all parts clean from contaminants.

Contaminants may cause rapid wear and shortened component life.

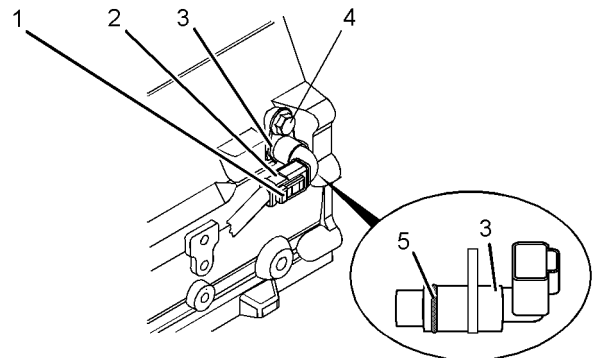

Illustration 298

g01270854

Typical example

1. Slide locking tab (1) into the unlocked position.
 2. Disconnect harness assembly (2) from position sensor (3).
 3. Remove bolt (4).
 4. Carefully remove position sensor (3) from the cylinder block.
- Note:** Do not use a lever to remove the position sensor from the cylinder block.
5. Remove O-ring seal (5) from position sensor (3).

Installation Procedure

i02589175

Table 76

Required Tools			
Tool	Part Number	Part Description	Qty
A	21820221	POWERPART Rubber Grease	1

NOTICE

Keep all parts clean from contaminants.

Contaminants may cause rapid wear and shortened component life.

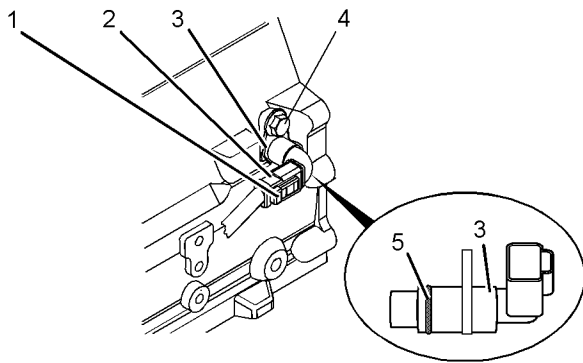

Illustration 299

g01270854

Typical example

1. Install a new O-ring seal (5) to the groove in position sensor (3). Lubricate the new O-ring seal with Tooling (A).

2. Align the hole in position sensor (3) with the hole in the cylinder block. Install the position sensor to the cylinder block.

Note: Do not use bolt (4) to pull the position sensor into position against the cylinder block.

3. Install bolt (4). Tighten the bolt to a torque of 22 N·m (16 lb ft).

4. Connect harness assembly (2) to position sensor (3).

5. Slide locking tab (1) into the locked position.

Coolant Temperature Sensor - Remove and Install

Removal Procedure

NOTICE

Keep all parts clean from contaminants.

Contaminants may cause rapid wear and shortened component life.

NOTICE

Care must be taken to ensure that fluids are contained during performance of inspection, maintenance, testing, adjusting, and repair of the product. Be prepared to collect the fluid with suitable containers before opening any compartment or disassembling any component containing fluids.

Dispose of all fluids according to local regulations and mandates.

1. Drain the coolant from the cooling system, to a level below the coolant temperature sensor, into a suitable container for storage or for disposal. Refer to Operation and Maintenance Manual, "Cooling System Coolant - Change" for the correct draining procedure.

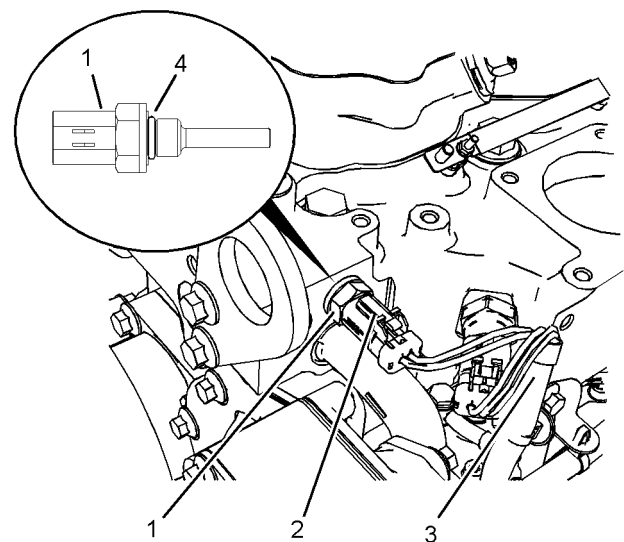

Illustration 300

g01254109

Typical example

2. Slide locking tab (2) into the unlocked position.

3. Disconnect harness assembly (3) from coolant temperature sensor (1).

Note: The coolant temperature sensor has a two-wire plug.

4. Use a deep socket to remove coolant temperature sensor (1) from the cylinder head.

Note: If necessary, remove the bracket for the harness assembly from the bypass tube.

5. Remove O-ring seal (4) from coolant temperature sensor (1).

Installation Procedure

Table 77

Required Tools			
Tool	Part Number	Part Description	Qty
A	21820221	POWERPART Rubber Grease	1

NOTICE

Keep all parts clean from contaminants.

Contaminants may cause rapid wear and shortened component life.

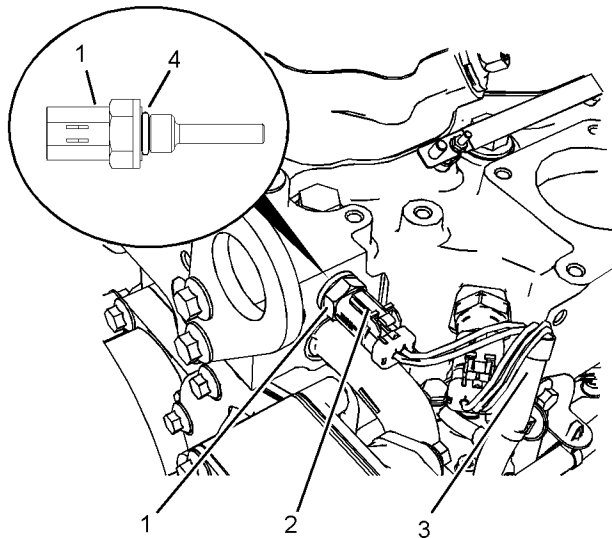

Illustration 301

g01254109

Typical example

1. Install a new O-ring seal (4) to the groove in coolant temperature sensor (1). Lubricate the new O-ring seal with Tooling (A).

2. Use a deep socket in order to install coolant temperature sensor (1) to the cylinder head. Tighten the coolant temperature sensor to a torque of 15 N·m (11 lb ft).

3. Connect harness assembly (3) to coolant temperature sensor (1).

Note: If necessary, install the bracket for the harness assembly to the bypass tube.

4. Slide locking tab (2) into the locked position.

5. Fill the cooling system to the correct level. Refer to Operation and Maintenance Manual, "Cooling System Coolant Level - Check" and refer to Operation and Maintenance Manual, "Cooling System Coolant - Fill" for the correct filling procedure.

i02589174

Engine Oil Pressure Sensor - Remove and Install

Removal Procedure

NOTICE

Keep all parts clean from contaminants.

Contaminants may cause rapid wear and shortened component life.

NOTICE

Care must be taken to ensure that fluids are contained during performance of inspection, maintenance, testing, adjusting, and repair of the product. Be prepared to collect the fluid with suitable containers before opening any compartment or disassembling any component containing fluids.

Dispose of all fluids according to local regulations and mandates.

Note: The engine oil pressure sensor may be located in the cylinder block, on a plate or in the engine oil filter base. Ensure that the engine oil pressure sensor is installed in the correct position.

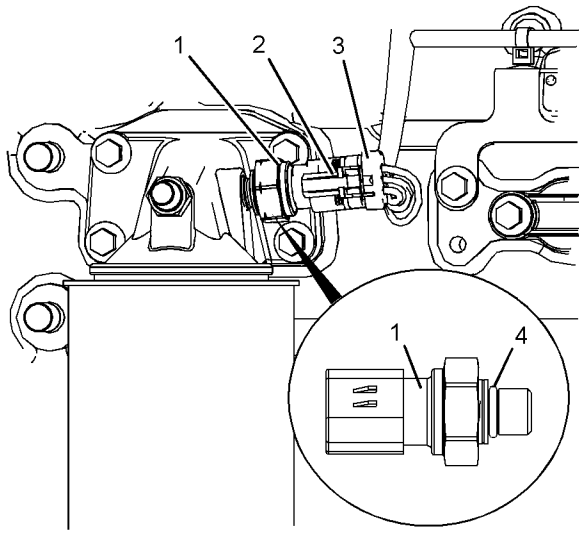

Illustration 302
Typical example g01245956

1. Slide locking tab (2) into the unlocked position.
2. Disconnect harness assembly (3) from engine oil pressure sensor (1).
3. If necessary, remove the engine oil filter in order to gain access to engine oil pressure sensor (1). Refer to Operation and Maintenance Manual, "Engine Oil and Filter - Change".
4. If necessary, remove the dipstick tube in order to gain access to engine oil pressure sensor (1). Refer to Disassembly and Assembly, "Engine Oil Pan - Remove and Install".
5. Use a deep socket to remove engine oil pressure sensor (1).
6. Remove O-ring seal (4) from engine oil pressure sensor (1).

Installation Procedure

Table 78

Required Tools			
Tool	Part Number	Part Description	Qty
A	21820221	POWERPART Rubber Grease	1

NOTICE

Keep all parts clean from contaminants.

Contaminants may cause rapid wear and shortened component life.

Note: The engine oil pressure sensor may be located in the cylinder block, on a blanking plate or in the engine oil filter base. Ensure that the engine oil pressure sensor is installed in the correct position.

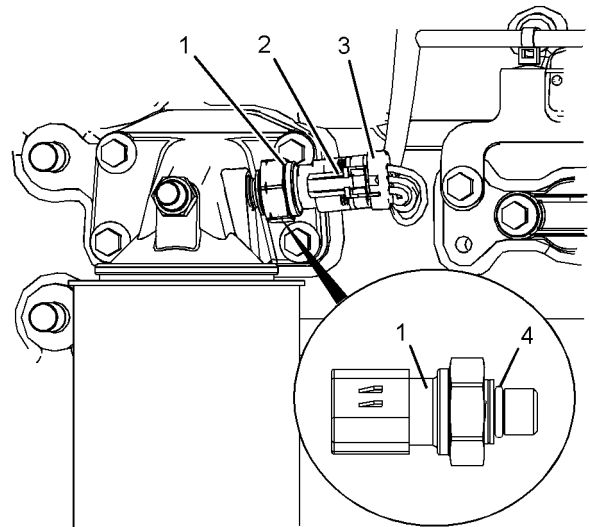

Illustration 303
Typical example g01245956

1. Install a new O-ring seal (4) to the groove in engine oil pressure sensor (1). Lubricate the new O-ring seal with Tooling (A).
2. Use a deep socket to install engine oil pressure sensor (1). Tighten the engine oil pressure sensor to a torque of 10 N·m (89 lb in).
3. If necessary, install the engine oil filter. Refer to Operation and Maintenance Manual, "Engine Oil and Filter Change".
4. If necessary, install the dipstick tube. Refer to Disassembly and Assembly, "Engine Oil Pan - Remove and Install".
5. Connect harness assembly (3) to engine oil pressure sensor (1).
6. Slide locking tab (2) into the locked position.

7. If necessary, fill the engine oil pan to the correct level that is indicated on the engine oil level gauge. Refer to Operation and Maintenance Manual, "Engine Oil Level - Check".

i02589176

Position Sensor (Fuel Injection Pump) - Remove and Install

Removal Procedure

NOTICE

Keep all parts clean from contaminants.

Contaminants may cause rapid wear and shortened component life.

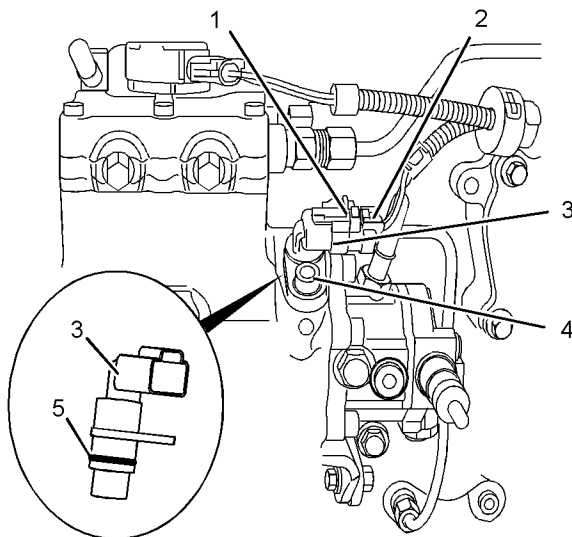

Illustration 304

g01262753

Typical example

1. Slide locking tab (1) into the unlocked position.
2. Disconnect harness assembly (2) from position sensor (3).
3. Remove bolt (4).
4. Carefully remove position sensor (3) from the fuel injection pump.

Note: Do not use a lever to remove the position sensor from the fuel injection pump.

5. Plug the hole for the position sensor in the fuel injection pump with a new plug.
6. Remove O-ring seal (5) from position sensor (3).

Installation Procedure

Table 79

Required Tools			
Tool	Part Number	Part Description	Qty
A	21820221	POWERPART Rubber Grease	1

NOTICE

Keep all parts clean from contaminants.

Contaminants may cause rapid wear and shortened component life.

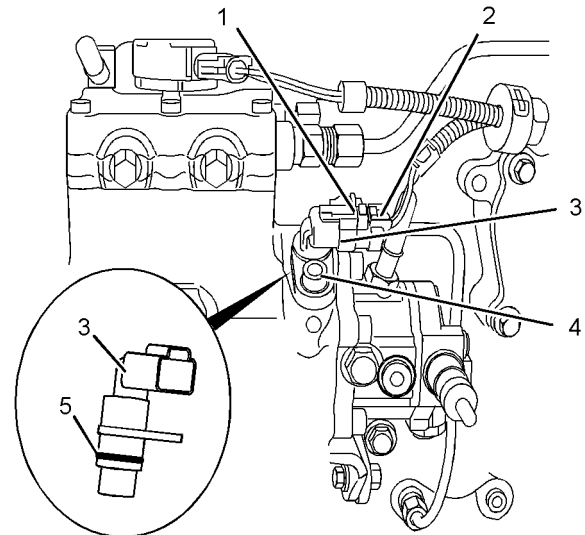

Illustration 305

g01262753

Typical example

1. Install a new O-ring seal (5) to the groove in position sensor (3). Lubricate the new O-ring seal with Tooling (A).
 2. Remove the plug from the hole in the fuel injection pump for the position sensor.
 3. Align the hole in position sensor (3) with the hole in the fuel injection pump. Install the position sensor to the fuel injection pump.
- Note:** Do not use bolt (4) to pull the position sensor into position against the fuel injection pump.
4. Install bolt (4). Tighten the bolt to a torque of 22 N·m (16 lb ft).
 5. Connect harness assembly (2) to position sensor (3).
 6. Slide locking tab (1) into the locked position.

i02589178

Fuel Pressure Sensor - Remove and Install

Removal Procedure

Table 80

Required Tools			
Tool	Part Number	Part Name	Qty
A	-	Seal Pick	1

WARNING

Contact with high pressure fuel may cause fluid penetration and burn hazards. High pressure fuel spray may cause a fire hazard. Failure to follow these inspection, maintenance and service instructions may cause personal injury or death.

NOTICE

Ensure that all adjustments and repairs that are carried out to the fuel system are performed by authorised personnel that have the correct training.

Before beginning ANY work on the fuel system, refer to Operation and Maintenance Manual, "General Hazard Information and High Pressure Fuel Lines" for safety information.

Refer to Systems Operation, Testing and Adjusting Manual, "Cleanliness of Fuel System Components" for detailed information on the standards of cleanliness that must be observed during ALL work on the fuel system.

NOTICE

Care must be taken to ensure that fluids are contained during performance of inspection, maintenance, testing, adjusting and repair of the product. Be prepared to collect the fluid with suitable containers before opening any compartment or disassembling any component containing fluids.

Dispose of all fluids according to local regulations and mandates.

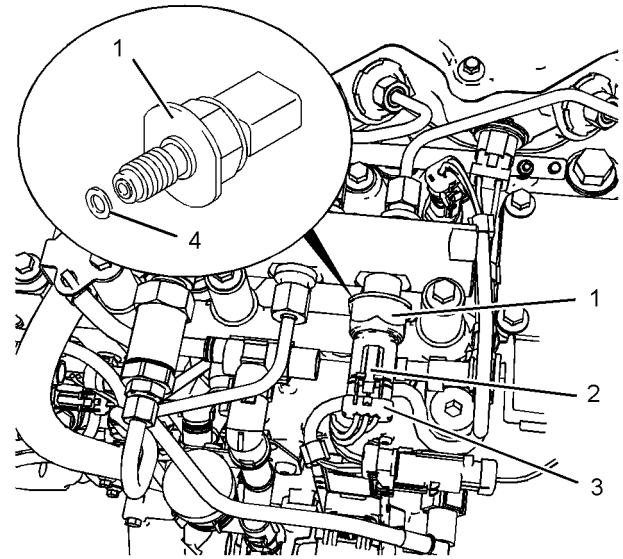

Illustration 306

g01296350

Typical example

1. Slide locking tab (2) into the unlocked position.
 2. Disconnect harness assembly (3) from fuel pressure sensor (1).
 3. Use a deep socket to remove fuel pressure sensor (1) from the fuel manifold.
 4. If necessary, use Tooling (A) in order to remove sealing washer (4) from the fuel manifold.
- Note:** Do not damage the seat for the washer in the fuel manifold. Ensure that no debris enters the fuel manifold during the removal of the sealing washer.
5. Plug the open port in the fuel manifold immediately with a new plug.

Installation Procedure

NOTICE

Keep all parts clean from contaminants.

Contaminants may cause rapid wear and shortened component life.

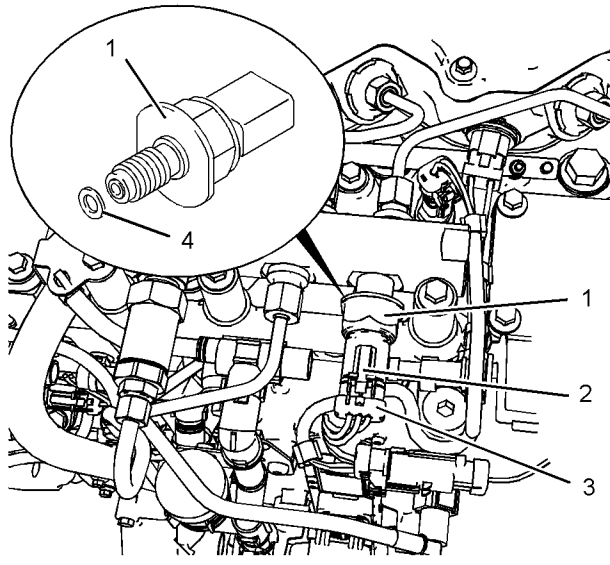

Illustration 307

g01296350

Typical example

1. Position a new sealing washer (4) onto fuel pressure sensor (1).
2. Remove the plug from the fuel manifold.
3. Install fuel pressure sensor (1) to the fuel manifold. Use a deep socket to tighten the fuel pressure sensor to a torque of 34 N·m (25 lb ft).
4. Connect harness assembly (3) to fuel pressure sensor (1).
5. Slide locking tab (2) into the locked position.
6. Remove the air from the fuel system. Refer to Operation and Maintenance Manual, "Fuel System - Prime".

i02589180

Boost Pressure Sensor - Remove and Install

Removal Procedure

NOTICE

Keep all parts clean from contaminants.

Contaminants may cause rapid wear and shortened component life.

Note: The boost pressure sensor may be located on the secondary fuel filter base or in the cylinder head.

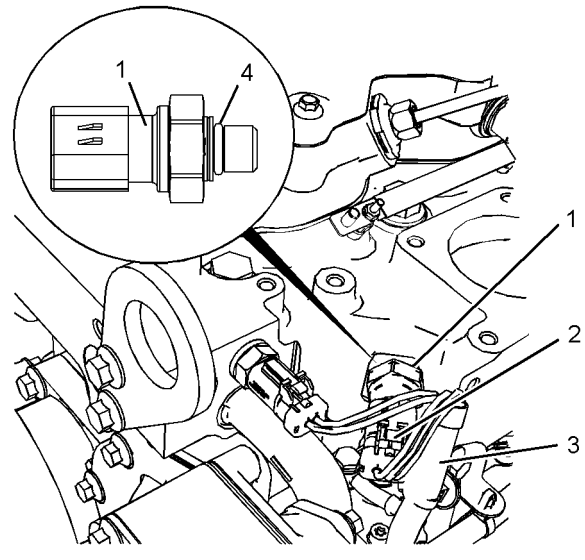

Illustration 308

g01254121

Typical example

1. Slide locking tab (2) into the unlocked position.
2. Disconnect harness assembly (3) from boost pressure sensor (1).

Note: The boost pressure sensor has a three-wire plug.

3. Use a deep socket to remove boost pressure sensor (1).

Note: If necessary, remove the bracket for the harness assembly from the bypass tube.

4. Remove O-ring seal (4) from boost pressure sensor (1).

Installation Procedure

Table 81

Required Tools			
Tool	Part Number	Part Description	Qty
A	21820221	POWERPART Rubber Grease	1

NOTICE

Keep all parts clean from contaminants.

Contaminants may cause rapid wear and shortened component life.

Note: The boost pressure sensor may be located on the secondary fuel filter base or in the cylinder head.

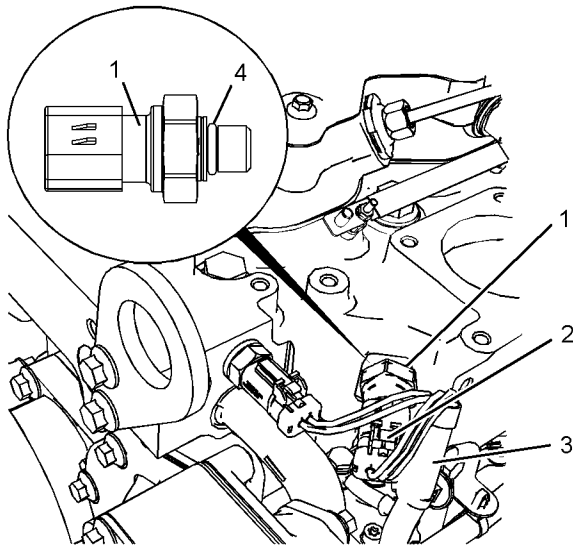

Illustration 309 g01254121

Typical example

1. Install a new O-ring seal (4) to the groove in boost pressure sensor (1). Lubricate the new O-ring seal with Tooling (A).
2. Use a deep socket to install boost pressure sensor (1). Tighten the boost pressure sensor to a torque of 10 N·m (89 lb in).

Note: If necessary, install the bracket for the harness assembly to the bypass tube.

3. Connect harness assembly (3) to boost pressure sensor (1).
4. Slide locking tab (2) into the locked position.

i02589252

Inlet Air Temperature Sensor - Remove and Install

Removal Procedure

NOTICE

Keep all parts clean from contaminants.

Contaminants may cause rapid wear and shortened component life.

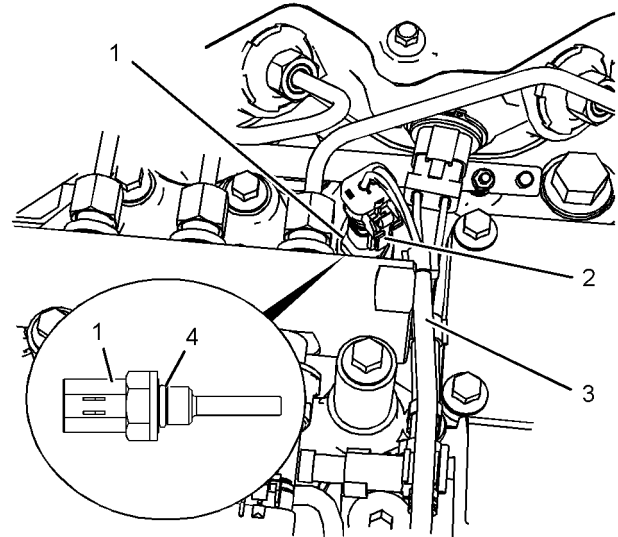

Illustration 310 g01245945

Typical example

1. Slide locking tab (2) into the unlocked position.
2. Disconnect harness assembly (3) from inlet air pressure sensor (1).

Note: The inlet air temperature sensor has a two wire plug.

3. Use a deep socket in order to remove inlet air temperature sensor (1) from the cylinder head.
4. Remove O-ring seal (4) from inlet air temperature sensor (1).

Installation Procedure

Table 82

Required Tools			
Tool	Part Number	Part Description	Qty
A	21820221	POWERPART Rubber Grease	1

NOTICE

Keep all parts clean from contaminants.

Contaminants may cause rapid wear and shortened component life.

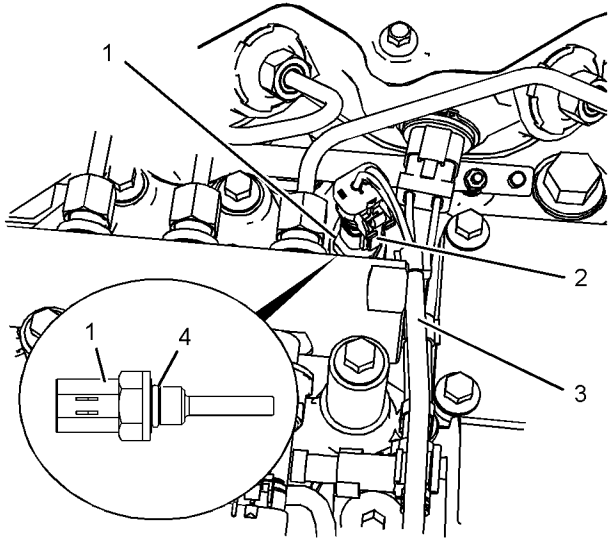

Illustration 311
Typical example g01245945

1. Install a new O-ring seal (4) to the groove in inlet air temperature sensor (1). Lubricate the new O-ring seal with Tooling (A).
2. Install inlet air temperature sensor (1) to the cylinder head. Use a deep socket in order to tighten the inlet air temperature sensor to a torque of 20 N·m (15 lb ft).
3. Connect harness assembly (3) to inlet air temperature sensor (1).
4. Slide locking tab (2) into the locked position.

i02589259

Glow Plugs - Remove and Install

Removal Procedure

NOTICE

Keep all parts clean from contaminants.

Contaminants may cause rapid wear and shortened component life.

1. Isolate the electrical supply.

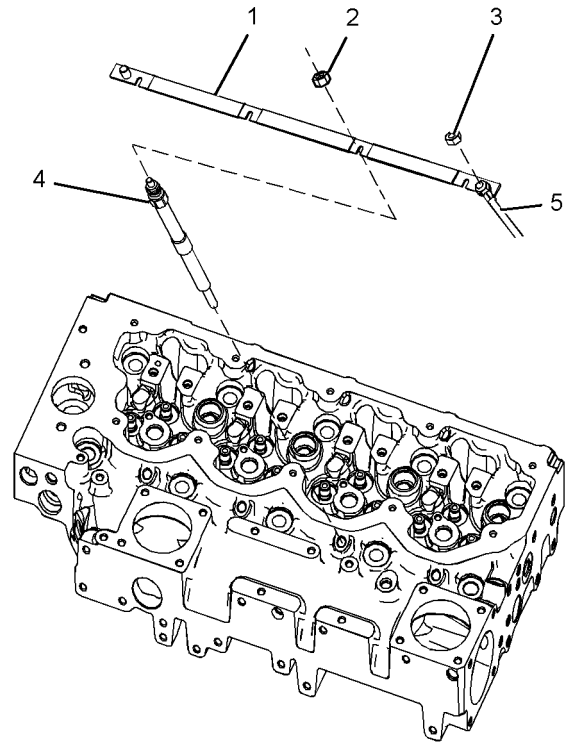

Illustration 312
Typical example g01245944

2. Remove nut (3) and disconnect wire (5) from bus bar (1).
- Note:** The wire may be connected to either end of the bus bar. Note the position of the wire.
3. Remove nuts (2) that secure bus bar (1) to glow plugs (4).
4. Remove bus bar (1) from glow plugs (4).
5. Remove glow plugs (4) from the cylinder head.

Installation Procedure

Table 83

Required Tools			
Tool	Part Number	Part Name	Qty
A	27610296	Torque Wrench	1

NOTICE

Keep all parts clean from contaminants.

Contaminants may cause rapid wear and shortened component life.

1. Ensure that the threads of the glow plugs are clean and free from damage. Replace any damaged glow plugs.

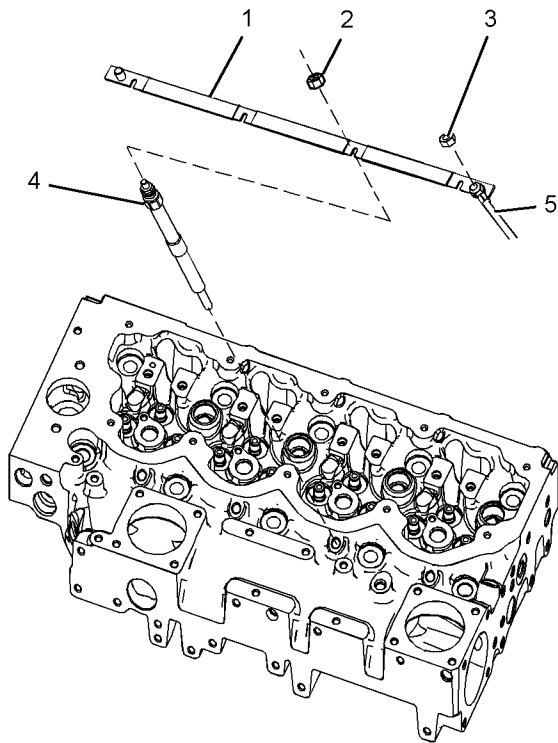

Illustration 313
Typical example

2. Install glow plugs (4) into the cylinder head. Tighten the glow plugs to a torque of 15 N·m (132 lb in).
 3. Position bus bar (1) onto glow plugs (4). Install nuts (2) onto the glow plugs. Use Tooling (A) in order to tighten the nuts to a torque of 2 N·m (17 lb in).
 4. Connect wire (5) to the stud on bus bar (1).
- Note:** The wire may be connected to either end of the bus bar. Ensure that the wire is installed in the correct position.
5. Install nut (3) to the stud on bus bar (1). Tighten the nut to a torque of 6 N·m (53 lb in).
 6. Restore the electrical supply to the engine.

i02589274

V-Belts - Remove and Install (Engines Without an Automatic Belt Tensioner)

Removal Procedure

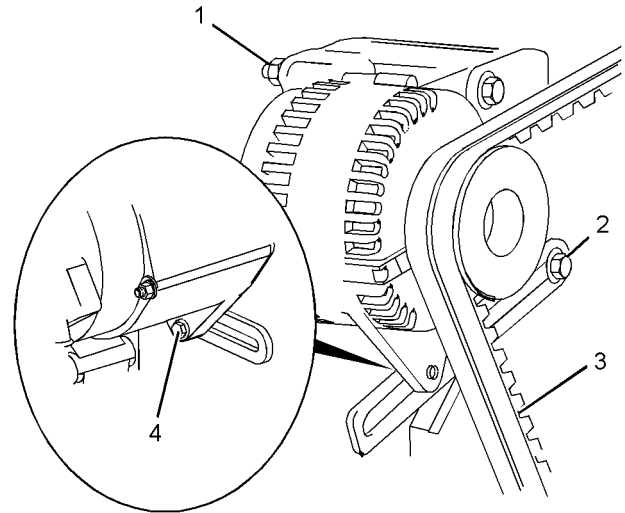

Illustration 314
Typical example

1. If the engine has fan guards, remove the fan guards.
2. Loosen nut (1), bolt (2) and bolt (4). Slide the alternator toward the engine.
3. Remove V-belts (3).

Note: Mark the position and direction of rotation if the V-belts will be reused. Never replace single V-belts. Always replace V-belts as a pair.

Installation Procedure

Table 84

Required Tools			
Tool	Part Number	Part Description	Qty
A	-	Belt Tension Gauge	1

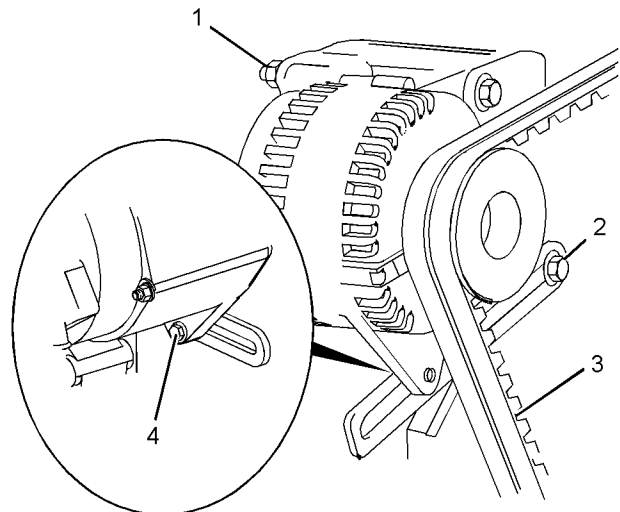

Illustration 315

g01254466

Typical example

1. Install V-belts (3) onto the correct pulleys.

Note: Used V-belts should be installed in the original position and direction of rotation.

2. Adjust the tension on the V-belts by moving the alternator away from the engine. Use Tooling (A) in order to achieve the correct belt tension. Refer to Specifications, "Belt Tension Chart" for more information. Tighten bolt (4) to a torque of 22 N·m (16 lb ft).
3. Tighten bolt (2) to a torque of 44 N·m (32 lb ft).
4. Tighten nut (1) to a torque of 22 N·m (16 lb ft).
5. If the engine has fan guards, install the fan guards.

i02589352

Alternator Belt - Remove and Install (Engines With an Automatic Belt Tensioner)

Removal Procedure

Table 85

Required Tools			
Tool	Part Number	Part Description	Qty
A	-	Locking Pin (Ø 8mm by 85 mm)	1

1. If the engine has fan guards, remove the fan guards.

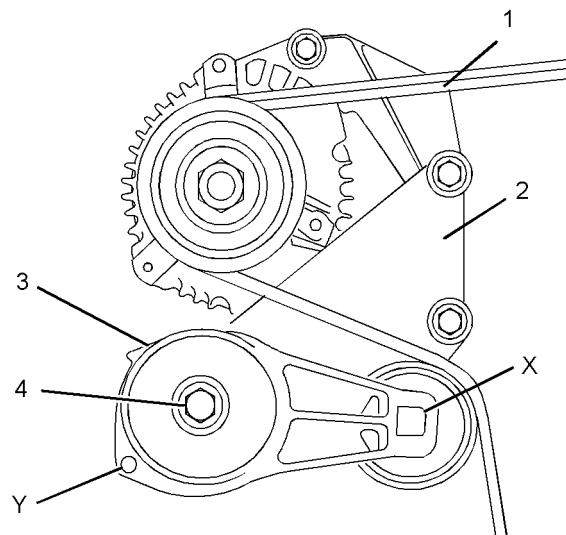

Illustration 316

g01260739

Typical example

2. Install a suitable square drive tool into hole (X) in tensioner (3). From the front of the engine, turn the tool in a clockwise direction.
 3. Insert Tooling (A) into hole (Y). Release the pressure on the square drive tool.
 4. Remove alternator belt (1).
- Note:** Mark the direction of rotation if the belt will be reused.
5. From the front of the engine, turn the square drive tool in a clockwise direction. Release the pressure on Tooling (A). Remove Tooling (A) from hole (Y).
 6. Release the pressure on the square drive tool and remove the tool from hole (X).
 7. If necessary, follow Steps 7.a and 7.b in order to remove tensioner (3) from mounting bracket (2).
 - a. Remove bolt (4) that secures tensioner (3) to mounting bracket (2).
 - b. Remove tensioner (3) from mounting bracket (2).

Installation Procedure

Table 86

Required Tools			
Tool	Part Number	Part Description	Qty
A	-	Locking Pin (Ø 8mm by 85 mm)	1

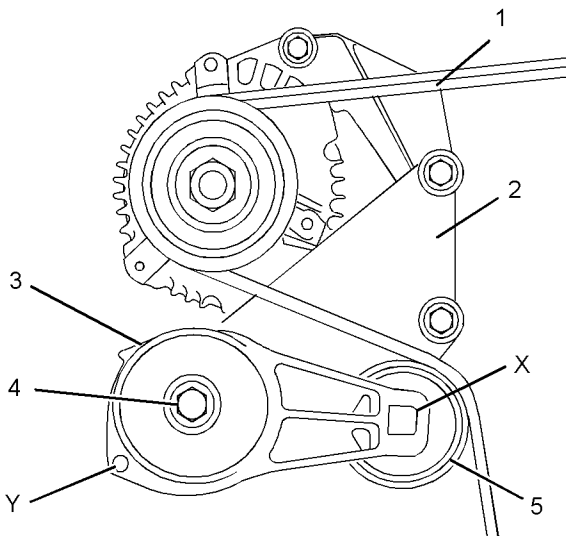

Illustration 317

g01270907

Typical example

1. If the tensioner was previously removed, follow Steps 1.a through 1.c in order to install the tensioner.
 - a. Align the dowel in the back of tensioner (3) with the hole in mounting bracket (2).
 - b. Install tensioner (3) to mounting bracket (2).
 - c. Install bolt (4). Tighten the bolt to a torque of 45 ± 5 N·m (33 ± 3 lb ft).
2. Install a suitable square drive tool into hole (X) in tensioner (1). From the front of the engine, turn the tool in a clockwise direction.
3. Insert Tooling (A) into hole (Y). Release the pressure on the square drive tool.
4. Install alternator belt (1). Ensure that the alternator belt is centered on pulley (5). A used alternator belt should be installed in the original direction of rotation.

Note: The ribs on the alternator belt must be located into the ribs of all pulleys.

5. From the front of the engine, turn the square drive tool in a clockwise direction. Release the pressure on Tooling (A). Remove Tooling (A) from hole (Y).

6. Release the pressure on the square drive tool until the alternator belt is tensioned. Remove the tool from hole (X).

Note: The tensioner should be at the nominal position.

7. If the engine has fan guards, install the fan guards.

i02589437

Fan - Remove and Install

Removal Procedure

Start By:

- a. If the engine is equipped with an automatic belt tensioner, remove the Alternator Belt. Refer to Disassembly and Assembly, "Alternator Belt - Remove and Install". If the engine is not equipped with an automatic belt tensioner, remove the V-Belts. Refer to Disassembly and Assembly, "V-Belts - Remove and Install".

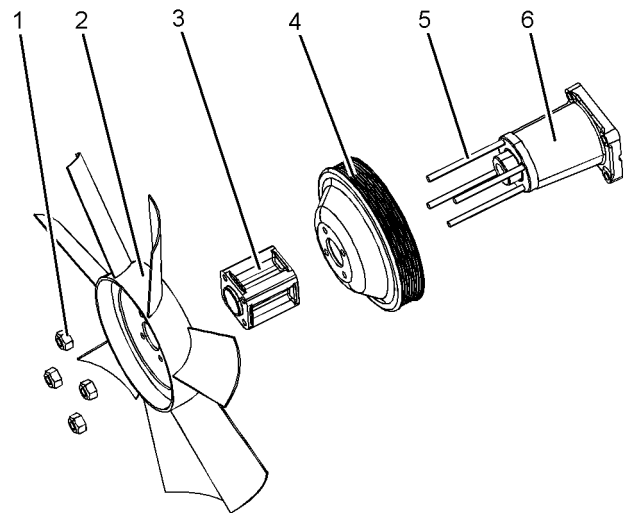

Illustration 318

g01270917

Typical example

1. Remove locking nuts (1).
2. Remove fan (2).

Note: Note the orientation of the fan.

i02589445

3. Remove fan adapter (3).
4. Remove fan pulley (4).
5. If necessary, remove studs (5) from fan drive (6).

Installation Procedure

1. Ensure that all the components are free from wear or damage. If necessary, replace any components that are worn or damaged.

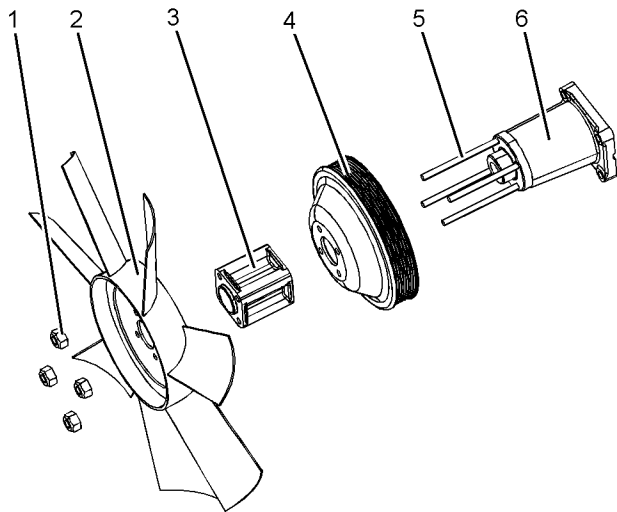

Illustration 319

g01270917

Typical example

2. If necessary, install studs (5) to fan drive (6).
3. Install fan pulley (4).
4. Install fan adapter (3).
5. Install fan (2).

Note: Ensure that the fan is correctly oriented.

6. Inspect the condition of locking nuts (1). If necessary, replace the locking nuts. Install locking nuts (1) and tighten to a torque of 22 N·m (16 lb ft).

End By:

- a. If the engine is equipped with an automatic belt tensioner, install the Alternator Belt. Refer to Disassembly and Assembly, "Alternator Belt - Remove and Install". If the engine is not equipped with an automatic belt tensioner, install the V-Belts. Refer to Disassembly and Assembly, "V-Belts - Remove and Install".

Fan Drive - Remove and Install

Removal Procedure

Start By:

- a. Remove the fan. Refer to Disassembly and Assembly, "Fan - Remove and Install".

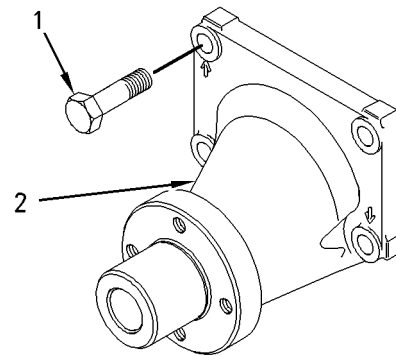

Illustration 320

g00944500

Typical example

1. Remove bolts (1) from fan drive (2).

Note: Identify the orientation and the position of the fan drive.

2. Remove fan drive (2).

Installation Procedure

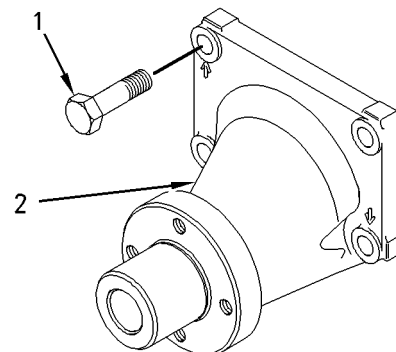

Illustration 321

g00944500

Typical example

1. Check the fan drive for wear or damage. The fan drive is not a serviceable item. If the fan drive is worn or damaged, replace the fan drive.
2. Install fan drive (2).

Note: Ensure the correct orientation of the fan drive.

3. Install bolts (1). Tighten the bolts to a torque of 44 N·m (32 lb ft).

End By:

- a. Install the fan. Refer to Disassembly and Assembly, "Fan - Remove and Install".

i02589457

Electronic Control Module - Remove and Install

Removal Procedure

NOTICE

Ensure that all adjustments and repairs that are carried out to the fuel system are performed by authorised personnel that have the correct training.

Before beginning ANY work on the fuel system, refer to Operation and Maintenance Manual, "General Hazard Information and High Pressure Fuel Lines" for safety information.

Refer to Systems Operation, Testing and Adjusting Manual, "Cleanliness of Fuel System Components" for detailed information on the standards of cleanliness that must be observed during ALL work on the fuel system.

NOTICE

Care must be taken to ensure that fluids are contained during performance of inspection, maintenance, testing, adjusting and repair of the product. Be prepared to collect the fluid with suitable containers before opening any compartment or disassembling any component containing fluids.

Dispose of all fluids according to local regulations and mandates.

Note: Put identification marks on all hoses, on all hose assemblies, on wires and on all tube assemblies for installation purposes. Plug all hose assemblies and tube assemblies. This helps to prevent fluid loss and this helps to keep contaminants from entering the system.

Note: Some engines do not have a fuel supply to the electronic control module.

1. Isolate the electrical supply to the engine.

2. If the electronic control module is equipped with a fuel supply, isolate the fuel supply to the engine.

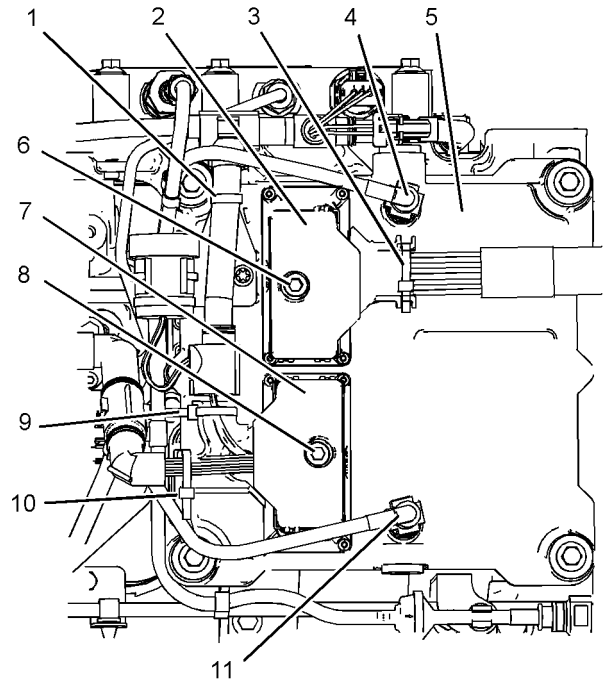

Illustration 322

g01271315

Typical example

3. Cut cable tie (3). Unscrew bolt (6) that secures machine wiring harness (2) to electronic control module (5). Disconnect the machine wiring harness from the electronic control module.
4. Cut cable ties (1), (9) and (10). Unscrew bolt (8) that secures engine harness (7) to electronic control module (5). Disconnect the engine harness from the electronic control module.
5. If the electronic control module is equipped with a fuel supply, disconnect plastic tube assemblies (4) and (11).

Note: If the tube assemblies have quick fit connections, ensure that the connections are clean before the tube assemblies are plugged.

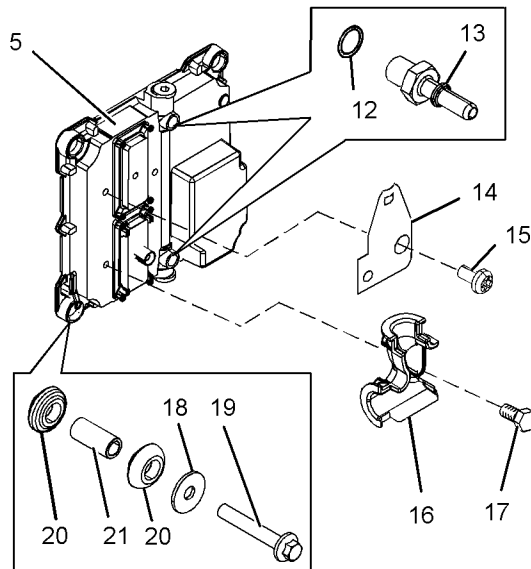

Illustration 323

g01271316

Typical example

6. Remove bolts (19) and remove the assembly of the electronic control module. Note the position of any brackets that are secured by bolts (19). Note the orientation of the electronic control module.
7. Remove bolts (19) and remove washers (18) from electronic control module (5). Note the position of the ground strap for the electronic control module.
8. If necessary, follow Steps 8.a through 8.e in order to disassemble the electronic control module.
 - a. Remove isolation mounts (20) and spacers (21).
 - b. Remove connectors (13). Remove O-ring seals (12) from the connectors.
 - c. Remove bolt (15) and remove bracket (14) for the engine wiring harness. Note the orientation of the bracket.
 - d. Loosen bolt (17) and remove bracket (16) from the engine wiring harness. Note the orientation of the bracket.
 - e. Remove the bolt and remove the support bracket for the machine wiring harness. Note the orientation of the bracket.

Installation Procedure

Table 87

Required Tools			
Tool	Part Number	Part Name	Qty
A	27610296	Torque Wrench	1

1. If a replacement electronic control module is installed, the module must be programmed with the correct information. Refer to Troubleshooting, "Replacing the ECM" and refer to Troubleshooting, "Flash Programming" for the correct procedure.
2. Ensure that the electronic control module is clean and free from damage. If necessary, replace the electronic control module.

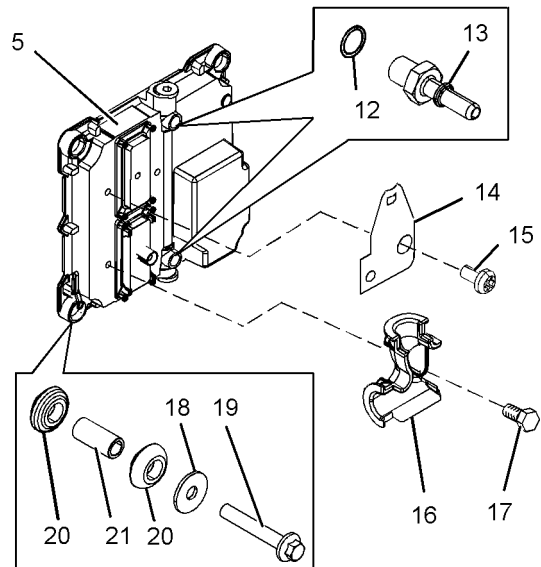

Illustration 324

g01271316

Typical example

3. If necessary, follow Steps 3.a through 3.e in order to assemble the electronic control module.
 - a. Install new O-ring seals (12) to connectors (13). Install connectors (13) to electronic control module (5). Tighten the connectors to a torque of 18.5 N·m (13.6 lb ft).
 - b. Position bracket (14) on electronic control module (5). Ensure that the bracket is correctly oriented. Install torx screw (15). Tighten the torx screw to a torque of 14 N·m (10 lb ft).
 - c. Position bracket (16) on electronic control module (5). Ensure that the bracket is correctly oriented. Install bolt (17). Tighten the bolt to a torque of 14 N·m (10 lb ft).

- d. Position the bracket for the machine wiring harness on electronic control module (5). Ensure that the bracket is correctly oriented and install the bolt. Tighten the bolt to a torque of 20 N·m (14 lb ft).

- e. Install isolation mounts (20) and spacers (21) to electronic control module (5).

4. Install washers (18) and bolts (19) to electronic control module (5).

Note: Ensure that the ground strap for the electronic control module is clamped between the washer and the appropriate bolt.

5. Install the assembly of the electronic control module to the mounting bracket. Ensure that any brackets that are secured by bolts (19) are installed in the correct position. Tighten bolts (19) to a torque of 22 N·m (16 lb ft).

Note: Ensure that the electronic control module is correctly oriented. Ensure that the ground strap is not strained as the bolt is tightened.

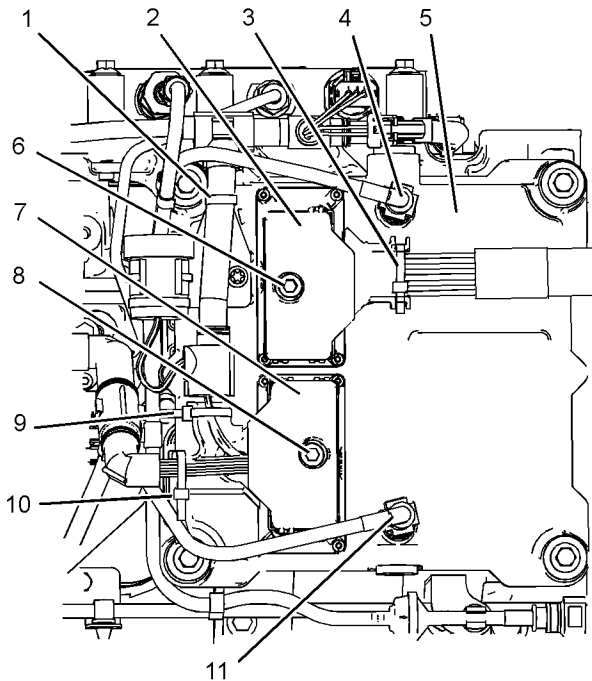

Illustration 325

g01271315

Typical example

6. If the electronic control module is equipped with a fuel supply, connect plastic tube assemblies (4) and (11) to electronic control module (5).

Note: If the tube assemblies have quick fit connections, ensure that the connections are clean before the tube assemblies are connected.

7. Connect engine wiring harness (7) to electronic control module (5). Use Tooling (A) to tighten bolt (8) to a torque of 5 N·m (44 lb in). If the engine is equipped with a diagnostic connection, install the diagnostic connection to the support clip.

Note: Care must be taken in order to avoid damage to the connector pins during installation of the harness.

8. Position the assembly of the engine wiring harness onto brackets (14) and (16). Use new cable ties (1), (9) and (10) in order to secure the harness assembly to the brackets.

9. Connect machine wiring harness (2) to electronic control module (5). Use Tooling (A) to tighten bolt (6) to a torque of 5 N·m (44 lb in).

Note: Care must be taken in order to avoid damage to the connector pins during installation of the harness.

10. Use a new cable tie (3) in order to secure the machine wiring harness (2).

11. If the electronic control module is equipped with a fuel supply, restore the fuel supply.

12. Restore the electrical supply to the engine.

13. If the electronic control module is equipped with a fuel supply, remove the air from the fuel system. Refer to Operation and Maintenance Manual, "Fuel System - Prime".

i02589500

ECM Mounting Bracket - Remove and Install

Removal Procedure

Start By:

- a. Remove the electronic control module. Refer to Disassembly and Assembly, "Electronic Control Module - Remove and Install".

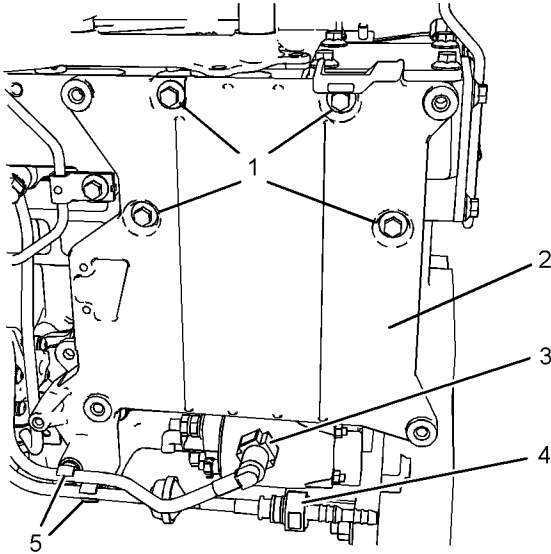

Illustration 326

g01254468

Typical example

1. Remove plastic tube assemblies (3) and (4) from clips (5).
2. Cut the cable tie and position the engine wiring harness away from mounting bracket (2).
3. Remove bolts (1) and remove mounting bracket (2) from the cylinder head.
4. If necessary, remove clips (5) from mounting bracket (2).

Installation Procedure

1. Ensure that the mounting bracket for the electronic control module is clean and free from damage. If necessary, replace the mounting bracket.

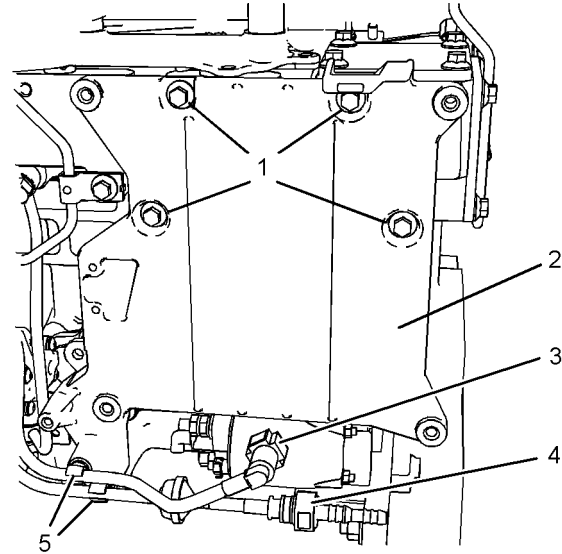

Illustration 327

g01254468

Typical example

2. If necessary, install clips (5) to mounting bracket (2).
3. Position mounting bracket (2) against the cylinder head. Install bolts (1). Tighten the bolts to a torque of 22 N·m (16 lb ft).
4. Position the engine wiring harness against mounting bracket (2). Secure the engine wiring harness with a new cable tie.
5. Install plastic tube assemblies (3) and (4) to clips (5).

End By:

- a. Install the electronic control module. Refer to Disassembly and Assembly, "Electronic Control Module - Remove and Install".

i02589511

Alternator - Remove (Engines Without an Automatic Belt Tensioner)

Removal Procedure

Start By:

- a. Remove the V-belts. Refer to Disassembly and Assembly, "V-belts - Remove and Install".

i02589521

NOTICE

Keep all parts clean from contaminants.

Contaminants may cause rapid wear and shortened component life.

1. Isolate the electrical supply to the engine.
2. Make temporary identification marks on the connections of the harness assembly.

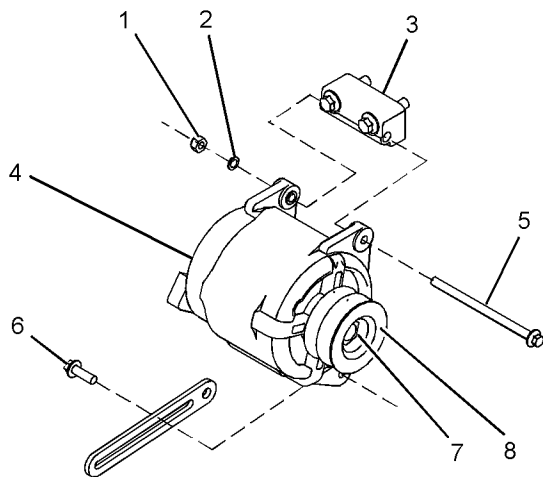

Illustration 328

g01255718

Typical Example

3. Disconnect the harness assembly from alternator (1).
4. Remove bolt (6) from alternator (4).
5. Remove nut (1) and washer (2). Remove bolt (5) from alternator (4). Remove alternator (4) from alternator bracket (3).
6. If necessary, remove pulley (8) from alternator (4). Follow Steps 6.a and 6.b for the method in order to remove the pulley from the alternator.

Note: This method may not be suitable for some configurations of pulley.

- a. Hold the shaft of alternator (4) with an allen wrench. Use a cranked ring spanner (box wrench) in order to loosen nut (7).
- b. Remove nut (7) and pulley (8) from alternator (4).

Alternator - Remove (Engines With an Automatic Belt Tensioner)

Removal Procedure

Start By:

- a. Remove the alternator belt. Refer to Disassembly and Assembly, "Alternator Belt - Remove and Install".

NOTICE

Keep all parts clean from contaminants.

Contaminants may cause rapid wear and shortened component life.

1. Isolate the electrical supply to the engine.
2. Make temporary identification marks on the connections of the harness assembly.

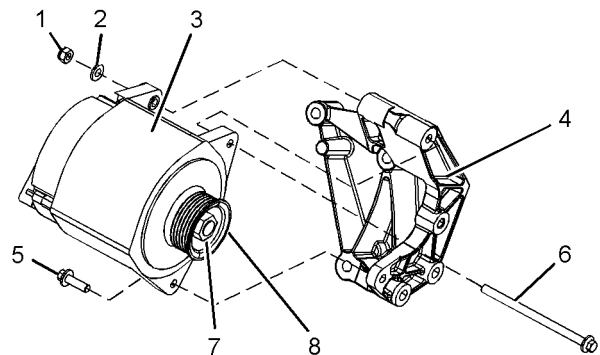

Illustration 329

g01271317

Typical example

3. Disconnect the harness assembly from alternator (3).
4. Remove bolt (5) from alternator (3).
5. Remove nut (1) and washer (2). Remove bolt (6) from alternator (3). Remove the alternator from alternator bracket (4).
6. If necessary, follow Steps 6.a and 6 in order to remove pulley (8) from alternator (1).
 - a. Hold the shaft of alternator (3) with an allen wrench. Use a cranked ring spanner (box wrench) in order to loosen nut (7).

- b. Remove nut (7) and pulley (8) from alternator (1).

i02590297

Alternator - Install (Engines Without an Automatic Belt Tensioner)

Installation Procedure

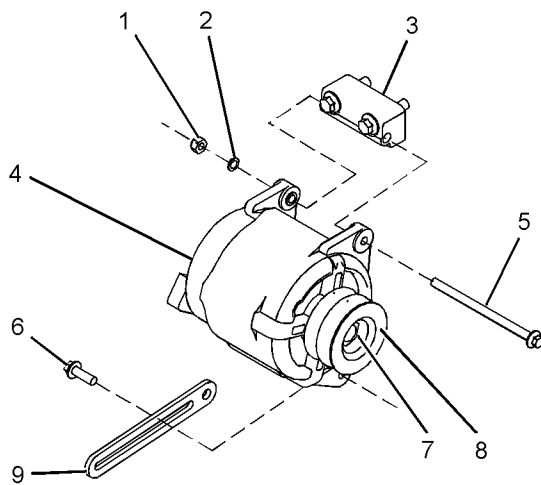

Illustration 330

g01263045

Typical example

1. If necessary, install the pulley to the alternator. Follow Steps 1.a and 1.b for the method in order to install the pulley to the alternator.

Note: This method may not be suitable for some configurations of pulley.

- a. Install pulley (8) and nut (7) to the shaft of alternator (4).
 - b. Hold the shaft of the alternator with an allen wrench. Use a cranked ring spanner (box wrench) in order to tighten nut (7). Tighten the nut to a torque of 80 N·m (59 lb ft).
2. Install alternator (4) to bracket (3) and install bolt (5) to alternator (4).
 3. Install washer (2) and nut (1) to bolt (5) finger tight.
 4. Install bolt (6) through adjusting link (9) to alternator (4) finger tight.

5. Install the V-belts. Refer to the Disassembly and assembly, "V-belts - Remove and Install" for the correct procedure.
6. Tighten nut (1) and bolt (6) to a torque of 22 N·m (16 lb ft).
7. Connect the wiring harness assembly to alternator (4).
8. Restore the electrical supply.

i02590293

Alternator - Install (Engines With an Automatic Belt Tensioner)

Installation Procedure

NOTICE

Keep all parts clean from contaminants.

Contaminants may cause rapid wear and shortened component life.

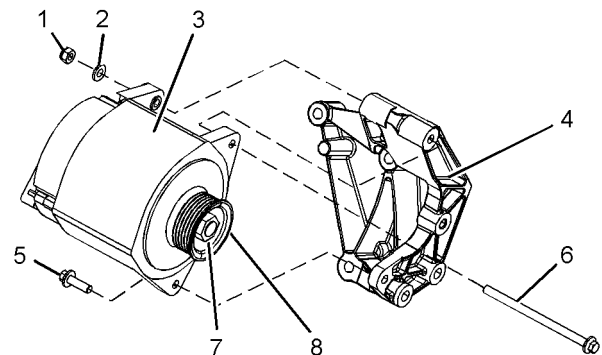

Illustration 331

g01271317

Typical example

1. If necessary, install pulley (8) and nut (7) to alternator (3). Hold the shaft of the alternator with an allen wrench. Use a cranked ring spanner (box wrench) in order to tighten nut (7).

Note: Different types of alternator have different sizes of nut. Ensure that the correct torque value is used for the nut.

Tighten M16 and M17 nuts to a torque of 80 N·m (59 lb ft). Tighten 5/8 inch - 18 UNF nuts to a torque of 102 N·m (75 lb ft).

2. Position alternator (3) on alternator mounting bracket (4).

3. Install bolt (6) to alternator (3). Install washer (2) and nut (1) to bolt (6).
4. Install bolt (5) to alternator (3).
5. Tighten nut (1) and bolt (5) to a torque of 22 N·m (16 lb ft).
6. Connect the wiring harness assembly to alternator (3).
7. Install the alternator belt. Refer to Disassembly and Assembly, "Alternator Belt - Remove and Install".
8. Restore the electrical supply.

i02590299

Electric Starting Motor - Remove and Install

Removal Procedure

WARNING

Accidental engine starting can cause injury or death to personnel working on the equipment.

To avoid accidental engine starting, disconnect the battery cable from the negative (-) battery terminal. Completely tape all metal surfaces of the disconnected battery cable end in order to prevent contact with other metal surfaces which could activate the engine electrical system.

Place a Do Not Operate tag at the Start/Stop switch location to inform personnel that the equipment is being worked on.

1. Disconnect the battery.
2. If necessary, remove the hose for the crankcase breather. Refer to Disassembly and Assembly, "Crankcase Breather - Remove".
3. Make temporary identification marks on the harness assemblies that are connected to the electric starting motor and to the solenoid.

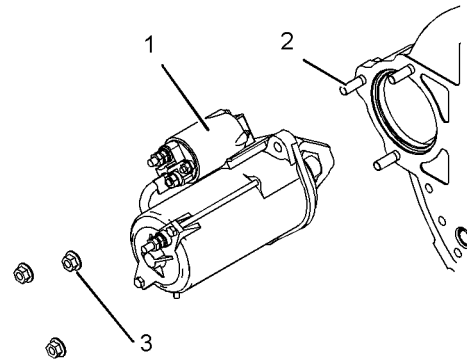

Illustration 332

g01261155

Typical example

4. Disconnect the harness assemblies from the electric starting motor and from the solenoid.
5. Remove nuts (3) from electric starting motor (1).

Note: Support the weight of the electric starting motor as the nuts are removed.

6. Remove electric starting motor (1).
7. If necessary, remove studs (2).

Installation Procedure

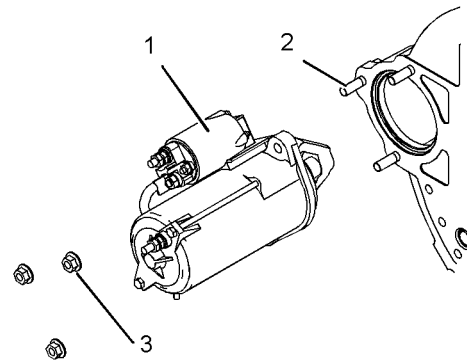

Illustration 333

g01261155

Typical example

1. If necessary, install studs (2).
2. Align electric starting motor (1) to studs (2). Install the electric starting motor.
3. Install nuts (3).

Tighten M10 nuts to a torque of 44 ± 11 N·m (32 ± 8 lb ft).

Tighten M12 nuts to a torque of 78 ± 19.5 N·m (57 ± 14 lb ft).

4. Connect the harness assemblies to the electric starting motor and the solenoid.
5. Connect the battery.

End By:

- a. If necessary, install the hose for the crankcase breather. Refer to Disassembly and Assembly, "Crankcase Breather - Install".

i02590351

Air Compressor - Remove and Install

Removal Procedure

Table 88

Required Tools			
Tool	Part Number	Part Name	Qty
A ¹	21825576	Crankshaft Turning Tool	1
A ²	27610291	Barring Device Housing	1
	27610289	Gear	1
B	27610211	Crankshaft Timing Pin	1
C	-	Puller (Three Leg)	1

Note: Either Tooling (A) can be used. Use the Tooling that is most suitable.

NOTICE

Care must be taken to ensure that fluids are contained during performance of inspection, maintenance, testing, adjusting and repair of the product. Be prepared to collect the fluid with suitable containers before opening any compartment or disassembling any component containing fluids.

Dispose of all fluids according to local regulations and mandates.

NOTICE

Keep all parts clean from contaminants.

Contaminants may cause rapid wear and shortened component life.

Note: Put identification marks on all hoses, on all hose assemblies and on all tube assemblies for installation purposes. Plug all hose assemblies and tube assemblies. This helps to prevent fluid loss and this helps to keep contaminants from entering the system.

WARNING

Do not disconnect the air lines until the air pressure in the system is at zero. If hose is disconnected under pressure it can cause personal injury.

1. Release the pressure from the air system.
2. Drain the coolant from the cooling system into a suitable container for storage or for disposal. Refer to Operation and Maintenance Manual, "Cooling System Coolant - Change" for the correct draining procedure.
3. Remove the front cover. Refer to Disassembly and Assembly, "Front Cover - Remove and Install".
4. If the engine is equipped with a hydraulic pump on the rear of the air compressor, remove the hydraulic pump.
5. Use Tooling (A) in order to rotate the crankshaft so that number one piston is at the top center position on the compression stroke. Refer to Systems Operation, Testing and Adjusting, "Finding Top Centre Position for No.1 Piston".

Note: The air compressor must be timed with the engine in order to minimize engine vibration.

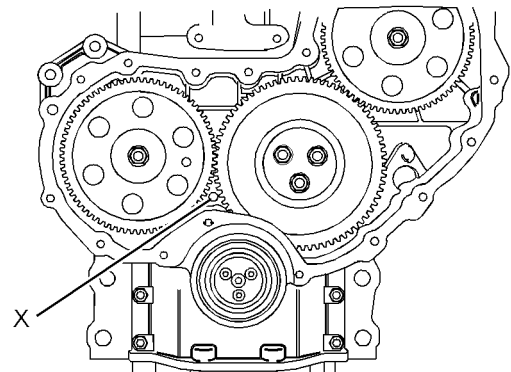

Illustration 334

g01272266

Typical example

6. Install Tooling (B) through hole (X) in the front housing. Use Tooling (B) in order to lock the crankshaft.

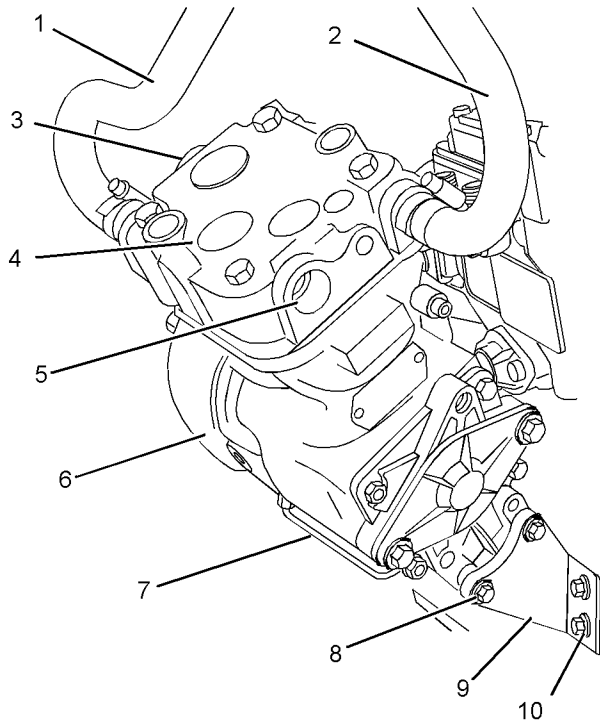

Illustration 335 g01250794

Typical example

7. Disconnect coolant hoses (1) and (2) from air compressor (4).
8. Disconnect the air lines from ports (3) and (5).
9. Remove tube assembly (7) from air compressor (4) and from the cylinder block.
10. Remove bolts (8) and (10) from support bracket (9) and remove the support bracket.

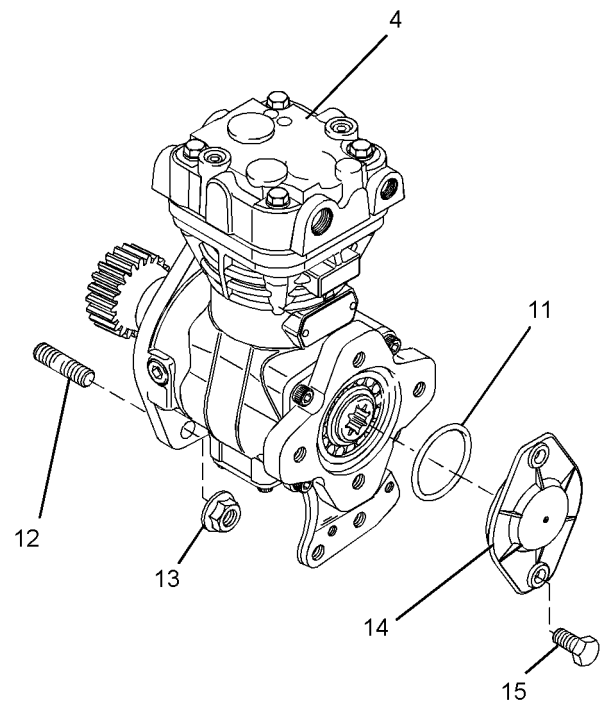

Illustration 336 g01250816

Typical example

11. Support air compressor (4). Remove nuts (13) and remove the air compressor from front housing (6).

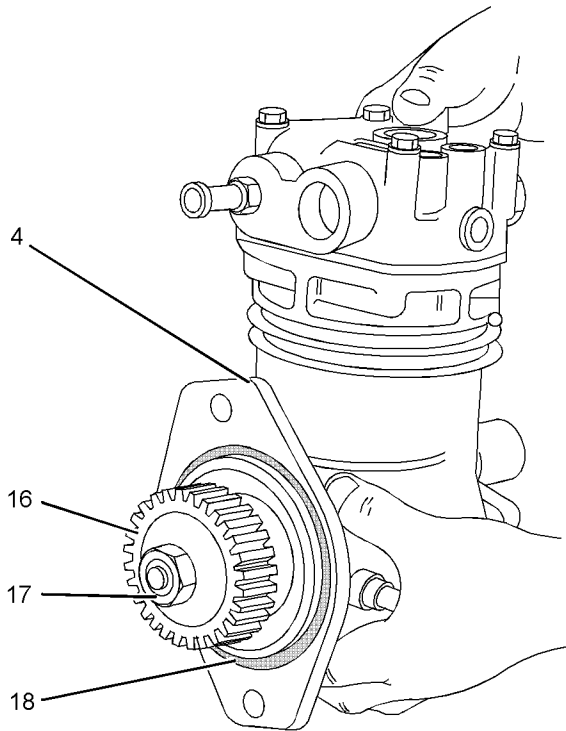

Illustration 337 g01250889
Typical example

- 12. Remove O-ring seal (18) from air compressor (4).
- 13. If necessary, remove bolts (15) and remove plate (14). Remove O-ring seal (11) from plate (14). Refer to Illustration 336.
- 14. If necessary, remove nut (17) and remove the spring washer. Use Tooling (C) in order to remove gear (16) from the crankshaft of the air compressor.

Installation Procedure

Table 89

Required Tools			
Tool	Part Number	Part Name	Qty
B	27610211	Crankshaft Timing Pin	1
D	21826051	POWERPART High Strength Retainer	-
E	21820221	POWERPART Rubber Grease	-

NOTICE

Keep all parts clean from contaminants.

Contaminants may cause rapid wear and shortened component life.

NOTICE

Care must be taken to ensure that fluids are contained during performance of inspection, maintenance, testing, adjusting and repair of the product. Be prepared to collect the fluid with suitable containers before opening any compartment or disassembling any component containing fluids.

Dispose of all fluids according to local regulations and mandates.

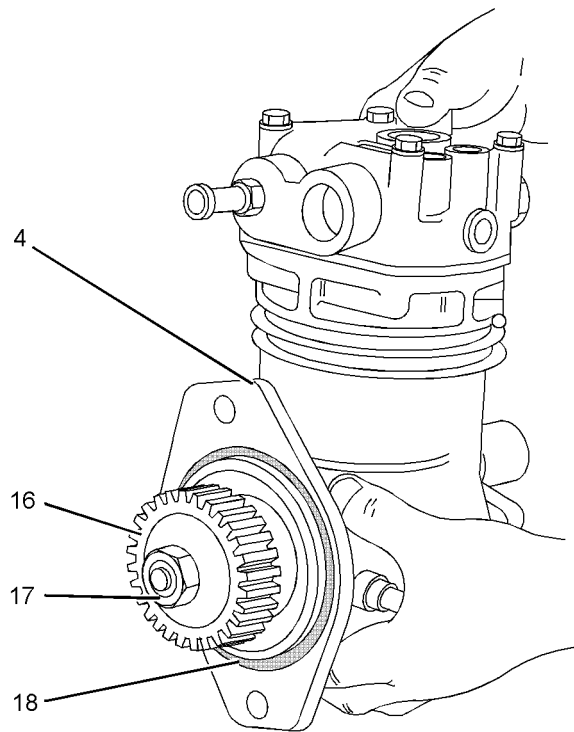

Illustration 338 g01250889
Typical example

- 1. If necessary, follow Steps 1.a through 1.b in order to install the gear to the air compressor.
 - a. Ensure that the shaft of air compressor (4) is clean and dry. Ensure that gear (16) is clean and free from damage.
 - b. Install gear (16) and a new spring washer to the shaft of the air compressor.
 - c. Apply Tooling (D) to the threads of the shaft. Install nut (17) to the shaft of air compressor (4). Tighten the nut to a torque of 120 N·m (89 lb ft).
- 2. Install the O-ring seal to air compressor (4). Use Tooling (E) in order to lubricate the O-ring seal.

3. Ensure that number one piston is at the top center position on the compression stroke. Refer to the Systems Operation, Testing and Adjusting, "Finding Top Center Position for No. 1 Piston".

Note: The air compressor must be timed with the engine in order to minimize engine vibration.

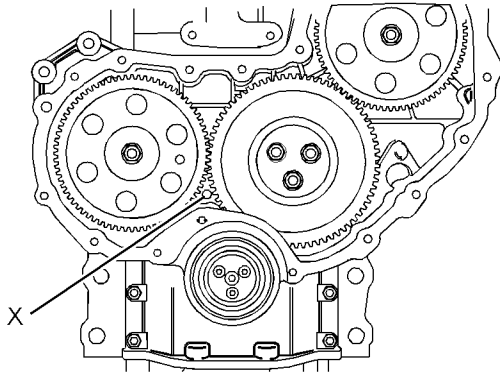

Illustration 339
Typical example
g01272266

4. Ensure that Tooling (B) is installed in hole (X) in the front housing. Use Tooling (B) in order to lock the crankshaft in the correct position.

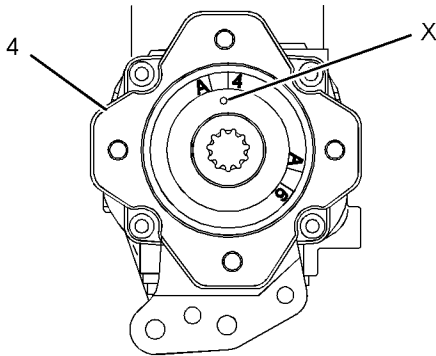

Illustration 340
Typical air compressor with a SAE drive
g01250968

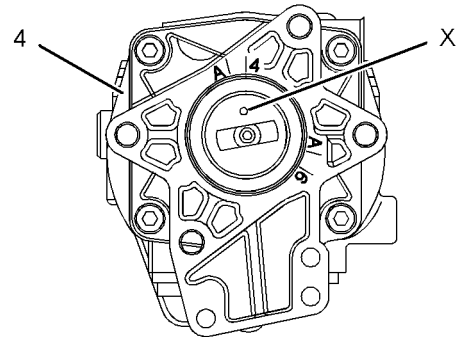

Illustration 341
Typical air compressor with a DIN drive
g01251223

5. Rotate the crankshaft of the air compressor until the timing mark (X) is aligned with the timing mark A4 on the rear face of air compressor (4). Refer to Illustration 340 for air compressors with a SAE drive. Refer to Illustration 341 for air compressors with a DIN drive.

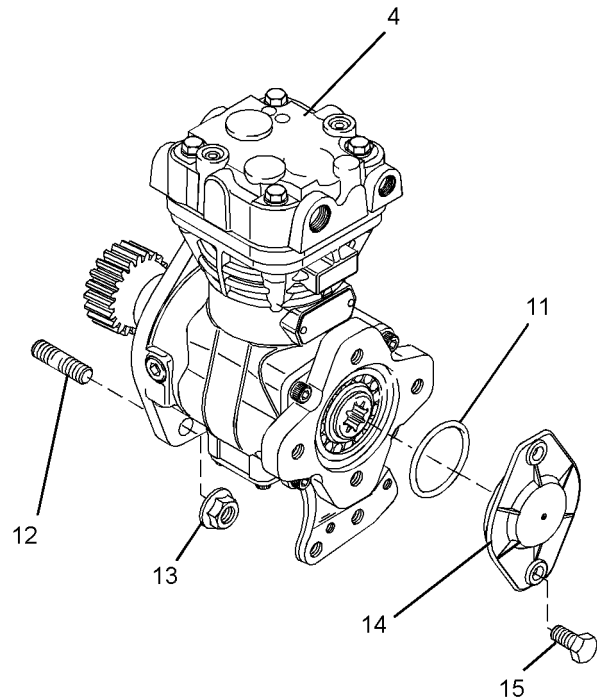

Illustration 342
Typical example
g01250816

6. Align the air compressor (4) with studs (12). Install the air compressor to the front housing. If necessary, rotate the crankshaft of the air compressor in a clockwise direction in order to align the gears.

Note: Ensure that timing mark (X) is aligned with the timing mark A4. Refer to Illustration 340 for air compressors with a SAE drive. Refer to Illustration 341 for air compressors with a DIN drive.

7. Install nuts (13). Tighten the nuts to a torque of 78 N·m (58 lb ft).
8. If necessary, follow Steps 8.a through 8.c in order to install cover (14).
 - a. Install a new O-ring seal (11) to cover (14). Use Tooling (E) in order to lubricate the O-ring seal.
 - b. Install cover (14) to air compressor (4).
 - c. Install bolts (15). Tighten the bolts to a torque of 13 N·m (9.5 lb ft).

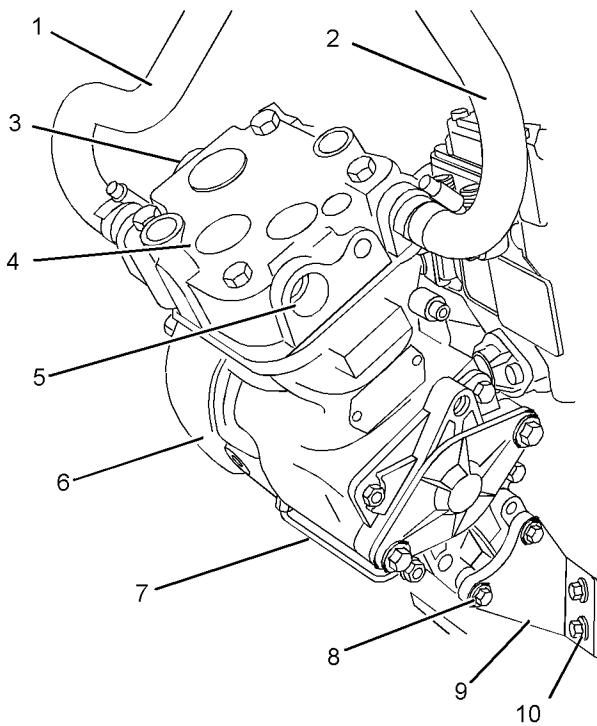

Illustration 343

g01250794

Typical example

9. Position support bracket (9) onto air compressor (4). Install bolts (8) finger tight.
10. Install bolts (10) finger tight.
11. Tighten the bolts (8) to a torque of 22 N·m (16 lb ft). Tighten the bolts (10) to a torque 22 N·m (16 lb ft).

Note: Ensure that the air compressor is not stressed as the bolts are tightened.

12. Install tube assembly (7) to air compressor (4) and to the cylinder block. Tighten the nuts to a torque of 9 N·m (80 lb in).
13. Remove Tooling (B) from hole (X) in the front housing.
14. Install the front cover. Refer to Disassembly and Assembly, "Front Cover - Remove and Install".
15. If the engine is equipped with a hydraulic pump on the rear of the air compressor, install the hydraulic pump.
16. Connect the air lines to ports (3) and (5) in the air compressor.
17. Connect coolant hoses (1) and (2) to air compressor (4).
18. Fill the cooling system with coolant to the correct level. Refer to the Operation and Maintenance Manual.

i02590301

Vacuum Pump - Remove and Install

Removal Procedure

NOTICE

Keep all parts clean from contaminants.

Contaminants may cause rapid wear and shortened component life.

Note: Put identification marks on all hoses, on all hose assemblies and on all tube assemblies for installation purposes. Plug all hose assemblies and tube assemblies. This helps to prevent fluid loss and this helps to keep contaminants from entering the system.