

Disassembly and Assembly

402D-403D-404D Industrial Engine

GG (Engine)
GH (Engine)
GJ (Engine)
GK (Engine)
GL (Engine)
GM (Engine)
GN (Engine)
GP (Engine)
GQ (Engine)
GS (Engine)

Important Safety Information

Most accidents that involve product operation, maintenance and repair are caused by failure to observe basic safety rules or precautions. An accident can often be avoided by recognizing potentially hazardous situations before an accident occurs. A person must be alert to potential hazards. This person should also have the necessary training, skills and tools to perform these functions properly.

Improper operation, lubrication, maintenance or repair of this product can be dangerous and could result in injury or death.

Do not operate or perform any lubrication, maintenance or repair on this product, until you have read and understood the operation, lubrication, maintenance and repair information.

Safety precautions and warnings are provided in this manual and on the product. If these hazard warnings are not heeded, bodily injury or death could occur to you or to other persons.

The hazards are identified by the "Safety Alert Symbol" and followed by a "Signal Word" such as "DANGER", "WARNING" or "CAUTION". The Safety Alert "WARNING" label is shown below.



The meaning of this safety alert symbol is as follows:

Attention! Become Alert! Your Safety is Involved.

The message that appears under the warning explains the hazard and can be either written or pictorially presented.

Operations that may cause product damage are identified by "NOTICE" labels on the product and in this publication.

Perkins cannot anticipate every possible circumstance that might involve a potential hazard. The warnings in this publication and on the product are, therefore, not all inclusive. If a tool, procedure, work method or operating technique that is not specifically recommended by Perkins is used, you must satisfy yourself that it is safe for you and for others. You should also ensure that the product will not be damaged or be made unsafe by the operation, lubrication, maintenance or repair procedures that you choose.

The information, specifications, and illustrations in this publication are on the basis of information that was available at the time that the publication was written. The specifications, torques, pressures, measurements, adjustments, illustrations, and other items can change at any time. These changes can affect the service that is given to the product. Obtain the complete and most current information before you start any job. Perkins dealers or Perkins distributors have the most current information available.



When replacement parts are required for this product Perkins recommends using Perkins replacement parts.

Failure to heed this warning can lead to premature failures, product damage, personal injury or death.

Table of Contents

Disassembly and Assembly Section

Fuel Filter Base - Remove and Install (403D-11, 403D-15, 403D-15T, 403D-17, 404D-15, 404D-22, 404D-22T and 404D-22TA Engines)	4
Fuel Filter Base - Remove and Install (402D-05 and 403D-07 Engines)	5
Fuel Transfer Pump - Remove and Install (Mechanical Fuel Transfer Pump)	7
Fuel Transfer Pump - Remove and Install (Electrical Fuel Transfer Pump)	8
Fuel Injection Lines - Remove and Install	9
Fuel Shutoff Solenoid - Remove and Install	12
Fuel Injection Pump - Remove and Install	13
Fuel Injector - Remove and Install	15
Turbocharger - Remove and Install	16
Exhaust Manifold - Remove and Install	18
Inlet and Exhaust Valve Springs - Remove and Install	19
Inlet and Exhaust Valves - Remove and Install	22
Engine Oil Line - Remove and Install	24
Engine Oil Cooler - Remove and Install	26
Engine Oil Relief Valve - Remove and Install	27
Engine Oil Pump - Remove	28
Engine Oil Pump - Install	30
Water Pump - Remove and Install (403D-11, 403D-15, 403D-15T, 403D-17, 404D-15, 404D-22, 404D-22T and 404D-22TA Engines)	32
Water Pump - Remove and Install (402D-05 and 403D-07 Engines)	33
Water Temperature Regulator Housing - Remove and Install	35
Water Temperature Regulator - Remove and Install (402D-05 and 404D-07 Engines)	36
Water Temperature Regulator - Remove and Install (403D-11, 403D-15, 403D-15T, 403D-17, 404D-15, 404D-22, 404D-22T and 404D-22TA Engines) ...	38
Flywheel - Remove	39
Flywheel - Install	40
Crankshaft Rear Seal - Remove and Install	41
Crankshaft Wear Sleeve (Rear) - Remove and Install	43
Flywheel Housing - Remove and Install	44
Flywheel Housing - Remove and Install (Engines with Flywheel Housing and Back Plate)	45
Crankshaft Pulley - Remove and Install	47
Crankshaft Front Seal - Remove and Install	48
Housing (Front) - Remove	49
Housing (Front) - Disassemble	50
Housing (Front) - Assemble	52
Housing (Front) - Install	55
Crankcase Breather - Remove and Install (Turbocharged Engines)	56
Crankcase Breather - Remove and Install (Naturally Aspirated Engines)	58
Valve Mechanism Cover - Remove and Install	60
Rocker Shaft and Pushrod - Remove	62

Rocker Shaft - Disassemble (403D-15, 403D-15T, 403D-17, 404D-22, 404D-22T and 404D-22TA Engines)	62
Rocker Shaft - Disassemble (402D-05, 403D-07, 403D-11 and 404D-15 Engines)	63
Rocker Shaft - Assemble (403D-15, 403D-15T, 403D-17, 404D-22, 404D-22T and 404D-22TA Engines)	64
Rocker Shaft - Assemble (402D-05, 403D-07, 403D-11 and 404D-15 Engines)	65
Rocker Shaft and Pushrod - Install	66
Cylinder Head - Remove	67
Cylinder Head - Install	69
Lifter Group - Remove and Install	71
Camshaft - Remove	72
Camshaft - Disassemble	73
Camshaft - Assemble	74
Camshaft - Install	74
Engine Oil Pan - Remove and Install	76
Pistons and Connecting Rods - Remove	77
Pistons and Connecting Rods - Disassemble	78
Pistons and Connecting Rods - Assemble	80
Pistons and Connecting Rods - Install	81
Connecting Rod Bearings - Remove (Connecting rods in position)	83
Connecting Rod Bearings - Install (Connecting rods in position)	83
Connecting Rod Bearings - Install	84
Crankshaft Main Bearings - Remove	85
Crankshaft Main Bearings - Install	86
Crankshaft - Remove	88
Crankshaft - Install	89
Bearing Clearance - Check	90
Coolant Temperature Switch - Remove and Install (403D-11, 403D-15, 403D-15T, 403D-17, 404D-15, 404D-22, 404D-22T and 404D-22TA Engines) ...	91
Coolant Temperature Switch - Remove and Install (402D-05 and 403D-07 Engines)	92
Engine Oil Pressure Switch - Remove and Install	93
Glow Plugs - Remove and Install	95
V-Belts - Remove and Install	96
Fan - Remove and Install	96
Alternator - Remove and Install (65 Amp and 85 Amp Alternators)	97
Alternator - Remove and Install (55 Amp Alternator)	99
Alternator - Remove and Install (40 Amp Alternator)	99
Alternator - Remove and Install (14 Amp and 15 Amp Alternators)	101
Electric Starting Motor - Remove and Install	102

Index Section

Index	103
-------------	-----

Disassembly and Assembly Section

i02959949

Fuel Filter Base - Remove and Install (403D-11, 403D-15, 403D-15T, 403D-17, 404D-15, 404D-22, 404D-22T and 404D-22TA Engines)

Removal Procedure

NOTICE

Do not allow dirt to enter the fuel system. Thoroughly clean the area around a fuel system component that will be disconnected. Fit a suitable cover over disconnected fuel system component.

NOTICE

Care must be taken to ensure that fluids are contained during performance of inspection, maintenance, testing, adjusting and repair of the product. Be prepared to collect the fluid with suitable containers before opening any compartment or disassembling any component containing fluids.

Dispose of all fluids according to local regulations and mandates.

NOTICE

Keep all parts clean from contaminants.

Contaminants may cause rapid wear and shortened component life.

Note: Place identification marks on all hoses for installation purposes. Plug all hoses and all the ports in the fuel filter base. This helps prevent fluid loss, and this helps to keep contaminants from entering the system.

1. Turn the fuel supply to the OFF position.

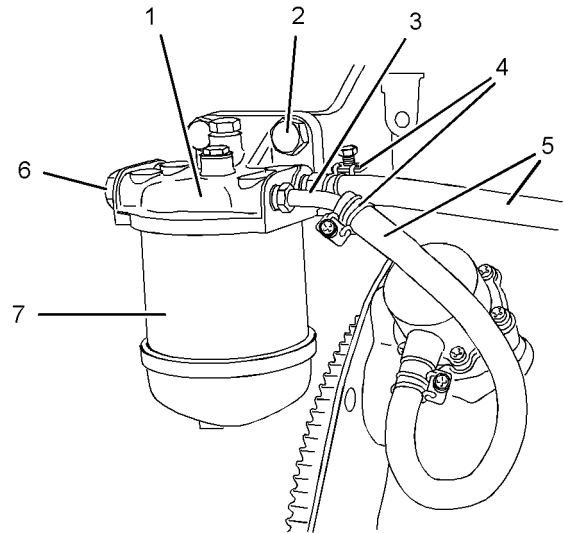

Illustration 1

g01302737

Typical example

2. Loosen hose clamps (4) and disconnect hoses (5).
3. If necessary, remove fuel filter element (7) from fuel filter base (1). Refer to Operation and Maintenance Manual, "Fuel System Filter - Replace".
4. Remove fasteners (2) and remove fuel filter base (1) from the mounting bracket.
5. If necessary, remove plugs (6) and washers (not shown) from fuel filter base (1). Remove tube assemblies (3) and rubber olives (not shown) from fuel filter base (1).

Installation Procedure

NOTICE

Keep all parts clean from contaminants.

Contaminants may cause rapid wear and shortened component life.

Note: If the engine is equipped with a hand priming pump, the hand priming pump is mounted on the fuel filter base. The assembly of the fuel filter base and the hand priming pump is not serviceable.

1. Ensure that the fuel filter base is clean and free from damage. If necessary, replace the fuel filter base.

i02645711

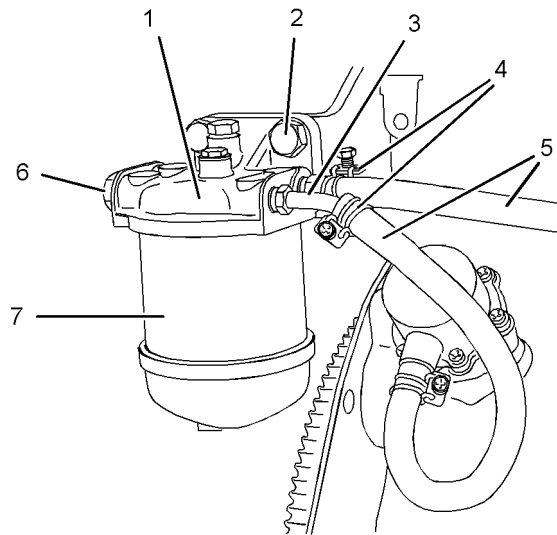

Illustration 2

g01302737

Typical example

2. If necessary, install new rubber olives (not shown) onto tube assemblies (3). Install tube assemblies (3) to fuel filter base (1). Ensure the correct orientation of the tube assemblies. Tighten the nuts to a torque of 9 N·m (80 lb in).
 3. Install washers (not shown) onto plugs (6). Install plugs (6) to fuel filter base (1). Tighten the plugs to a torque of 23 N·m (17 lb ft).
 4. Align fuel filter base (1) with the mounting bracket. Install fasteners (2). Tighten the fasteners to a torque of 50 N·m (37 lb ft).
 5. If necessary, install a new fuel filter element (7) to fuel filter base (1). Refer to Operation and Maintenance Manual, "Fuel System Filter - Replace".
 6. Connect hoses (5) and tighten hose clamps (4).
- Note:** Ensure that the hoses do not contact any other engine components.
7. Turn the fuel supply to the ON position.
 8. Remove the air from the fuel system. Refer to Operation and Maintenance Manual, "Fuel System - Prime".

Fuel Filter Base - Remove and Install (402D-05 and 403D-07 Engines)

Removal Procedure

NOTICE

Do not allow dirt to enter the fuel system. Thoroughly clean the area around a fuel system component that will be disconnected. Fit a suitable cover over disconnected fuel system component.

NOTICE

Care must be taken to ensure that fluids are contained during performance of inspection, maintenance, testing, adjusting and repair of the product. Be prepared to collect the fluid with suitable containers before opening any compartment or disassembling any component containing fluids.

Dispose of all fluids according to local regulations and mandates.

NOTICE

Keep all parts clean from contaminants.

Contaminants may cause rapid wear and shortened component life.

Note: Place identification marks on all hoses for installation purposes. Plug all hoses and all the ports in the fuel filter base. This helps prevent fluid loss, and this helps to keep contaminants from entering the system.

1. Turn the fuel supply to the OFF position.

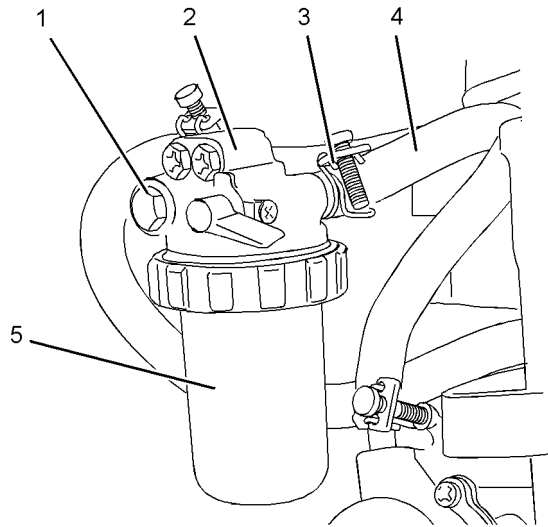

Illustration 3
Typical example g01303701

2. Loosen hose clamps (3) and disconnect hoses (4).
3. If necessary, remove fuel filter element (5). Refer to Operations and Maintenance Manual, "Fuel System Filter - Replace".
4. Remove bolt (1) and remove fuel filter base (2) from the mounting bracket.

Installation Procedure

NOTICE

Keep all parts clean from contaminants.

Contaminants may cause rapid wear and shortened component life.

1. Ensure that the fuel filter base is clean and free from damage. If necessary, replace the fuel filter base.

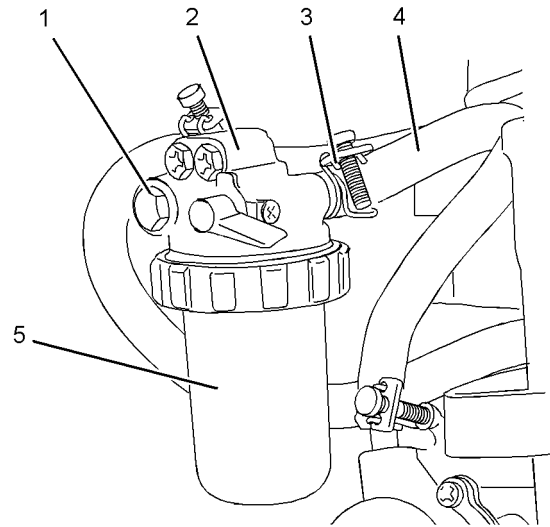

Illustration 4
Typical example g01303701

2. Align fuel filter base (2) with the mounting bracket. Install bolt (1). Tighten the bolt to a torque of 25 N·m (18 lb ft).
3. If necessary, install a new fuel filter element (6) to fuel filter base (2). Refer to Operation and Maintenance Manual, "Fuel System Filter - Replace".
4. Connect hoses (4) and tighten hose clamps (3).

Note: Ensure that the hoses do not contact any other engine components.

5. Turn the fuel supply to the ON position.
6. Remove the air from the fuel system. Refer to Operation and Maintenance Manual, "Fuel System - Prime".

i02645722

Fuel Transfer Pump - Remove and Install (Mechanical Fuel Transfer Pump)

Removal Procedure

NOTICE

Do not allow dirt to enter the fuel system. Thoroughly clean the area around a fuel system component that will be disconnected. Fit a suitable cover over disconnected fuel system component.

NOTICE

Care must be taken to ensure that fluids are contained during performance of inspection, maintenance, testing, adjusting and repair of the product. Be prepared to collect the fluid with suitable containers before opening any compartment or disassembling any component containing fluids.

Dispose of all fluids according to local regulations and mandates.

NOTICE

Keep all parts clean from contaminants.

Contaminants may cause rapid wear and shortened component life.

Note: Place identification marks on all hoses for installation purposes. Plug all hoses and all the ports in the fuel transfer pump. This helps prevent fluid loss, and this helps to keep contaminants from entering the system.

1. Turn the fuel supply to the OFF position.

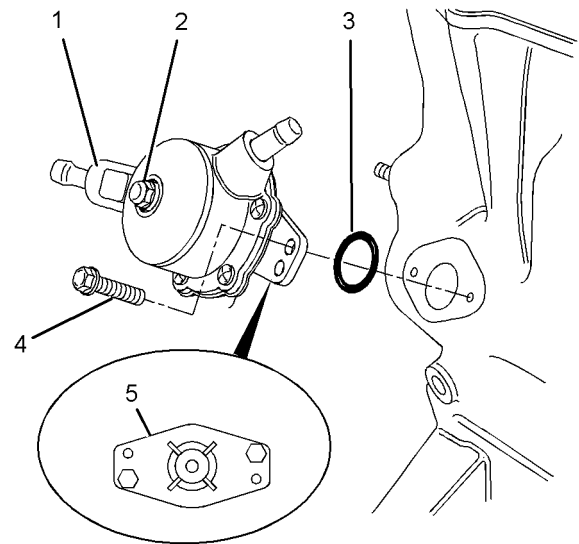

Illustration 5

g01326306

Typical example

Note: The fuel transfer pump can be oriented in two positions. Before removing the fuel transfer pump from the cylinder block, note the orientation of flange (5) on fuel transfer pump (1) for assembly.

2. Loosen the hose clamps and disconnect the hoses (not shown) from fuel transfer pump (1).
3. Evenly loosen bolts (4) and remove fuel transfer pump (1) from the cylinder block.

Note: In order to remove the fuel transfer pump, it may be necessary to rotate the crankshaft until the operating plunger of the fuel transfer pump is not under pressure.

4. Remove O-ring seal (3) from fuel transfer pump (1).

Installation Procedure

NOTICE

Keep all parts clean from contaminants.

Contaminants may cause rapid wear and shortened component life.

i02645719

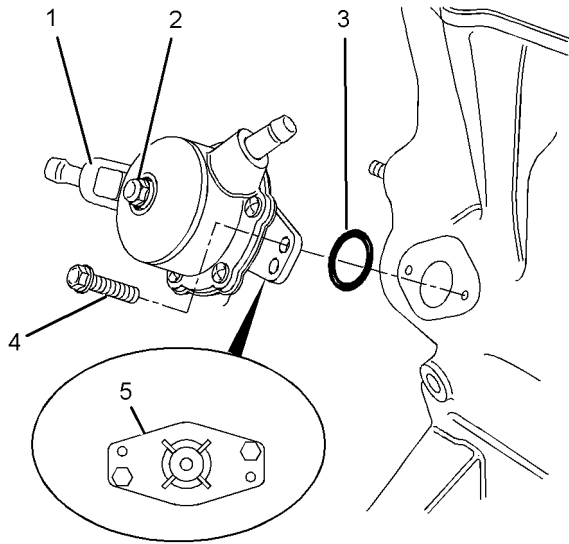

Illustration 6 g01326306

Typical example

1. Clean the mating surfaces of the cylinder block and flange (5) on the fuel transfer pump.

Note: Ensure that the camshaft lobe for the fuel transfer pump is at minimum lift before the fuel transfer pump is installed. The fuel transfer pump can be oriented in two positions. Ensure that the fuel transfer pump is oriented in the correct position.

2. Install a new O-ring seal (3) to fuel transfer pump (1).
3. Lubricate the operating plunger of fuel transfer pump (1) with clean engine oil.
4. Position fuel transfer pump (1) on the cylinder block. Ensure that the operating plunger is positioned correctly on the camshaft lobe. Install bolts (4). Tighten the bolts to a torque of 6 N·m (53 lb in).
5. Connect the hoses (not shown) to fuel transfer pump (1). Tighten the hose clamps.

Note: The inlet for the fuel transfer pump can be rotated 360 degrees by loosening bolt (2). The fuel inlet is adjustable in 15 degree increments. If adjustment is made to the position of the fuel inlet, tighten bolt (2) to a torque of 2.5 N·m (22 lb in).

6. Turn the fuel supply to the ON position.
7. Prime the fuel system. Refer to Systems Operation, Testing and Adjusting, "Fuel System - Prime" for additional information.

Fuel Transfer Pump - Remove and Install (Electrical Fuel Transfer Pump)

Removal Procedure

NOTICE

Care must be taken to ensure that fluids are contained during performance of inspection, maintenance, testing, adjusting and repair of the product. Be prepared to collect the fluid with suitable containers before opening any compartment or disassembling any component containing fluids.

Dispose of all fluids according to local regulations and mandates.

NOTICE

Keep all parts clean from contaminants.

Contaminants may cause rapid wear and shortened component life.

Note: Put identification marks on all hoses, on all hose assemblies, on wires and on all tube assemblies for installation purposes. Plug all hose assemblies and tube assemblies. This helps to prevent fluid loss and this helps to keep contaminants from entering the system.

1. Turn the fuel supply to the OFF position.
2. Turn the battery disconnect switch to the OFF position.

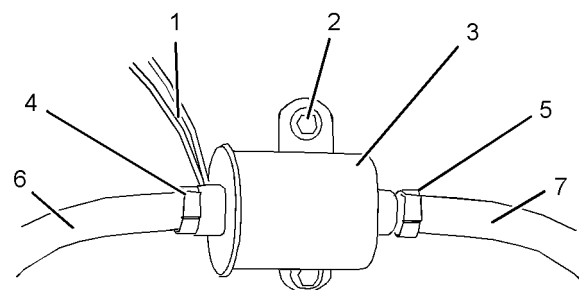

Illustration 7
Typical example

g01304057

3. Disconnect harness assembly (1).

i02959953

4. Loosen hose clamps (4) and (5). Disconnect hoses (6) and (7).
5. Remove bolts (2) and remove electric transfer pump (3).

Installation Procedure

1. Ensure that the electric transfer pump is clean and free from damage. If necessary, replace the electric transfer pump.

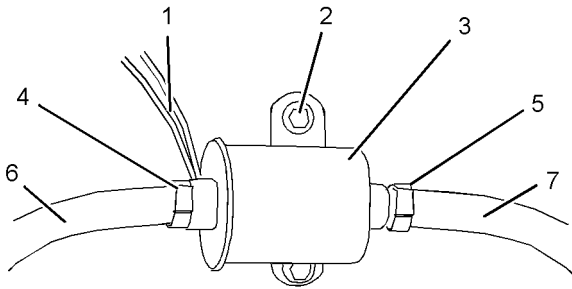

Illustration 8

g01304057

Typical example

2. Position electric transfer pump (3) on the mounting and install bolts (2).
3. Tighten bolts (2) to a torque of 9 N·m (79 lb in).
4. Connect hoses (6) and (7). Tighten hose clamps (4) and (5).
5. Connect harness assembly (1).
6. Turn the fuel supply to the ON position.
7. Turn the battery disconnect switch to the ON position.
8. Remove the air from the fuel system. Refer to Operation and Maintenance Manual, "Fuel System - Prime".

Fuel Injection Lines - Remove and Install

Removal Procedure

NOTICE

Keep all parts clean from contaminants.

Contaminants may cause rapid wear and shortened component life.

NOTICE

Care must be taken to ensure that fluids are contained during performance of inspection, maintenance, testing, adjusting and repair of the product. Be prepared to collect the fluid with suitable containers before opening any compartment or disassembling any component containing fluids.

Dispose of all fluids according to local regulations and mandates.

NOTICE

Do not let the tops of fuel injectors turn when the fuel line nuts are loosened or tightened.

The fuel injectors will be damaged if the top of the injector turns in the body.

The engine will be damaged if a defective fuel injector is used because the shape of fuel (spray pattern) that comes out of the nozzle will not be correct.

Note: Place identification marks on all tube assemblies for installation. Plug all lines and tube assemblies in order to prevent contamination.

1. Turn the fuel supply to the OFF position.

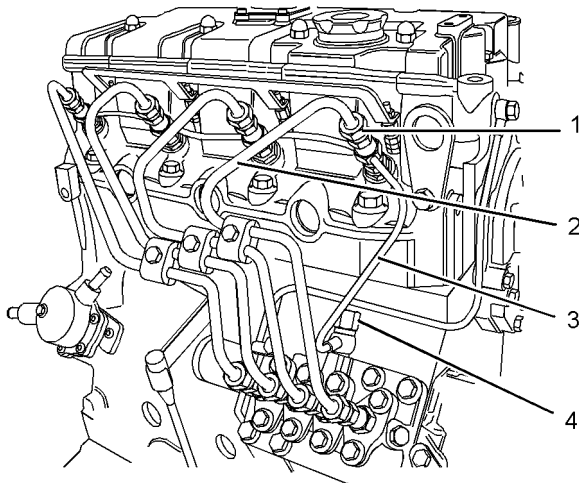

Illustration 9
Typical example

2. Disconnect nuts (1) for fuel injection lines (2) from the fuel injectors.
3. Disconnect nuts (1) for fuel injection lines (2) from the fuel injection pump.
4. Remove fuel injection lines (2) from the engine as a unit.
5. Use suitable caps in order to plug the open ports of the fuel injection pump immediately.
6. The 403D-15, 403D-15T, 403D-17, 404D-22, 404D-22T and 404D-22TA engines have a rigid fuel return line.

For engines with a rigid fuel return line, remove banjo bolt (4) from fuel return line (3). Remove washers (8).

The 402D-05, 403D-07, 403D-11 and 404D-15 engines have a flexible fuel return hose.

For engines with a flexible fuel return hose, disconnect the hose from the fuel injection pump.

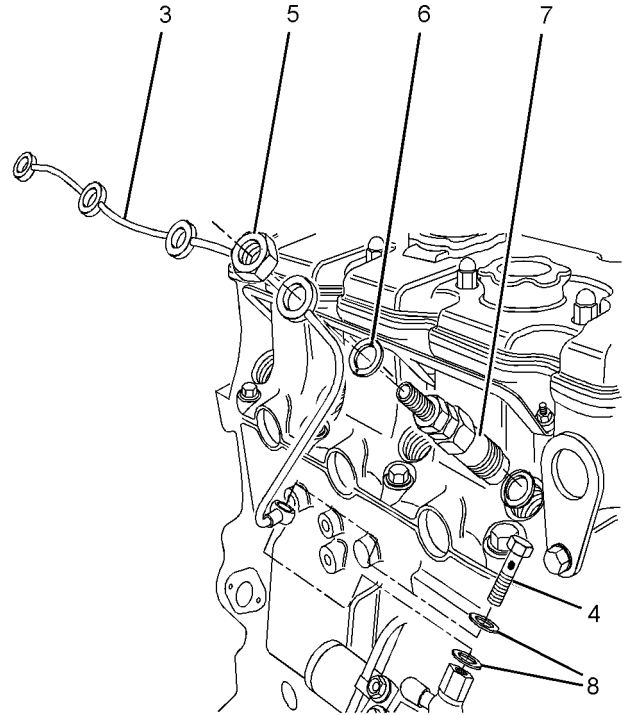

Illustration 10
Typical example

7. Remove nuts (5) from fuel injectors (7).
- Note:** For engines with a rigid fuel return line, ensure that the fuel return line is not distorted when the nuts are loosened.
8. Remove fuel return line (3) and washers (6) from fuel injectors (7).
 9. Use suitable caps in order to plug the fuel injectors immediately.

Installation Procedure

Table 1

Required Tools			
Tool	Part Number	Part Name	Qty
A	27610294	Injector Pipe Nut Tool	1

NOTICE

Keep all parts clean from contaminants.

Contaminants may cause rapid wear and shortened component life.

NOTICE

Do not let the tops of fuel injectors turn when the fuel line nuts are loosened or tightened.

The fuel injectors will be damaged if the top of the injector turns in the body.

The engine will be damaged if a defective fuel injector is used because the shape of fuel (spray pattern) that comes out of the nozzle will not be correct.

Note: The installation procedure is similar for the two cylinder, the three cylinder and the four cylinder engines.

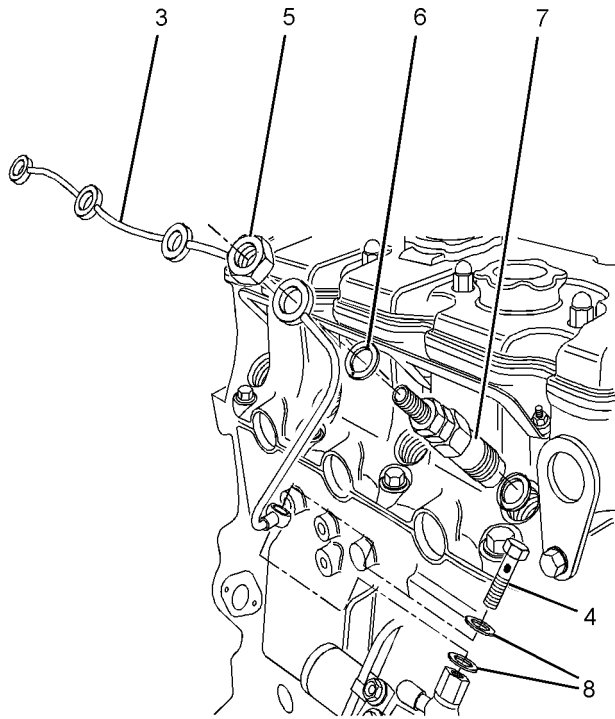

Illustration 11

g01326555

Typical example

1. Remove the caps from fuel injectors (7). Install new washers (6) and fuel return line (3) to fuel injectors (7).

Note: The washers (6) have two small holes.

2. Install nuts (5) to fuel injectors (7).
3. The 403D-15, 403D-15T, 403D-17, 404D-22, 404D-22TA and 404D-22TA engines have a rigid fuel return line.

For engines with a rigid fuel return line, install new washers (8) to fuel return line (3) and install banjo bolt (4) to the fuel injection pump. Tighten banjo bolt (4) to a torque of 7 N·m (62 lb in).

The 402D-05, 403D-07, 403D-11 and 404D-15 engines have a flexible fuel return hose.

For engines with a flexible fuel return hose, connect the fuel return hose to the fuel injection pump.

4. Tighten nuts (5) to a torque of 27 N·m (20 lb ft).

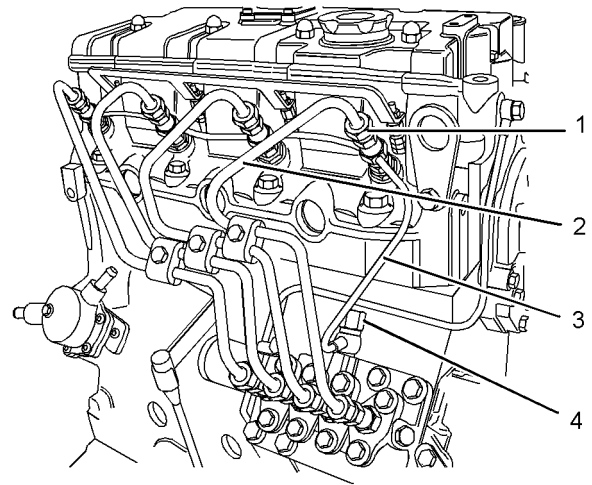

Illustration 12

g01326550

Typical example

5. Remove the caps from the outlet connections of the fuel injection pump. Install the fuel injection lines to the engine as a unit.
6. Connect fuel injection lines (2) to fuel injectors (7). Tighten the union nuts (1) finger tight.
7. Use Tooling (A) to tighten union nuts (1) at the fuel injection pump.

For 402D-05 and 403D-07 engines, tighten union nuts (1) to a torque of 20 N·m (15 lb ft).

For 403D-11, 403D-15, 403D-15T, 403D-17, 404D-15, 404D-22, 404D-22T and 404D-22TA engines, tighten the union nuts (1) to a torque of 23 N·m (17 lb ft).

Note: For the three cylinder and the four cylinder engines, tighten the center union nuts first.

8. Use Tooling (A) to tighten union nuts (1) at the fuel injections.

For 402D-05 and 403D-07 engines, tighten union nuts (1) to a torque of 20 N·m (15 lb ft).

For 403D-11, 403D-15, 403D-15T, 403D-17, 404D-15, 404D-22, 404D-22T and 404D-22TA engines, tighten the union nuts (1) to a torque of 23 N·m (17 lb ft).

9. Turn the fuel supply to the ON position.
10. Prime the fuel system. Refer to Operation and Maintenance Manual, "Fuel System - Prime" for more information.

i02645718

Fuel Shutoff Solenoid - Remove and Install

Removal Procedure

NOTICE

Care must be taken to ensure that fluids are contained during performance of inspection, maintenance, testing, adjusting and repair of the product. Be prepared to collect the fluid with suitable containers before opening any compartment or disassembling any component containing fluids.

Dispose of all fluids according to local regulations and mandates.

NOTICE

Keep all parts clean from contaminants.

Contaminants may cause rapid wear and shortened component life.

1. Turn the battery disconnect switch to the OFF position.

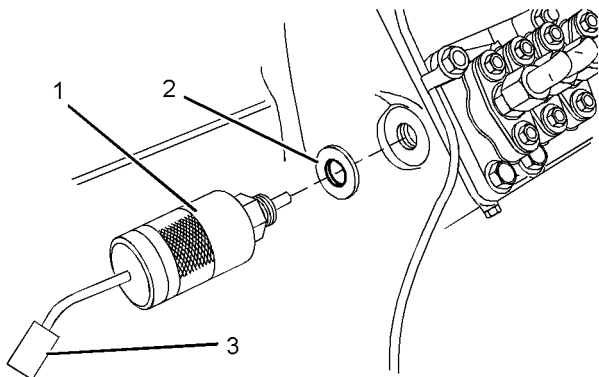

Illustration 13

g01326564

Typical example

2. Disconnect electrical connection (3) from the harness assembly (not shown). Mark all connections for installation.
3. Remove fuel shutoff solenoid (1) from the fuel injection pump housing by rotating the fuel shutoff solenoid in a counterclockwise direction.
4. Remove sealing washer (2) from fuel shutoff solenoid (1).

Installation Procedure

NOTICE

Keep all parts clean from contaminants.

Contaminants may cause rapid wear and shortened component life.

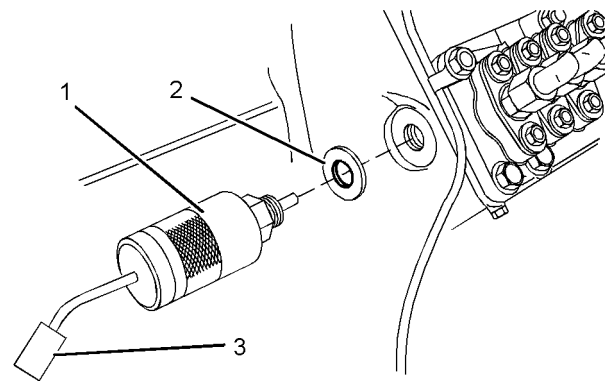

Illustration 14

g01326564

Typical example

1. Install sealing washer (2) to fuel shutoff solenoid (1).
2. Install fuel shutoff solenoid (1) into the fuel injection pump housing by rotating the fuel shutoff solenoid in a clockwise direction. Tighten the fuel shutoff solenoid to a torque of 17 N·m (12 lb ft).
3. Connect electrical connection (3) to the harness assembly (not shown).
4. Turn the battery disconnect switch to the ON position.

i02959957

Fuel Injection Pump - Remove and Install

Removal Procedure

Start By:

- a. Remove the fuel shutoff solenoid. Refer to Disassembly and Assembly, "Fuel Shutoff Solenoid - Remove and Install".

NOTICE

Care must be taken to ensure that fluids are contained during performance of inspection, maintenance, testing, adjusting and repair of the product. Be prepared to collect the fluid with suitable containers before opening any compartment or disassembling any component containing fluids.

Dispose of all fluids according to local regulations and mandates.

NOTICE

Keep all parts clean from contaminants.

Contaminants may cause rapid wear and shortened component life.

Note: The removal procedure is similar for the two cylinder, the three cylinder and the four cylinder engines. The Illustrations show a four cylinder engine.

1. Remove the fuel injection lines. Refer to Disassembly and Assembly, "Fuel Injection Lines - Remove and Install" for more information.

The 402D-05, 403D-07, 403D-11 and 404D-15 engines have a flexible fuel return hose.

For engines with a flexible fuel return hose, disconnect the fuel hose from the inlet connection of the fuel injection pump.

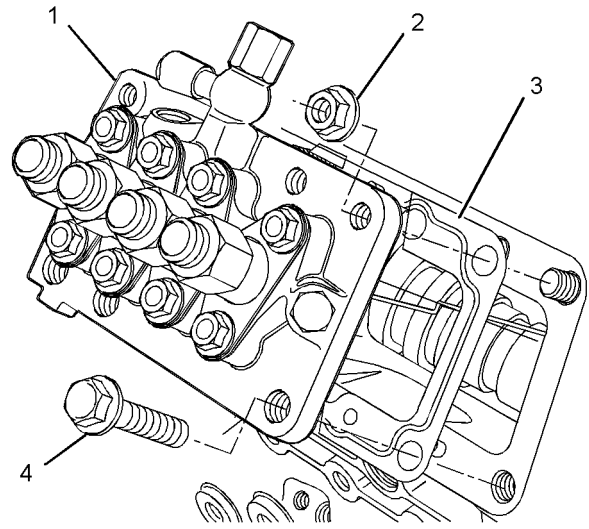

Illustration 15

g01327005

Typical example

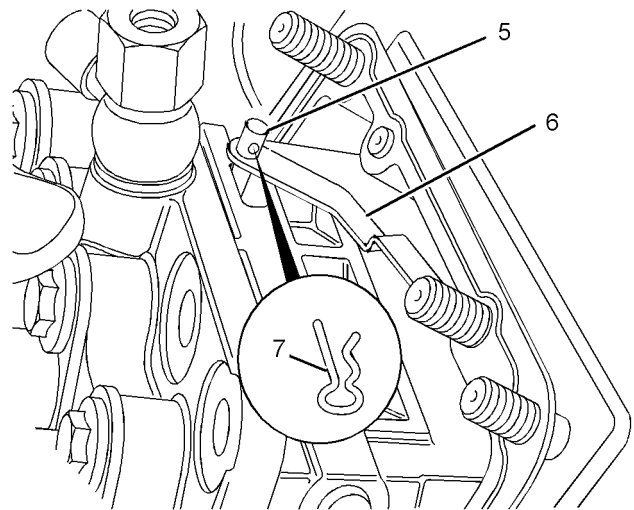

Illustration 16

g01327006

Typical example

2. Gradually loosen bolts (4) and nuts (2) that fasten the fuel injection pump to the cylinder block.
3. Carefully raise fuel injection pump (1) from the cylinder block and remove clip (7) that connects link (6) to fuel rack control (5).
4. Remove fuel injection pump (1) from the cylinder block.
5. Remove shims (3) from the mounting face of the cylinder block.

Note: Record the thickness of each shim and the number of shims for reassembly. The fuel injection timing is determined by the thickness of the shim pack that is between the fuel injection pump and the mounting face on the cylinder block. Refer to Specifications, “Fuel Injection Pump” for more information.

Installation Procedure

NOTICE

Keep all parts clean from contaminants.

Contaminants may cause rapid wear and shortened component life.

Note: The installation procedure is similar for the two cylinder, the three cylinder and the four cylinder engines. The Illustrations show a four cylinder engine.

1. Clean the mating surfaces of the cylinder block and the fuel injection pump.

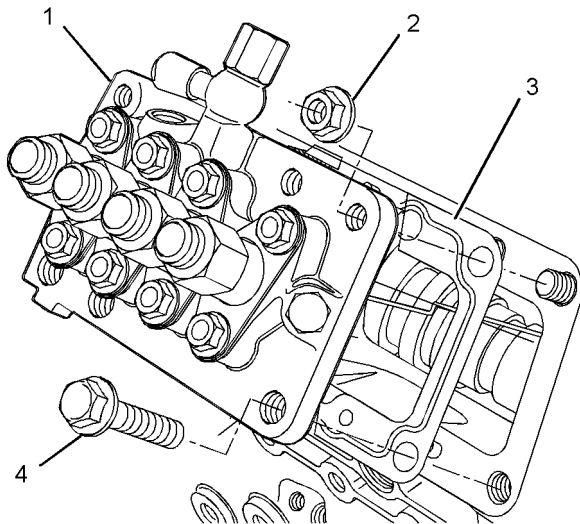

Illustration 17
Typical example

2. New shims (3) must be used during assembly. Install the correct thickness and the correct number of shims on the mounting face of the cylinder block. Refer to Specifications, “Fuel Injection Pump” for more information.

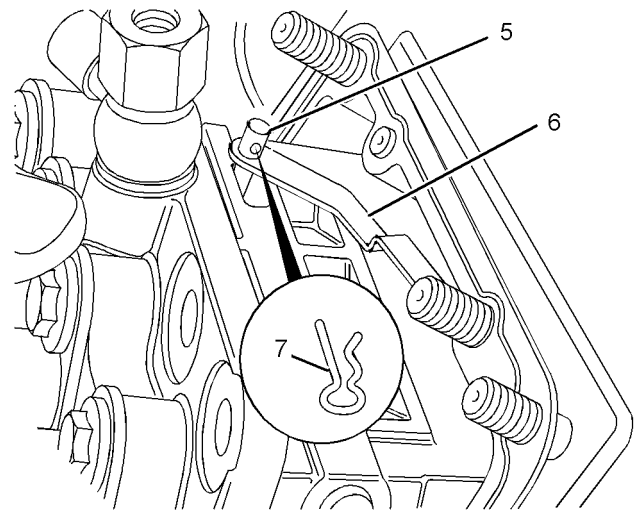

Illustration 18
Typical example

3. Position fuel injection pump (1) close to the mounting face of the cylinder block, and connect link (6) and fuel rack control (5) with clip (7).
4. Align fuel injection pump (1) with the studs on the cylinder block. Install the fuel injection pump to the cylinder block.
5. Install bolts (4) and nuts (2). Ensure that the tube clip for the engine oil line is secured by the appropriate fastener.

For 402D-05, 403D-07, 403D-11 and 404D-15 engines, evenly tighten bolts (4) and nuts (2) to a torque of 6 N·m (53 lb in).

For 403D-15, 403D-15T, 403D-17, 404D-22, 404D-22T and 404D-22TA engines, evenly tighten bolts (4) and nuts (2) to a torque of 15 N·m (11 lb ft).

6. Install the fuel injection lines. Refer to Disassembly and Assembly, “Fuel Injection Lines - Remove and Install”.

The 402D-05, 403D-07, 403D-11 and 404D-15 engines have a flexible fuel return hose.

For engines with a flexible fuel return hose, connect the fuel hose to the inlet connection of the fuel injection pump.

End By:

- a. Install the fuel shutoff solenoid. Refer to Disassembly and Assembly, "Fuel Shutoff Solenoid - Remove and Install".

i02959963

Fuel Injector - Remove and Install

Removal Procedure

Start By:

- a. Remove the fuel injection lines. Refer to Disassembly and Assembly, "Fuel Injection Lines - Remove and Install".

NOTICE

Care must be taken to ensure that fluids are contained during performance of inspection, maintenance, testing, adjusting and repair of the product. Be prepared to collect the fluid with suitable containers before opening any compartment or disassembling any component containing fluids.

Dispose of all fluids according to local regulations and mandates.

NOTICE

Keep all parts clean from contaminants.

Contaminants may cause rapid wear and shortened component life.

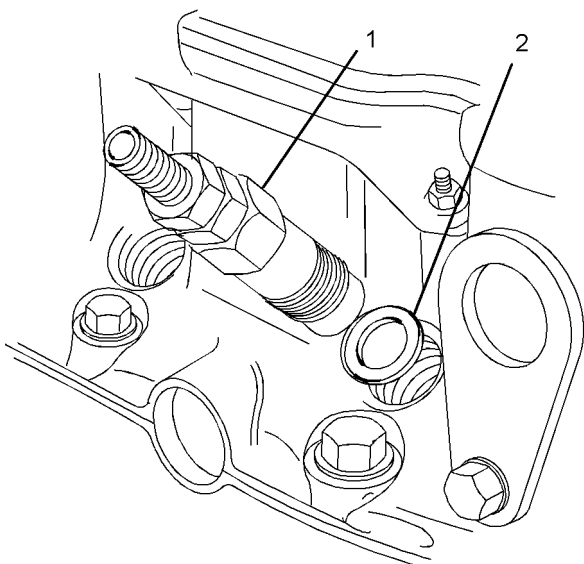

Illustration 19
Typical example

g01320610

1. Use a deep socket to remove fuel injector (1) from the cylinder head.
2. Remove seat washers (2) from the cylinder head.

Note: 402D-05 and 403D-07 engines have two seat washers. The seat washers are different diameters. The 403D-11, 403D-15, 403D-15T, 403D-17, 404D-15, 404D-22, 404D-22T and 404D-22TA engines have one seat washer.

3. Cap all openings or plug all openings immediately.

Installation Procedure

Table 2

Required Tools			
Tool	Part Number	Part Description	Qty
A	1861117	POWERPART Universal Jointing Compound	1

NOTICE

Keep all parts clean from contaminants.

Contaminants may cause rapid wear and shortened component life.

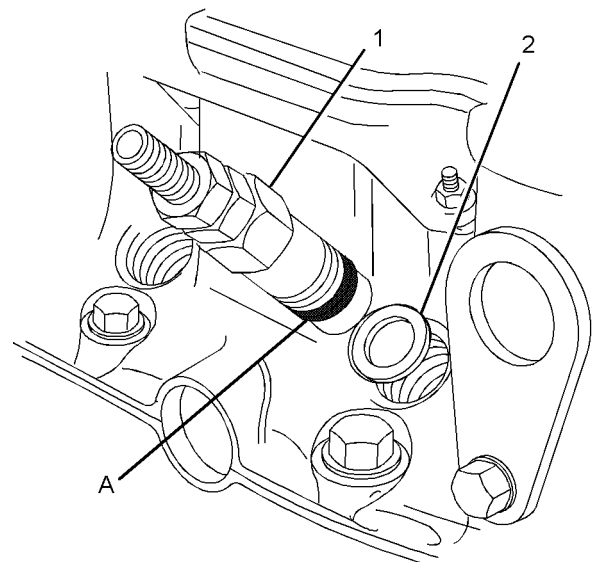

Illustration 20
Typical example

g01304054

1. Clean the bore for the fuel injector in the cylinder head. Ensure that no debris enters the cylinder. Clean the threads on the body of the fuel injector.
2. Install new seat washers (2) into the bore for the fuel injector in the cylinder head.

Note: 402D-05 and 403D-07 engines have two seat washers. The seat washers are different diameters. The 403D-11, 403D-15, 403D-15T, 403D-17, 404D-15, 404D-22, 404D-22T and 404D-22TA engines have one seat washer.

3. Apply a bead of Tooling (A) to the first two threads of the fuel injector that engage into the cylinder head. The bead should have a diameter of 2 mm (0.08 inch) and a length of 6 mm (0.25 inch).

Note: Ensure that Tooling (A) does not cover the body of the fuel injector below the threads.

4. Install fuel injector (1) into the cylinder head. Use a deep socket to tighten the fuel injector to a torque of 64 N·m (47 lb ft).

End By:

- a. Install the fuel injection lines. Refer to Disassembly and Assembly, "Fuel Injection Lines - Remove and Install".

i02645771

Turbocharger - Remove and Install

Removal procedure

NOTICE

Care must be taken to ensure that fluids are contained during performance of inspection, maintenance, testing, adjusting and repair of the product. Be prepared to collect the fluid with suitable containers before opening any compartment or disassembling any component containing fluids.

Dispose of all fluids according to local regulations and mandates.

NOTICE

Keep all parts clean from contaminants.

Contaminants may cause rapid wear and shortened component life.

Note: Plug and cap all open ports and tube assemblies.

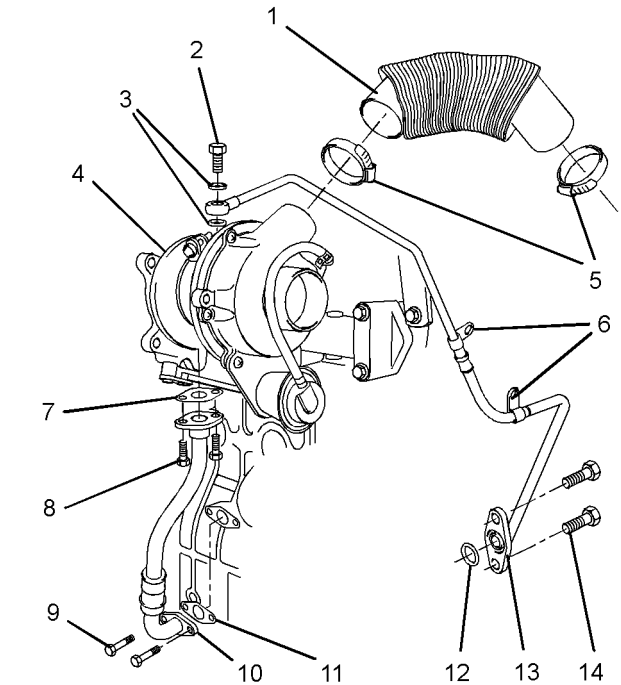

Illustration 21

g01304121

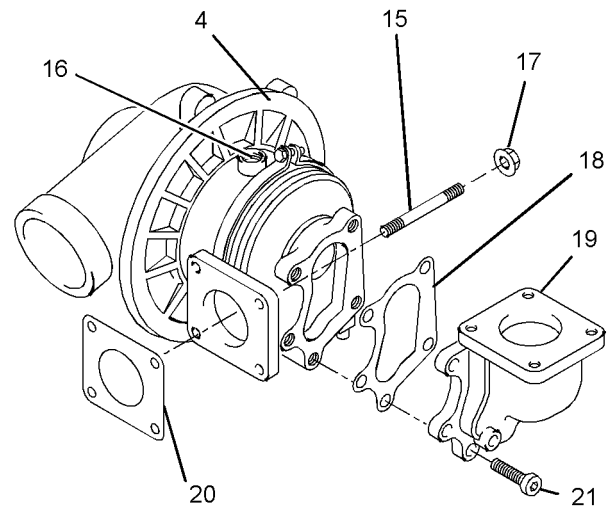

Illustration 22

g01304528

1. Loosen hose clamps (5) and remove air inlet hose (1).
2. Remove allen head screws (21) and remove exhaust elbow (19) from turbocharger (4). Remove gasket (18) from the turbocharger.

3. Remove banjo bolt (2) and washers (3). Remove the fasteners and the spacers (not shown) for tube clips (6). Remove bolts (14) and remove tube assembly (13) from the cylinder block. Remove O-ring seal (12).
4. Remove bolts (8) and disconnect tube assembly (10) from the turbocharger. Remove joint (7).

If necessary, remove bolts (9) and remove tube assembly (10) from the cylinder block. Remove joint (11).
5. Remove nuts (17) and remove turbocharger (4) from the exhaust manifold. Remove gasket (20) from the exhaust manifold. If necessary, remove studs (15) from the exhaust manifold.

Note: Do not use the actuator rod of the wastegate to lift the turbocharger.

Installation procedure

NOTICE

Keep all parts clean from contaminants.

Contaminants may cause rapid wear and shortened component life.

1. Ensure that the turbocharger is clean and free from damage. Inspect the turbocharger for wear. If the turbocharger is worn, the complete turbocharger must be replaced.
2. Test the actuator for correct operation. Refer to Systems Operation, Testing and Adjusting, "Wastegate - Test" for more information. If the actuator is damaged or the actuator does not operate within the specified limits, the complete turbocharger must be replaced.

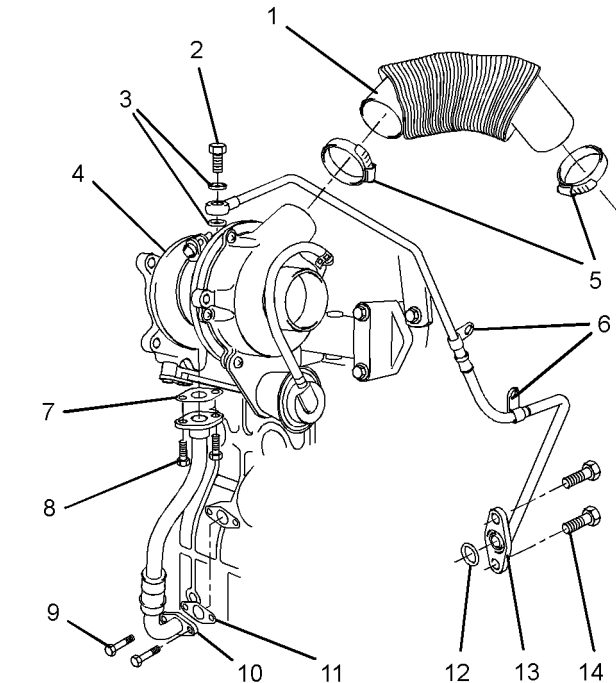

Illustration 23

g01304121

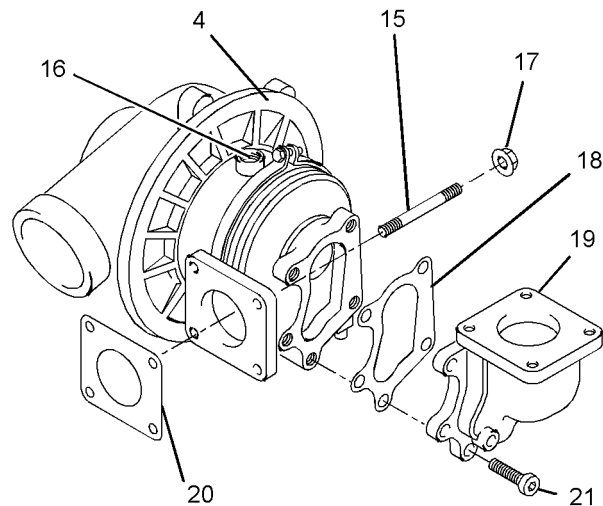

Illustration 24

g01304528

3. Clean the mating surfaces of the exhaust manifold. If necessary, install studs (15) to the exhaust manifold. Tighten the studs to a torque of 18 N·m (13 lb ft). Install a new gasket (20) over the studs.
4. Position turbocharger (4) onto the exhaust manifold. Install nuts (17) and tighten to a torque of 25 N·m (18 lb ft).

Note: Do not use the actuator rod of the wastegate to lift the turbocharger .

i02959965

5. Ensure that tube assemblies (10) and (13) are clean and free from damage. If necessary, replace the tube assemblies.
6. If necessary, position a new joint (11) and tube assembly (10) onto the cylinder block. Install bolts (9). Tighten the bolts finger tight.

Position a new joint (7) on tube assembly (10). Align tube assembly (10) to the bottom of the turbocharger. Install bolts (8). Tighten the bolts finger tight.

Tighten bolts (8) and (9) to a torque of 10 N·m (89 lb in).

7. Lubricate the bearings of turbocharger (4) with clean engine oil through oil inlet port (16). Rotate the shaft of the turbocharger in order to distribute the lubricant.
8. Install a new O-ring seal (12) to tube assembly (13). Position tube assembly (13) against the cylinder block. Install bolts (14). Tighten the bolts to a torque of 10 N·m (89 lb in).
9. Install new washers (3) and banjo bolt (2) to tube assembly (13). Position tube assembly (13) onto turbocharger (4). Tighten the banjo bolt finger tight.
10. If necessary, install the spacer and install the fasteners (not shown) to tube clips (6). Torque the fasteners to 10 N·m (89 lb in).
11. Tighten banjo bolt (2) to a torque of 18 N·m (13 lb ft).

Note: Ensure that the tube assembly does not come into contact with any other components.

12. Clean the mating surfaces of exhaust elbow (19). Position a new gasket (18) and exhaust elbow (19) on turbocharger (4). Install allen head screws (21). Tighten the bolts to a torque of 32 N·m (24 lb ft).
13. Ensure that inlet hose (1) is clean and free from defects or restrictions. Loosely install hose clamps (5) to air inlet hose (1). Install the air inlet hose to the connection of the inlet manifold (not shown) and to the turbocharger. Tighten the hose clamps.

Exhaust Manifold - Remove and Install

Removal Procedure

Start By:

- a. If the engine is equipped with a turbocharger, remove the turbocharger. Refer to Disassembly and Assembly, "Turbocharger, Remove and Install".

NOTICE

Keep all parts clean from contaminants.

Contaminants may cause rapid wear and shortened component life.

Note: The two cylinder, the three cylinder and the four cylinder engines have different exhaust manifolds. The removal procedure is similar for all models.

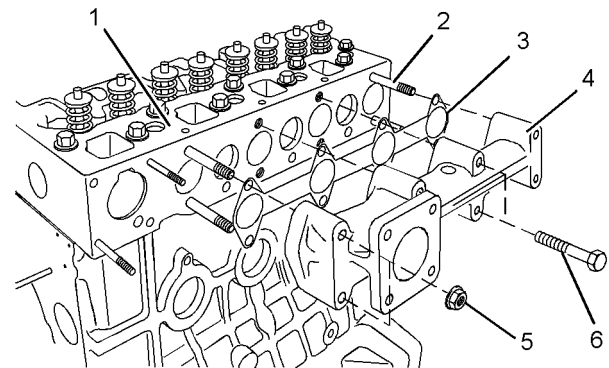

Illustration 25

g01326567

Typical example

1. Loosen nuts (5) and bolts (6).

Note: In order to prevent distortion of the exhaust manifold, loosen the outer fasteners first.

2. Remove nuts (5) and bolts (6).

Note: Identify bolts of different lengths so that the bolts can be installed in the correct positions.

3. Remove exhaust manifold (4) from cylinder head (1). Note the orientation of the exhaust manifold for installation.
4. Remove gasket (3) from cylinder head (1).

- If necessary, remove exhaust manifold studs (2) from cylinder head (1).

Installation Procedure

NOTICE

Keep all parts clean from contaminants.

Contaminants may cause rapid wear and shortened component life.

Note: The two cylinder, the three cylinder and the four cylinder engines have different exhaust manifolds. The installation procedure is similar for all models.

- Ensure that the mating surfaces of the cylinder head and the exhaust manifold are clean and free from damage.

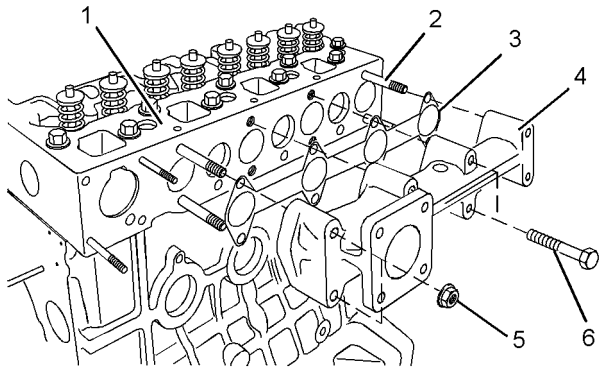

Illustration 26

g01326567

Typical example

- If necessary, install exhaust manifold studs (2) to cylinder head (1).
- Install a new exhaust manifold gasket (3) to cylinder head (1).
- Align exhaust manifold (4) with studs (2) and install the exhaust manifold to cylinder head (1).

Note: Ensure that the exhaust manifold is installed in the correct orientation.

- Install nuts (5) and bolts (6) finger tight.

Note: Ensure that bolts of different lengths are installed in the correct positions.

- For 402D-05, 403D-07, 403D-11, 403D-15, 403D-15T, 403D-17, and 404D-15 engines, tighten nuts (5) and bolts (6) to a torque of 10 N·m (89 lb in).

For 404D-22, 404D-22T and 404D-22TA engines, tighten nuts (5) and bolts (6) to a torque of 25 N·m (18 lb ft).

Note: On three cylinder engines and four cylinder engines, tighten the inner bolts first.

End By:

- If the engine is equipped with a turbocharger, install the turbocharger. Refer to Disassembly and Assembly, "Turbocharger, Remove and Install".

i02959972

Inlet and Exhaust Valve Springs - Remove and Install

Removal Procedure

Table 3

Required Tools			
Tool	Part Number	Part Description	Qty
A	21825739	Valve Spring Compressor	1
B ⁽¹⁾	-	Adapter	1
B ⁽²⁾	27610235	Adapter	1
B ⁽³⁾	21825934	Adapter	1

(1) 402D-05 and 403D-07 engines

(2) 403D-11 and 404D-15 engines

(3) 403D-15, 403D-17, 403D-17, 404D-22, 404D-22T and 404D-22TA engines

Start By:

- Remove the rocker shaft assembly. Refer to Disassembly and Assembly, "Rocker Shaft and Pushrod - Remove".

WARNING

Personal injury can result from being struck by parts propelled by a released spring force.

Make sure to wear all necessary protective equipment.

Follow the recommended procedure and use all recommended tooling to release the spring force.

NOTICE

Keep all parts clean from contaminants.

Contaminants may cause rapid wear and shortened component life.

NOTICE

Install suitable plugs to the inlet ports of the cylinder head in order to prevent the entry of loose parts into the engine.

NOTICE

Plug the apertures for the push rods in the cylinder head in order to prevent the entry of loose parts into the engine.

Note: The removal procedure is similar for the two cylinder, the three cylinder and the four cylinder engines. The following procedure should be adopted in order to remove the valve springs when the cylinder head is installed to the engine. Refer to Disassembly and Assembly, "Inlet and Exhaust Valves - Remove and Install" for the procedure to remove the valve springs from a cylinder head that has been removed from the engine.

Note: Ensure that the appropriate piston is at the top center position before the valve spring is removed. Failure to ensure that the piston is at the top center position may allow the valve to drop into the cylinder bore.

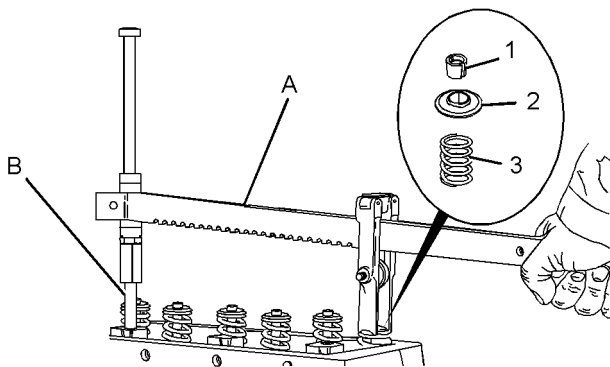

Illustration 27

g01304583

Typical example

1. Follow Steps 1.a through 1.d in order to position the appropriate piston at top center.
 - a. Install Tooling (A) and (B) in position on the cylinder head in order to compress a valve spring for the appropriate piston.
 - b. Use Tooling (A) in order to compress valve spring (3) and open the valve slightly.

Note: Do not compress the spring so that the valve spring retainer (2) touches the valve stem seal.

- c. Carefully rotate the crankshaft until the piston touches the valve.

Note: Do not use excessive force to turn the crankshaft. The use of force can result in bent valve stems.

- d. Continue to rotate the crankshaft and gradually release the pressure on Tooling (A) until the piston is at the top center position. The valve is now held in a position that allows the valve spring to be safely removed.

NOTICE

Ensure that the valve spring is compressed squarely or damage to the valve stem may occur.

2. Use tool (A) in order to compress valve spring (3). Remove valve keepers (1).

Note: For four cylinder engines, if all valve springs require replacement the procedure can be carried out on two cylinders at the same time. The procedure can be carried out on the following pairs of cylinders. 1 with 4 and 2 with 3. Ensure that all of the valve springs are installed before changing from one pair of cylinders to another pair of cylinders.

NOTICE

Do not turn the crankshaft while the valve springs are removed.

3. Apply sufficient pressure to Tooling (A) in order to allow removal of the valve keepers (1).

Note: Do not compress the spring so that the valve spring retainer (2) touches the valve stem seal.

Remove valve keepers (1).

4. Slowly release the pressure on Tooling (A).
5. Remove valve spring retainer (2) and remove valve spring (3).
6. Remove Tooling (A) and (B).

Installation Procedure

Table 4

Required Tools			
Tool	Part Number	Part Description	Qty
A	21825739	Valve Spring Compressor	1
B ⁽¹⁾	-	Adapter	1
B ⁽²⁾	27610235	Adapter	1
B ⁽³⁾	21825934	Adapter	1

(1) 402D-05 and 403D-07 engines

(2) 403D-11 and 404D-15 engines

(3) 403D-15, 403D-15T, 403D-17, 404D-22, 404D-22T and 404D-22TA engines

NOTICE

Keep all parts clean from contaminants.

Contaminants may cause rapid wear and shortened component life.

NOTICE

Do not turn the crankshaft while the valve springs are removed.

NOTICE

Plug the apertures for the push rods in the cylinder head in order to prevent the entry of loose parts into the engine.

NOTICE

Install suitable plugs to the inlet ports of the cylinder head in order to prevent the entry of loose parts into the engine.

1. Inspect the valve springs for the correct length. Refer to Specifications, "Cylinder Head Valves".

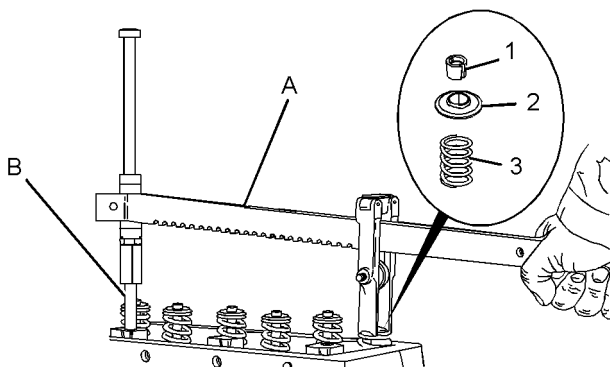

Illustration 28

g01304583

Typical example

2. Install valve spring (3) onto the cylinder head. Position valve spring retainer (2) onto valve spring (3).

WARNING

Improper assembly of parts that are spring loaded can cause bodily injury.

To prevent possible injury, follow the established assembly procedure and wear protective equipment.

NOTICE

Ensure that the valve spring is compressed squarely or damage to the valve stem may occur.

3. Install Tooling (A) and (B) in the appropriate position on the cylinder head in order to compress the valve spring.

4. Apply sufficient pressure to Tooling (A) in order to install valve keepers (1).

Note: Do not compress the spring so that valve spring retainer (2) touches the valve stem seal.

Install the valve spring keepers.

5. Carefully release the pressure on Tooling (A).

Note: Ensure that the valve keepers are correctly seated.

WARNING

The valve spring keepers can be thrown from the valve when the valve spring compressor is released. Ensure that the valve spring keepers are properly installed on the valve stem. To help prevent personal injury, keep away from the front of the valve spring keepers and valve springs during the installation of the valves.

6. Remove Tooling (A). Ensure that all of the valves are secured in place by a valve spring and valve keepers. Rotate the crankshaft through about 45 degrees in order to clear the piston from the valve. Lightly strike the top of the valve with a soft hammer in order to ensure that the valve keepers are properly installed.

End By:

- a. Install the rocker shaft assembly. Refer to Disassembly and Assembly, "Rocker Shaft and Pushrod - Install".

i02959973

Inlet and Exhaust Valves - Remove and Install

Removal Procedure

Table 5

Required Tools			
Tool	Part Number	Part Description	Qty
A	21825663	Valve Spring Compressor	1

Start By:

- a. Remove the cylinder head. Refer to Disassembly and Assembly, "Cylinder Head - Remove".

NOTICE

Keep all parts clean from contaminants.

Contaminants may cause rapid wear and shortened component life.

Note: The removal procedure is identical for the two cylinder, the three cylinder and the four cylinder engines. The Illustrations show a four cylinder engine.

1. Clean the bottom face of the cylinder head.
Check the depth of the valves below the face of the cylinder head before the valve springs are removed. Refer to Specifications, "Cylinder Head Valves" for the correct dimensions.
2. Place a temporary identification mark on the heads of the valves in order to identify the correct position.

Note: Do not stamp the heads of the valves. Stamping or punching the heads of the valves could cause the valves to fracture.

WARNING

Personal injury can result from being struck by parts propelled by a released spring force.

Make sure to wear all necessary protective equipment.

Follow the recommended procedure and use all recommended tooling to release the spring force.

NOTICE

Ensure that the valve spring is compressed squarely or damage to the valve stem may occur.

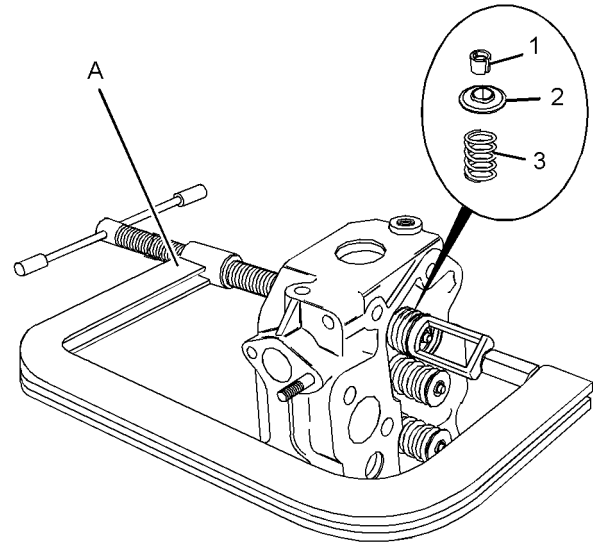

Illustration 29

g01315963

Typical example

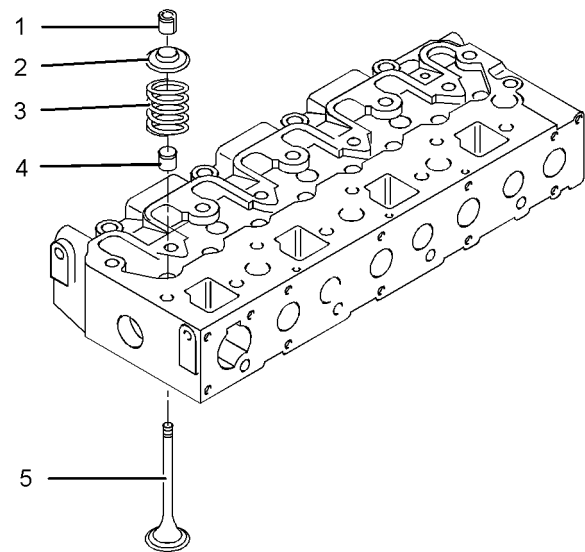

Illustration 30

g01325840

Typical example

3. Use Tooling (A) in order to compress the appropriate valve spring (3). Remove valve keepers (1).

Note: Do not compress the valve spring so that valve spring retainer (2) touches valve stem seal (4).

4. Remove Tooling (A).

5. Remove valve spring retainer (2). Remove valve spring (3).
6. Remove valve (5).
7. Remove valve stem seal (4).
8. Repeat Steps 3 to 7 for the remaining valves.

Installation Procedure

Table 6

Required Tools			
Tool	Part Number	Part Description	Qty
A	21825663	Valve Spring Compressor	1
B ⁽¹⁾	21825622	Valve Stem Seal Replacer	1
B ⁽²⁾	21825623	Valve Stem Seal Replacer	1

⁽¹⁾ 402D-05 and 403D-07 engines

⁽²⁾ 403D-11, 403D-15, 403D-15T, 403D-17, 404D-15, 404D-22, 404D-22T and 404D-22TA engines

NOTICE

Keep all parts clean from contaminants.

Contaminants may cause rapid wear and shortened component life.

Note: The installation procedure is identical for the two cylinder, the three cylinder and the four cylinder engines. The Illustrations show a four cylinder engine.

1. Clean all components of the cylinder head assembly. Ensure that all ports, all coolant passages and all lubrication passages in the cylinder head are free from debris. Follow Steps 1.a through 1.e in order to inspect the components of the cylinder head assembly. Replace any components that are worn or damaged.
 - a. Inspect the cylinder head for wear and for damage. Refer to Systems Operation, Testing and Adjusting, "Cylinder Head Inspect".
 - b. Inspect the valve seats for wear and for damage. Refer to Specifications, "Cylinder Head Valves" for further information.
 - c. Inspect the valve guides for wear and for damage. Refer to Specifications, "Cylinder Head Valves" and Systems Operation, Testing and Adjusting, "Valve Guide - Inspect" for further information.
 - d. Inspect the valves for wear and for damage. Refer to Specifications, "Cylinder Head Valves".
 - e. Inspect the valve springs for the correct length. Refer to Specifications, "Cylinder Head Valves".

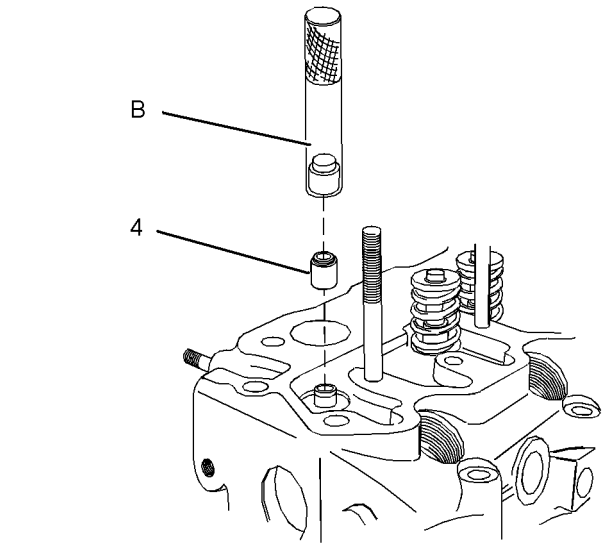

Illustration 31

g01315893

Typical example

2. Use Tooling (B) to install new valve stem seals (4) onto each of the valve guides.

Note: The outer face of the valve guides must be clean and dry before installing the valve stem seals.

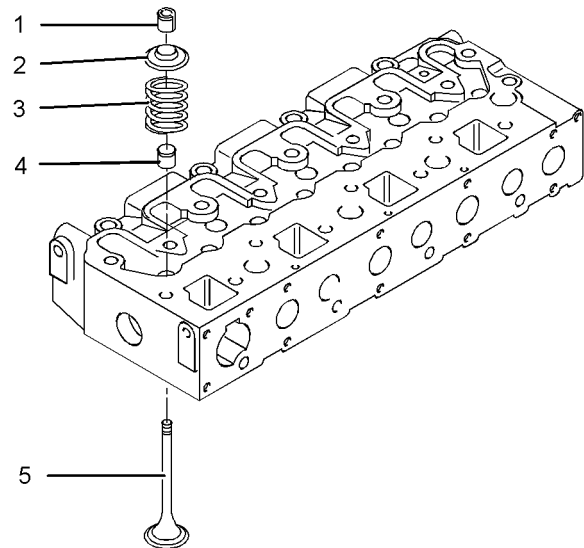

Illustration 32

g01325840

Typical example

3. Lubricate the stem of valve (5) with clean engine oil. Install valve (5) in the appropriate position in the cylinder head. Check the depth of the valve below the face of the cylinder head. Refer to Systems Operation, Testing and Adjusting, "Valve Depth - Inspect" for more information.

4. Install valve spring (3) to the cylinder head.
Position valve spring retainer (2) onto valve spring (3).

⚠ WARNING

Personal injury can result from being struck by parts propelled by a released spring force.

Make sure to wear all necessary protective equipment.

Follow the recommended procedure and use all recommended tooling to release the spring force.

NOTICE

Ensure that the valve spring is compressed squarely or damage to the valve stem may occur.

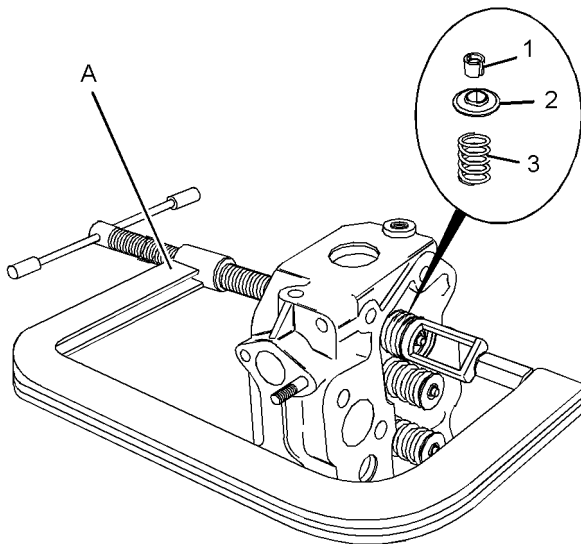

Illustration 33
Typical example

g01315963

5. Use Tooling (A) in order to compress valve spring (3). Install valve keepers (1).

Note: Do not compress the spring so that valve spring retainer (2) touches valve stem seal (4).

⚠ WARNING

The valve spring keepers can be thrown from the valve when the valve spring compressor is released. Ensure that the valve spring keepers are properly installed on the valve stem. To help prevent personal injury, keep away from the front of the valve spring keepers and valve springs during the installation of the valves.

6. Remove Tooling (A).
7. Repeat Steps 4 to 6 for the remaining valves.
8. Place the cylinder head on a suitable support. Ensure that the heads of the valves are not obstructed. Gently strike the top of the valves with a soft hammer in order to ensure that valve keepers (1) are properly installed.

End By:

- a. Install the cylinder head. Refer to Disassembly and Assembly, "Cylinder Head - Install".

i02959976

Engine Oil Line - Remove and Install

Removal Procedure

NOTICE

Keep all parts clean from contaminants.

Contaminants may cause rapid wear and shortened component life.

NOTICE

Care must be taken to ensure that fluids are contained during performance of inspection, maintenance, testing, adjusting and repair of the product. Be prepared to collect the fluid with suitable containers before opening any compartment or disassembling any component containing fluids.

Dispose of all fluids according to local regulations and mandates.

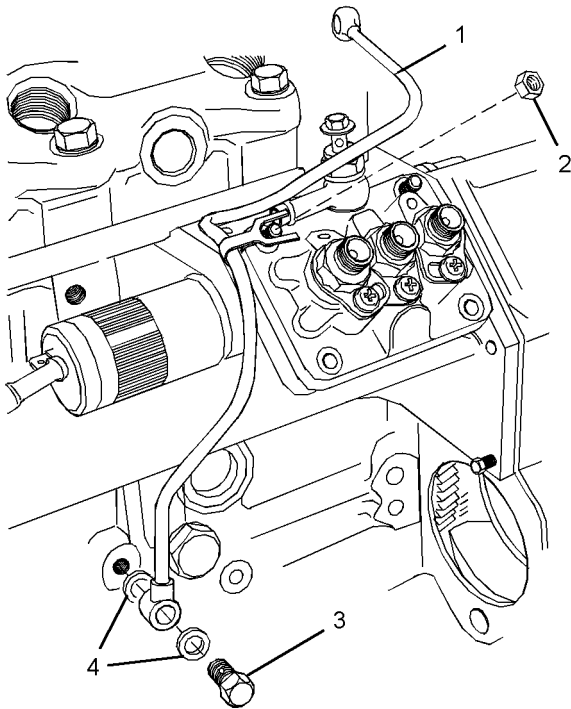

Illustration 34
Typical example

g01304820

1. Loosen nut (2) that attaches the clip on oil line (1) to the fuel injection pump.
2. Remove banjo bolt (3) and remove washers (4) from the cylinder block.

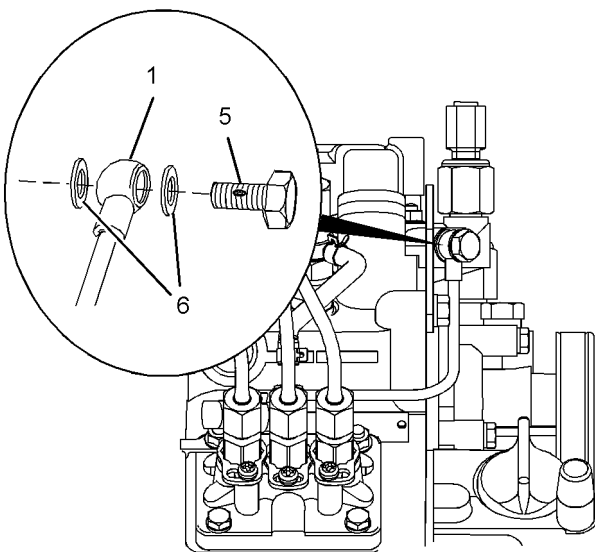

Illustration 35
Typical example

g01307372

3. Remove banjo bolt (5) and remove washers (6) from the cylinder head.

4. Remove oil line (1) from the engine.

Installation Procedure

NOTICE

Keep all parts clean from contaminants.

Contaminants may cause rapid wear and shortened component life.

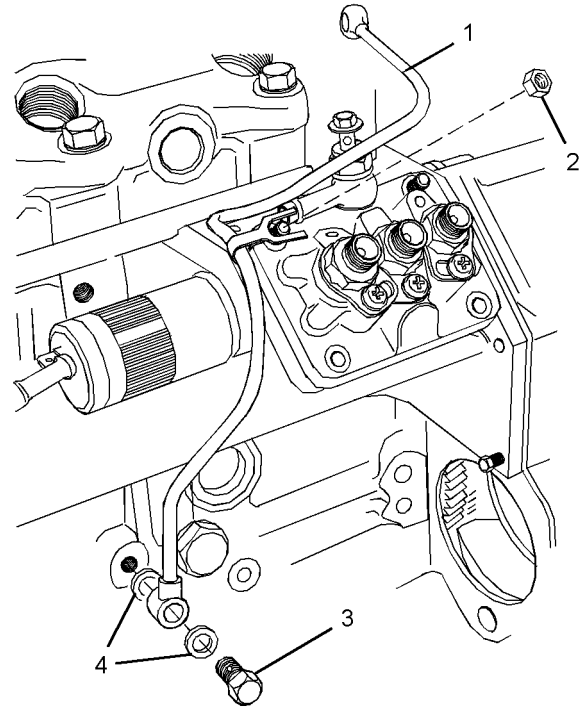

Illustration 36
Typical example

g01304820

1. Place oil line (1) on the engine. Ensure that the clip on the oil line is located below nut (2).
2. Position banjo bolt (3) and new washers (4) onto oil line (1). Install the banjo bolt and oil line to the cylinder block finger tight.

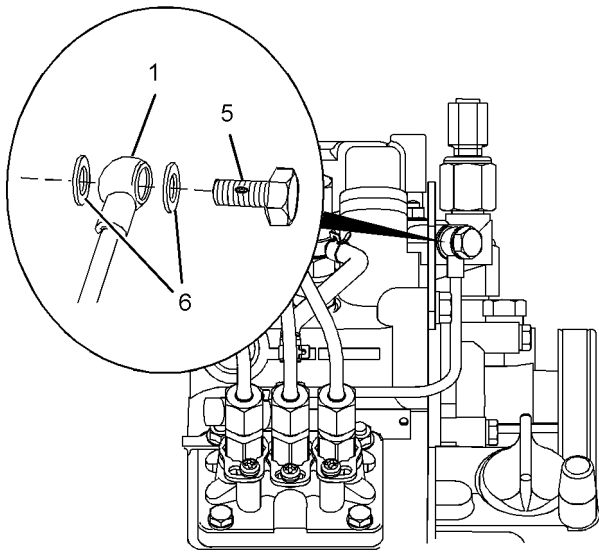

Illustration 37
Typical example g01307372

3. Position banjo bolt (5) and new washers (6) onto oil line (1). Install the banjo bolt and the oil line to the cylinder head finger tight.
4. Tighten nut (2) that attaches the clip on oil line (1) to the fuel injection pump.

For 402D-05, 403D-07, 403D-11 and 404D-15 engines, tighten nut (2) to a torque of 6 N·m (53 lb in).

For 403D-15, 403D-15T, 403D-17, 404D-22, 404D-22T and 404D-22TA engines, tighten nut (2) to a torque of 15 N·m (133 lb in).

5. Tighten banjo bolts (3) and (5) to a torque of 12 N·m (106 lb in).

i02645673

Engine Oil Cooler - Remove and Install

Removal Procedure

Table 7

Required Tools			
Tool	Part Number	Part Description	Qty
A	-	Strap Wrench	1

NOTICE

Care must be taken to ensure that fluids are contained during performance of inspection, maintenance, testing, adjusting and repair of the product. Be prepared to collect the fluid with suitable containers before opening any compartment or disassembling any component containing fluids.

Dispose of all fluids according to local regulations and mandates.

NOTICE

Keep all parts clean from contaminants.

Contaminants may cause rapid wear and shortened component life.

1. Drain the coolant from the cooling system into a suitable container. Refer to Operation and Maintenance Manual, "Cooling System Coolant - Drain" for the correct procedure.
2. Drain the engine lubricating oil into a suitable container. Refer to Operation and Maintenance Manual, "Engine Oil and Filter - Change" for the correct procedure.

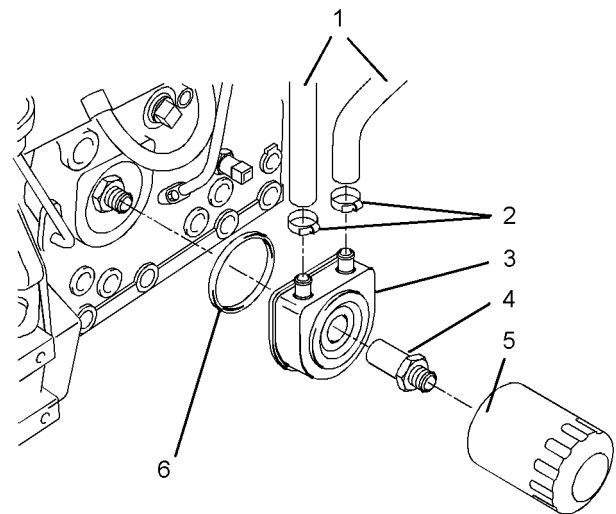

Illustration 38
Typical example g01304837

3. Use Tooling (A) to remove oil filter element (5).
4. Loosen hose clamps (2) and disconnect hoses (1). Note the positions of the coolant inlet and the coolant outlet for installation.
5. Remove adapter (4) and remove oil cooler (3) from the cylinder block.

i02645679

Note: Make a temporary mark in order to show the orientation of the oil cooler for installation.

- Remove O-ring seal (6) from oil cooler (3).

Installation Procedure

NOTICE

Keep all parts clean from contaminants.

Contaminants may cause rapid wear and shortened component life.

- Ensure that the oil cooler is clean and free from damage. Clean the mating surfaces of the cylinder block.

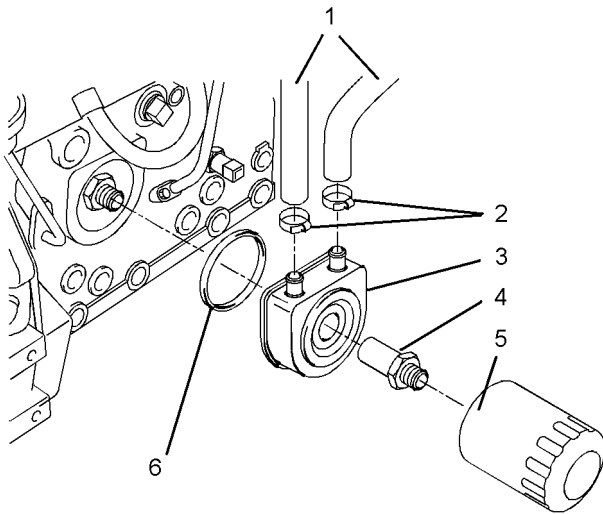

Illustration 39

g01304837

Typical example

- Install a new O-ring seal (6) to oil cooler (3). Position oil cooler (3) on the cylinder block and install adapter (4). Tighten adapter (4) to a torque of 34 N·m (25 lb ft).

Note: Ensure that the oil cooler is correctly oriented.

- Connect hoses (1) to the coolant inlet and the coolant outlet on oil cooler (3). Tighten hose clamps (2).
- Install a new oil filter element (5).
- Fill the cooling system to the correct level. Refer to Operation and Maintenance Manual, "Cooling System Coolant - Fill" for the correct procedure.
- Fill the engine oil pan to the correct level. Refer to Operation and Maintenance Manual, "Engine Oil Filter - Change" for the correct procedure.

Engine Oil Relief Valve - Remove and Install

Removal Procedure

NOTICE

Keep all parts clean from contaminants.

Contaminants may cause rapid wear and shortened component life.

NOTICE

Care must be taken to ensure that fluids are contained during performance of inspection, maintenance, testing, adjusting and repair of the product. Be prepared to collect the fluid with suitable containers before opening any compartment or disassembling any component containing fluids.

Dispose of all fluids according to local regulations and mandates.

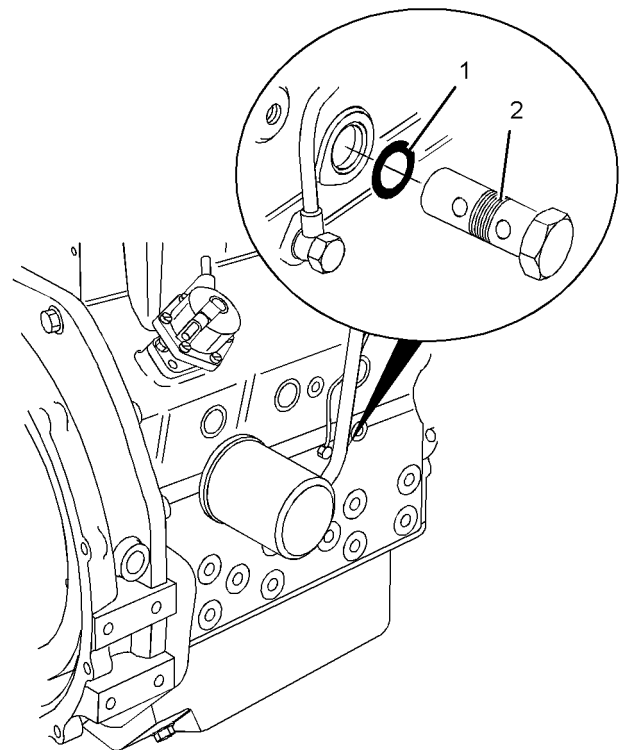

Illustration 40

g01316066

Typical example

- Remove engine oil relief valve (2) from the cylinder block.
- Remove O-ring seal (1) from engine oil relief valve (2).

Installation Procedure

NOTICE

Keep all parts clean from contaminants.

Contaminants may cause rapid wear and shortened component life.

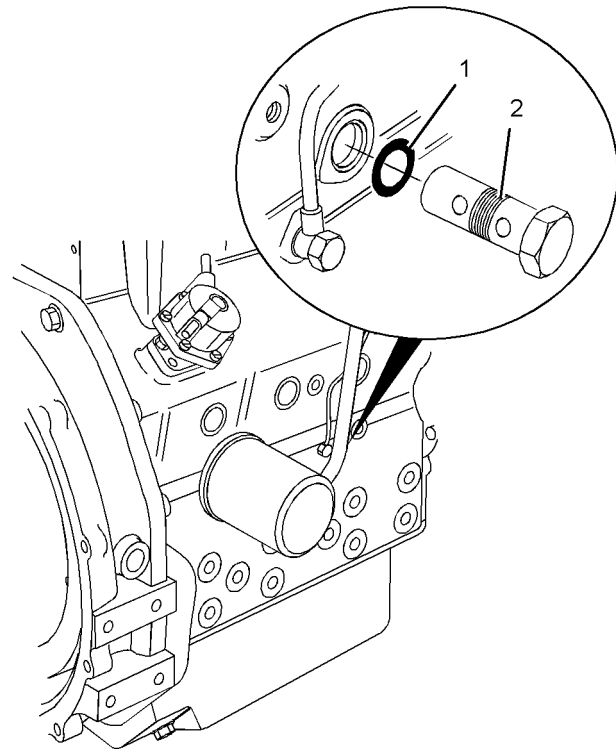

Illustration 41

g01316066

Typical example

1. Install a new O-ring seal (1) to engine oil relief valve (2).
2. Lubricate engine oil relief valve (2) with clean engine oil.
3. Install engine oil relief valve (2) into the cylinder block. Tighten the engine oil relief valve to a torque of 64 N·m (47 lb ft).

Engine Oil Pump - Remove

i02645678

Removal Procedure

Start By:

- a. Remove the front housing. Refer to Disassembly and Assembly, "Housing (Front) - Remove".

NOTICE

Care must be taken to ensure that fluids are contained during performance of inspection, maintenance, testing, adjusting and repair of the product. Be prepared to collect the fluid with suitable containers before opening any compartment or disassembling any component containing fluids.

Dispose of all fluids according to local regulations and mandates.

NOTICE

Keep all parts clean from contaminants.

Contaminants may cause rapid wear and shortened component life.

NOTICE

If the front housing is not installed, do not turn the crankshaft. Damage to the engine may occur.

Engine Oil Pump

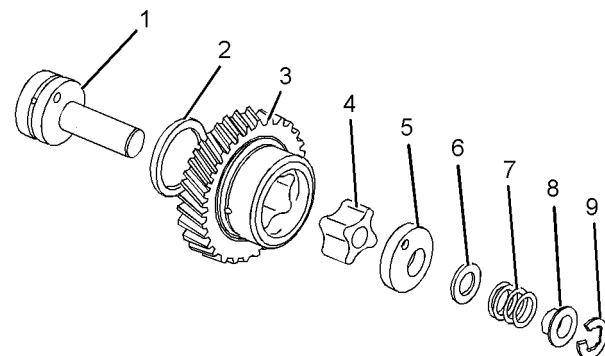

Illustration 42

g01304840

⚠ WARNING

Personal injury can result from being struck by parts propelled by a released spring force.

Make sure to wear all necessary protective equipment.

Follow the recommended procedure and use all recommended tooling to release the spring force.

1. Remove C-clip (9) that retains idler gear (3) on idler hub (1).
2. Remove the following items from idler hub (1):
 - Collar (8)
 - Spring (7)
 - Shim (6)
 - Oil pump cover (5)
3. Remove idler gear (3) from idler hub (1).
4. Remove inner rotor (4) from idler hub (1).
5. Remove thrust washer (2) from idler hub (1).
6. In order to remove the suction pipe, follow Steps 6.a through 6.d .

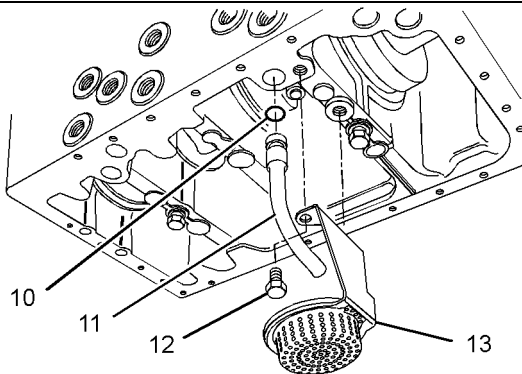

Illustration 43

g01327023

- a. Remove the engine oil pan. Refer to Disassembly and Assembly, "Engine Oil Pan - Remove and Install".
- b. Remove bolts (12) and oil strainer (13) from the cylinder block. Inspect the oil strainer for damage. If the oil strainer is damaged, use a new part for replacement.
- c. Remove suction pipe (11) from the cylinder block.
- d. Remove O-ring seal (10) from the suction pipe.

Idler Hub

Illustration 44

g01320621

Typical example

1. Remove camshaft (16). Refer to Disassembly and Assembly, "Camshaft - Remove".
2. Remove bolts (17) and plate (14) from the cylinder block. Remove joint (15).
3. Remove crankshaft (18). Refer to Disassembly and Assembly, "Crankshaft - Remove".

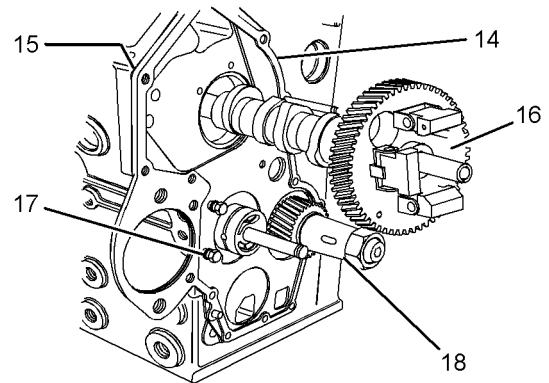
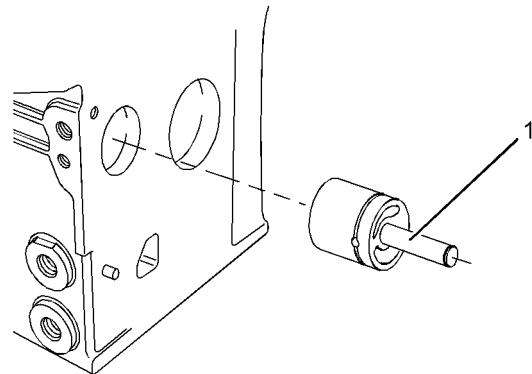

Illustration 45

g01311490

Typical example

4. Use a hammer and use a suitable drift to remove idler hub (1) from the cylinder block. Align the drift to the rear face of the hub and drive the hub from the inside of the cylinder block outward.

i02960005

Engine Oil Pump - Install

Installation Procedure

Table 8

Required Tools			
Tool	Part Number	Part Description	Qty
A ⁽¹⁾	21825624	Alignment Tool	1
A ⁽²⁾	21825625	Alignment Tool	1
A ⁽³⁾	27610324	Alignment Tool	1
B	-	Multipurpose Grease	1

(1) 402D-05 and 403D-07 engines

(2) 403D-11 and 404D-15 engines

(3) 403D-15, 403D-15T, 403D-17, 404D-22, 404D-22T and 404D-22TA engines

NOTICE

Keep all parts clean from contaminants.

Contaminants may cause rapid wear and shortened component life.

NOTICE

If the front housing is not installed, do not turn the crankshaft. Damage to the engine may occur.

Idler Hub

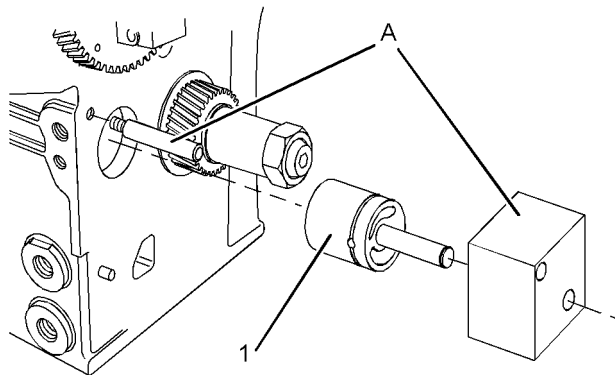

Illustration 46

g01305803

Typical example

1. Install the pin of Tooling (A) to the cylinder block.
2. Install idler hub (1) into the guide plate of Tooling (A). Align the guide plate of Tooling (A) with pin of Tooling (A).

3. Use a hammer in order to strike the guide plate of Tooling (A). Drive idler hub (1) into the cylinder block until the guide plate contacts the front of the cylinder block.

4. Remove Tooling (A).

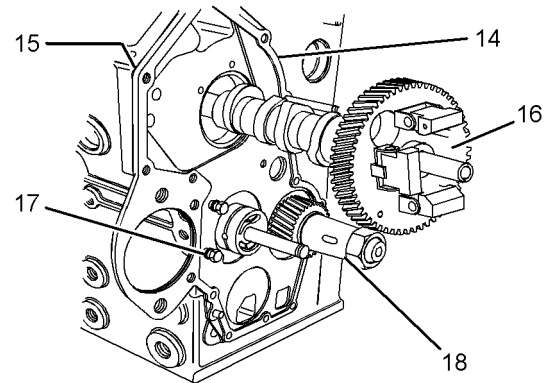

Illustration 47

g01320621

5. Install crankshaft (18). Refer to Disassembly and Assembly, "Crankshaft - Install".
6. Position a new joint (15) on the cylinder block. Align plate (14) with the dowels in the cylinder block and install the plate. Install bolts (17) and tighten to a torque of 10 N·m (89 lb in).
7. Install camshaft (18). Refer to Disassembly and Assembly, "Camshaft - Install".

Engine Oil Pump

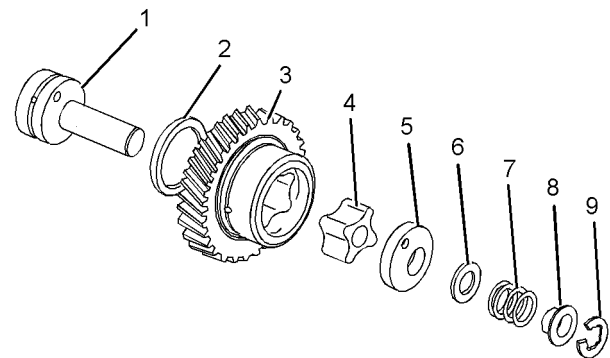

Illustration 48

g01304840

Typical example

1. Install thrust washer (2). Lubricate the thrust washer with clean engine oil.

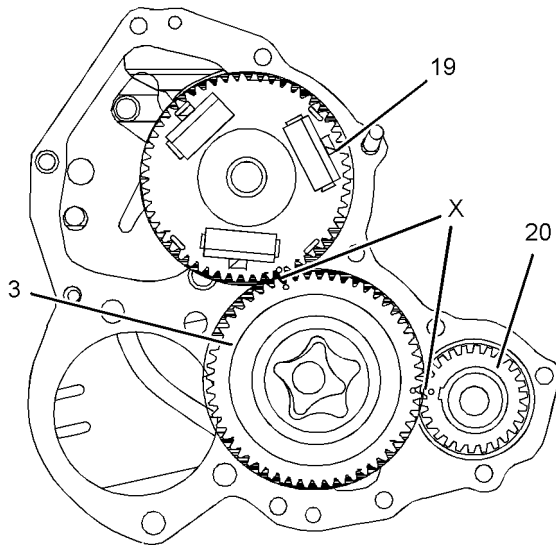

Illustration 49

g01305805

Typical example

⚠ WARNING

Improper assembly of parts that are spring loaded can cause bodily injury.

To prevent possible injury, follow the established assembly procedure and wear protective equipment.

2. Apply Tooling (B) to the faces of inner rotor (4) and to the vanes of idler gear (3).
3. Align timing marks (X) on idler gear (3) with the respective timing marks on gears (19) and (20). Install idler gear (3) onto idler hub (1).
4. Install inner rotor (4) to idler gear (3).

⚠ WARNING

Personal injury can result from the release of the spring force.

The drive shaft, the piston, and the drive gear are under spring force.

Use a press to slowly release the spring force before the components are removed.

5. Install the following items to idler hub (1):

- Oil pump cover (5)
- Shim (6)
- Spring (7)

- Collar (8)

Refer to Illustration 48.

6. Install retaining ring (9) on idler hub (1).

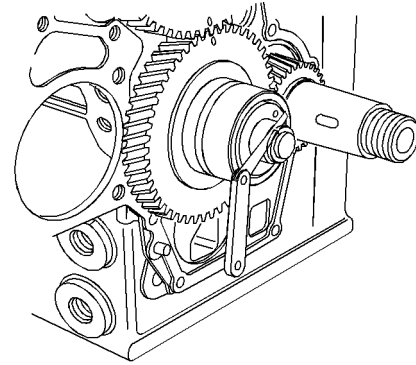

Illustration 50

g01320625

Checking end play by using a feeler gauge

7. Use a feeler gauge in order to measure the end play of the engine oil pump. Refer to Specifications, "Engine Oil Pump".
8. If the oil strainer was removed, follow Steps 8.a through 8.c in order to install the oil strainer.

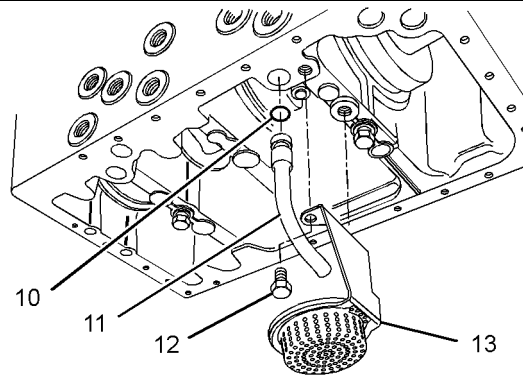

Illustration 51

g01327023

- a. Install a new O-ring seal (10) on oil tube assembly (11).
- b. Install oil suction pipe (11) in the cylinder block.
- c. Install oil strainer (13) to the cylinder block and tighten bolts (12) to a torque of 11 N·m (97 lb in).

End By:

- a. Install the front housing. Refer to Disassembly and Assembly, "Housing (Front) - Install".
- b. Install the engine oil pan. Refer to Disassembly and Assembly, "Engine Oil Pan - Remove and Install".

i02960013

Water Pump - Remove and Install (403D-11, 403D-15, 403D-15T, 403D-17, 404D-15, 404D-22, 404D-22T and 404D-22TA Engines)

Removal Procedure

Start By:

- a. Remove the fan. Refer to Disassembly and Assembly, "Fan - Remove and Install".
- b. Remove the alternator. Refer to Disassembly and Assembly, "Alternator - Remove and Install".

NOTICE

Keep all parts clean from contaminants.

Contaminants may cause rapid wear and shortened component life.

NOTICE

Care must be taken to ensure that fluids are contained during performance of inspection, maintenance, testing, adjusting and repair of the product. Be prepared to collect the fluid with suitable containers before opening any compartment or disassembling any component containing fluids.

Dispose of all fluids according to local regulations and mandates.

1. Drain the coolant from the cooling system into a suitable container for storage or disposal. Refer to Operation and Maintenance Manual, "Cooling System Coolant - Drain" for more information.
2. Loosen the hose clamp and disconnect the hose (not shown) from the water pump inlet.

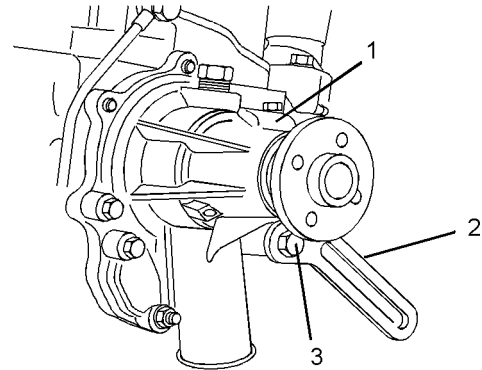

Illustration 52
Typical example

g01304930

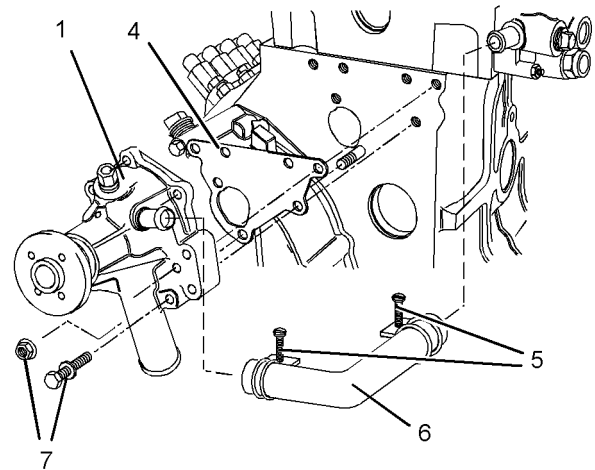

Illustration 53
Typical example

g01305206

3. Loosen hose clamps (5) and remove hose (6) from water pump (1).
4. Remove bolt (3) and alternator bracket (2) from water pump (1).

Note: The alternator bracket on some engines is secured by two bolts.

5. Remove fasteners (7) and remove water pump (1).

Note: If necessary, gently tap the water pump with a soft faced hammer in order to loosen the water pump.

6. Remove joint (4) from the cylinder block.

Installation Procedure

NOTICE

Keep all parts clean from contaminants.

Contaminants may cause rapid wear and shortened component life.

1. Ensure that the mating surfaces of the water pump and the cylinder block are clean and free from damage.

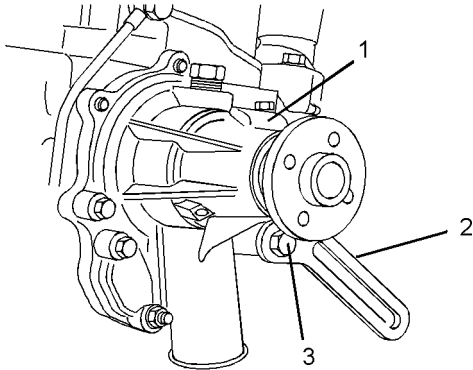

Illustration 54
Typical example

g01304930

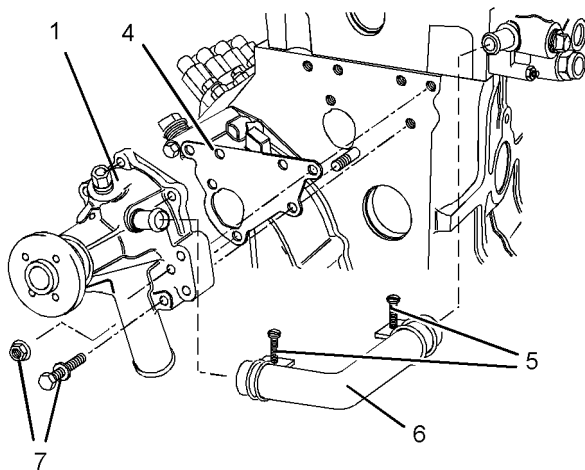

Illustration 55
Typical example

g01305206

2. Install a new joint (4) to the cylinder block.
3. Place water pump (1) in position and install fasteners (7) finger tight.
4. Position alternator bracket (2) on the water pump. Install bolt (3) finger tight.

Note: The alternator bracket on some engines is secured by two bolts.

5. For engines that have an alternator bracket that is secured by one bolt, tighten fasteners (7) to a torque of 10 N·m (89 lb in).

For engines that have an alternator bracket that is secured by two bolts, tighten fasteners (3) and (7) to a torque of 10 N·m (89 lb in).

6. Connect the hose (not shown) to the water pump inlet and tighten the hose clamp. Install hose (6) on the water pump and tighten hose clamps (5).
7. Fill the cooling system with coolant. Refer to Operation and Maintenance Manual, "Cooling System Coolant - Fill" for the correct procedure.

End By:

- a. Install the alternator. Refer to Disassembly and Assembly, "Alternator - Remove and Install".
- b. Install the fan. Refer to Disassembly and Assembly, "Fan - Remove and Install".

i02645778

Water Pump - Remove and Install (402D-05 and 403D-07 Engines)

Removal Procedure

Start By:

- a. Remove the fan. Refer to Disassembly and Assembly, "Fan - Remove and Install".
- b. Remove the alternator. Refer to Disassembly and Assembly, "Alternator - Remove and Install".

NOTICE

Keep all parts clean from contaminants.

Contaminants may cause rapid wear and shortened component life.

NOTICE

Care must be taken to ensure that fluids are contained during performance of inspection, maintenance, testing, adjusting and repair of the product. Be prepared to collect the fluid with suitable containers before opening any compartment or disassembling any component containing fluids.

Dispose of all fluids according to local regulations and mandates.

1. Drain the coolant from the cooling system into a suitable container for storage or disposal. Refer to Operation and Maintenance Manual, "Cooling System Coolant - Drain" for more information.
2. Loosen the hose clamp and disconnect the hose (not shown) from the water pump inlet.

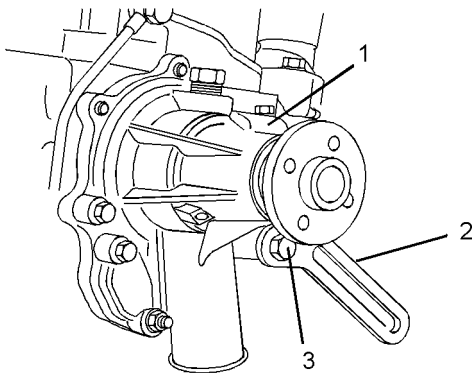

Illustration 56
Typical example

g01304930

3. Remove bolt (3) and remove adjusting link (2) for the alternator from water pump (1).

Note: On some engines, the adjusting link for the alternator is secured by two bolts.

4. Remove fasteners (7) and remove water pump (1).

Note: If necessary, gently tap the water pump with a soft faced hammer in order to loosen the water pump.

5. Remove joint (6) from the cylinder head.

If the water pump has a spacer, remove spacer (5), and remove joint (4).

Installation Procedure

NOTICE

Keep all parts clean from contaminants.

Contaminants may cause rapid wear and shortened component life.

1. Ensure that the mating surfaces of the water pump and the cylinder block are clean and free from damage. If the water pump has a spacer, ensure that the mating surfaces of the spacer are clean and free from damage.

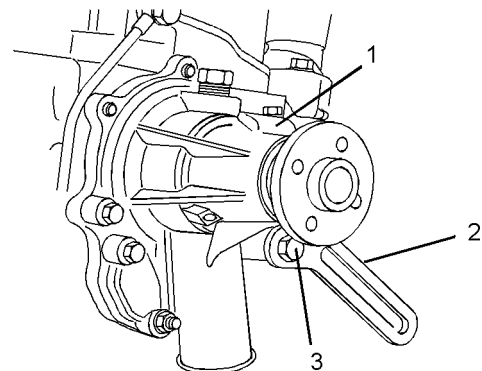

Illustration 58
Typical example

g01304930

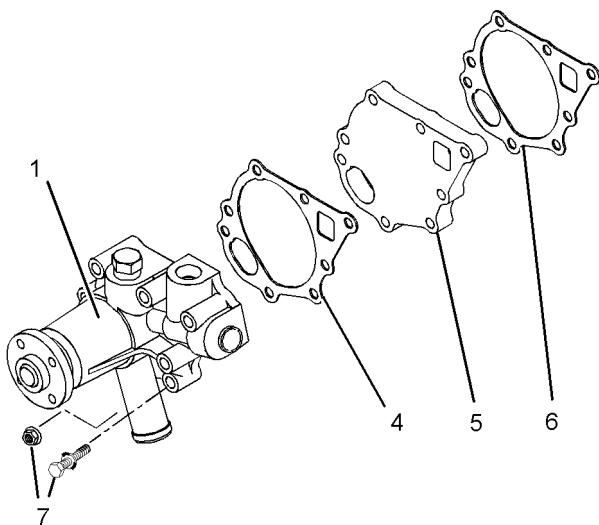

Illustration 57
Typical example

g01308309

i02645789

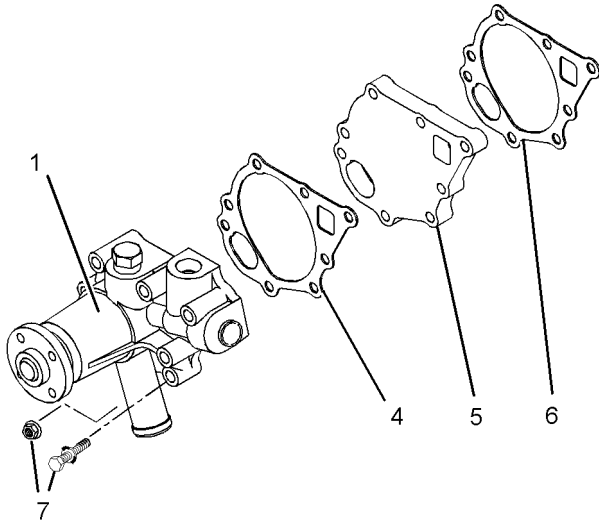

Illustration 59

g01308309

Typical example

2. Install a new joint (6) to the cylinder head.
If the water pump has a spacer, install spacer (5) and install a new joint (4) to the cylinder head.
 3. Place water pump (1) in position and install fasteners (7). Tighten the fasteners finger tight.
 4. Position adjusting link (2) for the alternator on the water pump. Install bolt (3) finger tight.
- Note:** On some engines, the adjusting link for the alternator is secured by two bolts.
5. If the adjusting link for the alternator is secured by one bolt, tighten fasteners (7) to a torque of 10 N·m (89 lb in).
If the adjusting link for the alternator is secured by two bolts, tighten fasteners (3) and (7) to a torque of 10 N·m (89 lb in).
 6. Connect the hose (not shown) to the water pump inlet and tighten the hose clamp.
 7. Fill the cooling system with coolant. Refer to Operation and Maintenance Manual, "Cooling System Coolant - Fill" for the correct procedure.

End By:

- a. Install the alternator. Refer to Disassembly and Assembly, "Alternator - Remove and Install".
- b. Install the fan. Refer to Disassembly and Assembly, "Fan - Remove and Install".

Water Temperature Regulator Housing - Remove and Install

Removal Procedure

NOTICE

Keep all parts clean from contaminants.

Contaminants may cause rapid wear and shortened component life.

NOTICE

Care must be taken to ensure that fluids are contained during performance of inspection, maintenance, testing, adjusting and repair of the product. Be prepared to collect the fluid with suitable containers before opening any compartment or disassembling any component containing fluids.

Dispose of all fluids according to local regulations and mandates.

1. Drain the coolant from the cooling system into a suitable container for storage or disposal. Refer to Operation and Maintenance Manual, "Cooling System Coolant - Drain" for more information.

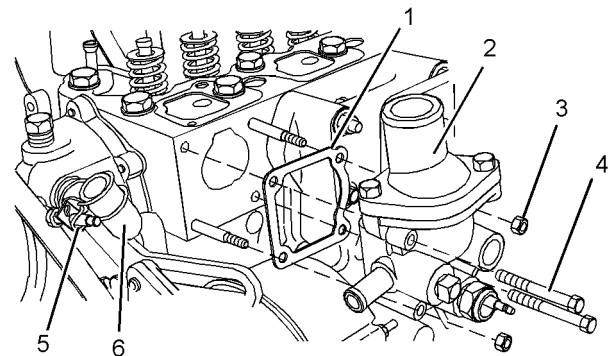

Illustration 60

g01307377

Typical example

2. Loosen hose clamps (5) and disconnect hose (6) from water temperature regulator housing (2).
3. Remove bolts (4) and nuts (3).
4. Remove water temperature regulator housing (2) from the cylinder head.
5. Remove joint (1) from the cylinder head.

6. If necessary, remove the water temperature regulator. Refer to Disassembly and Assembly , “Water Temperature Regulator - Remove and Install”.

i02645783

Water Temperature Regulator - Remove and Install (402D-05 and 404D-07 Engines)

Installation Procedure

NOTICE

Keep all parts clean from contaminants.

Contaminants may cause rapid wear and shortened component life.

1. Ensure that the mating surfaces of the cylinder head and the water temperature regulator housing are clean and free from damage.

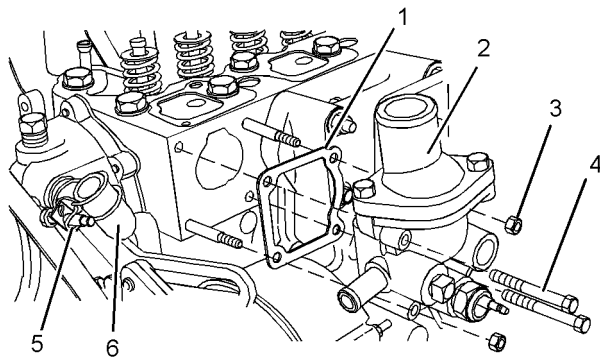

Illustration 61
Typical example

g01307377

2. Install a new joint (1) to the cylinder head.
3. Install water temperature regulator housing (2) to the cylinder head.
4. Install bolts (4) and nuts (3). Tighten the fasteners to a torque of 10 N·m (89 lb in).
5. Connect hose (6) to water temperature regulator housing (2). Tighten hose clamps (5).
6. If necessary, install the water temperature regulator. Refer to Disassembly and Assembly , “Water Temperature Regulator - Remove and Install”.
7. Fill the cooling system with coolant. Refer to Operation and Maintenance Manual, “Cooling System Coolant - Fill” for the correct procedure.

Removal Procedure

NOTICE

Keep all parts clean from contaminants.

Contaminants may cause rapid wear and shortened component life.

NOTICE

Care must be taken to ensure that fluids are contained during performance of inspection, maintenance, testing, adjusting and repair of the product. Be prepared to collect the fluid with suitable containers before opening any compartment or disassembling any component containing fluids.

Dispose of all fluids according to local regulations and mandates.

1. Drain the coolant from the cooling system into a suitable container for storage or disposal. Refer to Operation and Maintenance Manual, “Cooling System Coolant - Drain” for more information.

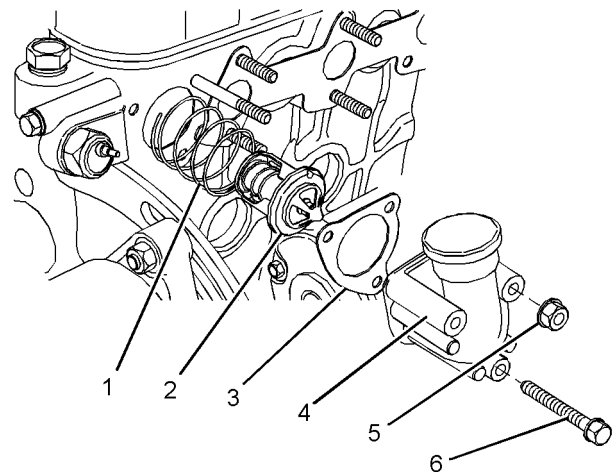

Illustration 62
Typical example

g01327025

⚠ WARNING

Personal injury can result from parts and/or covers under spring pressure.

Spring force will be released when covers are removed.

Be prepared to hold spring loaded covers as the bolts are loosened.

2. Remove bolts (6) and nuts (5).
3. Remove outlet connection (4).
4. Remove joint (3).
5. Remove water temperature regulator (2) and spring (1).

Installation Procedure**NOTICE**

Keep all parts clean from contaminants.

Contaminants may cause rapid wear and shortened component life.

1. Inspect the water temperature regulator for wear, damage and correct operation. Refer to Systems Operation, Testing and Adjusting, "Water Temperature Regulator - Test" for more information. If necessary, replace the water temperature regulator.
2. Ensure that the mating surfaces of the outlet connection and the cylinder head are clean and free from damage.

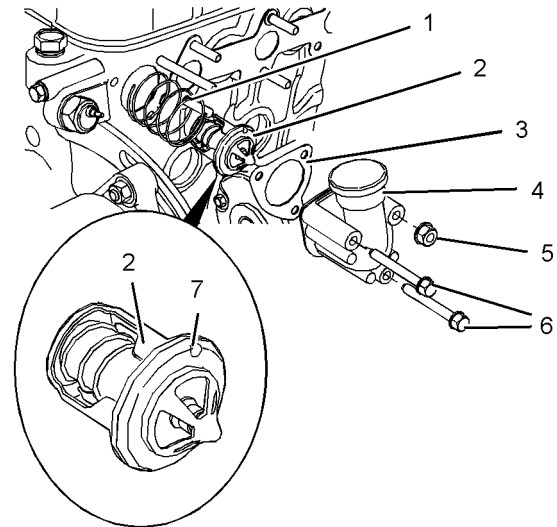

Illustration 63

g01326174

Typical example

⚠ WARNING

Personal injury can result from parts and/or covers under spring pressure.

Spring force will be released when covers are removed.

Be prepared to hold spring loaded covers as the bolts are loosened.

3. Install spring (1) and water temperature regulator (2) to the cylinder head. Ensure that jiggle pin (7) on water temperature regulator (2) is in the vertically upward position.
4. Install a new joint (3) to the cylinder head.
5. Position outlet connection (4) onto the cylinder head. Install nut (5) and bolts (6) to outlet connection (4). Tighten the fasteners to a torque of 8 N·m (71 lb in).
6. Fill the cooling system with coolant to the correct level. Refer to Operation and Maintenance Manual, "Cooling System Coolant - Fill" for more information.

i02960059

Water Temperature Regulator - Remove and Install (403D-11, 403D-15, 403D-15T, 403D-17, 404D-15, 404D-22, 404D-22T and 404D-22TA Engines)

Removal Procedure

NOTICE

Keep all parts clean from contaminants.

Contaminants may cause rapid wear and shortened component life.

NOTICE

Care must be taken to ensure that fluids are contained during performance of inspection, maintenance, testing, adjusting and repair of the product. Be prepared to collect the fluid with suitable containers before opening any compartment or disassembling any component containing fluids.

Dispose of all fluids according to local regulations and mandates.

1. Drain the coolant from the cooling system into a suitable container for storage or disposal. Refer to Operation and Maintenance Manual, "Cooling System Coolant - Drain" for more information.

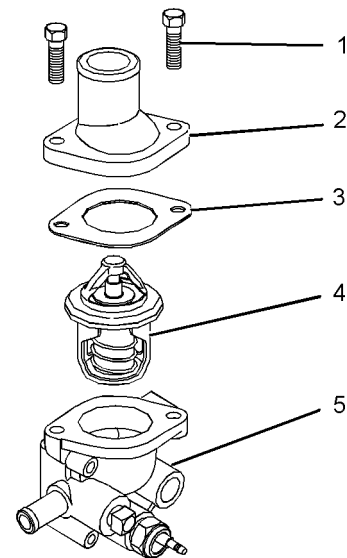

Illustration 64

g01327027

Typical example

2. Remove fasteners (1).
3. Remove outlet connection (2).

Note: Identify the orientation of the outlet connection for installation.

4. Remove joint (3).
5. Remove water temperature regulator (4) from water temperature regulator housing (5).

Installation Procedure

NOTICE

Keep all parts clean from contaminants.

Contaminants may cause rapid wear and shortened component life.

1. Inspect the water temperature regulator for wear, damage and correct operation. Refer to Systems Operation, Testing and Adjusting, "Water Temperature Regulator - Test" for more information. If necessary, replace the water temperature regulator.
2. Ensure that the mating surfaces of the outlet connection and the water temperature regulator housing are clean and free from damage.

i02645699

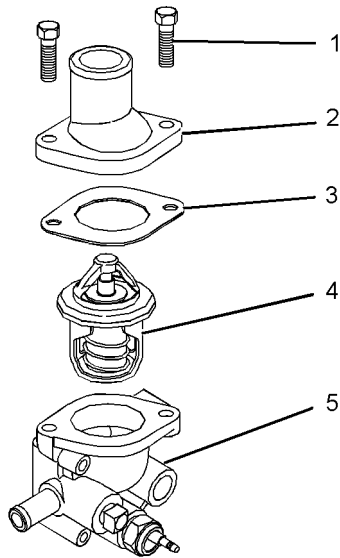

Illustration 65

g01327027

Typical example

3. Install water temperature regulator (4) to water temperature regulator housing (5). Refer to Specifications, "Water Temperature Regulator Housing for 403D-11, 403D-15, 403D-15T, 403D-17, 404D-15, 404D-22, 404D-22T and 404D-22TA Engines" for the correct orientation of the water temperature regulator.

4. Install a new joint (3).

5. Install outlet connection (2) to water temperature regulator housing (5).

Note: Ensure the correct orientation of the outlet connection.

6. Install fasteners (1).

For 403D-11 and 404D-15 engines, tighten the fasteners to a torque of 6 N·m (53 lb in).

For 403D-15, 403D-15T, 403D-17, 404D-22, 404D-22T and 404D-22TA engines, tighten the fasteners to a torque of 14 N·m (124 lb in).

7. Fill the cooling system with coolant to the correct level. Refer to Operation and Maintenance Manual, "Cooling System Coolant -Fill" for more information.

Flywheel - Remove

Removal Procedure

Table 9

Required Tools			
Tool	Part Number	Part Description	Qty
A	-	Lifting Bracket	1
B	-	Guide Stud (M10 x 1.25 mm by 80mm)	2

Start By:

- a. Remove the electric starting motor. Refer to Disassembly and Assembly, "Electric Starting Motor - Remove and Install".

NOTICE

Keep all parts clean from contaminants.

Contaminants may cause rapid wear and shortened component life.

Note: The two cylinder, the three cylinder and the four cylinder engines have different flywheels. The removal procedure is similar for all models.

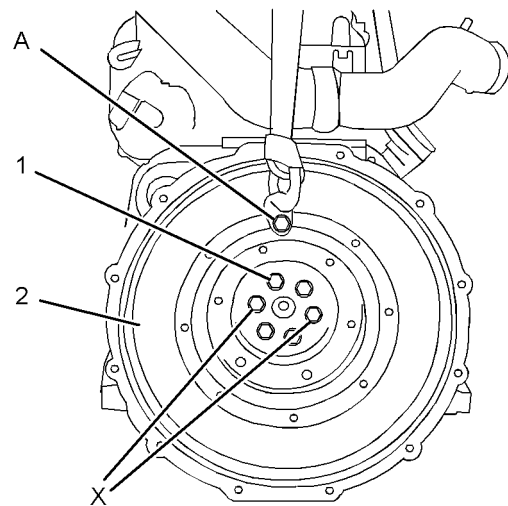

Illustration 66

g01305297

Typical example

1. Install Tooling (A) and a suitable lifting device to flywheel (2). The weight of the flywheel is approximately 42 kg (93 lb).

i02645696

2. Remove two bolts (1) from positions (X) on the flywheel.
3. Install Tooling (B) in positions (X) on the flywheel.
4. Remove the remaining bolts (1) and remove flywheel (2).

Note: On some three cylinder engines, a roll pin is located between the crankshaft and the flywheel.

5. Inspect ring gear (3) and flywheel (2) for wear or damage. If the ring gear or the flywheel is worn or damaged, use new parts for replacement.

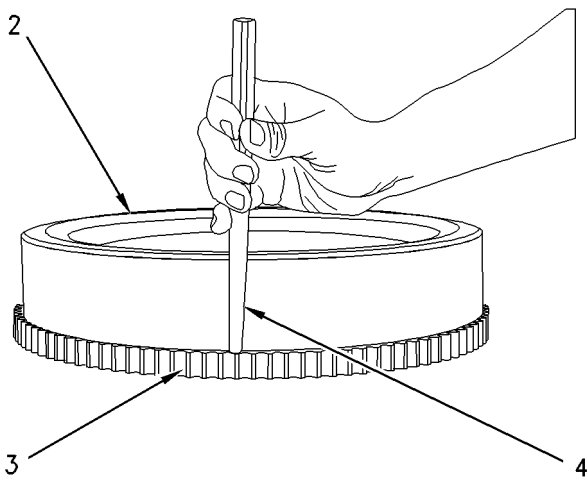

Illustration 67
Typical example
g00825639

6. To remove ring gear (3) from flywheel (2), place the flywheel on a suitable support. Use a hammer (not shown) and a punch (4) in order to remove the ring gear from the flywheel.

Flywheel - Install

Installation Procedure

Table 10

Required Tools			
Tool	Part Number	Part Description	Qty
A	-	Lifting Bracket	1
B	-	Guide Stud (M10 x 1.25 mm by 80mm)	2

NOTICE

Keep all parts clean from contaminants.

Contaminants may cause rapid wear and shortened component life.

WARNING

Always wear protective gloves when handling parts that have been heated.

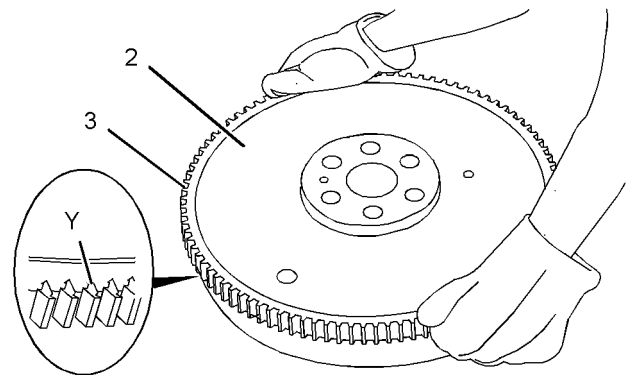

Illustration 68
Typical example
g01305341

1. If the ring gear was removed, follow Steps 1.a through 1.c in order to install ring gear (3) to flywheel (2).
 - a. Identify the orientation of the new ring gear in order to install the ring gear correctly onto the flywheel.

Note: The chamfered side of gear teeth (Y) must face toward the starting motor when the flywheel is installed. This will ensure the correct engagement of the starting motor.

- b. Heat ring gear (3) in an oven to a maximum temperature of 150°C (302°F) prior to installation.

Note: Do not use a torch to heat the ring gear.

- c. Ensure that the orientation of ring gear (3) is correct and quickly install the ring gear onto flywheel (2).

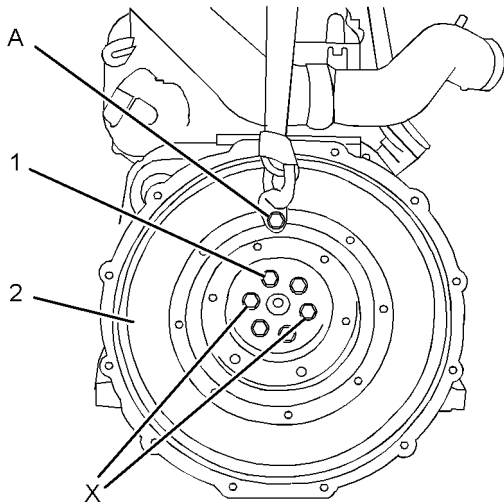

Illustration 69

g01305297

Typical example

2. Thoroughly clean the flywheel housing. Inspect the crankshaft rear seal for leaks. If there are any oil leaks replace the crankshaft rear seal. Refer to Disassembly and Assembly, "Crankshaft Rear Seal - Remove and Install".
3. Install Tooling (B) to positions (X) in the crankshaft.
4. Install Tooling (A) and a suitable lifting device to flywheel (2). The weight of the flywheel is approximately 42 kg (93 lb).
5. Position flywheel (2) onto Tooling (B).

On three cylinder engines that have a roll pin, ensure that the roll pin is installed to the crankshaft and that the roll pin is free from damage. Align the hole in the flywheel with the roll pin in the crankshaft.
6. Install bolts (1) finger tight.
7. Remove Tooling (B) and install the two remaining bolts (1).
8. Use a suitable tool to prevent flywheel (2) from rotating. Tighten bolts (1) to a torque of 74 N·m (54 lb ft).

9. Remove Tooling (A) and the lifting device from the flywheel.

End By:

- a. Install the electric starting motor. Refer to Disassembly and Assembly, "Electric Starting Motor - Remove and Install".

i02960085

Crankshaft Rear Seal - Remove and Install

Removal Procedure

Start By:

- a. Remove the flywheel. Refer to Disassembly and Assembly, "Flywheel - Remove".

NOTICE

Keep all parts clean from contaminants.

Contaminants may cause rapid wear and shortened component life.

NOTICE

Care must be taken to ensure that fluids are contained during performance of inspection, maintenance, testing, adjusting and repair of the product. Be prepared to collect the fluid with suitable containers before opening any compartment or disassembling any component containing fluids.

Dispose of all fluids according to local regulations and mandates.

Note: The two cylinder, the three cylinder and the four cylinder engines have different configurations for the flywheel housing and the back plate. The removal process is similar for all models.

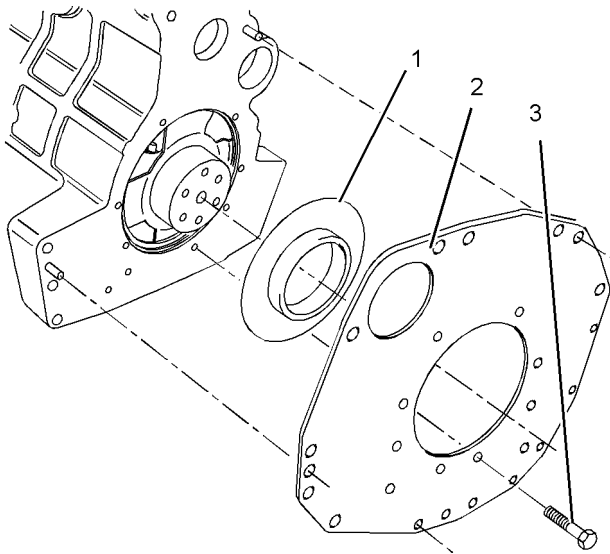

Illustration 70
Typical example

1. Remove bolts (3) and remove the flywheel housing or back plate (2) from the cylinder block. Refer to Disassembly and Assembly, "Flywheel Housing - Remove and Install" for more information.
2. Remove crankshaft rear seal (1) from the cylinder block. Discard the crankshaft oil seal.

Installation Procedure

Table 11

Required Tools			
Tool	Part Number	Part Description	Qty
A	21826038	POWERPART Silicone Adhesive	1

NOTICE

Keep all parts clean from contaminants.

Contaminants may cause rapid wear and shortened component life.

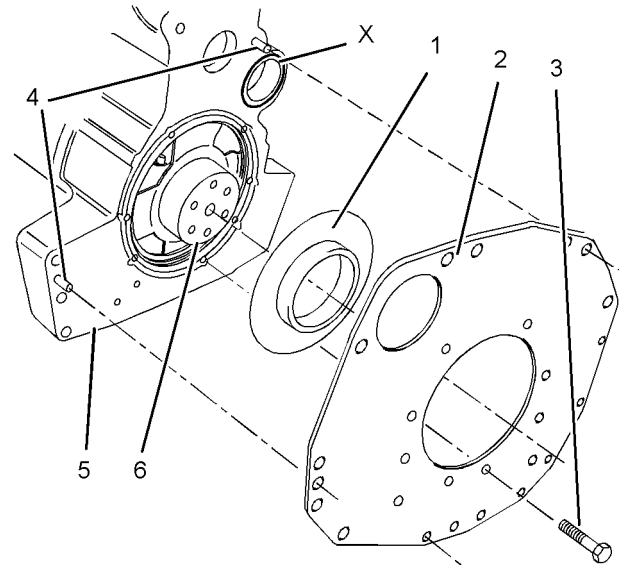

Illustration 71
Typical example

1. Ensure that the mating surface of cylinder block (5) and the flywheel housing or back plate (2) are clean and free from damage. Inspect dowels (4). If the dowels are damaged, use new parts for replacement.
2. Ensure that crankshaft flange (6) is clean and free from damage. It is possible to reclaim a crankshaft flange that has a worn seal surface, or a damaged seal surface by installing a wear sleeve. Refer to Disassembly and Assembly, "Crankshaft Wear Sleeve (Rear) - Remove and Install" for more information.
3. Apply clean engine lubricating oil to the flange of crankshaft (6) around the running surface of crankshaft rear seal.
4. Align a new crankshaft rear seal (1) with the flange of crankshaft (6). Carefully install crankshaft rear seal (1) onto the crankshaft flange.
5. Apply a continuous bead of Tooling (A) to the rear face of the cylinder block around the edge of crankshaft rear seal (1). Apply a continuous bead of Tooling (A) around plug (X).
6. Align the flywheel housing or back plate (2) to dowels (4). Install the flywheel housing or back plate (2) and install bolts (3) to cylinder block (5). Refer to Disassembly and Assembly, "Flywheel Housing - Remove and Install" for more information.
7. Tighten bolts (3).

For 402D-05 and 403D-07 engines, tighten the bolts to a torque of 15 N·m (11 lb ft).

For 403D-11 and 404D-15 engines, tighten the bolts to a torque of 50 N·m (37 lb ft).

For 403D-15, 403D-15T, 403D-17, 404D-22, 404D-22T and 404D-22TA engines, tighten the bolts to a torque of 25 N·m (19 lb ft).

End By:

- a. Install the flywheel. Refer to Disassembly and Assembly, "Flywheel - Install".

i02645791

Crankshaft Wear Sleeve (Rear) - Remove and Install

Removal Procedure

Start By:

- a. Remove the crankshaft rear seal. Refer to Disassembly and Assembly, "Crankshaft Rear Seal - Remove and Install".

NOTICE

Keep all parts clean from contaminants.

Contaminants may cause rapid wear and shortened component life.

Note: Wear sleeves are used to reclaim worn seal surfaces or damaged seal surfaces. Wear sleeves are not original equipment.

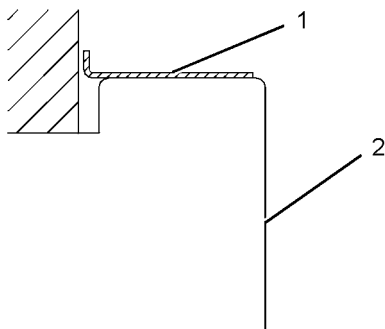

Illustration 72

g01266598

Sectional view of the crankshaft and of the wear sleeve

- 1. Use a sharp tool to score a deep line across crankshaft wear sleeve (1).

Note: Take care to avoid damaging the crankshaft.

- 2. Insert a thin blade between crankshaft wear sleeve (1) and crankshaft (2) below the scored line. The crankshaft wear sleeve will separate along the line.

- 3. Remove crankshaft wear sleeve (1) from crankshaft (2). Discard the crankshaft wear sleeve.

Installation Procedure

Table 12

Required Tools		
Tool	Part Number	Part Description
A	21820518	POWERPART Liquid Gasket

NOTICE

Keep all parts clean from contaminants.

Contaminants may cause rapid wear and shortened component life.

- 1. Ensure that the crankshaft is thoroughly clean and dry. Remove any areas of raised damage.

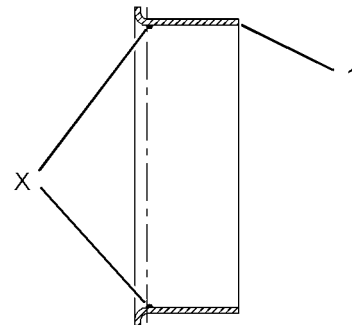

Illustration 73

g01269521

Sectional view of the wear sleeve

- 2. Apply a small continuous bead of Tooling (A) to the inner surface of crankshaft wear sleeve (1) at position X. Apply the bead of Tooling (A) 5.00 mm (0.2 inch) from the flange end of the crankshaft wear sleeve.

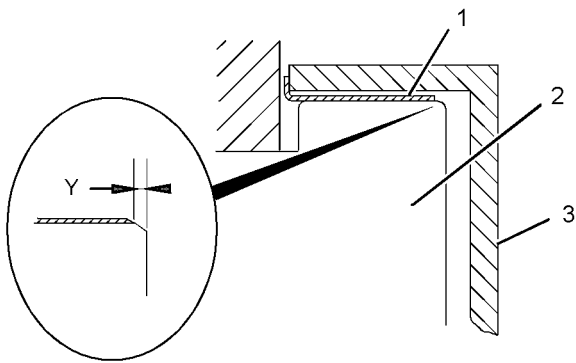

Illustration 74 g01318215
Sectional view of the crankshaft, the wear sleeve and the installation tool

3. Align crankshaft wear sleeve (1) with crankshaft (2). Position installation tool (3) that is provided with the crankshaft wear sleeve over the crankshaft. Use a hammer to drive the crankshaft wear sleeve onto the crankshaft. Ensure that dimension (Y) is 2.5 ± 0.1 mm (0.098 ± 0.004 inch).

Note: Dimension (Y) is the distance from the edge of the crankshaft wear sleeve from the rear face of the crankshaft.

4. Remove installation tool (3).
5. Ensure that the crankshaft wear sleeve has no rough edges.

End By:

- a. Install a new crankshaft rear seal. Refer to Disassembly and Assembly, "Crankshaft Rear Seal - Remove and Install".

i02960993

Flywheel Housing - Remove and Install

Removal Procedure

Start By:

- a. Remove the flywheel. Refer to Disassembly and Assembly, "Flywheel - Remove".

NOTICE

Keep all parts clean from contaminants.

Contaminants may cause rapid wear and shortened component life.

Note: The two cylinder, the three cylinder and the four cylinder engines have different flywheel housings. The removal procedure is similar for all models.

1. Support the engine.
2. Install a suitable lifting device to the flywheel housing. Support the weight of the housing. The weight of the flywheel housing is approximately 30 kg (66 lb).

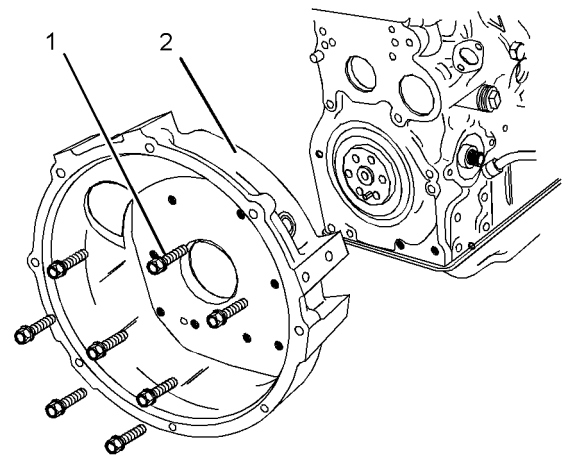

Illustration 75 g01305734
Typical example

3. Remove bolts (1) that fasten flywheel housing (2) to the cylinder block.
4. Use the lifting device to remove flywheel housing (2) from the engine.

Installation Procedure

NOTICE

Keep all parts clean from contaminants.

Contaminants may cause rapid wear and shortened component life.

i02645702

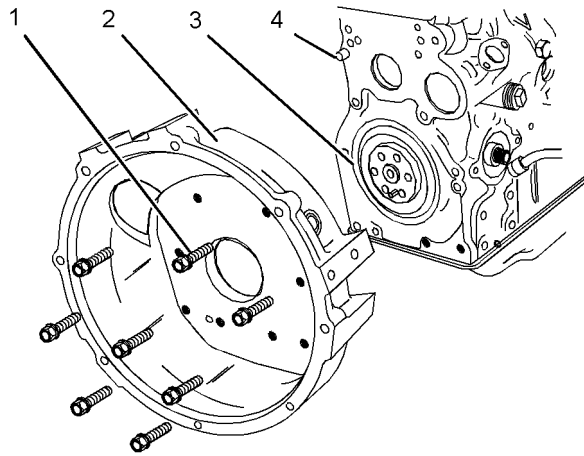

Illustration 76

g01326595

Typical example

1. Ensure that the mating surfaces of flywheel housing (2) are clean and free from damage. Inspect the crankshaft rear seal (3) for leaks. If necessary, replace the crankshaft rear seal. Refer to Disassembly and Assembly, "Crankshaft Rear Seal - Remove and Install" for the correct procedure. Inspect dowels (4) for damage. If the dowels are damaged, use new parts for replacement.
2. Use a suitable lifting device to align flywheel housing (2) to dowels (5) and install the flywheel housing. The weight of the flywheel housing is approximately 30 kg (66 lb).
3. Install bolts (1).

For 402D-05 and 403D-07 engines, tighten the bolts to a torque of 15 N·m (11 lb ft).

For 403D-11 and 404D-15 engines, tighten the bolts to a torque of 50 N·m (37 lb ft).

For 403D-15, 403D-15T and 403D-17 engines, tighten the bolts to a torque of 25 N·m (19 lb ft).
4. Remove the lifting device from the flywheel housing.

End By:

- a. Install the flywheel. Refer to Disassembly and Assembly, "Flywheel - Install".

Flywheel Housing - Remove and Install (Engines with Flywheel Housing and Back Plate)

Removal Procedure

Start By:

- a. Remove the flywheel. Refer to Disassembly and Assembly, "Flywheel - Remove".

NOTICE

Keep all parts clean from contaminants.

Contaminants may cause rapid wear and shortened component life.

1. Support the engine.
2. Install a suitable lifting device to the flywheel housing. Support the weight of the housing. The weight of the flywheel housing is approximately 30 kg (66 lb).

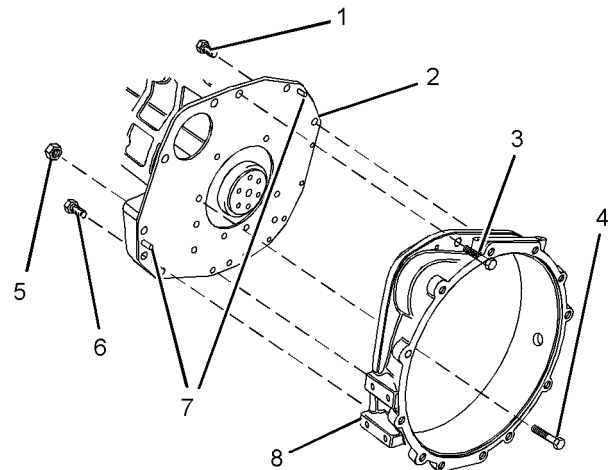

Illustration 77

g01326591

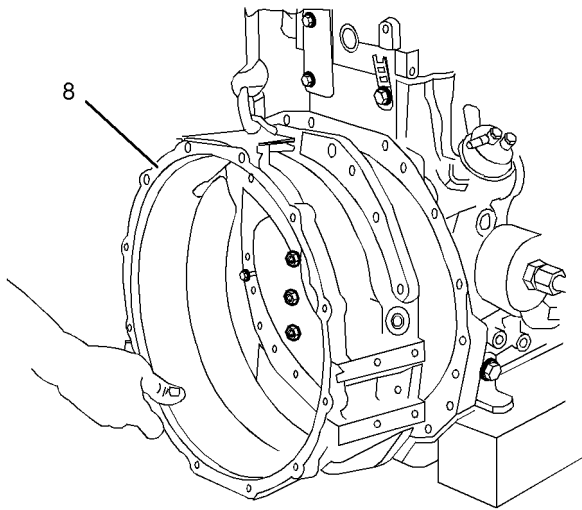

Illustration 78 g01305649
Typical example

3. Remove bolts (3) and (4) that fasten flywheel housing (8) to the cylinder block.
4. Remove bolts (6) on each side of the cylinder block. These bolts fasten flywheel housing (8) to the cylinder block.
5. Remove bolts (1) that fasten back plate (2) to flywheel housing (8).
6. Remove nuts (5) and the bolts (not shown) that fasten back plate (2) to flywheel housing (8).
7. Carefully remove flywheel housing (8) from back plate (2) and dowels (7). Use a suitable lifting device to remove the flywheel housing.

Installation Procedure

NOTICE

Keep all parts clean from contaminants.

Contaminants may cause rapid wear and shortened component life.

1. Ensure that the mating surfaces of back plate (2) and flywheel housing (8) are clean and free from damage. Inspect the crankshaft rear seal (not shown) for leaks. If necessary, replace the crankshaft rear seal. Refer to Disassembly and Assembly, "Crankshaft Rear Seal - Remove and Install" for the correct procedure. Inspect dowels (7) for damage. If the dowels are damaged, use new parts for replacement.

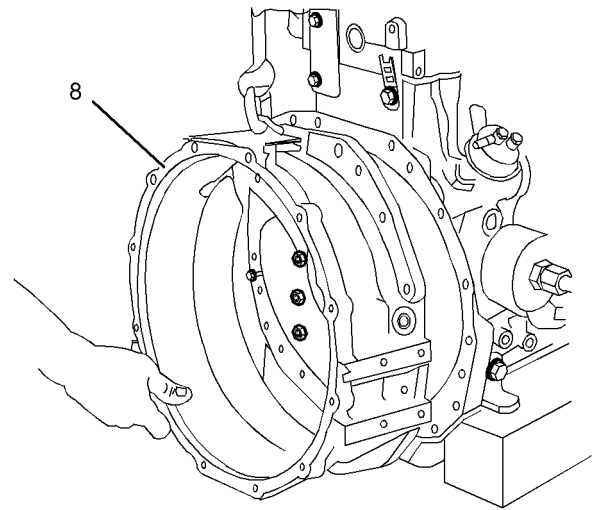

Illustration 79 g01305649

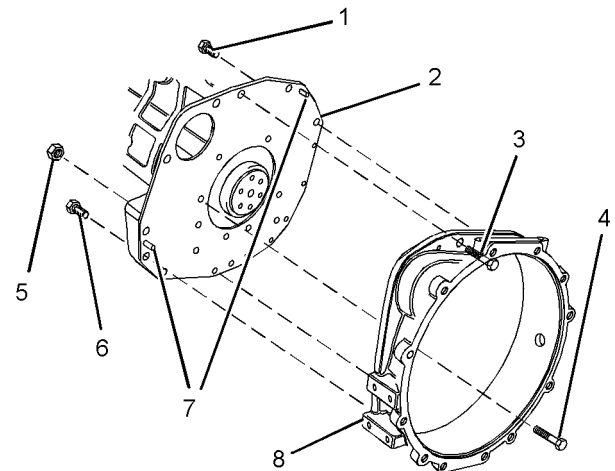

Illustration 80 g01326591
Typical example

2. Use a suitable lifting device to align flywheel housing (8) to dowels (7). The weight of the flywheel housing is approximately 30 kg (66 lb). Install the flywheel housing to the back plate.
3. Install nuts (5) and the bolts (not shown) that fasten back plate (2) to flywheel housing (8).
4. Install bolts (1) that fasten back plate (2) to flywheel housing (8).
5. Install bolts (6) on each side of the cylinder block. These bolts fasten flywheel housing (8) to the cylinder block.

6. Remove the lifting device from the flywheel housing.
7. Install bolts (3) and (4) that fasten flywheel housing (8) to the cylinder block.
8. Tighten the fasteners to a torque of 25 N·m (19 lb ft).

End By:

- a. Install the flywheel. Refer to Disassembly and Assembly, "Flywheel - Install".

i02961010

Crankshaft Pulley - Remove and Install

Removal Procedure

Start By:

- a. Remove the V-belt. Refer to Disassembly and Assembly, "V Belts Remove and Install" for more information.

Table 13

Required Tools			
Tool	Part Number	Description	Qty
A	21825619	Puller	1
	-	Bolt	3

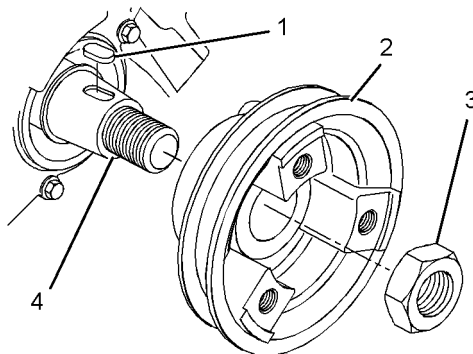

Illustration 81

g01326646

Typical example

1. Loosen nut (3).

Note: Do not remove the nut at this time.

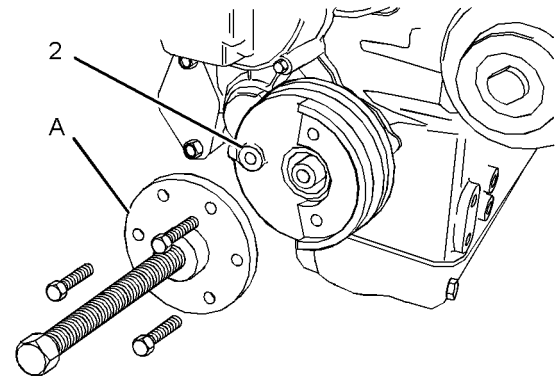

Illustration 82

g01305772

2. Install Tooling (A) to crankshaft pulley (2). Use Tooling (A) in order to remove crankshaft pulley (2) from crankshaft (4). Remove Tooling (A).
3. Remove nut (3).
4. Remove pulley (2) from crankshaft (4).
5. Remove woodruff key (1) from crankshaft (4).

Installation Procedure

1. Ensure that the following components are clean and free from damage: the taper of the crankshaft, the woodruff key, and the bore of the crankshaft pulley. Replace any components that are damaged. Ensure that the taper of the crankshaft and the bore of the crankshaft pulley are clean and dry before assembly.

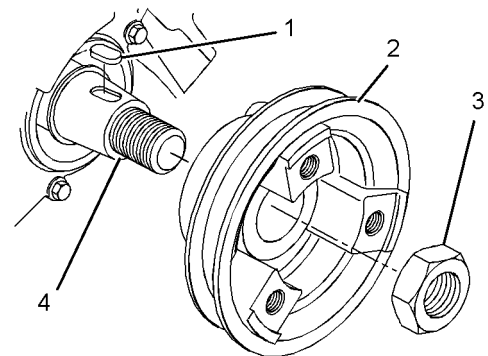

Illustration 83

g01326646

Typical example

2. Install woodruff key (1) to crankshaft (4).
3. Install crankshaft pulley (2) to crankshaft (4).
4. Lubricate nut (3) with clean engine oil and install the nut.

For 402D-05 and 403D-07 engines, tighten nut (5) to a torque of 93 N·m (69 lb ft).

For 403D-11 and 404D-15 engines, tighten nut (5) to a torque of 123 N·m (91 lb ft).

For 403D-15, 403D-15T, 403D-17, 404D-22, 404D-22T and 404D-22TA engines, tighten nut (5) to a torque of 304 N·m (224 lb ft).

End By:

- a. Install the V-belt to the engine. Refer to Disassembly and Assembly, “V Belts Remove and Install”.

i02645666

Crankshaft Front Seal - Remove and Install

Removal Procedure

Table 14

Required Tools			
Tool	Part Number	Part Description	Qty
A	27610311	Slide Hammer Puller	1

Start By:

- a. Remove the crankshaft pulley. Refer to Disassembly and Assembly, “Crankshaft Pulley - Remove and Install”.

NOTICE

Keep all parts clean from contaminants.

Contaminants may cause rapid wear and shortened component life.

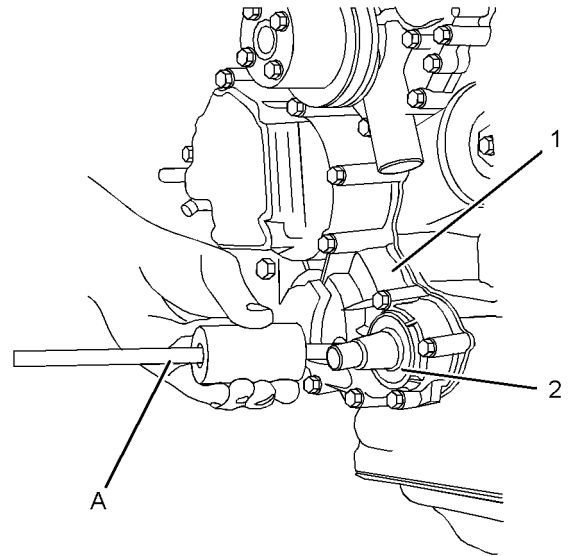

Illustration 84

g01310976

Typical example

1. Use a 4 mm (0.158 inch) drill in order to make three holes in crankshaft front seal (2).

NOTICE

Ensure that the main lip is used in order to remove the crankshaft front seal. Do not damage the edge of the housing for the crankshaft front seal.

Note: Do not damage the crankshaft during the removal process of the crankshaft front seal.

2. Use Tooling (A) to carefully remove crankshaft front seal (2). Alternate the position of Tooling (A) from one hole to another hole. This will allow you to evenly remove the crankshaft front seal from front housing (1).

Alternative Removal Procedure

Start By:

- a. Remove the crankshaft pulley. Refer to Disassembly and Assembly, “Crankshaft Pulley - Remove and Install”.
- b. Remove the front housing. Refer to Disassembly and Assembly, “Housing (Front) - Remove”.

NOTICE

Keep all parts clean from contaminants.

Contaminants may cause rapid wear and shortened component life.

i02645726

Note: This is an alternative procedure to remove the crankshaft front oil seal. This procedure may be used if the front housing has been removed from the engine.

1. Use a suitable mandrel and a press in order to remove the oil seal from the front cover. Ensure that the front cover is supported in order to prevent damage to the cover while the oil seal is being removed.

Installation Procedure

NOTICE

Keep all parts clean from contaminants.

Contaminants may cause rapid wear and shortened component life.

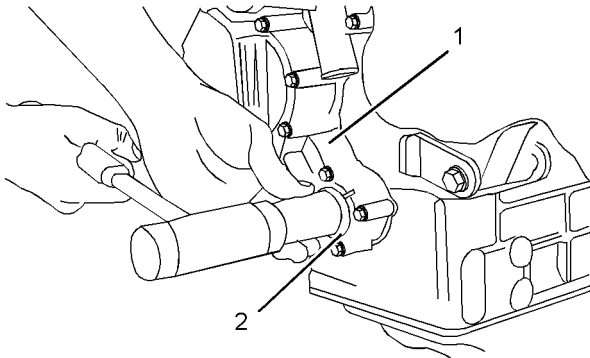

Illustration 85

g01311777

Typical example

1. Ensure that the bore in front housing (1) and the nose of the crankshaft are clean and free from damage.
2. Lubricate the lip of a new crankshaft front seal (2) with clean engine oil.
3. Position crankshaft front seal (2) in the bore of front housing (1).

NOTICE

Ensure that the lip of the crankshaft front seal that is spring loaded is facing toward the inside of the front housing and that it is square with the bore of the housing for the crankshaft front seal.

4. Use a suitable tool to install crankshaft front seal (2) to front housing (1).

End By:

- a. Install the crankshaft pulley. Refer to Disassembly and Assembly, "Crankshaft Pulley - Remove and Install".

Housing (Front) - Remove

Removal Procedure

Start By:

- a. Remove the fuel injection pump. Refer to Disassembly and Assembly, "Fuel Injection Pump - Remove".
- b. Remove the crankshaft pulley. Refer to Disassembly and Assembly, "Crankshaft Pulley - Remove and Install".

NOTICE

Keep all parts clean from contaminants.

Contaminants may cause rapid wear and shortened component life.

NOTICE

Care must be taken to ensure that fluids are contained during performance of inspection, maintenance, testing, adjusting and repair of the product. Be prepared to collect the fluid with suitable containers before opening any compartment or disassembling any component containing fluids.

Dispose of all fluids according to local regulations and mandates.

i02902054

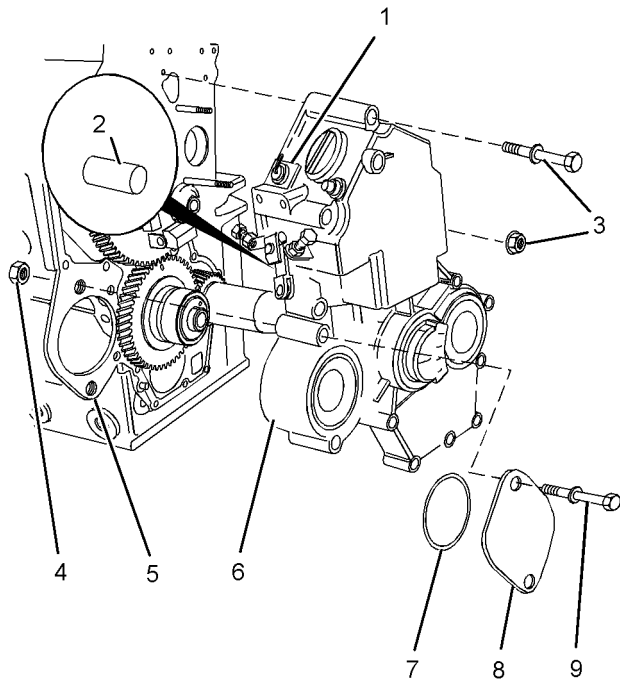

Illustration 86
Typical example

g01357158

1. If the engine is equipped with a turbocharger, disconnect the hose from connection (1).
2. Remove nuts (4) and bolts (9).
3. Remove cover (8) and O-ring seal (7).
4. Remove fasteners (3). Identify the position of the different fasteners for installation.
5. Carefully remove front housing (6) from plate (5). Ensure that pin (2) remains in the front housing.

Note: The front housing is aligned to the plate and to the cylinder block with dowels.

6. Remove the joint (not shown).

Housing (Front) - Disassemble

Disassembly Procedure

Start By:

- a. Record the governor settings. Refer to Systems Operation, Testing and Adjusting, "Governor - Adjust"
- b. Remove the engine front housing. Refer to Disassembly and Assembly, "Housing (Front) - Remove".

WARNING

Personal injury can result from being struck by parts propelled by a released spring force.

Make sure to wear all necessary protective equipment.

Follow the recommended procedure and use all recommended tooling to release the spring force.

NOTICE

Keep all parts clean from contaminants.

Contaminants may cause rapid wear and shortened component life.

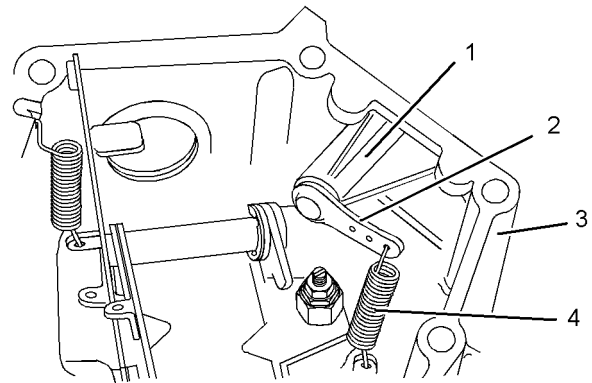

Illustration 87
Typical example

g01357675

1. Remove spring (4) from arm (2) on the assembly of throttle control (1).

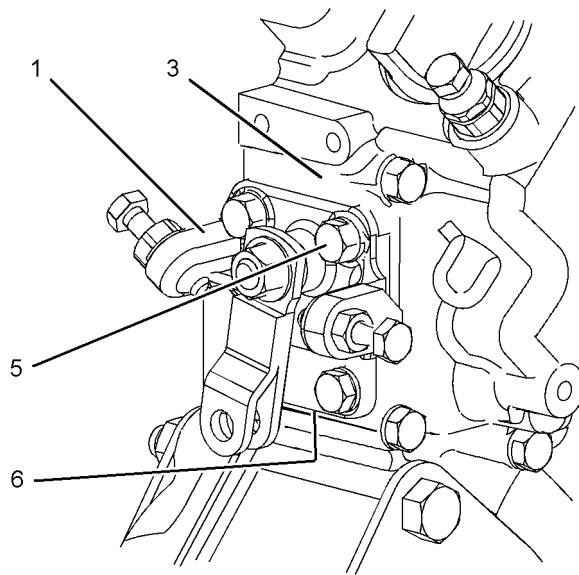

Illustration 88

g01354631

Typical example

2. Remove bolts (5) and remove the assembly of throttle control (1) from front housing (3).
3. Remove joint (6).

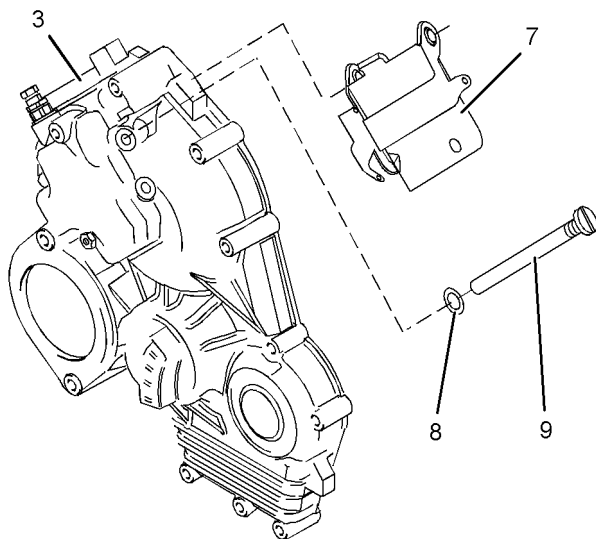

Illustration 89

g01357717

Typical example

4. Remove shaft (9) from front housing (3).
5. Remove lever assembly (7) from front housing (3).
6. Remove sealing washer (8) from shaft (9).

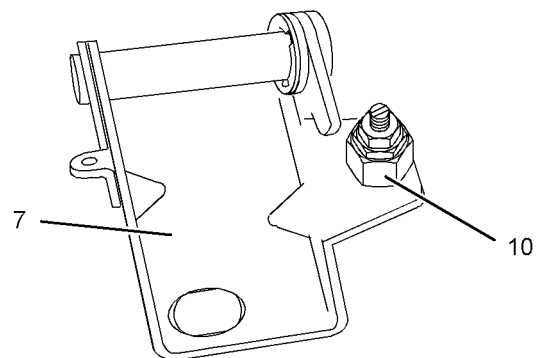

Illustration 90

g01357689

7. If the engine is equipped with an angleich unit, remove angleich unit (10) from lever assembly (7).

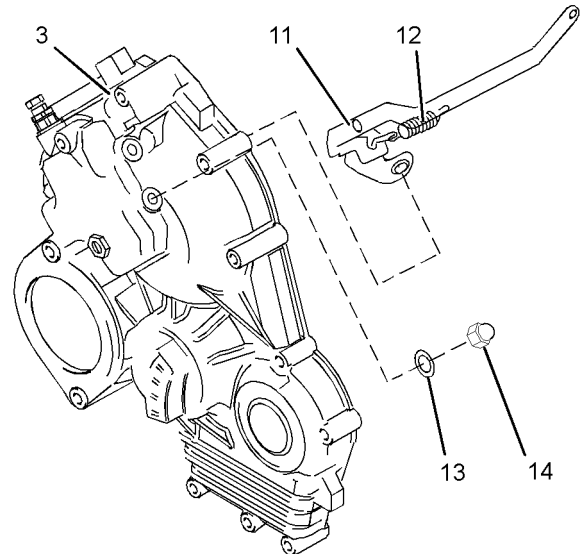

Illustration 91

g01357693

Typical example

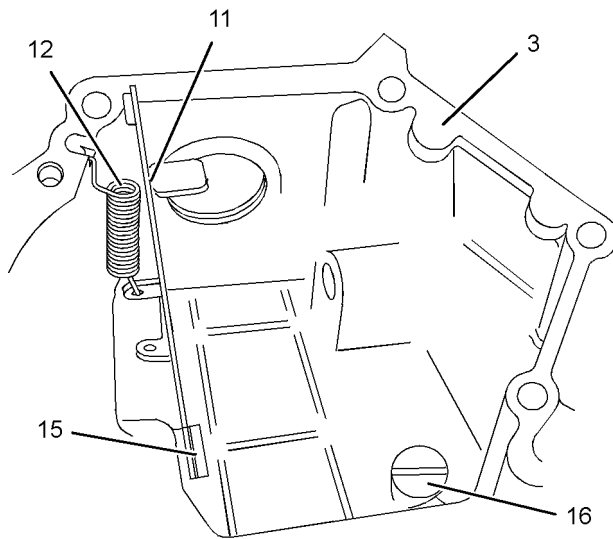

Illustration 92
Typical example g01357727

8. Disconnect spring (12) from front housing (3).
9. Remove nut (14) and remove sealing washer (13) from front housing (3).
10. Remove shaft (15) and remove lever assembly (11) from front housing (3).

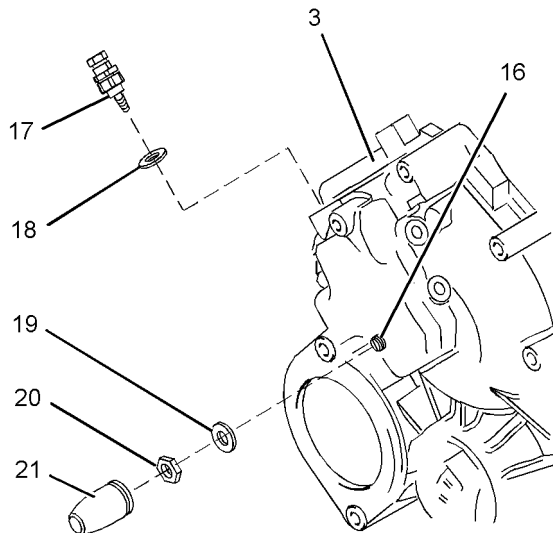

Illustration 93
Typical example g01358077

11. Remove spring assembly (17) and remove sealing washer (18) from front housing (3).

Note: The position of fuel screw (16) controls the emissions of the engine. Do not remove the fuel screw unless a different front housing will be installed. Do not adjust the fuel screw. Refer to **Systems Operation, Testing and Adjusting, "Governor"** for further information.

12. If necessary, remove cap (21), locknut (20) and sealing washer (19) from front housing (3). Remove fuel screw (16).

i02706594

Housing (Front) - Assemble

Assembly Procedure

Table 15

Required Tools			
Tool	Part Number	Part Description	Qty
A	21820117	POWERPART Thread Lock	1

⚠ WARNING

Improper assembly of parts that are spring loaded can cause bodily injury.

To prevent possible injury, follow the established assembly procedure and wear protective equipment.

NOTICE

Keep all parts clean from contaminants.

Contaminants may cause rapid wear and shortened component life.

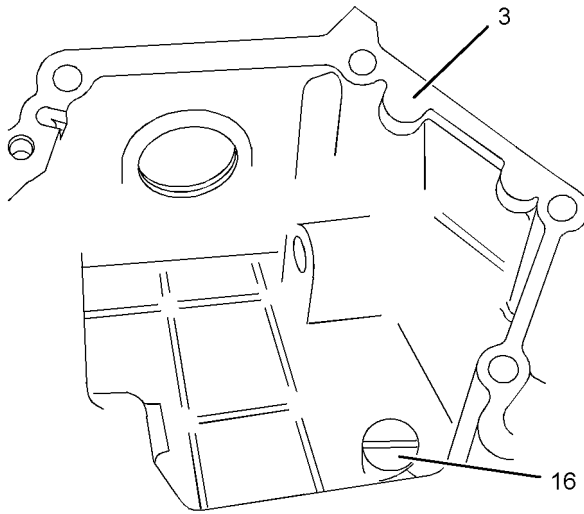

Illustration 94
Typical example
g01358537

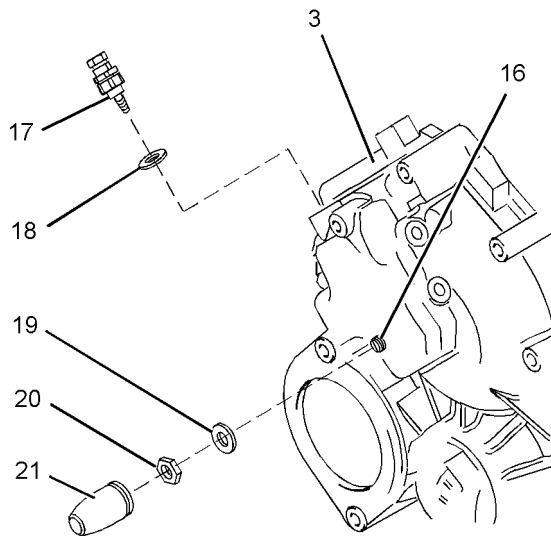

Illustration 95
Typical example
g01358077

Note: The position of stop (16) controls the emissions of the engine. Ensure correct adjustment of the stop.

1. If the original front housing has been replaced by a different item, follow Steps 1.a through 1.d.
 - a. Install stop (16) to front housing (3).
 - b. Install a new sealing washer (19) to stop (16).
 - c. Loosely install locknut (20) to stop (16). The procedure that is used to set the position of the stop is described in Systems Operation, Testing and Adjusting, "Governor".

d. Install a new emissions label to front housing (3).

2. Install a new sealing washer (18) to spring assembly (17). Loosely install spring assembly (17) to front housing (3).

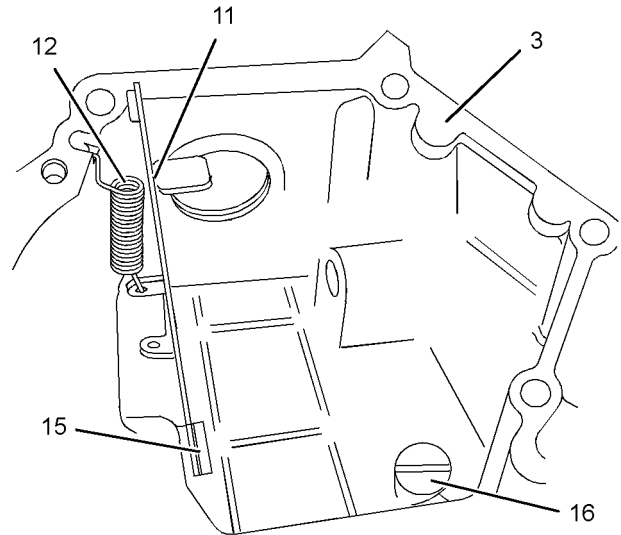

Illustration 96
Typical example
g01357727

3. Place lever assembly (11) in position in front housing (3) and install shaft (15).

Note: Ensure the correct orientation of the lever assembly.

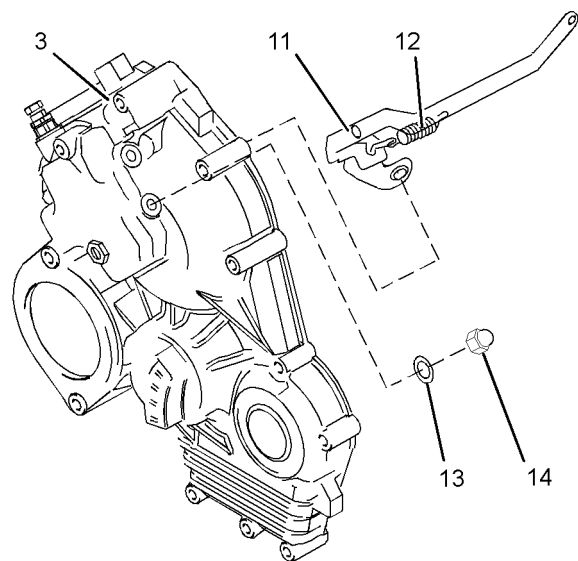

Illustration 97
Typical example
g01357693

4. Install a new sealing washer (13) and nut (14) to front housing (3). Tighten the nut to a torque of 6 N·m (53 lb in).

5. Connect spring (12) to front housing (3). Refer to Illustration 96.

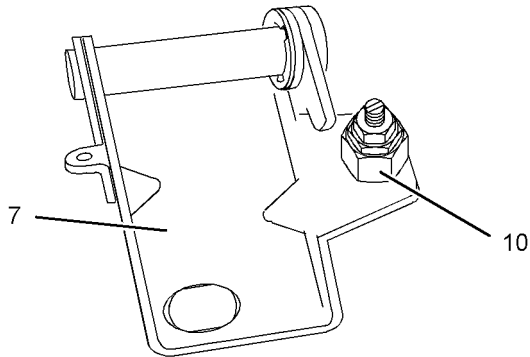

Illustration 98

g01357689

6. If the engine is equipped with an angleich unit, follow Steps 6.a and 6.b in order to install the angleich unit.
- a. Apply Tooling (A) to the first two threads of angleich unit (10).
 - b. Install angleich unit (10) to lever assembly (7). Tighten the angleich unit to a torque of 6 N·m (53 lb in).

Note: Ensure that Tooling (A) is not allowed to contaminate the plunger assembly of the angleich unit. Contamination of the plunger assembly will render the angleich unit inoperative.

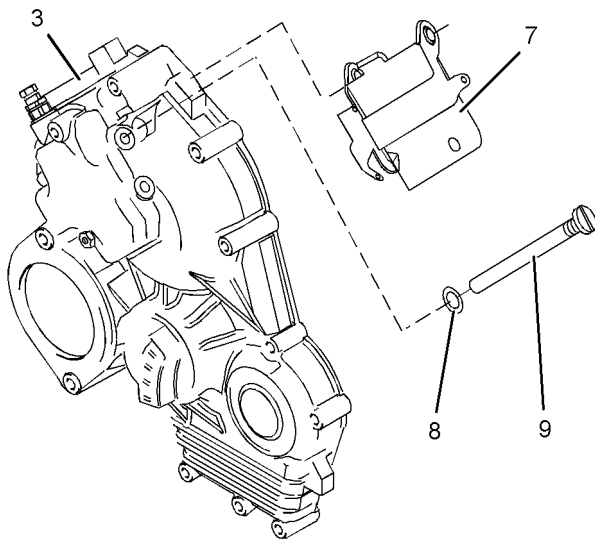

Illustration 99

g01357717

Typical example

7. Install a new sealing washer (8) to shaft (9).

8. Place lever assembly (7) in position in front housing (3) and install shaft (9). Tighten the shaft to a torque of 16 N·m (142 lb in).

Note: Ensure the correct orientation of the lever assembly.

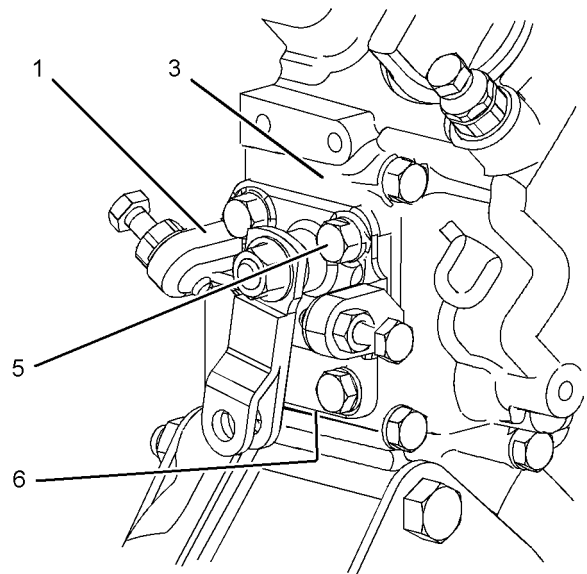

Illustration 100

g01354631

Typical example

9. Position a new joint (6) and position the assembly of throttle control (1) onto front housing (3).
10. Install bolts (5). Tighten the bolts to a torque of 11 N·m (97 lb in).

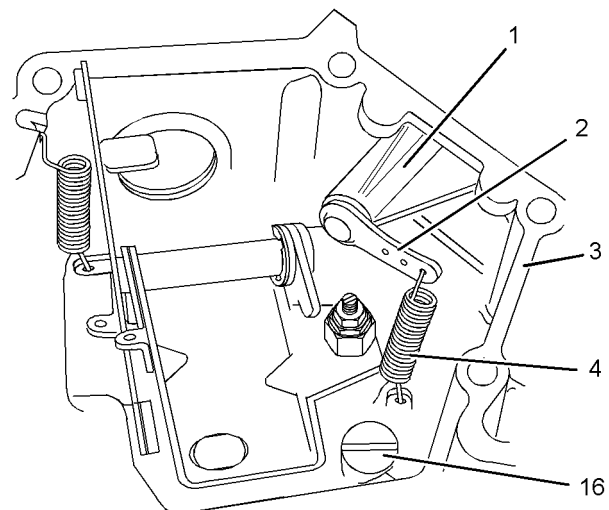

Illustration 101

g01354629

Typical example

11. Install spring (4).

- 12. If the position of stop (16) has been altered, the stop must be reset. Refer to Systems Operation, Testing and Adjusting, "Governor" for the correct procedure.
- 13. Install the front housing. Refer to Disassembly and Assembly, "Housing (Front) Install" for more information.
- 14. Set the position of the spring assembly (17). Refer to Illustration 95. The procedure that is used to set the position of the spring assembly is described in Systems Operation, Testing and Adjusting, "Governor". Tighten the spring assembly to a torque of 34 N·m (25 lb ft).
- 15. Install a new new cap (21) to nut (20). Refer to Illustration 95.

i02965670

Housing (Front) - Install

Installation Procedure

Table 16

Required Tools			
Tool	Part Number	Part Description	Qty
A ⁽¹⁾	21825620	Seal Protector	1
A ⁽²⁾	21825621	Seal Protector	1

(1) 402D-05, 403D-07, 403D-11 and 404D-16 engines
 (2) 403D-15, 403D-15T, 403D-17, 404D-22, 404D-22T and 404D-22TA engines

NOTICE

Keep all parts clean from contaminants.

Contaminants may cause rapid wear and shortened component life.

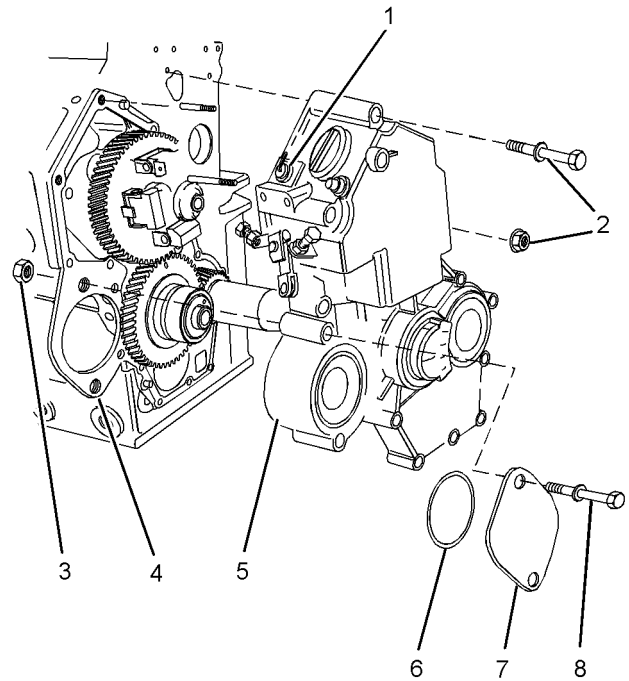

Illustration 102
Typical example

g01494813

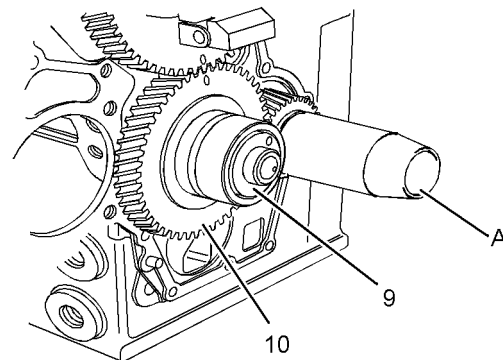

Illustration 103
Typical example

g01495533

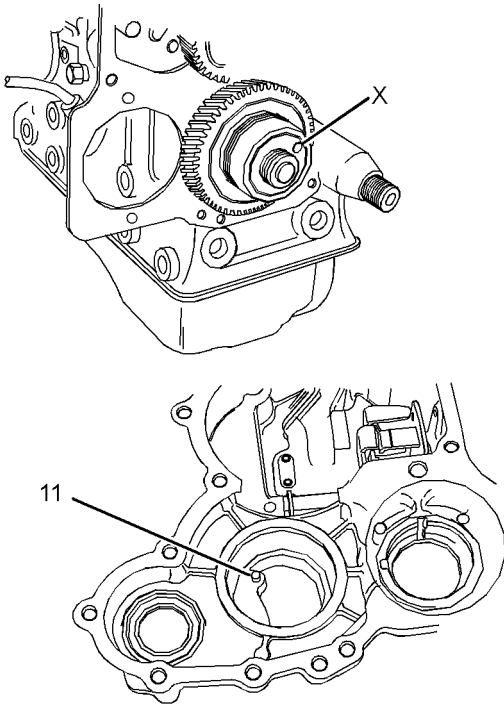

Illustration 104
Typical example

g01495653

1. Ensure that the assembly of front housing (5) and the nose of the crankshaft are clean and free from damage. Clean the mating surface of plate (4).
2. Install Tooling (A) on the nose of the crankshaft.
3. Align pin (11) with Hole (X) in oil pump cover (9). Ensure that the oil pump cover is concentric to idler gear assembly (10).
4. Install a new joint to plate (4).
5. Guide the linkage for the fuel injection pump into position so that the link is free to move inside the aperture on the cylinder block for the fuel injection pump. Align front housing (5) to the dowels in plate (4). Install front housing (5) to plate (4).
6. Install fasteners (2) and tighten to a torque of 10 N·m (89 lb in).
7. Remove Tooling (A) from the nose of the crankshaft.
8. Install a new O-ring seal (6) to front housing (5). Position cover (7) on front housing (5) and install nuts (3) and bolts (8).
9. Tighten nuts (3) to a torque of 50 N·m (37 lb ft).

10. If the engine is equipped with a turbocharger, connect the hose to connection (1).

End By:

- a. Install the crankshaft pulley. Refer to Disassembly and Assembly, "Crankshaft Pulley - Remove and Install".
- b. Install the fuel injection pump. Refer to Disassembly and Assembly, "Fuel Injection Pump - Install".

i02970280

Crankcase Breather - Remove and Install (Turbocharged Engines)

Removal Procedure

NOTICE

Keep all parts clean from contaminants.

Contaminants may cause rapid wear and shortened component life.

NOTICE

Care must be taken to ensure that fluids are contained during performance of inspection, maintenance, testing, adjusting and repair of the product. Be prepared to collect the fluid with suitable containers before opening any compartment or disassembling any component containing fluids.

Dispose of all fluids according to local regulations and mandates.

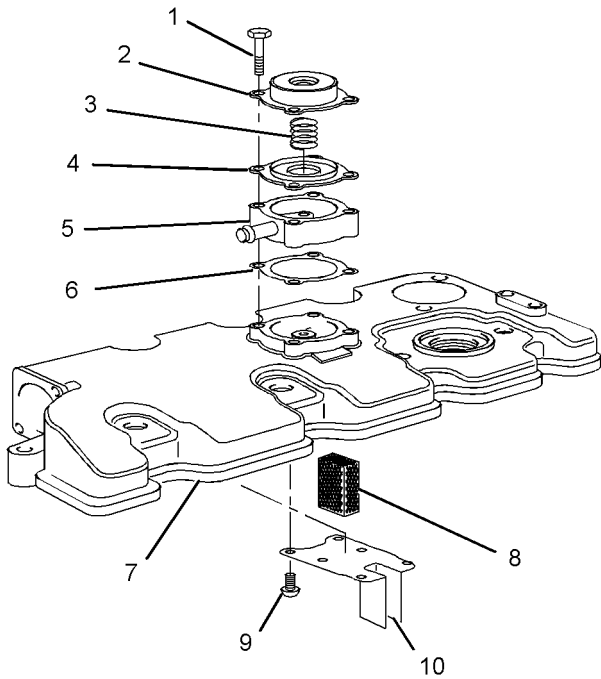

Illustration 105

g01310618

Typical example

WARNING

Personal injury can result from parts and/or covers under spring pressure.

Spring force will be released when covers are removed.

Be prepared to hold spring loaded covers as the bolts are loosened.

1. Remove bolts (1) and remove the assembly of cover (2), spring (3) and diaphragm (4). Note the orientation of cover (2).
2. Remove spring (3) and diaphragm (4) from cover (2).
3. Remove adapter (5) and joint (6) from valve mechanism cover (7).

Note: Make a temporary mark in order to show the orientation of the adapter for installation.

4. If necessary, follow Steps 4.a through 4.c in order to remove the gauze for the breather.
 - a. Remove valve mechanism cover (7). Refer to Disassembly and Assembly, "Valve Mechanism Cover - Remove and Install" for the correct procedure.

- b. Remove screws (9) and carefully remove plate (10).

- c. Remove gauze (8) from valve mechanism cover (7).

Installation Procedure

Table 17

Required Tools			
Tool	Part Number	Part Description	Qty
A	27610296	Torque Wrench	1

NOTICE

Keep all parts clean from contaminants.

Contaminants may cause rapid wear and shortened component life.

NOTICE

Make sure that the components of the breather assembly are installed correctly. Engine damage may occur if the breather assembly is not working properly.

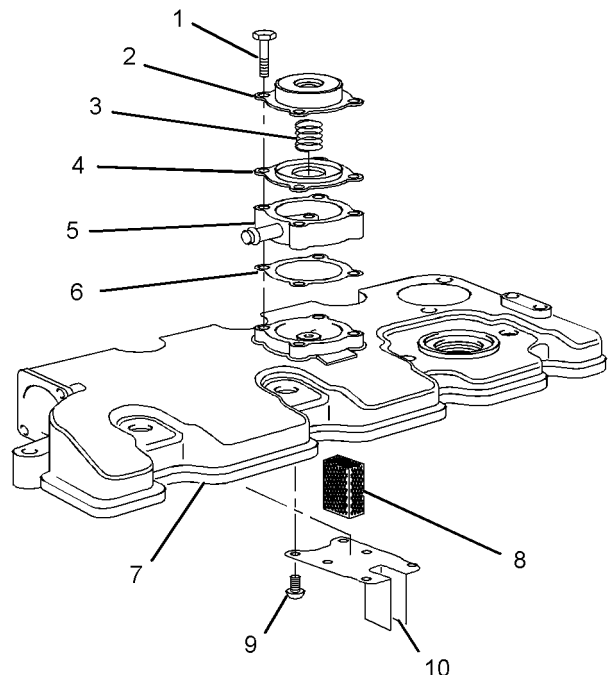

Illustration 106

g01310618

Typical example

i02970301

1. Clean all parts and inspect all parts. Replace any parts that are worn or damaged. Ensure that the cavity for the breather in the valve mechanism cover is clean. Ensure that vent hole in adapter (5) and the vent hole in cover (2) are free from restriction.
2. If necessary, follow Steps 2.a through 2.d in order to install the gauze for the breather.
 - a. Install gauze (8) to valve mechanism cover (7).
 - b. Position plate (10) on valve mechanism cover (7) and install screws (9).
 - c. Tighten screws (9) to a torque of 1.5 N·m (13 lb in).
 - d. Install valve mechanism cover (7). Refer to Disassembly and Assembly, "Valve Mechanism Cover - Remove and Install" for the correct procedure.
3. Position a new joint (6) on the valve mechanism cover and install adapter (5).

Note: Ensure the correct orientation of the adapter. The vent hole should face upward.

 **WARNING**

Personal injury can result from being struck by parts propelled by a released spring force.

Make sure to wear all necessary protective equipment.

Follow the recommended procedure and use all recommended tooling to release the spring force.

4. Install diaphragm (4) and spring (3) to cover (2).
5. Position the assembly of cover (2), spring (3) and diaphragm (4) onto valve mechanism cover (7).

Note: Ensure the correct orientation of the cover.

6. Install bolts (1). Use Tooling (A) in order to tighten bolts to a torque of 3 N·m (27 lb in).

Crankcase Breather - Remove and Install (Naturally Aspirated Engines)

Removal Procedure

NOTICE

Keep all parts clean from contaminants.

Contaminants may cause rapid wear and shortened component life.

NOTICE

Care must be taken to ensure that fluids are contained during performance of inspection, maintenance, testing, adjusting and repair of the product. Be prepared to collect the fluid with suitable containers before opening any compartment or disassembling any component containing fluids.

Dispose of all fluids according to local regulations and mandates.

The two cylinder, the three cylinder and the four cylinder engines have different crankcase breathers. The removal procedure is similar for all models.

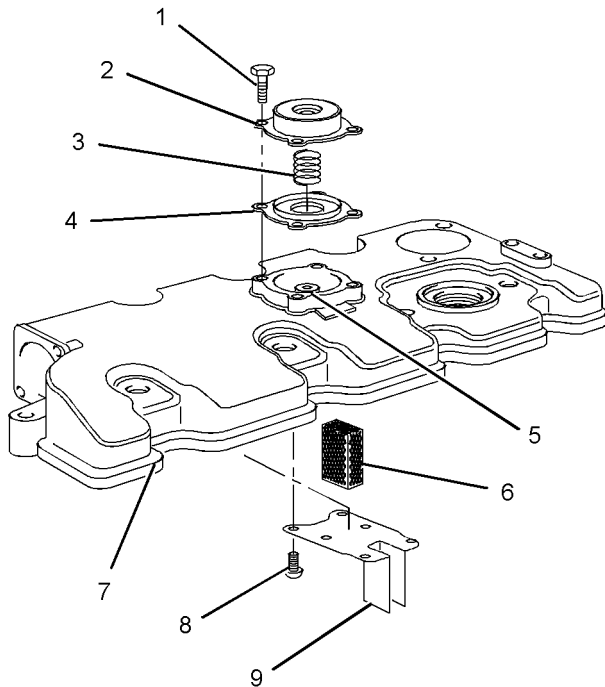

Illustration 107

g01307795

Typical example

WARNING

Personal injury can result from parts and/or covers under spring pressure.

Spring force will be released when covers are removed.

Be prepared to hold spring loaded covers as the bolts are loosened.

1. Remove bolts (1) and remove the assembly of cover (2), spring (3) and diaphragm (4). Note the orientation of cover (2).
2. Remove spring (3) and diaphragm (4) from cover (2).
3. If necessary, follow Steps 3.a through 3.c in order to remove the gauze for the breather.
 - a. Remove valve mechanism cover (7). Refer to Disassembly and Assembly, "Valve Mechanism Cover - Remove and Install" for the correct procedure.
 - b. Remove screws (8) and carefully remove plate (9).
 - c. Remove gauze (6) from valve mechanism cover (7).

Installation Procedure

Table 18

Required Tools			
Tool	Part Number	Part Description	Qty
A	27610296	Torque Wrench	1

NOTICE

Keep all parts clean from contaminants.

Contaminants may cause rapid wear and shortened component life.

NOTICE

Make sure that the components of the breather assembly are installed correctly. Engine damage may occur if the breather assembly is not working properly.

The two cylinder, the three cylinder and the four cylinder engines have different crankcase breathers. The installation procedure is similar for all models.

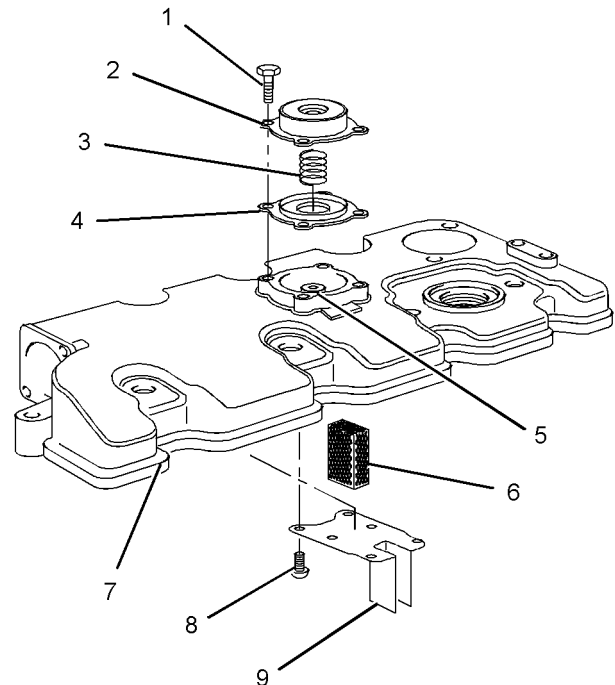

Illustration 108

g01307795

Typical example

1. Clean all parts and inspect all parts. Replace any parts that are worn or damaged. Ensure that the cavity for the breather in the valve mechanism cover is clean. Ensure that vent hole (5) and the vent hole in cover (2) are free from restriction.

2. If necessary, follow Steps 2.a through 2.d in order to install the gauze for the breather.
 - a. Install gauze (6) to valve mechanism cover (7).
 - b. Position plate (9) on valve mechanism cover (7) and install screws (8).
 - c. Tighten screws (8) to a torque of 1.5 N·m (13 lb in).
 - d. Install valve mechanism cover (7). Refer to Disassembly and Assembly, "Valve Mechanism Cover - Remove and Install" for the correct procedure.

⚠ WARNING

Personal injury can result from being struck by parts propelled by a released spring force.

Make sure to wear all necessary protective equipment.

Follow the recommended procedure and use all recommended tooling to release the spring force.

3. Install diaphragm (4) and spring (3) to cover (2).
4. Position the assembly of cover (2), spring (3) and diaphragm (4) onto valve mechanism cover (7).

Note: Ensure the correct orientation of the cover.

5. Install bolts (1). Use Tooling (A) in order to tighten bolts to a torque of 3 N·m (27 lb in).

i02961022

Valve Mechanism Cover - Remove and Install

Removal Procedure

NOTICE

Keep all parts clean from contaminants.

Contaminants may cause rapid wear and shortened component life.

NOTICE

Care must be taken to ensure that fluids are contained during performance of inspection, maintenance, testing, adjusting and repair of the product. Be prepared to collect the fluid with suitable containers before opening any compartment or disassembling any component containing fluids.

Dispose of all fluids according to local regulations and mandates.

Note: The removal procedure is similar for the two cylinder, the three cylinder and the four cylinder engines. The illustrations show the four cylinder engine.

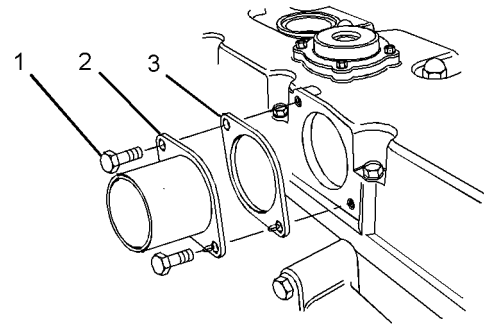

Illustration 109

g01316539

Typical example

1. Loosen the hose clamps and disconnect the hose (not shown) from connection (2).

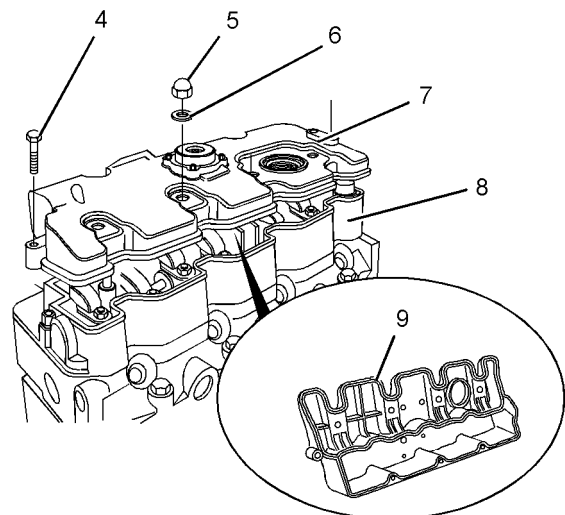

Illustration 110

g01316551

Typical example

2. Remove nuts (5) and washers (6) from valve mechanism cover (7).
3. Remove bolts (4) from valve mechanism cover (7).

Note: Loosen the bolts evenly in order to avoid distortion of the valve mechanism cover.

4. Remove valve mechanism cover (7) from base (8). Remove joint (9) from valve mechanism cover (7).
5. If necessary, remove bolts (1) and remove connection (2) from valve mechanism cover (7). Remove gasket (2).
6. If necessary, remove the crankcase breather. Refer to Disassembly and Assembly, "Crankcase Breather - Remove and Install" for more information.

Installation Procedure

NOTICE

Keep all parts clean from contaminants.

Contaminants may cause rapid wear and shortened component life.

Note: The installation procedure is similar for the two cylinder, the three cylinder and the four cylinder engines. The illustrations show the four cylinder engine.

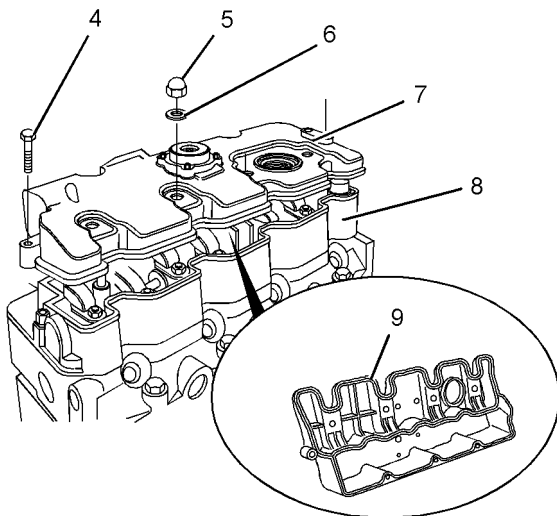

Illustration 111
Typical example

g01316551

1. Ensure that the valve mechanism cover is clean and free from damage. Clean the mating surface of base (8).

2. If necessary, install the crankcase breather. Refer to Disassembly and Assembly, "Crankcase Breather - Remove and Install" for more information.
3. Install a new joint (9) to valve mechanism cover (7).
4. Position valve mechanism cover (7) onto housing (8) and install bolts (4) finger tight.
5. Install new washers (6) and nuts (5) finger tight.
6. For 402D-05, 403D-07, 403D-11 and 404D-15 engines, evenly tighten bolts (4) to a torque of 10 N·m (89 lb in). Tighten nuts (5) to a torque of 10 N·m (89 lb in).

For 403D-15, 403D-15T, 403D-17, 404D-22, 404D-22T and 404D-22TA engines, evenly tighten bolts (4) to a torque of 10 N·m (89 lb in). Tighten nuts (5) to a torque of 14 N·m (124 lb in).

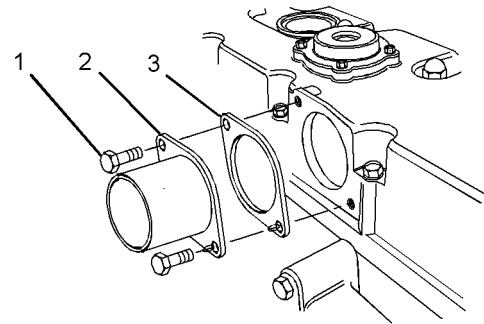

Illustration 112
Typical example

g01316539

7. If necessary, position a new gasket (3) onto valve mechanism cover (7) and install connection (2). Install bolts (1) and tighten to a torque of 14 N·m (124 lb in).
8. Connect the hose (not shown) to connection (2) and tighten the hose clamps.

i02645767

Rocker Shaft and Pushrod - Remove

Removal Procedure

Start By:

- a. Remove the engine oil line. Refer to Disassembly and Assembly, "Engine Oil Line - Remove and Install".
- b. Remove the valve mechanism cover. Refer to Disassembly and Assembly, "Valve Mechanism Cover - Remove and Install".

NOTICE

Keep all parts clean from contaminants.

Contaminants may cause rapid wear and shortened component life.

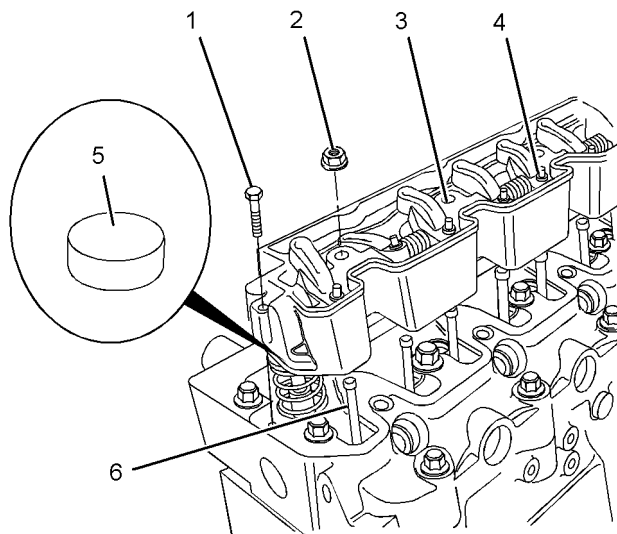

Illustration 113

g01316901

Typical example

1. Loosen the nuts and adjustment screws (4) on all rocker arms.
2. Remove bolts (1) and nuts (2) from rocker shaft assembly (3).
3. Remove rocker shaft assembly (3) from the cylinder head.
4. Place temporary identification marks on caps (5) and pushrods (6).

Note: Identification will ensure that the pushrods and the caps can be reinstalled in the original positions. Do not interchange the positions of used pushrods or caps.

5. Remove pushrods (6) from the cylinder head. Remove caps (5) from the valve stems.

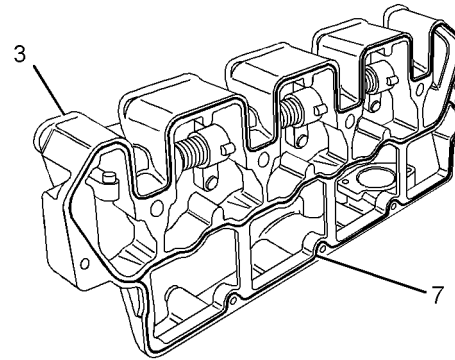

Illustration 114

g01317309

Typical example

6. Remove joint (7) from the base of rocker shaft assembly (3).

i02961061

Rocker Shaft - Disassemble (403D-15, 403D-15T, 403D-17, 404D-22, 404D-22T and 404D-22TA Engines)

Disassembly Procedure

Start By:

- a. Remove the rocker shaft and the pushrods. Refer to Disassembly and Assembly, "Rocker Shaft and Pushrod - Remove".

NOTICE

Keep all parts clean from contaminants.

Contaminants may cause rapid wear and shortened component life.

1. Make a temporary identification mark on each rocker arm assembly in order to show the location.

Note: Used components must be reinstalled in the original location. Do not interchange components.

i02645756

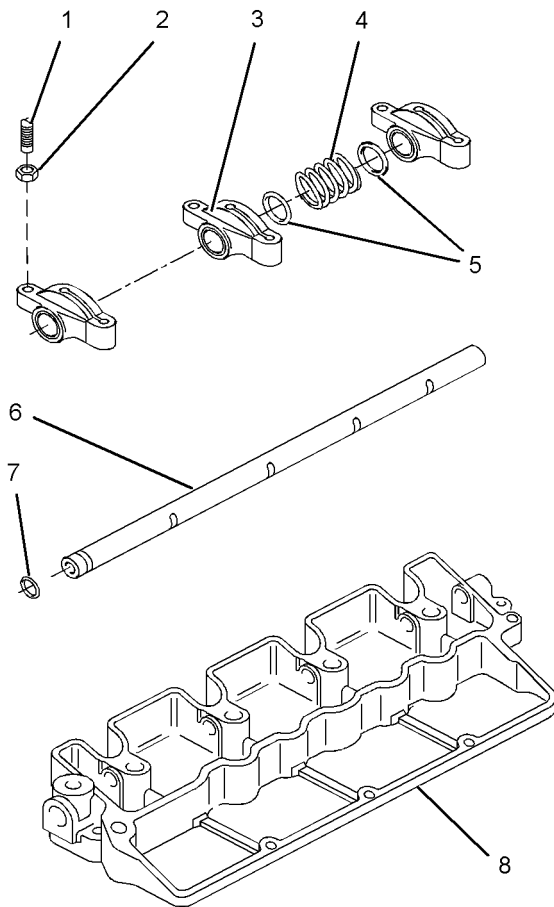

Illustration 115

g01317304

Typical example

2. In order to remove rocker shaft (6), install a suitable bolt into the end of the rocker shaft. Use the bolt to pull the rocker shaft from base (8).

WARNING

Personal injury can result from being struck by parts propelled by a released spring force.

Make sure to wear all necessary protective equipment.

Follow the recommended procedure and use all recommended tooling to release the spring force.

3. Remove rocker arms (3), washers (5), and springs (4).
4. Remove O-ring seal (7) from rocker shaft (6).
5. Remove adjustment screws (1) and nuts (2) from rocker arms (3).

Rocker Shaft - Disassemble (402D-05, 403D-07, 403D-11 and 404D-15 Engines)

Disassembly Procedure

Start By:

- a. Remove the rocker shaft and the pushrods. Refer to Disassembly and Assembly, "Rocker Shaft and Pushrod - Remove".

NOTICE

Keep all parts clean from contaminants.

Contaminants may cause rapid wear and shortened component life.

1. Make a temporary identification mark on each rocker arm assembly in order to show the location.

Note: Used components must be reinstalled in the original location. Do not interchange components.

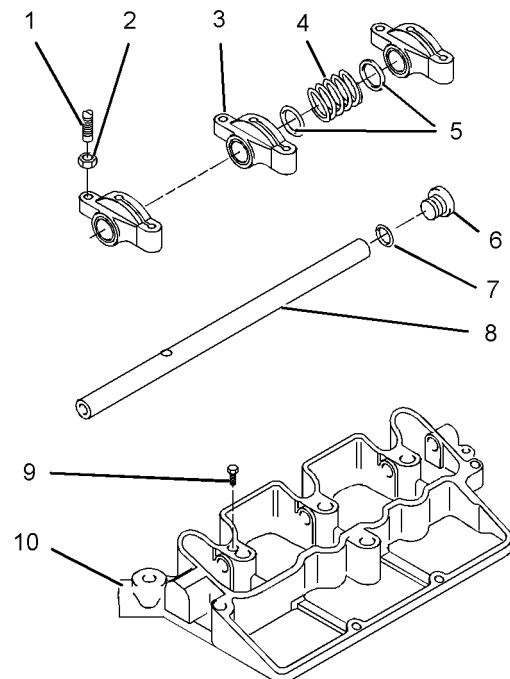

Illustration 116

g01316925

Typical example

1. Remove plug (6) from base (10).
2. Remove O-ring seal (7) from plug (6).

3. On 403D-07, 403D-11 and 404D-15 engines, remove screw (9).

Note: Screw (9) is not used on 402D-05 engines.

4. In order to remove rocker shaft (8), install a suitable bolt into the end of the rocker shaft. Use the bolt to pull the rocker shaft from base (10).

 **WARNING**

Personal injury can result from being struck by parts propelled by a released spring force.

Make sure to wear all necessary protective equipment.

Follow the recommended procedure and use all recommended tooling to release the spring force.

5. Remove rocker arms (3), washers (5), and springs (4).
6. Remove adjustment screws (1) and nuts (2) from rocker arms (3).

Rocker Shaft - Assemble (403D-15, 403D-15T, 403D-17, 404D-22, 404D-22T and 404D-22TA Engines)

Assembly Procedure

 **WARNING**

Personal injury can result from being struck by parts propelled by a released spring force.

Make sure to wear all necessary protective equipment.

Follow the recommended procedure and use all recommended tooling to release the spring force.

NOTICE

Keep all parts clean from contaminants.

Contaminants may cause rapid wear and shortened component life.

1. Ensure that all components are clean and free from wear or damage. Refer to Specifications, "Rocker Shaft" for more information. If necessary, replace any components that are worn or damaged.

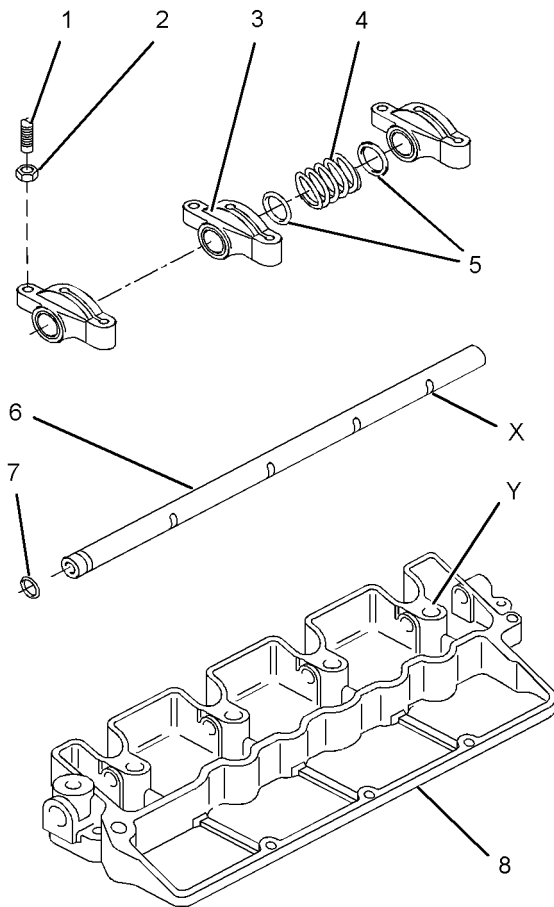

Illustration 117

g01317298

Typical example

2. Lubricate adjustment screw (1) with clean engine oil. Install adjustment screw (1) and nut (2) to rocker arm (3). Repeat the process for the remaining rocker arms.
3. Install a new O-ring seal (7) onto rocker shaft (6). Lubricate the rocker shaft with clean engine oil.
4. Position the end of rocker shaft (6) into the bore in base (8). Align recesses (X) on the rocker shaft with holes (Y) in the base.
5. Gradually insert rocker shaft (6) into the base (8). Install rocker arm (3).
6. Continue to insert rocker shaft (6) and install the following components to the rocker shaft:
 - Rocker arm (3)
 - Washer (5)
 - Spring (4)
 - Washer (5)

- Rocker arm (3)

7. Repeat Steps 5 and 6 in order to install the remaining components.
8. Ensure that rocker shaft (6) is fully engaged into base (8). Check that recesses (X) on the rocker shaft are aligned with holes (Y) in the base.

End By:

- a. Install the rocker shaft and the pushrods. Refer to Disassembly and Assembly, "Rocker Shaft and Pushrod - Install".

i02645751

Rocker Shaft - Assemble (402D-05, 403D-07, 403D-11 and 404D-15 Engines)

Assembly Procedure

Table 19

Required Tools			
Tool	Part Number	Part Description	Qty
A	21820117	POWERPART Threadlock and Nutlock	1

⚠ WARNING

Personal injury can result from being struck by parts propelled by a released spring force.

Make sure to wear all necessary protective equipment.

Follow the recommended procedure and use all recommended tooling to release the spring force.

NOTICE

Keep all parts clean from contaminants.

Contaminants may cause rapid wear and shortened component life.

1. Ensure that all components are clean and free from wear or damage. Refer to Specifications, "Rocker Shaft" for more information. If necessary, replace any components that are worn or damaged.

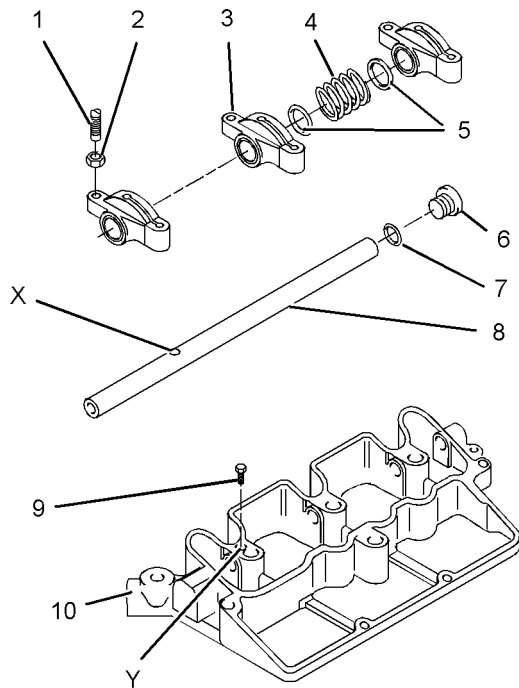

Illustration 118

g01316988

Typical example

2. Lubricate adjustment screw (1) with clean engine oil. Install adjustment screw (1) and nut (2) to rocker arm (3). Repeat the process for the remaining rocker arms.

3. Lubricate rocker shaft (8) with clean engine oil. Position the end of the rocker shaft into the bore of base (10).

For 402D-05 engines, align the two recesses (not shown) on the rocker shaft with the holes in base (10).

For 403D-07, 403D-11 and 404D-15 engines, align hole (X) in the rocker shaft with hole (Y) in base (10).

4. Gradually insert rocker shaft (8) into base (10). Install rocker arm (3).

5. Continue to insert rocker shaft (8) and install the following components to the rocker shaft:

- Rocker arm (3)
- Washer (5)
- Spring (4)
- Washer (5)

- Rocker arm (3)

6. Repeat Steps 5 and 4 in order to install the remaining components.

7. For 403D-07, 403D-11 and 404D-15 engines, Apply Tooling (A) to the first two threads of screw (9). Install screw (9) in hole (Y) in the base.

Note: Ensure that Tooling (A) is allowed to contaminate the oil gallery in the rocker shaft.

8. Install a new O-ring seal (7) to plug (6).

9. Install plug (6) to base (10). Tighten the plug to a torque of 15 N·m (11 lb ft).

End By:

a. Install the rocker shaft and the pushrods. Refer to Disassembly and Assembly, "Rocker Shaft and Pushrod - Install".

i02961082

Rocker Shaft and Pushrod - Install

Installation Procedure

NOTICE

Keep all parts clean from contaminants.

Contaminants may cause rapid wear and shortened component life.

1. Ensure that all components are clean and free from wear or damage. Refer to Specifications, "Rocker Shaft" for more information. Replace any components that are worn or damaged.

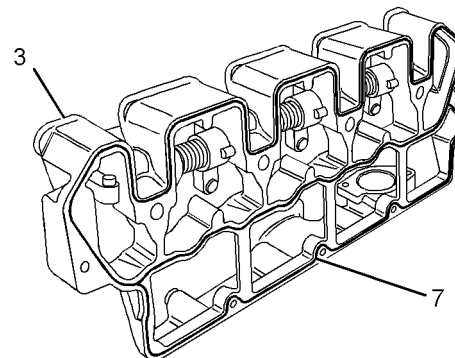

Illustration 119

g01317309

Typical example

2. Install a new joint (7) to the base of rocker shaft assembly (3).

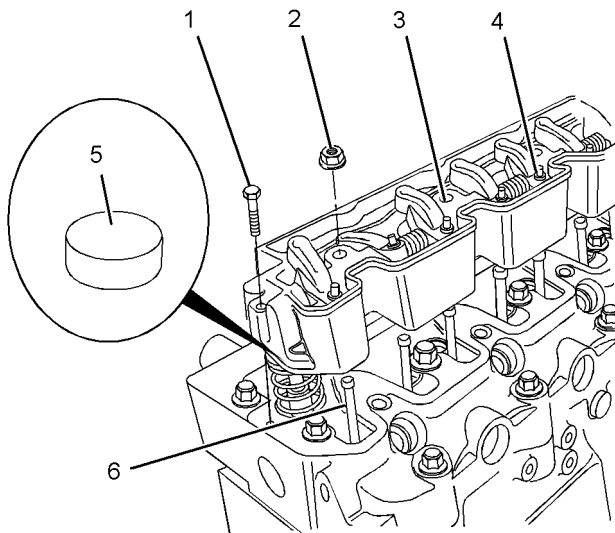

Illustration 120

g01316901

Typical example

3. Apply clean engine lubricating oil to both ends of pushrods (6). Install the pushrods to the engine with the cup upward. Ensure that the pushrods are installed correctly in the socket of the valve lifters.

Note: If the pushrods have been used, ensure that the pushrods are installed in original positions.

4. Lubricate the top of the valve stems with clean engine oil. Install caps (5) to the valve stems.

Note: If the caps have been used, ensure that the caps are installed in original positions.

5. Install rocker shaft assembly (3) to the cylinder head.

Note: Ensure that the ends of adjustment screws (4) are correctly seated in ends of pushrods (6).

6. Install nuts (2). Use a deep socket to evenly tighten the nuts. Begin at the center of the rocker shaft and work outward.

For 402D-05 and 403D-07 engines, tighten nuts (2) to a torque of 10 N·m (88 lb in).

For 403D-11 and 404D-15 engines, tighten nuts (2) to a torque of 23 N·m (17 lb ft).

For 403D-15, 403D-15T, 403D-17, 404D-22, 404D-22T and 404D-22TA engines, tighten nuts (2) to a torque of 33 N·m (24 lb ft).

7. Install bolts (1) and tighten to a torque of 10 N·m (88 lb in).

8. Adjust the valve lash. Refer to Systems Operation, Testing and Adjusting, "Engine Valve Lash - Inspect/Adjust" for the correct procedure.

End By:

- a. Install the valve mechanism cover. Refer to Disassembly and Assembly, "Valve Mechanism Cover - Remove and Install".
- b. Install the engine oil line. Refer to Disassembly and Assembly, "Engine Oil Line- Remove and Install".

i02961089

Cylinder Head - Remove

Removal Procedure

Start By:

- a. Remove the exhaust manifold. Refer to Disassembly and Assembly, "Exhaust Manifold - Remove and Install".
- b. Remove the fuel filter base. Refer to Disassembly and Assembly, "Fuel filter Base - Remove and Install".
- c. Remove the fuel injectors. Refer to Disassembly and Assembly, "Fuel Injector - Remove".
- d. Remove the glow plugs. Refer to Disassembly and Assembly, "Glow Plugs- Remove and Install".
- e. Remove the rocker shaft and the pushrods. Refer to Disassembly and Assembly, "Rocker Shaft and Pushrod - Remove".
- f. Remove the water pump. Refer to Disassembly and Assembly, "Water Pump - Remove and Install".

NOTICE

Keep all parts clean from contaminants.

Contaminants may cause rapid wear and shortened component life.

NOTICE

Care must be taken to ensure that fluids are contained during performance of inspection, maintenance, testing, adjusting and repair of the product. Be prepared to collect the fluid with suitable containers before opening any compartment or disassembling any component containing fluids.

Dispose of all fluids according to local regulations and mandates.

1. Drain the coolant from the cooling system into a suitable container for storage or for disposal. Refer to Operation and Maintenance Manual, "Cooling System Coolant - Drain" for the correct draining procedure.

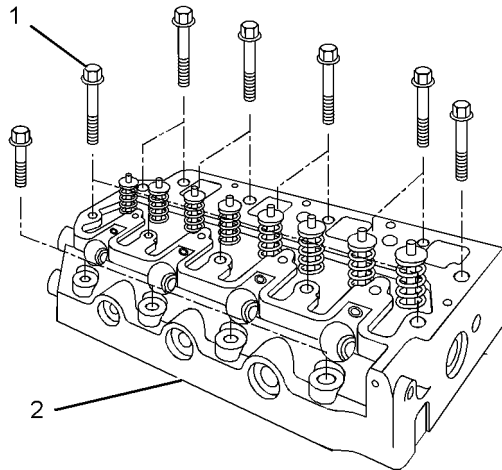

Illustration 121
Typical example
g01309672

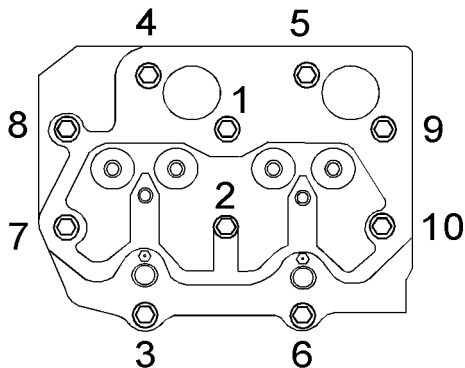

Illustration 122
The cylinder head tightening sequence for two cylinder engine
g01317344

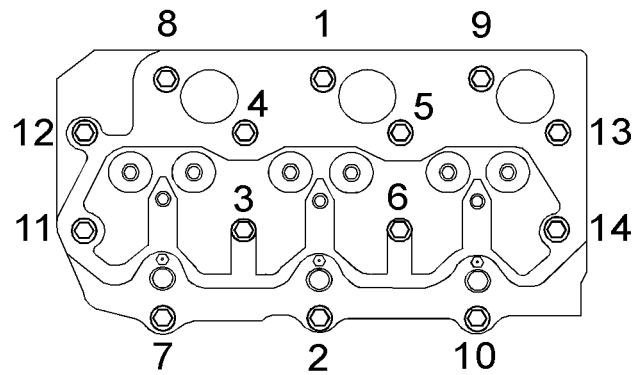

Illustration 123
The cylinder head tightening sequence for three cylinder engine
g01317351

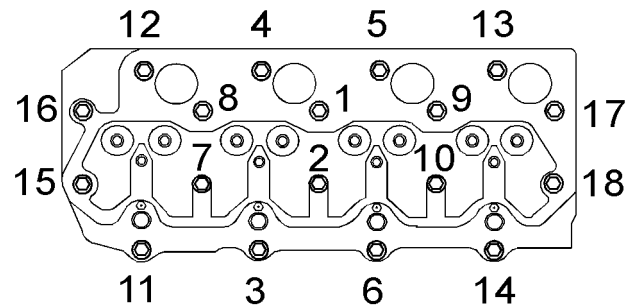

Illustration 124
The cylinder head tightening sequence for four cylinder engine
g01309552

2. Gradually loosen bolts (1) in reverse numerical order. This will prevent distortion of the cylinder head.

For 402D-05 engines, loosen the cylinder head bolts in the reverse order to the sequence that is shown in Illustration 122.

For 403D-07, 403D-11, 403D-15, 403D-15T and 403D-17 engines, loosen the cylinder head bolts in the reverse order to the sequence that is shown in Illustration 123.

For 404D-15, 404D-22, 404D-22T and 404D-22TA engines, loosen the cylinder head bolts in the reverse order to the sequence that is shown in Illustration 124.

3. Remove bolts (1) from cylinder head (2).
4. Attach a suitable lifting device to cylinder head (2). The weight of the cylinder head is approximately 30 kg (66 lb). Carefully lift the cylinder head off the cylinder block.

Note: Do not use a lever to separate the cylinder head from the cylinder block. Take care not to damage the machined surfaces of the cylinder head during the removal procedure. Avoid contamination of the cylinder bores with coolant or with debris.

NOTICE

Place the cylinder head on a surface that will not scratch the face of the cylinder head.

5. Remove the cylinder head gasket.

Note: The old gasket for the cylinder head should be retained for the purpose of identification. Gaskets of different thickness are available. Refer to Specifications, "Cylinder Head".

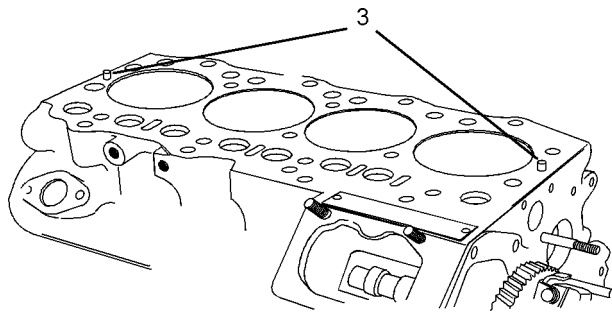

Illustration 125
Typical example
g01317405

- 6. Note the position of dowels (3) in the cylinder block. Do not remove the dowels unless the dowels are damaged.
- 7. If necessary, remove the water temperature regulator from the cylinder head. Refer to Disassembly and Assembly, "Water Temperature Regulator - Remove and Install".

i02961101

Cylinder Head - Install

Installation Procedure

NOTICE

Keep all parts clean from contaminants.

Contaminants may cause rapid wear and shortened component life.

Table 20

Required Tools			
Tool	Part Number	Part Description	Qty
A ⁽¹⁾	-	Guide Bolt (M8 by 60 mm)	2
A ⁽²⁾	-	Guide Bolt (M9 by 95 mm)	2
A ⁽³⁾	-	Guide Bolt (M11 by 100 mm)	2

- (1) 402D-05 and 403D-07 engines
- (2) 403D-11 and 404D-15 engines
- (3) 403D-15, 403D-15T, 403D-17, 404D-22 , 404D-22T and 404D-22TA engines

1. Thoroughly clean the mating surfaces of the cylinder head and the cylinder block. Do not damage the mating surfaces of the cylinder head or the cylinder block. Ensure that no debris enters the cylinder bores, the coolant passages, or the lubricant passages.
2. Inspect the mating surface of the cylinder head for distortion. Refer to Specifications, "Cylinder Head" for more information. If the mating surface of the cylinder head is distorted beyond maximum permitted limits, replace the cylinder head.

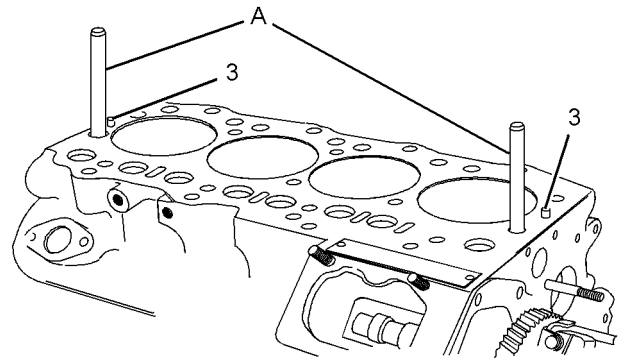

Illustration 126
Typical example
g01317467

3. Inspect dowels (3) for damage. If necessary, replace the dowels in the cylinder block.
4. Install Tooling (A) to the cylinder block. Refer to Illustration 126.

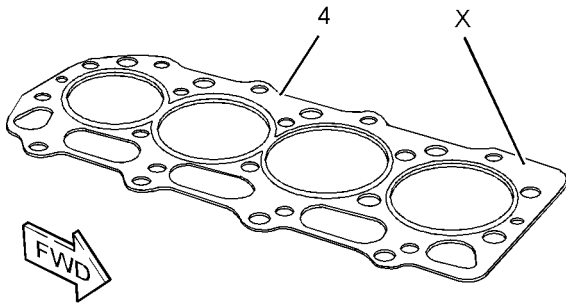

Illustration 127
Typical example
g01317471

5. Ensure that the new cylinder head gasket (4) is the same thickness as the cylinder head gasket that was previously removed. The thickness of the cylinder head gasket is indicated by the number that is shown at position (X). Refer to Specifications, "Cylinder Head" for more information.
6. Align cylinder head gasket (4) with Tooling (A) and with dowels (3). Install the cylinder head gasket onto the cylinder block.
7. Use a suitable lifting device to lift the cylinder head. The weight of the cylinder head is approximately 30 kg (66 lb).

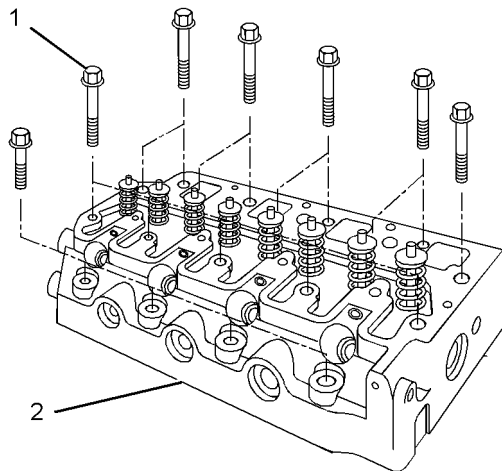

Illustration 128
Typical example
g01309672

8. Use Tooling (A) to align cylinder head (2) with the cylinder block. Install the cylinder head to the cylinder block.

Note: Ensure that the cylinder head is correctly positioned onto dowels (3).

9. Remove Tooling (A).
10. Install bolts (1) to cylinder head (2).

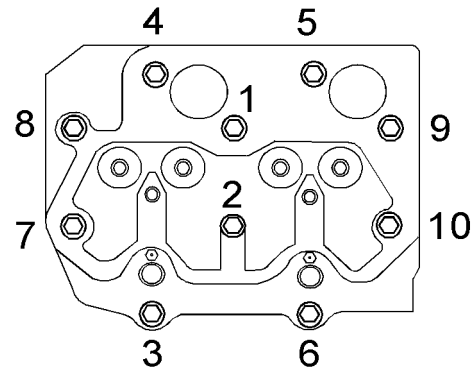

Illustration 129
The tightening sequence for a two cylinder engine
g01317344

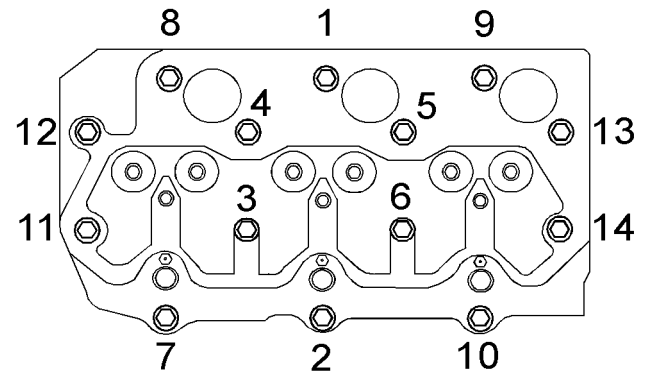

Illustration 130
The tightening sequence for a three cylinder engine
g01317351

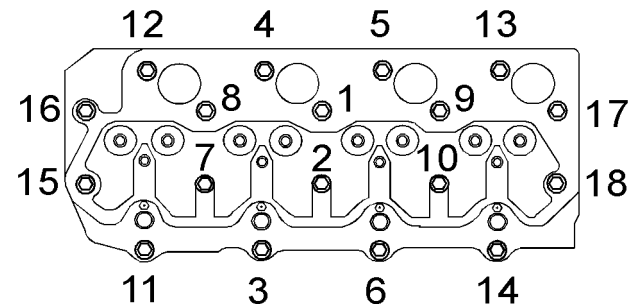

Illustration 131
The tightening sequence for a four cylinder engine
g01309552

11. For 402D-05 engines, tighten bolts (1) to a torque of 37 N·m (27 lb ft). Use the numerical sequence that is shown in Illustration 129.

For 403D-07 engines, tighten bolts (1) to a torque of 37 N·m (27 lb ft). Use the numerical sequence that is shown in Illustration 130.

For 403D-11 engines, tighten bolts (1) to a torque of 51 N·m (38 lb ft). Use the numerical sequence that is shown in Illustration 130.

For 403D-15, 403D-15T and 403D-17 engines, tighten bolts (1) to a torque of 101 N·m (75 lb ft). Use the numerical sequence that is shown in Illustration 130.

For 404D-15 engines, tighten bolts (1) to a torque of 51 N·m (38 lb ft). Use the numerical sequence that is shown in Illustration 131.

For 404D-22, 404D-22T and 404D-22TA engines, tighten bolts (1) to a torque of 101 N·m (75 lb ft). Use the numerical sequence that is shown in Illustration 131.

12. If necessary, install the water temperature regulator to the cylinder head. Refer to Disassembly and Assembly, "Water Temperature Regulator- Remove and Install".

End By:

- a. Install the water pump. Refer to Disassembly and Assembly, "Water Pump - Install".
- b. Install the rocker shaft and the pushrods. Refer to Disassembly and Assembly, "Rocker Shaft and Pushrod - Install".
- c. Install the glow plugs. Refer to Disassembly and Assembly, "Glow Plugs - Remove and Install".
- d. Install the fuel injectors. Refer to Disassembly and Assembly, "Fuel Injector - Install".
- e. Install the fuel filter base. Refer to Disassembly and Assembly, "Fuel filter Base - Remove and Install".
- f. Install the exhaust manifold. Refer to Disassembly and Assembly, "Exhaust Manifold - Remove and Install".

i02645737

Lifter Group - Remove and Install

Removal Procedure

Table 21

Required Tools			
Tool	Part Number	Part Description	Qty
A	-	Telescopic Magnet	1

Start By:

- a. Remove the cylinder head. Refer to Disassembly and Assembly, "Cylinder Head - Remove".

NOTICE

Keep all parts clean from contaminants.

Contaminants may cause rapid wear and shortened component life.

NOTICE

Care must be taken to ensure that fluids are contained during performance of inspection, maintenance, testing, adjusting and repair of the product. Be prepared to collect the fluid with suitable containers before opening any compartment or disassembling any component containing fluids.

Dispose of all fluids according to local regulations and mandates.

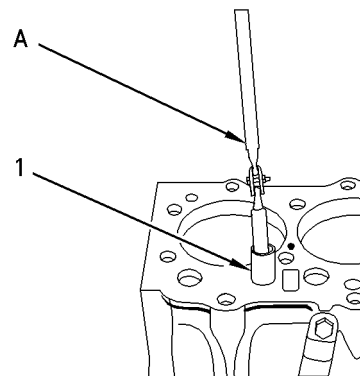

Illustration 132

g00828101

1. Use Tooling (A) to remove lifter (1) from the cylinder block.

Note: Make a temporary identification mark on each lifter in order to identify the correct location.

2. Repeat Step 1 for the remaining lifters.

i02963920

Installation Procedure

NOTICE

Keep all parts clean from contaminants.

Contaminants may cause rapid wear and shortened component life.

NOTICE

It is strongly recommended that all lifters should be replaced when a new camshaft is installed.

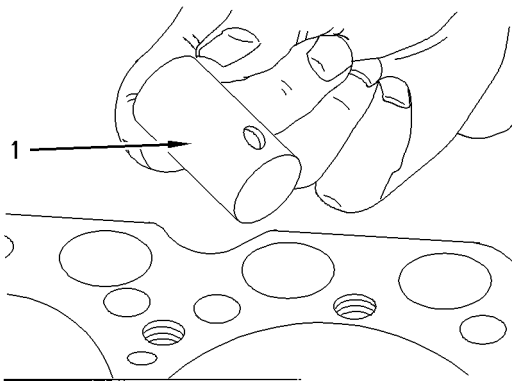

Illustration 133

g00692979

1. Clean lifters (1). Follow Steps 1.a through 1.c in order to inspect the lifters. Replace lifters that are worn or damaged.
 - a. Inspect the seat of the pushrod in the lifter for visual wear or damage. Ensure that oil holes in the lifter are not restricted.
 - b. Inspect the shank of the lifter for wear or damage. Refer to Specifications, "Lifter Group" for more information.
 - c. Inspect the face of the lifter that runs on the camshaft for visual wear or damage.
2. Lubricate lifters (1) with clean engine oil.
3. Install lifters (1) into the cylinder block.

Note: The lifters should be free to rotate. If the lifters have been used, ensure that the lifters are installed in the original positions.

End By:

- a. Install the cylinder head. Refer to Disassembly and Assembly, "Cylinder Head - Install".

Camshaft - Remove

Removal Procedure

Start By:

- a. Remove the lifters. Refer to Disassembly and Assembly, "Lifter Group - Remove and Install".
- b. Remove the front housing. Refer to Disassembly and Assembly, "Housing (Front) - Remove".

NOTICE

Keep all parts clean from contaminants.

Contaminants may cause rapid wear and shortened component life.

NOTICE

Care must be taken to ensure that fluids are contained during performance of inspection, maintenance, testing, adjusting and repair of the product. Be prepared to collect the fluid with suitable containers before opening any compartment or disassembling any component containing fluids.

Dispose of all fluids according to local regulations and mandates.

1. If the engine is equipped with a mechanical fuel transfer pump, remove the fuel transfer pump. Refer to Disassembly and Assembly, "Fuel Transfer Pump - Remove and Install".

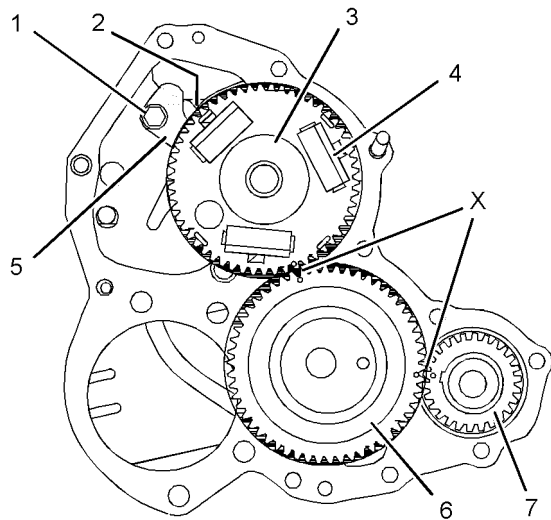

Illustration 134
Typical example
g01311407

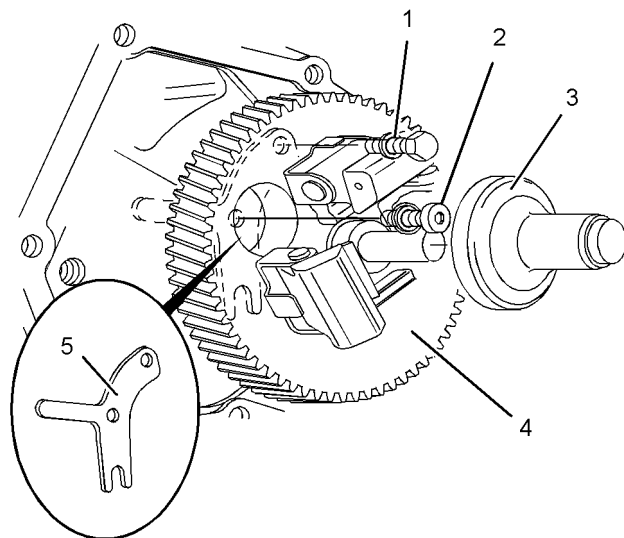

Illustration 135
Typical example
g01311411

2. Remove slider (3) from camshaft gear (4).

Note: 402D-05, 403D-07, 403D-11, and 404D-15 engines have a different camshaft retainer and different fasteners to 403D-15, 403D-15T, 403D-17, 404D-22, 404D-22T and 404D-22TA engines. The removal procedure is similar for all models.

3. Rotate camshaft gear (4) in order to align the access hole in the camshaft gear with fastener (2).

For 402D-05, 403D-07, 403D-11, and 404D-15 engines, remove allen head screw (2) and remove bolt (1).

For 403D-15, 403D-15T, 403D-17, 404D-22, 404D-22T and 404D-22TA engines, remove bolt (2). Rotate camshaft gear (4) in order to align the access hole in the camshaft gear with bolt (1). Remove bolt (1).

4. Remove camshaft retainer (5).

5. Rotate the crankshaft until timing marks (X) are aligned on the following gears:

- Crankshaft gear (7)
- Camshaft gear (4)
- Idler gear (6)

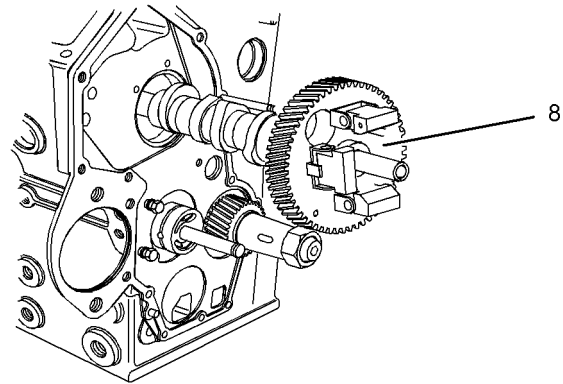

Illustration 136
Typical example
g01311416

6. Carefully remove camshaft assembly (8) from the cylinder block.

Note: Ensure that the lobes of the camshaft and the camshaft bearings are not damaged.

102645655

Camshaft - Disassemble

Disassembly Procedure

Table 22

Required Tools			
Tool	Part Number	Part Name	Qty
A	-	Combination Puller	1

Start By:

- a. Remove the camshaft assembly. Refer to Disassembly and Assembly, "Camshaft - Remove".

NOTICE

Keep all parts clean from contaminants.

Contaminants may cause rapid wear and shortened component life.

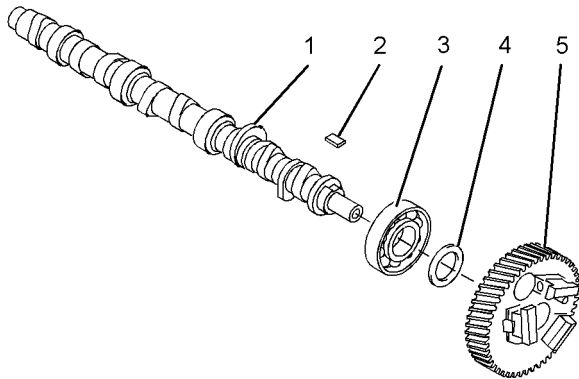

Illustration 137
Typical example

g01326129

1. Use Tooling (A) to remove gear (5) from camshaft (1).

Note: The gear should be positioned on a suitable support in order to prevent damage to the governor flyweights during disassembly.

2. Remove spacer (4) and woodruff key (2) from camshaft (1).

3. Use Tooling (A) to remove bearing (3) from camshaft (1).

Note: Identify the orientation of the bearing for installation.

i02645654

Camshaft - Assemble

Assembly Procedure

NOTICE

Keep all parts clean from contaminants.

Contaminants may cause rapid wear and shortened component life.

1. Ensure that all components of the camshaft assembly are clean and free from damage.

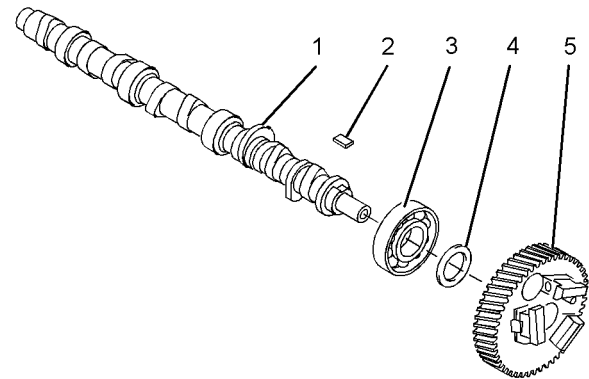

Illustration 138

g01326129

Typical example

2. Lubricate the nose of camshaft (1) with clean engine oil. Use a suitable press to install bearing (3) to the camshaft.

Note: Ensure that the bearing is installed in the correct orientation. The camshaft bearing should be pressed squarely onto the camshaft or damage to the bearing may occur. Do not press on the outer race of the bearing.

3. Install spacer (4) and woodruff key (2) to camshaft (1).

4. Align gear (5) with woodruff key (2). Use a suitable press to install the gear to the nose of camshaft (1).

Note: The gear should be positioned on a suitable support in order to prevent damage to the governor flyweights during installation.

End By:

- a. Install the camshaft assembly. Refer to Disassembly and Assembly, "Camshaft - Install".

i02963926

Camshaft - Install

Installation Procedure

NOTICE

Keep all parts clean from contaminants.

Contaminants may cause rapid wear and shortened component life.

1. Ensure that the assembly of the camshaft is clean and free from damage.
2. Lubricate the bearings of the camshaft with clean engine oil.

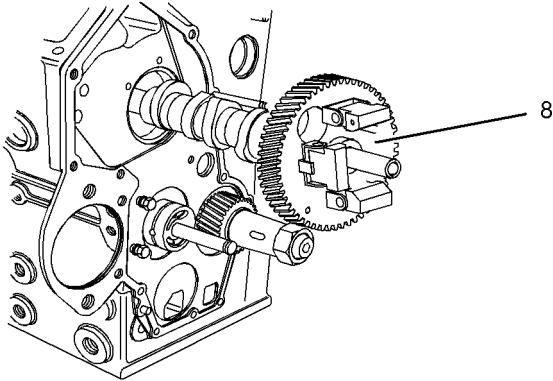

Illustration 139

g01311416

Typical example

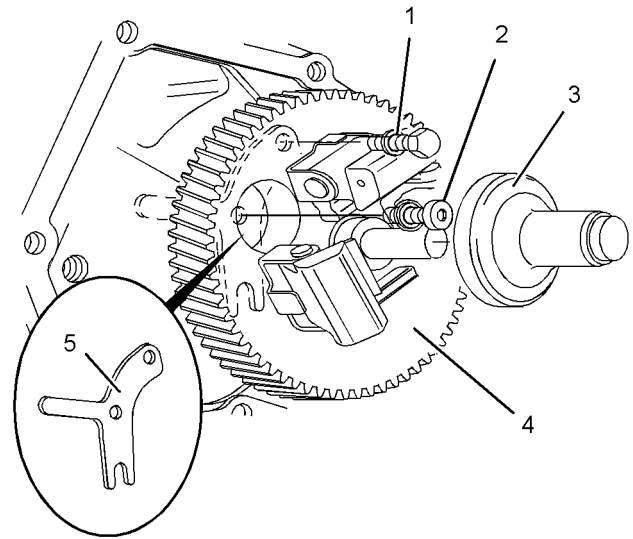

Illustration 141

g01311411

Typical example

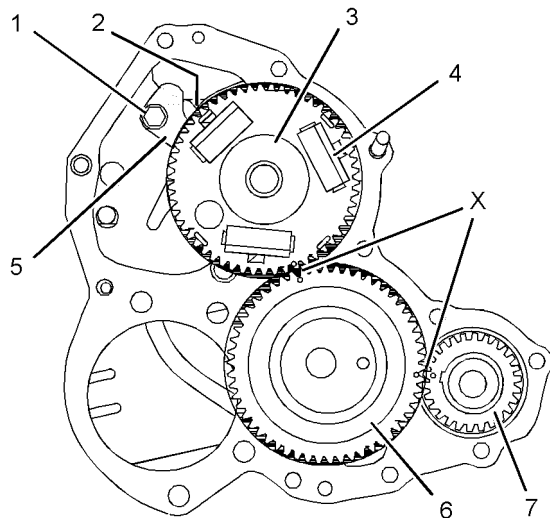

Illustration 140

g01311407

Typical example

3. Carefully install camshaft assembly (8) into the cylinder block. Ensure that timing marks (X) are aligned on the following gears:

- Crankshaft gear (7)
- Camshaft gear (4)
- Idler gear (6)

Note: Do not damage the lobes of the camshaft or the camshaft bearings.

Note: 402D-05, 403D-07, 403D-11, and 404D-15 engines have a different camshaft retainer and different fasteners to 403D-15, 403D-15T, 403D-17, 404D-22, 404D-22T and 404D-22TA engines. The installation procedure is similar for all models.

4. Place camshaft retainer (5) in position. Align the holes in the retainer with the holes in the cylinder block.
5. Rotate camshaft gear (4) in order to align the access hole in the camshaft gear with the hole for fastener (2).

For 402D-05, 403D-07, 403D-11, and 404D-15 engines, install allen head screw (2) and bolt (1). Tighten fasteners (1) and (2) to a torque of 10 N·m (89 lb in).

For 403D-15, 403D-15T, 403D-17, 404D-22, 404D-22T and 404D-22TA engines, install bolt (2) and tighten to a torque of 10 N·m (89 lb in). Rotate camshaft gear (4) in order to align the access hole in the camshaft gear with the hole for bolt (1). Install bolt (1) and tighten to a torque of 10 N·m (89 lb in).

6. Install slider (3) to camshaft gear (4).
7. If the engine is equipped with a mechanical fuel transfer pump, install the fuel transfer pump. Refer to Disassembly and Assembly, "Fuel Transfer Pump - Remove and Install".

End By:

- a. Install the lifters. Refer to Disassembly and Assembly, "Lifter Group- Remove and Install".

- b. Install the front housing. Refer to Disassembly and Assembly, "Housing (Front) - Install".

i02645675

Engine Oil Pan - Remove and Install

Removal Procedure

NOTICE

Keep all parts clean from contaminants.

Contaminants may cause rapid wear and shortened component life.

NOTICE

Care must be taken to ensure that fluids are contained during performance of inspection, maintenance, testing, adjusting and repair of the product. Be prepared to collect the fluid with suitable containers before opening any compartment or disassembling any component containing fluids.

Dispose of all fluids according to local regulations and mandates.

Note: The two cylinder, the three cylinder and the four cylinder engines have different engine oil pans. The removal procedure is similar for all models.

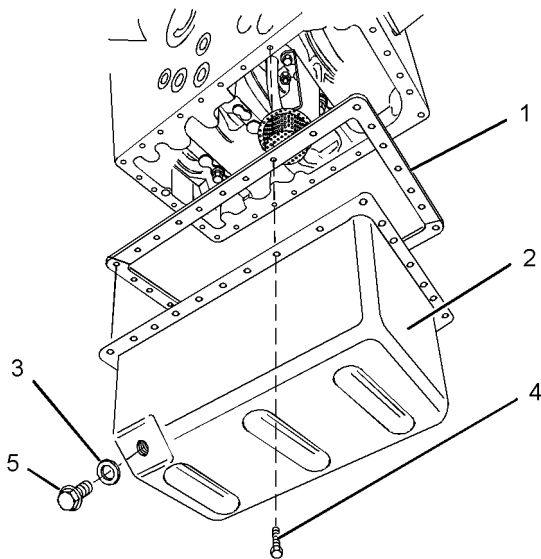

Illustration 142
Typical example

g01326659

1. Remove drain plugs (5) from engine oil pan (2). Drain the engine oil into a suitable container for storage or disposal. Refer to Operation and Maintenance Manual, "Oil Filter Change" for the correct procedure.
2. Remove sealing washers (3) from drain plugs (5).
3. Remove bolts (4) from engine oil pan (2).
4. Remove engine oil pan (2) from the engine.
5. Remove joint (1).

Installation Procedure

NOTICE

Keep all parts clean from contaminants.

Contaminants may cause rapid wear and shortened component life.

Note: The two cylinder, the three cylinder and the four cylinder engines have different engine oil pans. The installation procedure is similar for all models.

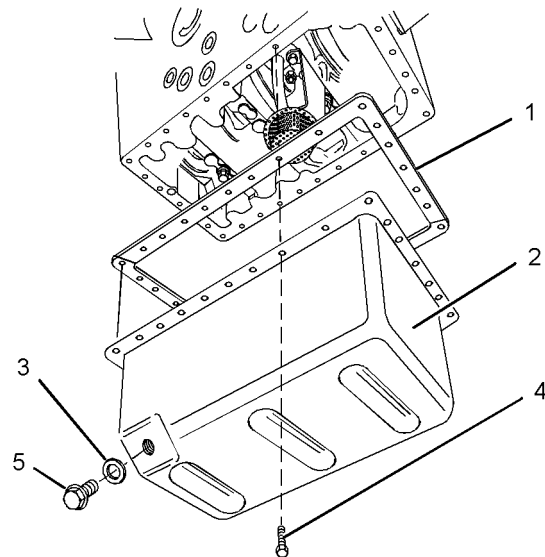

Illustration 143

g01326659

1. Ensure that the engine oil pan is clean and free from damage. Clean the mating surface of the cylinder block.
2. Install a new joint (1) and engine oil pan (2) to the engine.
3. Install bolts (4) and tighten to a torque of 11 N·m (97 lb in).

4. Install drain plugs (5) and sealing washers (3) to oil pan (2). Tighten the drain plugs to a torque of 34 N·m (25 lb ft).
5. Fill the engine oil pan to the correct level. Refer to Operation and Maintenance Manual, "Engine Oil Filter Change" for the correct procedure.

i02645749

Pistons and Connecting Rods - Remove

Removal Procedure

Table 23

Required Tools			
Tool	Part Number	Part Description	Qty
A	27610274	Ridge Reamer	1

Start By:

- a. Remove the cylinder head. Refer to Disassembly and Assembly, "Cylinder Head - Remove".
- b. Remove the suction pipe. Refer to Disassembly and Assembly, "Engine Oil Pump - Remove".

NOTICE

Keep all parts clean from contaminants.

Contaminants may cause rapid wear and shortened component life.

1. Position the piston that is being removed in the bottom center position.
2. Use Tooling (A) in order to remove the carbon from the inner surface of the cylinder bore.

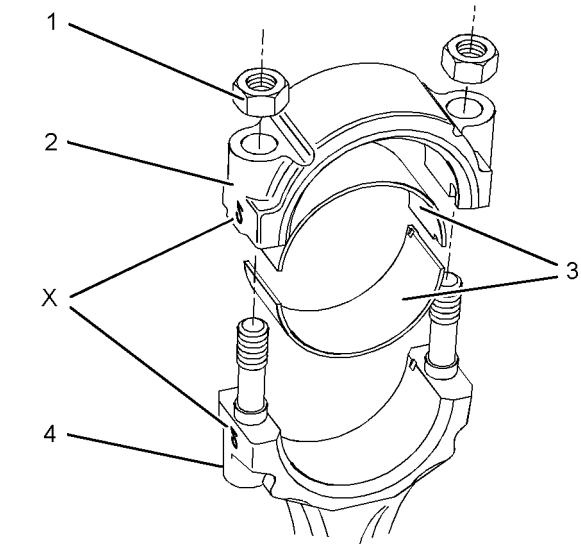

Illustration 144

g01317717

3. The connecting rod and the connecting rod cap should have an etched number (X) on the side. The number on the connecting rod and the connecting rod cap must match. Ensure that connecting rod (4) and connecting rod cap (2) are marked for the correct location. If necessary, make a temporary mark on the connecting rod and the connecting rod cap in order to identify the cylinder number.

Note: Do not stamp the connecting rod assembly.

4. Remove nuts (1) and remove connecting rod cap (2) from connecting rod (4).

Note: Use tape or rubber tubing on the threads of the connecting rod bolts in order to protect the crankshaft journals. The sharp edges of the connecting rod bolts could damage the crankshaft journals.

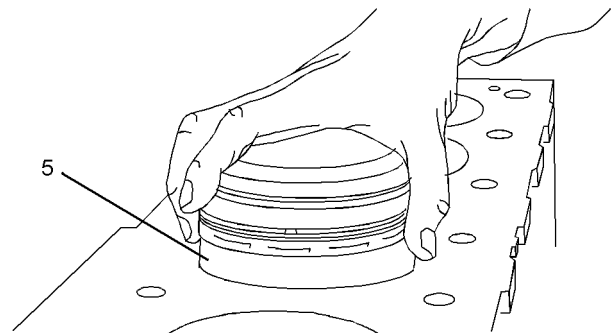

Illustration 145

g01317733

Typical example

5. Carefully push piston (5) and the connecting rod assembly out of the cylinder bore. Lift the piston out of the top of the cylinder block.

Note: Make an identification mark underneath the piston on the pin boss in order to identify the position on the piston for installation. Always mark the front pin boss.

6. Keep connecting rod bearings (3) with the respective connecting rod (4) and cap (2).
7. Repeat Steps 1 through 6 in order to remove the remaining pistons and connecting rods.

i02645741

Pistons and Connecting Rods - Disassemble

Disassembly Procedure

Table 24

Required Tools			
Tool	Part Number	Part Description	Qty
A	-	Retaining Ring Pliers	1
B	-	Ring Expander	1

Start By:

- a. Remove the pistons and connecting rods. Refer to Disassembly and Assembly, "Pistons and Connecting Rods - Remove".

NOTICE

Keep all parts clean from contaminants.

Contaminants may cause rapid wear and shortened component life.

1. Make a temporary mark on the components of the piston and connecting rod assembly. This will ensure that the components of each piston and connecting rod assembly can be reinstalled in the original cylinder. Mark the front of the piston and the front of the connecting rod. Do not interchange components.

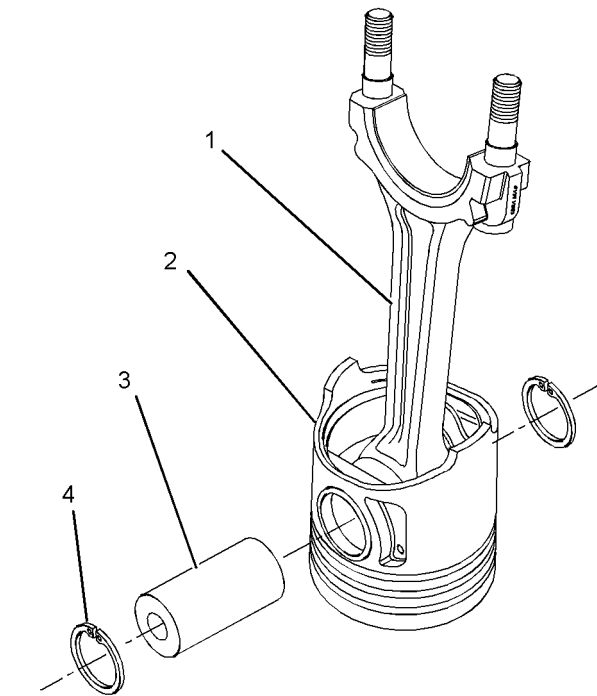

Illustration 146

g01311807

Typical example

2. Place the piston and connecting rod assembly on a suitable surface with the connecting rod upward. Use Tooling (A) in order to remove retaining rings (4).
3. Remove piston pin (3) and connecting rod (1) from piston (2).

Note: If the piston pin cannot be removed by hand, heat the piston to a temperature of $45 \pm 5 \text{ }^\circ\text{C}$ ($113 \pm 9 \text{ }^\circ\text{F}$). Do not use a torch to heat the piston.

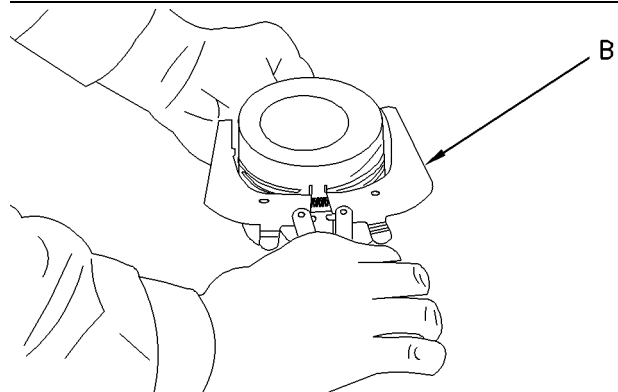

Illustration 147

g00829406

Typical example

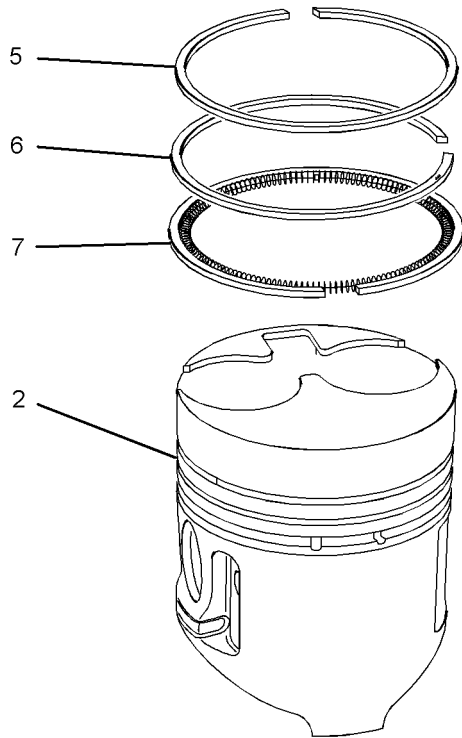

Illustration 148

g01311809

4. Place the piston on a suitable surface with the crown upward. Use Tooling (B) in order to remove compression rings (5) and (6), and oil control ring (7) from piston (2).

Note: Identify the orientation of the piston rings for installation.

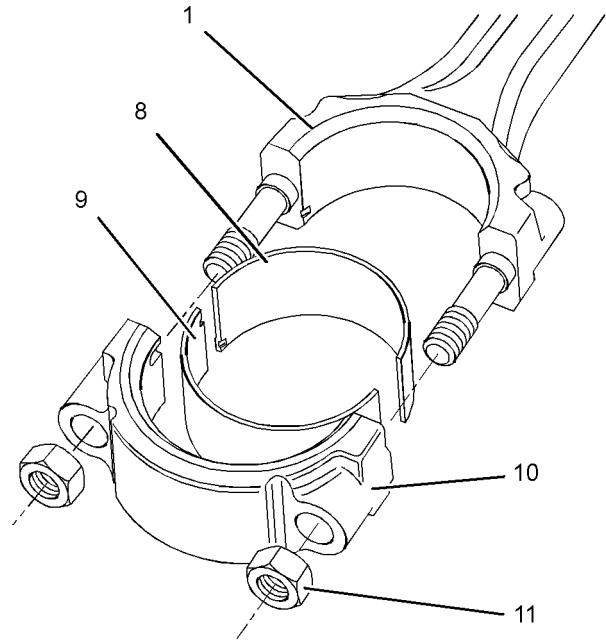

Illustration 149

g01311837

Typical example

5. Remove nuts (11) and connecting rod cap (10) from connecting rod (1).
6. Remove the lower half of connecting rod bearing (9) from connecting rod cap (10). Remove the upper half of connecting rod bearing (8) from connecting rod (1). Keep the bearing shells together.

NOTICE

Removal of the piston pin bushing in the connecting rod must be carried out by personnel with the correct training. Also special machinery is required. For more information refer to your authorized Perkins dealer.

7. Inspect the connecting rod for wear or damage. If necessary, replace the connecting rod or replace the bush for the piston pin.

i02645739

Pistons and Connecting Rods - Assemble

Assembly Procedure

Table 25

Required Tools			
Tool	Part Number	Part Description	Qty
A	-	Retaining Ring Pliers	1
B	-	Ring Expander	1

NOTICE

Keep all parts clean from contaminants.

Contaminants may cause rapid wear and shortened component life.

1. Ensure that all components are clean and free from wear or damage. If necessary, replace any components that are worn or damaged.
2. Follow Steps 2.a through 2.e in order to install the piston rings to the piston.

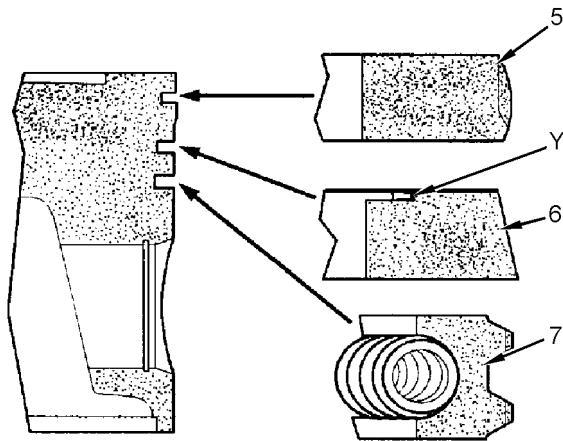

Illustration 150

g01038129

- a. Position the spring for oil control ring (7) into the oil ring groove in the piston. The central wire must be located inside the end of the spring.

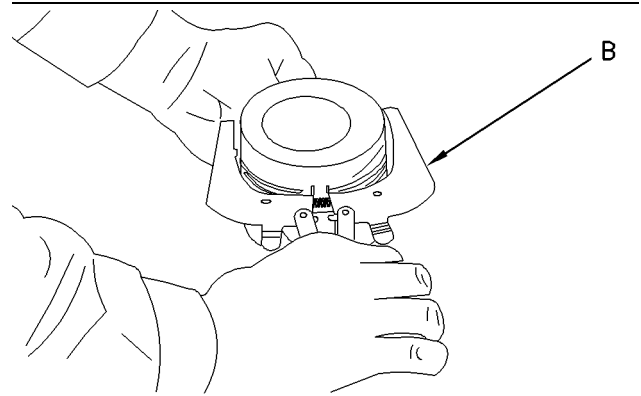

Illustration 151

g00829406

Typical example

- b. Use Tooling (B) to install oil control ring (7) over the spring.

Note: Ensure that the central wire is 180 degrees from the ring gap.

- c. Use Tooling (B) to install intermediate compression ring (6) into the second groove in the piston. The letter "T" and the chamfer (Y) on the inner face of the ring must be upward.
- d. Use Tooling (B) to install top compression ring (5) into the top groove in the piston. The letter "T" must be upward.
- e. Position the piston ring gaps at 120 degrees away from each other.

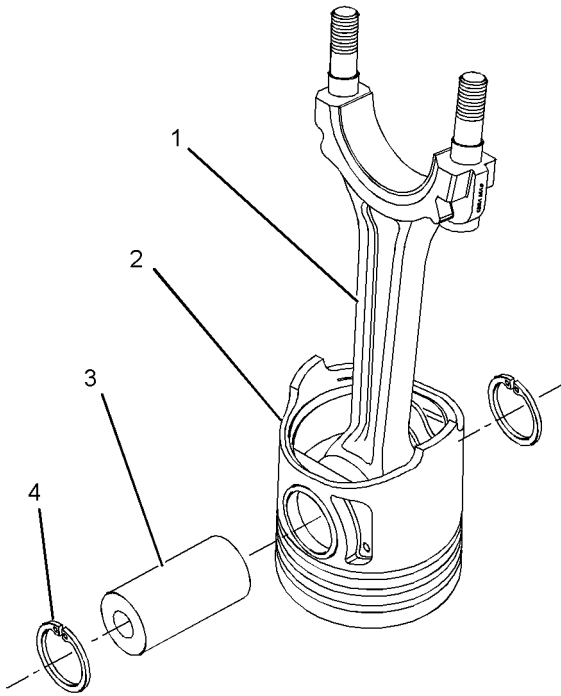

Illustration 152

g01311807

Typical example

3. Lubricate the bush in connecting rod (1) and lubricate the bore for the piston pin in piston (2) with clean engine oil.
4. Place the piston on a suitable surface with the crown downward. Install connecting rod (1) and piston pin (3) to piston (2). The name Shibaura inside the piston must align with the stamped number on the connecting rod. Ensure the correct orientation of the connecting rod in the piston.

Note: If the piston pin cannot be installed by hand, heat the piston to a temperature of $45 \pm 5 \text{ }^\circ\text{C}$ ($113 \pm 9 \text{ }^\circ\text{F}$). Do not use a torch to heat the piston.

5. Use Tooling (A) in order to install retaining rings (4) to the piston pin bore in piston (2).

Note: Ensure that the retaining rings are seated in the grooves in the piston.

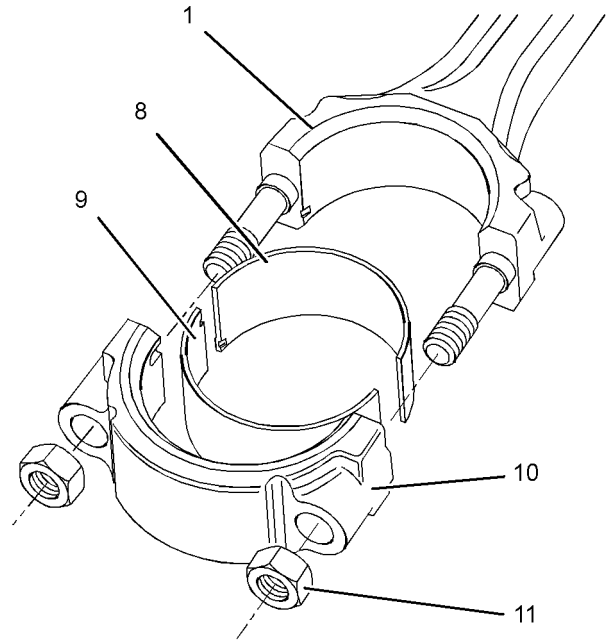

Illustration 153

g01311837

Typical example

6. Install the upper half of connecting rod bearing (8) to connecting rod (1).
7. Install the lower half of connecting rod bearing (9) to connecting rod cap (10).

End By:

- a. Install the pistons and the connecting rods. Refer to Disassembly and Assembly, "Piston and Connecting Rods - Install".

i02961862

Pistons and Connecting Rods - Install

Installation Procedure

Table 26

Required Tools			
Tool	Part Number	Part Description	Qty
A	21825491	Piston Ring Compressor	1

NOTICE

Keep all parts clean from contaminants.

Contaminants may cause rapid wear and shortened component life.

1. If the connecting rod caps were temporarily installed, remove the connecting rod caps. If necessary, thoroughly clean all of the components.
2. Apply clean engine oil to the cylinder bore, to the piston rings, to the outer surface of the piston and to the connecting rod bearings.

Note: Install the connecting rod bearings dry when clearance checks are performed. Refer to Disassembly and Assembly, "Bearing Clearance - Check". Apply clean engine oil to the connecting rod bearings during final assembly.

3. Rotate the crankshaft until the crankshaft pin is at the bottom center position. Lubricate the crankshaft pin with clean engine oil.
-

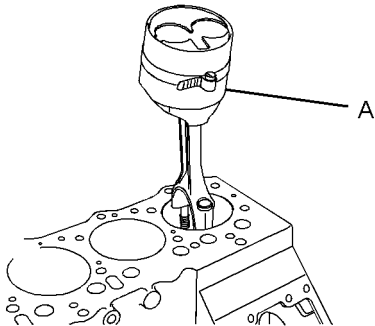

Illustration 154

g01311916

Typical example

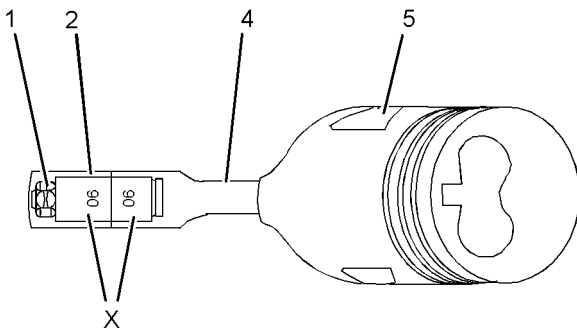

Illustration 155

g01311924

Typical example

4. Ensure that the gaps for the piston rings are at 120 degrees away from each other. Install Tooling (A) onto piston (5). Use tape or rubber tubing on the connecting rod bolts to protect the crankshaft journals.

Note: Ensure that Tooling (A) is installed correctly and that the piston can easily slide from the tool. Ensure that the piston and the connecting rod assembly are installed in the correct cylinder. Align number (X) on the side of the connecting rod to the right side of the cylinder block. The right hand side is determined from the flywheel end of the engine.

5. Carefully push the piston and the connecting rod assembly into the cylinder bore and onto the crankshaft pin.

Note: Do not damage the finished surface of the crankshaft pin.

6. Install connecting rod cap (2) onto connecting rod (4). Ensure that number (X) on the connecting rod cap matches number (X) on the connecting rod. Install nuts (1).

For 402D-05 and 403D-07 engines, tighten nuts (1) to a torque of 23 N·m (16 lb ft).

For 403D-11 and 404D-15 engines, tighten nuts (1) to a torque of 32 N·m (24 lb ft).

For 403D-15, 403D-15T, 403D-17, 404D-22, 404D-22T and 404D-22TA engines, tighten nuts (1) to a torque of 52 N·m (38 lb ft).

7. Repeat Steps 1 through 6 for the remaining pistons and connecting rods.
8. Ensure that the installed connecting rod assembly has tactile side play. Carefully rotate the crankshaft in order to ensure that there is no binding.

End By:

- a. Install the suction pipe. Refer to Disassembly and Assembly, "Engine Oil Pump - Install".
- b. Install the cylinder head. Refer to Disassembly and Assembly, "Cylinder Head - Install".

i02645659

Connecting Rod Bearings - Remove (Connecting rods in position)

Removal Procedure

Start By:

- a. Remove the suction pipe. Refer to Disassembly and Assembly, "Engine Oil Pump - Remove".

NOTICE

Keep all parts clean from contaminants.

Contaminants may cause rapid wear and shortened component life.

Note: If all connecting rod bearings require replacement on a four cylinder engine, the procedure can be carried out on two cylinders at the same time. The procedure can be carried out on the following pairs of cylinders. 1 with 4 and 2 with 3. **Ensure that both pairs of the connecting rod bearings are installed before changing from one pair of cylinders to another pair of cylinders..** Refer to Disassembly and Assembly, "Connecting Rod Bearings - Install".

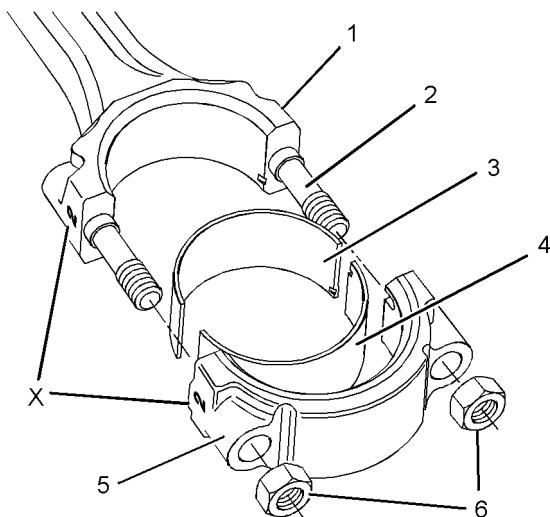

Illustration 156

g01317759

Typical example

Note: The connecting rod and the connecting rod cap should have matching numbers at position (X). If necessary, make a temporary mark on connecting rod (1) and on connecting rod cap (5).

1. Rotate the crankshaft until the piston is at the bottom center position. Remove nuts (6) and remove connecting rod cap (5) from connecting rod (1).
2. Remove lower connecting rod bearing (4) from connecting rod cap (5).
3. Carefully push connecting rod (1) into the cylinder bore. Remove upper connecting rod bearing (3) from the connecting rod.

Note: Use tape or rubber tubing on connecting rod bolts (2) in order to protect the crankshaft journals. The sharp edges of the connecting rod bolts could damage the crankshaft journals.

i02961864

Connecting Rod Bearings - Install (Connecting rods in position)

Installation Procedure

NOTICE

Keep all parts clean from contaminants.

Contaminants may cause rapid wear and shortened component life.

1. Inspect the pins of the crankshaft for damage. If the crankshaft is damaged, replace the crankshaft or recondition the crankshaft. Refer to Disassembly and Assembly, "Crankshaft - Remove" and Disassembly and Assembly, "Crankshaft - Install". Ensure that the connecting rod bearings are clean and free from wear or damage. If necessary, replace the connecting rod bearings.

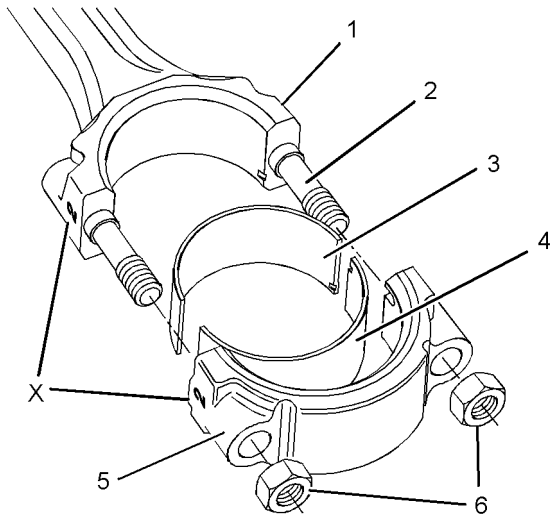

Illustration 157
Typical example

g01317759

2. Clean the bearing surface of connecting rod (1) and connecting rod cap (5). Ensure that number (X) on connecting rod cap (5) aligns with number (X) on connecting rod (1).
3. Install upper connecting rod bearing (3) to connecting rod (1). Lubricate the bearing surface of the connecting rod bearing with clean engine oil.

4. Carefully pull connecting rod (1) against the crankshaft pin.

Note: Use tape or rubber tubing on connecting rod bolts (2) in order to protect the crankshaft journals. The sharp edges of the connecting rod bolts could damage the crankshaft journals.

5. Clean the connecting rod cap. Install lower connecting rod bearing (4) to connecting rod cap (5).
6. Lubricate the pin of the crankshaft and lubricate lower connecting rod bearing (3) with clean engine oil.

NOTICE

When the connecting rod caps are installed, ensure that the identification marks are aligned.

7. Install connecting rod cap (5).
8. Install nuts (4).

For 402D-05 and 403D-07 engines, tighten nuts (4) to a torque of 23 N·m (16 lb ft).

For 403D-11 and 404D-15 engines, tighten nuts (4) to a torque of 32 N·m (24 lb ft).

For 403D-15, 403D-15T, 403D-17, 404D-22, 404D-22T and 404D-22TA engines, tighten nuts (4) to a torque of 52 N·m (38 lb ft).

9. Ensure that the installed connecting rod assembly has tactile side play. Carefully rotate the crankshaft in order to ensure that there is no binding.

Note: If all connecting rod bearings require replacement on a four cylinder engine, the procedure can be carried out on two cylinders at the same time. The procedure can be carried out on the following pairs of cylinders. 1 with 4 and 2 with 3. **Ensure that both pairs of the connecting rod bearings are installed before changing from one pair of cylinders to another pair of cylinders.** Refer to Disassembly and Assembly, "Connecting Rod Bearings - Remove" for more information.

End By:

- a. Install the suction pipe. Refer to Disassembly and Assembly, "Engine Oil Pump - Install".

i02186171

Connecting Rod Bearings - Install

Installation Procedure

NOTICE

Keep all parts clean from contaminants.

Contaminants may cause rapid wear and shortened component life.

NOTICE

When the connecting rod caps are installed, ensure that the identification marks are aligned.

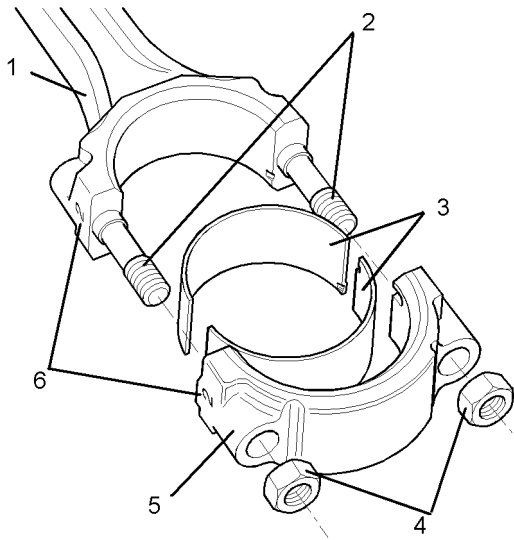

Illustration 158

g01111763

Typical example

1. Check the clearance between the connecting rod bearing and the connecting rod bearing journal of the crankshaft. Install the connecting rod bearings dry when the clearance checks are made. Refer to Disassembly and Assembly, "Bearing Clearance - Check" for information on bearing clearance checks.
2. Clean the bearing surface of the connecting rod (1) and the connecting rod cap (5). Ensure that the number (6) on the connecting rod cap (5) aligns with the number (6) on the connecting rod (1).
3. Clean the upper connecting rod bearing (3) and lubricate the bearing face with clean engine oil.
4. Clean the lower connecting rod bearing (3) and lubricate the bearing face with clean engine oil.

Note: Align the tabs on the back of the connecting rod bearings (3) with the tab grooves in the connecting rod (1) and the tab grooves on the connecting rod cap (5).

5. Install the upper connecting rod bearing (3) to the connecting rod (1).
6. Position the connecting rod (1) against the crankshaft.
7. Install the lower connecting rod bearing (3) in the connecting rod cap (5).
8. Install the connecting rod cap (5) in position on the connecting rod (1) and install the nuts (4) to the connecting rod bolts (2). Refer to Disassembly and Assembly, "Pistons and Connecting Rods - Install" for the correct torque of the connecting rod nuts (4).

Note: The identification marks must face the right hand side of the engine for the correct installation.

9. Repeat Steps 2 through 8 for the installation of the remaining connecting rod bearings.

End By:

- a. Install the oil supply tube. Refer to Disassembly and Assembly, "Crankshaft - Install".
- b. Install the engine oil pan. Refer to Disassembly and Assembly, "Engine Oil Pan - Remove and Install".

i02645668

Crankshaft Main Bearings - Remove

Removal Procedure

Start By:

- a. Remove the crankshaft assembly. Refer to Disassembly and Assembly, "Crankshaft - Remove".

NOTICE

Keep all parts clean from contaminants.

Contaminants may cause rapid wear and shortened component life.

Crankshaft Main Bearings

1. Ensure that the bearing caps are marked for orientation and the correct position.

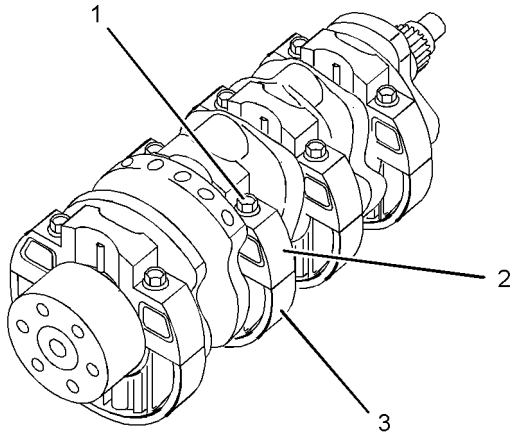

Illustration 159

g01327056

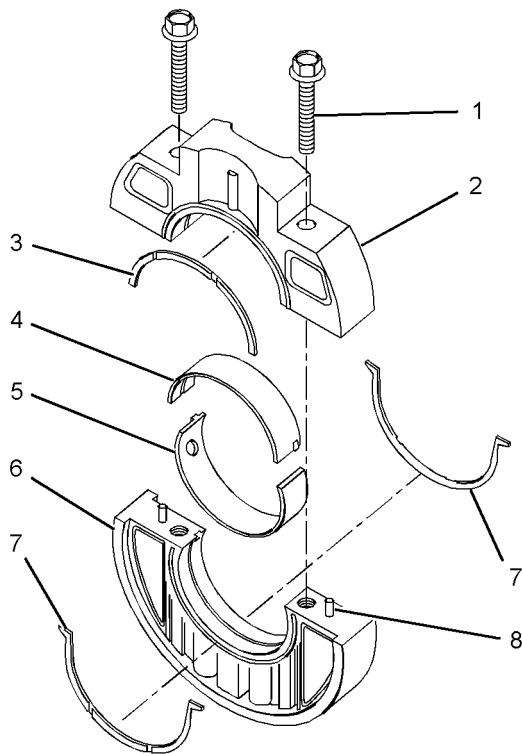

Illustration 160

g01327033

Typical example

2. Remove bolts (1) and upper main bearing cap (2) from lower main bearing cap (6).
3. For C1.5 engines, remove thrust washers (7).

For C2.2 engines, remove thrust washers (3) and (7).

4. Remove main bearings (4) and (5) from the main bearing caps. Keep the main bearings with the respective bearing caps.
5. Do not remove dowels (8) from the main bearing caps.

Crankshaft Bearing (Front)

Table 27

Required Tools			
Tool	Part Number	Part Description	Qty
A	27610275	Driver	1

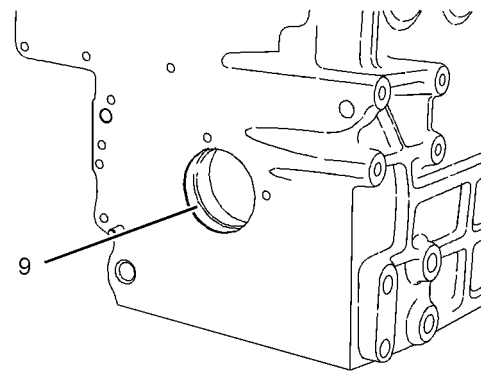

Illustration 161

g01327066

1. Use Tooling (A) to remove crankshaft bearing (9) from the cylinder block.

i02963756

Crankshaft Main Bearings - Install

Installation Procedure

Crankshaft Main Bearings

1. Clean the crankshaft and inspect the crankshaft for wear or damage. Refer to Specifications, "Crankshaft" for more information.
2. Clean the main bearings and the main bearing caps. For 403D-15, 403D-15T, 403D-17, 404D-22, 404D-22T and 404D-22TA engines, clean the thrust washers. Inspect all components for wear or damage.

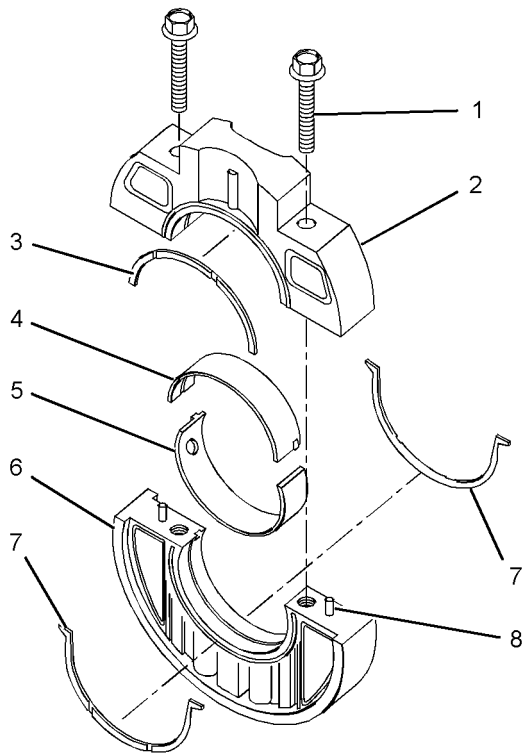

Illustration 162
Typical example

g01327033

4. Install lower main bearing (5) to lower main bearing cap (6). Ensure that the locating tab for the main bearing is seated in the slot in the main bearing cap.

Note: The lower bearing is a plain bearing that has oil holes.

5. Lubricate main bearings (4) and (5) with clean engine oil.
6. Position the upper half of main bearing cap (2) in position on the crankshaft. Position the lower half of main bearing cap (6) in position on the crankshaft. Ensure the correct location and orientation of the bearing caps. The locating tabs for the upper and the lower bearings should be on the same side of the engine. Ensure that dowels (8) are in the correct position. This will ensure that the two halves of the main bearing caps are aligned.

For 403D-15, 403D-15T and 403D-17 engines, install thrust washers (7).

For 404D-22, 404D-22T and 404D-22TA engines, install thrust washers (3) and (7).

Note: Ensure that the thrust washers are aligned correctly and that the oil grooves are facing the crankshaft.

7. Install bolts (1).

For 402D-05, 403D-07, 403D-11, and 404D-15 engines, tighten the bolts to a torque of 23 N·m (17 lb ft).

For 403D-15, 403D-15T, 403D-17, 404D-22, 404D-22T and 404D-22TA engines, tighten the bolts to a torque of 52 N·m (38 lb ft).

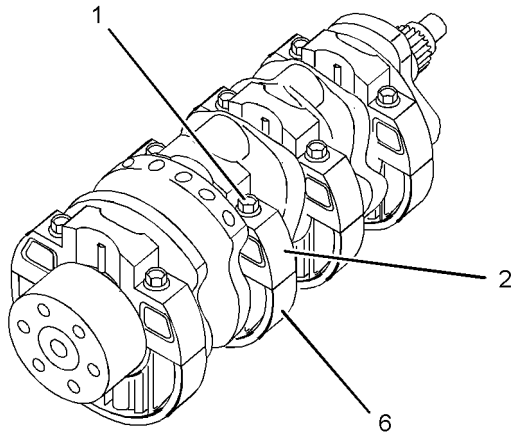

Illustration 163
Typical example

g01485913

3. Install upper main bearing (4) to upper main bearing cap (2). Ensure that the locating tab for the main bearing is seated in the slot in the main bearing cap.

Note: The upper bearing has a groove.

Crankshaft Bearing (Front)

Table 28

Required Tools			
Tool	Part Number	Part Description	Qty
A	27610275	Driver	1

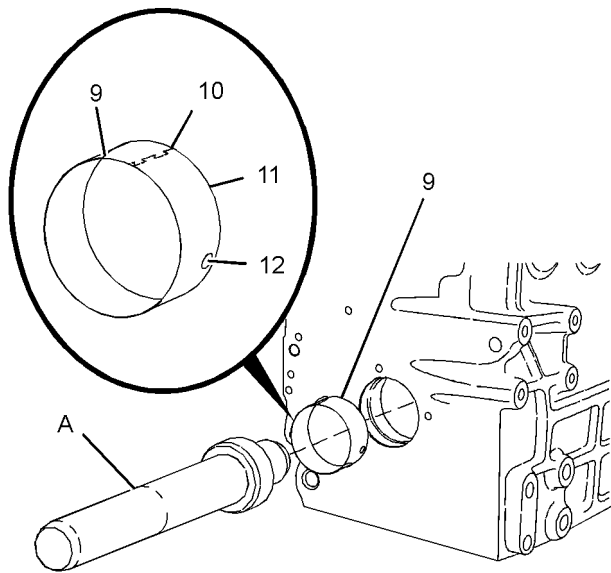

Illustration 164

g01485933

1. Use Tooling (A) to install crankshaft bearing (9) to the cylinder block. Follow Steps 1.a through 1.c in order to install the crankshaft bearing.
 - a. Ensure that oil supply hole (12) is aligned with the oil gallery in the cylinder block.
 - b. Ensure that joint (10) is upward.
 - c. Ensure that chamfer (11) faces toward the cylinder block.

End By:

- a. Install the crankshaft assembly. Refer to Disassembly and Assembly, "Crankshaft - Install".

i02645665

Crankshaft - Remove

Removal Procedure

Start By:

- a. Remove the engine oil relief valve. Refer to Disassembly and Assembly, "Engine Oil Relief Valve - Remove and Install".
- b. Remove the crankshaft rear seal. Refer to Disassembly and Assembly, "Crankshaft Rear Seal - Remove and Install".

- c. Remove the engine oil pump and the suction pipe. Refer to Disassembly and Assembly, "Engine Oil Pump - Remove".
- d. Remove the pistons and the connecting rods. Refer to Disassembly and Assembly, "Pistons and Connecting Rods - Remove".

NOTICE

Keep all parts clean from contaminants.

Contaminants may cause rapid wear and shortened component life.

1. The engine should be mounted in a suitable stand with the rear end upward.

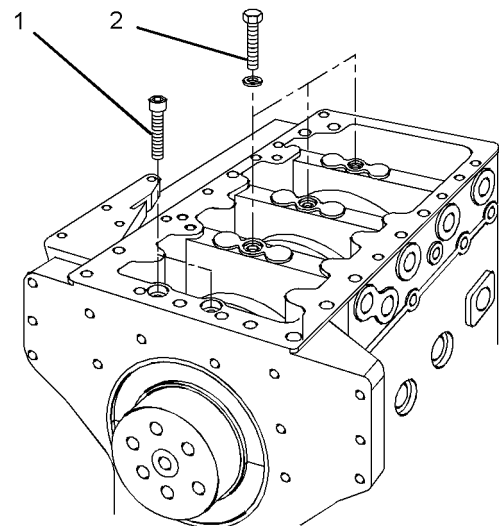

Illustration 165

g01311526

Typical example

2. Remove bolts (2) from the cylinder block.
3. Remove allen head screws (1) from the cylinder block.

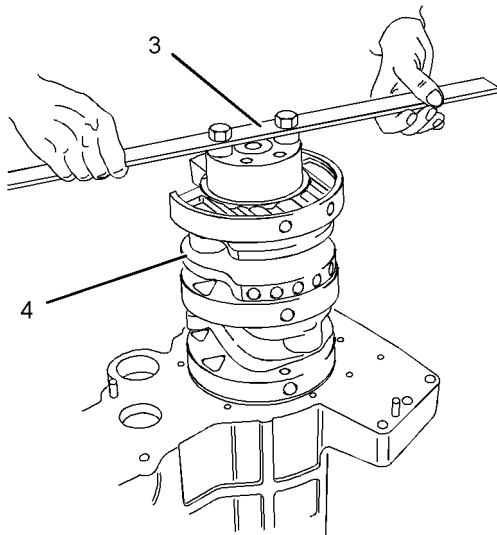

Illustration 166 g01311527
Typical example

4. Attach a suitable lifting device (3) to crankshaft assembly (4).
5. Carefully lift crankshaft assembly (4) from the cylinder block. If necessary, gently tap the nose of the crankshaft with a soft faced hammer.

Note: Install the nut for the crankshaft pulley in order to protect the nose of the crankshaft. Do not scratch any of the finished surfaces on the crankshaft.

i02961985

Crankshaft - Install

Installation Procedure

Table 29

Required Tools			
Tool	Part Number	Part Description	Qty
A	21825617	Dial Indicator Group	1

1. The engine should be mounted in a suitable stand with the rear end upward.
2. Ensure that the crankshaft assembly is clean and free from damage.

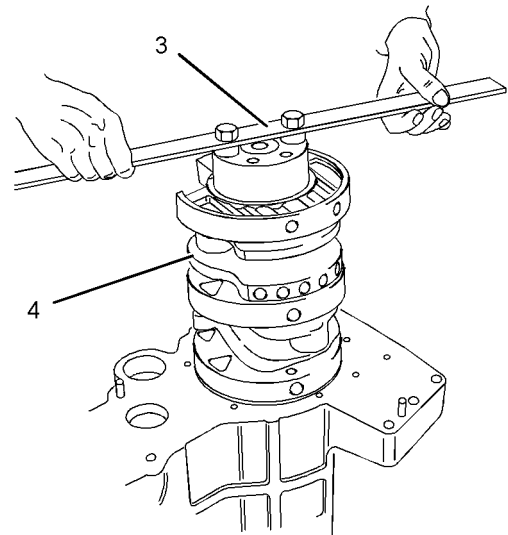

Illustration 167 g01311527
Typical example

3. Attach a suitable lifting device (3) to crankshaft assembly (4). Lubricate the front journal of the crankshaft with clean engine oil.

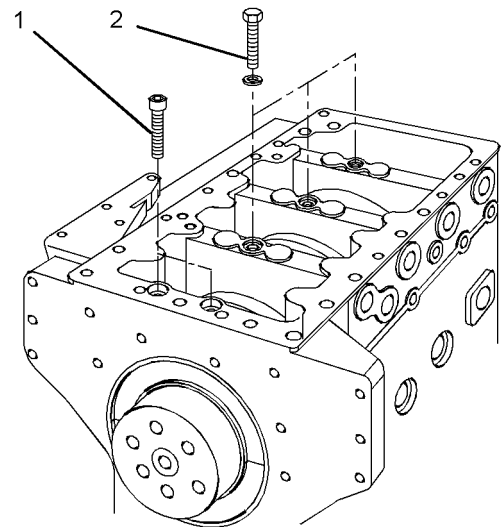

Illustration 168 g01311526
Typical example

NOTICE

Ensure that the oil passages in the main bearings align with the oil passages in the cylinder block.

i02748526

4. Align the holes in the crankshaft assembly for bolts (2) with the holes in the cylinder block. Align the holes in the crankshaft assembly for allen head screws (1) with the holes in the cylinder block. Carefully lower the crankshaft assembly (4) into the cylinder block. If necessary, gently tap the rear of the crankshaft with a soft faced hammer.
5. Remove lifting device (3) from crankshaft assembly (4).
6. Install allen head screws (1) finger tight.
7. Install bolts (2).

For 402D-05, 403D-07, 403D-11 and 404D-15 engines, tighten bolts (2) to a torque of 27 N·m (20 lb ft).

For 403D-15, 403D-15T, 403D-17, 404D-22, 404D-22T and 404D-22TA engines, tighten bolts (4) to a torque of 52 N·m (38 lb ft).
8. Tighten allen head screws (1) to a torque of 27 N·m (20 lb ft).
9. Rotate the crankshaft in order to ensure that there is no binding.
10. Check the crankshaft end play. Push the crankshaft toward the front of the engine. Install Tooling (A) to the cylinder block and the rear face of the crankshaft. Push the crankshaft toward the rear of the engine. Use Tooling (A) to measure the crankshaft end play. Refer to Specifications, "Crankshaft" for the maximum permissible crankshaft end play.

End By:

- a. Install the pistons and the connecting rods. Refer to Disassembly and Assembly, "Pistons and Connecting Rods - Install".
- b. Install the engine oil pump and the suction pipe. Refer to Disassembly and Assembly, "Engine Oil Pump - Install".
- c. Install the crankshaft rear seal. Refer to Disassembly and Assembly, "Crankshaft Rear Seal - Remove and Install".
- d. Install the engine oil relief valve. Refer to Disassembly and Assembly, "Engine Oil Relief Valve - Remove and Install".

Bearing Clearance - Check

Measurement Procedure

Table 30

Required Tools			
Tool	Part Number	Part Description	Qty
A	-	Plastic Gauge (Green) 0.025 to 0.076 mm (0.001 to 0.003 inch)	1
	-	Plastic Gauge (Red) 0.051 to 0.152 mm (0.002 to 0.006 inch)	1
	-	Plastic Gauge (Blue) 0.102 to 0.229 mm (0.004 to 0.009 inch)	1
	-	Plastic Gauge (Yellow) 0.230 to 0.510 mm (0.009 to 0.020 inch)	1

NOTICE

Keep all parts clean from contaminants.

Contaminants may cause rapid wear and shortened component life.

Note: Perkins does not recommend the checking of the actual clearances of the bearing shells particularly on small engines. This is because of the possibility of obtaining inaccurate results and of damaging the bearing shell or the journal surfaces. Each Perkins bearing shell is quality checked for specific wall thickness.

Note: The measurements should be within specifications and the correct bearings should be used. If the crankshaft journals and the bores for the block and the rods were measured during disassembly, no further checks are necessary. However, if the technician still wants to measure the bearing clearances, Tooling (A) is an acceptable method. Tooling (A) is less accurate on journals with small diameters if clearances are less than 0.10 mm (0.004 inch).

NOTICE

Lead wire, shim stock or a dial bore gauge can damage the bearing surfaces.

The technician must be very careful to use Tooling (A) correctly. The following points must be remembered:

i02962020

- Ensure that the backs of the bearings and the bores are clean and dry.
 - Ensure that the bearing locking tabs are properly seated in the tab grooves.
 - The crankshaft must be free of oil at the contact points of Tooling (A).
1. Put a piece of Tooling (A) on the crown of the bearing that is in the cap.

Note: Do not allow Tooling (A) to extend over the edge of the bearing.

2. Use the correct torque-turn specifications in order to install the bearing cap. Do not use an impact wrench. Be careful not to dislodge the bearing when the cap is installed.

Note: Do not turn the crankshaft when Tooling (A) is installed.

3. Carefully remove the cap, but do not remove Tooling (A). Measure the width of Tooling (A) while Tooling (A) is in the bearing cap or on the crankshaft journal. Refer to Illustration 169.

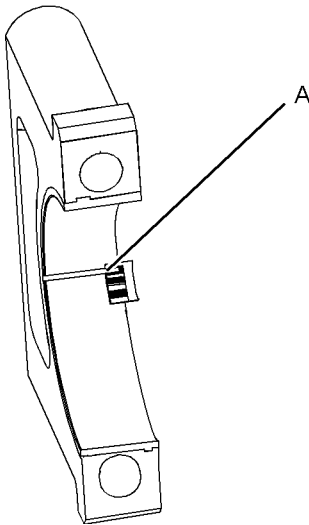

Illustration 169
Typical Example

g01152855

4. Remove all of Tooling (A) before you install the bearing cap.

Note: When Tooling (A) is used, the readings can sometimes be unclear. For example, all parts of Tooling (A) are not the same width. Measure the major width in order to ensure that the parts are within the specification range. Refer to Specifications Manual, “Connecting Rod Bearing Journal” and Specifications Manual, “Main Bearing Journal” for the correct clearances.

Coolant Temperature Switch - Remove and Install (403D-11, 403D-15, 403D-15T, 403D-17, 404D-15, 404D-22, 404D-22T and 404D-22TA Engines)

Removal Procedure

NOTICE

Keep all parts clean from contaminants.

Contaminants may cause rapid wear and shortened component life.

NOTICE

Care must be taken to ensure that fluids are contained during performance of inspection, maintenance, testing, adjusting and repair of the product. Be prepared to collect the fluid with suitable containers before opening any compartment or disassembling any component containing fluids.

Dispose of all fluids according to local regulations and mandates.

1. Drain the coolant from the cooling system into a suitable container for storage or disposal. Refer to Operation and Maintenance Manual, “Cooling System Coolant - Drain” for more information.

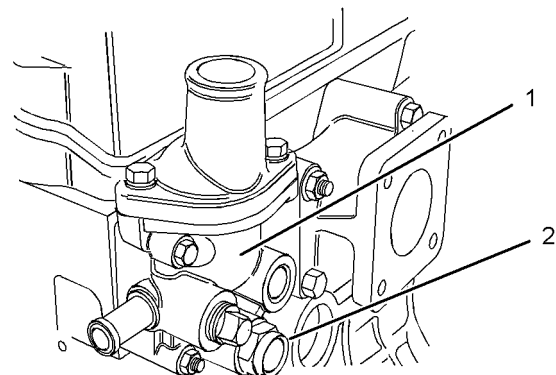

Illustration 170
Typical example

g01326627

2. Disconnect the harness assembly (not shown) from coolant temperature switch (2).
3. Remove coolant temperature switch (2) from water temperature regulator housing (1).

Installation Procedure

i02645660

Table 31

Required Tools			
Tool	Part Number	Part Description	Qty
A	21820122	POWERPART Pipe Sealant	1

NOTICE

Keep all parts clean from contaminants.

Contaminants may cause rapid wear and shortened component life.

1. Inspect the coolant temperature switch for damage and correct operation. Refer to Systems Operation, Testing and Adjusting, "Coolant Temperature Switch - Test" for more information. If necessary, replace the coolant temperature switch.

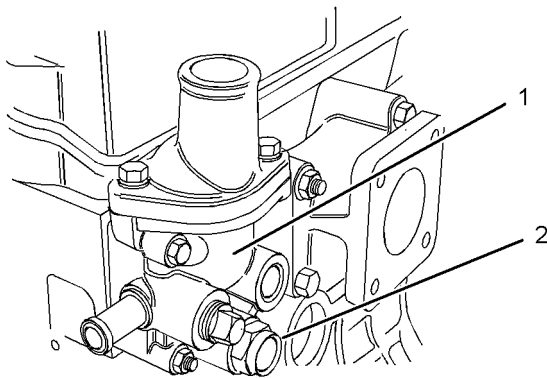

Illustration 171

g01326627

Typical example

2. Install coolant temperature switch (2) to water temperature regulator housing (1). Use a deep socket to tighten the coolant temperature switch to a torque of 27 N·m (20 lb ft).

Note: If a used coolant temperature switch is installed, apply a thin layer of Tooling (A) to the threads of the coolant temperature switch.

3. Connect the harness assembly (not shown) to coolant temperature switch (2).
4. Fill the cooling system with coolant to the correct level. Refer to Operation and Maintenance Manual, "Cooling System Coolant - Fill" for more information.

Coolant Temperature Switch - Remove and Install (402D-05 and 403D-07 Engines)

Removal Procedure

NOTICE

Keep all parts clean from contaminants.

Contaminants may cause rapid wear and shortened component life.

NOTICE

Care must be taken to ensure that fluids are contained during performance of inspection, maintenance, testing, adjusting and repair of the product. Be prepared to collect the fluid with suitable containers before opening any compartment or disassembling any component containing fluids.

Dispose of all fluids according to local regulations and mandates.

1. Drain the coolant from the cooling system into a suitable container for storage or disposal. Refer to Operation and Maintenance Manual, "Cooling System Coolant - Drain" for more information.

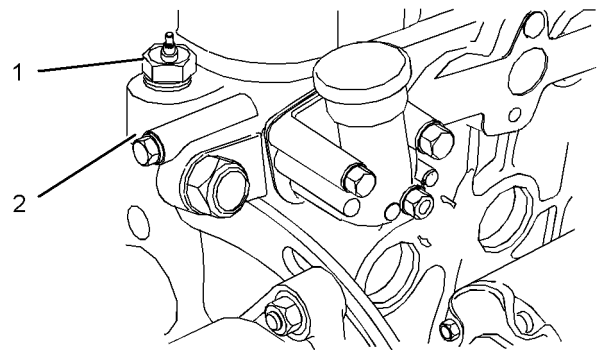

Illustration 172

g01325724

Typical example

2. Disconnect the harness assembly (not shown) from coolant temperature switch (1).
3. Remove coolant temperature switch (1) from water pump (2).

Installation Procedure

i02645676

Table 32

Required Tools			
Tool	Part Number	Part Description	Qty
A	21820122	POWERPART Pipe Sealant	1

NOTICE

Keep all parts clean from contaminants.

Contaminants may cause rapid wear and shortened component life.

1. Inspect the coolant temperature switch for damage and correct operation. Refer to Systems Operation, Testing and Adjusting, "Coolant Temperature Switch - Test" for more information. If necessary, replace the coolant temperature switch.

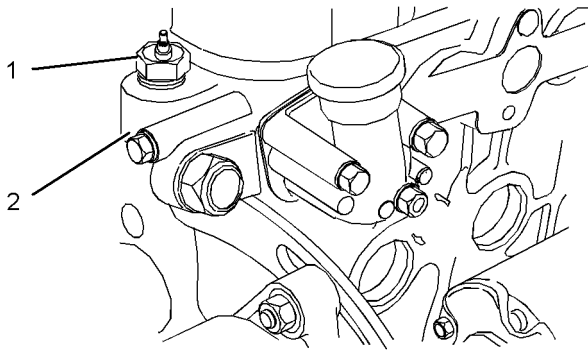

Illustration 173

g01325724

Typical example

2. Install coolant temperature switch (1) to water pump (2). Use a deep socket to tighten the coolant temperature switch to a torque of 27 N·m (20 lb ft).

Note: If a used coolant temperature switch is installed, apply a thin layer of Tooling (A) to the threads of the coolant temperature switch.

3. Connect the harness assembly (not shown) to coolant temperature switch (1).
4. Fill the cooling system with coolant to the correct level. Refer to Operation and Maintenance Manual, "Cooling System Coolant - Fill" for more information.

Engine Oil Pressure Switch - Remove and Install

Removal Procedure

NOTICE

Keep all parts clean from contaminants.

Contaminants may cause rapid wear and shortened component life.

NOTICE

Care must be taken to ensure that fluids are contained during performance of inspection, maintenance, testing, adjusting and repair of the product. Be prepared to collect the fluid with suitable containers before opening any compartment or disassembling any component containing fluids.

Dispose of all fluids according to local regulations and mandates.

Note: The engine oil pressure switch may be located in the valve mechanism cover or in the cylinder block. Refer to Specifications, "Engine Oil Pressure Switch" for the correct location.

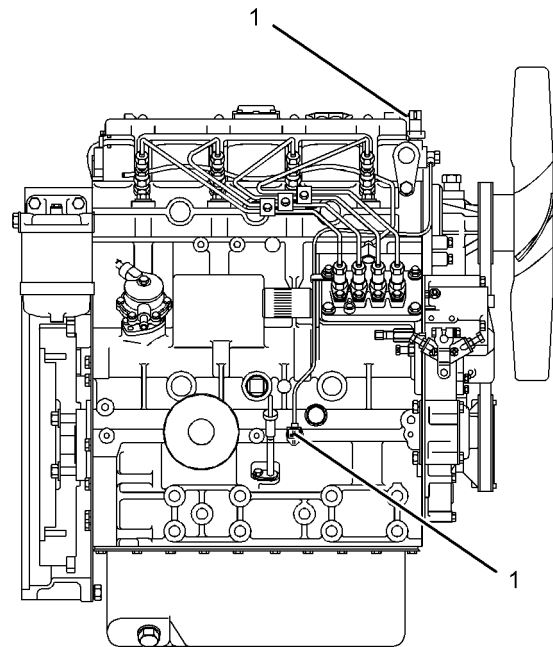

Illustration 174

g01307413

Typical example

1. Disconnect the harness assembly (not shown) from engine oil pressure switch (1).
2. If engine oil pressure switch (1) is located in the valve mechanism cover, remove the engine oil pressure switch from the valve mechanism cover.

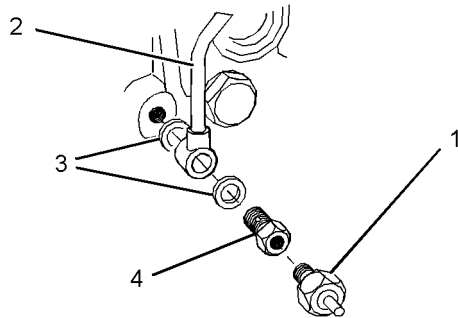

Illustration 175 g01307450
Typical example

3. If engine oil pressure switch (1) is located in the cylinder block follow Steps 3.a through 3.c in order to remove the engine oil pressure switch.
 - a. Remove engine oil pressure switch (1) and adapter (4) as an assembly from oil line (2).
 - b. Remove washers (3).
 - c. Remove engine oil pressure switch (1) from adapter (4).

Installation Procedure

Table 33

Required Tools			
Tool	Part Number	Part Description	Qty
A	21820122	POWERPART Pipe Sealant	1

Note: The engine oil pressure switch may be located in the valve mechanism cover or in the cylinder block. Refer to Specifications, "Engine Oil Pressure Switch" for the correct location.

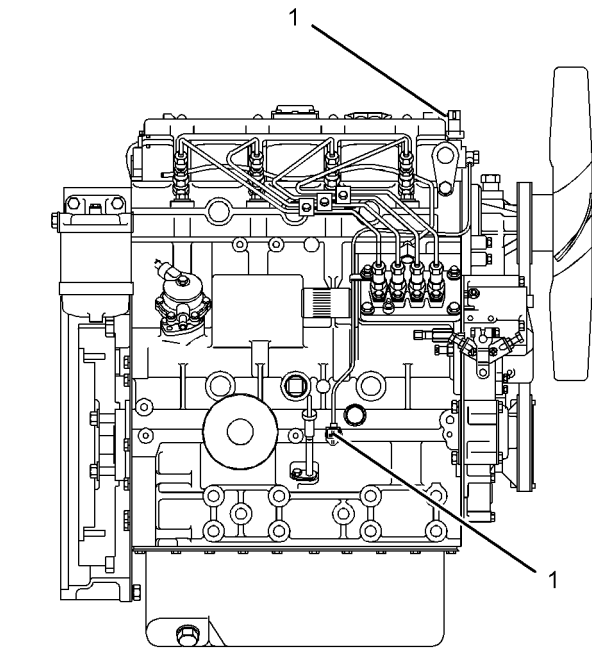

Illustration 176 g01307413
Typical example

Note: If a used engine oil pressure switch is installed, apply a thin layer of Tooling (A) to the threads of the engine oil pressure switch.

1. If engine oil pressure switch (1) is located in the valve mechanism cover, install the engine oil pressure switch and tighten to a torque of 11 N·m (97 lb in).

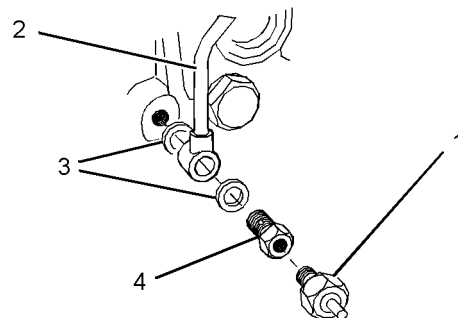

Illustration 177 g01307450
Typical example

2. If engine oil pressure switch (1) is located in the cylinder block follow Steps 2.a through 2.c in order to install the engine oil pressure switch.

- a. Install engine oil pressure switch (1) to adapter (4). Tighten the engine oil pressure switch to a torque of 23 N·m (17 lb ft).

Note: If a used engine oil pressure switch is installed, apply a thin layer of Tooling (A) to the threads of the engine oil pressure switch.

- b. Position new washers (3) onto oil line (2) and install the assembly of engine oil pressure switch (1) and adapter (4) to the cylinder block.
 - c. Tighten adapter (4) to a torque of 11 N·m (97 lb in).
3. Connect the harness assembly (not shown) to engine oil pressure switch (1).

i02962102

Glow Plugs - Remove and Install

Removal Procedure

1. Turn the battery disconnect switch to the OFF position.

NOTICE

Keep all parts clean from contaminants.

Contaminants may cause rapid wear and shortened component life.

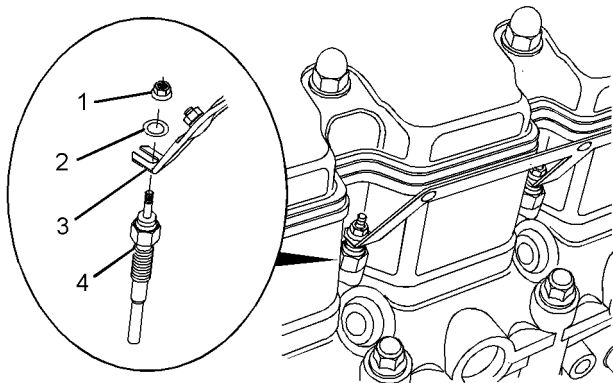

Illustration 178

g01326605

Typical example

2. Remove nuts (1) and washers (2) from bus bar (3).
3. Remove bus bar (3) from glow plugs (4).
4. Remove glow plugs (4) from the cylinder head.

Installation Procedure

Table 34

Required Tools			
Tool	Part Number	Part Name	Qty
A	27610296	Torque Wrench	1

NOTICE

Keep all parts clean from contaminants.

Contaminants may cause rapid wear and shortened component life.

1. Ensure that the threads of the glow plugs are clean and free from damage. Replace any damaged glow plugs.

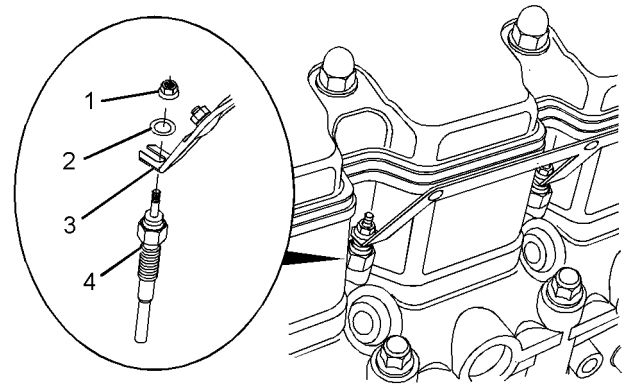

Illustration 179

g01326605

Typical example

2. Install glow plugs (4) into the cylinder head.

For 402D-05, 403D-07, 403D-11 and 404D-15 engines, tighten the glow plugs to a torque of 12 N·m (106 lb in).

For 403D-15, 403D-15T, 403D-17, 404D-22, 404D-22T and 404D-22TA engines, tighten the glow plugs to a torque of 18 N·m (159 lb in).

3. Position bus bar (3) onto glow plugs (4).
4. Install washers (2) and nuts (1) to glow plugs (4). Use Tooling (A) to tighten the nuts to a torque of 1.2 N·m (10.6 lb in).
5. Turn the battery disconnect switch to the ON position.

i02645773

V-Belts - Remove and Install

Removal Procedure

NOTICE

Keep all parts clean from contaminants.

Contaminants may cause rapid wear and shortened component life.

1. If the engine is equipped with fan guards, remove the fan guards.

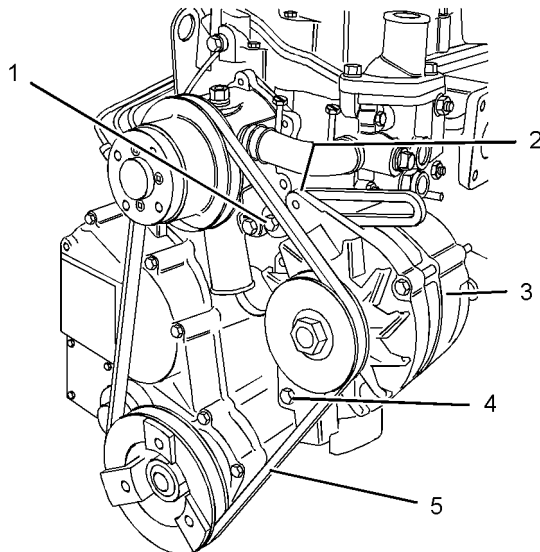

Illustration 180

g01325726

Typical example

2. Loosen bolts (1), (2) and (4).
3. Push alternator (3) toward the engine and remove V-belt (5).

Note: Mark the direction of rotation if the V-belt will be reused.

Installation Procedure

NOTICE

Keep all parts clean from contaminants.

Contaminants may cause rapid wear and shortened component life.

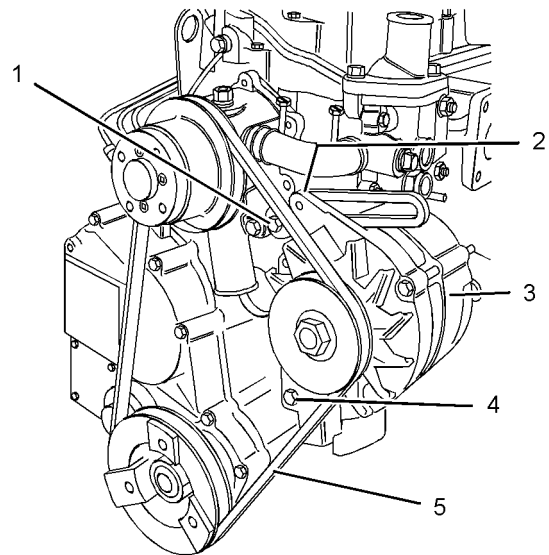

Illustration 181

g01325726

Typical example

1. Check the condition of the V-belt . If the V-belt is worn or damaged, use a new V-belt for replacement.
 2. Install V-belt (5) in position on the engine.
- Note:** A used V-belt should be installed in the original direction of rotation.
3. Slide alternator (3) away from the engine. Refer to Systems Operation, Testing and Adjusting, "Belt Tension Chart" for information on the correct belt tension. Tighten bolts (1), (2) and (4) to a torque of 25 N·m (18 lb ft).
 4. If the engine is equipped with fan guards, install the fan guards.

i02645681

Fan - Remove and Install

Removal Procedure

Start By:

- a. Remove the V-Belt. Refer to Disassembly and Assembly, "V-Belts - Remove and Install".

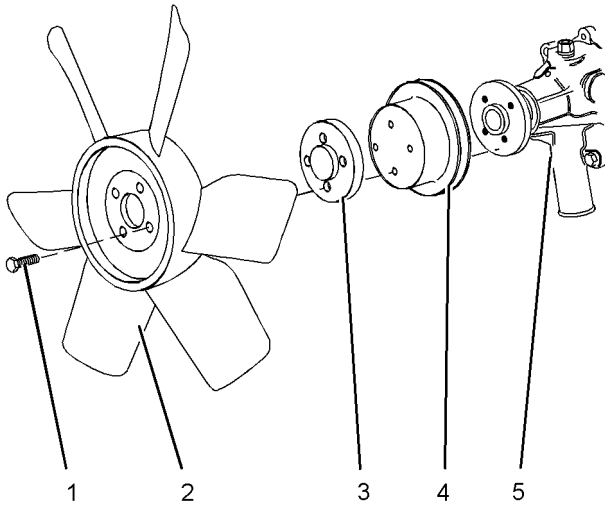

Illustration 182

g01318055

Typical example

1. Remove bolts (1) and remove fan (2).

Note: Mark the orientation of the fan for installation.

2. Remove spacer (3) and pulley (4) from water pump (5).

Installation Procedure

1. Ensure that all components are clean and free from damage. Replace any components that are worn or damaged.

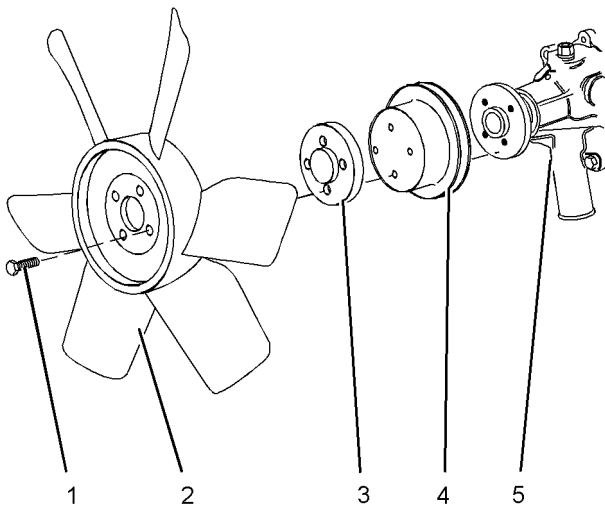

Illustration 183

g01318055

Typical example

2. Position pulley (4) and spacer (3) on water pump (5). Ensure that the bolt holes are aligned.

3. Install fan (2).

Note: Ensure the correct orientation of the fan.

4. Install bolts (1) and tighten to a torque of 11 N·m (97 lb in).

End By:

- a. Install the V-Belt. Refer to Disassembly and Assembly, "V-Belts - Remove and Install".

i02645653

Alternator - Remove and Install (65 Amp and 85 Amp Alternators)

Removal Procedure

Start By:

- a. Remove the V-Belt. Refer to Disassembly and Assembly, "V-Belts - Remove and Install".

NOTICE

Keep all parts clean from contaminants.

Contaminants may cause rapid wear and shortened component life.

1. Turn the battery disconnect switch to the OFF position.
2. Make temporary identification marks on the connections of the harness assembly.

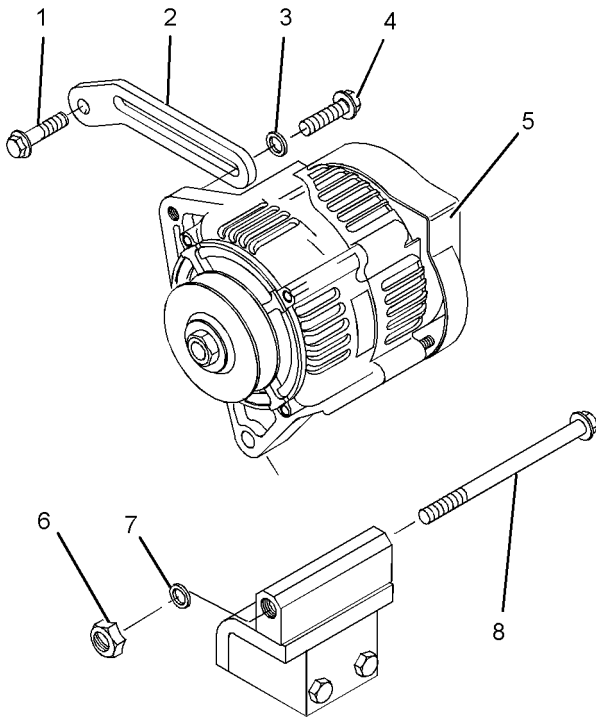

Illustration 184

g01308285

Typical example

3. Disconnect the harness assembly (not shown) from alternator (5).
4. Remove bolt (4) and washer (3) from alternator (5).
5. Remove washer (7) and nut (6). Remove bolt (8) and alternator (5) from the mounting bracket.
6. If necessary, remove bolt (1) and remove adjusting link (2).

Installation Procedure

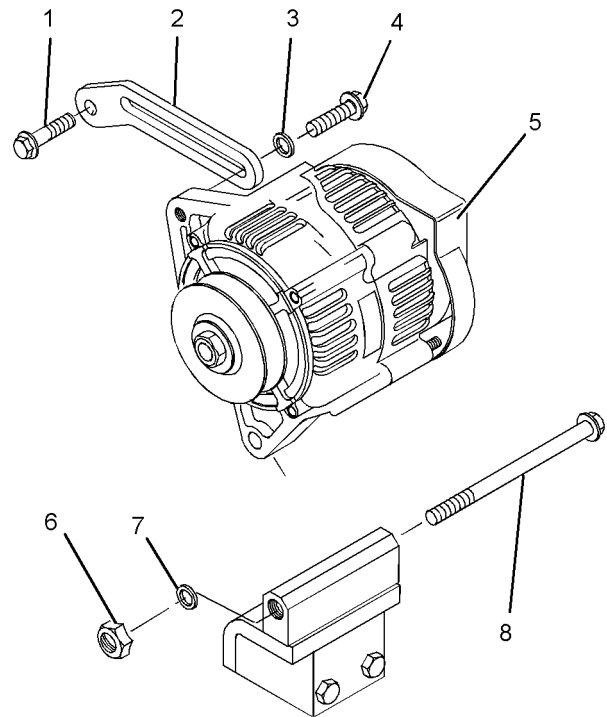

Illustration 185

g01308285

Typical example

1. If necessary, install adjusting link (2) and install bolt (1) finger tight.
2. Position alternator (5) on the mounting bracket.
3. Install bolt (8), washer (7) and nut (6) finger tight.
4. Install bolt (4) and washer (3) finger tight.
5. Install the V-Belt. Refer to Disassembly and Assembly, "V-Belts - Remove and Install".

Note: Ensure that the alternator pulley is in alignment with the crankshaft pulley. Ensure that all fasteners are tightened.

6. Connect the harness assembly (not shown) to the alternator.
7. Turn the battery disconnect switch to the ON position.

i02645652

Alternator - Remove and Install (55 Amp Alternator)

Removal Procedure

Start By:

- a. Remove the V-Belt. Refer to Disassembly and Assembly, "V-Belts - Remove and Install".

NOTICE

Keep all parts clean from contaminants.

Contaminants may cause rapid wear and shortened component life.

1. Turn the battery disconnect switch to the OFF position.
2. Make temporary identification marks on the connections of the harness assembly.

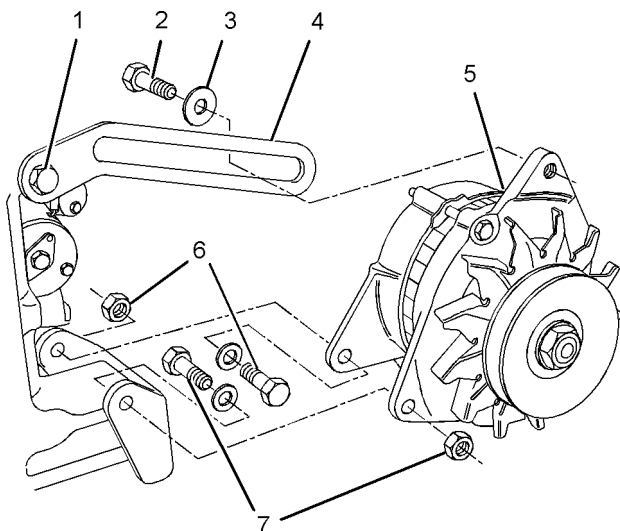

Illustration 186

g01308282

Typical example

3. Disconnect the harness assembly (not shown) from alternator (5).
4. Remove bolt (2) and washer (3) from alternator (5).
5. Remove fasteners (6) and (7) and remove alternator (5) from the mounting bracket.
6. If necessary, remove bolt (2) and remove adjusting link (4).

Installation Procedure

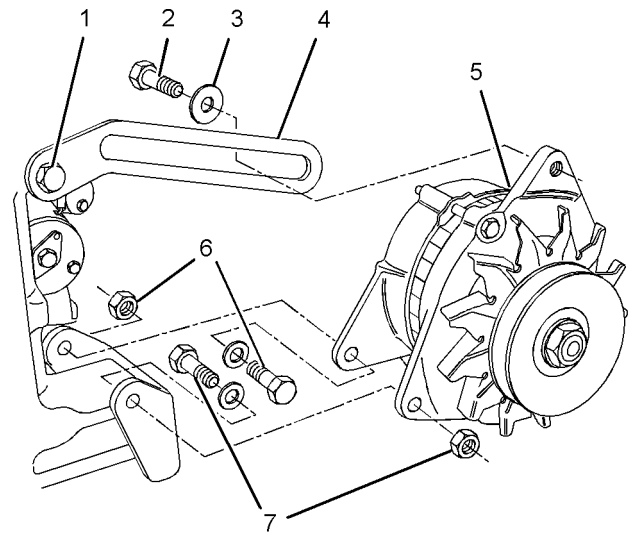

Illustration 187

g01308282

Typical example

1. If necessary, install adjusting link (4) and install bolt (1) finger tight.
2. Position alternator (5) on the mounting bracket.
3. Install fasteners (6) and (7) finger tight.
4. Install bolt (2) and washer (3) finger tight.
5. Install the V-Belt. Refer to Disassembly and Assembly, "V-Belts - Remove and Install".

Note: Ensure that the alternator pulley is in alignment with the crankshaft pulley. Ensure that all fasteners are tightened.

6. Connect the harness assembly (not shown) to the alternator.
7. Turn the battery disconnect switch to the ON position.

i02645651

Alternator - Remove and Install (40 Amp Alternator)

Removal Procedure

Start By:

- a. Remove the V-Belt. Refer to Disassembly and Assembly, "V-Belts - Remove and Install".

NOTICE

Keep all parts clean from contaminants.

Contaminants may cause rapid wear and shortened component life.

1. Turn the battery disconnect switch to the OFF position.
2. Make temporary identification marks on the connections of the harness assembly.

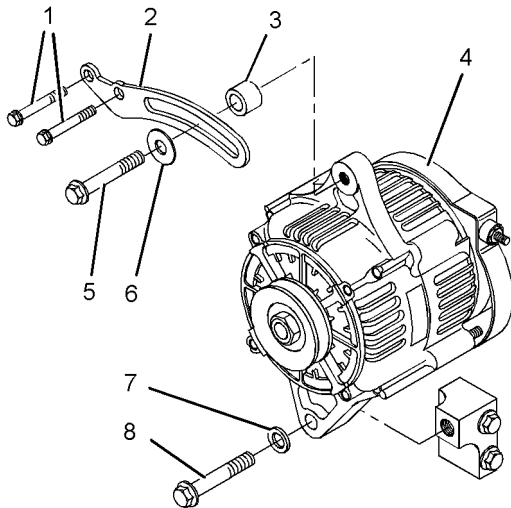

Illustration 188

g01308278

Typical example

3. Disconnect the harness assembly (not shown) from alternator (4).
4. Remove bolt (5), washer (6) and spacer (3) from alternator (4).
5. Remove bolt (8) and washer (7). Remove the alternator (4) from the mounting bracket.
6. If necessary, remove bolts (1) and remove adjusting link (2).

Installation Procedure

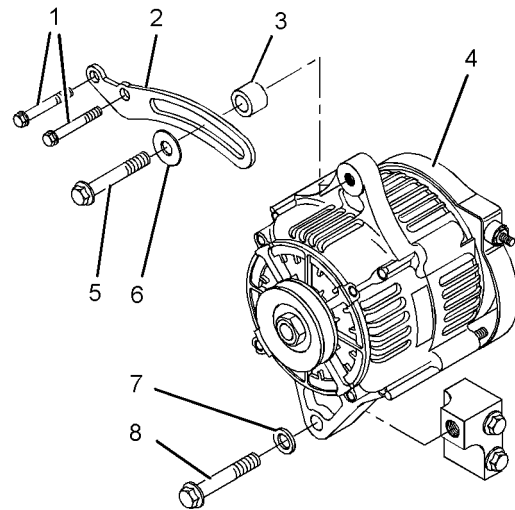

Illustration 189

g01308278

Typical example

1. If necessary, install adjusting link (2) and install bolts (1). Tighten bolts (1) to a torque of 10 N·m (89 lb in).
2. Position alternator (4) on the mounting bracket and install bolt (8) and washer (7) finger tight.
3. Install bolt (5), washer (6) and spacer (3) finger tight.
4. Install the V-Belt. Refer to Disassembly and Assembly, "V-Belts - Remove and Install".

Note: Ensure that the alternator pulley is in alignment with the crankshaft pulley. Ensure that all fasteners are tightened.

5. Connect the harness assembly (not shown) to the alternator.
6. Turn the battery disconnect switch to the ON position.

i02645650

Alternator - Remove and Install (14 Amp and 15 Amp Alternators)

Removal Procedure

Start By:

- a. Remove the V-Belt. Refer to Disassembly and Assembly, "V-Belts - Remove and Install".

NOTICE

Keep all parts clean from contaminants.

Contaminants may cause rapid wear and shortened component life.

1. Turn the battery disconnect switch to the OFF position.
2. Make temporary identification marks on the connections of the harness assembly.

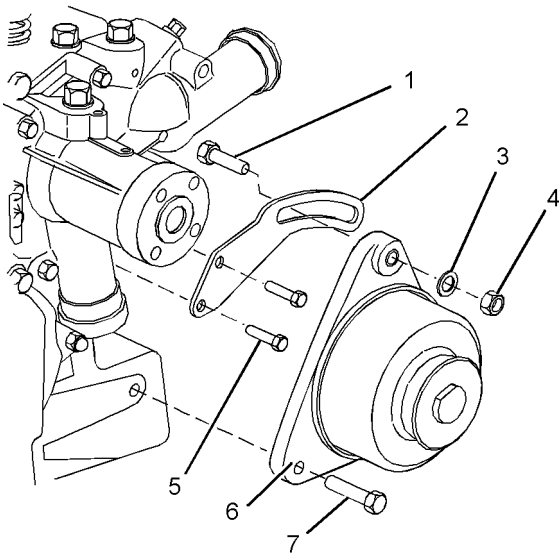

Illustration 190
Typical example

g01308275

3. Disconnect the harness assembly (not shown) from alternator (6).
4. Remove bolt (1), washer (3) and nut (4) from alternator (6).
5. Remove bolt (7) and remove alternator (6) from the engine.

6. If necessary, remove bolts (5) and remove adjusting link (2).

Note: The adjusting link on some engines is secured by one bolt.

Installation Procedure

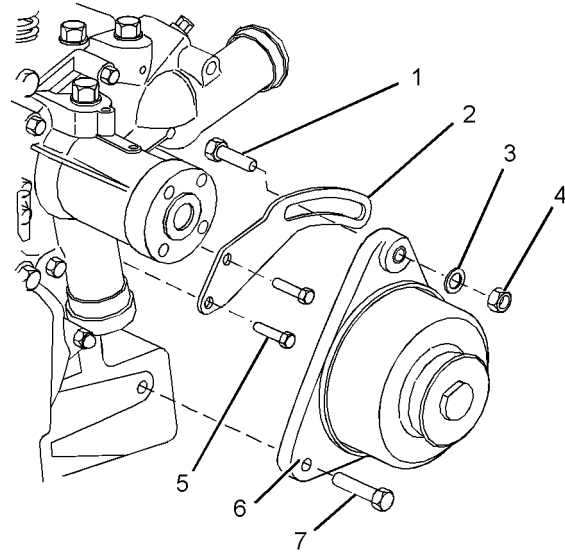

Illustration 191

g01308275

Typical example

1. If necessary, install adjusting link (2) and install bolts (5) finger tight.

Note: The adjusting link on some engines is secured by one bolt.

2. For engines that have an adjusting link that is secured by one bolt, leave bolt (5) loose.

For engines that have an adjusting link that is secured by two bolts, tighten bolts (5) to a torque of 10 N·m (89 lb in).

3. Position alternator (6) on the engine and install bolt (7) finger tight.
4. Install bolt (1), washer (3) and nut (4) finger tight.
5. Install the V-Belt. Refer to Disassembly and Assembly, "V-Belts - Remove and Install".

Note: Ensure that the alternator pulley is in alignment with the crankshaft pulley. Ensure that all fasteners are tightened.

6. Connect the harness assembly (not shown) to the alternator.
7. Turn the battery disconnect switch to the ON position.

i02645769

Electric Starting Motor - Remove and Install

Removal Procedure

WARNING

Accidental engine starting can cause injury or death to personnel working on the equipment.

To avoid accidental engine starting, disconnect the battery cable from the negative (-) battery terminal. Completely tape all metal surfaces of the disconnected battery cable end in order to prevent contact with other metal surfaces which could activate the engine electrical system.

Place a Do Not Operate tag at the Start/Stop switch location to inform personnel that the equipment is being worked on.

1. Disconnect the battery.
2. Make temporary identification marks on the harness assemblies that are connected to the electric starting motor.

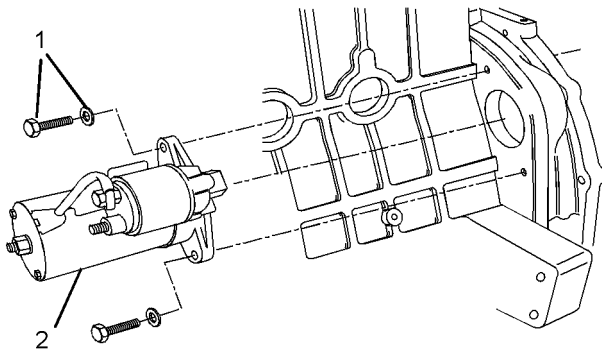

Illustration 192
Typical example

g01326136

3. Disconnect the harness assemblies (not shown) from electric starting motor (2).
4. Remove fasteners (1) that secure electric starting motor (2).

Note: Support the weight of the electric starting motor as the fasteners are removed.

5. Remove electric starting motor (2) from the engine.

Installation Procedure

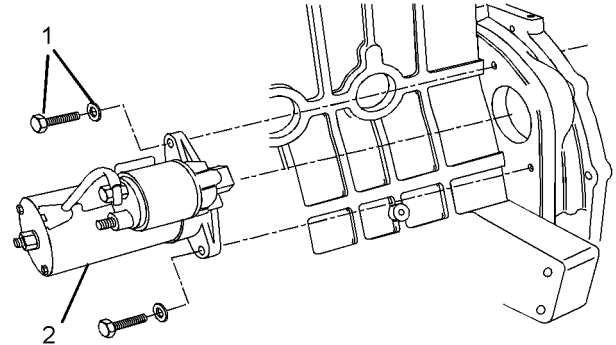

Illustration 193

g01326136

Typical example

1. Install electric starting motor (2) in position on the engine.
2. Install fasteners (1) and tighten to a torque of 50 N·m (37 lb ft).
3. Connect the harness assemblies (not shown) to electric starting motor (2).
4. Connect the battery.

Index

A

Alternator - Remove and Install (14 Amp and 15 Amp Alternators)	101
Installation Procedure	101
Removal Procedure	101
Alternator - Remove and Install (40 Amp Alternator)	99
Installation Procedure	100
Removal Procedure	99
Alternator - Remove and Install (55 Amp Alternator)	99
Installation Procedure	99
Removal Procedure	99
Alternator - Remove and Install (65 Amp and 85 Amp Alternators)	97
Installation Procedure	98
Removal Procedure	97

B

Bearing Clearance - Check	90
Measurement Procedure	90

C

Camshaft - Assemble	74
Assembly Procedure	74
Camshaft - Disassemble	73
Disassembly Procedure	73
Camshaft - Install	74
Installation Procedure	74
Camshaft - Remove	72
Removal Procedure	72
Connecting Rod Bearings - Install	84
Installation Procedure	84
Connecting Rod Bearings - Install (Connecting rods in position)	83
Installation Procedure	83
Connecting Rod Bearings - Remove (Connecting rods in position)	83
Removal Procedure	83
Coolant Temperature Switch - Remove and Install (402D-05 and 403D-07 Engines)	92
Installation Procedure	93
Removal Procedure	92
Coolant Temperature Switch - Remove and Install (403D-11, 403D-15, 403D-15T, 403D-17, 404D-15, 404D-22, 404D-22T and 404D-22TA Engines)	91
Installation Procedure	92
Removal Procedure	91
Crankcase Breather - Remove and Install (Naturally Aspirated Engines)	58
Installation Procedure	59
Removal Procedure	58

Crankcase Breather - Remove and Install (Turbocharged Engines)	56
Installation Procedure	57
Removal Procedure	56
Crankshaft - Install	89
Installation Procedure	89
Crankshaft - Remove	88
Removal Procedure	88
Crankshaft Front Seal - Remove and Install	48
Alternative Removal Procedure	48
Installation Procedure	49
Removal Procedure	48
Crankshaft Main Bearings - Install	86
Installation Procedure	86
Crankshaft Main Bearings - Remove	85
Removal Procedure	85
Crankshaft Pulley - Remove and Install	47
Installation Procedure	47
Removal Procedure	47
Crankshaft Rear Seal - Remove and Install	41
Installation Procedure	42
Removal Procedure	41
Crankshaft Wear Sleeve (Rear) - Remove and Install	43
Installation Procedure	43
Removal Procedure	43
Cylinder Head - Install	69
Installation Procedure	69
Cylinder Head - Remove	67
Removal Procedure	67

D

Disassembly and Assembly Section	4
--	---

E

Electric Starting Motor - Remove and Install	102
Installation Procedure	102
Removal Procedure	102
Engine Oil Cooler - Remove and Install	26
Installation Procedure	27
Removal Procedure	26
Engine Oil Line - Remove and Install	24
Installation Procedure	25
Removal Procedure	24
Engine Oil Pan - Remove and Install	76
Installation Procedure	76
Removal Procedure	76
Engine Oil Pressure Switch - Remove and Install	93
Installation Procedure	94
Removal Procedure	93
Engine Oil Pump - Install	30
Installation Procedure	30
Engine Oil Pump - Remove	28
Removal Procedure	28

Engine Oil Relief Valve - Remove and Install	27
Installation Procedure	28
Removal Procedure	27
Exhaust Manifold - Remove and Install	18
Installation Procedure	19
Removal Procedure	18

F

Fan - Remove and Install	96
Installation Procedure	97
Removal Procedure	96
Flywheel - Install	40
Installation Procedure	40
Flywheel - Remove	39
Removal Procedure	39
Flywheel Housing - Remove and Install	44
Installation Procedure	44
Removal Procedure	44
Flywheel Housing - Remove and Install (Engines with Flywheel Housing and Back Plate)	45
Installation Procedure	46
Removal Procedure	45
Fuel Filter Base - Remove and Install (402D-05 and 403D-07 Engines)	5
Installation Procedure	6
Removal Procedure	5
Fuel Filter Base - Remove and Install (403D-11, 403D-15, 403D-15T, 403D-17, 404D-15, 404D-22, 404D-22T and 404D-22TA Engines)	4
Installation Procedure	4
Removal Procedure	4
Fuel Injection Lines - Remove and Install	9
Installation Procedure	10
Removal Procedure	9
Fuel Injection Pump - Remove and Install	13
Installation Procedure	14
Removal Procedure	13
Fuel Injector - Remove and Install	15
Installation Procedure	15
Removal Procedure	15
Fuel Shutoff Solenoid - Remove and Install	12
Installation Procedure	12
Removal Procedure	12
Fuel Transfer Pump - Remove and Install (Electrical Fuel Transfer Pump)	8
Installation Procedure	9
Removal Procedure	8
Fuel Transfer Pump - Remove and Install (Mechanical Fuel Transfer Pump)	7
Installation Procedure	7
Removal Procedure	7

G

Glow Plugs - Remove and Install	95
Installation Procedure	95
Removal Procedure	95

H

Housing (Front) - Assemble	52
Assembly Procedure	52
Housing (Front) - Disassemble	50
Disassembly Procedure	50
Housing (Front) - Install	55
Installation Procedure	55
Housing (Front) - Remove	49
Removal Procedure	49

I

Important Safety Information	2
Inlet and Exhaust Valve Springs - Remove and Install	19
Installation Procedure	21
Removal Procedure	19
Inlet and Exhaust Valves - Remove and Install	22
Installation Procedure	23
Removal Procedure	22

L

Lifter Group - Remove and Install	71
Installation Procedure	72
Removal Procedure	71

P

Pistons and Connecting Rods - Assemble	80
Assembly Procedure	80
Pistons and Connecting Rods - Disassemble	78
Disassembly Procedure	78
Pistons and Connecting Rods - Install	81
Installation Procedure	81
Pistons and Connecting Rods - Remove	77
Removal Procedure	77

R

Rocker Shaft - Assemble (402D-05, 403D-07, 403D-11 and 404D-15 Engines)	65
Assembly Procedure	65
Rocker Shaft - Assemble (403D-15, 403D-15T, 403D-17, 404D-22, 404D-22T and 404D-22TA Engines)	64
Assembly Procedure	64
Rocker Shaft - Disassemble (402D-05, 403D-07, 403D-11 and 404D-15 Engines)	63
Disassembly Procedure	63
Rocker Shaft - Disassemble (403D-15, 403D-15T, 403D-17, 404D-22, 404D-22T and 404D-22TA Engines)	62
Disassembly Procedure	62
Rocker Shaft and Pushrod - Install	66
Installation Procedure	66

Rocker Shaft and Pushrod - Remove.....	62
Removal Procedure	62

T

Table of Contents.....	3
Turbocharger - Remove and Install	16
Installation procedure.....	17
Removal procedure.....	16

V

V-Belts - Remove and Install	96
Installation Procedure	96
Removal Procedure	96
Valve Mechanism Cover - Remove and Install.....	60
Installation Procedure	61
Removal Procedure	60

W

Water Pump - Remove and Install (402D-05 and 403D-07 Engines).....	33
Installation Procedure	34
Removal Procedure	33
Water Pump - Remove and Install (403D-11, 403D-15, 403D-15T, 403D-17, 404D-15, 404D-22, 404D-22T and 404D-22TA Engines)	32
Installation Procedure	33
Removal Procedure	32
Water Temperature Regulator - Remove and Install (402D-05 and 404D-07 Engines).....	36
Installation Procedure	37
Removal Procedure	36
Water Temperature Regulator - Remove and Install (403D-11, 403D-15, 403D-15T, 403D-17, 404D-15, 404D-22, 404D-22T and 404D-22TA Engines)....	38
Installation Procedure	38
Removal Procedure	38
Water Temperature Regulator Housing - Remove and Install	35
Installation Procedure	36
Removal Procedure	35

