

Disassembly and Assembly

1103 and 1104 Industrial Engines

DC (Engine)
DD (Engine)
DJ (Engine)
DK (Engine)
RE (Engine)
RG (Engine)
RJ (Engine)
RR (Engine)
RS (Engine)
DF (Engine)
DG (Engine)

Important Safety Information

Most accidents that involve product operation, maintenance and repair are caused by failure to observe basic safety rules or precautions. An accident can often be avoided by recognizing potentially hazardous situations before an accident occurs. A person must be alert to potential hazards. This person should also have the necessary training, skills and tools to perform these functions properly.

Improper operation, lubrication, maintenance or repair of this product can be dangerous and could result in injury or death.

Do not operate or perform any lubrication, maintenance or repair on this product, until you have read and understood the operation, lubrication, maintenance and repair information.

Safety precautions and warnings are provided in this manual and on the product. If these hazard warnings are not heeded, bodily injury or death could occur to you or to other persons.

The hazards are identified by the "Safety Alert Symbol" and followed by a "Signal Word" such as "DANGER", "WARNING" or "CAUTION". The Safety Alert "WARNING" label is shown below.



The meaning of this safety alert symbol is as follows:

Attention! Become Alert! Your Safety is Involved.

The message that appears under the warning explains the hazard and can be either written or pictorially presented.

Operations that may cause product damage are identified by "NOTICE" labels on the product and in this publication.

Perkins cannot anticipate every possible circumstance that might involve a potential hazard. The warnings in this publication and on the product are, therefore, not all inclusive. If a tool, procedure, work method or operating technique that is not specifically recommended by Perkins is used, you must satisfy yourself that it is safe for you and for others. You should also ensure that the product will not be damaged or be made unsafe by the operation, lubrication, maintenance or repair procedures that you choose.

The information, specifications, and illustrations in this publication are on the basis of information that was available at the time that the publication was written. The specifications, torques, pressures, measurements, adjustments, illustrations, and other items can change at any time. These changes can affect the service that is given to the product. Obtain the complete and most current information before you start any job. Perkins dealers or Perkins distributors have the most current information available.



When replacement parts are required for this product Perkins recommends using Perkins replacement parts.

Failure to heed this warning can lead to premature failures, product damage, personal injury or death.

Table of Contents

Disassembly and Assembly Section

Fuel Priming Pump - Remove and Install 4
 Fuel Filter Base - Remove and Install 6
 Fuel Injection Lines - Remove 9
 Fuel Injection Lines - Install 9
 Fuel Injector Cover - Remove and Install (If Equipped) 10
 Fuel Injection Pump - Remove (Delphi DP210) 11
 Fuel Injection Pump - Remove (Delphi STP) 13
 Fuel Injection Pump - Remove (Delphi DPG) 14
 Fuel Injection Pump - Remove (Bosch EPVE for the 1104 engines only) 16
 Fuel Injection Pump - Remove (Delphi DPA) 17
 Fuel Injection Pump - Install (Delphi DP210) 19
 Fuel Injection Pump - Install (Delphi STP) 20
 Fuel Injection Pump - Install (Delphi DPG) 22
 Fuel Injection Pump - Install (Bosch EPVE for the 1104 engines only) 24
 Fuel Injection Pump - Install (Delphi DPA) 26
 Fuel Injector - Remove 27
 Fuel Injector - Install 28
 Turbocharger - Remove 29
 Turbocharger - Install 30
 Exhaust Manifold - Remove and Install 31
 Exhaust Elbow - Remove and Install (If Equipped) 33
 Inlet and Exhaust Valve Springs - Remove and Install 34
 Inlet and Exhaust Valves - Remove and Install 36
 Inlet and Exhaust Valve Guides - Remove and Install 39
 Inlet and Exhaust Valve Seat Inserts - Remove and Install 41
 Engine Oil Filter Base - Remove and Install 43
 Engine Oil Cooler - Remove 47
 Engine Oil Cooler - Install 48
 Engine Oil Relief Valve - Remove and Install (Engine Oil Pump) 50
 Engine Oil Relief Valve - Remove and Install (Balancer Unit for the 1104 engines only) 51
 Engine Oil Pump - Remove (Engines Without a Balancer) 52
 Engine Oil Pump - Install (Engines Without a Balancer) 53
 Water Pump - Remove 54
 Water Pump - Disassemble 54
 Water Pump - Assemble 56
 Water Pump - Install 57
 Water Temperature Regulator - Remove and Install 58
 Flywheel - Remove 61
 Flywheel - Install 61
 Crankshaft Rear Seal - Remove 62
 Crankshaft Rear Seal - Install 63
 Crankshaft Wear Sleeve (Rear) - Remove 65
 Crankshaft Wear Sleeve (Rear) - Install 66
 Flywheel Housing - Remove and Install 66
 Crankshaft Pulley - Remove and Install 68

Crankshaft Front Seal - Remove 71
 Crankshaft Front Seal - Install 72
 Crankshaft Wear Sleeve (Front) - Install 73
 Front Cover - Remove and Install 73
 Gear Group (Front) - Remove 74
 Gear Group (Front) - Install 76
 Idler Gear - Remove and Install 78
 Housing (Front) - Remove 83
 Housing (Front) - Install 84
 Accessory Drive - Remove and Install 85
 Crankcase Breather - Remove and Install 87
 Valve Mechanism Cover - Remove and Install 90
 Rocker Shaft and Pushrod - Remove 91
 Rocker Shaft - Disassemble 92
 Rocker Shaft - Assemble 93
 Rocker Shaft and Pushrod - Install 94
 Cylinder Head - Remove 95
 Cylinder Head - Install 97
 Lifter Group - Remove and Install 100
 Camshaft - Remove and Install 101
 Camshaft Gear - Remove and Install 102
 Camshaft Bearings - Remove and Install 102
 Engine Oil Pan - Remove and Install 103
 Balancer - Remove (Some 1104 Engines Only) .. 106
 Balancer - Install (Some 1104 Engines Only) 107
 Piston Cooling Jets - Remove and Install 108
 Pistons and Connecting Rods - Remove 109
 Pistons and Connecting Rods - Disassemble 110
 Pistons and Connecting Rods - Assemble 111
 Pistons and Connecting Rods - Install 112
 Connecting Rod Bearings - Remove 113
 Connecting Rod Bearings - Install 114
 Crankshaft Main Bearings - Remove 115
 Crankshaft Main Bearings - Install (Crankshaft in Position) 116
 Crankshaft - Remove 118
 Crankshaft - Install 120
 Crankshaft Gear - Remove and Install 124
 Bearing Clearance - Check 125
 Glow Plugs - Remove and Install (If Equipped) .. 126
 V-Belts - Remove and Install 127
 Fan - Remove and Install 128
 Fan Drive - Remove and Install 129
 Alternator - Remove 129
 Alternator - Install 130
 Electric Starting Motor - Remove and Install 130
 Vacuum Pump - Remove and Install (Some 1104 engines only) 131
 Hydraulic Pump (Steering) - Remove 132
 Hydraulic Pump (Steering) - Install 132

Index Section

Index 133

Disassembly and Assembly Section

i02219291

Fuel Priming Pump - Remove and Install

Removal procedure

There are two types of fuel priming pump. Type 1 is mounted above the starter motor. Type 1 is combined with the fuel filter. Type 2 is mounted below the starter motor. Type 2 is not combined with the fuel filter. Type 2 is used on 4 cylinder engines only.

Removal Procedure for Type 1

Start By:

- a. Remove the assembly of the filter case and the fuel filter element. Refer to this Disassembly and Assembly Manual, "Fuel Filter Base - Remove and Install".

Note: There is an option for the three cylinder engine. The fuel priming pump and the fuel filter can be installed onto the application rather than onto the engine. If this is the case, refer to the appropriate installation manual that is supplied by the OEM for further information.

Note: Put identification marks on all fuel hose assemblies and on all tube assemblies for installation purposes. After being disconnected, plug all fuel hose assemblies and plug all tube assemblies. This helps prevent fluid loss, and this helps to keep contaminants from entering the system.

NOTICE

Keep all parts clean from contaminants.

Contaminants may cause rapid wear and shortened component life.

NOTICE

Care must be taken to ensure that fluids are contained during performance of inspection, maintenance, testing, adjusting and repair of the product. Be prepared to collect the fluid with suitable containers before opening any compartment or disassembling any component containing fluids.

Dispose of all fluids according to local regulations and mandates.

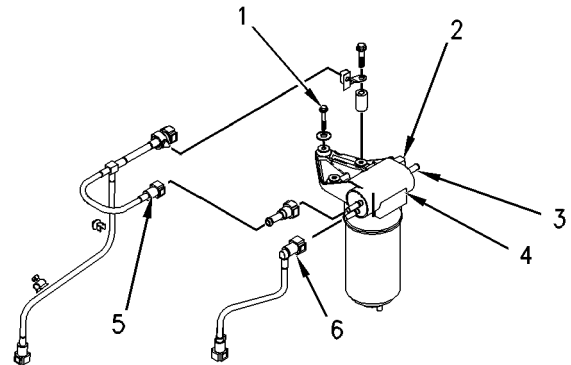

Illustration 1

g00952432

Typical example

1. Disconnect the tube assembly (5). Disconnect the tube assembly (6). Install dust covers onto the connectors for the fuel priming pump.
2. Disconnect the fuel return line from the connector (3). Install a dust cover to the connector (3).
3. Disconnect the harness assembly from the connector (2).
4. Support the fuel priming pump. Remove the three setscrews (1) and discard the rubber washers. Remove the fuel priming pump (4).

Removal Procedure for Type 2

Note: Put identification marks on the two fuel hose assemblies for installation purposes. After being disconnected, plug all fuel hose assemblies. This helps prevent fluid loss, and this helps to keep contaminants from entering the system.

NOTICE

Keep all parts clean from contaminants.

Contaminants may cause rapid wear and shortened component life.

NOTICE

Care must be taken to ensure that fluids are contained during performance of inspection, maintenance, testing, adjusting and repair of the product. Be prepared to collect the fluid with suitable containers before opening any compartment or disassembling any component containing fluids.

Dispose of all fluids according to local regulations and mandates.

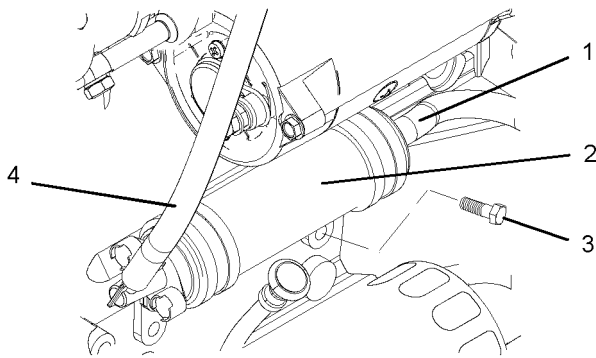

Illustration 2

g01121719

1. Disconnect the fuel hose assembly (1). Disconnect the fuel hose assembly (4). Install dust covers onto the connectors for the fuel priming pump.
2. Disconnect the harness assembly from the electrical connector on the fuel priming pump(2).
3. Support the fuel priming pump. Remove the two setscrews (3). Remove the fuel priming pump (2).

Installation Procedure

There are two types of fuel priming pump. Type 1 is mounted above the starter motor. Type 1 is combined with the fuel filter. Type 2 is mounted below the starter motor. Type 2 is not combined with the fuel filter. Type 2 is used on 4 cylinder engines only.

Installation Procedure for Type 1

NOTICE

Keep all parts clean from contaminants.

Contaminants may cause rapid wear and shortened component life.

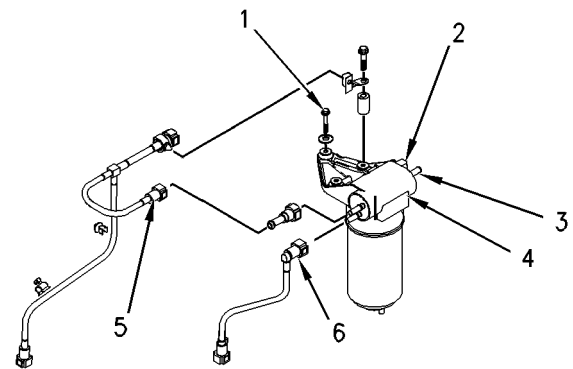

Illustration 3

g00952432

Typical example

1. Clean the external surfaces of the fuel priming pump (4). Position the fuel priming pump (4) and install the three setscrews (1) and new rubber washers.
2. Remove the dust covers from the fuel priming pump (4). Remove the plugs from the tube assemblies. Connect the tube assembly (5). Connect the tube assembly (6).
3. Connect the fuel return line to the connector (3).
4. Connect the harness assembly to the connector (2).
5. Remove the air from the fuel system. Refer to the Operations and Maintenance Manual, "Fuel System - Prime".

Installation Procedure for Type 2

NOTICE

Keep all parts clean from contaminants.

Contaminants may cause rapid wear and shortened component life.

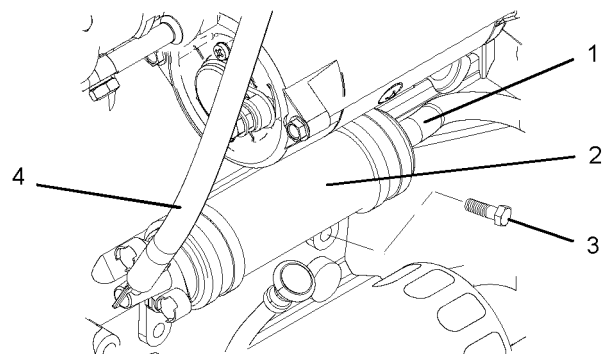

Illustration 4

g01121719

1. Clean the external surfaces of the fuel priming pump (2). Position the fuel priming pump (2) and install the two setscrews (3).
2. Remove the dust covers from the fuel priming pump. Remove the plugs from the fuel hose assemblies. Connect the fuel hose assembly (1). Connect the fuel hose assembly (4).
3. Connect the harness assembly to the electrical connector on the fuel priming pump (2).
4. Remove the air from the fuel system. Refer to the Operations and Maintenance Manual, "Fuel System - Prime".

i02224029

Fuel Filter Base - Remove and Install

Removal Procedure

There are two types of fuel filter. The element filter has a fuel filter element in a filter case. The element filter is combined with the fuel priming pump. The spin-on filter is self-contained. The spin-on filter is not combined with the fuel priming pump. The spin-on filter is used on 4 cylinder engines only.

Removal Procedure for the Element Filter

Note: There is an option for the three cylinder engine. The fuel filter and the fuel priming pump can be installed onto the application rather than onto the engine. If this is the case, refer to the appropriate OEM information as well to this text.

NOTICE

Keep all parts clean from contaminants.

Contaminants may cause rapid wear and shortened component life.

NOTICE

Care must be taken to ensure that fluids are contained during performance of inspection, maintenance, testing, adjusting and repair of the product. Be prepared to collect the fluid with suitable containers before opening any compartment or disassembling any component containing fluids.

Dispose of all fluids according to local regulations and mandates.

Note: The removal procedure is identical for the four cylinder and the three cylinder engines. The illustrations show the four cylinder engine.

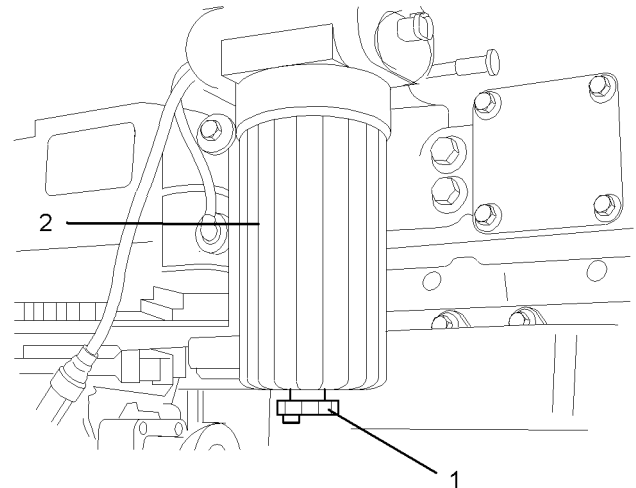

Illustration 5

g01010637

Typical example

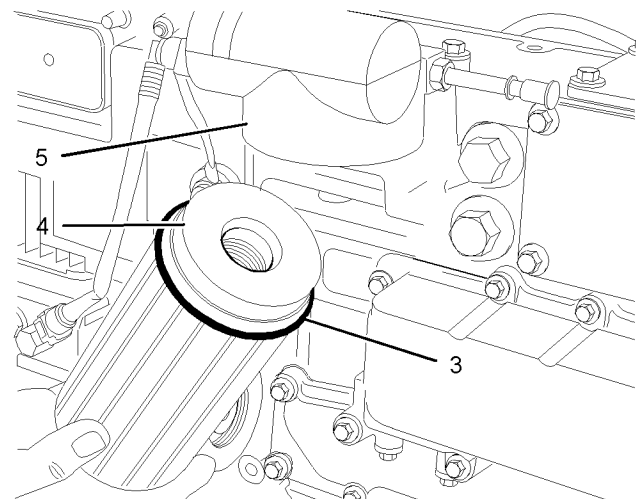

Illustration 6

g01010595

Typical example

1. Place a suitable container below the filter in order to collect the spilled fuel. Thoroughly clean the outside surfaces of the fuel filter. Open the drain (1) in order to drain the fuel from the filter.
2. Use a suitable strap wrench to loosen the filter case (2). Remove the filter case (2) from the filter head (5).

3. Push down against the spring pressure that is applied to the filter element (4). Rotate the filter element (4) counterclockwise in order to release the filter element from the filter case (2).
4. Discard the filter element (4) and the O-ring (3).

Removal Procedure for the Spin-on Filter

NOTICE

Keep all parts clean from contaminants.

Contaminants may cause rapid wear and shortened component life.

NOTICE

Care must be taken to ensure that fluids are contained during performance of inspection, maintenance, testing, adjusting and repair of the product. Be prepared to collect the fluid with suitable containers before opening any compartment or disassembling any component containing fluids.

Dispose of all fluids according to local regulations and mandates.

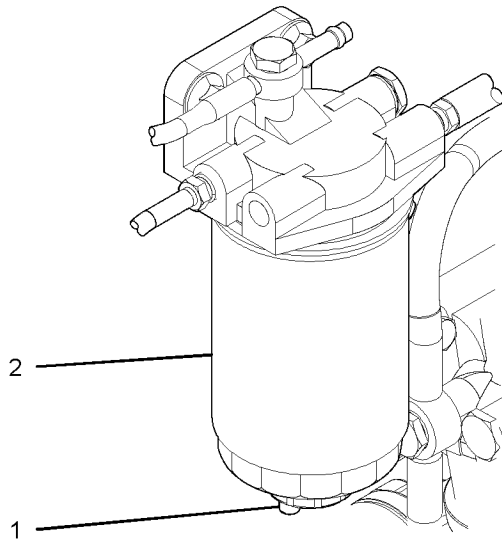

Illustration 7

g01121724

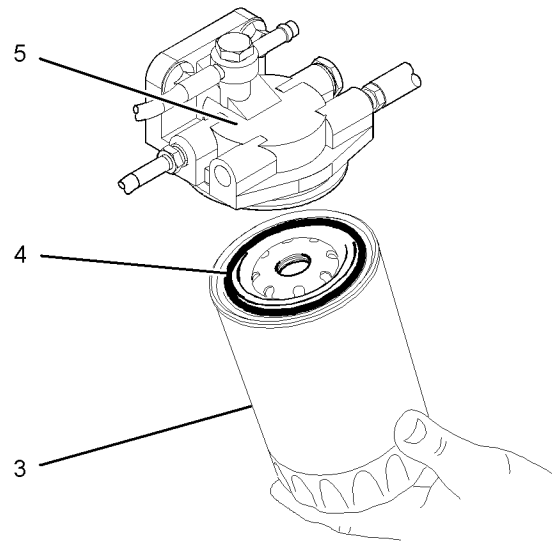

Illustration 8

g01121763

1. Turn the valves for the fuel lines (if equipped) to the OFF position before performing this maintenance. Place a tray under the fuel filter in order to catch any fuel that might spill. Clean up any spilled fuel immediately.
2. Clean the outside of the fuel filter assembly. Open the fuel drain (1) and drain the fuel into a suitable container.
3. Use a suitable tool in order to remove the spin-on filter (2) from the filter head (5).
4. Discard the filter element (3) and the O-ring (4).

Installation Procedure

There are two types of fuel filter. The element filter has a fuel filter element in a filter case. The element filter is combined with the fuel priming pump. The spin-on filter is self-contained. The spin-on filter is not combined with the fuel priming pump.

Installation Procedure for the Element Filter

NOTICE

Keep all parts clean from contaminants.

Contaminants may cause rapid wear and shortened component life.

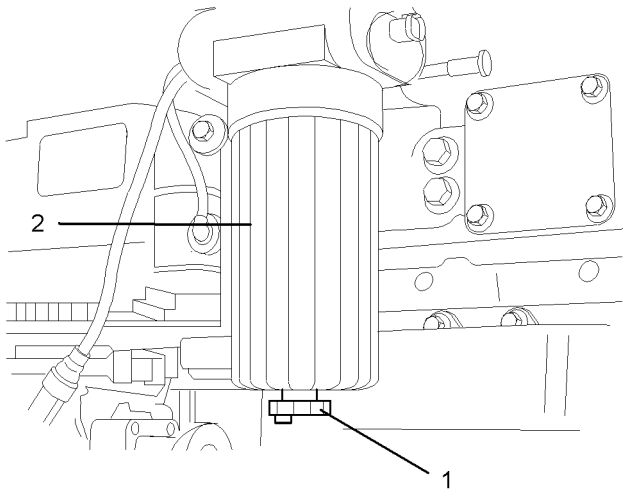

Illustration 9
Typical example
g01010637

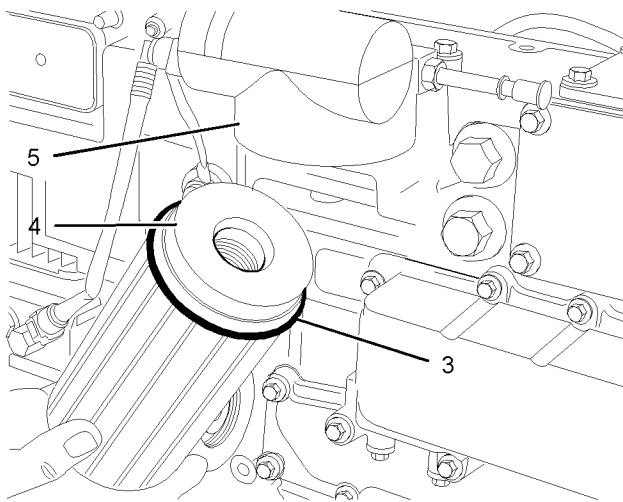

Illustration 10
Typical example
g01010595

1. Thoroughly clean the inside of the filter case (2) and thoroughly clean the lower face of the filter head (5).
2. Inspect the thread of a new filter element (4) in order to ensure that the thread is not damaged. Inspect the thread of the adapter in the filter head (5) in order to ensure that the thread is not damaged.
3. Inspect the condition of the spring and ensure that the spring is correctly located within the filter case (2).

4. Install the new filter element (4) into the filter case (2). Push the filter element against the spring pressure and rotate the filter element in a clockwise direction in order to secure the filter element within the filter case (2).
5. Lightly lubricate a new O-ring (3) with clean fuel oil. Install the new O-ring (3) into the recess within the filter case (2).
6. Close the drain (1).
7. Remove the air from the fuel system. Refer to the Operations and Maintenance Manual, "Fuel System - Prime". Remove the suitable container and dispose of the fuel that has drained as waste.

Installation Procedure for the Spin-on Filter

NOTICE

Keep all parts clean from contaminants.

Contaminants may cause rapid wear and shortened component life.

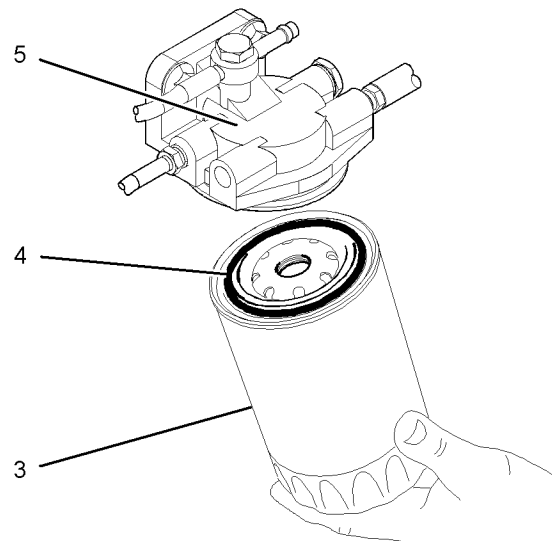

Illustration 11
g01121763

1. Thoroughly clean the lower face of the filter head (5).
2. Inspect the thread of a new filter element (3) in order to ensure that the thread is not damaged. Inspect the thread of the adapter in the filter head (5) in order to ensure that the thread is not damaged.
3. Lubricate the sealing ring (4) with clean fuel oil.

4. Install the spin-on filter (3) onto the filter head (5).
5. Tighten the spin-on filter by hand until the sealing ring contacts the filter head. Rotate the spin-on filter through 90 degrees.
6. Close the drain (1).
7. Prime the fuel system. Refer to Operation and Maintenance Manual, "Fuel System - Prime".

i02221357

Fuel Injection Lines - Remove

Removal Procedure

Start By:

- a. If equipped, remove the cover for the fuel injectors. Refer to this Disassembly and Assembly Manual, "Fuel Injector Cover - Remove and Install".

NOTICE

Keep all parts clean from contaminants.

Contaminants may cause rapid wear and shortened component life.

NOTICE

Care must be taken to ensure that fluids are contained during performance of inspection, maintenance, testing, adjusting and repair of the product. Be prepared to collect the fluid with suitable containers before opening any compartment or disassembling any component containing fluids.

Dispose of all fluids according to local regulations and mandates.

Note: The removal procedure is identical for four cylinder and three cylinder engines. The illustration shows the four cylinder engine.

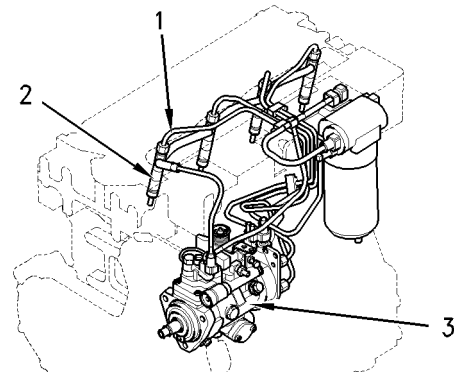

Illustration 12

g00955826

Typical example

1. Disconnect the fuel injection lines (1) at the fuel injectors (2).
2. Disconnect the fuel injection lines (1) at the fuel injection pump (3).
3. If it is necessary remove the clamps for the fuel injection lines or loosen the clamps for the fuel injection lines. Remove the fuel injection lines (1).
4. Install dust caps onto the ports of the fuel injectors and onto the ports of the fuel injection pump. Install dust caps onto both ends of the fuel injection lines.

i02221359

Fuel Injection Lines - Install

Installation Procedure

NOTICE

Keep all parts clean from contaminants.

Contaminants may cause rapid wear and shortened component life.

NOTICE

Care must be taken to ensure that fluids are contained during performance of inspection, maintenance, testing, adjusting and repair of the product. Be prepared to collect the fluid with suitable containers before opening any compartment or disassembling any component containing fluids.

Dispose of all fluids according to local regulations and mandates.

Note: The installation procedure is identical for the four cylinder and the three cylinder engines. The illustration shows the four cylinder engine.

i02221380

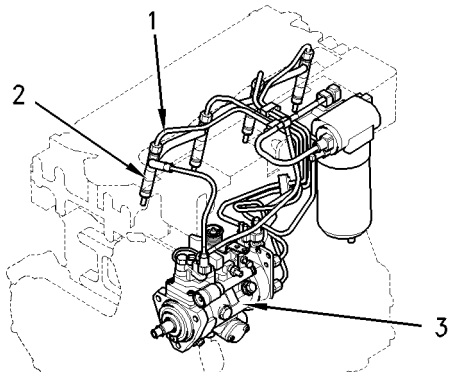

Illustration 13
Typical example

1. Inspect the fuel injection lines (1) for wear and for damage. Replace any fuel injection line (1) that is worn or any fuel injection line that is damaged.
2. Loosely install the clamps for the fuel injection lines (1).
3. Remove the dust caps from the fuel injection pump (3) and from the fuel injectors (2). Remove the dust caps from the fuel injection lines (1).
4. Loosely connect the nuts at both ends of the fuel injection lines (1).
5. Ensure that each fuel injection line (1) does not contact any other fuel injection line or any other engine component. Tighten the fasteners for the clamps for the fuel injection lines (1). Check that the fuel injection lines (1) are still clear of other components.
6. Tighten the fuel injection lines (1) at the fuel injectors (2) to a torque of 30 N·m (22 lb ft).
7. Tighten the fuel injection lines (1) at the fuel injection pump (3) to 30 N·m (22 lb ft).
8. Remove the air from the fuel system. Refer to the Operations and Maintenance Manual, "Fuel System - Prime".

End By:

- a. If equipped, install the cover for the fuel injectors. Refer to this Disassembly and Assembly Manual, "Fuel Injector Cover - Remove and Install".

Fuel Injector Cover - Remove and Install (If Equipped)

Removal Procedure

NOTICE

Keep all parts clean from contaminants.

Contaminants may cause rapid wear and shortened component life.

Note: The removal procedure is identical for the four cylinder and the three cylinder engines. The illustration shows the four cylinder engine.

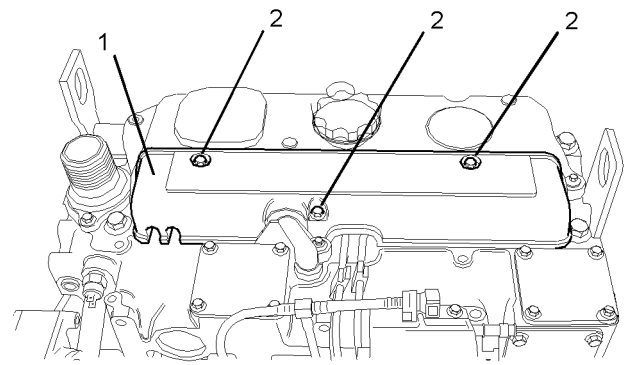

Illustration 14
Typical example

1. Thoroughly clean all of the outer surfaces of the cover (1) for the fuel injectors.
2. Remove the setscrews (2) from the cover (1).
3. Remove the cover (1).

Installation Procedure

i02216956

NOTICE

Keep all parts clean from contaminants.

Contaminants may cause rapid wear and shortened component life.

Note: The installation procedure is identical for the four cylinder and the three cylinder engines. The illustration shows the four cylinder engine.

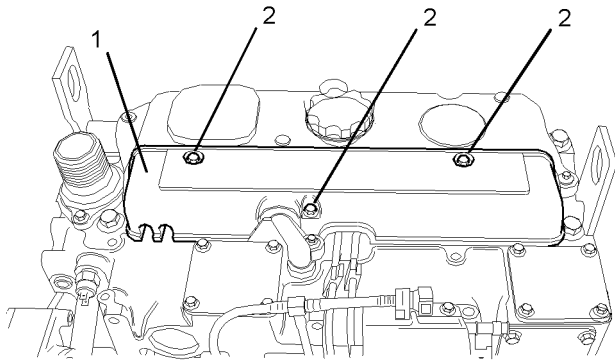

Illustration 15

g01011111

Typical example

1. Thoroughly clean all of the inner surfaces of the cover (1) for the fuel injectors.
2. Install the cover (1).
3. Install the setscrews (2) for the cover (1). Tighten the setscrews (2) to a torque of 9 N·m (7 lb ft).

Fuel Injection Pump - Remove (Delphi DP210)

Removal Procedure

Start By:

- a. Remove the fuel injection lines. Refer to this Disassembly and Assembly Manual, "Fuel Injection Lines - Remove".
- b. Remove the crankshaft pulley. Refer to this Disassembly and Assembly Manual, "Crankshaft Pulley - Remove and Install".
- c. Remove the front cover. Refer to this Disassembly and Assembly Manual, "Front Cover - Remove and Install".

Note: The removal procedure is identical for the four cylinder and the three cylinder engines. The illustrations show the four cylinder engine.

NOTICE

Keep all parts clean from contaminants.

Contaminants may cause rapid wear and shortened component life.

1. Ensure that the No. 1 cylinder is at top dead center on the compression stroke. Refer to the Testing and Adjusting Manual, "Finding Top Center Position for No. 1 Piston".

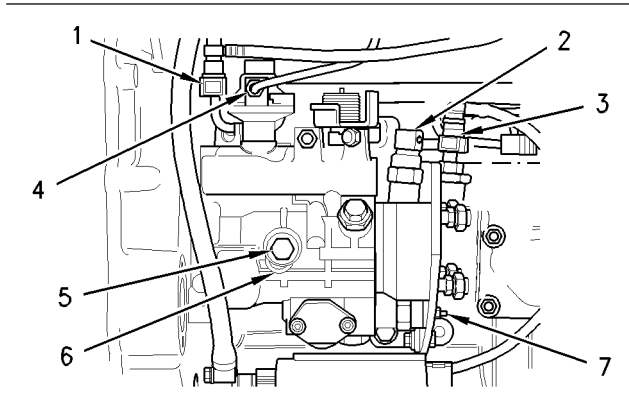

Illustration 16
Typical example g00956204

2. Loosen the locking screw (5). Rotate the spacer (6) in order to allow the locking screw (5) to tighten against the shaft of the fuel injection pump. Rotate the fuel injection pump gear in a counterclockwise direction in order to remove the backlash. Tighten the locking screw (5) to a torque of 17 N·m (13 lb ft).

Note: The locking screw (5) must be tightened in order to prevent the shaft of the fuel injection pump from rotating. The shaft of the fuel injection pump must not be rotated after the fuel injection pump has been removed from the engine.

Note: Put identification marks on all fuel hose assemblies and on all tube assemblies for installation purposes. After being disconnected, plug all fuel hose assemblies and plug all tube assemblies with suitable plastic plugs. Also install dust caps on all of the connectors on the fuel injection pump. This helps prevent fluid loss, and this helps to keep contaminants from entering the system.

3. Disconnect the fuel return line (1). Disconnect the tube assembly (4) from the fuel injection pump.
4. Disconnect the fuel line (3).
5. Disconnect the harness assembly (2) from the timing advance solenoid (7).

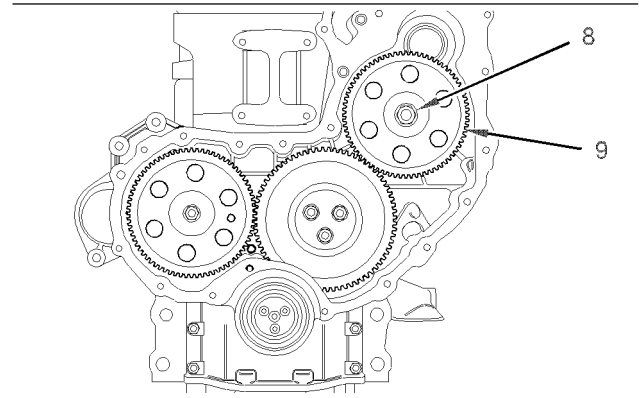

Illustration 17
Typical example g01011369

6. Remove the nut (8) and the washer from the shaft of the fuel injection pump.
7. Use a suitable puller in order to remove the fuel injection pump gear (9).

Note: Do not pry the fuel injection pump gear (9) from the shaft of the fuel injection pump.

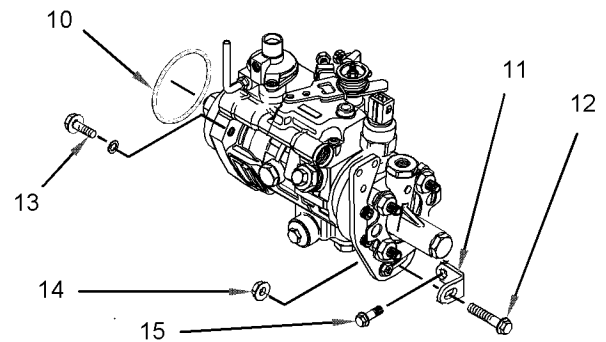

Illustration 18
Typical example g01062058

Note: The two steps that follow are only required if the bracket (11) is installed on the fuel injection pump.

8. Remove the nut (14). Remove the bolt (12).
9. If necessary, remove the setscrew (15) and the bracket (11) from the cylinder block.
10. Remove the setscrews (13) in order to remove the fuel injection pump.

11. Remove the fuel injection pump from the front housing. Remove the O-ring (10) and discard the O-ring from the fuel injection pump.

i02075326

Fuel Injection Pump - Remove (Delphi STP)

Removal Procedure

Start By:

- a. Remove the fuel injection lines. Refer to this Disassembly and Assembly Manual, "Fuel Injection Lines - Remove".
- b. Remove the crankshaft pulley. Refer to this Disassembly and Assembly Manual, "Crankshaft Pulley - Remove and Install".
- c. Remove the front cover. Refer to this Disassembly and Assembly Manual, "Front Cover - Remove and Install".

NOTICE

Keep all parts clean from contaminants.

Contaminants may cause rapid wear and shortened component life.

1. Ensure that the No. 1 cylinder is at top dead center on the compression stroke. Refer to the Testing and Adjusting Manual, "Finding Top Center Position for No. 1 Piston".

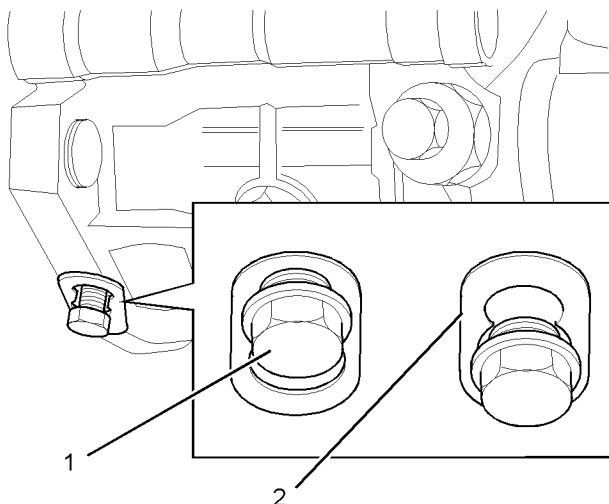

Illustration 19

g01061708

2. Loosen the locking screw (1). Rotate the spacer (2) in order to allow the locking screw (1) to tighten against the shaft of the fuel injection pump. Rotate the fuel injection pump gear in a counterclockwise direction in order to remove the backlash. Tighten the locking screw (1) to a torque of 13 N·m (9.6 lb ft).

Note: The locking screw (1) must be tightened in order to prevent the shaft of the fuel injection pump from rotating. The shaft of the fuel injection pump must not be rotated after the fuel injection pump has been removed from the engine.

Note: Put identification marks on all fuel hose assemblies and on all tube assemblies for installation purposes. After being disconnected, plug all fuel hose assemblies and plug all tube assemblies with suitable plastic plugs. Also install dust caps on all of the connectors on the fuel injection pump. This helps prevent fluid loss, and this helps to keep contaminants from entering the system.

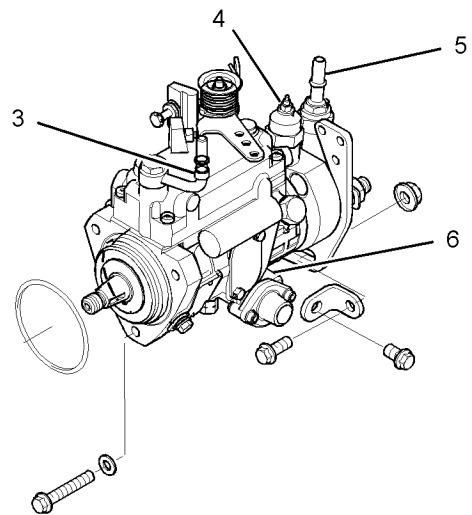

Illustration 20

g01062395

3. Disconnect the fuel return line (3).
4. Disconnect the fuel line (5).
5. Disconnect the harness assembly (4) from the timing advance solenoid (6).

i02224700

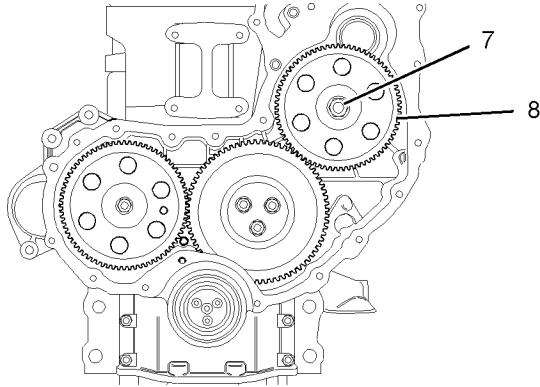

Illustration 21
Typical example

6. Remove the nut (7) and the washer from the shaft of the fuel injection pump.
7. Use a suitable puller in order to remove the fuel injection pump gear (8).

Note: Do not pry the fuel injection pump gear (9) from the shaft of the fuel injection pump.

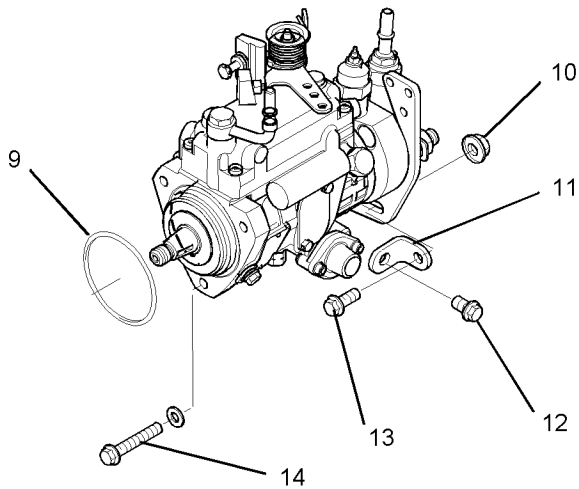

Illustration 22

8. Remove the nut (10). Remove the bolt (13).
9. If necessary, remove the setscrew (14) and the bracket (11) from the cylinder block.
10. Remove the setscrews (14) in order to remove the fuel injection pump.
11. Remove the fuel injection pump from the front housing. Remove the O-ring (9) and discard the O-ring from the fuel injection pump.

Fuel Injection Pump - Remove (Delphi DPG)

Removal Procedure

Start By:

- a. Remove the fuel injection lines. Refer to this Disassembly and Assembly Manual, "Fuel Injection Lines - Remove".
- b. Remove the crankshaft pulley. Refer to this Disassembly and Assembly Manual, "Crankshaft Pulley - Remove and Install".
- c. Remove the front cover. Refer to this Disassembly and Assembly Manual, "Front Cover - Remove and Install".

NOTICE

Keep all parts clean from contaminants.

Contaminants may cause rapid wear and shortened component life.

1. Ensure that the No. 1 cylinder is at top dead center on the compression stroke. Refer to the Testing and Adjusting Manual, "Finding Top Center Position for No. 1 Piston".

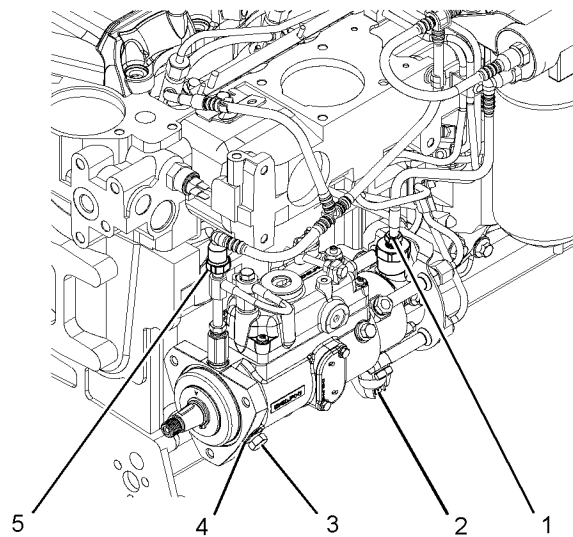

Illustration 23

g01122132

2. Loosen the locking screw (3). Rotate the spacer (4) in order to allow the locking screw (3) to tighten against the shaft of the fuel injection pump. Rotate the fuel injection pump gear in a counterclockwise direction in order to remove the backlash. Tighten the locking screw (3) to a torque of 13 N·m (9.6 lb ft).

Note: The locking screw (3) must be tightened in order to prevent the shaft of the fuel injection pump from rotating. The shaft of the fuel injection pump must not be rotated after the fuel injection pump has been removed from the engine.

Note: Put identification marks on all fuel hose assemblies and on all tube assemblies for installation purposes. After being disconnected, plug all fuel hose assemblies and plug all tube assemblies with suitable plastic plugs. Also install dust caps on all of the connectors on the fuel injection pump. This helps prevent fluid loss, and this helps to keep contaminants from entering the system.

3. Disconnect the fuel return line (5).
4. Disconnect the fuel line (1).
5. Disconnect the harness assembly from the fuel shutoff solenoid (2).

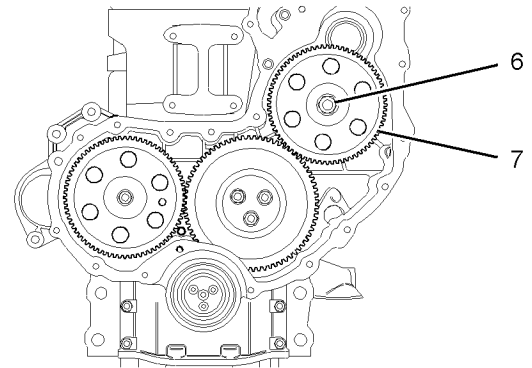

Illustration 24

g01122133

6. Remove the nut (6) and the washer from the shaft of the fuel injection pump.
7. Use a suitable puller in order to remove the fuel injection pump gear (7).

Note: Do not pry the fuel injection pump gear (7) from the shaft of the fuel injection pump.

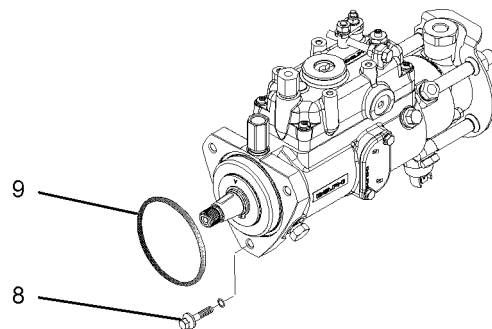

Illustration 25

g01122134

8. Remove the setscrews (8) in order to remove the fuel injection pump.
9. Remove the fuel injection pump from the front housing. Remove the O-ring (9) and discard the O-ring from the fuel injection pump.

i01941022

Fuel Injection Pump - Remove (Bosch EPVE for the 1104 engines only)

Removal Procedure

Start By:

- a. Remove the fuel injection lines. Refer to this Disassembly and Assembly Manual, "Fuel Injection Lines - Remove and Install".
- b. Remove the crankshaft pulley. Refer to this Disassembly and Assembly Manual, "Crankshaft Pulley - Remove and Install".
- c. Remove the front cover. Refer to this Disassembly and Assembly Manual, "Front Cover - Remove and Install".

NOTICE

Keep all parts clean from contaminants.

Contaminants may cause rapid wear and shortened component life.

1. Ensure that the No. 1 cylinder is at top dead center on the compression stroke. Refer to the Testing and Adjusting Manual, "Finding Top Center Position for No. 1 Piston".

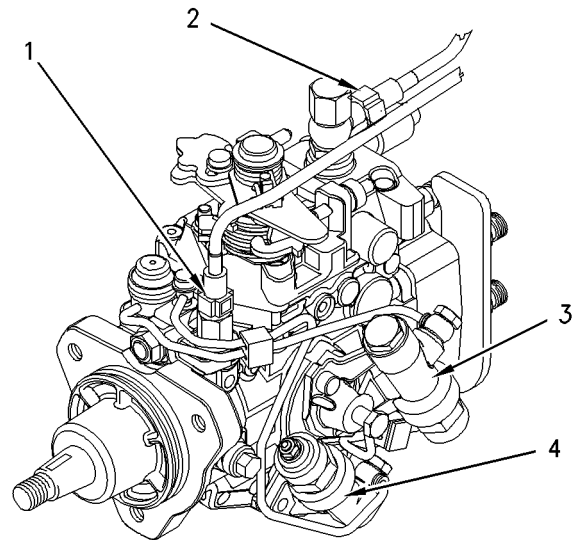

Illustration 26

g00996409

Note: Put identification marks on all fuel hose assemblies and on all tube assemblies for installation purposes. After being disconnected, plug all fuel hose assemblies and plug all tube assemblies with suitable plastic plugs. Also install dust caps on all of the connectors on the fuel injection pump. This helps prevent fluid loss, and this helps to keep contaminants from entering the system.

2. Disconnect the tube assembly (1) from the fuel injection pump. Disconnect the tube assembly (2) from the fuel injection pump.
3. Disconnect the wiring harness assembly from the cold start advance unit (3). Disconnect the wiring harness assembly from the engine shutoff solenoid (4).

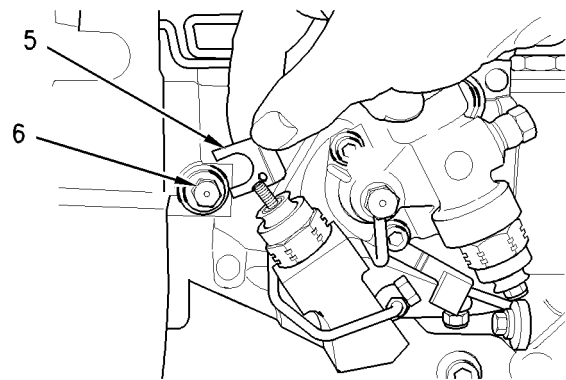

Illustration 27

g00996410

4. Loosen the locking screw (6). Move the spacer (5) in order to allow the locking screw (6) to tighten against the shaft of the fuel injection pump. Rotate the fuel injection pump gear in a counterclockwise direction in order to remove the backlash. Tighten the locking screw (6) to a torque of 31 N·m (23 lb ft).

Note: The locking screw (6) must be tightened in order to prevent the shaft of the fuel injection pump from rotating. The shaft of the fuel injection pump must not be rotated after the fuel injection pump has been removed from the engine.

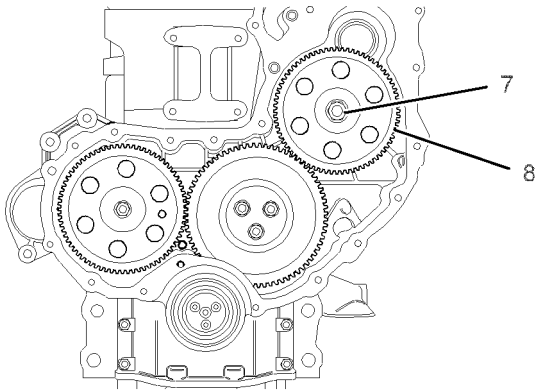

Illustration 28

g01011474

5. Remove the nut (7) and the washer from the shaft of the fuel injection pump.
6. Use a suitable puller in order to remove the fuel injection pump gear (8).

Note: Do not pry the fuel injection pump gear from the shaft of the fuel injection pump.

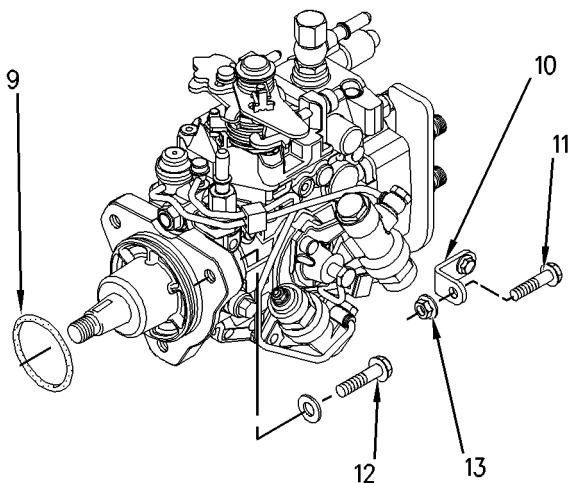

Illustration 29

g00996474

8. If necessary, remove the setscrew and the bracket (10) from the cylinder block.
9. Remove the setscrews (12) in order to remove the fuel injection pump.
10. Remove the fuel injection pump from the front housing. Remove the O-ring (9) from the fuel injection pump and discard the O-ring.

i02220108

Fuel Injection Pump - Remove (Delphi DPA)

Removal Procedure

Start By:

- a. Remove the fuel injection lines. Refer to this Disassembly and Assembly Manual, "Fuel Injection Lines - Remove".
- b. Remove the crankshaft pulley. Refer to this Disassembly and Assembly Manual, "Crankshaft Pulley - Remove and Install".
- c. Remove the front cover. Refer to this Disassembly and Assembly Manual, "Front Cover - Remove and Install".

NOTICE

Keep all parts clean from contaminants.

Contaminants may cause rapid wear and shortened component life.

1. Ensure that the No. 1 cylinder is at top dead center on the compression stroke. Refer to the Testing and Adjusting Manual, "Finding Top Center Position for No. 1 Piston".

7. Remove the nut (13). Remove the bolt (11).

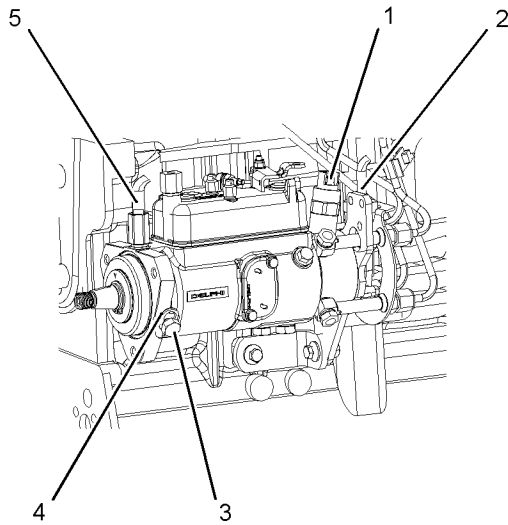

Illustration 30 g01120559
Typical example

2. Loosen the locking screw (3). Rotate the spacer (4) in order to allow the locking screw (3) to tighten against the shaft of the fuel injection pump. Rotate the fuel injection pump gear in a counterclockwise direction in order to remove the backlash. Tighten the locking screw (3) to a torque of 13 N·m (9.6 lb ft).

Note: The locking screw (3) must be tightened in order to prevent the shaft of the fuel injection pump from rotating. The shaft of the fuel injection pump must not be rotated after the fuel injection pump has been removed from the engine.

Note: Put identification marks on all fuel hose assemblies and on all tube assemblies for installation purposes. After being disconnected, plug all fuel hose assemblies and plug all tube assemblies with suitable plastic plugs. Also install dust caps on all of the connectors on the fuel injection pump. This helps prevent fluid loss, and this helps to keep contaminants from entering the system.

3. Disconnect the fuel return line (5).
4. Disconnect the fuel line (2).
5. Disconnect the harness assembly from the fuel shutoff solenoid (1).

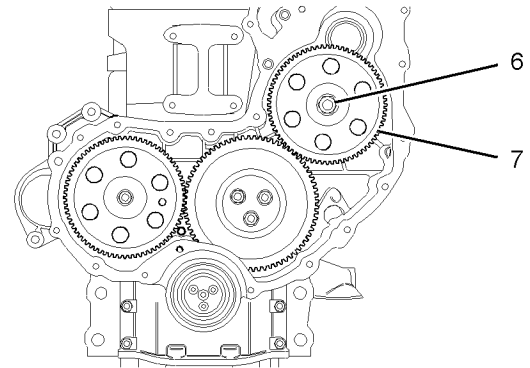

Illustration 31 g01120567
Typical example

6. Remove the nut (6) and the washer from the shaft of the fuel injection pump.
7. Use a suitable puller in order to remove the fuel injection pump gear (7).

Note: Do not pry the fuel injection pump gear (7) from the shaft of the fuel injection pump.

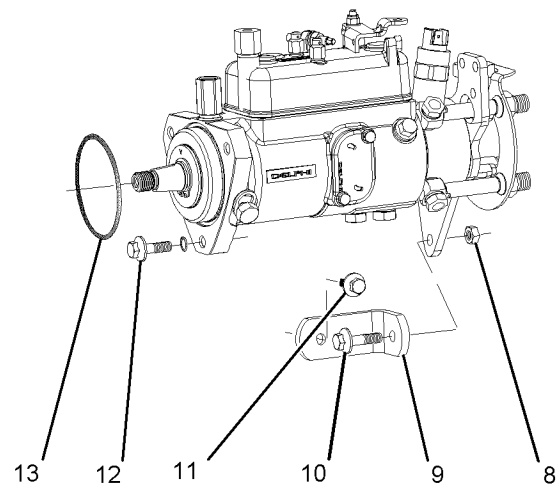

Illustration 32 g01120575
Typical example

8. Remove the nut (8). Remove the bolt (10).
9. If necessary, remove the setscrew (11) and the bracket (9) from the cylinder block.
10. Remove the setscrews (12) in order to remove the fuel injection pump.

11. Remove the fuel injection pump from the front housing. Remove the O-ring (13) and discard the O-ring from the fuel injection pump.

i02216957

Fuel Injection Pump - Install (Delphi DP210)

Installation Procedure

Note: The installation procedure is identical for the four cylinder and the three cylinder engines. The illustrations show the four cylinder engine.

Note: The shaft of the fuel injection pump must remain locked until the timing gear (9) has been installed and tightened onto the shaft of the fuel injection pump. The locking screw (5) must remain locked until you are instructed to loosen the locking screw. The fuel injection pump must be returned to your Perkins Dealer if the shaft of the fuel injection pump was rotated accidentally.

NOTICE

Keep all parts clean from contaminants.

Contaminants may cause rapid wear and shortened component life.

1. Ensure that the No. 1 cylinder is at top dead center on the compression stroke. Refer to the Testing and Adjusting Manual, "Fuel Injection Timing - Check".

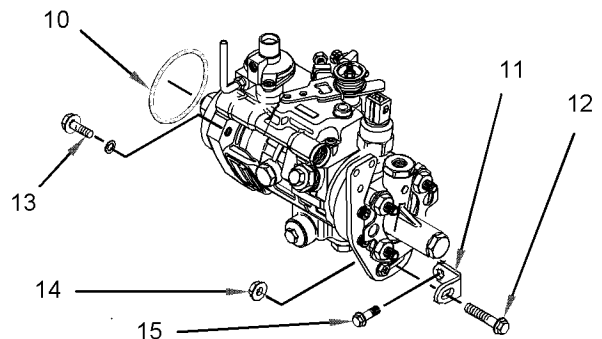

Illustration 33

g01062058

Typical example

Note: Do not lubricate the new O-ring (10). The O-ring should be installed dry.

2. Install the new O-ring (10) onto the fuel injection pump. Position the fuel injection pump onto the front housing. Install the setscrews (13). Tighten the setscrews (13) to a torque of 25 N·m (18 lb ft).

Note: The two steps that follow are only required if the bracket (11) is installed on the fuel injection pump.

3. Install the setscrew (15) and the bracket (11) onto the cylinder block if the bracket was previously removed. Ensure that the bracket (11) supports the fuel injection pump without applying any other external force on the fuel injection pump. Tighten the setscrew (15) to a torque of 44 N·m (32 lb ft).

4. Install the bolt (12) and the nut (14).

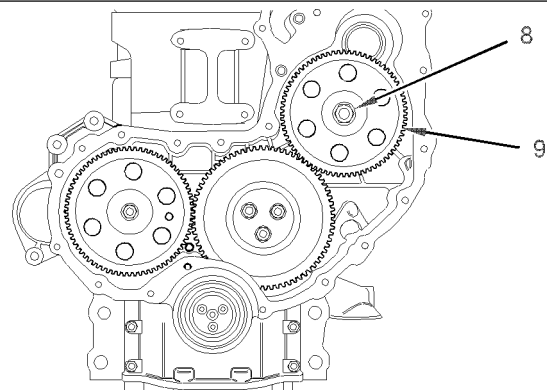

Illustration 34

g01011369

Typical example

Note: Ensure that the mating surfaces of the fuel injection pump gear and the shaft of the fuel injection pump are clean. Lubricate the threads of the shaft for the fuel injection pump. The nut (8) must turn freely until contact is made with the fuel injection pump gear.

5. Position the fuel injection pump gear (9) onto the shaft of the fuel injection pump. Install the washer and the nut (8). Rotate the fuel injection pump gear (9) in a counterclockwise direction in order to remove the backlash. Tighten the nut (8) to a torque of 24 N·m (17 lb ft).

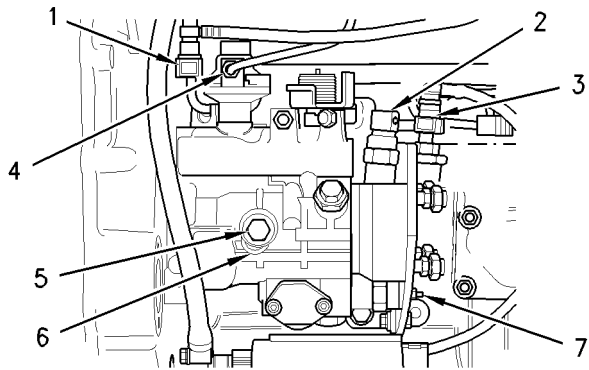

Illustration 35
Typical example
g00956204

6. Connect the harness assembly to the timing advance solenoid (7).
7. Connect the harness assembly (2).
8. Remove all of the dust caps from the connectors on the fuel injection pump. Remove all of the plugs from the fuel hose assemblies and from the tube assemblies.
9. Connect the fuel line (3), the fuel return line (1), and the tube assembly (4) to the fuel injection pump.
10. Loosen the locking screw (5). Move the spacer (6) in order to prevent the locking screw (5) from tightening against the shaft of the fuel injection pump. Tighten the locking screw (5) to a torque of 12 N·m (106 lb in).

Note: The spacer (6) must be correctly positioned and locking screw (5) must be tightened in order to prevent the locking screw from contacting the shaft of the fuel injection pump.

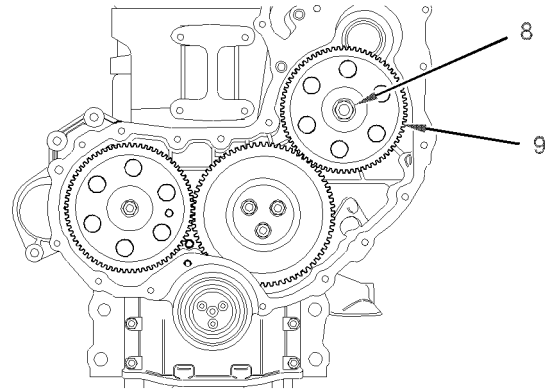

Illustration 36
Typical example
g01011369

11. Tighten the nut (8) to a torque of 88 N·m (65 lb ft).

End By:

- a. Install the front cover. Refer to this Disassembly and Assembly Manual, "Front Cover - Remove and Install".
- b. Install the crankshaft pulley. Refer to this Disassembly and Assembly Manual, "Crankshaft Pulley - Remove and Install".
- c. Install the fuel injection lines. Refer to this Disassembly and Assembly Manual, "Fuel Injection Lines - Install".

i02075327

Fuel Injection Pump - Install (Delphi STP)

Installation Procedure

Note: The shaft of the fuel injection pump must remain locked until the timing gear (8) has been installed and tightened onto the shaft of the fuel injection pump. The locking screw (1) must remain locked until you are instructed to loosen the locking screw. The fuel injection pump must be returned to your Perkins Dealer if the shaft of the fuel injection pump was rotated accidentally.

NOTICE

Keep all parts clean from contaminants.

Contaminants may cause rapid wear and shortened component life.

1. Ensure that the No. 1 cylinder is at top dead center on the compression stroke. Refer to the Testing and Adjusting Manual, "Fuel Injection Timing - Check".

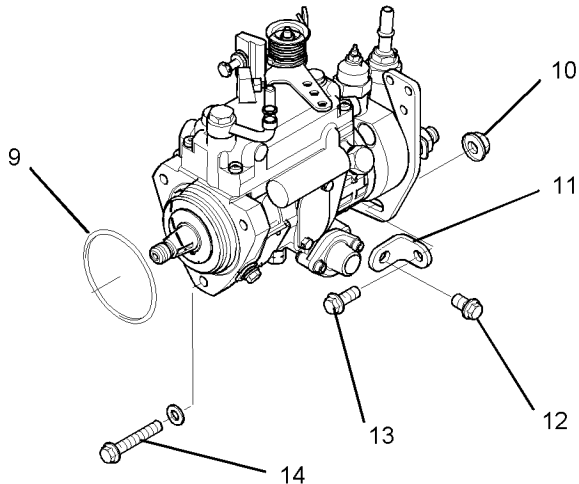

Illustration 37 g01062396

Note: Do not lubricate the new O-ring (9). The O-ring should be installed dry.

2. Install the new O-ring (9) onto the fuel injection pump. Position the fuel injection pump onto the front housing. Install the setscrews (14). Tighten the setscrews (14) to a torque of 25 N·m (18 lb ft).
3. Install the setscrew (12) and the bracket (11) onto the cylinder block if the bracket was previously removed. Ensure that the bracket (11) supports the fuel injection pump without applying any other external force on the fuel injection pump. Tighten the setscrew (12) to a torque of 44 N·m (32 lb ft).
4. Install the bolt (13) and the nut (10).

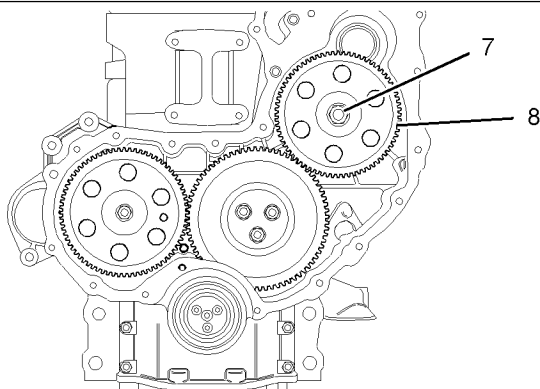

Illustration 38 g01062397

Typical example

Note: Ensure that the mating surfaces of the fuel injection pump gear and the shaft of the fuel injection pump are clean. Lubricate the threads of the shaft for the fuel injection pump. The nut (7) must turn freely until contact is made with the fuel injection pump gear.

5. Position the fuel injection pump gear (8) onto the shaft of the fuel injection pump. Install the washer and the nut (7). Rotate the fuel injection pump gear (8) in a counterclockwise direction in order to remove the backlash. Tighten the nut (7) to a torque of 24 N·m (17 lb ft).

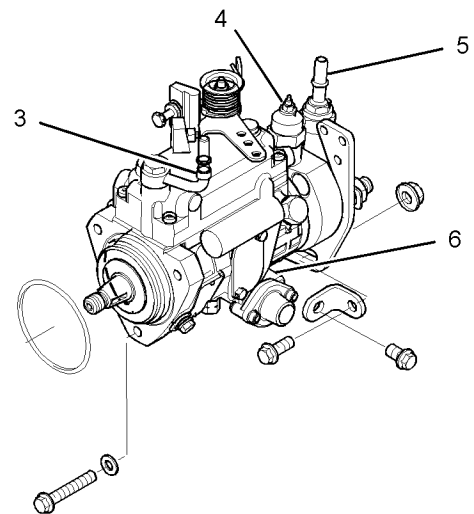

Illustration 39 g01062395

6. Connect the harness assembly to the timing advance solenoid (6).
7. Connect the harness assembly (4).
8. Remove all of the dust caps from the connectors on the fuel injection pump. Remove all of the plugs from the fuel hose assemblies and from the tube assemblies.
9. Connect the fuel line (5) to the fuel injection pump. Connect the fuel return line (3) to the fuel injection pump.

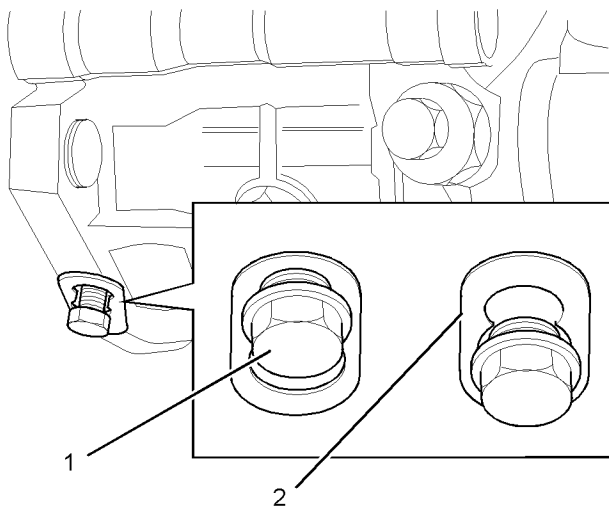

Illustration 40

g01061708

10. Loosen the locking screw (1). Move the spacer (2) in order to prevent the locking screw (1) from tightening against the shaft of the fuel injection pump. Tighten the locking screw (1) to a torque of 12 N·m (8.8 lb ft).

Note: The spacer (2) must be correctly positioned and locking screw (1) must be tightened in order to prevent the locking screw from contacting the shaft of the fuel injection pump.

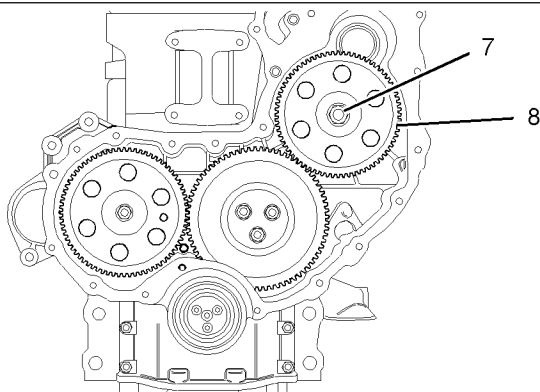

Illustration 41

g01062397

Typical example

11. Tighten the nut (7) to a torque of 88 N·m (65 lb ft).

End By:

a. Install the front cover. Refer to this Disassembly and Assembly Manual, "Front Cover - Remove and Install".

- b. Install the crankshaft pulley. Refer to this Disassembly and Assembly Manual, "Crankshaft Pulley - Remove and Install".
- c. Install the fuel injection lines. Refer to this Disassembly and Assembly Manual, "Fuel Injection Lines - Install".

i02224733

Fuel Injection Pump - Install (Delphi DPG)

Installation Procedure

Note: The installation procedure is identical for the four cylinder and the three cylinder engines. The illustrations show the four cylinder engine.

Note: The shaft of the fuel injection pump must remain locked until the timing gear (7) has been installed and tightened onto the shaft of the fuel injection pump. The locking screw (3) must remain locked until you are instructed to loosen the locking screw. The fuel injection pump must be returned to your Perkins Dealer if the shaft of the fuel injection pump was rotated accidentally.

NOTICE

Keep all parts clean from contaminants.

Contaminants may cause rapid wear and shortened component life.

- 1. Ensure that the No. 1 cylinder is at top dead center on the compression stroke. Refer to the Testing and Adjusting Manual, "Fuel Injection Timing - Check".

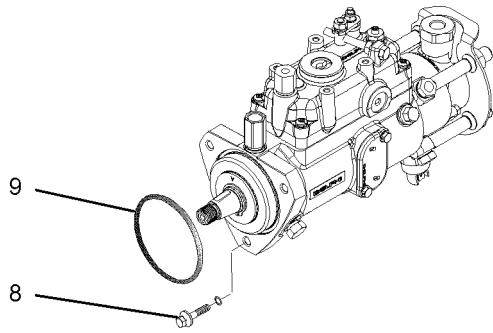

Illustration 42
Typical example
g01122134

Note: Do not lubricate the new O-ring (9). The O-ring should be installed dry.

2. Install the new O-ring (9) onto the fuel injection pump. Position the fuel injection pump onto the front housing. Install the setscrews (8). Tighten the setscrews (8) to a torque of 25 N·m (18 lb ft).

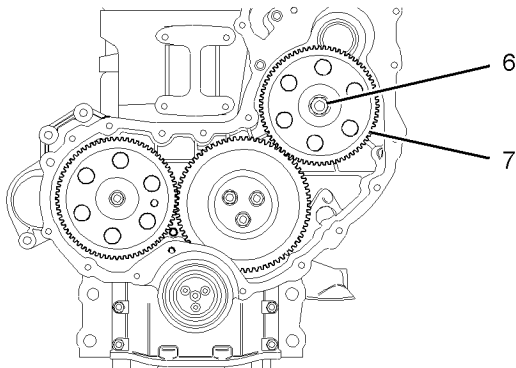

Illustration 43
g01122133

Note: Ensure that the mating surfaces of the fuel injection pump gear and the shaft of the fuel injection pump are clean. Lubricate the threads of the shaft for the fuel injection pump. The nut (6) must turn freely until contact is made with the fuel injection pump gear.

3. Position the fuel injection pump gear (7) onto the shaft of the fuel injection pump. Install the washer and the nut (6). Rotate the fuel injection pump gear (7) in a counterclockwise direction in order to remove the backlash. Tighten the nut (6) to a torque of 24 N·m (17 lb ft).

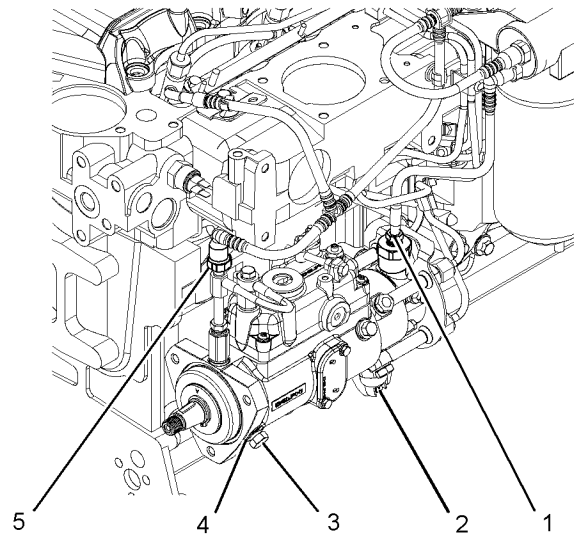

Illustration 44
g01122132

4. Connect the harness assembly to the fuel shutoff solenoid (2).
5. Remove all of the dust caps from the connectors on the fuel injection pump. Remove all of the plugs from the fuel hose assemblies and from the tube assemblies.
6. Connect the fuel line (1) and the fuel return line (5) to the fuel injection pump.
7. Loosen the locking screw (3). Move the spacer (4) in order to prevent the locking screw (3) from tightening against the shaft of the fuel injection pump. Tighten the locking screw (3) to a torque of 12 N·m (106 lb in).

Note: The spacer (4) must be correctly positioned and locking screw (3) must be tightened in order to prevent the locking screw from contacting the shaft of the fuel injection pump.

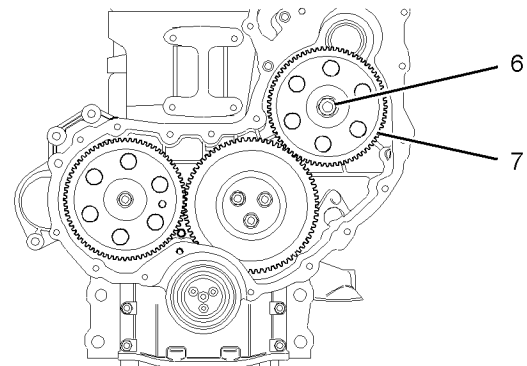

Illustration 45
g01122133

8. Tighten the nut (6) to a torque of 88 N·m (65 lb ft).

End By:

- a. Install the front cover. Refer to this Disassembly and Assembly Manual, "Front Cover - Remove and Install".
- b. Install the crankshaft pulley. Refer to this Disassembly and Assembly Manual, "Crankshaft Pulley - Remove and Install".
- c. Install the fuel injection lines. Refer to this Disassembly and Assembly Manual, "Fuel Injection Lines - Install".

i01943877

Fuel Injection Pump - Install (Bosch EPVE for the 1104 engines only)

Installation Procedure

Note: The shaft of the fuel injection pump must remain locked until the timing gear (8) has been installed and tightened onto the shaft of the fuel injection pump. The locking screw (6) must remain locked until you are instructed to loosen the locking screw. The Bosch EPVE fuel injection pump can be timed to the engine by a technician. Refer to the Testing and Adjusting Manual, "Fuel Injection Pump Timing - Check and Fuel Injection Pump Timing - Adjust" if the shaft of the fuel injection pump was rotated accidentally.

NOTICE

Keep all parts clean from contaminants.

Contaminants may cause rapid wear and shortened component life.

1. Ensure that the No. 1 cylinder is at top dead center on the compression stroke. Refer to the Testing and Adjusting Manual, "Fuel Injection Timing - Check".

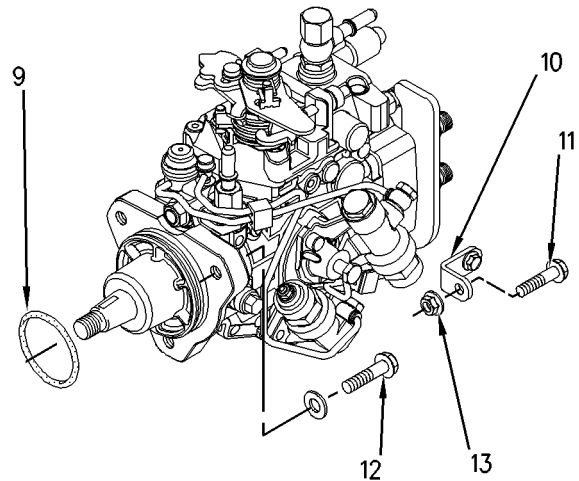

Illustration 46

g00996474

2. Lightly lubricate a new O-ring (9) with Perkins 1766-501 Silicone Fluid MS200/1000. Install the new O-ring (9) onto the fuel injection pump. Position the fuel injection pump on the front housing. Install the setscrews (12). Tighten the setscrews to a torque of 25 N·m (18 lb ft).
3. Install the setscrew and the bracket (10) onto the cylinder block if the bracket (10) was previously removed. Ensure that the bracket (10) supports the fuel injection pump without applying any other external force on the fuel injection pump. Tighten the setscrew to a torque of 44 N·m (32 lb ft).
4. Install the bolt (11) and the nut (13).

Note: Ensure that the mating surfaces of the fuel injection pump gear (8) and the shaft of the fuel injection pump are clean. Lubricate the threads of the shaft for the fuel injection pump. The nut (7) must turn freely until contact is made with the fuel injection pump gear (8).

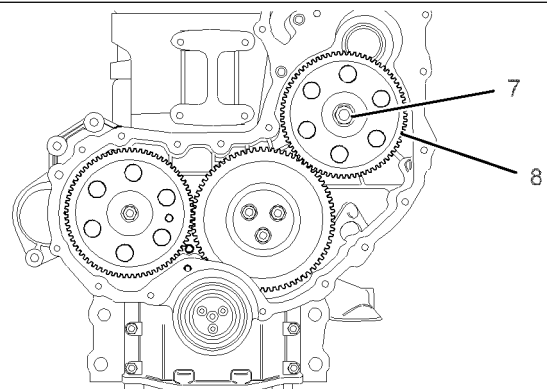

Illustration 47

g01011474

5. Position the fuel injection pump gear (8) onto the shaft of the fuel injection pump. Install the washer and the nut (7). Rotate the fuel injection pump gear (8) in a counterclockwise direction in order to remove the backlash. Tighten the nut (7) to a torque of 24 N·m (17 lb ft).

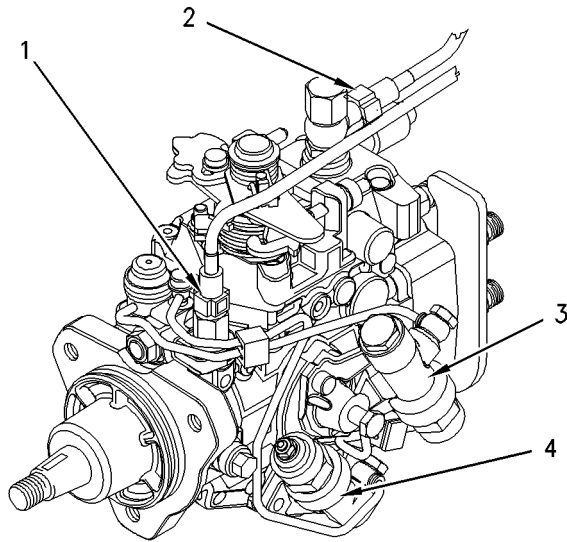

Illustration 48

g00996409

6. Connect the wiring harness assembly to the engine shutoff solenoid (4).
7. Connect the wiring harness assembly to the cold start advance unit (3).
8. Remove all of the dust caps from the connectors on the fuel injection pump. Remove all of the plugs from the fuel hose assemblies and from the tube assemblies.
9. Connect the tube assembly (2) to the fuel injection pump. Connect the tube assembly (1) to the fuel injection pump.

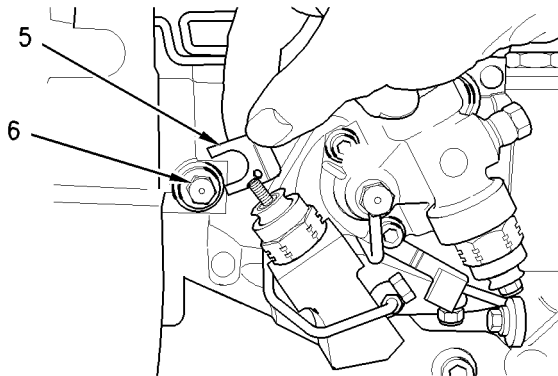

Illustration 49

g00996410

10. Loosen the locking screw (6). Move spacer (5) in order to prevent the locking screw (6) from tightening against the shaft of the fuel injection pump. Tighten the locking screw (6) to a torque of 12 N·m (106 lb in).

Note: The spacer (5) must be installed and the locking screw (6) must be tightened in order to prevent the locking screw from contacting the shaft of the fuel injection pump.

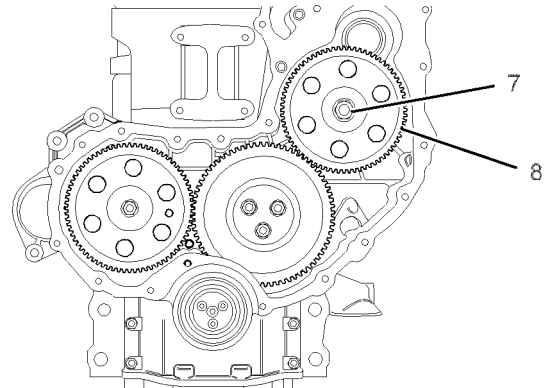

Illustration 50

g01011474

11. Tighten the nut (7) to a torque of 88 N·m (65 lb ft).

End By:

- a. Install the front cover. Refer to this Disassembly and Assembly Manual, "Front Cover - Remove and Install".
- b. Install the crankshaft pulley. Refer to this Disassembly and Assembly Manual, "Crankshaft Pulley - Remove and Install".
- c. Install the fuel injection lines. Refer to this Disassembly and Assembly Manual, "Fuel Injection Lines - Install".

i02224693

Fuel Injection Pump - Install (Delphi DPA)

Installation Procedure

Note: The shaft of the fuel injection pump must remain locked until the timing gear (7) has been installed and tightened onto the shaft of the fuel injection pump. The locking screw (3) must remain locked until you are instructed to loosen the locking screw. The fuel injection pump must be returned to your Perkins Dealer if the shaft of the fuel injection pump was rotated accidentally.

NOTICE

Keep all parts clean from contaminants.

Contaminants may cause rapid wear and shortened component life.

1. Ensure that the No. 1 cylinder is at top dead center on the compression stroke. Refer to the Testing and Adjusting Manual, "Fuel Injection Timing - Check".

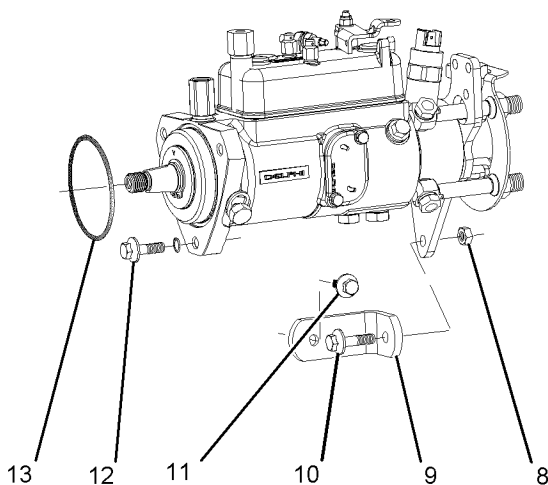

Illustration 51

g01120575

Note: Do not lubricate the new O-ring (13). The O-ring should be installed dry.

2. Install the new O-ring (13) onto the fuel injection pump. Position the fuel injection pump onto the front housing. Install the setscrews (12). Tighten the setscrews (12) to a torque of 25 N·m (18 lb ft).
3. Loosely install the setscrew (11) and the bracket (9) onto the cylinder block if the bracket was previously removed. Loosely install the bolt (10) and the nut (8). Ensure that the bracket (9) supports the fuel injection pump without applying any other external force on the fuel injection pump. Tighten the setscrew (11), the bolt (10) and the nut (8) to a torque of 44 N·m (32 lb ft).

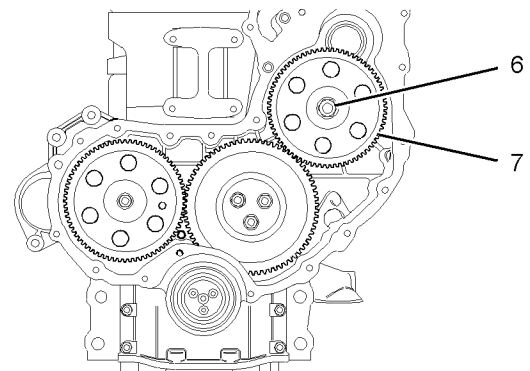

Illustration 52

g01120567

Note: Ensure that the mating surfaces of the fuel injection pump gear and the shaft of the fuel injection pump are clean. Lubricate the threads of the shaft for the fuel injection pump. The nut (6) must turn freely until contact is made with the fuel injection pump gear.

4. Position the fuel injection pump gear (7) onto the shaft of the fuel injection pump. Install the washer and the nut (6). Rotate the fuel injection pump gear (7) in a counterclockwise direction in order to remove the backlash. Tighten the nut (6) to a torque of 24 N·m (17 lb ft).

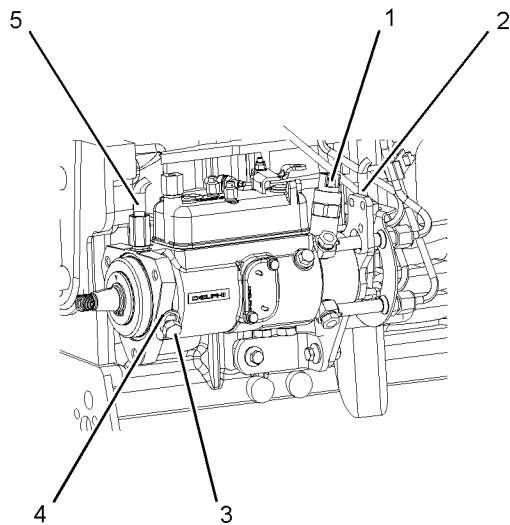

Illustration 53

g01120559

5. Connect the harness assembly to the fuel shutoff solenoid (1).
6. Remove all of the dust caps from the connectors on the fuel injection pump. Remove all of the plugs from the fuel hose assemblies and from the tube assemblies.
7. Connect the fuel line (2) and the fuel return line (5) to the fuel injection pump.
8. Loosen the locking screw (3). Move the spacer (4) in order to prevent the locking screw (3) from tightening against the shaft of the fuel injection pump. Tighten the locking screw (3) to a torque of 12 N·m (106 lb in).

Note: The spacer (4) must be correctly positioned and locking screw (3) must be tightened in order to prevent the locking screw from contacting the shaft of the fuel injection pump.

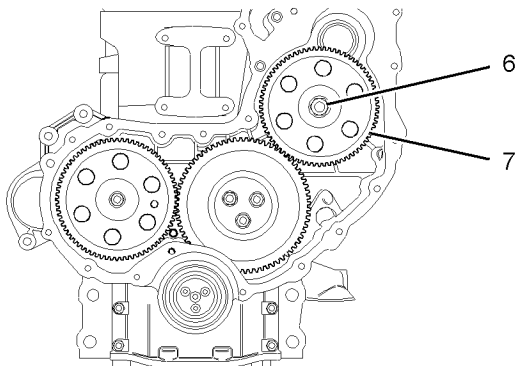

Illustration 54

g01120567

9. Tighten the nut (6) to a torque of 88 N·m (65 lb ft).

End By:

- a. Install the front cover. Refer to this Disassembly and Assembly Manual, "Front Cover - Remove and Install".
- b. Install the crankshaft pulley. Refer to this Disassembly and Assembly Manual, "Crankshaft Pulley - Remove and Install".
- c. Install the fuel injection lines. Refer to this Disassembly and Assembly Manual, "Fuel Injection Lines - Install".

i01938589

Fuel Injector - Remove

Removal Procedure

Start By:

- a. Remove the cover for the fuel injectors. Refer to this Disassembly and Assembly Manual, "Fuel Injector Cover - Remove and Install".
- b. Remove the fuel injection lines. Refer to this Disassembly and Assembly, "Fuel Injection Lines - Remove".

NOTICE

Keep all parts clean from contaminants.

Contaminants may cause rapid wear and shortened component life.

NOTICE

Care must be taken to ensure that fluids are contained during performance of inspection, maintenance, testing, adjusting and repair of the product. Be prepared to collect the fluid with suitable containers before opening any compartment or disassembling any component containing fluids.

Dispose of all fluids according to local regulations and mandates.

1. Disconnect the tube assemblies from the fuel filter base for the fuel inlet and the fuel outlet.

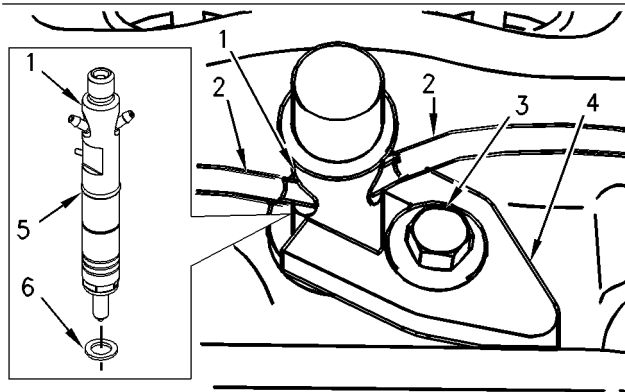

Illustration 55

g00975056

2. Remove the fuel hose (2) from the fuel injector (1).
3. Remove the setscrew (3). Remove the clamp (4) from the fuel injector (1).
4. Remove the fuel injector (1) from the cylinder head. Remove the O-ring seal (5) from the fuel injector (1) and discard the O-ring.
5. Remove the seat washer (6) from the cylinder head and discard the seat washer.

Note: If the original seat washer is not removed, the projection of the fuel injector will be incorrect when a new seat washer is installed.

i02241916

Fuel Injector - Install

Installation Procedure

NOTICE

Keep all parts clean from contaminants.

Contaminants may cause rapid wear and shortened component life.

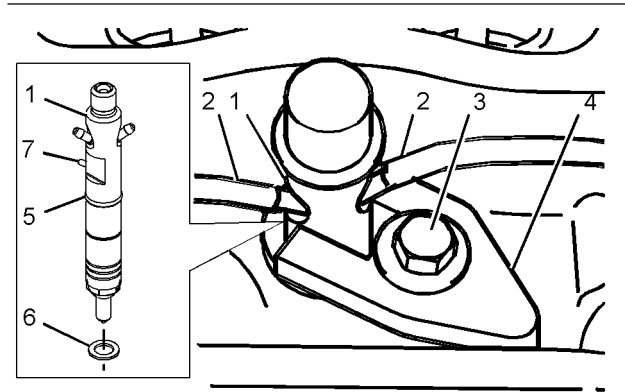

Illustration 56

g01129982

1. Lubricate the seat washer (6) with clean engine oil. Install a new seat washer (6) in the cylinder head.
- Note:** If the original seat washer (6) is reused, the projection of the fuel injector (1) will be incorrect.
2. Install a new O-ring seal (5) on fuel injector (1). Install the fuel injector (1) in the cylinder head.
- Note:** Alignment Pin (7) must be located opposite clamp (4).
3. Position clamp (4) on the fuel injector (1). Install setscrew (3). Tighten the setscrew to a torque of 27 N·m (20 lb ft).
 4. Install hose (2) to the fuel injector (1).

End By:

- a. Install the fuel injection lines. Refer to this Disassembly and Assembly, "Fuel Injection Lines - Install".
- b. Install the cover for the fuel injectors. Refer to this Disassembly and Assembly Manual, "Fuel Injector Cover - Remove and Install".

i01944022

Turbocharger - Remove

Removal Procedure

NOTICE

Keep all parts clean from contaminants.

Contaminants may cause rapid wear and shortened component life.

NOTICE

Care must be taken to ensure that fluids are contained during performance of inspection, maintenance, testing, adjusting and repair of the product. Be prepared to collect the fluid with suitable containers before opening any compartment or disassembling any component containing fluids.

Dispose of all fluids according to local regulations and mandates.

Note: The removal procedure is identical for the three cylinder and the four cylinder engines.

1. Thoroughly clean the outer surfaces of the turbocharger (1).
2. Loosen the hose clamps and remove the air inlet hose at the turbocharger compressor housing.

Note: Exhaust elbows are only an option for the four cylinder engines.

3. Remove the exhaust pipe from the turbocharger outlet or remove the exhaust pipe from the exhaust elbow. Refer to the OEM provided information for the correct procedure in order to remove the exhaust pipe.

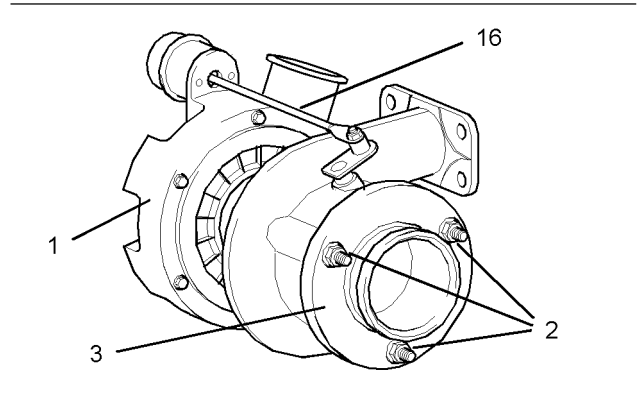

Illustration 57
Typical example

g01038600

4. If an exhaust elbow is installed, remove the exhaust elbow. Refer to this Disassembly and Assembly Manual, "Exhaust Elbow - Remove and Install".
5. Remove the nuts (2) and remove the exhaust adapter (3) from the turbocharger (1).
6. Place a suitable container below the turbocharger (1) in order to collect any spillage of oil.

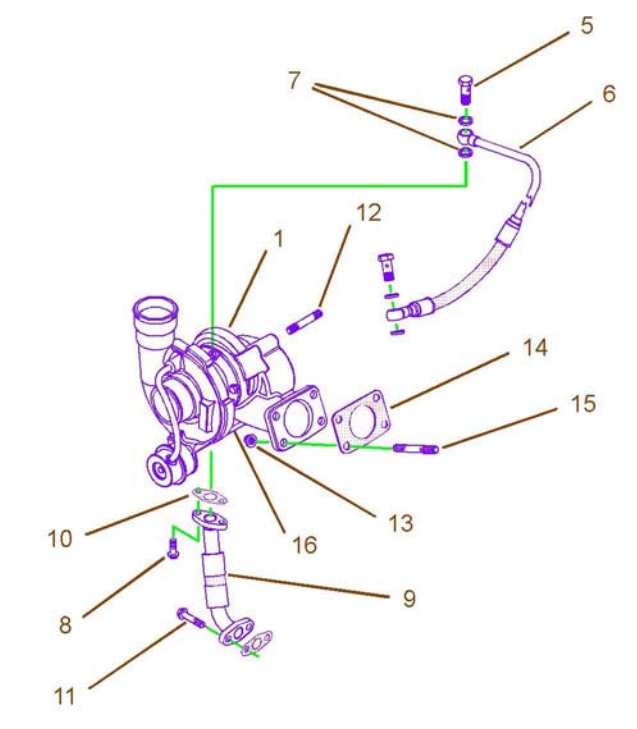

Illustration 58
Typical example

g01038396

7. Remove the banjo bolts (5). Remove the oil supply tube assembly (6) and the washers (7) from the turbocharger (1). Discard the washers (7). If necessary, remove the oil supply tube assembly (6) from the cylinder block and discard the washers.
8. Remove the setscrews (8). Remove the oil drain tube assembly (9) from the turbocharger (1). Remove the joint (10) and discard the joint. If necessary, remove the setscrews (11) and remove the oil drain tube assembly (9) from the cylinder block. Discard the joint.
9. If necessary, remove the studs (12) from the turbocharger housing.

Note: Do not use the actuator rod of the wastegate (16) to lift the turbocharger (1).

10. Remove the nuts (13). Remove the turbocharger (1). Remove the gasket (14). Discard the gasket (14). If necessary, remove the studs (15) from the exhaust manifold.

11. Install suitable plastic plugs into the oil supply and into the oil drain ports of the turbocharger (1). Install suitable plastic covers to the inlet and to the outlet of the turbocharger (1). Install suitable plastic plugs to the oil supply tube assembly (6) and to the oil drain tube assembly (9). Install suitable plastic covers to the manifold ports.

i01944024

Turbocharger - Install

1. Remove all of the plastic plugs from all of the ports of the turbocharger (1). Clean the mating surfaces of the exhaust manifold and the turbocharger. Clean the mating surfaces of the turbocharger to the oil supply tube assembly (6) and the turbocharger to the oil drain tube assembly (9).
2. Ensure that all of the turbocharger inlet and outlet ports are clean and free from restrictions. The turbocharger shaft must rotate freely.

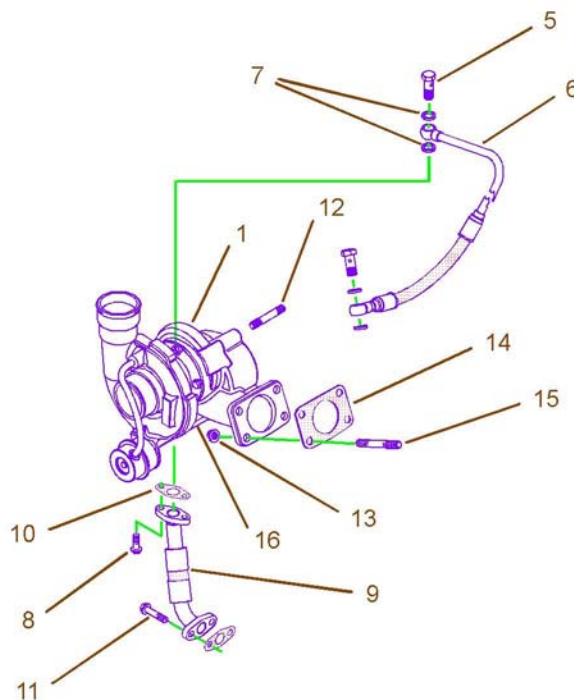

Illustration 59

g01038396

Typical example

3. If the studs (15) were previously removed, install the studs into the exhaust manifold. Install a new gasket (14) over the studs (15).

Note: Do not use any sealant on the gasket (14).

Note: Do not use the actuator rod of the wastegate (16) to lift the turbocharger (1).

4. Position the turbocharger (1) onto the exhaust manifold.
5. Install the nuts (13). Tighten the nuts (13) to a torque of 47 N·m (35 lb ft).
6. Lubricate the bearing housing of the turbocharger (1) with clean engine oil.
7. Inspect all of the oil hose assemblies (6 and 9). If necessary, replace the hose assemblies (6 and 9).

Installation Procedure

NOTICE

Keep all parts clean from contaminants.

Contaminants may cause rapid wear and shortened component life.

Note: The installation procedure is identical for the three cylinder and the four cylinder engines.

Note: The top flange of the oil drain tube assembly (9) is secured to the turbocharger (1) with 6 mm setscrews (8). The bottom flange of the oil drain tube assembly (9) is secured to the cylinder block with 8 mm setscrews (11).

8. Position a new joint (10) and the oil drain tube assembly (9) onto the bottom of the turbocharger (1). Install the 6 mm setscrews (8). Tighten the 6 mm setscrews (8) to a torque of 9 N·m (80 lb in).
9. Position a new joint and the oil drain tube assembly (9) onto the cylinder block. Tighten the 8 mm setscrews (11) to a torque of 22 N·m (16 lb ft).
10. Position the new washers (7) and the oil supply tube assembly (6) onto the turbocharger (1). Install the banjo bolt (5). Tighten the banjo bolt (5) to a torque of 22 N·m (16 lb ft).

Note: Ensure that the oil supply tube assembly (6) does not come into contact with any other component when the assembly is installed onto the engine.

11. Install the new washers and the oil supply tube assembly (6) to the cylinder block. Tighten the banjo bolt to a torque of 22 N·m (16 lb ft).
12. If the studs (12) were previously removed, install the studs into the turbocharger housing.

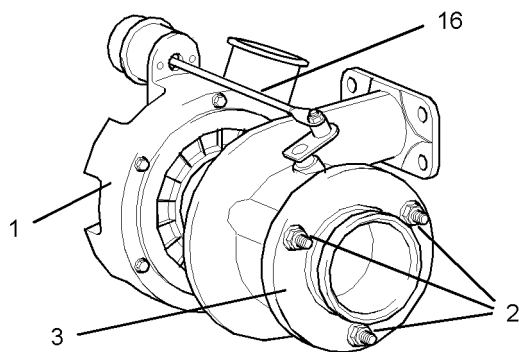

Illustration 60

g01038406

Typical example

13. Position the exhaust adapter (3) onto the studs (12). Install the nuts (2). Do not tighten the nuts (2) at this time.

Note: Exhaust elbows are only an option for the four cylinder engines.

14. If equipped, install the exhaust elbow onto the exhaust adapter (3). Refer to this Disassembly and Assembly Manual, "Exhaust Elbow - Remove and Install".

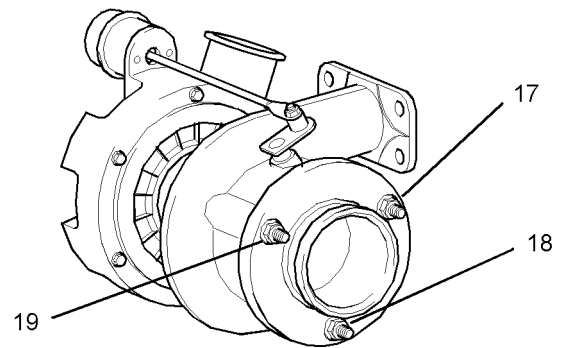

Illustration 61

g01038456

15. Tighten the three nuts finger tight in the sequence (17), (18), and (19). Tighten the nuts (17), (18), and (19) in the same sequence to a torque of 25 N·m (18 lb ft).
16. Ensure that there is no restriction in the inlet hose. Position the air inlet hose on the turbocharger compressor housing. Install the hose clamps. Tighten the hose clamps to a torque of 5 N·m (44 lb in).

Note: The air inlet hose has a reflective heat shield that partially covers the hose. The reflective heat shield must be installed toward the engine. The reflective heat shield must be kept clean and free from dust, oil or paint.

Note: Apply a solution of water and 5% soap to the inlet of the turbocharger in order to install a new air inlet hose. Do not use oil or grease in order to install the air inlet hose.

17. Position the exhaust pipe onto the exhaust elbow or onto the turbocharger outlet (3). Refer to the OEM information for the correct procedure in order to install the exhaust pipe.

i01946913

Exhaust Manifold - Remove and Install

Removal Procedure for the Three Cylinder Engine

Start By:

- a. Remove the turbocharger, if equipped. Refer to this Disassembly and Assembly Manual, "Turbocharger - Remove".

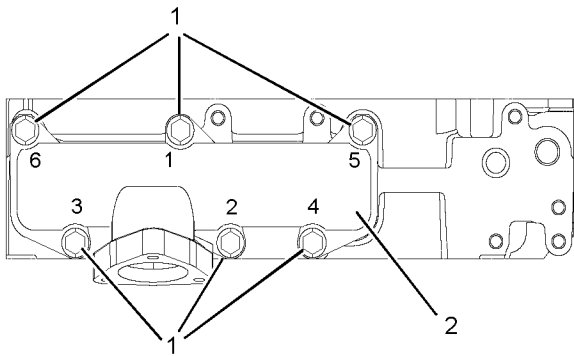

Illustration 62

g01038601

1. Remove the setscrews (1) in the reverse numerical order to the Illustration 62. This will help to prevent any distortion of the exhaust manifold (2).
2. Remove the exhaust manifold gasket from the cylinder head and remove the exhaust manifold (2). Discard the exhaust manifold gasket.

Installation Procedure for the Three Cylinder Engine

Note: The improper installation of the exhaust manifold (2) can result in a cracked exhaust manifold. The setscrews (1) for the exhaust manifold must be tightened in the correct sequence and tightened to the correct torque.

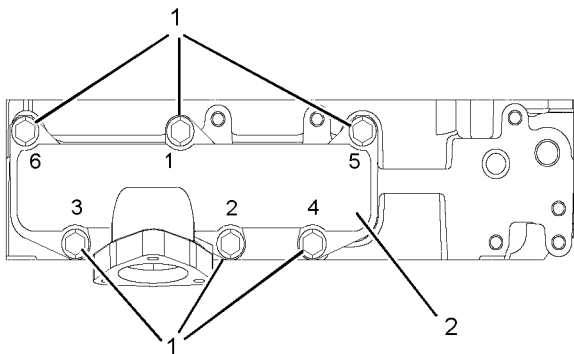

Illustration 63

g01038601

1. Loosely install two suitable studs into the holes (5 and 6) as guides.

Note: Do not use any sealant on the exhaust manifold gasket.

2. Position the new exhaust manifold gasket onto the studs in the cylinder head. Position the exhaust manifold (2) onto the studs. Install the setscrews (1) finger tight in order to secure the exhaust manifold to the cylinder head.
3. Remove the two studs and install the remaining setscrews (1). Ensure that the setscrews (1) are tightened in the sequence that is shown in Illustration 63. Tighten the setscrews evenly to a torque of 33 N·m (24 lb ft).

End By:

- a. Install the turbocharger, if equipped. Refer to this Disassembly and Assembly Manual, "Turbocharger - Install".

Removal Procedure for the Four Cylinder Engine

Start By:

- a. Remove the turbocharger, if equipped. Refer to this Disassembly and Assembly Manual, "Turbocharger - Remove".

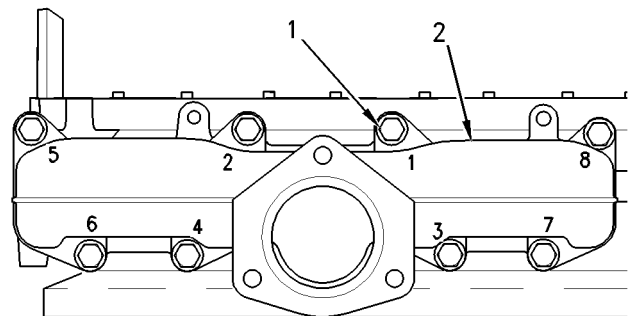

Illustration 64

g00951398

1. Remove the setscrews (1) in the reverse numerical order to the Illustration 64. This will help to prevent any distortion of the exhaust manifold (2).
2. Remove the exhaust manifold gasket from the cylinder head and remove the exhaust manifold (2). Discard the exhaust manifold gasket.

Installation Procedure for the Four Cylinder Engine

Note: The improper installation of the exhaust manifold (2) can result in a cracked exhaust manifold. The setscrews (1) for the exhaust manifold must be tightened in the correct sequence and tightened to the correct torque.

i02216959

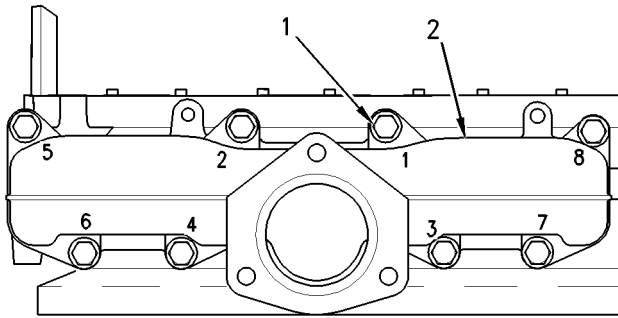

Illustration 65

g00951398

1. Loosely install two suitable studs into the holes (5 and 8) as guides.

Note: Do not use any sealant on the exhaust manifold gasket.

2. Position the new exhaust manifold gasket onto the studs in the cylinder head. Position the exhaust manifold (2) onto the studs. Install the setscrews (1) finger tight in order to secure the exhaust manifold to the cylinder head.
3. Remove the two studs and install the remaining setscrews (1). Ensure that the setscrews (1) are tightened in the sequence that is shown in Illustration 65. Tighten the setscrews evenly to a torque of 33 N·m (24 lb ft).

End By:

- a. Install the turbocharger, if equipped. Refer to this Disassembly and Assembly Manual, "Turbocharger - Install".

Exhaust Elbow - Remove and Install (If Equipped)

Removal Procedure

Start By:

- a. Remove the exhaust pipe. Refer to the OEM information for the correct procedure in order to remove the exhaust pipe.

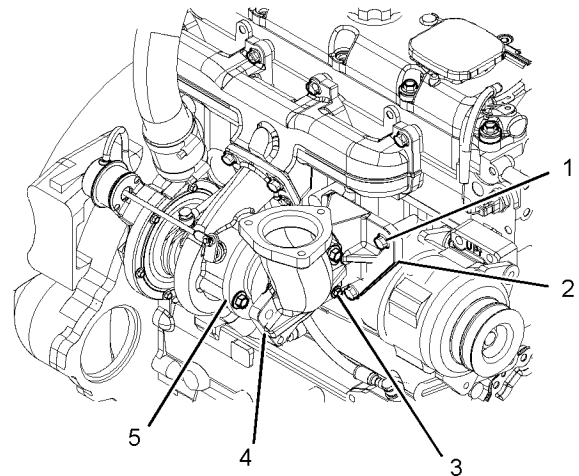

Illustration 66

g01135897

Typical example

1. Remove the setscrews (3) from the exhaust elbow (4). Remove the setscrews (1) and remove the bracket (2) from the cylinder block. Remove the exhaust elbow (4) from the exhaust adapter (5).

Installation Procedure

i01947651

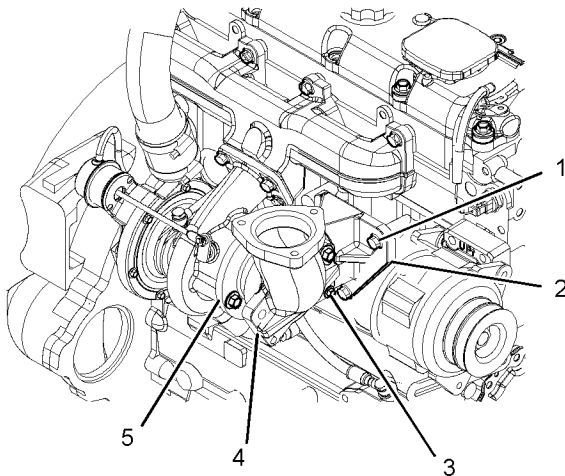

Illustration 67

g01135897

Typical example

1. Thoroughly clean the exhaust elbow (4) and the exhaust adapter (5).
2. Install the exhaust elbow (4) onto the exhaust adapter (5). Position the bracket (2) onto the cylinder block and install the setscrews (1). Tighten the setscrews (1) finger tight. Align the exhaust elbow with the bracket (2). Install the setscrews (3) in order to secure the exhaust elbow (4) to the bracket (2). Tighten the setscrews (1) and tighten the setscrews (3) to a torque of 44 N·m (33 lb ft).

End By:

- a. Install the exhaust pipe. Refer to the OEM information for the correct procedure in order to install the exhaust pipe.

Inlet and Exhaust Valve Springs - Remove and Install

Removal Procedure

Table 1

Required Tools		
Part Number	Part Description	Qty
21825666	Valve Spring Compressor	1
27610235	Setscrew Adapter	1

Start By:

- a. Remove the rocker shaft assembly. Refer to this Disassembly and Assembly Manual, "Rocker Shaft and Pushrod - Remove".

NOTICE

Keep all parts clean from contaminants.

Contaminants may cause rapid wear and shortened component life.

Note: The following procedure should be adopted in order to remove the valve springs when the cylinder head is still installed onto the cylinder block. Refer to this Disassembly and Assembly Manual, "Inlet and Exhaust Valves - Remove and Install" for the correct procedure that should be used to remove the valve springs from a cylinder head that has been removed from the cylinder block.

Note: Ensure that the appropriate piston is at top dead center before the valve spring is removed. Failure to ensure that the piston is at top dead center may allow the valve to drop into the cylinder block.

1. Use the following procedure in order to find the top dead center position for the appropriate piston.

WARNING

Personal injury can result from being struck by parts propelled by a released spring force.

Make sure to wear all necessary protective equipment.

Follow the recommended procedure and use all recommended tooling to release the spring force.

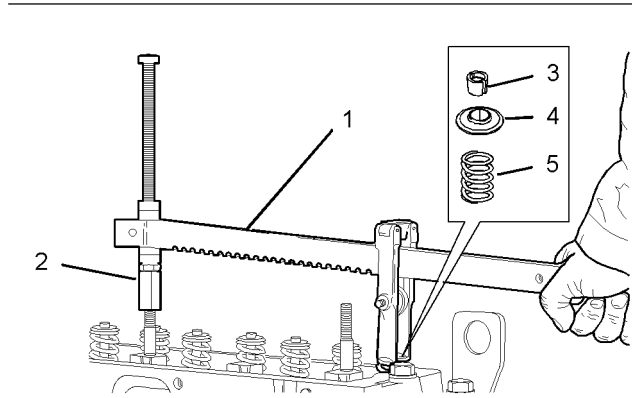

Illustration 68

g01015085

- a. Install 21825666 Valve Spring Compressor (1) and the appropriate 27610235 Setscrew Adapter (2) in position on the cylinder head in order to compress the appropriate valve spring (5).

NOTICE

Ensure that the valve spring is compressed squarely or damage to the valve stem may occur.

- b. Compress the valve spring (5) sufficiently in order to open the valve only. Do not compress the valve spring sufficiently so that the valve keepers (3) could be removed from the recess in the valve stem.
- c. Turn the crankshaft until the piston touches the valve.
- d. Continue to turn the crankshaft until the valve stem is at the highest point. The piston is now at top dead center. Release the applied pressure of the valve spring compressor (1) at the top center position.

NOTICE

Do not turn the crankshaft while the valve springs are removed.

- 2. Use the valve spring compressor (1) in order to compress the valve spring (5). Remove the valve keepers (3).
- 3. Carefully release the pressure on the valve spring compressor (1). Remove the valve spring retainer (4) and the valve spring (5).

Note: If you are replacing all of the valve springs, the procedure can be done on two cylinders at the same time. The procedure can be done on cylinder 1 and cylinder 4, and on cylinder 2 and cylinder 3. Remember that the crankshaft must not be turned while the valve springs are removed. Ensure that all of the valve springs are installed before changing from one pair of cylinders to the other pair of cylinders.

Installation Procedure

Table 2

Required Tools		
Part Number	Part Description	Qty
21825666	Valve Spring Compressor	1
27610235	Setscrew	1

NOTICE

Keep all parts clean from contaminants.

Contaminants may cause rapid wear and shortened component life.



Improper assembly of parts that are spring loaded can cause bodily injury.

To prevent possible injury, follow the established assembly procedure and wear protective equipment.

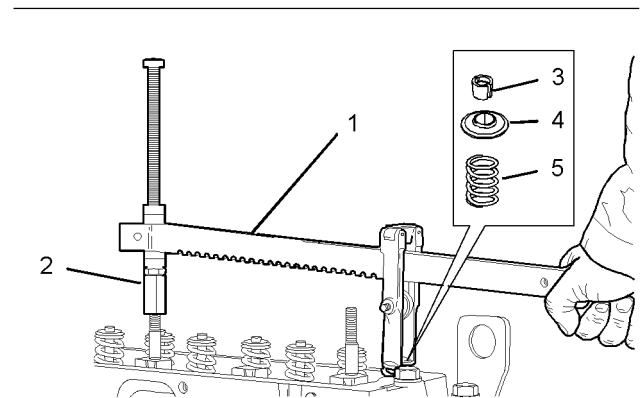

Illustration 69

g01015085

- 1. Place the new valve spring (5) into position.
- 2. Install the valve spring retainer (4).

NOTICE

Ensure that the valve spring is compressed squarely or damage to the valve stem may occur.

3. Install the valve spring compressor (1) in position on the cylinder head in order to compress the appropriate valve spring (5). Compress the valve spring (5).

4. Install the valve keepers (3).

NOTICE

Do not turn the crankshaft while the valve springs are removed.

5. Carefully release the pressure on the valve spring compressor (1). Remove the valve spring compressor (1). Ensure that all of the valves are secured in place by a valve spring and valve keepers. Rotate the crankshaft through about 45 degrees in order to clear the piston from the valve. Lightly strike the top of the valve with a soft hammer in order to ensure that the valve keepers (3) are properly installed.

Note: If you are replacing all of the valve springs the procedure can be done on two cylinders at the same time. The procedure can be done on cylinder 1 and cylinder 4, and on cylinder 2 and cylinder 3.

End By:

a. Install the rocker shaft assembly. Refer to this Disassembly and Assembly, "Rocker Shaft and Pushrod - Install".

i01947652

Inlet and Exhaust Valves - Remove and Install

Removal Procedure

Table 3

Required Tools		
Part Number	Part Description	Qty
21825496	Valve Depth Gauge	1
21825666	Valve Spring Compressor	1
27610235	Setscrew Adapter	1

Start By:

a. Remove the cylinder head assembly. Refer to this Disassembly and Assembly Manual, "Cylinder Head - Remove".

Note: Ensure that the machined face of the cylinder head is kept on a clean, soft surface in order to prevent damage to the machined surface.

NOTICE

Keep all parts clean from contaminants.

Contaminants may cause rapid wear and shortened component life.

Note: The removal procedure is identical for the three cylinder and the four cylinder engines. The illustrations show the four cylinder engine.

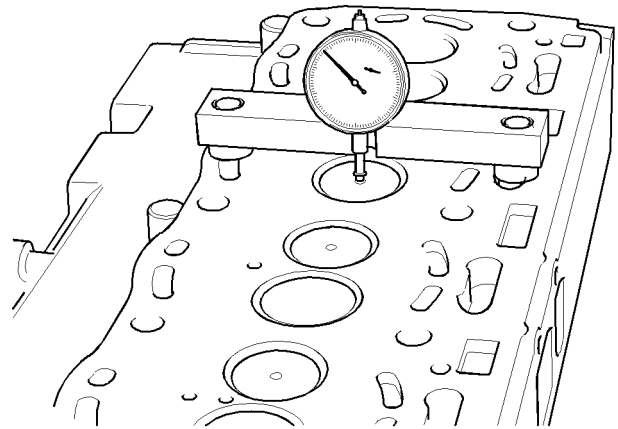

Illustration 70

g01015306

Typical example

1. Use a dial indicator to check the depth of the valves below the face of the cylinder head before the valve springs are removed. Refer to the illustration 70 and refer to Specifications, "Cylinder Head Valves" for the correct dimensions.

Note: The head of the inlet valve has a larger diameter than the head of the exhaust valve.

2. Place a numerical index mark on the heads of the inlet valves and on the exhaust valves so that each valve can be installed in the correct sequence during installation.

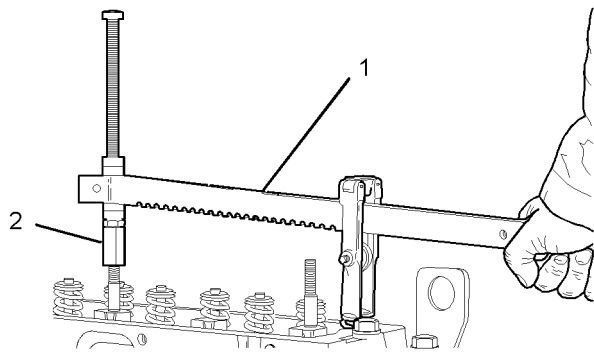

Illustration 71
Typical example
g01015303

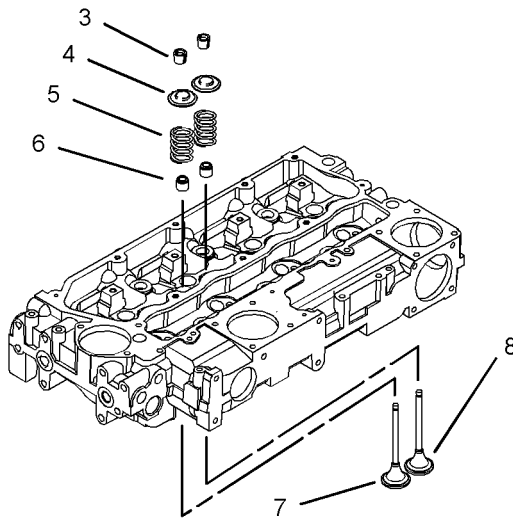

Illustration 72
Typical example
g01015305

3. Install 21825666 Valve Spring Compressor (1) and the appropriate 27610235 Setscrew Adapter (2) in position on the cylinder head in order to compress the appropriate valve spring (5).

⚠ WARNING

Personal injury can result from being struck by parts propelled by a released spring force.

Make sure to wear all necessary protective equipment.

Follow the recommended procedure and use all recommended tooling to release the spring force.

NOTICE

Ensure that the valve spring is compressed squarely or damage to the valve stem may occur.

4. Compress the valve spring (5).
5. Remove the valve keepers (3).
6. Carefully release the pressure on the valve spring compressor (1). Remove the valve spring compressor (1) and the setscrew adapter (2) from the cylinder head.
7. Remove the valve spring retainer (4).
8. Remove the valve spring (5).
9. Remove the valve stem seal (6). Discard the valve stem seal (6).
10. Remove the appropriate valve (7 or 8).
11. Repeat Step 3 to Step 10 for each inlet valve (7) and for each exhaust valve (8).

Installation Procedure

Table 4

Required Tools		
Part Number	Part Description	Qty
21825666	Valve Spring Compressor	1
27610235	Setscrew Adapter	1
21825496	Valve Depth Gauge	1

NOTICE

Keep all parts clean from contaminants.

Contaminants may cause rapid wear and shortened component life.

Note: The installation procedure is identical for the three cylinder and the four cylinder engines. The illustrations show the four cylinder engine.

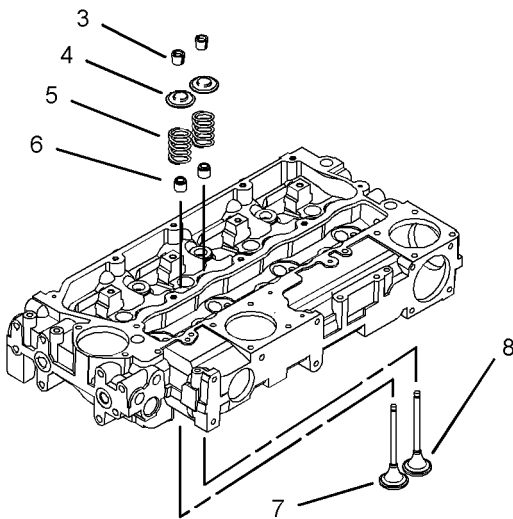

Illustration 73
Typical example

1. Carefully clean the bottom face of the cylinder head. Ensure that there is no debris in the inlet and exhaust ports. Also ensure that there is no debris in the coolant passages and in lubrication passages. Inspect the cylinder head. Refer to the Testing and Adjusting Manual, "Cylinder Head Inspect" for further information.
2. Inspect all of the valve seats for wear and for damage. Refer to the Specifications Manual, "Cylinder Head Valves" for further information. Also refer to this Disassembly and Assembly Manual, "Inlet and Exhaust Valve Seat Inserts - Remove and Install" and refer to Testing and Adjusting Manual, "Valve Depth - Inspect" for further information. Replace any worn parts.
3. Inspect all of the valve guides for wear and for damage. Refer to the Specifications Manual, "Cylinder Head Valves" for further information. Also refer to this Disassembly and Assembly Manual, "Inlet and Exhaust Valve Guides - Remove and Install" and refer to Testing and Adjusting Manual, "Valve Guide - Inspect" for further information. Replace any worn parts.
4. Inspect the valves if the valves are not replacement parts. Refer to the Specifications Manual, "Cylinder Head Valves" for further information.
5. Lubricate the stems of all of the inlet valves (7) and lubricate the stems of all of the exhaust valves (8) with clean engine oil. Install the inlet valves (7) and the exhaust valves (8) in the appropriate positions.

6. Carefully turn over the cylinder head and ensure that all of the valves remain in place. Place the machined surface of the cylinder head onto a clean, soft surface.

Note: The valve guides must be clean and dry before installing the valve stem seals (6).

7. Install a new valve stem seal (6) onto each of the valve guides.
8. Inspect the valve springs (5) for wear and for the correct installed length. Refer to the Specifications Manual, "Cylinder Head Valves" for further information on the correct installed length of the valve springs (5). Replace any worn parts.
9. Install the valve springs (5) onto the cylinder head.
10. Install the valve spring retainers (4).

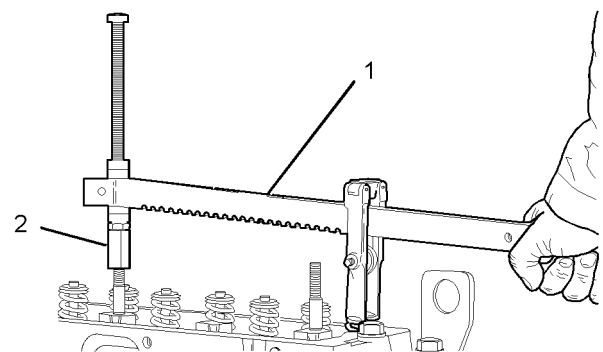

Illustration 74
Typical example

WARNING

Personal injury can result from being struck by parts propelled by a released spring force.

Make sure to wear all necessary protective equipment.

Follow the recommended procedure and use all recommended tooling to release the spring force.

NOTICE

Ensure that the valve spring is compressed squarely or damage to the valve stem may occur.

11. Install 21825666 Valve Spring Compressor (1) and the appropriate 27610235 Setscrew Adapter (2) in position on the cylinder head in order to compress the appropriate valve spring (5).
12. Install the valve keepers (3).

13. Carefully release the pressure on the valve spring compressor (1). Remove the valve spring compressor (1) and the setscrew adapter (2) from the cylinder head. Gently strike the top of the appropriate valves with a soft hammer in order to ensure that the valve keepers (3) are properly installed.

14. Repeat Step 11 to Step 13 for all of the valves (7 and 8).

15. Turn over the cylinder head. Use a dial indicator to check the depth of the new valves below the face of the cylinder head. Refer to Illustration 70 and refer to the Specifications Manual, "Cylinder Head Valves" for more information on the inlet valves and the exhaust valves. If the depth of the new valves is below the correct depth, the valve seat inserts must be replaced. Refer to this Disassembly and Assembly Manual, "Inlet and Exhaust Valve Seat Inserts - Remove and Install".

End By:

- a. Install the cylinder head assembly. Refer to this Disassembly and Assembly Manual, "Cylinder Head - Install".

i01947653

Inlet and Exhaust Valve Guides - Remove and Install

Removal Procedure

Table 5

Required Tools		
Part Number	Part Description	Qty
21825478	Valve Guide Remover/Replacer	1
21825479	Valve Guide Adapter	1

Start By:

- a. Remove the cylinder head. Refer to this Disassembly and Assembly Manual, "Cylinder Head - Remove".
- b. Remove the inlet valves and the exhaust valves. Refer to this Disassembly and Assembly Manual, "Inlet and Exhaust Valves - Remove and Install".

NOTICE

Keep all parts clean from contaminants.

Contaminants may cause rapid wear and shortened component life.

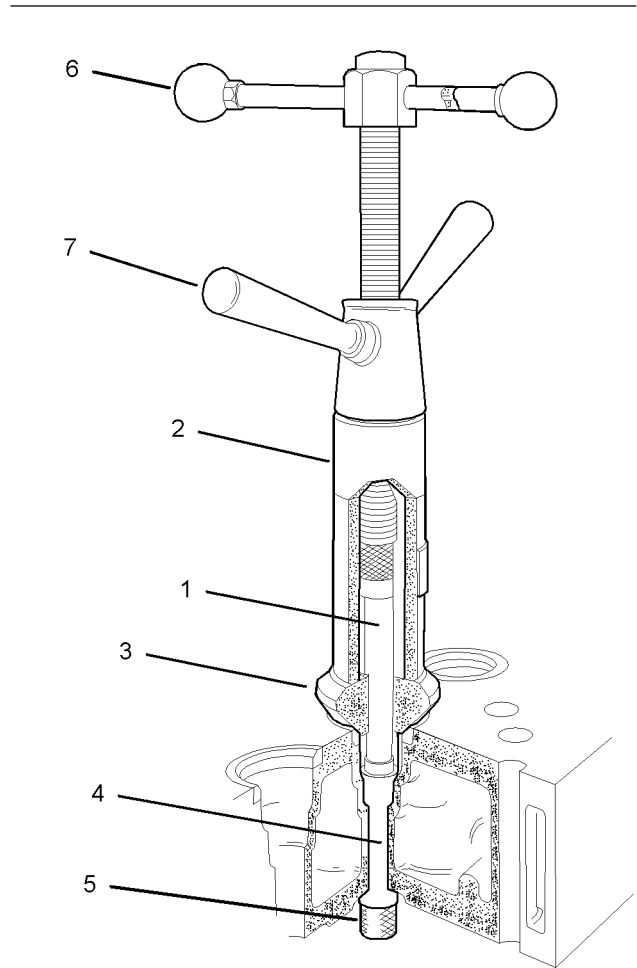

Illustration 75

g01016267

1. Install the 21825479 Valve Guide Adapter (1) into the 21825478 Valve Guide Remover/Replacer (2).
2. Place the spacer (3) into the appropriate valve seat.
3. Pass the adapter (1) through the valve guide (4) and install the valve guide remover/replacer (2) onto the spacer (3).
4. Install the attachment (5) in order to secure the adapter (1) to the valve guide (4).
5. Hold the top handle (6) and turn the bottom handle (7) counterclockwise in order to push the valve guide (4) from the cylinder head.
6. Repeat Step 2 to Step 5 in order to extract each appropriate valve guide (4).
7. Discard all of the valve guides (4) that were removed from the cylinder head.

Note: When new valve guides are installed, new valves and new valve seat inserts must be installed.

- Remove the valve seat inserts. Refer to this Disassembly and Assembly Manual, "Inlet and Exhaust Valve Seat Inserts - Remove and Install".

Installation Procedure

Table 6

Required Tools		
Part Number	Part Description	Qty
21825478	Valve Guide Remover/Replacer	1
27610234	Valve Guide Adapter	1

NOTICE

Keep all parts clean from contaminants.

Contaminants may cause rapid wear and shortened component life.

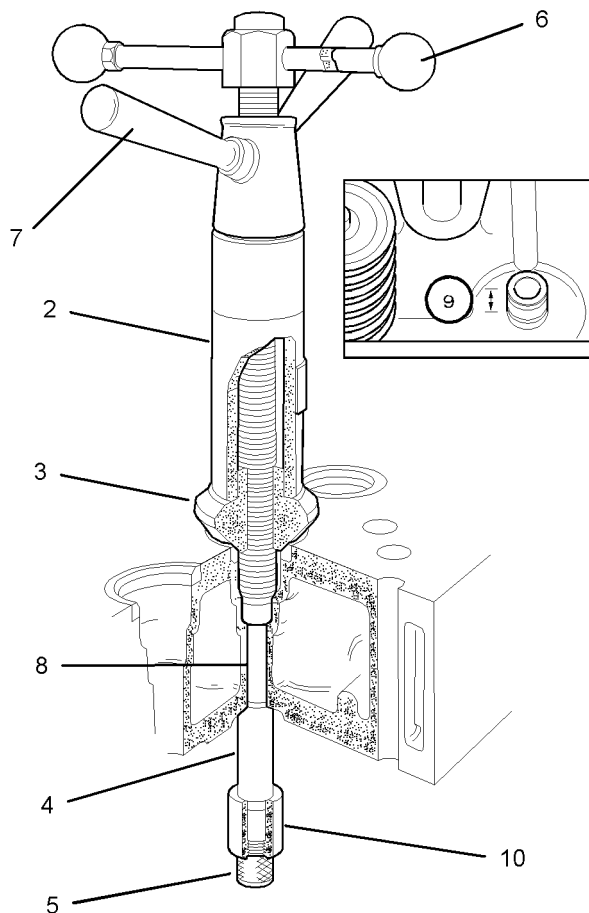

Illustration 76

g01016462

- Clean the parent bores in the cylinder head for all of the appropriate valve guides (4).

- Install the 27610234 Valve Guide Adaptor (8) into the 21825478 Valve Guide Remover/Replacer (2).

- Install the spacer (3) into the appropriate valve seat.

- Lubricate the outer surface of a new valve guide (4) with clean engine lubricating oil. Pass the adapter (8) through the parent bore for the valve guide (4) and position the valve guide remover/replacer (2) onto the spacer (3).

- Install the adapter (10) beneath the valve guide (4). Install the attachment (5) in order to secure the adapter (10) to the valve guide (4).

Note: The valve guide (4) should protrude above the cylinder head. Ensure that the protrusion (9) is within limits.

- Hold the top handle (6) and turn the bottom handle (7) clockwise in order to pull the valve guide (4) into the cylinder head. Continue to pull the valve guide (4) into the cylinder head until the correct amount of protrusion (9) is reached. The valve guides should protrude 12.35 to 12.65 mm (0.4862 to 0.4980 inch) above the valve spring recess.

- Repeat the Step 3 to Step 6 in order to install each appropriate valve guide.

Note: The parent bores of the valve guides must be reamed to the correct size after the valve guides have been installed into the cylinder head. Also, the valve inserts must be inserted and the seat faces must be cut to the correct angle. The same tool is used to finish both components.

- Install the valve seat inserts and finish both components. Refer to this Disassembly and Assembly Manual, "Inlet and Exhaust Valve Seat Inserts - Remove and Install".

End By:

- Install the inlet valves and the exhaust valves. Refer to this Disassembly and Assembly Manual, "Inlet and Exhaust Valves - Remove and Install".

i01947654

Inlet and Exhaust Valve Seat Inserts - Remove and Install

Removal Procedure

Start By:

- a. Remove the inlet valves and the exhaust valves. Refer to this Disassembly and Assembly Manual, "Inlet and Exhaust Valves - Remove and Install".

NOTICE

Keep all parts clean from contaminants.

Contaminants may cause rapid wear and shortened component life.

Note: When new valve seat inserts are installed, new valves and new valve guides must be installed.

1. Remove the appropriate valve guides. Install partially finished valve guides. Refer to this Disassembly and Assembly Manual, "Inlet and Exhaust Valve Guides - Remove and Install".

Note: The inserts for the inlet valves are a larger diameter than the exhaust valve inserts.

2. Use the partially finished bore of the valve guide as a pilot bore in order to remove the valve insert by machining. Also use the partially finished bore of the valve guide as a pilot bore in order to machine a recess for a new valve seat. Refer to the Specifications Manual, "Cylinder Head Valves" for the required dimensions of the recess for the valve seat. Remove all debris from the cylinder head ports and passages.

3. Repeat the Step 2 for all of the appropriate valve seats.

Installation Procedure

Table 7

Required Tools		
Part Number	Part Description	Qty
27610030	Valve Guide/Valve Seat Reamer/Cutter	1

NOTICE

Keep all parts clean from contaminants.

Contaminants may cause rapid wear and shortened component life.

Note: If the cylinder head has been previously ground then the bottom face of valve seat must be ground in order to ensure that the valve seat will be installed correctly into the cylinder head. A 30 degree chamfer must be machined to the outer edge of the valve seat after the back face of the valve insert has been ground to the correct dimensions. The 30 degree chamfer must be within the tolerance of 0.91 mm (0.036 inch) to 1.3 mm (0.051 inch). Also, the chamfer must be inclined to the vertical face of the valve insert.

Note: Do not use a hammer in order to install the valve insert into the machined recess in the cylinder head.

Note: Do not apply any lubricant before the new valve seat insert is installed into the cylinder head.

1. Use a suitable tool to install the valve seat insert into the machined recess in the cylinder head.

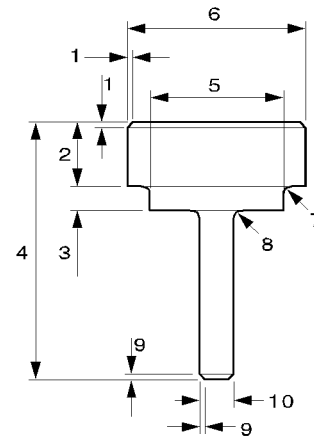

Illustration 77

g01016768

2. If necessary, a suitable tool can be manufactured. Refer to the illustration 77. Also refer to the table 8 and refer to the table 9 for suitable dimensions.

Table 8

Tool for the Inlet Valve Seat Inserts	
Callout	Dimension
1	1.5 mm (0.06 inch)
2	20 mm (0.80 inch)
3	6.8 mm (0.268 inch) to 7.1 mm (0.279 inch)
4	100 mm (3.94 inch)
5	38.1 mm (1.500 inch) to 38.3 mm (1.508 inch)
6	46.25 mm (1.82 inch) to 46.5 mm (1.83 inch)
7	Maximum radius 1.4 mm (0.055 inch)
8	Maximum radius 1.5 mm (0.06 inch)
9	1.5 mm (0.06 inch)
10	8.77 mm (0.345 inch) to 8.80 mm (0.346 inch)

Table 9

Tool for the Exhaust Valve Seat Inserts	
Callout	Dimension
1	1.5 mm (0.06 inch)
2	20 mm (0.80 inch)
3	7.2 mm (0.283 inch) to 7.5 mm (0.295 inch)
4	100 mm (3.94 inch)
5	34.38 mm (1.353 inch) to 34.58 mm (1.361 inch)
6	41.75 mm (1.643 inch) to 42.00 mm (1.653 inch)
7	Maximum radius 1.4 mm (0.055 inch)
8	Maximum radius 1.5 mm (0.06 inch)
9	1.5 mm (0.06 inch)
10	8.77 mm (0.345 inch) to 8.80 mm (0.346 inch)

- Put the appropriate valve seat insert in position. Install the special tool that was manufactured previously, through the valve seat insert and use the pilot bore of the valve guide in order to center the tool and the insert into the recess. Lightly tap the valve seat insert in order to start the installation. Press the valve seat insert into the recess with a suitable press. Ensure that the bottom of the valve seat insert is against the bottom of the recess.
- Repeat Step 3 for the remaining valve seat inserts.

- After installing the valve guides and valve seat inserts, the valve guides must be reamed and the valve seat inserts must be cut to the finished diameter. The valve guides and valve seat inserts are cut and reamed in one operation. This procedure ensures the concentricity of the valve seat to the valve guide in order to create a good seal. Refer to the Specifications Manual, "Cylinder Head Valves" for the finished diameter of the valve guides and valve seat inserts.

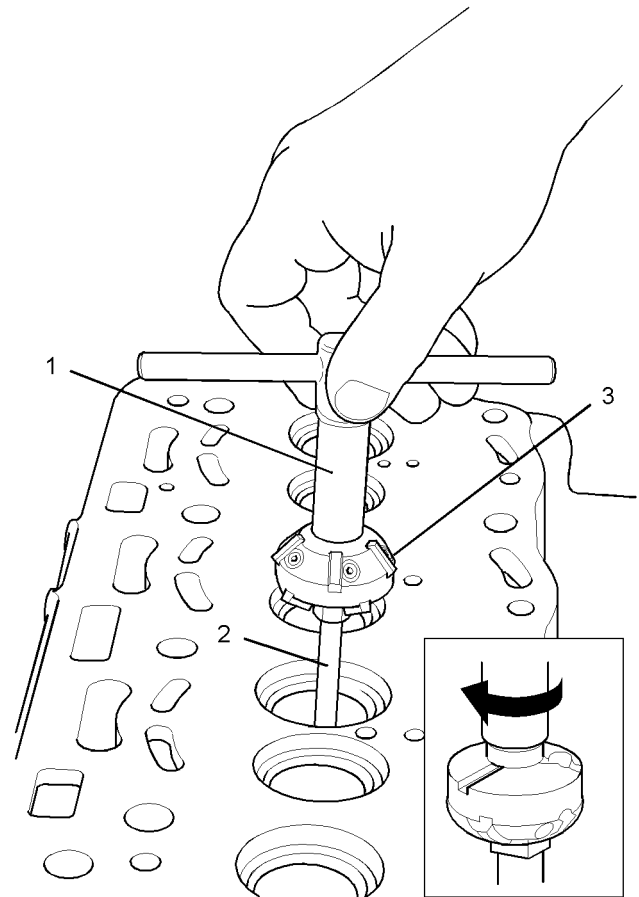

Illustration 78

g01017975

Note: Ensure that the 27610030 Valve Guide/Valve Seat Reamer/Cutter is assembled correctly with the correct angle of cutter (3) for the valve seat toward the cylinder head.

Note: Ensure that the cutter (3) for the valve seat is not allowed to contact the valve seat insert until the valve guide has been reamed to the correct size.

6. Set the diameter of the cutter (3) to the correct size for the valve seat to be cut. Refer to the Specifications Manual, "Cylinder Head Valves" for the correct diameter. Position the reamer (2) of the tool (1) into the appropriate valve guide. Carefully turn the handle in a clockwise direction and gradually move the reamer (2) into the valve guide until the valve guide is reamed to the finished size.
7. Continue to turn the handle in a clockwise direction in order to cut the valve seat insert. Remove the minimum amount of material in order to ensure a good valve seat. Keep the valve seat as narrow as possible.
8. Remove the tool (1). Clean the debris from the valve guide and the valve seat.
9. Repeat Step 6 to Step 8 in order to cut all of the appropriate valve seats.

End By:

- a. Install the inlet valves and the exhaust valves. Refer to this Disassembly and Assembly Manual, "Inlet and Exhaust Valves - Remove and Install".

i02262593

Engine Oil Filter Base - Remove and Install

Removal Procedure for an Oil Filter with a Separate Filter Element

Note: This procedure is for the removal of an oil filter with an oil filter housing and a separate oil filter element.

Note: The oil filter can be installed vertically or the oil filter can be installed horizontally.

NOTICE

Keep all parts clean from contaminants.

Contaminants may cause rapid wear and shortened component life.

NOTICE

Care must be taken to ensure that fluids are contained during performance of inspection, maintenance, testing, adjusting and repair of the product. Be prepared to collect the fluid with suitable containers before opening any compartment or disassembling any component containing fluids.

Dispose of all fluids according to local regulations and mandates.

1. Remove all dirt, oil, and grease from the engine oil filter assembly and from the drain plug of the engine oil pan. Place a suitable container beneath the drain plug of the engine oil pan.
2. Operate the engine until the engine is warm. Stop the engine.
3. Remove the oil drain plug and the O-ring from the engine oil pan. Drain the engine oil into the container for storage or disposal.

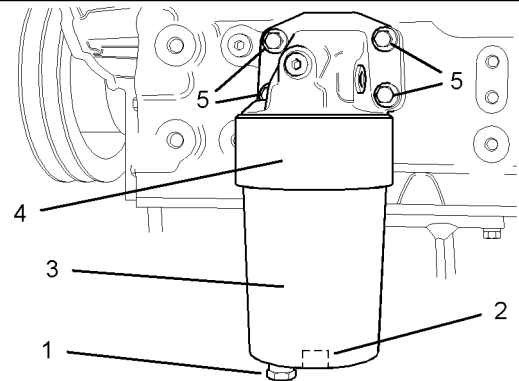

Illustration 79

g01018261

Typical example

Note: The drain plug (1) in the horizontal type of oil filter is installed in the filter head (4) instead of the oil filter housing (3). Do not remove the drain plug (1) from this type of oil filter.

4. Place a suitable container beneath the drain plug (1) in the oil filter housing (3). Remove the drain plug (1) from the oil filter housing (3) and remove the O-ring from the drain plug (1). Discard the O-ring. Collect any engine oil that drains from the oil filter housing (3).
5. Install a ratchet with a 1/2 inch square drive into the recess (2) in the base of the oil filter housing (3) in order to remove the oil filter housing.

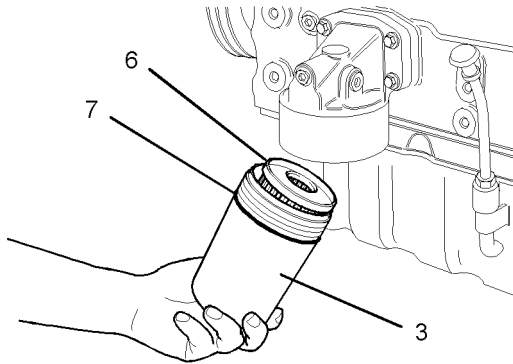

Illustration 80

g01018307

Typical example

6. Remove the oil filter element (6) from the oil filter housing (3). Remove the O-ring (7) from the oil filter housing (3). Discard the O-ring (7).

Note: Step 1 to Step 6 is the procedure for removing the oil filter element. Step 6 to Step 9 is the additional procedure for removing the oil filter base (4).

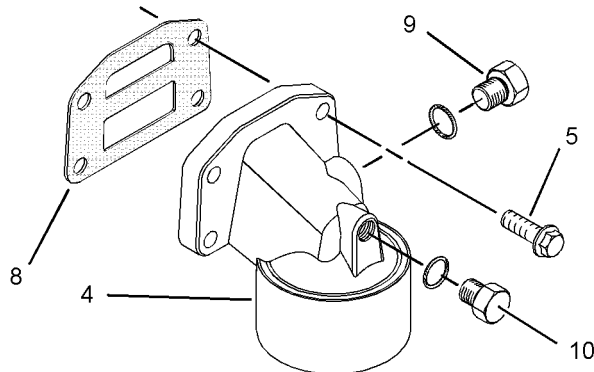

Illustration 81

g01018337

Typical example

7. Remove the setscrews (5).
8. Remove the engine oil filter base (4) from the cylinder block. Remove the joint (8) and discard the joint.
9. If necessary, remove the plug (9) and the O-ring.
10. If necessary, remove the plug (10) and the O-ring.

Installation Procedure for an Oil Filter with a Separate Filter Element

NOTICE

Keep all parts clean from contaminants.

Contaminants may cause rapid wear and shortened component life.

Note: Step 1 to Step 5 is the procedure for installing the oil filter base if the oil filter base was previously removed. Step 6 to Step 11 is the procedure for installing the oil filter element.

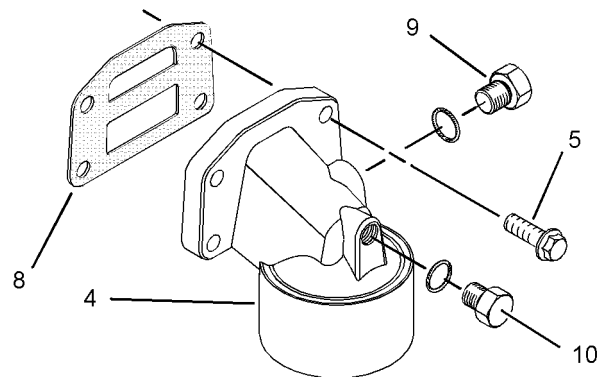

Illustration 82

g01018337

Typical example

1. Clean the oil passages within the oil filter base (4). Clean the mating surfaces of the cylinder block and the engine oil filter base (4).
2. Inspect the O-ring for the plug (10) if the plug was removed from the oil filter base (4). If necessary, replace the O-ring. Install the O-ring and the plug (10) into the oil filter base (4). Tighten the plug (10) to a torque of 12 N·m (9 lb ft).
3. Inspect the O-ring for the plug (9) if the plug was removed from the oil filter base (4). If necessary, replace the O-ring. Install the O-ring and the plug (9) into the oil filter base (4). Tighten the plug (9) to a torque of 12 N·m (9 lb ft).

Note: New setscrews (5) have sealant on the first 13 mm (0.5 inch) of the threads. In order to reuse the old setscrews (5), clean the old sealant from the setscrews and apply 21820117 POWERPART Threadlock and Nutlock to the setscrews.

Note: Do not lubricate the new joint (8).

4. Install the setscrews (5) into the oil filter base (4). Install a new joint (8) onto the setscrews (5). Install the setscrews (5) into the cylinder block.

5. Evenly tighten the setscrews (5) to a torque of $22 \pm 5 \text{ N}\cdot\text{m}$ ($16 \pm 4 \text{ lb ft}$).

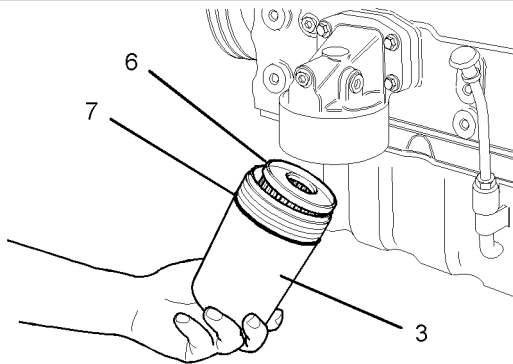

Illustration 83

g01018307

Typical example

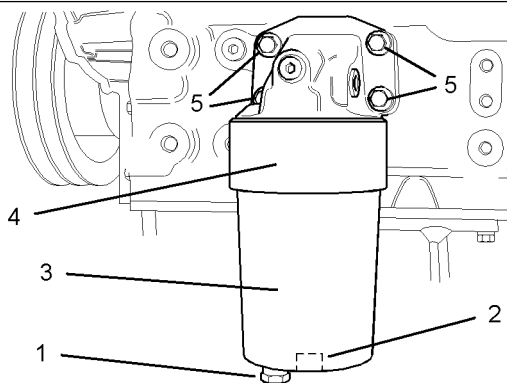

Illustration 84

g01018261

Typical example

6. Clean the inner surface of the oil filter housing (3). Clean the mating surfaces of the oil filter base (4) and the oil filter housing (3). Install a new O-ring onto the drain plug (1) if the drain plug was removed previously. Install the drain plug (1) into the oil filter housing (3). Tighten the drain plug (1) finger tight.
7. Lubricate a new O-ring (7) with clean engine lubricating oil. Install the new O-ring (7) onto the oil filter housing (3). Install a new oil filter element (6) into the oil filter housing (3). Rotate the oil filter element (6) in order to lock the element in the oil filter housing (3).

Note: Add clean engine lubricating oil into the oil filter housing (3) if the oil filter is installed vertically on the engine. Allow sufficient time for the added oil to flow through the oil filter element (6).

8. Screw the oil filter housing (3) into the oil filter base (4) by hand. Install a 1/2 inch square drive into the recess (2) in order to tighten the oil filter housing (3) to a torque of $25 \text{ N}\cdot\text{m}$ (18 lb ft).

9. Tighten the drain plug (1) to a torque of $12 \text{ N}\cdot\text{m}$ (9 lb ft).

10. Inspect the O-ring for the drain plug for the engine oil pan. If necessary, replace the O-ring. Install the O-ring onto the drain plug for the engine oil pan and install the drain plug into the engine oil pan. Tighten the drain plug to the correct torque. Refer to this Disassembly and Assembly Manual, "Engine Oil Pan - Remove and Install" for the correct torque. Remove the suitable containers beneath the engine oil pan and beneath the oil filter housing.

11. Fill the engine oil to the correct level that is indicated on the engine oil level gauge. Refer to the Operation and Maintenance Manual, "Refill Capacities" for the lubrication system capacity of the engine.

Removal Procedure for a Spin-On Oil Filter

Note: This procedure is for the removal of an oil filter with an oil filter element that has an integral housing.

Note: The oil filter can be installed vertically or the oil filter can be installed horizontally.

NOTICE

Keep all parts clean from contaminants.

Contaminants may cause rapid wear and shortened component life.

NOTICE

Care must be taken to ensure that fluids are contained during performance of inspection, maintenance, testing, adjusting and repair of the product. Be prepared to collect the fluid with suitable containers before opening any compartment or disassembling any component containing fluids.

Dispose of all fluids according to local regulations and mandates.

1. Remove all dirt, oil, and grease from the engine oil filter assembly and from the drain plug of the engine oil pan. Place a suitable container beneath the drain plug of the engine oil pan.
2. Operate the engine until the engine is warm. Stop the engine.
3. Remove the oil drain plug and the O-ring from the engine oil pan. Drain the engine oil into the container for storage or disposal.

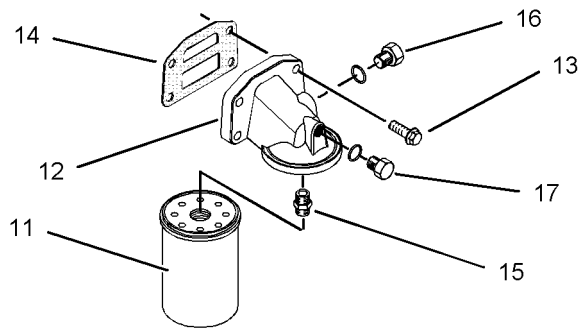

Illustration 85
Typical example

4. Place a suitable container beneath the oil filter element (11).
5. Use a suitable strap wrench in order to remove the oil filter element (11). Discard the oil filter element (11) in a suitable manner.

Note: Step 1 to Step 5 is the procedure for removing the oil filter element (11). Step 6 to Step 9 is the additional procedure for removing the oil filter base (12).

6. Remove the setscrews (13).
7. Remove the engine oil filter base (12) from the cylinder block. Remove the joint (14) and discard the joint.
8. If necessary, remove the adapter (15) from the oil filter base (12).
9. If necessary, remove the plug (16) and the O-ring.
10. If necessary, remove the plug (17) and the O-ring.

Installation Procedure for a Spin-On Oil Filter

NOTICE

Keep all parts clean from contaminants.

Contaminants may cause rapid wear and shortened component life.

Note: Step 1 to Step 6 is the procedure for installing the oil filter base if the oil filter base was previously removed. Step 7 to Step 10 is the procedure for installing the oil filter element.

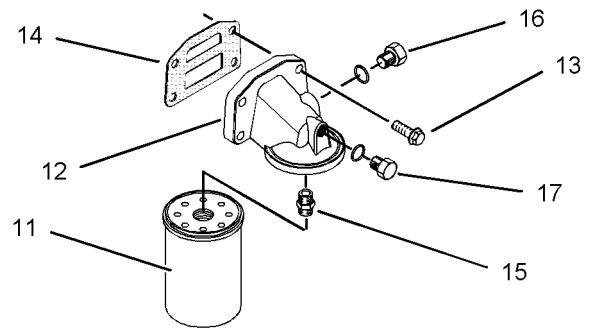

Illustration 86
Typical example

1. Clean the oil passages within the oil filter base (12). Clean the mating surfaces of the cylinder block and the engine oil filter base (12).
2. Inspect the adapter (15) if the adapter was removed from the oil filter base (12). Apply 21820117 Powerpart to the last 10 mm (0.34 inch) of the thread on the adapter. Install the adapter (15) into the oil filter base (12). Tighten the adapter (15) to a torque of 28 ± 4 N·m (20.7 ± 3 lb ft).
3. Inspect the O-ring for the plug (17) if the plug was removed from the oil filter base (12). If necessary, replace the O-ring. Install the O-ring and the plug (17) into the oil filter base (12). Tighten the plug (17) to a torque of 12 N·m (9 lb ft).
4. Inspect the O-ring for the plug (16) if the plug was removed from the oil filter base (12). If necessary, replace the O-ring. Install the O-ring and the plug (16) into the oil filter base (12). Tighten the plug (16) to a torque of 12 N·m (9 lb ft).

Note: New setscrews (13) have sealant on the first 13 mm (0.5 inch) of the threads. In order to reuse the old setscrews (13), clean the old sealant from the setscrews and apply 21820117 POWERPART Threadlock and Nutlock to the setscrews.

Note: Do not lubricate the new joint (14).

5. Install the setscrews (13) into the oil filter base (12). Install a new joint (14) onto the setscrews (13). Install the setscrews (13) into the cylinder block.
6. Evenly tighten the setscrews (13) to a torque of 22 ± 5 N·m (16 ± 4 lb ft).
7. Clean the mating surface of the oil filter base (12) to the oil filter element (11).

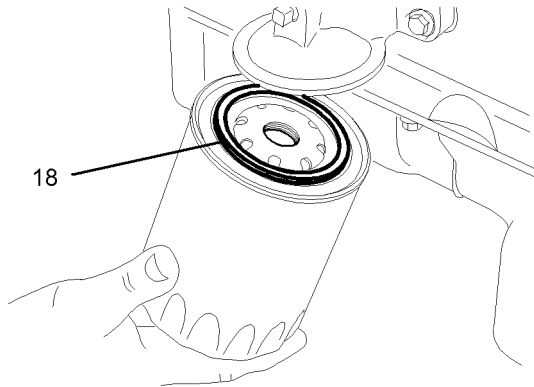

Illustration 87

g01018743

8. Lubricate the top of the O-ring (18) with clean engine lubricating oil. Spin the new oil filter element (11) onto the adapter (15). Tighten the oil filter element (11) by hand. Do not use a strap wrench to tighten the oil filter element (11).
9. Inspect the O-ring for the drain plug for the engine oil pan. If necessary, replace the O-ring. Install the O-ring onto the drain plug for the engine oil pan and install the drain plug into the engine oil pan. Tighten the drain plug to the correct torque. Refer to this Disassembly and Assembly Manual, "Engine Oil Pan - Remove and Install" for the correct torque. Remove the suitable containers beneath the engine oil pan and beneath the oil filter housing.
10. Fill the engine oil to the correct level that is indicated on the engine oil level gauge. Refer to the Operation and Maintenance Manual, "Refill Capacities" for the lubrication system capacity of the engine.

i02259834

Engine Oil Cooler - Remove

Removal Procedure for Three Cylinder Engine

NOTICE

Keep all parts clean from contaminants.

Contaminants may cause rapid wear and shortened component life.

NOTICE

Care must be taken to ensure that fluids are contained during performance of inspection, maintenance, testing, adjusting and repair of the product. Be prepared to collect the fluid with suitable containers before opening any compartment or disassembling any component containing fluids.

Dispose of all fluids according to local regulations and mandates.

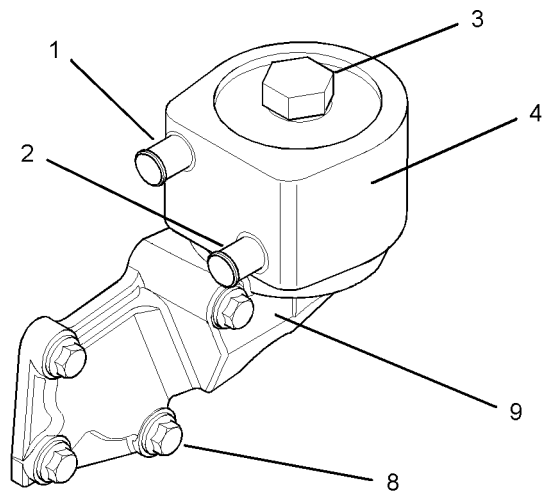

Illustration 88

g01041195

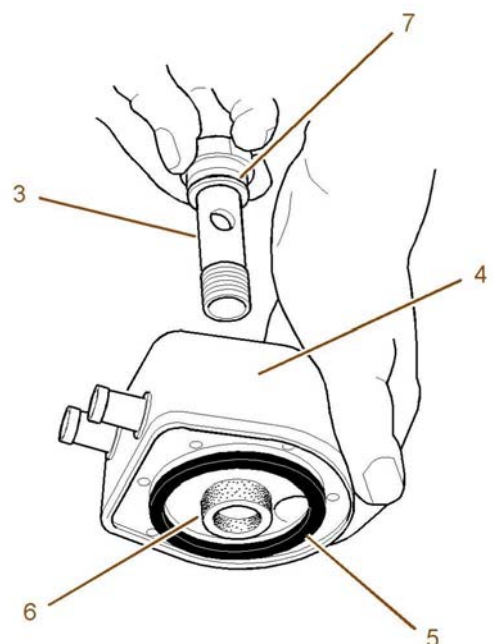

Illustration 89

g01041194

1. Drain the coolant from the engine into a suitable container. Drain the engine oil from the engine into a suitable container. Refer to the Operation and Maintenance Manual for the procedure on draining the engine coolant and the engine oil.
2. Remove the hose clamp and the hose from the coolant inlet (1). Remove the hose clamp and the hose from the coolant outlet (2).
3. Remove the adapter (3) from the oil cooler body (4).
4. Remove the O-rings (5) and (6). Discard the O-rings (5) and (6).
5. Remove the sealing ring (7). Discard the sealing ring (7).
6. If necessary, remove the setscrews (8) in order to remove the oil cooler base (9) from the cylinder block. Remove the joint from the cylinder block. Discard the joint.

Removal Procedure for Four Cylinder Engine

NOTICE

Keep all parts clean from contaminants.

Contaminants may cause rapid wear and shortened component life.

NOTICE

Care must be taken to ensure that fluids are contained during performance of inspection, maintenance, testing, adjusting and repair of the product. Be prepared to collect the fluid with suitable containers before opening any compartment or disassembling any component containing fluids.

Dispose of all fluids according to local regulations and mandates.

1. Drain the coolant from the engine into a suitable container. Drain the engine oil from the engine into a suitable container. Refer to the Operation and Maintenance Manual for the procedure on draining the engine coolant and the engine oil.

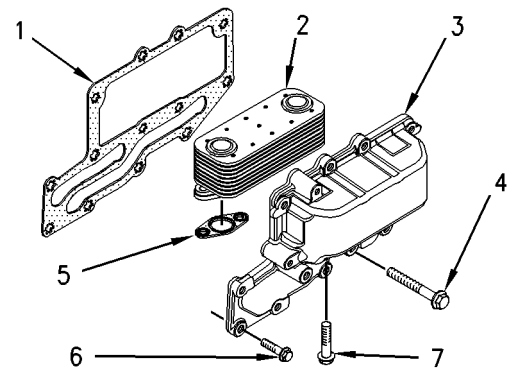

Illustration 90

g00952614

Note: Do not remove the setscrews (7) at this time.

2. Remove the setscrews (6). Remove the setscrews (4).
3. Remove the housing (3) from the cylinder block.
4. Remove the setscrews (7). Remove the engine oil cooler (2) and the seals (5) from the housing (3). Discard the seals (5).
5. Remove the joint (1) from the cylinder block. Discard the joint (1).

i02641598

Engine Oil Cooler - Install

Installation Procedure for the Three Cylinder Engine

NOTICE

Keep all parts clean from contaminants.

Contaminants may cause rapid wear and shortened component life.

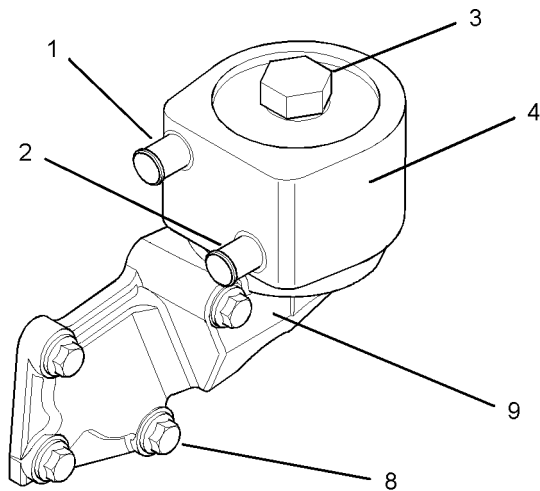

Illustration 91

g01041195

1. Clean the mating surfaces of the oil cooler base (9) and the oil cooler body (4). If the oil cooler base (9) was removed, clean the mating surfaces of the oil cooler base and the cylinder block.

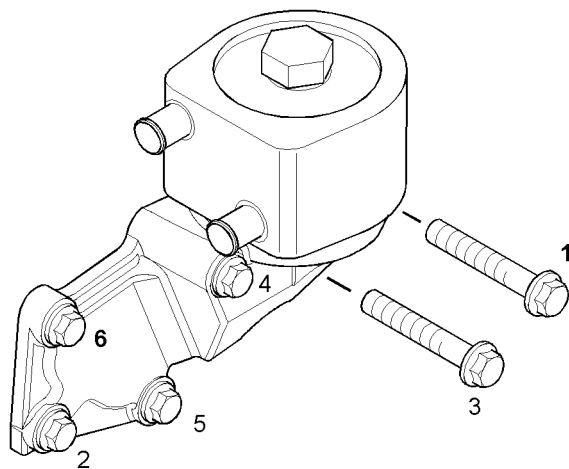

Illustration 92

g01041030

Tightening sequence

Note: Do not use sealant on the new joint between the cylinder block and the oil cooler base (9).

2. If the oil cooler base (9) was removed from the cylinder block, install setscrews into setscrew holes (1) and (6) in the oil cooler base. Install a new joint onto the two setscrews and secure the oil cooler base (9) to the cylinder block. Install the remainder of the setscrews (8). Tighten the setscrews (8) in the sequence 1, 2, 3, 4, 5, and 6 to a torque of 22 N·m (16 lb ft). Refer to the illustration 92.

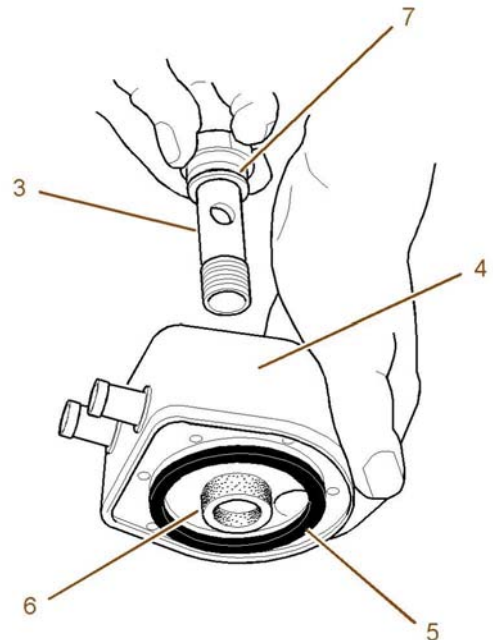

Illustration 93

g01041194

3. Install new O-rings (5) and (6) onto the oil cooler body (4). Position the oil cooler body (4) onto the oil cooler base (9).
4. Install a new sealing ring (7) onto the adapter (3). Install the adapter (3) through the oil cooler body (4) and into the oil cooler base (9). Tighten the adapter (3) to a torque of 57 N·m (42 lb ft).
5. Install the appropriate hose to the coolant outlet (2). Tighten the hose clamp to a torque of 3.5 N·m (31 lb in).
6. Install the appropriate hose to the coolant inlet (1). Tighten the hose clamp to a torque of 3.5 N·m (31 lb in).
7. Fill the cooling system with coolant. Fill the lubrication system with engine oil. Refer to the Operation and Maintenance Manual, "Refill Capacities" for the cooling system capacity and for the lubrication system capacity of the engine.

Installation Procedure for the Four Cylinder Engine

NOTICE

Keep all parts clean from contaminants.

Contaminants may cause rapid wear and shortened component life.

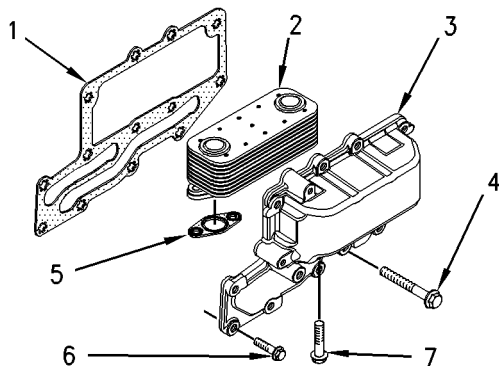

Illustration 94

g00952614

1. Clean the mating surfaces of the housing (3) and the cylinder block.
2. Position the engine oil cooler (2) and the new seals (5) in the housing (3). Install the setscrews (7) in order to secure the engine oil cooler (2) to the housing (3).

Note: Do not use sealant on the joint (1).

3. Position the housing (3) and the new joint (1) onto the cylinder block. Install the setscrews (4) and the setscrews (6) in order to secure the housing (3) to the cylinder block.
4. Tighten all of the setscrews (4, 6 and 7) to the correct torque. Tighten the setscrews to a torque of 22 N·m (16 lb ft).

Note: Refer to the Operation and Maintenance Manual, "Refill Capacities" for the cooling system capacity and for the lubrication system capacity of the engine.

5. Fill the cooling system with coolant. Fill the lubrication system with engine oil.

Engine Oil Relief Valve - Remove and Install (Engine Oil Pump)

i01958106

Removal Procedure

Start By:

- a. Remove the engine oil pan. Refer to this Disassembly and Assembly Manual, "Engine Oil Pan - Remove and Install".

NOTICE

Keep all parts clean from contaminants.

Contaminants may cause rapid wear and shortened component life.

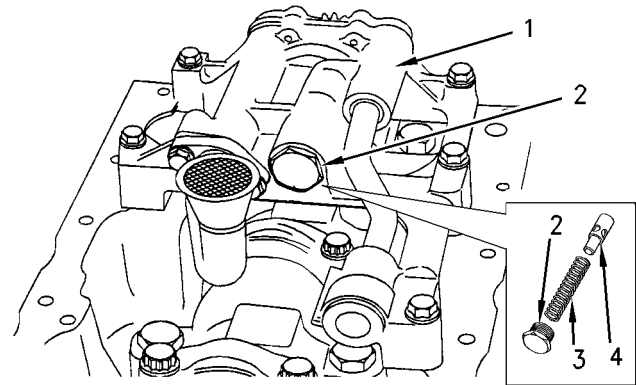

Illustration 95

g00959674

WARNING

Personal injury can result from being struck by parts propelled by a released spring force.

Make sure to wear all necessary protective equipment.

Follow the recommended procedure and use all recommended tooling to release the spring force.

1. Remove the plug (2). Remove the spring (3) and the plunger (4) from the engine oil pump (1).

i01958108

Installation Procedure

NOTICE

Keep all parts clean from contaminants.

Contaminants may cause rapid wear and shortened component life.

1. Clean the spring (3) and the plunger (4) of the engine oil relief valve. Check the spring (3) and the plunger (4) for wear or for other damage. The plunger (4) must slide easily within the bore of the oil relief valve within the engine oil pump (1). Lubricate the spring (3) and the plunger (4) with clean engine oil.

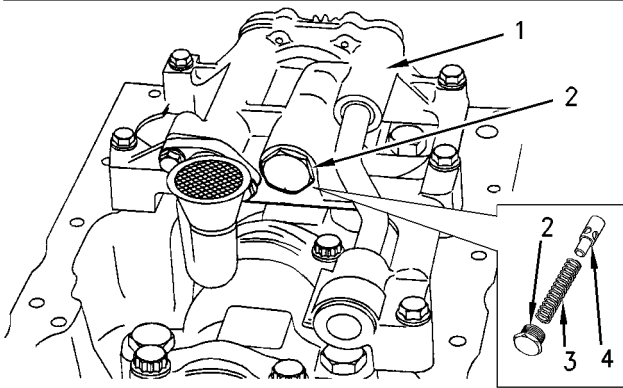

Illustration 96

g00959674

WARNING

Improper assembly of parts that are spring loaded can cause bodily injury.

To prevent possible injury, follow the established assembly procedure and wear protective equipment.

2. Install the plunger (4) and the spring (3) in the engine oil pump (1).
3. Install the plug (2). Tighten the plug (2) to a torque of 22 N·m (16 lb ft).

End By:

- a. Install the engine oil pan. Refer to this Disassembly and Assembly Manual, "Engine Oil Pan - Remove and Install".

Engine Oil Relief Valve - Remove and Install (Balancer Unit for the 1104 engines only)

Removal Procedure

Start By:

- a. Remove the engine oil pan. Refer to this Disassembly and Assembly Manual, "Engine Oil Pan - Remove and Install".

NOTICE

Keep all parts clean from contaminants.

Contaminants may cause rapid wear and shortened component life.

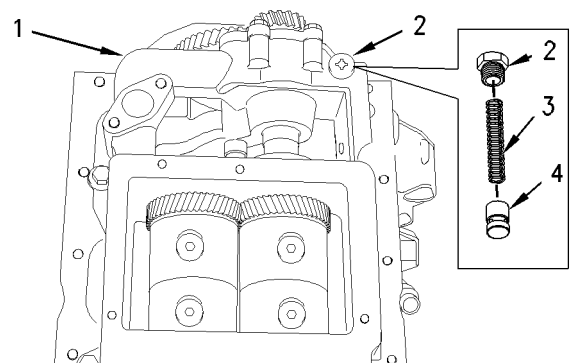

Illustration 97

g00979780

WARNING

Personal injury can result from being struck by parts propelled by a released spring force.

Make sure to wear all necessary protective equipment.

Follow the recommended procedure and use all recommended tooling to release the spring force.

i01958101

1. Remove the plug (2). Remove the spring (3) and the plunger (4) from the balancer unit (1).

Installation Procedure

NOTICE

Keep all parts clean from contaminants.

Contaminants may cause rapid wear and shortened component life.

1. Clean the spring (3) and the plunger (4) of the engine oil relief valve. Check the spring (3) and the plunger (4) for wear or for other damage. The plunger (4) must slide easily within the bore of the oil relief valve within the balancer unit (1). Lubricate the spring (3) and the plunger (4) with clean engine oil.

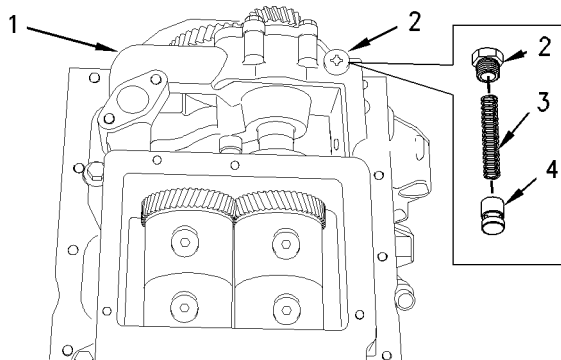

Illustration 98

g00979780

WARNING

Improper assembly of parts that are spring loaded can cause bodily injury.

To prevent possible injury, follow the established assembly procedure and wear protective equipment.

2. Install the plunger (4) and the spring (3) into the balancer unit (1).
3. Install the plug (2). Tighten the plug (2) to a torque of 22 N·m (16 lb ft).

End By:

- a. Install the engine oil pan. Refer to this Disassembly and Assembly Manual, "Engine Oil Pan - Remove and Install".

Engine Oil Pump - Remove (Engines Without a Balancer)

Removal Procedure

Start By:

- a. Remove the engine oil pan. Refer to this Disassembly and Assembly Manual, "Engine Oil Pan - Remove and Install".

Note: This procedure is for the removal of the engine oil pump on engines that are not equipped with a balancer. Refer to this Disassembly and Assembly Manual, "Balancer Group - Remove" for information on the removal of the engine oil pump on engines that are equipped with a balancer.

NOTICE

Keep all parts clean from contaminants.

Contaminants may cause rapid wear and shortened component life.

NOTICE

Care must be taken to ensure that fluids are contained during performance of inspection, maintenance, testing, adjusting and repair of the product. Be prepared to collect the fluid with suitable containers before opening any compartment or disassembling any component containing fluids.

Dispose of all fluids according to local regulations and mandates.

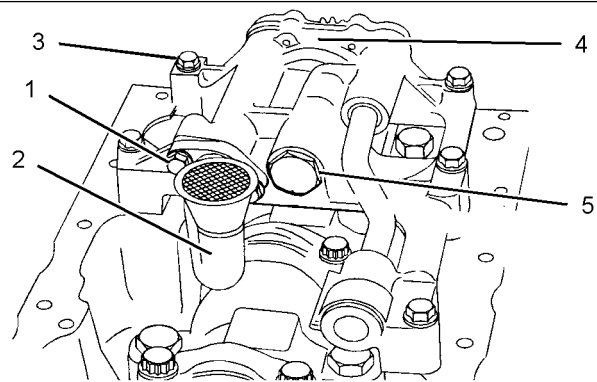

Illustration 99

g01019045

1. Remove the setscrews (1) and the suction pipe (2).

2. Remove the setscrews (3). Remove the assembly of the engine oil pump (4) from the cylinder block.
3. If necessary, remove the pressure relief valve (5) from the assembly of the engine oil pump (4). Refer to this Disassembly and Assembly Manual, "Engine Oil Relief Valve - Remove and Install".

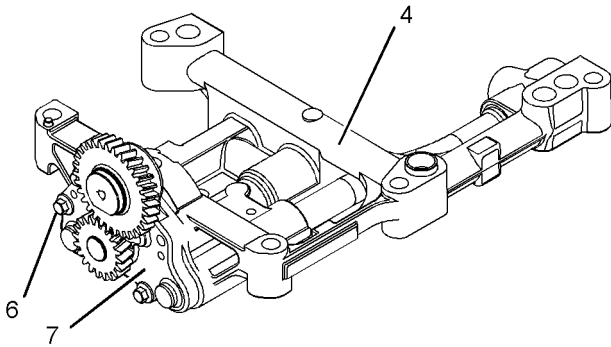

Illustration 100

g01019047

4. Remove the setscrews (6). Remove the engine oil pump (7) from the assembly of the engine oil pump (4).
5. If necessary, remove the setscrews and remove the front cover assembly from the engine oil pump (7) in order to inspect the components within the engine oil pump.

i01958102

Engine Oil Pump - Install (Engines Without a Balancer)

Installation Procedure

Note: This procedure is for the installation of the engine oil pump on engines that are not equipped with a balancer. Refer to this Disassembly and Assembly Manual, "Balancer Group - Install" for information on the installation of the engine oil pump on engines that are equipped with a balancer.

NOTICE

Keep all parts clean from contaminants.

Contaminants may cause rapid wear and shortened component life.

NOTICE

If any of the parts on the engine oil pump are worn or damaged, the entire pump must be replaced.

1. Clean all of the internal components of the oil pump if the front cover of the oil pump was previously removed in order to inspect the internal components. Check the internal components for wear and for other damage. Check the clearance between the outer rotor of the oil pump and the oil pump body. Check the clearance between the outer rotor and the inner rotor. Check the end play movement of the rotor. Refer to the Systems Operation/Testing and Adjusting Manual, "Engine Oil Pump - Inspect". Replace the engine oil pump if any of the components are worn or damaged.
2. Lubricate the inner rotor and the outer rotor of the engine oil pump with clean engine lubricating oil. Install the front cover of the engine oil pump onto the body of the oil pump. Install the setscrews and tighten the setscrews in order to secure the front cover to the body.

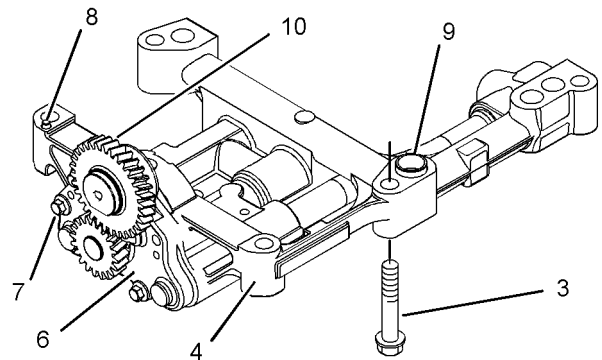

Illustration 101

g01019312

3. Fill engine oil pump (6) with clean engine oil.
4. Install the engine oil pump (6) into the assembly of the engine oil pump (4). Install the setscrews (7). Tighten the setscrews to a torque of 9 N·m (80 lb in).
5. Ensure that the dowel pin (8) and the hollow dowel (9) are correctly located in the cylinder block. Install the assembly of the engine oil pump (4) onto the dowels (8 and 9).
6. Install the setscrews (3). Tighten the setscrews to a torque of 44 N·m (32 lb ft).
7. Check the backlash between the idler gear (10) of the oil pump and the crankshaft gear. Refer to the Specifications Manual, "Gear Group - Front" for further information.

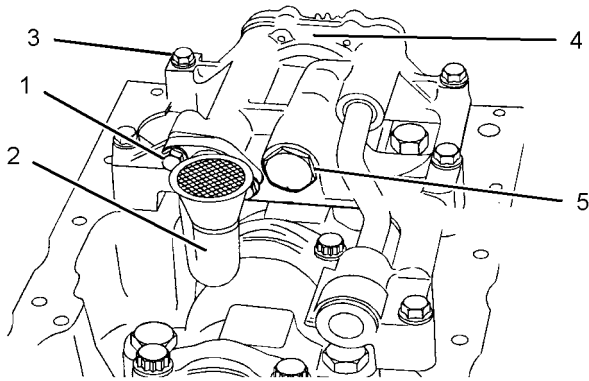

Illustration 102

g01019045

8. If the pressure relief valve (5) was removed, install the pressure relief valve. Refer to this Disassembly and Assembly Manual, "Engine Oil Relief Valve - Remove and Install" for further information.
9. Position the suction pipe (2) and install the setscrews (1).

End By:

- a. Install the engine oil pan. Refer to this Disassembly and Assembly Manual, "Engine Oil Pan - Remove and Install".

i01991657

Water Pump - Remove

Removal Procedure

Start By:

- a. Remove the fan. Refer to this Disassembly and Assembly Manual, "Fan - Remove and Install".

NOTICE

Keep all parts clean from contaminants.

Contaminants may cause rapid wear and shortened component life.

NOTICE

Care must be taken to ensure that fluids are contained during performance of inspection, maintenance, testing, adjusting and repair of the product. Be prepared to collect the fluid with suitable containers before opening any compartment or disassembling any component containing fluids.

Dispose of all fluids according to local regulations and mandates.

1. Drain the coolant from the cooling system into a suitable container for storage or disposal.
2. Loosen the clamps and remove the hose from the water pump inlet.

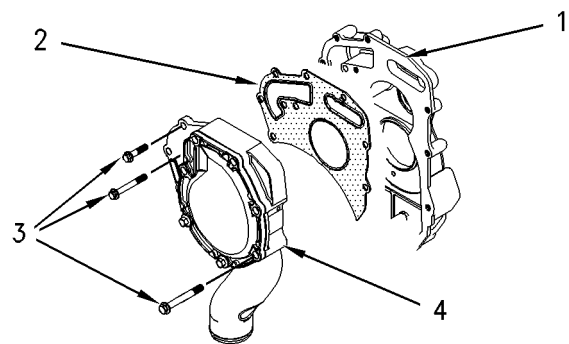

Illustration 103

g00952695

3. Remove the setscrews (3) that fasten the water pump (4) to the front housing (1).
4. If necessary, gently tap the water pump (4) with a soft hammer in order to loosen the water pump.
5. Remove the water pump (4). Remove the joint (2) from the front housing (1) and the water pump (4). Discard the joint (1).

i01962207

Water Pump - Disassemble

Disassembly Procedure

Start By:

- a. Remove the water pump. Refer to this Disassembly and Assembly Manual, "Water Pump - Remove and Install".

NOTICE

Keep all parts clean from contaminants.

Contaminants may cause rapid wear and shortened component life.

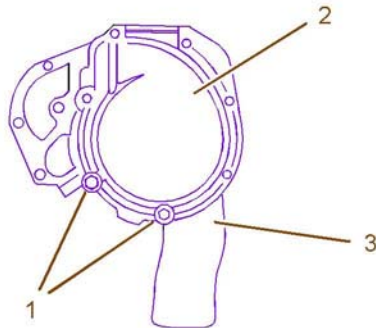

Illustration 104

g01019550

1. Remove the setscrews (1) from the cover (2) of the water pump (3). Remove the joint between the cover (2) and the water pump (3). Discard the joint.

Note: All of the other setscrews are removed during the removal of the water pump.

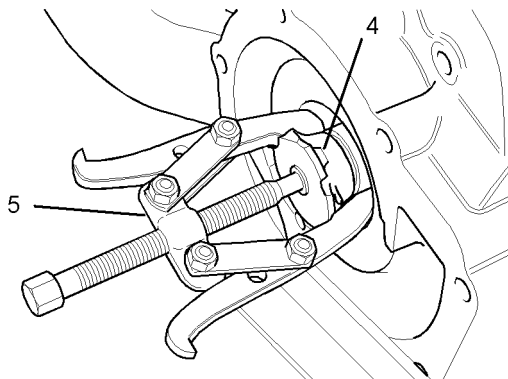

Illustration 105

g01019566

2. Drill twelve 6.35 mm (0.25 inch) holes between the existing holes in the impeller (4). Break pieces from the impeller (4) in order to install a suitable puller (5) with two legs onto the impeller. Remove the impeller (4) with the suitable puller (5).

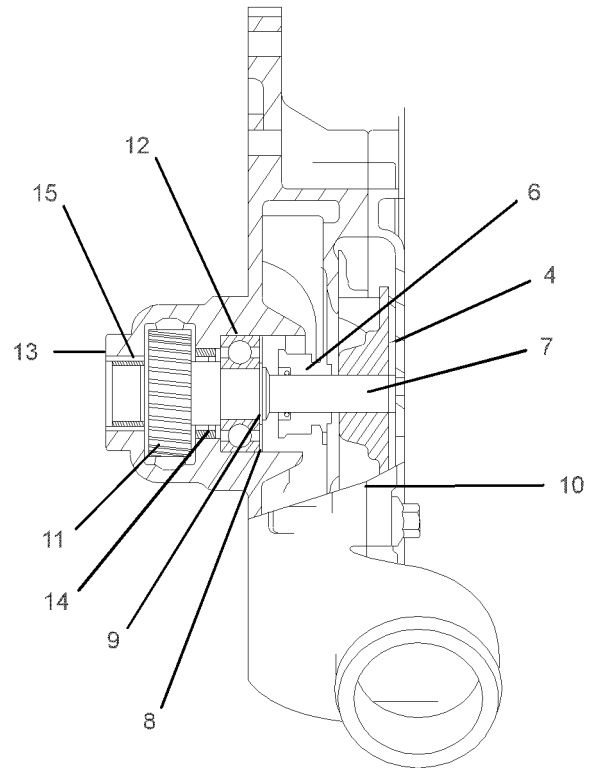

Illustration 106

g01020061

Note: It will be necessary to break the coolant seal (6) in order to remove the coolant seal from the water pump (3).

3. Drill three 3.175 mm (0.125 inch) holes that are equally spaced into the coolant seal (6). The holes should be drilled into the face of the coolant seal (6) that would have faced the impeller (4). Insert three 25.4 mm (1.00 inch) long self-tapping screws into the drilled holes. Insert a suitable lever into the coolant inlet of the water pump (3). Use the suitable lever under the self-tapping screws in order to evenly pull the coolant seal (6) off the shaft (7). If necessary, remove the center sleeve of the coolant seal from the shaft with a suitable extractor.
4. Remove the outer circlip (8) and discard the outer circlip. Remove the inner circlip (9) and discard the inner circlip.

5. Support the machined face (10) of the housing of the water pump (3) on a suitable support. Press on the shaft (7) until the gear (11) and the bearing (12) are free from the shaft. Discard the shaft (7) and the bearing (12). Remove the gear (11) through the side of the housing of the water pump (3).
6. Support the machined face (13) of the housing of the water pump (3) on a suitable support. Insert a suitable mandrel on the oil seal (14) and press the oil seal out of the housing of the water pump (3). The oil seal (14) can be removed through the side of the housing of the water pump (3) after the seal has been released from the housing. Discard the oil seal (14).
7. Use a suitable mandrel to press the needle bearing (15) out of the housing of the water pump (3). Discard the needle bearing (15).

i01962206

Water Pump - Assemble

Assembly Procedure

NOTICE

Keep all parts clean from contaminants.

Contaminants may cause rapid wear and shortened component life.

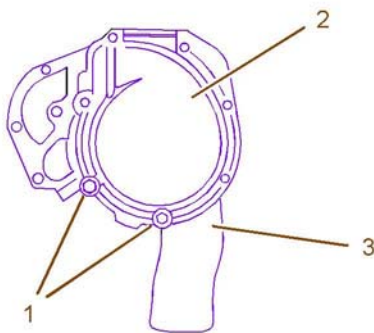

Illustration 107

g01019550

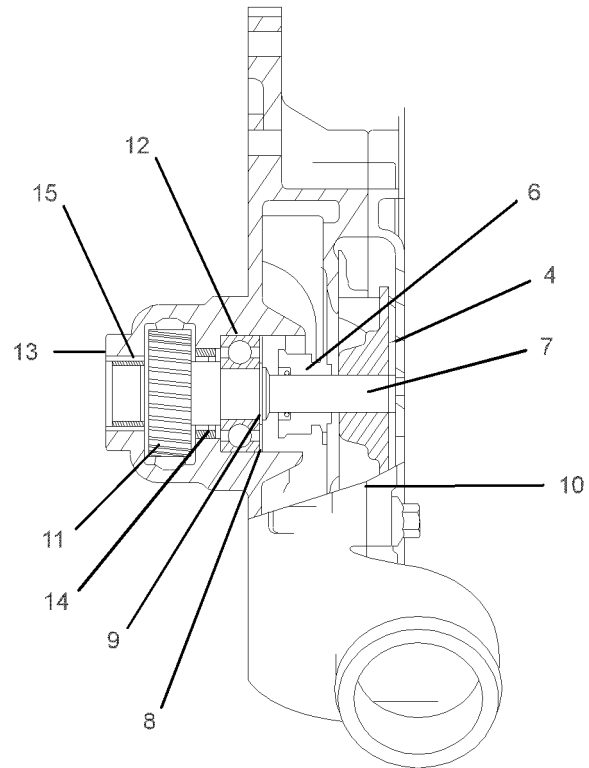

Illustration 108

g01020061

1. Thoroughly clean the inside of the housing of the water pump (3). Ensure that the bores for the bearings (12 and 15) and the coolant seal (6) are clean and free from corrosion.
2. Inspect the gear (11) for wear and/or damage. If necessary, replace the gear (11).
3. Support the machined face (13) of the housing of the water pump (3). Use a suitable mandrel and a suitable press to press a new oil seal (14) into the housing of the water pump (3). Stop pressing the oil seal (14) into the housing when the lower face of the oil seal is level with the lower face of the recess for the oil seal.
4. Install the gear (11) through the side of the housing for the water pump (3). Use a suitable adapter to press the shaft (7) through the oil seal (14) and into the gear (11). Continue to press the shaft (7) into the gear (11) until there is a gap of 1.5 mm (0.060 inch) between the gear and the top of the housing for the gear within the housing of the water pump (3).

5. Use a suitable adapter in order to press the bearing (12) against the shoulder of the recess for the bearing.
6. Install a new circlip (8) into the recess with the housing for the water pump (3). Install a new circlip (9) into the recess in the shaft (7). Ensure that both circlips (8 and 9) are installed correctly.
7. Support the machined face (10) of the housing of the water pump (3) on a suitable support. Press the needle bearing (15) into the housing for the bearing. Continue to press the needle bearing (15) into the housing until the needle bearing is either level with the top face of the housing or the needle bearing is no more than a maximum of 0.5 mm (0.020 inch) below the top face of the housing.
8. Support the machined face (13) of the housing of the water pump (3) on a suitable support.

Note: Avoid hand contact with the coolant seal (6). The coolant seal (6) must not be contaminated by oil or grease. The coolant seal (6) must only be touched and/or held at the edge of the outer flange.

Note: Do not lubricate the coolant seal (6).

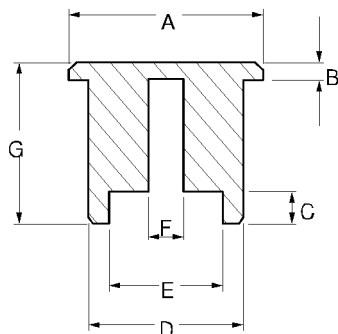

Illustration 109

g01019850

9. Manufacture a suitable tool in order to press the new coolant seal (6) into position. The tool should be made to the dimensions shown in the illustration 109 and the table 10.

Table 10

Dimensions			
A	54.0 mm (2.126 inch)	E	44.0 mm (1.732 inch)
B	6.0 mm (0.236 inch)	F	18.0 mm (0.709 inch)
C	10.0 mm (0.394 inch)	G	54.0 mm (2.126 inch)
D	48.0 mm (1.890 inch)		

10. Install the new coolant seal (6) onto the shaft (7) with the largest diameter of the coolant seal toward the bearing (12). Push the coolant seal (6) onto the shaft (7) until the coolant seal is in contact with the counterbore for the coolant seal. Ensure that the coolant seal (6) is square with the counterbore. Use a suitable adapter in order to press the coolant seal (6) into the counterbore until the outer flange of the coolant seal is in contact with the body of the water pump (3). Maintain the pressure on the coolant seal (10) for about 10 seconds in order to ensure that the coolant seal remains in position.
11. Press the impeller (4) onto the shaft (7) until the top of the impeller is level with the top of the shaft.
12. Install a new joint for the cover (2) to the body of the water pump (3). Install the cover (2) to the water pump (3).
13. Install the setscrews (1). Torque the setscrews (1) to a torque of 22 N·m (16 lb ft).

End By:

- a. Install the water pump. Refer to this Disassembly and Assembly Manual, "Water Pump - Remove and Install".

i01991661

Water Pump - Install

Installation Procedure

NOTICE

Keep all parts clean from contaminants.

Contaminants may cause rapid wear and shortened component life.

1. Inspect the drive gear for the water pump (4) for wear or other damage. If necessary, replace the drive gear.
2. Clean the joint faces of the water pump (4) and the front housing (1).

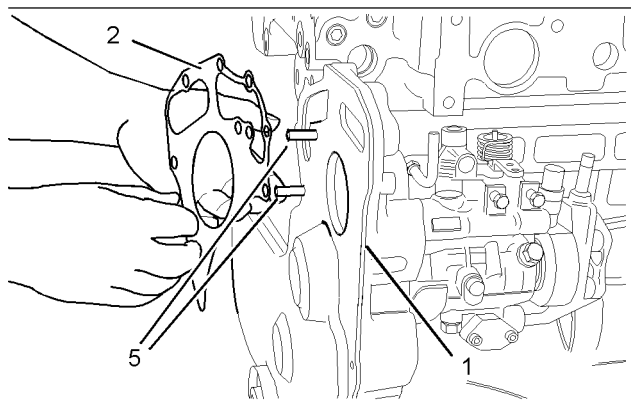

Illustration 110 g01019549

3. Install two guide studs (5) into the front housing (1).

Note: Do not use sealant on the new joint (2) for the water pump (4).

4. Install the new joint (2) onto the front housing (1).
5. Install the water pump (4) onto the front housing (1).

Note: New setscrews have sealant to the first 13 mm (0.5 inch) of the threads. In order to reuse the old setscrews, clean the old sealant from the setscrews and apply 21820117 POWERPART Threadlock and Nutlock to the setscrews (3).

6. Install the setscrews (3) that fasten the water pump (4) to the front housing (1). Do not tighten the setscrews (3) at this time.
7. Remove the guide studs (5) and install the remaining setscrews (3).

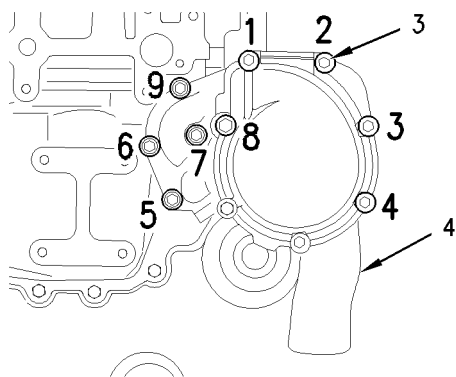

Illustration 111 g00952731

Note: Tighten the setscrews (3) evenly in order to pull the water pump (4) into the front housing (1).

8. Tighten the setscrews (3) in the sequence that is shown in the illustration 111 to a torque of 22 N·m (16 lb ft).
9. Install the hose to the water pump inlet. Tighten the hose clamps.
10. Fill the cooling system with coolant. Refer to the Operation and Maintenance Manual, "Refill Capacities" for the cooling system capacity.

End By:

- a. Install the fan. Refer to this Disassembly and Assembly Manual, "Fan - Remove and Install".

i02641605

Water Temperature Regulator - Remove and Install

Removal Procedure

Table 11

Required Tools		
Part Number	Part Description	Qty
27610226	Thermostat Tool	1

NOTICE

Keep all parts clean from contaminants.

Contaminants may cause rapid wear and shortened component life.

NOTICE

Care must be taken to ensure that fluids are contained during performance of inspection, maintenance, testing, adjusting and repair of the product. Be prepared to collect the fluid with suitable containers before opening any compartment or disassembling any component containing fluids.

Dispose of all fluids according to local regulations and mandates.

1. Drain the coolant from the cooling system to a level below the water temperature regulator into a suitable container for storage or disposal.

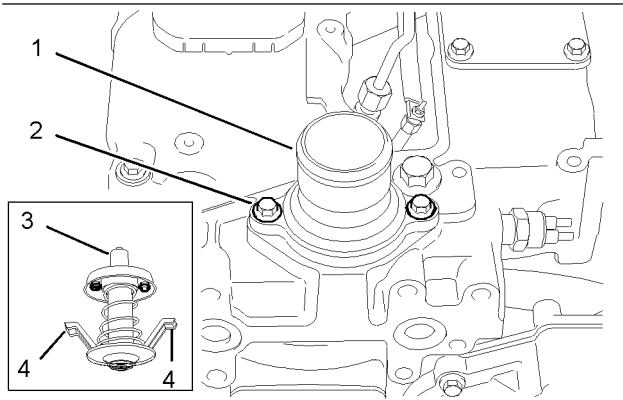

Illustration 112

g01019333

2. Loosen the hose clamps from the upper radiator hose and remove the upper radiator hose from the water temperature regulator housing (1).
3. Remove the setscrews (2) that hold water temperature regulator housing (1) in position on the cylinder head. Remove the water temperature regulator housing (1). Remove the O-ring from the water temperature regulator housing (1). Discard the O-ring.

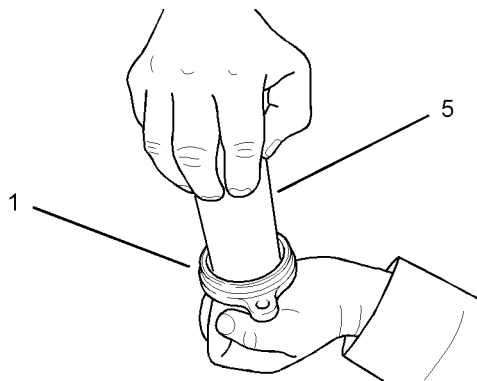

Illustration 113

g01019344

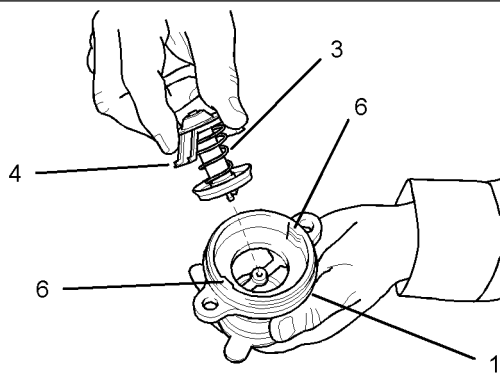

Illustration 114

g01019356

4. Install the 27610226 Thermostat Tool (5) into the water temperature regulator housing (1). Press on the tool (5) in order to squeeze the retainers (4). Rotate the tool (5) in order to release the water temperature regulator (3) from the tabs (6) of the water temperature regulator housing (1). Remove the tool (5) from the water temperature regulator housing (1). Remove the water temperature regulator (3) from the water temperature regulator housing (1).
5. Refer to the Systems Operation/Testing and Adjusting Manual, "Water Temperature Regulator - Test" for the correct procedure on testing the water temperature regulator. If necessary, replace the water temperature regulator (3).

Installation Procedure

Table 12

Required Tools		
Part Number	Part Description	Qty
27610226	Thermostat Tool	1

NOTICE

Keep all parts clean from contaminants.

Contaminants may cause rapid wear and shortened component life.

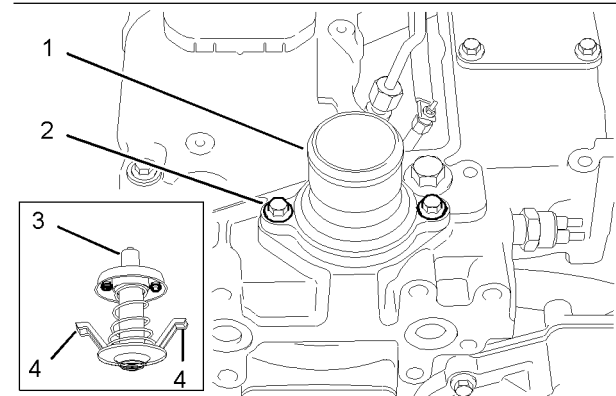

Illustration 115

g01019333

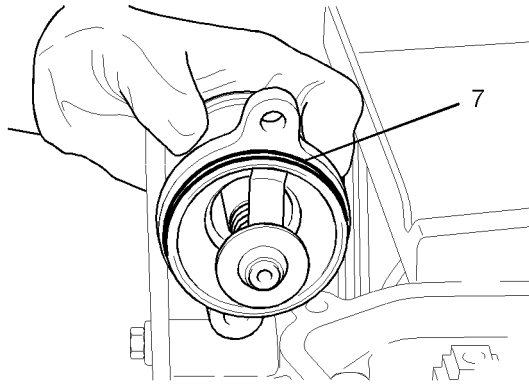

Illustration 116

g01019377

1. Clean the water temperature regulator housing (1). Ensure that the tabs (6) for the retainers (4) are clean. Ensure that the seat for the O-ring (7) is clean.

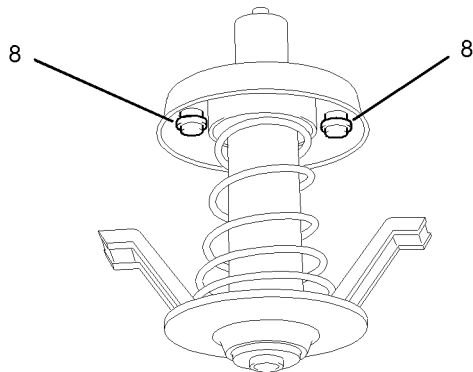

Illustration 117

g01019381

2. The water temperature regulator (3) has two vents (8) that are opened and closed by a valve pin. These two vents (8) bleed hot water and/or air through the water temperature regulator (3) when the water temperature regulator is in the closed position. Ensure that the valve pins (8) can move freely in the vents.
3. Lubricate the new O-ring (7) with 21820221 POWERPART Red Rubber Grease. Install the O-ring (7) into the appropriate groove in the water temperature regulator housing (1).

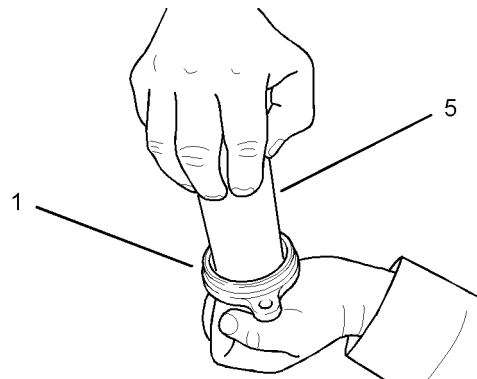

Illustration 118

g01019344

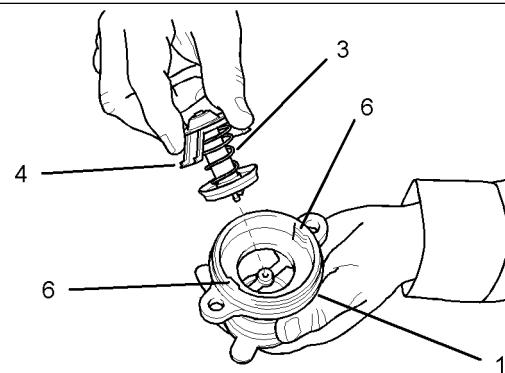

Illustration 119

g01019356

4. Position the water temperature regulator (3) in the water temperature regulator housing (1). Install the 27610226 Thermostat Tool (5) in order to squeeze the retainers (4). Rotate the tool (5) in order to secure the water temperature regulator (3) into the water temperature regulator housing (1).

Note: The retainers (4) must be inserted behind the tabs of the water temperature regulator housing (1) in order to secure the water temperature regulator (3) during engine operation.

5. Ensure that the retainers (4) are correctly installed within the tabs (6). Position the water temperature regulator housing (1) onto the cylinder head.
6. Install the setscrews (2) that fasten the water temperature regulator housing (1) to the cylinder head. Tighten the setscrews (2) to a torque of 44 N·m (32 lb ft).
7. Install the upper radiator hose and tighten the hose clamps securely.
8. Fill the cooling system to the proper level. Refer to the Operation and Maintenance Manual, "Refill Capacities" for further information.

i02259836

Flywheel - Remove

Removal Procedure

NOTICE

Keep all parts clean from contaminants.

Contaminants may cause rapid wear and shortened component life.

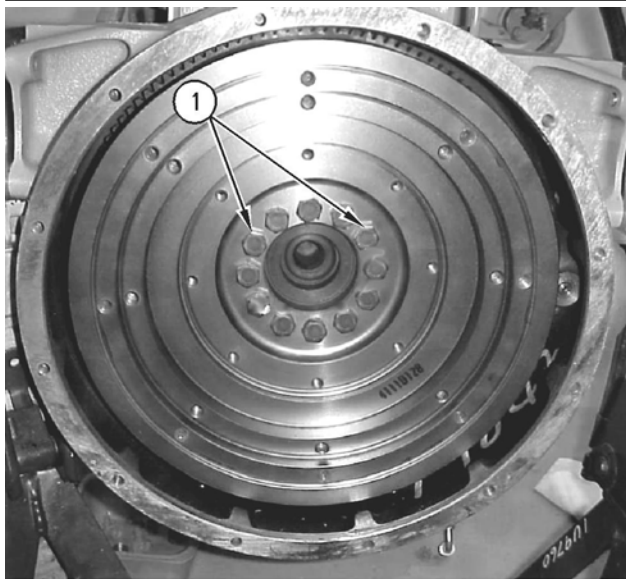

Illustration 120

g00905926

1. Remove the two setscrews (1).

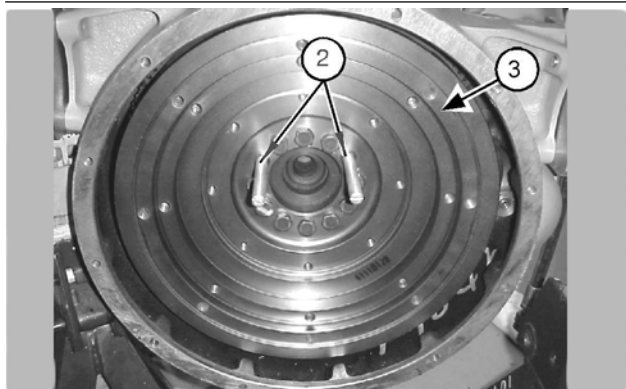

Illustration 121

g01020091

Typical example

2. Install two suitable studs (2) as guides.

Note: The flywheel (3) is heavy. Use suitable lifting equipment to support the flywheel (3) before the remainder of the setscrews (1) are removed.

3. Remove the remaining setscrews (1) that secure flywheel (3) to the crankshaft and then remove the flywheel.

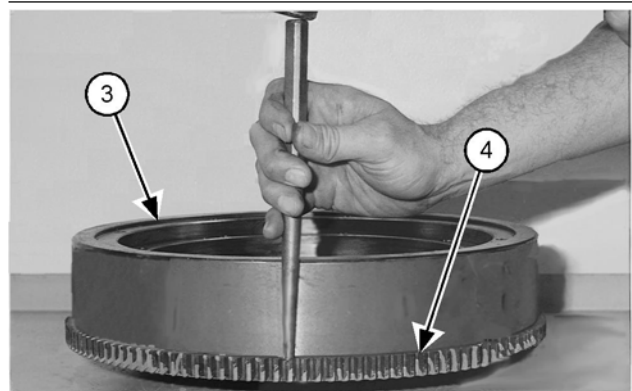

Illustration 122

g01020099

4. Check the condition of the ring gear (4). Remove the ring gear (4) if the ring gear is worn or damaged.

Note: Identify the orientation of the ring gear on the flywheel and the position of the chamfer on the teeth for the correct positioning when the new ring gear is installed.

5. Place the flywheel (3) and the ring gear (4) on a suitable support. Use a hammer and a chisel in order to remove the ring gear (4) from the flywheel (3).

i02231069

Flywheel - Install

Installation Procedure

NOTICE

Keep all parts clean from contaminants.

Contaminants may cause rapid wear and shortened component life.



Always wear protective gloves when handling parts that have been heated.

1. Thoroughly clean the flywheel housing. Inspect the crankshaft rear seal for leaks. If there are any oil leaks refer to this Disassembly and Assembly Manual, "Crankshaft Rear Seal - Remove".

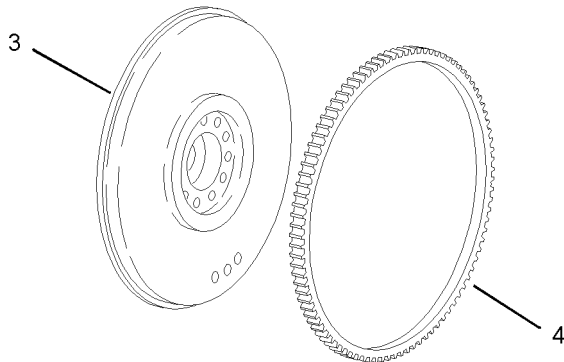

Illustration 123

g01020131

Note: If the ring gear (4) has been removed from the flywheel (3), identify the orientation of the new ring gear in order to install the ring gear correctly onto the flywheel.

Note: Do not use a torch to heat the ring gear (4).

- Heat the ring gear (4) to 250 °C (480 °F) in an oven in order to install the ring gear onto the flywheel (3). Ensure that the orientation of the ring gear (4) is correct and quickly install the ring gear onto the flywheel (3).
- Clean the flywheel (3) and the ring gear (4) when the ring gear has cooled.

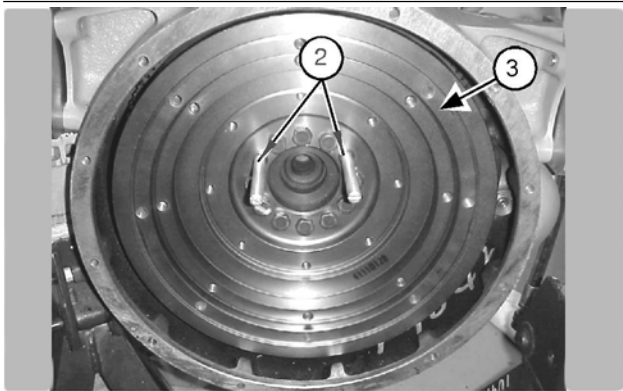

Illustration 124

g01020091

- Ensure that the guide studs (2) are still installed in the crankshaft.
- If an alignment pin is installed, ensure that the alignment hole in the mounting face of the flywheel is aligned with the alignment pin on the mounting face on the crankshaft.

Note: The flywheel (3) is heavy. Use suitable lifting equipment to support the flywheel until the setscrews (1) have been installed.

- Install the flywheel (3) onto the two guide studs (2).

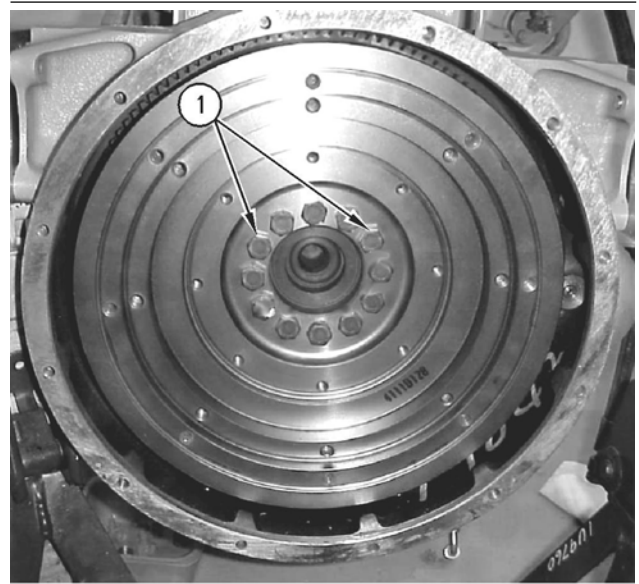

Illustration 125

g00905926

- Install most of the setscrews (1) finger tight. Remove the guide studs (2). Install the remainder of the setscrews (1).
- Tighten the setscrews (1) to a torque of 105 N·m (77 lb ft).
- Check the alignment of the flywheel (3) with the crankshaft. Refer to the Testing and Adjusting Manual, "Flywheel - Inspect".

i01963624

Crankshaft Rear Seal - Remove

Removal Procedure

Start By:

- Remove the flywheel. Refer to this Disassembly and Assembly Manual, "Flywheel - Remove".

NOTICE

Keep all parts clean from contaminants.

Contaminants may cause rapid wear and shortened component life.

NOTICE

Care must be taken to ensure that fluids are contained during performance of inspection, maintenance, testing, adjusting and repair of the product. Be prepared to collect the fluid with suitable containers before opening any compartment or disassembling any component containing fluids.

Dispose of all fluids according to local regulations and mandates.

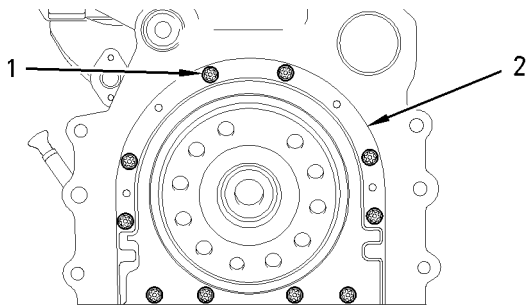

Illustration 126

g00991388

Note: The assembly of the crankshaft rear seal (2) is nonserviceable. If the assembly of the crankshaft rear seal (2) is removed, the assembly must be replaced.

1. Remove the setscrews (1) from the assembly of the crankshaft rear seal (2).
2. Remove the assembly of the crankshaft rear seal (2) from the cylinder block. Discard the assembly of the crankshaft rear seal (2).

i01963627

Crankshaft Rear Seal - Install

Installation Procedure

Note: The crankshaft rear seal and the housing for the crankshaft rear seal are manufactured as a one-piece assembly. The assembly of the crankshaft rear seal uses ten setscrews in order to fasten the assembly to the cylinder block.

Note: The assembly of the crankshaft rear seal is lubricated during manufacture. Do not lubricate the seal or the crankshaft flange before installation.

Note: Inspect the crankshaft rear seal and replace the assembly if there is the slightest sign of damage to the seal.

Note: The following procedure assumes that the crankshaft rear seal is a replacement assembly.

NOTICE

Keep all parts clean from contaminants.

Contaminants may cause rapid wear and shortened component life.

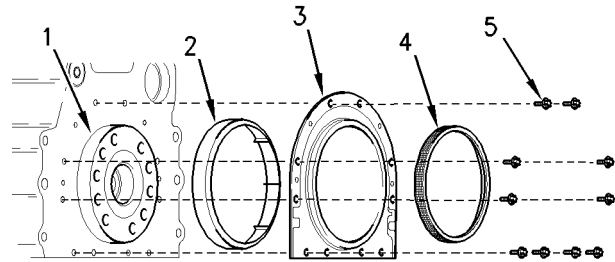

Illustration 127

g01004915

1. Ensure that the crankshaft flange (1) is clean, dry and free from rough metal edges. Ensure that the face of the cylinder block and the bridge in the crankcase are clean and dry.
2. Remove the packaging from the new assembly of the crankshaft rear seal (3). Ensure that the plastic sleeve (2) is squarely installed within the seal of the assembly of the crankshaft rear seal (3). The plastic sleeve (2) is included in order to protect the lip of the seal as the lip is pushed over the crankshaft flange (1).

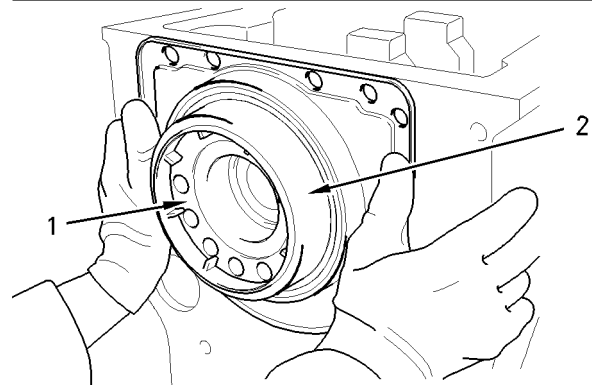

Illustration 128

g01004958

Typical example

3. Place the assembly of the crankshaft rear seal (3) over the crankshaft flange (1) and engage the plastic sleeve (2) onto the crankshaft flange.

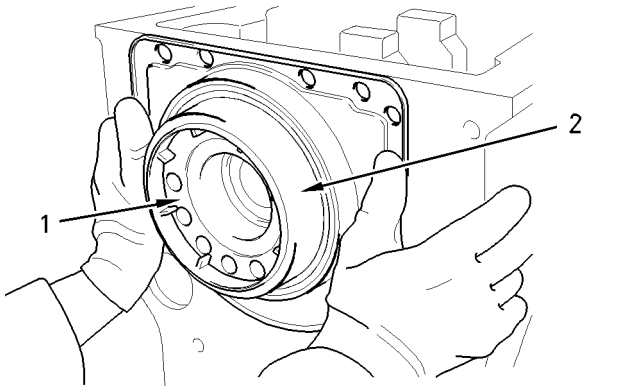

Illustration 129 g01004958
Typical example

4. Ensure that the plastic sleeve (2) is engaged onto the crankshaft flange (1). Push the assembly of the crankshaft rear seal (3) evenly and push the assembly smoothly onto the crankshaft flange (1) until the assembly is against the cylinder block. During this process, the plastic sleeve (2) will be forced out of the assembly of the crankshaft rear seal (3). Discard the plastic sleeve (2).

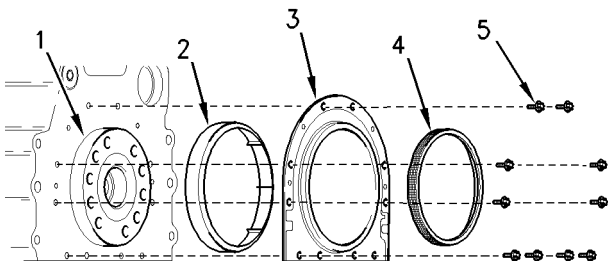

Illustration 130 g01004915

5. Rotate the assembly of the crankshaft rear seal (3) in order to align the setscrew holes in the assembly with the setscrew holes in the rear face of the cylinder block.
6. By using the ten setscrews (5), loosely secure the assembly of the crankshaft rear seal (3) to the cylinder block.

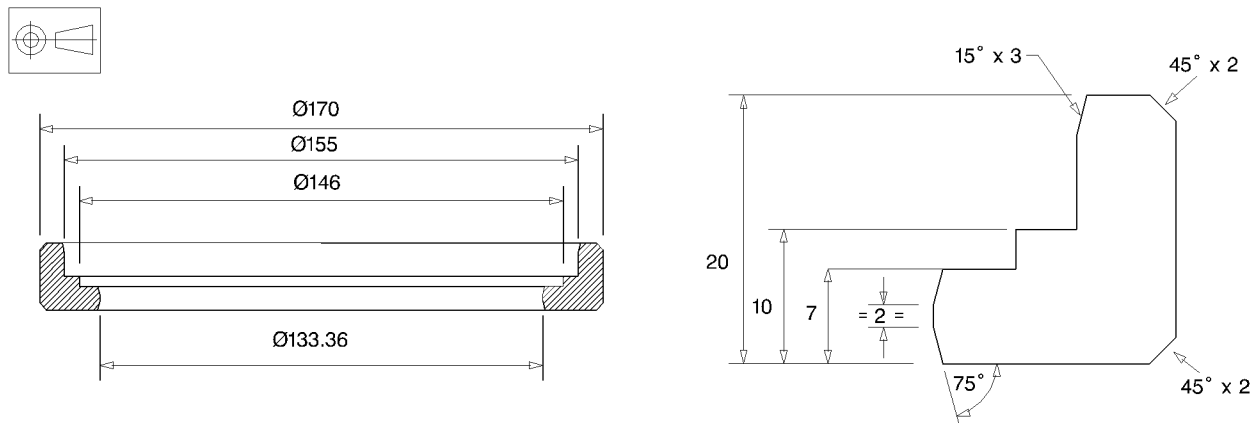

Illustration 131

g00975010

Note: The alignment tool (4) is not currently available from Perkins. Refer to the illustration 131 for the required dimensions in order to manufacture an alignment tool (4) locally.

- Install the alignment tool (4) onto the crankshaft flange (1) and over the assembly of the crankshaft rear seal (3) in order to align the assembly with the crankshaft flange.

End By:

- Install the flywheel housing. Refer to this Disassembly and Assembly Manual, "Flywheel Housing - Remove and Install".
- Install the flywheel. Refer to this Disassembly and Assembly Manual, "Flywheel - Install".

i01964071

Crankshaft Wear Sleeve (Rear) - Remove

Removal Procedure

Start By:

- Remove the crankshaft rear seal. Refer to this Disassembly and Assembly Manual, "Crankshaft Rear Seal - Remove".

NOTICE

Keep all parts clean from contaminants.

Contaminants may cause rapid wear and shortened component life.

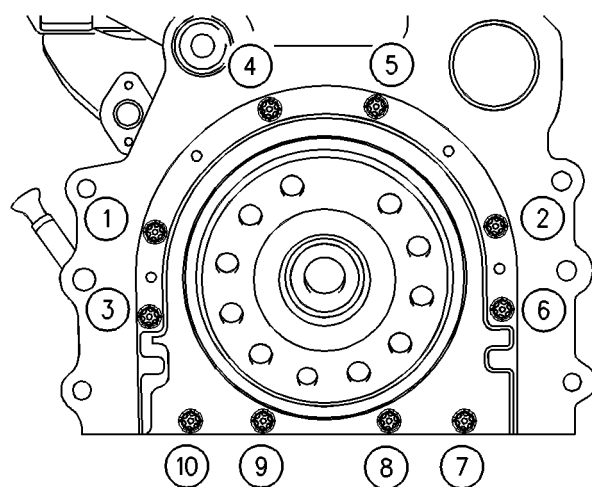

Illustration 132

g00915076

- Tighten the setscrews (5) in the sequence 1, 2, 3, 4, 5, 6, 7, and 10 to a torque of 22 N·m (16 lb ft). Refer to the illustration 132.
- Remove the alignment tool (4). Tighten the setscrews 8 and 9 to a torque of 22 N·m (16 lb ft). Refer to the illustration 132.

- Install a deep score mark along the length of the wear sleeve.

2. Insert a suitable tool between the crankshaft flange and the wear sleeve next to the score mark. The wear sleeve should break along the score mark. Remove the wear sleeve. Discard the wear sleeve.
3. Use a suitable solvent in order to remove any old sealant from the crankshaft.

i01964075

Crankshaft Wear Sleeve (Rear) - Install

Installation Procedure

NOTICE

Keep all parts clean from contaminants.

Contaminants may cause rapid wear and shortened component life.

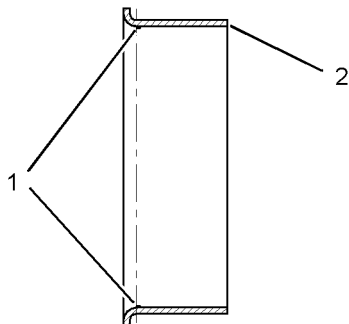

Illustration 133

g01020643

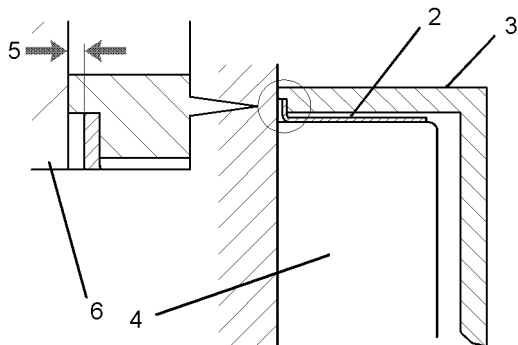

Illustration 134

g01020497

1. Ensure that the crankshaft flange (4) is thoroughly clean, dry, and free from old sealant prior to the installation of a new crankshaft wear sleeve (2). Remove any rough edges from the crankshaft flange (4).
2. Use a prybar to move the crankshaft toward the front of the engine.
3. Apply a small continuous bead (1) of 21820518 POWERPART Liquid Gasket to the inner surface 5.00 mm (0.197 inch) from the flange end of crankshaft wear sleeve (2).
4. Position crankshaft wear sleeve (2) on the crankshaft flange (4). Position the installation tool (3) that is provided with the new crankshaft wear sleeve (2) over the crankshaft wear sleeve. Use a hammer to drive the crankshaft wear sleeve (2) onto the crankshaft flange (4). The flange of the crankshaft wear sleeve (2) must be within (5) 0.40 to 0.60 mm (0.017 to 0.024 inch) of the cylinder block (6).
5. Remove the installation tool (3). Measure the distance between the flange of the crankshaft wear sleeve (2) and the cylinder block (6) in two places that are 180 degrees from each other. The correct distance (5) is 0.40 to 0.60 mm (0.017 to 0.024 inch).
6. After the crankshaft wear sleeve (2) has been installed, remove any rough edges from the crankshaft flange (4) and the crankshaft wear sleeve (2).

End By:

- a. Install the crankshaft rear seal. Refer to this Disassembly and Assembly Manual, "Crankshaft Rear Seal - Install".

i01963628

Flywheel Housing - Remove and Install

Removal Procedure

Start By:

- a. Remove the electric starting motor. Refer to this Disassembly and Assembly Manual, "Electric Starting Motor - Remove and Install".
- b. Remove the flywheel. Refer to this Disassembly and Assembly Manual, "Flywheel - Remove".

NOTICE

Keep all parts clean from contaminants.

Contaminants may cause rapid wear and shortened component life.

NOTICE

Care must be taken to ensure that fluids are contained during performance of inspection, maintenance, testing, adjusting and repair of the product. Be prepared to collect the fluid with suitable containers before opening any compartment or disassembling any component containing fluids.

Dispose of all fluids according to local regulations and mandates.

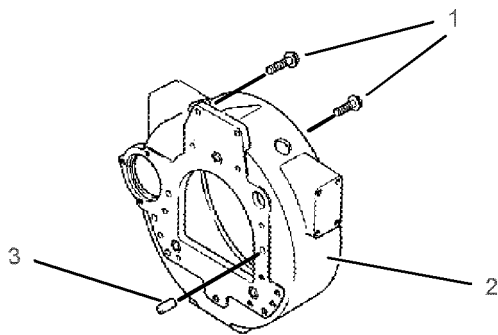

Illustration 135

g01020398

Note: The flywheel housing (2) is heavy. Use suitable lifting equipment to support the flywheel housing (2) while the setscrews (1) are being removed and while the flywheel housing is being removed.

1. Remove all of the setscrews (1) from the flywheel housing (2).
2. Remove the flywheel housing (2). If necessary, hit the flywheel housing with a soft faced hammer in order to separate the flywheel housing (2) from the dowels (3) in the cylinder block.

Installation Procedure

NOTICE

Keep all parts clean from contaminants.

Contaminants may cause rapid wear and shortened component life.

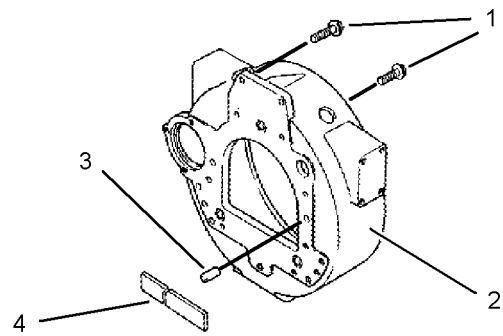

Illustration 136

g01020405

1. Clean the rear face of the cylinder block and the mating surface of the flywheel housing (2).
2. If a felt seal (4) is installed, replace the felt seal. Inspect the dowels (3) in the cylinder block that align the flywheel housing (2). Replace the dowels (3), if necessary.

Note: The flywheel housing (2) is heavy. Use suitable lifting equipment to support the flywheel housing (2) while the flywheel housing is being lifted and while the setscrews (1) are being installed.

3. Install the flywheel housing (2) onto the dowels (3) that are in the cylinder block.
4. Install all of the setscrews (1) that attach the flywheel housing (2) to the cylinder block.

Tighten the setscrews (1) to the following torque:

M10 "8.8"	44 N·m (33 lb ft)
M10 "10.9"	63 N·m (46 lb ft)
M12 "8.8"	75 N·m (55 lb ft)
M12 "10.9"	115 N·m (85 lb ft)

5. Check the alignment of the flywheel housing (2) with the cylinder block. Refer to the Testing and Adjusting Manual, "Flywheel Housing - Inspect".

End By:

- a. Install the flywheel. Refer to this Disassembly and Assembly Manual, "Flywheel - Install".
- b. Install the electric starting motor. Refer to this Disassembly and Assembly Manual, "Electric Starting Motor - Remove and Install".

i02217476

Crankshaft Pulley - Remove and Install

Standard and Non-standard Pulleys

Start By:

- a. Remove the V-Belts. Refer to this Disassembly and Assembly Manual, "V-Belts - Remove and Install".

NOTICE

Keep all parts clean from contaminants.

Contaminants may cause rapid wear and shortened component life.

Identify the type of pulley that is installed on the engine. The standard pulley has four apertures. Refer to illustration 137. The non-standard pulley has three apertures and a weight in place of the fourth aperture. Refer to illustration 138. Refer to the applicable procedure that follows.

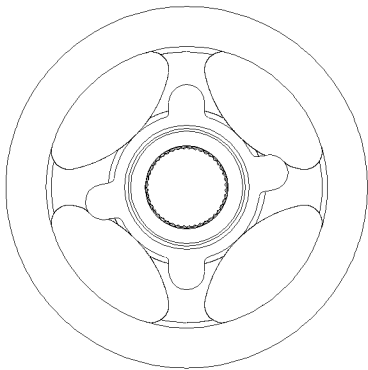

Illustration 137
Standard Pulley

g01126952

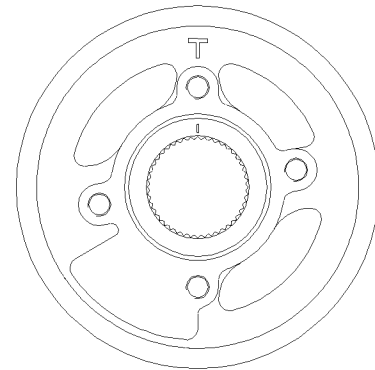

Illustration 138
Non-standard Pulley

g01126955

Removal and Installation of the Standard Pulley (if equipped)

Remove the Standard Pulley

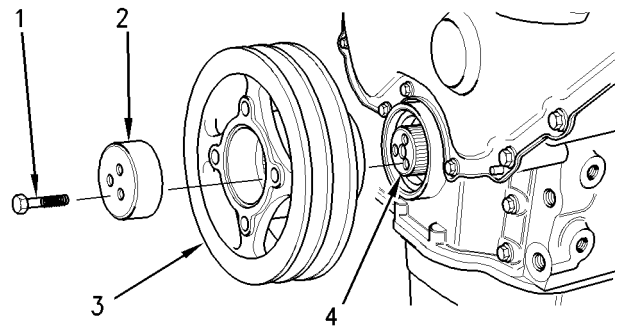

Illustration 139

g00952102

1. Remove the setscrews (1) and then remove the thrust block (2).
2. Remove the pulley (3) from the crankshaft (4).

Install the Standard Pulley

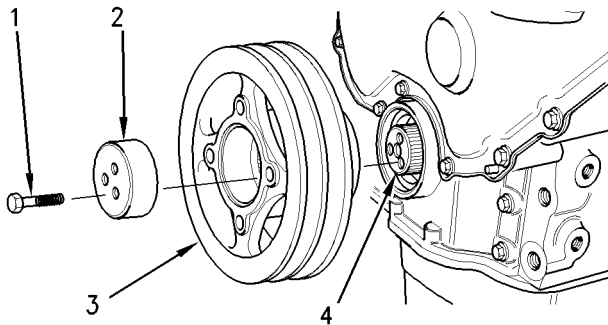

Illustration 140

g00952102

1. Clean the pulley (3) and clean the thrust block (2). Inspect the pulley (3) and the thrust block (2) for wear and for damage. If necessary, replace any damaged component. Inspect the area on the pulley that is normally in contact with the crankshaft front seal. If there is excessive wear then a wear sleeve can be installed. Refer to the Disassembly and Assembly Manual, "Crankshaft Wear Sleeve (Front) - Remove and Crankshaft Wear Sleeve (Rear) - Install" for further details.
2. Position the pulley (3) onto the crankshaft (4).
3. Lubricate the threads and the shoulder of the setscrews (1) with clean engine oil. Position the thrust block (2) and install the setscrews (1). Tighten the setscrews evenly to a final torque of 115 N·m (85 lb ft).
4. Tighten each of the setscrews (1) again to the same torque in order to ensure that the setscrews are still at the required torque.

Removal and Installation of the Non-standard Pulley (if equipped)

There are two procedures for removal and installation of the non-standard pulley. One procedure is used when the crankshaft is not replaced. The second procedure is used when the non-standard pulley is removed prior to replacement of the crankshaft.

Remove the Non-standard Pulley when the Crankshaft is Not Replaced

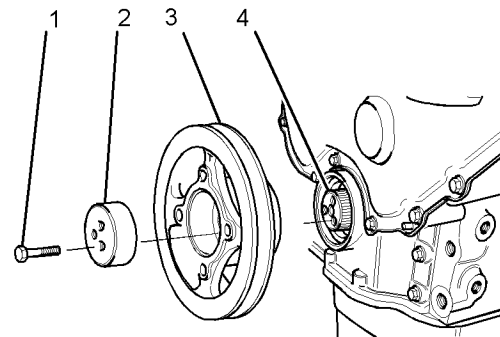

Illustration 141

g01127338

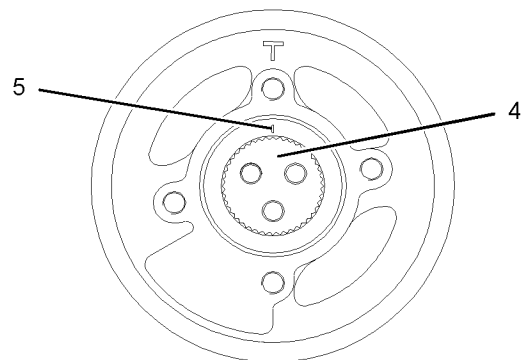

Illustration 142

g01127411

1. Remove the setscrews (1) and then remove the thrust block (2).
2. Apply a mark on the front face of the crankshaft (4) that is aligned with the mark on the pulley (5).
3. Remove the pulley (3) from the crankshaft (4).

Install the Non-standard Pulley when the Crankshaft is Not Replaced

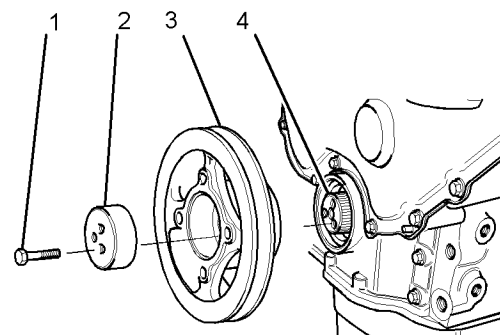

Illustration 143

g01127338

1. Clean the pulley (3) and clean the thrust block (2). Inspect the pulley (3) and the thrust block (2) for wear and for damage. If necessary, replace any damaged component. Inspect the area on the pulley that is normally in contact with the crankshaft front seal. If there is excessive wear then a wear sleeve can be installed. Refer to the Disassembly and Assembly Manual, "Crankshaft Wear Sleeve (Front) - Remove and Crankshaft Wear Sleeve (Rear) - Install" for further details.

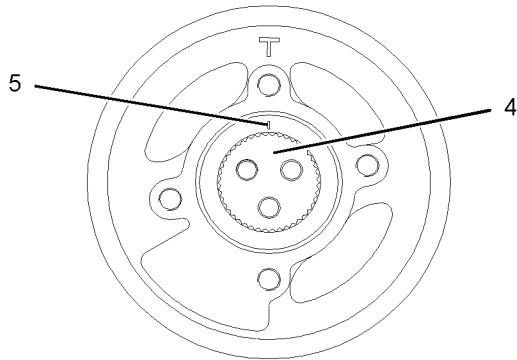

Illustration 144

g01127411

2. Align the mark on the pulley (5) with the mark on the front face of the crankshaft (4) and then install the pulley on the crankshaft.
3. Lubricate the threads and the shoulder of the setscrews (1) with clean engine oil. Position the thrust block (2) and install the setscrews (1). Tighten the setscrews evenly to a final torque of 115 N·m (85 lb ft).
4. Tighten each of the setscrews (1) again to the same torque in order to ensure that the setscrews are still at the required torque.

Remove the Non-standard Pulley when the Crankshaft is Replaced

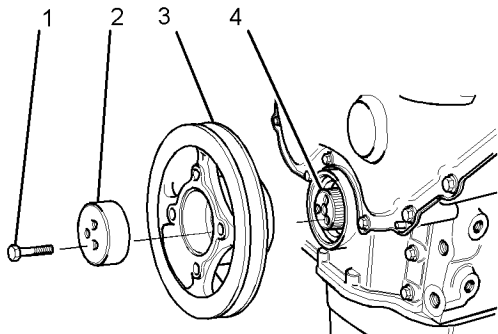

Illustration 145

g01127338

1. Remove the setscrews (1) and then remove the thrust block (2).
2. Remove the pulley (3) from the crankshaft (4).

Install the Non-standard Pulley when the Crankshaft is Replaced

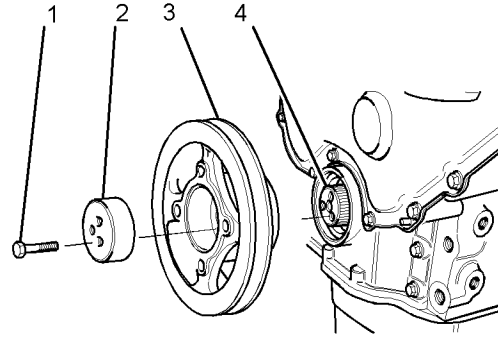

Illustration 146

g01127338

1. Clean the pulley (3) and clean the thrust block (2). Inspect the pulley (3) and the thrust block (2) for wear and for damage. If necessary, replace any damaged component. Inspect the area on the pulley that is normally in contact with the crankshaft front seal. If there is excessive wear then a wear sleeve can be installed. Refer to the Disassembly and Assembly Manual, "Crankshaft Wear Sleeve (Front) - Remove and Crankshaft Wear Sleeve (Rear) - Install" for further details.
2. Put the No. 1 piston at the top center position. Refer to Testing and Adjusting, "Finding Top Center Position for the No. 1 Piston".

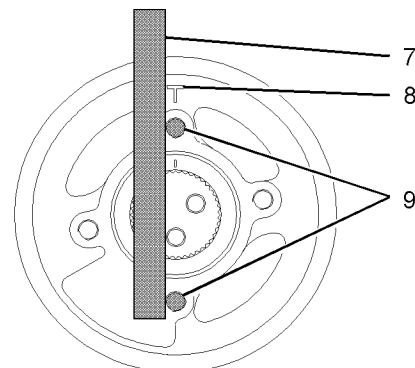

Illustration 147

g01127795

3. Align the front pulley with the "T" mark (8) at the top. Install temporary guide pins (9) in the top and bottom threaded holes in the pulley. Refer to illustration 147.

4. Align the pulley with the "T" mark (8) at the top and in line with the center line of the engine and then install the pulley on the crankshaft. Use a suitable straight edge (7) against the guide pins (9) to aid alignment of the pulley.

Note: The pulley can be rotated by a maximum of 4 degrees in a clockwise direction or a counterclockwise direction in order to align the splines in the pulley with the splines on the crankshaft. This is within acceptable limits.

5. Remove the straight edge (7) and the two guide pins (9).
6. Lubricate the threads and the shoulder of the setscrews (1) with clean engine oil. Position the thrust block (2) and install the setscrews (1). Tighten the setscrews evenly to a final torque of 115 N·m (85 lb ft).
7. Tighten each of the setscrews (1) again to the same torque in order to ensure that the setscrews are still at the required torque.

End By:

- a. Install the V-Belts. Refer to this Disassembly and Assembly, "V-Belts - Remove and Install".

i01964539

Crankshaft Front Seal - Remove

Removal Procedure

Table 13

Required Tools		
Part Number	Part Description	Qty
27610230	Three legged puller	1

Start By:

- a. Remove the crankshaft pulley. Refer to this Disassembly and Assembly Manual, "Crankshaft Pulley - Remove and Install".
- b. Thoroughly clean the area around the housing for the crankshaft front seal.

NOTICE

Keep all parts clean from contaminants.

Contaminants may cause rapid wear and shortened component life.

NOTICE

Care must be taken to ensure that fluids are contained during performance of inspection, maintenance, testing, adjusting and repair of the product. Be prepared to collect the fluid with suitable containers before opening any compartment or disassembling any component containing fluids.

Dispose of all fluids according to local regulations and mandates.

Note: Do not remove the crankshaft front seal at this time if the housing (front) will also be removed. It is easier to remove the crankshaft front seal when the housing (front) has been removed from the engine. Refer to this Disassembly and Assembly Manual, "Housing (Front) - Remove".

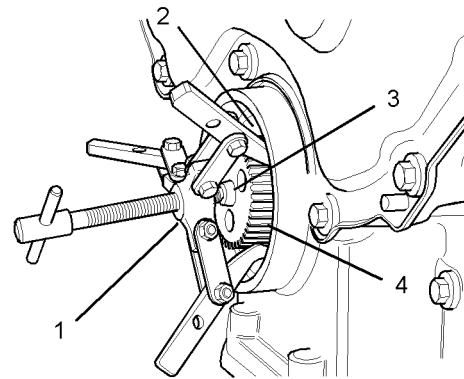

Illustration 148

g01020672

1. Install the legs of the puller (1) under the crankshaft front seal (2) and lock the legs into position.
2. Install a suitable adapter (3) between the crankshaft (4) and the puller (1).

NOTICE

Ensure that the main lip is used in order to remove the crankshaft front seal. Do not damage the edge of the housing for the crankshaft front seal.

3. Use the puller (1) in order to remove the crankshaft front seal (2). Discard the crankshaft front seal (2).

i01964540

Crankshaft Front Seal - Install

Installation Procedure

Table 14

Required Tools		
Part Number	Part Description	Qty
21825577	Crankshaft Front Seal Replacer	1
21825580	Fastener Plate	1
21825578	Pressure Plate	1
27610217	Adapter	1

NOTICE

Keep all parts clean from contaminants.

Contaminants may cause rapid wear and shortened component life.

Note: This procedure assumes that the housing (front) is still on the engine. Do not follow this procedure if the housing (front) has been removed from the engine. Refer to this Disassembly and Assembly Manual, "Housing (Front) - Install" if the housing (front) has been removed from the engine.

1. Clean the oil seal housing (8) and inspect the oil seal housing for damage. If necessary, replace the housing (front). Refer to this Disassembly and Assembly Manual, "Housing (Front) - Remove and Housing (Front) - Install".
2. Check the face on the pulley that contacts the crankshaft front seal for wear. If necessary, repair the crankshaft pulley. Refer to this Disassembly and Assembly Manual, "Crankshaft Wear Sleeve (Front) - Remove and Crankshaft Wear Sleeve (Front) - Install" for further details.

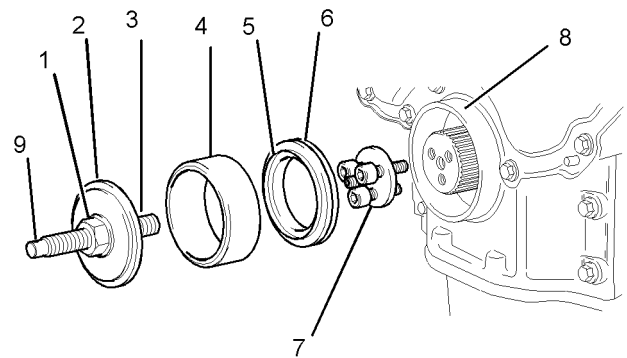

Illustration 149

g01020716

Note: A sleeve (5) is attached to the new crankshaft front seal (6). Do not remove the sleeve (5) at this time. Discard the new crankshaft front seal (6) if the sleeve (5) is not installed on the new crankshaft front seal.

3. Install the 21825580 Fastener Plate (7) to the front of the crankshaft.
4. Install the nut (1) and 21825578 Pressure Plate (2) onto the threaded bar (3).
- Note:** Do not lubricate the crankshaft front seal (6). Do not lubricate the oil seal housing (8).
5. Align the assembly of the sleeve (5) and the crankshaft front seal (6) to the front of the oil seal housing (8).
6. Install the 27610217 Adapter (4) onto the sleeve (5).
7. Install the pressure plate (2) onto the adapter (4) and tighten the threaded bar (3) onto the fastener plate (7). Check the alignment of the assembly and the crankshaft front seal (6) to the oil seal housing (8).
8. Insert a suitable rod through the hole (9) in the threaded bar (3) in order to prevent the threaded rod from turning as the nut (1) is tightened. Tighten the nut (1) in order to push the crankshaft front seal (6) into the oil seal housing (8). Continue to tighten the nut (1) until contact is made with the bottom face of the oil seal housing (8).
9. Remove items (1), (2), (3), and (4).
10. Turn the sleeve (5) counterclockwise and pull the sleeve at the same time in order to remove the sleeve from the oil seal housing (8). Remove the adapter (7).

i02254888

11. Immediately install the crankshaft pulley. Refer to this Disassembly and Assembly Manual, "Crankshaft Pulley - Remove and Install".

i01964526

Crankshaft Wear Sleeve (Front) - Install

Installation Procedure

NOTICE

Keep all parts clean from contaminants.

Contaminants may cause rapid wear and shortened component life.

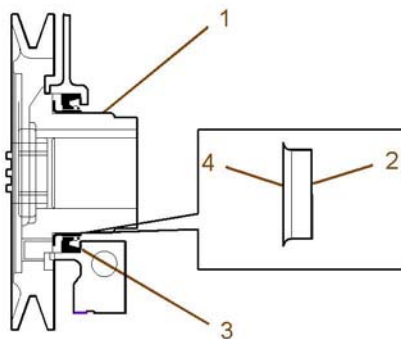

Illustration 150

g01021717

1. Install a new crankshaft front seal (3). Refer to this Disassembly and Assembly Manual, "Crankshaft Front Seal - Install".
2. Thoroughly clean the crankshaft pulley (1).
3. Install the crankshaft wear sleeve (front) (2). Refer to the installation information in the packaging for the crankshaft wear sleeve (front) (2).

Note: It is not necessary to remove the flange (4) from the crankshaft wear sleeve (front) (2) after the crankshaft wear sleeve (front) has been installed onto the crankshaft pulley (1).

End By:

- a. Install the crankshaft pulley. Refer to this Disassembly and Assembly Manual, "Crankshaft Pulley - Remove and Install".

Front Cover - Remove and Install

Removal Procedure

Start By:

- a. Remove the water pump. Refer to this Disassembly and Assembly Manual, "Water Pump - Remove and Install".

Note: In order to remove the front cover, it is not necessary to remove the cooling fan, the fan drive, the crankshaft pulley, or the alternator. Removal of the fan and fan drive will assist the access to the front cover. For illustration purposes, these components have been removed.

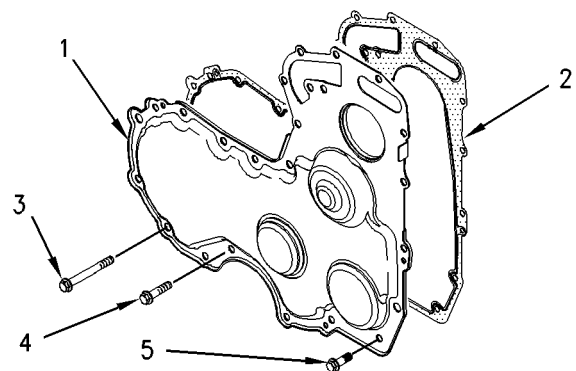

Illustration 151

g00955548

1. Remove the setscrews (3), the setscrews (4), and the setscrew (5) from the front cover (1).
2. Remove the front cover (1) from the front housing.
3. Remove the joint (2) from the front cover (1). Discard the joint (2).

Installation Procedure

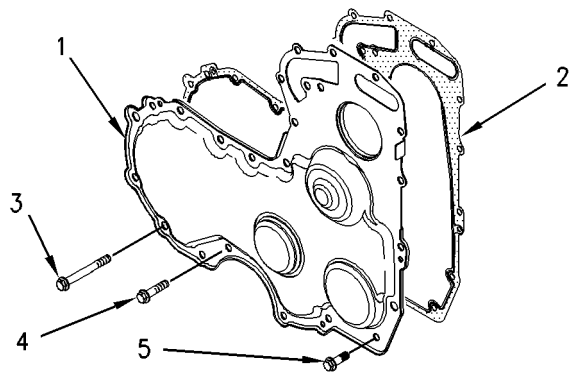

Illustration 152

g00955548

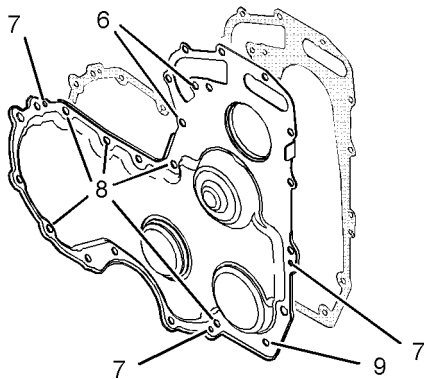

Illustration 153

g01020892

1. Thoroughly clean all the surfaces of the front cover (1) and clean the joint face of the housing (front).
2. Install two guide studs into the appropriate holes (6) within the housing (front).
3. Position the joint (2) onto the front cover (1).

Note: The joint is located by the three locating dowels (7) on the front cover.

4. Position the front cover (1) and the joint (2) on the front housing. Install setscrews (3) into holes (8). Install setscrew (5) into hole (9). Remove the two guide studs from the holes (6). Install the remainder of the setscrews (4). Tighten all of the setscrews finger tight.
5. Loosely install the water pump. Refer to this Disassembly and Assembly Manual, "Water Pump - Remove and Install".
6. Tighten all of the setscrews (3, 4, and 5) for the front cover (1) and tighten all of the setscrews for the water pump to a torque of 22 N·m (16 lb ft).

End By:

- a. If necessary, install the fan drive. Refer to this Disassembly and Assembly, "Fan Drive - Remove and Install".
- b. If necessary, install the fan. Refer to this Disassembly and Assembly Manual, "Fan - Remove and Install".

i02217477

Gear Group (Front) - Remove

Removal Procedure

Table 15

Required Tools		
Part Number	Part Description	Qty
27610211	Crankshaft timing pin	1
27610212	Camshaft timing pin	1

Start By:

- a. Remove the front cover. Refer to this Disassembly and Assembly Manual, "Front Cover - Remove and Install".

NOTICE

Keep all parts clean from contaminants.

Contaminants may cause rapid wear and shortened component life.

NOTICE

Care must be taken to ensure that fluids are contained during performance of inspection, maintenance, testing, adjusting and repair of the product. Be prepared to collect the fluid with suitable containers before opening any compartment or disassembling any component containing fluids.

Dispose of all fluids according to local regulations and mandates.

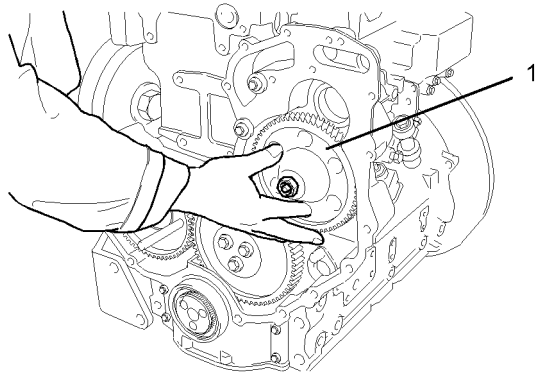

Illustration 154 g01021972
Typical example (Bosch drive gear)

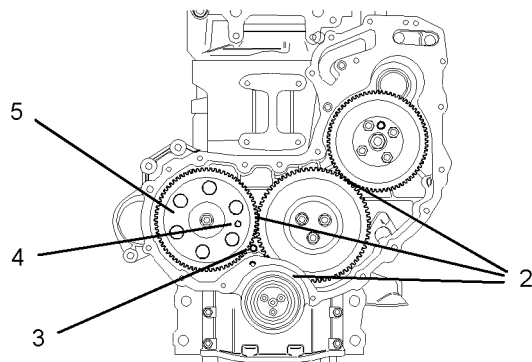

Illustration 155 g01021973
Typical example (Delphi fuel pump drive gear)

Note: Care must be taken in order to ensure that the fuel injection pump timing is not lost during the removal of the fuel injection pump and/or fuel injection pump gear. Carefully follow the appropriate instructions in order to remove the fuel injection pump and/or fuel injection pump gear.

Note: If necessary, remove the glow plugs in order to allow the crankshaft to rotate more freely. Refer to this Disassembly and Assembly Manual, "Glow Plugs - Remove and Install".

1. Rotate the crankshaft to top dead center. Refer to the Testing and Adjusting Manual, "Finding Top Center for No. 1 Piston". Apply hand pressure to the fuel injection pump gear (1) in a counterclockwise direction in order to remove the backlash (2) in the gears. Mark the orientation of each of the gears for installation purposes.

Note: Timing pins are used in order to time the engine at top dead center. The timing pins are a slip fit. Do not use excessive force to install the timing pins. Do not use the timing pins to lock the engine during repairs.

2. Insert the 27610211 Crankshaft timing pin (3) through the housing (front) and into the web of the crankshaft. Insert the 27610212 Camshaft timing pin (4) through the camshaft gear (5) and into the housing (front).

3. Remove the rocker shaft. Refer to this Disassembly and Assembly Manual, "Rocker Shaft and Pushrod - Remove".

Note: The fuel injection pump must be locked before proceeding further.

Note: The three cylinder engine can be equipped with either the Delphi DP210 or the Delphi DPG fuel injection pump.

Note: The four cylinder engine can be equipped with the Delphi DP210, the Delphi DPA or the Bosch EPVE fuel injection pump. The various types of fuel injection pump have a different procedure for locking the fuel injection pump shaft.

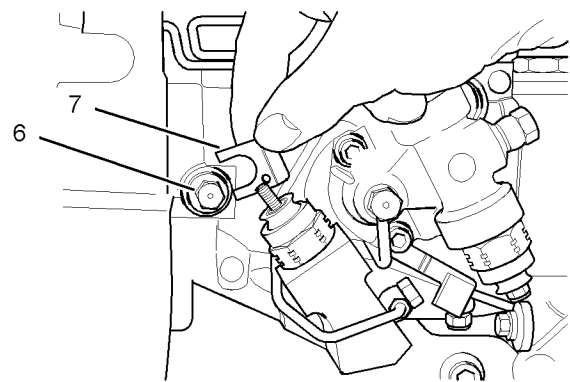

Illustration 156 g01022971
Four cylinder engine only

4. In order to lock the Bosch EPVE fuel injection pump, loosen the locking screw (6) and remove the washer (7). Tighten the locking screw (6) to a torque of 31 N·m (23 lb ft).

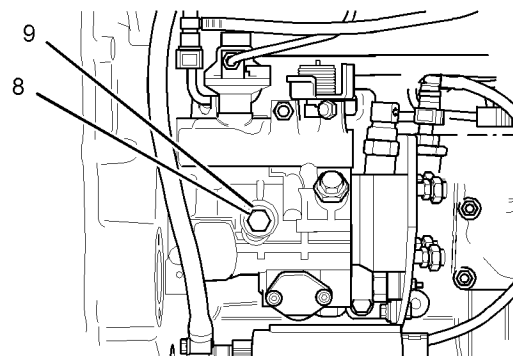

Illustration 157 g01022972
Three cylinder and four cylinder engines

- In order to lock the Delphi DP210 fuel injection pump, loosen the locking screw (8) and move the washer (9). Ensure that the washer (9) can now turn about the locking screw (8) and tighten the locking screw to a torque of 17 N·m (12 lb ft).

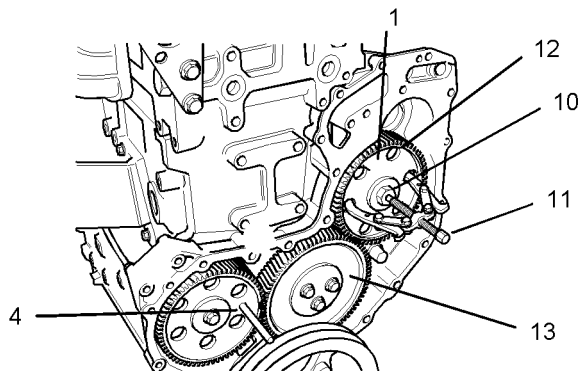

Illustration 158

g01022973

- Release the nut (10). Install a suitable puller with two legs (11) through two holes (12) in the fuel injection pump gear (1). Tighten the puller (11) in order to release the gear (1) from the fuel injection pump. Remove the nut (10), the gear (1), and the puller (11).
- Remove the camshaft gear (5). Refer to this Disassembly and Assembly Manual, "Camshaft Gear - Remove and Install".
- Remove the idler gear (13). Refer to this Disassembly and Assembly Manual, "Idler Gear - Remove and Install".
- If necessary, remove the crankshaft gear. Refer to this Disassembly and Assembly Manual, "Crankshaft Gear - Remove and Install".

i02217478

Gear Group (Front) - Install

Installation Procedure

Table 16

Required Tools		
Part Number	Part Description	Qty
27610211	Crankshaft timing pin	1
27610212	Camshaft timing pin	1

NOTICE

Keep all parts clean from contaminants.

Contaminants may cause rapid wear and shortened component life.

Note: The fuel injection pump shaft must remain locked until this procedure instructs you to unlock the fuel injection pump shaft.

- If necessary, install the crankshaft gear. Refer to this Disassembly and Assembly Manual, "Crankshaft Gear - Remove and Install".
- Thoroughly clean the housing (front).
- Thoroughly clean all of the components and inspect all of the components of the front gear group. If necessary, replace any worn components and/or any damaged components of the front gear group.
- Ensure that no. 1 piston is still at top dead center. Refer to the Testing and Adjusting Manual, "Finding Top Center for No. 1 Piston".

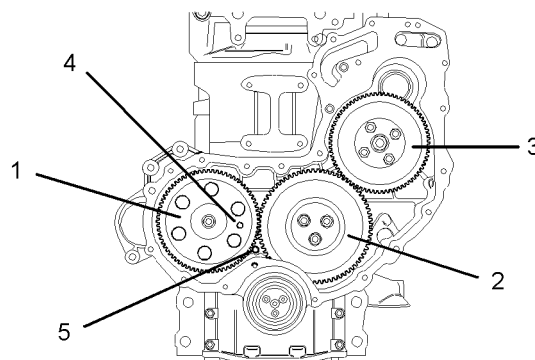

Illustration 159

g01023249

Typical example (Delphi fuel injection pump drive gear)

- Install the camshaft gear (1). Refer to this Disassembly and Assembly Manual, "Camshaft Gear - Remove and Install".
- Install the idler gear (2). Refer to this Disassembly and Assembly Manual, "Idler Gear - Remove and Install".
- Ensure that the mesh of the idler gear (2) is correct with the camshaft gear (1).

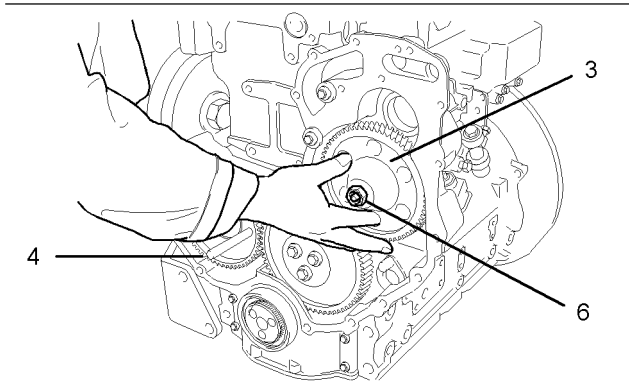

Illustration 160
Typical example (Bosch fuel injection pump drive gear)

- 8. Install the fuel injection pump gear (3) onto the fuel injection pump shaft. Ensure that the mesh of the fuel injection pump gear (3) is correct with the idler gear (2). Install the washer and the nut (6) finger tight.
- 9. Apply hand pressure to the fuel injection pump gear (3) in a counterclockwise direction in order to remove the backlash in the gears (1), (2), and (3). Tighten the nut (6) to a torque of 24 N·m (18 lb ft).
- 10. Ensure that all of the timing marks on the gears (1), (2), and (3) are in alignment.

Note: The three cylinder engine can be equipped with either the Delphi DP210 or the Delphi DPG fuel injection pump.

Note: The four cylinder engine can be equipped with the Delphi DP210, the Delphi DPA or the Bosch EPVE fuel injection pump. The various types of fuel injection pump have a different procedure for locking the fuel injection pump shaft.

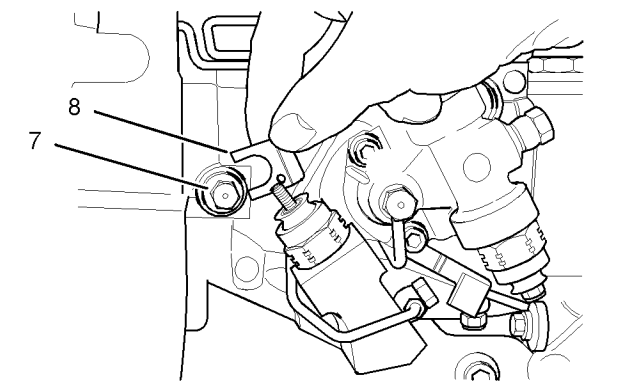

Illustration 161
Four cylinder engine only

- 11. Release the locked fuel injection pump shaft. In order to unlock the Bosch EPVE fuel injection pump shaft, loosen the locking screw (7) and install the washer (8). Tighten the locking screw (7) onto the washer (8) to a torque of 12 N·m (9 lb ft).

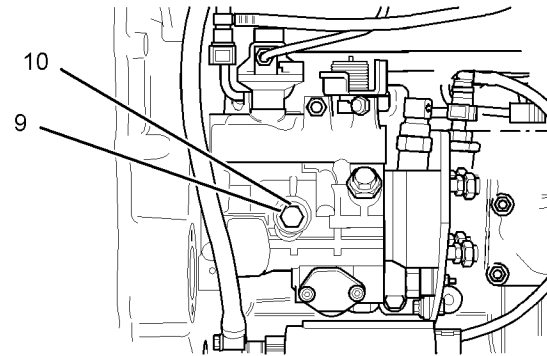

Illustration 162
Three cylinder and four cylinder engines

- 12. In order to unlock the Delphi DP210 fuel injection pump shaft, loosen the locking screw (9) and move the washer (10). Tighten the locking screw (9) onto the washer (10) to a torque of 12 N·m (9 lb ft).
- 13. Tighten the nut (6) to an increased torque of 90 N·m (66 lb ft). Refer to illustration 160.
- 14. Remove the timing pins (4) and (5). Refer to illustration 159.
- 15. Check the backlash value for the fuel injection pump gear (3). Refer to the Specifications Manual, "Gear Group (Front)" for further information.
- 16. Check the end play of the idler gear (2). Refer to this Disassembly and Assembly Manual, "Idler Gear - Remove and Install" and refer to the Specifications Manual, "Gear Group (Front)" for further information.
- 17. Check the backlash value for the idler gear (2). Refer to this Disassembly and Assembly Manual, "Idler Gear - Remove and Install" and refer to the Specifications Manual, "Gear Group (Front)" for further information.
- 18. Check the end play of the camshaft gear (1). Refer to this Disassembly and Assembly Manual, "Camshaft Gear - Remove and Install".
- 19. Check the backlash value for the camshaft gear (1). Refer to this Disassembly and Assembly Manual, "Camshaft Gear - Remove and Install" and refer to the Specifications Manual, "Gear Group (Front)" for further information.
- 20. Lightly lubricate each gear with clean engine lubricating oil.

End By:

- a. Install the front cover. Refer to Disassembly and Assembly, "Front Cover - Remove and Install".
- b. Install the glow plugs. Refer to this Disassembly and Assembly Manual, "Glow Plugs - Remove and Install".
- c. Install the rocker shaft. Refer to this Disassembly and Assembly Manual, "Rockershaft and Pushrod - Install".

i02217480

Idler Gear - Remove and Install

Removal Procedure

Table 17

Required Tools		
Part Number	Part Name	Qty
27610212	Camshaft (Timing Pin)	1
27610211	Crankshaft (Timing Pin)	1

Start By:

- a. Remove the front cover if the front cover has not previously been removed. Refer to this Disassembly and Assembly Manual, "Front Cover - Remove and Install".

NOTICE

Keep all parts clean from contaminants.

Contaminants may cause rapid wear and shortened component life.

NOTICE

Care must be taken to ensure that fluids are contained during performance of inspection, maintenance, testing, adjusting and repair of the product. Be prepared to collect the fluid with suitable containers before opening any compartment or disassembling any component containing fluids.

Dispose of all fluids according to local regulations and mandates.

Note: There are two types of idler gear that may be installed on these engines. The standard idler gear is supported on the hub by two bushes. The heavy-duty idler gear is supported on the hub by two roller bearings.

Note: If necessary, remove the glow plugs in order to allow the crankshaft to rotate more freely. Refer to this Disassembly and Assembly Manual, "Glow Plugs - Remove and Install".

Note: The three cylinder engine can be equipped with either the Delphi DP210 or the Delphi DPG fuel injection pump.

Note: The four cylinder engine can be equipped with the Delphi DP210, the Delphi DPA or the Bosch EPVE fuel injection pump. The various types of fuel injection pump have a different procedure for locking the fuel injection pump shaft.

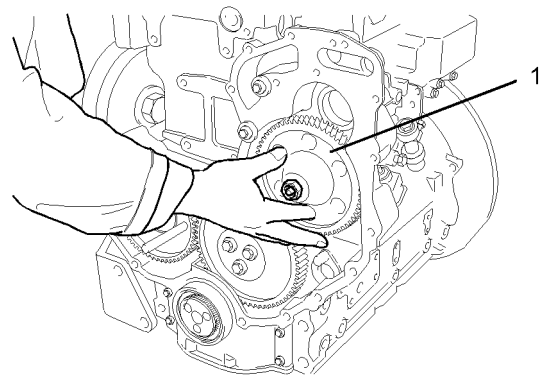

Illustration 163

g01021972

Typical example (Bosch fuel injection pump drive gear)

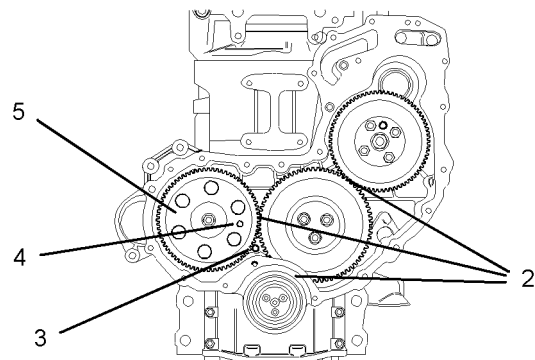

Illustration 164

g01021973

Typical example (Delphi fuel injection pump drive gear)

1. Ensure that the No. 1 cylinder is at top dead center on the compression stroke. Refer to the Testing and Adjusting Manual, "Finding Top Center Position for No. 1 Piston". Apply hand pressure to the fuel injection pump gear (1) in a counterclockwise direction in order to remove backlash (2) in the gears. Mark the orientation of each of the gears for installation purposes.

Note: Timing pins are used in order to time the engine at top dead center. The timing pins are a slip fit. Do not use excessive force to install the timing pins. Do not use the timing pins to lock the engine during repairs.

2. Insert the 27610211 Crankshaft timing pin (3) through the housing (front) and into the web of the crankshaft if the timing pin has not previously been installed. Insert the 27610212 Camshaft timing pin (4) through the camshaft gear (5) and into the housing (front) if the timing pin was not previously installed.
3. Remove the rocker shaft if the rocker shaft was not previously removed. Refer to this Disassembly and Assembly Manual, "Rocker Shaft and Pushrod - Remove".
4. Remove the fuel injection pump gear (1) if the gear has not previously been removed. Refer to this Disassembly and Assembly Manual, "Gear Group (Front) - Remove".

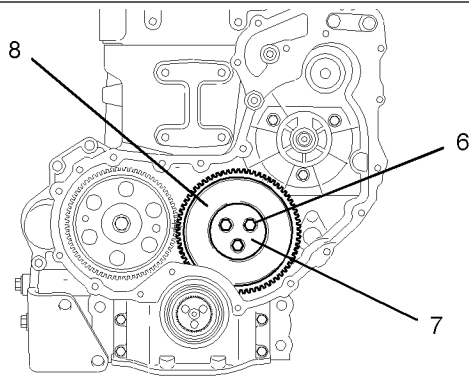

Illustration 165 g01038900

5. Remove the three setscrews (6) from the idler gear (8). Remove the plate (7) from the idler gear (8).

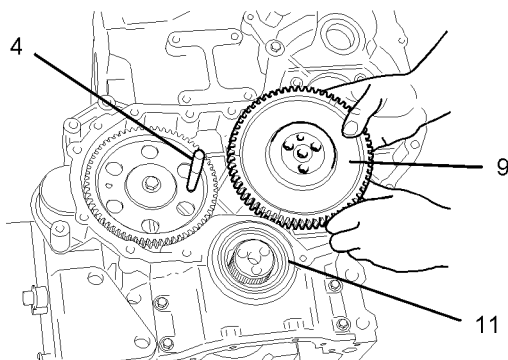

Illustration 166 g01023843

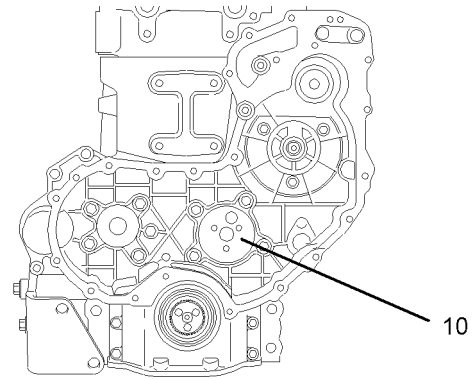

Illustration 167 g01038902

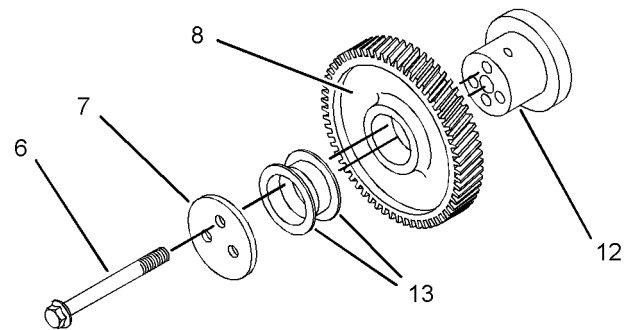

Illustration 168 g01023845
Standard idler gear assembly

6. Remove the assembly (9) of the idler gear (8) and the hub from the recess (10) in the cylinder block. The assembly (9) must be lifted over the housing for the crankshaft front seal (11) as the assembly is moved forward.
7. Disassemble the assembly (9) of the idler gear (8) and the hub. In order to disassemble the standard assembly (9), slide the hub (12) out of the idler gear (8). Inspect the bushes (13) in the idler gear (8) for wear and/or damage. If necessary, remove the bushes (13) from each side of the idler gear (8).

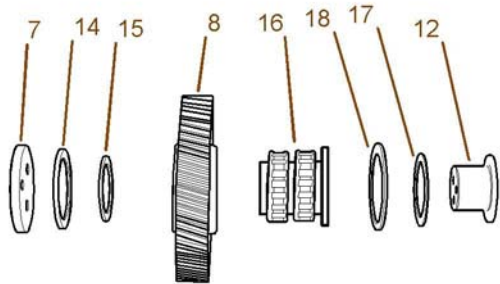

Illustration 169 g01023942
Heavy-duty idler gear assembly

8. In order to disassemble the heavy-duty idler gear, press the hub (12) out of the bearing assembly (16). Remove the circlip (14) and the thrust washer (15) from the idler gear (8). If the bearing assembly (16) is worn and/or damaged, slide the bearing assembly out of the idler gear (8). Discard the bearing assembly (16). Remove the circlip (17) and the thrust washer (18).

Installation Procedure

Table 18

Required Tools		
27610212	Timing Pin (Camshaft)	1
27610211	Timing Pin (Crankshaft)	1

NOTICE

Keep all parts clean from contaminants.

Contaminants may cause rapid wear and shortened component life.

1. Clean all of the components and inspect all of the components that were removed in the previous procedure. If necessary, replace any worn component and/or any damaged component.

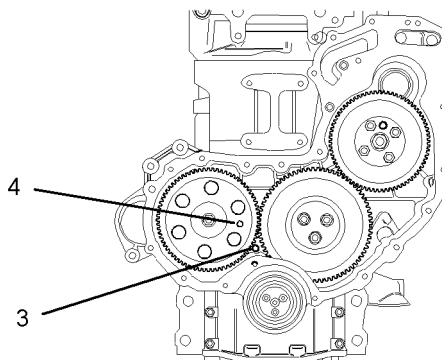

Illustration 170 g01024162
Typical example (Delphi fuel injection pump drive gear)

Note: Timing pins are used in order to time the engine at top dead center. The timing pins are a slip fit. Do not use excessive force to install the timing pins. Do not use the timing pins to lock the engine during repairs.

2. Ensure that the No. 1 cylinder is still at top dead center on the compression stroke. If necessary, refer to the Testing and Adjusting Manual, "Finding Top Center Position for No. 1 Piston". Ensure that the timing pin (3) for the crankshaft is installed and that the timing pin (4) for the camshaft is installed.

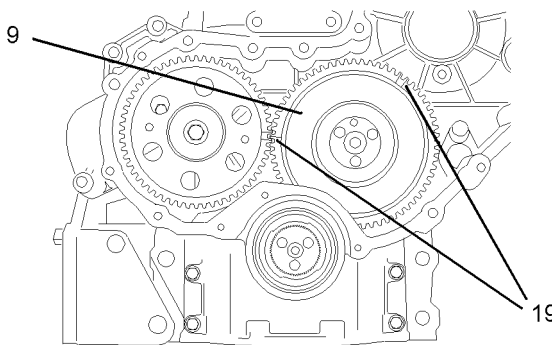

Illustration 171 g01024165

Note: Ensure that the marks (19) on the idler gear (8) face toward the front of the engine when the assembly (9) of the idler gear and the hub is being assembled.

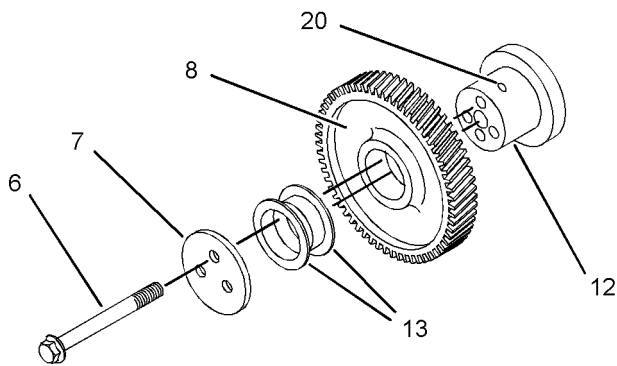

Illustration 172
Standard idler gear assembly
g01024432

3. Assemble the assembly (9) of the idler gear and the hub. In order to assemble the standard assembly, press new bushes (13) into the idler gear (8) if the bushes were previously removed. Lubricate the hub (12) with clean engine lubricating oil. Slide the hub (12) into the idler gear (8). Ensure that the oil hole (20) is to the top of the hub (12) and ensure that the marks (19) are to the front of the idler gear (8).

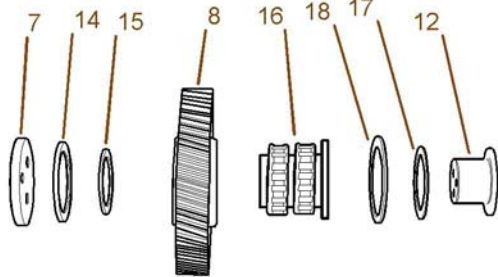

Illustration 173
Heavy-duty idler gear assembly
g01023942

Note: The new bearing assembly (16) is supplied with a protective sleeve. Do not remove this protective sleeve. The protective sleeve prevents the rollers from falling out of the roller bearings.

4. In order to assemble the heavy-duty idler gear, install the circlip (17) into the back face of the idler gear (8). Place the back face of the idler gear (8) onto a clean, flat surface. Insert the thrust washer (18) through the idler gear (8) and onto the circlip (17). Ensure that the flange face of the bearing assembly (16) is toward the bottom and that the protective sleeve is still in place. Insert the new bearing assembly (16) into the idler gear (8). Push the new bearing assembly (16) into the idler gear (8) until the bearing assembly comes into contact with the thrust washer (18). As the bearing assembly (16) is pushed into the idler gear (8) the protective sleeve will remain on the top face of the idler gear. Discard the protective sleeve. Install the thrust washer (15) and install the circlip (14). Lightly lubricate the hub (12) with clean engine lubricating oil. Press the hub (12) into the idler gear (8).

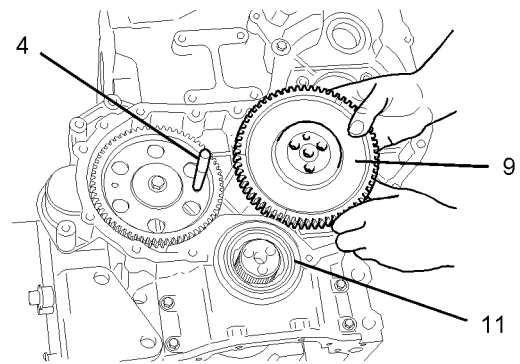

Illustration 174
g01023843

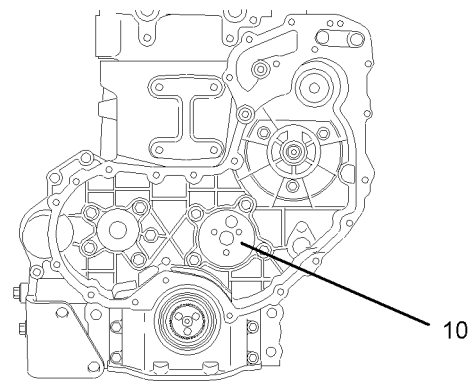

Illustration 175
g01038902

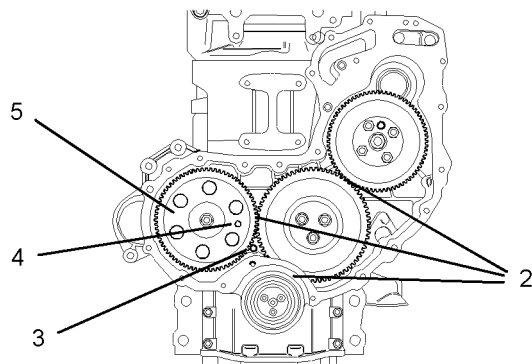

Illustration 176

g01021973

5. Lift the assembly (9) of the idler gear and the hub over the housing for the crankshaft front seal (11) and insert the hub into the recess (10) in the cylinder block.

Note: Ensure that the oil hole (20) is to the top of the hub (12).

Note: Ensure that the marks (19) on the idler gear assembly (9) align with the marks on the camshaft gear and with the crankshaft gear. Refer to the illustration 171.

6. Align the holes in the plate (7) with the holes in the hub (12). Insert the setscrews (6) through the plate (7) and into the hub (12).
7. Evenly tighten the setscrews (6) to a torque of 44 N·m (32 lb ft).

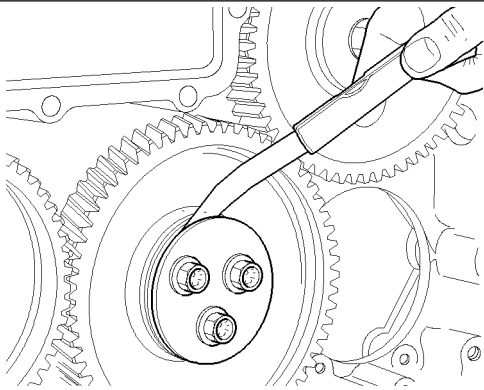

Illustration 177

g00944081

8. Check the end play for the idler gear. Refer to the illustration 177 and refer to the Specifications Manual, "Gear Group (Front)" for more information.

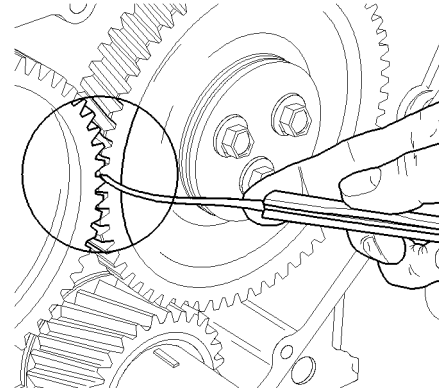

Illustration 178

g00944084

9. Check the backlash between the idler gear and the camshaft gear. Refer to the illustration 178 and refer to the Specifications Manual, "Gear Group (Front)" for more information.

10. Check the backlash between the idler gear and the crankshaft gear. Refer to the Specifications Manual, "Gear Group (Front)" for more information.

Note: The three cylinder engine can be equipped with either the Delphi DP210 or the Delphi DPG fuel injection pump.

Note: The four cylinder engine can be equipped with the Delphi DP210, the Delphi DPA or the Bosch EPVE fuel injection pump. The various types of fuel injection pump have a different procedure for locking the fuel injection pump shaft.

11. Install the fuel injection pump gear. Refer to this Disassembly and Assembly Manual, "Gear Group (Front) - Install".
12. Remove the timing pin for the crankshaft (3) and remove the timing pin for the camshaft (4).
13. Lightly lubricate all of the gears with clean engine lubricating oil.

End By:

- a. Install the rocker shaft. Refer to this Disassembly and Assembly Manual, "Rocker Shaft and Pushrod - Install".
- b. Install the glow plugs if the glow plugs were previously removed. Refer to this Disassembly and Assembly Manual, "Glow Plugs - remove and Install".
- c. Install the front cover. Refer to this Disassembly and Assembly Manual, "Front Cover - Remove and Install".

i01964553

Housing (Front) - Remove

Removal Procedure

Start By:

- a. Drain the coolant into a suitable container for storage or disposal.
- b. Remove the fan drive. Refer to this Disassembly and Assembly Manual, "Fan Drive - Remove and Install".
- c. If necessary, remove the alternator. Refer to this Disassembly and Assembly Manual, "Alternator - Remove".
- d. Remove the fuel injection pump. Refer to the appropriate fuel injection pump within this Disassembly and Assembly Manual, "Fuel Injection Pump - Remove".
- e. Remove the engine oil pan. Refer to this Disassembly and Assembly Manual, "Engine Oil Pan - Remove and Install".
- f. Remove the gear group (front). Refer to this Disassembly and Assembly Manual, "Gear Group (Front) - Remove".

NOTICE

Keep all parts clean from contaminants.

Contaminants may cause rapid wear and shortened component life.

NOTICE

Care must be taken to ensure that fluids are contained during performance of inspection, maintenance, testing, adjusting and repair of the product. Be prepared to collect the fluid with suitable containers before opening any compartment or disassembling any component containing fluids.

Dispose of all fluids according to local regulations and mandates.

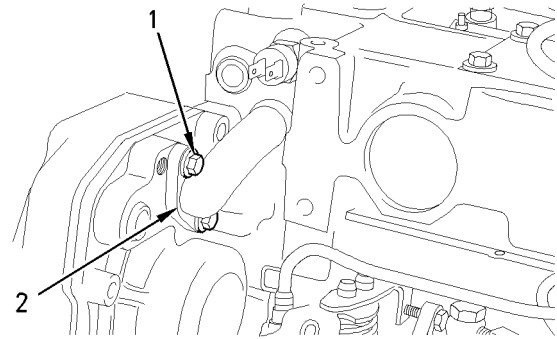

Illustration 179

g00995185

1. Remove the setscrews (1). Remove the bypass tube (2) from the cylinder head. Remove the O-rings from the bypass tube (2). Discard the O-rings.

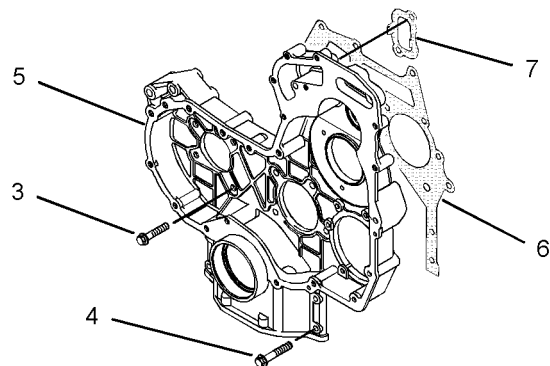

Illustration 180

g01024469

2. Remove the setscrews (3) and the setscrews (4) that fasten the front housing (5) to the cylinder block.
3. Remove the front housing (5). Remove the joint (6) from the cylinder block and the front housing (5).
4. Remove the joint (7) from the back side of the front housing (5).

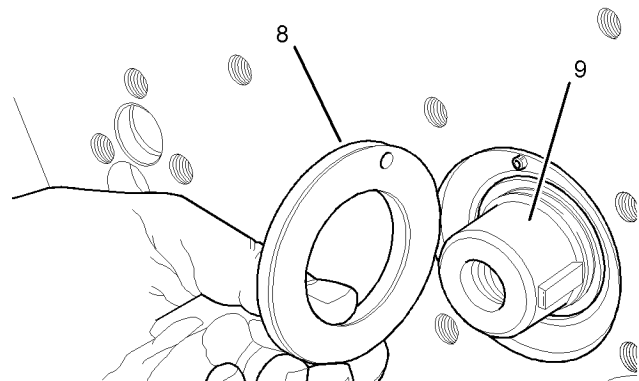

Illustration 181

g01024472

- Remove the thrust washer (8) from the camshaft (9).

i01964552

Housing (Front) - Install

Installation Procedure

Table 19

Required Tools		
Part Number	Part Name	Qty
27610216	Alignment Tool	1

NOTICE

Keep all parts clean from contaminants.

Contaminants may cause rapid wear and shortened component life.

Note: The installation procedure is identical for the three cylinder and the four cylinder engines. The illustrations show the four cylinder engine.

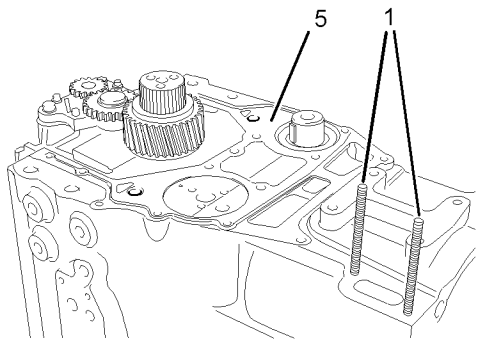

Illustration 182
Typical example

g01024529

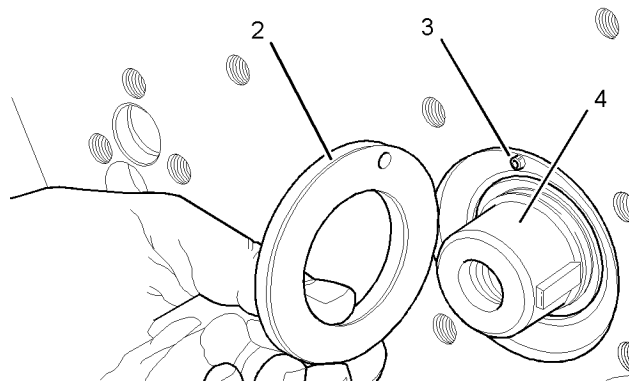

Illustration 183

g01024492

- Thoroughly clean the mating surfaces on the cylinder block for the front housing. Install two temporary studs (1) into the cylinder block. Ensure that the thrust washer (2) is aligned with the hollow dowel (3). Install the thrust washer onto the camshaft (4). Install a new joint (5) onto the cylinder block.

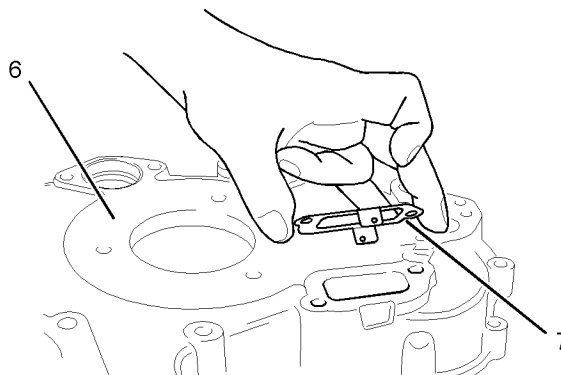

Illustration 184

g01024547

- Thoroughly clean the front housing (6). Especially clean the mating surfaces of the front housing (6). Inspect the front housing (6) for wear and for damage. If necessary, replace the front housing (6).

Note: If it is necessary to replace the front housing (6), it may also be necessary to install blanking plugs which should be sealed with a suitable sealant into the front housing.

- Install a new joint (7) to the front housing (6).

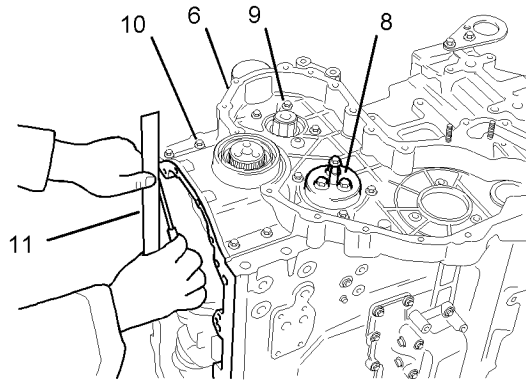

Illustration 185

g01024551

Typical example

4. Install the 27610216 Alignment Tool (8) into the recess within the cylinder block. Install the front housing (6) onto the cylinder block.
5. Install the setscrews (9). Tighten the setscrews (9) finger tight. Except for the two holes with the temporary studs (1), install the setscrews (10). Tighten the setscrews (10) finger tight. Remove the two temporary studs (1). Install the remainder of the setscrews (10). Tighten the remaining two setscrews (10) finger tight.
6. Align the front housing (6) to the lower machined face of the cylinder block (11). Use a suitable straight edge and a feeler gauge to check the tolerance for the alignment (11). Refer to the Specifications Manual, "Front Housing and Covers" for further information.
7. With the alignment within tolerance, tighten the setscrews (9) and the setscrews (10) to a torque of 22 N·m (16 lb ft). Remove the alignment tool (8).

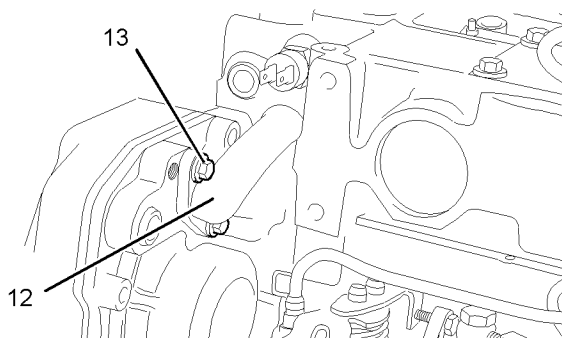

Illustration 186

g01024687

8. Install new O-rings onto the bypass tube (12). Apply POWERPART 21820221 Red Rubber Grease to the O-rings. Install the bypass tube (12) into the cylinder head. Install the setscrews (13).

End By:

- a. Install the gear group (front). Refer to this Disassembly and Assembly Manual, "Gear Group (Front) - Install".
- b. Install the engine oil pan. Refer to this Disassembly and Assembly Manual, "Engine Oil Pan - Remove and Install".
- c. Install the fuel injection pump. Refer to the appropriate fuel injection pump within this Disassembly and Assembly Manual, "Fuel Injection Pump - Install".
- d. Install the alternator if the alternator was removed previously. Refer to this Disassembly and Assembly Manual, "Alternator - Install".
- e. Install the fan drive. Refer to this Disassembly and Assembly Manual, "Fan Drive - Remove and Install".
- f. At the appropriate time, fill the cooling system.

i02641608

Accessory Drive - Remove and Install**Removal Procedure****NOTICE**

Keep all parts clean from contaminants.

Contaminants may cause rapid wear and shortened component life.

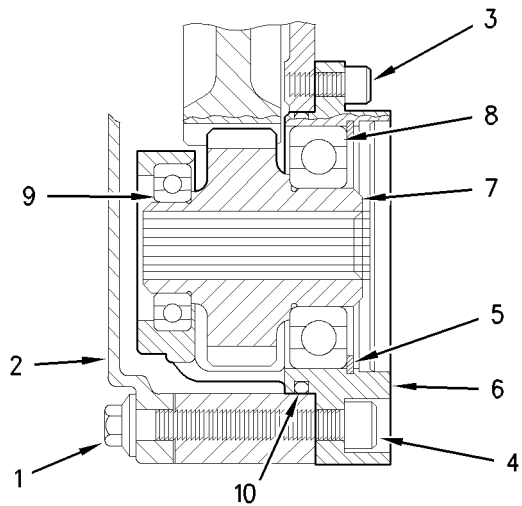

Illustration 187

g01004414

1. Remove the setscrews (1) and the front cover (2).
2. Remove the Allen head screws (3) and (4). Remove the accessory drive assembly from the rear face of the front housing (6).
3. Remove the circlip (5).
4. Place the flange of the front housing (6) onto a suitable support. Press the assembly of the gear (7) and the bearings (8 and 9) out of the front housing (6). Use a suitable puller in order to remove the bearings (8 and 9) from the gear (7).
5. Remove the O-ring (10) from the front housing (6) and discard the O-ring.

Installation Procedure

NOTICE

Keep all parts clean from contaminants.

Contaminants may cause rapid wear and shortened component life.

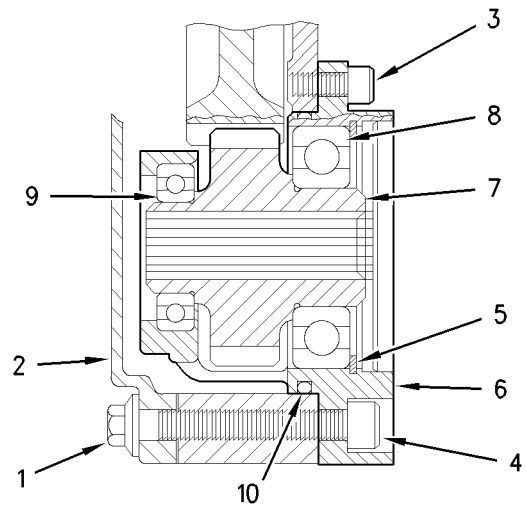

Illustration 188

g01004414

1. Inspect the condition of the teeth and the splines of the gear (7), the bearings (8 and 9), the circlip (5), and the groove for the circlip in the front housing (6) for wear and for damage. Replace any worn component or any damaged component.

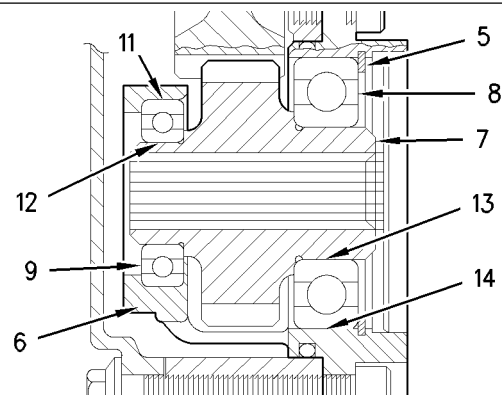

Illustration 189

g01004637

2. Apply a small continuous bead (11) of 21820603 POWERPART Retainer (oil tolerant) to the outer surface of the bearing (9). Place the front flange of the front housing (6) onto a suitable support. Press on the outer race of the bearing (9) until the bearing is against the front face of the recess for the bearing in the front housing (6). Remove any excess sealant.
3. Apply a small continuous bead (12) of 21820603 POWERPART Retainer (oil tolerant) to the inner surface of the bearing (9). Place the front face of the inner race of the bearing (9) onto a suitable support. Press the smaller shaft of the gear (7) into the bearing (9) until the shoulder of the gear is against the bearing. Remove any excess sealant.

i02217688

4. Apply a small continuous bead (14) of 21820603 POWERPART Retainer (oil tolerant) to the outer surface of the bearing (8). Apply a small continuous bead (13) of 21820603 POWERPART Retainer (oil tolerant) to the inner surface of the bearing (8). Ensure that the front face of the inner race of the bearing (9) is still on a suitable support. Press the bearing (8) onto the larger shaft of the gear (7) until the bearing (9) is against the shoulder of the gear. Remove any excess sealant.
5. Install the circlip (5) into the groove in the front housing (6). Ensure that the circlip (5) is correctly positioned in the groove.

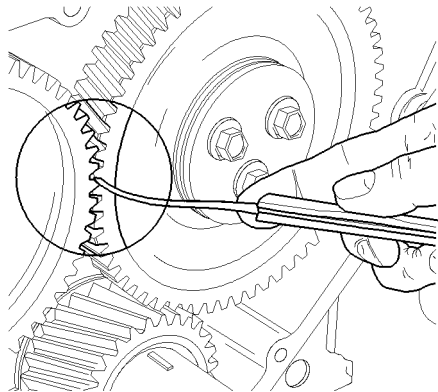

Illustration 190

g00946787

Typical Example

6. Refer to the illustration 190 and check the backlash between the idler gear and gear (7). The backlash should be within 0.11 mm (0.004 inch) to 0.17 mm (0.007 inch).
7. Lightly lubricate a new O-ring (10) with 21820221 POWERPART Red Rubber Grease and install the O-ring into the recess in the front housing (6). Lightly lubricate the bearing (8), the bearing (9), and the gear (7) with clean engine lubricating oil.
8. By using the Allen head screws (3 and 4), install the assembly of the accessory drive to the rear of the front housing (6). Torque the Allen head screws to a torque of 22 N·m (16 lb ft).
9. By using the setscrews (1), install the front cover (2). Refer to this Disassembly and Assembly Manual, "Front Cover - Remove and Install."

Crankcase Breather - Remove and Install

Removal Procedure for the Diaphragm Valve

Note: All naturally aspirated three cylinder and four cylinder engines in the 1100 Series except for models DJ and RR are equipped with a closed breather system. A closed breather system is optional for turbocharged three cylinder and four cylinder engines in the 1100 Series.

Note: 1103 engines, models DJ and DK that are equipped with an open crankcase breather do not have a diaphragm valve in the valve mechanism cover.

Note: 1103 engines, models DC, DD, DF, DG and all 1104 engines that are equipped with a closed breather system have a diaphragm valve in the valve mechanism cover.

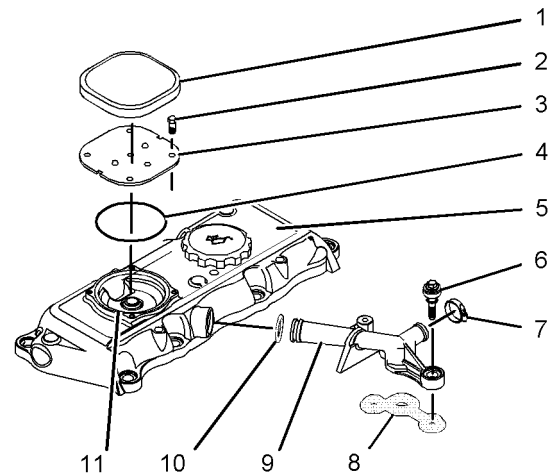

Illustration 191

g01122584

1103 engine, models DJ and DK

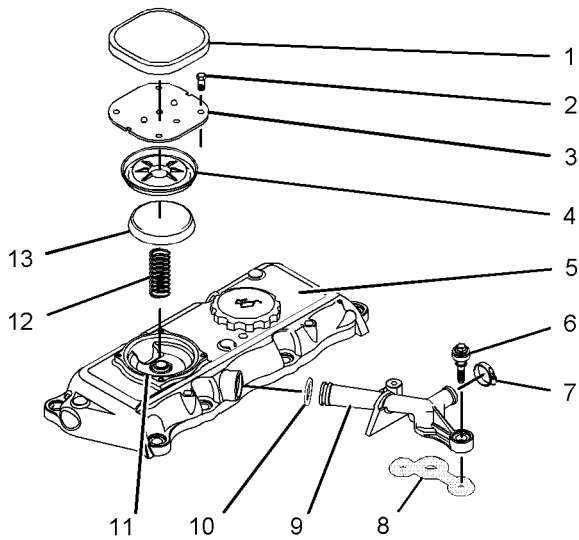

Illustration 192 g01122835
1103 engine, models DC, DD, DF and DG

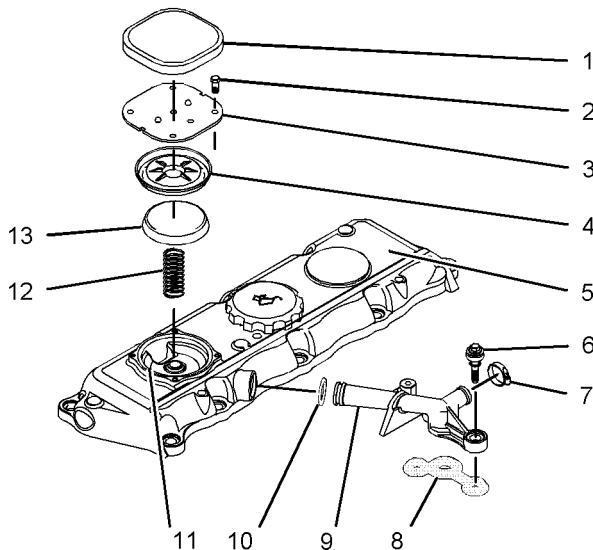

Illustration 193 g01122836
1104 engine

1. Refer to the appropriate illustration 191, 192 or 193. Loosen the hose clamp (7) and release the hose from the connector (9).
2. Remove the fasteners (6) and remove the connector (9) from the cylinder head and from the valve mechanism cover (5). Remove the O-ring (10) from the connector (9). Discard the O-ring (10). Remove the joint (8). Discard the joint (8).
3. Remove the plastic cover (1) from the valve mechanism cover (5).

⚠ WARNING

Personal injury can result from parts and/or covers under spring pressure.

Spring force will be released when covers are removed.

Be prepared to hold spring loaded covers as the bolts are loosened.

4. Remove the screws (2). Remove the plate (3).
5. If equipped, remove the seal ring (4). Refer to illustration 191.
6. If equipped, remove the diaphragm (4) and the cap (13). Remove the spring (12). Refer to illustration 192 or 193.
7. If the recess (11) for the assembly of the diaphragm valve needs to be cleaned, remove the valve mechanism cover (5). Refer to this Disassembly and Assembly Manual, "Valve Mechanism Cover - Remove and Install". If necessary, thoroughly clean the valve mechanism cover (5) and especially clean the recess (11).

Installation Procedure for the Diaphragm Valve

Note: 1103 engines, models DJ and DK that are equipped with a closed breather system do not have a diaphragm valve in the valve mechanism cover.

Note: 1103 engines, models DC, DD, DF, DG and all 1104 engines that are equipped with a closed breather system have a diaphragm valve in the valve mechanism cover.

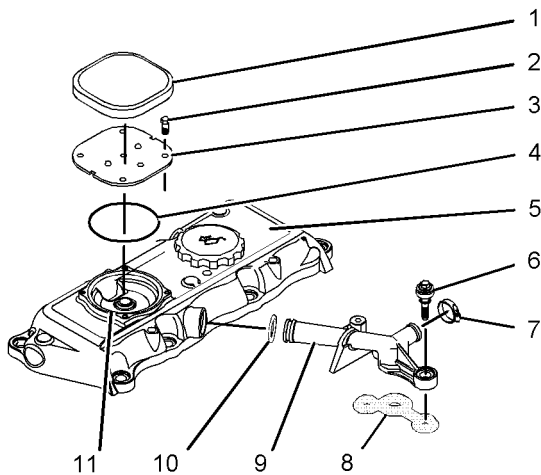

Illustration 194 g01122584
1103 engine, models DJ and DK

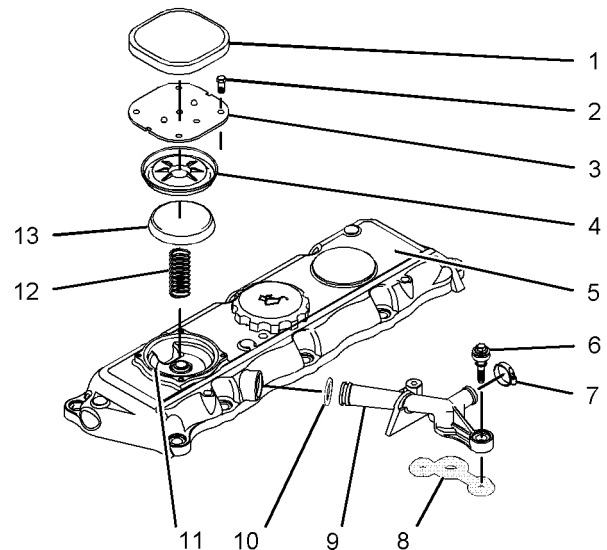

Illustration 196 g01122836
1104 engine

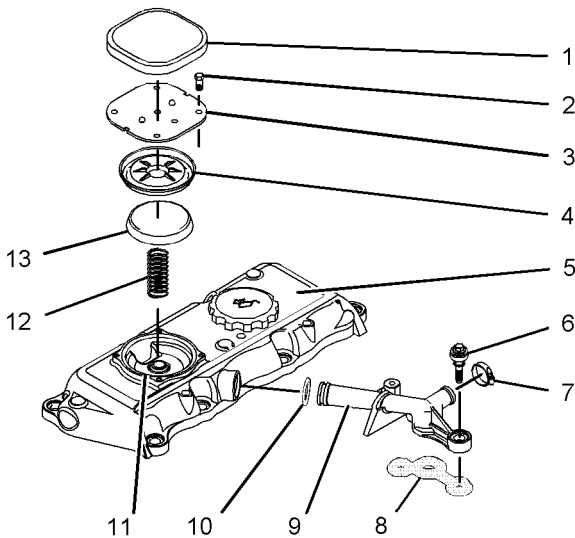

Illustration 195 g01122835
1103 engine, models DC, DD, DF and DG

1. Refer to the appropriate illustration 194, 195 or 196. Thoroughly clean all of the previously removed components. Inspect all of the components for wear and for damage. Especially check the condition of the hose for the connector (9) and the diaphragm or the seal ring (4) for damage. Replace any component that is worn and/or damaged.
2. If the valve mechanism cover (5) was removed, install the valve mechanism cover. Refer to this Disassembly and Assembly Manual, "Valve Mechanism Cover - Remove and Install".
3. If equipped, install the seal ring (4) in the recess (11) in the valve mechanism cover (5).

WARNING

Improper assembly of parts that are spring loaded can cause bodily injury.

To prevent possible injury, follow the established assembly procedure and wear protective equipment.

4. If equipped, install the spring (12), the cap (13), and the diaphragm (4) into the recess (11) in the valve mechanism cover (5).
5. If equipped, ensure that the two domes on the plate (3) are uppermost and ensure that the offset hole is toward the connector (9) of the valve mechanism cover (5). Install the plate (3). Install the screws (2). Tighten the screws (2) to a torque of 1.3 N·m (11.5 lb in).

6. Push the plastic cover (1) onto the valve mechanism cover (5).
7. Install a new O-ring (10) onto the connector (9).
8. Install a new joint (8) to the connector (9). Install the connector (9) into the valve mechanism cover (5) and onto the cylinder head.
9. Install the fasteners (6). Tighten the fasteners (6) to a torque of 9 N·m (80 lb in).
10. Install the hose onto the connector (9). Ensure that the hose is clear of all hot surfaces, clear of all components that move, and clear of all components that vibrate when the engine is operating. Tighten the hose clamp (7) to a torque of 5 N·m (44 lb in).

i01947656

Valve Mechanism Cover - Remove and Install

Removal Procedure

Start By:

- a. Remove the heat shields, if equipped.
- b. Remove the cover for the fuel injectors. Refer to this Disassembly and Assembly Manual, "Fuel Injector Cover - Remove and Install".

NOTICE

Keep all parts clean from contaminants.

Contaminants may cause rapid wear and shortened component life.

NOTICE

Care must be taken to ensure that fluids are contained during performance of inspection, maintenance, testing, adjusting and repair of the product. Be prepared to collect the fluid with suitable containers before opening any compartment or disassembling any component containing fluids.

Dispose of all fluids according to local regulations and mandates.

Note: The removal procedure is identical for the three cylinder and the four cylinder engines. The illustration shows the four cylinder engine.

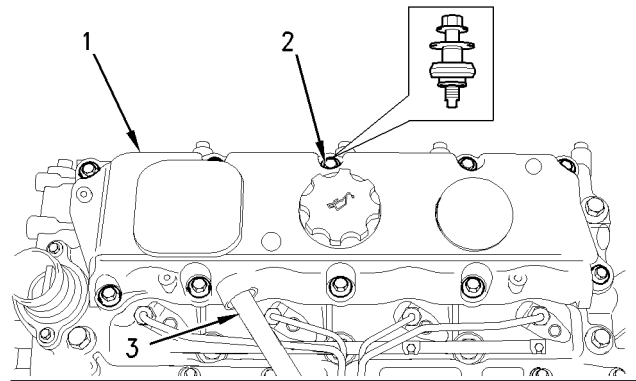

Illustration 197

g00951080

Typical example

1. Remove the breather tube (3) from the valve mechanism cover (1). Refer to this Disassembly and Assembly Manual, "Crankcase Breather - Remove and Install".
2. Remove the fasteners (2). Remove the valve mechanism cover (1). Remove the joint for the valve mechanism cover and discard the joint.

Installation Procedure

Note: The installation procedure is identical for the three cylinder and the four cylinder engines. Only the sequence for tightening the fasteners for the valve mechanism cover is different. Refer to the appropriate illustration for further information.

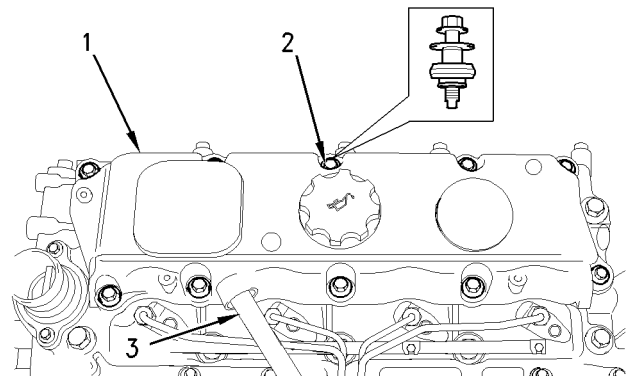

Illustration 198

g00951080

Typical example

1. Thoroughly clean the valve mechanism cover (1). Ensure that the groove for the joint for the valve mechanism cover (1) is clean and dry. Ensure that the mating face on the cylinder head is clean and dry.

2. If the valve mechanism cover (1) is equipped with an oil filler cap, check the condition of the O-ring for the oil filler cap. If necessary, replace the O-ring.
3. Install a new joint to the valve mechanism cover (1) and install the valve mechanism cover onto the cylinder head.
4. Check the condition of the fasteners (2). Replace the fasteners (2), if necessary. Install the fasteners (2).

6. If you are working on a four cylinder engine, tighten the fasteners for the valve mechanism cover in the sequence that is shown in Illustration 200. Tighten the fasteners to a torque of 9 N·m (80 lb in).
7. Connect the breather tube (3) to the valve mechanism cover (1). Refer to this Disassembly and Assembly Manual, "Crankcase Breather - Remove and Install".

End By:

- a. Install the cover for the fuel injectors. Refer to this Disassembly and Assembly Manual, "Fuel Injector Cover - Remove and Install".
- b. If equipped, ensure that the heat shields are clean and free from dust, oil, and paint. Install the heat shields.

i01947657

Rocker Shaft and Pushrod - Remove

Removal Procedure

Table 20

Required Tools		
Part Number	Part Description	Qty
27610227	Rocker Assembly Tool	4

Start By:

- a. Remove the valve mechanism cover. Refer to this Disassembly and Assembly Manual, "Valve Mechanism Cover - Remove and Install".

NOTICE

Keep all parts clean from contaminants.

Contaminants may cause rapid wear and shortened component life.

Note: The removal procedure is identical for the three cylinder and the four cylinder engines. The illustrations show the four cylinder engine.

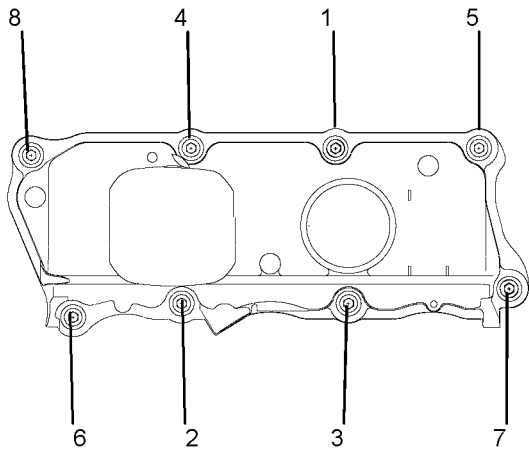

Illustration 199 g01018519
Sequence for tightening the fasteners for the three cylinder engine

5. If you are working on a four cylinder engine, go to Step 6. If you are working on a three cylinder engine, tighten the fasteners for the valve mechanism cover in the sequence that is shown in Illustration 199. Tighten the fasteners to a torque of 9 N·m (80 lb in). Go to Step 7

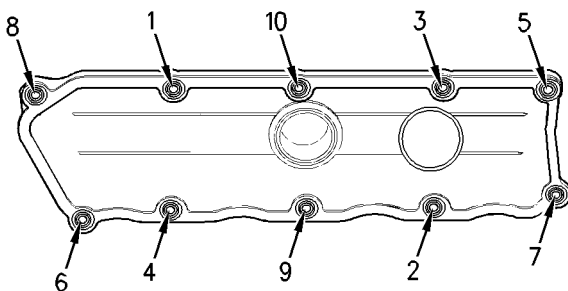

Illustration 200 g00908011
Sequence for tightening the fasteners for the four cylinder engine

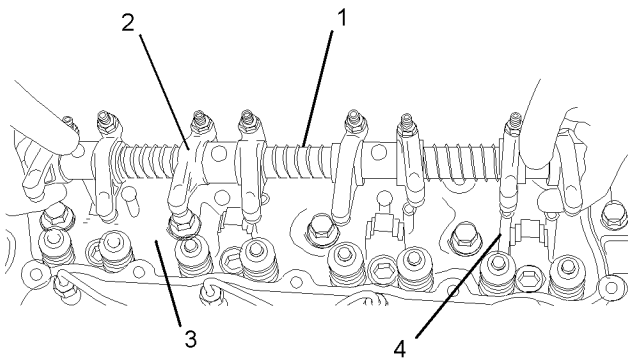

Illustration 201
Typical example

g01014000

i01947658

2. Start from the ends of the rocker shaft assembly (1) and work toward the center of the rocker shaft assembly in order to remove the torx screws (5). Evenly loosen the torx screws (5) in order to remove the rocker shaft assembly (1).
3. Remove the rocker shaft assembly (1) from the cylinder head (3).
4. Place an identification mark on the pushrods (4) for installation. Remove the pushrods (5) from the cylinder head (3).

Rocker Shaft - Disassemble

Disassembly Procedure

Table 21

Required Tools	
Part Description	Qty
Suitable Pliers for External Circlips	1

Start By:

- a. Remove the rocker shaft assembly. Refer to this Disassembly and Assembly Manual, "Rocker Shaft and Pushrod - Remove".

WARNING

Personal injury can result from being struck by parts propelled by a released spring force.

Make sure to wear all necessary protective equipment.

Follow the recommended procedure and use all recommended tooling to release the spring force.

Note: The disassembly procedure is identical for the three cylinder and the four cylinder engines. The illustration shows the four cylinder engine.

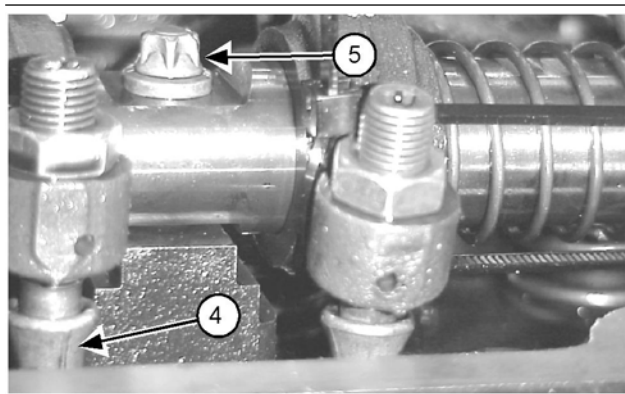

Illustration 202

g01013998

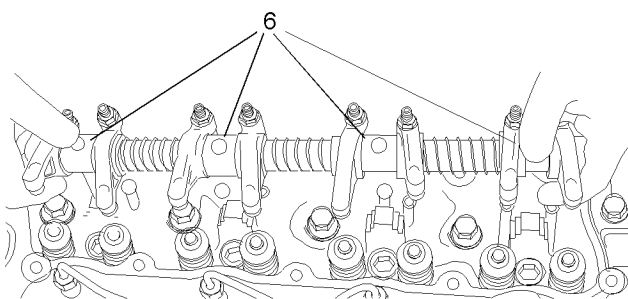

Illustration 203
Typical example

g01015730

1. If the rocker shaft will not be disassembled, install the rocker assembly tools (6) between each pair of rocker arms (2). The rocker arms (2) must be held away from the machined face of the cylinder head (3) during reassembly.

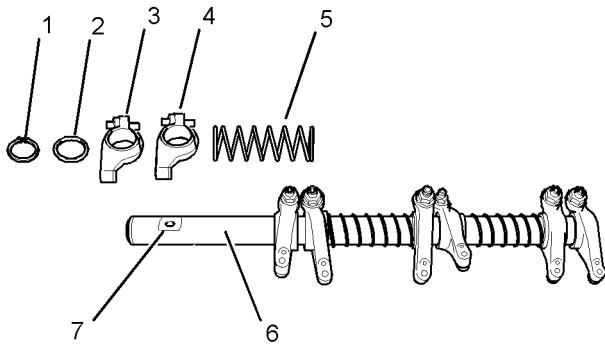

Illustration 204
Typical example

1. Remove the circlip (1) and remove the washer (2) from both ends of the rocker shaft assembly.
- Note:** The rocker shaft (6) is not symmetrical as there is a machined flat (7) toward one end of the shaft.
2. Place an identification mark on each of the components for installation. Ensure that you note the component's relationship to the machined flat (7).
 3. Remove the rocker arm assembly (3) for the inlet valve from the rocker shaft (6). Remove the rocker arm assembly (4) for the exhaust valve from the rocker shaft (6).
 4. Remove the spring (5) from the rocker shaft (6).
 5. Repeat Step 3 and Step 4 in order to completely disassemble the rocker shaft assembly.

i01947659

Rocker Shaft - Assemble

Assembly Procedure

Table 22

Required Tools	
Part Description	Qty
Suitable Pliers for External Circlips	1

Note: The assembly procedure is identical for the three cylinder and the four cylinder engines. The illustration shows the four cylinder engine.

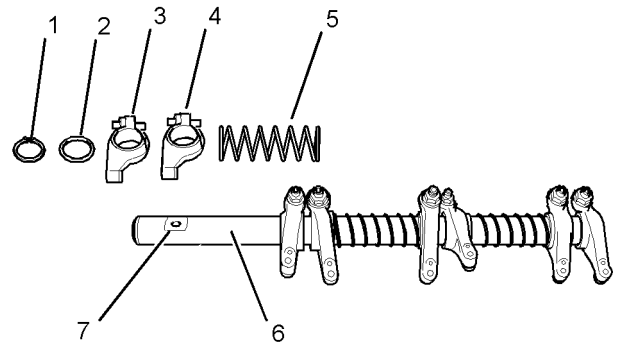

Illustration 205
Typical example

1. Clean all of the components and inspect all of the components. Inspect the grooves for the circlips (1) and ensure that all of the oil holes in the rocker shaft (6) and in the rocker arms (3 and 4) are not plugged before you begin the assembly procedure. If necessary, replace any worn components and any damaged components.
 2. Check the clearance between the rocker shaft (6) and the bushing of every rocker arm (3 and 4). Refer to the Specifications Manual, "Rocker Shaft" or further information. If necessary, replace any worn components.
 3. Lubricate all of the components with clean engine oil before assembly.
- Note:** Ensure that the machined flat (7) on the rocker shaft (6) is facing upward.
4. Install a circlip (1) onto the end of the rocker shaft (6) that is closest to the machined flat (7). Install a washer (2) onto the rocker shaft (6).
 5. Install the rocker arm assembly (3) for the inlet valve onto the rocker shaft (6). Install the rocker arm assembly (4) for the exhaust valve onto the rocker shaft (6).
 6. Install the spring (5) onto the rocker shaft (6).
 7. Repeat Step 5 and Step 6 in order to assemble the rocker shaft assembly.



Improper assembly of parts that are spring loaded can cause bodily injury.

To prevent possible injury, follow the established assembly procedure and wear protective equipment.

8. Install the remaining washer (2) and the remaining circlip (1) onto the rocker shaft (6).

End By:

- a. Install the rocker shaft assembly. Refer to this Disassembly and Assembly Manual, "Rocker Shaft and Pushrod - Install".

i01947661

Rocker Shaft and Pushrod - Install

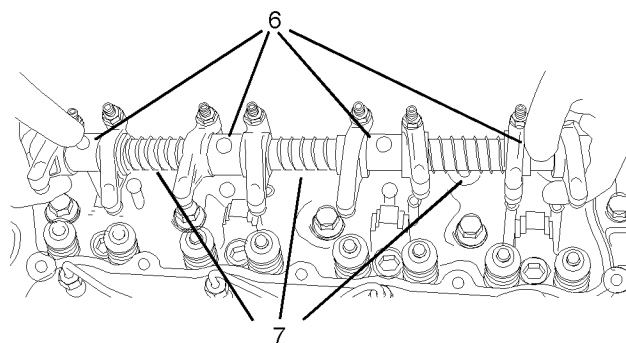

Illustration 207

g01015738

Typical example

Installation Procedure

Table 23

Required Tools		
Part Number	Part Description	Qty
27610227	Rocker Assembly Tool	4

NOTICE

Keep all parts clean from contaminants.

Contaminants may cause rapid wear and shortened component life.

Note: The installation procedure is identical for the three cylinder and the four cylinder engines. The illustrations show the four cylinder engine.

1. Apply clean engine lubricating oil to both ends of the pushrods (4). Install the pushrods (4).

Note: Ensure that the pushrods (4) are installed in the original location and that the pushrods are seated in the valve lifters correctly.

2. If the rocker shaft assembly was disassembled, install 27610227 Rocker Assembly Tool (6) around the rocker arms (2) in order to slightly compress the spring (7). The rocker arms (2) must be held away from the machined face of the cylinder head (3) during reassembly.

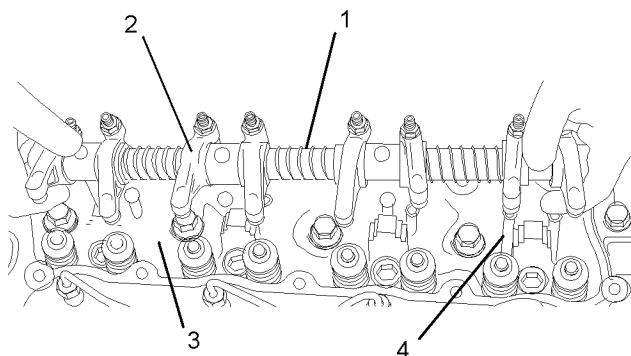

Illustration 206

g01014000

Typical example

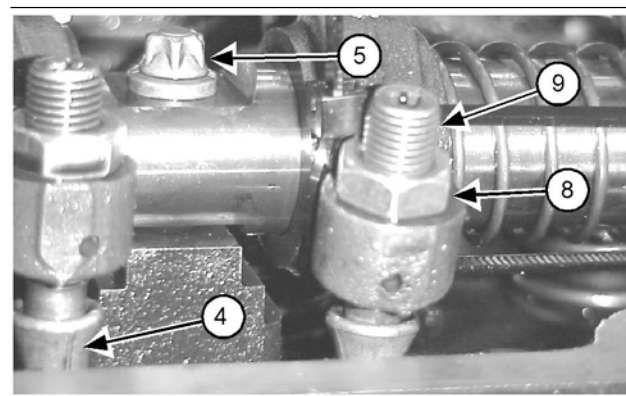

Illustration 208

g01015827

3. Loosen the nut (8) and the adjustment screw (9) on each rocker arm (2). This will help prevent a bent valve or a bent pushrod during the installation of the rocker shaft.

i01947662

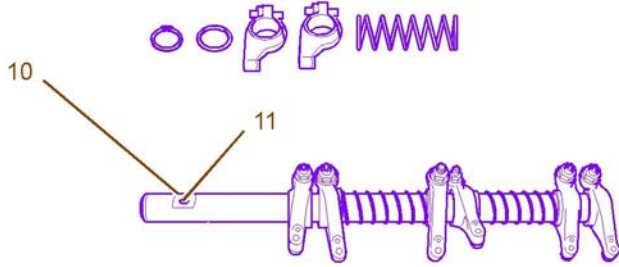

Illustration 209

g01015836

Typical example

Note: The rocker shaft of the rocker shaft assembly (1) is not symmetrical. The rocker shaft has a machined flat (10) at the front end of the shaft. Ensure that the machined flat (10) is toward the top and toward the front end of the engine.

4. Position the rocker shaft assembly (1) onto the cylinder head (3).
 5. Install the torx screws (5) in the rocker shaft (3).
- Note:** The longest torx screw (5) must be installed at the front of the cylinder head in hole (11).
6. Ensure that the adjustment screws (9) are properly seated in the ends of pushrods (4).
 7. Alternately tighten the torx screws (5). Start from the center and work toward the outside. Tighten torx screws (5) to a torque of 35 N·m (26 lb ft).
 8. Remove the rocker assembly tool (6) from the rocker shaft assembly (1).
 9. Adjust the inlet valve lash to 0.20 mm (0.008 inch) and adjust the exhaust valve lash to 0.45 mm (0.018 inch). Refer to the Testing and Adjusting Manual, "Engine Valve Lash - Inspect/Adjust" for more information on adjusting the valve lash.

End By:

- a. Install the valve mechanism cover. Refer to this Disassembly and Assembly Manual, "Valve Mechanism Cover - Remove and Install".

Cylinder Head - Remove

Removal Procedure

Start By:

- a. Drain the coolant from the engine into a suitable container for storage or disposal. Drain the engine oil from the engine into a suitable container. Refer to the Operation and Maintenance Manual for the procedure on draining the engine coolant and the engine oil.
- b. Remove the hose from the air filter to the integral air inlet. Refer to the OEM information for further details.
- c. Remove the fuel priming pump. Refer to this Disassembly and Assembly Manual, "Fuel Priming Pump - Remove and Install".
- d. Remove the pipe for the boost control, if equipped.
- e. Remove the fuel injectors. Refer to this Disassembly and Assembly Manual, "Fuel Injector - Remove".
- f. Remove the exhaust manifold. Refer to this Disassembly and Assembly Manual, "Exhaust Manifold - Remove and Install".
- g. Remove the rocker shaft assembly and the pushrods. Refer to this Disassembly and Assembly Manual, "Rocker Shaft and Pushrod - Remove".
- h. Remove the glow plugs. Refer to this Disassembly and Assembly Manual, "Glow Plugs - Remove and Install".

NOTICE

Keep all parts clean from contaminants.

Contaminants may cause rapid wear and shortened component life.

NOTICE

Care must be taken to ensure that fluids are contained during performance of inspection, maintenance, testing, adjusting and repair of the product. Be prepared to collect the fluid with suitable containers before opening any compartment or disassembling any component containing fluids.

Dispose of all fluids according to local regulations and mandates.

Note: The removal procedure is identical for the three cylinder and the four cylinder engines.

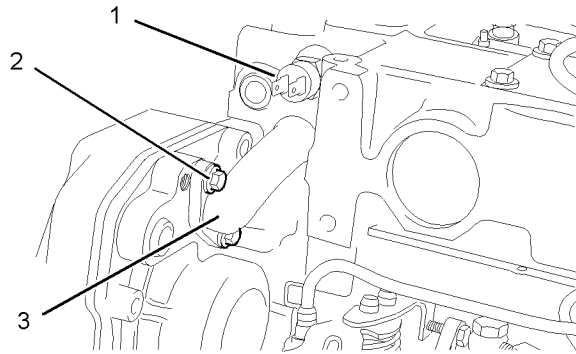

Illustration 210
Typical example
g01039425

1. Disconnect the harness assembly from the coolant temperature sensor (1).
2. Remove the setscrews (2). Remove the bypass tube (3) from the cylinder head (4). Remove the O-rings from the bypass tube (3).

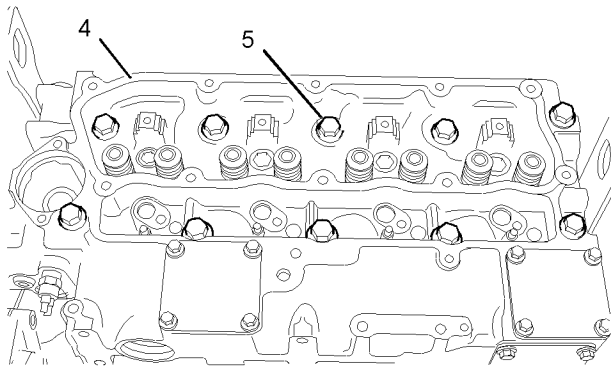

Illustration 211
Typical example
g01039484

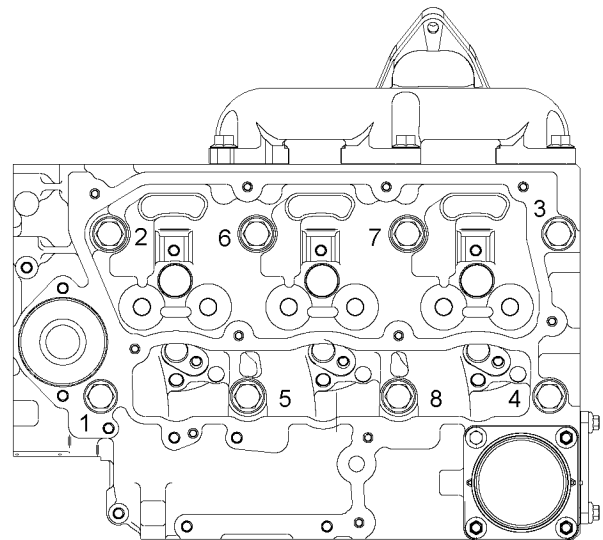

Illustration 212
Sequence for tightening the setscrews for the three cylinder engine
g01039487

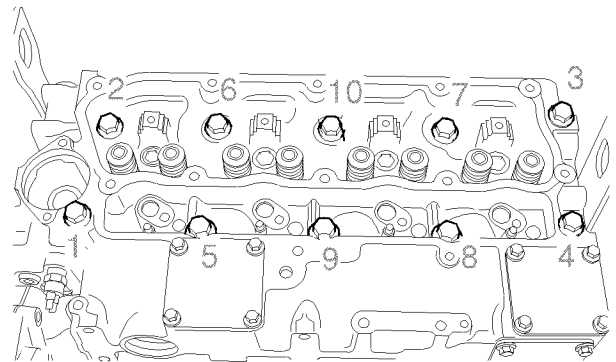

Illustration 213
Sequence for tightening the setscrews for the four cylinder engine
g01039483

3. Refer to the illustration 212 for three cylinder engines or illustration 213 for four cylinder engines. Gradually loosen the setscrews (5) in the reverse numerical order. This will help prevent distortion of the cylinder head (4).
4. Remove the setscrews (5) from the cylinder head (4).

Note: The cylinder head (4) is heavy. To avoid injury, take care when the cylinder head (4) is lifted. Also take care not to damage the machined surfaces of the cylinder head (4) during lifting and lowering the cylinder head.

Note: Do not use a lever to separate the cylinder head (4) from the cylinder block.

NOTICE

Place the cylinder head on a surface that will not scratch the face of the cylinder head.

5. Use a suitable lifting device and carefully lift the cylinder head (4) off the cylinder block.
6. Remove the cylinder head gasket and discard the cylinder head gasket.
7. Note the location of the dowels in the cylinder block for installation purposes.

i01947663

Cylinder Head - Install

Installation Procedure

Table 24

Required Tools		
Part Number	Part Description	Qty
21825607	Angle Gauge	1

NOTICE

Keep all parts clean from contaminants.

Contaminants may cause rapid wear and shortened component life.

Note: The installation procedure is identical for the three cylinder and the four cylinder engines. Unless the illustration is otherwise indicated, the illustrations show the four cylinder engine.

Note: Thoroughly clean the top of the cylinder block (1) and the bottom of the cylinder head (2). Ensure that there is no debris in the cylinder bores, the coolant passages, and the lubricant passages.

Note: Thoroughly clean the hole in the cylinder head for the gas that is ventilated from the crankcase. Ensure that the hole is not restricted by debris and/or oil deposits.

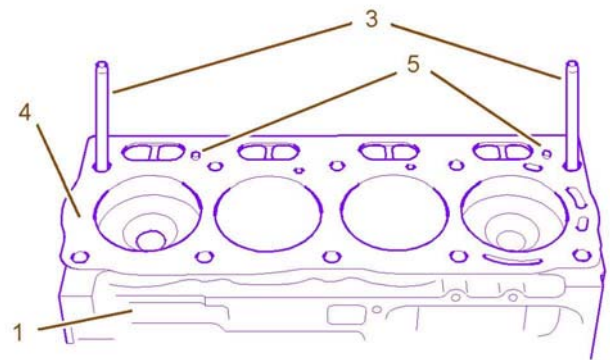

Illustration 214

g01039834

Typical example

1. Install suitable studs (3) into the cylinder block (1) in the setscrew holes 2 and 3. Refer to the illustration 217 for the three cylinder and refer to the illustration 218 for the four cylinder head.

Note: Do not use any sealant or compound on the cylinder head gasket (4).

2. Install the cylinder head gasket (4) onto the studs (3) and onto the dowels (5) in the top of the cylinder block (1).

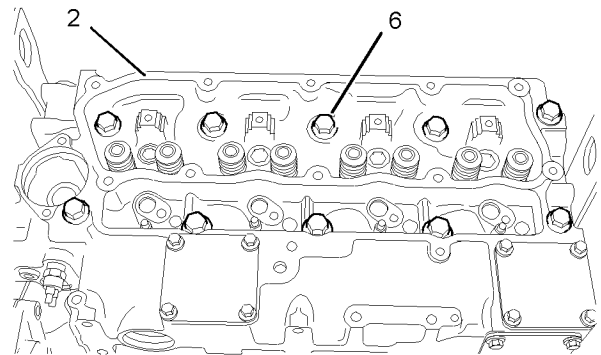

Illustration 215

g01039835

Typical example

Note: The cylinder head (2) is heavy. To avoid injury, take care when the cylinder head (2) is lifted. Also take care not to damage the machined surfaces of the cylinder head (2) during lifting and lowering the cylinder head.

3. Use a suitable lifting device to install the cylinder head (2).

Note: Ensure that the cylinder head (2) is positioned onto the dowels (5).

4. Remove the studs (3).

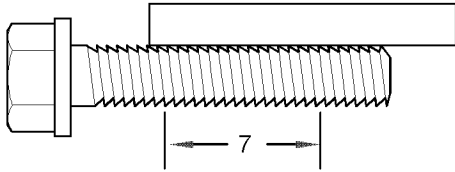

Illustration 216

g01039873

5. Clean the threads of the setscrews (6) for the cylinder head (2). Inspect the setscrews (6) for the cylinder head (2).

Note: Do not use the setscrews (6) if there is any visual reduction in the diameter of the threads (7) that have not been engaged with the cylinder block (1). Use a straight edge to check the setscrews (6). Refer to illustration 216.

6. Lubricate the threads and the shoulder of the setscrews (6) for the cylinder head (2) with clean engine oil before installation.

Note: There are two different lengths of setscrew (6) for the cylinder head (2).

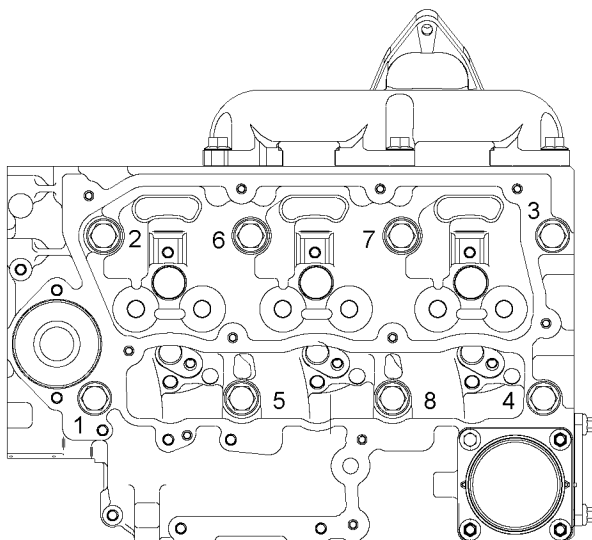

Illustration 217

Three cylinder engine

g01039487

Note: For the three cylinder engine, the short setscrews (6) are installed into the holes that are marked 2, 5, 6, 7, and 8. The long setscrews (6) are installed into the holes that are marked 1, 3, and 4. Refer to the illustration 217.

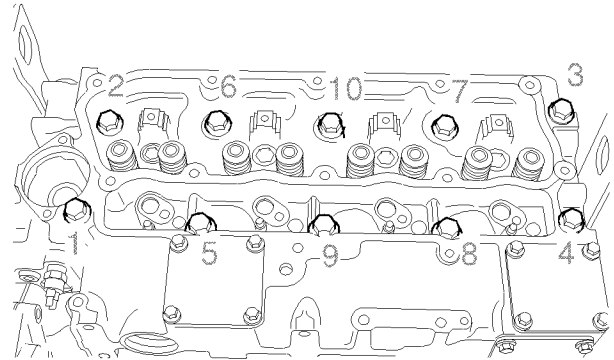

Illustration 218

Four cylinder engine

g01039483

Note: For the four cylinder engine, the short setscrews (6) are installed into holes that are marked 2, 5, 6, 7, 8, 9, and 10. The long setscrews (6) are installed into the holes that are marked 1, 3, and 4. Refer to illustration 218.

7. Install the appropriate setscrews (6) into the cylinder head (2).
8. Tighten the setscrews (6) for the cylinder head (2) in numerical order to a torque of 50 N·m (37 lb ft). Refer to the illustration 217 for the three cylinder and refer to illustration 218 for the four cylinder engine.
9. Tighten the setscrews (6) for the cylinder head (2) again in the appropriate numerical order to a torque of 100 N·m (74 lb ft). Refer to the illustration 217 for the three cylinder and the illustration 218 for the four cylinder engine.

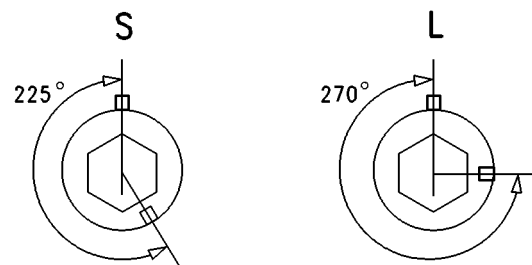

Illustration 219

g00951562

10. Finally tighten the setscrews (6) for the cylinder head (2) in the appropriate numerical order by an additional amount of degrees.

- a. Turn the short setscrews (2, 5, 6, 7, and 8) for the three cylinder or turn the short setscrews (2, 5, 6, 7, 8, 9, and 10) for the four cylinder engine for an additional 225 degrees.
- b. Turn the long setscrews (1, 3, and 4) for an additional 270 degrees.

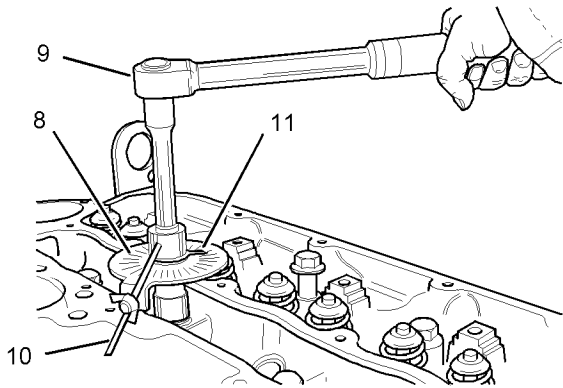

Illustration 220

g01040089

Typical example

11. Use 21825607 Angle Gauge in order to achieve the correct final torque.

12. Install the angle gauge (8) onto a suitable ratchet wrench (9). Refer to the appropriate illustration for the first setscrew (6) of the tightening sequence, illustration 217 for the three cylinder and illustration 218 for the four cylinder engine. Position the stop (10) against a suitable protrusion on the cylinder head (2) in order to prevent movement of the angle gauge (8) in a clockwise direction. Align the pointer (11) of the angle gauge (8) with the appropriate angle on the dial of the angle gauge. Tighten the appropriate setscrew (6) until the pointer aligns with the zero on the dial of the angle gauge (8).

13. Repeat Step 12 for all of the cylinder head setscrews (6) in the correct tightening sequence. Refer to illustration 217 for the three cylinder and illustration 218 for the four cylinder engine.

Note: The following alternative method can be used if 21825607 Angle Gauge is not available.

Note: For reference, 225 degrees of rotation is equal to 3.75 flats on the setscrew and 270 degrees of rotation is equal to 4.5 flats on the setscrew.

14. Place an index mark on the cylinder head (2) in line with a corner of each setscrew (6). Make another mark in a counter clockwise direction and at the correct angle for the length of setscrew (6) on the edge of the setscrew.

15. Tighten the setscrews (6) for the cylinder head (2) in numerical order. Refer to the illustration 217 for the three cylinder and illustration 218 for the four cylinder engine.

16. Turn the short setscrews (2, 5, 6, 7, and 8) or turn the short setscrews (2, 5, 6, 7, 8, 9, and 10) through an additional 225 degrees.

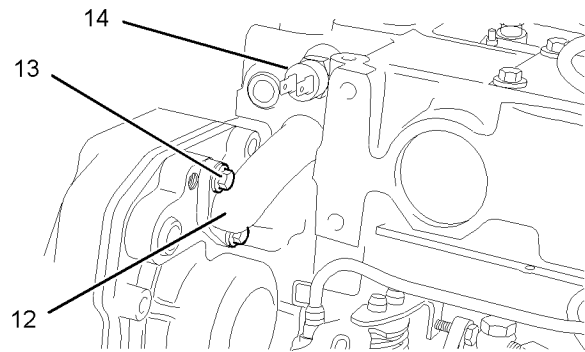

Illustration 221

g01040100

Typical example

17. Apply 21820221 POWERPART Red Rubber Grease to the new O-rings before the O-rings are installed onto the bypass tube (12). Install the new O-rings onto the bypass tube (12). Install the bypass tube (12) into the cylinder head (2). Install the setscrews (13).

18. Connect the harness assembly onto the coolant temperature sensor (14).

End By:

- a. Install the glow plugs. Refer to this Disassembly and Assembly Manual, "Glow Plugs - Remove and Install".
- b. Install the rocker shaft and the pushrods. Refer to this Disassembly and Assembly Manual, "Rocker Shaft and Pushrod - Install".
- c. Install the exhaust manifold. Refer to this Disassembly and Assembly Manual, "Exhaust Manifold - Remove and Install".
- d. Install the fuel injectors. Refer to this Disassembly and Assembly Manual, "Fuel Injector - Install".
- e. Install the pipe for the boost control, if equipped.
- f. Install the fuel priming pump. Refer to this Disassembly and Assembly Manual, "Fuel Priming Pump - Remove and Install".
- g. Install the hose from the integral air inlet to the air filter. Refer to the OEM information for further details.

- h. Refill the engine with coolant and engine oil. Refer to the Operation and Maintenance Manual for the correct procedure, the quantities, the coolant specification, and the specification for the engine oil.

i01977577

Lifter Group - Remove and Install

Removal Procedure

Start By:

- a. Remove the cylinder head if the cylinder head has not previously been removed. Refer to this Disassembly and Assembly Manual, "Cylinder Head - Remove".
- b. Remove the engine oil pan if the engine oil pan has not previously been removed. Refer to this Disassembly and Assembly Manual, "Engine Oil Pan - Remove and Install".
- c. Remove the camshaft. Refer to this Disassembly and Assembly Manual, "Camshaft - Remove and Install".

NOTICE

Keep all parts clean from contaminants.

Contaminants may cause rapid wear and shortened component life.

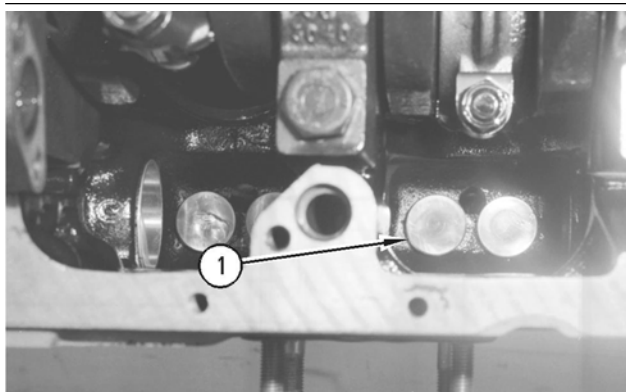

Illustration 222

g00540954

- 1. Use a suitable magnet to remove each cam follower (1).

Note: Place an identification mark on each cam follower for installation purposes.

Installation Procedure

NOTICE

Keep all parts clean from contaminants.

Contaminants may cause rapid wear and shortened component life.

- 1. Lubricate each cam follower (1) with clean engine oil.

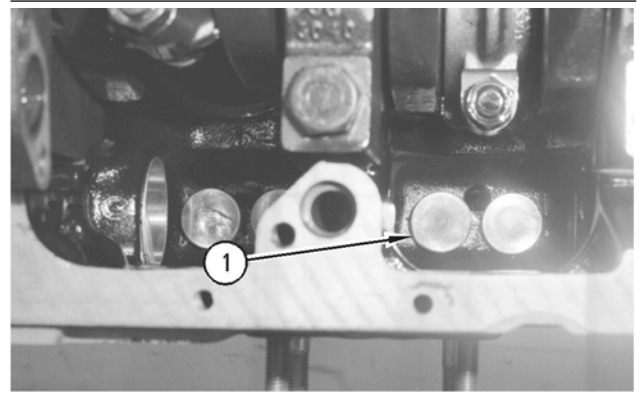

Illustration 223

g00540954

- 2. Install each cam follower (1) into the appropriate housing in the cylinder block.

Note: Ensure that each cam follower (1) is installed in the original location and that each cam follower is seated correctly.

End By:

- a. Install the camshaft. Refer to this Disassembly and Assembly Manual, "Camshaft - Remove and Install".
- b. Install the engine oil pan if this is the appropriate time. Refer to this Disassembly and Assembly Manual, "Engine Oil Pan - Remove and Install".
- c. Install the cylinder head if this is the appropriate time. Refer to this Disassembly and Assembly Manual, "Install".

i01977579

Camshaft - Remove and Install

Removal Procedure

Start By:

- a. Remove the cylinder head if the cylinder head has not previously been removed. Refer to this Disassembly and Assembly Manual, "Cylinder Head - Remove".
- b. Remove the front housing if the front housing has not previously been removed. Refer to this Disassembly and Assembly, "Housing (Front) - Remove".

NOTICE

Keep all parts clean from contaminants.

Contaminants may cause rapid wear and shortened component life.

1. Turn the engine upside-down so that the cam followers are held in a position away from the camshaft.

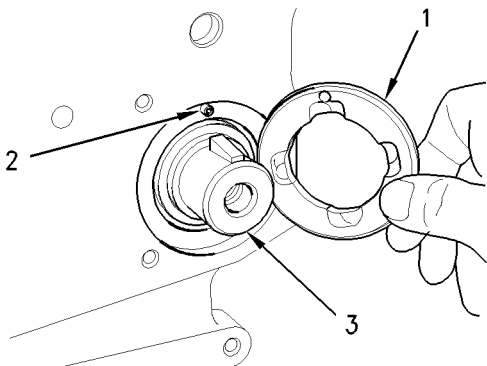

Illustration 224

g00951938

2. Remove the thrust washer (1) if the thrust washer has not previously been removed. Make a note of the location of the hollow dowel (2) for installation purposes.

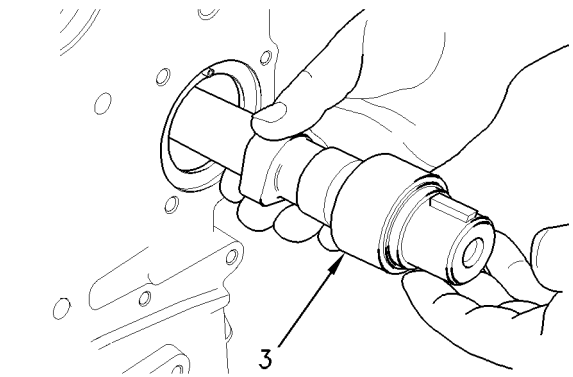

Illustration 225

g00951934

NOTICE

Do not damage the lobes or the bearings when the camshaft is removed or installed.

3. Carefully remove the camshaft (3) from the cylinder block.

Installation Procedure

NOTICE

Keep all parts clean from contaminants.

Contaminants may cause rapid wear and shortened component life.

Note: Ensure that the camshaft (3) is clean. Lubricate the camshaft (3) with clean engine oil prior to installation.

NOTICE

Do not damage the lobes or the bearings when the camshaft is removed or installed.

1. Carefully install the camshaft (3) into the cylinder block.
2. Put the thrust washer (1) in position if this is the appropriate time. Make sure that the thrust washer (1) is aligned with the hollow dowel (2).

End By:

- a. Install the front housing if this is the appropriate time. Refer to this Disassembly and Assembly Manual, "Housing (Front) - Install".
- b. Install the cylinder head if this is the appropriate time. Refer to this Disassembly and Assembly Manual, "Cylinder Head - Install".

i01977601

Camshaft Gear - Remove and Install

Removal Procedure

Start By:

- a. Remove the front cover if the front cover has not previously been removed. Refer to this Disassembly and Assembly Manual, "Front Cover - Remove and Install".
- b. Remove the idler gear if the idler gear has not previously been removed. Refer to this Disassembly and Assembly Manual, "Idler Gear - Remove and Install".

NOTICE

Keep all parts clean from contaminants.

Contaminants may cause rapid wear and shortened component life.

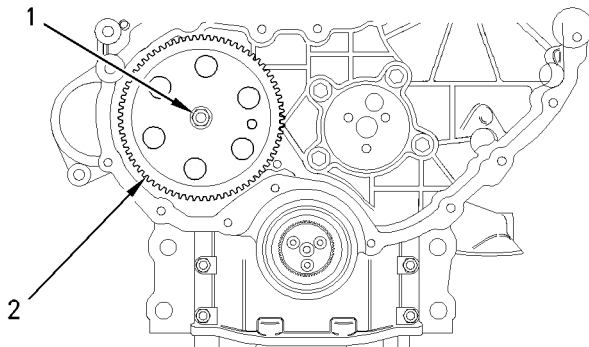

Illustration 226

g00954352

1. Remove the setscrew (1) and the washer from the camshaft gear (2).
2. Remove the camshaft gear (2) from the camshaft.

Note: Do not lose the key that is located in the camshaft for the camshaft gear (2).

Installation Procedure

NOTICE

Keep all parts clean from contaminants.

Contaminants may cause rapid wear and shortened component life.

1. Inspect the camshaft gear (2) and the key in the camshaft for wear or damage.

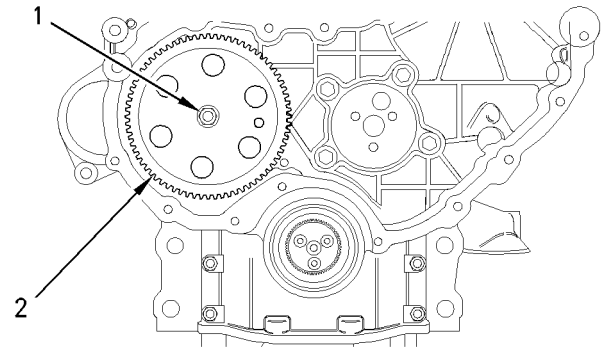

Illustration 227

g00954352

2. Ensure that the marked teeth on the camshaft gear (2) are facing toward the front and that the key is installed in the camshaft. Install the camshaft gear (2) onto the camshaft. If necessary, tap the camshaft gear (2) with a soft hammer in order to seat the key in the keyway.
3. Install the setscrew (1) and the washer onto the camshaft gear (2). Tighten the setscrew (1) to a torque of 95 N·m (70 lb ft).

End By:

- a. Install the idler gear if this is the appropriate time. Refer to this Disassembly and Assembly Manual, "Idler Gear - Remove and Install".
- b. Install the front cover if this is the appropriate time. Refer to this Disassembly and Assembly Manual, "Front Cover - Remove and Install".

i02242609

Camshaft Bearings - Remove and Install

Removal Procedure

Start By:

- a. Remove the camshaft. Refer to this Disassembly and Assembly Manual, "Camshaft - Remove and Install".

NOTICE

Keep all parts clean from contaminants.

Contaminants may cause rapid wear and shortened component life.

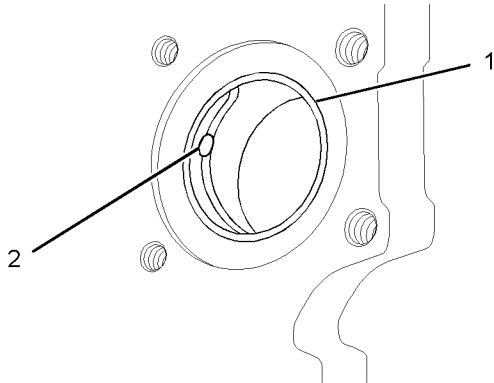

Illustration 228

g01130526

Typical example

1. If the camshaft bearing (1) is worn or damaged use a suitable adapter in order to press the bearing out of the cylinder block.

Installation Procedure**NOTICE**

Keep all parts clean from contaminants.

Contaminants may cause rapid wear and shortened component life.

1. Ensure that the bearing housing in the cylinder block is clean. Ensure that the oil hole in the bearing housing is clean and free from debris.

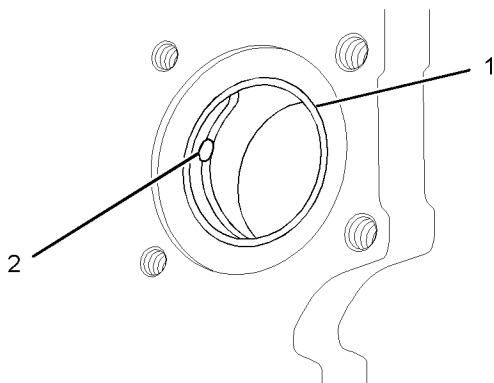

Illustration 229

g01130526

Typical example

Note: Align the oil hole in camshaft bearing (2) with the oil hole in the cylinder block.

2. Use a suitable adapter in order to press the camshaft bearing (1) into the cylinder block. Continue to press the camshaft bearing (1) into the cylinder block until the bearing is flush with the face of the recess in the cylinder block. Ensure that the oil holes are still in alignment.

End By:

- a. Install the camshaft. Refer to this Disassembly and Assembly Manual, "Camshaft - Remove and Install".

i01958105

Engine Oil Pan - Remove and Install**Removal Procedure****NOTICE**

Keep all parts clean from contaminants.

Contaminants may cause rapid wear and shortened component life.

NOTICE

Care must be taken to ensure that fluids are contained during performance of inspection, maintenance, testing, adjusting and repair of the product. Be prepared to collect the fluid with suitable containers before opening any compartment or disassembling any component containing fluids.

Dispose of all fluids according to local regulations and mandates.

Note: Ensure that the engine oil pan is fully supported before the oil pan is removed. Particular care must be taken with the cast iron version of the engine oil sump as this version is heavy.

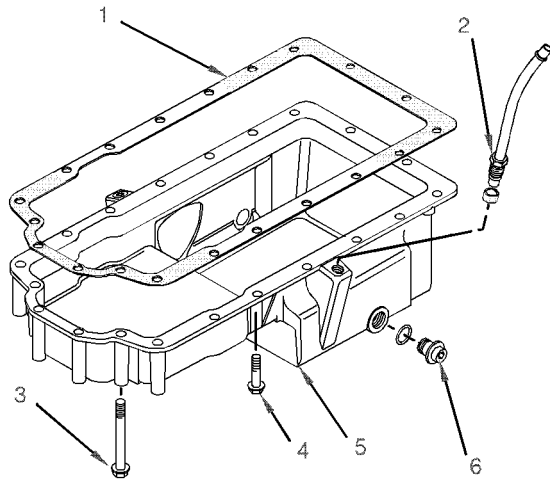

Illustration 230

g01042307

1. Remove all dirt, oil, and grease from the exterior surfaces of the oil pan (5).
2. Operate the engine until the engine is warm. Stop the engine.
3. If necessary, remove the nut (2), the seal, and the tube assembly from the engine oil pan (5).
4. Remove the oil drain plug (6) and the O-ring. Drain the engine oil into a suitable container for storage or disposal.
5. Remove the setscrews (3) and the setscrews (4) from the engine oil pan (5).
6. Remove engine oil pan (5) and remove the joint (1) from the cylinder block. Discard the joint (1).
7. Clean the engine oil pan (5) with a suitable cleaning fluid. Ensure that all of the cleaning fluid is removed.

Installation Procedure

NOTICE

Keep all parts clean from contaminants.

Contaminants may cause rapid wear and shortened component life.

Note: If the bridge for the cylinder block and/or the timing case have just been installed the engine oil pan must be installed before the silicon sealant has cured.

Note: Ensure that any old silicon rubber sealant is removed from the mating surfaces of the engine oil pan when the sump is installed.

1. Clean the flange face of the engine oil pan (5) and the flange face of the cylinder block.

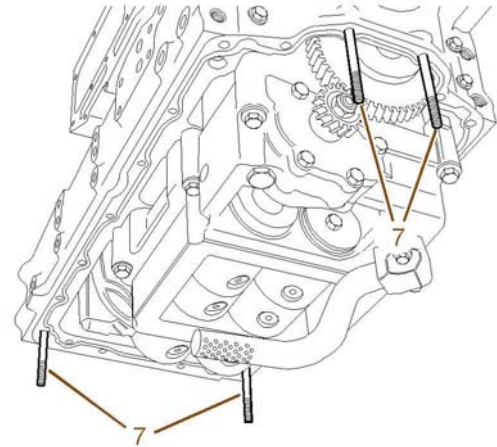

Illustration 231

g01042312

2. Install four temporary studs (7) as guides. Refer to illustration 231 for the correct location of the temporary studs (7).

Note: When the joint for the engine oil pan is removed, damage may occur to the existing sealant in the bridge of the cylinder block.

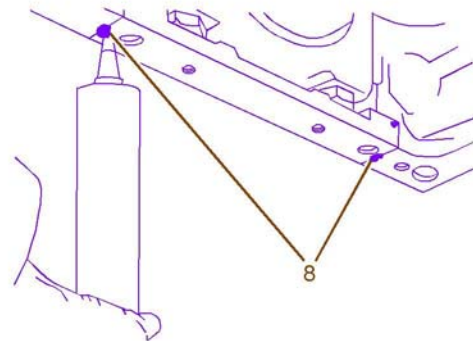

Illustration 232

g01042275

3. If the silicon sealant is damaged, apply a sufficient amount of 21826038 POWERPART Silicone Rubber Sealant in order to fill the groove (8).

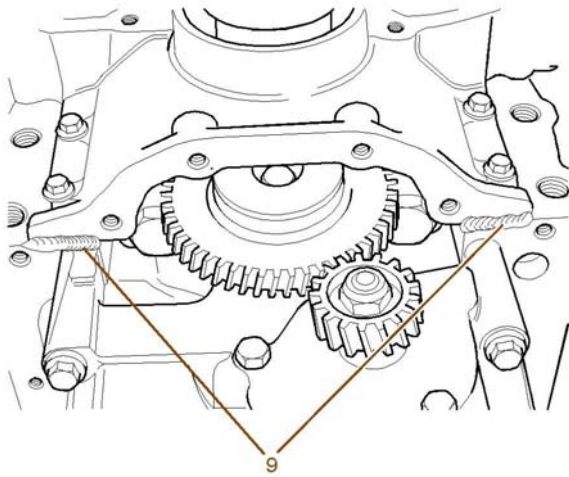

Illustration 233

g01042276

4. Also, apply a sufficient amount of new silicon rubber sealant if the silicon rubber sealant (9) between the cylinder block and the front cover is damaged.

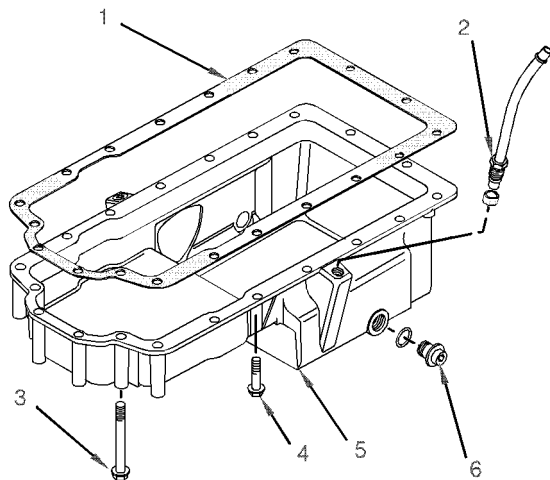

Illustration 234

g01042307

5. Carefully position the joint (1) over the temporary studs (7). Ensure that the engine oil pan is properly supported while the engine oil pan (5) is installed onto the temporary studs (7). The cast iron sump is heavy.

Note: New setscrews have sealant on the first 13 mm (0.5 inch) of the threads. In order to reuse the old setscrews, clean the old sealant from the setscrews and apply 21820117 POWERPART Threadlock and Nutlock to the setscrews.

6. Install the setscrews (4) in order to secure the engine oil pan (5) to the cylinder block. Tighten the setscrews (4) finger tight.

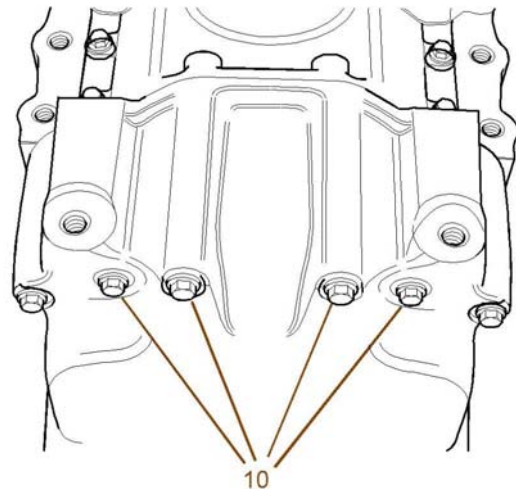

Illustration 235

g01042277

7. Remove the temporary studs (7) and install the remaining setscrew (3 and 4). Tighten the four setscrews (10) to a torque of 22 N·m (16 lb ft).
8. Tighten remaining setscrews (3) and setscrews (4) to a torque of 22 N·m (16 lb ft).
9. Inspect the O-ring for the drain plug (6). Replace the O-ring if it is necessary. Install the O-ring seal and drain plug (6). Tighten the drain plug (6) to a torque of 34 N·m (25 lb ft).
10. If necessary, install the seal and the tube assembly in the engine oil pan. Tighten the nut (2) to a torque of 18 N·m (13 lb ft).
11. Fill the engine oil pan to the correct level that is indicated on the engine oil level gauge. Refer to the Operation and Maintenance Manual, "Refill Capacities" for the lubrication system capacity of the engine.

i02242016

Balancer - Remove (Some 1104 Engines Only)

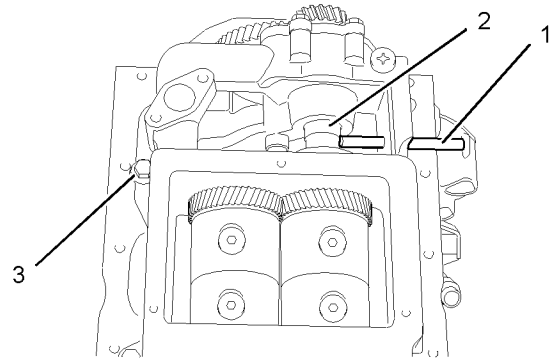

Illustration 236

g01026243

Removal Procedure

Table 25

Required Tools		
Part Number	Part Name	Qty
27610225	Timing Pin (Balancer)	1

Start By:

- a. Remove the engine oil pan. Refer to this Disassembly and Assembly Manual, "Engine Oil Pan - Remove and Install".
- b. Remove the engine oil relief valve. Refer to this Disassembly and Assembly Manual, "Engine Oil Relief Valve - Remove and Install (Balancer Unit for the Engine)".

NOTICE

Keep all parts clean from contaminants.

Contaminants may cause rapid wear and shortened component life.

NOTICE

Care must be taken to ensure that fluids are contained during performance of inspection, maintenance, testing, adjusting and repair of the product. Be prepared to collect the fluid with suitable containers before opening any compartment or disassembling any component containing fluids.

Dispose of all fluids according to local regulations and mandates.

1. Put the No. 1 cylinder at top dead center on the compression stroke. Refer to this Testing and Adjusting Manual, "Fuel Injection Timing - Check".

2. Install the 27610225 Timing Pin into the balancer. Ensure that the timing pin (1) is fully located into the drive shaft (2).

Note: The balancer is heavy. Take care when the balancer is lifted and/or when the balancer is lowered. If the engine is not inverted, support the balancer before removing the setscrews (3).

3. Refer to the Note above and remove the setscrews (3). Use a suitable lifting device to remove the balancer.

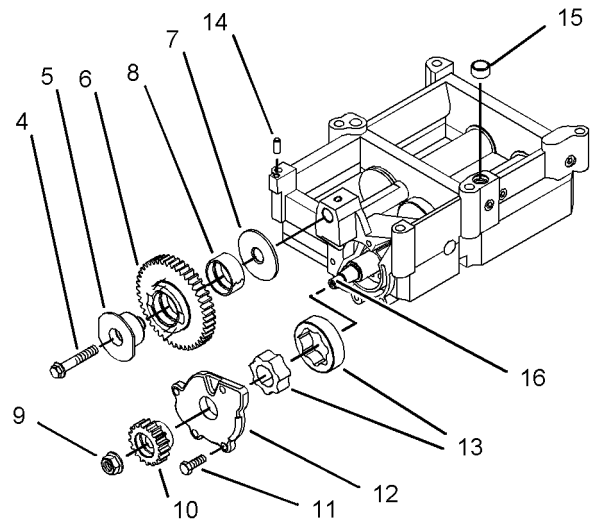

Illustration 237

g01026290

Note: The balancer is a nonserviceable item. Use the following procedure in order to remove the engine oil pump from the balancer.

4. Remove the setscrew (4) and the shaft (5). Remove the idler gear (6) and the thrust washer (7). Use a suitable adapter in order to press the bearing (8) from the idler gear (6). Discard the bearing (8).

5. Remove the nut (9). Use a suitable puller in order to remove the gear (10) from the shaft.
6. Remove the setscrews (11). Remove the cover (12).
7. Remove the rotor assembly (13).
8. If necessary, remove the dowel (14) and the hollow dowel (15).

i01979489

Balancer - Install (Some 1104 Engines Only)

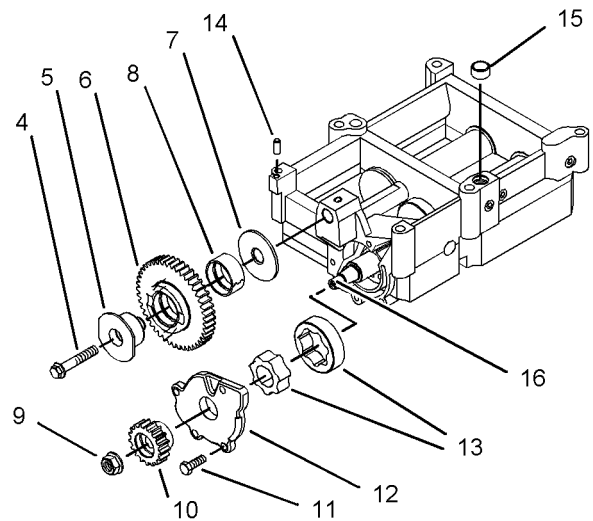

Illustration 238

g01026290

Installation Procedure

Table 26

Required Tools		
Part Number	Part Name	Qty
27610225	Timing Pin (Balancer)	1

NOTICE

Keep all parts clean from contaminants.

Contaminants may cause rapid wear and shortened component life.

1. Clean all of the components and inspect all of the components that were removed previously. Replace any component that is worn or damaged.
2. Clean the mating surfaces of the cylinder block and the balancer.

3. Install the rotor assembly (13). Check the clearance between the outer rotor and the body. Check the clearance between the inner rotor and the outer rotor. Check the end play for the rotor assembly. Refer to the Specifications Manual, "Engine Oil Pump" for information.
4. Lubricate the rotor assembly (13) with clean engine oil. Install the cover (12). Install the setscrews (11). Tighten the setscrews (11) to a torque of 28 N·m (21 lb ft).
5. Ensure that the threads (16) of the shaft are clean and dry. Position the oil pump gear (10) onto the shaft. Install the nut (9). Tighten the nut (9) to a torque of 95 N·m (70 lb ft).
6. Install a new bearing (8) into the idler gear (6).
7. Lubricate the bearing (8) with clean engine oil. Install the shaft (5) into the idler gear (6).
8. Position the idler gear (6) and the thrust washer (7) onto the balancer. Ensure that the threads of the setscrew (4) are clean and dry. Apply 21820117 POWERPART Threadlock and Nutlock to the threads of the setscrew (4) and install the setscrew. Tighten the setscrew (4) to a torque of 26 N·m (19 lb ft).
9. Check the end play for the idler gear (6). Refer to the Specifications Manual, "Engine Oil Pump".
10. Check the backlash between the gear (10) for the engine oil pump and the idler gear (6). Refer to the Specifications Manual, "Engine Oil Pump".
11. Ensure that the dowel (14) and the hollow dowel (15) are installed in the balancer.

12. Ensure that the No. 1 piston is at top dead center on the compression stroke. Refer to the Testing and Adjusting Manual, "Fuel Injection Timing - Check".

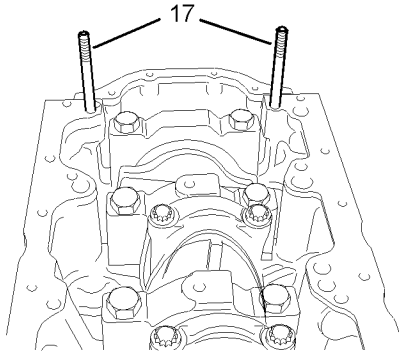

Illustration 239

g01026330

13. Install two temporary studs (17) into the cylinder block.

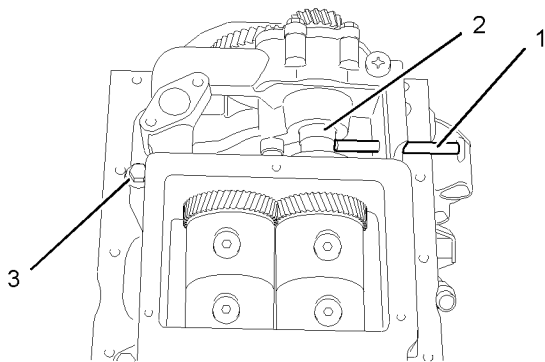

Illustration 240

g01026243

14. Install the 27610225 Timing Pin (1) into the shaft (2).
15. Carefully position the balancer onto the temporary studs (17). Ensure that the teeth of the idler gear (6) and the crankshaft gear are aligned.
16. Install two setscrews (3) into the center of the balancer. Tighten the setscrews (3) to a torque of 54 N·m (40 lb ft).
17. Remove the temporary studs (17) and install the remaining setscrews (3). Tighten the remaining setscrews to a torque of 54 N·m (40 lb ft).
18. Remove the timing pin (1). Rotate the crankshaft in order to ensure that the balancer turns freely.

End By:

- a. Install the engine oil relief valve. Refer to this Disassembly and Assembly Manual, "Engine Oil Relief Valve - Remove and Install (Balancer Unit for the Engine)".
- b. Install the engine oil pan. Refer to this Disassembly and Assembly Manual, "Engine Oil Pan - Remove and Install".

i01979959

Piston Cooling Jets - Remove and Install

Removal Procedure

Start By:

- a. Remove the engine oil pan. Refer to this Disassembly and Assembly Manual, "Engine Oil Pan - Remove and Install".

NOTICE

Keep all parts clean from contaminants.

Contaminants may cause rapid wear and shortened component life.

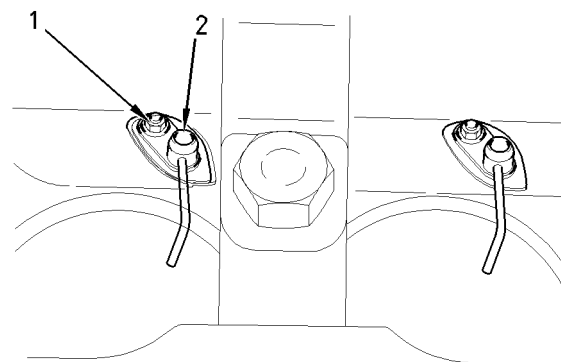

Illustration 241

g00952340

1. Remove the setscrew (1). Remove the piston cooling jet assembly (2) from the cylinder block.

Note: The engine crankshaft may be rotated in order to access all of the piston cooling jet assemblies.

Installation Procedure

NOTICE

Keep all parts clean from contaminants.

Contaminants may cause rapid wear and shortened component life.

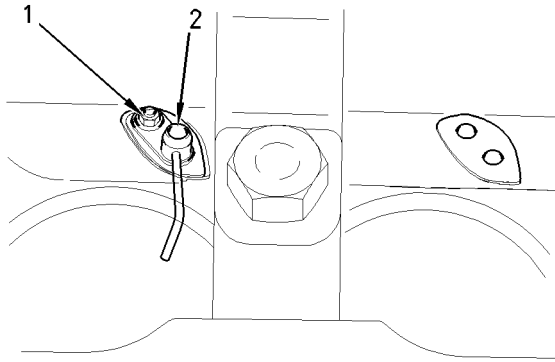

Illustration 242

g00952363

1. Clean each piston cooling jet assembly (2). Inspect each assembly for damage and especially check that the tube of the piston cooling jet assembly (2) has not been damaged. Ensure that the ball moves freely within each valve assembly of the piston cooling jet (2). Replace any damaged assembly.
2. Install each piston cooling jet assembly (2) into the cylinder block. Install the setscrew (1). Tighten the setscrew (1) to a torque of 9 N·m (80 lb in).

Note: Ensure that piston cooling jet assembly (2) is properly located on the cylinder block. Refer to the Specifications Manual, "Piston Cooling Jet" for the correct procedure for the alignment of the piston cooling jet.

End By:

- a. Install the engine oil pan. Refer to this Disassembly and Assembly Manual, "Engine Oil Pan - Remove and Install".

i01939118

Pistons and Connecting Rods - Remove

Removal Procedure

Start By:

- a. Remove the cylinder head. Refer to Disassembly and Assembly, "Cylinder Head - Remove".

- b. Remove the engine oil pump. Refer to Disassembly and Assembly, "Engine Oil Pump - Remove".
- c. Remove the piston cooling jets. Refer to Disassembly and Assembly, "Piston Cooling Jets - Remove and Install".

Note: The removal procedure is identical for the three cylinder and the four cylinder engines. The illustration shows the four cylinder engine.

NOTICE

Keep all parts clean from contaminants.

Contaminants may cause rapid wear and shortened component life.

1. Position the pistons that are being removed at the bottom center position.
2. Remove the carbon buildup from the inner surface of the top of the cylinder liner.
3. Ensure that the connecting rod and the cap are correctly marked to the cylinder.

Note: Do not punch the connecting rod or stamp the connecting rod assembly as this may cause damage.

4. Remove the torx screws (1) from the connecting rod.

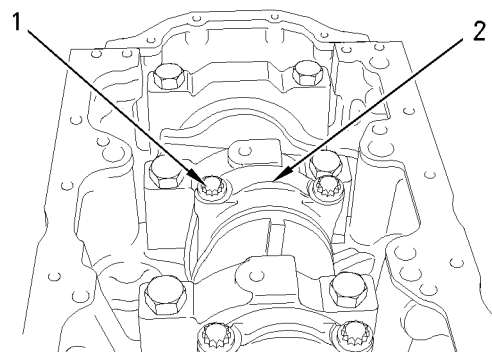

Illustration 243

g00970465

Typical example

5. Remove the connecting rod cap (2) with the bearing shell.
6. Push the piston and the connecting rod through the top of the cylinder block.

Note: Make a mark under the piston on the pin boss in order to identify the cylinder. Always mark the front pin boss to aid installation.

7. The bearing shell for the connecting rod and the bearing shell for the connecting rod cap must be placed with the correct rod and the correct connecting rod cap.
8. Always tighten the connecting rod cap to the connecting rod, when the assembly is out of the engine. Tighten the assembly to the following torque 20 N·m (14 lb ft).

i02280401

Pistons and Connecting Rods - Disassemble

Disassembly Procedure

Start By:

- a. Remove the pistons and the connecting rods. Refer to Disassembly and Assembly, "Piston and Connecting Rods - Remove".

NOTICE

Removal of the piston pin bushing must be carried out by personnel with the correct training. Also special machinery is required. For more information refer to your authorized Perkins dealer or your Perkins distributor.

NOTICE

Keep all parts clean from contaminants.

Contaminants may cause rapid wear and shortened component life.

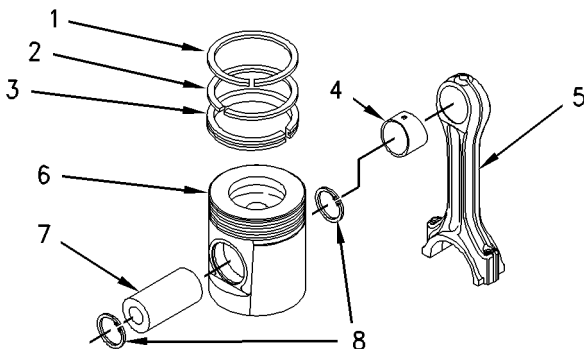

Illustration 244

g00964585

1. Use a suitable ring expander in order to remove the three piston rings (1) and (2), and the oil control ring (3) from the piston (6). Remove the lower connecting rod bearing from the connecting rod cap. Remove the upper connecting rod bearing from the connecting rod.

Note: If necessary, note the orientation of the old piston rings for assembly.

2. Use suitable pliers in order to remove the circlips (8).

3. Remove the piston pin (7) from the piston (6).

Note: If the piston pin cannot be removed by hand, heat the piston to a temperature of $45 \pm 5 \text{ }^\circ\text{C}$ ($113 \pm 9 \text{ }^\circ\text{F}$). Do not use a oxyacetylene torch to heat the piston.

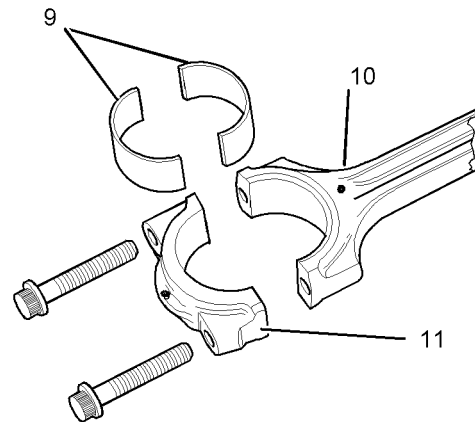

Illustration 245

g01015731

4. Remove the bearing shells (9) from the connecting rod (10) and the connecting rod cap (11).

5. Use a suitable press and a suitable adapter in order to remove the piston pin bushing (4) from the connecting rod (5).

i01939858

Pistons and Connecting Rods - Assemble

Assembly Procedure

NOTICE

Keep all parts clean from contaminants.

Contaminants may cause rapid wear and shortened component life.

NOTICE

Installation of the piston pin bushing must be carried out by personnel with the correct training. Also special machinery is required.

Note: A new piston pin bushing is in a shape of a wedge. For further information on installation of the piston pin bushing, refer to your authorized Perkins dealer or your Perkins distributor for assistance.

1. Refer to Testing and Adjusting, "Connecting Rod - Inspect" for the correct height grade for the fractured split connecting rod.



Illustration 246

g01000785

Alignment of the shell

2. The bearing shells for the connecting rod and the connecting rod cap must be aligned by a tool before the bearing shells are installed. Refer to illustration 246. Check the alignment of the bearing shells and remove the alignment tool from the assembly. The bearing shell must be an equal distance from each end. Refer to illustration 247.

Note: The alignment tool is supplied with new bearing shells .

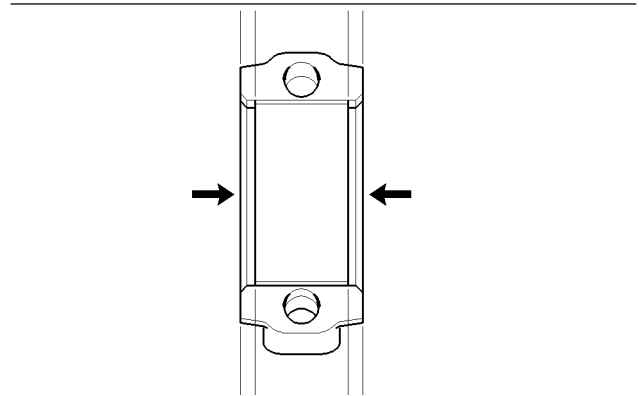

Illustration 247

g01001160

Aligned shell

3. Align the mark (1) on the connecting rod to the boss cutout (2) of the piston. Also check that the arrow (3) that is marked on top of the piston is aligned. Install the piston pin into the piston and through the connecting rod.

Note: If the piston pin cannot be installed by hand, use hot water in order to heat the piston to a temperature of $45^{\circ} \pm 5^{\circ}\text{C}$ ($113^{\circ} \pm 9^{\circ}\text{F}$).

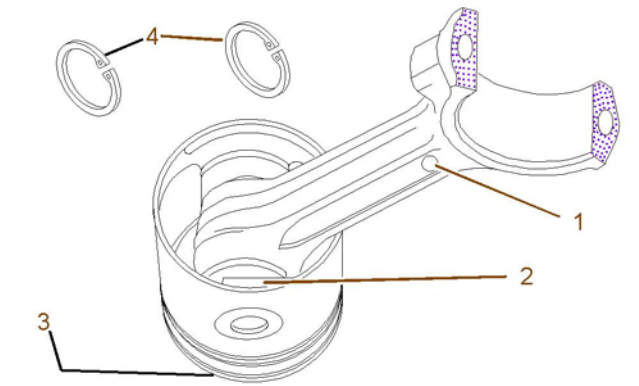

Illustration 248

g01009410

Align the connecting rod to the piston.

4. Use suitable pliers in order to install the circlips (4) that hold the piston pin in position.
5. Use a suitable ring expander in order to install the piston rings on the piston with the following steps.

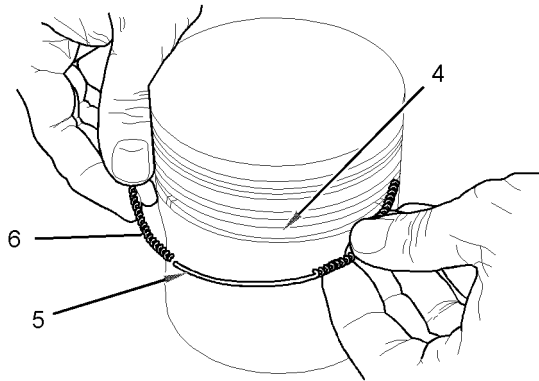

Illustration 249

g01010864

- a. Install the spring (6) for the oil control piston ring (7) in the groove (4) that is lowest on the piston. The latch pin (5) must be located inside the ends of the spring. Locate the oil control ring (7) over the internal spring (6).

Note: Ensure that the latch pin is 180 degrees from the oil control ring gap.

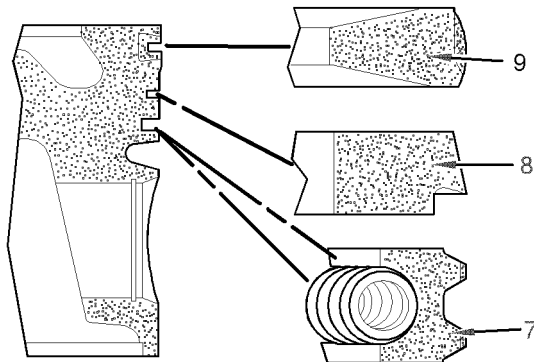

Illustration 250

g01010865

- b. Install the intermediate piston ring (8) with the tapered face into the second groove on the piston. The stamp "TOP" must be toward the top of the piston.

Note: Intermediate piston rings that are new have a green mark which must be on the left of the piston ring gap when the piston ring is installed.

- c. Install the top piston ring (9) with the barrel face and the molybdenum insert into the top groove on the piston. The top piston ring has a keystone ring. The stamp "TOP" must be toward the top of the piston.

Note: Top piston rings that are new have a red mark which must be on the left of the ring gap when the ring is installed.

- d. Position the piston ring gaps at 120 degrees away from each other.

End By:

- a. Install the pistons and the connecting rods. Refer to Disassembly and Assembly, "Piston and Connecting Rods - Install".

i02280830

Pistons and Connecting Rods - Install

Installation Procedure

Table 27

Required Tools		
Part Number	Part Description	Qty
21825615	Piston sleeve (installation tool)	1

NOTICE

Keep all parts clean from contaminants.

Contaminants may cause rapid wear and shortened component life.

1. Thoroughly clean all of the components.
2. Lubricate the piston and the cylinder bore with clean engine oil.

Note: The piston and connecting rod are matched to a specific cylinder. Ensure that the connecting rod and pistons are installed in the correct cylinder.

3. Rotate the crankshaft until the connecting rod journal is at the bottom center. Lubricate the connecting rod journal with clean engine oil.
4. Ensure that the piston assembly is correctly marked to the cylinder.
5. Lubricate the bearing shells for the connecting rod with clean engine oil.

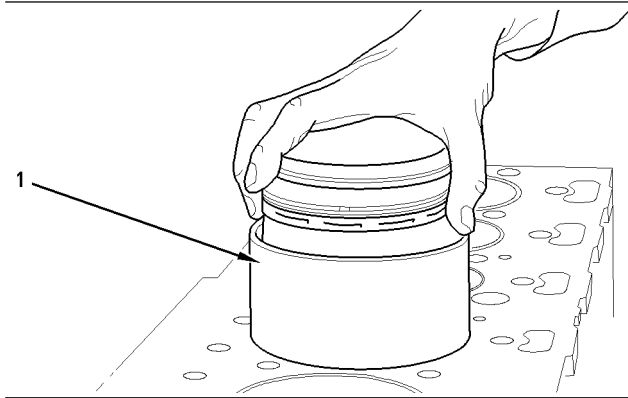

Illustration 251

g00999752

6. Lubricate the piston sleeve (1) with clean engine oil and install the piston sleeve.

Note: The arrow or the “FRONT” mark that is on the top of the piston must be toward the front of the engine. Ensure that the piston rings are 120 degrees away from each other.

Note: Ensure that the piston sleeve is installed correctly and that the piston can easily slide from the tool and into the cylinder.

7. Push the piston and the connecting rod assembly into the cylinder and onto the connecting rod journal.

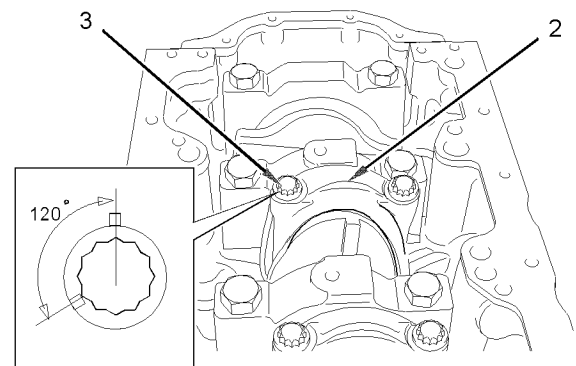

Illustration 252

g01141423

Typical example

Note: New setscrews must be installed.

Note: Ensure that the etched number on connecting rod bearing cap (2) matches the etched number on connecting rod.

8. Install the cap (2) with the bearing shell onto the connecting rod journal and the new setscrews for the cap.
9. Tighten the new setscrews to 20 N·m (14 lb ft).

Refer to Testing and Adjusting, “Piston Height - Inspect” for the correct procedure on checking the height of the piston above the cylinder block.

10. Tighten the setscrews (3) to 70 N·m (51 lb ft). Again tighten the setscrews by 120 degrees. Refer to the insert in the illustration 252. Check that there is no binding after this tightening sequence in step 9 and step 10.

End By:

- a. Install the piston cooling jets. Refer to Disassembly and Assembly, “Piston Cooling Jets - Remove and Install”.
- b. Install the engine oil pump. Refer to Disassembly and Assembly, “Engine Oil Pump - Install”.
- c. Install the cylinder head. Refer to Disassembly and Assembly, “Cylinder Head - Install”.

i01954554

Connecting Rod Bearings - Remove

Removal Procedure

Start By:

- a. Remove the engine oil pump. Refer to Disassembly and Assembly, “Engine Oil Pump - Remove”.

NOTICE

Keep all parts clean from contaminants.

Contaminants may cause rapid wear and shortened component life.

Note: Remove one pair of connecting rod caps at a time and install one pair at a time. Damage can occur when the fractured split connecting rods are separated.

1. In order to remove the connecting rod caps, rotate the crankshaft in a clockwise direction until one pair of pistons is at the bottom center position.

Note: Check that the connecting rod and the cap are correctly marked to the cylinder. If the connecting rod assembly requires marking do not punch the connecting rod assembly or stamp the connecting rod assembly as this may cause damage.

2. Remove the torx screws from the caps and remove both pair of caps with the bearing shells. Push both pair of connecting rods into the cylinder. Do not allow the connecting rods to contact the piston cooling jets.
3. Carefully rotate the crankshaft in order to give access to both pair of connecting rods.
4. Remove the bearing shells from the connecting rods and the caps.
5. Before continuing with the next pair of connecting rods, install all the new bearing shell into the connecting rods and caps. Refer to Disassembly and Assembly , "connecting rod bearing - install".

i01953533

Connecting Rod Bearings - Install

Installation Procedure

NOTICE

Keep all parts clean from contaminants.

Contaminants may cause rapid wear and shortened component life.

1. Carefully rotate the crankshaft in order to give access to the connecting rod.
2. Ensure that the components are clean before the components are assembled.

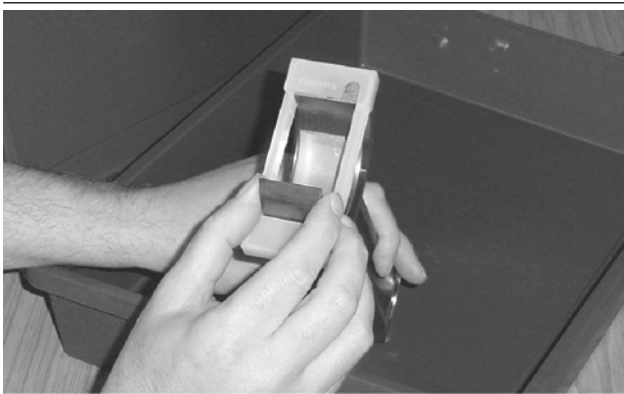

Illustration 253

g01000785

Alignment of the shell

Note: The alignment tool is supplied with the new bearing shells.

3. The bearing shell for the connecting rod must be aligned by a tool before the bearing shells are installed. Refer to illustration 253. Check the alignment of the shell and remove the tool from the assembly. The bearing shell must be an equal distance from each end. Refer to illustration 254. Lubricate both the bearing shells and lubricate the crankshaft journal.

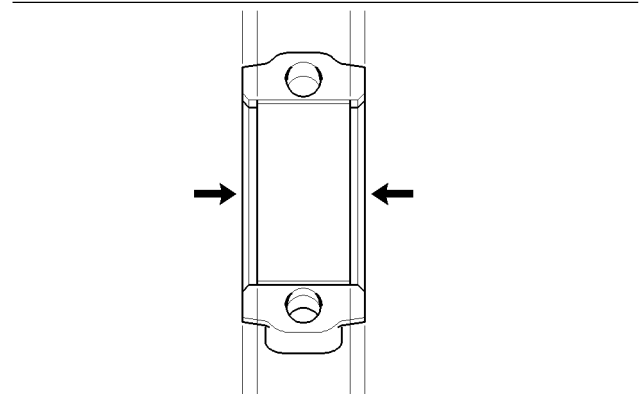

Illustration 254

g01001160

Aligned shell

4. Pull the connecting rod onto the crankshaft journal and install the correctly marked cap with the bearing shell onto the connecting rod.

Note: Do not allow the connecting rod into contact with the piston cooling jet.

5. Install new torx screws into the connecting rod assembly. Tighten the torx screws to 20 N·m (14 lb ft). Rotate the crankshaft in order to check for binding. Again tighten the torx screws to 70 N·m (51 lb ft).

Finally rotate the torx screws by 120 degrees.

Note: Rotate the crankshaft in order to recheck that there is no binding.

End By:

- a. Install the piston cooling jets. Refer to Disassembly and Assembly, "Piston Cooling Jets - Remove and Install".
- b. Install the engine oil pump. Refer to Disassembly and Assembly, "Engine Oil Pump - Install".
- c. Install the cylinder head. Refer to Disassembly and Assembly, "Cylinder Head - Install".

i01980468

Crankshaft Main Bearings - Remove

Removal Procedure

Start By:

- a. Remove the engine oil pan. Refer to this Disassembly and Assembly Manual, "Engine Oil Pan - Remove and Install".
- b. Only if the engine is not equipped with a balancer, remove the engine oil pump. Refer to this Disassembly and Assembly Manual, "Engine Oil Pump - Remove".
- c. If the engine is equipped with a balancer, remove the balancer. Only remove the engine oil pump if it is necessary. Refer to this Disassembly and Assembly Manual, "Balancer - Remove".
- d. Remove the flywheel housing in order to remove the rear main bearing with the crankshaft in position. Refer to this Disassembly and Assembly Manual, "Flywheel Housing - Remove and Install".
- e. Remove the crankshaft rear seal in order to remove the rear main bearing with the crankshaft in position. Refer to this Disassembly and Assembly Manual, "Crankshaft Rear Seal - Remove".

NOTICE

Keep all parts clean from contaminants.

Contaminants may cause rapid wear and shortened component life.

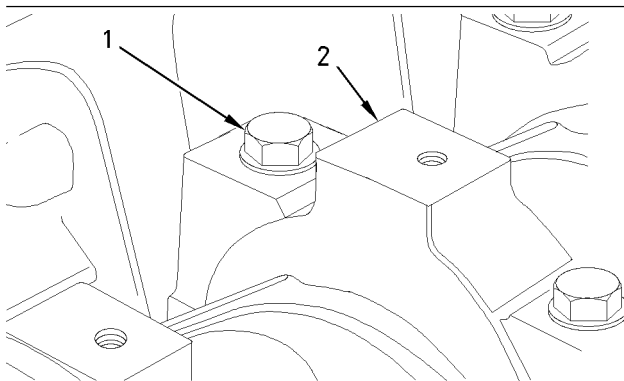

Illustration 255

g00947823

Note: The main bearings and the main bearing caps (2) must be installed in the same location when the engine is reassembled.

- 1. Make sure that the main bearing caps (2) are marked for the location and direction for installation.
- 2. Remove the setscrews (1) and the main bearing cap (2).

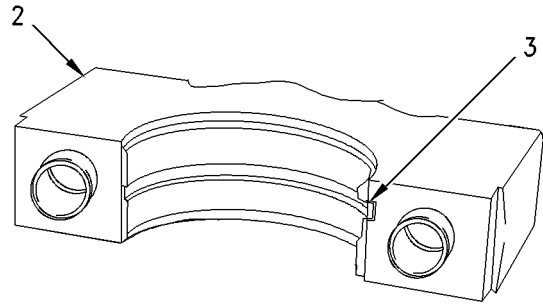

Illustration 256

g00934803

- 3. Remove the lower bearing shell (3) from the main bearing cap (2). Keep the respective bearing shell (3) and the main bearing cap (2) together for proper installation.

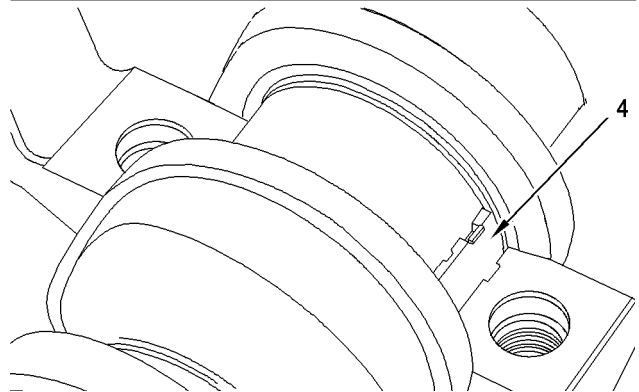

Illustration 257

g00934767

- 4. Push the upper bearing shell (4) from the opposite side of the bearing tab with a suitable tool. Carefully rotate the crankshaft while you push on the bearing shell (4). Remove the upper bearing shell (4) from the cylinder block. Keep all of the upper halves of the bearing shells (4) together in order to ensure proper installation.
- 5. Repeat Step 2 through Step 4 for the remaining main bearings.

Note: Thrust washers (5) and (6) are installed onto one main bearing in order to limit crankshaft end play. These thrust washers are installed onto the No. 3 main bearing of the three cylinder and onto the center main bearing of the four cylinder engine. The removal procedure is identical for the three cylinder and the four cylinder engines. The appropriate illustrations show the four cylinder engine.

i01980478

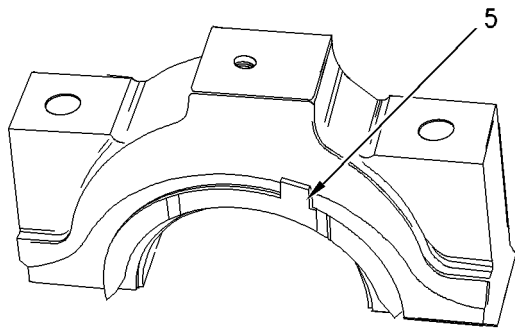

Illustration 258
Typical example

6. Remove the lower half of the thrust washer (5) from each side of the appropriate main bearing cap.

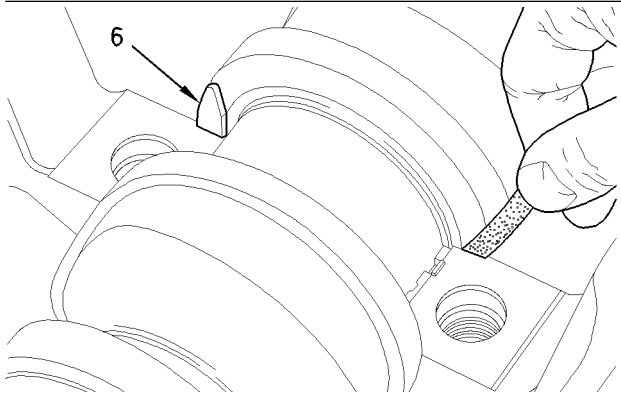

Illustration 259
Typical example

7. Remove the upper half of the thrust washer (6) from each side of the appropriate main bearing in the cylinder block with a suitable tool. Carefully rotate the crankshaft while you push on the thrust washer (6). If necessary, move the crankshaft to the front or to the rear of the engine in order to loosen a tight thrust washer (6).

Crankshaft Main Bearings - Install (Crankshaft in Position)

Installation Procedure

NOTICE

Keep all parts clean from contaminants.

Contaminants may cause rapid wear and shortened component life.

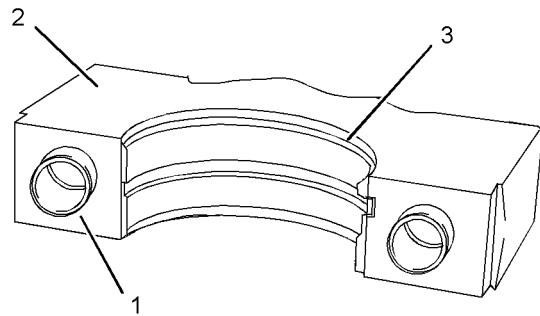

Illustration 260
g01026621

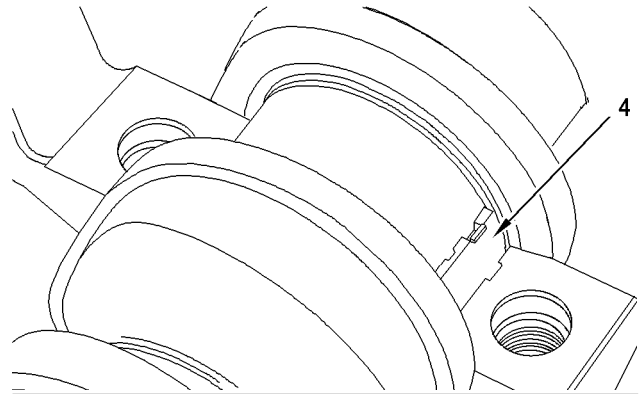

Illustration 261
g00934767

Note: Ensure that the lower bearing shells (3), the upper bearing shells (4), and the appropriate main bearing caps (2) are kept in sets and in the correct sequence for installation.

1. Ensure that all of the main bearing caps (2) are clean and dry. Ensure that both of the hollow dowels (1) are not damaged and that the hollow dowels are securely in place within the main bearing cap (2).

2. Gently wipe the lower bearing shells (3) and the upper bearing shells (4) in order to ensure that the bearing shells are clean and dry. Inspect the lower bearing shells (3) and the upper bearing shells (4). If necessary, replace the bearing shells that are worn or damaged.

Note: Bearing shells must be replaced in pairs. If a pair of bearing shells need to be replaced, consider replacing all of the bearing shells at the same time.

Note: The upper bearing shell for the No. 1 crankshaft journal has a lubricating oil slot. The remaining upper bearing shells have an oil hole for lubrication. All new upper bearing shells will have the slot for lubrication.

3. Gently wipe the main journals of the crankshaft in order to ensure that the main journals are clean and dry.
4. Lubricate the bearing surface of the upper bearing shell (4) and lubricate the appropriate main journal with clean engine oil.

Note: Ensure that the upper bearing shell (4) is installed so that the bearing tabs fit into the notch in the cylinder block.

NOTICE

Only the upper half of the main bearing has lubrication holes. Make sure the upper half of the main bearing is installed correctly in the cylinder block to ensure proper lubrication.

5. Slide the upper bearing shell (4) into position between the appropriate crankshaft journal and the cylinder block.
6. Lubricate the bearing face of the appropriate lower bearing shell (3) with clean engine oil.

Note: Ensure that the lower bearing shell (3) is installed so that the bearing tab fits into the notch in the appropriate main bearing cap.

7. Install the lower bearing shell (3) into the appropriate main bearing cap (2). Install the main bearing cap (2) into the appropriate position and ensure that the hollow dowels (1) are located within the main bearing cap and within the recesses in the cylinder block.
8. Repeat Step 4 through Step 7 for the remaining main bearings.

Note: Thrust washers (5) and (6) are installed onto one main bearing in order to limit crankshaft end play. These thrust washers are installed onto No. 3 main bearing of the three cylinder and onto the center main bearing of the four cylinder engine. The installation procedure is identical for the three cylinder and the four cylinder engines. The appropriate illustrations show the four cylinder engine.

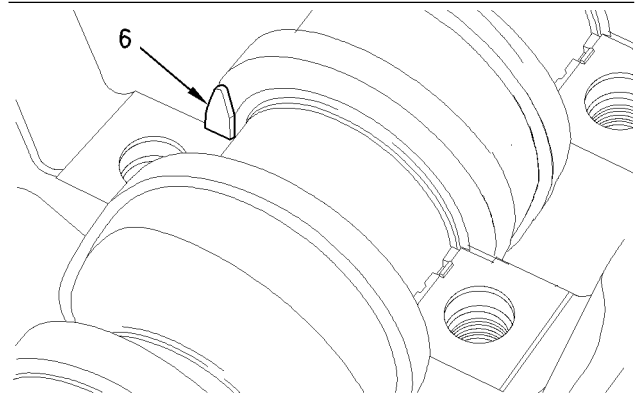

Illustration 262

g00947861

Typical example

9. Gently wipe the upper thrust washers (6) and the lower thrust washers (5) in order to ensure that the thrust washers are clean and dry. Inspect the upper thrust washers (6) and the lower thrust washers (5). If necessary, replace any damaged thrust washers.
10. Lightly lubricate the upper thrust washers (6) with clean engine oil. Install the upper thrust washers (6) onto each side of the appropriate main bearing in the cylinder block. The grooves on the upper thrust washers (6) must be located against the crankshaft. If necessary, move the crankshaft to the front or to the rear in order to install the thrust washers (6).

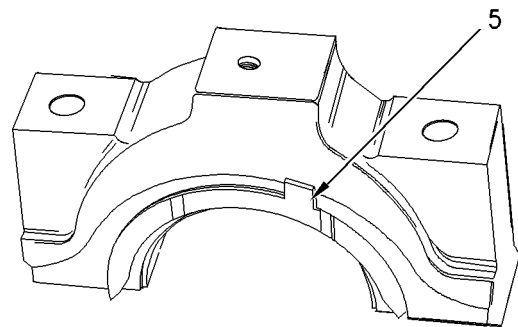

Illustration 263

g00934744

Typical example

11. Lightly lubricate the lower thrust washers (5) with clean engine oil. Install the lower thrust washers (5) onto each side of the appropriate main bearing cap. The grooves on the lower thrust washers (5) must be located against the crankshaft.

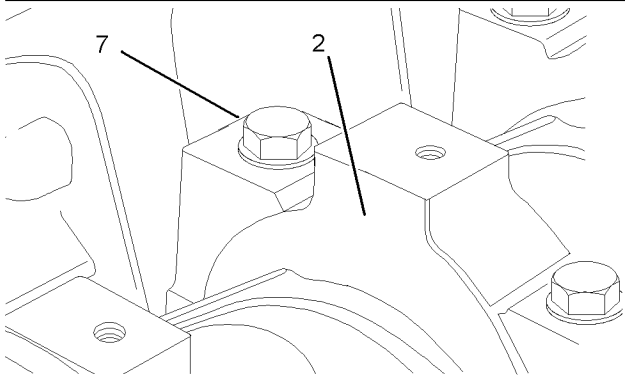

Illustration 264

g01026633

12. Lubricate the threads of the setscrews (7) with clean engine oil.

13. Install the setscrews (7). Tighten the setscrews (7) to a torque of 245 N·m (181 lb ft).

14. Rotate the crankshaft in order to ensure that the crankshaft turns freely.

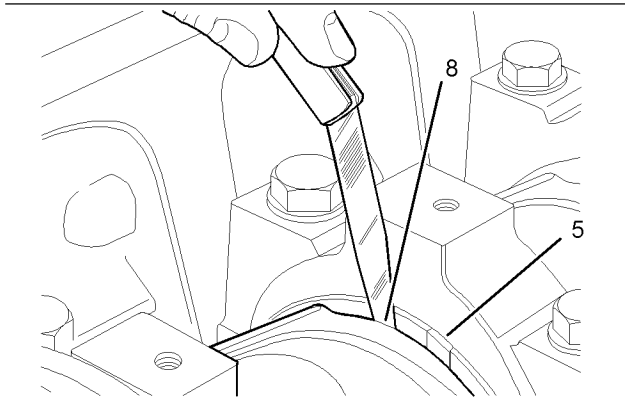

Illustration 265

g01026647

15. Check the crankshaft end play. Use a prybar to move the crankshaft toward the front of the engine. Use a suitable feeler gauge to measure the end play (8) between rear thrust washer (5) and the crankshaft. The maximum permissible crankshaft end play is 0.51 mm (0.020 inch).

End By:

- a. Install the rear bridge. Refer to this Disassembly and Assembly Manual, "Crankshaft - Install".

- b. Install the crankshaft rear seal. Refer to this Disassembly and Assembly Manual, "Crankshaft Rear Seal - Install".

- c. Install the flywheel housing. Refer to this Disassembly and Assembly Manual, "Flywheel Housing - Remove and Install".

- d. If the engine is equipped with a balancer and the engine oil pump was removed from the balancer, install the engine oil pump. Install the balancer. Refer to this Disassembly and Assembly Manual, "Balancer - Install".

- e. If the engine is not equipped with a balancer, install the engine oil pump. Refer to this Disassembly and Assembly Manual, "Engine Oil Pump - Install".

- f. Install the engine oil pan. Refer to this Disassembly and Assembly Manual, "Engine Oil Pan - Remove and Install".

i01981186

Crankshaft - Remove

Removal Procedure

Start By:

- a. Remove the engine oil pan. Refer to this Disassembly and Assembly Manual, "Engine Oil Pan - Remove and Install".
- b. Only if the engine is not equipped with a balancer, remove the engine oil pump. Refer to this Disassembly and Assembly Manual, "Engine Oil Pump - Remove".
- c. If the engine is equipped with a balancer, remove the balancer. Only remove the engine oil pump if it is necessary. Refer to this Disassembly and Assembly Manual, "Balancer - Remove".
- d. Remove the flywheel housing. Refer to this Disassembly and Assembly Manual, "Flywheel Housing - Remove and Install".
- e. Remove the crankshaft rear seal. Refer to this Disassembly and Assembly Manual, "Crankshaft Rear Seal - Remove".
- f. Remove the front housing. Refer to this Disassembly and Assembly Manual, "Housing (Front) - Remove".

NOTICE

Keep all parts clean from contaminants.

Contaminants may cause rapid wear and shortened component life.

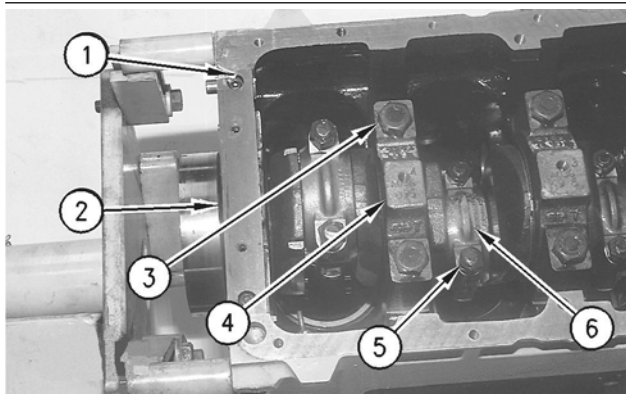

Illustration 266
Typical example
g00975296

1. Remove the Allen head screws (1) from the bridge (2).
2. Remove the bridge (2) from the cylinder block.

Note: Make sure that the main bearing caps (4) and the connecting rod caps (6) are marked for the location and direction for installation.

Note: This procedure assumes that the engine has been removed from the application and that the engine has been inverted. **If the engine is not inverted or if the bottom end of the engine has not been moved through at least 90 degrees horizontally, remove the connecting rods from the cylinder bores.** Refer to this Disassembly and Assembly Manual, "Pistons and Connecting Rods - Remove" for further information. Proceed to Step 6.

3. If the engine has been inverted or if the bottom end of the engine has been moved through at least 90 degrees horizontally, remove the setscrews (5) from the connecting rods. Discard the setscrews (5).

Note: Do not reuse the setscrews (5). Use new setscrews in order to secure the connecting rod cap for reassembly.

4. Remove the connecting rod bearing caps (6) from the connecting rods. Remove the bearing shells from the connecting rod bearing caps. Keep the bearing shell for the connecting rod cap with the appropriate connecting rod cap.

NOTICE

Do not allow the connecting rods to strike the piston cooling jets. Damage or misalignment may occur.

5. Push the piston assemblies into the cylinder bores.

Note: This procedure assumes that the engine has been removed from the application and that the engine has been inverted. **If the engine has not been inverted, ensure that the crankshaft is fully supported before removing the setscrews (3) for the main bearing caps (4).**

6. Remove the setscrews (3) from the main bearing caps (4).

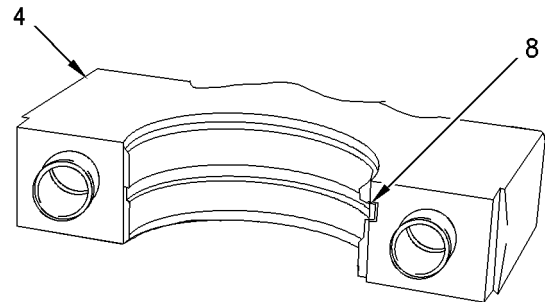

Illustration 267
g00975478

7. Remove the main bearing caps (4) from the cylinder block. Remove the bearing shells (8) from the main bearing caps (4). Keep the main bearing shells (8) with the respective main bearing cap (4).
8. Attach lifting straps and a suitable lifting device to the crankshaft. Lift the crankshaft out of the cylinder block. Take care to ensure that you do not scratch any of the finished surfaces on the crankshaft.

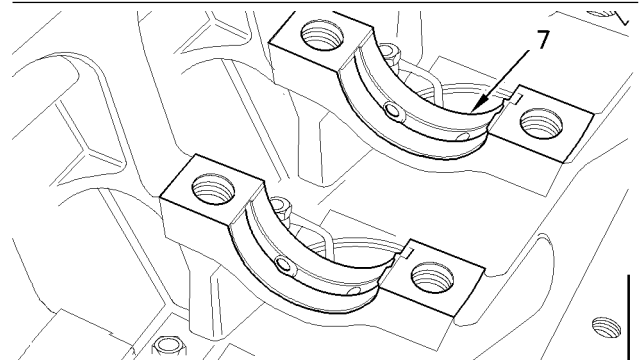

Illustration 268
g00975313

9. Remove the upper main bearing shells (7). Keep the upper main bearing shells with the respective main bearing caps (4).

Note: Thrust washers (9) and (10) are installed onto one main bearing in order to limit crankshaft end play. These thrust washers are installed onto the No. 3 main bearing of the three cylinder and the center main bearing of the four cylinder engine. The removal procedure is identical for the three cylinder and the four cylinder engines. The appropriate illustrations show the four cylinder engine.

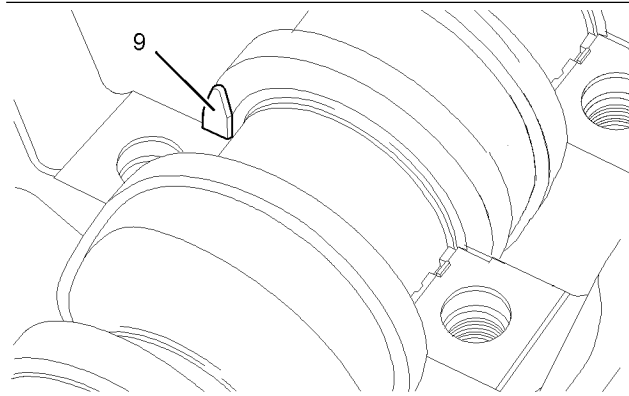

Illustration 269
Typical example

10. Remove the upper thrust washers (9) from the appropriate main bearing block.

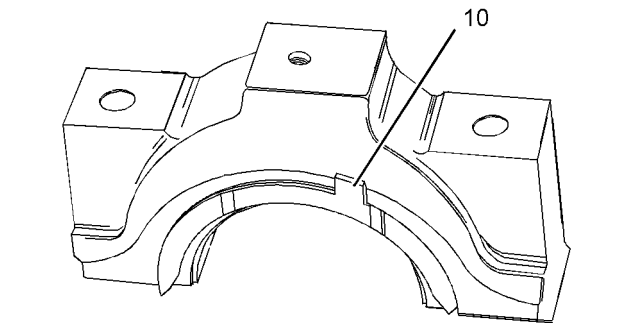

Illustration 270
Typical example

11. Remove the lower thrust washers (10) from the appropriate main bearing cap.

i01981309

Crankshaft - Install

Installation Procedure

NOTICE

Keep all parts clean from contaminants.

Contaminants may cause rapid wear and shortened component life.

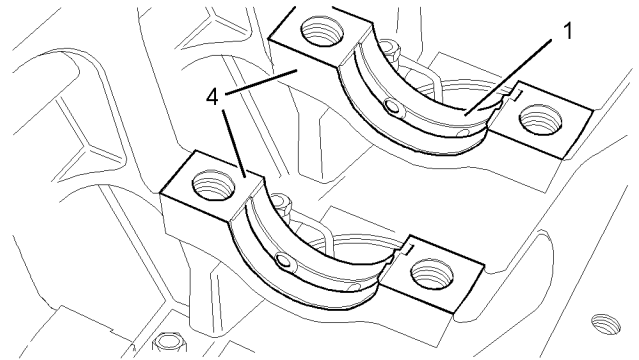

Illustration 271

g01027152

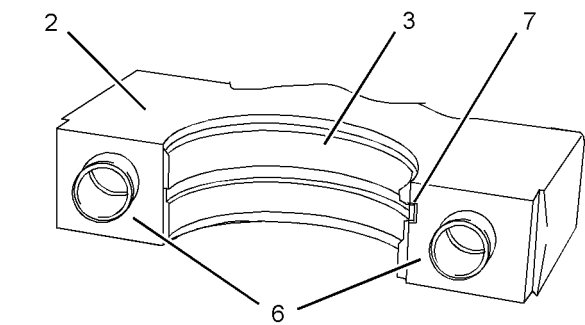

Illustration 272

g01027338

Typical example

Note: Ensure that the upper bearing shells (1), the appropriate main bearing caps (2), and the appropriate lower bearing shells (3) are kept in sets and in the correct sequence for installation.

1. Ensure that all of the housings (4) in the cylinder block for the upper bearing shells (1) are clean and dry. Ensure that all of the lubrication passages in the housings (4) are clean and free from debris.

2. Gently wipe the lower bearing shells (3) and the upper bearing shells (1) in order to ensure that the bearing shells are clean and dry. Inspect the lower bearing shells (3) and the upper bearing shells (1). If necessary, replace the bearing shells that are worn or damaged.

Note: Bearing shells must be replaced in pairs. If a pair of bearing shells need to be replaced, consider replacing all of the bearing shells at the same time.

Note: The upper bearing shell for the No. 1 crankshaft journal has a lubricating oil slot. The remaining upper bearing shells (1) have an oil hole for lubrication. All new upper bearing shells (1) will have the slot for lubrication.

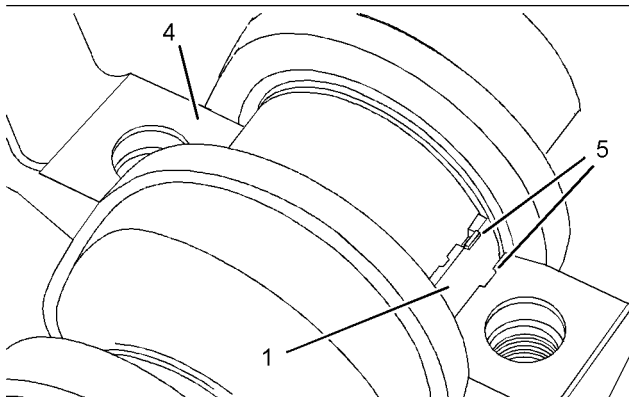

Illustration 273

g01027337

3. Install the upper main bearing shells (1). The bearing tabs (5) for the upper main bearing shells (1) must be located in the correct position in the cylinder block (5). Lubricate the upper main bearing shells (1) with clean engine oil.
4. Ensure that all of the main bearing caps (2) are clean and dry. Ensure that both of the hollow dowels (6) are not damaged and that two hollow dowels are securely in place within each of the main bearing caps (2).

Note: This procedure assumes that the engine has been removed from the application and that the engine has been inverted. **If the engine has not been inverted, ensure that the crankshaft is completely supported until the main bearing caps (2) and setscrews are completely installed.**

5. Gently wipe the main journals of the crankshaft in order to ensure that the main journals are clean and dry. Attach suitable lifting straps to the crankshaft.

6. Take care to ensure that you do not scratch any of the finished surfaces on the crankshaft and that you do not damage the upper main bearing shells (1) or dislodge the upper main bearing shells. The crankshaft is heavy. Use suitable lifting equipment to carefully lift the crankshaft into the upper main bearing shells (1).
7. Install the appropriate lower main bearing shells (3) into main bearing caps (2) with the bearing tabs (7) in the correct position. Lubricate the lower main bearing caps (2) with clean engine oil.

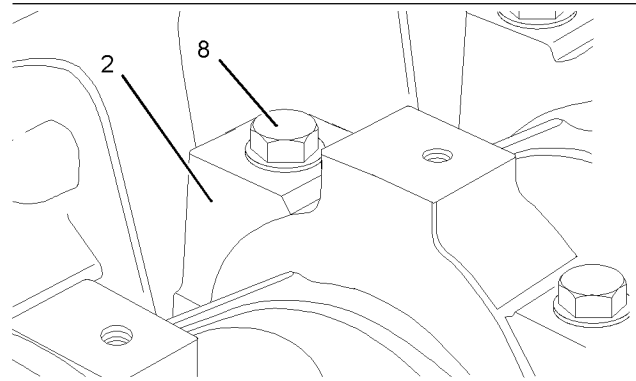

Illustration 274

g01027339

Note: Do not install the No. 3 main bearing cap of the three cylinder or the center main bearing cap of the four cylinder engine at this time.

8. Use the hollow dowels (6) in order to locate the appropriate main bearing caps (2) and install the main bearing caps into the appropriate housing (4) in the cylinder block. Insert the setscrews (8) finger tight.

Note: Thrust washers (9) and (10) are installed onto one main bearing in order to limit crankshaft end play. These thrust washers are installed onto the No. 3 main bearing of the three cylinder and the center main bearing of the four cylinder engine. The installation procedure is identical for the three cylinder and the four cylinder engines. The appropriate illustrations show the four cylinder engine.

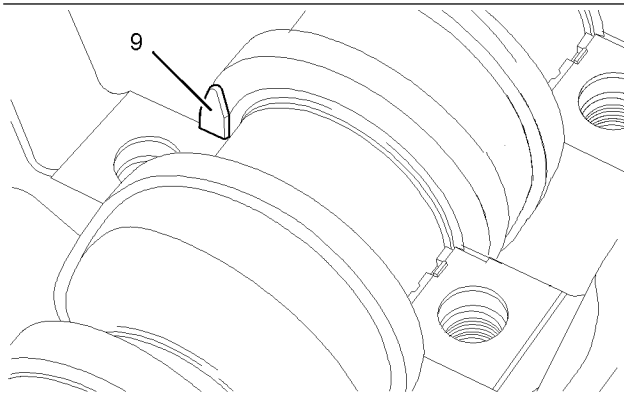

Illustration 275

g01026869

Typical example

- 9.** Clean the upper half of the thrust washers (9) and lubricate the upper half of thrust washers. Place the upper half of the thrust washers (9) into both side recesses in the cylinder block next to the housing for the appropriate main bearing shell. The grooves on the thrust washer (9) must be located against the crankshaft.

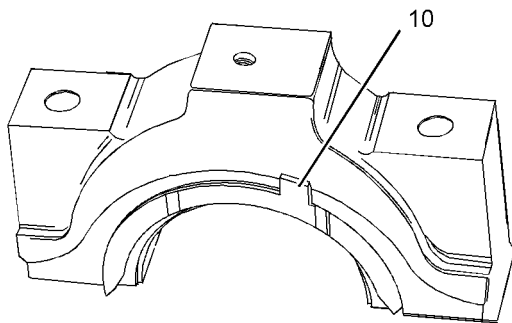

Illustration 276

g01026870

Typical example

- 10.** Clean the lower half of the thrust washers (10) and lubricate the lower half of thrust washers. Place the lower half of the thrust washers (10) on both sides of the appropriate main bearing cap. The grooves on the thrust washers (10) must be located against the crankshaft.
- 11.** Install the No. 3 main bearing cap onto the crankshaft of the three cylinder or the center main bearing cap onto the crankshaft of the four cylinder engine. Install the remaining setscrews (8).
- 12.** Tighten all of the setscrews (8) to a torque of 245 N·m (181 lb ft).

- 13.** If the piston assemblies were removed previously, install the piston assemblies. Refer to this Disassembly and Assembly Manual, "Pistons and Connecting Rods - Install". Go to Step 18.

- 14.** If the piston assemblies are still inside the cylinder bores, ensure that the upper bearing shells for the connecting rods are centered in the connecting rods. Ensure that the lower bearing shells for the connecting rods are centered in the connecting rod caps (11). Lubricate the faces of the bearing shell with clean engine oil.

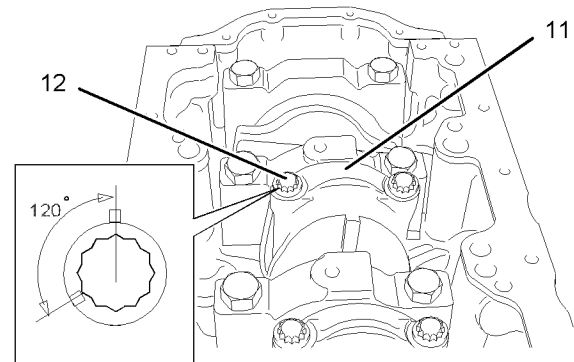

Illustration 277

g01027370

Typical example

- 15.** Install the connecting rod caps (11). Install new setscrews (12) into the connecting rods. Tighten the setscrews (12) evenly to an initial torque of 18 N·m (13 lb ft).

Note: Do not reuse the old setscrews (12) in order to secure the connecting rod caps (11).

Note: Ensure that the etched number on the connecting rod bearing cap matches the etched number on the connecting rod. Ensure that the etched numbers are on the same side.

- 16.** The setscrews must be tightened again to a higher torque. Tighten the setscrews (12) to a torque of 70 N·m (52 lb ft).
- 17.** Finally tighten the setscrews (12) for an additional 120 degrees. Refer to the insert in the Illustration 277 in order to achieve the correct final torque.
- 18.** Rotate the crankshaft in order to ensure that there is no binding.

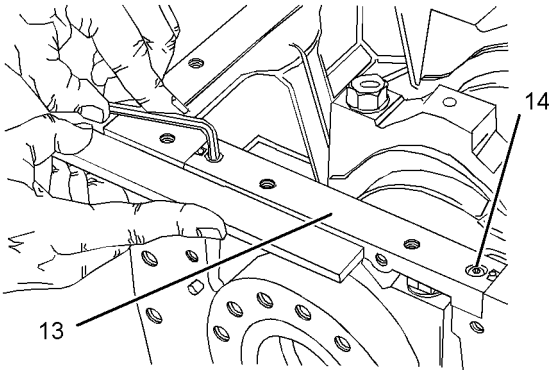

Illustration 278

g01027384

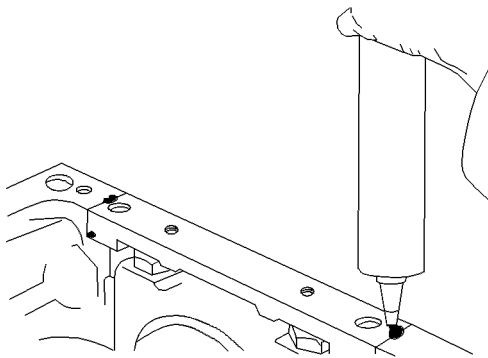

Illustration 279

g00541498

19. Clean the bridge (13) and the face of the cylinder block. Apply a thin bead of 21826038 POWERPART Silicone Adhesive onto the corners of the seat for the bridge. Also apply POWERPART Silicone Adhesive around the thread holes in the seat for the bridge. Use the following steps when you apply POWERPART Silicone Adhesive to the cylinder block and the bridge.

- a. Apply a 3.0 mm (0.12 inch) bead of the POWERPART Silicone Adhesive along the corner of the top recess in the cylinder block.

Note: The maximum protrusion for the bridge (13) from the outside of the cylinder block is 0.075 mm (0.0029 inch).

- b. Install the bridge (13). Use a straight edge to line up the bridge with the face of the cylinder block. Tighten the socket head screws (14) to a torque of 16 N·m (12 lb ft). Tighten the socket head screws (14) evenly.
- c. When the bridge (13) is positioned and the socket head screws (14) have been tightened, inject POWERPART Silicone Adhesive into the groove that is at each end of the bridge. The groove must be completely filled.

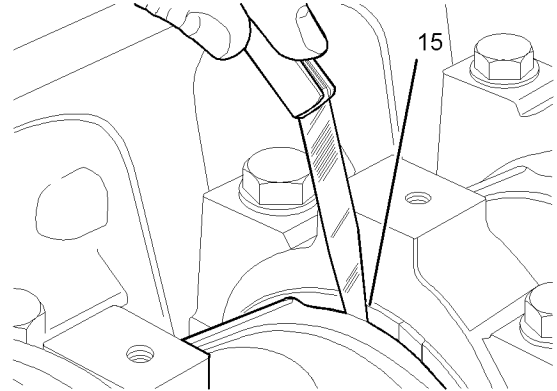

Illustration 280

g01027386

20. Check the crankshaft end play. Use a prybar to move the crankshaft toward the front of the engine. Use a feeler gauge to measure the end play (15) between the rear thrust washer and the crankshaft. Refer to the Specifications Manual, "Crankshaft" for the further information.

End By:

- a. Install the front housing. Refer to this Disassembly and Assembly Manual, "Housing (Front) - Install".
- b. Install the crankshaft rear seal. Refer to this Disassembly and Assembly Manual, "Crankshaft Rear Seal - Install".
- c. Install the flywheel housing. Refer to this Disassembly and Assembly Manual, "Flywheel Housing - Remove and Install".
- d. If the engine is equipped with a balancer, install the balancer. Refer to this Disassembly and Assembly Manual, "Balancer - Install".
- e. If the engine is not equipped with a balancer, install the engine oil pump. Refer to this Disassembly and Assembly Manual, "Engine Oil Pump - Install".
- f. Install the engine oil pan. Refer to this Disassembly and Assembly Manual, "Engine Oil Pan - Remove and Install".

i01981176

Crankshaft Gear - Remove and Install

Removal Procedure

NOTICE

Keep all parts clean from contaminants.

Contaminants may cause rapid wear and shortened component life.

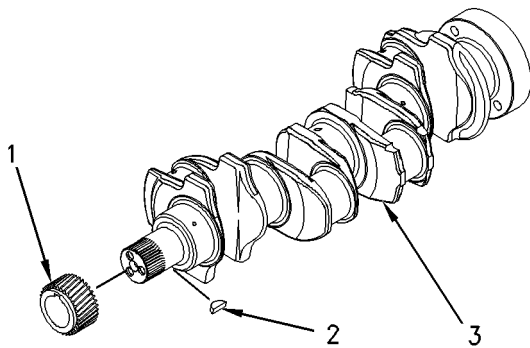

Illustration 281

g00970345

Typical example

Note: The crankshaft gear (1) may be a slip fit on the crankshaft (3). If the crankshaft (3) is installed in the engine, use a suitable tool to ensure that the crankshaft gear (1) is not a slip fit before the crankshaft is removed from the engine.

1. If the crankshaft gear (1) is a slip fit on the crankshaft (3), use a suitable tool to remove the crankshaft gear and proceed to Step 4.
2. If the crankshaft gear (1) is not a slip fit on the crankshaft (3), remove the crankshaft from the engine. Refer to this Disassembly and Assembly Manual, "Crankshaft - Remove".
3. Use suitable tooling to remove the crankshaft gear (1) from the crankshaft (3).
4. Remove the key (2) from the crankshaft (3).

Installation Procedure

NOTICE

Keep all parts clean from contaminants.

Contaminants may cause rapid wear and shortened component life.

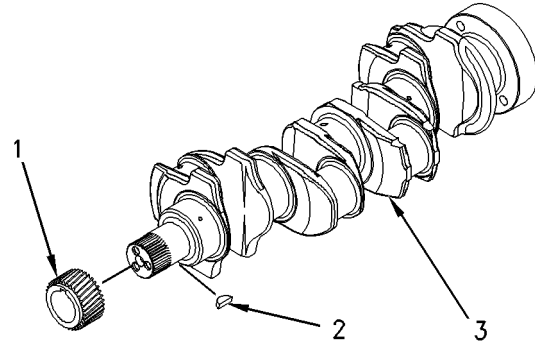

Illustration 282

g00970345

Typical example

1. Thoroughly clean the journal on the crankshaft (3) for the crankshaft gear (1) and the keyway slot for the key (2). Inspect the journal for the crankshaft gear (1), the keyway slot, and the key for wear and/or damage. If necessary, replace any damaged component.

2. Install the key (2) into the keyway slot in the crankshaft (3).

Note: The crankshaft gear (1) may be a slip fit on the crankshaft (3).

3. Check if the crankshaft gear (1) is a slip fit on the crankshaft (3). If the crankshaft gear (1) is a slip fit on the crankshaft (3), proceed to Step 5.

Note: Ensure that heat is applied to the crankshaft gear (1) only. Do not apply heat directly onto the crankshaft (3).

Note: Ensure that suitable clothing is worn in order to handle the heated crankshaft gear.

4. If the crankshaft gear is not a slip fit on the crankshaft, heat the crankshaft gear in an oven to 200 °C (392 °F).

5. Ensure that the shoulder on the crankshaft gear (1) is installed toward the front of the crankshaft (3). Install the crankshaft gear (1) onto the crankshaft (3) and the key (2).

End By:

- a. If the crankshaft was removed from the engine, install the crankshaft (3) at an appropriate time. Refer to this Disassembly and Assembly Manual, "Crankshaft - Install".

i01981742

Bearing Clearance - Check

Measurement Procedure

Table 28

Required Tools	
Description	Qty
Plastic Gauge (Green) 0.025 to 0.076 mm (0.001 to 0.003 inch)	1
Plastic Gauge (Red) 0.051 to 0.152 mm (0.002 to 0.006 inch)	1
Plastic Gauge (Blue) 0.102 to 0.229 mm (0.004 to 0.009 inch)	1
Plastic Gauge (Yellow) 0.230 to 0.510 mm (0.009 to 0.020 inch)	1

NOTICE

Keep all parts clean from contaminants.

Contaminants may cause rapid wear and shortened component life.

Note: Perkins does not recommend the checking of the actual clearances of the bearing shells particularly on small engines. This is because of the possibility of obtaining inaccurate results and the possibility of damaging the bearing shell or the journal surfaces. Each Perkins bearing shell is quality checked by Perkins for specific wall thickness.

Note: The measurements should be within specifications and the correct bearing shells should be used. No further checks are necessary if the main journals and the bearing shells were measured during disassembly of the engine. No further checks are necessary if the crank pins of the crankshaft and the bearing shells were checked during the disassembly of the connecting rods. However, Plastic Gauge is an acceptable method if the technician still wants to measure the clearance of the bearing shell. Plastic Gauge is less accurate on journals with small diameters if clearances are less than 0.10 mm (0.004 inch).

NOTICE

Lead wire, shim stock or a dial bore gauge can damage the bearing surfaces.

The technician must be very careful to use Plastic Gauge correctly. The following points must be remembered:

- Ensure that the backs of the bearing shells and the bores of the bearing shells are clean and dry.
- If the bearing shells have locking tabs ensure that the locking tabs are properly seated in the tab grooves.
- The crankshaft must be free of oil at the contact points of the Plastic Gauge.

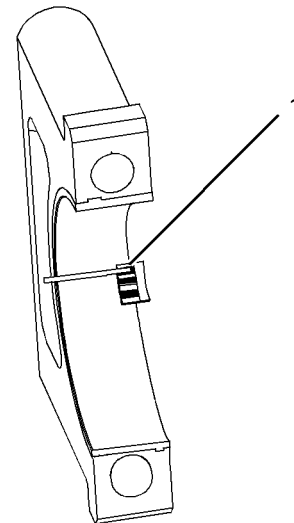

Illustration 283

g01010832

Typical example

1. Put a piece of the Plastic Gauge (1) on the crown of the bearing shell that is in the cap.

Note: Do not allow the Plastic Gauge (1) to extend over the edge of the bearing shell.

2. Use the correct torque-turn specifications in order to install the bearing cap. Do not use an impact wrench. Be careful not to dislodge the bearing shell when the cap is installed.

Note: Do not turn the crankshaft when the Plastic Gauge (1) is installed.

3. Carefully remove the bearing cap, but do not remove the Plastic Gauge (1). Measure the width of the Plastic Gauge (1) while the Plastic Gauge is in the bearing cap or on the crankshaft journal. Refer to the Illustration 283.

4. Remove all of the Plastic Gauge (1) before you install the bearing cap.

Note: When Plastic Gauge is used, the readings can sometimes be unclear. For example, all parts of the Plastic Gauge are not the same width. Measure the major width in order to ensure that the parts are within the specification range. Refer to the Specifications Manual, "Connecting Rod Bearing Journal" and refer to the Specifications Manual, "Main Bearing Journal" for the correct clearances.

i02280117

Glow Plugs - Remove and Install (If Equipped)

Removal Procedure

NOTICE

Keep all parts clean from contaminants.

Contaminants may cause rapid wear and shortened component life.

Note: The removal procedure is identical for the three cylinder and the four cylinder engines. The illustrations show the four cylinder engine.

1. Turn the disconnect switch to the OFF position.

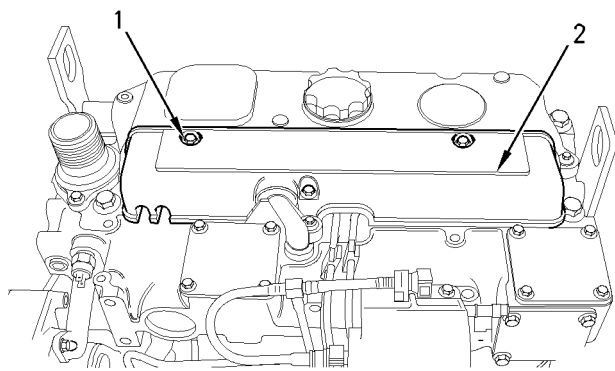

Illustration 284

g01001306

Typical example

2. Remove the setscrews (1). Remove the cover (2) from the cylinder head.

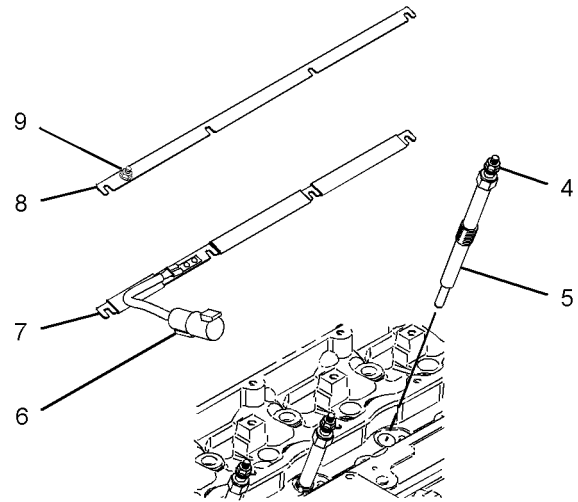

Illustration 285

g01119840

3. Disconnect the harness assembly from the Deutsch connector(6) on the bus bar (7), if equipped.
4. Disconnect the harness assembly from the stud (9) on the bus bar (8), if equipped.
5. Loosen the nuts (4) that secure the bus bar (7) or (8) to the glow plugs (5).
6. Remove the bus bar from the glow plugs.
7. Remove the glow plugs from the cylinder head.

Installation Procedure

NOTICE

Keep all parts clean from contaminants.

Contaminants may cause rapid wear and shortened component life.

Note: The installation procedure is identical for the three cylinder and the four cylinder engines. The illustrations show the four cylinder engine.

i02011941

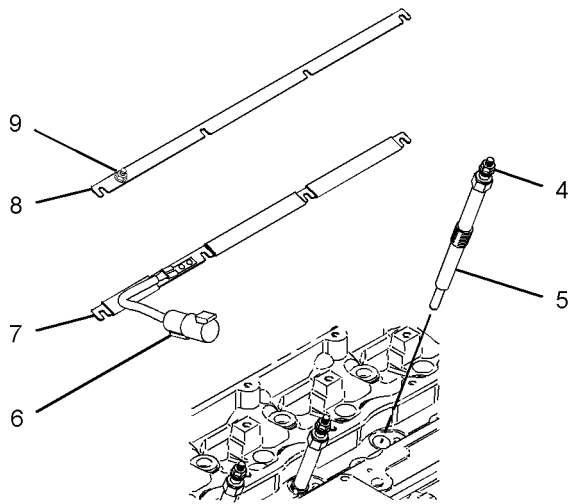

Illustration 286
Typical example

g01119840

1. Clean the threads of the glow plugs.
2. Install the glow plugs (5) into the cylinder head. Tighten the glow plugs to a torque of 15 N·m (11 lb ft).
3. Position the bus bar (7) or (8) onto the glow plugs. Tighten the nuts (4) on the glow plugs to a torque of 2 N·m (17 lb in).
4. Connect the harness assembly to the Deutch connector (5) on the bus bar (7), if equipped.
5. Connect the harness assembly to the stud (9) on the bus bar (8), if equipped.

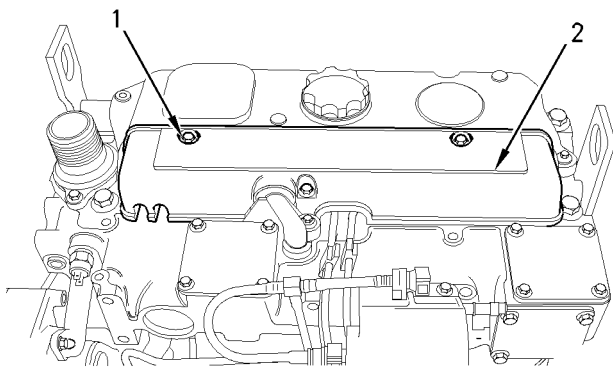

Illustration 287
Typical example

g01001306

6. Position the cover (2) onto the cylinder head. Install the setscrews (1). Tighten the setscrews to a torque of 9 N·m (80 lb in).
7. Turn the disconnect switch to the ON position.

V-Belts - Remove and Install

Removal Procedure

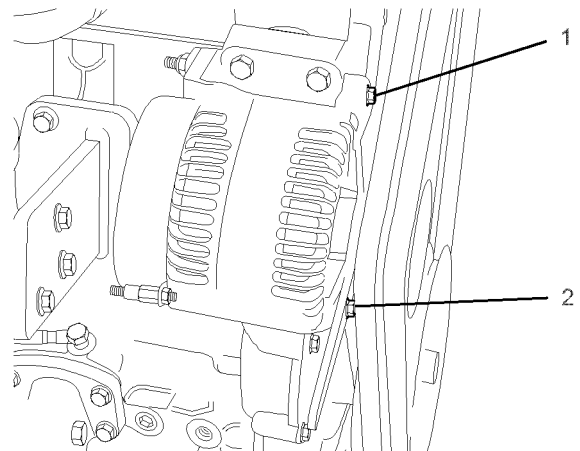

Illustration 288

g01015311

1. Loosen the setscrew (1), and the tension adjustment setscrew (2). Slide the alternator toward the engine.
2. Maneuver the V-belts around the fan and remove the V-belts.

Note: Never replace only one V-belt. Always replace the V-belts as a set.

Installation Procedure

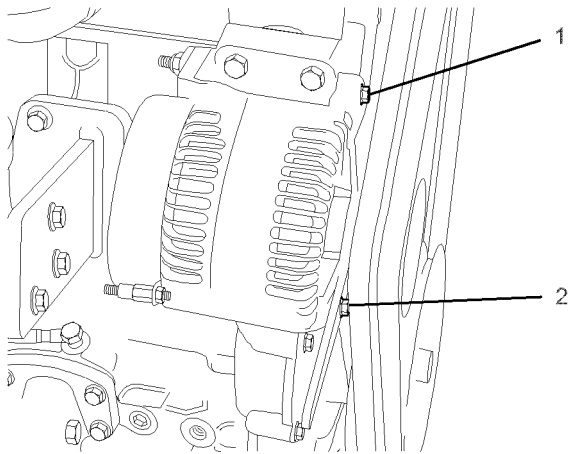

Illustration 289

g01015311

1. Install the V-belts behind the fan and onto the correct pulleys.
2. Adjust the tension on the V-belts by moving the alternator away from the engine. Tighten the tension adjustment setscrew (2) after the correct belt tension is made. Refer to Specifications, "Belt Tension Chart" for the correct tension of the V-belts. Tighten the tension adjustment setscrew (2) to a torque of 78 N·m (58 lb ft).
3. Tighten the setscrew (1) to a torque of 22 N·m (16 lb ft).
4. Tighten the nut (1) to a torque of 22 N·m (16 lb ft).

i01987612

Fan - Remove and Install

Removal Procedure

Start By:

- a. Remove the V-Belts. Refer to this Disassembly and Assembly Manual, "V-Belts - Remove and Install".

Note: The removal procedure is identical for the three cylinder and the four cylinder engines. The illustration shows the four cylinder engine.

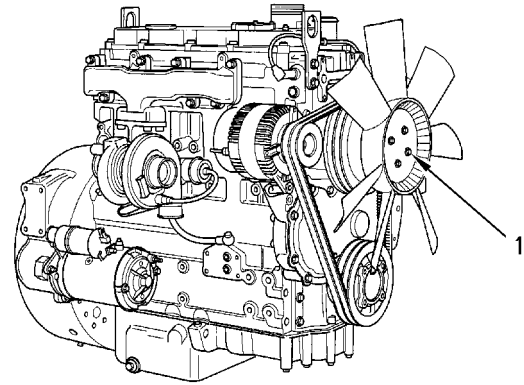

Illustration 290

g00926178

Typical example

1. Remove the setscrews (1).
2. Remove the fan.
3. If equipped, remove the extension for the fan.
4. Remove the fan pulley.

Installation Procedure

Note: The installation procedure is identical for the three cylinder and the four cylinder engines. The illustration shows the four cylinder engine.

1. Inspect the condition of the fan pulley. Replace the fan pulley, if necessary.
2. Install the fan pulley.
3. If the engine is equipped with an extension for the fan, install the extension.
4. Inspect the condition of the fan and replace the fan, if necessary.
5. Install the fan.

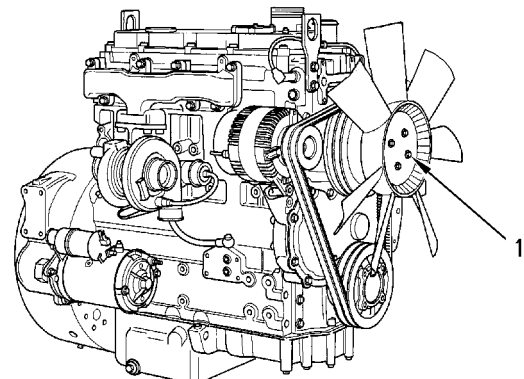

Illustration 291

g00926178

Typical example

6. Install the setscrews (1). Tighten the setscrews (1) to a torque of 12 N·m (9 lb ft).

End By:

- a. Install the V-Belts. Refer to this Disassembly and Assembly Manual, "V-Belts - Remove and Install".

i02011983

Fan Drive - Remove and Install

Removal Procedure

Start By:

- a. Remove the fan. Refer to this Disassembly and Assembly Manual, "Fan - Remove and Install".

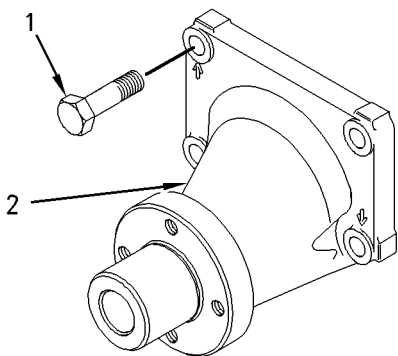

Illustration 292

g00944500

1. Remove the setscrews (1) from the fan drive (2).
2. Remove the fan drive (2).

Installation Procedure

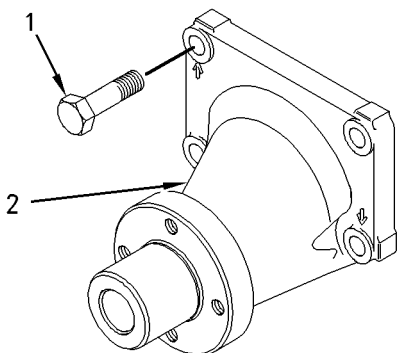

Illustration 293

g00944500

1. Install the fan drive (2).

2. Install the setscrews (1). Tighten the setscrews to a torque of 44 N·m (32 lb ft).

End By:

- a. Install the fan. Refer to this Disassembly and Assembly Manual, "Fan - Remove and Install".

i02012014

Alternator - Remove

Removal Procedure

1. Turn the battery disconnect switch to the OFF position.

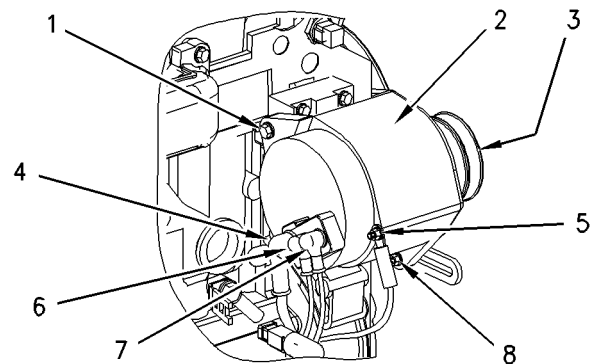

Illustration 294

g00999883

Typical Example

2. Place an index mark on all of the harness assemblies that are connected to the alternator.
3. Disconnect the harness assemblies (4), (6), and (7) from the alternator.
4. Disconnect the ground harness assembly (5) from the alternator.
5. Loosen the nut and the setscrew (1).
6. Remove the tension adjustment setscrew (8) and slide the alternator (2) toward the engine. Remove the V-belts from the alternator pulley.
7. Remove the setscrew (1) from the alternator bracket. Remove the alternator (2) from the engine.
8. If necessary, remove the nut (3) and the alternator pulley from the alternator.

i02245824

i01987613

Alternator - Install

Installation Procedure

Note: If the alternator pulley was removed, install the alternator pulley and the nut (3). Tighten the nut to a torque of 80 N·m (59 lb ft).

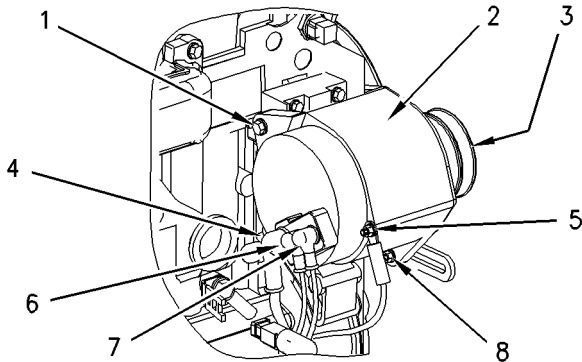

Illustration 295

g00999883

Typical Example

1. Put the alternator (2) in position onto the engine.
2. Install the nut and the setscrew (1). Tighten the nut finger tight.
3. Install the tension adjustment setscrew (8) through the adjustment bracket and into the alternator. Do not tighten the tension adjustment setscrew (8) at this time.
4. Install the V-belts onto the alternator pulley. Adjust the tension on the V-belts by moving the alternator (2) away from the engine. Tighten the tension adjustment setscrew (8) after the correct belt tension is made. Refer to the Specifications Manual, "Belt Tension Chart" for the correct tension of the V-belts.
5. Tighten the nut and the setscrew (1).
6. Connect the harness assemblies (4), (6), and (7) to the alternator.
7. Connect the ground harness assembly (5) to the alternator.
8. Refer to the Specifications Manual, "Alternator" for the correct torque for the terminal nuts.
9. Turn the battery disconnect switch to the ON position.

Electric Starting Motor - Remove and Install

Removal Procedure

Note: The removal procedure is identical for the three cylinder and the four cylinder engines. The illustrations show the four cylinder engine.

1. Ensure that the battery is disconnected or isolated.
2. Place an identification mark on all of the harness assemblies that are connected to the starting motor (4).

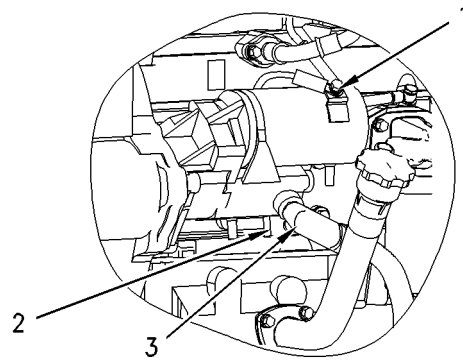

Illustration 296

g00999973

Typical Example

3. Disconnect the ground harness assembly (1) from the starting motor (4).
4. Disconnect the harness assembly (2) and disconnect the harness assembly (3) from the starting motor (4).

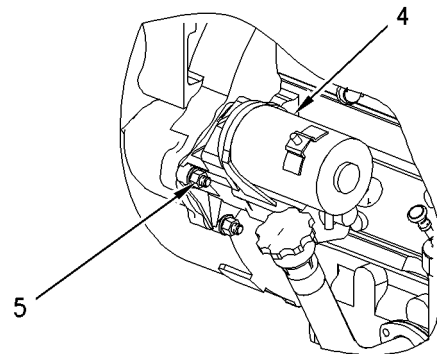

Illustration 297

g00999956

Typical Example

5. Remove the nuts (5) from the studs.
6. Remove the electric starting motor (4) from the flywheel housing.

Installation Procedure

Note: The installation procedure is identical for the three cylinder and the four cylinder engines. The illustrations show the four cylinder engine.

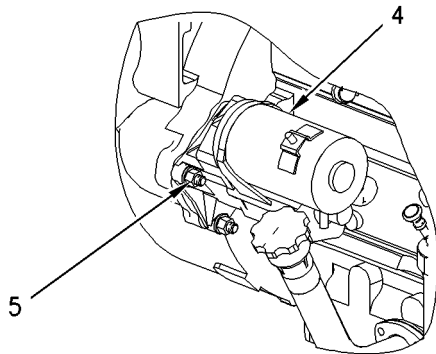

Illustration 298

g00999956

Typical Example

1. Install the electric starting motor (4) onto the flywheel housing.
2. Install the nuts (5) onto the studs. Tighten the nuts (5) to a torque of 44 N·m (32 lb ft).

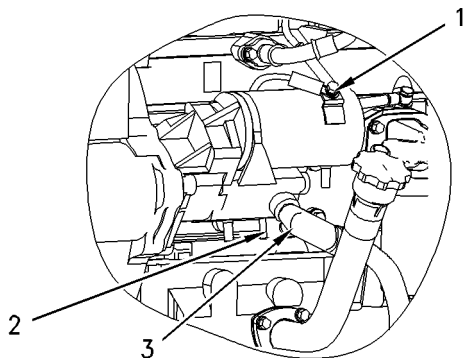

Illustration 299

g00999973

Typical Example

3. Connect the harness assembly (3), and the harness assembly (2) to the electric starting motor (4). Refer to the Specifications Manual, "Starter Motor" for the appropriate torques for the terminal nuts.
4. Connect the harness assembly (1) to the electric starting motor (4). Refer to the Specifications Manual, "Starter Motor" for the appropriate torques for the terminal nuts.

5. Turn the isolator for the battery to the ON position or reconnect the battery.

i02641613

Vacuum Pump - Remove and Install (Some 1104 engines only)

Removal Procedure

1. Disconnect the oil line from the vacuum pump and install a plastic cap onto the oil line. Install a plastic cap into the oil port in the vacuum pump.
2. Disconnect the vacuum line from the vacuum pump and install a plastic cap into the vacuum line. Install a plastic cap into the vacuum port in the vacuum pump.
3. Remove the setscrews and remove the vacuum pump from the front housing.
4. Remove the joint from the front housing and discard the joint.

Installation Procedure

1. Clean all dirt and oil from the surface area around the ports in the vacuum pump. Clean the mating faces on the vacuum pump and the front housing.
2. Install a new joint to the front housing and install the vacuum pump onto the housing with the setscrews. Tighten the setscrews to a torque of 22 N·m (16 lb ft).
3. Remove the plastic caps from the vacuum line and from the port in the vacuum pump. Install the vacuum line to the vacuum pump.
4. Remove the plastic caps from the oil line and from the port in the vacuum pump. Install the oil line to the vacuum pump.

i01981808

Hydraulic Pump (Steering) - Remove

Removal Procedure

1. Disconnect all of the hydraulic fluid lines from the hydraulic steering pump. Insert plastic caps into all of the open ports in the hydraulic steering pump and insert plastic caps onto the open ends of the hydraulic fluid lines.
2. Remove the setscrews that secure the hydraulic steering pump to the front housing and remove the hydraulic steering pump from the front housing.
3. Remove the O-ring from the front of the hydraulic steering pump. Discard the O-ring.

i02641617

Hydraulic Pump (Steering) - Install

Installation Procedure

1. Clean all dirt and oil from the surface area around the ports in the hydraulic steering pump. Clean the location of the O-ring at the front of the hydraulic steering pump. Clean the drive gear or the drive coupling for the hydraulic steering pump. Clean the mating surfaces of the hydraulic steering pump and the front housing.
2. Lubricate a new O-ring with clean engine oil. Install the O-ring onto the front of the hydraulic steering pump.
3. Install the hydraulic steering pump onto the front housing with the setscrews. Tighten the setscrews to a torque of 22 N·m (16 lb ft).
4. Remove the plastic caps from the hydraulic fluid lines and from the ports in the hydraulic steering pump. Install the hydraulic fluid lines to the hydraulic steering pump.

Index

A

Accessory Drive - Remove and Install..... 85
 Installation Procedure 86
 Removal Procedure 85
 Alternator - Install 130
 Installation Procedure 130
 Alternator - Remove 129
 Removal Procedure 129

B

Balancer - Install (Some 1104 Engines Only)..... 107
 Installation Procedure 107
 Balancer - Remove (Some 1104 Engines Only).. 106
 Removal Procedure 106
 Bearing Clearance - Check 125
 Measurement Procedure 125

C

Camshaft - Remove and Install 101
 Installation Procedure 101
 Removal Procedure 101
 Camshaft Bearings - Remove and Install 102
 Installation Procedure 103
 Removal Procedure 102
 Camshaft Gear - Remove and Install 102
 Installation Procedure 102
 Removal Procedure 102
 Connecting Rod Bearings - Install 114
 Installation Procedure 114
 Connecting Rod Bearings - Remove 113
 Removal Procedure 113
 Crankcase Breather - Remove and Install..... 87
 Installation Procedure for the Diaphragm Valve.. 88
 Removal Procedure for the Diaphragm Valve... 87
 Crankshaft - Install..... 120
 Installation Procedure 120
 Crankshaft - Remove..... 118
 Removal Procedure 118
 Crankshaft Front Seal - Install 72
 Installation Procedure 72
 Crankshaft Front Seal - Remove 71
 Removal Procedure 71
 Crankshaft Gear - Remove and Install 124
 Installation Procedure 124
 Removal Procedure 124
 Crankshaft Main Bearings - Install (Crankshaft in Position)..... 116
 Installation Procedure 116
 Crankshaft Main Bearings - Remove..... 115
 Removal Procedure 115

Crankshaft Pulley - Remove and Install 68
 Removal and Installation of the Non-standard Pulley (if equipped) 69
 Removal and Installation of the Standard Pulley (if equipped) 68
 Standard and Non-standard Pulleys 68
 Crankshaft Rear Seal - Install..... 63
 Installation Procedure 63
 Crankshaft Rear Seal - Remove..... 62
 Removal Procedure 62
 Crankshaft Wear Sleeve (Front) - Install 73
 Installation Procedure 73
 Crankshaft Wear Sleeve (Rear) - Install 66
 Installation Procedure 66
 Crankshaft Wear Sleeve (Rear) - Remove 65
 Removal Procedure 65
 Cylinder Head - Install 97
 Installation Procedure 97
 Cylinder Head - Remove 95
 Removal Procedure 95

D

Disassembly and Assembly Section..... 4

E

Electric Starting Motor - Remove and Install 130
 Installation Procedure 131
 Removal Procedure 130
 Engine Oil Cooler - Install..... 48
 Installation Procedure for the Four Cylinder Engine 50
 Installation Procedure for the Three Cylinder Engine 48
 Engine Oil Cooler - Remove 47
 Removal Procedure for Four Cylinder Engine .. 48
 Removal Procedure for Three Cylinder Engine.. 47
 Engine Oil Filter Base - Remove and Install 43
 Installation Procedure for a Spin-On Oil Filter ... 46
 Installation Procedure for an Oil Filter with a Separate Filter Element 44
 Removal Procedure for a Spin-On Oil Filter 45
 Removal Procedure for an Oil Filter with a Separate Filter Element..... 43
 Engine Oil Pan - Remove and Install..... 103
 Installation Procedure 104
 Removal Procedure 103
 Engine Oil Pump - Install (Engines Without a Balancer) 53
 Installation Procedure 53
 Engine Oil Pump - Remove (Engines Without a Balancer) 52
 Removal Procedure 52
 Engine Oil Relief Valve - Remove and Install (Balancer Unit for the 1104 engines only)..... 51
 Installation Procedure 52
 Removal Procedure 51

Engine Oil Relief Valve - Remove and Install (Engine Oil Pump).....	50	Fuel Injection Pump - Remove (Bosch EPVE for the 1104 engines only).....	16
Installation Procedure	51	Removal Procedure	16
Removal Procedure	50	Fuel Injection Pump - Remove (Delphi DP210).....	11
Exhaust Elbow - Remove and Install (If Equipped)	33	Removal Procedure	11
Installation Procedure	34	Fuel Injection Pump - Remove (Delphi DPA)	17
Removal Procedure	33	Removal Procedure	17
Exhaust Manifold - Remove and Install	31	Fuel Injection Pump - Remove (Delphi DPG).....	14
Installation Procedure for the Four Cylinder Engine	32	Removal Procedure	14
Installation Procedure for the Three Cylinder Engine	32	Fuel Injection Pump - Remove (Delphi STP).....	13
Removal Procedure for the Four Cylinder Engine	32	Removal Procedure	13
Removal Procedure for the Three Cylinder Engine	31	Fuel Injector - Install	28
		Installation Procedure	28
		Fuel Injector - Remove	27
		Removal Procedure	27
		Fuel Injector Cover - Remove and Install (If Equipped)	10
		Installation Procedure	11
		Removal Procedure	10
		Fuel Priming Pump - Remove and Install	4
		Installation Procedure	5
		Installation Procedure for Type 1	5
		Installation Procedure for Type 2	5
		Removal procedure.....	4
		Removal Procedure for Type 1	4
		Removal Procedure for Type 2	4
F			
Fan - Remove and Install	128		
Installation Procedure	128		
Removal Procedure	128		
Fan Drive - Remove and Install	129		
Installation Procedure	129		
Removal Procedure	129		
Flywheel - Install.....	61		
Installation Procedure	61		
Flywheel - Remove.....	61		
Removal Procedure	61		
Flywheel Housing - Remove and Install	66		
Installation Procedure	67		
Removal Procedure	66		
Front Cover - Remove and Install.....	73		
Installation Procedure	74		
Removal Procedure	73		
Fuel Filter Base - Remove and Install	6		
Installation Procedure	7		
Installation Procedure for the Element Filter.....	7		
Installation Procedure for the Spin-on Filter.....	8		
Removal Procedure	6		
Removal Procedure for the Element Filter.....	6		
Removal Procedure for the Spin-on Filter.....	7		
Fuel Injection Lines - Install	9		
Installation Procedure	9		
Fuel Injection Lines - Remove	9		
Removal Procedure	9		
Fuel Injection Pump - Install (Bosch EPVE for the 1104 engines only).....	24		
Installation Procedure	24		
Fuel Injection Pump - Install (Delphi DP210).....	19		
Installation Procedure	19		
Fuel Injection Pump - Install (Delphi DPA)	26		
Installation Procedure	26		
Fuel Injection Pump - Install (Delphi DPG).....	22		
Installation Procedure	22		
Fuel Injection Pump - Install (Delphi STP).....	20		
Installation Procedure	20		
		G	
		Gear Group (Front) - Install	76
		Installation Procedure	76
		Gear Group (Front) - Remove	74
		Removal Procedure	74
		Glow Plugs - Remove and Install (If Equipped)...	126
		Installation Procedure	126
		Removal Procedure	126
		H	
		Housing (Front) - Install	84
		Installation Procedure	84
		Housing (Front) - Remove	83
		Removal Procedure	83
		Hydraulic Pump (Steering) - Install.....	132
		Installation Procedure	132
		Hydraulic Pump (Steering) - Remove.....	132
		Removal Procedure	132
		I	
		Idle Gear - Remove and Install.....	78
		Installation Procedure	80
		Removal Procedure	78
		Important Safety Information	2
		Inlet and Exhaust Valve Guides - Remove and Install	39
		Installation Procedure	40
		Removal Procedure	39

Inlet and Exhaust Valve Seat Inserts - Remove and Install 41
 Installation Procedure 41
 Removal Procedure 41
 Inlet and Exhaust Valve Springs - Remove and Install 34
 Installation Procedure 35
 Removal Procedure 34
 Inlet and Exhaust Valves - Remove and Install 36
 Installation Procedure 37
 Removal Procedure 36

L

Lifter Group - Remove and Install..... 100
 Installation Procedure 100
 Removal Procedure 100

P

Piston Cooling Jets - Remove and Install..... 108
 Installation Procedure 109
 Removal Procedure 108
 Pistons and Connecting Rods - Assemble 111
 Assembly Procedure 111
 Pistons and Connecting Rods - Disassemble 110
 Disassembly Procedure 110
 Pistons and Connecting Rods - Install..... 112
 Installation Procedure 112
 Pistons and Connecting Rods - Remove..... 109
 Removal Procedure 109

R

Rocker Shaft - Assemble..... 93
 Assembly Procedure 93
 Rocker Shaft - Disassemble 92
 Disassembly Procedure 92
 Rocker Shaft and Pushrod - Install..... 94
 Installation Procedure 94
 Rocker Shaft and Pushrod - Remove..... 91
 Removal Procedure 91

T

Table of Contents..... 3
 Turbocharger - Install 30
 Installation Procedure 30
 Turbocharger - Remove 29
 Removal Procedure 29

V

V-Belts - Remove and Install 127
 Installation Procedure 128
 Removal Procedure 127

Vacuum Pump - Remove and Install (Some 1104 engines only) 131
 Installation Procedure 131
 Removal Procedure 131
 Valve Mechanism Cover - Remove and Install..... 90
 Installation Procedure 90
 Removal Procedure 90

W

Water Pump - Assemble..... 56
 Assembly Procedure 56
 Water Pump - Disassemble 54
 Disassembly Procedure 54
 Water Pump - Install 57
 Installation Procedure 57
 Water Pump - Remove 54
 Removal Procedure 54
 Water Temperature Regulator - Remove and Install 58
 Installation Procedure 59
 Removal Procedure 58

